

AD-A086 320

SRI INTERNATIONAL MENLO PARK CA
OPERATION OF THE PAVE PAWS RADAR SYSTEM AT BEALE AIR FORCE BASE--ETC(U)
JUL 80

F/G 17/9

F08635-76-D-0132

UNCLASSIFIED

AFSC-TR-80-09

NL

1 of 6

AD-A086 320

AD-A086 320

AD-A086 320

AD-A086 320

AD-A086 320

AD-A086 320

AD-A086 320

AD-A086 320

AD-A086 320

AD-A086 320

AD-A086 320

AD-A086 320

AD-A086 320

AD-A086 320

AD-A086 320

AD-A086 320

AD-A086 320

AD-A086 320

AD-A086 320

AD-A086 320

AD-A086 320

AD-A086 320

AD-A086 320

AD-A086 320

AD-A086 320

AD-A086 320

AD-A086 320

AD-A086 320

AD-A086 320

AD-A086 320

AD-A086 320

AD-A086 320

AD-A086 320

AD-A086 320

AD-A086 320

AD-A086 320

AD-A086 320

AD-A086 320

AD-A086 320

AD-A086 320

AD-A086 320

AD-A086 320

AD-A086 320

AD-A086 320

AD-A086 320

AD-A086 320

AD-A086 320

AD-A086 320

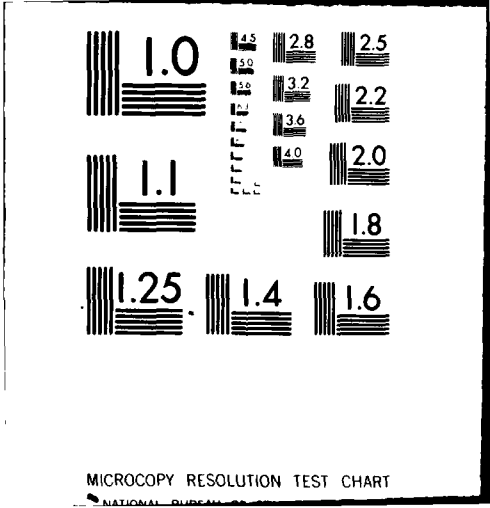

9 Final environmental impact statement.

16 2059

Unclassified

SECURITY CLASSIFICATION OF THIS PAGE (When Data Entered)

19 REPORT DOCUMENTATION PAGE		<small>READ INSTRUCTIONS BEFORE COMPLETING FORM</small>	
1 REPORT NUMBER AFSC TR-80-09	2 GOVT ACCESSION NO AD A088320	3 RECIPIENT'S CATALOG NUMBER	
4 TITLE (and Subtitle) Operation of the <u>Pave Paws</u> Radar System at Beale Air Force Base, California. Part 1. Basic EIS & Appendices.		5 TYPE OF REPORT & PERIOD COVERED FEIS - July 1980	6 PERFORMING ORG. REPORT NUMBER
7 AUTHOR(s) Department of the Air Force	8 CONTRACT OR GRANT NUMBER (if any) F08635-76-0132-0008 <i>New</i>	10 PROGRAM ELEMENT, PROJECT, TASK AREA & WORK UNIT NUMBERS 12432F/2059	
9 PERFORMING ORGANIZATION NAME AND ADDRESS <i>M...</i> SRI International-Palo Alto CA		11 CONTROLLING OFFICE NAME AND ADDRESS Department of the Air Force Office of the Assistant Secretary/Deputy for Environment & Safety Washington 20330	
12 MONITORING AGENCY NAME & ADDRESS (if different from Controlling Office) <i>12 486</i>		13 NUMBER OF PAGES 494	
		15 SECURITY CLASS. (of this report) Unclassified	
16 DISTRIBUTION STATEMENT (of this Report) Unclassified/Unlimited Distribution			
17 DISTRIBUTION STATEMENT (of the abstract entered in Block 20, if different from Report)			
18 SUPPLEMENTARY NOTES			
19 KEY WORDS (Continue on reverse side if necessary; and identify by block number) Pave Paws Beale Air Force Base Environmental Impact Statement (Final)			
20 ABSTRACT (Continue on reverse side if necessary; and identify by block number) The document is the Final Environmental Impact Statement on the Operation of the Pave Paws Radar System at Beale Air Force Base California.			

410281 DM

FINAL ENVIRONMENTAL IMPACT STATEMENT

OPERATION OF THE PAVE PAWS RADAR SYSTEM
AT BEALE AIR FORCE BASE, CALIFORNIA

U.S. AIR FORCE

JULY 1980

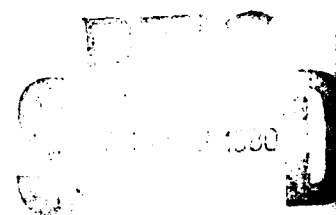

A

DISTRIBUTION STATEMENT A
Approved for public release;
Distribution Unlimited

Copies of this document are available as follows. Registered users of the Defense Technical Information Center (DTIC) may obtain copies from DTIC, Cameron Station, Alexandria VA 22314, in accordance with established procedures. Others may order from the National Technical Information Service, 5285 Port Royal Road, Springfield VA 22161, Telephone (703) 557-4650.

The Final EIS contains markings in the margin to indicate the text that was amended from the Draft version. A plus (+) sign indicates lines that are revised or deleted, and a double plus (++) , used once at the beginning of revised text, indicates that major revisions were made for a whole section, a paragraph or portion of a paragraph, or a table or figure.

ACCOMPLISHED	
SEARCHED	
SERIALIZED	
INDEXED	
FILED	
APR 1971	
FBI - WASHINGTON	
DIST	
A	

Preface

In response to requests made by residents of Yuba and Sutter Counties, members of the California Congressional Delegation, and State Officials, the Air Force, since the fall of 1978, has voluntarily undertaken to provide a further study of the environmental effects of the PAVE PAWS radar facility. This study has been prepared in the format and according to the procedures used for an Environmental Impact Statement (EIS).

The Air Force contracted with SRI International (Contract #FO8635-76-D-0132-0008) to provide inputs to this EIS.

The principal participants in the project at SRI International were the project leader, Dr. Ronald K. White, Program Manager and physicist; Dr. Marilyn K. Bland, Senior Ecologist, biology; Dr. Buford R. Holt, Senior Ecologist, botany; Ms. Susan J. Mara, Senior Resource Analyst, geology; Ms. Tracy H. Walklet, Resource Analyst, land use; Ms. Kristin M. Clark, Research Analyst, pollutants; Ms. Therese A. Freeman, Social Analyst, socioeconomics; Ms. Denise E. Conley, Urban Analyst, socioeconomics; Mr. John W. Ryan, Program Manager, socioeconomics; Dr. William A. Edson, Staff Scientist, radar fields; Mr. Ronald I. Presnell, Senior Research Engineer, radar fields; Mr. Richard A. Shepherd, Senior Research Engineer, electromagnetic interference; Mr. Bruce C. Tupper, Senior Research Engineer, electromagnetic interference; Dr. Peter Polson, Senior Biomedical Engineer, bioeffects; Dr. John S. Krebs, Senior Biophysicist, bioeffects; Dr. David C. Jones, Director, Toxicology Laboratory, bioeffects, Mr. Louis N. Heynick, Staff Physicist, bioeffects.

Throughout the environmental impact analysis process, the documents were reviewed by members of the following Air Force organizations: Office of the Secretary of the Air Force; Headquarters, U.S. Air Force; Headquarters, Air Force Systems Command; Headquarters, Aerospace Defense Command; Electronic Systems Division; Aerospace Medical Division; and USAF School of Aerospace Medicine.

The Draft EIS, filed with the U.S. Environmental Protection Agency and made available to the public on 27 July 1979, was amended in response to public and agency comment to produce this Final EIS. A transcript of a public hearing on the Draft EIS, copies of other public and agency comments, and responses to comments are provided in a separate attachment to this Final EIS. ++

SUMMARY

FINAL ENVIRONMENTAL IMPACT STATEMENT (EIS) Operation of the PAVE PAWS Radar System at Beale Air Force Base, California

Description of the Action

PAVE PAWS is a new surveillance and tracking radar operated by the U.S. Air Force (USAF). Its primary purpose is to detect, track, and provide early warning of sea-launched ballistic missiles. PAVE PAWS maintains a long-range, wide-area coverage utilizing phased-array technology. The substantially improved missile detection and tracking capability that it will provide is essential to characterize adequately a sea-launched ballistic missile attack and to provide earlier warnings to strategic forces. The secondary purpose of PAVE PAWS is to assist the USAF SPACETRACK System by tracking objects that are orbiting the earth.

PAVE PAWS is located at Beale Air Force Base (AFB), California, and is the second such installation. The first installation is at Otis AFB, Massachusetts. With PAVE PAWS in operation at Beale AFB, older radars at Mt. Hebo Air Force Station (AFS), Oregon, Mill Valley AFS, California, and Mt. Laguna AFS, California, will be retired. PAVE PAWS is expected to operate continuously for at least 10 years. Environmental impacts of PAVE PAWS installations other than at Beale AFB are not addressed in this EIS. A Final EIS for PAVE PAWS at Otis AFB has been published.

PAVE PAWS is housed in a large main building with associated facilities on a site of approximately 11 acres. Fifty additional acres are fenced and posted to prevent humans and some animals from approaching close to the radar face. Approximately 225 operating and maintenance personnel are required. Deactivation of the radars to be replaced will reduce manpower requirements by a total of 231 positions.

The PAVE PAWS system is designed to accommodate a potential power increase, i.e., the growth option. However, approval has not been given to incorporate such enhanced capability.

Environmental Effects

Human Health. Radiation safety is of paramount importance. The environmental analysis in this area includes an in-depth, critical review of the available literature on the subject, extensive calculations of worst case predicted signal levels, and measurement of actual radiation levels under conditions representative of the maximum signals during full-scale operation.

The literature review addresses the present state of scientific knowledge regarding the biological effects of radiofrequency radiation (RFR) in the range of 10 to 18,000 MHz. The documents judged both most significant scientifically and most relevant to the operational characteristics of PAVE PAWS and the anticipated electromagnetic radiation power densities were selected from the large body of available literature. The hundreds of research studies reviewed indicated many different RFR-induced biological effects, but only at radiation levels much greater than those to which the general public will be exposed by PAVE PAWS.

For the general public, long-term exposures for persons in the communities and working areas both on and off Beale AFB should be less than 0.35 microwatts/cm². Neither climatic conditions, time of year, nor even the growth option, should increase this actual long-term exposure.

If persons enter Beale AFB and cross the military reservation to reach the PAVE PAWS 1,000 ft exclusion fence, the average power densities should not exceed 30 microwatts/cm² even with the growth option. At the security fence, the maximum average power density is calculated to be 47 microwatts/cm² with the basic system and 90 microwatts/cm² with the growth option. Measured values confirmed these estimates. The airborne exposure situation was thoroughly evaluated. The conclusion is that there is no biological hazard even with the growth option.

No scientific evidence was discovered to indicate that any ill effects will result from long-term exposure to the PAVE PAWS emissions. The relatively few retrospective epidemiology studies of health effects from RFR exposure done in the United States and the USSR are not considered to contain evidence that the PAVE PAWS emissions will constitute a hazard to the population. Also, there is no clear experimental evidence that exposure of animals to the PAVE PAWS average and pulse power densities results in any biological hazards. The general public exposure from PAVE PAWS is far lower than any existing or proposed safety standard. PAVE PAWS should not be affected by any new environmental standard.

The inherent safety of PAVE PAWS has been supported by several other reviewers. The National Academy of Sciences concluded that "it is improbable that exposure will present any hazard to the

public." The National Telecommunications and Information Administration concluded "there is probably no environmental hazard." Similarly, the Environmental Protection Agency stated "PAVE PAWS radiation is unlikely to cause health effects in the general population of the area where prolonged exposure is expected."

Electromagnetic Interference. Some interference with TV reception, certain military aircraft radar altimeters, aircraft and land mobile radios and ham radios in the area is possible. In most cases, this interference will probably not be seriously disruptive. For disruptive cases, interference could be somewhat reduced by adjustments to the receiving equipment, or possibly by changes in the operation of the PAVE PAWS radar.

People with cardiac pacemakers are very unlikely to be affected outside the fenced "exclusion zone" on the ground or in the air.

Land Use. No significant effects on land use are anticipated. When operation of PAVE PAWS ends, the 50 fenced acres could be returned to their prior use as cattle grazing area. However, as the structures may not be removed, the loss of 11 acres of cattle grazing area may result for an indefinite period.

Population and Economics. The expected demographic and economic effects of PAVE PAWS are minor. The small changes in the working and civilian population at the affected USAF installations will be very small compared with historical changes in the areas.

Alternatives Considered

No Action. PAVE PAWS would not be operated at Beale AFB, and operation of radars that it is scheduled to replace would continue.

Postpone Action. Full-scale operation of PAVE PAWS would be postponed to allow the resolution of specific problems or issues related to PAVE PAWS operation.

Different Location. The PAVE PAWS facility now built at Beale Air Force Base would be removed and reconstructed at one of three other sites: Mt. Hebo AFS, Oregon; Mill Valley AFS, California; or at another site at Beale AFB.

Modify the Radar or its Surroundings. To minimize interference, certain frequencies would not be used during PAVE PAWS operation. Earthen berms and sheet metal or wire screens would be used to shield specific areas.

Conclusion

Operating PAVE PAWS at its current location on Beale AFB will have no significant environmental impact. The possibility that new information would reveal a significant environmental impact has not been dismissed, but it is judged to be unlikely.

Public Concerns and the Air Force Response

Some common concerns expressed in the comments on the Draft EIS related to: (1) the reliability of the radar's beam control procedures; (2) the need for additional radiation and public health monitoring; and (3) the lack of absolute proof concerning the safety of RFR at the PAVE PAWS power densities (i.e., general public exposure at the sub-microwatt/cm² level).

The following is an overview of the USAF position with regard to the common concerns listed above.

- (1) The triple-redundant procedures that control the positioning of the radar beam are adequate and secure. The control reliability has also been independently verified by the National Academy of Sciences.
- (2) Additional continuing radiation monitoring would not serve a useful purpose because the radar cannot expose the public to higher levels of radiation than are described in the EIS. Public health monitoring would not serve a useful purpose because general public exposure from PAVE PAWS will be in the sub-microwatt/cm² range even if the growth option is implemented.
- (3) Absolute proof of safety is not possible; however, the EIS represents a thorough evaluation of the potential environmental impact of operating PAVE PAWS and, at the PAVE PAWS power densities, no hazard is predicted from either the basic or growth systems. This conclusion has also been reached by the National Academy of Sciences.

DISTRIBUTION LIST

Federal Agencies

14 AD/CC
Attn: Brig. Gen. J. A. Brashear
Beale AFB, CA 95903

Hq ADCOM/DEVP
Attn: Capt. R.J. Michaels
Peterson AFB, CO 80914

Hq AFESC/DV
Attn: Mr. Kibler
Tyndall AFB, FL 32403

Hq AFSC/SDED
Washington, DC 20330

AMD/RD
Attn: Col. Mohr
Brooks AFB, TX 78235

100 AREFW/OI
Beale AFB, CA 95903

Senator Alan Cranston
229 Russell Office Building
Washington, DC 20510

1880 3CS/CC
Attn: Major Miller
Beale AFB, CA 95903

100 CSG/CC
Attn: Col. Lapp
Beale AFB, CA 95903

100 CSG/DE
Beale AFB, CA 95903

100 CSG/DEE
Attn: Mr. G. Coffey
Beale AFB, CA 95903

100 CSG/JA
Attn: LTC James Stanton
Beale AFB, CA 95903

DISTRIBUTION LIST (Continued)

ECAC
Attn: DOKE
North Severn
Annapolis, MD 21402

1839 EIG/EPE
Attn: Mr. R. J. Burgess
Keesler AFB, MS 39534

Environmental Protection Agency
Director, Office of Federal Activities
401 M Street, S.W.
Washington, DC 20460

Environmental Protection Agency
EIS Coordinator
801 I Street
Sacramento, CA 95814

Environmental Protection Agency
Office of Radiation Programs
9100 Brookeville S-4 Road
Silver Springs, MD 20910

ESD/JA
Hanscom AFB, MA 01731

ESD/DE
Attn: Mr. Scansaroli
Hanscom AFB, MA 01731

ESD/OI
Attn: Mr. Levinson
Hanscom AFB, MA 01731

Congressman Vic Fazio
Box 1512
Marysville, CA 95901

Senator S. I. Hayakawa
6217 Dirksen Office Building
Washington, DC 20510

Congressman Harold Johnson
320 Vernon Street
Roseville, CA 95678

DISTRIBUTION LIST (Continued)

Congressman D. Matsui
House of Representatives
State of California
Washington, DC

7 MWS
Attn: Col. Montgomery
Beale AFB, CA 95903

7 MWS/XPD
Attn: LTC R. Saccoliti
Beale AFB, CA 95903

National Academy of Sciences
2101 Constitution Avenue, N.W.
Washington, DC 20520

National Academy of Sciences
Environmental Studies Board
Attn: Adelle King
2101 Constitution Avenue
Washington, DC 20418

Hq RADC/OCSP
Attn: Mr. E. Malowicki
Griffiss AFB, NY 13440

Hq SAC/XPF
Offutt AFB, NE 68113

SAF/LL
Washington, DC 20330

SAF/OI
Washington, DC 20330

USAF Hospital/SGPB
Attn: Capt. Fink
Beale AFB, CA 95903

Hq USAF/JAJT
Attn: Col. A. C. Smith
Washington, DC 20234

Hq USAF/LEEV
Washington, DC 20330

DISTRIBUTION LIST (Continued)

Hq USAF/RDSD
Washington, DC 20330

USAF SAM/RZP
Attn: Mr. John Mitchell
Brooks AFB, TX 78235

U.S. Army Corps of Engineers
Sacramento Regional Office
650 Capitol Mall
Sacramento, CA 95814

U.S. Department of Commerce
Director of Spectrum Plans & Policies
National Telecommunications & Information Admin.
Room 259
1325 G Street, N.W.
Washington, DC 20005

U.S. Department of Commerce
National Bureau of Standards
Washington, DC 20234

U.S. Department of Commerce
Office of Environmental Affairs
Washington, DC 20230

U.S. Department of HEW
Bureau of Radiological Health
5600 Fishers Lane
Rockville, MD 20857

U.S. Department of HEW
National Institute of Occ. Safety and Health
5600 Fishers Lane
Rockville, MD 20857

U.S. Department of Housing & Urban Development
Office of Community Planning & Development
451 Seventh Street, S.W.
Washington, DC 20410

U.S. Department of the Interior
Office of Environmental Project Review
Attn: Lillian Stone
Washington, DC 20240

DISTRIBUTION LIST (Continued)

**U.S. Department of Justice
Land and Natural Resource Development
Attn: Thomas Riley
Washington, DC 20530**

**U.S. Department of Justice
U.S. Attorney
650 Capitol Mall
Sacramento, CA 95814
Attn: Ms. B. Wolf**

**U.S. Department of Labor
Occupational Safety & Health Admin.
200 Constitution Avenue, N.W.
Washington, DC 20210**

**U.S. Department of Transportation
FAA
Office of Environmental Quality
800 Independence Avenue, SW
Washington, DC 20330**

**U.S. Geological Survey Area
Attn: Jane Pratt
345 Middlefield Road
Mail Stop 92
Menlo Park, CA 94025**

**U.S. Geological Survey
2800 Cottage Way
Sacramento, CA 95825**

State and Local Agencies

**Air Resources Board
1102 Q Street
Sacramento, CA 95814**

**The Honorable Jerry Brown
Governor of California
Sacramento, CA 95814**

**California Department of Fish and Game)
1416-9th Street
Sacramento, CA 95814**

DISTRIBUTION LIST (Continued)

California Energy Resources Conservation and Development Commission
1111 Howe Street
Sacramento, CA 95825

California Office of Planning and Research
1400-10th Street
Sacramento, CA 95814

California State University Library
California State University
Chico, CA 95926

The Honorable Mike Curb
Lieutenant Governor of California
Sacramento, CA 95814

Mr. Joseph Fraser
Mayor of Yuba City
441 Colusa Avenue
Yuba City, CA 95991

Golden Gate National Recreation Area
450 Golden Gate Avenue
San Francisco, CA 94102

Mr. Grady Lamon
Mayor of Marysville
P.O. Box 150
Marysville, CA 95901

Linda Public Library
Linda, CA 95901

The Mayor of Linda
Linda, CA 95901

Marysville City Planning Commission
526 C Street
Marysville, CA 95901

Marysville Unified School District
Marysville, CA 95901

Marin County Planning Department
San Rafael, CA 94902

Marin Municipal Water District
Division of Land Management
San Rafael, CA 94902

DISTRIBUTION LIST (Continued)

**Olivehurst Town Hall
4981 Olivehurst Avenue
Olivehurst, CA 95961**

**Sacramento Regional Area Planning Commission
800 H Street
Sacramento, CA 95814**

**Sacramento State Library
California State University Sacramento
6000 J Street
Sacramento, CA 95819**

**The Mayor of Smartville
Smartville, CA 95977**

**Spenceville Wildlife Refuge
California Department of Fish and Game
Smartville, CA 95977**

**Sutter County Health Department
370 Del Norte Avenue
Yuba City, CA 95991**

**Sutter County Planning Board
Yuba City, CA 95991**

**Sutter County Public Library
Yuba County, CA 95991**

**University of California Library
University of California
Davis, CA 95616**

**Wheatland City Planning Commission
313 Main Street
Wheatland, CA 95692**

**The Mayor of Wheatland
Wheatland, CA 95692**

**Wheatland Union School District
Superintendent of Schools
Wheatland, CA 95692**

DISTRIBUTION LIST (Continued)

Yuba City Planning Commission
204 C Steet
Yuba City, CA 95991

Yuba City Unified School District
Director, Administration Services
Yuba City, CA 95991

Yuba College Library
Yuba College
Marysville, CA 95901

Yuba County Board of Supervisors
215-5th Street
Marysville, CA 95901

Yuba County Health Department
370 Del Norte Avenue
Yuba City, CA 95991

Yuba County Planning and Economic Development Department
938-14th Street
Marysville, CA 95901

Yuba County Planning Commission
Marysville, CA 95901

Yuba County Public Library
Marysville, CA 95901

Other

Mr. S. William Abel
PO Box 927
Colusa, CA 95932

Mr. Dan Adams
Station KHSL-TV News
Chico, CA 95926

Mr. George Allender
318 I Street
Marysville, CA 95901

American Radio Relay League
Attn: David Summer
Newington, CT 06111

DISTRIBUTION LIST (Continued)

The Appeal-Democrat
319 G Street
Marysville, CA 95901

Mr. Willard Bradshaw
PO Box 183
Wheatland, CA 95692

Billie Burky
1800 Starr St.
Yuba City, CA 95991

Citizens Concerned About PAVE PAWS
c/o Mrs. Lala Cade
12419 Krosens, Loma Rica
Marysville, CA 95901

Mr. Robert Coe
PO Box 698
Wheatland, CA 95692

Mr. Don Crawford
27 E. 12th St.
Marysville, CA 95901

Mr. R. A. Draeger
Division Manager
Pacific Gas and Electric Company
Marysville, CA 95901

Mr. Ruben Ebanes
316 C Street
Marysville, CA 95901

Mr. Mel Eckerstrom
2210 Greeley Drive
Marysville, CA 95901

Terry Eisenbeisz
4141 Octavia St.
Beale AFB, CA 95903

Pat Fennacy
1310 East Swift
Fresno, CA 93704

DISTRIBUTION LIST (Continued)

Mr. R. L. Ficklin
Southern Pacific Transport Co.
#1 Market Plaza, Rm. 926
San Francisco, CA 94107

Randy Fitch
North West Radio
P.O. Box 1049
Colusa, CA 95932

Mr. A. M. FitzSimons
978 Queen Anne Court
El Dorado Hill, CA 95630

Mr. Ross Forbes
1205 E. 22nd St.
Marysville, CA 95901

Mr. Rex Gunnison
311 B Street
Yuba City, CA 95991

Mr. Chet Hancock
Station KOVR-TV
1216 Arden Way
Sacramento, CA 95815

Health Effects Research Lab
Experimental Biology Division
Mail Stop 71
Attn: Dr. Cahill
Research Triangle Park, NC 27709

Mr. Peter Ingram
P.O. Box 178
Susanville, CA 96130

Mr. Bruce R. James
1025 E. 22nd St.
Marysville, CA 95901

Mr. Craig Jarvis
The Morning Herald
430 Center Street
Yuba City, CA 95991

DISTRIBUTION LIST (Continued)

Kapri Kaupper
PO Box 178
Smartville, CA 95977

Mr. Brad Knickerbocker
Christian Science Monitor
625 Market Street
San Francisco, CA 94105

Mr. Bill Lawrence
Sacramento Bee
21st and 2nd Street
Sacramento, CA 95816

Dr. Egon E. Loebner
2934 Alexis Drive
Palo Alto, CA 94304

Mr. John Markhoff
Pacific News Service
604 Mission Street, Room 1001
San Francisco, CA 94015

Mr. Ed Mendel
Sacramento Union
301 Capitol Mall
Sacramento, CA 95812

Ms. Mabel McFarland
2327 Edward St.
Marysville, CA 95901

MITRE Corporation
Attn: Div. 83 Mr. W. Clevon
Bedford, MA 01730

Motorola C&E
Attn: Mr. Bernie Olson
1170 Chess Drive
Foster City, CA 94404

Mr. Stanley Nass
Yuba County Court House
Marysville, CA 95901

DISTRIBUTION LIST (Continued)

Mr. Robert Nelson
3947 Seven Trees Blvd., B-109
San Jose, CA 95111

Ms. Dianna Nichols
1605 Simpson Lane
PO Box 631
Marysville, CA 95901

J. J. O'Brien
6606 5th Street
Rio Linda, CA 95673

Mr. Carl B. Olson
1170 Chess Drive
Foster City, CA 94404

Pacific Legal Foundation
455 Capitol Mall, Suite 465
Sacramento, CA 95814

M. Packard
12646 LaCresta Drive
Los Altos Hills, CA 94022

Mr. Arthur W. Pearce
5042 Loop Road
Marysville, CA 95901

Ms. Marlene Poston
2571 Franklin Road
Yuba City, CA 95991

Mr. William Rafferty
1058 Celestial Way
Yuba City, CA 95991

Raytheon Company - Equipment Division
Equipment Division Laboratory
Attn: Mr. J. Caswell
Boston Post Road
Wayland, MA 01778

Ms. Adrienne Sciutto
883 Urbano Street
San Francisco, CA 94127

DISTRIBUTION LIST (Concluded)

**Ms. Marilyn Seirer
921 Ashley Way
Yuba City, CA 95991**

**Dr. Louis Slesin
NRDC - 45th Floor
122 East 42nd Street
New York, NY 10017**

**Mr. Gar Smith
Box 27
Berkeley, CA 94701**

**Mr. Therom Smith
32384 Hampton Ct.
Union City, CA 94587**

**Mr. Harold R. Spies
397 Neil Drive
Yuba City, CA 95991**

**Mr. Ron Stanton
City Hall
Yuba City, CA 95991**

**Ms. Nancy W. Taft
3569 Dumosa Way
Beale AFB, CA 95903**

**Vaden, Berger and Norton
Attn: Miss Seros
501 Santa Monica Boulevard
Suite 600
Santa Monica, CA 90406**

**The Valley Herald
430 Center Street
Yuba City, CA 95991**

**Mr. Martin F. Young
P.O. Box 227
Dobbins, CA 95935**

TABLE OF CONTENTS

Part 1

Chapters

1	INTRODUCTION	1-1
1.1	Project Description	1-1
1.2	Existing Site Characteristics	1-8
1.2.1	Beale AFB, California	1-8
1.2.1.1	Biophysical Characteristics	1-11
1.2.1.1.1	Plants and Animals	1-11
1.2.1.1.2	Electromagnetic Environment	1-16
1.2.1.1.3	Soil, Water, Air, and Noise	1-17
1.2.1.1.4	Minerals and Other Resources	1-20
1.2.1.1.5	Natural Disasters	1-21
1.2.1.2	Socioeconomic Characteristics	1-22
1.2.1.2.1	Land Use and Aesthetics	1-22
1.2.1.2.2	Demographics and Economics	1-27
1.2.2	Mt. Hebo AFS, Oregon	1-40
1.2.2.1	Biophysical Characteristics	1-40
1.2.2.2	Socioeconomic Characteristics	1-45
1.2.3	Mill Valley AFS, California	1-47
1.2.3.1	Biophysical Characteristics	1-50
1.2.3.2	Socioeconomic Characteristics	1-53
1.2.4	Mt. Laguna AFS, California	1-56
1.2.4.1	Biophysical Characteristics	1-57
1.2.4.2	Socioeconomic Characteristics	1-57
2	RELATIONSHIP OF THE PROPOSED ACTION TO LAND USE PLANS, POLICIES, AND CONTROLS FOR THE AFFECTED AREA	2-1
2.1	The Affected Area	2-1

Chapters

2.2	Plans	2-7
2.3	Policies	2-12
2.4	Controls	2-17
3	PROBABLE IMPACT OF THE PROPOSED ACTION ON THE ENVIRONMENT	3-1
3.1	Beale AFB, California	3-1
3.1.1	Exposure to Electromagnetic Radiation (EMR)	3-1
3.1.2	Biophysical Impacts	3-16
3.1.2.1	Human Health	3-16
3.1.2.1.1	Introduction	3-17
3.1.2.1.2	Present Climate and Context	3-20
3.1.2.1.3	Problems of Risk Assessment	3-21
3.1.2.1.4	Assessment of Scientific Information	3-24
3.1.2.1.5	Other Assessments and Reviews	3-25
3.1.2.1.6	Present State of Knowledge Regarding Physical Effects	3-25
3.1.2.1.7	Present State of Knowledge Regarding Biological Effects	3-35
3.1.2.1.8	Unresolved Issues	3-57
3.1.2.1.9	PAVE PAWS and Safety to Human Populations	3-57
3.1.2.1.10	Other Viewpoints	3-60
3.1.2.2	Plants and Animals	3-60
3.1.2.3	Electromagnetic Environment	3-65
3.1.2.4	Soil, Water, Air, Noise, and Solid Waste	3-76
3.1.2.5	Minerals and Other Resources	3-81
3.1.2.6	Natural Disasters	3-81
3.1.3	Socioeconomic Impacts	3-82
3.1.3.1	Land Use and Aesthetics	3-82
3.1.3.2	Demographics and Economics	3-86
3.1.4	Growth System	3-91

Chapters

3.2	Mt. Hebo AFS, Oregon	3-98
3.3	Mill Valley AFS, California	3-99
3.4	Mt. Laguna AFS, California	3-102
4	ALTERNATIVES	4-1
4.1	No Action	4-1
4.2	Postpone Action	4-2
4.3	Different Locations	4-2
4.3.1	Mt. Hebo AFS, Oregon	4-7
4.3.2	Mill Valley AFS, California	4-12
4.3.3	Location No. 1, Beale AFB, California	4-19
4.4	Modify Radar or Surroundings	4-24
5	PROBABLE ADVERSE ENVIRONMENTAL EFFECTS THAT CANNOT BE AVOIDED	5-1
6	RELATIONSHIP BETWEEN LOCAL SHORT-TERM USE OF MAN'S ENVIRONMENT AND THE MAINTENANCE AND ENHANCEMENT OF LONG-TERM PRODUCTIVITY	6-1
7	IRREVERSIBLE AND IRRETRIEVABLE COMMITMENTS OF RESOURCES	7-1
8	CONSIDERATIONS THAT OFFSET THE ADVERSE ENVIRONMENTAL EFFECTS	8-1
9	DETAILS OF UNRESOLVED ISSUES	9-1
9.1	Biological Effects	9-1
9.2	Electromagnetic Interference	9-1
10	BIBLIOGRAPHIC REFERENCES	10-1

Appendices

A.	RADAR AND ANTENNA CHARACTERISTICS	A-1
A.1	Introduction	A-1
A.2	System Characteristics	A-1
A.3	EMR Field Model Description	A-10
A.4	Determination of Ground-Level Field	A-21
A.5	Summary	A-34
A.6	References.	A-36
B.	ELECTROMAGNETIC RADIATION (EMR) FIELD MEASUREMENTS AND COMPARISON WITH CALCULATIONS	B-1
B.1	Introduction	B-1
B.2	Ambient Field Measurements	B-1
B.3	PAVE PAWS EMR Field Measurements	B-1
B.3.1	Test Locations	B-1
B.3.2	Test Conditions	B-6
B.3.3	Test Instrumentation	B-6
B.3.4	Test Procedure	B-7
B.3.5	Results and Comparisons	B-9
B.4	Summary	B-9
B.5	References	B-11
C.	HUMAN EXPOSURE TO RADIOFREQUENCY RADIATION (RFR)	C-1
C.1	Introduction	C-1
C.2	Present Climate and Context.	C-5
C.3	Problems of Risk Assessment.	C-7
C.4	Assessment of Scientific Information	C-9
C.5	Other Assessments and Reviews	C-12
C.6	Present State of Knowledge Regarding Physical Effects	C-15
C.7	Present State of Knowledge Regarding Biological Effects	C-27
C.7.1	Epidemiology	C-27
C.7.2	Mutagenic and Cytogenetic Effects	C-34
C.7.3	Studies on Teratogenesis and Developmental Abnormalities	C-37
C.7.4	Ocular Effects	C-40
C.7.5	Nervous System Studies	C-43
C.7.6	Effects on Behavior	C-54
C.7.7	Endocrinological Effects	C-57
C.7.8	Immunological Effects	C-60
C.7.9	Biochemical and Physiological Effects	C-64
C.7.10	Cellular Effects	C-66
C.8	Unresolved Issues	C-71

C.9	PAVE PAWS and Safety to Human Populations	C-72
C.10	Other Viewpoints	C-73
C.11	References	C-73
D.	ELECTROMAGNETIC INTERFERENCE AND HAZARDS TO SYSTEMS	D-1
D.1	Introduction	D-1
D.2	PAVE PAWS Electromagnetic Fields	D-4
D.3	PAVE PAWS Effects on Systems	D-20
D.3.1	Telecommunications Systems	D-20
D.3.1.1	Effects on Amateur Radio-- A Secondary Service.	D-20
D.3.1.2	Interference to Television	D-31
D.3.1.3	Effects on UHF/FM Land Mobile Radios	D-49
D.3.1.4	High-Power Effects to System	D-60
D.3.1.5	Airborne Systems	D-64
D.3.1.6	Effects in Harmonically-Related Bands.	D-76
D.3.2	Hazard Effects	D-78
D.4	References	D-93

Part 2
(Bound Separately)

Attachment: Public Comment on the Draft
Environmental Impact Statement and the Air Force response.

LIST OF FIGURES

1-1	Location of PAVE PAWS Sites at Otis Air Force Base and Beale Air Force Base. Also shown are Affected West Coast Air Force Stations	1-2
1-2	PAVE PAWS Radar and Power Plant Buildings	1-3
1-3	PAVE PAWS Site Plan at Beale Air Force Base	1-4
1-4	Artist's Sketch of PAVE PAWS EMR Pattern.	1-7
1-5	Beale Air Force Base, California	1-9
1-6	Habitat Cover Map Showing the Dominant Vegetation at Beale Air Force Base	1-11
1-7	Land Uses at Beale Air Force Base	1-25
1-8	Existing and Potential Land Use on the Periphery of Beale Air Force Base	1-26
2-1	Sacramento Regional Planning Area	2-2
2-2	The Environs of Beale Air Force Base	2-4
2-3	Regional Analysis Districts (RADs) in Yuba County	2-6
2-4	Proposed Land Use Plans on the Periphery of Beale Air Force Base	2-9
2-5	Areas of Critical Environmental Concern in the Vicinity of Beale Air Force Base	2-14
3-1	PAVE PAWS Azimuth from Location No. 2, Beale Air Force Base	3-3
3-2	Calculated PAVE PAWS EMR Power Density at Ground Level, 1,000-1,500 ft Range	3-4
3-3	Calculated PAVE PAWS EMR Power Density for Sector 1, 1,500-5,000 ft Range	3-5
3-4	Calculated PAVE PAWS EMR Power Density for Sector 1, 5,000-25,000 ft Range	3-6

3-5	Calculated PAVE PAWS EMR Power Density for Sector 2, 1,500-5,000 ft Range	3-7	
3-6	Calculated PAVE PAWS EMR Power Density for Sector 2, 5,000-25,000 ft Range	3-8	
3-7	Calculated PAVE PAWS EMR Power Density for Sector 3, 1,500-5,000 ft Range	3-9	
3-8	Calculated PAVE PAWS EMR Power Density for Sector 3, 5,000-25,000 ft Range	3-10	
3-9	Sector 3 at Close Range, 200 to 1,000 Feet	3-12	
3-10	Developed Areas in and Around Beale Air Force Base . .	3-14	
3-11	View of PAVE PAWS from the Beale Air Force Base Hospital	3-84	
3-12	View of PAVE PAWS from the Beale Air Force Base Firing Range	3-85	
3-13	Calculated PAVE PAWS EMR Power Density for Growth System at Ground Level, 1,400-3,000 Ft Range . .	3-92	
3-14	Calculated PAVE PAWS EMR Power Density for Growth System, Sectors 1 and 3, 3000-7000 Ft Range . .	3-93	+
3-15	Calculated PAVE PAWS EMR Power Density for Growth System, Sectors 1 and 3, 7,000-25,000 Ft Range .	3-94	+
3-16	Calculated PAVE PAWS EMR Power Density for Growth System, Sector 2, 3,000-10,000 Ft Range.	3-95	++
3-17	Calculated PAVE PAWS EMR Power Density for Growth System, Sector 2, 10,000-25,000 Ft Range	3-96	++
4-1	Locations of Alternative Sites: Beale Air Force Base, Mt. Hebo Air Force Station, and Mill Valley Air Force Station	4-5	
4-2	PAVE PAWS Azimuth from the Mt. Hebo Air Force Station Alternative	4-8	
4-3	PAVE PAWS Azimuth from the Mill Valley Air Force Station Alternative	4-14	
4-4	PAVE PAWS Azimuth from Location No. 1, Beale Air Force Base Alternative	4-22	

A-1	Formation of PAVE PAWS Radar Beam, Basic System	A-4	
A-2	Subarray Positions	A-8	
A-3	Main Beam On-Axis Field Strength for a Circular Antenna	A-11	
A-4	Antenna Patterns for Far Field and Transition Region	A-13	
A-5	Polar Plot of Relative Power Density Variation with Azimuth Angle, Basic System, With Same Duty Cycle Applied to Both Faces.	A-18	
A-6	Scanning Effect of First Sidelobe, Basic System	A-20	
A-7	Intersection of Far-Field Radiation Patterns with the Ground in Selected Directions from Beale AFB PAVE PAWS	A-23	
A-8a	Antenna Near-Field Elevation Patterns, Basic System	A-25	
A-8b	Antenna Near-Field Elevation Patterns, Growth System. . .	A-26	
A-9	Beale AFB - Sites Selected for Analysis	A-30	
B-1	Beale AFB - Sites Selected for Measurement	B-3	++
B-2	PAVE PAWS Site Plan at Beale AFB - Sites Selected for Measurement	B-4	++
B-3	Beale AFB PAVE PAWS Test Instrumentation	B-8	++
D-1	Nominal Radar Resource Template	D-7	
D-2	Long-Range and Short-Range Surveillance Resources . . .	D-9	
D-3	Track Resources	D-10	
D-4	Vertical Plane Cut of PAVE PAWS Beam Basic System in Surveillance Mode	D-14	
D-5	Vertical Plane Cut of PAVE PAWS First Sidelobe (Basic System) in Surveillance Mode	D-16	
D-6	PAVE PAWS Signal Levels at Mountaintop Repeaters . . .	D-25	
D-7	Relative Spectral Density Bounds of PAVE PAWS Pulses	D-26	

D-8	Conceptual Diagram of the Cable TV System in the Vicinity of Beale Air Force Base	D-33
D-9	Television Receiver Spurious-Response Frequencies In and Near the PAVE PAWS Band ($p = 2, q = 1$)	D-39
D-10	TV Channel-10 Interference Threshold for $p = 2,$ $q = 1$ Spurious Response	D-40
D-11	Interference Threshold Increase Factor for TV Signal Strength Higher than -77 dBm	D-41
D-12	PAVE PAWS Signal Strength and Effects on TV Reception	D-45
D-13	Filter to Exclude PAVE PAWS Signals from TV Receiver	D-48
D-14	Locations of Civilian UHF Land-Mobile Repeaters Within About 62 Miles of PAVE PAWS	D-51
D-15	Locations of Government-Owned UHF Land-Mobile Base Stations and Repeaters Within 60 Miles of PAVE PAWS	D-53
D-16	Susceptibility Thresholds (and Lower Bounds) for Some Airborne Electronic Systems (PAVE PAWS Basic System)	D-71
D-17	Effects of PAVE PAWS on Pacemakers, Basic System	D-83
D-18	Volume Probed by Surveillance-Mode Main Beam (Within 1 Mile), Basic System	D-84
D-19	Average and Pulse Power Densities for PAVE PAWS, Basic System	D-91

LIST OF TABLES

1-1	Rare and Endangered Wildlife Species Whose Distribution Includes Beale AFB	1-14
1-2	Estimated Land Use on Beale Air Force Base	1-23
1-3	Facilities on Developed Land Areas at Beale AFB	1-24
1-4	Assigned Beale AFB Employees	1-28
1-5	Labor Force and Employment by Industry in Sutter and Yuba Counties.	1-29
1-6	Sutter and Yuba Counties Labor Force and Unemployment Rates	1-30
1-7	Sutter-Yuba Population Characteristics 1975 and 1980	1-30
1-8	Sutter and Yuba County Population Estimates and Projections.	1-32
1-9	Personal Income in Sutter and Yuba Counties 1971, 1974, 1976	1-32
1-10	Sutter-Yuba Region Housing Stock 1970, 1975.	1-34
1-11	1978 Housing Stock	1-35
1-12	Residential Distribution of Personnel Living Off-Base, 1977	1-37
1-13	School Enrollment by District.	1-38
1-14	Approximate Linear Distances from Local Areas of Interest to Mt. Hebo, Oregon AFS	1-41
1-15	Housing Distribution of Personnel Affected by PAVE PAWS Mt. Hebo AFS, April 1979	1-48
1-16	Approximate Linear Distances from Local Areas of Interest to Mill Valley AFS, California.	1-49
1-17	Population in Marin County and Selected Cities 1970, 1978, 1980	1-55

2-1	Estimated Land Use in the Sacramento Regional Planning Area.	2-3
2-2	Land Use in Yuba County Regional Analysis Districts (R&D).	2-5
3-1	Calculated Power Densities Along Selected Radials in Sector 3	3-13
3-2	Calculated EMR Exposures in Populated Areas Near PAVE PAWS	3-15
3-3	Area and Location of Land to Receive Various Power Densities at Ground Level from PAVE PAWS.	3-63
3-4	Noise Levels of Typical Sounds and Associated Human Response	3-80
3-5	Estimated PAVE PAWS Noise Levels at Three Locations	3-82
3-6	Population Influx Resulting from PAVE PAWS Operations.	3-87
3-7	Education Impact of PAVE PAWS at Beale AFB.	3-90
4-1	Estimated Costs of Relocating PAVE PAWS	4-6
4-2	Population Change due to PAVE PAWS Mt. Hebo	4-11
4-3	Housing Influx due to PAVE PAWS at Mt. Hebo	4-12
4-4	Population Change due to PAVE PAWS Mill Valley.	4-17
4-5	Housing Impact of PAVE PAWS at Mill Valley	4-18
4-6	Approximate Linear Distances from Important Areas to Location No. 1, Beale AFB.	4-20
A-1	Characteristics of PAVE PAWS System at Beale AFB	A-3
A-2	Calculated System Characteristics	A-17
A-3	Calculated Near-Field Ground Level Power Density PAVE PAWS System - Beale AFB	A-27

A-4	Calculated Transition Region Ground Level Power Density PAVE PAWS System - Beale AFB	A-28	
A-5	Calculated Far-Field Ground Level EMR - Basic System PAVE PAWS Radar - Beale AFB	A-31	
A-6	Calculated Far-Field Ground Level EMR - Growth System PAVE PAWS Radar - Beale AFB	A-32	
A-7	Far Field Ground Level EMR Comparison of Appendix A and Hankin (1977) Calculated Values	A-33	
A-8	Summary of Calculated Ground Level Field Strengths PAVE PAWS System - Beale AFB	A-35	
B-1	Comparison of Measured Maximum Ambient EMR Fields and Calculated PAVE PAWS EMR Fields for Selected Locations	B-2	
B-2	Beale AFB Site Identifications (11-12 September 1979)	B-5	++
B-3	Comparison of Measured and Calculated EMR for Beale AFB PAVE PAWS	B-10	++
D-1	Possible Test Variables for Television Receiver Susceptibility Tests	D-3	
D-2	PAVE PAWS Frequencies	D-12	
D-3	Some Amateur Radio Repeaters	D-23	
D-4	PAVE PAWS Pulse Rates at Mountaintop Repeaters	D-24	
D-5	Some Parameters of Currently Orbiting Amateur Satellites	D-30	
D-6	TV Channels Received in the Vicinity of PAVE PAWS	D-32	
D-7	Cable TV Channels and Their Reception	D-35	
D-8	Interference Threshold Levels for VHF TV Video PAVE PAWS Band	D-42	
D-9	Repeaters in the Civilian UHF Land Mobile Band Between 450 and 457 MHz and Within About 62 Miles of PAVE PAWS	D-52	

D-10	Frequency Assignments in the Government UHF Land Mobile Band Locations Within 60 Miles of PAVE PAWS	D-54
D-11	Portions of Land Mobile Bands Affected by PAVE PAWS	D-58
D-12	Summary of Susceptibility Thresholds for High-Power Effects	D-63
D-13	Characteristics of Two Radar Altimeters	D-66
D-14	VORTAC/DME Stations in the PAVE PAWS AREA	D-69
D-15	High-Power Effect Thresholds for Some Airborne Navigation Systems	D-70
D-16	Characteristics of Ground and Aircraft UHF/AM Transceivers	D-74
D-17	Safe Exposure Limits for EEDs at PAVE PAWS Frequencies	D-89

Chapter 1

INTRODUCTION

1.1 Project Description

PAVE PAWS (i.e., Phased Array Warning System) is a new surveillance and tracking radar system operated by the U.S. Air Force (USAF). The primary purpose of this radar is to detect, track, and provide early warning of sea-launched ballistic missiles launched against the continental United States, but it will also assist the USAF Spacetrack System by tracking objects in earth orbit.

This Environmental Impact Statement (EIS) discusses the effects of operating PAVE PAWS at Beale Air Force Base (AFB) California. Chapters 1 and 2 provide background information on existing environmental conditions at the selected PAVE PAWS site and other affected sites. Chapter 3 contains information on the probable impacts of the proposed action. Alternative actions and the probable impacts from them are discussed in Chapter 4. Chapters 5-9 summarize the impacts and consider them in the broad context of productivity and resources, and Chapter 10 lists bibliographic references. Fuller discussion of technical issues is contained in four appendices. Operation of the facility by the USAF Aerospace Defense Command (ADCOM) will permit deactivation of older radars at Mt. Hebo Air Force Station (AFS), Oregon, and the deactivation or modified use of radars at Mill Valley AFS and Mt. Laguna AFS in California (Figure 1-1). A separate EIS, addressing the PAVE PAWS East Coast site at Otis AFB, Massachusetts, has already been prepared, processed through public and governmental reviews, and filed (USAF, 1979b). +

Most of the PAVE PAWS radar system will be contained in a building 105 feet high and approximately 100 feet by 150 feet at its base (see Figure 1-2). The PAVE PAWS facility has been constructed to meet California seismic safety codes for Seismic Risk Zone III. Five floors of the building will house radar equipment, maintenance areas, office space, and a cafeteria. Figure 1-3, p. 1-4, shows other facilities on the approximately 11-acre site, including an access road, parking areas, a gatehouse, fuel storage, fencing, and utilities (i.e., facilities for water supply and distribution, electric power generation and distribution.) Many of the support facilities, e.g. sewage treatment plant and staff housing, are already present at Beale AFB. A zone extending about 1,000 feet from the radar and encompassing about 50 additional acres is fenced (8-foot,

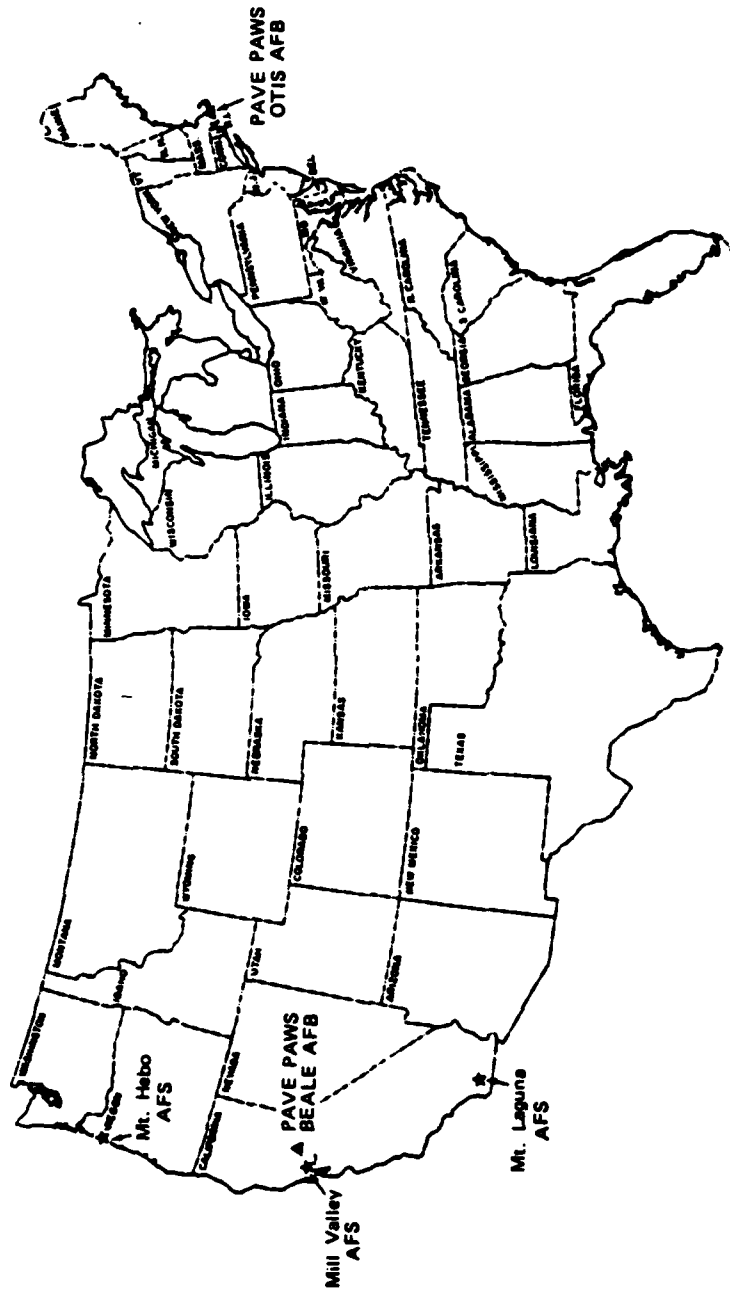
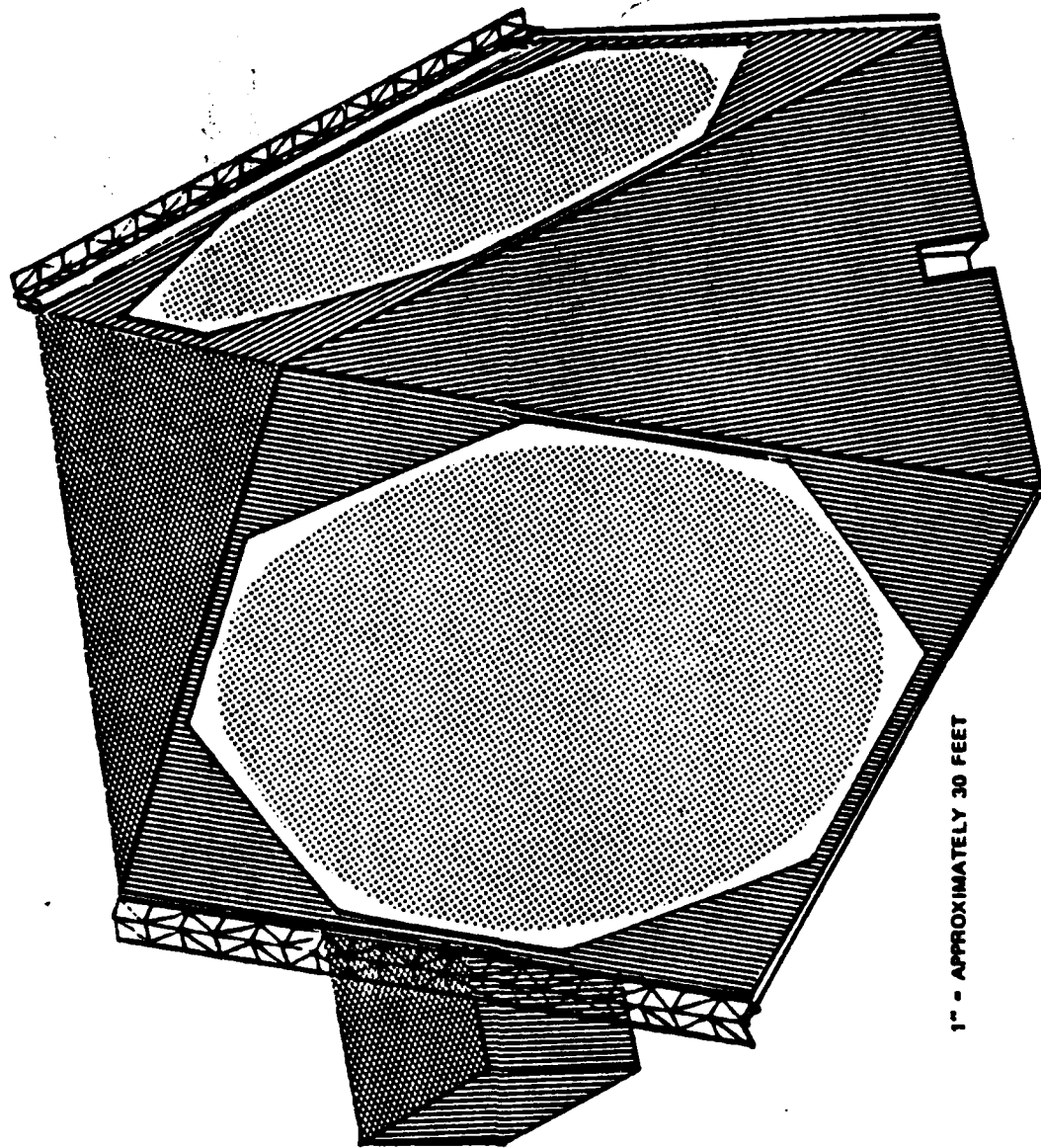

FIGURE 1-1. LOCATION OF PAVE PAWS SITES AT OTIS AIR FORCE BASE AND BEALE AIR FORCE BASE . ALSO SHOWN ARE AFFECTED WEST COAST AIR FORCE STATIONS



1" - APPROXIMATELY 30 FEET

FIGURE 1-2. PAVE PAWS RADAR AND POWER PLANT BUILDINGS

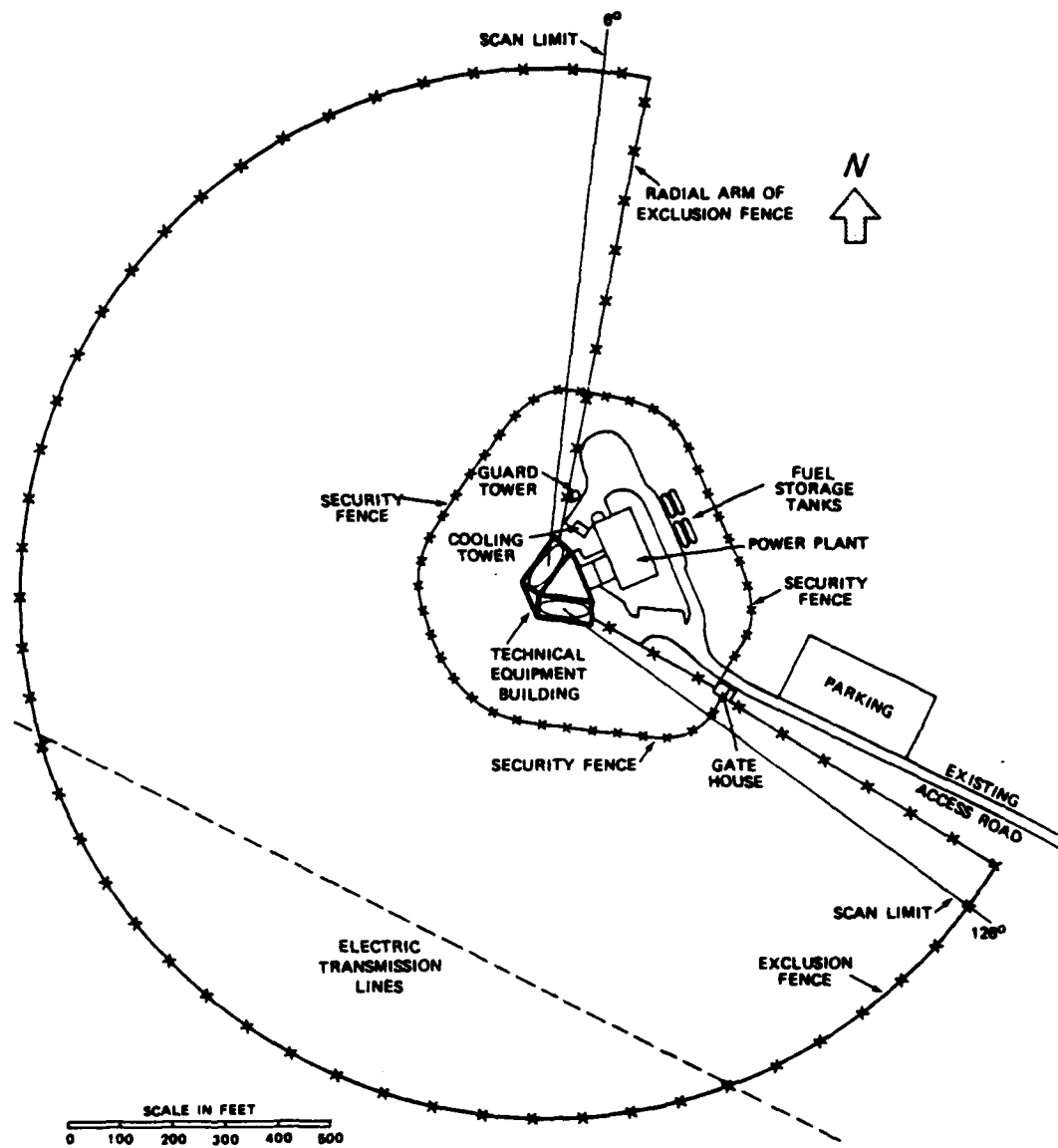

FIGURE 1-3. PAVE PAWS SITE PLAN AT BEALE AIR FORCE BASE

chain-link exclusion fence) and posted to prevent humans and some animals from inadvertently approaching too close to the radar beam. A security fence 200-300 feet from the radar (8-foot chain-link fence with barbed wire) will surround the buildings and other facilities. A perimeter detection system, to be buried just outside the security fence, will signal to the guards the presence of any intruder.

Current plans call for PAVE PAWS to operate continuously for 10-20 years, and for the installation at Beale AFB to begin normal operations in 1980. Approximately 225 operating and maintenance personnel are required, about 53 of whom are civilian employees. This total includes administration and management personnel, as well as staff for three shifts.

As shown in Figure 1-2, p. 1-3, the main building is roughly triangular in shape. Instead of a rotating dish-shaped antenna, the PAVE PAWS has two flat antenna arrays that make up two walls of the main building. The two walls form a 60 deg angle and are tilted back 20 deg from the vertical. When the system is operating, each antenna array forms an electromagnetic beam.

Each array is composed of 5,354 individual antenna elements, of which 1,792 (3,584 in a "growth system" option) are electrically activated. During operation, a prescribed electric current delivered to those elements generates local electric and magnetic fields. Spreading and merging of the fields from the many elements creates the radar beam. The radar may operate at any of 24 specific frequencies between 420 and 450 megahertz (MHz). By way of reference, this band (shared with the radio amateurs) is located just below the frequency bands used in such mobile land communication systems as fire, police, and taxi radios.

Each antenna array broadcasts electromagnetic radiation (EMR) throughout a portion of a hemisphere centered on the array face. (Appendix A contains a detailed description.) Three EMR regions with distinct characteristics are created: (1) the near field, less than about 600 feet from the antenna array; (2) the transition zone, between about 600 and 1,450 feet; and (3) the far field, beyond about 1,450 feet. (Those distances are approximately doubled for the growth system.) The EMR environment in all regions is very complicated, but its important features can be described simply. In the near field, nearly all of the radiated power appears in a well-defined portion of the hemisphere, approximately a cylinder. At the edge of this cylinder, the power density (i.e., the amount of power per unit of cross-sectional area in microwatts/cm²) is about 1/10 of the power density at the beam axis. (In this EIS, the term power density is used to mean time-average power density, in contrast to the power density of a single pulse.) Therefore, the radar beam can be described as a cylinder centered on the array (see Figure A-1, p. A-4).

In the transition zone, the EMR field evolves into a pattern which in the far field resembles a set of cones. The main beam occupies the innermost cone within 2.6 deg (1.8 deg for the growth system) of the direction in which it is aimed (see Figure 1-4, and Figure A-1, p. A-4). The remainder of the hemisphere contains sidelobes, the first of which occupies a hollow cone centered on the main beam (see Figure 1-4). The higher order sidelobes are individual, irregularly shaped cones distributed in a pseudo-random fashion throughout the hemisphere. In the far field, about half of the radiated power is concentrated in the main radar beam; the remainder appears in the sidelobes. However, the power density of the sidelobes is at most 1/100 (first sidelobe) to 1/1,000 (higher-order sidelobes) of the main beam power density. Because power densities a relatively few degrees away from the beam axis are such small fractions of the main beam power density, the PAVE PAWS radar beam is functionally a highly focused, narrow beam of radiation.

Neither the main beam nor the sidelobes radiated by the antenna array occupies the entire hemispheric volume at all times. The radar beam is actually a series of electromagnetic pulses whose characteristics are prescribed by surveillance and tracking requirements. Thus, the beam is intermittent rather than continuous. PAVE PAWS will transmit only about 18% of the time, and will receive reflected EMR during the remaining 82%. (Section D.2, p. D-4, contains a detailed description.)

Each radar beam can be "steered" or pointed electronically from 3 deg to 85 deg above the horizontal. It can also be steered as much as 60 deg to the left or right (that is, +60 deg in azimuth), for a total of 240 deg of azimuth coverage by the two antenna arrays (see Section A.2.3, p. A-2). The radar beams can search for or track objects as much as 3,000 nautical miles away. To detect sea-launched ballistic missiles, the radar beams will scan continuously through their azimuth range at 3 deg above the horizontal (although the scanning elevation may occasionally be raised to as much as 10 deg above the horizontal). One antenna face points northwest and the other points southwest. The scanning will range counterclockwise from 6 to 126 deg by the compass, or roughly from east of north, to north, to west, to south, to southeast. For satellite or missile tracking, the radar beams will be pointed as much as 85 deg above the horizontal. The scanning action of the radar beams will be so rapid that any given point will be "in" the main beam for only a fraction of a second at about 1.4-second intervals. However, points not "in" the main beam are exposed to the low-level sidelobe EMR during each pulse.

The basic PAVE PAWS system is designed to permit a power increase. However, although the potential improvements have been defined and identified as the "growth system," approval has not been given for incorporating them into the system. The primary improvements would be an increase in radiated power and a narrower

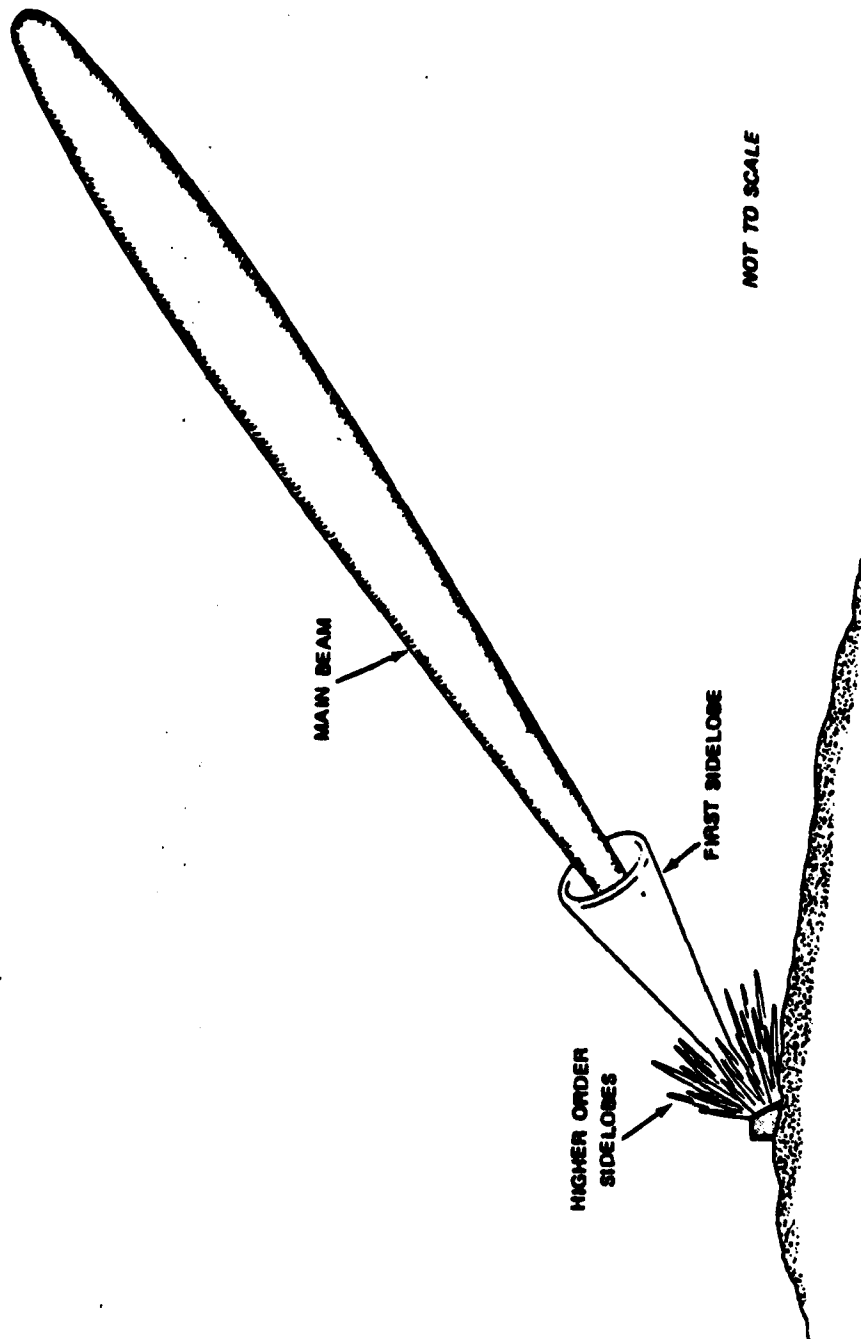

NOT TO SCALE

FIGURE 1-4. ARTIST'S SKETCH OF PAVE PAWS EMR PATTERN

main radar beam. All other principal parameters would remain the same. This EIS fully addresses the environmental impacts of the growth system as well as the basic system.

1.2 Existing Site Characteristics

1.2.1 Beale AFB, California

Beale AFB (see Figure 1-5) is a 23,000 acre reservation 12 miles east of the metropolitan center of Marysville and Yuba City on federally-owned land in Southwestern Yuba County. It is a Strategic Air Command (SAC) base composed of the 9th Strategic Reconnaissance Wing, the 14th Air Division, the 100th Air Refueling Wing, the 100th Combat Support Group, and various tenant organizations.

Situated at the western edge of the Sierra Nevada foothills, the terrain at Beale AFB varies from moderately rolling in the eastern portion to fairly flat in the western regions. Elevations range from 600 feet at the northeastern corner to 80 feet on the western edge. The flat agricultural lands of the Sacramento Valley and the Feather River lie to the west of the base. The Yuba River and the Yuba Gold Field lie a few miles north of Beale, and the Bear River and the Camp Far West Reservoir lie a few miles south of the base.

Beale AFB has a Mediterranean climate that is strongly influenced by the Sierra Nevada Mountains. The average annual precipitation of 23 inches occurs mainly as rainfall during the months of November through April. Little or no rainfall occurs from May through October. Snow is uncommon. Winds are highly directionalized by the topography of the Sacramento Valley, and generally trend south-southeast or north-northeast.

Historically, Beale AFB was much larger than it is today, extending eastward into Nevada County. In the 1960s the California Department of Fish and Game acquired a large tract of surplus Beale AFB land (see Sections 1.2.1.2.1.1, p. 1-22 and 2.2.2.3, p. 2-11) that the Department currently manages adjacent to the eastern edge of Beale AFB as the Spenceville Wildlife and Recreation Area.

The major developed portions of the base are the cantonment area, flight operations area, housing area, sewage treatment plant, and hospital. Most of the undeveloped areas which comprise over 80% of the base are undulating grassy plains that are leased out for cattle grazing. More than three-fourths of Beale AFB is suitable for wildlife and domestic livestock grazing. Small areas are leased out for dry land and irrigated farming.

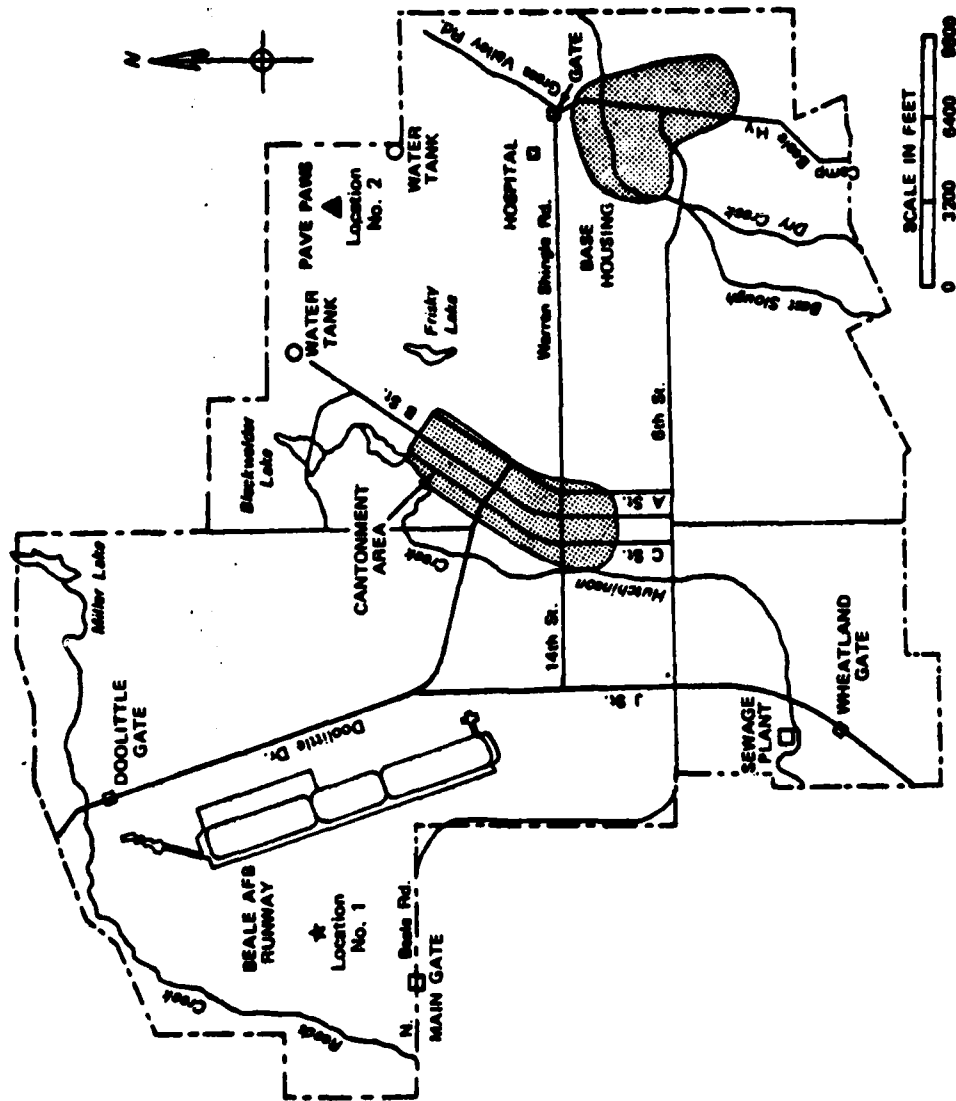

FIGURE 1-5. BEALE AIR FORCE BASE, CALIFORNIA

1.2.1.1 Biophysical Characteristics

1.2.1.1.1 Plants and Animals Information on the biological resources on and in the vicinity of Beale AFB was obtained through a field reconnaissance survey at the radar site and nearby areas, November 27-29, 1978; through personal interviews with governmental officials and private individuals knowledgeable about the biota in the region; and through a literature review.

Beale AFB is situated in the California Grassland Ecoregion (Bailey, 1976), and encompasses two regional potential natural vegetation types, the California Steppe and the California Oakwoods (Kuchler, 1975). Presently, six distinct localized vegetative cover types can be distinguished at the base. About 85% of the undeveloped land is covered with a dry grassland type of vegetation characterized by introduced annual grasses that have become naturalized over the last century, and by native and introduced forbs (broad-leaved herbaceous plants). Common species include grasses, such as brome, fescue, wild oats, wild rye, and poverty threeawn, and forbs, such as filaree, lupine, California poppy, bur clover, and star thistle. These species are all typical of California grasslands today, and are adapted to hot dry summers and winter rains.

Four wetland/aquatic vegetative cover types are present at Beale AFB, and together they cover about 10% of the undeveloped area at the base. Swale vegetative cover types occur in the low, seasonally wet, depressed areas, especially in the western part of the base and along the drainage ways. The swale vegetative type is dominated by native perennials such as sedges and rushes. A marsh cover type is present along the intermittent and permanent streams at the base and in areas where water is ponded for several months of the year. Cattails, rushes, spikerushes and smartweeds characterize these areas. A riparian (streamside) woodland and shrubland vegetative type occurs largely along or between Dry Creek and Best Slough in the southeastern section of the base. Common plant species along the stream are cottonwood, willow, and box elder. Stream aquatic cover types are associated with the floating aquatic plants, such as duckweed and algae, in the streams and lakes at the base.

The sixth vegetative type at Beale AFB is agricultural cropland. Approximately 2700 acres are leased to local farmers for dryland farming of wheat, barley, and oats and irrigated farming of rice, much of it in the southern part of the Base (USAF, 1977).

A habitat cover map indicating grassland, woodland, fields, aquatic habitat, denuded vegetation, and urban areas of the major portion of Beale AFB is presented in Figure 1-6. In the urban areas, several ornamental trees and shrubs have been planted, including European olive groves, fig trees, and stands of sweetgum and mulberry.

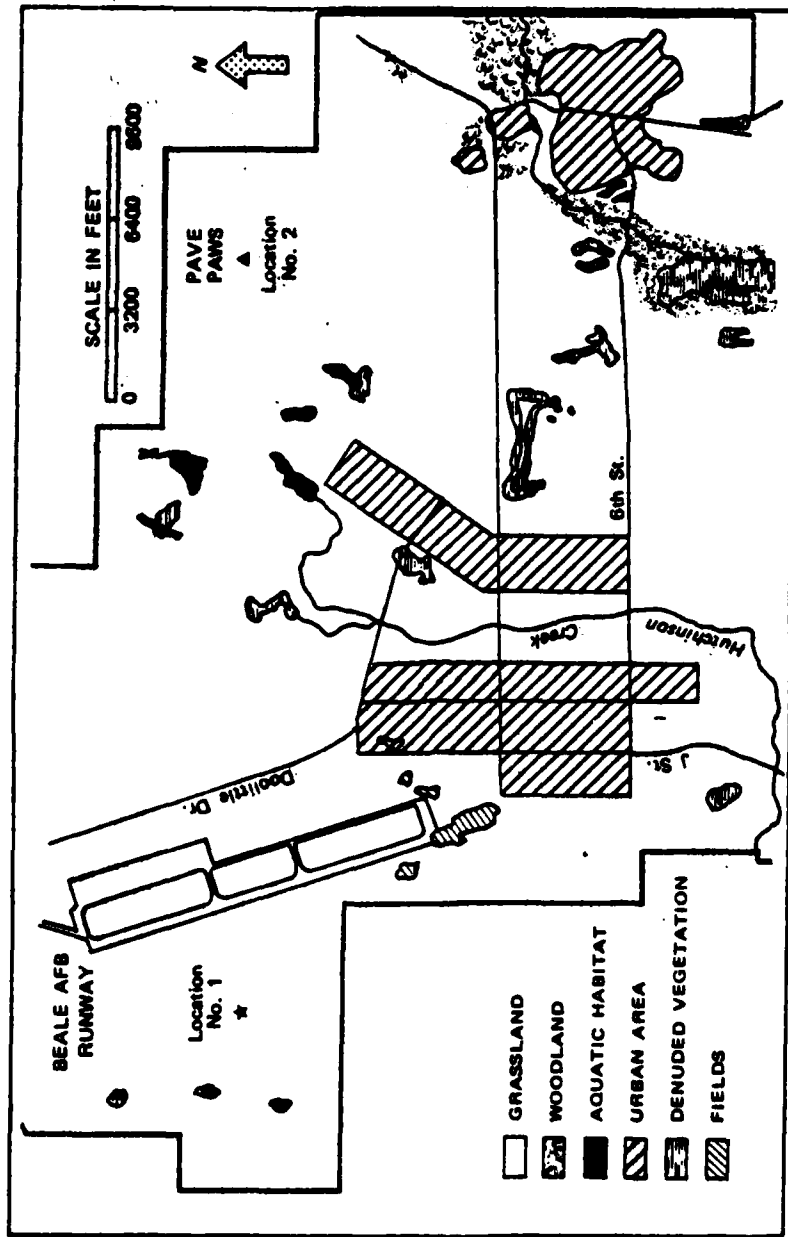

Source: Adapted from USAF (1976)

FIGURE 1-6. HABITAT COVER MAP SHOWING THE DOMINANT VEGETATION AT BEALE AIR FORCE BASE

Beale AFB provides a limited wildlife refuge and a locally important recreational hunting area for base personnel (USAF, 1975). The major factors limiting the wildlife habitat are a scarcity of watering areas and lack of adequate vegetation to fulfill the needs of small game for food, escape routes and roosting places (USAF, 1977).

Beale has seven artificial lakes, and two streams in addition to Dry Creek and Best Slough. Reed's Creek flows from Miller Lake at the extreme northern boundary and follows the northwestern boundary to North Beale Road, where it leaves the base. Hutchinson Creek runs north to south through the center of the base and exits at the southwest corner of the base (see Figure 1-5, p. 1-9). Trout are stocked in Beale Lake and Parks Lake and the other lakes are stocked with bluegill and bass. Trout ponds are of importance to local anglers on base and are sufficient to fulfill limited seasonal fishing demands. Late spring heat raises the local water temperature high enough to kill the stocked trout (USAF, 1977).

Wildlife is most numerous along riparian areas, particularly in the southwestern section of Beale. The principal native game species at the base are quail, doves, gray squirrels, rabbits, and deer. In addition, pheasants are raised as game for base personnel on the Beale Pheasant Farm in the southwestern part of the base, south of Hutchinson Creek. Between 1,000 and 4,500 Chinese and Mongolian pheasants are released yearly, depending on breeding success (USAF, 1975).

Species lists of amphibians, reptiles, birds, and mammals that may occur at Beale AFB can be found in an environmental assessment for a proposed coal-fired power plant near Wheatland (PG&E, 1977) and in an unpublished list prepared by the California Department of Fish and Game for Spenceville Wildlife and Recreation Area (1974-1975). A U.S. Air Force report (USAF, 1975) lists the potentially common animal species endemic to Beale AFB. According to these lists, up to 30 species of land vertebrates and 135 species of birds and bats could occur at the base; however, most of the base lacks adequate cover and food to support large numbers of wildlife. Nonetheless, the open habitats at Beale are suitable for several species common to grassland habitats, such as gophers, field mice, shrews, and songbirds. No unique breeding or nesting areas or land migratory routes are present at Beale AFB, but a heron rookery is located 3 miles east of the base in the Spenceville Wildlife and Recreation area.

Beale AFB lies a few miles east of a major bird migratory route of the Pacific flyway (Kozlik and Johnson, 1974). Because of the base's proximity to the Central Valley waterfowl migratory route, migrant waterfowl occasionally pass over the base, but most of the migratory flocks pass to the west of Beale. One of the principal waterfowl habitats in the state is approximately 10

miles northwest of Beale near the confluence of the Feather and Yuba Rivers; however, the small lakes and pools at and near Beale do not attract very many birds (Hodson, 1978). With only a few rice fields nearby, the food sources in the immediate vicinity of Beale are fairly limited. The large reservoir that has been proposed approximately 5 miles north of Beale AFB (Marysville Lake, see Section 2.2.2.2, p. 2-10) would probably not attract a large number of birds except as a temporary resting area, because it will not be specifically managed for waterfowl. In addition, as a result of the long lead time required for the design, approval and construction of a major reservoir, it is unlikely that the reservoir will be in operation until 1993 (U.S. Army Engineer District, 1977). Small flocks of migratory songbirds, however, are common in riparian areas in the vicinity of Beale AFB. An annotated list of 126 birds that may migrate through Beale is presented in USAF, 1976.

Beef cattle are the primary commercial animals on the base. Most of the grasslands at Beale are leased to local ranchers as pasture. Small enclosure areas are provided for wildlife within the pastures.

The dry summers make the grasslands very susceptible to burning, however, accidental fires occur infrequently. The lack of extensive forestation at Beale AFB helps to keep these fires under control, and fire breaks are provided at roads, structures, and property lines (USAF, 1977).

Except for periodic fires, the primary environmental perturbations in this area have resulted from the grazing activities of domestic livestock and from military operations. Early gold mining activity beginning in the second half of the nineteenth century also altered the natural ecosystems of the area, particularly the streams. Large amounts of sedimentation occurred as a result of mining.

No federal- (USDI, 1976) or state-listed (Powell, 1974) rare or endangered plants have been recorded for the lands now occupied by Beale AFB, and none was found during the site investigation. The California Native Plant Society has a record of an endangered plant species found 1 mile south of Beale's southern boundary in the Johnson Rancho area. An endangered dodder plant (Bogg's Lake dodder, Cuscuta howelliana Rubtzoff) has also been observed there (T. Griggs, 1978). No endangered plant species have been observed on or within 1 mile of the base.

Although the distribution of four federal- (USDI, 1977) or state-listed (California Department of Fish and Game, 1976) endangered or rare fauna includes Beale AFB (see Table 1-1) none of these species is known to inhabit the base, and none was observed during the site investigation. Two of these endangered species, the peregrine falcon and the southern bald eagle, have

Table 1-1
 MAKE AND ENDANGERED WILDLIFE SPECIES WHOSE DISTRIBUTION INCLUDES BEALE AFB

Common Name	Scientific Name	Status		Comments
		Federal	State	
Peregrine falcon	Falco peregrinus anatum	E	E*	Statewide breeding along California coast and in higher mountains inland; potential rare winter migrant
Aleutian Canada goose	Branta canadensis leucoparvia	E		Winters in Central Valley of California. potential occurrence in winter
Southern bald eagle	Haliaeetus leucocephalus leucocephalus	E	E*	Statewide potential occurrence in winter
California yellow-billed cuckoo	Coccyzus americanus occidentalis		R*	Riparian habitat; Sacramento River and Butte Creek; potential occurrence in riparian habitat.

Status:

Federal

E Endangered Species: "any species which is in danger of extinction throughout all or a significant portion of its range other than a species of the Class Insecta determined by the Secretary to constitute a pest whose protection under the provisions of this Act would present an overwhelming and overriding risk to man."

State

E Endangered: "an animal of a species or subspecies of birds, mammals, fish amphibians, or reptiles, the prospects of survival and reproduction of which are in immediate jeopardy from one or more causes, including loss of habitat, change in habitat, overexploitation, predations, competition, or disease."

R Rare: "an animal of a species or subspecies of birds, mammals, fish, amphibians, or reptiles that, although not presently threatened with extinction, is in such small numbers throughout its range that it may be endangered if its environment worsens."

* Fully Protected: "an animal of a species or subspecies of birds, mammals, fish, amphibians, or reptiles that by law may not be taken or possessed at any time."

Sources: United States Congress, 1973; California State Legislature, 1970; California Department of Fish and Game, 1975 and 1976; and U.S. Fish and Wildlife Service, 1977.

statewide distributions and could potentially use the site for hunting; however, they are not now known to nest at or near Beale AFB (PG&E, 1977). A third endangered species, the Aleutian Goose, winters in the Sacramento Valley. This subspecies has not been sighted closer to Beale AFB than near the town of Meridian, about 25 miles west. The fourth species, the rare California yellow-billed cuckoo, may be found in the riparian habitat at Beale AFB, most likely between Dry Creek and Best Slough. However, the only documented nest sites of this species occur along the Sacramento River and Butte Creek, about 30 miles northwest of Beale AFB.

Additional endangered or threatened faunal species that can be found within 50 miles of Beale AFB are listed in the references (USAF, 1977; USAF, 1975). However the known distributions of these species do not include Beale AFB, and the base does not provide a suitable habitat for most of them.

Four other special-interest species may occasionally come to Beale AFB to obtain food: the golden eagle and the white-tailed kite, both of which are fully protected species under California state law (California Department of Fish and Game, 1975), and the prairie falcon and the tule white-fronted goose, species whose numbers are known to be declining. One prairie falcon was observed at Beale AFB in 1971 (Philip A. Lehenbauer, 1978) but, none of these special-interest species is known to inhabit the base at present.

Discussed below in Section 1.2.1.1.1 are the ecological characteristics specific to the selected site (Location No. 2). Existing site characteristics specific to the alternative site at Beale AFB, Location No. 1, are described in Section 4.3.3.1 (see Figure 1-5, P. 1-9).

1.2.1.1.1 Habitat at Location No. 2. The 61-acre PAVE PAWS radar site at Beale (Location No. 2, see Figure 1-5, p. 1-9), is situated in the undulating foothills of the northeastern section of the base. Elevations at the site range from 295 to 375 feet above mean sea level.

The site is a well drained, rolling grassland on shallow, rocky soils (see section 1.2.1.1.3, p. 1-18) traversed by two small, intermittent streams. The streams drain into Frisky Lake which is stocked with bluegill and bass. A spring that emerges outside the 1,000-foot exclusion fence of the northern sector of the site provides a continuous water supply in all but the driest of years. A small (less than one-fourth acre) cattail-bullrush marsh is present in the southeastern portion of the site, where the road has dammed up a portion of one of the intermittent streams. No large bodies of water, however, lie within 1 mile of the site.

As is typical of dry California grasslands today, most of the undeveloped part of the 61-acre site is covered with introduced annual grasses with some native and introduced forbs. The vegetation along and near the stream channels is dominated by a swale vegetative type characterized by sedges and rushes. All of the grassland vegetation at or near the site has been grazed at the rate of one cow per 10 acres for several years.

Domestic livestock, along with the larger wildlife species, are now fenced out by the exclusion fence, which was built in 1978 during construction of PAVE PAWS. The vertebrate wildlife presently at the site consists of common grassland species such as gophers, field mice and shrews, and birds such as the western meadowlark. The site normally provides very little cover for game animals. None was observed during the site visit, which occurred a few weeks after the grassland area within the 1000-foot exclusion fence had been burned in late fall of 1978 as a fire prevention measure. The nearest tracts of woodland and shrubs lie about 2 miles south and 2 miles east of the site. A few trees are growing near the artificial lakes 2 miles northwest of the site. The only woody plants observed within 1 mile of the site were two small (less than 7-foot-tall) willows immediately outside the exclusion fence along the western portion of the site.

No rare or endangered fauna or flora were observed at or near the site. Any of the four rare or endangered bird species discussed in Section 1.2.1.1.1, p. 1-10, might infrequently fly over or briefly stop at the site (see Table 1-1, p. 1-14). The California Native Plant Society has no record of any rare plant species in the 7½ minute quadrangle (the Smartville Quadrangle) that includes Location No. 2 (T. Griggs, 1978).

1.2.1.1.2 Electromagnetic Environment. The electromagnetic environment in the Beale AFB area and the Sacramento River Valley can be described by discussing the electromagnetic spectrum there. The electromagnetic spectrum in the area is a renewable resource having the dimensions of amplitude, time, frequency, and space. It can be used continuously. In areas large enough to permit sufficient geographical separation, the spectrum will accommodate a number of users on the same frequency simultaneously. In smaller areas the spectrum will accommodate a large number of users only if they are separated in frequency. A high-amplitude signal can override a low-amplitude signal on the same frequency. The electromagnetic environment at a particular location at a particular time comprises all the electromagnetic fields that are arriving there from numerous sources, both manmade and natural.

Some of the manmade contributions to the electromagnetic environment in the Beale AFB/Sacramento Valley area are intentional, but others are accidental, and are incidental to some other activity. Radio signals of all sorts are intentional

manmade contributions. The electromagnetic environment in the area consists in part of signals from various radio and TV stations at least as far away as Sacramento, from the radios of local law enforcement and fire departments and other users of land mobile radio; from local or transient amateur and CB operators; from the microwave communication systems of the telephone company and the cable TV company; from air navigation aids; from passing aircraft; and so on. Because some signals, much lower in frequency than PAVE PAWS, can be reflected back to earth by high-altitude ionospheric layers, part of the electromagnetic environment in the area consists of transmissions from stations thousands of miles away.

The unintentional manmade contributions to the electromagnetic environment in the area are called manmade electromagnetic noise. Such noise is radiated by power lines, fluorescent lights, household lighting dimmer switches, household appliance motors, computers, hand-held calculators, and so on. A major contributor is the automobile ignition system, which radiates a pulse of energy over all the communication bands with each spark-plug firing.

Nature contributes noise to the electromagnetic environment. Lightning strokes in storm centers in Africa and South America cause "static" in Northern California radios, thousands of miles away. This noise is an intermittent major feature of part of the area's electromagnetic spectrum. In some parts of the electromagnetic spectrum, noise from the sun and from the stars (galactic noise) is often the predominant feature of the local electromagnetic environment.

Overall, however, the Beale AFB area is a low power density area in comparison with a major metropolitan area. Ambient field measurements there indicate that background signals are far weaker than those expected from the PAVE PAWS radar (see Section B.2, p. B-1).

Human beings are not generally capable of sensing the electromagnetic environment or changes in it. However, radio receivers regularly do this. They sample portions of the spectrum to extract a small amount of energy, which they then amplify and convert to a usable signal. This signal might be in the form of a picture on channel 12 from Chico, music from KMYC, a long-distance telephone conversation, an airline navigation signal, or many others.

1.2.1.1.3 Soil, Water, Air and Noise

1.2.1.1.3.1 Soil. Beale AFB is situated in the transition zone between the sedimentary and volcanic rocks of the Central Valley and the granitic rocks of the Sierra Nevada batholith. This zone,

known as the Foothills metamorphic belt, consists of a complex sequence of metamorphosed volcanic, sedimentary, and intruded basic rocks that have been faulted and folded (Bennett, 1978). During the last ice age, the streams draining the Sierra Nevada had extremely high discharge compared to the present discharge. Consequently, deep alluvial deposits were formed along the Yuba, Bear, and Feather Rivers, and these provide abundant supplies of sand and gravel, make good farmland, and are excellent aquifers. The sediments washed from the gold-rich Sierra Nevada have formed rich placer deposits of gold, silver, and platinum along the Yuba River north of Beale AFB.

The topography of the base varies significantly from east to west and is related to the regional geology. The western portion consists of gentle, rolling grasslands typical of the Sacramento Valley, but the extreme eastern portion is characterized by steep, hilly terrain with scattered rock outcrops, ranging from 200 to 600 feet in elevation. The PAVE PAWS site is located in this eastern portion, which is underlain by granitic and metamorphic rocks (Page, 1979). Location No. 1, on the other hand, is in the western portion, where alluvial deposits predominate.

The complex geology at the PAVE PAWS site is reflected in the soils that are found there. Three soil associations join in the vicinity of the site (T15N, R6E, Section 19; USAF, 1975). The southwest corner of the site is underlain by well-drained, fine-textured, yellowish, gravelly loam with hardpan developed from mixed alluvium (Redding-Corning Association), whereas the eastern half consists of shallow, rocky, well-drained brown loam developed on bedrock (Auburn-Argonaut Association) (Rogers, 1967). The northernmost portion of the site consists of very shallow, well-drained, cobbly brown loam and rock outcrops developed on bedrock (Toomes-Rockland Association) (Rogers, 1967). These soils make excellent rangeland: drainage is good, and the erosion hazard is moderate. However, some kinds of development on these soils are limited because the slopes in the area are steep, and the soils are highly corrosive to untreated steel pipe. These soils also provide poor filtration capacity for septic tanks, and are characterized by moderate to high shrink-swell behavior (Rogers, 1967).

1.2.1.1.3.2 Water. Surface water drainage is well developed on the base, particularly in the eastern hilly portion. Four intermittent streams drain generally southwest or west across the base, following the topographic features. Dry Creek has its headwaters near Pilot Peak approximately 30 linear miles northeast of the base and empties into the Bear River southwest of Wheatland. Hutchinson Creek, Reeds Creek, and Best Slough discharge into a channelized portion of Alsodon Slough which flows into the Bear River southwest of Beale AFB. Although no natural lakes exist on the base, seven small manmade lakes have been

constructed. Virtually all precipitation occurs during 6 months of the year, and drainage on the flat western portions of the base is a problem. The available stream channels have neither the size nor the gradient to accommodate the volume of runoff from roads and other paved surfaces on the base. In addition, the shallow soil in the area is underlain by hardpan, which effectively retards infiltration. Consequently, ponding and flooding are common during the wet season.

Groundwater is the major source of the water supply for Yuba, Sutter, and Butte counties. The alluvial deposits of sand and gravel along the Feather, Yuba, and Bear Rivers are the primary aquifers. Large withdrawals of ground-water for agriculture in the region have contributed to a downward trend in water levels. In the last 25 years, water levels in most wells have dropped an average of 30 feet (USAF, 1977)..

Water levels at Beale AFB generally declined between 1950 and 1971, but have remained fairly constant since then (Page, 1979), possibly because water demand on the base has been reduced by water conservation practices. The base's well field of nine wells located in the alluvial aquifer has an average depth of 309 feet (USAF, 1977). Static water levels average about 110 feet. Water quality is generally good, although manganese levels are somewhat high at 0.04 mg/l (USAF, 1977), which is close to the 0.05 mg/l permissible under Environmental Protection Agency National Interim Primary Drinking Water Standards. High manganese levels are not dangerous, but they can cause the water to act as a laxative. Saline water occurs at a depth of 400 feet, but at present pumping rates, it's not expected to affect groundwater quality.

No information concerning water levels or aquifer characteristics at the PAVE PAMS site is available (Page, 1979). The type of bedrock found there typically has poor water yield and storage characteristics, except along joint or fracture planes. Seasonal springs are present in the vicinity of the site, which indicates that some groundwater is being transmitted along fracture planes. The site is in a recharge area, but the low permeability of the bedrock causes most of the rainfall that is not evaporated to leave the area as surface runoff.

Wastewater from Beale AFB is treated at the secondary sewage treatment facility that empties into Hutchinson Creek at a discharge rate of 1.1 million gallons per day (Barker, 1978). The base has a National Pollution Discharge Elimination System (NPDES) permit from the state of California that requires the removal of 85% of the biological oxygen demand (BOD) and suspended solids from the sewage (USAF, TAB A-1, 1977). The plant usually attains 90% removal (Barker, 1978). Some wastewater is recycled in the summer to irrigate the base's golf course. Sludge from the facility is dried, mixed with other material, and used as a soil conditioner. Wastewater from the base reconnaissance photography

laboratory is treated at a separate photo waste treatment plant and injected into the subsurface (Barker, 1978). Additional monitoring of this system will soon be necessitated by new state and federal laws associated with deep well injection provisions of the Safe Drinking Water Act. Storm water runoff is controlled separately from wastewater, and the runoff is carried in open gutters and culverts to the natural creek drainage ways (USAF, 1977).

1.2.1.1.3 Air. Beale AFB is in the Sacramento Valley Air Quality Control Region (AQCR) Number 28. According to the Environmental Protection Agency (EPA) classification, the Yuba County portion of AQCR 28 is a non-attainment area (has air more polluted than federal law permits) for total suspended particulates and oxidants. Sufficient data on sulfur dioxide, oxides of nitrogen, and carbon monoxide are not collected in the Yuba County portion of the AQCR to classify the area for those pollutants (Federal Register, 1978a). The air quality monitoring stations closest to Beale AFB--in Smartville, Marysville, and Wheatland--monitor only particulate levels (ARB, 1977). In 1977, the 24-hour total suspended particulate concentrations in Smartville, Marysville, and Wheatland were 34.7, 51.6, and 55.8 micrograms/m³, respectively (ARB, 1978). Those levels were below the California standard of 100 micrograms/m³ and the federal primary and secondary standards of 260 and 150 micrograms/m³. The apparent conflict between the EPA classification and the actual data, which are below (cleaner than) the standards, reflects differences in air quality within the AQCR as well as EPA and state expectations of future air quality problems in that area (Federal Register, 1978b). The main sources of air pollutants in the vicinity of Beale AFB are aircraft emissions, agricultural activities (especially agricultural burning), and automobile traffic.

1.2.1.1.3.4 Noise. The major source of noise from Beale AFB is air traffic. Noise also results from normal base activities such as motor vehicle traffic and firing range use. Noise from these minor sources is noticeable only in the vicinity of these activities. The principal sources of noise at the PAVE PAWS site are air traffic and possibly the firing range.

1.2.1.1.4 Minerals and Other Resources. The major mineral resources mined in the vicinity of Beale AFB are gold, sand and gravel. The production of sand and gravel is the largest source of revenue from mineral resources in Yuba County. In 1976, the value of sand and gravel production in Yuba County was approximately \$1.2 million (Clark, 1978a). The chief sources in the County are the streambed deposits and dredge tailings along the Yuba River in the Marysville area. The sand and gravel are used primarily for concrete aggregate, road base, and drain rock,

and the sand is used for plaster, and blast and engine applications. The placer-gold operation, about 1 mile north of Beale AFB and owned by Yuba Goldfields, Incorporated, is one of the last large bucket-line dredges in California (Clark, 1978b). In the past, this field was the principal placer-gold operation in the State and also produced a high percentage of California's output of silver- and platinum-group metals (U.S. Bureau of Mines, 1963). The dredge operated until 1968 and again in 1975 and 1976. The company announced that 5,600 ounces of gold were produced in the 1975-76 period (Clark, 1978b), with a value of approximately \$700,000.

1.2.1.1.5. Natural Disasters

1.2.1.1.5.1 Earthquake Hazard. Beale AFB is located in Seismic Risk Zone III (USAF, 1977) of the national classification system, which ranks all regions of the U.S. in one of four zones (0 to III). Most of California is classified in Zone III, which is indication that major destructive earthquakes may occur. The Foothills fault system is the primary source of seismic activity in the region and has been the subject of intensive studies since the magnitude 5.7 earthquake at Oroville in August 1975. An extension of this fault system, known as the Bear Mountain Fault Zone, passes through the northeastern edge of Beale AFB, where the shear zone ranges from 1 to 2 miles wide (Sacramento Regional Area Planning Commission, 1976). This fault zone has been relatively inactive along the segment from Honcut to Auburn, California, throughout recorded history (post-1769) (Cramer, 1978). The recent earthquakes monitored have magnitudes around 1.0 on the Richter scale and no earthquake with a magnitude greater than 4.0 has been recorded on this segment (Cramer, 1978). Studies of regional seismicity at the Auburn Dam site, 25 miles southeast of the base within the Bear Mountain fault zone, have concluded that the probability of active faults (displacement within the last 100,000 years) in the dam foundation ranges from 1 in 10 to 1 in 100 (Bennett, 1978). In addition to the Oroville earthquake, two others in the magnitude range of 5 to 6 have been recorded--one in 1909 and one in 1888--about 9 miles northeast of Nevada City (Cramer, 1978). The epicenters for all three of these earthquakes were from 40 to 50 miles away from Beale AFB on different segments of the Foothills fault system. However, studies have shown that these earthquakes resulted in damage with an intensity of V on the modified Mercalli Scale at Beale AFB (Cramer, 1978). Before 1880, three large earthquakes of unknown magnitude occurred in the western portion of the Foothills fault system on the Melones Fault Zone near Downieville (Bennett, 1977).

1.2.1.1.5.2 Fire. The grasslands surrounding the PAVE PAWS are highly flammable during the drier half of the year. There is, however, an extensive program of fire control on the base.

1.2.1.1.5.3 Floods. Floods may occur either as a result of rainfall or snowmelt in the Sierras, with floods in excess of levee capacity about once in 80 years. However, the lowest lying portions of the base are roughly 40 feet higher than Yuba City, the site of the last major flood which killed 38 people and flooded 3,300 homes (U.S. Army Engineer District, 1977). The major portion of the base is at least 60 feet higher and the PAVE PAWS site is about 260 feet higher than Yuba City.

1.2.1.1.5.4 Severe Storms. Severe storms such as thunderstorms and tornadoes occur in the Central Valley, but are infrequent. Only 1 to 2 tornadoes occur in California per year, and their impacts are generally less severe than in the midwestern states. Thunderstorms occur throughout the year but are likewise infrequent and generally rather weak. Hail, with stones up to 1/2 inch in diameter, is occasionally reported, but serious damage is infrequent (Elford, 1974).

1.2.1.2 Socioeconomic Characteristics

1.2.1.2.1 Land Use and Aesthetics

1.2.1.2.1.1 Land Use. Beale AFB is a military reservation occupying about 23,000 acres of federally owned land. In 1942, the base opened with over 86,000 acres of land; since then, it periodically decreased in size and its present area was established in 1965 (see Figure 1-5, p. 1-9).

About 3,930 acres of base land have been developed, primarily for operational, housing, and airfield uses (see Table 1-2). Specific facilities included in the cantonment, housing, flightline, and recreational areas are indicated in Table 1-3, p. 1-24. The undeveloped portions of the base, mainly grasslands, are leased to local ranchers and farmers for grazing or are used for other purposes (e.g., firing range, sanitary landfill) (see Figure 1-7, p. 1-25).

Beale AFB is surrounded by a variety of land use areas. Immediately adjacent to the base on the eastern side is the 11,200 acre Spenceville Wildlife and Recreation Area. Most of the remaining land directly adjacent to the base to the north, west, and south is considered prime farmland. In the agricultural areas, some low density (10- to 20-acres per parcel) housing exists (see Figure 1-8, p. 1-26). The nearest densely populated area is the Yuba College campus near Linda.

Table 1-2

ESTIMATED LAND USE ON BEALE AFB

<u>Description</u>	<u>Amount (Acres)</u>
Unimproved grounds leased for grazing	13,247.0
Other	<u>5,582.0</u>
Subtotal	18,829.0
Semi-improved grounds	
Taxiways and airfield clearance	369.5
Rifle and pistol range	291.6
Ammunition storage	934.2
Golf course	<u>176.0</u>
Subtotal	1,771.3
Improved grounds	
Flightline area	10.0
Golf course	43.9
Athletic field and track	4.0
Baseball field	4.0
Housing/cantonment area	<u>1,493.4</u>
Subtotal	1,555.3
Areas beneath facilities	
Housing	111.6
Streets, pavements, runway	<u>494.8</u>
Subtotal	606.4
Lakes	<u>183.0</u>
Total	22,945.0

Source: Doidge (1978).

Table 1-3

FACILITIES ON DEVELOPED LAND AREAS AT BEALE AFB

Cantonment Area

Administrative facilities
Education center
Base Exchange (BX)
Commissary
Library
Hobby shops
Recreation facilities
Bank/Credit union
Post office
Chapel
Trailer court
Fire station

Base Housing Area

Single-family dwelling
Multi-family units
Schools (2)
Officers' Club
Noncommissioned Officers' Club
Child Day Care Center
Church
Youth Center
Fire station
Hospital

Recreational Areas

Flight-Line Area

Airfield
Terminal
Administrative offices
Maintenance facilities

Beale Game Reserve
Pheasant farm
Dry Creek Saddle Club
Rod and gun club
Golf course
Fishing lakes
Nature trail

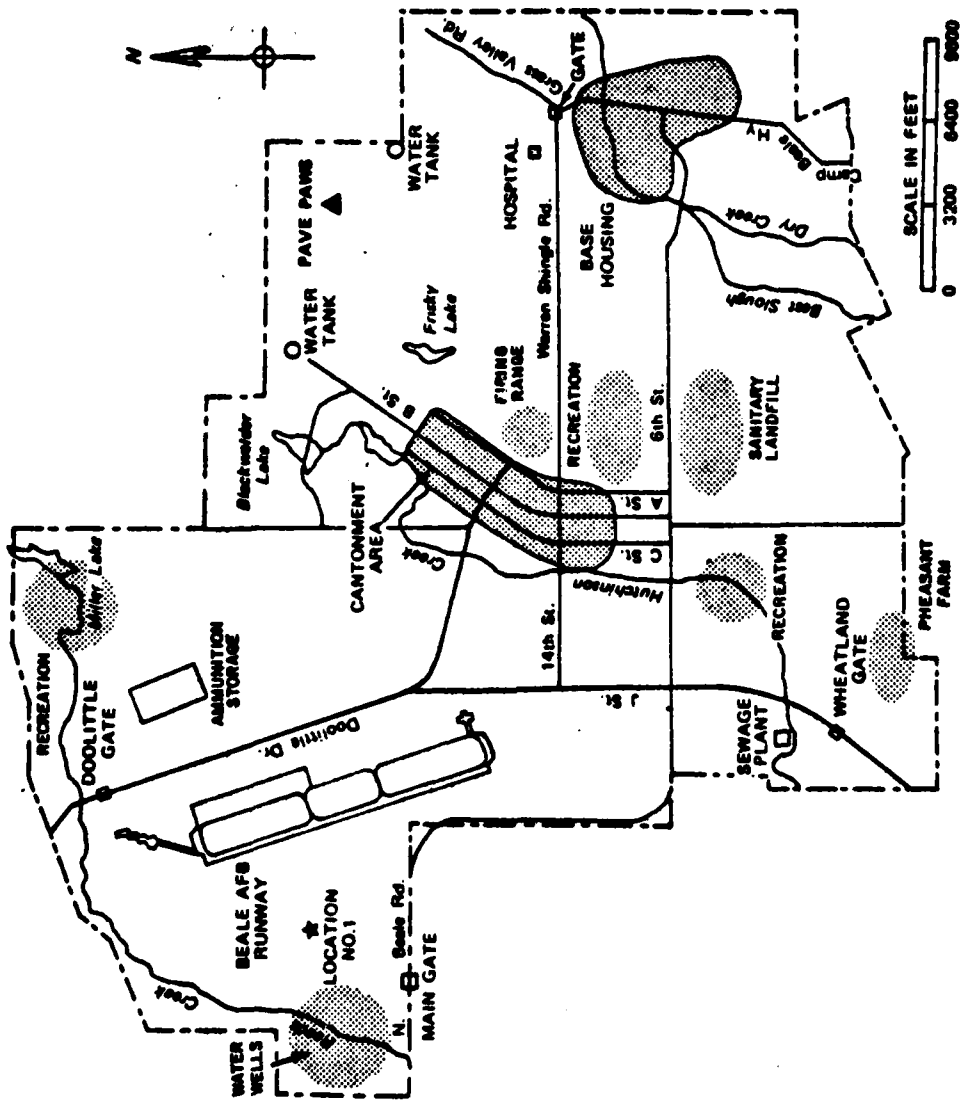

Source: BEALE AFB MASTER PLAN, Tab. No. LM-5, October 1978

FIGURE 1-7. LAND USE ON BEALE AIR FORCE BASE

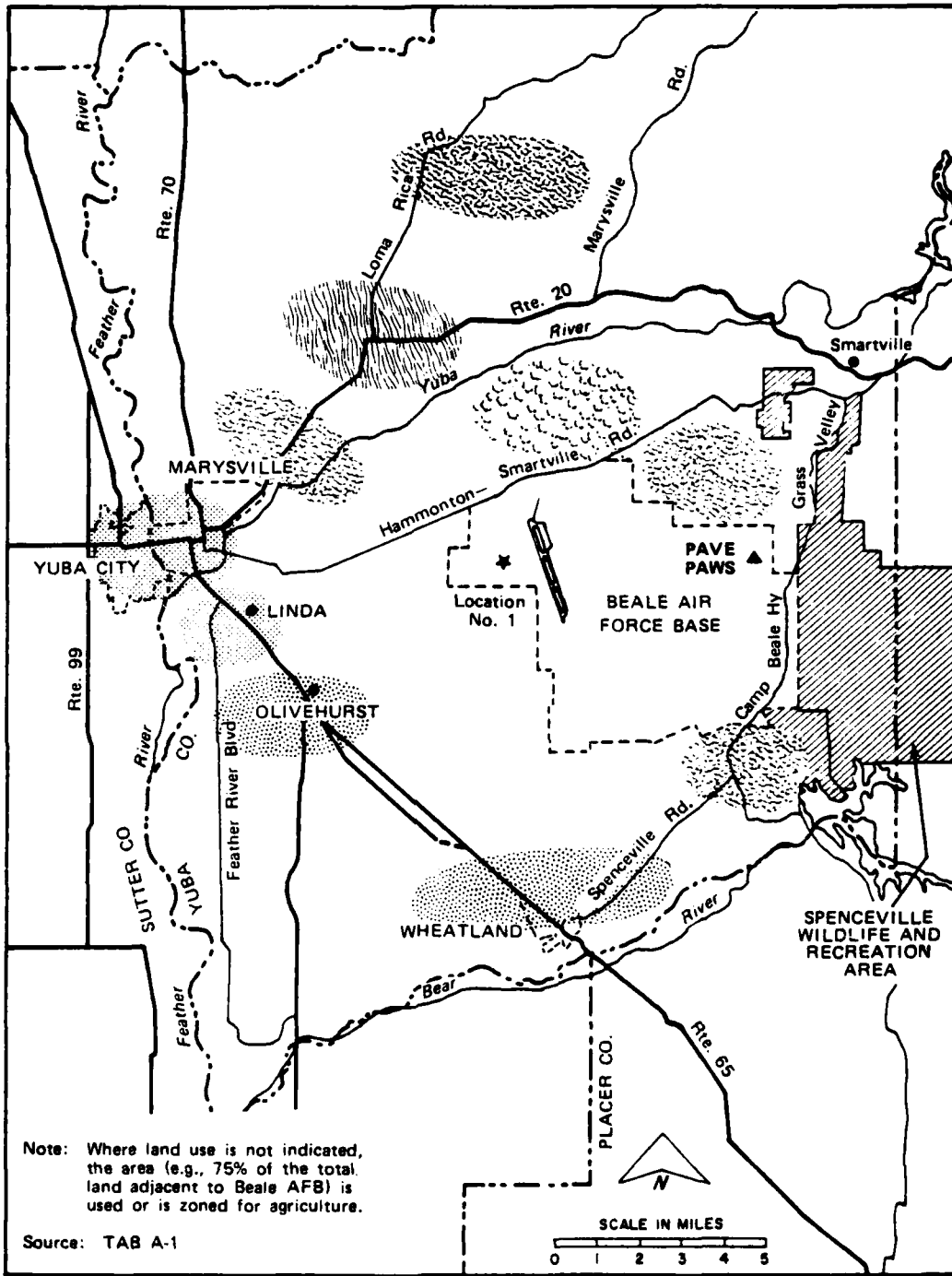

Note: Where land use is not indicated, the area (e.g., 75% of the total land adjacent to Beale AFB) is used or is zoned for agriculture.

Source: TAB A-1

- | | | | |
|---|---------------------|---|------------------------------------|
|  | URBAN AREA |  | CONSERVATION/RECREATION |
|  | RURAL RESIDENTIAL |  | MEDIUM DENSITY HOUSING; COMMERCIAL |
|  | LOW DENSITY HOUSING | | |

FIGURE 1-8. EXISTING AND POTENTIAL LAND USE ON THE PERIPHERY OF BEALE AIR FORCE BASE

1.2.1.2.1.2 Aesthetics. The PAVE PAWS site is at the base of the low, rolling grasslands that are the beginning of the foothills of the Sierra-Nevada Mountains. West of PAVE PAWS, terrain flattens toward the base cantonment area and the towns of Marysville and Yuba City. East of PAVE PAWS, the grassland becomes steeply rolling. On clear days, the PAVE PAWS site is clearly visible from most areas on base and possibly from some areas in Marysville and Yuba City. Haze and fog, which are present much of the time in California inland valleys, greatly reduce the visibility of the site from most areas outside the base.

1.2.1.2.2 Demographics and Economics. Beale AFB is located in Yuba County. More than 90% of Beale personnel and their dependents live in Yuba County or the adjacent Sutter County (U.S. Air Force, 1977). Therefore, the analysis of existing conditions in this chapter and the analysis of impacts in Chapter 3 are based on the two-county Sutter-Yuba region.

1.2.1.2.2.1 Employment. The Sutter-Yuba County region was first settled during the gold rush, when discovery of the nearby "Mother Lode" first attracted large numbers of settlers. The exploitation of natural resources (agriculture, timber, and mining) is still a major economic activity in the region. However, the region's economy is becoming more diverse, and agriculture is no longer the predominant source of income and employment. In 1978, about 6,700 jobs, or 16% of regional employment, were located in this sector (see Table 1-5, p. 1-29). Sutter County's economy is much more dependent on agricultural income than is Yuba County's.

The government sector is a major source of employment in the region. In 1978, 8,175 persons, or 19.6% of the civilian labor force, were employed by federal, state, and local governments. A large part of the region's government employment, including Beale AFB, is located in Yuba County. Beale AFB employs 5,250 people, including 891 civilians, as shown in Table 1-4.

Manufacturing employment is a small but growing part of the economic and employment base of Sutter and Yuba Counties comprising 9% of 1978 employment. Food processing and lumber and wood production are the most important manufacturing activities, employing 79% of manufacturing workers. Employment in both of these areas is subject to seasonal fluctuations, peaking in late summer to early fall and reaching its lowest levels in the spring (see Table 1-5, p. 1-29). These fluctuations are large enough to cause the overall unemployment rate to vary considerably during the year.

The regions' civilian labor force numbered 41,675 in 1978, of which 14% or 5,750 people were unemployed. Employment grew at an average annual rate of 3.5% between 1970 and 1978. However, the

Table 1-4
 ASSIGNED BEALE AFB EMPLOYEES
 30 September 1978

Military ^a	
Enlisted	3,817
Officers	<u>542</u>
Total	4,359
Civilian ^b	
Appropriated fund	550
Nonappropriated fund	129
Base exchange	132
Contract	<u>80</u>
Total	891
 TOTAL	 5,250

Sources: ^aBeale AFB Information Office (1978)
^bBeale AFB Housing Office (1978a)

labor force has grown at 3.9%, so unemployment rates have increased (see Table 1-6, p. 1-30).

In the absence of changes by the Air Force, the Sutter-Yuba region is expected to continue to experience average annual employment growth of 3.5% through 1980. Projected employment in 1980 is 38,440. Assuming the labor force participation remains constant at the 1978 rate of 43.5%, unemployment is projected to fall to 12.9% (see Table 1-6).

1.2.1.2.2 Population. The population of Yuba and Sutter counties has increased at an average annual rate of 2.3% in the period between 1950 and 1978. The population of Sutter County is slightly larger and has been growing at a faster rate than that of Yuba County. Total populations of Yuba and Sutter counties were 46,695 and 49,150, respectively, in 1978 (California Department of Finance, December 1977).

Table 1-7 shows the 1975-80 population characteristics of Yuba and Sutter counties. The region has a high proportion of children and young adults. The median age is 25 in Yuba County, and 28 in

Table 1-5

LABOR FORCE AND EMPLOYMENT BY INDUSTRY IN SUTTER AND YUBA COUNTIES
1978

	January	March	June	September	Average 1978
Civilian Labor Force ^a	38,425	40,150	42,325	43,750	41,675
Employment	32,500	32,750	36,400	40,275	35,925
Unemployment	5,925	7,400	5,925	3,475	5,750
Unemployment rate (%)	15.4	18.4	14.0	7.9	13.8
Wage and Salary Workers ^b	28,175	28,100	32,150	37,175	32,175
Agricultural wage and salary service, forestry and fisheries	3,675	3,525	6,350	10,575	6,725
Nonagricultural wage and salary	24,500	24,575	25,800	26,600	25,450
Construction and mining	1,275	1,375	1,575	1,650	1,450
Manufacturing	3,200	3,325	3,450	4,450	3,650
Food processing	1,325	1,275	1,250	2,150	1,450
Lumber and wood	1,175	1,300	1,450	1,525	1,450
Other manufacturing	700	750	750	775	750
Transportation and public utilities	1,400	1,400	1,525	1,600	1,525
Wholesale trade	1,025	1,050	1,150	1,200	1,075
Retail trade	4,875	4,825	5,175	5,175	4,950
Financial, insurance and real estate	925	950	975	975	925
Services	3,600	3,600	3,700	3,800	3,700
Government	8,200	8,050	8,250	7,750	8,175
Federal	1,375	1,325	1,400	1,450	1,425
State	925	925	925	925	925
Local and education	5,900	5,800	5,925	5,375	5,825

^a Labor force, employment and unemployment by place of residence. Employment includes persons involved in labor-management trade disputes.

^b Employment reported by place of work and does not include persons involved in labor-management trade disputes.

Source: California Department of Employment Development

Table 1-6

SUTTER AND YUBA COUNTIES
LABOR FORCE AND UNEMPLOYMENT RATES

	<u>1970</u>	<u>1975</u>	<u>1978</u>	<u>Projected 1980</u>
Labor force	30,080	35,650	41,675	44,148 ^a
Employment	27,300	30,925	35,925	38,440 ^b
Unemployment rate(%)	9.3	13.3	13.8	12.9

Sources: California Employment Development Department (1978);
U.S. Census, 1970

^aBased on 43.5% labor force participation rate for 1980
projected population of 101,490 (see Table 1-7).

^bBased on historical (1970-1978) growth rate of 3.5%.

Table 1-7

SUTTER-YUBA POPULATION CHARACTERISTICS
1975 and 1980

<u>1975</u>	<u>Sutter County</u>		<u>Yuba County</u>		<u>Sutter-Yuba</u>	
	<u>Number</u>	<u>Percent</u>	<u>Number</u>	<u>Percent</u>	<u>Number</u>	<u>Percent</u>
<u>Age Distribution</u>						
Under 18	15,284	32.9	15,082	33.4	30,366	33.2
18-64	27,000	58.2	26,497	58.6	53,497	58.4
Over 64	4,115	8.9	3,617	8.0	7,732	8.4
Total	46,399	100.0	45,196	100.0	91,595	100.0
<u>Projected 1980</u>						
<u>Age Distribution</u>						
Under 18	15,304	29.7	15,724	31.4	31,028	30.6
18-64	31,245	60.7	29,800	59.6	61,045	60.1
Over 64	4,934	9.6	4,483	9.0	9,417	9.3
Total	51,483	100.0	50,007	100.0	101,490	100.0

Source: California Department of Finance (1977).

Sutter County. Slightly more than half of each county's residents are male. Average household size is approximately 2.8 individuals in both counties (California Department of Finance, 1977).

Beale AFB employs approximately 5,250 people (see Table 1-4, p. 1-28). Approximately 83% of these are military personnel. Data on manpower at Otis AFB (the sister PAVE PAWS site) indicate that the average size of the households of the military personnel is 3.5 individuals (USAF, 1979a). This analysis assumes that the demographic characteristics of the AF civilian population do not differ significantly from those of the county population in general.

The projected 1980 population of the Sutter and Yuba Region is approximately 101,500 (California Department of Finance, 1978). This represents a 6% increase over the 1978 population (see Table 1-8). Most of this growth will occur in Yuba County, which will thereby increase its proportion of the regional population from 48.7% in 1978 to 49.3% in 1980. Children and young adults will continue to be well represented in the regional population, but median age will increase to 27 in Yuba County and to 30 in Sutter County. Males will continue to constitute slightly more than half of the regional population (California Department of Finance, 1977).

No significant changes in the demographic characteristics of Beale AFB personnel are expected between 1978 and 1980 (Doidge, 1978).

1.2.1.2.2.3 Income. Per capita income for the Sutter-Yuba region was estimated at \$6,013 in 1976 (all income data are in current dollars). Sutter County has a higher total and per capita income than Yuba County (see Table 1-9). The distribution of income by source is quite different in the two counties. For example, farm income comprised 23.7% of personal income in Sutter County, whereas in Yuba County farm income only amounted to 12.8%. In contrast, government income was only 7.9% of the total in Sutter County, whereas the Yuba County location of Beale AFB and several state agencies resulted in government contributing 45% of the county's income.

Personal income has grown at an average annual rate of 5.8% in the region in the period between 1974 and 1976. This rate is markedly different from the 16.5% growth rate enjoyed between 1970 and 1974. The combined effects of the national recession from 1974 to 1976 and the 1975-1977 drought are responsible for this change.

Assuming a future annual income growth rate of 5.8%, 1980 regional income and per capita income will be \$700 million and \$6,900, respectively.

Table 1-8

SUTTER AND YUBA COUNTY POPULATION ESTIMATES AND PROJECTIONS

<u>County</u>	<u>1950</u>	<u>1960</u>	<u>1970</u>	<u>1977</u>	<u>1978</u>	<u>Projected 1980</u>
Sutter	26,239	33,859	41,935	47,900	49,150	51,483
Yuba	24,420	33,380	44,736	46,250	46,700	50,007
Sutter/Yuba	50,659	67,239	86,671	94,150	95,850	101,490

Sources: California Department of Finance (1977); U.S. Air Force (1977).

TABLE 1-9

 PERSONAL INCOME IN SUTTER AND YUBA COUNTIES
 1971, 1974, 1976
 (current dollars)

<u>County</u>	<u>1971</u>	<u>1974</u>	<u>1976</u>	<u>Annual Change (%) 1974 - 1976</u>
Personal Income (thousands)				
Sutter	177,973	291,187	320,115	4.85
Yuba	161,861	216,355	246,696	6.78
Sutter/Yuba	339,834	507,542	566,811	5.67
Per Capita Income				
Sutter	4,134	6,422	6,729	2.36
Yuba	4,723	6,042	5,283	-6.49
Sutter/Yuba	4,438	6,232	6,013	-1.77

Source: California Department of Finance (1978).

1.2.1.2.2.4 Housing. Table 1-10 shows housing data for Sutter and Yuba counties and selected cities in the Sutter-Yuba Region. The number of housing units in the region increased by 12.6% or 4,093 units in the period 1970-1975. The housing stock in Sutter County grew at a higher rate (13.8%) than that of Yuba County (11.5%). Yuba City had the largest growth rate in the region during this period. Vacancy rates for the region as a whole remained fairly stable from 1970 to 1975. However, Sutter County had lower vacancy rates in 1975 than it had in 1970, whereas vacancy rates in Yuba County increased during this period. This combination of greater growth in housing stock and declining vacancy rates in Sutter County indicates that the demand for housing in Sutter County is increasing faster than that in Yuba County.

In general, the region followed the national trend toward a more diversified housing stock. The proportion of single family homes declined and the proportion of multifamily units and mobile homes increased in both counties and in the region as a whole. The cities of Marysville and Wheatland are exceptions to this rule; most new housing units in these two cities during this period were single family homes.

In 1975, 12% of the region's housing stock was in substandard condition. The cities of Yuba City and Marysville had a smaller percentage of substandard units (7.4%), but the smaller communities of Live Oak and Wheatland had higher rates of 19.3% and 10%, respectively. The unincorporated areas of the region have a larger percentage of substandard housing (19.2%) than the region as a whole (Sacramento Regional Area Planning Commission, 1977).

Sutter County's housing stock increased by 27% between 1975 and 1978, to 20,776 units (see Table 1-11). One-quarter of this growth occurred in Yuba City, where the housing stock increased by 18% in this period. Multifamily units and mobile homes comprise much of the new county housing, and the proportion of single family homes has correspondingly decreased from 75.4% (1975) to 69.8% (1978). If the housing stock continues to grow at 1970 to 1980 rates, the housing supply in 1980 will total about 23,300 units.

Since 1975, the housing stock in Yuba County has continued to grow. The 1978 housing supply totals 12,202 units, a 7.2% increase over the supply in 1975. Single family homes still predominate, but multifamily units and mobile homes continue to increase in importance (see Table 1-11). Housing in the unincorporated areas of Linda and Olivehurst is growing rapidly at present, and 1,000 new single family units have recently been completed. An additional 300 units are being considered or planned (Wieland, 1978). If the county housing stock continues to grow at the 1975-8 annual growth rate, the total housing supply in 1980 will be about 18,000 units.

Table 1-10

SUTTER-YUBA REGION HOUSING STOCK 1970, 1975

Location	No. of Units ^a	Occupied Units ^a	Vacancy Rate	Percent Distribution		
				Single Family ^b	Multi- Family ^b	Mobile Home ^b
Sutter County						
1970	14,102	13,159	6.7	83.5	12.7	3.8
1975	16,355	15,454	5.5	75.4	18.5	6.1
Yuba City						
1970	5,252	4,971	5.4	70.9	26.7	2.4
1975	6,197	5,902	4.5	61.2	35.7	3.1
Yuba County						
1970	14,202	13,074	7.0	75.7	17.0	7.3
1975	16,042	14,451	9.9	67.8	19.5	12.7
Marysville						
1970	3,574	3,384	5.3	62.8	26.3	10.9
1975	3,939	3,502	8.4	66.8	31.1	2.0
Wheatland						
1970	425	NA	NA	68.5	30.8	0.7
1975	479	463	3.3	70.1	28.9	1.0
Region						
1970	28,304	26,253	7.3	79.6	14.8	5.4
1975	32,397	29,905	7.5	71.6	19.0	9.4

^aU.S. Air Force (1977).

^bCalculations based on data from Sacramento Regional Area Planning Commission (1977)

Table 1-11

1978 HOUSING STOCK

<u>Location</u>	<u>Single Family</u>		<u>Multifamily</u>		<u>Mobile Homes</u>		<u>Totals</u>
	<u>Number</u>	<u>Percent</u>	<u>Number</u>	<u>Percent</u>	<u>Number</u>	<u>Percent</u>	
Yuba County							
Marysville	2,647	64.1	1,401	33.9	80	1.9	4,128
Wheatland	390	72.4	144	26.7	5	0.9	539
Unincorporated areas	<u>3,257</u>	<u>65.9</u>	<u>1,863</u>	<u>14.9</u>	<u>2,415</u>	<u>19.3</u>	<u>7,535</u>
Totals	6,294	51.6	3,408	27.9	2,500	20.5	12,202
Sutter County							
Yuba City	4,003	54.9	3,065	42.0	228	3.2	7,296
Live Oak	797	83.5	117	12.3	41	4.3	955
Unincorporated areas	<u>9,696</u>	<u>77.4</u>	<u>1,611</u>	<u>12.9</u>	<u>1,218</u>	<u>9.7</u>	<u>12,525</u>
Totals	14,496	69.8	4,793	23	1,487	7.2	20,776

Source: Sacramento Regional Area Planning Commission (1978).

Beale AFB's housing stock consists of 1,737 family units, 270 mobile home spaces, and 1,074 dormitory beds. These facilities house about 60% of the military personnel. Family unit and dormitory vacancy rates are less than 5%, but about half of the mobile home spaces are unoccupied. Construction of a 100-bed dormitory is planned for 1984. No other changes in the on-base housing facilities are expected (Beale AFB Housing Office, 1978a). The majority of the civilian and military personnel who live off-base reside in Marysville/Linda and Yuba City (see Table 1-12).

1.2.1.2.2.5 Education. School enrollments for each district in the Sutter-Yuba region are given in Table 1-13.

1.2.1.2.2.5.1 Marysville. The Marysville Unified School District serves Marysville, the unincorporated areas of Linda and Olivehurst, and the rest of Yuba County, excluding Wheatland, Plumas, and Comptonville. The district has 17 elementary schools, 4 intermediate schools, and 3 secondary schools. Total district enrollment was 8,012 on November 3, 1978, a decrease of 2% from 1977 enrollment of 8,172. Enrollment has decreased at an average annual rate of 1.7% over the last 7 years. Most of this decrease has occurred in the elementary schools, whereas the secondary schools have experienced slight increases in enrollment. With the exception of Lindhurst High School, which serves the communities of Linda and Olivehurst, the schools have ample capacity to accommodate new students.

The geographic area covered by the district is quite large, and many students ride buses to school. School officials estimate that the current bus system could accommodate more than 500 new students without new equipment or significant additional cost (Smith, 1978).

In FY 1979, 263 dependents of Beale AFB personnel (both military and civilian) were enrolled in Marysville schools. Public Law 81-874 reimbursements for these students amounted to approximately \$220,300. This represents less than 1% of the total district expenditures of \$13.7 million. (Marysville Unified School District, 1978).

1.2.1.2.2.5.2 Wheatland. The Wheatland community is served by two separate school districts. The Wheatland School District includes four elementary schools, two of which are located on Beale AFB. Of the 1,658 students served by this district, 82.7% or 1,371 are dependents of Beale AFB personnel. Wheatland Union High School constitutes a school district of its own. Of the 550 students in the district, 98.4% or 541 students are Beale AFB dependents. The two districts are coterminous and include the

Table 1-12

RESIDENTIAL DISTRIBUTION OF PERSONNEL LIVING OFF-BASE, 1977
(Percent)

<u>Location</u>	<u>Military^a</u>	<u>Civilian^b</u>
Sutter County		
Yuba City	31.3	23.1
Other	0.6	1.1
Yuba County		
Marysville/Linda	47.3	33.4
Wheatland	3.1	6.8
Olivehurst	2.5	10.0
Other	1.0	8.3
Sacramento Area	6.6	5.0
Other		
Nevada County	1.2	6.6
Placer County	2.1	4.4
Butte County	1.0	1.3
Other	<u>3.2</u>	<u>0.0</u>
Total	100.0	100.0

^aResidential distribution from Beale AFB Housing Office (1978b).

^bResidential distribution from U.S. Air Force (1977).

Table 1-13

SCHOOL ENROLLMENT BY DISTRICT

<u>School District</u>	<u>Enrollment 1977-1978</u>	<u>Enrollment 1978-1979</u>	<u>Change (%)</u>	<u>Excess Capacity^a 1978-1979</u>
Marysville Unified				
Elementary	5,627	5,466	-2.9	1,813
Secondary	<u>2,545</u>	<u>2,546</u>	<u>0.0</u>	<u>404</u>
Total	8,172	8,012	-2.0	2,217
Wheatland				
Elementary	1,845	1,658	-10.1	1,210
Wheatland Union High	<u>541</u>	<u>550</u>	<u>1.7</u>	<u>800</u>
Total	2,386	2,208	-7.5	2,010
Yuba City Unified				
Elementary	4,713	4,641	-1.5	464
Secondary	<u>2,658</u>	<u>2,570</u>	<u>-3.3</u>	<u>(-396)</u>
Total	7,371	7,211	-2.2	68
Sutter-Yuba Region	17,929	17,431	-2.8	4,295

^aRefers to difference between maximum capacity and 1978-1979 enrollment.

Sources: Marysville U.S.D. (1978); Wheatland School District (1978); Wheatland Union School District (1978); Yuba City U.S.D. (1978).

town of Wheatland, Beale AFB, and the surrounding agricultural areas.

The Wheatland schools are operating at substantially less than optimal enrollment levels. Current enrollment totals 1,658 for the elementary district (down 10.1% from FY 1978), and 550 for the high school (up 1.7% from FY 1978). District officials report that during the Vietnam conflict enrollment was considerably higher, as a result of higher staffing levels at Beale AFB. Additional classroom construction was completed in the mid-1970s in anticipation of even higher staffing levels at Beale. Instead, the Beale-related population has decreased substantially in subsequent years, and this decrease has contributed to a total excess capacity of 47.7% or 2,010 students in Wheatland schools.

According to officials at both districts, 200-300 extra students could be served with minimal increase in operating expenditures for maintenance, transportation, teachers, and so on. This is especially true at the high school, which is operating at only 40.7% of capacity. Thus, additional students will result in very low incremental costs, and they will generate additional revenues from PL 81-874, as well as from other federal and state sources. The two districts receive approximately \$1.32 million in PL 81-874 impact aid. This represents 24.7% of the \$5.33 million budgets for the two districts combined.

1.2.1.2.2.5.3 Yuba City. Yuba City Unified School District serves Yuba and Butte Counties. The district has 11 elementary schools, 1 comprehensive high school, and 1 continuation high school. Although the area has recently experienced a substantial increase in number of households, the school-age population has remained stable. This reflects the national trend toward a smaller number of children per household.

Yuba City's elementary schools are operating at optimal capacity, but the high schools are currently overcrowded. Current elementary and secondary enrollments are 4,641 and 2,570, respectively, a decrease of 2.2% from FY 1978. Church-sponsored private schools are gaining in popularity in Yuba City. Greater private school enrollment is expected to result in a 1-1.5% annual decrease in public school enrollment in the next 2-3 years (Bravos, 1978). An additional 126 students (predominately high school students) have been allowed to transfer to schools outside the district to ease overcrowding.

Yuba City school enrollments include 260 dependents of Beale AFB personnel. PL 81-874 reimbursements for these students equaled approximately \$50,272, or 0.4% of the total annual budget.

1.2.2 Mt. Hebo AFS, Oregon

Operation of the PAVE PAWS radar facility at Beale AFB would result in subsequent shutdown of Detachment 2, 14th Missile Warning Squadron at Mt. Hebo AFS, which is located approximately 60 miles southwest of Portland (see Figure 1-1, p. 1-2). Mt. Hebo AFS is maintained by the Aircraft Detection Unit of the 689th Radar Squadron. In a separate action, the Aircraft Detection Unit is scheduled to close in the spring of 1979, at which time about 80 support personnel will be transferred to Detachment 2, 14th Missile Warning Squadron (USAF, 1978). Currently, approximately 200 people are based at Mt. Hebo AFS, 150 in the Aircraft Detection Unit and 50 in Detachment 2. As of the spring of 1979, approximately 130 people will be based at Mt. Hebo AFS, all Detachment 2.

Mt. Hebo AFS straddles the border of Tillamook and Yamhill counties on approximately 88 acres of federally owned land. This land will revert to the U.S. Forest Service when Mt. Hebo AFS closes. All of the lands surrounding Mt. Hebo AFS are part of the Siuslaw National Forest. The town of Hebo lies approximately 5 miles west, and the City of Tillamook lies 19 miles north of the Station. Table 1-14 gives distance from Mt. Hebo AFS to other points of interest nearby.

The radar operations at Mt. Hebo AFS include three radars (search, height-finder, and FSS-7 missile detector), all enclosed in white radomes. The station is largely self-sufficient with respect to various support facilities. Two government-owned water systems from nearby streams serve the requirements for fire protection and domestic water. A water pumping plant located at Three Rivers supplies water to all facilities within the operations and cantonment area. The water pumping plant located at Cedar Creek supplies water to the family housing area. The station has two small trickling filter sewage treatment plants, one for the operations area and one for the housing area. Mt. Hebo AFS has 27 family housing units, a Base Exchange, a dormitory for unmarried airmen, recreational and dining facilities, administration and maintenance buildings, and communication facilities. Electricity is provided by the Tillamook Peoples Utility District (PUD). Standby electrical power is provided by a diesel electric generating plant located in the operations area. Fuel and other supplies are trucked in. A single two-lane paved road from the town of Hebo provides the only public access to the summit.

1.2.2.1 Biophysical Characteristics

Information on the biophysical resources at and in the vicinity of Mt. Hebo AFS was obtained through a field

Table 1-14

APPROXIMATE LINEAR DISTANCES^a FROM LOCAL AREAS
OF INTEREST TO MT. HEBO, OREGON AFS

<u>Populated Area (nearest edge)</u>	<u>Distance to Mt. Hebo AFS (miles)</u>
Nearest off-base residential area	4.9
Nearest on-base residential area	1.5
Mt. Hebo Forest Camp	0.2
Hebo Lake	2.2
Hebo	5.0
Hebo Ranger Station	5.0
Hebo Work Camp	4.3
Hebo Fish Hatchery	4.6
Cloverdale	6.1
Siuslaw National Forest Scout Camp	10.2
North Lake	0.4
South Lake	1.2
Rocky Bend Forest Camp	6.0
Boyer	10.3
Thomas Hill	11.5
Grand Ronde	12.0
Valley Junction	13.0
Fort Hill	13.7
Round Top Woods	5.3
Tillamook	14.0
Midway	9.6
Oretown	10.8
Pacific City	10.0
Cape Kiwanda	11.0
Cape Lookout State Park	15.0
Blaine	5.5
Sandlake	11.0
Hemlock	8.0
Tierra Del Mar	12.0
Castle Rock	6.1
Little Nestucca Park	10.2
Happy Hollow	7.0
Pleasant Valley	10.6
Cascade Head Scenic and Recreational Area	17.0

^aLinear distances obtained from U.S. Geological Survey 7-1/2 minute topographical maps of the area.

reconnaissance survey, December 11-23, 1978; through personal interviews of government officials and private individuals knowledgeable about the region's ecology; and through literature reviews.

Mt. Hebo AFS is situated in the Hebo Planning Unit of Siuslaw National Forest in the Coast Range of western Oregon. The topography of the area is characterized by the steep slopes and sharp ridges of a series of low mountains that form long narrow valleys parallel to the coast. The rugged terrain of the Coast Range has been formed by uplifted marine sedimentary rocks that have been intruded by large bodies of igneous rocks, and locally altered by extensive volcanic activity (Beaulieu, 1973; Schlicker, 1972). Soils in the Mt. Hebo area are classified in the Hembre-Kilchis-Astoria-Trask association, and are described as the strongly sloping to steep soils of forested uplands (USDA, 1964). Natural erosion rates are high in these steep areas, and the soils vary considerably in depth depending on slope and geology. They are moderately coarse textured and moderately fertile (USFS, 1978).

The major part of Mt. Hebo AFS (the operations and cantonment area) is situated on the Main Point of the summit of Mt. Hebo on the border of Tillamook and Yamhill Counties at an elevation of 3,150 feet above mean sea level. The family housing area, at an elevation of 2000 feet above mean sea level, is located about 2.5 miles down the road from the summit leading to the town of Hebo.

The summit of Mt. Hebo receives about 150 inches of rain per year. It also receives very strong winds, frequently up to 80 to 90 knots, rising to at least 150 knots during storms. Decreasing amounts of rainfall and more gentle winds occur at the lower elevations. In general, the Coast Range has a temperate, humid, maritime climate because of the moderating influence of the Pacific Ocean. Winters at the lower elevations are mild, cloudy, and wet; summers are cool, clear, and relatively dry (USFS, 1978).

Based on Bailey's ecoregion classification System, Mt. Hebo is located in the Sitka Spruce-Cedar Hemlock Forest Section of the Pacific Forest Province (Bailey, 1976). The spruce forests are actually confined to the coastal fog belt, which extends inland only a few miles (Franklin, 1973). Mt. Hebo is about 12 miles from the coast, where the climax species is hemlock; however, the dominant vegetation today is Douglas fir. Unlike the shade-tolerant species of hemlock, Douglas fir is well adapted to open, disturbed conditions.

Although the Mt. Hebo area escaped the devastating Tillamook Burn that began in the 1930s, it was subject to several earlier fires, the last major one occurring in 1910. During the next 20 years, the USFS planted approximately 8,000 acres in the Mt. Hebo area, largely to Douglas fir. Smaller areas were planted with pine, spruce, and hardwoods. Except for some in the open areas on

the summit of Mt. Hebo and small pockets of residual timber which escaped the burns, most of the vegetation in the Mt. Hebo area today is part of a 50-to 70-year-old conifer stand, with trees approximately 15 to 25 inches in diameter at breast height (USFS, 1978). Red alder is common in moist sites, particularly along roadsides. Common understory plants include blackberry, red huckleberry, and elderberry.

The stumps of the trees remaining on the summit of Mt. Hebo indicate that the exposed highlands of Mt. Hebo supported a very thin stand of trees before 1910. Few if any trees probably grew in the small areas of thin soils and on rocky outcrops on the peak, which are very poor timber sites. Because military activities have been conducted for more than 20 years on the summit of Mt. Hebo, very little of the native vegetation remains there today. The small (less than 1 acre) grassy openings that are currently present might be vegetated with plant species similar to those on the grassy balds of the Oregon's Coast Range (Merkle, 1951; Detling, 1954; Chambers, 1973; and Aldrich, 1972); however, most of the peak is covered with roads or structure, or has been reseeded with introduced grasses, presumably for erosion control. The AFS areas further down the slope (including the housing area and the water supply areas) are surrounded by the Douglas firs successfully planted by the USFS early this century.

Wildlife found in the Hebo Planning Unit of the Siuslaw National Forest includes a considerable variety and abundance of game animals, fur-bearing animals, rodents, fish, waterfowl, and birds. The most common large game animal is the black-tailed deer, which can often be seen feeding in the cleared areas along the access road to Mt. Hebo. Roosevelt elk and black bear are also present in the area. Listings of the 310 wildlife species found in the Hebo Planning Unit of the Siuslaw National Forest can be found in the Final Environmental Study recently completed for this unit (USFS, 1978).

Mt. Hebo lies between two major routes of the Pacific Flyway, the coastal route, 10 miles to the west, and the Willamette Valley route, 30 miles to the east (Loy, 1977). Tillamook Bay, 20 miles northwest of Mt. Hebo, provides an important wintering area for ducks, but no important wintering areas for waterfowl are found in the immediate vicinity of Mt. Hebo.

Migratory routes for large game animals along the coast are not well defined because of the mild climate, although it is known that deer and elk tend to feed at lower elevations during the winter. The most critical habitats for deer and elk in the Hebo area are gentle slopes that face south and have up to 15 years of forest regrowth to provide winter forage. Both deer and elk are adapted to disturbed vegetation.

Special-interest species that might occur in the Mt. Hebo Region include one that is on federal and state lists of endangered species, the American peregrine falcon; one on federal and state lists of threatened species, the northern bald eagle; and one on a state list of threatened species, the northern spotted owl. However, none of these species is known to nest in the Mt. Hebo area. Potential nesting areas for the peregrine falcon are present, but old growth forests with snaggle-topped trees are required for spotted owls and bald eagles, and few old growth forests remain in the Mt. Hebo area. Three other listed species might briefly fly over the Mt. Hebo area: federal- and state-listed endangered California brown pelican in postbreeding movements; the federal- and state-listed endangered Aleutian Canadian goose during winter migrations; and erratic individuals of a state-listed threatened coastal species, the western snowy plover (USDI, 1977, 1978; Oregon Department of Fish and Wildlife, 1978). Oregon State University has designated as rare several additional species whose ranges include the Hebo Planning Unit of the Siuslaw National Forest (USFS, 1978). No endangered or threatened plant species are known to occur in the Hebo Planning Unit, although some may be discovered during a thorough investigation (see USFS, 1978, Exhibit IX for a listing of the proposed federal designated endangered plant species with known ranges in Oregon).

Aquatic habitats in the Mt. Hebo area include several streams, including Three Rivers and Cedar Creek, which supply pure water for Mt. Hebo AFS. These streams drain into the Nestucca River, which flows into Nestucca Bay. In addition, four small lakes are present near the Mt. Hebo area, including Hebo Lake and South Lake, which are stocked with cutthroat trout and have adjacent campgrounds (Oregon Department of Fish and Wildlife, undated).

The streams near Mt. Hebo are characterized by:

- o Relatively high anadromous fish (fish that ascend rivers from the sea for breeding) productivity
- o Relatively low levels of dissolved nutrients
- o Large variations in flow that result from large seasonal variations in rainfall quantity
- o Relatively youthful channel development (i.e. steep gradient, straight alignment, poorly defined banks, and steep slopes adjacent to streams)
- o Generally excellent water quality, with cool stream temperatures, low levels of natural suspended sediment and very low concentrations of toxins
- o Dense streamside vegetation

- o Accumulations of woody debris incorporated into the stream channel
- o Spawning and rearing habitats for one to four species of anadromous fish (USAF, 1978).

Downstream portions of Three Rivers and Nestucca River are considered by the Oregon Department of Environmental Quality to have severe stream bank erosion and sedimentation problems (Rickert, 1978).

Three roadless areas (Nos. 151, 152, and 153, all located near Mt. Hebo), of 5,000 acres or more occur in the Mt. Hebo area. The USFS is currently studying the possibility of giving these areas wilderness status in their RARE II program (see USFS, 1978). No paved roads have been built from Mt. Hebo AFS down to towns in Yamhill County. The natural resource value of the Mt. Hebo area is highly regarded locally and regionally for its timber, its wildlife habitats, and its scenic, recreational, and watershed values. In addition, the air quality of the area is unusually high. No valuable mineral resources are known, however, and no major mining activity occurs in the vicinity of Mt. Hebo AFS.

1.2.2.2 Socioeconomic Characteristics

1.2.2.2.1 Land Use. Mt. Hebo AFS encompasses approximately 88 acres of federally owned (U.S. Forest Service) land, including 67 acres of permitted, 10 acres of leased, and 11 acres of easement land. The land is used as follows;

Main station area (Yamhill County)	22 acres
Housing area (Tillamook County)	25 acres
Ground-to-air transmitter receiver (GATR) (Tillamook County)	4 acres
Water facilities (Pumping plants and distribution systems Tillamook and Yamhill Counties)	20 acres
Miscellaneous uses (Including access roads Tillamook and Yamhill Counties)	17 acres

At the main station site, the land is used for such facilities as:

- o Administration and support buildings (cantonment area)
- o Radar and other electronic equipment
- o Wind tunnels (between the buildings)
- o Sewage treatment plant

1.2.2.2.2 Demographics and Economics. Although Mt. Hebo AFS straddles Tillamook and Yamhill Counties, the major socioeconomic impact of base employees and their dependents is felt in Tillamook County. Most personnel live in Tillamook County. Although the base does extend into Yamhill County, there is no access road from the base to that county.

1.2.2.2.2.1 Employment. In 1976 the Tillamook County labor force was 7,750 people, of which 6,970 were employed; 10.1% were jobless. The largest and fastest growing sectors of the economy were government and wholesale trade, comprising 19.7% and 15.7% of total employment, respectively. Employment in both of these sectors has been growing at a faster rate than total employment. In contrast, employment in lumber and wood products manufacturing decreased from 19.8% in 1970 to 14.1% in 1976 (Oregon Department of Economic Development, 1979). Other manufacturing employment, particularly in high technology type firms, is increasing and is expected to increase further in the future (Tillamook Planning Office, 1978).

Detachment 2 currently has a staff of 50 persons, of which 2 are civilians. As a result of an unrelated Air Force action, 80 additional persons, including 24 civilians, will be transferred to Detachment 2 in April 1979 following closure of the Aircraft Detection Unit. It is estimated that, because of natural attrition, only 124 people would still be stationed at Mt. Hebo by the time PAVE PAWS is scheduled to become operational. Therefore, a staff of 124 persons is used as the baseline condition for estimating the effect of closure or expansion of base operations.

In the absence of Air Force action, 1980 employment and unemployment in Tillamook County are projected to be 7,245 and 13.7%, respectively, assuming that average annual employment, labor force participation rates, and population growth remain constant.

1.2.2.2.2.2. Population. The population of Tillamook County was 18,800 in 1975. Demographic data from 1970 reveal that the population pyramid is heavily weighted in favor of the very young (27.9% of the residents are younger than 15 years old) and the old (24.7% of the residents are more than 55 years old). The

median age is 31.1 years old. The number of retirees in the County is large: 13% of the population is more than 65 years old. In the absence of Air Force action, projected population in 1980 is 20,364.

1.2.2.2.3 Income. In 1975, Tillamook County had personal and per capita income of \$88,500,000 and \$4,838, respectively. Between 1970 and 1975, personal income increased by 55.8% (in current dollars). Dairy production, most notably cheese and butter production, has historically been an important source of county income, contributing \$26 million, or 29%. In recent years, income from government operations and manufacturing has become relatively more important. Tourism is an important and growing source of county income (Army Corps of Engineers, 1974). Mt. Hebo personnel who will be affected by PAVE PAWS operation have total annual wages of \$1,653,000 (U.S. Air Force, 1979).

In the absence of Air Force action, 1980 projected personal and per capita income are \$137,883,000 and \$6,770, assuming income grows at the same rate as during the period 1970-1975.

1.2.2.2.3 Housing. No current data on housing in Tillamook County are available. There are 27 family units and 52 bachelor units on base at Mt. Hebo.

Table 1-15, shows the distribution of Mt. Hebo personnel who will be affected by operation of PAVE PAWS (see Section 1.2.2.2.1, above). The housing distribution of the six people who are expected to leave Mt. Hebo before PAVE PAWS operates (due to attrition) is not available. Sixty of these people, or 46%, live in housing on the Base. The other 42% live in surrounding cities.

1.2.2.2.5 Education. Dependents of Mt. Hebo AFS personnel attend Tillamook School District #9. Current enrollment in the district is 1,912 students. The total budget is approximately \$3.6 million. Currently, 49 dependents of Detachment 2 personnel attend Tillamook Schools. The district receives approximately \$29,600 in PL 81-874 funds per year for these students.

Because total pupil enrollment has been declining for the last 10 years, capacity is adequate to accommodate new students (U.S. Army Corps of Engineers, 1974).

1.2.3 Mill Valley AFS, California

Operation of the PAVE PAWS radar at Beale AFB would result in a significant reduction in the staff of Detachment 3 of the 14th Missile Warning Squadron at Mill Valley AFS, California (Figure 1-1, p. 1-2), and would permit a Joint Surveillance System to be

Table 1-15

HOUSING DISTRIBUTION OF PERSONNEL AFFECTED BY PAVE PAWS
Mt. Hebo AFS, April 1979

<u>Location</u>	<u>Number</u>	<u>Percent</u>
On Base	60	46.2
Tillamook	17	13.1
Hebo	17	13.1
Pacific City	15	11.5
Beaver	12	9.2
Cloverdale	5	3.8
Lincoln City	3	2.3
Bay City	1	0.8
Total ^a	130	100.0

^a1980 total will be lower because of attrition.

Source: ADCOM (1979).

implemented between the Federal Aviation Administration (FAA) and the USAF at Mill Valley. The 53 people now with Detachment 3 would be reduced to 7. These 7, along with 13 people from FAA, would operate the Joint Surveillance System.

Mill Valley AFS, with current staff of approximately 200, is maintained by the 666th Radar Squadron. As a result of separate action, the 147 people now in the 666th Radar Squadron will be leaving Mill Valley in 1980, at about the same time that PAVE PAWS is scheduled to become operational.

Mill Valley AFS is about 15 miles northwest of San Francisco in Marin County on about 100 acres of land leased from the Marin Municipal Water District (MMWD). All of the lands immediately surrounding Mill Valley AFS are part of MMWD. However, the access road leading up to the AFS, Ridgecrest Boulevard, is maintained by the Mt. Tamalpais State Park. Distances to other points of interest near Mill Valley AFS are presented in Table 1-16.

Table 1-16

APPROXIMATE LINEAR DISTANCES* FROM LOCAL AREAS
OF INTEREST TO MILL VALLEY AFS, CALIFORNIA

<u>Populated Area (nearest edge)</u>	<u>Distance to Mill Valley AFS (miles)</u>
Nearest off-base residential area	0.9
Nearest on-base residential area	0.3
Muir Woods National Monument	2.0
Pan Toll Ranger Station	1.5
Mt. Tamalpais State Park	0.9
Camp Eastwood	1.6
Lake Lagunitas	1.4
Bon Tempe Lake	1.7
Alpine Lake	1.8
Stinson Beach (town and state park)	3.0
San Rafael	5.1
Corte Madera	4.0
Sausalito	6.5
Golden Gate Bridge	6.7
Mill Valley	3.2
Ridgecrest Blvd.	0.1
Panoramic Highway	0.8
Kentfield	3.0
Ross	3.3
Larkspur	3.3
Phoenix Lake	2.2
Point Reyes National Seashore	6.2
Bolinas Lagoon	4.0
Cronkite Beach	6.2
Muir Beach	4.6

*Linear distances obtained from U.S. Geological Survey 7-1/2
minute topographic maps of the area.

Major facilities at Mill Valley AFS include the radar operation facilities, with the search radar and the FSS-7 missile detector radar enclosed in white radomes, and an exposed height finding radar; a tertiary sewage treatment plant; nine family housing units; a Base Exchange; a dormitory for unmarried airmen; recreational facilities; administration buildings; communication facilities; maintenance building; dining hall; and a backup water supply from a well. The major water supply comes from Lake Lagunitas, where a pump station operates. Solid waste is handled by an authorized contractor, who disposes of the waste in a sanitary landfill in Marin County. Electricity is obtained by contract from Pacific Gas and Electric Company. Mill Valley AFS has its own distribution system and a standby power plant operated by five diesel engines.

1.2.3.1 Biophysical Characteristics

Information on the biophysical resources near Mill Valley AFS was obtained through a field reconnaissance survey on December 21, 1978; through personal interviews with governmental officials and private individuals knowledgeable about the region's ecology; and through literature reviews. Because of the high value of the natural resources in the region and their proximity to a large urban population, several environmental land use management studies are in progress or have recently been completed in the vicinity of Mill Valley AFS. These include an Environmental Planning Study by MMWD (Dickert, undated); resource inventories by the Mt. Tamalpais Planning Unit of the California Department of Parks and Recreation (in progress); and a Preliminary Information Base by the National Park Service of the Golden Gate National Recreation Area (GGNRA) (Nadeau, 1975). Mt. Tamalpais, which includes Mill Valley AFS, is within the authorized boundaries of GGNRA as established by federal law in 1972, but it remains under the jurisdiction of the MMWD.

Mill Valley AFS is situated on the West Peak of Mt. Tamalpais in the western region of the MMWD. Located 3 miles from the Pacific Ocean, 4 miles from San Francisco Bay, and 8 miles from the Golden Gate Bridge, Mt. Tamalpais is one of the major visual focal points of the San Francisco area. Before military activities began in 1942, West Peak was the highest of the three peaks (East, Middle, and West) of Mt. Tamalpais. Construction of military facilities flattened the peak from 2,580 to 2,568 feet above mean sea level. Today, East Peak, 1.5 miles northeast of West Peak, is the highest peak of Mt. Tamalpais at 2,571 feet above mean sea level, and it is generally considered as the mountain top. With steep slopes on three sides, East Peak is also more open than West Peak, which is surrounded by extensive tracts of high land.

The lands in the vicinity of Mill Valley AFS include narrow ridges, steep-walled, V-shaped valleys, and gently sloping upland. The rock types underlying this area are part of the metasedimentary-metavolcanic-serpentine assemblage of the late Jurassic and Cretaceous Franciscan Formation, which is widespread in the San Francisco Area. The rock types at Mill Valley AFS are those of the most disrupted zone of the Franciscan, called melange, and serpentine rock. Melange consists of thoroughly sheared and broken rock formed as a result of the movement and attendant crushing and shearing along now inactive faults. The active fault closest to Mill Valley AFS is the San Andreas, 3 miles to the west.

Serpentine rock consists of a chemically and physically unique altered igneous rock type originating below the crust of the earth; it commonly occurs as extensive masses in melange. Serpentine rock contains no aluminum, an important ingredient in the development of clayey soils, and very little potassium, calcium, and sodium, all important nutrients for plant life. Serpentine areas on Mt. Tamalpais exist as essentially bare rock at the surface, with little or no soil cover and sparse plant growth. The plants capable of growing on the serpentine terrain are usually highly adapted to this unusual environment and highly restricted to it (Dickert, undated).

Areas underlain by melange and serpentine exhibit highly erratic slope stability characteristics. Moderately steep slopes of the crushed and sheared melange often exhibit evidence of slow downhill creep or debris flow landslides, but the unsheared masses of coherent rock enclosed in the melange have high slope stability (Marin County Planning Department, 1977).

Soils at Mill Valley AFS are largely classified in the Maymen Series. Maymen soils consist of shallow, well-drained gravelly loam soils with very gravelly loam subsoils. Effective rooting depth is 10 to 20 inches, (Kashiwagi, 1978).

Unlike that of nearby San Francisco, the climate at Mill Valley AFS is quite warm in the summer because the summit of Mt. Tamalpais is usually above the fog. The winters are mild and wet; average annual precipitation is 84 inches, almost entirely in the form of rain. Snow is very uncommon. Winds are often strong, and maximum gusts up to 115-120 knots have been recorded. Runoff is rapid, and the hazard of water erosion is high.

The potential climax vegetation of the area suggests that Mill Valley AFS is located on the border of two ecoregions: the California Mixed Evergreen Forest (oak-madrone-Douglas fir) and the Redwood Forest (redwood-Douglas fir) of the Pacific Forest (Bailey, 1976). Actually, more than one-half of the 100-acre Mill Valley AFS is covered with manmade structures and supports no vegetation, and the vegetation and soils that are present have

been variously disturbed by human occupation and, before the 1940s, by fire. The vegetated areas at Mill Valley AFS are composed of broadleaf evergreen shrubs, small islands of hardwood and hardwood-conifer or conifer-hardwood woodlands, and small grassland meadows. Mixed shrub vegetation, composed of such species as ceanothus, leather oak, manzanita, and chamise, dominates the shallow soils of the steepest slopes at Mill Valley AFS and the upper reaches of the adjacent south slopes of Mt. Tamalpais. Hardwoods, including black oak, live oak, white oak and madrone, and conifers, primarily Douglas fir, occur in pockets of deeper soils present in the northern part of Mill Valley AFS and on the adjacent northern and western slopes of Mt. Tamalpais. For a vegetation map of the MMWD, see Dickert, undated.

The shrub, hardwood, and hardwood-conifer vegetation types at and near Mill Valley AFS provide diverse habitats for a wide variety of wildlife. More than 260 species of vertebrates are known to use MMWS lands (Dickert, undated). A small number of these species, including black-tailed deer, would be expected in the vegetated parts of Mill Valley AFS. Because livestock grazing has been excluded on MMWD lands for about 30 years, deer are the largest herbivores in the area, and often play a critical role in preventing the establishment of hardwood species through their browsing activities. The population density averages about 50 deer per square mile in MMWD lands. The population is nonmigratory because weather conditions in the area are mild (Dickert, undated).

Animals at and near Mill Valley AFS are primarily of ecological and aesthetic, as opposed to commercial or hunting, value. MMWD lands, including Mill Valley AFS, are a part of the California State Game Refuge, a refuge system created by California state law. Although these areas are not actively managed by the California Department of Fish and Game, Section 10500 of the California Fish and Game Code prohibits the taking of wildlife in the area without a special permit.

No permanent aquatic habitats are present at Mill Valley AFS. The station's water supply comes from one of the six lakes within MMWD, Lake Lagunitas, 1.5 miles down the north slope of Mt. Tamalpais. Lake Lagunitas is an eutrophic lake capable of supporting a warm water fishery (Dickert, undated). A well at Mill Valley AFS serves as backup supply of water.

Mill Valley AFS lies a few miles inland from the center of one of the major routes of the Pacific Flyway, the one along the Pacific coast (Kozlik, 1974). Most of the migratory waterfowl that fly this route are concentrated in a band west of the station, although some individuals probably fly over the station. No major or unique breeding or nesting area have been observed at Mill Valley AFS or in the adjacent uplands.

No species on federal or state lists of endangered or threatened wildlife are known to inhabit Mill Valley AFS or surrounding MMWD lands. Two federally listed endangered species that occur statewide, the American peregrine falcon and the southern bald eagle, might be sighted from Mill Valley AFS, but no nesting sites of either species have been observed at Mill Valley AFS or in MMWD lands (Nadeau, 1975). Other wildlife species that are rare locally are present in the region, however (Nadeau, 1975; Dickert, undated).

The California Native Plant Society (CNPS) has identified 19 species of rare and endangered plants for the San Rafael, California, 7 and 1/2 minute Quadrangle, the US. Geological Survey Quadrangle in which Mill Valley AFS is located (Griggs, 1978). The U.S. Fish and Wildlife Service (1976) has proposed that several of these species be listed as nationally endangered. Five CNPS-listed species have been reported within a few thousand feet of Mill Valley AFS, and it is likely that at least a few individuals of some of these species are found in vegetated areas at the station, particularly on the serpentine slopes. Rare species characteristic of serpentine areas near Mill Valley AFS include the Tamalpais manzanita, the Mt. Tamalpais thistle, and the canyon jewel flower (for additional species, see Powell, 1974, and compare with Munz and Keck, 1968).

In summary, Mill Valley AFS is in a biophysical setting that is unique for several reasons: it is situated on one of the peaks of Mt. Tamalpais, which dominates the view from much of the San Francisco Bay Area; a diversity of habitats and wildlife is found in surrounding lands; the scenic views from the station are varied; and a large number of rare and endangered flora are found on serpentine rocks near and perhaps on Mill Valley AFS.

1.2.3.2 Socioeconomic Characteristics

1.2.3.2.1 Land Use. Mill Valley AFS is located on 106 acres of land leased from the Marin Municipal Water District and adjacent to Mt. Tamalpais State Park. (An additional 17 acres are leased by the Air Force for a right-of-way.) The three radar facilities currently in operation at the site are at the top of West Peak, an elevation of approximately 2,568 feet. Other facilities in the cantonment area at the station include:

- | | |
|------------------------|-------------------------------|
| o Family housing units | o Central heating plant |
| o Dormitory barracks | o Helicopter pad |
| o Maintenance shop | o Sewage plant & pump station |
| o Post Exchange | o Open mess & dining hall |

- o Civil engineering operations building
- o Administration and support buildings
- o Recreation facilities (bowling alley, theater, swimming pool, tennis court)

1.2.3.2.2 Demographics and Economics. Virtually all Mill Valley AFS personnel and their dependents live in Marin County. This analysis will describe the current demographic and economic conditions of Marin County. The impact of PAVE PAWS operation at Mill Valley in Marin County is estimated in Chapter 3.

1.2.3.2.2.1 Employment. Nearly one-third of the Marin County civilian labor force works outside of the County. Most of these people work elsewhere in the San Francisco-Oakland Standard Metropolitan Statistical Area (SMSA). The 1978 civilian labor force in the SMSA was 1,555,000 people, of which 1,460,000 were employed and 6.1% were jobless (California Employment Development Department, 1978).

Marin County supplied 99,000 of the SMSA's labor force. Wage and salary employment in the county was 62,100 persons in 1978. The largest and fastest growing employment sectors in the county are retail trade (particularly food and drink establishments and food stores) and services. These sectors supplied approximately 50% of county employment in 1978.

Mill Valley AFS has a total complement of 200 persons. The host 666th Radar Squadron and tenant Detachment 3 of the 14th Missile Warning Squadron employ 147 and 53 persons, respectively. Eighty percent of base personnel and their families live on base at Mill Valley AFS or Hamilton AFB in Novato.

In the absence of Air Force action, the projected 1980 San Francisco-Oakland labor force, employment level, and unemployment rate are 1,595,300, 1,510,400, and 5.3%, respectively (California Employment Development Department, 1978).

1.2.3.2.2.2 Population. Marin County had a total population of 226,500 in 1978. Between 1970 and 1978, the annual average population growth rate was 1.2% (see Table 1-17). Males accounted for 49.7% of this population. Average household size was 2.69 persons. In 1975, the median age was 31 years (California Department of Finance, 1978).

Marin County population is expected to grow to 228,700 by 1980. This represents a 1% population growth rate, well under the 1.2% average annual growth experienced from 1970 to 1978 and the 3.5% average annual rate in the 1960s. This declining growth rate is attributed both to falling birth and immigration rates in recent years. The median age in 1980 is projected to be 34 years (California Department of Finance, 1978).

Table 1-17

**POPULATION IN MARIN COUNTY AND SELECTED CITIES
1970, 1978, 1980**

<u>Location</u>	<u>1970^a</u>	<u>1978^b</u>	<u>Projected 1980^c</u>
Marin County	206,758	226,500	228,700
Mill Valley	12,942	13,800	14,100
Novato	31,006	39,250	41,550
San Rafael	38,977	45,000	45,400

Sources: ^aU.S. Census (1970).

^bCalifornia Department of Finance "Population of California Cities" (1978).

^cPopulation projections for cities from calculations based on 1976-78 annual growth rates.

1.2.3.2.2.3 Income. Total personal income in Marin County was \$2,010 million in 1976. Per capita income was \$9,166. In comparison, per capita income for the state of California was \$7,219 in 1976.

In the absence of Air Force action, projected 1980 Marin County income and per capita income is \$2,774 million and \$12,129 respectively, assuming 1971-1976 average annual growth rates prevail.

1.2.3.2.2.4 Housing. The Marin County housing stock increased at an average annual rate of 2.7%, or about 1,950 units, from 1970 to 1978. During this period, the vacancy rate declined from 5.0% to 3.8%. New construction opportunities in the county are limited by relatively strict land use regulations. Therefore, the housing stock is expected to continue to grow at very low rates despite strong demand and low vacancy rates (Marin County Planning Department, 1978).

The majority of Mill Valley AFS personnel and their families live on Mill Valley AFS or Hamilton AFB in Novato, which house 38.7% and 41.6% of the households, respectively. An additional 11.6% live in San Rafael and the remaining 8.1% live in other Marin County locations (Mill Valley AFS Housing Office, 1979).

1.2.3.2.2.5 Education. There is no school on Mill Valley AFS. Most of the children of the base personnel attend schools in the Novato Unified School District (near Hamilton AFB). The District's enrollment totaled 10,462 in June 1978. Nearly 70% of those students were in kindergarten or grades 1-8. Elementary schools are operating at about 90% of their capacity, but secondary schools (which include junior high schools) are operating at slightly less than 60% of capacity. Enrollment has been declining recently, and is expected to continue to decrease by about 200 students per year for the next few years. The District's 1977-1978 operating expenditures totaled \$18.0 million, and revenues were \$18.3 million. PL 81-874 funds for the District's 1,709 federally related students comprised 5% of the 1977-1978 operating revenues.

Mill Valley School District also educates some of the children of base personnel. This District's enrollment totaled 2,299 in January 1979, 75% of the capacity of the existing educational facilities. Enrollment has been decreasing at the rate of 200 students per year for the past 4 years. This decline is expected to continue until at least 1982. The District's 1977-1978 operating expenditures totaled approximately \$4.864 million, and revenues were \$4.858 million. This operating deficit is not atypical; district expenditures have exceeded revenues for the past few years. The District does not have enough federally related students to qualify for PL 81-874 funds.

1.2.4 Mt. Laguna AFS, California

Operation of the PAVE PAWS radar at Beale AFB would result in the subsequent shutdown of Detachment 4, 14th Missile Warning Squadron at Mt. Laguna AFS, California (Figure 1-1, p. 1-2), and would permit a Joint Surveillance System to be implemented between the Federal Aviation Administration (FAA) and the USAF at Mt. Laguna. All of the 45 to 50 members of Detachment 4 would be reassigned.

Mt. Laguna AFS, with a current staff of approximately 200, is maintained by the 751st Radar Squadron. Other operations currently at Mt. Laguna, in addition to those of the USAF, include those of the FAA and the U.S. Customs.

Mt. Laguna AFS is about 40 miles northeast of San Diego, California, in the Peninsular Ranges of San Diego County. It occupies 140 acres of land leased from the U.S. Forest Service. The lands immediately surrounding Mt. Laguna AFS are part of Cleveland National Forest.

The major facilities at Mt. Laguna include radar operation facilities with four radars enclosed in white radomes (search, height finder, FSS-7, and Joint Surveillance System radars); 27 family housing units; dormitories for unmarried airmen; a secondary sewage treatment plant; a diesel-fueled power plant which supplies all of the station's electricity; maintenance buildings; fire department; communication facilities; administration facilities; recreational facilities; and a dining hall. Water is obtained from nearby wells. Solid waste is handled by an authorized contractor.

1.2.4.1 Biophysical Characteristics

Because the biophysical characteristics of the Mt. Laguna site will be relatively unaffected by the deactivation of Detachment 4, a detailed description of them is not provided.

1.2.4.2 Socioeconomic Characteristics

1.2.4.2.1 Land Use. Mt. Laguna AFS is located on approximately 20 acres of federally owned (U.S. Forest Service) land. The major uses of land on the base include a housing area, a cantonment area, and a recreation area. Facilities within the cantonment and recreation areas include:

- o Commissary
- o Small post exchange
- o Fire house
- o Medical facility
- o Buildings occupied by the civil engineering group
- o Mess and dining hall
- o Administration buildings
- o Bowling alley
- o Indoor tennis court
- o Miscellaneous support buildings

1.2.4.2.2 Demographics and Economics

1.2.4.2.2.1 Employment. San Diego County's civilian labor force numbered 644,300 in 1977. On the average, approximately 587,000 of these individuals were employed. Unemployment averaged 8.1%, although levels fluctuated throughout the year from a high of 10.6% in January to a low of 6.4% in December. Although the number of civilians in the county labor force increased 12.5% between 1975 and 1978, the unemployment rate fell from 10.4% to 8.7% (California Employment Development Department, 1978).

1.2.4.2.2.2 Population. San Diego County had a total population of 1,694,800 people in 1978. Between 1975 and 1978 the average annual population growth rate was 2.1%. Males comprised 48.2% of this population. In 1975, the median age was 27 years (California Department of Finance, 1978).

Mt. Laguna AFS has a total complement of 200. The 751st Radar Squadron and Detachment 4 of the 14th Missile Warning Squadron are staffed by 152 and 48 persons, respectively. Nearly half of base personnel live on base.

In the absence of Air Force action, 1980 population and median age in San Diego County will be 1,804,100 and 29 years, respectively. (California Department of Finance, 1978).

1.2.4.2.2.3 Income. Total personal income in San Diego county was \$10.4 billion in 1976. Per capita income was \$6,401 as compared to the 1977 state average of \$7,984. Mount Laguna AFS personnel received approximately \$828,600 in wages and salaries in 1978 (California Department of Finance, 1978). Of total earnings, 35.1% is derived from government and government enterprises, and service and manufacturing industries account for 16.8% and 14.4%, respectively.

In the absence of Air Force action, projected San Diego county income and per capita income in 1980 are \$13.0 billion, and \$7,206, respectively, assuming 1971-1976 average annual growth rates prevail.

1.2.4.2.2.4 Housing. San Diego County's housing stock totaled 127,333 units as of January 1, 1978. The majority of these units (85%) were single family residences, and 71% of the total housing units were owner-occupied. The overall housing vacancy rates averaged 4.9%. The average annual growth of the housing stock was 6,262 units between 1970 and 1978. Continued annual growth of 6% is expected between 1978 and 1985 (Lock, 1979). Nearly half of the Mt. Laguna AFS personnel live on base. The remainder reside in areas surrounding the base.

1.2.4.2.2.5 Education. Most of the children of Mt. Laguna AFS personnel are enrolled in schools in the following four school districts: Cajon Valley Union School District; Mountain Empire Unified School District; Julian Union School District; and Grossmont Union High School. Because of recent population growth in those areas, many of the schools in each district are overcrowded. In the absence of the AF action, enrollment is expected to continue to increase during the next few years.

Chapter 2

RELATIONSHIP OF THE PROPOSED ACTION TO LAND USE PLANS, POLICIES, AND CONTROLS FOR THE AFFECTED AREA

Beale AFB is situated in the southeastern corner of Yuba County which is within the jurisdiction of the Sacramento Regional Area Planning Commission (SRAPC) (see Figure 2-1). Although the AFB is entirely on federally-owned property, activities on the base could have an indirect effect on land use in the county and the region as well. Therefore, knowledge of the land use plans, policies, and controls of the county, the region, and the state of California as a whole is a useful background for understanding total land use impacts.

2.1 The Affected Area

The SRAPC covers an area of approximately 2,123,123 acres (3,317 square miles). Roughly 11% of the region, a large part of which is the Sacramento metropolitan area, is considered urban land, whereas 89% is designated as nonurban open space (see Table 2-1, p. 2-3). Half of the rural land is irrigated and cultivated; the remaining half is either dry pasture, forest, or grassland.

The rich and fertile agricultural land is primarily in the flood plains of the Sacramento and Feather Rivers. The dry pasture areas in southeastern Sacramento County and in mid-Yuba County are used for grazing and nonintensive agricultural purposes. The only commercial forestry activities in the region take place in the Sierra Nevada mountains of northern Yuba County. Some vacant land remains on the urban fringes, as marshland or under piles of tailings left when gold was dredged. A good portion of the region's land (as much as 1.4 million acres) is potentially available for urban development or more intensive agricultural use.

Yuba County, the northernmost county in the Sacramento Regional Planning Area at the northeastern edge of California's Central Valley, is 408,019 acres (about 640 square miles) in size. About 9% of the county is urbanized. The major urban area in the county is the City of Marysville, which is closely related, economically and socially, to Yuba City, across the Feather River

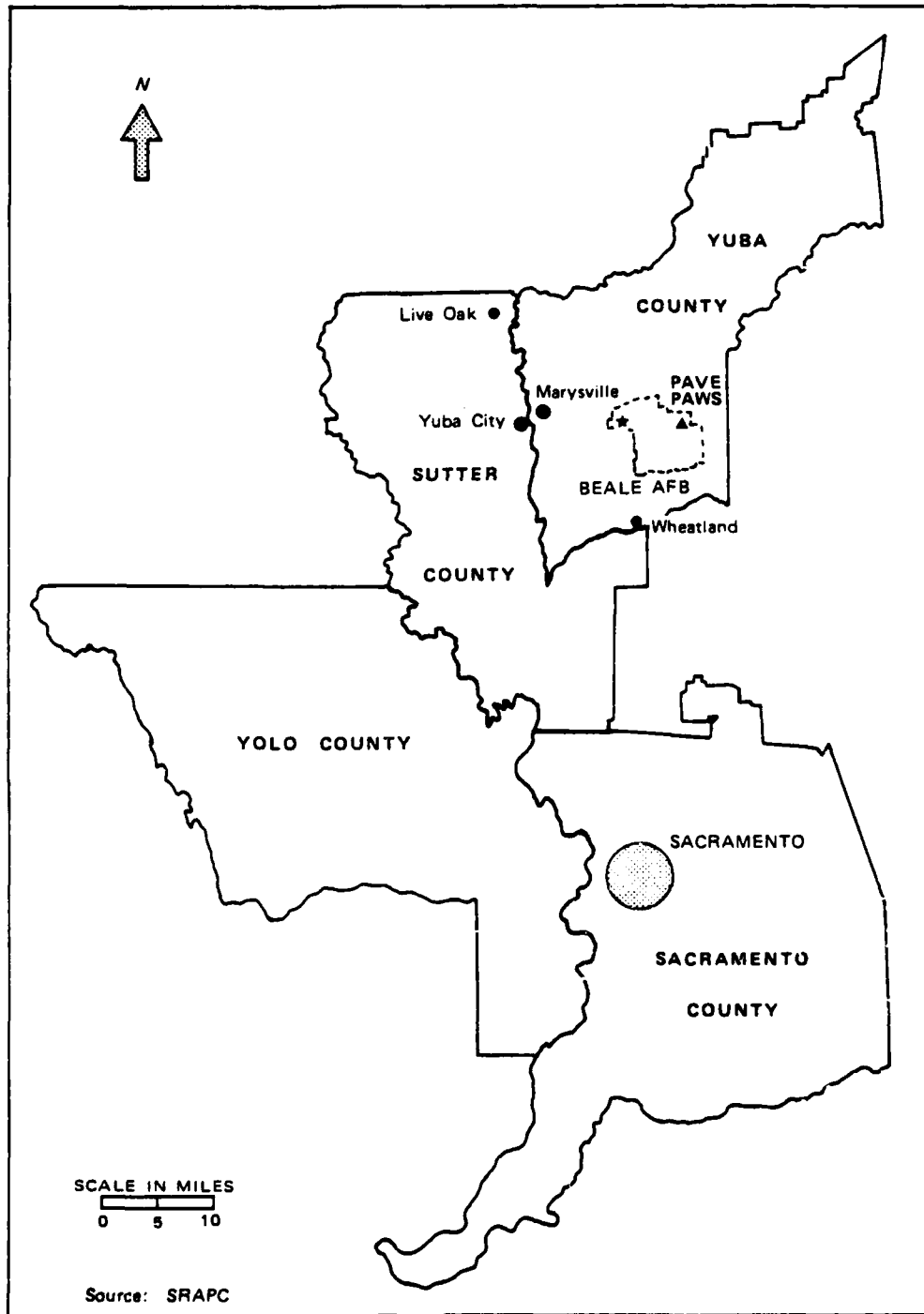

FIGURE 2-1. SACRAMENTO REGIONAL PLANNING AREA

Table 2-1

ESTIMATED LAND USE IN THE SACRAMENTO REGIONAL PLANNING AREA

	<u>Acres</u>	<u>Percent of Total</u>
Urban Area		
Developed	206,500	10
Vacant	27,000	1
	-----	-----
Subtotal	233,500	11
Open Space		
Agricultural	950,000	45
Dry pasture, forest land	939,623	44
	-----	-----
Subtotal	1,889,623	89
	-----	-----
Total	2,123,123	100

Source: SRAPC (1978).

in Sutter County. Other population centers in Yuba County include Wheatland (incorporated; see Figure 2-2) and Linda-Olivehurst (unincorporated). Smaller "urban" communities are scattered throughout the county. Approximately 91% of the county is open land used for irrigated agriculture, dry-farming, grazing, or recreation (see Table 2-2, p. 2-5, and Figure 2-3, p. 2-6, for data on the county regional analysis districts). In 1976 about 290,000 acres of county land were actively farmed; about 70% of this land, or 203,000 acres, was used for nonirrigated pasture, and about 24%, or 70,000 acres, was irrigated (California Energy Resources Conservation and Development Commission, 1978). Beale AFB encompasses 6% of the land area in the county.

In the past, when policies and regulations for development did not exist, development in the county consisted of low-density, interspersed urban and rural areas. Now, however, the county has adopted zoning ordinances and is endeavoring to plan for and regulate growth. In fact, the county is actively encouraging industrial development and is currently experiencing significant growth (Weiland, 1978). According to the most recent general plan

AD-A088 320

SRI INTERNATIONAL MENLO PARK CA
OPERATION OF THE PAVE PAWS RADAR SYSTEM AT BEALE AIR FORCE BASE—ETC(U)
JUL 80

F/B 17/9

F08635-76-D-0132

UNCLASSIFIED

AFSC-TR-80-09

NL

2 of 6

40
10/2/80

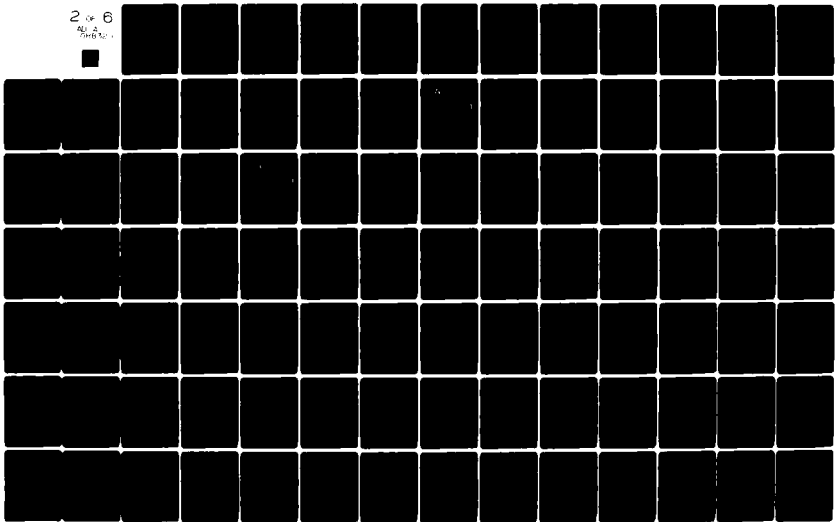

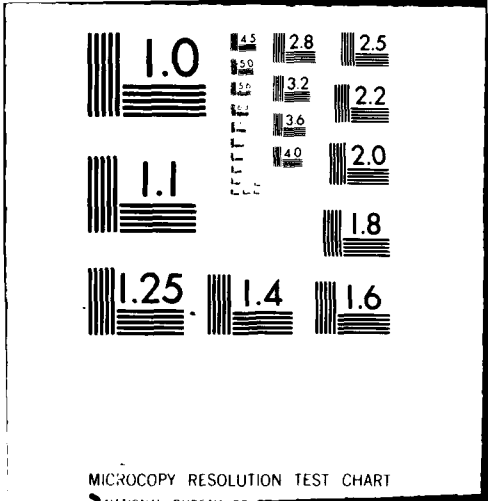

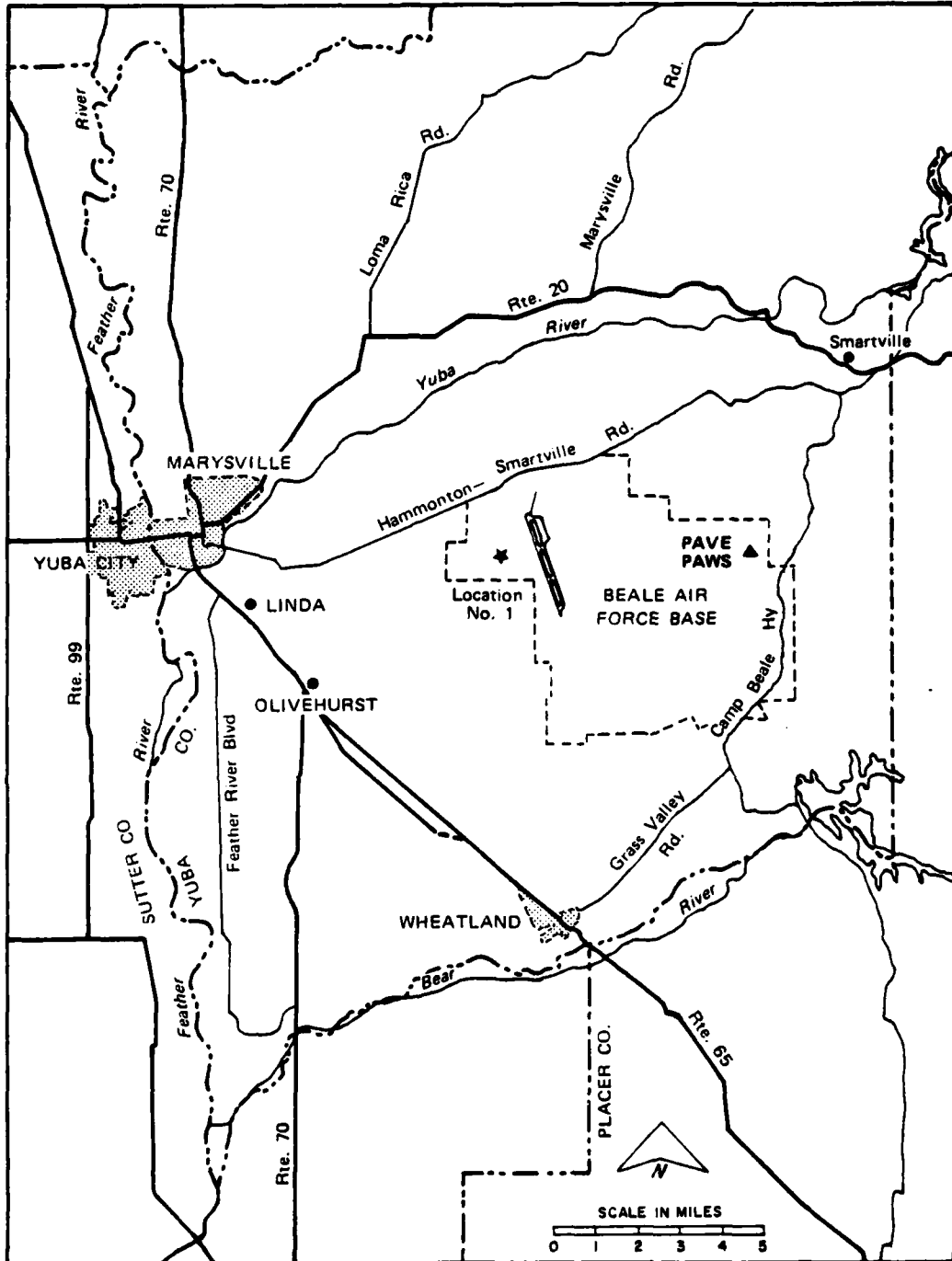

Source: SACRAMENTO REGIONAL AREA PLANNING COMMISSION, 1976

FIGURE 2-2. THE ENVIRONS OF BEALE AIR FORCE BASE

Table 2-2

LAND USE IN YUBA COUNTY REGIONAL ANALYSIS DISTRICTS (RAD)

	RAD										Total County	Percent of Total Acreage
	40	41	42	43	44	45	46	47	48	49		
Residential	183.0	644.9	695.7	364.7	247.8	531.3	884.8	728.6	4,280.8			1.0
Industrial non-manufacturing	19.4	15.4	86.8	14.0	54.1	60.6	167.0	21.2	438.5			.1
Manufacturing	2.3	20.9	9.2	--	5.7	7.1	13.8	34.2	93.2			.02
Transportation, Communication, Utilities	90.5	138.6	550.9	3.0	154.0	211.0	184.9	27.2	1,360.1			.3
Retail activities	1.8	40.1	122.7	1.5	8.3	66.2	12.5	9.5	262.6			.06
Office activities	11.0	0.8	4.0	5.5	3.3	17.8	2.0	10.2	54.6			.01
Public and quasi-public buildings and uses	2.7	45.9	193.3	24,210.7	44.8	103.7	6.0	20.0	24,627.1			6.0
Public and quasi-public open space	--	42.6	231.6	9.6	8.1	41.5	60.2	124.9	518.5			.1
Streets and highways	303.3	456.5	432.8	818.0	381.2	542.4	1011.7	1359.9	5365.8			1.3
TOTAL DEVELOPED	614.0	1,405.7	2,327.0	25,427.0	907.3	1,581.6	2,342.9	2,325.7	36,941.2			9.1
Open Space	22,120.0	6,523.0	10,713.1	52,787.2	25,467.8	6,238.9	107,714.6	139,513.3	371,077.9			90.9
TOTAL ACRES	22,734.0	7,928.7	13,040.1	78,214.2	26,375.1	7,820.5	110,057.5	141,849.0	408,019.1			100.0

Note: The Regional Analysis Districts for which these land use figures are applicable are illustrated in the map which appears as Figure 2.3.

Source: Sacramento Regional Area Planning Commission, Research and Information Service, 1975 Land Use Module.

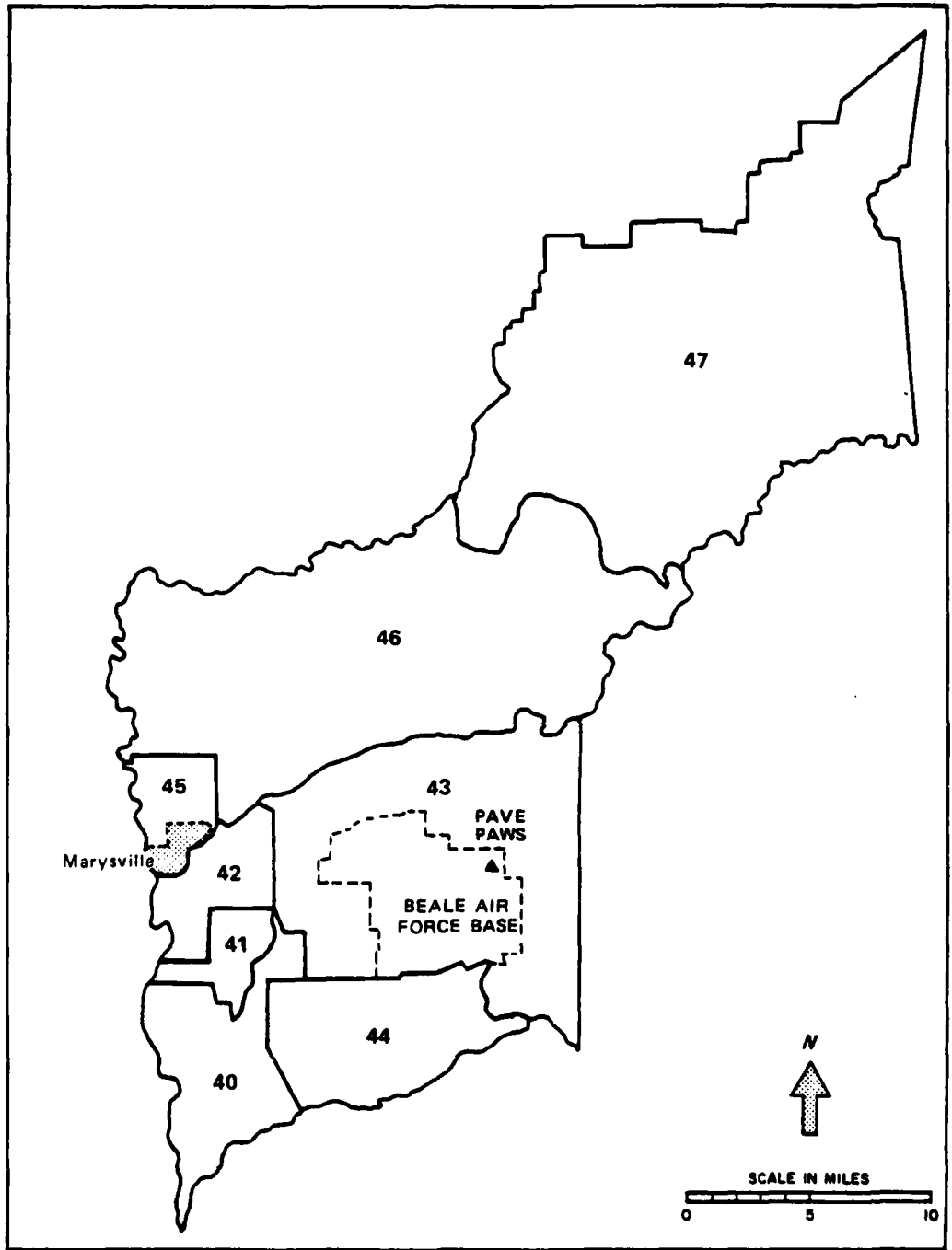

Source: Sacramento Regional Area Planning Commission

FIGURE 2-3. REGIONAL ANALYSIS DISTRICTS (RAD) IN YUBA COUNTY

for Yuba County (1967), land use in the county will shift more and more toward urban uses, and by 1985 the density ratio (e.g., persons per acre) may increase in urban areas from 3.4 (1967) to 10.0 and in rural, nonagricultural areas, from 2.5 (1967) to 5.0. Nevertheless, less than one-third of the county is expected to be urbanized by 1985 (Wilsey & Ham, 1967).

2.2 Plans

Two kinds of plans affecting land use conditions are pertinent to this analysis: (1) general land use plans that have been prepared by a planning agency or commission in an effort to project and direct the rate and location of growth; and (2) plans for specific development projects that have been proposed by private or public groups.

2.2.1 General Land Use Plans

Two general land use plans, one at the regional level and one at the county level, have been prepared for the area around Beale AFB that is likely to be affected by changes on the base.

2.2.1.1 Regional

SRAPC, an association of local governments created in 1965, is an areawide comprehensive planning agency and clearinghouse that provides a forum for review of land use issues. SRAPC functions in an advisory capacity and makes recommendations concerning implementation of proposed projects and plans in Yuba, Sutter, Yolo, and Sacramento counties. The Commission does not have regulatory or permitting authority. In 1974, SRAPC initiated a comprehensive regional land use action program, which was presented in Regional Land Use Plan: 2001, Alternatives for the Future (September 1976 and Draft, April 1978). These documents contain a discussion of existing land use policy and programs; state and federal land use requirements; and issues pertinent to the land use decision-making process in the Sacramento region. The Regional Land Use Plan is the basis on which additional ongoing land use planning activities will be enacted.

As part of its overall Environmental Management Program, SRAPC is also in the process of revising or preparing other documents that will be influenced by and related to the Regional Land Use Plan. These include:

- o Physical Development Element
- o Environmental Quality Element

- o Conservation and Open Space Plan
- o Transportation Plan
- o Energy Conservation Plan
- o Housing Plan
- o Air Quality Plan
- o Water Quality Plan

2.2.1.2 Local

In 1969, Yuba County adopted a General Plan, which is essentially a statement of public policy regarding the general physical structure and organization of the various land use elements in the county. Although the plan does not include detailed predictions of future development, it does, according to its authors, establish a framework or set of guidelines within which growth, development, and change can take place (Wilsey and Ham, 1967).

As part of the General Plan, a Land Use Element was prepared; it is currently being revised by the Yuba County Planning Department (Weiland, 1978). A Circulation Plan for transportation was also prepared in conjunction with the General Plan and was amended in 1970. In 1973, SRAPC prepared an Open Space and Conservation Element to accompany the General Plan. The purpose of the Open Space and Conservation Element was to provide a mechanism for coordinating and guiding decisions related to the undeveloped land and water surfaces that occupy a significant amount of the county's land area. This element identifies areas suitable for development and those that would have important value if left in a natural state.

The proposed action (specifically, operation of PAVE PAWS) does not conflict with elements of either the land use plan for the region or the general plan for the county.

2.2.2 Specific Development Plans

Several major land use projects have been proposed for the area surrounding Beale AFB (see Figure 2-4):

- o A coal-fired power plant
- o The Marysville Lake
- o The Spenceville Wildlife and Recreation Area Improvement Program

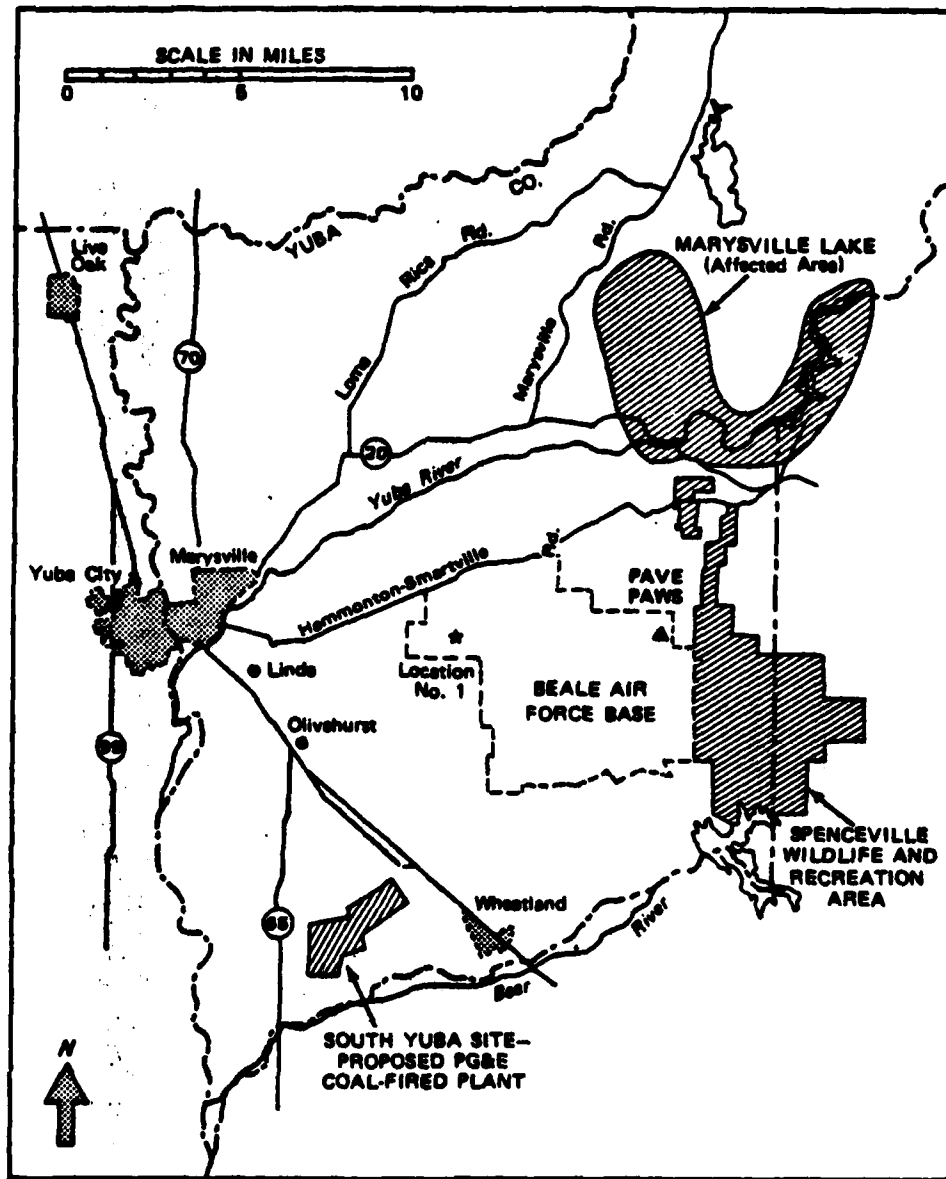

Source: SRAPC, 1976; PG&E, 1977; U.S. ARMY ENGINEER DISTRICT, 1977.

FIGURE 24. PROPOSED LAND USE PLANS ON THE PERIPHERY OF BEALE AIR FORCE BASE

2.2.2.1 Coal-Fired Power Plant

In 1977, Pacific Gas & Electric Company (PG&E) filed a notice of intent to seek certification to construct a 1,600 megawatt coal-fired electric power plant at an estimated cost of \$2 billion. One of the four potential plant locations in Northern California selected by PG&E is a 2600 acre site in southern Yuba County about 10 miles southeast of Marysville/Yuba City and 4 miles west of Wheatland. Land at the proposed site is currently used for agricultural production. The company indicates that it has designed the facilities in conformance with county land use and zoning regulations.

The estimated startup dates for PG&E's two generating units (known as Fossil 1 and 2) are early 1984 and mid-1985. Although the Yuba County Board of Supervisors has approved the proposed PG&E project, the Director of the Yuba County Planning Department does not believe the plant will be approved at the state level and thus does not foresee its construction in the near-term (Weiland, 1978). Moreover, PG&E has indicated a preference for one of the other sites. At present, none of the electrical generating stations in California uses coal as a primary fuel. +

Even if construction of the plant were initiated in the near future, direct conflicts in land use between PAVE PAWS and the proposed PG&E project do not seem likely. The easternmost edge of the PG&E site is about 3.5 miles from the southwestern corner of Beale AFB, the point on the base farthest from PAVE PAWS. Construction activities at the existing PAVE PAWS site will probably be completed long before the earliest date that PG&E could possibly begin construction of its project. The 200 operating personnel needed for the PAVE PAWS project, along with their families, are expected to reside in existing housing. They will probably be settled before the arrival of the 500 new construction workers and 225 operating personnel that would be attracted to the local area by PG&E's project. +

2.2.2.2 Marysville Lake

The Army Corps of Engineers has proposed the construction of a \$1 billion, multipurpose dam reservoir and power plant facility. According to its sponsors, this would provide power and improve water conservation, flood control, recreation, and fishery production. The project, which is proposed for completion in 1990, includes a 420-foot dam on the Yuba River; a 360-foot dam on Dry Creek; a lake consisting of 916,000 acre-feet of water with a surface area of 6,640 acres (it would not be filled until 1993); an afterbay dam; and a 1,350 megawatt power plant (initial capacity in 1993). The project would require altering land use on 27,120 acres roughly 5 miles north of Beale AFB and 15 miles northeast of Marysville.

The proposed Marysville Lake project has considerably greater potential land use impact than the PAVE PAWS project. The land use effects of the two projects would not overlap or conflict.

2.2.2.3 Spenceville Wildlife and Recreation Area Improvement Program

The Spenceville Wildlife and Recreation Area, currently maintained by the California Department of Fish and Game, consists of 9,450 acres of land that belonged to Beale AFB until 1962 and 1,768 acres that were acquired in 1965. The 11,218-acre area has two sections, one of which is adjacent to Beale AFB, and is located in both Yuba and Nevada counties. The Department of Fish and Game is preparing a Five Year Plan (July 1977-June 1982) for the area that "provides for the preservation and enhancement of natural resources and for reasonable use and enjoyment of these resources by the public" (Hodson, 1978). The basis of the Five Year Plan is the habitat improvement program, which includes experimentation to assure increased tree and shrub growth. In late 1978, some of the actions recommended in the Five Year Plan (vegetation planting and small water hole development) were curtailed temporarily for lack of funds. The Department of Fish and Game will continue to permit grazing and will promote recreational use of the land (Hodson, 1978).

The proposed Marysville Lake project would create a lake immediately north of the Wildlife Area that could provide irrigation for 1,000 acres and thus increase the overall wildlife carrying capacity of the area by 20%.

Although construction and operation of PAVE PAWS is not expected to conflict directly with current or planned land use at the Spenceville Wildlife and Recreation Area, certain indirect land use impacts are anticipated. At present, damage to the area is periodically caused by persons who apparently enter through the base housing area (known as "Beale Heights"). The housing area is less than one-half mile from the border of the wildlife area and a road connects between the two areas. Members of the State Department of Fish and Game assigned to Spenceville anticipate that an increase in the number of residents on the base as a result of PAVE PAWS could potentially lead to somewhat increased misuse of the land. The Department is understaffed because of a decrease in permanent staff and a freeze on hiring "seasonal aid" personnel; therefore, it will have some difficulty protecting the Wildlife Area.

2.3 Policies

2.3.1 State

In 1970, the California Legislature passed a directive to assure the establishment of a state land use policy and to require the governor to prepare and periodically revise a state environmental goals and policy report. The purpose of such a report was to "articulate the state's policies on growth, development and environmental quality; to recommend specific state, local and private actions needed to carry out these policies; and to serve as the basis for the preparation of the state's environmental plan." (Office of Planning and Research, 1978). The legislature also directed the California Office of Planning and Research (OPR) to design a statewide plan and related implementation program for protecting land and water resources of statewide significance in terms of natural resources and environmental quality.

One primary goal and four state policies were adopted for the initial Environmental Goals and Policy Report (1973). The goal is "to identify and protect the significant and critical environmental resources and hazards of the State for the benefit and enjoyment of present and future generations." The policies adopted were:

- o To identify all potentially significant and critical environmental resources and hazards throughout California and, after thorough evaluation, define those geographic areas which are of statewide interest or of critical concern
- o To undertake actions to minimize all activities which will have a detrimental effect on areas of critical concern
- o To encourage local units of government to consider areas of critical concern in the preparation of their individual general plans
- o To consider areas of critical concern as high priority in any statewide acquisition, lease, or enforcement programs.

OPR designated fourteen areas of "critical environmental concern" within three major categories as follows:

Scenic, Scientific, Educational and Recreational Resource Areas

Park, reserve and wilderness areas
Recreation, access and connecting links
Historic, archeological and cultural areas
Wildlife habitats
Open-space surrounding metropolitan areas

Resource Production Areas

Forest lands
Agricultural lands
Mineral areas
Water sources
Energy sources

Hazardous Areas

Geologic hazard areas
Fire hazard areas
Flood prone areas
Critical air areas

As Figure 2-5 illustrates, Beale AFB encompasses agricultural land, riparian habitat, and wildlife habitat, as well as a fire hazard area and a fault with surface rupture potential. The PAVE PAWS facility itself is within the fire hazard area and close to the geologic hazard area.

Within a short distance from the Beale AFB boundary there is agricultural land, riparian habitat, wildlife habitat, a water source, a fire hazard area, a mineral area, and a geologic hazard area (see Section 1.2.1.1.5.1)

After enumerating areas of critical concern, OPR sponsored the development of guidelines to aid local governments in evaluating the extent to which projects might affect areas of statewide critical concern. Specifically, the guidelines were designed to assist land use planners in recognizing:

- o The effects of different kinds of development on the resource value or hazard of critical concern
- o The types of mitigation measures that can be taken to reduce adverse impacts on the values associated with the critical concern area
- o The types of development that should not be undertaken in critical concern areas except under strict control of planning and design standards
- o The land uses that are incompatible with the resource value or hazard of critical concern.

2.3.2 Regional

In the latest Environmental Goals and Policy Report (1978), OPR emphasizes that although the state has an obligation to articulate a land use strategy and to establish goals, local governments working in coordination with their regional councils of government are responsible for actually implementing land use policies.

The predominant elements of the overall land use policy expressed by the SRAPC are:

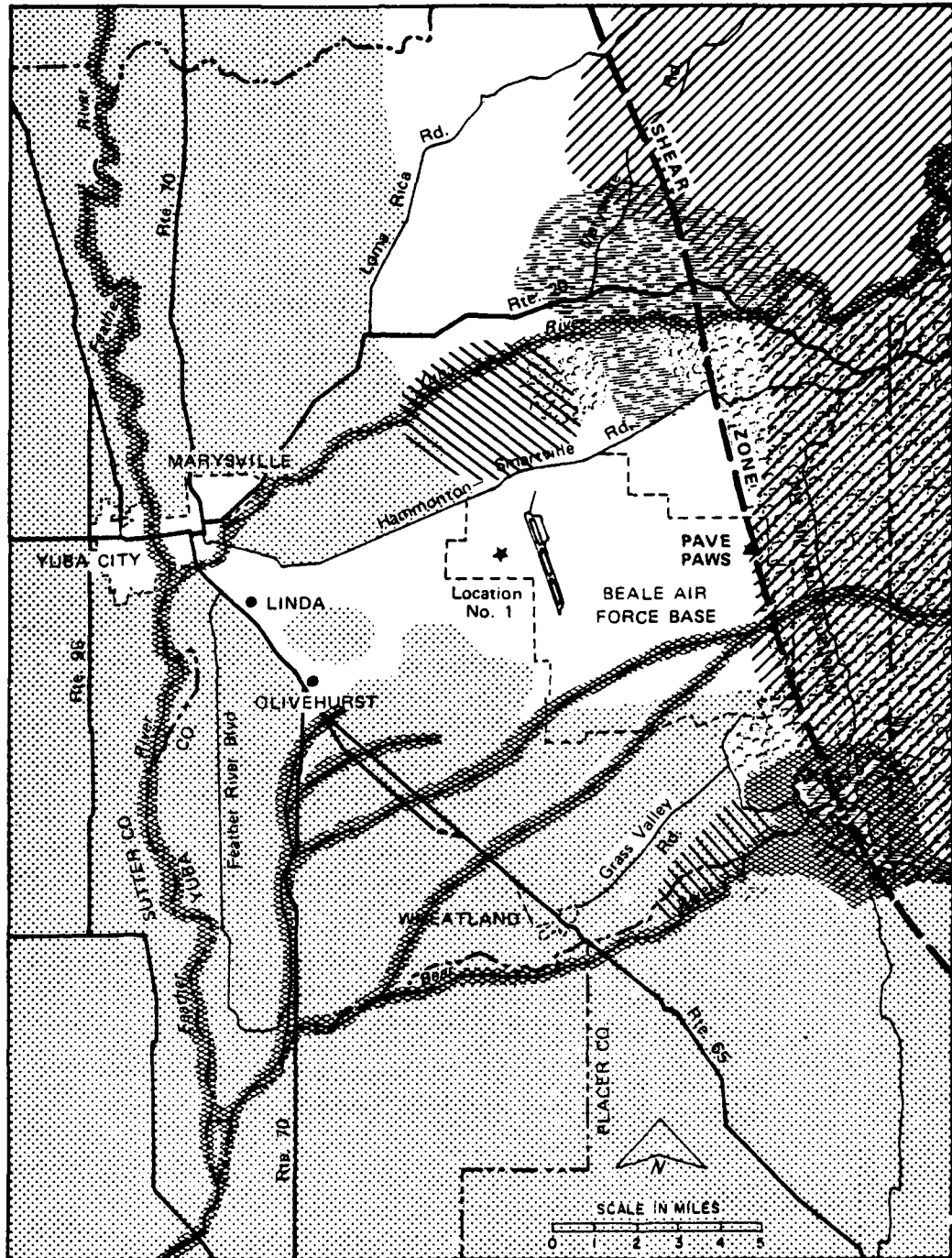

- | | |
|----------------------------|-------------------|
| RIPARIAN HABITAT | WATER SOURCES |
| OTHER WILDLIFE HABITAT | MINERAL AREAS |
| AGRICULTURAL LANDS | FIRE HAZARD AREAS |
| FAULT WITH SURFACE RUPTURE | |

Source: SACRAMENTO REGIONAL AREA PLANNING COMMISSION

FIGURE 2-5. AREAS OF CRITICAL ENVIRONMENTAL CONCERN IN THE VICINITY OF BEALE AIR FORCE BASE

- o Take special precautions to identify and preserve open space resources, particularly
 - areas of riparian or streambed habitat (especially urban areas)
 - rare, significant, or endangered environmental features
 - natural areas used for recreation
- o Protect and preserve prime agricultural lands wherever possible, (because agriculture is the major industry in the region, local governments should increase efforts to keep agricultural lands in production and should oppose any actions that impair this goal)
- o Encourage and support the efforts of rural centers (e.g., Wheatland, Live Oaks) to develop an appropriate economic base to ensure their continued survival
- o Prevent urban sprawl; rehabilitate and redevelop cities and suburbs before building new subdivisions
 - Renew and maintain existing urban areas
 - Develop vacant land that is within existing urban areas and is currently served by streets, water, sewer, and other public services
 - If it is necessary to develop land outside existing urban areas, develop only the land immediately adjacent to the existing areas
- o Maintain a high level of environmental (water, land) quality and improve the quality of the air by
 - Reducing unnecessary automobile travel
 - Increasing the use of mass transit
 - Limiting or prohibiting industry that pollutes the air.

In Regional Land Use Plan: 2001, SRAPC indicates that the above policies will essentially be enacted and enforced by local (city and county) government, although the commission will assist in facilitating areawide coordination. Specifically, SRAPC will participate in implementation of the land use plan for the Sacramento region by:

- o Reviewing all federal and state funding applications from the region, as well as environmental impact reports on projects of areawide significance, to determine whether they conform with stated policies

- o Providing a public intergovernmental forum for coordinating and monitoring projects as part of an environmental management program
- o Working with member jurisdictions to interpret and apply the regional land use plan to existing city and county policy
- o Conducting related research studies that will provide public officials with information they can use in making land use decisions.

To fulfill one part of its role as a clearinghouse organization, SRAPC was asked to comment on the plan for PAVE PAWS when it was initially proposed. The Commission issues unfavorable or negative comments if it believes that problems are associated with a proposed project plan or an application for funding. In some cases, SRAPC will elaborate on its decision by describing the unfavorable factors or attaching specific recommendations (e.g., delay action) to its public comment. A favorable or positive comment is issued when the Commission does not oppose a proposed action; such a comment does not imply support. SRAPC issued a favorable or positive comment in the case of PAVE PAWS (Harnish, 1978).

2.3.3 Local

The fundamental land use policies enumerated in the Yuba County General Plan are:

- o Develop uses for the county's natural resources so that their full potential is realized
- o Arrange the urban and agricultural uses in such a way as to maximize productive efficiencies and promote environmental quality
- o Establish the major growth areas expected to occur within the near future
- o Promote the economic advancement of the county

In regard to specific land uses, the county policy is described as follows:

- o Open space--maintain and enhance the natural resources, open space land uses and scenic beauty of Yuba County to protect the quality of the environment, the county's economy, and the health and well-being of present and future residents

- o **Agriculture**--continue the utilization of the prime farm lands of the planning area as a valuable component of the county's economic base and protect these lands from unnecessary urban expansion
- o **Residential**--protect existing residential neighborhoods from the intrusion of conflicting uses and encourage upgrading of depressed areas, higher densities within established urban areas, and expansion adjacent to existing residential areas to provide for efficient sewer, water and other utility services
- o **Commercial**--concentrate activities serving the region and improve vehicular access to them; enlarge the range of goods and services available to capture a market currently satisfied only by Sacramento; and provide adequate land for increased activity to meet the needs of the future population
- o **Industrial**--promote the development of new industry that will make use of available raw materials and employ labor during winter months near major transportation routes, power sources, and disposal facilities, yet at a distance from residential areas
- o **Transportation**--open major recreation areas to vehicular traffic, reduce existing congestion by segregating traffic and improve accessibility to highway systems and between living and working areas by constructing new roads.

The operation of PAVE PAWS will not conflict with land use policy in Yuba County.

2.4 Controls

2.4.1 State

Because Beale AFB is owned by the federal government, actions on the base that affect land use are not subject to state or local control. However, state regulations that influence land use on the periphery of and in the region surrounding Beale are:

- o **California Environmental Quality Act (CEQA) (amended in 1977)**
 - Specifies that it is the policy of the state to develop and maintain a high quality environment now and in the future, and to take all action necessary

to protect, rehabilitate, and enhance the environmental quality of the state

- Promotes the long-term protection of the environment as the guiding criterion in public decisions
 - Declares that it is the policy of the state that public agencies should not approve projects as proposed if feasible alternatives or mitigation measures are available that would substantially lessen the significant environmental effects of such projects
- o California State Planning Law (1951), California Government Code, Section 65000 et seq.
- Establishes a state office of Planning and Regional Planning Districts
 - Requires each county and city legislative body to establish a planning agency, department, or commission
 - Requires the development and maintenance of a general plan by the planning agency of each county and city
 - Provides that a planning agency may develop specific plans, regulations and programs needed to implement a general plan
 - Provides that the contents of specific plans may include regulations of the use of land and buildings, the height and bulk of buildings and the open spaces surrounding buildings
 - Lists the elements that must be included in each county and city general plan
 - land use element
 - circulation element
 - open space element
- o California Assembly Bill 2207 (1973)
- Permits a County Airport Land Use Commission to include within their planning jurisdiction the area surrounding military airports; in particular, they may specify use of land, may develop height restrictions on buildings, and may determine building standards

- o California Subdivision Map Act, California Government Code, 11500 et seq.
- Directs a local governing body to deny approval of a subdivision map if the site is not physically suitable for the density of the development, or if the subdivision's design will conflict with public easements for access through or use of the property.

2.4.2 County

The land use controls in effect in Yuba County are:

- o The County Zoning Ordinance, which covers all of the county except the incorporated cities and Beale AFB
- o The City Zoning Ordinances of Marysville and Wheatland
- o A special ordinance regulating land use in the area surrounding the Marysville Airport.

2.4.3 Agencies

Implementing agencies with responsibility for enforcing regulations pertaining to land use include:

State

- o California State Office of Planning and Research
- o California Resources Agency
- o California Real Estate Board
- o California Department of Fish and Game
- o California Department of Water Resources
- o California Division of Soil Conservation

Regional

- o Sacramento Regional Area Planning Commission

County

- o Yuba County Board of Supervisors

- o Yuba County Planning Commission
- o Yuba County Airport Land Use Commission

Local

- o City Planning Commissions

Chapter 3

PROBABLE IMPACT OF THE PROPOSED ACTION ON THE ENVIRONMENT

3.1 Beale AFB, California

3.1.1 Exposure to Electromagnetic Radiation (EMR)

Because the proposed action is the operation of the PAVE PAWS radar, the direct impacts on the environment depend primarily on the magnitude, nature, and distribution of the EMR. A comprehensive technical description of the EMR is given in Appendix A, and a comparison of calculated values with measurements at specified locations is presented in Appendix B. Special features of the EMR that pertain to electromagnetic interference are further described in Appendix D. Calculated values in this section are based on the field model described in Section A.3, p. A-9. Comparison of the measured and calculated values permits the conclusion that the field model is well-founded and conservative (see Table B-3, p. B-10).

This section describes the power density of the basic system EMR in the immediate vicinity of PAVE PAWS at and near ground level, 100-800 ft above mean sea level. (The growth system EMR is described in Section 3.1.4, p. 3-91.) Below 400 ft elevation, only the first- and higher-order sidelobes will contribute to the power density of the EMR. The ground level exceeds 400 ft at only a few nearby locations within the scan of PAVE PAWS (see Section A.3.1, p. A-12 and Table A-5, p. A-31). Because the power density increases as the antenna face is approached, the highest densities that can be encountered without entering the posted exclusion fence area are found just outside the exclusion fence (see Figure 1-3, p. 1-4), well within the boundaries of the military reservation.

The following description (and Section 3.1.4, p. 3-91, for the growth system) provides a context for the later sections that describe effects that have been attributed to EMR similar to that of PAVE PAWS. For that purpose, in this section time averages of the EMR are used in all tables and figures, and an 18% duty cycle (the maximum percentage of time that the system radiates for simultaneous operation of both faces) is assumed. However, some specific effects related to electromagnetic interference depend on the pulse power density and other technical specifications of the individual pulses. Appendix D must be consulted for a technical description of the EMR related to those effects. Appendix A also exhibits pulse power densities.

3.1.1.1 General Description of EMR Power Density from PAVE PAWS

3.1.1.1.1 Power Density at Distances Greater than 1,000 Ft.

Figure 3-1 shows the immediate vicinity of the PAVE PAWS radar at Beale AFB. The radial lines mark the boundaries of the sectors in which the EMR power density will be described. The sectors differ in power density because of the geometry describing the radar coverage of each face. The first sidelobe, which follows the main beam, sweeps through 120 degrees in azimuth centered on each face (240 deg in azimuth overall), but the higher-order sidelobes, taken together, fill the hemisphere in front of each face. These hemispheres overlap in Sector 1 of Figure 3-1. Consequently, EMR is highest in that sector. In Sector 3, the power density is solely attributable to the higher-order sidelobes. Hence, EMR is generally lowest in that sector. Finally, in Sector 2, the EMR power density is generally intermediate in value compared with the density in the adjoining sectors. Each sector shown is keyed to figures that describe EMR power density in relation to distance from PAVE PAWS and to elevation above mean sea level (MSL). The partial circles shown in Figure 3-1 denote distance from the radar.

Figures 3-2 through 3-8, pp. 3-4 through 3-10, describe the calculated EMR power density from the basic PAVE PAWS system. The EMR power densities shown in all figures assume no attenuation from vegetation or from intervening terrain, and are based on calculated rather than measured values. (See Appendix B for the comparison which shows that, within respective uncertainties, the measured values were less than or equal to calculated values.) The power densities actually experienced at any location could be smaller than those illustrated by a factor of up to about 10 because of intervening vegetation, and by a similar factor because of intervening terrain (i.e., by a combined factor of up to 100). Power densities could also be slightly higher over some limited regions (hot spots), because of reinforcing reflections, but actual field measurements to date have indicated power densities equal to (within the measurement uncertainty) or less than calculated values. +

Figure 3-2 describes the EMR at ground level of the part of the transition region that extends from the exclusion fence at 1,000 ft to the beginning of the far field region, about 1,500 ft from the face. Figures 3-3 through 3-8 describe EMR power density 1,500 to 25,000 ft from the radar and 100 to 800 ft MSL (elevations above 400 ft are encountered only in Sector 2). The figures are keyed to the sectors defined in Figure 3-1. Power density varies with elevation because elevation affects proximity to the first sidelobe and main beam. At higher elevations, exposure to the first sidelobe may occur for three to four adjacent pulse intervals as the main beam makes a sweep over 120 deg in azimuth at 2-deg intervals (see Appendix A for details of the geometry). This circumstance increases exposure from the first sidelobe to a maximum factor about 2.5 times larger than the maximum exposure from one pulse. +

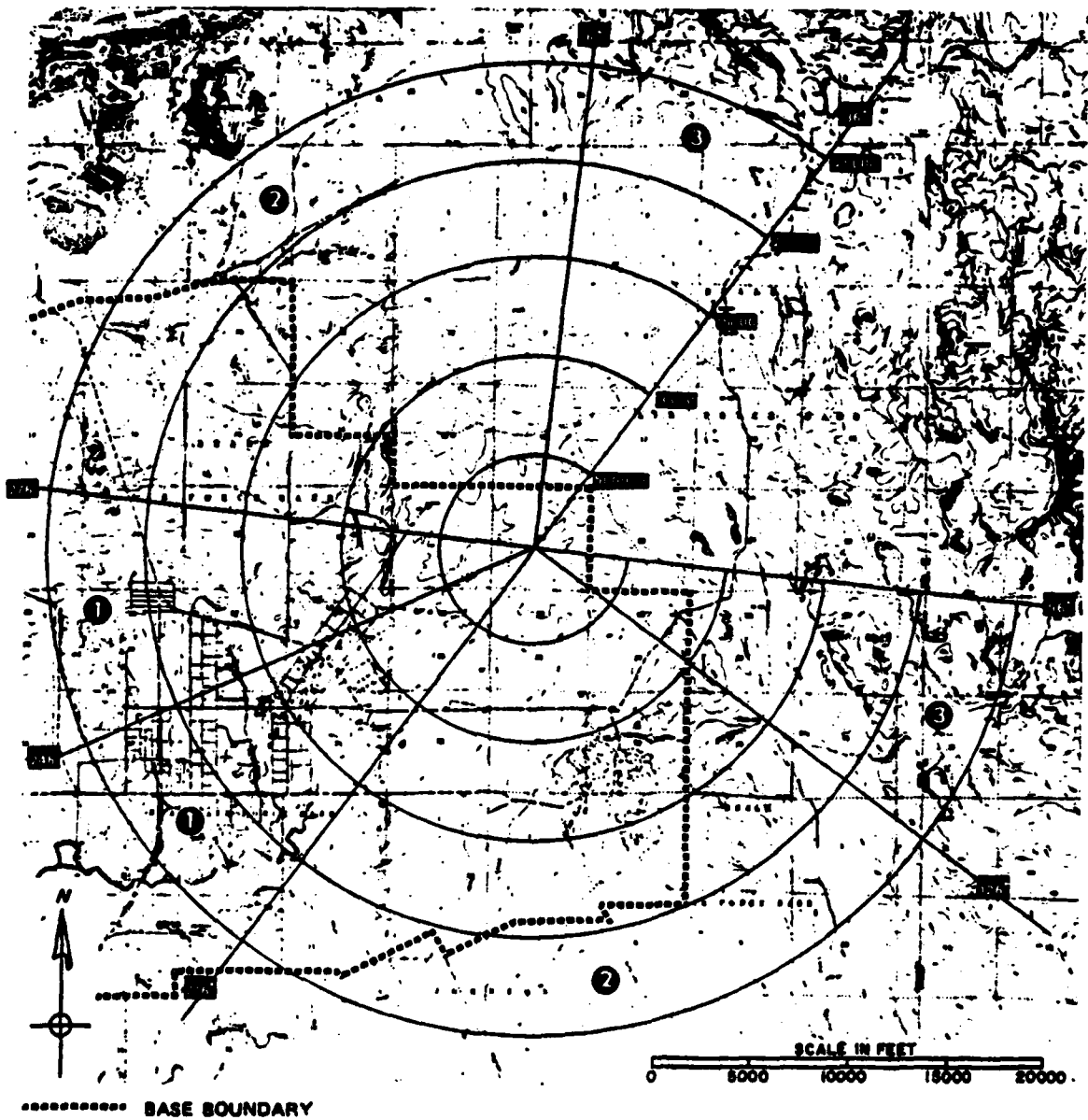

FIGURE 3-1. PAVE PAWS AZIMUTH FROM LOCATION NO. 2, BEALE AIR FORCE BASE

THIS PAGE IS BEING QUANTITATIVELY PRACTICABLE
 FROM DUTY FORWARDED TO SPO

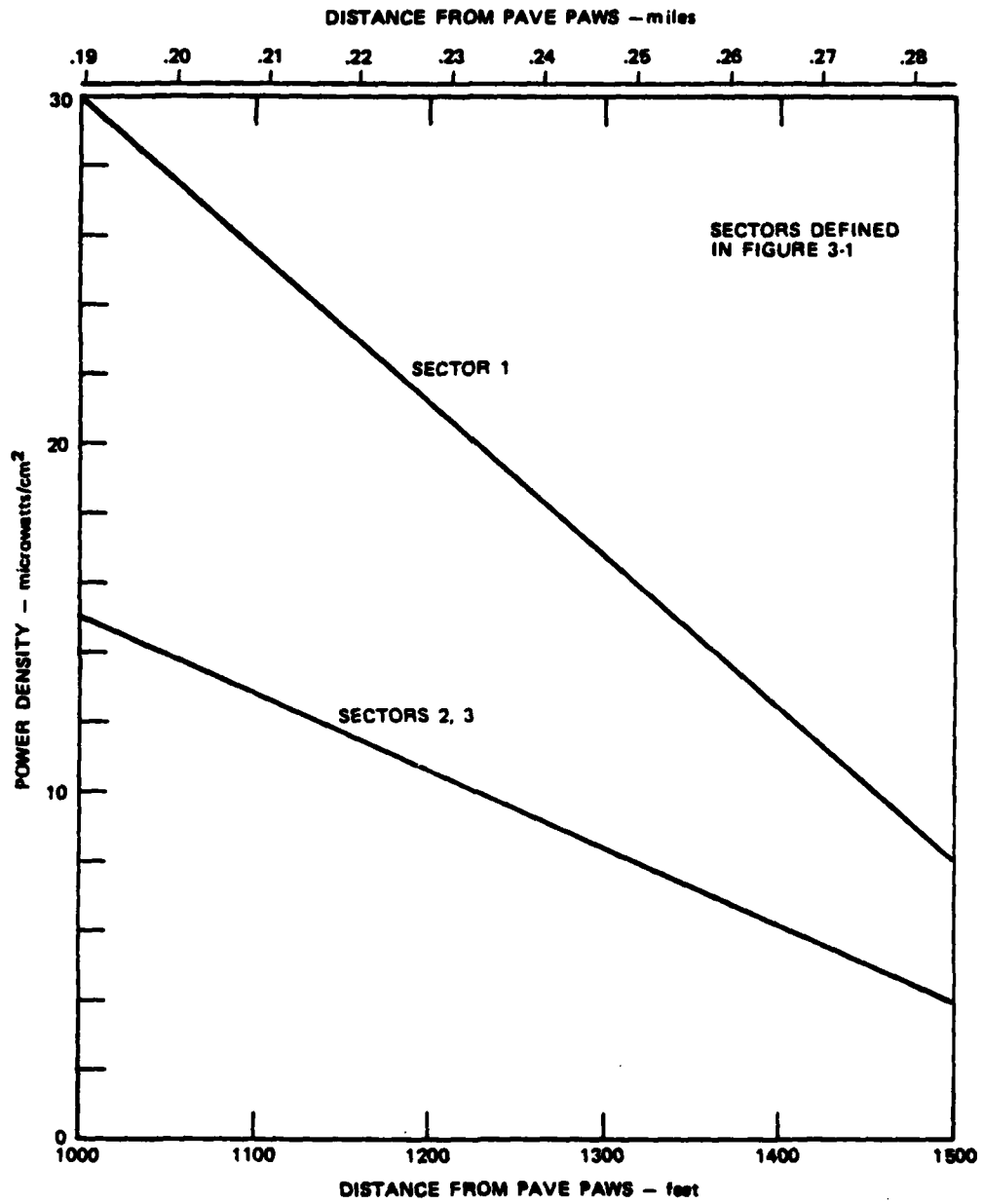

FIGURE 3-2. CALCULATED PAVE PAWS EMR POWER DENSITY AT GROUND LEVEL, 1,000-1,500 FT RANGE

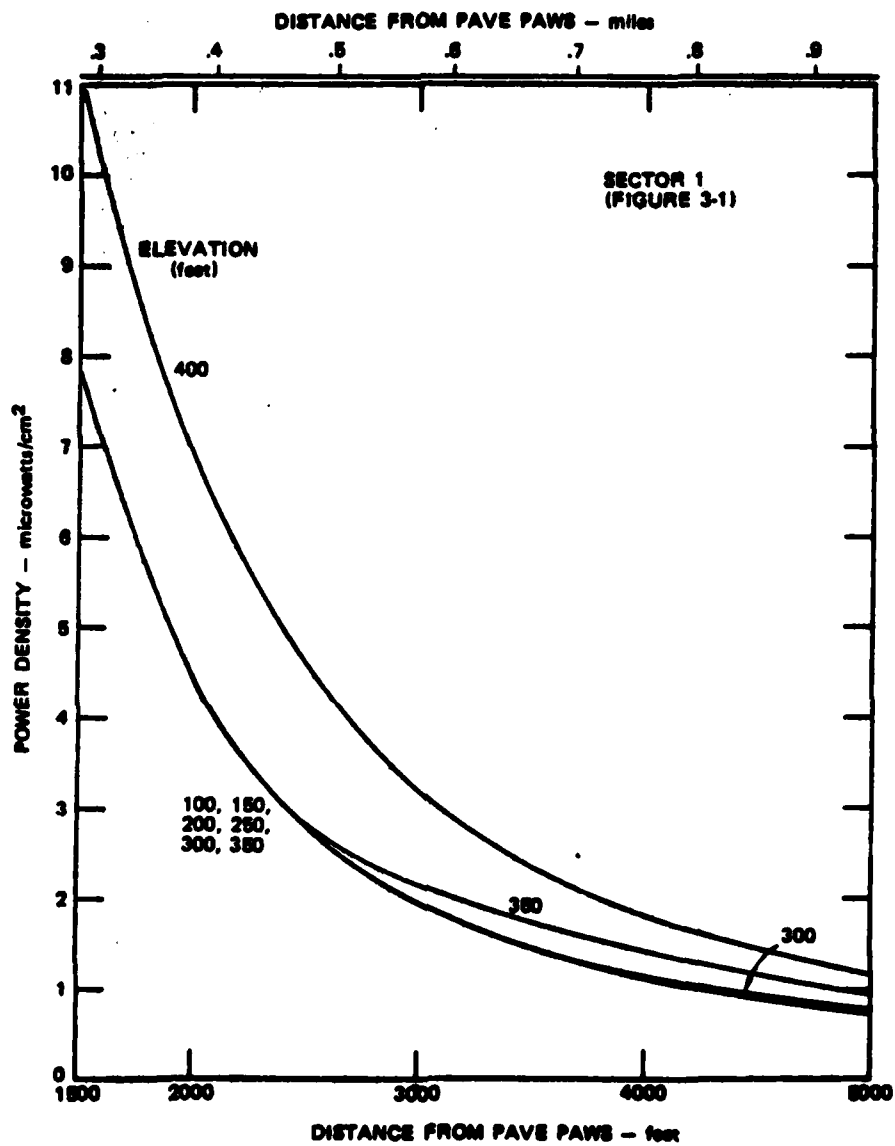

FIGURE 3-3. CALCULATED PAVE PAWS EMR POWER DENSITY FOR SECTOR 1, 1,500-8,000 FT RANGE

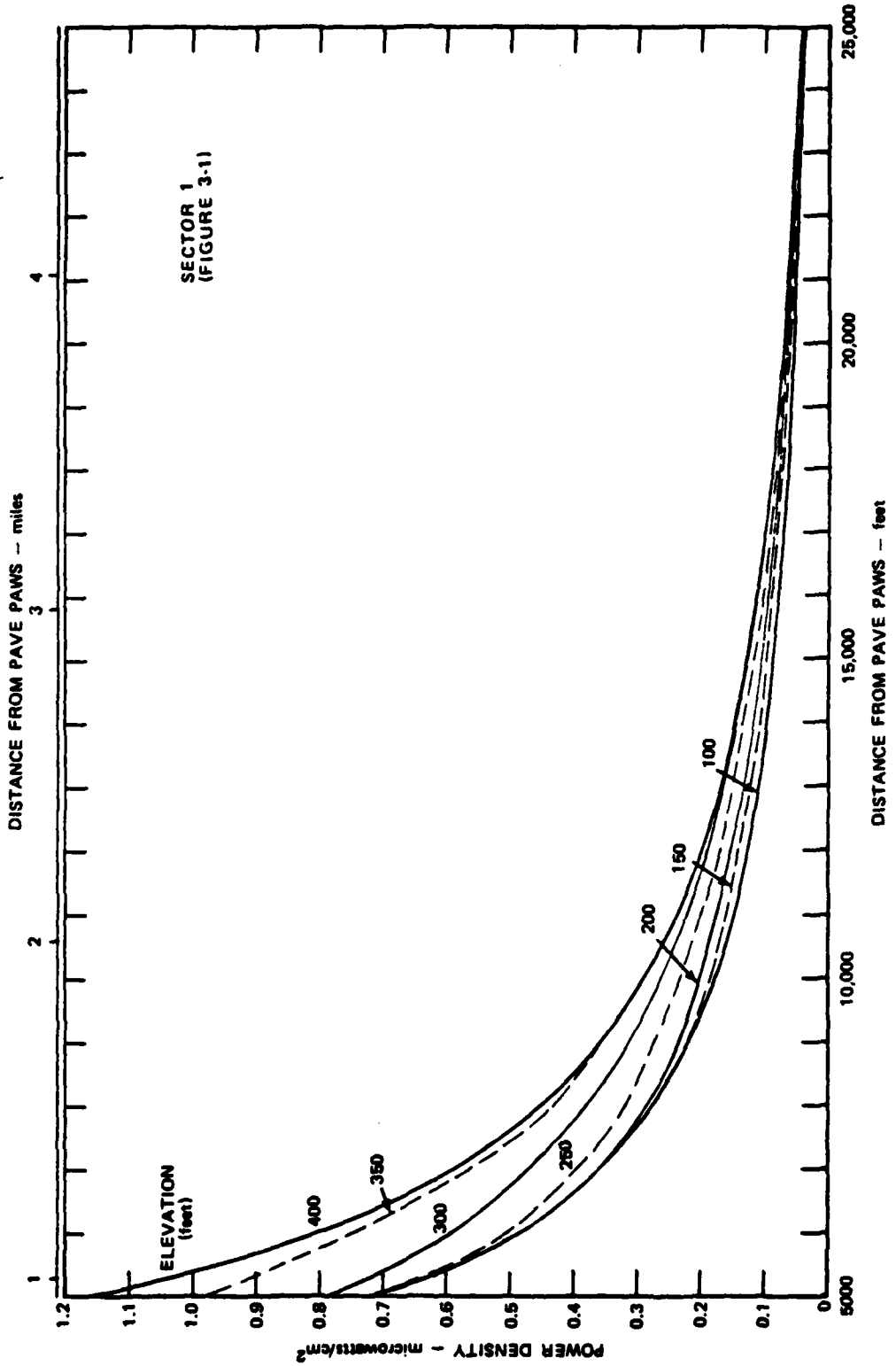

FIGURE 3-4. CALCULATED PAVE PAWS EMR POWER DENSITY FOR SECTOR 1, 5,000-25,000 FT RANGE

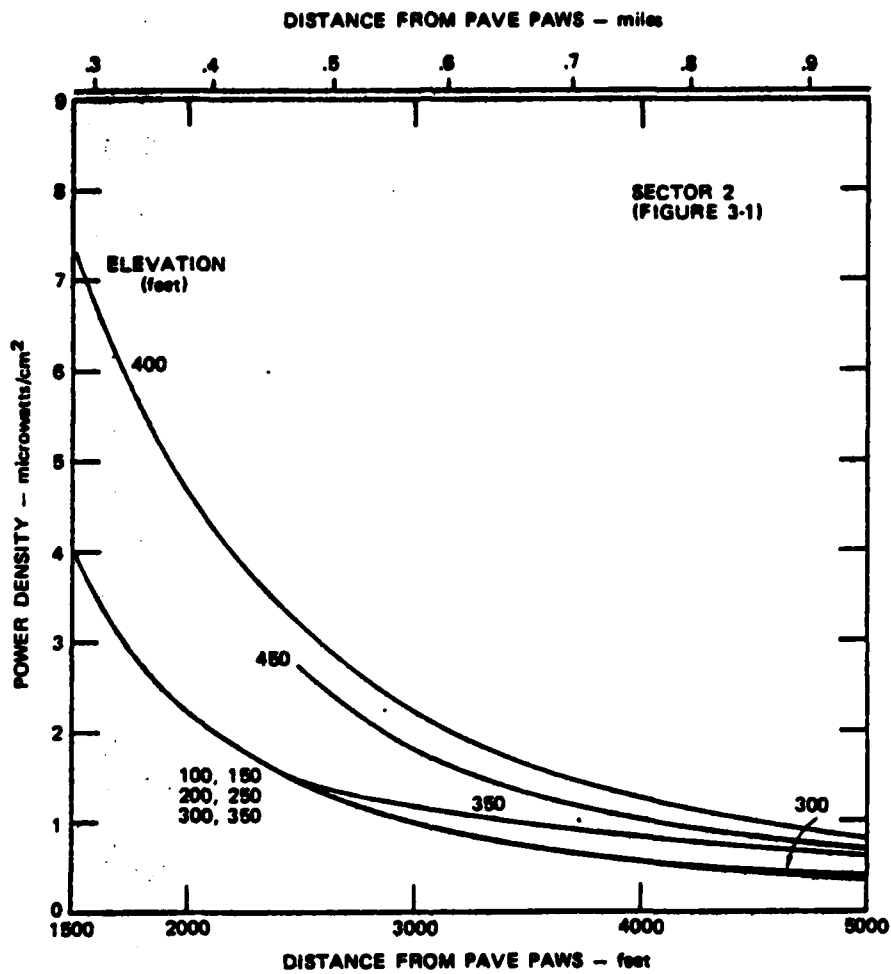

FIGURE 3-5. CALCULATED PAVE PAWS EMR POWER DENSITY FOR SECTOR 2, 1,500-5,000 FT RANGE ↔

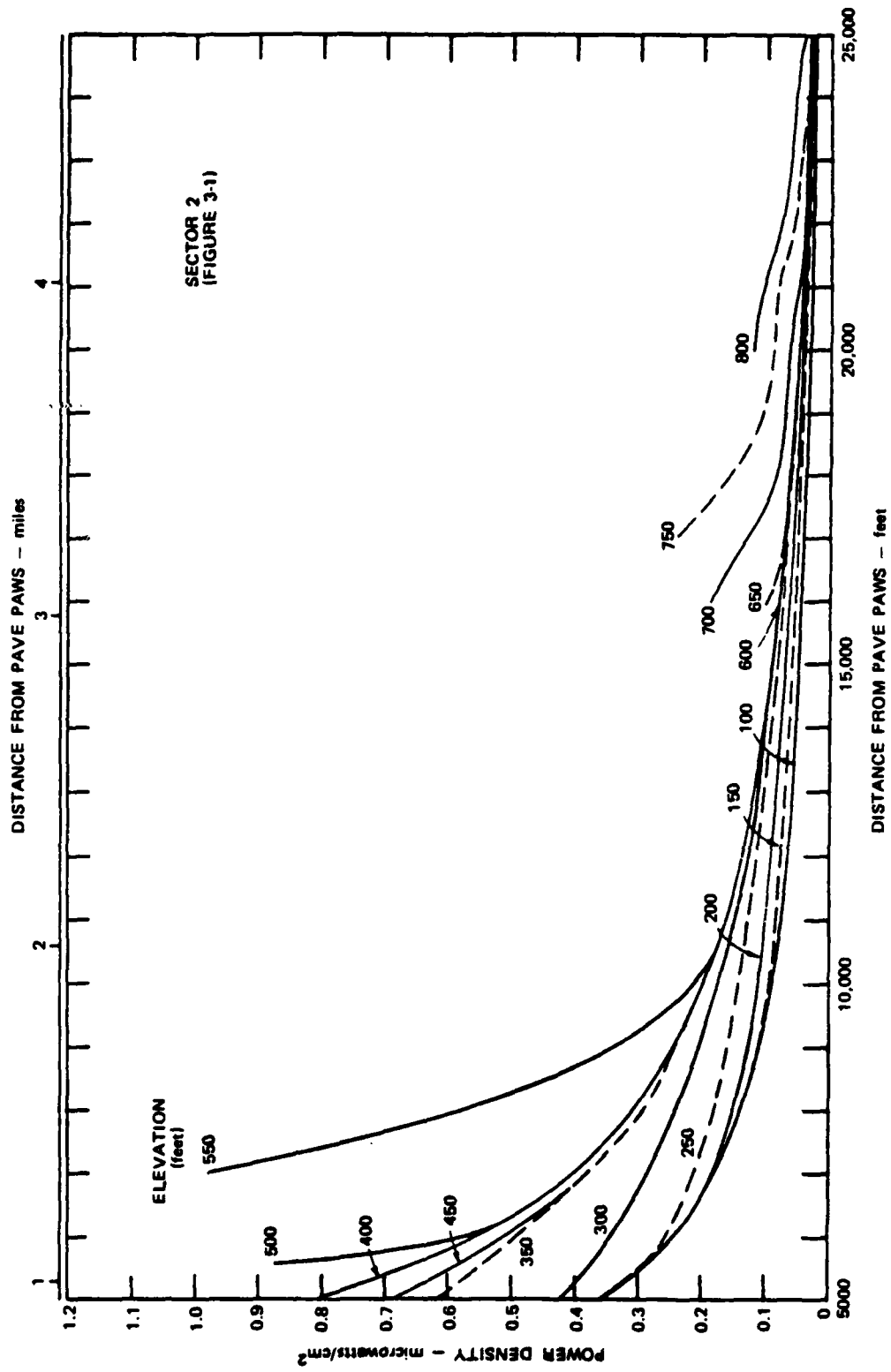

FIGURE 3-6. CALCULATED PAVE PAWS EMR POWER DENSITY FOR SECTOR 2, 5,000-25,000 FT RANGE ++

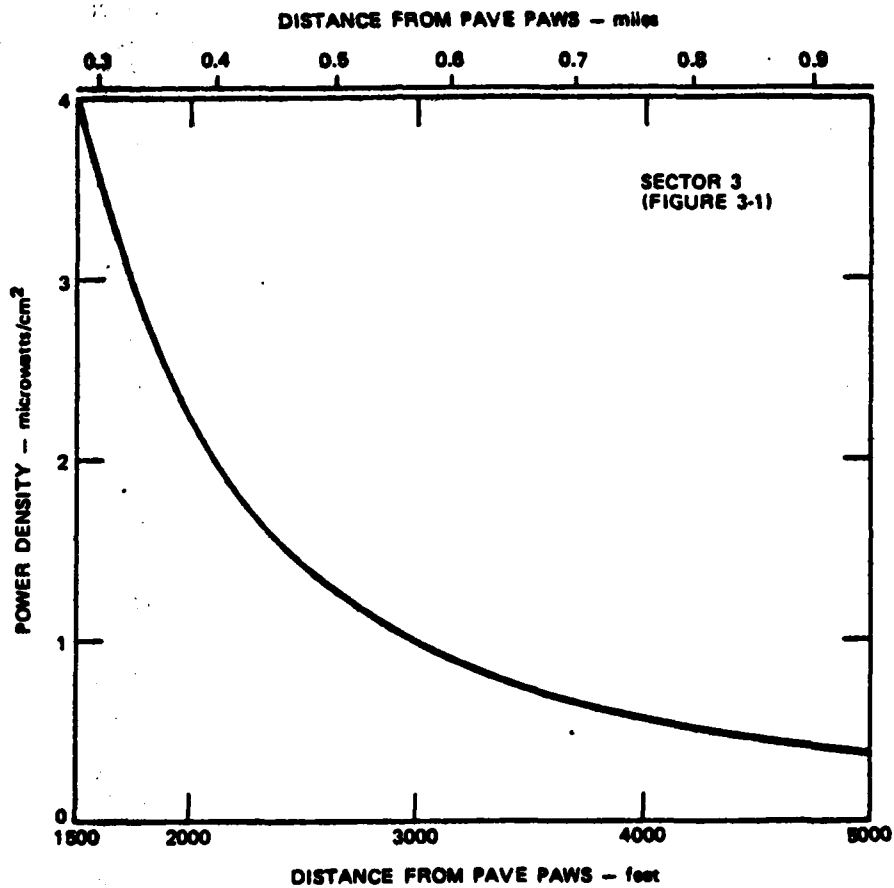

FIGURE 3-7. CALCULATED PAVE PAWS EMR POWER DENSITY FOR SECTOR 3, 1,500-5,000 FT RANGE

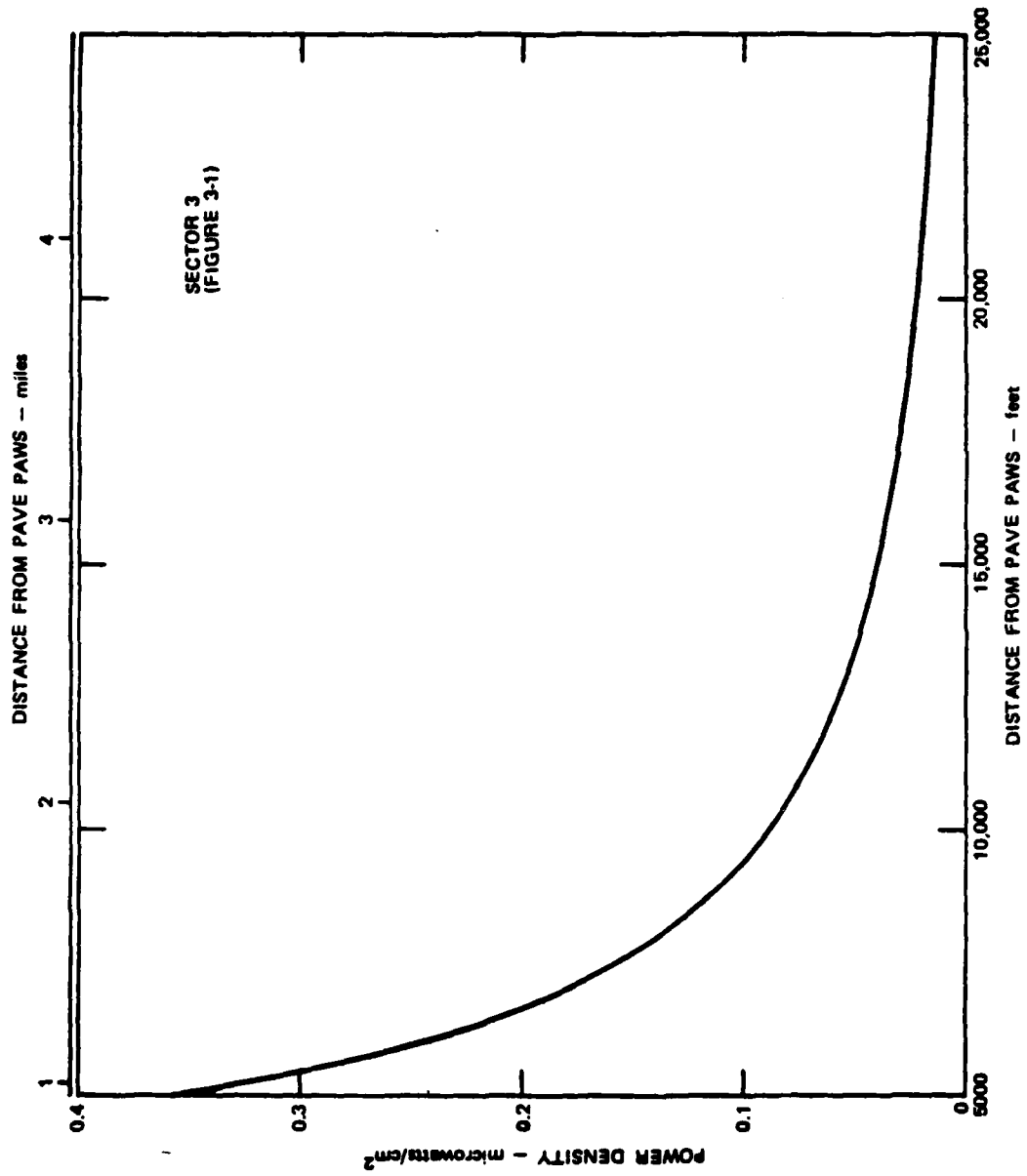

FIGURE 3-8. CALCULATED PAVE PAWS EMR POWER DENSITY FOR SECTOR 3, 5,000-25,000 FT RANGE

3.1.1.1.2 Power Densities Within 1,000 ft of the Antenna. The exclusion fence is intended to prevent people and some animals from inadvertently approaching closer than about 1,000 ft from the antenna faces. However, the fence extends over a sector of only 248 deg, slightly larger than the 240-deg sector swept by the cylindrical beam of the near field and part of the transition zone field (see Figures 1-3, p. 1-4, and A-1, p.A-4). Although the power density falls rapidly outside the cylinder containing most of the power, it increases rapidly as the antenna face is approached along the exclusion fence boundary extending radially at 122 deg and at 10 deg. Consequently, in this section we address the power density in Sector 3 (Figure 3-1, p. 3-3) from 1,000 ft to as little as 200 ft from the radar. In this part of sector 3, shown in Figure 3-9, the power density varies with azimuth, falling to essentially zero at the 96-deg and 36-deg radials that bound Sector 3. The power density at ground level in this region is characterized by the calculated values given in Table 3-1. The radials selected are along the exclusion fence and at the midline of each part of Sector 3. At the limits to public access created by the security fence, about 350 ft to the side from the center of the array on the north and 330 ft on the southeast, the power density is calculated to be 42 and 47 microwatts/cm², respectively (Figure 3-9). Measurements have been made to verify these estimates (see Appendix B).

3.1.1.2 EMR Power Densities in Developed Areas

Using the methodology described above, this section describes the numbers and general locations of people and the power densities to which they will be exposed when the PAVE PAWS installation is operating. As above, power densities given for each area are estimates based on the calculated free-field radiation pattern from PAVE PAWS; that is, the estimates assume that the power is moving out through space, and is free of interference from terrain, buildings, or vegetation, which reduce the power density. Thus, the calculated power density given for each area can be considered an upper estimate, approached but not likely to be exceeded.

Figure 3-10 shows major areas of development and other points of interest within 25,000 ft of PAVE PAWS in relation to the sectors described in Section 3.1.1.1, p. 3-2. The power density and approximate population in each area are given in Table 3-2, p. 3-15. The estimate of power density for each area is not expected to exceed those values because of the following assumptions:

- (1) The distance from the radar to each area was taken to be the distance to the closest boundary of the area, whereas the power diminishes as one moves farther away from PAVE PAWS within the area.

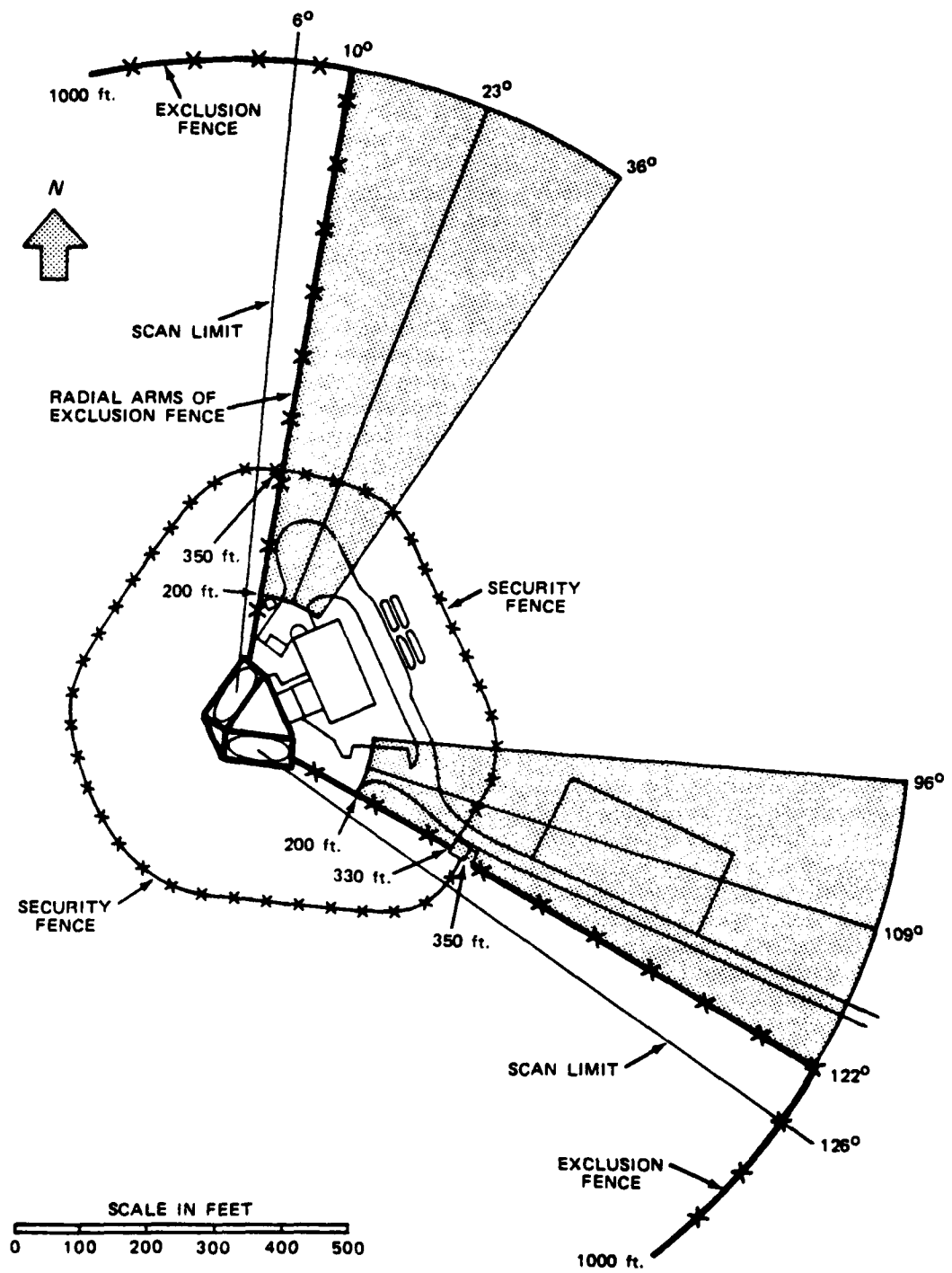

FIGURE 3-9. SECTOR 3 AT CLOSE RANGE, 200 TO 1000 FEET

Table 3-1

CALCULATED POWER DENSITIES ALONG SELECTED RADIALS IN SECTOR 3

Distance from Array Center (ft)	Power Density (microwatts/cm ²)	
	122- and 10-deg Radial (along exclusion fence)	109- and 23-deg Radial (midsector)
1,000	3.9	1.3
800	6.5	2.2
600	12.0	4.2
400	30.0	11.0
350	42.0	15.0
330	47.0	18.0
200	150.0	58.0

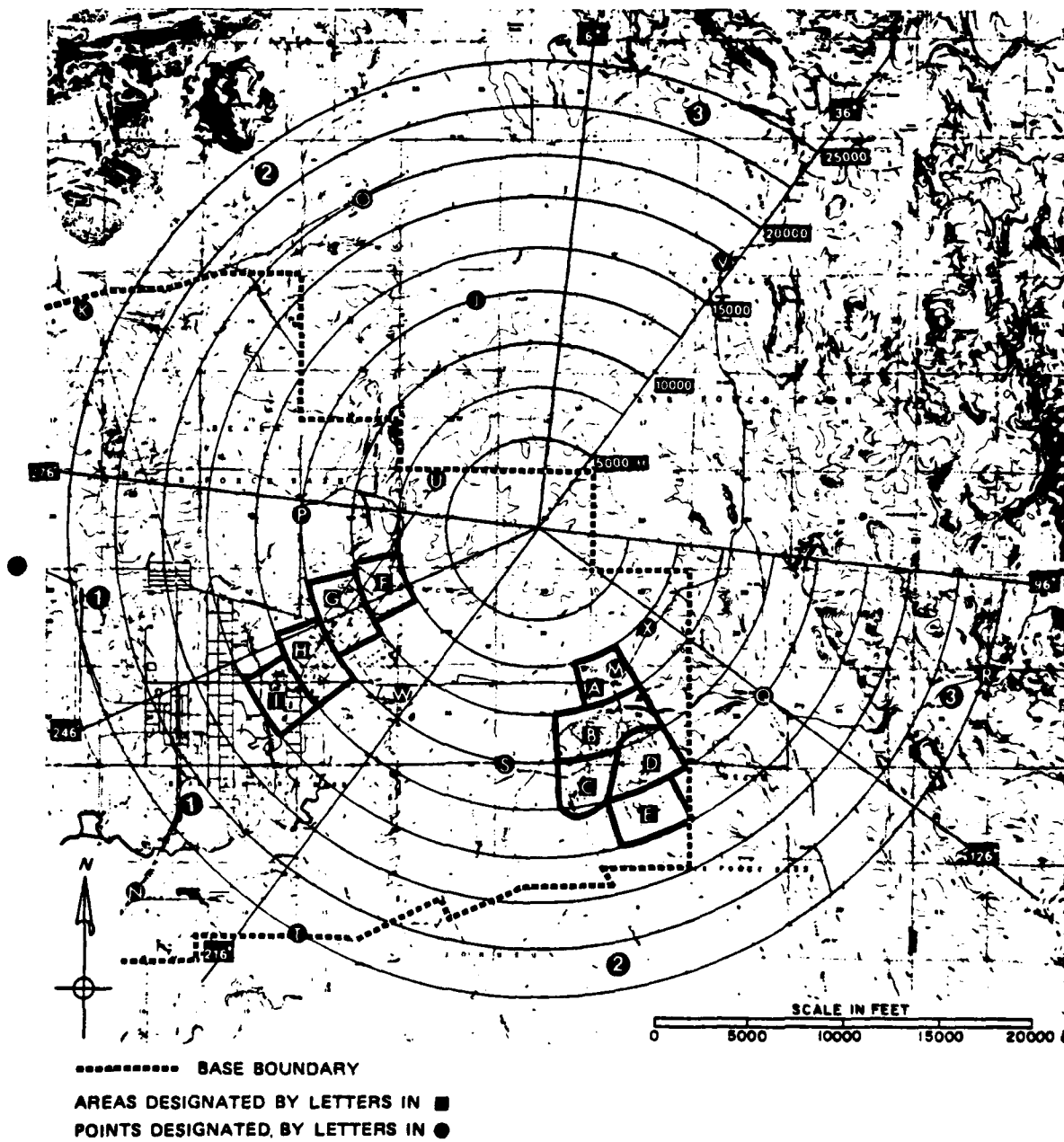

FIGURE 3-10. DEVELOPED AREAS IN AND AROUND BEALE AIR FORCE BASE

Table 3-2
CALCULATED EMR EXPOSURES IN DEVELOPED AREAS NEAR PAVE PANS

Area ^a	Description	Sector ^b	Elevation (ft) ^c	Distance (ft) ^d	Power Density (Microwatts/cm ²) ^e	Approximate Residential Population ^f
A	Base Hospital & Off. Club	2	250	7,500	0.20	293
B	Base family housing	2	250	10,000	0.15	1,760
C	Base family housing	2	250	12,500	0.11	587
D	Base family housing	2	300	12,500	0.12	2,640
E	Base family housing	2	300	15,000	0.09	587
F	Base mobile home park	1	150	7,500	0.32	156
G	Base mobile home park/ contaminant	1	150	10,000	0.19	156
H	Base contaminant	1	150	12,500	0.13	
I	Base contaminant	1	100	15,000	0.09	
J	Developed Area, North	2	300	12,500	0.12	
K	Deolittle Gate	2	150	27,500	0.03	
L	Main Gate (W. Basie Rd)	1	100	30,000	0.04	
M	Grass Valley Gate	2	250	7,500	0.20	
N	Wheatland Gate	1	100	27,500	0.04	
O	Hammonton-Smartville Rd.	2	300	20,000	0.05	
P	Laughlin or Erie Rd.	1	150	12,500	0.13	
Q	Walde Junction (Spencer-ville-Smartville Rd)	2	300	15,000	0.09	
R	Spencer-ville	3	400	25,000	0.015	
S	6th Street	2	150	12,500	0.07	
T	Ostrom Rd.	2	100	25,000	0.04	
U	Water Tank	2	300	5,000	0.42	
V	Wheatland-Smartville Rd	3	700	15,000	0.04	
W	Base Golf Course	1	150	10,000	0.19	
X	Grass Valley Road	2	350	7,500	0.34	

- ^a Areas are shown on topographic maps in Figure 3-10, p. 3-14.
^b Sectors are described in Section 3.1.1.1, p. 3-2.
^c Elevation represents the highest residential portion of the area (to the closest 50 ft).
^d Distance is measured from the closest boundary of an area or the closest 2,500 ft radial for a geographic point.
^e These values represent the calculated upper estimate of the long-term average power that would be received in each area. (See Section 3.1.1.2, p. 3-11, for a discussion of assumptions made for this calculation.)
^f Apportioned according to area (see text).

- (2) The elevation of each area was taken to be the highest in the area (to the next highest 50-ft interval), whereas power densities at lower elevations in an area may be lower because of greater distance from the first sidelobe.
- (3) Each area was taken to have an unobstructed view of PAVE PAWS.

As of 30 September 1978, 5,867 military personnel and dependents lived in the family housing area encompassed by areas A through E in Table 3-2. (Population was apportioned to those areas according to the area of the development.) As of the same date, 312 military personnel and dependents lived in the mobile home park included in areas F and G.

An estimate of power density at any location not listed in Table 3-2 and within 25,000 ft (approximately 4.5 miles) of PAVE PAWS may be obtained by using the procedures described in Section 3.1.1.1. (For distances greater than 25,000 ft, see Section A.3.3, p. A-15.) For example, the base hospital in area A is approximately 7,500 ft from PAVE PAWS, at an elevation of 260 ft, in Sector 2. Figure 3-6, p. 3-8, shows power densities for Sector 2 from 5,000 to 25,000 ft from PAVE PAWS. At a distance of 7,500 ft and an elevation of 250 ft (the closest 50 ft interval), the estimated power density is about 0.2 microwatts/cm².

3.1.2 Biophysical Impacts

3.1.2.1 Human Health

Because there has been considerable ongoing interest from concerned citizens about human health aspects of PAVE PAWS, this section has been written in a style that is less technical than Appendix C. Appendix C, written in the form of a detailed critical review, including a bibliography, expands on this human health section with specific reference citations. The two sections are organized in parallel, with the letter "C" in the appendix paragraph number equivalent to the paragraph number prefix "3.1.2.1" in this chapter. Specific bibliographic references are not included in this section.

The generic term radiofrequency radiation (RFR) has been used to include other terms commonly found in the literature, such as electromagnetic radiation (EMR), nonionizing electromagnetic

radiation (NIEMR), microwave radiation, electromagnetic fields (EMF), microwave fields, and others. The term RFR, as used here, is intended to apply to the frequency band from approximately 10 to 18,000 MHz (18 GHz). The PAVE PAWS frequency band is 420 to 450 MHz.

3.1.2.1.1 Introduction. The primary issue addressed in this EIS is whether brief or continual exposure of people to the power densities of RFR produced by PAVE PAWS is likely to adversely affect their health. This issue has been examined in depth by conducting a critical review of the present state of knowledge regarding biological effects of RFR. The review was based largely on the selection and analyses of documents, from the large body of literature on the subject, that are most significant scientifically and pertinent to the operational characteristics of PAVE PAWS and to the power densities of RFR to be encountered in the geographic region around the radar that may be of concern.

3.1.2.1.1.1 The Problem

Humans can be exposed to the RFR from PAVE PAWS under two circumstances. First, people may be airborne in the vicinity of PAVE PAWS. In this event they may be exposed to the main beam and first sidelobe in addition to higher order sidelobes (see Appendix A for a complete description). Second, populations outside the exclusion area will be exposed more or less continuously to the low-intensity RFR existing near the ground for several miles from the radar. (Possible exposure of individuals within the exclusion area is excluded from consideration because the Site Command will provide appropriate protective and control measures.)

3.1.2.1.1.2 Airborne Exposure

Exposure of an airplane to the main beam is a possibility shared with many operational high-power radar systems. However, as far as is known, there is no case of harm to humans from any such incidental exposure, and there is no reason to believe that the PAVE PAWS situation would be significantly different from that of other radar installations in this respect. The threshold for human perception of individual pulses as apparent sound is a pulse power density of about 300,000 microwatts/cm² (see Section 3.1.2.1.6.1.2, p. 3-30). Based on field calculations (Section A.3.3.1, p. A-15), this value of pulse power density would be exceeded for distances on the axis of the main beam less than about 1,100 ft for the basic system and 2,200 ft for the growth system. There is no experimental evidence that such persons would experience effects ascribable to the pulse repetition rates per se (modulations) from exposures of a few minutes.

The maximum average power densities above ground level are located in the surveillance volume (see Section D.3.2.1.3, p. D-82, for a description). For the basic system, the maximum average power density in the surveillance volume is about 140,000 microwatts/cm² adjacent to the array faces, 270 microwatts/cm² at 1,440 ft, and 20 microwatts/cm² at one mile. In the surveillance volume of the growth system, the values are 142,500 microwatts/cm² adjacent to the array faces, 275 microwatts/cm² at 2,850 ft, and 80 microwatts/cm² at one mile. Again, there is no experimental evidence that persons within an aircraft exposed to the main beam for durations of even a few minutes at these distances would be affected. Moreover, flying closer to the ground and the radar building would constitute a physical hazard unacceptable to the prudent pilot.

Because of these considerations, the likelihood of a biological health hazard to persons in aircraft is considered negligible, and not given further attention in this assessment.

3.1.2.1.1.3 Ground-Level Exposure. For both the basic and growth systems, the calculated average power densities to which the general public may be chronically exposed ("general public exposure") are less than 1 microwatt/cm²; measurements indicate that the actual values of general public exposure are less than 0.15 microwatt/cm². Members of the public may be exposed to higher power densities for relatively brief intervals if they elect to approach PAVE PAWS along the roads leading to the site or by traversing the off-road area up to the exclusion fence. Referring to Figure 3-2, p. 3-4, at the 1,000-ft radius of the exclusion fence, the calculated maximum average power densities for the basic system are approximately 30 microwatts/cm² in Sector 1 (defined in Figure 3-1, p. 3-3, as the sector in which the higher-order sidelobes from the two faces overlap), and approximately 15 microwatts/cm² in Sectors 2 and 3 (in which the sidelobes do not overlap). The measured power density at 1,000 ft in Sector 2 was 1.55 microwatts/cm² (see Section B.3.5, p. B-8). Along the boundaries of the radial arms of the exclusion fence (Figure 3-9, p. 3-12) the average power densities increase to 42 microwatts/cm² at 350 ft and to 47 microwatts/cm² at 330 ft. These two distances correspond to the locations where the exclusion and security fences meet, representing the points of closest possible public approach.

Regarding maximum pulse power densities, the highest values for individual pulses were calculated directly rather than inferred from mean duty cycles. The results are: 460 microwatts/cm² at the 1,000-ft exclusion fence and 700 microwatts/cm² at the 330-ft point of closest public approach. Accordingly, the latter value of maximum pulse power density and 47 microwatts/cm² maximum average power density were assumed for assessing whether the RFR from the basic PAVE PAWS system constitutes a possible health problem to humans. These values are

quite conservative because realistic long-term exposures are likely to be at fractions of a microwatt/cm², both pulse and average, because of the rapid decrease in power density with distance from the site.

For the growth option, similar calculations indicate that maximum average power densities of 29 microwatts/cm² would be obtained at the 1,000-ft radius of the exclusion fence, and 90 microwatts/cm² at the 330-ft point of closest public approach. The corresponding pulse power densities are approximately 1,160 and 1,400 microwatts/cm², respectively. Therefore, the latter value of pulse power density and 90 microwatts/cm² average power density were assumed to be the maxima for the growth system.

3.1.2.1.1.4 Data Base and Literature Selection. Many sources were used in acquiring a working data base for this assessment, including: reference bibliographies provided in previous reviews of the literature; a comprehensive bibliography prepared by U.S. Government personnel; published proceedings of recent seminars and meetings on the biologic effects of RFR; the computerized data base on Biological Effects of Electromagnetic Radiation (BEER file) of the Mead Technology Corporation, Dayton, Ohio; and the compilations of articles published by the Franklin Institute. Consideration was also given to recent symposia on the biological effects of RFR.

Several criteria were used in selecting articles for inclusion in this review. Preference was given to complete papers published in scientific journals or proceedings of scientific symposia. Where details of the procedures and findings were sufficiently clear and complete, abstracts of presentations at recent scientific symposia were also used. Considerations included: the date of publication (more recent articles were preferred because of improvements in the technology of exposure and dose measurement), the frequencies of the RFR (especially frequencies close to those of PAVE PAWS, but also others in the general range from 10 MHz to 18 GHz as appropriate), and the significance of the findings to human health (e.g., studies of human populations to ascertain whether the occurrence of specific effects is statistically higher in population samples exposed to RFR than in similar population samples not exposed, and experiments involving long-term exposure of animals). Other criteria included the relevance of an article to others on the same topic, and possible relevance to concerns expressed by citizens' groups. The number of articles selected was necessarily limited, because of the large number of references on the biologic effects of RFR. However, the articles selected are representative of the entire body of literature on this subject.

3.1.2.1.1.5 Eastern European Bioeffects Literature. Probably the most controversial aspects of research on the biological effects

of RFR are the large discrepancies between results, at low levels of RFR, reported in the Eastern European literature, and those obtained in Western countries such as the United States, and the basic differences in philosophy between the two groups of countries in prescribing safety standards or guidelines for the protection of humans against possible hazards from exposure to RFR. Differences in philosophy of hazard assessment are discussed in more detail in Section 3.1.2.1.3.

From the end of World War II to about the late 1960s, few of the scientific reports on bioeffects research in the USSR (or other Eastern European countries) were amenable to critical review because they lacked essential information. In the early 1970s, starting essentially with an international conference on the bioeffects of RFR in Warsaw in 1973 under the joint sponsorship of the World Health Organization (WHO), the U.S. Department of Health, Education, and Welfare (HEW), and the Scientific Council to the Minister of Health and Social Welfare of Poland, international interchanges of information increased materially, and translations of Eastern European articles became easier to obtain. Because most of the Eastern European documents prior to 1973 (and many since then) are merely abstracts that contain no details of the experimental method, number of subjects, or analytical approach used in the study, evaluation of them proved difficult. More recent Eastern European studies contain more detail, and a number of them are cited in the bibliography of Appendix C to this EIS.

The bioeffects literature of the Eastern European countries was evaluated, especially with regard to purported effects at low average power densities, and those of pulsed RFR. Because the average power densities from PAVE PAWS for chronic exposure of the general public (calculated to be less than 1 microwatt/cm², actual measurements show less than 0.15 microwatt/cm²) are smaller than the USSR safety standard of 5 microwatts/cm² for continuous (24-hour) exposure of the general population, the controversy regarding the large differences in the US and USSR "standards" is not really relevant to the issue of whether the RFR from PAVE PAWS is hazardous to human health.

3.1.2.1.2 Present Climate and Context. Public use of RFR-generating devices and acceptance of their benefits have been growing almost exponentially over a number of years. Public television and radio broadcasting stations, ham radio transmitters, citizens band radios, ground level and satellite communication systems, civil and military aircraft navigation systems, airport traffic control systems, medical diathermy units, defense tracking systems, remote garage door opening devices, microwave ovens, and a variety of units for industrial heating and processing of materials, all contribute to the expansion of RFR in this country. All of these devices are regulated by the Federal government, mainly the Federal Communications Commission, and all are restricted as to what frequency band they may operate in. Most are also restricted as to what power levels they may emit.

Still, with the growing number of devices, the background level of RFR in this country, particularly in urban and industrial centers, is bound to increase, and it is appropriate to ask the question whether this increasing level of RFR will be deleterious to human health.

Various agencies of the Federal government have established programs to deal with the question of effects of RFR on human health. The EPA is conducting a study of environmental levels of RFR. The Bureau of Radiological Health (BRH) has promulgated a performance standard for permissible microwave oven leakage (21 CFR 1010, "Performance Standards for Electronic Products"). The National Institute for Occupational Safety and Health (NIOSH) is investigating use of industrial microwave devices. All three of these agencies, together with the Department of Defense (DOD), maintain research programs on the biological effects of RFR, with the objective of assessing effects on human health. None of the results of this surveillance gives any cause for alarm. Reported biological effects of RFR are largely confined to average power densities of thousands and tens of thousands of microwatts/cm². Present maximum environmental levels in cities are generally in the range of 0.01 to 5 microwatts/cm², with the occasional exception of regions in the vicinity of broadcast towers where the environmental levels may range from 10 to higher than 50 microwatts/cm². Environmental RFR levels of 0.01 to 5 microwatts/cm² are currently found in the neighborhood of some civilian and military facilities. Surveys of RFR power densities in the vicinity of these facilities have yielded values that are comparable to or greater than those calculated for PAVE PAWS beyond the exclusion fence.

3.1.2.1.3 Problems of Risk Assessment. The issue stated to be most significant in assessing the environmental impact of the PAVE PAWS facility is the question of whether the RFR from the facility will be hazardous to the health of the population in the surrounding region. To consider this issue in its proper context, it is necessary first to define what is meant by a hazard, and second to review the philosophical and scientific principles on which the determination of a hazard might be based.

The term "hazard" as used here does not refer to a scientific investigation or conclusion. It is a judgmental term implying that the probability or risk of certain biological effects of a force or substance is an unacceptable threat to human health, safety, or well-being. Scientific evidence and expertise are crucial to the formal judgment that a hazard exists, but they do not constitute the sole basis of judgment. Hazard determination must also consider other questions, such as: What level of risk is acceptable? Which biological effects should be considered and which ignored? What kinds of and how many people are at risk? What consideration should be given to the rare individual who

might be exceptionally sensitive? Who should bear the burden of proof in determining whether a hazard exists? What are the political, economic, and social consequences of a decision that a hazard exists?

There are no fixed answers to the above questions, and persons who evaluate hazards give varying weight to the different questions, according to circumstances. Two of the questions are of particular importance to this EIS. The first question concerns what level of risk is acceptable. There is no environmental condition to which man may be exposed that is absolutely free of risk. Even natural foods that man has eaten for thousands of years present some risk to certain people and in certain circumstances. The second question concerns which biological effects to consider in evaluating hazard. In this EIS all reported biological effects of RFR have been considered in assessing the potential hazard of PAVE PAWS, but the most careful and detailed analysis has been applied to those effects usually considered to be irreversible and harmful to the individuals affected.

A process closely related to hazard evaluation is the setting of exposure standards or limits. An exposure standard is a concentration, intensity, or amount of a substance or force that is believed to pose little or no hazard to the human population. Such a standard does not necessarily imply that exposure at higher levels is harmful, nor does it guarantee that exposure below the standard is absolutely safe for everyone. It is merely a best judgment of an acceptable level for human protection. Setting exposure standards involves answering the same questions as those mentioned above for hazard evaluation. In addition, it is often complicated by the technical problems in estimating the probable dose-effect relationships of a substance in human beings from data obtained in experimental animals.

Standard setting for minimizing hazard is often thought of as a function of legislative bodies, courts, and government agencies. However, in the United States and Western European countries, health and safety standards may also be set by individual corporations for their employees, by insurance companies for their clients, by industries through mutual agreement or negotiation with labor unions, and by other processes. In each case, the considerations for evaluating the hazard differ, and thus the principles for setting the standard are different. The result is that in the United States there is no uniform philosophy which governs the setting of exposure standards, and in various areas of consideration -- food and drugs, chemical manufacturing, mining, air pollution, and others -- different principles are used. In the USSR and the Eastern European countries, by contrast, standards are set by a Council of Ministers, and the philosophy for evaluating the risks and setting the standards is relatively uniform. In this EIS biological effects of RFR are considered

from the viewpoint of potential human hazard. However, there is no attempt to set exposure standards for RFR, and existing or contemplated exposure standards anywhere in the world are not at issue here.

In the USSR, the official maximum permissible average power densities for people occupationally exposed to RFR in the frequency range from 300 MHz to 300 GHz (encompassing the PAVE PAWS frequencies) emitted from stationary antennas are 10 microwatts/cm² for a full working day, 100 microwatts/cm² for 2 hours, and 1,000 microwatts/cm² for 20 minutes. The maximum value for continuous (24-hour) exposure of the general population is 5 microwatts/cm². The armed forces of the USSR are specifically exempt from this regulation. The process by which these standards were arrived at is unknown because the Council of Ministers does not publish its proceedings. However, the guiding principle for occupational exposure standards in the USSR is that they should be set at a value that will not produce, in any of the persons exposed, any deviation from normal or any disease. "Any deviation from normal," then, bars any biological effect, whether it has significance for health or not, and whether or not it represents a temporary deviation to which the human will readily accommodate. The principle also implies that all persons, including the unusually susceptible, shall be protected by the standards.

The United States has no official maximum permissible exposure limit for RFR for the general population. The Occupational Safety and Health Administration (OSHA) has promulgated a radiation protection guideline (RPG) of 10,000 microwatts/cm² for persons occupationally exposed for greater than 6 minutes to radiation in the frequency range from 10 MHz to 100 GHz based on the same RPG value of the American National Standards Institute, and this guideline has been adopted by a number of organizations, including the DOD. (Air Force has used the 10,000 microwatts/cm² occupational standard since the 1960s.) The principle underlying such a guideline is the belief, based on existing scientific evidence, that nearly all workers can be exposed to such a level during the normal series of working days without adverse effect. The guideline recognizes, then, that the RFR might cause biological effects that have no medical consequence, or that the workers could readily accommodate to the effects. Occasionally, workers might also suffer minor adverse effects that could be detected before serious medical consequences developed. However, it is possible that the occupational standard may be revised in the future to include more detailed specifications of frequency-dependent maximum exposure levels related to exposure durations. The question of a need for an environmental limit or standard is still under consideration by the EPA.

Aside from these differences in what kinds and levels of biological effect are considered in formulating exposure standards, another important philosophical difference exists between

the USSR and the United States in evaluating environmental and occupational hazards. Medical theory in the USSR, under the influence of Pavlovian tradition, places strong emphasis on the role of the central nervous system (CNS) in health and disease and uses neurological and behavioral tests extensively for diagnosis and evaluation. Medical theory in the United States strongly emphasizes pathological processes and conditions and tends to restrict attention primarily to those regions of the body where the disease is localized. The relative merits of the two viewpoints is not an issue in this document, but one should note that they can produce different evaluations of the same data and different assignments of risk at the same exposure level.

The analysis of the biological effects in this document generally follows the principle that biological effects reported from exposure to RFR should be examined in the context of the physiological mechanisms involved and the power density levels employed in the experiments. Evidence for the presence or absence of threshold values of power density is particularly important. Finally, although no evidence of potential hazard is totally disregarded, the biological effects of RFR reported in the literature are examined carefully for evidence of scientifically valid performance and interpretation. Unsupported statements of opinion and scientific reports that do not meet reasonable criteria of validity are given little or no weight in the evaluation of hazard.

3.1.2.1.4 Assessment of Scientific Information. Interpreting the available research findings to predict whether RFR from PAVE PAWS is likely to be hazardous to the human population in its vicinity is not a simple process. The most conclusive information would come from studies involving well-controlled and carefully specified exposures of people of a variety of ages and states of health to RFR identical to that of PAVE PAWS. Such studies should ideally be carried out by experts and should include full understanding of the physical and biological mechanisms underlying any identifiable effects. This kind of information is not available. The information that is available comes from a variety of studies, none designed specifically to assess the effects of PAVE PAWS, that must be interpreted in the PAVE PAWS context. All of the available information requires some extrapolation or modification to apply it in the assessment of PAVE PAWS. The greater the extrapolation or other modification that is made, the more likely that experts will differ in their interpretation of the available data. A critical problem regarding negative results in scientific studies tends to occur regularly in disputes regarding environmental hazards. A negative result in a scientific study cannot prove the absence of biological effects -- harmful or otherwise -- and any number of repetitions of such a study, with negative results in each case, cannot conclusively prove the absence of effect. Hence, one can never prove that any environmental agent is "completely harmless." Regulatory agencies

and others concerned with public safety are not always in a position to take such a rigid stand, and hence public reviews of environmental hazards often contain statements about possible effects of an agent that are sometimes confused with statements of fact.

3.1.2.1.5 Other Assessments and Reviews. Two other assessments of PAVE PAWS and nine previous reviews on the biological effects of RFR published within the past six years were examined in the course of preparing this EIS. Detailed descriptions of these assessments and reviews may be found in Section C.5, p. C-12.

3.1.2.1.6 Present State of Knowledge Regarding Physical Effects

3.1.2.1.6.1 Interactions of Fields with Biological Entities.

Interactions of electromagnetic fields with biological entities are often loosely characterized in the bioeffects literature as "thermal" or "nonthermal," a usage that has led to confusion and controversy. Therefore, it is appropriate at this point to introduce working definitions of these terms, with the recognition that the boundary between these types of interaction is not sharp.

The interaction of an agent (e.g., RFR) with an entity (biological or nonbiological) can be characterized as thermal if the energy absorbed by the entity is transformed at the absorption site into heat. Heat absorption, in turn, is defined in classical thermodynamics as either an increase in the mean random speed (or kinetic energy) of the molecules at the site (a local increase in temperature), or as an increase in the disorder or randomness of the molecular motion without an increase in mean random speed or temperature (analogous to the process involved in ice melting at 0° C), or both.

An entity can also absorb energy at specific discrete frequencies in the form of energy packets or "quanta," each of which has an energy proportional to one of the discrete frequencies. The constituents and configurations of the various molecular species comprising the entity determine the specific frequencies or characteristic spectra at which such absorption can occur. The kinds of interactions involved are numerous and of varying degrees of complexity. They include alterations of molecular orientations and configurations that do not change the basic identities of the molecules, disruption of intermolecular or intramolecular bonds, and excitation of atoms or molecules to higher electron states (including ionization). Such interactions can be characterized as "short-range" processes. There are also cooperative interactions among subunits of molecules within biological cells, in cell membranes, and in extracellular fluids.

Cooperative interactions are often characterized as "long-range" because absorption of energy at one specific site in a structure, e.g., in a membrane or in a biological macromolecule, can affect a process elsewhere in the structure, or a function of the structure as a whole can be triggered by the release of energy stored in the structure, thereby producing biological amplification.

Conceptually, all such quantum interactions can be characterized as nonthermal. However, if most of the energy thus absorbed is subsequently transformed locally into heat (as defined above), then the distinction between nonthermal and thermal is blurred. Pragmatically, therefore, characterization of an interaction of RFR with a biological entity as nonthermal requires that the interaction give rise to a frequency-specific effect that is experimentally distinguishable from heating effects due to thermalization of the absorbed RFR energy.

3.1.2.1.6.1.1 Thermal Effects of Time-Averaged Power Density and Dose-Rate Considerations; Nonthermal Effects of CW RFR

Consider now the effects of CW RFR on a human or an animal. The relative magnetic permeability of most organic constituents is about unity. Therefore, thermal interactions (as defined above) can be described in terms of the dielectric, electrical-conductivity, and thermal properties of the body organs, tissues, fluids, and so forth, as well as the characteristics of the RFR (frequency, power density, polarization). Measurements of these properties have been made for various mammalian tissues, blood, cellular suspensions, protein molecules, and bacteria over the frequency range from about 10 Hz to 20 GHz. In the subrange from about 300 MHz to about 10 GHz, the dielectric constant of such constituents as skin, muscle, and blood vary little with frequency, and the differences in values among such constituents are largely due to differences in water content. In addition, electrical conductivity increases slowly with frequency in this subrange.

Because the index of refraction of any material is related to its dielectric constant, RFR is reflected and refracted at boundaries between regions of differing dielectric properties, such as at the surface of a body (whether organic or inorganic), for the same physical reasons as for light at a glass-air interface. Thus, RFR at normal incidence to a relatively thick planar specimen is partially reflected at the surface, and the fraction of the power density entering the specimen suffers progressive attenuation with depth because of energy absorption. The concept of "penetration depth" is often used. For homogeneous specimens, the penetration depth is defined as the distance at which the electric field strength is about 37% of its value or the power density is about 14% of its value just within the surface, and the numerical values depend on the electrical properties of

the material. Both the reflection ratio and penetration depth vary inversely with frequency. At 450 MHz, about 65% of the incident power density is reflected at the air-skin interface and the penetration depths for skin, muscle, and blood are about 3 cm (1.2 in) and is about sixfold larger for fat. Therefore, the 35% entering the body passes through the skin and its underlying fat layer into the muscular tissue with relatively little attenuation. At 100 kHz, the penetration depths of all constituents are quite large, but the reflection ratio is essentially 100%. On the other hand, at approximately 10 GHz and higher, a somewhat smaller fraction of the incident power density than at 450 MHz is reflected, but penetration is largely confined to the skin.

In the RFR-bioeffects literature, the rate of energy absorption by a small region or sample divided by its weight is called its Specific Absorption Rate (SAR) and is expressed in terms of W/kg or mW/g. The numerical value of SAR in any small region within a biological entity depends on the characteristics of the incident RFR (power density, frequency, polarization) as well as on the properties of the entity and the location of the region. In general, therefore, the spatial variation of SAR within a biological entity is dependent on the attenuation characteristics of its constituents and on the reflection ratios at the interfaces between dissimilar constituents. For biological entities having complex internal distributions of constituents, spatial variations of SAR are not readily calculated. Therefore, the concept of "mean SAR," representing the spatial average value for the body per unit of incident power density, is often used because it is a quantity that can be measured experimentally (e.g., by calorimetry), without requiring knowledge of the internal SAR distribution.

Many investigators have studied relatively simple geometric models, including homogeneous and multilayered spheroids, ellipsoids, and cylinders, having weights and dimensions approximately representative of various species, including humans. Such models were assumed to be or were actually exposed to linearly polarized plane waves, to determine the dependence of mean SAR on frequency and orientation relative to the polarization direction of the RFR. An important result of this work is that the largest mean SAR is obtained when the longest dimension of each kind of model is parallel to the electric component of the field and when the wavelength of the incident radiation is about $2\frac{1}{2}$ times the longest dimension. The adjective "resonant" is often applied to the frequency corresponding to this wavelength. For circularly polarized RFR (the type of polarization used in PAVE PAWS), resonances of this kind would also occur. However, the major contribution to the resonant mean SAR values would be from only half the incident power density, because circularly polarized RFR can be regarded as consisting of two equal, mutually perpendicular, linearly polarized components, only one of which would be parallel to the largest dimension of the body. The SAR contribution of the other

component would depend on the body dimension parallel to that component.

Based on prolate-spheroidal models (and linearly polarized RFR), the resonant frequency for an "average" man, approximately 5 ft 9 in tall (1.75 m) and weighing about 154 lb (70 kg) is about 70 MHz; at this frequency the mean SAR is about 0.2 W/kg for 1,000 microwatts/cm² incident power density, or about 1/6 of his resting metabolic rate, or about 1/21 to 1/90 of his metabolic rate when performing exercise ranging from walking to sprinting. An alternative interpretation of this mean SAR value is that exposure to 1,000 microwatts/cm² for, say, 1 hour would produce a mean temperature rise of about 0.2 deg C in the absence of any heat-removal mechanisms. However, actual temperature increases would be lower or even zero because physical heat-exchange mechanisms (conduction, convection, radiation) are always present, and for mammals (and other warm-blooded species) these mechanisms are controlled by thermoregulatory systems.

Similarly, the resonant frequency for an "average" woman about 5 ft 3 in tall is about 80 MHz, and her mean SAR is about the same as for the average man. The resonant frequency of a 10-year-old is about 95 MHz; for a 5-year-old, about 110 MHz; and for a 1-year-old, about 190 MHz. The mean resonant SAR values for such children are about 0.3 W/kg for 1,000 microwatts/cm².

If a model human were to be standing on a wet surface or near other electrically conductive surfaces (reflectors), the resonant frequency would be lower and the mean SAR (at the lower resonant frequency) would be higher. However, because the values of incident power density from PAVE PAWS at ground level beyond the exclusion area are much lower than 1,000 microwatts/cm² and its operational frequencies are considerably higher than the resonant frequencies in either the absence or presence of nearby reflecting surfaces, no changes in body temperature would be expected.

The foregoing discussion of mean SAR is also largely applicable to pulsed RFR (and other types of modulated RFR) at corresponding carrier frequencies and time-averaged incident power densities. (However, as discussed in the next section, there are several differences in interaction between CW and pulsed RFR.)

Because RFR can also be refracted at the air-surface and internal interfaces between dissimilar constituents, internal convergence is possible under certain conditions, notably for convex entities of dimensions that are comparable with the wavelength of the incident field; the action somewhat resembles the convergence of light by a lens. Therefore, despite the attenuation with depth mentioned above, there may be internal regions at which the local SAR values are higher than at the surface facing the source. For convenience, such internal local regions of relative maximum SAR have been dubbed "hot spots," even for

combinations of incident power density and exposure duration that would produce biologically insignificant temperature rises at such spots.

The conditions under which hot spots could occur within the head were studied by a number of investigators, using homogeneous and multilayered spherical models. They found that hot spots can occur only with specific head-diameter and frequency domains; i.e., for heads less than about 16 cm (6 in.) in diameter and for frequencies between about 300 MHz and 12 GHz, the sizes of these two domains being interrelated. To cite a specific example relevant to PAVE PAWS: for a head about 10 cm (about 4 in) in diameter, the hot spots are internal over the frequency range from approximately 400 MHz to approximately 3 GHz, with the highest relative maximum SAR occurring at about 1 GHz. Above and below this frequency range, the maximum SAR is at or just beneath the surface facing the source; as the frequency is increased from 400 MHz, the hot spots shift inward and then outward toward the source because of the decrease of penetration depth with frequency. At 450 MHz, the hot spot is close to the front surface and its SAR is about 15% larger than the front-surface SAR at 400 MHz. However, for a head 20 cm (about 8 in) in diameter (about the size of an adult human head), there are no internal hot spots at any frequency; the maximum SAR values are always at or just within the surface facing the source.

Results of theoretical analyses of such relatively simple geometric models have been verified experimentally by constructing physical models from synthetic biological materials (having approximately the same electromagnetic characteristics as their corresponding biological constituents), exposing such models to sufficient power densities to obtain readily measurable temperature rises, and measuring such temperature rises immediately after exposure. Although much useful information has been obtained in this way, human and animal configurations are far more complicated and different from one another. Therefore, SAR distributions in animal carcasses and figurine-shaped physical models have been determined experimentally.

Among the qualitative results of general interest obtained with human figurines are that, at frequencies near resonance, the local fields can be much higher for certain regions such as the neck and groin than for other body locations, and that field distributions for nonprimates are quite different from those for primates, a point that should be given proper consideration when endeavoring to extrapolate experimental bioeffects findings on any laboratory animal species to humans or to compare experimental results on one laboratory species with those on another species. However, the PAVE PAWS frequencies are much higher than the human resonance values (e.g., 70 MHz for the model average man) and the corresponding mean SAR values are considerably lower than the resonance values (e.g., about 0.026 at 450 MHz versus 0.2 at 70

MHz). Consequently, for the reasons stated previously, local temperature rises in body regions such as the neck and groin would be negligible for the power densities beyond the exclusion area.

For the short-range quantum interactions (as defined above) of CW RFR, the discrete frequencies are in the infrared range from about 19,000 to 240,000 GHz, and the lower end of this range is about 42,000 times higher than a quantum of RFR at 450 MHz. Conversely, the quantum energy of 450-MHz radiation is too low (by a factor of 50,000 or more) for such interactions. Therefore, the existence of nonthermal biological effects of CW RFR ascribable to such short-range molecular interaction mechanisms is extremely doubtful.

Biological generation of fields such as brain waves, which have frequencies in the ELF range (below 100 Hz), is regarded as evidence for the occurrence of cooperative or long-range interactions. Theoretical models of nerve-cell membranes indicate that the frequencies for cooperative processes can be much lower than those for short-range interactions. Because the thermal energy corresponding to the physiological temperature 37°C (98.6°F) is more than adequate for spontaneously triggering cooperative processes, the question has been raised whether theoretically postulated effects of weak RFR would be distinguishable from such spontaneously induced effects. Alternatively, separation of such RFR interactions from thermally triggered interactions may require that the effects of the former exceed those of the latter, implying the existence of a threshold. However, the theoretical considerations for these and many other factors on both sides of this issue are as yet highly speculative. Experimental effects ascribed to such cooperative processes have been reported in preparations of excised tissue exposed to brain-wave frequencies, notably the lower calcium efflux from brains removed from newly hatched chicks, incubated in physiological solution, and exposed to fields in the ELF range. This effect was not observed with CW (unmodulated) RFR at 147 MHz or 450 MHz; however higher calcium efflux was reported for 147 MHz and 450 MHz modulated at frequencies in the ELF range (as discussed in the next section).

3.1.2.1.6.1.2 Interactions of Pulsed RFR and Nonthermal Effects

Precise usage of the term CW RFR implies the presence of only a single frequency (and unvarying incident power density). Because of the time variations of power density and frequency in pulsed RFR (and other forms of modulation), possible biological effects ascribable to the pulse characteristics per se rather than to the time-averaged power density must also be considered.

The interactions of individual RFR pulses with an entity (biological or nonbiological) are analogous to those of mechanical impulses, an impulse being defined as the sudden application of a

force to an entity for a brief time interval, resulting in an abrupt increase in momentum. The total energy imparted to the entity depends on the magnitude of the force and the duration of its application. The interaction can be characterized as nonthermal or thermal, depending on the properties of the entity that determine the disposition of the energy. The impact of a piano hammer on a string, which excites the string into vibration at its discrete resonant frequencies (the fundamental frequency and integer-multiples thereof or harmonics) is an example of an essentially nonthermal interaction as defined previously; most of the energy is transformed into sound, which is converted into heat elsewhere.

A sudden blow to an entity such as a block of material having a set of resonant frequencies that are not necessarily harmonically related to one another will excite many of these frequencies; this illustrates the principle that an impulse contains a broad spectrum of frequencies. The results of an impact on a church bell can be characterized as nonthermal for the same reason as that given for the piano string. By contrast, the effects of a blow to a block of lead or asphalt are essentially thermal; even though some sound is produced, most of the energy is converted into heat on the surface of impact.

One impulse effect of RFR known to occur in humans and animals is the phenomenon of "microwave hearing" or the perception of single or repetitive short pulses of RFR as apparently audible clicks (also discussed in Section 3.1.2.1.7.5.1, p. 3-45). The interaction mechanisms involved are not yet completely understood. However, almost all of the experimental results tend to support the theory that pulse perception occurs because of transduction of the electromagnetic energy into sound pressure waves in the head and normal detection by the auditory apparatus. In one group of suggested mechanisms, transduction is postulated to occur at a boundary between layers having widely different dielectric properties (e.g., at the boundary between the skull and the skin or dura). The energy in a pulse arriving at such a boundary is converted into an abrupt increase in momentum that is locally thermalized; the resulting volumetric temperature rise can be negligible, but the temperature gradient across the boundary (rate of change of temperature with distance) can be large. Under such conditions, rapid local differential expansion would occur, giving rise to a pressure (sound) wave. Thus, whether to characterize this phenomenon as thermal or nonthermal on the basis of such interaction mechanisms is not clear. However, this effect is often characterized as nonthermal because the power density averaged over two or more pulses can be miniscule. For example, consider the arrival and perception of a single pulse of 20-microseconds duration and pulse power density of 1,000,000 microwatts/cm². If a second pulse of the same duration and power density arrives and is perceived, say, 10 seconds later, the time-averaged power density for these two pulses would be only 2

microwatts/cm², whereas it would be half this value if the second pulse arrives 20 seconds later. Therefore, the time-averaged power density has no relevance to the perception of the pulses.

Irrespective of how the microwave hearing phenomenon is characterized, the significant point is that most of the experimental results indicate that the pulses are perceived as actual sound rather than by direct RFR stimulation of the auditory nerves or the brain.

In typical experiments with human volunteers exposed to pulsed RFR (at 3 GHz), pulse durations of the order of 10 microseconds and minimum pulse power densities of 300,000 microwatts/cm² were needed for perception. Therefore, this phenomenon should not be a source of concern about PAVE PAWS because the pulse power densities at ground levels outside the PAVE PAWS exclusion fence are less than 700 microwatts/cm² for the basic system and 1,400 microwatts/cm² for the growth system, or at least two orders of magnitude lower than the thresholds for human perception. +

Periodically pulsed RFR constitutes a particular type of amplitude-modulated RFR in which the pulse repetition rates are the primary modulation frequencies. Biological effects ascribable to modulation frequencies per se (as distinguished from those due to individual pulses) have been postulated. The occurrence of such effects would require the existence of some nonlinear interaction mechanism to separate the modulation frequencies (rectify the modulated RFR waveform and filter out the carrier frequency). Although the nonlinear mechanisms of interaction underlying this phenomenon are conjectural, the aforementioned results on calcium efflux from chick brains exposed to ELF-modulated 147 MHz or 450 MHz RFR (and the absence of this effect for unmodulated RFR at these frequencies) are regarded as experimental evidence for the occurrence of modulation effects. These results are relevant to PAVE PAWS (especially those with modulated 450 MHz) because the pulse repetition rates of PAVE PAWS are approximately the same as the modulation frequencies used in these experiments. In brief, the calcium efflux reported for chick-brain hemispheres exposed to 147 MHz modulated at frequencies between 6 and 20 Hz was higher than that reported for control hemispheres. The incident average power density was 800 microwatts/cm², and the effect was largest at 16 Hz. Higher calcium efflux was also obtained with 16 Hz-modulated 450 MHz RFR at incident average power densities in the range from 100 to 1,000 microwatts/cm² but not below or above this range, indicating the existence of a power-density "window." Preliminary results of increased calcium efflux from the cerebral cortex of the paralyzed awake cat exposed to 450 MHz modulated at 16 Hz were reported in 1977 for an incident average power density of 375 microwatts/cm². The calculated maximum time-average power densities from the basic PAVE PAWS system at ground level outside the exclusion fence,

i.e., 47 microwatts/cm² at the 330-ft location of closest possible public approach and 30 microwatts/cm² at the 1,000-ft exclusion fence, are below the average power densities for the chick-brain and preliminary cat-brain results. Thus, there is no evidence that similar effects would occur in humans exposed to the RFR from the basic system at ground levels outside the exclusion fence. This statement is also applicable to the growth system beyond the 1,000-ft exclusion fence, where the maximum average power density is 29 microwatts/cm²; the region along the entire north radial arm of the exclusion fence; and the region along the entire southeast radial arm from 1,000 ft to about 330 ft, in which the calculated average power density increases to 90 microwatts/cm² (just below the lower limit of the power-density window for the chick-brain results). Furthermore, measurements on the basic system in this small area have indicated actual levels only 60% of the calculated values.

3.1.2.1.6.2 RFR Instrumentation and Measurements

3.1.2.1.6.2.1 Instrumentation. Much of the early laboratory research on bioeffects of electromagnetic fields suffered from lack of adequate instrumentation for measuring incident fields or energy absorption rates; therefore, many of the early results can be questioned, at least from a quantitative standpoint. During the last decade, however, major advances have been made in instrumentation for determining both incident-field intensities for biological research and internal energy-absorption rates.

Instruments are now available for measuring average power densities. These meters span the range from 10 MHz to 18 GHz, are isotropic in response, and do not perturb the incident RFR to a significant extent or yield readings containing significant errors due to spurious responses to RFR (e.g., pickup by the lead wires from the sensors). The most sensitive range of these instruments provides full-scale readings of about 200 microwatts/cm². Their response times are about 1 ms or longer, so they cannot be used for measuring pulse power densities of short pulses. Therefore, incident pulse power densities are usually calculated from measurements of average power density and duty cycle (or pulse duration and pulse repetition frequency). The use of sophisticated equipment for directly measuring pulse power densities at low average power density, such as the calibrated instrumentation employed for measuring the fields from PAVE PAWS, is the exception.

Magnetic-field probes have been developed, but only for relatively low frequency ranges, as exemplified by two devices developed at NBS for near-field measurements in the Industrial, Scientific, and Medical (ISM) bands within the range from 10 to 40 MHz with free-space equivalent power density ranges as sensitive as 10,000 microwatts/cm².

Recently developed implantable or insertable probes for measuring RFR-induced temperature changes or local fields within biological entities during exposure have diminished, to a large extent, problems such as perturbation of the temperature or local field or readout errors ascribable to the presence of the sensor and its lead wires. However, the relevance of such developments to the PAVE PAWS analysis is peripheral at best, because temperature changes due to the power densities from PAVE PAWS will be negligible, even at so-called hot spots within biological entities. This brief mention is included here in the context that such devices were not available or used in most of the bioeffects research to date but are expected to be more widely used in future research.

Also of peripheral relevance to the PAVE PAWS analysis are current developmental efforts toward reducing errors and artifacts in the measurement, during exposure, of biologically generated fields and potentials, such as the electroencephalogram (EEG) and electrocardiogram (ERG).

3.1.2.1.6.2.2 Measurements of RFR Power Densities in Selected Cities. The EPA is measuring environmental field intensities at selected locations within various U.S. cities to permit estimations of cumulative fractions of the total population being exposed at or below various power-density levels. A recent report discusses the results for 12 cities (a total of 373 sites). The field intensities at each site were measured at 21 ft above ground level.

The measured average power densities, integrated over the frequency bands included in the analyses (i.e., from 54 to 890 MHz), ranged from about 0.001 to 2.5 microwatts/cm², the FM band (88-108 MHz) being the major contributor. The total power density measured at any given site is the result of RFR from many sources at different distances and in different directions from the site. EPA used the site measurements in a computer program to estimate power-density values at other locations. It then derived an estimate of the population-weighted median exposure value for the city; the median exposure value indicates that half of the city's population is being exposed at or below that power density (assuming a static population distribution). These median exposure values range from 0.002 microwatts/cm² (for Chicago) to

0.020 microwatts/cm² (for Portland, Oregon), and the population-weighted median for all 12 cities is 0.0053 microwatts/cm². Also, the calculations showed that approximately 99% of the population studied is potentially exposed to 1 microwatt/cm² or less, or conversely that 1% is being exposed to more than 1 microwatt/cm².

Although the values above may be of some interest for possible comparison purposes, the method used for estimating power density values at unmeasured locations is not appropriate for PAVE PAWS because the radar constitutes a single source. Instead, the calculations of power densities and their verification by field measurements, discussed in Appendices A and B of this document, provide more direct and accurate data for statistical analyses of population exposure to the RFR from PAVE PAWS.

3.1.2.1.7 Present State of Knowledge Regarding Biological Effects

3.1.2.1.7.1 Epidemiology. Epidemiology, as used in the context of this document, refers to assessments of the effects of exposure to RFR on groups of humans. Although epidemiological data eliminate the need for extrapolation from animal data to the human situation, epidemiologic information tends to be imprecise in other ways (Section C.4, p. C-9). It is usually based on imprecise estimates of exposure characteristics (frequency, power density, and duration). The extent to which the control group matches the exposed group is sometimes open to question. Because matching on all relevant factors except exposure is the basis for concluding that any observed differences between the groups are related to the RFR exposure, selection of an appropriate control group is critical.

Ten recent reports representing different points of view were selected for review -- five from the United States, one each from Poland and Czechoslovakia, and three from the USSR. They provide a representative sample of the kinds of information currently available.

In an earlier study of the causes of mongolism in U.S. children, an apparent correlation was found between this inherited condition and exposure of the fathers of affected children to RFR before the conception of the child. However, after expanding the original study of 216 children to 344 children with mongolism, each matched with a normal child of the same sex born at about the same time whose mother was about the same age, no such correlation was found. Thus, the earlier conclusion, based on a smaller sample, that exposure to RFR contributed to mongolism in offspring, was not confirmed. No quantitative assessment of the extent of the father's exposure was possible.

The causes of mortality in World War II U.S. Navy personnel are being monitored in an attempt to establish whether exposure to RFR is associated with causes of death, or with life expectancies. By 1977, the records of about 20,000 deceased veterans whose military occupational titles indicated more probable exposure to RFR had been compared with those for an approximately equal number of less-exposed veterans. No quantitative exposure data were available. No differences between groups emerged in overall mortality rates or in the rates for about 20 specific categories of cause of death. However, death rates differed significantly for two categories: death rates from arteriosclerotic heart disease were lower and those from trauma were higher in the RFR-exposed group. The trauma category included military aircraft accidents, and a higher proportion of the exposed group had become fliers. It therefore appeared unreasonable to attribute the higher trauma death rate to greater previous RFR exposure. Overall death rates for both groups were lower than those for the general U.S. population of the same age.

A sample of 605 RFR workers at various U.S. military bases was examined by two ophthalmologists. The incidences of 3 kinds of damage to the lens of the eye were compared with those for a group of 493 age-matched persons with no known history of exposure to RFR. Although the usual age-related increase in incidence of changes in the lens was observed in both groups, no differences between groups were observed. No attempt at specifying the level of microwave exposure for the exposed group was made.

The incidences of fetal anomalies and fetal death rates reported in birth records for white children born in the vicinity of the Army Aviation Center at Fort Rucker, Alabama between 1969 and 1972 were evaluated in a series of three reports. Fort Rucker is of interest because of the concentration of radar units on or near the base. Taken together, these reports identify unusually high incidences of certain fetal anomalies and high fetal death rates in the two counties adjacent to Fort Rucker as compared with the corresponding statewide Alabama statistics, and at the Lyster General Hospital (Fort Rucker) as compared with other military and civilian hospitals. A high incidence of fetal death at the Eglin AFB Hospital is also reported. No further mention is made of the Eglin data in the remainder of the report. However, there was also evidence that these high rates for Fort Rucker could not be attributed specifically to the unquantified radar exposures at or near Fort Rucker on the basis of the birth record data: Coffee and Dale counties ranked only sixth and eighth for anomaly incidence among the 67 Alabama counties, Lyster Hospital's anomaly and fetal death rates were not significantly higher than several other comparable "non-radar" hospitals in Alabama and were in the range of values predicted from carefully controlled studies done in other states, there was no clustering of the residences of mothers bearing anomalous infants near radar sites, and there was significant time-clustering of anomalies reported at Lyster,

indicating a high anomaly-reporting rate for one or two specific physicians on the Lyster staff.

The report on the medical assessment of personnel assigned to the U.S. Embassy in Moscow from 1953-1976 was published in 1978. RFR beams of low intensity, ranging from 15 microwatts/cm² down to fractions of microwatts/cm² over daily periods of from 9 to 18 hours at frequencies from 2.5 to 4.0 GHz were directed at the Embassy. The authors compared medical examination records and health questionnaires for persons assigned to the Moscow Embassy and their dependents with those from comparable groups assigned to other East European embassies that have not been irradiated with microwaves. The authors of the study noted several limitations of the study (summarized in Section C.7.1, p. C-27), but were able to draw the conclusions that, with few exceptions, there were no differences in health status between the two groups on the basis of the information available to them and that they had found no convincing evidence that any adverse health effects among the Moscow embassy personnel were related to exposure to microwave radiation.

Male Polish radar workers were assigned to two groups based on whether they had been exposed for a period of years at an estimated power density greater or less than 200 microwatts/cm². The incidences of changes in the lens of the eye and several neurotic disturbances in the two groups were compared. No significant differences were found. The lack of a control group weakens the findings somewhat, but the two groups were apparently well-matched except for the intensity of exposure. The higher exposure group had 507 men, the other had 334.

Fifty-eight employees of Czechoslovakian television transmitter stations (48.5 to 230 MHz) with estimated exposures at 0 to 22 microwatts/cm² for an average of 7.2 years were subjected to a battery of medical evaluations, including electrocardiograms, chest x-rays, blood counts and blood chemistry, organ function tests, and psychological tests. Although no comparable control group was evaluated, the only finding that was not within the normal range was a higher blood protein level. The significance of this single positive finding among this wide range of tests conducted is unclear, even to the author, who states "we do not have any explanation for this mean higher plasma protein level."

The following three recent reports from the USSR are representative of the literature on RFR from that country, which reports a wide variety of clinically measurable effects in personnel exposed to RFR. No similar studies have been carried out by Western investigators.

Sixteen kinds of symptoms were evaluated in a study comparing workers exposed to RFR at power densities ranging from less than a few tens up to a few thousands of microwatts/cm² with a nonexposed

control group matched for age and type of work. Incidences of the symptoms were higher in the exposed groups than in the nonexposed group for all 16 kinds of symptoms. Fatigue, irritability, sleepiness, partial loss of memory, heart rate changes, blood pressure changes, and pain in the region of the heart were among the symptoms evaluated. The report concludes that unless persons suffering from "microwave sickness" are removed from the RFR exposure area, the symptoms will continue.

Another survey of Soviet workers occupationally exposed to "non-thermal" intensities of RFR at 40-200 MHz for periods of 1 to 9 years indicated that symptoms of nervous system disorder, cardiovascular changes, blood cholesterol elevation and gastrointestinal disorders were more common in the workers exposed to RFR than in controls. No statistical methods or descriptions of the control group characteristics were included in the report.

A third report was an assessment of workers exposed to RFR at 1-150 MHz, 300-800 MHz, or 3-30 GHz, with power densities, where specified, from 100-3,300 microwatts/cm², depending on their particular occupations. Changes were reported in brain wave patterns and in blood sugar, proteins, and cholesterol levels, as compared with those in administrative (nonexposed) personnel. The 300-800 MHz range includes the PAVE PAWS frequencies, but no estimates of power density were given in the report.

The U.S. studies as well as the Polish and Czechoslovakian studies provide no evidence of detrimental effects on populations exposed to microwave radiation. The USSR studies conclude that exposure to RFR does result in various symptoms, but the power densities described in the USSR studies are much higher than those predicted for PAVE PAWS. In addition, the manner of presentation of the USSR findings is such that the findings are largely not amenable to critical evaluation. Hence, the significance to be attached to the USSR findings is based on the degree to which the conclusions are accepted at face value. We conclude that, taking all ten of the studies together, the epidemiologic information does not provide evidence that the PAVE PAWS emissions will constitute a hazard to the population in the vicinity of the facility.

3.1.2.1.7.2 Mutagenic and Cytogenetic Effects. Several published reports indicate that mutations have been found in biological test systems exposed to RFR. Other studies find no evidence of mutations as a result of RFR exposure. Two questions arise under these circumstances: Is the statement that exposure to RFR produces mutations a valid conclusion from the data? If so, do the mutations result from effects of the radiation on deoxyribonucleic acid (DNA), or do they arise as secondary effects resulting from heating, drying, or other thermal effects of the radiation?

Studies of mutagenic effect of RFR in fruit flies and bacteria (both standard test systems for mutagenesis) had negative results.

No mutations were found. Yet a study of so-called dominant lethal effects of RFR in mice (another standard test system for mutagenesis) gave marginal positive evidence of mutation, and a similar type of study in plants also had positive results. The study with mice has two serious flaws. First, two studies were performed by the same investigator at approximately the same time in the same type of mice, and for the two studies there was a large difference in the incidence of naturally occurring mutations. Exposure produced very small increases in the incidence of mutations, and if the value given for the natural incidence is at all questionable, the conclusion that the radiation caused lethal mutations in the mice is probably invalid. The second flaw is that the mice were anesthetized during exposure, and anesthesia in mice blocks the normal mechanisms for control of body temperature. Hence, the effective dose of RFR in terms of heating may have been rather higher than the reported dose. Thus, any true mutations produced by the radiation might have resulted from overheating the testes of the mice. A more recent study in rats failed to find evidence of dominant lethal mutation.

The study in plants found evidence of lethal mutations in the second generation of seeds derived from pollen exposed to RFR. However, the degree of mutagenic effects was not a linear function of the time of exposure, as one might expect if it was a direct effect of the RFR on the genetic material. Four hours of exposure caused no mutations, 12 hours increased the incidence of mutations to 2 to 3 times the natural rate, and 44 hours increased the incidence to 3 or 4 times the natural rate. The results indicate very strongly that the mutations were caused not by the action of the RFR on the genetic material, but by some secondary effect on the pollen, such as heating or drying of the pollen.

Other studies have been conducted on effects of RFR on the structure of chromosomes in cells. Such effects are generally considered to indicate the possibility of genetic effects, but do not constitute absolute proof of genetic effects. Four RFR studies were reviewed for this document. One claimed to find chromosome aberrations in cells after exposure, but in fact did not; two of the studies were conducted at such high power density levels that heating of the culture was virtually certain, although no temperature measurements were reported; and the fourth study reported a rise in the temperature of the culture.

All of the studies on mutagenic effects of RFR exposure reviewed here indicate that it is likely that the effects that have been found are related to heating. There is no evidence that power density levels incapable of producing significant heat, such as those outside the PAVE PAWS exclusion area, are likely to cause mutagenic effects.

3.1.2.1.7.3 Studies on Teratogenesis and Developmental Abnormalities. Teratogenesis is the production of malformed infants by processes affecting their development in utero (i.e., in the womb). The term developmental abnormalities, as used here, refers to processes affecting the development of infants after birth. Teratogenic and developmental abnormalities occur naturally at a low rate in most animal species, and relatively little is known about their cause. In a few cases, however, specific agents have been shown to cause significant teratogenic effects, and hence the possibility of teratogenic effects from RFR is an appropriate matter of public concern.

Teratogenic studies with RFR have used a variety of animal models. One set of studies was performed on pupae of the darkling beetle, Tenebrio molitor. Several reports from two different laboratories stated that relatively low levels of RFR would produce developmental abnormalities in the pupae. Exact doses, referable to RFR fields in the environment, were not stated in these reports. However, a follow-up study in one of the laboratories reported that the number of developmental anomalies depended on such factors as the source of the larvae and the diet fed to them before they entered the pupal stage. This study reported also that under worst conditions, production of developmental anomalies required exposure for 2 hours at a mean SAR of 54 milliwatts/g (approximately equivalent to 192,000 microwatts/cm²) -- a substantial dose. Under the circumstances, there is no evidence from the beetle studies that RFR at the levels anticipated from PAVE PAWS is teratogenic.

Teratogenic studies have also been carried out on the incubating eggs of birds. A carefully performed series of studies was conducted on the eggs of Japanese quail, which were exposed continuously at 5,000 microwatts/cm² for the first 12 days of incubation. Incubator temperatures were controlled so that exposed and nonexposed eggs were at substantially the same temperature at all times. No gross deformities were seen in the exposed chicks at hatching, and the only differences observed between control and exposed birds were slight differences in hemoglobin (contained in red blood cells and important in oxygen transport) and monocyte (a form of white blood cell) counts at 36 hours after hatching, and slight differences in the weights of the male birds for the first 5 weeks of life.

Other RFR studies with chicken eggs have reported effects on cranial development at an average power density of 3,300 microwatts/cm² and other teratogenic effects at 20,000 microwatts/cm². Neither study reported details on control of temperature inside the eggs. In the first study the authors claimed that the results might indicate an "adverse athermal effect" because the incubator temperatures were below the optimum for incubation. However, the direction of the effects produced depended on the temperature of the incubator, which suggests a thermal effect of the RFR. In the second study, the whole

exposure session involved a heat input of at least 42 cal/g, which would cause a significant temperature rise under the exposure circumstances, so heat is extremely likely to have caused the teratogenic effects that were reported.

Several studies have been performed to test for teratogenic effects of RFR in mice. In a study done on the 8th day of gestation, RFR doses in the range of 3 to 8 cal/g (approximately equivalent to 123,000 microwatts/cm² for 2 to 5 min) produced a number of abnormalities, including exencephaly, a disorder in which the skull does not close and the brain is exposed ("brain hernia"). No abnormalities were reported at doses less than 3 cal/g — which is about 25 to 30% of the lethal dose in these animals. In another study, done on various days of pregnancy, several different teratogenic effects were found after exposure to RFR. The types of effects found depended on the day of pregnancy on which the animals were exposed and were not different from effects produced by known teratogenic agents. Radiation dose levels were not specified, but the report stated that no malformations were produced in the offspring unless the pregnant animal's rectal temperature rose by at least 2 deg C (3.6 deg F). In a third study, mice were exposed to RFR at a dose of 5.5 cal/g (approximately 135,000 microwatts/cm² for 10 min) on the 11th through the 14th days of pregnancy; no teratogenic abnormalities were produced. In a fourth study, radiation doses estimated at 2.5 to 20 joules per gram (3,400-28,000 microwatts/cm² for 100 min) were given to mice daily during pregnancy. The authors reported finding 27 anomalies among 3,362 live fetuses exposed to RFR, as compared with 12 among 3,528 controls. Because of the small number of results for each individual anomaly, inconsistencies in dose response, and irregularities in the distribution of findings among groups, the authors were unable to accept the results as clearly due to RFR exposure.

Several studies have been conducted in rats and monkeys to determine whether RFR exposure during pregnancy will have any effect on the development of neurological function or normal behavior patterns in the offspring. Exposure at low levels (100-10,000 microwatts/cm²) had no effect on these functions.

In summary, all of the studies showing significantly demonstrable teratogenic effects in mice following exposure to RFR have involved power density levels that are capable of producing a significant heat load to the animals. The results indicate in general that a threshold of heat induction or temperature increase must be exceeded before teratogenic effects are produced. Because the normal human metabolic rate is of the order of 1,000 to 2,000 microwatts/g, even the calculated power density of 90 microwatts/cm² at one small portion of the PAVE PAWS exclusion fence with the growth option will not have any significant effect on body temperature to cause teratogenic effects. Human infants in utero could not be affected by the maximum environmental level of RFR from PAVE PAWS.

3.1.2.1.7.4 Ocular Effects. The fear that RFR can cause cataracts is a recurring theme in newspapers and other popular media. Indeed, based on many investigations with animals by various researchers during the past 30 years, it is undoubtedly true that if a person's eyes were exposed to intensities high enough to elevate the temperature of the lens of the eye by about 5 deg C (9 deg F) or more, the lens would quickly suffer damage. The power density necessary for such a temperature rise in the lens is about 500,000 microwatts/cm² at 2.45 GHz and is higher at lower frequencies (e.g., at 450 MHz). Also, the lens is the most vulnerable region of the eye because other regions have more effective heat-removal means such as greater blood circulation, evidenced by much smaller temperature elevations in these regions than in the lens at the same incident power density. Therefore, the basic controversy regarding ocular effects is centered on whether exposure to much lower intensities (i.e., to power-density levels that would produce much smaller lens-temperature elevations) for long periods of time, either continuously or intermittently, can cause eye damage.

Implicit in this controversy is whether effects (if any) of long-term, low-level exposure in the eye are cumulative, as is the case for, say, the continual ingestion of certain toxic substances in minute amounts, each of which is well below rapid-toxicity levels.

3.1.2.1.7.4.1 Animals. Investigations with animals indicate that progressively lower intensities than about 500,000 microwatts/cm² require increasingly longer exposure durations to produce eye damage. For example, exposure of the eyes of a rabbit for 1-2 minutes at about 500,000 microwatts/cm² produces cataracts, whereas about 20 minutes is necessary at about 200,000 microwatts/cm². Also, at slightly lower power densities, the exposure time for cataracts increases greatly. In fact, exposure for 100 minutes at approximately 100,000 microwatts/cm² failed to produce cataracts. (Longer exposures were not used in this investigation.) Curves of power density versus exposure duration based on such experimental data show that the power density asymptotically approaches a constant power density or threshold value of about 150,000 microwatts/cm² for cataract generation, implying that exposure of power densities below the threshold will not cause cataracts no matter how long the exposure duration. Moreover, there is no experimental evidence of delayed onset of cataracts (latency), i.e., their occurrence long after exposure is terminated. The existence of a cataractogenesis threshold of about the same value has been reported by a number of independent investigators.

Several investigators compared the ocular effects of pulsed RFR at average power densities well above 100,000 microwatts/cm² with the effects of continuous-wave (CW) RFR at equivalent power densities and could not detect any differences. Also, in a very

recent study, rabbits were exposed to pulsed RFR at a pulse power density of 1,500,000 microwatts/cm² at a duty cycle of 0.001, equivalent to an average power density of 1,500 microwatts/cm², for 2 hours per day over a period of 3 months, with no evidence of eye damage.

All of the foregoing experiments with animals indicate that cataract generation by exposure to RFR is essentially a gross thermal effect. Indeed, in several investigations, cooling of the eye while exposing it to power densities normally high enough to damage the lens failed to cause damage.

3.1.2.1.7.4.2 Humans. With regard to ocular damage in humans, ophthalmologist Dr. M. M. Zaret contends that there are RFR-induced cataracts in a number of his patients, who presumably were occupationally exposed on military bases, in an industrial factory that manufactures and tests military radar or communications equipment, or other analogous circumstances. It is conceivable that patients of Dr. Zaret exhibiting significant vision impairment may have been exposed to power densities sufficient to cause thermal damage, but we do not believe that such vision impairment was due to prolonged exposure to power densities well below threshold. We base our opinion on the previously discussed results on animals and on studies of personnel at a number of military bases for possible cataracts due to RFR exposure, conducted by a group of ophthalmologists led by Dr. B. Appleton over a period of 5 years. In these studies, military personnel identified as having been occupationally exposed to RFR were matched in age and sex with other military personnel not occupationally exposed at the same bases. The eyes of personnel from both groups were examined by ophthalmologists for three signs, taken for purposes of the survey as diagnostic precursors of cataracts: opacities, vacuoles, and posterior subcapsular iridescence. The examination procedure used ensured that the examining ophthalmologists did not know to which group (exposed or control) each person belonged. Statistical analyses of the results indicated that although the numbers of persons exhibiting these diagnostic signs increased with age, differences between exposed and control groups were not statistically significant.

A common feature in both Dr. Zaret's and Dr. Appleton's work is the lack of adequate information regarding previous exposure histories and conditions (e.g., power densities, durations, frequencies). However, in Dr. Appleton's work, it is likely that most of the people in the control groups received very little, if any, exposure and most of the people in the exposed groups did. Therefore, the finding of no statistically significant differences between exposed and control populations should be accorded greater weight than claims that do not offer analogous comparisons.

In summary, based on the experimental results with animals that indicate the existence of a threshold power density of

approximately 150,000 microwatts/cm² and the finding of no statistically significant differences between exposed and control groups of humans on military bases, there is no evidence that prolonged exposure of humans to the RFR from PAVE PAWS at the power densities existing outside the exclusion area is likely to cause eye damage.

3.1.2.1.7.5 Nervous System Studies. Several types of studies have been conducted on effects of RFR on the nervous system of animals. These studies are considered particularly important in the USSR, where RFR is believed to stimulate the nervous system directly and thereby cause a variety of physiological effects. Scientists in the United States tend to doubt that RFR interacts directly with the nervous system except, possibly, under special circumstances (to be discussed later in this section), and they consider most RFR effects to result from other sources.

In summary, three of the effects considered in this section (RFR hearing, blood-brain barrier permeability, and brain histopathology) are most probably thermal in nature and involve RFR power density levels considerably greater than those that would be encountered in the neighborhood of PAVE PAWS outside the exclusion area. Another reported effect (that of changes in brainwave pattern) is probably not a real effect of RFR but an artifact produced by experimental procedure. Also discussed is the RFR-induced alteration of calcium exchange between brain tissue samples and the fluid bathing them. The general evidence provides no indication that the RFR outside the PAVE PAWS exclusion area will have any adverse effect on the nervous system or neurophysiological function of humans.

3.1.2.1.7.5.1 RFR-Hearing Effect. The phenomenon of RFR hearing has attracted widespread interest among scientists in the United States (also discussed in Section 3.1.2.1.6.1.2, p. 3-30). Much of the interest arises from theoretical implications of the process for study of the interaction of RFR with biological structures in vivo (i.e., studies on live animals). Briefly, if an RFR beam is directed at the head of a human subject in the form of a relatively intense (300,000 microwatts/cm² or higher), short duration (about 20 microseconds) pulse, then that pulse can be heard by the subject as an audible "click." A number of theoretical and experimental studies have been conducted on the cause of the sound and the conditions under which it can be heard. The consensus of the results is that the sound arises from a thermally generated shock wave that is transmitted to the middle ear and then heard as a click. Persons with impaired hearing are unable to hear the click, and experimental animals in which the cochlea (the inner ear) has been destroyed will not exhibit brainstem-evoked responses. Therefore, this phenomenon is unlikely to be attributable to direct RFR stimulation of the brain. Because the

hearing effect involves the intense, short-duration pulse, low average power density thresholds calculated on the basis of a train of pulses spaced relatively far apart is not particularly meaningful.

3.1.2.1.7.5.2 Calcium Efflux. Exposure of samples of neonatal chick brain tissue to RFR that has been amplitude-modulated at low frequency has been reported to increase the rate of exchange of calcium ion between the tissue and the fluid bathing it. This effect has been confirmed by independent studies in a second laboratory. Preliminary observations of the effect in the brains of awake, paralyzed cats have also been reported. The effect is scientifically interesting, in that it represents a rare instance where RFR may be producing a biological effect by processes other than thermal mechanisms. There are, however, several difficulties in the interpretation of the results with regard to human health and safety. First, the phenomenon is subtle. Second, the observations are highly variable and difficult to reproduce. Third, the circumstances of experimental methodology are such that the observations of changes of calcium exchange appear to apply to the surface region of the brain rather than to the brain as a whole. Finally, the phenomenon depends upon the amplitude modulation of the RFR in a narrow frequency band around 16 Hz and only occurs for a narrow range of average power densities -- a "window" -- between 100 and 1,000 microwatts/cm². Nevertheless, because this window is above the levels of general public exposure from PAVE PAWS, the occurrence of this effect in humans is unlikely.

3.1.2.1.7.5.3 Blood-Brain Barrier Effects. In most regions of the brain there is little or no movement of large molecules, e.g., proteins or polypeptides, from the blood into the surrounding tissue. The resistance to this movement is described as the "blood-brain barrier"; no visible physical structure is implied. Effects of RFR on the blood-brain barrier have been studied in several laboratories, using a variety of test systems. Two of the studies explicitly reported that increased permeability of the blood-brain barrier occurred only when the RFR produced a rise in brain temperature. In another study, the power density and duration of exposure of the RFR (10,000 microwatts/cm² for 2 to 8 hours) implied that very probably the temperature of local regions of the brain was raised. One study reported an increased permeability of the blood-brain barrier after exposure to RFR at 30 to 3,000 microwatts/cm², but the exposure system at the lower power densities required a particular schedule of pulsing. Two independent attempts to repeat this work gave negative results. One of the studies reported that apparent permeability of the blood-brain barrier existed in about 20% of the control animals, and that after exposure the incidence of permeability rose to about 50% of the exposed animals. The same study noted that the RFR-produced

permeability of the blood-brain barrier was a transient effect that disappeared within two hours of termination of the exposure. On the basis of the evidence available, it is unlikely that the RFR in the population centers around PAVE PAWS would have any detectable effect on the permeability of the blood-brain barrier.

3.1.2.1.7.5.4 Histopathology of the CNS. Histopathological studies of the effects of RFR on the brain have been conducted both in the United States and in the USSR. Studies in the USSR have covered a wide range of frequencies, but the reporting of dosimetry and methods is inadequate in many instances. Exposure of animals (species not described) to their so-called decimeter waves (500 MHz to 1 GHz, no additional information on frequency) at 10,000 microwatts/cm² for 1 hr/day for 10 months resulted in various changes from normal appearance of nerve cells of the brain, as detected by delicate elective neurohistological methods (not otherwise specified). The authors reported that the power density did not raise body temperature, but the method of exposing the animals was such that the absorbed dose of radiation must have varied considerably among the animals. The reported changes in appearance were similar to those found in other experiments of a frankly thermal nature, and it is most probable that the reported effects in the chronic experiments were also of thermal origin.

Histopathological studies in the United States of the effects of RFR on the brain have been conducted on hamsters exposed to power density levels between 10,000 and 50,000 microwatts/cm² for periods of between 30 minutes and 24 hours. Chronic exposures have also been conducted at similar power density levels over a period of 22 days. Pathological changes in these studies were found only in the hypothalamus and subthalamus, two regions near the center and base of the brain. Reviewers of this study noted that the nature of RFR absorption inside the skull of such a small animal at the frequency used could lead to regions in the brain where the absorbed dose would be tens of times higher than that expected from the nominal power density. Rectal temperature measurements in the animals would not reflect such a condition. The observed pathological effects seem likely to have resulted from thermal processes.

3.1.2.1.7.5.5 EEG Studies. A number of studies have been attempted on the effect of RFR on EEG or other electrophysiological properties of the nervous system. These studies have encountered considerable technical difficulties. Where studies attempt to measure EEG changes during application of the RFR, the electrodes and leads used to pick up EEG signals will also pick up electrical transients from the fields, causing artifacts that render the recordings difficult to interpret. Where EEG studies are made after radiation exposure, the time consumed in placing and attaching the electrodes and the variability of placement of

the electrodes introduce additional problems of interpretation. To meet the latter difficulty, experiments have been conducted with indwelling electrodes. However, such indwelling electrodes will perturb the electric fields in their vicinity, and produce great enhancement of energy absorption, thereby creating still another artifact in the biological data. To meet these problems, specially designed indwelling electrodes of high-resistivity materials that do not cause field perturbation have been constructed and employed. Results obtained in experiments using either type of electrode (metallic, or high resistivity) are discussed below.

Two groups of researchers, using implanted metallic electrodes, reported changes in EEG patterns after acute or chronic exposure of rabbits to RFR. Another group, using implanted electrodes made of carbon instead of metal (an attempt to avoid the field distortion artifact) reported no significant differences in EEG between irradiated and control rabbits after 3 months of RFR exposure (1,500 microwatts/cm², 2 hr/day). Another study, using electrodes externally placed after exposure, rather than indwelling ones, reported no differences in EEG pattern between control and RFR-exposed monkeys at the end of a period of more than 12 months of exposure. Finally, a study of rats exposed to RFR before birth through age 92 days (indwelling electrodes again not used) showed no differences from control animals when both groups were tested at 140 days of age.

3.1.2.1.7.6 Effects on Behavior. Very many experimental studies have been conducted on the effects of RFR on animal behavior. The results of such studies are considered particularly important in the USSR, where they are often considered to be evidence for direct effects of RFR on the CNS. Scientists in the United States do not always agree that behavioral effects necessarily imply direct effects on the CNS. However, behavioral effects are very sensitive indicators of biological function, and hence receive appropriate attention on both sides of the Iron Curtain.

3.1.2.1.7.6.1 Radiation Avoidance Response. One type of behavioral study involves determining whether the subject animal can perceive or sense the radiation, and if so, whether it will avoid the radiation or treat it as a noxious stimulus. One series of studies in the United States found that if a rat were able to move freely in the exposure chamber, it would orient itself so as to minimize absorption of the radiation. Another experiment in the same series showed that when a mouse was able to turn off the RFR for a brief period (by interrupting a light beam), the mouse would do so regularly and repeatedly. In another experiment in the same series, the exposure to RFR was coupled with drinking sugar solution. When the rats were tested with more sugar solution 24 hours

later, they drank it quite readily, indicating that the sugar solution was not associated with an unpleasant experience. This experiment was a repetition of a classic study done over 15 years ago with ionizing radiation. In the ionizing radiation study, the rats associated the sweet solution with the radiation as an unpleasant experience, and refused to drink it again when tested later. The overall results in the current study with RFR suggest that the animals may avoid the radiation, but they do not perceive the radiation as a noxious stimulus or the source of unpleasant experience. The avoidance of the radiation itself may simply be an avoidance of the heat load generated by the radiation.

3.1.2.1.7.6.2 Acute Effects: Behavior Depression. In another type of behavioral study, a number of experimenters have shown that RFR can interfere with or suppress the performance of tasks by trained rats and monkeys. In acute studies a power density threshold had to be exceeded before the performance decrement occurred. The power density thresholds were 5,000 to 50,000 microwatts/cm², and the threshold seemed to depend somewhat on the complexity of the task and the level of discrimination required of the subject. The mechanism of the interference is not known, but one study of rats that were subjected to a swimming test after a very large RFR dose noted that the animals seemed to tire more quickly than unexposed controls.

3.1.2.1.7.6.3 Chronic Effects. Suppression of performance of tasks was also found when trained animals were exposed chronically to RFR. Power density levels varied; in one series of experiments, it was 1,000 to 10,000 microwatts/cm², clearly in the thermal range for these animals. In this experiment, the results were similar to those found in the acute exposure studies, and the author reported that the animals did not accommodate to the exposure during the experiment. In another experiment, rats were exposed to RFR at 10 or 50 microwatts/cm², 7 hours per day for 90 days. The author reported changes in the rate of learning an avoidance response and changes in the threshold for electric shock to the foot.

3.1.2.1.7.6.4 Pulsed RFR Effects on Natural Behavior. Some studies have been conducted on the effect of RFR on the so-called "natural" behavior of animals. RFR exposure was found to inhibit exploratory behavior of rats placed in novel situations, to inhibit an aggressive response of rats to acute pain, and to disturb the motor coordination in a balancing test. Some of these effects were obtained at pulse power density levels from 50 to 700 microwatts/cm².

3.1.2.1.7.6.5 Summary of Behavioral Effects. It is difficult to relate most of the behavioral studies in animals to humans. Many studies on "natural" behavior involve tests that can be performed

only once on a given animal; hence, no information is available on the question of whether the effect of the exposure is transient or not. In addition, all behavior studies are directly relevant to the nature of the species being studied, and the conclusions of a given study do not readily transfer to another species. The most general conclusion that can be drawn from the studies reviewed here is that the majority of the RFR effects on behavior involve power density levels that appear to be in the thermal range. Of the studies conducted at lower values, some are of questionable value and the others involve results that have no demonstrated relevance to humans. At the power density levels outside the PAVE PAWS exclusion fence, these studies provide no evidence of adverse effects on human behavior.

3.1.2.1.7.7 Endocrinological Effects. Endocrinological effects of RFR fall into four classes: direct stimulatory (heating) effects on the organ itself, responses to whole-body heat load, responses to stress, and effects on the male reproductive system.

Direct stimulatory effects were found during local exposure of the thyroid glands of dogs. In response to the radiation, the glands increased their output of thyroxine (a hormone controlling metabolic rate in other cells in the animal) by a factor between 2 and 10. However, the effect occurred only at large power density levels, more than 70,000 microwatts/cm², and was accompanied by a significant increase in the temperature of the gland. If the temperature of the gland did not increase, no effect on output was observed. At the levels of RFR expected outside the PAVE PAWS exclusion area, no temperature rise in the thyroid gland would be possible; hence no change would occur in thyroxine output of the gland.

Typical responses to heat load were found in rats exposed to moderate power density levels over a period of several hours to several days. During the first 1-2 hours at levels of 10,000-20,000 microwatts/cm², the thyroxine level of the blood remained steady, but the level of thyrotropic hormone (a hormone that is secreted by the pituitary gland in the base of the brain and which control the production of thyroxine) began to decrease. After 4-8 hours, the thyroxine level of the blood also decreased. When the rats were exposed at slightly lower power density levels for 8 hours a day for 7-21 days, thyroxine and thyrotropic hormone levels of blood also decreased, and alpha-globulin (special blood protein) levels of blood plasma increased. The change in this protein was considered to be a secondary effect of the decreases in thyroid hormone levels.

The changes in thyroxine and thyrotropic hormone observed in these animals are predictable responses to additional heat loads. They did not differ from the expected effects of changing environmental loads in other ways (e.g., by changing the thermostat setting in the animal quarters). At the power density levels expected outside the PAVE PAWS exclusion area, heat loads will not be increased measurably. If temperature does not increase, there is no change in thyroid hormone release.

Typical stress responses were found in rats exposed to moderately high power densities of RFR, 20,000 to 50,000 microwatts/cm². Responses were increases in corticosterone (a hormone secreted by the adrenal gland) and decreases in growth hormone (secreted by the pituitary gland) in the blood plasma. The stress response varied with power density level and duration of exposure and was associated with a rise in body temperature. Power density levels having only a marginal effect on body temperature produced no stress response. Stress response at the even lower power density levels of PAVE PAWS outside the exclusion fence is most improbable. (See Section 3.1.2.1.7.8.2, p. 3-51, for additional RFR-induced stress studies.)

Exposure of rats to RFR levels of 10,000 microwatts/cm² caused irregular and unexplained changes in the levels of luteinizing hormone and follicle-stimulating hormone in the pituitary glands. The effect was studied over a period of several weeks, and it did not appear to be progressive or cumulative. Another study (at an unspecified power level) showed that after 24 hours of exposure, the level of plasma testosterone in rats increased briefly. This effect could represent an effect of the RFR on the testes, which are notoriously sensitive to small temperature changes. Changes in the testes caused by heat or RFR are readily reversible, unless the heating is prolonged. Slightly reduced sperm counts have been found in men occupationally exposed to RFR, but their basic testicular function was not affected. At power density levels below 200 to 300 microwatts/cm², it is doubtful that the effect would occur. Thus, at the power density levels outside the PAVE PAWS exclusion area, effects on testicular function are doubtful.

3.1.2.1.7.8 Immunological Effects. Effects of RFR on the immune system of animals have been studied extensively. Most of the investigations were motivated by questions of potential hazard to humans. RFR stimulation of the immune system might also be medically useful in treatment of human disease, and that provided an additional impetus for the other studies. The studies on the immune system reviewed here represent three general categories: in vitro studies (i.e., studies on isolated cells), in vivo studies involving acute RFR exposure, and in vivo studies involving chronic RFR exposure.

3.1.2.1.7.8.1 In-Vitro Studies. In vitro studies are all related to the question of whether RFR can stimulate human or animal lymphocytes (a type of white blood cell of key importance in the immune system) to transform into lymphoblasts (active forms of lymphocytes) and undergo cell division when they are cultured outside of the body. Normally, such cells are cultured in the presence of a mitogen (an agent, normally chemical) that stimulates blast transformation (i.e., lymphocyte to lymphoblast) and cell division. About 11 years ago, a report was published claiming that if the cells were cultured without a mitogen present and the cells were subsequently exposed to RFR, they would undergo blast transformation anyway. Since that time a number of studies have been conducted in an attempt to repeat this finding. Some of the results have been positive, some negative, and some equivocal. However, most of the results indicate that RFR can stimulate the blast transformation of lymphocytes, but that the effect depends in a rather complex way on a rise in temperature of the culture medium.

3.1.2.1.7.8.2 In-Vivo Studies: Acute Exposures. Acute (i.e., short duration) in vivo studies, in which the RFR is administered one time over a period of five minutes to one hour, have all involved high power densities in animals, whose body temperature was virtually certain to rise. In general, the effects of acute RFR exposure on the immune system appear to be stimulatory. The number of circulating lymphocytes in the blood increases, as does the ability of the immune system to manufacture antibody to foreign substances. The number of cells involved in production of immune complement (a complicated series of interacting chemicals in the blood) also increases. The mechanism of those effects is not certain, but one study reported that the effects could be produced by injection of cortisone, suggesting that the effects on the immune system may be a secondary result of the stress induced in the animals by the RFR-produced heat or possibly by other stresses such as handling the animals. Other studies on RFR-induced stress are discussed in the section on hormonal effects. (Section 3.1.2.1.7.7, p. 3-49)

3.1.2.1.7.8.3 In-Vivo Studies: Chronic Exposure. Chronic RFR exposure of animals has resulted in mixed reports of effects on the immune system. Exposure of mice to 500 microwatts/cm² for 2 hr/day caused a general stimulation of the immune system that was observed after 6 weeks of exposure. When the exposure was continued to 12 weeks, the degree of stimulation was much smaller, suggesting that the immune system was returning to its normal state. Exposure of rats to 5,000 or 10,000 microwatts/cm² for 4 hr/day from pre-birth through 40 days of age also resulted in a stimulation of the immune system. Exposure of rabbits to 10,000 microwatts/cm² for 23 hr/day for 6 months resulted in a mild reduction in the numbers of B-type lymphocytes (a subclass of lymphocytes associated with antibody production) in the spleen.

Finally, studies in the USSR reported that exposure at 10 to 500 microwatts/cm² for 7 hr/day for 30 days resulted in a "downward trend" in numbers of T-type lymphocytes (a subclass associated with the thymus gland) in rats, but general stimulation of the immune system in guinea pigs.

Although temperatures are not reported in the chronic studies, exposures at 5,000 to 10,000 microwatts/cm² must be considered in the thermal range. Exposures at 500 microwatts/cm² may or may not involve local thermal effects, depending on animal size and frequency employed, and exposures at 50 microwatts/cm² or less are probably not thermal. The overall results suggest that RFR exposure initially causes a general stimulation of the immune system, but if the exposure continues, the stimulatory effect disappears, and may possibly be replaced by some degree of inhibition. As mentioned earlier, the mechanism of the stimulation is not known, but because many of the chronic studies were conducted at thermal or near-thermal power levels, the stimulation may have resulted from stress reactions induced by the RFR. Alternatively, the response may not have been related to exposure, but rather to other stresses such as handling, cold, etc. There is no evidence that RFR power densities outside the PAVE PAWS exclusion fence would be capable of inducing such reactions in humans.

3.1.2.1.7.8.4 Health and Disease. There is no evidence that PAVE PAWS-induced effects on the immune system are likely to prove hazardous for humans. Experimental studies have shown that RFR exposure does not increase the susceptibility of animals to death from infectious diseases, and some studies indicate that it may even have a protective effect against disease at high power density levels.

3.1.2.1.7.8.5 Conclusion. There is sufficient evidence to conclude that, under certain circumstances, exposure to RFR affects the immune system of mammals. For in vitro exposures, the effect appears to be a result of temperature change. For exposures of the intact animal, it is likely that the effect is of a general nature and is mediated via the pituitary and adrenal glands, as occurs for any stress situation. Less likely is the possibility of a direct effect on the cells of the immune system. Those studies reporting effects at low-level, longer-duration exposures (10s to 100s of microwatts/cm² for up to 30 days) in general have not been independently verified, but the effects cannot be excluded.

3.1.2.1.7.9 Biochemical and Physiological Effects. The literature on biochemical and physiological effects associated with RFR is extensive. Many of the reported effects are associated with other events (e.g., changes in hormonal levels or stress adaptation), some are questionable for various reasons, and others do

not have a clear medical significance. The brief review in this section addresses three principal questions: (1) Does RFR have any direct effect on respiration? (2) Does RFR have any direct effect on blood plasma composition or trace element content of the body? (3) Does RFR have any direct effect on deoxyribonucleic acid (DNA)?

Exposure of mice to RFR has been shown to cause a compensatory decrease in the animals' oxygen consumption. Exposure of germinating peas with RFR caused a decrease in oxygen consumption that was attributed to interference with the starch-glucose conversion system. The effect was associated with a rise in temperature in the peas. Exposure of cultured mammalian cells (Ehrlich ascites tumor cells from mice), subcellular units (mitochondria), and enzyme systems had no effect on the rate of oxygen consumption or metabolism. It can be concluded that if RFR had any effect at all on respiration rate, it is a secondary effect of heat absorption or temperature change.

RFR exposure has caused minor changes in the level of serum triglycerides, in the relative concentrations of the blood proteins, and in the amount and rate of various trace elements in the blood and tissues. The change in the level of serum triglycerides was found in mice exposed continuously over a span of 60 hours to a moderate level (3,000 to 4,000 microwatts/cm²) of RFR. Although the effect could have resulted from direct stimulation by the RFR, it is more likely to be a secondary result of the not insignificant heat load. Changes in concentration of blood proteins were observed in the mice mentioned above and also in a group of workers at a television transmitting station in Czechoslovakia (see Section 3.1.2.1.7.1, p. 3-35). Although the changes observed in mice were probably secondary effects of the heat load, the changes in the Czech workers were probably unrelated to heat load. The findings thus may represent a possibly nonthermal biological effect of RFR. The report of this study stated that although the changes in protein concentration were statistically significant, the concentrations were still within the normal physiological range and the workers were in good health. In another study, changes in the concentration and rate of turnover of trace elements, notably copper, molybdenum, iron, and manganese, were reported in a study of rats exposed to RFR at power densities ranging from 10 to 1,000 microwatts/cm². The results are somewhat difficult to interpret, because tissue levels of these substances increased at high power densities but decreased at low power densities.

Overall, some of the changes in blood and tissue composition attributable to RFR are probably secondary effects of heat, but some may not be. The relationship of the changes to human health is uncertain. However, in one study workers who were probably exposed to higher power density levels than would be found in the vicinity of PAVE PAWS beyond the exclusion area were found to be in good health.

Studies of the effects of RFR on DNA in vitro have been conducted, but the reports do not present power density levels, so the results cannot be assessed quantitatively. An in vivo study of the effects of RFR on DNA in the testes of mice has also been reported. This work was part of the study of induction of dominant lethal mutations in mice that is discussed in the section on mutagenic and cytogenetic effects (Section 3.1.2.1.7.2, p. 3-38). After exposure of the testes to RFR at a substantial power density for 30 minutes under conditions that rendered the temperature regulatory system of the animal inoperative, the DNA in cells of the testes were found to have undergone some minor changes in physical properties. The author of the study attributed the changes to strand separation of the DNA molecules.

In summary, no evidence has been found that RFR affects oxidative metabolism or DNA structure except as a secondary result of the heat deposited by the RFR. RFR may possibly have effects on proteins of blood and trace elements in tissue at power densities below the level at which heat production would be significant. However, there is no evidence that such changes, if they occur, are harmful to human health.

3.1.2.1.7.10. Cellular Effects. A number of reported cellular effects of RFR have been discussed in other sections of this document. Effects of RFR on the chromosome structure of cells were discussed in the section on mutagenic and cytogenetic effects (Section 3.1.2.1.7.2, p. 3-38). Effects of RFR on lymphocytes and the induction of blast transformation in these cells were discussed in the section on immunological effects (Section 3.1.2.1.7.8, p. 3-50). Finally, effects of RFR on the respiratory metabolism of cells were discussed in the section on biochemical and physiological effects (Section 3.1.2.1.7.9, p. 3-52). Topics remaining to be discussed in this section are the technical problems of study of RFR effects in cells, effects of RFR on cell membrane permeability, and effects of RFR on cell viability and proliferative capacity. Studies reviewed in this section involved exclusively in vitro work.

The principal technical problems in studying RFR effects on cells is that the studies are often conducted using conventional apparatus designed for cell studies -- flasks, dishes, holders, agitators, water baths, incubators and the like -- and various elements of the apparatus may distort the RF fields in such a way that the specific absorption rate of energy in the cell cultures may be severalfold higher or lower than field measurements would indicate. Some progress has been made in designing cell culture apparatus that will provide accurate, calibrated exposure to RF fields, but results of much of the formerly published work on cell and tissue cultures must be questioned with regard to the actual absorbed RFR dose in the cell culture media.

A number of earlier studies reported that exposure of cells to RFR causes increased cell membrane permeability, leading to loss of vital cell contents. More recent studies, conducted with careful control of media temperature, have found no effects of RFR on cell membrane permeability other than those attributable to temperature rise.

Studies of effect of RFR on cell viability have been conducted on tumor cells and bacterial cells, using apparatus designed to avoid problems of RFR field distortion and also to keep the media temperature constant. Effects on tumor cell viability were evaluated by measuring the latency period for tumor development in animals following injection of the exposed cells. RFR fields approximately equivalent to 60,000 or 250,000 microwatts/cm² for 20 minutes had no effect on the viability of the tumor cells when constant temperature was maintained. Effects on bacterial cell viability were evaluated by measurement of cell plating efficiency. In addition, molecular structure of cell contents was determined by infrared spectroscopy. RFR exposure at power densities of 250,000 microwatts/cm² for 10 hours had no effect on either cell viability or molecular structure when constant temperature was maintained.

In summary, many of the reported effects of RFR on cells in vitro are questionable because of uncertainties in the actual absorbed doses in the culture media. This reservation applies not only to studies reported in this section, but also to the cytogenetic, immunological, and biochemical studies reported elsewhere. All of the studies on cultured cells have employed power density levels ranging from 100 to 2,000 times the levels expected outside the PAVE PAWS exclusion area, many of the results have been negative, and most of the rest can be clearly traced to temperature changes. There is no evidence from these cellular effects (or lack of effects) of RFR to imply any potential hazard to human health from the RFR associated with PAVE PAWS outside the exclusion area.

3.1.2.1.7.11 Other Effects. Two major health effects that have been attributed to RFR are increases in cancer and cardiovascular disease. Examination of reports of these effects shows that the evidence does not support the claims.

3.1.2.1.7.11.1 Cancer Studies. Claims for cancer induction have been found in only three scientific reports. In the first, the author claimed that the incidence of cancer in a district of Finland increased after construction of radar facilities across the border in the USSR. The statement was not supported by either data or references. The second was a publication suggesting that the incidence of leukemia in mice rose after chronic, long-term RFR exposure. Details of pathological diagnoses were not given.

When the data were analyzed by appropriate statistical methods, no difference between mice exposed to the RFR and unexposed controls was found. The third report cited the first two and then uncritically reviewed reports of cytogenetic and mutagenic effects from RFR. Although such effects have been associated at times with chemical carcinogens, the review in the document failed to consider the likelihood that these are secondary effects caused by heat rather than direct effects of exposure. A more extensive discussion of this latter question is given in the section on mutagenic and cytogenetic effects (Section 3.1.2.1.7.2, p. 3-38).

3.1.2.1.7.11.2 Cardiovascular Studies. The report that claimed an increase in cancer in Finland also stated that the incidence of cardiovascular disease increased in the same region during the same period. Again, the statement was not supported with data or references.

Various studies in the United States and the USSR have claimed or denied that RFR has increased or decreased the rate of heart-beat in humans and experimental animals. Heart rate may change temporarily for a variety of reasons, and in the absence of a consistent trend based on interference with known mechanisms of cardiac control, claims for effects of RFR on heart rate are of dubious medical significance. Reliable reports of persistent hypertension or arteriosclerosis associated with exposure to RFR have not been found.

3.1.2.1.7.11.3 General Health; Chronic Studies. A number of studies have been conducted on animals (usually mice or rats) that were chronically or repeatedly exposed to RFR for a significant period of time. Indicators of general health commonly used in such studies -- body weight, food consumption, blood-cell counts, and life span -- have shown that animals can be exposed to substantial power density levels of RFR daily without evidence of gross harm.

3.1.2.1.7.11.4 Summary. In summary, there is no evidence that cumulative harmful effects have resulted from chronic exposure to RFR, other than specific effects caused by overheating of tissues at high power densities. While scattered references point to effects of RFR on cardiac function, no evidence shows that serious cardiovascular disease has been caused by RFR exposure. Higher incidences of cancer were not found in animals chronically exposed to RFR, nor were they found in epidemiological surveys of people occupationally exposed to RFR. Furthermore, a review of other physiological effects of RFR reveals no evidence that RFR exposure at the ground level power densities calculated for PAVE PAWS are likely to promote cancer. Overall, there is no evidence to indicate that RFR at power densities in the range of those of PAVE PAWS outside the exclusion area will be harmful to humans.

3.1.2.1.8 Unresolved Issues. The potential biological effects of RFR from the PAVE PAWS facility have been assessed from existing studies in the 10 MHz to 18 GHz range. On the basis of these studies, with recognition that the negative findings reported in some studies may have been obtained because the investigations were poorly conducted, there is no evidence that general population exposure to the RFR from PAVE PAWS will be hazardous to human health. However, there are certain gaps in the knowledge of biological effects of RFR which the present data do not adequately cover. These gaps may be identified as follows:

- a) Lack of sufficient experimental data and mathematical models to extrapolate studies done on animals to determine precisely the biological effects expected in humans. Moreover, most animal research is usually not done where continuous exposure occurs for times on the order of an animal's lifetime. These deficiencies apply both to the question of experiments done at different RFR frequencies and to differences in biological response among various species.
- b) A lack of prospective epidemiological studies of effects of RFR on humans exposed to RFR. The present epidemiological studies, while extensive and reasonably well-done, are all retrospective in nature, and subject to certain inherent defects of method.

Because of the low levels of general population exposure from PAVE PAWS, the ability to assess whether the RFR from the radar will be potentially hazardous to humans is not affected by the existence of these gaps.

3.1.2.1.9 PAVE PAWS and Safety to Human Populations. In the previous subsections of Section 3.1.2.1 (beginning on p. 3-16), current state of knowledge regarding the biological effects of RFR was examined on a topic-by-topic basis by reviewing and analyzing representative articles relevant to PAVE PAWS from the large body of scientific literature published in this field. Discussions were also presented on related topics such as: background information on other RFR-emitting devices and equipment in the United States; problems of risk assessment, with regard to the scientific, philosophical, and range of legal applicability of such standards; mechanisms of interaction of RFR with biological entities, involving definitions of "thermal" and "nonthermal" and distinctions between interactions of CW and pulsed RFR; uncertainties in retrospective epidemiological studies; and the basic problems of assessing possible hazards to humans of any environmental agent by extrapolating results of experimental research performed on animals. The conclusions regarding whether the evidence indicates that operation of PAVE PAWS constitutes a possible hazard to humans and the basis for those conclusions are summarized below, with cognizance of the topics mentioned above.

The preponderance of U.S. experiments with animals that yielded recognizable and repeatable effects due to RFR were performed at incident average power densities of more than about 2,000 microwatts/cm². Such effects are thermal, in the sense that enough energy is absorbed as widely distributed heat that increases the whole-body temperature or as internally localized heat that is biologically significant, even with natural heat-exchange and thermoregulatory mechanisms operating. The existence of threshold average power densities for such effects has been shown or postulated. Exposure to RFR at average power densities exceeding the threshold for a specific effect for durations of a few minutes to a few hours (depending on the value) can cause irreversible tissue alterations, whereas for indefinitely long or chronic exposures at values well below the threshold, the heat produced is not accumulated because its rate of production is readily compensated for by heat-exchange processes or thermoregulation. Most investigations involving chronic exposures of mammals yielded either no effects or reversible, non-cumulative behavioral or physiological effects for average power densities exceeding 2,000 microwatts/cm². Also, researchers who used pulsed and CW RFR at the same average power densities and otherwise similar conditions generally found no differences in such thermal effects for the two classes of RFR. In the few cases where irreversible adverse effects of exposure were found, such effects were absent for average power densities below 2,000 microwatts/cm². Therefore, it is unlikely that exposure of humans to the average power densities from PAVE PAWS anywhere along the exclusion fence (calculated to be less than 47 microwatts/cm² for the basic system and less than 90 microwatts/cm² for the growth system) or anywhere for the general public (calculated to be less than 1 microwatt/cm² for both systems; measured at less than 0.1 microwatt/cm² for the basic system) would cause such thermal effects.

Few experiments show biological effects of RFR at incident average power densities less than 2,000 microwatts/cm². Such effects are often grouped under the label "nonthermal," to distinguish them from those considered above. However, such usage of "nonthermal" is confusing and imprecise because the interaction mechanisms involved in each such effect differ considerably from those for the other effects and clear distinctions between "thermal" and "nonthermal" based on precise scientific definitions of these terms are difficult to discern in the interactions. Because the RFR from PAVE PAWS is pulsed, the RFR-auditory and calcium-efflux phenomena are relevant and are considered below.

The existence of the RFR-auditory phenomenon, i.e., perception of short pulses of RFR individually as audible clicks, is well established experimentally. For perception of an individual pulse by a human, the pulse duration must be about 10 microseconds or longer and the pulse power density must exceed a threshold value of about 300,000 microwatts/cm². Most of the experimental

results with animals indicate that pulses are perceived as actual sound by the auditory apparatus rather than because of direct RFR-stimulation of the auditory nerves or the brain. The effect is well explained by absorption of energy from a pulse arriving at an interface between tissues of widely different properties in the head; the energy is converted to heat at the interface, thereby causing sudden thermoelastic expansion and generation of sound waves that propagate to the auditory apparatus. Because the phenomenon can occur with a single pulse, the average power density is not a relevant parameter. Rather, the characteristics of each pulse are of importance. This phenomenon is not of concern relative to PAVE PAWS because the maximum pulse power densities at the exclusion fence (700 microwatts/cm² for the basic system and 1,400 microwatts/cm² for the growth system) are several orders of magnitude lower than the threshold pulse power density for human perception.

Calcium efflux has been reported for chick brains exposed to 147 MHz RFR modulated at 9, 11, 16, and 20 Hz, with the maximum effect at 16 Hz. Similar results were reported for 450 MHz RFR modulated at 16 Hz. The effect was absent for unmodulated 147 MHz or 450 MHz RFR. The existence of a power-density "window" was also reported. Specifically, with 450 MHz modulated at 16 Hz, the effect was detected for incident average power densities between 100 and 1,000 microwatts/cm² but not for values below or above this range. Preliminary results of calcium efflux from the cerebral cortex of the paralyzed, awake cat exposed to 16 Hz modulated 450 MHz RFR at an incident average power density of 375 microwatts/cm² were reported in 1977. The highest calculated value of average power density for the basic PAVE PAWS system is 47 microwatts/cm² (at the 330-ft location along one radial arm of the exclusion fence), a value that is smaller than both the lower limit of the power-density window for the chick-brain results and the value for the cat-brain results. For the growth system, the highest calculated average power density is 90 microwatts/cm² (at the same 330-ft location). This value is also smaller than both the lower limit of the power-density window for the chick-brain results and the value for the cat-brain results. Moreover, measurements on the basic system indicate actual power density values are less than the calculated values.

The relatively few retrospective epidemiological studies done in the United States and USSR are not considered evidence that the PAVE PAWS emissions are likely to constitute a hazard to the population.

In summary there is no reliable evidence to support the conclusion that any hazard will result from either short-term or long-term exposure of people to the RFR from PAVE PAWS outside the exclusion fence for either the basic or growth system.

3.1.2.1.10 Other Viewpoints. Some of the general concerns expressed following review of the Draft Environmental Impact Statements for both PAVE PAWS installations are: First, there are insufficient data upon which to base an assessment of potential hazard to human health; second, research on the effects of long-term, low-level exposures is only in its infancy; third, little is currently known about the details of mechanisms of interaction of RFR with biological tissues, with the consequence that potentially hazardous effects that may occur have not been more precisely targeted for study; fourth, there are specific studies in the literature that report effects at average power densities less than 100 microwatts/cm²; fifth, even though some studies report negative findings (i.e., no effects as a result of RFR exposure), such negative findings can possibly be attributed to faulty experimental design or procedures; sixth, epidemiological studies from the Soviet Union have reported various symptoms in persons exposed for many years to RFR at levels in the range from tens to hundreds of microwatts/cm² -- symptoms that when taken together are called the "microwave radiation syndrome" -- but that such symptoms are not recognized in Western epidemiology studies; seventh, although we know a lot more today than we did 10 years ago, we will know even more 10 years from now and it is therefore likely that with this additional knowledge will come recognition of new, hazardous effects of long-term, low-level exposure to RFR; eighth, safe power thresholds for RFR exposure of the general population have not been established, and, further, safety standards vary from country to country; and ninth, there has been insufficient research on possible alterations of genetic material and carcinogenic effects of long-term, low-level exposure to RFR.

Documentary evidence that has been presented by commenters as reasons for these concerns include: The studies by Bawin and Adey on calcium efflux changes; the studies by Frey on blood-brain barrier permeability changes and modifications of behavior, the studies by Shandala on changes in the immune system; the studies by Oscar on changes in permeability of the blood-brain barrier to certain radiotracer-labelled molecules. Many of the above references have been discussed in Appendix C.

We see no evidence that the low levels of general public exposure to PAVE PAWS RFR are hazardous. We are supported in this conclusion by the study recently completed by the National Academy of Sciences.

3.1.2.2 Plants and Animals

Significant effects on plants or animals are not expected to result from the operation of PAVE PAWS, either from the basic or growth-option systems. Temporary effects may occur in the

near-field, for example, the temporary repelling or attracting of species that are sensitive to noise and other human disturbances associated with the radar operation. It is unlikely that any of these potential effects would substantially alter the local or regional ecosystems.

The quantitative data presented below are based on the basic system; however, the power densities calculated for the growth option system do not differ enough to substantially alter any of the qualitative analysis.

3.1.2.2.1 Radiofrequency Radiation (RFR)

3.1.2.2.1.1 Main Beam Exposure. At its lowest, the PAVE PAWS main beam is pointed at 3 degrees above the horizontal. Only at a few locations and only for the basic system does the outermost edge of the main beam hit the ground, the nearest a grassy hilltop approximately 8,500 ft north of the radar site. The power density of the main beam at this location is about double the peak density of the first-order sidelobe and the average power density is less than 1 microwatt/cm². The average power density is even less at other locations grazed by the beam. No ecological effects would be anticipated at a level this low (see Table A-8, p. A-35). ++

The biota that could be potentially affected by the main beam are airborne fauna, e.g. birds in flight and possibly airborne bats and high-flying insects.

Of ecological interest are the migrating birds which might be affected. Beale AFB is located a few miles east of a major route of the Pacific Flyway (see Section 1.2.1.1.1, p. 1-10). In general, most birds migrate at altitudes between 1,500 ft and 2,500 ft, and 90% of the migrants are below 6,500 ft. Daytime migrations are expected to be somewhat lower (Bruderer and Steidinger, 1972; Nisbet, 1963). Therefore, most of the migratory birds will not be exposed to any main beam radiation from PAVE PAWS at distances greater than 18 miles from the radar, and 90% of the migratory birds will be below the beam at distances greater than 25 miles from PAVE PAWS. The Sutter National Wildlife Refuge, the Gray Lodge State Waterfowl Area, the Butte Sink, and the District 10 seasonal marsh are within the 25-mile sector. No substantial impacts on migrating birds, including effects on their navigational ability, are anticipated even in this zone because of the low power densities from the main beam. The average RFR power density from the main beam only exceeds 500 microwatts/cm² within about 1,000 ft from the radar. As explained in Section 3.1.2.1.1.3, p. 3-18, the biological effects literature suggests that biological effects, not necessarily hazardous, are possible at 500 microwatts/cm² and upward. Thus, the only potential area of concern due to near and transition field exposure consists of those few airborne organisms flying between about 300 ft and 400

ft MSL in the 240 deg span of surveillance, and only 1,000 ft and closer to the radar. The maximum length of exposure would be but a few minutes while the airborne organisms traverse this area. Airborne fauna directly in front of one face of the radar in the middle of the beam could be exposed to as much as 140,000 microwatts/cm² for brief periods of time (while the other face is limited to 60,000 microwatts/cm²). There are no endangered or threatened flying animals in the area, and the few individuals and the extremely short duration of time the local airborne fauna would spend in traversing even these RFR fields indicates that adverse ecological effects would not result from their brief exposure to main beam radiations.

Minor localized effects may result in the near and transition field volume specified above. The radiation from PAVE PAWS might tend to cause birds to avoid the radar, and thus help eliminate the possibility of birds striking it (see Tanner and Romero-Sierra, 1969). On the other hand, birds might learn to seek out the radiation for warmth during cold weather (Gandhi et al., 1978). Based on existing information, the anticipated effects, if any, on birds are unclear. The possibility of a wide spectrum of effects occurring might be explained by the biological variation among bird species, or by the fact that slightly different RFR levels could produce different biological effects. Regardless, any potential thermal effects from PAVE PAWS would be of very short duration, as well as being very localized.

"Nonthermal" effects on birds from low level RFR have been claimed by a few researchers (Tanner, 1966 and Tanner et al., 1967), but the methodology used in these experiments has been questioned (Krupp, 1976; Eastwood, 1967). Temperature measurements of the experimental subjects were not made, and the effects may have been thermal. Irrespective of whether the effects were thermal or nonthermal, the experimental arrangements (caged birds in highly restricted areas with horn antenna mounted on the cages) bear little relationship to the habitats in which a bird normally operates. Tanner and Romero-Sierra (1974) themselves have concluded that external environmental parameters such as temperature, humidity, and atmospheric pressure, as well as internal factors of the experimental subject, such as the type and temperature of the animals being studied, should be taken into consideration when analyzing RFR effects on organisms.

The RFR fields from PAVE PAWS will be similar to existing military and civilian radar systems which have been operating continuously for many years without any noticeable ecological damage. Also, animal behaviorists and ornithologists for over a decade have considered radar as a legitimate tool for studying animal migration, navigation, and homing (Eastwood, 1967; Krupp, 1976; Williams et al., 1977; Schmidt-Koenig and Keaton, 1978).

With respect to insects, Gary and Westerdahl (1978) have summarized a variety of effects caused by exposure of insects to RFR which have been reported in the literature. The effects ranged from unrest to death, depending on the level and duration of the exposure and the species studied. The lowest levels of any reported effects were somewhat below 10,000 microwatts/cm² at frequencies of 9 to 10 GHz. Abnormal development of beetle pupae were reported at these levels.

In summary, no significant ecological effects from PAVE PAWS main beam exposure are expected. At most, only a few airborne individuals of fauna common to the area might be affected in a localized area near the radar, and even these effects may not be hazardous.

3.1.2.2.1.2 Ground and Near Ground-Level Exposure. Plants and animals at the ground and near-ground levels will be exposed to power densities much lower than those of the main beam. Table 3-3 presents data on the approximate areas and locations of land near PAVE PAWS which are calculated to receive various power densities at ground level. (Exposure at higher elevations can be calculated from Figures 3-3 through 3-8.)

Table 3-3

AREA AND LOCATION OF LAND TO RECEIVE VARIOUS
POWER DENSITIES AT GROUND LEVEL FROM PAVE PAWS^a

<u>Ground Level RFR Power Density (microwatts/cm²)</u>	<u>Area of Land To Be Affected (Acres)</u>	<u>Location of Land and Habitat Type to be Affected (see Figure 1-3, p. 1-4)</u>
500 - 4,400	0.5	Within security fence; cleared land, no vegetation
30 - 500	40.0	Extending from security fence to the 1,000-ft exclusion fence; grassland
5 - 30	35.0	Extending from the exclu- sion fence to 900 ft beyond the exclusion fence; grassland

^aBased on data for the basic system as provided in Section 3.1.1.1, p. 3-2, and Table A-3, p. A-27.

Power density levels incapable of producing substantial heating evidently have no adverse effects on living organisms (Section 3.1.2.1.9, p. 3-57). The only ground area which will receive RFR power density levels greater than 500 microwatts/cm² (far less than the average power density required for heating) is a small (less than one-half acre) area of land immediately adjacent to the radar. This area has been cleared of all vegetation and has a 8-ft high security fence that will keep large animals, including deer and cattle, from straying into the area.

With respect to the thermal effect of producing cataracts, the value of a cataractogenesis threshold has been reported by a number of independent investigators as being about 150,000 microwatts/cm² (Section 3.1.2.1.9, p. 3-60). Thus, it appears there is essentially no possibility that RFR from PAVE PAWS will cause cataracts (or any other noticeable abnormalities) in deer and other large mammals (e.g. beef cattle) in the area.

The grassland habitat immediately surrounding the security fence has been calculated to receive, at most, 500 microwatts/cm² of RFR. In the area from the security fence to the 1,000-ft exclusion fence, the power density has been calculated to decrease to 30 microwatts/cm². By comparison, some towns with broadcast transmitters have power densities of 10-50 microwatts/cm². About 900 feet from the 1,000-ft exclusion fence, the power density has been calculated to decrease to 5 microwatts/cm², a power density that approximates maximum environmental levels of RFR in many cities (Section 3.1.2.1.2, p. 3-20). A total of about 75 acres of natural habitat will be exposed to power densities of RFR that exceed that power density. As with potential effects from the main beam, any possible impacts arising from ground level exposure would be very localized.

In summary, ecological effects from ground or near-ground level RFR exposure from PAVE PAWS are not anticipated, due to the very low power density levels in the surrounding area.

3.1.2.2.2 Non-RFR Effects. The operation of PAVE PAWS will have the familiar effects of any facility that uses a road and occupies grounds and structures in the Beale AFB region. The most noticeable of these effects will probably result from the potential increase in fires, from increased noise levels, increased access into the area, and the increased likelihood of chemical pollution of surface waters.

A slight increase in the number of accidental fires may occur with the greater number of people (approximately 225) entering the site. However, since the site is under supervision by guards twenty-four hours a day, and an extensive fire prevention program is implemented at Beale AFB, any fire which may be started would be quickly detected. The ecological impact of any fire is minimized because the local biota is tolerant to fire.

Intermittent and continuous noise will be created by the operation of the generators, automobiles, and cooling towers (see Section 3.1.2.4.4, p. 3-79). Most vertebrates that use sound for communication are sensitive to sounds in the range of 0.5 to 6 kHz, the frequency range of much of the generator noise. Consequently, the intermittent operation of the generators may interfere somewhat with the behavior of the local fauna, primarily with that of nesting birds up to 2,000 feet from the facility. However, the loudest noises (70 dB) that can be expected in uncleared areas at least 100 feet from the radar will be one-hundredth that which could permanently damage the hearing of songbirds and small mammals (Benitez et al., 1972; Carder et al., 1971; Marler et al., 1973; Miller et al., 1963; Saunders et al., 1974). In addition, these noise levels would generally only occur for approximately 15 hours per week.

The physical presence and movement of people and their motorized vehicles will probably also result in some minor behavioral effects on animals near the access route into the site. All of the effects discussed in this section are expected to be negligible increments to existing problems at Beale AFB.

Most of the surface waters from the site drain into Frisky Lake, which supports a small warm water fishery (Figure 1-5, p. 1-9). No substantial amounts of toxic materials are known to presently exist in Frisky Lake (Barker, 1979). Accidental spills or unplanned movement of any potentially toxic chemicals used in the operation of PAVE PAWS to nearby surface waters could result in adverse impacts on the local aquatic biota, depending on the resulting concentration levels of the chemicals. Little if any ecological impact is actually anticipated, because measures can be quickly taken to clean up any accidental spills, and the likelihood of significantly increasing the level of potentially toxic chemicals in the lake is low (see Section 3.1.2.4.2.2, p. 3-76).

3.1.2.3 Electromagnetic Environment

3.1.2.3.1 PAVE PAWS Contribution to the Electromagnetic Environment. Operation of PAVE PAWS will change the electromagnetic environment during its pulses, generally over the frequency bands of its operation, and within the physical space its pulses reach. (Appendix D comprises a detailed analysis of the change.) This change can be described both as an actual addition to the electromagnetic environment, and in terms of how the change affects other systems and thus becomes perceptible to those using the systems. In this section the addition to the environment is described; in the following Section 3.1.2.3.2, p. 3-67, systems effects are described.

Civilian use of the radio spectrum is under the control of the Federal Communications Commission; government use is under the

control of the National Telecommunications and Information Administration (NTIA), formerly the Office of Telecommunications Policy (OTP). Since PAVE PAWS is a military system, a detailed application for spectrum support was made through Air Force channels to the Interdepartment Radio Advisory Committee (IRAC) of the OTP, which subsequently authorized operation of the radar.

PAVE PAWS transmits pulses in the band from 420 to 450 MHz, which is within what is commonly called the UHF (Ultra-High Frequency) band. The band is shared with various other radars, with radar altimeters in aircraft, and with the Amateur Radio Service, which currently has two satellite relays in orbit, and which operates a number of mountaintop repeaters in the area. The band immediately below that of PAVE PAWS (406 to 420 MHz) is used exclusively by the Federal government for both fixed links and mobile services. The band immediately above (450-470 MHz) is used for other land mobile services. Users of that band include public safety groups (police, fire, forestry, highway, and emergency services), industries (power, petroleum, pipeline, forest products, and so forth), and providers of land transportation (taxis, railroads, buses, trucks). They too, have mountaintop repeaters to increase their areas of coverage. The UHF TV channels -- channels 14 through 83 -- are in the band from 470 to 890 MHz.

Each of the two faces of PAVE PAWS is essentially an independent radar system. Each face transmits a narrow beam of energy; within a few tens of millionths of a second, the beam is switched electronically to some other direction. Each face of the radar can form beams over an azimuthal angle of 120 deg, so that the radar can observe in a 240-deg azimuthal sector from 126 deg. to 006 deg.

PAVE PAWS will generally be searching for objects rising through the surveillance volume (usually at an elevation angle of 3 deg, but sometimes higher), but some time will be used for tracking objects previously found. When searching, it will transmit closely spaced clusters of pulses -- a pair of 8-milli-second (ms) pulses, a triplet of 5-ms pulses, or a sequence of triplets of 0.3-ms pulses. Its pulse widths for tracking are selected by the PAVE PAWS computer and are determined by the distance to the target, the target trajectory, and the like. When searching, the beams from the two faces move in synchronism; when tracking, the beam from each face is independent.

PAVE PAWS has 24 evenly spaced frequency channels, between 420 and 450 MHz, and it changes frequency for each succeeding pulse according to rules programmed into the system's computers and under the influence of the actions of any targets being tracked. It generally changes frequency by at least 3.6 MHz from pulse to pulse.

The pulse and frequency-switching behavior of PAVE PAWS cannot be predicted exactly, because, although controlled by rules programmed into the computer, the behavior depends on the number and orbital characteristics of the objects it is called upon to track. Only average characteristics of PAVE PAWS emissions can be predicted.

PAVE PAWS points its main beam at an angle in the range from 3 to 85 deg above the horizon. However, only about half of the power is in the main beam. There is also a concentration of power in the first sidelobe, which has its maximum about 3.4 deg off the main beam axis for the basic system, and 2.4 deg off for the growth system (see Figure 1-4, p. 1-7, and D-4, p. D-14). The maximum power density of the first sidelobe is 1/100 or less of the maximum power density of the main beam. PAVE PAWS also has many minor concentrations of power in higher-order sidelobes, at increasingly greater angles off the main beam axis. The power density of the greatest of these is 1/1,000 or less of the main-beam power density. Most of these higher-order sidelobes are much weaker than the maximum, and the averages are about 1/6,200 and 1/12,300 of the main-beam power density for the basic system and the growth system, respectively.

The main beam does not illuminate the ground generally (some exceptions are discussed in Section A.3.1, p. A-12) and is not used to track aircraft. However, an aircraft flying within the surveillance volume is illuminated by some sort of main-beam surveillance pulse about once every 1.4 seconds and by the first sidelobe about twice as often. In the much larger tracking volume, illumination by the main beam will occur only about once per minute. In the volume scanned, as well as outside it, the aircraft is illuminated by the higher-order sidelobes. The higher-order sidelobes extend in all directions in the hemisphere centered on each face, so an object illuminated by them receives a signal on each pulse -- surveillance and tracking. Objects on or near the ground are illuminated mainly by the higher-order sidelobes, and, in some areas, less frequently by the first sidelobe. (See Section 3.1.1.1, p. 3-2, and Figure A-7, p. A-23).

3.1.2.3.2 The Effects of PAVE PAWS on the Electromagnetic Environment. PAVE PAWS' contribution to the electromagnetic environment could possibly affect people or systems already using the electromagnetic environment and systems not intended to receive electromagnetic energy. Other users of the spectrum include TV, radio, and other radars; systems or processes not intended to receive electromagnetic energy include cardiac pacemakers, electroexplosive devices, and fuel handling processes.

In the calculations and predictions of interference presented in Appendix D and summarized here, many of the terms and factors had to be assumed. Medians and averages were often used, but

conditions under specific circumstances can deviate considerably from the average. Effects of interference on various receiver systems were evaluated subjectively on the basis of engineering judgment -- only interference tests could resolve some of the uncertainties. The interference effects of the growth system will be similar to those of the basic system, but experienced at greater distances.

3.1.2.3.2.1 Effects on Telecommunication Systems

3.1.2.3.2.1.1 The PAVE PAWS Basic System. Two types of military aircraft radar altimeters share the spectrum with PAVE PAWS, but their operation is to be eventually discontinued. The Office of Telecommunications Policy (OTP) has extended the cut-off date several times already. Neither type is used for landing approaches, and one is not to be used within 50 miles of land (i.e., within about 160 miles of PAVE PAWS.) (These altimeters supplement the required barometric altimeter, which is unaffected by PAVE PAWS.) It is known that land-based radars interfere with these altimeters. Study indicates that both types will be affected when they are in radio line-of-sight of PAVE PAWS. The one known to be used only over the sea will be shielded from PAVE PAWS by the coastal mountain range except when the aircraft is above about 14,000 ft, so that low-altitude use will not be affected. Even when the altimeter is illuminated by PAVE PAWS, it may continue to provide useful altitude information. Use of the other altimeter is not known to be limited to overwater flight, but its maximum altitude is only 4,000 ft, limiting the area in which it may be illuminated by PAVE PAWS. If the aircraft is flying over the ocean, the coast range will shield it from PAVE PAWS.

The Amateur Radio Service (the Hams) shares the entire 420-450 MHz band with PAVE PAWS and the other radar systems. Although the Amateur Service is the primary service in some bands, it is a secondary service in this band, permitted to operate but not permitted to interfere with the operation of any government radar or to claim protection from interference caused by government radars. (See Section D.3.1.1, p. D-20). In the upper 10 MHz of the band, the Hams' mobile operations are augmented by the use of repeaters on the mountaintops. A number of those repeaters are in direct line of sight of PAVE PAWS and, being illuminated by the radar's first and higher-order sidelobes, will receive interfering pulses much larger than their desired signals. PAVE PAWS pulses are mostly so short that they will not operate the receiver's squelch circuit. (Breaking squelch on a mobile or base receiver would cause a short burst of noise; at a repeater the noise burst would be retransmitted). When a desired signal is present at the receiver to hold the squelch open, only those PAVE PAWS pulses that are stronger than the desired signal will be heard. The pulse rate may be as high as about 30 per second, resulting both from on-frequency pulses and from the wide emission spectrum of

some PAVE PAWS pulses several megahertz from the frequency of the Ham receiver. The degree of annoyance or disruption to the Hams' communications cannot be determined on the basis of information now available. Some impulse-blanker circuitry, such as is used to discriminate against ignition noise, could possibly be used to reduce the effects of the PAVE PAWS pulses. In addition to fixed and mobile systems, the amateurs operate two orbiting satellite transponders and conduct moon-bounce communications. One satellite receives on 432 MHz and the other transmits on 435 MHz. In operation, PAVE PAWS avoids illumination of the moon with the main beam. However, interference with the satellites and with moon-bounce is possible when the satellites (or the moon) are above the horizon, because it appears that the power density from the higher-order sidelobes is sufficient. Interference could be alleviated, operational requirements permitting, if PAVE PAWS could discontinue its use of those two frequencies when the satellites (or the moon) are in sight.

The spectrum immediately adjacent to PAVE PAWS is used for UHF land mobile communications. Below PAVE PAWS, from 406 to 420 MHz, is the federal government UHF land mobile band used by the Forest Service, the Department of the Interior, the military services, and others. Above PAVE PAWS, from 450 to 470 MHz, is the non-federal government UHF land mobile band. It is used by local governments and by businesses. The same equipment (narrow-band FM voice transceivers) are used in both bands. More than 100 UHF land mobile base stations and repeaters operate within about 60 miles of PAVE PAWS, and many of them, located high to increase their own coverage area, are directly in the line-of-sight of the radar. PAVE PAWS' signals will enter those receivers at strengths that depend on the distance between the radar and the receiver, the frequency offset between an individual PAVE PAWS pulse and the receiver's center frequency, the type of transmitted pulse, the antenna lobe that illuminates the receiver, and the characteristics of the receiving facility. When a receiver is not receiving a desired signal, its squelch circuit will keep the audio portion of the receiver shut off. PAVE PAWS pulses are generally so short that the squelch circuit does not have time to respond during a pulse. Therefore, when there is no desired signal, PAVE PAWS will not cause effects perceptible to the listener. When a desired signal holds the squelch circuit open, the PAVE PAWS pulses, which will generally be stronger than the desired signal, may be heard as pops and clicks. They will occur at such low pulse rates (several seconds between pulses) that it is doubtful that they will disrupt voice communication.

Communications between aircraft and ground at Beale AFB are handled by UHF/AM systems in the band between 225 and 400 MHz. At the ground station, power from PAVE PAWS higher-order sidelobes is expected to be slightly above system sensitivity, and it will probably cause an annoying rough buzz unless the AM receiver squelch can be set sufficiently high. The first sidelobe will

produce stronger pulses at a much lower rate (about 1.5 pps), but they are not expected to interfere seriously with the voice signal from the aircraft. When the aircraft is within about 20 miles, its signal may completely override the interfering PAVE PAWS signal. No interference with communications from the ground to the aircraft is expected.

Interference with various air-navigation systems (besides communications and in-band radar altimeters) has been considered. TACAN and VORTAC stations provide range and distance information to aircraft. There are about 10 VORTAC/DME stations in the PAVE PAWS area. They will not be affected by PAVE PAWS. However, the receivers in the aircraft will exhibit a spurious response to one of the PAVE PAWS pulses. (The specific pulse frequency depends on the ground station the aircraft is using). This spurious response requires a very strong PAVE PAWS signal, such as could be provided only by the PAVE PAWS main beam. Such a main beam pulse would illuminate the aircraft only about once every 34 seconds if the aircraft were in the surveillance volume. Because PAVE PAWS does not track aircraft, and because the tracking volume is much larger and receives fewer main-beam pulses, illumination by a main-beam pulse at the correct frequency in the tracking volume would be much less frequent. Even so, those pulses would not affect operation of the airborne DME receiver, which is designed to ignore pulses other than the return from the ground-station of its own downlink pulses. Tests with the airborne components showed that neither of the two aircraft DME receivers tested was affected at power density levels corresponding to PAVE PAWS basic-system main-beam illumination at about 3 and 5 miles. (Those were the maximum power density levels available from the testing equipment, so it is possible that there would be no effects even at smaller distances.)

The term high-power effects is used to describe the coupling of energy directly into an electronic system through its case or internal wiring. High-power measurements have been conducted on some airborne navigation system receiver units. Some effects were experienced at power density levels corresponding to illumination by the main beam at distances as great as 3 miles. Such effects would depend strongly on the frequency of the interfering (PAVE PAWS) signal and the strength of the desired signal. High-power effects have been observed in two Army OH-58A helicopters operating about 500 ft above ground about 1.2 mi away from the PAVE PAWS at Otis AFB. PAVE PAWS caused false readings in their fuel gauges and in their engine-rpm indicators. Some laboratory measurements have been made at PAVE PAWS frequencies (but not using PAVE PAWS pulse widths or pulse rates) to learn the interference levels that would cause effects in home high-fidelity stereo units, AM radios, land-mobile transceivers, and so on. Very small samples were used, sometimes only one or two items. On the basis of these limited tests, it appears that effects are likely in the base housing area and they may occur as far away as Yuba City and Marysville.

PAVE PAWS may interfere with reception of television channels 9 and 10 by means of spurious responses that can occur when the radar is transmitting on frequencies in the bands 420 to 425 MHz and 431 to 437 MHz, respectively. Channel 10 originates from a major Sacramento station, but channel 9 is broadcast from Redding and its signals enter the Yuba City/Marysville area principally by way of the cable television system. Also, TV receivers in the Beale AFB base housing area that are in line-of-sight of the radar may experience high-power effects on other channels. A high proportion of the TV viewers in the Yuba City/Marysville area and on Beale AFB subscribe to cable TV, and, if there were a problem, it would be possible to filter out the PAVE PAWS signal directly at the cable TV system's master receivers, so that it never appears at the subscriber's TV set. For other TV viewers, the occurrence of interference depends not only on the relative strengths of the PAVE PAWS signal and the desired channel-10 signal, but also on the susceptibility of their particular TV set. The signal strengths can be estimated, but the susceptibilities are unknown except in a gross statistical sense. In the towns of Marysville and Yuba City, somewhat fewer than half of the TV receivers not connected to the cable system may be affected while tuned to channel 10. Some TV receivers within line-of-sight of PAVE PAWS and as far away as 100 miles could possibly be affected. A simple and inexpensive filter designed to be attached to the back of a TV receiver (and which will be provided by the Air Force on request) will permit unaffected reception of channel 10 for the majority of TV sets within line-of-sight of PAVE PAWS and as close as Marysville and Yuba City. Another filter has been designed that is even more effective and would make interference to TV receivers in the area of the two cities almost impossible. The channel-10 interference would be caused by only 6 of the 24 PAVE PAWS frequencies -- those from 431 to 437 MHz. This band includes the frequencies used by the Hams, in their satellite work. If operational requirements permit, discontinuing use of those six frequencies would eliminate problems both with Ham satellites and with TV. Experiments could determine whether discontinuing the use of fewer than six frequencies would accomplish the same end.

No interference with communication systems such as point-to-point microwave links is expected to result from the harmonics of the PAVE PAWS signal for either the basic system or the growth system.

3.1.2.3.2.1.2 The PAVE PAWS Growth System. The growth option will increase the radiated pulse and average power densities in the main beam and the first sidelobe by a factor of four. Thus, at a given distance, the power density increases by that factor of four. If one is concerned with a particular pulse or average power density from the main beam or the first sidelobe, it would be found at twice the former distance. The effect of this is to double the distances at which effects are expected. Only airborne

objects are illuminated by the main beam of the growth system. *

At any given location illuminated only by the higher-order sidelobes, the power density of the growth system simply doubles. A particular power density would then be found for the growth system about 1.4 times as far away as it would be found for the basic system.

For receiver systems susceptible to the basic system, the kind of interference effects of the growth option will be generally the same.

3.1.2.3.2.2 Effects on Pacemakers, Electroexplosive Devices, and Fuel Handling

3.1.2.3.2.2.1 The Basic System. A design susceptibility threshold of 200 V/m (the electric field equivalent to a power density of 10,000 microwatts/cm²) has been suggested for cardiac pacemakers in a draft standard by the Association for the Advancement of Medical Instrumentation. Newer models of cardiac pacemakers have been tested against signals very similar to those to be radiated by PAVE PAWS, and most are unaffected by pulsed fields as high as 330 V/m. The pulse field in line-of-sight at ground level at the 1,000-ft exclusion fence is only about 42 V/m. Therefore, it seems unlikely that an earthbound owner of a pacemaker with a susceptibility threshold of 200 V/m would be affected by PAVE PAWS.

The suggested 200 V/m susceptibility threshold will be regularly exceeded by the PAVE PAWS signal only in the main beam surveillance volume at distances within 1 mile of the radar -- a location that can be reached only by helicopters and fixed-wing aircraft disregarding basic flight safety in flying close to the ground. Because that one mile volume is located within the airport traffic area, permission must be obtained from the Beale AFB control tower to enter it. That portion of the surveillance volume is quite small. Viewed from above, the volume is a 240 deg sector extending 1 mi from PAVE PAWS; in cross-section it is a narrow wedge, with a maximum thickness of only 200 ft at a mile from PAVE PAWS (see Figure D-18, p. D-84). At a half-mile it is only 100 ft thick. Entering that volume requires flying below about 400 ft. Because of its proximity to the ground, a cautious flyer would not enter it, nor could he keep his aircraft in it for more than a few seconds at a time. No commercial flight paths traverse the volume, nor is it entered by aircraft in the Beale AFB flight patterns. It presents no hazard to pacemaker owners whose pacemakers meet or exceed the suggested 200 V/m susceptibility threshold. If the aircraft has metal skin, which would provide some shielding from EMR, the volume of concern becomes much smaller.

Despite improvements in reducing the susceptibility of newer models of pacemakers, some that are susceptible at levels well below 200 V/m are still in use. However, pacemakers are replaced every 2 to 5 years when their batteries are exhausted. The physicians who replace them have the opportunity to implant pacemakers with improved interference-rejection abilities.

Air Force Technical Manual T.O. 31Z-10-4, on electromagnetic radiation hazards, instructs that fuel handling operations (fueling of aircraft and so on) should not be undertaken in electromagnetic fields with pulse power greater than 5,000,000 microwatts/cm². The growth-system pulse power at the 1,000-ft exclusion fence is only about 5,700 microwatts/cm². Therefore, it is not anticipated that PAVE PAWS will constitute a hazard to fuel handling operations.

Power densities at ground level that exceed the no-fire safety criteria for electroexplosive devices (EEDs) can be encountered only within a few hundred feet of the radar. The criteria for safe average power density are:

- o 75 microwatts/cm² for exposed EEDs
- o 663 microwatts/cm² for EEDs in taxiing aircraft
- o 10,000 microwatts/cm² for EEDs in aircraft in flight or stored in metal containers.

The most stringent criterion (that for exposed EEDs) is not exceeded at distances beyond about 800 ft from the radar; such EEDs are not used at Beale AFB. The main beam can illuminate EEDs in or on aircraft. The average power density criterion for airborne EEDs is 10,000 microwatts/cm², but the time period appropriate for the average has not been specified. In the worst case (no time averaging) the power density criterion would be exceeded within about 5,000 ft of the radar. If time averaging is appropriate, then the criterion is exceeded only well within the 1,000 ft exclusion fence and within 100 ft of the ground. Aircraft are not expected to operate so close to the ground and the radar building. It is unlikely that airborne EEDs will be affected by PAVE PAWS.

3.1.2.3.2.2 The Growth System. As discussed before, the power density in the far field doubles at a given ground location illuminated by only higher-order sidelobes, and the distance along the ground at which some effect will occur for the growth system is about 1.4 times as great (in higher-order sidelobes) as it is for the basic system. The most sensitive EEDs can safely be handled outside of about 1,500 ft; fuel handling will be safe outside the exclusion fence. In the main beam and first sidelobe, the power density at a particular distance quadruples; any particular effect caused by the basic system would be experienced

at twice the distance under the growth option. The volume within which the electromagnetic field exceeds 200 V/m becomes larger in radius and also shallower, but it still is not entered by commercial flights, by aircraft in Beale AFB patterns, or by cautious private flyers.

3.1.2.3.2.3 Effects Observed During PAVE PAWS Testing at Otis AFB

3.1.2.3.2.3.1 Instrumentation in Helicopters

PAVE PAWS at Otis AFB (identical to the Beale AFB installation) was observed to produce false indications in instruments in helicopters. Two Army OH-58A helicopters each noted misleading indications in their instruments as they approached to within about 2500-3000 meters (1.6-1.9 miles) of the radar and within the main beam surveillance volume. They had previously received clearance to enter the restricted area. In both helicopters, the fuel gauge indicator suddenly began to register falsely high and, at the same time, the pilots were alerted by lights and an audio alarm meant to indicate low engine RPM. These latter are designed to alert the pilot to a potential engine (or rotor) failure. The pilots quickly realized that there were no engine problems and that the alarm indications themselves were erroneous. There was no effect on the actual performance of the helicopters.

The helicopters, at a range of about 2 km, were being illuminated with pulse power densities of about 48 dBm/m² or 7,300 microwatts/cm². The effects depended on the orientation of the helicopter relative to the radar; they ceased as the helicopters turned away from PAVE PAWS. These are examples of high-power effects. The fuel gauge problem in OH-58A helicopters is not new; that gauge is known to give false indications when an onboard AN/ARC-114 FM radio is keyed on.

The Federal Aviation Administration (FAA) is active in investigating potential problems in air navigation. Flights were made by the FAA on 9 and 10 February 1979 near Otis AFB to test the effects of the radar on several air navigation instrument types. They also paid special attention to note abnormal operation of their cockpit instruments; no abnormalities were noted. The FAA trip report concludes, "Since the radar's burst of RF energy occurs for only a fraction of a second on a specific frequency, and appears to occur only one time in several minutes, it is concluded that the radar does not present potential interference to our navigational facilities." (FAA, 1979)

Further tests were conducted at Otis AFB on 22 March 1979, with helicopters carrying measurement instrumentation. The tests involved the Massachusetts National Guard and the U.S. Coast Guard, and it was learned that the Coast Guard helicopters were not affected as close as the 1,000 ft exclusion fence. A UH-1

helicopter experienced flashing of its low-rpm indicator light when within about 1 mile of the radar. Work is underway to establish procedures for Army helicopters operating near that radar, and a Notice to Airmen (NOTAM) was issued as follows:

"NOTAM

Aircraft operating below 2,000 feet and within three miles of the PAVE PAWS radar site located in restricted area 4101, Bourne, Mass., may experience momentary erratic operation of cockpit instruments or navigational equipment. Pilots are encouraged to submit reports of such occurrences to the nearest FAA Air Traffic facility."

3.1.2.3.2.3.2 Powerline Waveform Irregularities

There were complaints that the dc power supply of the Otis AFB PAVE PAWS caused a 720 Hz ripple on the 60 Hz voltage of the power distribution system in the Sandwich area. Such a ripple could occur as the result of the rectification of the 60 Hz supply to provide the dc needed by the radar's solid-state circuitry. It would not affect most other devices, appliances, or systems connected to the power distribution system. Users of power for lighting, heating, refrigerating, and for the operation of motors of all sorts would not be affected. However, some sensitive scientific equipment may not tolerate the low-level 720 Hz component on the 60 Hz line voltage. Efforts are underway to define the problem and to seek solutions. Measurements of line voltages have been taken with the Otis AFB PAVE PAWS operating on its own power and with it operating on power supplied by New Bedford Gas and Electric Light Company. Resolution of the problem awaits the analysis of the data from these tests.

3.1.2.3.2.3.3 Interference to TV Preamplifiers

Interference was reported by four TV owners having the same type of TV antenna with a built-in preamplifier. Their distances from the Otis AFB PAVE PAWS range from 2 to 20 miles. The interference occurred on all channels, indicating that the interference mechanism was not of the spurious-response type described in Section D.3.1.2.2.2, p. D-37. The evidence is strong that the broad-band preamplifier is sensitive to the PAVE PAWS pulses. Work is under way to determine whether an Air Force-supplied filter (not the same one described in Section D.3.1.2.4, p. D-46) will alleviate the problem.

3.1.2.3.2.4 Classified Systems at Beale AFB. Certain classified communications and electronics equipment is used in or associated with aircraft based at Beale AFB. This EIS does not deal with any

potential problems of electromagnetic interference to those items of equipment. Those problems, however, have not been neglected. In December 1978, the information in Section D.2 was provided to the appropriate operational groups. That section describes the operation of the radar in terms relevant to its possible interaction with other electromagnetic systems. No expressions of concern have been received from any of those groups operating at or out of Beale AFB.

3.1.2.4 Soil, Water, Air, Noise and Solid Waste

3.1.2.4.1 Soil. Leveling during site construction resulted in the development of minor rills and gullies along the relatively unvegetated, steep slopes leading from the site into the natural drainageways that drain into Frisky Lake or are tributary to Hutchinson Creek. The soils at the site are both permeable and sandy, and those are prone to erosion unless they are stabilized by vegetation, berms, or other sediment catchment structures. No plans for erosion control, landscaping, or fire control have been formulated for the site (Coffey, 1978). The site will naturally revegetate to grassland after construction is completed, but manual reseeding of the area would speed the process. Because fire danger is high during the late summer and fall, a fire break may be constructed around the PAVE PAWS site by removing the vegetation. Therefore, it may be necessary to control surface water runoff on the site to prevent significant erosion.

3.1.2.4.2 Water

3.1.2.4.2.1 Water Use The operation of PAVE PAWS will not result in any significant depletion of the groundwater. Water will be supplied to the site by the base system which includes nine wells with a total capacity of 8,815 gal/min (12.7 million gal/day). An auxiliary, engine-driven capacity of 4,000 gal/min can be used if commercial power is lost. (USAF, 1977). Current base demand is only 63% of capacity. Water demands for fire control, personnel use, and equipment cooling and washing for PAVE PAWS are estimated at about 12,000 gal/day (8 gal/min). This volume represents only 0.2% of available pumping capacity and is equivalent to the daily requirements for a town with a population of 70. Although groundwater levels in the region are declining (Page, 1979), the additional water demand associated with PAVE PAWS will not significantly affect the availability of groundwater for other uses.

3.1.2.4.2.2 Water Quality. PAVE PAWS is not expected to affect regional water quality. The radar is located on bedrock, and infiltration to underground aquifers is extremely small except along highly permeable joint or fracture planes. Travel time of

groundwater is so slow that any contaminants entering the groundwater at the site would be filtered out long before reaching the base's water supply wells about 5 linear miles to the southwest. Excess runoff from the site will be channeled into the natural drainageways in the area that are tributary to Hutchinson Creek. Although the runoff will contain road salt, oil, minerals, and some heavy metals, the quantities of these materials are not expected to exceed those from any similar group of buildings, parking lots, and roads. Wastewater from the site will be treated at the base's secondary sewage treatment facility, about 9 miles downstream from PAVE PAWS. The additional load from PAVE PAWS will not affect the facility, which now operates at only 25% of capacity (Barker, 1978).

One potential source of contamination is the diesel fuel handling and storage facilities. Four 40,000-gallon, steel underground tanks have been installed for storing diesel fuel. The tanks have been coated with an asphalt-based paint to prevent corrosion (Coffey, 1978). A drainage system has been installed in both the fuel-loading site at the storage tanks and the generator area of the power plant. The drainage system leads waste to an oil/water separator before it is discharged into the base's sanitary sewer system. The drainage system should capture any small amounts of fuel, oil, or grease that spill in the area. Seventeen other oil/water separators exist on the base, and a continuing program of periodic pumping of the separators has been established to assure their effectiveness (Barker, 1978). All the waste oil from the base is collected in underground tanks and sold to contractors for recycling.

The diesel generators will be used about 15 hours per week. Given the design and the proposed operating conditions (see Section 3.1.2.4.3), a major spill seems unlikely.

In the unlikely event that the transformer ruptures, the dielectric fluid would spill onto the ground surface (Coffey, 1978). Nevertheless, contamination of the groundwater or surface water is not expected, because the volume of fluid is small.

Beale AFB has an Oil and Hazardous Substances Pollution Contingency Plan (OHSPC) that is updated every 3 years. The Petroleum, Oil, and Lubricants (POL) facilities are inspected every day for leaks and the inflow to the sewage treatment facility is constantly monitored to detect possible problems. Spills of oil or jet fuel into the sanitary sewer occur two to three times per year (Barker, 1978). Increased emphasis is being placed on this problem by base supervisors to prevent future pollution incidents.

The base currently has three cooling towers that discharge into the system (Barker, 1978). Cooling of the diesel generators and the PAVE PAWS facility would be supplied by two separate

systems: the tower water system, and the closed-loop system (Coffey, 1978). The closed-loop system would supply cooling to both the solid-state modules and the building's air handling system. No discharges would occur from this system. The tower water system, on the other hand, would cycle water from the cooling tower through the chiller. The chiller then would cool the freon, which subsequently would cool the liquid in the closed-loop system. The water in the closed-loop system is to be treated with chemicals to maintain standard pH and hardness. The conductivity in the tower water system would be continuously monitored. When it rises above 750 micromhos, approximately 500 gallons of water would be purged from the system (cooling tower blowdown) and replaced by fresh water from the water supply system. The purged water would be discharged to the sanitary sewer system. The discharge water would be higher in total dissolved solids and in temperature than the domestic sewage, but neither of these characteristics would adversely affect the operation of the sewage treatment facility.

3.1.2.4.3 Air. When PAVE PAWS is in operation, air pollutants will be emitted by the vehicles operated by the employees and by the diesel-powered electric generators in the power plant.

Amounts of air pollutants emitted by the vehicles of the 225 PAVE PAWS employees traveling to work will be very small in comparison with the emissions of aircraft taking off and landing at the base. Thus, vehicle emissions would not be expected to add measurably to existing pollutant levels in and around Beale AFB.

The PAVE PAWS facility requires 2.5 MW for normal operation compared with a total of 750 kW for the three FSS-7s that PAVE PAWS replaces. Power will be drawn via overhead transmission lines from the commercial power grid. The on-site power plant (see Figures 1-2 and 1-3, pp. 1-3 and 1-4) will serve as a backup in case of an emergency, such as a severe storm or an overload, that could cause a blackout or brownout in the commercial power grid. The diesel electric generators will also be run regularly for operational exercises and maintenance.

In a typical week, the power plant would run four of the six engines for approximately 15 hr, during which time the power plant will produce 33 lb/hr of oxides of nitrogen (NO_x), 0.67 lb/hr of hydrocarbons (HC), and 2.2 lb/hr of carbon monoxide (CO). To make these estimates, it was assumed that each of the engines will produce 625 kW with approximately 840 hp, and emission rates of 4.5 grams/hp-hr for NO_x , 0.10 g/hp-hr for HC, and 0.30 g/hp-hr for CO were used. Emissions of particulates and sulfur dioxide are negligible (Gotterba, 1978).

By comparison, the weekly emissions of the power plant would produce about one-twentieth the hydrocarbons and one-twelfth the carbon monoxide produced by one landing and one takeoff of a military transport aircraft. Thus, the power plant emissions of HC and CO for PAVE PAWS will be miniscule relative to aircraft emissions at Beale AFB. It would take about four landings and takeoffs to produce an amount of nitrogen oxides equivalent to the weekly power plant emissions (EPA, 1973). Because many more than four planes land and take off each week, the additional contribution of the power plant is not likely to add significantly to the emissions related to the operation of the base. Furthermore, the area is classified as having cleaner air than the federal NO_x standard, and the addition of the power plant is not likely to cause the base to violate that standard.

The Yuba County Air Pollution Control District (APCD) is responsible for regulating and permitting certain pollution sources in the county. Although other point sources of air pollution are required by the APCD to have permits, piston type internal combustion engines such as the diesels in the PAVE PAWS power plant are specifically exempted from the permit requirement.

To produce 2.5 MW for PAVE PAWS less 750 kW used by FSS-7s, commercial power plants would emit slightly more air pollution than otherwise. The additional pollution would be 0.96 lb/hr particulates, 9.6 lb/hr of sulfur dioxide, 0.37 lb/hr of carbon monoxide, 0.25 lb/hr of hydrocarbons, and 0.25 lb/hr of oxides of nitrogen. These estimates are based on the assumption that the commercial plant uses fuel oil with a 0.5% sulfur content, and the assumption that available hydropower would be fully exploited regardless of PAVE PAWS operation.

3.1.2.4.4 Noise. Noise will be generated during the operation of PAVE PAWS by the cooling equipment and by the diesel generators in the power plant, both of which are located directly behind the radar building.

The cooling tower operates continuously; from 20 feet, its noise level is estimated to be approximately 60 dB. At the guard tower, about 50 feet from the cooling tower, the noise level from the cooling towers should be about 52 dB.

The diesel generators will operate on an irregular schedule as required for power and maintenance. During operation, the generators will produce about 68 dB as measured 125 feet away (the approximate distance to the guard tower). Table 3-4 presents the noise levels of familiar sounds for comparison.

AD-A088 320

SRI INTERNATIONAL MENLO PARK CA
OPERATION OF THE PAVE PAWS RADAR SYSTEM AT BEALE AIR FORCE BASE--ETC(U)
JUL 80

F/6 17/9

F08635-76-D-0132

UNCLASSIFIED

AFSC-TR-80-09

NL

3 of 6
Pages

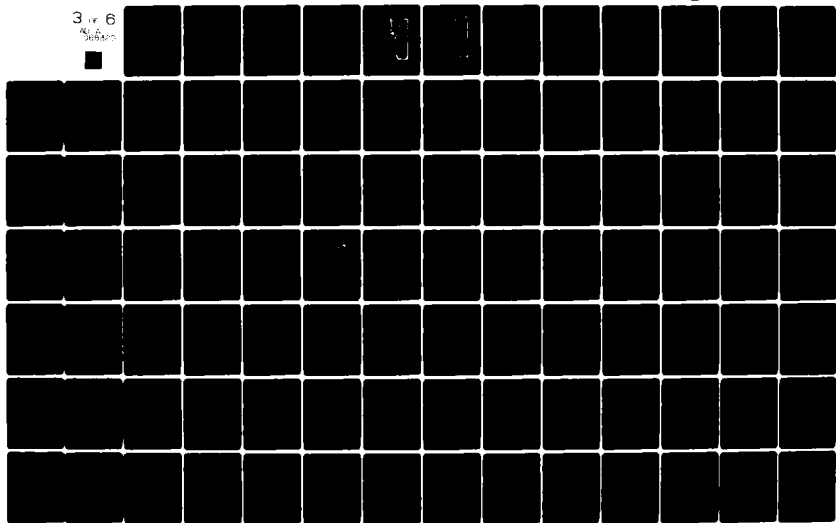

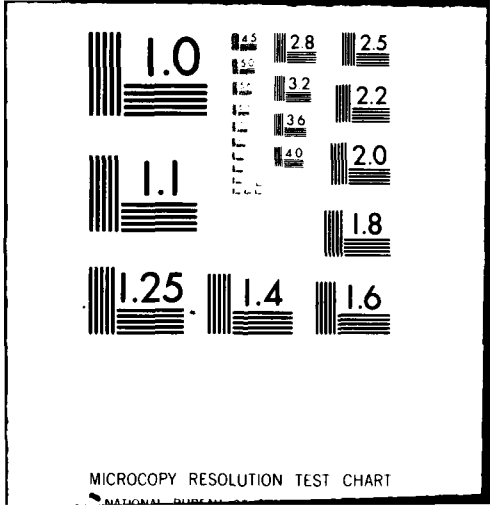

Table 3-4

NOISE LEVELS OF TYPICAL SOUNDS AND ASSOCIATED HUMAN RESPONSE

Typical Sounds	Noise Level (dB) ^a	Response	Conversational Relationships
Carrier Deck Jet Operation	150		
Jet Takeoff (60 m)	140		
Discotheque	130	Painfully loud Limit of amplified speech	
Auto Horn (1 m)	120		
Riveting Machine	110		Shouting in ear
Jet Takeoff (600 m)	100		Shouting at 0.61 m Very loud conversation at 0.61 m
Garbage Truck	90		
New York Subway	80	Very annoying Hearing damage (8 hours) Annoying	
Heavy Truck (15 m)	70 ^b		
Pneumatic Drill (15 m)	60		
Alarm Clock	60		
Freight Train (15 m)	60		
Freeway Traffic (15 m)	60		
Air Conditioning Unit (6 m)	60		
Light Auto Traffic (30 m)	50		
Transmission Line (3-conductor bundle); average during rain at edge of right-of-way	47		
Library	30		
Soft Whisper (4.6 m)	20		
Broadcasting Studio	10		
	0	Just audible Threshold of hearing	

^a Zero dB is equivalent to a sound pressure level of 0.0002 dynes/cm².

^b Contribution to hearing impairment begins.

Source: "Noise Pollution," U.S. Environmental Protection Agency, August 1972.

In a direct path, sound levels are expected to decrease as the distance between the listener and the noise source increases. Table 3-5, shows the levels of noise expected from PAVE PAWS at the guard tower and the gatehouse on the PAVE PAWS site (see Figure 1-3, p. 1-4, for the site plan), and at the base hospital. The noise levels given in Table 3-5, are approximate and do not allow for accentuation or attenuation by physical or meteorological factors such as buildings, terrain, humidity and wind direction.

Because the closest points of routine public access to the site are farther away than the hospital, where the noise level is quite low (Table 3-5), the PAVE PAWS should not be audible to the public.

3.1.2.4.5 Solid Waste. Only a small quantity of solid waste will be generated at the PAVE PAWS site. It will be disposed of at the sanitary landfill on Beale AFB. With the additional load from PAVE PAWS, the present landfill still has sufficient capacity to operate for 25 years (Barker, 1978). Ample space is available for expansion of the landfill.

3.1.2.5 Minerals and Other Resources. The operation of PAVE PAWS at Beale AFB is expected to have no effect on the availability or the mining of mineral resources in the region. No significant resources exist at the site itself or on Beale AFB. Neither the mining of gold at the Yuba River placer operations, nor the production of sand and gravel in the vicinity of Marysville will be affected by the operation of PAVE PAWS.

3.1.2.6 Natural Disasters

3.1.2.6.1 Earthquake Hazard. It is not possible to predict whether a damaging earthquake will occur during the 10- to 20-year life span of PAVE PAWS. Only three earthquakes with magnitudes greater than 5.0 on the Richter Scale have been recorded on the Foothill Fault System since about 1880 A.D. All three involved other segments of the fault system and had epicenters 40 to 50 miles from Beale AFB. No studies have been conducted on the Bear Mountain Fault Zone portion of the Foothills fault system which passes through the PAVE PAWS site, but no earthquakes centered along that segment with a magnitude greater than 4.0 have been recorded (Cramer et al., 1978).

Table 3-5

ESTIMATED PAVE PAWS NOISE LEVELS AT THREE LOCATIONS

	<u>Approximate Distance (ft)</u>		<u>Noise Level (dB)</u>	
	<u>Cooling Tower</u>	<u>Power Plant</u>	<u>Cooling Tower</u>	<u>Power Plant</u>
Guard Tower	50	50	52	76
Gatehouse	380	250	35	62
Hospital	8,000	8,000	8	32

An earthquake of magnitude 5.0 or greater on the Foothill fault system could have two effects. First, damage to the PAVE PAWS facility could result in a temporary closure of the radar that would impair our national defense system. However, the PAVE PAWS facility has been constructed to meet California seismic safety codes for Seismic Risk Zone III which will allow the structure to withstand an earthquake intensity VIII on the Modified Mercalli Scale. This roughly translates to a ground acceleration of 0.25 g at Beale AFB, or an earthquake of magnitude 6.0 on the Bear Mountain Fault Zone. Therefore, the damage from an earthquake up to magnitude 7.0 would be slight, and any closure would be brief. Second, the wave motion associated with an earthquake might cause the beam to move away from its normal position. If this occurs, the equipment is designed to shut down automatically before the movement could significantly affect the normal operating electromagnetic field. (Coffey, 1978).

3.1.2.6.2 Other Hazards Several other sources of natural disasters, including fire, floods, drought, wind and hail storms, are discussed in Section 1.2.1.1.5. None of these appears to be a significant threat to PAVE PAWS. Extensive fire control programs are implemented; the relatively high elevation of the PAVE PAWS site makes flooding of the site very unlikely. Other natural disasters are infrequent and are not expected to adversely impair radar operations.

3.1.3 Socioeconomic Impacts

3.1.3.1 Land Use and Aesthetics

3.1.3.1.1 Land Use. The site selected for the construction of PAVE PAWS at Beale AFB is one of three that were considered. The present site was designated as the prime site because construction

and operation there would have the smallest effects on the natural and man-made environment. Before construction activities were initiated, the land surrounding the radar site was leased for cattle grazing; no alternatives were planned for that land, except occasional use for parachute training when grazing animals were absent.

To date, 4 acres of land at the site have been required for the construction of the radar and the necessary supporting facilities, including electrical power generation and distribution; water and sewer lines; fuel storage; parking, and a guard house. An additional 7 acres were required for construction of a 1.5-mile paved access road from a major thoroughfare on the base to the site. The 1,000-foot radius exclusion fence will enclose about another 50 acres. Therefore, construction and operation of PAVE PAWS will occupy approximately 61 acres which will thus be unavailable for other uses during the planned operational lifetime of the radar facility (10-20 years).

The 50 acres within the exclusion fence have been and will continue to be periodically burned to prevent the possibility of damage to the radar from an uncontrolled grass fire during the dry summer months. During the rainy winter season, any grass that takes seed will be allowed to grow to improve the appearance of the area. After the road was constructed, all the land bordering it that had been disturbed was reseeded; however, shortly thereafter, the land adjacent to the access road was burned by base maintenance personnel. There are no further plans for planting grass along the access road.

The arrival of the new PAVE PAWS employees is not expected to affect existing land use at Beale. The employees are expected to reside in existing housing facilities either on the base or in neighboring communities and to use the facilities already available to other Beale AFB personnel and their dependents. The only possible secondary land use impact is the potential for misuse of land in the nearby Spenceville Wildlife and Recreation Area by new base residents driving off-road vehicles. This issue was discussed in more detail in Chapter 2.

3.1.3.1.2 Aesthetics. PAVE PAWS is clearly visible from most areas of Beale AFB. The radar can be seen clearly from the base hospital (Figure 3-11) and the cantonment area, but only parts of the family housing area have a clear view of the radar. Figure 3-12, p. 3-85, shows the view of PAVE PAWS from the base firing range. Haze frequently obliterates the view of PAVE PAWS from areas outside the base, including the views from roads leading to the base. On clear days, PAVE PAWS is visible from high buildings in Marysville and in Yuba City. The PAVE PAWS building is relatively simple, lacking the complex structures visible on a dish-type radar. The shape of the building is shown in Figure 1-2, p. 1-3. The metal exterior is painted a light brown to

Faint, illegible text at the top of the page, possibly a header or introductory paragraph.

... support
... and
... park
... for
...
... land
...
... of
... plan
... years

... have been
... to prevent
... during
... any
... the
... all
... however
... was
... plans

... is not
... The
... on
...
... and
... the
... driving
... in

... is
... can
... the
... a
...
...
... to

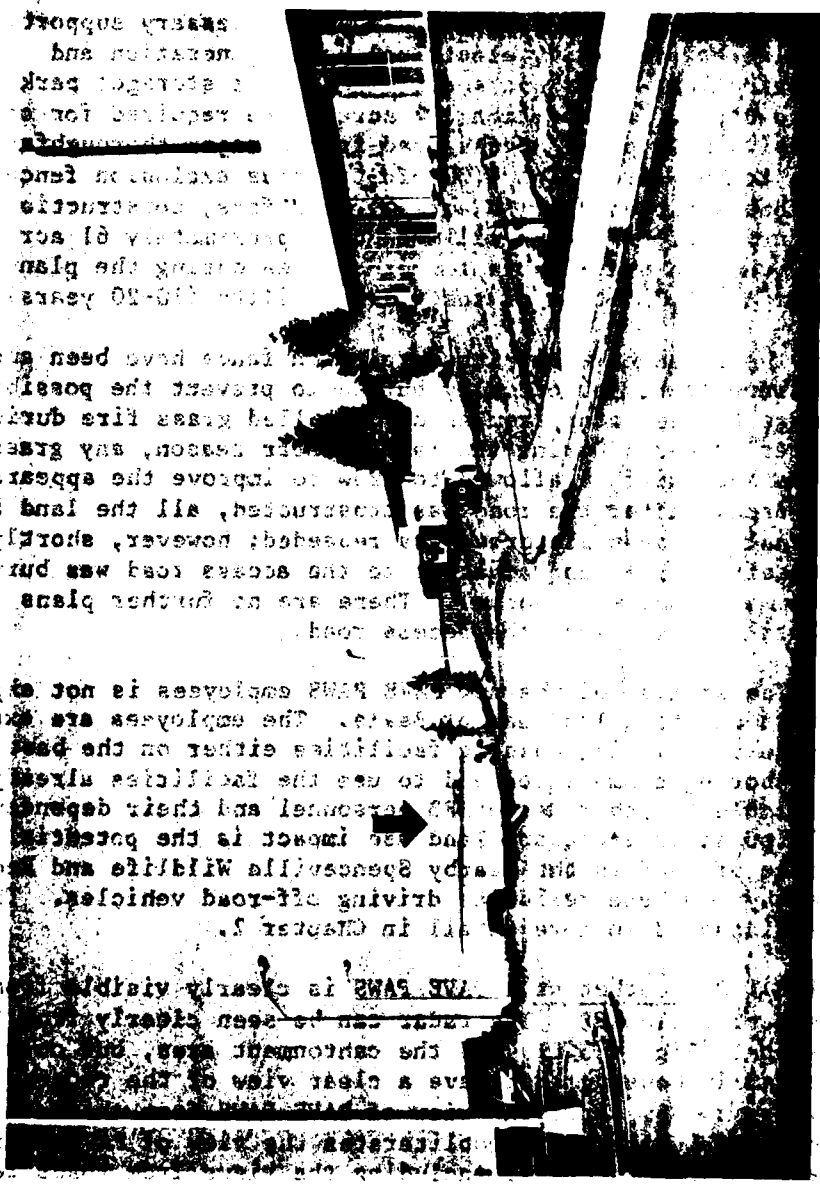

Faint, illegible text at the bottom of the page, possibly a footer or concluding paragraph.

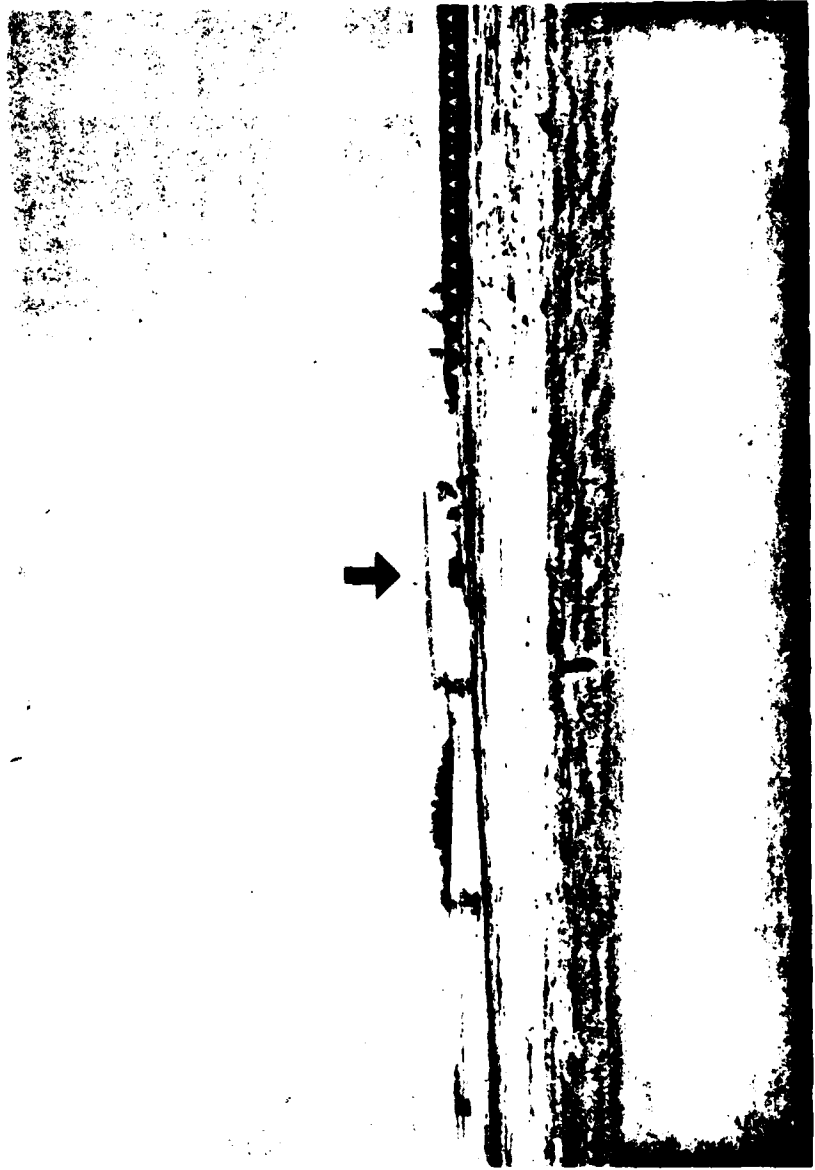

blend with the surrounding grassland which is dry and brown from about May to January. At certain times of the day, the sun reflects from the brushed aluminum surface behind the antenna elements. The resulting glare makes the PAVE PAWS building more noticeable and visible at greater distances.

3.1.3.2 Demographics and Economics

3.1.3.2.1 Employment. PAVE PAWS operations will add 225 jobs (military and civilian) at Beale AFB. Wages and salaries from additional base employment will result in higher spending in the local economy. This will generate new jobs off-base. The total job creation effect of PAVE PAWS in the Sutter-Yuba region will be 422 positions, of which 250 are civilian jobs. The change in the unemployment rate because of Air Force action is quite small (-0.3%). Because this is less than seasonal changes, PAVE PAWS will have little impact on regional employment and unemployment.

3.1.3.2.2 Population. The Aerospace Defense Command (ADCOM) estimates that 225 additional Air Force personnel would be required at Beale AFB if PAVE PAWS becomes operational. Approximately 76% of these additional people would be military personnel (24 officers and 148 enlisted men). Thus, assuming an average family size of 3.5 individuals (USAF, 1979a), the total incoming military population would number about 602.

The number of civilian personnel who will enter the area as a result of PAVE PAWS will depend on how many of the 53 authorized civilian positions are filled by individuals from the regional civilian labor force. Most of these positions are for programmers, computer operators, computer maintenance personnel, and civil engineers. Administrative support personnel will fill the remaining positions. Although unemployment is relatively high in the region, very few of the currently unemployed people are likely to be qualified for these positions. Therefore, to provide an estimate of the most extensive probable impacts of the Air Force action, this analysis assumes that none of the necessary additional civilian personnel will be hired locally. Therefore, based on an average household size of 2.8 individuals (USAF, 1979a), approximately 148 civilian personnel and their dependents would enter the region as a result of the Air Force action.

Thus, incoming military and civilian Air Force personnel and their dependents would total about 750. Assuming that the residential distribution of the incoming population follows that of the existing population, 90% of this incoming population would reside in the Yuba/Sutter county region (see Table 3-6). This influx would increase the projected 1980 population of the

TABLE 3-6

POPULATION INFLUX RESULTING FROM PAVE PAWS OPERATIONS

<u>Location</u>	<u>Number of Military Personnel and Dependents</u>	<u>Number of Civilian Personnel and Dependents</u>
Sutter County		
Yuba City	103	34
Other	<u>2</u>	<u>2</u>
Total	105	36
Yuba County		
Marysville/Linda	428	49
Wheatland	10	10
Olivehurst	9	14
Other	<u>3</u>	<u>13</u>
Total	450	86
Sacramento Area	20	8
Other		
Nevada County	4	10
Placer County	7	6
Butte County	5	2
Other	<u>11</u>	<u>0</u>
Total	27	18
Total	602	148

region by less than 1%. This increase is equivalent to 4 months of population growth at the rates projected for 1978 to 1980. Yuba County would absorb 79% of the new regional population and would experience a 1.1% population increase. Much of this growth would occur in Marysville/Linda, where population would increase by 477 individuals or 5.1%. Sutter County's population increase would be concentrated in Yuba City. Approximately 137 of the 141 new Sutter County residents would reside in Yuba City, thereby increasing the city population by 0.8%.

About 73 of the incoming Air Force personnel and their dependents (10%) would reside outside of the Yuba/Sutter county region. Table 3-6 summarizes the residential distribution of these households.

Because these population changes are small relative to existing and projected city and county populations and fall within the range of historical variations in population levels, these areas should be able to accommodate the population growth without significant adverse impacts. Provision of public services should be able to keep pace with the accelerated population growth. Given the small number of new residents and the similarity of their demographic characteristics with those of the region's current residents, the impacts of growth on the demand for public and private services and community social structure should be negligible.

3.1.3.2.3 Income. Operation of PAVE PAWS will generate an additional \$6.1 million in wage income, 0.9% of projected 1980 personal income. Per capita income will increase by approximately 0.9% to \$6,850. These changes are equal to slightly less than 2 months normal income growth and will have little impact on the regional economy. Possible income generated by second jobs held by PAVE PAWS personnel and additional base procurement has been excluded from this calculation. Income from these sources would only marginally change the total impact on personal income in the region.

3.1.3.2.4 Housing. All of the incoming civilian personnel and their dependents and a proportion of the military personnel and their dependents will seek housing off-base. On the basis of past experience, the Beale AFB housing office estimates that 55% of the incoming military personnel will want to live off-base, even though on-base housing is sufficient to accommodate all of the additional military personnel. Therefore, about 150 military and civilian households would enter local housing markets.

Assuming that the incoming civilian and military households distribute their residences among communities in a pattern similar to the residential distribution of the existing personnel living off-base, the Sutter/Yuba County region would absorb about 125 households (85%) of the incoming personnel who would live off-base. Marysville/Linda and Yuba City would house most of this regional population influx. Approximately 65 households would seek housing in Marysville/Linda, and about 45 would look to Yuba City for housing. The remaining households (25) would be dispersed throughout the greater Sacramento area (see Table 3-6, p. 3-87).

The impact of these population changes on local and regional housing markets should be small. The increased housing demand could raise rental rates temporarily in some areas. Housing construction or rehabilitation may be necessary if the existing housing stock does not meet the needs (in terms of quantity, quality, location, and so on) of the new residents. However, because the projected population change is small relative to the total city and county population and, in all cases, falls well within the range of historical variations in population, city and regional housing markets should be able to accommodate the incoming Air Force personnel with no long-term adverse effects.

3.1.3.2.5 Education. Ninety percent of the households and, therefore, of the school-age children who will enter the region as a result of PAVE PAWS operation will locate in Marysville, Linda, Wheatland, Yuba City, or on the Base. These areas are covered by the three school districts described above (see Section 1.2.1.2.2). The Marysville, Wheatland, and Yuba City school districts will receive 182 new students as a result of PAVE PAWS operation (see Table 3-7.)

Each of the affected districts has adequate excess capacity to accommodate the additional students. In particular, the two Wheatland districts are so far below optimal operating levels that additional students can be accommodated with little or no extra operating costs.

Estimated increase in PL 81-874 entitlements as a result of student population increases in Marysville, Wheatland and Yuba City are \$13,000, \$61,500, and \$7,500, respectively. Because the Wheatland districts serve students who live on-base, they receive higher per-pupil compensation rates under PL 81-874 than Marysville and Yuba City districts receive.

Table 3-7

EDUCATION IMPACT OF PAVE PAWS AT BEALE AIR FORCE BASE

District	1980 Projected		Change with PAVE PAWS	
	Students ^a	Entitlement ^b	Students ^c	Entitlement ^d
Marysville Unified	522	\$ 111,304	61	\$ 13,000
Wheatland (2 Districts)	1,762	1,321,648	82	61,500
Yuba City Unified	260	50,272	39	7,500
Total Sutter/ Yuba/Beale related students	2,554	\$1,483,224	182	\$ 82,000

^aEstimate based on data from records of all four school districts.

^bEstimated entitlement for Beale-related students only. Calculation based on average PL 81-874 entitlement per federally-related student in each district.

^cEstimate based on Beale AFB average of 0.863 school-age dependents per military and civilian employee. This average was applied to the total number of new households in each city that would result from PAVE PAWS operation.

^dChange in entitlement is based on the number of new children in each district multiplied by that district's 1978-1979 average entitlement per federally related student.

Sources: Marysville U.S.D. (1978); Wheatland School District (1978); Wheatland Union School District (1978); Yuba City U.S.D. (1978).

3.1.4 Growth System

Sections 3.1.2 and 3.1.3 (pp. 3-16 and 3-82) included consideration of the growth system generally. In this section, we consider the growth system specifically, bringing together in one place a consideration of the effects anticipated should the basic system someday be expanded. (Currently there are no plans to implement a growth system.) Power densities for the growth system are presented in the same format used in Section 3.1.1 (p. 3-1) for the basic system. Then modifications of the expected biophysical and socioeconomic impacts are summarized.

3.1.4.1 Exposure to EMR in the Growth System

The main beam of the growth system does not illuminate even the few locations at ground level illuminated by a portion of the main beam of the basic system. Moreover, whereas the first sidelobe for the basic system increased the power density significantly at elevations below 400 ft MSL, depending on range, the first sidelobe for the growth system does not increase the power density significantly at those elevations. The reason is that the first sidelobe, like the main beam, is focused into a narrower angle. At the minimum 3-deg elevation of the main beam, the small portion of the first sidelobe in the growth system that is radiated below the antenna center (at 420 ft MSL) is comparable in power density to the higher-order sidelobes. Consequently, the calculated power density for the growth system varies only with distance from the radar for any elevation up to about 350 ft MSL. Between 350 and 800 ft MSL, power density varies with elevation as well as distance from the radar.

Figure 3-13 shows power density at ground level for the growth system in the range 1,400-3,000 ft, which extends through most of the transition zone to the beginning of the far field (the comparable range is 1,000-1,500 ft in the basic system). The figure shows that the power densities at 1,400 ft in the growth system are comparable to the power densities at 1,000 ft (near the exclusion fence) in the basic system.

Figures 3-14 through 3-17 indicate the power density for the growth system in the range 3,000-25,000 ft from the radar. All five figures for the growth system can be used together with Figure 3-1 (p. 3-3) to estimate power density for ground elevations up to 800 ft MSL (elevations above 400 ft are encountered only in Sector 2).

With regard to sector 3 at close range (see Figure 3-9, p. 3-12), values for the growth system of 80 and 90 microwatts/cm² were calculated for the points of closest approach, outside the exclusion and security areas on the north

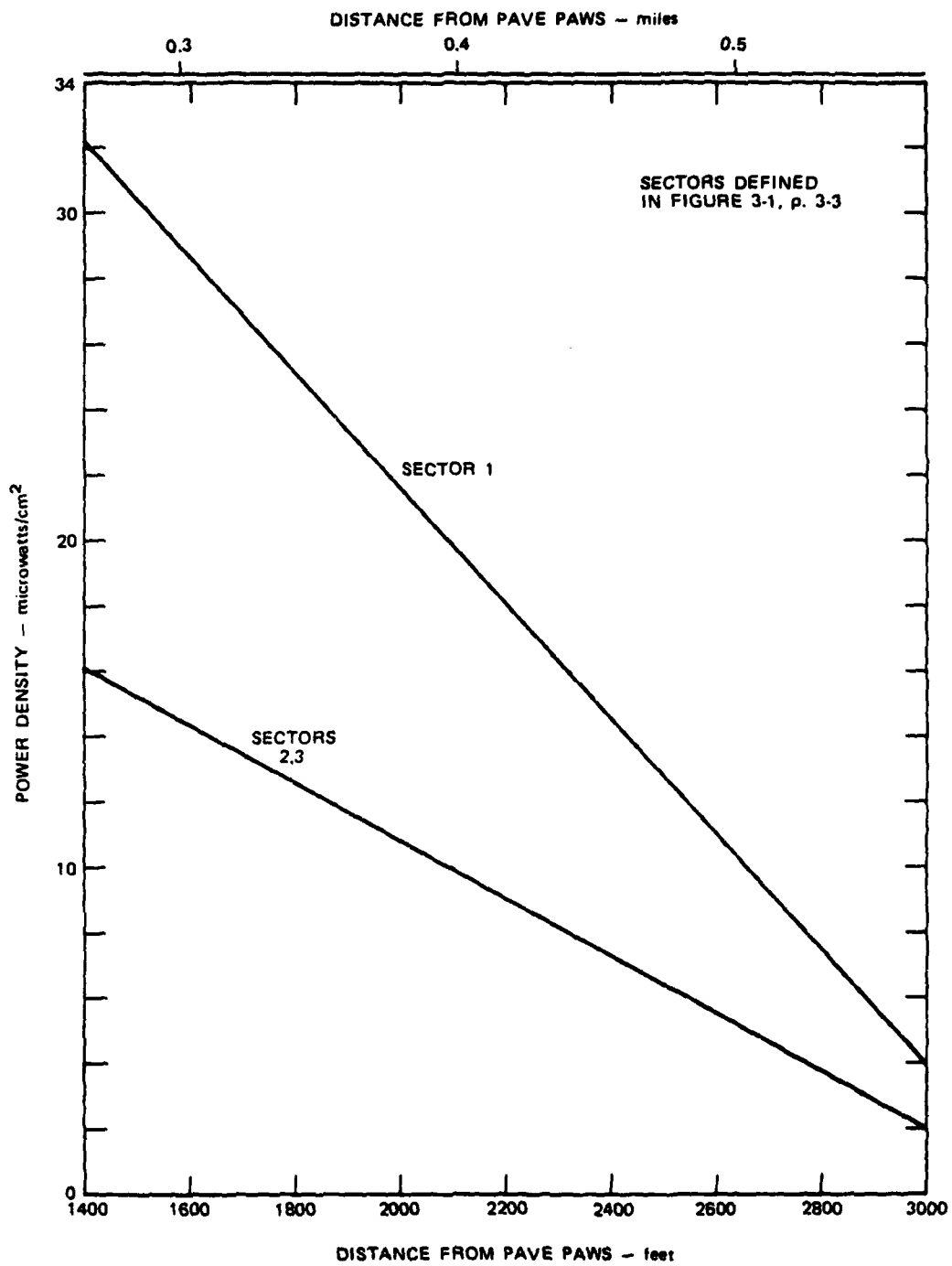

FIGURE 3-13. CALCULATED PAVE PAWS EMR POWER DENSITY FOR GROWTH SYSTEM, AT GROUND LEVEL, 1400-3000 FT RANGE

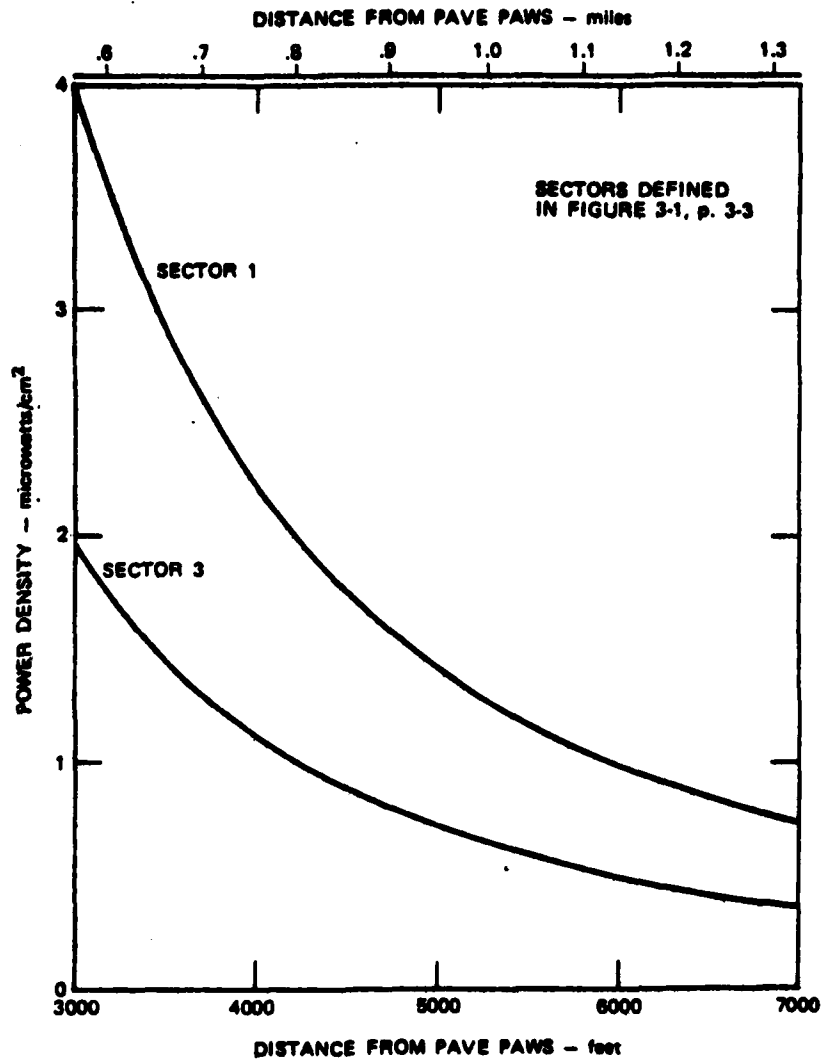

FIGURE 3-14. CALCULATED PAVE PAWS EMR POWER DENSITY FOR GROWTH ++
SYSTEM, SECTORS 1 AND 3, 3000-7000 FT RANGE

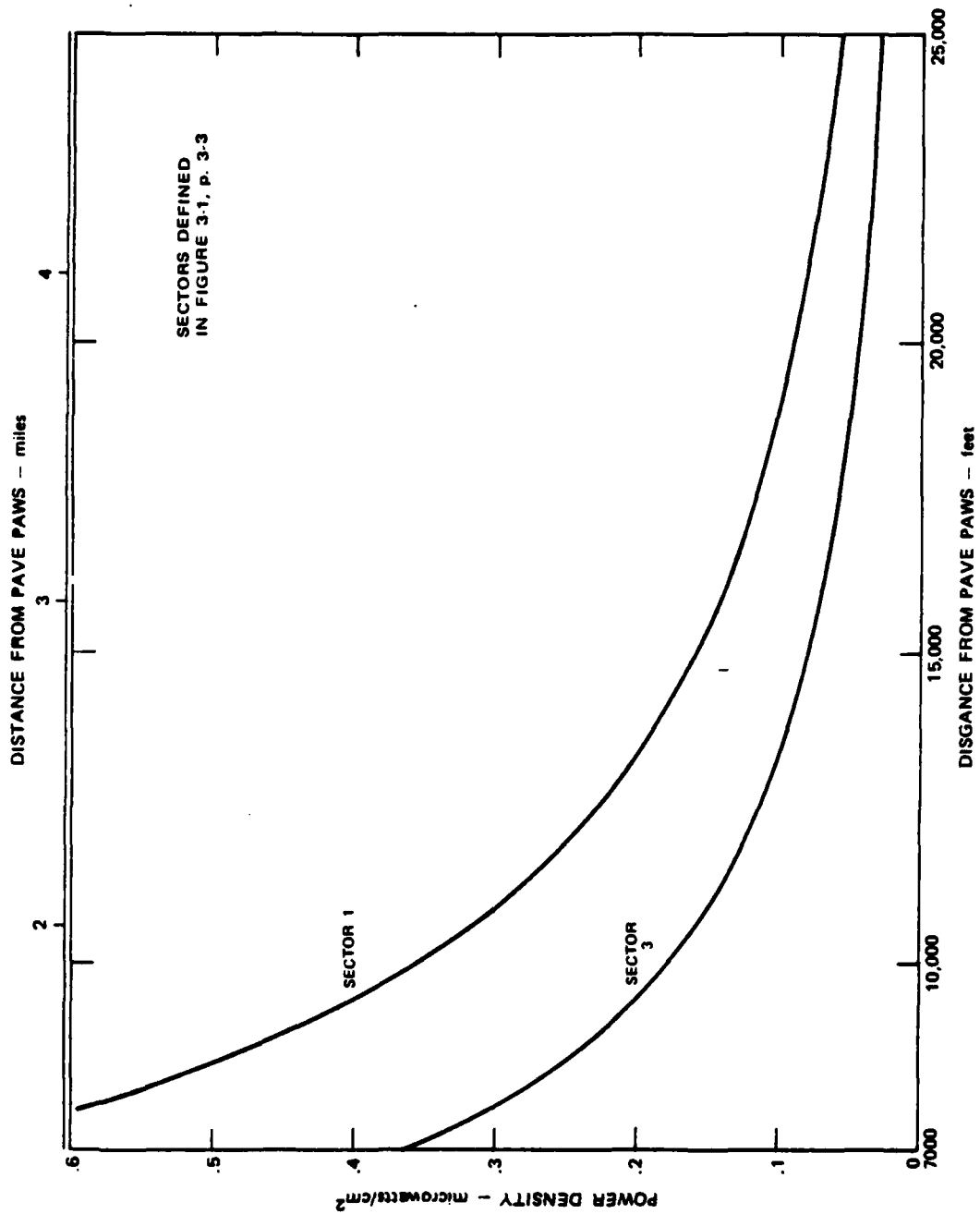

FIGURE 3-15. CALCULATED PAVE PAWS EMR POWER DENSITY FOR GROWTH SYSTEM, ++
SECTORS 1 AND 3, 7,000-25,000 FT RANGE

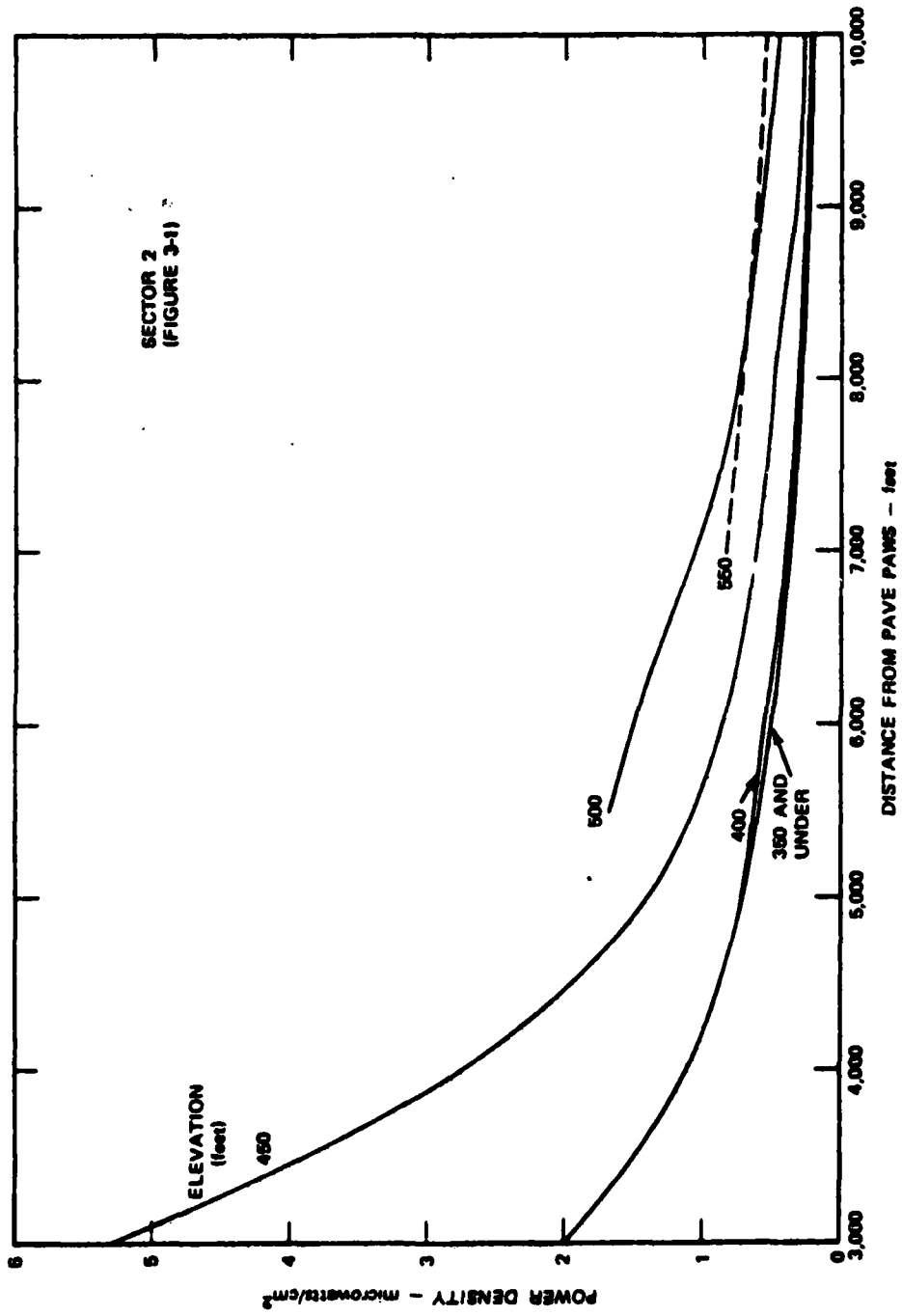
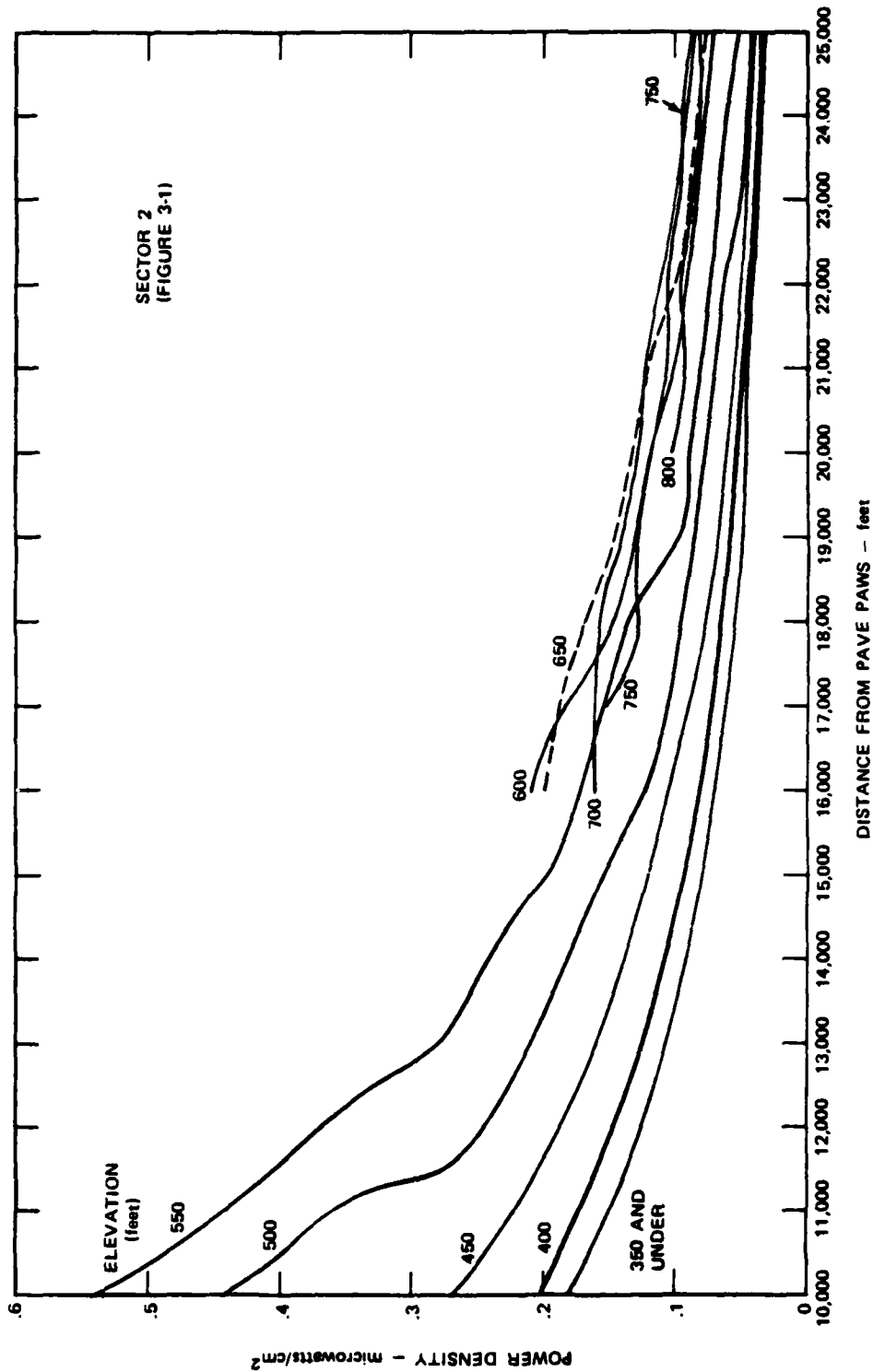

FIGURE 3-16. CALCULATED PAVE PAWS EMR POWER DENSITY FOR GROWTH SYSTEM, SECTOR 2, 3000-10,000 FT RANGE



SECTOR 2
(FIGURE 3-1)

FIGURE 3-17. CALCULATED PAVE PAWS EMR POWER DENSITY FOR GROWTH SYSTEM, ++
SECTOR 2, 10,000-25,000 FT RANGE

(350 ft) and southeast (330 ft), respectively. These values compare with 42 and 47 microwatts/cm², respectively, for the basic system (see Table 3-1, p. 3-13).

A broad comparison of the growth system with the basic system exposures at ground level cannot be made both simple and accurate because of the irregular terrain near PAVE PAWS at Beale AFB and the variation of exposure with elevation. Generally, it may be said that exposures from the growth system are from 0.6 to 3 times as high as exposures from the basic system at a given distance in the far field. Other characterizations of the relative power densities must rely on the detailed figures referenced above.

3.1.4.2 Biophysical Impact in the Growth System

A specific account of changes in expected impacts, in the case that the growth system is implemented, is included in the various subsections of Section 3.1.2 (p. 3-16). Briefly, the changes for the far-field may be summarized as follows:

- (1) Because average power densities in the growth system near ground level range from about 0.6 to 3 times those basic-system power densities, effects that depend on average power would occur at 0.8 to 1.8 times the distance for the basic system effect. Effects that depend on pulse power or maximum electric field intensity would occur at 1.4 times the distance for the basic system effect in areas illuminated only by higher-order sidelobes of either system. In areas that are illuminated by the first sidelobe of either system or grazed by the main beam of the basic system, a simple comparison is precluded by the strong altitude dependence of maximum pulse power and electric field intensity. However, in many places the maximum pulse power or electric field intensity will be much higher for the basic system than for the growth system. (Compare Tables A-5 and A-6, pp. A-31 and A-32.
- (2) Main-beam on-axis power densities are 4 times as high in the growth system as in the basic system. Effects that depend upon pulse or average power or electric field intensity of the main beam would occur at 2 times the distance for the basic system effect. None of the effects occurs at or near ground level (below 800 ft MSL, depending on distance) because the main beam does not significantly penetrate there; only airborne systems may be affected by the main beam.

3.1.4.3 Socioeconomic Effects of the Growth System

If the growth system were implemented, virtually no additional demographic or economic effects would result beyond those

anticipated as a result of current operating plans. No additional personnel would be required to operate the radar or in supporting activities.

3.2 Mt. Hebo AFS, Oregon

3.2.1 Biophysical Impacts

The potential biophysical effects of the discontinuation of Detachment 2 of the 14th Missile Warning Squadron at Mt. Hebo AFS will relate directly to the land use impacts discussed in Section 3.2.2.1. When the land reverts to the U.S. Forest Service, opportunities will be available to increase the natural resource values of the area through land management programs (USFS, 1978). Consequently, various beneficial biophysical effects are anticipated from the proposed action (e.g., an increased amount of wildlife habitat through restoration of certain areas of the AFS to natural vegetation, and decreased noise and air pollution from a reduction of automobile traffic). In addition, with the dismantling of the FSS-7s (Section 3.2.2.1.1), the EMR contribution to the environment will be eliminated.

3.2.2 Socioeconomic Impacts

3.2.2.1 Land Use and Aesthetics

3.2.2.1.1 Land Use. When Detachment 2 at Mt. Hebo AFS is reassigned in conjunction with the startup of PAVE PAWS, the 88 acres of land currently occupied by the station will be returned to the U.S. Forest Service, and will thus become part of the Hebo Planning Unit, Siuslaw National Forest.

The Forest Service recently agreed on a management plan for the Hebo Unit that permits timber development on 87% of the land. The remaining 13%, including the land that is now the AFS, would be included in an activity zone designated for recreational uses (e.g., cross country skiing). At the main site, it is anticipated that all buildings, including the three white radomes, would probably be removed and the land would be returned as much as possible to its original natural state. The housing facilities and some facilities at the peak may be left intact for use by the Forest Service. The electronic facilities east of the main site, which currently operate under special use permits, would be allowed to continue to do so (Barney, 1979).

3.2.2.1.2 Aesthetics. Over time, the land, if left undisturbed, will become revegetated. The peak of Mt. Hebo would thus acquire a more natural appearance which would be considered by some viewers, especially visitors to the Cascade Head Scenic and Recreation Area, as an aesthetic improvement.

3.2.2.2 Demographics and Economics

3.2.2.2.1 Employment. When Detachment 2 is shut down as a result of PAVE PAWS operation at Beale AFB, Tillamook County will lose 124 AF jobs. This employment change will generate additional employment losses in the county through the multiplier effect. The total job loss is estimated roughly at 210 jobs. This represents 2.7% of projected 1980 employment.

3.2.2.2.2 Population. When Detachment 2 personnel leave Mt. Hebo AFS, the total population loss in Tillamook County will be approximately 330 people. This represents 1.6% of 1980 projected populations, and is equal to one year's average population growth.

This estimate assumes that all military and civilian personnel will choose to leave the area. To the extent that Mt. Hebo civilian employees decide to look for other jobs in the area or that military personnel choose to retire in the area, this analysis will overestimate the impact of base closure on Tillamook County population.

3.2.2.2.3 Income. If Detachment 2 is deactivated in 1980, the regional economy would lose approximately \$1.65 million in annual income from the wages of the transferred personnel. This will generate further income losses throughout the economy through a multiplier effect. The total impact of this loss is approximately \$2.8 million. This amount is equal to 2% of projected 1980 personal income, or approximately 2 month's average growth in personal income.

3.2.2.2.4 Housing. Transfer of Detachment 2 personnel will result in the addition of approximately 57 vacant housing units on the civilian housing market. The cities of Tillamook and Hebo will be most strongly affected, with each gaining 17 vacant housing units.

3.2.2.2.5 Education. Closure of Mt. Hebo as a result of PAVE PAWS will result in relocation of 49 dependents who now attend Tillamook schools. The district will also lose approximately \$29,400 in PL 81-874 funds.

3.3 Mill Valley AFS, California

3.3.1 Biophysical Impacts

The potential biophysical effects of the reduction of staff of Detachment 3 of the 14th Missile Warning Squadron at Mill Valley

AFS will relate directly to the land use impacts discussed in Section 3.3.2.1. Whether the natural resource value of the site is increased will depend primarily on the extent, if any, to which the AFS is returned to its natural state. Regardless, with the reduction in number of operating radars (3.3.2.1.2), the contribution to the EMR environment will be reduced.

3.3.2 Socioeconomic Impacts

3.3.2.1 Land Use and Aesthetics

3.3.2.1.1 Land Use. When PAVE PAWS becomes operational and most of the staff in Detachment 3 at Mill Valley AFS are reassigned, the MMWD will reassume responsibility for use of most of the land except for small radar operations sites. This portion is to be a JSS site (see Section 1.2.3), and both of the white domes enclosing the radars are to remain, along with a few radar operations support buildings. MMWD plans to hold a workshop in May 1979 to discuss alternative future uses for the remainder of the site with representatives of the community. Possible uses being considered at this point include (Van de Weg, 1979):

- o Return the site to its natural state by dismantling all facilities and implementing a landscaping program
- o Lease the site, for example, to a resort or hotel manager who will use the existing facilities and construct additional facilities
- o Use the existing facilities to establish a county fire station and heliport to support government and community fire-fighting crews (e.g., Civilian Conservation Corps); assign a fire ranger to reside in one of the housing units
- o Establish a hostel for use by hikers and backpackers
- o Allow the GGNRA to use the land, for example, as a nature camp for underprivileged children.

3.3.2.1.2 Aesthetics. Mt. Tamalpais, on which the Mill Valley AFS is located, is highly visible all over the northern San Francisco Bay Area. Of the AFS facilities, the two white radomes are visible from the farthest distances; the associated buildings and the exposed radar cannot be distinguished as far away as the domes. When PAVE PAWS begins operating, some of the low buildings will be removed, and the FSS-7 will be removed from one radome and replaced by the exposed radar. Thus, although some facilities

will be removed, the most visible elements, the two white radomes, will remain. The result will be a minor visual improvement generally detectable only from relatively short distances.

3.3.2.2 Demographics and Economics

3.3.2.2.1 Employment. Sixty-six persons will be transferred from Mill Valley AFS when PAVE PAWS becomes operational at Beale AFB. This change will generate additional employment losses through the multiplier effect. The total job loss is therefore estimated at 160 jobs, 94 of which are held by civilians. This job loss is less than 0.2% of the 1978 wage and salary employment in the county. This represents an insignificant portion (less than 0.05%) of projected Oakland-San Francisco SMSA 1980 employment and should have little impact on the area's economy.

3.3.2.2.2 Population. Shutdown of Mill Valley AFS due to PAVE PAWS will result in a total population loss of 213 people. This represents less than 0.1% of projected 1980 population and will, therefore, have little effect on Marin County population and demographics.

3.3.2.2.3 Income. When Detachment 2 is deactivated as a result of PAVE PAWS, the Marin County economy will lose approximately \$849,000 in annual wage income. This amounts to less than 0.1% of projected 1980 Marin County income, and should not affect the local economy.

3.3.2.2.4 Housing. Sixty-six persons will be transferred from Mill Valley AFS when PAVE PAWS becomes operational at Beale AFB. Of this number, 32 are now residing in Mill Valley in base housing and 29 are living on Hamilton AFB. The remaining 5 persons and their dependents will vacate housing in various locations in Marin County. The impact of these 5 households on the 87,000 household Marin County housing market will be negligible.

3.3.2.2.5 Education. When Detachment 2 personnel are transferred from Mill Valley AFS as a result of PAVE PAWS, the Novato and Mill Valley School Districts would lose a combined total of approximately 30 students. This loss would contribute to the enrollment decline already being experienced by both school districts and to the existing excess capacity. Both districts would also lose average daily attendance (ADA) revenues for those students. The Novato Unified School District also expects to lose PL 81-874 funds, but the loss would be less than \$2,000.

3.4 Mt. Laguna AFS, California

3.4.1 Biophysical Impacts

The potential biophysical effects of the discontinuation of Detachment 4 of the Missile Warning Squadron at Mt. Laguna AFS are minor. With the dismantling of the FSS-7 radar, the contribution to the EMR environment will be eliminated.

3.4.2 Socioeconomic Impacts

3.4.2.1 Land Use and Aesthetics

3.4.2.1.1 Land Use. When the PAVE PAWS radar becomes operational, most of the radar facilities at Mt. Laguna are to be used as a part of the JSS (see Section 1.2.4). The FSS-7 radar will be dismantled, but the other three white radomes will remain. No significant land use changes are anticipated.

3.4.2.1.2 Aesthetics. Because the operation of PAVE PAWS is not expected to result in visible changes in the facilities on Mt. Laguna, no significant aesthetic impacts are anticipated.

3.4.2.2. Demographics and Economics

3.4.2.2.1 Employment. Dismantling Detachment 4 as a result of PAVE PAWS will result in a loss of 48 jobs at Mt. Laguna AFS. This loss will be amplified in the local economy through a multiplier effect. The total employment loss is estimated at 115 jobs; this decrease will have little impact on the San Diego economy.

3.4.2.2.2 Population. Dismantling Detachment 4 will result in a population loss of 133 people. A population change of this size will not affect San Diego County's demographic profile.

3.4.2.2.3 Income. When Detachment 4 personnel are transferred from Mt. Laguna, San Diego County would lose approximately \$61,000 in monthly wages. Because of multiplier effects, this income loss will result in a total income loss of \$145,000 in San Diego County. This represents 1.1% of the area's personal income or approximately 1 average month's income growth, and it should not significantly affect the area's economy.

3.4.2.2.4 Housing. When Detachment 4 is deactivated, approximately 23 units of on-base housing (14 family units and 9 bachelor units) would become available for occupancy. Residences of the 25 outgoing personnel who live off-base would also be vacated. Almost all (85%) of those off-base personnel rent or lease their residences, and almost half of them reside in El Cajon. Because this number of units is very small compared with housing supply in the county, the AF action should have no appreciable impact on San Diego County's housing market.

3.4.2.2.5 Education. The school districts in the vicinity of Mt. Laguna AFS would lose about 24 students as a result of the deactivation of Detachment 4. This loss would be distributed among about 10 schools. The impact of these losses on the various school districts' revenues, expenditures, and facility utilization levels should be negligible.

Chapter 4

ALTERNATIVES

In this chapter, four possible alternatives to the proposed action (i.e., operation of the PAVE PAWS radar facility at Location No. 2 at Beale AFB) will be considered. They are:

- o Do not operate PAVE PAWS
- o Postpone full-scale operation of PAVE PAWS
- o Move the radar to one of three possible alternative locations
- o Modify the radar or its surroundings.

Each of the alternatives is described in the paragraphs that follow.

4.1 No Action

The no-action alternative is not to operate the PAVE PAWS facility at Beale AFB. All the major impacts of construction have already been experienced. Therefore, if this alternative is pursued, the principal effects that can be avoided are those relating to the operation of the radar.

Not operating PAVE PAWS also means forgoing the requirements of national security and defense to be gained by its operation. If PAVE PAWS is not operated, radars that it is scheduled to replace will continue to operate. However, those radars have been outdated by technical advances in surveillance and tracking radars, and by evolution in the nature of the threat from sea-launched ballistic missiles. Specifically, the PAVE PAWS radar, based on the phased-array technology, can track many targets concurrently (as opposed to being dedicated to only a single target at a time), can do so more accurately and at 3,000 nautical miles range (as opposed to a range of less than 1,000 miles). In addition, it can simultaneously search for objects as well as track objects, thus permitting detection and accurate counting of all attacking sea-launched ballistic missiles. It is this superior ability to warn and to characterize missile attacks that would be sacrificed if PAVE PAWS were not operated.

No alternative methods of radar surveillance and tracking other than continued operation of obsolete radars will be available in the foreseeable future to substitute for PAVE PAWS. Consequently, changes in defensive military strategies, and

possibly national policies, might be necessary if information characterizing an attack (which PAVE PAWS would provide) were not available.

4.2 Postpone Action

This alternative would involve postponing full-scale operation of PAVE PAWS. Neither the characteristics of PAVE PAWS operation nor the affected characteristics of the environment would change with the passage of time. Therefore, postponement would delay occurrence of the impacts discussed in Chapter 3, but not alter them.

However, no apparent environmental benefit would be gained by postponement. Although complete and detailed knowledge of biological effects is not available, current information does not indicate any significant risk and is being used to provide safeguards, such as exclusions.

On the other hand, given the real threat posed by sea-launched ballistic missiles, a lengthy postponement would increase the risk to the security of the United States. Radars now in operation are incapable of adequately characterizing a sea-launched ballistic missile attack and providing ample warning time to strategic forces. Existing Soviet missiles can overfly the present radars, thereby avoiding detection. The resulting gap in warning capability makes a surprise attack possible.

4.3 Different Locations

The original site selection process for the West Coast PAVE PAWS radar facility took approximately 18 months. Initially, eight potential locations for the radar were identified and then compared using a set of siting criteria. The eight sites were: Almaden AFS, Beale AFB, Castle AFB, Mather AFB, Mill Valley AFS, and Pt. Arena AFS, all in California; Mt. Hebo AFS, Oregon; and Othello AFS, Washington. Each proposed site had to satisfy the first five of the following ten criteria as a minimum requirement before it would be given further consideration. The basic siting criteria used were:

- (1) Choice of real estate in descending order of priority: DOD property, other federal property, state and municipal property, and privately owned property
- (2) Geographical location--extensive northern coverage was desired, consequently an area approximately 200 miles wide starting in the southern San Francisco region and extending about 600 miles north along the coast was considered

- (3) Unobstructed line-of-sight view for 240 deg in azimuth (westerly 6 deg counterclockwise to 126 deg) and for 2 deg or less above the horizon
- (4) Safe radiation hazard distances for people
- (5) Safe distances for persons wearing cardiac pacemakers
- (6) Avoidance of fuel and ordnance hazards
- (7) Minimization of possible electromagnetic interference (EMI) to nearby military and civilian electronics installation and to home entertainment devices
- (8) Proximity to airfields, approach patterns, and restrictions to aircraft flying near the site
- (9) Availability of access roads, commercial power, water supply, sewage disposal, communications systems, housing, transportation, schools, churches, recreational, and other support facilities
- (10) Cost of site preparation.

After careful screening, it was determined that Beale AFB was the only site that could meet all of the criteria. Of the sites surveyed, only Beale AFB had the required acreage (58 acres) located far enough from the main part of the installation to avoid radio frequency radiation (RFR) hazards.

A comprehensive analysis of Beale AFB reaffirmed that the site was appropriate for the PAVE PAWS radar. Within Beale, three potential sites (Location No. 1, Location No. 2, and Location No. 3) were evaluated before Location 2 was selected as the site for the radar. The other two sites were eliminated for the following reasons:

- o Location No. 1 lies in close proximity to local highways, established flight line activities, and the base proper. Radiation characteristics of the radar were determined not to be compatible with this location
- o Location No. 3 is located on the periphery of the base property. The extent of the buffer zone associated with Location No. 3 requires greater electroexplosive device use restrictions outside the boundary of Beale AFB than Location No. 2 does. Likewise, the possibility of adverse impacts to the off base environment is greater at Location No. 3.

After the environmental assessments were made, the screening process completed, and after approval, construction started. Nevertheless, it would still be feasible, although costly, to relocate the facility elsewhere.

Therefore, to address reasonable options in this study, three of the previous prospective sites will be examined as alternatives to the proposed action. (The relative instability of ships and airplanes makes them operationally unacceptable for a PAVE PAWS, although they are suitable as platforms for other radar applications.) Because the radar facility is already in place, choosing another location at this point would necessitate the costly dismantling of the nearly completed radar and its support buildings, transporting of the major pieces of the radar structure to the new site, and reconstructing the radar and constructing ancillary buildings at a new location. The three alternative sites (see Figure 4-1) meeting operational criteria are:

- o Mt. Hebo AFS, Oregon
- o Mill Valley AFS, California
- o Location No. 1, Beale AFB, California.

Location No. 3, situated less than 1 mile northeast of Location No. 2, was not selected because the environmental impacts associated with constructing and operating PAVE PAWS at Location No. 3 would be quite similar to those described for the prime location (Location No. 2), and thus Location No. 3 does not represent a distinct environmental alternative. Othello AFS in Washington was eliminated because it is no longer federally-owned property. In 1977, Othello AFS was deactivated, and the land was sold to private individuals. The remaining four locations, Pt. Arena AFS, Almaden AFS, Mather AFB, and Castle AFB, all have serious limitations as radar sites because of electromagnetic compatibility, radiation hazards, topography, or environmental considerations.

During 1977, some general assumptions were made about the termination of activities at the existing PAVE PAWS site at Otis AFB and estimates of the cost of relocating that radar facility were made (J. Thornton, 1978). Those assumptions were:

- o All production and procurement activities will continue
- o Critical hardware will be put in temporary storage
- o All hardware will be retested after storage
- o Termination costs will be paid to current construction subcontractors
- o New construction contracts will be awarded
- o Relocation would delay the schedule by 33 months (including all construction and startup activities).

The principal estimates for relocation costs that still apply today, expressed in 1977 dollars and uncorrected for additional expenditures made since 1977, are presented in Table 4-1. Those estimated costs represent the best information available on the costs for relocation of the PAVE PAWS at Beale AFB.

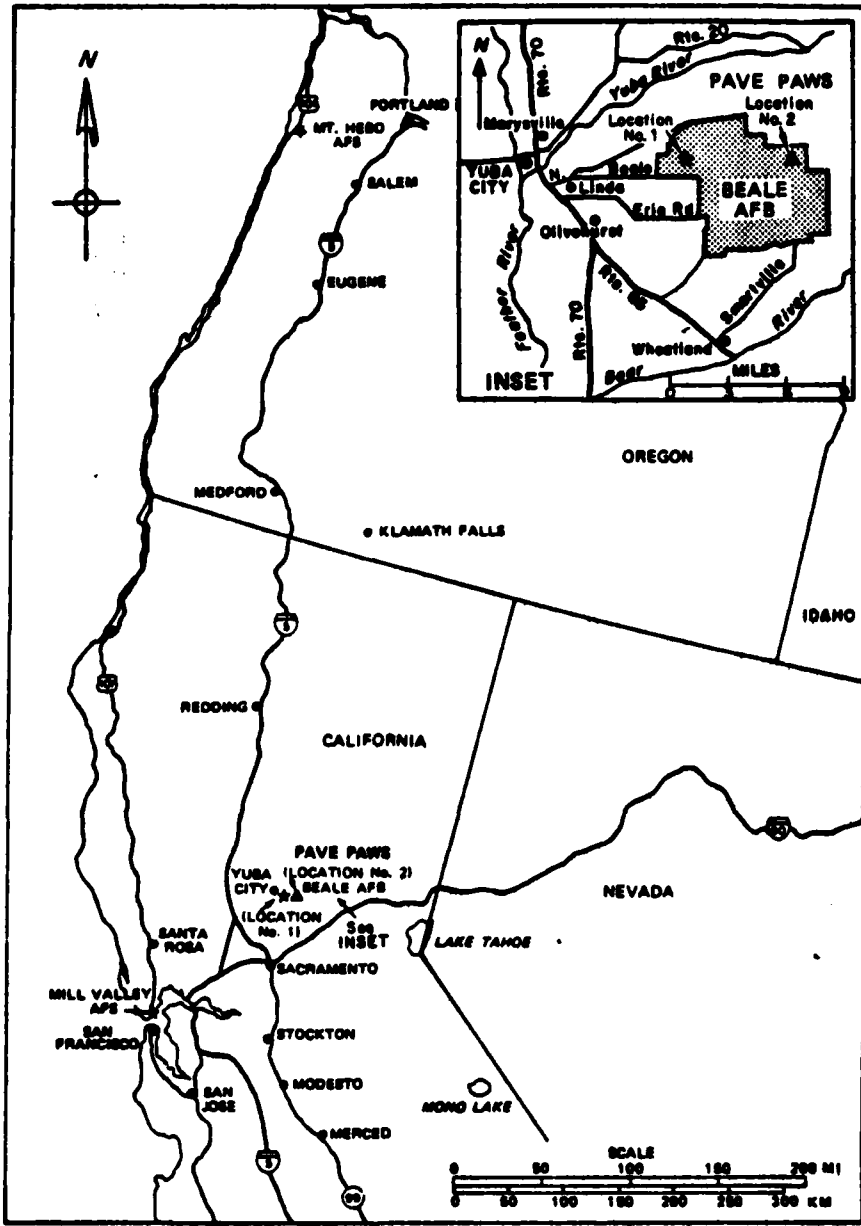

FIGURE 4-1. LOCATION OF ALTERNATIVE SITES: BEALE AIR FORCE BASE, MT. HEBBO AIR FORCE STATION, AND MILL VALLEY AIR FORCE STATION

Table 4-1

ESTIMATED COSTS OF RELOCATING PAVE PAWS

	<u>Estimated Cost</u>
New construction subcontract	\$9,000,000
Storage of hardware	400,000
Retest of stored hardware	450,000
Labor escalation for installation and test personnel	250,000
Replacement of failed hardware	1,100,000
Hardware dismantling	250,000
Extension of key contractor program office personnel	900,000
Miscellaneous material replacement and publication effort	240,000
Installation and test efficiency loss	300,000
Interest expense on current contract	2,650,000
New architectural and engineering effort	<u>200,000</u>
Subtotal	\$15,740,000
Escalation increase for 2-year delay	<u>790,000</u>
Total additional costs	\$16,530,000

Source: USAF, Electronic Systems Division (1978)

4.3.1 Mt. Hebo AFS, Oregon

4.3.1.1 Existing Site Characteristics

Currently Mt. Hebo AFS is a radar site at which the Aircraft Detection Unit of the 689th Radar Squadron is the host unit and Detachment 2 of the 14th Missile Warning Squadron is the tenant unit. Because the operation of the PAVE PAWS radar facility at Beale AFB would result in subsequent shutdown of Detachment 2, the existing site characteristics of Mt. Hebo AFS have been described in Section 1.2.2, p. 1-40). As a result of a separate action, the Aircraft Detection Unit at Mt. Hebo AFS is scheduled to leave in the spring of 1979.

4.3.1.2 Probable Impact of the Proposed Action on the Environment

Relocation of the PAVE PAWS facility to Mt. Hebo AFS would require the dismantling of existing buildings at Mt. Hebo AFS, dismantling of the radar hardware now in place at Location No. 2 on Beale AFB, and, of course, reconstruction of the radar at Mt. Hebo AFS.

Figure 4-2 shows the vicinity of Mt. Hebo AFS with an exposure grid superimposed, analogous to Figure 3-1 (p. 3-3) for the site at Location No. 2 on Beale AFB. Because the center of the antenna at Mt. Hebo AFS would be about 2,780 feet higher than at Location No. 2, Figures 3-3 through 3-8 (pp. 3-5 through 3-10), 3-14, and 3-15 (pp. 3-93 and 3-94) may be used to estimate exposures in the vicinity of Mt. Hebo AFS with the following adjustment. From any elevation of interest at Mt. Hebo AFS below about 3,180 feet, subtract 2,780 feet. The resultant adjusted elevation (together with the appropriate distance) and Figures 3-3 through 3-6 may then be used to obtain the exposure estimate for Mt. Hebo AFS. (Exposure for adjusted elevations below 100 ft may be estimated using the 100 ft curve.) Use of Figures 3-7 and 3-8, as well as Figures 3-14 and 3-15 for the growth system, does not require an elevation. Qualitatively, it is clear that the Mt. Hebo AFS site is more remote from population centers than Location No. 2, and would result in lower overall exposure to RFR.

In other respects, such as kind of effects expected and degree of interference or hazard at specified exposures to RFR from PAVE PAWS, conclusions in Chapter 3 and the appendices regarding the Location No. 2 site apply also to the site at Mt. Hebo AFS.

The main station area at Mt. Hebo AFS, consisting of about 22 acres, is large enough to accommodate the 4 acres required for the PAVE PAWS radar facility. However it does not include sufficient land for an exclusion area which requires about 50 additional acres contiguous to the radar. Thus it would be necessary for additional land to be leased from the US Forest Service.

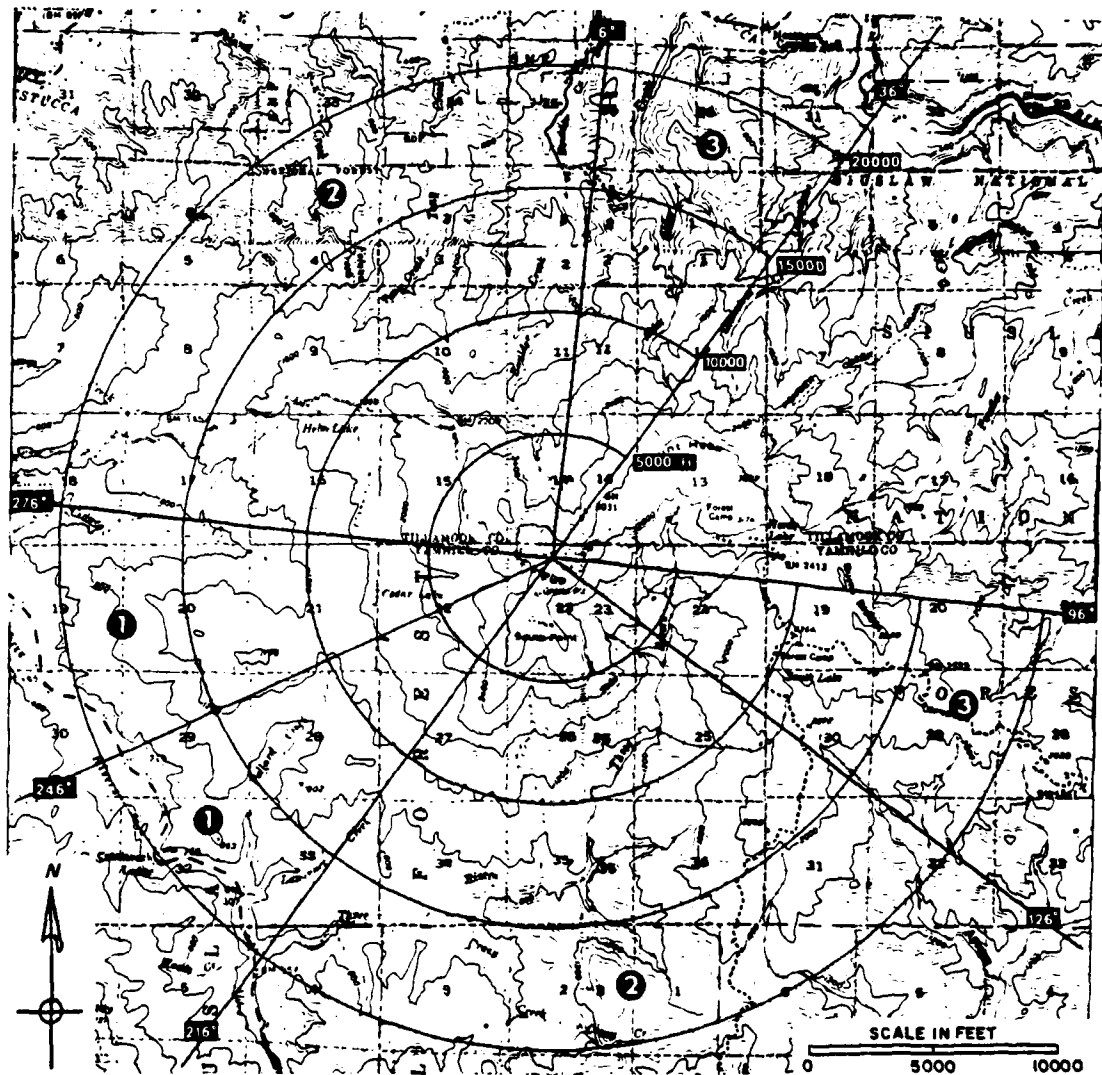

FIGURE 4-2. PAVE PAWS AZIMUTH FROM THE MT. HEBO AIR FORCE STATION ALTERNATIVE

The construction of PAVE PAWS at Mt. Hebo AFS would probably cause some adverse impacts related to mass movement and soil erosion. The station is situated in a region where mass movement is a widespread problem. The area directly east and south of Mt. Hebo AFS has been identified as having a high potential for slumps and surficial landslides (Oregon Department of Environmental Quality, 1978). Although the station is on bedrock and would not be directly affected, some facilities associated with the operation might be impacted by blockage of roads, downed utility lines, or destruction of buildings. Construction in potential slide areas should be avoided and facilities should be built to minimize the concentration of runoff and infiltration on the ground surface.

Generally, earthquake activity is only one of many factors that can initiate sliding, and it should be regarded as a hazard of secondary importance (Beaulieu, 1973). There is no direct evidence of recent activity along any of the faults in the Mt. Hebo area, but a moderate earthquake (5.0 magnitude) in the area could trigger a significant mass movement. Historical records show that an earthquake of Intensity IV occurred near Tillamook in 1939, and an earthquake of Intensity VI was centered near Beaver in 1957 (approximate magnitudes of 3.5 and 5.0, respectively) (Beaulieu, 1973).

The Nestucca and Three Rivers basins in the Mt. Hebo Region have been identified by the Oregon Department of Environmental Quality (1978) as "hot spots" for environmental problems in the state. In particular, these river basins are prone to severe sedimentation, severe streambank erosion, and moderate problems of excessive debris (presence of logs, slash, and other materials in amounts large enough to hinder the beneficial uses of water). The Mt. Hebo area yields sediment at the high rate of 200 to 400 tons per square mile per year. Denudation of the land surface would significantly increase these rates. Although flash flooding is a problem in many parts of western Oregon, there is a low potential that such floods will occur in the Nestucca and Three Rivers basins.

Regional water quality might be significantly impaired from increased erosion. Presently the water quality of the small streams right at Mt. Hebo is quite good (see Section 1.2.2.1). Sediment control for all phases of construction and operation would be a necessity in order to maintain this quality. However, the potential for significant contamination of surface water or groundwater from oil spills or other discharges is low due to high rates of precipitation, dense vegetation, and lengthy travel times from the discharge point to the nearest domestic water supply. Water supply, wastewater treatment, and solid waste removal would be accommodated by current station facilities and no adverse impact is expected, although both the water supply and the wastewater treatment facilities might have to be expanded.

No mineral resources are found in the area, and therefore no mining activities would be affected by the construction of PAVE PAWS at Mt. Hebo.

If water quality of the streams were significantly impaired, aquatic biota would be adversely affected. Terrestrial habitats of Mt. Hebo AFS are currently quite disturbed, although native vegetation occurs outside the periphery of the station. Further habitat degradation on the summit of Mt. Hebo would be expected to result from construction of PAVE PAWS. The severity of this disturbance would depend on the location of the radar. The major terrestrial ecological impacts anticipated would be those related to soil moving activities, increased soil erosion, noise, and physical movement of men and machines during construction of the radar facility.

The existing radar buildings on the summit of Mt. Hebo are not visible from much of the surrounding area including the town of Hebo, because of the rugged forested terrain and frequent inclement weather (Section 1.2.2.1). However, on clear days the summit is visible from areas along the Pacific coast, including the Cascade Head Scenic and Recreational Area (17 miles southwest of Mt. Hebo). Of the three existing radomes, two stand 120 ft high and one 175 ft. If PAVE PAWS were built on Mt. Hebo, its 105 ft building would be less conspicuous than the three white radomes present because of its smaller size and because of its natural paint color. Should PAVE PAWS move to Mt. Hebo, the existing radomes could eventually be removed, resulting in a more natural view. However, the 1,000 ft radius exclusion fence might require the clearing of some trees. If a swath were needed, it would be visible on clear days. Clearing of vegetation would have definite ecological impacts because habitat modifications would result.

4.3.1.3 Demographics and Economics

4.3.1.3.1 Employment. Operation of PAVE PAWS at Mt. Hebo would result in a net increase of 101 jobs on the base. This is equal to the number of personnel brought in to staff the new radar minus the number transferred out when Detachment 2 is deactivated. This new on-base employment would generate additional jobs in Tillamook County through the multiplier effect. The total increase in Tillamook County employment as a result of Air Force action would be approximately 170 jobs. This is equal to 2.4% of projected 1980 employment.

4.3.1.3.2 Population. Operation of PAVE PAWS at Mt. Hebo would result in a net population increase of 454 persons, the number of military and civilian PAVE PAWS personnel and their families minus

the number of people who would leave Tillamook County when Detachment 2 is deactivated (see Table 4-2). The increase is 2.3% of projected 1980 population and is equal to nearly 18 months of average population growth. A population change of this size could affect the County's demographic profile, and might have a significant impact on the demand for public and private services, and the community's social structure.

Table 4-2

POPULATION CHANGE DUE TO PAVE PAWS MT. HEBO

<u>Personnel and Dependents</u>	<u>Increase Due To PAVE PAWS</u>	<u>Decrease Due To PAVE PAWS^a</u>	<u>Net Change Due To PAVE PAWS</u>
Officers	84 ^b	19	65
Enlisted Men	429 ^c	174	255
Civilians	<u>146^d</u>	<u>11</u>	<u>135</u>
Total	659	204	455

^aBased on actual household size of Detachment 4 personnel.

^bBased on average officer's household size at PAVE PAWS, Otis AFB, of 3.5.

^cBased on average enlisted man's household size at PAVE PAWS, Otis AFB of 2.9.

^dBased on average household size of all civilians employed by the Air Force of 2.75.

Source: U.S. Air Force (1979).

4.3.1.3.3 Income. Operation of PAVE PAWS at Mt. Hebo would generate an additional \$1,670,000 in wages in Tillamook County if all civilian personnel required for PAVE PAWS are recruited from outside the county. (If some of the civilians are hired within the county, this figure will overestimate the increase in income.)

The effect of the additional \$1,670,000 would be multiplied throughout the economy, and the total effect will be an additional \$2,824,000 in personal income. This amount is equal to approximately 2% of projected 1980 total personal income, or 2 months average growth in personal income.

4.3.1.3.4 Housing. Operation of PAVE PAWS at Mt. Hebo would require 225 employees. These people will replace current Detachment 2 personnel. Because Detachment 2 would employ 124 people in 1980, an additional 101 households will be brought into the region.

Table 4-3 shows the projected housing distribution of the incoming personnel. This analysis assumes that additional employees who cannot find accommodations on base will distribute themselves in Tillamook County in the same pattern followed by current Detachment 2 personnel. It also assumes that all civilians required for PAVE PAWS operation will move into the region from outside of the county. To the extent that this last assumption is not true, the analysis will overestimate the housing impact of operation of PAVE PAWS. Currently 84% of all civilian employees at Mt. Hebo AFS were recruited from outside the county (U.S. Air Force, 1978). A housing influx of this magnitude in these small communities could affect vacancy rates and push up local rents and housing prices.

Table 4-3

HOUSING INFLUX DUE TO PAVE PAWS AT MT. HEBO

<u>Location</u>	<u>Households</u>
On-Base	19
Tillamook	20
Hebo	20
Pacific City	18
Cloverdale	14
Lincoln City	6
Bay City	4
Total	<u>101</u>

4.3.1.3.5 Education. Operation of PAVE PAWS at Mt. Hebo would result in a net addition in Tillamook schools of about 40 children. The district would receive approximately \$24,200 in additional PL 81-874 funds for these students. Adequate excess capacity exists for these 40 new students.

4.3.2 Mill Valley AFS, California

4.3.2.1 Existing Site Characteristics

Currently, Mill Valley AFS is a radar site at which the Aircraft Detection Unit of the 666th Radar Squadron is the host

unit and Detachment 3 of the 14th Missile Warning Squadron is the tenant unit. Because operation of the PAVE PAWS radar facility at Beale AFB would result in subsequent deactivation of Detachment 3, the existing site characteristics at Mill Valley AFS have been described in Section 1.2.3, p. 1-47. As a result of a separate action, the host unit at Mill Valley AFS is scheduled to leave Mill Valley AFS at approximately the same time that PAVE PAWS at Beale AFB is scheduled to begin operations (1980).

4.3.2.2 Probable Impact of the Proposed Action on the Environment

Relocation of the PAVE PAWS facility to Mill Valley AFS would require the dismantling of some existing buildings at Mill Valley AFS, dismantling of the radar hardware now in place at Location No. 2 on Beale AFB, and, of course, reconstruction of the radar at Mill Valley AFS.

Figure 4-3 shows the vicinity of Mill Valley AFS with an exposure grid superimposed, analogous to Figure 3-1 (p. 3-3) for the site at Location No. 2 on Beale AFB. Because the center of the antenna at Mill Valley AFS would be about 2,200 feet higher than at Location No. 2, Figures 3-3 through 3-8 (pp. 3-5 through 3-10), 3-14, and 3-15 (pp. 3-93 and 3-94) may be used to estimate exposures in the vicinity of Mill Valley AFS with the following adjustment. From any elevation of interest at Mill Valley AFS below about 2,600 feet, subtract 2,200 feet. The resultant adjusted elevation (together with the appropriate distance) and Figures 3-3 through 3-6 may then be used to obtain the exposure estimate for Mill Valley AFS. (Exposure for adjusted elevations below 100 ft may be estimated using the 100 ft curve.) Use of Figures 3-7 and 3-8, as well as Figures 3-14 and 3-15 for the growth system, does not require an elevation. Qualitatively, it is clear that the Mill Valley AFS site is somewhat more remote from population centers than Location No. 2, and would result in lower overall exposure to RFR.

In other respects, such as kind of effects expected and degree of interference or hazard at specified exposures to RFR from PAVE PAWS, conclusions in Chapter 3 and the appendices regarding the Location No. 2 site apply also to the site at Mill Valley AFS.

About 70 acres of Mill Valley AFS are occupied by existing buildings. Several additional acres are used for other purposes, such as for the spray field associated with the sewage treatment plant. The remaining acreage is sufficient to accommodate the PAVE PAWS radar facility (4 acres), however the slope of land may be too steep for construction, and several buildings might have to be removed to make way for the radar. Considerable alteration of existing land uses and of the surface of the land itself (including leveling the slope) would be necessary for a 50-acre exclusion area around the radar.

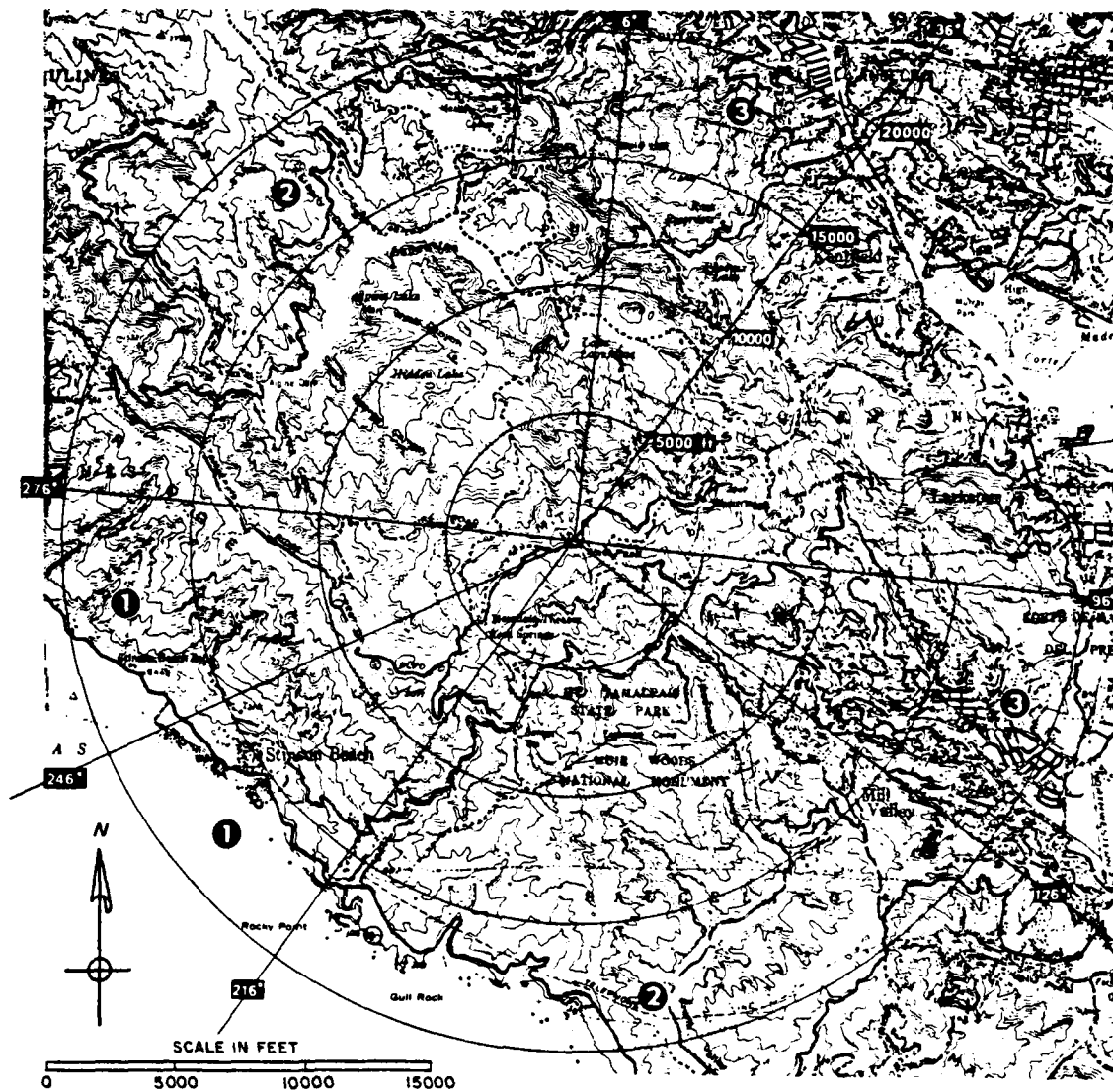

FIGURE 4-3. PAVE PAWS AZIMUTH FROM THE MILL VALLEY AIR FORCE STATION ALTERNATIVE

No significant soil or water impacts would be expected from the construction of PAVE PAWS at Mill Valley AFS. However, because a portion of the station is underlain by serpentine which is highly susceptible to mass movement and soil erosion, any construction should avoid those areas where possible, or provide the necessary structural and soils engineering to minimize the potential for disruption of foundations or larger-scale mass movement.

The station is located within a watershed belonging to the Marin Municipal Water District. Therefore, surface water or groundwater contamination at Mill Valley AFS could adversely affect the water supply in Marin County. The potential for oil spills or other discharges from activities at PAVE PAWS is slight, however, and the quantities of contaminants possible are so small and the distance to the water supply so large that such contamination is highly unlikely.

The station is in Seismic Risk Zone III which means that damaging earthquakes can occur. The San Andreas Fault Zone, 3 miles to the west (Blake et al., 1974), has been the location of several large earthquakes in the last 100 years. The 1906 earthquake, which heavily damaged San Francisco, was responsible for several rockfalls on the southern slope of Mt. Tamalpais that cut swaths through the trees (Youd and Hoose, 1978). The San Geronimo Valley Fault is approximately 8 miles north of the station and has shown movement at times during the Quaternary (last 3 million years). However, no activity has been measured along this fault during the historical record (Borcherdt, 1975). The construction of PAVE PAWS on non-sheared bedrock, away from cliffs or serpentine outcrops, would minimize the potential for earthquake damage.

Water supply, wastewater treatment, and solid waste disposal would be accommodated by current station facilities. Although the water supply or waste water treatment facilities may have to be expanded, no adverse impacts are expected.

No unique mineral resources are found in the area, and therefore no mining activities would be affected by the construction of PAVE PAWS at Mill Valley.

Any significant contamination of the permanent surface water in the Mt. Tamalpais area would result in adverse ecological effects on the local aquatic biota. The major terrestrial ecological impacts anticipated would relate to the degree that soil moving operations are required; the physical movement of men and machines; and increased noise levels during construction. It is likely that at least a few acres of the shrubby and meadow vegetation would be disrupted, and some woodland habitats at or near the AFS could be affected. A few individuals of rare or

endangered plant species that are present near and possibly on Mill Valley AFS (Section 1.2.3.1) might be damaged or destroyed.

One of the major impacts of relocating PAVE PAWS to Mill Valley is the visual impact of the radar building. PAVE PAWS would be located near the three existing radars on the top of Mt. Tamalpais. The white radomes covering two of the radar are visible for many miles around because Mt. Tamalpais is a major focal point of the North Bay area. Residents and recreational visitors have objected to the view of the 50 and 70 ft high domes because their considerable visibility decreases the scenic value of Mt. Tamalpais (Donnelly, 1978; McGuire, 1978). Adding the 105 ft PAVE PAWS building would probably be considered even more objectionable, and would at least raise considerable public controversy.

4.3.2.3 Demographics and Economics

4.3.2.3.1 Employment. Operation of PAVE PAWS at Mill Valley AFS would result in a net increase of 156 jobs on-base. These new jobs would themselves generate additional employment in Marin County, resulting in a total employment increase of 383 jobs. This is less than 0.1% of projected 1980 employment in the SMSA, and it would not affect the unemployment rate.

4.3.2.3.2 Population. The net population impact of PAVE PAWS would be the number of persons brought into the region minus those who leave when Detachment 3 is deactivated (see Table 4-4). Operation of PAVE PAWS at Mill Valley would add 450 people to Marin County's population, which is roughly equal to 0.2% of projected 1980 population. This relatively small increase would not affect the County's demographic profile.

4.3.2.3.3 Income. If PAVE PAWS is moved to Mill Valley AFS, the region would have a net increase of \$2,492,000 in wages of base personnel. This new income would itself generate additional income in Marin County, resulting in a total increase in County personal income of \$6,214,000. This is 0.2% of 1980 projected personal income.

4.3.2.3.4 Housing. Because locating PAVE PAWS at Mill Valley would involve removing personnel currently serving there on Detachment 3, the net impact on the Marin County housing market can be described as the inflow of new PAVE PAWS personnel minus the outflow of Detachment 3 personnel.

Table 4-4

POPULATION CHANGE DUE TO PAVE PAWS MILL VALLEY

<u>Personnel and Dependents</u>	<u>Increase Due To PAVE PAWS</u>	<u>Decrease Due To PAVE PAWS^a</u>	<u>Net Change Due To PAVE PAWS</u>
Officers	84 ^b	19	65
Enlisted Men	429 ^c	183	246
Civilians	<u>146^d</u>	<u>11</u>	<u>135</u>
Total	659	213	446

^aBased on actual household size of Detachment 3 personnel.

^bBased on average officer's household size at PAVE PAWS, Otis AFB, of 3.5.

^cBased on average enlisted man's household size at PAVE PAWS, Otis AFB, of 2.9.

^dBased on average household size of all civilians employed by the Air Force of 2.75.

Source: U.S. Air Force (1979).

Assuming that the proportion of PAVE PAWS military personnel that seek on-base housing would be the same as the current proportion of Mill Valley personnel, 80.2% of PAVE PAWS military personnel, or 138 households, would seek housing at Mill Valley AFS or Hamilton AFB. Another 11.6%, or 20 households, would seek housing in San Rafael, and the remaining 8.1%, or 14 households, would live elsewhere in Marin County. All 53 civilians would seek housing off-base (see Table 4-5).

The net impact of PAVE PAWS operation at Mill Valley would be 32 additional households at Mill Valley AFS and 42 households at Hamilton AFB. These households could be accommodated on-base in vacancies created by the closure of the 666th Squadron. An additional 82 households would be housed in the rest of Marin County. Despite Marin County's low vacancy rates, 82 households would not seriously affect the housing market, because they represent only 0.1% of the 1978 housing stock and are approximately equal to the increase in the housing stock for 1 average week at the average annual growth rates for 1970-1978.

Table 4-5

HOUSING IMPACT OF PAVE PAWS AT MILL VALLEY

	Current Mill Valley AFS	Household Influx Due To PAVE PAWS	Household Outflow Due To PAVE PAWS	Net Impact From PAVE PAWS
	Number ^a	Percent ^b	Number	Percent
<u>Military</u>				
Mill Valley AFS	67	38.7	67	39.7
Hamilton AFB	72	41.6	71	41.3
San Rafael	20	11.6	20	11.6
Other Marin	14	8.1	14	8.1
<u>Civilians</u>				
Marin County	27	100.0	53	100.0
Total	200	100.0	225	100.0

^a Represents number of households of Mill Valley personnel in each area.

^b Civilians and military calculated separately.

Source: ADCOM (1978).

4.3.2.3.5 Education. Because of declining enrollments and excess capacity, the Novato Unified School District and the Mill Valley School District would easily be able to accommodate the children of the incoming personnel associated with the operation of PAVE PAWS at Mill Valley AFS.

4.3.3 Location No. 1, Beale AFB, California

4.3.3.1 Existing Site Characteristics

The general existing characteristics of Beale Air Force Base have been presented in Section 1.2.1 (p. 1-8). Location No. 1 is situated in the northwestern portion of Beale AFB approximately three-fourths of a mile west of the flight line and about the same distance east of the base water supply wells. This alternative site is about 5 miles west of Location No. 2. Location No. 1 is an essentially undeveloped site, but it is within a mile of the nearest paved road (the Flight Line Patrol Road) and the gatehouse at North Beale Road. An FAA Airport Surveillance Radar (ASR) is located near the North Beale gatehouse. Location No. 1 is about 1.5 miles from the operations area, four miles from the cantonment areas, 6 miles from the base hospital, and 7 miles from the base housing areas. The nearest off-base inhabited structures closest to Location No. 1 are a few private residences south of North Beale Road, less than 1 mile away. Distances to points of interest near Location No. 1 are presented in Table 4-6.

This alternative site is a low, gently sloping area at an elevation of approximately 90 feet MSL. Natural drainage flows southward into an unnamed creek that meanders over the flat terrain at a change in grade of about 5 feet per mile and joins Reeds Creek 5.5 miles downstream from the site. Existing noise levels vary greatly from fairly quiet to very noisy when heavy jet aircraft take off and land at the nearby runway.

The soils at Location No. 1 are in the Yokohl-Kimball Association, which consists of well-drained, fine-textured reddish-brown to brown loams underlain with a clay hardpan developed from alluvium. These soils occupy nearly level to gently sloping low terraces. Depth to the clay subsoil varies from 15 to 36 inches. Because of fine textures and shallowness, these soils have severe limitations for septic tank filter fields and untreated steel pipe. These soils also have a high shrink-swell behavior, but their erosion hazard is only slight. Their inherent fertility is low, and most areas are used for pastures or cereal grain production. The flatter slopes are sometimes used for rice crops (Rogers, 1967).

Location No. 1 is a grassland periodically interrupted by small swales that occasionally contain standing water during the rainy season. No trees or shrubs are present at the site. The

Table 4-6

APPROXIMATE LINEAR DISTANCES^a FROM IMPORTANT AREAS TO
LOCATION NUMBER 1, BEALE AFB

<u>Populated Area (nearest edge)</u>	<u>Distance to Location No. 1 (miles)</u>
Nearest off-base residential area	0.8
Nearest on-base residential area	6.3
Extended flight-line activities, Beale AFB	0.8
Flight-line activities, Yuba County Airport	6.5
Brophy School	2.1
Linda	4.9
Olivehurst	5.7
Beale AFB Hospital	6.1
Hammonton-Smartville Road	1.5
Laughlin Road	2.6
North Beale Road	0.7
Spenceville-Smartville Road	7.5
Sixth Street	2.6
Ostram Road	4.3
Spenceville Wildlife and Recreation Area	6.9

^aLinear distances obtained from U.S. Geological Survey 7-1/2 minute topographic maps of the area.

nearest trees are cottonwoods located about 0.5 mile south and west of the site. Broad-leaved herbaceous plants such as star thistle are frequent in low-lying areas. One foot high hummocks, 2 to 3 feet in diameter, with tall grasses growing on them are also common.

Although much of the grassland at Beale AFB has been opened for grazing in the past, the fenced enclosure in which Location No. 1 is situated had, until recently, not been grazed since the 1940s. Land management plans at Beale AFB now include leasing this area for cattle grazing. +
+
+

Among the most noticeable wildlife at Location No. 1 are birds characteristic to grassland habitats (e.g., western meadowlark, mourning dove, and California quail). Rodents are also quite common, and much gopher burrowing activity is noticeable. Coyote or fox dens are also present. Other wildlife species characteristic to California grassland areas (see Section 1.2.1) would also be expected to occur at Location No. 1.

No federally-listed endangered or threatened wildlife species or state-listed endangered or rare species are known to inhabit Location No. 1 on Beale AFB (see Section 1.2.1.1.1, p. 1-10). Potential occurrences of endangered or rare wildlife for Location No. 1 would be similar to those for Location No. 2 (see Table 1-1, p. 1-14). No known major breeding or nesting areas are found at Location No. 1, and no major migratory routes pass over or through it.

The California Native Plant Society (CNPS) has no record of any rare or endangered plant species having been observed or collected in the 7 and 1/2 minute quadrangle of the Browns Valley Quadrangle, on which the site is located (Powell, 1974, 1978). The nature of the habitat at Location No. 1, makes it unlikely that any rare or endangered plant species would occur there, including the proposed federally listed endangered plant species (U.S. Fish and Wildlife Service, 1976).

4.3.3.2 Probable Impact of the Proposed Action on the Environment

Relocation of the PAVE PAWS facility to Location No. 1 on Beale AFB would require dismantling of the radar hardware now in place at Location No. 2, and reconstruction of the radar at Location No. 1.

Figure 4-4 shows the vicinity of Location No. 1 with an exposure grid superimposed, analogous to Figure 3-1 (p. 3-3) for the Location No. 2 site. Because the center of the antenna at Location No. 1 would be about 280 feet lower than at Location No. 2, Figures 3-3 through 3-8 (pp. 3-5 through 3-10), 3-14, and 3-15 (pp. 3-93 and 3-94) may be used to estimate exposures in the vicinity of Location No. 1 with the following adjustment. To any elevation of interest at Location No. 1 below about 120 feet, add 280 feet. The resultant adjusted elevation (together with the appropriate distance) and Figures 3-3 through 3-6 may then be used to obtain the exposure estimate for Location No. 1. Use of Figures 3-7 and 3-8, as well as Figures 3-14 and 3-15 for the growth system, does not require an elevation. Qualitatively, it is clear that the Location No. 1 site is less remote from population centers than Location No. 2, and would result in higher overall exposure to RFR.

In other respects, such as kind of effects expected and degree of interference or hazard at specified exposures to RFR from PAVE PAWS, conclusions in Chapter 3 and the appendices regarding the Location No. 2 site apply also to the site at Location No. 1.

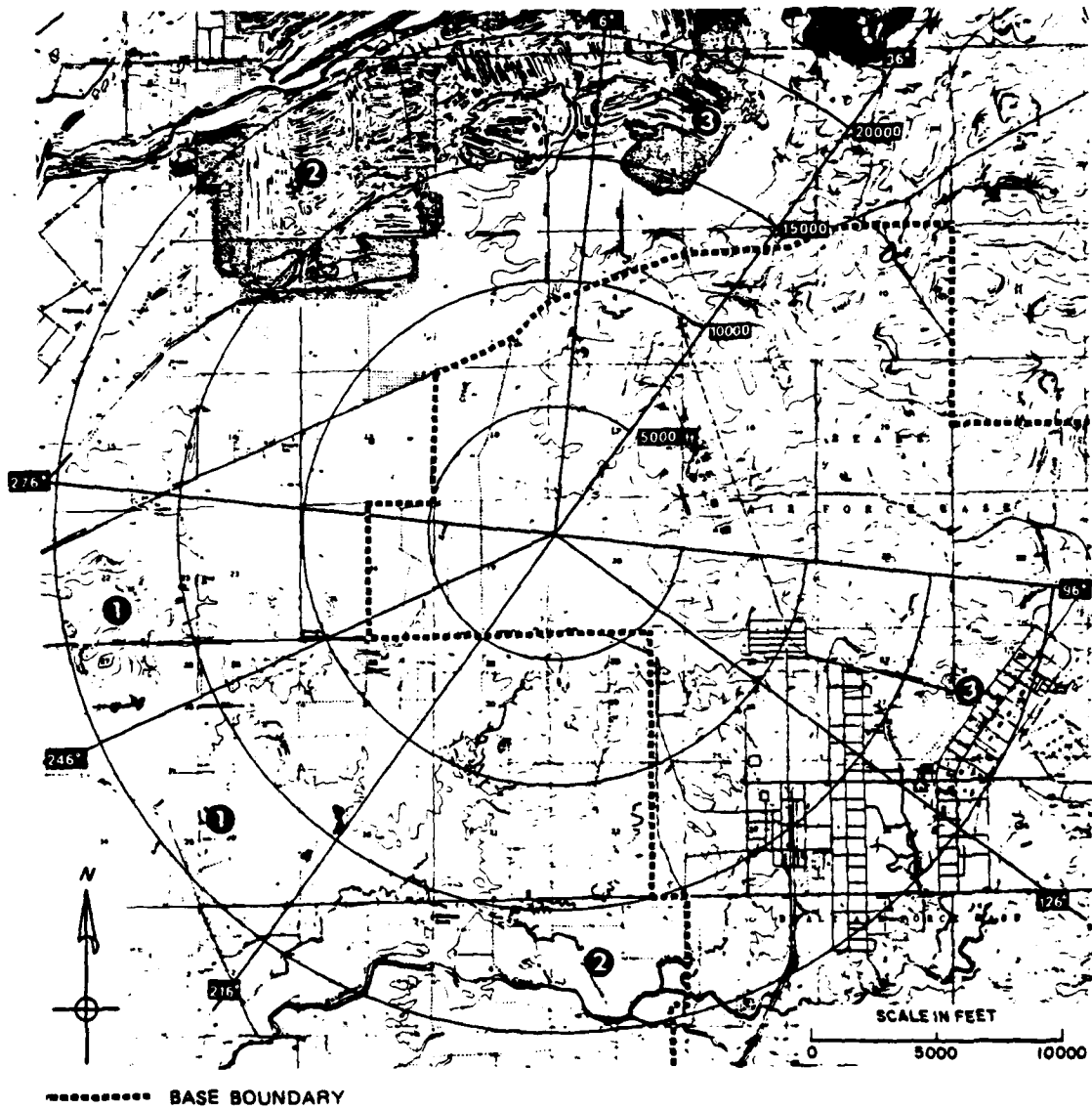

FIGURE 4-4. PAVE PAWS AZIMUTH FROM LOCATION NO. 1,
BEALE AIR FORCE BASE ALTERNATIVE

There is sufficient developable land (over 60 acres) at Location 1 for the radar facility and support buildings, as well as for the 1,000 ft exclusion fence that would be required in front of the radar face. However, the site is quite close to public roads and private lands adjacent to the base, and land use outside the base boundary could not be strictly controlled.

Location 1 is about 5-3/4 miles closer to Marysville and Yuba City than the present site, Location 2. Because visibility increases as distance decreases, PAVE PAWS at Location 1 would be significantly more visible in the towns of Linda, Olivehurst, Marysville, and Yuba City. (The difference in the elevations of the two sites is more than offset by the difference in horizontal distances.)

The potential soil and water impacts from construction of PAVE PAWS at Location No. 1 differ somewhat from those expected at the current site (Location No. 2). Location No. 1 is situated in the floodplain of Reeds Creek approximately 0.5 miles east of the stream. The main tributary of Reeds Creek is dammed at its headwaters (Miller Lake, 5.5 miles upstream), while a secondary tributary has its headwaters along a terrace of the Yuba River (7 miles upstream). Although the risk of structural damage from an earthquake is essentially the same at both locations, Location No. 1 has an additional risk of seismically-induced flooding from a breach of either the dam at Miller Lake or the proposed Marysville Dam on the Yuba River.

Location No. 1 is less than 1 mile east of the base well field where the regional groundwater flow is to the west with discharge points at Reeds Creek and the Feather River. The groundwater depth at the site is approximately 94 ft (Page, 1979). Any large oil spill or discharge at Location No. 1 would enter the groundwater and flow downgradient to the base water supply wells, possibly with little filtration. In addition, the contaminants would enter Reeds Creek through base flow, thereby adversely affecting water quality in the stream. If PAVE PAWS were constructed at Location No. 1, provision would have to be made to decrease response time to an accident and to provide impermeable catchment basins for any spills at the site. Such improvements in the facility design would also reduce the potential for surface water contamination by groundwater movement or surface water runoff.

Water supply, wastewater treatment, and solid waste removal would be accommodated by current base facilities and no adverse impact is expected.

Because of gentle slopes and low-velocity runoff, significant erosion is not expected at Location No. 1, and therefore no sediment control structures would be required.

Aquatic and terrestrial ecological impacts would be similar to those described for Location No. 2 at Beale AFB (Section 3.1.2.2). A minor difference with Location No. 1 is that grassland vegetation adapted to wetter, more poorly drained sites would be affected. In addition, site No. 1 has not been used for cattle pasture in the past few years, whereas site No. 2 has been open for cattle grazing. Construction of PAVE PAWS at site No. 1 would continue the practice of excluding cattle grazing in the exclusion area. Aquatic biota in Reeds Creek could potentially be affected through chemical or physical habitat alteration.

The socioeconomic impacts of locating PAVE PAWS at Location No. 1 would be essentially the same as those described for Location No. 2 (Section 3.1.3.2, p. 3-86).

4.4 Modify Radar or Surroundings

This section describes measures that might be taken to ameliorate effects regardless of the location of the antenna.

4.4.1 Radar Modification

It is conceivable that only certain frequencies or surveillance fence elevations would cause interference with other systems, and then only at certain times or locations. In this case, the interference may be mitigated by suppressing the use of those frequencies under the specified circumstances. The limits on the use of this measure would be imposed by operational requirements.

4.4.2 Shielding

Because the earth absorbs and reflects EMR, and the attenuation is very high at the frequencies used by PAVE PAWS, an earthen barrier is a very effective shield against EMR. For example, an earthen berm placed close to the subject area would provide the best shielding. The power that would penetrate directly through such a berm would be negligible compared with the power that would be scattered and diffracted into the region shadowed from the radar by the berm. On the basis of the concept of optical shadowing, the shielding factor created by an earthen barrier should exceed 10:1 and might easily be as large as 100:1.

Trees are also effective for shielding EMR. The effect could be created by planting suitable trees at appropriate places. Sheet metal or wire screen with mesh sizes of at most

a few inches are effective reflectors of power at the PAVE PAWS frequencies. They could also be used to shield areas where appropriate. However, shielding around PAVE PAWS is not warranted because of the very low levels of radiation at ground level at the school, hospital, and all other locations outside the exclusion fence.

++

Chapter 5

PROBABLE UNAVOIDABLE ADVERSE ENVIRONMENTAL EFFECTS

5.1 Land Use

Only minor land use effects are anticipated. A small amount of land (about 11 acres) has been committed to permanent structures. Another 50 acres has been fenced off to exclude people and some animals from the near field of the radar. These 50 acres are part of a 3,019-acre tract lease for cattle grazing. The 50 acres could be returned to their prior use as a cattle pasture when operation of PAVE PAWS ends. However, it is possible that the permanent PAVE PAWS structures will not be removed at that time, and 11 acres of cattle pasture may be lost indefinitely.

5.2 Demographics and Economics

The expected demographic and economic effects of PAVE PAWS are also minor. Small changes in the working and civilian population in the vicinity of Beale AFB, Mt. Hebo AFS, Mill Valley AFS, and Mt. Laguna AFS are expected. Some of these changes will be viewed as beneficial, some as adverse. However, all of them will be very small compared with historical changes in these areas, and therefore they will not be significant.

5.3 Electromagnetic Interference

Some interference with TV reception, certain military aircraft radar altimeters, aircraft and land mobile radios, and ham radios in the area is likely. In most cases, this interference would probably not be seriously disruptive. For disruptive cases, interference could be somewhat reduced by adjusting the receiving equipment, or possibly by changes in the operation of the PAVE PAWS radar.

PAVE PAWS operation could affect cardiac pacemakers. However, units worn by people on the ground are very unlikely to be affected outside the exclusion zone, which was defined, in part, by consideration of the susceptibility of pacemakers to EMR. To bring an aircraft carrying a pacemaker owner into the part of the PAVE PAWS surveillance volume where the pacemaker could be affected requires ignoring basic flight safety rules limiting low-level flight. Moreover, even with low level penetration of that shallow volume, the duration of exposure would not exceed a few seconds.

5.4 Human Health

To assess the potential effects of EMR on human health, an extensive review of research literature was undertaken. The results indicate that human health could be affected by EMR from PAVE PAWS at distances very close to the antenna array. However, the potentially hazardous region is within the exclusion fence. Thus, avoidance of hazard to human health depends on maintaining the integrity of the exclusion fence.

Chapter 6

RELATIONSHIP BETWEEN LOCAL SHORT-TERM USE OF MAN'S ENVIRONMENT AND THE MAINTENANCE AND ENHANCEMENT OF LONG-TERM PRODUCTIVITY

Operation of PAVE PAWS will be a local and short-term use of the environment. PAVE PAWS will enhance the security of the United States over its operational lifetime. In exchange for this benefit, permanent structures will be built on a small amount of land (11 acres), and another 50 acres will be temporarily unavailable as cattle pasture.

During the useful life of PAVE PAWS, large mammals will be denied access to the 50 acres, but the natural features of the area will not otherwise be disturbed. PAVE PAWS operation will affect only a small part of the area leased out for grazing, and thus will probably cause only a very small reduction in the short-term productivity of the local environment. Furthermore, the 50 acres can easily be returned later to use as a pasture for livestock. The permanent structures can also be removed to return the remaining 11 acres to pasture use. Consequently, the inevitable reduction in long-term productivity of the environment is small at most.

A likely result of PAVE PAWS operation will be interference with telecommunications systems and other devices. Much of the possible interference will not be very disruptive or can be mitigated to some degree. Moreover, interference will cease when operation of PAVE PAWS is discontinued. Therefore, no permanent loss of productivity will result.

Operating PAVE PAWS will require shifting manpower requirements -- fewer at three other AFSs, and increasing the number at Beale AFB. The short-term effects of the losses and gains will not be significant. The long-run effects will be hardly noticeable.

Although PAVE PAWS will have local, short-term effects on the use of the environment and its productivity, no significant short- or long-term losses of productivity are expected. In particular, future options for use of the site will not be restricted.

Chapter 7

IRREVERSIBLE AND IRRETRIEVABLE COMMITMENTS OF RESOURCES

Operation of PAVE PAWS will involve the use of land, money, materials, and energy. Once put to use, all of these resources, except land, are irreversibly and irretrievably committed. This includes the fuel used to generate 2.5 megawatts of operating power, although the energy required for PAVE PAWS does not represent a totally new commitment if allowance is made for the 750 kW of power saved by deactivating the three FSS-7 radars that PAVE PAWS will replace. The money required to pay employees and to purchase materials and services to operate the facility will be similarly offset. Materials to build the facility have been irretrievably committed, unless recovery of resources from solid wastes begins to be practiced on a larger scale. Energy efficient construction methods and material were used in compliance with federal guidelines.

The PAVE PAWS facility occupies about 4 acres of land including a parking area, a gate house, fuel storage, and utilities. Another 7 acres are required for the access road. Permanent structures are constructed only on these 11 acres. However, even these structures could be removed, and the relatively small area could be restored to its previous condition or one so close to it that it could again serve as a cattle pasture.

Operation of PAVE PAWS will also require fencing off approximately 50 acres to prevent humans and large animals from coming too close to the radar. However, the land that will be occupied or fenced off during PAVE PAWS operation will not be irreversibly and irretrievably committed.

Chapter 8

CONSIDERATIONS THAT OFFSET THE ADVERSE ENVIRONMENTAL EFFECTS

As described in the previous sections, the environmental effects of operating PAVE PAWS are either insignificant or can be reduced to acceptable levels. Therefore, the benefits of operating PAVE PAWS can be obtained at little cost to the environment.

The environmental effects tend to be offset by the substantially improved sea-launched ballistic missile detection and tracking capability that will be provided by PAVE PAWS. In view of the real threat posed by more sophisticated sea-launched ballistic missiles, the PAVE PAWS capability, which is more advanced than the radars it will supersede, is essential to maintaining the security of the United States. PAVE PAWS is needed to characterize a sea-launched ballistic missile attack adequately and to provide warnings to strategic forces.

All the alternatives discussed in Chapter 4 except choosing not to operate the radar (e.g., no action) would provide the same benefits as those expected from operating at PAVE PAWS Location No. 2 on Beale AFB. On the other hand, of the alternatives described in Chapter 4, only taking no action would result in significantly fewer environmental effects. In fact, additional adverse effects would be created by abandoning (or dismantling) the existing facility and constructing a new one, and the benefits would be significantly delayed while a new facility is constructed. The necessity for new construction makes all the alternatives except no action equivalent to postponing the action. Thus, all of the alternatives to the proposed action except no action would delay the benefits of PAVE PAWS and increase its adverse environmental effects. The no-action alternative, although it would avoid all adverse effects, would deliver no benefits.

Chapter 9

DETAILS OF UNRESOLVED ISSUES

9.1 Biological Effects

The potential biological effects of RFR from the PAVE PAWS facility have been assessed out of necessity from existing studies in the 10 MHz to 18 GHz range. The conclusion is that the RFR will have no perceptible biological effects on the human population in the vicinity of PAVE PAWS. The fundamental bases for this conclusion are the substantial evidence for dependence of many reported effects on exogenous heat production in the biological material; the considerable difference between the power densities in the neighborhood of PAVE PAWS and those lowest power densities at which a few biological effects have been reported -- amounting in most cases to between 2 and 4 orders of magnitude; and the absence of reliable evidence of objective human disease in persons exposed to RFR in the past. The substantial weight of these considerations allows the conclusion of absence of bioeffects from the RFR of PAVE PAWS without considering the two gaps in knowledge of the extrapolation of experimental results from animals to humans and the adequacy of epidemiological studies in humans.

The extrapolation of experimental results from one frequency to another and from one animal species was discussed briefly in Section C.4, p. C-9. Some progress has been made in the development of theoretical models for extrapolating from one frequency to another (as discussed in Section C.6.1.1, p. C-16) but the present level of knowledge is inadequate for predicting precisely the biological effects of RFR in humans from studies performed in mice or other experimental animals.

The existing epidemiological studies were reviewed in Section C.7.1, p. C-27. The studies were competently performed, but they are all retrospective in nature, i.e., undertaken after the occurrence of RFR exposure, and they suffer from certain inherent defects of retrospective studies, such as uncertainty about the level and duration of exposure, possible selective factors in locating members of the exposed population, and the difficulty in constructing adequate control groups. Prospective studies, in which the exposed population is identified before exposure begins, would eliminate such defects and provide a better basis for conclusions about effects of RFR on human health.

These two issues, extrapolation and epidemiology, remain unresolved issues in the assessment of bioeffects of RFR, though they do not affect the conclusions reached in this EIS. These issues are presently receiving considerable attention at the federal level.

9.2 Electromagnetic Interference

9.2.1 Telecommunication Systems

++

Further operating experience is necessary to determine the extent, if any, of the following potential interference situations:

- o Television reception
- o Airborne and ground electronics.

9.2.2 Other Devices

There is almost no possibility that PAVE PAWS will affect pacemakers that meet the 200 V/m susceptibility criterion. Pacemakers now being made generally do meet that standard. However, a complete assessment of the risk requires answering this question: What is the present distribution of the susceptibility thresholds of the pacemaker population, and what will it be in the near future?

Chapter 10

BIBLIOGRAPHIC REFERENCES

All references for Section 3.1.2.1 are at the end of Appendix C. ++
Other references for Chapters 1-9 are in this chapter. References for
all appendices are given at the end of each appendix.

Air Resources Board, "California Air Quality Data, Summary of 1977
Air Quality Data for Gaseous and Particulate Pollutants," Volume
IX, Annual Summary, p. 39 (1978).

Air Resources Board, "California Air Quality Data, October,
November, December 1976," Volume VIII, pp. 29-30 (November 4, 1977).

Aldrich, F. T., A Chorological Analysis of the Grass Balds in the
Oregon Coast Range, Ph.D. Thesis, Oregon State University,
Corvallis, Oregon (1972).

Army Corps of Engineers, Draft Environmental Impact Statement:
Operation and Maintenance of Jetties and Dredging Projects in
Tillamook Estuary, Oregon, Portland, Oregon (December 1974).

Arnold, Gerald, Superintendent of Schools, Wheatland School
District, personal communication (December 1978).

Bailey, R. D., Ecoregions of the United States, U.S. Department of
Agriculture, Forest Service, Ogden, Utah (1976).

Barker, Thomas, Civil Engineering Squadron, Beale Air Force Base,
Marysville, California, personal communication (November 1978).

Barker, Thomas, Civil Engineering Squadron, Beale Air Force Base,
Marysville, California, personal communication (December 1978).

Barker, Thomas, Civil Engineering Squadron, Beale Air Force Base,
Marysville, California, personal communication (May, 1979).

Barney, James, Environmental Planner, U.S. Forest Service, Siuslaw
National Forest, personal communication (January 1979).

Beale Air Force Base Housing Office, Marysville, California,
personal communication (December 1978a).

Beale Air Force Base Housing Office, Marysville, California, "Personnel
Living Off-Base as of 9 Nov. 1978" (1978b).

Beale Air Force Base Information Office, Marysville, California,
personal communication (December 1978).

- Beaulieu, John D., "Environmental Geology of Inland Tillamook and Clatsop Counties, Oregon," Oregon Department of Geology and Mineral Industries, Bulletin 79 (July 1973).
- Bennett, John H., "Foothills Fault System and the Auburn Dam," California Geology, Vol. 31, No. 8, pp. 175-176 (August 1978).
- Bennett, John H., Gary C. Taylor, and Tousson R. Topozada, "Crustal Movements in the Northern Sierra Nevada," California Geology, Vol. 30, No. 3, pp. 51-57 (March 1977).
- Blake, M. C., Jr., J. A. Bartow, V. A. Frizzell, Jr., J. Schlocker, D. Sorg, C. M. Wentworth, and R. H. Wright, "Preliminary Geologic Map of Marin and San Francisco Counties and parts of Alameda, Contra Costa, and Sonoma Counties, California," U.S. Geological Survey, Miscellaneous Field Studies Map MF 574, U.S. Government Printing Office, Washington, D.C. (1974).
- Borcherdt, R. D. (ed.), "Studies for Seismic Zonation of the San Francisco Bay Region," U.S. Geological Survey, Professional Paper 941-A, U.S. Government Printing Office, Washington, D.C. (1975).
- Bravos, M., Director Administrative Services, Yuba City Unified School District, personal communication (December 1978).
- California Department of Employment Development, Annual Planning Information, San Francisco, California (May 1978).
- California Department of Finance, "Personal Income by Major Sources," Sacramento, California (July 1978).
- California Department of Finance, Population Projection for California Counties 1975-2020 (December 1977).
- California Department of Fish and Game, At the Crossroads, The Resources Agency, Sacramento, California (1976).
- California Department of Fish and Game, "Spenceville Wildlife Area," unpublished wildlife species list of the Spenceville Wildlife Refuge (July 1974-November 1975).
- California Employment Development Department, Labor Market Newsletter Sutter/Yuba, Sacramento, California (March 1978).
- California Employment Development Department, Projections of Employment by Industry and Occupation 1980-1985, Sacramento, California (September 1978).

- California Energy Resources Conservation and Development
Commission, Preliminary Report on the Pacific Gas & Electric
Company's Notice of Intention To Seek Certification for a
Coal-Fired Power Plant Fossil 1 & 2 Docket No. 77-NOI-4
(November 1978).
- California State Office of Planning and Research, An Urban
Strategy for California - Environmental Goals and Policy
Report (February 1978).
- Chambers, K. L., "Floristic Relationships of Onion Peak with Saddle
Mountain, Clatsop County, Oregon," Madrono Vol. 22, pp.
105-114 (1973).
- Clark, William B., "1976-1977 California Mining Review," California
Geology, Vol. 31, No. 9, pp. 206-211 (September 1978a).
- Clark, William B., "Gold Rush of the 1970s," California Geology,
Vol. 31, No. 9, pp. 203-205 (September 1978b).
- Coffey, Gerald, Beale Air Force Base, Marysville, California,
personal communication (November 1978).
- Coffey, Gerald, personal communication (December 1978).
- Cramer, C. H., T. R. Topozada, and D. L. Parke, "Seismicity of
the Foothills Fault System Between Folsom and Oroville,
California," California Geology, Vol. 31, No. 8, pp. 183-185
(August 1978).
- Detling, L. E., "Significant Features of the Flora of Saddle
Mountain, Clatsop County, Oregon," Northwest Science, Vol.
28, pp. 52-60 (1954).
- Dickert, T. G., and R. H. Twiss, Environment Planning Study, Marin
Municipal Water District, Craftsman Press, Berkeley,
California (n.d.).
- Doidge, Herman, Civil Engineering Squadron, Beale Air Force Base,
Marysville, California, personal communication (December
1978).
- Dunbar, Christine, Assistant Principal, Wheatland Union School
District, personal communication (December 1978).
- Elford, C. R., "The Climate of California," in Climates of the
States, Vol. II, pp. 538-594 (1974).
- Federal Aviation Administration, "Trip Report - Interference
Investigation of the Otis AFB Missile Tracking Radar," Flight
Standards National Field Office, PO Box 2082, Oklahoma City,
Oklahoma (14 February 1979).

Federal Register, "States Attainment Status," Vol. 43, No. 43, pp. 8970-8975 (March 3, 1978a).

Federal Register, "Attainment Status Designations," Vol. 43, No. 176, pp. 40412-40414 (September 11, 1978b).

Franklin, J. F., and C. T. Pynes, "Natural Vegetation of Oregon and Washington," USDA Forest Service General Technical Report PNW-8, U.S. Government Printing Office, Washington, D.C. (1973).

Griggs, Tom, California Native Plant Society, personal communication (December 1978).

Harnish, James, Associate Planner, Sacramento Regional Area Planning Commission, personal communication (December 1978).

Hodson, Ernest, Wildlife Habitat Supervisor, Spenceville Wildlife Refuge, California Department of Fish and Game, personal communication (November and December 1978).

Jones & Stokes Associates, Inc., Development Guidelines for Areas of Statewide Critical Concern, Vol. I & II, prepared for the Office of Planning and Research (July 1974).

Kashiwagi, J., Soil Conservation Service, Petaluma, California, personal communication (January 1979).

Kozlik, F. M. and P. B. Johnson, "Waterfowl of California," California Department of Fish and Game, Sacramento, California (1974).

Kuchler, A. W., Potential Natural Vegetation of the Conterminous United States, American Geographical Society, New York (1975).

Lehenbauer, Philip A., Acting Endangered Species Coordinator, USDI, Fish and Wildlife Service, personal communication (May 1974).

Lock, L., San Diego County Planning Department, personal communication (February 1979).

Loy, W. G., S. Allen, C. P. Patton, and R. D. Plank, "Migratory Waterfowl Flyways," Atlas of Oregon, Academic Book Center, Portland, Oregon (1977).

Marin County Planning Department, "Environmental Hazards Element," Marin Countywide Plan, San Rafael, California (1977).

Marysville Unified School District, "Space Survey and Enrollment Projections," Marysville, California (January 1978).

Merkle, J., "An Analysis of the Plant Communities of Mary's Peak, Western Oregon," Ecology, Vol. 32, pp. 618-640 (1951).

Munz, P. A., and D. D. Keck, A California Flora, University of California Press, Berkeley, California (1968).

Nadeau, D., Planning Coordinator, Golden Gate National Recreation Area, San Francisco, California, personal communication (January 1979).

Nadeau, D., Preliminary Information Base of the Golden Gate National Recreation Area - North, U.S. Department of the Interior, National Park Service, Washington, D.C. (1975).

Oregon Department of Economic Development, "Oregon County Economic Indicators," Portland, Oregon (1977).

Oregon Department of Environmental Quality, "Oregon's Statewide Assessment of Nonpoint Source Problems," Portland, Oregon (August 1978).

Oregon Department of Fish and Wildlife, "Lakes of the Fremont, Rogue, Siskiyou, Siuslaw, Umpqua & Winema National Forests," Portland, Oregon (n.d.).

Oregon Department of Fish and Wildlife, "Oregon's Threatened or Endangered Wildlife," Portland, Oregon (October 1978).

Pacific Gas and Electric Company, Notice of Intention Fossil 1 and 2, submitted to California State Energy Resources and Conservation Development Commission (December 1977).

Page, Ron, Hydrologist, U.S. Geological Survey, Sacramento, California, personal communication (January 1979).

Powell, W. R., Inventory of Rare and Endangered Vascular Plants of California, California Native Plant Society, Spec. Pub. No. 1, Berkeley, California (1974).

Rickert, D. A., Oregon's Statewide Assessment of Nonpoint Source Problems, Oregon Department of Environmental Quality, Portland, Oregon (August 1978).

Rogers, John H., "Report and General Soil Map, Yuba County, California," Soil Conservation Service, Marysville, California (May 1967).

Sacramento Regional Area Planning Commission, Draft Environmental Impact Report, Regional Transportation Plan (January 1977).

- Sacramento Regional Area Planning Commission, "Housing Module by Major Zone and Jurisdiction" (1978).
- Sacramento Regional Area Planning Commission, "Regional Land Use Plan 2001, Alternatives for the Future," Sacramento, California (September 1976).
- Sacramento Regional Area Planning Commission, "Regional Land Use Plan: 2001, Draft" (April 1978).
- Sacramento Regional Area Planning Commission, Yuba County General Plan - Open Space and Conservation Element (December 1973).
- Schlicker, H. G., R. J. Beacon, J. D. Beaulieu, and G. W. Olcott, Environmental Geology of the Coastal Region of Clatsop and Tillamook Counties, Oregon Department of Geology and Mineral Resources, Bulletin 74 (1972).
- Smith, Jim, Sacramento Regional Office, Army Corps of Engineers, personal communication (December 1978).
- Smith, George E., Superintendent of Schools, Marysville Unified School District, personal communication (December 1978).
- Tellefson, Roy, Graphics Supervisor, Sacramento Regional Area Planning Commission, personal communication (December 1978).
- Tillamook County, "Tillamook County's Annual Overall Economic Development Plan Report to the Economic Development Administration," Tillamook, Oregon (1977).
- U.S. Air Force, Beale Air Force Base, "TAB A-1 Environmental Report," Marysville, California (May 1977).
- U.S. Air Force, Beale Air Force Base, Electronic Systems Division, Hanscom Air Force Base, Massachusetts (1978a).
- U.S. Air Force, Environmental Assessment Addressing Closure of Mt. Hebo Air Force Station, Oregon, McChord Air Force Base, Washington (January 1978b).
- U.S. Air Force, Environmental Assessment for Phased Array Warning System (PAVE PAWS), Beale Air Force Base, California (March 1976).
- U.S. Air Force, Environmental Systems Division, Hanscom Air Force Base, "Ecological Survey Report for PAVE PAWS Site at Beale Air Force Base" (November 1975).
- U.S. Air Force, Headquarters, Aerospace Defense Command, "Socio-economic Data for PAVE PAWS" (January 1979a).

- U.S. Air Force, Final Environmental Impact Statement, Operation of the PAVE PAWS Radar System at Otis Air Force Base, Massachusetts, (May 1979b). ↔
- U.S. Army Engineer District, Draft Environmental Statement, Marysville Lake, Yuba River, California, Sacramento, California (March 1977).
- U.S. Department of Agriculture Soil Conservation Service and the Oregon Agricultural Experiment Station, Soil Survey Tillamook Area Oregon, Series 1957, No. 18, U.S. Government Printing Office, Washington, D.C. (1964).
- U.S. Environmental Protection Agency, Compilation of Air Pollutant Emission Factors (1973; rev. February 1976).
- U.S. Department of the Interior, Fish and Wildlife Service, "Bald Eagle's Status Listed for 48 States," Endangered Species Technical Bulletin, Vol. 3 (March 1978).
- U.S. Department of the Interior, Fish and Wildlife Service, "Endangered and Threatened Species: Plants," Federal Register, Vol. 41, No. 117, pp. 24524-24571 (1976).
- U.S. Department of the Interior, Fish and Wildlife Service, "Endangered and Threatened Wildlife and Plants," Federal Register, Vol. 42, No. 135, pp. 36420-36421 (1977).
- U.S. Forest Service, Final Environmental Statement, Hebo Planning Unit, Hebo Land Management Plan, Region 6, Pacific Northwest Region, Corvallis, Oregon (1978).
- U.S. Bureau of Mines, Minerals Yearbook - Volume II, Area Reports - Domestic, 1961, Government Printing Office, Washington, D.C. (1963).
- Wieland, H. C., Director, Yuba County Planning and Economic Development Department, personal communication (December 1978).
- Weisbecker, L. W., et al., "Earthquake Prediction, Uncertainty, and Policies for the Future," SRI International, Menlo Park, California, report for the National Science Foundation (January 1977).
- Wilsey & Ham, Consultants, 1967 General Plan Program - Yuba County, California - Technical Supplement (n.d.).

Youd, T. L. and S. N. Hoose, "Historic Ground Failures in Northern California Triggered by Earthquakes," U.S. Geological Survey, Professional Paper 993, U.S. Government Printing Office, Washington, D.C. (1978).

Van de Weg, J., Manager, Division of Land Management, Marin Municipal Water District, personal communication (January 1979).

Appendix A

RADAR AND ANTENNA CHARACTERISTICS

A.1 Introduction

This appendix describes the principal characteristics of the PAVE PAWS radar system (identical systems are installed at Beale AFB and Otis AFB) and the analytical procedure used to calculate the electric field intensities and time-averaged power densities that will result from its electromagnetic radiation (EMR). To avoid repetition in this appendix, the term field strength is used as a general term to mean both power density and electric field intensity. Known characteristics of the radar system and proven analytical techniques are used to establish a model of the EMR field distribution. From this model, probable values of the time-averaged power densities and electric field intensities are calculated for points of interest near ground level at various locations and elevations in the vicinity of the PAVE PAWS site. Power densities at the center of the beam are also calculated to provide a basis for estimating their effect on the personnel and electronic systems in aircraft and on migratory birds.

This analytic technique allows predictions that are quite accurate in free space. However, the results are affected by the presence of the ground and of objects such as trees, buildings, and power lines. In the real world, the ground terrain is irregular and objects such as trees, buildings, and other structures are randomly distributed. When they block the line of sight to the antenna, they tend to absorb, reflect, and scatter the field. In such circumstances, the strength of the field is lower than it would be in free space. In other situations, the power reflected from the earth or other objects adds to that propagated directly, thus increasing the intensity of the radiation. Under circumstances relevant to PAVE PAWS, the electric field strength is rarely as much as doubled in this way. Field enhancement of this kind is much more important in calculations of maximum electric field strengths than of time-averaged power densities.

A.2 System Characteristics

A.2.1 System Parameters

The characteristics of the PAVE PAWS radar used in this analysis were obtained from the PAVE PAWS Program Office, Hanscom

Air Force Base, Massachusetts (Etkind, 1978). These characteristics are listed in Table A-1. The basic system has now been installed; the growth system represents a possible option to upgrade the performance of the system at some future date.

The primary function of this radar is to detect sea-launched missiles at very great distances. To perform this function, the radar must radiate a very strong, well-focused beam of electromagnetic energy and must provide a corresponding sophistication in receiving any echo that is returned from a distant missile. These considerations force the system designer to use a very large antenna and provide a strong motivation for refining the design so that most of the power is concentrated in the main beam. The PAVE PAWS antenna meets these criteria, concentrating about 60% of the available power in the main beam (Etkind, 1978b).

A general idea of the beam forming process is provided by Figure A-1. Near the antenna face, the energy moves forward in a circular column of roughly constant diameter. At a greater distance, the energy expands as a cone with an included angle of 5.2 deg with its apex at the center of the antenna face. A slender conical beam of this kind is commonly referred to as a pencil beam. The intersection of the cone and cylinder occurs at a distance of about $0.33 D^2/L$, where D is the active array diameter and L is the radiation wavelength. A more detailed description of the beam is provided in following sections.

A.2.2 Antenna Scanning Characteristics

To carry out its tasks, the pencil beam formed by the antenna is scanned continuously. Using a complex time-sharing technique, the radar generates a surveillance fence (scan) at a minimum elevation of 3 deg above horizontal and covering 240 deg in azimuth; it also executes special satellite searches and numerous target tracks, all within as short a time as 44 seconds. This great versatility is made possible by the electronic beam scanning characteristics of the phased array, which can change beam locations from any direction in the coverage volume to any other direction within tens of microseconds. (To perform their basic functions, radar systems operate in very brief units of time. The conventional unit is the microsecond, i.e., one-millionth of a second; it is to be distinguished from the millisecond, which is one-thousand times longer.) In the present context, the major effect of beam scanning is to reduce the time-averaged power density.

A.2.3 Antenna Scanning Limits

The PAVE PAWS antenna system is designed to prevent the transmitted beam from being directed below a minimum elevation

Table A-1

CHARACTERISTICS OF PAVE PAWS SYSTEM AT BEALE AFB

<u>System Characteristic</u>	<u>Basic System</u>	<u>Growth System</u>
Frequency (MHz)	420-450	420-450
Peak power ^a (kW)	582.4	1164.8
Duty cycle (%)		
Scan mode average	11 ^b	11 ^b
Track mode max (average)	14 (7)	14 (7)
Total max (average)	25 (18)	25 (18)
Active array diameter (ft)	72.5	102
Antenna gain (ratio) compared to non-directional antenna at 420 MHz	6,200	12,300
Beam width at half power density (deg)	2.2	1.5
Main beam null (deg off-axis)	2.6	1.8
First sidelobe -- max (deg off-axis)	3.4	2.4
First sidelobe relative power density -- max (ratio)	0.01	0.01
First sidelobe null (deg off-axis)	4.8	3.3
Secondary sidelobe maximum power density -- relative to main beam (ratio)	0.001	0.001
Secondary sidelobe average power density -- relative to main beam (ratio)	0.00016	0.00008
Angle of antenna face relative to vertical (deg)	20	20
Minimum elevation angle of beam (deg)	+3	+3
Scan sector (deg), (north = 360 deg, east = 90 deg, etc.)	126 to 6	126 to 6

^aConsistent with other sections of this document, we refer to the root-mean-square (rms) value of the pulse when present.

^bRepresentative long-term value.

VARIATION OF ELECTRIC FIELD THROUGH CROSS-SECTION OF BEAM

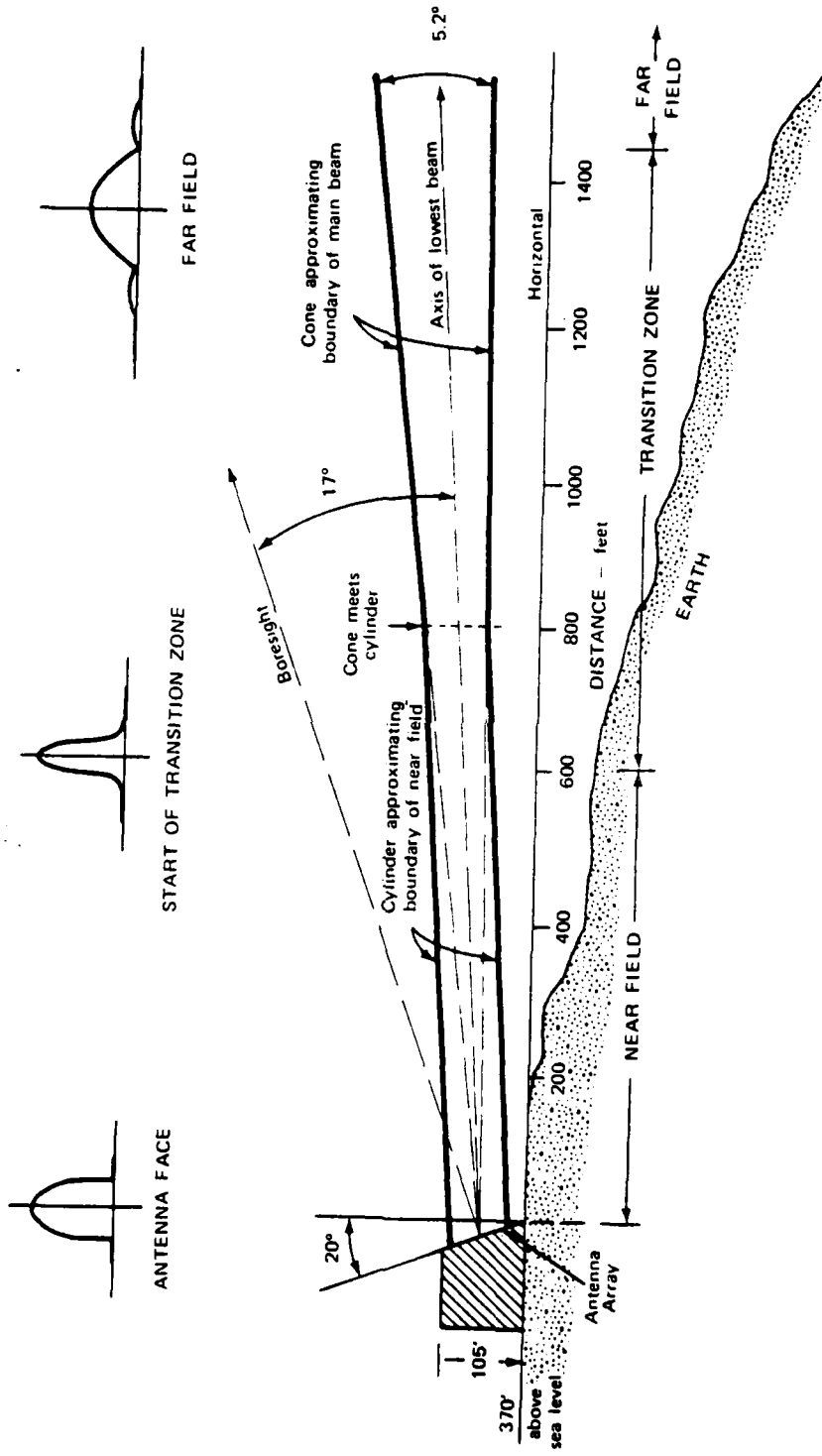

FIGURE A.1. FORMATION OF PAVE PAWS RADAR BEAM, BASIC SYSTEM

angle or in any other direction outside its normal angular coverage. The minimum allowed elevation angle is 3 deg; redundant automatic interlocks are provided to inhibit transmission of power in the improbable event of some system failure that might attempt to direct the beam outside the normal coverage defined by +3 deg to +85 deg elevation and +60 deg azimuth on either face. These interlocks are contained in the Tactical Software, the Radar Control Computer Software, and in the Beam Steering Unit hardware.

Simultaneous failure of two software units and of the hardware interlocks would be required to direct the beam outside the approved coverage. The Tactical Software Interlock checks all radar commands before they leave the central computer. If a beam position outside the coverage volume were commanded, the command would be changed to stop transmission of the pulse. Beam directing commands are passed from the central computer to the radar control computer, where they are translated into commands that control individual elements of the radar hardware. Command sequences are checked to assure that the beam does not stop scanning for more than 16 consecutive pulses, and test commands from the Radar Control Computer Console are checked to assure that they are legitimate.

One of the hardware units controlled by the Radar Control Computer is the Beam Steering Unit. On a pulse-by-pulse basis this unit feeds the beam steering commands to the radar array (transmit/receive antenna) and controls on-off and transmit-receive switching. Each set of beam steering commands is checked in a hardware arithmetic unit for consistency to assure that they will direct the beam inside the coverage volume. If an illegal command is received, the transmitter is turned off so that the illegal pulse is not transmitted. In effect, two safety checks are built into the computer program, and a final check is implemented in the hardware.

This combination of design features and interlocks provides a design that would require simultaneous failure of at least three parts of the system in order to transmit a single pulse outside the intended radar coverage. The probability of such an occurrence is extremely low (NAS, 1979); no statistical base exists for developing a numerical value.

A.2.4 Antenna Grating Lobes

If the antenna element spacing exceeds half a wavelength in a phased array such as PAVE PAWS, additional lobes (known as grating lobes) can appear in the antenna radiation pattern. They are formed by the radiation from the elements adding in phase and forming additional wavefronts in directions for which the relative path lengths are integral multiples of one wavelength. When circumstances permit, grating lobes first form parallel to the

array face (i.e., at 90 deg from the boresight direction) at the highest operating frequency of the radar, and when the main beam is at the maximum scan angle. Unless suppressed in some way, the grating lobes could have an intensity equal to that of the main beam. In any practical phased array system the element spacing is chosen to prevent grating lobes from forming.

For a phased array with the equilateral triangular element distribution used by PAVE PAWS, the maximum scan angle for a radiation pattern free of grating lobes is given by the following expression for a generally horizontal scan:

$$S_m = \arcsin \left(\frac{L}{d \cos 30 \text{ deg}} - 1 \right) \quad (\text{Kahrilas, 1976})$$

where

S_m = maximum scan angle from array normal (deg)

d = interelement spacing = 40.85 (cm)

L = radiation wavelength at 450 MHz = 66.7 (cm).

Evaluating this expression gives a maximum scan angle from the array normal of 62.5 deg. No grating lobes will be formed because the maximum azimuth scan angle is 60 deg.

Similar analyses have been performed for other scan directions to verify that grating lobes will not be formed for any scan direction. For example, the PAVE PAWS system must scan upward through 65 deg to reach the elevation of +85 deg. However, the governing equation for vertical scanning is

$$S_m = \arcsin \left(\frac{L}{d/2} - 1 \right) .$$

This equation is not satisfied by any real angle; therefore, grating lobes cannot form in vertical scanning.

A.2.5 Antenna Subarrays

An important advantage of phased array radar systems is that several of the elements can fail without seriously degrading the overall performance. An undesirable consequence of this feature is that considerable vigilance is required to detect and correct failure or malfunction of the individual elements.

The design of the PAVE PAWS radar includes diagnostic subsystems to solve this problem. Each face of the array is divided into 56 subarrays; each subarray consists of 32 transmitting/receiving elements and is capable of forming a beam; however, the resulting beams are necessarily much broader and less intense than those of the complete array. The disposition of the subarrays is shown in Figure A-2.

About 200 feet in front of each face and about 12 feet above local ground level a test antenna is located. It consists of a standard crossed dipole element mounted on a circular metal disk about 3 feet in diameter. This antenna is connected through coaxial cables to monitoring equipment housed in the radar building; it is capable of both transmitting and receiving.

The receiving capabilities of the radar are tested by occasionally sending pulses of 50 microseconds duration from the test antenna. The receiving capability of any single element -- or group of elements -- can be evaluated by comparing the response with a precalibrated reference, which includes the path lengths and angles involved.

The test antenna is also used to monitor the functioning of the transmitting components of the radar. In this case, the test antenna functions in a receiving mode. Once every 30 seconds each subarray delivers a 50 microsecond pulse that is focused on the test antenna. Again the response is compared with a standard that includes the particular geometrical arrangement of the subarray being tested.

The test antenna is approximately level with the lowest element of the 102-ft array. It is therefore lower than any active element of the basic system and below the center of any possible subarray. Consequently, the test beam strikes the ground within a few hundred feet of the array face.

Most of the power that is radiated for such tests will strike the ground. However, some of it will be scattered and will add to the diffuse time-averaged power density associated with the higher order sidelobes.

The power per subarray (rms of pulse) is $582.4/56 = 10.4$ kW. The time averaging coefficient for all subarrays is $(56 \times 50 \times 10^{-6})/30 = 9.33 \times 10^{-5}$. The product of these two numbers is the total time-averaged power -- 0.97 watts. This value is compared with $582.4 \times 0.18 \times 0.4 = 41.9$ kW, which is the time-averaged power distributed in sidelobes from the total radar face, assuming 60% of the power is in the main beam. The ratio of those numbers is about 40,000. Therefore, the power devoted to

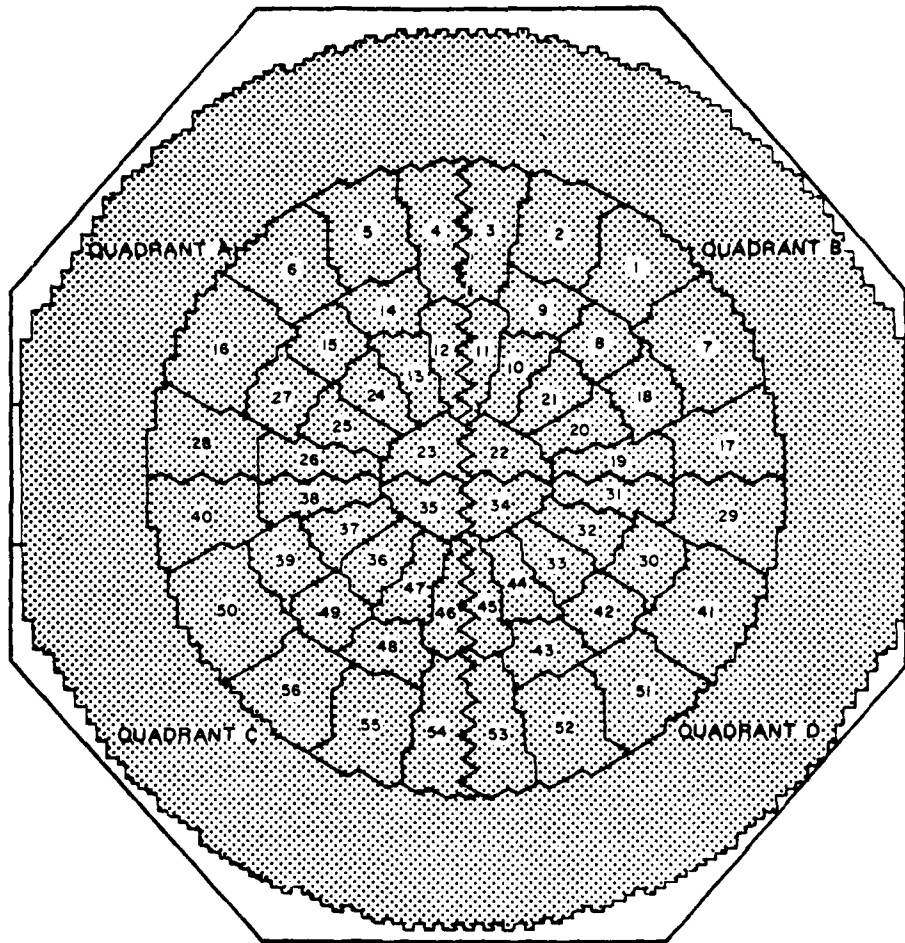

FIGURE A-2. SUBARRAY POSITIONS

transmitter diagnostics has no significant effect on the total EMR field.

A.2.6 Transmitted Pulse Codes

Pulses transmitted by the radar are allocated to specific tasks in accordance with the radar energy requirements of those tasks and the priority allocated to each. In task scheduling, time is divided into radar intervals or "resources" that last 54 milliseconds (ms). In normal operation, about half of these resources are used to generate a surveillance fence that has an elevation of 3 to 10 deg and covers an angular sweep of 240 deg in azimuth. Every eighteenth or twentieth resource is used for calibration and performance monitoring. The remaining resources are available for use in tracking objects detected in the surveillance fence or tasked by the Spacetrack System. The central computer selects transmitted pulse groups from 11 codes according to the position and measured characteristics of objects currently in track, tracked objects entering coverage, and recent detections by the surveillance fence. Each transmitted pulse may be at any of 24 operating frequencies (see Table D-2, p. D-12) within the allocated frequency band of 420 to 450 MHz. The frequency is varied slightly during each pulse to obtain additional information about any target within the beam.

Pulses that produce the surveillance fences are transmitted from both faces simultaneously and at the same relative position. All other pulses are transmitted from one face or the other but never simultaneously.

Under normal circumstances, each face of the radar emits power about 18% of the time. That is, the duty cycle averages 18%. The duty cycle used for maintaining the routine surveillance fence averages 11%. Under very exceptional circumstances of heavy tracking assignment, the duty cycle of either face can be increased to 25%; under those conditions, the duty cycle of the other face is necessarily reduced to 11%. The principal significance of these statements with respect to the EMR field at ground level is that the duty cycle reduces the time-averaged power density. The maximum possible duty cycle of 25% is used in subsequent calculations in the interest of estimating the maximum possible power density. Power densities corresponding to 18% duty cycle should be used in all considerations of long-term cumulative exposure, as in Section 3.1.1.1, p. 3-2.

A.3 EMR Field Model Description

A.3.1 Introduction and Assumptions

A large antenna that is many wavelengths in diameter produces a radiation field that is concentrated in a small volume of space and is commonly referred to as a narrow or pencil beam. The PAVE PAWS antenna falls into this class. The major characteristics of such a pencil beam radiation field are determined by the following features of the array:

- (1) Shape
- (2) Diameter in wavelengths
- (3) Power distribution
- (4) Overall efficiency.

The mathematical description of the complete field produced by large antennas is very complicated. Therefore, approximate expressions have been developed to facilitate calculation.

The resulting electromagnetic field is normally described by dividing it into three regions, to which different sets of analytical conditions apply. Those regions are the near field, the transition region, and the far field. The boundaries of the three regions are not sharply defined; rather, EMR field conditions gradually change with increasing distance from the face of the antenna. Different approximations apply to the different regions. The boundaries between the regions are defined by the acceptable error in the approximations that are made.

The far field is defined as a region over which the analytic conditions are constant and the fields vary inversely with distance (i.e., the power density varies inversely with the square of the distance). The distance from the array face beyond which the true far field exists is $2D^2/L$, where D is the active array diameter and L is the radiation wavelength. An outer transition region exists at distances between $0.6 D^2/L$ and $2D^2/L$. Here the field conditions resemble those in the far-field region, but the sidelobes increase slightly in strength, and pattern nulls are somewhat filled in. For convenience and because it involves no significant errors, we henceforth treat this outer transition region as part of the far field. In an inner transition region between $0.25 D^2/L$ and $0.6 D^2/L$, the sidelobes degenerate into bumps on the sides of the mainbeam.

The near field exists in the region between the antenna face and $0.25 D^2/L$. Here the sidelobes are not identifiable, and the on-axis field strength varies rapidly in a complex manner.

A smoothed approximation of the variation of field strength in the main beam on-axis with distance from a tapered circular antenna such as PAVE PAWS is shown in Figure A-3, for distances out to $2D^2/L$ (Hansen, 1964). As the distance from the antenna

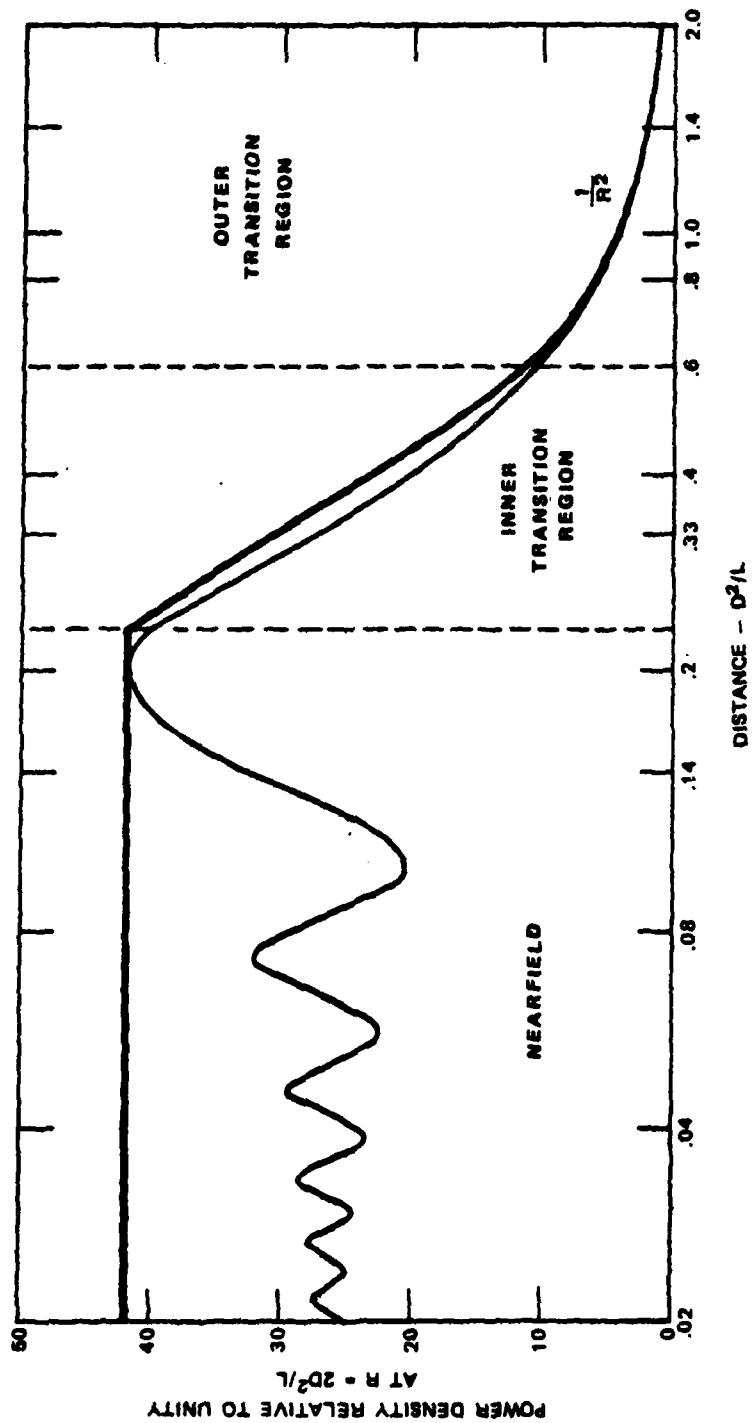

FIGURE A-3. MAIN BEAM ON-AXIS FIELD STRENGTH FOR A CIRCULAR ANTENNA
 Heavy Line Represents Values Used in Three Zones

face increases, the field strength varies in a roughly cyclic manner; at the distance $0.2 D^2/L$, the field strength reaches its maximum value, which is 42 times the value at $2D^2/L$. Figure A-3 shows that beyond about $0.6 D^2/L$, the power density in the beam decreases as the reciprocal of distance squared. In the range $0.25 D^2/L$ to $0.6 D^2/L$, the variation is nearly linear; it appears curved because of the logarithmic abscissa scale.

Only a small portion of the main beam of the PAVE PAWS radar ever strikes the ground, and then only within a narrow range of angles both north and southeast of the antenna and only for the basic system. (The closest such location is site 12 in Figure A-9, p. A-30.) In all cases, calculations of near ground-level conditions require consideration of power densities at angles away from the axis of the main beam. In the far field, such calculations are based on known sidelobe distributions. At closer distances, the procedure is more complicated. Figure A-4 shows the theoretical far-field pattern for the PAVE PAWS antenna. Also shown are theoretical patterns for three distances within the transition region (Hu, 1961).

Following the general method used by Hankin, and using some of his text (Hankin 1977) in this and following sections, we calculate the EMR electric field strength and power density at ground level at various locations. To facilitate the calculations of possible radiation exposure, we apply the following conditions and assumptions:

- (1) The phased array antenna can be approximated by a circular aperture, and circular aperture models can be used to calculate EMR fields.
- (2) In most cases the greatest possible field strength near ground level will exist when the antenna main beam is pointed in that particular direction and has the minimum elevation angle of 3 deg above the horizontal plane. All calculations of field strength are made for the case of a +3 deg elevation angle.
- (3) The main beam and its first sidelobe are considered to have circular symmetry as implied by Figure A-4 and sketched in Figure 1-4, p. 1-7. Actually, the width of the beam increases as the scan limits are approached.
- (4) The near-field extent R_{nf} can be approximated by the relationship $R_{nf} = 0.25 D^2/L$ (Hansen, 1964).
- (5) The maximum possible power density in the near field, W_{nf} , is assumed to exist throughout the near field along the main beam axis. (See solid line in Figure A-3, p. A-11).

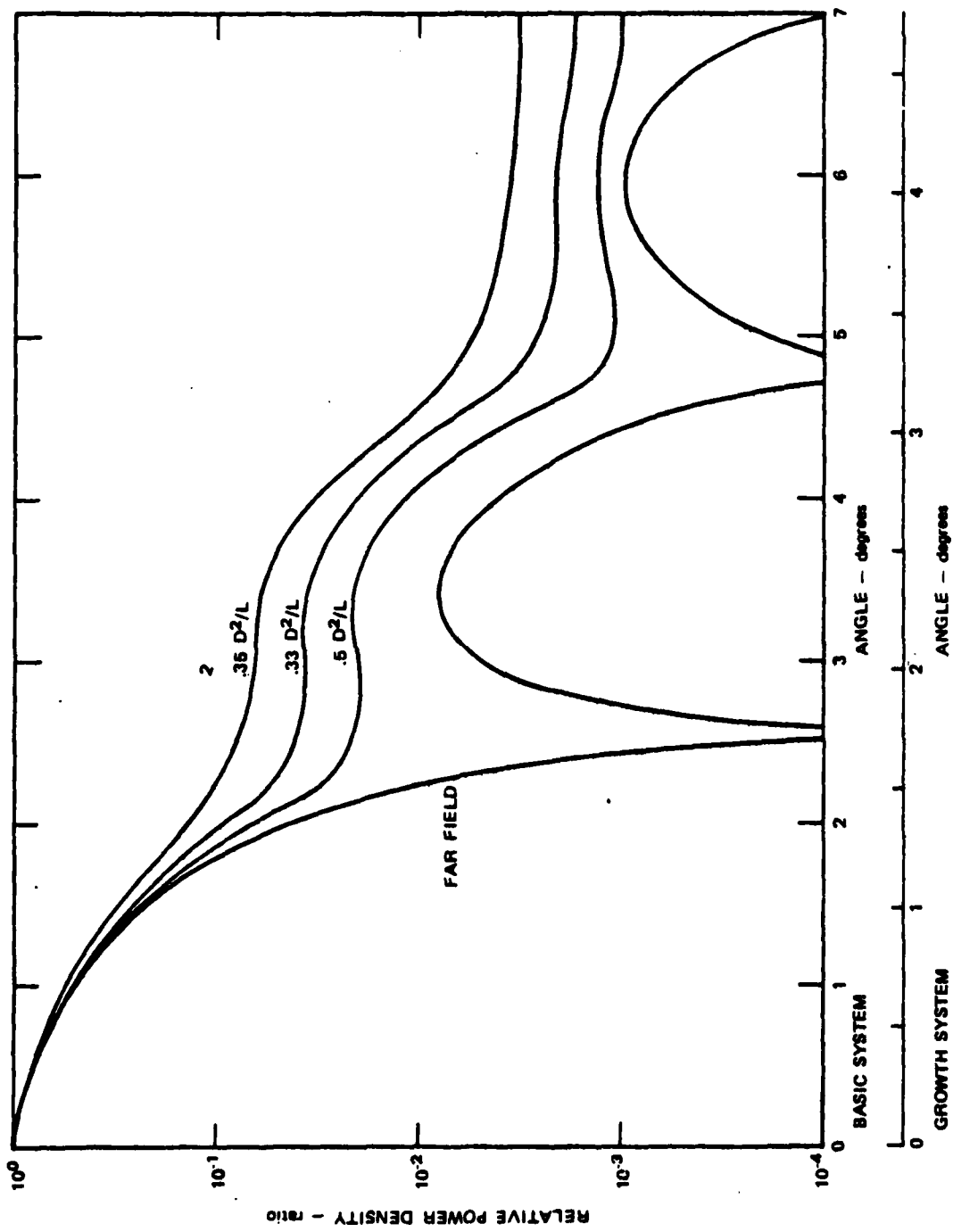

FIGURE A-4. ANTENNA PATTERNS FOR FAR FIELD AND TRANSITION REGION

- (6) The far field is assumed to start at a distance from the antenna of $0.6 D^2/L$.
- (7) In this appendix, the calculation of EMR field strengths at any distance from the PAVE PAWS radar up to 15 miles is based on direct line-of-sight propagation because all other modes of propagation, such as ducting due to temperature inversion, diffraction or tropospheric scatter or reflection, are weaker (Kerr, 1951; NAS, 1979). Ground-level areas that are shadowed by intervening terrain will be illuminated by the diffraction mode of propagation. The EMR field strengths in such areas will be overestimated because the calculations are based on direct line-of-sight propagation.

A.3.2 Key Parameters

A.3.2.1 Radiation Wavelength L

$$L = C/f$$

C = speed of light (cm/s)

$$L = 3 \times 10^{10} / 450 \times 10^6$$

f = frequency (Hz)

$$L = 66.7 \text{ cm or } 2.19 \text{ ft}$$

A.3.2.2 Near-Field Extent, R_{nf}

$$R_{nf} = 0.25 D^2/L$$

$$R_{nf} = 1.83 \times 10^4 \text{ cm or } 601 \text{ ft (basic system)}$$

$$R_{nf} = 3.62 \times 10^4 \text{ cm or } 1,190 \text{ ft (growth system)}$$

A.3.2.3 Start of Far-field, R_{ff}

$$R_{ff} = 0.6 D^2/L$$

$$R_{ff} = 4.39 \times 10^4 \text{ cm or } 1,440 \text{ ft (basic system)}$$

$$R_{ff} = 8.69 \times 10^4 \text{ cm or } 2,850 \text{ ft (growth system)}$$

A.3.3 EMR Field Model

A.3.3.1 Field Strength On-Axis in the Main Beam at any Distance from the Antenna

At any specific distance R from the antenna, the field strength on-axis in the main beam is given by the following expressions, in which the coefficients are adjusted to conform to our uniform usage of power density in microwatts/cm², and the symbols have the following meanings:

- P = total transmitted power, rms of pulse (watts)
- G = antenna gain (ratio)
- D = active array diameter (cm)
- R = distance to antenna (cm)
- L = radiation wavelength (cm)

For R less than 0.25 D²/L, the near field pulse power density W_{nf} is:

$$W_{nf} = \frac{836,000 PGL^2}{D^4} \quad (\text{Hansen, 1964, p. 39})$$

This expression for W_{nf} is consistent with a detailed computer calculation of the near field of PAVE PAWS (RADC, 1978). (A later model for a tapered circular aperture by Hansen (1976) would yield slightly smaller values, and Hankin (1977) calculated similar smaller values.)

For R = 0.6 D²/L, at the start of the far field, the pulse power density is:

$$W_{ff} = \frac{79,580 PGL^2}{0.36 D^4}$$

For R greater than 0.25 D²/L but less than 0.6 D²/L (transition region), the on-axis pulse power in the main beam at distance R is obtained by linear interpolation between W_{ff} and W_{nf}:

$$W = W_{ff} + \frac{(W_{nf} - W_{ff})(R_{ff} - R)}{(R_{ff} - R_{nf})}$$

For R greater than 0.6 D²/L (far field)

$$W = \frac{79,580 PG}{R^2}$$

For the parameters of the PAVE PAWS basic system and using all distances in feet, these pulse power expressions simplify to

$$W_{nf} = 562,500 \quad \text{for } R \text{ less than } 601 \text{ ft}$$

$$W = 858,200 - 492R \quad \text{for } R \text{ between } 601 \text{ and } 1,440 \text{ ft}$$

$$W = (3.09 \times 10^{11})/R^2 \quad \text{for } R \text{ beyond } 1,440 \text{ ft.}$$

A.3.3.2 Field Strength Outside of the Main Beam at any Distance from the Antenna

Field strengths outside of the main beam are calculated for three distance intervals relative to the antenna. The field strength at any point, a distance R from the antenna center, that is not within the main beam may be calculated by determining the on-axis main beam field strength at that distance and then reducing this figure by the appropriate relative intensity factor for off-axis radiation.

- (1) For R less than $0.25 D^2/L$:
Field strengths in the near-field region are derived from computer-modeled radiation patterns provided by Rome Air Development Center (RADC, 1978). (See Figure A-8, pp. A-25 and A-26.)
- (2) For R between $0.25 D^2/L$ and $0.6 D^2/L$:
Field strength due to transition region radiation can be determined by inspection of the antenna radiation pattern in the transition region (Figure A-4, p. A-13).
- (3) For R greater than $0.6 D^2/L$:
Field strength resulting from far-field radiation can be determined by inspection of the antenna radiation pattern, which is also shown in Figure A-4, p. A-13.

The principal characteristics of the PAVE PAWS EMR are given in Table A-2.

The distribution of power density with azimuth angle at ground level is not uniform around the radar because the azimuth scan coverage is limited to specific sectors. In addition, the power density near the ends of the scan limits of each array face is controlled by the radiation pattern of the array element. Figure A-5, p. A-18, shows a polar plot of the array element pattern for both faces and how they overlap. The overlap causes an increase in the power density in the Central 60-deg sector. In order to simplify the estimate of maximum power density as a function of azimuth, the power density attributed to higher order sidelobes has been assumed doubled in the overlap region (with 18% duty cycle on both faces as assumed in Section 3.1.1) and constant to 30 deg beyond the ends of the scan coverage as indicated by the dotted line. For the 25% duty cycle used in this appendix, and with the remaining available 11% applied to the other face, power

Table A-2

CALCULATED SYSTEM CHARACTERISTICS^a

System Characteristic	Calculated Values	
	Basic System	Growth System
Near-field extent, R_{nf} , cm, (ft)	1.83×10^4 (601)	3.62×10^4 (1,190)
Near-field on-axis maximum time-averaged power density, W_{nf} (microwatts/cm ²)	140,000	142,500
Far-field begins $0.6 D^2/L$, cm (ft)	4.39×10^4 (1,440)	8.69×10^4 (2,850)
On-axis main beam power density at $0.6 D^2/L$, W_{ff} (microwatts/cm ²)	37,200	37,700
First sidelobe maximum power density at $0.6 D^2/L$ (microwatts/cm ²)	372	377
Second sidelobe maximum power density at $0.6 D^2/L$ (microwatts/cm ²)	37	38

^aThese values are based on the maximum allowable duty cycle of 25%.

density has been assumed to increase by 44% in the overlap region in comparison with the remaining region in the scan of the face at 25% duty cycle. The result is that the maximum power density assumed for the overlap region relates only to the total combined duty cycle for both faces (36%) regardless of the proportion to each array face.

A.3.3.3 Beam Motion Effects

In PAVE PAWS operation, the main beam is pointed in a given direction only for the duration of a single pulse, after which the

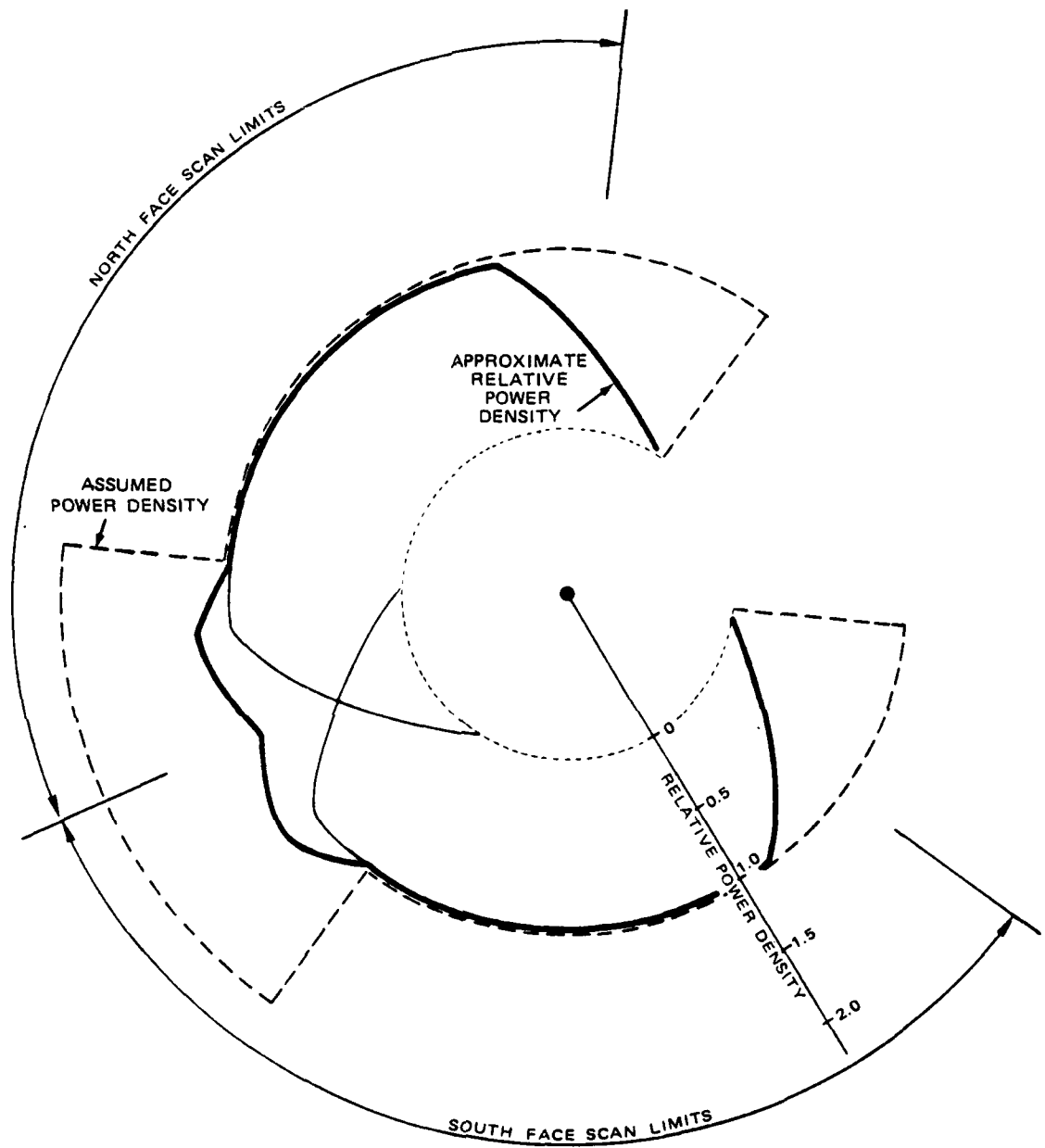

FIGURE A-5. POLAR PLOT OF RELATIVE POWER DENSITY VARIATION WITH AZIMUTH ANGLE, BASIC SYSTEM, WITH SAME DUTY CYCLE APPLIED TO BOTH FACES

main beam is pointed in a different direction, with essentially no overlap at the previous location. The mobility of the radar main beam has an averaging effect on the EMR field power density. In other words, it can reduce the effect of the main beam and sidelobes as well as "fill in" nulls between lobes of the field pattern. The averaging factor will differ depending on whether the area is illuminated by the main beam or by some combination of sidelobes. The averaging factor becomes less important at close ranges, where the diameter of the radiation column is comparable to the distance through which it is swept.

The majority of ground-level exposure is caused by the secondary (beyond first) sidelobes. Unlike the first sidelobe, these are almost random in nature. The system specification, confirmed by measurements, limits the power of these secondary sidelobes to a maximum value of 0.001 relative to the main beam. The effect of beam motion is to reduce this upper limit to an average value for the secondary sidelobes relative to the main beam of 0.00016 (1/6,200; i.e., -38 dB) for the basic system and 0.000080 (1/12,300; i.e., -41 dB) for the growth system.

The average level of the secondary sidelobes can be estimated by using conservation of energy. The gain of the antenna is 6,200 (basic system) relative to an isotropic (nondirectional) reference. Moreover, at least half of the available power is concentrated in the slender main beam. If the remainder of the power were distributed uniformly over the remaining angular space it would be $6,200 \times 2 = 12,400$ times weaker than the main beam, the factor of 2 representing the effect of concentrating half the energy into the main beam. If the remaining (sidelobe) power were distributed uniformly in half space, a condition reasonably associated with a flat array, the factor of 2 is cancelled out and the average sidelobe level is $1/6200 = 0.00016$ relative to the main beam. A similar argument produces 0.00008 relative to the main beam for the growth system.

For the basic system, the first sidelobe and a small fraction of the main beam intersect some high-ground areas, but only during the surveillance fence mode of operation at an elevation angle of 3 deg. For the growth system, the main beam never strikes the ground, but the first sidelobe intersects some high-ground areas during surveillance mode operation at 3 deg elevation.

The surveillance fence uses 60 beam positions mutually separated by 2 deg as shown in Figure A-6. On the boresight azimuth, where the beam is nearly circular, the first null, which represents the boundary of the main beam, occurs 2.6 deg off the main beam axis; i.e., at an elevation +0.4 deg relative to horizontal. The maximum of the first sidelobe occurs at 3.4 deg or -0.4 deg relative to (i.e., below) horizontal. The null of the first sidelobe occurs at 4.8 deg or -1.8 deg relative to horizontal. The horizontal width of the beam and the

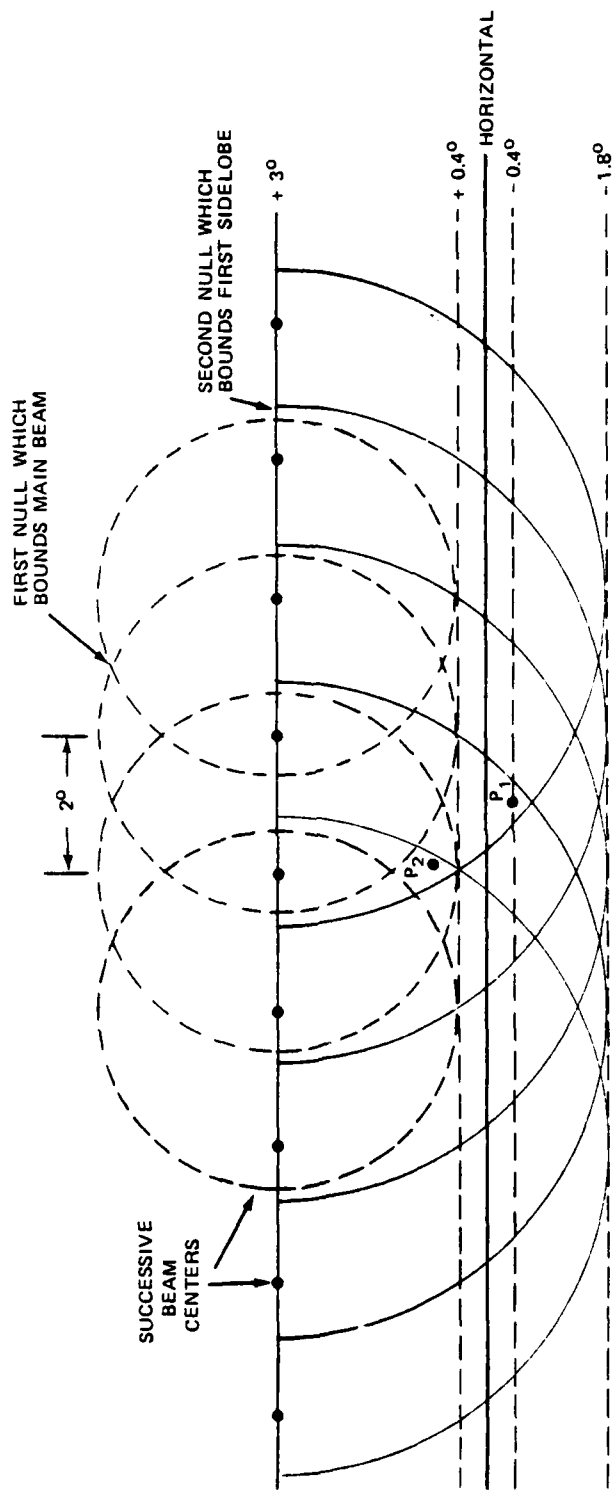

FIGURE A-6. SCANNING EFFECT OF FIRST SIDELobe, BASIC SYSTEM

center-to-center separation of adjacent beams both increase near the azimuth scan limits.

As evident in Figure A-6, a particular point P_1 at an elevation of -0.4 deg and halfway between two beam positions receives some first sidelobe energy from four adjacent positions of the main beam. The sidelobe power is near maximum for two beam positions, and quite small for the other two. On the basis of this observation, the energy contributed to point P_1 is estimated as 2.5 times that contributed by one pulse of the first sidelobe.

A point P_2 at an elevation of 540 feet exists 8,500 feet north of the antenna array. Thus, it has an elevation of $+0.8$ deg. relative to the center of the antenna face as indicated in Figure A-6. It can be struck only once by the edge of the main beam of the basic system, but it receives first sidelobe energy from four adjacent positions of the main beam. However, the sidelobe power is lower than the two higher values applicable to P_1 . Therefore, we conclude that the total time-averaged power density at P_2 does not exceed that at P_1 . Similar arguments apply to several locations grazed by the main beam about 3 miles southeast of the antenna array. +
+
+

Energy is assigned to the surveillance fence during 11% of the time on average. Using this number, the fact that the maximum sidelobe power is 0.01 times that of the main beam, and the 2.5 out of 60 factor resulting from Figure A-6, we conclude that the time-averaged power at points P_1 or P_2 is $(0.11 \times 0.01 \times 2.5/60 + 0.00016/4)$ of the on-axis main beam pulse power density. The last term in the parentheses represents the contribution of random high order sidelobes for a total duty cycle of 25%. The resultant coefficient is 0.000086, of which nearly half is contributed by the secondary sidelobes. Coefficients for other points illuminated by the first sidelobe are calculated similarly.

The beam motion factors used in Tables A-3, 4, 5, and 6, pp. A-27, 28, 31, and 32, respectively, account for the effect of the beam motion only. For example, for the basic system the beam motion factor can be as high as 1.6 for ground level exposure to a null in the far field pattern which is below the average secondary sidelobe level. The beam motion factor would be 1.0 for an elevated location immediately in front of the array. The smallest beam motion factor (0.023) applies when part of the main beam strikes the ground. The factor 0.034 occurs for many locations that are fully exposed to the first sidelobe. +
+
+

A.4 Determination of Ground-Level Field

A.4.1 Introduction

Values of EMR field strength have been calculated for many selected locations in the vicinity of the PAVE PAWS antenna. The

calculated values are intended to represent realistic estimates (i.e., it is expected that the field strength at any given location produced by operation of the PAVE PAWS system may be either larger or smaller (by a factor of 2) than the calculated values). The conditions assumed for the calculation of field strength at any location are: (1) during 11% of the time the radar creates a surveillance fence with a beam elevation of 3 deg; (2) during an additional 14% of the time the radar performs tracking functions using many beams all at elevations above 3 deg; and (3) the far-field radiation pattern used in the analysis for the main beam elevation angle of +3 deg is the same as Figure A-4, p. A-12; i.e., the pattern in the vertical plane computer for the main beam directed at the antenna boresight.

Figure A-7 shows the intersections of the first sidelobe with the ground (in the vertical plane) at Beale for three directions and for both the basic system and the growth system. This figure includes a topographic description of the ground plotted as height above sea level as a function of distance from the antenna site. The figure provides only a general graphic description of the terrain and the radiation patterns at ground level when the main beam points in the directions specified and the beam axis is at +3 deg. The main beam axis, main beam null, first sidelobe maximum, and first sidelobe null are shown (in the vertical plane) relative to the horizontal at the center of the antenna. The nulls are considered to define the main beam and the first sidelobe; the second sidelobe is assumed to begin immediately below the second null (first sidelobe null). Table A-5, p. A-31, identifies the points in the far field that were analyzed and the relative sidelobe intensities that illuminate them for the basic system. Figure A-7 indicates that for the growth system the ground is not exposed to the main beam, and it receives very little first sidelobe radiation.

To facilitate general calculations of on-axis main beam field strength at a specific distance r from the antenna, we define r as a distance along the main beam axis. For near-surface locations, the points selected for analysis are described by the horizontal distance R between the antenna and the selected location. For the 3 deg elevation angle, $R = r \cos 3 \text{ deg} = 0.999r$. Therefore, horizontal distance R can be used in place of axial distance r with negligible error.

The beam diameter in the near field, considered to be the diameter of the antenna cross-section projected in the direction of the beam axis, is determined by the antenna diameter and the angle between the antenna axis and the beam axis. This angle is 17 deg for the case of the 3 deg elevation angle and the PAVE PAWS face inclination angle of 20 deg. The projected beam diameter, $D \cos 17 \text{ deg} = 0.956D$, can be approximated by D with negligible error.

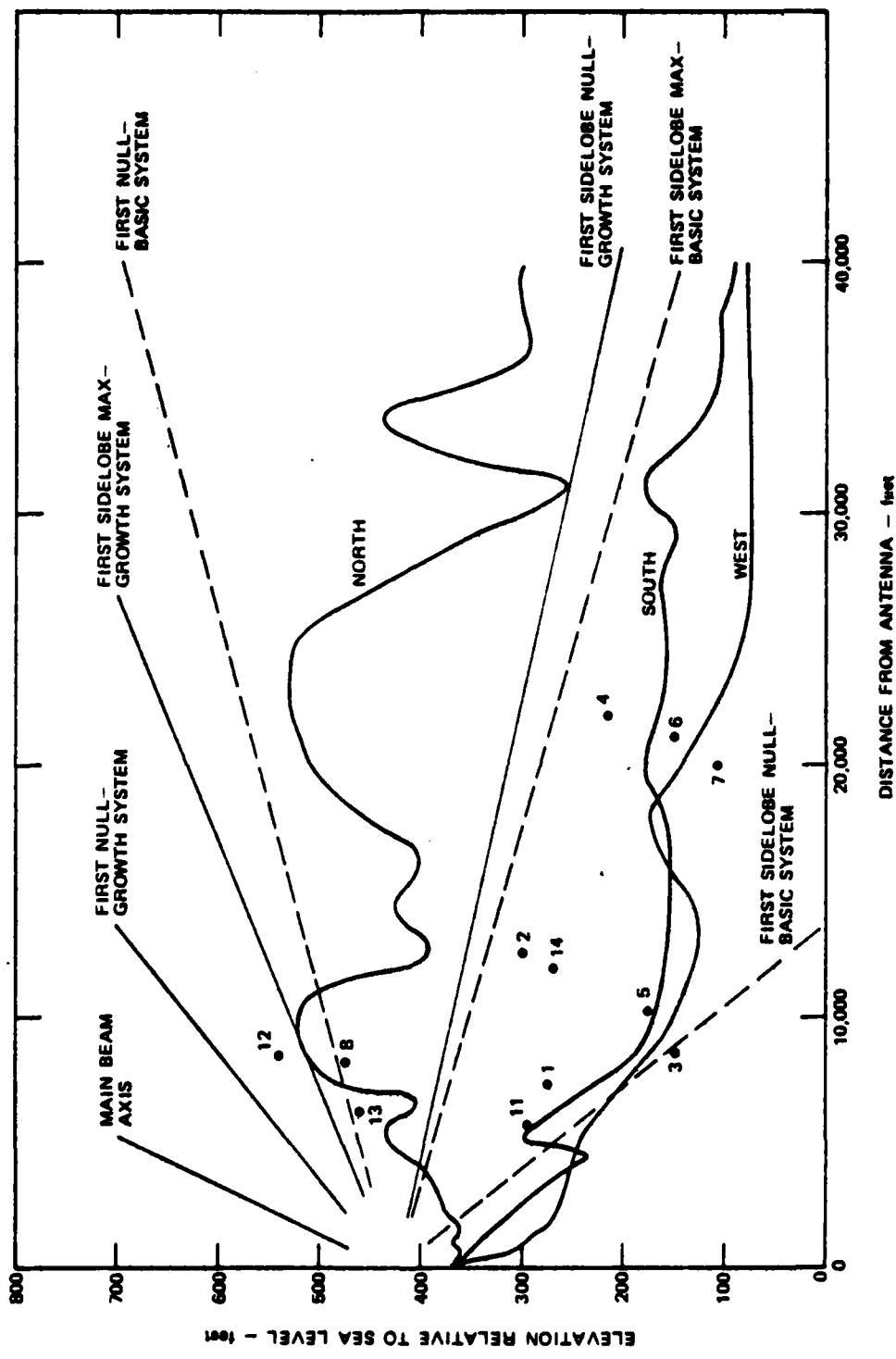

FIGURE A-7. INTERSECTION OF FAR-FIELD RADIATION PATTERNS WITH THE GROUND IN SELECTED DIRECTIONS FROM BEALE AFB PAVE PAWS

A.4.2 Near-Field

The power density that exists near ground level in the near field for the basic and growth systems can be estimated by using antenna elevation patterns generated by computer modeling (RADC, 1978) and reproduced with minor changes in Figure A-8a. The center of the array face is 53 ft above ground level. Thus, points at ground level that are 145, 290, and 580 ft respectively in front of the array face center are below the horizontal at (depression) angles of 20° , 10.4° , and 5.2° , respectively.

Those critical angles appear on the three curves. The greatest power density, relative to the maximum on-axis power density in the near field, for any larger angle is then expressed by the ratios: 0.025, 0.0126, and 0.00125, respectively. Those values determine the maximum average power density that strikes the ground directly below the beam at the specified distance. These values, modified by the beam motion factor, result in time-averaged ground level power densities. Values for the growth system were computed in a similar way using data like that shown in Figure A-8b. Values corresponding to the three given distances were plotted to produce the values presented in Table A-3, p. A-27.

A.4.3 Transition Region

The field strength in the transition region near ground level is determined for selected locations near the PAVE PAWS site. The on-axis main beam average power density is determined by making a linear interpolation between values computed at distances of $0.25 D^2/L$ and $0.6 D^2/L$. As shown in Figure A-3, p. A-11, the on-axis main beam power density decreases almost linearly with increasing distance within the transition region.

The off main beam axis angle is computed by using the distance from the site location to the antenna and the height of the antenna beam center above the site location. The distance to the site location is converted into fractions of D^2/L . Using the family of curves shown in Figure A-4, p. A-13, which are parametric in D^2/L , a relative strength for the site location is found. The field strength near ground level is equal to the on-axis main beam value reduced by the relative strength value. Table A-4, p. A-28, lists the locations and the computed field strengths.

A.4.4 Far Field

Far-field strengths near ground level have been determined for 14 selected locations in the general vicinity of the PAVE PAWS site at Beale AFB. These locations are identified in Table A-5, p. A-31, and are described by horizontal distances from the

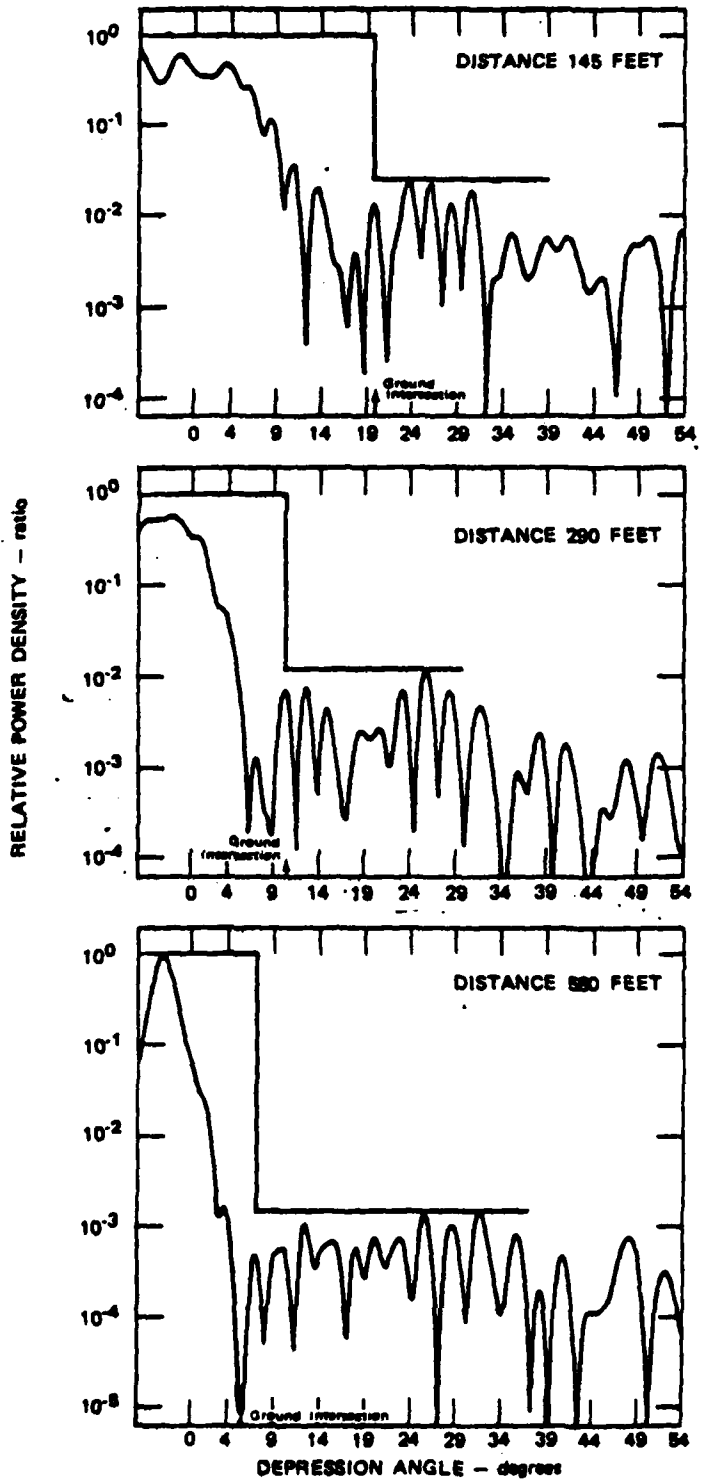

FIGURE A-8a. ANTENNA NEAR-FIELD ELEVATION PATTERNS, BASIC SYSTEM

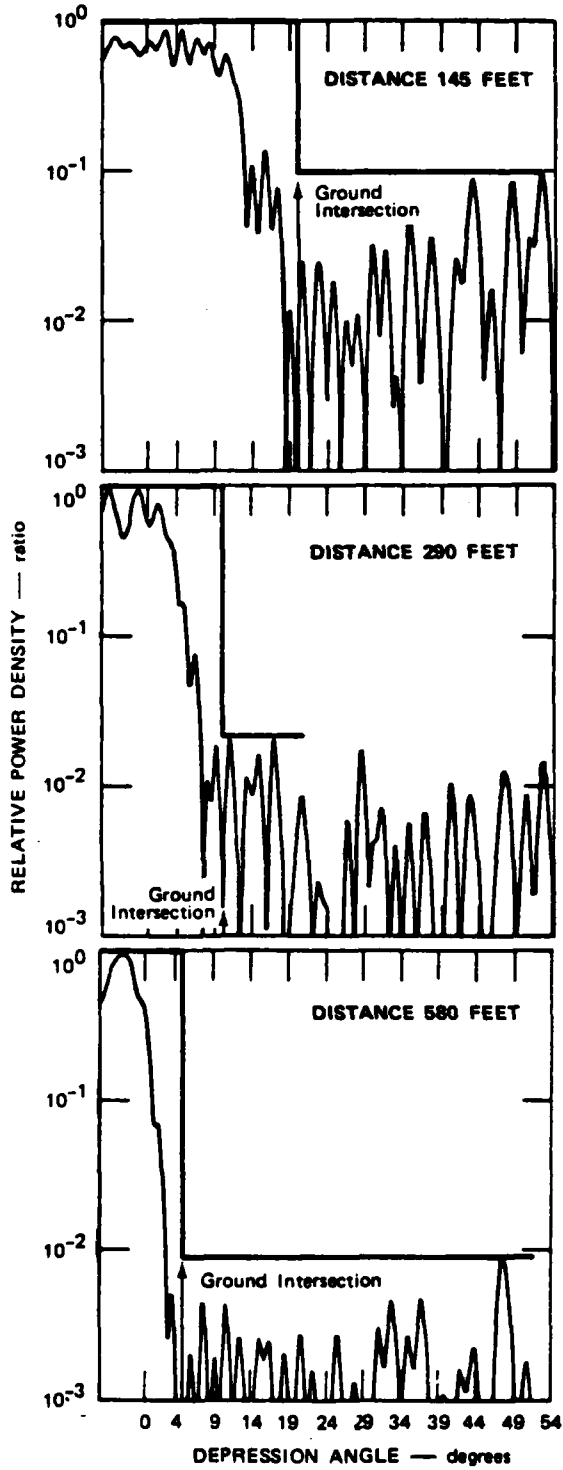

FIGURE A-8b. ANTENNA NEAR-FIELD ELEVATION PATTERNS, GROWTH SYSTEM

Table A-3
 CALCULATED NEAR-FIELD GROUND LEVEL POWER DENSITY
 PAVE PANS System - Basic AFS

System	R (ft.)	On Main Beam Axis Average Power Density ^c (microwatts/cm ²)	Off Main Beam Axis Angle (Deg)	Relative Intensity (Ratio)	Off Main Beam Axis (Ground) Level) Average Power Density ^c (microwatts/cm ²)	Beam Motion Factor ^b (Ratio)	Ground Level Moving Beam Average Power Density ^c (microwatts/cm ²)
Basic ^a 0.25 D ² /L = 401	100	140,000	30.9	.0317	4,440	.9	4,000
	200	140,000	17.8	.0158	2,210	.3	663
	400	140,000	10.5	.0063	890	.2	176
	600	140,000	8.0	.0033	170	.15	25
Growth ^a 0.25 D ² /L = 1,190	100	142,500	30.9	.101	16,300	.9	12,900
	200	142,500	17.8	.0400	5,700	.3	1,710
	400	142,500	10.5	.0158	2,250	.2	450
	600	142,500	8.0	.0055	500	.15	75
	1,000	142,500	6.0	.0020	285	.1	29
	1,190	142,500	5.6	.0013	185	.1	19

a The off main beam axis average power densities for both the basic system and the growth system have been calculated using computer generated near-field antenna patterns (SADC, 1978), an improvement over methods used in earlier documents (Rankin, 1977).

b The beam motion factor decreases rapidly with distance because of the shape of the beam in the near field.

c These values are based on a maximum possible 25% duty cycle.

d Max ground level.

Table A-4
 CALCULATED TRANSITION REGION GROUND LEVEL POWER DENSITY
 PAVE PAMS System, Beale AFB

	(ft.)	(D/L)	On Main Beam Axis Average Power Density ^a (microwatts/cm ²)	Off Main Beam Axis Angle (Deg)	Relative Intensity (ratio)	Off Main Beam Axis (Ground Level) Average Power Density ^a (microwatts/cm ²)	Beam Motion Factor (ratio)	Ground Level Hovering Beam Average Power Density ^a (microwatts/cm ²)
Basic	1,000	0.42	91,000	7.0	0.0013	115	0.13	15.0
	.6 D ² /L = 1440'	0.58	38,000	5.9	0.0013	48	0.13	6.2
Growth	1,400	0.29	129,000	5.9	0.0032	408	0.040	16.1
	.6 D ² /L = 2850'	0.42	91,000	5.0	0.0013	115	0.065	7.5
	2,800	0.59	38,000	4.4	0.001	38	0.080	3.0

^a These values are based on a maximum possible 25% duty cycle and ground elevations of 370 feet.

^b Not ground level.

antenna site, ground elevation, and the general direction of the selected location relative to the antenna. Each location is given an identifying number. A visual portrayal of the selected locations with regard to the antenna site is provided in Figure A-9, p. A-30.

The positions of these selected locations in the far-field radiation pattern of the basic and growth systems, with the main beam axis elevation angle at 3 deg, are shown in Figure A-7, p. A-23. For the basic system, all the selected locations except site 8 receive EMR from the first sidelobe when the beam is oriented in the general direction of that location; the relative intensities are 0.002 to 0.01. At site 12 (an unoccupied hilltop north of the radar), an edge of the main beam strikes the ground, but only with a power density double that of the first sidelobe maximum. (The power densities at all other locations grazed by the main beam are lower than for site 12.) For the growth system, the main beam never strikes the ground, and the first sidelobe strikes the ground only at sites 12 and 13.

Calculations of near ground-level field strength produce the results shown in Tables A-5 and A-6 for the basic and growth systems, respectively. Main beam on-axis field strength at the distance from the antenna of each selected location and the maximum relative intensity to which each location is exposed are given to permit calculation of the maximum electric field intensity. The time-averaged power density for a moving beam is computed by multiplying the main beam average power density values by the beam motion factor.

The electric field intensities shown are derived from the corresponding power densities by using the relationship

$$E_p = (3.77 W_p)^{1/2}$$

where E_p is the electric field intensity (V/m) and W_p is the pulse power density (microwatts/cm²). The pulse power density is obtained from the off main beam axis (ground level) average power density by dividing by the duty cycle, 0.25.

The methodology used for Tables A-5 and A-6 was also used for a selection of locations chosen by Hankin and Jones (1977). The comparison of their results with the results using the methods of this Appendix is shown in Table A-7 for the locations selected. Differences in the electric field column are attributed to differences of elevation for those particular locations. It appears that Hankin and Jones had incomplete information on terrain elevations. Differences in the average power column are attributed to differences of methodology, especially the beam motion factor, for which Hankin and Jones chose an extremely conservative approach.

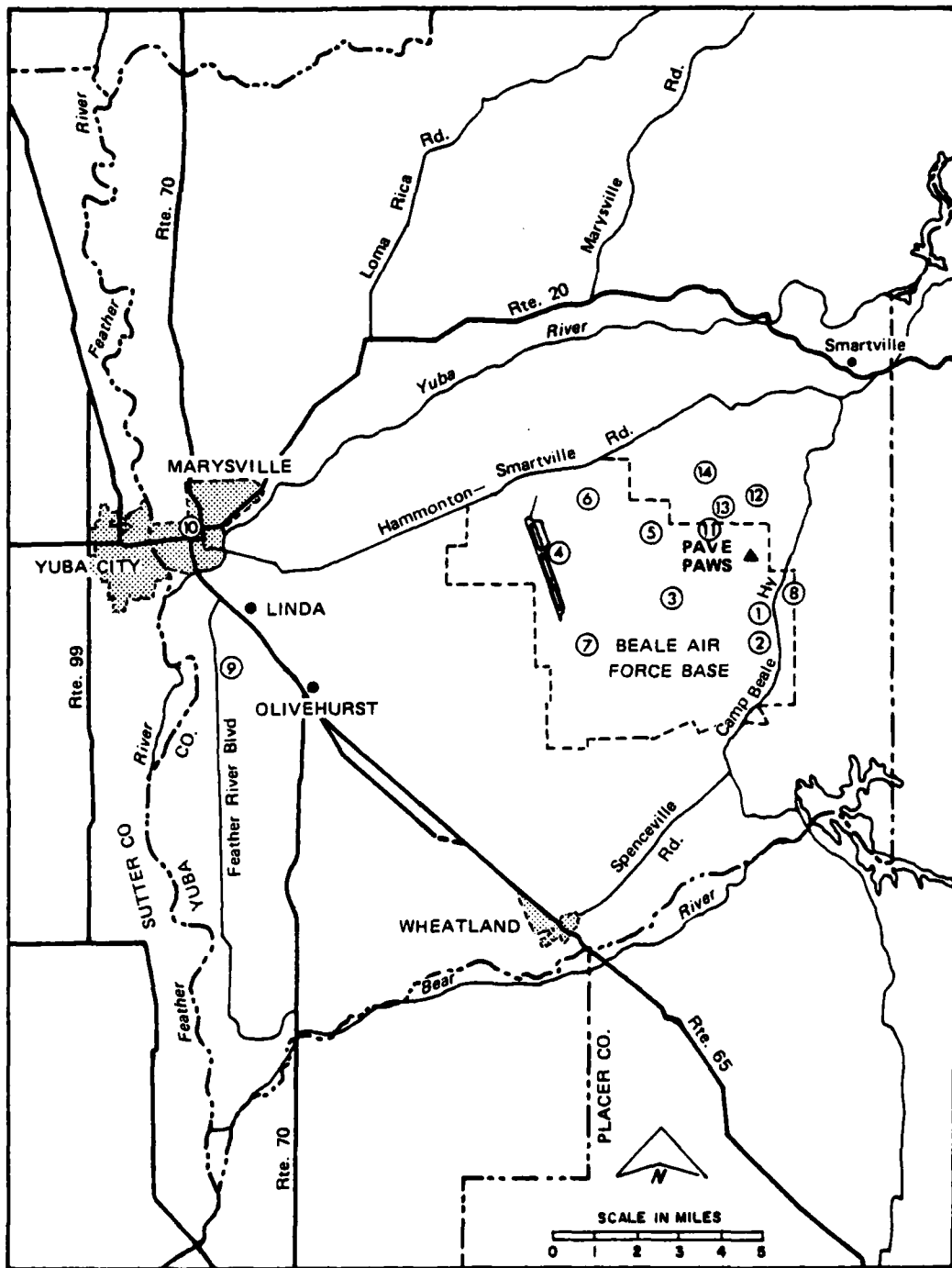

FIGURE A-9. BEALE AIR FORCE BASE – SITES SELECTED FOR ANALYSIS

Table A-5
CALCULATED FAR FIELD GROUND LEVEL EME - BASIC SYSTEM
PAVE PANS RADAR - BEALE AFB

Location	Location Number	Azimuth (deg)	Distance (ft)	Elevation (ft)	On Main Beam ^d Axis Average Power Density ^c (micro watt/cm ²)	Relative Intensity (Ratio)	Off Main Beam Axis (Ground) Level) Average Power Density ^c (micro watt/cm ²)	Beam Motion Factor (Ratio)	Ground Level Moving Beam Average Power Density ^c (micro watt/cm ²)	Ground Level Maximum Electric Field Intensity ^{b,c} (V/m)	Ground Level Maximum Pulse Power Density (micro watts/cm ²)
End of near field	--	--	601	--	140,000	--	--	--	--	--	--
Beginning of far field	--	--	1,442	--	37,200	--	--	--	--	--	--
Hospital	1	157	7,400	275	1,410	.005	7.05	.050	.353	10.3	28.2
Lone Tree and Far West schools	2	157	12,600	300	488	.01	4.88	.034	.166	8.6	19.6
Trailer Park	3 ^b	248	8,700	150	1,020	.001	2.04	.14	.286	3.9	4.1
Control Tower	4	280	22,000	215	160	.01	1.60	.034	.054	4.9	6.4
Explosive ordinance disposal area	5	286	10,300	175	730	.002	3.65	.050	.183	3.6	3.5
Weapons storage area	6	298	21,200	150	172	.008	.86	.050	.043	4.6	5.5
Petroleum, oil, and lub. area	7 ^b	239	20,000	110	193	.005	.97	.072	.069	3.8	3.8
Grease Valley Road	8 ^f	108	8,200	475	1,150	.0002	.23	.150	.036	1.9	.92
Tuba County Airport	9 ^b	258	63,000	60	20	.01	.20	.049	.010	1.7	.77
Travelodge, Marysville	10 ^b	273	69,000	60	16	.01	.16	.049	.008	1.6	.68
Main base water tank	11	298	5,800	294	2,300	.002	11.50	.050	.575	8.3	18.4
Hilltop north of Bader	12 ^e	5	8,500	540	1,070	.02	21.40	.023	.492	18.0	86.0
Hilltop NW of Bader	13	333	6,100	460	2,080	.01	20.80	.034	.707	17.7	83.0
Hilltop NE of Bader	14	344	12,000	270	538	.08	5.38	.034	.183	8.1	17.2

a Exposures are the maximum time-averaged power densities (i.e., they also include the secondary sidelobe contribution for first sidelobe exposures).
b These locations are exposed by both antenna faces, which increases the average power density.
c These values are based on a maximum possible 25% duty cycle.
d Not ground level.
e This location is exposed by lower edge of main beam.
f This location is 18° beyond the scan limit; the relative intensity ratio is consistent with Figure A-5, p. A-18.

Table A-b
CALCULATED FAR FIELD GROUND LEVEL EMR - GROWTH SYSTEM
FAVE PAMS RADAR - BEALE AFB

Location	Location Number	Azimuth (deg)	Distance (ft)	Elevation (ft)	On Main Beam ^d Axis Average Power Density ^c (microwatt/cm ²)	Relati: Intensity (Ratio)	Off Main Beam Axis (Ground) Level) Average Power Density ^c (microwatt/cm ²)	Beam Motion Factor (Ratio)	Ground Level Moving Beam Average Power Density ^{a,c} (microwatt/cm ²)	Ground Level Maximum Electric Field Intensity ^{a,c} (V/m)	Ground Level Maximum Pulse Power Density (microwatts/cm ²)
End of near field	--	--	1,190	--	142,500	--	--	--	--	--	--
Beginning of far field	--	--	2,850	--	37,700	--	--	--	--	--	--
Hospital	1	157	7,400	275	5,600	.001	5.60	.080	0.448	9.2	22.4
Lone Tree and Far West schools	2	157	12,600	300	1,930	.001	1.93	.080	0.154	5.4	7.7
Trailer park	3 ^b	248	8,700	150	4,050	.001	4.05	.120	0.486	7.8	16.1
Control tower	4	280	22,000	215	633	.001	.63	.080	0.051	3.1	2.5
Explosive ordnance disposal area	5	286	10,300	175	.890	.001	2.89	.080	0.231	6.6	11.5
Weapons storage area	6	298	21,200	150	682	.001	.68	.080	0.054	3.2	2.7
Petroleum, oil, and lub. area	7 ^b	239	20,000	110	766	.001	.77	.120	0.092	3.4	3.1
Grass Valley Road	8 ^e	108	8,200	475	4,560	.0002	.91	.080	.073	3.7	3.6
Yuba County Airport	9 ^b	258	63,000	60	77	.001	.08	.120	0.009	1.1	0.32
Travelodge, Marysville	10 ^b	273	69,000	60	64	.001	.06	.120	0.008	.98	0.25
Main base water tank	11	298	5,800	294	9,110	.001	9.11	.080	0.729	11.7	36.3
Hilltop north of Radar	12	5	8,500	540	4,240	.01	42.40	.038	0.96	25.3	170 +
Hilltop NW of Radar	13	333	6,100	460	8,230	.01	82.30	.038	1.27	28.1	210 +
Housing NW of Radar	14	344	12,000	270	2,130	.001	2.13	.080	0.170	5.7	8.6

^a Exposures are the maximum time-averaged power densities.
^b These locations are exposed by both antenna faces, which increases the average power density.
^c These values are based on a maximum possible 25% duty cycle.
^d Max. ground level.
^e This location is 180 beyond the scan limit; the relative intensity ratio is consistent with Figure A-5, p. A-18.

AD-A088 320

SRI INTERNATIONAL MENLO PARK CA
OPERATION OF THE PAVE PAWS RADAR SYSTEM AT BEALE AIR FORCE BASE--ETC(U)
JUL 80 F08635-76-D-0132

F/G 17/9

UNCLASSIFIED

AFSC-TR-80-09

NL

4 of 6

ALL INFORMATION CONTAINED HEREIN IS UNCLASSIFIED

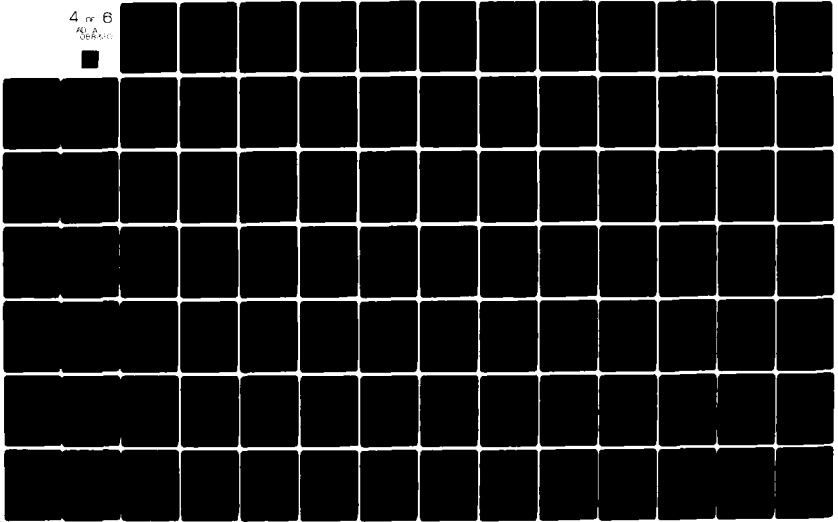

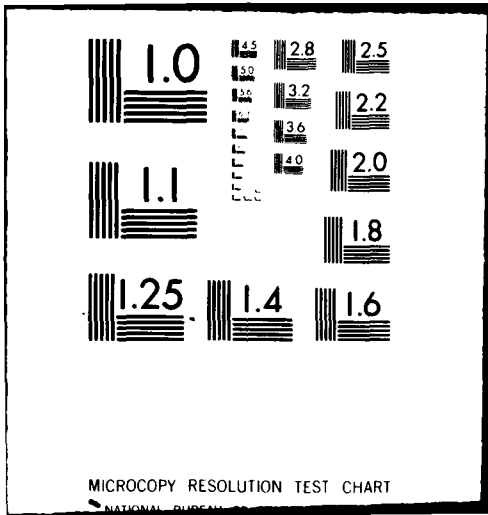

Table A-7
 FAR FIELD GROUND LEVEL EMR COMPARISON OF
 APPENDIX A AND HANKIN (1977) CALCULATED VALUES

System	Distance (ft)	Azimuth (deg)	Elevation ^a (ft)	Average Power Density (microwatts/cm ²)		Maximum Electric Field Intensity (V/m)	
				Appendix A Calculated	Hankin (1977) Calculated	Appendix A Calculated	Hankin (1977) Calculated
Basic	5,000	0	400	1.1	3.1	21.6	8.6 ^b
	7,400	180	200	.28	1.4	6.5	4.6
	8,000	270	150	.59	1.2	4.3	4.3
	10,000	180	160	.15	0.8	4.8	6.0
	20,000	180	140	.049	0.2	3.8	5.4
Growth	5,000	0	400	.98	12.0	13.0	13.0
	7,400	180	200	.45	5.6	9.2	9.2
	8,000	270	150	.57	4.8	8.5	8.5
	10,000	180	160	.25	3.1	6.8	6.8
	20,000	180	140	.061	0.8	3.4	3.4

^a Our estimate of the elevations of these points differs from that of Hankin and Jones in several cases. This difference explains most of the discrepancy between estimates of maximum electric field intensity.

^b Hankin and Jones appear to have underestimated the intensity of first sidelobe power reaching this point.

A.5 Summary

Maximum time-averaged power densities at ground level at locations within the exclusion fence do not exceed 4,000 microwatts/cm² (12,900 microwatts/cm² for the growth system); they decrease at the exclusion fence (1,000 ft) to 15 microwatts/cm² for the basic system (increased to 22 microwatts/cm² in the overlap sector), and to 29 microwatts/cm² for the growth system. Ground-level time-averaged power densities continue to decrease as distance (beyond the fence) increases, in a manner difficult to describe quantitatively, until the far-field region begins. At that point, 1,440 and 2,850 feet from the antenna for the basic and growth systems, respectively, time-averaged power density exposures are caused mainly by secondary sidelobes. The time-averaged power densities at the beginning of the far field are 5.86 and 2.92 microwatts/cm² for the basic and growth systems, respectively (increased in the overlap sector).

The time-averaged power densities at any far-field location, in any direction from the antenna site, cannot exceed those calculated for continuous exposure to secondary sidelobes at a relative intensity of 0.001, because exposure to main beam radiation does not occur except at one location, where the intensity of momentary exposure to main beam radiation is too low to affect average power density significantly.

Maximum electric field intensities at any location are derived from the maximum pulse power density possible at that location, i.e., the maximum power density experienced during beam scanning operations.

A summary of the calculated maximum expected time-averaged power densities and electric field intensities is shown in Table A-8. Several of the locations nearest the PAVE PAWS antenna, on the base itself, on nearby roads, and in adjacent communities, are included.

Table A-3
 SUMMARY OF CALCULATED GROUND LEVEL FIELD STRENGTHS
 PAVE PAMS SYSTEM, SCALE AFV

Location	No.	Distance (ft)	Average Power Density ^a (microwatts/cm ²)		Maximum Electric Field Intensity (V/m)		Maximum Pulse Power Density ^a (microwatts/cm ²)	
			Basic	Growth	Basic	Growth	Basic	Growth
Exclusion fence		1,000	15 ^b	29	42	66	470	1150
		1,440	5.9 ^b	16 ^b	27	78	190	1600
Hospital	1	7,400	.353	.448	10.3	9.2	28.2	22.4
Lone Tree and Far West schools	2	12,600	.166	.154	8.6	5.4	19.6	7.7
Trailer park	3 ^c	8,700	.286	.486	3.9	7.8	4.1	16.1
Control tower	4	22,000	.054	.051	4.9	3.1	6.4	2.5
Explosives ordnance disposal area	5	10,300	.183	.231	3.6	6.6	3.5	11.5
Weapons storage area	6	21,200	.043	.054	4.6	3.2	5.5	2.7
Petroleum, oil, and lub. area	7 ^c	20,000	.069	.092	3.8	3.4	3.8	3.1
Grass Valley Road	8 ^d	8,200	.036	.073	1.9	3.7	.92	3.6
Yuba County Airport	9 ^c	63,000	.010	.009	1.7	1.1	.77	.32
Travelodge, Marysville	10 ^c	69,000	.008	.008	1.6	.98	.68	.25
Main base water tank	11	5,800	.575	.729	8.3	11.7	18.4	36.3
Hilltop N of Radar	12	8,500	.492	.96	18.0	25.3	86.0	170
Hilltop NW of Radar	13	6,100	.707	1.27	17.7	28.1	83.0	210
Housing NW of Radar	14	12,000	.183	.170	8.1	5.7	17.2	8.6

^a These values are based on a maximum possible 25% duty cycle.

^b Increased by a factor of 1.4 in overlap region, see Figure A-5, p. A-18.

^c These locations are exposed by both antenna faces, which increases the average power density.

^d This location is outside the scan limits, which decreases the field strength.

A.6 References

- Etkind, I., "PAVE PAWS Parameters," Electric Systems Division, Air Force Systems Command, Hanscom AFB, Massachusetts. (May 1978a).
- Etkind, I., personal communication (September 1978b).
- Hankin, N. N., and David E. Jones, "Environmental Impact Analysis -- Project PAVE PAWS," U.S. Environmental Protection Agency, Silver Spring, Maryland (October 1977).
- Hansen, R. C., Microwave Scanning Antennas, Vol. 1, "Apertures," Academic Press, New York and London (1964).
- Hansen, R. C., "Circular-Aperture Axial Power Density," Microwave Journal, p. 50 (February 1976).
- Hu, M. K., "Fresnel Region Fields of Circular Aperture Antennas," Journal of Research, National Bureau of Standards, Vol. 65D, No. 2 (March-April 1961).
- Kahrilas, P. J., Electronic Scanning Radar Systems (ESRS) Design Handbook, Artech House, Inc. (1976).
- Kerr, D. E., Propagation of Short Radio Waves, McGraw-Hill (1951).
- NAS, "Radiation Intensity of the PAVE PAWS Radar System," National Academy of Sciences, Washington D.C. (1979).
- RADC, personal communication (October 1978).

Appendix B

ELECTROMAGNETIC RADIATION (EMR) FIELD MEASUREMENTS AND COMPARISON WITH CALCULATIONS

B.1 Introduction

This appendix describes the measurements that were made to evaluate both the ambient and the PAVE PAWS EMR fields at and near Beale AFB, and compares them to the calculated PAVE PAWS EMR fields. ++

On 10, 11 and 12 January 1979, an Air Force/ECAC team measured the ambient fields at nine locations on and near Beale AFB (Lemke, 1979). These measurements were conducted to determine the ambient EMR environment produced by sources such as radio and television stations, other radars, and local communications links. On 11 and 12 September 1979, an Air Force survey team measured the EMR field radiated from the PAVE PAWS antenna system at many locations in the near and far field. ++

B.2 Ambient Field Measurements

The ambient field measurements (Lemke, 1979) made during January are compared with the calculated PAVE PAWS field in Table B-1. The ambient field measurements were made over a frequency range of 48-630 MHz; however, only the reading for the largest signal in that range is listed in Table B-1. The measurements indicate that the ambient power densities produced by all existing sources are much weaker than the power density that will be produced by the PAVE PAWS radar. (The only exceptions were several measurements, all near the Beale AFB control tower, where the power density was as high as 0.089 microwatts/cm².) Because of this great disparity, it is not productive to make further comparisons between the PAVE PAWS emissions and the existing ambient. +

B.3 PAVE PAWS EMR Field Measurements

B.3.1 Test Locations

On 11 and 12 September 1979, field measurements were made at 18 test sites in the near and far field of the north and south faces of the antenna. Figures B-1 and B-2, pp. B-3 and B-4, are maps of the communities near Beale AFB and the PAVE PAWS site showing the test site locations, which are further identified in Table B-2, p. B-5. Location numbers are consistent with those used in Appendix A to illustrate the calculated fields. ++

Table B-1

COMPARISON OF MEASURED MAXIMUM AMBIENT EMR FIELDS
AND CALCULATED PAVE PAWS EMR FIELDS FOR SELECTED LOCATIONS

<u>Location</u>	<u>Location No.^a</u>	<u>Distance (ft)</u>	<u>Maximum Ambient EMR Power Density (microwatts/cm²)</u>	<u>Calculated Ground- Level Average Power Density for Basic System (microwatts/cm²)</u>
Hospital	1	7,400	0.000141	0.353
Lone Tree and Far West schools	2	12,600	0.0000056	0.166
Trailer park	3	8,700	0.00000035	0.286
Control tower	4	22,000	0.089	0.054
Explosive ordinance disposal area	5	10,300	0.0000056	0.183
Weapons storage area	6	21,200	0.00000071	0.043
Petroleum, oil and lub. area	7	20,000	0.0000022	0.069
Grass Valley Road	8	8,200	0.0000089	0.012
Yuba County Airport	9	63,000	0.0000039	0.010

^aThese location numbers correspond to those in Appendix A.

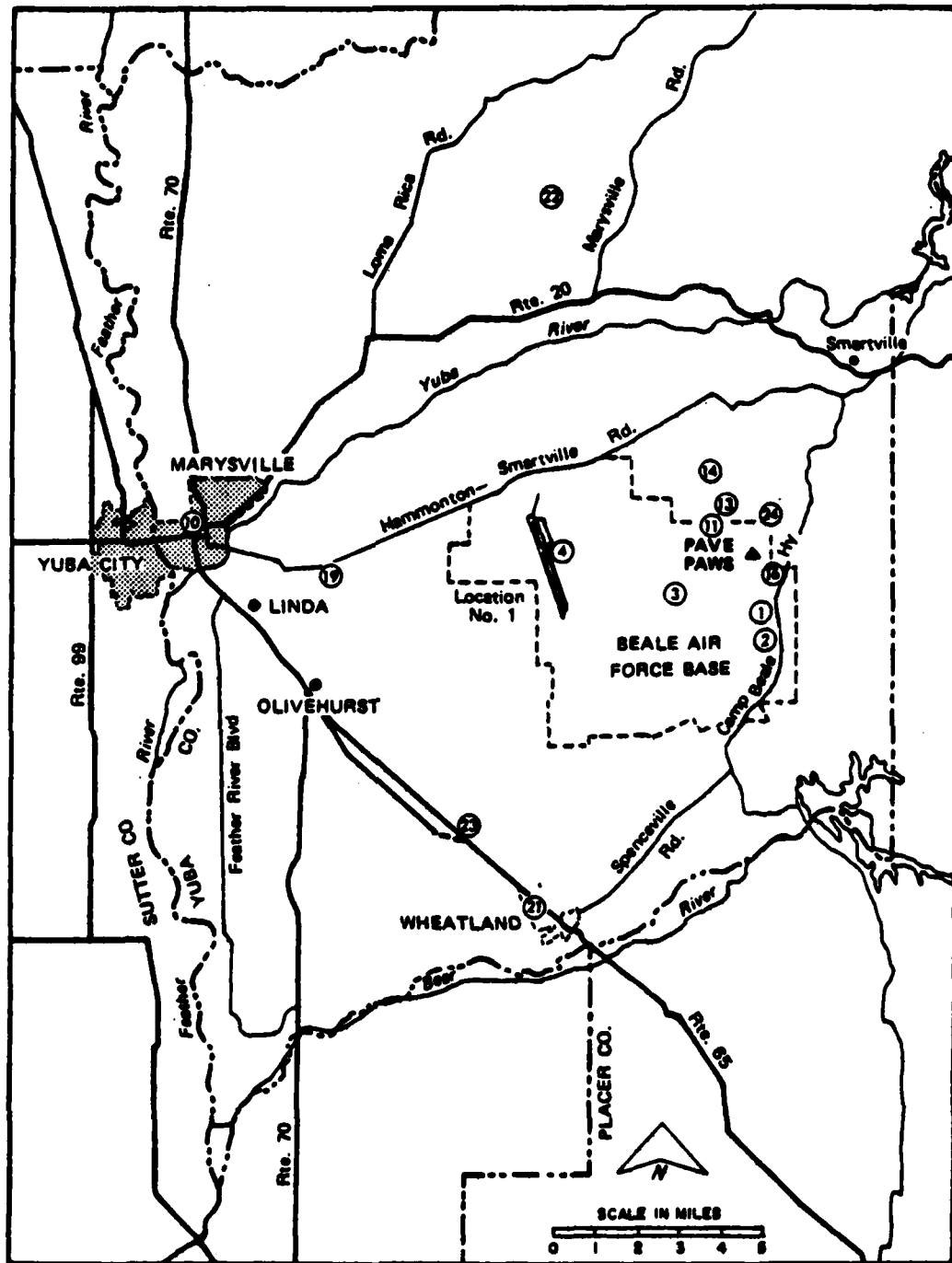

FIGURE B-1. BEALE AIR FORCE BASE - SITES SELECTED FOR MEASUREMENT



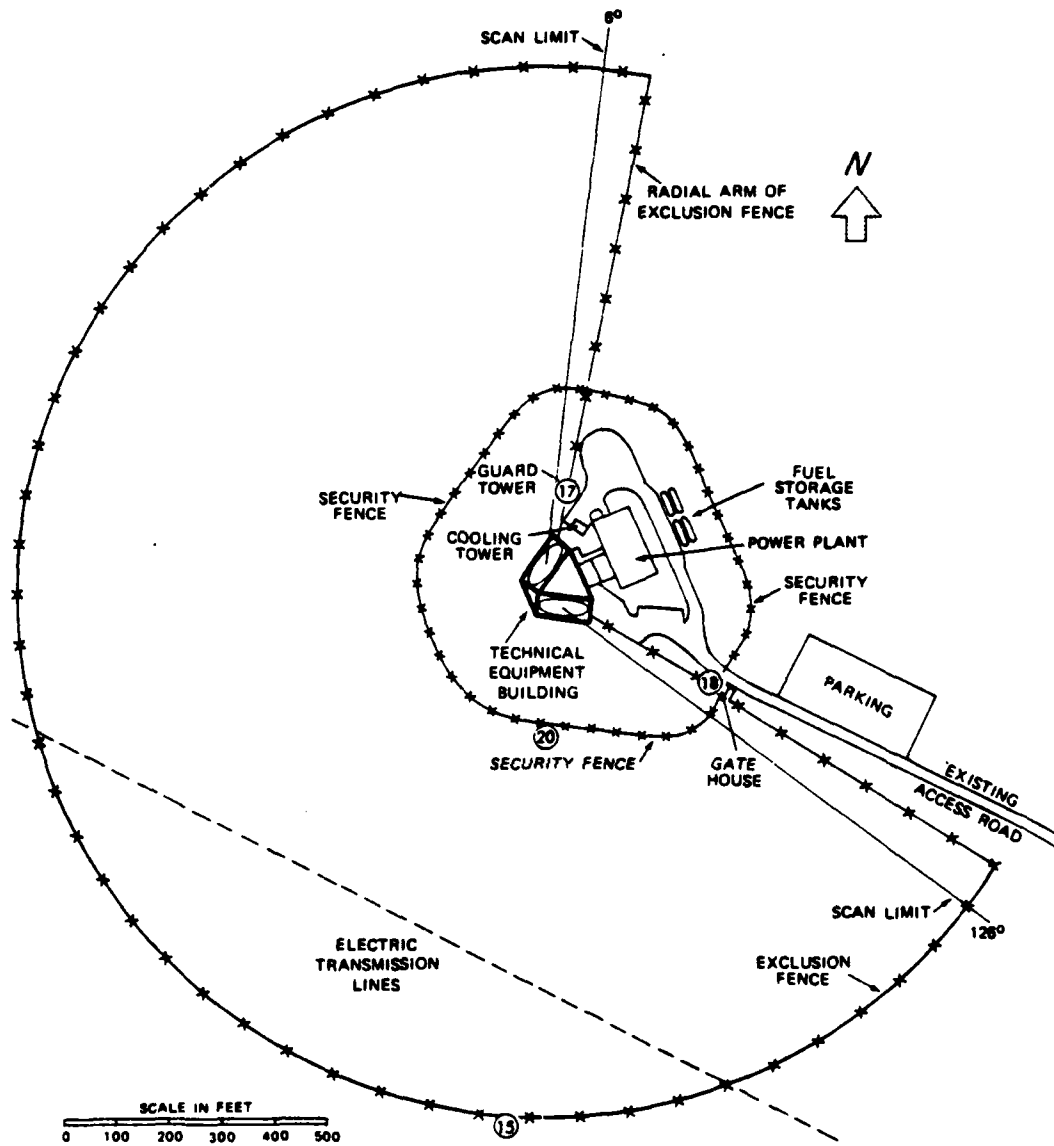

FIGURE B-2. PAVE PAWS SITE PLAN AT BEALE AIR FORCE BASE - SITES SELECTED FOR MEASUREMENT

++

Table B-2

BEALE AFB SITE IDENTIFICATIONS
(11-12 September 1979)

<u>Test Site^a</u>	<u>Location</u>	<u>Azimuth (deg)</u>	<u>Distance (ft)</u>	<u>Elevation (ft)</u>
1	Hospital	157	7,400	275
2	Lone Tree School	157	12,600	300
3	Trailer Park	248	8,700	150
4	Control Tower	280	22,000	215
10b	Travelodge, Marysville	273	69,000	60
11	Main Base Water Tank	298	5,800	294
13c	Hilltop NW of Radar	333	6,100	460
14	Housing NW of Radar	344	12,000	270
15	Exclusion Fence	186	950	360
16	Access Road	130	3,250	440
17	Guard Tower	22	150	395
18	Gate House	116	330	370
19	Yuba College	267	53,500	70
20	Security Fence	186	290	360
21	Wheatland High School	211	51,700	75
22	Browns Valley	311	51,700	400
23	Rte. 65 and S. Beale Rd.	226	47,500	75
24c	Hilltop NE of Radar	22	5,100	600

^aTest site numbers 1-14 correspond to those in Appendix A.

^bSites 5-9 were replaced with sites 15-24 in response to public comment at the premeasurement meeting on 10 September 1979.

^cSite 24 was misidentified as site 12 during the measurement session and the public hearing on 20 September 1979.

B.3.2 Test Conditions

Throughout the 11-12 September 1979 measurements, the radar was operated in an enhanced surveillance mode with 18% duty cycle applied to each face to produce the maximum possible exposure at ground level. For each location visited by the measurement team, the elevation of the surveillance fence was initially set at 3 deg; it was subsequently increased to 6 deg and 10 deg upon request from the field measurements team. Communication between test site and radar was maintained by a mobile radio link. Radar operating parameters were recorded during each measurement.

Under normal operations the radar frequency is automatically sequenced through 24 frequency channels about equally spaced through the band from 420 to 450 MHz. During the EMR field measurements, the radar was operated at one frequency, 435 MHz.

B.3.3 Test Instrumentation

The test equipment, made up of unmodified standard commercial items, was configured to measure the EMR field generated by the PAVE PAWS radar. Calibration and certification of the test equipment were performed by the Keesler AFB Precision Measurement Equipment laboratory, and all standards are traceable to the National Bureau of Standards. Extensive testing and system calibration were performed in the 1839th Electronics Installation Group Laboratory to verify the ability of the test instrumentation to measure accurately the complex electromagnetic radiation from the PAVE PAWS radar. Laboratory tests performed on the electric field intensity measurement system (field intensity meter, analog-to-digital (A/D) converter, and computer) showed an accuracy of ± 2.7 dB (multiplied or divided by 1.36) in the measurement of the voltage of pulsed signals with the characteristics of the PAVE PAWS radar. Laboratory tests performed on the average power measurement system (power sensor, power meter, A/D converter, and computer) showed an accuracy of ± 0.7 dB (multiplied or divided by 1.17) in the measurement of the the power of pulsed signals produced by two signal generators with different pulse widths, pulse repetition frequencies, and power levels. On-site tests with the instrumentation in the van showed an uncertainty of ± 0.3 dB (multiplied or divided by 1.03 in voltage or 1.07 in power) in the RF cable, attenuators, and power divider. The gain of the test antenna was known to an accuracy of ± 1.0 dB (multiplied or divided by 1.12 in voltage or 1.26 in power). Combining these uncertainties yields an overall system accuracy for the electric field measurements of ± 4.0 dB (multiplied or divided by a factor of 1.6), and an accuracy of ± 2.0 dB (multiplied or divided by a factor of 1.6) for average power density measurements. Because the measurement of pulse power density is derived from the electric field strength measurement, it has an overall system accuracy of ± 4.0 dB

(multiplied or divided by a factor of 2.5). (The apparent contradiction in these statements results from the fact that power varies as the square of the electric field.)

The instrumentation shown in Figure B-3 was installed in a screened enclosure in the mobile van used for all the measurements in the survey. The screened enclosure prevented possible EMR interference with the equipment resulting from instrument penetration by EMR signals or noise.

B.3.4 Test Procedure

At each designated location for the far-field measurements, the dipole test antenna was placed on a tripod and elevated 2 meters above the ground. The antenna and tripod were then moved horizontally until the received signal was maximized on the field intensity meter (tuned to the radar operating frequency of 435 MHz). This usually occurred within a horizontal distance of 1.4 meters (2 wavelengths). This procedure established "worst case" conditions resulting from the addition of reflected signals to the incident signal. The test antenna was then oriented along three orthogonal axes, and the radiated signal for each antenna orientation was measured.

The electric field measurement needed to determine the value of the pulse power density was accomplished with a Singer NM-37/57 field intensity meter (FIM), and the data were processed by a desk-top computer (Hewlett-Packard 9825A) and recorded on magnetic tape. The A/D converter sampled the FIM output 50 times per second, and provided the interface between the FIM and the computer. The average power density measurements were made with a Hewlett-Packard 436A power meter and 8484A power sensor. The A/D converter sampled the power meter output 167 times per second and provided the interface between the power meter and the computer.

The total average power density was calculated by summing the results of the individual measurements made with the test antenna in the three orthogonal orientations. This was done at each test location for each radar beam elevation measured. The total electric field was the vector sum of the individual orthogonal measurements (i.e., the square root of the sum of the squares of the three orthogonal measurements). Measuring with the dipole antenna in three orthogonal planes was essentially the same as measuring with an isotropic (nondirectional) antenna.

A total instrumentation verification was performed before and after the field measurements to validate the operation and accuracy of all test equipment and accessories.

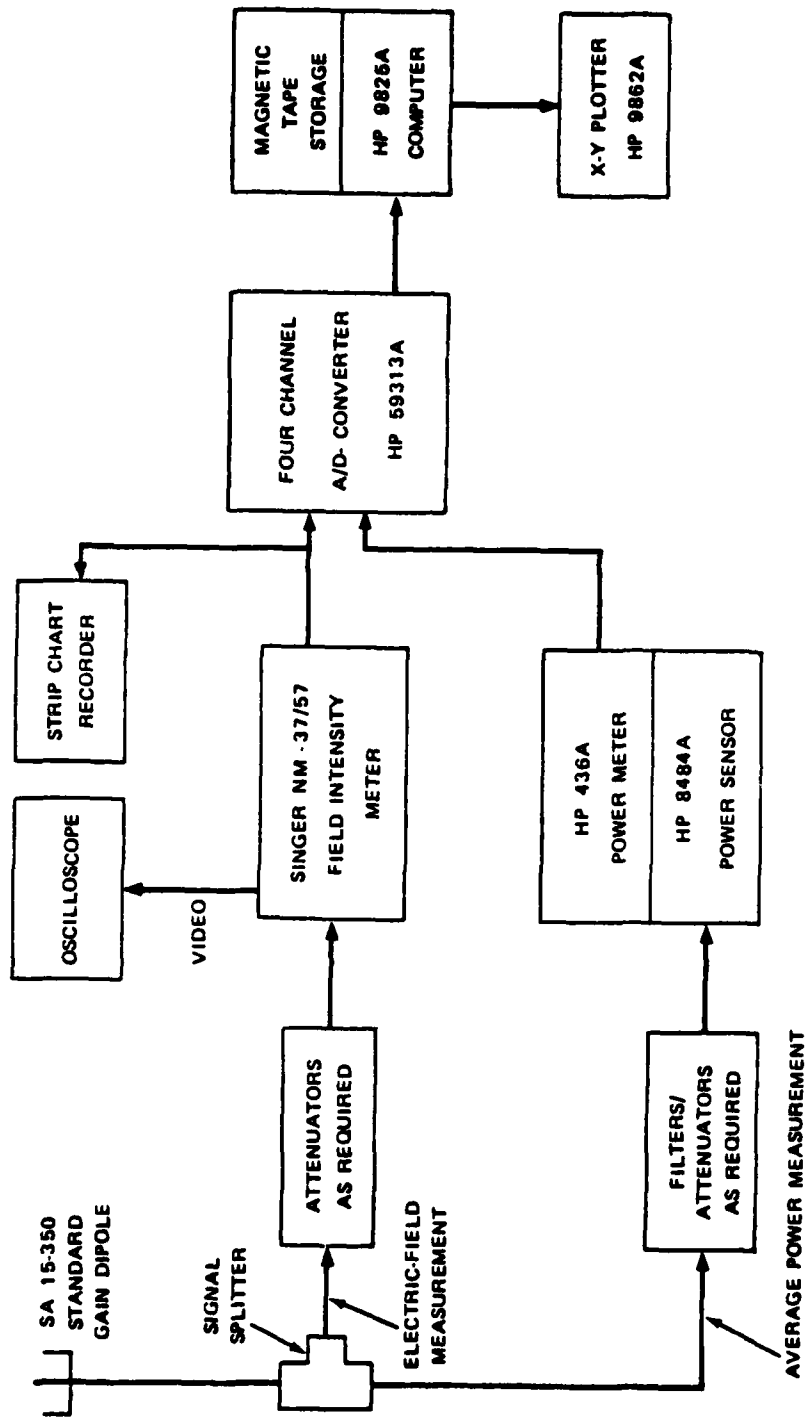

FIGURE B-3. BEALE AFB PAVE PAWS TEST INSTRUMENTATION

+

B.3.5 Results and Comparisons

++

Table B-3 compares the measured field at 3 deg beam elevation angle with values calculated by the methods of Appendix A; the calculated values have been adjusted to an 18% duty cycle and are thus directly comparable with the measured values.

At all but four test sites, the measured values were lower than the calculated values. Differences in measured and calculated values that exceed the overall measurement system accuracy can be readily attributed to attenuation by foliage, blockage of the line-of-sight to the radar, diffraction, and reflection from nearby objects or terrain irregularities.

At Sites 13, 20, and 24, five of the six independent measurements exceed the calculated values, but the differences are within the overall measurement system accuracy.

At Site 11, both independent measurements exceed the calculated values, but the electric field difference is within overall measurement system accuracy. However, the average power density measurement exceeds the calculated value by a factor of 2.0 (3.1 dB), slightly larger than the measurement system accuracy factor of 1.6 (2.0 dB). This slight discrepancy is readily explained by reflections from the large metal water tank at the site. Such reflections may account for as much as a factor of 2 deviation from the line-of-sight calculation (see Section A.4.1, p. A-21).

B.4 Summary

Excepting only the site near the Beale AFB control tower, as mentioned in Section B.2, p. B-1, the predicted EMR field strengths of the Beale PAVE PAWS radar are large compared with the ambient fields that exist in the vicinity of the radar. The measured values of electric field and average power density radiated by PAVE PAWS at Beale AFB were compared with predicted values; measured values were lower than those predicted by the field model at all but 3 locations for average power density, and at all but 4 locations for maximum electric field. However, six of the seven measurements that exceeded calculated values were within the uncertainty of the measurement. The measured average power density at one location exceeded the calculated value by a factor slightly larger than the uncertainty of the measurement. This circumstance can be attributed to reflections from the nearby large metal water tank. Comparison of the measured and calculated values for Beale AFB permits the conclusion that the field model developed in Appendix A is well founded and conservative.

++

Table B-3

**

COMPARISON OF MEASURED AND CALCULATED EMR
FOR BEALE AFB PAVE PAWS

Test Site ^a	Maximum Electric Field (V/m)		Pulse Power Density (microwatts/cm ²)		Average Power Density (microwatts/cm ²)	
	Calculated ^c	Measured	Calculated ^c	Measured ^d	Calculated ^c	Measured
	1	10.3	8.48	28.2	19.1	0.418
2	8.6	5.50	19.6	8.03	0.203	0.047
3	3.9	2.11	4.0	1.18	0.238	0.041
4	4.9	3.21	6.4	2.73	0.066	0.014
10 ^e	1.6	0.13	0.68	0.005	0.013	b
11	8.3	8.35	18.4	18.5	0.391	0.80
13 ^f	17.7	20.0	83.0	106.	0.74	0.96
14	8.1	2.77	17.2	2.04	0.224	0.013
15	42.4	17.9	476.	85.3	11.0	1.55
16	33.2	21.7	293.	125.3	2.61	2.52
17	205.	120.	11,200.	3820.	202.	126.
18	115.	111.	3,550.	3250.	202.	104.
19	2.0	0.47	1.1	0.06	0.022	b
20	72.7	106.	1400.	3000.	250.	111.
21	2.1	0.37	1.2	0.04	0.012	b
22	2.1	0.04	1.2	b	0.012	b
23	2.3	0.55	1.4	0.08	0.014	b
24 ^f	3.4	4.66	3.0	5.77	0.085	0.133

^aThese test site numbers correspond to those listed in Table B-2, p. B-5, and shown in Figures B-1 and B-2, pp. B-3 and B-4.

^bBelow reportable levels (less than 0.001 microwatts/cm²).

^cCalculated by the methods of Appendix A.

^dThe "measured" pulse power density is calculated from the measured maximum electric field using the equation on p. A-29.

^eSites 5-9 were replaced with Sites 15-24 in response to public comment at the premeasurement meeting on 10 September 1979.

^fSite 24 was misidentified as Site 12 during the measurement session and the public hearing on 20 September 1979.

B.5 Reference

**Lenke, M. A., "PAVE PAWS Baseline Measurements," Electromagnetic
Compatibility Analysis Center, North Severn, Annapolis MD
(January 1979).**

Appendix C

HUMAN EXPOSURE TO RADIOFREQUENCY RADIATION (RFR)

C.1 Introduction

This appendix is written in the form of a detailed critical review, including a bibliography, of selected scientific articles from the published literature on RFR effects. It is recognized that in this form it may not be easily comprehensible to the interested layperson. A more readable form that parallels the organization of this appendix is provided in the basic EIS. The letter "C" in paragraph numbers in this appendix is equivalent to the paragraph number prefix "3.1.2.1" in the basic EIS. (Specific bibliographic references are not included in the basic EIS).

To provide uniformity of presentation and to improve the readability of this appendix, the generic term radiofrequency radiation (RFR) has been used to include other terms commonly found in the literature, such as electromagnetic radiation (EMR), nonionizing electromagnetic radiation (NIEMR), microwave radiation, electromagnetic fields (EMF), microwave fields, and others. The term RFR, as used here, is intended to apply to the frequency band from approximately 10 to 18,000 MHz (18 GHz). The PAVE PAWS frequency band is 420 to 450 MHz.

This appendix is organized as follows: In the Introduction (C.1), the problem (potential impact on human health of exposure to the PAVE PAWS field) is described, and the methods used to develop information pertinent to assessing the problem (data base selection and evaluation) are given. In the next section (C.2, p. C-5), a summary is given of the present situation as it exists in the United States with regard to RFR-emitting devices in general and to high-power radar systems in particular. Because there are many considerations, problems, and interdependent processes that usually are not explicitly stated as being an integral part of the hazard or risk assessment process, but which are vital to it, the following two sections (C.3, p. C-7, C.4, p. C-9) discuss the general problems involved, as well as those more specific to interpretation of scientific research in the context of the PAVE PAWS problem. The next section (C.5, p. C-12) catalogs recent reviews in the area of bioeffects of RFR. The present state of knowledge of physical mechanisms of interaction of RFR with biological entities and of field measurements is contained in the next section (C.6, p. C-15). The present state of knowledge of biological effects is described in a series of subject-specific

subsections of C.7, p. C-27. Following the review, there is a brief mention of major unresolved issues, namely the problem of determining exact equivalence between effects on animals and those on humans and the problems inherent in retrospective epidemiological studies (C.8, p. C-71). Sections C.9 and C-10, p. C-72, refer the reader to the main body (Sections 3.1.2.1.9, p. 3-57, and 3.1.2.1.10, p. 3-60) where all this information is integrated, and it is concluded that the likelihood of adverse effects on human health from exposure to PAVE PAWS radiation is very small. A comprehensive bibliography comprises the last section (C.11, p. C-73) of this Appendix.

C.1.1 The Problem

The main question of concern in this appendix is whether exposure to the RFR produced by PAVE PAWS is likely to produce a significant impact on human health. Two situations must be considered. First, people may be airborne in the vicinity of PAVE PAWS. In this event they may be exposed to the main beam and first sidelobe in addition to higher order sidelobes (see Appendix A for a complete description). Second, people at ground level outside the exclusion fence will be exposed to the higher-order sidelobes and, at some elevations and distances for the basic system only, the first sidelobe and a portion of the main beam as well. (Possible exposure of individuals within the exclusion fence, e.g., military personnel, civilian employees, and visitors, is excluded from consideration because the Site Command will provide appropriate protective and control measures as required by the USAF Occupational Safety and Health program.)

C.1.2 Airborne Exposure

Exposure of an airplane to the main beam is a possibility shared with many operational high-power radar systems. However, as far as is known, there is no medically-documented case of harm to humans from any such incidental exposure, and there is no reason to believe that the PAVE PAWS situation would be significantly different from that of other radar installations in this respect. The calculated maximum pulse power density on the axis of the main beam of the basic system is approximately 560,000 microwatts/cm² for distances up to about 600 ft (the start of the transition region), and it diminishes to 300,000 microwatts/cm² at about 1,100 ft (within the transition region), to approximately 150,000 microwatts/cm² at 1,440 ft (the start of the far-field region), and to about 11,000 microwatts/cm² at 1 mile (see Section A.3.3.1, p. A-14). Corresponding pulse power densities for the growth system are approximately: 570,000 microwatts/cm² for distances up to about 1,200 ft (the start of the transition region); 300,000 microwatts/cm² at about 2,200 ft (within the transition region); 150,000 microwatts/cm² at 2,850 ft (the start of the far-field region); and 44,000

microwatts/cm² at 1 mile. The threshold for human perception of individual pulses as apparent sound is about 300,000 microwatts/cm² (see Section C.6.1.2, p. C-21). Therefore, a person within an aircraft that flies through the main beam would not hear individual pulses unless the aircraft is closer than approximately 1,100 ft for the basic system or 2,200 ft for the growth system, if it is assumed that the aircraft provides no attenuation and that the ambient noise level within the aircraft is negligible. In addition, there is no experimental evidence that such persons would experience effects ascribable to the pulse repetition rates per se (modulation effects) from exposures of the order of 1 minute (see below). In Section D.3.2.1.3, p. D-82, a model is presented to show the volume of airspace near PAVE PAWS containing surveillance mode main beam power density, the highest average power densities to which an aircraft could be exposed. That volume is within a few hundred feet of the ground, airspace not normally used by aircraft. The maximum average power density in that volume for the basic system is about 140,000 microwatts/cm² adjacent to the array faces, 270 microwatts/cm² at 1,440 ft from the radar, and about 20 microwatts/cm² at one mile from the radar. The values for the growth system in the surveillance volume are about 142,500 microwatts/cm² adjacent to the array faces, 270 microwatts/cm² at 2,850 ft, and 80 microwatts/cm² at one mile. Thus, aircraft flying closer to the radar in that volume could be exposed to average power densities between about 275 and about 142,500 microwatts/cm² for a few seconds at most, but the proximity of the ground and the radar building would constitute a physical hazard unacceptable to the prudent pilot. Aircraft penetrating that volume on the longest path, as shown in the referenced section, are exposed for less than a minute. Because of these considerations, the likelihood of a biological health hazard to persons in aircraft is considered negligible, and not given further attention in this assessment.

C.1.3 Ground-Level Exposure

For both the basic and growth systems, calculations indicate that the average power densities to which the general public may be chronically exposed ("general public exposure") are less than 1 microwatt/cm²; field measurements indicate that the actual values are less than 0.15 microwatt/cm². Exposure to higher power densities for relatively brief intervals may occur for individuals who elect to approach the radar along the roads leading to the site or by traversing the off-road area up to the exclusion fence. Calculations for the basic system indicate that the maximum average power density at 1,440 ft along the ground is approximately 4 microwatts/cm² for Sectors 2 and 3 (defined in Figure 3-1, p. 3-3), and double that value (i.e., approximately 8 microwatts/cm²) for Sector 1 in which the higher-order sidelobes from the two PAVE PAWS faces overlap. The distance from

1,440 ft to the exclusion fence, located 1,000 ft from the faces of the radar, includes part of the so-called transition zone of the radiated field. Power density increases linearly (approximately) in this region. At the 1,000-ft exclusion fence, the calculated maximum average power densities are approximately 30 microwatts/cm² in Sector 1 and approximately 15 microwatts/cm² in Sectors 2 and 3. The measured power density at 1,000 ft in Sector 2 was 1.55 microwatts/cm² (see Section B.3.5, p. B-8). Along the outside of the radial arms of the exclusion fence (Figure 3-9, p. 3-12), the average power density rises to 42 microwatts/cm² at 350 ft on the north security fence boundary and to 47 microwatts/cm² at 330 ft on the southeast security fence boundary (see Table 3-1, p. 3-13). These two distances correspond to the locations where the exclusion and security fences intersect, and they represent the points of closest possible public approach.

To determine pulse power densities, the highest values for individual pulses were calculated directly rather than inferred from mean duty-cycle considerations. The results for the basic system are 460 microwatts/cm² in Sector 1 at 1,000 ft and 700 microwatts/cm² at the 330-ft point of closest public approach. Therefore, the latter value of pulse power density and 47 microwatts/cm² average power density were used for assessing whether the RFR from the basic PAVE PAWS system would be potentially hazardous to human health.

Similar calculations of power densities for the growth option yielded the following values: At 2,850 ft, the maximum average power densities are 4 microwatts/cm² for Sector 1, and 2 microwatts/cm² for Sectors 2 and 3. At the 1,000-ft exclusion fence the maximum average power density is 29 microwatts/cm² and at the 330-ft location of closest approach, the value is 90 microwatts/cm². The corresponding pulse power densities are 1,160 and 1,400 microwatts/cm², respectively. Thus, the latter value of pulse power density and 90 microwatts/cm² average power density were taken as the maxima at ground level for the growth system.

C.1.4 Data Base and Literature Selection

A variety of sources was used in the acquisition of a working data base for this assessment. These sources included: reference bibliographies provided in previous reviews of the literature (C.5, p. C-12); the comprehensive bibliography of Glaser (1976, 1977); published proceedings of recent seminars and meetings on the biologic effects of RFR (Tyler, 1975; Czerski, 1974a; NATO, 1975, Johnson, 1976; Justesen, 1977; Hazzard, 1977); the computerized data base on Biological Effects of Electromagnetic Radiation (BEER file) of the Mead Technology Corporation, Dayton, Ohio; and the compilations of articles published by the Franklin Institute

(1978). Consideration was also given to recent symposia (Abstracts, Airlie, 1977; Abstracts, Ottawa, 1978; Abstracts, Helsinki, 1978), whenever the abstracts contained sufficient detail on procedures and results to allow reasonable evaluation.

Articles were selected from the above data base for inclusion in this review by several criteria, such as: date of publication, frequency band of the radiation (preferably, close to that of PAVE PAWS, but also other frequencies in the general range 10 MHz to 18 GHz), significance to human health (e.g., long-term exposure of animals and humans, the latter including epidemiology studies and reports of congenital defects), previous recognition of a paper as significant, possible relevance to concerns expressed by citizens' groups, or because the article helps to complete the overall picture provided by a series of other articles. Because of the large number of references in this general research area, the number of articles selected was necessarily limited, but it is representative of the total.

C.1.5 Eastern European Bioeffects Literature

Although there are many translations available of Eastern European research on the bioeffects of RFR that were published in the 1960s, many of these are difficult to assess critically because important details are lacking.

Starting with the Warsaw Conference (Czerski, 1974a) held in 1973, there has been an increase in scientific exchange between the United States and Eastern European countries on the bioeffects of RFR. This has resulted in an increasing number of Eastern European research reports in Western publications in a style that is amenable to critical review. These reports, together with those available in translation through the Joint Publications Research Service, have been considered for inclusion in this appendix. Criteria for selection of Eastern European publications were the same as those discussed in Section C.1.4 of this appendix, and the Eastern European literature constitutes approximately 15% of the bibliography.

C.2 Present Climate and Context

PAVE PAWS has been introduced in a general climate of widespread proliferation and usage of RFR-emitting devices and systems. Demand for the services and facilities of these devices is reflected by the following figures for the United States (McRee, 1978). During 1976, sales of communications and electronics products are estimated to have totalled \$38 billion. The FCC, as of 1977, had authorized transmissions by over 9 million

transmitters. Between 1971 and 1978 there was an increase of 87% in the number of FM stations operating in the 88-108 MHz band. The National Institute of Occupational Safety and Health (NIOSH) has estimated that there are over 35 million industrial RF sources for heating and drying in use in the plastics, paper, and other industries. Approximately 5 million microwave ovens are presently installed in homes in the United States (McConnell, 1978). There are presently on the order of 30 million citizen band (CB) radios licensed, with those operating in the 27 MHz band capable of emitting up to 4 watts. There are also many thousands of mobile radios, each permitted to radiate at up to 110 watts, that are specifically licensed for the frequency band 470-512 MHz, adjacent to the PAVE PAWS operational band. Domestic and business satellite communications systems are burgeoning. Air and maritime navigation makes widespread use of fixed and mobile radar systems. Thus, there exists a widespread climate of acceptance of the benefits of RFR devices for communications, radar, and industrial processes. On the other hand, there are those who question whether the proliferation of usage of RFR devices may be associated with some as-yet undefined hazardous biological effects. It is the purpose of the present document to address such concerns.

The RFR from PAVE PAWS may be compared with the fields from existing military and defense radar systems. Many of the high-power search and height-finder radars that comprise the U.S. early warning system have been operating continuously (except for routine maintenance) for years. Recently, Air Force personnel conducted a survey of RFR levels in the area surrounding and on North Truro Air Force Station, Massachusetts (U.S. Air Force, 1978b). Three high-power early-warning-system radars are operational on the base: an AN/FPS-107 search radar, an AN/FPS-26A height finder radar and an AN/FPS-6 height finder radar. More than 65,000 data points were recorded during the survey at 44 different test locations. Locations were previously recommended by EPA and also by the local citizens' groups. The radar units were positioned so that the maximum ground level radiation intensities would be recorded. Results of this survey yielded time-averaged power densities of less than 10 microwatts/cm² at all but 4 test locations. Two of these four sites were on base and yielded measurements of 42 and 19 microwatts/cm². The other two sites located adjacent to the base yielded measurements of 25 and 20 microwatts/cm². The majority of the measurements were less than 1 microwatt/cm². These measurements are quite comparable with those already made, or those calculated for the environs of the PAVE PAWS radar. The measured maximum pulse power densities at the same four sites where average power densities exceeded 10 microwatts/cm² ranged from 194,000 to 369,000 microwatts/cm². Questions concerning the impact on human health of PAVE PAWS may therefore justifiably be viewed in the context of impacts, or lack thereof, on human health at and around existing defense high-power radar facilities, and in the general context of

scientific evidence of hazards, or lack thereof, resulting from the widespread usage of RFR devices in society today.

C.3 Problems of Risk Assessment

The assessment of risk to human health and the setting of standards to protect it are extremely complex problems. In addition to purely technical and scientific questions, there are problems of philosophy, law, administration, and feasibility of programs that are still only vaguely recognized. It is clearly beyond the scope of this document to deal with those subjects in detail, but it is important that they be mentioned. The present section will concentrate on three problems relevant to the present issue: the scope of biological effects considered in setting standards, the overall approach to setting standards, and standards of protection from microwave radiation in the United States and the USSR.

The problem of choosing biological effects to consider and determining the acceptable degree of risk or undesirable effect can be illustrated by comparing occupational air pollution standards prevailing until recently in the USSR and the United States (Zielhuis, 1974). In the USSR, maximum allowable concentrations (MACs) for airborne noxious agents are set at a value that will not produce any deviation from normal in physiological parameters, or any disease in anyone exposed (occupational or general population). In the United States, threshold limit values (TLVs) for airborne noxious agents are set at a level such that nearly all workers can be exposed regularly during the working day without adverse effect. The differences stand out clearly: in the USSR, all biological effects are considered without regard to medical significance or possibility of human adaptation, and the level of protection must extend ideally to the most susceptible member of the population. In the United States, only harmful effects are considered, and protection of the susceptible workers is generally excluded, except that a safety factor is generally included in the TLV such that an adverse reaction in an individual can be detected before serious medical consequences ensue.

Both of the approaches in the preceding paragraph are predicated on the existence of a threshold concentration; that is, on a concentration below which no biological effect will occur. In the absence of a true threshold, one is faced with absolute choices about the level of protection to give to the population versus the cost and technical feasibility of that protection. These choices are the foundation of risk/benefit analysis in the assessment of environmental hazard. The subject of the existence or nonexistence of thresholds has been debated at length, but much of the debate has been conducted at a level of opinion rather than fact. As a practical scientific matter, thresholds for noxious or deleterious effects must exist at least for some substances, because

many naturally-occurring substances are essential to life at one concentration and highly toxic at higher concentrations (Horne, 1972). In this document, the possibility of threshold levels for RFR effects is considered on a case-by-case basis, with due regard for the physiological mechanisms of effect.

The overall approach to standard-setting can be considered in terms of the conservative (Lowrance, 1976) versus the liberal (Stokinger, 1971) approach. The principal distinction in the two viewpoints is that the conservative approach is strongly concerned with the danger of noxious agents that may have long-term irreversible effects, while the liberal approach is more concerned with practical problems in dealing with agents that have immediate and well-recognized deleterious effects. The difference is primarily a matter of assignment of priorities, but when taken to extremes, the difference can lead to unrealistic or scientifically unsupportable positions on the presence or absence of human hazard from environmental pollution. Analysis of hazards from RFR in this document takes the liberal position in matters of scientific proof of real or potential biological effects and a conservative position in matters of potential consequences of effects, particularly those effects that are likely to be irreversible.

Safety standards for occupational and general exposure in various countries are cited in terms of average power densities (or free-space-equivalent electric and magnetic field intensities), permissible exposure durations, and frequency ranges of applicability. In the USSR (which has the lowest permissible levels), the maximum permissible occupational power densities in the frequency range from 300 MHz to 300 GHz for exposure to stationary antennas are 10 microwatts/cm² for a full working day, 100 microwatts/cm² for 2 hours, and 1,000 microwatts/cm² for 20 minutes; the values for rotating antennas are 100 microwatts/cm² for a full working day and 1,000 microwatts/cm² for 2 hours (Stuchly, 1978). The maximum value for continuous (24-hour) exposure of the general population is 5 microwatts/cm² (Shandala, 1978). The principles on which the standard was developed are not known to us. Presumably the principle of no effect in any person (Zielhuis, 1974; Baranski, 1976) was applied, together with other considerations. Soviet armed forces are specifically exempt from this standard (Stuchly, 1978). There is no official standard for RFR exposure in the United States, but the American National Standards Institute has set a radiation protection guideline for occupational exposure of 10,000 microwatts/cm² averaged over any 6 minute period (Stuchly, 1978), and recommends that the limit not be exceeded "without sound reason." This guideline has been adopted by Department of Labor's Occupational Safety and Health Administration (OSHA) and the DOD.

In the analysis of the possible biological effects of radiation from the PAVE PAWS facility, the health and well-being of the

population living in the vicinity is considered to be of primary importance. The basis for decision is the presence or absence of documentable evidence of harmful effects at maximum public exposure to PAVE PAWS radiation levels that may be produced by the facility. Existing or contemplated exposure standards are not at issue, and do not form the basis for any of the recommendations contained in this document. Further elaboration of details of RFR protection standards in many countries is given in Stuchly (1978).

C.4 Assessment of Scientific Information

In an assessment of the potential biological effects of PAVE PAWS RFR, certain quantitative relationships must be considered among (1) the physical parameters of the RFR such as frequency, power density, polarization, and pulse characteristics; (2) the mechanisms of absorption and distribution of energy within the biological organism; and (3) the resultant biological effects as measured by some functional or anatomic alteration. Like all scientific theory, the body of biophysical theory that links these three factors has been synthesized from a variety of experimental evidence. The theory is dynamic, in that it is subject to refinement or revision as further valid evidence accumulates that is inconsistent with the current theory. Nevertheless, the present theory furnishes the context in which new experimental evidence is considered.

Experimental evidence comes from the observation of experimental animals and, sometimes, of humans who have been exposed to RFR. The physical characteristics of the radiation, the mechanisms of interaction, and the biological response are known in some cases, at least qualitatively. Obviously, the most directly applicable experimental evidence relative to possible bioeffects of PAVE PAWS would be from experiments in which humans were exposed to the specific frequency, waveform characteristics, and power density values that are calculated to emanate from PAVE PAWS. Further, it would involve quantitative evaluation of a large number of biological endpoints. Such data, however, do not exist. The available information is indirect because it is derived primarily from experiments with animals and therefore requires at least some extrapolation among species, field characteristics, duration of exposure, and biological effects.

The usual experiment involves the exposure of groups of animals to a single frequency, either continuous wave or at a given pulse schedule. Each group is exposed under a combination of a specific power density and exposure time. It should be noted, however, that magnetrons were used as microwave power sources in many of the experiments reported in the literature, and that most magnetrons operate in the pulsed mode, although frequently this point is not mentioned. It is not uncommon, therefore, to find studies in the literature in which the RFR used might be taken as

CW when pulsed RFR was actually used. In the present context, the uniqueness of the radiation characteristics of PAVE PAWS (frequency, waveform, and power densities) renders all known experimental evidence indirect as it relates to the exposure parameters.

Retrospective epidemiologic studies are those in which the data are acquired after the event to be studied has occurred. While the subjects of such studies are, by definition, human and thus might furnish direct evidence from a species standpoint, epidemiologic evidence remains indirect, for two reasons. Not only are the exposure parameters unlike those predicted for the PAVE PAWS facility, the exposure parameters for most epidemiologic studies are not known with sufficient precision. In addition, the selection of an appropriate, unexposed control group of people, ideally identical to the exposed population in every respect except for the exposure itself, is practically impossible in the absolute sense. Since the conclusions of epidemiologic studies are almost always based upon comparisons between so-called matched populations, the extent to which the control population actually matches the experimental one becomes a critical matter in assessing the validity of the conclusions.

Regardless of the particular line of evidence being considered, certain concepts and constraints affect the interpretation of the evidence. In particular, there is disagreement as to whether an effect, especially one that is reversible or can be compensated, constitutes a hazard. Only rarely is any specific experimental study subjected to confirmation through the performance of an identical experiment by another investigator. More often, an analogous -- but not identical -- experiment is conducted with the objective of clarifying or expanding the results of the initial experiment. Thus, the second experiment ideally provides a better means of incorporating the findings into the theory that forms the body of knowledge in a particular field of investigation.

Still another consideration is also important: scientific findings are probabilistic in nature, in that facts are known only to some level of probability for a given population; applicability of those facts to a specific individual may be constrained. For example, the median effective dose for a certain agent describes the dose that will elicit the response characteristic of that agent in one-half of the exposed individuals. Before the dose is administered, however, it cannot be predicted whether any specific individual will respond. (Nonetheless, the prediction that any specific individual will have a 50% chance of showing the response is valid.) In effect, the probabilistic nature of scientific evidence means that there are no scientific data on which a guarantee of absolute safety for any individual or group of individuals can be based. There is disagreement as to whether the conventional scientific approach, whereby an investigator finds or fails to find a statistically significant (very low probability of

chance occurrence) difference between experimental and control groups, is appropriate to considering potential hazards to humans. The scientist's statement that no statistically significant differences between the groups are discernible is not equivalent to the absolute statement that there is no difference between the groups. Thus, no scientific evidence can provide proof that any agent is safe in the absolute sense.

Sometimes the magnitude of the difference in response between experimental and control populations is small. Biological studies designed to detect such a small, statistically significant difference require large numbers of animals and, in some cases, long exposure times. Therefore, the resources necessary to perform such studies are very large. Often the expenditure in time and money reaches the point where sponsoring institutions with limited budgets may decide that such studies are not cost-effective, in view of their overall objectives. As a frequent alternative, predictions of effects at very low levels are made from extrapolation of findings at higher levels, on the basis of assumptions about the mathematical relationship between the level (or dose) of the agent and the degree of the effect. Such assumptions are open to challenge, however, so this approach frequently leads to disagreement over the matter of whether there is a threshold below which no effects of the agent exist.

It must also be remembered that scientists, like everyone else, have personal values, goals, and attitudes. It has been said that there is no such thing as an unbiased expert, since to become an accepted authority involves a personal commitment and dedication over a period of time, which leads to emphasis of a certain viewpoint. Thus, like the probabilistic nature of scientific findings, objectivity may well apply to scientists as a group, but not necessarily to any individual scientist. Personal bias can consciously or unconsciously affect how the experiment is designed, how the data are interpreted, and, particularly, the applicability of the results to decision-making. The latter is especially important when the decision to be made is in an area outside the scientist's field of expertise.

Finally, scientific experiments are usually restricted, almost by definition, to the evaluation of only one factor. The real world, however, does not involve the operation of only one factor. The contributions of other factors, for example, is illustrated in the case of uranium miners, who show an increase in incidence of lung cancer that is presumed to result from inhalation of radioactive material associated with their occupation. The extent of the increase in nonsmoking miners is marginal, but miners who smoke cigarettes show a much larger increase in lung cancer than in either nonsmoking miners or the general population. Thus, any given scientific evidence can only supply probabilistic information that is relatively narrow when applied to the real world.

C.5 Other Assessments and Reviews

Two other assessments of PAVE PAWS and nine representative general reviews, including two by Eastern European authors, are described in this section. All have been published between 1972 and the present. These reviews were used as a resource to identify relevant articles in the literature and as a means of assuring that the scientific literature was adequately covered for preparing the EIS. The conclusions and opinions of the authors of the assessments and reviews were considered and compared to those in the EIS; however, since each document was developed from a different viewpoint concerning RFR effects, the conclusions stated in the EIS and this Appendix were independently derived, explicitly considering the problems posed by the PAVE PAWS facility.

The Assembly of Life Sciences of the National Academy of Sciences appointed the Panel on the Extent of Radiation from the PAVE PAWS radar system to examine the levels of RFR to which the public may be exposed. In April 1979, the Panel released its report (NAS, 1979), entitled "Analysis of the Exposure Levels and Potential Biologic Effects of the PAVE PAWS Radar System." The report covers essentially the same topics as those addressed in the EIS, including: the RFR levels of PAVE PAWS to which the general population may be exposed, the various biological effects of RFR in animals, and reported effects of RFR in humans. The distinction between an effect and a hazard is made, and the difficulties of risk assessment are discussed, including the lack of adequate epidemiological studies. For discussing the biological effects of RFR, an average power density of 1,000 microwatts/cm² was selected as the arbitrary boundary between "high-intensity" and "low-intensity" effects. A total of 170 references are cited, many of which are the same as those in the EIS or which include comparable information. A general conclusion was that exposure of humans to low-intensity RFR can have effects, but that on the basis of current information, the known or suspected effects are reversible and not associated with increased morbidity or mortality. The specific conclusion with regard to PAVE PAWS is quoted below.

"In conclusion, the PAVE PAWS radar may be anticipated to expose a limited number of members of the general public intermittently to low intensities of pulse-modulated microwave fields with maximal instantaneous intensities of 100 microwatts/cm² or less and time-averaged intensities lower by two orders of magnitude. There are no known irreversible effects of such exposure on either morbidity or mortality in humans or other species. Thus, it is improbable that exposure will present any hazard to the public. In view of the known sensitivity of the mammalian CNS to electromagnetic fields, especially those modulated at brainwave frequencies, the

possibility cannot be ruled out that exposure to PAVE PAWS radiation may have some effects on exposed people. Because these effects are still hypothetical, it is not feasible to assess their health implications. Such assessment will require additional research and surveillance and must be addressed in future evaluations of the potential exposure effects of PAVE PAWS and other high-power-output radar systems."

Another assessment written specifically for PAVE PAWS is that by the Radiobiology Division, USAF School of Aerospace Medicine (U.S. Air Force, 1978a), entitled "Biologic Judgments in Support of PAVE PAWS Environmental Assessment." Some 173 references are cited. Sections of the review discuss the Air Force RFR research program, epidemiologic studies concerning DoD personnel, chronic and acute studies of animals, effects of pulsed radiation versus those of CW radiation, review papers, and a section on "Opinions Related to Special Interest Questions" (the latter raised in a letter from Congressman Studts to the Air Force). The special interest questions are those concerning the Moscow Embassy; congenital abnormalities; effects on the immune system, behavior, flora and fauna; electromagnetic interference with cardiac pacemakers; interaction with biological media; effects on brain tissue and neurochemistry; and U.S. exposure standards versus those in the USSR.

The nine reviews that follow are presented with the most recent first.

Two reviews, one covering RFR biophysics and the other discussing biologic and pathophysiologic effects of exposure to RFR, are contained in the transactions of a short course held in Ottawa, Canada, in June 1978. Lin (1978) presents an assessment of the current knowledge about RFR interactions with biological systems, with emphasis on the dielectric properties of tissue materials, propagation and absorption of RFR in tissues, and basic physical mechanisms of interaction. There are 76 references cited.

Michaelson (1978), after reviewing fundamental principles related to biomedical research in the laboratory and extrapolation to man, discusses topics including the concept of scaling, cellular effects, chromosomes, genetic effects, growth and development, the gonads, neuroendocrine response, effects on the nervous system, cardiovascular effects, hematopoiesis, effects on immunity, the auditory response, cataractogenesis, epidemiologic and incidence studies, and interference with implanted, electronic cardiac pacemakers. Michaelson provides 209 reference citations.

Stuchly (1977) reviews potentially hazardous RFR sources, citing 38 references. The review discusses those sources judged to have potential for producing hazardous levels of RFR under normal operating conditions and under possible malfunction, and considers satellite communications systems, radar systems, communications systems, and microwave-power devices for generating heat.

Dodge and Glaser (1977) assess international trends in research, development, and occupational health and safety, concentrating on events since 1975. Some 25 references are cited. Sections discuss exposure standards, research on bioeffects, effects of RFR on humans, and U.S. Federal RFR health and safety programs.

Cleary (1977) provides a critical review of the results of 12 studies on various aspects of biological effects of RFR. Also included are references to 100 other articles. Sections of the review discuss physical characteristics of RFR, RFR absorption in biological and model systems, effects of nonuniform RFR absorption, and a major section on physiological effects of RFR exposure. The latter includes hematopoietic effects, neuroendocrine effects, and RFR effects on pathogenic organisms. Also included are RFR/drug interactions, effects on sensory organs, effects on reproduction and development, cellular and subcellular effects, neural effects, effects on excitable cell systems. Additional consideration is given to behavioral effects, molecular interactions, dosimetry, and standards for human exposure.

Carpenter (1977) gives a critical, comprehensive presentation of RFR and its effects, emphasizing RFR as an environmental agent. Sections deal with physical characteristics and properties of RFR, effects on tissue, "thermal" and "nonthermal" effects (see definitions in Section C.6.1, p. C-15), exposure levels, biological effects of RFR on human beings and experimental animals, as well as RFR effects on the eye, the testes, the nervous system, and on development. Carpenter cites 110 references.

Baranski and Czerski (1976) have published the most comprehensive compilation and discussion of the literature to date. The 234-page book contains references to 614 articles, with wide representation given to both Eastern European and Western studies. Chapters include an introduction, physical characteristics of RFR, interactions of RFR with living systems, biological effects of RFR (experimental data), the health status of personnel occupationally exposed to RFR (symptoms of microwave over-exposure), safe exposure limits and prevention of health hazards, and final comments.

Sudakov and Antimoniy (1973) provide an extensive review (224 references) of the neurophysiology and behavior of animals and humans, in an English translation of the original Russian article

by the Joint Publications Research Service. The authors appear to accept as uncontested the premise that RFR has direct effects (denoted by them as "nonthermal") upon the nervous systems of animals. The review is in two main sections. The first is concerned with biological aspects of the effects of RFR on the central nervous system (CNS) of animals and man, and contains subsections on natural RFR as a factor in evolution, the effects of natural RFR on animals and man, RFR on the activity of the CNS, the sensing of RFR by living organisms, and the effects of RFR on the behavior and conditioned activity of animals and man. The second main section is concerned with neurophysiological mechanisms of action of RFR, with subsections on bioelectrical activity of the brain during exposure to RFR, morphological and functional changes in the CNS upon exposure to RFR, and selective action of RFR on structures of the CNS.

Milroy and Michaelson (1972) review information available until that date on RFR cataractogenesis. They include 59 references. Sections include animal experimentation, discussion of experimental data, human studies, discussion of human data, and conclusions.

C.6 Present State of Knowledge Regarding Physical Effects

C.6.1 Interactions of Fields with Biological Entities

Interactions of electromagnetic fields with biological entities are often loosely characterized in the bioeffects literature as "thermal" or "nonthermal," a usage that has led to confusion and controversy. Therefore, it is appropriate at this point to introduce working definitions of these terms, with the recognition that the boundary between these types of interaction is not sharp.

The interaction of an agent (e.g., RFR) with an entity (biological or nonbiological) can be characterized as thermal if the energy absorbed by the entity is transformed at the absorption site into heat. Heat absorption, in turn, is defined in classical thermodynamics as either an increase in the mean random speed (or kinetic energy) of the molecules at the site (a local increase in temperature), or as an increase in the disorder or randomness of the molecular motion without an increase in mean random speed (a first-order phase change), or both.

An entity can also absorb energy at specific discrete frequencies in the form of energy packets or "quanta," each of which has an energy proportional to one of the discrete frequencies. The constituents and configurations of the various molecular species comprising the entity determine the specific frequencies or characteristic spectra at which such absorption can

occur. The kinds of interactions involved are numerous and of varying degrees of complexity. They include alterations of molecular orientations and configurations that do not change the basic identities of the molecules, disruption of intermolecular or intramolecular bonds, and excitation of atoms or molecules to higher electron states (including ionization). Such interactions can be characterized as "short-range" processes. There are also cooperative interactions among subunits of molecules within biological cells, in cell membranes, and in extracellular fluids. Cooperative interactions are often characterized as "long-range" because absorption of energy at one specific site in a structure, e.g., in a membrane or in a biological macromolecule, can affect a process elsewhere in the structure, or a function of the structure as a whole can be triggered by the release of energy stored in the structure, thereby producing biological amplification.

Conceptually, all such quantum interactions can be characterized as "nonthermal". However, if most of the energy thus absorbed is subsequently transformed locally into heat (as defined above), the distinction between "nonthermal" and thermal is blurred. Pragmatically, therefore, characterization of an interaction of RFR with a biological entity as nonthermal requires that the interaction give rise to a frequency-specific effect that is experimentally distinguishable from heating effects due to thermalization of the absorbed RFR energy.

C.6.1.1 Thermal Effects of Time-Averaged Power Density and Dose-Rate Considerations; Nonthermal Effects of CW RFR

Consider now the effects of CW RFR on a human or an animal. The relative magnetic permeability of most organic constituents is about unity. Therefore, thermal interactions (as defined above) can be described in terms of the dielectric, electrical-conductivity, and thermal properties of the bodily organs, tissues, fluids, and so forth, as well as the characteristics of the RFR (frequency, power density, polarization). Measurements of these properties have been made for various mammalian tissues, blood, cellular suspensions, protein molecules, and bacteria over the spectral region from about 10 Hz to 20 GHz, notably by Schwan and coworkers (Schwan, 1963, 1957; Schwan and Piersol, 1955; Schwan and Li, 1953) and others (Lin, 1975; Cook, 1951, 1952). In general, the dielectric constants were found to vary inversely with frequency in a separate characteristic manner for each of three parts of that frequency range ("alpha," "beta," and "gamma" dispersion regions), ascribable to different predominant relaxation mechanisms, each characterized by specific time constants (Schwan, 1957). In the low and intermediate frequency ranges (about 10 Hz to about 100 MHz), encompassing the "alpha- and beta-dispersion" regions, the properties of cell membranes, which have large specific capacitances (about 1 microfarad/cm²), predominate. In the range above about 10 GHz

("gamma-dispersion" region), membrane impedances are negligible, and the behavior of the water and electrolyte content are most predominant. As an example of the large numerical variation of dielectric constant, the values for muscular tissue decrease by five orders of magnitude, from about 3×10^6 at 10 Hz to 30 at 20 GHz.

In the frequency range from about 300 MHz to about 10 GHz, the dielectric constants of skin, muscle, and blood vary little with frequency because the transition between the beta- and gamma-dispersions occurs in this range. The mean dielectric constants for these three constituents are about 40, 50, and 60, respectively; the differences in values are largely ascribable to the proportion of water in each constituent, water having a dielectric constant of about 80.

Because the index of refraction of any material is related to its dielectric constant, electromagnetic fields are reflected and refracted at the air-surface interface and at internal boundaries between constituents of widely different dielectric properties, e.g., at interfaces between the skull and the dura or between a body cavity and adjacent tissues, thereby affecting the internal field distributions. At 450 MHz, for example, about 65% of the incident power density is reflected at the air-skin interface (Johnson, 1972), and the approximately 35% that enters the body is progressively attenuated with depth because of energy absorption.

The attenuation constant (rate of energy absorption with distance) of any material is proportional to the square root of its electrical conductivity. The concept of "penetration depth" (inverse to attenuation constant) is often used. For homogeneous specimens, the penetration depth is defined as the distance at which the electric field amplitude is $1/e$ (37%) of its value or the power density is $1/e^2$ (14%) of its value just within the surface. The electrical conductivities of skin, muscle, blood, and other constituents of the body increase slowly with frequency up to about 1 GHz and rapidly from about 1 GHz upward. At about 450 MHz, the penetration depth for muscle (and blood) is about 3 cm, and it is about six times greater for fat. (At about 10 GHz and higher, field penetration is largely confined to the skin.) In the literature on bioeffects of RFR, thermal energy absorption from an electromagnetic field is usually characterized by the Specific Absorption Rate (SAR), defined as the rate of energy absorption in a small volume at any locale within an entity, divided by the mean density of the constituents in that volume. SAR is expressed in terms of W/kg or mW/g. The numerical value of SAR in any small region within a biological entity depends on the characteristics of the incident field (power density, frequency, polarization) as well as on the properties of the entity and the location of the region. For biological entities that have complex shapes and internal distributions of constituents, spatial variations of SAR are not readily calculated. Therefore, the

concept of "mean SAR," which represents the spatial average value for the body per unit of incident power density, is often used because it is a quantity that can be measured experimentally--e.g., by calorimetry--without requiring information on the internal SAR distribution.

Many investigators have studied relatively simple geometric models, including homogeneous and multilayered spheroids, ellipsoids, and cylinders that have weights and dimensions approximately representative of various species, including humans. Such models were actually, or were assumed to be, irradiated with linearly polarized plane waves to determine the dependence of mean SAR on frequency and orientation relative to the polarization direction of the RFR. Many of the significant data have been included in a compendium (Durney et al., 1978) that is useful for very approximate frequency-scaling and interspecies comparisons of mean SAR values. An important result of this work is that the largest value of mean SAR is obtained when the longest dimension of each kind of model is parallel to the electric component of the field and when the wavelength of the incident RFR is about 2.5 times the longest dimension. The adjective "resonant" is often applied to the frequency corresponding to this wavelength. The resonant value of mean SAR for each model is also inversely dependent on the dimension perpendicular to the polarization direction (and propagation direction) of the field, i.e., the model has characteristics somewhat similar to those of a lossy dipole antenna in free space. Resonances would also occur for circularly polarized RFR. Such RFR can be resolved into two mutually perpendicular components, each having half the total power density. Therefore, an entity exposed to circularly polarized RFR would have lower resonant mean SAR values than it would have if exposed to linearly polarized RFR of the same total power density.

Based on prolate-spheroidal models (and linearly-polarized RFR), the resonant frequency for an "average" man, approximately 5 ft 9 in tall (1.75 m) and weighing about 154 lb (70 kg), is about 70 MHz; at this frequency the mean SAR is about 0.2 W/kg for 1,000 microwatts/cm² incident power density, or about 1/6 of his resting metabolic rate, or about 1/21 to 1/90 of his metabolic rate when performing exercise ranging from walking to sprinting (Ruch and Patton, 1973). Similarly, the resonant frequency for an "average" woman about 5 ft 3 in tall is about 80 MHz, and her mean SAR is about the same as for the average man. The resonant frequency of a 10-year old is about 95 MHz; for a 5-year old, about 110 MHz; and for a 1-year old, about 190 MHz. The resonant mean SAR values for such children are about 0.3 W/kg for 1,000 microwatts/cm². The presence of a ground plane or other reflecting surfaces shifts the resonant frequencies downward and can produce higher values of mean SAR at the lower resonant frequencies (Gandhi et al., 1977; Gandhi, 1975).

The foregoing discussion of mean SAR is also largely applicable to pulsed RFR (and other types of modulated RFR) at corresponding carrier frequencies and time-averaged incident power densities. (However, as discussed in the next section, there are several differences in interaction between CW and pulsed RFR.)

To illustrate how the concept of mean SAR can be interpreted, consider the resonant value for the model man (0.2 W/kg for 1,000 microwatts/cm² at 70 MHz). Exposure of such a model man to 100 microwatts/cm² average power density at 70 MHz for about 1 hr in the absence of any heat-removal mechanisms would produce a mean temperature rise of 0.02°C. Exposure to the same power density for the same duration, but at frequencies in the PAVE PAWS range would produce considerably smaller increases in mean temperature. If reflecting surfaces are nearby, then the PAVE PAWS frequencies are further from resonance, which compensates at least partially for the higher mean SAR at the downward-shifted resonant frequency. (The resulting numerical values of mean SAR in the PAVE PAWS frequency region would depend on the specific nature and configuration of the reflecting surfaces).

On the basis of such mean SAR considerations, it can be concluded that chronic exposure of humans (*in vivo*) to the RFR from PAVE PAWS at the average power densities outside the exclusion fence at ground levels (see Section C.1.3, p. C-3) is most unlikely to cause any rise in mean body temperature.

Homogeneous and multilayered spheroidal and cylindrical experimental models, having appropriate electromagnetic and thermal characteristics to represent various parts of the body, such as the head and limbs, have been studied as well (Wu and Lin, 1977; Neuder, 1976; Kritikos and Schwan, 1976; Kritikos and Schwan, 1975; Weil, 1975; Joines and Spiegel, 1974). The primary objective of the studies has been to determine the internal spatial field distributions created by linearly-polarized plane waves. Probably the most significant findings for spherical head models have been the discoveries of local regions of relative maximum SAR values and the manner in which the locations of such regions depend on the size of the head, the electromagnetic characteristics of its layers, and the wavelength of the incident field. These regions have been conveniently dubbed "hot spots," even for combinations of incident power density and exposure duration that would produce biologically insignificant temperature rises at such spots. As representative examples of such findings, two multilayered spherical head models with diameters of 10 and 20 cm were analyzed (Kritikos and Schwan, 1976). For the 10-cm head, the hot spots are internal over the frequency range from about 400 MHz to about 3 GHz; the highest relative maximum SAR occurs at about 1 GHz. Above and below that frequency range, the hot spots are at, or just within, the surface facing the field source (front surface). At 450 MHz, the hot spot is close to the front surface and its SAR is about 15% larger than the front-surface hot-spot

SAR at 400 MHz. By contrast, for the 20-cm head (about the diameter of an adult human head), there are no deep internal hot spots at any frequency; the hot spots are always at or just beneath the front surface.

Results of theoretical analyses of simple geometric models have been verified experimentally by (1) constructing physical models from synthetic biological materials (having approximately the same electromagnetic characteristics as their corresponding biological constituents), (2) exposing such models to sufficient power densities to obtain readily measurable temperature rises, and measuring such rises in temperature immediately after irradiation. Although much useful information has been obtained from models that have relatively simple geometries, human and animal configurations are far more complicated and different from one another. Therefore, SAR distributions in animal carcasses and figurine-shaped physical models have been determined experimentally (Gandhi et al., 1977; Guy et al., 1976a). Calorimetry has been used to measure whole-body mean SAR values (Kinn, 1977; Hunt and Phillips, 1972). A widely used technique to determine internal field distributions is to section a carcass or physical model along appropriate parting planes, then reassemble and expose it. The spatial temperature distribution over each parting plane is then measured with scanning infrared thermography immediately after exposure. However, such spatial temperature distributions should not be regarded as the corresponding in vivo internal temperature distributions, because the heat-transfer characteristics of such carcasses and physical models are significantly different from those of live animals and do not have the thermoregulatory mechanisms of the latter. Instead, such measured temperature distributions represent approximations to the internal field or SAR distributions.

Among the qualitative results of general interest with human figurines is that at frequencies near resonance, the local fields can be much higher for certain regions, such as the neck and groin, than for other body locations. In addition, field distributions for nonprimates are quite different from those for primates; this is a point that should be given proper consideration when the analyst attempts to extrapolate experimental findings on any laboratory animal species to humans, or to compare experimental results on different laboratory species.

Regarding quantum interactions of CW RFR, the activation energies for short range effects at the molecular level extend from about 0.08 eV (1.3×10^{-20} J) for hydrogen-bond disruption to about 10 eV (1.6×10^{-18} J) for ionization. The corresponding quantum frequencies range from about 19 to 240 THz (1 THz = 10^3 GHz) (Cleary, 1973). However, an electromagnetic quantum at 450 MHz has an energy of only 1.8×10^{-6} eV (2.9×10^{-25} J), or approximately 0.00002 of the energy required for hydrogen-bond disruption, which is at the lower end of the

energy-activation range previously cited. Therefore, the existence of nonthermal biological effects of CW RFR ascribable to such short-range molecular interaction mechanisms is extremely doubtful.

Biological generation of fields having frequencies in the ELF range (below 100 Hz) such as the EEG is regarded as evidence for the occurrence of cooperative or long-range interactions. Several theoretical models of neuronal membranes (e.g., Schmitt and Samson, 1969; Frohlich, 1975a; Frohlich, 1975b; Grodsky, 1976) indicate that activation energies or frequencies for cooperative processes can be much lower than those for short-range interactions. Because the thermal energy corresponding to the physiological temperature 37°C is about 0.027 eV, corresponding to a spectrum that encompasses the quantum frequency range for cooperative processes, the question has been raised whether postulated effects of weak RFR on cooperative processes, based on theoretical models, would be distinguishable from effects that are spontaneously induced thermally. Alternatively, separation of such RFR interactions from those thermally induced may require that the rates of occurrence of the former exceed the rates for the latter. This requirement implies that for manifestation of such effects of RFR, the intensity of the incident field must exceed minimum values or thresholds related to the specific processes. Because predictions from various theoretical models and related considerations conflict to a significant extent (see Adey and Bawin, 1977b; Taylor and Cheung, 1978), the issue of whether weak external fields at frequencies well below the infrared range (i.e., RFR) can alter biological processes is not yet resolved. However, *in vitro* effects ascribed to such cooperative processes have been reported, notably field-induced increases and decreases of calcium-ion binding to cell membranes of isolated neonate chick brains, a phenomenon called "calcium efflux" (irrespective of the direction of the change). Specifically, lower calcium efflux was reported for chick-brain hemispheres excised, incubated in physiological solution, and exposed to fields in the ELF range than similarly treated but unexposed hemispheres (Bawin and Adey, 1976b). This phenomenon was not observed with CW (unmodulated) RFR at 147 MHz (Bawin, Kaczmarek, and Adey, 1975) or at 450 MHz (Bawin, Sheppard, and Adey, 1978a); however, higher calcium efflux was reported for brain hemispheres exposed to ELF-modulated RFR at these carrier frequencies, as discussed in the next section.

C.6.1.2 Interactions of Pulsed RFR and Nonthermal Effects

Precise usage of the term CW RFR implies the presence of only a single frequency (and unvarying incident power density). Because of the time variations of power density and frequency in pulsed RFR (and other forms of modulation), possible biological effects ascribable to the pulse characteristics per se must also be considered.

The temperature rise of any given region within a biological entity due to the arrival of a single RFR pulse would be small, because of the relatively large thermal time constants of biological materials and the operation of heat-exchange mechanisms. However, if the region contains a boundary between layers of widely different dielectric properties, then the temperature gradient (rate of change of temperature with distance) can be large at such a boundary even though the mean temperature rise of the region is small.

One single-pulse effect known to occur in vivo is the phenomenon of "microwave hearing" (Frey, 1961) (discussed also in Section C.7.5.1, p. C-43), or the perception of single or repetitive short pulses of RFR as apparently audible clicks. In human volunteers subjected to pulsed fields at 3 GHz, pulse durations of the order of 10 microseconds and longer and minimum peak power densities of 300,000 microwatts/cm² were needed for perception (Cain and Rissman, 1978). The interaction mechanisms involved are not yet completely understood. However, almost all of the experimental results tend to support the theory that pulse perception occurs because of transduction of the electromagnetic energy into sound pressure waves in the head and normal detection by the auditory apparatus. In one group of suggested mechanisms, transduction is postulated to occur at a boundary between layers having widely different dielectric properties (e.g., at the boundary between the skull and the skin or dura). The energy in a pulse arriving at such a boundary is converted into an abrupt increase in momentum that is locally thermalized, producing a negligible volumetric temperature rise but a large temperature gradient across the boundary. Under such conditions, rapid local differential expansion would occur, giving rise to a pressure (sound) wave. This effect is often characterized as nonthermal because the power density averaged over two or more pulses can be miniscule. For example, consider two successive pulses, each 20 microseconds in duration and having 1,000,000 microwatts/cm² pulse power density (i.e., values well above the threshold). The time-averaged power density would be proportional to these values but inversely proportional to the time interval between the arrival of the pulses at the perceiver. This interval could be indefinitely long without affecting the perception of each pulse. Therefore, the time-averaged power density has no relevance to perception. Irrespective of how the microwave-hearing phenomenon is characterized, the significant point is that the preponderance of experimental evidence indicates that the pulses are converted into actual sound in the head, rather than perceived by direct RFR stimulation of the auditory nerves or the brain.

This phenomenon should not be a source of concern about PAVE PAWS because the pulse power densities at ground levels outside the PAVE PAWS exclusion fence are less than 700 microwatts/cm² for the basic system and 1,400 microwatts/cm² for the growth system, or at least two orders of magnitude lower than the thresholds for human perception.

Periodically pulsed RFR constitutes a particular type of amplitude-modulated RFR in which the pulse repetition rates are the primary modulation frequencies. Biological effects ascribable to modulation frequencies per se (as distinguished from those caused by individual pulses) have been postulated. The occurrence of such effects would require demodulation and filtering of the pulsed RFR, by the biological entity, to yield the modulation frequencies. Although postulated nonlinear interaction mechanisms (e.g., Adey, 1975b; Adey and Bawin, 1977b) are conjectural, the aforementioned results on calcium efflux from neonate chick brains exposed to ELF-modulated 147 MHz or 450 MHz RFR (and the absence of this effect for unmodulated RFR at these frequencies), reported by Bawin and coworkers, are regarded as experimental evidence for the occurrence of modulation effects. These results are relevant to PAVE PAWS (especially those with modulated 450 MHz RFR) because the pulse repetition rates of PAVE PAWS are approximately the same as the modulation frequencies used by them. In brief, the calcium efflux reported for chick-brain hemispheres exposed to 147 MHz modulated at frequencies between 6 and 20 Hz was higher than reported for control hemispheres. The incident average power density was 800 microwatts/cm², and the effect was largest at 16 Hz. Higher calcium efflux was also obtained with 16 Hz-modulated 450 MHz RFR at incident average power densities in the range from 100 to 1,000 microwatts/cm² but not below or above this range, indicating the existence of a power-density "window." Preliminary results of increased calcium efflux from the cerebral cortex of the paralyzed awake cat exposed to 16 Hz-modulated 450 MHz RFR at an incident power density of 375 microwatts/cm² were reported (Bawin et al., 1977c). Irrespective of the interaction mechanisms involved, there is no evidence that similar effects would occur in humans exposed to the basic or growth systems at ground levels outside the exclusion fence because the time-averaged power densities are below the average power densities for the chick-brain or preliminary cat-brain results. Furthermore, measurements on the basic system in this small area have indicated actual levels only 60% of the calculated values.

C.6.2 Radiofrequency Radiation (RFR) Instrumentation and Measurements

C.6.2.1 Instrumentation

Much of the early laboratory research on bioeffects of RFR suffered from lack of adequate instrumentation for measuring incident fields or energy absorption rates (e.g., as internal temperature rises at high incident levels) within biological entities. Moreover, the available instrumentation was often incorrectly used, or was the source of significant errors in numerical values, or of spurious biological findings (artifacts) traceable to perturbations introduced by the presence of the sensors. For these reasons, many of the early results should be viewed as question-

able, at least from a quantitative standpoint. During recent years, however, major advances have been made in instrumentation, both for determining incident-field intensities for biological research, and for determining internal energy-absorption rates.

Considering first the instrumentation for determining incident fields, a representative device for measuring average power densities is the commercially available broadband isotropic monitor (Aslan, 1972). Its sensors consist of linear arrays of thermocouple elements, each array comprising a lossy antenna of relatively small length and capable of adequate response over the frequency range from 300 MHz to 18 GHz, for which a calibration curve is provided by the manufacturer. Isotropic response is obtained by incorporation of three mutually-perpendicular sensor arrays. To minimize errors in the direct-current output values of the sensor assembly caused by possible induction of spurious RF currents in the lead wires, the wires used are of very high resistivity (about 60 kilohms/ft). Also, the sensors are only lightly coupled to the incident field, so that perturbations of the field caused by scattering are minimal. The sensors respond to the mean-square of only the electric component of the field. Nevertheless, the use of the instrument for measuring average power densities in the far-field region is fully justified because the ratio of the amplitudes of the electric and magnetic components has essentially the same value (377 ohms, the "impedance" of free space) at all points in that region, and the instrument is calibrated to read total average power density. (In the near-field region of an antenna, it is necessary to measure the intensities of both the electric and magnetic components.) The most sensitive model of this instrument has a full-scale range of 200 microwatts/cm².

A more recently developed instrument is the National Bureau of Standards (NBS) Model EDM-2 Electric Energy Density Meter, designed for the 10-to-500 MHz range (Belsher, 1975; Bowman, 1974). Its sensor consists of three mutually perpendicular integral dipole-diodes ("rectennas") that also respond only to the electric component of the field. An 18-inch handle from the sensor contains high-resistivity lead wires to minimize field perturbation and spurious pickup. The most sensitive range of the instrument is 0.003 microjoules/m³ full-scale (equivalent to approximately 176 microwatts/cm²), and its response time (rise time plus fall time) is about 1 ms in this range.

Field survey instruments of this kind have been analyzed for possible sources of error (Wacker and Bowman, 1971). Because of relatively long response times of such instruments, they cannot be used for measuring the pulse power densities of short pulses. Therefore, in research programs on possible bioeffects of pulsed fields, incident pulse power densities are usually calculated from measurements of average power density and duty cycle (or pulse duration and pulse repetition frequency), made with commonly

available and readily calibrated components and instrumentation. The use of sophisticated equipment for directly measuring pulse heights (or instantaneous pulse power densities) at low average power densities, such as the NBS-referable calibrated instrumentation employed for measuring the fields from PAVE PAWS, is the exception.

Magnetic-field probes have been developed for relatively low frequency ranges, as exemplified by the two devices developed at NBS for near-field measurements in the Industrial, Scientific, and Medical (ISM) bands within the range from 10 to 40 MHz (Greene, 1975). The probes consist of single-turn, balanced-loop antennas of 10-cm and 3.16-cm diameter for the amplitude ranges 0.5 to 5 A/m and 5 to 50 A/m, respectively. (The free-space equivalent power density is proportional to the square of the amplitude. For example, the power density equivalents to 0.5 and 5 A/m are approximately 10,000 and 1,000,000 microwatts/cm², respectively.)

The development of assemblies of electric dipoles and magnetic loops for simultaneously measuring both components in the near field for frequencies below 300 MHz was reported from Poland (Babij and Trzaska, 1976).

Recent developments of implantable or insertable probes for measuring RFR-induced temperature changes or local fields within biological entities during exposure have largely diminished the problem of perturbation of the temperature or local field caused by the sensor and its lead wires. They have also reduced the magnitude of readout errors caused by electromagnetic pickup in the lead wires and by spurious potentials at junctions between sensors and lead wires. Examples of such progress include the miniaturized isotropic dipole-diode probe developed and evaluated by Bassen and coworkers (Bassen et al., 1977; Bassen et al., 1975) and the liquid-crystal/fiber-optic probe developed by Johnson and coworkers (Johnson et al., 1975). However, the relevance of such developments to PAVE PAWS is indirect, because temperature changes caused by the power densities from PAVE PAWS will be immeasurable in biological entities, even at so-called hot spots. This brief mention is included here because such devices are expected to be more widely used in future research, even though they were not available or used in most of the bioeffects research to date.

Developmental efforts are also underway toward reducing errors and artifacts in the measurement, during exposure, of biologically generated fields and potentials such as the EEG and the EKG, as exemplified by the recently-reported work from the USSR (Tyazhelov, 1977a).

C.6.2.2 Measurements of RFR Power Densities in Selected Cities

The Environmental Protection Agency (EPA) is measuring environmental values of field intensity at selected locations

within various U.S. cities. A recent report (Tell and Mantiply, 1978) discusses the results for 12 cities (a total of 373 sites). The field intensities were measured at 6.4 m (21 ft) above ground at each location. Site selections in each city were based on the use of the population figures for the 1970 census enumeration districts in a manner that would permit estimations of cumulative fractions of the total population exposed at or below various power-density levels.

The frequency ranges covered (Janes, 1977) were: 0.5 to 1.6 MHz (standard AM-radio broadcast band), 54 to 88 MHz and 174 to 216 MHz (VHF-TV bands), 88 to 108 MHz (FM-radio broadcast band), ca. 150 and ca. 450 MHz (land-mobile bands), and 470 to 890 MHz (UHF-TV band). A separate antenna of appropriate design was used for each of the 7 bands. However, data taken in the 0.5 to 1.6 MHz band were not included in the analyses because that band is below the 10-MHz lower frequency limit of the U.S. radiation protection guide.

The measured average power densities, integrated over the frequency bands included in the analyses (i.e., from 54 to 890 MHz), ranged from about 0.001 to 2.5 microwatts/cm² (Athey, 1978); the FM band is the major contributor. Because many sources (ranging from 11 in Las Vegas to 43 in Los Angeles) contribute to the total power density at any given site, the site values measured in each city were used in conjunction with the corresponding census figures to obtain an estimate of the population-weighted median exposure value for that city, with the meaning that half of its population is being exposed at or below that power density (assuming a static population distribution). These median exposure values range from 0.002 microwatts/cm² (for Chicago) to 0.020 microwatts/cm² (for Portland, Oregon); the population-weighted median for all 12 cities is 0.0053 microwatts/cm². Also calculated were the cumulative population percentages exposed to higher (and lower) values than the medians, with the conclusion that approximately 99% of the population studied are exposed to 1 microwatt/cm² or less, or conversely, that 1% are potentially being exposed to greater than 1 microwatt/cm².

The relevance of these studies to PAVE PAWS is indirect; i.e., the measured power densities of such urban sites are of interest for purposes of comparison; however, the calculations of power densities and their verification by field measurements, discussed in other sections of this document, provide more direct and accurate data for analyses of population exposure to the RFR from PAVE PAWS than the method used by EPA.

C.7 Present State of Knowledge Regarding Biological Effects

C.7.1 Epidemiology

Ten recent reports based on epidemiologic evidence that bear some relevance to the PAVE PAWS evaluation in one or more respects are presented here. Although none of them involved exposure to a well specified RFR or to fields similar to those predicted for PAVE PAWS, they represent recently available epidemiologic information on exposure to RFR. Only three specify the frequencies involved, and estimates of power densities are provided only in some cases.

There have been two reports concerned with the relationship between Down's syndrome and exposure of the father to radar emissions. The initial report, entitled "Radiation Exposure in Parents of Children with Mongolism (Down's Syndrome)," by A. T. Sigler, A. M. Lilienfeld, B. H. Cohen and J. E. Westlake was published in the Bulletin of the Johns Hopkins Hospital, in Vol. 117, pp. 374-399 (1965). The data came from Baltimore Hospital records and interviews with parents. The major thrust of this report concerned the association between parental exposure to RFR and mongolism, but noted that 63.1% of the mongolism fathers had been in the military, as compared with 56.6% of the control fathers, and that 8.7% of the mongolism fathers and only 3.3% of the control fathers reported intimate contact with radar both in and outside of the armed forces, a difference that was statistically significant. The study involved 216 mongoloid children and 216 control children matched for hospital of birth (or at home), sex, date of birth, and maternal age at birth, and covered the period from January 1946 to October 1962. The authors concluded that "the only truly puzzling association is the suggested relationship between Mongolism and paternal radar exposure," and that "one can only speculate concerning possible mechanisms, but the association between Mongolism and radar exposure deserves further investigation."

Referring to the initial study as the Original Series, B. H. Cohen, A. M. Lilienfeld, S. Kramer, and L. C. Hyman published a second report entitled "Parental Factors in Down's Syndrome--Results of the Second Baltimore Case-Control Study" in Population Genetics-Studies in Humans, E. B. Hook and I. H. Porter, Eds., Academic Press, N.Y. 1977. The data from the Original Series were considered with the data for an additional 128 matched pairs (Current Series). More detailed questions about radar/microwave exposure and military service were incorporated in the Current Series questionnaires and service record information on the fathers was acquired. An attempt was made to acquire similarly detailed data on the fathers of the Original Series. In addition, a chromosome study of the fathers was undertaken in order to determine whether there was any detectable residual damage in the chromosomes of the peripheral blood. The results of

this segment of the study are not included in the report, but are described as "to be reported elsewhere in detail" (NB: Conversation with Dr. Cohen on 3/21/79 indicates that the report on chromosomal effects is still in preparation.) After considering the more detailed exposure information the following findings were reported in the Current Series: 15.7% of case fathers and 21.3% of control fathers had received radar exposure; combining the probably-exposed with the definitely-exposed groups, the corresponding values were 26.0% and 28.3%. The reevaluated Original Series values for definitely-exposed fathers were 18.6% for case fathers and 15.2% for controls, and when probably-exposed fathers were added the values were 20.6% and 15.7%.

In terms of military services, without regard to radar exposure, there was a slightly higher frequency of case fathers with previous military service than control fathers: 64.2% vs 61.3% for both series combined, 60.2% vs 56.5% for the Original Series and 71.1% vs 69.5% for the Current Series.

When the data from the Original Series and from the Current Series were combined, the values for case vs control fathers were 17.4% vs 17.5% for definitely exposed and 22.7% vs 20.6% when "some" exposure was included. None of the foregoing comparisons showed statistically significant differences.

The authors concluded that the Current Series did not confirm the suggestions of the Original Series that there was either an excess of radar exposure or a larger proportion among fathers with military service prior to the conception of the Down's case. The authors note that "in view of the suggestive findings of the original series with regard to a possible radar association, it was certainly necessary to investigate this question further. The initial steps were taken. A replication study was the simplest and least expensive immediate approach. Supplementing it with the independent search of service records added an objective approach eliminating any possible differential in parental responses. These methods having been attempted with inconclusive findings, it is now necessary to look to the prospective, longitudinal, surveillance studies to resolve the issue."

Robinette and Silverman (1977) examined the causes of mortality in World War II Navy personnel through 1977. About 40,000 decedents were assigned in approximately equal numbers to either RFR-exposed or control groups on the basis of Navy occupational title (no quantitative exposure data were available). The exposed group consisted of repair men (electronics, fire control and aircraft electronics technicians) and the control group consisted of radio-frequency equipment operators (radiomen, radarmen and aircraft electrician's mates). The exposed group was considered as having more chance of being exposed to radar emissions than the control group. While an unexposed group would have strengthened the study, the two groups selected were presumably similar in

terms of non-radar factors. Assigning cases to groups on the basis of occupational titles is a common procedure in RFR epidemiological studies (see below). They found a significantly higher death rate from trauma in the exposed group; however, many of the trauma-associated deaths resulted from military aircraft accidents and a higher proportion of the exposed group had subsequently become flyers. The incidence of deaths associated with arteriosclerotic heart disease was significantly lower in the exposed group. No significant differences were noted between the two groups in terms of total mortality or in terms of mortality from any of about 20 assigned categories of causes of death. The overall death rates for both groups were lower than those for the comparable age group in the U.S. population at large.

In a summary of the results of ophthalmologic examinations of 605 RFR workers and 493 individuals with no known exposure to RFR, Appleton (1973) presents data that indicate no significant differences between age-matched groups in terms of opacities, vacuoles, or posterior subcapsular iridescences in the lens of the eye. The level of microwave exposure was not quantified, but remained in qualitative terms, i.e., "could have been exposed" and "almost certainly had not been exposed." A more detailed discussion of this study is given in Section C.7.4.2, p. C-42.

In 1971, Peacock, et al. used birth records to compare the incidences of congenital anomalies in each of the 67 Alabama counties during the 17-month period from July 1969 to November 1970. Using the statewide average to compute the expected number of anomalies, they reported that anomaly incidences of specific categories departed significantly from a random distribution for white populations in six counties: Calhoun, Henry, Butler, Jefferson, Coffee and Dale (2 categories) Counties. For non-white populations, only Calhoun County had a significant departure from the expected incidence. No interpretation in terms of causal factors associated with the excess incidences was included in the report.

In November 1973, Peacock, Williams, and Nash submitted a report to the EPA from the Southern Research Institute based on both a reexamination of the birth-record data included in the 1971 report of Peacock et al., and examination of additional birth records so that a four-year period from 1968 to 1972 was covered. This report focused on the anomaly and fetal death rates in Coffee and Dale Counties and at the Fort Rucker military hospital (Lyster General) and invoked a causal association between anomaly rates and fetal deaths and emissions from the 46 radar installations in and around Fort Rucker, which is located in Coffee and Dale Counties. Alabama statewide incidences and incidences at other "non-radar" military hospitals were used as controls. In addition, the fetal death rate for the hospital at Eglin AFB, another "radar" hospital, was also reported. The authors reported

that, on the basis of the 4-year data and after making adjustments for "non-radar" factors, the Lyster Hospital anomaly rates in several categories were abnormally high for all anomalies, heart, genital organs and musculoskeletal categories, and that the evidence was strong that the rates were also abnormally high for fetal deaths, circulatory and respiratory systems, cleft palate, and in the skin-hair-nail categories. The Eglin AFB Hospital fetal death rate was nearly identical to that for Lyster Hospital. Upon reevaluation, the apparently high rate for clubfoot, initially a category that pointed most convincingly to a localized problem, was attributed to reporting differences.

The Coffee and Dale County data were not subjected to adjustments for "non-radar" factors. Compared with the statewide incidences and assuming random distribution and consistent reporting practices the authors reported statistically significant excesses for all anomalies and for fetal deaths in both counties and for heart anomalies in Dale County, and abnormally high incidences for four other categories in each of the two counties. The abnormally high rates of reported anomalies were described as primarily a phenomenon of the white population in the two counties.

In March 1977, Burdeshaw and Schaffer submitted a report from the Southern Research Institute to the EPA based on the same Alabama birth record anomaly data from 1968-1972. Instead of using statewide averages as a control for county incidences, Burdeshaw and Schaffer compared the Coffee and Dale County data with that for each of the other 65 Alabama counties on a score and rank basis. In addition they sent questionnaires to 46 Alabama hospitals in order to acquire more detailed information on hospital characteristics and reporting procedures and used the more detailed information to predict expected values for Lyster General Hospital. They considered the findings that the two highest hospital anomaly rates were from Fort Rucker and Maxwell AFB (both military aviation centers) and that 13 of 17 Alabama counties with anomaly rates in the upper quartile were in a contiguous band from southeast to westnorthwest Alabama as evidence that there was a geographically distributed anomaly problem. However, they also found evidence against the conclusion that there was an unusually high anomaly incidence rate specifically in the Fort Rucker area: Overall rates for Coffee and Dale Counties ranked only sixth and eighth among the 67 Alabama counties; at least five other Alabama hospitals reported anomaly incidences that were not significantly lower than for Lyster Hospital; Lyster's overall rate was within predicted limits for hospitals with its characteristics; there was no clustering of residences of mothers with anomalous children in the vicinity of radar sites; carefully controlled surveys from other (non-Alabama) hospitals revealed anomaly incidences consistent with Lyster's; and significant time-clustering of anomalies at Lyster indicated a high reporting rate for one or two particular physicians. In conclusion, they stated that on the basis of the birth record

data, it could not be concluded that an unusually large number of infants with congenital anomalies were born to military personnel at Fort Rucker or to other residents in the immediate area.

It is estimated that the U.S. Embassy in Moscow has been subjected to microwave irradiation since 1953. Prior to 1963 the presence of the microwave signal was noted during intermittent routine checks. Beginning in 1963, nearly continuous monitoring of the signal characteristics has been in process. A report on the evaluation of the health status of U.S. personnel who had been assigned to the Moscow embassy during the period 1953-1976 was published on July 31, 1978. It is entitled "Foreign Service Health Status Report," subtitled "Evaluation of Health Status of Foreign Service and Other Employees from Selected Eastern European Ports," and was prepared under the direction of Abraham Lilienfeld, M.D., of the Johns Hopkins University.

The report estimates that signal frequencies have ranged from 2.5 to 4.0 GHz. The maximum incident power densities were described according to time period: 1953 to May 1975, 5 microwatts/cm², 9 hours/day; June 1975 to February 7, 1976, 15 microwatts/cm², 18 hours/day; since February 7, 1976, fractions of a microwatt/cm², 18 hours/day.

After considerable effort spent in tracing employees and dependents, 1,827 employees and 1,228 dependents were identified as having been at the Moscow embassy during the 1953-1976 period. 2,561 employees and 2,072 dependents assigned to embassies and consulates in Budapest, Leningrad, Prague, Warsaw, Belgrade, Bucharest, Sofia and Zagreb during the same time period were identified as controls. Periodic tests for microwave radiation at the control sites showed only background levels.

Medical records were reviewed for 1,209 Moscow employees and 834 dependents. The corresponding numbers for the control group were 1,882 and 1,507. Health questionnaires were returned by 969 Moscow employees and 1,129 control employees. The number of completed dependent questionnaires is not clearly specified in the report.

The authors of this study recognized and commented on the limitations placed on the study by their inability to acquire complete sets of medical records, death certificates and returned health questionnaires, and by the imprecision of the classification of the individual employees according to probable extent of radiation exposure. Further, they noted that the highest exposure levels were recorded late in the study and therefore, for the subgroup with the highest exposure, the period of time during which health effects might become apparent was the shortest. They also noted that the size of the study population was insufficient to detect excess risks that were less than

two-fold for many of the medical conditions studied. However, despite these acknowledged limitations, the authors were able to draw the conclusions below.

There were no discernible differences between the Moscow and control groups in total mortality or mortality from specific causes, nor were there differences in mortality between the Moscow and control groups of dependent children or adults. With the exception of cancer-related deaths among female employee groups (both Moscow and control), mortality rates for both Moscow and control groups were less than for the U.S. population at large. While the study groups were subject to a large variety of health problems, on the basis of the medical records these problems were shared nearly equally by both Moscow and control groups with two exceptions: the Moscow male employees had a three-fold higher risk of acquiring protozoal infections and both men and women of the Moscow group were found to have slightly higher frequencies of most of the common kinds of health conditions reported. However, the authors could not relate these two exceptions to microwave radiation. From the health questionnaire information, the authors reported that there were some excesses in the Moscow employee groups as compared with the controls: more correctable refractive eye problems, more psoriasis in men and anemia in women, and more frequent cases of depression, irritability, difficulty in concentrating and memory loss. However, the authors noted that "In view of the possibilities which had been publicized of the increased danger to their health and that of their children, it is not at all surprising that the Moscow group might have had an increase in symptoms such as those reported. However, no relationship was found between the occurrence of these symptoms and exposure to microwaves; in fact, the four symptoms mentioned earlier, which showed the strongest differences between the Moscow and Comparison groups, were all found to have occurred most frequently in the group with the least exposure to microwaves."

For dependents, the authors found no differences between the adult Moscow and control groups. Moscow dependent children had twice as high a frequency of mumps as the control children. The incidence of congenital anomalies occurring in children born after arrival of the parents at the duty station were comparable between the Moscow and control groups.

Finally, the authors summarized as follows: "With very few exceptions, an exhaustive comparison of the health status of the State and Non-State Department employees who had served in Moscow with those who had served in other Eastern European posts during the same period of time revealed no differences in health status as indicated by their mortality experience and a variety of morbidity measures. No convincing evidence was discovered that would directly implicate the exposure to microwave radiation experienced by the employees at the Moscow embassy in the causation of any adverse health effects as of the time of this analysis."

Siekierzynski (1974) compared the causes of unfitness for work and incidences of lens translucency and of several neurotic disturbances in 507 Polish male radar station workers occupationally exposed to more than 200 microwatts/cm² with those for a group of 334 men at the same radar stations exposed to less than this value for periods ranging from 2 to 16 years. No correlations between the degree of exposure or the duration of employment and any of the criteria of effect were found. The author states that no appropriate control (unexposed) group was available and that the two groups were highly matched except for exposure intensity.

Pazderova (1971), also cited in Section C.7.9, p. C-64, reported on the results of a battery of medical evaluations carried out on 58 employees of Czech television transmitter stations. Exposure fields were estimated to range from 48.5 to 230 MHz at field intensities equivalent to 0 to 22 microwatts/cm², with a mean exposure duration of 7.2 years (10.6 hr/workday). These exposure parameters appear similar to those predicted for PAVE PAWS. Electrocardiograms, heart and lung X-rays, erythrocyte sedimentation rates, urinalyses, and liver function tests were conducted, as well as hematologic, serologic, ophthalmologic, neurologic, gynecologic, psychiatric, and psychologic examinations. The only statistically significant finding was that the mean plasma protein levels were higher than "normal" values taken from the literature, a finding that even the author finds unexplainable. The appropriateness of the use of literature control values is highly questionable, and the author notes the desirability of a control group matched for "age, way of life and educational background."

Sadcikova (1974) summarized data for two groups of USSR RFR workers; 1,000 people who were subjected to up to a few thousand microwatts/cm² and 180 workers who were exposed to up to a few tens of microwatts/cm² were compared with a group matched for age and character of work but not exposed to RFR. (Note that, although the Soviet occupational standard for exposure to RFR is 10 microwatts/cm², Sadcikova was able to locate 1,000 people exposed to up to several hundred times this level.) Of 16 kinds of symptoms reported, the incidences were higher for the higher-power-density group in 5 cases, higher for the lower-power-density group in 9 cases, and essentially equal in 2 cases. Values of symptoms for the control group were less than those for at least 1 of the 2 exposed groups in all 16 cases. Symptoms reported included fatigue, irritability, sleepiness, partial loss of memory, bradycardia, hypertension, hypotension, cardiac pain, and systolic murmur. A table in the report describes 100 cases of "microwave sickness," and the text predicts little chance for recovery unless the patient is removed from the work environment.

Kalyada, et al. (1974) related narrative clinical evidence indicating that a number of symptoms were observed in people occupationally exposed to "non-thermal intensities" of RFR at 40-200 MHz for periods ranging from 1 to 9 years. The symptoms were described as vegetative dysfunction of the central nervous system, thermoregulatory pathology, cardiovascular changes, elevation of plasma cholesterol, and gastritis and ulcers. The authors refer to statistically significant changes, but no actual statistical data are presented. The authors also refer to control subjects, but the incidences of these symptoms in exposed workers is not compared with that in the general population.

Klimkova-Deutschova (1974) surveyed various industrial worker populations including metal welders, steel factory workers, plastic welders, technicians operating radio or television transmitters, and people working in research institutes and other industries that involve exposure to RFR. Miscellaneous administrative staff members were studied for comparison. Frequencies varied according to the place of exposure, ranging from 1 to 150 MHz, 300 to 800 MHz, or from 3 to 30 GHz, and the power densities, where specified, ranged from 100-3,300 microwatts/cm². The observations involved 530 people, and the findings included electroencephalographic disorders, consisting of synchronized waves of high amplitude and slow rhythm, and biochemical changes, including elevation of fasting blood glucose, serum beta-lipoprotein, and cholesterol. Changes in brain-wave patterns and in blood sugar, protein and cholesterol levels were described as more pronounced in the people exposed in the 3-30 GHz range.

The U.S., Polish, and Czechoslovakian studies offer no evidence of detrimental effects associated with exposure of the general population to RFR. Consistent with the voluminous, earlier Soviet literature, the Soviet studies offer findings that occupational exposure to RFR at higher levels than expected for general public exposure to PAVE PAWS does result in various symptoms, particularly those associated with CNS disorders. Since the USSR symptomatology has never been reported in Western studies, and because there are marked differences in the procedures used in reporting data between the Soviet and Western publications, a prediction based on epidemiologic evidence as to whether PAVE PAWS emissions will present a hazard depends on an individual's willingness to accept Soviet findings at face value. It is concluded that, taken as a whole, these epidemiologic reports do not constitute evidence that the PAVE PAWS emissions will constitute a hazard to the population.

C.7.2 Mutagenic and Cytogenetic Effects

Mutagenic effects of RFR have been reported for almost 30 years (Brauer, 1949), and cytogenetic effects were first reported almost 20 years ago (Heller, 1959). Mutagenesis has been studied

in plants, bacteria, fruit flies, and mammals. Cytogenetic studies (of abnormalities of chromosomes and mitotic figures) have been performed on a variety of cells, including cultured human lymphocytes and other mammalian cells. Mutagenic studies on bacteria with RFR have generally had negative results (Blackman, 1976).

A study of mutagenesis in the flowering plant Antirrhinum majus L. was performed at 20 MHz. The pollen was exposed to field strengths of 1.5 V/m for 4 to 44 hours and crossed to styles of plants not exposed; embryonic death in the following generation was observed (Harte, 1975). Exposure for 4 hours produced no mutations, but exposure for 12 hours increased the embryonic death rate to 2.5 times the control level and exposure for 43.75 hours increased the embryonic death rate to 3.25 times the control level. Although a direct mutagenic effect of the radiation cannot be ruled out, the effect appears to have a definite, rather high, dose (field strength times time) threshold, and for a considerable range of doses, mutagenesis does not increase with increasing dose. Neither of these patterns is normally produced by agents that are directly mutagenic. A possible explanation for the effect is suggested by a study of corn seeds exposed to RFR (Bigu-Del-Blanco, 1977). The irradiated corn seeds were found to have lost considerably more water than control seeds incubated at the same temperature, and this water loss resulted in arrested growth. Water loss from the pollen in the Antirrhinum experiment is a mechanism that could account for the observed kinetics of the effects.

Studies of mutagenesis by RFR have been carried out in the fruit fly, Drosophila melanogaster. Most of these studies appear to have been performed at higher (10-100 GHz) or lower (20-35 MHz) frequencies than the present region of interest (ca. 450 MHz). In a study of nondisjunction of X and Y chromosomes at mating (a conventional mutagenesis test), Mickey (1975) found no effect from 4 hours of exposure to pulsed RFR at 20-35 MHz. Another study with RFR at 17 and 73 GHz (Dardalhon, 1977) showed no mutagenic effect in Drosophila, even after 2 hours of exposure at 60,000-100,000 microwatts/cm².

Studies of RFR-induced dominant lethal mutation in mammals have also been carried out. Varma (1976a) exposed male Swiss mice to 1.7 GHz microwaves at 50,000 microwatts/cm² for 30 minutes, or to 10,000 microwatts/cm² for 80 minutes, and then bred the mice to unexposed females for 7 to 8 weeks after irradiation. Females were examined on the 13th day of gestation, and the number of implants and early embryonic deaths (dominant lethals) were scored. Another study (Varma, 1976b) used the same technique but different doses of radiation (2.45 GHz, 100,000 microwatts/cm² for 10 min; or 50,000 microwatts/cm² for 3 x 10 min. in 1 day or 4 x 10 min. in 2 weeks). From the first study, the authors concluded that dominant lethal mutations occurred after exposure at

both power density levels. From the second study, they concluded that the single exposure at the higher power densities was mutagenic, but the multiple exposures at the lower power densities were not. Review of the actual data shows a considerable discrepancy in the spontaneous rate of occurrence of dominant lethal mutations in the two studies (1% in the first, 5% in the second), even though the same types of animals were used and the two studies were conducted by the same principal investigator at the same location; furthermore, in recalculation, errors were found in the computation of the chi-square used for evaluation of the results. If the two studies are considered separately, and the chi-square values are recalculated, the first study shows a marginal, but significantly increased number of dominant lethal mutations for both the 10,000 and 50,000 microwatts/cm² exposures, and the second study shows no increase for either the 10,000 or 50,000 microwatts/cm² exposure. If both studies are consolidated, no mutagenic effect can be shown. The irradiation was performed on anesthetized animals, and the description of the method does not indicate that the scoring of mutations was blind (performed by an observer with no knowledge of group identification).

A more recent study on dominant lethal mutations in rats (Berman, 1978a) used a variety of power densities (5,000-28,000 microwatts/cm²) at frequencies of 425 MHz and 2.45 GHz and involved repeated daily exposures over periods as long as 3 months. The study found no evidence of impaired reproductive efficiency or mutagenesis. The abstract stated that reevaluation of data previously published by others on RFR-induced dominant lethals in rodents did not confirm the existence of mutagenic effects, but details of the analysis are not currently available.

A large number of cytogenetic studies with RFR have been conducted. Heller (1959) first reported the induction of chromosome aberrations in cells of garlic root-tips by exposure to 27 MHz RFR. A calculation from the sketchy description of exposure conditions indicates that the power density was somewhere between 2,500 and 600,000 microwatts/cm². Another study co-authored by Heller (Mickey, 1975) reported the induction of chromosome aberrations in lung cells, bone marrow cells, and spermatogonia of Chinese hamsters exposed in vivo. The same study reported induction of similar effects by exposure of Chinese hamsters in vivo with pulsed K- and X-band RFR (approximately 18 and 10 GHz, respectively). The report is not well organized, making it difficult to determine the exact experimental conditions used in each section of the study; however, all of the studies involved long exposures, up to 35 hours, at relatively high power levels (200,000-500,000 microwatts/cm²), with inadequate dosimetry.

In another study of cytogenetic effects (Chen, 1974), Chinese hamster cells and human amnion cells were exposed in vitro to 2.45 GHz RFR at power levels from 200,000 to 500,000 microwatts/cm² for periods ranging from 1.5 to 20 minutes. A variety of chromo-

somal aberrations was observed. The incidence of aberrations did not increase with increasing dose or duration of exposure, and the findings were not significantly different from those in controls, although the author described individual clusters of aberrations as varying "noticeably from control."

Another study of Chinese hamster ovary cells (Livingston, 1977) exposed in vitro to 2.45 GHz RFR showed that the exposure increased the level of sister chromatid exchange frequency above the control level, but that the same effects could be produced by heating the cultures in a water bath to the same temperature as that produced by the RFR.

A study of human lymphocyte cultures exposed to pulsed RFR (2.95 GHz) at 7,000 or 20,000 microwatts/cm² showed that chromosomal aberrations were produced after exposure at 20,000 microwatts/cm² for 10 minutes or longer (Stodolnik-Baranska, 1974b). The temperature of the culture medium rose slightly during the 20,000 microwatts/cm² exposure, but remained constant during the 7,000 microwatts/cm² exposure. No chromosomal aberrations were reported for the exposure to 7,000 microwatts/cm², though the exposure was continued for 3 to 4 hours.

In summary, mutations and chromosome aberrations have been produced following RFR exposure in a number of experimental test systems. All of the results have occurred under conditions of comparatively high power levels, prolonged duration of exposure, or both. The conditions of exposure and the kinetics of the rate of production of either mutations or chromosome aberrations are consistent with the assumption that the results are produced by incidental effects of the radiation, e.g., heat arising from absorption of the RF energy. No evidence of intrinsic mutagenic activity of RFR has been found. Somewhat conflicting results were found in separate studies in mammals, using the dominant lethal test. The difference may partly be explained by the fact that in one pair of studies showing positive results, the animals were anesthetized during exposure. Anesthesia in mice and rats suppresses the normal body temperature control mechanisms, rendering the animals much more susceptible to large increases in temperature in localized regions of the body. In the other study, using power levels meeting currently radiation exposure guidelines, no evidence of mutation was found, even though exposures were protracted.

C.7.3 Studies on Teratogenesis and Developmental Abnormalities

Teratogenic effects have been studied in insects, birds, mice, and monkeys. The insect model has commonly been the darkling beetle, Tenebrio molitor. An early preliminary report (Rosenbaum, 1977) indicated that exposure of beetle pupae for 8 hours at 500 microwatts in a waveguide at 9 GHz produced teratogenic effects.

Details of the findings were not given, and changes in temperature were not reported. Another study from the same laboratory (Green, 1977) reported teratological effects at power levels greater than 20,000 microwatts (9 GHz, 2 hours exposure). Temperature increase in these experiments was stated to be less than 2 deg C. It was also stated that previously traumatized pupae were more susceptible to RFR-induced teratogenesis. A separate study (Pickard, 1977) found that both the spontaneous and the RFR-induced abnormalities of the beetles depended on the source of the larvae and the diet fed to them before they entered the pupal stage. Whether RFR-produced abnormalities occurred also depended on the orientation of the beetles with respect to the electric and magnetic vectors of the field. Under conditions that promoted the induction of abnormalities, a marginal teratogenic effect was produced at 5.96 GHz by a 2-hour exposure at a mean SAR of 54 mW/g (approximately equal to 192,000 microwatts). A report from a separate laboratory (d'Ambrosio, 1977) showed that exposure to 9.55 GHz at 10 milliwatts waveguide power (no estimate of power density at animal possible) for 2 hours increased developmental abnormalities; temperature changes and environmental control measures were not reported.

More recent evidence involving infrared thermography of pupae (Olsen, 1978) indicates that the distribution of temperature under RFR exposure is significantly nonuniform as a result of differential distribution of water content in the pupa, and that localized regions may have elevated temperatures adequate to explain the observed teratogenic effects. This nonuniform temperature distribution would not be obtained by elevating the temperature of the pupa by conventional means.

Exposure of chick embryos during the first 5 days of development at a mean power density of 3,300 microwatts/cm² (frequency and other experimental conditions not stated) resulted in changes in the cranial size of the embryos at day 5 of development (Fisher, 1977). The effect appeared to depend upon the temperature of the incubator, opposite effects being obtained at incubation temperatures of 33.5 deg C and 35.1 deg C. Other teratogenic effects have been reported in chick embryos exposed during development to 20,000 microwatts/cm² for 280 to 300 min. (Wheater, 1977). Studies of Japanese Quail embryos exposed to continuous RFR exposure (2.45 GHz, 5,000 microwatts/cm²) during the first 12 days of development (McRee, 1977) found no gross deformities at hatching. A slight increase in blood hemoglobin and a slight decrease in blood monocyte count was observed in the exposed birds. A further study (Hamrick, 1977b) showed that exposed male birds were slightly smaller than control birds at 4 and 5 weeks of age. Exposed birds had the same level of immunocompetence as control birds.

Several independent studies have been conducted on the teratogenic effects of RFR on mice and rats. Dietzel (1975) exposed

rats to 27.12 MHz RFR on various days of pregnancy. Doses were monitored by measuring rise in rectal temperature. Fetal malformations differed according to the day of gestation that was chosen for exposure; the malformations were not different from those produced by other teratogenic agents. No malformations were produced unless the radiation dose was high enough to raise rectal temperature by 2 deg C. Rugh (1975) exposed mice to RFR (2.45 GHz) at doses of 3 to 8 cal/g (123,000 microwatts/cm² for 2 to 5 minutes) on the eighth day of pregnancy and found a number of abnormalities in the fetuses, including resorptions and exencephaly. The incidence of abnormalities was dose-dependent; no abnormalities were reported below 3 cal/g (2 minutes exposure), and the incidence of abnormalities in controls was not stated. Chernovetz et al. (1975) exposed mice to RFR (2.45 GHz) at a dose of 22.8 J/g (135,000 microwatts/cm² for 10 minutes) on the 11th through 14th days of pregnancy, and they observed a marginal increase in fetal abnormalities. Of 131 fetuses in the exposed group, 10 were abnormal; 7 of 138 in the control group were abnormal. The difference is not significant (Fischer exact test). Berman et al. (1978b) exposed mice to RFR (2.45 GHz) at 3,400-28,000 microwatts/cm² for 100 min/day during gestation, and found 27 anomalies among 3,362 live fetuses exposed to RFR, as opposed to 12 among 3,528 sham-irradiated controls. Because of the small number of results for each individual anomaly and irregularities in the dose response and distribution of findings among the groups, the authors were in general unable to conclude that the anomalies resulted from the RFR exposure. The study was very well designed and executed, and illustrates and discusses very well the difficulties encountered in quantifying events that may be expected to occur only rarely in a population. The bibliography of this study is more extensive than could be covered in the present document, and the reader may consult it for further references.

Rugh et al. (1975) included fetal resorptions with structural anomalies in their presentation of data. There was no breakdown by type of anomaly, no information on fetal weight and, as noted above, no tabulation of control incidence of anomalies. Chernovetz et al. (1975) presented a tabulation of fetal resorptions and dead fetuses, but no data on fetal weight. Among the controls there were 156 implantations, 19 fully resorbed fetuses, and 4 stillborn mice. The corresponding numbers for RFR-exposed mice were 144 implantations, 15 full resorptions, and 5 stillborn mice. The differences are not significant. Berman et al. (1978b) presented a tabulation of both mean number of dead per litter and mean live fetal weight. There was no significant difference between irradiated and control mice in the number of dead per litter at any dose level. There was a slight (8%) reduction in live fetal weight in mice exposed to the highest dose level (28,000 microwatts/cm²), but no weight reduction in any other group. Because fetal weight was affected only at a high power density, the weight change probably resulted from

++

temperature rise or other stress in the dams; no such effect would be expected at the power densities prevailing in the vicinity of PAVE PAWS.

Several studies have been conducted in rats and monkeys (Reiter, 1976; Rosenstein, 1976; Kaplan, 1978 -- also discussed in C.7.5.5, p. C-52, and C.7.11.3, p. C-69) to determine the effects of RFR exposure (425 MHz, 2,450 MHz; 100-10,000 microwatts/cm²) of pregnant animals in the neurological and behavioral development of their offspring. All tests for behavioral and neurological effects have shown negative results (no effects).

In summary, a number of teratogenic effects are produced by RFR at various frequencies. In mammals the effects appear to be associated with the production of heat in the gravid animal and an increase in body temperature. In bird eggs and insect pupae, the effects are also generally associated with temperature increases.

Teratogenic effects are generally caused by disturbances in the rate of growth and development of the embryological structures, rather than by direct cytotoxic effects of the teratogenic agent. Hence, in poikilothermic systems (bird eggs, insect pupae), relatively small temperature differentials can cause unbalanced growth that could lead to structural abnormalities. In mammals, there is the additional complication that handling the animals may cause stress, which may contribute to the teratogenic effect.

The studies on RFR-induced teratogenesis support the conclusion that the effects are due to heat production and do not reflect any special teratogenic properties of RFR. At the power densities existing at or beyond the 1,000-ft exclusion fence of PAVE PAWS there is no evidence of potential hazard to children in utero at any stage of development.

+
+

C.7.4 Ocular Effects

C.7.4.1 Animals

Many studies on animals of ocular effects due to RFR exposure, conducted over the past 30 years, strongly indicate that eye damage results only if intraocular temperatures increase by 5 deg C (9 deg F) or more (Guy, 1974; Williams, 1955; Daily, 1952, Richardson, 1948). This conclusion is supported by investigations in which lens opacifications produced by RFR exposure alone did not occur when the eye was cooled during exposure (Kramar, 1975; Baillie, 1969a, 1969b).

The inverse relationship between average power density and exposure duration for cataractogenesis is evident from the variety of exposure conditions used in these investigations. The evidence indicates the existence of a threshold power-density/exposure-time

value of about 150,000 microwatts/cm² for single or multiple exposures of tens of minutes or more (Carpenter, 1977; Ferri, 1977, Guy, 1974; Appleton, 1973; Stodolnik-Baranska, 1974a; Birenbaum, 1969; Williams, 1955). For example (Guy, 1974), at power densities ranging downward from 500,000 microwatts/cm² to about 200,000 microwatts/cm² at 2.45 GHz, the exposure duration necessary to produce cataracts in the rabbit increased from 1-2 minutes to about 20 minutes. Also (Kramar, 1975), several series of in vivo intraocular temperature measurements taken at 200,000 microwatts/cm² during a 40-minute exposure period (using a thermocouple probe inserted immediately after each successive 5-minute exposure period with the RFR off) indicated that the vitreous temperature rose from the normal body temperature of about 37 deg C (98.6 deg F) to about 42 deg C (107.6 deg F) during the first 10 minutes of exposure and remained at the latter temperature for the remaining 30 minutes of exposure. Presumably the plateau temperature represents equilibrium between the rate of energy absorption and the various heat removal mechanisms in that portion of the eye. After termination of exposure, the vitreous temperature rapidly returned to normal. By contrast, the temperature of the orbit, which is cooled to a greater extent by blood flow than the vitreous, rose to a plateau of less than 40 deg C (104 deg F). Most significant in these investigations, however, was evidence of the previously mentioned cataractogenesis threshold power density of about 150,000 microwatts/cm²; i.e., curves of power density versus exposure duration show that the power density for cataractogenesis approaches this value asymptotically. Also, exposure at 100,000 microwatts/cm² for durations of up to at least 100 minutes failed to produce any cataracts. (Exposures of longer duration were not used in this investigation.) The experimental results of others (Carpenter, 1977; Birenbaum, 1969; Williams, 1955) also indicated the existence of a cataractogenesis threshold of comparable magnitude.

Much of the ocular work cited here was performed at frequencies above 1 GHz (typically at 2.45 GHz, but ranging up to 24 GHz). However, there is some experimental evidence that the cataractogenesis threshold value at 918 MHz is higher than at 2.45 GHz (Guy, 1974), which suggests that it would be still higher at 450 MHz. Also, in earlier experimental work (Cogan, 1958), no eye damage was observed in rabbits exposed at 385 or 468 MHz to power densities of about 60,000 microwatts/cm².

Several researchers (Ferri, 1977; Reider, 1971; Richardson, 1951) compared the ocular effects of pulsed and CW RFR at equivalent average power densities greater than 100,000 microwatts/cm². Exposure periods were typically about 1 hour/day for several weeks. No significant differences between the effects of pulsed and CW RFR could be detected.

The results summarized above have been regarded as strong evidence that single or multiple exposures over indefinitely long periods of time at power densities well below the threshold (e.g.,

at 10,000 microwatts/cm² or lower) would not cause eye damage to humans or any other species. Consequently, very little experimental research has been done on possible cataractogenesis in animals, using chronic exposures at low-levels. One investigation currently under way (Chou, 1978) has several biological endpoints. In this study so far, one group of six rabbits was exposed to 2.45 GHz CW at 1,500 microwatts/cm² for 2 hours per day over a period of 3 months; another group was similarly exposed to pulsed RFR at the same frequency and average power density at a duty cycle of 0.001 (10-microsecond pulses of 1,500,000 microwatts/cm² pulse power density at 100 pulses/s), and a third group was sham-exposed. No statistically significant differences among the three groups were observed in periodic eye examinations for cataract formation or in measurements of body weights, EEG and evoked potentials, hematology, or blood serum chemistry.

The findings above on animals indicate that RFR cataractogenesis is essentially a gross thermal effect.

C.7.4.2 Humans

Retrospective epidemiological studies of RFR-induced cataractogenesis have been carried out by Zaret (1961) and Appleton (1973), among others. Appleton, for example, conducted retrospective epidemiological studies of military personnel at several bases over a period of 5 years. In these studies, military personnel identified as having been occupationally exposed to RFR (from radars and communications systems) were matched in age and sex with controls, other military personnel at the same bases who were not occupationally exposed. Exposed and control personnel were examined by ophthalmologists for opacities, vacuoles, and posterior subcapsular iridescence, taken as diagnostic precursors of cataracts. The procedure used in these examinations ensured that the ophthalmologists did not know whether the person examined belonged to the exposed group or the control group. The data were analyzed statistically by age group, numbers of persons per age group, and the presence or absence of these three diagnostic criteria. More people in older age groups exhibited these signs, but analysis of the pooled data from several Army installations showed no statistically significant differences between exposed and control groups.

The principal investigator emphasized that the presence of any of the three diagnostic criteria did not necessarily mean that significant vision impairment had occurred. He also indicated that the use of the presence or absence of these signs as binary numerical data for the statistical analysis was necessary because of the complexity of the eye, and he recognized the unavoidable judgmental aspects in the diagnoses of each examining ophthalmologist. For example, the results of two of the ophthalmologists involved in the study of personnel at Tyndall AFB indicated the

presence of opacities in 96% of the personnel in the exposed group and 93% in the control group. However, these ophthalmologists also concluded that "no optically significant opacities were found in either group."

It is difficult to ascertain the extent of the exposure histories (intensities, durations, etc.) prior to such a study. Also, the presence or absence of the three diagnostic criteria is only a crude measure of eye damage for use in statistical analyses. Despite these limitations of the study, its finding that there are no statistically significant differences between exposed and control groups is probably valid.

The results of these retrospective analyses of military personnel support the conclusion above that RFR cataractogenesis is a gross thermal effect. Therefore, it is extremely unlikely that prolonged exposure to the RFR from PAVE PAWS, certainly at the power densities outside the exclusion fence, will cause eye damage in humans.

C.7.5 Nervous System Studies

This section includes studies on the RFR-hearing effect and field effects on calcium efflux from brain tissue (both also discussed in Section C.6.1.2, pp. C-22, C-23), studies of blood-brain barrier permeability, histopathology of the CNS, and studies of the EEG and evoked potentials.

C.7.5.1 RFR-Hearing Effect

Using 2,450 MHz radiation, Foster and Finch (1974) repeated and extended White's (1963) findings that acoustic transients can be thermally generated in water by pulsed RFR energy. The peak pressure level of these transients, measured within the audible frequency band as a function of the RFR pulse parameters, is adequate to explain the "clicks" heard by people exposed to pulsed RFR of high pulse power density. They concluded that these thermally induced transients elicit the RFR "hearing effect" in humans.

Cain and Rissman (1976) investigated RFR hearing threshold parameters (3.0 GHz) for cats, dogs, chinchillas, and humans. Threshold auditory-evoked responses in the animals were obtained at an average density per pulse of 10.3 microjoules/cm² at pulse widths less than 20 microseconds. For similar pulse widths in humans, the average energy density for threshold of hearing the pulse was 10.6 microjoules/cm². However, three of the eight subjects could not hear pulses below 20 microseconds at maximum pulse power settings. The authors believe that an inability to hear RFR pulses might be correlated with hearing losses above a frequency of 8 kHz. The values for threshold detection of the

acoustic effect corresponds approximately to 300,000 microwatts/cm², pulse power density, for a 20-microsecond pulse, which is more than two orders of magnitude above the calculated PAVE PAWS pulse power densities at the exclusion fence.

Chou and Guy (1977) used 918 MHz radiation and guinea pigs to investigate thresholds for brainstem-evoked responses. They found that, for pulse widths less than 30 microseconds, the threshold was independent of the absorbed energy per pulse, which agrees with Cain and Rissman. For pulse widths greater than 70 microseconds, the threshold was independent of the pulse power density. Chou and Guy indicated that their experimental results agreed well with the predictions of the thermal expansion theory.

Chou and Galambos (1977) extended the above findings to investigate effects of external-ear blocking, middle-ear damping, and middle-ear destruction on the brainstem-evoked responses to both acoustic and RFR stimuli. They found that only when the cochlea was intact was the animal capable of hearing pulsed RFR.

In two papers, Lebovitz and Seaman (1977a, 1977b) reported on single unit responses (eighth-nerve related) to 915 MHz CW and pulsed RFR. The threshold for CW activation of vestibular units was significantly above 10,000 microwatts/cm² (i.e., above a level for significant intracranial thermogenesis). For cochlear units, use of pulse widths of 100-250 microseconds or longer confirmed that pulse parameters were a more appropriate independent variable than average power density. Single unit responses were observed at pulse energy densities of 4 microjoules/g and lower (comparable with results in previously discussed papers). The response of a given single auditory unit to pulsed RFR was very similar to its response to traditional acoustic click stimuli, differing only in amplitude.

Lin (1977a, 1977b) has reported on detailed theoretical studies of the RFR auditory effect. He assumed that the auditory sensation results from acoustic waves generated in the tissues of the head by rapid thermal expansion of the tissues upon microwave absorption (which is the general consensus of the foregoing reviewed papers). The theoretical results indicate the frequency of the auditory signals generated is independent of both the frequency of the incident RFR and the absorbed energy distribution. This indicates that this phenomenon, studied at frequencies such as 915, 2,450, and 3,000 MHz, would occur in the 420-450 MHz band if the peak power density and pulse duration were above the minimum values stated previously. Frequency of the auditory signal is dependent on head size. The smaller the head size, the higher the frequency of the RFR-induced auditory sensation. For a human infant, predicted fundamental frequency is 18 kHz. For an adult human, predicted fundamental frequency is 13 kHz.

Tyazhelov (1977b) reported on some peculiarities that Soviet researchers had noted concerning the RFR auditory sensation in human observers at 800 MHz. Confirming some of the work reviewed above, they noted that for pulse widths of 5 to 30 microseconds the threshold of pulse power density was essentially flat from 1 pps to approximately 1,000 pps. The threshold then rose and reached cutoff between 8,000 and 10,000 pps (maximum pulse power density 2,000,000 microwatts/cm²). The average power density in these experiments on occasion must have been of the order of 100,000 microwatts/cm² or more for the Soviet subjects. Other observations included the successful generation of beat-frequency responses with an acoustic stimulus greater than 8 kHz, and an increase in threshold level as pulse widths increased toward 100 to 120 microseconds, with concomitant decrease in pitch. The authors concluded that current models of RFR hearing would require further development. Further refinements of theory and experiment appear to be in progress.

Thus, in this one area, pulsed RFR effects are different from those of CW RFR at the same average power densities. The RFR hearing effect appears to be well understood in terms of thermoelastic expansion of tissues resulting from absorption of a pulse of microwave energy, with subsequent conduction of the acoustic pulse to the cochlear apparatus. Threshold for detection of a pulse by persons with normal hearing is of the order of 300,000 microwatts/cm², well above any levels predicted for the ground level vicinity of PAVE PAWS.

C.7.5.2 Calcium Efflux

Over the last 4 years, Adey and Bawin have reported extensively on their studies of changes of radioactive calcium ion (⁴⁵Ca⁺⁺) efflux from neonate chick brain preparations and isolated samples of cat cortex under very specific regimes of amplitude modulation frequencies and power densities for ELF, VHF, and UHF fields (Adey, 1975a, 1975b, 1976, 1977a, 1977b, 1978a, 1978b; Bawin, 1974, 1975, 1976a, 1976b, 1977a, 1977b, 1977c, 1978a, 1978b).

Certain of these reports are relevant to PAVE PAWS because they describe effects at 450 MHz, at relatively low power densities (100 to 1,000 microwatts/cm²). The pulse rates of PAVE PAWS are also approximately the same as the modulation frequencies of Bawin and Adey. For these reasons, these studies are given emphasis in this EIS.

Extensive details of the experimental protocol are given in Bawin (1976b, 1977a). Briefly, following decapitation, forebrain hemispheres of neonate chicks were obtained by rapid dissection. The hemispheres were separated and one was used for exposure and the other as control. Each was incubated in a specified

physiological solution containing $^{45}\text{Ca}^{++}$ for 30 minutes. At the end of incubation, the samples were rinsed three times with nonradioactive solution. The samples were then transferred to new glass test tubes, bathed in 1.0 ml of solution and exposed or sham-exposed for 20 minutes. Sets of ten brain samples (ten exposed hemispheres, ten control hemispheres) were used simultaneously. At the conclusion of exposure, aliquots of 0.2 ml of the bathing solution were taken, and radioactivity assayed by scintillation counting. Radioactivities (counts per minute, cpm, per gram) were normalized to the mean value of counts obtained in control effluxes. All normalized data were compared (by t-test) with matched samples of control values. Data from experiments with approximately 190 chick brains for 450 MHz exposures are given in Adey (1977a). Power densities of 500, 1,000, 2,000, and 5,000 microwatts/cm² were used, for 16 Hz amplitude modulation of the field. At 1,000 microwatts/cm², a significant (p less than 0.001) difference (9.3%) was observed between the normalized means of radioactivity counts of control and exposed brains. Exposed brains had the higher mean. A significant (p less than 0.01) difference was also observed for 500 microwatts/cm² (exposed mean 21% greater than control). Differences for 2,000 microwatts/cm² (exposed 1% greater) and 5,000 microwatts/cm² (exposed 3.5% less) were not statistically significant. The same data were reported by Bawin (1977a), with the caution that the experiment must be repeated to be compared with the other extensively studied field conditions (ELF, and 147 MHz).

A different set of data for 450 MHz has subsequently been reported by Bawin (1978a) and repeated by Adey (1978b). At 1,000 microwatts/cm², a significant (p less than 0.05) increase (10.9%) was observed between exposed and controls. A significant (p less than 0.05) increase (7.9%) was observed at 100 microwatts/cm². Increases of 3.4% and 2.1% at 2,000 and 5,000 microwatts/cm² were not statistically significant, nor was a 6.1% decrease at 50 microwatts/cm².

From the two sets of data therefore, statistically significant increases were seen at 100, 500, and 1,000 microwatts/cm², but not at 50, 2,000 or 5,000 microwatts/cm², for 450 MHz RFR amplitude-modulates at 16 Hz. A recent paper (Bawin, 1978b) describes experiments aimed at a better definition of the calcium sites responding to weak electrical stimulation. Changes in efflux were studied with and without imposed electromagnetic fields (450 MHz, 16 Hz amplitude modulation, 375 or 2,000 microwatts/cm²) to ascertain the effect of calcium concentration in the exchanging medium. Also tested were pH and bicarbonate-free solutions. The second half of the study examined modification of calcium release by the addition of lanthanum to the bathing solution, for both no-field and with-field stimulation conditions. Efflux of $^{45}\text{Ca}^{++}$ in the standard physiological solution was the "control" for these experiments, and each half brain was tested against the corresponding hemisphere in any test series.

The results confirmed the previous findings by Bawin and Adey that amplitude-modulated 450 MHz fields can stimulate the release of preincubated $^{45}\text{Ca}^{++}$ from isolated brain tissue. This release was significantly different, statistically, at extracellular Ca^{++} concentrations of 2.16 and 4.16 mM, but not in Ca^{++} -free solutions. The release was enhanced by addition of H^+ (0.108 mM, as HCl), even though this did not affect the efflux in the absence of the field. Omission of HCO_3^- resulted in a decrease (not statistically significant) in efflux of $^{45}\text{Ca}^{++}$ both with and without field stimulation. Addition of La^{+++} to the HCO_3^- -free solution resulted in a statistically-significant decrease in $^{45}\text{Ca}^{++}$ efflux (compared with an increase in the other cases, above) for an extracellular concentration of 2.0 mM La^{+++} for both no-field and with-field (375 and 2,000 microwatts/cm²) situations. These results taken together are stated to support the hypothesis that a limited number of extracellular cationic binding sites are involved in the transaction of weak extracellular electrical events and suggest that the electrosensitive sites in La^{+++} -treated samples are in the class of sites responsible for the field response in the "standard" solution.

Bawin (1977c) has also reported on results from a preliminary study involving the monitoring of calcium efflux from the intact cortex of 12 awake, paralyzed cats. The methods were similar to those utilized in the chick brain experiments. The cats were exposed for 20 minutes to 450 MHz fields amplitude modulated at 16 Hz. Power densities were 375 or 1,000 microwatts/cm². Results are stated to be a clear increase in $^{45}\text{Ca}^{++}$ efflux during and following the exposure in 8 of 12 animals. However, some animals apparently responded to the presence of the experimenter during sampling. Further experiments are now in progress to remove the possibility of artifact and to elaborate on these preliminary findings.

Blackman (1977) reported on an attempt to verify and extend Bawin and Adey's findings for chick brain at 147 MHz. Treated tissue was exposed in a Crawford chamber to power densities between 500 and 2,000 microwatts/cm² and amplitude modulation of the carrier at selected frequencies between 3 and 30 Hz. They found a statistically significant increase in calcium efflux (p less than 0.05) when the frequency of modulation was 16 Hz and power density was 750 microwatts/cm². Their presentation constitutes the first reported independent confirmation at one power density and modulation frequency of Bawin and Adey's work at 147 MHz. Blackman experienced considerable difficulties initially in the work, but now has been able to repeat this finding on several occasions.

The work of Adey and Bawin represents one of the very few cases where RFR effects have been found at average power densities in a possibly non-thermal range (100-1,000 microwatts/cm²).

Schwan (1977, p. 207) has expressed the opinion that if the findings of Adey and Bawin can be confirmed and if it can be shown that they are caused by direct interaction with the CNS, entirely new modes of interaction of electrical fields with biological systems are indicated. It is also important to note again that the RFR carrier frequency used by Adey and Bawin (450 MHz) is very close to that of PAVE PAWS (420-450 MHz) and that the modulation frequency (16 Hz) is very close to the pulse repetition rates of PAVE PAWS (see Appendix D). However, there is no evidence at present that the findings of Adey and Bawin imply any hazard to humans. Average and pulse power density levels of PAVE PAWS RFR to which the general public may be exposed will be lower than the threshold average power density found by Adey and Bawin.

C.7.5.3 Blood-Brain Barrier Effects

Non-RFR studies by Rodzilsky and Olszewsky (1957) revealed that permeability changes in cerebral blood vessels occurred under various conditions, including those that produced heat necrosis. Sutton (1973) used 2,450-MHz radiation to produce selective hyperthermia of the brain in rats. He then studied the integrity of the blood-brain barrier with horseradish peroxidase (HRP), a protein tracer that can be detected both morphologically and quantitatively. Brains were heated to 40, 42, and 45 deg C. Barrier integrity was disrupted after heating for more than 45 min at 40 deg C. Animals with brains heated to 45 deg C survived for only 8 to 15 min. The most common site of vascular leakage was the white matter adjacent to the granular cell layer of the cerebellum. Sutton concluded that to prevent blood-brain barrier disruption, brain temperatures must not exceed 40 deg C in the absence of body-core hypothermia.

Frey (1975) exposed groups of anesthetized rats to pulsed or CW RFR at 1.2 GHz for 30 minutes. The pulse and average power densities of the pulsed RFR were 2,100 and 200 microwatts/cm², respectively, and the average power density of the CW RFR was 2,400 microwatts/cm². Sham-exposed rats were used as controls. After exposure, sodium fluorescein was injected into the femoral vein. Five minutes after injection, the blood of the rat was withdrawn and the brain was removed, embedded in gelatin, refrigerated, and sectioned. The sections were viewed under ultraviolet light for fluorescence, the intensity of which was scored by the viewer. Greater fluorescence was reported for pulsed than CW RFR, and some control specimens also exhibited slight fluorescence. The investigators regard these results as evidence that exposure to RFR alters the blood-brain barrier. However, Spackman (1978) performed a similar investigation in mice, using fluorescein and several nonphysiological amino acids as test substances. Groups of mice were exposed to sham, CW, or pulsed RFR at 918 MHz for 30 minutes. The average power densities in both the pulsed and CW modes were 2,500 and 33,000 microwatts/cm². The duty cycle of the pulsed RFR was 0.001.

Exposure to 132,000 microwatts/cm² CW was also tested. A spectrofluorometer and an automatic amino acid analyzer were used to measure concentrations of fluorescein and the test amino acids, respectively, in the brain and blood plasma. Using these more sensitive methods, the investigators did not detect any significant differences in blood-brain-barrier permeability between RFR-exposed and control mice.

Albert (1977a) also used HRP as a tracer and reported regions of leakage in the microvasculature of the brains of Chinese hamsters exposed to 2,450-MHz radiation at 10,000 microwatts/cm² for 2-8 hr. In control animals, extravascular reaction product was found only in brain regions normally lacking a blood-brain barrier. In a later paper, Albert (1977b) reported that continuation of the earlier studies indicated that a partial restoration of the blood-brain barrier's impermeability may have occurred within 1 hr after exposure ceased, and that restoration was virtually complete within 2 hr. Albert believes that these changes may be clinically subacute and probably cause no lasting ill effects. Further discussion of the possible thermal nature of these effects is given in Section C.7.5.4, p. C-51, in the discussion of Albert and De Santis (1975). Note that these leakages of the microvasculature of the brain occur irregularly. During the formal discussion period following presentation of a paper by Preston at the 1978 International Symposium on Biological Effects of Electromagnetic Fields in Ottawa, 27 June 1978, Albert indicated that such leakage is observed in approximately 50% of his exposed animals, and also in approximately 20% of his control animals.

Changes in permeability of the blood-brain barrier to D-mannitol were investigated by Oscar and Hawkins (1977a), who exposed rats to 1.3-GHz pulsed or CW RFR for 20 min at various power densities. Permeability changes were measured by the Oldendorf technique; that is, 0.2 ml of a mixture of ¹⁴C-labeled mannitol and tritiated water was injected rapidly into each rat's carotid artery after exposure, the animal was sacrificed 15 s later, and brain sections were dissected out and prepared for assays of radioactivity using a liquid scintillation counter. The ratio of counts of ¹⁴C-labeled D-mannitol to counts of freely diffusible tritiated water in samples of brain tissue was normalized to a similar ratio for the injected solution. This normalized ratio, expressed as a percentage, is defined as the brain uptake index (BUI). Oscar and Hawkins found statistically significant changes in BUI at average power densities less than 3,000 microwatts/cm². They also found that pulsed energy is not always more effective in causing permeability changes than CW energy. Instead, depending on certain pulse characteristics, pulsed energy can be either more or less effective than CW energy of the same average power density. They found that under conditions of high pulse power density, large pulse widths, and a few pulses per second, mannitol uptake could be affected at an average power density of only 30 microwatts/cm².

These results appear to be relevant to possible effects of PAVE PAWS RFR. However, attempts by Merritt (1977) to repeat the experiment did not confirm the original finding of increased permeability. Data from three separate experiments by Merritt indicated that hyperthermia of the brain was necessary to alter permeation.

Preston (1978) also attempted to determine whether 2,450-MHz CW exposure increased blood-brain barrier permeability to ^{14}C -mannitol. Rats were exposed to 100, 500, 1,000, or 10,000 microwatts/cm², and controls were sham exposed. Most methods were identical with those used by Oscar and Hawkins (1977). No evidence that the RFR exposure increased blood-brain barrier permeability to mannitol was found.

Chang (1978) used a technique involving radiolabeled ^{131}I albumin to investigate alterations of the blood-brain barrier in dogs. The dogs' heads were exposed to various power densities between 2,000 and 200,000 microwatts/cm². In general, no statistically significant differences were observed between exposed and sham-exposed animals, but the number of animals reported in this study was too small for a high level of statistical confidence.

In summary, it appears that blood-brain barrier permeability to HRP can be altered by levels of RFR sufficiently high to cause substantial temperature elevation. It is also possible that lower average power densities, in the vicinity of 10,000 microwatts/cm², may cause randomly distributed, clinically subacute, reversible alterations, although such alterations also occur (though less frequently) in unexposed controls. These effects are highly unlikely to occur at the radiation levels expected outside the PAVE PAWS exclusion fence. Radiotracer techniques have shown changes in permeability of the blood-brain barrier to D-mannitol at power densities less than 3,000 microwatts/cm², but other investigations have failed so far to confirm these findings. Oscar (1977b) has pointed out that most techniques used to measure blood-brain barrier permeability in fact measure the net influence of several variables on brain uptake, and do not differentiate among the effects of changes in the vascular space, alterations of blood flow, and membrane permeability. Several research projects to refine knowledge of blood-brain barrier permeability change under RFR are apparently now underway.

C.7.5.4 Histopathology of the Central Nervous System

Tolgskaya and Gordon (1973) reported a number of effects of RFR (frequencies 500 kHz to 100 GHz) on a large number (approximately 646) of animals, predominantly rats. Their so-called decimeter band (500 MHz - 1 GHz, exact frequency or frequencies not

specified) is closest to the PAVE PAWS frequencies. Pathological effects claimed for high-intensity (20,000 to 240,000 microwatts/cm²) radiation included multiple perivascular hemorrhages in the brain and other organs, degeneration of apical dendrites in the cortex, cloudy swelling of cytoplasm, cytoplasmic shrinkage, formation of vacuoles, unevenness of staining, disappearance of cytoplasmic structures, fatty degeneration, decrease in ribonucleoprotein, and occasional karyocytolysis. The intensities of exposure were capable of causing death of the animals (clinical signs of hyperthermia, temperature rises up to 42 deg to 45 deg C) in several minutes to several hours. Photographs of the exposure arrangement show multiple animal exposures at the same time in a room appearing not to have radiation absorbing material on the walls. It is likely that the specific absorption rates (SARs) for individual animals under these conditions varied widely. Because all of these effects are clearly thermal in nature, they provide no evidence that the PAVE PAWS levels might prove harmful.

Low-intensity exposures were also carried out. The authors define threshold field intensities for nonthermal effects ("intensity not raising body temperature") for decimeter microwaves as 40,000 microwatts/cm² (Tolgskaya and Gordon, 1973, Table 3, p. 56). Exposures at so-called low intensity for decimeter waves were generally at or slightly below 10,000 microwatts/cm² for 60 minutes daily for 10 months. Investigation of the animals by ordinary morphological methods revealed practically no vascular disorders in the nervous system. "Delicate elective neurohistological methods" (unspecified) showed disappearance of spines from cortical dendrites, the appearance of beading and irregular thickening of dendrites, swelling of cytoplasm of individual cells (with appearance of vacuoles) in the basal ganglia and hypothalamus, focal and diffuse proliferation of microglial cells, with microglial processes showing initial signs of degeneration.

Many of these effects are similar to those described for the high-intensity exposures. In view of the approximately 10,000 microwatts/cm² exposure levels, the previously described exposure arrangement, and the knowledge of the possibility of localized regions of high SAR, it seems likely that the described effects (more subtle than those of frank hyperthermia) were also thermal in origin.

Albert and De Santis (1975) have also reported changes in the hypothalamus and subthalamus of Chinese hamsters exposed to 2,450 MHz radiation at either 50,000 microwatts/cm² for durations from 30 minutes to 24 hours, or 25,000 microwatts/cm² for 14 hours/day for 22 days. Changes were not evident in the hippocampus, cerebellum, thalamus, or spinal cord ventral horn. In the discussion printed with this paper, Guy pointed out that his laboratory had measured mean SARs as high as 4 W/kg per incident 1,000 microwatts/cm² in animals of similar size. Peak SARs could have reached 40 to 200 W/kg in selected brain regions of

Albert's animals; this range far exceeds what is normally used for diathermy treatment in 20-minute exposures of patients. Rectal temperature measurement would not necessarily reflect such high SARs in localized areas.

Albert and DeSantis (1976) studied CNS histological effects in 60 Chinese hamsters exposed to 1,700 MHz radiation at power densities of 10,000 and 25,000 microwatts/cm². Cytopathology was observed after 30 to 120 minutes of exposure in hypothalamic and subthalamic areas, but not in other areas. These observed effects were also likely thermal in origin for the same reasons as above.

In summary, RFR can cause observable histopathological changes in the CNS of animals, but it appears that these changes are of a thermal nature and would not occur at the power densities existing outside the exclusion area.

C.7.5.5 EEG Studies

Many studies on the electroencephalogram (EEG) and/or evoked responses (ERs) of animals exposed to RFR have been conducted. Some of these have been carried out with metal electrodes either implanted in the brain or attached to the scalp during exposure. Johnson and Guy (1972) pointed out that such metallic electrodes grossly perturb the fields and produce greatly enhanced absorption of energy (i.e., field enhancement) in the vicinity of the electrodes. Such enhancement produces major artifacts in the biological preparation under investigation. Such artifacts are not to be confused with the recording artifact that is produced by pickup of fields by the electrodes and leads during the recording of EEGs or ERs while the animal is being exposed. In addition to these cautions concerning methodology, it should be noted that most EEG studies are performed on heavily sedated animals, with phenobarbital as the usual drug. Hence the responses reported do not necessarily reflect those that would be expected in normal alert animals.

Tyazhelov (1977a) has discussed these problems and pointed out that, even for the coaxial electrode developed by Frey (1968), diffraction of EM waves is still a major source of error because of the electrode's metallic nature and large dimensions. Tyazhelov solved the problems by developing electrodes of high linear resistance (greater than 100 kilohms/m) and proper filtering of the recorded signal. This paper indicates an awareness in the USSR that questions may be raised about the validity of data and conclusions from many experiments involving animals with indwelling electrodes both in the USSR and the United States.

Dumanskij and Shandala (1974) reported changes in the biocurrents in the brain cortex of rabbits after 60 days exposure to RFR (50 MHz, 2.45 GHz, 10 GHz). Changes (vaguely specified as "an increase in the rhythm of slow waves and a decrease in the rhythm

of intermediate and fast waves") were described at 10 microwatts/cm² and 1.9 microwatts/cm², but not at 0.01 microwatts/cm². Although the rather sketchy nature of their description precludes definitive critique of these results, it appears that the use of indwelling electrodes may have contributed artifacts, as described above.

In a more recent presentation, Shandala (1976) reported on observations of rabbits with implanted EEG electrodes, and again claimed quite variable, but statistically significant EEG changes at 10 microwatts/cm² exposures (2.375 GHz) for 7 hr/day for 1 month. The same questions about implanted electrodes possibly causing artifactual data may be raised.

Goldstein and Cisko (1974) studied the EEGs of sedated rabbits to determine whether RFR exposure would evoke arousal. They used 9.3 GHz RFR at 700 to 2,800 microwatts/cm². The EEG of each rabbit was recorded for about one hour. After the first ten minutes, the rabbit was sedated with sodium pentobarbital. Five minutes later, the rabbit was exposed or sham exposed to the RFR for five minutes. The EEGs showed no arousal during RFR exposure but indicated alternations of arousal and sedation characteristics starting 3 to 12 minutes after exposure. Control animals also exhibited alternations having shorter arousal durations, rendering interpretation of these results difficult. These investigators were aware of the potential problem of metals in the pathway of the RFR and claimed to have mitigated it by using thin (0.01 inch) insulated, implanted stainless steel electrodes. It is unlikely that this reduced the artifacts significantly, if at all. They also stated that "under everyday conditions, the EEG patterns of rabbits are quite variable. The animals oscillate between sedation and arousal unpredictably." This variability is another potential source of error in any experiments on the EEG of rabbits.

Chou (1978) used implanted carbon electrodes to avoid the artifactual problems associated with metal ones. Two groups of rabbits (six animals/group, three males, three females) were exposed to 2,450 MHz, 1,500 microwatts/cm² radiation for 2 hours daily for 3 months. One group received CW, the other pulsed radiation (10 microseconds, 100 pps, 1,500,000 microwatts/cm² pulse power density). A similar group of six animals was sham-exposed. No significant differences were observed between groups at the end of three months with regard to EEG and evoked potentials.

Kaplan (1978) (also discussed in Section C.7.11.3, p. C-70) reported that, from the beginning of the second trimester of pregnancy, 33 squirrel monkeys were exposed for 3 hr/day in special cavity/cage modules to 2,450 MHz pulsed radiation at whole-body mean SARs equivalent to those resulting from plane-wave exposure to 100, 1,000, and 10,000 microwatts/cm² and compared with a group of eight pregnant sham-exposed monkeys. Eighteen of the exposed mothers were exposed with their offspring for an addi-

tional 6 months after parturition, and then their offspring were exposed alone for another six months after weaning. No statistically significant differences were found between exposed and nonexposed adults nor between exposed and nonexposed offspring on resting EEG and photically driven EEG parameters. (No chronically attached or indwelling electrodes were used.)

Rosenstein (1976) exposed one group of eight female rats to 10,000 microwatts/cm² at 425 MHz for 4 hours/day from the 12th day after breeding until parturition, and another group of 12 dams to 5,000 microwatts/cm² at 2,450 MHz for 4 hours/day from the 6th day after breeding until parturition. The offspring were then exposed for 92 days. Control groups having the same population number were used for each frequency. Evaluation of the EEGs and the visual ERs of the offspring at 140 days of age indicated no significant difference between the exposed and control groups. (Again, indwelling electrodes were not used.)

In summary, the use of indwelling metallic electrodes in studies on the effects of RFR on the EEG and/or evoked potentials may be questioned as a procedure likely to introduce artifactual effects in the preparation under study, as well as in the recordings themselves. These artifacts may be minimized by use of electrodes appropriately designed from high resistivity materials. Experiments where such specially constructed electrodes were used, or where electrodes were applied after exposure, show no evidence of statistically significant differences in EEGs or evoked responses between control and RFR-exposed animals.

C.7.6 Effects on Behavior

The very large number and variety of behavioral studies in animals exposed to RFR makes the classification and interpretation of results very difficult. Also, the use of pulsed magnetrons or klystrons in some of the behavioral investigations may have inadvertently introduced auditory clues such as arcing noises and "pocks" produced by the incidence of RFR pulses on the walls of the exposure chambers. The analysis presented below represents a balanced selection of results from the recent literature on the subject.

C.7.6.1 Radiation Avoidance Responses

Mice exposed to RFR at 2.45 GHz (continuous wave), power levels not given, under conditions where they were relatively free to move around, tended to orient themselves so as to minimize the amount of energy absorbed (Monahan, 1978). In another study (Monahan, 1977a), rats were allowed to drink 10% sucrose solution for 15 minutes and were then exposed to 915 MHz radiation for 15

minutes in a waveguide at forward power levels of 5,000,000 to 19,000,000 microwatts (83,000-315,000 microwatts/cm²). When the rats were offered a 10% sucrose solution 24 hours later, there was no evidence of avoidance of the sucrose, indicating that the sucrose was not associated with an intensely unpleasant experience. In a third study (Monahan, 1977b) mice were exposed to 2.45 GHz radiation at mean SARs of 46 mW/g (approximately 51,000 microwatts/cm²) in an experimental arrangement where the mice could turn off the RFR repeatedly for 12 sec each time by interrupting a light beam. The mice responded by regularly turning off the light beam, which is frequently taken, in the psychological literature, to constitute an escape or avoidance response.

C.7.6.2 Acute Effects: Behavior Depression

Studies have been conducted on the effects of relatively high power densities of RFR on performance of trained tasks by animals (Sanza, 1977; de Lorge, 1977; D'Andrea, 1977; Lin, 1977c; Gage, 1976; Galloway, 1976). Animals studied were rats, rhesus monkeys, and squirrel monkeys. All of the studies indicated that the radiation would suppress performance of the trained task, and that a radiation power density/dose threshold for achieving the suppression existed. Depending on duration and other parameters of exposure, the threshold power density for affecting trained behavior ranged from 5,000 to 50,000 microwatts/cm².

Rats exposed to pulsed radiation, 2.45 GHz at 6-11 mW/g (mean SAR), for single 30 minute sessions (Hunt, 1975), showed a temporary decrease in exploratory activity when placed in a test situation immediately after exposure. Similar results were found after the rats were subjected to pulsed RFR, 9.4 GHz at 700 microwatts/cm² (time not stated) (Gillard, 1975). On the other hand, chronic exposure to 3 or 10.7 GHz, 500 to 25,000 microwatts/cm², for total times ranging from 185 to 408 hours (Roberti, 1975), did not result in any change in spontaneous motor activity.

Rats exposed to relatively large doses of RFR showed decreased performance in a forced swimming test (Hunt, 1975). The effect appeared to be an early onset of fatigue after exposure.

C.7.6.3 Chronic Effects

A study in rabbits and rats exposed to 3 GHz RFR at 1,000 to 10,000 microwatts/cm² for 60 min daily for up to six months (Lobanova, 1974) found a weakening of conditioned reflexes in the animals, as shown by increased latency or absence of response and failure to recognize the conditioned stimulus. The effect was intensified when inbred rats having a high level of excitability of the central nervous system were used, from which the author concluded that the RFR acted directly on the central nervous system.

In another study (Shandala, 1977b), rats exposed to 2.375 GHz radiation at 10 or 50 microwatts/cm², 7 hr/day for 90 days were tested periodically for learning an avoidance response, open field exploratory activity, and threshold of electric shock to the foot. Avoidance learning and foot shock threshold showed biphasic character of the responses. Avoidance learning was more rapid in exposed animals than in controls in the beginning of the study and slower at the end of the study. The foot shock threshold was lower in exposed than in control animals in the beginning and higher at the end. The author attributes the results to an initial excitation of the central nervous system, followed by inhibition.

A third study (Mitchell, 1977) reported that rats exposed chronically to 2.45 GHz at 2.3 mW/g (mean SAR) over a 22-week period showed an increase in locomotor activity and a disturbance of differential responding to operant behavior. The changes were detected almost immediately after beginning the study.

C.7.6.4 Pulsed-RFR Effects on Natural Behavior

Exposure of rats to pulsed radiation (0.1-0.5 microseconds, 1,000/s) at 1, 1.3, or 1.5 GHz and peak levels of 50-200 microwatts/cm² inhibited an aggressive response in the rats, which is normally induced by acute pain (Frey, 1977). The pulse power density threshold of the response was between 50 and 100 microwatts/cm². Continuous wave exposure (power density not given) also blocked the aggressive response, but not as effectively as pulsed RFR. Pulsed RFR at a pulse power density level of 400 to 28,000 microwatts/cm² also caused a disturbance of motor coordination in a balancing test.

C.7.6.5 Summary of Behavioral Effects

RFR does cause changes in behavior of animals, but most results have been obtained at power density levels in which the heat load is likely to have been significant, or local SAR values at specific locations were much higher than the mean SAR, as discussed in Section C.7.5.4, p. C-50. The studies on RFR avoidance were patterned after earlier studies 15 years ago using ionizing radiation. In the ionizing radiation studies the rats avoided the radiation when possible, and developed a strong aversion to saccharin solution when it was coupled with even modest radiation exposure (15-25 rad). In current experiments the rats did, indeed, avoid the RFR, but developed no aversion to the sucrose. The mean SAR of the avoided radiation was 27 to 46 mW/g, which for a 30-g mouse translates into a heat input of between 12 and 20 calories per minute. Therefore, based on these reports, RFR is not intrinsically aversive or noxious.

The inhibition of trained behavior in rats during or following RFR exposure seems to be consistently tied to threshold levels of power density and duration of exposure. Although the number of results reviewed is small, the inhibition threshold appears to be related to the complexity of the task and the type of discrimination required in performing it. The mechanism for behavioral inhibition is not known. The central nervous system may be involved, but at the power density threshold found for most studies, it is unnecessary to postulate direct stimulation of the central nervous system.

Inhibition of exploratory activity generally involves the natural timidity of rats placed abruptly into novel situations. The results of the studies on voluntary and exploratory activity suggest that when exposure is coupled with a novel situation, the sense of novelty is heightened by the exposure (which is also a novel experience). The results in animals exposed over a period of time suggest that the animals become accustomed to the RFR as an experience.

The studies of Lobanova and Mitchell suggest that the disturbance of trained behavior found for acute exposure can also be produced by chronic exposure, possibly at slightly lower power densities. The results also suggest that if the power density and exposure time are sufficient to produce an effect on learned behavior, then the animal will not recover its normal behavior response while the RFR continues.

The results reported by Shandala and Frey are curious, and difficult to interpret in the context of other studies. Frey's results refer to innate behavior in the animal and imply that this behavior is perturbed by low power densities of RFR. The results of Gillard, obtained at 700 microwatts/cm², give some support to this conclusion. Shandala's results imply that there is a transition in behavioral effects during the course of chronic RFR exposure, an effect that was not found by Lobanova and Mitchell. Since Shandala's experiments involve continuous and repeated handling of the animals while they are being subjected to a minimal radiation stimulus, the experiment is highly susceptible to introduction of extraneous factors that then may become the principal determinant of results.

C.7.7. Endocrinological Effects

Several studies of the effect of RFR on hormones levels in blood and glands have been reported. Most effects reported are related to the adaptation of the animal to the heat load or non-specific stress arising from exposure or other circumstances of the experiment.

The rate of release of thyroxine from the thyroid gland during RFR exposure was studied in dogs (Magin, 1977a, b). Measurement of the rate of release of thyroxine from locally exposed (2.45 GHz) glands in situ showed that exposure to 72,000 microwatts/cm² doubled the rate of release over a 2-hour period and exposure to 236,000 microwatts/cm² increased the rate of release ten-fold. Temperature of the thyroid gland was 39 deg C for the 72,000 microwatts/cm² exposure and 45 deg C for the 236,000 microwatts/cm² exposure. During the higher level of exposure, blood flow through the thyroid increased by 70%. The authors believe that the elevated thyroxine release is a direct response of the gland to a rise in temperature.

A study of thyroid function in rats exposed whole body to 2.45 GHz CW RFR at 10,000 or 20,000 microwatts/cm² for 1 to 2 hours (Lu, 1977) showed a steady level of thyroxine in the blood, but a decrease in the level of circulating thyrotropin (TSH). After 4 to 8 hours, the TSH remained depressed and the thyroxine levels also fell. Exposure of rats to 1,000 microwatts/cm² for four hours caused a rise in rectal temperature and a transitory increase in blood thyroxine level.

A study of chronic exposure of rats exposed to RFR (2.45 GHz) also showed effects on thyroid function (Travers, 1978). Rats were exposed 8 hours per day for 7, 14, or 21 days to 4,000 or 8,000 microwatts/cm². Findings included decreases in serum levels of thyroxine, TSH, and albumin and increases in alpha-globulin and thyroxine-binding capacity. The changes in serum proteins were considered to be secondary metabolic effects of lowered thyroxine levels. Observed changes in thyroid function were dependent on power density and duration of exposure.

Studies of the adrenocortical response of rats exposed to RFR (2.45 GHz) have shown a time-power density threshold for effect (Lotz, 1976 and 1977a). Rats exposed for 30 or 60 min showed increases in the plasma corticosterone level only when the power density was 50,000 microwatts/cm² or more. Rats exposed for 120 min showed increases in plasma corticosterone at power densities of 20,000 microwatts/cm² or more. There was a strong correlation between plasma corticosterone rise and colonic temperature rise. Exposure of hypophysectomized rats or rats treated with dexamethasone produced no increase in plasma corticosterone, indicating that the increase was mediated through the anterior pituitary rather than by direct stimulation of the adrenal gland.

Another study of plasma corticosterone levels following RFR exposure (2.45 GHz, 24 hours, power density not specified) showed that the increased level was transient, lasting only a matter of minutes (Deschaux, 1977). By contrast, the level of plasma testosterone rose following exposure and remained elevated for several days.

Studies of the effects of RFR (2.45 GHz) on plasma levels of pituitary growth hormone showed a response similar to that of corticosterone, but with reversed direction (Lotz, 1977b; Michaelson, 1975). For 30 or 60 min exposures, the growth hormone level was decreased only when the power density was equal to or greater than 50,000 microwatts/cm². For 120 min exposures, the growth hormone level was decreased when the power density was 13,000 microwatts/cm² or more.

Another study of the effect of RFR (2.86-2.88 GHz) on plasma corticosterone confirmed the power density-time threshold effect (Mikolajczyk, 1974). Exposure of rats for 15 minutes at 10,000 microwatts/cm² had no effect on corticosterone levels of either the blood plasma or the adrenal gland. Exposure of rats 2 hours/day at 10,000 microwatts/cm² for 35 days caused a decrease in the pituitary level of luteinizing hormone (LH), and irregular effects on the follicle-stimulating hormone (FSH). Exposure of rats a single time at 10,000 microwatts/cm² for 6 hours caused an increase in both LH and FSH. In a follow-up study (Mikolajczyk, 1976), exposure of rats 6 hours/day at 10,000 microwatts/cm² for 35 days also caused an increase in LH, but had no effects on FSH or growth hormone. The results suggest that duration of exposure over a single day, rather than the cumulative effect of serial exposure, is the primary determinant of effects on LH and FSH.

In summary, the effects of RFR exposure on endocrine function in mammals is generally consistent with both immediate and long-term responses of the animals to thermal load and to nonspecific stress, which can also arise from thermal load. The immediate response of the thyroid of the dog to local RFR exposure is an increase in thyroid hormone production, presumably resulting from the increased metabolic rate in the gland. The long-term response of animals to whole-body RFR exposure at thermally significant power density is a decrease in the level of pituitary thyrotropic hormone in the blood plasma, followed by a decrease in the level of thyroxine. This response is homeostatically appropriate to the increased heat load, requiring a lower level of metabolism, and would be expected to appear rather promptly in an animal as small as a rat, where the thermal load/metabolic rate balance is somewhat labile.

Changes found in plasma levels of corticosterone and growth hormone are typical reactions of animals to nonspecific stress; indeed, great care is required in performing the experiments to ensure that the changes in hormone level do not result from stress caused by handling of the animals or novelty of the experimental situation.

Changes in level of LH in the pituitary may be either a response to stress or a metabolic adaptation to heat load. The overall results, showing that the response depended on duration of exposure each day, suggest the latter explanation.

The changes in level of plasma testosterone following a 24-hour exposure to RFR are difficult to evaluate in the absence of information on the power density level. If the level were sufficient to inhibit spermatogenesis or deplete spermatogonia, the increased testosterone level could be a compensating mechanism to restore gonadal function. The spermatogonia of the testes are rather more sensitive to heat than other cells, and protracted exposure (9.27 GHz, 100,000 microwatts/cm², 4.5 min/day, 5 days/week) causes testicular atrophy in mice, beginning after 4 months of exposure (Prausnitz, 1962, also cited in Sections C.7.8.4, p. C-62, and C.7.11.1, p. C-67, and C.7.11.3, p. C-69). Hormonal measurements were not made in this study. However, a study of men occupationally exposed to RFR at levels of up to several hundred microwatts/cm² (Lancranjan, 1975) showed slightly reduced sperm counts, but normal plasma levels of 17-ketosteroid and gonadotropin, indicating that there was no basic damage to the testes. Since sperm counts can be influenced by diet, age, temperament, sexual activity, personal problems in employment and social life, and other factors, the significance of the findings is not clear.

C.7.8 Immunological Effects

Several studies have been reported on the effects of RFR exposure on the immune systems of experimental animals. The results have been somewhat contradictory, with some studies indicating stimulation and others suppression of the immune system. Because of the complexity of the mammalian immune system and the variety of test systems available, it seems desirable to discuss the observed effects by separate types of experiments.

C.7.8.1 In Vitro Studies

These studies have been conducted to determine whether RFR exposure can induce lymphoblastoid transformation of lymphocytes in cell culture. Blast-transformation of cultured human lymphocytes was reported by Stodolnik-Baranska (1967) following exposure of the culture to 10-cm (3 GHz) RFR at 7,000 or 14,000 microwatts/cm². In an attempt to repeat the study, Czerski (1975) also reported evidence of blast-transformation in human lymphocytes exposed to RFR, but stated that the results were poorly reproducible. In another publication (Baranski, 1976), blast transformation of human lymphocytes was reported following exposure with 3-cm (10 GHz) RFR at 5,000 to 15,000 microwatts/cm². The report stated that power density levels below 5,000 microwatts/cm² were ineffective, that power density levels above 20,000 microwatts/cm² only killed the cells, and that between 5,000 and 15,000 microwatts/cm² the blast transformation depended upon stopping the exposure at the moment when the temperature of the medium reached 38.5 deg C. Another study (Smialowicz, 1976) reported complete failure to induce blast transformation in lymphocytes

derived from mouse spleen by exposure to 2.45 GHz RFR at 10,000 microwatts/cm² for 1, 2, or 4 hours. The temperature during the exposure remained stable, and there was no evidence of cell death as a result of the exposure.

The seemingly contradictory findings in the above studies may reflect some differences in the methodology and materials in the separate experiments. Stodolnik-Baranska identified blast transformation by histological observation; Czerski, by a macrophage migration inhibition test; and Smialowicz, by measuring incorporation of ³H-thymidine into DNA. In addition, the studies reported by Stodolnik-Baranska, Czerski, and Baranski used human lymphocyte cultures, while that of Smialowicz used mouse spleen lymphocyte cultures. The most consistent conclusion is that the blast transformation of lymphocytes depends -- perhaps in a complex way -- on temperature effects in the medium, and there is no evidence of ability of the RFR to stimulate the cells directly to undergo transformation.

C.7.8.2 In Vivo Studies: Acute Exposures

Relatively intense RFR exposure over short periods of time has been reported to produce specific changes in cell proliferation and differentiation in the immune systems of experimental animals. Exposure of mice to 2.45 GHz RFR at 100,000 microwatts/cm² for 5 minutes (Rotkowska, 1975) caused an increase in the number of circulating lymphocytes in the blood at 4 and 7 days after exposure. The effect was associated with an increase in the number of nucleated cells in the spleen over the same time period. Exposure of mice to 2.6 GHz RFR at 10,000, 15,000, and 20,000 microwatts/cm² for various periods of time, followed by inoculation with sheep red blood cells (SRBC) (Krupp, 1977) resulted in an increase in the number of SRBC-antibody producing cells in the spleen, as compared to nonexposed SRBC-inoculated mice. The effect was obtained whenever the exposure conditions resulted in a 3 deg C rise in rectal temperature, and it could be elicited by administration of cortisone, instead of RFR exposure, indicating that the effect was mediated through the pituitary-adrenal axis. In other studies (Wiktor-Jedrzejczak, 1977) exposure to 2.45 GHz RFR at 10-20 mW/g (11,000-22,000 microwatts/cm²) for 30 to 45 minutes resulted in changes in the number and distribution of cell types in the spleen. Both the frequency of cells bearing a receptor for the Fc portion of the immunoglobulin molecule and those bearing a receptor for complement increased. The results indicated a selective stimulatory effect of the RFR on these subpopulations of B lymphoid cells.

C.7.8.3 In Vivo Studies: Chronic Exposures

In a study of the effects of RFR on direct immune response to antigenic stimulation (Czerski, 1975) mice were exposed to 2-hour daily sessions of 2.95 GHz pulsed RFR at 500 microwatts/cm² for 6 or 12 weeks, and then injected with sheep red blood cells. After 6 weeks of exposure there was a large increase, as compared to unexposed controls, in the relative numbers of lymphoblastoid cells and plasmocytes and the absolute number of antibody-producing cells in the lymph nodes of exposed animals. The results were essentially similar to those of Krupp, cited above. After 12 weeks of exposure, however, the lymphoid cell response had returned to the level of the unexposed animals.

More general studies of the effects of chronic exposure to RFR on the immune system have also been performed. Exposure of guinea pigs and mice to 2.95 GHz pulsed RFR at 1,000 microwatts/cm² for 4 hours/day for 14 days (Czerski, 1974b) resulted in shifts in the circadian rhythm of a number of mitotic figures in cells of the bone marrow. Exposure of rats to 425 MHz RFR at 5,000 microwatts/cm² for 4 hours/day daily from prebirth through age 40 days (Smialowicz, 1977) resulted in a neutropenia and leukocytosis. This was not evidenced in rats exposed to 2.45 GHz. Both groups of animals showed enhanced response of lymph node lymphocytes to stimulation with T- and B-lymphocyte mitogens. In contrast to this finding, another study (Shandala, 1976, 1977a) reported that exposure of rats to 2.375 GHz RFR at 500 microwatts/cm², 7 hr/day daily for periods up to 30 days resulted in a "downward trend" in numbers of mitogen-responding T-cell lymphocytes. Exposure at 50 and 10 microwatts/cm² resulted in an initial increase in T-cell lymphocytes, followed by a decrease. The same study claimed that at 500 microwatts/cm², autoallergenic activity was observed. Another study from the same laboratory (Vinogradov, 1975) reported that similar exposure of guinea pigs at 1 to 50 microwatts/cm² resulted in leukocytosis, neutrophilic and eosinophilic granulocytosis, and increased complement titer and phagocytic activity of granulocytes in the circulating blood. Finally, a study of rabbits exposed to 2.45 GHz RFR at 10,000 microwatts/cm² for 23 hours/day for 6 months (Guy, 1976b) showed a decrease in numbers of spleen lymphoid cells responding to pokeweed mitogen, but no change in numbers responding to phytohemagglutinin or concanavalin A, indicating a possible suppression in the B-cell lymphocytes after prolonged exposure.

C.7.8.4 Health and Disease

A number of studies that have been conducted relate directly or indirectly to the question of whether the immunological effects of RFR exposure have any significance for disease resistance. Exposure of rabbits to 3 GHz RFR at 3,000 microwatts/cm² for 6 hours/day for 6 or 12 weeks resulted in some changes in the

immunological response of the animals to experimental infection with Staphylococcus aureus (Szmigielski, 1975). Exposed animals showed a depression in peripheral granulocyte count, a depression in the granulocyte reserve that could be mobilized by bacterial endotoxin, and an increased lysozyme activity of serum. However, none of the animals died from the infection. Another study considered the possibility that RFR-stimulation of the immune system might be beneficial in treatment of infection. Exposure of mice to RFR (no frequency or intensity reported), 6 hours per day for 6 days (Pautrizel, 1975), was reported to protect mice against an otherwise fatal experimental infection with Trypanosoma equiperdum. Finally, long-term exposure of mice to 9.27 GHz RFR, 100,000 microwatts/cm², 4.5 min/day (Prausnitz, 1962, also cited in Sections C.7.7, p. C-57, C.7.11.1, p. C-67, and C.7.11.3, p. C-69), was found to protect mice against a pneumonia infection inadvertently introduced into the colony 9 months into the study.

C.7.8.5 Conclusion

There is abundant, if conflicting, evidence that exposure to RFR affects the immune system of mammals. Studies in vitro indicate that if RFR directly stimulates cells of the immune system, the effect is mediated through temperature changes. Studies of acute exposure in vivo indicate that RFR effects on the immune system may be mediated through the pituitary-adrenal axis, but the possibility of a direct effect of the radiation on the cells of the immune system is not excluded. All acute effects have been elicited at power density levels that are in the range of thermal effects.

Chronic exposure to RFR is purported to elicit effects on the immune system at power density levels that are sufficiently low (10s to 100s of microwatts/cm²) for the effects to be unlikely to be the result of simple temperature rise. The overall nature and significance of the effects is not yet understood, nor have individual reports been independently verified. The study of Czernski suggests that RFR causes a temporary change in the responsiveness of the immune system that returns to normal levels under continued exposure; this result suggests that there may be a phase of biological adaptation to the RFR. The studies of Shandala and Vinogradov report what are essentially opposite effects from the same conditions and durations of exposure in different species of animals. Since their studies were not continued beyond 30 days, it is not yet known whether their findings represent temporary shifts in the immune system prior to developing biological accommodation.

There is presently no evidence that reported RFR effects on the immune systems of animals at average power densities less than 1,000 microwatts/cm² would occur in humans or that such effects would be hazardous to human health. The only study that even

suggested that RFR exposure might inhibit disease-combatting ability was conducted at power-density levels in the thermal region (3,000 microwatts/cm²), and the animals in this study all survived. Other studies suggested that the RFR might even be beneficial. If chronic low-level RFR exposure did impair the ability to resist disease, then a relatively high rate of infectious diseases should occur among people occupationally exposed to RFR, and it is highly unlikely that this would not have been noticed. The possible low-level effects are taken seriously in the USSR because Soviet doctrine on environmental and occupational health (Zielhuis, 1974) holds that any biological effect of any environmental agent is considered to be an unacceptable hazard to man, regardless of its real medical significance. (This is discussed in Section C.3, p. C-7.) Under such a doctrine, Shandala may find immunosuppressive effects and Vinogradov may find immunostimulatory effects under the same conditions, and the Soviet Ministry of Health may regard either of these findings or both of them together as sufficient reason for setting exposure standards at a level where no effect is likely.

C.7.9 Biochemical and Physiological Effects

A number of reported biochemical and physiological effects of RFR that can be attributed to known adaptive mechanisms of animals to heat or stress have been noted in other sections of this EIS. Other observations, e.g., body weight and hematological observations, have been noted in connection with studies of chronic exposure, where such measurements are commonly made. This section is addressed to other studies of metabolism, blood chemistry, and DNA structure that are not reported elsewhere.

A study of mice exposed to 2.45 GHz RFR in the mean SAR range of 21-31 mW/g (23,000-33,000 microwatts/cm²) showed that the mice decreased consumption of oxygen in response to the added heat load (Ho, 1977). Ability of the animals to compensate for the added heat load was partly determined by the size of the holding container; narrowly confined mice compensated more poorly than less restrained mice. A study of germinating peas (Carley, 1976) exposed to 3.3 GHz RFR at 5,000, 3,500, 2,000, 1,000, and 500 microwatts/cm² showed a decrease in oxygen consumption by the peas that was approximately related to power density level, with 500 microwatts/cm² showing no effect. The author claimed the effect to be nonthermal, but another study (Grunewald, 1978) found a selective increase in the internal temperature of the peas, as compared to surrounding air, during the exposure. This study noted that the metabolic pathway affected by the RFR was the starch-to-glucose path, but the evidence indicates that the effect was probably thermal in nature. At a somewhat lower level of biological organization, RFR exposure was found to have no effect on the metabolic rates of Ehrlich ascites tumor cells in culture (Plontek, 1977), isolated rat liver mitochondria (Elder, 1976), or cell membrane-bound enzyme systems of the rat (Allis, 1977).

A study of serum triglyceride levels in mice exposed to 2.35- to-2.50 GHz RFR at 3,000 to 4,000 microwatts/cm² continuously for 60 hours (Deficis, 1977) showed that the serum triglyceride level rose in the exposed animals. Changes were also observed in levels of serum beta-lipoproteins. A report from Czechoslovakia (Pazderova, 1974) (see Section C.7.1, p. C-33) noted that workers in television and radio transmitting stations showed changes in blood proteins, with decreased albumin and increased alpha and beta globulins, as compared with values for people not working there. Power density levels were not given, but the author noted that although the changes were statistically significant, the protein levels were still within the normal physiological ranges for the age and physical condition of the subjects. A report from the USSR (Gabovich, 1977) noted that rats exposed to 2.37 GHz RFR, 10-1,000 microwatts/cm², for 8 hr/day for 4 months, showed changes in turnover of trace elements, notably copper, molybdenum, iron, and manganese. The reported changes appeared to be irregularly dependent on power density, with increases in tissue content of elements being reported at the higher levels and decreases at the lower levels.

Studies in vitro at UHF frequencies (Krey, 1978) have shown that calf thymus DNA showed a relaxation effect that appeared to depend upon configurational parameters of mononucleotides within the molecule. Power density levels were not stated.

In vivo studies of the effect of RFR exposure on the DNA structure of the mouse testes (Varma, 1977) have also been reported. Exposure to 1.7 GHz RFR for 30 minutes at 50,000 microwatts/cm² resulted in an increase in the asymmetry ratio, a hyperchromic decrease, and a decrease in the melting temperature. The author postulates that the effects noted were a result of RFR-induced strand separation -- a highly credible conclusion in view of the high power-density levels employed. This work was performed in parallel with the studies reported in Section C.7.2, p. C-36, on the possibility of dominant lethal mutations being induced by the exposure.

In summary, effects of RFR on metabolic rate of animals appear to reflect normal physiological changes in response to heat load. Effects reported in germinating seeds appear to reflect changes in pathways of glucose metabolism, but their significance is not known. There were no effects of RFR on oxidative metabolism of cultured cells, mitochondria, or enzyme systems.

RFR is reported to influence the levels of plasma lipids and proteins in vivo. The experimental results in mice may be secondary to stress, as the thermal load in the experiment was not insignificant. The results of the studies in Czechoslovakia and the USSR on the changes in plasma proteins and mineral trace elements are interesting, but difficult to evaluate. The Czech study observed that the workers examined

appeared to be in good health, so the significance of the findings for health of the population is presumably minimal. The study from the USSR notes opposite effects from different power levels; this finding suggests the possibility of a transient change in response to the RFR.

The in vitro studies on effects of RFR on DNA appear to be primarily oriented toward investigation of the macrostructure of DNA, and do not per se suggest an effect under ordinary conditions in vivo. The in vivo studies in the mouse clearly reflect thermal effects of the RFR exposure. For the high power-density levels used, even the observed effects are minimal in degree.

C.7.10 Cellular Effects

Guy (1977) has described the development and characteristics of a transmission line cell-culture sample holder suitable for use in exposing a sample of cells in a culture medium for short periods to controlled broadband radiofrequency fields and controlled temperatures. Guy indicates that:

"In analyzing the data of many earlier experiments involving the effects of EM fields on cell cultures, blood samples and solutions containing microorganisms, one can raise questions concerning the exact magnitude of the fields and the temperatures of solutions during exposure. . . . Samples are often placed in fields of known strength and power density, but, due to the complex shape of vessels that hold the samples, the actual fields acting on the cells and the temperature in the sample are unknown. These unknowns make it difficult in many cases to determine whether observed effects are due specifically to the fields, or simply to a rise in temperature."

These comments are relevant to evaluating the results and conclusions of the several papers reported in this section and other sections. Michaelson (1970) made similar points with regard to evaluating studies on isolated cell systems, emphasizing that the interpretation of the biological results, e.g., cytogenetic effects, is difficult and does not necessarily lead to meaningful conclusions because of the many variables in tissue culture technique, e.g., influence of heat, viruses, chemicals, etc., that must be taken into consideration. In his most recent review, Michaelson (1978) has again emphasized the problems of interpretation of in vitro studies.

Riley (1978) reported on the application of the Guy cell-culture exposure system to neoplastic cells. Riley had previously established that differences in tumor latency periods are a linear function of the number of viable neoplastic cells injected into appropriate recipient animals. Any significant RFR-induced damage

to viable neoplastic cells is reflected as an increase in tumor latency period. Using this bioassay, Riley found no significant differences in tumor latency among 0, 500, and 1,000 V/m of 30 MHz RFR applied for 20-minute periods, with temperature of the culture medium maintained at 43 deg C by recirculating it through a constant temperature bath. (The free-space-equivalent power densities are approximately: 0; 66,000; and 270,000 microwatts/cm², respectively.)

There have been several studies on the effects of RFR on lymphocytes in cell culture. Discussions of selected examples of these studies are contained in Section C.7.8.1, p. C-60.

Changes of cell membrane permeability have also been attributed to RFR (Baranski, 1974). More recent publications (Liu, 1977; Peterson, 1978) have failed to find effects, apart from those resulting from RFR-heating. Janiak (1977) likewise reported no significant differences in the sequence and time-course of cell membrane injury between cells heated in a water bath and those heated with RFR (2,450 MHz).

Corelli (1977) investigated the effects of 2.6-4.0 GHz RFR on colony-forming-ability (CFA) and molecular structure (determined by infrared spectroscopy) of Escherichia coli B bacterial cells in aqueous suspension. Cells were exposed for 10 hours at SARs of 20 W/kg (this can be estimated to be approximately equivalent to 50,000 microwatts/cm² plane-wave exposure). No RFR-induced effects on either CFA or molecular structure were observed.

In summary, most of the results of experiments presented here on the effects of RFR on cell cultures are difficult to interpret because of questions concerning the exact magnitude of the fields and the temperatures during exposure. The available studies provide no evidence of effects other than those that can be attributed to an RFR-heating effect at levels far greater than those calculated to exist outside the PAVE PAWS exclusion fence.

C.7.11 Other Effects

Various other purportedly hazardous effects have been attributed to RFR. These effects will be considered briefly in this section.

C.7.11.1 Cancer Studies

A technical report published recently (Dwyer, 1978) by the National Institute of Occupational Safety and Health (NIOSH) reviewed the evidence in the literature concerning the possible carcinogenic properties of RFR. Only two papers in the literature cited made direct reference to carcinogenesis by RFR.

The first paper (Zaret, 1976) stated that the incidence of cardiovascular disease and cancer in the North Karelian district of Finland had increased recently. This district borders on a region of the USSR that has large radar installations forming part of that nation's missile warning system. Zaret asserted that increase in cardiovascular disease and cancer in Finland is due to the RFR from USSR installations. No documentation of the alleged increase in these diseases is given. Zaret mentioned a study of the problem sponsored by WHO, but did not cite it. Three WHO publications specifically dealing with potential hazards of RFR (WHO, 1971; WHO, 1974, Suess, 1974) made no mention of the problem in North Karelia. The statements of Zaret are not supported.

The second paper reviewed in the NIOSH document (Prausnitz, 1962 -- also cited in Sections C.7.7, p. C-60, C.7.8.4, p. C-63, and C.7.11.3, p. C-69) reported a somewhat higher percentage of leucosis in mice exposed chronically to RFR. The authors interpreted the finding to indicate a higher percentage of leukemia in the irradiated mice. Technically speaking, leucosis (more properly spelled leukosis) means an increase in the count of white blood cells over that found normally. Such a condition can occur in leukemia; it can also occur in the presence of infections or abscesses, both of which were found in the colony during the course of the experiment. Proper diagnosis of leukemia requires histopathological assessment of bone marrow, lymph node, and spleen specimens, and the methods and criteria of diagnosis used in this study are inadequately described. The increased incidence of leucosis was found among animals that died during the course of the exposure. Pathology samples from many of these animals were lost because of tissue autolysis, and the diagnostic reliability of the remaining animals is questionable. A number of mice were also sacrificed during or following the RFR exposure, and were assessed for the presence of "leucosis." Among these animals, 18 out of 87 irradiated and 5 of 29 control mice had "leucosis." The difference is statistically insignificant. Thus, even if adequate diagnostic criteria were used (which is questionable), there is no evidence that the RFR caused leukemia in the mice.

In addition to the two papers reviewed above, the NIOSH document reviews without critical comment a number of papers summarizing other biological effects of RFR, including genetic, cytogenetic, immunological and endocrine effects reviewed elsewhere in this appendix. No discussion is presented on the power density threshold aspects of these findings.

In the final paragraph, the NIOSH document states: "At present, the evidence linking RF/MW (radiofrequency/microwave) radiation to carcinogenesis is speculative and circumstantial." A more positive statement is that there is no scientific evidence at present that relates RFR to carcinogenesis.

C.7.11.2 Cardiovascular Studies

Pulsed RFR may have effects on artificial cardiac pacemakers by overriding the function signal from the heart. These effects are treated in Section D.3.2.1, p. D-78. Apart from pacemaker effects, RFR has been reported to cause bradycardia or tachycardia in a variety of experimental situations.

A report from the USSR (Gordon, 1974) stated that bradycardia could be produced by exposure of experimental animals to RFR (frequency not specified) in the power density range of 1,000-10,000 microwatts/cm². Mice, rats, rabbits, and cats were mentioned in the report, but it is not certain which species were used in the cardiovascular studies. A study in the United States (Kaplan, 1971) did not find any effects on the heart rate of rabbits from exposure to 2.4 GHz RFR at 10,000 microwatts/cm² for 20 minutes. Increasing the power density to 40,000 microwatts/cm² increased the respiration rate, and increasing it to 80,000 microwatts/cm² increased the body temperature. Only when the power density level reached 100,000 microwatts/cm² did the heart rate increase. It is likely that the increase observed at 100,000 microwatts/cm² represented a compensatory physiological adjustment to the heat load being experienced by the animals.

Other studies have been conducted on the effects of RFR on heart rate in turtles and frogs. Turtles exposed to 960 MHz radiation at 100 to 10,000 microwatts/cm² showed no effect on heart rate (Flanigan, 1977). Frogs exposed to 5 microsecond pulses of 1.25 GHz RFR that were timed by electronic feedback to coincide with the rise of the R-wave of the electrocardiogram exhibited tachycardia (Eichert, 1977), but when the pulses were timed to coincide with the T-wave the results were inconclusive. Therefore, under very precisely controlled conditions of exposure, RFR could function as a cardiac pacemaker.

From a medical viewpoint, bradycardia and tachycardia allegedly produced by RFR is only of marginal interest. The only report that we have found that claims any significant increase in cardiovascular fatalities as a result of RFR exposure is that of Zaret cited above, Section C.7.11.1, p. C-67. The lack of supporting evidence in the paper has already been noted.

C.7.11.3 General Health; Chronic Studies

Various studies have been conducted on effects of chronic, long-term exposure of animals to RFR. Because of technical problems it is very difficult to expose animals on a round-the-clock basis; hence, many of the studies have been performed by exposing the animals for some fixed duration each day. Although this design may not be completely satisfactory, it does address the question of cumulative effects of the RFR.

The study by Prausnitz (1962) has already been cited in Sections C.7.7, p. C-60, C.7.8.4, p. C-63, and C.7.11.1, p. C-68 of this EIS. The study involved exposure of mice to pulsed 9.27 GHz RFR at 100,000 microwatts/cm² average power density for 4.5 minutes per day 5 days/week for 59 weeks. Each day's exposure was equal to one-half of the acute LD₅₀ for the animals (i.e., one half of the dose that would prove lethal to 50% of animals exposed to it). Atrophy of the testes was observed in exposed mice -- not surprising in view of the power density. At the end of the 59 weeks of exposure, 50% of the control mice had died, as compared with 35% of the exposed mice, i.e., the exposed mice lived longer.

Another study (Spalding, 1971) involved exposure of mice to 800 MHz RFR at 43,000 microwatts/cm² for 2 hours/day for 5 days/week for 35 weeks. After completion of the exposure the mice were observed for the remainder of their life spans. Five of the mice died during the exposure, and these deaths were attributed to thermal effects caused by faulty positioning of the animal holders. The mean life-span of the remaining exposed mice was not significantly different from that of the controls. White blood cell (WBC) counts showed occasional, but unsystematic differences between exposed and control animals, but other parameters measured (erythrocyte count, body weight, voluntary activity) did not differ between exposed and control animals. Since WBC counts are extremely labile, the differences reported are probably insignificant.

Another study (Baum, 1976) entailed exposure of rats to electromagnetic pulses (5 pulses/sec, 447 kV/m) continuously over a period of 94 weeks. The spectrum of the pulses corresponded very approximately in its center frequency to the PAVE PAWS frequency band (420-450 MHz). There was no effect of the pulses on blood chemistry, blood count, bone marrow cellularity, fertility, embryological development, cytology, histopathology, or occurrence of cancer even after 200 million pulses.

Chronic exposure studies have also been carried out where the period of exposure and observation was more limited in time. Exposure of rats to 2.4 GHz RFR at 5,000 microwatts/cm², 1 hour/day for 90 days (Djordjevic, 1977) had no effect on hematologic parameters during or following the exposure period and no effect on body weight or histological appearance of tissues. A similar study in mice (Koessler, 1977) reported a similar absence of effect. Another study currently in progress (Chou, 1978) involves exposure of rabbits to 2.45 GHz RFR, CW or pulsed, at 1,500 microwatts/cm² average power density for 2 hours/day for 3 months. Ongoing measurements of hematological parameters, electroencephalographic patterns, and lenses of the eyes show no effects of the exposure on any of these functions.

Occasionally, chronic exposure to RFR has been associated with death of the subject animals. The cause of death is not reliably known, and its relationship to the experimental procedures is un-

certain. In one study (Shore, 1977) rats exposed in utero from day 3 through 19 of gestation to 2.45 GHz RFR at 10,000 microwatts/cm², 5 hours/day were found to have a higher neonatal mortality than unexposed animals. The authors discount the mortality data because the experiment was not designed to measure mortality. In another study (Kaplan, 1978) (also discussed in Section C.7.5.5, p. C-53), squirrel monkeys exposed to RFR in utero during the second and third trimester of pregnancy and continuing for 12 months after birth (2.45 GHz pulsed, 10,000 microwatts/cm² average power density, 3 hr/day) showed a high infant mortality (4 out of 5 animals, as compared to 0 out of 8 in controls). However, infant mortality is historically common among these animals, and the distribution of mortality over all of the different exposure level groups was only marginally significant because of the small number of animals used in each group. In a third study (Stavinoha, 1976), mice and rats were exposed to 19-MHz RFR in a near-field synthesizer for 40 min/day for 5 days. There was a selective high mortality of male mice, but not female mice. There was no selective mortality for male and female rats. Thermal heating to levels equivalent to that produced by the RFR was found to produce the same effect. Finally, a group of Polish engineers (Bem, 1976) observed a pair of sparrows that built a nest near the feedline of an operating very-high-power broadcast antenna and raised a brood of young. To conform with the Polish RFR exposure standards, authorities had located all previous human inhabitants of the area outside a 10-km radius from the antenna. No deleterious effects were observed on either the adult sparrows or the young despite exposures to fields in the kilovolts per meter range, and in the proper course of time the young sparrows matured and flew away.

C.7.11.4 Summary

In summary, there is no credible evidence that RFR causes cardiovascular disease or cancer. There is no evidence at present in the scientific literature to suggest the possibility that it could be a contributing cause to these diseases. A number of studies of chronic exposure of animals to RFR fails to show any evidence of cumulative effect of the RFR or of deleterious consequences that can realistically be attributed to the RFR on any basis other than its heating effect. Power densities sufficiently high to cause heating far exceed the densities from PAVE PAWS beyond the exclusion area.

C.8 Unresolved Issues

The potential biological effects of RFR from the PAVE PAWS facility have been assessed out of necessity from existing studies in the 10 MHz to 18 GHz range, with recognition that the negative findings reported in some studies may have been obtained because

the investigations were poorly conducted. The conclusion is that the RFR will have no perceptible biological effects on the human population in the vicinity of PAVE PAWS. The fundamental bases for this conclusion are the evidence of power density thresholds for many of the reported effects; the considerable difference between the power densities in the neighborhood of PAVE PAWS and those at which biological effects have been reported -- amounting in most cases to between 3 and 6 orders of magnitude; and the absence of reliable evidence of objective human disease in persons exposed to RFR in the past. The substantial weight of these considerations allows the conclusion of absence of bioeffects from the RFR of PAVE PAWS regardless of the problem of extrapolating experimental results from animals to humans, the point that most animal research is usually not conducted using exposures extending over most of the normal lifespan of the animal, and the inadequacy of epidemiological studies in humans.

The problem of extrapolation of experimental results from one frequency to another and from one animal species was discussed briefly in Section C.4, p. C-9. Some progress has been made in the development of theoretical models for extrapolating from one frequency to another (as discussed in Section C.6.1, p. C-15) but the present level of knowledge is inadequate for predicting precisely the biological effects of RFR in humans from studies performed in mice or other experimental animals.

A number of investigations involving chronic exposures of animals to RFR have been conducted at power densities well above the levels of general population exposure from PAVE PAWS. Similar studies in which animals are continuously exposed over most of their lifespans may provide additional information regarding effects of chronic exposure.

The existing epidemiological studies were reviewed in Section C.7.1, p. C-27. The studies were competently performed, but they are all retrospective in nature, i.e., undertaken after the occurrence of RFR exposure, and they suffer from certain inherent defects of retrospective studies, such as uncertainty about the level and duration of exposure, possible selective factors in locating members of the exposed population, and the difficulty in constructing adequate control groups. Prospective studies, in which the exposed population is identified before exposure begins, would eliminate such defects and provide a better basis for conclusions about effects of RFR on human health.

The points above remain unresolved issues in the assessment of bioeffects of RFR, though they do not affect the conclusions reached in this EIS.

C.9 PAVE PAWS and Safety to Human Populations

(This summary is fully covered in Section 3.1.2.1.9, p. 3-57.)

C.10 Other Viewpoints

(This summary is fully covered in Section 3.1.2.1.10, p. 3-60.)

C.11 References

- Abstracts, Airlie, Abstracts of Scientific Papers given at the 1977 International Symposium on the Biological Effects of Electromagnetic Waves, at Airlie, Virginia (30 October-4 November 1977).
- Abstracts, Ottawa, Abstracts of Scientific Papers given at the 1978 Symposium on Electromagnetic Fields in Biological Systems, at Ottawa, Canada (27-30 June 1978).
- Abstracts, Helsinki, Abstracts of Scientific Papers given at the Open Symposium on the Biological Effects of Electromagnetic Waves, held at the XIX General Assembly of the International Union of Radio Science in Helsinki, Finland (1-8 August 1978).
- Adey, W. R., "Introduction: Effects of Electromagnetic Radiation on the Nervous System," Ann. N.Y. Acad. Sci., Vol. 247, pp. 15-20 (1975a).
- Adey, W. R., "Evidence for Cooperative Mechanisms in the Susceptibility of Cerebral Tissue to Environmental and Intrinsic Electric Fields," in F. O. Schmitt, D. M. Schneider, and D. M. Crothers (eds.), Functional Linkage in Biomolecular Systems, Raven Press, New York, pp. 325-342 (1975b).
- Adey, W. R., "Models of Membranes of Cerebral Cells as Substrates for Information Storage," paper presented at Symposium on Memory Control Systems, Acad. Sci. USSR and Acad. Med. Sci. USSR, Leningrad (17 November 1976).
- Adey, W. R., "Progress Report -- Problem Area IV. Study of the Biological Effects of Environmental Physical Factors. Topic 1: The Effects of Nonionizing Radiation on the Central Nervous System and Behavior. Project 1: The Study of the Effects of Microwaves on Isolated Nerves, Synaptic Function and Transmission of Neural Impulses," D. I. McRee, U.S. Coordinator for Problem IV, U.S.-USSR Cooperative Program, NIEHS, North Carolina 27709 (1977a).
- Adey, W. R. and S. M. Bawin (eds.), Brain Interaction with Weak Electric and Magnetic Fields, Neurosciences Research Program Bulletin, Vol. 15, No. 1, MIT Press (1977b).
- Adey, W. R. and S. M. Bawin (eds.), "Brain Cell Surfaces in Cooperative Binding and Release of Calcium by Low Level Electromagnetic Fields," in Abstracts of Open Symposium on the Biological Effects of Electromagnetic Waves, Helsinki, Finland (1978a).

- Adey, W. R., "Experiment and Theory in Long Range Interactions of Electromagnetic Fields at Brain Cell Surfaces," in Proceedings of the Biomagnetic Effects Workshop, April 6-7, Lawrence Berkeley Laboratory, Report LBL-7452 pp. 53-75 (1978b).
- Albert, E. N. and M. DeSantis, "Do Microwaves Alter Nervous System Structure?" Ann. N.Y. Acad. Sci., Vol. 247, pp. 87-108 (1975).
- Albert, E. N. and M. DeSantis, "Histological Observations on Central Nervous System," in C. C. Johnson and M. L. Shore (eds.), Biological Effects of Electromagnetic Waves, U.S. Department of Health, Education, and Welfare, Washington, D.C., HEW Publication (FDA) 77-8010, pp. 299-310 (1976).
- Albert, E. N., L. Grau, and J. Kerns, "Morphologic Alterations in Hamster Blood-Brain Barrier After Microwave Irradiation," J. Microwave Power, Vol. 12, No. 1, pp. 43-44 (1977a).
- Albert, E. N., "Reversibility of the Blood-Brain Barrier," in Abstracts of 1977 International Symposium on the Biological Effects of Electromagnetic Waves, Airlie, Virginia (1977b).
- Allis, J. W. and M. L. Fromme, "Activity of Membrane-Bound Enzymes Exposed to Amplitude-Modulated 2,450-MHz Radiation," in Abstracts of 1977 International Symposium on the Biological Effects of Electromagnetic Waves, Airlie, Virginia (1977).
- Appleton, B., Results of Clinical Surveys for Microwave Ocular Effects, U.S. Dept. of Health, Education, and Welfare, Washington, D.C., Public Health Service report, HEW Publication (FDA) 73-8031, BRH/DBE 73-3 (February 1973).
- Aslan, E., "Broad-Band Isotropic Electromagnetic Radiation Monitor," IEEE Trans. Instr., Measurement, Vol. IM-21, pp. 421-424 (1972).
- Athey, et al., "Nonionizing Radiation Levels and Population Exposure in Urban Areas of the Eastern United States," Health Phys., Vol. 33 No. 6, p. 661 (1978).
- Babij, T. M., and H. Trzaska, "Omnidirectional Power Density Probes," Program and Abstracts of Annual Meeting of URSI, Amherst, Massachusetts (October 1976).
- Baillie, H. D., "Thermal and Nonthermal Cataractogenesis by Microwaves," presented at Symp. on Biol. Effects and Health Implications of Microwave Irradiation, Richmond, Virginia (1969a).
- Baillie, H. D., A. G. Heatons, and D. K. Pai, "The Dissipation of Microwaves as Heat in the Eye," presented at Symp. on Biol. Effects and Health Implications of Microwave Irradiation, Richmond, Virginia (1969b).

- Baranski, S., S. Szmigielski, and J. Moneta, "Effects of Microwave Irradiation In Vitro on Cell Membrane Permeability," in P. Czerski et al. (eds.), Biologic Effects and Health Hazards of Microwave Radiation, Polish Medical Publishers, Warsaw, pp. 173-177 (1974).
- Baranski, S. and P. Czerski, Biological Effects of Microwaves, Dowden, Hutchinson & Ross, Inc., Stroudsburg, Pennsylvania, p. 133 (1976).
- Bassen, H., M. Swicord, and J. Abita, "A Miniature Broad-Band Electric Field Probe," Ann. N. Y. Acad. Sci., Vol. 247, pp. 481-493, (1975).
- Bassen, H., et al., "Evaluation of an Implantable Electric-Field Probe Within Finite Simulated Tissues," Radio Science, Vol. 12, No. 6(S), pp. 15-25 (1977).
- Baum, S. J., et al., "Biological Measurements in Rodents Exposed Continuously Throughout Their Adult Life to Pulsed Electromagnetic Radiation," Health Phys., Vol. 30, pp. 161-166 (1976).
- Bawin, S. M., in Summary of the ERMAC Work Session on Nervous System and Behavioral Effects of Nonionizing Electromagnetic Radiations, Office of Telecommunications Policy, Washington, D.C. 20504 (1974).
- Bawin, S. M., L. K. Kaczmarek, and W. R. Adey, "Effects of Modulated VHF Fields on the Central Nervous System," Ann. N.Y. Acad. Sci., Vol. 247, pp. 74-81 (1975).
- Bawin, S. M., and W. R. Adey, "Interactions Between Nervous Tissue and Weak Environmental Electric Fields," in C. C. Johnson and M. Shore (eds.), Biological Effects of Electromagnetic Waves, Vol. I, pp. 323-330, U.S. Department of Health, Education, and Welfare, Washington, D.C., HEW Publication (FDA) 77-8010 (1976a).
- Bawin, S. M., and W. R. Adey, "Sensitivity of Calcium Binding in Cerebral Tissue to Weak Environmental Electric Fields Oscillating at Low Frequency," Proc. Natl. Acad. Sci., Vol. 73, No. 6, pp. 1,999-2,003 (1976b).
- Bawin, S. M., and W. R. Adey, "Calcium Binding in Cerebral Tissue," in D. G. Hazzard (ed.), Symposium on Biological Effects and Measurement of Radio Frequency/Microwaves, U.S. Department of Health, Education, and Welfare, Washington, D.C., HEW Publication (FDA) 77-8026 (1977a).
- Bawin, S. M., A. R. Sheppard, and W. R. Adey, "Models of Long-Range Order in Cerebral Macromolecules: Effects of ELF, VHF and UHF Fields in Calcium Binding," in Abstracts of 1977 International Symposium on the Biological Effects of Electromagnetic Waves, Airlie, Virginia (1977b).

- Bawin, S. M. et al., "Electromagnetic Radiation and Biological Systems," Final Report, U.S. Public Health Services Grant 1 R01 FD-678-03, Brain Research Institute, University of California, Los Angeles, CA (1977c).
- Bawin, S. M., A. R. Sheppard, and W. R. Adey, "Possible Mechanisms of Weak Electromagnetic Field Coupling in Brain Tissue," Bioelectrochem. Bioenergetics, Vol. 5, pp. 67-76 (1978a).
- Bawin, S. M. et al., "Ionic Factors in Release of $^{45}\text{Ca}^{2+}$ from Chicken Cerebral Tissue by Electromagnetic Fields," Proc. Nat. Acad. Sci., Vol. 75, pp. 6314-6318 (1978b)
- Belsher, D. R., Development of Near-Field Electric Energy Density Meter Model EDM-2, HEW Publication (NIOSH) 75-140, (1975).
- Bem, D. J., and H. Trzaska, "The Insouciant Sparrows of Constantinov: A Case Study of Electromagnetic Ethology," in C. C. Johnson and M. Shore (eds.), Biological Effects of Electromagnetic Waves, U.S. Department of Health, Education, and Welfare, Washington D.C., HEW Publication (FDA) 77-8010 (1976).
- Berman, E., and H. B. Carter, "Mutagenic and Reproductive Tests in Male Rats Exposed to 425 or 2,450 MHz (CW) Microwaves," in Abstracts of Open Symposium on the Biological Effects of Electromagnetic Waves, Helsinki, Finland (1978a).
- Berman, E., J. B. Kinn, and H. B. Carter, "Observations of Mouse Fetuses after irradiation with 2.45 GHz Microwave," Health Phys., in Vol. 35, pp. 791-801 (1978b).
- Bigu-Del-Blanco, J., J. M. Bristow, and C. Romero-Sierra, "Effects of Low-Level Microwave Radiation on Germination and Growth Rate in Corn Seeds," Proc. IEEE, Vol. 65, pp. 1,086-1,088 (1977).
- Birenbaum, L., G. M. Groszof, S. W. Rosenthal, and M. M. Zaret, "Effect of Microwaves on the Eye," IEEE Trans BME, Vol. 16, pp. 7-14 (1969).
- Blackman, C. F., et al., "Two Parameters Affecting Radiation-Induced Calcium Efflux from Brain Tissue," in Abstracts of 1977 International Symposium on the Biological Effects of Electromagnetic Waves, Airlie, Virginia (1977).
- Blackman, C. F., et al., "The Effect of Microwave Exposure on Bacteria Mutation Induction," in C. C. Johnson and M. Shore (eds.), Biological Effects of Electromagnetic Waves, U.S. Department of Health, Education, and Welfare, Washington, D.C., HEW Publication (FDA) 77-8010 (1976).

- Bowman, R. R., "Some Recent Developments in the Characterization and Measurement of Hazardous Electromagnetic Fields," in P. Czerski et al. (eds.), Biologic Effects and Health Hazards of Microwave Radiation, Polish Medical Publishers, Warsaw, pp. 67-74 (1974).
- Brauer, I., "Experimentelle Untersuchungen über die Wirkung von Materwellen Verschiedener Feldstärke auf das Teilungswachstum der Pflanzen," Chromosoma, Vol. 3, pp. 483-509 (1949).
- Burdeshaw, J. A. and S. Schaffer, Factors Associated with the Incidence of Congenital Anomalies: A Localized Investigation, Final Report, Report No. XXIII, May 24, 1973-March 31, 1976, EPA 600/1-77-016 (March 1977).
- Cain, C. A. and W. J. Rissman, "Microwave Hearing in Mammals at 3.0 GHz," in C. C. Johnson and M. Shore (eds.), Biological Effects of Electromagnetic Waves, Vol. I, pp. 79-88, U.S. Department of Health, Education, and Welfare, Washington, D.C., HEW Publication (FDA) 77-8010 (1976).
- Cain, C. A. and W. J. Rissman, "Mammalian Auditory Responses to 3.0 GHz Microwave Pulses," IEEE Trans. Biomed. Eng., Vol. BME-25, No. 3, pp. 288-293 (1978).
- Carley, A. L., Some Effects of 3,300 MHz Microwaves on Oxygen Uptake in Germinating Peas. Ph.D dissertation, University of Wisconsin, Milwaukee (1976). Available from Xerox Univ. Microfilms, Ann Arbor, Michigan 48106, Order No. 77-15,989.
- Carpenter, R. L., "Microwave Radiation," in D. H. K. Lee (ed.), Handbook of Physiology (Section 9: "Reactions to Environmental Agents"), American Physiological Society, Bethesda, Maryland, pp. 111-125 (1977).
- Chang, B. K., et al., "The Effect of Microwave Radiation (1.0 GHz) on the Blood-Brain Barrier in Dogs," Abstracts of Open Symposium on Biological Effects of Electromagnetic Waves, Helsinki, Finland (1978).
- Chen, K. M., A. Samuel, and R. Hoopingarner, "Chromosomal Aberrations of Living Cells induced by Microwave Radiation," Envir. Lett., Vol. 6, pp. 37-46 (1974).
- Chernovetz, M. E., et al., "Teratology, Survival, and Reversal Learning After Fetal Irradiation of Mice by 2,450 MHz Microwave Energy," J. Microwave Power, Vol. 10, pp. 391-409 (1975).
- Chou, C. K. and A. W. Guy, "Threshold Energy for Hearing Microwave Pulses of 10- to 500-Microseconds Duration," in Abstracts of 1977 International Symposium on the Biological Effects of Electromagnetic Waves, Airlie, Virginia (1977).

- Chou, C. K. and R. Galambos, "Middle-Ear Impairment and Microwave Hearing," in Abstracts of 1977 International Symposium on the Biological Effects of Electromagnetic Waves, Airlie, Virginia (1977).
- Chou, C. K., et al., "Effects of Continuous and Pulsed Chronic Microwave Radiation on Rabbits," in Abstracts of Open Symposium on the Biological Effects of Electromagnetic Waves, Helsinki, Finland (1978).
- Cleary, S. F., "Uncertainties in the Evaluation of the Biological Effects of Microwave and Radiofrequency Radiation," Health Physics, Vol. 25, pp. 387-404 (1973).
- Cleary, S. F., "Biological Effects of Microwave and Radiofrequency Radiation," CRC Critical Reviews in Environmental Control, Vol. 8, pp. 121-166 (1977).
- Cogan, D. G., et al., "Cataracts and Ultrahigh Frequency Radiation," AMA Arch. Ind. Health, Vol. 18, pp. 299-302 (1958).
- Cohen, B. H., et al., "Parental Factors in Down's Syndrome -- Results of the Second Baltimore Case-Control Study," in E. B. Hook and I. M. Porter (eds.), Population Genetics Studies in Humans, Academic Press, New York, pp. 301-331 (1977).
- Cook, H. F., "Dielectric Behavior of Some Types of Human Tissues at Microwave Frequencies," Brit. J. Appl. Phys., Vol. 2, pp. 295-300 (1951).
- Cook, H. F., "A Comparison of Dielectric Behavior of Pure Water and Human Blood at Microwave Frequencies," Brit. J. Appl. Phys., Vol. 3, pp. 249-255 (1952).
- Corelli, J. C., et al., "Effects of 2.6-4.0 GHz Microwave Radiation on E-Coli B," J. Microwave Power, Vol. 12, No. 2, pp. 141-144 (1977).
- Czerski, P., et al., (eds.), Biologic Effects and Health Hazards of Microwave Radiation, proceedings of an International Symposium in Warsaw on October 15-18, 1973, sponsored by WHO, DHEW, and the Scientific Council to the Minister of Health and Social Welfare, Poland, Polish Medical Publishers, Warsaw (1974a).
- Czerski, P., et al., "Influence of Microwave Radiation on the Hemopoietic System," in P. Czerski et al. (eds.), Biologic Effects and Health Hazards of Microwave Radiation, Polish Medical Publishers, Warsaw, pp. 67-74 (1974b).
- Czerski, P., "Microwave Effects on the Blood-Forming System With Particular Reference to the Lymphocyte," Ann. N.Y. Acad. Sci., Vol. 247, pp. 232-242 (1975).

- Daily, L., et al., "The Effects of Microwave Diathermy on the Eye of the Rabbit," Am J. Ophthalmol., Vol. 35, pp. 1,001-1,017 (1952).
- d'Ambrosio, G., "Perception of Static Fields by Living Organisms and Teratogenic Effects of Microwaves," Proc. of Second Electromagnetic Compatibility Symposium and Exhibition, sponsored by EUREL, URSI, EMC Gp, Inc, Montreux, Switzerland, pp. 447-482 (1977).
- D'Andrea, J. A., O. P. Gandhi, and J. L. Lords, "Behavioral and Thermal Effects of Microwave Radiation at Resonant and Non-resonant Wave Lengths," Radio Sci., Vol. 12, No. 6(S), pp. 251-256 (1977).
- Dardalhon, M., A. J. Berteaud, and C. Auerbeck, "Microwave Effects in Drosophila melanogaster," in Abstracts of 1977 International Symposium on the Biological Effects of Electromagnetic Waves, Airlie, Virginia (1977).
- Deficis, A., et al., "A Comparative Study of the Action of Two Types of Microwave Irradiation on Lipid Metabolism in Mice," in Abstracts of 1977 International Symposium on the Biological Effects of Electromagnetic Waves, Airlie, Virginia (1977).
- de Lorge, J., Operant Behavior and Colonic Temperature of Squirrel Monkeys (Saimiri sciureus) During Microwave Irradiation, Naval Aerospace Medical Res. Lab, Pensacola, Florida 32508 (1977). Available from NTIS, Springfield, Virginia 22161, #AD A043706.
- Deschaux, P. and J. P. Pelissier, "Effect of Microwaves on Steroids Plasma Level in Male Rats," J. Microwave Power, Vol. 12, pp. 46-47 (1977).
- Dietzel, F., "Effects of Electromagnetic Radiation on Implantation and Intrauterine Development of the Rat," Ann. N.Y. Acad. Sci., Vol. 247, pp. 367-376 (1975).
- Djordjevic, Z., N. Lazarevic, and V. Djokovic, "Studies on the Hematologic Effects of Long-term, Low-dose Microwave Exposure," Aviat., Space, and Envir. Med., Vol. 48, pp. 516-518 (1977).
- Dodge, C. H. and Z. R. Glaser, "Trends in Nonionizing Electromagnetic Radiation Bioeffects Research and Related Occupational Health Aspects," J. Microwave Power, Vol. 12, No. 4, pp. 319-334 (1977).
- Dumanskij, J. D. and M. G. Shandala, "The Biologic Action and Hygienic Significance of Electromagnetic Fields of Superhigh and Ultrahigh Frequencies in Densely Populated Areas," in P. Czerski et al. (eds.), Biologic Effects and Health Hazards of Microwave Radiation, Polish Medical Publishers, Warsaw, pp. 67-74 (1974).

- Durney, C. H. et al., Radiofrequency Radiation Dosimetry Handbook (ed. 2), USAF School of Aerospace Medicine, Brooks AFB, Texas; Report SAM-TR-78-22 (1978).
- Dwyer, M. J., Carcinogenic Properties of Ionizing and Nonionizing Radiation, Vol. II: Microwave and Radiofrequency Radiation, U.S. Department of Health, Education, and Welfare, HEW Publication (NIOSH) 78-134 (March 1978).
- Eichert, E.S. and A. H. Frey, "Heart Rate Modification in Vivo From Irradiation by Electromagnetic Energy," in Abstracts of 1977 International Symposium on the Biological Effects of Electromagnetic Waves, Airlie, Virginia (1977).
- Elder, J. et al., "A Coaxial Air Line Microwave Exposure System: Respiratory Activity of Mitochondria Irradiated at 2-4 GHz," in C. C. Johnson and M. Shore (eds.), Biological Effects of Electromagnetic Waves, U.S. Department of Health, Education, and Welfare, Washington, D.C., HEW Publication (FDA) 77-8010 (1976).
- Ferri, E. S. and M. E. G. Foti, "Cataractogenic Response of Rabbits to Pulsed Microwaves of High-Peak Low-Average Power," in Abstracts of 1977 International Symposium on the Biological Effects of Electromagnetic Waves, Airlie, Virginia (1977).
- Fisher, P., J. K. Lauber, and W. A. Voss, "Effects of Chronic Exposure to Microwaves at Low Power Densities on the Mass and Cranial Size of Developing Chicken Embryos," in Abstracts of 1977 International Symposium on the Biological Effects of Electromagnetic Waves, Airlie, Virginia (1977).
- Flanigan, W. F., W. R. Lowell, and R. L. Seely, "Absence of ECG and Respiratory Changes in Turtles and Tortoises Exposed to Microwave Fields of Low Density," in Abstracts of 1977 International Symposium on the Biological Effects of Electromagnetic Waves, Airlie, Virginia (1977).
- Foster, K. R. and E. D. Finch, "Microwave Hearing: Evidence for Thermoacoustic Auditory Stimulation of Pulsed Microwaves," Science, Vol. 185, pp. 256-258 (1974).
- Franklin Institute, Biological Effects of Nonionizing Electromagnetic Radiation (Series), Franklin Institute Research Laboratories, Philadelphia, Pennsylvania (1978).
- Frey, A. H., "Auditory System Response to Radio-Frequency Energy," Aerospace Med., Vol. 32, pp. 1,140-1,142 (1961).
- Frey, et al., "A Coaxial Pathway for Recording from the Cat Brain During Illumination with UHF Energy," Physiol. and Behav., Vol. 3, pp. 263-364 (1968).

- Frey, A. H., "Behavioral Effects of Electromagnetic Energy," in D. G. Hazzard (ed.), Symposium on Biological Effects and Measurement of Radio Frequency/ Microwaves, U.S. Department of Health, Education, and Welfare, Washington, D.C., HEW Publication (FDA) 77-8026 (1977).
- Frey, A. H., S. R. Feld, and B. Frey, "Neural Function and Behavior: Defining the Relationship," Ann. N.Y. Acad. Sci., Vol. 247, pp. 433-439 (1975).
- Frohlich, H., "Evidence for Bose Condensation-Like Excitation of Coherent Modes in Biological Systems," Phys. Lett., Vol. 51A, pp. 21-22 (1975a).
- Frohlich, H., "The Extraordinary Dielectric Properties of Biological Materials and the Action of Enzymes," Proc. Nat. Acad. Sci., Vol. 72, pp. 4211-4215 (1975b).
- Gabovich, R. D., et al., "Metabolism and Distribution in the Organs of Iron, Copper, Molybdenum, Manganese, and Nickel Under the Effect of Electromagnetic Fields of Industrial and Superhigh Frequency," Gig. Sanit., Vol. 7, pp. 26-33 (1977).
- Gage, M., The Study of the Effects of Microwaves on Behavior of Animals, Their Conditioned Reflex Activity, and on Chemical, Cytochemical, and Immunological Properties of Blood, Progr. Rept. on Proj. 3, Topic 4.1 of the U.S./USSR Cooperative Program, D. McRee (Coordinator), NIEHS, Research Triangle Park, North Carolina (1976).
- Galloway, W. D., The Study of the Effects of Microwaves on Behavior of Animals, Their Conditioned Reflex Activity, and on Chemical, Cytochemical, and Immunological Properties of Blood, Progr. Rept. on Proj. 3, Topic 4.1 of the U.S./USSR Cooperative Program, D. McRee (Coordinator), NIEHS, Research Triangle Park, North Carolina (1976).
- Gandhi, O. P., "Conditions of Strongest Electromagnetic Power Deposition in Man and Animals," IEEE Trans. Microwave Theory and Techn., Vol. MTT-23, pp. 1,021-1,029 (1975).
- Gandhi, O. P., E. L. Hunt, and A. D. D'Andrea, "Deposition of Electromagnetic Energy in Animals and in Models of Man With and Without Grounding and Reflector Effects," Radio Science, Vol. 12, pp. 39-47 (1977).
- Gillard, J., et al., "Study of the Microwave-Induced Perturbations of the Behavior by the Open-Field Test in the White Rat," in C. C. Johnson and M. Shore (eds.), Biological Effects of Electromagnetic Waves, U.S. Department of Health, Education, and Welfare, Washington, D.C., HEW Publication (FDA) 77-8010 (1975).

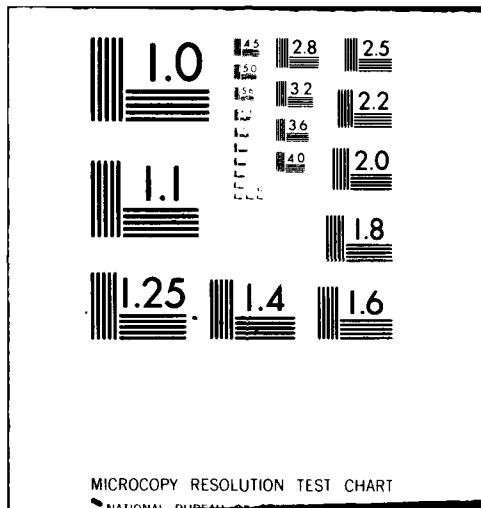

MICROCOPY RESOLUTION TEST CHART

NATIONAL BUREAU OF STANDARDS-1963-A

- Glaser, Z. R., P. F. Brown, and M. S. Brown, Bibliography of Reported Biological Phenomena ("Effects") and Clinical Manifestations Attributed to Microwave and Radio-Frequency Radiation: Compilation and Integration of Report and Seven Supplements, Naval Medical Research and Development Command, Bethesda, Maryland (September 1976). Supersedes AD No. 734-391, No. 750-271, No. 770-621, No. 784-007, No. A015-622, and No. A-25-354.
- Glaser, Z. R., et al., Bibliography of Reported Biological Phenomena ("Effects") and Clinical Manifestations Attributed to Microwave and Radio-Frequency Radiation -- Ninth Supplement to Bibliography of Microwave and RF Biologic Effects, U.S. Department of Health, Education, and Welfare, Cincinnati, Ohio, HEW Publication (NIOSH) 78-126 (November 1977).
- Goldstein, L. and Z. Cisko, "A Quantitative Electroencephalographic Study of the Acute Effects of X-Band Microwaves in Rabbits," in P. Czerski et al. (eds.), Biologic Effects and Health Hazards of Microwave Radiation, Polish Medical Publishers, Warsaw, pp. 67-74 (1974).
- Gordon, Z. V., A. V. Roscin, and M. S. Byckov, "Main Directions and Results of Research Conducted in the USSR on the Biologic Effects of Microwaves," in P. Czerski et al. (eds.), Biologic Effects and Health Hazards of Microwave Radiation, Polish Medical Publishers, Warsaw (1974).
- Green, D. R., F. J. Rosenbaum, and W. F. Pickard, "Biological Effects of Microwaves on the Pupae of Tenebrio molitor," in D. G. Hazzard (ed.), Symposium on Biological Effects and Measurement of Radio Frequency/Microwaves, pp. 11-12, U.S. Department of Health, Education, and Welfare, Washington, D.C., HEW Publication (FDA) 77-8026 (1977).
- Greene, F. M., "Development of Magnetic Near-Field Probes," U.S. Department of Health, Education, and Welfare, Washington, D.C., HEW Publication (NIOSH) 75-140 (1975).
- Grodsky, I. T., "Neuronal Membrane: A Physical Synthesis," Math. Bio. Sci., Vol. 28, pp. 191-219 (1976).
- Grunewald, R. and A. L. Carley, "Some Effects of 3,300 MHz Microwaves on Oxygen Uptake in Germinating Peas," Health Phys., Vol. 33, p. 662 (1978).
- Guy, A. W., et al., Quantitation of Microwave Radiation Effects on the Eyes of Rabbits at 2,450 MHz and 918 MHz, University of Washington Scientific Report No. 2, Seattle, Washington (1974).

- Guy, A. W., M. D. Webb, and C. C. Sorensen, "Determination of Power Absorption in Man Exposed to High Frequency Electromagnetic Fields by Thermographic Measurements on Scale Models," IEEE Trans. Biomed. Eng., Vol. 23, pp. 361-371 (1976a).
- Guy, A. W., D. I. McRee, and F. McConnell, The Study of the Effects of Microwaves on Behavior of Animals, Their Conditioned Reflex Activity, and on Chemical, Cytochemical, and Immunological Properties of Blood, Progr. Rept. on Proj. 3, Topic 4.1 of the U.S./USSR Cooperative Program, D. McRee (Coordinator), NIEHS, Research Triangle Park, North Carolina (1976b).
- Guy, A. W., "A Method for Exposing Cell Cultures to Electromagnetic Fields Under Controlled Conditions of Temperature and Field Strength," Radio Science, Vol. 12, No. 6(S), pp. 87-96 (1977).
- Harrick, P. E., et al., "Humoral Immunity of Japanese Quail Subjected to Microwave Radiation During Embryogeny," Health Phys., Vol. 33, pp. 23-33 (1977).
- Harte, C., "Mutagenesis by Radiowaves in Antirrhinum majus L.," Mutation Res., Vol. 29, pp. 71-75 (1975).
- Hazzard, D. G. (ed.), Symposium on Biological Effects and Measurement of Radio Frequency Microwaves, Proceedings of a Conference held in Rockville, Maryland on February 16-18, 1977. U.S. Department of Health, Education, and Welfare, Washington, D.C., HEW Publication (FDA) 77-8026 (July 1977).
- Heller, J. H. and A. A. Teixeira-Pinto, "A New Physical Method of Creating Chromosomal Aberrations," Nature, Vol. 183, pp. 905-906 (1959).
- Ho, H. S. and W. P. Edwards, "Dose Rate and Oxygen Consumption Rate in Mice Confined in a Small Holder During Exposure to 2,450 MHz Microwave Radiation," Radiat. Environ. Biophys., Vol. 14, pp. 251-256 (1977).
- Horne, R. A., "Biological Effects of Chemical Agents," Science, Vol. 177, pp. 1,152-1,153 (1972).

- Hunt, E. L. and R. D. Phillips, "Absolute Physical Dosimetry for Whole Animal Experiments," Digest of Papers of the Microwave Density Workshop, Atlanta, Georgia, June 1-2, 1972, sponsored by Department of Microwave Research, Walter Reed Army Institute of Research (1972).
- Hunt, E. L., N. W. King, and R. D. Phillips, "Behavioral Effects of Pulsed Microwave Radiation," Ann. N.Y. Acad. Sci., Vol. 247, pp. 440-453 (1975).
- Janiak, M., and S. Szmigielski, "Injury of Cell Membranes in Normal and SV40-Virus Transformed Fibroblasts Exposed In Vitro to Microwave (2,450 MHz) or Water-Bath Hyperthermia (43 deg C)," in Abstracts of 1977 International Symposium on the Biological Effects of Electromagnetic Waves, Airlie, Virginia (1977).
- Janes, D. E., et al., "Radio-Frequency Radiation Levels in Urban Areas," Radio Science, Vol. 12, No. 6(S), pp. 49-56 (1977).
- Johnson, C. C. and A. W. Guy, "Nonionizing Electromagnetic Wave Effects in Biological Materials and Systems," Proc. IEEE, Vol. 60, pp. 692-718 (1972).
- Johnson, C. C., et al., "Fiberoptic Liquid Crystal Probe for Absorbed Radio-Frequency Power Temperature Measurement in Tissue During Irradiation," Ann. N.Y. Acad. Sci., Vol. 247, pp. 527-531 (1975).
- Johnson, C. C. and M. L. Shore (eds.), Biological Effects of Electromagnetic Waves -- Selected Papers of the USNC/URSI Annual Meeting at Boulder, Colorado, October 20-23, 1975, Vols. I and II, U.S. Department of Health, Education, and Welfare, Bureau of Radiological Health, Rockville, Maryland, HEW Publication (FDA) 77-8010 and 77-8011 (1976).
- Joines, W. T. and R. J. Spiegel, "Resonance Absorption of Microwaves by Human Skull," IEEE Trans. Biomed. Eng., Vol. BME-21, pp. 46-48 (1974).
- Justesen, D. R. and A. W. Guy (eds.), "Special Issue: Biological Effects of Electromagnetic Radiation," Radio Science, Vol. 12, No. 6(S), (1977).
- Kalyada, T. V., P. P. Fukolova, and N. N. Goncarova, "Biologic Effects of Radiation in the 30-300 MHz Range," in P. Czernski et al. (eds.), Biologic Effects and Health Hazards of Microwave Radiation, Polish Medical Publishers, Warsaw, pp. 67-74 (1974).
- Kaplan, I. T. et al., "Absence of Heart-Rate Effects in Rabbits During Low-Level Microwave Irradiation," IEEE Trans. Microwave Theor. Tech. MTT-19(2), pp. 74-80 (1971).

- Kaplan, J., et al., "Biological and Behavioral Effects of Pre- and Postnatal Exposure to 2,450-MHz Electromagnetic Radiation in the Squirrel Monkey," Abstracts of Open Symposium on the Biological Effects of Electromagnetic Waves, Helsinki, Finland (1978).
- Kinn, J. B., "Whole Body Dosimetry of Microwave Radiation in Small Animals: The Effect of Body Mass and Exposure Geometry," Radio Science, Vol. 12, No. 6(S), pp. 61-64 (1977).
- Klimkova-Deutsova, E., "Neurological Findings in Persons Exposed to Microwaves," in P. Czernski et al. (eds.), Biologic Effects and Health Hazards of Microwave Radiation, Polish Medical Publishers, Warsaw, pp. 268-272 (1974).
- Koessler, F., et al., "Physiological and Biochemical Parameters Following Two Long-Term Exposures of Mice to Microwave Fields," meeting abstract, Z. Gesamte Hyg., Vol. 23, p. 250 (1977).
- Kramer, P. O., et al., "The Ocular Effects of Microwaves on Hypothermic Rabbits: a Study of Microwave Cataractogenic Mechanisms," Ann. N.Y. Acad. Sci., Vol 247, pp 155-163 (1975).
- Krey, A. K., "Microwave Relaxation Effects of Nucleic Acids and Nucleotides," meeting abstract, Biophys. J., Vol. 21, p. 112a (1978).
- Kritikos, H. N. and H. P. Schwan, "The Distribution of Heating Potential Inside Lossy Spheres," IEEE Trans. on Biomed. Eng., Vol. BME-22, pp. 457-463 (1975).
- Kritikos, H. N. and H. P. Schwan, "Formation of Hot Spots in Multilayer Spheres," IEEE Trans. Biomed. Eng., Vol. 22, pp. 168-172 (1976).
- Krupp, J. H., "The Relationship of Thermal Stress to Immune-System Response in Mice Exposed to 2.6 GHz Radio-Frequency Radiation," in Abstracts of 1977 International Symposium on the Biological Effects of Electromagnetic Waves, Airlie, Virginia (1977).
- Lancranjan, I., et al., "Gonadic Function in Workmen With Long-Term Exposure to Microwaves," Health Phys., Vol. 29, pp. 381-385 (1975).
- Lebovitz, R. M. and R. L. Seaman, "Vestibulo-Cochlear Single Unit Responses to Microwave Radiation," in D. G. Hazzard (ed.), Symposium on Biological Effects and Measurement of Radio Frequency/Microwaves, U.S. Department of Health, Education, and Welfare, Washington, D.C., HEW Publication (FDA) 77-8026 (1977a).

- Lebovitz, R. M. and R. L. Seaman, "Eighth-Nerve Derived, Single-Neuron Responses to Acute Microwave Radiation of the Head," in Abstracts of 1977 International Symposium on the Biological Effects of Electromagnetic Waves, Airlie, Virginia (1977b).
- Lilienfeld, A. M., et al., "Foreign Service Health Status Study: Evaluation of Health Status of Foreign Service and Other Employees from Selected Eastern European Posts," Final Report, July 31, 1978, Contract No. 6025-619073, Dept. of Epidemiology, School of Hygiene and Public Health, The Johns Hopkins University, Baltimore, MD (1978).
- Lin, J. C., "Microwave Properties of Fresh Mammalian Brain Tissues at Body Temperature," IEEE Trans. Biomed. Eng., Vol. 22, pp. 74-76 (1975).
- Lin, J. C., "Further Studies on the Microwave Auditory Effect," IEEE Trans. MTT, Vol. 25, No. 11, pp. 938-943 (1977a).
- Lin, J. C., "Theoretical Calculations of Frequencies and Thresholds of Microwave-Induced Auditory Signals," Radio Science, Vol. 12, No. 6(S), pp. 237-242 (1977b).
- Lin, J. C., A. W. Guy, and L. R. Caldwell, "Thermographic and Behavioral Studies of Rats in the Near Field of 918-MHz Radiations," IEEE Trans. Microwave Theory Techniques, Vol. 25, pp. 833-836 (1977c).
- Lin, J. C., "Microwave Biophysics," in M.A. Stuchly (ed.), Microwave Bioeffects and Radiation Safety, Trans. IMPI, Vol. 8, The International Microwave Power Institute, Edmonton, Alberta, Canada, pp. 15-54 (1978).
- Liu, L-M., and S. F. Cleary, "Effects of Microwave Radiation on Erythrocyte Membranes," in Abstracts of 1977 International Symposium on the Biological Effects of Electromagnetic Waves. Airlie, Virginia (1977).
- Livinston, G. K., C. C. Johnson, and L. A. Dethlefsen, "Comparative Effects of Water Bath and Microwave-Induced Hyperthermia on Cell Survival and Sister Chromatid Exchange in Chinese Hamster Ovary Cells," in Abstracts of 1977 International Symposium on the Biological Effects of Electromagnetic Waves, Airlie, Virginia (1977).
- Lobanova, E. A., "The Use of Conditioned Reflexes to Study Microwave Effects on the Central Nervous System," in P. Czerski et al. (eds.), Biologic Effects and Health Hazards of Microwave Radiation, Polish Medical Publishers, Warsaw, pp. 67-74 (1974).

- Lotz, W. G., Stimulation of the Adrenal Axis in the Microwave Exposed Rat, Ph.D dissertation, University of Rochester (1976). Available from Xerox Univ. Microfilms, Ann Arbor, Michigan, 48106, Order No. 77-25,571.
- Lotz, W. G. and S. M. Michaelson, "Effects of Hypophysectomy and Dexamethasone on the Rat's Adrenal Response to Microwave Irradiation," in Abstracts of 1977 International Symposium on the Biological Effects of Electromagnetic Waves, Airlie, Virginia (1977a).
- Lotz, W. G., S. M. Michaelson, and N. J. Lebeda, "Growth Hormone Levels of Rats Exposed to 2,450-MHz (CW) Microwaves," in Abstracts of 1977 International Symposium on the Biological Effects of Electromagnetic Waves, Airlie, Virginia (1977b).
- Lowrance, W. W., Of Acceptable Risk: Science and the Determination of Safety, William Kaufmann, Inc., Los Altos (1976).
- Lu, S-T., N. Lebeda, and S. M. Michaelson, "Effects of Microwave Radiation on the Rat's Pituitary-Thyroid Axis," in Abstracts of 1977 International Symposium on the Biological Effects of Electromagnetic Waves, Airlie, Virginia (1977).
- Magin, R. L., S-T. Lu, and S. M. Michaelson, "Stimulation of Dog Thyroid by Local Application of High Intensity Microwaves," Am. J. Physiol., Vol. 233, pp. E363-E368 (1977a).
- Magin, R. L., S-T. Lu, and S. M. Michaelson, "Microwave Heating Effect on the Dog Thyroid," IEEE Trans Biomed. Eng., Vol. 24, pp. 522-529 (1977b).
- McConnell, D. R., "Editorial Introduction," J. Microwave Power, Vol. 13, No. 1, p.1 (1978).
- McRee, D. I. and P. E. Hamrick, "Exposure of Japanese Quail Embryos to 2.45 GHz Microwave Radiation During Development," Radiat. Res., Vol. 71, pp. 355-366 (1977).
- McRee, D., (Chairman), "A Technical Review of the Biological Effects of Non-Ionizing Radiation," Report to the Office of Science and Technology Policy by ad hoc Working Group (Draft) (15 May, 1978).
- Merritt, J. H., "Studies of Blood-Brain Barrier Permeability After Microwave Radiation," in Abstracts of 1977 International Symposium on Biological Effects of Electromagnetic Waves, Airlie, Virginia (1977).
- Michaelson, S. M., "Effects of 2,450 MHz Microwave Radiation on Cultivated Rat Kangaroo Cells" (discussion section following the paper), in S. F. Clearly (ed.), Biological Effects and Health Implications of Microwave Radiation, HEW Publication Number BRH/DBE 70-2, p. 133 (1970).

Michaelson, S. M., et al., "Biochemical and Neuroendocrine Aspects of Exposure to Microwaves," Ann. N.Y. Acad. Sci., Vol. 247, pp. 21-45 (1975).

Michaelson, S. M., "Biologic and Pathophysiologic Effects of Exposure to Microwaves," in M. A. Stuchly (ed.) Microwave Bioeffects and Radiation Safety, Trans. IMPI, Vol. 8, The International Microwave Power Institute, Edmonton, Alberta, Canada, pp. 55-94 (1978).

Mickey, G. H., J. H. Heller, and E. Snyder, Non-thermal Hazards of Exposure to Radio-Frequency Fields, "Microwave Studies, Office of Naval Research Contract No. N0014-69-C-0176 Final Report (July 1975).

Mikolajczyk, H. J., "Microwave Irradiation and Endocrine Functions," in P. Czerski et al. (eds.), Biologic Effects and Health Hazards of Microwave Radiation, Polish Medical Publishers, Warsaw, pp. 46-51 (1974).

Mikolajczyk, H. J., "Microwave-Induced Shifts of Gonadotropic Activity in Anterior Pituitary Gland of Rats," in C. C. Johnson and M. Shore (eds.), Biological Effects of Electromagnetic Waves, U.S. Department of Health, Education, and Welfare, Washington, D.C., HEW Publication (FDA) 77-8010 (1976).

Milroy, W. C. and S. M. Michaelson, "Microwave Cataractogenesis: A Critical Review of the Literature," Aerospace Medicine, Vol. 43, No. 1, pp. 67-75 (1972).

Mitchell, D. S., W. G. Switzer, and E. L. Bronaugh, "Hyperactivity and Disruption of Operant Behavior in Rats After Multiple Exposures to Microwave Radiation," Radio Sci., Vol. 12, No. 6(S), pp. 263-271 (1977).

Monahan, J. C. and W. W. Henton, "Free-Operant Avoidance and Escape from Microwave Radiation," in D. G. Hazzard (ed.), Symposium on Biological Effects and Measurement of Radio Frequency/Microwaves, U.S. Department of Health, Education, and Welfare, Washington, D.C., HEW Publication (FDA) 77-8026 (1977a).

Monahan, J. C. and W. W. Henton, "Microwave Absorption and Taste Aversion as a Function of 915 MHz Radiation," in D. G. Hazzard (ed.), Symposium on Biological Effects and Measurement of Radio Frequency/ Microwaves, U.S. Department of Health, Education, and Welfare, Washington, D.C., HEW Publication (FDA) 77-8026 (1977b).

Monahan, J. C. and W. W. Henton, "Behavioral Stimulus Properties of Microwave Radiation," in Abstracts of Open Symposium on the Biological Effects of Electromagnetic Waves, Helsinki, Finland (1978).

NAS, "Analysis of the Exposure Levels and Potential Biologic Effects of the PAVE PAWS Radar System," National Academy of Sciences, Washington, DC (1979).

Neuder, S. M. et al., "Microwave Power Density Absorption in a Spherical Multilayered Model of the Head," in C. C. Johnson and M. Shore (eds.), Biological Effects of Electromagnetic Waves, Department of Health, Education, and Welfare, Washington, D.C., HEW Publication (FDA) 77-8011, pp. 199-210 (1976).

North Atlantic Treaty Organization, "Radiation Hazards," AGARD-LS-78, presented at a lecture series in The Netherlands (September 22-23, 1975), Germany (September 25-26, 1975), and in Norway (September 29-30, 1975), North Atlantic Treaty Organisation Advisory Group for Aerospace Research and Development, Neuilly sur Seine, France (ADA015200) (August 1975).

Olsen, R. G., and W. C. Hammer, "Thermographic Analysis of Waveguide-Irradiated Insect Pupae," in Abstracts of Open Symposium on the Biological Effects of Electromagnetic Waves, Helsinki, Finland (1978).

Oscar, K. J. and T. D. Hawkins, "Microwave Alteration of the Blood-Brain Barrier System of Rats," Brain Res., Vol. 126, pp. 281-293 (1977a).

Oscar, K. J., "Determinants of Brain Uptake," in Abstracts of 1977 International Symposium on the Biological Effects of Electromagnetic Waves, Airlie, Virginia (1977b).

Pautrizel, R., et al., "Stimulation of the Defenses of Mice with Trypanosomiasis by Exposure to Radiation Associated with a Magnetic Field and Electromagnetic Waves," Compt. Rend. D., Vol. 280, pp. 1,915-1,918 (1975).

Pazderova, J., "Workers' State of Health under Long-Term Exposure to Electromagnetic Radiation in the VHF Band (30-300 MHz)," Pracovni Lekarstvi (Czech), Vol. 23, No. 8, pp. 265-271 (October 1971). English Translation: JPRS No. UDC 616-001.228.1-057-07 (1971).

Pazderova, J., J. Pickova, and V. Bryndova, "Blood Proteins in Personnel of Television and Radio Transmitting Stations," in P. Czernski et al. (eds.), Biologic Effects and Health Hazards of Microwave Radiation, Polish Medical Publishers, Warsaw, pp. 281-288 (1974).

- Peterson, D. J., L. M. Partlow, and O. P. Gandhi, "Lack of an Effect of Microwave Irradiation on Red Blood Cell Permeability," in Abstracts of Open Symposium on the Biological Effects of Electromagnetic Waves, Helsinki, Finland (1978).
- Pickard, W. F. and R. G. Olsen, "Development Effects of Microwaves in Tenebrio molitor: Experiments to Detect Possible Influences of Radiation Frequency and of Culturing Protocols," in Abstracts of 1977 International Symposium on the Biological Effects of Electromagnetic Waves, Airlie, Virginia (1977).
- Plontek, G. E., C. A. Cain, and J. A. Milner, "The Effects of Hyperthermia, Microwave Radiation, and Ascorbic Acid on the Metabolism of Ehrlich Ascites Carcinoma Cells in Vitro," in Abstracts of 1977 International Symposium on the Biological Effects of Electromagnetic Waves, Airlie, Virginia (1977).
- Pollack, H., Statement Before the Committee on Commerce, Science, and Transportation, U.S. Senate (27 June 1977).
- Prausnitz, S. and C. Susskind, "Effects of Chronic Microwave Irradiation on Mice," IRE Trans. Bio-Med. Electron., pp. 104-108 (1962).
- Preston, E., E. J. Vavsour, and H. M. Assenheim, "Effects of 2,450-MHz Microwave Irradiation on Permeability of the Blood-Brain Barrier to Mannitol in the Rat," in Abstracts of 1978 Symposium on Electromagnetic Fields in Biological Systems, Ottawa, Canada (1978).
- Reider, D. R., D. L. Epstein, and J. H. Kirk, "Aeromedical Review: Possible Cataractogenic Effects of Radiofrequency Radiation," U.S. Air Force School of Aerospace Medicine Reviews 3-71, Brooks Air Force Base, San Antonio, Texas (August 1971).
- Reiter, L., Effects on Reflex Development and Age at Eye Opening, Prog. Rept. on Proj. 3, Topic 4.1 of the U.S./USSR Cooperative Program, D. McRee (Coordinator), NIEHS, Research Triangle Park, North Carolina (1976).
- Richardson, A. W., T. D. Duane, and H. M. Hines, "Experimental Lenticular Opacities Produced by Microwave Irradiation," Arch. Phys. Med., Vol. 29, p. 765 (1948).
- Richardson, A. W., T. D. Duane, and H. M. Hines, "Experimental Cataracts Produced by 3-centimeter Pulsed Microwave Irradiation," AMA Arch. Ophthalmol., Vol. 45, pp. 382-386 (1951).

- Riley, V. R., et al., "Neoplastic Cells as Sensitive Targets for Examining the Biological and Pathological Effects of RF and Microwave Irradiation," Abstracts of Open Symposium on Biological Effects of Electromagnetic Waves, Helsinki, Finland (1978).
- Roberti, B., et al., "Preliminary Investigation of the Effects of Low-Level Microwave Radiation on Spontaneous Motor Activity in Rats," Ann. N.Y. Acad. Sci., Vol. 247, pp. 417-424 (1975).
- Robinette, C. D. and C. Silverman, "Causes of Death Following Occupational Exposure to Microwave Radiation (RADAR) 1950-1974," in D. G. Hazzard (ed.), Symposium on Biological Effects and Measurement of Radiofrequency/Microwaves, Department of Health, Education, and Welfare, Washington, D.C., HEW Publication No. (FDA) 77-8026 (1977).
- Rodzilsky, B. and J. Olszewski, "Permeability of Cerebral Blood Vessels Studied by Radioactive Iodinated Bovine Albumin," Neurology, Vol. 7, pp. 279-279 (1957).
- Rosenbaum, F. J., "Cumulative Teratogenesis from Low Level Microwaves," briefing presented to the Electromagnetic Radiation Management Advisory Council of the Office of Telecommunications Policy, Washington, D.C. 20504 (5 April 1977).
- Rosenstein, L., EEG Investigations in Animals Exposed to Microwave Radiation, Progr. Rept. on Proj. 2, Topic 4.1, of the U.S.-USSR Cooperative Program, D. McRee (Coordinator), NIEHS, Research Triangle Park, North Carolina (1976).
- Rotkowska, D. and A. Vacek, "The Effect of Electromagnetic Radiation on the Hematopoietic Stem Cells of Mice," Ann. N.Y. Acad. Sci., Vol. 247, pp. 243-250 (1975).
- Ruch, T. C. and H. D. Patton, Physiology and Biophysics, Vol. III, W. B. Saunders Co., Philadelphia, Pennsylvania (1973).
- Rugh, R., et al., "Responses of the Mouse to Microwave Radiation During Estrous Cycle and Pregnancy," Radiat. Res., Vol. 62, pp. 225-241 (1975).
- Sadcikova, M. N., "Clinical Manifestations of Reactions to Microwave Irradiation in Various Occupational Groups," in P. Czernski et al. (eds.), Biologic Effects and Health Hazards of Microwave Radiation, Polish Medical Publishers, Warsaw, pp. 261-267 (1974).
- Sanza, J. N. and J. de Lorge, "Fixed Interval Behavior of Rats Exposed to Microwaves at Low Power Densities," Radio Sci., Vol. 12, No. 6(S), pp. 273-277 (1977).

- Schmitt, F. O. and F. E. Samson, "Brain Cell Microenvironment," Neurosciences Res. Prog. Bull., Vol. 7, pp. 277-417 (1969).
- Schwan, H. P. and K. Li, "Capacity and Conductivity of Body Tissues at Ultrahigh Frequencies," Proc. IRE, Vol. 41, pp. 1,735-1,740 (1953).
- Schwan, H. P. and G. M. Piersol, "The Absorption of Electromagnetic Energy in Body Tissue, Part II," Amer. J. Phys. Med., Vol. 34, pp. 425-448 (1955).
- Schwan, H. P., "Electrical Properties of Tissue and Cell Suspension," in Advances in Biological and Medical Physics, Vol. 5, pp. 147-209, Academic Press, New York (1957).
- Schwan, H. P., "Electrical Characteristics of Tissues: A Survey," Biophysik, Vol. 1, pp. 198-208 (1963).
- Schwan, H. P., "Principles of Interaction of Microwave Fields at the Cellular and Molecular Level," in P. Czerski et al. (eds.), Biologic Effects and Health Hazards of Microwave Radiation, Polish Medical Publishers, Warsaw, pp. 152-159 (1974).
- Schwan, H. P., "Field Interaction with Biological Matter," Ann. N.Y. Acad. Sci., Vol. 303, pp. 198-203 (1977).
- Shandala, M. G. et al., Study of the Effects of Non-Ionizing Microwave Radiation on the Central Nervous System and Behavioral Responses, First Report on Topic 4.1 of the U.S./USSR Cooperative Program, D. McRee (Coordinator), NIEHS, Research Triangle Park, North Carolina (1976).
- Shandala, M. G., et al., "Immunological and Hematological Effects of Microwaves at Low Power Densities," in Abstracts of 1977 International Symposium on the Biological Effects of Electromagnetic Waves, Airlie, Virginia (1977a).
- Shandala, M. G., M. I. Rudnev, and M. A. Navakatlan, "Patterns of Change in Behavioral Reactions to Low Power Densities of Microwaves," in Abstracts of 1977 International Symposium on the Biological Effects of Electromagnetic Waves, Airlie, Virginia (1977b).
- Shandala, M.G., Discussion following presentation of his paper at the Open Symposium on the Biological Effects of Electromagnetic Waves, Helsinki, Finland (1978). ++

- Shore, M. L., R. P. Felton, and A. Lamanna, "Effect of Repetitive Prenatal Low-Level Microwave Exposure on Development in the Rat," in D. G. Hazzard (ed.), Symposium on Biological Effects and Measurement of Radio Frequency/ Microwaves, U.S. Department of Health, Education, and Welfare, Washington, D.C., HEW Publication (FDA) 77-8026 (1977).
- Siekierzynski, M., "A Study of the Health Status of Microwave Workers," in P. Czernski et al. (eds.), Biologic Effects and Health Hazards of Microwave Radiation, Polish Medical Publishers, Warsaw, pp. 273-280 (1974).
- Smialowicz, R. J., "The Effect of Microwaves on Lymphocyte Blast Transformation in Vitro," in C. C. Johnson and M. Shore (eds.), Biological Effects of Electromagnetic Waves, U.S. Department of Health, Education, and Welfare, Washington, D.C., HEW Publication (FDA) 77-8010 (1976).
- Smialowicz, R. J., et al., "Chronic Exposure of Rats to 425- or 2,450-MHz Microwave Radiation: Effects on Lymphocytes," in Abstracts of 1977 International Symposium on the Biological Effects of Electromagnetic Waves, Airlie, Virginia (1977).
- Spackman, D. H., and V. Riley, "Studies of RF Radiation Effects on Blood-Brain Barrier Permeability Using Fluorescein and Amino Acids," in Abstracts of Open Symposium on the Biological Effects of Electromagnetic Waves, Helsinki, Finland (1978).
- Spalding, J. F., R. W. Freyman, and L. M. Holland, "Effects of 800 MHz Electromagnetic Radiation on Body Weight, Activity, Hematopoiesis, and Life Span in Mice," Health Phys., Vol. 20, pp. 421-424 (1971).
- Stavinoha, W. B. et al., "The Effects of 19 Megacycle Irradiation on Mice and Rats," in C. C. Johnson and M. Shore (eds.), Biological Effects of Electromagnetic Waves, U.S. Department of Health, Education, and Welfare, Washington, D.C., HEW Publication (FDA) 77-8010 (1976).
- Stodolnik-Baranska, W., "Lymphoblastoid Transformation of Lymphocytes in Vitro After Microwave Irradiation," Nature, Vol. 214, pp. 102-103 (1967).
- Stodolnik-Baranska, W., "Experimental Microwave Ocular Effects," in P. Czernski et al. (eds.), Biologic Effects and Health Hazards of Microwave Radiation, Polish Medical Publishers, Warsaw, pp. 186-188 (1974a).
- Stodolnik-Baranska, W., "The Effects of Microwaves on Human Lymphocyte Cultures," in P. Czernski et al. (eds.), Biologic Effects and Health Hazards of Microwave Radiation, Polish Medical Publishers, Warsaw, pp. 189-195 (1974b).

- Stokinger, H. E., "Sanity in Research and Evaluation of Environmental Health," Science, Vol. 174, pp. 662-665 (1971).
- Stuchly, M. A., "Potentially Hazardous Microwave Radiation Sources -- A Review," J. Microwave Power, Vol. 12 No. 4, pp. 369-381 (1977).
- Stuchly, M. A. and M. H. Repacholi, "Microwave and Radiofrequency Protection Standards," in Microwave Bioeffects and Radiation Safety, Transactions of the International Microwave Power Institute, Vol. 8, pp. 95-101 (1978).
- Sudakov, K. V. and G. D. Antimoni, "Central Mechanisms of Action of Electromagnetic Fields," Uspekhi Fiziologicheskikh Nauk, No. 2 JPRS 60711, pp. 101-135 (1973).
- Suess, M. J., "Development of a Long-Term Programme on Non-Ionization Radiation Protection," Health Phys., Vol. 27, pp. 514-522 (1974).
- Sutton, C. H., R. L. Nunnally, and F. B. Carroll, "Protection of the Microwave-Irradiated Brain with Body-Core Hypothermia," Cryobiology, Vol. 10, p. 513 (1973).
- Sutton, C. H., "Effects of Microwave-Induced Hyperthermia on the Rat Blood-Brain Barrier," Abstracts of 1977 International Symposium on the Biological Effects of Electromagnetic Waves, Airlie, Virginia (1977).
- Szmigielski, S., J. Jeljazewicz, and M. Wiranowska, "Acute Staphylococcal Infections in Rabbits Irradiated with 3-GHz Microwaves," Ann. N.Y. Acad. Sci., Vol. 247, pp. 305-311 (1975).
- Taylor, L. S. and A. Y. Cheung (eds.), The Physical Basis of Electromagnetic Interactions with Biological Systems, U.S. Department of Health, Education, and Welfare, Washington, D.C., HEW Publication (FDA) 78-8055 pp. 35-112 (1978).
- Tell, R. A., and E. D. Mantiply, Population Exposure to VHF and UHF Broadcast Radiation in the United States, Technical Note ORP/EAD-78-5, United States Environmental Protection Agency, Office of Radiation Programs (June 1978).
- Tolgskaya, M. S. and Z. V. Gordon, Pathological Effects of Radio Waves, Consultants Bureau, New York-London, 146 pp. (1973) (Translated from the original Russian text published by Meditsina Press, Moscow, 1971).

- Travers, W. D. and R. J. Vetter, "Low Intensity Microwave Effects on the Synthesis of Thyroid Hormones and Serum Proteins," meeting abstract, Health Phys., Vol. 33, p. 662 (1978).
- Tyazhelov, V. V., R. E. Tigranian, and E. P. Khizhniak, "New Artifact-Free Electrodes for Recording of Biological Potentials in Strong Electromagnetic Fields," Radio Science Vol. 12, No. 6(S), pp. 121-123 (1977a).
- Tyazhelov, V. V., et al., "Some Peculiarities of the Auditory Sensation Evolved by Pulsed Electromagnetic Radiation," in Abstracts of 1977 International Symposium on the Biological Effects of Electromagnetic Waves, Airlie, Virginia (1977b).
- Tyler, P. E. (ed.), Biologic Effects of Nonionizing Radiation, N.Y. Acad. of Sciences Conference held February 12-15, 1974, Ann. N.Y. Acad. Sci., Vol. 247 (1975).
- U.S. Air Force, Biologic Judgments in Support of PAVE PAWS Environmental Assessment, Radiobiology Division, School of Aerospace Medicine, Brooks Air Force Base, Texas (1978a).
- U.S. Air Force, "Department of the Air Force Radiofrequency Radiation Survey, North Truro Air Force Station, Massachusetts, 1 June 1978," Radiobiology Division, School of Aerospace Medicine, Brooks Air Force Base, Texas (1978b).
- Varma, M. M., E. L. Dage, and S. R. Joshi, "Mutagenicity Induced by Non-Ionizing Radiation in Swiss Male Mice," in C. C. Johnson and M. Shore (eds.), Biological Effects of Electromagnetic Waves, U.S. Department of Health, Education, and Welfare, Washington, D.C., HEW Publication (FDA) 77-8010 (1976a).
- Varma, M. M., E. L. Dage, and S. R. Joshi, "Evaluation of Dominant Lethal Test and DNA Studies in Measuring Mutagenicity Caused by Non-Ionizing Radiation," in C. C. Johnson and M. Shore (eds.), Biological Effects of Electromagnetic Waves, U.S. Department of Health, Education, and Welfare, Washington, D.C., HEW Publication (FDA) 77-8010 (1976b).
- Varma, M. M. and E. A. Traboulay, Jr., "Comparison of Native and Microwave Irradiated DNA," Experientia, Vol. 33, pp. 1,649-1,650 (1977).
- Vinogradov, G. I., "The Effect of Ultrahigh Frequency Electromagnetic Field on Immunobiological Reactivity," Urach. Delo., Vol. 6, pp. 122-125 (1975).
- Wacker, P.F., and R. R. Bowman, "Quantifying Hazardous Electromagnetic Fields: Scientific Basis and Practical Considerations," IEEE Trans. MTT-19, pp. 178-187 (1971).

- Weil, C. M., "Absorption Characteristics of Multilayered Sphere Models Exposed to VHF/Microwave Radiation," IEEE Trans. Biomed. Eng., Vol. BME-22, pp. 468-476 (1975).
- Wheater, R. and G. G. Howen, "Microwave Radiation Not Known to be Teratogenic," letter, J. Amer. Med. Assn., Vol. 238, p. 895 (1977).
- White, R. M., "Generation of Elastic Waves by Transient Surface Heating," J. Appl. Phys., Vol. 34, pp. 3,559-3,567 (1963).
- Wiktor-Jedrzejczak, W., et al., "Increase in the Frequency of Fc Receptor (FcR) Bearing Cells in the Mouse Spleen Following a Single Exposure of Mice to 2,450 MHz Microwaves," Biomedicine Express, Vol. 27, pp. 250-252 (1977).
- Williams, D. B., et al., "Biological Effects of Studies on Microwave Radiation: Time and Power Thresholds for the Production of Lens Opacities by 12.3 cm Microwaves," AMA Arch Ophthalmol, Vol. 54, pp. 863-874 (1955).
- World Health Organization, Health Effects of Ionizing and Nonionizing Radiation: Report on a Working Group, EURO Rept. 4701, Vol. 1, pp. 1-33 (1971). Available from Regional Office for Europe, WHO, Copenhagen, Denmark.
- World Health Organization, Long Term Program in Environmental Pollution Control in Europe: ; Health Hazards from Exposure to Microwaves, EURO Rept. 3170 (1974). Available from Regional Office for Europe, WHO, Copenhagen, Denmark.
- Wu, C. L. and J. C. Lin, "Absorption and Scattering of Electromagnetic waves by Prolate Spheroidal Models of Biological Structures," IEEE Antenna and Propagation Society Int. Symp. Digest, pp. 142-145 (1977).
- Zaret, M., S. Cleary, B. Pasternack, and M. Eisenbud, "Occurrence of Lenticular Imperfections in the Eyes of Microwave Workers and Their Association with Environmental Factors," Rome Air Development Center Report RADN-TN-61-226, New York University, N.Y. (1961).
- Zaret, M. W., "Electronic Smog as a Potentiating Factor in Cardiovascular Disease," Med. Res. Engr., Vol. 12, No. 3, pp. 13-16 (1976).
- Zielhuis, R. L., "Permissible Limits for Occupational Exposure to Toxic Agents," Int. Arch. Arbeitsmed., Vol. 33, pp. 1-13 (1974).

Appendix D

ELECTROMAGNETIC INTERFERENCE AND HAZARDS TO SYSTEMS

D.1 Introduction

This appendix presents an analysis of the potential effects of the operation of the PAVE PAWS radar system at Beale AFB on other systems. The systems considered include those that use the electromagnetic spectrum, as well as others that are not designed to be users of the electromagnetic spectrum, but may nevertheless be susceptible to the energy radiated by the radar. Systems in the first group include telecommunication systems and other radars, all of which are designed to sense electromagnetic energy. Systems in the second group include cardiac pacemakers and electroexplosive devices (EEDs), which may inadvertently be subjected to the radar energy.

Section D.2, p. D-4, of this appendix describes the frequency and time behavior of the radar. Basic to an analysis of the effects of any emitter of electromagnetic fields on other systems is an understanding of the characteristics of the emission. PAVE PAWS is a complicated system operating under computer control according to preprogrammed operating algorithms. Its beams do not sweep; rather, they probe from one azimuth to another in a seemingly pseudorandom manner. PAVE PAWS has a repertoire of pulse widths, and it continually switches frequency. The operation is not predictable from moment to moment, because the radar alters its routine surveillance operation to provide tracking data on some of the objects it detects, and also because it may decide not to use some of its available frequencies if they are experiencing interference. At all times, it is responding to outside influences according to well-defined rules programmed into the computer.

Section D.3, p. D-20, analyzes incidental electromagnetic effects of PAVE PAWS. It is divided into two subsections. In Section D.3.1, p. D-20, we discuss other telecommunication systems, and in Section D.3.2, p. D-78, we discuss three inadvertent receivers of energy. In both sections, the approach is to determine whether and how the subject system may be susceptible to the characteristics of the PAVE PAWS signal. We first consider the PAVE PAWS pulse widths, its apparent pulse repetition frequency (PRF), and its frequency-switching characteristics, and then we attempt to determine the PAVE PAWS

signal levels at which the subject system will experience some effect. When those levels have been determined, we can estimate the distance from PAVE PAWS at which the effect will occur.

D.1.1 Background

To determine the likelihood that electromagnetic interference (EMI) to some other system will be caused by an emitter of electromagnetic fields, some knowledge is required of the operating characteristics of both systems and of the means by which the electromagnetic energy is propagated from one to the other. We often speak of the threshold of susceptibility for a system subject to interference. It is the lowest level of undesired signal that will cause some perceptible effect on the susceptible system (or activity). The systems include radar and communication systems and cardiac pacemakers; activities include the handling of volatile fuels and electroexplosive devices. The threshold of susceptibility typically must be determined separately for each pair of interfering system and potentially interfered-with system. That is because the threshold of susceptibility depends not only upon the power density of the undesired signal at the potentially susceptible system (and therefore on the distance between them), but also upon the frequency of the undesired signal, its pulse length and PRF and, when applicable, on the strength and frequency of the desired signal. (Examples: TV receivers tuned to channel 10 would show effects that would not occur if they were tuned to channel 12. A satellite communication system may be susceptible to interference from only a few of the 24 PAVE PAWS channels. A cardiac pacemaker will be insensitive to the difference in frequency between the PAVE PAWS channels, but will react differently to different pulse rates. A certain radar altimeter is affected in the same way by all of the PAVE PAWS frequencies, but it becomes increasingly susceptible as the interfering pulse widths increase.) Potentially susceptible systems of the same class (such as land mobile receivers) will differ in actual susceptibility, as a result of differences in their design.

Theory is useful in predicting likely modes of interference, and it can go far in helping to predict thresholds of susceptibility. Measurements however, are often needed, either when theory is not sufficient, or to confirm the theoretical results. Unfortunately, each new situation is usually unique in some way, and susceptibility thresholds applicable to that situation are generally not available. For example, inquiries to the persons responsible for EMI in the Electronics Industries Association and in a major U.S. manufacturer of TV receivers reveal that they have no data bearing upon the effects of radars such as PAVE PAWS on their products. Table D-1 (taken in part from Donaldson, 1978) shows the variables that should be considered in a test program to define the effect clearly. If

each possible test configuration were used, 1.53×10^{10} (more than 15 billion) tests would be required, which is clearly unrealistic. (This example uses TV receivers, but the nature of the problem would be similar for some other potentially susceptible system.)

PAVE PAWS generates signals of a highly unusual type, and little information is available to define accurately the

Table D-1

POSSIBLE TEST VARIABLES FOR TELEVISION
RECEIVER SUSCEPTIBILITY TESTS

50	Television sets
82	Channels
24	Interference source frequencies
3	Desired-signal levels
3	Interference-signal levels
3	Pulse widths
3	Pulse repetition frequencies
2	Effects (audio and video)
4	Television orientations
5	Television antennas
2	Picture scenes
4	Test configurations
	o Television and antenna
	o Television alone
	o Antenna alone
	o Power line
2	Receiver types (color and monochrome)
3	Independent viewers

susceptibility thresholds of the various systems in its vicinity to its unique type of interfering signal. Some measurements were taken almost 10 years ago on the effects of a phased-array radar, in the same 420-450 MHz band, on some systems, and we have used

that information to the extent possible (Conklin, 1974). However, that radar's PRF and pulse width (and possibly its frequency-hopping) were different, so the results are not directly applicable.

Because of a combination of circumstances, definitive statements are rarely possible regarding distances from the radar beyond which a given system will not be affected. Available measured susceptibility levels are generally based on measurements of only a very few units, generally selected in the hope that they are representative or typical of their type. However, they could be either more or less susceptible than the entire population of units of that type. The variation in the susceptibility levels of all the units of a type (taken as a group) may be quite large, but it is generally unknown. Also, circuit designs change, and the susceptibilities of the systems change with them. The nature of radio-wave propagation over irregular terrain is such that the level of the interfering signal will not be the same at all locations at the same distance from the source. At a given location, the level varies with time, and so it is common to deal with expected, or median, values. That is also true of the desired signals, when they are applicable.

In some situations, it is not necessary to attempt to determine actual susceptibility; standards for maximum fields have been established so that the devices or systems are said to be safe if that field is not exceeded. Such is the case for electroexplosive devices and for fuel handling, and a draft standard exists for cardiac pacemakers.

D.1.2 Scope

In the analyses that follow, in Section D.3, p. D-20, combinations of theory and measured data are used as applicable to generate those statements that can be made regarding the EMI impact of the PAVE PAWS electromagnetic fields.

D.2 PAVE PAWS Electromagnetic Fields

D.2.1 Purpose

The purpose of this section is to explain certain characteristics of the PAVE PAWS signal, specifically, the behavior of the signal in time, frequency, and space. This explanation has particular relevance to electromagnetic interference and is supplementary to the description and analysis of Appendix A.

D.2.2 Basic Radar Operation

A radar operates by transmitting a pulse of electromagnetic energy and then waiting to receive energy reflected back to the radar from a target illuminated by the pulse. The radar interprets the time interval between the transmitted pulse and the return as a measure of the distance from the radar to the target.

It is highly advantageous, for several reasons, for the radar to concentrate its transmitted energy (and to limit its receiving capability) in a relatively narrow beam. A narrower beam permits greater certainty regarding the direction in which the energy was sent and from which it returned, thus better defining the direction from the radar to the target. A narrower beam not only conserves the available energy (because it concentrates it into a single direction), it can also receive weaker returns from a particular direction while discriminating against electromagnetic noise or extraneous, interfering signals that may arrive from other directions.

Radars have long used parabola-shaped reflectors, or dishes, to form beams in the same manner that the silvered reflector of an automobile headlight forms a beam from the light emanating from the lamp's filament. In both cases, the radiating element is often hardly noticeable in front of the reflecting dish. To move the beam, the radar dish (and the radiating element) are typically rotated at a particular fixed rate to sweep past a given azimuth every second or so.

D.2.3 PAVE PAWS Beam

D.2.3.1 General

PAVE PAWS differs from a conventional radar in several respects. Each of its two faces is covered with a large number of small fixed radiating elements, each of which is driven by its own transmitter under the control of a computer. The computer can adjust the phase of the transmitted (and received) energy of each radiating element relative to that of the others to form a very narrow beam of energy. Each complete antenna face is known as a phased array. Because it has no moving mechanical parts, the phased array can switch its beam from one part of the sky to another within a few microseconds, unhampered by mechanical inertia. Thus, instead of sweeping, the PAVE PAWS beam can be thought of as probing from any given direction (azimuth and elevation) to any other within its limits. Each of the two faces of the PAVE PAWS radar covers an azimuthal sector 120 deg wide. Together they can make observations in a 240 deg sector from 6 deg (i.e., 6 deg east of north) counterclockwise to 126 deg (i.e., 54 deg east of south).

D.2.3.2 Beam Structure

Each of the two faces of PAVE PAWS forms a single and separate main beam with associated sidelobes, as indicated in Table A-1, p. A-3, and Figure 1-4, p. 1-6. The sidelobes result from the inability of the radar to concentrate absolutely all of the energy in the main beam. The location and level of the first sidelobe are fairly well known. The higher order (and very minor) sidelobes are distributed at various, almost random, angles. They have power densities no greater than 0.001 (one one-thousandth) of that of the main beam; some have as little as 0.00003 (three one-hundred thousandths) of the power density of the main beam. There are a large number of these minor sidelobes, and their average level in the basic system is about 0.00016 of that of the main beam power density (0.00008 for the growth system).

D.2.3.3 Beam Motion

PAVE PAWS is used both for surveillance and for tracking space objects. Operating time is broken into 54-ms intervals called resources. Successive resources can be used for surveillance, for tracking, or for calibration and monitoring of performance and interference. Time is shared between the various functions of the radar. A nominal template (an arrangement of 54-ms resources) is shown in Figure D-1. The pattern repeats every $38 \times 54 \text{ ms} = 2.052 \text{ s}$.

Fifty percent of the resources are used for tracking, 44.7% for surveillance, and 5.3% for calibration and monitoring of performance and interference. During reduced surveillance, only about one out of four resources is devoted to surveillance; the others are used for tracking. During enhanced surveillance, more than half of the resources are used for surveillance.

D.2.3.3.1 Long-Range Surveillance. Both faces of the radar search simultaneously, and their beams are synchronized. The beam normally remains at a 3 deg elevation angle, but can be moved up to 10 deg in increments for operational reasons. The beam is switched from one azimuth to another in a complicated but fixed manner during a scan sequence, hitting each spot in the 120 deg sector about 7 to 24 times. (The spots toward the edges of the sector are hit more often than those toward the center.) In normal operation, the sequence takes 43.97 seconds, and then it repeats itself. (During this time, the radar is also conducting its short-range surveillance and tracking). In enhanced or reduced surveillance, the sequence takes a shorter or a longer time, but the same spots are still hit in the same order.

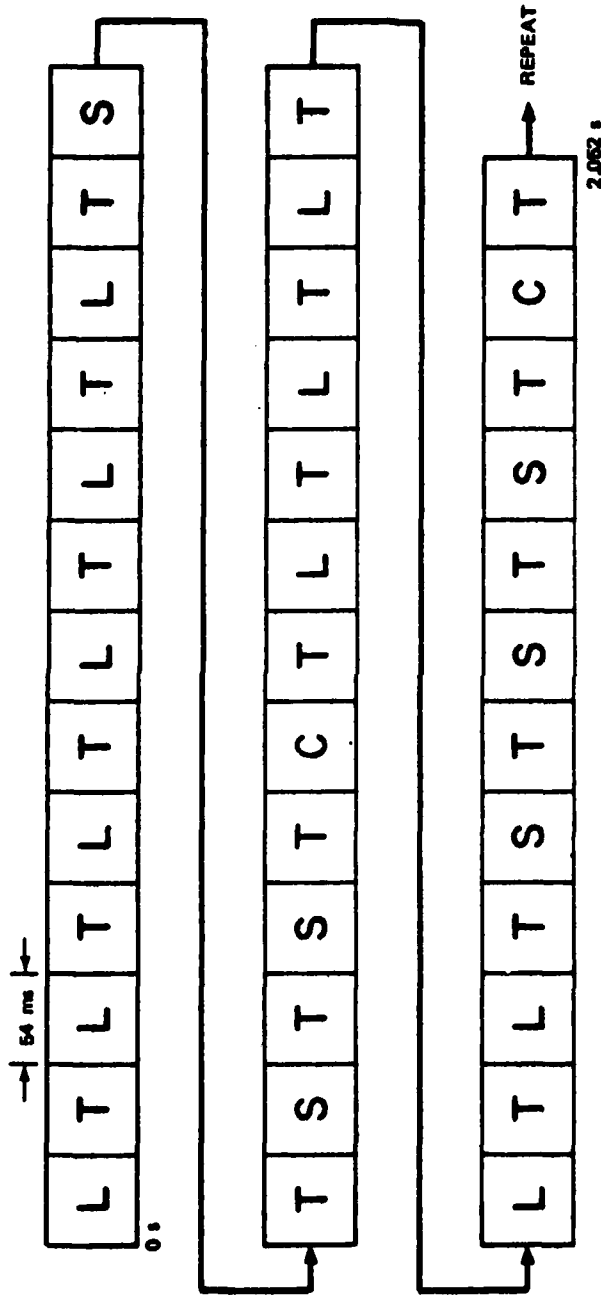

- L - LONG-RANGE SURVEILLANCE
- S - SHORT-RANGE SURVEILLANCE
- T - TRACK OR VERIFICATION
- C - CALIBRATION AND PERFORMANCE MONITORING (EVERY 18th OR 20th RESOURCE, ALTERNATELY)

FIGURE D-1. NOMINAL RADAR RESOURCE TEMPLATE

D.2.3.3.2 Short-Range Surveillance. In this mode, the beam's elevation angle is the same as it was for long-range surveillance, and both faces continue to search simultaneously and in synchronism. At a normal surveillance rate (see Figure D-1), the beam takes about 9.22 seconds to hit each part of the 120-deg sector the four or five times required for short-range surveillance.

D.2.3.3.3 Tracking. The two faces track independently, according to the number and locations of objects needing to be tracked. The beam is limited to a minimum elevation angle of 3 deg and a maximum of 85 deg. Tracking is time-shared with the radar's surveillance functions; when fewer objects must be tracked, more of the resources are available for surveillance. Tracking pulses are never sent simultaneously from both faces.

D.2.4 PAVE PAWS Pulses and Duty Cycles

The 54-ms radar resource is divided into transmit and receive (listen) periods. Figure D-2(a) shows that both two-pulse clusters and three-pulse clusters are used in long-range surveillance. The beam position is moved only slightly (about 2 deg) between successive pulses of a particular cluster. However, each successive cluster may be widely separated in azimuthal angle from the last. The duty cycle for a single 54-ms long-range surveillance resource is 27.8 to 29.6%.

In short-range surveillance, the 54-ms resource is broken up into three 12-ms sections, each with a cluster of three 0.3-ms pulses, and an 18-ms segment with a single 3-ms pulse (see Figure D-2(b)). The duty cycle for a single short-range surveillance resource is about 11%.

Surveillance pulses are chirped (varied continuously in frequency) over a 100-kHz band.

Figure D-3, p. D-10, shows four patterns for breaking a 54-ms resource into transmit and receive periods for tracking. Patterns are selected according to the distance to the target. There may be more than one pulse in a transmit period. Any number of pulses up to eight can occur in the transmit period of the resources labeled T_1 , T_2 , and T_3 ; only one pulse can be in the 2-ms transmit periods of T_4 . Any part of the transmit period may also be empty, reducing the duty cycle of a single 54-ms track resource to less than its maximum possible duty cycle of 29.6%.

Track pulses are chirped over a frequency band of 1 MHz, and the available pulse widths range from 16 to 0.25 ms.

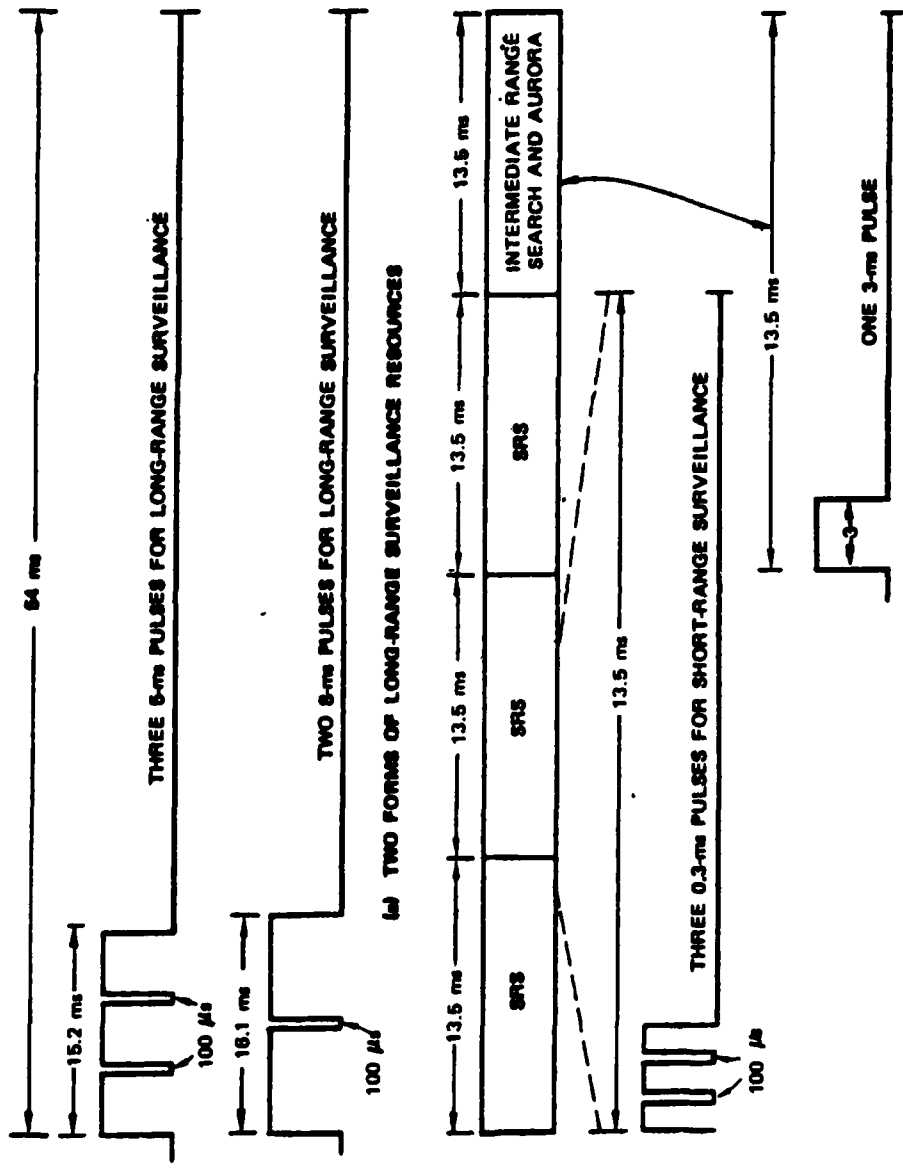

(a) THE BREAKDOWN OF A SHORT-RANGE SURVEILLANCE RESOURCE (SRS)

FIGURE D-2. LONG-RANGE AND SHORT-RANGE SURVEILLANCE RESOURCES

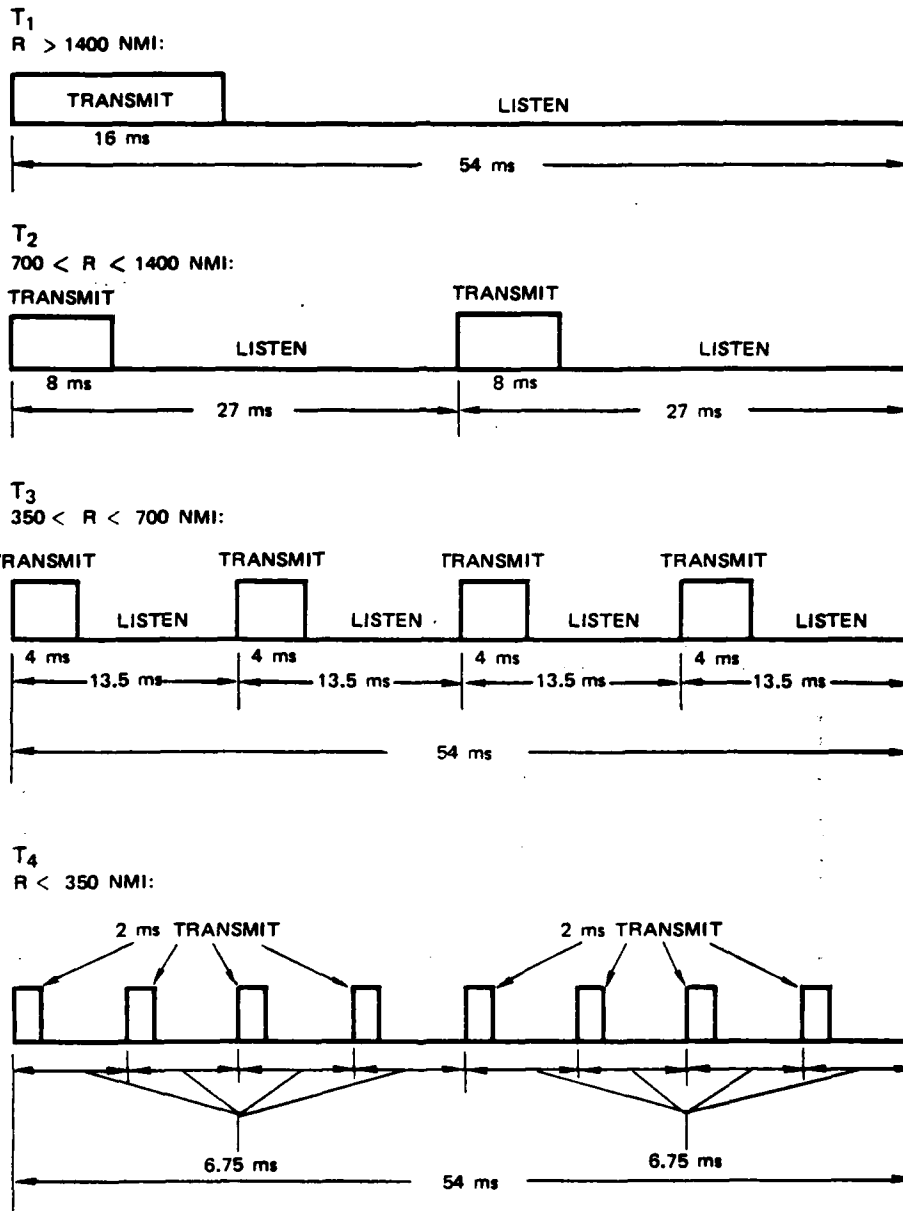

FIGURE D-3. TRACK RESOURCES

Various algorithms dictate the tracking pulses. Among the constraints are :

- o Track pulses must not be transmitted simultaneously on both faces.
- o For any 1-second interval, the duty cycle for all radar activities on a face must be less than or equal to 25%.

The latter constraint is imposed by the limitations on the radar's ability to cool the transmitter modules. The duty cycle for each face is expected almost always to be about 18%. (11% in surveillance and the rest in tracking.) The 25% duty cycle is expected to occur only under the most stressful circumstances (for example, during a missile attack), when one face would be used heavily for tracking targets. If that were to occur, the duty cycle for the other face would have to be reduced to about 11% to avoid exceeding the system's ability to cool the transmitter modules.

D.2.5 PAVE PAWS Frequency Switching

The PAVE PAWS radar transmits on the 24 channels illustrated in Table D-2 generally switching frequency between one pulse and the next. Although the pulses of the two- or three-pulse clusters of the long-range surveillance resources differ in frequency by only about 200 kHz, every other surveillance or tracking pulse is shifted at least 3.6 MHz from the preceding pulse. A different frequency is used for each short-range search pulse in the same resource and also for each tracking pulse in the same resource. Also, no frequency can be used in a long-range surveillance resource that has been used in the immediately preceding track resource.

The 24 center frequencies, spaced at 1.2-MHz intervals from 420 to 450 MHz, are interleaved in three sets of eight, as illustrated in Table D-2. The radar selects increasingly higher frequencies from set A, recycling through the set A frequencies for about 31 resources (approximately 1.67 seconds). The radar then proceeds similarly with the set B frequencies, and then the set C frequencies. Thus, the normal jump from one pulse to the next is $3 \times 1.2 \text{ MHz} = 3.6 \text{ MHz}$. (The frequency shift is less within the pulse cluster of the long-range surveillance resource mode and greater when the radar jumps from one frequency set to the next.) It takes about 2.56 seconds for a signal to propagate to the moon and back, and the result of using the three frequency sets sequentially is that the radar's receiving system is tuned for frequencies from sets B and C when the moon echoes of the set A frequencies are finally returned to earth. The same holds true, of course, for the other two frequency sets so that the radar is never confused by a moon echo.

Table D-2

PAVE PAWS FREQUENCIES

<u>Channel Number</u>	<u>Center Frequency (MHz)</u>	<u>Frequency Set</u>
1	421.3	A
2	422.5	B
3	423.7	C
4	424.9	A
5	426.1	B
6	427.3	C
7	428.5	A
8	429.6	B
9	430.8	C
10	432.0	A
11	433.2	B
12	434.4	C
13	435.6	A
14	436.8	B
15	438.0	C
16	439.2	A
17	440.4	B
18	441.5	C
19	442.7	A
20	443.9	B
21	445.1	C
22	446.3	A
23	447.5	B
24	448.7	C

The radar operator can choose to delete any of the possible frequencies from those available for use. Frequencies are also deleted automatically if an auxiliary receiver at the PAVE PAWS building detects undue interference on any of them. Thus, PAVE PAWS switches from one frequency to another at least as often as every 54 ms; the exact frequency usage cannot be predicted because it depends upon the number and the locations of the objects being tracked.

D.2.6 The Received PAVE PAWS Signal

D.2.6.1 Illumination of an Airborne Object

An aircraft or other object flying in the 240-deg sector covered by PAVE PAWS would be illuminated by the surveillance-mode main beam when it is in the upper shaded region indicated in Figure D-4. This raises the possibility that PAVE PAWS could affect airborne systems. This possibility will be discussed in Section D.3.1.5, p. D-64.

The object would not be illuminated often and, if it is an aircraft, it would never be tracked. There are 60 surveillance beam positions per face, spaced approximately every 2 deg. In normal operation, the radar completes its long-range surveillance sequence in 43.97 seconds, illuminating a total of 642 beam positions at an average rate of 14.6 beam positions per second. Although some beam positions are illuminated more often than others, on the average, a beam position (and any object in it) would be illuminated by only 1/60 of the long-range surveillance pulses, or only 0.24 times per second. Thus, the main beam could illuminate an airborne object with the 5-ms or 8-ms long-range surveillance pulse only about once every 4.1 seconds.

A similar analysis of the short-range surveillance mode shows that the radar illuminates 261 beam positions during its normal 9.22-second sequence, for an average rate of 28.3 beam positions per second. Each of the 60 beam positions would be illuminated by a 300-microsecond short-range surveillance pulse at an average rate of 0.47 times per second, or once every 2.1 seconds.

Because the radar switches the beam from one part of the sky to another with each succeeding pulse, the object -- moving or stationary -- will not be illuminated with consecutive pulses. While it is in the surveillance volume, we would expect the object to be illuminated by the main beam with a long-range surveillance pulse about 0.24 times per second and with a short-range surveillance pulse about 0.47 times per second. Thus, some sort of main-beam surveillance pulse hits, on the average, about 0.71 times per second, or once every 1.4 seconds. Track pulses may also illuminate the object occasionally, but PAVE PAWS will not track aircraft. Because the tracking volume is approximately 26 times larger than the surveillance volume, and because the main

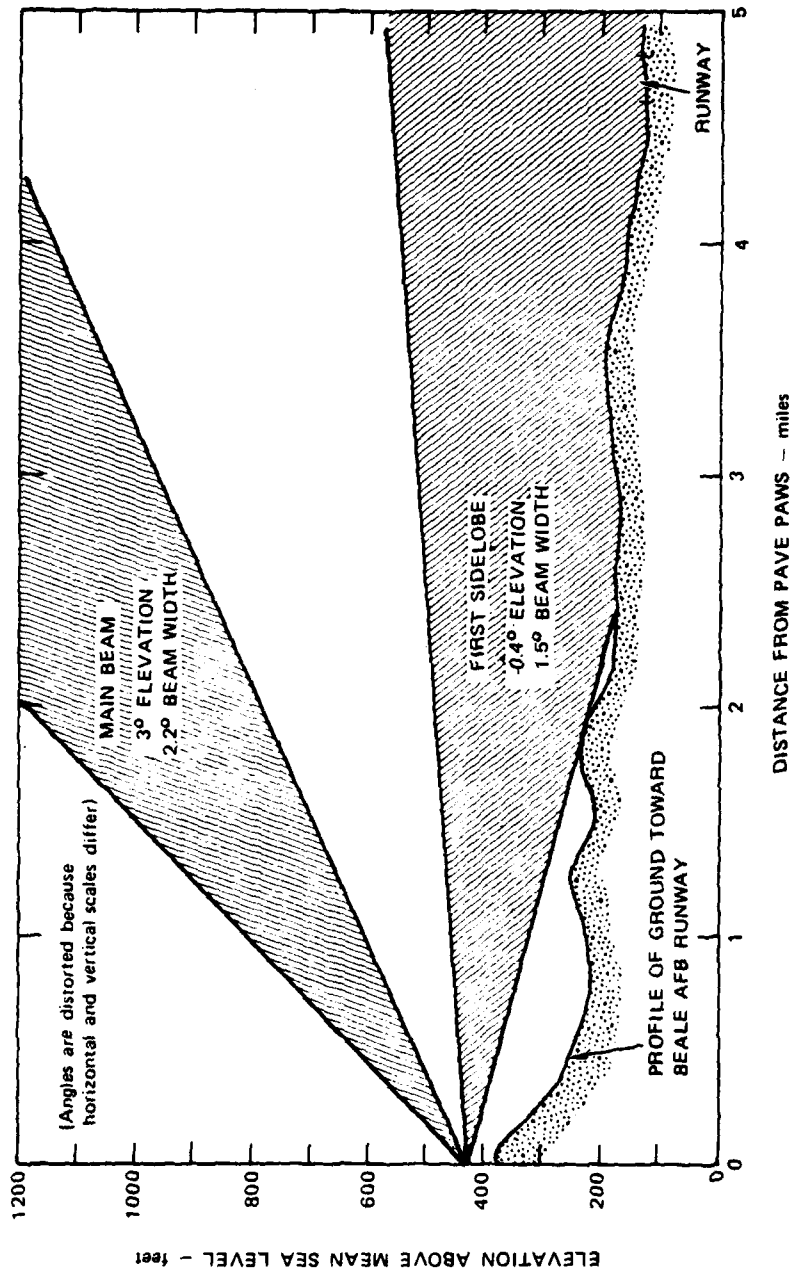

FIGURE D-4. VERTICAL PLANE CUT OF PAVE PAWS BEAM (BASIC SYSTEM) IN SURVEILLANCE MODE

beam spends only about 7% of the time in the tracking volume in contrast with 11% in the surveillance volume on average, an aircraft would be illuminated with a track pulse only about once every 57 seconds on average.

An aircraft in position to be illuminated with the main beam would also be illuminated by energy from the first sidelobe (with a power density 0.01--20 dB less than--that of the main beam power density) and by the minor sidelobes (with power density averaging about 0.00016--38 dB less than--that of the main beam). First-sidelobe energy would illuminate the aircraft in the surveillance volume only when the surveillance mode main beam is directed to either side of the aircraft or when a track beam is very close. These first-sidelobe pulses would therefore hit the craft about twice as often as main-beam surveillance pulses do, or about 1.4 times per second. During each transmitter pulse for which the aircraft is illuminated by neither the main beam nor the first sidelobe, the aircraft would be illuminated by the higher-order sidelobes. Even when the aircraft is not within the surveillance volume, it could be illuminated by the first sidelobe, as is indicated in Figures D-4 and D-5, and by the higher-order sidelobes.

D.2.6.2 Illumination of a Ground-Based Object

The main-beam grazes the earth only at a few hilltop locations, the closest about 8,500 ft from the radar (see Section A.3.1, p. A-12). First-sidelobe energy of the basic system strikes the earth at various distances as close as about 1 or 2 miles from the radar, depending on the terrain at a particular azimuth (see Figure D-5). Objects nearer than that will be illuminated only by the radar's higher-order sidelobes (that is, those beyond the first). The higher-order sidelobes are located at angles greater than about 4 deg from the main beam. From this it follows that a nearby object is likely to be illuminated by one of the higher-order sidelobes regardless of the direction of the main beam, and that the object will be illuminated during each of the radar's pulses. Objects beyond one or two miles (depending on the terrain) will also be illuminated by the first sidelobe.

PAVE PAWS does not have a specific PRF, as most radars do, because it adapts its operation to the targets being tracked. The number of pulses per second can be estimated, but that will not be a PRF in the usual sense. Each second, an average of 14.6 long-range surveillance pulses and 28.3 short-range surveillance pulses are emitted. During that same second, about 40% of the 18.5 resources are used for tracking--with unpredictable pulse formats. An estimate of an average of 4 pulses per tracking resource leads to about 30 tracking pulses per second. Thus, there will be about 73 pulses of some kind per second. They will be of various widths and have various interpulse intervals.

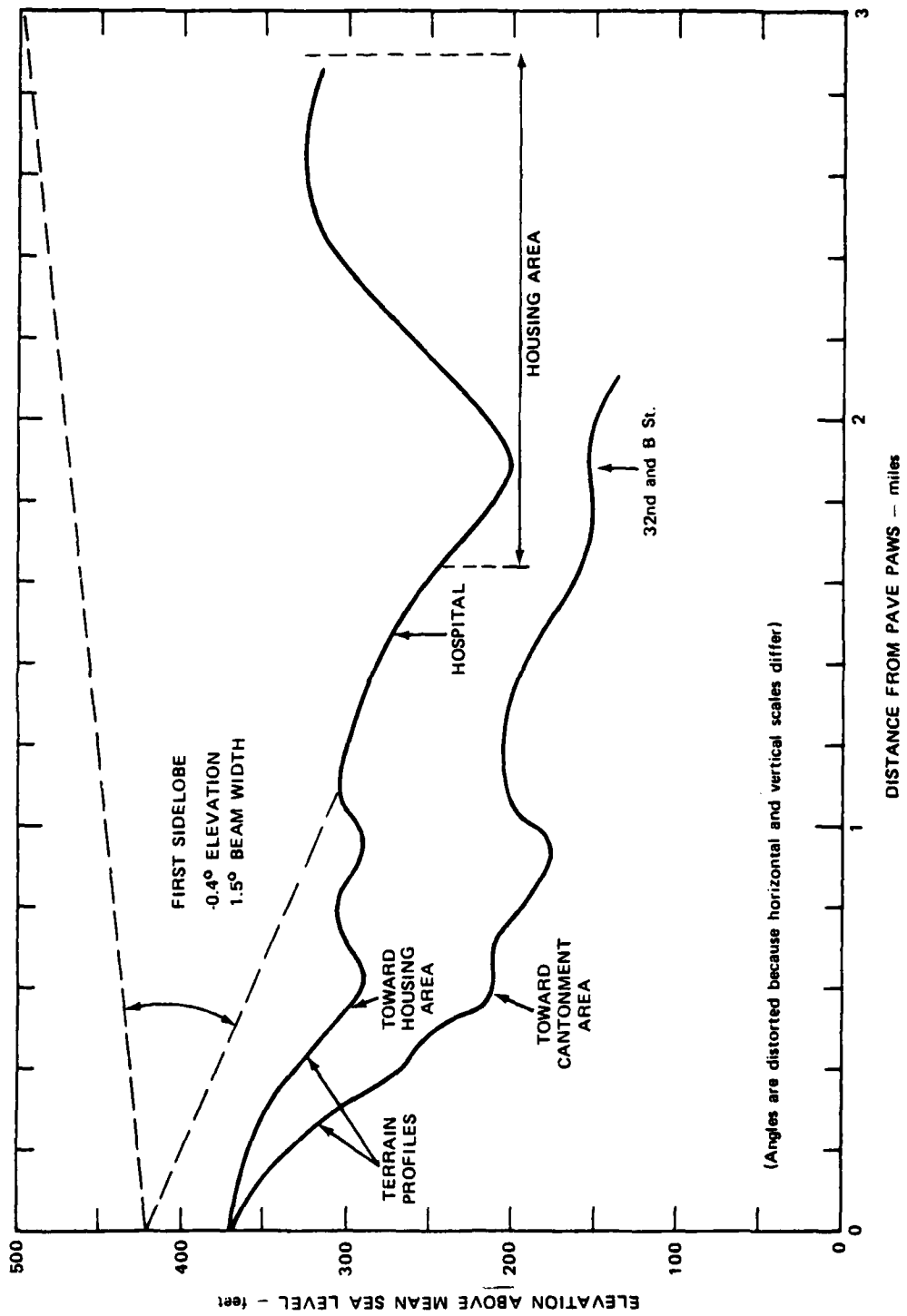

FIGURE D-5. VERTICAL PLANE CUT OF PAVE PAWS FIRST SIDELOBE
(BASIC SYSTEM) IN SURVEILLANCE MODE

Now consider the duration that an object is illuminated by the higher-order sidelobes. Of the 14.6 long-range surveillance pulses emitted each second, each pulse is either 5 ms or 8 ms long. The 8-ms pulses are used at azimuthal angles greater than 45 deg off the boresight. An average of 28.3 300-microsecond short-range surveillance pulses are also emitted each second. If we assume that half of the long-range surveillance pulses are 8 ms long and half are 5 ms long, and if we add them and the short-range pulses, we find that an object is illuminated by surveillance pulses for about 104 ms per second, or about 10.4% of the time. For up to about another 7% of the time, it may also be illuminated by track pulses.

In addition to illumination by the higher-order sidelobes as just described, those objects illuminated by the first sidelobe would experience its less frequent but more powerful pulses. There will be about 1.4 surveillance pulses per second (about 0.48 long-range surveillance pulses and about 0.94 short-range surveillance pulses per second). For tracking, the main beam will generally be pointed higher than the 3 deg elevation angle, and therefore, first-sidelobe tracking pulses at ground level are not likely. The time duration for first sidelobe illumination, combining long-range and short-range surveillance pulses as in the previous paragraph, is about 3.4 ms per second, or about 0.34% of the time.

D.2.6.3 Pulse Power Density

At distances greater than about 1,400 feet and in the main beam, the power density of a PAVE PAWS pulse in the basic system is (from the far-field equation of Section A.3.3.1, p. A-15)

$$P_r = 50.5 - 20 \log d \text{ dBm/m}^2$$

for d miles. (The dimension dBm/m^2 means decibels relative to 1 milliwatt per square meter.) The pulse power density of the first sidelobe is 20 dB less than that of the main beam:

$$P_r = 30.5 - 20 \log d \text{ dBm/m}^2.$$

The maximum value for the higher-order sidelobes is about 30 dB lower than that of the main beam, so illumination by that particular sidelobe has a pulse power density of

$$P_r = 20.5 - 20 \log d \text{ dBm/m}^2.$$

The rms value of the numerous high-order sidelobes for the basic system is about 38 dB less than that of the main beam, so the pulse power density from the typical high-order sidelobe is

$$P_r = 12.5 - 20 \log d \text{ dBm/m}^2.$$

The pulse power densities derived by these equations apply in line-of-sight situations throughout the surveillance and the tracking volumes. In other situations, the pulse power density will be much less. For areas that are shadowed by terrain, a conservative estimate would be that the pulse power density is at most 1/10th as great (at least 10 dB lower).

In the growth system, the transmitter power is doubled and the antenna gain is doubled, so (beyond about 2,800 ft) the main-beam received power and the first-sidelobe received power are increased by a factor of 4 (6 dB). However, the rms value of the high-order-sidelobe gain becomes 41 dB less than the main-beam gain (as opposed to 38 dB less for the basic system), so that the pulse power density of the higher-order sidelobes is only doubled (increased by 3 dB).

D.2.6.4 Average Power Density

Average (rather than pulse) power density is relevant for some evaluations such as evaluation of electroexplosive device hazards, and for that use it is more convenient to express distance from the radar in feet rather than in miles. The main beam time-averaged power density, at a distance of d_f feet, is then (from the first equation of Section D.2.6.3):

$$P_r = 125 - 20 \log d_f + D \text{ dBm/m}^2,$$

where the term D is a form of effective duty cycle based on beam motion as well as on the radar transmitter's duty cycle. This effective duty cycle, for a specific point in the illumination volume, is

$$D = 10 \log (\text{pulse on-time/total time}),$$

where "pulse on-time" refers to the duration for which the beam is directed at that point.

D.2.6.4.1 Surveillance Volume. For the main beam in the surveillance volume, an 8-ms or 5-ms long-range surveillance pulse is transmitted toward the airborne target about every 4 seconds, and a 0.3-ms short-range surveillance pulse about every 2.1 seconds. Aircraft are not tracked. Considering both pulse types, the effective duty cycle (as seen by the aircraft) is then about $D = -26.8$ dB, so the average power density from the main beam is about

$$P_r \text{ surveillance, main beam} = 98.2 - 20 \log d_f \text{ dBm/m}^2$$

The first sidelobe illuminates the target in the surveillance volume just as frequently as the main beam. However, the pulse

power density is 20 dB below that of the main beam. Therefore, the average power density is

$$P_r \text{ surveillance, first sidelobe} = 78.2 - 20 \log d_f \text{ dBm/m}^2$$

which is a factor of 100 less than that of the main beam. For higher-order sidelobes, the average power density at the airborne target is calculated using a gain 38 dB below that of the main beam. the 18% radar transmitter duty cycle converts to $D = -7.4$ dB, so that

$$P_r \text{ higher-order sidelobes} = 79.6 - 20 \log d_f \text{ dBm/m}^2,$$

which is almost 19 dB (a factor of 80) less than the average power density of the main beam. As can be seen from these equations, power density at the aircraft in the surveillance volume is primarily determined by the power of the main beam, which comprises about 98% of the total. These equations apply only in line-of-sight situations and in the far field of the radar (beyond about 1,400 ft).

In the growth system, the transmitter power is doubled and the antenna gain is also doubled, so both the average main-beam received power and the first-sidelobe average received power are increased by 6 dB (a factor of 4). However, the rms value of the higher-order sidelobe antenna gain for the growth system is 3 dB less than for the basic system, so that the average power density for the growth system higher-order sidelobes is only 3 dB higher (doubled). The main beam still contributes about 98% of the total average power density.

D.2.6.4.2 Tracking Volume. An aircraft within the tracking volume may occasionally be illuminated by a main beam tracking pulse. The pulse power density will be the same as in the surveillance volume. (See Section D.2.6.3, p. D-17.) However, because the illumination would be so infrequent, the average power density from the main beam will be much lower. The tracking volume is about 26 times greater than the surveillance volume, but the radar will devote only about 7% of the time there, as opposed to 11% of the time in the surveillance volume on average (see Table A-1, p. A-3). Combining these factors, the average power density from main-beam illumination in the tracking volume is lower than in the surveillance volume by a factor of 1/41 (or by 16.1 dB), so that it can be expressed as

$$P_r \text{ track, main beam} = 82.1 - 20 \log d_f \text{ dBm/m}^2.$$

Average power density resulting from first sidelobe illumination will be lower by the same 16.1 dB, but higher by

about 8.8 dB to account for the increased coverage of the first sidelobe in the tracking volume so that

$$P_r \text{ track, first sidelobe} = 70.9 - 20 \log d_f \text{ dBm/m}^2.$$

Illumination by the higher-order sidelobes would be the same as in the surveillance volume, or

$$P_r \text{ higher-order sidelobes} = 79.6 - 20 \log d_f \text{ dBm/m}^2.$$

Thus, although average power density in the tracking volume is mostly the result of infrequent illumination by the main beam, which contributes about 60% of the total, the more frequent illumination by the much weaker higher-order sidelobes provides over half as much, about 35% of the total. The remaining 5% results from illumination by the first sidelobe. These equations apply only in line-of-sight situations and in the far field of the radar (beyond about 1,400 ft).

For the growth system, both main beam and first sidelobe average power densities would increase by 6 dB, and higher-order sidelobe average power density would increase by 3 dB, as described in Section D.2.6.4.1, p. D-18. Hence, the relative contributions to average power density would be about 75%, 5%, and 20%, respectively.

D.3 PAVE PAWS Effects on Systems

D.3.1 Telecommunication Systems

D.3.1.1 Effects on Amateur Radio -- A Secondary Service

Besides sharing the 420 to 450 MHz band with other radars, PAVE PAWS shares it with the Amateur Radio Service. Although the amateurs operate as the primary service in some bands, the FCC considers the Amateur Radio Service to be a secondary service in this band; the band's primary service is radiolocation (i.e., radars). Secondary services do not enjoy the privileges of primary services. The following, quoted from Vol. II, Section 2.105, of the FCC's Rules and Regulations, defines the rights of each.

Note 1. Geneva Radio Regulation No. 138: Permitted and primary services have equal rights, except that, in the preparation of frequency plans, the primary services as compared with the permitted services, shall have prior choice of frequencies.

Note 2: Geneva Radio Regulation No. 139: Stations of a secondary service: (a) Shall not cause harmful interference to stations of primary or permitted services to which frequencies are already assigned or to which frequencies may be assigned at a later date; (b) cannot claim protection from harmful interference from stations of a primary or permitted service to which frequencies are already assigned or may be assigned at a later date; (c) can claim protection, however, from harmful interference from stations of the same or other secondary service(s) to which frequencies may be assigned at a later date.

D.3.1.1.1 Effects on Amateur Repeater Operation. The amateurs operate a number of FM repeaters (relays) in the band between 440 and 450 MHz to permit communication over greater distances than would otherwise be possible. To obtain coverage of large areas, the repeaters are generally placed on mountaintops. A repeater typically consists of a receiver and a transmitter; the receiver output is fed directly into the transmitter, operating at a frequency just 5 MHz away. In Northern California, the repeater's receiving frequency is 5 MHz higher than its transmitting frequency; in Southern California and in some other parts of the country the reverse is true.

A repeater must receive and transmit simultaneously. Some repeaters have a single antenna, and to keep the transmitter's signal from overwhelming the receiver, the transmitter and the receiver are connected to the antenna through a duplexer. (The duplexer is an arrangement of filters that allows the weak incoming signal to pass with low loss to the receiver; simultaneously it passes the transmitter signal to the antenna to be radiated, but keeps this strong signal from reaching the receiver.) Some repeaters use separate transmit and receive antennas, typically spaced vertically on the same antenna mast, and rely on the antenna patterns (and possibly also on a bandpass cavity filter with a deep notch at the transmit frequency) to protect the receiver from desensitization by the transmitter.

Because of the repeaters' mountaintop placements, many will be directly illuminated by PAVE PAWS' relatively strong first sidelobe. (See Figure D-4, p. D-14.) A search was conducted for those repeaters with the assistance of the American Radio Relay League, (Baldwin, December, 1978), and the Northern Amateur Relay Council (NARC) Frequency Coordination Committee (P. Fennacy, 1978, and S. Hanselman, 1979). NARC records are maintained principally for coordinating frequency usage on the 400 25-kHz-wide channels, and although more than 300 amateur repeaters were identified in Northern California, they are listed only by frequency and the name of the mountaintop. There were 113 different mountaintops or other locations listed; most had only one repeater, but several had ten or more. Geographical coordinates are not available through NARC to pinpoint the repeater locations, so only repeaters

on the more widely known mountains and ridges could be accurately located. Table D-3 lists some of the repeaters known to be within line-of-sight of PAVE PAWS. There may be others. Included in the table is a ham repeater on the Sutter Buttes only about 25 miles from PAVE PAWS, but not included in either the NARC listing or in the ARKL Directory (Powell, 1978). Some amateur repeaters in the San Francisco Bay Area, such as those on Grizzley Peak and Mt. Allison, are either in line-of-sight, or just beyond so that PAVE PAWS signals might be diffracted to them.

Section D.2.6.2 discusses the illumination of ground-based objects. A given mountaintop repeater could be illuminated by the first sidelobe when the surveillance main beam was in two adjacent beam positions, but generally only surveillance beams (and not tracking beams) would be directed at such low angles. Estimates for the pulse rates resulting from the first sidelobe and the higher-order sidelobes (without consideration of frequency-hopping) are as shown on the first two lines of Table D-4. Because PAVE PAWS hops among 24 channels in the 420 to 450 MHz band, only one out of 24 of the PAVE PAWS pulses transmitted will be at the frequency of the receiver. Those on-frequency pulses are indicated on the lower half of the table. The on-frequency pulses will not occur frequently, and those from the first sidelobe will be so infrequent that they will be of no real concern.

A typical repeater has an antenna with gain of about 10 dBi and has about 1 dB loss in the antenna-to-receiver feedline. Its sensitivity (for 20 dB quieting) is about -117 dBm. Assuming that the mountaintop repeater is in line-of-sight of PAVE PAWS at a distance of d miles and that it will be illuminated by the PAVE PAWS first sidelobe, the on-frequency PAVE PAWS signal level will be about

$$I = 25.3 - 20 \log d \quad \text{dBm}$$

at the receiver input terminals. This is shown as the top curve on Figure D-6. The on-frequency signal from the higher-order sidelobes will be about 18 dB lower at

$$I = 7.3 - 20 \log d \quad \text{dBm},$$

which is also shown on Figure D-6. Some PAVE PAWS pulses spread considerable energy outside their nominal frequency. The most commonly occurring PAVE PAWS pulse (see Section D.2.6.2, p. D-15) is the 300-microsecond short-range surveillance pulse; it is also the one with the greatest frequency spread. Figure D-7 shows an estimate of the upper bound of this pulse's frequency spread (from Beran, 1978), which can be used as a subtractive term on the equations above to estimate the level of the PAVE PAWS pulse at frequencies above or below its nominal frequency. Thus, the level

Table D-3

SOME AMATEUR RADIO REPEATERS

AND THE ESTIMATED PAVE PAWS SIGNAL LEVELS

Location And No. of Repeaters	Approximate Distance from PAVE PAWS (Mi)	Direction	Approximate Height (Ft)	PAVE PAWS Line-of- Sight Signal Levels (dBm)		
				First Sidelobe	Higher- Order Sidelobes	
Sutter Buttes (1)	25	NW	2,100	- 3	-21	
Cohasset Ridge (2)	55	N	2,000	-10	-28	
Berryessa Peak (1)	55	SW	3,000	-10	-28	
Mt. Vaca (18)	65	SW	2,900	-11	-29	
Mt. Diablo (9)	70	S	3,800	-12	-30	
Grizzly Peak (6)	70	SW	2,000			
Mt. Allison (7)	100	S	2,600			

Table D-4

PAVE PAWS PULSE RATES AT MOUNTAINTOP REPEATERS

Source (Type of Sidelobe)	Pulse Type			
	Long-Range Surveillance	Short-Range Surveillance		
All 24 PAVE PAWS Channels	First	0.48 pps	0.94 pps	0a
	Higher-Order	14.6 pps	28.3 pps	30 pps
Any Single PAVE PAWS Channel	First	0.02 pps (1 pulse/50s)	0.04 pps (1 pulse/25s)	0a
	Higher-Order	0.61 pps (1 pulse/1.6s)	1.2 pps (1 pulse/0.35s)	1.25 pps (1 pulse/0.8s)

a The tracking pulses would not generally be directed so low that the first sidelobe would hit the horizon.

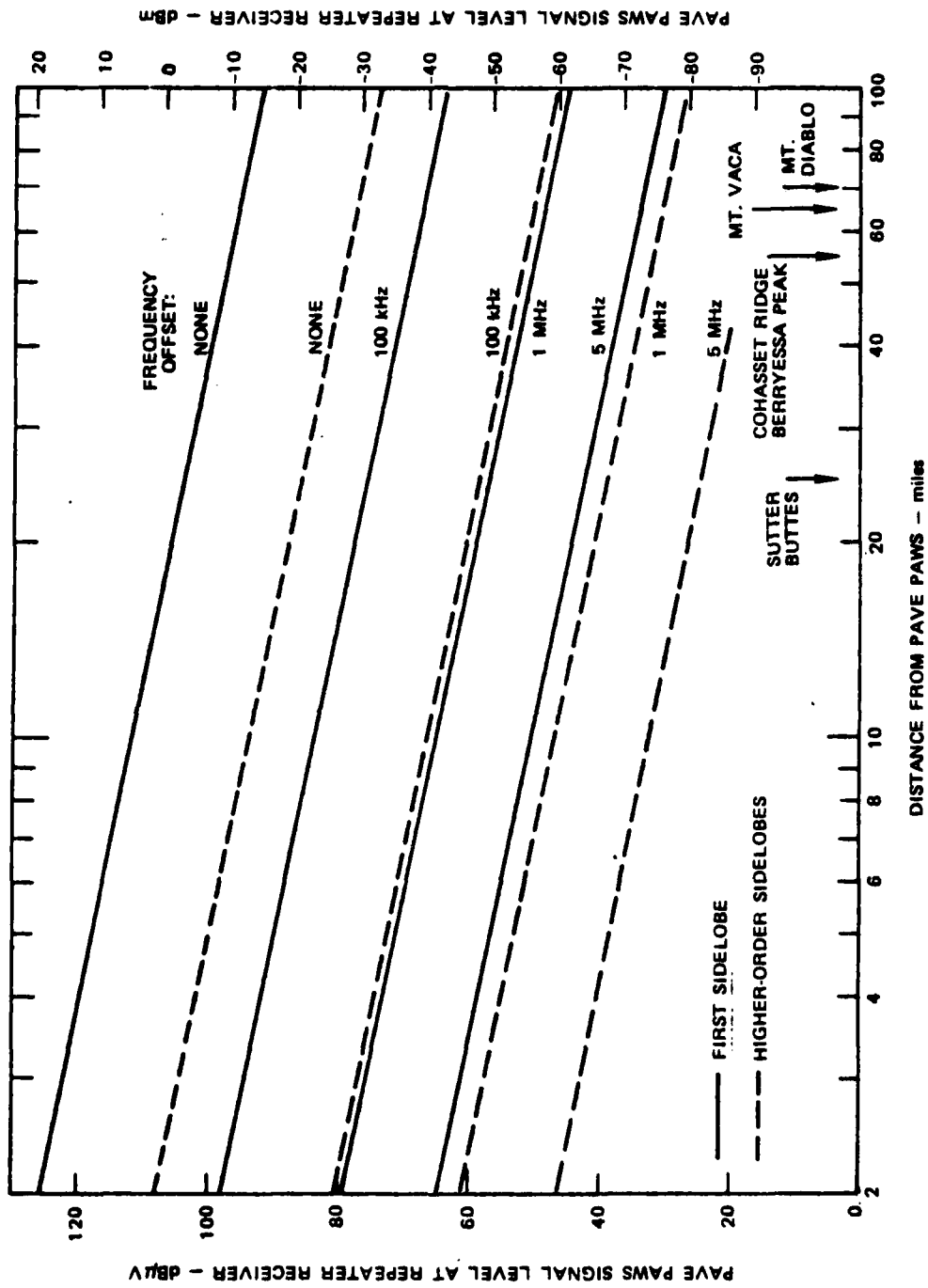
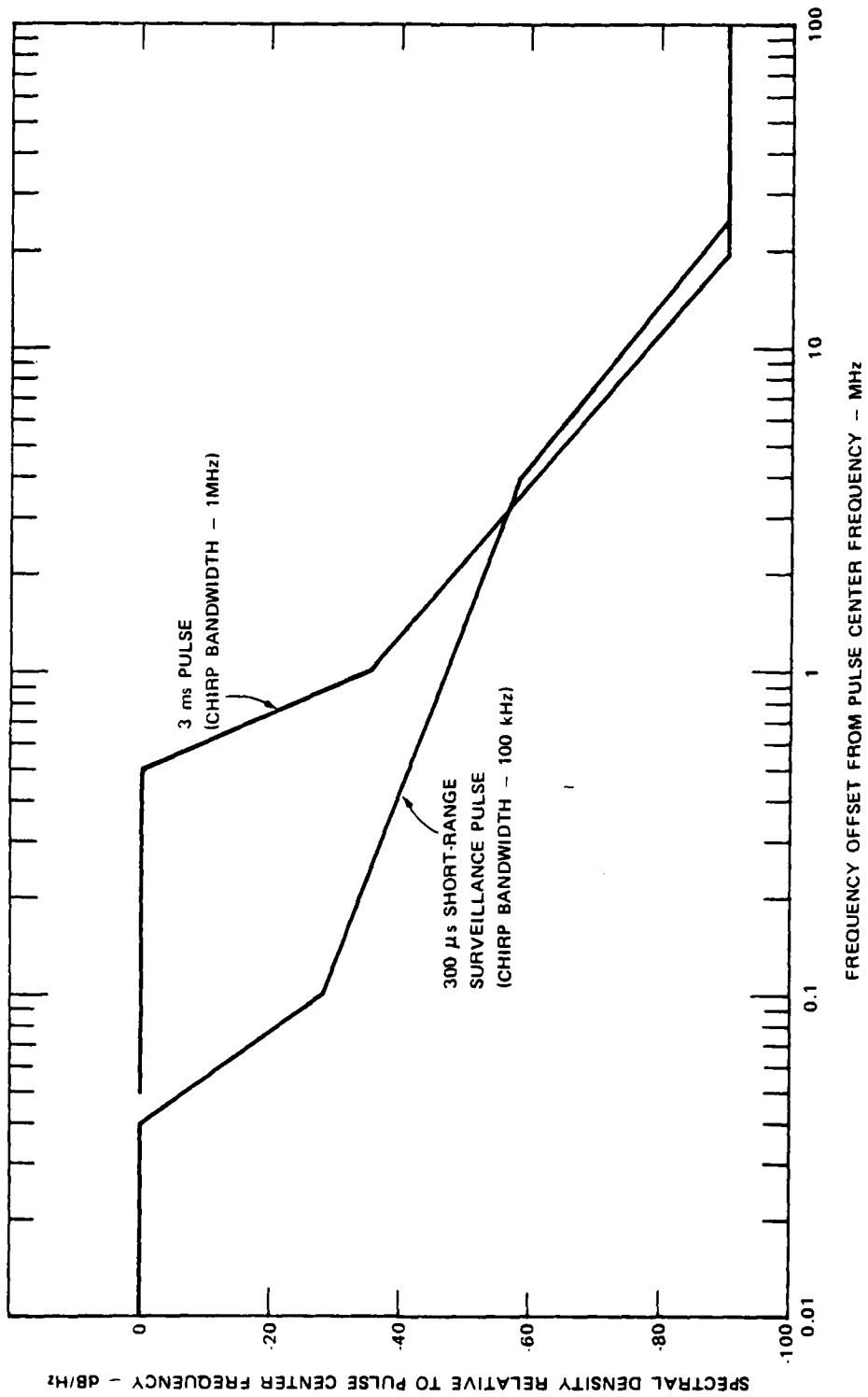

FIGURE D-6. PAVE PAWS SIGNAL LEVELS AT MOUNTAIN-TOP REPEATERS



Source: BERAN, 1978

FIGURE D-7. RELATIVE SPECTRAL DENSITY BOUNDS OF PAVE PAWS PULSES

caused by the first sidelobe when it is offset from the frequency of the repeater is about

$$I = 25.3 - OF - 20 \log d \quad \text{dBm.}$$

The off-frequency term, OF, can be taken directly from Figure D-7 and is about 28 dB for PAVE PAWS signals 100 kHz (0.1 MHz) from the repeater's receiver frequency, about 47 dB when PAVE PAWS is 1 MHz from the repeater's frequency, and so on. Various signal-level estimates for off-frequency PAVE PAWS pulses are also shown on Figure D-6.

The levels of the desired signals will, naturally, vary widely, but they can reasonably be estimated to be below about -67 to -57 dBm (50 to 60 dB above system sensitivity). It follows, then, that the PAVE PAWS signals that sweep directly through the repeater's bandwidth will have strength far exceeding that of the desired signals. Although the stronger, first-sidelobe, pulses will occur very infrequently, the higher-order sidelobe pulses will occur at a rate of about 3 pulses per second (including both surveillance and tracking pulses). The receiver will also be subject to some of the off-frequency, short-range surveillance pulses; if those pulses have sufficient energy at the receiver frequency, the receiver will react as if they were simply additional on-frequency pulses. The apparent pulse rate would then be higher; if all of the 300-microsecond, short-range surveillance pulses were received, it would be almost 30 pps.

From the standpoint of the receiver, the pulses would all be on-frequency pulses, and they could not be excluded by filtering. In general, though, they will affect a receiver only when it is also receiving a desired signal. Receivers have a squelch circuit that cuts off the audio system in the absence of a desired signal. Hurt and Sigurst (1978) state that a signal must be present continuously for 10 ms or more for the squelch to operate. (The time varied from 10 to 78 ms among four different units they tested.) Similar circuitry is used in repeaters so that received pulses are not sent to the transmitter portion for retransmission. If the squelch were to open, the effect at a repeater would be that the transmitter would transmit noise for an appreciable fraction of a second; squelch break at an ordinary receiver would give the listener a similar, short burst of noise. One type of tracking pulse is 16 ms long, and higher-order-sidelobe energy from this pulse might cause squelch break in some receivers. The occurrence statistics of this pulse depend on the objects being tracked, and are not known. Shorter pulses would not be likely to break squelch.

When the receiver is being kept "on" by a desired signal, those pulses that are stronger than the desired signal will be heard, although it is not clear how they will affect efforts to communicate. A similar type of interference is caused by

automobile ignition noise, for which the pulse rates are typically about 100-200 pps, although they are much shorter. Many mobile receivers use an impulse blanker to cut off the signal to the audio stages for the duration of an impulse. (Germain, 1962; Smith, 1962). Similar impulse-blanking techniques may be useful to reduce the effect of the PAVE PAWS pulses.

Discussion thus far has centered on the on-frequency energy, whether caused by PAVE PAWS pulses that were on-frequency or by the spreading of energy from pulses that were not on-frequency. PAVE PAWS will also induce strong off-frequency signals on the receiver antenna. They may be strong enough to desensitize the receiver, or if there are other nearby transmitters, their signals may combine with the PAVE PAWS signals to result in the generation of intermodulation products in the receiver and therefore to degrade performance. That is a common problem when several transmitters are operated in close proximity. If insufficient isolation is provided by the duplexer (which is principally used to keep the transmitter signal out of the receiver), then additional filtering is required. Simple band-pass cavity filters, available commercially, will provide almost 20 dB additional attenuation at 1 MHz from the receiver center frequency, 40 dB at about 7 MHz from the receiver frequency and so on. They are also available with tunable notches to discriminate greatly against particular frequencies.

To summarize the probable effects of PAVE PAWS on amateur radio operation in the 440-450 MHz band, it appears that many mountaintop repeaters in Northern California will be affected. The PAVE PAWS signal is not generally expected to break the squelch, so that there would be an effect only when the receiver is receiving a desired signal. Then, the PAVE PAWS pulses will be heard, although annoyance to the listener or their effect on the intelligibility of conversation is not known. From the standpoint of the receiver, the pulses will be on-frequency pulses that cannot be filtered out. Impulse-blanker techniques may be useful to minimize their effects on the listener. Strong off-frequency PAVE PAWS signals, which may mix with other strong signals to produce intermodulation products, can be excluded by using bandpass cavity filters.

Mobile operation will often be carried on through the mountaintop repeaters. Then, even though the mobile units can expect lower PAVE PAWS signal levels, any PAVE PAWS pulses that affect the repeaters would be retransmitted to the mobile unit. (This would apply even if the mobile unit were located where no PAVE PAWS signal reached.)

D.3.1.1.2 Moon-Bounce. A small number of amateurs are engaged in weak-signal experimentation in the band 432.0-432.1 MHz. About 100 amateur stations communicate by moon-bounce (Baldwin, 1978).

That is, they propagate signals to other stations by reflecting them off the moon, using antennas with gains in the vicinity of 24 dBi. Thus, assuming a 1-kw (60 dBm) transmitter power, their effective radiated power is about 84 dBm. The effective radiated power of the higher-order sidelobes for the PAVE PAWS basic system is about 88 dBm (2.5 times as great as the amateurs' signals). Thus we can expect that an amateur moon-bounce link could receive moon-bounce interference from PAVE PAWS when the moon is visible to both of the amateur stations involved and to a face of PAVE PAWS. Because of PAVE PAWS frequency-hopping, the moon-bounce experimenters would receive 1/24th of the PAVE PAWS pulses. The PAVE PAWS main beam is never directed toward the moon.

D.3.1.1.3 The OSCAR Satellites. The amateurs are authorized to use satellite transponders in the band 435 to 438 MHz. Currently, two amateur satellites are in orbit, OSCAR 7 and OSCAR 8 (Orbiting Satellite Carrying Amateur Radio); both are in near-polar orbit. Table D-5 presents some information on their orbits and frequencies (Kleinman, 1978; Harris, 1978; Glassmeyer, 1978). Both OSCARs transmit information on the condition of the satellites' batteries and other subjects. Each has two linear transponders that accept single-sideband voice or CW (code) signals in one band and retransmit them in another. OSCAR 7's "Mode B" transponder receives within the PAVE PAWS band and Oscar 8's "Mode J" transponder transmits within that band.

According to the magazine QST, "the Mode J transponder is expected to be operational during weekends, although not continuously." More recent information is that operation now averages 96 hours per week (Tuesdays, Fridays, Saturdays, and Sundays, Universal Time) (Baldwin, 1979b). +

OSCAR 7 and OSCAR 8 orbit the earth 12.5 and 14.0 times per day respectively. On passes that go directly over PAVE PAWS, OSCAR 7 will be in the line of sight of the radar for 22 minutes and OSCAR 8 for 17 minutes. These are maximum line-of-sight times; the time will be less for all other satellite passes. When they are within the line of sight, the satellites are illuminated by the radar in the same way as are the aircraft discussed in Section D.2.6.1, p. D-13. Radar energy reflected from the moon could also illuminate the satellites as well as the amateurs' ground stations.

No analysis of the susceptibility of the OSCAR satellites and the ground receivers to the PAVE PAWS is included here, although the amateurs themselves are said to be "carefully studying the problem" (Ham Radio Magazine, August 1978). As yet, the OSCAR satellites are not heavily used, partly because the required equipment (particularly for receiving OSCAR 8's 435-MHz downlink) is not widely available (Kleinman, 1978). Another satellite is planned for launch early in 1980 (King, 1977; Baldwin, 1979a).

Table D-5

SOME PARAMETERS OF CURRENTLY ORBITING AMATEUR SATELLITES

	<u>OSCAR 7</u>	<u>OSCAR 8</u>
Orbit period	115 min	103 min
Orbits per day	12.5	14.0
Maximum time per orbit within view of PAVE PAWS	22 min	17 min
Altitude	1,500 km	900 km
Inclination ^a	102 deg	99 deg
Frequencies (MHz)		
"Mode A"		
Uplink	145.88-145.95	145.85-145.95
Downlink	29.4 - 29.5	29.4 - 29.5
"Mode B"		
Uplink	432.125-432.175	--
Downlink	145	--
"Mode J"		
Uplink	--	145.9 -146.0
Downlink	--	435.1 -435.2
Telemetry Beacons	29.502, 145.972	29.402, 435.095

^a Inclination is the angle between the orbit's track and the equator. Zero degrees describes an equatorial orbit, with the satellite moving east; 90 deg is a polar orbit. Angles greater than 90 deg imply that the satellite moves west.

It may be possible, because the satellites' orbits are known, to program PAVE PAWS frequency usage (consistent with operational requirements) so that the PAVE PAWS frequencies that would interfere with a satellites' transponder would not be used during the periods that the satellite is visible. It may also be possible, when operational requirements permit, to avoid use of the 432-MHz frequency when the moon is visible, to avoid interference to moon-bounce communications.

D.3.1.2 Interference to Television

D.3.1.2.1 The Television Environment near Beale AFB. Several of the VHF TV channels (those between 2 and 13) and UHF TV channel 40 are received directly in the vicinity of PAVE PAWS. (Other TV signals are brought into the area by microwave.) Table D-6 lists the directly received channels and shows the frequency bands they occupy.

The Marysville/Yuba City/Beale AFB area is about 60 miles north of the 1,500-ft transmitting tower used by some of the Sacramento TV stations and is about 50 miles south of Chico. The area is generally on or within the Grade B service contours for Sacramento stations and within the Grade A contour for the Chico station. The contours are of predicted TV signal strength. At the Grade A contour, the median field strength at a 30-ft antenna height must be such as to provide service, at the best 70% of the receiving locations, that the median observer would consider "acceptable" at least 90% of the time, using an antenna equivalent to a half-wave dipole. At the Grade B contour, the median field strength at the 30-ft antenna height is such as to provide the median observer with "acceptable" TV reception, but only at the best 50% of the receiving locations and only if an antenna with a gain 6 dB better than that of a dipole is used.

Some TV viewers in the Marysville/Yuba City/Beale AFB area receive broadcast TV signals directly, using their own antennas, but about 75% of the approximately 20,000 TV households in the area subscribe to a cable service provided by NorCal Cablevision of Yuba City. The system also provides service to other communities in the upper Sacramento Valley.

The three major parts of the cable TV system serving Beale AFB and the surrounding communities are:

- (1) The receiving system in Marysville
- (2) The receiving and distribution system on Kelly Ridge near Oroville
- (3) The cable TV signal distribution system.

They are shown in the block diagram of Figure D-8. Basically, some TV signals are received at Marysville through common-carrier microwave and are then retransmitted to Kelly Ridge, about 25 miles northeast of Marysville and about 3 miles east of Oroville, by the cable TV company's microwave system. In addition, various broadcast TV signals are directly received at Kelly Ridge, and some programming is received there via satellite. Those signals are combined with the ones on the microwave link from Marysville, and the entire package of TV signals is sent by six separate microwave links to surrounding communities. One of the microwave links brings the signals back to Marysville, from which they are

Table D-6
 TV CHANNELS RECEIVED IN THE VICINITY OF PAVE PAWS^a

TV Channel	Band (MHz)	Video Carrier Frequency (MHz)	Local Oscillator Frequency (f) (MHz) LO	Origin
2	54-60	55.25	101	Oakland
3	60-66	61.25	107	Sacramento
6	82-88	82.25	129	Sacramento
7	174-180	175.25	221	San Francisco
9	186-192	187.25	233	Redding
10	192-198	193.25	239	Sacramento
12	204-210	205.25	251	Chico
13	210-216	211.25	257	Sacramento
40	626-632	627.25	673	Sacramento

^aThis includes TV signals picked off-the-air by NorCal Cablevision, but excludes those brought into the area by microwave.

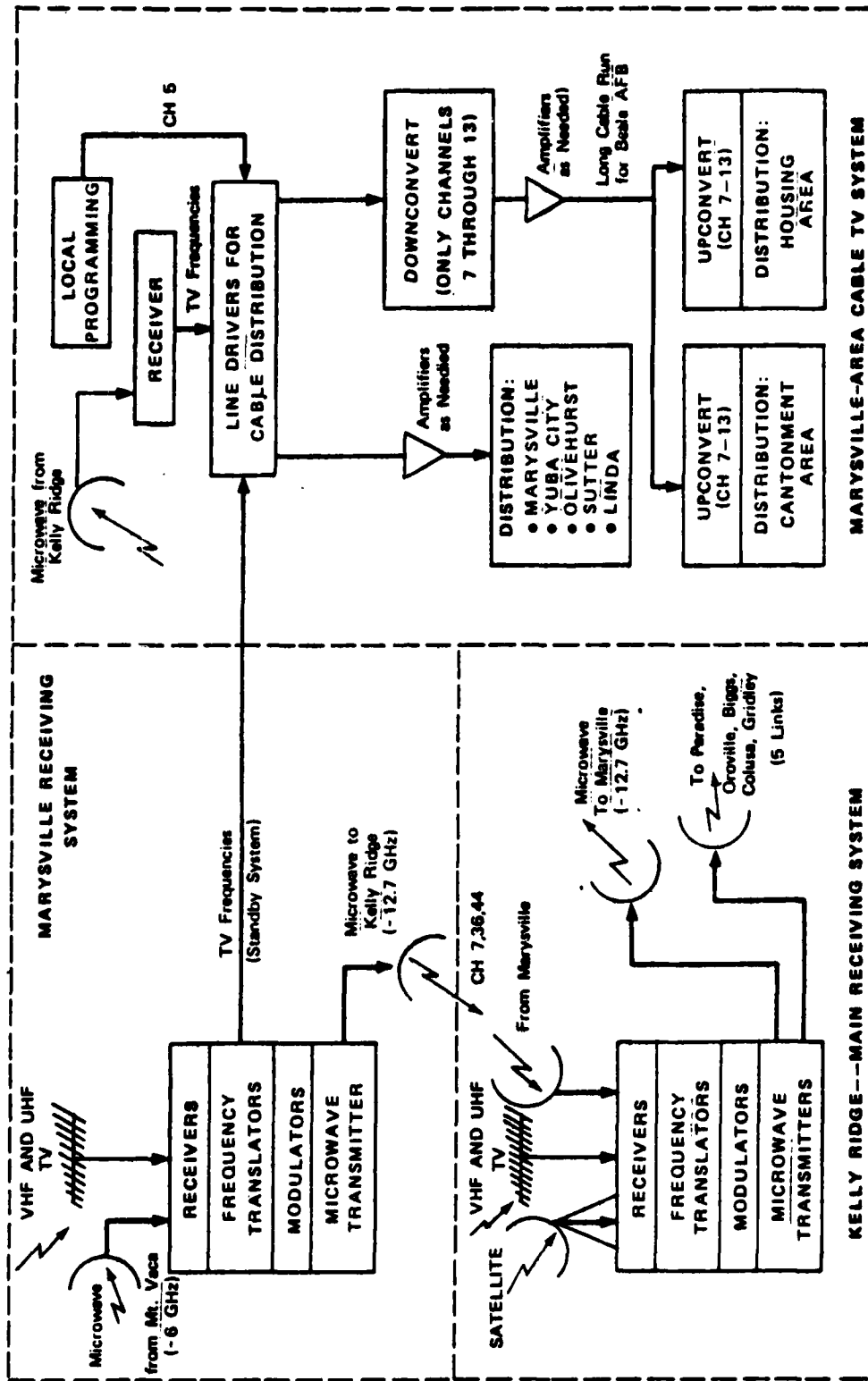

FIGURE D-8. CONCEPTUAL DIAGRAM OF THE CABLE TV SYSTEM IN THE VICINITY OF BEALE AFB

distributed by cable throughout the Marysville/Yuba City area and also to Sutter, Olivehurst, and Beale AFB. (The identical package of signals is not sent to each of the communities. For example, in the Marysville area, channels 7 and 9 (as distributed) are derived from San Francisco's channel 9 and from San Jose's channel 36 -- both relayed by microwave link; in other areas, channels 7 and 9 contain the programming of those channels as broadcast in Chico.

Normally, only channels 7, 36, and 44 are received (by microwave) at Marysville, and all the other reception takes place at the 100-ft tower on 1,000-ft Kelly Ridge. However, if the microwave link between Marysville and Kelly Ridge fails, broadcast TV signals received at an 80-ft tower in south Marysville are used for distribution by the Marysville area cable system. (The standby link is shown in Figure D-8.)

Typically the receiving systems use 10-element Yagi antennas for receiving TV broadcast signals, and dishes for the microwave signals. The TV frequencies as distributed to the subscribers' TV receivers are not, in all cases, the same as originally received. Table D-7 indicates the frequency translations, which are done at the receiving sites. The receivers resemble standard TV tuners in that their local oscillators are about 44 MHz above the RF frequency, and the IF band is from 41 to 47 MHz. In all cases, the TV signals are brought down to the IF and then remixed to translate them back up to a frequency band in the VHF TV spectrum. As examples, channel 3 remains in the 60-66 MHz band, but channel 40 is translated from its UHF band (626-632 MHz) so that the subscriber will find it in the channel-11 position--198 - 204 MHz. Several TV channels (for example, San Francisco's channel 7 and San Jose's channel 36) are translated to frequencies not accessible to the normal TV receiver. There is spectrum space for about 14 TV channels between channel 6 and channel 7; the programming placed on the cable system at those frequencies can be made available to the subscriber's receiver through a special frequency-converter on the premises.

If the microwave link between Kelly Ridge and Marysville fails, all reception for the Marysville area takes place at Marysville. Some signals will then not be available to local subscribers. The channel 2 signal, normally received at Kelly Ridge as a broadcast signal, will then be received at Marysville by means of the common-carrier 6-GHz microwave link.

The distribution system uses mostly above-ground coaxial cable, with amplifiers spaced appropriately. The cable generally carries all of the VHF TV signals (including the midband channels between channels 6 and 7) at the frequencies to which they have been translated. The exception to this rule is the bandwidth-limited cable run to Beale AFB. There, channels 2 through 6 and FM radio are at their normal frequencies, but

Table D-7
CABLE TV CHANNELS AND THEIR RECEPTION

TV Signals Distributed in the Marysville Area		Signals as received at the Kelly Ridge Receiving Station			Signals as received at the Marysville Receiving Station				
Channel	Frequency (MHz)	Original Channel	Frequency (MHz)	Location	Receive Mode *	Original Channel	Frequency (MHz)	Location	Receive Mode *
2	54 - 60	2	54 - 60	Oakland	Broadcast	2	~ 6000	Oakland	S micro
3	60 - 66	3	60 - 66	Sacramento	Broadcast	3	60 - 66	Sacramento	Broadcast
4	66 - 72	44	12700	San Francisco	MC micro	44	6000	San Francisco	S micro
5	76 - 82	(Channel 5 is local programming inserted at Marysville)							
6	82 - 88	6	82 - 88	Sacramento	Broadcast	6	82 - 88	Sacramento	Broadcast
4	120 - 126	7	12700	San Francisco	MC micro	Not received here			
6	156 - 162	36	12700	San Jose	MC micro	Not received here			
8	162 - 168	Special programming via satellite							
1	168 - 174	Not received here							
7	174 - 180	7	174 - 180	Redding	Broadcast	7	6000	San Francisco	S micro
8	180 - 186	31	572 - 578	Sacramento	Broadcast	31	572 - 578	Sacramento	Broadcast
9	186 - 192	9	186 - 192	Redding	Broadcast	36	6000	San Jose	S micro
10	192 - 198	10	192 - 198	Sacramento	Broadcast	10	192 - 198	Sacramento	Broadcast
11	198 - 204	40	626 - 632	Sacramento	Broadcast	40	626 - 632	Sacramento	Broadcast
12	204 - 210	12	204 - 210	Chico	Broadcast	12	204 - 210	Chico	Broadcast
13	210 - 216	13	210 - 216	Sacramento	Broadcast	13	210 - 216	Sacramento	Broadcast

* Broadcast means off-the-air reception of broadcast TV, MC micro means NorCal Cablevision microwave link, S micro means Sierra Microwave link

channels 7 through 13 are converted to frequencies 168.25 MHz lower than normal, placing them lower in frequency than channel 2. (The midband channels are eliminated.) Two upconverters translate channels 7 through 13 back to their normal position so that the subscribers' TV receivers can use them. One upconverter is located near the intersection of Warren Shingle Road and Beale Highway to serve the housing area. The other is near Warren Shingle Road and C Street to serve the cantonment area.

D.3.1.2.2 Television Receiver Susceptibility to Interference.

Degradation to TV reception is said to occur when an observer can detect the presence of the interfering signal. For television reception, interference with the video portion generally occurs first. That is, the video effect is usually perceptible at lower interfering-signal levels than are required for a perceptible audio effect.

Only very limited tests have been conducted using real and simulated PAVE PAWS signals to determine their ability to interfere with TV reception. MITRE has experimented with simulated PAVE PAWS signals, using 3 monochrome TV receivers and 1 color TV receiver, and they have also operated a small, portable, battery-operated, black-and-white TV receiver in the vicinity of the East Coast PAVE PAWS (MITRE, 1978). Their work with the simulated signals corroborates other results described here. They were able to operate that particular portable set within 3,400 ft of PAVE PAWS (although the set was probably shielded by heavy vegetation) without noticeable degradation to the channel 10 signal. They have also observed TV reception at two motels in Sandwich within about 2 miles of the radar and could see no interference. However, that town is better shielded by both terrain and foliage than are the West Coast communities.

D.3.1.2.2.1 Saturation Responses. Tests by Conklin (1974)

suggest that strong signals in the PAVE PAWS frequency band can affect TV reception. The pulse width of the interfering signal apparently does not make much difference in the interference threshold. Conklin describes the appearance of (nonsaturating) pulsed interference as dashes appearing at the beginning and at the end of the pulse, saying that "nothing is visible during the remaining period that the pulse is on, since the steady-state portion is regarded by the receiver the same as a CW signal is." Thus, a nonsaturating pulse provides two groups of dashes at widely separated parts of the TV screen. However, if the interfering signal is strong enough to saturate the TV receiver, the pulse width is important because the pulse wipes out the picture for an instant between the two groups of dashes.

For reasons having to do with the PAVE PAWS pulse repetition frequency and the frequency offset from the TV channels, strong

PAVE PAWS signals could saturate a TV receiver. Conklin says that the saturation response level is relatively insensitive to the level of the TV signal itself and that saturation will occur at an interference power level at the receiver of approximately 12 mW (+11 dBm). No information was given on how many TV sets were examined to obtain that number or on how many viewers were used as subjects.

The power level at the receiver terminals can be related to the corresponding electromagnetic field power density by considering the TV antenna's effective aperture and accounting for some loss in the feedline. The effective receiving area, a , of an antenna is directly proportional to its gain, g . (See P. 25-8 of Reference Data for Radio Engineers.) At a frequency of 435 MHz (the middle of the PAVE PAWS band), the aperture is approximately $a = 0.038g$ square meters.

TV antennas near PAVE PAWS will generally be pointed either south for the Sacramento stations or north for Chico. Therefore, the circularly polarized and far out-of-band PAVE PAWS signal will generally hit the horizontally polarized antenna from the side. Antenna gain for such an unexpected situation is not documented, so we estimated that the average gain will be that of an isotropic antenna (i.e., $g = 1$). In that case, the receiving area would be about $a = 0.038 \text{ m}^2$. Power density and power at the receiver terminals are typically expressed in decibels; a similar expression for the receiving area is

$$A = 10 \log a = -14.2 \text{ dB relative to } 1 \text{ m}^2.$$

Now the power density (in dBm/m²) corresponding to some known power at the TV receiver (in dBm) can be estimated by adding 14.2 dB for the aperture plus about 2 dB to account for losses in the antenna lead (O'Connor, 1968). Applying this method to the 11-dBm saturation level of Conklin yields an equivalent field of $11 + 14.2 + 2 = 27.2 \text{ dBm/m}^2$, which is quite close to the power density levels found for threshold high-power effects.

D.3.1.2.2.2 Spurious Responses. A receiver can accept and process signals at frequencies far from the one to which it is tuned. Such an action is called a spurious response, and the interfering frequency that produces it is called a spurious response frequency. Spurious response frequencies, f_{sr} , are found by solving the equation:

$$f_{sr} = \text{abs}\left(\frac{p f_{LO} \pm f_{IF}}{q}\right)$$

where f_{LO} = the receiver's local oscillator frequency (about 44 MHz higher than the center of the TV channel)

f_{IF} = the receiver's intermediate frequency
 p, q = integers denoting the harmonics of the local oscillator and the interfering frequency, respectively,

and abs indicates the absolute value of the expression.

PAVE PAWS frequencies can cause spurious responses in TV receivers. The TV receiver IF passband extends from 41 to 47 MHz. When we set $p = 2$, $q = 1$, we are in effect searching for strong external signals that can mix with the second harmonic of the local oscillator so that the difference frequency falls within the IF passband and is amplified as if it were part of the desired TV signal. Figure D-9, shows that VHF channels 9 through 11 are potentially susceptible to spurious responses of the type $p = 2$, $q = 1$ caused by PAVE PAWS. Higher-order spurious responses in the VHF TV band may also occur, but only when the levels of the interfering signal are much higher. Channels 9 and 10 will be of concern because they are used in the PAVE PAWS area, whereas channel 11 is not. Spurious responses would also occur in UHF TV channels 60 through 83 for $p = 1$, $q = 2$, but those TV channels are not in use in the vicinity of PAVE PAWS.

The channel-10 spurious response of 12 color TV receivers were measured; the results, shown in Figure D-10, show a large range in the susceptibility thresholds of various TV receivers. The two curves indicate the mean susceptibility level and a level for the more susceptible receivers. No data were provided for the less susceptible half of the sample. The interfering signal had pulse widths of 100 microseconds, 200 microseconds, and 1,000 microseconds, with a PRF of 40 pps. Although the frequencies involved are the same as those of PAVE PAWS, this information does not permit us to predict whether higher or lower thresholds of susceptibility would result from using the actual PAVE PAWS signal, with its mix of pulse widths and its unusual "PRF." The measurements represented by Figure D-10 were made at a TV signal level of -77 dBm at the TV receiver terminals. Figure D-11 shows how the pulse interference threshold increases as TV signal strengths increase.

D.3.1.2.2.3 High Power Effects. High power effects result when a strong signal couples power directly into a system's internal circuitry and components. Measurement programs have been conducted to determine power-density thresholds for high power effects for TV receivers. The PRF and pulse widths of a radar system somewhat similar to PAVE PAWS were used. In one program, five black-and-white and two color sets, all made in or before 1967, were used. Mean power density thresholds of about 30 dBm/m² (100 microwatts/cm²) were found, which are independent of the level of the desired TV signal. Use of a preamplifier with

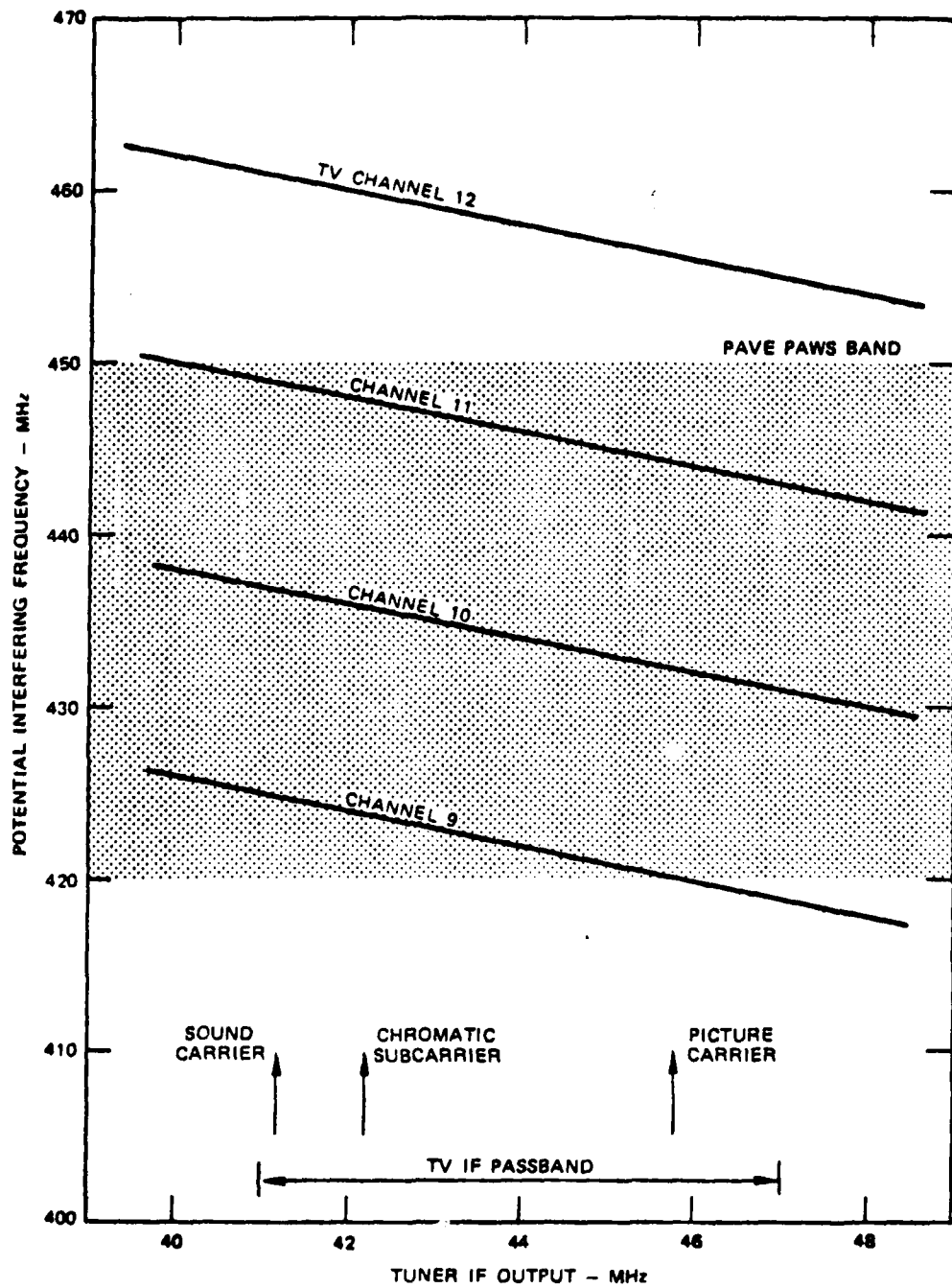

FIGURE D-9. TELEVISION RECEIVER SPURIOUS-RESPONSE FREQUENCIES IN AND NEAR THE PAVE PAWS BAND ($p = 2, q = 1$)

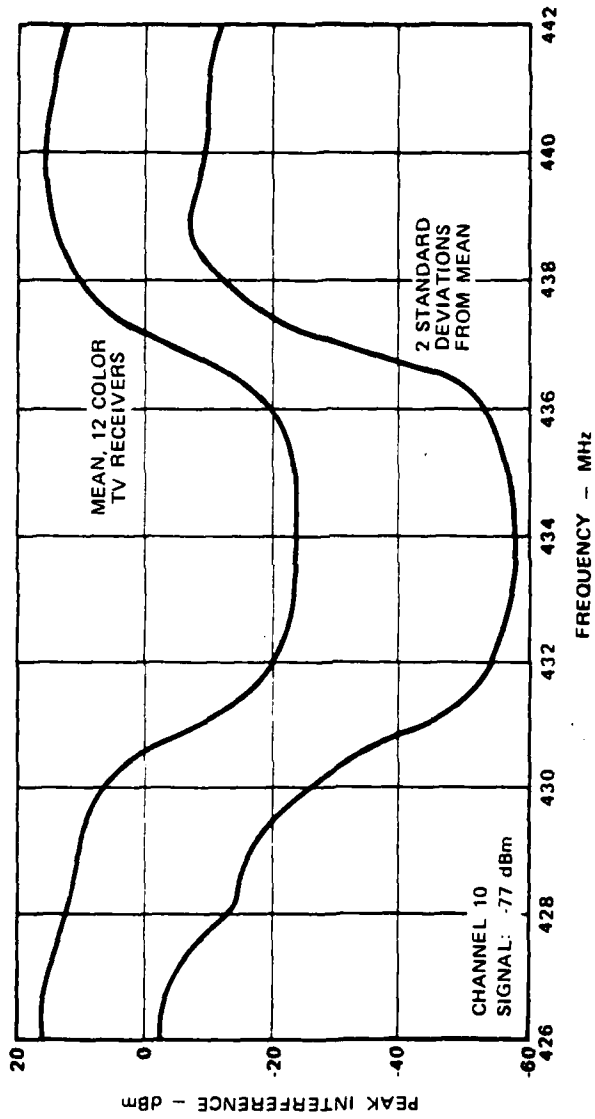

FIGURE D-10. TV CHANNEL-10 INTERFERENCE THRESHOLD FOR $p = 2, q = 1$ SPURIOUS RESPONSE

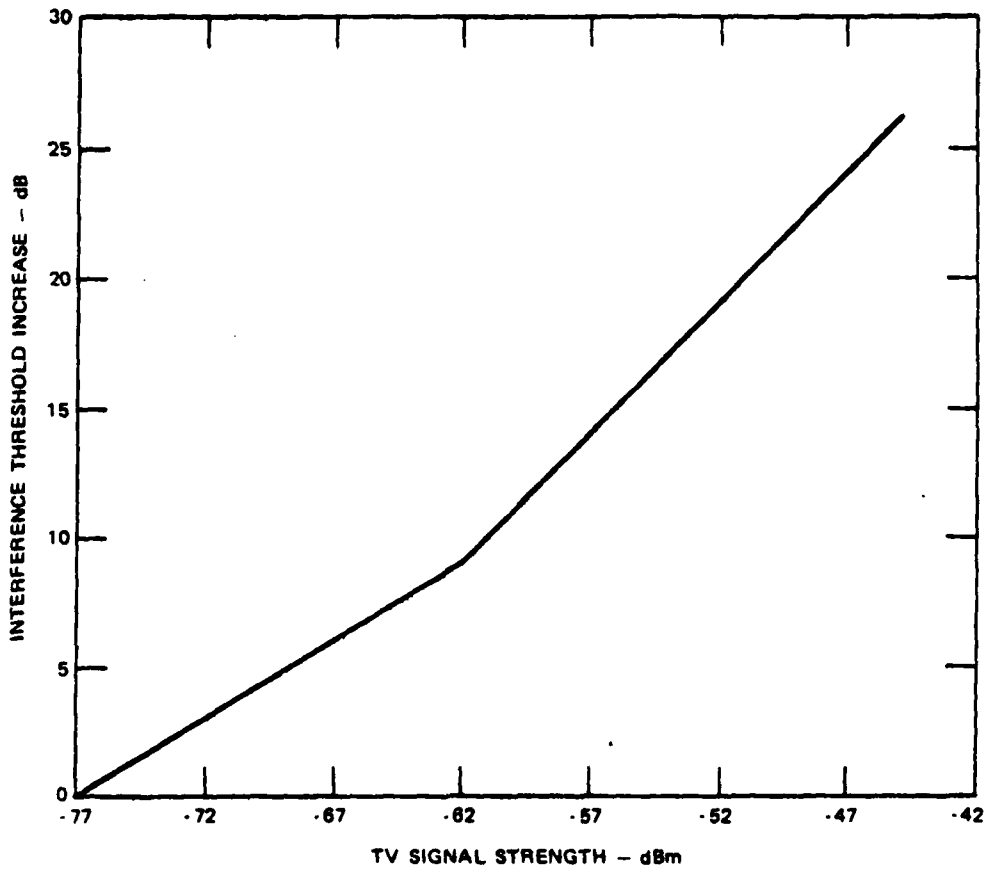

FIGURE D-11. INTERFERENCE-THRESHOLD INCREASE FACTOR FOR TV SIGNAL STRENGTH HIGHER THAN -77 dBm

the TV antenna resulted in threshold susceptibility levels about 10 dB lower. Some of these data have recently become more widely available (Donaldson, 1978).

In another program, 45 TV receivers (1970 models, 15 monochrome and 30 color) were used. At the PAVE PAWS frequency, the mean susceptibility threshold was about 24 dBm/m². This work was done at a PRF of 300 pps with a pulse width of 10 microseconds; PAVE PAWS signals may be less disruptive. The data included here as Table D-8 were reported, and although the measurement conditions used to obtain those data were not specified, the frequency band (420 to 450 MHz) is appropriate. Another program reports that for TV channels below 18, most of the degradation results from antenna-coupled interference.

D.3.1.2.2.4 TV Receiver Susceptibility to PAVE PAWS Signals.

Based on the foregoing analysis, our best estimate is that reception of VHF TV channels could be affected by PAVE PAWS signals greater than about 11 dBm at the antenna terminals (or a power density of about 27 dBm/m²) regardless of the strength of the desired TV signal strength. Channel 10 will be particularly sensitive, through the spurious response mechanism, to PAVE PAWS signals in the frequency range 431 to 437 MHz; channel 9 will be similarly sensitive to those in the range 420 to 425 MHz. The effect is more pronounced when the signal-to-interference level is lower.

The TV receiver susceptibilities are best compared in terms of electromagnetic field quantities. The high-power effects presented in Table D-8 are already in power density terms. Using the procedure discussed in Section D.3.1.2.2.1, the 11-dBm saturation threshold suggested by Conklin (1974) is converted to approximately 27 dBm/m² (50 microwatts/cm²) as the equivalent field power density.

Table D-8

INTERFERENCE THRESHOLD LEVELS FOR VHF TV VIDEO
HIGH-POWER EFFECTS FROM SIGNALS IN THE PAVE PAWS BAND --
in dBm/m²^a and (microwatts/cm²)

	Threshold	
	Worst Case	Mean
Wide-band response	18 (6.3)	(87)
Spurious response	-29 (0.00013)	-7.3 (0.019)

^adBm/m² = decibels above 1 milliwatt per square meter

The same method can be applied to the vertical scale of Figure D-10, p. D-40, to determine that the 434-MHz power density that would affect the more susceptible half of the TV receivers is about $-24 + 16 = -8 \text{ dBm/m}^2$ ($0.016 \text{ microwatts/cm}^2$) when the desired channel-10 signal strength (at the receiver terminals) is -77 dBm . Presumably, similar results would be obtained at about 422 MHz for channel 9. Because the concern is principally with reception of TV channel 10 in the area of PAVE PAWS, the Channel 10 signal strength is needed. According to the Television Factbook (1974), the area surrounding PAVE PAWS is about halfway between Grade A and Grade B contours for KXTV channel 10. That means that the median predicted TV field strength there is approximately $E = 64 \text{ dB above } 1 \text{ microvolt/m}$ (0.0016 V/m). O'Connor (1965) relates the field strength to the voltage, V_L , across the receiver terminals, by

$$V_L = E + K_d + G - L \text{ dB above 1 microvolt}$$

where V_L and E are already defined, L is the loss in the antenna lead, G is the TV antenna gain in decibels relative to a dipole, and K_d is called a dipole factor. For the channel 10 frequency band (192 to 198 MHz), $K_d = -6 \text{ dB}$. The line loss will be about $L = 2 \text{ dB}$ and the gain of a typical good Yagi antenna will be about 9 dB relative to a dipole. Therefore, the median value of V_L is about

$$V_L = 64 - 6 + 9 - 2 = 65 \text{ dB above 1 microvolt} = 1,800 \text{ microvolts,}$$

and the power level at the 300-ohm terminals is about

$$\frac{(1,800 \text{ microvolts})^2}{300} = 1.1 \times 10^{-5} \text{ mW} = -49 \text{ dBm.}$$

Figure D-11, p. D-41, which gives the TV signal strength correction factor for Figure D-10, indicates that for a TV signal strength of -49 dBm , we must increase the channel-10 spurious-signal susceptibility by about 23 dB . Therefore, about half of the TV sets would display some perceptible effect when the PAVE PAWS power density is about $-8 \text{ dBm/m}^2 + 24 \text{ dB} = +16 \text{ dBm/m}^2$ ($4 \text{ microwatts/cm}^2$). Figure D-10 indicates that the more susceptible TV sets may be affected by PAVE PAWS signals about 35 dB lower, or at about -19 dBm/m^2 .

The channel 10 spurious-response frequencies lie in the band from 431 to 437 MHz. Six of the PAVE PAWS's 24 frequencies (see Table D-2, page D-12) are therefore capable of producing that spurious response. The channel 10 response to the other 18 PAVE PAWS frequencies would be the same as that of the other TV channels. Therefore, only one-third of the radar pulses are of a frequency that can cause that spurious response.

D.3.1.2.3 Effects of PAVE PAWS on TV Reception Near Beale AFB.

The two preceding subsections discussed the TV environment in the Beale AFB area and the susceptibility of TV receivers in terms of the PAVE PAWS power density. Information of both kinds must be combined to determine the probable effects of PAVE PAWS on TV reception in the area.

TV receivers in the cantonment area of Beale AFB will be illuminated by the PAVE PAWS higher-order sidelobes. In the Beale AFB housing area and in the Yuba City/Marysville area, the TV receivers will be illuminated by the first sidelobe. Figure D-12 shows the pulse power densities for the first sidelobe and for the rms value of the higher-order sidelobes. The curves show the maximum possible power density at a given distance, taking into account only the power loss that results because the available energy spreads over a greater area at a greater distance; this estimate ignores any losses that might be caused by rough terrain or by heavy vegetation, neither of which are particularly applicable to the locale being considered. The curves apply to TV receivers in a clear line-of-sight path to a face of PAVE PAWS. Under the growth option, the curve for the first sidelobe power density would be 6 dB higher and the curve for the higher-order sidelobes would be 3 dB higher.

It was shown earlier that TV receivers would exhibit their saturation response on most channels if the off-tuned PAVE PAWS signal reached levels of about 27 dBm/m² (50 microwatts/cm²) and that high-power effects would occur for only slightly higher levels. Figure D-12 shows that, for the basic system, TV receivers in the cantonment area and the housing area probably will not be saturated. However, for the growth system, there may be both saturation and high-power effects in the housing area but probably still no effects in the cantonment area (because it is not illuminated by the first sidelobe). Although saturation effects would be expected only on receivers using their own antennas, high-power effects are coupled into the receiver through the case and may affect even those TV receivers connected to the cable TV system. The available data are sufficient to suggest a potential problem, but they are not sufficient to define its extent clearly.

The range of thresholds for the channel 10 spurious response is also shown in Figure D-12. (The threshold of susceptibility varies from TV receiver to TV receiver.) Figure D-10, page D-40, and subsequent discussions suggest that about half of the TV receivers would be affected by PAVE PAWS levels of about 16 dBm/m² (4 microwatts/cm²) and above, and that the most susceptible TV receivers would be affected by PAVE PAWS signals 35 dB lower, or -19 dBm/m² (0.0013 microwatts/cm²). (The four sets tested by MITRE, 1978, in their laboratories fall toward the more susceptible end of this range.) Indications are that the most susceptible TV receivers might be affected as far away as 100 miles or more, if they are in the direct line of sight of the PAVE PAWS basic system and are receiving a relatively weak channel 10 signal.

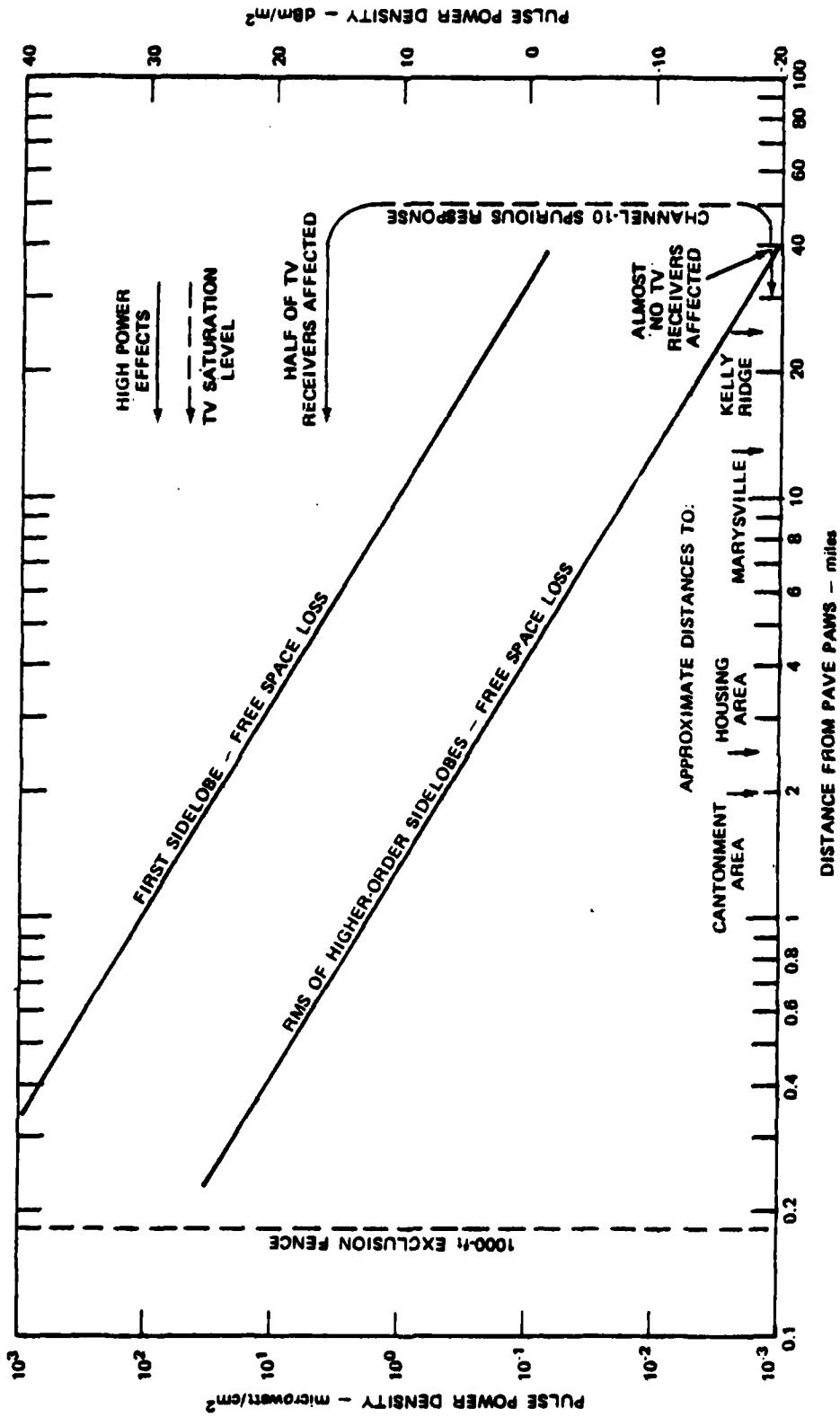

FIGURE D-12. PAVE PAWS SIGNAL STRENGTH AND EFFECTS ON TV RECEPTION

The Marysville/Yuba City area is about 12 miles from and in the line-of-sight of PAVE PAWS, and will be illuminated by the first sidelobe. Figure D-12 indicates that somewhat fewer than half of the TV receivers there that receive channel 10 directly may be affected. For the growth system, about half would probably be affected. There are other communities, as well as many farms, in the Sacramento Valley beyond Marysville. Disruption to channel 10 reception would be less likely there than in Marysville because of the greater distance from the radar. Even so, degradation may occur at distances of 100 miles or more, depending upon the relative strengths of the channel 10 signal and the PAVE PAWS signal, and the susceptibility of the individual TV sets involved.

For the approximately 75% of the TV households in the Marysville/Yuba City area that subscribe to cable TV, the effects of PAVE PAWS will depend on the susceptibility of the NorCal Cablevision receivers that receive the broadcast channel 9 and channel 10 signals directly. If those receivers exhibit a spurious response to the PAVE PAWS signal, that spurious response will be sent to all of the subscribers. Normally the receiver system at Kelly Ridge will supply both channel 9 and channel 10; in the event of difficulties with the NorCal microwave system between Kelly Ridge and Marysville, the Marysville receiving system will receive channel 10 directly, but not channel 9.

The only available data on the thresholds of susceptibility of TV receivers to spurious responses from signals in the PAVE PAWS band apply to home TV receivers, not to those used by the cable TV companies. Their receivers, however, have the same local oscillator and IF frequencies as the tuner in the home TV receiver; therefore, the spurious response mechanism is the same. High-gain antennas are used atop high towers at both receiving locations; therefore, the TV signals at the NorCal receiver terminals are almost certainly considerably higher than those at home installations in the same vicinity.

Because of those differences, it would be difficult to predict the likelihood of PAVE PAWS interference to the cable TV system on the basis of the results of a few tests on home TV receivers. However, enough evidence exists to indicate that PAVE PAWS may cause interference to channels 9 and 10 when it is transmitting in the bands 420 to 425 MHz and 431 to 437 MHz, respectively. Fortunately, preventing the PAVE PAWS signals from entering the cable system's channel 9 and channel 10 receivers to cause the spurious response is not difficult, as will be discussed in the following subsection.

D.3.1.2.4 Ways to Mitigate Interference To Channels 9 and 10.
Although the potential exists for interference with channel 9 and channel 10 in the vicinity of Beale AFB, a number of steps might be taken to alleviate the situation.

First, because this analysis is based on a very limited amount of real data, the interference may be more or less severe than the analysis suggests. Only 12 TV receivers were measured in the late 1960s; PRFs and pulsewidths other than those of PAVE PAWS were used, although the radar frequency band was the same. Susceptibility is also dependent on the TV signal strength. Although the best available estimate was used for the median signal strength for the Marysville area, it could be much higher or lower in particular situations. In addition, the cable TV system's antenna installations are engineered to provide higher signal strengths to the receivers than do most home antennas. Furthermore, the propagation of the PAVE PAWS signal will be highly variable except when in the line of sight. Thus, the extent of the problems with channels 9 and 10 could be somewhat different from what the analysis shows.

The Electromagnetic Compatibility Analysis Center (ECAC) has experimented with simple filters to attach to the back of individual home TV receivers. Figure D-13 shows a sketch of the most simple type; it is a 5 3/8-in piece of flat TV lead-in cable, connected as shown. This filter, which the Air Force would provide on request, can reduce susceptibility, for those sets not on the Cablevision system, by a factor of more than 100 (20 dB). That would make interference in the Marysville area highly unlikely. Experiments indicate that a slightly more sophisticated filter can attenuate the PAVE PAWS signal by a factor of more than 10,000 (40 dB). The latter filter would improve the susceptibility thresholds of Figure D-12, p. D-45, by 40 dB. Then, interference to TV receivers in the Marysville area would be almost impossible.

For the Cablevision system, filters would be needed only at the Kelly Ridge and Marysville receiving systems. Probably coaxial line is used there between the antennas and the receivers, so the filter shown in Figure D-13 would not be appropriate. However, the concept of the open quarter-wave stub filter to short-circuit the PAVE PAWS signal is still applicable, and such filters could easily be designed and installed on the channel 9 and channel 10 receivers at Kelly Ridge and the channel 10 receiver at Marysville.

The TV channel 10 problem results from PAVE PAWS operation only in the band from 431 to 437 MHz, which includes only 6 of the 24 PAVE PAWS channels. If operational requirements permit discontinuing the use of those six PAVE PAWS channels, there would be no spurious signal problem on channel 10. A less radical alternative may be possible, following experiments to determine which of the 6 PAVE PAWS channels are most disruptive to TV reception. The PAVE PAWS signal frequencies causing spurious responses near the TV picture carrier are probably much more of a concern than the others are. Perhaps deleting only one or two PAVE PAWS channels in the 431 to 437 MHz band (when it would not

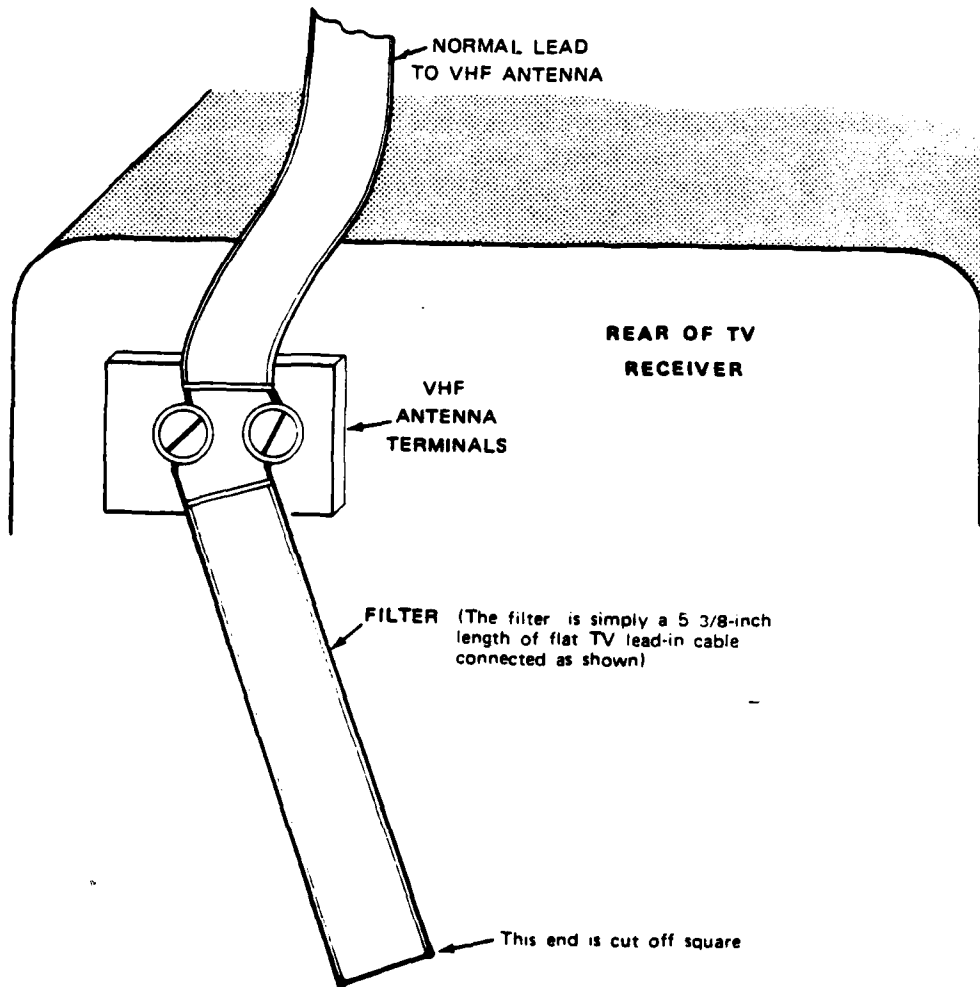

FIGURE D-13. FILTER TO EXCLUDE PAVE PAWS SIGNALS FROM TV RECEIVER

jeopardize PAVE PAWS operations) would accomplish the objective of alleviating the spurious signal problem for channel 10. The channel 9 problem involves PAVE PAWS frequencies from 420 to 425 MHz--about four of the radar's 24 channels. However, TV channel 9 is not received directly by most local viewers, and therefore effects on it could be more easily treated by a filter at the Cablevision receiving system.

D.3.1.3 Effects on UHF/FM Land Mobile Radio

D.3.1.3.1 Land Mobile Radio Usage. The bands adjacent to PAVE PAWS, both above and below, are used by UHF land mobile radio. The frequency band below PAVE PAWS (i.e., from 406 to 420 MHz) is used by agencies of the federal government, such as the Department of the Interior, the Forest Service, the Air Force, and others. It is under the control of the National Telecommunications and Information Administration. The frequency band above PAVE PAWS (i.e., from 450 to 470 MHz) is used by the non-federal government land mobile service, which includes users such as local governments (police, fire, highway maintenance, and such services), land transportation, industry, business, and so on. That portion of the spectrum is under the control of the Federal Communications Commission (FCC).

Identical equipment (narrow-band FM voice systems) is used in both bands and, incidentally, also by the ham operators who share the PAVE PAWS band. Communication is typically between a base station and associated mobile units. Very often, a mountaintop or rooftop repeater is used to extend the coverage area of the particular network. Those repeaters are as described in Section D.3.1.1.1. The repeater transmits on a frequency 5 MHz lower than its receive frequency. The repeaters are the most vulnerable part of the land mobile networks, for two reasons. First, the repeaters are located at high elevations to cover a large area, with the result that many of them will be in the line of sight of PAVE PAWS. Second, because so much of the land mobile voice traffic passes through the repeaters, interference caused to the repeaters would be retransmitted to base stations and to mobile units not themselves located so as to be directly affected by the radar.

Using a computer-based retrieval system still under development, the FCC provided a listing of a number of the non-federal-government repeaters within 100 km (62 miles) of PAVE PAWS and in the frequency range 450-457 MHz (J. Linthicum, February 1979). This is only a part of the land mobile band; because the retrieval system was still under development and because the data base is continually changing, it was estimated that the listing was probably 80% - 90% correct for the frequency range covered. However, the listing does provide information on

the locations of some of the repeaters of interest. Figure D-14 is a map of the Sacramento Valley, and shows the locations of some of the repeaters and of PAVE PAWS itself. Some favorably situated mountaintops or buildings accommodate numerous repeaters, and some repeaters are shared by several users; Table D-9 lists the repeaters or buildings mentioned by the FCC, and is keyed to the map to show their approximate locations. Letters on the map are generally used to represent the presence of several collocated facilities. The table lists the repeaters' transmit frequencies; the frequencies on which they receive are 5 MHz higher. Repeaters beyond 62 miles, even though they may be of interest, are not included in the map or the table.

Discussions with operators of repeaters in the vicinity of PAVE PAWS confirm that the list of repeaters of Table D-9 is indeed only fragmentary. For example, there are a group of more than 20 repeaters on the Sutter Buttes receiving on frequencies between about 466 and 469 MHz, and transmitting on frequencies 5 MHz lower. (G. Fitch, December 1978). Since the list provided by the FCC was limited in both frequency (450 - 457 MHz) and range (62 miles from PAVE PAWS), there are probably many other land mobile systems in the area that are not covered here.

Records of frequency assignments in the government land mobile band for 102 systems operating within 60 miles of PAVE PAWS were supplied by the Electromagnetic Compatibility Analysis Center (ECAC) (R. W. Willats, February, 1979). Some are base stations and others are repeaters; they are listed by the transmitting frequency. Figure D-15 and Table D-10 indicate most of the government land mobile systems in the immediate locale of PAVE PAWS. (Letters and numbers relate the map and table, as was done for the civilian systems). A few systems have been deleted for security reasons, but they are not atypical from the standpoints of type of system, frequency, or location.

A typical land mobile base or repeater system will have an antenna with gain of about $G_r = 10$ dBi. Loss in the feedline, L_f , will be about another 1 dB. A signal level of about $P_r = -117$ dBm at the receiver terminals will be needed to provide a strong audio signal for the listener (or for retransmission by a repeater). RF signal levels above that level provide added protection against multipath fading, noise, and interference. A mobile unit would have an antenna with gain of about $G_m = 2$ dBi and negligible loss in the feedline. The power output of a base or repeater would be about 100-300 W ($P_t = 50$ to 55 dBm) and that of the mobile unit would typically be about 25-50 W ($P_t = 44$ to 47 dBm).

Assuming a line-of-sight path from a mobile unit to a repeater or base station d miles away, the level of the mobile unit's

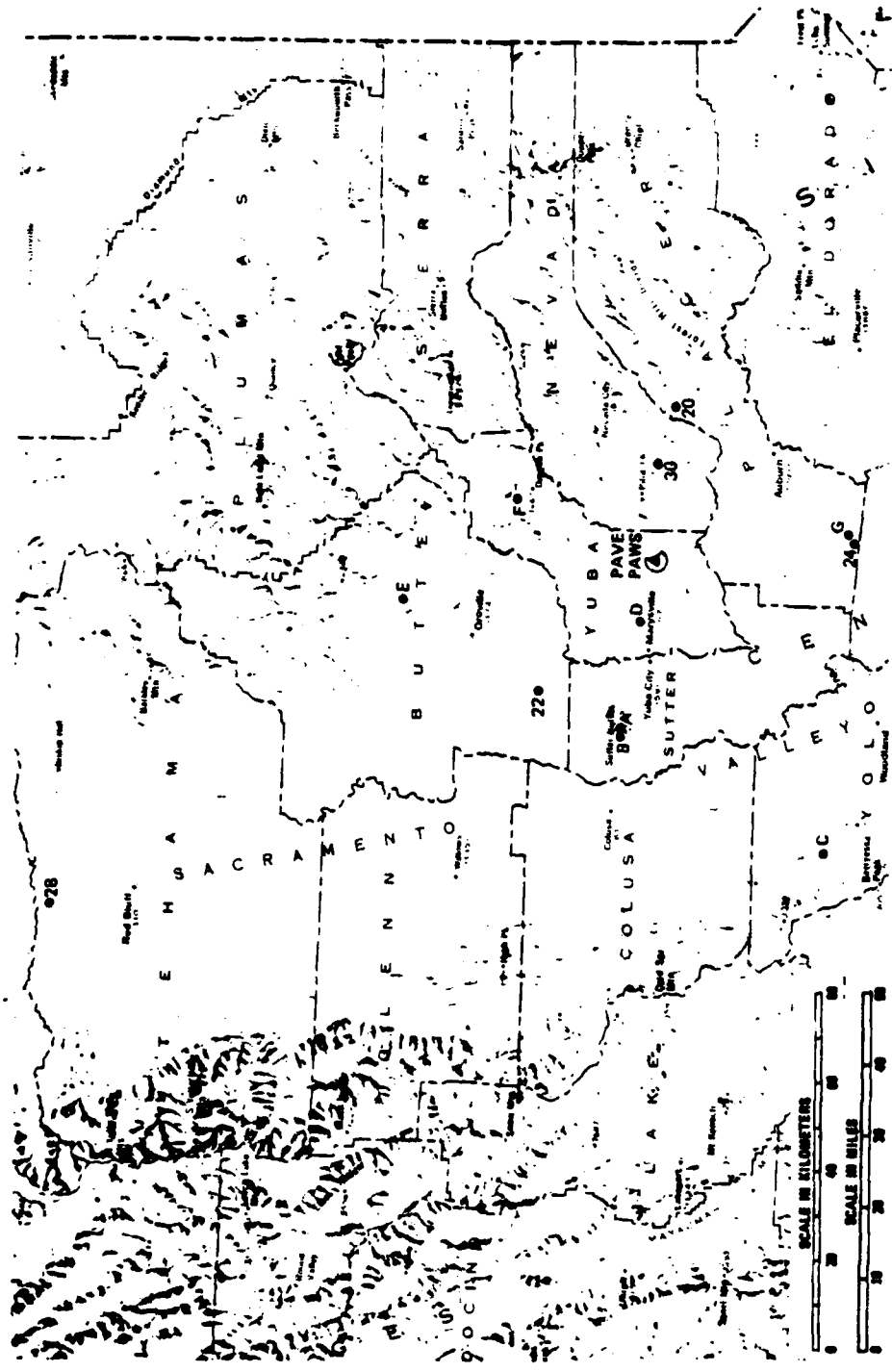

FIGURE D-14. LOCATIONS OF CIVILIAN UHF LAND-MOBILE REPEATERS WITHIN ABOUT 62 MILES OF PAVE PAWS

Table D-9

REPEATERS IN THE CIVILIAN UHF LAND MOBILE BAND BETWEEN
450 and 457 MHz AND WITHIN ABOUT 62 MILES OF PAVE PAWS

<u>Frequency (MHz)</u>	<u>Call Sign</u>	<u>Location Key For Map</u>
451.125	KMF393	C
451.425	KJB635	F
451.500	KEU816	G
451.525	KJD960	A
451.570	KYE351	B
451.675	KWN310	20
451.675	KUO845	22
451.675	KUO844	24
451.775	KSV410	A
451.850	KAL229	28
451.875	KTA533	30
451.875	KWD835	B
451.875	KXS522	B
451.900	KIY357	C
451.900	KXQ456	A
451.925	KEQ766	D
451.925	KEQ766	D
451.950	KOK729	B
451.950	KZP554	B
452.000	KGX246	C
452.025	KE9979	B
452.075	KXY932	A
452.125	KCX461	B
452.125	KWZ318	B
452.125	KXH612	B
452.125	KYU362	B
452.125	KYV592	B
452.175	KBN977	C
453.400	KDJ359	C
453.450	KCT451	G
453.800	KCW431	C
453.875	KYD966	E

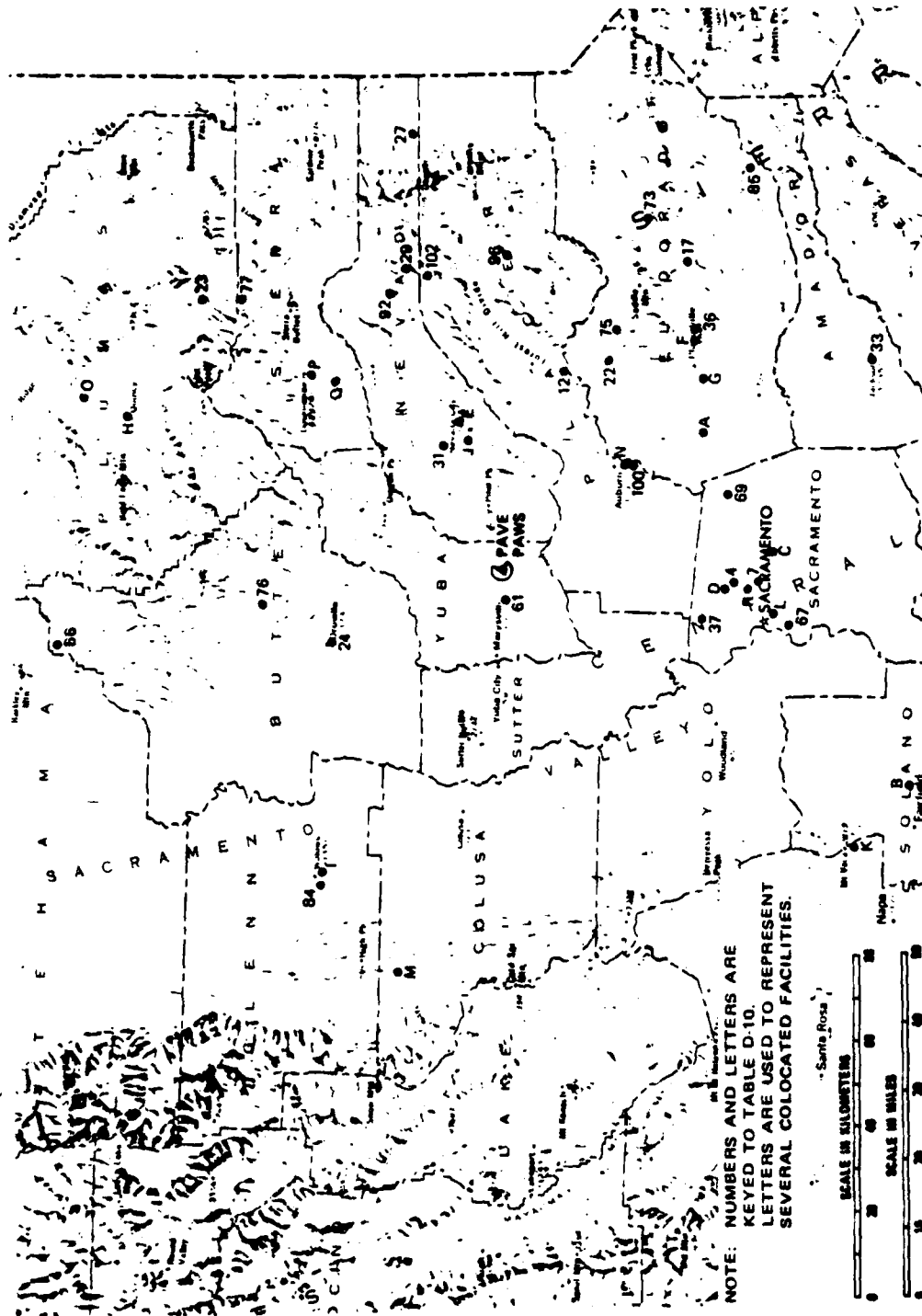

FIGURE D-15. LOCATIONS OF GOVERNMENT-OWNED UHF LAND-MOBILE BASE STATIONS AND REPEATERS WITHIN 60 MILES OF PAVE PAWS

Table D-10

FREQUENCY ASSIGNMENTS IN THE GOVERNMENT UHF LAND MOBILE BAND
LOCATIONS WITHIN 60 MILES OF PAVE PAWS

++

<u>Frequency (MHz)</u>	<u>Agency *</u>	<u>Location Key For Map</u>	<u>Frequency (MHz)</u>	<u>Agency *</u>	<u>Location Key For Map</u>
406.475	DoI	A	413.2	USAF	B
407.325	USAF	B	413.2375	USA	L
407.375	USAF	C	413.275	USAF	D
407.4	USAF	4	413.3	USAF	C
407.425	USAF	D	413.3	USAF	D
407.525	USAF	B	413.3	USAF	B
408.425	DoI	7	413.325	USAF	D
408.475	DoI	A	413.35	USAF	C
409.05	USAF	D	413.375	USAF	D
409.125	USAF	D	413.45	USAF	61
409.15	DoA	E	413.45	USAF	L
409.15	DoA	12	413.45	USAF	D
409.65	DoA	E	413.45	USAF	B
409.65	DoA	P	413.475	USAF	B
410.2	USAF	D	414.2	DoJ	66
411.225	DoA	F	414.25	DoJ	67
411.225	DoA	17	414.475	DoJ	L
411.225	DoA	G	415.025	DoI	69
411.225	DoA	H	415.075	DoI	M
411.275	DoA	I	415.125	DoI	M
411.325	DoA	F	415.15	DoI	N
411.325	DoA	22	415.225	DoA	73
411.325	DoA	23	415.225	DoA	0
411.325	DoA	24	415.325	DoA	75
411.325	DoA	G	415.325	DoA	76
411.35	DoA	H	415.325	DoA	77
411.35	DoA	27	415.35	DoA	0
411.425	DoA	I	415.45	DoA	P
411.525	DoA	29	415.45	DoA	Q
411.525	DoA	I	415.475	DoA	0
411.55	DoA	31	415.55	DoA	0
411.55	DoA	H	415.55	DoA	J
411.575	DoA	33	415.55	DoA	84
411.575	DoA	F	415.575	DoA	85
411.575	DoA	G	416.125	DoI	N
411.575	DoA	36	416.125	DoI	N
412.675	DoI	37	416.55	DoI	R
412.4	DoA	E	416.675	DoI	R
412.4	DoA	J	417.2	GSA	L
412.575	DoJ	K	417.475	DoI	R
412.8375	USA	L	417.65	DoA	92
413.0	USAF	D	417.725	DoI	N
413.025	USAF	D	417.725	DoI	N
413.075	USAF	B	418.55	DoI	R
413.1	USAF	B	419.15	DoA	96
413.1	USAF	B	419.175	GSA	L
413.125	USAF	D	419.25	DoJ	L
413.175	USAF	C	419.425	DoJ	K
413.2	USAF	C	419.625	DoI	100
413.2	USAF	D	419.65	DoA	Q
413.2	USAF	B	419.825	DoI	102

* Abbreviations: DoI - Department of the Interior
 USAF - United States Air Force
 DoA - Department of Agriculture
 GSA - General Services Administration

DoJ - Department of Justice
 USA - United States Army

signal at the terminals of the receiver is about

$$P_r = P_t + G_r + G_m - L_f - 89 - 20 \log d_{\text{miles}} \quad \text{dBm.}$$

Using the antenna gains mentioned previously, and a 44-dBm mobile unit about 80 miles from the repeater, the power will be about $P_r = -72$ dBm, far above the minimum signal necessary for the system. Different assumptions will affect this estimated level somewhat; but if the distance is halved (or doubled) the level will increase (or decrease) by only 6 dB.

D.3.1.3.2 PAVE PAWS Signals at the Land Mobile Receivers.

Because the land mobile systems operate both above and below the band used by PAVE PAWS, the power that PAVE PAWS spreads outside its own band and into theirs is of interest. Figure D-7 shows estimates of emission spectrum upper bounds for PAVE PAWS' most common pulse -- the 300-microsecond, chirped, short-range-surveillance pulse -- and also for a 3-ms chirped pulse. The latter pulse is not actually in the PAVE PAWS pulse repertoire, but it was used in some analysis by Beran (1978), and is similar to one used in experimental work by Hurt and Sigurst (1978). The bandwidth of a land mobile receiver (about 15 kHz) is narrow with respect to these emission spectra. Therefore, the PAVE PAWS power that the receiver, which is at some frequency offset from the PAVE PAWS pulse center-frequency, would accept (relative to what the receiver would accept if the receiver were tuned to the pulse center-frequency) is determined principally by the relative levels of the emission spectrum at the two frequencies. For example, at a frequency offset of 10 MHz between the land mobile system and the pulse center frequency, the receiver will be subject to about 75 dB less PAVE PAWS power than if there were no offset. This is called frequency-dependent rejection (FDR), and we can estimate the PAVE PAWS signal power at a receiver that is in the line of sight of the radar by

$$P_r = P + G_r + G_p - L_f - 89 - 20 \log d_{\text{miles}} - \text{FDR} \quad \text{dBm}$$

where P_p and G_p are PAVE PAWS' power ($P_p = 88$ dBm) and antenna gain. Systems in the vicinity of PAVE PAWS will be illuminated by the first sidelobe and by the higher-order sidelobes, with gains of 18 dBi and 0 dBi respectively. Assuming the same base station (or repeater) as before, the PAVE PAWS power at the receiver will be about

$$P_r = 26 - 20 \log d_{\text{miles}} - \text{FDR} \quad \text{dBm}$$

for the first sidelobe and about

$$P_r = 8 - 20 \log d_{\text{miles}} - \text{FDR} \quad \text{dBm}$$

for the higher-order sidelobes.

The distance from PAVE PAWS to the stations and repeaters on the mountain range to the west of the Sacramento Valley is about 50 miles, so the distance attenuation term in the equations above is about 34 dB. At the Sutter Buttes it is about 28 dB, and at locations 100 miles from the radar, it is about 40 dB. Thus, the PAVE PAWS signal level at the mountains is about

$$P_r = -8 - FDR \quad \text{dBm}$$

for the first sidelobe, and about

$$P_r = -26 - FDR \quad \text{dBm}$$

for the higher-order sidelobes. The FDR term, of course, is a function of the frequency offset between a particular receiver and a particular PAVE PAWS pulse; it varies widely as PAVE PAWS hops among its 24 frequency channels.

D.3.1.3.3 Effects of the PAVE PAWS Signal Even at the maximum estimated FDR (90 dB for frequency offset greater than about 20 MHz), the PAVE PAWS first-sidelobe signals are expected to be considerably above the typical land mobile system threshold (about -117 dBm) and the radar's higher-order-sidelobe signals will be approximately at the threshold. (These approximations can only be rough because they are considering all of the local land mobile systems as a class; they could be made more precise if specific individual systems were to be considered.)

As was discussed in Section D.3.1.1.1, these pulses are relatively strong, but are generally shorter than the FM receiver's attack time -- the time required to produce an audio signal after application of an acceptable RF signal. Therefore, they will not generally produce an audible response from a receiver that is not already receiving a desired signal. Occasionally, a 16-ms PAVE PAWS track pulse may open the squelch to produce a sound like a pop, but that will probably occur very infrequently.

PAVE PAWS pulses may sometimes be heard in a receiver (or be retransmitted by a repeater) if the receiver's squelch circuit is already held open by a desired signal. A characteristic of an FM receiver is that the receiver is "captured" by the strongest of the signals in its passband. If a potentially interfering signal is weaker than the desired signal, it will not cause perceptible interference; likewise, if the potentially interfering signal is the stronger, then it will capture the receiver. Momentary capture of an FM receiver by a pulse would probably result in the listener hearing a pop or a click for each pulse that exceeded the level of the desired signal. However, if the pulses occur infrequently enough and are brief enough, they may never be

noticed. At any rate, the desired and the undesired signal levels must be estimated along with the approximate pulse rates.

The desired-signal level will be approximately -72 dBm, as was estimated in Section D.3.1.3.1. In specific circumstances, the level might be either considerably higher or lower. The level of the PAVE PAWS signal at the land mobile receiver is a strong function of the FDR (Section D.3.1.3.2). The equations in that section indicate that PAVE PAWS' first-sidelobe signal will exceed the assumed desired-signal level of -72 dBm when the FDR is less than about 64 dB; the radar's higher-order sidelobes will be above the desired signal for FDR less than about 46 dB. The FDR curves of Figure D-7, p. D-26 translate an FDR term into its equivalent frequency offset. They show that the radar's first-sidelobe signal will exceed the estimated level of the desired signal for radar pulses within about 5 MHz of the receiver frequency; the higher-order sidelobes will exceed the level only for pulses with center frequency within about 1 MHz of the receiver frequency. The upper and lower center frequencies for PAVE PAWS are at 448.7 MHz and 421.3 MHz, respectively, with a guard-band of 1.3 MHz between them and the nearest land mobile frequencies. Thus, under the present assumptions, higher-order sidelobe pulses would not affect the land mobile radio systems. Table D-11 shows the portions of the land mobile frequency bands that might be affected by the PAVE PAWS first sidelobe. PAVE PAWS channels and their center frequencies are listed on Table D-2, p. D-12. Effects from the highest PAVE PAWS channel might be felt as high as $448.7+5 = 453.7$ MHz; the second-highest PAVE PAWS channel might then cause effects as high as $447.5+5 = 452.5$ MHz, and so on. The "PRF" for a first-sidelobe short-range surveillance pulse on a given PAVE PAWS channel and in a given direction is only about 0.04 pps, or 1 pulse every 25 seconds (see Table D-4, p. D-24). Those land mobile channels closest to the PAVE PAWS band would be affected by pulses on four of the PAVE PAWS channels. The number of PAVE PAWS channels causing effects decreases as the frequency offset increases until, in the frequency range between 452.5 and 453.7 MHz, only PAVE PAWS channel 24 would cause effects. The civilian and the federal government bands would be affected similarly, as the two halves of Table D-11 show. Interfering pulses at such low "PRF," as was just described, would not themselves cause any loss in the ability to pass voice-modulated information over a land mobile channel.

In the foregoing calculations, it was assumed that the receiver (or repeater) was on the ridge to the west of PAVE PAWS and that it was receiving a signal well above its threshold. Now consider receivers atop the Sutter Buttes, where the PAVE PAWS first-sidelobe signal at the receiver terminals will be about

$$P_r = -2 -FDR \quad \text{dBm}$$

Table D-11
 PORTIONS OF LAND MOBILE BANDS AFFECTED BY PAVE PAWS
 (Under Certain Assumptions)

Portions of Land Mobile Bands Affected by PAVE PAWS	PAVE PAWS Channels Causing an effect	Approximate Interfering PRF (pps)	Approximate Interval Between Pulses (Seconds)
<u>Government Band</u>			
416.3 - 417.5 MHz	1	0.04	25
417.5 - 418.7 MHz	1, 2	0.08	12
418.7 - 419.9 MHz	1, 2, 3	0.12	8
419.9 - 420.0 MHz	1, 2, 3, 4	0.16	6
<u>Civilian Band</u>			
450.0 - 450.1 MHz	21, 22, 23, 24	0.16	6
450.1 - 451.3 MHz	22, 23, 24	0.12	8
451.3 - 452.5 MHz	23, 24	0.08	12
542.5 - 453.7 MHz	24	0.04	25

and the higher-order sidelobe signals will be about

$$P_r = -20 -FDR \quad \text{dBm.}$$

Consider also a much lower desired-signal level of -92 dBm, which is 20 dB less than in the previous example. Then the PAVE PAWS first-sidelobe power will exceed the desired signal unless the FDR is greater than about 88 dB (implying a frequency offset more than about 20 MHz); the higher-order sidelobe power will exceed the desired signal unless the FDR is greater than about 70 dB (implying a frequency offset of about 7 MHz). A frequency offset of 20 MHz can be obtained only at the extreme high end of the 450-470 MHz civilian land mobile band; within the band, the interfering first-sidelobe "PRF" will range from about 1 pulse per second near 450 MHz to only about 0.04 pulses per second near 470 MHz. In the federal government land mobile band, the first-sidelobe "PRF" will range from about 1 pps near 420 MHz to about 0.3 pps near 406 MHz. The "PRF" of the higher-order sidelobes will be about 7 pps in the channels directly adjacent to PAVE PAWS and will decrease to nothing by about 457 MHz in the civilian land mobile band and 413 MHz in the government band. Again, considering the low pulse rates and the short pulse lengths involved, it is unlikely that PAVE PAWS would significantly affect the ability to convey information by voice, and might never be noticed.

Similar analysis could be done for mobile units. However, a mobile unit operating through a mountaintop repeater illuminated by PAVE PAWS would receive the PAVE PAWS signal regardless of its own location relative to the radar. The previous conclusions regarding the inability of PAVE PAWS to open the squelch apply also to the mobile units. Thus, the only unique concern is how the mobile receiver would be affected when receiving from a base station without benefit of a repeater. The level of the desired signal at the mobile unit would be similar to that at a base or repeater. But, propagation between PAVE PAWS and the mobile unit would often not be line-of-sight, so the PAVE PAWS signal strength could be considerably less at a mobile unit than at an elevated antenna at the same distance. Assuming that the mobile receiver were located close enough that the PAVE PAWS signal always exceeded the desired signal, the results would be as described for land mobile channels at frequencies essentially adjacent to PAVE PAWS (i.e., there would be several pops every second). Again, the low "PRFs" and short pulse lengths would not be expected to cause serious disruption to voice communications.

D.3.1.3.4 Summary of UHF Land Mobile Susceptibility. Although PAVE PAWS' pulses will certainly appear at the input terminals of any land mobile receiver within the line of sight of the radar, they are not expected to cause serious disruption to voice communication. PAVE PAWS' pulses are generally not long enough to

open the squelch circuit of the receivers, and therefore, they would not cause any perceptible effect to a receiver that is not already receiving a desired signal. Although they will be strong pulses, they will be very brief, and will occur at such low pulse rates that conversation should be possible despite an occasional pop or click.

Some of the assumptions underneath this analysis differ from those used by Hurt and Sigurst (1978) and by Beran (1978), who concluded that interference would take place only within 10 or 12 miles. Perhaps the same conclusions would have been drawn in the previous studies had a common set of assumptions been used. In some instances, the different assumptions used here result from a better description than was previously available concerning the way the radar works. In other instances, though, the assumptions or models of the other studies did not seem appropriate to the actual situation. As examples, both previous studies considered only the higher-order sidelobes, ignoring the stronger first sidelobe, which will also illuminate the terrain in front of the radar when PAVE PAWS is operating in its surveillance mode (see Figure D-4, p. D-14). PAVE PAWS is situated on a hilltop about 370 ft above sea level. From there, it overlooks the Sacramento Valley, (much of which is only a few feet above sea level) and it is in direct line of sight of a large number of land mobile base stations and repeaters situated on promontories such as the Sutter Buttes and the mountains on the west side of the valley. The assumptions (Beran, 1978) of antenna heights of 75 ft for PAVE PAWS and 25 ft for the land mobile receivers and the use of a smooth-earth propagation model do not agree well with the actual geography involved. Hurt and Sigurst used an irregular-terrain propagation model, with PAVE PAWS and the base-station antennas at heights of 50 ft and 100 ft above rough terrain more like that in the Sierra behind the radar than that in the wide valley in front of PAVE PAWS.

D.3.1.4 High-Power Effects to Systems

High-power interference to a system's operation results from the direct coupling of the interfering signal to internal circuits and components via the equipment case, antenna leads, power line, or signal leads. The meager data available suggest that high-power effects will probably be a problem with some home phonographs, radios, and televisions at distances at least as far as Marysville and Yuba City. Donaldson (1978) describes high-power effects as being "significantly different from the classical, frequency dependent EMI problems (co-channel interference, spurious responses, inter-modulation, etc.)." The systems potentially subject to interference are divided into civilian and military.

D.3.1.4.1 Civilian Systems. Moss (1978) has stated, as a summary of some work done previously for the Air Force, that high-power interference "can occur in civilian electronics equipment when the peak power density is in excess of 30 dBm/m²" (100 microwatts/cm²). Siemen (1978) used the same number. However, the situation is not really so clear-cut that a single susceptibility level can be applied to all such electronics equipment.

Donaldson (1978) sampled 20 home stereo systems, each consisting of an AM/FM-stereo receiver, a tuner, an amplifier, a record changer, and speakers. All were solid state. Four major manufacturers were represented. The units covered a wide cost range and differed widely in chassis configuration. Donaldson's tests were in the frequency range from 400 to 450 MHz, but he did not present any further details of the interference source. He found wide variations from unit to unit in thresholds for minimum perceptible interference. For all operating modes (FM/FM-stereo, AM, phonograph, or tape), the average threshold was about 7 dBm/m² (0.5 microwatts/cm²). Susceptibility varied widely (by a factor of 100 (20 dB)) with orientation, and was also affected by the level of the desired signal.

Measurements have been made on a transistor AM receiver. At approximately 450 MHz, thresholds were about 22 to 32 dBm/m² (16 to 160 microwatts/cm²). Varying the pulse width and PRF had little effect on the thresholds.

Tests were also made on a single solid-state AM/FM broadcast receiver. A threshold of about 20 dBm/m² (10 microwatts/cm²) was noted at about 450 MHz for the pulse width and PRF used. We estimated that the threshold might be about the same at a pulse width of about 300 microseconds and a PRF of about 70 pps. (Those are the most common PAVE PAWS pulse width and a typical PAVE PAWS "PRF". See Section D.2.6.2, p. D-15.)

In addition, tests were made on three "inexpensive phonographs and a tape recorder" using a PRF of 40 pps with pulse widths of 0.2 ms, 1.0 ms, and 6.0 ms. At the 0.2-ms pulse-width, the susceptibility thresholds ranged from 1 to 6 dBm/m² (0.13 to 0.4 microwatts/cm²).

Susceptibility of 16 hearing aids ranged from about -17 to +38 dBm/m², with a median of about +16 dBm/m² (0.002 to 630 microwatts/cm², median 4 microwatts/cm²).

Tests were also conducted on a single UHF land mobile transceiver (without its antenna connected) operating in the 450 to 470 MHz band. The threshold of high-power susceptibility for the radar characteristics used was about 42 dBm/m² (1,600 microwatts/cm²). The threshold for susceptibility to PAVE PAWS would probably be about 35 dBm/m² (320 microwatts/cm²).

Two VHF FM land mobile transceivers were tested. They were different solid-state models, by the same manufacturer, that operate in the 136 to 174 MHz range. Tests were made not only to

determine the threshold of interference with the desired signal, but also to find whether the interfering signal could be made to break squelch. When the transceivers were receiving, the thresholds were 16 and 25 dBm/m² (4 and 32 microwatts/cm²) for the two units. When the equipment was not receiving, the interfering signal could not break squelch at levels up to the maximum available power density of 37 dBm/m² (500 microwatts/cm²). Curves were not provided, in this instance, that would permit an extrapolation of the data to the pulse width and PRF of PAVE PAWS.

A single, high-fidelity tape recorder was tested at various frequencies, PRFs, and pulsewidths. At the pulse width and "PRF" applicable to the PAVE PAWS signal, it was judged that the unit's susceptibility threshold for the PAVE PAWS signal would be about 14 dBm/m² (2.5 microwatts/cm²).

High-power effects on television were discussed in Section D.3.1.2.2.3 (page D-38).

D.3.1.4.2 Military Communications Systems. Moss (1978) states that the threshold criterion for military electronics is 40 dBm/m² (1,000 microwatts/cm²).

Tests were made on two military ground receivers, an AN/GRR-23 and an AN/GRR-24; both are solid state, single-channel HF/VHF-AM receivers. The interfering signal pulse-width was 80 microseconds and the PRF was 1,250 pps. Susceptibility thresholds for high-power effects were greater than 42 dBm/m² (1,600 microwatts/cm²), and a spurious response was found in the AN/GRR-23 for an interfering frequency of 439.3 MHz at 41 dBm/m² (1,300 microwatts/cm²).

Measurements were made on a single VHF/FM mobile unit, the receiver portion RT-246/VRC of an AN/VRC-12. No high-power effects were noted at around 430 MHz at field levels as high as almost 40 dBm/m² (1,000 microwatts/cm²).

D.3.1.4.3 Susceptibility to PAVE PAWS. The sparse information on susceptibility is summarized in Table D-12. All of the systems described in this analysis are ground-based systems, that would be exposed to either the first sidelobe or to the higher-order sidelobe structure of the PAVE PAWS beam. The susceptibility thresholds can be compared with the top curve in Figure D-12, p. D-46, which applies to locations greater than a mile or two from PAVE PAWS (depending on the intervening terrain) that are illuminated directly by PAVE PAWS' first sidelobe. (Much of the Beale AFB housing area and the surrounding communities are contained in that area.) Power density levels corresponding to some of the susceptibility thresholds of Table D-12 occur

Table D-12
 SUMMARY OF SUSCEPTIBILITY THRESHOLDS
 FOR HIGH-POWER EFFECTS

<u>System Type</u>	<u>Units Tested</u>	<u>Threshold</u>	
		<u>(dBm/m²)</u>	<u>Micro-watts/cm²</u>
Civilian			
AM/FM receivers, record changer, etc.	20	7 (average)	0.5
AM receiver	1	22-32	16-160
AM/FM receiver	1	20 (approx.)	10
"Inexpensive" phonograph	3	1-6 (range)	0.13-0.4
Hearing aids	16	16 (median)	4
UHF FM land mobile receiver	1	35 (approx.)	320
VHF FM land mobile receiver	2	16 and 25	4 and 32
Hi-Fi tape system	1	14	2.5
Military			
HF/VHF AM receiver	2	greater than 42	greater than 1,600
Mobile FM receiver	1	greater than 40	greater than 1,000

at distances beyond Yuba City and Marysville, suggesting that high-power effects on civilian stereos and broadcast receivers seem likely there. As an example, the average threshold of susceptibility of 20 home stereo systems was at about 7 dBm/m² (0.5 microwatts/cm²), a level that may be reached within about 15 miles. Shielding by terrain features and losses through vegetation and home structure may make the effects less widespread. However, better definition of the extent of the potential problem cannot be made, for two reasons. First, the susceptibility testing that has been done did not use the particular pulse-width and PRF parameters applicable to PAVE PAWS; thresholds are dependent not only on frequency, but also on pulse width and PRF. Second, only a very small sample of electronic units has been tested, and their responses are not necessarily representative of those of all of the systems that will be exposed.

D.3.1.5 Airborne Systems

D.3.1.5.1 In-Band Radar Altimeters. Two aircraft radar altimeters -- the SCR-718 and the AN/APN-1 -- share the 420-to-450-MHz band with PAVE PAWS and other radar systems. That the altimeters can experience interference from in-band ground-based radars is well known. Dates for the retirement of these altimeters have been set and extended by the Office of Telecommunications Policy, which has been succeeded by the National Telecommunications and Information Agency, but the altimeters are still in use at this time. Neither is used for approaches for landing; and Tech Order LC-135A-1 states that the SCR-718 is not to be used within 50 miles of land. Since PAVE PAWS is about 110 miles inland, the SCR-718 would not be used closer than about 160 miles from PAVE PAWS. The usage restrictions greatly reduce the likelihood of PAVE PAWS' interference causing a hazardous situation.

The SCR-718 altimeter will generally be affected by PAVE PAWS when its aircraft is within radio line-of-sight of PAVE PAWS. The limit of the line of sight depends on the aircraft's altitude and the intervening terrain. The coastal mountains (about 3,000 feet high and about 60 miles west of PAVE PAWS) will help to screen aircraft from the PAVE PAWS signal unless the aircraft is at considerable altitude. For example, aircraft over the sea at the 160-mile distance just mentioned and below about 14,000 ft would not be illuminated by the PAVE PAWS signal (even considering refraction of the radar signal to permit it to travel farther than the geometry would indicate). At 250 miles, aircraft below about 30,000 feet would not be illuminated. An SCR-718 altimeter may still be able to provide useful information despite some interference by PAVE PAWS; experiments would confirm or refute this. Because radar interference to this altimeter is already

acknowledged to occur, operation of PAVE PAWS will not pose a unique threat.

The AN/APN-1 altimeter will be affected by PAVE PAWS when the PAVE PAWS signals are about the same order of magnitude as the altimeter's ground return (Siemen, 1977). However, because this altimeter's power output and antenna characteristics were not listed, the area in which it would be affected cannot be defined. However, its maximum altitude is 4,000 ft, and, at that altitude or below, it would be beyond the unobstructed radio horizon for PAVE PAWS (and therefore would be unaffected) at about 120 miles. Anywhere over the ocean, and up to the maximum 4,000 ft altitude, the coast range will shield aircraft using this altimeter. Again, because this altimeter already operates in the same band as other radars and is not used to determine altitude during approaches, PAVE PAWS should be no additional hazard to its use.

The general characteristics of the two altimeters are shown in Table D-13. The SCR-718 type is used in some C-97, C-118, C-121, C-130, C-131, and C-135 aircraft; the AN/APN-1 type is used in some A-3, C-117, C-118, C-119, and P-2 aircraft.

D.3.1.5.1.1 The SCR-718 Pulse Radar Altimeter. The operating frequency for the SCR-718 is 440 MHz, and the transmitter power depends upon the altitude range in use (See Table D-13). Calculations show that it is not possible to provide enough physical separation between the altimeter and PAVE PAWS to attenuate the PAVE PAWS signal to levels that will not affect the SCR-718. It appears that the only way for the SCR-718 radar altimeter to be unaffected by PAVE PAWS is for it to be used beyond the radar horizon.

Generally, when in radio line of sight of PAVE PAWS, an aircraft would be exposed to PAVE PAWS higher-order sidelobes. As discussed in Section D.2.6.2, p. D-15, the aircraft would be illuminated for about 18% of the time. However, because of PAVE PAWS' frequency hopping, the SCR-718 would not be susceptible to all PAVE PAWS pulses. The SCR-718's receiver response curve suggests that although it is illuminated about 18% of the time, it would be susceptible to only a few of the PAVE PAWS frequencies. It is a pessimistic estimate that the SCR-718 would be affected as much as 9% of the time. Whether this would adversely affect the function of the altimeter would have to be determined, probably by experimentation.

An SCR-718 illuminated by a strong PAVE PAWS signal may still be usable. The display on the SCR-718 radar altimeter is a cathode ray tube (CRT) on which a spot continually moves in a circle. The spot takes about 10 microseconds for a revolution

Table D-13

CHARACTERISTICS OF TWO RADAR ALTIMETERS

Nomenclature	SCR-718		AN/APN-1	
Frequency	440 MHz		Varies sinusoidally, 120-Hz rate	
Emission Type	Pulse (0.3 microseconds)		FM-CW	
Altitude range (ft)	0-5,000	0-50,000	0-400	0-4,000
Pulse power (dBm)	38.5	37	not given	
PRF (pps)	98,350	9,835	not applicable	
Frequency range (MHz)	not applicable		420-460	443-447
Sensitivity threshold (dBm)	-70	-70	-87	-87

Source: Siemen, 1977.

when the altimeter is in the low-altitude range and about 100 microseconds when it is in the high-altitude range. The return pulse causes the trace to deflect radially outward, placing a bump on the circle. Numbers superimposed on the CRT face allow the placement of the bump to be interpreted as aircraft altitude. The angle covered by the bump is dictated by the duration of the received signal (the transmitted pulse is 0.3 microseconds long, so the bump is small). Reception of a longer pulse, such as a PAVE PAWS long-range surveillance pulse (8 or 5 ms), would cause deflection of the entire circular trace for many revolutions of the spot. The persistence of the CRT face may permit the desired trace to be seen when it occurs, despite the whole-circle deflection occurring occasionally. Experiments would have to be performed to determine whether this is so.

D.3.1.5.1.2 The AN/APN-1 FM-CW Radar Altimeter. This FM-CW altimeter transmits continually, varying its frequency in a sinusoidal manner (at a 120-Hz rate) between the frequency limits shown in Table D-13. The frequency of the signal returned from the ground is the frequency that was being transmitted a short while before, because the radar is continually changing

frequency during the signal's round trip from plane to ground to plane. The radar mixes the return signal with the frequency currently being transmitted. The difference frequency is then amplified in an audio-frequency amplifier and limited to obtain square waves at the difference frequency. The square waves are converted to a dc voltage proportional to their frequency and thus proportional to the altitude of the aircraft.

A strong interfering signal (such as one from PAVE PAWS) can enter the receiver to mix with the frequency being transmitted, and if their frequency difference is within the pass-band of the audio amplifier, the square waves from that frequency will be converted to a dc value to drive the altimeter's meter. If the interfering frequency is present long enough, the meter response will be determined totally by the interfering frequency. If the interfering frequency is present only for a short while, the meter will simply read inaccurately.

In the low-altitude range, the frequency of the altimeter swings between 420 and 460 MHz; in the high-altitude range it swings between 443 and 447 MHz. Therefore, the frequency is likely to swing through a PAVE PAWS signal, which would cause interference. In the high-altitude range, the altimeter would be susceptible to interference only from the PAVE PAWS signals inside roughly the 443 to 447 MHz band, and so only 5 of the 24 PAVE PAWS frequencies seem likely to pose any problem in that altitude range. In the low-altitude range, the altimeter would be susceptible to all 24 of the PAVE PAWS frequencies, but the altimeter's 40-MHz frequency swing also takes it 10 MHz above the PAVE PAWS band. Because the altimeter operates outside the PAVE PAWS band for 25% of the time, only the other 75% is of concern to PAVE PAWS. However, in the 25% of the time the altimeter operates above the PAVE PAWS band, it may be susceptible to interference from land mobile radio, which operates there.

Interference from PAVE PAWS will occur only when the altimeter signal and the PAVE PAWS signal are close enough in frequency to permit their difference frequency (Δf) to pass through the altimeter's audio frequency amplifier. Siemen (1977) points out that during the brief interference periods, the difference frequency sweeps from high values of Δf through zero frequency and back through high values of Δf . The metering system operates so that it responds very rapidly to the high Δf of the interfering signal, but then it relaxes so slowly when the interference is removed that it takes about a half-second to recover. While under the control of the PAVE PAWS signal, the altimeter will attempt to read high (since high Δf also implies high altitude). The extent to which the meter can be dragged high depends on the audio amplifier's rejection of increasingly high frequencies and on the duration of the interference each time it occurs.

Apparently, a PAVE PAWS signal 10 dB above the altimeter's own return signal would control the altimeter. However, the ECAC analysis (Siemen, 1977) provides no information on the expected level of the altimeter's own input signal other than to say that the threshold level of the AN/APN-1 is -87 dBm. Without calculations of received power levels or of the levels of the PAVE PAWS signal that would lead to degrading effects, it is impossible to predict the distance from PAVE PAWS that an aircraft equipped with the AN/APN-1 must be to operate without interference. Siemen says that approximately 190 miles would be sufficient when the aircraft is at 4,000 ft (the maximum altitude for this altimeter). That is well beyond the unobstructed radio horizon, which is at about 120 miles for an aircraft at 4,000 ft. The coast range will shield aircraft using the AN/APN-1 over the ocean.

D.3.1.5.2 Other Aids to Navigation. Radio-operated aids to air navigation, maintained throughout the United States, consist of ground stations and equipment in the aircraft. There are ground-stations in the vicinity of Beale AFB, and aircraft using them will be illuminated by PAVE PAWS. Nevertheless, effects at ranges greater than a mile or so from PAVE PAWS do not appear likely on the basis of the meager measurements available.

D.3.1.5.2.1 TACAN and DME. In these extensively-used systems, aircraft use radio transmissions between themselves and a ground station to determine two items of information: the distance to the ground station, and the bearing to it. The methods and frequencies of the distance measuring equipment (DME) are identical for military and civilian aircraft, and both can use the same ground stations. Aircraft using the military equipment, Tactical Air Navigation System (TACAN), can extract both distance and bearing from a TACAN ground station. Civilian aircraft can use the TACAN ground station with their DME systems to measure distance. They obtain bearings from a VHF Omni-range (VOR) collocated with the TACAN beacon. Such a collocated VOR/TACAN system is called a VORTAC.

The VOR system operates in the 108 to 118 MHz band (just above the FM broadcast band and far below the PAVE PAWS band). TACAN and DME operate in the band from 960 to 1,215 MHz. Each of the VOR frequencies is paired with a set of DME uplink and downlink frequencies. The VORTAC or TACAN stations in the general vicinity of PAVE PAWS are listed in Table D-14. Second and third harmonics of PAVE PAWS are in the bands 840 to 900 MHz and 1,260 to 1,350 MHz, respectively, so they can be ruled out as an interference mechanism to TACAN. Moss (1977) mentions that spurious responses involving the second harmonic of the TACAN receiver's local oscillator and the fifth harmonic of the PAVE PAWS signal are possible. That type of spurious response will occur only for the airborne receivers. The particular frequencies are those

underlined in Table D-14. (The spurious response frequencies not underlined in the table are outside the PAVE PAWS band.) Even so, interference is not expected, for the following reasons. First, only 1 of the 24 PAVE PAWS frequencies would be involved, and a mainbeam pulse at that frequency would illuminate the aircraft only about once every 34 seconds. Second, the airborne DME receiver is designed to ignore pulses other than the ground-station returns of its own downlink pulses. Thus, an occasional spurious pulse should present no problem. Finally, spurious response rejection in TACAN receivers is at least 92 dB to frequencies in the 420 to 450 MHz band.

Some tests have been made on two airborne units, one a military TACAN system and the other a DME-70 for military or

Table D-14

VORTAC/DME STATIONS IN THE PAVE PAWS AREA

Call Letters	Location	Operating Frequencies (MHz)		Spurious Response Frequencies*			
		Uplink	Downlink	(MHz)			
				Aircraft	Beacon		
BAB	Beale AFB	984	1,047	<u>431.4</u> , 406.2	406.2,	406.2,	381.0
CIC	Chico	996	1,059	<u>436.2</u> , 411.0	411.0,	411.0,	385.8
ILA	Williams	1,178	1,115	458.6, <u>433.4</u>	483.8,	483.8,	458.6
MCC	McClellan AFB	990	1,053	<u>433.8</u> , 408.6	408.6,	408.6,	383.4
MHR	Mather AFB	1,168	1,105	454.6, <u>429.4</u>	479.8,	479.8,	454.6
MXW	Maxwell	998	1,061	<u>437.0</u> , 411.8	411.8,	411.8,	386.6
MYV	Marysville	1,006	1,069	<u>440.2</u> , 415.0	415.0,	415.0,	389.8
RBL	Red Bluff	1,191	1,128	463.8, <u>438.6</u>	489.0,	489.0,	463.8
SAC	Sacramento	1,186	1,123	461.8, <u>436.6</u>	487.0,	487.0,	461.8
SUU	Travis AFB	1,200	1,137	467.4, <u>442.2</u>	492.6,	492.6,	467.4

* $F_{sp} = \frac{1}{q} \text{abs}(pF_{LO} \pm F_{IF})$, where $p = 2$, $q = 5$.

general aviation. High-power effects were not noted on either unit at the maximum available power density levels in the 420 to 450 MHz range. These maximum levels were 37 dBm/m² for the TACAN receiver and 43 dBm/m² for the DME receiver (500 and 2,000 microwatts/cm², respectively). Although such pulse power densities are not reached even by the first sidelobe outside the 1,000-ft exclusion fence (see Figure D-16), they can be reached within the main beam at distances of about 5 miles or less. Because the susceptibility thresholds are greater than the power density numbers mentioned previously, the aircraft may be able to come closer than 5 miles with no effect. When it is in the main-beam surveillance volume, an aircraft would be illuminated by the main beam at a rate of about once every 1.4 seconds. (Surveillance pulses account for that rate; PAVE PAWS will not track aircraft.) If it is affected only so infrequently, the TACAN/DME airborne interrogator may only momentarily lose lock, and switch from its tracking mode of operation to its searching mode.

D.3.1.5.2.2 Miscellaneous Systems. Measurements of high-power effects have been made on some other air-navigation aids. The pertinent results are given in Table D-15. The units were tested with desired-signal levels "representing either realistic maximum use distances or design-maximum distances for the receivers." The susceptibility thresholds quoted are all for antenna-coupled

Table D-15

HIGH-POWER EFFECT THRESHOLDS
FOR SOME AIRBORNE NAVIGATION SYSTEMS

Equipment	Frequency (MHz)	Desired Signal Level (dBm/m ²)	Slant Range (Nmi)	Susceptibility Threshold (for 420-450 MHz Signals) (dBm ² /m)	
				Spurious Response	Wideband Response
VOR/LOC	108.1	-66	150	45	greater than 73 ^a
Glideslope	330	-65	20	41	greater than 73
Marker Beacon	75	-49	2	56	greater than 73 +

^a Maximum available power density.

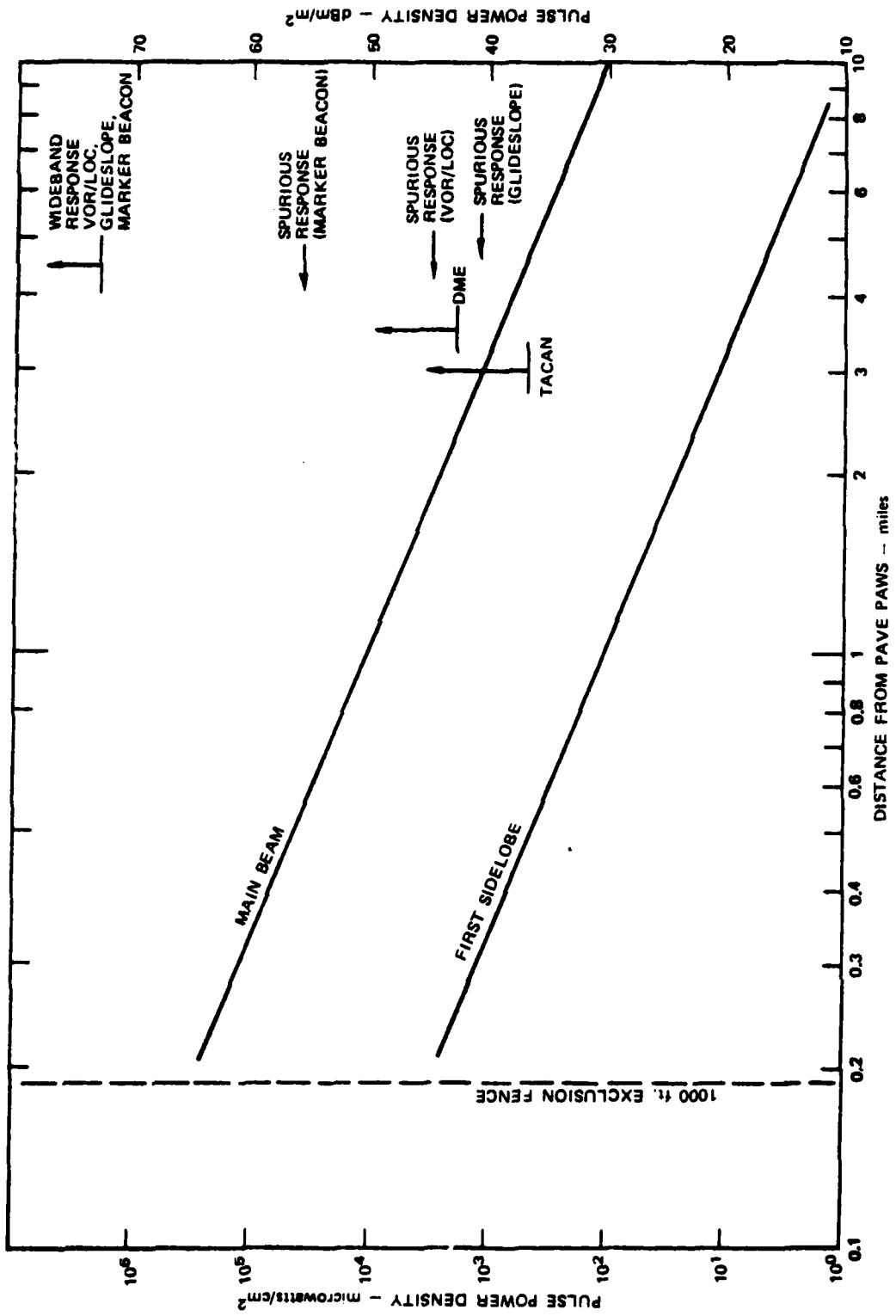

FIGURE D-18. SUSCEPTIBILITY THRESHOLDS (AND LOWER BOUNDS) FOR SOME AIRBORNE ELECTRONIC SYSTEMS (PAVE PAWS BASIC SYSTEM)

interference, based on lab measurements and an assumption of the gain of the system's antenna to the interfering signal. The susceptibility levels will probably increase under most circumstances, because the systems will be receiving higher levels of desired signals.

Even so, after placing the susceptibility thresholds of Table D-15 on the power density plot of Figure D-16, it does not appear that airborne navigation systems of these types will suffer interfering effects from PAVE PAWS. No information was given on the spurious response frequencies, but, because of the nature of spurious responses, not all of the PAVE PAWS frequencies would be involved.

D.3.1.5.3 Experimental Balloon Flights. A launching facility for high-altitude experimental balloons is maintained by the Air Force at the Chico Airport, approximately 77 km (48 mi) northwest of PAVE PAWS. High-altitude balloon launchings are conducted irregularly (over a two-to-three-month period at approximately yearly intervals) by the Air Force Geophysical Laboratory, based at Hanscom AFB, Bedford, Massachusetts. The launchings support high-altitude research for various Air Force programs (T. Danaher, 1979).

The balloons carry large instrumentation packages, weighing 500-2,000 lbs, to altitudes up to 100,000 ft. Flight areas are generally east-west and depend upon upper atmospheric winds. Most operations are conducted within a 200-mile radius of Chico.

Data from the flight are collected by on-board instrumentation and telemetered to a ground receiver at Chico. Under federal air regulations and DoD directives, the ground station is required to have positive control of the balloon at all times. The control is provided by a telemetry uplink from the ground station to the telemetry receiver in the instrumentation package. The receiver can be activated by a tone-coded carrier and commanded to sever the cables holding the instrumentation package, which is then parachuted to the ground for recovery. The balloon subsequently rises, is destroyed, and returns to the ground by a separate parachute. For safety and for recovery of the instrumentation package, the balloon is tracked by both radar and a transponder at all times.

Generally, the balloon package is dropped at the preplanned termination of a flight (lasting several hours), so that the instruments can be recovered. The balloon mission can be terminated in three ways. The primary control is a UHF/FM telemetry link operating at assigned frequencies of 423.6 and 437.5 MHz, which are in the PAVE PAWS band. The alternate control system is an HF (3 to 30 MHz) radio link. Finally, as a backup,

the instrumentation package contains a timer that will drop the package at a preset release time.

The UHF/FM telemetry system is the primary means of sending commands to and receiving telemetry data from the balloon. The system uses a CTM 405K transmitter and a CAR 210 receiver. The ground transmitter sends an IRIG (Inter-Range Instrumentation Group) tone-coded carrier to the balloon at 10W (40 dBm) using a 10-turn helix antenna with a gain of 13 dBi. An omnidirectional disccone antenna and a CAR 210 receiver receives the signal. The antenna gain is about 1 dBi and the receiver sensitivity is about -110 dBm. The receiver IF bandwidth is 200 kHz, with 60-dB rejection at \pm 700 kHz. The FM receiver has a dynamic range exceeding 80 dB.

The package-release signal, called the command-destruct signal, is initiated by pushing a button. The signal, consisting of three simultaneous IRIG audio tones, must be received for a period of at least 100 ms. The button would likely be held down for a period far exceeding the required 100-ms period. The primary tone frequencies 10.76, 12.14, and 13.70 kHz, (alternative frequencies are 15.45, 17.43, and 19.66 kHz) are fed into extremely narrow-bandwidth crystal filters following the FM receiver's discriminator and audio amplifier.

Analysis of a similar FM telemetry receiver, the CR-105, by ECAC (Van Hudson, January 1978), and (Michael P. Scheidt, April 1978), indicates that the receiver is safe from capture by an interfering signal if the signal-to-interference ratio is greater than 2 dB. Also, the receiver attack time is about 13 ms, so that only longer pulses could capture it. Hence, when illuminated by the PAVE PAWS main beam or its first sidelobe, the balloon FM receiver will be captured for an interval that could only be as long as the PAVE PAWS 16-ms tracking pulse less the 13-ms attack time. When thus captured, it will not recognize control signals from the ground. However, such a long on-frequency PAVE PAWS pulse would probably not occur very frequently. Also, if it occurred while the command-destruct button is held down, it would result in only a brief interruption; 100 ms of the 3-tone signal would still be received.

For an interfering signal to activate the command-destruct function, it must cause the receiver to receive the correct baseband tones. A high-PRF (160 pps) radar was analyzed by ECAC (Scheidt, 1978) to see whether the discrete tones generated from integer multiples of the 160-pps PRF would be of sufficient strength to activate the command-destruct receiver. Since high harmonics of the PRF would be required, the power spectral density at such high multiples would be extremely small. ECAC concluded that that radar presented no threat to the CR-105 telemetry receiver. The "PRF" of the PAVE PAWS radar is significantly lower than 160 pps and is not strictly periodic. It is concluded that

PAVE PAWS will not activate the CAR 210 receiver command-destruct function. Also, a command-destruct signal sent from the CTM 405K ground transmitter for greater than 100 ms will activate the command-destruct receiver and initiate instrumentation separation.

During balloon operations from Chico, the first sidelobe from PAVE PAWS will exceed the threshold of the FM receivers used for telemetry of data. Hence, the data stream received at the ground will be interrupted every 1-2 seconds by the first sidelobe. The balloon, in flight and in the line of sight of PAVE PAWS, will experience similar, large, interfering signals from the main beam and first sidelobe.

D.3.1.5.4 Air-to-Ground Communications at Beale AFB The band between 225 and 399.9 MHz is used for UHF/AM voice communications between aircraft and ground. A ground transceiver with an antenna gain estimated to be about 3 dBi is located at Beale AFB approximately 4 miles (7 kilometers) from PAVE PAWS. The transceiver characteristics are given in Table D-16.

The ground-based transceiver will be illuminated by the first and the higher-order sidelobes of the PAVE PAWS radar. The highest frequency used by the Air Force at Beale for air-to-ground communication is 390.8 MHz, which is nominally 30 MHz below the PAVE PAWS band (Siemen, 1978). Reduction of the strength of any of the PAVE PAWS pulses, because of the frequency separation

Table D-16

CHARACTERISTICS OF GROUND AND AIRCRAFT
UHF/AM TRANSCEIVERS

	<u>Ground</u>	<u>Aircraft</u>
Type	--	AN/ARC-115
Power	50 W (47 dBm)	10 W (40 dBm)
Antenna Gain	3 dBi	0 dBi
ERP	50 dBm	40 dBm
Receiver Sensitivity	-107 dBm	-107 dBm

between PAVE PAWS and the UHF/AM band, is about 90 dB, according to emission-spectrum estimates by ECAC (Siemen, 1978). The PAVE PAWS first-sidelobe signal level at the receiver terminals would be about -82 dBm, and the level of the higher-order sidelobes would be about -100 dBm, according to calculations using the 90-dB frequency-offset estimate and free-space path loss. Two situations must be considered: communication from aircraft to ground and from ground to aircraft.

D.3.1.5.4.1 Aircraft-to-Ground. When there is no communication signal from an aircraft, the ground-based UHF/AM receiver will receive only first-sidelobe and higher-order-sidelobe energy from the PAVE PAWS radar. The first-sidelobe pulses will exceed the receiver threshold by about 25 dB, and will very likely be heard by the operator. The pulses will occur at the rate associated with the first sidelobe illuminating the fixed ground station on all of PAVE PAWS' frequencies. Because the ground station is at a lower elevation than the radar, first-sidelobe energy only from surveillance pulses would illuminate it. (Tracking beams would generally be directed too high.) That pulse rate will be only about 1.5 pps (see Table D-4, p. D-24). The main effect of the pulses will be annoyance to the operator. The higher-order sidelobe pulses will exceed the receiver threshold by about 7 dB, and because the higher-order sidelobe pulses are emitted in all directions, both surveillance and tracking pulses need to be considered. Assuming that energy from all of the PAVE PAWS channels would propagate there, the resulting "PRF" would be about 73 pulses (of various pulse widths) per second (see Section D.2.6.2, p. D-15). That would probably be very annoying, although perhaps the squelch could be adjusted to block out those pulses, resulting in a loss of about 7 dB in system sensitivity.

An aircraft will be able to communicate with the ground station despite the occasional pulses of first-sidelobe interference from PAVE PAWS. Using the aircraft system parameters in Table D-16, free-space path loss, and assuming that a 10-dB signal-to-interference ratio will be sufficient to override the PAVE PAWS pulses, it appears that an aircraft equipped with a 10-W transceiver can communicate with the ground station without interference if it is within about 20 miles (32 kilometers). As the aircraft moves farther away, the signal-to-interference ratio will decrease, becoming 0 dB at about 63 miles (101 kilometers). With the aircraft at that distance, the communication signal from the aircraft will be at the same level as the pulse from PAVE PAWS' first sidelobe. Although aircraft-to-ground communications will still be received, the interfering pulse will be noticeable at the ground station.

D.3.1.5.4.2 Ground-to-Aircraft. For ground-to-aircraft communications, the Beale AFB transmitter and PAVE PAWS are close enough to be considered collocated. The signal-to-interference ratio at the aircraft can be computed by directly comparing the

effective radiated powers (ERP) of the communication transmitter and the PAVE PAWS radar. From Table D-16, the ERP of the communication transmitter is 50 dBm. For PAVE PAWS, approximately 30 MHz below the lower edge of its band, the ERP is about 16 dBm for the first sidelobe, and -2 dBm for the higher-order sidelobes; the main beam is of no concern, since PAVE PAWS will not track aircraft. At the aircraft, the signal-to-interference ratio will be about 34 dB and 52 dB for first-sidelobe and for higher-order sidelobes, respectively. Communications to the aircraft from the Beale ground station should not be affected by the PAVE PAWS radar.

D.3.1.6 Effects in Harmonically-Related Bands.

Harmonics of a desired frequency can be generated by nonlinearities. If nonlinearity is present in a transmitter or receiver, harmonic frequencies, particularly odd harmonics of the fundamental, can be expected. In a transmitter, the ratio of the magnitude of the fundamental with respect to the magnitudes of such harmonics is termed the harmonic suppression ratio, and is generally specified in decibels. Harmonic and spurious-frequency suppression for PAVE PAWS has been specified to be at least 90 dB. That is, harmonic and spurious-frequency power is less than that of the fundamental frequency by a factor of 1/1,000,000,000 (90 dB). Under such a specification, the ERP for harmonics and spurious signals of the basic PAVE PAWS system would not exceed +16 dBm for the first sidelobe, and -2 dBm for the higher-order sidelobes. Actual ERP for both even-order and higher-order harmonics, such as the fourth, could be less.

In general, the probability of interference to receivers operating at frequencies harmonically related to those in the 420-450 MHz band is small. Such a low probability results from (1) the harmonic suppression specified for the radar, and (2) significantly higher basic transmission loss for the harmonic frequencies compared to the fundamental (where the concern is with the harmonic signal itself propagating), and (3) receiver rejection of out-of-band signals that could cause in-band harmonics within the receiver. Finally, communication systems in the microwave portion of the spectrum are generally used for point-to-point communication. They generally employ directional antennas aligned to the communication path so as to attenuate electromagnetic energy arriving from other directions.

The following sections discuss frequency bands that contain frequencies harmonically related to those of the PAVE PAWS environment.

D.3.1.6.1 840-900 MHz. This band, allocated to non-federal government land mobile users, could receive emissions caused by second harmonics from PAVE PAWS. However, in an ECAC search of frequency allocations, they found no receivers operating in this band in the vicinity of Beale AFB (Siemen, 1978).

D.3.1.6.2 1260-1350 MHz. The third harmonic from PAVE PAWS covers this band, which is allocated to radars or aeronautical radio-navigation equipment. According to the Electromagnetic Compatibility Analysis Center (ECAC), no such ground receivers are located in the area around Beale AFB, nor are there aircraft that use radar in this frequency band (Siemen, 1978).

D.3.1.6.3 1680-1800 MHz. Equipment operating in this band is at the fourth harmonic of PAVE PAWS. This band is used by radiosonde meteorological aids and by government line-of-sight microwave links. A radiosonde receiver (GMD-2) operates 2 months each year at 1682 to 1685 MHz at Chico, California, in support of experiments by the AF Geophysical Laboratory experiments, (see Section D.3.1.5.3). The GMD-2 ground receiver tracks a balloon-borne radio beacon, which transmits to the ground tracking unit. Interference from the PAVE PAWS fourth harmonic to the ground tracking unit, almost 50 miles away, is unlikely.

D.3.1.6.4 2100-2250 MHz. The 2100-2250 MHz band is a portion of the common carrier line-of-sight microwave band. The PAVE PAWS fifth harmonic has the potential to cause interference to receivers operating in that band. ECAC identified many users (systems) in that frequency band near Beale AFB, examined each case, and predicted no interference to these systems (Siemen, 1978).

D.3.1.6.5 420-450 MHz. This is the fundamental (first harmonic) of the PAVE PAWS band. Radar altimeters and the Amateur Radio Service have already been discussed (see Sections D.3.1.1, p. D-20, and D.3.1.5.1, p. D-64), but for completeness, some systems not discussed elsewhere are mentioned in the following sections.

D.3.1.6.5.1 Ground Systems A computer search was made of the IRAC Government Master File (Willats, 1979) for frequency assignments within the 420-450 MHz band and within 120 miles of Beale AFB. Only 9 assignments were found.

- o Three frequencies -- 423.6, 430.0 and 437.5 MHz -- are assigned to the AF Geophysical Laboratory for balloon telemetry. A phone call to that facility (Danaher, 1979) confirmed the use of those frequencies. This use is discussed in Section D.1.5.3
- o Two frequencies are used by NASA in Mountain View, California. One is used for experimental purposes; the second is used for ground testing of flight hardware. Neither case was investigated because of the distance from PAVE PAWS
- o Two U.S. Navy systems and one U.S. Army radar system are licensed to operate in this band. Locations were not given in the Master File printout, and the cases were not investigated

- o Finally, there is an assignment for the PAVE PAWS radar itself.

D.3.1.6.5.1 Airborne Systems. The IRAC listing indicated 116 frequency assignments in the 420-450 MHz band. Fifty-three were made to the Air Force and 43 to the Navy. The assignments are for support of airborne radio systems that may operate anywhere within the United States. Ground control stations listed are primarily at military facilities outside California. No cases were analyzed other than the radar altimeters discussed in Section D.3.1.5. California and Nevada ground control locations are:

- o Long Beach, California
- o China Lake, California
- o Fallon, Nevada
- o Pt. Mugu, California
- o Fortuna, California
- o WSMR, California
- o Edwards AFB, California
- o Camp Pendleton, California.

D.3.2 Hazard Effects

This section discusses the potential effects of PAVE PAWS electromagnetic fields on equipment other than telecommunication systems. They are termed hazard effects, because they describe three potentially dangerous situations that high amplitude RF fields can cause under certain circumstances. They are: interference with the normal operation of implanted cardiac pacemakers, accidental detonation of electroexplosive devices (EEDs), and ignition of liquid fuels while they are being handled.

D.3.2.1 Cardiac Pacemakers

Cardiac pacemakers are potentially subject to electromagnetic interference, leading to the concern that PAVE PAWS could affect pacemaker wearers on the ground in its vicinity. Furthermore, PAVE PAWS will illuminate aircraft as discussed in Section D.2.6.1, (p. D-13), so there is also concern that pacemakers in such aircraft could also be affected. Whether PAVE PAWS will affect pacemakers depends upon the susceptibility of the individual device and upon the effectiveness of the shielding provided by the aircraft. The likelihood is very small that a pacemaker owner, either on the ground or in the air, would enter a potentially dangerous area or could remain there long enough to be affected.

D.3.2.1.1 Background. The heart can be considered to be an electrically operated pump. It is a set of muscles that contracts

rhythmically in response to a periodic electrical impulse that originates naturally in a certain portion of the cardiac tissue. Some people who suffer impaired operation of the natural pacemaker or of the conducting paths in the cardiac tissue rely on an artificial pacemaker, which supplies the electrical signal to make the heart beat when it should. From 100,000 to 300,000 people in the United States have pacemakers.

Four general types of cardiac pacemakers are employed: asynchronous (or fixed-rate), P-wave synchronous, R-wave synchronous, and R-wave inhibited. Because the last three types are designed to sense cardiac electrical activity, they may be subject to effects from external electromagnetic fields. The R-wave inhibited pacemaker supplies a pulse only on demand (i.e., when the heart requires it). It senses the electrical signal of the main pumping action of the heart. If that fails to occur when it should, the pacemaker supplies the signal to trigger the heart's action. Currently, 80 to 90% of pacemakers in use are of the R-wave inhibited type. R-wave inhibited pacemakers are generally more susceptible to electromagnetic interference (EMI) than are the other types.

Pacemakers do not fail permanently when exposed to strong RF fields; instead, if the field is sufficiently intense, they may exhibit one of four types of dysfunction:

- o Inhibition -- the pacemaker does not generate the required pulses
- o Irregular Pulses -- the pacemaker does not maintain a steady rhythm
- o Excessive or Insufficient Pulses -- the pacemaker rate exceeds 150 pulses per minute (ppm) or is less than 50 ppm
- o Reversion -- (for a synchronous pacemaker) the pacemaker reverts to a benign fixed rate; it is designed to respond to RF by becoming, for the time being, an asynchronous pacemaker. Reversion is not always considered a form of dysfunction, but neither is it altogether desirable.

D.3.2.1.2 Susceptibility to Pulsed RF Fields. The susceptibility of pacemakers to RF fields at or near 450 MHz has been measured by several researchers. Denny, et al. (1977) state that pacemakers have become noticeably less susceptible in recent years. They describe the results of measurements of susceptibility thresholds for pacemakers in saline solution. Their published results include old and new pacemakers, as well as prototypes that may not have gone into production (Denny and Toler, private communication, September 1978). Schlentz, et al. (1976) have shown that results

of tests in saline solution are entirely equivalent, at 450 MHz, to tests of implanted pacemakers. In either situation, the field strengths are defined and measured in the air outside the body or in saline solution.

A pacemaker wearer who approaches PAVE PAWS on the ground will not generally be exposed to the fields from the main beam. At the close distances of interest, only the higher-order sidelobes will illuminate the ground. The long-range surveillance resources take place at an average rate of about 5.5 pulse clusters (pulse pairs and triplets) per second. Tracking pulses would also take place, possibly in clusters. How the pacemaker would interpret this "PRF" is uncertain, both because PAVE PAWS does not have a specific deterministic PRF and because it is uncertain whether a pacemaker's circuitry would "see" the pulse clusters within a resource as individual pulses or would see each cluster as if it were one pulse (approximately 16 ms long in the case of a long-range surveillance resource). Assuming the latter, less favorable case, the pacemaker would probably interpret the PRF to be less than 10 pulses per second (pps).

There is an unoccupied hilltop about 8,500 ft north of PAVE PAWS that is brushed by the lower part of the main beam. There the fields would be as just described with the addition of the main-beam pulse about every 1.4 seconds. (This weak pulse is discussed in Section A.4.4, p A-24.)

A pacemaker owner in an aircraft could be subjected to the higher-order sidelobe pulses and possibly to the energy of the main beam or the first sidelobe as well. If the aircraft were in the volume of the main surveillance beam, the person would be illuminated with a pulse from the main beam at least once every 1.4 seconds (or at a rate of about 0.71 pps). Only surveillance pulses are included here, because PAVE PAWS does not track aircraft.

There is a device-dependent field intensity threshold above which a pacemaker will react to RF pulses. According to Denny et al., at low PRFs (less than 10 pps) an R-wave inhibited pacemaker is likely to misinterpret such pulses as the heart's electrical activity and become inhibited. At higher PRFs, it is more likely to revert to asynchronous operation. Long-term inhibition (for durations greater than about five normal heartbeats) may constitute a health hazard for some owners, whereas reversion is less serious.

Although pulse-susceptibility data are available in the literature (Denny, et al., 1977; Mitchell, et al., n.d.; Mitchell and Hurt, 1976), this information must be interpreted with caution. For example, the published version of the work of Denny et al. (1977) does not mention that their plots of susceptibility thresholds were developed using many prototype or developmental

pacemakers, some of which did not go into production as tested because of the low susceptibility thresholds shown in the paper. Thus, although that paper shows the results of many tests, the data do not necessarily represent the susceptibility thresholds of the pacemakers that have actually been manufactured and implanted in cardiac patients.

Susceptibility levels, based on 450 MHz tests in August 1975 were published by Mitchell and Hurt (1976). These levels, which range from 4 V/m to more than 260 V/m with ten 20-ms pulses per second, represent a smaller sample; however, the pacemakers referred to are actual units (serial-numbered or model-numbered). That report on the 1975 tests states that the susceptibility levels presented "are believed most representative of the current state of technology." The report also states that "if pacemakers were designed and tested to be compatible with the minimum E-field level, viz 200 V/m, associated with the unrestricted 10 mW/cm² (10,000 microwatts/cm²) personnel exposure level, potential EMI situations would be substantially reduced or effectively eliminated." Such a 200-V/m testing level is described in a draft standard prepared by the Association for the Advancement of Medical Instrumentation (AAMI) for the Food and Drug Administration. The pacemaker is submerged in a tank of saline solution to simulate body tissue and its catheter is aligned for maximum coupling with the electromagnetic field. Testing is to be done at, but not necessarily above, 200 V/m within 50 MHz of 450 MHz and at pulse repetition frequencies of 125% \pm 10% of the basic rate of the pacemaker.

Both Mitchell and Denny (personal communications, September 1978) suggest that the manufacturers are certainly trying to meet and may now be meeting the 200-V/m level in their newer models. Some preliminary data from measurements by Mitchell in 1977 indicate that many are not susceptible at levels as high as 330 V/m. Denny stated that the threshold for most of the newly released pacemakers is above 300 V/m. He also stated, however, that manufacturers' catalogues show that some of the unshielded and unfiltered, and therefore highly susceptible, pacemakers are still being offered for implantation. Talks with manufacturers confirm this.

Manufacturers contacted state that their newer pacemakers meet the draft AAMI standard, and one manufacturer said that the manual for a particular model states that it has been tested to 295 V/m. However, many older pacemakers are still functioning, so the actual susceptibility thresholds of all the pacemakers currently in use remain unknown. Complete information directly relevant to PAVE PAWS requires knowledge of the mix of the pacemakers now in operation, by manufacturer and by model, and of the susceptibility of each type of unit to the specific pulse width, PRF, and frequency-hopping characteristics of PAVE PAWS. Collecting this information is nearly impossible, because the pacemaker

AD-A088 320

SRI INTERNATIONAL MENLO PARK CA F/G 17/9
OPERATION OF THE PAVE PAWS RADAR SYSTEM AT BEALE AIR FORCE BASE--ETC(U)
JUL 80 F08635-76-D-0132

UNCLASSIFIED

AFSC-TR-80-09

NL

6 of 6

3/20



END
DATE
FILMED
9-80
DTIC

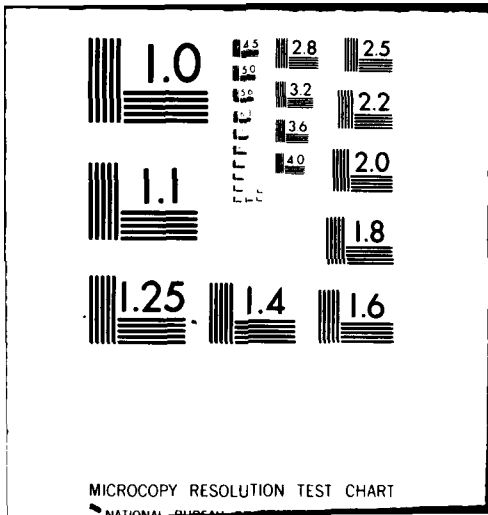

manufacturers typically do not provide any 450-MHz susceptibility information on their specification sheets. Moreover, the situation is in a state of flux. An entirely new pacemaker must be implanted in an individual when the battery becomes exhausted, and so the physician has an opportunity, but not a mandate, to implant a pacemaker less susceptible to EMI. When mercury cells were the only types of battery used, pacemaker replacement was necessary about every 2 to 3 years; lithium iodide batteries last 4 or 5 years or more and are now the type more frequently used. (An atomic power source, with a life of 15-20 years, is very rarely used. It is very expensive and is used only with very young patients.) Thus, the statistical EMI characteristics of all of the pacemakers in use cannot be accurately specified.

D.3.2.1.3 Susceptibility to PAVE PAWS. Figure D-17 compares the suggested 200-V/m susceptibility threshold with the predicted PAVE PAWS field strength. Pacemakers with that susceptibility will be affected only if the owner is in the main-beam volume and within 1 mile of the basic system or within 2 miles of the growth system. On the hilltop brushed by the lower edge of the main beam, the resulting field strength pulse is estimated to be about 18 V/m. (The hilltop is Site 12 on Table A-5, p. A-31.) The device would not be affected by any of the sidelobes.

To be illuminated by the main portion of the main beam, the pacemaker's owner must be airborne; a pacemaker owner on the ground is not jeopardized, providing his pacemaker meets the suggested 200-V/m minimum susceptibility level. Furthermore, for the owner to be affected, the airborne pacemaker must remain in the main-beam volume for a period of time. The School of Aerospace Medicine advises that five successive beats of the pacemaker must be interfered with to create a significant effect. At a rate of 72 heartbeats per minute, 5 beats require about 4 seconds.

PAVE PAWS will not track aircraft, so its tracking pulses will not be a threat to the pacemaker owner. It will be very difficult for an aircraft within a mile of PAVE PAWS to remain within the search volume -- that volume probed by the PAVE PAWS main beam in the surveillance mode -- long enough for a pacemaker owner to be affected. The volume probed by the PAVE PAWS main beam in the surveillance mode is defined by the beam elevation angle and its beamwidth and by the 240 deg azimuthal coverage of PAVE PAWS. The beam elevation is normally 3 deg in the surveillance mode and the beamwidth, for the basic system, is 2.2 deg (the growth option beamwidth is 1.5 deg). Figure D-18 shows a plan view and a cross section of that volume within a mile of PAVE PAWS; it is the volume within which a pacemaker with a susceptibility threshold of 200 V/m might be affected by the basic system. (The cross-sectional view shown here exaggerates the thickness of the

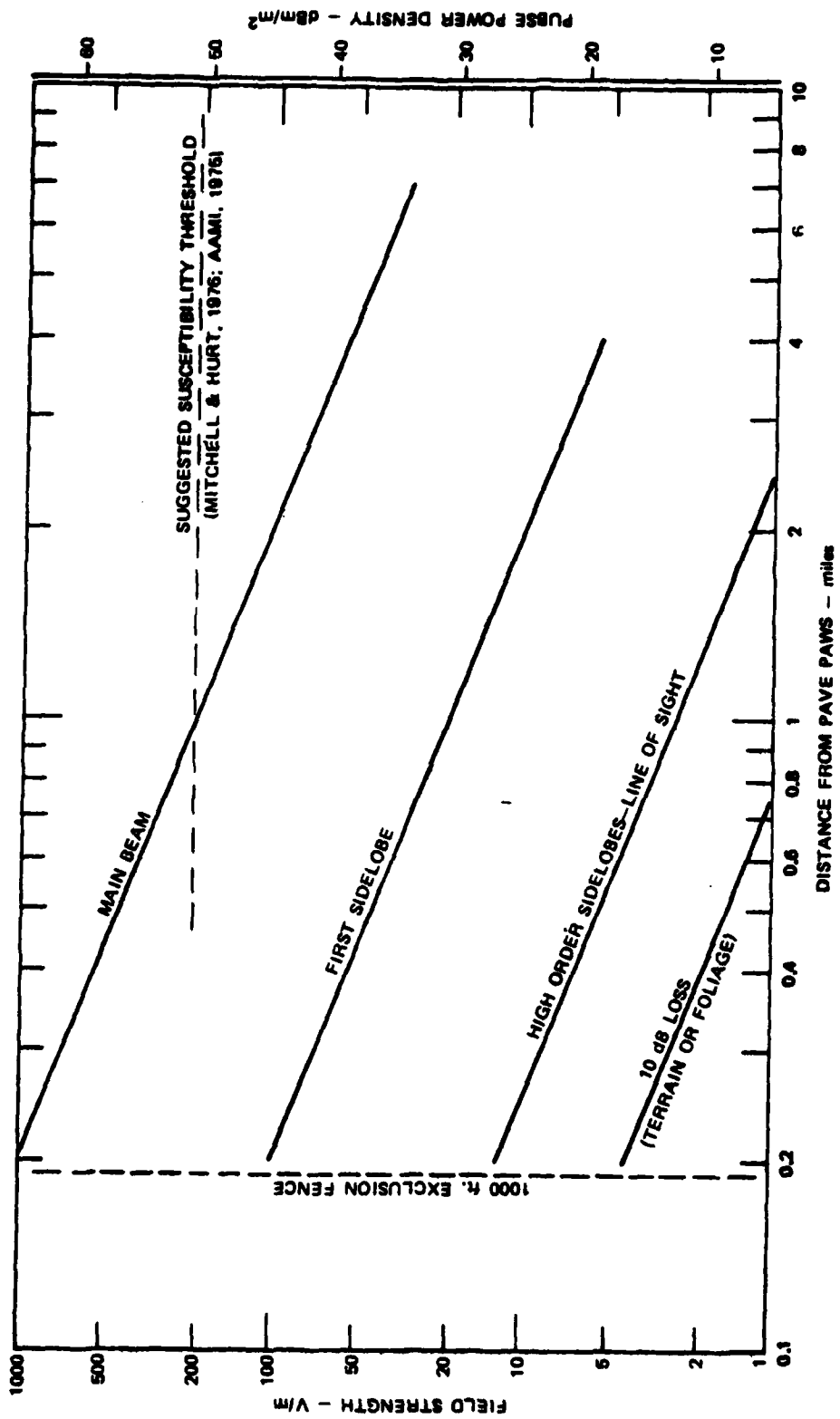

FIGURE D-17. EFFECTS OF PAVE PAWS ON PACEMAKERS, BASIC SYSTEM

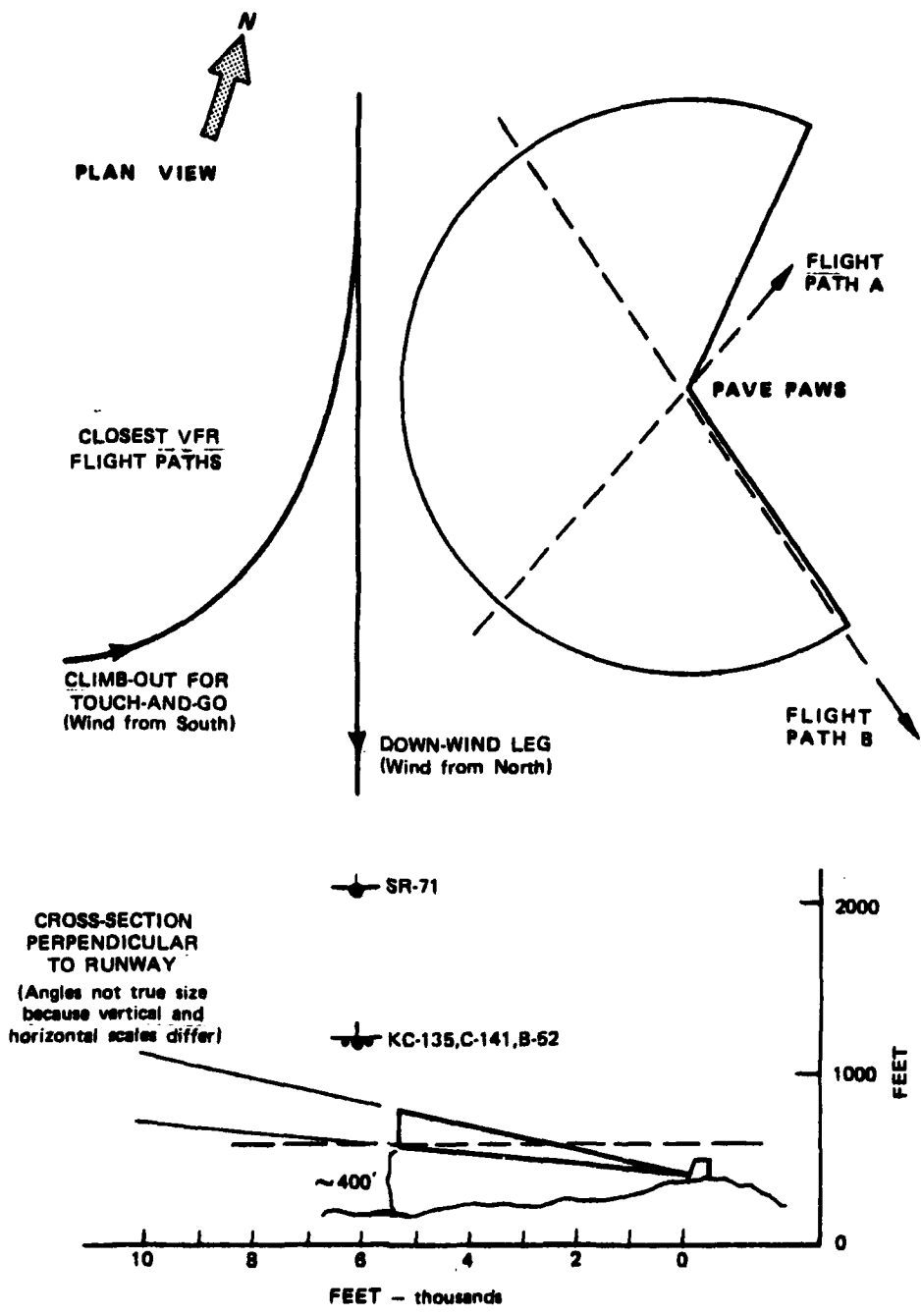

FIGURE D-16. VOLUME PROBED BY SURVEILLANCE-MODE MAIN BEAM (Within 1 Mile), BASIC SYSTEM

volume, which is only about 200 ft at a mile.) Any aircraft flying more than a mile away or more than about 380 ft above the PAVE PAWS elevation will never be within the volume where the field exceeds 200 V/m. No established flight paths pass through the volume. Therefore, pilots following FAA recommendations against flying within 500 ft of persons or structures will not place their aircraft within that volume.

The closest flight paths for visual-flight-rule (VFR) flying for Beale AFB are shown in Figure D-18 to be more than a mile (about 6,000 ft) from the radar. The cross section shows that the larger aircraft--KC-135s, C-141s, B-52s, and so on--are at an altitude of about 1,200 ft at their point of closest approach; that is about 400 ft above the beam. The SR-71 aircraft are at an altitude of about 2,100 ft at their point of closest approach. Other aircraft using Beale AFB fly patterns closer to the runway and therefore farther from PAVE PAWS. When instrument flight rules (IFR) apply, the pattern is on the west side of the runway, which is about 4 miles away. Even though it is highly unlikely that military aircraft would be carrying passengers with pacemakers, they do not come into the volume in which even an unshielded pacemaker would be susceptible to the radar's field.

Pilots who ignore both the established patterns for Beale AFB and the FAA rules could perform maneuvers that would bring their aircraft into the volume for various lengths of time, depending on the flight path and the aircraft speed. A straight and level flight directly over PAVE PAWS (see flight path A on Figure D-18) would bring the aircraft within the volume for a duration that depends on the aircraft altitude. At a height of about 175 ft above the radar, the aircraft would enter the volume at a distance of 1 mile, and emerge above it at a distance of about 2300 ft (higher or lower altitudes would cause less exposure, as the cross-section of Figure D-18 indicates). The duration within the volume would be $t = 2,030/r$ seconds, where r is the aircraft speed in miles per hour (about 20 seconds for a slow, 100 mi/hr aircraft). For flight path B at the same 175-ft altitude, the same slow aircraft would be within the volume for two 20-second periods, separated by a period of about 32 seconds as it passed over the radar.

Various other flight paths, such as those passing near, but not over, the radar could be discussed. All, however, would demonstrate the same situation: it requires very imprudent flying and disregard of basic flight safety to bring an aircraft within the volume where the field strength exceeds 200 V/m.

If the aircraft provides any shielding at all for the pacemaker wearer, the volume of concern will be greatly decreased. For a very moderate shielding of 3 dB, the radius defining the outer range of the volume will shrink by a factor of 1.4. In that case, an aircraft will have to fly lower to enter

the volume, and it will not be able to remain in it for so long. For the growth option, the radius of concern becomes 2 miles, but the beam is narrower, and, at that distance, it extends from a height of about 415 ft to about 690 ft above the radar. A slow aircraft overflying the growth-option PAVE PAWS by a prudent 500 ft would be within the volume for two 20-second periods separated by about 100 seconds.

If a pacemaker in the surveillance volume were to be affected by each PAVE PAWS pulse, it would be inhibited for portions of the durations just indicated. The main-beam "PRF" is about 0.7 pps (see Section D.2.6.1, p. D-13), and short and long surveillance pulses are emitted in a pseudorandom sequence. If a demand pacemaker were to interpret each PAVE PAWS pulse it receives as cardiac R-wave activity, it would be inhibited for a period of about 900 ms after each pulse. Multiplying 0.7 pps by 0.9 seconds of inhibition per pulse indicates that the pacemaker would be inhibited by the radar about 63% of the time it is in the surveillance volume within 1 mile of the basic PAVE PAWS. If the pacemaker reacts only to the long pulses of the long-range surveillance, it would still be inhibited part of the time (Denny et al. indicate that susceptibility increases with pulse length). The average PRF of these long pulses is about 0.24 pps, implying inhibition during about 21% of the time the aircraft is in the surveillance volume within 1 mile of the basic PAVE PAWS.

However, various circumstances make it highly unlikely that a pacemaker will be affected by each PAVE PAWS pulse even within the surveillance volume where the field exceeds 200 V/m. For one thing, susceptibility testing is done with the pacemaker's catheter extended and aligned for maximum coupling with the 200-V/m electromagnetic field. An implanted pacemaker's catheter is neither extended nor is it necessarily optimally aligned with the field, a circumstance that decreases the susceptibility of an implanted pacemaker. Normal minor shifts in body attitude relative to an impinging electromagnetic field can also cause great changes in the susceptibility of a pacemaker. Also, the shielding afforded by the aircraft (which will depend on the attitude of the aircraft relative to the beam, on the aircraft type, on the window size, and on many other variables) will decrease the size of the volume of concern. A small volume will be more difficult for the careless flyer to enter and the duration he can spend in it will also be reduced. Thus, even if a flyer carelessly were to enter the volume where the field exceeds 200 V/m, other circumstances would still make extended durations of pacemaker dysfunction unlikely, so that harmful effects on the pacemaker's owner would be unlikely.

D.3.2.2 Fuel Handling

The military has long been concerned over the possibility that high-powered radars (such as those on an aircraft carrier) could ignite volatile fuels as they are transferred. Ignition would result if the high RF fields caused a spark across a gap in a fuel-air mixture that had certain proportions. Experiments have determined the dc spark energy required to ignite fuel; according to (A.F. Technical Manual, T.O. 31Z-10-4), "The amount of RF voltage required to break down a similar gap is unknown but is believed, until proven otherwise, to be approximately the same as the dc-voltage value." For fuel handling near a radar, "a peak power density of 5 watts/cm² (5,000,000 microwatts/cm²) or less can be considered safe."

Fuel-handling operations will take place at the fuel storage area near the corner of 6th and F Streets, in the flight-line area, and at the motor pool in the cantonment area. The last area, the closest of the three to PAVE PAWS, is a little more than 2 miles away. Like the other two areas, it is illuminated by the radar's first sidelobe. The pulse power density for the basic system is expected to be about 0.000025 watts/cm² (25 microwatts/cm²), only a tiny fraction of the 5 watt/cm² maximum safe level. For the growth system, the pulse power density there would be about 0.0001 watts/cm² (100 microwatts/cm²). Because the motor pool area is the closest, the power density at the other two areas will be even less.

Even for the PAVE PAWS growth system, the pulse power density at the 1,000-ft exclusion fence for the higher-order sidelobes is only about 5,700 microwatts/cm², about one-tenth of one percent of the maximum safe power density level. At 100 ft in front of the growth system, the pulse power density is about 51,600 microwatts/cm², about one percent of the maximum safe level.

PAVE PAWS will not pose a hazard to fuel handling operations.

D.3.2.3 Electro-Explosive Devices (EEDs)

D.3.2.3.1 Types of EEDs. EEDs are used to activate secondary explosive charges, to ignite propellant systems, and to actuate electroexplosive switches. There are four basic types of EEDs. The types, actuation mechanisms, and uses are as follows (Hovan, 1978):

- o Exploding bridgewire: Requires a high-energy capacitive discharge pulse to explode bridgewire.
- o Normal bridgewire: An explosive mix is glued to the bridgewire. Electrical current heats the bridgewire, detonating the adhesive primer.

- o Composition mix: Uses conductive explosive mix. Current passes through the mix, igniting it.
- o Carbon bridge type: Used internally in three or four weapons systems and in 20-mm cartridge primers. This type of EED, when used in 20-mm cartridge primers, is the type most sensitive to RF fields. It is also sensitive to static electricity. The hazard for the 20-mm primer comes from ground crews touching the base primer during loading. If RF energy (or static electricity) is present, personnel touching the primer can couple energy into the EED. There are special handling-safety precautions for 20-mm ammunition.

D.3.2.3.2 Safe Separation Distance Criteria. EEDs are susceptible to ignition by exposure to radiated fields. The degree of susceptibility depends on many variables: the safe no-fire threshold of the EED, the ability of the EED leads to capture RF energy, the frequency and average power density of the RF energy, and the condition of exposure of the EED -- whether contained in a shielded canister, mounted inside an aircraft with partial shielding provided by the skin of the aircraft, or exposed to the environment with no shielding present. The safe exposure criterion is expressed as a safe power density, in W/m^2 , or as a safe separation distance. It should be noted that as the distance, d , between an EED and the RF transmitter is increased, the power density at the EED decreases as $1/d^2$.

The safe separation distances specified by AF Regulation AF 127-100, Explosive Safety Standards, applies to storage, transport and loading of EEDs, and to aircraft with EEDs taxiing and in flight. The distances are based on a worst-case situation, that is, on the most sensitive EED currently in inventory, shielded or unshielded, with its leads or circuitry inadvertently formed into a resonant antenna. Again, it should be noted that the criteria are based on the safe, no-fire threshold of the EED. Exceeding that threshold does not imply that the EED will fire. The actual firing threshold of the EED is several orders of magnitude above the safe no-fire threshold.

D.3.2.3.3 Electromagnetic Field Safety Standards for EEDs. The AF Reg. 127-100 criteria for safe power flux density exposure for EEDs are summarized in Table D-17. All safe exposure limits are given in terms of average power density except for item 2 in the table, which is specified in terms of pulse power density.

D.3.2.3.4 Other Safety Standards. Air Force safety standards for EEDs apply to the manufacture, testing, storage, transport, loading, and operational use of systems containing EEDs. The

Table D-17

SAFE EXPOSURE LIMITS FOR EEDs AT PAVE PAWS FREQUENCIES

Exposure or Storage Condition for EED	Average Power Density W/m ² Microwatts/cm ²	
<u>Exposed Condition</u>		
(1) EEDs in storage or transport, in nonmetallic containers, leads shorted	0.75	75
(2) EEDs in exposed condition (20-mm ammunition handling criteria)	0.75 ^a	75 ^a
(3) EEDs in exposed condition, leads formed into half-wavelength dipole antenna, at 420 MHz	.75	75
<u>Aircraft Taxiing</u>		
(4) Aircraft taxiing with externally-loaded weapons	6.63	663
<u>Storage or Inflight</u>		
(5) EEDs stored and transported in metallic containers	100.00	10,000
(6) Shipment of EEDs inside cargo aircraft	100.00	10,000
(7) Inflight aircraft with externally-loaded weapons	100.00	10,000

^aThis limit only is pulse power density rather than average.

Source: Explosive Safety Standards AF Regulation 127-100 (March 1978).

standards have been established to minimize the accidental detonation of weapons by environmental causes or by personnel. In addition to the electromagnetic field hazards to EEDs, AF Regulation 127-100 (31 March 1978) considers various electrical hazards, including location of power lines and electrical equipment, lighting, static electricity and grounding, and lightning protection.

D.3.2.3.5 EEDs at Beale AFB According to discussions with Beale AFB personnel, the following types of aircraft are stationed there: T-38, U-2, SR-71, and KC-135. Of those four, only the KC-135 tanker aircraft is equipped with EEDs which, in this case, activate an internal fire extinguisher. When activated, the fire extinguisher discharges CO₂ into the auxilliary power compartment. Filling the compartment with CO₂ creates no hazard to the aircraft (Coffey, 1978).

No EEDs are handled, assembled, or stored at Beale AFB. No 20-mm ammunition is stored on the base, or used by aircraft stationed there, or unloaded from visiting aircraft.

The earlier environmental assessment for PAVE PAWS (USAF, 1976) identified several models of the B-52 as having AN/ALA-17A flares, which are EED-released. Thirty-six of the flares are located in the horizontal stabilizer of the aircraft to be dropped upon command from the cockpit (Coffey, 1978). These flares are used to confuse heat-seeking missiles and are not normally carried. When dropped, the flares constitute no hazard to the aircraft, but if inadvertently released at very low altitudes they could cause brush fires, etc. Discussions with site personnel indicated that no B-52 aircraft are currently based at Beale AFB. However, transient B-52 aircraft occasionally land there. Other aircraft also visit Beale on a transient basis. The presence of EEDs on transient aircraft cannot be accurately predicted. It is therefore assumed that aircraft visiting Beale could be equipped with EEDs. +

D.3.2.3.6 PAVE PAWS Power Densities. Pulse and average power densities are given in Sections D.2.6.3 and D.2.6.4, pp. D-17 and D-18, and are plotted in Figure D-19 along with the EED safe-exposure limits. Most of these limits are in terms of average power density. However, AFR 127-100 does not indicate the time duration over which the power density should be averaged. Further, another Air Force publication, TO 31Z-10-4, states that when sufficiently large currents are applied to some EEDs, detonation may occur within microseconds. Many of the PAVE PAWS pulses are several milliseconds long, providing sufficient time for those EEDs to fire within the duration of a single pulse if the power density is high enough.

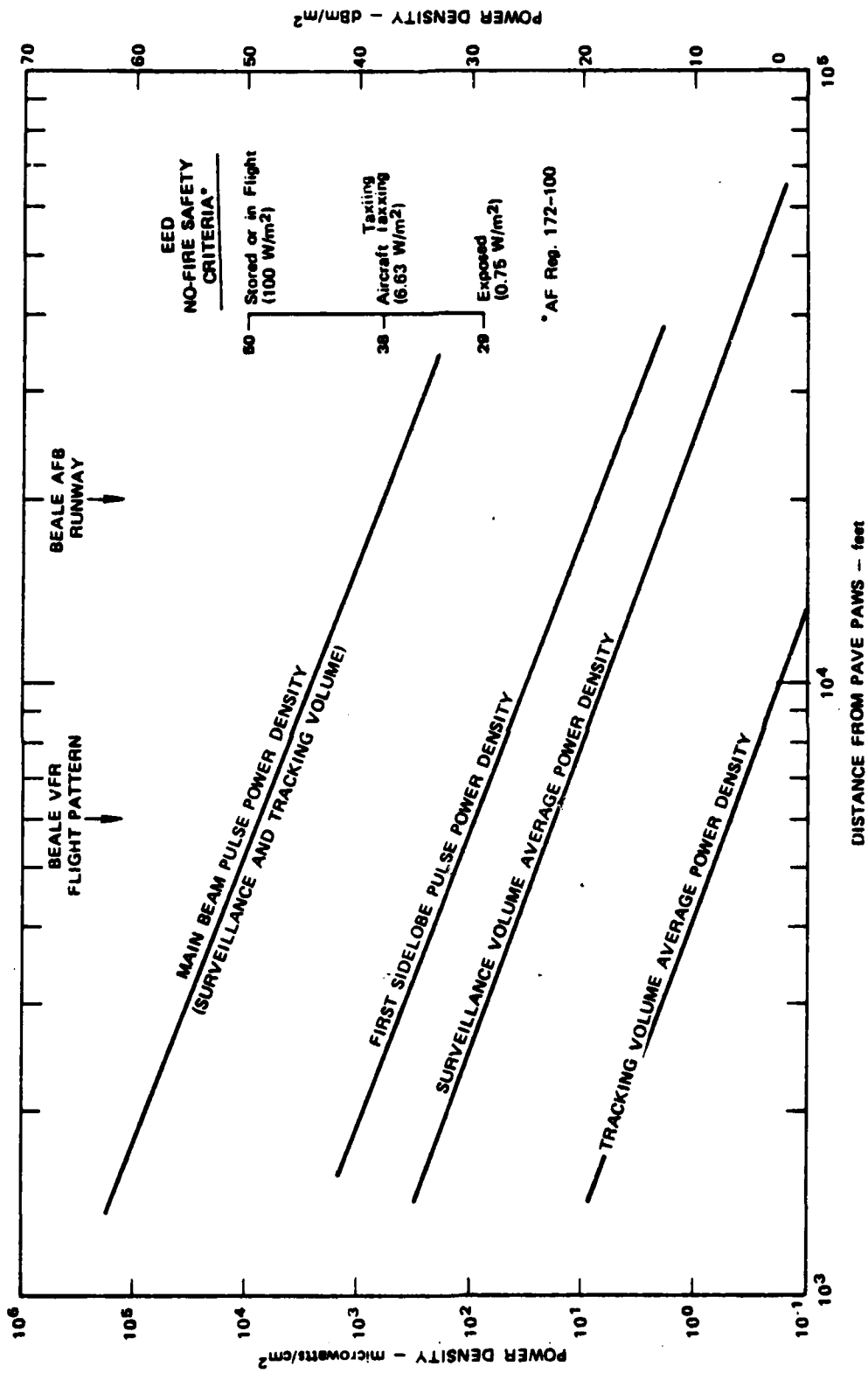

FIGURE D-19. AVERAGE AND PULSE POWER DENSITIES FOR PAVE PAWS, BASIC SYSTEM

The $100\text{W}/\text{m}^2$ (10,000 microwatt/ cm^2) average power criterion for stored EEDs or EEDs in aircraft in flight indicates that such EEDs in the far field (beyond about 1,400 ft) are not in a hazardous location if long-term average PAVE PAWS power densities are applicable (see Figure D-19). If no time-averaging is considered, a single main-beam pulse at distances within about 5,000 ft would exceed the no-fire safety criterion. That conclusion does not necessarily mean that the EED would fire. However, the closest part of the Beale AFB VFR pattern is at about 6,000 ft, so that aircraft will frequently be very close to that 5,000-ft distance.

The Beale AFB flight line is at a distance of about 20,000 ft from PAVE PAWS, and parts of it are illuminated by the first sidelobe. The first-sidelobe pulse power density at the flight line (see Figure D-19) is about $0.079\text{ W}/\text{m}^2$ (7.9 microwatts/ cm^2), in comparison with the criterion of $6.63\text{ W}/\text{m}^2$ (663 microwatts/ cm^2). The average power density -- no matter how the average is taken -- will be even less. Hence, aircraft taxiing with EEDs will not be subjected to hazard from operations of PAVE PAWS.

No EEDs in exposed condition, for which the criterion is $0.75\text{ W}/\text{m}^2$ (75 microwatts/ cm^2) are used at Beale AFB. No 20-mm ammunition is stored or handled at Beale AFB. That type of ammunition, for which the safe pulse power density is $0.75\text{ W}/\text{m}^2$ (75 microwatts/ cm^2), could be handled on the flight line without exceeding the criterion.

For main beam and first sidelobe exposure in the growth system, particular power densities occur at twice the distance for the basic system. Alternatively, the power density at a given location in the main beam or first sidelobe increases by a factor of four. There is still no concern for EEDs in aircraft in flight if average power density is considered. The pulse power density, though, exceeds the no-fire safety criterion within about 10,000 ft of the radar. The first sidelobe pulse power density at the flight line will increase to about $0.32\text{ W}/\text{m}^2$ (32 microwatts/ cm^2), still far below the 663 microwatts/ cm^2 criterion for EEDs in taxiing aircraft. Twenty-millimeter ammunition could still be handled on the flight line without exceeding the safe criterion.

No EEDs in exposed condition, for which the criterion is $0.75\text{ W}/\text{m}^2$ (75 microwatts/ cm^2) are used at Beale AFB. No 20-mm ammunition is stored or handled at Beale AFB. That type of ammunition, for which the safe pulse power density is $0.75\text{ W}/\text{m}^2$ (75 microwatts/ cm^2), could be handled on the flight line without exceeding the criterion.

D.4 References

- American Petroleum Institute, "The Storage and Hauling of Jet Fuels at Airports," API Bulletin 1503, American Petroleum Institute, 1271 Avenue of the Americas, New York (December 1965).
- Baldwin, R. L., General Manager, American Radio Relay League, Inc., letter to Headquarters USAF/RDS, Pentagon Washington, D. C., (September 1, 1978).
- Baldwin, R. L., Personal Communication (December 12, 1978).
- Baldwin, R. L., letter to Assistant Secretary of the Air Force (SAF/MIQ) commenting on PAVE PAWS at Otis AFB (February 27, 1979a).
- Baldwin, R. L., letter to Assistant Secretary of the Air Force (SAF/MIQ) commenting on PAVE PAWS at Beale AFB (September 28, 1979b) ++
- Beran, E. W., "The EMI Impact of the PAVE PAWS Radar on a Narrow-band FM Mobile System," Consultative Report ECAC-CR-77-038 (Rev. 1) Electromagnetic Compatibility Analysis Center (ECAC), Annapolis, Maryland 21402 (February 1978).
- Coffey, G. L., Site Manager, PAVE PAWS-Beale AFB, personal communication with B. C. Tupper, SRI, regarding survey of EED use and systems located at Beale AFB. (January 1979).
- Conklin, W. S., Analysis of Pulsed Interference to Television Receivers, ESD-TR-74-079, Electromagnetic Compatibility Analysis Center (ECAC), Annapolis, Maryland (October 1974).
- Danaher, T., Air Force Geophysical Laboratory, Hanscom AFB, Massachusetts, personal communication, (February 1979).
- Denny, H. W., B. M. Jenkins, and J. C. Toler, "Behavior of Cardiac Pacemakers in Pulsed RF Fields," Proceedings of the 1977 IEEE International Symposium on Electromagnetic Compatibility, pp. 272-277 (1977).
- Department of the Air Force, "Explosive Safety Standards," AF Regulation 127-100 (31 March 1978).
- Doepfner, T. W., G. H. Hagn, and L. G. Sturgill, "Electromagnetic Propagation in a Tropical Environment," Journal of Defense Research, Part B (Winter), pp. 353-404 (1972).
- Donaldson, E. E., Jr., "Susceptibility of Home Entertainment Equipment to High Power Interference," 1978 IEEE International Symposium on Electromagnetic Compatibility, IEEE Ref 78-CH-1304-5, p. 122-127 (June 1978).

- Electromagnetic Radiation Hazards, Technical Manual, T.O.
31Z-10-4, Air Force Communications Service (1 August 1966 and
Change 2, 1 June 1971).
- Engineering Considerations for Microwave Communications Systems,
GTE-Lenkurt, Inc., San Carlos, California (1972).
- Federal Communications Commission Rules and Regulations, Vol. II,
Washington, D.C. (September 1972).
- Fennacy, P., Chairman, Northern Amateur Relay Council, personal
communication (December 1978).
- Fitch, G., Colusa Communications, Colusa, California, personal
communication (20 December, 1978).
- Germain, J., "Extender Operation - Ignition Noise Suppression Built
Right into the Radio Receiver," IRE Trans. on Vehicular
Communications, Volume VC-11, No. 1, pp. 40-43, (August 1962).
- Glassmeyer, B., and C. J. Harris, "OSCAR 8 Has a Message for You,"
QST, Vol. LXII, No. 7, pp. 39-42 (July 1978).
- Ham Radio Magazine, Vol. 11, No. 8, p. 8 (August 1978).
- Hanselman, S. Frequency Coordinator, Northern Amateur Relay
Council, personal communications (December 1978 through
February 1979).
- Harris, C. J., "Tracking the Next OSCAR," QST, Vol. LXII, No. 2,
pp. 38-40 (February 1978).
- Head, H. T., "The Influence of Trees on Television Field Strengths
at Ultra-High Frequencies," Proc. IRE, Vol. 48, pp. 1,016-
1,020 (1960).
- Hovan, T., Aeronautical Systems Division, Wright-Patterson AFB,
Ohio, personal communication (23 October 1978).
- Hudson, V., "Analysis of Potential PAVE PAWS Radar Interference to
Command-Destruct Receivers," Consultative Report
ECAC-CR-78-001, Electromagnetic Compatibility Analysis Center
(ECAC), Annapolis, Maryland 21402, (January 1978).
- Hurt, G. F., and A. L. C. Sigurst, "Electromagnetic Compatibility
of VHF Land Mobile Receivers and the PAVE PAWS Radar,"
NTIA-TM-78 National Telecommunications and Information
Administration, U.S. Department of Commerce, Washington, D.C.
(May 1978).
- Jakes, W. C., Jr., Microwave Mobile Communications, John
Wiley and Sons, New York, New York, (1972).

- Jennings, R. D., and S. J. Paulson, "Communication System Performance Model for VHF and Higher Frequencies," OT Report 77-128, Office of Telecommunications, U.S. Department of Commerce, Boulder, Colorado (October 1977).
- King, J. A., "Phase III: Toward the Ultimate Amateur Satellite," Part 1, QST, pp. 11-14 (June 1977).
- King, J. A., *ibid*, Part 2, QST, pp. 52-55 (July 1977).
- King, J. A., *ibid*, Part 3, QST, pp. 11-13 (August 1977).
- Kleinman, J. P., "A Brand-New OSCAR," QST, Vol. LXII, No. 1, pp. 55-57 (January 1978).
- "Labeling Requirements, Performance Requirements, and Terminology for Implantable Artificial Cardiac Pacemakers," Draft Standard, FDA Contract No. 223-74-5083, The Association for the Advancement of Medical Instrumentation, Suite 602, 1901 N. Ft. Myer Dr., Arlington, Virginia 22209 (August 1975).
- LaGrone, A. H., "Forecasting Television Service Fields," Proc. IRE, Vol. 48, p. 1011 (June 1960).
- Linthicum, J., Federal Communications Commission, personal communication, (January and February, 1979).
- Longley, A. G., and P. L. Rice, "Prediction of Tropospheric Radar Transmission Loss over Irregular Terrain, a Computer Method -- 1968," ESSA Technical Report ERL-79-ITS 67, U.S. Department of Commerce, Boulder, Colorado NTIS No. 676-874 (1968).
- Luczak, D. S., et al., "PAVE PAWS Propagation Analysis, Executive Summary," RADC-TR-76-222, Vol. 1 (of 2), In-House Technical Report, Rowe Air Development Center, Griffiss Air Force Base, New York, 13441 (August 1976).
- Lustgarten, M. N., and R. D. Grigg, "Effects of Radar Interference on Search Radar Performance," 1977 IEEE International Symposium on Electromagnetic Compatibility, 77CH 1231-0 EMC, pp. 190-195 (August 1977).
- Mitchell, J.C., and W. D. Hurt, "The Biological Significance of Radio Frequency Radiation Emission on Cardiac Pacemaker Performance," Report SAM-TR-76-4, USAF School of Aerospace Medicine (RAP), Aerospace Medical Division (AFSC), Brooks AFB, Texas, 78235 (January 1976).
- Mitchell, J. C., W. D. Hurt, T. O. Steiner, "EMC Design Effectiveness in Electronic Medical Prosthetic Devices," in S. M. Michaelson and M. W. Miller, eds., Fundamental and Applied

- Aspects of Nonionizing Radiation, Plenum Publishing Corp., 227 West 17th St., New York, New York, 10011, pp. 351-363 (date unknown).
- Morris, J., Ed., ARRL Repeater Directory 1977-78 The American Radio Relay League Inc., Newington, Connecticut (1977).
- Moss, D. R., "Updated EMC Analysis of the PAVE PAWS (AN/FPS-115) at Otis AFB," Final Report ECAC-PR-78-035, Contract F-19628-78-C-0006, Electromagnetic Compatibility Analysis Center (ECAC), Annapolis, Maryland 21402 (July 1978).
- O'Connor, R. A., "Understanding Television's Grade A and Grade B Service Contour," IEEE Transactions on Broadcasting, Vol. BC-14, No. 4 (December 1968).
- PAVE PAWS Program Office, "System Performance Specifications, PAVE PAWS," SS-OCLU-75-1 (April 1975).
- "PAVE PAWS System Performance Specification," Specification No. SS-OCLU-75-1A, Code Ident: 49956, Raytheon Company, PAVE PAWS Program Office, Wayland, Massachusetts 01778 (December 1977).
- Piersstorff, B. C., P. Rosenthal, and C. M. Hanes, "Simulation of Radar/Radar Interference at RF for the Evaluation of Interference Effects on Operator Performance," 1977 IEEE International Symposium on Electromagnetic Compatibility, Yuba City, California, 77CH 1231-0 EMC, pp. 196-200 (August 1977).
- Powell, J., Amateur Call Sign WA6FGZ, Yuba City, California, personal communication, December 1978.
- Reference Data for Radio Engineers, Fifth Edition, Howard W. Sams Inc. of ITT (1973 printing).
- Scheidt, M. P., "Analysis of Potential Interference to Command-Destruct Receivers on the Eastern Test Range," Consultative Report ECAC-CR-78-029, Electromagnetic Compatibility Analysis Center (ECAC), Annapolis, Maryland 21402, (April 1978).
- Schlentz, R. J., K. L. Larson, and K. W. Exworth, "Evaluation of In Vivo Versus In Vitro Test Methods for the Determination of Electromagnetic Compatibility of Implantable Cardiac Pacemakers at 450 MHz," 1976 International Symposium on Electromagnetic Compatibility, Symposium Record 76-CH-1104-9EMC, pp. 231-236 (July 1976).
- Shackford, R.F., MITRE Corporation, letter with attachment, D83-1244 (14 November 1978).

Siemen, H. A., Sr., "PAVE PAWS/Radar Altimeter EMC Analysis," Consultative Report, ECAC-CR-77-076, Electromagnetic Compatibility Analysis Center (ECAC), Annapolis, Maryland (October 1977).

Siemen, H. A., SR., "Updated EMC Analysis of the PAVE PAWS (AN/FPS-115) at Beale AFB," Draft Report, Electromagnetic Compatibility Analysis Center (ECAC), Annapolis, Maryland (November 1978).

Skolnik, M. I., Introduction to Radar Systems, McGraw-Hill, New York, New York (1962).

Smith, J. S., "Impulse Noise Reduction in Narrow-Band FM Receivers: A Survey of Design Approaches and Compromises" IRE Trans. on Vehicular Comm., Volume VC-11, No. 1, pp. 22-26, (August 1962).

Television Factbook, 1974-1975 Edition/No. 44, Television Digest, Inc., 1836 Jefferson Place, NW, Washington, D.C.

U.S. Air Force, Environmental Assessment for Phased Array Warning System (PAVE PAWS), Beale Air Force Base, California (March 1976).

++