

AD-A084 155

NAVAL POSTGRADUATE SCHOOL MONTEREY CA

F/G 19/4

A-10/GAU-8 LOW ANGLE FIRINGS VERSUS SIMULATED SOVIET TANK COMPA--ETC(U)

APR 80 R H STOLFI, R R MCEACHIN

NIPR-ACFR-79-177

UNCLASSIFIED

NPS-56-80-004

NL

1 OF
40
AD-A084 155

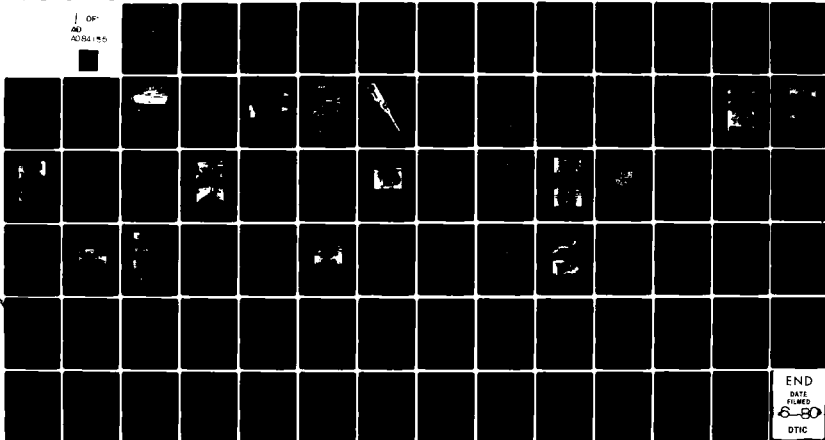

END
DATE
FILMED
6-80
DTIC

② LEVEL II

NPS-56-80-004

ADA 084155

NAVAL POSTGRADUATE SCHOOL

Monterey, California



DTIC
ELECTE
MAY 15 1980

B

Special copy

COMBAT DAMAGE ASSESSMENT TEAM
A-10/GAU-8 LOW ANGLE FIRINGS
VERSUS
SIMULATED SOVIET TANK COMPANY (ARRAY 17)
(LAVP Lot Number AJD 79A181-001, AEROJET)
(14 AUGUST 1979).
Rosen, H.S. STOLFI
R.R. MCEACHIN
APR 1980

D. M. S. - REF - 79-270

Approved for public release; distribution unlimited.

Prepared for: A-10 System Program Office
Wright Patterson Air Force Base
Ohio 45433

20145

80 5 14 013

DDG FILE COPY

NAVAL POSTGRADUATE SCHOOL
Monterey, California

Rear Admiral James J. Ekelund
Superintendent

Jack R. Borsting
Provost

The work reported herein was supported by the A-10 System Program Office, Wright-Patterson Air Force Base, Ohio. The reproduction of all or part of this report is authorized.



Russel H.S. Stolfi
Associate Professor of
History

Reviewed by:

For: Patrick J. Parker
Chairman
Department of National
Security Affairs

Released by:

W.M. Tolles
Dean of Research

Unclassified

SECURITY CLASSIFICATION OF THIS PAGE (When Data Entered)

REPORT DOCUMENTATION PAGE		READ INSTRUCTIONS BEFORE COMPLETING FORM
1. REPORT NUMBER NPS-56-80-004	2. GOVT ACCESSION NO. AD-A084155	3. RECIPIENT'S CATALOG NUMBER
4. TITLE (and Subtitle) A-10/GAU-8 Low Angle Firing versus Simulated Soviet Tank Company (Array/17) (14 August 1979) (LAVP Lot #AJD 79A181- 001) (Aerojet)		5. TYPE OF REPORT & PERIOD COVERED Special report for Array Firings of 14 August 1979
7. AUTHOR(s) R.H.S. Stolfi R.R. McEachin		6. PERFORMING ORG. REPORT NUMBER
9. PERFORMING ORGANIZATION NAME AND ADDRESS Naval Postgraduate School Monterey, California 93940		8. CONTRACT OR GRANT NUMBER(s)
11. CONTROLLING OFFICE NAME AND ADDRESS A-10 System Program Office Wright-Patterson Air Force Base Ohio 45433		10. PROGRAM ELEMENT, PROJECT, TASK AREA & WORK UNIT NUMBERS MIPR # ACFR 79-177
14. MONITORING AGENCY NAME & ADDRESS (if different from Controlling Office)		12. REPORT DATE April 1980
		13. NUMBER OF PAGES 74
		15. SECURITY CLASS. (of this report) Unclassified
		15a. DECLASSIFICATION/DOWNGRADING SCHEDULE
16. DISTRIBUTION STATEMENT (of this Report) Approved for public release; distribution unlimited		
17. DISTRIBUTION STATEMENT (of the abstract entered in Block 20, if different from Report)		
18. SUPPLEMENTARY NOTES		
19. KEY WORDS (Continue on reverse side if necessary and identify by block number)		
1. automatic cannon ammunition 5. empirical firing tests 2. GAU-8 cannon 6. combat stowed targets 3. A-10 aircraft 7. gun ammunition lethality 4. main battle tank (MBT) 8. MBT vulnerability & survivability		
20. ABSTRACT (Continue on reverse side if necessary and identify by block number)		
This report describes firings of the A-10/GAU-8 weapon system on 14 August 1979 against a Soviet tank company simulated by 10 combat loaded M-47 tanks. The pilots making the firing passes attacked at low altitude and used correspondingly low dive angles in order to simulate movement through a hostile air defense system. Ammunition used in the attacks comprised Aerojet Lot Number AJD 79A181-001 30mm armor piercing incendiary (API) rounds, which proved to be effective damage agents against substantial areas		

DD FORM 1473
1 JAN 73

EDITION OF 1 NOV 65 IS OBSOLETE
S/N 0102-014-6601

Unclassified
SECURITY CLASSIFICATION OF THIS PAGE (When Data Entered)

Unclassified

SECURITY CLASSIFICATION OF THIS PAGE(When Data Entered)

(block 20 concluded)

of the U.S. MK-47 tanks used as targets. The pilot in nine firing passes (one target was not fired on, and the pilot missed one intended target) fired a total of 565 rounds, of which 140 impacted the targets. Of the projectiles impacting on targets, 17 achieved perforations of the armored envelope. Significant results include:

- one tank immobilized and silenced;
- one tank silenced, mobility seriously degraded;
- three tanks immobilized only;
- two tanks immobilized, firepower seriously degraded
- one tank light firepower damage;
- two tanks suffered no damage.

SECURITY CLASSIFICATION OF THIS PAGE(When Data Entered)

CONTENTS

	Page
EXECUTIVE SUMMARY.	1
Attack Parameters.	1
Weapon Effects	1
Damage Assessment.	1
Test Conditions.	2
Results.	2
BACKGROUND	4
TEST PHILOSOPHY.	4
SIMULATED GROUND COMBAT SITUATION.	6
TARGET TANKS	7
TEST PERFORMANCE AND RESULTS	7
DAMAGE ASSESSMENT.	15
Tank Number 38	16
Tank Number 41	21
Tank Number 34	24
Tank Number 4	27
Tank Number 33	31
Tank Number 31	37
Tank Number 29	40
Tank Number 23	44
SUMMARY AND CONCLUSIONS	47
APPENDIX A	49
APPENDIX B	54

FIGURES

1. Russian T-62 Medium Tank	8
2. U.S.A.F./Fairchild Republic A-10 Aircraft.	10
3. Fairchild A-10 Series Aircraft	11
4. GAU-8/A 30mm Gun System.	12
5. 30mm Armor Piercing Incendiary (API) Round	13
6. Approximate Tank Layout	14
7. Impact Diagram, Tank 38	17

FIGURES (continued)

8. Perforation 3 into Fighting Compartment.	18
9. Perforation of Left Hull into Fuel Tank.	18
10. Tank 38 Commander - Front	19
11. Tank 38 Commander - Back	19
12. Tank 38 Loader	20
13. Tank 38 Gunner	20
14. Impact Diagram, Tank 41	22
15. Tank 41 Hull Perforation into Left Fuel Cell	23
16. Tank 41 Casualty	23
17. Impact Diagram, Tank 34	25
18. Impact 1, Tank 34 Hull Perforations	26
19. Impact Diagram, Tank 4	28
20. Tank 4 Rear/Side Damage.	29
21. Tank 4 Left/Center Damage.	29
22. Impact 4, Tank 4 Tank Commander.	30
23. Impact Diagram, Tank 33	32
24. Impact Diagram, Tank 33 Rear	33
25. Impact Diagram, Tank 33 Top	34
26. Tank 33 Turret	35
27. Tank 33 Loader	36
28. Tank 33 Gunner	36
29. Impact Diagram, Tank 31	38
30. Tank 31 Perforation of Range Finder Blister	39
31. Impact Diagram, Tank 29 Left Side	41
32. Impact Diagram, Tank 29 Rear	42

FIGURES (concluded)

33. Close-in View of Impacts 13 and 19, Tank 29. . . . 43
 34. Reference View of Impacts 13 and 19, Tank 29 . . . 43
 35. Impact Diagram, Tank 23 Top 45
 36. Impact Diagram, Tank 23 Left Side 46
 A-1. Array 17 Attack Aspect Summary 53

TABLES

I. Array 17 Summary of A-10 Aircraft in Low Angle
 Gun Attack versus Simulated Soviet Tank
 Company 3
 II. Comparison of Ideal & Practical Test
 Situations 5
 A-I. Array 17 Results Summary 50
 A-II. Array 17 Perforation Location Summary 51
 A-III. Array 17 Aircraft Attack Parameters 52

ACCESSION	
NTIS	Write Section <input checked="" type="checkbox"/>
DDC	Buff Section <input type="checkbox"/>
EXTENSION	<input type="checkbox"/>
JUSTIFICATION	
BY	
DISTRIBUTION/AVAILABILITY CODES	
Dist. and/or SPECIAL	
A	

COMBAT DAMAGE ASSESSMENT COMMITTEE (CDAC) EXECUTIVE SUMMARY

Under the technical direction of the Combat Damage Assessment Committee (CDAC), the Combat Damage Assessment Team (CDAT) conducted firings of the A-10/GAU-8 weapon system against an array of 10 tanks simulating a Soviet tank company deployed for an attack. The CDAT used M-47 tanks stowed with main gun ammunition, diesel fuel, lubricating oil, and crew manikins to simulate the Soviet tanks. The pilot of the A-10 aircraft used in the firings conducted firings at low altitudes and low dive angles which simulated attack below the altitude of effective engagement for opposing air defense networks employing acquisition and fire control radar. The purpose of the test was to evaluate the effects of Aerojet 30mm API anti-tank ammunition (lot number AJD 79A181-001) of the GAU-8 gun under challenging conditions of engagement for the A-10/GAU-8 system against realistically simulated Soviet main battle tanks.

The CDAC assessed the results of the low angle cannon firings of the A-10 aircraft against the simulated Soviet tank company as follows:

1. Attack Parameters: The pilot of the A-10 aircraft attacked the simulated Soviet tank company for 16 minutes 55 seconds at low altitude and dive angles. The GAU-8 cannon has a ground selectable nominal fire rate of either 4200 rounds per minute or 2100 rounds per minute. The system was set to fire at the 4200 round per minute rate during this test. The pilot made a total of nine passes, each at a primary target tank. The passes resulted in projectile impacts on eight primary target tanks. The attack dive angles averaged 4.5 degrees for the nine passes. Open-fire slant ranges averaged 2939 feet. The pilot fired 565 rounds in nine bursts averaging 63 rounds and 0.96 second each.

2. Weapons Effects: The A-10/GAU-8 weapon system achieved 140 impacts on the eight tanks which were fired on, of which 37 were ricochets off the ground. The ratio of direct impacts to total rounds fired was 0.18. Ricochet hits are also capable of causing damage. If the ricochet hits are added to the direct impacts, the overall ratio of impacts to rounds fired becomes 0.25. The weapon system achieved 17 perforations of the armored envelopes of the tanks with a ratio of perforations to total impacts of 0.12. The ratio of perforations to direct impacts was 0.17. Many projectiles, which did not perforate armor, severely damaged exterior track and suspension components of the tanks as well as command and control optical devices and gun tubes.

3. Damage Assessment: The attacking A-10/GAU-8 weapon system inflicted no catastrophic kills on tanks in the company array. Of the damaged tanks, one was rendered incapable of both fire and movement, one was silenced and seriously degraded in mobility, two were immobilized and seriously degraded in firepower, and three were immobilized with no degradation in firepower. One tank suffered a minor degradation in firepower and two tanks were unscathed (one was missed, the other was not

attacked). As a formation, the simulated Soviet tank company was immobilized and incapable of sustained offensive combat.

4. Test Conditions: The target tanks were sited in open, flat desert terrain with no cover and little concealment. Aerial weather conditions were ones of unlimited ceiling and visibility. Shortly after the initial firing, clouds of white dust from projectile impacts were evident. Such conditions effectively simulated the actual obscuration which would have been presented to the pilots in combat.

5. Results: The overall results of the test are summarized in Table I.

TABLE 1. Array 17 Summary of A-10 Aircraft in Low Angle Gun Attack versus Simulated Soviet Tank Company (14 AUGUST 1979)

Tank No.	A-10 Primary Pass	A-10 Speed (fps)	Approach		A-10 Attack		Gun Effects		Damage			Tank Immob ?	Attack Aspect (degrees)
			Alt (ft)	Open Range (ft)	Fire Range (ft)	Dive Angle (degrees)	Rounds (each)	Impacts (each)	Perfs (each)	M %	F %		
38	1	572	218	2516	4.6	69	6	4	100	95	---	Yes	260
41	2	564	284	3090	5.0	41	22	2	100	40	---	Yes	247
7	3*	554	197	3172	3.7	55	0	0	N.A.	N.A.	N.A.	N.A.	---
35**	---	---	---	---	---	---	---	---	---	---	---	---	---
34	4	430	73	3321	2.3	41	2	1	100	---	---	Yes	270
4	5	538	226	2840	4.6	69	38	2	90	100	---	No	235
33	6	539	220	***	4.4	55	25	2	100	100	---	Yes	235
31	7	441	165	***	4.2	97	17	1	0	20	---	No	285
29	8	494	201	2309	6.3	83	21	4	100	---	---	Yes	230
23	9	573	278	3322	5.3	55	9	1	100	---	---	Yes	265
Applicable													
Totals:		523	207	2939	4.5	565	140	17	1	1	1	6	LEFT
Averages:						63	15.5	1.9				TANKS IMMOB.	REAR

1 TANK IMMOBILIZED AND SILENCED;
 1 TANK SILENCED; MOBILITY SERIOUSLY DEGRADED
 3 TANKS IMMOBILIZED ONLY
 2 TANKS IMMOBILIZED; FIREPOWER SERIOUSLY DEGRADED
 1 LIGHT FIREPOWER DAMAGE
 2 NO DAMAGE

* The pilot missed the tank on this pass
 ** Tank not fired on
 *** Range uncertain

BACKGROUND

Since February, 1978, the Armament Directorate, A-10 System Program Office, Wright Patterson Air Force Base, Ohio, has conducted firing tests using the A-10/GAU-8 system in low-level, air-to-ground engagements of armored targets. The tests have been conducted within the framework of the GAU-8 30mm ammunition Lot Acceptance Verification Program (LAVP) - Airborne. The LAVP has the following objectives which apply to the present tests:

- A. To evaluate the performance of existing production lots of GAU-8 ammunition when fired from the air under operational conditions.
- B. To evaluate the lethality of GAU-8 ammunition against armored targets when fired at low level from A-10 aircraft using operational tactics.

To conduct the LAVP program, the Armament Directorate has cooperated with Headquarters, Tactical Air Command, Langley AFB, Virginia and, in turn, with the Tactical Fighter Weapons Center, Nellis AFB, Nevada. Within the framework of that cooperation, the Armament Directorate has set up a Combat Damage Assessment Team (CDAT) to plan and execute the firing tests and evaluate the results. The CDAT functions under the direction of a Combat Damage Assessment Committee (CDAC) which has prepared this report of the firing test of 14 August, 1979.

TEST PHILOSOPHY

To generate realistic data, the CDAC determined to use a highly empirical technique of destructive testing of actual tank targets. Tests have involved firings at individual tanks in November, 1977, and February - March, 1978, and, more recently, arrays of tanks in tactical formations. The experimental setup for the firings of 14 August, 1979 involved the use of a multi-target, tactically arrayed tank formation for attack by the A-10/GAU-8 system. The CDAT elected to simulate a Soviet tank company, as organized within a tank division, as the target array for two attacking A-10 aircraft. As few constraints as possible were placed on the attacking pilots in an attempt to develop as much realism as possible. Table II shows the test factors which would have been ideal in the test of 14 August, 1979 and the practical setup which was achieved.

Table II. Comparison of Ideal and Practical Test Situations

Ideal Test Parameters	Practical Test Parameter
1. <u>Air Attack Realism</u>	1. <u>Air Attack Realism</u>
a. Actual A-10/GAU-8 b. 30mm API c. European weather & terrain d. Optimum open-fire ranges (2000 ft) e. Low altitude attack angle (< 6 degrees)	a. Actual A-10/GAU-8 b. 30mm API c. Nevada weather & desert terrain d. Average open fire range: 2939 feet. e. Low altitude attack angle (< 6 degrees)
2. <u>Air Defense Realism</u>	2. <u>Air Defense Realism</u>
a. Automatic cannon firing at aircraft b. Missile systems firing at aircraft c. Small arms firing at aircraft d. AD suppression by aircraft	a. Low-altitude, low-angle, minimum-exposure attacks versus assumed AD system b. Low-altitude, low-angle, minimum-exposure attacks versus assumed AD system c. Low-altitude, low-angle, minimum-exposure attacks versus assumed AD system d. No suppression simulation in test
3. <u>Threat Targets and Doctrine</u>	3. <u>Threat Targets and Doctrine</u>
a. T62/T64/T72 high fidelity targets b. Stowed combat loads (in T62/T64/T72) c. Realistic crew station postures d. Dynamic combat formation e. Maneuvering evasive targets	a. Simulated Soviet tanks b. Stowed combat loads (in US M-47) c. Wooden crew manikins d. Static combat formation e. Stationary targets

SIMULATED GROUND COMBAT SITUATION

The firing test of 14 August 1979 simulated the attack by two A-10 aircraft on a Soviet tank company. One of these aircraft experienced an inflight engine failure prior to actual engagement, necessitating immediate withdrawal from the test. The CDAC hypothesized the Soviet tank company to be the lead march security detachment for its battalion, which in turn, is the advance guard of a larger mobile formation. The lead detachment operates approximately five kilometers in front of the Soviet battalion column. The mission of the advance company is to ensure the uninterrupted advance of the battalion and provide security against attack. Upon meeting heavy resistance, the company deploys into an appropriate combat formation to reduce the resistance, or form a base of fire for offensive action by the remainder of the battalion.

A Soviet tank company would probably have other units attached to it for its support. Attached units might include any one or all of the following elements: (1) motorized rifle platoon; (2) engineer detachment; (3) chemical defense specialists; (4) 122mm howitzer battery; (5) air defense element. The company simulated in the firing test consisted of tanks alone. The pure tank formation was arranged with two platoons up and one back, simulating an assault posture. The tanks used in the firing test were US M-47 tanks, largely intact, containing crew manikins, and stowed with ammunition, fuel, and oil. The tanks were not maneuvered during the firing test and the formation remained essentially a snapshot of the company at a single point in time.

TARGET TANKS

The most effective tanks available in sufficient numbers to simulate Soviet T-55 and T-62 (Figure 1) tanks were the US M-47 tanks. Both of the Soviet tank models are similar in armor protection to the M-47. With the appropriate purging of the gasoline fuel system of the US tanks, the CDAT managed to field a tank similar in survivability to the T-55 and T-62 tanks from the viewpoint of ignitable internal material. Few data are available on the Soviet T-64 and later model tanks from the viewpoints of armor protection and the arrangement of internal components. The decision was made, accordingly, to simulate the earlier model Soviet tanks with the readily available US tanks.

The M-47 tanks used for targets were in excellent condition from the viewpoint of damage assessment. The exterior components were complete and the tanks have proven to be effective targets for the collection of exterior mobility damage. Interior components were less complete in the target tanks. All of the most essential items were present, e.g., main gun, engine, transmission, fuel tanks, ammunition racks, etc., but other items such as oil coolers, range finders, vision devices, and radios, have not been present in all tanks.

The most sensitive internal items from the viewpoint of catastrophic kills and high percentage Mobility (M) and Firepower (F) kills are the following, which were placed in the test tanks as noted:

<u>Generic Sensitive Item</u>	<u>Test Item</u>
1. Ammunition -----	US Cartridge, 90-mm TP-T
2. Fuel -----	Number 2 Diesel
3. Oil -----	Oil in Engine, Transmission and Drive Components.
4. Personnel -----	Articulated Plywood Manikins

The tanks were static during the test and their engines were not running, with the result that the fuel and oil were much cooler and more inert than would have been the case with a moving tank or a static vehicle with its engine running. The kill ratio achieved in the firing test of 14 August, 1979, therefore, is probably conservative from the viewpoint of fires resulting from ignited fuel and oil.

TEST PERFORMANCE AND RESULTS

The test itself consisted of bringing together the ammunition, gun, aircraft, pilots, and combat arrayed and loaded tanks into a several minutes simulation of combat. In essence, the



Russian T62 Medium Tank

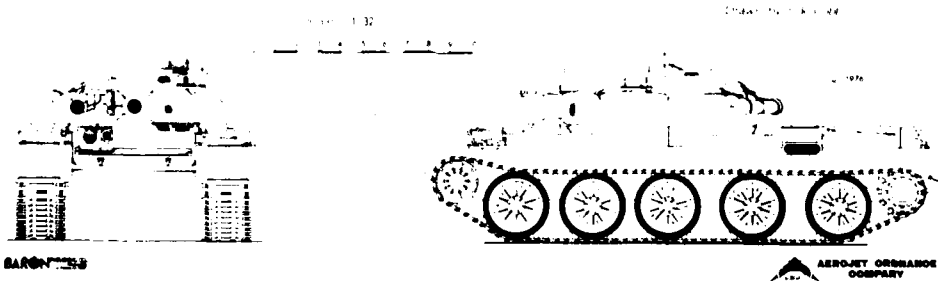

FIGURE 1. Russian T62 Medium Tank

decisive elements which were fed into the test immediately prior to the firing were the following:

1. Aerojet 30mm API ammunition, lot number AJD 79A181-001.
2. General Electric GAU-8 Gatling gun.
3. Fairchild Republic A-10 attack aircraft.
4. Fighter pilots, 66th FWS, Nellis AFB.
5. US M-47 main battle tanks.

The combat simulation itself comprised the aerial fire and maneuver of the attacking A-10 aircraft. A realistic way of presenting the combat simulation is to outline the sequence of pertinent events in each firing pass. These events and the pertinent data which the CDAT attempted to collect, in order to reconstruct the simulated combat firing of 14 August, 1979, were as follows:

<u>Sequence</u>	<u>Event</u>	<u>Data</u>
1.	Aircraft Approach	Speed, Altitude
2.	Aircraft Attack	Open-fire Range, Dive Angle
3.	Aircraft Attack	Burst Time, Rounds Fired
4.	Aircraft Attack	Cease-fire Range, Dive Angle
5.	Gun Effects, (Accuracy)	Impacts on Tanks
6.	Gun Effects, (Lethality)	Perforations through Armor
7.	Tank Damage	Catastrophic (K-Kill), Mobility (M-Kill), and Firepower (F-Kill) Kills

The data noted immediately above were collected through the combined efforts of the CDAT and range support personnel at Nellis AFB, working together and using TSPI equipment, motion picture and still cameras, the industrial efforts required to repair, refurbish, and field the tank targets, and various systematic research techniques used to describe weapon effects and combat damage. The most basic materiel used in the test; i.e., the aircraft, gun, and projectile are illustrated in Figures 2, 3, 4, and 5. The tanks were arrayed in the tactical formation of a Soviet tank company as shown in Figure 6.

The pilots making the attack flew from the base area in a two-ship, mutually supporting element and employed operational tactics immediately before and during the firing passes. The pilots approached the target area at low altitude and simulated target acquisition with the help of a forward air controller. Prior to actual engagement, the lead aircraft experienced an inflight engine failure, necessitating its immediate withdrawal. The remaining pilot then proceeded alone to attack the entire tank company at low altitudes and dive angles, simulating operation below the altitudes for effective acquisition and engagement by opposing air defense missile and gun systems.

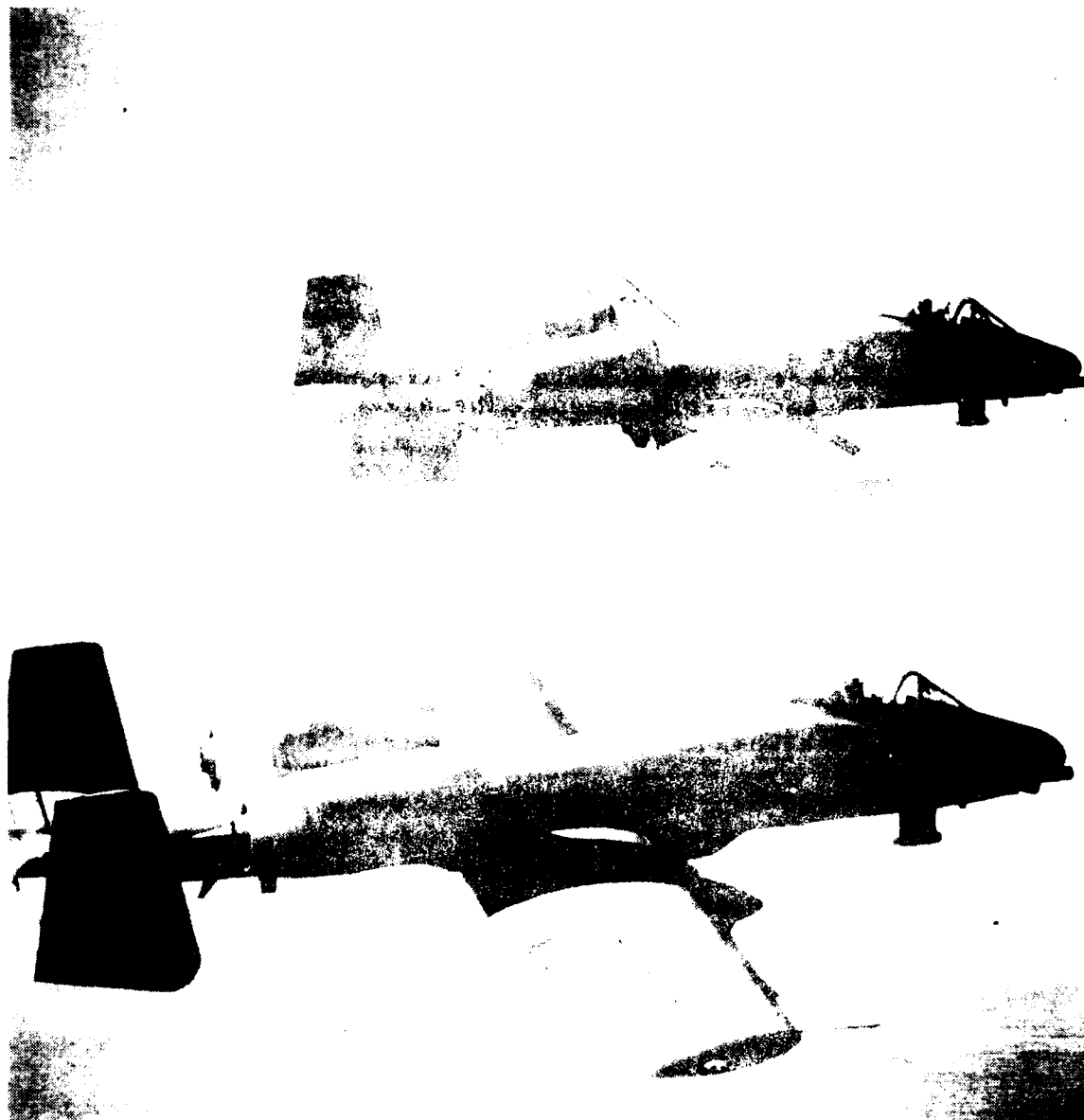

FIGURE 2. (a) Small aircraft in flight. (b) Large aircraft in flight.

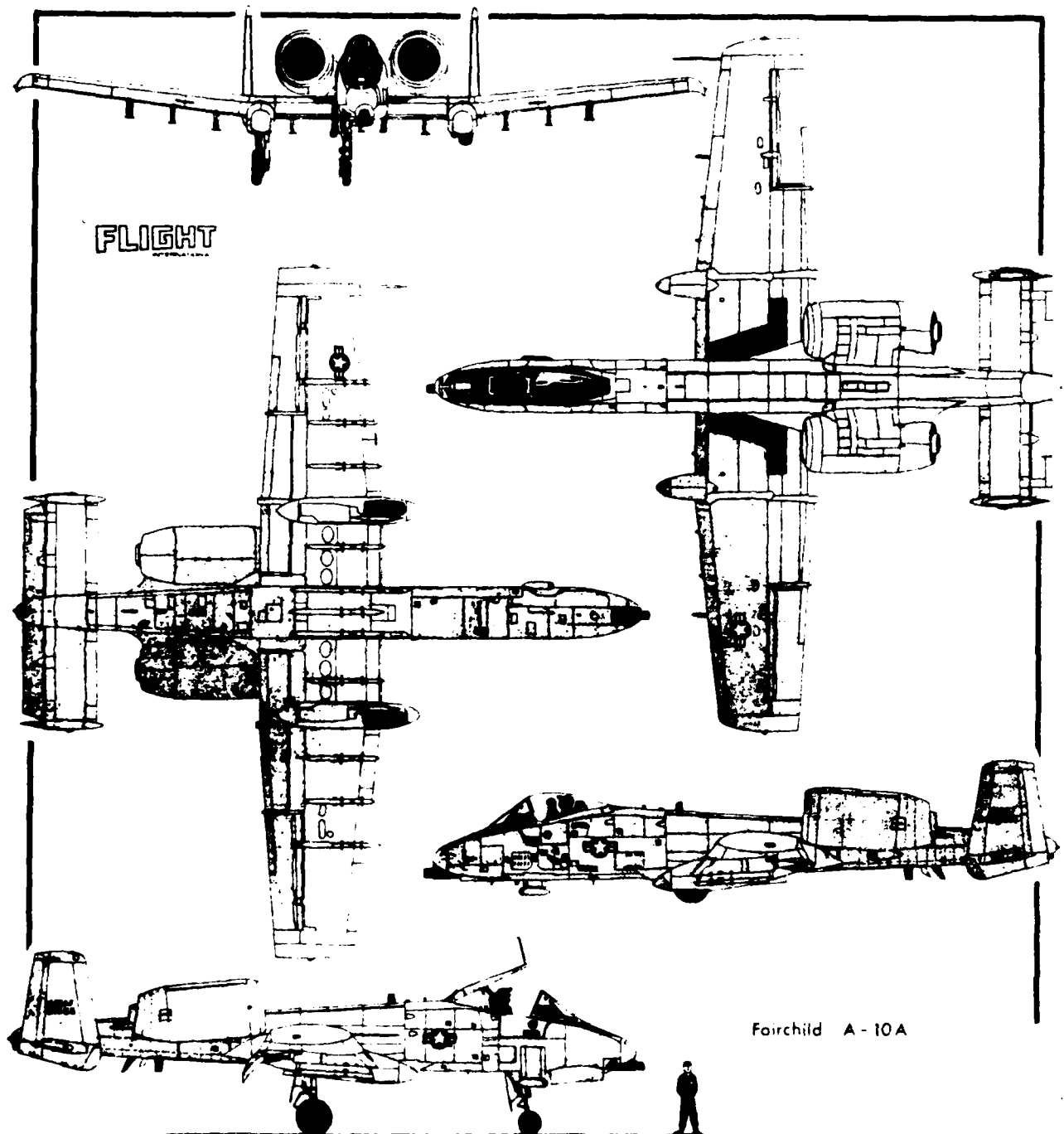

FIGURE 3. Fairchild A-10 Series Aircraft.

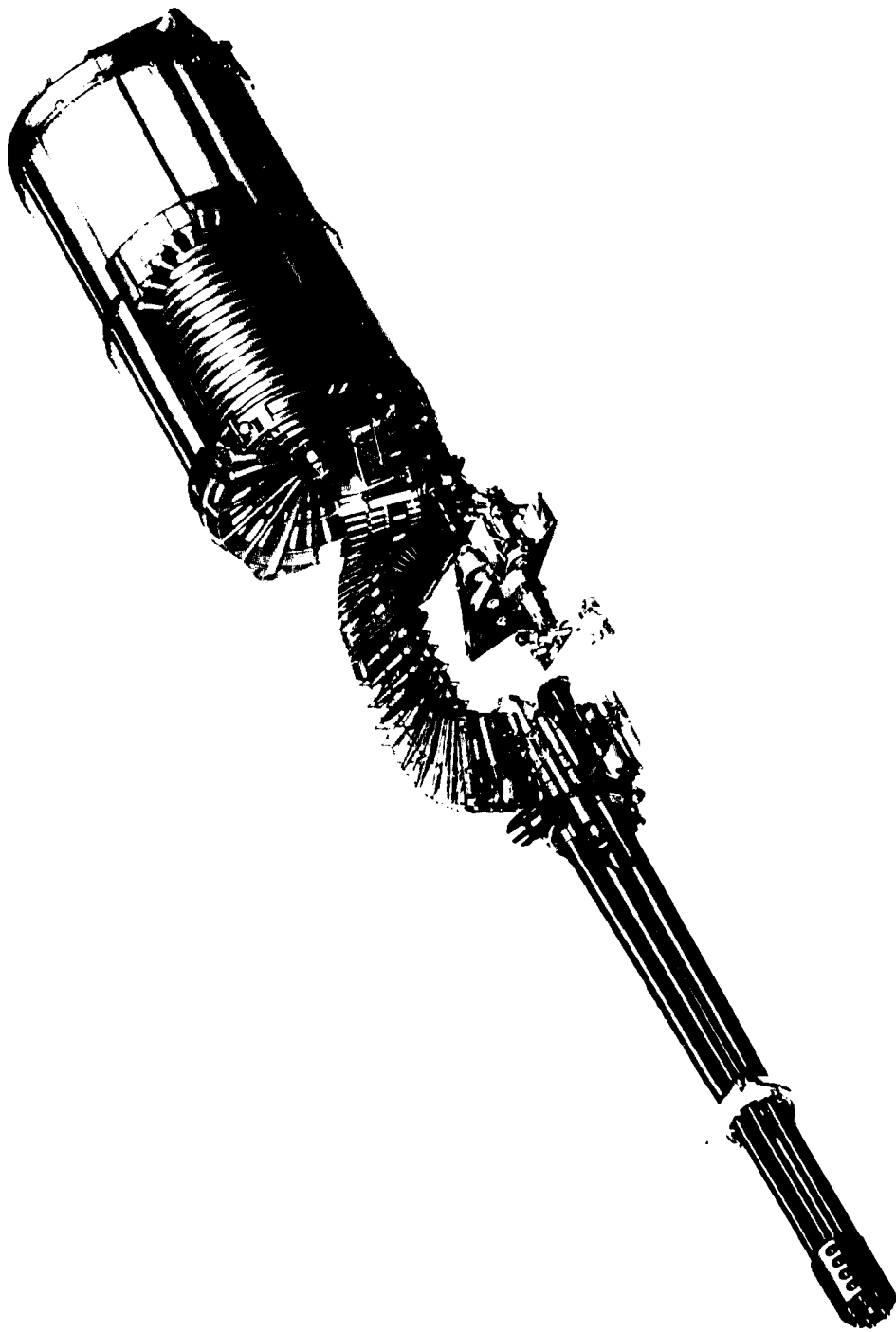

FIGURE 4. GAU-8/A 30mm Gun System

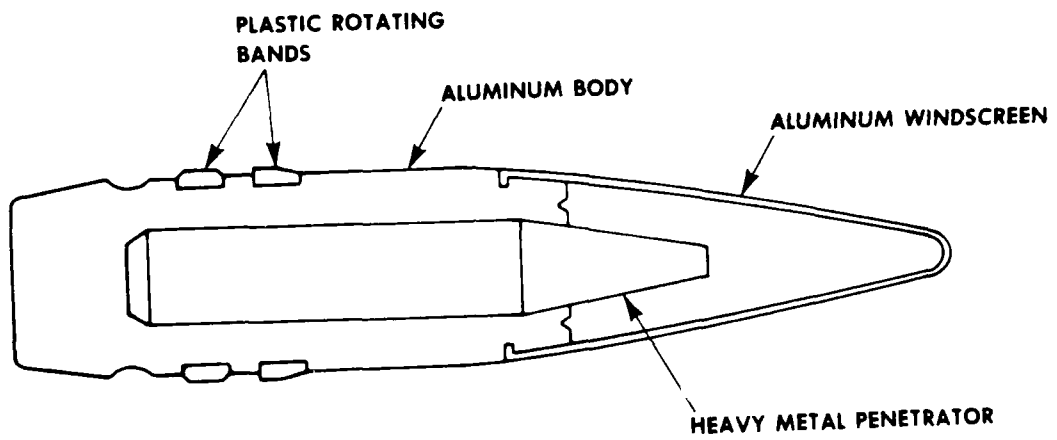

FIGURE 5. 30mm Armor Piercing Incendiary (API) Projectile.

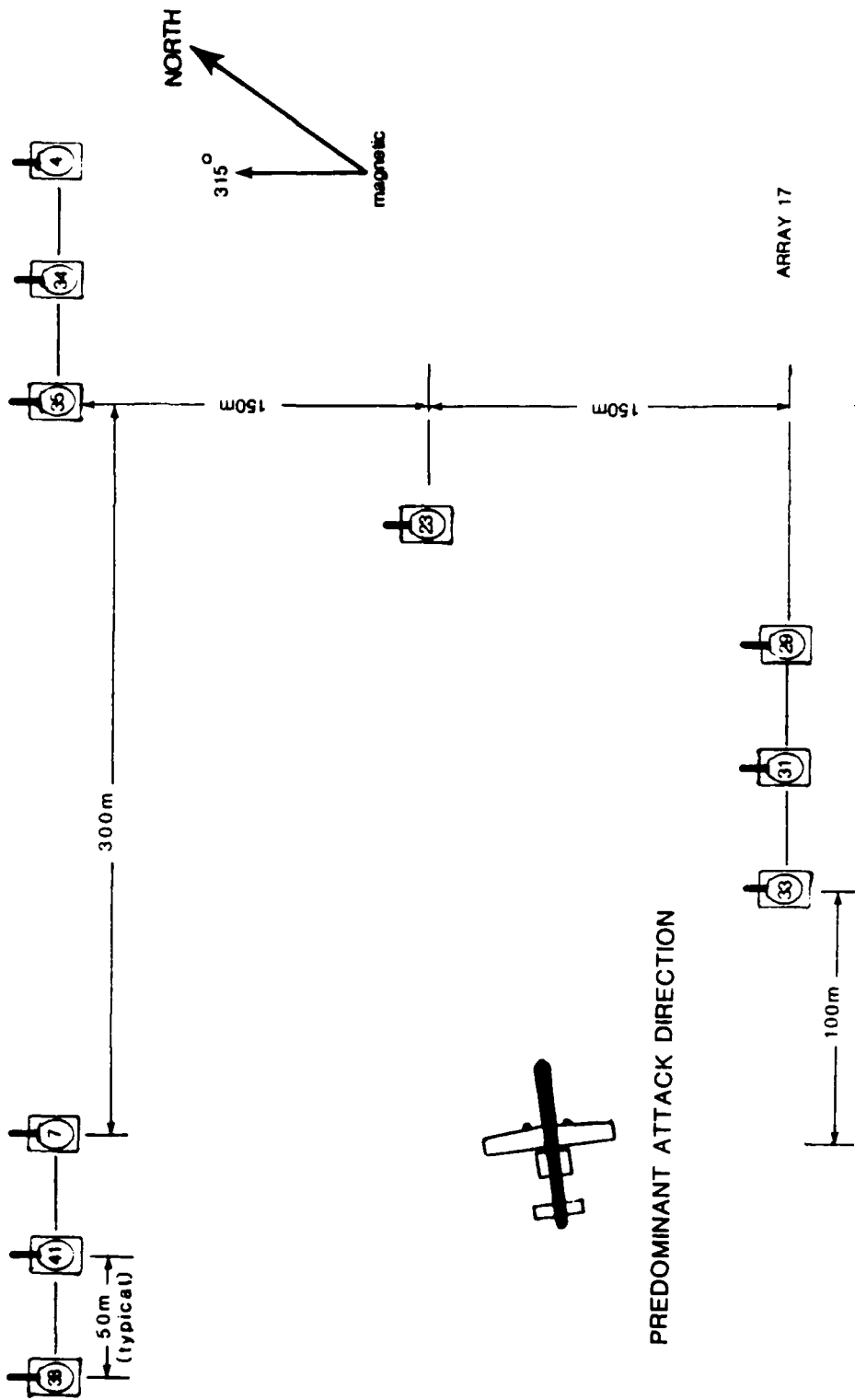

FIGURE 6. Approximate Tank Layout.

DAMAGE ASSESSMENT

Results of the damage assessment conducted by the CDAT are presented on the following pages together with photographs showing results of actual impacts. Tanks 35 and 7, which were not impacted during any firing pass are not included in the damage assessment. Appendix A following the damage assessment section contains graphical and tabular information relative to the mission in general and summaries of the damage assessments; for example, aircraft attack parameters, weapon effects, and summaries of damage.

Terms used in the damage assessment summaries are defined in Appendix B.

Impacts on tanks were arbitrarily numbered for identification purposes. The impacts were numbered sequentially, first at the turret level, then at the hull level. If additional impacts were discovered during the combat damage assessment (as was sometimes the case) they were given the next sequential number, i.e., no attempt was made to "correct" the sequence. THE READER IS CAUTIONED THAT THIS NUMBERING SYSTEM HAS NO RELATIONSHIP WHATSOEVER TO THE ARRIVAL SEQUENCE OF PROJECTILES ON THE TANK OR TO THE PORTION OF THE BURST IMPACTING THE TANK.

TARGET TANK DAMAGE SUMMARY

M-47 Tank Number 38

1. Description:

The target tank was impacted at an attack aspect of 260 degrees (left side) during one pass in which the attacking aircraft expended 69 rounds.

2. Kill Assessment:

100% M-Kill and 95% F-Kill resulting from the following observed effects (Figure 7):

a. Perforations	:	4
b. Significant Impacts:		0
c. Insignificant Impacts:		<u>2</u>
TOTAL IMPACTS	:	6

3. Rationale for Kill Assessment:

a. M-Kill: The assessment of 100% M-Kill is based on perforation 3 (Figure 8) through the turret which caused 3 crew casualties, perforation 4 through the left fuel cell near the bottom, and perforation 6 (Figure 9) through the left side of the engine compartment with damage to major engine components, e.g., oil cooler and carburetor.

b. F-Kill: The assessment of 95% F-Kill is based on perforation 3 which caused fragment and spall impacts on crew manikins. Examination of manikin damage supports a view that the tank commander (Figure 10 and 11) and loader (Figure 12) were killed and the gunner (Figure 13) seriously wounded.

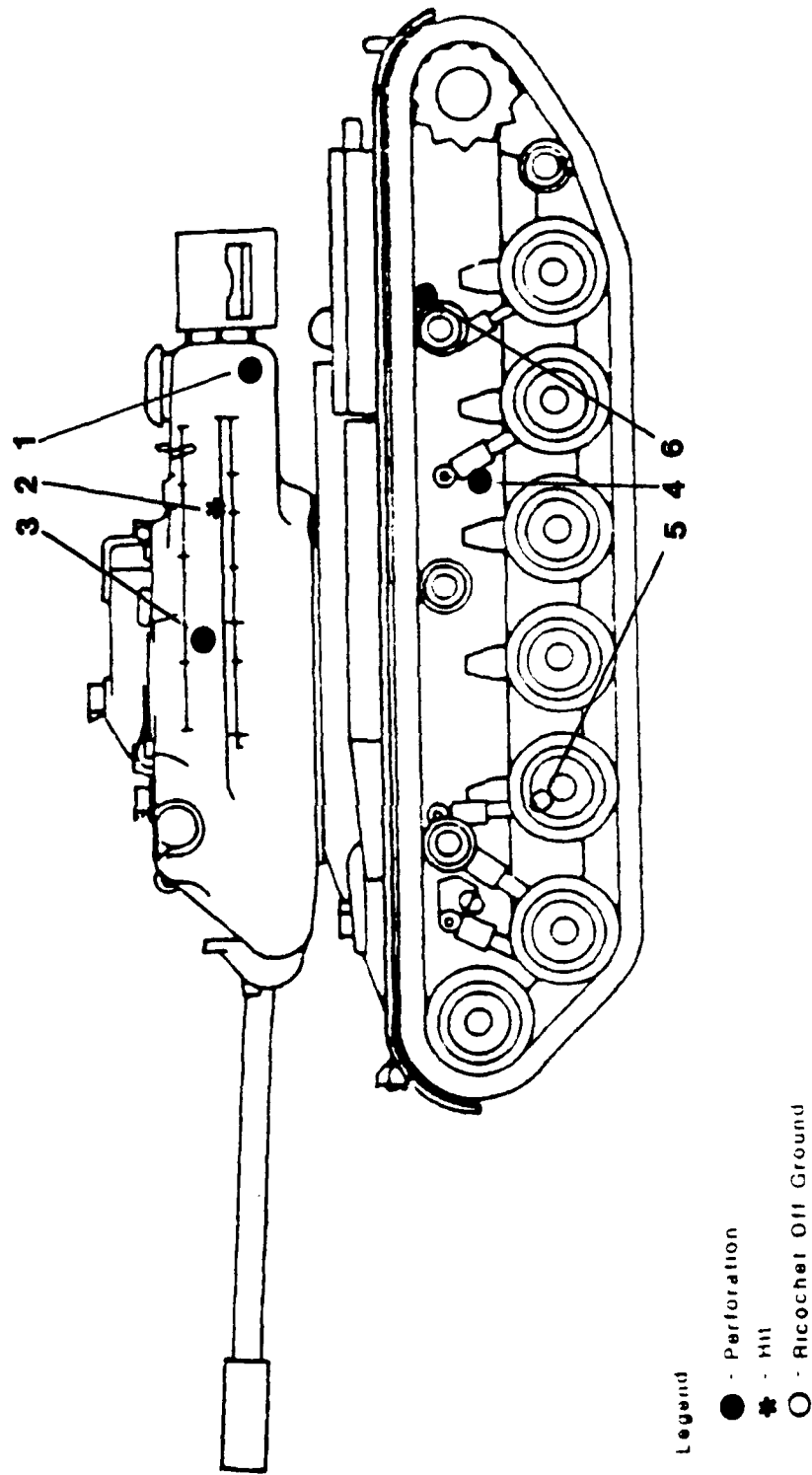

FIGURE 7. Impact Diagram, Tank 38.

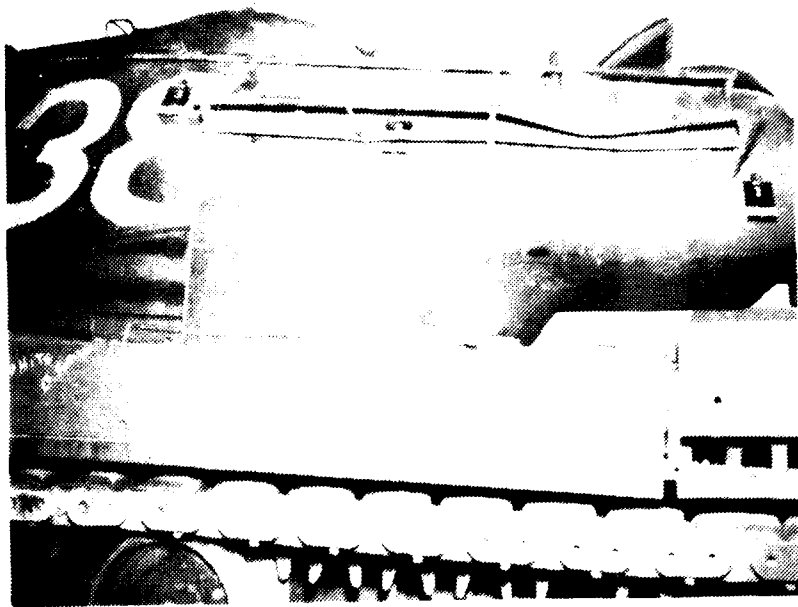

FIGURE 8. Perforation 3 into Fighting Compartment.

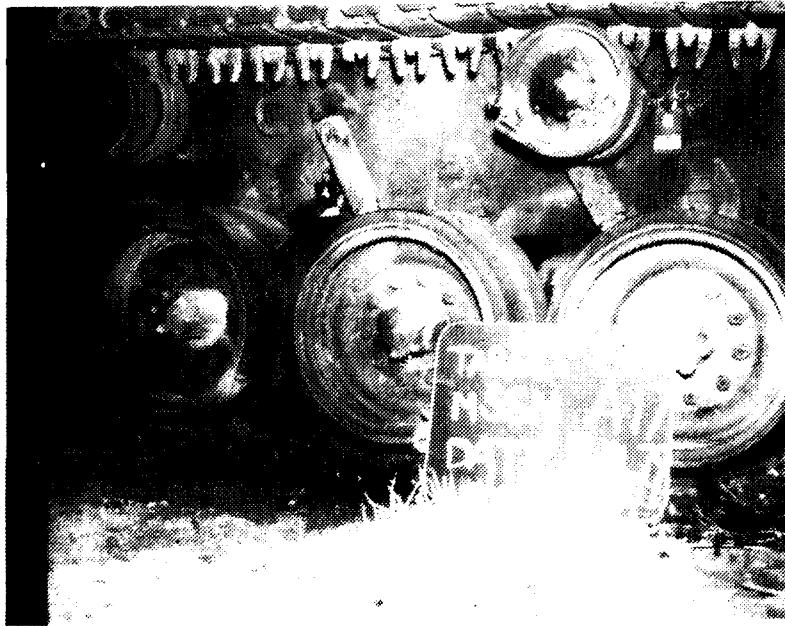

FIGURE 9. Perforation of Left Hull into Fuel Tank.



FIGURE 10. Tank 38 Commander - Front.



FIGURE 11. Tank 38 Commander - Back.



FIGURE 12. Tank 38 Loader.

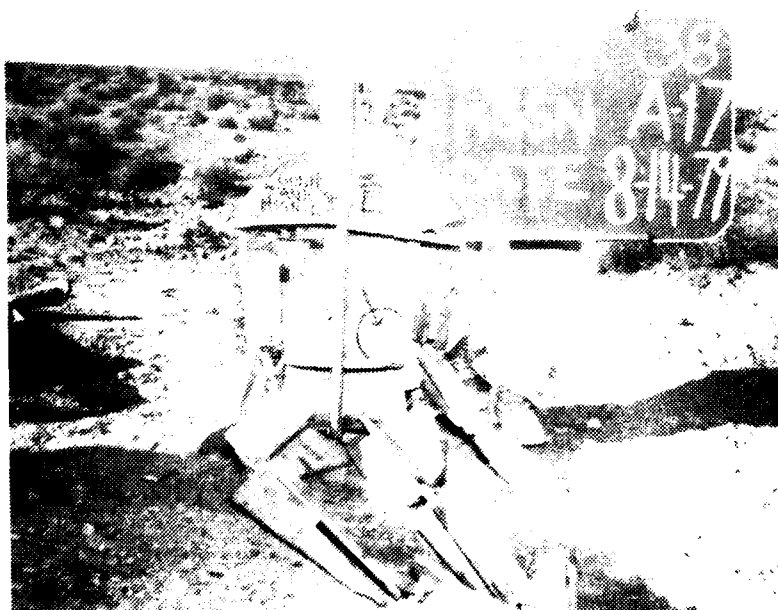

FIGURE 13. Tank 38 Gunner.

TARGET TANK DAMAGE SUMMARY

M-47 Tank Number 41

1. Description:

The target tank was impacted at an attack aspect of 247 degrees (left side) during one firing pass in which the attacking aircraft expended 41 rounds.

2. Kill Assessment:

100% M-Kill and 40% F-Kill resulting from the following observed effects (Figure 14):

a. Perforations	:	2
b. Significant Impacts	:	2
c. Insignificant Impacts:		<u>18</u>

TOTAL IMPACTS	:	22
---------------	---	----

3. Rationale for Kill Assessment:

a. M-Kill: The assessment of 100% M-Kill is based on impact 19, which perforated the left side of the hull (Figure 15) and penetrated into the left fuel cell, and impact 11, which perforated the driver's compartment wounding the driver and assistant driver.

b. F-Kill: The assessment of 40% F-Kill is based on impact 1 (Figure 16) which perforated one wall of the bore evacuator and gun tube, and impact 11, which degraded the firepower of the tank through crew casualties.

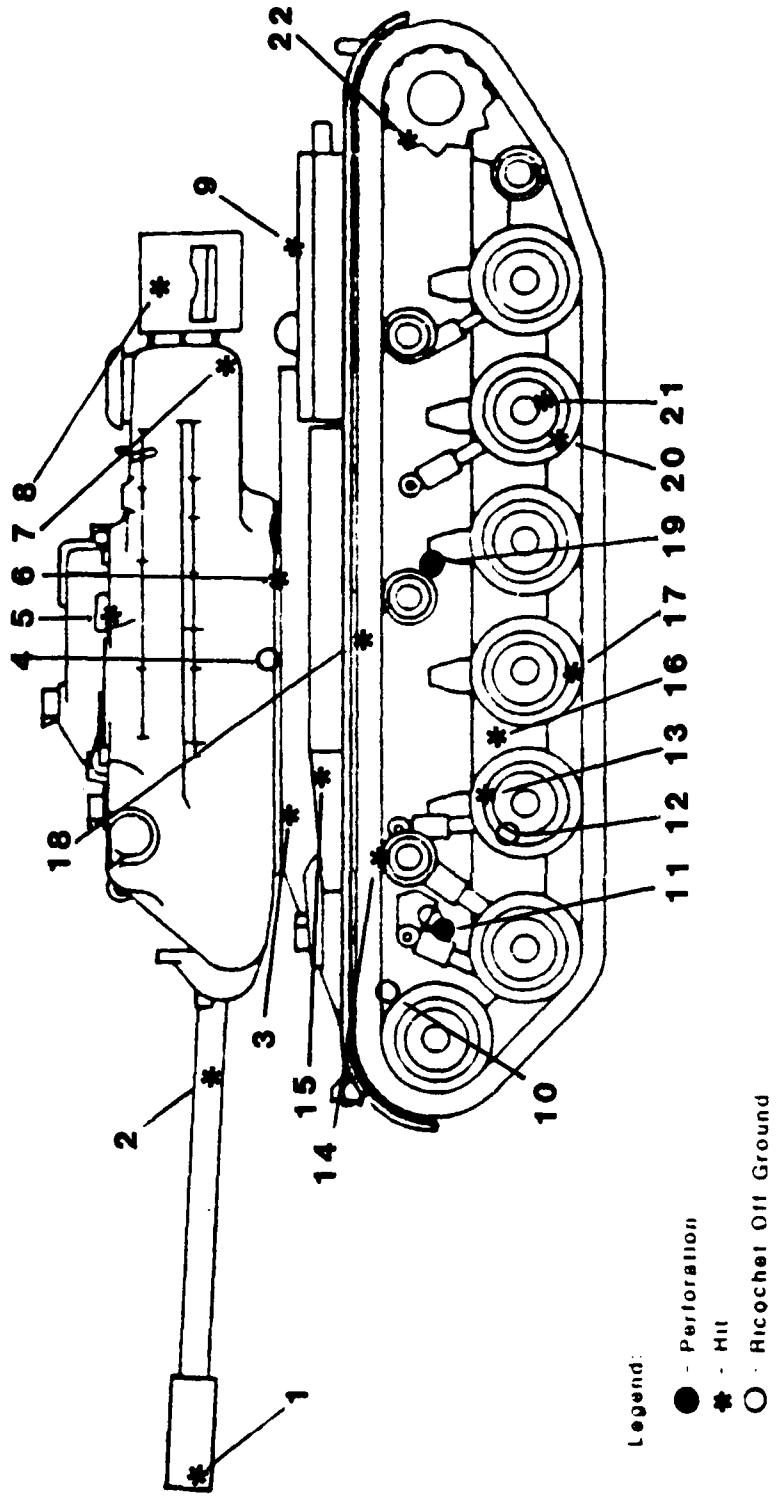

FIGURE 14. Impact Diagram, Tank 41.

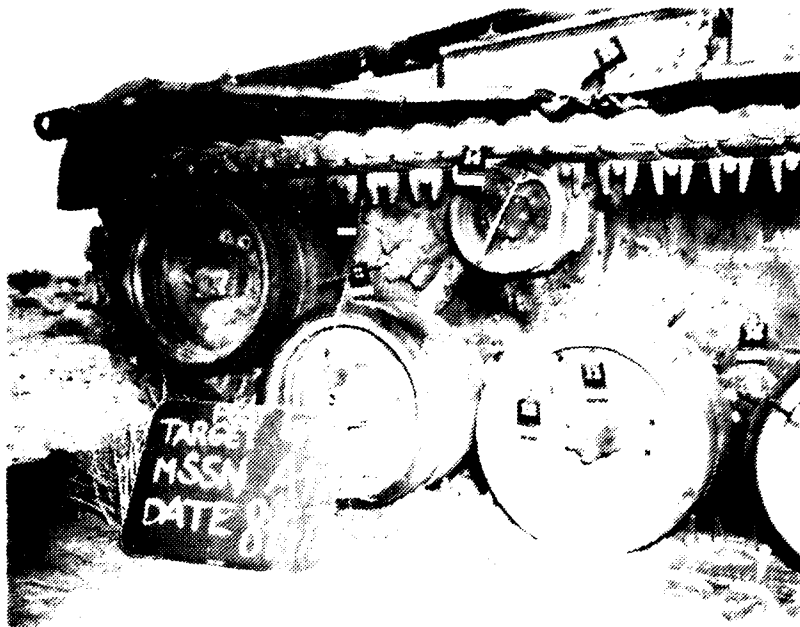

FIGURE 15. Tank 41 Hull Perforation into Left Fuel Cell.



FIGURE 16. Tank 41, Casualties

TARGET TANK DAMAGE SUMMARY

M-47 Tank Number 34

1. Description:

The target tank was impacted at an attack aspect of 270 degrees (left side) during one firing pass in which the attacking aircraft expended 41 rounds.

2. Kill Assessment:

100% M-Kill resulting from the following observed effects (Figure 17):

a. Perforations : 1
b. Significant Impacts : 0
c. Insignificant Impacts: 1

TOTAL IMPACTS : 2

1. Rationale for Kill Assessment:

An assessment of 100% M-Kill is based on impact number 1, which perforated the left side of the hull and penetrated into the left fuel cell (Figure 18). The hazard represented by the fuel running into the floor of the engine and fighting compartments would have to be mastered by the crew immediately.

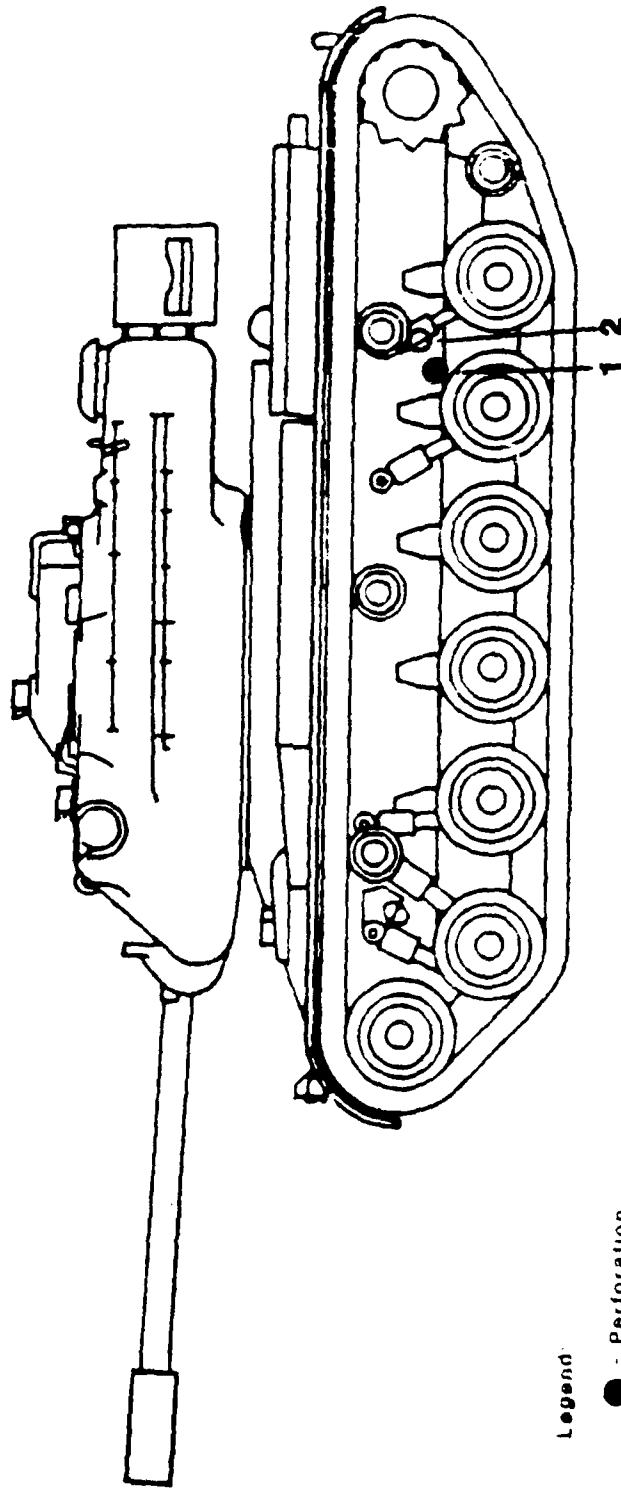

Legend:

- - Perforation
- ★ - Hit
- - Ricochet Off Ground

FIGURE 17. Impact Diagram, Tank 34.

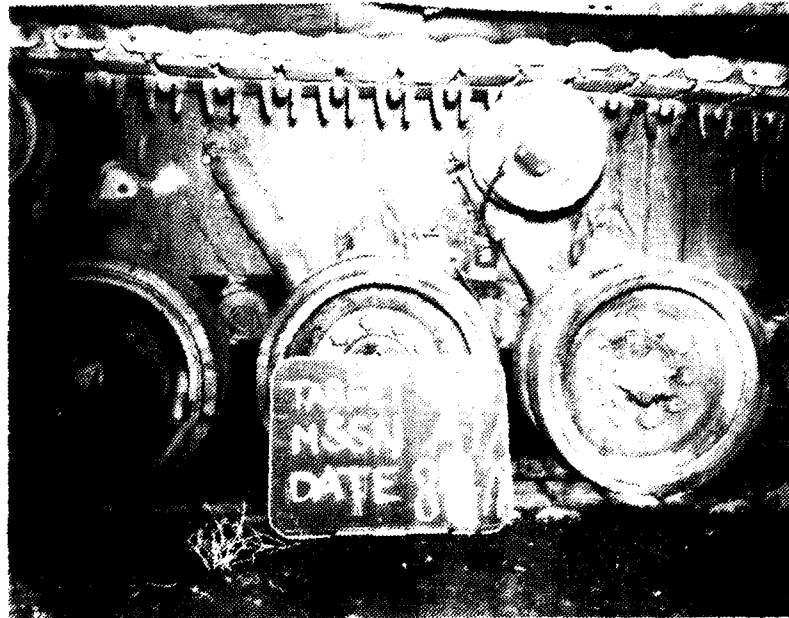

FIGURE 18. Impact 1, Tank 34 Hull Perforation.

TARGET TANK DAMAGE SUMMARY

M-47 Tank Number 4

1. Description:

The target tank was impacted at an attack aspect of 235 degrees (left side toward rear) during one firing pass in which the attacking aircraft expended 69 rounds.

2. Kill Assessment:

90% M-Kill and 100% F-Kill resulting from the following observed effects (Figure 19):

a. Perforations	:	2
b. Significant Impacts	:	8
c. Insignificant Impacts:		<u>28</u>

TOTAL IMPACTS : 38

3. Rationale for Kill Assessment:

- a. M-Kill: The assessment of 90% M-Kill is based on impacts 6 and 7, which incapacitated the tank commander, gunner, and loader, and impacts 13, 20, 22, 24, 25, 30, and 31, which caused significant cumulative damage to the track and suspension system (Figures 20 and 21).
- b. F-Kill: The assessment of 100% F-Kill is based on impact 4, which jammed the turret and impacts 6 and 7, which perforated the left side of the turret killing the tank commander (Figure 22) and wounding the gunner and loader, as assessed from fragment damage to crew manikins.

NOTE: Hits 35, 36 and 37 are on the front of the tank.
 These hits are considered insignificant and are not shown.

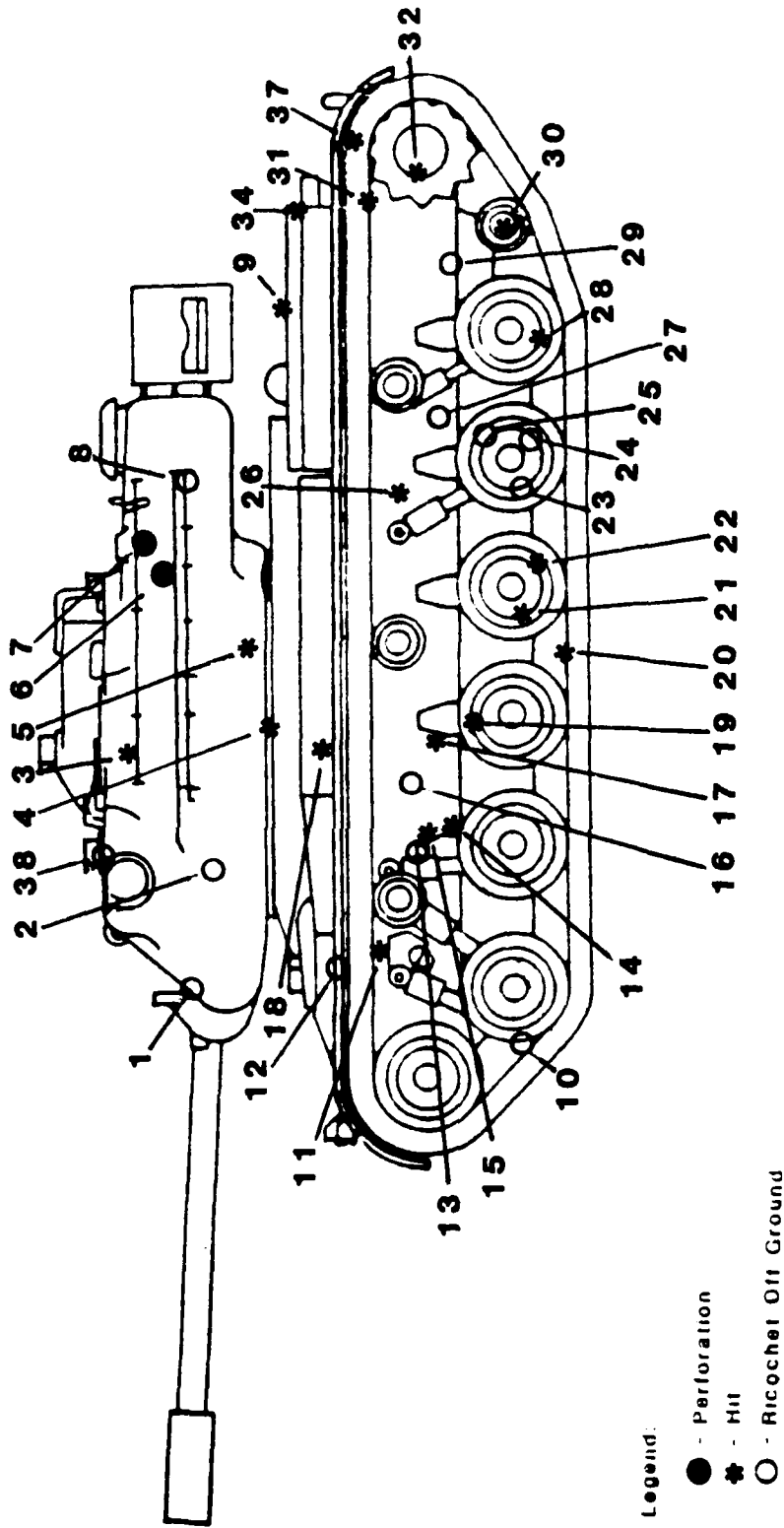

FIGURE 19. Impact Diagram, Tank 4.

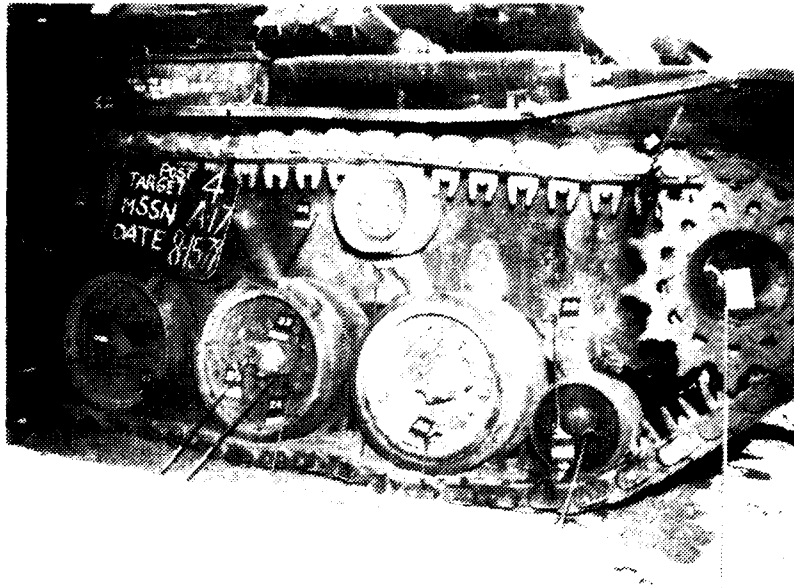

FIGURE 20. Tank 4 Rear/Side Damage.

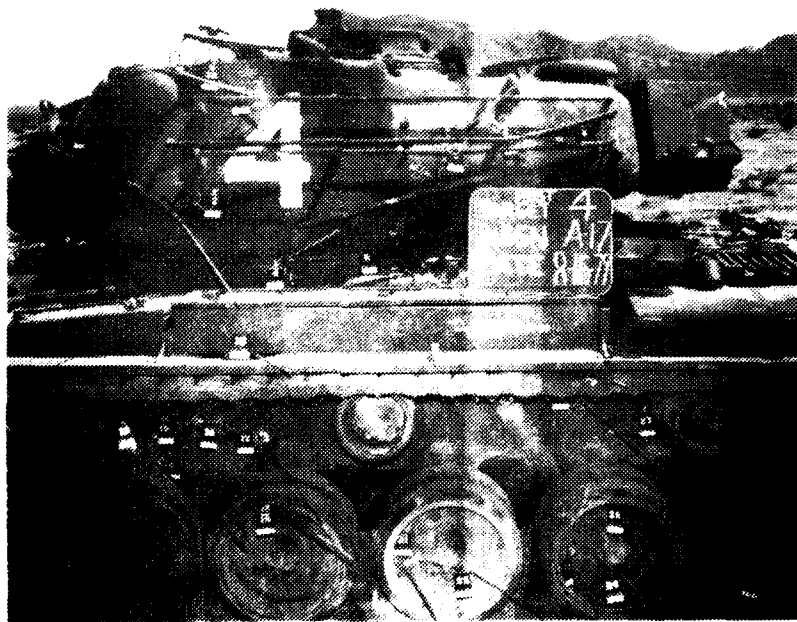

FIGURE 21. Tank 4 Left/Center Damage.



FIGURE 22. Impact 4, Tank 4 Tank Commander.

TARGET TANK DAMAGE SUMMARY

M-47 Tank Number 33

1. Description:

The target tank was impacted at an attack aspect of 235 degrees (left side toward rear) during one firing pass in which the attacking aircraft expended 55 rounds.

2. Kill Assessment:

100% M-Kill and 100% F-Kill resulting from the following observed effects (Figures 23, 24, and 25):

a. Perforations	:	2
b. Significant Impacts	:	6
c. Insignificant Impacts:		<u>17</u>

TOTAL IMPACTS	:	25
---------------	---	----

3. Rationale for Kill Assessment:

a. M-Kill: The assessment of a 100% M-Kill is based on impact 23 which perforated the left hull and penetrated 3 valve covers and the oil cooler and on minor damage to the track and suspension system caused by impacts 10, 13, and 15.

b. F-Kill: The assessment of a 100% F-Kill is attributed to impacts 1, 3, and 6 which jammed the turret and penetrated the gun tube, and to crew casualties (gunner & loader) caused by impact 4 which perforated the left turret into the fighting compartment (Figures 26 through 28):

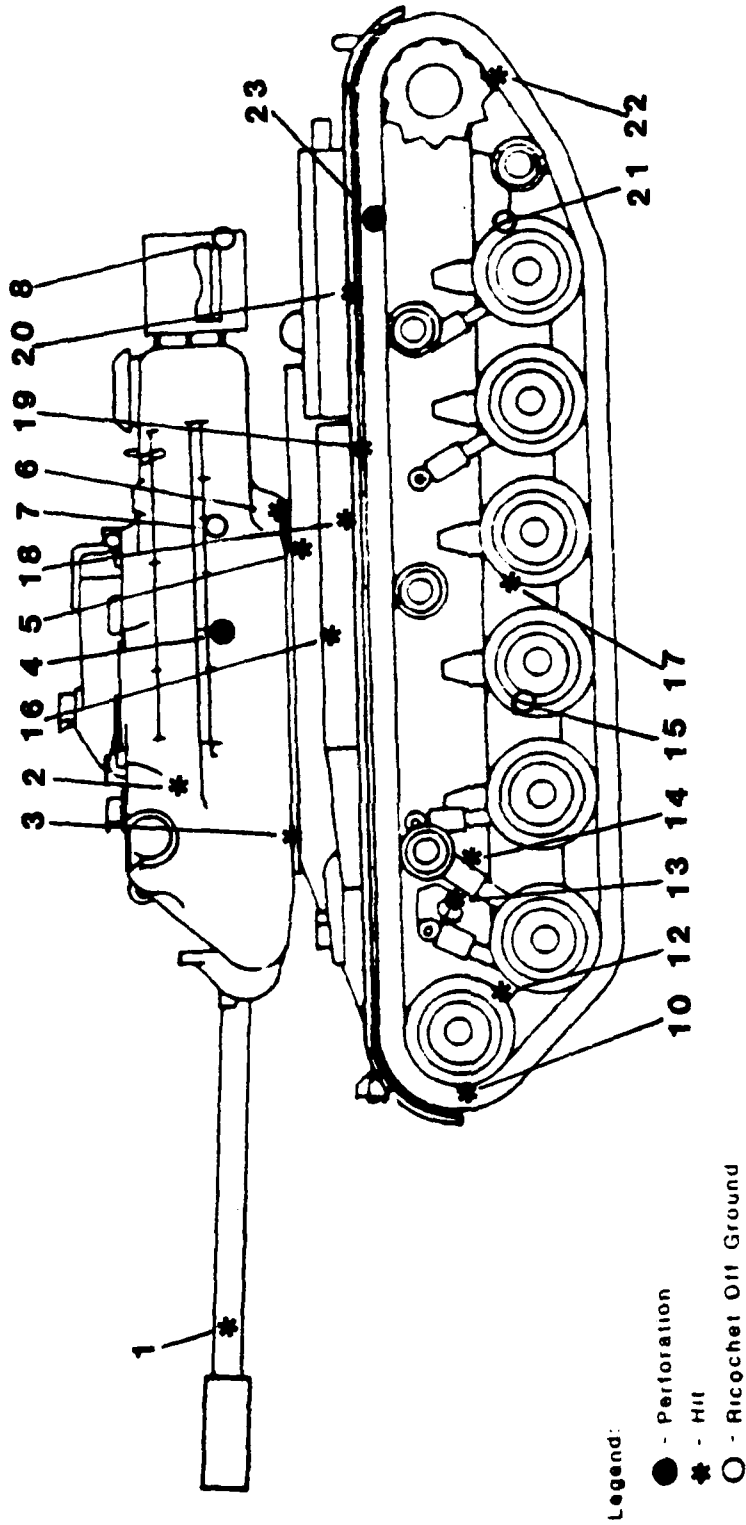
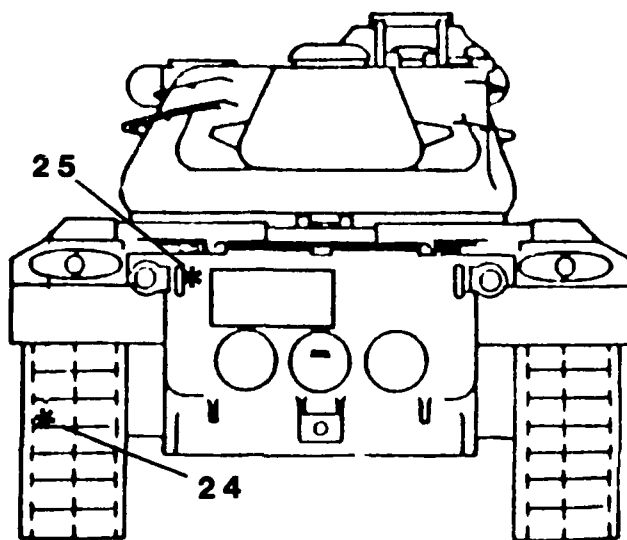

FIGURE 23. Impact Diagram, Tank 33.



Legend:

- - Perforation
- * - Hit
- - Ricochet Off Ground

FIGURE 24. Impact Diagram, Tank 33 Rear.

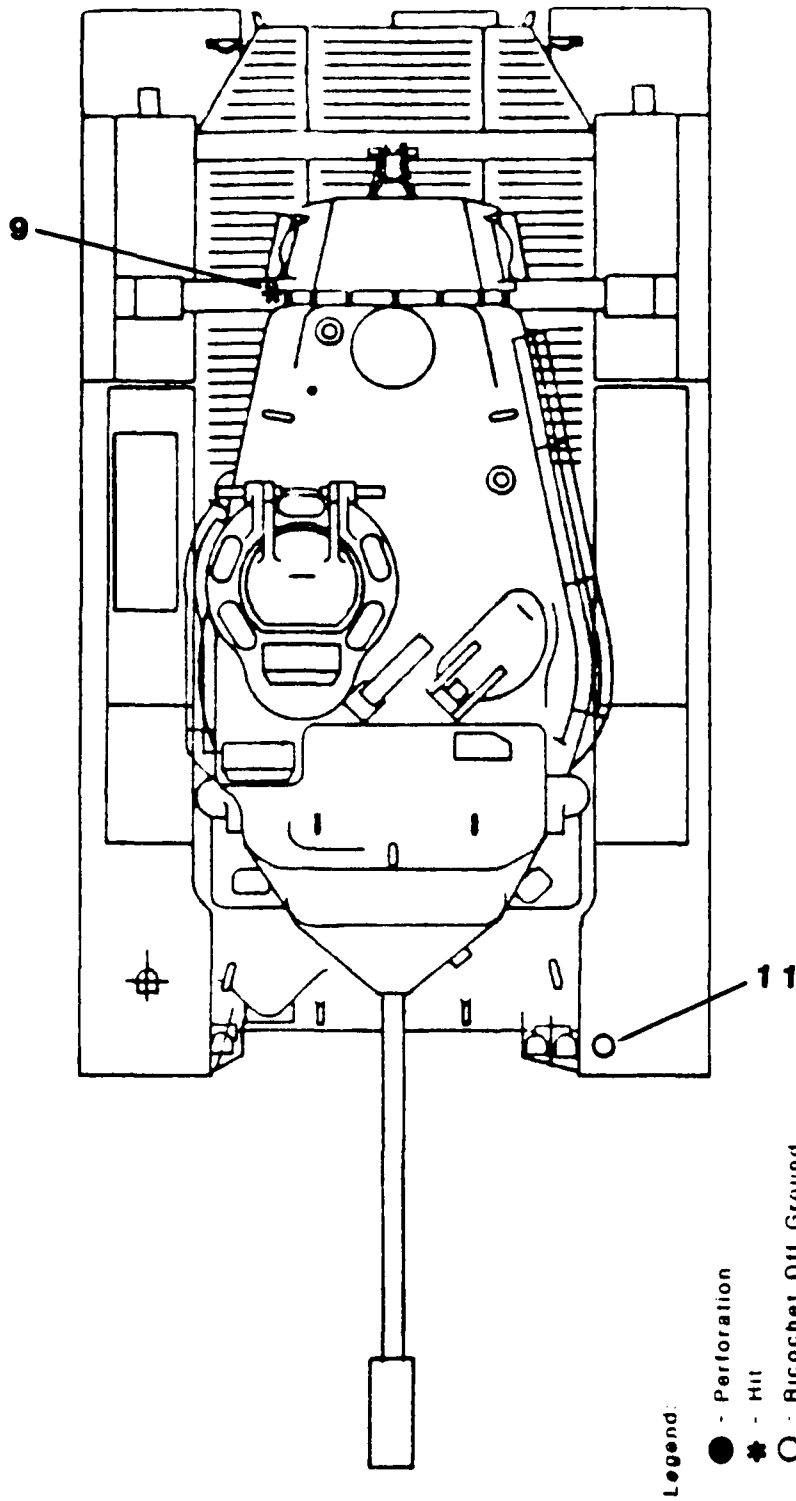

FIGURE 25. Impact Diagram, Tank 33 Top.



FIGURE 26. Tank 33 Turret.



FIGURE 27. Tank 33 Loader.



FIGURE 28. Tank 33 Gunner.

TARGET TANK DAMAGE SUMMARY

M-47 Tank Number 31

1. Description:

The target tank was impacted at an attack aspect of 285 degrees (left side) in one firing pass in which the attacking aircraft expended 97 rounds.

2. Kill Assessment:

20% F-Kill resulting from the following impacts (Figure 29):

a. Perforations	:	1
b. Significant Impacts	:	0
c. Insignificant Impacts:		<u>16</u>

TOTAL IMPACTS : 17

3. Rationale for Kill Assessment:

An assessment of a 20% F-Kill is based on impact 2 which perforated the left range finder blister and damaged the end housing assembly denying use of the range finder in determination of range to target (Figure 30).

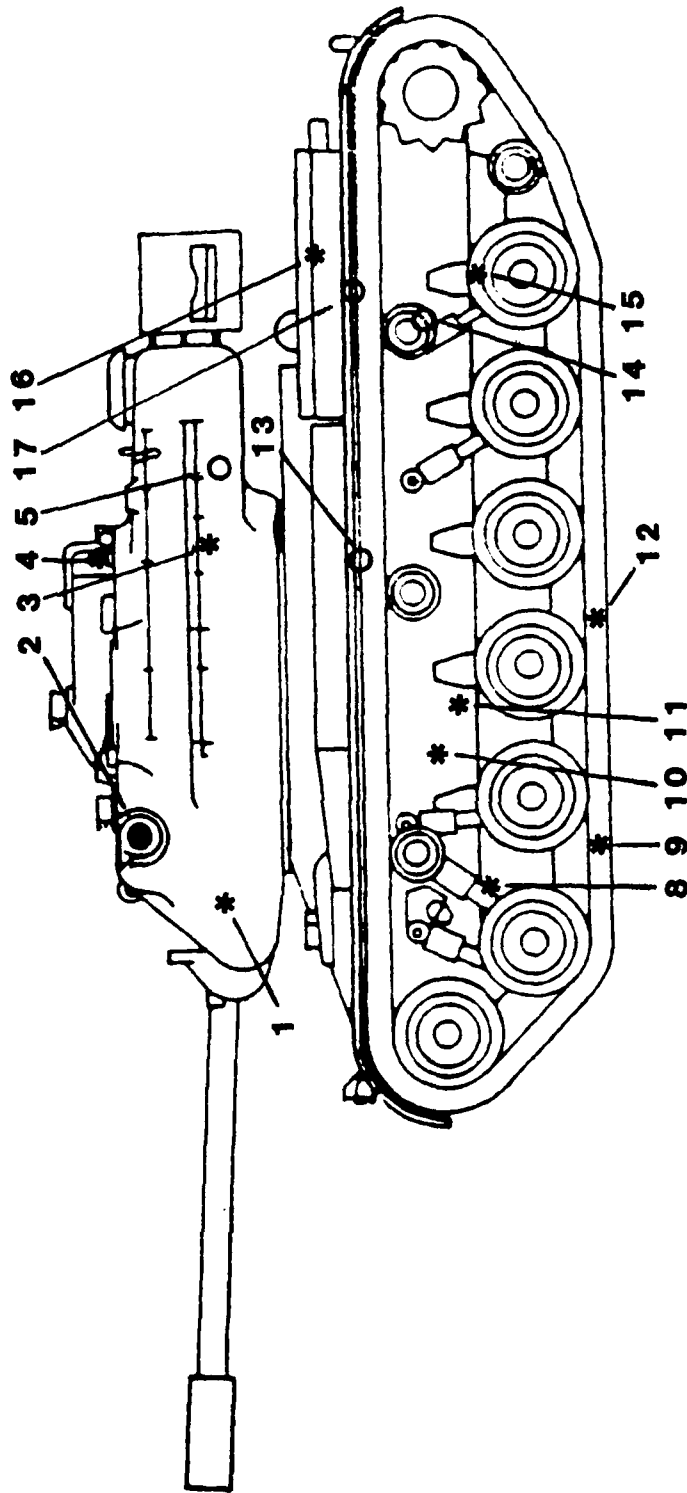

NOTE: Hits 6 and 7 are on the front of the tank. These hits are considered insignificant and are not shown. Impact two was a ricochet off the ground.

Legend:

- - Perforation
- * - Hit
- - Ricochet Off Ground

FIGURE 29. Impact Diagram, Tank 31.

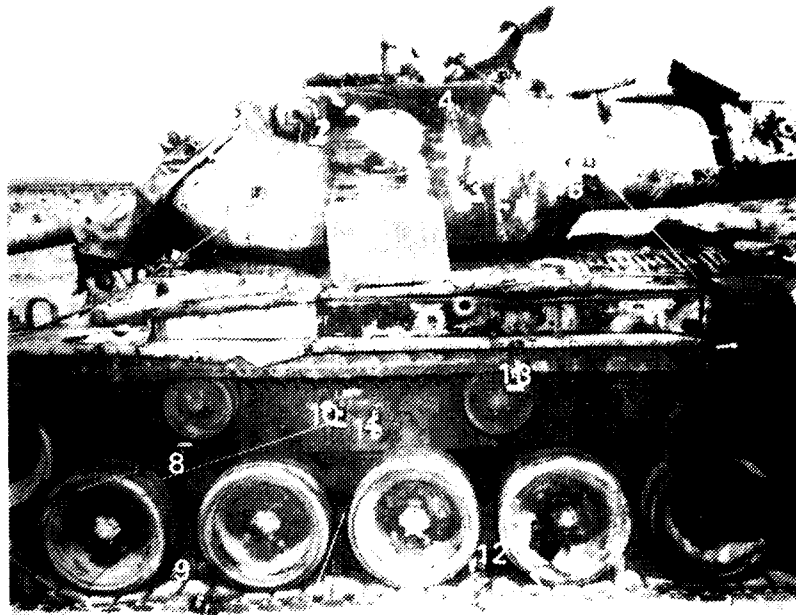

FIGURE 30. Tank 31 Perforation of Range Finder Blister.

TARGET TANK DAMAGE SUMMARY

M-47 Tank Number 29

1. Description:

The target tank was impacted at an attack aspect of 230 degrees (left rear) during one firing pass in which the attacking aircraft expended 83 rounds.

2. Kill Assessment:

100% M-Kill resulting from the following observed effects (Figures 31 and 32):

a. Perforations	:	4
b. Significant Impacts	:	0
c. Insignificant Impacts:		<u>17</u>

TOTAL IMPACTS	:	21
---------------	---	----

3. Rationale for Kill Assessment:

The assessment of 100% M-Kill is based on impacts 13 and 19 (Figures 33 and 34) which perforated the rear of the hull and penetrated into the transmission case. The resulting effects on the transmission, i.e., loss of transmission oil and fragment and spall damage to gears, would result in complete loss of function of the transmission and immobilization of the tank.

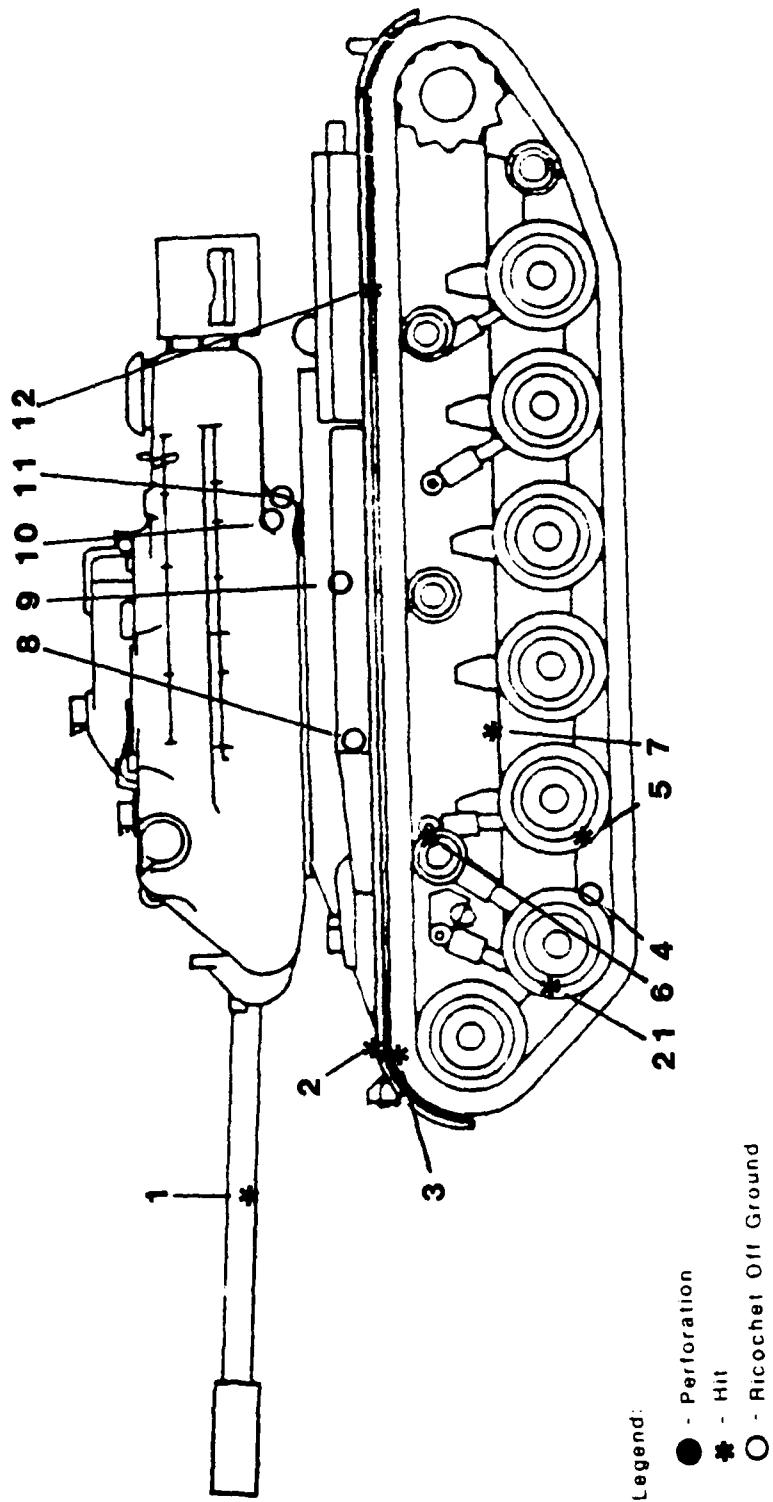

FIGURE 31. Impact Diagram, Tank 29 Left Side.

Legend:

- - Perforation
- * - Hit
- - Ricochet Off Ground

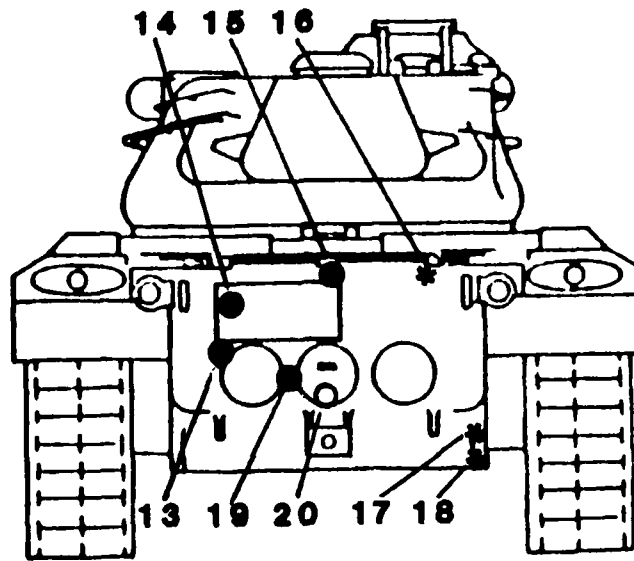

FIGURE 32. Impact Diagram, Tank 29 Rear.

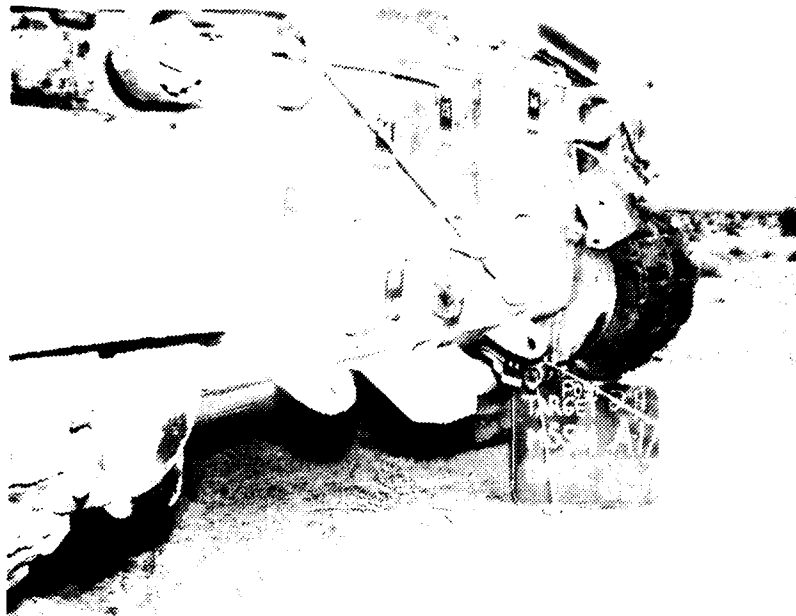

FIGURE 33. Close-in View of Impacts 13 and 19, Tank 29.

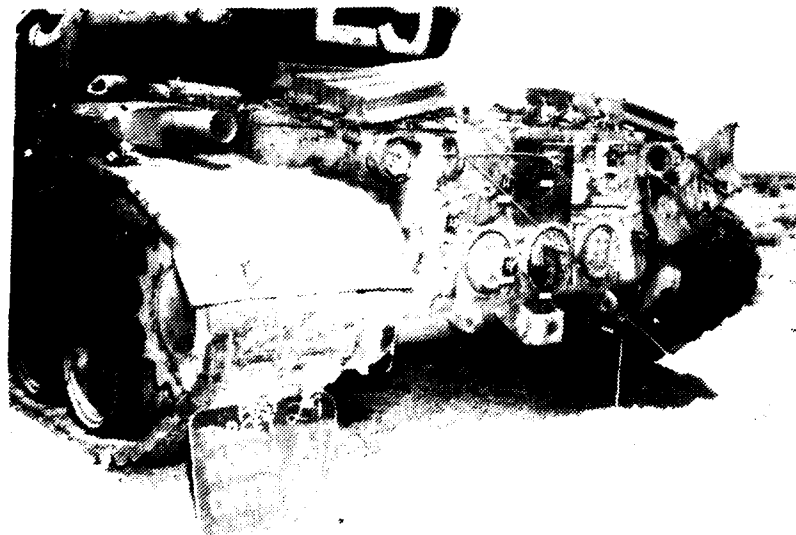

FIGURE 34. Reference View of Impacts 13 and 19, Tank 29.

TARGET TANK DAMAGE SUMMARY

M-47 Tank Number 23

1. Description:

The target tank was impacted at an attack aspect angle of 265 degrees (left side) during one firing pass in which the attacking aircraft expended 55 rounds.

2. Kill Assessment:

100% M-Kill resulting from the following observed effects (Figures 35 and 36):

a. Perforations	:	1
b. Significant Impacts	:	0
c. Insignificant Impacts:		<u>8</u>

TOTAL IMPACTS : 9

3. Rationale for Kill Assessment:

This tank was observed to be a delayed burn, probably caused by impact 4 which perforated the left hull into the engine compartment penetrating an oil cooler line and a valve cover, apparently igniting a small fire which spread into a killing fire.

Since there were no crew casualties the CDAT assumed that the crew could have controlled a small grease or oil fire thereby limiting damage to a mobility kill.

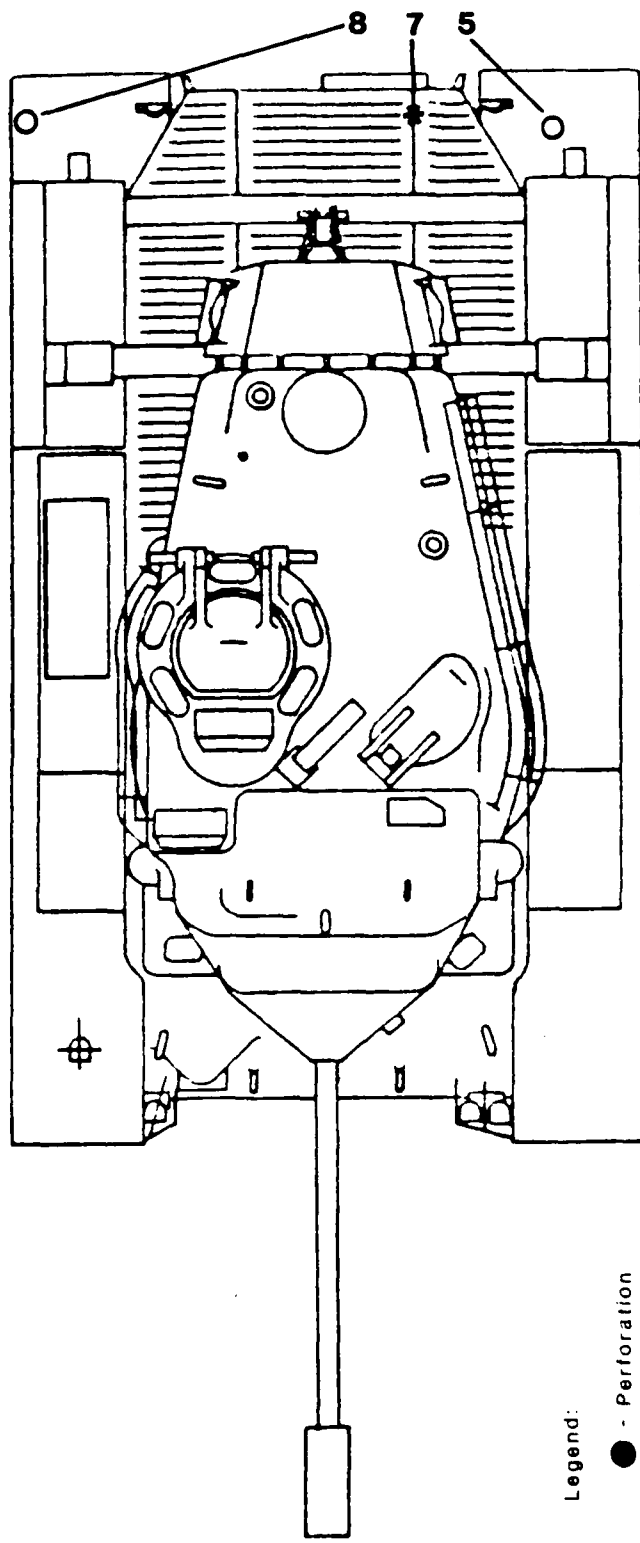

FIGURE 35. Impact Diagram, Tank 23 Top.

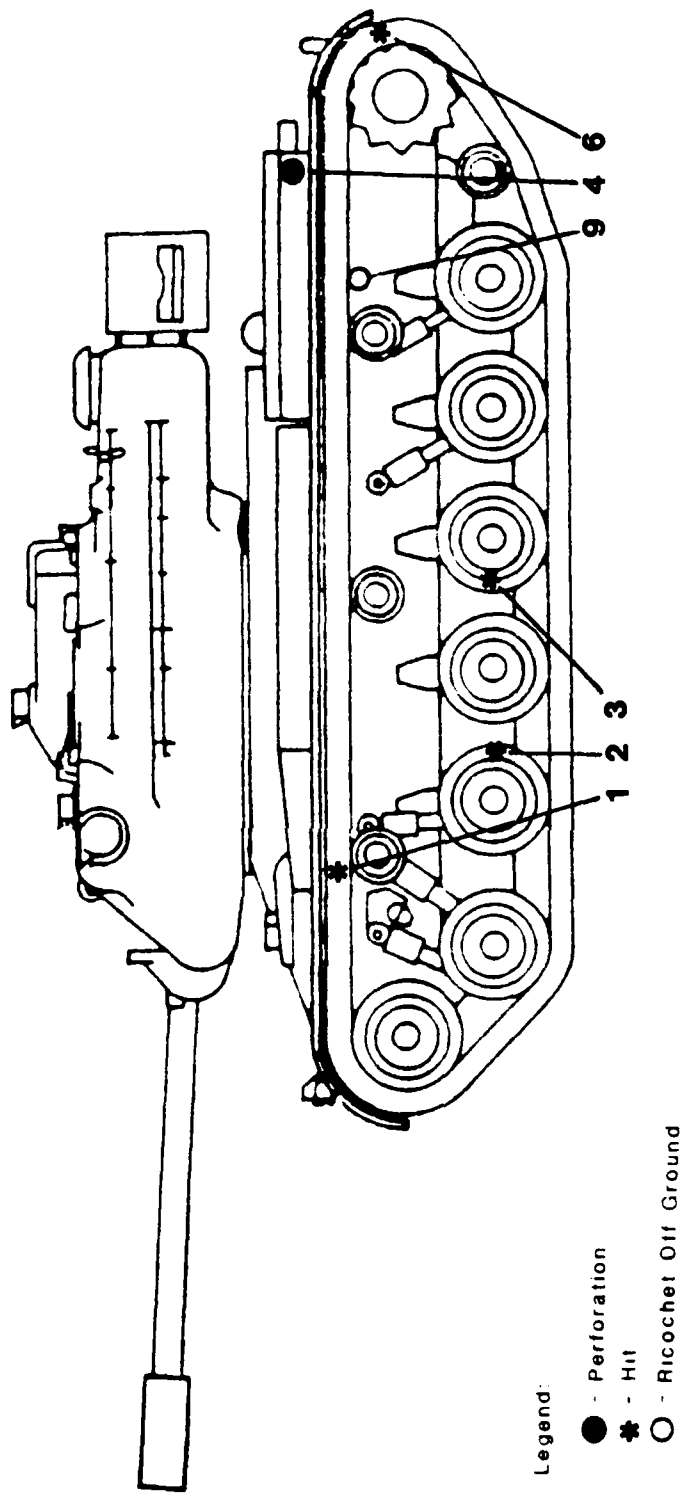

FIGURE 36. Impact Diagram, Tank 23 Left Side.

SUMMARY AND CONCLUSIONS

On 14 August, 1979 at Nellis AFB, Nevada, the Combat Damage Assessment Team (CDAT) conducted firings of the A-10/GAU-8 weapon system against an array of 10 tanks simulating a Soviet tank company deployed for an attack. The purpose of the firing test was to evaluate the effects of Aerojet lot number AJD 79A181-001 30mm API anti-tank ammunition of the GAU-8 gun under challenging conditions of engagement for the A-10/GAU-8 system against realistically simulated Soviet tank formations. The CDAT used M-47 tanks stowed with main gun ammunition, diesel fuel, lubricating oil, and crew manikins to simulate the Soviet tanks. The pilot of the A-10 aircraft used in the firings conducted his attacks at low altitudes and low dive angles which simulated attack below the altitude of the effective engagement for opposing air defense systems using acquisition and fire control radar.

The firing test can be summarized in terms of the following data which were collected and/or extracted from the firings:

Aircraft Parameters

1. Open-fire Speed (average)-----523 ft/sec
2. Altitude (average)-----207 ft
3. Dive Angle (average)-----4.5 degrees
4. Open-fire Slant Range (average)-----2939 ft
5. Burst Length/Rounds (averages)-----0.96 sec/63
6. Number Passes (primary)-----9
7. Target Aspects (predominantly)-----left rear

Weapon Effects

1. Rounds Fired-----565
2. Impacts-----140
3. Ricochets (off ground)-- 37
4. Direct Impacts-----103
5. Perforations----- 17

Target Damage

1. K-Kills-----0
2. M+F-Kills-----1
3. M-Kills-----5
4. F-Kills-----1
5. Light or no damage-----2

These data and the more detailed base from which they were extracted can be arranged into measures of effectiveness for the A-10/GAU-8 system under conditions similar to those in the firing test, i.e., empirical combat simulation. The following values of effectiveness are based on the firing test of 14 August 1979.

Measures of Effectiveness

Accuracy Related Ratio:

$$\frac{\text{Total Impacts}}{\text{Rounds Fired}} = 0.25$$

$$\frac{\text{Direct Impacts}}{\text{Rounds Fired}} = 0.18$$

Lethality Related Ratio:

$$\frac{\text{Perforations}}{\text{Total Impacts}} = 0.12$$

$$\frac{\text{Perforations}}{\text{Direct Impacts}} = 0.17$$

Weapon System Effectiveness Ratio

$$\frac{\text{Tanks Immobilized}}{\text{Passes}} = 0.67$$

$$\frac{\text{Tanks K-Killed}}{\text{Passes}} = 0.0$$

The nine target tanks were attacked predominately from the left rear and suffered the damage shown in Table I and Table A-I.

The measures of effectiveness summarized above, and other data contained in this report, support several inferences or conclusions:

1. The A-10/GAU-8 weapon system in realistic simulation of combat may be capable of inflicting catastrophic and F-Kills on M-47 and similarly protected main battle tanks, e.g. Soviet T-55 and T-62 tanks.
2. The weapon system, in low level attacks, can perforate the side and rear surfaces of the hulls and turrets of M-47 and similarly protected main battle tanks.
3. The weapon system is an effective killing agent against the side and rear surfaces of M-47 and similar tanks when firing moderate length bursts of 0.65 to 1.45 seconds containing 41 to 97 rounds.
4. From the viewpoint of GAU-8 30mm API ammunition effects and resulting damage to combat stowed main battle tanks, the tactic of low level attack in this firing test was shown to be a successful one.

APPENDIX A

Graphical and Summary Information

Table A-I contains a summary of the results of Mission 17 of 14 August, 1979. Table A-II contains a summary of damage assessment based on perforation locations. Table A-III contains a summary of aircraft attack parameters. Figure A-1 depicts aircraft attack aspect by tank number as a function of open-fire range.

TABLE A-I. Array 17 Results Summary
(14 August 1973)

Target Tank No.	Damage Assessment* (M%) (F%) (K%)	All Target Impacts	Direct Impacts	Rounds Fired	Total Perforations
38	100 95 -	6	5	69	4
41	100 40 -	22	19	41	2
7**	- - -	0	0	55	0
35***	- - -	-	-	-	-
34	100 - -	2	2	41	1
4	90 100 -	38	22	69	2
33	100 100 -	25	20	55	2
31	- 20 -	17	12	97	1
29	100 - -	21	17	83	4
23	100 - -	9	6	55	1
TOTALS:		140	103	565	17

*K = Catastrophic Kill; M = Mobility Kill; F = Firepower Kill

**pilot missed target

***Target not fired on

TABLE A-II. Array 17 Perforation Location Summary
(14 August 1979)

Target Tank	Damage Assessment*		Turret Perforations (Fighting Compt)	Hull Perforations		Total Perforations	
	(M%)	(F%)		Fighting Compt	Engine Compt	Drivers Compt	Engine Compt
38	100	95	2	-	-	2	4
41	100	40	-	-	1	1	2
7	-	-	PILOT MISSED TARGET		-	-	-
35	-	-	TARGET NOT FIRED ON		-	-	-
34	100	-	-	-	-	1	1
4	90	100	2	-	-	-	2
33	100	100	1	-	-	1	2
31	-	20	1	-	-	-	1
29	100	-	-	-	-	4	4
23	100	-	-	-	-	1	1

TOTALS: 6 1 10 17

*K = Catastrophic Kill; M = Mobility Kill; F = Firepower Kill

TABLE A-III. Array 17 Aircraft Attack Parameters
(14 August 1979)

Acft Pass *	Tank No.	Open Fire Slant Rng (feet)	Dive Angle Open/Cease (degrees)	Altitude (feet)	Velocity Open/Cease (ft./sec)	Burst Length (seconds)	Source
1/1	38	2516	5.4/3.7	218	572/568	1.05	TSPI
1/2	41	3090	5.3/4.8	284	564/564	.65	TSPI
1/3	7	3172	4.2/3.1	197	554/551	.85	TSPI
1/4	34	3321	2.5/2.0	73	430/431	.65	TSPI
1/5	4	2840	5.0/4.1	226	538/472	1.05	TSPI
1/6	33	**	5.0/3.8	220	539/547	.85	TSPI
1/7	31	**	5.4/3.0	165	441/452	1.45	TSPI
1/8	29	2309	8.8/3.7	201	494/495	1.25	TSPI
1/9	23	3322	5.4/5.2	278	573/570	.85	TSPI
Averages:		2939	4.5	207	523/517	.96	

*1/1 means pilot 1, pass 1, etc.

**Slant ranges uncertain

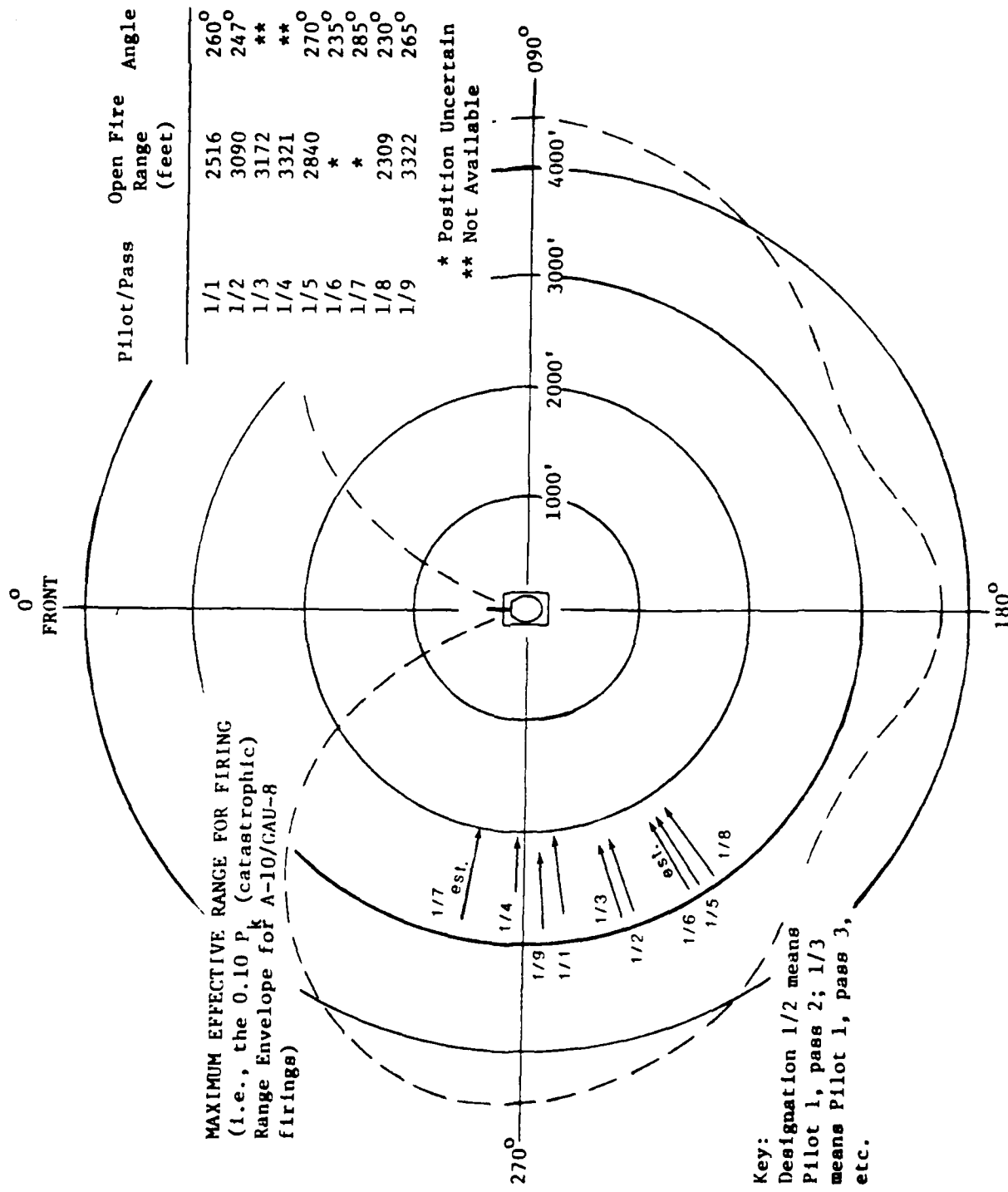

FIGURE A-1. Array 17 Attack Aspect Summary.

APPENDIX B

DEFINITIONS

The terms used in this report are defined below:

IMPACT -- Any evidence of a projectile strike against any portion of the target. Ground ricochets striking the target were classified as "impacts".

PERFORATION -- Any rupture of the armored envelope caused by an impacting projectile which results in a complete rupture of an armored surface by the projectile or spall fragments. A perforation can occur only when the armor is impacted. The word "Perforation" was deliberately selected to avoid the ambiguities which may occur through use of the word "penetration". Behind-the-plate effects may or may not result from a perforation.

HIT -- Any impact not classified as a perforation.

MOBILITY KILL (M-KILL) -- Loss of tactical mobility resulting from damage which cannot be repaired by the crew on the battlefield. A tank is considered to have sustained a 100% M-Kill when it is no longer capable of executing controlled movement on the battlefield. Mobility is DEGRADED when a tank can no longer maintain position in its formation.

FIREPOWER KILL (F-KILL) -- Loss of tactical firepower resulting from damage which cannot be repaired by the crew on the battlefield. A tank is considered to have sustained a 100% F-Kill when it is incapable of delivering controlled fire from its main armament. Firepower is DEGRADED when a tank can no longer maintain its "normal" rate-of-fire, velocity, accuracy, time to shift targets, etc.

CATASTROPHIC KILL (K-KILL) -- A tank is considered to have sustained a K-Kill when both an M-Kill and a F-Kill have occurred as the result of killing fires and explosions from ignited fuel and/or ammunition. A tank which has suffered a K-Kill is considered not to be economically repairable, and, by U.S. standards, would be abandoned on the battlefield.

ATTACK ASPECT -- The angle of approach of the aircraft with respect to the orientation of the tank with zero degrees representing the front of the tank (gun forward) and 180 degrees representing the rear of the tank.

SIGNIFICANT IMPACTS -- Impacts which damage systems, components or sub-systems resulting in their destruction or partial loss of function. This type damage contributes to the assessed kill.

INSIGNIFICANT IMPACTS -- Impacts which damage non-critical structural, convenience, or accessory components and which may result in their destruction or partial loss of function, but with no impact on mobility or firepower considerations. Good maintenance practices contemplate repair or replacement of such items at the earliest opportunity consistent with accomplishment of the mission.

DISTRIBUTION LIST FOR LAVP RESULTS

	No. Copies
1. Mr. R.L. Saley Aerojet 1025 Connecticut Avenue, N.W. 12th Floor Washington, DC 20036	1
2. Mr. Marshall Hoyler, Analyst Congressional Budget Office 2nd & D Streets, S.W. Washington, DC 20024	1
3. Dr. John Barmby U.S. General Account Office 441 C Street N.W. Washington, DC 20548	1
4. Lt. Col. Neal Edward Tash USAF/XOOTR Pentagon Washington, DC 20330	1
5. Lt. Col. Donald E. Madonna BQ AFSC/XRLA Andrews AFB, MD Washington, DC 20331	1
6. Col. John R. Boyd USAF, (ret.) OASD/PA&E, Room 2C 281 Pentagon Washington, DC 20301	1
7. Dept. of the Air Force The Albert F. Simpson Historical Research Center/HOH Arthur W. McCants, Jr., Lt. Col. Chief, Oral History Branch Maxwell Air Force Base, Alabama 36112	1
8. 354 TFW/DOW Myrtle Beach AFB, SC 29577	5
9. 81 TFW/CC RAF Bentwaters APO NY 09755	1

10.	81 TFW/DO RAF Bentwaters APO NY 09755	20
11.	23 TFW/DO England AFB, LA 71301	2
12.	USAF/TFWC/TE Nellis AFB, NV 89191	5
13.	Mr. Jerome H. Stolarow U.S. General Accounting Office 441 C Street, N.W. Washington, DC 20548	1
14.	MGEN Bernard E. Trainor Education Center MCDEC Quantico, VA 22134	1
15.	Maj O.W. McCormack Supporting Arms Instruction Division Education Center MCDEC Quantico, VA 22134	1
16.	Capt J.L. Dawson Supporting Arms Instruction Division Education Center MCDEC Quantico, VA 22134	1
17.	Mr. William Lind Office of Senator Gary Hart 254 Russel Building Washington, DC 20510	2
18.	Capt. Kenneth W. Estes USMC 102 Clemson Court Jacksonville, NC 28540	1
19.	Deputy Chief of Staff for Intelligence Headquarters Tactical Air Command Col. Herrmann Langley AFB, VA 23665	5
20.	Mr. James O. Carson Central Intelligence Agency/OSR Washington, DC 20505	1

21.	Mr. Robert Korn Central Intelligence Agency Washington, DC 20505	1
22.	Mr. John Cuzzordo Central Intelligence Agency Washington, DC 20505	1
23.	Mr. Richard R. Hallock Intrac, Inc. 606 Wilshire Boulevard - Suite 400 Santa Monica, CA 90401	5
24.	Mr. C.M. Gordon GE 777 14th, N.W. Washington, DC 20005	1
25.	Maj. M.R. Janay, USMC HQ DARCOM - Code DRCGS-F 5001 Eisenhower Avenue Alexandria, VA 22304	1
26.	Mr. Raymond R. McEachin P.O. Box 273 Hazlehurst, GA 31539	5
27.	L.C. Hayes, USMC Headquarters, Marine Corps Washington, DC 20380	1
28.	K.R. Town, USMC Headquarters, U.S. Marine Corps Washington, DC 20380	1
29.	John C. McKay, USMC Headquarters, U.S. Marine Corps Washington, DC 20380	1
30.	Mr. Tyler W. Tandler 1012 Deadrun Drive McLean, VA 22101	1
31.	Mr. E. Elko AOMC 9236 Rast Hall Road Downey, CA 90241	1

32. Mr. K.H. Wolvington 5
GE
Lakeside Avenue
Burlington, VT 05401
33. Mr. Kwai Chan 1
U.S. General Accounting Office
441 C Street, N.W.
Washington, DC 20548
34. HQ TAC/D000 2
Langley AFB, VA 23665
35. USAF Academy 2
Library
USAF Academy, CO 80840
36. Herrrn Dr. Horst Boog 2
Wiss Oberrat
Militargeschichtliches Forschungsamt
7800 Freiburg im Breisgau
West Germany
37. Albert F. Simpson 2
Historical Research Center
Attention: Mr. Fletcher
Maxwell AFB, AL 36112
38. CMDR Naval Air Systems Command 1
Attention: PMA 235 B
Washington, DC 20361
39. DASD/ISA/ED 1
Room 4D800
The Pentagon
Washington, DC 20301
40. Lt. Col. Howard J. Pierson 10
139 Booker Street
Little Rock, AR 72204
41. USAF 2
DCS/Plans & Operations Tactical Division
BF939B
The Pentagon
Washington, DC 20301

42.	USAF DCS/Programs & Resources Director of Programs Tactical Branch 4C152 The Pentagon Washington, DC 20301	2
43.	USAF DCS/Research & Development Directorate of Operational Requirements & Development Plans Tactical Division 5E381 The Pentagon Washington, DC 20301	2
44.	HQ TAC/DO AT Langley AFB, VA 23665	1
45.	HQ TAC/DO O Langley AFB, VA 23665	5
46.	Mr. Andrew W. Marshall Director Not Assessment Room 3A930 Pentagon Washington, DC 20301	5
47.	Dr. James A. Ross Institute for Defense Analyses 400 Army Navy Drive Arlington, VA 22202	1
48.	Lt. Col. Lanny T. Lancaster HDQ TAC/CCS Langley AFB, VA 23665	10
49.	Mr. Thomas E. Gaines P.O. Box 225907 Vought Corporation Dallas, TX 75265	1
50.	Mr. Emil H. Seaman Aerojet Ordnance Company 9236 East Hall Road Downey, CA 90241	1
51.	Mr. Charles E. Myers 2000 S. Eads #113 Arlington, VA 22202	1

52.	Mr. David G. Opheim Honeywell, Inc. 600 Second Street, N.E. Hopkins, MN 55343	1
53.	Mr. John D. Pafenberg HQ USAF/ING - Pentagon, Room 4A882 Washington, DC 20330	1
54.	Col. W.E. Barrineau, Jr. TFW/DO APO NY 01923	1
55.	HQ TAC/DOOF Langley AFB, VA 23665	1
56.	HQ TAC/XP Langley AFB, VA 23665	1
57.	USAF TFWC/SA Nellis AFB, NV 89191	1
58.	57 FWW/DO Nellis AFB, NV 89191	1
59.	12 AF/DO Bergstrom AFB, TX 78743	2
60.	9 AF/DO Shaw AFB, SC 29152	2
61.	CINCUSAFE/DO Ramstein AFB APO 09012	1
62.	CINCUSAFE/DOOF Ramstein AFB APO 09012	2
63.	CINCUSAFE/DOOT Ramstein AFB APO 09012	2
64.	CINCUSAFE/DOST Ramstein AFB APO 09012	2
65.	USAF Maj. Gen. Kelly TFWC/CC Nellis AFB, NV 89191	5

66.	66 FWC/CC Nellis AFB, NV 89191	50
67.	Thomas P. Christie DASD (Tactical Air Program) PA&E Room 2E330 Pentagon Washington, DC 20301	50
68.	Maj. Davies (ASD/YXA) USAF/Aeronautical Systems Division A-10 System Program Office Directorate of Armament Wright-Patterson AFB, OH 45433	10
69.	Battelle Columbus Laboratories Tactical Technology Center Room 13-4127 Attention: Mr. J. Tuck Brown 505 King Avenue Columbus, OH 43201	5
70.	HQ USAF DSC/RDF Pentagon - 4D283 Washington, DC 20330	5
71.	Lt. Gen. (USA Ret) H.R. Aaron 7722 Kalorama Road Annandale, VA 22003	1
72.	Maj. Robert. K. Redlin Commandant of the Marine Corps Code R&P Headquarters, U.S. Marine Corps Washington, DC 20380	1
73.	Lt. Gen P.X. Kelly, USMC Deputy Chief of Staff, Requirements & Programs Headquarters U.S. Marine Corps Washington, DC 20380	1
74.	Lt. Col. G. W. Keiser (Code RP) U.S. Marine Corps Requirements & Programs Washington, DC 20380	1

75.	Mr. John F. Blake 9312 Crown Place Alexandria, VA 22308	1
76.	Mr. Richard Eppard Central Intelligence Agency Office of Logistics Washington, DC 20505	1
77.	Mr. Rudolf A. Endors 10101 Colebrook Avenue Potomac, MD 20854	1
78.	Maj. Gen. Thomas P. Lynch Commanding General U.S. Army Armor Center Fort Knox, KY 40121	1
79.	Lt. Col. John H. Ridge U.S. Army Armor Center Fort Knox, KY 40121	1
80.	Maj. Barry D. Watts OSD/Office of Net Assessment Pentagon - 3A930 Washington, DC 20301	1
81.	HQ TAC/CC Langley AFB, VA 23665	2
82.	Defense Documentation Center Cameron Station Alexandria, VA 22314	2
83.	Dept. Chairman Dept. of National Security Affairs Naval Postgraduate School Monterey, CA 93940	2
84.	Professor R.H.S. Stolfi Dept. of National Security Affairs Naval Postgraduate School Monterey, CA 93940	30
85.	AFIT/CIP (Library) Wright-Patterson AFB, OH 45433	2
86.	AFIS/INH Ft. Belvoir, VA 22060	1

87.	Brig. Gen. Reed 355 TFW/CC Davis Monthan AFB, AZ 85707	5
88.	Col. Wayne E. Davis 1411 Gemini Circle Moody AFB Valdosta, CA 31601	1
89.	Brig. Gen. W.S. Harpe 14 TFW Columbus, MS 39701	5
90.	354 TFW/DCM Myrtle Beach AFB, SC 29577	1
91.	TAC/DR Langley AFB, VA 23665	1
92.	CIA/HQ Washington, DC 20505	2
93.	General Elwood Quesada (Retd.) L'Enfanc Plaza Washington, DC 20024	1
94.	Mr. P.M. Sprey Box 264, R.D. 1 Glenn Dale, MD 20769	5
95.	Mr. Mike Mecca Fairchild Industries Germantown, MD 20767	2
96.	Industrial College of the Armed Forces Library Ft. Lesley J. McNair Washington, DC 20319	1
97.	Mr. Bernard Kornhauser System Planning Corp. 1500 Wilson Blvd. Suite 1500 Arlington, VA 22209	1
98.	Maj. Gerald H. Felix, USAF 112 TFG Greater Pittsburgh Airport Pennsylvania Air Guard Pittsburgh, PA 15180	5

99.	USMCDEC Firepower Division Air Branch/Code D092 Attention: Ms. Kearns Quantico, VA 22134	5
100.	USAF TAWC Eglin AFB, FL 32542	1
101.	Headquarters U.S. Marine Corps Chief of Staff Arlington Annex Room 2010 Columbia Pike & Arlington Ridge Road Arlington, VA 20370	5
102.	USAF Air University Library Maxwell AFB, AL 36112	2
103.	CMDR, Naval Weapons Center Attention: Mr. Bates China Lake, CA 93555	2
104.	Col. Robert M. Gomez/DRXSR Deputy Director/Commanding Officer Ballistic Research Laboratory Building 328 Aberdeen Proving Ground, MD 21005	1
105.	GE, Armament Systems Dept. Director Lakeside Ave. Burlington, VT 05401	1
106.	HQ TAC/DO Langley AFB, VA 23665	5
107.	354 TFW/CC Myrtle Beach AFB, SC 29577	5
108.	23 TFW/CC England AFB, LA 71301	1
109.	356 TFS/DO Attention: Maj. Lt. Col. Jenny Myrtle Beach AFB, SC 29577	5
110.	USAC 4SC Ft. Leavenworth, KS 66027	1

111.	355 TFW/DOW Davis Monthan AFB, AZ 85707	1
112.	355 TFW/DO (A-7) Davis Monthan AFB, AZ 85707	5
113.	355 TFW/DO (A-10) Davis Monthan AFB, AZ 85707	5
114.	333 TETS/CC Davis Monthan AFB, AZ 85707	1
115.	333 TETS/DO Davis Monthan AFB, AZ 85707	5
116.	OLAC 4444 OPS SQ (ISD) Davis Monthan AFB, AZ 85707	1
117.	355 TTS/CC Davis Monthan AFB, AZ 85707	1
118.	Herrn Dr. Stahl Bundesarchiv-Militararchiv <u>78 Freiburg im Breisgau</u> Wiesentr 10 West Germany	2
119.	Mr. Richard E. Tuck U.S. General Accounting Office 441 C Street, N.W. Washington, DC 20548	1
120.	Col. Paul N. Chase HQ USAF AF/SAGP Pentagon - 1D373 Washington, DC 20330	1
121.	Mr. Peter McDavitt Honeywell 600 Second Street, N.E. Hopkins, MN 55343	1
122.	Col. Carl Case Fighter Division Air Force Studies & Analysis Pentagon - 1D380B Washington, DC 20330	1

123. Lt. Col. John L. Welde 1
354 TFW/DO
MB AFB, SC 29577

124. Dr. Dieter H. Schwebs 1
U.S. General Accounting Office
441 C Street, N.W.
Room 6478
Washington, DC 20548

125. Col. Michael L. Wardinski 1
HQ Department of the Army
DAMI-RT
Pentagon - BF722
Washington, DC 20310

126. Mr. John Sloan 1
HQ Department of the Army
DAMI-RT
Pentagon - BF722
Washington, DC 20310

127. Mr. W.R. Beuch 1
HQ Department of the ARMy
DAMI-RT
Pentagon - BF722
Washington, DC 20310

128. FMC Corporation 1
1105 Coleman Avenue
Box 1201
Attention: Mr. Don Loughlin, MD510
San Jose, CA 95108

129. Lt. Col. J.W. Lent 1
HQ MC (Code RPR-7)
Washington, DC 20380

130. Edward Fuge (Major, Retired, USAF) 1
Department of Political Science
University of New Mexico
Albuquerque, New Mexico 87131

131. Mr. Arthur G. Hanley 1
Central Intelligence Agency
Procurement Management Staff
Washington, DC 20505

132. 50 TFW/CC 1
APO NY 09109

133.	50 TFW/DO APO NY 09109	5
134.	50 TFW/DO 496 TFS Attention: Maj. Ratley APO NY 09109	5
135.	Energy Efficiency System Attention: Mr. Verdi 187 W. Orangethorpe Road Suite P Placentia, CA 92670	1
136.	Col. Richard C. Head Council on Foreign Relations The Harold Pratt House 58 East 68 Street New York, NY 10021	1
137.	General Hermann Balck <u>7144 Asperg</u> Egerstr. 23 Federal Republic of Germany	1
138.	Col. Faybanic AWC/DAUM Maxwell AFB, AL 36112	1
139.	Mr. Cobleigh Hughes Aircraft Canoga Park, CA 91304	1
140.	Boeing Attention: Mr. Bud Nelson P.O. Box 3999, M/S 40-30 Seattle, WA 98124	1
141.	IDA Attention: Dr. Whittemore 400 Army Navy Drive Arlington, VA 22202	1
143.	Lt. Gen. Mahlke <u>2350 Heikendorf</u> Steenkamp 8 Federal Republic of Germany	1

144. HQ USAF 1
Attention: Lt. Gen. John Pustay
Office of Chief of Staff
Pentagon
Washington, DC 20330
145. Studiengruppe Luftwaffe 1
Suchrunga Akademic der Bundeswehr
2000 Hamburg 55
Manteuffelatr. 20
Federal Republic of Germany
146. Gen. Wilke 1
31 Alle
Schlepegrellstr. 30
Federal Republic of Germany
147. General F.W. von Mellenthin 1
Box 67759
Bryanston 2021
Johannesburg
Republic of South Africa
148. Herrn Brigadegeneral a.D. Paul-Werner Hozzel 1
Salierster. 4
D7500 Karlsruhe
Federal Republic of Germany
149. 91 TFS/CC/Dow 1
APO 09405
New York, New York 09012
150. 78 TFS/CC/DOW 1
APO 09405
New York, New York 09012
151. 92 TFS/CC/DOW 1
APO 09755
New York, New York 09012
152. Military Attache 1
U.S. Embassy (Rome, Italy)
APO 90794
New York, New York 09012
153. Millitary Attache 1
U.S. Embassy (Bonn, Federal Republic of Germany)
APO 09080
New York, New York 09012

154. Military Attache U.S. Embassy (Saudi, Arabia) APO 09697 New York, New York 09012	1
155. Military Attache U.S. Embassy Attention: Air Attache New Delhi, India	1
156. Military Attache U.S. Embassy Attention: Maj. McBaron Canberra, Australia	1
157. AFIS/INC Attention: Col. Kuiper Building 520 Bolling AFB, DC 20332	1
158. Mr. William Jenisch Aerojet Ordnance Manufacturing Company 9336 East Hall Road Downey, CA 90241	1
159. USAFE/DOOW Attention: Maj. Lindsey APO New York, New York 09012	1
160. Mr. James Simon Central Intelligence Agency Washington, DC 20505	1
161. Mr. David Keener Central Intelligence Agency Washington, DC 20505	1
162. Mr. Aris Pappas Central Intelligence Agency Washington, DC 20505	1
163. Mr. Andrew Hamilton Congressional Budget Office/NSIA 4th Floor HOB, Annex #2 U.S. Congress Washington, DC 20515	1
164. Mr. Pat Hillier Congressional Budget Office/NSIA 4th Floor HOB, Annex #2 U.S. Congress	1

Washington, DC 20515

165. Dr. Dov Zakheim 1
Congressional Budget Office/NSIA
4th Floor HOB, Annex #2
Washington, DC 20515

166. Mr. John Hamre 1
Congressional Budget Office/NSIA
4th Floor HOB, Annex #2
U.S. Congress
Washington, DC 20515

167. Ms. Grace P. Hayes 1
T.K. Dupuy Associates, Inc.
P.O. Box 157
Dunn Loring, VA 22027

168. Mr. C. Curtiss Johnson 1
T.N. Dupuy Associates, Inc.
P.O. Box 157
Dunn Loring, VA 22027

169. Ms. Lucille Patterson 1
T.N. Dupuy Associates, Inc.
P.O. Box 157
Dunn Loring, VA 22027

170. Col. A.J. Kettering 1
OSD/OUSTR&E
Pentagon
Washington, DC 20301

171. Mr. Robert S. Dotson 1
Senate Armed Services Committee
212 Russell Senate Office Building
Washington, DC 20510

172. Mr. Steven Canby 1
10871 Springknoll Drive
Potomac, MD 20854

173. Director 1
U.S. Army Aberdeen Research & Development Center
Army Materiel Systems Analysis Activity/DRXS
Aberdeen Proving Ground, MD 21005

174. Mr. Michael W. Iten/DRXS-C 1
U.S. Army Materiel Systems Analysis Activity
Aberdeen Proving Ground, MD 21005

175. Mr. G.A. Zoller 1
U.S. Army Materiel Systems Analysis Activity/DRXSY
Aberdeen Proving Ground, MD 21005

176. Maj. J.F. Balda 1
U.S. Army Materiel Systems Analysis Activity/DRXSY
Aberdeen Proving Ground, MD 21005

177. Mr Arif R. Zaky 1
U.S. Army Materiel Systems Analysis Activity/DRXSY
Aberdeen Proving Ground, MD 21005

178. Mr. Arthur W. Garrett 1
U.S. Army Materiel Systems Analysis Activity/DRXSY
Aberdeen Proving Ground, MD 21005

179. Mr. T.A. Romanko 1
U.S. Army Material Systems Analysis Activity/DRXSY
Aberdeen Proving Ground, MD 21005

180. Mr. Stanley Eibertz 1
U.S. General Accounting Office
441 C Street, N.W.
Washington, DC 20548

181. Mr. Fredic S. Feer 1
Analytical Assessments Cooperation
P.O. Box 9102
Arlington, VA 22209

182. Mr. Dan Costello 1
OMB
New Executive Office Building
R10026
Washington, DC 20503

183. Mr. Gordon P. Lynch 1
Boeing Aerospace Company
Box 3999 - M/S 47-63
Seattle, WA 98124

184. Lt. Col. George W. Burkley 1
1875 Temple Hills Drive
Laguna Beach, CA 96215

185. Mr. Gerald Mayefskie 1
Quest Research Corporation
6845 Elm Street
McLean, VA 22101

186.	Dr. John E. Tashjean BDM 7915 Jones Branch Drive McLean, VA 22101	1
187.	Mr. David A. Brinkman U.S. General Accounting Office 441 C Street, N.W. - Room 6478 Washington, DC 20548	1
188.	Mr. Wayne H. Coloney P.O. Box 5258 Tallahassee, FL 32301	1
189.	Lt. Gen. M.P. Casey, USAF (ret.) Wayne H. Coloney Company P.O. Box 5258 Tallahassee, FL 32301	5
190.	Mr. Richard W. Oates General Electric Lakeside Avenue Burlington, VT 05401	5
191.	Lt. Col. James Cord Command and Staff College Marine Corps Development & Education Command Quantico, VA 22314	1
192.	Brig. General W.H. Fitch Deputy Chief of Staff, R&D and Studies USMC Arlington Annex Washington, DC 20380	1
193.	Mr. Jim Erickson Grumman Aerospace BOS-05 Bethpage, NY 11714	1

194.	Professor Andrew Cyorgy Sino-Soviet Institute George Washington University 2029 G Street, N.W. Washington, DC 20052	1
195.	Mr. Charles Bernard Director, Land Warfare OSD/OUUSDRE Pentagon Washington, DC 20301	1
196.	162 TFG/FWS P.O. Box 11037 Tucson, AZ 85734 Attention: Lt. Col. O'Donnell	10
197.	Mr. P. Nichols Ayres Corp. P.O. Box 3090 Albany, GA 31706	1
198.	Herrn Brigadegeneral a.D Loytved-Hardegg 41 Odenbergerstr. <u>5800 Nurnberg</u> Federal Republic of Germany	1
199.	Herrn Oberst a.D. Poetter 21-2 Alter Remise <u>8941 Kronburg</u> Federal Republic of Germany	1
200.	Dr. Richard Staar Dir. International Studies Pgms. Hoover Institute Stanford, CA 94305	1
201.	Armament Systems, Inc. 712-F N. Valley St. Anaheim, CA 92801 Attention: Mr. Tom Gilbert	1
202.	Library, Code 0212 Naval Postgraduate School Monterey, California 93940	2
203.	Dean of Research, Code 012 Naval Postgraduate School Monterey, California 93940	1

