

3

RESEARCH AND DEVELOPMENT BRANCH
DEPARTMENT OF NATIONAL DEFENCE
CANADA

ADA 083899

LEVEL

DTIC
ELECTE
MAY 6 1980
C

DEFENCE RESEARCH ESTABLISHMENT OTTAWA

DREO TECHNICAL NOTE NO. 80-1
DREO TN 80-1

A COMPREHENSIVE REVIEW OF TRAVELLING-WAVE TUBE TECHNOLOGY

by
R. Luiz



DOC FILE COPY

PROJECT NO.
31000

NOVEMBER 1979
OTTAWA

00 4-28 057

CAUTION

This information is furnished with the express understanding
that proprietary and patent rights will be protected.

RESEARCH AND DEVELOPMENT BRANCH
DEPARTMENT OF NATIONAL DEFENCE
CANADA

3

DEFENCE RESEARCH ESTABLISHMENT OTTAWA

9 TECHNICAL NOTE NO. 80-1

14 [unclear] - TN - 80 - 1

DTIC
ELECTE
MAY 6 1980
S D C

6 A COMPREHENSIVE REVIEW OF TRAVELLING-WAVE TUBE TECHNOLOGY

by
30 Robert Luiz
Radar ESM Section
Defence Electronics Division

PROJECT NO.
31800

11 NOVEMBER 1979
OTTAWA
12 80

404576

502

ABSTRACT

A review of TWT technology is presented comparing selected aspects and design procedures relative to application.

The general theory of operation of various types of TWT designs is discussed together with a review of principles of their construction and trade offs.

RÉSUMÉ

Une revue de la technologie des tubes à ondes progressives (TWT) est présentée, comparant certains aspects et procédures par rapport aux applications.

La théorie générale d'opération de plusieurs modèles de tubes à ondes progressives est présentée, avec une revue des principes de fabrication ainsi que des avantages et desavantages de chaque type.

Accession For
NTIS OADR
DSC TAB
Unannounced
Justification

By _____

Distribution/

Availability Codes

Dist	Avail and/or special
A	

TABLE OF CONTENTS

	<u>PAGE</u>
<u>ABSTRACT/RÉSUMÉ</u>	iii
<u>TABLE OF CONTENTS</u>	v
1.0 <u>INTRODUCTION</u>	1
2.0 <u>DESCRIPTION OF THE TWT</u>	1
3.0 <u>BASIC OPERATION</u>	2
4.0 <u>THE CHARACTERISTICS OF TWT'S AND VARIOUS CONFIGURATIONS</u>	2
4.1 <u>The Gain, Bandwidth and Efficiency</u>	4
4.2 <u>The Sever</u>	5
4.3 <u>Power and Perveance</u>	6
4.4 <u>Large Signal (Non-linear) Operation</u>	7
4.5 <u>Noise</u>	8
4.6 <u>Millimeter-wave Tube</u>	8
4.7 <u>Backward-wave Amplifier</u>	9
4.8 <u>Saturation</u>	10
4.9 <u>Dual Mode</u>	12
4.10 <u>Modulation and Control</u>	12
4.11 <u>The Crossed-field TWT</u>	13
5.0 <u>SLOW-WAVE STRUCTURES</u>	14
5.1 <u>Amplification Process</u>	14
5.1.1 <u>The Helix</u>	14
5.2 <u>High Power Limitations</u>	16
5.3 <u>Other Helical Structures</u>	17
a) <u>Twin Crosswound Helix</u>	17
b) <u>Sheath Helix</u>	17

TABLE OF CONTENTS (CONTINUED)

	<u>PAGE</u>
c) <u>Tape Helix</u>	18
d) <u>Bifilar Helix</u>	18
e) <u>Ring and Bar Contrawound Helix</u>	19
5.4 <u>"Forbidden" Zones</u>	19
5.5 <u>Dielectric Loading</u>	19
5.6 <u>Derived Structures</u>	19
5.6.1 <u>Folded Transmission Lines</u>	20
5.7 <u>Coupled-cavity Structures</u>	20
6.0 <u>THE ELECTRON BEAM SYSTEM</u>	22
6.1 <u>Electron Guns</u>	22
6.1.1 <u>Lens Compensated Guns</u>	23
6.1.2 <u>Anode Projection - Müller's Principle</u>	24
6.1.3 <u>Anode-lip Gun (Mathias and King Version of Müller Gun</u> ..	24
6.1.4 <u>Hollow Beam Gun</u>	24
7.0 <u>THE BEAM AND THE FOCUSING SYSTEM</u>	25
7.1 <u>Magnetic Field Parallel to the Axis</u>	25
7.2 <u>Beam Focusing</u>	26
7.2.1 <u>Uniform Magnetic Field</u>	27
7.2.2 <u>Periodic Permanent Magnet (PPM) Focusing</u>	28
7.2.3 <u>Periodic Electrostatic Focusing (PEF)</u>	28
7.3 <u>Collectors</u>	29
7.3.1 <u>Depressed Potential Collectors</u>	29
7.3.2 <u>Methods of Cooling</u>	30

TABLE OF CONTENTS (CONTINUED)

	<u>PAGE</u>
8.0 <u>MATHEMATICAL FORMULATION OF TWT</u>	30
8.1 <u>Travelling-wave Tube Gain</u>	36
8.2 <u>The Effect of Space Charge</u>	37
8.3 <u>The Helix as a Spiral Slot Transmission Line</u>	38
8.4 <u>Phase Velocity and Group Velocity</u>	39
8.5 <u>Coupled-cavity Structures - A Lumped Circuit Model</u>	41
8.6 <u>Hollow Beams</u>	42
9.0 <u>CONCLUDING REMARKS</u>	44
<u>REFERENCES</u>	45
FIGURE 1 - PORTION OF THE TRAVELING-WAVE AMPLIFIER PERTAINING TO ELECTRONIC INTERACTION WITH RADIO-FREQUENCY FIELDS AND RADIO-FREQUENCY GAIN	51
FIGURE 2 - SCHEMATIC OF THE TRAVELING-WAVE AMPLIFIER	51
FIGURE 3 - TWO-SECTION SEVERED TRAVELLING-WAVE TUBE	52
FIGURE 4 - DIAGRAM SHOWING DIRECTIONS OF ELECTRON AND POWER FLOW FOR: (a) NORMAL TRAVELLING-WAVE TUBE (FORWARD WAVE AMPLIFIER); (b) BACKWARD WAVE AMPLIFIER	52
FIGURE 5 - CROSSED-FIELD TWT	53
FIGURE 6 - SLOW WAVE STRUCTURES	53
FIGURE 7 - TWIN CROSSWOUND HELIX	53
FIGURE 8 - SHEATH HELIX	54
FIGURE 9 - TAPE HELIX	54
FIGURE 10 - HELIX STRUCTURES	55
FIGURE 11 - SLOW WAVE STRUCTURES	56
FIGURE 12 - COUPLED CAVITY STRUCTURE (CHODOROW-NALOS STRUCTURE)	57
FIGURE 13 - THE "HUGHES" STRUCTURE	57

TABLE OF CONTENTS (CONTINUED)

	<u>PAGE</u>
FIGURE 14 - THE "CENTIPEDE" STRUCTURE (COUPLING PLATE)	57
FIGURE 15	58
FIGURE 16 - PIERCE GUN	58
FIGURE 17 - TWO ANODE LENS-COMPENSATED GUN	59
FIGURE 18 - GUN DESIGNED BY MATHIAS ACCORDING TO MÜLLER'S PRINCIPLE	59
FIGURE 19 - MATHIAS AND KING'S HIGH VOLTAGE VERSION OF MÜLLER-TYPE GUN	60
FIGURE 20 - PERSPECTIVE VIEW SHOWING PATHS OF OUTER ELECTRONS	60
FIGURE 21 - A PRACTICAL ARRANGEMENT FOR LAUNCHING BRILLOUIN FLOW	61
FIGURE 22 - A PRACTICAL ARRANGEMENT FOR LAUNCHING SMOOTH FLOW AT FIELDS ABOVE BRILLOUIN	61
FIGURE 23 - ELECTRON GUN CONTROL ELECTRODES	62
FIGURE 24 - BOWING OF FIELD LINES	63
FIGURE 25 - C-MAGNET	63
FIGURE 26 - SOLENOID WITH SEPARATE COILS AND IRON END PLATES	63
FIGURE 27 - CYLINDRICAL POT PERMANENT MAGNET	64
FIGURE 28 - PPM-FOCUSING STRUCTURE EMPLOYING AXIALLY MAGNETIZED RINGS	64
FIGURE 29 - PERIODIC FOCUSING BY CONVERGING MAGNETIC LENSES	64
FIGURE 30 - DEPRESSED COLLECTOR T.W.T.	65
FIGURE 31 - A DEPRESSED COLLECTOR WHICH SUPPRESSES SECONDARY CURRENT	65
FIGURE 32 - EQUIVALENT CIRCUITS	66
FIGURE 33 - SPACE CHARGE EFFECT	67
FIGURE 34	67
FIGURE 35 - EQUIVALENT LUMPED CIRCUITS FOR THE COUPLED-CAVITY STRUCTURE	68

TABLE OF CONTENTS (CONTINUED)

	<u>PAGE</u>
FIGURE 36 - HOLLOW BEAM GUNS	69
FIGURE 37 - CROSS-SECTION OF HOLLOW BEAM	69

1.0 INTRODUCTION

The travelling-wave tube (TWT) was invented by R. Kompfner in 1943, and the principle of TWT amplification was demonstrated by him at Birmingham University in the same year. A small signal theory of this device was extensively developed by J.R. Pierce.

The TWT has been constructed to operate at many wavelengths, ranging from one meter to one millimetre. It has found wide application primarily because at any given frequency or power level, it offers much more bandwidth than any of its competitors.

The travelling-wave tube, though structurally simple, is a "Constructed Complication". Because of its structural simplicity, TWTs have been built to operate at frequencies as high as 50 GHz. Modern requirements for TWT amplifiers often call for very wide bandwidths combined with high power output.

For any practical application an ideal TWT is seldom available as an "off-the-shelf" item mainly because more than two dozen independent parameters are required in order to completely describe the tube.

With the introduction of the TWT two chief limitations of Magnetrons and Klystrons, namely, their narrow bandwidth and slow tuning capabilities, were largely overcome. The field of Electronic Counter Measures (ECM) has immensely benefited from the unique capabilities of the TWT.

The TWT is one of the thoroughly researched technologies. Therefore, appropriate references should be consulted if the reader is interested in further details on any of the topics described in this report. Several references used in the preparation of this report are listed.

2.0 DESCRIPTION OF THE TWT

The TWT is a device to transfer energy from a stream of electrons to an alternating, radio frequency, current, (Figure 1). Unlike Klystrons and Magnetrons which depend upon standing waves to produce the high frequency fields with which the beam interacts locally, the TWT makes use of the principle of a distributed interaction mechanism between the electron beam and the travelling electromagnetic waves. Referring to Figure 2, the TWT consists of a Gun assembly (heater, cathode and anode) which produces a stream of electrons called an electron beam, a beam focussing system which produces sufficient longitudinal magnetic field to keep the electron beam from spreading, a collector to absorb the spent beam, a cooling system to help dissipate excess heat and a helix through which the electron beam passes before being absorbed by the collector.

3.0 BASIC OPERATION

Referring to Figure 2, at the input the wave is transferred from a wave guide to the helix by means of a short antenna and, similarly, at the output the wave is transferred from the helix to a short antenna from which it is radiated into the output wave guide. The purpose of the helix is to slow down electromagnetic wave which is travelling, nominally, at the speed of light, to some required velocity. The signal amplification of a TWT is created from the interaction between the electron beam and the electromagnetic wave travelling through the helix. The amplification is most effective when the speed of the electrons in the beam and the speed of the travelling wave are about equal. For example, the speed of electrons produced by a beam voltage of 1500V is about 1/13 of the speed of light. Therefore, in order to slow down the electromagnetic wave travelling at the nominal speed of light, a helix made of a wire of length 13 times the length of the helix itself is required.

The helix, in the absence of the electron stream, supports the propagation of a wave with an axial electric field and such a wave may travel in either direction. It is found that in the presence of the electron beam the wave travelling against the electron motion is little affected, but the wave travelling in the direction of electron motion is broken up into three components. For a lossless helix one of these forward waves is attenuated, one is unattenuated, and the third increases in amplitude as it travels (or experiences negative attenuation). On the average, the electrons travel a little faster than the amplified wave.

As the electrons move in synchronism with the amplified wave, they become bunched. These bunches, while moving rapidly in opposing field regions of the helix, give up energy to the field. For a given electromagnetic energy travelling down the helix, the stronger the field that acts on the electrons, the more the bunching and the more energy the bunches give up to produce greater signal amplification. It is found that as the frequency is increased the EM wave tends to cling close to the helix such that the electric field intensity decreases near the axis of electron flow. For this reason the gain tends to decrease as the frequency increases because the field is constrained closer to the helix. At very low frequencies the helix will be only a few wavelengths long and therefore the gain is low at very low frequencies. We thus obtain a broad gain maximum with respect to frequency.

4.0 THE CHARACTERISTICS OF TWT'S AND VARIOUS CONFIGURATIONS

Two basic types of slow-wave structures (or circuits) have received considerable attention as the interaction structures for travelling-wave tubes. These are the helix and the periodically-loaded wave guide, which is a band-pass microwave filter.

The helix has many advantages when used as a travelling-wave propagation structure. It is by nature a broad band device to which it is relatively easy to couple over a wide frequency range. Attenuation may easily be added at various places along the helix to prevent the tube from oscillating when used as an amplifier.

However, high power requirements coupled with broad bandwidth persuaded scientists to design many modified forms of helices, each one specifically suited for a particular application. In spite of all these, pulse operated power tubes requiring outputs of several megawatts, with duty cycle ranging from a fraction of a percent to several percents, were required. However, the voltage handling limitation of the helices was found to be 10 KV giving a peak RF power output of a few kilowatts. Beyond that, the pitch of the helix became coarse and the RF coupling to the beam became very poor.

Therefore, loaded wave guides or transmission lines found increasing application as circuits for TWTs. These structures are filter type circuits consisting of wave guides with periodic loading to slow the wave velocity to that of the electrons in the beam. They have advantages over the helix-type structure by being much more rugged and are capable of dissipating much larger amounts of heat, because the entire structure is made out of metal that can be easily cooled. These coupled-cavity circuits are the fundamental building blocks of an extremely important class of high-power TWTs. The versatility of the coupled-cavity circuit is demonstrated by the fact that it is widely used from L-band to millimeter waves and for power levels from 1-500 KW.

Though helix and coupled cavity circuits are two different structures to meet the same requirements, there are some distinguishing differences between them.

One logical criterion for a high gain circuit is its impedance value, given by

$$Z_0 = E^2 / 2B^2P \quad (1)$$

where E = is the peak axial field strength

P = is the power flowing in the helix

β = is the phase constant and is defined by $\frac{\omega}{v}$, where ω is the radian frequency and v is the velocity of the wave.

One way to make Z_0 large is to decrease the power, which is a function of stored energy for a given field strength. In an electromagnetic wave, half of the stored energy is electric and half is magnetic. Thus, to make the total stored energy for a given field strength small, we must make the energy stored in the electric field small. For a broad-band amplifier the phase velocity must be constant; that is, β must be proportional to the frequency. Therefore, two desirable circuit properties for high gain are high impedance and constant phase velocity.

4.1 Gain, Bandwidth and Efficiency

The principal factors which causes the gain to vary with frequency are: 1) variation in the velocity of the wave on the circuit with which the beam interacts; 2) variation in the effective length of the tube in wavelengths; 3) variation in the strength of the axial electric field interacting with the beam; 4) variation of the impedance match at the input and output transducers, and at the attenuator.

The effect of increasing the beam thickness on the gain vs. frequency characteristic of the forward wave amplifier is to increase the frequency at which the gain is a maximum, for a given beam radius, and to increase the bandwidth.

The gain of a travelling-wave tube is proportional to the number of wavelengths in the tube at the electron velocity. The gain per wavelength is increased by increasing the beam perveance, and the wavelength is decreased as the voltage is decreased.

The physical size of a travelling-wave tube tends to be inversely proportional to the centre frequency. As the frequency is decreased, it becomes a major design problem to keep the tube size from becoming too large.

Coupled-cavity TWTs are used for applications for which Klystrons have insufficient bandwidth. These applications include communication systems requiring multiple carrier operation, radar applications, and electronic counter measures (ECM). Coupled-cavity TWTs are used in these systems as the output amplifiers and sometimes as drivers for crossed-field amplifiers.

Coupled-cavity TWT interaction is similar to helix TWT interaction in one respect, that is, power flows along the circuit. Coupling between adjacent cavities is introduced to obtain increased bandwidth. (Coupling is achieved by means of slots or loops in the cavity end walls.) The cavities are normally highly over-coupled, resulting in a bandpass-filter type of characteristic. One of the important functions in coupled-cavity TWT interaction is the phase change occurring between cavities as a function of frequency. A decreasing phase characteristic is obtained if the mutual inductance of the coupling slot is positive, and an increasing phase characteristic is obtained for negative mutual inductive coupling of the slot.

The electron beam interacts with a component of the circuit field that has an increasing phase characteristic with frequency. Because of the periodicity of the coupled-cavity circuit, the electric and magnetic fields can be expressed mathematically in terms of a Fourier expansion. Therefore, the circuit periodicity can give rise to field components. For the circuit having positive mutual inductive coupling between cavities, the electron beam velocity is adjusted to be approximately equal to the phase velocity of the first forward-wave space harmonic. For the circuits employing negative mutual inductive coupling, the fundamental component of the circuit wave is suitable for synchronism with the electron beam. Examples of coupled-cavity TWT

circuits having fundamentally forward wave characteristic, and hence negative mutual inductive coupling, are clover leaf and centipede circuits. Examples of circuits having positive mutual coupling between cavities are space harmonic and long-slot circuits.

Optimum interaction characteristics are obtained by proper design of the cavity geometry. The cavity resonant frequency in the absence of magnetic coupling determines the high frequency cut-off of the interaction mode. The coupling slot in turn determines the amount of bandwidth in the interaction mode and interaction impedance is determined primarily by the cavity height and by the gap and tube geometry.

Coupled-cavity TWTs are constructed with a limited amount of gain per section of cavities to ensure stability. Each cavity section is terminated at each end, either into a matched load or the input or output line, in order to reduce the gain variations with frequency. The sections are normally "severed" with coupling between sections only through the electron beam interaction, and with negligible amount of RF leakage through the beam hole. Cavity sections are cascaded to obtain higher tube gains than can be tolerated in one section of cavities producing stable gain greater than 60 dB over about 30 percent bandwidth.

The gain of a coupled-cavity tube is quite sensitive to the beam velocity. In designing the tube, the beam voltage and cavity period are typically adjusted to give a flat gain characteristic with frequency. This adjustment does not necessarily give the best power transfer to the circuit at the tube output. Therefore, some further adjustments in beam velocity or circuit periodicity are required at the output end of the TWT. Typically, this adjustment has been made by reducing the period of the last few cavities (taper) to improve the energy exchange. Alternatively, beam voltage can be increased near the tube output, also resulting in a similar improvement in tube efficiency. Also, an improvement in efficiency can be obtained in helix TWTs by increasing the circuit period in an appropriate manner.

The overall efficiency of the tube is determined by the amount of energy converted to RF energy relative to that dissipated by the collector. Overall efficiencies of 20 to 55 percent have been obtained, including the energy recovered by collector depression.

Another factor affecting the design of coupled-cavity TWTs is the tube stability, where oscillations can be predicted from the calculation of gain. The most severe oscillation problem occurs when the beam is approximately synchronous with the band edge frequency. This corresponds to the " π " phase shift-per-cavity frequency for clover leaf circuits and to the " 2π " phase shift-per-cavity frequency for space harmonic circuits.

4.2 The Sever

The simple TWT has one serious disadvantage because of a possible feedback path from output to input by way of the slow wave structure. Any power reflected at a mismatch on the output terminal travels back down the structure and, as there is usually a mismatch at the input, is reflected

again to give a feedback signal. Whenever the amplitude of this signal rises above a certain value and its phase is such as to give positive feedback the tube bursts into oscillation.

It might be argued that it should be possible to adjust the phase of the reflected signal so that the feedback is always negative. Unfortunately in a wide band amplifier containing a large number of wavelengths between input and output there is always likely to some frequency at which there is sufficient gain to cause oscillations. This situation is further complicated by the fact that reflections at the input and output may well reverse their signs over the frequency range. Therefore, some sort of non-reciprocal element which inserts loss only into the feedback path may be used. One method of introducing a non-reciprocal element is to sever the slow wave structure as shown in Figure 3, where each end of the break is terminated in a matched load. For fairly low average power operation lossy buttons may be placed internal to the cavity structure. For higher average powers, circuit matches are made by wave guides (or coaxial lines) which are then terminated in resistive loads. Wave guide water load terminations are especially good for very high power tubes if the water is used as the coolant medium. Water coolant is accomplished by inserting a hollow ceramic cylinder across a section of wave guide and water is passed through the ceramic cylinder. The water acts as the lossy medium in which the RF power is dissipated.

4.3 Power and Perveance

When discussing the power capability of TWTs it is important to make a clear distinction between the peak and average power since these two are limited by totally different considerations. The average power at a given frequency is almost always limited by thermal considerations relative to the RF propagating circuit. The electron beam focusing is never perfect, and a sizable fraction of the total beam power is intercepted by the RF circuit. At some point the circuit temperature may approach the melting point of copper or the Curie temperature of iron in the case of a Periodic Permanent Magnet (PPM) TWT. In both cases the tube is close to destruction, and this condition defines the average power capability of that device. Peak RF power capability is closely dependent upon the voltage for which the TWT is designed. The beam current varies as the 3/2 power of the voltage, that is

$$I_0 = K V_0^{3/2} \quad (2)$$

where,

I_0 = is the beam current

V_0 = is the beam voltage

K = is a constant known as perveance

The beam power, P_B , is given by

$$\begin{aligned} P_B &= I_0 V_0 \\ &= K V_0^{5/2} \end{aligned} \quad (3)$$

Perveance is a function of gun geometry only and does not depend on absolute dimensions. It is generally limited to a value not much greater than 2×10^{-6} (MKS) and most existing TWTs utilize a value between 1 or 2×10^{-6} . Once the perveance is fixed, the required voltage for a given peak power may be determined.

It will be noted that if the voltage is increased, the peak and average power capabilities increase considerably. This variation is a direct consequence of the way in which the circuit dimensions are selected. Large circuits will accommodate larger amounts of thermal dissipation, and higher beam power will permit more peak RF power. At some point the peak RF power will be limited by wave guide arcing problems and voltage breakdown in the electron - gun region.

In general, for very large percentage bandwidths, the average power capability may have to be reduced as much as 50 percent.

4.4 Large Signal (Non-linear) Operation

For small signal (linear) analysis one of the assumptions made is that the space charge forces between electrons are negligible. However, under large signal conditions, the space charge field is not negligible, and in some cases may even be much greater than the circuit field.

The large signal behaviour of the TWT is difficult to predict. Any adequate theory requires a detailed non-linear analysis which is both time consuming and expensive without assurance that all important factors such as space charge, coupling parameter, loss etc., can be included correctly.

Most TWT applications require operation well into the non-linear region of the amplifier. At large signal level the gain is reduced approximately 4 to 6 dB in comparison to small signal gain. The effect of operation near saturation (maximum possible power output) for single-frequency input is to reduce the effect of change in input power on the power output or to reduce the amplitude changes as a function of frequency, compared to the small-signal amplitude response.

Operation at large-signal levels produces harmonic outputs that are typically 30 dB below the fundamental. The phase response does not deteriorate at large signals as does the amplitude response and at a single input frequency the phase increases as the input power is increased. This happens because the beam slows down as energy is exchanged with the RF wave.

A measure of this phase change with drive power is called the AM to PM conversion coefficient. Also, intermodulation is produced as a result of large signal effects and this will add noise in the frequency band of operation.

In large signal operation the field along the slow-wave structure is composed of an infinite number of components orthogonal to one another. Phase velocities of the space-harmonic fields are lower than those of the fundamental field. The electron beam will interact appreciably only with the fundamental field since the beam is approximately in synchronism with the phase velocity of the fundamental field. Consequently, the space-harmonic fields in a helix may carry power along the slow-wave structure but not contribute to the gain of the amplifier. The presence of space-harmonic fields lowers the actual helix impedance.

4.5 Noise

The noise figure of an amplifier is defined as the ratio of the total available noise output power to that part of the total available noise power output which is due solely to the noise generated by the source. The source of noise is due to thermal noise (Boltzman) which may not be solely dependent upon the noise temperature of the source, for example, when an antenna is connected to the input.

Sources of noise are: 1) from streams of electrons emitted from a temperature limited cathode (shot noise); 2) thermal noise due to temperature; 3) noise generated by the grids of the gun system (partition noise); 4) pressure; 5) anode-helix separation; 6) degrees of space charge in the gun; 7) power supply ripple modulation of tube electrodes.

In practice the noise figure may be reduced if:

1. The electrons are not allowed to be intercepted by other electrodes (less number of electrodes).
2. The beam current is constant over the beam length.
3. A strong magnetic focusing field is applied so that electrons cannot move transversely.

4.6 Millimeter-wave Tube

The TWT interaction takes place when the electron velocity is equal to the phase velocity of the wave. However, if the electron velocity is very much slower than the phase velocity of the wave, the interaction can still take place between the electrons and the first harmonic of the electromagnetic wave. In operating the amplifier in this harmonic mode rather than

the fundamental, the electron speed is reduced by a factor $(2\pi + \theta)$, (the beam voltage by the square of this factor) where $\theta = \frac{2\pi d}{\lambda}$, the phase displacement between centre of adjacent slots separated by a distance d , and λ is the wavelength in the structure.

For higher order spatial harmonics the reduction factor in the electron speed is given by $(2\pi n + \theta)$. However, there is little or no practical advantage in extending the principle of spatial harmonic beyond $n = 1$, since this would not lead to wider resonator slots for any given voltage.

In general, millimeter wave tubes utilize very low perveance electron guns which create some unusual electron beam focusing problems associated with the proper containment of the "thermal" electrons. Hence, millimeter-wave tubes have frequently been equipped with heavy solenoids. Aside from the focusing structure, the major challenge in the manufacture of millimeter-wave tube is the precision and tight tolerances required for extremely small and fragile circuit parts.

4.7 Backward-wave Amplifier

As explained earlier it is possible for the electron beam to cause the signal to build up along the structure in a direction opposite to the movement of electrons. The power flow and the electron flow are then in opposite directions, as shown in Figure 4. Therefore, backward amplification is possible. This is not a broad band phenomenon as in a normal TWT, for at any given beam voltage there is only a narrow band of frequencies over which there is substantial gain. The backward wave is inherently regenerative due to the fact that the beam interacts with oppositely directed group and phase velocities.

An important property of backward waves is that the phase velocity is a strongly-varying function of frequency. Therefore, for a given beam velocity, interaction can take place only over a narrow band of frequencies, and for a fairly weak interaction, the device acts as a narrow-band regenerative amplifier. Since the frequency at which this interaction takes place depends on the electron velocity, the amplifier can be continuously tuned in frequency by changing the beam voltage.

A careful analysis will show that as the beam loses energy to the wave, the wave tends to grow in amplitude. Since the backward wave, with which the beam is interacting, carries power in a direction opposite to the motion of the beam, the effect is for the wave to grow towards the gun end of the tube. This causes even stronger bunching of electrons, and the result is a built-in feedback of a regenerative nature. For a given physical length of the tube there is a critical beam current, called the "Starting Current" above which the regeneration is strong enough to cause the tube to oscillate at certain frequencies. Below the starting current, a signal which is introduced at the input (collector end of the tube) will be amplified if its frequency is near this value. As with all regenerative

amplifiers, the gain can be very large, but is critically dependent on beam current and signal frequency.

The large signal calculations for backward-wave interaction including space-charge effects may be compared with small signal analysis as follows:

1. At small-signal levels, the phase velocity of the circuit wave is unaffected by the presence of the electron beam even when space-charge effects are included. At large signal levels, the phase velocity of the circuit wave is only slightly altered by the presence of the beam.
2. The starting current of the backward-wave oscillator decreases initially with an increase in the output voltage amplitude when space charge effects are small. When these effects are large, the starting current increases at all times for an increase in the output amplitude.
3. The large signal gain of the backward-wave amplifier decreases with an increase in space charge effects.
4. A major part of the current is collected on a very short section of the circuit. This limits the average power capabilities of the crossed-field devices since a short section of the circuit must dissipate most of the beam power.
5. The individual electron trajectories at large signal levels differ appreciably when cases in which space charge effects have been included are compared with similar cases in which space charge effects are neglected. The shape of the bunched beam is not significantly changed.

4.8 Saturation

As the phase lag between the alternating component of the beam current and the field increases, currents which normally interact with the field to deliver power to the circuit eventually come into phase where they subtract power from the circuit. When this happens, the power on the circuit begins to fall and the tube is said to be saturated. The maximum power is obtained at this point and it is useless to allow interaction to continue beyond this condition.

The actual amount of power that can be extracted from the beam depends to what extent the bunches can be slowed down before saturation. The efficiency of the tube improves as the beam velocity is increased above the synchronous value. However, there is a limit to this process. If the beam velocity is made too high the gain falls off and eventually amplification drops. In general the beam velocity which gives maximum efficiency is higher than that which gives maximum gain.

Retardation in the phase of beam current is not the only factor causing saturation. The bunches, being a transient phenomena, have appreciable electron velocity spread which contributes to their destruction before any useful energy transfer is completed. Space charge forces also cause a debunching effect which must be taken into account.

As explained above, saturation is to some extent due to the reduction in beam velocity caused by the overall transfer of kinetic energy from the electrons to the field. This suggests that the efficiency could be improved if the circuit was modified so that the phase velocity of the circuit wave also decreased toward the output end of the tube. Then, even though the bunches lose energy to the field and are therefore slowed down, they still keep in "step" with the field and continue to deliver power to the wave. This is called "velocity tapering". In addition to increasing efficiency, velocity tapering has another important effect, that is, the beam voltage at which maximum gain and maximum efficiency occur become the same. In an untapered tube, particularly one in which space charge forces are relatively low, the beam voltage which produces the best efficiency is greater than that which produces the highest gain. If the taper is designed correctly these two voltages can be made the same, particularly in those tubes which employ highly dispersive slow wave structures.

To look at the velocity tapering another way, at the output end of the tube, where the majority of the power transfer from the beam to the wave takes place, it is desirable that the bunches should be in the maximum decelerating field so that the beam current and the wave are in phase and the power transfer between them is maximum. This can be done by increasing the beam velocity to exceed the phase velocity of the wave. However, then the bunching process suffers and gain falls off. The best bunching occurs when the beam is near synchronism with the circuit wave, but then the phase of the beam current is incorrect for power transfer.

Tapering provides one method for improving the power factor, however, it is advantageous only when space charge forces are relatively low. As the space charge increases the beam voltage for maximum gain also increases and becomes more nearly equal to that which gives maximum efficiency. Again, with large space charge, debunching tends to destroy the bunches before there is any question of them becoming "out of step" with the circuit field, due to loss of kinetic energy.

4.9 Dual Mode

A subject of serious concern to the ECM systems engineer is a dual mode TWT. The purpose of such a device is to provide two different power levels in a single amplifier with no major changes and with good efficiency for both conditions. Typically the higher power level is the pulsed mode with duty cycle requirement of 10 percent or less, and the lower power mode is CW for noise, barrage, jamming. The higher pulsed power can be accommodated by merely pulsing the grid of the electron gun with a positive signal to increase the beam current and thus the beam power. Since grid modulation can be accomplished with a relatively simple, compact, solid-state circuit, the system is quite flexible in meeting different types of radar threats with only one output TWT.

If two separate TWTs are employed rather than one, the flexibility and performance parameters can be somewhat improved. The driver is normally a CW tube, which must be more powerful than in the conventional system to overcome the insertion loss of the output tube. The overall efficiency of such a chain can be made very significant.

4.10 Modulation and Control

Amplitude or phase modulation can be produced in a travelling-wave amplifier by appropriate variation of the beam current or beam voltage. This property makes possible a number of attractive master-oscillator and power-amplifier applications.

Amplitude modulation results when the beam current is varied, usually by means of a control grid in the gun, while a constant signal level is applied at the input. Incidental phase modulation is also produced in this case, and thus the method may be limited to those applications where the RF phase is relatively unimportant.

Phase modulation occurs when the helix voltage changes, because of the change in the velocity of the beam as a function of the number of wavelengths along the tube. Since the gain of the tube depends rather critically on synchronism between the wave and the beam, the helix voltage can be changed only by a small amount before incidental amplitude modulation becomes serious.

A wide variety of combinations of amplitude and phase modulation is possible with a TWT, which allows the synthesis of practically any kind of microwave spectral distribution within the bandwidth limitations of the tube and its modulating electrodes. For example, balanced or suppressed-carrier modulation can be accomplished by amplitude-modulating with a full-wave-rectified signal, and simultaneously reversing the phase with a square-wave version of the signal applied to the helix.

Thus, the travelling-wave amplifier is an extremely flexible device for producing a wide range of different kinds of microwave signals, and is capable of accomplishing this over a large frequency range without the need for any mechanical tuning adjustments.

4.11 The Crossed-field TWT

The fundamental distinction between a crossed-field travelling-wave tube and the normal TWT lies in the arrangement of the steady electric and magnetic fields used to form and maintain the electron beam.

In a normal TWT the electrons are drawn from the cathode and are accelerated to the correct velocity by a steady, axial, electric field in the gun region. Subsequent beam spreading is prevented by applying an axial magnetic field. All this field does is to inhibit transverse motions of the electrons; it does not play any major part in the RF process. As long as it is of adequate strength to keep the transverse motions within the beam tunnel, its value is not critical.

In the crossed-field TWT Figure 5, the steady electric field is applied between two parallel electrodes, one of which is the slow wave structure. The magnetic field is applied in a direction perpendicular to the electric field. If the electrons are injected into this system with correct velocity they move in a straight line perpendicular to both electric and magnetic fields.

Although the crossed-field TWT also involves interaction between travelling waves and electrons moving at nearly the same velocity, it differs from the ordinary TWT in two principal ways. First, the means for focusing the beam uses an adjustment between crossed electric and magnetic fields. Second, the electron's loss of energy to RF fields is accomplished by the extraction of potential energy from the static electric field as the electrons propagate in the circuit. Thus, the interaction process does not extract net kinetic energy from the beam; the electrons stay in synchronism with the circuit wave to convert large amounts of potential energy into RF energy. For this reason crossed-field TWTs provide high efficiency. Power capacities of these tubes may be increased by operating at higher voltages, by improving the interaction efficiency, or by increasing the beam current.

The crossed-field arrangement has the practical advantage of providing a much more convenient magnetic field configuration. Because the magnetic field has only to be applied across the width of the tube, the air gap in the magnet is considerably less than in the case of an ordinary TWT. Therefore, less magneto-motive force is necessary and this often results in a considerable saving of weight, particularly when permanent magnets are used.

However, crossed-field systems have some drawbacks. One is that, if the high efficiency is to be realized, the slow wave structure is likely to receive much more intense electron bombardment than in an ordinary TWT, and this imposes limitations on its average power-handling capacity. Also

there is a very high noise content in the output of crossed-field TWTs and there are severe difficulties in preventing feedback and obtaining stable gain operation.

5.0 SLOW-WAVE STRUCTURES

The following sections discuss design considerations for the development of slow-wave structures for TWT applications.

5.1 Amplification Process

Travelling-wave amplification takes place when the electron velocity is approximately equal to the phase velocity of the travelling electromagnetic wave. In practice, electron velocities range from about two-thirds the velocity of light, in very high power tubes, to about one-tenth the velocity of light, in low power tubes. On the other hand, the phase velocities of an electromagnetic wave supported by normal transmission lines are usually either equal to or greater than the speed of light. Therefore, in order to make use of the property of travelling-wave amplification means must be provided to slow the propagating electromagnetic waves down to a speed equal to the velocity of electrons in the beam. It is for this situation that the use of slow-wave circuits or slow-wave structures becomes important. The purpose of a slow-wave structure is, therefore, to slow down the propagating electromagnetic wave to velocities corresponding to the electron beam velocity.

A wide variety of slow-wave structures are available; a few of these which have found practical application will be considered here.

As shown in Figure 6, slow-wave structures may be divided into two distinct groups, namely, uniform structures, like the helix, and periodic structures with filter-like properties such as the coupled-cavity arrangements.

5.1.1 The Helix

A "loaded" transmission line such as a helix is the simplest slow-wave circuit. To a first approximation the helix can be regarded as a spiral slot transmission line around which the energy propagates at approximately the velocity of light. When an electromagnetic wave is made to propagate down the helix, the fringing field adds up to give a longitudinal travelling field along the axis, expressed by,

$$E_F = E \sin \omega \left(\tau - \frac{z}{V_p} \right) \quad (4)$$

where,

E = the longitudinal electric field

ω = the radio frequency

z = the axial distance along the helix

V_p = the phase velocity of the axial field

where,

$$V_p = c \sin \psi$$

and,

ψ = the pitch of the helix

This approximation is only valid over the range of about four turns per wavelength. When a large number of turns per wavelength are used the metal between the slots tend to short out the current associated with the adjacent slots, and this will alter the propagation constants. For a helical slow-wave structure, if the frequency is not too low, the RF wave travels essentially along the wire at the velocity of the light, so that the components of its velocity along the axis of the helix is reduced by approximately the helix pitch, P , to the helix circumference. The fields inside and outside can be found by solving MAXWELL's equations.

The helix is often used as a slow wave propagating circuit in a TWT, because it is easy to construct and it can propagate a wide-band, non-dispersive, forward wave which has relatively high impedance. Based on theory and measurement the helix is far superior to any other type of propagating structure. The low power helix TWT is still the 'king of bandwidth' because it provides virtually constant phase velocity at all frequencies. The helix type TWTs have bandwidths in excess of an octave. Since the helix geometry does not involve large metallic surfaces, the stored energy for a given power level, as compared to other structures, is very low. It can produce maximum axial electric field in the region of the electron beam and it can maintain constant phase velocity (no dispersion). The helix also possesses a very manageable mode structure which is another reason for its superiority over other structures. Because of its natural uniformity it can provide a strong interaction between the electric field and the beam. This phenomenon is referred to as the circuit impedance even though it relates to the electric field which is available for interaction with the electron beam and is not the same impedance generally employed in ordinary microwave circuits. Helix type TWTs are quite capable of delivering several kilowatts of CW power at S-band and C-band over an octave of frequency coverage.

Aside from purely electrical considerations, the helix is an ideal structure from the mechanical standpoint because of its simple and precise fabrication and it can be accurately assembled in structures with minimum cost.

5.2 High Power Limitations

A helix cannot be designed to work with high voltage electron beams which is necessary for high power. The electron velocities at high voltages are very damaging for the helix, because as the helix pitch becomes coarse the RF coupling to the beam becomes poor. Therefore, the limit of helix TWTs is about 10 KV and a peak RF power output of a few kilowatts. Also at higher power levels, the bandpass characteristics of helix slow-wave structures leads to band-edge oscillation problems. Furthermore, both forward and backward waves may propagate on the RF structure, leading to the possibility of backward-wave oscillations. In order to avoid backward-wave oscillations it is necessary that the operating point of the TWTs be set around 4 turns/wavelength.

Although the helix TWT is a broad band device its relatively low power output may be explained as follows. In order to increase the power output, beam power must be increased. In order to maintain the power density in the beam at reasonable levels it is necessary to increase beam diameter which requires an increase in helix diameter. At high voltages the increased helix diameter is advantageous as far as the interaction between the beam and the travelling-waves are concerned. However, the increased diameter makes the helix an open structure and the increased velocity of electrons causes the space-charge to build up. Then the efficiency and the fundamental helix impedance will be greatly reduced and the tendency toward backward-wave oscillation increases considerably. Thus the only alternative (with a single helix) is to return to smaller helix diameters and higher power densities in the beam. Because of its limited cooling possibilities the helix is limited in the amount of power it can dissipate.

Another important practical limit is the value of the axial magnetic field required to confine the electron flow to exactly axial directions. There comes a point when this field is so high that the magnetic system needed to provide the axial field becomes uneconomical in size, weight and power consumption. Also, at longer wavelengths, the field has to be maintained over a longer length.

When the economic limit to the beam current is reached, the only way to raise the power level is to increase the voltage. As the voltage is increased the pitch angle should be increased to raise the phase velocity. Then more and more energy goes to the transverse fields which are not useful for interaction with the electron beam. As a result of this loss in energy the impedance and efficiency falls.

5.3 Other Helical Structures

a) Twin Crossound Helix

The twin, crossound helix circuit shown in Figure 7 consists of a right hand spiral of wire superimposed on a left hand spiral of the same radius. This arrangement suppresses the odd order space harmonics and the useless magnetic component of the field, so that all the energy goes into the even-order electric fields. The result is an increase in coupled impedance and for a given pitch angle the phase velocity is higher than for a single helix. This means that the crossound helix can be operated at higher voltages. However, as the crossound helix is dispersive (i.e. phase velocity varies with frequency), the bandwidth is reduced so that the TWT is only capable of maintaining synchronism over a limited range of frequencies.

b) Sheath Helix

The sheath helix shown in Figure 8 is a right circular cylinder tube which is perfectly conducting in a helical direction and non-conducting at right angles to this. The sheath helix is a perfectly smooth structure which is capable of conducting a backward mode, that is, one whose phase and group velocities are oppositely directed.

The sheath helix may be considered as a multifilar helical structure as the number of wires increases without limit while the wire size is correspondingly reduced to be equal to the wire spacing. Because of its cylindrical symmetry, waves which have exponential dependence on distance (horizontal axis) exist and these correspond to waves guided by the helix.

In a sheath helix an infinite set of modes exist characterized by different angular variations and some of these may have their phase and group velocities in opposite directions. The sheath helix can cause high dispersive characteristics under certain conditions.

One of the striking differences between a sheath helix and a unifilar helix is that the former does not have forbidden operating regions, although its impedance is relatively higher. This subject will be discussed later.

A great deal of research work has been carried out on the sheath helix. Some types are, the helix surrounded by a dielectric medium or surrounded by a metallic outer coaxial conductor or surrounded by a concentric cylinder that has finite resistance; a helix with a coincident finite resistance surface surrounded by a perfectly conducting coaxial shield and a sheath helix with or without an outer coaxial uniformly-conducting shield.

As a special case, when the pitch angle $\psi = 0$, the sheath helix becomes a sheath ring and when $\psi = 90^\circ$, the sheath helix becomes a sheath tube.

c) Tape Helix

Although the sheath helix yields much insight of scientific importance the limitations resulting from the omission of the periodic character of the helix, as well as the finite wire size, are serious. These limitations can be overcome if the tape helix, shown in Figure 9, is used. For analysis purposes the tape helix is assumed to be wound of infinitely thin conducting tape. This model restricts current flow to a tape and is a refinement of the sheath model which only restricts current flow to a preferred direction. The impedance calculated from the tape helix model is about half that obtained from a sheath helix model analysis.

As before more work has been done in this area, such as, shielded and unshielded tape helices, narrow gap tape helix, etc.

d) Bifilar Helix

In Figure 10(a) two helices, wound in the same rotary direction, are concentric and spaced axially by half their pitch. This can be regarded as a cylinder with two spiral slot transmission lines around which waves travel with constant phase velocity. The characteristics are similar to the twin crosswound helix. In the analysis one must take account of the fact that in a twin helix the electron has only to travel the half pitch length between gaps. The bifilar tape helix, Figure 10(b) has the combined qualities of the bifilar wire helix and the tape helix. The strapped bifilar helix, Figure 10(c), provides extremely wide bandwidth combined with its ability to operate at large values of the ratio of circumference to free-space wavelength. The advantage of the strapped bifilar helix compared with the simple bifilar helix lies in the suppres-

sion of the anti-symmetric mode which would otherwise cause backward-wave oscillations. A large increase in peak power may also be derived from this sort of structure.

e) Ring and Bar Contrawound Helix

Crosswound helices are more dispersive due to the finite size of the crossing points which cause periodic loading. Because they are difficult to manufacture to the high tolerances necessary, they have found little practical application. A Ring and Bar structure, Figure 10(d), is comparatively easy to manufacture. It consists of, as its name implies, a series of rings connected one to another by bars at alternate ends of a diameter. Since the cross points are now the bars, it creates even heavier periodic loading. This structure is even more dispersive than others.

5.4 "Forbidden" Zones

Under certain conditions a helix made of a single wire can radiate power into free space. When this occurs the slow waves are rapidly attenuated by radiation losses or the propagation is termed "Forbidden". The forbidden zones exist only if the helix is in free space. If it is surrounded by a conducting shield the radiation is confined by reflections from the shield and propagation without loss can occur.

5.5 Dielectric Loading

Another reason why practical helices often operate differently than their design expectations is that they have to be held in position by dielectric supports.

Such supports impose a periodic capacitive loading which lowers the impedance and decreases the phase velocity. In low power TWTs support is done by means of three glass or ceramic rods contained in an outer glass or ceramic tube which can be the vacuum envelope. In high power tubes the helix can be soldered to three vanes made of high thermal conductivity dielectric such as beryllia.

5.6 Derived Structures

Just as the helices are derived from the spiral transmission line, other types of structures can be derived from different configurations of wave guides and discs to achieve the basic required principles.

5.6.1 Folded Transmission Lines

A folded line structure consists of a zig-zag, folded, parallel plate, transmission line. In this structure the fast waves travel around the long path formed by the folded line, while the electrons take the short path through the tunnel. The folding produces a geometric phase reversal of π at each crossing, so that travelling-wave amplification takes place whenever the phase delay around the circuit differs from that along the electron beam by an odd multiple of π . The direct consequence of this geometric phase reversal produced by folding is that the fundamental slow wave for this structure is a backward wave. Therefore, this structure is ideal for backward-wave tubes. Again the presence of box walls creates a low frequency cut off.

Other variety of slow-wave structures are the ones which can operate with strip beams (interdigital line), periodically loaded wave guides, disc loaded rod, internal helical wave guide structures, slotted-ridge wave guide and apertured-disc structure. Some of which are shown in Figure 11.

5.7 Coupled-Cavity Structures

Another class of structure which can be considered is a stack of resonant cavities coupled together by apertures in their common walls to give the required bandpass characteristics as shown in Figures 12, 13 and 14. Coupled cavity structures are important because, by an appropriate choice of cavity height, they can be made to work with high voltage electron beams, that is, at very high peak power levels. Furthermore, their geometry is such that there is a good heat path away from those parts of the structure which intercept electrons.

A coupled cavity circuit is a complete departure from the helical structure both in electrical behaviour and in mechanical configuration. Because of its tremendous flexibility it constitutes the fundamental building block of an extremely important class of highpower TWTs. Its inherent superior qualities are summarized below:

1. Excellent electrical characteristics in terms of impedance, bandwidth and mode structure.
2. Mechanical simplicity.
3. Ideally suited to PPM focusing.
4. Rugged from both a mechanical and thermal point of view.
5. Very versatile; simple procedures for scaling frequency, power and bandwidth.

It is widely used from L band to millimeter waves and for power levels from 1 to 500 KW. Probably 90 percent of highpower TWTs employ this type of filter structure.

In a coupled cavity structure the coupling of the magnetic field is provided by a long slot in the wall of each cavity in such a manner that the pass-band of the circuit is primarily a function of the geometry of the slot. For small slots or holes the pass-band is quite narrow and when the slot angle is somewhat larger than 180° , the pass-band is close to its practical limit. The length of the cavity is determined by beam interaction considerations, but the optimum design for a given bandwidth is not a critical function of the gap length. In fact, all the important cavity dimensions can be adjusted over a broad range to accommodate tradeoffs between thermal requirements and electrical performances without seriously degrading the circuit capability. However, once the dimensions are set, the tolerances of the circuits dimensions must be very closely maintained.

Each half-cavity section can be fabricated in laminated form from high purity iron which is subsequently plated with copper to reduce RF losses. The iron structure channels the magnetic field in a very efficient way to the beam region where its effectiveness is maximized.

Perhaps the most outstanding advantage of the coupled cavity circuit is its natural adaptability to light weight PPM focusing. It is also relatively easy to provide channels for liquid cooling so that the TWT may be used for higher power levels.

If the slot size is fixed the bandwidth then depends on the beam voltage. As the phase change per cavity is fixed the only way to alter the phase velocity is to vary the cavity height. Therefore, if the beam voltage is to be raised the phase velocity must be increased by making the cavities higher and it is not a very practical solution. Therefore, the maximum pass-band that can be obtained from this kind of structures is less in high voltage versions than in low voltage versions. Again the chances for self-oscillation is higher due to reflection and feedback.

A number of coupled-cavity structures are described below:

The structure shown in Figure 12, consists of a series of drift tubes supported on the axis of a tube by crosspieces, but it can be considered to be a stack of cavities with two aligned holes in their adjacent walls. If the coupling holes are kept within the limitations of resonance considerations the pass-band between cutoffs is about 20% for a high (100 KV) voltage structure. At lower voltages the bandwidth is generally limited by partial resonance effects and is rarely much wider. Moreover, this structure has a backward fundamental and, therefore, must be used in the second space harmonic if it is to be a forward-wave amplifier. This also causes some stability problems.

This structure is ideally suited for application of periodic magnetic focusing.

Other forms of structures may also be used for this purpose. Examples of such structures are: rectangular, parallelogram, "hour-glass" and cloverleaf structures, Figure 15.

Cavities made in the shape of parallelograms are capable of giving larger bandwidths, when used with windows or irises which allow negative mutual inductance coupling, than are rectangular cavities at the same resonant frequency. The "hour-glass" structure shows considerable promise as a travelling-wave tube circuit, since, the bandwidth is adequate for some applications and can be improved by refinements in design.

The "cloverleaf" structure is the easiest way to obtain the desired coupling. It has been found to have considerable application, is easy to manufacture, and has high impedance, good thermal dissipation, but limited bandwidth.

6.0 THE ELECTRON BEAM SYSTEM

The second most important agent which causes amplification in the TWT is the electron beam. Basically the electron beam is produced by a gun system and the spent beam is absorbed by collectors. Means must be provided to confine the beam to a constant cross-section and this is usually done by a focusing system.

6.1 Electron Guns

The electron guns used in TWTs are generally of the Pierce type, non-converging or converging, depending on the focusing system used. Pierce's method is based on the electron flow between concentric spheres where the inner surface of the outer sphere is coated with an emissive material and the inner sphere (anode) is made positive with respect to the outer sphere (cathode). This principle is used in a practical gun but the anode is apertured for passage of the beam. The electrons originate from a cathode with a low work-function surface, typically obtained by coating nickel with a mixture of barium and strontium oxide then heating to around 800°C. Basically, the current density required in the electron beam should be considerably greater than the emission density that can be drawn from the

cathode surface. Therefore, it is necessary to make the cathode area larger than the beam area and design some method of focusing the electron flow in the gun.

The field pattern in the immediate vicinity of the aperture is assumed to act as an ideal thin diverging lens and beyond the anode, the only fields acting are those resulting from the space charge of the beam itself. The space charge fields produce a radial repulsive force which prevents the beam from achieving a point focus. Instead, the beam converges to a minimum diameter beyond the anode and then diverges again. As shown in Figure 16 immediately after passing through the anode the beam is converging towards the centre of the spheres (anode and cathodes). However, as it is now in a field-free region, and the beam begins to spread under the space charge forces and at some point M the beam will have its minimum diameter $2r_m$ (Figure 16). In low power tubes the beam is made to pass through the anode aperture covered by a fine mesh grid. One of the reasons for using mesh grid is that the aperture, without mesh grid, reduces the convergence of the beam as it passes through the anode. Thus the minimum diameter increases and the point at which it occurs will be extended.

In the gun design by Pierce the electron flow is assumed to be essentially laminar in character with no crossing of paths. The factor which most seriously limits the achievable convergence of the gun at a given perveance is the non-linearity of the electron flow, that is, electron path cross-overs.

6.1.1 Lens Compensated Guns

In the two-anode gun suggested by Pierce, Figure 17, as the electrons pass through the first anode they acquire an outward radial velocity, which, in the presence of the magnetic field, is converted into cycloidal motion. Sometime later they return to the starting radius and then have an inward radial velocity equal but opposite to those passing through the first anode. The second anode is introduced at this point and potentials are adjusted so that the diverging effect of the aperture is equal to that of the lens at the first anode. The radial velocity is then cancelled and the beam is launched with all the electrons flowing axially.

The anode focal length may be adjusted by changing anode potentials, in such a way that when the potential of the first anode (close to the gun) is increased the focal length is reduced and when the potential of the 2nd anode is increased the focal length is increased.

Since beam perturbation increases as anode potentials are altered, the lens compensation is only suitable for a fixed value of voltage and current. This is not very convenient since beam voltage needs to be adjusted. King demonstrated that this type of gun becomes much more tolerant of electrode potential variation if the transit between the two anodes is made one complete cyclotron period.

In King's gun the anode voltages and spacing can be adjusted so that the two lenses are of opposite sign. The opposite polarities of the lenses are used in such a way that, within a whole cycle between the lenses, altering the potential at one lens modifies the strength at the other in a compensating manner and substantially a parallel beam may be produced.

The gun described above works quite well for a perveance up to 1×10^{-6} . Above this value the effect of the ungridded anode aperture is used to reduce the actual perveance obtained in practice.

Anode and cathode spacings may be reduced to increase the perveance. Thus, the reduction due to the anode aperture can completely offset the increase otherwise to be expected from the closer spacing. Then no further increase in perveance can be obtained by bringing the anode closer to the cathode

6.1.2 Anode Projection - Müller's Principle

To overcome this limitation, Müller suggested an anode tube projecting into the focus electrode toward the cathode, Figure 18.

Although this modification helped to increase the perveance, it produced serious non-uniformity in the current distribution, both in the final beam and at the cathode surface.

6.1.3 Anode-lip Gun (Mathias and King Version of Müller Gun)

Mathias and King designed guns based on Müller's principles but modified for high voltage as summarized in Figure 19. The effect of anode-lip is to draw current predominantly from an annulus of the cathode. The weak field on the axis causes the electrons from the centre of the cathode to diverge and eventually cross-over to form the outside of the beam. These effects might be reduced by making the cathode some shape other than the cap of a sphere and also by having a suitably shaped magnetic field in the cathode-anode region.

6.1.4 Hollow Beam Gun

Although, in principle, it should be possible to extend Pierce's principle to the design of hollow beam guns, in practice there are many difficulties. The real difficulty starts when it is necessary to build a convergence system with the gun as it is difficult in maintaining the hollow beam. This will be discussed further in a later section.

7.0 THE BEAM AND THE FOCUSING SYSTEM

Generally TWTs require a long electron beam of constant cross-section. But because of the mutually repulsive forces between electrons, the tendency of the beam is to spread within the structure ruining the possibility of maximizing or optimizing the key parameters of the TWT.

One method of suppressing the beam spreading is by applying a strong uniform magnetic field in the direction of the beam. Another method is by employing a series of magnetic or electrostatic electron lenses which periodically converge the beam to a required diameter.

7.1 Magnetic Field Parallel to the Axis

When a strong magnetic field is applied in the direction of the electron flow the space charge forces, which causes the beam spreading, act against the magnetic field which in turn forces the beam to become confined into some desired cross-section. As a result a "scalloped" profile is developed as shown in Figure 20.

When the beam is acted upon by a magnetic field, there is a minimum amount of field that can confine the beam to the desired diameter. Under this condition the beam current is called Brillouin flow, and the minimum field is often referred to as the Brillouin field for the beam. A typical arrangement for obtaining Brillouin flow is shown in Figure 21. A parallel beam of electrons is formed by purely electrostatic means and injected into the magnetic field through a hole in a soft iron pole piece before appreciable spreading under space charge forces can occur.

Unfortunately, Brillouin flow works only if the current density in the beam remains constant. This is not true in the case of power tubes, since the large RF currents cause local increases in the current density by two or three times. The beam then expands to about twice its radius and may collide with slow-wave structures. Also, in practice, the space charge effects are very unpredictable due to the presence of positive ions which neutralize the electron space charge causing periodic contractions in the beam. For these reasons Brillouin flow is seldom used in TWTs.

In an attempt to avoid or minimize these effects, it is required to work with magnetic fields considerably above the Brillouin value. Also it is necessary that a design be achieved where the cathode is linked by a correct amount of flux and it must, therefore, be partially shielded from the field. However, when fields higher than the Brillouin value are used the outer electrons travel faster than the inner ones, producing annular shearing of the beam. Electrons may be made to start from different radii in order to compensate this effect.

Correct flux linkage on the cathode may be achieved by means of making final adjustments on a "bucking coil" as shown in Figure 22.

Beam control electrodes are used either as an on-off switch for the beam or to adjust beam current independent of beam voltage. A basic difficulty is that the adjustment of the control electrode voltage from the design value will not only change the total beam current but will also alter the shape of the electron trajectory within the gun. This will in general, result in beam scalloping and beam interception on the circuit. This difficulty increases at higher convergences and perveances.

One of the common types of control electrodes is shown in Figure 23. If the focusing electrode of a solid beam gun is biased sufficiently negative with respect to the cathode, the beam current may be reduced to zero. To avoid significant interception, the focus electrode must not exceed the cathode potential during the beam on-time. However, this beam control device is essentially an on-off switch and cannot be used to adjust beam current because of serious defocusing of the beam trajectories when the focus electrode voltage substantially differs from the cathode voltage. The interelectrode capacitance is somewhat higher because of the close proximity of the control electrode to the anode.

The most significant development in recent years is the introduction of the non-intercepting gridded gun. This technique uses two, closely spaced, aligned grids, one near the cathode at cathode potential, and the other slightly removed and at a positive potential. The first, or shadow grid, suppresses electron emission from those portions of the cathode which would give rise to interception at the second or control grid. This approach has been used for tubes at various power levels.

Two other forms of non-intercepting gridded guns are: 1) high transparency, spider web patterned, grids near a smooth cathode and; 2) lower transparency grids having many round apertures each drawing current from a corresponding diopole in the shaped cathode surface.

7.2 Beam Focusing

Most tubes require a relatively long and thin beam. A length-to-diameter ratio of 100 is not unusual. At higher power levels near perfect beam transmission (over 90%) is required, but for very low duty cycle beam transmission as low as 60% can be tolerated. The space charge spreading effect, for a drifting beam, becomes appreciable in a drift distance of about 1 beam diameter and completely limits beam transmission beyond about 5 diameters in the absence of a focusing system.

The basic types of beam focusing system use uniform axial magnetic fields, periodic magnetic fields, or periodic electrostatic fields.

The magnetic field used to confine the electron beam may be generated either by an electromagnet or by a permanent magnet. If the field strength of the magnet is not kept to a constant value, and the general direction of the field is not aligned with the axis of the TWT, the initial component of the electron velocity at right angles to the direction of the field may be converted into a spiralling motion.

7.2.1 Uniform Magnetic Field

Ordinarily, the focusing magnetic field is derived from a long solenoid which has iron shielding around the outside diameter and pole pieces with small apertures for the beam at both sides. The magnetic field strength used is generally between 200 to 3000 gauss, but sometimes as high as pole pieces magnetic materials will permit, such as, in the neighbourhood of 10,000 gauss for high frequency tubes. Wire wound solenoids are least expensive. Size, weight, and power requirements can be reduced by increasing the packing factor of the conductors. In cases where weight and power savings are of extreme importance, such as in airborne applications, foil solenoids wound directly on the tubes have been used successfully.

One of the difficult tasks is to produce a distortion free (uniform) magnetic field. Two common problems are shown in Figure 24.

Unless the pole piece area is large compared with the spacing there will be considerable bowing of the field lines. Unfortunately, large area pole pieces lead to high fluxes and very massive magnets.

Pole pieces may be made in appropriate shapes in order to minimize bowing, as shown in the C-magnet, Figure 25.

A better arrangement is to employ a combination of solenoid and pole pieces Figure 26. The pole pieces act like magnetic mirrors, effectively extending the solenoid to infinity. However, even the highest-purity soft iron is not a very good "reflector" and it is usually necessary to boost the current at the ends of the solenoid to avoid field distortion.

Cooling must be provided for most electromagnets. For fields up to 400 to 500 gauss forced air cooling is generally sufficient, but for higher fields, liquid cooling is usually necessary. Some foil-wound magnets, however, have been made to work with air cooling in the 1000 to 2000 gauss region.

Many tubes requiring only a short interaction region may be focused with a permanent magnet. The end pole pieces of such tubes are joined by external permanent magnets. A cylindrical "pot" permanent magnet closed at each end by soft iron plates may be used in some cases, as shown in Figure 27.

For higher fields a barrel-shaped magnet with re-entrant pole pieces can be designed. However, as the length of the magnetic material is increased, the leakage flux rises and the cross-section has to be increased. However, the weight of the magnet will soon topple the advantage in field strength obtained.

Although the magnet power and cooling requirements have been eliminated by using permanent magnets they are heavier than comparable solenoids by at least a factor of 2. However, the advent of samarium cobalt will now permit a substantial reduction in the weight of the permanent magnet.

7.2.2 Periodic Permanent Magnet (PPM) Focusing

PPM focusing is achieved by a series of magnetic lenses. The beam is focused within each lens and spreads from space charge repulsion between the lenses. As the spacing of the lenses is increased from zero, the necessary lens strength first rises and then falls. However, the farther apart the lenses, the greater the variation in beam diameter.

The periodic magnetic field is usually obtained by stacking pole pieces alternately with axially magnetized ring magnets as shown in Figure 28. The ring magnets are generally made of high coercive force magnetic material. An alternative configuration is the radial PPM structure, which employs radially magnetized sectors of rings at the outer diameter of the pole pieces and an iron outer sleeve to provide a magnetic flux return path. This design requires magnets with a high flux-carrying capacity, and since the focal length of the lenses depends only on the magnitude of the field and not its direction field reversals are immaterial. On the other hand, reversing the field greatly reduces the leakage field. Thus the magnets may be made much smaller in cross-section with a considerable saving of weight (sometimes more than 10 times). It is this feature that gives PPM the advantage over non-PPM focusing.

Converging magnetic lens focusing, Figure 29, was initially used in helix TWTs and subsequently has found application in high power coupled cavity TWTs.

Recent improvements in magnetic materials have increased the ease of providing PPM focusing. The older Alnico (aluminium-nickel-cobalt alloy) and barium ferrite magnets have been superseded by Alnico 8 and Alnico 9 which have higher flux carrying capabilities, lower temperature coefficient, and higher coercive forces. (Samarium cobalt has four times the magnetomotive force of Alnico 9, per unit length of magnetization.)

One drawback of PPM focusing is that the beam is not well focused for voltages below operating value. This may create tube body dissipation problems in cathode-pulsed tubes during pulse rise and fall times.

7.2.3 Periodic Electrostatic Focusing (PEF)

Periodic focusing may also be produced by a series of electric lenses. A system of alternating positive and negative lenses of equal strength can be used to focus the electron beam.

Some of the reasons why PEF has failed to find universal acceptance are difficulty of analysis, fundamental limitations of capability to focus, and the relative complexity of tube construction. Unlike PPM focusing, the beam is focused equally well at all beam voltages because electrostatic trajectories depend only upon the geometry of electrodes as long as all voltages are held in proportion.

An important limitation to achieve high power and high frequency operation is voltage breakdown between lens electrodes and the tube body.

7.3 Collectors

The collector is an electrode used to absorb the spent beam and the residual energy of electrons. In low-power tubes the design of the collector rarely presents any problem, but in high-power tubes it is essential to ensure that the power dissipated over any area on the collector surface does not exceed the safe limit for the material and the cooling system.

It is usual to remove the beam-confining magnetic field by passing the electrons into the collector through a hole in a soft-iron pole piece. The beam after entering the collector entrance spreads, in the absence of a magnetic field, under the influence of its own space charge effect.

In beams having smooth flow at fields above Brillouin the electrons acquire angular velocity upon leaving the confining field and subsequent beam spread will be faster. For this reason cylindrical pot collectors, shown in Figure 30, are designed to collect some of the beam current on the side walls.

The size of the collector is determined by both average and peak power. Average dissipation density is normally limited to about 1 KW/Cm^2 . Since beam interception in the collector is quite non-uniform, the surface area must be several times larger than that determined by average collector power. For pulsed tubes, the temperature rise during the pulse may become a limiting factor. Two problems must be guarded against, namely, surface melting during the pulse and cyclic stress in the material caused by expansion and contraction during pulsing. These phenomena are particularly important for tubes in the megawatt range.

7.3.1 Depressed Potential Collectors

In order to increase overall tube efficiency, it is frequently advantageous to collect the spent beam at a voltage below the interaction structure voltage. Since electrons of various energy classes are present, this is done most efficiently by segmenting the collector and biasing each portion at a different voltage. The amount of permissible voltage depression is determined by the velocity distribution in the spent beam, which differs from one device to another. The depressed collectors, Figure 30, are mostly used on TWTs which have a lower interaction efficiency (from 20 to 30 percent). Typically, using a single-stage collector, 40 percent depression can be achieved in a high average power device, and 50 percent depression at the lower power levels. Collector insulation, therefore, must be substantial. The amount of depression is ultimately linked by the returned electrons from the collector, which cause heating of the interaction structure and provides HF feedback.

These returning electrons (secondary current) may be suppressed by fitting a plate, with an aperture just large enough to pass the beam, across the mouth of the collector as shown in Figure 31. A tilted plate is used to collect the electrons that are turned back.

Finally it should be noted that the collector depression only allows the D.C. power input to a tube to be reduced. It does not allow the RF output to be increased since to do this it would be necessary to increase the beam power, and presumably this is limited by other considerations.

7.3.2 Methods of Cooling

For typical linear-beam tubes, from 50-80 percent of the D.C. input power is converted to heat. Substantial cooling of components must, therefore, be provided if the average power is high. Although most of the cooling is required in the collector, some cooling is also necessary for the interaction structure because of its heating by intercepted beam current and RF losses.

Cooling is accomplished by convection, conduction, forced air, vapor phase and heat pipe, and forced-flow liquid, in the order of increasing dissipation density requirements.

Convection and conduction cooling are limited to devices of a few hundred watts RF power output. Forced air, however, is used extensively up to several kilowatts level. Air cooled collectors are usually larger than water-cooled collectors because of the lower tolerable power density and larger fans.

Forced-flow liquid cooling is by far the most commonly used system for high power linear-beam tubes. Although water is preferred as the cooling medium various concentrations of ethylene glycol solutions are used for low-temperature environments, and hydraulic fluids such as silicone oils are used for airborne applications.

Vapour phase cooling takes advantage of the latent heat of water evaporation by allowing it to boil at the collector surface. The steam is then condensed in a heat exchanger and returned to the collector, forming a closed system. Vapour phase cooled collectors have found application in tubes up to the 50 KW output level.

8.0 MATHEMATICAL FORMULATION OF TWT

In order to obtain some theoretical understanding about the behaviour of the TWT a number of assumptions are necessary to simplify the analysis. Using small signal analysis the equations governing the

electron flow can be linearized by deleting certain quantities which are negligible and a wave type solution can be achieved.

Some of the main simplifying assumptions used to arrive at a solution are:

- a) Electrons in the electron flow are acted on by the same AC field when the diameter of the electron beam is small (constant axial field).
- b) Electrons are displaced in the axial direction only, (no transverse motion of electrons).
- c) The attenuation in the slow-wave structure and the effect of space charge are neglected, (lossless circuit).

If one considers that the signal current in the circuit is the result of the distributed electron stream acting on the circuit and the disturbances on the electron stream is the result of the fields of the circuit acting on the electrons, the problem can then be divided into two parts.

- i) The Circuit Problem - to find the field acting on the beam in terms of the driving current supplied by the beam.
- ii) The Electronic Problem - to find the current in the beam in terms of the field acting on the beam.

Overall behaviour of a TWT may be obtained by combining the solutions of these two parts.

The mathematical model for the small signal operation of a TWT can be developed from the work of Grittins and Pierce. In a travelling-wave tube both the voltage and the current converge to the same rate of exponential growth and reach a constant phase difference. This suggests that the travelling-wave amplification can be expressed in terms of a wave equation of the form.

$$A_n \exp(j\omega t - \Gamma_n Z)$$

where Γ_n is the complex propagation constant.

The equivalent circuit used by J.R. Pierce has distributed series inductance L and shunt capacitance C with current I and voltage V , as shown in Figure

32(a). Because the charge density in the electron beam at any point varies periodically with time it induces a current J , in the capacitors given by,

$$J = \frac{\delta \rho}{\delta \tau} dz \quad (5)$$

where ρ is the AC component of the charge per unit length.

However, conservation of charge states that,

$$\frac{\delta \rho}{\delta \tau} = - \frac{\delta i}{\delta z} \quad (6)$$

From (5) and (6)

$$J = - \frac{\delta i}{\delta z} dz \quad (7)$$

From Figure 32(b) and (c) we get

$$\frac{\delta v}{\delta z} = - j\omega LI \quad (8)$$

$$\frac{\delta I}{\delta z} = -(j\omega CV + \frac{\delta i}{\delta z}) \quad (9)$$

Since all quantities vary as $\exp(j\omega t - \Gamma z)$ equations (8) and (9) may be written as

$$\begin{aligned} \Gamma V &= j\omega LI \\ \text{and } \Gamma I &= j\omega CV - \Gamma I \end{aligned}$$

Eliminating I , we get

$$V = - \frac{j\Gamma \omega Li}{\Gamma^2 + \omega^2 LC} \quad (10)$$

Assuming that the electrons pass very close to the slow-wave structure, the field E acting on the electrons is given by

$$E = -\frac{\delta V}{\delta Z} = -\frac{j\Gamma^2\omega Li}{\Gamma^2 + \omega^2 LC} \quad (11)$$

The total convection current must be equal to the total charge density times the total velocity.

$$(I_0 + i) = \mu_0 (\rho_0 + \rho) + v(\rho_0 + \rho) \quad (12)$$

where μ_0 is the average beam velocity

ρ_0 is the average charge per unit length

v is the AC component of the electron velocity

ρ is the AC component of charge per unit length

I_0 is the DC beam current (negative per electrons beam)

Neglecting the product terms of AC quantities equation (12) reduces to

$$i = \mu_0 \rho + v\rho_0 \quad (13)$$

Since we are interested in small signal analysis we only want to deal with linear differential equations. Therefore, we can replace the differentiation with respect to time by multiplication by $j\omega$ and differentiation with respect to distance by multiplication by $-\Gamma$. Thus, the conservation equation (6) becomes.

$$j\omega\rho = \Gamma i$$

$$\text{or} \quad \rho = \frac{j\Gamma i}{\omega} \quad (14)$$

Substituting equation (14) in equation (13)

$$i = \frac{\omega \rho_0 v}{\omega + \mu_0 j \Gamma} \quad (15)$$

Electron velocity v is a function of electron mass m , and the electron charge e .

The time rate of change of velocity is equal to the charge-to-mass ratio times the electron gradient.

$$\frac{d(\mu_0 + v)}{dt} = \frac{e}{m} \frac{\delta V}{\delta Z}$$

Under small signal conditions, the AC velocity v can be shown,

$$v = - \frac{\frac{e}{m} \Gamma V}{j\omega - \Gamma \mu_0} \quad (16)$$

Substituting equation (16) in equation (15) we get

$$i = \frac{j I_0 \beta \Gamma V}{2 V_0 (j\beta - \Gamma)^2} \quad (17)$$

$$\text{where } \beta = \frac{\omega}{\mu_0}, \quad I_0 = \rho_0 \mu_0 \quad \text{and} \quad \mu_0^2 = 2 \frac{e}{m} V_0$$

where V_0 is the D.C. beam voltage.

Equations (10) and (17) involve both V and i and, therefore, combining them we get the overall equation.

$$\frac{j I_0 \beta \Gamma^2 \Gamma_1 Z_0}{2 V_0 (j\beta - \Gamma)^2 (\Gamma^2 - \Gamma_1^2)} = 1 \quad (18)$$

where Z_0 is the characteristic impedance = $\sqrt{\frac{L}{C}}$

and $\Gamma_1 = j\omega\sqrt{LC}$, the natural propagation constant.

Equation (18) applies for any electron velocity, specified by β and any wave velocity and attenuation, specified by the real and imaginary parts of the propagation constant Γ .

Equation (18) contains the fourth power of the propagation constant Γ and, therefore, this suggests that the travelling-wave amplification may be expressed by four waves.

A complete analysis of this fourth power equation will reveal:

- a) one wave which is increasing, travelling slower than the beam;
- b) second one which is decreasing, travelling slower than the beam;
- c) third one which is unattenuated, travelling faster than the beam;
- d) the fourth one which is an unattenuated wave, travelling backwards.

In the forward direction, there is a cumulative interaction between waves and electrons because both are moving at about same speed and the increasing wave becomes dominant. The wave travelling against the electron flow is less affected because the wave and electrons are moving in opposite directions.

Two physically significant parameters are the power flow in the circuit and the electron field associated with it which acts on the electron stream. In terms of the magnitude of the voltage the magnitude of field is given by, $E = IV$.

The power flow in the circuit is given, in terms of circuit voltage, by

$$P = \frac{V^2}{2Z_0} \quad (19)$$

$$\text{Therefore, } Z_o = \frac{E}{2\Gamma^2 P} \quad (20)$$

8.1 Travelling-wave Tube Gain

The most valid relationship between gain and power output is given by Pierce. It can be seen that the process of calculation of gain is rather complex and involves large number of parameters.

For the case of a no-loss circuit and an electron velocity equal to circuit phase velocity, the three forward waves are set up with equal voltages, each given 1/3 of the applied voltage.

$$\text{That is } V = V_1 = V_2 = V_3 \quad (21)$$

$$\text{and } V_1 = V_2 = V_3 = \frac{V}{3} \quad (22)$$

where V is the total beam voltage at distance $Z = 0$. If V_z is the voltage at distance Z , the gain can be expressed as

$$G = 20 \log \frac{V_z}{V} \quad (23)$$

Expanding this concept, Pierce suggested the fundamental equation for gain

$$G = (A + BCN) \text{ dB} \quad (24)$$

where A is the loss in initiating the amplified wave (approx. 10 db)

B is the factor depending mainly on the exact relation of the beam to the circuit velocities

C is the gain parameter

N is the number of active wavelengths in the tube.

The quantity C is related to the characteristic impedance, Z_o , and the beam impedance by,

$$C^3 = Z_o \frac{I_o}{4V_o} \quad (25)$$

$$\text{or } C^3 = \left(\frac{1}{2} \frac{E}{\Gamma^2 P}\right) \left(\frac{1}{2} \frac{I_o}{V_o}\right)$$

Therefore, C^3 is the circuit impedance times $\frac{1}{2}$ the beam impedance.

8.2 The Effect of Space Charge

In deriving the above equations one of the assumptions made was that the effect of space charge in the system was negligible. However, in practice there is an additional force on the electrons due to their mutual repulsion, and this can be accounted for in terms of a space charge field. Pierce suggested that the effect of space charge could be represented by a coupling capacitor between the beam and the circuit as shown in Figure 33.

The space charge field is $-\frac{j\Gamma_1^2}{\omega C_1}$ where C_1 is a new parameter which has the dimensions of capacity per unit length. If the current through this capacitor is $-\frac{\delta i}{\delta z}$ or $\Gamma_1 i$; then the voltage dropped across the capacitor is $-\frac{j\Gamma_1}{\omega C_1}$

$$\text{The equivalent voltage acting on the beam, } V_o = V - \frac{j\Gamma_1}{\omega C_1} \quad (26)$$

where V is the circuit voltage.

$$\begin{aligned} \text{The total field acting on the electron, } E_1 &= -\frac{\delta V}{\delta z} \\ &= \Gamma V - \frac{j\Gamma_1^2 i}{\omega C_1} \quad (27) \end{aligned}$$

Now equation (10) can be rewritten in terms of Γ_1 , and Z_o , as

$$V = -\frac{\Gamma \Gamma Z_o i}{(\Gamma^2 - \Gamma_1^2)} \quad (28)$$

Similarly equation (11) becomes

$$E = -\frac{\Gamma^2 \Gamma Z_o i}{(\Gamma^2 - \Gamma_1^2)} \quad (29)$$

Thus equivalent voltage, equation (26), and total field, equation (27), becomes.

$$V_1 = \left[\frac{\Gamma \Gamma_1 Z_0}{(\Gamma_1^2 - \Gamma^2)} - \frac{j\Gamma}{\omega C_1} \right] i \quad (30)$$

and

$$E_1 = \left[\frac{\Gamma^2 \Gamma_1 Z_0}{(\Gamma_1^2 - \Gamma^2)} - \frac{j\Gamma^2}{\omega C_1} \right] i \quad (31)$$

Equation (18), the overall equation, may be modified as

$$\frac{j I_0 \beta \Gamma}{2V_0 (j\beta - \Gamma)^2} \left[\frac{\Gamma \Gamma_1 Z_0}{(\Gamma_1^2 - \Gamma^2)} - \frac{j\Gamma}{\omega C_1} \right] = \dots \quad (32)$$

Equation (30) may be simply written as

$$V_1 = V - V_s$$

where V is the voltage due to the space charge. The terms in the bracket of equation (30) represent impedance. If the wavelength of the impressed current is long or if the wave is faster than the natural phase velocity of the circuit, the inductance has a higher impedance than the shunt capacitance to ground; the capacitive effect predominates and the circuit impedance is capacitive.

8.3 The Helix as a Spiral Slot Transmission Line

As discussed earlier, the helix can be regarded as a spiral slot transmission line, around which the energy propagates at approximately the velocity of light. The longitudinal travelling field on the axis is of the form,

$$E \sin \omega \left(t - \frac{z}{v_p} \right) \quad (33)$$

The phase velocity of the axial field is given by $v_p \approx c \sin \chi^*$ where c is the velocity of light and χ is the helix pitch angle.

The radial propagation constant γ is defined by

$$\gamma^2 = \beta^2 - \beta_0^2 \quad (34)$$

where $\beta = \frac{\omega}{v_p}$ and $\beta_0 = \frac{\omega}{c}$ from which,

$$\frac{v_p}{c} = \frac{\beta_0}{\beta} \quad (35)$$

β_0 is the phase constant of the wave travelling with the speed of light, which would vary with distance in the z direction as $\exp(-j\beta_0 z)$. The actual phase constant, β , varies with distance as $\exp(-j\beta z)$.

8.4 Phase Velocity and Group Velocity

The velocity of the axial field of a helix of pitch angle χ is given by

$$v_p \approx c \sin \chi \quad (36)$$

On a ω - β diagram (frequency-phase diagram) the phase velocity at any point is the slope of the line joining that point to the origin, as

*This approximation is valid over the range around four turns per wavelength where helices are normally operated. It ceases to be valid when there are large number of turns per wavelength.

$$v_p = \frac{\omega}{\beta} \quad (37)$$

The electron beam can be represented by a straight line through the origin, whose slope is the beam velocity. Where this line cuts the frequency-phase characteristic, the beam and natural circuit wave velocities are equal and conditions are right for synchronous operation.

The slope of the frequency-phase characteristic is given as the group velocity, V_g

$$V_g = \frac{d\omega}{d\beta} \quad (38)$$

Group velocity is the velocity at which the energy travels in the slow-wave structure. It is the velocity with which the group of frequency components, making up the pulse, travel down the circuit. It is the propagation velocity of the energy stored in the electric and magnetic fields of the circuit.

Figure 34 shows a radio frequency pulse varying with time as $f(t)$. The envelope varies with time as $F(t)$. The pulse may be produced by modulating a radio frequency source with $F(t)$.

Mathematical analysis show, if a pulse envelope, as shown in Figure 34, is applied at the input, the output will be of the same shape as the input, but arrives a time τ later, where

$$\tau = \frac{d\beta}{d\omega} \ell \quad (39)$$

when ℓ is the length

This implies that it travels with a velocity V_g , where,

$$V_g = \frac{\ell}{\tau} = \frac{d\omega}{d\beta} \quad (40)$$

Since $V_p = \frac{\omega}{\beta}$, the group velocity V_g may be derived as follows. Rearranging the equation for phase velocity, we get

$$\beta = \frac{\omega}{V_p} \quad (41)$$

Differentiating

$$\begin{aligned} \frac{d\beta}{d\omega} &= \frac{1}{v_p} - \frac{\omega}{v_p^2} \frac{dv_p}{d\omega} \\ &= \frac{1}{v_p} \left(1 - \frac{\omega}{v_p} \frac{dv_p}{d\omega} \right) \end{aligned} \quad (42)$$

from (40),

$$\begin{aligned} \frac{d\omega}{d\beta} = v_g &= \left[\frac{1}{v_p} \left(1 - \frac{\omega}{v_p} \frac{dv_p}{d\omega} \right) \right]^{-1} \\ &= \frac{v_p}{\left(1 - \frac{\omega}{v_p} \frac{dv_p}{d\omega} \right)} \end{aligned} \quad (43)$$

For interaction of electrons with a wave to give gain in a TWT, the electrons must have a velocity near the phase velocity v_p . Hence, for gain over a broadband of frequencies, v_p must not change with frequency and if v_p does not change with frequency then, $\frac{dv_p}{d\omega} = 0$ and $v_g = v_p$.

8.5 Coupled-Cavity Structures - A Lumped Circuit Model

The general behaviour of coupled-cavity structures may be studied by analysing its lumped circuit analogy. This approach is much easier than using Maxwell's equation which becomes very difficult due to the complicated boundary conditions imposed by the geometry of the structures.

The Chodorow-Nalos structure, discussed earlier, may be represented by its lumped circuit shown in Figure 35. Each cavity can be represented by a resonant circuit made up of a condenser C_1 , and an inductance L_1 , so that the resonant frequency, ω_c is given by:

$$\omega_c = \frac{1}{\sqrt{L_1 C_1}}$$

The coupling slots between adjacent cavities are represented by a parallel circuit made up of C_2 and L_2 . Thus the slot resonant frequency ω_s ,

$$\omega_s = \frac{1}{\sqrt{L_2 C_2}}$$

The circulating current in each cavity can be divided into three parts, one which links the coupling slot to the previous cavity, another which links the coupling slot to the following cavity and the third one with no linkage. This has been represented by splitting L_1 into the parallel structures of magnitude $\frac{2L_1}{k}$, $\frac{2L_1}{k}$, $\frac{L_1}{(1-k)}$ where k is the fraction of the coupling current which takes part in the coupling. These are shown in the lumped circuit model, Figure 35(a). This circuit may be reduced to the basic cells shown in Figure 35(b).

The values of Z_A , Z_B and Z_C are shown below, where,

$$Z_A = \frac{2j\omega L_1}{k}$$

$$Z_B = \frac{2j\omega L_1}{1 - k - \omega^2 L_1 C_1}$$

$$\text{and } Z_C = \frac{j\omega L_2}{1 - \omega^2 L_2 C_2}$$

It is suggested that the reader consult Gittins for a thorough discussion of this subject.

8.6 Hollow Beams

The physical size of the TWT tends to be inversely proportional to the centre frequency. The use of hollow electron beams provides much higher values of total perveance thereby offsetting the requirement for a larger tube size. Typical hollow beams used in VHF tubes have perveances of the order of 100×10^{-6} as compared with typical high frequency solid beam tube perveance of the order of 1×10^{-6} . The results of operation at these high values of perveance is the possibility of using much lower beam voltage for a given beam power that can be used in low perveance tubes. The gain of the TWT in dB is proportional to the number of wavelengths in the tube at the electron velocity and to gain per wavelength. The gain

per wavelength is increased by increasing the beam perveance and the wavelength is decreased as the voltage is decreased, so both factors favour a shorter tube when perveances are increased.

The bandwidth and the gain may be increased, as the frequency is increased, if the thickness of the beam is increased. However, as the current in a thick hollow beam is increased, the potential of the inner electrons is depressed in comparison with the potential of the outer electrons, as a result of an increasing space charge in the beam.

Under certain conditions hollow beams become unstable in that the beam breaks up into separate beams. In the presence of the magnetic field the excess charge produces a displacement of the nearby electrons. As the beam current is increased from a very low value the initially circular trace departs from circular symmetry, both in shape and brightness. Further increase causes the beam to curve away in a number of places, eventually forming a separate beam. The number of beams depends on the current density and the magnetic field.

Electrostatic focusing methods may be used in order to completely eliminate the magnetic field in the circuit region of the tube. This method is uniform in contrast to the various periodic focusing systems and is advantageous for certain applications. See Figure 36 for gun designs.

The interaction impedance of a lossless helix is given by

$$Z_0 = \frac{E^2}{2\beta^2 P}$$

where E is the electric field in the direction of beam velocity.

$$\beta = \frac{\omega}{V_p}, \quad V_p \text{ being axial phase velocity of the wave}$$

$$\beta = \frac{\omega}{c}, \quad c \text{ being the velocity of light}$$

$$P = \text{power transmitted for a field } E$$

$$\gamma^2 = \beta^2 - \beta_0^2$$

For a hollow beam at a radius r_0 , (Figure 37), the impedance at r_0 is given by

$$Z_o = \frac{30}{\beta_o r_o} \left[\frac{\gamma}{\beta} \right]^3 e^{-2\gamma(a-r_o)}$$

where 'a' is the radius of the helix.

For voltages, below 10 Kv, $\beta \gg \beta_o$ and γ and β may be used interchangeably.

$$\begin{aligned} \text{Thus } Z_o &\approx \frac{30}{\beta_o r_o} e^{-2\gamma(a-r_o)} \\ &\approx \left(\frac{c}{v} \right) \frac{30}{\gamma r_o} e^{-2\gamma(a-r_o)} \end{aligned}$$

9.0 CONCLUDING REMARKS

The TWT is a 'mature device' and no major break-through in its technology is anticipated. However, there is ample room for improvements practically in every aspect of TWT parameters.

Because of the high power, and increased bandwidth requirements, radar and electronic countermeasures are turning their attention more and more to TWTs. TWTs have also penetrated deep into Communications Satellite Technology.

The use of the computer in simulating and analysing TWT parameters will be a key factor for future improvements. A good example of this is the development of a large signal computer program to study the beam-circuit interaction in the 200w TWT used for the Communications Technology Satellite.

As power level increase and high frequency bands become more attractive, TWTs will remain unchallenged in years to come.

REFERENCES

1. A. Staprans, E.W. McCune and J.A. Vuetz "High Power Linear Beams Tubes". Proceedings of the IEEE, Vol. 61, No. 3, March 1973.
2. J.T. Mendel "Helix and Coupled-cavity Traveling-Wave Tubes". Proceedings of the IEEE, Vol. 61, No. 3, March 1973.
3. F.N.H. Robinson and R. Kompfner, "Noise in Traveling-Wave Tubes". Proceedings of the IRE, August, 1951.
4. D.G. Dow, "Behavior of Traveling-Wave Tubes Near Circuit Cut Off". IRE Transaction on Electron Devices, July 1960.
5. M. Chodorow and R.A. Craig, "Some New Circuits for High-Power Traveling-Wave Tubes". Proceedings of IRE, August 1957.
6. D.A. Dunn, "Traveling-Wave Amplifiers and Backward-wave Oscillators for VHF". IRE Transactions on Electron Devices, July 1957.
7. J.R. Pierce, "Instability of Hollow Beams". IRE Transactions on Electron Devices. October 1956.
8. C.B. Crumby, "A VHF Traveling-Wave Amplifier Tube Employing an Electrostatically Hollow Beam". IRE Transactions - Electron Devices, January 1956.
9. H. Sobol and J.E. Rowe, "Theoretical Power Output and Bandwidth of Traveling-Wave Amplifiers". IRE Transactions on Electron Devices, April 1960.
10. D.J. Connolly and T.A. O'Malley, "A Contribution to Computer Analysis of Coupled-Cavity Traveling-Wave Tubes". IEEE Transactions on Electron Devices, Vol. ED. 24, No. 1, Jan. 1977.
11. D.A. Watkins and D.G. Dow, "Strapped Bifilar for High-Peak-Power Traveling-Wave Tubes". IRE Transactions on Electron Devices, January 1959.
12. D.C. Buck, "Traveling-Wave Tube Interaction Circuit". Correspondence, IEEE Transactions on Electron Devices, October 1967.
13. S.E. Webber, "Calculation of Wave Propagation on a Helix in the Attenuation Region". Presented at 1953 West Coast IRE-AIEE Conference on Electron Tube Research.
14. W.H. Watson and J.R. Whinnery, "Study of a Plane Short on a Shielded Helix". IRE Transaction - Electron Devices, October 1955.

15. R.W. Gould, "A Coupled Mode Description of the Backward-Wave Oscillator and the Kompfner Dip Condition". IRE Transactions - Electron Devices, October 1955.
16. C.K. Birdsall and T.E. Everhart, "Modified Contra-Wound Helix Circuits for High Power Traveling-Wave Tubes". IRE Transaction on Electron Devices, October 1956.
17. J.A. Lucken, "Some Aspects of Circuit Power Dissipation in High Power C.W. Helix Traveling-Wave Tubes". Part I: General Theory, Part II: Scaling Laws, IEEE Transactions on Electron Devices, Vol. ED. 16, No. 9, September 1969.
18. W.G. Worcester, A.L. Weitzmann and R.J. Townley, "Light-weight Aluminum Foil Solenoids for Traveling-Wave Tubes". IRE Transactions - Electron Devices, January 1956.
19. H.R. Johnson, T.E. Everhart and A.E. Siegman, "Wave Propagation on Multifilar Helices". IRE Transactions on Multifilar Helices". IRE Transactions - Electron Devices, January 1956.
20. H.G. Kosmahl and P. Ramins, "Small-Size 81- to 83.5 Percent Efficient 2- and 4 Stage Depressed Collectors for Octave-Bandwidth High-Performance TWT's". IEEE Transaction on Electron Devices. Vol. ED. 24, No. 1, January 1977.
21. M.J. Schindler, "An Improved Procedure for the Design of Periodic-Permanent-Magnet Assemblies for Traveling-Wave Tubes". IEEE Transactions on Electron Devices, Vol. ED. 13, No. 12, December 1966.
22. M.S. Glass, "Straight-Field Permanent Magnets of Minimum Weight for TWT Focusing-Design and Graphic Aids in Design". Proceedings of the IRE, August 1957.
23. J.T. Mendel, "Magnetic Focusing of Electron Beams". Proceedings of the IRE, March 1955.
24. C.C. Cutler and M.E. Hines, "Thermal Velocity Effects in Electron Guns". Proceedings of the IRE, March 1955.
25. A. Nordsieck, "Theory of the Large Signal Behavior of Traveling-Wave Amplifiers". Proceedings of the IRE, May 1953.
26. T. Kageyama, Y. Morizumi and E. Watanabe, "A Large-Signal Analysis of Broad-Band Klystrons with Design Applications". IEEE Transactions on Electron Devices, Vol. ED. 24, No. 1, January 1977.
27. A. Kiel and P. Parzen, "Non-linear Wave Propagation in Traveling-Wave Amplifiers". IRE Transactions - Electron Devices, October 1955.
28. S. Sensiper, "Electromagnetic Wave Propagation on Helical Structures". Proceedings of the IRE, February 1955.

29. I.P. Kaminow, R. Kompfner and W.H. Louisell, "Improvements in Light Modulators of the Traveling-Wave Type". IRE Transactions on Microwave Theory and Techniques, September 1962.
30. J.R. Pierce, "An Interesting Wave Amplifier". IRE Transactions on Electron Devices, April 1960.
31. A.R. Iverson, "High Average Power Dissipation in Helix Tubes". IRE Transactions on Electron Devices, April 1960.
32. K. Miyauchi, "Traveling-Wave Tube Nanosecond Pulse Generator in 24 - Gc Region". IEEE Transaction on Microwave Theory and Techniques, January 1963.
33. C. Loo, "Calculation of the Suppression of Signals and Intermodulation Noise when Multiple Unequal Carriers are Amplified by a TWT". Presented at the Canadian Communications and Power Conference, Montreal 1976.
34. C. Loo, "Calculations of Intermodulation Noise Due to Hard and Soft Limiting of Multiple Carriers". Presented at the ICC, 1974.
35. L.M. Field, "Some Slow-Wave Structures for Traveling-Wave Tubes". Proceedings of the IRE, January 1949.
36. M. Scotto and P. Parzen, "The Electronic Theory of Tape-Helix Traveling-Wave Structures". IRE Transactions - Electron Devices, October 1955.
37. R.R. Warneke, W. Kleen, A. Lerbs, O. Döhler and H. Huber, "The Magnetron-Type Traveling-Wave Amplifier Tube". Proceedings of the IRE, May 1950.
38. W.H. Louisell, "Approximate Analytic Expressions for TWT Propagation Constants". IRE Transactions on Electron Devices, October 1958.
39. E.J. Nalos, "A Hybrid Type Traveling-Wave Tube for High-Power Pulsed Amplification". IRE Transactions on Electron Devices, July 1958.
40. M. Meyer, T. Van Duzer, "Traveling-Wave Amplification and Power Flow in Conducting Solids". IEEE Transactions on Electron Devices, March 1970.
41. R.W. Gerchberg, K.B. Niclas, "The Positively Tapered Traveling-Wave Tube". Correspondence, IEEE Transactions on Electron Devices, September 1969.
42. R.C. Honey and E.M.T. Jones, "A Wide-Band UHF Traveling-Wave Variable Reactance Amplifier IRE Transaction on Microwave Theory and Techniques, May 1960.
43. R.H. Pastell, F.D. Coleman and R.C. Becker, "Dielectric Slow-Wave Structures for the Generation of Power at Millimeter and Sub Millimeter Wavelengths". IRE Transactions on Electron Devices, July 1958.

44. O.L. Hoch and D.A. Watkins, "A Gun and Focusing System for Crossed-field Traveling-Wave Tubes". IRE Transactions on Electron Devices, January 1959.
45. C.C. Cutler and D.J. Brangaccio, "Factors Affecting Traveling-Wave Tube Power Capacity". IRE, Vol. ED. 3, June 1953.
46. D.A. Dunn, G.S. Kino and G.W.C.M.C. Mathers, "Traveling-Wave Tube Propagation Constants for Finite Values of Gain per Wavelength", IRE Transaction on Electron Devices, October 1958.
47. J.J. Caldwell Jr. and O.L. Hoch, "Large Signal Behavior of High Power Traveling-Wave Amplifiers". IRE Transactions - Electron Devices, January 1956.
48. J.E. Rowe, "A Large Signal Analysis of the Travelling-Wave Amplifier: Theory and General Results". IRE Transaction - Electron Devices, January 1956.
49. P.K. Tien, L.K. Walker and V.M. Wolontis, "A Large Signal Theory of Traveling-Wave Amplifiers". Proceedings of the IRE, March 1955.
50. L.J. Chu and J.D. Jackson, "Field Theory of Traveling-Wave Tubes". Proceedings of the IRE, July 1948.
51. J.R. Pierce and L.M. Field, "Traveling-Wave Tubes". Proceedings of the IRE, February 1947.
52. J.R. Pierce, "Theory of the Beam-Type Traveling-Wave Tube". Proceedings of the IRE, February 1947.
53. P.K. Tien, "Traveling-Wave Tube Helix Impedance". Proceedings of the IRE, November 1953.
54. S. Millman, "A Spatial Harmonic Traveling-Wave Amplifier for Six Millimeters Wavelength". Proceedings of the IRE, September 1951.
55. J.A. Boyd, D.B. Harris, D.D. King and H.W. Welch, Jr., "Electronic Counter Measures". Prepared by the Institute of Science and Technology of the University of Michigan for the U.S. Army Signal Corps. Published in 1961.
56. M. Chodorow, E.K. Ginzton and E.J. Nelos, "Debunching of Electron Beams Constrained by Strong Magnetic Field". Proceedings of the IRE, August 1953.
57. D.A. Watkins, "Low Noise Traveling-Wave Tubes for X-Band". Proceedings of the IRE, December 1953.
58. F.K. Mullen, "Traveling-Wave Tubes with Ferrite Attenuators". IRE Transactions on Electron Devices, July 1961.

59. M.R. Currie and D.C. Forster, "The Gain and Bandwidth Characteristics of Backward-Wave Amplifiers". IRE Transactions on Electron Devices, January 1957.
60. N.H. Pond and R.J. Twiggs, "Improvements of Traveling-Wave Tube Efficiency Through Period Tapering". IEEE Transactions on Electron Devices, Vol. ED. 13, No. 12, December 1966.
61. S.A. Cohen, "Traveling-Wave Tube Gain Fluctuations with Frequency". IRE Transactions on Electron Devices, January 1957.
62. L.W. Holmboe and M. Ettenberg, "Development of a Medium Power L-B and Traveling-Wave Amplifier". IRE Transactions on Electron Devices, January 1957.
63. C.K. Birdsall and C.C. Johnson, "Traveling-Wave Efficiency Degradation Due to Power Absorbed in an Attenuator". IRE Transaction on Electron Devices, January 1959.
64. A.G. Mungall, "Noise in Traveling-Wave Tubes". IRE Transactions - Electron Devices, April 1955.
65. J.W. Sedin, "A Large Signal Analysis of Beam Type Crossed Field Traveling-Wave Tubes". IRE Transactions on Electron Devices, January 1962.
66. A.H. Iverson, "Precision Helix Winding and a Mechanism of Loss Variation", p.p. 205-206, IRE Transactions on Electron Devices, October 1956.
67. C.C. Cutler, "The Calculation of Traveling-Wave Tube Gain". Proceedings of the IRE, August 1951.
68. R. Kompfner, "The Traveling-Wave Tube as Amplifier at Microwaves". Proceedings of the IRE, February 1947.
69. S.E. Webber, "Electron Bunching and Energy Exchange in a Traveling-Wave Tube". IRE Transactions on Electron Devices, January 1957.
70. W.E. Mathews, "Traveling-Wave Amplification by Means of Coupled Transmission Lines". Proceedings of the IRE, September 1951.
71. H.R. Johnson and J.R. Whinnery, "Traveling-Wave Tube Oscillators". IRE Transaction on ED., August 1954.
72. C.K. Birdsall and G.R. Brewer, "Traveling-Wave Tube Characteristics for Finite Values of C". IRE Transaction on Electron Devices, Vol. ED-1, August 1954.
73. J.J. Caldwell, Jr., "High Power Traveling Wave Tube Gain and Saturation Characteristics as a Function of Attenuator Configuration and Resistivity". Trans. IRE, PGED, Vol. 4, December 1953.

74. A.W. Scott, "Why a Circuit Sever Affects Traveling-Wave Tube Efficiency". IRE Transactions on Electron Devices, January 1962.
75. J.F. Gittins, "Travelling-Wave Tubes", New York American Elsevier Pub. Co., 1965.
76. J.R. Pierce, "Travelling-Wave Tubes", New York Van Nostrand, 1950.
77. King, S.E.R.L. Tech. J., Vol. 4, p. 9, 1954
78. Mathias and King, IRE Transaction on Electron Devices, Vol. ED. 4, p. 280, 1957.

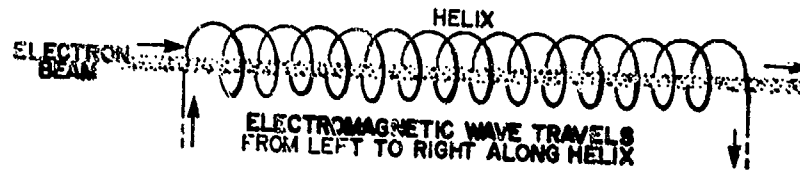


FIGURE 1 - PORTION OF THE TRAVELING-WAVE AMPLIFIER PERTAINING TO ELECTRONIC INTERACTION WITH RADIO-FREQUENCY FIELDS AND RADIO-FREQUENCY GAIN

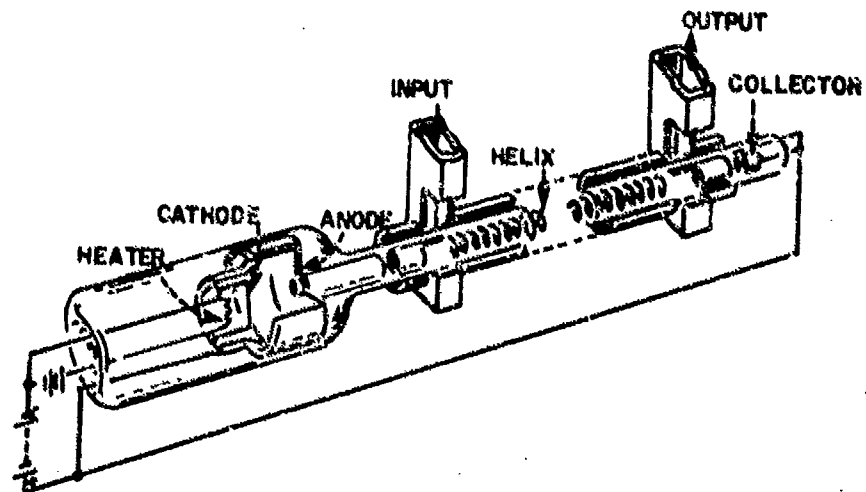


FIGURE 2 - SCHEMATIC OF THE TRAVELING-WAVE AMPLIFIER

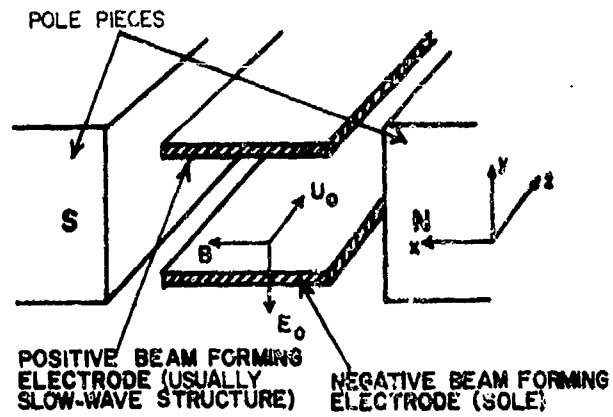


FIGURE 5 - CROSSED-FIELD TWT

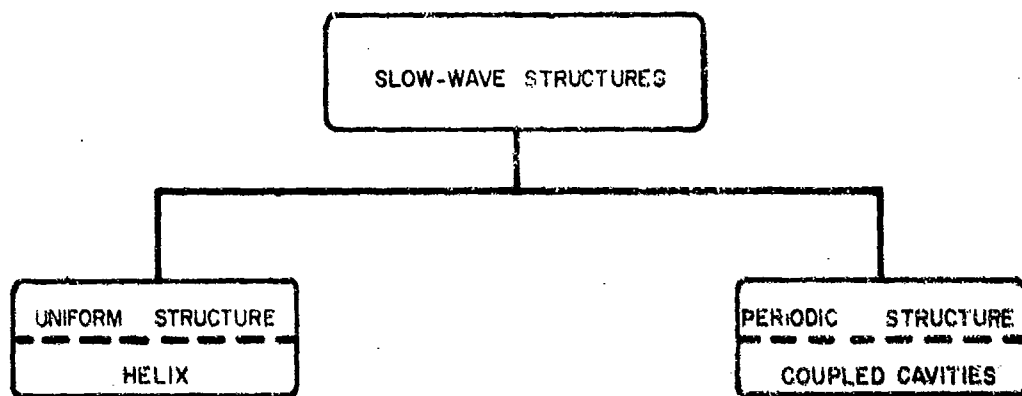


FIGURE 6 - SLOW WAVE STRUCTURES

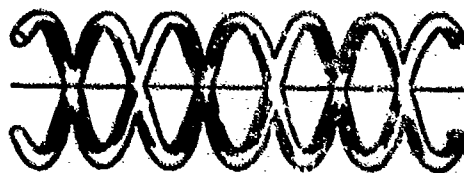


FIGURE 7 - TWIN CROSSWOUND HELIX

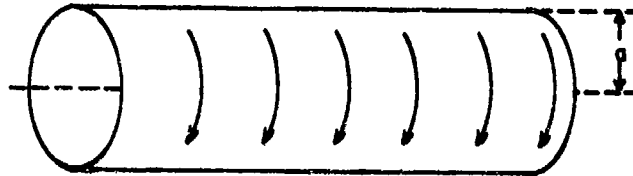


FIGURE 8 - SHEATH HELIX

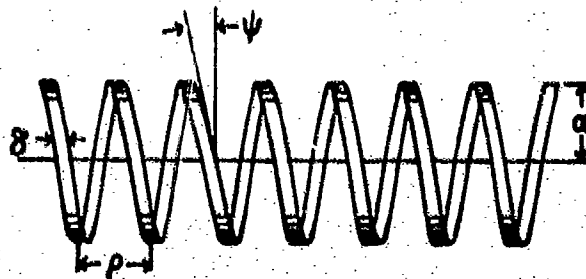


FIGURE 9 - TAPE HELIX



FIGURE 10(a) - BIFILAR WIRE HELIX

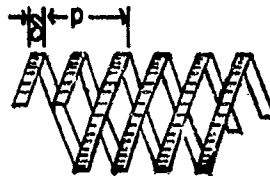


FIGURE 10(b) - BIFILAR TAPE HELIX

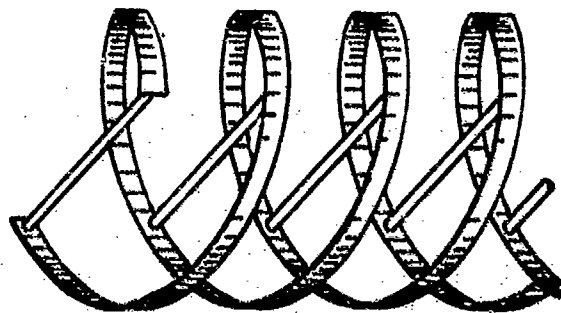


FIGURE 10(c) - STRAPPED BIFILAR HELIX



FIGURE 10(d) - RING AND BAR CONTRAWOUND HELIX

FIGURE 10 - HELIX STRUCTURES

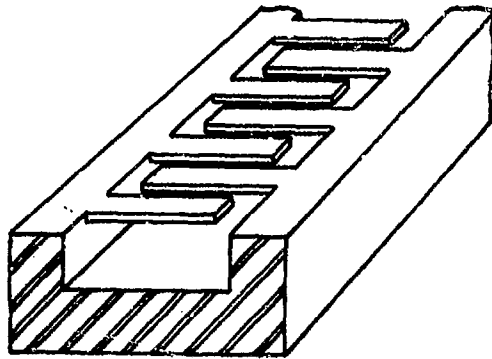


FIGURE 11(a) - INTERDIGITAL LINE

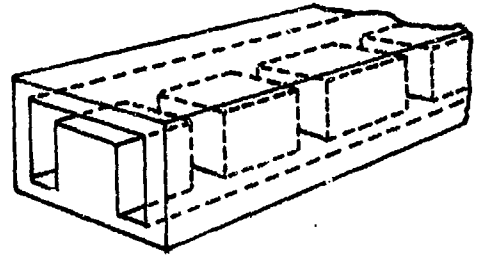


FIGURE 11(b) - SLOTTED RIDGE WAVEGUIDE

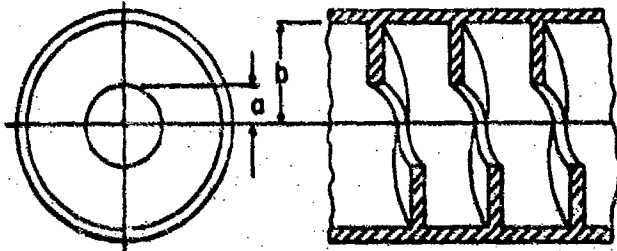
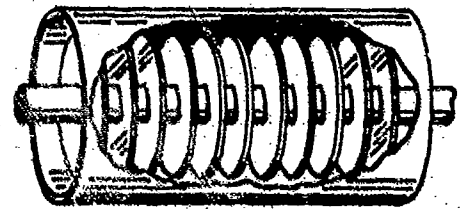
FIGURE 11(c) - INTERNAL HELICAL-
WAVEGUIDE STRUCTURE

FIGURE 11(d) - DISK-ON-ROD CIRCUIT

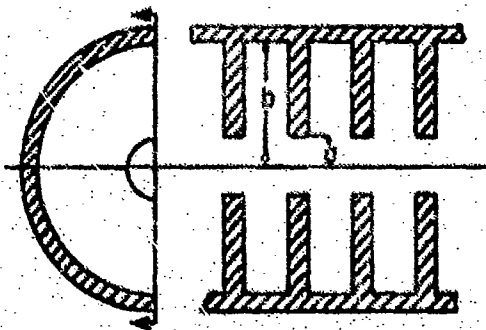
FIGURE 11(e) - APERTURED-DISK
STRUCTUREFIGURE 11(f) - LOADED WAVEGUIDE
CIRCUIT

FIGURE 11 - SLOW WAVE STRUCTURES

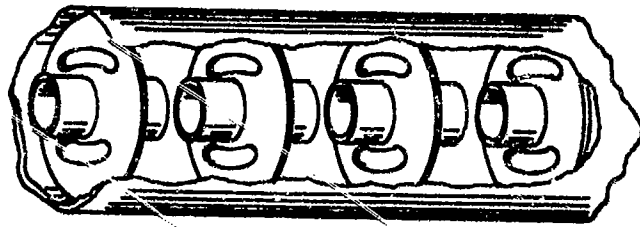


FIGURE 12 - COUPLED CAVITY STRUCTURE (CHODOROW-NALOS STRUCTURE)

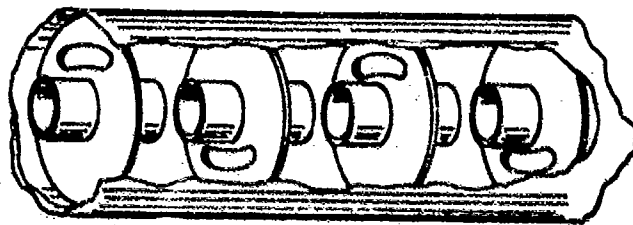


FIGURE 13 - THE "HUGHES" STRUCTURE

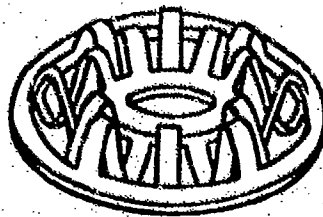


FIGURE 14 - THE "CENTIPEDE" STRUCTURE (COUPLING PLATE)

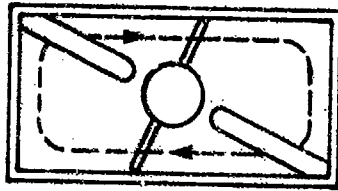


FIGURE 15(a) - RECTANGULAR STRUCTURE



FIGURE 15(b) - PARALLELOGRAM STRUCTURE

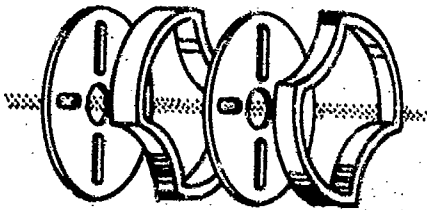


FIGURE 15(c) - "HOURLASS" STRUCTURE

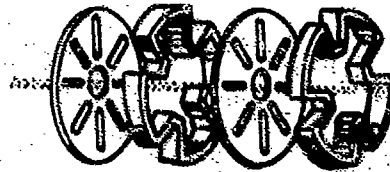


FIGURE 15(d) - "CLOVER LEAF" STRUCTURE

FIGURE 15 - COUPLED-CAVITY STRUCTURES

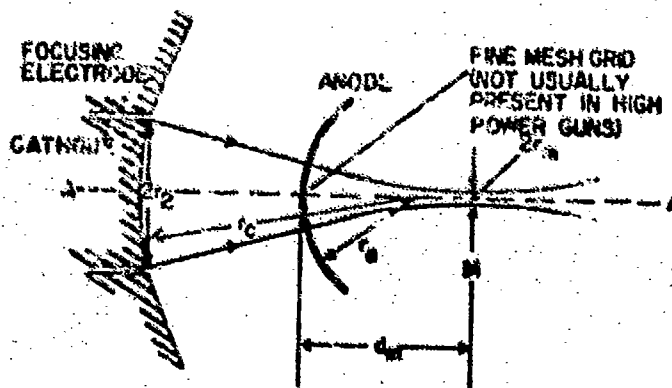
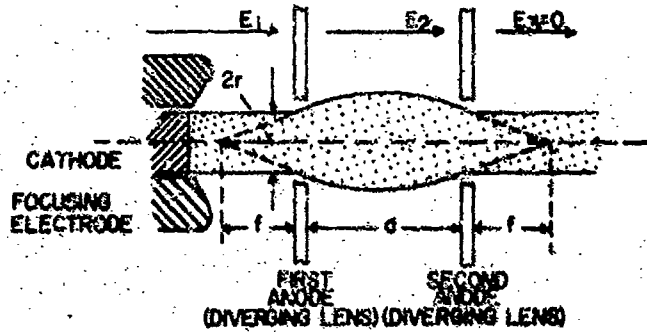


FIGURE 16 - PIERCE GUN



- N.B.
- (a) ANODE APERTURES GIVE LENSES OF EQUAL STRENGTH.
 - (b) WHOLE GUN IS IMMERSSED IN A UNIFORM PARALLEL MAGNETIC FIELD.
 - (c) NEGLIGIBLE SPACE CHARGE ASSUMED.
 - (d) TRANSIT TIME BETWEEN ANODES IS HALF A CYCLOTRON PERIOD.

FIGURE 17 - TWO ANODE LENS-COMPENSATED GUN

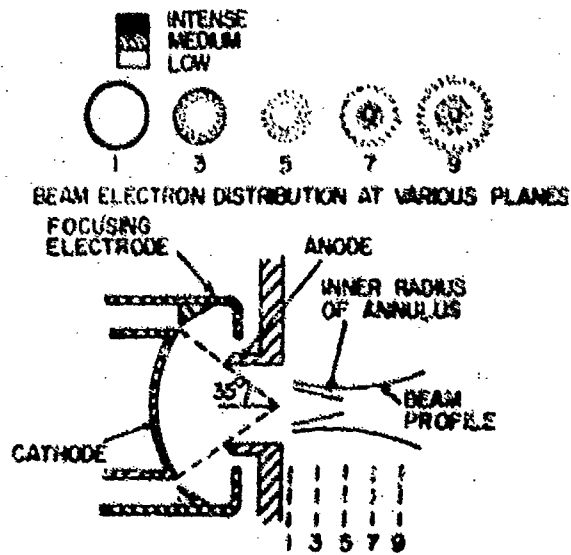


FIGURE 18 - GUN DESIGNED BY MATHIAS ACCORDING TO MÜLLER'S PRINCIPLE

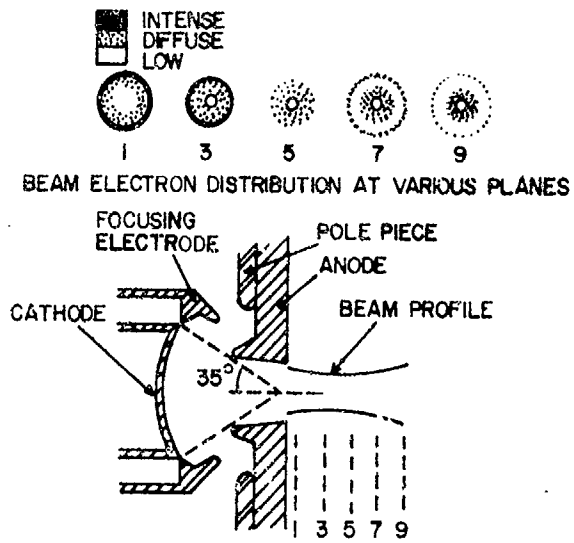


FIGURE 19 - MATHIAS AND KING'S HIGH-VOLTAGE VERSION OF MÜLLER-TYPE GUN

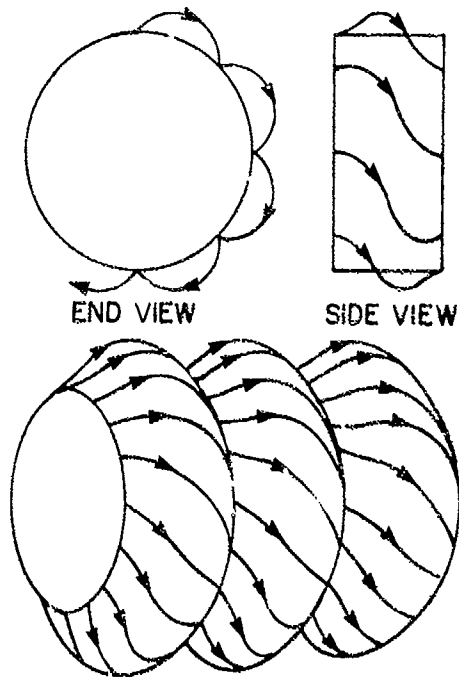


FIGURE 20 - PERSPECTIVE VIEW SHOWING PATHS OF OUTER ELECTRONS

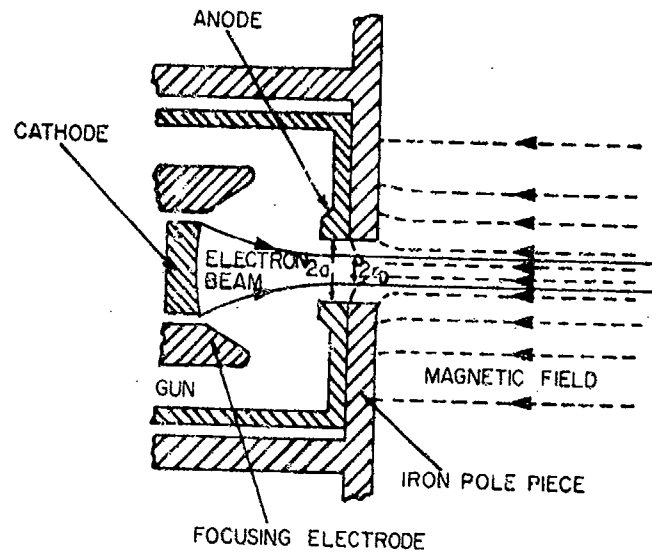


FIGURE 21 - A PRACTICAL ARRANGEMENT FOR LAUNCHING BRILLOUIN FLOW

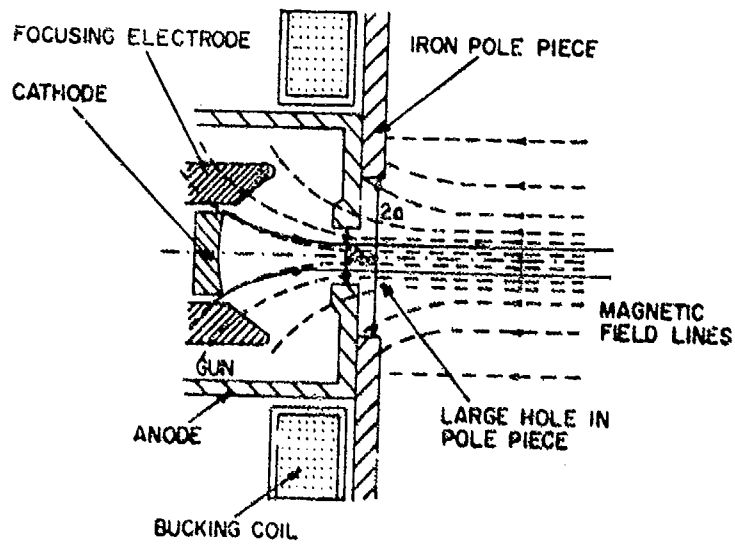


FIGURE 22 - A PRACTICAL ARRANGEMENT FOR LAUNCHING SMOOTH FLOW AT FIELDS ABOVE BRILLOUIN

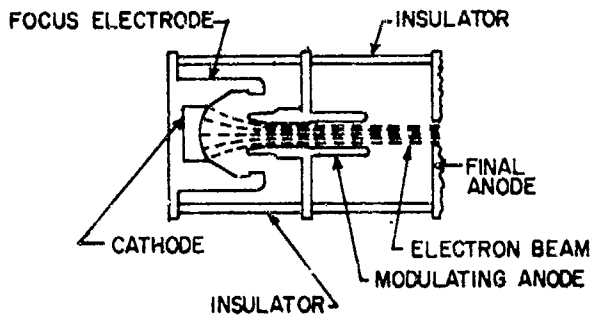


FIGURE 23(a) - MODULATING ANODE GUN

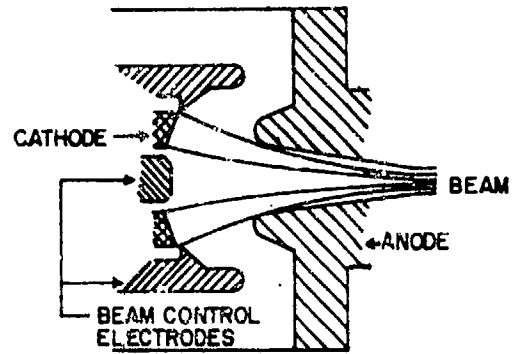


FIGURE 23(b) - CONTROL FOCUS ELECTRODE GUN

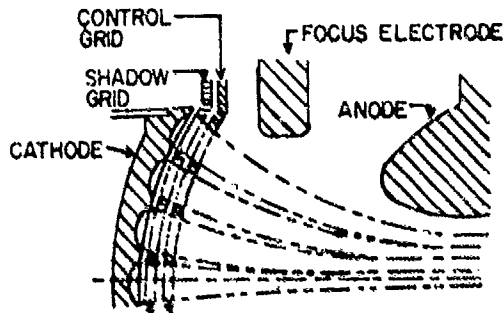
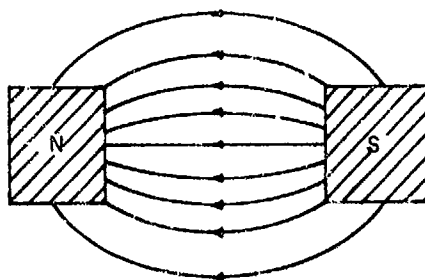
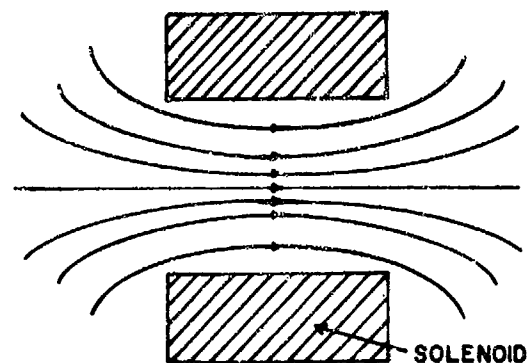


FIGURE 23(c) - SHADOW GRIDDED GUN

FIGURE 23 - ELECTRON GUN CONTROL ELECTRODES



Field distortion characteristic of finite pole pieces.



Field distortion characteristic of finite solenoids.

FIGURE 24 - BOWING OF FIELD LINES
POLE PIECE

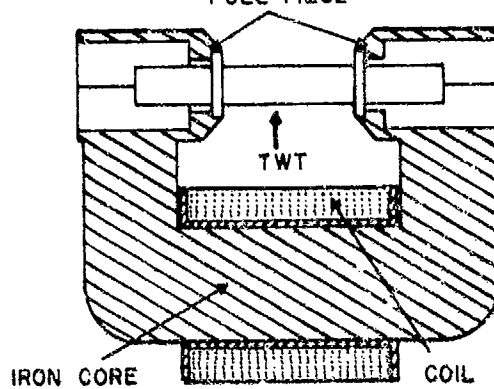


FIGURE 25 - C-MAGNET

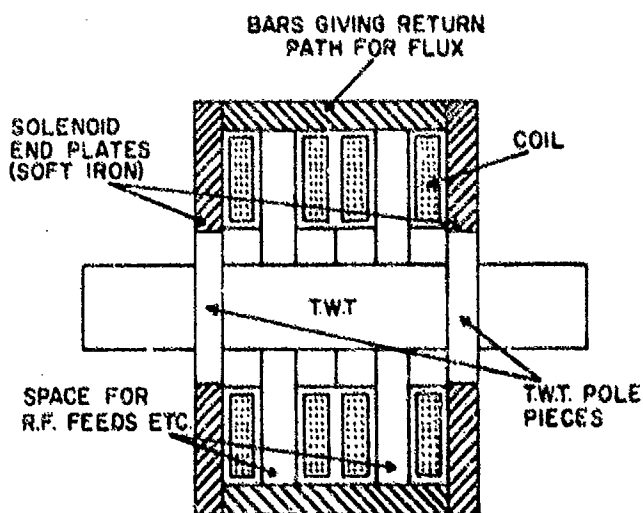


FIGURE 26 - SOLENOID WITH SEPARATE COILS AND IRON END PLATES

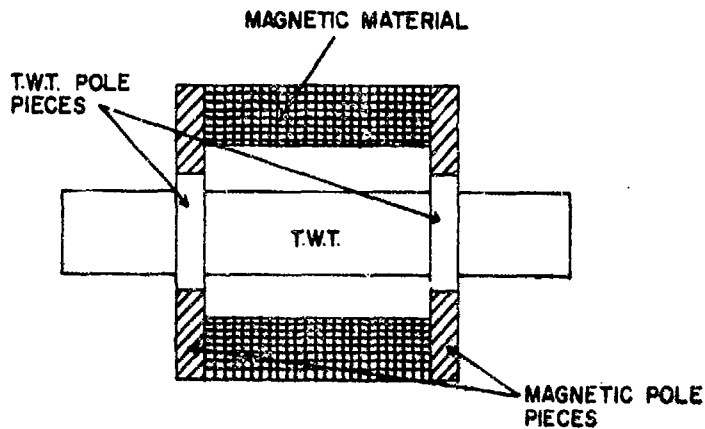


FIGURE 27 - CYLINDRICAL POT PERMANENT MAGNET

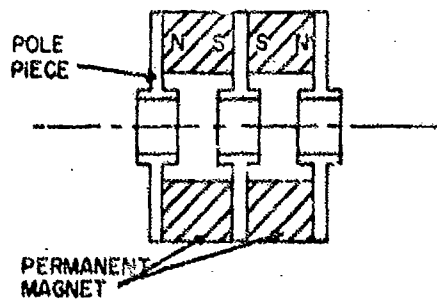


FIGURE 28 - PPM-FOCUSING STRUCTURE EMPLOYING AXIALLY MAGNETIZED RINGS
ELECTRON BEAM SOFT IRON POLE PIECES

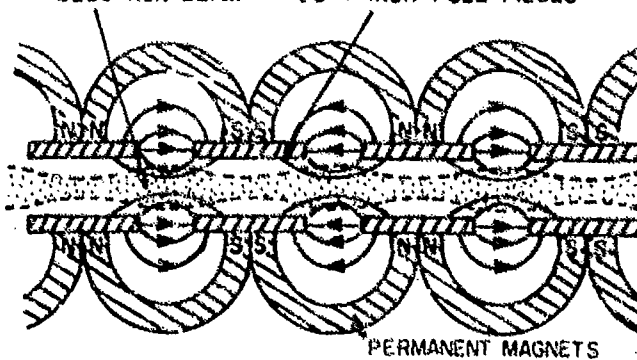


FIGURE 29 - PERIODIC FOCUSING BY CONVERGING MAGNETIC LENSES

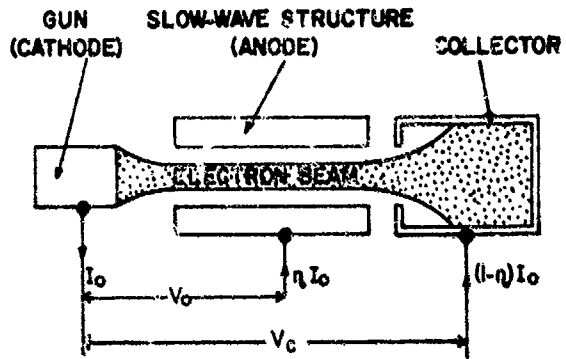


FIGURE 30 - DEPRESSED COLLECTOR T.W.T.

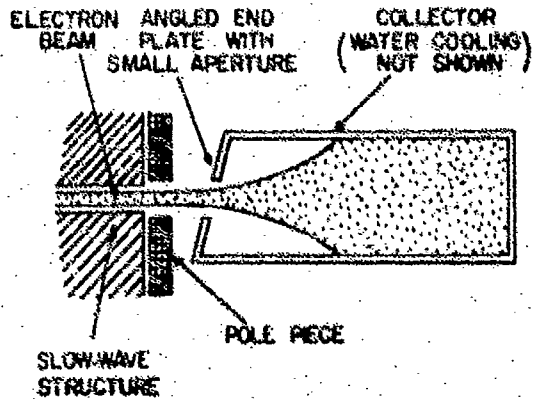


FIGURE 31 - A DEPRESSED COLLECTOR WHICH SUPPRESSES SECONDARY CURRENT

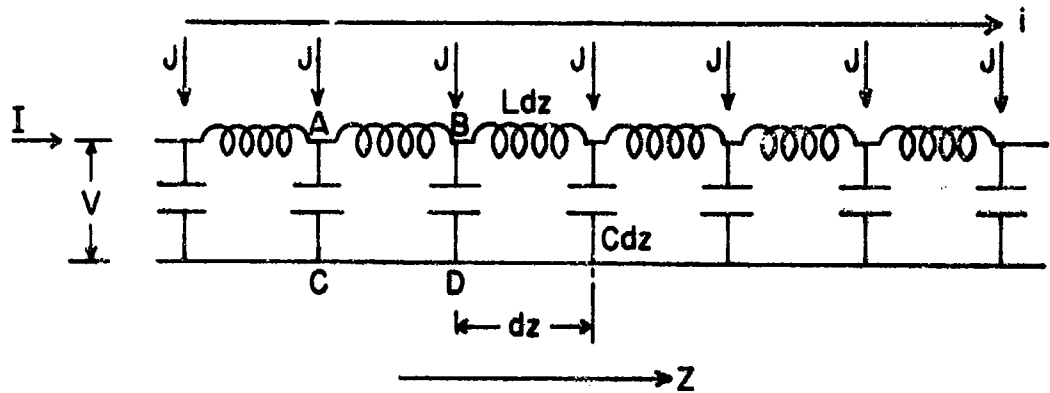


FIGURE 32(a) - EQUIVALENT TRANSMISSION LINE USED BY PIERCE
IN SMALL-SIGNAL WAVE THEORY

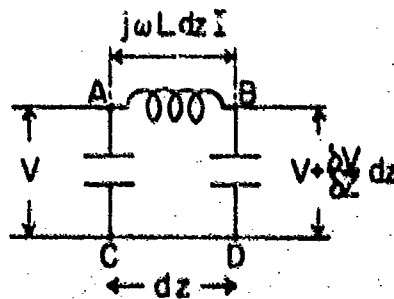


FIGURE 32(b) - DISTRIBUTED INDUCTANCE AND CAPACITANCE

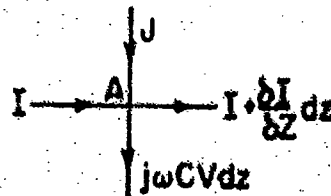


FIGURE 32(c) - CURRENT FLOW AT JUNCTION A

FIGURE 32 - EQUIVALENT CIRCUITS

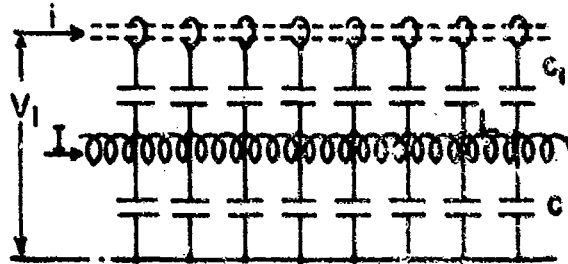


FIGURE 33 - SPACE CHARGE EFFECT

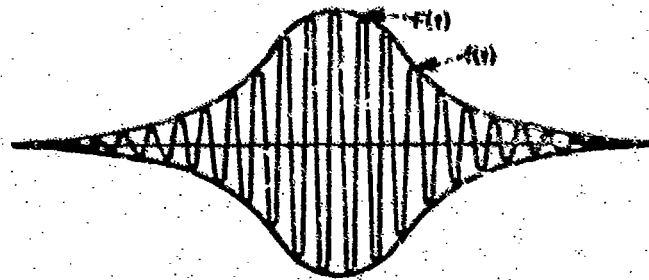


FIGURE 34

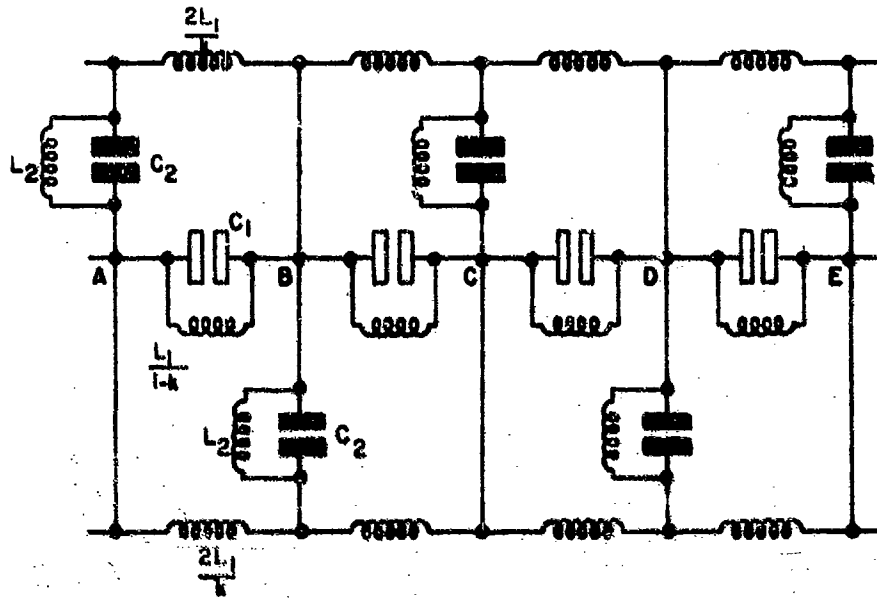


FIGURE 35(a) - CIRCUIT IN MICROWAVE FORM

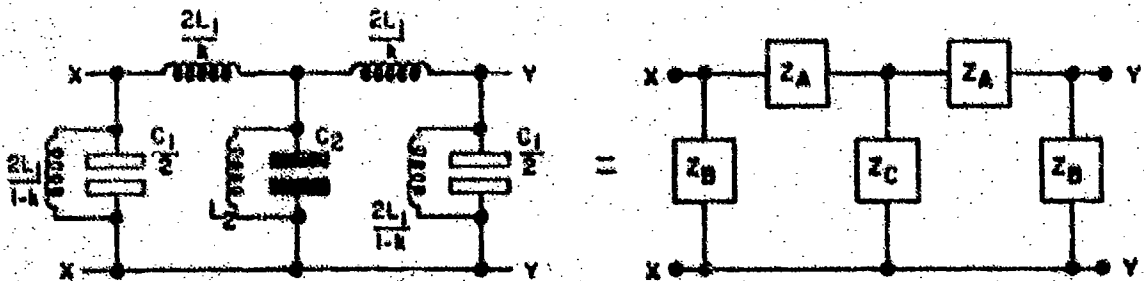


FIGURE 35(b) - BASIC CELL

FIGURE 35 - EQUIVALENT LUMPED CIRCUITS FOR THE COUPLED-CAVITY STRUCTURE

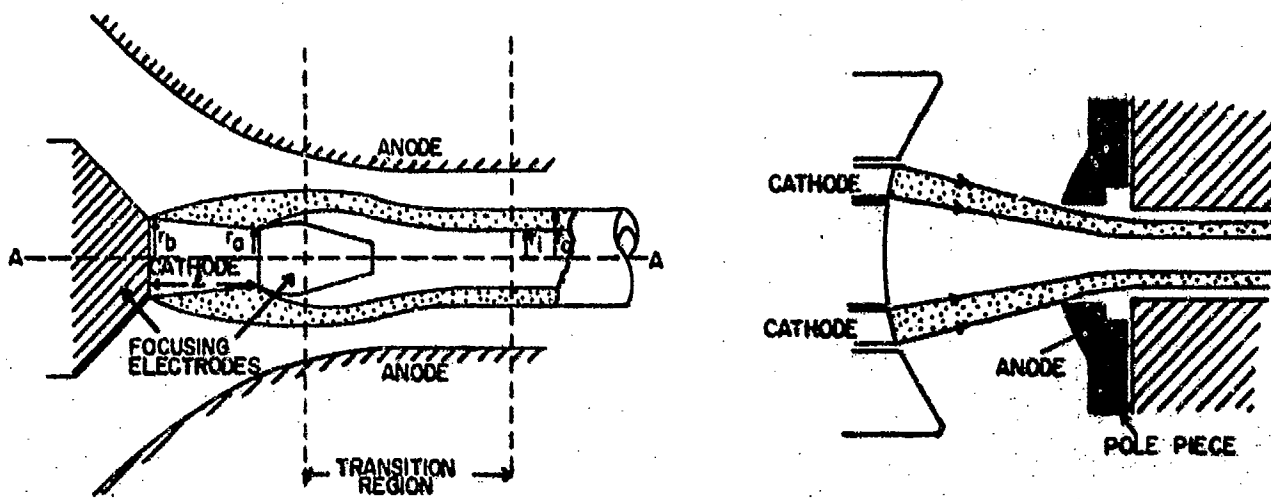


FIGURE 36 - HOLLOW BEAM GUNS

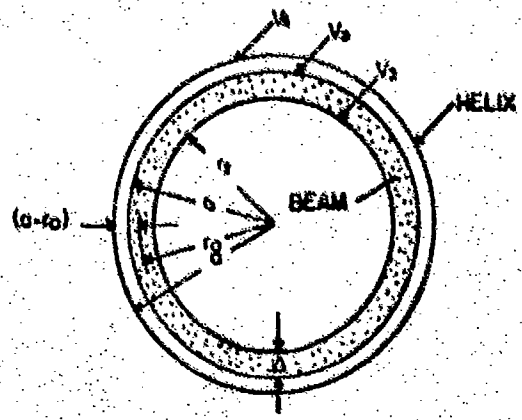


FIGURE 37 - CROSS-SECTION OF HOLLOW BEAM

AD-A083 899

UNCLASSIFIED
Security Classification

DOCUMENT CONTROL DATA - R & D		
(Security classification of title, body of abstract and indexing annotation must be entered when the overall document is classified)		
1. ORIGINATING ACTIVITY Defence Research Establishment Ottawa, National Defence Headquarters, Ottawa, Ontario, K1A 0Z4	2a. DOCUMENT SECURITY CLASSIFICATION UNCLASSIFIED	
	2b. GROUP IV	
3. DOCUMENT TITLE A COMPREHENSIVE REVIEW OF TRAVELLING-WAVE TUBE TECHNOLOGY (U)		
4. DESCRIPTIVE NOTES (Type of report and inclusive dates) TECHNICAL NOTE # 80-1		
5. AUTHOR(S) (Last name, first name, middle initial) LUIZ, Robert		
6. DOCUMENT DATE NOVEMBER 1979	7a. TOTAL NO. OF PAGES 76	7b. NO. OF REFS 78
8a. PROJECT OR GRANT NO. DREO 31B00	9a. ORIGINATOR'S DOCUMENT NUMBER(S) DREO TN-80-1	
8b. CONTRACT NO.	9b. OTHER DOCUMENT NO.(S) (Any other numbers that may be assigned this document)	
10. DISTRIBUTION STATEMENT QUALIFIED REQUESTERS MAY OBTAIN COPIES OF THIS DOCUMENT FROM THEIR DEFENCE DOCUMENTATION CENTRE		
11. SUPPLEMENTARY NOTES	12. SPONSORING ACTIVITY DND/CRAD	
13. ABSTRACT (UNCLASSIFIED) A review of TW technology is presented comparing selected aspects and design procedures relative to application. The general theory of operation of various types of TW designs is discussed together with a review of principles of their construction and trade offs.		

KEY WORDS

**BACKWARD WAVE AMPLIFIER, COUPLED CAVITY TWT,
DIELECTRIC LOADING, FOLDED TRANSMISSION LINES,
FORBIDDEN ZONES, HELIX, PERVEANCE, SLOW WAVE
STRUCTURES, TRAVELLING-WAVE TUBE**

INSTRUCTIONS

1. **ORIGINATING ACTIVITY:** Enter the name and address of the organization issuing the document.
- 2a. **DOCUMENT SECURITY CLASSIFICATION:** Enter the overall security classification of the document including special warning labels whenever applicable.
- 2b. **GROUP:** Enter security reclassification group number. The three groups are defined in Appendix 'M' of the DRG Security Regulations.
3. **DOCUMENT TITLE:** Enter the complete document title in all capital letters. Titles in all cases should be unclassified. If a sufficiently descriptive title cannot be selected without classification, show title classification with the usual one-capital-letter abbreviation in parentheses immediately following the title.
4. **DESCRIPTIVE NOTES:** Enter the category of document, e.g. technical report, technical note or technical letter. If appropriate, enter the type of document, e.g. interim, progress, summary, annual or final. Give the inclusive dates when a specific reporting period is covered.
5. **AUTHOR(S):** Enter the name(s) of author(s) as shown on or in the document. Enter last name, first name, middle initial. If military, show rank. The name of the principal author is an absolute minimum requirement.
6. **DOCUMENT DATE:** Enter the date (month, year) of Establishment approval for publication of the document.
- 7a. **TOTAL NUMBER OF PAGES:** The total page count should follow normal pagination procedures, i.e., enter the number of pages containing information.
- 7b. **NUMBER OF REFERENCES:** Enter the total number of references cited in the document.
- 8a. **PROJECT OR GRANT NUMBER:** If appropriate, enter the applicable research and development project or grant number under which the document was written.
- 8b. **CONTRACT NUMBER:** If appropriate, enter the applicable number under which the document was written.
- 9a. **ORIGINATOR'S DOCUMENT NUMBER(S):** Enter the official document number by which the document will be identified and controlled by the originating activity. This number must be unique to this document.
- 9b. **OTHER DOCUMENT NUMBER(S):** If the document has been assigned any other document numbers (either by the originator or by the sponsor), also enter this number(s).
10. **DISTRIBUTION STATEMENT:** Enter any limitations on further dissemination of the document, other than those imposed by security classification, using standard statements such as:
 - (1) "Qualified requesters may obtain copies of this document from their defence documentation center."
 - (2) "Announcement and dissemination of this document is not authorized without prior approval from originating activity."
11. **SUPPLEMENTARY NOTES:** Use for additional explanatory notes.
12. **SPONSORING ACTIVITY:** Enter the name of the departmental project office or laboratory sponsoring the research and development. Include address.
13. **ABSTRACT:** Enter an abstract giving a brief and factual summary of the document, even though it may also appear elsewhere in the body of the document itself. It is highly desirable that the abstract of classified documents be unclassified. Each paragraph of the abstract shall end with an indication of the security classification of the information in the paragraph (unless the document itself is unclassified) represented as (TS), (S), (C), (R), or (U).

The length of the abstract should be limited to 20 single spaced standard typewritten lines, 12 inches long.
14. **KEY WORDS:** Key words are technically meaningful terms or short phrases that characterize a document and could be helpful in cataloging the document. Key words should be selected so that no security classification is required. Identifiers, such as equipment model designation, trade name, military product code name, geographic location, may be used as key words but will be followed by an indication of technical context.