

MICROCOPY RESOLUTION TEST CHART

NATIONAL BUREAU OF STANDARDS-1963-A

AA082531

12

LEVEL #

RESEARCH PRODUCT 79-16

PROGRAM MANAGEMENT FOR TANK CREWMAN
SKILLS TRAINING PROGRAM

DTIC
ELECTE
APR 8 1980

ARI Field Unit at Fort Knox, Kentucky

NOVEMBER 1979

ARI FILE COPY

This document has been approved
for public release and sale; its
distribution is unlimited.



80 4 2 008

U.S. ARMY RESEARCH INSTITUTE for the BEHAVIORAL and SOCIAL SCIENCES

**U. S. ARMY RESEARCH INSTITUTE
FOR THE BEHAVIORAL AND SOCIAL SCIENCES**

**A Field Operating Agency under the Jurisdiction of the
Deputy Chief of Staff for Personnel**

JOSEPH ZEIDNER
Technical Director

FRANKLIN A. HART
Colonel, US Army
Commander

Research accomplished
under contract to the Department of the Army

Human Resources Research Organization

NOTICES

FINAL DISPOSITION: This report may be destroyed when it is no longer needed. Please do not return it to the U. S. Army Research Institute for the Behavioral and Social Sciences.

NOTE: The findings in this report are not to be construed as an official Department of the Army position, unless so designated by other authorized documents.

18 ARI

UNCLASSIFIED

SECURITY CLASSIFICATION OF THIS PAGE (When Data Entered)

REPORT DOCUMENTATION PAGE		READ INSTRUCTIONS BEFORE COMPLETING FORM
1. REPORT NUMBER Research Product 79-16 19 RP-5	2. GOVT ACCESSION NO.	3. RECIPIENT'S CATALOG NUMBER
4. TITLE (and Subtitle) PROGRAM MANAGEMENT FOR TANK CREWMAN SKILLS TRAINING PROGRAM	5. PERFORMING ORG. REPORT NUMBER 14 HUMRRO-RP-WD(KY)-79-14	6. PERFORMING ORG. REPORT NUMBER
7. AUTHOR(s) Richard E. O'Brien William J. Crum	8. AUTHORING OR PERFORMING ORGANIZATION NUMBER(s)	9. DATE OF REPORT & PERIOD COVERED Research Product
9. PERFORMING ORGANIZATION NAME AND ADDRESS Human Resources Research Organization (HumRRO) 300 North Washington Street Alexandria, Virginia 22314	10. PROGRAM ELEMENT, PROJECT, TASK AREA & WORK UNIT NUMBERS	11. REPORT DATE November 1979
11. CONTROLLING OFFICE NAME AND ADDRESS U.S. Army Research Institute for the Behavioral and Social Sciences 5001 Eisenhower Avenue Alexandria, Virginia 22333	12. NUMBER OF PAGES 196	13. NUMBER OF PAGES
14. MONITORING AGENCY NAME & ADDRESS (if different from Controlling Office)	15. SECURITY CLASS. (of this report) UNCLASSIFIED	15a. DECLASSIFICATION/DOWNGRADING SCHEDULE
16. DISTRIBUTION STATEMENT (of this Report) Approved for open release; distribution unlimited.		
17. DISTRIBUTION STATEMENT (of the abstract entered in Block 20, if different from Report) 16 20763743A773		
18. SUPPLEMENTARY NOTES Work performed by HumRRO, Fort Knox Office, P.O. Box 293, Fort Knox, Kentucky 40121, and monitored by Donald F. Haggard, Chief, ARI Field Unit-Fort Knox.		
19. KEY WORDS (Continue on reverse side if necessary and identify by block number) Armor Training Skills Training Tank Gunnery Skills Testing M60A1 Training Management		
20. ABSTRACT (Continue on reverse side if necessary and identify by block number) This document explains the development of the Tank Crewman Skills Training Program and provides guidelines for managing the program. General developmental procedures for diagnostic testing and remedial training are given first. Remaining sections of the report give detailed program management guidance for training managers and trainers about training responsibilities, required training resources, administering readiness tests and training modules, and maintenance of training records.		

DD FORM 1 JAN 73 1473 EDITION OF 1 NOV 65 IS OBSOLETE

1

UNCLASSIFIED SECURITY CLASSIFICATION OF THIS PAGE (When Data Entered)

405260

Lu

UNCLASSIFIED

SECURITY CLASSIFICATION OF THIS PAGE(When Data Entered)

↙ When used with three companion documents, Tank Crewman (M60A1) Readiness Tests, Tank Crewman (M60A1) Training Modules, and Tank Crew (M60A1) Performance Exercise, the program management for tank crewman skills training program provides guidance for implementing an integrated 'train-up' package for annual gunnery evaluation. ↗

UNCLASSIFIED

SECURITY CLASSIFICATION OF THIS PAGE(When Data Entered)

RESEARCH PRODUCT RP-79-16

PROGRAM MANAGEMENT FOR TANK CREWMAN SKILLS TRAINING PROGRAM

Richard E. O'Brien
William J. Crum

Human Resources Research Organization (HumRRO)

Submitted by:

Donald F. Haggard, Chief
ARI Field Unit, Fort Knox, Kentucky

Approved by:

E. Ralph Dusek, Director
PERSONNEL & TRAINING
RESEARCH LABORATORY

Joseph Zeidner
TECHNICAL DIRECTOR

U.S. ARMY RESEARCH INSTITUTE FOR THE BEHAVIORAL AND SOCIAL SCIENCES
5001 Eisenhower Avenue, Alexandria, Virginia 22333

Office, Deputy Chief of Staff for Personnel
Department of the Army

November 1979

Approved for public release; distribution unlimited.

FOREWORD

The Fort Knox Field Unit of the Army Research Institute for the Behavioral and Social Sciences (ARI) carries out research and exploratory development in the area of Armor training. An objective of this work is to develop, through analytic and field research, tank crew training methods that are effective and efficient.

This report is one of a set of four dealing with the development and maintenance of proficiency in M60A1 tank crewman with special emphasis on application in reserve training.

Companion documents are:

1. Tank Crewman (M60A1) Readiness Tests, ARI Research Product RP-79-13 , November 1979.
2. Tank Crewman (M60A1) Training Modules, ARI Research Product RP-79-14 , November 1979.
3. Tank Crew (M60A1) Performance Exercise, ARI Research Product RP-79-15 , November 1979.

The project of which this report is a part was conducted by personnel of the Human Resources Research Organization (HumRRO) under Contract No. DAHC 19-76-C-0001 and monitored by Donald F. Haggard, Chief of ARI Field Unit at Fort Knox. The research was done under Army Project 2Q763743A773 and is responsive to requirements of the U.S. Army Armor School at Fort Knox, the Army Training and Doctrine Command, and the Army Forces Command.

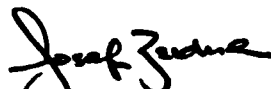

JOSEPH ZEIDNER
Technical Director

Accession For	
NTIS O&A	<input checked="" type="checkbox"/>
DOC TAB	<input type="checkbox"/>
Unannounced	<input type="checkbox"/>
Justification	<input type="checkbox"/>
By _____	
Distribution/	
Availability Codes	
Dist	Avail and/or special
A	

SUMMARY

This report explains the development of a modular, performance based, individually paced M60A1 tank crewman skills training program (TCST) and provides guidelines for managing the program. The first part of the report establishes the training goal and the task base. It also includes developmental procedures for diagnostic testing and remedial training. The second part of the report provides battalion, company, and tank commanders with a management tool for administering the program.

To administer the tank crewman skills training program, training managers and trainers must be thoroughly familiar with Research Products: RP-79-13, Tank Crewman (M60A1) Readiness Tests, RP-79-14, Tank Crewman (M60A1) Training Modules, and RP-79-15, Tank Crew (M60A1) Performance Exercise.

When used with the three companion documents listed above, this report provides guidance for implementing an integrated "train-up" package for annual gunnery evaluation.

TABLE OF CONTENTS

	<u>Page</u>
INTRODUCTION.	1
BACKGROUND.	1
PURPOSE	2
PROGRAM DEVELOPMENT	3
CREW INTERACTION PERFORMANCE TEST	3
Identifying Representative Engagements	3
Identifying Preparation for Operations Tasks	6
Identifying Tactical Operations Tasks.	6
Verifying Criticality of Tasks	6
Clustering Preparation for Operations Tasks.	7
Clustering Tactical Operations Tasks	7
Clustering Preparations for Operations Activities	7
Clustering Tactical Operations Activities.	7
Clustering Activities into Preparations for Operations and Tactical Operations Modules	7
DUTY POSITION READINESS TESTS	31
Identifying Tasks for Each Crewman	31
Clustering Tasks into Functional Groups.	31
Selecting Test Methodology	31
Clustering Functional Groups, by Test Methodology, into Readiness Tests.	32
Structuring Readiness Tests.	32
DUTY POSITION TRAINING MODULES.	33
Pretraining Conditions	34
Objective.	34
Method of Instructions	34
Equipment and Materials.	34
Estimated Time to Complete the Module.	34
Procedure for Administering Each Module.	34
Explanatory Notes.	35

TABLE OF CONTENTS (Cont'd.)

	<u>Page</u>
PROGRAM MANAGEMENT.	39
PROGRAM FAMILIARIZATION.	39
The TCST Concept.	39
The TCST Management Model	39
Diagnostic Testing.	39
Remedial Training	42
Crew Diagnostic Testing and Remedial Training	42
TRAINING MANAGER'S RESPONSIBILITIES.	43
Battalion Commander	44
Battalion Training Officer.	44
Company Commander	44
Company Training Officer/NCO.	45
Platoon Leader.	45
Tank Commander.	45
TRAINING SUPPORT	45
Higher Headquarters	46
Army Advisors	46
Branch Assistance Team (BAT).	46
Training and Audio-Visual Support Center (TASC)	46
Major Training Area (MTA) Commanders.	47
IMPLEMENTING THE PROGRAM	48
Training Manager's Guide.	48
Tank Commander's Training Guide	48
REFERENCES.	49
APPENDIXES.	50

LIST OF TABLES AND FIGURES

	<u>Page</u>
TABLE	
1. GUNNERY ENGAGEMENTS FOR CIPT TACTICAL OPERATIONS MODULE	5
2. TRAINING RESOURCE REQUIREMENTS	55
3. RESPONSIBILITIES FOR TRAINING RESOURCES	59
4. BATTALION TCST PLANNING CALENDAR	66
5. TRAINING SUPPORT FORCAST	67
6. READINESS TESTING SCHEDULE FOR KEY TANK COMMANDERS . . .	68
7. READINESS TESTING SCHEDULE FOR OTHER TC'S	70
8. BATTALION CREWMAN READINESS CHART	76
9. COMPANY CREWMAN READINESS CHART	78

FIGURE	
1. Tank crew skills training development model	4
2. Structuring the crew interaction performance test . . .	6
3. Master task list (MTL)	8
4. Preparation for operations task list	17
5. Tactical operations task list	20
6. Clustering pre-operations tasks by crew activity . . .	22
7. Clustering tactical operations tasks by crew activity .	23
8. Outline of preparation for operations module	26
9. Outline of tactical operations module	29
10. Functional groups	32
11. Outline of readiness tests by methodology	33
12. Self-instructional sound-slide presentation model . . .	36
13. One-on-one instructor controlled performance training module	37

LIST OF TABLES AND FIGURES (Cont'd.)

	<u>Page</u>
FIGURE	
14. Tank crew skills training concept.	40
15. Tank crew skills training management model	41
16. Training decision process.	42
17. Remedial training process.	42
18. Crew interaction performance test sequence process	43
19. Command and assistance lines for implementing TCST	43
20. Instructions for administering and scoring TEC pre-tests.	71
21. County fair testing and training layout.	73
22a. DRIVER flow diagram for TCST program	156
22b. LOADER flow diagram for TCST program	157
22c. GUNNER flow diagram for TCST program	158
22d. TANK COMMANDER flow diagram for TCST program	159

PROGRAM MANAGEMENT
TANK CREWMAN SKILLS TRAINING PROGRAM

INTRODUCTION

This report explains the development of the Tank Crewman Skills Training (TCST) program and provides guidelines for managing the program. Companion documents are:

- . Tank Crewman (M60A1) Readiness Tests, ARI Research Product RP-79-13, November 1979.
- . Tank Crewman (M60A1) Training Modules, ARI Research Product RP-79-14, November 1979.
- . Tank Crew (M60A1) Performance Exercise, ARI Research Product RP-79-15, November 1979.

BACKGROUND

In 1977 the training needs of Reserve Component units were changing. The M48A1 tank was being replaced with the M48A5 tank and the draft had been eliminated. Equipment and personnel turbulence was on the increase and the cost of training related items was on the rise.

Recognizing the need for a new approach to Reserve Component Training, the U.S. Army Research Institute for the Behavioral and Social Sciences (ARI) initiated research to design training plans for operating and maintaining the M48A5 tank.

In July 1977 a survey, Armor and Cavalry National Guard Training Constraints (O'Brien, Ford, and Boldovici, 1977), was published. The survey showed: number of personnel in each unit, time available for training, distance to local and major training areas and frequency of their use, training facilities at armories and training areas, type and quantity of training devices, and support from mobile training teams. From the data acquired, a hypothetical National Guard tank company, considered to be an average representation of all National Guard tank companies, was structured.

In August 1977 the Tank Crewman Skills Training (TCST) program was developed to accommodate the ARI requirement for a new approach to Reserve Component training. The TCST program was published as Reserve Component Training for Operating and Maintaining the M48A5 Tank (Harris, Osborn, and Boldovici, 1977). Before the program was implemented, however, two events occurred which necessitated major revisions of the program;

- . Selection for trial implementation of a unit equipped with the M60 tank.
- . Revision of Field Manual, FM 17-12, "Tank Gunnery" to include target engagements of increased complexity.

PURPOSE

This report explains the development of the Tank Crewman Skills Training (TCST) program and provides a tool to aid training managers in implementing the program. The first part of the report describes the development process. The second part explains responsibilities of the training managers at various levels and the procedures and techniques for implementing the program.

PROGRAM DEVELOPMENT

In the initial phase of program development, a training model was designed to accommodate tank gunnery requirements of the "average representation" National Guard tank company. The following were considered in developing the model:

- . Minimal dependence on skills learned outside the program.
- . Being deliverable, as much as possible, at armories.
- . Use of pre-tests to determine areas of mastery or deficiency.

The major components of the model, shown in Figure 1 are: a crew interaction performance test, duty position readiness tests, and duty position training modules.

CREW INTERACTION PERFORMANCE TEST (CIPT)

The CIPT consists of a preparation for operations module and a tactical operations module; designed to evaluate a tank crew's ability to prepare their tank for combat and engage target arrays representative of target arrays in tank gunnery Table VII, Field Manual FM 17-12, "Tank Gunnery," Structuring the CIPT included actions shown in Figure 2.

Identifying Representative Engagements

Table VII includes nine engagements, each with a different target array. The arrays consist of variations of--single, multiple, point, area, stationary, and moving--targets. The targets include tanks, BRDM, ATGM Tms, RPG Tms, and troops. Engagement methods are battlesight, precision, non-precision, and RCLD. Three of the engagements are at night with IR/Passive or flare illumination and three are in an NBC environment. Main gun engagements by the tank commander, or by the gunner using the telescope, are not indicated. The engagements selected for the CIPT are shown in Table 1.

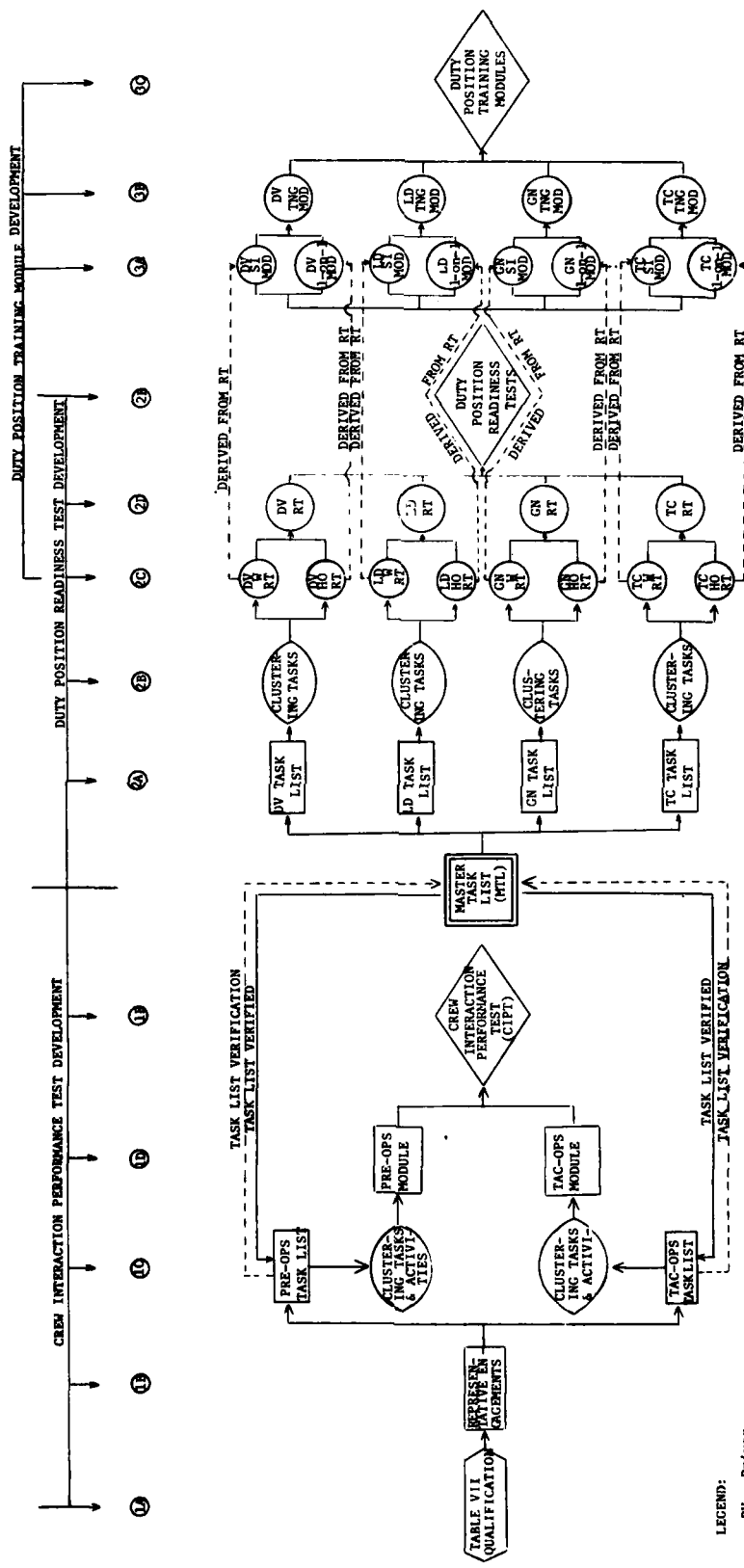

Figure 1. Tank crew skills training development model.

TABLE 1. GUNNERY ENGAGEMENTS FOR CIP/T TACTICAL OPERATIONS MODULE

EXER NBR	FIRE VEH MOTION	TARGET		DAY OR NIGHT	FIRE CONTROL INSTRUMENT	AMMO	STANDARDS		METHOD OF FIRE DELIVERY			
		MOTION	TYPE				VISI- BILITY	(METERS)		NBR RDS	NBR HITS	TIME* (SEC)
1	MOV	STA	1-Tk	VIS	1400-1600	DAY	GRN/PER,D	SABOT	2	1	16	BS
2**	STA	MOV	2-Tks	VIS	1200-1600	DAY	GRN/PER,D	SABOT	4	2	30	BS
3	STA	STA	INF SQD	VIS	600-800	DAY	GRN/TNF TC/PER,D	COAX CAL 30	100 50	3/5 1	30	NP NP
4	STA	STA	2-Tks 1-BRDM	VIS	1800-2000 1000-1200	DAY	GRN/PER,D TC/PER,D	SABOT CAL 50	4 50	2 1	40	PRE NP
5	STA	STA	3-Tks	VIS	800-1100	DAY	GRN/PER,D	HEAT	5	3	40	BS

NIGHT PHASE

6(7) ***	STA	STA	2-Tks INF SQD	IR	800-1000 800-1000	NGT	GRN/PER,IR TC/PER,IR	HEAT CAL 50	4 50	2 3/5	40	BS NP
7(9)	STA	STA	STA MOV	1-Tk 1-Tk	FLARE 1200-1400 1200-1600	NGT	GRN/PER,D GRN/PER,D	SABOT SABOT	2 2	1 1	40	BS BS

NOTES: * Time to complete engagements for qualification
 ** NBC environment, crew buttoned up
 *** RCLD
 () Indicates Table VII numbered engagement

When task worksheets were completed, each task was verified for criticality by comparing it with tasks listed in the priority section of the Master Task List (MTL). If the task was in the priority section

Verifying Criticality of Tasks

These tasks are actions which individual crewmen perform during target engagements. In the CIP model, these are tasks required to be performed when firing representative engagements. As each task was identified it was listed on a worksheet for verification as to criticality.

Identifying Tactical Operations Tasks

These tasks are actions which individual crewmen perform in preparing a tank for combat. In the CIP model these are tasks required to prepare the tank for firing representative engagements. As each task was identified it was listed on a worksheet for verification as to criticality.

Identifying Preparation for Operations Tasks

Figure 2. Sequential structuring of crew interaction performance test.

1. Identifying representative engagements.
2. Identifying preparation for operations tasks.
3. Identifying tactical operations tasks.
4. Verifying criticality of tasks.
5. Clustering preparation for operations tasks.
6. Clustering tactical operations tasks.
7. Clustering preparation for operations activities.
8. Clustering tactical operations activities.
9. Clustering activities into preparation for operations module.
10. Clustering activities into tactical operations module.

1. Identifying representative engagements.
2. Identifying preparation for operations tasks.
3. Identifying tactical operations tasks.
4. Verifying criticality of tasks.
5. Clustering preparation for operations tasks.
6. Clustering tactical operations tasks.
7. Clustering preparation for operations activities.
8. Clustering tactical operations activities.
9. Clustering activities into preparation for operations module.
10. Clustering activities into tactical operations module.

Figure 2. Sequential structuring of crew interaction performance test.

Identifying Preparation for Operations Tasks

These tasks are actions which individual crewmen perform in preparing a tank for combat. In the CIPT model these are tasks required to prepare the tank for firing representative engagements. As each task was identified it was listed on a worksheet for verification as to criticality.

Identifying Tactical Operations Tasks

These tasks are actions which individual crewmen perform during target engagements. In the CIPT model, these are tasks required to be performed when firing representative engagements. As each task was identified it was listed on a worksheet for verification as to criticality.

Verifying Criticality of Tasks

When task worksheets were completed, each task was verified for criticality by comparing it with tasks listed in the priority section of the Master Task List (MTL). If the task was in the priority section

it was retained for clustering, by duty position, in with the preparations for operations or tactical operations task list. (Figure 3, the Master Task List, is divided into three categories: priority tasks, listed in Selecting Items for a Tank Gunnery Test (Boldovici, Wheaton, and Boycan, 1976), initiating tasks, required to initiate a priority task, and engagement tasks, detailed actions required during gunnery engagements).

Clustering Preparation for Operations Tasks

After each task, which involved the preparation of a tank for operations, had been verified with the MTL, it was listed by crewmember and placed in chronological order by crewmember in the preparation for operations task list shown in Figure 4.

Clustering Tactical Operations Tasks

The above procedure was repeated for those tasks which involved tactical operations. This task list is shown in Figure 5.

Clustering Preparation for Operations Activities

Tasks in the preparation for operations task list were next clustered into activities. An activity being individual actions performed by one or more crewmen to accomplish a functional task. Figure 6 shows an example, "Zero tank main gun," of a preparation for operations activity which involves all crewmembers.

Clustering Tactical Operations Activities

The above procedure was repeated for tasks involving tactical operations. Figure 7 shows two examples, "Main gun engagement--moving to a halt--stationary point target," and "Main gun/caliber .50 simultaneous engagement--moving to a halt--stationary point targets," of tactical operations activities which involves all crewmembers.

Clustering Activities into Preparation for Operations and Tactical Operations Modules

The last phase of developing the CIPT was clustering all preparation for operations activities into a test module and all tactical operations activities into a second test module. Figure 8 is an outline of the activities included in the preparation for operations module and Figure 9 is the same for the tactical operations module. The complete CIPT, which includes the preparation for operations module, the tactical operations module, administrative guidelines, and an equipment list, is contained in ARI Research Product RP-79-15, Tank Crew (M60A1) Performance Exercise, 1979.

MASTER
TASK
LIST
(MTL)

PRIORITY TASKS	DV	LD	GN	TC
1. Perform before-operations maintenance checks and services on engine and transmission oil levels.	X*	X		
2. Perform before-operations maintenance checks and services on M24(IR) and M27 periscopes.	X*			
3. Place the tank in motion.	X			
4. Check track tension.	X*	X		
5. Adjust track tension.	X*	X		
6. Install and operate AN/VRC-12 or AN/VRC-64 radio.		X		
7. Operate the tank intercommunications system.	X	X	X	X
8. Perform prepare-to-fire procedures.	X*	X*	X*	X*
9. Place the turret into power operation.			X*	X*
10. Disassemble the M219 machinegun.		X*	X*	X*
11. Assemble the M219 machinegun.		X*	X*	X*
12. Disassemble the M85 machinegun.		X*	X*	X*
13. Assemble the M85 machinegun.		X*	X*	X*
14. Disassemble the main gun breechblock.		X*	X*	X*
15. Assemble the main gun breechblock.		X*	X*	X*
16. Stow main gun ammunition.		X*	X*	X*
17. Stow machinegun ammunition.		X*	X*	X*
18. Stow coax ammunition in the ready (banana) box.		X*	X*	X*
19. Index announced ammunition into computer and perform computer test.			X*	X*

Figure 3. Master Task List (MTL)

	DV	LD	GN	TC
20. Prepare azimuth indicator for operation.			X*	
21. Operate the elevation quadrant.			X*	
22. Prepare the tank for boresighting.	X	X	X	X
23. Prepare the Gunner's telescope for operation.			X	
24. Prepare the Gunner's periscope for operation.			X	
25. Prepare the rangefinder for operation.				X*
26. Boresighting the Gunner's telescope and apply established zero.			X*	X*
27. Boresight the daylight sight of the Gunner's periscope and apply established zero.			X*	X*
28. Boresight the IR sight of the Gunner's periscope and apply established zero.			X*	X*
29. Boresight the rangefinder with the main gun bore axis alined on an aiming point at 1200 meters.				
30. Boresight the M219 machinegun.		X*	X*	X*
31. Boresight the M85 machinegun.				X*
32. Boresight the searchlight using the primary method.			X*	X*
33. Boresight the searchlight using the alternate method.			X*	X*
34. Load the M219 machinegun.		X*	X*	X*
35. Zero the M219 machinegun.		X*	X*	X*
36. Clear and unload the M219 machinegun.		X*	X*	X*
37. Load the M85 machinegun.		X*	X*	X*
38. Zero the M85 machinegun.				X*
39. Clear and unload the M85 machinegun.		X*	X*	X*
40. Change the M219 machinegun barrel.		X*	X*	X*
41. Load the main gun.		X*	X*	X*
42. Zero the main gun.			X*	X*

Figure 3. (Continued) Master Task List (MTL)

	DV	LD	GN	TC
43. Drive the tank over varied terrain with the hatch open/closed.	X*			
44. Operate the tank across a water obstacle.	X	X	X	
45. Identify armor vehicles.	X*	X*	X*	X*
46. Acquire targets.	X*	X*	X*	X*
47. Drive in response to fire commands.	X			
48. Designate crew sectors of responsibility for target acquisition.				X*
49. Lay main gun for direction.				X*
50. Determine if target is within battlesight range.				X*
51. Determine range to target with the rangefinder.				X*
52. Issue initial fire command.				X*
53. Main gun engagement-moving to a halt - stationary point target.	X	X	X	X
54. Main gun engagement - moving to a halt - multiple moving point targets.	X	X	X	X
55. Coax/Caliber .50 simultaneous engagement - moving to a halt - stationary area and moving point target.				
56. Main gun/Caliber .50 simultaneous engagement - moving to a halt - multiple stationary point targets.	X	X	X	X
57. Main gun engagement - moving to a halt - multiple stationary point targets.	X	X	X	X
58. Install M24(IR) periscope.	X*			
59. Place M24(IR) periscope into operation.	X*			
60. Main gun/Caliber .50 simultaneous engagement - at the halt - multiple stationary and area targets.				
61. Main gun engagement - at the halt - moving and stationary point targets.	X	X	X	X
62. Drive to defilade firing position upon enemy contact.	X*			

Figure 3. (Continued) Master Task List (MTL)

	DV	LD	GN	TC
63. Perform evasive maneuvers upon enemy contact.	X			X
64. Operate the tank in neutral steer.	X			
65. Apply immediate action to reduce stoppage of M219 machinegun.		X*	X*	X*
66. Apply immediate action to reduce stoppage of the M85 machinegun.		X*	X*	X*
67. Perform misfire procedures for the main gun.		X*	X*	X*
68. Remove a misfired main gun round.		X*	X*	X*
69. Determine corrective action required by the replenisher tape.		X*	X*	X*
70. Sense rounds.	X*		X	X
71. Issue subsequent fore command.				X*
72. Apply burst-on-target (BOT) adjustment.			X*	X*
73. Apply target form (TF) adjustment.			X*	X*
74. Apply standard adjustment.			X*	X*
75. Lay telescope reticle on target properly.			X*	X*
76. Perform during-operations maintenance checks and services on steering, accelerator shift, and brake controls.				
77. Perform during-operations checks on instruments, gages, and warning lights.	X			
INITIATING TASKS				
1. Inspect track suspension system for deficiencies.	X	X		
2. Inspect battery cables, hatch latches, fire extinguishers, and oil coolers for deficiencies.	X	X		
3. Check brakes for proper action.	X			
4. Follow safety precautions during fueling.	X	X		

Figure 3. (Continued) Master Task List (MTL)

	DV	LD	GN	TC
5. Remove the M27 periscope.	X			
6. Start the tank engines.	X			
7. Position the tank for checking track tension.	X	X		
8. Perform before-operations checks and services on the gas particulate unit.	X	X	X	X
9. Charge the manual elevation system.			X	
10. Remove the M219 machinegun from the tank.		X	X	X
11. Inspect the M219 machinegun.		X	X	X
12. Check the operation of the M219 machinegun.		X	X	X
13. Mount the M219 machinegun in the tank.		X	X	X
14. Remove the M85 machinegun from the tank.		X	X	X
15. Inspect the M85 machinegun.		X	X	X
16. Check the operation of the M85 machinegun.		X	X	X
17. Mount the M85 machinegun in the tank.		X	X	X
18. Check the boresight alignment of the main gun.		X		
19. Ready M219 machinegun in response to fire commands.		X		
20. Conduct a quick search scan of the area.	X	X	X	X
21. Estimate range to targets in the area.	X	X	X	X
22. Report locations of targets in the area.	X	X	X	X
23. Preset SABOT battlesight information.			X	X
24. Preset HEAT information.			X	X
ENGAGEMENT TASKS				
1. Announce GUNNER.				X
2. Lay gun for direction.				X
3. Announce BATTLESIGHT.				X

Figure 3. (Continued) Master Task List (MTL)

	DV	LD	GN	TC
4. Announce TANK.				X
5. Announce FIRE.				X
6. Sense round.	X		X	X
7. Give subsequent fire commands.				X
8. Announce CEASE FIRE.			X	X
9. Observe sector.	X	X	X	X
10. Announce TWO MOVING TANKS - RIGHT TANK FIRST.				X
11. Announce TARGET.				X
12. Announce LEFT TANK.			X	X
13. Announce DRIVER STOP.				X
14. Announce COAX.				X
15. Announce TROOPS.				X
16. Announce FIRE AND ADJUST.				X
17. Insure cupola is unlocked.				X
18. Place cupola power switch in ON position.				X
19. Place caliber .50 safety in FIRE position.				X
20. Insure rate of fire selector is in LOW (L) rate of fire.				X
21. Announce CALIBER FIFTY.				X
22. Lay rangeline leadline on center of mass of target.				X
23. Fire caliber .50 at moving point target.				X
24. Announce TC COMPLETE after target hit.				X
25. Place caliber .50 safety in OFF position.				X
26. Announce SABOT.				X
27. Range to target.				X

Figure 3. (Continued) Master Task List (MTL)

	DV	LD	GN	TC
28. Lay rangeline on center of mass of target.				X
29. Fire caliber .50 at stationary point target.				X
30. Announce THREE TANKS - LEFT TANK FIRST.				X
31. Announce DIRECT FIRE.				X
32. Announce INDEX HEP - FIRE HEAT.				X
33. Announce RED LIGHT.				X
34. Announce TWO TANKS - LEFT TANK FIRST.				X
35. Announce DEFLECTION SEVEN ZERO LEFT.				X
36. Announce SIXTEEN HUNDRED - QUADRANT PLUS ONE SIX.				X
37. Announce TARGET ILLUMINATED.				X
38. Turn IR power switch on M36 periscope ON.				X
39. Lay rangeline crosshair at near edge of target.				X
40. Fire caliber .50 at troop target.				X
41. Adjust fire to cover entire target.			X	X
42. Turn IR power switch OFF.	X		X	X
43. Announce MOVING TANK.				X
44. Turn ON main gun switch.			X	
45. Index SABOT into computer.			X	
46. Look through sight and find target.			X	X
47. Announce IDENTIFIED.			X	
48. Lay crosshair at center of base of target.			X	X
49. Announce ON THE WAY.			X	X
50. Fire main gun.			X	X
51. Announce sensing and BOT or LOST.			X	X

Figure 3. (Continued) Master Task List (MTL)

	DV	LD	GN	TC
*52. Lay aiming point on target.			X	X
53. Turn main gun switch OFF.			X	
54. Turn ON machinegun switch.			X	
55. Index HEP into computer.			X	
56. Look through unity window and find target.			X	
57. Insure target is within unity window of infinity sight.			X	
58. Fire coax at stationary area target.			X	
59. Announce TARGET - CEASE FIRE.			X	
60. Turn OFF machinegun switch.			X	
61. Lay crosshair at center of mass of target.			X	X
62. Traverse gun to announced deflection.			X	
63. Read back DEFLECTION SEVEN ZERO LEFT.			X	
64. Elevate or depress main gun to applied elevation.			X	
65. Level bubble.			X	
66. Read back SIXTEEN HUNDRED QUADRANT PLUS ONE SIX.			X	
67. Index SABOT into computer and announce SABOT INDEXED.			X	
68. Turn IR power switch on M32 periscope ON.			X	
69. Check turret ring for obstructions.		X		
70. Check path of recoil.		X		
71. Place safety switch in FIRE position.		X		
72. Announce UP.		X		
73. Prepare to load subsequent rounds.		X		
74. Brace.	X	X		
75. Load subsequent rounds.		X		
76. Place safety switch in SAFE position.		X		

Figure 3. (Continued) Master Task List (MTL)

	DV	LD	GN	TC
77. Place coax safety switch in FIRE position.		X		
78. Place coax safety switch in SAFE position.		X		
79. Slow speed of tank.	X			
80. Bring tank to a smooth halt.	X			
81. Lock brakes and remove hands from steering controls.	X			
82. Unlock brakes.	X			
83. Turn IR power switch on M24 periscope ON.	X			
84. Lay crosshair leadline at center of base of target.			X	X
85. Lay circle reticle at near edge of target.			X	

*Tank Crew Gunnery Skills Test (TCGST) tasks. (FM 17-12)

Figure 3. (Continued) Master Task List (MTL)

PREPARATIONS FOR OPERATIONS

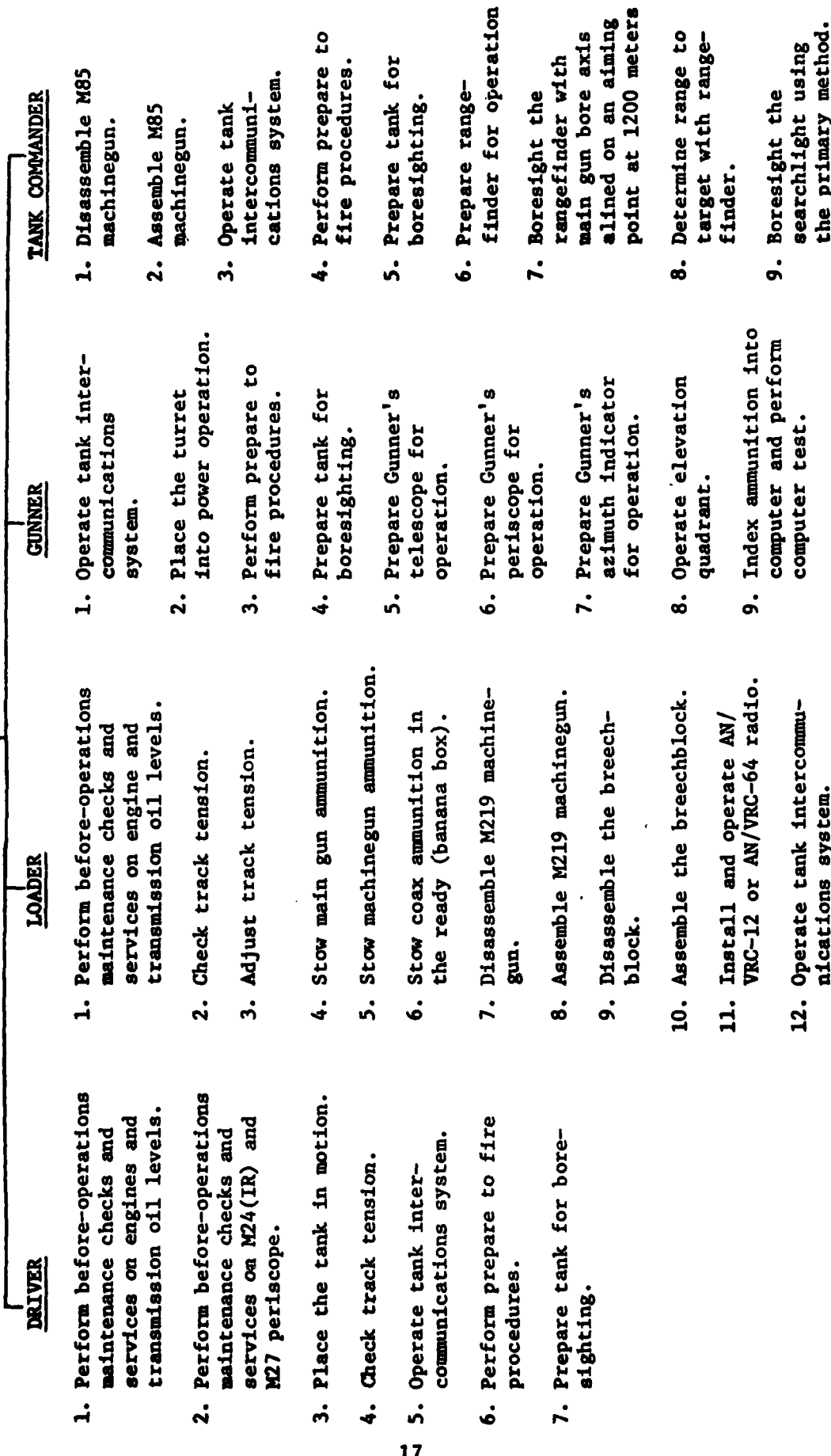

Figure 4. Preparation for Operations Task List

PREPARATIONS FOR OPERATIONS

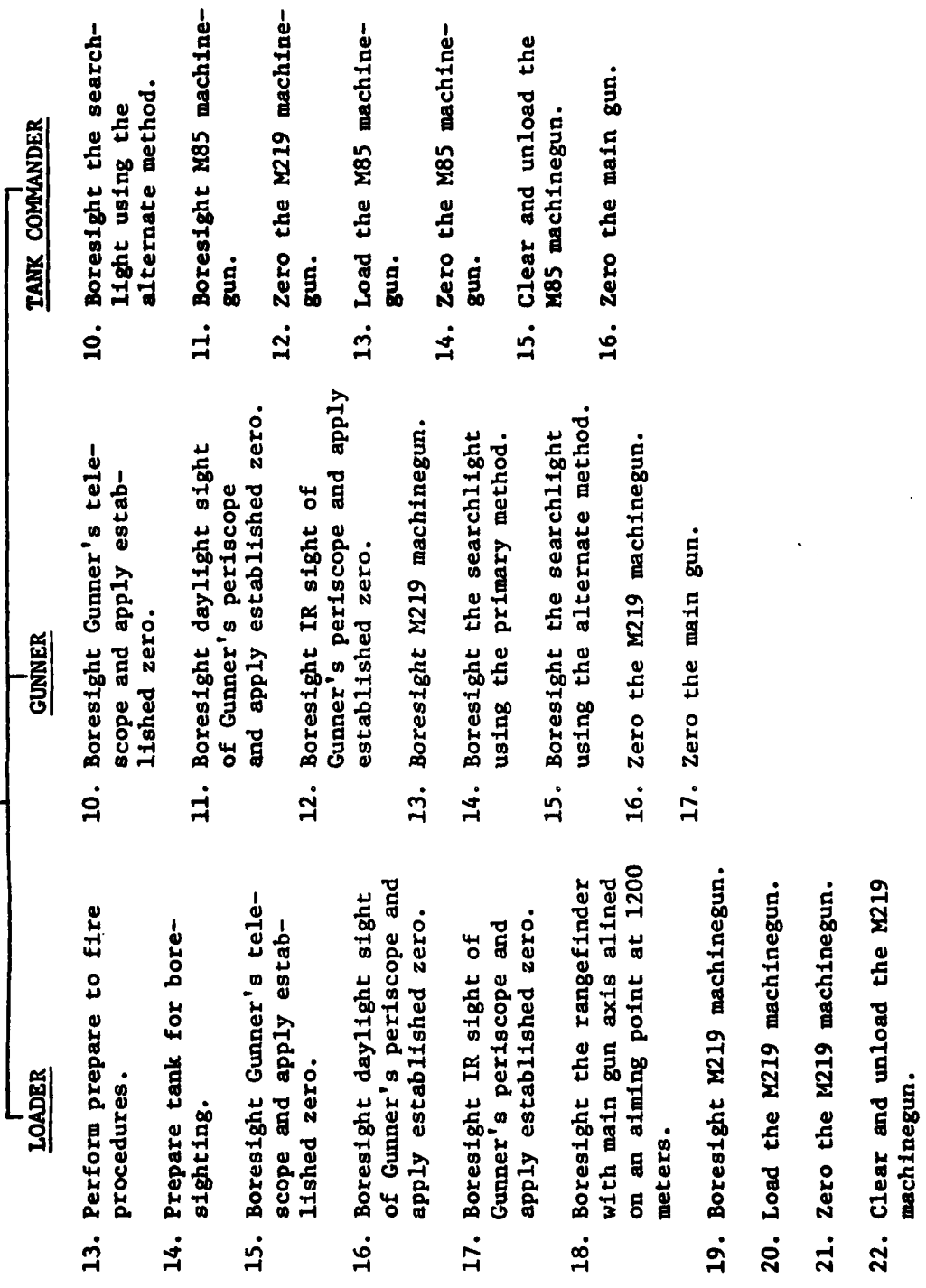

Figure 4. (Continued) Preparation for Operations Task List

PREPARATIONS FOR
OPERATIONS

LOADER

- 23. Change the M219 machine-
gun barrel.
- 24. Load the main gun.
- 25. Zero the main gun.

Figure 4. (Continued) Preparation for Operations Task List

TACTICAL
OPERATIONS

DRIVER

1. Drive the tank over varied terrain with the hatch open/closed.

2. Operate the tank across a water obstacle.

3. Acquire targets.

4. Drive in response to fire commands.

5. Main gun engagement-moving to a halt-stationary point target.

6. Main gun engagement-moving to a halt-multiple moving point targets.

7. Coax/Caliber .50 simultaneous engagement-moving to a halt-stationary area and moving point targets.

8. Main gun/Caliber .50 simultaneous engagement-moving to a halt-multiple stationary point targets.

9. Main gun engagement-moving to a halt-multiple stationary point targets.

LOADER

1. Operate the tank across a water obstacle.

2. Acquire targets.

3. Main gun engagement-moving to a halt-stationary point target.

4. Main gun engagement-moving to a halt-multiple moving point targets.

5. Coax/Caliber .50 simultaneous engagement-moving to a halt-stationary area and moving point targets.

6. Main gun/Caliber .50 simultaneous engagement-moving to a halt-multiple stationary point targets.

7. Main gun engagement-moving to a halt-multiple stationary point targets.

8. Main gun/Caliber .50 simultaneous engagement-at the halt-multiple stationary point and area targets.

GUNNER

1. Operate the tank across a water obstacle.

2. Acquire targets.

3. Main gun engagement moving to a halt-stationary point targets.

4. Main gun engagement-moving to a halt-multiple moving point targets.

5. Coax/Caliber .50 simultaneous engagement-moving to a halt-stationary area and moving point targets.

6. Main gun/Caliber .50 simultaneous engagement-moving to a halt-multiple stationary point targets.

7. Main gun engagement-moving to a halt-multiple stationary point targets.

TANK COMMANDER

1. Acquire targets.

2. Designate crew sectors of responsibilities for target acquisition.

3. Determine if target is within battlesight range.

4. Issue initial fire command.

5. Main gun engagement-moving to a halt-stationary point target.

6. Main gun engagement-moving to a halt-multiple moving point targets.

7. Coax/Caliber .50 simultaneous engagement-moving to a halt-stationary area and point targets.

8. Main gun/Caliber .50 simultaneous engagement-moving to a halt-multiple stationary point targets.

Figure 5. Tactical Operations Task List

TACTICAL
OPERATIONS

DRIVER

10. Install M24(IR) periscope.
11. Place M24(IR) periscope into operation.
12. Main gun/Caliber .50 simultaneous engagement-at the halt-multiple stationary point and area targets.
13. Main gun engagement-at the halt-moving and stationary point targets.
14. Drive to defilade firing position upon enemy contact.
15. Perform evasive maneuvers upon enemy contact.
16. Sense rounds.
17. Perform during-operations maintenance checks and services on steering, accelerator shift, and brake controls.
18. Perform during operations checks on instruments, gages, and warning lights.

LOADER

9. Main gun engagement-at the halt-moving and stationary point targets.
10. Apply immediate action to reduce stoppage of M219 machinegun.
11. Perform misfire procedures for the main gun.
12. Remove a misfired main gun round.
13. Determine corrective action required by the replenisher tape.

GUNNER

8. Main gun/Caliber .50 simultaneous engagement-at the halt-multiple stationary point and area targets.
9. Main gun engagement-at the halt-moving and stationary point targets.
10. Perform misfire procedures for the main gun.
11. Remove misfired main gun round.
12. Sense rounds.
13. Apply burst-on-target (BOT) adjustment.
14. Apply target form (TF) adjustment.
15. Apply standard adjustment.

TANK COMMANDER

9. Main gun engagement-moving to a halt-multiple stationary point targets.
10. Main gun/Caliber .50 simultaneous engagement-at the halt-multiple stationary point and area targets.
11. Main gun engagement-at the halt-moving and stationary point targets.
12. Perform evasive maneuvers upon enemy contact.
13. Apply immediate action to reduce stoppage of M85 machinegun.
14. Sense rounds.
15. Issue subsequent fire command.

Figure 5 (Cont'd.). Tactical Operations Task List

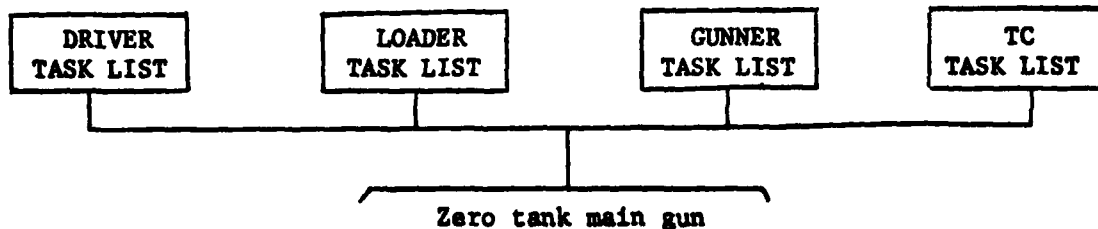

1. TC - Turn computer switch ON.
2. GN - Index ammunition element into ballistic computer.
3. TC - Index range into rangefinder.
4. LD - Load main gun - Announce UP.
5. GN - Lay sight reticle on center of mass of target by operating the manual elevation and traversing handles.
6. GN/LD - Fire a three round group.
7. GN - Unlock boresight knobs and move sight reticle to the center of the shot group without disturbing the lay of the gun.
8. GN - Relay main gun back to center of mass by operating the manual elevation and traversing handles.
9. GN/LD - Fire a check round.
10. GN - Relay main gun back to center of mass by operating manual elevation and traversing handles.
11. GN - Record elevation and deflection readings on all sights.

Figure 6. Clustering Pre-Operations Tasks by Crew Activity

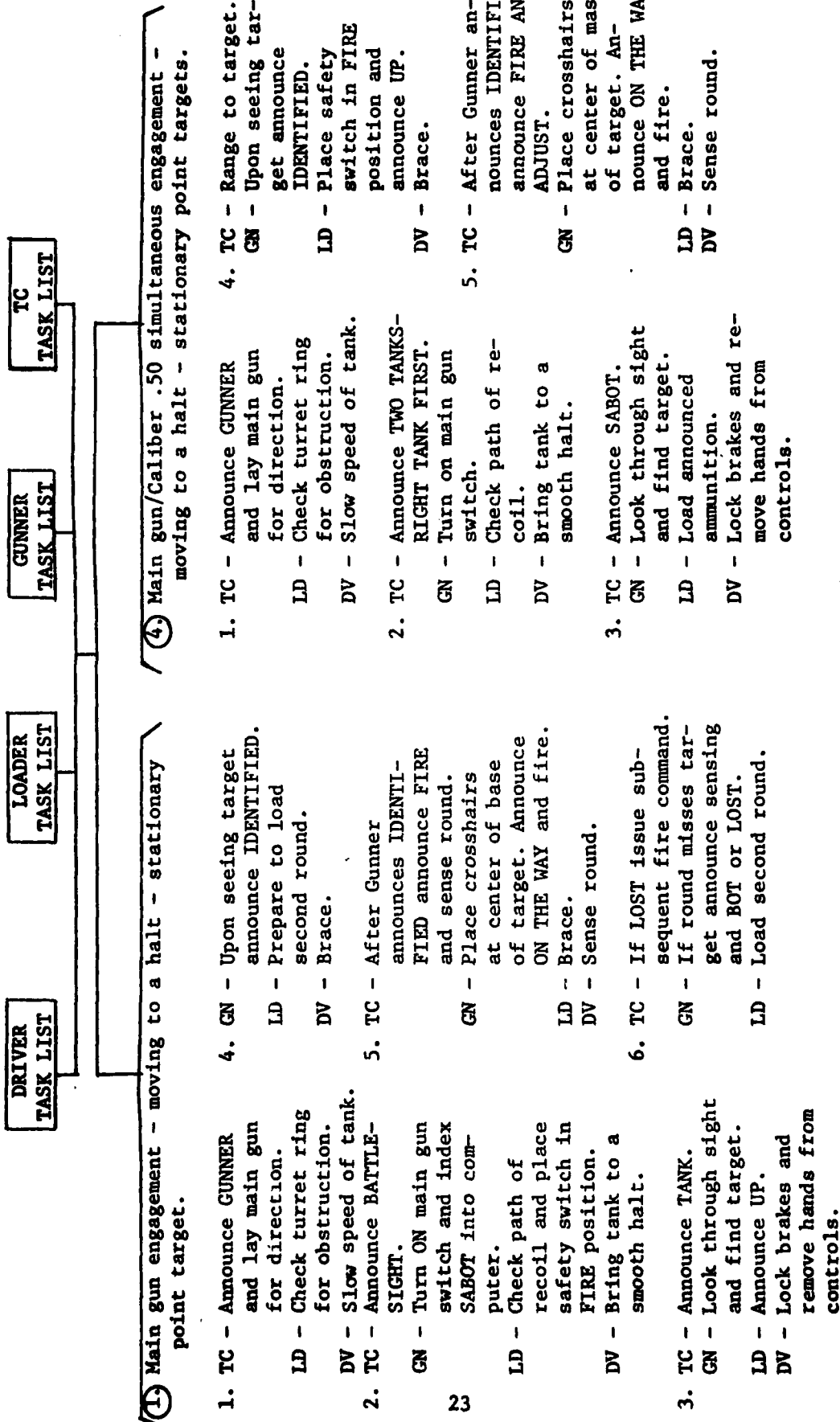

Figure 7. Clustering Tactical Operations Tasks by Crew Activity.



① Main gun engagement - moving to a halt - stationary point target.

④ Main gun/Caliber .50 simultaneous engagement - moving to a halt - stationary point targets.

- 7. GN - Lay aiming point on target.
LD - Announce UP.
DV - Brace.
- 8. TC - Sense round.
GN - Announce ON THE WAY and fire.
LD - Brace.
DV - Sense round.
- 9. TC - Announce CEASE FIRE after target hit.
GN - Turn main gun switch OFF.
LD - Place safety switch in SAFE position.
DV - Unlock brakes.
- 10. TC - Observe sector with binoculars.
GN - Observe sector.
LD - Observe sector.
DV - Observe sector.

- 6. TC - Insure cupola is unlocked.
GN - If round misses target announce sensing and BOT or LOST.
LD - Load second round.
DV - Brace.
- 7. TC - Place cupola power switch in ON position, place caliber .50 safety switch in FIRE position. Insure rate of fire selected is on LOW (L) rate of fire.
GN - Lay aiming point on target.
LD - Announce UP.
- 8. TC - Announce CALIBER FIFTY.
GN - Announce ON THE WAY and fire.
LD - Brace.
DV - Sense round.

- 9. TC - Lay rangeline crosshair at center of mass of target.
GN - Announce TARGET after target hit. Announce LEFT TANK.
LD - Load third round.
DV - Brace.
- 10. TC - Fire caliber .50 at stationary point target.
GN - Place crosshairs at center of mass of target. Announce ON THE WAY and fire.
LD - Announce UP.
DV - Sense round.

Figure 7. (Continued) Clustering Tactical Operations Tasks by Crew Activity.



④ Main gun/Caliber .50 simultaneous engagement - moving to a halt - stationary point targets.

11. TC - Announces TC COMPLETE after target hit. Place caliber .50 safety in OFF position.
 GN - If round misses target announce sensing and BOT or LOST.
 LD - Load fourth round.
 DV - Brace.
12. TC - Observe sector with binoculars.
 GN - Lay aiming point on target.
 LD - Announce UP.
13. GN - Announce ON THE WAY and fire.
 LD - Brace.
 DV - Sense round.
14. GN - Announce TARGET-CEASE FIRE. Turn main gun switch OFF.
 LD - Place safety switch in SAFE position.
 DV - Unlock brakes.
15. GN - Observe sector.
 LD - Observe sector.
 DV - Observe sector.

Figure 7. (Continued) Clustering Tactical Operations Tasks by Crew Activity.

1. PERFORM BEFORE-OPERATIONS MAINTENANCE CHECKS AND SERVICES ON ENGINE AND TRANSMISSION OIL LEVELS [DRIVER/LOADER].
2. PERFORM BEFORE-OPERATIONS MAINTENANCE CHECKS AND SERVICES ON M24 (IR) PERISCOPE AND M27 PERISCOPE [DRIVER].
3. PLACE A TANK IN MOTION [DRIVER].
4. CHECK TRACK TENSION [DRIVER/LOADER].
5. ADJUST TRACK TENSION [LOADER].
6. STOW MAIN GUN AMMUNITION [LOADER].
7. STOW MACHINEGUN AMMUNITION [LOADER].
8. STOW COAX AMMUNITION IN THE READY (BANANA) BOX [LOADER].
9. DISASSEMBLE M219 MACHINEGUN [LOADER].
10. ASSEMBLE M219 MACHINEGUN [LOADER].
11. DISASSEMBLE BREECHBLOCK [LOADER].
12. ASSEMBLE BREECHBLOCK [LOADER].
13. DISASSEMBLE M85 MACHINEGUN [TANK COMMANDER].
14. ASSEMBLE M85 MACHINEGUN [TANK COMMANDER].
15. INSTALL AND OPERATE AN/VRC-12 OR AN/VRC-64 RADIO [LOADER].
16. OPERATE TANK INTERCOMMUNICATIONS SYSTEM [DRIVER/LOADER/GUNNER/TANK COMMANDER].
17. PLACE TURRET INTO POWER OPERATION [GUNNER].
18. PERFORM PREPARE TO FIRE PROCEDURES [DRIVER/LOADER/GUNNER/TANK COMMANDER].
19. PREPARE TANK FOR BORESIGHTING [DRIVER/LOADER/GUNNER/TANK COMMANDER].

Figure 8. Outline of Preparation for Operations Module.

20. PREPARE GUNNER'S TELESCOPE FOR OPERATION [GUNNER].
21. PREPARE GUNNER'S PERISCOPE FOR OPERATION [GUNNER].
22. PREPARE RANGEFINDER FOR OPERATION [TANK COMMANDER].
23. PREPARE AZIMUTH INDICATOR FOR OPERATION [GUNNER].
24. OPERATE ELEVATION QUADRANT [GUNNER].
25. INDEX AMMUNITION INTO COMPUTER AND PERFORM COMPUTER TEST [GUNNER].
26. BORESIGHT GUNNER'S TELESCOPE AND APPLY ESTABLISHED ZERO [LOADER/GUNNER].
27. BORESIGHT DAYLIGHT SIGHT OF GUNNER'S PERISCOPE AND APPLY ESTABLISHED ZERO [LOADER/GUNNER].
28. BORESIGHT IR SIGHT OF GUNNER'S PERISCOPE DURING DAYLIGHT AND APPLY ESTABLISHED ZERO [LOADER/GUNNER].
29. BORESIGHT RANGEFINDER WITH MAIN GUN BORE AXIS ALINED ON AN AIMING POINT AT 1200 METERS [LOADER/TANK COMMANDER].
30. DETERMINE RANGE TO TARGET WITH RANGEFINDER [TANK COMMANDER].
31. BORESIGHT M219 MACHINEGUN [LOADER/GUNNER].
32. BORESIGHT SEARCHLIGHT USING PRIMARY METHOD [GUNNER/TANK COMMANDER].
33. BORESIGHT SEARCHLIGHT USING ALTERNATE METHOD [GUNNER/TANK COMMANDER].
34. BORESIGHT M85 MACHINEGUN [TANK COMMANDER].
35. LOAD M219 MACHINEGUN [LOADER].
36. ZERO M219 MACHINEGUN [LOADER/GUNNER/TANK COMMANDER].
37. CLEAR AND UNLOAD M219 MACHINEGUN [LOADER].
38. LOAD M85 MACHINEGUN [TANK COMMANDER].
39. ZERO M85 MACHINEGUN [TANK COMMANDER].

Figure 8. (Continued) Outline of Preparation for Operations Module.

40. CLEAR AND UNLOAD M85 MACHINEGUN [TANK COMMANDER].
41. CHANGE M219 MACHINEGUN BARREL [LOADER].
42. LOAD MAIN GUN [LOADER].
43. ZERO MAIN GUN [LOADER/GUNNER/TANK COMMANDER].

Figure 8. (Continued) Outline of Preparation for Operations Module

1. DRIVE THE TANK OVER VARIED TERRAIN WITH DRIVER HATCH IN THE OPEN/CLOSE POSITION [DRIVER].
2. OPERATE A TANK ACROSS A WATER OBSTACLE [DRIVER/LOADER/GUNNER].
3. ACQUIRE TARGETS [DRIVER/LOADER/GUNNER/TANK COMMANDER].
4. ASSIGN CREW SECTORS OF RESPONSIBILITY FOR TARGET ACQUISITION [TANK COMMANDER].
5. DETERMINE IF TARGET IS WITHIN BATTLESIGHT RANGE [TANK COMMANDER].
6. ISSUE INITIAL FIRE COMMAND [TANK COMMANDER].
7. DRIVE IN RESPONSE TO FIRE COMMANDS [DRIVER].
8. MAIN GUN ENGAGEMENT - MOVING TO A HALT - STATIONARY POINT TARGET [DRIVER/LOADER/GUNNER/TANK COMMANDER].
9. MAIN GUN ENGAGEMENT - MOVING TO A HALT - MULTIPLE MOVING POINT TARGETS [DRIVER/LOADER/GUNNER/TANK COMMANDER].
10. COAX/CALIBER .50 SIMULTANEOUS ENGAGEMENT - MOVING TO A HALT - STATIONARY AREA AND MOVING POINT TARGETS [DRIVER/LOADER/GUNNER/TANK COMMANDER].
11. MAIN GUN/CALIBER .50 SIMULTANEOUS ENGAGEMENT - MOVING TO A HALT - STATIONARY POINT TARGETS [DRIVER/LOADER/TANK COMMANDER].
12. MAIN GUN ENGAGEMENT - MOVING TO A HALT - STATIONARY POINT TARGETS [DRIVER/LOADER/GUNNER/TANK COMMANDER].
13. INSTALL M24(IR) PERISCOPE [DRIVER].
14. PLACE M24(IR) PERISCOPE INTO OPERATION [DRIVER].
15. MAIN GUN/CALIBER .50 SIMULTANEOUS ENGAGEMENT - AT THE HALT - MULTIPLE STATIONARY POINT AND AREA TARGETS [DRIVER/LOADER/GUNNER/TANK COMMANDER].
16. MAIN GUN ENGAGEMENT - AT THE HALT - STATIONARY AND MOVING POINT TARGETS [DRIVER/LOADER/GUNNER/TANK COMMANDER].
17. DRIVE TO DEFILADE FIRING POSITION ON ENEMY CONTACT [DRIVER].
18. PERFORM EVASIVE MANUEVERS UPON ENEMY CONTACT [DRIVER/TANK COMMANDER].

Figure 9. Outline of Tactical Operations Module.

19. APPLY IMMEDIATE ACTION TO REDUCE STOPPAGE OF M219 MACHINEGUN [LOADER].
20. PERFORM MISFIRE PROCEDURES FOR MAIN GUN [LOADER/GUNNER].
21. REMOVE MISFIRED MAIN GUN ROUND [LOADER/GUNNER].
22. DETERMINE CORRECTIVE ACTION REQUIRED BY REPLENISHER TAPE [LOADER].
23. APPLY IMMEDIATE ACTION TO REDUCE STOPPAGE OF M85 MACHINEGUN [TANK COMMANDER].
24. SENSE ROUNDS [DRIVER/GUNNER/TANK COMMANDER].
25. APPLY MAIN GUN ADJUSTMENT [GUNNER].
26. ISSUE SUBSEQUENT FIRE COMMAND [TANK COMMANDER].
27. PERFORM DURING-OPERATIONS MAINTENANCE CHECKS AND SERVICES ON STEERING, ACCELERATOR, SHIFT, AND BRAKE CONTROLS [DRIVER].
28. PERFORM DURING-OPERATIONS CHECKS ON INSTRUMENTS, GAGES AND WARNING LIGHTS [DRIVER].

Figure 9. (Continued) Outline of Tactical Operations Module

DUTY POSITION READINESS TESTS

Readiness tests developed for each duty position consisted of written and hands-on subtests designed to assess a crewman's knowledge and skill in performing critical tasks. The tests provide a diagnostic instrument for determining a crewman's mastery or deficiency of required skills.

The process followed in developing readiness tests included:

- . Identify tasks for each crewman.
- . Clustering tasks into functional groups.
- . Selecting test methodology.
- . Clustering functional groups, by test methodology, into readiness tests.
- . Structuring readiness tests.

Identifying Tasks for Each Crewman

This action was completed during the development of the MTL shown in Figure 3. The tasks for readiness tests included all categories in the MTL--priority, initiating, and engagement.

Clustering Tasks Into Functional Groups

Each task in the MTL was next clustered into a functional group. For example a functional group for the driver was, "Before-Operations Procedures and Tank Start-Up," and it included such individual tasks as, "Perform before-operations maintenance checks and services on the M24 (IR) and M27 periscope," and "Start tank engine." A list of functional groups by crewmember is shown in Figure 10.

Selecting Test Methodology

In determining the method of testing the following were considered:

- . The way to measure a crewman's knowledge of required tasks.
- . The way to measure a crewman's skill in performing a required task.
- . Being deliverable, as much as possible, at armories and local training areas.

DRIVER

Operational Checks and Services
 Before-Operations Procedures
 and Tank Start-Up
 Target Acquisition
 Tactical Driving

LOADER

Weapons Maintenance
 Mission Preparation
 Combat Loading
 Target Acquisition

GUNNER

Weapons Maintenance
 Before-Operations Procedures
 Weapon Systems Preparation
 Combat Loading
 Target Acquisition
 Tactical Operations

TANK COMMANDER

Weapons Maintenance
 Before-Operations Procedures
 Weapon Systems Preparation
 Combat Loading
 Target Acquisition
 Tactical Operations

Figure 10. Functional groups.

The answers to these considerations were the selection of a series of U.S. Army technical tests to measure knowledge and the structuring of a series of hands-on tests to measure skill. Both types of tests were deliverable at the armories and the local training areas.

Clustering Functional Groups, by Test Methodology Into Readiness Tests

When possible written tests (TEC tests) were identified for each functional group. For example, the functional group, "Target Acquisition" included four written tests. "Target Range Determination," "Locating and Reporting Targets," "Target Acquisition Scanning Techniques," and "Armor Vehicle Recognition." A hands-on test was developed for every functional group. For example, the written test for the functional group "Target Acquisition," has a companion hands-on test, "Locating and Reporting Targets." A list of written and hands-on tests is shown in Figure 11.

Structuring Readiness Tests

Each cluster of functional groups was clustered by crewmembers into a readiness test package. Written tests included: administrative instructions, a task list, tests, answer sheets, and scoring keys. Hands-on tests included: a statement of conditions, instructions for the crewman, a task list, clarifying notes, and a score sheet.

The complete package of duty position readiness tests is contained in ARI Research Product RP-79-13, Tank Crewman (M60A1) Readiness Tests, 1979.

DRIVER

Operational Checks and Services (W)
 Before-Operations Procedures
 and Tank Start-Up (HO)
 Target Acquisition (W)
 Locating and Reporting Targets (HO)
 Tactical Driving (HO)

LOADER

Weapons Maintenance (W)
 Weapons Maintenance (HO)
 Mission Preparation (W)
 Mission Preparation (HO)
 Combat Loading (W)
 Combat Loading (HO)
 Target Acquisition (W)
 Locating and Reporting
 Targets (HO)

GUNNER

Weapons Maintenance (W)
 Weapons Maintenance (HO)
 Before-Operations Procedures (HO)
 Weapon Systems Preparation (W)
 Weapon Systems Preparation (HO)
 Combat Loading (W)
 Combat Loading (HO)
 Target Acquisition (W)
 Locating and Reporting Targets (HO)
 Tactical Operations (W)
 Tactical Operations (HO)

TANK COMMANDER

Weapons Maintenance (W)
 Weapons Maintenance (HO)
 Before-Operations Proce-
 dures (HO)
 Weapon Systems Preparation (W)
 Weapon Systems Preparation (HO)
 Combat Loading (W)
 Combat Loading (HO)
 Target Acquisition (W)
 Locating and Reporting Tar-
 gets (HO)
 Tactical Operations (W)
 Tactical Operations (HO)

NOTE: W = written test, HO = hands-on test.

Figure 11. Summary of Readiness Tests

DUTY POSITION TRAINING MODULES

The last phase of program development was structuring duty position training modules. The modules were designed to provide a system for conducting remedial training of deficiencies noted during the administration of readiness tests. For each readiness test a companion training module was developed. Training techniques selected to correct deficiencies were: self-instructional sound-slide presentations for knowledge deficiencies and self-instructional audio tapes and one-on-one instructor controlled performance training for skill deficiencies. Each training module contained guidance related to:

- . Pretraining conditions
- . Objective

- . Method of instruction
- . Equipment and materials
- . Estimated time to complete the module
- . Procedure for administering the module
- . Explanatory notes

Pretraining Conditions

These are conditions leading to the need for mastering the contents of the module: for example, failure to meet a standard on a part of a readiness test.

Objective

This is a global statement of a desired behavior and the conditions under which the behavior is to be demonstrated.

Methods of Instruction

This is a brief statement of stimulus materials and response modes appropriate for mastery of the module: for example, self-instructional or one-on-one instructor controlled training.

Equipment and Materials

These are resources required to conduct the training, e.g., TEC lessons, Beseler Cue/See, M60A1 tank with BII, or sub-caliber moving target range.

Estimated Time to Complete the Module

This is a variable time dependent upon individual requirements, i.e., an experienced crewman with few task failures will require less time than an inexperienced crewman with many task failures.

Procedure for Administering Each Module

This is an outline of the sequence of instructional events leading to mastery of the module.

Explanatory Notes

These are answers to questions that are expected to arise upon reading the outline.

Figures 12 and 13 are examples of self-instructional sound-slide presentations and one-on-one instructor controlled performance training modules. The complete package of duty position training modules is contained in ARI Research Product RP-79-14, Tank Crewman (M60A1) Training Modules, 1979.

MODULE D-1. OPERATIONAL CHECKS AND SERVICES

PRETRAINING CONDITIONS:

Driver failed to meet standard on pre-test for TEC lessons 020-171-5366-F through 020-171-5370-F (Part A, Driver's Readiness Test).

OBJECTIVE:

Given pictures or descriptions of tank components, driver will recognize unserviceable parts and describe actions necessary to service them.

METHOD:

Self-instructional sound-slide presentation with written response.

EQUIPMENT/MATERIALS:

- a. Five filmstrip cartridges and audio cassettes (TEC Lessons 020-171-5366-F through 020-171-5370-F)
- b. Beseler Cue/See
- c. Paper and pencil

ESTIMATED TIME:

1-5 hours

PROCEDURE:

- a. Driver selects lesson corresponding to task elements failed on pre-test in Part A, Driver's Readiness Test.
- b. Driver completes relevant portion of assigned lesson and takes post-test.
- c. Driver reviews those lessons keyed on post-test for items missed.
- d. Driver has satisfactorily completed the lesson when he has completed relevant portions of post-test with no errors.

NOTE: Some of the maintenance tasks covered in these lessons are not considered to be priority training tasks. But since they are integrated with priority tasks, and since the lessons are not very long, the driver should be required to master the knowledge aspects of them as represented in the post-test.

Figure 12. Self-instructional Sound-Slide Presentation Module.

MODULE D-2. BEFORE OPERATING PROCEDURES AND TANK START-UP

PRETRAINING CONDITIONS:

Driver passed Part A of Driver's Readiness Test but failed to meet standard for one or more tasks in Part B, Driver's Readiness Test.

OBJECTIVES:

- a. Given an M60A1 tank with M27 periscope installed, an M24(IR) periscope in stowage box and a procedural job-aid, driver will remove M27, install M24 and place it in operation. All steps in this three-task objective will be performed in accordance with Parts B.5, B.7, and B.8, Driver's Readiness Test and within 15 minutes without damage to equipment.
- b. Given an M60A1 tank, a procedural job-aid and an indication from the Loader that he wants to check engine and transmission oil levels; driver will start and idle tank engine according to procedures in Part B.9 and B.10, Driver's Readiness Test.
- c. Given an M60A1 on level ground with engine running, a request to move the vehicle into position for checking track tension, and guidance from the Loader; driver will drive the tank forward and coast it to a stop with track in proper position according to procedures in Part B.12, Driver's Readiness Test.
- d. Given an M60A1 with Driver's hatch open and the command, "PREPARE-TO-FIRE", driver will perform Driver's prepare-to-fire procedures, according to procedures in Part B.14, Driver's Readiness Test.
- e. Given an M60A1 tank with gas particulate unit mounted, driver will inspect gas particulate units for cleanliness and serviceability and will check the unit for operation according to procedures in Part B.15 of Driver's Readiness Test.

METHOD:

One-on-one instructor controlled performance training.

EQUIPMENT/MATERIALS:

- a. M60A1 tank.
- b. Pocket-sized job-aids listing steps in M27 periscope removal, M24 periscope installation and operational check-out, starting the tank engine and idling the engine for oil checks and placing the gas particulate unit into operation.

Figure 13. One-on-One Instructor Controlled Performance Training Module.

ESTIMATED TIME:

1 hour

PROCEDURE:

- a. TC makes sure driver has pocket job-aids and urges him to refer to them during task performance.
- b. TC explains to driver task elements failed in Part B, Driver's Readiness Test.
- c. TC "talks driver through" task elements to be learned; driver performs as these oral directions are given.
- d. Driver then practices with instructor available to coach as necessary.
- e. Driver is retested on relevant portion of Part B, Driver's Readiness Test.

NOTES:

- a. This module should be conducted as remedial training immediately following administration of Part B of the Driver's Readiness Test.
- b. Procedures for remedial training should be followed as given. Demonstrations of performance by the instructor or lengthy lectures on principles of equipment operation, while the trainee is idle, usually slows down the learning process.
- c. Checking and servicing the periscope are not covered here because of difficulty in providing a variety of damaged periscopes. Knowledge aspects of the task are covered in Module D-1.

Figure 13 (Continued). One-on-One Instructor Controlled Performance Training Module.

PROGRAM MANAGEMENT

This section provides guidelines for administering the Tank Crewman Skills Test (TCST) program by the battalion commander, company commander, and tank commander.

PROGRAM FAMILIARIZATION

In the previous section the program development model was explained. Figure 1 shows the steps followed in structuring the crew interaction performance test (CIPT), duty position readiness tests (DPRTs), and duty position training modules (DPTMs). The first step in implementing the TCST program is a thorough understanding of the TCST concept and its' procedures.

TCST Concept

This concept is a continuous cycle of diagnostic testing, remedial training, and goal achievement which facilitates transition to subsequent training years. The concept consists of a series of activities which determines knowledge and skill levels, provides for remedial training to correct deficiencies noted, progresses to a crew test, and culminates in crew qualification. The concept is shown in Figure 14.

TCST Management Model

After the development model was completed the management model was developed. Whereas the development model, Figure 1, started with the tank gunnery Table VII and progressed through representative engagements, crew interaction performance test, duty position readiness tests, and duty position training modules, the management model, Figure 15, generally reverses that order. This model starts with readiness tests and progresses through training modules and a crew interaction performance test to tank gunnery Table VII.

Diagnostic Testing

The management model and the TCST concept indicates that a crewman enters the program at the readiness test level. After the tests are scored the training manager, following the process shown in Figure 16, directs the crewman to the next phase of the program.

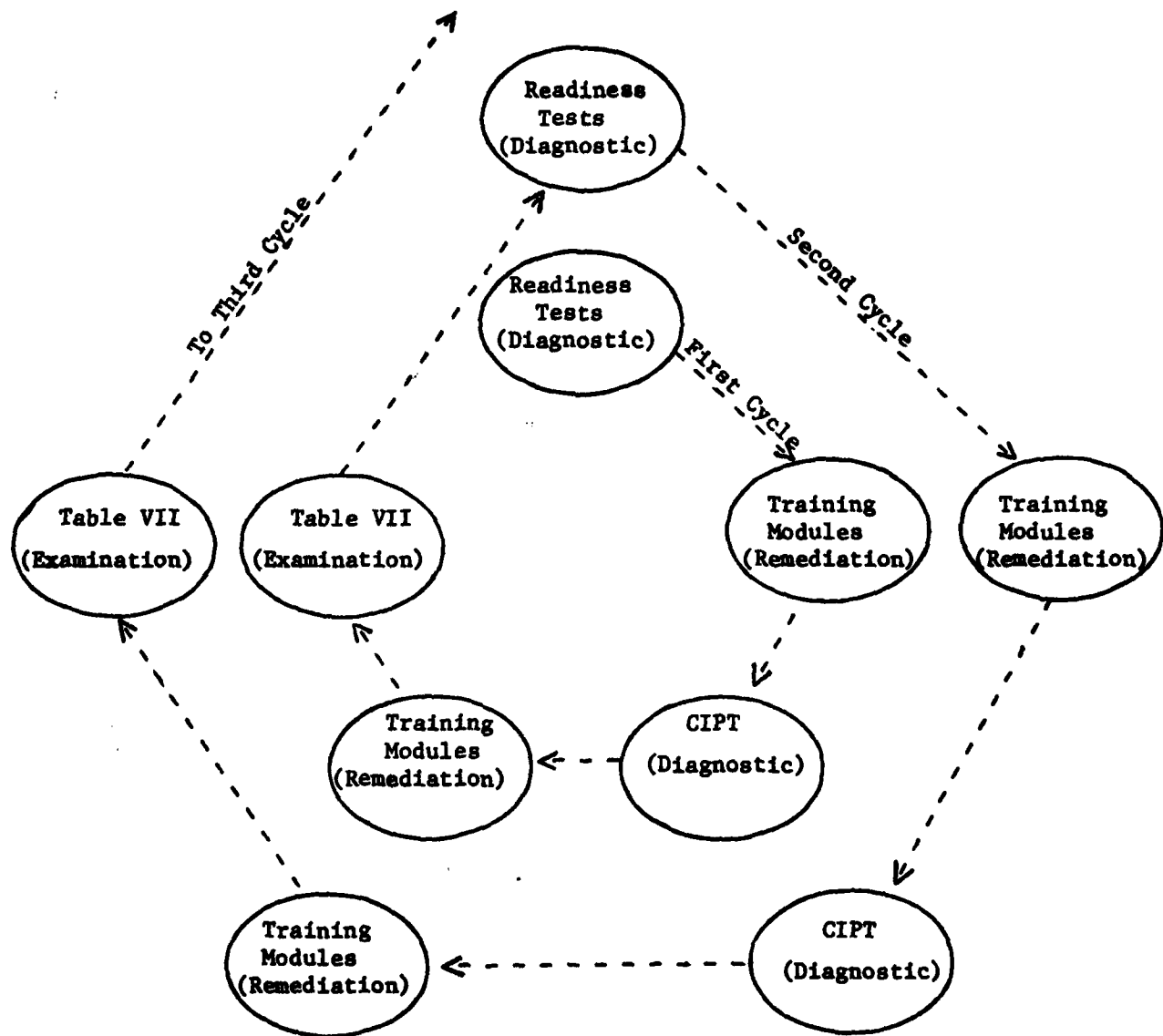
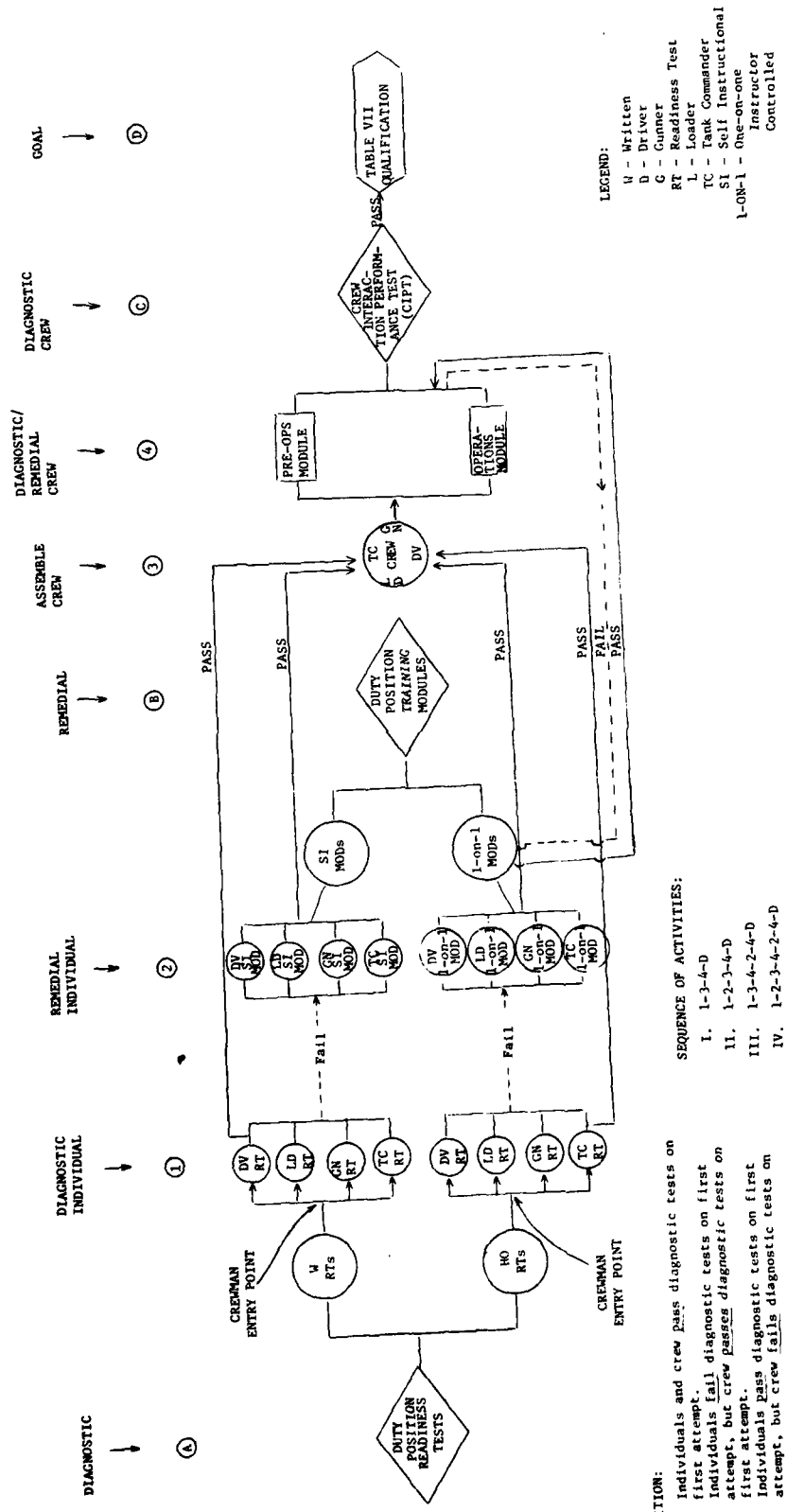

Figure 14. Tank Crew Skills Training Concept.



- SEQUENCE OF ACTIVITIES:
- I. 1-3-4-D
 - II. 1-2-3-4-D
 - III. 1-3-4-2-4-D
 - IV. 1-2-3-4-2-4-D

- CONDITION:
- I. Individuals and crew pass diagnostic tests on first attempt.
 - II. Individuals fail diagnostic tests on first attempt, but crew passes diagnostic tests on first attempt.
 - III. Individuals pass diagnostic tests on first attempt, but crew fails diagnostic tests on first attempt.
 - IV. Individuals and crew fail diagnostic tests on first attempt.

Figure 15. Tank crew skills training management model.

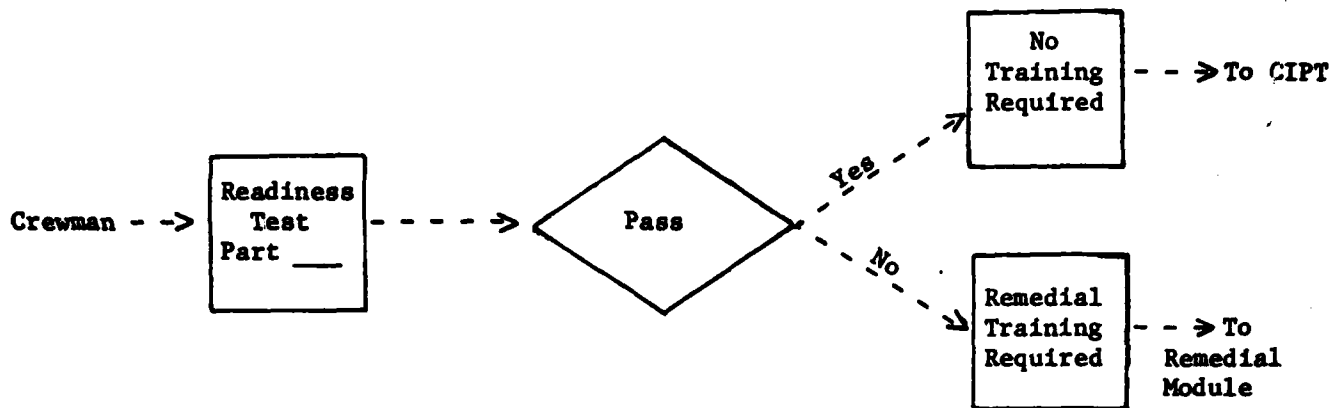

Figure 16. Training Decision Process.

Remedial Training

When diagnostic tests indicate a training need the training manager, following the process shown in Figure 17, directs the crewman to the appropriate training module.

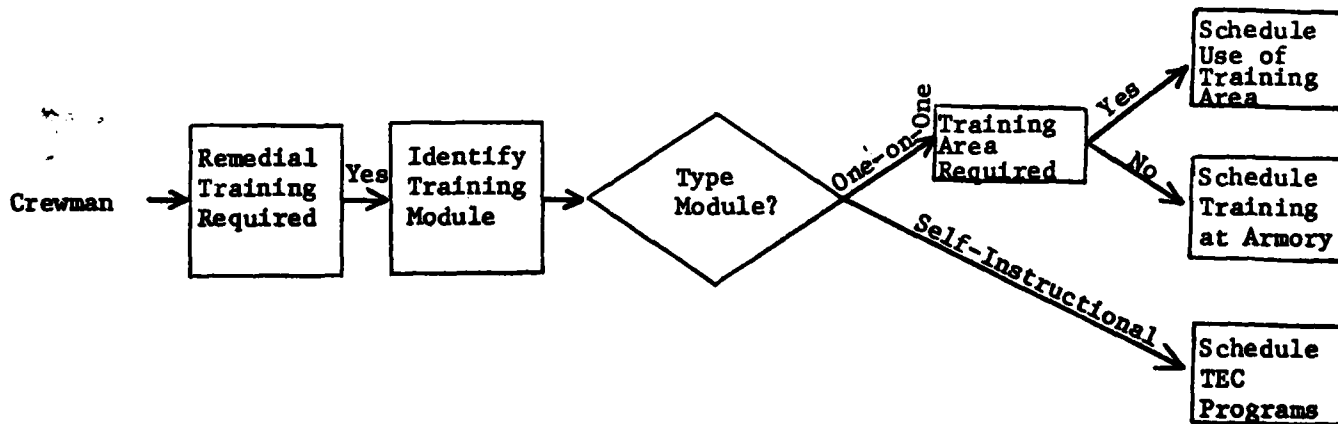

Figure 17. Remedial Training Process.

Crew Diagnostic Testing and Remedial Training

After individual crewmember task deficiencies have been corrected crews are formed and administered the crew interaction performance test. Deficiencies noted during the test are corrected by referring

crewmembers to appropriate training modules. When all deficiencies have been corrected the crews fire appropriate gunnery tables to include Table VII. Figure 18 shows this sequence of activities.

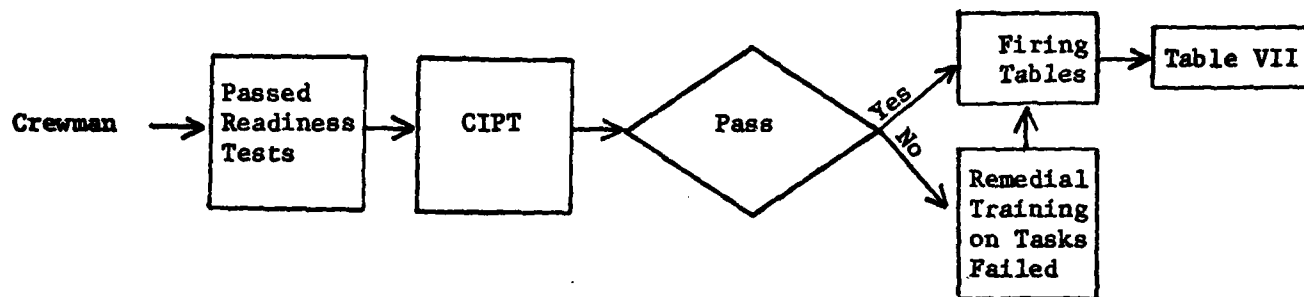

Figure 18. Crew Interaction Performance Test Sequence Process.

TRAINING MANAGER RESPONSIBILITIES

In the U.S. Army the commander is responsible for training his personnel. Within the tank battalion this responsibility starts with the battalion commander and ends with the tank commander. At the battalion level the commander is assisted by a training officer who is a staff member. At the company level the commander is assisted by a designated training officer or NCO. Figure 19 illustrates command and assistance lines within a tank battalion.

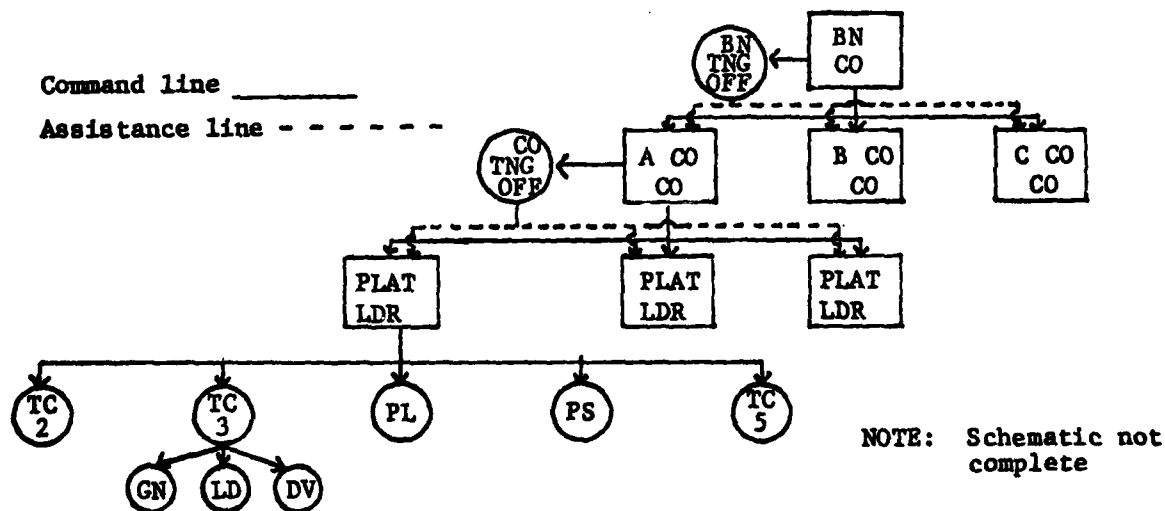

Figure 19. Command and Assistance Lines for Implementing TCST.

Battalion Commander

The battalion commander's training responsibilities are:

- . Analyzing training needs. The commander determines training needs by reviewing past performances and directed training requirements.
- . Assigning training goal. The training goal of the TCST program is "to qualify tank crews on Table VII by the end of ANACDUTRA."
- . Assigning training tasks. The major tasks of the TCST program are to complete duty position readiness tests, conduct necessary remedial training, conduct crew interaction performance test, and fire required tank gunnery tables prior to Table VII.
- . Determining training support requirements. Support requirements include the need for facilities, training areas, equipment, training aid/devices, software, outside assistance, ammunition and time.
- . Providing command guidance. Command guidance includes such items as announcing priorities, providing assistance, resolving problems, and a policy for monitoring training progress.
- . Monitoring training progress. This action includes command visits, training assistance visits and provisions for training progress feedback.

Battalion Training Officer

This staff officer is responsible for carrying out the battalion commander's training guidance. In doing so, he provides assistance to subordinate units and creates a training environment conducive to accomplishing the training goal.

Company Commander

The company commander's training responsibilities are generally the same as the battalion commander. However, being closer to training activities he becomes more personally involved and must plan and execute the program in more detail.

Company Training Officer/NCO

This individual, designated by the company commander, has generally the same responsibilities at his level as does the training officer at the battalion. He should not be a platoon leader, platoon sergeant, or a tank commander as they will be fully involved in training their crews. Specific duties of the training officer/NCO include allocating resources, scheduling and organizing training activities, administering written readiness tests, issuing TCST material, and maintaining training records.

Platoon Leader

The platoon leader executes the commander's guidance, coordinates training within his platoon, and monitors training progress. He is responsible that his tank commanders are trained and qualified to train their crewmembers.

Tank Commander

The success of the TCST program rests with the tank commander. His responsibilities include:

- . Mastery of all TC tasks
- . Knowledgeable and skilled in other crew tasks
- . Training crewmembers
- . Administering hands-on readiness tests
- . Administering/supervising remedial training
- . Maintaining crewmen readiness records

TRAINING SUPPORT

Reserve Component organizations have available to them training support from outside agencies. These agencies are:

- . Higher headquarters
- . Army advisors
- . Branch Assistance Teams (BAT)
- . Maintenance Assistance and Instruction Teams (MAIT)
- . Administration and Supply Teams (A&S)

- . Mobile Training Teams
- . Maneuver Area Command and Maneuver Training Command (MAC/MTC)
- . Army Service Schools
- . Army Training and Audio Visual Support Centers (TASC)
- . Training Support Center (TSC)
- . Army Training Board (ATB)
- . Major training area (MTA) commanders

All of the above contribute to supporting Reserve Component Units. However, the following ones provide core support for the TCST program.

Higher Headquarters

Brigade and division headquarters act as expediting agents for resolving major training problems. Through their efforts facilities, training areas, equipment, training aids/devices, and ammunition are obtained and allocated.

Army Advisors

Advisory personnel are assigned to Reserve Component units to assist in planning and conducting training and resolving problems. Their close association with organization personnel fosters on accurate appreciation of the training status. They are considered to be an augmenting staff officer for the commander.

Branch Assistance Team (BAT)

This team, provided by the supporting readiness group furnishes branch oriented expertise and assists in the planning and conduct of mission oriented training.

Training and Audio Visual Support Center (TASC)

The TASC supports Reserve Component units by the issue and maintenance of training aids and simulation devices.

Major Training Area (MTA) Commanders

When a Reserve Component commander does not have a facility for conducting training, such as service firing, he can resolve the problem by scheduling the training at the closest major training area which has such a facility. This action also facilitates drawing ammunition which is normally available at major training areas.

IMPLEMENTING THE PROGRAM

To implement the Tank Crewman Skills Training (TCST) program commanders and training officers/NCOs at all levels must be familiar with the three documents listed in the introduction. These documents describe the program's major training activities.

TRAINING MANAGER'S GUIDE

The training manager's guide is at Appendix A. It includes:

- . Training support requirements
- . Training resources inventory
- . Requisitioning/developing training resources
- . Maintaining training resources
- . Command guidance
- . Implementing training activities
- . Monitoring training activities

TANK COMMANDER'S TRAINING GUIDE

The tank commander's training guide is at Appendix B. It includes procedures for:

- . Training a tank crew
- . Administering hands-on readiness tests
- . Conducting one-on-one instructor controlled performance training.
- . Supervising self-instructional training
- . Maintaining crew readiness records.

REFERENCES

- Boldovici, J.A., Wheaton, G.R., and Boycan, G.G. Selecting Items for a Tank Gunnery Test. Fort Knox, Kentucky: Human Resources Research Organization (HumRRO), 1976.
- Harris, J.H., Osborn, W.C., and Boldovici, J.A. Reserve Component Training for Operating and Maintaining the M48A5 Tank. Alexandria, Virginia: U.S. Army Research Institute for the Behavioral and Social Sciences (ARI), 1977.
- O'Brien, R.E., Ford, J.P., and Boldovici, J.A. Armor and Cavalry National Guard Training Constraints. Alexandria, Virginia: Human Resources Research Organization (HumRRO), 1977.

APPENDIXES

Appendix	Page
A. Training Manager's Guide.	52
ANNEX 1. Training Support Requirements	79
Encl. 1. TCST Materials.	80
a. List of Duty Positions Readiness Tests.	81
b. List of Duty Position Training Modules.	82
c. Crew Interaction Performance Test (omitted)	--
d. Task Books (driver, loader, gunner, TC)	83
e. Tank Crewman's Readiness Book	92
Encl. 2. Training Facilities	101
a. Tactical Driving Course	102
b. Target Acquisition Course	104
c. Tank Crew Qualification Course.	106
d. Laser Firing Range (omitted).	--
e. Live Firing Range (omitted)	--
f. Armory Boresight, Zero, and Tracking Range	108
Encl. 3. Equipment Requirements.	109
Encl. 4. Training Aids/Devices	110
a. Beseler Cue/See (omitted)	--
b. Dummy Main Gun Ammunition	111
c. Belt Linked Empty Coax Ammo (omitted)	--
d. Belt Linked Empty .50 Caliber (omitted)	--
e. Ammunition Stowage Plan (omitted)	--
f. Cardboard Representation of Coax Ammo Box	112
g. Cardboard Representation of .50 Caliber Ammo Box.	112

	Page
h. Replenisher Tape Mockup.	113
i. Laser Firing Device (omitted).	--
j. Burst-on-Target Trainer (omitted).	--
k. TEC Tapes.	115
Encl. 5. Outside Support.	116
Encl. 6. Ammunition	117
Encl. 7. Targets.	118
ANNEX 2. Training Assets Inventory.	119
B. Tank Commander's Training Guide.	131
ANNEX 1. Procedures for Conducting the TCST Program . . .	134
ANNEX 2. Procedures for Conducting the Readiness Tests. .	140
Encl. 1. Procedures for Administering Written Readiness Tests.	141
Encl. 2. Procedures for Administering Hands-On Readiness Tests.	143
Encl. 3. Readiness Test Outline	145
ANNEX 3. Procedures for Conducting Remedial Training. . .	154
Encl. 1. Procedures for Self-Instructional Sound-Slide Presentation Remedial Training	157
Encl. 2. Procedures for Audio Tape Controlled Practice Remedial Training	158
Encl. 3. Procedures for One-on-One Instructor Controlled Performance Training.	159
Encl. 4. List of Training Modules	164
ANNEX 4. Proccedures for Scheduling Remedial Training and Maintaining Training Records	172
Encl. 1. Scheduling Remedial Training	173
Encl. 2. Training Records	175

Appendix A

Training Manager's Guide

INTRODUCTION

This appendix describes action procedures for battalion and company commanders for implementing and monitoring the Tank Crewman Skills Training (TCST) program. These action procedures are: determining training resource requirements, providing and maintaining training resources, providing command guidance, implementing training activities, and monitoring training progress.

Other training management responsibilities such as analyzing training needs, assigning a training goal, and assigning training tasks are resolved once the commander decides to implement the TCST program. These responsibilities are identified in the program.

As previously indicated major parts of the program, duty position readiness tests (DPRTs), duty position training modules (DPTMs) and the crew interaction performance test (CIPT) are contained in ARI Research Products RP-79-13, "Tank Crewman (M60A1) Readiness Tests," RP-79-14, "Tank Crewman (M60A1) Training Modules," and RP-79-15, "Tank Crew (M60A1) Performance Exercise."

DETERMINING TRAINING RESOURCE REQUIREMENTS

To implement the program battalion and company commanders must know what are the training resource requirements. Specific items required to administer DPRTs, DPTMs, and the CIPT are listed in their respective appendixes. However, this guide includes a consolidated list of requirements and outlines procedures for conducting a training resources inventory.

TRAINING RESOURCE REQUIREMENTS

There are seven categories of training resources that are required for the program: TCST material, training facilities, equipment, training aids/devices, outside support, ammunition, and targets (see Table 2 and Annex 1.)

TCST Material

This category includes DPRTs, DPTMs, CIPT, task books, crewman readiness book, tank commander's training guide, and the training manager's guide.

Training Facilities

Five types of facilities are required for the program: driving course, target acquisition course, tank crew qualification course, laser firing range, and live firing ranges. The first three facilities are developed, maintained, and scheduled by the battalion. The laser firing range is developed and maintained by the company. The live firing ranges are normally located at the major training area (MTA).

Equipment

Major items of equipment required are: tanks, machineguns, binoculars, radios, and protective masks. One tank for each platoon should be located at the armory and the remaining tanks should be located at the unit training and equipment site (UTES).

Training Aids/Devices

Included in this category are: Beseler Cue/See audio/visual projector, dummy main gun ammunition, linked empty machinegun cart-ridge cases, cardboard representations of machinegun ammunition boxes, replenisher tape mockup, laser firing device, conduct-of-fire trainer, and TEC tapes.

Table 2

TRAINING RESOURCE REQUIREMENTS

Reference	Item	Auth	
		Bn	Co
Annex 1	TCST MATERIAL		
Encl 1	Readiness Tests	41	13
	Training Modules	77	25
	CIPT	41	13
	Task Books	41	13
	Crewman's Readiness Book	41	13
	TC Training Guide	41	13
Annex 1	TRAINING FACILITIES		
Encl 2	Driving Course	1	0
	Target Acquisition Course	1	0
	TCQC (dry)	1	0
	Laser Firing Range	3	1
	Live Firing Range	MTA	MTA
Annex 1	EQUIPMENT		
Encl 3	M60 Tank	Allocation	Allocation
	Coax	Allocation	Allocation
	.50 Caliber Machinegun	Allocation	Allocation
	Binoculars	Allocation	Allocation
	Protective Mask	Allocation	Allocation
	Radios	Allocation	Allocation
Annex 1	TRAINING AIDS/DEVICES		
Encl 4	Beseler Cue/See	7	2
	Dummy Main Gun Ammo	9	3
	Linked Dummy Coax Ammo	9	3
	Linked Dummy .50 Caliber Ammo	9	3
	Ammo Stowage Plan	41	13
	Cardboard Rep. Coax Ammo	270	90
	Cardboard Rep. .50 Caliber Ammo	90	30
	Replenisher Tape Mockup	9	3
	Laser Firing Device	9	3
	Conduct-of-Fire Trainer	9	3
	TEC Tapes	116	29
Annex 1	OUTSIDE SUPPORT		
Encl 5	Five man armor BAT Team	1	0
Annex 1	AMMUNITION		
Encl 6	Tables IV and V and CIPT	FM 17-12-2 & App. D	FM 17-12-2 & App. D
Annex 1	TARGETS		
Encl 7	Boresight/Zero MG & Machineguns	FM 17-12 & TC 17-12-5	FM 17-12 & TC 17-12-5
	Tables I thru V and CIPT	TC 17-12-5 & App. D	TC 17-12-5 & App. D
	Driving, Target Acquisition, and TCQC Courses	TC 17-12-5 & App. D	TC 17-12-5 & App. D

These training aids/devices are required at each company in the following quantities:

- . Two Beseler Cue/See audio/visual projectors.
- . Three sets of dummy main gun ammunition.
- . Three belts (10 rounds each) linked empty 7.62 and .50 caliber machineguns empty cartridge cases.
- . Three sets of cardboard representations of machinegun ammunition boxes.
- . Three replenisher tape mockups.
- . Three laser firing devices.
- . Three conduct-of-fire trainers.
- . One set of TCST TEC tapes.

Outside Support

One, five-man armor branch assistance team to test and train "key" tank commanders from each company.

Ammunition

Ammo requirements include firing Tables IV and V (subcaliber) and the CIPT (service). (Tables I, II and III are fired using the laser firing device.)

Targets

Requirements for targets include: boresight and zero range and the laser firing range targets at the armory and targets for the boresight and zero range, and tactical driving, target acquisition, and tank crew qualification courses at the UTES. Additional targets are required at the MTA for subcaliber and service firing.

TRAINING RESOURCES INVENTORY

After resource requirements have been identified an inventory is taken to determine the sufficiency, adequacy, and operability of existing resources. Each company inventories its' resources and forwards to battalion a copy of the report. The battalion training officer then consolidates the reports, along with the report of the battalion headquarters resources. (The Training Assets Inventory Form at Annex 2 is used for the inventory.)

Physical Training Resources

This inventory provides data from which the commander can develop or improve facilities and requisition shortages of equipment and training aids/devices.

Personnel Training Resources

This part of the inventory reflects the status of crew personnel and support personnel, such as track, turret and radio mechanics and training assistants.

Time Training Resources

This critical resource is limited to 48, four hour periods each year. The time is divided between mandatory training, TCST training, and other mission training requirements. (The TCST program requires 28 1/2 four hour drill periods or 59% of the training time.)

PROVIDING AND MAINTAINING TRAINING RESOURCES

Providing for training resources is accomplished by requisitioning authorized quantities, requesting special allocations, and developing or requesting the use of facilities. The efficient use of the resources is dependent upon a scheduled maintenance program.

REQUISITIONING/DEVELOPING TRAINING RESOURCES

After the inventory has been completed shortages are requisitioned or developed. Table 3 indicates command responsibilities and actions to be taken.

TCST Material

These materials are reproduced and issued by the battalion and received, controlled, and further issued by the company.

Training Facilities

The battalion develops new facilities and improves existing ones. These facilities are: driving, target acquisition, and crew qualification courses, and, terrain and safety considerations permitting, live firing ranges. Each company develops or improves their laser firing range.

Equipment

Requisition for equipment shortages are initiated by each company. Unserviceable items are turned in for replacement.

Training Aids/Devices

Shortages of standard items are requisitioned from the training aids support center (TASC). Requests for fabrication of non-standard items are forwarded through command channels, with detailed instructions and justification.

Outside Support

The battalion requests a five man branch assistant team (BAT) from the supporting readiness group. The request includes: type of training to be conducted, reference to appropriate publications,

Table 3

RESPONSIBILITIES FOR TRAINING RESOURCES

Item	Battalion Action	Company Action
TCST MATERIAL		
Readiness Tests	Reproduce and issue	Issue, control, and administer
Training Modules	Reproduce and issue	Issue, control, and administer
CIPT	Reproduce and issue	Issue, control, and administer
Task Books	Reproduce and issue	Issue
Crew Readiness Book	Reproduce and issue	Issue
TC Training Guide	Reproduce and issue	Issue
TRAINING FACILITIES		
Driving Course	Develop, maintain, and schedule	Schedule and use
Tgt. Acq. Course	Develop, maintain, and schedule	Schedule and use
TCQC (dry)	Develop, maintain, and schedule	Schedule and use
Laser Firing Range	Assist procurement of materials	Develop, maintain, and schedule
Live Firing Range	Request from major training area	Request use from battalion
EQUIPMENT (TOE)		
	Monitor requisition	Requisition shortages
TRAINING AIDS/DEVICES		
Beseler Cue/See	Monitor requisition to TASC	Requisition shortages from TASC
Dummy MG Ammo	Consolidate and forward request to TASC	Request fabrication from TASC
Dummy MchGn Ammo		
Coax	Monitor request to ASP	Request links and cartridges from ASP
.50 caliber	Monitor request to ASP	Request links and cartridges from ASP
Ammo Stowage Plan	Develop and issue	Issue
Cardboard Rep. Coax Ammo	Procure and issue material	Fabricate and issue aids
Cardboard Rep. .50 Caliber	Procure and issue material	Fabricate and issue aids
Replenisher Tape Mockup	Procure material, fabricate devices, and issue	Issue

Table 3 (Cont'd.)

Item	Battalion Action	Company Action
TRAINING AIDS/DEVICES (CONT'D.)		
Laser firing device	Monitor requisition to TASC	Requisition shortages
TEC Tapes	Monitor requisition to TASC	Requisition shortages
Conduct-of-fire trainer (COFT)	Monitor requisition to TASC	Requisition shortages
OUTSIDE SUPPORT		
Five man armor BAT Trn.	Request Tm, provide facilities, direct activities	Provide key TCs and required training assets
AMMUNITION		
Table IV	Forecast requirements	Forward requisition to ASP
Table V	Forecast requirements	Forward requisition to ASP
CIPT	Forecast requirements	Forward requisition to ASP
TARGETS		
Main gun boresight zero	Monitor requisition	Requisition shortages
Coax boresight zero	Monitor requisition	Requisition shortages
.50 caliber bore-sight and zero	Monitor requisition	Requisition shortages
Table IV	Monitor requisition	Requisition shortages
Table V	Monitor requisition	Requisition shortages
CIPT	Monitor requisition	Requisition shortages

time and location of training, and qualification of personnel required. The BAT will be used to test and train key tank commanders.

Ammunition

Forecasts for ammunition are forwarded to the appropriate supply agency. Forecasts exceeding normal authorization are forwarded through command channels.

Targets

The acquisition, assembly, and installation of targets is a major training support effort. These actions are initiated early in the program to preclude a loss of training time.

MAINTAINING TRAINING RESOURCES

The maintenance of training resources is a continuous process. However, prior to the start of the training program a special maintenance effort is conducted to bring all facilities, equipment, and devices up to a high state of readiness.

Training Facilities

Battalion and company training officers/NCOs are responsible for maintaining their respective facilities. This responsibility simply stated is, "the facility must be operational when training is scheduled and deficiencies occurring during training are corrected immediately."

Equipment

The major equipment item required are the M60A1 tanks. The tanks are inspected by maintenance personnel assisted by crew members. Deficiencies noted are corrected on the spot.

- . The track vehicle mechanic, assisted by the driver, inspects automotive components and the suspension system.
- . The turret mechanic, assisted by the gunner and loader, inspects all weapons and fire control components.
- . The radio mechanic, assisted by the loader, inspects all radios and intercommunication equipment.

Training Devices

These devices are inspected by the training officer/NCO for operability and are maintained as necessary. Items requiring higher echelon maintenance are forwarded to the TASC for exchange.

COMMAND GUIDANCE

Prior to the start of training each commander announces his training guidance. The guidance includes the commander's concept of training, special emphasis requirements, and priorities for training support.

BATTALION COMMANDER

The battalion commander's guidance includes: a definition of the training concept, allocation of training resources, operability and maintenance of facilities, scheduling training activities, resolution of training problems, and command participation in training activities.

Training Concept

Tank gunnery training will consist of a series of individual crewman diagnostic tests followed by remedial training of deficiencies noted and culminate in a crew test. Training will be decentralized to the crew level.

Allocation of Training Resources

The allocation of resources will be compatible with the training needs of each company. When necessary equipment and devices may be shuttled between companies. If appropriate, resources may be reallocated between units.

Operability and Maintenance of Facilities

Facilities will be operable when training begins and will be maintained in a high state of readiness.

Scheduling

Only one company will be scheduled for training on a weekend in order to maximize the use of facilities, equipment, and devices.

Command Participation

All company commanders will actively participate in the training program. Participation includes being tested and conducting remedial training.

COMPANY COMMANDER

The company commander's guidance is the same, whenever appropriate, as the battalion commander's. Additional guidance includes: establishing priorities, stabilizing crews, and the training support concept.

Priorities for Training

Training priorities, in the sequence of importance, are the mastery of critical tasks, tank crew gunnery skills test tasks, supporting tasks, and cross training tasks.

Stabilizing Crews

Once training begins duty positions within crews will not be changed without approval.

Training Support Concept

The first priority of all personnel, to include non-tank personnel, is to support the tank crewman skills training program.

IMPLEMENTING TRAINING ACTIVITIES

This section addresses the responsibilities of battalion and company commanders in carrying out tank crewman skills training activities.

BATTALION COMMANDER

Once the training guidance has been announced the commander implements TCST activities through the use of a planning calendar, a training support forecast, and unit schedules. (Examples of these documents are shown in DA Training Circular TC 21-5-7, "Training Management in Battalions," December 1977.) TCST information to be included in these documents are indicated below.

TCST Planning Calendar

The planning calendar shown in Table 4 includes information pertaining to: training activity, location, support requirements and responsible command. The calendar covers twelve months and reflects a progressive accumulation of unit training activities (UTAs) required to complete the program.

TCST Support Forecast

A primary responsibility of the commander is to provide an environment which is conducive to efficient training. The reduction of a company's administrative and logistical training burden significantly enhances its' training efficiency. The support forecast, Table 5, is a tool for the commander to use in assisting the companies in implementing the program. The forecast is an aid for the battalion training officer in carrying out his support responsibilities.

Unit Schedules

Training schedules are published at battalion after input from each company commander. They include: date, subunit, mission, trainers, location/facilities, time reserved, and notes. (See TC 21-5-7). When necessary special schedules are prepared for specific activities. An example of a special schedule is shown in Table 6. It reflects the first training activity of the program which is testing and training three key "tank commanders" from each company. This activity can be accomplished by a five man branch assistance team during a two day period. The battalion training officer is responsible for directing and supporting this activity.

Table 4

BATTALION TCST PLANNING CALENDAR

JUL UTAS-0 ACCUM UTAS-0	AUG UTAS-0 ACCUM UTAS-0	SEP UTAS-4 ACCUM UTAS-4	OCT UTAS-4 ACCUM UTAS-4
<p><u>Activity:</u> Maintain facilities and equipment</p> <p><u>Location:</u> UTES and Armory</p> <p><u>Support:</u> None</p> <p><u>Resp Cmd:</u> Battalion and company</p>	<p><u>Activity:</u> Test and train key TCs</p> <p><u>Location:</u> UTES</p> <p><u>Support:</u> One, five man armor BAT team, appropriate field courses, equipment, Cue/See, TEC tapes & test material</p> <p><u>Resp Cmd:</u> Battalion</p>	<p><u>Activity:</u> a) Key TCs test and train remaining TCs b) GN, LD, DVs take written tests</p> <p><u>Location:</u> a) UTES b) Armory</p> <p><u>Support:</u> a) Key TCs, appropriate field courses, equipment, Cue/See & TEC tapes & test material b) Test material</p> <p><u>Resp Cmd:</u> Company</p>	<p><u>Activity:</u> Remedial training of deficiencies noted on written tests</p> <p><u>Location:</u> Armory or UTES</p> <p><u>Support:</u> Field courses, equipment, training aids/devices, training modules</p> <p><u>Resp Cmd:</u> Company</p>
<p><u>NOV UTAS-4 ACCUM UTAS-8</u></p> <p><u>Activity:</u> GN, LD, DVs complete HO tests & continue remedial training deficiencies noted</p> <p><u>Location:</u> Armory or UTES</p> <p><u>Support:</u> Field courses, equipment, trng aids/devices, test material & training modules</p> <p><u>Resp Cmd:</u> Company</p>	<p><u>DEC UTAS-0 ACCUM UTAS-8</u></p> <p><u>Activity:</u> Maintain facilities and equipment</p> <p><u>Location:</u> Armory or UTES</p> <p><u>Support:</u> None</p> <p><u>Resp Cmd:</u> Bat & Company</p>	<p><u>JAN UTAS-4 ACCUM UTAS-12</u></p> <p><u>Activity:</u> Remedial training and fire Tables I, II, and III (day or night)</p> <p><u>Location:</u> Armory or UTES</p> <p><u>Support:</u> Field courses, equipment, trng aids/devices, training modules</p> <p><u>Resp Cmd:</u> Company</p>	<p><u>FEB UTAS-4 ACCUM UTAS-16</u></p> <p><u>Activity:</u> Remedial training & fire subcaliber Tables IV and V</p> <p><u>Location:</u> UTES or MTA</p> <p><u>Support:</u> Live firing ranges, equipment, trng aids/devices, training modules</p> <p><u>Resp Cmd:</u> Company</p>
<p><u>MAR UTAS-4 ACCUM UTAS-20</u></p> <p><u>Activity:</u> Remedial training</p> <p><u>Location:</u> Armory or UTES</p> <p><u>Support:</u> Field courses, equip, trng aids/device trng modules</p> <p><u>Resp Cmd:</u> Company</p>	<p><u>APR UTAS-4 ACCUM UTAS-24</u></p> <p><u>Activity:</u> Conduct crew interaction performance test (CIPT)</p> <p><u>Location:</u> MTA</p> <p><u>Support:</u> Live firing range, equip, test material</p> <p><u>Resp Cmd:</u> Company</p>	<p><u>MAY UTAS-4 ACCUM UTAS-28</u></p> <p><u>Activity:</u> Remedial trng of CIPT deficiencies</p> <p><u>Location:</u> Armory or UTES</p> <p><u>Support:</u> Field courses, equip, trng aids/devices trng modules</p> <p><u>Resp Cmd:</u> Company</p>	<p><u>JUN UTAS-0 ACCUM UTAS-28</u></p> <p><u>Activity:</u> Prepare for ANACDUTRA</p> <p><u>Location:</u> Armory</p> <p><u>Support:</u> None</p> <p><u>Resp Cmd:</u> Bat & Company</p>

Table 5
TRAINING SUPPORT FORECAST

JUL	AUG	SEP	OCT
<ol style="list-style-type: none"> 1. Print & issue TCST materials 2. Inventory trng resources 3. Fill trng resources shortages 4. Develop trng facilities 5. Request branch assistance team 6. Publish unit schedules 	<ol style="list-style-type: none"> 1. Arrange facility for testing & trng "key" TCs 2. Supervise testing & trng "key" TCs 	<ol style="list-style-type: none"> 1. Monitor testing and trng of other TCs 2. Request Table IV and V & CIPT ranges from MTA 3. Maintain trng facilities 	<ol style="list-style-type: none"> 1. Monitor testing and remedial training 2. Maintain training facilities
<ol style="list-style-type: none"> 1. Monitor testing and remedial training 2. Maintain training facilities 	<ol style="list-style-type: none"> 1. Maintain training facilities 2. Forward ammunition forecasts for Tables IV and V and CIPT 	<ol style="list-style-type: none"> 1. Monitor remedial trng & firing of Tables I, II, and III 2. Maintain training facilities 	<ol style="list-style-type: none"> 1. Monitor remedial trng and firing of Tables IV & V 2. Maintain training facilities
<ol style="list-style-type: none"> 1. Monitor remedial training 2. Maintain training facilities 	<ol style="list-style-type: none"> 1. Monitor CIPT 2. Maintain training facilities 	<ol style="list-style-type: none"> 1. Monitor remedial training 2. Maintain training facilities 	<ol style="list-style-type: none"> 1. Direct training resources inventory for next testing year 2. Maintain training facilities

Table 6
 READINESS TESTING SCHEDULE FOR KEY TANK COMMANDERS

TC #	DAY ONE										DAY TWO							
	8-9	9-10	10-11	11-12	1-2	2-3	3-4	4-5	5-6	8-9	9-10	10-11	11-12	1-2	2-3	3-4	4-5	5-6
1					Tn-1 RT-B				Tn-4 RT-G		Tn-2 RT-C	Tn-5 RT-I		Tn-3 RT-E				
2					Tn-2 RT-C	Tn-1 RT-B	Tn-5 RT-I			Tn-3 RT-E		Tn-4 RT-G		Tn-2 RT-K				
3					Tn-2 RT-C	Tn-1 RT-B	Tn-5 RT-I			Tn-3 RT-E		Tn-4 RT-G		Tn-1 RT-K				
4					Tn-3 RT-E	Tn-2 RT-C	Tn-1 RT-B			Tn-4 RT-G		Tn-5 RT-I		Tn-1 RT-K				
5					Tn-4 RT-G	Tn-2 RT-C	Tn-1 RT-B			Tn-1 RT-B	Tn-5 RT-I	Tn-3 RT-E		Tn-5 RT-K				
6					Tn-5 RT-I	Tn-3 RT-E	Tn-2 RT-C			Tn-1 RT-B	Tn-5 RT-I	Tn-3 RT-E		Tn-5 RT-K				
7					Tn-4 RT-G	Tn-3 RT-E	Tn-2 RT-C			Tn-2 RT-C	Tn-5 RT-I	Tn-2 RT-K		Tn-4 RT-G	Tn-4 RT-K			
8					Tn-5 RT-I	Tn-4 RT-G	Tn-3 RT-E			Tn-2 RT-C	Tn-1 RT-B	Tn-1 RT-K		Tn-3 RT-E				
9					Tn-5 RT-I	Tn-3 RT-E	Tn-2 RT-C			Tn-3 RT-E	Tn-4 RT-G	Tn-1 RT-B		Tn-3 RT-E				

Written Tests

Hands-On Tests

LEGEND

- Tn 1 thru 5 equals Trainers 1-5
- Readiness Tests
- B-lhr. Weapons Maintenance
- C-3/4hrs. Before Opn. Maintenance
- E-1 1/4hrs. Weapon Syst. Prep.
- G-1 1/4hrs. Combat Loading
- I-3/4hr. Locating & Reporting Targets
- K-2hrs. Tactical Operations

COMPANY COMMANDER

In the TCST concept training is decentralized to the tank crew level. In this context the company commander is a training manager and has responsibilities similar to that of the battalion commander. He must provide the tank commanders with an environment which facilitates training. Specific management activities are indicated below.

Provide Tank Commanders for Cadre Training

The training concept requires that a cadre of the most knowledgeable and skilled tank commanders from each company be tested and trained by a branch assistance team of the supporting readiness group. After the cadre has been trained it will test and train the remaining tank commanders in their respective companies. The commander selects the best tank commander from each platoon to make up the cadre and has them available for testing and training at the designated place and time.

Test and Training Remaining Tank Commanders

The cadre tank commanders test and training the remaining tank commanders. The schedule at Table 7 indicates that this activity can be accomplished on a company basis in a two day period. (Additional personnel, tank commander qualified officers/NCOs will significantly reduce the time to complete this activity.) During the time the tank commanders are being tested and trained the remaining crewmembers are administered written readiness tests by the training officer/NCO at the armory. Figure 20 includes instructions for administering and scoring written tests.

Complete Readiness Testing

After all written tests have been completed the tank commanders administer hands-on tests to their crewmembers. The commander provides necessary training resources. (A tank commander cannot test three crewmembers simultaneously; therefore, during this time two of the crewmembers can participate in self-instructional remedial training of deficiencies noted on the written tests.)

Conduct Remedial Training

After readiness tests are completed and the results recorded remedial training of deficiencies noted is conducted. The commander provides necessary training resources. Figure 21 illustrates a "county-fair" layout for testing and training.

Table 7
 READINESS TESTING SCHEDULE FOR OTHER TC'S

TC #	DAY ONE												DAY TWO										
	8-9	9-10	10-11	11-12	1-2	2-3	3-4	4-5	5-6	6-7	7-8	8-9	9-10	10-11	11-12	1-2	2-3	3-4	4-5	5-6	6-7	7-8	
1					Tn-1 RT-B	Tn-1 RT-C	Tn-1 RT-B		Tn-4 RT-G	Tn-3 RT-E	Tn-2 RT-C	Tn-2 RT-I	Tn-3 RT-E	Tn-3 RT-I	Tn-3 RT-E	Tn-3 RT-K							
2					Tn-2 RT-B	Tn-2 RT-C	Tn-1 RT-B		Tn-4 RT-E	Tn-4 RT-G	Tn-3 RT-E	Tn-2 RT-I	Tn-2 RT-E	Tn-4 RT-G	Tn-4 RT-G	Tn-4 RT-K							
3					Tn-2 RT-C	Tn-2 RT-C	Tn-1 RT-B		Tn-4 RT-G	Tn-4 RT-G	Tn-3 RT-E	Tn-2 RT-I	Tn-2 RT-E	Tn-1 RT-K	Tn-1 RT-K								
4					Tn-3 RT-E	Tn-1 RT-B	Tn-1 RT-B		Tn-4 RT-G	Tn-4 RT-G	Tn-4 RT-G	Tn-2 RT-I	Tn-2 RT-E	Tn-2 RT-I	Tn-2 RT-I	Tn-1 RT-K							
5						Tn-2 RT-C	Tn-2 RT-C		Tn-1 RT-B	Tn-1 RT-B	Tn-2 RT-C	Tn-4 RT-G	Tn-3 RT-E	Tn-3 RT-E	Tn-2 RT-I	Tn-3 RT-K							
6						Tn-3 RT-E	Tn-2 RT-C		Tn-1 RT-B	Tn-1 RT-B	Tn-1 RT-B	Tn-4 RT-G	Tn-4 RT-G	Tn-2 RT-I	Tn-2 RT-I	Tn-4 RT-K							
7					Tn-4 RT-G				Tn-3 RT-E	Tn-3 RT-E	Tn-1 RT-B	Tn-1 RT-B	Tn-3 RT-E	Tn-1 RT-B	Tn-2 RT-I	Tn-1 RT-K							
8						Tn-4 RT-G			Tn-2 RT-C	Tn-2 RT-C	Tn-3 RT-E	Tn-3 RT-E	Tn-1 RT-B	Tn-1 RT-B	Tn-2 RT-I	Tn-2 RT-I					Tn-3 RT-K	Tn-4 RT-K	
9						Tn-4 RT-G			Tn-4 RT-E	Tn-3 RT-E	Tn-2 RT-B	Tn-1 RT-B	Tn-1 RT-B	Tn-1 RT-B	Tn-2 RT-I	Tn-2 RT-I					Tn-2 RT-I	Tn-4 RT-K	

Written Tests

Hands-On
 Readiness Tests

LEGEND

- Tn 1 thru 4 equals Trainers 1-4
- Readiness Tests
- B-lhr. Weapons Maintenance
- C-3/4hr. Before Opn. Maintenance
- E-1 1/4hrs. Weapon Syst. Maint.
- G-1 1/4hrs. Combat Loading
- I-3/4hr. Locating and Reporting Targets
- K-2hrs. Tactical Operations

1. These instructions apply to scoring the following Readiness Test Parts:
 - . Driver's Readiness Test Parts A and C.
 - . Loader's Readiness Test Parts A, E, and G.
 - . Gunner's Readiness Test Parts A, D, F, H, and J.
 - . Tank Commander's Readiness Test Parts A, D, F, H, and J.
2. Station Set-Up: Insure the following items are present at the test site:
 - . One copy of appropriate pre-test per crewmember.
 - . One pencil per crewmember.
 - . Answer sheet for each pre-test.
 - . One answer key for each pre-test.
 - . Sufficient seats and writing space to accommodate crewmembers being tested.
3. Test Procedure:
 - . Issue pre-tests.
 - . Instruct crewmembers not to mark on the test sheet.
 - . Instruct crewmembers to place their name, SSAN and date on the answer sheet.
 - . Instruct crewmembers to begin answering the questions on the pre-test.
 - . Do not provide any assistance to the person taking the pre-test.
 - . Collect the pre-tests and answer sheets.
 - . Score the answer sheets.
 - . Determine which crewmembers met or exceeded the standard of the readiness test and which crewmembers should take TEC lessons.

Figure 20. Instructions for administering and scoring TEC pre-tests.

4. Scoring Standards:

- . Use the answer provided on the answer sheet.
- . Do not assume that the crewmember knows anything that he does not write on his answer sheet.
- . Do not give partial credit for any answer.
- . The maximum and passing score is listed in the answer key.

5. Reporting of Results:

- . Record the results, "G" or "N" of the testing in the Company Readiness Record.
- . Report the results to the tank commanders.

Figure 20. (Cont'd). Instructions for administering and scoring TEC pre-tests.

DRILL HALL

Tables

DV	DV	LD	LD
RTs	Tng Mods	RTs	Tng Mods

GN	GN	TC	TC
RTs	Tng Mods	RTs	Tng Mods

⊗ Tng Mgr Station

TCST	Co Readiness	TEC
Prog.	Record	Tapes

Cue/See
Loaders

COAX

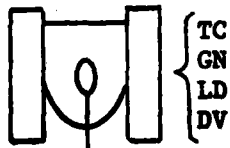

Cue/See
Drivers

.50 Cal.

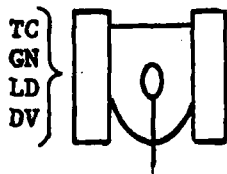

Cue/See
TCs

Cue/See
Gunners

Figure 21. County fair testing and training layout.

Fire Tables I, II, and III

Subcaliber tables are fired at the armory using the laser firing device. The commander provides the facility and equipment and operates and schedules the use of the range.

Fire Tables IV and V

These tables are fired at the MTA. The ranges are requested by the battalion training officer. The company commander provides transportation, equipment, ammunition, and logistical support and insures that the ranges are ready when the crews arrive.

Administering Crew Interaction Performance Test

The CIPT requires a facility which will accommodate non-firing and firing training modules. A table VII range at a MTA is satisfactory for this purpose. The commander provides necessary support and organizes and administers the test.

Conduct Remedial Training of CIPT Deficiencies

Deficiencies noted during the crew interaction performance test are corrected by remedial training on appropriate training modules at the armory or UTES.

MONITORING TRAINING PROGRESS

The battalion and company commanders establish procedures which insure timely and accurate training feedback. This feedback is essential for early identification of training problems and for the expeditious resolution of these problems.

BATTALION COMMANDER

Training monitorship at the battalion level includes command visits, staff visits, and training reports.

Command Visits

These visits are scheduled to make efficient use of training time and to create a command relationship of training assistance. The commander must appreciate the decentralized nature of the training program and observe at the individual crewman level to determine training effectiveness. Visits should determine the adequacy of training resources, the effectiveness of the organization for training, and the accuracy of training progress records.

Staff Visits

The training officer visits units in response to requests for assistance. Problems should be resolved or if this is not possible they should be referred to the battalion commander.

Training Reports

The training officer charts the progress of training within each unit by consolidating reports from each company. The chart shown in Table 8 is used for this purpose. Pencil entries allow for making changes from a NO GO to a GO status as changes occur.

COMPANY COMMANDER

The company commander's training monitorship includes overseeing training progress, assisting in resolving problems, and maintaining training progress records. He motivates the training program by taking readiness tests and doing required remedial training.

Table 6
BATTALION CREWMAN READINESS CHART

READINESS TESTS

READINESS TEST PART ->	DRIVER			LOADER			GUNNER			TANK COMMANDER		
	JA	BA	CA	DA	EA	FA	GA	HA	IA	JA	KA	LA
Operational Checks and Services												
Before Operations Procedures and Tank Set-Up												
Target Acquisition												
Locating and Reporting												
Tactical Driving												
Weapons Maintenance												
Weapons Maintenance												
Weapons Preparation												
Weapons Preparation												
Combat Loading												
Combat Loading												
Target Acquisition												
Locating and Reporting												
Tactical Operations												
Weapons Maintenance												
Weapons Maintenance												
Before Operations Procedures												
Before Operations Procedures												
Weapon Systems Preparation												
Weapon Systems Preparation												
Combat Loading												
Combat Loading												
Target Acquisition												
Locating and Reporting												
Tactical Operations												
Tactical Operations												
Table IV												
Table IV												
CIFT												

a Written tests
b Hands-on tests

READINESS TEST PART ->
CO-BO GO RATING ->

- A Company
- Driver
- Loader
- Commander
- TC
- B Company
- Driver
- Loader
- Commander
- TC
- C Company
- Driver
- Loader
- Commander
- TC
- Battalion
- Driver
- Loader
- Commander
- TC

NOTE: Battalion training officer/MCO enters data from company training officer/MCO crewman readiness report. Entries should be made in pencil so that changes in readiness status between CO and BO GO ratings can be reflected.

Overseeing Training Progress

The commander closely observes training activities, questions individuals on training progress, and checks each TC's tank crewman's readiness book.

Resolving Problems

As the commander oversees training progress he identifies and resolves training problems. Problems beyond his capabilities and resources are promptly reported to the battalion.

Training Progress Record

Table 9 is an example of a company crewman's readiness chart. Whenever a crewman completes a readiness test the TC records the results in the crewman's readiness book and reports the results to the company training officer/NCO who records the information on the chart. As training modules are completed the results are likewise reported. Data from the chart are forwarded to battalion for consolidating and recording on the battalion crewman's readiness chart.

Table 9

COMPANY CREWMAN READINESS CHART

RT/TM Part	DV11	DV12	DV13	DV14	DV21	DV22	DV23	DV24	DV31	DV32	DV33	DV34
A												
B												
C												
D												
E												
	LD11	LD12	LD13	LD14	LD21	LD22	LD23	LD24	LD31	LD32	LD33	LD34
A												
B												
C												
D												
E												
F												
G												
H												
	GN11	GN12	GN13	GN14	GN21	GN22	GN23	GN24	GN31	GN32	GN33	GN34
A												
B												
C												
D												
E												
F												
G												
H												
I												
J												
K												
	TC11	TC12	TC13	TC14	TC21	TC22	TC23	TC24	TC31	TC32	TC33	TC34
A												
B												
C												
D												
E												
F												
G												
H												
I												
J												
K												
IV												
V												
CIPT												

ANNEX 1

TRAINING SUPPORT REQUIREMENTS

This annex includes information pertaining to specific support requirements for the tank crewman skills training program.

- Enclosure 1 TCST Materials**
- Enclosure 2 Training Facilities**
- Enclosure 3 Equipment**
- Enclosure 4 Training Aids/Devices**
- Enclosure 5 Outside Support**
- Enclosure 6 Ammunition**
- Enclosure 7 Targets**

ENCLOSURE 1. TCST MATERIALS

- a. Readiness test (list only, tests are in ARI Research Product RP-79-13).
- b. Training modules (list only, tests are in ARI Research Product RP-79-14).
- c. Crew interaction performance test, (test is in ARI Research Product RP-79-15).
- d. Task books.
- e. Tank crewman's readiness book.
- f. Training manager's guide (Appendix A, this report).
- g. Tank commander's training guide (Appendix B, this report).

Enclosure 1-a. List of duty position readiness tests.

READINESS TESTS (WRITTEN)		READINESS TESTS (HANDS-ON)	
POSITION	PART	DESCRIPTION	DESCRIPTION
Driver	A	Operational checks and services	Before operations procedures and tank start-up
	C	Target acquisition	Locating and reporting targets Tactical driving
Loader	A	Weapons maintenance	Weapons maintenance
	C	Mission preparation	Mission preparation
	E	Combat loading	Combat loading
	G	Target acquisition	Locating and reporting targets
Gunner	A	Weapons maintenance	Weapons maintenance
	D	Weapon systems preparation	Before operations procedures
	F	Combat loading	Weapon systems preparation
	H	Target acquisition	Combat loading
	J	Tactical operations	Locating and reporting targets
TC	A	Weapons maintenance	Weapons maintenance
	D	Weapon systems preparation	Before Operations procedures
	F	Combat loading	Weapons systems preparation
	H	Target acquisition	Combat loading
	J	Tactical operations	Locating and reporting targets

Enclosure 1-b. List of duty position training modules.

TRAINING MODULES		TRAINING MODULES (Cont'd)	
POSITION	PART	POSITION	PART
Driver	D-1	Gunner	G-1
	D-2		G-2
	D-3		G-3
	D-4		G-4
	D-5		G-5
			G-6
			G-7
			G-8
			G-9
			G-10
			G-11
Loader	L-1	TC	TC-1
	L-2		TC-2
	L-3		TC-3
	L-4		TC-4
	L-5		TC-5
	L-6		TC-6
	L-7		TC-7
	L-8		TC-8
			TC-9
			TC-10
			TC-11

NOTE: (k) = knowledge
(s) = skill

Enclosure 1-d. Task Books

This enclosure includes task books for the driver, loader, gunner, and tank commander. The books contain major technical tasks and in sequential order the subtasks required to perform the major tasks. The books are printed to facilitate reproduction at the organizational level.

DRIVER TASK BOOK

Name _____
SSN _____
Unit _____

INSTRUCTIONS FOR DRIVER

YOUR RESPONSIBILITIES: You are personally responsible to perform many jobs as a member of your tank crew. Many of these tasks have a number of steps which must be performed to correctly complete the task. The nature of each task determines which ones must be committed to memory and which tasks need not be memorized. This booklet will help you to perform those tasks which need not be memorized.

HOW TO USE THIS BOOKLET: Keep this booklet handy to use as a guide when you are required to perform these tasks. Make the notes you desire in the space provided.

CROSSTRAINING TASKS: This task book does not include crosstraining tasks.

REMOVE M27 PERISCOPE

- Loosen wing nuts on both sides of the periscope.
- Rotate the retainers until they are clear of the periscope mounting lugs.
- Remove the periscope from the bracket.

INSTALL M24 (IR) PERISCOPE

- Close driver's hatch.
- Place master battery switch OFF.
- Instruct a crew member to rotate the turret so that the gun tube is forward.
- Pull periscope holder lid handle (on latch cover) down with the fingers of your left hand and push UP on the lid latch with your thumb.
- Push UP and open lid.
- Reach to the rear of your seat and unlatch both catches on the IR periscope stowage box.
- Remove the periscope from the stowage box.

DO NOT EXPOSE THE PERISCOPE TO DIRECT SUNLIGHT

- Pull UP (rearward) on the elevation adjustment lever making sure that the bind (tension) has been released on the elevation clamp and elevation clamp pivots.
- Loosen the jam nut on the elevation clamp.
- Using both hands, position the periscope in the periscope holder.
- Push up on periscope until it locks in the holder. (Insure that the periscope locks in the holder before releasing.)
- Insure that the elevation clamp is positioned in the periscope holder detent.
- Tighten the adjustment screw on front right hand inside of the elevation clamp until the elevation clamp is firmly seated in the periscope holder detent.
- Tighten the elevation clamp adjustment screw jam nut.
- Push elevation adjustment lever downward (forward) and lock periscope.
- Unscrew dust cap from power receptacle (center) location.
- Unscrew power cable connecting plug from stowage receptacle on righthand side of compartment.
- Thread power cable connecting plug into periscope receptacle and hand tighten

PLACE THE M24 (IR) PERISCOPE INTO OPERATION

- Turn the Master Battery switch ON.
- Place the Blackout Selector switch in BO DRIVE.
- Turn the IR switch ON.
- Visually check to insure IR indicator lamp is lit.
- Turn the Lighting Control switch handle to the left.
- Pull the elevation adjustment lever UP.
- Adjust periscope elevation angle to a comfortable position by moving periscope with both hands.
- Push elevation adjustment lever down to lock the periscope in position.
- As necessary, loosen the two outer wing nuts on the headrest until the proper eye distance is obtained, then retighten (handtight) both wing nuts.
- As necessary, bend headrest to fit head contour by pulling, pushing, or twisting on each side of the headrest.
- Allow periscopes to warm up for 5 minutes before adjusting focus.
- Unscrew left and right dust caps from bottom focus controls.
- Rotate left and right focus control knobs until the view through each eyepiece appears with maximum sharpness.
- Screw left and right dust covers back over focus control knobs and tighten finger tight.

START TANK ENGINE

- Lock hatches in open or closed position.
- Check that drain valves are closed.
- Lock parking brakes by depressing the brake pedal and placing the transmission shift lever in PARK.
- Place steering control in center position.
- Place fuel shut-off valve handle to ON position.
- Place fuel pump switch in the ON position.
- Place generator switch in the ON position.
- Place Master Battery switch in ON position.
- Check that power plant warning lamp and master control switch indicator lamp are lit.
- Check to insure fuel gauges are operating.
- Purge the fuel lines of air, if tank has not been operated within the past week.
- Depress accelerator pedal about 2/3 way down, then release and firmly press and hold starter switch until engine starts, but no longer than 15 seconds.
- As soon as engine starts, release starter switch and allow the generator to run in operating.
- Allow engine to warm up for 5 minutes before shifting.
- Reduce engine RPM to a speed suitable for shifting.

AD-A082 531

HUMAN RESOURCES RESEARCH ORGANIZATION ALEXANDRIA VA
PROGRAM MANAGEMENT FOR TANK CREWMAN SKILLS TRAINING PROGRAM
NOV 79 R E O'BRIEN, W J CRUM
HUMRO-RP-WD(KY)-79-14

/6 5/9

U)

001

ML

UNCLASSIFIED

ARI-RP-79-16

2-2

5/79

■

	■										
				—							

END
DATE
FILMED
5-80
DTIC

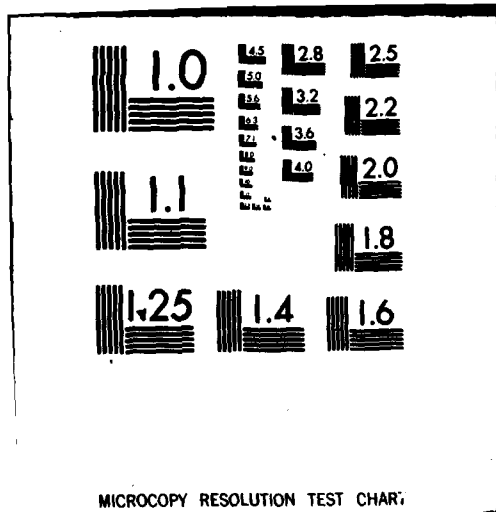

MICROCOPY RESOLUTION TEST CHART

INSTRUCTIONS FOR LOADER

YOUR RESPONSIBILITIES: You are personally responsible to perform many jobs as a member of your tank crew. Many of these tasks have a number of steps which must be performed to correctly complete the task. The nature of each task determines which ones must be committed to memory and which tasks need not be memorized. This booklet will help you to perform those tasks which need not be memorized.

HOW TO USE THIS BOOKLET: Keep this booklet handy to use as a guide when you are required to perform these tasks. Make the notes you desire in the space provided.

CROSSTRAINING: This task book does not include crosstraining tasks.

LOADER TASK BOOK

Name _____
SSN _____
Unit _____

PERFORM BEFORE-OPERATIONS CHECKS AND SERVICES ON TANK ENGINE AND TRANSMISSION OIL LEVELS

- Check engine and transmission oil levels.
- Add engine oil until presence of oil indicated on gage is to the ADD mark (if required).
- Add transmission oil until level indicated on gage is to the ADD mark (if required).
- Tell Driver to start engine.
- Wait until engine is warm and idling at 700-750 RPM.
- Add or drain engine oil until level indicated on gage is above the ADD mark (if required).
- Add or drain transmission oil until level indicated on gage is above the ADD mark (if required).

CHECK TRACK TENSION (T97 TRACK)

- Direct Driver to coast to a stop so that a track link is centered on the #2 support roller.
- Coordinate with Driver by arm and hand signals so that tank coasts to a stop with track link in proper position.
- Raise the track with a crowbar at the number two support roller and place a block (1" thick by 6" square) between the number two support roller and the track link.
- Measure the clearance between the bottom of the track and the top of a string or straight edge between support rollers: Acceptable clearance is 1/4 to 5/16 inch (midway between Nos. 2 and 3 support rollers).

CHECK TRACK TENSION (T142 TRACK)

- Direct Driver to coast to a stop so that a track link is centered on the #2 support roller.
- Coordinate with Driver by arm and hand signals so that tank coasts to a stop with track link in proper position.
- Remove dirt and mud from outboard end connectors between first and second support rollers.
- Place string with weights on both ends over the end connector.
- Measure the distance between the string and the end connector at the mid point between support rollers to insure that the distance is between 7/16 to 1/2 inches.

ADJUST TRACK TENSION

- Remove the track and adjusting link screw and washer from the top of the track adjusting link.
- Use the track adjusting wrench on the track adjusting link and pull UP to increase track tension (right side) or push DOWN to decrease track tension (right side). (Reverse directions for the left side.)
- Do not extend track adjusting link beyond the red painted groove.
- Adjust track tension to tolerance.
- Install lockwasher and lockscrew and tighten with wrench. Tighten until lockwasher is fully seated on the shoulder.

PREPARE TANK FOR BORESIGHTING

- Place black thread over witness lines on muzzle end of main gun and secure thread tautly.
- Remove firing mechanism from breechblock.
- Center right telescope of binocular over firing pinhole.

BORESIGHT AND ZERO COAX MACHINEGUNS

- Remove the solenoid electrical lead from the machinegun backplate assembly by pulling the solenoid plug down.
- Pull the right disconnecter ring rearward to disengage the disconnecter pin from the disconnecter hole.
- Rotate the receiver downward and pull rearward until disengaged from mounting block.
- Loosen support set screws located in the gun mount cover shield collar approximately 1 1/2 turns.
- Select the target used to boresight the main gun with a clearly defined right angle at a distance of 1200 meters.
- Align the machinegun bore vertically on target while viewing the aiming point through the right binocular M17A1 so as to adjust the machinegun elevation alignment with the bore of the main gun by loosening or tightening the adjusting screws.
- Align the machinegun bore horizontally while viewing the aiming point through the right binocular M17A1 so as to adjust the machinegun azimuth alignment with the bore of the main gun by loosening or tightening the front end and rear horizontal adjusting screws.
- Insure that all lock and jam nuts are tightened securely.
- Adjust support set screws in the gun mount cover shield collar until they contact the flash suppressor body then back them off 1/4 to 1/2 turn.

INSTALL AND OPERATE AN/VRC-12 OR AN/VRC-64 RADIO

a. Install AN/VRC-12 Radio.

- Place receiver-transmitter (RT-246) on mount (MT-1029/VRC) and tighten clamps to lock receiver-transmitter on mount.
- Connect antenna cable (CG-1773/U) to ANT receptacle on receiver-transmitter.
- Connect control cable assembly (CX-4722/VRC) to ANT COWT receptacle receiver-transmitter.
- Place receiver (R-442) on mount (MT-1898/VRC) and tighten clamp to lock receiver on mount.
- Connect antenna cable (CG-1773/U) to ANT receptacle on receiver.
- Assemble antenna sections and screw bottom section into antenna base (MX-6707/VRC).

b. Operate AN/VRC-12 Radio.

- Tell Driver to turn on master battery switch.
- Set amplifier (AM-1780/VRC) MAIN POWER switch to OTHER.
- Set receiver-transmitter (RT-246) POWER switch to LOW or HIGH.
- Set amplifier (AM-1780/VRC) POWER CRT BER switch to ON.
- Set receiver (R-442) POWER switch to ON.

c. Install AN/VRC-64 Radio.

- Place amplifier-power supply (AM-2060/GRC) on mount (MT-1029/VRC) and tighten clamps to lock amplifier-power supply on mount.
- Place receiver-transmitter (RT-841/PBC-77) on amplifier-power supply (AM-2060/GRC) and tighten clamps to lock receiver-transmitter on amplifier-power supply.
- Connect Cable Assembly Special Purpose (K-4635/GRC) to amplifier-power supply SET POWER connector and the receiver-transmitter POWER connector.
- Connect Cable Assembly (CG-1773/U) to receiver-transmitter ANT connector.
- Assemble antenna sections and screw bottom section into antenna base (MX-6707/VRC).

d. Operate AN/VRC-64 Radio.

- Tell Driver to turn ON master battery switch.
- Set amplifier-power supply (AM-2060/GRC) PWR switch to ON.
- Turn receiver-transmitter (RT-841/PBC-77) VOLUME control fully clockwise.
- Turn amplifier (AM-1780/VRC) MAIN PWR switch to NORM.
- Set POWER CRT BER switch to ON.

4

CHECK OPERATION OF M3 HEATER

- Rotate air heater knob to ON and check for indicator lamp operation.
- Check air flow through hose.
- Allow air to warm up for at least five minutes (only in arctic conditions).
- Check air temperature.
- Adjust protective mask and attach air hose.
- Remove and stow air hose and protective mask.
- Rotate air heater switch to OFF and listen for audible click.
- Report status of M3 Heater to the Driver.

OPERATE TANK INTERCOMMUNICATIONS SYSTEM

- Adjust CVC helmet to head.
- Insure CVC helmet radio-interphone switch is in center position.
- Connect interphona connector to plug at left bottom of control box.
- Connect radio/audio connector to plug at right bottom of control box.
- Place control box monitor switch in either ALL, A, INT ONLY, or B position.
- Transmit to TC, "LOADER READY."

PERFORM MAIN GUN PREPARE-TO-FIRE PROCEDURES

On command, "PREPARE TO FIRE":

- Check recoil oil by feeling replenisher indicator tape for one rough and one smooth edge.
- Add or drain recoil oil (if required).
- Move breachblock crank stop to the rear.
- Open breach and look in chamber for obstruction and cleanliness.
- Tighten M219 machinegun mounting bolts.
- Plug electrical lead into solenoid.
- Inspect turret stowed ammunition for completeness, type and serviceability.

On command, "CHECK FIRING SWITCHES":

- Place main gun safety switch in FIRE POSITION.
- Install circuit tester between breachblock and face of chamber.
- Observe for lighting of circuit tester bulb each time Gunner or TC announces, "ON THE WAY," and announce, "NO FIRE," any time bulb failed to light.
- Close the cover on the coaxial machinegun, charge it, and listen for forward action of barrel and barrel extension when Gunner and TC activates firing switches (recharging coax before each check).
- Remove and stow circuit tester.

On Gunner's alert, "POWER":

- Check for obstruction of turret traverse and unlock turret.
- Inspect hull stowed ammunition for completeness, type, and serviceability; coordinate turret traverse with Gunner in order to expose storage area.

On Command, "REPORT":

- Report, "LOADER READY."

5

NOTES

PRECEDING PAGE BLANK-NOT FILMED

INSTRUCTIONS FOR GUNNER

YOUR RESPONSIBILITIES: You are personally responsible to perform many jobs as a member of your task crew. Many of these tasks have a number of steps which must be performed to correctly complete the task. The nature of each task determines which ones must be committed to memory and which tasks need not be memorized. This booklet will help you to perform those tasks which need not be memorized.

HOW TO USE THIS BOOKLET: Keep this booklet handy to use as a guide when you are required to perform these tasks. Make the notes you desire in the space provided.

CROSSTRAINING TASKS: This task book does not include crosstraining tasks.

GUNNER TASK BOOK

Name _____
SSN _____
Unit _____

1

OPERATE TANK INTERCOMMUNICATIONS SYSTEM

- Adjust CVC helmet to head.
- Insure CVC helmet radio-interphone switch is in center position.
- Connect interphone-connector to plug at left bottom of control box.
- Connect radio audio connector plug at right bottom of control box.
- Place control box monitor switch in either the ALL, A, INT ONLY, or B position.
- Transmit to TC, "GUNNER READY."

CHARGE MANUAL ELEVATION SYSTEM

- Rotate the manual elevation handle to depress the main gun until the handle can no longer be rotated with one hand.

PLACE TURRET INTO POWER OPERATION

- Perform zero pressure check to insure accumulator charge of 490-500 PSI.
- Check hydraulic power pack oil level.
- Insure the tank and surrounding area are clear of obstruction.
- Insure crew is in safe position and Driver has lowered his seat and has his head down.
- Instruct Loader to release gun tube from travel lock.
- Unlock turret lock.
- Announce, "POWER," to alert the crew.
- Check that engine is running and set at 800 to 900 RPM.
- Insure manual traversing handle locking lever is in the detent position.
- Turn TURRET POWER switch ON.
- Insure that hydraulic pressure was between 1225 and 1275 PSI before operating controls.
- Squeeze magnetic brake switch and rotate Gunner's control handle to traverse turret.
- Rotate handles rearward and forward to elevate and depress gun.
- Check magnetic brake.
- Recheck oil in turret control system.

PERFORM MAIN GUN PREPARE-TO-FIRE PROCEDURES

- On command, "PREPARE-TO-FIRE," from TC:
- Observe Loader's action in checking replenisher tape.
 - Clean and inspect direct fire sights (interior).
 - Check operation of ballistic shield.
 - Check instrument lights.

PERFORM MAIN GUN PREPARE-TO-FIRE PROCEDURES (Cont'd)

On command, "CHECK FIRING SWITCHES":

- Turn main gun switch ON.
- Check firing trigger on power control handle and trigger on manual elevating control handle.
- Check main gun manual firing device.
- (NOTE: Announce ON THE WAY each time a trigger is checked for the main gun or the manual firing device is actuated.)
- Turn main gun switch OFF.
- Turn coaxial machinegun switch ON.
- Check firing trigger on manual elevating control handle.
- Turn coaxial machinegun switch OFF.

On command, "CHECK FIRING CONTROLS":

- Set range correction knob of ballistic computer at zero.
- Check manual operation of computer for bind in computer or linkage.
- Push RESET button on computer.
- Observe that pointers on computer synchronize at various indexed ranges.
- Observe that super-elevation counter indicates correct super-elevation for various ammunition and ranges.
- Turn range correction knob of ballistic computer to proper setting.
- Report, "GUNNER READY," on command, "REPORT."

CHECK OPERATION OF M3 HEATER

- Rotate air heater knob to ON and check for indicator lamp operation.
- Check air flow through hose.
- Allow air to warm up for at least five minutes (in arctic conditions).
- Check air temperature.
- Adjust protective mask and attach air hose.
- Remove and stow air hose and protective mask.
- Rotate air heater switch to OFF and listen for audible click.
- Report status of M3 heater to Driver.

PREPARE TANK FOR BORESIGHTING

After "LOADER" removes firing mechanism from breechblock:

- Align axis of 105mm gun bore on right angle of aiming point by operating the manual traversing and elevating handles according to the Loader's directions.

2

93

3

REPLACES DATE PLATE-NOT FILLED

PREPARE GUNNER'S TELESCOPE FOR OPERATION

- Inspect eyepiece hanger and screws for presence and tightness.
- Inspect the hanger assembly and quick-disconnect pin for presence, proper fit, and swivel movement.
- Inspect the holder assembly to insure that the pin on the telescope and the slot on the holder assembly are seated.
- Adjust headrest by loosening adjusting nut and sliding headrest to desired position and tightening nut.
- Clean lenses.
- Focus eyepiece by rotating diopter to the maximum plus reading and then rotating back until the view through the eyepiece appears with the maximum sharpness.
- Set reticle illumination by rotating the rheostat knob on instrument light.
- Remove filters from filter box.
- Clean if required, and inspect for cracks.
- Select proper filter if conditions warrant use of filters.
- Attach filter to telescope eyepiece.
- View through eyepiece and move reticle selector to each position checking to see that both reticles are visible.

PREPARE GUNNER'S PERISCOPE FOR DAYLIGHT OPERATION

- Inspect the M18 mount for general condition.
- Report any damage to mount to the vehicle commander.
- Adjust the daylight and IR headrest for proper fit.
- Open ballistic shield.
- Adjust diopter on the daylight sight by rotating the diopter to the maximum-plus reading and then back until the image seen through the eyepiece appears with the maximum sharpness.
- Set the reticle illumination by rotating the light source control knob until reticle appears with desired brightness.

OPERATE THE AZIMUTH INDICATOR

- Rotate rheostat knob until desired brightness is obtained.
- Place the aiming cross of the periscope on the reference point.
- Perform accuracy test by manually traversing turret 360 degrees to return to original reference point.
- Set the micrometer and azimuth pointers on zero.
- Perform slippage test by traversing the turret rapidly in power and stopping suddenly.
- Repeat this operation two or more times in same direction.
- Traverse turret manually in opposite direction to return to original reference point.
- Insure that both the micrometer and azimuth pointers are on zero.

BORESIGHT IR SIGHT OF GUNNER'S PERISCOPE DURING DAYLIGHT AND APPLY ESTABLISHED ZERO

- Open the ballistic shield.
- Place opaque material over the periscope head assembly with a 3/4 inch hole in line with the IR body.
- Place the IR switch in the 1.5 volt position.
- View through the IR eyepiece and rotate the IR diopter to the maximum plus reading then back until the grain on the converter tube surface as seen through the eyepiece appears clear and sharp.
- Rotate the light source control until the reticle illumination has the desired brightness.
- Sight through the eyepiece and rotate focusing ring until the target appears with the maximum sharpness.
- Disengage and rotate the elevation and deflection bore-sight knobs until the aiming cross of the reticle is aligned on the same aiming point as the muzzle cross threads.
- Rotate slip scales on the elevation and deflection bore-sight knobs to read 3 and 3.
- Check to insure that aiming cross on the reticle of the daylight scope is on the aiming point.
- Tell Loader to confirm that the muzzle cross threads are on the aiming point.
- Obtain established zero from DA Form 2404.
- Disengage and rotate elevation and deflection bore-sight knobs until established zero is indicated on the slip scales.
- Engage elevation and deflection bore-sight knobs.

BORESIGHT TANK SEARCHLIGHT USING PRIMARY METHOD (SIGHT ONLY)

After "TC" turns searchlight ON and control to VIS FOCUS mode:

- Remove all super-elevation from the fire control system using computer's super-elevation handcrank.
- Lay aiming cross of primary sight on the center of the bore-sight panel or target chosen.
- Center the bubble on the elevation quadrant using the micrometer knob.
- Apply plus 5 mile on elevation quadrant using the micrometer knob.
- Manually elevate the gun until the bubble is centered.

OPERATE ELEVATION QUADRANT

- Place aiming point on the center of the target and establish a line of sight.
- Measure the position of the gun tube by rotating the micrometer knob until the bubble is centered in the level vial.
- Read elevation from the elevation and micrometer scales.

BORESIGHT GUNNER'S TELESCOPE AND APPLY ESTABLISHED ZERO

- Set super-elevation counter on the ballistic computer to zero.
- Move reticle selector switch until reticle corresponding to type of ammunition that will be used to zero can be seen through the eyepiece.
- Unlock telescope mount elevation and deflection bore-sight knobs.
- Rotate the bore-sight knobs until the bore-sight aiming point is in the same position as the muzzle cross threads.
- Move elevation and deflection knob locking levers to the lock position.
- Rotate slip scales on the elevation and deflection knobs to read 3 and 3.
- Tell Loader to confirm that the muzzle cross threads are on the aiming point.
- Obtain established zero from DA Form 2404.
- Unlock telescope mount elevation and deflection bore-sight knobs.
- Rotate bore-sight knobs until established zero was indicated on slip scales.
- Lock telescope mount elevation and bore-sight knobs.

BORESIGHT DAYLIGHT SIGHT OF GUNNER'S PERISCOPE AND APPLY ESTABLISHED ZERO

- Sight through the eyepiece, disengage the elevation and deflection bore-sight knobs, and rotate the knobs until the aiming cross is on the same aiming point as the muzzle cross threads.
- Rotate slip scale on the elevation and deflection bore-sight knobs to read 4 and 4.
- Check to assure that the daylight sight reticle is on the aiming point.
- Tell Loader to confirm that the muzzle cross threads are on the aiming point.
- Obtain established zero from DA Form 2404.
- Unlock periscope mount elevation and deflection bore-sight knobs.
- Rotate bore-sight knobs until established zero was indicated on the slip scales.
- Lock periscope mount elevation and deflection bore-sight knobs.

BORESIGHT TANK SEARCHLIGHT USING THE ALTERNATE METHOD

After "TC" lays the bottom of the searchlight beam above and just touching the reference mark:

- Remove super-elevation from fire control system using computer's handcrank.
- Bore-sight main gun on lower cross.
- Center the bubble on the elevation quadrant using the micrometer knob.
- Apply plus 5 mile to elevation quadrant using the micrometer knob.
- Manually elevate the gun until the bubble is centered.

BORESIGHT THE COAX

After "LOADER" tightens both horizontal adjustment screws:

- Rotate, either to the left or right, the rheostat knob on the infinity sight M4C for periscope M31 or the rheostat knob of the light source control for periscope M32 in order to adjust brightness of reticle.
- Rotate both the elevation and deflection bore-sight knobs on the infinity sight so as to align the center reticle on aiming point of target.

ZERO MAIN GUN

After "TC" turns computer ON:

- Assure range correction knob of ballistic computer is indexed correctly.
- Index ammunition element into ballistic computer.
- Lay sight reticle on center of mass of target by operating the manual elevation and traversing handles.

After "LOADER" announces UP:

- Fire a three-round shot group.
- Unlock bore-sight knob and move sight reticle to center of shot group, without disturbing lay of the gun (with gun loaded).
- Relay main gun back to center of mass by operating the manual elevation and traversing handles.
- Fire a check round.
- Relay main gun back to center of mass by operating the manual elevation and traversing handles.
- Unlock bore-sight knob of Gunner's sight not used to zero and rotate knob until proper portion of reticle is laid on target aiming point.
- Record elevation and deflection readings on all sights.

INSTRUCTIONS FOR TANK COMMANDER

YOUR RESPONSIBILITIES: You are personally responsible to perform many jobs as a member of your tank crew. Many of these tasks have a number of steps which must be performed to correctly complete the task. The nature of each task determines which ones must be committed to memory and which tasks need not be memorized. This booklet will help you to perform those tasks which need not be memorized.

HOW TO USE THIS BOOKLET: Keep this booklet handy to use as a guide when you are required to perform these tasks. Make the notes you desire in the space provided.

CROSSTRaining TASKS: This task book does not include crosstraining tasks.

TANK COMMANDER TASK BOOK

Name _____

SSN _____

Unit _____

1

OPERATE TANK INTERCOMMUNICATIONS SYSTEM

- . Adjust CVC helmet to head.
- . Insure CVC helmet radio-interphone switch is in center position.
- . Connect interphone connector to plug at left bottom of control box.
- . Connect radio audio connector plug at right bottom of control box.
- . Place control box monitor switch in either the ALL, A, INT ONLY, or B position.
- . Transmitted to TC (scored), "TANK COMMANDER READY."

PERFORM MAIN GUN PREPARE-TO-FIRE PROCEDURES

- . Command PREPARE-TO-FIRE after GUNNER places turret into power operation.
- . Disconnect breakaway plug.
- . Clean exterior lens and vision devices on turret.
- . Check operation of shield on periscope.
- . Check instrument lights.
- . Command, "CHECK FIRING SWITCHES."
- . Check firing trigger on power control handle when main gun switch is ON.
- . Check firing trigger on power control handle when coaxial machine-gun switch is ON.
- . Command CHECK GUN CONTROLS.
- . Turn cupola power switch ON.
- . Check operation of .50 caliber machinegun mount and controls.
- . Check for binding on rangefinder.
- . Turn ballistic computer ON.
- . Index various ranges on rangefinder.
- . Tell GUNNER to insure they are indexed on ballistic computer.
- . Command, "REPORT."

CHECK GAS PARTICULATE UNIT

- . Rotate air heater knob to ON and check for indicator lamp operation.
- . Check air flow through hose.
- . Allow air to warm up for at least five minutes (only in arctic conditions).
- . Check air temperature.
- . Adjust protective mask and attach air hose.
- . Remove and stow air hose and protective mask.
- . Rotate air heater switch to OFF and listen for audible click.
- . Report deficiencies to Driver for entry on DA Form 2404, if required.

BORESIGHT TANK SEARCHLIGHT USING PRIMARY METHOD

- . Selected a target as near 1200 meters as possible.
- . Tell Driver to idle tank engine at 1000-1200 RPM.
- . Turn searchlight main power switch to the ON position and turn searchlight control to VIS FOCUS mode.
- . Adjust azimuth and elevation adjusting screws until the searchlight beam is centered on the target cross.
- . Tell the Gunner to elevate the gun 5 mils.
- . Align the searchlight so that the beam is again centered on the target cross.
- . Tighten the clamping nuts.

BORESIGHT TANK SEARCHLIGHT USING ALTERNATE METHOD

- . Direct Driver to position tank so the searchlight is approximately 10 meters from a wall.
- . Draw a cross on the wall approximately 7 feet from the ground.
- . Draw a second cross 16 1/2 inches directly above the first cross and vertically in line with the first cross.
- . Tell Driver to insure that the tank engine is running at a fast idle speed.
- . Turn searchlight main power switch to ON position and turn searchlight control to VIS FOCUS mode.
- . Adjust horizontal and vertical adjustment screws until the searchlight beam is centered on the upper cross.
- . Tell Loader to draw reference mark at the bottom edge of the searchlight beam.
- . Adjust vertical and horizontal adjustment screws until the bottom of the searchlight beam is above and just touching the reference mark.

PREPARE TANK RANGEFINDER FOR OPERATION

- . Adjust rangefinder headrest to fit the contour of your head.
- . Rotate occluder knob to the R position.
- . Rotate the diopter scale to the maximum plus reading.
- . Rotate the diopter scale until the view through the eyepiece appears with the maximum sharpness.
- . Move the filter switch to the left to place the filters into the optical system, if necessary.
- . Rotate the range scale rheostat to determine if range scale lamp is illuminated.
- . Set rheostat until desired brightness is obtained.
- . Rotate the occluder to the L position.
- . Move the reticle switch to the AUX-GUNSIGHT position.

2

3

PROCEEDING PAGE BLANK-NOT FILLED

PREPARE TANK RANGEFINDER FOR OPERATION (Cont'd)

- . Sight through the eyepiece and set red illuminated reticle for brightness by rotating reticle rheostat.
- . Rotate occluder knob to the center position and move reticle switch to the coincidence position.
- . Sight through the eyepiece and set coincidence reticle brightness by rotating the coincidence reticle rheostat.
- . Move reticle switch to the OFF position.
- . Rotate the occluder knob to the R position.
- . Index target range on range scale.
- . Rotate the occluder knob to the center position.
- . Sight through eyepiece and rotate the horizontal adjustment knob until the ghost image is positioned to the left of the actual image.
- . Rotate the vertical adjustment knob to bring the ghost image into vertical alignment with the actual image.
- . Rotate the horizontal adjustment knob to bring the ghost image into alignment with the actual image from the left to the right--stop the instant coincidence has been obtained.
- . Check target image coincidence by ranging on a known distance target
- . Move reticle switch to coincidence position.
- . Loosen the wing nut and swing the red ICS knob cover aside.
- . Rotate the ICS knob until vertical lines of the upper coincidences reticle were aligned.
- . Loosen the wing nut and swing the red halving knob cover aside.
- . Rotate halving knob until horizontal lines of the upper right half and the lower left portions of the coincidence reticle are aligned to form a cross.
- . Swing the ICS and halving knob covers into place and secure with wing nuts.
- . Move reticle switch to the OFF position.

BORESIGHT THE RANGEFINDER

- . Check coincidence reticle for alignment and if necessary, align reticle using horizontal and vertical adjustment knobs.
- . Index known tank to target range (1200 meters) on range scale.
- . Place the occluder knob on the rangefinder in the R position.
- . Move the locking levers of the main elevation and deflection boresight knobs to the unlocked position.
- . Sight through rangefinder eyepiece and align the black-etched cross on the sight reticle with the same aiming point as the main gun bore axis.
- . Move the boresight knob locking levers to the lock position.

4

BORESIGHT M85 (Cont'd)

- . Remove bolt assembly from barrel extension assembly and receiver assembly.
- . Hold feed lever of feed and ejector assembly and sight through machinegun barrel and align axis of gun bore on defined target approximately 500 meters in range.
- . Lock azimuth lock.
- . Adjust deflection without moving the gun or cupola.
- . Adjust elevation to align boresight cross on target aiming point.
- . Elevate and depress gun to check for backlash.
- . Install bolt assembly.
- . Install sear assembly.
- . Install bolt buffer group.
- . Install backplate.
- . Close machinegun cover assembly, access doors and cradle cover zipper.

ZERO M85

- . Select a target with a clearly defined aiming point at a range of 500 meters.
- . Lay the 500 meter aiming point of the Tank Commander's weapon sight on the aiming point of the zeroing targets with the elevating and traversing controls.
- . Fire a 10-20 round burst.
- . Move the 500-meter reticle to the center of the strike area without disturbing the lay of the gun.
- . Fire another 10-20 round burst to verify the zero.

BORESIGHT THE RANGEFINDER (Cont'd)

- . Rotate slip scale to read 2 on elevation boresight knob and 3 on deflection boresight knob.
- . Place the occluder knob in the L position.
- . Place the reticle switch on the rangefinder in the AUX-GUNSIGHT position.
- . Unlock auxiliary elevation and deflection knobs.
- . Rotate the knobs to align the red illuminated cross on the same aiming point as the main gun bore axis.
- . Lock AUX-GUNSIGHT elevation and deflection knobs.
- . Rotate slip scale on auxiliary elevation boresight knob to read 2 and the auxiliary deflection boresight knob to read 3
- . Check main gun bore axis, main gun laying reticle of the rangefinder, and the AUX-GUNSIGHT to assure that each is aligned on the same aiming point.

DETERMINE RANGE TO TARGET WITH RANGEFINDER

- . Place occluder knob in center position.
- . Range to the boresight target.
- . Rotate range knob until two target images merge.
- . Read range to target on range scale.

ZERO TANK MAIN GUN

- . Turn Computer switch ON.
- . Index range into rangefinder.

ZERO GUAX

- . Rotate the range knob of the rangefinder to range the target.

BORESIGHT M85

- . Assure safety is in S position.
- . Assure ammunition belt is clear of machinegun.
- . Assure machinegun is not loaded and bolt assembly is in forward position.
- . Disconnect solenoid lead connector.
- . Open cradle cover zipper, access doors and machinegun cover assembly.
- . Depress lock, raise latch and lift backplate assembly from receiver assembly.
- . Remove bolt buffer group from receiver assembly.
- . Remove sear from receiver assembly.

5

NOTES

7

Enclosure 1-e. Tank crewman's readiness book.

This enclosure provides a means for the tank commander to record the training progress of each crewman. The book provides space for the tank commander to record completion of each readiness test and to note the progress of remedial training. The book is printed to facilitate reproduction at the organizational level.

TANK
CREWMAN
READINESS
BOOK

DRIVER _____

LOADER _____

GUNNER _____

TC _____

TANK _____

UNIT _____

INSTRUCTIONS FOR TANK COMMANDER

RESPONSIBILITIES: You are responsible for individual training of your crewmen. The training program for each crew position is described in the tank commander's guide and it is your responsibility to assure that each crew member can perform the tasks listed in the guide.

TANK CREWMAN READINESS BOOK: Use this book to record the tasks that the crewman can or cannot do. Keep the book handy as a reference of the training status of your crew.

HOW TO USE THE BOOK: Begin by entering your crewman's name on the cover. As each crewman is tested, record the results and date in pencil.

CROSSTRAINING: #-Indicate crosstraining tasks. *-Indicate cross-training task required by TCGST, FM 17-12-2.

1

DRIVER

Knowledge

RT PART	DESCRIPTION	NO		DATE
		GO	GO	
A	Operational checks and services			
C	Target acquisition			

Skill

Before Operations Procedures and Tank Start-Up

RT PART	DESCRIPTION	NO		DATE
		GO	GO	
B	Inspect tank suspension system for deficiencies			
B	Inspect other components for deficiencies			
B	Check brakes for proper operation			
B	Explain safety precautions for refueling			
B	Remove M27 periscope			
B	Perform before operations checks and services on M24 (IR) and M27 periscope			
B	Install M24 (IR) periscope			
B*	Place M24 (IR) periscope into operation			
B	Start tank engine			
B*	Perform before operations checks and services on engine transmission oil levels			

Before Operations Procedures and Tank Start-Up
(Cont'd)

RT PART	DESCRIPTION	NO		DATE
		GO	GO	
B	Place tank in motion			
B*	Position tank for checking track tension			
B	Operate tank intercom system			
B*	Perform main gun prepare-to-fire procedures			
B	Perform before operations checklist and services on gas particulate unit			

Locating and Reporting Targets

RT PART	DESCRIPTION	NO		DATE
		GO	GO	
D	Conduct a quick scan of the area			
D*	Locate and identify targets in the area			
D	Estimate range to target in the area			
D	Report location of targets in the area			

Tactical Driving

RT PART	DESCRIPTION	CO	NO GO	DATE
E	Drive over varied terrain			
E	Drive into defilade firing position upon enemy contact			
E	Drive in response to fire commands			
E	Acquire targets			
E*	Observe and sense rounds			

4

DRIVER NOTES

5

LOADER

Knowledge

RT PART	DESCRIPTION	CO	NO GO	DATE
A	Weapons maintenance			
C	Mission preparation			
E	Combat loading			
G	Target acquisition			

Skill

Weapons Maintenance

RT PART	DESCRIPTION	CO	NO GO	DATE
B	Remove the coax from a tank			
B*	Disassemble the coax			

6

Weapons Maintenance (Cont'd)

RT PART	DESCRIPTION	CO	NO GO	DATE
B	Inspect the coax			
B*	Assemble the coax			
B	Check operation of the coax			
B	Mount the coax in a tank			
B	Remove the M85 from a tank			
B*	Disassemble the M85			
B	Inspect the M85			
B*	Assemble the M85			
B	Check operation of the M85			
B*	Disassemble main gun breechblock			
B*	Assemble main gun breechblock			

PRECEDING PAGE BLANK-NOT FILLED

Mission Preparation

RT PART	DESCRIPTION	GO	NO GO	DATE
D	Inspect tank suspension system for deficiencies			
D	Inspect other components for deficiencies			
D	Explain safety precaution for refueling			
D*	Perform before-operations checks and services on engine & transmission oil levels			
D*	Check track tension			
D*	Adjust track tension			
D	Prepare tank for boresighting			
D	Check boresight alignment of main gun			
D*	Boresight and zero coax			
D*	Stow machinegun ammo according to ammo storage plan			
D*	Stow coax ammo in ready (banana) box			
D*	Stow main gun rounds according to ammunition storage plan.			

Mission Preparation (Cont'd)

RT PART	DESCRIPTION	GO	NO GO	DATE
D	Install and operate AN/VRC-12 or AN-VRC/64 radio			
D	Operate tank intercom system			
D*	Perform main gun prepare-to-fire procedures			
D	Check operation of the M3 heater			

Combat Loading

RT PART	DESCRIPTION	GO	NO GO	DATE
F*	Determine corrective action required by replenisher tape			
F*	Load main gun in response to fire command			
F	Rotate round in main gun misfire procedure			
F*	Unload misfired main gun round			
F*	Load coax			

8

9

Combat Loading (Cont'd)

RT PART	DESCRIPTION	GO	NO GO	DATE
F	Ready coax in response to fire commands			
F#	Clear and unload coax			
F*	Apply immediate action to reduce coax stoppage			
F*	Change coax barrel			
F#*	Load M85			
F#*	Clear and unload M85			
F#*	Apply immediate action to reduce M85 stoppage			

Locating and Reporting Targets

RT PART	DESCRIPTION	GO	NO GO	DATE
H	Conduct quick search scan of the area			
H*	Locate and identify targets in the area			
H	Estimate range to targets in the area			
H	Report location of targets in the area			

LOADER NOTES

10

109

11

GUNNER

Knowledge

RT PART	DESCRIPTION	GO	NO GO	DATE
A	Weapons maintenance			
D	Weapon systems preparation			
F	Combat loading			
H	Target acquisition			
J	Tactical operations			

Skill

Weapons Maintenance

RT PART	DESCRIPTION	GO	NO GO	DATE
B	Remove the coax from a tank			
B#*	Disassemble the coax			

12

Weapons Maintenance
(Cont'd)

RT PART	DESCRIPTION	GO	NO GO	DATE
B	Inspect the coax			
B#*	Assemble the coax			
B	Check operation of the coax			
B	Mount the coax in a tank			
B	Remove the M85 from a tank			
B#*	Disassemble the M85			
B	Inspect the M85			
B#*	Assemble the M85			
B	Check operation of the M85			
B	Mount the M85 in a tank			
B#*	Disassemble the main gun breechblock			
B#*	Assemble the main gun breechblock			

13

Before Operations Procedures

RT PART	DESCRIPTION	GO	NO GO	DATE
C	Operate the tank intercom system			
C	Charge manual elevation system			
C*	Place turret into power operation			
C*	Perform main gun prepare-to-fire procedures			
C	Check operation of M3 heater			

Weapon Systems Preparation

RT PART	DESCRIPTION	GO	NO GO	DATE
E	Prepare the tank for boresighting			
E	Prepare Gunner's telescope for operation			
E	Prepare Gunner's periscope for daylight operation			

14

Weapon Systems Preparation
(Cont'd)

RT PART	DESCRIPTION	GO	NO GO	DATE
E*	Operate the azimuth indicator			
E*	Operate elevation quadrant			
E*	Boresight Gunner's telescope and apply established zero			
E*	Boresight daylight sight of Gunner's periscope and apply established zero			
E*	Boresight IR sight of Gunner's periscope and apply established zero			
E#	Boresight tank searchlight using primary method			
E#	Boresight tank searchlight using alternate method			
E#*	Boresight coax			
E*	Zero main gun			
E*	Zero coax			
E*	Index announced ammunition into computer and conduct computer check			

15

Combat Loading

RT PART	DESCRIPTION	GO	NO GO	DATE
G#*	Stow main gun rounds according to ammunition stowage plan			
G#*	Stow machinegun ammunition according to ammunition stowage plan			
G#*	Stow coax ammunition in ready (banana) box			
G#*	Determine corrective action required by replenisher tape			
G#*	Load main gun in response to fire command			
G#*	Rotate round in main gun misfire procedure			
G#*	Unload misfired main gun round			
G	Load coax			
G#*	Ready coax in response to fire command			
G#*	Clear and unload coax			
G#*	Apply immediate action to reduce coax stoppage			
G#*	Change coax barrel			
G#*	Load M85			

16

Tactical Operations

RT PART	DESCRIPTION	GO	NO GO	DATE
K	Acquire targets			
K	Preset SABOT battlesight information			
K	Main gun BS engagement, moving to a halt, one stationary target, SABOT			
K	Main gun BS engagement, moving to a halt, two moving targets, SABOT, Gunner masked			
K	Coax engagement, moving to a halt, one stationary target, coax			
K	Main gun precision engagement, moving to a halt, two stationary targets, SABOT			
K	Preset HEAT BS information			
K	Main gun engagement, moving to a halt, three stationary targets, HEAT			
K	Coax engagements, moving to a halt, two stationary targets, coax			
K	Main gun RCLDP engagement at the halt, two stationary targets, HEAT, Gunner masked, passive/IR			
K	Coax engagement, at the halt, one stationary target, coax, Gunner masked, passive/IR			
K	Main gun BS engagement, at the halt, one stationary target and one moving target, SABOT, flare			
K*	Apply immediate action in case of main gun failure to fire			

18

Combat Loading
(Cont'd)

RT PART	DESCRIPTION	GO	NO GO	DATE
G#*	Clear and unload M85			
G#*	Apply immediate action to reduce M85 stoppage			

Locating and Reporting Targets

RT PART	DESCRIPTION	GO	NO GO	DATE
I	Conduct a quick search scan of the area			
I*	Locate and identify targets in the area			
I	Estimate range to targets in the area			
I	Report location of targets in the area			

17

Tactical Operations
(Cont'd)

RT PART	DESCRIPTION	GO	NO GO	DATE
K*	Main gun BS engagement, moving to a halt, one stationary target, apply BOT			
K*	Main gun BS engagement, moving to a halt, one stationary target, apply target form			
K*	Main gun precision engagement, moving to a halt, one stationary target, apply standard adjustment			
K*	Lay telescope reticle on target properly			

19

GUNNER NOTES

Blank lined area for Gunner Notes.

TANK COMMANDER

Knowledge

RT PART	DESCRIPTION	GO	NO GO	DATE
A	Weapons maintenance			
D	Weapon systems preparation			
F	Combat loading			
H	Target acquisition			
J	Tactical operations			

Skill

Weapons Maintenance

RT PART	DESCRIPTION	GO	NO GO	DATE
B	Remove the coax from a tank			
B#	Disassemble the coax			

Weapons Maintenance
(Cont'd)

RT PART	DESCRIPTION	GO	NO GO	DATE
B	Inspect the coax			
B#	Assemble the coax			
B	Check operation of the coax			
B	Mount the coax in a tank			
B	Remove M85 from a tank			
B*	Disassemble the M85			
B	Inspect the M85			
B*	Assemble the M85			
B	Check operation of M85			
B	Mount the M85 in a tank			
B#	Disassemble main gun breechblock			
B#	Assemble main gun breechblock			

Before Operations Procedures

RT PART	DESCRIPTION	GO	NO GO	DATE
C	Operate tank intercom system			
C#	Place turret into power operation			
C*	Perform main gun prepare-to-fire procedure			
C	Check operation of M3 heater			

Weapon Systems Preparation

RT PART	DESCRIPTION	GO	NO GO	DATE
E	Prepare tank for boresighting			
E#	Boresight Gunner's telescope and apply established zero			
E#	Boresight daylight sight of Gunner's periscope and apply established zero			
E#	Boresight IR sight of Gunner's periscope and apply established zero			
E*	Boresight tank searchlight using primary method			

Weapon System Preparation
(Cont'd)

RT PART	DESCRIPTION	GO	NO GO	DATE
E*	Boresight tank searchlight using alternate method			
E*	Boresight the coax			
E*	Prepare tank rangefinder for operation			
E*	Boresight the rangefinder			
E*	Determine range to target with rangefinder			
E*	Zero tank main gun			
E*	Zero coax			
E*	Index announced ammunition into computer and conduct computer check			
E*	Boresight M85			
E*	Zero M85			

24

Combat Loading

RT PART	DESCRIPTION	GO	NO GO	DATE
G#*	Stow main gun rounds according to ammunition stowage plan			
G#*	Stow machinegun ammunition according to ammunition stowage plan			
G#*	Stow coax ammunition in ready (banana) box			
G#*	Determine corrective action required by replenisher tape readings			
G#*	Load main gun in response to fire commands			
G#*	Rotate round in main gun misfire procedures			
G#*	Unload misfired main gun round			
G#*	Load coax			
G#	Ready coax in response to fire command			
G#*	Clear and unload coax			
G#*	Apply immediate action to reduce stoppage			

25

Combat Loading
(Cont'd)

RT PART	DESCRIPTION	GO	NO GO	DATE
G#*	Change coax barrel			
G#*	Load M85			
G#*	Clear and unload M85			
G#*	Apply immediate action to reduce stoppage of M85			

Locating and Reporting Targets

RT PART	DESCRIPTION	GO	NO GO	DATE
I	Conduct a quick search scan of the area			
I*	Locate and identify targets in the area			
I	Estimate range to target in the area			
I	Report location of target in the area			

26

Tactical Operations

RT PART	DESCRIPTION	GO	NO GO	DATE
K*	Designate crew sections of responsibility for target acquisition			
K*	Acquire target			
K	Preset SABOT BS information			
K	Main gun BS engagement, moving to a halt, one stationary target, SABOT			
K	Main gun BS engagement, moving to a halt, two moving targets, SABOT, TC masked			
K	.50 caliber and coax engagements, moving to a halt, one moving and one stationary target, .50 caliber and coax			
K	.50 caliber and main gun precision engagement moving to a halt, three stationary targets, .50 caliber and SABOT			
K	Preset HEAT BS information			
K	Main gun BS engagement, moving to a halt, three stationary targets, HEAT			
K	.50 caliber and coax engagements, moving to a halt, three stationary targets, .50 caliber and coax			
K	Main gun RCLDP engagement, at the halt, three stationary targets, HEAT, TC masked			

27

Tactical Operations
(Cont'd)

TANK COMMANDER NOTES

RT PART	DESCRIPTION	GO	NO GO	DATE
K	.50 caliber and coax engagement, at the halt, two stationary targets, .50 caliber and coax, TC masked			
K	Main gun BS engagement, at the halt, one stationary target and one moving target, SABOT			
K*	Main gun BS engagement, moving to a halt, one stationary target, apply BOT			
K*	Main gun BS engagement, moving to a halt, one stationary target, apply target form			
K*	Main gun BS engagement, moving to a halt, one stationary target, apply standard adjustments			
K#*	Lay telescope reticle on target properly			

ENCLOSURE 2. TRAINING FACILITIES

- a. **Driving Course**
- b. **Target Acquisition Course**
- c. **Tank Crew Qualification Course (dry firing)**
- d. **Laser Firing Range (see TC 17-12-5)**
- e. **Live Firing Range (see TC 17-12-5)**
- f. **Armory Boresight, Zero, and Tracking Range**

Enclosure 2-a. Tactical driving course.

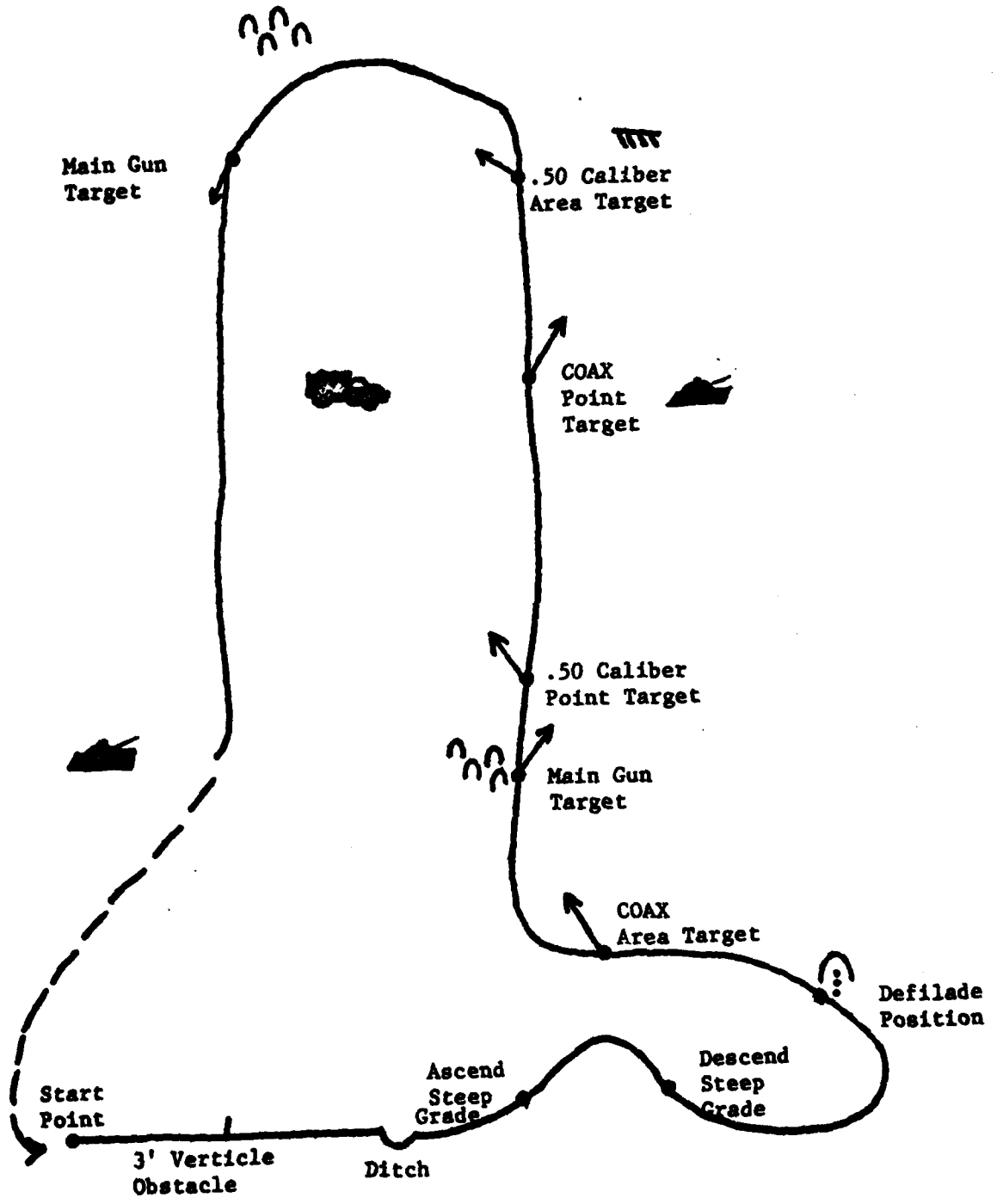

Enclosure 2-a (Cont'd). Tactical driving course
(Driver round sensing layout).

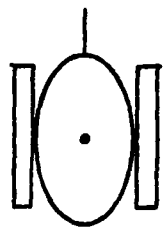
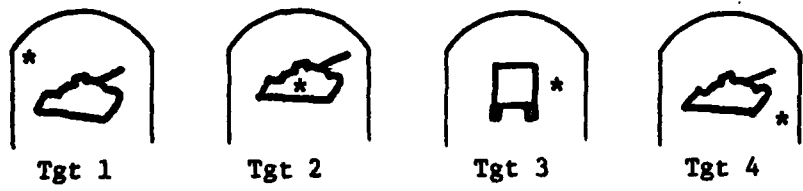

At the end of the tactical driving course the Driver will be directed to move to a firing position. Approximately 50 yards in front of the firing position will be four silhouette targets with a simulated tracer element positioned as a target hit or a target miss.

The TC will lay the gun on a target and give a fire command. The Gunner will identify the target, make a final precise lay, and simulate firing. The Gunner and TC will announce LOST and the Driver will immediately announce his sensings. (The scorer will act as TC, GN, and LD. The Driver will be buttoned up and use his M27 periscope to sense.

- | | |
|--|--|
| <p>Tgt #1 (TC) GUNNER-BATTLESIGHT-TANK (GN) IDENTIFIED
(LD) UP (TC) FIRE (GN) ON THE WAY (GN) LOST
(TC) LOST (DV) <u>OVER-LEFT</u></p> | |
| <p>Tgt #2 (TC) GUNNER-SABOT TANK (GN) IDENTIFIED (LD)
UP (TC) FIRE (GN) ON THE WAY (GN) LOST
(TC) LOST (DV) <u>TARGET</u></p> | |
| <p>Tgt #3 (TC) GUNNER-HEAT-PC (GN) IDENTIFIED (LD)
UP (TC) FIRE (GN) ON THE WAY (GN) LOST
(TC) LOST (DV) <u>DOUBTFUL-RIGHT</u></p> | |
| <p>Tgt #4 (TC) GUNNER-BATTLESIGHT-TANK (GN) IDENTIFIED
(LD) UP (TC) FIRE (GN) ON THE WAY (GN)
LOST (TC) LOST (DV) <u>SHORT-RIGHT</u></p> | |

Enclosure 2-b. Target acquisition course.

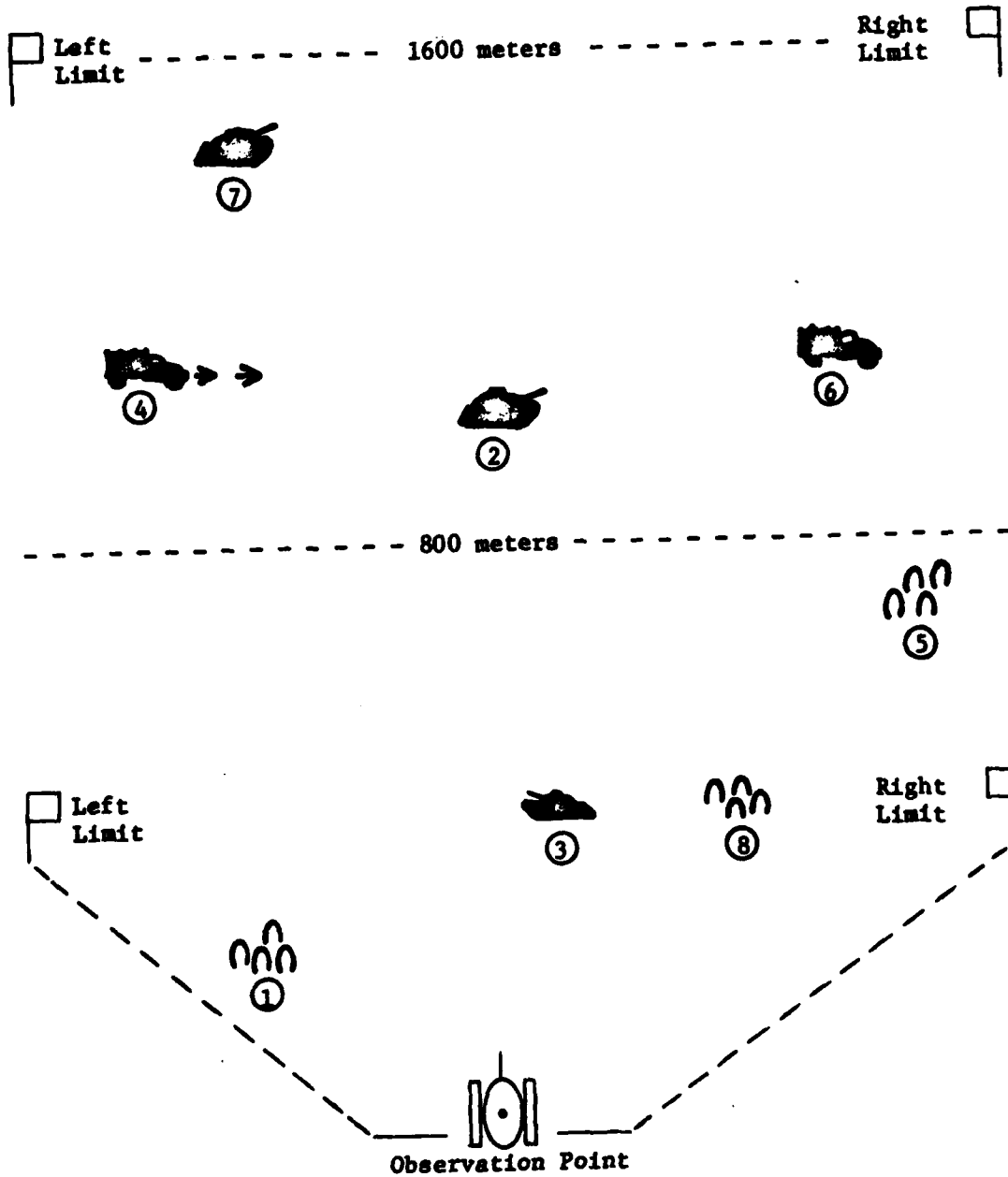

Enclosure 2-b (Cont'd). Target acquisition course
(Crewmembers areas of surveillance).

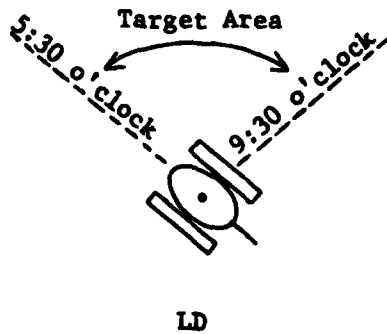
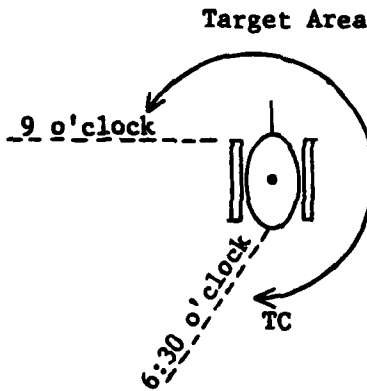
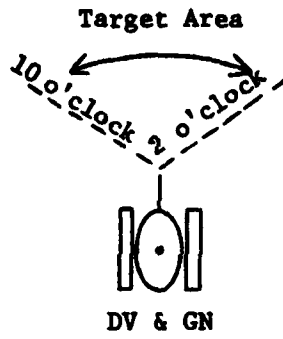

Enclosure 2-c. Tank crew qualification course (dry).

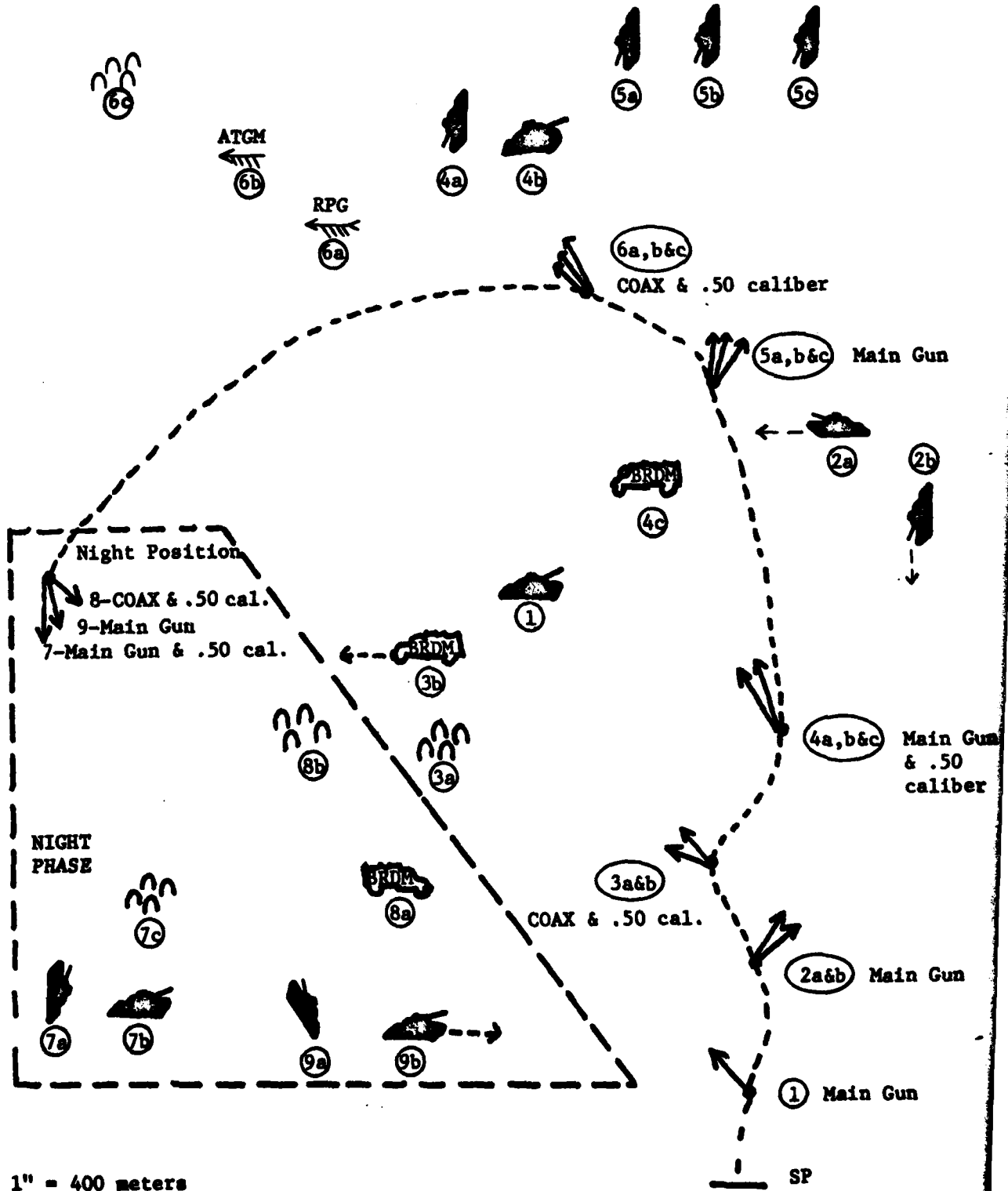

Enclosure 2-c (Cont'd). Tank crew qualification course (dry)
 (Second round adjustment target layout).

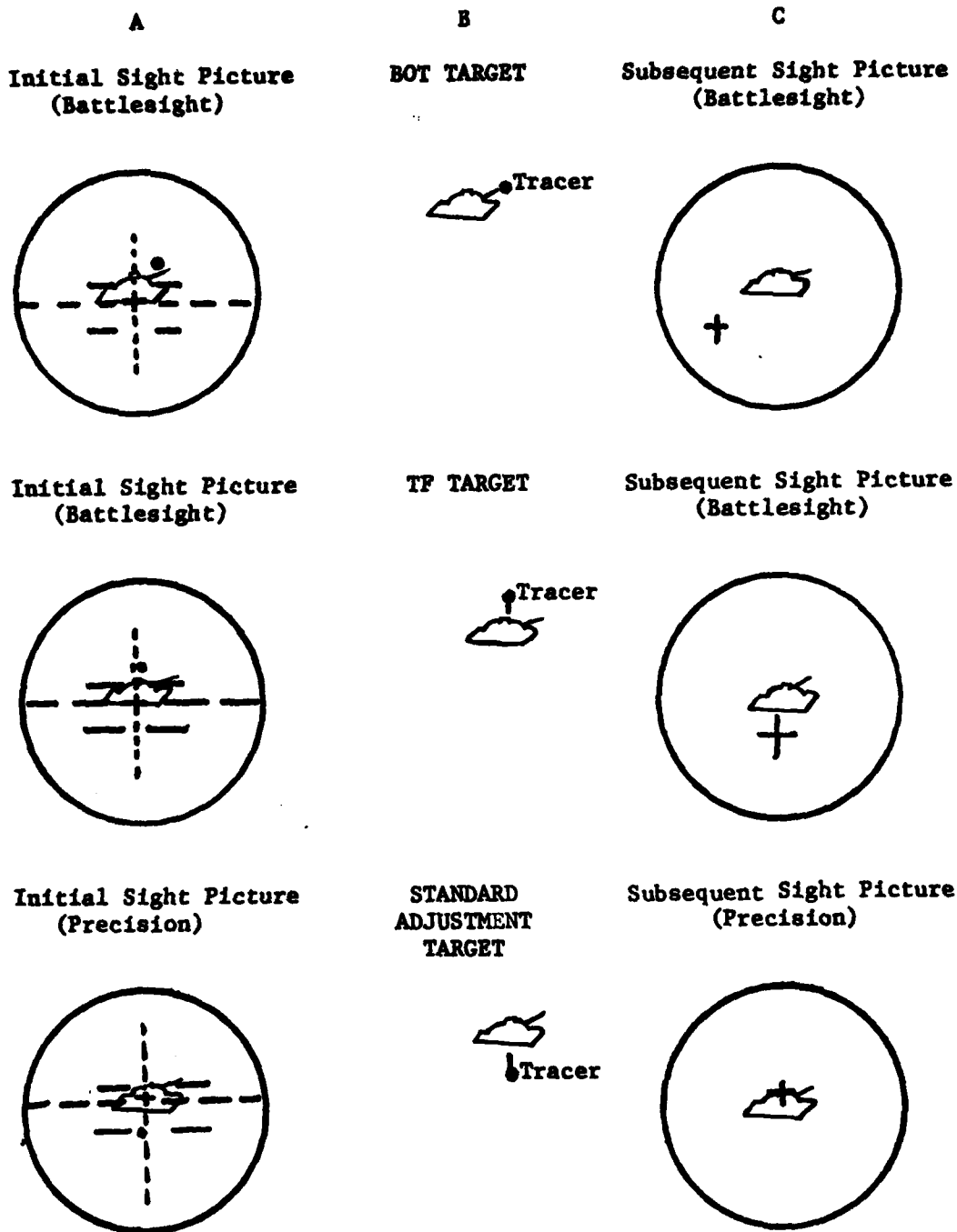

NOTE: Column A: Initial sight picture with tracer passing over or short of the target. Column B: Simulated tracer element mounted on targets. Column C: Subsequent sight picture after GN or TC applies BOT (Burst on Target), TF (target form), or SA (Standard adjustment).

Enclosure 2-f. Armory boresight, zero and tracking range.

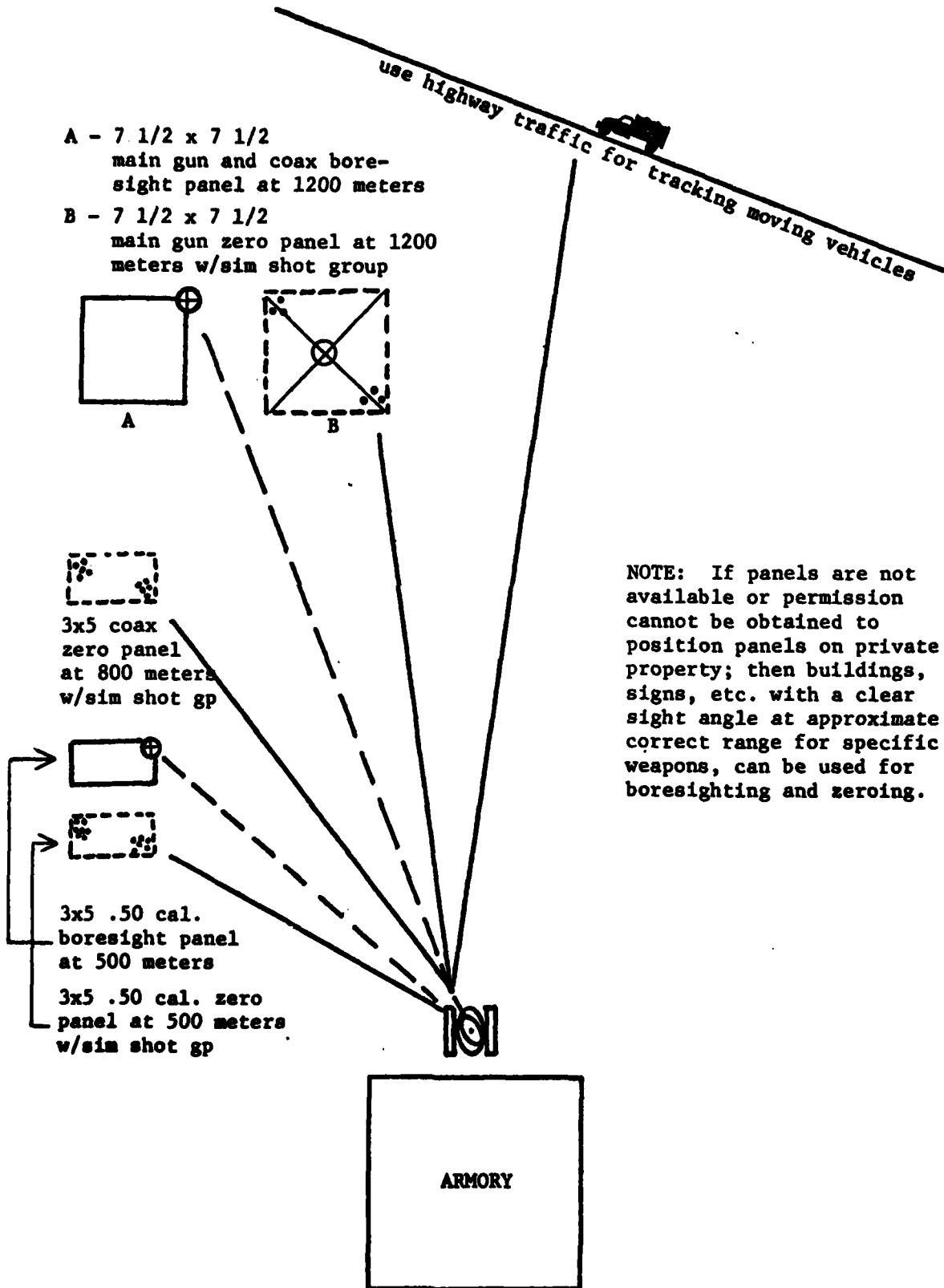

ENCLOSURE 3. EQUIPMENT

ITEM	QUANTITY	LOCATION	
		ARMORY	UTES
M60 tank w/BII	Per authorization	1 per plat.	Bal. auth.
Coax machinegun	Per authorization	1 per tank	Bal. auth.
.50 cal. machinegun	Per authorization	1 per tank	Bal. auth.
Binoculars	Per authorization	Per authorization	—
Protector's mask	Per authorization	1 per crewman	—
Equipment to remove breechblock	Per authorization	1 per tank	Bal. auth.
NOTE: UTES = unit training and equipment site			

ENCLOSURE 4. TRAINING AIDS/DEVICES

- a. Beseler Cue/Sec audio visual projector (omitted)
- b. Dummy main gun ammunition
- c. Belt linked empty coax ammunition (omitted)
- d. Belt linked empty .50 cal. ammunition (omitted)
- e. Ammunition stowage plan (battalion tactical SOP)
- f. Cardboard representation of coax ammunition boxes
- g. Cardboard representation of .50 cal. ammunition boxes
- h. Replenisher tape mockup
- i. Laser firing device (omitted)
- j. Burst-on-target trainer (omitted)
- k. TEC tapes

Enclosure 4-b. Dummy 105mm ammunition.

Combat loading in the TCST program includes several tasks for the TC, gunner, and loader which requires using main gun ammunition. The use of live ammunition for day-to-day training is not feasible and the one unpainted HEP replica training round issued with each tank is not adequate. Dummy rounds which are replicas in size, shape, weight, and color are required. The problem was resolved in an earlier TCST program by the fabrication of dummy training rounds by the supporting TASC. A set of dummy rounds consists of one HEP round, one SABOT round, one HEAT round, and one WP round. Specific steps in fabricating the rounds are:

- . Select and chamber expended shell casings.
- . Fabricate HEP, SABOT, HEAT, and WP projectiles from durable plastic.
- . Fill casings with ballast equal to weight of various type live rounds.
- . Attach projectile to shell casings.
- . Paint and stencil rounds as duplicates of various live rounds.

Dummy rounds have been fabricated by the TASC, Fort Carson, Colorado at an estimated cost of \$50.00 per set.

Enclosure 4-f and g. Cardboard representations of coax and .50 caliber machinegun ammunition.

Cardboard representations of tank machinegun ammunition facilitates testing crewmen in mission preparation tasks. The following diagrams indicate the size of the representations and the number required to represent a basic load for the M60 tank.

a. Coax ammunition.



b. .50 caliber ammunition.



Enclosure 4-h. Replenisher tape mockup.

Another combat loading task in the TCST program for the TC, gunner, and loader is reading the replenisher indicator tape. The actual replenisher may indicate any one of four readings, however, the instructor is required to add or delete oil to cause any of the other three readings to appear. The problem of adding or deleting oil can be resolved by the local fabrication of an inexpensive mockup shown below.

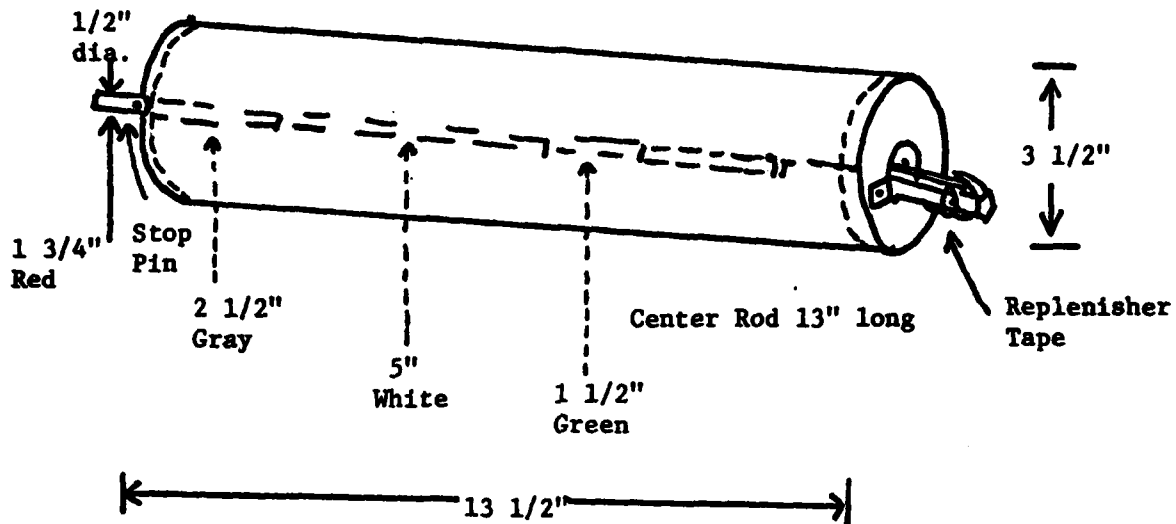

Diagram of Replenisher tape mockup

The body of the mockup is made from a 3 1/2" x 13 1/2" cardboard shipping cannister. The ends are blocked with 3/4" wood, cut in a circle and attached with small nails. The center rod is 1/2" dowel 13" long. The rod is painted, starting from the outer end going toward the inner end, red-1 3/4", gray-2 1/2", white-5", and green-1 1/2". Inside the cylinder, the rod is attached to a replenisher tape from an M60 series tank. Metal parts required for the mockup by FSN are:

1015-752-5667	guide	\$ 4.02
1015-752-5668	bracket	3.63
1015-752-5669	clamp	3.58
1015-752-5670	pin	1.59
1015-752-5676	tape	9.62
5305-543-5198	screw	.16
5310-081-8087	nut	.02

Enclosure 4-h (Cont'd.) Replenisher tape mockup.

The photo below shows the mockup with the rod fully extended. Moving the rod to various colors will cause the tape to indicate various readings. For example:

Red	Two long notches on tape
Gray	Two smooth notches on tape
White	One rough edge and one smooth edge on tape.
Green	Two rough edges on tape

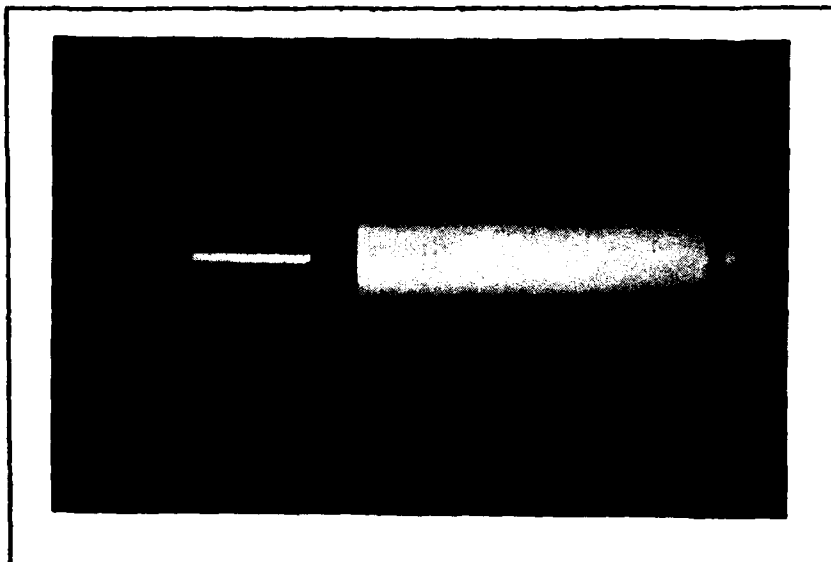

Photo of Replenisher Tape Mockup

To use the mockup follow the procedure below.

<u>Instructor*</u>	<u>Crewman Reads**</u>	<u>Crewman's Response</u>
Pull rod to WHITE	One rough edge and one smooth edge on tape	Normal, take no action
Leave rod in RED	Two long notches on tape	Drain recoil oil
Pull rod to GREEN	Two rough edges on tape	Add recoil oil
Pull rod to GRAY	Two smooth edges on tape	Noted before firing, drain recoil oil Noted during firing, drain recoil oil.

*Instructor should vary sequence of settings.

**Crewman "reads" means crewman feels tape to determine condition.

Enclosure 4-k. TEC tapes.

The following TEC tapes, used with the Beseler Cue/See audio/visual projector, are required for the TCST program. (1 per company)

<u>TEC TAPE</u>	<u>TITLE</u>	<u>DV</u>	<u>LD</u>	<u>GN</u>	<u>TC</u>
020-171-1611-F		X	X	X	X
020-171-1612-F		X	X	X	X
020-171-1614-F		X	X	X	X
935-171-0203-F		X	X	X	X
020-171-5366-F		X	X		
020-171-5367-F		X	X		
020-171-5368-F		X	X		
020-171-5369-F		X	X		
020-171-5370-F		X	X		
020-171-1132-F			X	X	X
020-171-1133-F			X	X	X
020-171-5229-F			X	X	X
020-171-5340-F					X
020-171-5343-F					X
020-171-5352-F			X	X	X
020-171-5353-F				X	X
020-171-5354-F				X	X
020-171-5355-F				X	X
020-171-5341-F				X	X
020-171-5351-F				X	X
020-171-5337-F				X	X
020-171-5331-F			X	X	X
020-171-5332-F			X	X	X
020-171-5346-F			X	X	X
020-171-5347-F			X	X	X
020-171-5348-F			X	X	X
020-171-5361-F					X
020-171-5364-F				X	X
020-171-5342-F				X	

ENCLOSURE 5. OUTSIDE SUPPORT

Outside support for conducting the TCST program consists of a five man armor branch assistance team to test and train cadre tank commanders. The team will require:

- . Tank commander readiness tests
- . Tank commander training modules
- . A target acquisition course
- . A tank crew qualification course (dry firing)
- . Items listed with each readiness test and training modules

ENCLOSURE 6. AMMUNITION

Ammunition requirements required for each crew are:

<u>Firing Exercise</u>	<u>Type Ammunition</u>	<u>Number Rounds*</u>
Table IV	7.62 or .50 cal.	66
Table V	7.62 or .50 cal.	68
CIPT	7.62	100
	.50 caliber	150
	SABOT	14
	HEAT	9

*Ammunition for one day run and one night run. The amounts shown does not include ammunition for zeroing.

ENCLOSURE 7. TARGETS

Following is a list of targets required to support the TCST program.

<u>Activity</u>	<u>Targets</u>	<u>Number</u>
Company boresight and zero range	7 1/2 x 7 1/2 main gun boresight panel	1
	7 1/2 x 7 1/2 main gun zero panel w/simulated shot group	1
	3' x 5' coax boresight panel	1
	3' x 5" coax zero panel w/simulated shot group	1
	3" x 5" .50 cal. boresight panel	1
	3" x 5" .50 caliber zero panel w/simulated shot group	1
Local training area boresight and zero range	Same as above	Same as above
Laser firing range	See TC 17-12-5	
Live firing range		
Table IV	Scaled stationary	13
	Scaled moving	5
Table V	Scaled stationary	20
CIPT	Full scale, stationary tank, front	8
	Full scale, stationary tank, side	1
	Full scale, moving tank, side	3
	Full scale, stationary truck, front	1
	Full scale, moving truck, side	1
	Silhouettes, group of six	2

ANNEX 2

TRAINING ASSETS INVENTORY

This annex includes inventory forms which are used at battalion and company levels to determine the status of training assets required for the TCST program. An explanation of the column headings follow.

Physical Assets Inventory Form

- . Item and Description. Self explanatory.
- . Authorization, battalion-company. This column indicates the quantities authorized. The battalion sub-column quantities are a summation of the companies authorization plus additional items required at battalion level.
- . On hand. This column is filled in at company level and consolidated at battalion level.
- . Over/Under. This column is filled in at company level and consolidated at battalion level. It serves as a source for requisitioning shortages at company and battalion level and for reallocation of assets at battalion level.
- . Remarks. This column is used for general remarks to include serviceability and maintenance comments.

NOTES:

1. Request from MTA.
2. Authorization level is in accordance with current allocation.
3. See TC 17-12-5.

PHYSICAL ASSETS INVENTORY

ITEM AND DESCRIPTION	AUTH		ON HAND	OVER/ UNDER	REMARKS
	BN	CO			
TCST MATERIAL					
Duty Position Readiness Tests					
DRIVER					
A-Opn checks & svcs (W)	41-13				
B-Before ops procedures (HO)	41-13				
C-Target acquisition (W)	41-13				
D-Locating & reporting targets (HO)	41-13				
E-Tactical driving (HO)	41-13				
LOADER					
A-Weapons maintenance (W)	41-13				
B-Weapons maintenance (HO)	41-13				
C-Mission preparation (W)	41-13				
D-Mission preparation (HO)	41-13				
E-Combat loading (W)	41-13				
F-Combat loading (HO)	41-13				
G-Target acquisition (W)	41-13				
H-Locating & reporting targets (HO)	41-13				
GUNNER					
A-Weapon maintenance (W)	41-13				
B-Weapons maintenance (HO)	41-13				
C-Before ops procedures (HO)	41-13				
D-Weapons systems prep (W)	41-13				
E-Weapon systems prep (HO)	41-13				
F-Combat loading (W)	41-13				
G-Combat loading (HO)	41-13				
H-Target acquisition (W)	41-13				
I-Locating & reporting targets (HO)	41-13				
J-Tactical operations (W)	41-13				
K-Tactical operations (HO)	41-13				

**PHYSICAL ASSETS INVENTORY
(CONT'D)**

ITEM AND DESCRIPTION	AUTH		ON HAND	OVER/ UNDER	REMARKS
	BN	CO			
TANK COMMANDER					
A-Weapons maintenance (W)	41-13				
B-Weapons maintenance (HO)	41-13				
C-Before ops procedures (HO)	41-13				
D-Weapon systems prep (W)	41-13				
E-Weapon systems prep (HO)	41-13				
F-Combat loading (W)	41-13				
G-Combat loading (HO)	41-13				
H-Target acquisition (W)	41-13				
I-Locating & reporting targets (HO)	41-13				
J-Tactical operations (W)	41-13				
K-Tactical operations (HO)	41-13				
Duty Position Training Modules					
DRIVER					
D-1 Opn checks & svcs	77-25				
D-2 Before ops procedures	77-25				
D-3 Target acquisition	77-25				
D-4 Locating & reporting targets	77-25				
D-5 Tactical driving	77-25				
LOADER					
L-1 Weapons maintenance	77-25				
L-2 Weapons maintenance	77-25				
L-3 Mission preparation	77-25				
L-4 Mission preparation	77-25				
L-5 Combat loading	77-25				
L-6 Combat loading	77-25				
L-7 Target acquisition	77-25				
L-8 Locating & reporting targets	77-25				

**PHYSICAL ASSETS INVENTORY
(CONT'D)**

ITEM AND DESCRIPTION	AUTH		ON HAND	OVER/ UNDER	REMARKS
	BN	CO			
GUNNER					
G-1 Weapons maintenance	77-25				
G-2 Weapons maintenance	77-25				
G-3 Before ops procedures	77-25				
G-4 Weapon systems prep	77-25				
G-5 Weapon systems prep	77-25				
G-6 Combat loading	77-25				
G-7 Combat loading	77-25				
G-8 Target acquisition	77-25				
G-9 Locating & reporting targets	77-25				
G-10 Tactical operations	77-25				
G-11 Tactical operations	77-25				
TANK COMMANDER					
TC-1 Weapons maintenance	77-25				
TC-2 Weapons maintenance	77-25				
TC-3 Before ops procedures	77-25				
TC-4 Weapon systems prep	77-25				
TC-5 Weapon systems pre	77-25				
TC-6 Combat loading	77-25				
TC-7 Combat loading	77-25				
TC-8 Target acquisition	77-25				
TC-9 Locating & reporting targets	77-25				
TC-10 Tactical operations	77-25				
TC-11 Tactical operations	77-25				
Crew Interaction Perform- ance Test	41-13				
Task Books					
DRIVER	41-13				
LOADER	41-13				
GUNNER	41-13				
TANK COMMANDER	41-13				

PHYSICAL ASSETS INVENTORY
(CONT'D)

ITEM AND DESCRIPTION	AUTH		ON HAND	OVER/ UNDER	REMARKS
	BN	CO			
Tank Crewmen's Readiness Book	41-13				
Tank Commander's Training Guide	41-13				
TRAINING FACILITIES					
Driving Course	1-0				
Target Acquisition Course	1-0				
Tank Crew Qualification Course (dry)	1-0				
Laser Firing Range	3-1				
Live Firing Range, Tables IV & V, CIPT	Note 1				
EQUIPMENT					
M60 Tank	Note 2				
Coax Machinegun	Note 2				
.50 Caliber Machinegun	Note 2				
Binoculars	Note 2				
Protective Mask	Note 2				
Radios	Note 2				

**PHYSICAL ASSETS INVENTORY
(CONT'D)**

ITEM AND DESCRIPTION	AUTH		ON HAND	OVER/ UNDER	REMARKS
	BN	CO			
TRAINING AIDS/DEVICES					
Beseler/Cue See		7-2			
Dummy Main Gun Ammo Sets		9-3			
Belt Linked Empty Coax Ammo		9-3			
Belt Linked Empty .50 Cal. Ammo		9-3			
Ammunition Stowage Plan		41-13			
Cardboard Representations Coax Ammo		270-90			
Cardboard Representations .50 Cal. Ammo		90-30			
Replenisher Tape Mockup		9-3			
Laser Firing Device		9-3			
Conduct-of-Fire Trainer		9-3			
TEC TAPES					
020-171-1611-F Tgt range determination		4-1			
020-171-1612-F Loc & rpt tgts		4-1			

**PHYSICAL ASSETS INVENTORY
(CONT'd)**

ITEM AND DESCRIPTION	AUTH		ON HAND	OVER/ UNDER	REMARKS
	BN	CO			
020-171-1614-F Target acquisition					
	4-1				
935-171-0203-F Armor vch. recognition					
	4-1				
020-171-5366-F Before operations maintenance					
	4-1				
020-171-5367-F Before operations maintenance					
	4-1				
020-171-5368-F During/halt checks & services					
	4-1				
020-171-5369-F After ops checks & services					
	4-1				
020-171-5370-F After ops Checks & services					
	4-1				
020-171-1132-F Clean & lubricate coax					
	4-1				
020-171-1133-F Trouble-shoot coax					
	4-1				
020-171-5229-F Trouble-shoot M85					
	4-1				

PHYSICAL ASSETS INVENTORY
(CONT'D)

ITEM AND DESCRIPTION	AUTH		ON HAND	OVER/ UNDER	REMARKS
	BN	CO			
020-171-5340-F RF famil.					
	4-1				
020-171-5343-F Opn xenon SL					
	4-1				
020-171-5352-F Boresight machineguns					
	4-1				
020-171-5353-F Zero main gun & MGs					
	4-1				
020-171-5354-F Boresight xenon SL					
	4-1				
020-171-5355-F Boresight main gun, tele/peri					
	4-1				
020-171-5341-F Prepare ballistic computer for opn					
	4-1				
020-171-5351-F Boresight main gun tele/peri					
	4-1				
020-171-5337-F Aux FC instruments					
	4-1				
020-171-5331-F Tank ammo: selecting					
	4-1				
020-171-5332-F Tank ammo: handling					
	4-1				

**PHYSICAL ASSETS INVENTORY
(CONT'D)**

ITEM AND DESCRIPTION	AUTH		ON HAND	OVER/ UNDER	REMARKS
	BN	CO			
020-171-5346-F 105mm: loading		4-1			
020-171-5347-F 105mm: misfire		4-1			
020-171-5348-F 105mm: unloading		4-1			
020-171-5361-F Initial fire commands		4-1			
020-171-5364-F Machinegun engagements		4-1			
020-171-5342-F Preparing peri/tele opns		4-1			
OUTSIDE SUPPORT					
Five Man Armor BAT Team		1-0			
AMMUNITION					
Table IV					
7.62 or .50 caliber		2376-792			
Table V					
7.62 or .50 caliber		2448-816			

**PHYSICAL ASSETS INVENTORY
(CONT'D)**

ITEM AND DESCRIPTION	AUTH		ON HAND	OVER/ UNDER	REMARKS
	BN	CO			
Crew Interaction Performance Test					
7.62			3600-1200		
.50 caliber			5400-1800		
SABOT			504-168		
HEAT			324-108		
TARGETS					
Bn and Co Boresight Zero Ranges					
7 1/2' x 7 1/2' main gun boresight panel			4-1		
7 1/2' x 7 1/2' main gun zero panel			4-1		
3' x 5' coax boresight panel			4-1		
3' x 5' coax zero panel			4-1		
3' x 5' .50 cal. boresight panel			4-1		
3' x 5' .50 cal. zero panel			4-1		
Laser Firing Range			Note 3		
Live Firing Range					
Table IV-scaled stationary			13-0		
Table IV-scaled moving			5-0		
Table V-scaled stationary			20-0		

PHYSICAL ASSETS INVENTORY
(CONT'D)

ITEM AND DESCRIPTION	AUTH		ON HAND	OVER/ UNDER	REMARKS
	BN	CO			
CIPT					
Fullscale-tk-stat-front		8-0			
Fullscale-tk-stat-side		1-0			
Fullscale-tk-mov-side		3-0			
Fullscale-trk-stat-front		1-0			
Fullscale-trk-mov-side		1-0			
Silhouettes, group of six		2-0			
CREW PERSONNEL*					
Driver		36-12			
Loader		36-12			
Gunner		36-12			
Tank Commander		36-12			
SPECIALIST PERSONNEL**					
Training Officer or NCO		4-1			
Track Vehicle Mechanic		3-1			
Tank Turret Mechanic		3-1			
C&E Equipment Mechanic		3-1			

NOTES:

* Twelve crew tank company

** Minimum requirements

TIME ASSETS INVENTORY

1.	2.	3.	4.	5.	6.	7.	8.
9.	10.	11.	12.	13.	14.	15.	16.
17.	18.	19.	20.	21.	22.	23.	24.
25.	26.	27.	28.	29.	30.	31.	32.
33.	34.	35.	36.	37.	38.	39.	40.
41.	42.	43.	44.	45.	46.	47.	48.

Unit Training Activity (UTA) Calendar

Requirements

TCST Training	28 1/2	UTAs
Mandatory Training		UTAs
Other Mission Training		UTAs
TOTAL	48	UTAs

COMMENTS:

Appendix B

Tank Commander's Training Guide

INTRODUCTION

This appendix explains procedures for the tank commander (TC) to follow when implementing the tank crewman skills training program.

In the program the TC is responsible for training his crew to the level of crew qualification on Table VII. To accomplish this responsibility he measures the knowledge and skill level of each crewman to determine which job tasks have not been mastered, next he trains each crewman in the mastery of knowledge and skill deficient tasks, and lastly he trains his crew as a team in the mastery of crew tasks.

Training techniques which the TC uses to fulfill the above responsibility are: readiness (diagnostic) testing to determine knowledge and skill levels, remedial training to correct deficiencies noted during readiness testing, and a crew interaction performance test to evaluate team performance. Procedures for this training are contained in ARI Research Products, RP 79-13, Tank Crewman (M60A1) Readiness Tests; RP 79-14, Tank Crewman (M60A1) Training Modules; and RP 79-15, Tank Crew (M60A1) Performance Exercise.

TANK CREWMAN SKILLS TEST TRAINING (TCST) PROGRAM

The TCST program consists of a series of readiness (diagnostic) tests and remedial training modules for each crewman. In addition a crew interaction performance test is used to evaluate team performance. Annex 1 is a detailed explanation of the sequential progression for conducting the TCST program and includes a flow diagram for each crew member.

READINESS (DIAGNOSTIC) TESTS

Readiness tests consist of a battery of separate tests for each crewmember. The battery consists of written and hands-on tests. The written tests are the pre-tests of the Army TEC program. The hands-on tests were structured for the TCST program and job tasks included reflect those indicated in appropriate technical manuals and FM 17-12, "Tank Gunnery," (See Annex 2)

TRAINING MODULES

Each readiness test has a companion training module. The modules for written tests are conducted by the self-instructional sound slide presentation method. Whereas, the modules for the hands-on tests are conducted by the audio tape controlled practice or the one-on-one instructor controlled performance methods. (See Annex 3)

CREW INTERACTION PERFORMANCE TEST

This test, administered by the company commander, is the culmination of the TCST program. It measures the crew's knowledge and skills in performing team tasks.

SCHEDULES AND TRAINING RECORDS

A major requirement for the TC is scheduling training activities of his crew members. He must consider the time available for conducting one-on-one instructor controlled performance training while at the same time scheduling other crew members on self-instructional training.

Another program task he must do is record the results of readiness testing and remedial training in the Tank Crewman Readiness Book and report the information to the company training officer/NCO for posting in the Company Crewman Readiness Record.

Annex 4 includes procedures for scheduling remedial training and maintaining training records.

ANNEX 1

PROCEDURES FOR CONDUCTING THE TCST PROGRAM

The most idealistic progression of activities within the program is: 1) written readiness tests, 2) remedial training, 3) hands-on readiness tests, 4) remedial training, 5) tank gunnery firing Tables I through VII, 6) crew interaction performance tests, and 7) remedial training. However, the limitation of time, facilities and equipment precludes this sequence of progression. A more realistic progression, which maximizes the use of limited training resources is: 1) written readiness tests, 2) hands-on readiness tests, 3) remedial training (one crewman conducts instructor controlled performance training and the other two conduct self instructional training), 4) tank gunnery firing Tables I through VI, 5) crew interaction performance tests, and 6) remedial training.

The preferred sequence of administering readiness tests and conducting remedial training within an individual crewman's program is to start with tests and training which can be conducted at the armory and finish with tests and training which requires a field site with such facilities as driving, target acquisition, and tank crew qualification (dry) courses. The following outlines the sequence of tests and training modules for each crewman's program.

- . Driver - Operational Checks and Services
Before Operations Procedures and Tank
Start Up
Target Acquisition
Locating and Reporting Targets
Tactical Driving
- . Loader - Weapons Maintenance
Mission Preparation
Combat Loading
Target Acquisition
Locating and Reporting Targets
- . Gunner - Weapons Maintenance
Before Operations Procedures
Weapon Systems Preparation
Combat Loading
Target Acquisition
Locating and Reporting Targets
Tactical Operations

- . Tank
 - Commander - Weapons Maintenance
 - Before Operations Procedures
 - Weapon Systems Preparation
 - Combat Loading
 - Target Acquisition
 - Locating and Reporting Targets
 - Tactical Operations

Figures 22a through 22d are flow diagrams illustrating the TCST program for each crewmember.

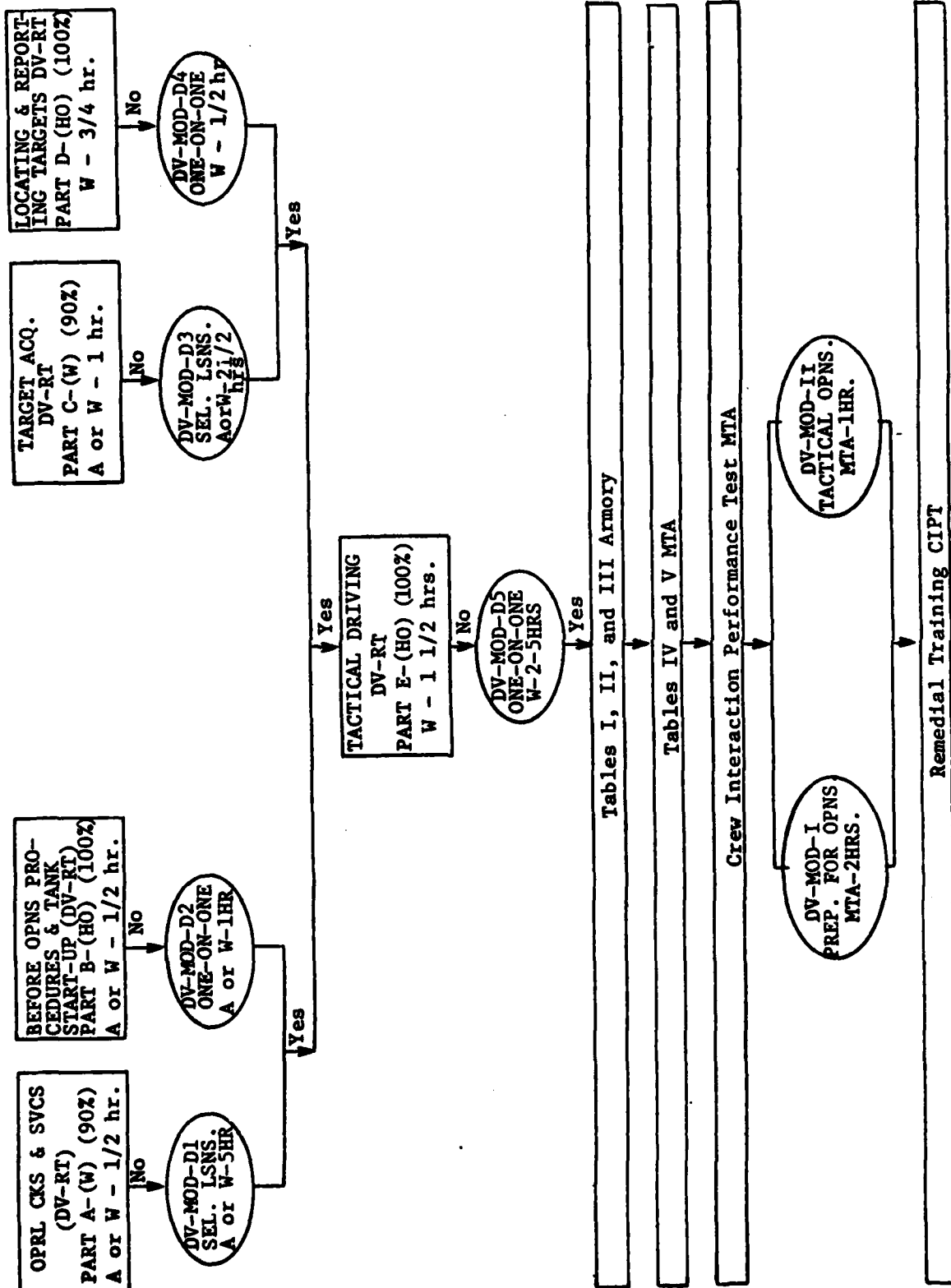

Figure 22a. DRIVER, flow diagram for TCST program.

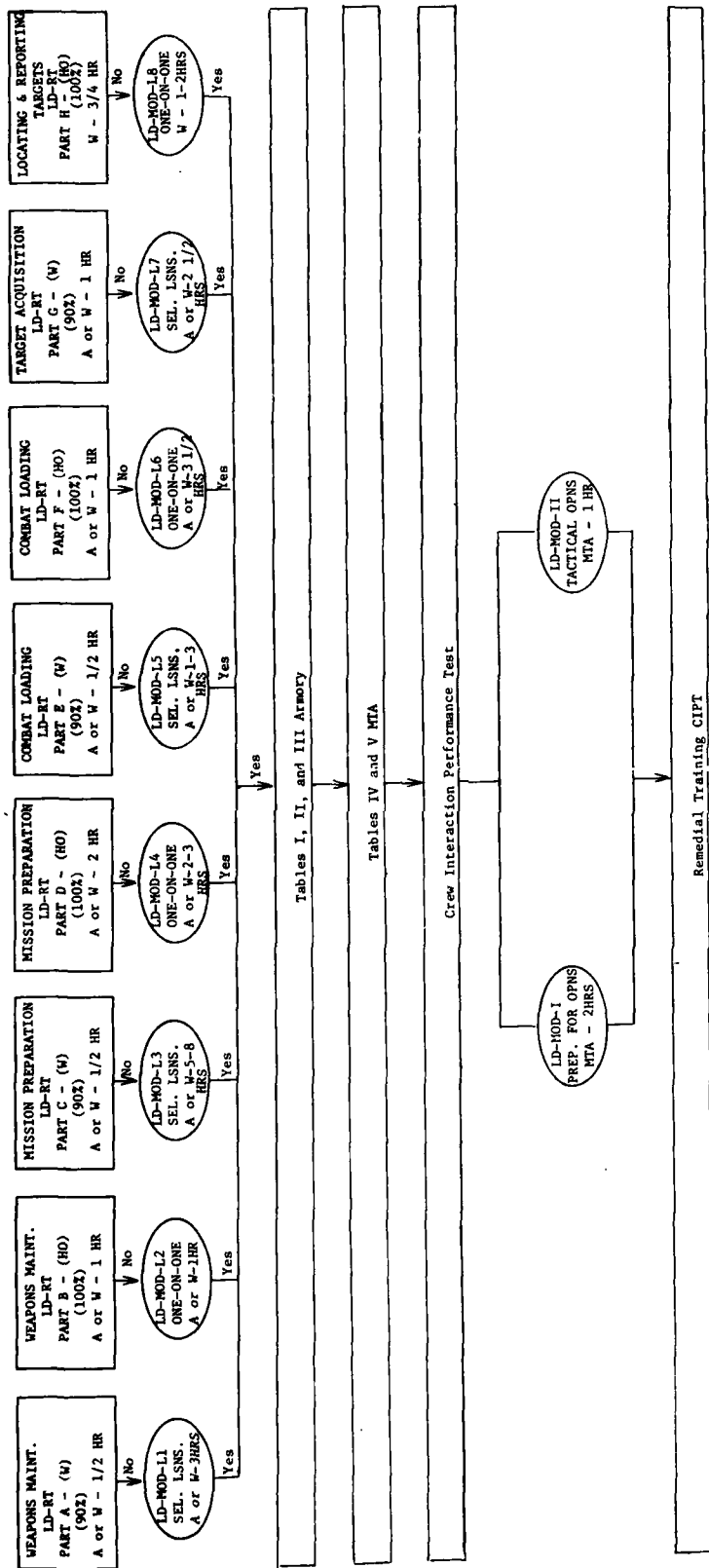

Figure 22b. LOADER, flow diagram for ICST program.

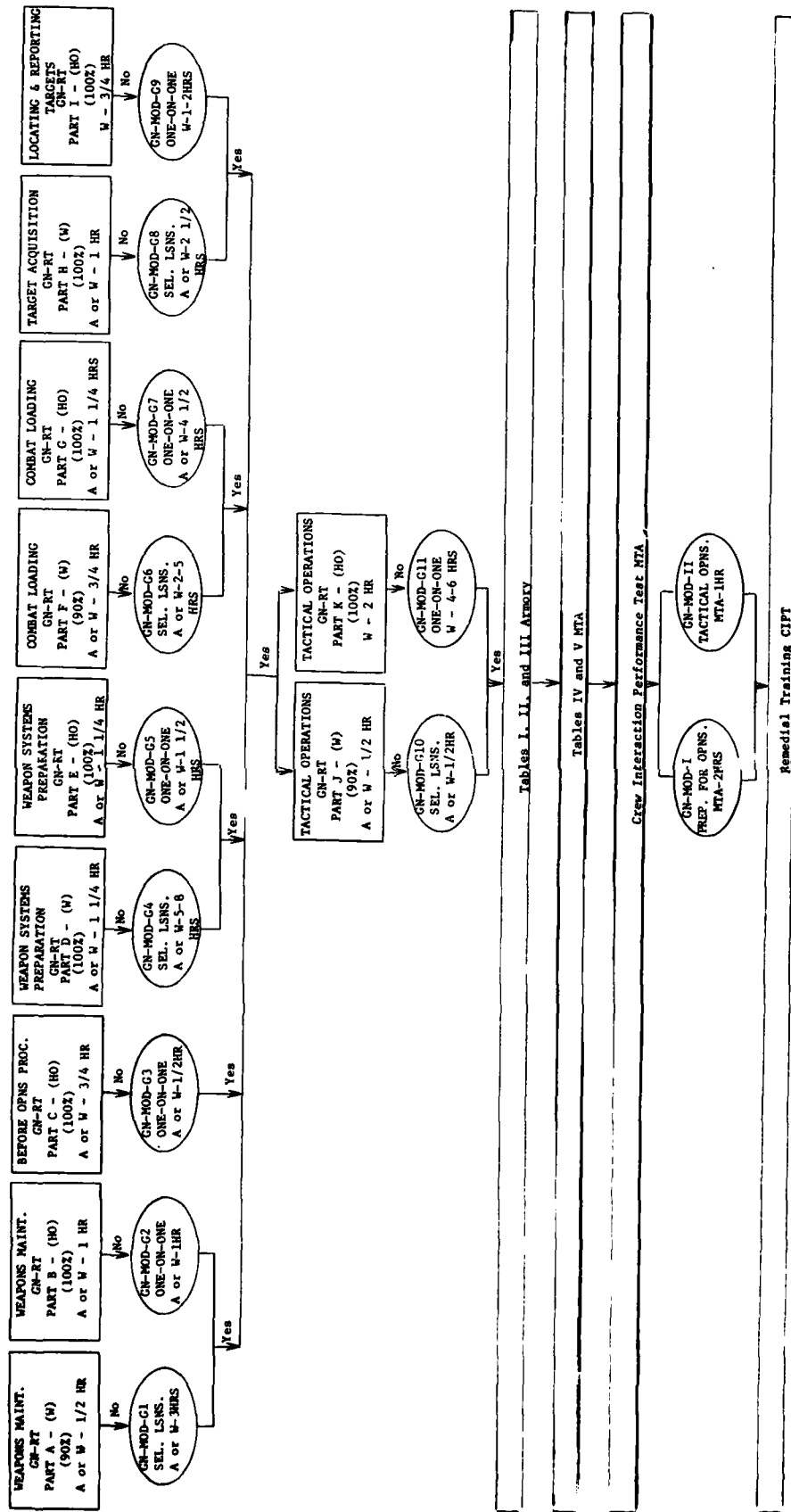

Figure 22c. CUNNER, flow diagram for ICST program.

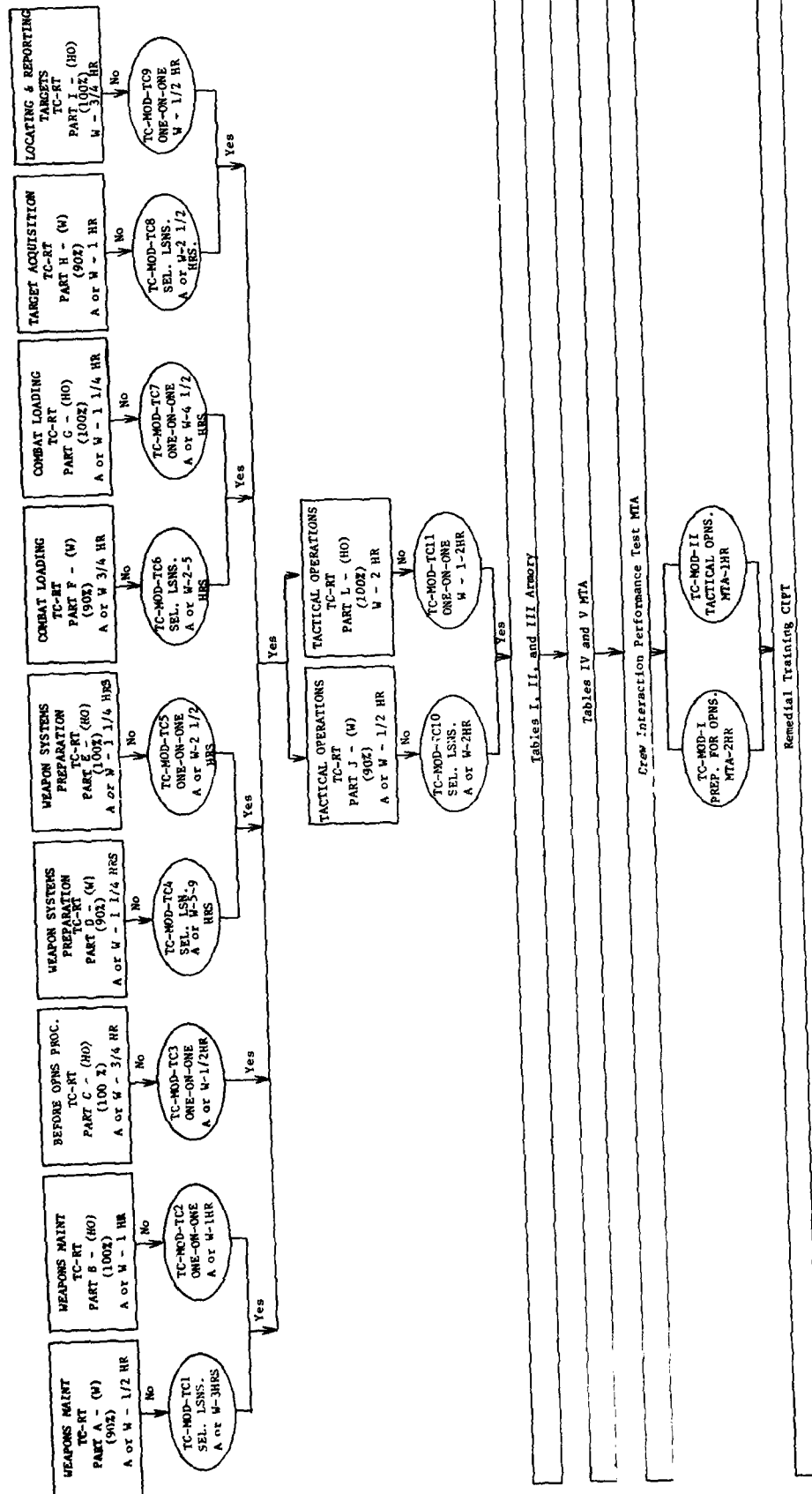

Figure 22d. TANK COMMANDER, flow diagram for TCSST program.

ANNEX 2

PROCEDURES FOR CONDUCTING READINESS TESTS

There are two types of readiness tests in the TCST program. The written tests are administered to the driver, loader, and gunner by the company training officer/NCO. Hands-on readiness tests are administered to these crewmen by their respective tank commanders.

The procedures for administering written tests are explained in enclosure 1. The tests include:

- . Driver's Readiness Tests, Parts A and C.
- . Loader's Readiness Tests, Parts A, C, E, and G.
- . Gunner's Readiness Tests, Parts A, D, F, H, and J.

The procedures for administering hands-on tests are explained in enclosure 2. The tests include:

- . Driver's Readiness Tests, Parts B, D, and E.
- . Loader's Readiness Tests, Parts B, D, F, and H.
- . Gunner's Readiness Tests, Parts B, C, E, G, I, and K.

A complete list of readiness tests which shows description, action, and remedial training is in enclosure 3.

**ENCLOSURE 1. PROCEDURES FOR ADMINISTERING
WRITTEN READINESS TESTS**

1. Station Set-Up: Insure the following items are present at the test site.

- . One copy of appropriate pre-test per crew member.
- . One pencil per crew member.
- . Blank paper for each pre-test.
- . One answer key for each pre-test.
- . Sufficient seats and writing space to accomodate crew members being tested.

2. Test Procedure:

- . Issue pre-test.
- . Instruct crew members not to mark on the test booklet.
- . Instruct crew members to place their name, SSN, and date on the answer sheet.
- . Instruct crew members to begin answering questions on the pre-test.
- . Do not provide assistance to persons taking the test.
- . Collect the pre-tests and answer sheets.
- . Score the answer sheets.
- . Determine which crew members meet the standard of the readiness test and which crew members should take remedial training.

3. Scoring Standards:

- . Use the answers provided on the answer key.
- . Do not assume that a crew member knows anything that he does not write on his answer sheet.
- . Do not give partial credit for any answer.
- . The maximum and passing scores are listed in the answer key.

4. Reporting Results:

- . Record the results as "GO" or "NO GO" in the company readiness record.
- . Report the results to the tank commanders.

**ENCLOSURE 2. PROCEDURES FOR ADMINISTERING
HANDS-ON READINESS TESTS**

Hands-on readiness tests measure skill levels of individual crew members. The role of the tank commander (scorer) is not to determine if a crew member passes or fails a task, but which tasks he knows and can perform and which tasks require additional training. The term "close enough for government work" cannot apply. The crew member either knows and can perform the task in the correct manner or he needs additional training on the task.

The steps and sequence of each task in the test areas are indicated in the M60A1 operator's manual and FM 17-12, "Tank Gunnery". Although some of the tasks can be performed in a different manner, i.e., "shortcuts", it is necessary for the crew member to perform each task exactly as indicated to determine if he has absolute mastery of the skill required.

To fulfill the diagnostic function of the tests, the tank commander scores the process as well as the product of each test. The difference between process and product scoring is best described by considering the scoring of a tank main gun engagement. If the product or result of the engagement is scored, a target hit would indicate crew mastery of the skills required to fire the engagement. If the round missed the target, it would indicate that the crew requires additional training. However, it would not be known which crew member needed additional training or what training was required. By evaluating the process, i.e., individual tasks and task steps of the engagement, it can be determined which crew members need additional training and to prescribe the training required.

Readiness tests are designed to allow crew members to demonstrate their ability to perform each task correctly rather than tell the scorer (TC) how the task is performed. If an individual can tell how to correctly lift 400 lbs., it doesn't mean that he can actually lift that weight.

The tank commander's actions as the scorer of readiness tests are guided by two principles:

- . Be sure the test conditions are the same for every crew member.
- . Be sure the standard is applied evenly for every crew member.

The steps listed below indicate the procedure for administering hands-on readiness tests:

- . Insure that the test site is properly set-up and equipment specified in the readiness test is present.
- . Record the crewman's name, tank number, and crew position on the score sheet.
- . Read the test requirements to the crew member and have him restate the requirements.
- . Evaluate and record every task step as it is completed.
- . Assist the crew member ONLY if assistance is specified in the scorer's instructions or if he is doing something that endangers himself or the equipment.
- . DO NOT answer any questions about how to perform a task.
- . Answer questions about which task to perform by rereading the instructions or an appropriate portion of them.
- . If a crewman stops during a test because he forgets what to do, tell him to do the best he can and do not stop the test or time.
- . If a distraction occurs during the test, reread the part where it occurs and continue to score the test as if there had been no distraction. If the crew member fails the test, determine if the distraction was the cause of the failure and decide whether to retest him.
- . Appropriate technical manuals may be used during the test for complicated procedural tasks such as, "conduct prepare-to-fire procedures".
- . At the completion of the test, record in the COMMENTS section all information which will help to determine the remedial training required.
- . Record the results of the test in Tank Crewman Readiness Book and report the results to the company training officer/NCO for posting in the Company Crewman Readiness Record.

ENCLOSURE 3. READINESS TEST OUTLINES

DRIVER'S READINESS TEST

PART A - OPERATIONAL CHECKS AND SERVICES

- Description - This is a written test which measures the driver's knowledge of basic tank maintenance indicators and procedures.
- Action - The company training officer/NCO administers the test.
- Remedial Training - If the driver does not get a score of 90% or better, refer to Module D-1.

PART B - BEFORE OPERATIONS PROCEDURES AND TANK START-UP

- Description - This is a hands-on test which measures the driver's ability to do tasks required to prepare for a night mission in an NBC environment.
- Action - Get a copy of the Driver's Readiness Test, Part B from the company training officer/NCO and read the "CONDITIONS" section. A tank, protective mask, and the equipment shown in that section will be required to administer the test. The test can be completed in about 90 minutes.
- Remedial Training - If the driver is scored "NO" on any task step in the test, refer to Module D-2.

PART C - TARGET ACQUISITION

- Description - This is a written test which measures the driver's knowledge of target acquisition, identification, reporting, and range determination.
- Action - The company training officer/NCO administers the test.
- Remedial Training - If the driver does not get a score of 90% or better, refer to Module D-3.

PART D - LOCATING AND REPORTING TARGETS

- Description - This is a hands-on test which measures the driver's ability to locate, identify, estimate range to, and report location of targets.

- Action - Get a copy of the Driver's Readiness Test, Part D from the company training officer/NCO and read the "CONDITIONS" section. A tank and a target acquisition course will be required to administer the test. The test can be completed in about 45 minutes.
- Remedial Training - If the driver is scored "NO" on any task step in the test, refer to Module D-4.

PART E - TACTICAL DRIVING

- Description - This is a hands-on test which measures the driver's ability to drive a tank over obstacles and during firing, and sense rounds.
- Action - Get a copy of the Driver's Readiness Test, Part E from the company training officer/NCO and read the "CONDITIONS" section. A tank and a driving course will be required to administer the test. The test can be completed in about 90 minutes.
- Remedial Training - If the driver is scored "NO" on any task step in the test, refer to Module D-5.

LOADER'S READINESS TEST

PART A - WEAPONS MAINTENANCE

- Description - This is a written test which measures the loader's knowledge of tank weapons.
- Action - The company training officer/NCO administers the test.
- Remedial Training - If the loader does not get a score of 90% or better, refer to Module L-1.

PART B - WEAPONS MAINTENANCE

- Description - This is a hands-on test which measures the loader's ability to disassemble and reassemble the breechblock and the tank machineguns.
- Action - Get a copy of the Loader's Readiness Test, Part B from the company training officer/NCO and read the "CONDITIONS" section. A tank, dummy 7.62 ammunition, and breechblock disassembly tools will be required to administer the test. The test can be completed in about 60 minutes.
- Remedial Training - If the loader is scored "NO" on any task step in the test, refer to Module L-2.

PART C - MISSION PREPARATION

- Description - This is a written test which measures the loader's knowledge of preoperations duties of the loader.
- Action - The company training officer/NCO administers the test.
- Remedial Training - If the loader does not get a score of 90% or better, refer to Module L-3.

PART D - MISSION PREPARATION

- Description - This is a hands-on test which measures the loader's ability to do preparations duties of the loader.
- Action - Get a copy of the Loader's Readiness Test, Part D from the company training officer/NCO and read the "CONDITIONS" section. A tank, protective mask, dummy ammunition, and other equipment shown in this section will be required to administer the test. The test can be completed in about 60 minutes.
- Remedial Training - If the loader is scored "NO" on any task step in the test, refer to Module L-4.

PART E - COMBAT LOADING

- Description - This is a written test which measures the loader's knowledge of the skills required to load the main gun and coax machinegun.
- Action - The company training officer/NCO administers the test.
- Remedial Training - If the loader does not get a score of 90% or better, refer to Module L-5.

PART F - COMBAT LOADING

- Description - This is a hands-on test which measures the loader's ability to respond to fire commands and perform immediate action procedures on the main gun and the coax machinegun.
- Action - Get a copy of the Loader's Readiness Test, Part F from the company training officer/NCO and read the "CONDITIONS" section. A tank, dummy ammunition, and a replenisher tape mockup will be required to administer the test. The test can be completed in about 75 minutes.
- Remedial Training - If the loader is scored "NO" on any task step in the test, refer to Module L-6.

PART G - TARGET ACQUISITION

- Description - This is a written test which measures the loader's knowledge of target acquisition, identification, reporting, and range determination.
- Action - The company training officer/NCO administers the test.
- Remedial Training - If the loader doesn't get a score of 90% or better, refer to Module L-7.

PART H - LOCATING AND REPORTING TARGETS

- Description - This is a hands-on test which measures the loader's ability to locate, identify, estimate range to, and report location of targets.
- Action - Get a copy of the Loader's Readiness Test, Part H from the company training officer/NCO and read the "CONDITIONS" section. A tank and a target acquisition course will be required to administer the test. The test can be completed in about 45 minutes.
- Remedial Training - If the loader is scored "NO" on any task step in the test, refer to Module L-8.

GUNNER'S READINESS TEST

PART A - WEAPONS MAINTENANCE

- Description - This is a written test which measures the gunner's knowledge of tank machineguns.
- Action - The company training officer/NCO administers the test.
- Remedial Training - If the gunner does not score 90% or better, refer to Module G-1.

PART B - WEAPONS MAINTENANCE

- Description - This is a hands-on test which measures the gunner's ability to disassemble and reassemble the breechblock and the tank machineguns.
- Action - Get a copy of the Gunner's Readiness Test, Part B from the company training officer/NCO and read the "CONDITIONS" section. A tank, dummy 7.62 ammunition, and breechblock disassembly tools will be required to administer the test. The test can be completed in about 60 minutes.

Remedial Training - If the gunner is scored "NO" on any task step in the test, refer to Module G-2.

PART C - BEFORE OPERATIONS PROCEDURES

Description - This is a hands-on test which measures the gunner's ability to do preparations duties of the gunner.

Action - Get a copy of the Gunner's Readiness Test, Part C from the company training officer/NCO and read the "CONDITIONS" section. A tank will be required to administer the test. The test can be completed in about 45 minutes.

Remedial Training - If the gunner is scored "NO" on any task step in the test, refer to Module G-3.

PART D - WEAPON SYSTEMS PREPARATION

Description - This is a written test which measures the gunner's knowledge of the procedure for preparing the weapon systems for operation.

Action - The company training officer/NCO administers the test.

Remedial Training - If the gunner does not get a score of 90% or better, refer to Module G-4.

PART E - WEAPON SYSTEMS PREPARATION

Description - This is a hands-on test which measures the gunner's ability to prepare fire control instruments for operation and to boresight and zero the main gun and coax machinegun.

Action - Get a copy of the Gunner's Readiness Test, Part E from the company training officer/NCO and read the "CONDITIONS" section. A tank with the coax machinegun mounted and boresight and zero panels will be required to administer the test. The test can be completed in about 75 minutes.

Remedial Training - If the gunner is scored "NO" on any task step in the test, refer to Module G-5.

PART F - COMBAT LOADING

Description - This is a written test which measures the gunner's knowledge of the skills required to load the main gun and coax machinegun.

Action - The company training officer/NCO administers the test.

Remedial Training - If the gunner does not get a score of 90% or better, refer to Module G-6.

PART G - COMBAT LOADING

- Description - This is a hands-on test which measures the gunner's ability to respond to fire commands and perform immediate action procedures on the main gun and coax machinegun.
- Action - Get a copy of the Gunner's Readiness Test, Part G from the company training officer/NCO and read the "CONDITIONS" section. A tank, dummy ammunition, and a replenisher tape mockup will be required to administer the test. The test will take about 75 minutes.
- Remedial Training - If the gunner scored "NO" on any task step in the test, refer to Module G-7.

PART H - TARGET ACQUISITION

- Description - This is a written test which measures the gunner's knowledge of target acquisition, identification, reporting, and range determination.
- Action - The company training officer/NCO administers the test.
- Remedial Training - If the gunner does not get a score of 90% or better, refer to Module G-8.

PART I - LOCATING AND REPORTING TARGETS

- Description - This is a hands-on test which measures the gunner's ability to locate, identify, estimate range to, and report location of targets.
- Action - Get a copy of the Gunner's Readiness Test, Part K from the company training officer/NCO and read the "CONDITIONS" section. A tank and a target acquisition course will be required to administer the test. The test can be completed in about 45 minutes.
- Remedial Training - If the gunner scored "NO" on any task step in the test, refer to Module G-9.

PART J - TACTICAL OPERATIONS

- Description - This is a written test which measures the gunner's knowledge of ammunition settings on the ballistic computer and correct range settings and sight pictures for coax machinegun engagements.
- Action - The company training officer/NCO administers the test.
- Remedial Training - If the gunner does not get a score of 90% or better, refer to Module G-10.

PART K - TACTICAL OPERATIONS

- Description - This is a hands-on test which measures the gunner's ability to acquire and fire at targets with the main gun and coax machinegun.
- Action - Get a copy of the Gunner's Readiness Test, Part K from the company training officer/NCO and read the "CONDITIONS" section. A tank with a coax machinegun mounted on a tank crew qualification course will be required to administer the test. The test can be completed in about 120 minutes.
- Remedial Training - If the gunner scored "NO" on any task step in the test, refer to Module G-11.

TANK COMMANDER'S READINESS TEST

PART A - WEAPONS MAINTENANCE

- Description - This is a written test which measures the tank commander's knowledge of tank machineguns.
- Action - The company training officer/NCO administers the test.
- Remedial Training - If the tank commander does not score 90% or better, refer to Module TC-1.

PART B - WEAPONS MAINTENANCE

- Description - This is a hands-on test which measures the tank commander's ability to disassemble and reassemble the breechblock and the tank machineguns.
- Action - Get a copy of the Tank Commander's Readiness Test, Part B from the company training officer/NCO and read the "CONDITIONS" section. A tank, dummy 7.62 ammunition, and breechblock disassembly tools will be required to administer the test. The test can be completed in about 60 minutes.
- Remedial Training - If the tank commander scored "NO" on any task step in the test, refer to Module TC-2.

PART C - BEFORE OPERATIONS PROCEDURES

- Description - This is a hands-on test which measures the tank commanders ability to do preparation duties of the tank commander.
- Action - Get a copy of the Tank Commander's Readiness Test, Part C from the company training officer/NCO and read the "CONDITIONS" section. A tank will be required to administer the test. The test can be completed in about 45 minutes.

Remedial Training - If the tank commander scored "NO" on any task step in the test, refer to Module TC-3.

PART D - WEAPON SYSTEMS PREPARATION

Description - This is a written test which measures the tank commander's knowledge of procedures for preparing weapon systems for operation.

Action - The company training officer/NCO administers the test.

Remedial Training - If the tank commander does not score 90% or better, refer to Module TC-4.

PART E - WEAPON SYSTEMS PREPARATION

Description - This is a hands-on test which measures the tank commander's ability to prepare fire control instruments for operation and to boresight and zero the main gun and the tank machineguns.

Action - Get a copy of the Tank Commander's Readiness Test, Part E from the company training officer/NCO and read the "CONDITIONS" section. A tank with machineguns mounted will be required to administer the test. The test can be completed in about 75 minutes.

Remedial Training - If the tank commander scored "NO" on any task step in the test, refer to Module TC-5.

PART F - COMBAT LOADING

Description - This is a written test which measures the tank commander's knowledge of the skills required to load the main gun and the tank machineguns.

Action - The company training officer/NCO administers the test.

Remedial Training - If the tank commander does not get a score of 90% or better, refer to Module TC-6.

PART G - COMBAT LOADING

Description - This is a hands-on test which measures the tank commander's ability to respond to fire commands and perform immediate action procedures on the main gun and tank machineguns.

Action - Get a copy of the Tank Commander's Readiness Test, Part G from the training officer/NCO and read the "CONDITIONS" section. A tank, dummy ammunition, and a replenisher tape mockup will be required to administer the test. The test will take about 75 minutes.

Remedial Training - If the tank commander scored "NO" on any task step in the test, refer to Module TC-7.

PART H - TARGET ACQUISITION

- Description - This is a written test which measures the tank commander's knowledge of target acquisition, identification, reporting and range determination.
- Action - The company training officer/NCO administers the test.
- Remedial Training - If the tank commander does not get a score of 90% or better, refer to Module TC-8.

PART I - LOCATING AND REPORTING TARGETS

- Description - This is a hands-on test which measures the tank commander's ability to locate, identify, estimate range to and report location of targets.
- Action - Get a copy of the Tank Commander's Readiness Test, Part I from the training officer/NCO and read the "CONDITIONS" section. A tank and a target acquisition course will be required to administer the test. The test can be completed in about 45 minutes.
- Remedial Training - If the tank commander scored "NO" on any task step in the test, refer to Module TC-9.

PART J - TACTICAL OPERATIONS

- Description - This is a written test which measures the tank commander's knowledge of correct fire commands, and range settings and sight pictures for coax machinegun engagements.
- Action - The company training officer/NCO administers the test.
- Remedial Training - If the tank commander does not get a score of 90% or better, refer to Module TC-10.

PART K - TACTICAL OPERATIONS

- Description - This is a hands-on test which measures the tank commander's ability to acquire and fire at targets with the main gun and the tank machineguns.
- Action - Get a copy of the Tank Commander's Readiness Test, Part K from the company training officer/NCO and read the "COMMENTS" section. A tank with machinegun mounted and a tank crew qualification course will be required to administer the test. The test can be completed in about 120 minutes.
- Remedial Training - If the tank commander scored "NO" on any task step in the test, refer to Module TC-11.

ANNEX 3

PROCEDURES FOR CONDUCTING REMEDIAL TRAINING

After readiness tests have been administered and training needs have been determined, remedial training to correct deficiencies noted begins.

Each training module contains the following information.

- Pretraining conditions. This section describes the conditions which will be present if the module is needed, i.e., the section will indicate that the crewman failed a written test or tasks of a hands-on test.
- Objective(s). This is a statement which indicates:
 - What tasks the crewman will be able to perform after training.
 - How he will know when to perform the task(s).
 - When he will perform the task(s).
 - How well he will perform the task(s).
 - What he can use to help him perform the task(s).
 - How he will perform the task(s).
- Method. This is a statement of how the training will be conducted. There are three different type modules.
 - Self-instructional sound-slide presentation with written response. The crewman views a sound slide TEC program on a Beseler Cue/See projector. The crewman controls the speed of the program to accommodate his learning speed. (The TEC programs and projector are available from the training officer/NCO.)
 - Audio tape controlled practice. The crewman obtains an audio cassette recording and cassette player from the training officer/NCO. The crewman follows the instructions on the cassette to practice the task to be learned until he feels that he can master it. Then the tank commander tests the crewman to make sure he can do the task.

(This training method frees the tank commander to conduct one-on-one instructor controlled performance training with another crewman.)

- One-on-one instructor controlled performance training. In this method, the tank commander "talks the crewman through" the task or task elements to be learned. It is important that the crewman performs the task as oral directions are given. The tank commander should not spend long periods explaining or showing the crewman how to perform the task while he listens or watches, this will slow down the learning process.
- . Equipment and Materials. This is a list of equipment and materials needed to conduct the training.
- . Estimated Time. The time listed in this section is an estimate as to how long it will take a crewman to learn a task or the task steps. This time and what is known about the crewman's training needs is used to plan the training time.
- . Procedure. This section is a step-by-step outline to guide the tank commander in the training.
- . Notes. Notes are included in some modules to answer questions which may arise during training.

Procedures to follow for implementing the different type training modules are explained in enclosures 1 through 3. The modules, by method, are:

- . Self-instructional sound-slide presentations.
 - Driver, D-1, D-3.1, D-3.2, D-3.3, D-3.4
 - Loader, L-1.1, L-1.2, L-1.3, L-3.1, L-3.2, L-3.3, L-5.1, L-5.2, L-7.1, L-7.2, L-7.3, L-7.4.
 - Gunner, G-1.1, G-1.2, G-1.3, G-4.1, G-4.2, G-8.1, G-8.2, G-8.3, G-8.4, G-10.
- . Audio tape controlled practice.
 - Driver, D-5.2 (alternate)
 - Loader, L-6.2
 - Gunner, G-7.3

. One-on-one instructor controlled performance training.

- Driver, D-2, D-4, D-5.1, D-5.2, D-5.3
- Loader, L-2, L-4, L-6.1, L-6.3, L-6.4, L-6.5,
L-6.6, L-8.
- Gunner, G-2, G-3, G-5.1, G-5.2, G-6.1, G-6.2,
G-7.1, G-7.2, G-7.4, G-7.5, G-7.6, G-7.7,
G-7.7, G-9, G-11.1, G-11.2.

A complete list of training modules indicating title, pretraining conditions, type of instruction, equipment, and time is at enclosure 4.

**ENCLOSURE 1. PROCEDURES FOR SELF-INSTRUCTIONAL
SOUND-SLIDE PRESENTATION REMEDIAL TRAINING**

Self-instructional sound-slide presentation training frees the tank commander to conduct one-on-one instructor controlled performance training with another crew member. The steps shown below are followed when conducting this type of training:

- . Determine crewman's training need from readiness test records.
- . Inform crewman of which TEC programs to review.
- . Inform crewman of TEC program schedule or obtain TEC programs and Beseler Cue/See from training officer/NCO.
- . Crewman views TEC program.
- . Monitor crewman's viewing of TEC program.
- . Crewman takes TEC program post-test.
- . Check crewman's post-test results.
- . Change "NO GO" status in Tank Crewman Readiness Book to a "GO" status and notify company training officer/NCO.

**ENCLOSURE 2. PROCEDURES FOR AUDIO TAPE
CONTROLLED PRACTICE REMEDIAL TRAINING**

This type of self-instruction allows the crewman to learn skills on the actual equipment while following the directions of an audio tape. It also frees the tank commander to train other crew members. The steps to follow in this type of training are shown below:

- . Determine crewman's training need from readiness test records.
- . Inform crewman of which tape to practice with.
- . Obtain audio cassette recording and cassette player from training officer/NCO.
- . Obtain necessary equipment for crewman to train on.
- . Crewman plugs cassette player into tank inter-communications system and takes appropriate crew station.
- . Crewman follows tape instructions and practices task performance.
- . Check crewman's mastery of task(s).
- . Change "NO GO" status in Tank Crewman Readiness Book to a "GO" status and notify company training officer/NCO.

**ENCLOSURE 3. PROCEDURES FOR ONE-ON-ONE
INSTRUCTOR CONTROLLED PERFORMANCE TRAINING**

One-on-one instructor controlled performance training allows the crewman to conduct hands-on training with actual equipment. This type of training demands that the tank commander (TC) be thoroughly knowledgeable and skilled in crewman tasks. The steps listed below explains the procedures to follow.

Preparation.

Determine crewman's training needs from readiness test records.

Obtain appropriate readiness test.

- . Knowledge of the readiness test is necessary for adequate emphasis of task steps during instruction.
- . The readiness test must be present to adequately check crewman performance after training.
- . The readiness test is required to identify the task(s) or task steps the crew member must learn.

Identify all acts and key points in the performance of the test.

- . The TC performs the task and pays careful attention to everything he does, regardless of how small an act may be, and asks himself why he does every step.
- . Note all possibilities for injury of self or others and how to avoid them.
- . Note all possibilities for damage to equipment or materials and how to avoid them.
- . Note all specific acts that must be done in sequence for adequate task performance.
- . Note all specific acts that must be done at certain points to make the task easier.
- . Note all states (conditions) of equipment or materials at certain points to make the task easier.

Prepare the set-up for demonstration so that the crewman can clearly see and hear.

- . Ensure that all equipment and materials are in the proper conditions to begin the task; e.g., power switches in proper position.
- . Assure that the crewman is in a position to clearly see the demonstration and hear the explanations. (If the engine must be running, use the intercom.)
- . When appropriate, provide the crewman with job aids, such as a task book or manual.

Presentation.

Introduction.

- . Briefly identify the equipment and/or materials and state their purpose.
 - Simply identify the equipment and/or materials by name.
 - Simply state what it does or its usefulness, but DO NOT give "nice-to-know" information such as historical background, technical characteristics, or HOW it does what it does.
- . Precisely state the training objective.
 - Tell the crewman exactly what he must be able to do upon completion of training.
- . Explain why he must accurately perform the task within the specified time limit.
 - Explain in a straight-forward manner. DO NOT waste time telling "war stories" or other anecdotes.
- . Explain the demonstration phase. (If used)
 - "I will demonstrate and explain how to _____, step-by-step while you watch and listen.
 - "After I perform and explain each step, you should ask questions about anything you don't understand."

- "When you feel you understand each step, you will immediately do it before I show you the next step."
- . Explain the walk-through phase.
 - "During this phase, don't try for speed, but concentrate on doing each task accurately and safely."
- . Explain the free-practice phase.
 - "When you know how to do each step in the correct sequence, you can start practicing for speed."
 - "When you think you have mastered the task, let me know and I will check your performance."
- . Explain the testing phase.
 - "When I check you out, if you do the task properly, I will tell you that your training is finished."

Demonstration Phase

- . This phase will only be used if both the tank commander and the crewman have a set of equipment, e.g., dismounted coax machineguns. This will not be possible for most TCST tasks inside the turret. The rule to follow is, DO NOT explain or demonstrate if the crewman is not able to perform along with the demonstration. For all tasks which cannot be demonstrated according to this rule, go directly to the walk through phase.

Walk Through Phase

- . Emphasize that the crewman must perform the task as it was explained to him.
- . Explain one step at a time in accordance with the readiness test.
 - Identify and point out the part or parts he will work with or in each step.
 - Explain what he will do, then how he will do it, and explain again how to do it as he does it.

- Strongly emphasize each key point noted in the analysis of the task.
- Explain why a step must be performed in a particular way. (to prevent injury, damage, or to avoid unnecessary difficulties in performing the step.)
- . After explaining and talking the crewman through each step, ask for and answer relevant questions, but defer irrelevant questions.
- . Pace the showing and explaining to the learning speed of the crewman.
 - Judge the appropriateness of the pace by the number and kinds of questions the crewman asks.
 - If he does not ask questions, ask him questions to check his understanding.
 - Reinforce correct performance by saying "That's right", "Good", "Fine", or the like.

Supervised Practice Phase

- . Allow the crewman to practice the task.
 - Coach the crewman as required.
 - Reinforce correct performance.

Free Practice Phase

- . Instruct the crewman to continue practice to develop skills.
 - Remind the crewman of the time standard.
- . Instruct the crewman to announce when he thinks he is ready for a check out on the skill.
- . Observe the crewman during practice to be sure he adheres to the correct procedure.

Testing Phase

- . Administer the task(s) exactly as called for in the readiness test.

- If the crewman correctly performs the task, inform him that it is a "GO", and change the "NO GO" rating to a "GO" rating in the Tank Crewman Readiness Book.
- If time permits, require a "NO GO" crewman to continue practice.
- If time does not permit, reschedule a "NO GO" crewman.
- Notify the company training officer/NCO of any change in the crewman's training status.

ENCLOSURE 4. LIST OF TRAINING MODULES

DRIVER MODULE	TITLE	PRETRAINING CONDITION	TYPE INSTRUC- TION	EQUIPMENT	TIME (MIN)
D-1	Operational Checks and Services	Failed written test 020-171-5366-F thru 5370-F (Part A, DV/RT)	TEC	TEC 020-171-5366-F thru 5370-F	60-300
D-2	Before Operations Procedures and Tank Start-Up	Passed Part A, DV/RT but failed Part B, DV/RT	Hands on	M60A1	60
D-3.1	Target Range Estimation	Failed written test 020-171-1611-F (Part C, DV/RT)	TEC	TEC 020-171-1611-F	30
D-3.2	Locating and Reporting Targets	Failed written test 020-171-1612-F (Part C, DV/RT)	TEC	TEC 020-171-1612-F	30
D-3.3	Target Acquisition Scanning Techniques	Failed written test 020-171-1614-F (Part C, DV/RT)	TEC	TEC 020-171-1614-F	30
D-3.4	Armor Vehicle Recognition	Failed written test 935-171-0203-F (Part C, DV/RT)	TEC	TEC 935-171-0203-F	60
D-4	Locating and Reporting Targets	Passed Part C, DV/RT but failed Part D, DV/RT	Hands on	M60A1 and target acquisition course	60-120
D-5.1	Varied Terrain Driving	Failed terrain driving Part E, DV/RT	Hands on	M60A1 and driving course	60-120
D-5.2	Target Engagement Driving	Failed engagement driving Part E, DV/RT	Hands on	M60A1 and driving course	60-120
D-5.3	Sensing Rounds	Failed sensing rounds, Part E, DV/RT	Hands on	M60A1 and driving course	60

LOADER

L-1.1	Cleaning, Inspection, and Lubricating Coax	Failed written test 020-171-1132-F (Part A, LD/RT)	TEC	TEC 020-171-1132-F	60
L-1.2	Troubleshooting Coax	Failed written test 020-171-1133-F (Part A, LD/RT)	TEC	TEC 020-171-1133-F	60
L-1.3	Troubleshooting M85 Machinegun	Failed written test 020-171-5229-F (Part A, LD/RT)	TEC	TEC 020-171-5229-F	60
L-2	Weapons Maintenance	Passed Part A, LD/RT but failed Part B, LD/RT.	Hands On	M60A1	60
L-3.1	Operational Checks and Services	Failed written test 020-171-5366-F thru 5370-F (Part C, LD/RT)	TEC	TEC 020-171-5366-F thru 5370-F	60-300
L-3.2	Ammunition Selecting and Handling	Failed written test 020-171-5331-F and 020-171-5332-F (Part C, LD/RT)	TEC	TEC 020-171-5331-F and 020-171-5332-F	60-120
L-3.3	Boresighting the Coax	Failed written test 020-171-5352-F (Part C, LD/RT)	TEC	TEC 020-171-5352-F	60
L-4	Mission Preparation	Passed Part C, LD/RT but failed Part D, LD/RT	Hands On	M60A1	120-180
L-5.1	Loading Ammunition	Failed written test 020-171-5346-F (Part E, LD/RT)	TEC	TEC 020-171-5346-F	60
L-5.2	Misfire and Unloading Procedures	Failed written test 020-171-5347-F and 020-171-5348-F (Part E, LD/RT)	TEC	TEC 020-171-5347-F and 020-171-5348-F	120
L-6.1	Replenisher Tape Reading	Failed replenisher tape section, Part F, LD/RT	Hands On	Replenisher Tape Mockup	30
L-6.2	Load Main Gun in Response to Fire Commands	Passed Part E, LD/RT but failed Part F, LD/RT	Hands On	M60A1 and dummy ammo, audio cassette	60

LOADER

L-6.3	Conduct Main Gun Misfire Procedures	Passed Part E, LD/RT but failed Part F, LD/RT	Hands On	M60A1 and dummy ammo	30
L-6.4	Load and Ready Coax in Response to Fire Commands	Passed Part E, LD/RT but failed Part F, LD/RT	Hands On	M60A1 and dummy ammo	30
L-6.5	Clear, Unload, and Reduce Coax Stoppage	Passed Part E, LD/RT but failed Part F, LD/RT	Hands On	M60A1 and dummy ammo	30
L-6.6	Load, Clear and Reduce Stoppage M85	Passed Part E, LD/RT but failed Part F, LD/RT	Hands On	M60A1 and dummy ammo	30
L-7.1	Target Range Estimation	Failed written test 020-171-1611-F (Part G, LD/RT)	TEC	TEC 020-171-1611-F	30
L-7.2	Locating and Reporting Targets	Failed written test 020-171-1612-F (Part G, LD/RT)	TEC	TEC 020-171-1612-F	30
L-7.3	Target Acquisition	Failed written test 020-171-1614-F (Part G, LD/RT)	TEC	TEC 020-171-1614-F	30
L-7.4	Armor Vehicle Recognition	Failed written test 935-171-0203-F (Part G, LD/RT)	TEC	TEC 935-171-0203-F	60
L-8	Locating and Reporting Targets	Passed Part G, LD/RT but failed Part H, LD/RT	Hands On	M60A1 and target acquisition course	60-120

GUNNER

G-1.1	Cleaning, Inspection, and Lubricating Coax	Failed written test 020-171-1132-F (Part A, GN/RT)	TEC	TEC 020-171-1132-F	60
G-1.2	Troubleshooting Coax	Failed written test 020-171-1133-F (Part A, GN/RT)	TEC	TEC 020-171-1133-F	60
G-2	Weapons Maintenance	Passed Part A, GN/RT but failed Part B, GN/RT	Hands On	M60A1, coax and cal. machinegun, gun roll	.50 60

G-3	Before Operations Procedures	Failed Part C, GN/RT	Hands On	M60A1 w/gas particulate unit & masks	30
G-4.1	Boresight Weapon Systems	Failed written test 020-171-5351-F, 020-171-5355-F, 020-171-5342-F, 020-171-5337-F, 020-171-5354-F, 020-171-5352-F, and 020-171-5341-F (Part D, GN/RT)	TEC	TEC 020-171-5351-F, 020-171-5355-F, 020-171-5342-F, 020-171-5337-F, 020-171-5354-F, 020-171-5352-F, and 020-171-5341-F	420
G-4.2	Zero Weapon Systems	Failed written test 020-171-5353-F (Part D, GN/RT)	TEC	TEC 020-171-5353-F	60
G-5.1	Boresight Weapon Systems	Passed Part D, GN/RT but failed Part E, GN/RT	Hands On	M60A1 w/coax and boresight panel & range	60
G-5.2	Zero Weapon Systems	Passed Part D, GN/RT but failed Part E, GN/RT	Hands On	M60A1 w/coax and zero panels & range	30
G-6.1	Selecting and Handling Tank Ammunition	Failed written test 020-171-5331-F and 020-171-5332-F (Part F, GN/RT)	TEC	TEC 020-171-5331-F and 020-171-5332-F	120
G-6.2	Loading, Misfire Procedures, and Unloading Main Gun	Failed written test 020-171-5346-F, 020-171-5347-F, and 020-171-5348-F (Part F, GN/RT)	TEC	TEC 020-171-5346-F, 020-171-5347-F, and 020-171-5348-F	180
G-7.1	Stow Tank Ammunition	Passed Part F, GN/RT but failed Part G, GN/RT	Hands On	M60A1 w/dummy main gun and machinegun ammo	60
G-7.2	Replenisher Tape Reading	Passed Part F, GN/RT but failed Part G, GN/RT	Hands On	Replenisher tape mockup	30
G-7.3	Load Main Gun in Response to Fire Commands	Passed Part F, GN/RT but failed Part G, GN/RT	Hands On	M60A1, dummy ammo, audio cassette	60
G-7.4	Conduct Main Gun Misfire Procedures	Passed Part F, GN/RT but failed Part G, GN/RT	Hands On	M60A1, dummy main gun ammo	30

G-7.5	Load and Ready Coax in Response to Fire Commands	Passed Part F, GN/RT but failed Part G, GN/RT	Hands On	M60A1 w/coax and dummy machinegun ammo	30
G-7.6	Clear, Unload, and Reduce Coax Stoppage	Passed Part F, GN/RT but failed Part G, GN/RT	Hands On	M60A1 w/coax and dummy machinegun ammo	30
G-7.7	Load, Clear, and Reduce Stoppage M85 Machinegun	Passed Part F, GN/RT but failed Part G, GN/RT	Hands On	M60A1 w/M85 and dummy machinegun ammo	30
G-8.1	Target Range Estimation	Failed written test 020-171-1611-F (Part H, GN/RT)	TEC	TEC 020-171-1611-F	30
G-8.2	Locating and Reporting Targets	Failed written test 020-171-1612-F (Part H, GN/RT)	TEC	TEC 020-171-1612-F	30
G-8.3	Target Acquisition Scanning Techniques	Failed written test 020-171-1614-F (Part H, GN/RT)	TEC	TEC 020-171-1614-F	30
G-8.4	Armor Vehicle Recognition	Failed written test 935-171-0203-F (Part H, GN/RT)	TEC	TEC 935-171-0203-F	60
G-9	Locating and Reporting Targets	Passed Part H, GN/RT but failed Part I, GN/RT	Hands On	M60A1 and target acquisition course	60-120
G-10	Tactical Operations I	Failed written test 020-171-5364-F (Part J, GN/RT)	TEC	TEC 020-171-5364-F	30
G-11.1	Target Engagements (COFT)	Passed Part J, GN/RT but failed Part K, GN/RT	Hands On	M60A1 w/laser firing devices and COFT	120-240
G-11.2	Target Engagements	Passed Part J, GN/RT but failed Part K, GN/RT	Hands On	M60A1 and tank crew qualification course	120

TANK COMMANDER

TC-1.1	Cleaning, Inspection, and Lubricating Coax	Failed written test 020-171-1132-F (Part A, TC/RT)	TEC	TEC 020-171-1132-F	60
TC-1.2	Troubleshooting Coax	Failed written test 020-171-1133-F (Part A, TC/RT)	TEC	TEC 020-171-1133-F	60
TC-1.3	Troubleshooting M85 Machinegun	Failed written test 020-171-5229-F (Part A, TC/RT)	TEC	TEC 020-171-5229-F	60
TC-2	Weapons Maintenance II	Passed Part A, TC/RT but failed Part B, TC/RT	Hands On	M60A1 w/coax and cal. .50 machinegun and gun roll	60
TC-3	Before Operations Procedures	Failed Part C, TC/RT	Hands On	M60A1 w/gas particulate unit and mask	30
TC-4.1	Boresight Weapon Systems	Failed written test 020-171-5340-F, 020-171-5343-F, 020-171-5352-F, 020-171-5354-F, 020-171-5355-F, 020-171-5341-F, 020-171-5351-F, 020-171-5337-F, (Part D, TC/RT)	TEC	TEC 020-171-5340-F, 020-171-5343-F, 020-171-5352-F, 020-171-5354-F, 020-171-5355-F, 020-171-5341-F, and 020-171-5337-F	480
TC-4.2	Zero Weapon Systems	Failed written test 020-171-5353-F (Part D, TC/RT)	TEC	TEC 020-171-5353-F	60
TC-5.1	Boresight Weapon Systems	Passed Part D, TC/RT but failed Part E, TC/RT	Hands On	M60A1 w/machineguns and boresight panels	60
TC-5.2	Ranging Test	Failed ranging test Part E-10, TC/RT	Hands On	M60A1 w/ranging panels	60
TC-5.3	Zero Weapon Systems	Passed Part D, TC/RT but failed Part E, TC/RT	Hands On	M60A1 w/machineguns and zero panels	30
TC-6.1	Selecting and Handling Tank Ammunition	Failed written test 020-171-5331-F and 020-171-5332-F (Part F, TC/RT)	TEC	TEC 020-171-5331-F and 020-171-5332-F	120

TC-6.2	Loading, Misfire Procedures, and Unloading Main Gun	Failed written test 020-171-5346-F, 020-171-5347-F, and 020-171-5348-F (Part F, TC/RT)	TEC	TEC 020-171-5346-F, 020-171-5347-F, and 020-171-5348	180
TC-7.1	Stow Tank Ammunition	Passed Part F, TC/RT but failed Part G, TC/RT	Hands On	M60A1 w/dummy main gun and machinegun ammo	60
TC-7.2	Replenisher Tape Reading	Passed Part F, TC/RT but failed Part G, TC/RT	Hands On	Replenisher tape mockup	30
TC-7.3	Load Main Gun in Response to Fire Commands	Passed Part F, TC/RT but failed Part G, TC/RT	Hands On	M60A1 w/dummy ammo and audio cassettes	60
TC-7.4	Conduct Main Gun Misfire Procedures	Passed Part F, TC/RT but failed Part G, TC/RT	Hands On	M60A1 w/dummy main gun ammo	30
TC-7.5	Load and Ready Coax in Response to Fire Commands	Passed Part F, TC/RT but failed Part G, TC/RT	Hands On	M60A1 w/coax and dummy machinegun ammo	30
TC-7.6	Clear, Unload, and Reduce Coax Stoppage	Passed Part F, TC/RT but failed Part G, TC/RT	Hands On	M60A1 w/coax and dummy machinegun ammo	30
TC-7.7	Load, Clear, and Reduce Stoppage M85 Machinegun	Passed Part F, TC/RT but failed Part G, TC/RT	Hands On	M60A1 w/M85 and dummy machinegun ammo	30
TC-8.1	Target Range Estimation	Failed written test 020-171-1611-F (Part H, TC/RT)	TEC	TEC 020-171-1611-F	30
TC-8.2	Locating and Reporting Targets	Failed written test 020-171-1612-F (Part H, TC/RT)	TEC	TEC 020-171-1612-F	30
TC-8.3	Target Acquisition Scanning Techniques	Failed written test 020-171-1614-F (Part H, TC/RT)	TEC	TEC 020-171-1614-F	30
TC-8.4	Armor Vehicle Recognition	Failed written test 935-171-0203-F (Part H, TC/RT)	TEC	TEC 935-171-0203-F	60

TC-9	Locating and Reporting Targets	Passed Part H, TC/RT but failed Part I, TC/RT	Hands On	M60A1 and target acquisition course	60-120
TC-10	Tactical Operations I	Failed written test 020-171-5361-F and 020-171-5364-F (Part J, TC/RT)	TEC	TEC 020-171-5361-F and 020-171-5364-F	120
TC-11	Tactical Operations II	Passed Part J, TC/RT but failed Part K, TC/RT	Hands On	M60A1 and tank crew qualification course	120

ANNEX 4

PROCEDURES FOR SCHEDULING REMEDIAL TRAINING AND MAINTAINING TRAINING RECORDS

A complex job that the tank commander (TC) has to perform in the TCST program is managing training in such a way that valuable time is not wasted. After readiness tests have been completed and the results recorded, the TC schedules remedial training for his crew. Each crew member will require a number of different training modules, and compounding the problem, every tank crew in the company will have similar training needs. Enclosure 1 is an example of how this problem can be resolved.

Another function of the TC is to maintain training records. He posts each crewman's progress in the Tank Crewman Readiness Book and provides the company training officer/NCO with any changes in a crewman's training record. The information in the book will aid the TC in scheduling the activities of the next training period. Enclosure 2 illustrates and explains the training records the TC uses.

ENCLOSURE 1. SCHEDULING REMEDIAL TRAINING

Scheduling remedial training requires the following actions by the tank commander (TC):

- . Review readiness test results to determine training needs.
- . Identify training modules required to correct knowledge and skill deficiencies.
- . Coordinate with the company training officer/NCO for necessary training resources.
- . Schedule training to maximize training time.

EXAMPLE:

A review of readiness test results indicates that crewmen failed the readiness tests indicated below. A crosscheck of the training modules list (Encl 4, Annex C) indicate that the modules shown below are required to correct the training deficiencies.

<u>Driver</u>		<u>Loader</u>		<u>Gunner</u>	
<u>RT</u>	<u>-</u> <u>TM</u>	<u>RT</u>	<u>-</u> <u>TM</u>	<u>RT</u>	<u>-</u> <u>TM</u>
Part B	D-2	Part A	L-1.1	Part C	G-3
Part C	D-3.1	Part B	L-2	Part D	G-4.2
Part C	D-3.2	Part C	L-3.2	Part E	G-5.1
Part C	D-3.3	Part C	L-6.2	Part E	G-5.2

After the TC identifies training needs, he coordinates with the training officer/NCO as to the availability of training resources. He will ask if TEC programs are scheduled, if equipment is available and when, and if facilities are available and when. From the answers he gets from these questions, the TC schedules his crew's training.

From enclosure 4, Annex 3, the TC can determine the TEC programs required for each training module, that Loader's module L-6.2 is self-instructional with audio tape, and that gunner's modules G-5.1 and G-5.2 can only be given at a boresight/zero range. With the information he now has, the TC places the modules in a matrix shown on the following page.

<u>Driver</u>		<u>Loader</u>		<u>Gunner</u>	
Hands-On (Min)	Sound-Slide/ Audio Tape (Min)	Hands-On (Min)	Sound-Slide/ Audio Tape (Min)	Hands-On (Min)	Sound-Slide/ Audio Tape (Min)
D-2 (60)	D-3.1 (30)	L-2 (60)	L-1.1 (60)	G-3 (30)	G-4.2 (60)
	D-3.2 (30)		L-3.2 (120)	G-5.1 (60)	
	D-3.3 (30)		L-6.2 (60)	G-5.2 (30)	

To satisfy the above schedule, a tank will be needed for 3 1/2 hours in the amory and for 1 1/2 hours at the boresight/zero range. Six TEC programs and one audio cassette will be required for various crew members. The driver will require 1 hour on a tank, the loader 2, and the gunner 2. TEC programs are scheduled so as not to interfere with the use of a tank.

ENCLOSURE 2. TRAINING RECORDS

The tank commander maintains the status of his crew's training progress in the Tank Crewman Readiness Book. The book is pocket size and has a section for each crew member. Each section contains a list of knowledge readiness tests and a list of major skill tasks. A page from the gunner's section of the Tank Crewman's Readiness Book is shown below.

**Combat Loading
(Cont'd.)**

RT PART	DESCRIPTION	GO	NO GO	DATE
F	Ready coax in response to fire commands			
F*	Clear and unload coax			
F*	Apply immediate action to reduce coax stoppage			
F*	Change coax barrel			
F**	Clear and unload M85			
F**	Apply immediate action to reduce M85 stoppage			

Locating and Reporting Targets

H	Conduct quick search scan of the area			
H*	Locate and identify targets in the area			
H	Estimate range to targets in the area			

The steps listed below are followed when using the Tank Crewman Readiness Book:

- . Enter the crew member's names, tank number, and unit on the front of the book.
- . Make all entries in pencil.
- . Record the results of the readiness test by making an X in the GO or NO GO column. Enter the date of the readiness test.
- . Upon the successful completion of a training module erase the X under the NO GO column and record an X in the GO column. Enter the date that the module was successfully completed.
- . If a crew member is changed during the training, enter his training status on the "Notes" page of the specific crew position section.
- . Cross training tasks required by TCGST, FM 17-12-2 are indicated by an asterisk. Other crosstraining tasks are indicated by the number symbol.

The results of readiness tests and remedial training will be reported to the company training officer/NCO for posting on the Company Crewman Readiness Record.