

CONFIDENTIAL

UNCLASSIFIED

LEVEL III MOST Project 31

DA071187

High Resolution Target Classification for SMC 26
SONAR Equipment

DALMO VICTOR

BELMONT, CALIFORNIA

DDC FILE COPY

DDC
RECEIVED
JUL 16 1979
F

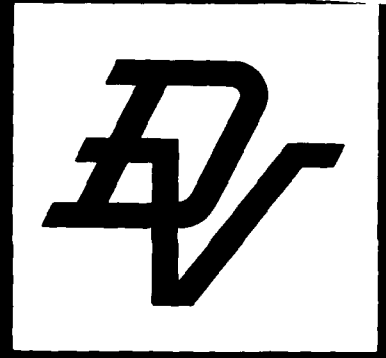

A **textron** DIVISION

~~UNCLASSIFIED~~
~~CONFIDENTIAL~~

LEVEL III

(6) HIGH RESOLUTION TARGET CLASSIFICATION

for the

SQS-26 SONAR EQUIPMENT*

Bureau of Ships Project Number 208-LR-85

(11) 11 February 1963

(12) 24

Prepared For: Bureau of Ships
Department of the Navy
Washington 25, D. C.

Prepared By: Dalmo Victor Company
Division of Textron Inc.
Belmont, California

DDC
RECEIVED
JUL 16 1979
F

Prepared By: [Signature]
Richard E. Baker
Electronics Staff Consultant

Approved By: [Signature]
R. D. Murie
Chief Engineer

DISTRIBUTION STATEMENT A
Approved for public release;
Distribution Unlimited

Reference: Dalmo Victor Report No. R-2850-3062,
"Sonar Target Classification"

(14) R-2850-3099

DOWNGRADED AT 3 YEAR INTERVALS
DECLASSIFIED AFTER 12 YEARS
DOD DIR 5200.10

UNCLASSIFIED
MDC# PI-20902-4A
~~CONFIDENTIAL~~
203 ISO [Signature]

[Large handwritten signature]

TABLE OF CONTENTS

<u>Para. No.</u>		<u>Page No.</u>
I.	Conclusions and Recommendations	1
II.	Introduction	4
III.	Evaluation of Digital and Linear Pulse Compression Techniques	9
IV.	Spectrum Analyzer Type FM Sonar	12

FIGURES

1.	Spectrum Analyzer Type FM Sonar	13
----	---------------------------------	----

ACCESSION for		
NTIS	White S...	✓
DOC	Ref. S...	
UNANNOUNCED		
JUSTIFICATION <i>Per Letter</i>		
<i>on file</i>		
BY		
DISTRIBUTION/AVAILABILITY CODE:		
Dist.	AVAIL.	and, or SPECIAL
<i>A</i>		<i>1</i>

CONFIDENTIAL

I. CONCLUSIONS AND RECOMMENDATIONS

This report is concerned with the mechanization of the SQS-26 Sonar Equipment to provide the facility for target classification with the high range resolution scattering clue. The details of this concept are discussed in the Dalmo Victor Company Report No. R-2850-3062, "Sonar Target Classification".

High range resolution can provide an effective means for rapidly classifying sonar targets. Considerable information about the physical properties of sonar targets can be obtained from the facility for comparing the signal strengths received from closely spaced range cells. The regularity of large surfaces on submarines will produce a high degree of correlation of their back scattered signal amplitudes from adjacent high resolution range cells. The random distribution of the discrete scatterers in a fish school will produce decorrelation between their back scattered signals.

The utilization of this approach can result in a system having the following salient features:

- (1) Rapid classification (a few target hits) and insensitivity to long term variations.

CONFIDENTIAL

CONFIDENTIAL

- (2) Simultaneous classification of several targets.
- (3) Simultaneous search and classification.
- (4) Utilizes long coded pulse transmission to obtain both high range resolution and long detection ranges.
- (5) Retains full gray scale rendition of target signal amplitudes to permit optimum target classification without creating ambiguous information.
- (6) Hardware implementation is relatively simple.

The conclusions of a preliminary investigation for the inclusion of this capability into the SQS-26 Sonar are:

- (1) The SQS-26 equipment's frequency response characteristic provides a 2.5 foot range resolution capability.
- (2) The nonlinear amplitude characteristic generated by the quantization employed with the digital processing of noise correlation sonars is undesirable for the classification of targets in that it destroys useful target information.
- (3) The existing SQS-26 equipment is adequate for the initial detection of suspicious targets and it appears that the addition of a spectrum analyzer type FM system would offer an optimum equipment solution for providing the high resolution classification feature in the SQS-26 Sonar.

CONFIDENTIAL

CONFIDENTIAL

It is recommended that an experimental and study program be instituted to provide (1) modified existing SQS-26 equipment capable of being used to evaluate the potential of the high resolution technique; (2) an experimental measure of the probability of the classification of submarine targets, and (3) further theoretical study, supplemented by the experimental results, of the classification problem.

CONFIDENTIAL

CONFIDENTIAL

II. INTRODUCTION

A high range resolution sonar target classification technique is discussed in the report "Sonar Target Classification" prepared by the Dalmo Victor Company for the Bureau of Ships on Project No. 208-LR-85.

Signals received from schools of fish, with conventional sonars, may appear to be similar to those received from submarines.

High range resolution can provide an effective means for rapidly differentiating between the back scattering characteristics of submarines and marine life. If the sonar range resolution is smaller than the extent in range of primary scattering surfaces on a submarine, it can be expected that the amplitude of the submarine echoes received from adjacent cells will have a high degree of correlation due to the structural regularity of the surfaces. The intensity of the signal scattered from fish in a high resolution range cell will be proportional to the absolute magnitude of the vector sum of signals from a large number of individual scatterers. The fish will be randomly distributed over the body of the school (as opposed to well ordered distributions) so that the random phase distribution of their back scattered signals will generate random fluctuations of the intensity of the signals received from adjacent range cells.

CONFIDENTIAL

The high resolution clue can be implemented to provide a classification display that would provide the facility for rapidly differentiating between submarine and false targets from the characteristics of the fine detail of the displayed information. The method employed to generate the high resolution classification information should have a large dynamic amplitude range to obtain maximum differentiation between the back scattering characteristics of sonar targets.

The detection range of a sonar is a function of the transmitted energy. The peak power that a sonar transducer can radiate is limited to a value below that required to generate cavitation. The best range resolution that can be achieved with any sonar system is completely determined by its overall bandwidth, not necessarily the duration of transmission. Pulse compression techniques provide means for increasing the transmitted pulse length, and consequently the radiated energy, and still provide high range resolution.

Existing pulse compression equipments employ both linear and digital data processing. The linear data processing methods preserve the target amplitude information. Noise correlation systems purposely destroy target amplitude information by quantizing the received information so that it is in a suitable form for digital processing. This loss of target information should not make a significant difference in the initial probability of detection.

CONFIDENTIAL

CONFIDENTIAL

Certain benefits are obtained from the random code and quantization for the initial detection, but target information that would be useful for classification is destroyed. ASPECT is dependent on high light amplitude information and the high resolution clue is dependent on the preservation of a large dynamic amplitude range.

The frequency response characteristic of the SQS-26 sonar equipment is adequate for the high resolution method of classification. It has a useful bandwidth of 1 kc (through the transmitter, transducer and preamplifier receiver stages) that could provide approximately 2.5 foot range resolution. The noise correlation pulse compression system presently employed in the equipment provides roughly 25 foot range resolution. Increasing the capacity of the digital processing equipment by an order of magnitude to provide high range resolution would probably require a major modification of existing equipment. This fact, in addition to its undesirable amplitude characteristic, precludes the feasibility of the modification of the digital processing equipment to provide the high resolution classification feature.

The choice of a method of implementing a linear pulse compression technique is influenced by equipment complexity, cost and reliability. A hybrid of FM and pulse compression techniques, that is discussed in detail

CONFIDENTIAL

CONFIDENTIAL

in Section IV, appears to offer an optimum equipment solution for the high resolution classification feature. Several parallel FM channels are employed to relax the bandwidth, dynamic range, and coherency requirements on an active pulse compression filter. The requirements on the active filter can be relaxed so that they can be easily satisfied by a relatively simple magnetic drum storage device. The transmitted and reference signals could be generated from information recorded on the drum to provide permanent mechanical synchronization between the transmitted signal, references and data processing. The processed information could be read out of the processing tracks on the drum, in time sequence, for presentation on an "A" type classification display. The stored information could be left on the drum as long as desired so that it could be read out once every revolution to provide a continuous presentation on a long persistence display tube phosphor.

The random noise correlation technique is attractive for the initial detection of targets because of its desirable ambiguity characteristic, insensitivity to the received signal strength, and its capacity for the selection of a variety of different codes to reduce interference. The interference would not be as severe during classification because a relatively small range interval would be displayed. It should be possible to transmit pulses at arbitrary spacings that are coded for the noise

CONFIDENTIAL

CONFIDENTIAL

correlation processing and the linear frequency change for classification, without significant interference between the received signals in their respective data processors.

A method that appears to be reasonable for classification consists of the following: The initial detection and target sorting would be accomplished with the existing SQS-26 equipment. The classification processor would then be switched to the beam channel or channels that contain suspicious targets. Cursorily positioned gates would provide the signals, for reasonable range increments, that are presented on "A" type displays and recorders. The high resolution "A" type presentation should provide the facility for rapidly eliminating a large percentage of false targets. It should also provide positive identification for submarines in most of the cases that would be encountered. In the event that a suspicious target could not be positively classified, time may be available for supplemental classification by the use of the ASPECT highlight clue and other time consuming techniques.

CONFIDENTIAL

III. EVALUATION OF DIGITAL AND LINEAR PULSE COMPRESSION TECHNIQUES

Existing pulse compression equipments employ both linear and digital data processing. The linear systems employ both passive and active matched filters. The digital data processors generate the cross-correlation between the received signals and a reference.

The linear pulse compression methods are theoretically capable of faithfully reproducing a large dynamic range of received signal amplitudes. The digital method employs quantization of the received signals to reduce it to digital form. The quantization of the input signals is a very non-linear process and severely limits the grey scale rendition.

The existing SQS-26 noise correlation sonar can provide roughly 25 foot range resolution with its 100 cycle noise bandwidth. Its effective compressed pulse length is roughly 1/50th of the 0.5 second transmitted pulse length. Each beam requires a capacity of 200 sampled bits of processing information. Each Deltic channel has the capacity to handle the information from 4 beams in time sequence.

To fully utilize the 1 kc bandwidth capability of the SQS 26 equipment to achieve the best resolution possible, it would be necessary to increase the capacity of the digital equipment by an order of magnitude. This

CONFIDENTIAL

would require extensive modification of the equipment.

The high resolution facility would not be required for the initial detection. In fact, it would not be possible to present large range extents of high resolution information without an effective loss of resolution (a display would only be capable of presenting a few hundred resolvable elements).

It is felt that the non-linear amplitude characteristic of the digital processing and the undesirability of extensive modification to the existing equipment makes the addition of a linear pulse compression system to the existing equipment an optimum solution for providing the high resolution classification feature.

Linear pulse compression equipment requires components that have a relatively large dynamic amplitude range.

The passive filter type of pulse compression systems are attractive for low compression ratios. When the required compression ratio is several hundred, the filters can become very complicated. To fully utilize the 1 kc bandwidth with the 0.5 second transmitted pulse length of the SQS-26 equipment, would require a pulse compression ratio of approximately 500. This large a ratio makes the use of a passive type filter unattractive.

CONFIDENTIAL

CONFIDENTIAL

The input signal is delayed and continuously recirculated in an active type of filter. The characteristics of such a filter are discussed in the appendix of the report, "Sonar Target Classification". It is shown in the report that the dynamic range and other requirements can be relaxed for a high resolution system by a hybrid of pulse compression and FM techniques. Such a system would consist of a few FM channels and a relatively simple magnetic drum type of spectrum analyzer.

It appears that the spectrum analyzer FM system offers an optimum equipment solution for the high resolution classification feature.

CONFIDENTIAL

CONFIDENTIAL

IV. SPECTRUM ANALYZER TYPE FM SONAR

The theory of operation of the spectrum analyzer type FM sonar is discussed in the appendix of the report "Sonar Target Classification" prepared by the Dalmo Victor Company for the Bureau of Ships on Project No. 208-LR-85.

Figure 1 is a functional block diagram of a spectrum analyzer type of FM sonar. The spectrum analyzer employs a magnetic drum. The processing is accomplished on 10 tracks.

The reference signals are permanently recorded on separate tracks. Their tracks are two turn helixes so that a reference signal can be read out during two revolutions of the drum to prevent duty cycle variations of the heterodyned signal over the range interval of interest. The drum rotates at a speed of 120 RPM so that the transmitted signal, read out for one revolution of the drum, has a pulse length of 0.5 second. The drum can be split into two portions, one with the reference and processing tracks and the other with the transmitted signal track, that are mechanically coupled with a differential so that the time between the starts of the transmitted signal and processing intervals is not required to be an integral multiple of the transmitted pulse length.

CONFIDENTIAL

CONFIDENTIAL

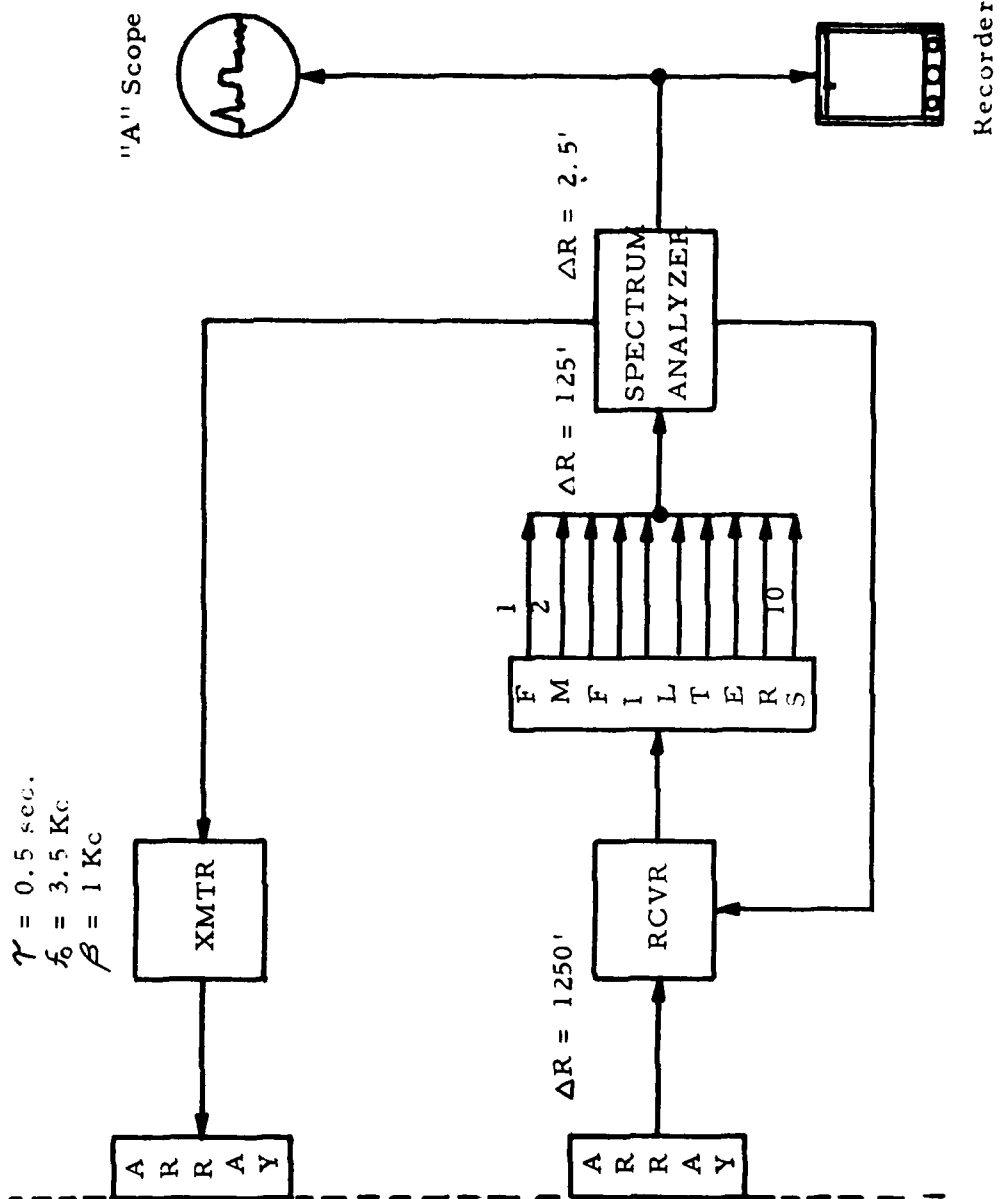

FIGURE 1. Spectrum Analyzer Type FM Sonar

CONFIDENTIAL

CONFIDENTIAL

The processing channels on the drum have a bandwidth of 5 kc and a dynamic range of more than 34 db. The dynamic range requirements are determined by the 34 db range required for coherent addition of 50 samples plus the desired dynamic range of signal amplitudes.

The frequency of the transmitted pulse, that is read out of the drum, varies in a linear fashion from 3 kc to 4 kc in 0.5 second. The received signals are heterodyned with one of the reference signals on the drum at a sonar echoing time determined by the position of a cursor on the detection display. The position of the cursor also selects the beam channel information to be processed. The selection of the reference to be employed is determined by the target's range rate information obtained during detection.

The frequency of the components of the heterodyned signal at the output of the receiver is associated with the sonar echoing time of the targets within a 1250 foot range interval over a 1 kc bandwidth. The uncertainty of the frequency of any one component is 2 cps. The equivalent range resolution that can be achieved is approximately 2.5 feet. (it has been assumed here that the wide band spectrum is rectangular in shape). The 1250 foot range interval can be resolved into 500 discrete range elements.

The primary effect of target velocity on a narrow band FM system is to

CONFIDENTIAL

CONFIDENTIAL

cause the indicated target range to vary as a function of its velocity.

The 1 kc bandwidth proposed to provide the high range resolution feature in the SQS-26 introduces another undesirable effect due to target velocity. The difference in doppler shift over the wide band is,

$$\Delta f_d = \frac{2 v_T}{v_m} [f_1 - f_2]$$

Where, f_1 & f_2 = the frequencies of the band edges.

v_T = the target's velocity

v_m = the velocity of propagation in the medium.

This difference in doppler frequency over the band changes the slope of the FM on the scattered signal. If the received signal is heterodyned with a reference signal that has the same slope as the transmitted signal, the signal component for a point reradiator will be frequency modulated by the change in doppler frequency during the pulse. This could increase the uncertainty of the width of the spectral component with a resulting increase in the size of a resolvable range cell.

A solution to the problem is to change the slope of the reference signal to match that generated in the received signal by the target's velocity. The effect in the time domain is to scan the system's high resolution aperture in range to track the target's motion. A few references with differing FM slopes can be permanently recorded on the drum to cover

CONFIDENTIAL

CONFIDENTIAL

the expected spread of target velocities in discrete steps, or the head

on one reference track may be moved during read out to provide the desired correction for target velocity.

The 1 kc bandwidth heterodyned signal is filtered into ten adjacent FM channels of 100 cps bandwidth. The spectral bands may then be translated to a convenient center frequency for additional filtering and processing.

The required delay of 10 milliseconds for the spectrum analyzer can be provided by two heads per track, spaced by 1/50th of the drum circumference. Each processing channel covers 1/10th of the total processed range interval. The variation of processing time for arbitrary target position within one channel's range increment will not be significant (approximately 10%).

The processed signals on the drum would be available at the delay heads as ten sets of information (each of 10 milliseconds duration) occurring at 50 millisecond intervals, beginning 0.5 second after the start of processing.

It would be desirable for continuity of the presentation to read the information out continuously, without the 40 milliseconds of dead time. This

CONFIDENTIAL

~~UNCLASSIFIED~~
~~CONFIDENTIAL~~

could be accomplished with separate read out heads displaced by $2/25$ th of the drum circumference. The read out would be completed one second after the start of processing.

The stored information could be left on the drum as long as desired so that it could be read out once very revolution to provide a continuous presentation on a long persistence display tube phosphor.

~~CONFIDENTIAL~~
UNCLASSIFIED