

AD-A067 688

RESEARCH SUPPORT INSTRUMENTS INC TIMONIUM MD
BALLOON BORNE ULTRAVIOLET SPECTROMETER.(U)
DEC 78 R F CRABBS, E F MACKAY

F/G 14/2

UNCLASSIFIED

1 OF 1
AD A067688

AFGL-TR-79-0008

F19628-75-C-0154
NL

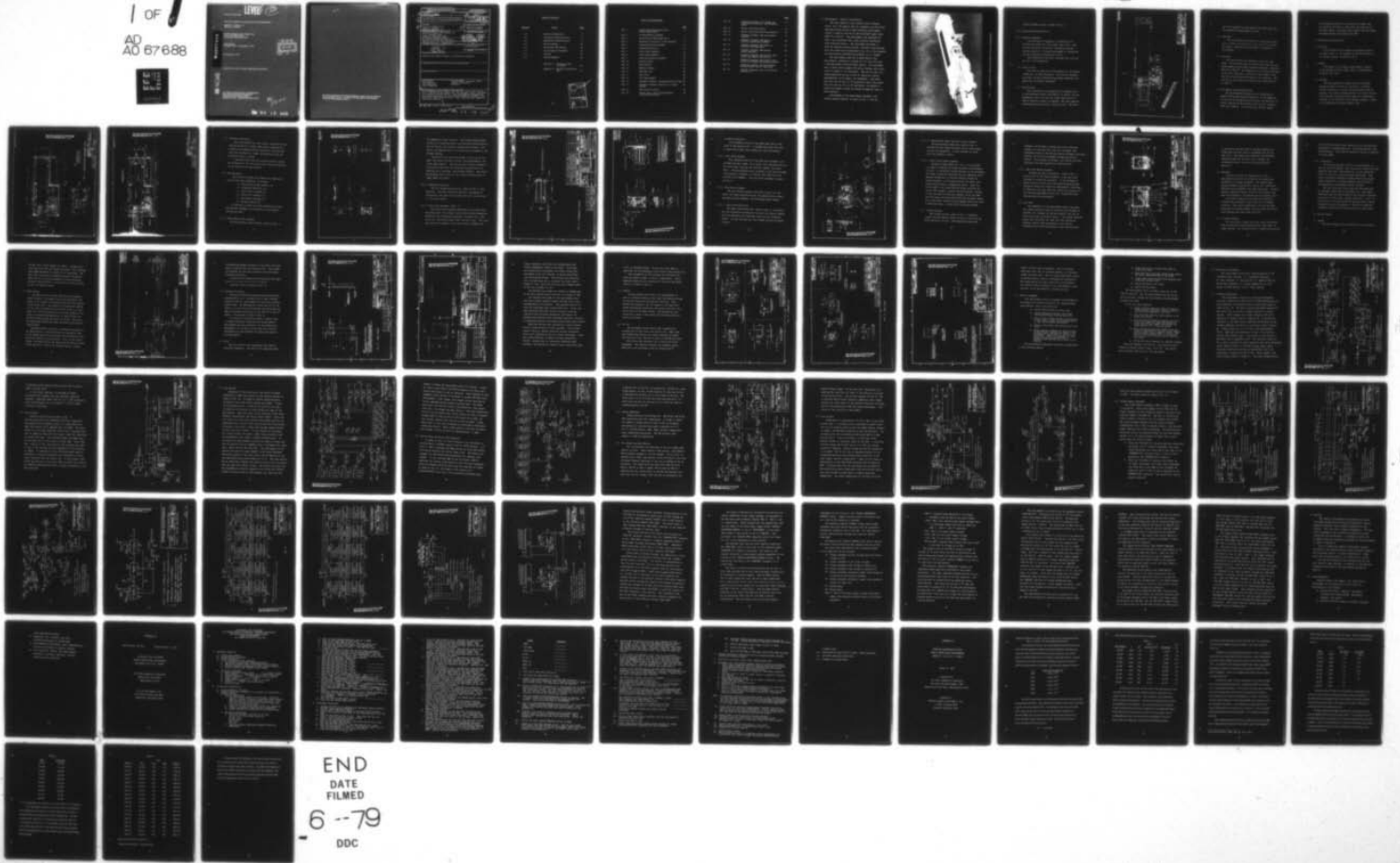

END
DATE
FILMED
6 --79
DDC

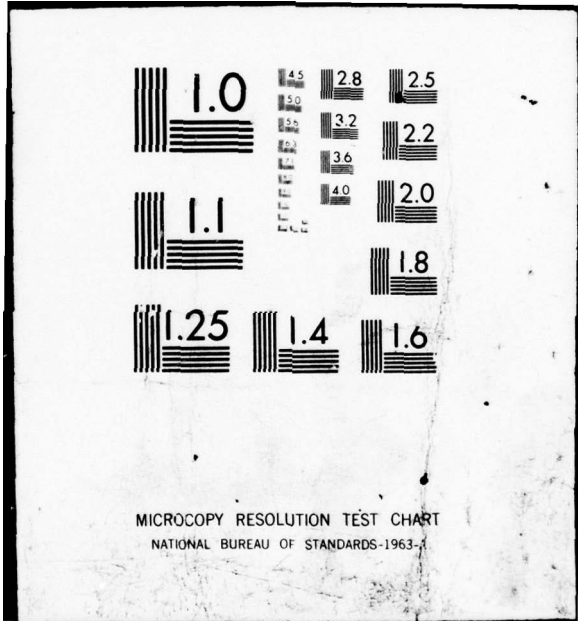

MICROCOPY RESOLUTION TEST CHART
NATIONAL BUREAU OF STANDARDS-1963-A

✓ **LEVEL** *IV* *(12)* *b*

AFGL-TR-79-0008

BALLOON BORNE ULTRAVIOLET SPECTROMETER

Robert F. Crabbs, Jr.
Edward F. Mackey

Research Support Instruments, Inc.
71 W. Timonium Road
Timonium, Maryland 21093

Final Report
16 April 1975 - 30 September 1978

28 December 1978

D D C
RECEIVED
APR 20 1979
C

Approved for public release; distribution unlimited.

AD A 067 688

DDC FILE COPY

**AIR FORCE GEOPHYSICS LABORATORY
AIR FORCE SYSTEMS COMMAND
UNITED STATES AIR FORCE
HANSCOM AFB, MASSACHUSETTS 01731**

s/d
393 152

29 04 19 029

Qualified requestors may obtain additional copies from the Defense Documentation Center. All others should apply to the National Technical Information Service.

19 REPORT DOCUMENTATION PAGE		READ INSTRUCTIONS BEFORE COMPLETING FORM	
1. REPORT NUMBER 18 AFGL-TR-79-0008	2. GOVT ACCESSION NO.	3. RECIPIENT'S CATALOG NUMBER 9 Rept.	
4. TITLE (and Subtitle) 6 Balloon Borne Ultraviolet Spectrometer,		5. TYPE OF REPORT & PERIOD COVERED Final 16 Apr 75- 30 Sept 78	
7. AUTHOR(s) 10 Robert F. /Crabbs, Jr. Edward F. /Mackey	8. CONTRACT OR GRANT NUMBER(s) 15 F19628-75-C-0154	9. PERFORMING ORG. REPORT NUMBER	
9. PERFORMING ORGANIZATION NAME AND ADDRESS Research Support Instruments, Inc. 71 W. Timonium Road Timonium, Maryland 21093	10. PROGRAM ELEMENT, PROJECT, TASK AREA & WORK UNIT NUMBERS 62101F 16 668706AB 17 46	11. CONTROLLING OFFICE NAME AND ADDRESS Air Force Geophysics Laboratory Hanscom Air Force Base, Massachusetts 0173 Manager/Charles W. Chagnon/LKO	12. REPORT DATE 11 28 December 78
14. MONITORING AGENCY NAME & ADDRESS (if different from Controlling Office) 1284 p.	13. NUMBER OF PAGES 88	15. SECURITY CLASS. (of this report) Unclassified	15a. DECLASSIFICATION/DOWNGRADING SCHEDULE
16. DISTRIBUTION STATEMENT (of this Report) Approved for public release; distribution unlimited			
17. DISTRIBUTION STATEMENT (of the abstract entered in Block 20, if different from Report)			
18. SUPPLEMENTARY NOTES			
19. KEY WORDS (Continue on reverse side if necessary and identify by block number) ultraviolet ground support equipment (GSE) spectrometers flight electronics instrumentation balloons solar radiation			
20. ABSTRACT (Continue on reverse side if necessary and identify by block number) An ultraviolet spectrometer, featuring all Invar construction, with 0.1A resolution capability, was designed, built, and flown on a research balloon system. The spectrometer obtained high resolution spectra of the sun between 2000A and 3100A, at an altitude of approximately 40 km. Four launches were supported under this contract.			

393 1529 04 19 029

Table of Contents

<u>Section</u>	<u>Title</u>	<u>Page</u>
1.0	General Introduction	1
2.0	Functional Characteristics	3
3.0	Mechanical Characteristics	6
4.0	Optical Design	20
5.0	Electronics Sub-System	33
6.0	Ground Support Equipment	46
7.0	Testing	62
8.0	Acknowledgements	62
	Appendix A - Acceptance Test Procedure	65
	Appendix B - Absolute Calibration Data	73

ACCESSION for

NTIS	White Section	<input checked="" type="checkbox"/>
DDC	Buff Section	<input type="checkbox"/>
UNANNOUNCED		<input type="checkbox"/>
JUSTIFICATION		
DISTRIBUTION/AVAILABILITY CODES		
		SPECIAL

A

List of Illustrations

		<u>Page</u>
Fig. 1	$\frac{1}{2}$ Meter High Resolution Ebert-Fastie Spectrometer	2
Fig. 2	UV Spectrometer Assembly	4
Fig. 3	Solar Balloon Experiment Ass'y	7
Fig. 4	Mechanical Interface, UV Spectrometer	8
Fig. 5	Spectrometer Body Assembly	10
Fig. 6	Integrated Detector	12
Fig. 7	Front Plate Assembly	13
Fig. 8	Sine Drive Assembly	15
Fig. 9	Input Flux Monitor Assembly	18
Fig. 10	Optical Layout	22
Fig. 11	Ebert Mirror	24
Fig. 12	Replica Grating	25
Fig. 13	Entrance Slit	28
Fig. 14	Exit Slits	29
Fig. 15	Slit Measurements	30
Fig. 16	Schematic Diagram, Integrated Detector Pkg.	34
Fig. 17	Schematic Diagram, Detector No. 1 Pulse Counter	36
Fig. 18	Scan Control System	38
Fig. 19	Master Clock, Serial Word Register and Analog Commutator	40

		<u>Page</u>
Fig. 20	Schematic Diagram, Slit Height and Dark Shutter Controls, and Reference Diode	42
Fig. 21	Battery and Power System	44
Fig. 22	Master Clock and Serial Word Register	45
Fig. 23	Schematic Diagram, GSE Spectrometer Controls	47
Fig. 24	Schematic Diagram, GSE Monitor Selector and Battery Charger	48
Fig. 25	Schematic Diagram, GSE Serial to Parallel Data Converter	49
Fig. 26	Schematic Diagram, GSE Display Strobe Generator	50
Fig. 27	Schematic Diagram, GSE Parallel Data Output and Display Detector #2	51
Fig. 28	Schematic Diagram, GSE Parallel Data Output and Display Wavelength Detector	52
Fig. 29	Schematic Diagram, GSE Spectrometer Enable/Disable Control Functions	53
Fig. 30	Schematic Diagram, GSE D/A Converters Detector #2	54

1.0 Spectrometer - General Introduction

The main purpose of this contract was to design, build, test, and support four (4) launches on an Air Force supplied balloon system a high resolution spectrometer system, to monitor the sun in the wavelength region from 2000 A° to 3100 A° . The spectrometer was designed and built, and interfaced with a Ball Brothers Corporation solar pointing control. The instrument was flown on four (4) separate balloon systems, and while some problems with the system were encountered on two (2) of the launches, the spectrometer performed successfully on all flights.

The spectrometer used was an Ebert-Fastie type spectrometer, modified to include two (2) exit slits and a correspondingly oversized Ebert mirror. The instrument was a $\frac{1}{2}$ meter focal length $f/20$ optical design, with slits sized to permit 0.1 A° resolution. The two (2) exit slit design permitted the use of two (2) detectors, spaced approximately 113 A° apart, for redundancy. The prime exit slit was set for 0.1 A° resolution, while the second exit slit was set for 1.0 A° resolution, but masked to reduce the height to keep the energy through-put equal to both detectors.

A photograph of the spectrometer assembly, with thermal housing removed, is shown in Fig. 1, and the

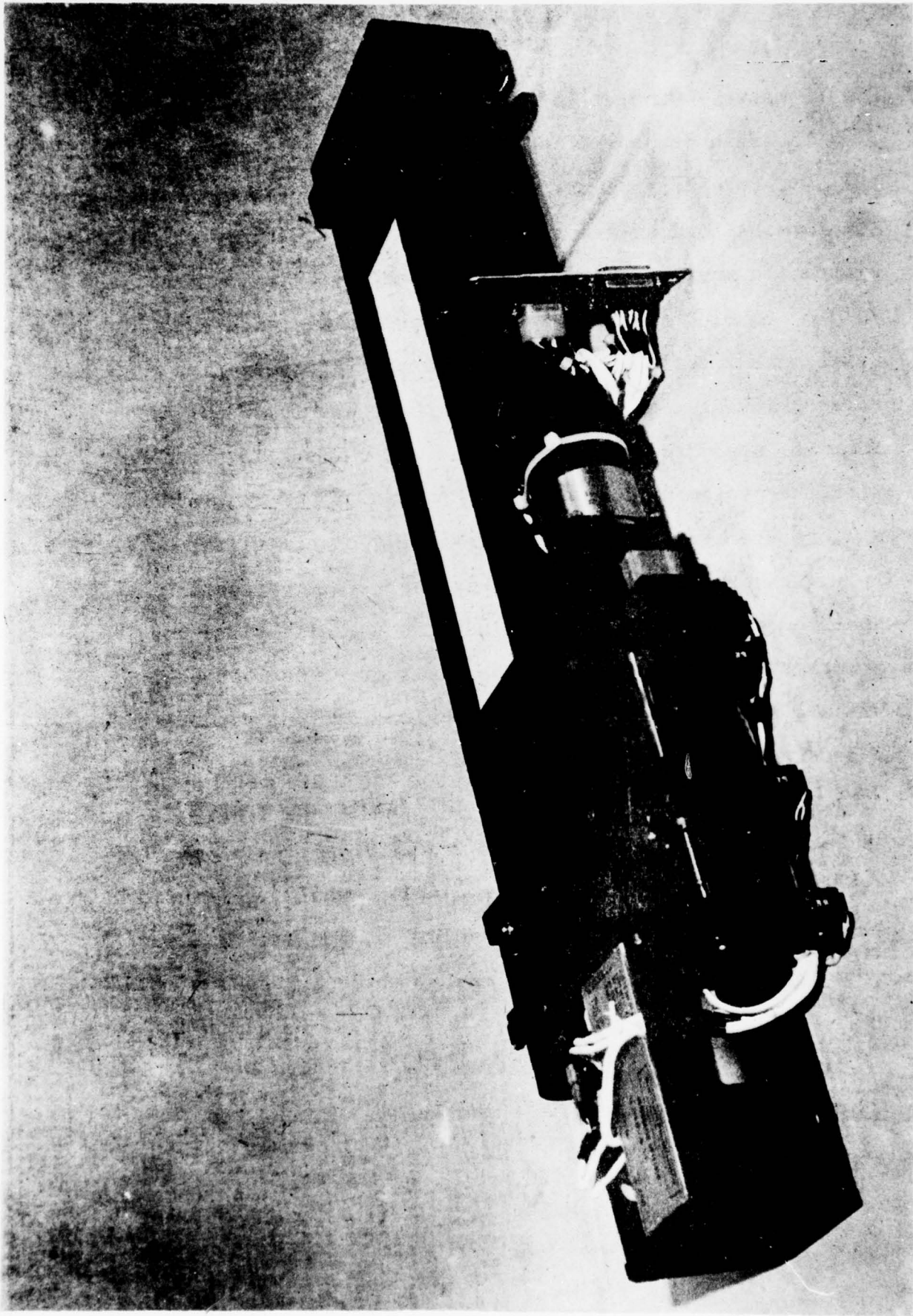

FIG. 1 - 1/2 METER HIGH RESOLUTION EBERT-FASTIE SPECTROMETER

overall assembly layout is shown in Fig. 2.

2.0 Functional Characteristics

2.1 Spectral Bandwidth

The instrumental bandwidth, as defined by the entrance and prime exit slit widths, was 0.1 \AA° . This was the theoretical resolution, calculated from the optical equations. By actual measurement in calibration the best resolution obtained was 0.12 \AA° .

The bandwidth of the outer, secondary exit slit was set for 1.0 \AA° resolution.

2.2 Field of View

The field of view of the spectrometer is .05 radians, $\pm .0008 \text{ rad.}$, in both directions. This was not measured precisely, but was calculated from design dimensions and mechanical and optical tolerances.

2.3 Scan Coverage

The spectrometer was designed to be primarily used in the wavelength region from 2000 \AA° to 3100 \AA° , but was designed in such a way that the region from 1500 \AA° to 3500 \AA° could be covered, if desired. The scan range was established using the prime, inner exit slit. The outer

REV	DATE	BY	CHKD
1			

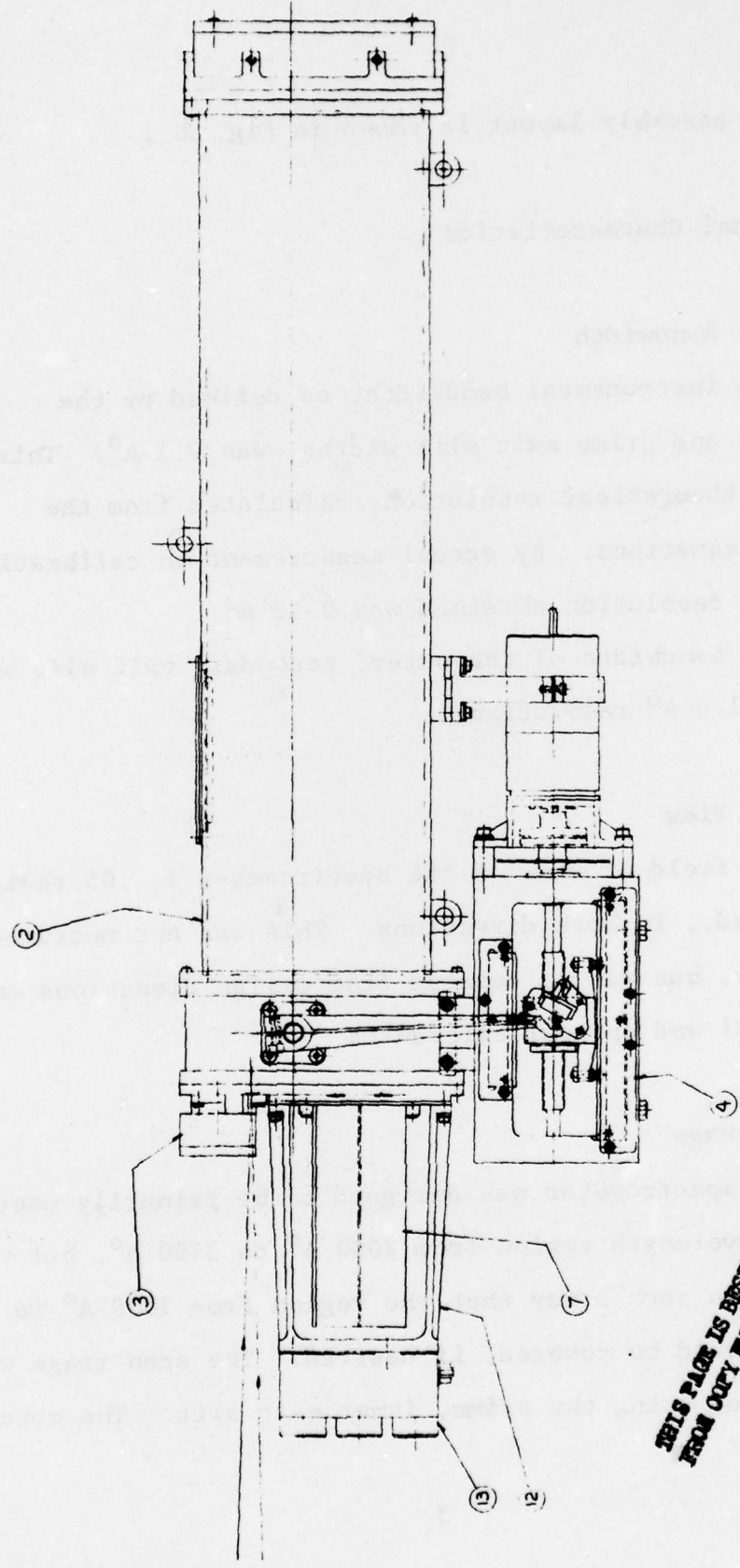

**THIS PAGE IS BEST QUALITY PRACTICABLE
FROM COPY FURNISHED TO DDD**

AIR FORCE CAMBRIDGE RES LAB		RAY LEE INSTRUMENTS	
PROJECT NO. 171		UV SPECTROMETER ASSEMBLY	
DATE: 10-7-0-1		DRAWN BY: [Signature]	
CHECKED BY: [Signature]		APPROVED BY: [Signature]	

FIG. 2 - UV SPECTROMETER ASSEMBLY

exit slit scanned the same range as the inner slit, but was advanced by approximately 113 \AA .

2.4 Scan Rate

The spectrometer drive system, a screw driven sine drive, scanned the grating at a rate of 2 \AA per second. This gave a complete scan from 2000 \AA to 3100 \AA in ~ 9.2 minutes.

2.5 Scan Mode

The spectrometer was designed with two (2) scan modes. In the normal mode the system would scan back and forth between low and high wavelength endpoints, nominally 2000 \AA to 3100 \AA . By command the drive could be switched to the short scan mode, in which the spectrometer would scan from a pre-selected mid-point to the high end. This mode was to allow spectral analysis from around 2600 \AA to 3100 \AA .

2.6 Slit Height Limiter/Dark Shutter

The spectrometer entrance slit was fitted with a height limiter/dark shutter mechanism. At the endpoints of the scan the mechanism would activate for about one (1) second, pulling the dark shutter over the slit to give a dark count reading. At the mid-point fiducial signal

the mechanism would pull the reduced slit height mask into position and hold it there while the drive was in the upper region, to prevent large signals from the longer wavelength region from damaging the PMT.

3.0 Mechanical Characteristics

3.1 Envelope

The envelope for the complete spectrometer package is shown in Fig. 2. The assembly of the spectrometer in its thermal housing, is shown in Fig. 3.

3.2 Weight

The weight of the complete spectrometer, mounted in its thermal housing, flight ready, is approximately 46 pounds (20.9 kg.).

3.3 Mounting

The spectrometer was mounted inside the thermal housing by means of three (3) tie-points, utilizing thermal insulators to isolate the spectrometer from the housing. The thermal housing mounted to the Ball Brothers solar pointing control system by means of a flange which attached to the side wall of the thermal housing, as shown in the mechanical interface drawing, Fig. 4.

THIS PAGE IS BEST QUALITY PRACTICABLE
FROM COPY FURNISHED TO DDG

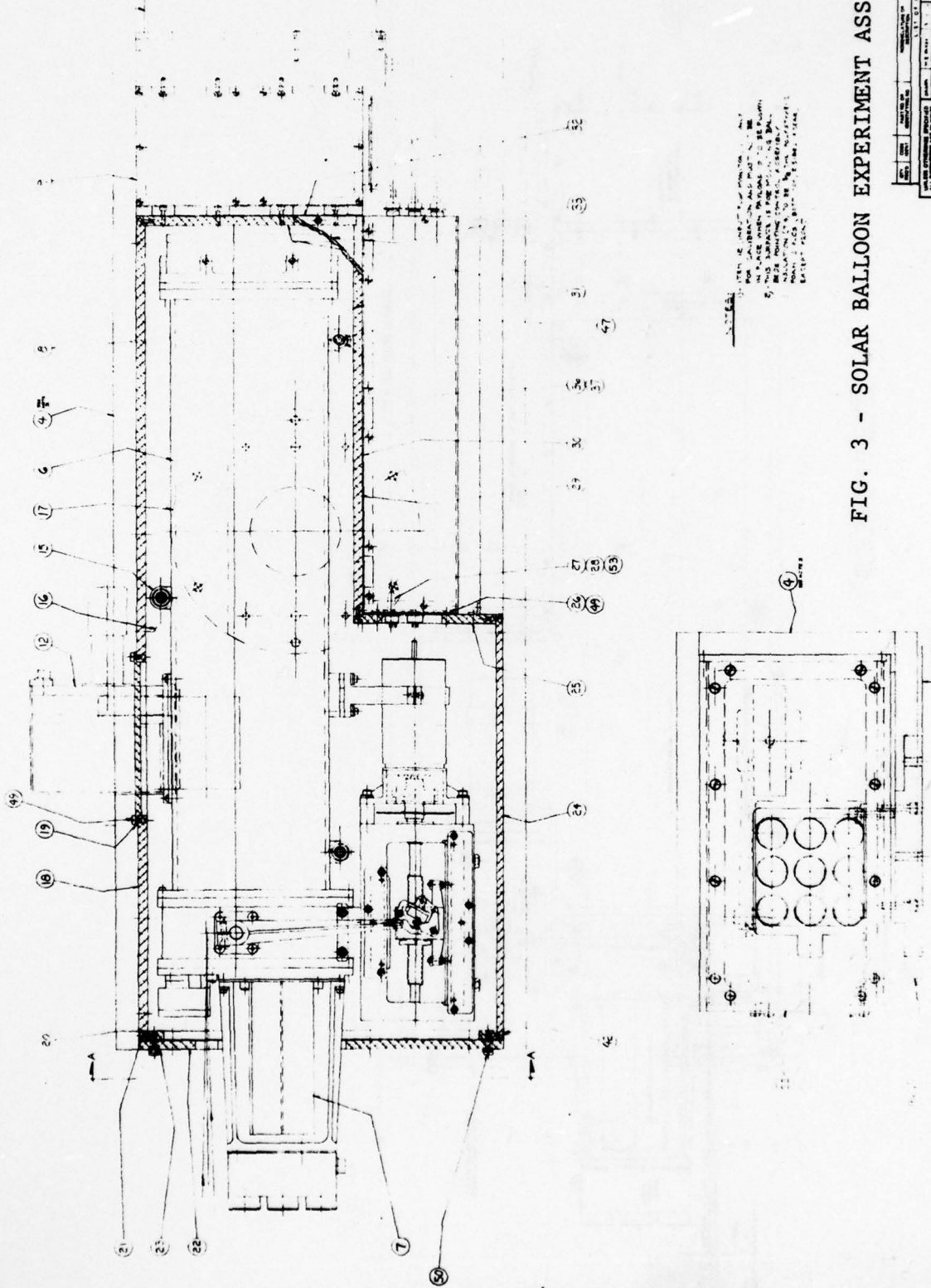

FOR CALIBRATION AND PLACEMENT
IN PLACE WITHIN THE BALLOON
BEFORE LAUNCHING. THE BALLOON
WILL BE LAUNCHED FROM THE
LAUNCHING AREA AT THE
LAUNCHING AREA.

FIG. 3 - SOLAR BALLOON EXPERIMENT ASS'Y

REVISIONS		DATE		BY		CHKD BY		APP'D BY	
1									
2									
3									
4									
5									
6									
7									
8									
9									
10									
11									
12									
13									
14									
15									
16									
17									
18									
19									
20									
21									
22									
23									
24									
25									
26									
27									
28									
29									
30									
31									
32									
33									
34									
35									
36									
37									
38									
39									
40									
41									
42									
43									
44									
45									
46									
47									
48									
49									

SEE FIGURE 8

3.4 External Connections

The spectrometer was electrically connected to the balloon system by a single cable which contained all telemetry and command system interfaces, and also GSE lines for operation in flight configuration from the dedicated control console.

A separate cable from the pointing control system was connected to the solar eye block, which was mounted on the front of the spectrometer.

3.5 Sub-Assemblies

The solar UV balloon spectrometer was made up of six (6) main sub-assemblies, as follows:

- a) Spectrometer Body Assembly (1)
- b) Integrated Detectors (2)
- c) Front Plate Assembly (1)
- d) Sine Drive Assembly (1)
- e) Electronics Package (1)
- f) Thermal Housing (1)

In addition to these main sub-assemblies an Input Flux Monitor Assembly was provided as a non-flight, calibration item.

3.5.1 Spectrometer Body Assembly

The spectrometer body assembly, shown in Fig. 5,

is composed of three sections. The central body section serves as a focussing spacer, and provides mounting points for the mirror cell section, grating cell section, sine drive, and mounting feet to tie the entire assembly to the thermal housing.

The mirror cell section attaches to the rear of the body, and houses the Ebert mirror, with adjustments, and stray light baffles. The grating cell section attaches to the front of the body, and contains the grating in its mounting cell, bearings, and internal baffles. The mirror and grating cells attach to the central body by means of light-tight lap joints.

3.5.2 Integrated Detectors

The two integrated detectors, shown in Fig. 6, were identical. The most sensitive detector, determined by calibration, was used on the prime exit slit (see Section 5.1 for more detail).

3.5.3 Front Plate Assembly (Fig. 7)

The front plate assembly consisted of the main front mounting plate, slit height limiter/dark shutter mechanism, mounts for the integrated detectors, entrance slit, exit slits (2), and filter mounts over the exit slits. The solar eye block also mounted to the front plate, bridging the

THIS PAGE IS BEST QUALITY PRACTICABLE
FROM COPY FURNISHED TO DDG

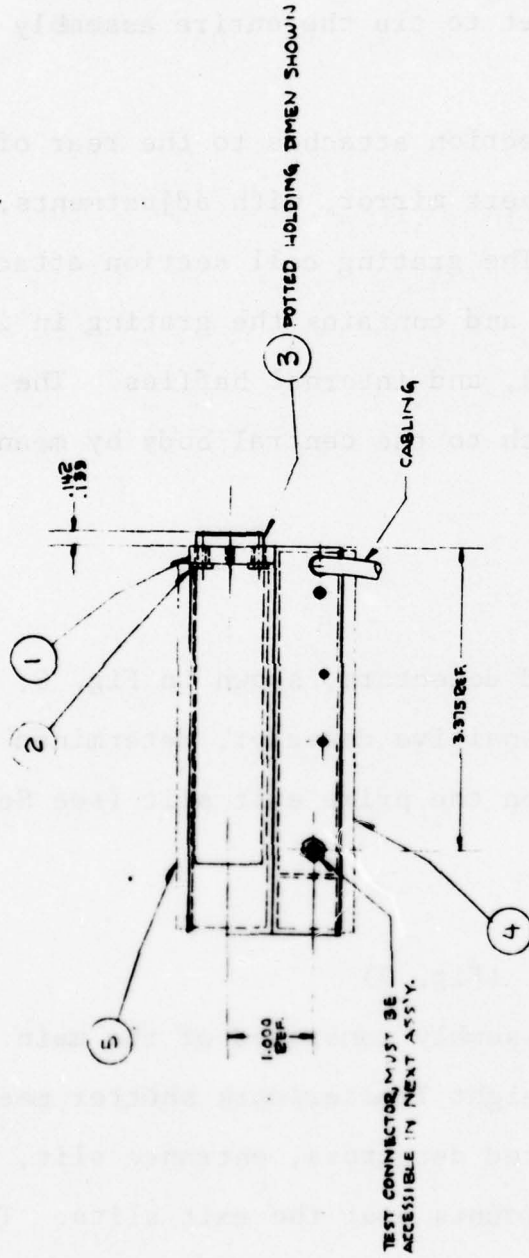

FIG. 6 - INTEGRATED DETECTOR

QTY.	CODE	PART NO. OR IDENTIFYING NO.	DESCRIPTION	MATERIAL SPECIFICATION	ITEM NO.
1	20-171-0-5		POTTING LID, TUBE		5
1	20-171-0-4		POTTING LID, ELECTRONICS		4
1	EMR 510F-03		PHOTOMULTIPLIER TUBE		3
4	20-171-0-3		BUSHING, INSULATING		2
1	20-171-0-2		HOUSING IDP PACKAGE		1

LIST OF MATERIAL		DATE
DRUM	11/18/75	
CHECKED		
APPROVED		
APPROVED		
APPROVED		
RELEASED		

CODE	DESCRIPTION	DATE	SIGNATURE
10-171-0-1	0-171-0-1		
HEAT ASSEMBLY	USED ON		

QTY.	CODE	DESCRIPTION	DATE	SIGNATURE
2	20-171-0-1	INTEGRATED DETECTOR		
2	20-171-0-1	UV SPECTROMETER		
2	20-171-0-1	SOLAR BALLOON EXPERIMENT		

SCALE	SCALE NO.	SCALE DATE
1:1	C	20-171-0-1

QTY.	CODE	DESCRIPTION	DATE	SIGNATURE
2	20-171-0-1	INTEGRATED DETECTOR		
2	20-171-0-1	UV SPECTROMETER		
2	20-171-0-1	SOLAR BALLOON EXPERIMENT		

integrated detectors.

This assembly mounted to the main body unit at the front of the grating cell. A stepped lap joint was used to keep stray light from leaking into the spectrometer.

3.5.4 Sine Drive Assembly

This assembly mounted to the main body assembly, and included the main frame, drive screw, sine carriage with nut and sine blade, grating arm, optical readers, and drive motor. The motor/gearbox unit attached to the drive through a non-metallic coupling, to restrict heat flow into the critical drive members. The sine drive assembly is shown in Fig. 8.

3.5.5 Electronics Package

The electronics package consisted of three (3) sub-units; the logic electronics box, the payload power supply and motor driver assembly, and the heater power supply.

3.5.5.1 Logic Electronics Box

The logic electronics box, shown in Fig. 4, contained all the electronics necessary to process the digital signals from the detectors and interface them with the telemetry system. It also contains all the command control interface circuits.

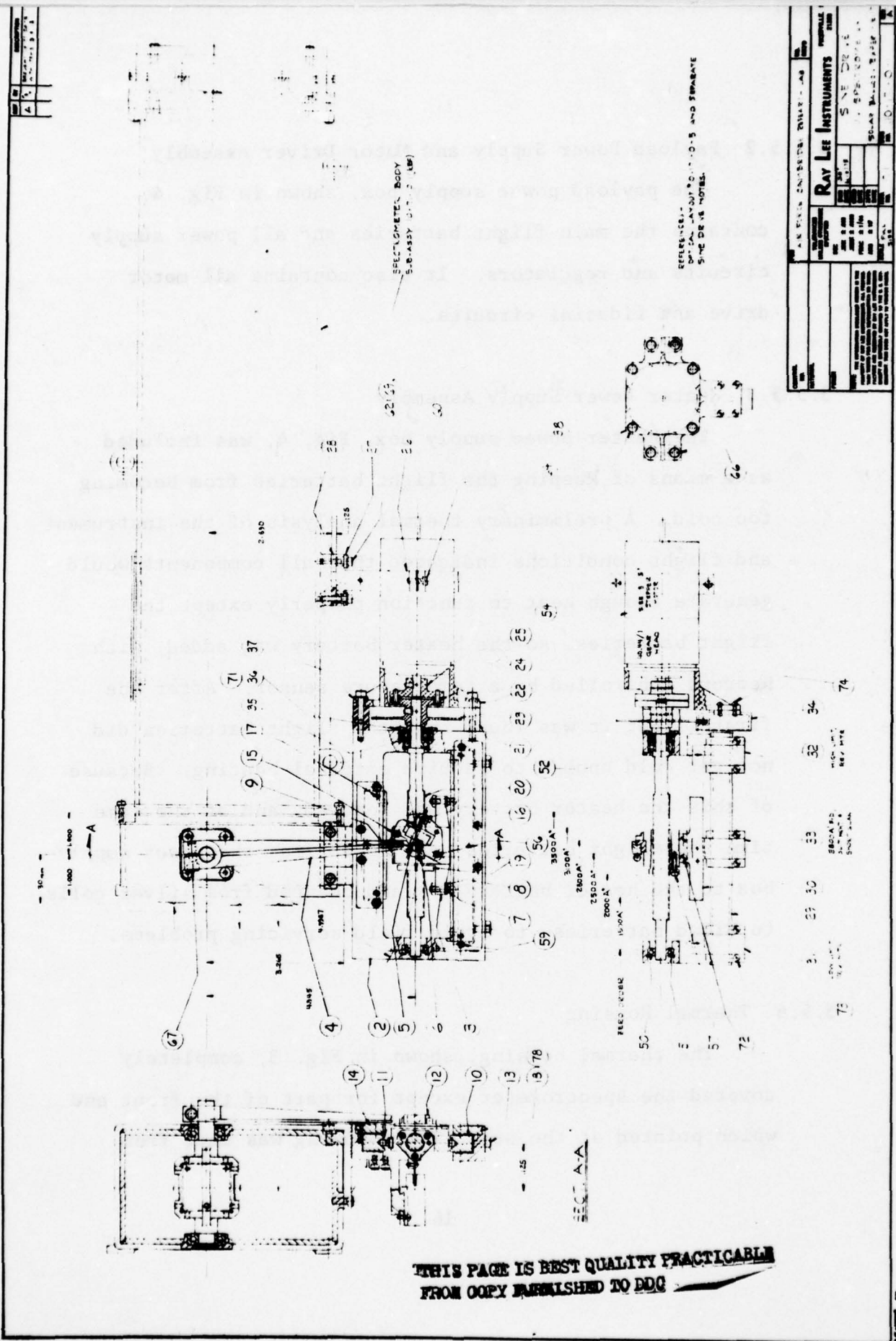

FIG. 8 - SINE DRIVE ASSEMBLY

3.5.5.2 Payload Power Supply and Motor Driver Assembly

The payload power supply box, shown in Fig. 4, contains the main flight batteries and all power supply circuits and regulators. It also contains all motor drive and fiducial circuits.

3.5.5.3 Heater Power Supply Assembly

The heater power supply box, Fig. 4, was included as a means of keeping the flight batteries from becoming too cold. A preliminary thermal analysis of the instrument and flight conditions indicated that all components would generate enough heat to function properly except the flight batteries, so the heater battery was added, with heaters controlled by a temperature sensor. After the first flight it was found that the flight batteries did not get cold enough to require external heating. Because of this the heater battery was removed, and at the same time the flight batteries were moved from the power supply box to the heater battery box and changed from silver cells to NiCad batteries, to avoid field servicing problems.

3.5.6 Thermal Housing

The thermal housing, shown in Fig. 3, completely covered the spectrometer except for part of the front end which pointed at the sun. This housing was made from

Aluminum, and provided a thermal path (the "racetrack" concept) for any heat input into the instrument, and minimizing inputs to the pointing control through a stainless fitting, and to the spectrometer through non-metallic washers. This housing, for flight, was covered with foam insulation and then wrapped with aluminized tape.

3.5.7 Input Flux Monitor Assembly

Although the input flux monitor, shown in Fig. 9, was not part of the flight hardware, it was built and provided as calibration equipment. It was designed to mount on a port in the side of the main housing, and when activated, would move inside the spectrometer, inserting a UV diode into the light path just inside the entrance slit. This allowed measurement of the full, undispersed light beam entering the spectrometer.

3.6 Light Path

The components of the spectrometer were so arranged that light within the field of view will pass through the entrance slit, through the internal baffles, and fill an area on one side of the Ebert mirror. The concave spherical mirror then collimates the light onto the diffraction grating, sized so that the grating is just filled. Diffracted light from the grating is then reflected back

to an area on the other side of the Ebert mirror, but larger than the first area to accommodate the two (2) exit slits. The mirror then refocusses the spectrally dispersed light onto the exit slits, through the attenuating filters, and onto the photomultiplier detectors.

3.7 Materials

The basic material of construction for the spectrometer was Invar 36, chosen for its nearly zero coefficient of thermal expansion. The complete main housing assembly, grating cell, mirror cell, sine drive, and front plate assemblies were made from Invar. Internal baffles, detector housings, and non-critical parts were made from Aluminium. All gearing was of stainless steel.

All optical components were made from precision annealed Cervit material, also chosen for its thermal stability. Sine drive sliding parts, such as the sine blade and the carriage guides, were also made from Cervit, with hardened steel ball slide followers.

3.7.1 Surface Finishes

All Invar parts, except the drive screw, were plated with a black oxide coating applied over a thin layer of copper plating. All internal optical surfaces were painted

with 3M 401-C10 Velvet Black, applied per our specification developed for extended space use. All Aluminium parts were black anodized. Slits were not painted or plated to preserve the sharp edges.

3.7.2 Lubrication

All bearings and gears used in the spectrometer, as well as the drive gearbox, were coated with a moly-di-sulfide based dry lubricant, vacuum baked by a process which has proven to hold up in long term space application. This type of lubricant eliminates creeping exhibited by hydrocarbon lubricants at reduced pressures, and also has no VCM outgassing to contaminate optical surfaces.

The sine drive main drive screw was lubricated with an extremely light grade of instrument oil. Moly based lubricants were not used because of the potential lubricant build-up in certain areas, causing tight spots. Also, the drive screw is located outside the optical cavity, making outgassing a minor consideration. This drive screw was carefully cleaned and re-lubricated prior to each launch.

4.0 Optical Design

4.1 General

The basic design of the spectrometer is an $f/20$ Ebert

system, with a focal length of $\frac{1}{2}$ meter. Straight slits were used since the slit height was short, still allowing good image properties to obtain 0.1 A° resolution. Two exit slits were used in conjunction with an oversized Ebert mirror to provide redundancy in data collection. Detailed characteristics of the optical system are shown in Fig. 10, Optical Layout.

4.2 Ebert Mirror

The Ebert mirror was made from precision annealed Cervit material. No weight relief was performed on the mirror in an attempt to eliminate distortion when mounted in the mirror cell. The radius of curvature was $1000 \text{ mm} \pm 1 \text{ mm}$, with a polished area of $98 \text{ mm} \times 51 \text{ mm}$, $\pm 0.1 \text{ mm}$. Three (3) flats were ground into the front surface of the mirror to provide mounting points, at which places non-metallic mounting pads contacted the mirror. The mirror was constrained around the sides and back by non-metallic tipped screws.

Although efforts were made to eliminate distortion in the Ebert mirror, it was found that the resolution limit of the design could not be attained, and distortion in the mirror was found to be the problem. Prior to the second flight a new Ebert mirror was made which was twice as thick (18 mm instead of 9 mm) as the original mirror, and the

corresponding changes necessary in the mirror cell were made to properly hold the thicker mirror. This seemed to eliminate the distortion problem, with much better resolution resulting.

The mirror was Aluminized and overcoated with MgF_2 , peaked for maximum reflectivity at 2000 \AA .

The Ebert mirror is shown in Fig. 11.

4.3 Diffraction Grating

The replica diffraction grating used was obtained from Hyperfine, Inc., and was ruled at 3600 lines/mm, blazed at 2400 \AA , and produced on a precision annealed Cervit blank. The grating had a ruled area of 25.4 mm square, ± 0.2 mm, and was aluminized and overcoated with MgF_2 for maximum reflectivity in the 2000 \AA to 3000 \AA region. The grating is shown in Fig. 12.

In actual use the grating seemed to exhibit some anomalous efficiency characteristics around 2600 \AA . This anomaly was never resolved, but the effects were determined to be of such a nature that they could be calibrated out, and therefore no changes were made in the spectrometer.

4.4 Slits

The slits used in the spectrometer were made as precision assemblies. The actual slit edges were hand

THIS PAGE IS BEST QUALITY PRACTICABLE
FROM COPY FURNISHED TO DDC

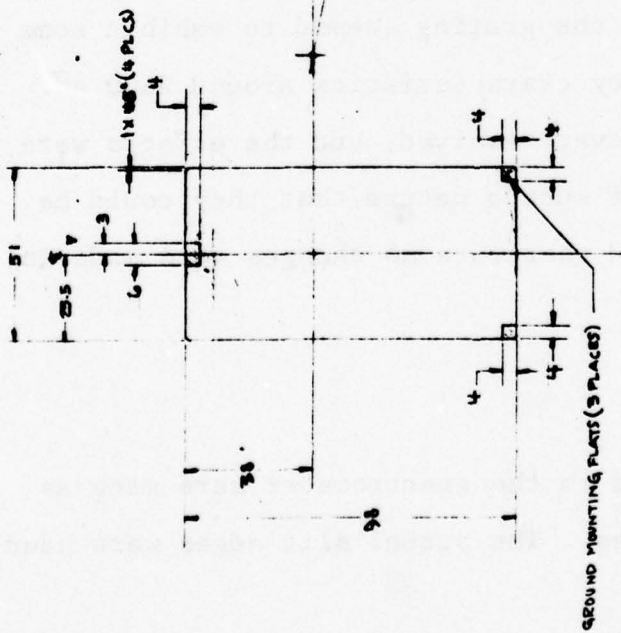
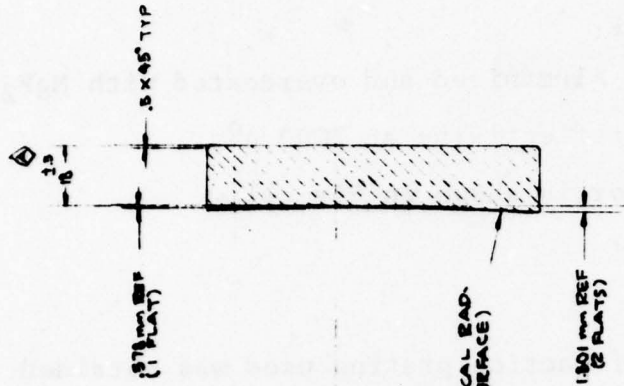

NOTES-
1) ALL DIMENSIONS ARE IN MILLIMETERS
TOLERANCE ± 0.1 mm

2) MIRROR SURFACE TO BE ALUMINUM COATED
WITH MgF₂ OVERCOATING OPTIMISED FOR
MAX. REFLECTANCE IN THE 2000Å TO 3000Å REGION

FIG. 11 - EBERT MIRROR

QTY. REQD.	CODE IDENT.	PART NO. OR IDENTIFYING NO.	NOMENCLATURE OR DESCRIPTION	MATERIAL DESCRIPTION	MATERIAL SPECIFICATION	ITEM NO.
LIST OF MATERIAL						
DRAWN			DET	RAY LEE INSTRUMENTS		
CHECKED				FREDERICK, MARYLAND		
APPROVED				EBERT MIRROR		
APPROVED				UV SPECTROMETER		
APPROVED				SOLAR BALLOON EXPERIMENT		
RELEASED				CODE IDENT NO.	SIZE	REMARKS
					C	10-17-0-10
SIGNATURE			DATE			
MATERIAL						
CER-VIT						
PREMIUM GRADE						
FINISH						
SEE NOTE 2						
APPLICATION						
NEXT ASSEMBLY USED ON						
NEXT ASSEMBLY FINAL USE						
QUANTITY						
SHEET						
OF						

lapped, measured, and fitted to a holder piece, and finally permanently fixed in the holder. The holder was fitted with an adjustment slot which allowed fine adjustment of the slit opening, to assure parallelism with the grating rulings. The entrance slit and prime exit slit were both set to a nominal 20μ width, with a height of 5 mm. The outer exit slit had a nominal width of 200μ and a height of 5 mm.

The entrance slit height was reduced on command and by the drive system control circuits to a height of 100μ .

The original slits made for the spectrometer were made from UV grade sapphire blanks with the actual slits microdeposited on the surface. This approach was felt to offer two advantages over conventional slits. First, the edge definition and width accuracy could be carefully controlled and accurately maintained, and second, the sapphire would provide short wavelength rejection, and help to eliminate potential scattering sources below about 1450 \AA .

These two features were realized but a major problem forced a reconsideration of this approach. The UV grade sapphire which is readily available contains impurities which cause transmission dips at various wavelengths. These dips become difficult to handle and make calibration a problem. Because the slit substrates exhibited these problems it was decided to change to more conventional open

slits, as described above. Filters were then added to gain back the low wavelength cutoff feature (see section 4.6).

Slit assemblies for the entrance slit and both exit slits are shown in Figs. 13 and 14, respectively. Actual measured dimensions and tolerances of the slits and height limiter are shown in Fig. 15.

4.5 Baffles

Internal baffles were used in the spectrometer to help to eliminate unwanted stray light from passing through the optical system and entering the detectors. These baffles were placed at two (2) stages in the light path around the grating inside both the entrance and exit slits, and in front of the Ebert mirror. The grating was also fitted with a mask to keep light from reaching unused portions of the blank.

4.6 Filters

Low wavelength cutoff filters were originally an integral part of the slits (see section 4.4). When these were removed new filters were added, mounting in holders over each exit slit, directly in front of the PMT detectors.

Six filters were provided, all of which were interchangeable. The substrate material was synthetic quartz, made with a low wavelength cutoff at around 1450 \AA ,

THIS PAGE IS BEST QUALITY PRACTICABLE FROM COPY FURNISHED TO DDC

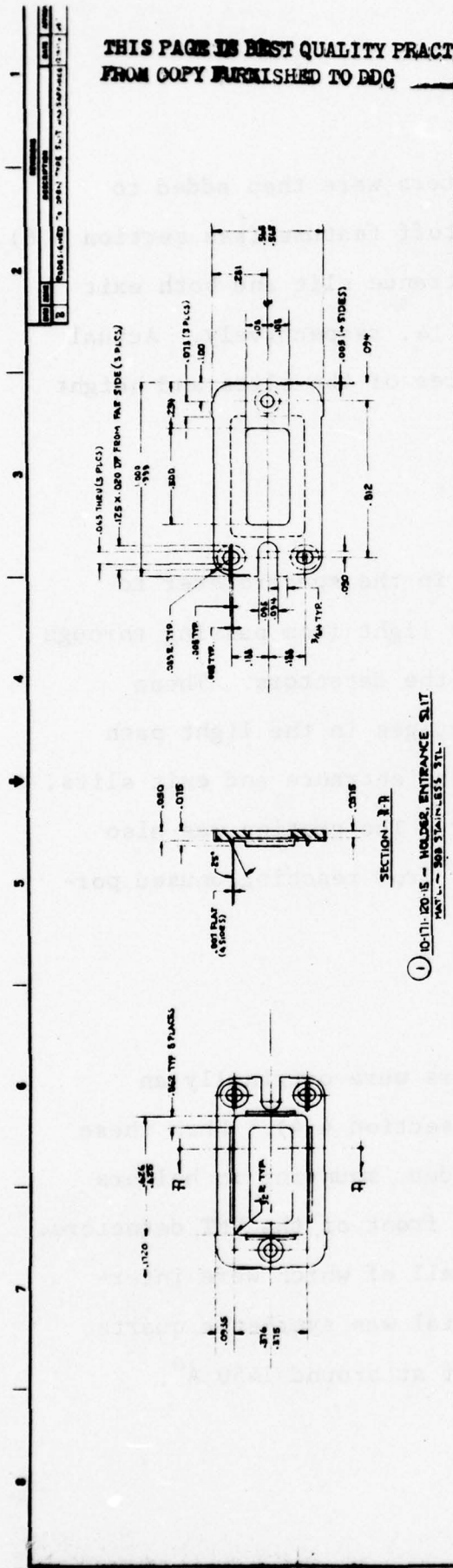

1 10-11-20-15 - HOLDER, ENTRANCE SLIT
MATERIAL - 303 STAINLESS STL.

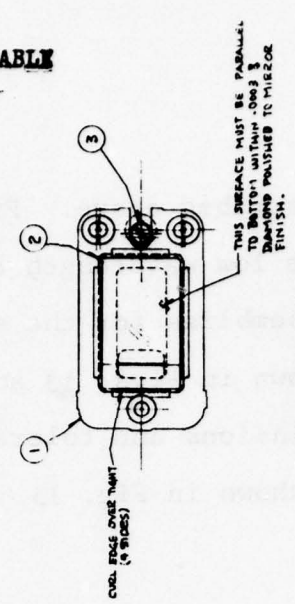

ASSEMBLY 10-11-20-14
SCALE - 1:1

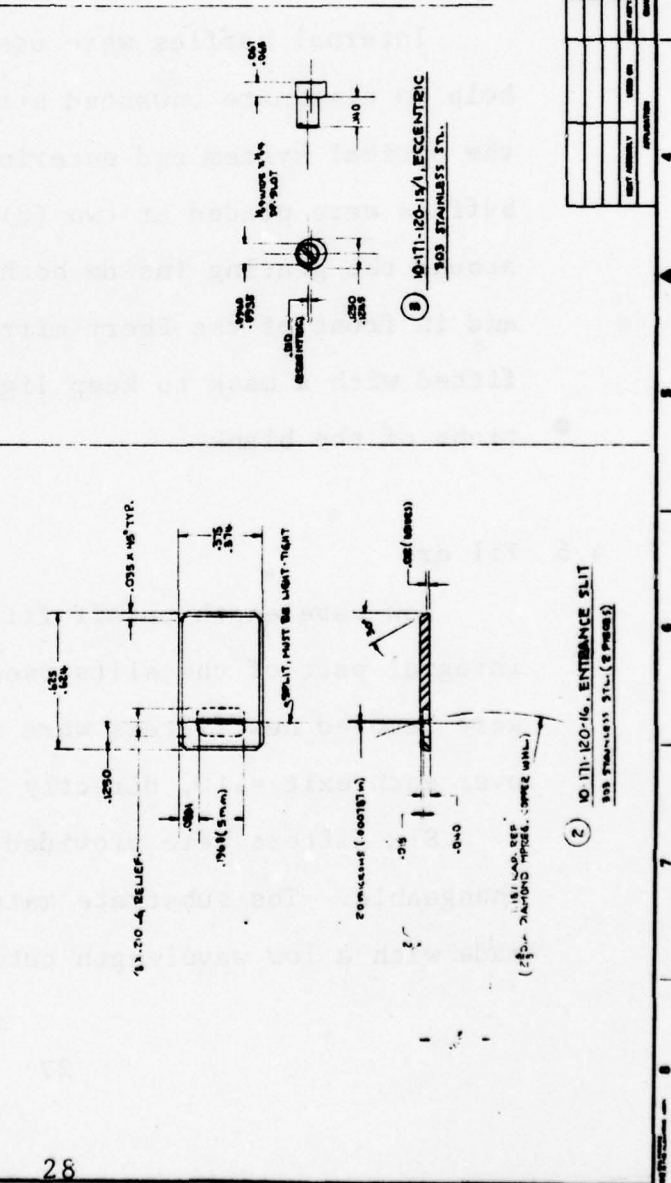

2 10-11-20-16, ENTRANCE SLIT
303 STAINLESS STL. (8 PLCS)

PART NO.		DESCRIPTION	QTY	UNIT
1	10-11-20-14	ECCENTRIC	313	STAINLESS STL.
1	10-11-20-15	ENTRANCE SLIT	313	STAINLESS STL.
1	10-11-20-16	HOLDER, ENTRANCE SLIT	313	STAINLESS STL.

LIST OF MATERIALS	
ITEM NO.	DESCRIPTION
1	ENTRANCE SLIT
2	UV SPECTROMETER
3	MAAR BALLOON EXP. HEAT

RAY LAB INSTRUMENTS	
DATE	11-26
BY	D
REV	10-11-20-4-5-49

REVISIONS	DATE	BY	APP'D
1			
2			
3			
4			
5			
6			
7			
8			
9			
10			

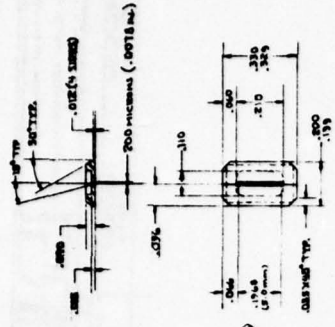

3 10-11-120-18 EXIT SLIT, OUTER
MATERIAL - STAINLESS STL-302 (2 PIECES)

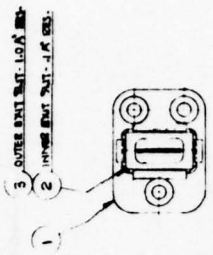

2 10-11-120-17 EXIT SLIT, INNER
MATERIAL - STAINLESS STL-302 (2 PIECES)

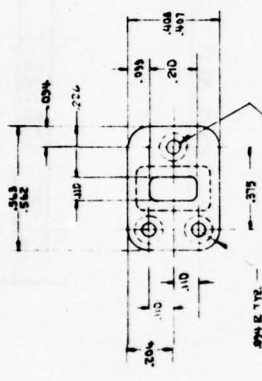

1 10-11-120-19 - HOLDER EXIT SLIT
MATERIAL - 302 STAINLESS STL.

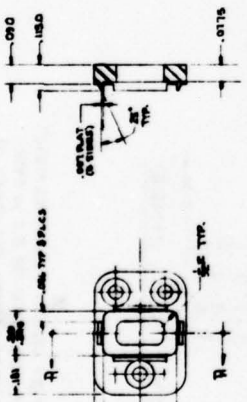

2 10-11-120-17 EXIT SLIT, INNER
MATERIAL - 302 STAINLESS STL (2 PIECES)

THIS PAGE IS BEST QUALITY PRACTICABLE FROM COPY FURNISHED TO DDG

ITEM NO.	DESCRIPTION	QTY	UNIT	DATE	BY	APP'D
1	10-11-120-18 EXIT SLIT, OUTER	2	PIECES			
2	10-11-120-17 EXIT SLIT, INNER	2	PIECES			
3	10-11-120-19 HOLDER, EXIT SLIT	1	PIECE			

DATE	BY	APP'D
1928	D	10-11-20-17, 18, 19

FIG. 14 - EXIT SLITS

THIS PAGE IS BEST QUALITY PRACTICABLE
FROM COPY FURNISHED TO BDC

REV	DATE	BY	APP
A			
SPECIFIED FOR 2nd REPAIR EFFORT			

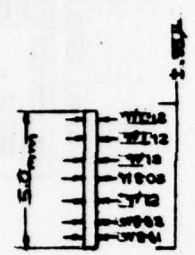

ENTRANCE SLIT

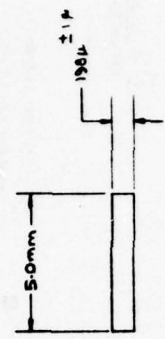

EXIT SLIT, OUTER

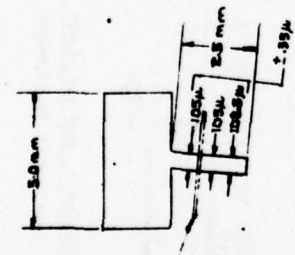

HEIGHT LIMITER
ENTRANCE SLIT

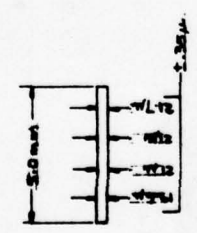

EXIT SLIT, INNER

POSITION OF ENTRANCE SLIT
WHEN SHUTTER IS ACTIVATED
TO REDUCE SLIT HEIGHT.

NOTE -
SLIT WIDTH DIMENSIONS ESTABLISHED BY DIRECT MEASUREMENT
UNDER A 43 POWER MICROSCOPE CALIBRATED TO 3.5 μ PER
RETICLE GRADUATION WITH AN ESTIMATED VISUAL ACCURACY OF
± 1.9 μ. MEASURED BY W.J. RITE 2/22/78

FIG. 15 - SLIT MEASUREMENTS

CITY, STATE, COUNTRY	PART NO. OR IDENTIFYING NO.	NUMERICAL VALUE OR DESCRIPTION	MATERIAL DESCRIPTION	ITEM NO.
LIST OF MATERIAL				
ENGLISH <input type="checkbox"/> METRIC <input checked="" type="checkbox"/> INCHES <input type="checkbox"/> MILLIMETERS <input checked="" type="checkbox"/> FRACTIONAL DECIMALS <input type="checkbox"/> X 10 ⁻¹ DECIMALS <input checked="" type="checkbox"/> X 10 ⁻² DECIMALS <input type="checkbox"/> X 10 ⁻³ DECIMALS <input type="checkbox"/> X 10 ⁻⁴		QTY	UNIT	DESCRIPTION
MATERIAL		QTY	UNIT	DESCRIPTION
PART NO. OR IDENTIFYING NO.		QTY	UNIT	DESCRIPTION
NUMERICAL VALUE OR DESCRIPTION		QTY	UNIT	DESCRIPTION
MATERIAL DESCRIPTION		QTY	UNIT	DESCRIPTION
ITEM NO.		QTY	UNIT	DESCRIPTION
REVISION		QTY	UNIT	DESCRIPTION
DATE		QTY	UNIT	DESCRIPTION
SIGNATURE		QTY	UNIT	DESCRIPTION
DATE		QTY	UNIT	DESCRIPTION
CODE IDENT NO.		QTY	UNIT	DESCRIPTION
56123		QTY	UNIT	DESCRIPTION
SCALE		QTY	UNIT	DESCRIPTION
7		QTY	UNIT	DESCRIPTION
REVISION		QTY	UNIT	DESCRIPTION
DATE		QTY	UNIT	DESCRIPTION
SIGNATURE		QTY	UNIT	DESCRIPTION
DATE		QTY	UNIT	DESCRIPTION
CODE IDENT NO.		QTY	UNIT	DESCRIPTION
56123		QTY	UNIT	DESCRIPTION
SCALE		QTY	UNIT	DESCRIPTION
7		QTY	UNIT	DESCRIPTION
REVISION		QTY	UNIT	DESCRIPTION
DATE		QTY	UNIT	DESCRIPTION
SIGNATURE		QTY	UNIT	DESCRIPTION
DATE		QTY	UNIT	DESCRIPTION
CODE IDENT NO.		QTY	UNIT	DESCRIPTION
56123		QTY	UNIT	DESCRIPTION
SCALE		QTY	UNIT	DESCRIPTION
7		QTY	UNIT	DESCRIPTION
REVISION		QTY	UNIT	DESCRIPTION
DATE		QTY	UNIT	DESCRIPTION
SIGNATURE		QTY	UNIT	DESCRIPTION
DATE		QTY	UNIT	DESCRIPTION
CODE IDENT NO.		QTY	UNIT	DESCRIPTION
56123		QTY	UNIT	DESCRIPTION
SCALE		QTY	UNIT	DESCRIPTION
7		QTY	UNIT	DESCRIPTION



RESEARCH SUPPORT INSTRUMENTS, INC.
TIMONIUM, MARYLAND

SLIT MEASUREMENTS
UV SPECTROMETER

CODE IDENT NO.	DATE	REVISION
56123	10-17-120-44	A
SCALE		
7		

REVISION	DATE	QTY	UNIT	DESCRIPTION

almost an exact copy of sapphire. Two (2) of these substrates were left as polished windows, for low wavelength rejection only. Two (2) other blanks were coated as neutral density filters, providing 10x attenuation. The remaining two (2) were coated for 3x attenuation. The filters could be mounted in the spectrometer in any position, to be determined by calibration data.

4.7 Optical Alignment

The spectrometer optical alignment was performed in accordance with standard procedures for aligning Ebert spectrometers, and is outlined below.

- a) Install Ebert mirror in mirror cell.
- b) Install grating in holder, with blaze arrow pointed away from entrance slit.
- c) Adjust focus of Ebert mirror, with grating in zero order, using the focussing spacer to make any necessary adjustments.
- d) Install cross hairs over entrance and exit slits.
- e) Adjust grating alignment by moving screws in grating box, keeping the image of the entrance slit cross hair on the exit slit cross hair. When this alignment is completed the grating rulings will be parallel with the axis of rotation of the grating.

The spectrometer wavelength setting was accomplished in the following manner:

- a) Align sine drive carriage with marks on sine drive frame.
- b) Move sine drive carriage 50,000 steps toward the short wavelength end of the drive.
- c) Insert zero order setting block between sine blade and follower ball.
- d) Adjust grating to zero order.
- e) Remove setting block.

The spectrometer drive carriage is now set at the 1500 A° position. The setting procedure has set up the drive correctly, making the spectrometer scan wavelength linearly with time.

To set the scan endpoints:

- a) Using a source lamp with known and identifiable spectral features, locate a spectral line near one endpoint of the scan.
- b) Stop the drive with the spectrometer on the known line center.
- c) Scan the drive toward the endpoint you want to set the number of Angstroms needed to reach the desired endpoint wavelength (50 steps equals 1 A°). Stop the drive.
- d) Move the endpoint optical reader until the blade is positioned in the gap of the reader, and the reader output reads 2.5 volts. The rotary fiducial reader must be positioned such that the hole in the disc is 180° from the reader.
- e) Follow the same procedure for opposite endpoint.

The scan endpoints are now set, and should be reproducible to within several steps, or 0.1 A° . The center point fiducial can be set in the same manner.

5.0 Electronics Sub-System

The spectrometer electronics system consists of the following major sections: 1) Integrated Detectors, 2) Data Counters, 3) Scan Control, 4) Master Clock and Serial Word Generator, 5) Analog Commutator, 6) Slit Height and Dark Shutter, and 7) Power System.

5.1 Integrated Detectors

The spectrometer contains two identical integrated detectors complete with EMR 510F-09-13-10000 photomultiplier, pulse amplifier and regulated high voltage power supply as shown in Fig. 16. The PMT is operated grounded cathode and the entire unit is potted to permit operation in corona regions. Anode charges are coupled through a 6KV rated capacitor to charge converter stage Q3-Q4. Following the converter is the gain control amplifier Q5-Q6 which drives inverter amplifier Q7 which in turn drives output follower Q8. Output pulses are 0 to \sim 5 volts and approximately 60 NS. Amplitude discrimination is done in the detector counter input Schmitt gate. Input power is raw battery or EXT power and is regulated by M1. The reference output of M1 is used to operate the pulse amplifier and the M1 adjustable output supplies power to the high voltage power supply. A sine wave oscillator and step up transformer drive a X8 multiplier to produce plus HV to 3KV. Three stages of HV filter reduce ripple to \sim 20mv P-P. The high voltage monitor

THIS PAGE IS BEST QUALITY PRACTICABLE
FROM COPY FURNISHED TO DDG

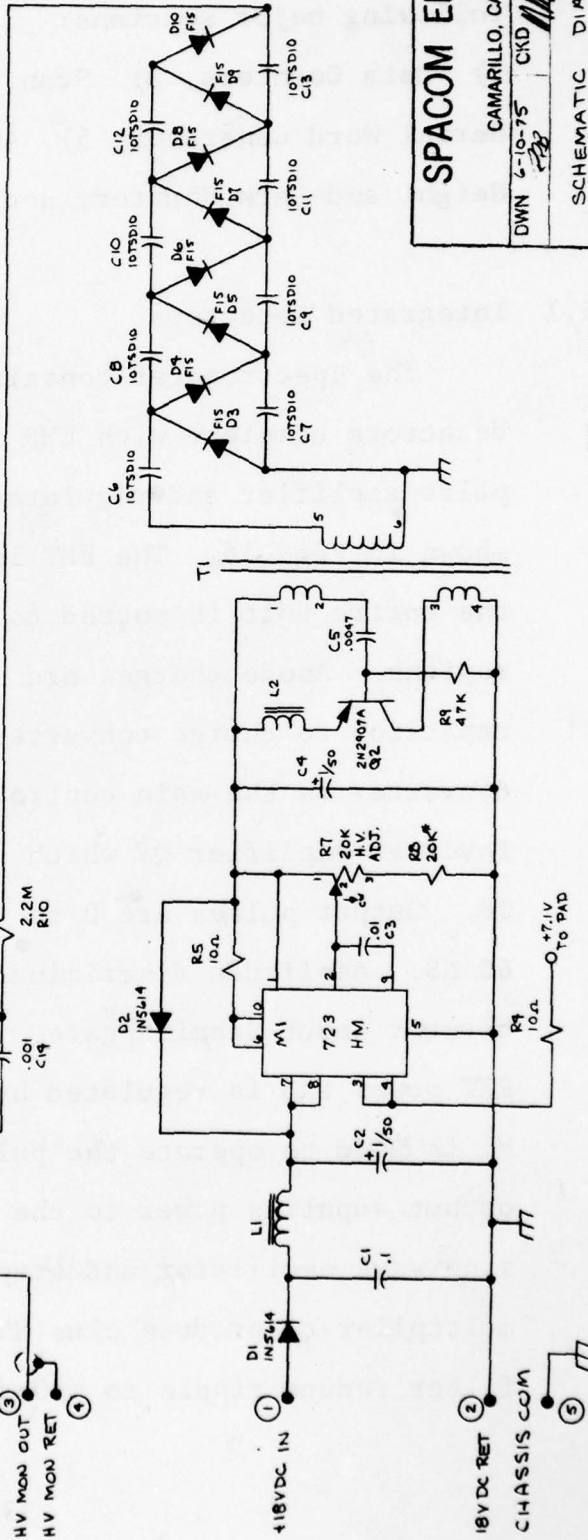
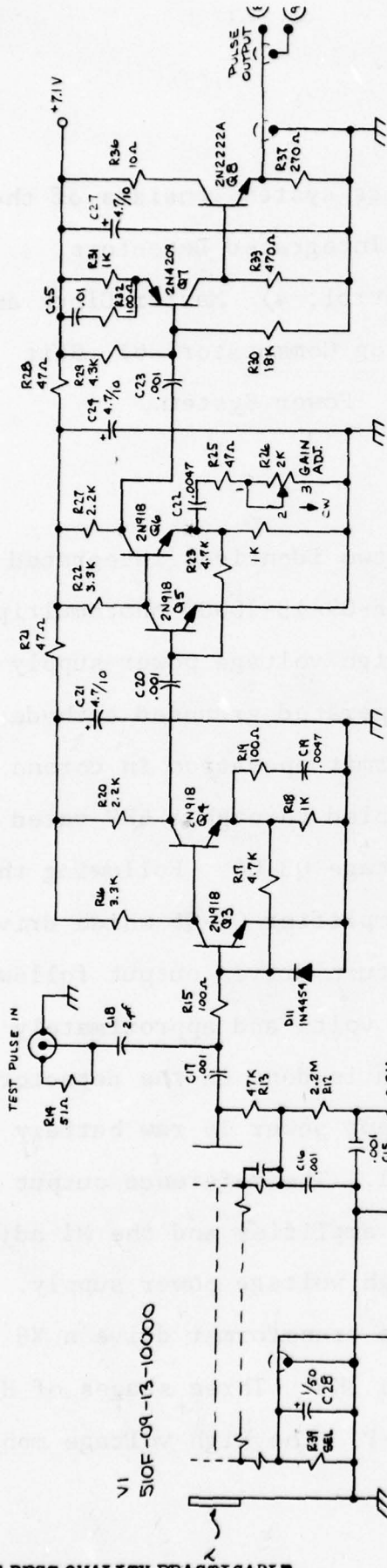

NOTES UNLESS OTHERWISE SPECIFIED
1. RESISTANCE IN OHMS, ALL RESISTORS 1/4W ±5%.
2. CAPACITANCE IN MICROFARADS
3. * DENOTES TEMP STABLE RESISTOR 10W ±1%.

SPACOM ELECTRONICS

CAMARILLO, CALIFORNIA 93010

DWN 6-10-75 CKD 5/18/76 APPD 5/28/76

SCHEMATIC DIAGRAM SE340-4
INTEGRATED DETECTOR PACKAGE
CRO 356

115426

REV 14-28-76 C

FIG. 16

is derived across dynode return resistor R39 to give a 1000:1 voltage ratio.

A test input connector is provided to permit injecting small charges into the amplifier input for checkout. Amplifier gains were set to 2×10^5 electrons/pulse and PMT gains set to a nominal 2×10^6 for good collection efficiency.

5.2 Data Counters

Detector pulse counters shown in Fig. 17 receive pulses from the integrated detectors, amplitude discriminate and accumulate counts in a high speed five digit BCD counter for a maximum count of 99999. The input decade is a low power Schottky counter with a minimum count rate of 35MHz in order that the counter chain not contribute to system dead time. The following digits are CMOS since the counting rate at this point is below 1MHz. Every 10ms, under control of the timer section, the counters are reset to zero so the average counting capability of the counters is 10mpps. An additional output from the Schmitt gate is buffered by a follower and pulses are presented to a test output connector for lab counter use. A load lockout input closes the gate for a μ s every 10ms to permit the counters to stabilize while parallel data is being transferred to the PISO registers.

5.3 Scan Control

Operation of the screw drive scan motor in normal operation is under the control of four optical sensors as shown in Fig. 18. In order to achieve precision motor operation a two stage sensor system was needed. A piece of shim material was carried by the drive nut so that at each end of the scan, it would block the light of the gap sensors. Near the center of the shim was a hole which would be uncovered by the center sensor (2650). Since the nut travel was very slow, precise step timing could not be guaranteed and a second level of precision was incorporated by having a disc with a single hole and gap sensor secured to the screw shaft itself. In this manner, by utilizing the coarse sensors for gates, single step precision could be accomplished with Schmitt buffers and Nand gates. In setting up the gap sensors care must be taken to insure that the nut sensors are not changing state at the moment the screw angle sensor detects the disc hole. The AND outputs of the sensors are used to control M206B,C latch which furnishes direction signals to the motor drive counter M208 and to the five BCD digit step counter M108,9,10,11,12. The step counter has an additional command input which causes an all 9's preset when the high scan reverse occurs. The center nut sensor can be programmed by external command to act as the low reverse sensor to shorten scan or when enabled, can cause the slit

height to reduce for wavelengths above its setting. A power up reset circuit M212-F and M210-B disables the short scan feature and forces a scan up condition. Each reversal of scan commands a dark shutter of operation to permit PMT dark count measurements. Scan length, slit height control and scan up can be commanded during flight by ground link. For bench operations, the GSE can control scan direction, scan length, step rate, slit height and dark shutter. The least significant two bits of the binary motor drive counter are sent to decimal decoder M209 so that as the two bits count up or down, the four decoder outputs will step up or down in phase. Single phase drive to the size 18 stepper is furnished by Darlington transistors Q403-6. Motor supply power is from the raw power bus through a series resistor of approximately 77 ohms.

5.4 Master Clock and Serial Word Generator

As shown in Fig. 19, basic timing for the instrument is derived from a 1.024MHz crystal clock of .005% accuracy. A 2^7 divider, M302, furnishes the 8KHz serial bit clock and further division by 80 gives the 100 Hz frame clock. The frame clock triggers one shot M305-A which generates the register load command. At the trailing edge of the load pulse, M305-B generates the counter reset pulses so that the next accumulate cycle can commence directly after the PISO register is loaded. As shown in Fig. 22, the frame to T/M consists of a 0111010101100101 sync word, a bit indicating shortened scan,

THIS PAGE IS BEST QUALITY PRACTICABLE
FROM COPY FURNISHED TO DDC

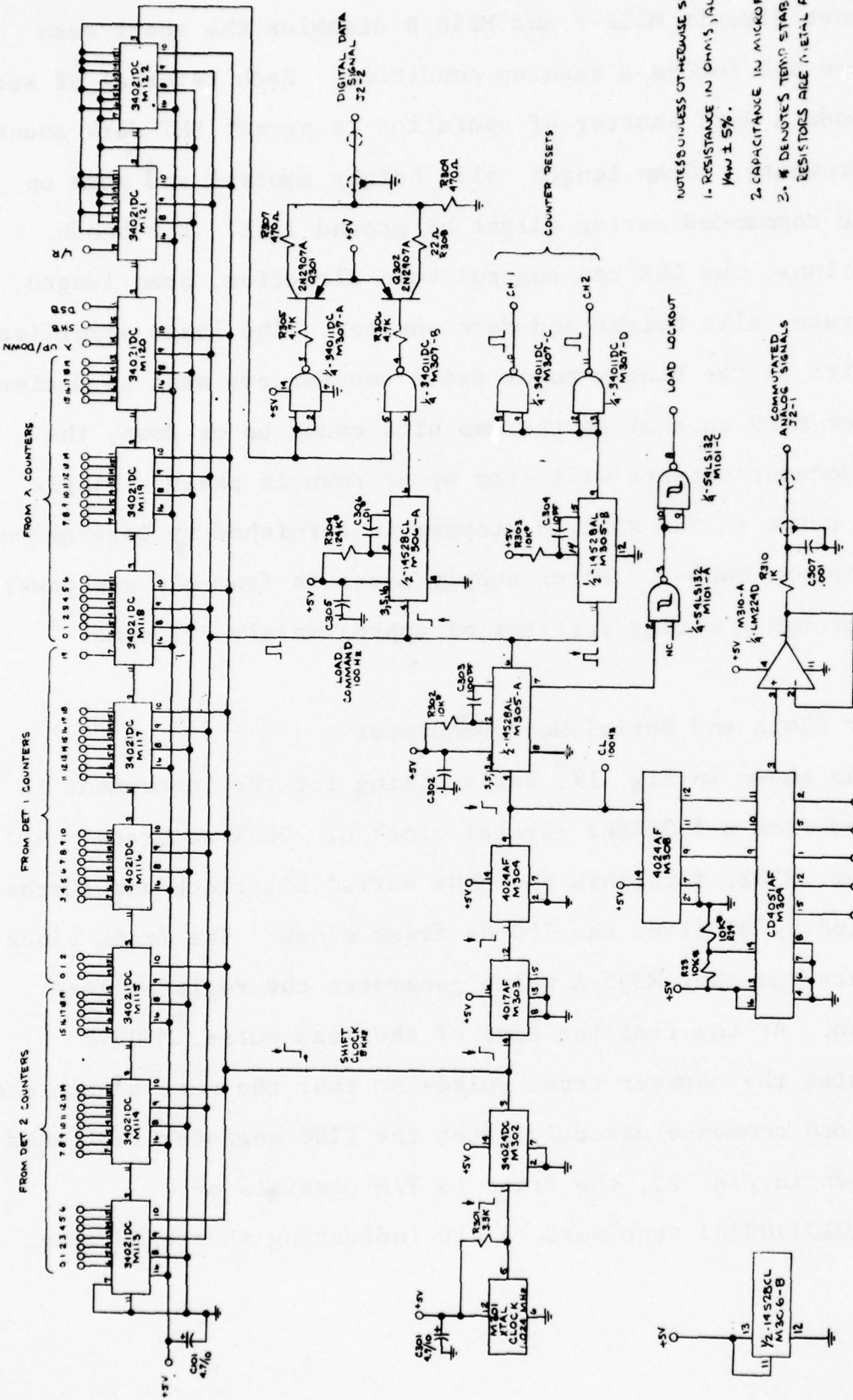

NOTES UNLESS OTHERWISE SPECIFIED
1. RESISTANCE IN OHMS, ALL RESISTORS
1/10W 1%.
2. CAPACITANCE IN MICROFARADS.
3. * DENOTES TEMP STABLE COMPONENTS.
RESISTORS ARE METAL FILM 1/10W 1%

SPACOM ELECTRONICS	
CAMARILLO, CALIFORNIA 93010	
DWN 11-7-75	CKD
REV 5/17/76	APP 1/11/76
CRL BALLOON SPECTROMETER MASTER CLOCK, SERIAL WORD REGISTER AND ANALOG COMPUTATOR	
CRO. 354	SE. 340-2
115 496	REV 4-2-76

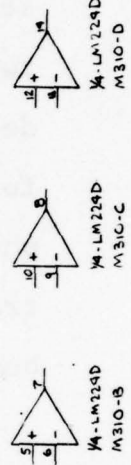

FIG. 19

a shutter bit, a slit bit, an up/down bit, 20 bits of λ step (5BCD digits), 20 bits of BCD detector #1 count and 20 bits of BCD detector #2 count for a total frame of 80 bits. The first three "1" bits of the sync word are boosted to $\sim +5$ volts with the rest of the bits at +2.5 volts for ease of synchronizing in the GSE.

5.5 Analog Commutator

Analog monitors are provided for: DET #1-HV, DET #2-HV, DET temperature and logic temperature. In order to reduce the number of analog monitor lines to T/M, an 8 channel multiplexer was utilized which gave a sequence of +5 V, +2.5 V, battery monitor, HV#1, HV#2, detector temperature, logic temperature and ground. The GSE presents this signal at a BNC for monitoring.

5.6 Slit Height and Dark Shutter

Fig. 20 indicates the operation of the slit height-dark shutter circuits. Under ground or GSE control, latch M205-A, M203-B permits changes to the slit height. If the latch is enabled (pin 6 high), gate M213-A can be activated at the time of center fiducial operation if the scan is moving in the up direction. The output from this gate will then set latch M213-C, M214-D so that a signal will be sent to Q407 to energize the slit torque motor to shorten the entrance slit. Note that the slit height latch can only be switched at the

center fiducial time. On the down scan, input scan up is high and the latch will be reset to the long slit (no power to the torque motor). End of scan signals "D" and "E" "OR" to one shot M210-A which produces a momentary drive signal to pull the torque motor in the opposite direction occulting the slit and permitting a PMT dark count measurement. This action is also possible by GSE command.

5.7 Power System

Prime power is supplied by a 15 cell, 4AH, 18 volt NiCd battery pack. A latching relay is provided to permit bench test use of external power as well as flight battery checkout. In flight, the EXP power position is the off condition. The latching relay can be activated with either EXT or flight battery power. A set of contacts on the power relay furnish current to indicator lights on the GSE. A resistive divider reduces the 18 volt bus to 1.8 volts for analog commutator sampling. Battery charge and monitor capability is included. The 18 volt bus is supplied directly to the integrated detectors and through series resistors to the scan stepper and slit torque motor. Logic +5 volt power is furnished by a step down DC/DC converter and 1C regulator M401. Previous power for the instrument was furnished by 3AH silver cells and an additional lead acid battery heater unit was provided to keep them to a proper operating temperature. The added complication of filling the silver

THIS PAGE IS BEST QUALITY PRACTICABLE
FROM COPY FURNISHED TO BDC

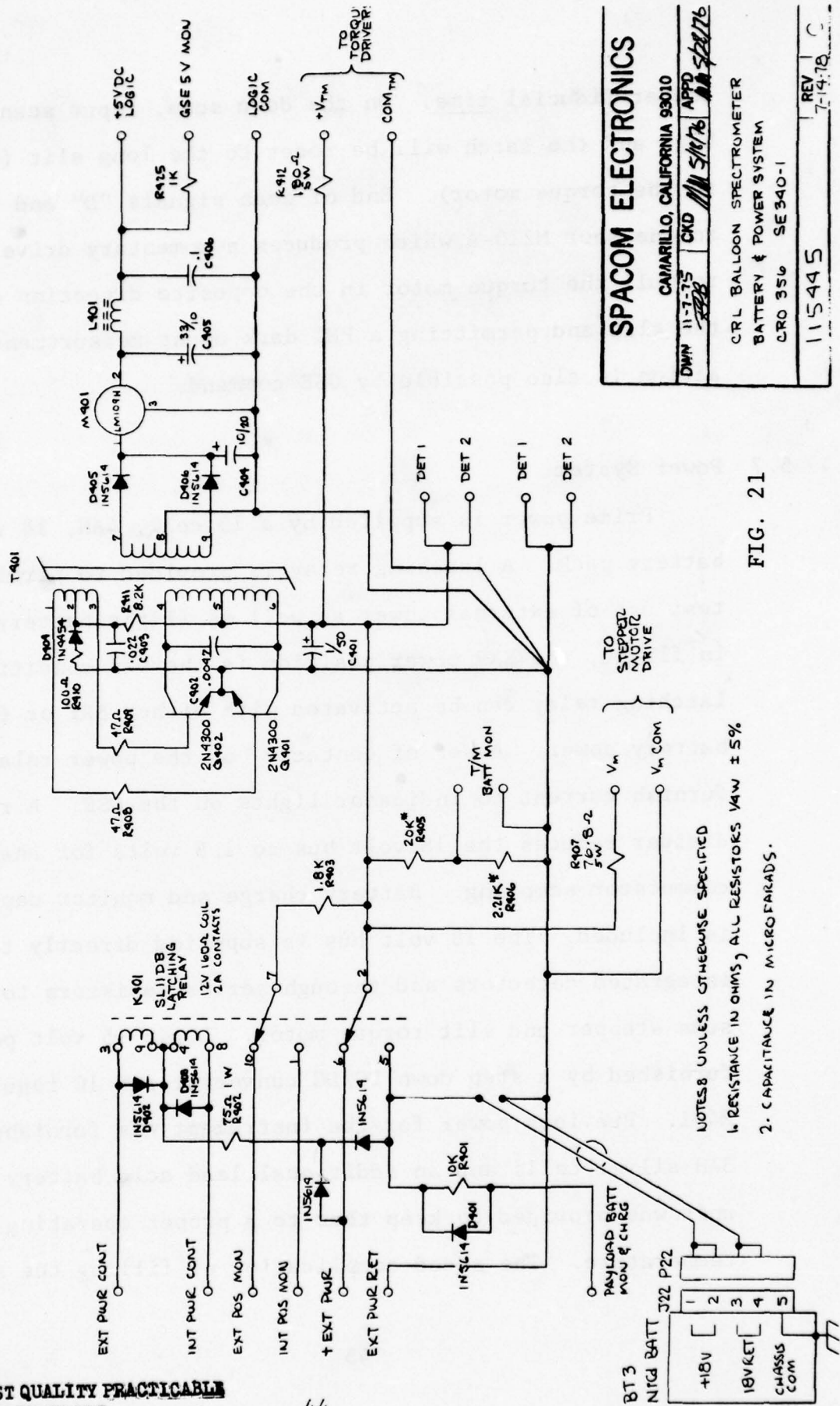

SPACOM ELECTRONICS	
CARMARILLO, CALIFORNIA 93010	
DRAWN 11-7-75 RBB	CKD S/R/76
APPROVED S/R/76	
CRL BALLOON SPECTROMETER BATTERY & POWER SYSTEM CRO 356 SE 340-1	
115445	REV 7-14-78 C

FIG. 21

NOTES UNLESS OTHERWISE SPECIFIED
1. RESISTANCE IN OHMS; ALL RESISTORS $\pm 5\%$
2. CAPACITANCE IN MICROFARADS.

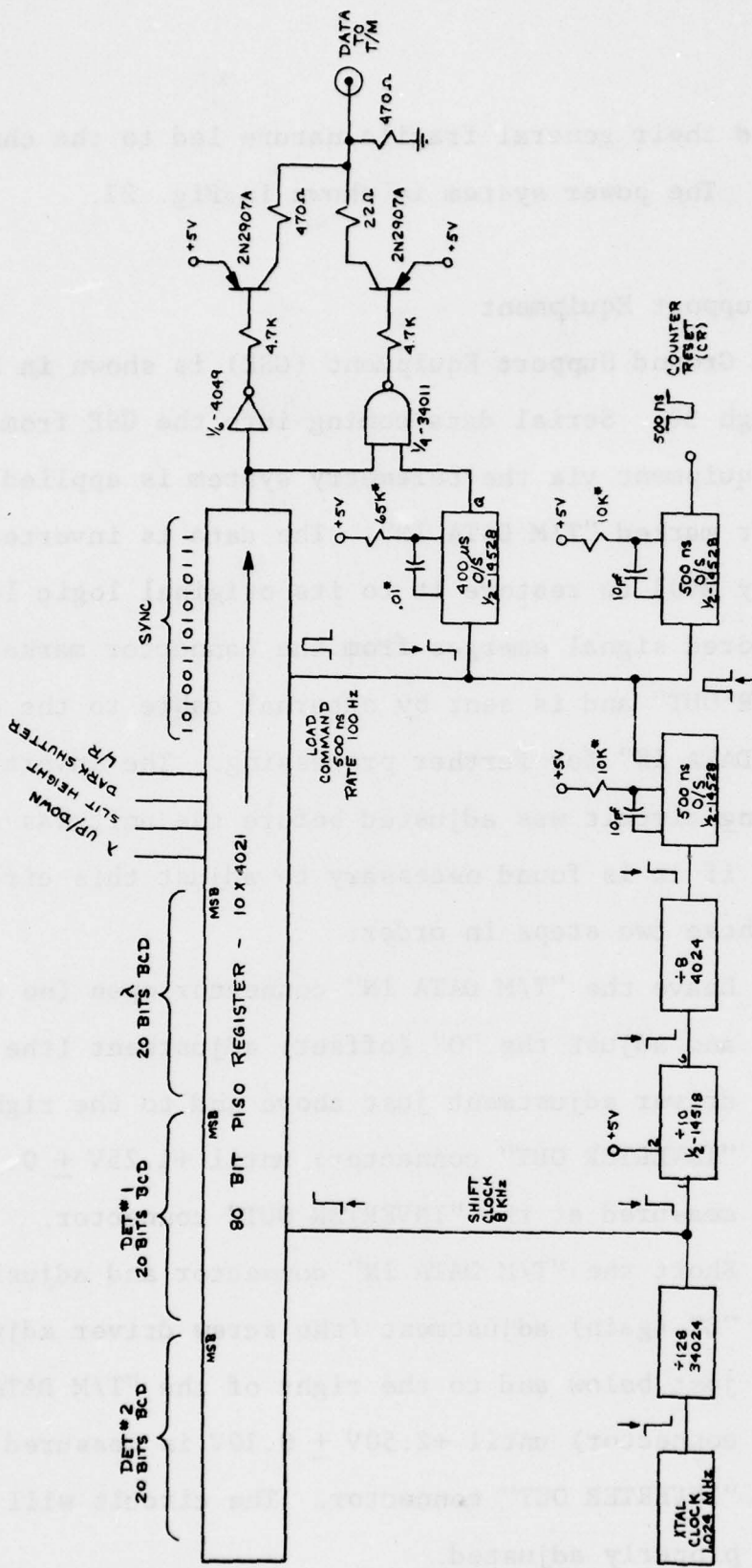

MASTER CLOCK AND SERIAL WORD REGISTER

FIG. 22

SPACOM ELECTRONICS
 CARPENTERS, CALIFORNIA 93010
 SAN 6-6-75
 CRL BALLOON SPECTROMETER
 CRO 356
 115422 REV

THIS PAGE IS BEST QUALITY PRACTICABLE
 FROM COPY FURNISHED TO DDC

cells and their general fragile nature led to the change to NiCd. The power system is shown in Fig. 21.

6.0 Ground Support Equipment

The Ground Support Equipment (GSE) is shown in Figs. 23 through 30. Serial data coming into the GSE from the flight equipment via the telemetry system is applied at the connector marked "T/M DATA IN". The data is inverted and offset by M401 to restore it to its original logic levels. The restored signal emerges from the connector marked "INVERTER OUT" and is sent by external cable to the connector marked "DATA IN" for further processing. The inverting and offsetting circuit was adjusted before the unit was shipped; however, if it is found necessary to adjust this circuit follow these two steps in order:

- 1) Leave the "T/M DATA IN" connector open (no connection) and adjust the "O" (offset) adjustment (the screw driver adjustment just above and to the right of the "INVERTER OUT" connector) until $+1.25V \pm 0.10V$ is measured at the "INVERTER OUT" connector.
- 2) Short the "T/M DATA IN" connector and adjust the "G" (gain) adjustment (the screw driver adjustment just below and to the right of the "T/M DATA IN" connector) until $+2.50V \pm 0.10V$ is measured at the "INVERTER OUT" connector. The circuit will then be properly adjusted.

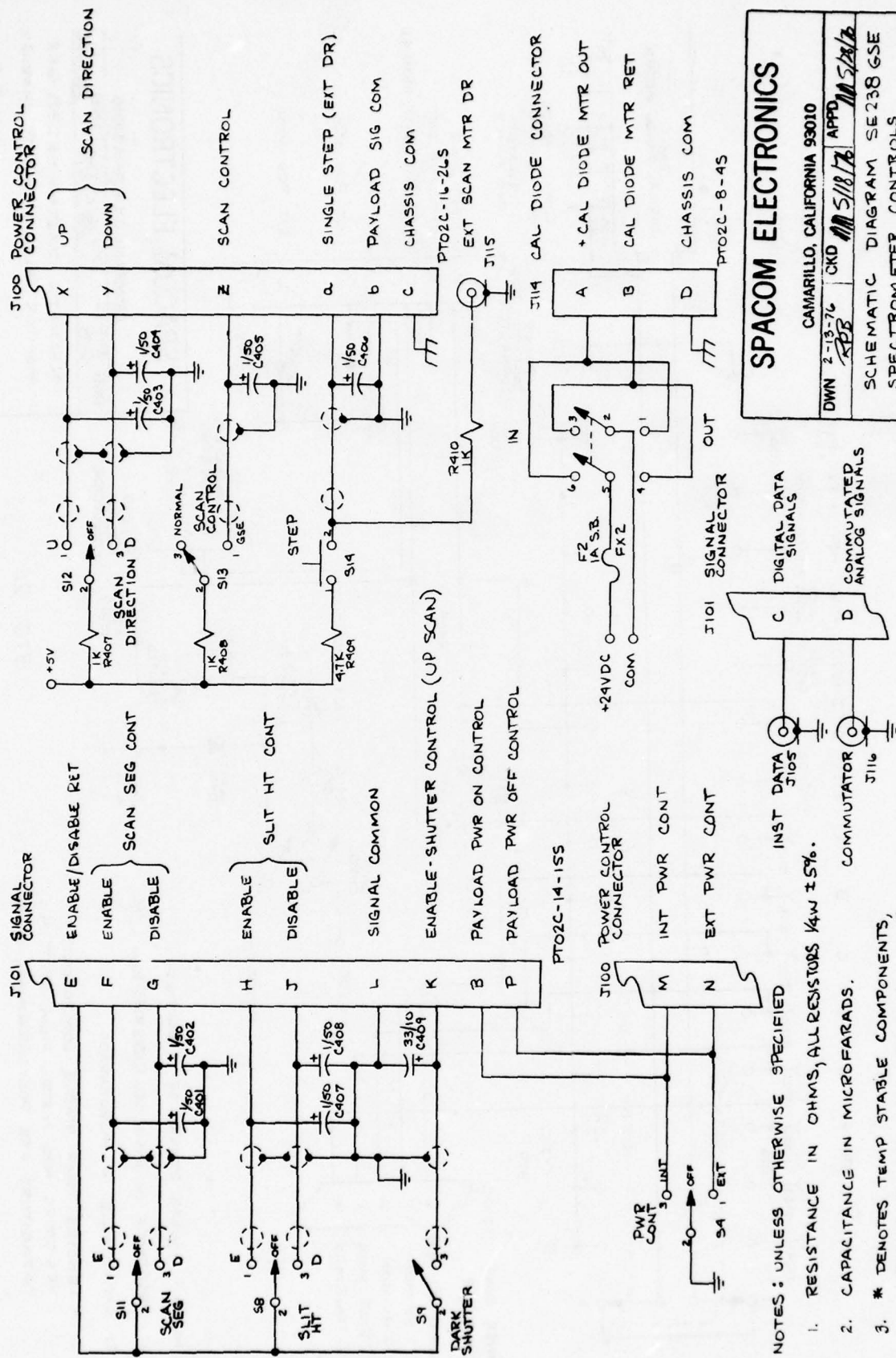

SPACOM ELECTRONICS	
CAMARILLO, CALIFORNIA 93010	
DWN 2-13-76	CKD 5/18/76
APB	APD 5/24/76
SCHEMATIC DIAGRAM SE 238 GSE	
SPECTROMETER CONTROLS	
CRO 356	
125301	REV 7-14-78 B

FIG. 23

- NOTES: UNLESS OTHERWISE SPECIFIED
1. RESISTANCE IN OHMS, ALL RESISTORS 1/4W ±5%.
 2. CAPACITANCE IN MICROFARADS.
 3. * DENOTES TEMP STABLE COMPONENTS, RESISTORS ARE METAL FILM 1/10W ±1%, CAPACITORS ARE POLYCARBONATE ±10%

THIS PAGE IS BEST QUALITY PRACTICABLE FROM COPY FURNISHED TO DDG

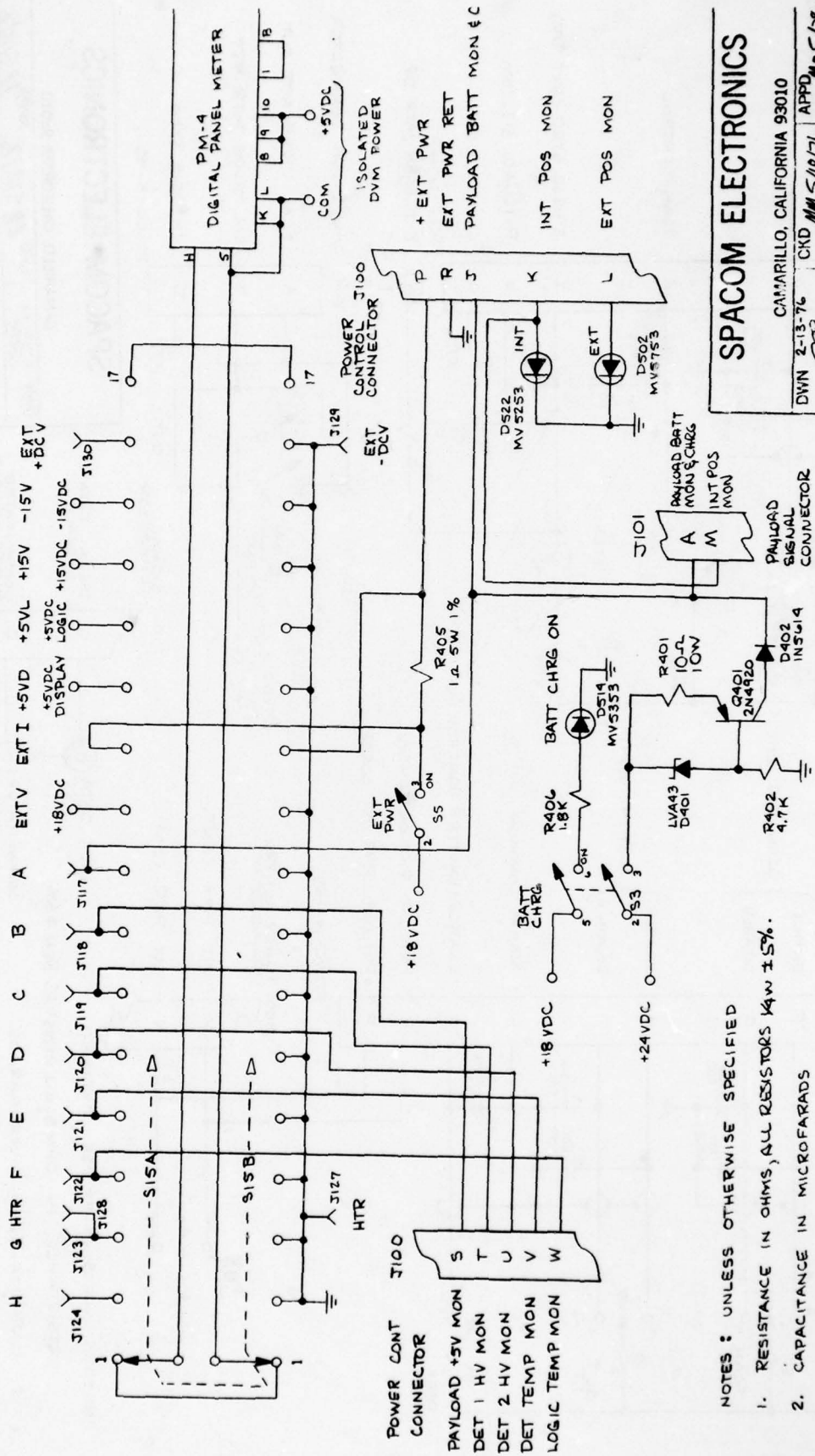

NOTES: UNLESS OTHERWISE SPECIFIED

1. RESISTANCE IN OHMS, ALL RESISTORS $1/4$ W $\pm 5\%$.
2. CAPACITANCE IN MICROFARADS
3. * DENOTES TEMP STABLE COMPONENTS, RESISTORS ARE METAL FILM $1/10$ $\pm 1\%$. CAPACITORS ARE POLYCARBONATE $\pm 10\%$.

SPACOM ELECTRONICS

CAMARILLO, CALIFORNIA 93010

DWN 2-13-76 CKD 5/18/76 APPD MA S/28/

SCHEMATIC DIAGRAM SE 238 GSE
MONITOR SELECTOR & BATT CHARGER

125302

CRO 356
1-14-78 B

FIG. 24

THIS PAGE IS BEST QUALITY PRACTICABLE
FROM COPY FURNISHED TO DDG

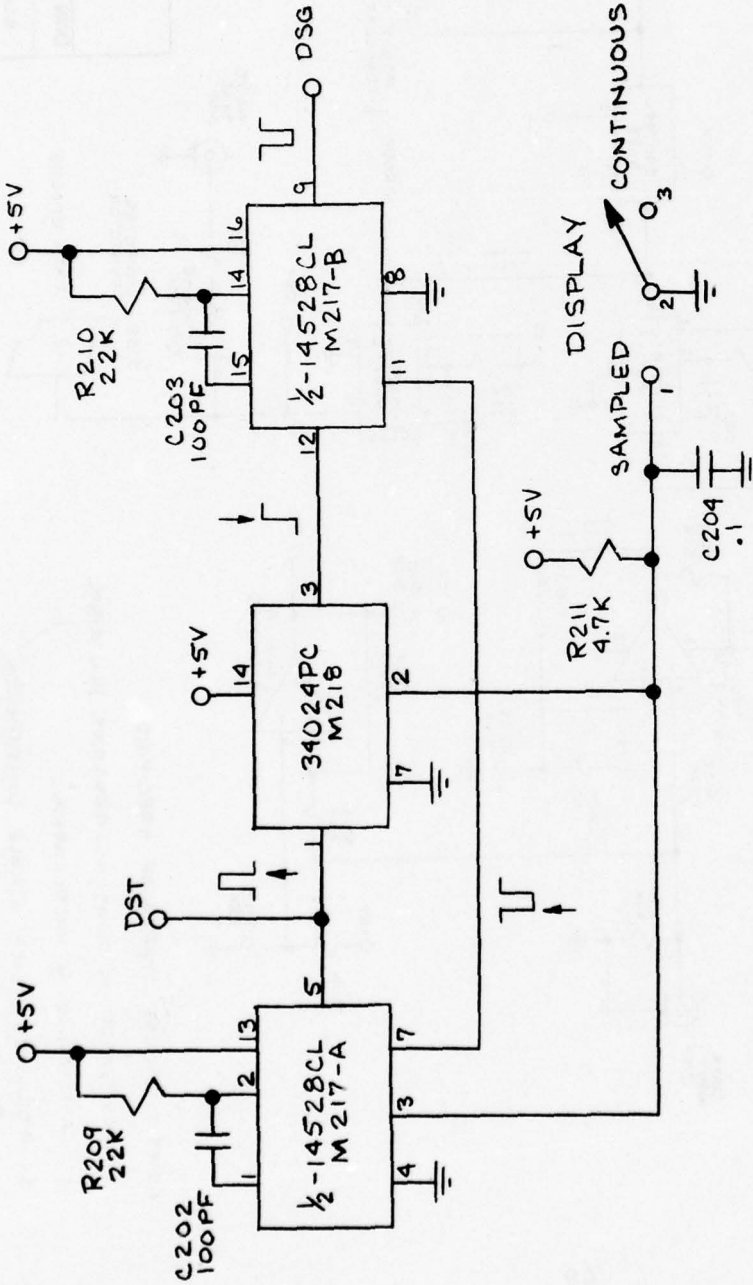

SPACOM ELECTRONICS

CAMARILLO, CALIFORNIA 93010

DWN 2-13-76 RPB OKD APPD MMS/18/76 5/28/76

SCHEMATIC DIAGRAM SE 238 GSE
DISPLAY STROBE GENERATOR

125304 REV 4-27-76 A

NOTES : UNLESS OTHERWISE SPECIFIED

1. RESISTANCE IN OHMS, ALL RESISTORS 1/4W ± 5%.
2. CAPACITANCE IN MICROFARADS.
3. * DENOTES TEMP STABLE COMPONENTS
RESISTORS ARE METALFILM 1/10W ± 1%
CAPACITORS ARE POLYCARBONATE ± 10%

FIG. 26

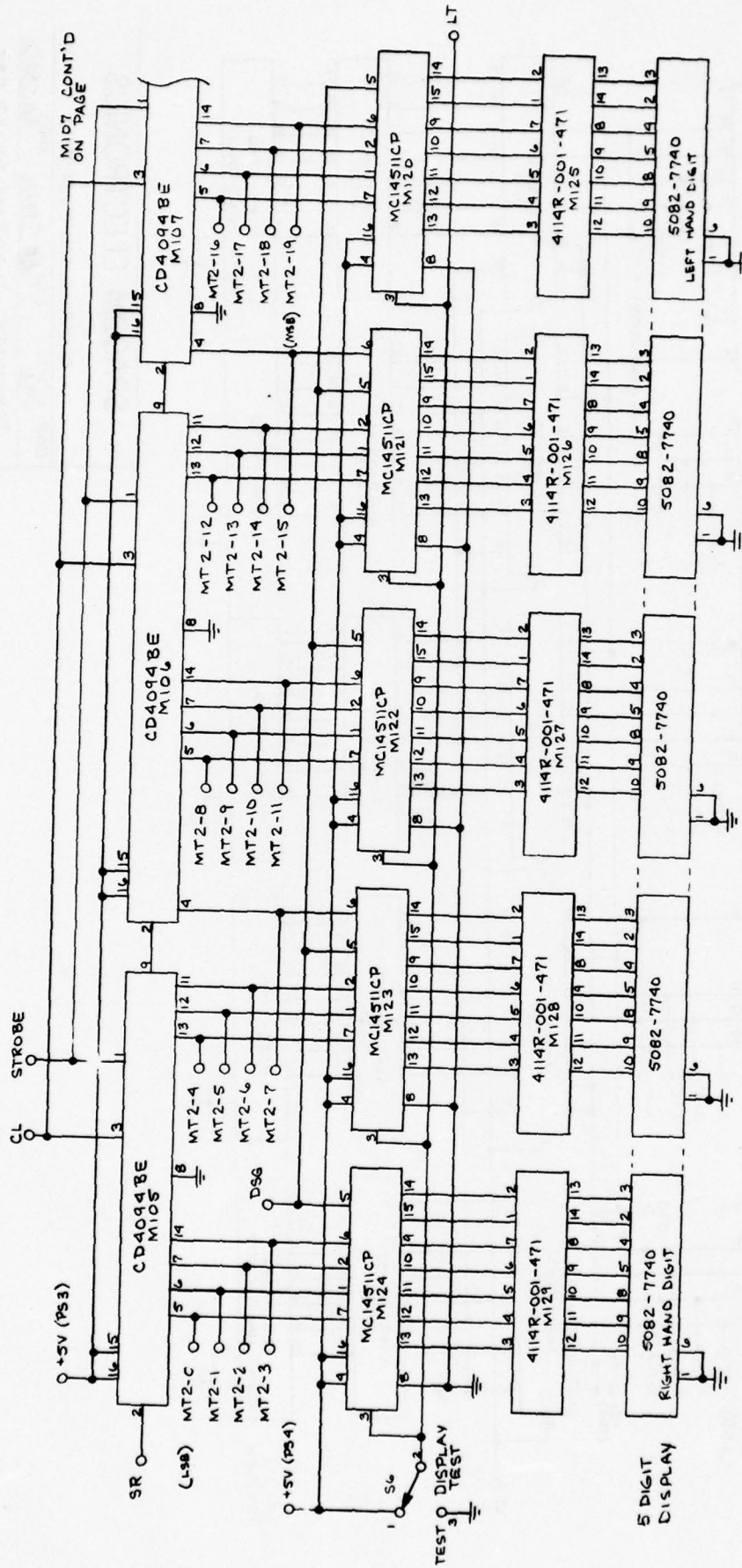

NOTES: UNLESS OTHERWISE SPECIFIED

1. MT1, MT2 SPECIFY DETECTOR NO'S, EG. MT1 = DET #1

SPACOM ELECTRONICS	
CAMARILLO, CALIFORNIA 93010	
DWN 2-3-76	CND <i>MS/S/8/76</i> APP <i>MS/5/8/76</i>
SCHEMATIC DIAGRAM SE23B GSE	
PARALLEL DATA OUTPUT & DISPLAY	
DETECTOR # 2	
C100356	
REV 5-3-76 A	
125305	

FIG. 27

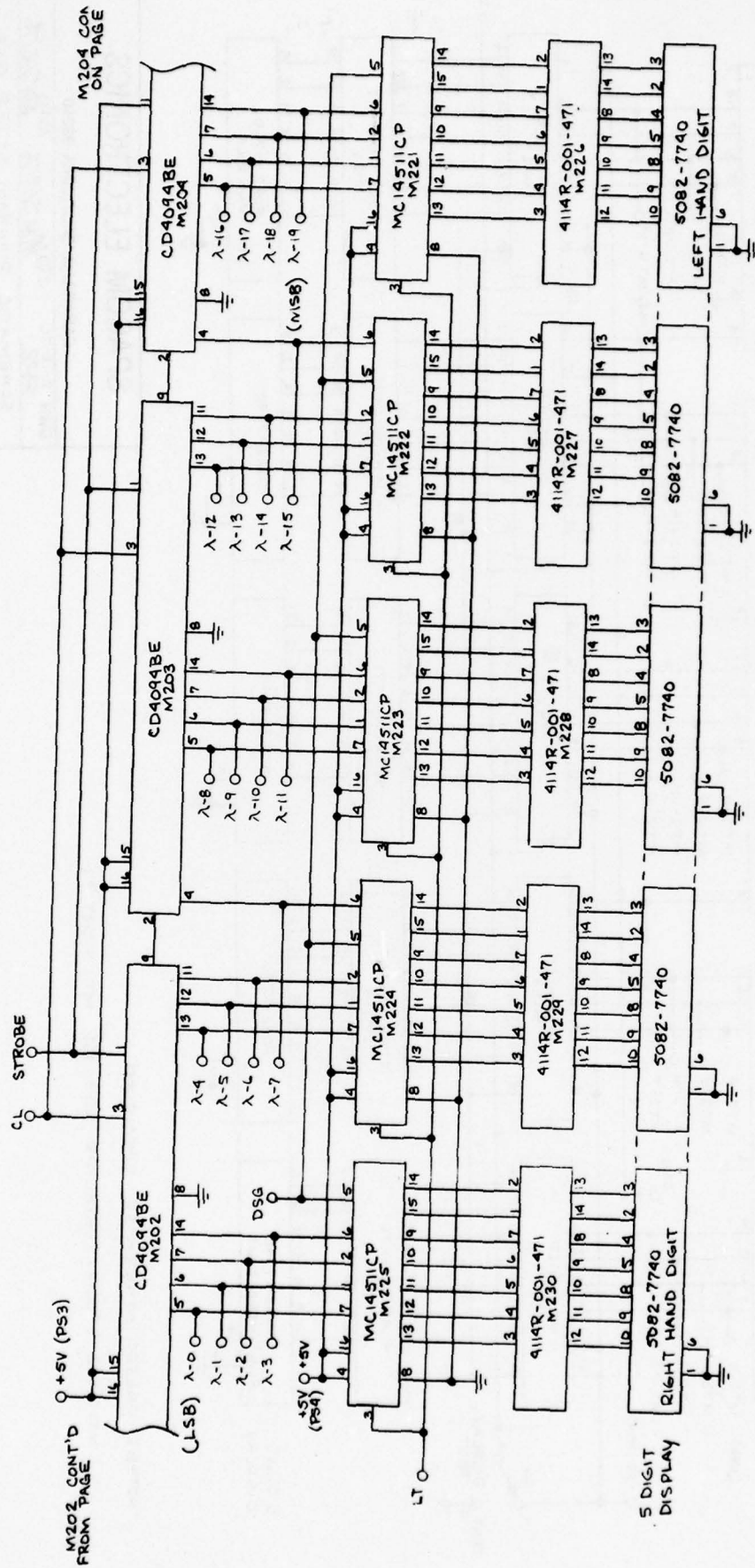

M204 CON
ON PAGE

M202 CONT'D
FROM PAGE

SPACOM ELECTRONICS
 CAMARILLO, CALIFORNIA 93010
 DWN 2-13-76 CND APPD
 S/18/76 APPD S/28/76
 SCHEMATIC DIAGRAM SE238 GSE
 PARALLEL DATA OUTPUT & DISPLAY
 WAVELENGTH (λ) DETECTOR
 CRO356
 125307 REV 5-576 A

FIG. 28

THIS PAGE IS BEST QUALITY PRACTICABLE
FROM COPY FURNISHED TO DDG

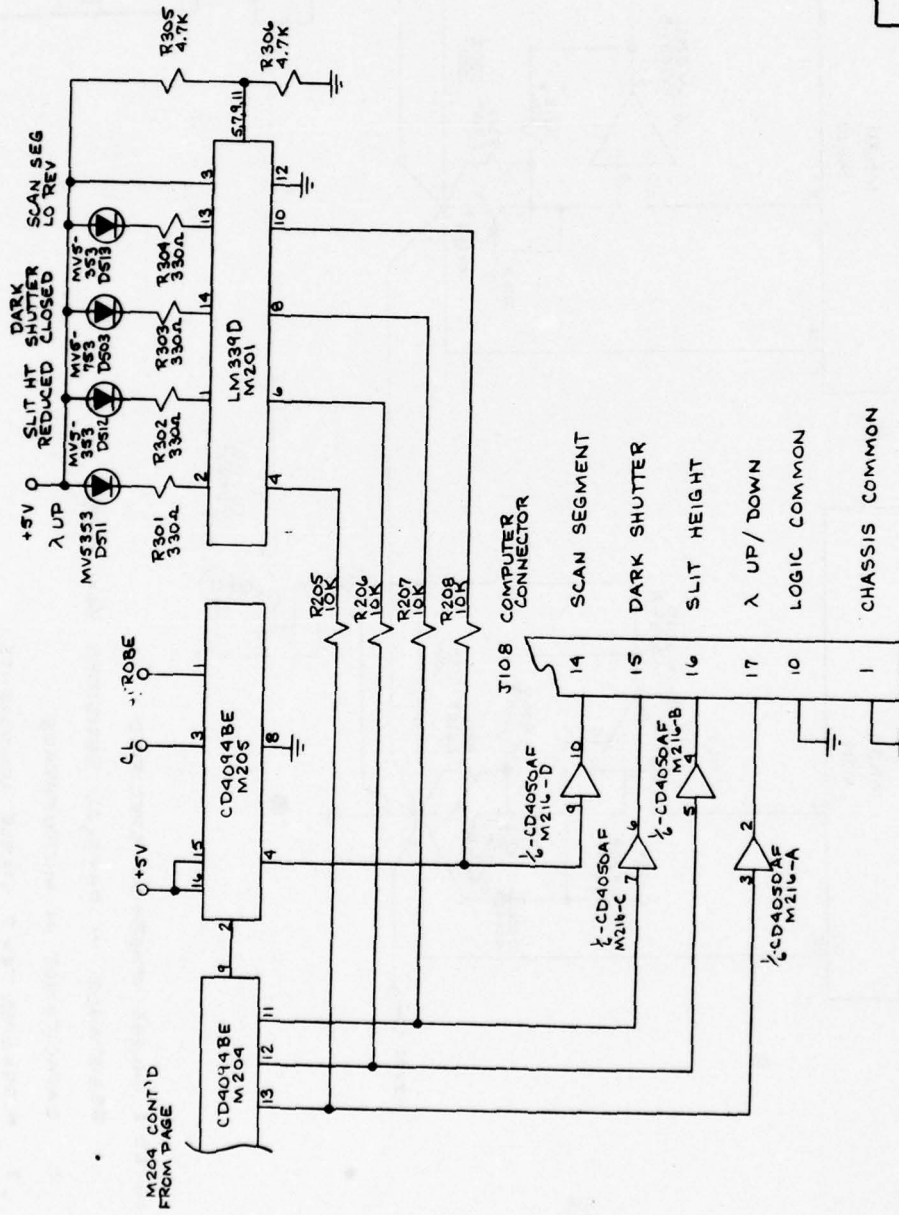

NOTES : UNLESS OTHERWISE SPECIFIED XAC755F2000

1. RESISTANCE IN OHMS, ALL RESISTORS 1/4W ± 5%.
2. CAPACITANCE IN MICROFARADS
3. * DENOTES TEMP STABLE COMPONENTS
RESISTORS ARE METAL FILM 1/10W ± 1%
CAPACITORS ARE POLYCARBONATE ± 10%

SPACOM ELECTRONICS	
CARMARILLO, CALIFORNIA 93010	
DWN 2-13-76	CKD <i>SR/76</i> APPD <i>SR/76</i>
SCHEMATIC DIAGRAM SE238 GSE	
SPECTROMETER ENABLE/DISABLE CONTROL	
FUNCTIONS INDICATORS & MONITORS	
CRO356	
125308	REV 10-7-74 B

FIG. 29

THIS PAGE IS BEST QUALITY PRACTICABLE
FROM COPY FURNISHED TO DDG

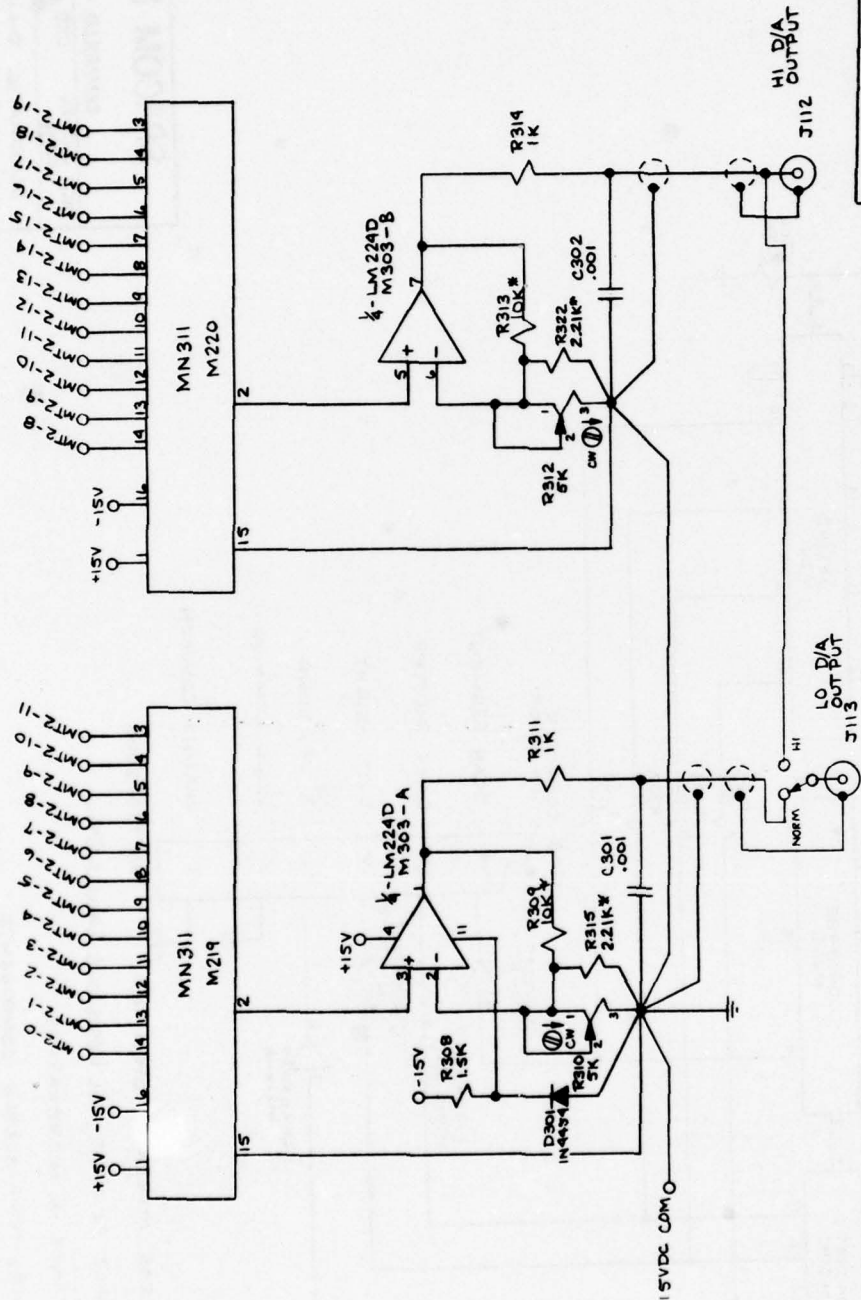

SPACOM ELECTRONICS	
CAMARILLO, CALIFORNIA 93010	
DWN 2-13-76 APP	CKD 5/19/76 APP
SCHEMATIC DIAGRAM SE238 GSE	
D/A CONVERTERS DETECTOR # 2	
125309	CRO356 REV 7-14-78 B

FIG. 30

- NOTES: UNLESS OTHERWISE SPECIFIED
1. RESISTANCE IN OHMS, ALL RESISTORS $V/4-W \pm 5\%$.
 2. CAPACITANCE IN MICROFARADS
 3. # DENOTES TEMP STABLE COMPONENTS
RESISTORS ARE METAL FILM $V/10W \pm 1\%$.
CAPACITORS ARE POLYCARBONATE $\pm 10\%$
 4. MT1, MT2 SPECIFY DETECTOR NO'S, EG. MT1 = DET#1

Serial data from the flight equipment coming directly to the GSE when in the benchtest mode enters the GSE through one pin of the connector marked "SIGNAL" and is sent directly to the connector marked "INST DATA". The serial data is then coupled from the "INST DATA" connector to the "DATA IN" connector through an external cable.

The 5V sync portion of the serial data entering the "DATA IN" connector, whether from the "INVERTER OUT" connector or the "INST DATA" connector, triggers comparator M101B, D which light the green LED marked "WORD SYNC". Comparator M101A normalizes serial data to 5V logic levels and sends it to the serial input of shift register M105-M205.

Serial data is shifted through the register by a clock from M103 which is derived by dividing down the 1.024MHz master crystal clock M104. The circuit is synchronized so that the data from each 0.01 sec measuring period of the spectrometer is in the shift register when the following 5V sync word triggers M101B. M101B then triggers M102A which in turn puts out a load pulse to the shift register that latches the data at the parallel outputs of the shift register. New data shifts through the register even though the parallel outputs are latched at the data from the previous frame until the next sync pulse comes from M102A to latch the outputs of the shift register at the new data. The occurrence of new data at the shift register parallel outputs is marked by an output pulse at the connector labeled "WORD SYNC".

The counts of Detector #1 and Detector #2 and the scan counter (M108-M112 in the flight package) are displayed on the GSE front panel readouts labeled "DET 1", "DET 2", and " λ " respectively. These readouts will be updated with each new data frame if the front panel toggle switch "DISPLAY-CONTINUOUS/SAMPLED" is set to "CONTINUOUS" or with every 128th frame if that switch is set to "SAMPLED". When activated, the "DISPLAY-TEST" momentary switch will cause all "8's" to be displayed on these readouts.

The parallel data from the shift register along with the "WORD SYNC" pulse is also sent to the connector marked "COMPUTER" for computer processing. The output at the computer connector is continuously updated regardless of the setting of the "DISPLAY-CONTINUOUS/SAMPLED" switch. The counter and scan data at the "COMPUTER" connector is in a BCD format.

The counts of Detector #1 and Detector #2 are sent to D/A's M301 and M302 and to D/A's M219 and M220, respectively, for conversion to analog signals. M301 and M302 convert the 12 least significant bits and the 12 most significant bits, respectively of the count from Detector #1 into analog signals and put these signals out on connectors "DET 1 D/A LO" and "DET 1 D/A HI", respectively. M219 and M220 operate similarly on the count from Detector #2 and put their data out on connectors "DET 2 D/A LO" and "DET 2 D/A HI", respectively. The D/A outputs are continuously updated

regardless of the setting of the "DISPLAY-CONTINUOUS/
SAMPLED" switch. Toggle switches permit switching HI D/A
on to the LO D/A connector if desired.

The connector labeled "SIGNAL" brings those flight
equipment data and control functions that are accessible
through the telemetry link to the GSE. All other monitor
control functions pass through the connector labeled
"PWR CONT".

The banana jacks labeled "HEATER" were used to monitor
the heater battery which has been removed from the system.

The front panel DVM monitors the following signals
at its respective switch settings:

- "A"- Flight equipment battery voltage when the battery
charger is OFF.
- "B"- Flight equipment 5 volt logic voltage.
- "C"- Flight equipment high voltage to Detector #1.
- "D"- Flight equipment high voltage to Detector #2.
- "E"- Flight equipment thermistor signal from thermistor
located near spectrometer entrance.
- "F"- Flight equipment thermistor signal from thermistor
located in logic box.
- "G"- Unused spare.
- "H"- Unused spare.
- "EXT V"- GSE 18 volt power supply voltage (the power
supply that supplies external power to the flight
equipment).

"EXT I"- Current being delivered to the flight equipment from the GSE 18 volt power supply.

"+5VD"- GSE 5 volt display power supply voltage (this is a GSE power supply used only to power the "DET 1", "DET 2", and " λ " displays).

"5VL"- GSE 5 volt power supply voltage.

"+15V"- GSE +15 volt power supply voltage.

"-15V"- GSE -15 volt power supply voltage.

"100 DCV MAX"- Separate meter inputs that can be used to read any DC voltage up to 100V.

The signals read on the DVM at switch settings "A" through "H" as given above can also be monitored at any time by measuring between the appropriately lettered jack and either of the two jacks labeled "COMMON" of the set of 10 jacks above the DVM readout.

The connector labeled "COMMUTATOR" supplies the commutated analog monitors from M310A in the flight electronics. The eight commutated analog monitors are not demultiplexed when they come out of this connector. The scan direction is controlled by the momentary switch "SCAN DIR-D/U". Switching this switch to "D" when the spectrometer is going up or to "U" when the spectrometer is going down will immediately change the scan direction. The yellow LED " λ UP" will be lit when the spectrometer is scanning upward and will be out when the spectrometer is scanning downward.

The scan segment is controlled by the momentary switch "SCAN SEG D/E". Switching this switch to "D" will permit a full scan between 2000 A° and 3100 A°. Setting this switch to "E" will cause the scan to be limited to the region 2650 A° - 3100 A°. The yellow LED "LO REV" will be out when a full scan is being permitted and will be lit when a limited scan is in effect.

The entrance slit height is controlled by the momentary switch "SLIT HT D/E". Setting this switch to "D" will leave the entrance slit at full height for the complete scan. Setting this switch to "E" will cause the slit to reduce in height when the spectrometer is in the 2650 A° - 3100 A° range. The slit is always at full height when the scan is in the 2000 A° - 2650 A° range. The slit height changes only at 2650 A° and will not change immediately when the "SLIT HT D/E" is activated. The yellow LED "REDUCED" indicates the height of the entrance slit. When the LED is off, the slit is full height and when it is lit, the slit height is reduced. Since the slit height will not change immediately upon activation of the "SLIT HT D/E" switch, the "REDUCED" LED will not change immediately upon activation of the switch. In the longest situation, a full scan can elapse between activation of the switch and a change in the LED.

The spectrometer entrance can be closed for 0.1 sec any time by activating the momentary switch labeled "DARK

SHUTTER". Upon activating this switch, the red LED labeled "CLOSED" will blink indicating the entrance was closed momentarily. The entrance will also be closed automatically at the scan endpoints (3100 A° and 2650 A° or 2000 A°) and will be so indicated by a blink of the LED labeled "CLOSED".

A 1.024MHz pulse train is available at the connector labeled "TEST PULSE". This pulse train can be applied at the input to the amplifiers in detector packages to check the amplifier circuit operation.

The toggle switch labeled "SCAN CONTROL-NORM/GSE" controls whether the scan operation of the spectrometer is in flight control or is under GSE control. When the scan is under GSE control the scan position can be changed by depressing the pushbutton labeled "STEP" or by applying pulses from an external pulser at any rate below 100Hz to the connector labeled "EXT DR".

The momentary switch labeled "CAL DIODE-OUT/IN" controls the position of the input flux monitor for the spectrometer. Directly above this switch is located the connector for the cable sending power to the diode assembly and above this connector is a fuse for the current flowing to the diode assembly through this connector.

The toggle switch labeled "AC PWR LINE" controls power to the GSE 18 volt power supply that delivers external power to the flight equipment and to the GSE 5 volt power supply which powers the GSE DVM. The "AC PWR LOGIC" toggle switch is in series with the "AC PWR LINE" switch and turning both

these switches on applies power to all GSE power supplies (+5 volt logic, +5 volt display, +15 volt and -15 volt). The red LED labeled "ON" that is located above the "AC PWR LINE" and "AC PWR LOGIC" switches will be on when the "AC PWR LINE" switch is on.

The toggle switch labeled "BATT CHRG" controls power to the flight equipment for charging the main flight battery. When the "BATT CHRG" switch is on, the yellow LED labeled "ON" that is directly above the "BATT CHRG" switch will be lit. The power source operating the flight equipment is controlled by the "PWR CONT-INT/EXT" momentary switch. When this switch is set to "INT", power to the flight equipment will come from the flight battery. This condition will be indicated by the green LED directly above the "INT" switch position being lit. This LED will be lit whenever the flight equipment is operating from the flight battery and the GSE is connected to the flight equipment through the "PWR CONT" regardless of whether the GSE "AC PWR LINE" switch is on or off. When the "PWR CONT -INT/EXT" is set to "EXT", the "EXT PWR" toggle switch is on and the "AS PWR LINE" switch is on the flight equipment will be receiving power from the GSE 18 volt power supply. This condition will be indicated by the red LED directly above the "EXT" position being lit. Turning the "EXT PWR" switch off stops any power from the GSE +18 volt power supply from operating the flight equipment electronics. This switch does not control the flight equipment battery charging power.

7.0 Testing

The complete spectrometer was assembled and tested for proper mechanical and electrical operation, using an approved Acceptance Test Procedure developed for this purpose. This test plan is shown in Appendix A. The test plan in Appendix A also includes an outline for optical calibration and verification. A calibration report for a complete absolute calibration performed on the spectrometer is shown in Appendix B.

Prior to launch the complete spectrometer package was mated to and interfaced with the Ball Brothers supplied solar pointing control, to assure compatibility. These tests were performed again in the field prior to launch.

Full optical calibration was performed both pre and post launch by AFGL personnel, in addition to the absolute calibration performed at The Johns Hopkins University facility.

8.0 Acknowledgements

Research Support Instruments, Inc. would like to acknowledge the following people and/or firms for contributing to this program.

- a) Spacom Electronics, Camarillo, California -
electronic sub-system design, fabrication,
assembly, and support
- b) Muffoletto Optical Company, Baltimore, Maryland -

Ebert spectrometer mirror

- c) Hyperfine, Inc., Fairport, New York -
diffraction grating for spectrometer
- d) Acton Research Corporation, Acton, Massachusetts -
UV optical coatings for mirrors, filters
- e) Prof. William G. Fastie, The Johns Hopkins
University, Baltimore, Maryland - optical
consultation and direction

(APPENDIX A)

Test Plan No. RLI 001

Prepared June 11, 1976

Acceptance Test Procedure
Balloon Borne Solar Spectrometer
RLI Model 10-171-0-1, S/N001

Air Force Geophysics Laboratory
Hanscom Air Force Base,
Massachusetts 01731

Ray Lee Instruments, Inc.
7103 Milford Industrial Road
Pikesville, Maryland 21208

ACCEPTANCE TEST PROCEDURE
FOR VERIFICATION OF OPERATION, SPECTRAL SENSITIVITY
AND RESOLUTION OF AFGL BALLOON BORNE
SOLAR SPECTROMETER
RLI MODEL 10-171-0-1, S/N 001

I. Equipment Required

- A. Flight Spectrometer
- B. Ground Support Equipment
- C. Interface Cables
- D. J.H.U. Calibration Test Equipment
 - 1. Calibrated Vacuum Ebert Spectrophotometer
 - 2. NBS Strip Filament Lamp & Precision power controls
 - 3. Hollow Cathode Pt-Ne discharge lamp & power controls
 - 4. Grating Calibration Chamber & Ref. Diode
- E. Electronic Equipment
 - 1. Bench regulated power supply . . . 0 to +24VDC @ 500MA
 - 2. Oscilloscope . . . Tektronix 541 or better with 10:1
 - 3. Digital Voltmeter . . . four digit $\pm 0.05\%$ or better
 - 4. Power supply . . . +2.5 \pm .05VDC
 - 5. Square Wave Generator . . . +5V. 0 to 100HZ
 - 6. Counter . . . 10MHZ, 40MV Sensitivity
 - 7. Brush Recorder

II. Preliminary Preparation

- A. Visual Mechanical Checkout
- B. Complete Electronic checkouts to validate all electronic & readout systems
 - 1. Pretest Operations:
 - a. Set bench power supply to +18 \pm .1VDC. Turn off supply. Connect to battery terminals inside instrument battery box (observe proper polarity). This will substitute for the internal flight battery for the following tests.
 - b. Insure all flight instrument cables are connected.
 - c. Install calibration diode position mechanism.
 - d. Flight battery not installed for following tests.
 - 2. GSE Setup Operations:
 - a. Turn the following switches on the GSE SE 238 to the off (down) position:
 - AC Pwr Line
 - AC Pwr Logic
 - Batt Chrg
 - Ext Pwr
 - b. Turn the DISPLAY-CONTINUOUS SAMPLED SWITCH TO CONTINUOUS.

- c. Turn the SCAN CONTROL-NORM/GSE, Switch to NORM.
- d. Plug in the 110V 60HZ AC line cord.
- e. Turn the AC PWR-LINE switch on. The red led ON will light and the front panel DVM will be energized.
- f. Turn the DVM selector to EXT V. The DVM will read _____
+ 18.00V +.50V.
- g. Connect the cable #125388 from the cal diode connector on the GSE (directly above the Cal Diode-Out/IN" switch) to the Cal Diode assembly on the spectrometer. Turn the "Cal/Diode-Out/In: switch to "IN". The cal Diode will move back out of position. Remove cable #125288.
- h. Turn the AC PWR-LOGIC" switch on.
- i. Turn the DVM selector to "+5VD"
The DVM will read +5.00V + 0.20V. _____
- j. Turn the DVM selector to "+5VL"
The DVM will read +5.00V + 0.20V. _____
- k. Turn the DVM selector to "+15V"
The DVM will read +15.00 + 0.20V. _____
- l. Turn the DVM selector to "-15V".
The DVM will read -15.00V + 0.20V. _____
- m. Press up on the "DISPLAY-TEST" switch. The DET 1, "DET 2" and "λ" Displays will indicate all "8's".
- n. Connect the Oscilloscope to the "TEST PULSE" connector. A pulse train approximately 0.04V P-P with a 50% Duty cycle will be observed. Remove the oscilloscope.
- o. Connect the counter to "TEST PULSE". A frequency of 1.024 MHz + 110Hz will be observed. Remove the counter. _____
- p. Short the "T/M DATA IN " connector. Connect a voltmeter to the "INVERTER OUT" Connector. Measure 2.5V +0.10V. Remove the short.
- q. Using an external DC voltage source, place +2.5V +0.05V on the "T/M Data IN" connector. Measure 0.04V + 0.04V with the voltmeter. Remove the voltage source and the voltmeter _____
- r. Turn off the "AC PWR LOGIC" switch.
- s. Turn off the "ACPWR LINE" Switch.

3. Instrument Operation:

- a. Connect the GSE to the payload with benchtest cables #125257 & #125258 (with adapter #125324A).
- b. Turn on bench 18V power supply to simulate flight battery.
- c. Jumper the connector INST DATA to the connector DATA IN on the GSE.
- d. Push the PWR CONT switch to INT. The green LED INT will light. Push the PWR cont switch to EXT.
- e. Turn on the AC PWR LINE switch.
- f. Turn on the BATT CHRG Switch. The yellow Led ON will light. Turn off the BATT CHRG Switch.
- g. Turn the EXT PWR Switch on. The RED LED EXT will light.
- h. Turn the DVM selector to "EXT 1". The DVM will read +.24 to .33A +.03A depending on slit height position.
- j. Turn the PWR CONT Switch to INT.

- k. Turn the DVM selector to A. The DVM will read 18.00V \pm .10V. Connect an external voltmeter across the A banana jack and one of the COM banana jacks. The external voltmeter will read the same value as the DVM. Remove the external voltmeter.
- i. Turn the DVM selector to B. The DVM will read +5.00V \pm .20. Connect an external voltmeter across the B banana jack and one of the COM banana jacks. The external voltmeter will read the same value as the DVM. Remove the external Voltmeter.
- m. Turn the DVM selector to C. The DVM will read HV#1 MON. Connect an external voltmeter across the C banana jack and one of the COM banana jacks. The external voltmeter will read the same value as the DVM. Remove the DVM. Remove the external voltmeter. Reading will vary with HV #1 setting.
- n. Turn the DVM selector to D. The DVM will read HV#2 MON. Connect an external voltmeter across the D banana jack and one of the COM banana jacks. The external Voltmeter will read the same value as the DVM. Remove the external voltmeter. Reading will vary with HV#2 setting.
- o. Turn the DVM selector to E. The DVM will read some value between zero and +4V depending on the temperature at the detectors. Connect an external voltmeter across the E banana jack and one of the COM banana jacks. The external voltmeter will read the same value as the DVM. Remove the external voltmeter.
- q. Turn the DVM selector to F. The DVM will read some value between zero and +4V depending on the temperature in the logic area. Connect an external voltmeter across the F banana jack and one of the COM banana jacks. The External voltmeter will read the same value as the DVM. Remove the external Voltmeter.
- r. Connect the heater battery to the HEATER banana jacks with heater battery cable #125285.
- s. Turn the DVM selector to G. The DVM should read between +12 and +14VDC. Connect an external voltmeter across the G Banana jack and one of the COM banana jacks. The external voltmeter will read the same value as the DVM. Remove the external voltmeter.
- t. Remove Cable #125285.
- u. Turn the DVM selector to the position indicating the banana jacks labeled 100 DCV MAX. Place some known DC voltage less than 100V across this pair of banana jacks. The DVM will read the value of the voltage. Remove the voltage source.
- v. Turn the DVM selector full CW and then full CCW. At each of these two extremes the DVM will read 00.00V \pm .01V.
- w. Connect the oscilloscope to the COMMUTATOR connector. There will be eight voltage levels continually repeated in a pulse train. The duration of each voltage will be 10MS to give a total duration of all eight levels of 80MS. Remove the oscilloscope.

<u>Level</u>	<u>Measured</u>
SYNC	_____
+5/2 MON	_____
+18/10 MON	_____
HV #1	_____
HV #2	_____
Temp. #1	_____
Temp. #2	_____
Zero	_____

- x. Turn the AC PWR LOGIC switch on.
- y. The green Led WORD SYNC will light.
- z. Connect the oscilloscope to the WORD SYNC connector. A pulse train \sim 4.5V amplitude with a repetition rate of 100HZ and A width of \sim 4 μ s for each pulse will be observed.
- aa. Turn the SCAN DIR-D/U switch to D. The yellow Led λ UP will go out and the " λ " counter count will decrease at a rate of 100 counts per second. Turn the "SCAN DIR-D/U" switch to "U" The up" LED will light and the " λ " counter count will increase at a rate of 100 counts per second.
- bb. Turn the DISPLAY-CONTINUOUS/SAMPLED switch to sampled. The λ counter count will increase by 128 counts every 1.28 seconds. Turn the switch back to CONTINUOUS.
- cc. Turn the SCAN CONTROL-NORM/GSE seitch to GSE. The λ Counter will stop. Depress the STEP Pushbutton several times. The λ Counter will advance one count with each actuation of the pushbutton.
- dd. Connect a +5V external generator with an output square wave of 100HZ or less to the EXT DR connector. The λ counter will advance one count with each pulse. Remove the Generator.
- ee. Return the SCAN CONTROL-NORM/GSE switch to NORM.
- ff. Press up on the DARK SHUTTER switch. The red Led CLOSED will flash each time the switch is pressed. While the system is scanning, observe a flash in the CLOSED Led at each change in scan direction.

- gg. Observe the wavelength scan with the λ counter for one full cycle. A full scan will be permitted and the yellow led LO REV is out. Push the SCAN SEG-D/E switch to E. The LO REV led will light. Wait up to one full scan cycle and observe that the scan is limited. Push out. Wait one half scan cycle and observe that a full scan is again permitted.
- hh. If the yellow Led REDUCED is off, wait up to one-half a full scan cycle for it to come on and proceed as follows: With the REDUCED Led on, wait one full scan cycle during which the REDUCED Led will go out to D. and wait one full scan cycle. Observe that the REDUCED led goes out but does not come back on. Push the switch to E. Wait one full scan cycle and observe that the REDUCED Led comes back on.
- ii. Connect cable #125286 between the TEST PULSE connector and connector J 18 on the spectrometer. Connect cable #125287 from J4 on the Logic box to the Laboratory counter. Connect the voltmeter to connector DET 1 D/A LO.
- jj. The Laboratory counter will read 1.0240MHZ _____
"Det 1 counter will read 10238 \pm 10. _____
The voltmeter will read +2.40V \pm .10V _____
Disconnect the voltmeter from "DET 1 D/A LO" and connect it to "DET 1 D/A HI". The voltmeter will read +1.02V \pm .03V. _____
- kk. Connect cable #125286 between the TEST PULSE connector and connector J17 on the spectrometer. Connect cable #125287 from J5 on the logic box to the laboratory counter. Connect the voltmeter to connector DET 2 D/A LO.
- The laboratory counter will read 1.024MHZ \pm 100HZ. _____
DET2 counter will read 10238 \pm 10 _____
The voltmeter will read +2.40V \pm .10V. _____
Disconnect the voltmeter from "DET 2 D/A LO" and connect it to DET 2 D/A HI. The voltmeter will read +1.02V \pm .03V. _____
Disconnect cables #125286 and #125287 and the voltmeter. _____
- ll. Switch PWR CONT to EXT.
- mm. Verify proper DVM monitor readings from the instrument as measured with power INT.
- nn. Return PWR CONT to INT.
- oo. Reduce laboratory power supply output voltage to +16VDC. Verify DVM monitor readings from the instrument.

- pp. Increase Laboratory power supply output voltage to +24 VDC. Verify DVM Monitor readings from the instrument.
 - qq. Return laboratory power supply output to 18VDC.
 - rr. Switch PWR CONT to EXT.
 - ss. Turn off EXT PWR, AC PWR LOGIC and AC PWR LINE switches.
- C. Confirm electronic calibration of D-A converter-Brush recorder output with Digital output.
- D. Absolutely calibrate vacuum Ebert Spectrometer (QT)
- E. Determine flux from Hollow cathode lamp by following procedure:
1. Place lamp at measured distance from entrance slit of vacuum Ebert Spectrometer so that all radiation passing through entrance slit strikes diffraction grating
 2. Adjust entrance slit width & height to accurately measured value.
 3. Set exit slit to width & height values in excess of entrance slit values.
 4. Set lamp current to 20 ma
 5. Record Spectrometer output for at least 10 spectral lines between 2000 and 3000A.
 6. Increase exit slit width by 50%
 7. Repeat II-D-5
 8. If 5 & 7 give same signal calculate absolute flux from lamps based on given QT of VACuum Ebert Spectrometer.
 9. If 5 & 7 are significantly different, increase exit slit width until no further signal increase is observed & recalculate absolute sensitivity.
- Note: The absolute calibration performed above is not intended as an ultimate absolute calibration but has the purpose of establishing that the absolute sensitivity of the Balloon Borne Spectrometer is within at least a factor of 2 of its calculated sensitivity in the range 2000 to 3000A.
10. Place the Pt-Ne lamp at an appropriate distance from the entrance slit of the flight spectrometer. Verify optical alignment by showing that slight lateral or vertical displacement of the lamp does not change observed Spectral Signal
 11. Record 2000 to 3000A spectrum on Brush recorder
 12. Calculate absolute sensitivity of flight spectrometer.
 13. Operate Brush recorder at high paper speed and record shapes of several Pt lines.
 14. Confirm that Spectral resolution is $.1A \pm .03A$
 15. Stop wavelength drive on appropriate bright line.
 16. Actuate slit height limiter.
 17. Record signal change
 18. With appropriate optics, illuminate flight spectrometer entrance slit with light from NBS calibrated standard strip

filament lamp.

- 19, Scan Spectral range 2500 to 3500A. Record Spectrum
20. Calculate absolute sensitivity.
21. Document all tested data.

(APPENDIX B)

ABSOLUTE CALIBRATION OF AFGL
NEAR UV EBERT SOLAR SPECTROMETER
MODEL NO. 10-171-0-1, S/N001

March 13, 1978

Prepared for:

Air Force Geophysics Laboratory
Air Force Systems Command, USAF
Hanscom Air Force Base, Massachusetts 01731

Prepared by:

Research Support Instruments, Inc.
71 West Timonium Road
Timonium, Maryland 21093

Absolute Calibration of AFGL Near UV Ebert Solar Spectrophotometer
Wm. G. Fastie, The Johns Hopkins University

The calibration source was a strip filament lamp (JHU #22) operated at 39.975 amperes at which current its blackbody temperature as measured with a Leeds and Northrup optical pyrometer was 2234°C. Based on an NBS calibration of an identical lamp (NBS #184123, running at 38.497 amp at which current the blackbody temperature should be 2234°C at the pyrometer wavelength), the filament brightness would be

λ	$B(\text{ph/cm}^2/\text{sec/ster/A})$
2410	4.056×10^{11}
2537	1.020×10^{12}
2625	1.820×10^{12}
2800	4.904×10^{12}
3000	1.277×10^{13}
3500	7.933×10^{13}

The AFGL spectrometer was illuminated by the strip filament of the working lamp (JHU #22). The filament was focused on the entrance slit with a quartz lens (transmission 93%). A diaphragm at the lens was 2.0225 cm² in area and was 68.5 cm from the spectrometer entrance slit. The slit widths (entrance slit and inner exit slit) were assumed to be 20.8μ and 500μ long as measured by RSI. The spectral band pass $\Delta\lambda$ was calculated from the formula

$$\Delta\lambda = a \cos \beta d\beta,$$

The following calibration values were obtained:

Table I

<u>Dial Reading</u>	<u>λ</u>	<u>$\Delta\lambda$</u>	<u>Ph/Δ in slit ($\times 10^{-6}$)</u>	<u>Counts/sec</u>	<u>QT $\%$</u>
60,000	2448	.102	.231	1,520	.66
65,000	2548	.102	.452	4,320	.96
70,000	2648	.101	.846	9,200	1.09
75,000	2748	.100	1.51	15,650	1.04
80,000	2848	.099	2.50	24,500	.98
85,000	2948	.098	3.82	32,800	.86
90,000	3048	.097	6.10	38,600	.63
95,000	3148	.095	8.68	38,500	.44
100,000	3248	.094	12.53	30,100	.24

To determine the count rate the output of the spectrometer count rate meter was measured with a digital voltmeter which had a very large capacitor across its input. This voltmeter was precalibrated with a precision potentiometer. The use of the capacitor did not affect the calibration of the voltmeter. The count rate meter was designed to give 10 mv/photoelectron and to integrate for 10 milliseconds (specified by Spacom to be accurate to at least 10 microseconds). The 10 mv/photoelectron value was confirmed by operating the count rate meter in the one reading per second mode and adding on a hand

calculator (2-man operation) a total of 20,000 counts and comparing with the filtered digital voltmeter reading. The values agreed to within 1%.

Subsequent to the measurements shown in Table I, the optical pyrometer was recalibrated at NBS (courtesy Dr. Henry Kostkowski) and found to have changed calibration since its last check at NBS by -6°C . (It produced a dial reading of 2248°C when observing a 2234°C blackbody as compared to its previous calibration of 2254°C for a 2234°C blackbody. This error suggests that the QT values in Table I are high by about 3%.

We have also made a direct comparison of the relative brightness of the working lamp (JHU #22), operating at 2234°C (according to the recalibrated pyrometer), and the NBS-calibrated lamp, operating at the same temperature according to the recalibrated pyrometer. This comparison was made by illuminating a 1/8-meter rocket spectrometer which employed a CsTe photomultiplier tube identical to the one employed in the AFGL spectrometer and which had been previously calibrated in our calibration test equipment* which uses NBS-calibrated solar blind (CsTe photodiodes) as a calibration transfer standard.

This comparison showed that the working lamp was less bright than the NBS-calibrated lamp by 11% at 2448 Å and 3% less bright at

*See Fastie and Kerr, Appl. Opt. 14, 2133, 1975.

3048 A with a linear increase over this range. Thus our best estimate of the QT of the AGL balloon spectrometer based on the strip filament lamp is

Table II

<u>Dial</u>	<u>λ</u>	<u>QT (lamp)</u>	<u>QT (CTE)</u>
60,000	2448	.71%	.68%
65,000	2548	1.02	1.04
70,000	2648	1.15	1.18
75,000	2748	1.08	1.10
80,000	2848	1.01	1.02
85,000	2948	.90	.94
90,000	3048	.65	.68
95,000	3148	.45	---
100,000	3248	.25	---

The last column of Table II was obtained by comparing the calibration of the 1/8-meter rocket spectrometer which was obtained in the calibration test equipment with a recalibration of that spectrometer with the strip filament lamp. We estimate that neither calibration is absolutely accurate to better than $\pm 5\%$.

We also measured the signal obtained from the second detector over the outside (wide) exit slit as shown below. The QT values derived from this data should be compared to the values obtained for the inner slit in Table I. The corrections indicated to obtain the QT (lamp) values shown in Table II should be applied at each wavelength to the QT values to be derived from Table III.

Table III

<u>Dial</u>	<u>Counts/sec</u>
55,000	22,600
60,000	57,200
65,000	102,500
70,000	147,500
75,000	185,000
80,000	177,100
85,000	171,000
90,000	119,500
95,000	66,500
100,000	29,500

No wavelength data were obtained, and no QT values were calculated.

The wavelength calibration for the inner slit was obtained by determining the dial reading for the peak signal from a number of emission lines of a platinum-neon hollow cathode lamp. The dial readings were made over a 3-month period and always after the wavelength drive had been run to its highest value (100,000), then to its lowest value (36,915). The peak value was always obtained with the wavelength drive running towards longer wavelength (larger dial) readings.

Table IV

<u>λ(A. U.)</u>	Dial			<u>Calc λ</u> *
	<u>Nov</u>	<u>Jan</u>	<u>Feb</u>	
2144.23	44,788	790	790	2144.23
2174.67	46,315	310	313	2174.70
2440.05	59,590	584	586	2440.10
2487.17	61,942	938	939	2487.15
2498.50	62,507	505	508	2498.49
2628.00	68,987	985	989	2628.05
2650.87	70,130	127	130	2650.89
2659.48	70,556	556	558	2659.44
2702.40	72,703	703	708	2702.39
2705.90	72,879	880	882	2705.89
2733.96	74,284	281	286	2733.96
2771.66	76,170	168	171	2771.67
2830.30	79,101	101	104	2830.30
2893.86	82,282	280	282	2893.86
2929.79	84,078	076	079	2929.79
2997.97	87,486	485	489	2997.95
3042.63	89,719	719	723	3042.60
3064.71	90,825	825	828	3064.71

Scale factor 50.01412 counts/A. U.

* Based on scale factor - assumed linear

We have studied the resolution of the spectrometer at the narrow slit by observing lines of the hollow cathode platinum neon lamp as recorded on a high-speed chart recorder. Throughout the range from about 2100 to 3000 Å almost all of the observed lines exhibited a full width at half maximum of 0.12 Å whereas the geometrical slit width over that range varies from 0.105 Å to .098 Å.