

construction  
engineering  
research  
laboratory



United States Army  
Corps of Engineers  
*Serving the Army  
Serving the Nation*

**12**  
INTERIM REPORT N-60  
January 1979  
Prediction of Noise Impact Within and  
Adjacent to Army Facilities

**LEV II**

ACOUSTIC DIRECTIVITY  
PATTERNS FOR ARMY WEAPONS

AD A0 66223

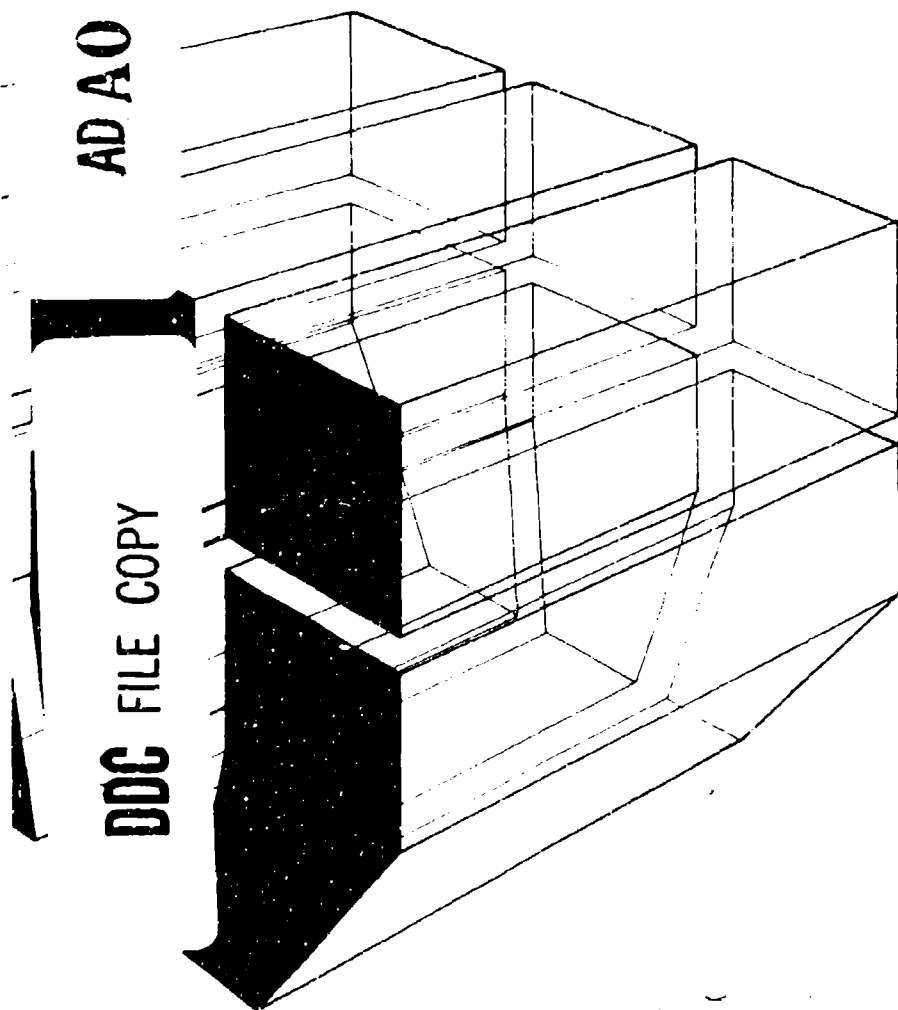

DDC FILE COPY

by  
P. D. Schomer  
L. M. Little  
A. B. Hunt

DDC  
RECEIVED  
MAR 22 1979  
D



Approved for public release; distribution unlimited.

The contents of this report are not to be used for advertising, publication, or promotional purposes. Citation of trade names does not constitute an official indorsement or approval of the use of such commercial products. The findings of this report are not to be construed as an official Department of the Army position, unless so designated by other authorized documents.

***DESTROY THIS REPORT WHEN IT IS NO LONGER NEEDED  
DO NOT RETURN IT TO THE ORIGINATOR***

REPORT DOCUMENTATION PAGE		READ INSTRUCTIONS BEFORE COMPLETING FORM
1. REPORT NUMBER 14 CERL-IR-N-60	2. GOVT ACCESSION NO.	3. RECIPIENT'S CATALOG NUMBER 9
4. TITLE (and Subtitle) 6 ACOUSTIC DIRECTIVITY PATTERNS FOR ARMY WEAPONS	5. TYPE OF REPORT & PERIOD COVERED INTERIM reptis	
7. AUTHOR(S) 10 P. D. Schomer L. M. Little A. B. Hunt		6. PERFORMING ORG. REPORT NUMBER
9. PERFORMING ORGANIZATION NAME AND ADDRESS U.S. ARMY CONSTRUCTION ENGINEERING RESEARCH LABORATORY P.O. Box 4005, Champaign, IL 61820		8. CONTRACT OR GRANT NUMBER(s)
11. CONTROLLING OFFICE NAME AND ADDRESS 12 125 PI		10. PROGRAM ELEMENT, PROJECT, TASK AREA & WORK UNIT NUMBERS 16 4A762720A896/03-001 17 03
14. MONITORING AGENCY NAME & ADDRESS (if different from Controlling Office)		12. REPORT DATE 11 January 1979
		13. REPORT TYPE 14. NUMBER OF PAGES 127
		15. SECURITY CLASS. (of this report) Unclassified
		15a. DECLASSIFICATION/DOWNGRADING SCHEDULE
16. DISTRIBUTION STATEMENT (of this Report) Approved for public release; distribution unlimited.		
17. DISTRIBUTION STATEMENT (of the abstract entered in Block 20, if different from Report)		
18. SUPPLEMENTARY NOTES Copies are obtainable from National Technical Information Service Springfield, VA 22151		
19. KEY WORDS (Continue on reverse side if necessary and identify by block number) noise pollution weapons noise directivity patterns		
20. ABSTRACT (Continue on reverse side if necessary and identify by block number) This report describes tests conducted by this investigation on 12 types of Army heavy weapons at Fort Sill, OK, and the development of precise sound-pressure level contours (directivity patterns) for Army weapons currently in use. The data obtained during these tests was also used to compile tables relating the charge weight to an equivalent weight of C-4 plastic explosive. 405 3.79 - next page		

Block 20 continued.

cont.

→ In addition, this investigation determined that elevation has little influence on weapon directivity patterns; the major factor affecting weapon directivity patterns was the muzzle brake, which causes directivity patterns to become almost circular. The exceptions were recoilless rifles. Weight equivalency tables were found to be a function of tube size, with the longest tubes being the quietest, since the charges within them are the most contained.



ADMISSION TO	
DTIC	Write Section <input checked="" type="checkbox"/>
DDI	Diff Section <input type="checkbox"/>
UNANNOUNCED	<input type="checkbox"/>
JUSTIFICATION	
BY	
DISTRIBUTION/CLASSIFICATION	
DATE	
A	

UNCLASSIFIED

SECURITY CLASSIFICATION OF THIS PAGE(When Data Entered)

## FOREWORD

This research was conducted for the Directorate of Military Programs, Office of the Chief of Engineers (OCE), under Project 4A762720A896, "Environmental Quality for Construction and Operation of Military Facilities"; Task 03, "Pollution Control Technology"; and Work Unit 001, "Prediction of the Noise Impact Within and Adjacent to Army Facilities." The QCR number is 1.03.011. Mr. F. P. Beck, DAEN-MPE-I, was the OCE Technical Monitor.

The work was performed by the Environmental Division (EN), U.S. Army Construction Engineering Research Laboratory (CERL). Dr. R. K. Jain is Chief of EN. Appreciation is expressed to M. L. Scala for her assistance in writing this report.

COL J. E. Hays is Commander and Director of CERL, and Dr. L. R. Shaffer is Technical Director.

## CONTENTS

	<u>Page</u>
DD FORM 1473	1
FOREWORD	3
LIST OF TABLES AND FIGURES	5
1 INTRODUCTION .....	7
Background	
Objective	
Approach	
Mode of Technology Transfer	
2 DATA COLLECTION .....	10
Test Sequence	
Measurement Apparatus	
Calibration	
3 DATA REDUCTION .....	17
4 DATA ANALYSIS .....	20
Correction Values	
Noise Contours	
Weight Equivalency Tables	
5 RESULTS .....	28
Prediction Method	
Additional Results	
6 CONCLUSIONS .....	32
APPENDIX A: Event Log	35
APPENDIX B: Weather Conditions for June 12 to 28, 1976 Fort Sill, OK	49
APPENDIX C: Directivity Patterns	57
APPENDIX D: Composite Directivity Patterns	111
APPENDIX E: Weight Equivalency Tables	125
DISTRIBUTION	

## FIGURES

<u>Number</u>		<u>Page</u>
1	Location of Measurement Microphones	9
2	Fort Sill Test Equipment	12
3	Block Diagram of Equipment Used in Data Reduction	18
4	Polar Plot Example	22
5	Flat-Weighted SEL vs C-4 Charge Weight	24
6	C-Weighted SEL vs C-4 Charge Weight	25
7	Weight/Weapon and Directivity Correction Factor Prediction Method	29
8	Directivity Pattern of a Self-Propelled 155-mm Howitzer	31
9	Directivity Pattern of a Towed 155-mm Howitzer	32

## TABLES

1	Weapons Tested	10
2	Barrel Lengths of Weapons Tested at Fort Sill	26
3	Equation Parameters and Correlation Factors ( $r^2$ ) for Weapons Tested at Fort Sill (F-Weighted SEL)	26
4	Equation Parameters and Correlation Factors ( $r^2$ ) for Weapons Tested at Fort Sill (C-Weighted SEL)	27

## ACOUSTIC DIRECTIVITY PATTERNS FOR ARMY WEAPONS

### 1 INTRODUCTION

#### Background

The impact of noise on man is increasingly recognized as a major source of annoyance. Studies of the effects of noise clearly show that people repeatedly exposed to high noise levels exhibit increased irritability and discomfort, severe nervous tension, loss of ability to concentrate, impaired aptitude to perform even simple tasks, and loss of sleep.<sup>1</sup>

U.S. Army Construction Engineering Research Laboratory (CERL) investigations into the prediction and assessment of noise impact on and adjacent to Army facilities have identified blast noise, rotary-wing aircraft, vehicles, and fixed sources as major noise sources, with blasts and rotary-wing aircraft selected as the major problems.

CERL is attempting to develop methods to predict the impact of blast noise. Important to this prediction method is the compilation of noise contours; these contours can be drawn to a distance scale compatible with a map of an installation and its surroundings, and can be used as an overlay to graphically show the noise impact of base operations. Given the operations, and/or types of weapons and their charges and locations, and frequency and time of operations, noise contours can help predict how changes in operations and different weapons and locations will affect blast-noise impact on installation environs.

In Predicting Community Response to Blast Noise,<sup>2</sup> CERL identified blast statistics, human and community response, and weapons contours as the data required to improve blast-noise impact prediction. In 1973, CERL measured blast propagation at Fort Leonard Wood, MO to develop

---

<sup>1</sup> Shultz, T. J., Noise Assessment Guidelines Technical Background, Report No. TE/NA 172 (Department of Housing and Urban Development, 1972), pp 81-87.

<sup>2</sup> Schomer, P. D., Predicting Community Response to Blast Noise, Technical Report E-17/AD773690 (U.S. Army Construction Engineering Research Laboratory [CERL], December 1973).



blast propagation statistics.<sup>3</sup> Psycho-acoustical tests have also been conducted<sup>4</sup> and a community attitudinal survey is underway.<sup>5</sup>

### Objective

The overall objective of this study is to predict blast-noise impact of artillery, demolition, and other blast operations within and adjacent to Army facilities.

Specifically, the objectives of this report are to (1) develop precise sound-pressure level contours (directivity patterns) for Army weapons currently in use, (2) develop tables relating the weight of charge to an equivalent weight of C-4 plastic explosive, and (3) present these contours and tables in a form suitable for use in manual and automated blast-noise prediction methods at Army installations.

### Approach

Noise measurements of 12 types of Army heavy weapons were made in July 1976 at Fort Sill, OK. Charge size and elevation of the weapons were varied. Sixteen measurement microphones were placed in two concentric circles at 250 and 500 m (Figure 1) around the weapons being tested. One omnidirectional 5-lb charge of C-4 immediately adjacent to the weapon being tested was detonated after every three shells fired. The purpose of these C-4 firings was to correct for the effects of wind and terrain upon blast propagation at the site.

Data was collected at the site with an Ampex PR-2200 14-track tape recorder and Nagra DJ scientific tape recorders. Subsequent data reduction was performed in the laboratory to determine, by microphone, positive and negative peak values for each blast, as well as frequency weight and measures. Data was transcribed into a digital format and then put into a minicomputer where weapons data was corrected by C-4 data; appropriate tables and contours were then developed.

---

<sup>3</sup> Schomer, P. D., R. J. Goff, and L. M. Little, The Statistics of Amplitude and Spectrum of Blasts Propagated in the Atmosphere, Volumes I and II, Technical Report N-13/ADA033475 and ADA033361 (CERL, November 1976).

<sup>4</sup> Young, J. R., Measurement of the Psychological Annoyance of Simulated Explosion Sequences, DACA 23-74-C-0008 (Stanford Research Institute, January 1975 and February 1976).

<sup>5</sup> Community Attitudes Survey, OMB 49-R0148 (CERL, April 1979).

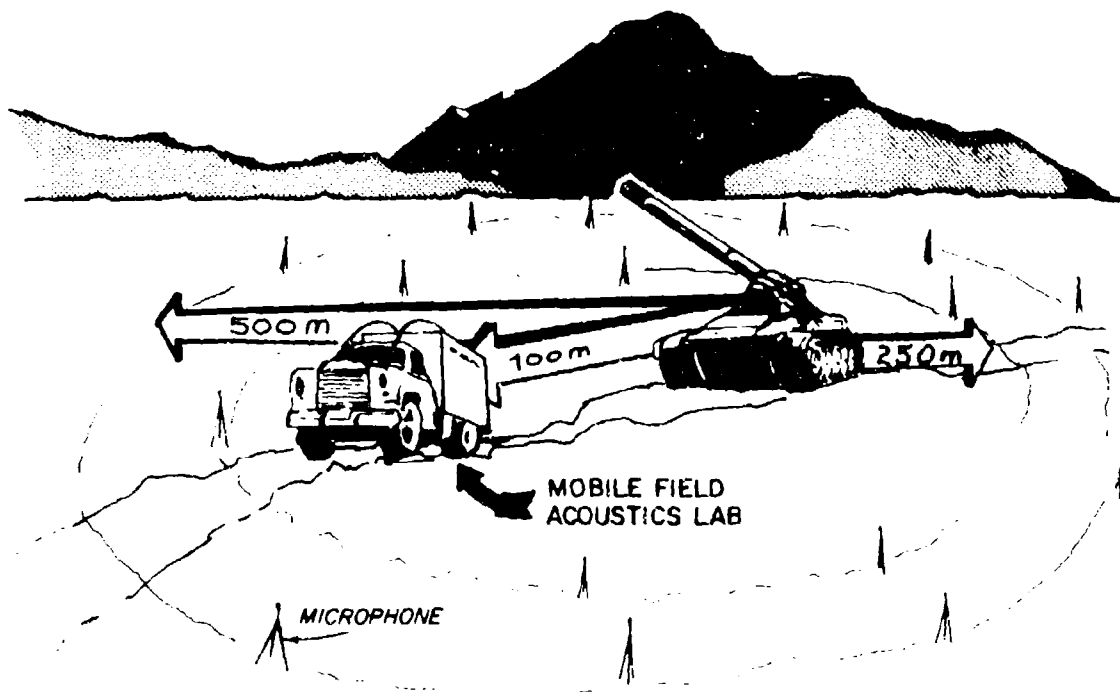

Figure 1. Location of measurement microphones.

Mode of Technology Transfer

The weapons contours and weight equivalency tables will be incorporated into CERL's Blast Noise Contour program. The Blast program itself is transferred to the field for official use by TM 5-803-2 (proposed), Environmental Protection: Planning in the Noise Environment, and by proposed AR 210-20, Master Planning.

## 2 DATA COLLECTION

Measurements were performed at Fort Sill in the south-central portion of Oklahoma. Fort Sill is the Army field artillery center and an extensive inventory of weapons is available there (one tank, the 152-mm Sheridan, was brought from Fort Hood, TX for the tests). The test site -- weapons ranges in a grassy field -- was accessed via a paved road. Because little training was ongoing at this site, it was a safe and convenient location for noise measurement.

### Test Sequence

During the Fort Sill test, 13 weapons were measured for blast noise. Table 1 lists these weapons, the days on which testing was performed, and the event numbers assigned to each particular weapon.

The main body of the test used C-4 plastic explosive as an undirectional calibration source. The test sequence consisted of one blast of C-4 followed by three shells from the weapon under test. The sound-pressure level contours emanating from the C-4 allowed correction for the effects of wind or terrain. This sequence was a compromise designed to place the weapon blast as close as possible to the C-4 blast without undue expense of resources or time. This investigation reasoned, given the speed of firing and changing weather, that the contour produced by the C-4 after two weapon blasts would not change greatly.

Table 1

#### Weapons Tested

<u>Type</u>	<u>Blast No.</u>	<u>Day</u>	<u>Name of Gun</u>	<u>Model</u>
1	1-23	12	8-in. self-propelled	M110A1
1	569-599	28	8-in. self-propelled	M110A1
2	24-65	13	105-mm tank	M60
3	76-104	14	4.2-in. mortar	M30
4	105-133	14	81-mm mortar	--
5	481-524	27	106-mm recoilless rifles	M40A1
6	438-480	26	90-mm recoilless rifles	M67
7	394-437	26	105-mm howitzer	M102
8	124-177	19	155-mm howitzer	M109
9	200-245	20	8-in. howitzer	M210
10	246-299	21	152-mm Sheridan (tank gun)	M551
11	525-568	27	155-mm howitzer	M114
12	350-393	22	155-mm howitzer	M109A1

## Measurement Apparatus

Microphones were deployed in two concentric rings with radii of 250 and 500 m, respectively, around the weapon (C-4) being measured. The inner ring had six microphones placed at  $60^\circ$  intervals around the firing point. The microphones were oriented so that one was directly in front and one directly behind the weapon, with two each on the left and right sides of the gun. The outer ring consisted of nine microphones at  $30^\circ$  intervals with a center microphone directly behind the gun. (No microphones were placed in front, or  $30^\circ$  either side, of the front of the weapon because of the possible damage to them from incoming shells and the danger involved in setting them up.)

Four types of microphone systems were used for measurements: the B&K 4921 outdoor microphone system, the B&K 141-B field microphone system, the B&K 2200 sound-level meter system, and the B&K 2631 FM carrier system. With the exception of the B&K 4921, all systems were operated with external microphone cartridges. (Figure 2 shows the equipment at each station.) The B&K 4921 and B&K 141 stations were powered by lines running from a van which served as a mobile field acoustics lab. The attended stations and the FM carrier system were self-contained.

An accelerometer station was also deployed; it consisted of three accelerometers oriented with respect to three mutually perpendicular axes. At first, the accelerometer station was placed 30, 60, or 90 m south of the blast site each day. However, after the first few days, it was found that if the station was always placed at 30 m, it registered the air wave almost exclusively, with little or no register of the ground wave.

Stations 33F, 36F, 3F, 9F, and 18F were the sound-level meter stations attended by field personnel. The peak sound level was measured on the sound-level meters at each station, and the flat-weighted output recorded on the Magna DJ tape recorder. In addition, a B&K 2631 FM carrier system with a B&K 4145 microphone specially sealed to measure low frequencies was used at station 18F.

Remote-controlled B&K 141 stations were placed at stations 6F and 12F, and operated by personnel at stations 3F and 9F, respectively. At station 27N, a B&K 1/4-in. microphone was used to allow the measurement of high frequencies and amplitudes.

Stations 33N, 3N, 9N, 15N, 21N, 21F, and 15F were B&K 4921 microphone systems powered by the mobile lab. The output from these stations, the signals from the FM carrier system, and the signals from the 1/4-in. microphone were recorded on the 14-channel Ampex PR 2200 FM tape recorder. Signals from the three B&K accelerometers (mounted in three dimensions to a cement block); the time code generator; and the wind

**B 8 K 141 WITH 1/4-IN. MICROPHONE**

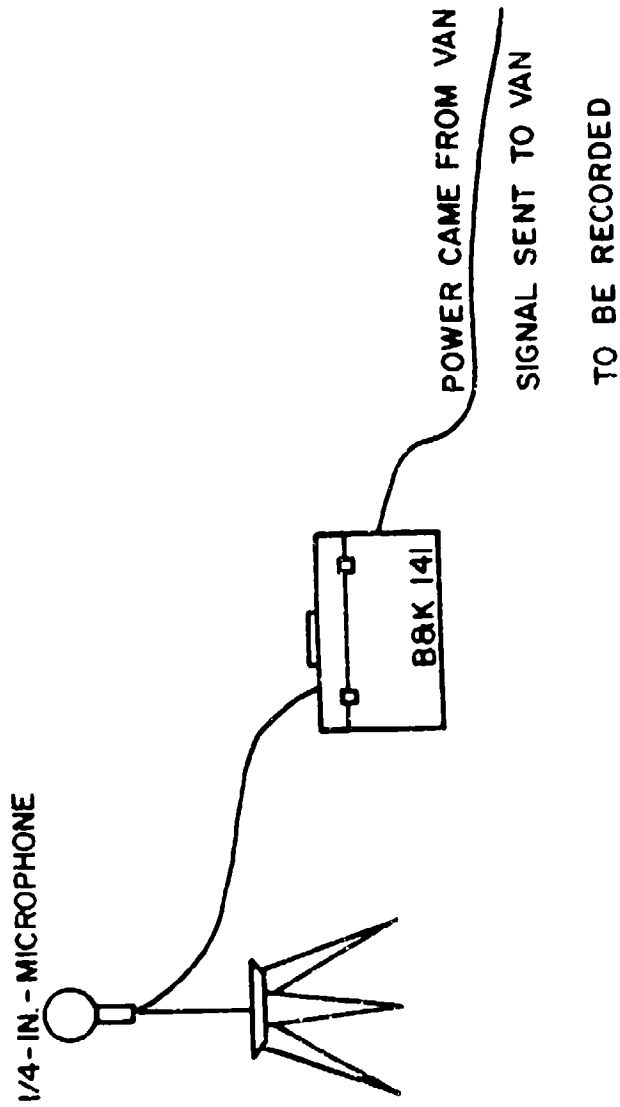

a. Station 27N

Figure 2. Fort Sill test equipment.

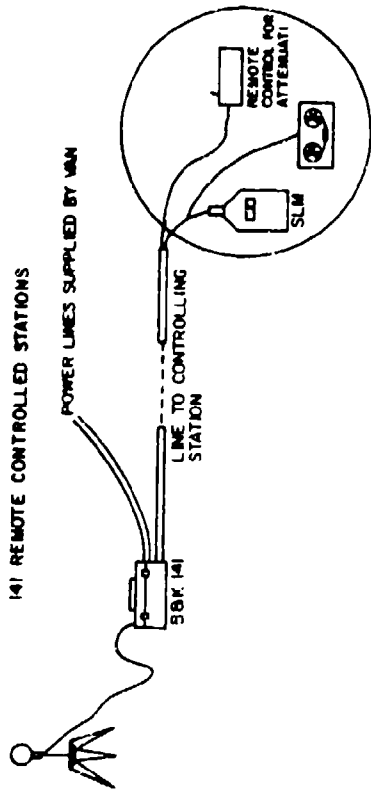

b. Stations 6F and 12F

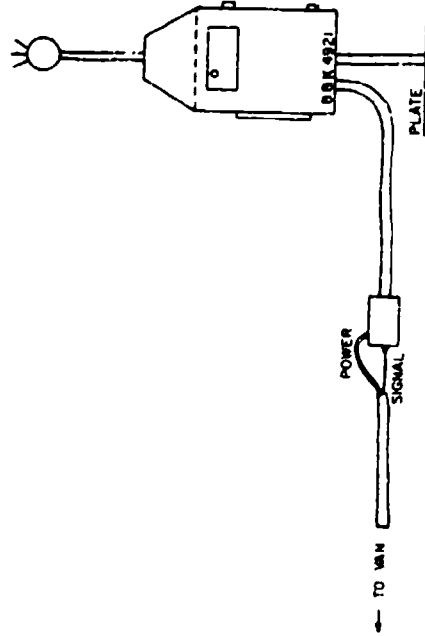

c. Stations 15F, 21F, 31I, 91I, 15N, and 21N

Figure 3. (Cont'd).

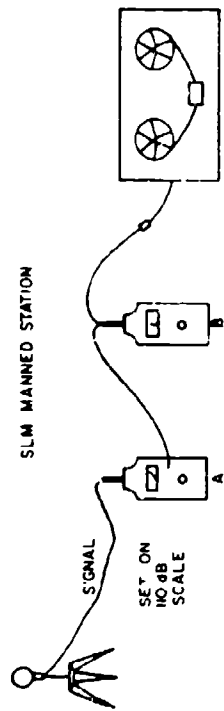

d. Stations 18F, 33F, 36F, 3F, and 9F

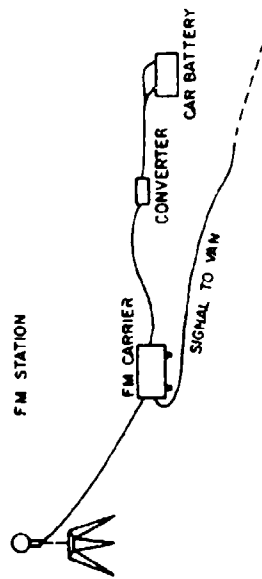

e. Station 19F  
Figure 2. (Cont'd).

direction and speed apparatus were also recorded on the Ampex PR 2200 during testing.

### Calibration

Calibration was performed (1) at the beginning of every new tape, (2) at the end of each tape and/or day, (3) when changes were made in equipment or equipment placement, or (4) when equipment malfunctioned. The unattended stations controlled by the mobile lab were set up first and were the first stations calibrated after setup of all stations was completed. This allowed all stations equal warm-up time before calibration.

The unattended stations were calibrated with B&K 4220 pistonphones in two groups of five and four, respectively.\* A 15-sec recording of the tone was made at a tape speed of 60 in./sec on the Ampex PR 2200. The B&K 4921 was calibrated using 30 dB of gain in the 4921 and 0 dB of gain in the Neff DC amplifier in the mobile lab. Adjustments were then made so that a 4-V peak-to-peak signal corresponded to the 124-dB root-mean-square (RMS) produced by the pistonphone. For most measurements, the B&K 4921 gain was reduced to 10 dB. This allowed measurement of sound-pressure levels of 150 dB peak without overloading the tape recorder. The Neff gain was increased for lower sound levels. For very low signal levels, the B&K 4921 gain was increased to 20 dB.

The FM system was calibrated using a pistonphone and all gain adjustments were performed in the mobile lab. During testing, the system used a 1-Hz cutoff.

The B&K 141 at station 27N was calibrated with its gain set for 40 dB and the Neff amplifier set for 0 dB. As with the B&K 4921, the B&K 141 was adjusted to produce a 4-V peak-to-peak signal at the mobile lab. The B&K 141 gain was decreased to 30 dB for measurements. The mobile lab was able to decrease the B&K 141 gain to 20 dB or 10 dB, if necessary. For signals over 150 dB, the gain was reduced to 20 dB.\*\* The attended stations were calibrated after the unattended stations. A pistonphone tone at least 1 minute in length was recorded on tape, followed by a detailed list of calibration settings, data, and any other information considered necessary by the investigators.

---

\*To allow calibration, the B&K 4921 outdoor microphone system windscreens and rain covers were removed and its microphone calibrated with a normal grid; however, the rain covers and windscreens were used during the testing.

\*\*This station was the most difficult to calibrate because of the problem of holding the pistonphones steady on the 1/4-in. microphone in the wind.



At the attended stations, two sound-level meters were used to increase the dynamic range of the peak readings. The output of the 1/2-in. microphone was channeled to sound-level meter A, which was calibrated by the pistonphone for 124 dB. The output of sound-level meter A was sent simultaneous to the input of sound-level meter B and to the Nagra DJ tape recorder. After sound-level meter A was calibrated, it was set to the 110-dB scale. (Sound-level meters have the same output range regardless of scale setting; the meters' range registers 17 dB above full scale. Since the signal at the attended stations was over 120 dB, the output of sound-level meter A was effectively increased 10 dB. Sound-level meter B was then calibrated to read 134 dB. This arrangement of the two sound-level meters allowed the peak to be read over a 20-dB range. Therefore, adjusting sound-level meter A allowed the upper level of the range to be varied.)

The B&K 141 stations at 6F and 12F were calibrated according to the following procedure: B&K 141 was set for 20 dB of gain and the attenuator control at the adjacent attended station was set for 0 dB. The Nagra attenuator was set for 3 dB and B&K 141 was adjusted so that the meter on the Nagra measured -10 VU. The sound-level meter was adjusted to 124 dB. The calibration tone was recorded into the Nagra for at least 1 minute, followed by a list of settings and necessary information.

### 3 DATA REDUCTION

Each event, i.e., each C-4 or gun blast, was recorded simultaneously at 16 separate stations. Depending on the recording station, data was stored on either an Ampex PR-2200 14-channel FM recorder or a Nagra DJ single-track AM recorder. Each tape channel's data was then reduced individually.

Figure 3 is a block diagram of equipment used in data reduction. The B&K 7502 Digital Transient Recorder, which acted as a delay line, received information from the tape. Each time a blast registered on the tape, the 7502 sent out a trigger signal which activated a special circuit. This circuit then relayed a trigger signal to an oscilloscope and to two CERL Model 270 noise monitors; the signals were sent such that the blast occurred in a preset window. This allowed the monitors to analyze the complete signal. Another trigger signal was sent to the noise monitors to signal the end of the data collection. After the monitors received the stop signal, and before another signal was relayed, a pause was allowed to enable the noise monitors to sample the noise level on the tape. The noise sample and the blast signal were both measured for the same time interval. The noise monitors then relayed this information (in  $L_{eq}$  form), and the sample-length time to a pair of Wang 600 calculators.<sup>eq</sup> At the beginning of each channel's analysis, equipment settings for calibration and measurement were entered into the calculator's memory. The calculators then computed the sound-exposure levels of blast noise and supplied a printout of the sound-exposure level of blast minus noise, and of noise level alone (all calculations were on an energy basis). Two noise monitors and two calculators were used in parallel so each blast could be measured with A, D, C, and flat weightings.

Positive and negative peaks were measured visually on the oscilloscope and their values entered into the calculators. The calculators used the previously given calibration values to compute positive, negative, and peak-to-peak values for each blast; this information, along with the blast number, was then printed.

Signals were checked visually for any clipping due to oversized inputs to the tape recorder. (It was not possible to overload the noise monitors or the calculators since none of the other equipment being used in the analysis was capable of inputting an excessive signal.)

The noise monitors were originally calibrated by inputting the pistonphone calibration tone from the tape recording and entering 124 dB as the pistonphone's RMS sound-pressure level. The noise monitors then calculated the appropriate gain constant to be used during data analysis. Any change in equipment settings from the calibration settings

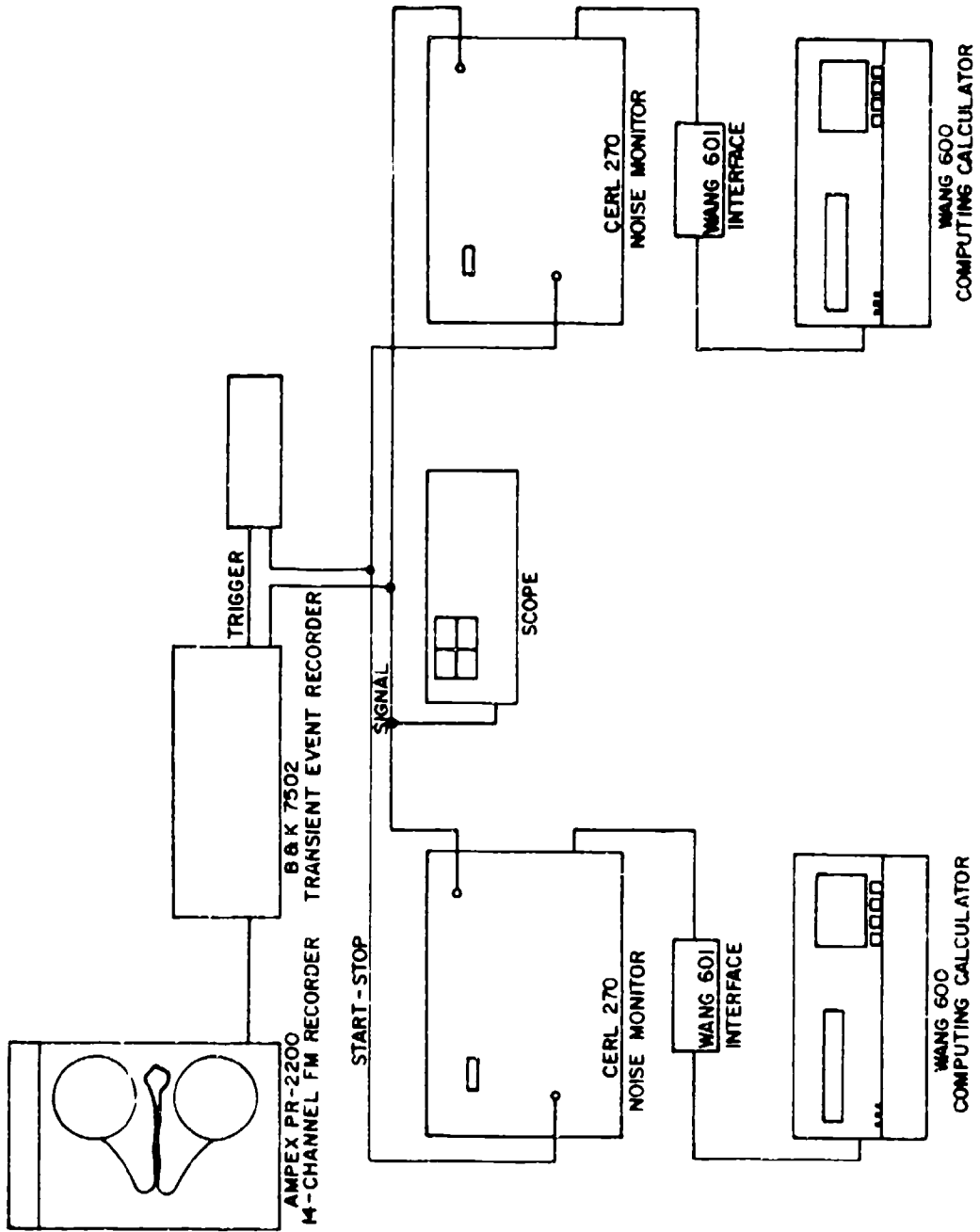

Figure 3. Block diagram of equipment used in data reduction.

and any changes made during the measurement period were entered into the calculators at the appropriate time. Necessary adjustments were made by the calculators.

Information listed on printouts produced by the Wang calculators was punched directly onto computer cards and stored on magnetic tape for easy retrieval by the Nova 1200 minicomputer during analysis.

This reduction, for each event at each station, produced the following:

Flat-weighted SEL	Peak-to-peak
A-weighted SEL*	Positive peak
C-weighted SEL	Negative peak
D-weighted SEL*	

In addition, logbooks kept by the investigating team during the tests described:

1. The day and time of each event.
2. Whether the event was a C-4 blast or a weapon blast.

If the event was a weapon blast, the team logged (1) the type of weapon, (2) the type and size of the propelling charge, (3) the elevation (if applicable), and (4) the range of the weapon's projectile (if applicable). If the event was a C-4 blast, the team described (1) the amount of C-4 used to produce the blast (pounds), and (2) whether the blast was on or above the ground (see Appendix A).

---

\*Data recorded at stations using a Nagra recorder was not reduced to A- and D-weightings because filters were not available to adjust for the frequency shift between the Nagra's original recording speed (1.5 in./sec) and the playback speed (15 in./sec).

#### 4 DATA ANALYSIS

Data reduced from recordings was first analyzed to determine the values necessary to correct for the effects of weather and terrain on noise levels. After these correction values were established, weapon-noise directivity plots and weight equivalency tables were developed.

##### Correction Values

Five pounds of C-4, when exploded under ideal weather and terrain conditions, transmits sound equally in all directions. The resulting noise-propagation pattern is circular.<sup>6</sup> The effect of inhomogeneous weather and terrain conditions, therefore, can be determined by observing how propagation patterns differ from the circular.

For the purpose of this study, it was assumed that:

1. Weather and terrain effects on C-4 noise-propagation patterns do not vary drastically over a short time (typically, 15 minutes).
2. The effects of weather and terrain on C-4 noise and gun noise are the same.

It was further assumed that once the effects of weather and terrain on C-4 blast noise were determined, they could be used to predict and correct for -- and therefore eliminate -- the effects of weather and terrain on gun noise.

As described in Chapter 1, each weapon firing (event) occurred within 15 minutes of a 5-lb C-4 calibration explosion. Data recordings for each event (C-4 and weapon) were made at 16 separate stations and reduced (Chapter 3). To determine the correction value for each weapon-firing event at each station, it was first necessary to identify the C-4 calibration explosion nearest to it in time.

Each C-4 event was analyzed to determine the difference from the ideal caused by weather\* and terrain. This difference was then used to

---

<sup>6</sup> Schomer, P. D., R. J. Goff, and L. M. Little, The Statistics of Amplitude and Spectrum of Blasts Propagated in the Atmosphere, Volumes I and II, Technical Report N-13/ADA033475 and ADA033361 (CERL, November 1976).

\*Weather conditions during testing for each day (by hour) are listed in Appendix B.

correct the noise-level data for the weapon-firing event nearest in time to the C-4 explosion.\* In this manner, correction values for the effects of weather and terrain on each event at each station were determined.

### Noise Contours\*\*

Reduced noise-level data was used to plot, against time, noise levels at each station for (1) each weapon type, and (2) each C-4 event. Both corrected and uncorrected data were plotted. This was done to:

1. Facilitate spotting errors in data recording and/or in the transcription or reduction of data.

2. Support this investigation's assumption that weather and terrain effects could be averaged over a short time.

These plots also showed that noise levels at all stations changed in a consistent manner, regardless of the position of the station, the type of weapon (C-4), or time.

Corrected, reduced noise-level data was then graphed vs angle on a polar plot (see Figure 4 for an example). Inner-ring data (dashed line) was plotted separately from outer-ring data (solid line).

The polar plots were not developed to determine how loud an event was at a point, but how noise levels varied with angle. The deviation at each angle for each event was determined from a single reference point (rear of the gun) and plotted. These plots are the weapon directivity patterns.

Separately plotted inner- and outer-ring contours were then compared. The comparison showed that both contours, for similar test events, typically varied less than  $\pm 1.5$  dB from each other. Because of this close comparison and since the noise contours for the inner and outer ring each contained points absent in the other (Chapter 2), the plots of both rings were combined for identical events, i.e., events with the same weapon (C-4), charge size or type, elevation, and range

---

\*As a check, C-4 events were analyzed and corrected using this method. They produced nearly perfect circular patterns.

\*\*Though analyses were done for both F- and C-weighted SEL, contours were produced for C-weightings only to weighting recommended by the Environmental Protection Agency (EPA) and approved by Department of Defense (DOD).

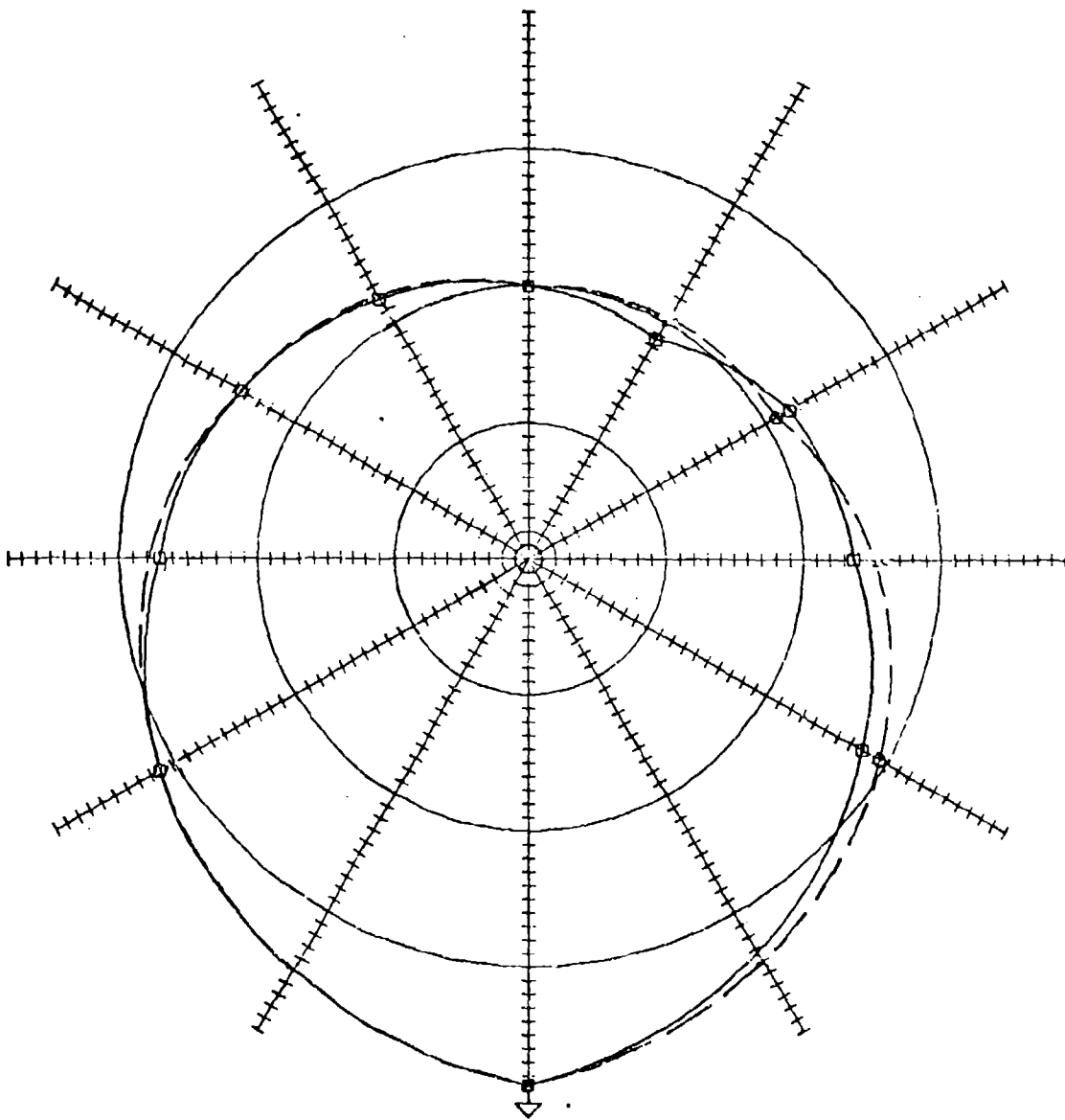

Figure 4. Polar plot example.

(Appendix C). The resulting contours showed that variation in charge size, elevation, or range did not consistently or significantly ( $\pm 2$  dB, typically) alter the noise contours.

Next, all contours for the same weapon (C-4) for varying events, i.e., at varying charge sizes and types, elevations, and ranges, were combined (see Appendix D). In addition, energy average\* in dB and the average differences in dB from the rear of the gun were compiled for each station. The average difference from the rear of the gun vs angle and the average difference from C-4 vs angle are found in Appendices C and D.

#### Weight Equivalency Tables

To develop appropriate weight equivalency tables, the energy average of the reduced noise-level data from the inner-ring stations was determined for each event of identical charge size and type, but varying elevation and range. These averages were then plotted against charge weights. When plotted, these averages showed that there was a logarithmic relationship between sound level and charge weight. All further calculations were therefore done using logarithm of weight. Appendix E lists the resulting weight equivalency tables.

Charge weight was also plotted against F- and C-weighted SEL (Figures 5 and 6)\*\*. These plots show that weapons which were in the same barrel-length group (Table 2) lie along the same line. Equation parameters for individual weapons and for grouped weapons are shown with their respective  $r^2$  in Tables 3 and 4.

---

\*By this method, dB are converted to energy (J), averaged, and then converted back to dB.

\*\*A 270 oz, five white bag charge for the 8-in. M110 gun was not plotted since the charge was nonstandard. The 450 oz, seven white bag charge was not plotted because of indications of excess attenuation caused by the C-weighting.

+The standard error is a measure of the amount of variation of the data about the prediction model. The  $r^2$  is the multiple correlation coefficient squared; when multiplied by 100, it is the percent of the variation in the data which is explained by the equation.



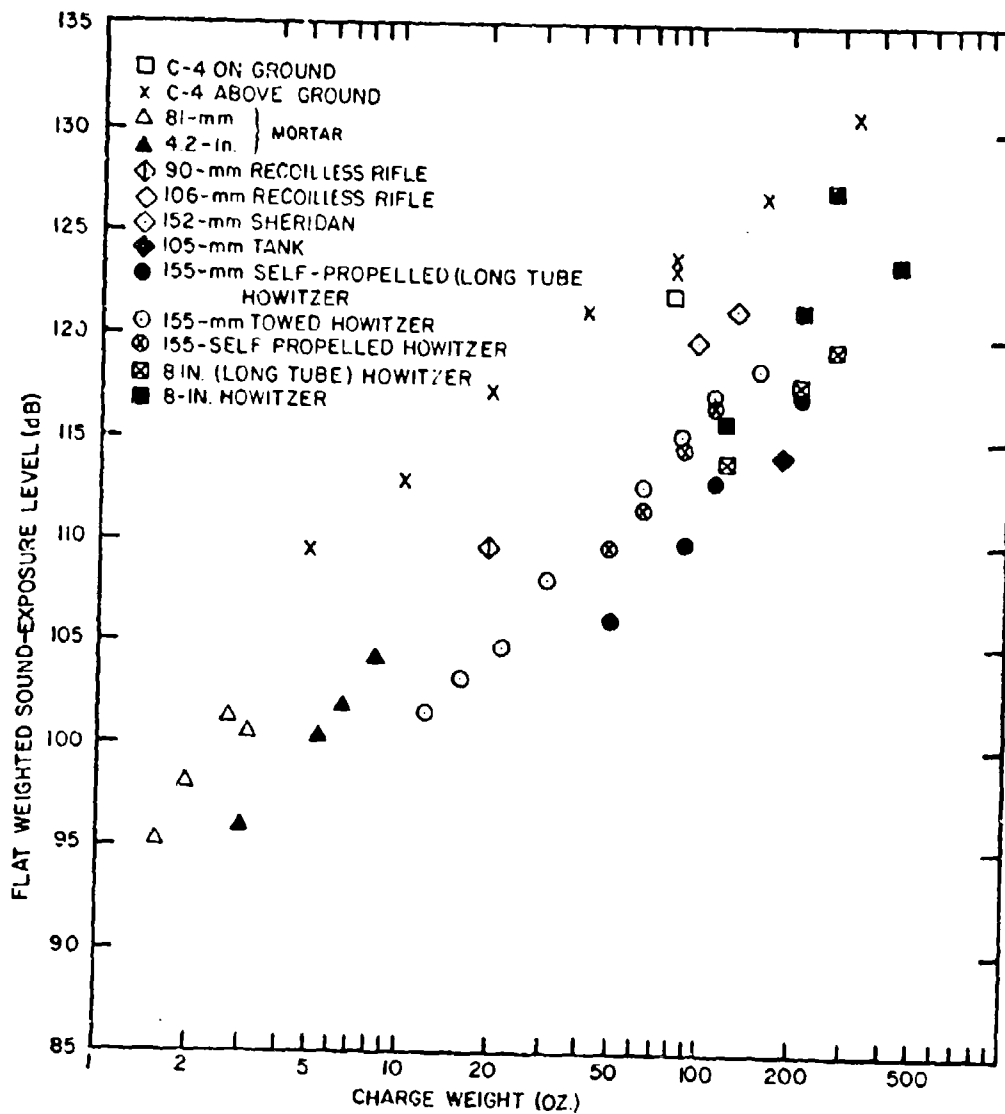

Figure 5. Flat-weighted SEL vs C-4 charge weight. Groupings are by tube length; point representing an 8-in. gun with a 270 oz. charge is a nonstandard charge.

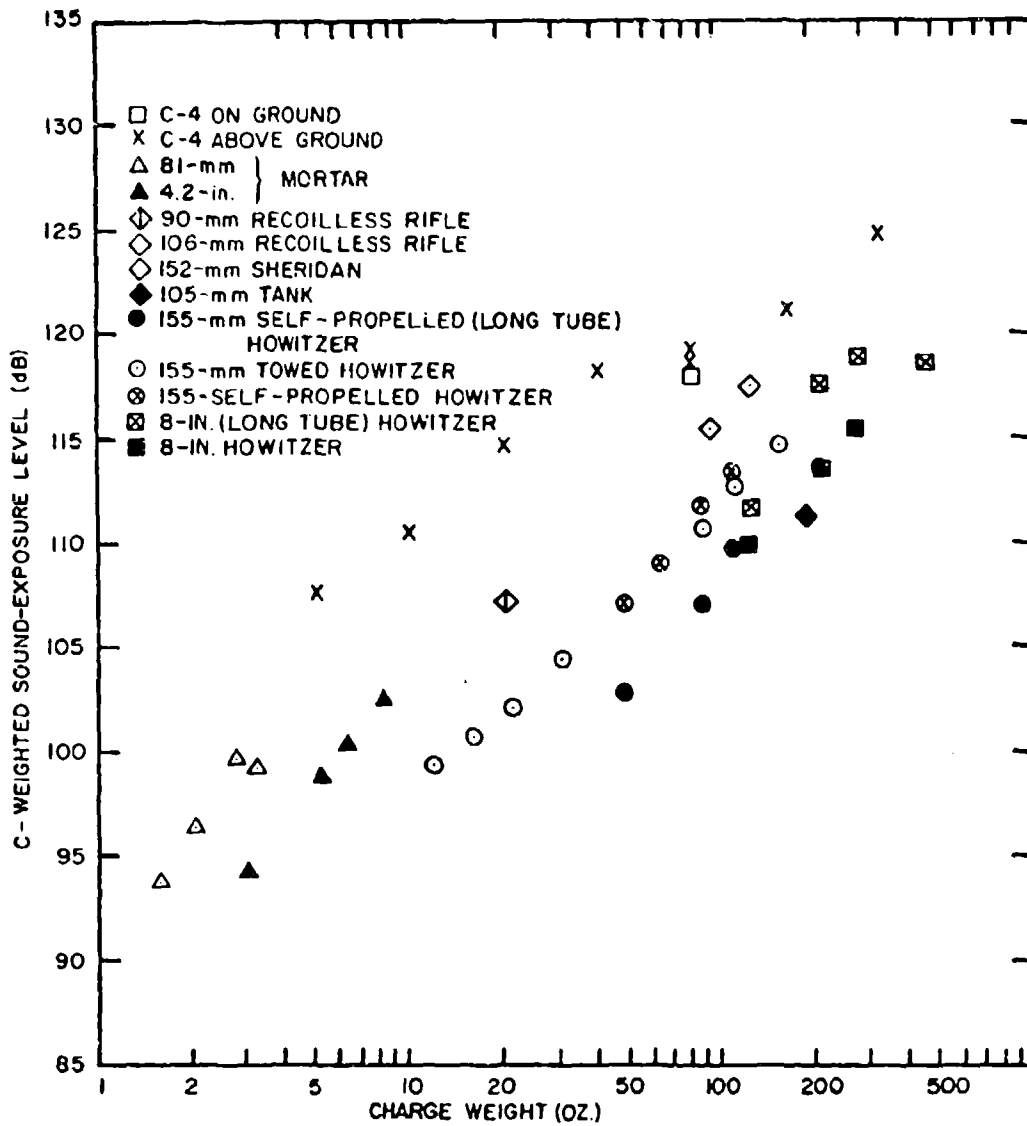

Figure 6. C-weighted SEL vs C-4 charge weight. Groupings are by tube length; the shift in the C-4 and 8 in. gun line at levels in excess of about 118 dB occurs because the C-weighting excludes the very low frequencies.

Table 2  
Barrel Lengths of Weapons Tested at Fort Sill

<u>Very short (very light)</u>	<u>Model</u>
81-mm mortar	
<u>Short tube</u>	
4.2-in. mortar	M30
106-mm recoilless rifles	M40A1
90-mm recoilless rifles	M67
152-mm Sheridan tank gun	M551
<u>Regular tube</u>	
105-mm howitzer	M102
155-mm howitzer	M109
8-in. howitzer	M110
155-mm howitzer	M114
<u>Long tube</u>	
155-mm howitzer	M109A1
8-in. self-propelled	M110A1
105-mm tank	M60

Table 3  
Equation Parameters and Correlation Factors ( $r^2$ )  
for Weapons Tested at Fort Sill (F-weighted SEL)

<u>Weapon</u>	<u>Model</u>	<u>Equation Parameters</u>		
		<u>A</u>	<u>B</u>	<u><math>r^2</math></u>
81-mm mortar		91.65	20.13	0.94
4.2-in. mortar	M30	87.05	18.38	0.99
106-mm recoilless rifles	M40A1	N/A	N/A	N/A
90-mm recoilless rifles	M67	N/A	N/A	N/A
152-mm Sheridan tank gun	M551	N/A	N/A	N/A
105-mm howitzer	M102	83.97	15.72	0.99
155-mm howitzer	M109	74.85	20.48	1.00
8 in. howitzer	10	88.30	13.62	0.95
105-mm howitzer	M114	84.93	15.59	0.97
155-mm howitzer	M109A1	75.16	18.23	0.98
8-in. self-propelled	M110A1	80.04	16.26	1.00
105-mm tank	M60	N/A	N/A	N/A
Short tube		89.14	15.63	1.00
Regular tube		84.40	15.48	0.99
Long tube		75.07	18.35	0.99
C4		101.59	11.85	0.99

$$\text{Level} = A + B * \text{Log}_{10} (\text{weight of propellant})$$

Table 4

Equation Parameters and Correlation Factors ( $r^2$ )  
for Weapons Tested at Fort Sill (C-weighted SEL)

<u>Weapon</u>	<u>Model</u>	<u>Equation Parameters</u>		
		<u>A</u>	<u>B</u>	<u><math>r^2</math></u>
81-mm mortar		90.27	19.57	0.94
4.2-in. mortar	M30	85.17	18.85	1.00
106-mm recoilless rifles	M40A1	N/A	N/A	N/A
90-mm recoilless rifles	M67	N/A	N/A	N/A
152-mm Sheridan tank gun	M551	N/A	N/A	N/A
105-mm howitzer	M102	83.78	13.91	0.98
155-mm howitzer	M109	75.74	18.51	1.00
8-in. howitzer	M110	60.91	24.49	1.00
155-mm howitzer	M114	80.81	15.59	0.98
155-mm howitzer	M109A1	72.08	18.11	0.99
8-in. self-propelled	M110A1	76.99	15.87	1.00
105-mm tank	M60	N/A	N/A	N/A
Short tube		88.75	13.85	0.99
Regular tube		82.22	14.99	0.99
Long tube		74.26	16.94	0.97

$$\text{Level} = A + B * \text{Log}_{10} (\text{weight of propellant})$$

## 5 RESULTS

### Prediction Method

CERL's previous noise propagation study at Fort Leonard Wood<sup>7</sup> established the noise-level standard for a 5-lb charge of C-4. The Fort Sill tests described in this report use the variance in gun-noise levels from this C-4 standard to develop correction factors which allow the prediction of the effects of gun type, charge size, and charge type on gun-noise levels.

The weight equivalency tables developed as a result of the study described in this report can also be used to predict gun-noise impacts. To do so requires that the weight equivalency plot in Figure 6 be used to determine the charge weight/weapon correction factor.

First, select the appropriate C-4 value from the weight relationship plotted in Figure 6. Second, select the appropriate inner-ring energy average for the weapon for which noise impact is to be predicted by the equations in Table 4. Finally, select the appropriate average difference from the rear-of-gun reference point for the weapon under consideration from Appendix D. (See Figure 7 for an example of this procedure.)

When the value for the C-4 plus the value of average difference from the rear-of-gun reference point is subtracted from the inner-ring energy average, the result is the charge weight/weapon correction factor (see Figure 7).

To determine the directivity correction factor, select the appropriate value from the tables in Appendix D and interpolate, if necessary (see Figure 7).

### Additional Results

Figure 6 exhibits a number of interesting relationships:

1. The amplitude vs weight of the C-4 charge curve is not a straight line, but more S-shaped. This results from the gradual shift to lower frequencies as the weight of charge is increased. And, as the

---

<sup>7</sup> Schomer, P. D., R. J. Goff, and L. M. Little, The Statistics of Amplitude and Spectrum of Blasts Propagated in the Atmosphere, Volumes I and II, Technical Report N13/ADA0333475 and ADA033361 (CERL, November 1976).

Find correction factors, for the side (90°) of a 155-mm towed howitzer (M114) for three green bags:

1. Three green bags = 49.4 oz of propellant

2. 49.4 oz of C-4 (C-weighted SEL from Figure 6) = 118.8dB ← ①

From Table 4

	A	B	r <sup>2</sup>
Short tube	88.75	13.85	0.99
Regular tube	82.22	14.99	0.99
Long tube	74.26	16.94	0.97

② → 107.61 = 82.22 + 14.99 \* Log<sup>10</sup> (49.4)

From Appendix D

NAME	155 MM HOWITZER	M114	
ELEVATION	ALL		
CHARGE SIZE	ALL		
CHANNEL	ENERGY	DIFFERENCE FROM REAR	ANGLE
1	112.57	9.80	0°
2	105.84	3.41	30°
3	103.24	0.00	60°
4	105.72	2.86	90°
5	113.15	10.71	120°
6	106.10	10.28	150°
7	99.41	3.09	180°
8	101.99	6.24	210°
9	115.69	14.93	240°
10	106.87	9.83	270°
11	103.64	7.42	300°
12	99.20	3.52	330°
13	97.15	1.51	
14	97.45	0.00	
15	97.43	1.61	
16	102.14	6.32	
			AVERAGE
			9.45

Weight/Weapon Correction = ② - ① - ③

-20.6 dB = 107.6 - 118.8 - 9.45

Directivity Correction ④ = 6.87

Figure 7. Weight/weapon and directivity correction factor prediction method.

shift is made to lower frequencies, the C-weighting gradually attenuates more and more of the signal. Thus, at higher charge sizes for the larger weapons, the weapon curves move very close to the C-4 curve. This is because of the spectral shift operating on the C-4, but not yet on the weapons.

2. Figure 5, which uses flat weighting, shows a straight line for the C-4 weight relationship, and a 3.6-dB increase when C-4 weight is doubled. Three sizes of weapons -- short, medium, and long tube -- are on this same curve. (The longer the tube, the more contained the charge, and, therefore, the smaller the noise.)

3. The weapon curves grow at a faster rate than those of the unconstrained C-4 curves, indicating that the bigger the charge in a given tube length, the more unconstrained it appears, and thus the more it approaches the C-4 curve.

4. The last major finding of this study was the effect of a muzzle brake on directivity patterns. Figures 8 and 9 show directivity patterns for a self-propelled and a towed 155-mm howitzer, respectively. The self-propelled howitzer uses a muzzle brake, the towed howitzer does not; the directivity pattern for the self-propelled howitzer is practically circular whereas the directivity pattern for the towed howitzer is strongly towards the front of the gun. This indicates that the muzzle brake causes some of the gases and noise which would go towards the front to be redirected toward the sides and rear: the result is an almost circular pattern. The same general relationship is true for the other weapons; i.e., with a muzzle brake, the directivity pattern is virtually circular. Without a muzzle brake, the directivity pattern is much stronger towards the front of the gun. The exceptions, of course, are the recoilless rifles which have a strong component both towards the front and the rear of the weapon.

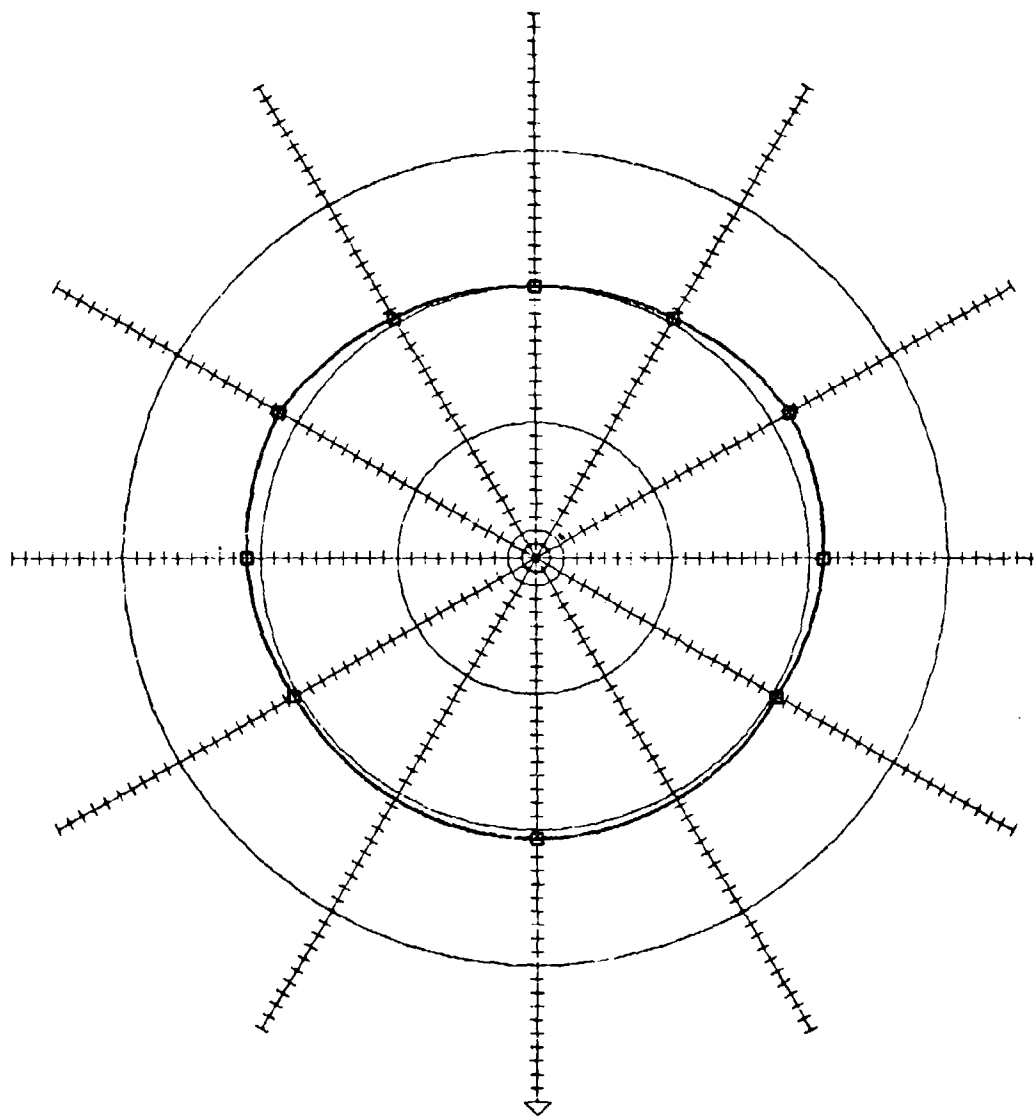

Figure 8. Directivity pattern of a self-propelled 155-mm howitzer. Each hatch mark is 1 dB. The absolute level at the rear of the gun is 100 dB.



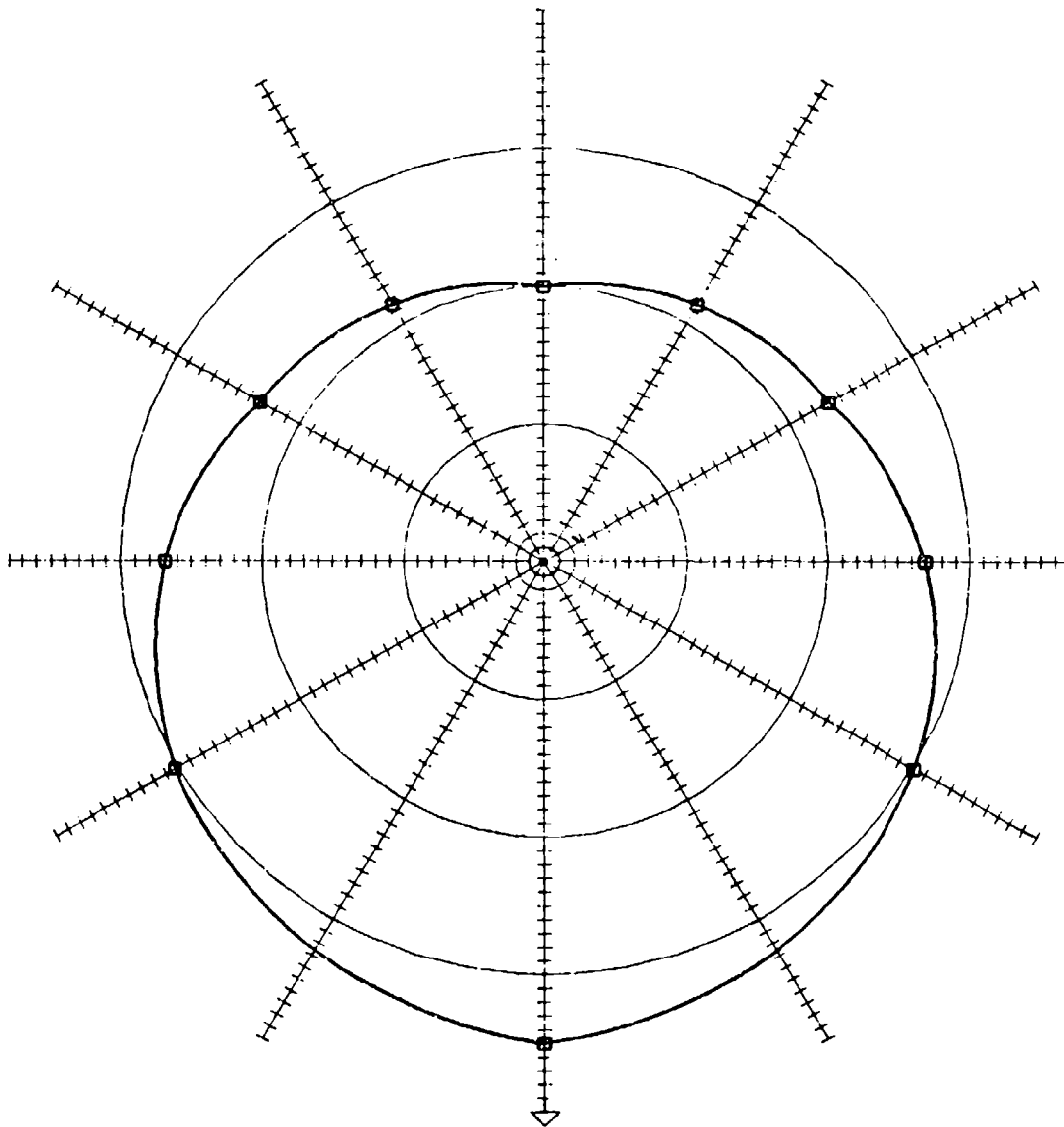

Figure 9. Directivity pattern of a towed 155-mm howitzer. Each hatch mark is 1 dB. The absolute level at the rear of the gun is 100 db.

## 6 CONCLUSIONS

Precise sound-pressure level contours (directivity patterns) and weight equivalence patterns which relate weight of charge to equivalent C-4 weight were developed for Army weapons in current use. Data and information developed as a result of this study are presented in a form suitable for use in manual or automated blast noise-impact prediction methods.

The following general technical conclusions can also be made from this study:

1. Elevation has little influence on directivity patterns; therefore, directivity patterns can be considered as independent of elevation. Muzzle brakes (except for recoilless rifles) are the biggest factor affecting weapon contour shapes. Muzzle brakes cause directivity patterns to become almost circular.
2. The weight equivalency tables developed are a function of tube size, with the longest tubes being the quietest because the charge is most contained.

APPENDIX A:

EVENT LOG

#	DAY	TIME	WEAPON	MODEL	CHARGE SIZE	ELEVA	RANGE
51	13	12:51:16	105 MM TANK	M60			
52	13	12:58:46	CALIBRATION		5.00 LBS.		
53	13	14:01:26	CALIBRATION		5.00 LBS.		
54	13	14:04:41	105 MM TANK	M60			
55	13	14:05:20	105 MM TANK	M60			
56	13	14:06:05	105 MM TANK	M60			
57	13	14:12:07	CALIBRATION		5.00 LBS.		
58	13	14:15:17	105 MM TANK	M60			
59	13	14:15:57	105 MM TANK	M60			
60	13	14:16:36	105 MM TANK	M60			
61	13	14:22:37	CALIBRATION		5.00 LBS.		
62	13	14:25:41	105 MM TANK	M60			
63	13	14:26:21	105 MM TANK	M60			
64	13	14:27:01	105 MM TANK	M60			
65	13	14:38:25	CALIBRATION		5.00 LBS.		
66	13	16:12:29	CALIBRATION		5.00 LBS.		
67	13	16:20:58	C4 ON GROUND		5.00 LBS.		
68	13	16:27:12	CALIBRATION		5.00 LBS.		
69	13	16:35:40	C4 ON GROUND		5.00 LBS.		
70	13	16:43:14	CALIBRATION		5.00 LBS.		
71	13	16:55:40	C4 ON GROUND		5.00 LBS.		
72	13	17:02:02	CALIBRATION		5.00 LBS.		
73	13	17:09:00	C4 ON GROUND		5.00 LBS.		
74	13	17:16:34	CALIBRATION		5.00 LBS.		
75	13	17:24:03	C4 ON GROUND		5.00 LBS.		
76	14	10:45:50	CALIBRATION		5.00 LBS.		
77	14	10:54:29	CALIBRATION		5.00 LBS.		
78	14	10:58:59	4.2 INCH MORTAR	M30	11 GREEN BAGS	900	
79	14	11:04:31	4.2 INCH MORTAR	M30	11 GREEN BAGS	900	
80	14	11:08:21	4.2 INCH MORTAR	M30	11 GREEN BAGS	900	
81	14	11:09:04	4.2 INCH MORTAR	M30	11 GREEN BAGS	900	
82	14	11:09:44	4.2 INCH MORTAR	M30	11 GREEN BAGS	900	
83	14	11:17:39	CALIBRATION		5.00 LBS.		
84	14	11:28:04	CALIBRATION		5.00 LBS.		
85	14	11:31:24	4.2 INCH MORTAR	M30	24 GREEN BAGS	900	
86	14	11:34:23	4.2 INCH MORTAR	M30	24 GREEN BAGS	900	
87	14	11:37:56	4.2 INCH MORTAR	M30	24 GREEN BAGS	900	
88	14	11:38:38	4.2 INCH MORTAR	M30	24 GREEN BAGS	900	
89	14	11:39:19	4.2 INCH MORTAR	M30	24 GREEN BAGS	900	
90	14	11:46:56	CALIBRATION		5.00 LBS.		
91	14	11:56:07	CALIBRATION		5.00 LBS.		
92	14	12:00:10	4.2 INCH MORTAR	M30	20 GREEN BAGS	1065	
93	14	12:06:03	4.2 INCH MORTAR	M30	20 GREEN BAGS	1065	
94	14	12:06:45	4.2 INCH MORTAR	M30	20 GREEN BAGS	1065	
95	14	12:07:07	4.2 INCH MORTAR	M30	20 GREEN BAGS	1065	
96	14	12:08:07	4.2 INCH MORTAR	M30	20 GREEN BAGS	1065	
97	14	12:13:30	CALIBRATION		5.00 LBS.		
98	14	12:26:05	CALIBRATION		5.00 LBS.		
99	14	12:30:11	4.2 INCH MORTAR	M30	31 GREEN BAGS	1065	
100	14	12:33:30	4.2 INCH MORTAR	M30	31 GREEN BAGS	1065	

#	DAY	TIME	WEAPON	MODEL	CHARGE SIZE	ELEVA	RANGE
101	14	12:34:11	4.2 INCH MORTAR	M30	31 GREEN BAGS	1065	
102	14	12:34:53	4.2 INCH MORTAR	M30	31 GREEN BAGS	1065	
103	14	12:35:36	4.2 INCH MORTAR	M30	31 GREEN BAGS	1065	
104	14	12:42:55	CALIBRATION		5.00 LBS.		
105	14	14:23:10	81 MM MORTAR		5.00 LBS.		
106	14	14:27:12	81 MM MORTAR		4 GREEN BAGS	900	2400
107	14	14:32:32	81 MM MORTAR		4 GREEN BAGS	900	2400
108	14	14:33:16	81 MM MORTAR		4 GREEN BAGS	900	2400
109	14	14:33:56	81 MM MORTAR		4 GREEN BAGS	900	2400
110	14	14:34:38	81 MM MORTAR		4 GREEN BAGS	900	2400
111	14	14:42:08	CALIBRATION		5.00 LBS.		
112	14	14:52:03	CALIBRATION		5.00 LBS.		
113	14	14:56:48	81 MM MORTAR		7 GREEN BAGS	900	3700
114	14	15:00:39	81 MM MORTAR		7 GREEN BAGS	900	3700
115	14	15:01:21	81 MM MORTAR		7 GREEN BAGS	900	3700
116	14	15:02:03	81 MM MORTAR		7 GREEN BAGS	900	3700
117	14	15:02:47	81 MM MORTAR		7 GREEN BAGS	900	3700
118	14	15:08:05	CALIBRATION		5.00 LBS.		
119	14	15:15:30	CALIBRATION		5.00 LBS.		
120	14	15:19:34	81 MM MORTAR		5 GREEN BAGS	1050	2525
121	14	15:23:27	81 MM MORTAR		5 GREEN BAGS	1050	2525
122	14	15:24:11	81 MM MORTAR		5 GREEN BAGS	1050	2525
123	14	15:24:52	81 MM MORTAR		5 GREEN BAGS	1050	2525
124	14	15:25:35	81 MM MORTAR		5 GREEN BAGS	1050	2525
125	14	15:30:37	CALIBRATION		5.00 LBS.		
126	14	15:38:56	CALIBRATION		5.00 LBS.		
127	14	15:42:15	81 MM MORTAR		8 GREEN BAGS	1050	3625
128	14	15:45:50	81 MM MORTAR		8 GREEN BAGS	1050	3625
129	14	15:46:31	81 MM MORTAR		8 GREEN BAGS	1050	3625
130	14	15:47:14	81 MM MORTAR		8 GREEN BAGS	1050	3625
131	14	15:47:55	81 MM MORTAR		8 GREEN BAGS	1050	3625
132	14	15:52:51	CALIBRATION		5.00 LBS.		
133	14	16:00:11	CALIBRATION		5.00 LBS.		
134	19	10:11:21	CALIBRATION		5.00 LBS.		
135	19	10:19:36	CALIBRATION		5.00 LBS.		
136	19	10:25:52	155 MM HOWITZER	M109	3 GREEN BAGS	150	
137	19	10:29:27	155 MM HOWITZER	M109	3 GREEN BAGS	150	
138	19	10:30:14	155 MM HOWITZER	M109	3 GREEN BAGS	150	
139	19	10:30:57	155 MM HOWITZER	M109	3 GREEN BAGS	150	
140	19	10:31:40	155 MM HOWITZER	M109	3 GREEN BAGS	150	
141	19	10:42:21	CALIBRATION		5.00 LBS.		
142	19	10:48:47	CALIBRATION		5.00 LBS.		
143	19	10:53:07	155 MM HOWITZER	M109	4 GREEN BAGS	300	
144	19	10:56:06	155 MM HOWITZER	M109	4 GREEN BAGS	300	
145	19	10:56:50	155 MM HOWITZER	M109	4 GREEN BAGS	300	
146	19	10:57:36	155 MM HOWITZER	M109	4 GREEN BAGS	300	
147	19	10:58:18	155 MM HOWITZER	M109	4 GREEN BAGS	300	
148	19	11:03:58	CALIBRATION		5.00 LBS.		
149	19	11:11:53	CALIBRATION		5.00 LBS.		
150	19	11:16:02	155 MM HOWITZER	M109	5 GREEN BAGS	350	

#	DAY	TIME	WEAPON	MODEL	CHARGE SIZE	ELEVA	RANGE
151	19	11:19:05	155 MM HOWITZER	M109	5 GREEN BAGS	350	
152	19	11:19:47	155 MM HOWITZER	M109	5 GREEN BAGS	350	
153	19	11:20:29	155 MM HOWITZER	M109	5 GREEN BAGS	350	
154	19	11:21:11	155 MM HOWITZER	M109	5 GREEN BAGS	350	
155	19	11:35:57	CALIBRATION		5.00 LBS.		
156	19	11:40:57	CALIBRATION		5.00 LBS.		
157	19	11:44:00	155 MM HOWITZER	M109	5 WHITE BAGS	60	
158	19	12:58:46	CALIBRATION		5.00 LBS.		
159	19	13:02:09	155 MM HOWITZER	M109	5 WHITE BAGS	60	
160	19	13:02:55	155 MM HOWITZER	M109	5 WHITE BAGS	60	
161	19	13:03:39	155 MM HOWITZER	M109	5 WHITE BAGS	60	
162	19	13:04:23	155 MM HOWITZER	M109	5 WHITE BAGS	60	
163	19	13:14:00	CALIBRATION		5.00 LBS.		
164	19	13:21:14	C4 ON GROUND		5.00 LBS.		
165	19	13:25:11	155 MM HOWITZER	M109	5 WHITE BAGS	350	
166	19	13:28:13	155 MM HOWITZER	M109	5 WHITE BAGS	350	
167	19	13:28:59	155 MM HOWITZER	M109	5 WHITE BAGS	350	
168	19	13:29:41	155 MM HOWITZER	M109	5 WHITE BAGS	350	
169	19	13:30:23	155 MM HOWITZER	M109	5 WHITE BAGS	350	
170	19	13:35:51	CALIBRATION		5.00 LBS.		
171	19	13:44:23	CALIBRATION		5.00 LBS.		
172	19	13:48:17	155 MM HOWITZER	M109	5 WHITE BAGS	1275	
173	19	13:53:01	155 MM HOWITZER	M109	5 WHITE BAGS	1275	
174	19	13:53:52	155 MM HOWITZER	M109	5 WHITE BAGS	1275	
175	19	13:54:34	155 MM HOWITZER	M109	5 WHITE BAGS	1275	
176	19	13:55:17	155 MM HOWITZER	M109	5 WHITE BAGS	1275	
177	19	14:00:55	CALIBRATION		5.00 LBS.		
178	19	15:13:32	C4		5.00 LBS.		
179	19	15:19:14	C4		0.31 LBS.		
180	19	15:26:17	C4		20.00 LBS.		
181	19	15:35:06	C4		1.25 LBS.		
182	19	15:42:46	C4		2.50 LBS.		
183	19	15:50:23	C4		10.00 LBS.		
184	19	15:56:29	C4		0.62 LBS.		
185	19	16:02:47	C4		5.00 LBS.		
186	19	16:09:40	C4		0.31 LBS.		
187	19	16:19:52	C4		20.00 LBS.		
188	19	16:26:35	C4		1.25 LBS.		
189	19	16:32:32	C4		2.50 LBS.		
190	19	16:39:59	C4		10.00 LBS.		
191	19	16:47:12	C4		0.62 LBS.		
192	19	16:52:34	C4		5.00 LBS.		
193	19	16:58:31	C4		0.31 LBS.		
194	19	17:05:39	C4		20.00 LBS.		
195	19	17:11:19	C4		1.25 LBS.		
196	19	17:16:50	C4		2.50 LBS.		
197	19	17:24:05	C4		10.00 LBS.		
198	19	17:30:06	C4		0.62 LBS.		
199	19	17:35:47	C4		5.00 LBS.		
200	20	9:47:53	CALIBRATION		5.00 LBS.		

#	DAY	TIME	WEAPON	MODEL	CHARGE SIZE	ELEVA	RANGE
201	20	10:08:33	CALIBRATION		5.00 LBS.		
202	20	10:22:05	8 INCH HOWITZER	M110	5 WHITE BAGS	100	
203	20	10:42:00	8 INCH HOWITZER	M110	5 WHITE BAGS	100	
204	20	10:57:09	8 INCH HOWITZER	M110	5 WHITE BAGS	100	
205	20	11:03:39	CALIBRATION		5.00 LBS.		
206	20	11:12:43	8 INCH HOWITZER	M110	5 WHITE BAGS	100	
207	20	11:17:36	8 INCH HOWITZER	M110	5 WHITE BAGS	100	
208	20	11:21:30	8 INCH HOWITZER	M110	5 WHITE BAGS	200	
209	20	11:28:23	CALIBRATION		5.00 LBS.		
210	20	11:40:01	8 INCH HOWITZER	M110	5 WHITE BAGS	200	
211	20	11:42:45	8 INCH HOWITZER	M110	5 WHITE BAGS	200	
212	20	11:44:51	8 INCH HOWITZER	M110	5 WHITE BAGS	200	
213	20	11:50:48	CALIBRATION		5.00 LBS.		
214	20	13:41:01	CALIBRATION		5.00 LBS.		
215	20	13:49:13	8 INCH HOWITZER	M110	5 WHITE BAGS	200	
216	20	13:53:53	8 INCH HOWITZER	M110	7 WHITE BAGS	100	
217	20	14:38:48	8 INCH HOWITZER	M110	7 WHITE BAGS	100	
218	20	14:45:16	CALIBRATION		5.00 LBS.		
219	20	15:50:43	CALIBRATION		5.00 LBS.		
220	20	15:59:22	8 INCH HOWITZER	M110	7 WHITE BAGS	100	
221	20	16:01:16	8 INCH HOWITZER	M110	7 WHITE BAGS	100	
222	20	16:03:09	8 INCH HOWITZER	M110	7 WHITE BAGS	100	
223	20	16:09:50	CALIBRATION		5.00 LBS.		
224	20	16:18:57	8 INCH HOWITZER	M110	3 GREEN BAGS	200	
225	20	16:21:08	8 INCH HOWITZER	M110	3 GREEN BAGS	200	
226	20	16:23:09	8 INCH HOWITZER	M110	3 GREEN BAGS	200	
227	20	16:29:51	CALIBRATION		5.00 LBS.		
228	20	16:37:17	8 INCH HOWITZER	M110	3 GREEN BAGS	200	
229	20	16:39:15	8 INCH HOWITZER	M110	3 GREEN BAGS	200	
230	20	16:43:44	8 INCH HOWITZER	M110	3 GREEN BAGS	400	
231	20	16:50:48	CALIBRATION		5.00 LBS.		
232	20	18:30:58	C4 ON GROUND		5.00 LBS.		
233	20	18:37:05	8 INCH HOWITZER	M110	3 GREEN BAGS	400	
234	20	18:39:04	8 INCH HOWITZER	M110	3 GREEN BAGS	400	
235	20	18:41:05	8 INCH HOWITZER	M110	3 GREEN BAGS	400	
236	20	18:46:43	CALIBRATION		5.00 LBS.		
237	20	18:52:24	8 INCH HOWITZER	M110	3 GREEN BAGS	400	
238	20	18:54:23	8 INCH HOWITZER	M110	5 GREEN BAGS	200	
239	20	18:56:24	8 INCH HOWITZER	M110	5 GREEN BAGS	200	
240	20	19:01:38	CALIBRATION		5.00 LBS.		
241	20	19:07:43	8 INCH HOWITZER	M110	5 GREEN BAGS	200	
242	20	19:09:44	8 INCH HOWITZER	M110	5 GREEN BAGS	200	
243	20	19:11:45	8 INCH HOWITZER	M110	5 GREEN BAGS	200	
244	20	19:18:23	CALIBRATION		5.00 LBS.		
245	20	19:25:10	CALIBRATION		5.00 LBS.		
246	21	9:44:31	CALIBRATION		5.00 LBS.		
247	21	9:51:01	CALIBRATION		5.00 LBS.		
248	21	9:55:58	152 MM SHERIDAN TANK			59	3095
249	21	10:00:21	152 MM SHERIDAN TANK			59	3095
250	21	10:01:17	152 MM SHERIDAN TANK			59	3095

#	DAY	TIME	WEAPON	MODEL.	CHARGE SIZE	ELEVA	RANGE
251	21	10:02:21	152 MM SHERIDAN TANK			59	3095
252	21	10:09:10	CALIBRATION		5.00 LBS.		
253	21	10:13:35	152 MM SHERIDAN TANK			59	3095
254	21	10:17:21	152 MM SHERIDAN TANK			59	3095
255	21	10:18:13	152 MM SHERIDAN TANK			59	3095
256	21	10:26:34	152 MM SHERIDAN TANK			59	3095
257	21	10:35:09	CALIBRATION		5.00 LBS.		
258	21	10:41:07	152 MM SHERIDAN TANK			59	3095
259	21	10:41:49	152 MM SHERIDAN TANK			59	3095
260	21	10:42:30	152 MM SHERIDAN TANK			50	2900
261	21	10:46:21	152 MM SHERIDAN TANK			50	2900
262	21	10:51:36	CALIBRATION		5.00 LBS.		
263	21	10:54:35	152 MM SHERIDAN TANK			50	2900
264	21	10:55:15	152 MM SHERIDAN TANK			50	2900
265	21	10:55:55	152 MM SHERIDAN TANK			50	2900
266	21	10:56:36	152 MM SHERIDAN TANK			50	2900
267	21	11:02:29	CALIBRATION		5.00 LBS.		
268	21	11:05:36	152 MM SHERIDAN TANK			50	2900
269	21	11:06:17	152 MM SHERIDAN TANK			50	2900
270	21	11:06:57	152 MM SHERIDAN TANK			50	2900
271	21	11:07:36	152 MM SHERIDAN TANK			50	2900
272	21	11:13:59	CALIBRATION		5.00 LBS.		
273	21	11:46:55	CALIBRATION		5.00 LBS.		
274	21	11:53:36	152 MM SHERIDAN TANK			45	2750
275	21	11:54:17	152 MM SHERIDAN TANK			45	2750
276	21	11:54:59	152 MM SHERIDAN TANK			45	2750
277	21	11:55:43	152 MM SHERIDAN TANK			45	2750
278	21	12:01:09	CALIBRATION		5.00 LBS.		
279	21	12:04:03	152 MM SHERIDAN TANK			45	2750
280	21	12:04:45	152 MM SHERIDAN TANK			45	2750
281	21	12:05:28	152 MM SHERIDAN TANK			45	2750
282	21	12:06:13	152 MM SHERIDAN TANK			45	2750
283	21	12:13:54	CALIBRATION		5.00 LBS.		
284	21	12:15:55	152 MM SHERIDAN TANK			45	2750
285	21	12:16:40	152 MM SHERIDAN TANK			45	2750
286	21	12:17:19	152 MM SHERIDAN TANK			40	2600
287	21	12:18:03	152 MM SHERIDAN TANK			40	2600
288	21	12:23:25	CALIBRATION		5.00 LBS.		
289	21	12:26:28	152 MM SHERIDAN TANK			40	2600
290	21	12:27:13	152 MM SHERIDAN TANK			40	2600
291	21	12:27:56	152 MM SHERIDAN TANK			40	2600
292	21	12:28:38	152 MM SHERIDAN TANK			40	2600
293	21	12:34:10	CALIBRATION		5.00 LBS.		
294	21	12:37:21	152 MM SHERIDAN TANK			40	2600
295	21	12:38:01	152 MM SHERIDAN TANK			40	2600
296	21	12:38:44	152 MM SHERIDAN TANK			40	2600
297	21	12:39:28	152 MM SHERIDAN TANK			40	2600
298	21	12:45:17	CALIBRATION		5.00 LBS.		
299	21	13:58:40	C4		5.00 LBS.		
300	21	14:07:15	C4		0.62 LBS.		



#	DAY	TIME	WEAPON	MODEL	CHARGE SIZE	ELEVA	RANGE
301	21	14:14:25	C-1		20.00 LBS.		
302	21	14:19:53	C-1		1.25 LBS.		
303	21	14:26:14	C-1		2.50 LBS.		
304	21	14:34:19	C-1		10.00 LBS.		
305	21	14:40:29	C-1		0.31 LBS.		
306	21	14:46:03	C-1		5.00 LBS.		
307	21	14:51:06	C-1		0.62 LBS.		
308	21	14:57:09	C-1		20.00 LBS.		
309	21	15:02:35	C-1		1.25 LBS.		
310	21	15:07:49	C-1		2.50 LBS.		
311	21	15:14:24	C-1		10.00 LBS.		
312	21	15:20:07	C-1		0.31 LBS.		
313	21	15:26:19	C-1		5.00 LBS.		
314	22	9:34:09	C-1		5.00 LBS.		
315	22	9:42:21	C-1		0.31 LBS.		
316	22	9:49:47	C-1		20.00 LBS.		
317	22	9:56:03	C-1		1.25 LBS.		
318	22	10:01:51	C-1		2.50 LBS.		
319	22	10:07:45	C-1		10.00 LBS.		
320	22	10:19:03	C-1		0.62 LBS.		
321	22	10:24:55	C-1		5.00 LBS.		
322	22	10:30:47	C-1		0.31 LBS.		
323	22	10:38:20	C-1		20.00 LBS.		
324	22	10:44:34	C-1		1.25 LBS.		
325	22	10:50:07	C-1		2.50 LBS.		
326	22	10:56:23	C-1		10.00 LBS.		
327	22	11:04:20	C-1		0.62 LBS.		
328	22	12:31:24	C-1		5.00 LBS.		
329	22	12:35:43	C-1		0.31 LBS.		
330	22	12:41:50	C-1		20.00 LBS.		
331	22	12:46:10	C-1		1.25 LBS.		
332	22	12:49:53	C-1		2.50 LBS.		
333	22	12:54:49	C-1		10.00 LBS.		
334	22	13:03:11	C-1		0.62 LBS.		
335	22	13:08:30	C-1		5.00 LBS.		
336	22	13:12:28	C-1		0.31 LBS.		
337	22	13:17:39	C-1		20.00 LBS.		
338	22	13:21:57	C-1		1.25 LBS.		
339	22	13:26:37	C-1		2.50 LBS.		
340	22	13:31:25	C-1		10.00 LBS.		
341	22	13:39:24	C-1		0.62 LBS.		
342	22	13:43:48	C-1		5.00 LBS.		
343	22	13:48:14	C-1		0.31 LBS.		
344	22	13:53:42	C-1		20.00 LBS.		
345	22	13:58:08	C-1		1.25 LBS.		
346	22	14:02:18	C-1		2.50 LBS.		
347	22	14:07:14	C-1		10.00 LBS.		
348	22	14:11:35	C-1		0.62 LBS.		
349	22	14:21:55	C-1		5.00 LBS.		
350	23	10:13:26	CALIBRATION		5.00 LBS.		

#	DAY	TIME	WEAPON	MODEL	CHARGE SIZE	ELEVA	RANGE
351	23	10:18:46	CALIBRATION		5.00 LBS.		
352	23	10:24:15	155 MM HOWITZER	M114A1	3 GREEN BAGS	200	2800
353	23	10:29:15	155 MM HOWITZER	M114A1	3 GREEN BAGS	200	2800
354	23	10:29:58	155 MM HOWITZER	M114A1	3 GREEN BAGS	200	2800
355	23	10:34:30	CALIBRATION		5.00 LBS.		
356	23	10:37:55	155 MM HOWITZER	M114A1	3 GREEN BAGS	200	2800
357	23	10:40:45	155 MM HOWITZER	M114A1	3 GREEN BAGS	200	2800
358	23	10:41:30	155 MM HOWITZER	M114A1	3 GREEN BAGS	500	5600
359	23	10:46:39	CALIBRATION		5.00 LBS.		
360	23	10:49:57	155 MM HOWITZER	M114A1	3 GREEN BAGS	500	5600
361	23	10:50:40	155 MM HOWITZER	M114A1	3 GREEN BAGS	500	5600
362	23	10:51:26	155 MM HOWITZER	M114A1	3 GREEN BAGS	500	5600
363	23	10:56:42	CALIBRATION		5.00 LBS.		
364	23	11:00:03	155 MM HOWITZER	M114A1	3 GREEN BAGS	500	5600
365	23	11:00:43	155 MM HOWITZER	M114A1	5 GREEN BAGS	200	4300
366	23	11:03:13	155 MM HOWITZER	M114A1	5 GREEN BAGS	200	4300
367	23	11:07:41	CALIBRATION		5.00 LBS.		
368	23	11:17:34	155 MM HOWITZER	M114A1	5 GREEN BAGS	200	4300
369	23	11:18:19	155 MM HOWITZER	M114A1	5 GREEN BAGS	200	4300
370	23	11:19:03	155 MM HOWITZER	M114A1	5 WHITE BAGS	200	
371	23	11:25:56	CALIBRATION		5.00 LBS.		
372	23	12:09:44	CALIBRATION		5.00 LBS.		
373	23	12:12:51	155 MM HOWITZER	M114A1	5 GREEN BAGS	185	7000
374	23	12:13:33	155 MM HOWITZER	M114A1	5 WHITE BAGS	185	7000
375	23	12:14:16	155 MM HOWITZER	M114A1	5 WHITE BAGS	185	7000
376	23	12:19:08	CALIBRATION		5.00 LBS.		
377	23	12:23:10	155 MM HOWITZER	M114A1	5 WHITE BAGS	185	4200
378	23	12:23:51	155 MM HOWITZER	M114A1	5 WHITE BAGS	185	4200
379	23	12:24:34	155 MM HOWITZER	M114A1	5 WHITE BAGS	348	7000
380	23	12:28:59	CALIBRATION		5.00 LBS.		
381	23	12:31:52	155 MM HOWITZER	M114A1	5 WHITE BAGS	348	7000
382	23	12:32:34	155 MM HOWITZER	M114A1	5 WHITE BAGS	348	7000
383	23	12:33:17	155 MM HOWITZER	M114A1	5 WHITE BAGS	348	7000
384	23	12:39:27	CALIBRATION		5.00 LBS.		
385	23	12:42:55	155 MM HOWITZER	M114A1	5 WHITE BAGS	348	7000
386	23	12:43:39	155 MM HOWITZER	M114A1	7 WHITE BAGS	185	7000
387	23	12:44:22	155 MM HOWITZER	M114A1	7 WHITE BAGS	185	7000
388	23	12:48:29	CALIBRATION		5.00 LBS.		
389	23	12:51:32	155 MM HOWITZER	M114A1	7 WHITE BAGS	185	7000
390	23	12:52:16	155 MM HOWITZER	M114A1	7 WHITE BAGS	185	7000
391	23	12:52:58	155 MM HOWITZER	M114A1	7 WHITE BAGS	185	7000
392	23	12:58:09	CALIBRATION		5.00 LBS.		
393	23	13:02:45	CALIBRATION		5.00 LBS.		
394	26	9:31:12	CALIBRATION		5.00 LBS.		
395	26	9:35:51	CALIBRATION		5.00 LBS.		
396	26	9:42:06	105 MM HOWITZER	M102	3 WHITE BAGS	250	2700
397	26	9:46:48	105 MM HOWITZER	M102	3 WHITE BAGS	250	2700
398	26	9:47:30	105 MM HOWITZER	M102	3 WHITE BAGS	250	2700
399	26	9:52:20	CALIBRATION		5.00 LBS.		
400	26	9:55:54	105 MM HOWITZER	M102	3 WHITE BAGS	250	2700

#	DAY	TIME	WEAPON	MODEL	CHARGE SIZE	ELEVA	RANGE
401	26	9:56:52	105 MM HOWITZER	M102	3 WHITE BAGS	250	2700
402	26	9:57:34	105 MM HOWITZER	M102	4 WHITE BAGS	250	3400
403	26	10:02:38	CALIBRATION		5.00 LBS.		
404	26	10:06:40	105 MM HOWITZER	M102	4 WHITE BAGS	250	3400
405	26	10:07:22	105 MM HOWITZER	M102	4 WHITE BAGS	250	3400
406	26	10:08:03	105 MM HOWITZER	M102	4 WHITE BAGS	250	3400
407	26	10:12:23	CALIBRATION		5.00 LBS.		
408	26	10:15:53	105 MM HOWITZER	M102	4 WHITE BAGS	250	3400
409	26	10:16:37	105 MM HOWITZER	M102	4 WHITE BAGS	450	5200
410	26	10:17:19	105 MM HOWITZER	M102	4 WHITE BAGS	450	5200
411	26	10:21:46	CALIBRATION		5.00 LBS.		
412	26	10:24:42	105 MM HOWITZER	M102	4 WHITE BAGS	450	5200
413	26	10:25:24	105 MM HOWITZER	M102	4 WHITE BAGS	450	5200
414	26	10:26:06	105 MM HOWITZER	M102	4 WHITE BAGS	450	5200
415	26	10:30:21	CALIBRATION		5.00 LBS.		
416	26	10:34:27	105 MM HOWITZER	M102	5 WHITE BAGS	250	4000
417	26	10:35:06	105 MM HOWITZER	M102	5 WHITE BAGS	250	4000
418	26	10:35:48	105 MM HOWITZER	M102	5 WHITE BAGS	250	4000
419	26	10:41:50	CALIBRATION		5.00 LBS.		
420	26	11:08:22	CALIBRATION		5.00 LBS.		
421	26	11:12:14	105 MM HOWITZER	M102	5 WHITE BAGS	250	4000
422	26	11:12:53	105 MM HOWITZER	M102	5 WHITE BAGS	250	4000
423	26	11:13:35	105 MM HOWITZER	M102	5 WHITE BAGS	450	6700
424	26	11:17:39	CALIBRATION		5.00 LBS.		
425	26	11:20:57	105 MM HOWITZER	M102	5 WHITE BAGS	450	6700
426	26	11:21:41	105 MM HOWITZER	M102	5 WHITE BAGS	450	6700
427	26	11:22:23	105 MM HOWITZER	M102	5 WHITE BAGS	450	6700
428	26	11:27:01	CALIBRATION		5.00 LBS.		
429	26	11:30:02	105 MM HOWITZER	M102	5 WHITE BAGS	450	6700
430	26	11:30:45	105 MM HOWITZER	M102	6 WHITE BAGS	250	5200
431	26	11:31:27	105 MM HOWITZER	M102	6 WHITE BAGS	250	5200
432	26	11:34:47	CALIBRATION		5.00 LBS.		
433	26	11:38:00	105 MM HOWITZER	M102	6 WHITE BAGS	250	5200
434	26	11:38:41	105 MM HOWITZER	M102	6 WHITE BAGS	250	5200
435	26	11:39:25	105 MM HOWITZER	M102	6 WHITE BAGS	250	5200
436	26	11:43:55	CALIBRATION		5.00 LBS.		
437	26	11:48:01	CALIBRATION		5.00 LBS.		
438	26	13:52:34	CALIBRATION		5.00 LBS.		
439	26	13:58:00	90 MM RECOILLESS RIFLE	M67			
440	26	14:02:32	90 MM RECOILLESS RIFLE	M67			
441	26	14:03:23	90 MM RECOILLESS RIFLE	M67			
442	26	14:10:18	CALIBRATION		5.00 LBS.		
443	26	14:14:10	90 MM RECOILLESS RIFLE	M67			
444	26	14:16:58	90 MM RECOILLESS RIFLE	M67			
445	26	14:17:41	90 MM RECOILLESS RIFLE	M67			
446	26	14:21:59	CALIBRATION		5.00 LBS.		
447	26	14:26:06	90 MM RECOILLESS RIFLE	M67			
448	26	14:26:49	90 MM RECOILLESS RIFLE	M67			
449	26	14:27:40	90 MM RECOILLESS RIFLE	M67			
450	26	14:31:54	CALIBRATION		5.00 LBS.		

#	DAY	TIME	WEAPON	MODEL	CHARGE SIZE	ELEVA	RANGE
451	26	15:26:51	CALIBRATION		5.00 LBS.		
452	26	15:30:24	90 MM RECOILLESS RIFLE	M67			
453	26	15:31:08	90 MM RECOILLESS RIFLE	M67			
454	26	15:31:53	90 MM RECOILLESS RIFLE	M67			
455	26	15:35:46	CALIBRATION		5.00 LBS.		
456	26	15:39:05	90 MM RECOILLESS RIFLE	M67			
457	26	15:39:47	90 MM RECOILLESS RIFLE	M67			
458	26	15:40:29	90 MM RECOILLESS RIFLE	M67			
459	26	15:44:11	CALIBRATION		5.00 LBS.		
460	26	15:47:33	90 MM RECOILLESS RIFLE	M67			
461	26	15:48:14	90 MM RECOILLESS RIFLE	M67			
462	26	15:48:56	90 MM RECOILLESS RIFLE	M67			
463	26	15:53:08	CALIBRATION		5.00 LBS.		
464	26	15:56:56	90 MM RECOILLESS RIFLE	M67			
465	26	15:57:41	90 MM RECOILLESS RIFLE	M67			
466	26	15:58:28	90 MM RECOILLESS RIFLE	M67			
467	26	16:02:16	CALIBRATION		5.00 LBS.		
468	26	16:10:31	90 MM RECOILLESS RIFLE	M67			
469	26	16:11:14	90 MM RECOILLESS RIFLE	M67			
470	26	16:11:55	90 MM RECOILLESS RIFLE	M67			
471	26	16:16:54	CALIBRATION		5.00 LBS.		
472	26	16:19:54	90 MM RECOILLESS RIFLE	M67			
473	26	16:20:35	90 MM RECOILLESS RIFLE	M67			
474	26	16:21:18	90 MM RECOILLESS RIFLE	M67			
475	26	16:27:05	CALIBRATION		5.00 LBS.		
476	26	16:29:59	90 MM RECOILLESS RIFLE	M67			
477	26	16:30:44	90 MM RECOILLESS RIFLE	M67			
478	26	16:31:28	90 MM RECOILLESS RIFLE	M67			
479	26	16:35:34	CALIBRATION		5.00 LBS.		
480	26	16:39:36	CALIBRATION		5.00 LBS.		
481	27	9:15:23	CALIBRATION		5.00 LBS.		
482	27	9:19:56	CALIBRATION		5.00 LBS.		
483	27	9:23:43	106 MM RECOILLESS RIFLE	M40A1			1200
484	27	9:34:52	106 MM RECOILLESS RIFLE	M40A1			1200
485	27	9:38:05	106 MM RECOILLESS RIFLE	M40A1			1200
486	27	9:44:25	CALIBRATION		5.00 LBS.		
487	27	9:47:26	106 MM RECOILLESS RIFLE	M40A1			1200
488	27	9:48:13	106 MM RECOILLESS RIFLE	M40A1			1200
489	27	9:48:58	106 MM RECOILLESS RIFLE	M40A1			1200
490	27	9:59:40	CALIBRATION		5.00 LBS.		
491	27	10:03:40	106 MM RECOILLESS RIFLE	M40A1			1500
492	27	10:04:21	106 MM RECOILLESS RIFLE	M40A1			1500
493	27	10:05:03	106 MM RECOILLESS RIFLE	M40A1			1500
494	27	10:37:47	CALIBRATION		5.00 LBS.		
495	27	10:41:14	106 MM RECOILLESS RIFLE	M40A1			1500
496	27	10:41:55	106 MM RECOILLESS RIFLE	M40A1			1500
497	27	10:42:38	106 MM RECOILLESS RIFLE	M40A1			1500
498	27	10:48:31	CALIBRATION		5.00 LBS.		
499	27	10:51:21	106 MM RECOILLESS RIFLE	M40A1			2000
500	27	10:52:01	106 MM RECOILLESS RIFLE	M40A1			2000

#	DAY	TIME	WEAPON	MODEL	CHARGE SIZE	ELEVA	RANGE
501	27	10:52:43	106 MM RECOILESS RIFLE	M40A1			2000
502	27	10:56:42	CALIBRATION		5.00 LBS.		
503	27	10:59:35	106 MM RECOILESS RIFLE	M40A1			2000
504	27	11:00:18	106 MM RECOILESS RIFLE	M40A1			2000
505	27	11:01:00	106 MM RECOILESS RIFLE	M40A1			2000
506	27	11:05:33	CALIBRATION		5.00 LBS.		
507	27	11:08:27	106 MM RECOILESS RIFLE	M40A1			2500
508	27	11:09:14	106 MM RECOILESS RIFLE	M40A1			2500
509	27	11:10:01	106 MM RECOILESS RIFLE	M40A1			2500
510	27	11:15:09	CALIBRATION		5.00 LBS.		
511	27	11:19:12	106 MM RECOILESS RIFLE	M40A1			2500
512	27	11:19:54	106 MM RECOILESS RIFLE	M40A1			2500
513	27	11:20:34	106 MM RECOILESS RIFLE	M40A1			2500
514	27	11:25:35	CALIBRATION		5.00 LBS.		
515	27	11:53:48	CALIBRATION		5.00 LBS.		
516	27	11:56:41	106 MM RECOILESS RIFLE	M40A1			3000
517	27	11:57:22	106 MM RECOILESS RIFLE	M40A1			3000
518	27	11:58:03	106 MM RECOILESS RIFLE	M40A1			3000
519	27	12:02:04	CALIBRATION		5.00 LBS.		
520	27	12:04:52	106 MM RECOILESS RIFLE	M40A1			3000
521	27	12:05:34	106 MM RECOILESS RIFLE	M40A1			3000
522	27	12:06:15	106 MM RECOILESS RIFLE	M40A1			3000
523	27	12:10:23	CALIBRATION		5.00 LBS.		
524	27	12:14:27	CALIBRATION		5.00 LBS.		
525	27	12:35:19	CALIBRATION		5.00 LBS.		
526	27	12:39:37	CALIBRATION		5.00 LBS.		
527	27	13:45:54	155 MM HOWITZER	M114	4 GREEN BAGS	200	3450
528	27	13:50:39	155 MM HOWITZER	M114	4 GREEN BAGS	200	3450
529	27	13:53:50	155 MM HOWITZER	M114	4 GREEN BAGS	200	3450
530	27	13:58:25	CALIBRATION		5.00 LBS.		
531	27	14:04:19	155 MM HOWITZER	M114	4 GREEN BAGS	200	3450
532	27	14:05:00	155 MM HOWITZER	M114	4 GREEN BAGS	200	3450
533	27	14:05:43	155 MM HOWITZER	M114	4 GREEN BAGS	400	5900
534	27	14:10:14	CALIBRATION		5.00 LBS.		
535	27	14:14:08	155 MM HOWITZER	M114	4 GREEN BAGS	400	5900
536	27	14:14:50	155 MM HOWITZER	M114	4 GREEN BAGS	400	5900
537	27	14:15:32	155 MM HOWITZER	M114	4 GREEN BAGS	400	5900
538	27	14:19:34	CALIBRATION		5.00 LBS.		
539	27	14:23:14	155 MM HOWITZER	M114	4 GREEN BAGS	400	5900
540	27	14:23:58	155 MM HOWITZER	M114	5 GREEN BAGS	200	4300
541	27	14:24:41	155 MM HOWITZER	M114	5 GREEN BAGS	200	4300
542	27	14:30:05	CALIBRATION		5.00 LBS.		
543	27	15:25:09	CALIBRATION		5.00 LBS.		
544	27	15:28:30	155 MM HOWITZER	M114	5 GREEN BAGS	200	4300
545	27	15:29:12	155 MM HOWITZER	M114	5 GREEN BAGS	200	4300
546	27	15:29:54	155 MM HOWITZER	M114	5 GREEN BAGS	200	4300
547	27	15:34:25	CALIBRATION		5.00 LBS.		
548	27	15:37:44	155 MM HOWITZER	M114	5 WHITE BAGS	200	4300
549	27	15:38:27	155 MM HOWITZER	M114	5 WHITE BAGS	200	4300
550	27	15:39:19	155 MM HOWITZER	M114	5 WHITE BAGS	200	4300

#	DAY	TIME	WEAPON	MODEL	CHARGE SIZE	ELEVA	RANGE
551	27	15:43:48	CALIBRATION		5.00 LBS.		
552	27	15:47:11	155 MM HOWITZER	M114	5 WHITE BAGS	200	4300
553	27	15:47:52	155 MM HOWITZER	M114	5 WHITE BAGS	200	4300
554	27	15:48:35	155 MM HOWITZER	M114	5 WHITE BAGS	350	6700
555	27	15:52:31	CALIBRATION		5.00 LBS.		
556	27	15:55:37	155 MM HOWITZER	M114	5 WHITE BAGS	350	6700
557	27	15:56:20	155 MM HOWITZER	M114	5 WHITE BAGS	350	6700
558	27	15:57:02	155 MM HOWITZER	M114	5 WHITE BAGS	350	6700
559	27	16:01:07	CALIBRATION		5.00 LBS.		
560	27	16:04:11	155 MM HOWITZER	M114	5 WHITE BAGS	350	6700
561	27	16:04:54	155 MM HOWITZER	M114	6 WHITE BAGS	200	5700
562	27	16:05:34	155 MM HOWITZER	M114	6 WHITE BAGS	200	5700
563	27	16:09:56	CALIBRATION		5.00 LBS.		
564	27	16:12:58	155 MM HOWITZER	M114	6 WHITE BAGS	200	5700
565	27	16:13:47	155 MM HOWITZER	M114	6 WHITE BAGS	200	5700
566	27	16:14:30	155 MM HOWITZER	M114	6 WHITE BAGS	200	5700
567	27	16:18:33	CALIBRATION		5.00 LBS.		
568	27	16:22:42	CALIBRATION		5.00 LBS.		
569	28	13:30:34	CALIBRATION		5.00 LBS.		
570	28	13:35:53	8 INCH SELF PROPELLED	M110A1	3 GREEN BAGS	200	
571	28	13:43:19	8 INCH SELF PROPELLED	M110A1	3 GREEN BAGS	200	
572	28	13:44:50	8 INCH SELF PROPELLED	M110A1	3 GREEN BAGS	200	
573	28	13:46:23	8 INCH SELF PROPELLED	M110A1	3 GREEN BAGS	200	
574	28	13:51:06	CALIBRATION		5.00 LBS.		
575	28	13:54:08	8 INCH SELF PROPELLED	M110A1	3 GREEN BAGS	200	
576	28	13:55:11	8 INCH SELF PROPELLED	M110A1	3 GREEN BAGS	350	
577	28	13:56:15	8 INCH SELF PROPELLED	M110A1	3 GREEN BAGS	350	
578	28	13:57:17	8 INCH SELF PROPELLED	M110A1	3 GREEN BAGS	350	
579	28	14:04:01	CALIBRATION		5.00 LBS.		
580	28	14:07:04	8 INCH SELF PROPELLED	M110A1	3 GREEN BAGS	350	
581	28	14:08:04	8 INCH SELF PROPELLED	M110A1	5 GREEN BAGS	200	
582	28	14:09:06	8 INCH SELF PROPELLED	M110A1	5 GREEN BAGS	200	
583	28	14:10:08	8 INCH SELF PROPELLED	M110A1	5 GREEN BAGS	200	
584	28	14:15:03	CALIBRATION		5.00 LBS.		
585	28	14:18:30	8 INCH SELF PROPELLED	M110A1	5 GREEN BAGS	200	
586	28	14:19:50	8 INCH SELF PROPELLED	M110A1	5 GREEN BAGS	200	
587	28	14:31:51	8 INCH SELF PROPELLED	M110A1	5 WHITE BAGS	200	
588	28	14:32:52	8 INCH SELF PROPELLED	M110A1	5 WHITE BAGS	200	
589	28	14:37:19	CALIBRATION		5.00 LBS.		
590	28	15:34:08	8 INCH SELF PROPELLED	M110A1	5 WHITE BAGS	200	
591	28	15:35:10	8 INCH SELF PROPELLED	M110A1	5 WHITE BAGS	200	
592	28	15:36:10	8 INCH SELF PROPELLED	M110A1	5 WHITE BAGS	200	
593	28	15:37:10	8 INCH SELF PROPELLED	M110A1	5 WHITE BAGS	300	
594	28	15:41:43	CALIBRATION		5.00 LBS.		
595	28	15:44:28	8 INCH SELF PROPELLED	M110A1	5 WHITE BAGS	300	
596	28	15:45:31	8 INCH SELF PROPELLED	M110A1	5 WHITE BAGS	300	
597	28	15:46:32	8 INCH SELF PROPELLED	M110A1	5 WHITE BAGS	300	
598	28	15:47:37	8 INCH SELF PROPELLED	M110A1	5 WHITE BAGS	300	
599	28	15:52:12	CALIBRATION		5.00 LBS.		

APPENDIX B:

WEATHER CONDITIONS FOR JUNE 12 TO 28, 1976,  
FORT SILL, OK

DAY	HOOR	TEMP (F)	DEW POINT	RELATIVE HUMIDITY	DIREC <sup>W</sup>	I N D SPEED	GUST
28	09	82	69	65	190	13	
28	10	84	70	63	200	16	
28	11	84	69	60	200	18	
28	12	87	70	57	200	08	
28	13	91	70	51	190	13	
28	14	97	69	40	190	10	
28	15	96	70	43	220	09	
28	16	95	68	41	160	08	
28	17	96	61	31	180	06	
28	18	93	66	41	130	06	
28	19	MISS	MISS	NA	090	10	
28	20	74	73	97	030	14	
28	21	70	70	100	130	12	
27	09	80	65	60	220	06	
27	10	87	67	51	230	10	
27	11	88	66	48	240	06	
27	12	87	67	51	250	12	
27	13	92	66	42	220	11	
27	14	95	65	37	180	16	
27	15	96	64	35	190	14	
27	16	95	64	36	190	10	
27	17	95	64	36	160	10	
27	18	94	62	35	170	10	
27	19	94	66	40	150	14	
27	20	91	63	39	160	12	
27	21	88	63	43	160	10	
26	09	79	64	60	220	06	
26	10	83	65	54	220	06	
26	11	85	66	53	220	04	
26	12	89	64	43	220	10	
26	13	93	67	42	220	10	
26	14	94	65	39	180	07	
26	15	94	63	36	150	05	18
26	16	96	62	33	190	10	
26	17	95	64	36	120	10	17
26	18	94	61	33	160	11	
26	19	93	61	34	180	10	
26	20	90	62	39	180	09	
26	21	87	63	44	170	09	



DAY	HOUR	TEMP (F)	DEW POINT	RELATIVE HUMIDITY	W I N D DIREC	SPEED	GUST
25	09	87	65	48	240	06	
25	10	89	63	42	CALM		
25	11	92	61	35	220	02	
25	12	95	61	33	330	04	
25	13	97	60	29	160	10	
25	14	97	64	34	220	10	
25	15	95	61	32	130	08	
25	16	91	65	42	160	08	
25	17	88	66	48	170	16	
25	18	87	67	51	200	12	18
25	19	83	67	58	230	10	
25	20	82	67	60	200	06	
25	21	82	66	58	250	02	
24	09	82	66	58	190	06	
24	10	85	66	53	160	08	
24	11	88	66	48	CALM		
24	12	90	62	39	190	04	
24	13	93	58	31	130	04	
24	14	95	61	33	120	10	
24	15	97	58	27	070	10	
24	16	96	60	30	090	06	
24	17	95	61	32	080	07	
24	18	94	62	35	090	08	
24	19	93	68	44	100	05	
24	20	89	66	46	090	06	
24	21	86	67	53	CALM		
23	09	80	68	66	220	08	
23	10	84	65	53	230	06	
23	11	86	62	45	190	08	
23	12	91	64	41	220	13	
23	13	90	63	41	200	07	
23	14	93	62	36	150	11	
23	15	93	61	34	210	07	
23	16	93	62	36	130	07	
23	17	92	62	37	140	12	
23	18	91	63	39	140	13	
23	19	90	63	40	150	13	
23	20	87	61	42	140	08	
23	21	84	61	46	150	05	

DAY	HOUR	TEMP (P)	DEW POINT	RELATIVE HUMIDITY	W I N D DIREC	SPEED	GUST
22	09	81	64	56	210	15	
22	10	83	64	53	210	08	18
22	11	85	62	46	220	11	18
22	12	88	63	43	210	13	19
22	13	90	63	41	210	08	23
22	14	90	60	37	190	10	
22	15	90	62	39	220	07	
22	16	90	61	38	170	11	
22	17	90	62	39	150	12	
22	18	87	60	40	160	18	
22	19	87	60	49	190	16	
22	20	84	60	44	170	06	
22	21	83	62	49	160	12	
21	09	82	63	52	210	12	16
21	10	84	63	49	210	10	
21	11	86	61	43	200	11	
21	12	89	61	39	210	08	18
21	13	91	61	37	210	08	24
21	14	92	63	38	180	14	21
21	15	92	61	35	180	11	18
21	16	92	59	33	190	12	20
21	17	92	60	34	140	11	
21	18	91	66	43	190	15	20
21	19	89	66	41	160	10	
21	20	84	62	47	140	14	
21	21	83	64	52	150	12	
20	09	82	68	62	200	14	
20	10	86	68	55	200	15	20
20	11	88	65	46	200	15	18
20	12	90	64	42	210	16	24
20	13	93	63	37	190	13	24
20	14	95	64	36	180	17	24
20	15	96	61	31	210	15	28
20	16	98	61	30	200	13	23
20	17	95	61	32	190	20	32
20	18	93	60	33	180	16	25
20	19	90	60	36	170	15	
20	20	87	61	41	170	14	23
20	21	85	64	49	170	13	

DAY	HR	TEMP(F)	DEW POINT	RELATIVE HUMIDITY	WIND DIR	WIND SPEED	WIND GUST
19	09	78	71	79	160	13	
19	10	81	71	71	160	12	
19	11	85	71	63	150	11	16
19	12	87	70	57	160	12	18
19	13	87	70	57	130	16	20
19	14	89	70	54	140	15	22
19	15	91	65	42	180	16	20
19	16	94	57	41	180	12	20
19	17	92	62	37	170	13	22
19	18	91	61	36	160	15	26
19	19	88	63	43	160	13	22
19	20	85	65	50	150	13	20
19	21	82	66	58	150	14	
18	09	79	72	79	180	05	
18	10	83	73	72	130	04	
18	11	86	72	63	180	05	
18	12	86	69	57	130	06	
18	13	88	69	53	130	08	14
18	14	90	69	50	150	12	
18	15	90	68	48	150	18	
18	16	90	66	45	160	16	25
18	17	86	67	52	180	14	
18	18	87	66	49	160	14	
18	19	84	68	58	160	18	
18	20	81	69	67	160	08	
18	21	80	69	69	170	02	
17	09	79	69	71	120	06	
17	10	80	68	66	160	10	
17	11	83	68	60	130	08	13
17	12	84	68	59	150	06	
17	13	86	68	55	120	05	
17	14	86	66	51	130	09	15
17	15	88	66	48	110	09	18
17	16	88	64	45	120	06	
17	17	88	64	45	110	08	
17	18	87	63	45	170	08	
17	19	86	63	46	130	07	
17	20	81	64	55	100	04	
17	21	78	64	62	120	04	

DAY	HOUR	TEMP (F)	DEW POINT	RELATIVE HUMIDITY	W I N D DIREC	SPEED	GUST
16	09	75	69	81	CALM		
16	10	76	69	79	010	02	
16	11	79	70	82	040	05	
16	12	81	71	71	050	03	
16	13	84	69	60	070	05	
16	14	86	69	57	070	11	
16	15	87	69	55	030	06	
16	16	86	66	48	050	10	
16	17	87	66	49	050	08	
16	18	87	66	50	070	08	
16	19	85	66	53	070	05	
16	20	80	67	64	080	04	
16	21	78	67	68	090	04	
15	09	71	69	93	200	08	
15	10	72	70	93	190	10	
15	11	73	70	90	220	12	20
15	12	77	72	84	200	08	
15	13	77	72	84	210	05	
15	14	81	70	69	200	12	
15	15	82	70	67	180	04	
15	16	85	70	60	170	06	
15	17	87	69	55	160	08	
15	18	86	67	53	190	04	
15	19	85	68	56	CALM		
15	20	82	70	67	CALM		
15	21	81	69	67	150	06	
14	09	78	67	68	210	10	
14	10	80	67	64	170	04	
14	11	81	66	60	150	10	
14	12	83	65	54	190	10	
14	13	85	64	49	170	14	22
14	14	85	65	51	160	14	23
14	15	87	67	51	170	10	
14	16	87	64	46	180	10	
14	17	86	65	49	200	08	15
14	18	78	65	64	130	10	15
14	19	82	67	60	150	08	
14	20	80	68	66	140	04	
14	21	78	69	73	140	07	

DAY	HOUR	TEMP (F)	DEW POINT	RELATIVE HUMIDITY	WIND DIREC	WIND SPEED	GUST
13	09	82	69	64	190	08	
13	10	84	68	59	180	12	
13	11	86	65	49	170	12	
13	12	87	64	46	180	08	
13	13	88	65	46	140	10	17
13	14	87	65	48	180	08	
13	15	88	64	45	190	10	
13	16	87	64	46	170	12	19
13	17	83	68	60	120	12	19
13	18	78	67	68	160	18	25
13	19	76	66	71	160	06	
13	20	75	66	73	160	03	
13	21	74	67	78	140	05	
12	09	78	69	73	180	12	
12	10	82	67	60	180	12	
12	11	83	67	58	180	16	
12	12	86	64	48	200	16	
12	13	88	65	46	190	10	23
12	14	90	63	41	210	10	
12	15	92	62	37	200	10	18
12	16	89	63	47	190	07	19
12	17	90	65	43	220	10	
12	18	89	64	43	160	14	18
12	19	81	67	62	200	09	17
12	20	78	65	64	160	04	
12	21	76	65	68	150	04	

APPENDIX C:  
DIRECTIVITY PATTERNS

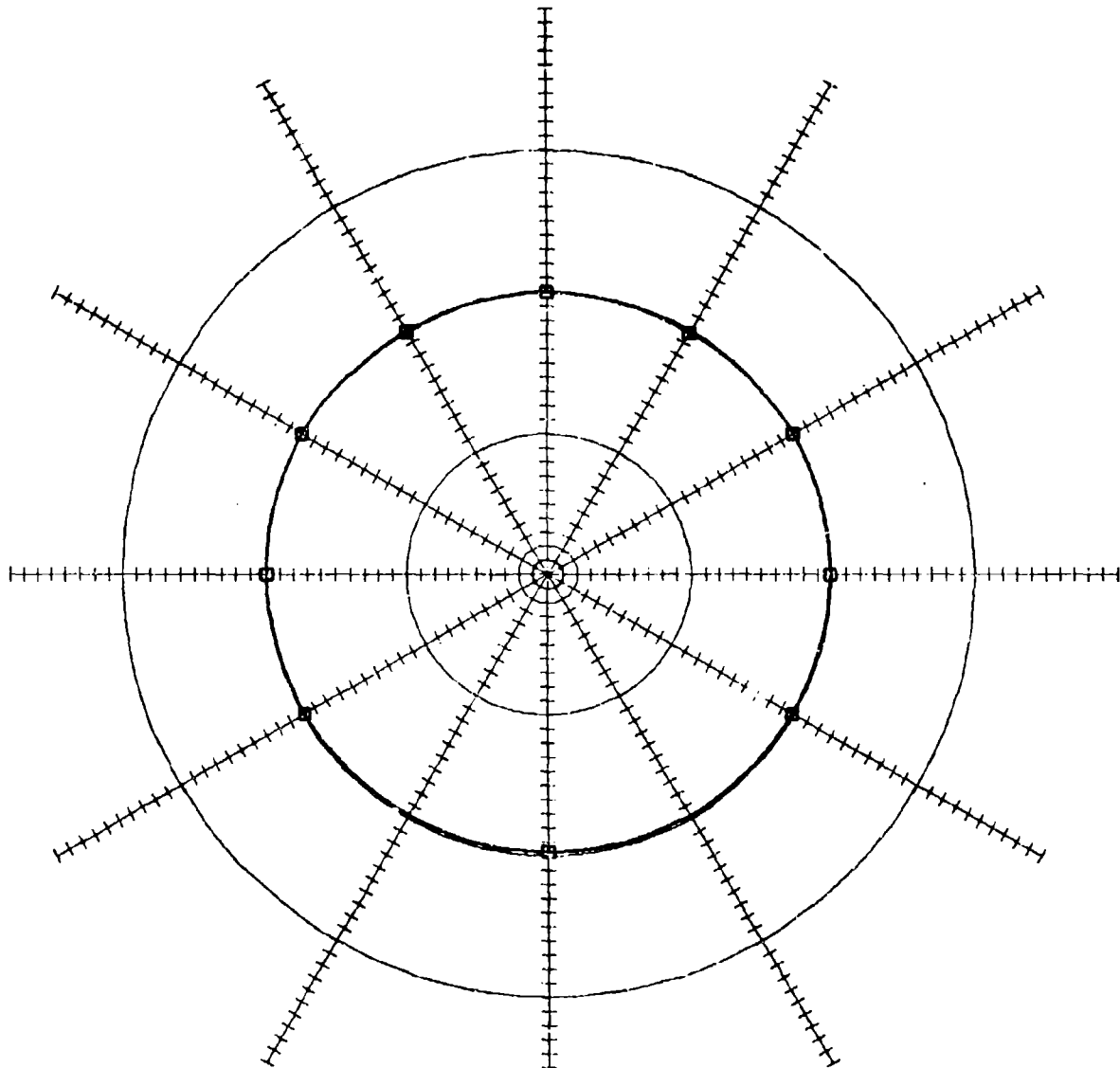

NAME CALIBRATION  
 ELEVATION 0  
 CHARGE SIZE 5.00 LBS.

CHANNEL	ENERGY	DIFFERENCE FROM REAR	ANGLE	DIFFERENCE FROM REAR	DIFFERENCE FROM C4
1	118.62	-0.17	0°	-0.33	-0.24
2	118.75	-0.08	30°	-0.27	-0.17
3	118.78	0.00	60°	-0.20	-0.10
4	118.93	0.08	90°	-0.09	-0.00
5	119.22	-0.11	120°	-0.00	0.09
6	112.85	-0.29	150°	-0.16	-0.05
7	113.16	0.10	180°	0.00	0.09
8	113.14	-0.25	210°	-0.16	-0.06
9	118.56	-0.33	240°	-0.00	0.09
10	112.65	-0.25	270°	-0.09	-0.00
11	112.95	0.19	300°	-0.20	-0.10
12	112.58	-0.13	330°	-0.27	-0.17
13	112.81	0.02			
14	113.00	0.00			
15	112.60	-0.35			
16	112.77	-0.44			
			AVERAGE	-0.15	-0.05

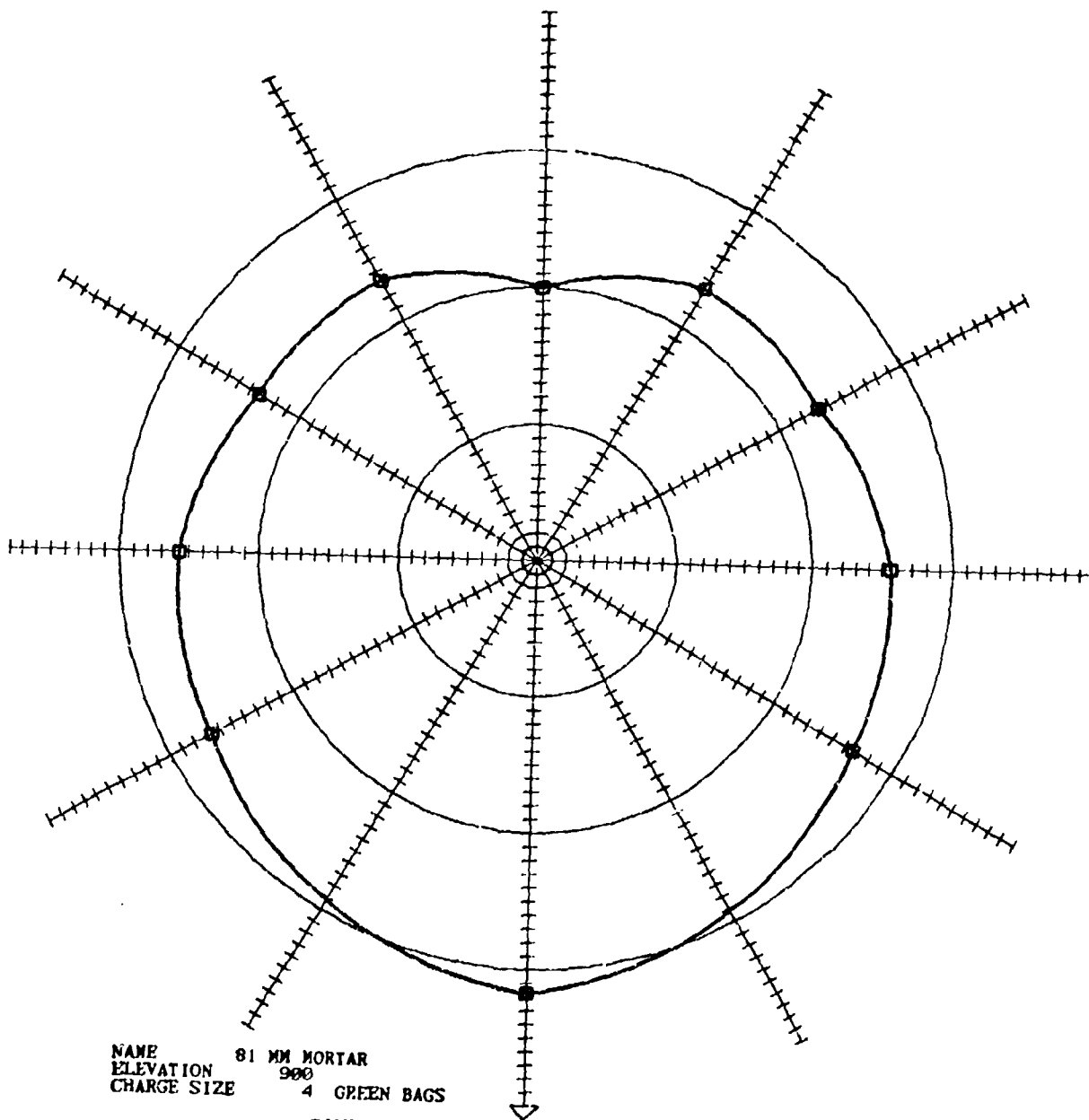

NAME 81 MM MORTAR  
 ELEVATION 900  
 CHARGE SIZE 4 GREEN BAGS

CHANNEL	ENERGY	DIFFERENCE FROM REAR	ANGLE	DIFFERENCE FROM REAR	DIFFERENCE FROM C4
1	95.25	9.03	0°	11.71	-21.42
2	91.56	5.20	30°	9.17	-23.96
3	86.40	0.00	60°	6.63	-26.50
4	87.12	1.06	90°	5.65	-27.49
5	91.35	5.10	120°	3.27	-29.86
6	82.81	3.40	150°	3.34	-29.79
7	77.86	-1.00	180°	0.00	-33.14
8	81.69	3.40	160°	3.34	-29.79
9	98.45	11.71	210°	3.27	-29.86
10	86.85	7.69	240°	5.65	-27.49
11	87.11	7.90	270°	6.63	-26.50
12	85.16	6.15	300°	9.17	-23.96
13	83.76	3.74	330°		
14	80.29	0.00			
15	83.63	3.34			
16	83.69	3.40			
			AVERAGE	6.00	-26.33



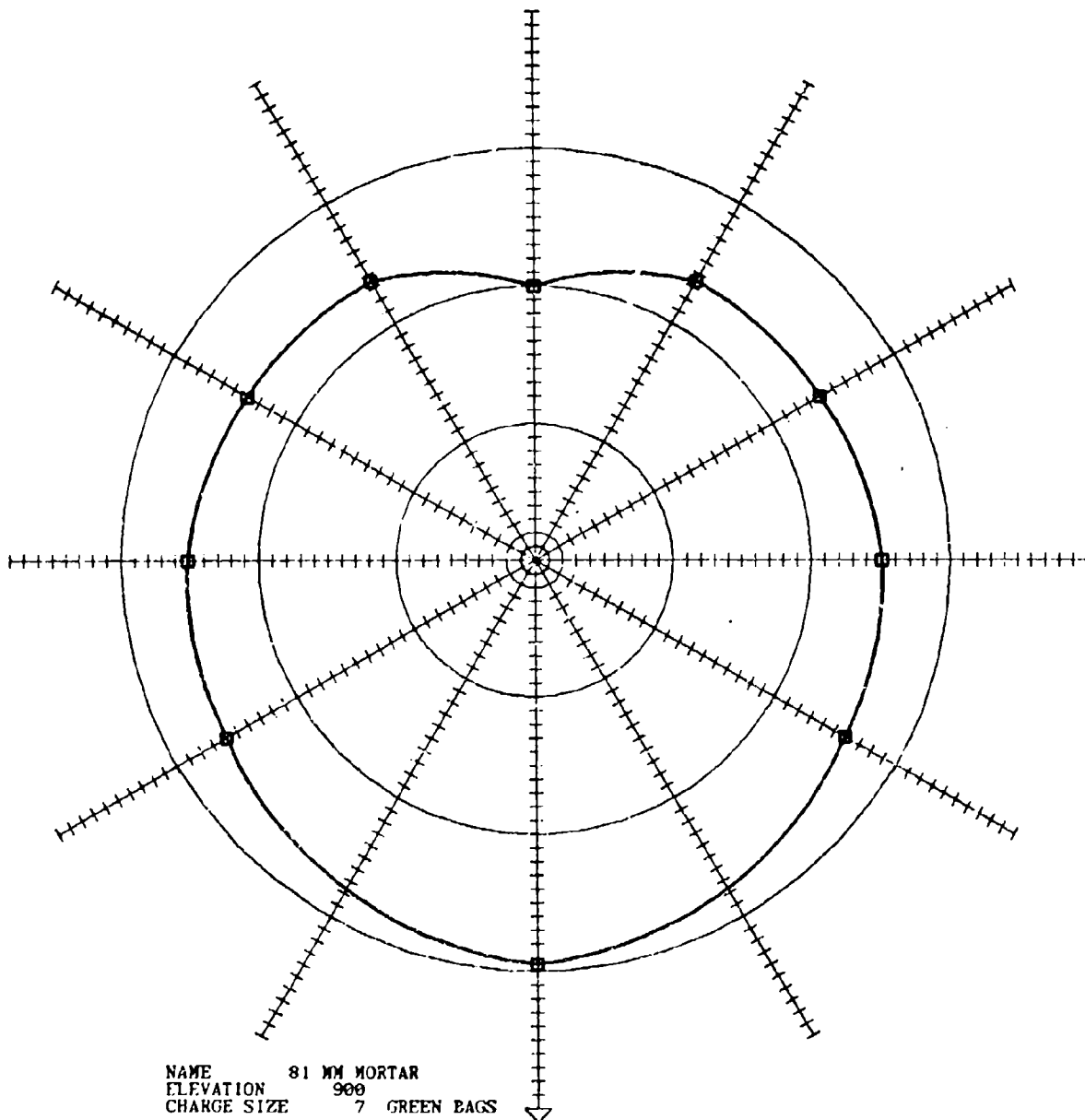

NAME 81 MM MORTAR  
 ELEVATION 900  
 CHARGE SIZE 7 GREEN BAGS

CHANNEL	ENERGY	DIFFERENCE FROM REAR	ANGLE	DIFFERENCE FROM REAR	DIFFERENCE FROM C4
1	100.42	6.41	0°	9.44	-16.91
2	98.73	4.72	30°	7.64	-18.71
3	94.04	0.00	60°	5.85	-20.50
4	96.73	2.58	90°	5.11	-21.25
5	97.67	3.67	120°	3.88	-22.47
6	90.82	5.34	150°	3.47	-22.88
7	87.61	2.08	180°	0.00	-26.36
8	88.93	3.30	210°	3.47	-22.88
9	103.51	9.44	240°	3.88	-22.47
10	93.43	7.96	270°	5.11	-21.25
11	92.34	6.92	300°	5.85	-20.50
12	91.61	6.16	330°	7.64	-18.71
13	88.95	3.48			
14	85.61	0.00			
15	89.09	3.47			
16	88.93	3.30			
			AVERAGE	5.73	-20.61

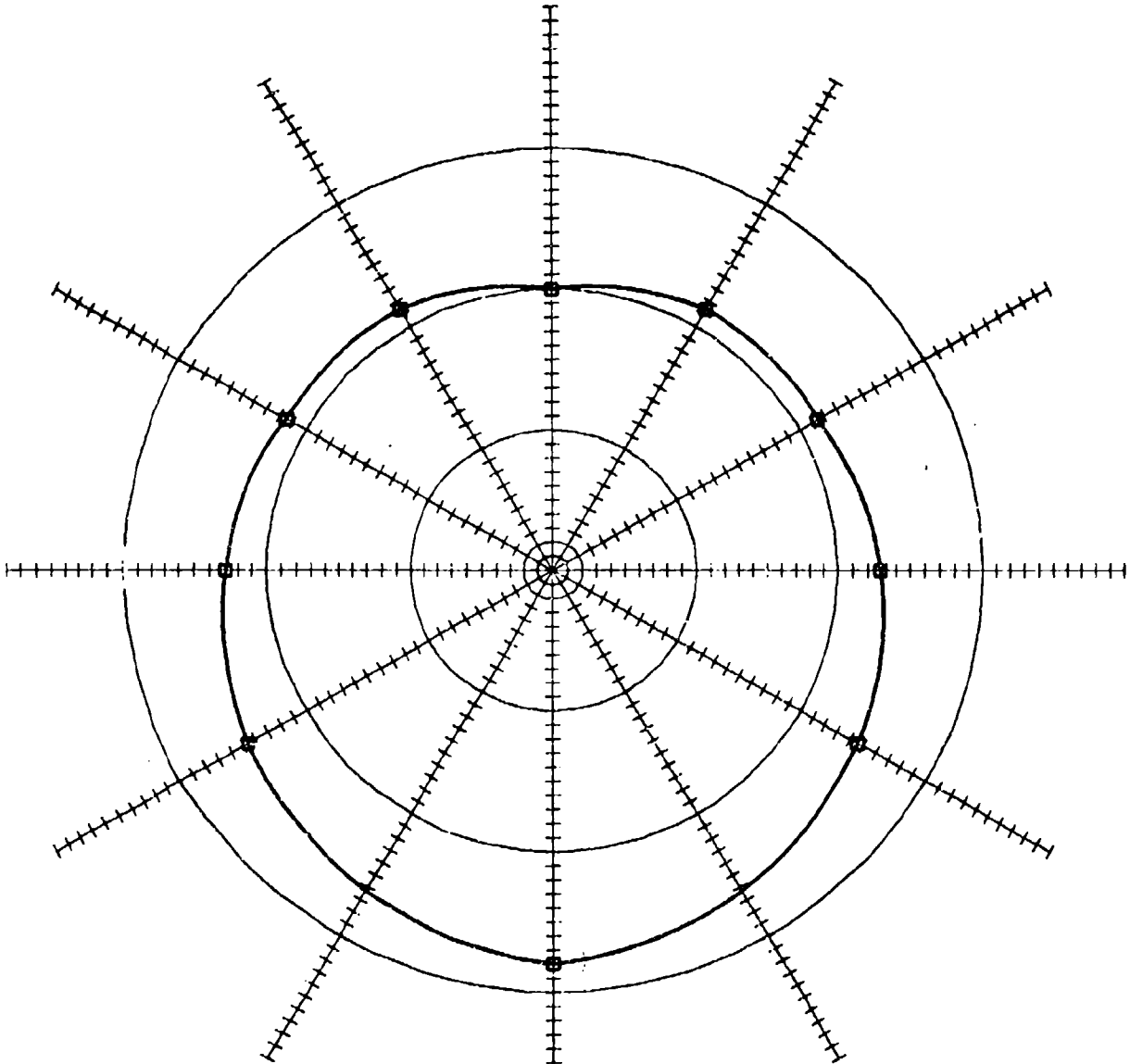

NAME 81 MM MORTAR  
 ELEVATION 1050  
 CHARGE SIZE 5 GREEN BAGS

CHANNEL	ENERGY	DIFFERENCE FROM REAR	ANGLE	DIFFERENCE FROM REAR	DIFFERENCE FROM C4
1	98.59	7.01	0°	7.93	-20.75
2	95.95	4.55	30°	6.25	-22.43
3	91.54	0.00	60°	4.57	-24.12
4	90.86	-0.90	90°	2.89	-25.01
5	94.29	2.55	120°	1.50	-27.18
6	86.53	2.77	150°	1.43	-27.25
7	81.47	-2.64	180°	0.00	-28.69
8	84.33	0.12	210°	1.43	-27.25
9	99.38	7.93	240°	1.50	-27.18
10	89.98	5.82	270°	2.89	-25.01
11	89.57	5.65	300°	4.57	-24.12
12	88.71	4.85	330°	6.25	-22.43
13	86.75	2.80			
14	84.64	0.00			
15	84.18	-4.00			
16	84.33	0.12			
			AVERAGE	4.10	-24.58

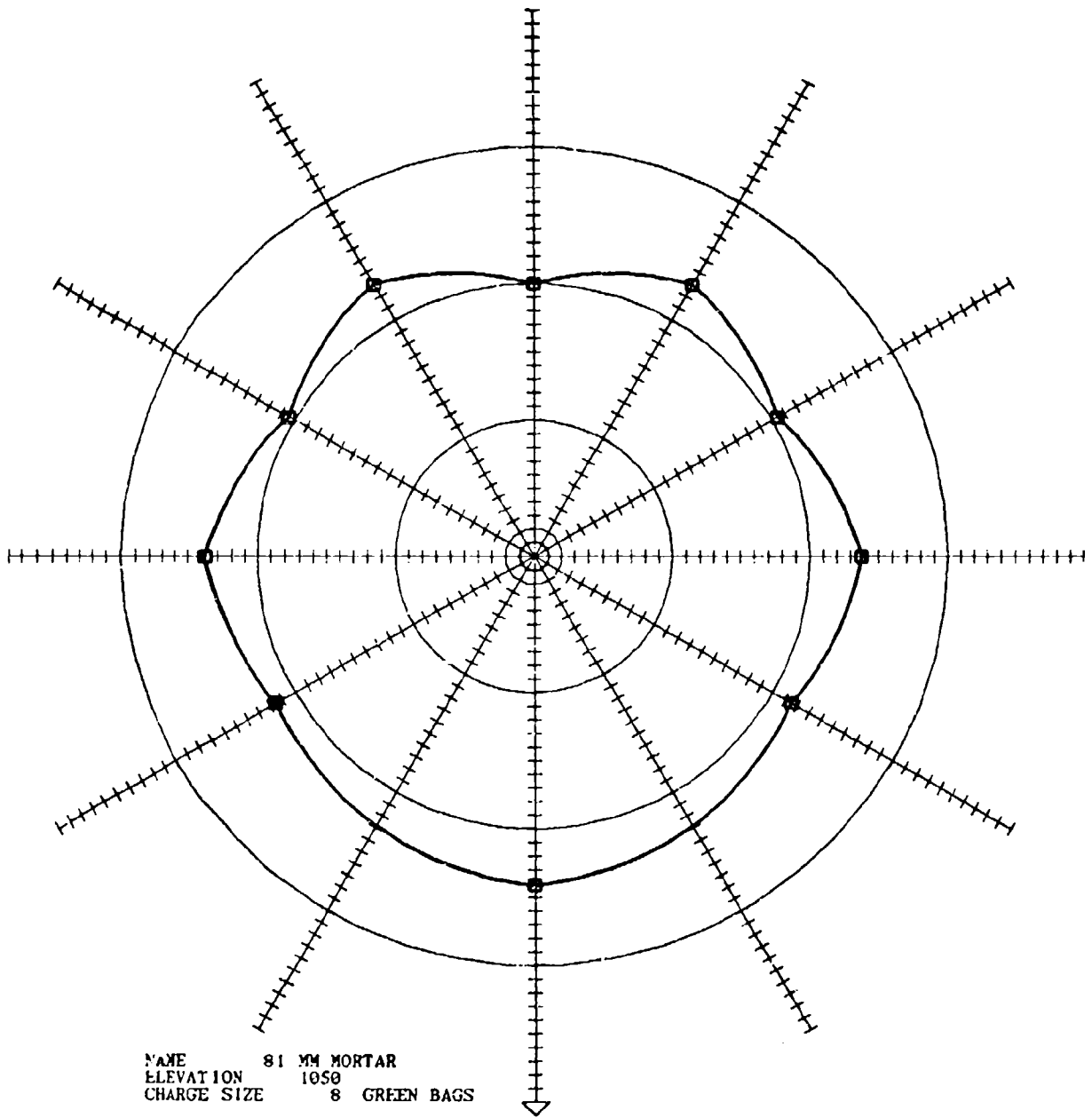

NAME 81 MM MORTAR  
 ELEVATION 1050  
 CHARGE SIZE 8 GREEN BAGS

CHANNEL	ENERGY	DIFFERENCE FROM REAR	ANGLE	DIFFERENCE FROM REAR	DIFFERENCE FROM C4
1	101.18	3.96	0°	4.10	-18.08
2	98.99	1.74	30°	2.81	-19.36
3	97.31	0.00	60°	1.53	-20.64
4	96.33	-1.05	90°	3.82	-18.36
5	97.02	-0.46	120°	0.44	-21.73
6	88.42	-1.71	150°	3.00	-19.18
7	91.04	-0.09	180°	0.00	-22.18
8	94.09	4.28	210°	3.00	-19.18
9	101.36	4.10	240°	0.44	-21.73
10	93.90	4.34	270°	3.82	-18.36
11	93.36	3.82	300°	1.53	-20.64
12	90.71	1.20	330°	2.81	-19.36
13	91.63	1.98			
14	90.26	0.00			
15	94.30	4.27			
16	0.00	-1.79			
			AVERAGE	2.48	-19.69

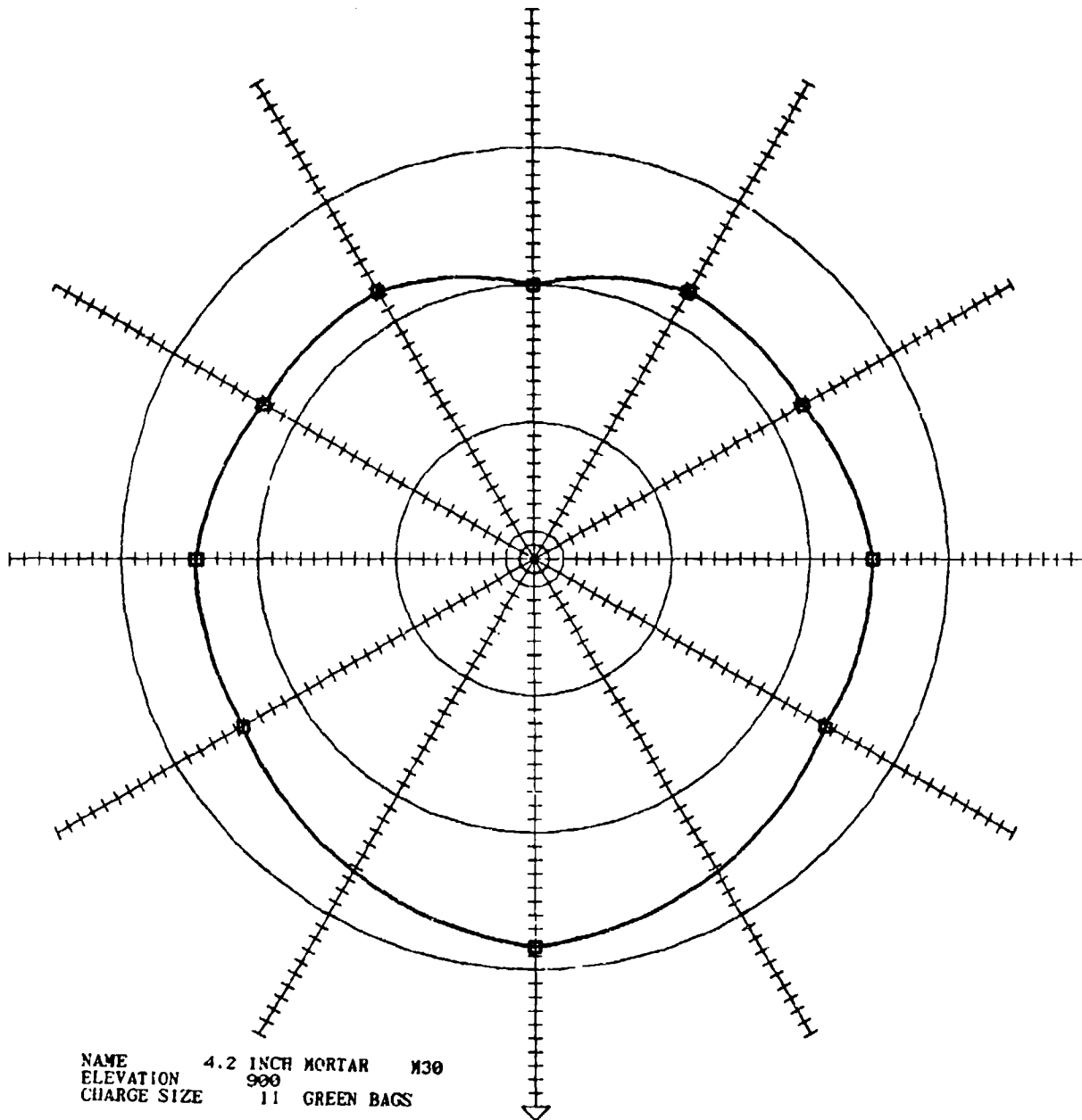

NAME 4.2 INCH MORTAR M30  
 ELEVATION 900  
 CHARGE SIZE 11 GREEN BAGS

CHANNEL	ENERGY	DIFFERENCE FROM REAR	ANGLE	DIFFERENCE FROM REAR	DIFFERENCE FROM C4
1	96.20	7.38	0°	8.30	-22.79
2	92.70	3.88	30°	6.33	-24.76
3	88.82	0.00	60°	4.36	-26.72
4	90.06	1.17	90°	4.50	-26.59
5	91.36	2.05	120°	2.55	-28.54
6	83.60	-0.10	150°	2.50	-28.59
7	83.50	1.32	180°	0.00	-31.09
8	84.46	2.93	210°	2.50	-28.59
9	97.84	8.30	240°	2.55	-28.54
10	88.90	7.66	270°	4.50	-26.59
11	87.43	6.07	300°	4.36	-26.72
12	85.30	3.82	330°	6.33	-24.76
13	83.44	2.45			
14	81.34	0.00			
15	84.09	2.56			
16	84.46	2.93			
AVERAGE				4.60	-26.49

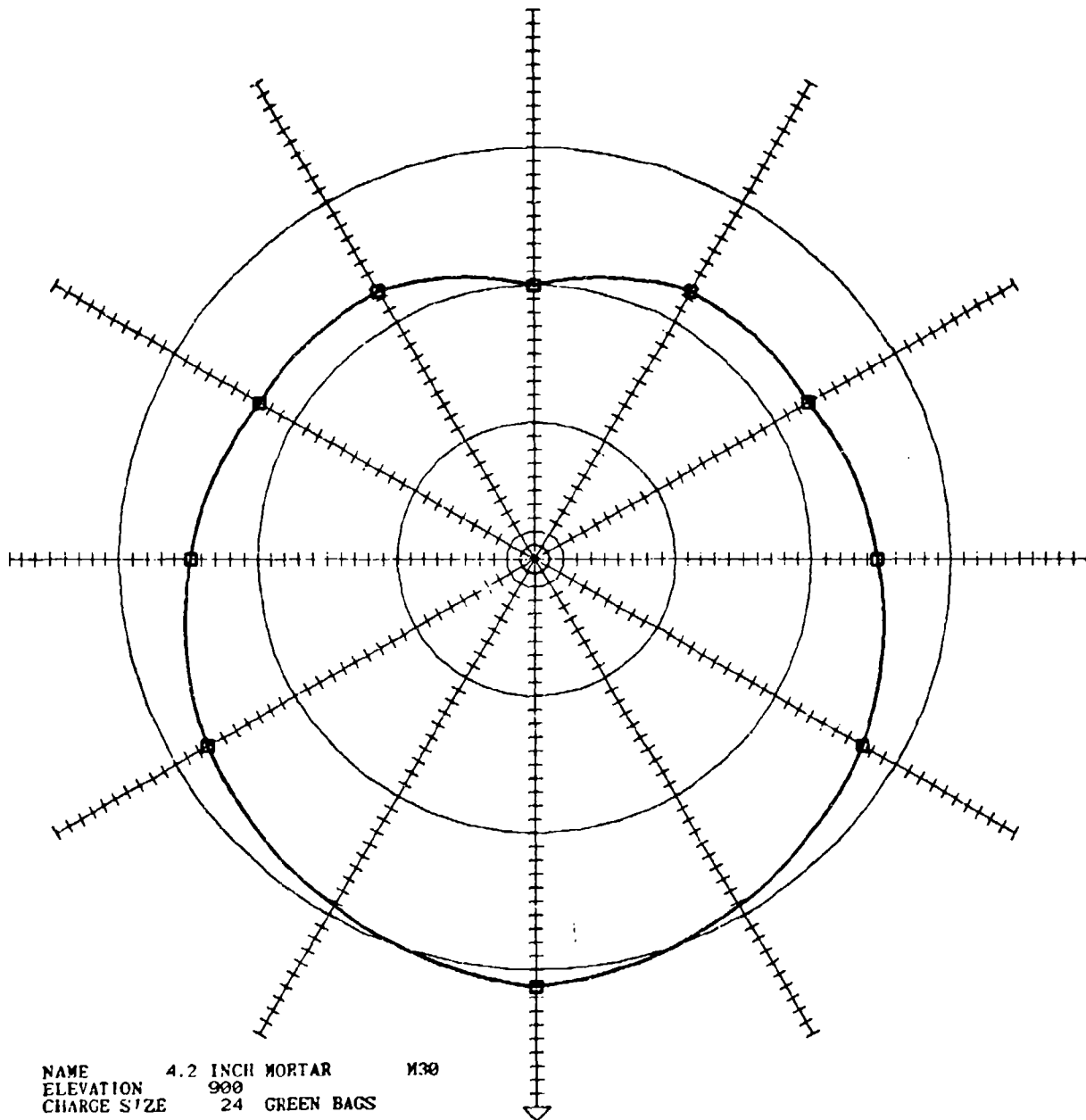

NAME 4.2 INCH MORTAR M30  
 ELEVATION 900  
 CHARGE SIZE 24 GREEN BAGS

CHANNEL	ENERGY	DIFFERENCE FROM REAR	ANGLE	DIFFERENCE FROM REAR	DIFFERENCE FROM C4
1	100.48	7.02	0°	11.21	-14.94
2	98.65	5.24	30°	9.22	-16.93
3	93.36	0.00	60°	7.23	-18.91
4	95.18	1.70	90°	4.76	-21.95
5	99.94	6.58	120°	2.85	-23.30
6	92.58	7.01	150°	2.59	-23.56
7	85.76	-0.12	180°	0.00	-26.16
8	88.52	2.85	210°	2.59	-23.56
9	104.61	11.21	240°	2.85	-23.30
10	93.92	8.34	270°	4.76	-21.95
11	92.42	6.66	300°	7.23	-18.91
12	90.04	4.60	330°	9.22	-16.93
13	87.68	2.18			
14	85.61	0.00			
15	88.69	2.99			
16	88.52	2.85			
			AVERAGE	6.61	-19.60

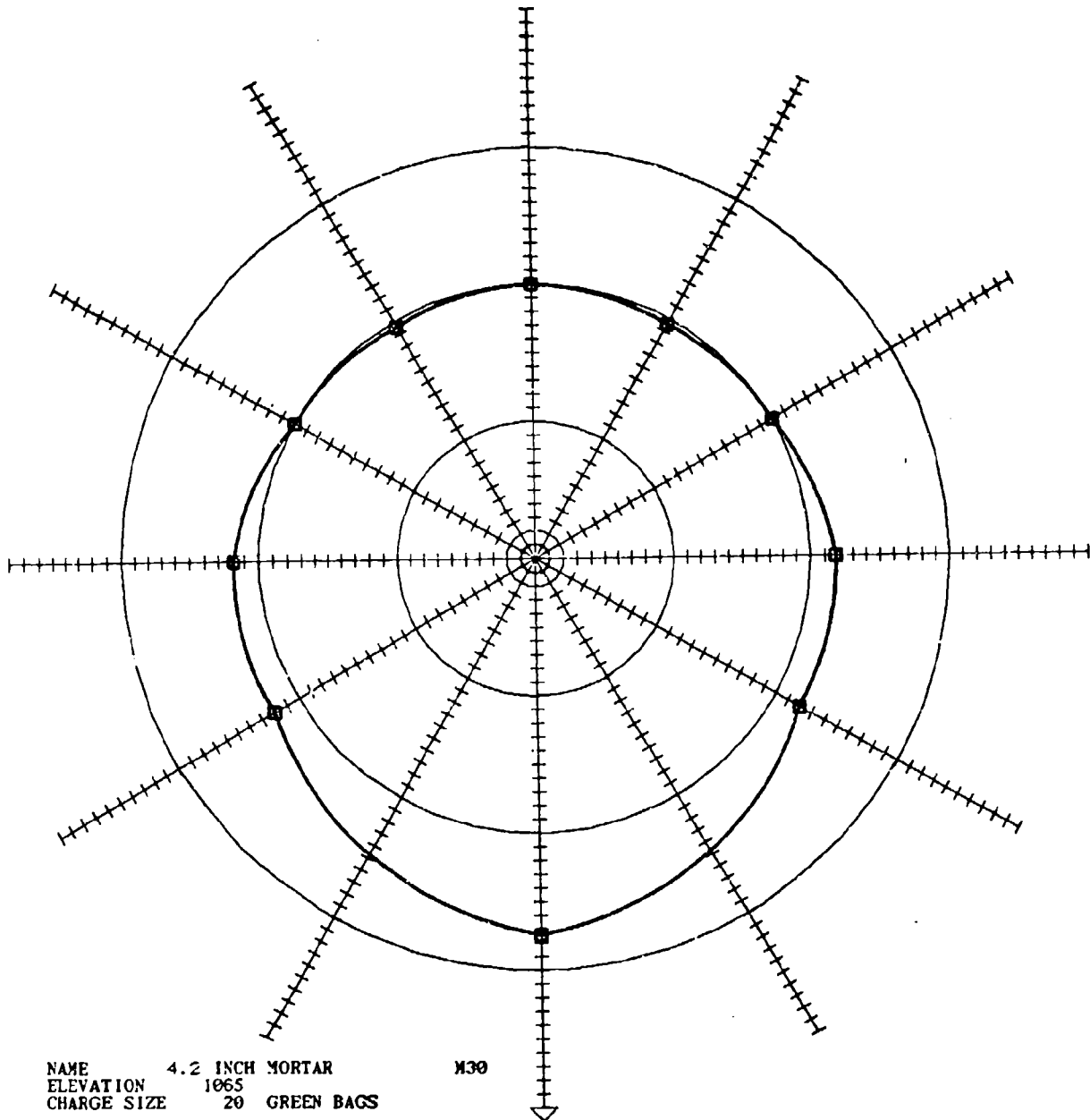

NAME 4.2 INCH MORTAR  
 ELEVATION 1065  
 CHARGE SIZE 20 GREEN BAGS

M30

CHANNEL	ENERGY	DIFFERENCE FROM REAR	ANGLE	DIFFERENCE FROM REAR	DIFFERENCE FROM C4
1	100.51	5.94	0°	7.39	-17.08
2	98.13	3.47	30°	4.69	-19.77
3	94.72	0.00	60°	2.00	-22.47
4	94.86	-0.23	90°	1.80	-22.46
5	95.69	0.92	120°	-0.02	-24.49
6	85.93	-2.89	150°	-0.41	-24.88
7	83.12	-5.40	180°	0.00	-24.48
8	88.30	-0.21	210°	-0.41	-24.68
9	102.12	7.39	240°	-0.02	-24.49
10	92.42	4.03	270°	1.80	-22.46
11	92.43	3.80	300°	2.00	-22.47
12	90.67	2.07	330°	4.69	-19.77
13	89.83	1.39			
14	88.97	0.00			
15	87.20	-2.21			
16	88.30	-0.21			
			AVERAGE	2.71	-21.73

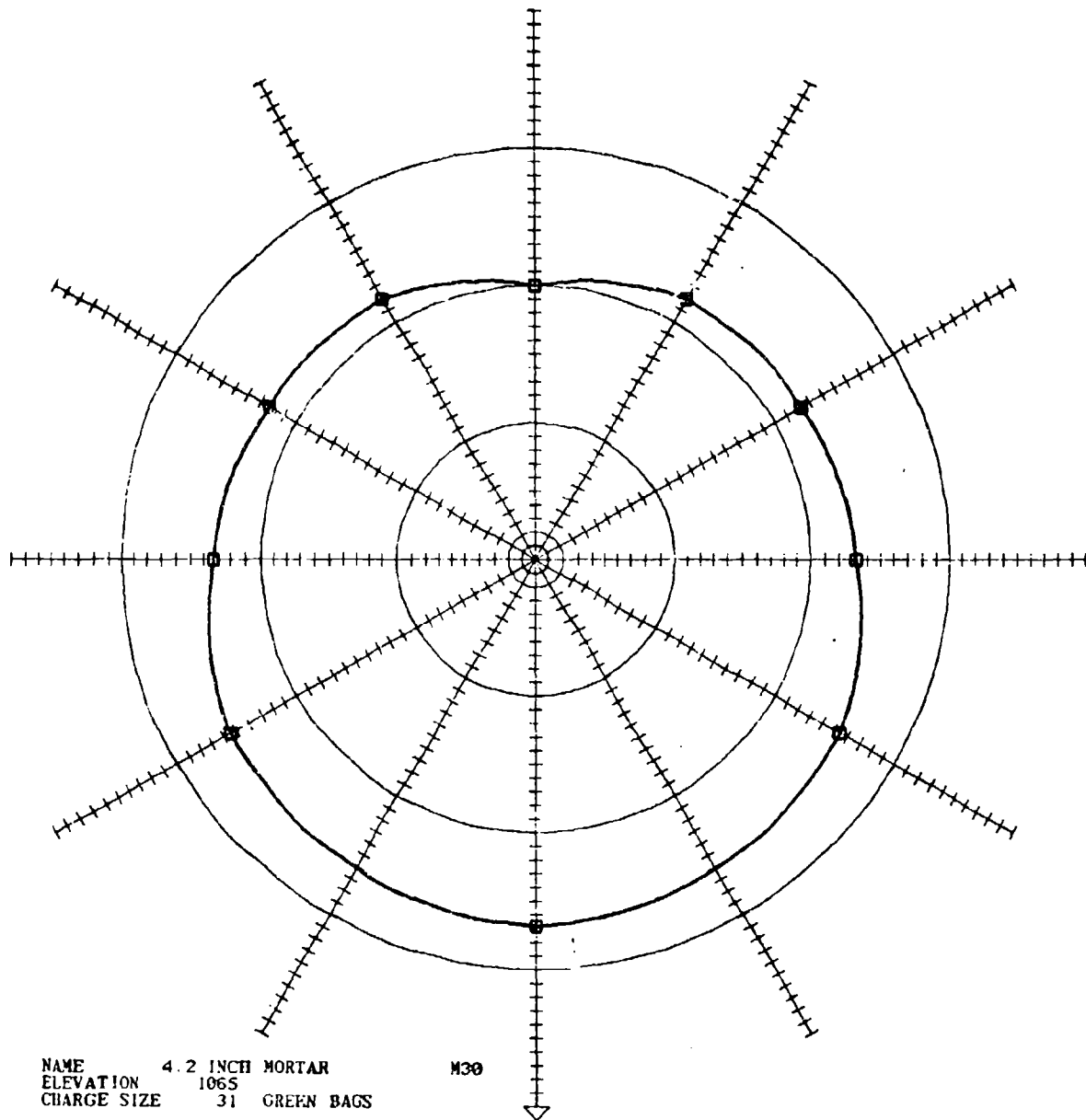

NAME 4.2 INCH MORTAR  
 ELEVATION 1065  
 CHARGE SIZE 31 GREEN BAGS

M30

CHANNEL	ENERGY	DIFFERENCE FROM REAR	ANGLE	DIFFERENCE FROM REAR	DIFFERENCE FROM C4
1	104.76	6.28	0°	6.77	-14.70
2	101.53	3.08	30°	6.10	-15.38
3	98.59	0.00	60°	5.42	-16.05
4	98.83	0.28	90°	3.18	-18.31
5	102.37	3.73	120°	2.27	-19.21
6	95.83	5.21	150°	1.92	-19.56
7	91.77	1.09	180°	0.00	-21.49
8	92.49	2.01	210°	1.92	-19.56
9	105.24	6.77	240°	2.27	-19.21
10	96.75	6.47	270°	3.18	-18.31
11	94.79	4.35	300°	5.42	-16.05
12	94.94	4.63	330°	6.10	-15.38
13	92.45	1.97			
14	91.19	0.00			
15	92.35	1.87			
16	92.49	2.01			
			AVERAGE	4.19	-17.28

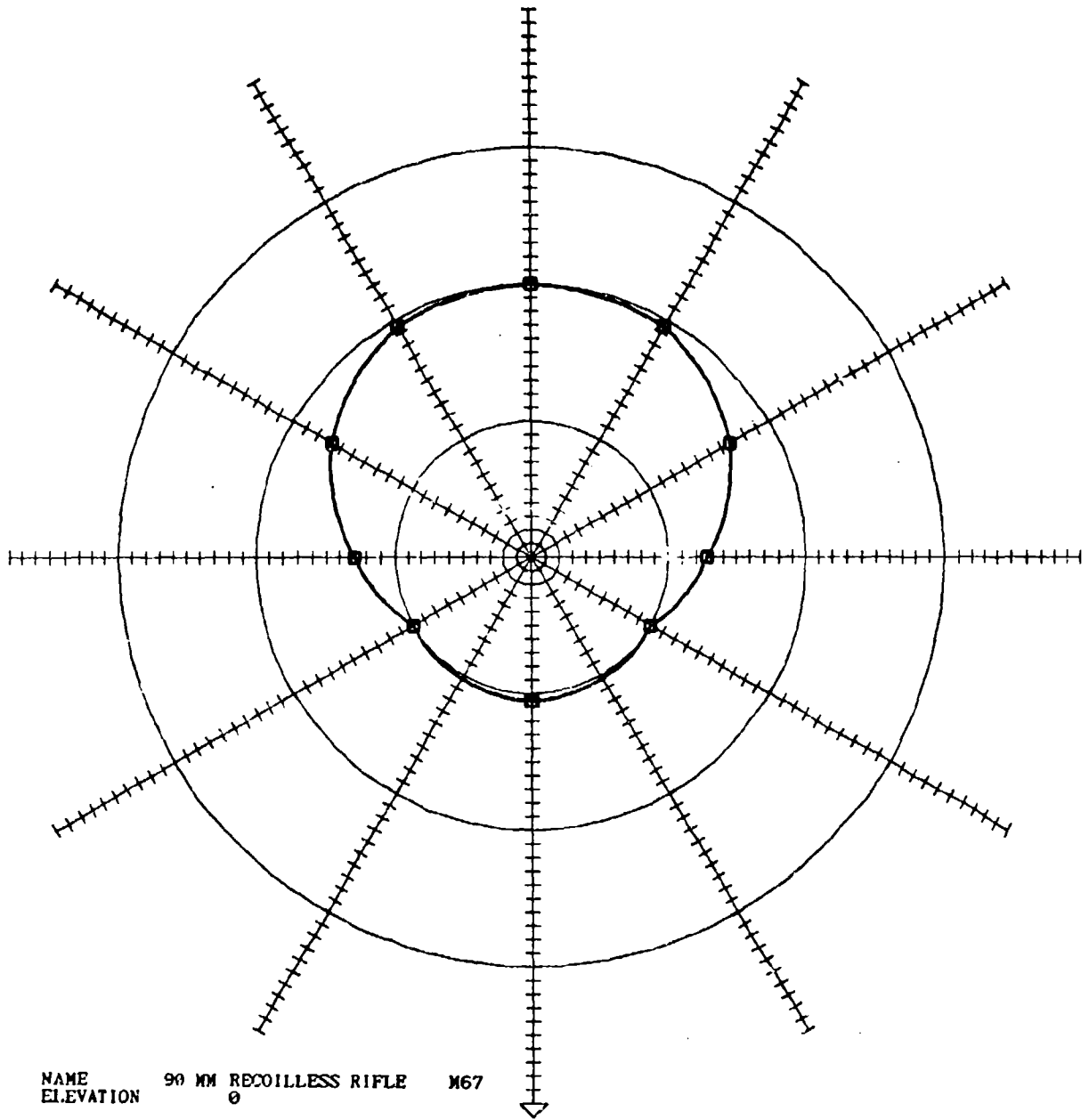

NAME 90 MM RECOILLESS RIFLE M67  
 ELEVATION 0

CHANNEL	ENERGY	DIFFERENCE FROM REAR	ANGLE	DIFFERENCE FROM REAR	DIFFERENCE FROM C4
1	102.66	-8.84	0°	-9.51	-16.51
2	107.71	-3.71	30°	-9.75	-16.75
3	111.26	0.00	60°	-9.98	-16.99
4	108.44	-2.81	90°	-7.18	-14.19
5	100.66	-10.59	120°	-3.17	-10.18
6	94.20	-11.68	150°	-0.49	-7.50
7	102.80	-3.37	180°	0.00	-7.00
8	97.30	-8.45	210°	-0.49	-7.50
9	102.01	-9.51	240°	-3.17	-10.18
10	98.65	-8.80	270°	-7.18	-14.19
11	98.97	-6.68	300°	-9.98	-16.99
12	102.80	-3.00	330°	-9.75	-16.75
13	105.64	0.04			
14	105.56	0.00			
15	104.57	-1.01			
16	99.33	-7.65			
			AVERAGE	-4.11	-11.11



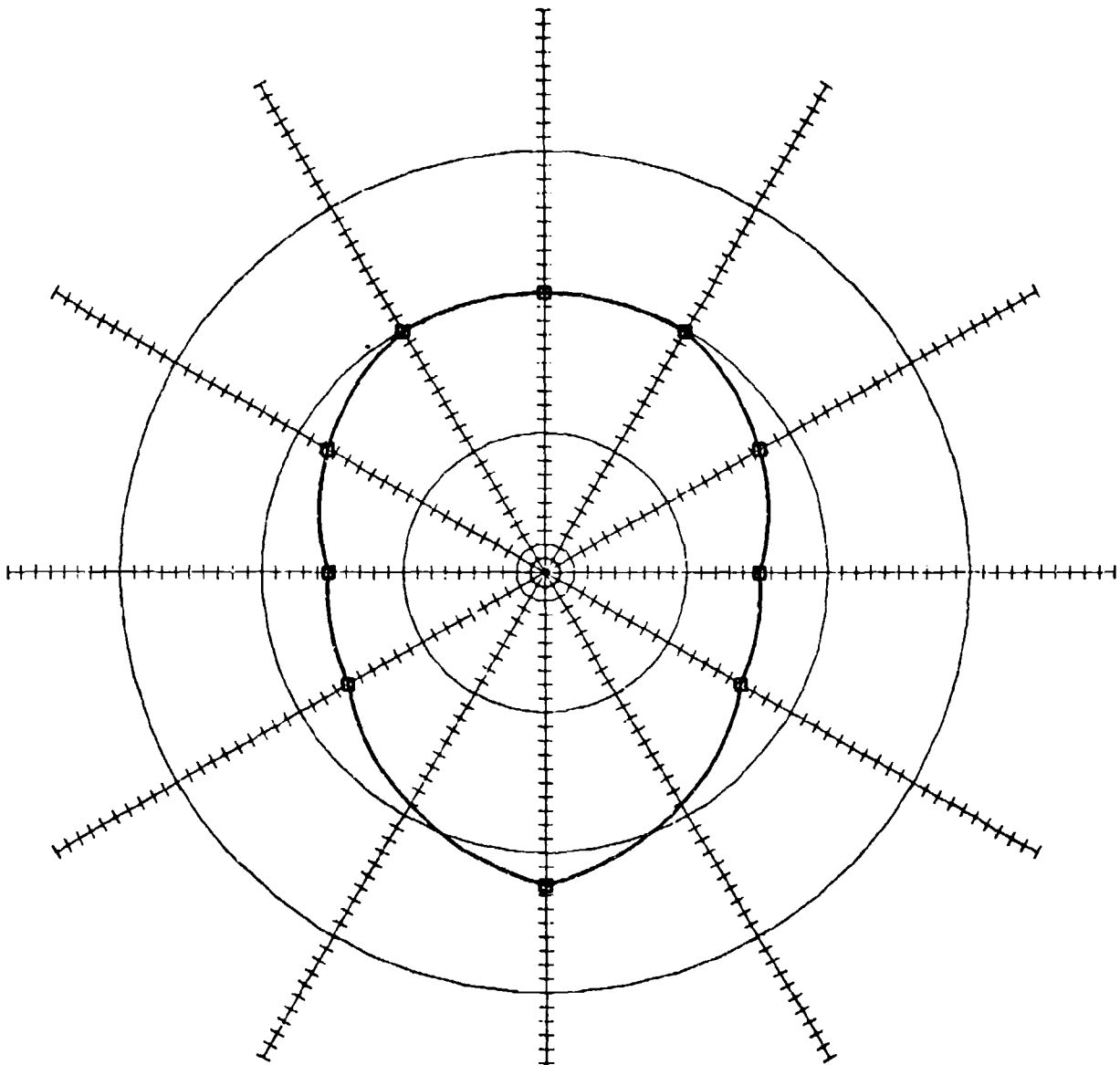

NAME  
ELEVATION

106 MM RECOILLESS RIFLE  
ALL

M40A1

CHANNEL	ENERGY	DIFFERENCE FROM REAR	ANGLE	DIFFERENCE FROM REAR	DIFFERENCE FROM C4
1	115.09	-4.06	0°	2.28	3.40
2	116.01	-3.41	30°	-0.87	0.24
3	119.17	0.00	60°	-4.02	-2.91
4	117.23	-1.93	90°	-4.77	-3.66
5	115.44	-3.79	120°	-2.40	-1.28
6	108.98	-4.02	150°	-0.07	1.03
7	111.31	-2.40	180°	0.00	1.11
8	108.75	-4.77	210°	-0.07	1.03
9	120.73	2.80	240°	-2.40	-1.28
10	108.51	-4.02	270°	-4.77	-3.66
11	107.40	-4.77	300°	-4.02	-2.91
12	109.81	-2.40	330°	-0.87	0.24
13	112.64	-0.07			
14	113.09	0.00			
15	113.09	-0.07			
16	108.81	-4.08			
			AVERAGE	-1.29	-0.18

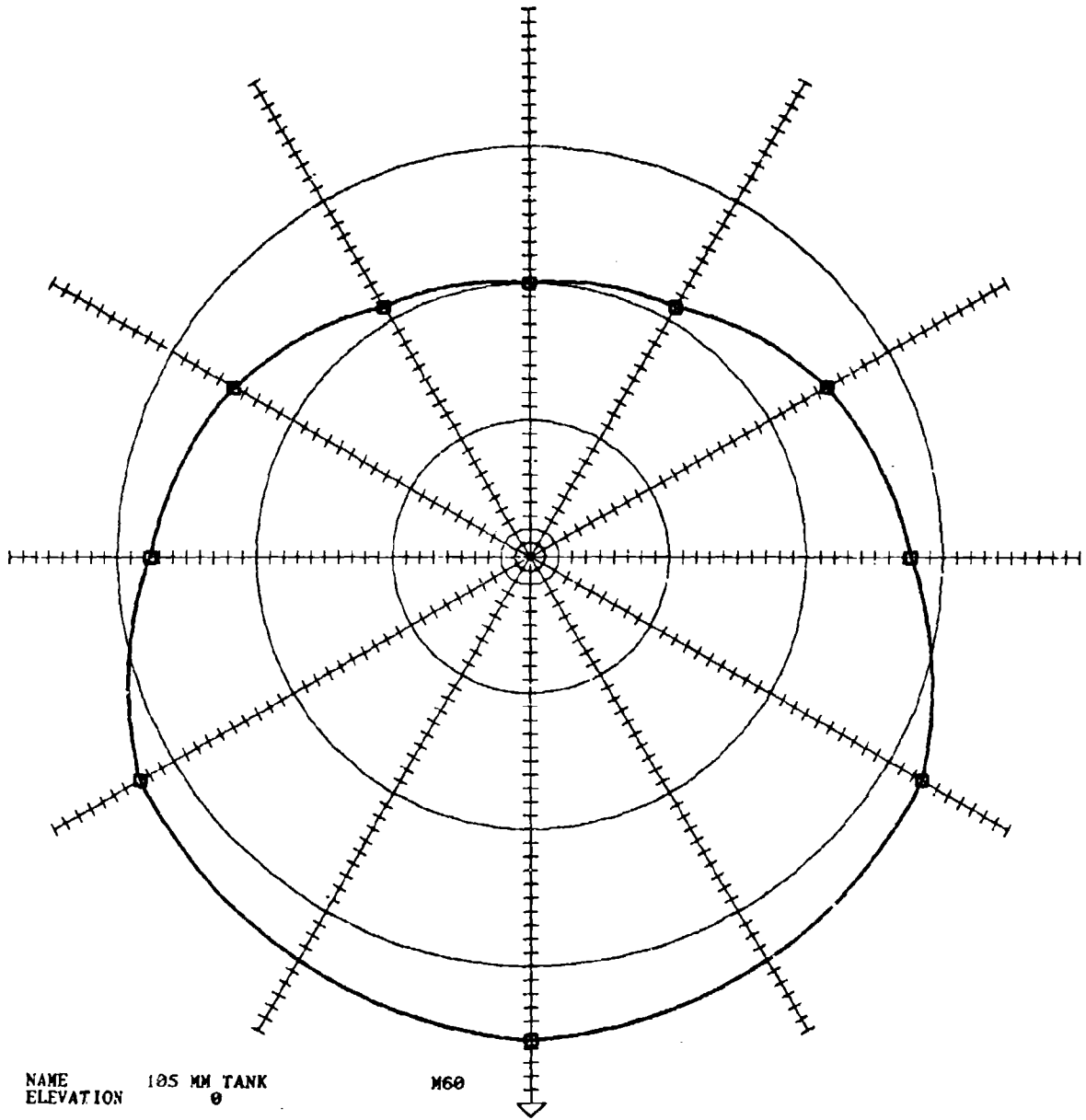

CHANNEL	ENERGY	DIFFERENCE FROM REAR	ANGLE	DIFFERENCE FROM REAR	DIFFERENCE FROM C4
1	113.04	13.09	0°	15.35	-3.96
2	105.87	5.98	30°	14.04	-5.27
3	100.07	0.00	60°	12.73	-6.58
4	104.39	4.24	90°	7.61	-11.70
5	113.07	12.68	120°	4.81	-14.50
6	106.63	12.81	150°	1.09	-18.22
7	97.69	3.36	180°	0.00	-19.31
8	99.98	5.55	210°	1.09	-18.22
9	115.47	15.35	240°	4.81	-14.50
10	106.29	12.28	270°	7.61	-11.70
11	103.08	9.06	300°	12.73	-6.58
12	99.70	5.66	330°	14.04	-5.27
13	96.08	1.97			
14	94.70	0.00			
15	94.43	0.33			
16	100.19	5.92			
			AVERAGE	10.78	-8.53

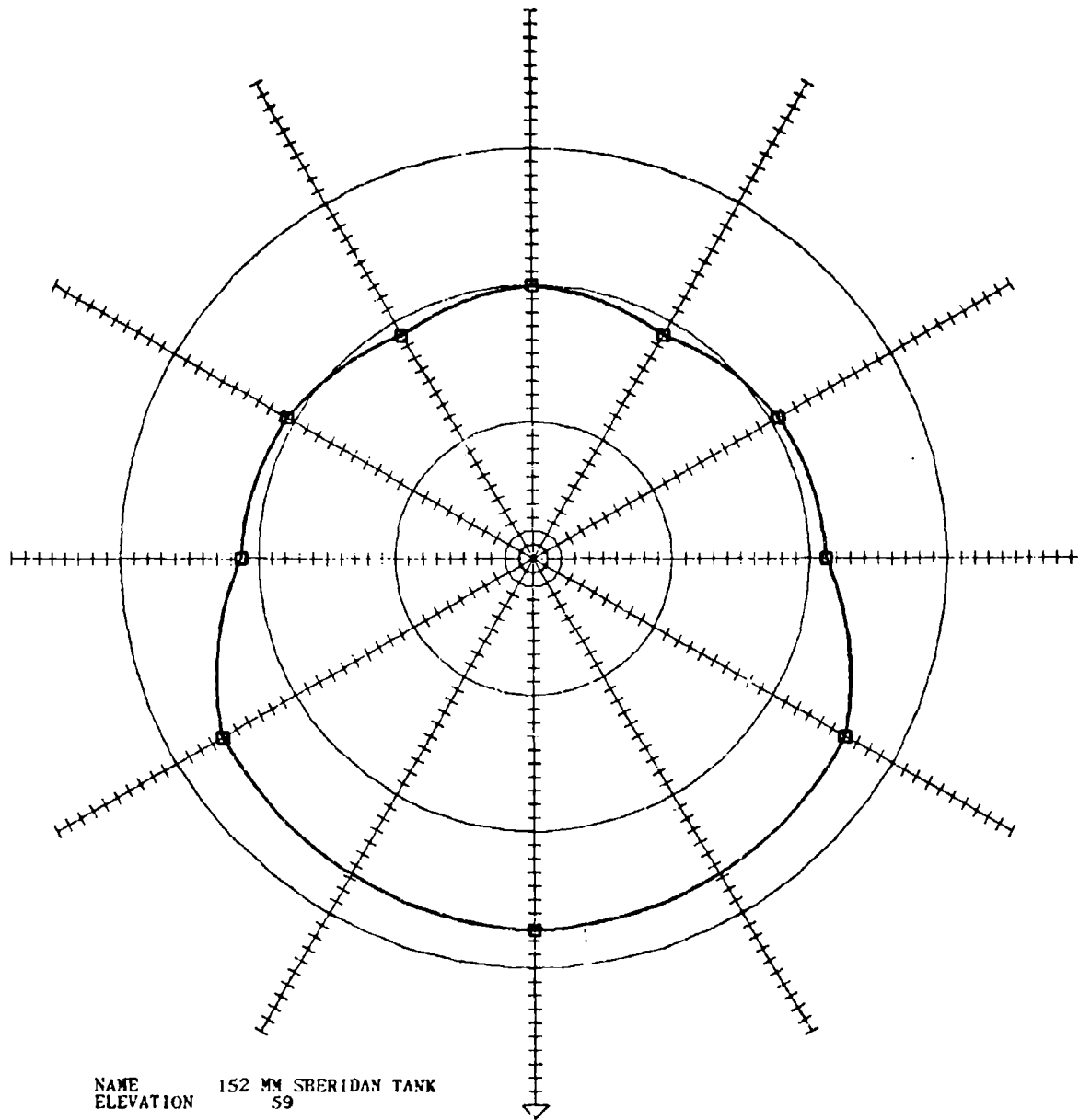

NAME 152 MM SBERIDAN TANK  
ELEVATION 59

CHANNEL	ENERGY	DIFFERENCE FROM REAR	ANGLE	DIFFERENCE FROM REAR	DIFFERENCE FROM C4
1	0.00	12.18	0°	7.22	-1.14
2	111.89	1.86	30°	6.66	-1.70
3	110.07	0.00	60°	6.10	-2.26
4	109.94	-0.08	90°	1.27	-7.09
5	115.21	5.26	120°	0.57	-7.79
6	112.39	7.37	150°	-1.11	-9.48
7	104.05	-0.85	180°	0.00	-8.36
8	105.97	1.08	210°	-1.11	-9.48
9	117.38	7.22	240°	0.57	-7.79
10	110.58	5.66	270°	1.27	-7.09
11	106.40	1.47	300°	6.10	-2.26
12	106.47	1.37	330°	6.66	-1.70
13	104.53	-0.41			
14	104.91	0.00			
15	103.13	-1.81			
16	105.98	1.07			
			AVERAGE	4.00	-4.35

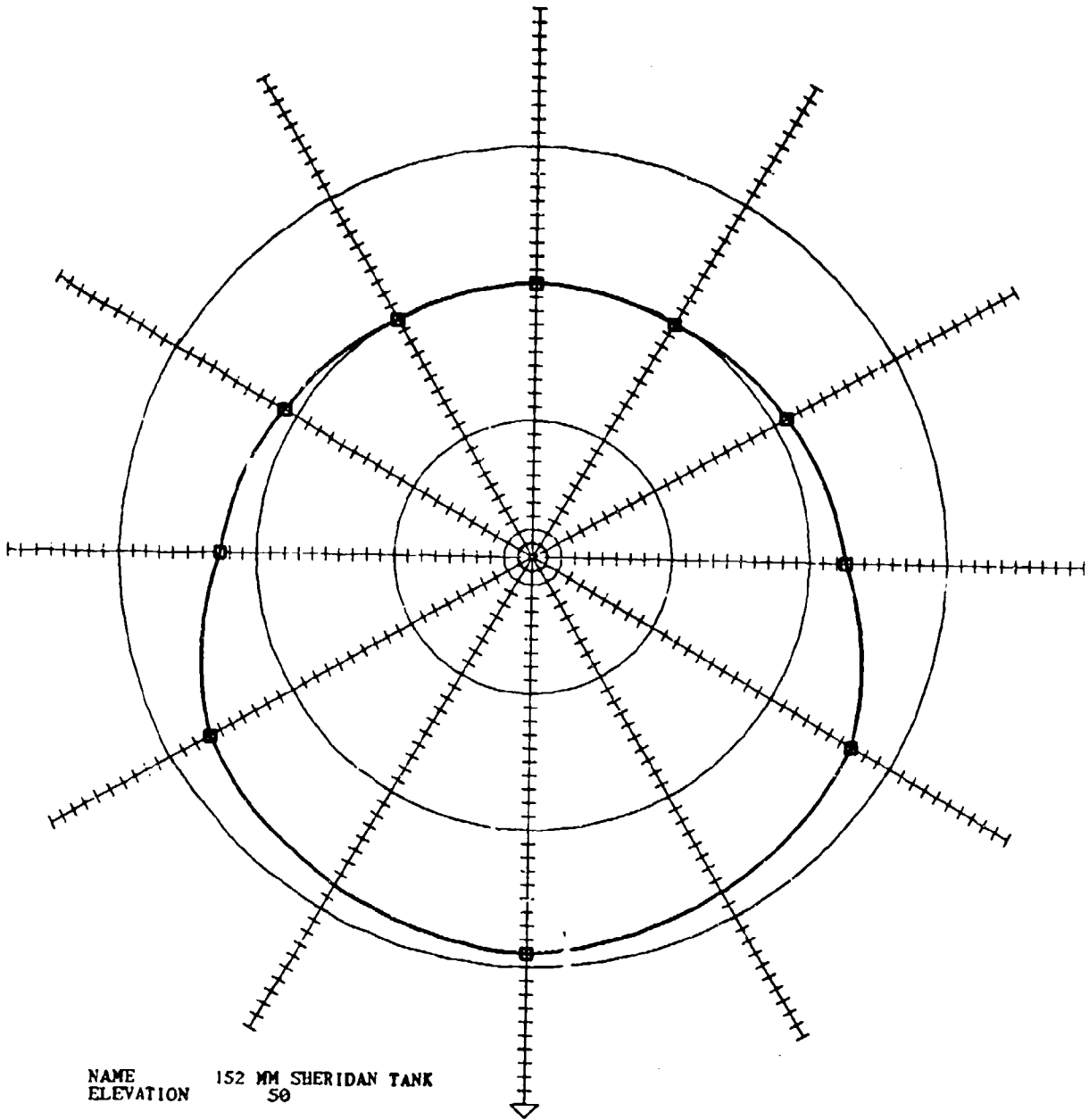

NAME 152 MM SHERIDAN TANK  
ELEVATION 50

CHANNEL	ENERGY	DIFFERENCE FROM REAR	ANGLE	DIFFERENCE FROM REAR	DIFFERENCE FROM C4
1	0.00	12.18	0°	9.00	-0.46
2	110.46	0.62	30°	7.93	-1.53
3	109.96	0.00	60°	6.86	-2.60
4	111.08	1.17	90°	2.69	-6.77
5	115.10	5.11	120°	0.96	-8.50
6	112.05	8.07	150°	-0.13	-9.60
7	105.04	1.29	180°	0.00	-9.46
8	106.18	2.18	210°	-0.13	-9.60
9	118.86	9.00	240°	0.96	-8.50
10	111.14	7.40	270°	2.69	-6.77
11	106.82	3.06	300°	6.86	-2.60
12	104.56	0.77	330°	7.93	-1.53
13	104.41	0.56			
14	103.84	0.00			
15	102.82	-0.83			
16	106.32	2.31			
			AVERAGE	5.14	-4.32

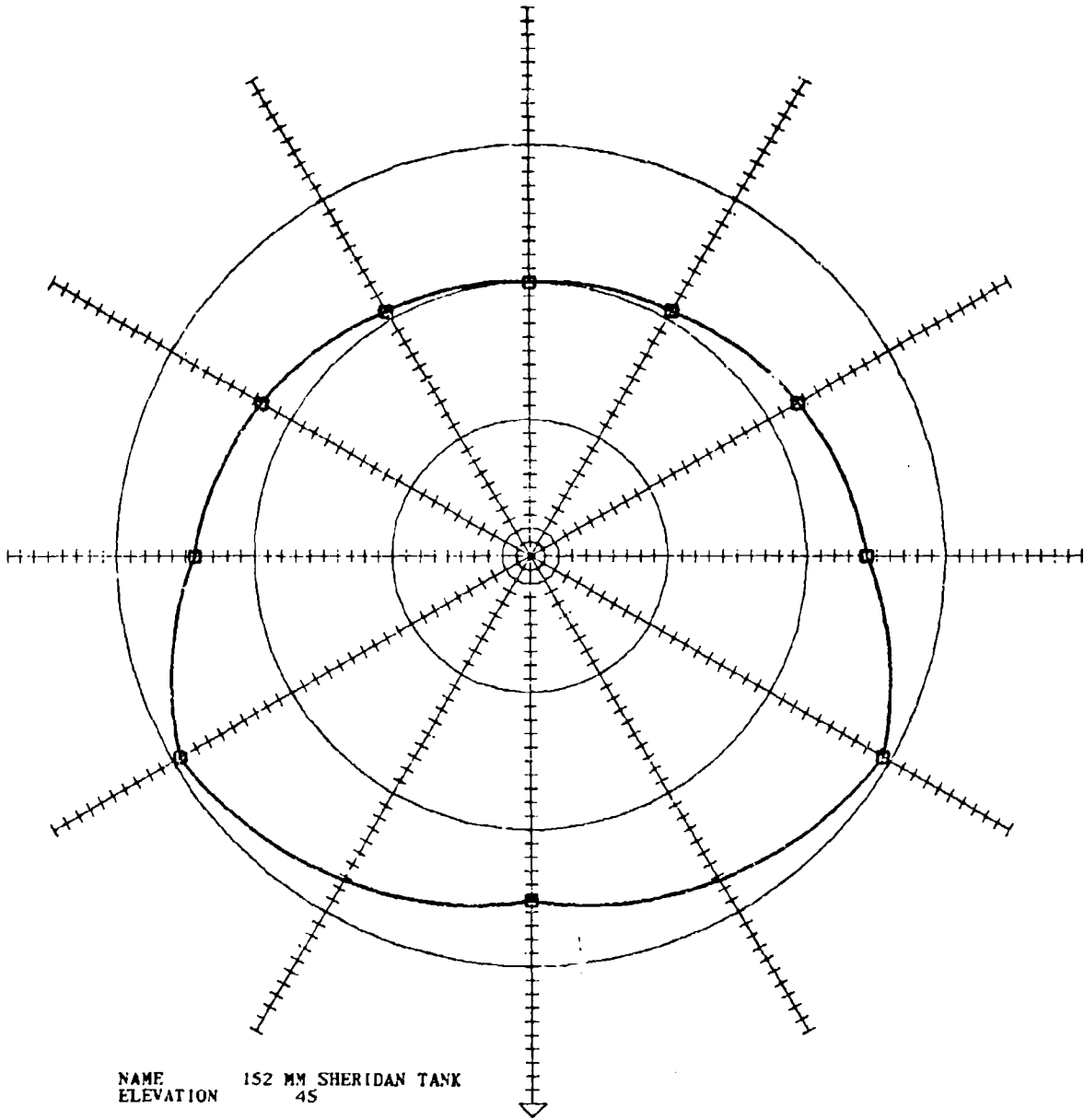

NAME 152 MM SHERIDAN TANK  
ELEVATION 45

CHANNEL	ENERGY	DIFFERENCE FROM REAR	ANGLE	DIFFERENCE FROM REAR	DIFFERENCE FROM C4
1	120.91	9.92	0°	5.17	-5.46
2	114.59	3.62	30°	7.28	-3.35
3	110.79	0.00	60°	9.39	-1.24
4	109.62	-0.28	90°	4.32	-6.31
5	119.68	8.07	120°	2.39	-8.24
6	110.51	9.09	150°	0.65	-9.98
7	103.38	2.31	180°	0.00	-10.63
8	102.08	-1.37	210°	0.65	-9.98
9	115.19	5.17	240°	2.39	-8.24
10	111.74	10.48	270°	4.32	-6.31
11	106.93	5.82	300°	9.39	-1.24
12	104.98	3.92	330°	7.28	-3.35
13	102.56	1.45			
14	101.23	0.00			
15	101.21	-0.13			
16	104.53	2.83			
			AVERAGE	5.60	-5.03

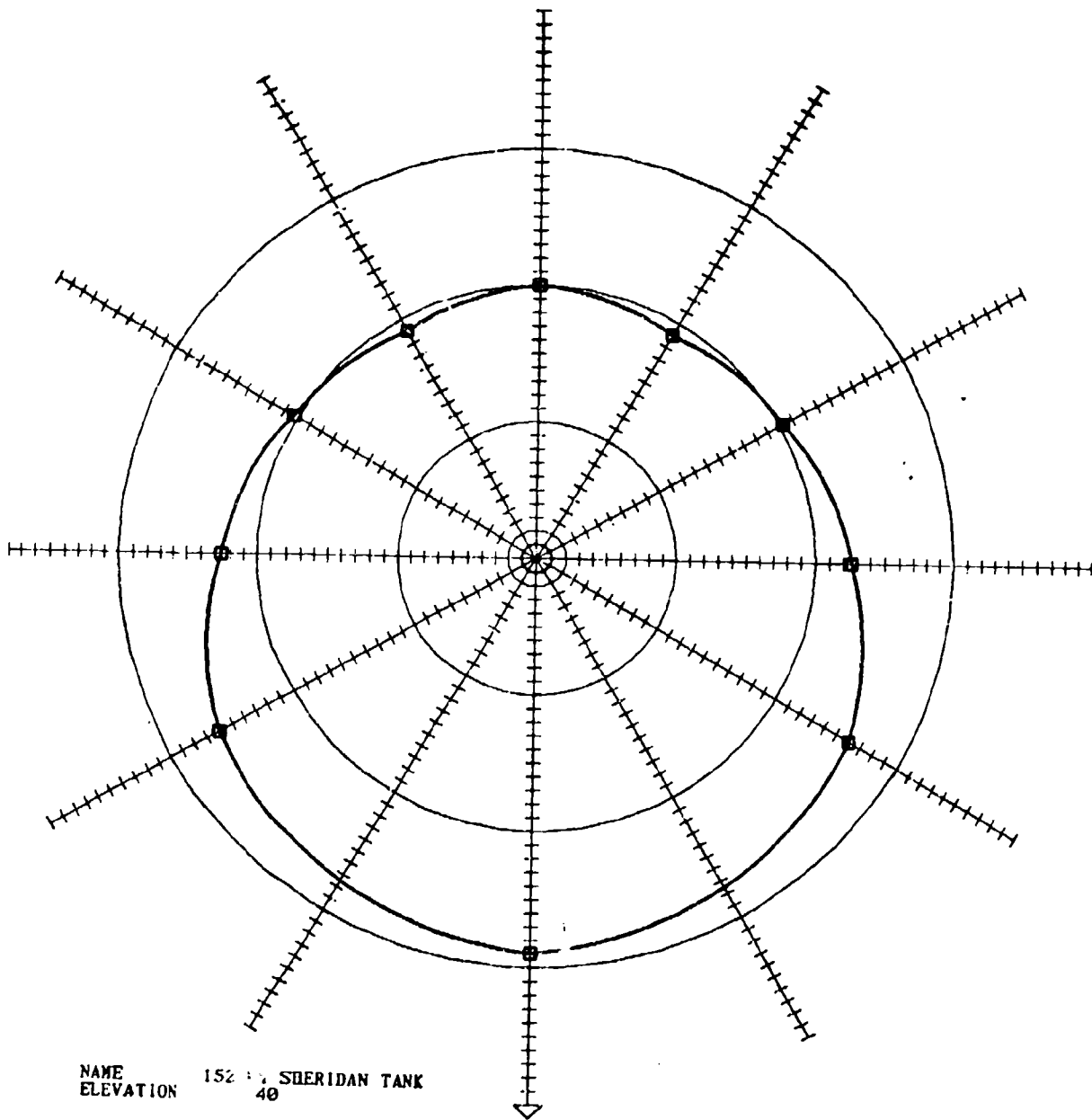

NAME 152 SHERIDAN TANK  
ELEVATION 40

CHANNEL	ENERGY	DIFFERENCE FROM REAR	ANGLE	DIFFERENCE FROM REAR	DIFFERENCE FROM C4
1	116.31	6.94	0°	8.89	-0.50
2	111.16	1.68	30°	7.48	-1.91
3	109.43	0.00	60°	6.07	-3.31
4	109.09	-0.27	90°	2.65	-6.73
5	114.79	5.36	120°	0.27	-9.11
6	109.63	5.17	150°	-0.96	-10.35
7	101.85	-1.97	180°	0.00	-9.39
8	104.32	0.32	210°	-0.96	-10.35
9	118.37	8.89	240°	0.27	-9.11
10	110.46	6.83	270°	2.65	-6.73
11	107.82	4.04	300°	6.07	-3.31
12	105.61	1.67	330°	7.48	-1.91
13	103.57	-0.07			
14	103.70	0.00			
15	101.95	-1.85			
16	105.24	1.27			
			AVERAGE	4.70	-4.68

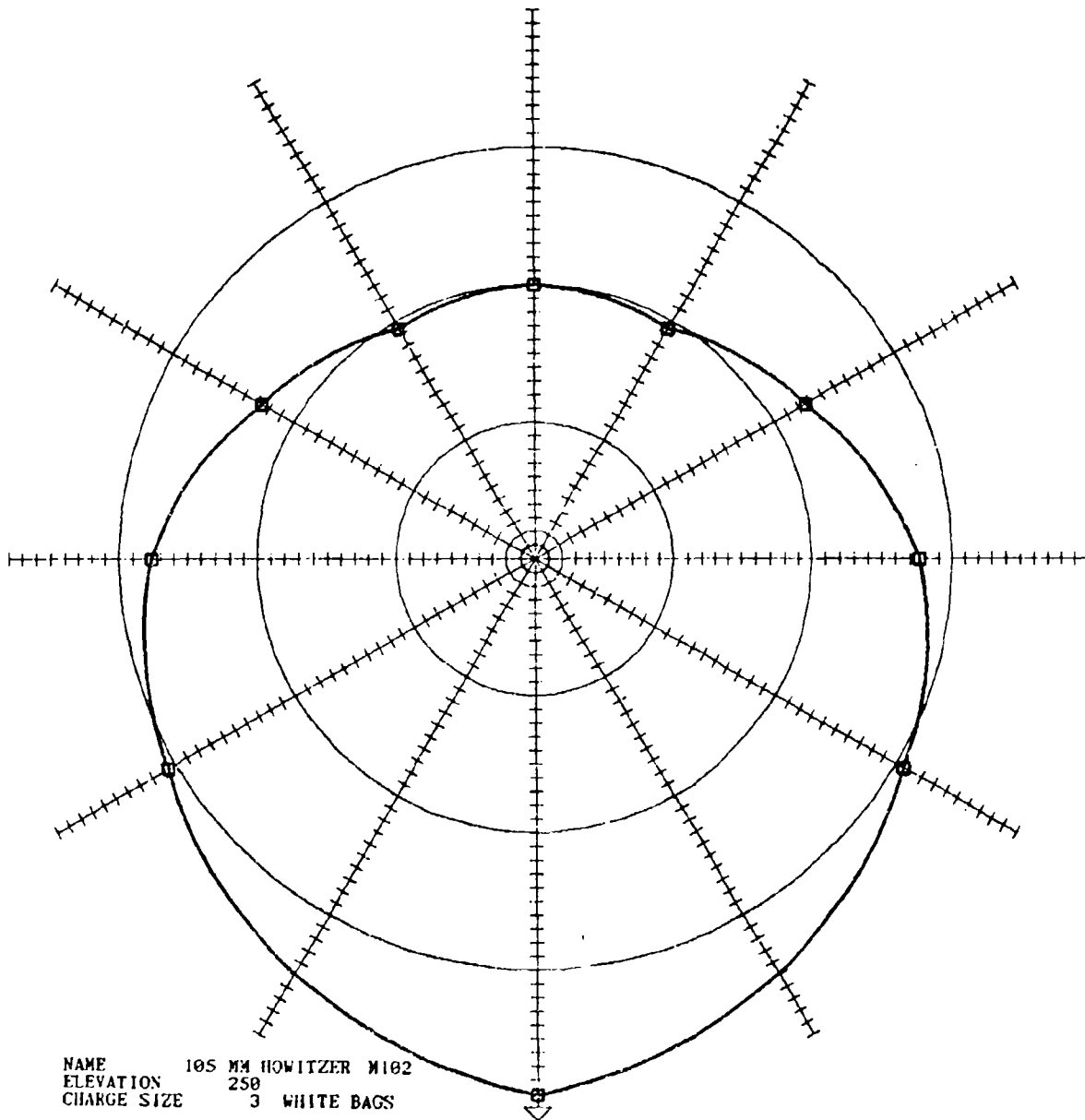

NAME 105 MM HOWITZER M102  
 ELEVATION 250  
 CHARGE SIZE 3 WHITE BAGS

CHANNEL	ENERGY	DIFFERENCE FROM REAR	ANGLE	DIFFERENCE FROM REAR	DIFFERENCE FROM C4
1	97.53	10.77	0°	19.12	-13.19
2	90.53	3.76	30°	14.86	-17.45
3	86.80	0.00	60°	10.61	-21.70
4	88.31	1.52	90°	7.65	-24.66
5	95.40	8.56	120°	2.60	-29.71
6	88.81	10.65	150°	-0.58	-32.90
7	80.19	2.05	180°	0.00	-32.32
8	84.32	6.19	210°	-0.58	-32.90
9	105.90	19.12	240°	2.60	-29.71
10	90.52	12.45	270°	7.65	-24.66
11	87.22	9.13	300°	10.61	-21.70
12	81.16	3.07	330°	14.86	-17.45
13	77.74	-0.34			
14	78.11	0.00			
15	77.00	-0.90			
16	84.27	5.79			
			AVERAGE	11.85	-20.46

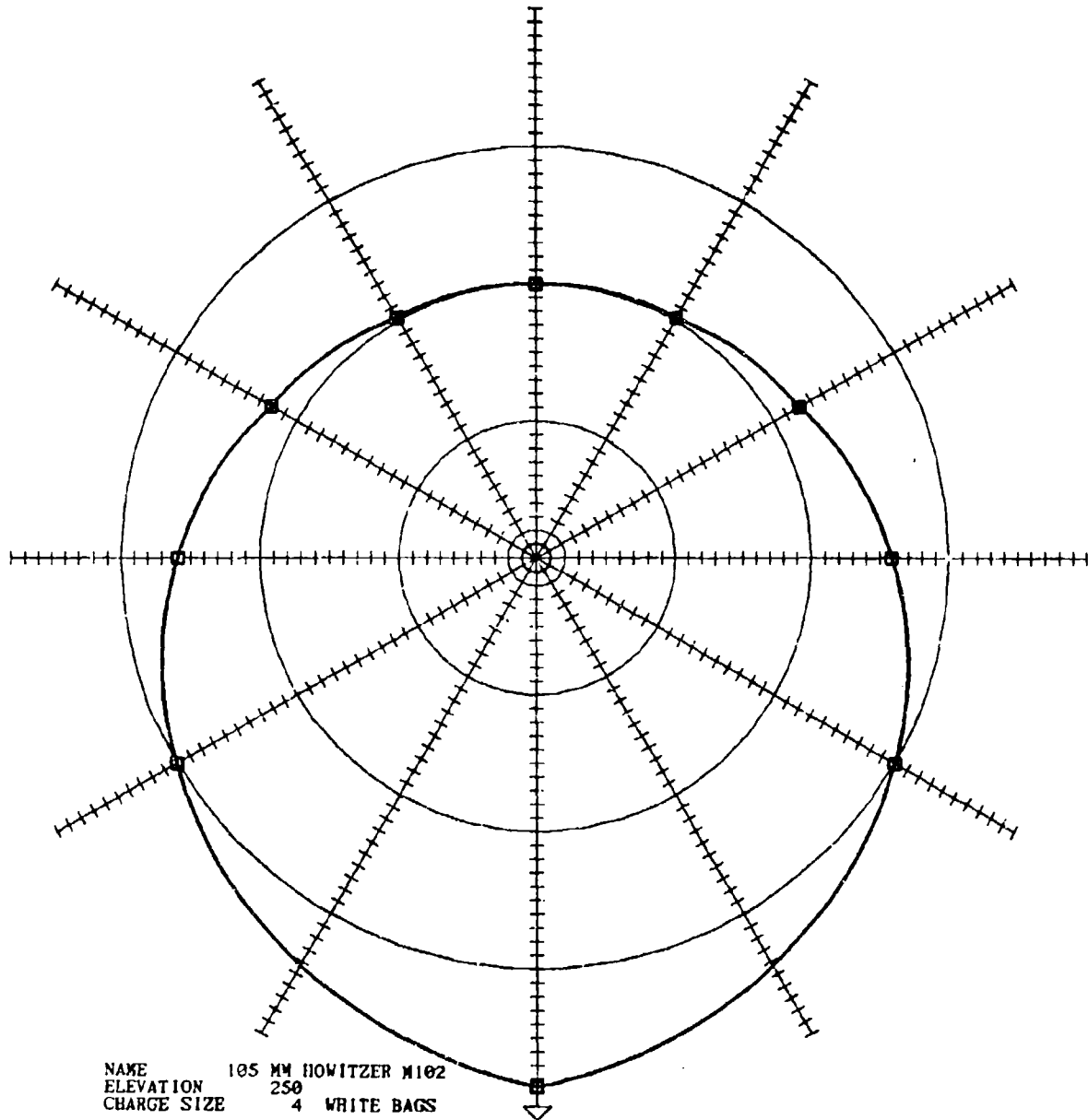

NAME 105 MM HOWITZER M102  
 ELEVATION 250  
 CHARGE SIZE 4 WHITE BAGS

CHANNEL	ENERGY	DIFFERENCE FROM REAR	ANGLE	DIFFERENCE FROM REAR	DIFFERENCE FROM C4
1	100.08	10.44	0°	18.54	-11.20
2	93.28	3.67	30°	14.29	-15.46
3	89.52	0.00	60°	10.04	-19.71
4	90.35	0.79	90°	5.86	-23.88
5	97.67	8.12	120°	2.08	-27.66
6	89.97	8.67	150°	0.21	-29.53
7	81.14	-0.12	180°	0.00	-29.75
8	86.34	4.82	210°	0.21	-29.53
9	108.11	18.54	240°	2.08	-27.66
10	93.35	12.33	270°	5.86	-23.88
11	88.58	7.49	300°	10.04	-19.71
12	84.62	3.61	330°	14.29	-15.46
13	81.95	0.97			
14	81.09	0.00			
15	80.48	-0.54			
16	85.31	4.23			
			AVERAGE	11.23	-18.51



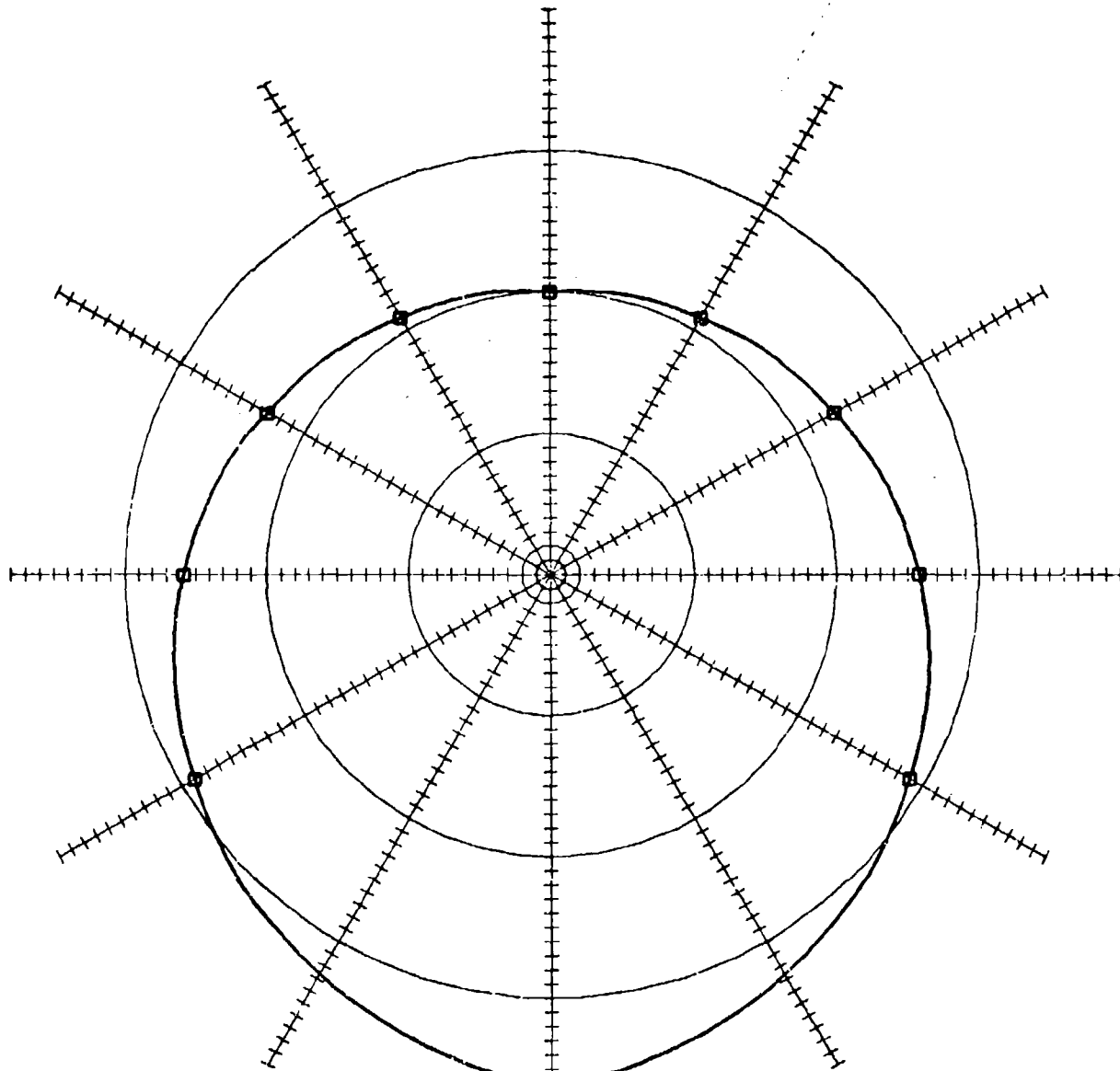

NAME 105 MM HOWITZER M102  
 ELEVATION 450  
 CHARGE SIZE 4 WHITE BAGS

CHANNEL	ENERGY	DIFFERENCE FROM REAR	ANGLE	DIFFERENCE FROM REAR	DIFFERENCE FROM C4
1	98.69	9.11	0°	16.30	-13.15
2	93.35	3.75	30°	12.64	-16.81
3	89.59	0.00	60°	8.99	-20.47
4	90.93	1.35	90°	5.80	-23.65
5	97.03	7.45	120°	2.91	-26.54
6	90.62	9.56	150°	0.95	-28.49
7	83.43	2.37	180°	0.00	-29.45
8	86.43	5.02	210°	0.95	-28.49
9	105.96	16.30	240°	2.91	-26.54
10	92.07	10.99	270°	5.80	-23.65
11	87.77	6.70	300°	8.98	-20.47
12	85.15	4.16	330°	12.64	-16.81
13	82.62	1.57			
14	81.06	0.00			
15	81.36	0.33			
16	85.99	4.90			
			AVERAGE	9.63	-19.82

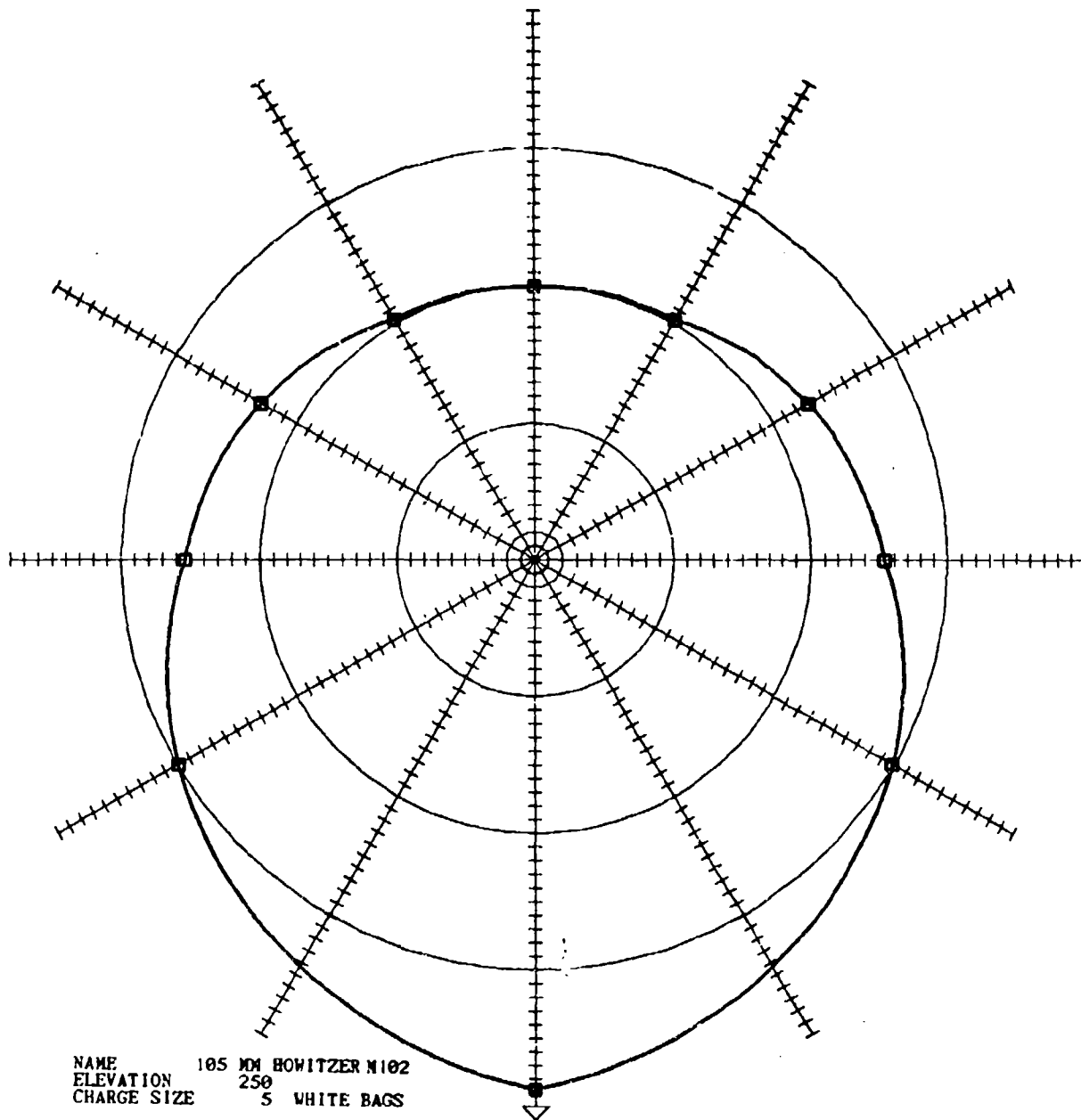

NAME 105 MM HOWITZER M102  
 ELEVATION 250  
 CHARGE SIZE 5 WHITE BAGS

CHANNEL	ENERGY	DIFFERENCE FROM REAR	ANGLE	DIFFERENCE FROM REAR	DIFFERENCE FROM C4
1	101.66	11.17	0°	18.74	-7.16
2	95.03	4.47	30°	14.30	-13.59
3	90.53	0.00	60°	9.86	-18.03
4	91.36	0.77	90°	5.36	-22.52
5	99.92	9.22	120°	2.93	-24.96
6	91.12	7.65	150°	0.27	-27.62
7	85.05	1.94	180°	0.00	-27.90
8	87.13	3.91	210°	0.27	-27.62
9	109.17	18.74	240°	2.93	-24.96
10	94.43	11.25	270°	5.36	-22.52
11	90.24	7.07	300°	9.86	-18.03
12	87.66	4.33	330°	14.30	-13.59
13	85.13	1.99			
14	83.18	0.00			
15	81.78	-1.44			
16	86.85	3.66			
			AVERAGE	11.30	-16.59

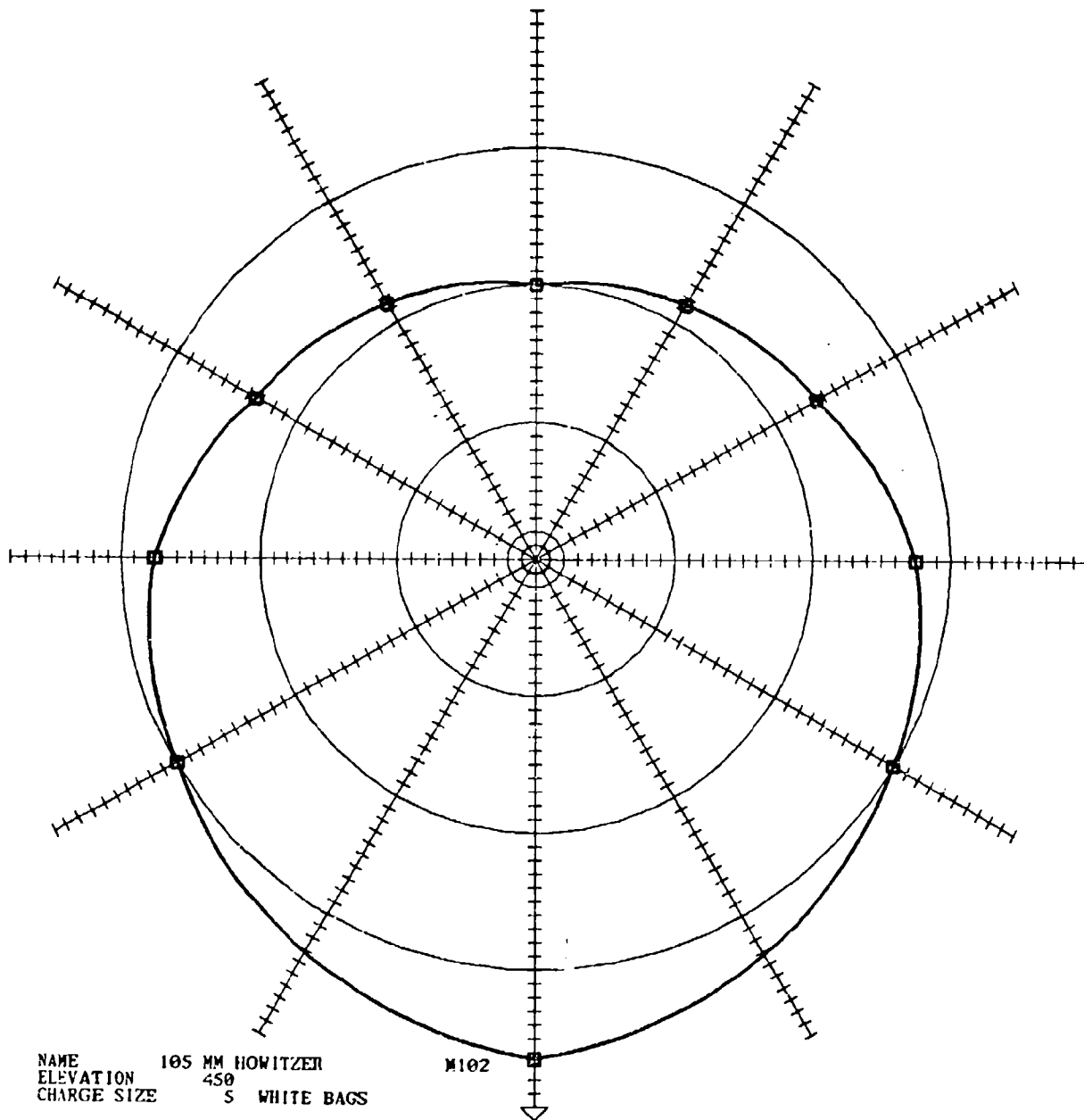

NAME 105 MM HOWITZER  
 ELEVATION 450  
 CHARGE SIZE S WHITE BAGS

CHANNEL	ENERGY	DIFFERENCE FROM REAR	ANGLE	DIFFERENCE FROM REAR	DIFFERENCE FROM C4
1	100.85	10.43	0°	16.45	-11.31
2	94.97	4.49	30°	13.19	-14.57
3	90.41	0.00	60°	9.93	-17.83
4	93.06	2.57	90°	7.48	-20.28
5	100.41	10.01	120°	3.41	-24.35
6	92.71	9.49	150°	1.48	-26.27
7	85.88	2.66	180°	0.00	-27.77
8	92.10	8.44	210°	1.48	-26.27
9	106.87	16.45	240°	3.41	-24.35
10	92.64	9.72	270°	7.48	-20.28
11	90.23	7.16	300°	9.93	-17.83
12	87.01	3.91	330°	13.19	-14.57
13	85.68	2.61			
14	83.07	0.00			
15	83.47	0.35			
16	91.53	7.89			
			AVERAGE	10.18	-17.58

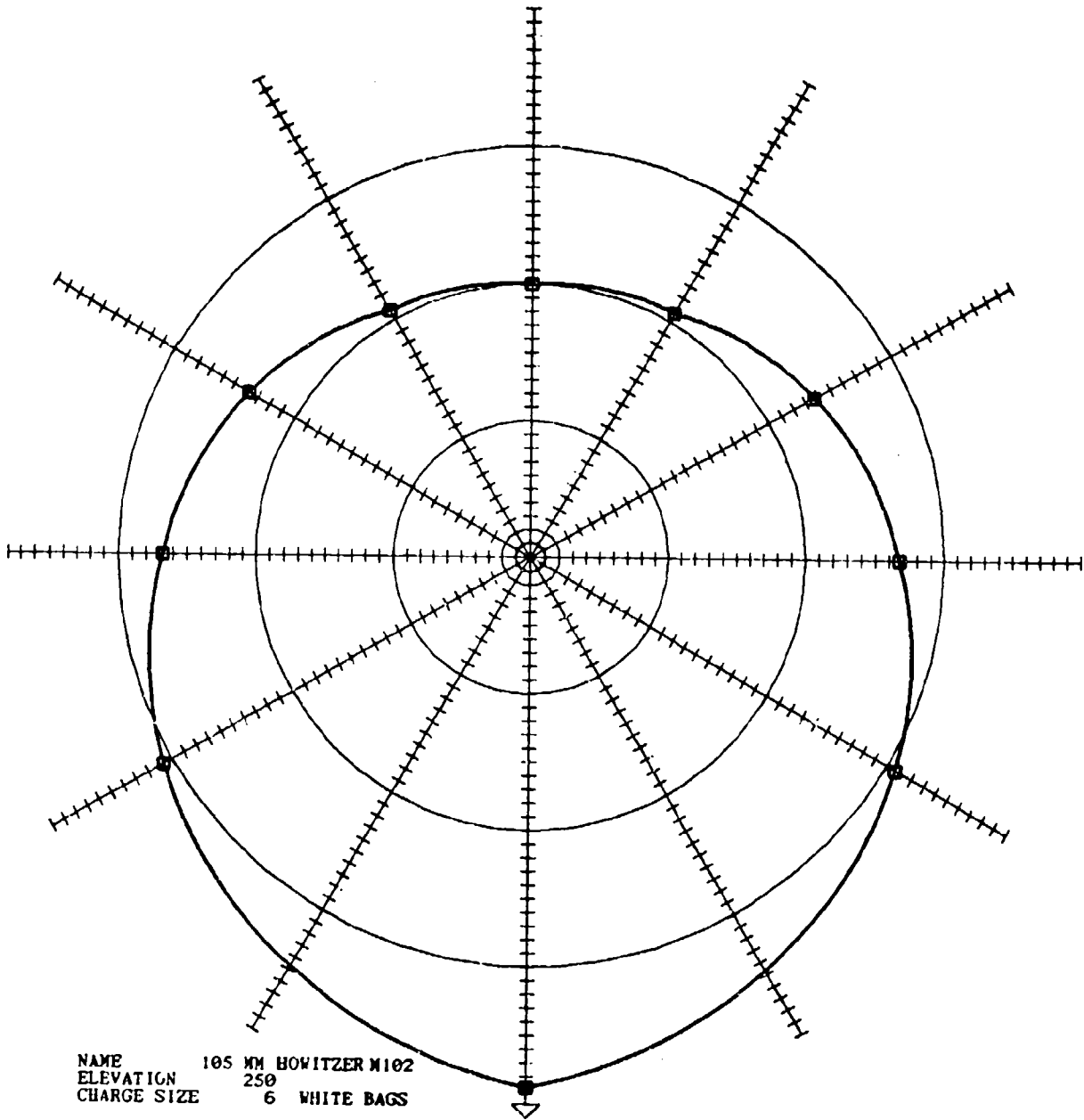

NAME 105 MM HOWITZER M102  
 ELEVATION 250  
 CHARGE SIZE 6 WHITE BAGS

CHANNEL	ENERGY	DIFFERENCE FROM REAR	ANGLE	DIFFERENCE FROM REAR	DIFFERENCE FROM C4
1	104.60	12.36	0°	0.00	-25.43
2	97.78	5.56	30°	5.32	-20.10
3	92.20	0.00	60°	10.65	-14.77
4	95.29	3.03	90°	6.73	-18.69
5	102.22	9.77	120°	3.75	-21.67
6	94.56	8.47	150°	0.73	-24.69
7	87.87	1.88	180°	0.00	-25.43
8	90.71	4.70	210°	0.73	-24.69
9	0.00	16.45	240°	3.75	-21.67
10	98.75	12.60	270°	6.73	-18.69
11	94.87	8.77	300°	10.65	-14.77
12	90.49	4.52	330°	5.32	-20.10
13	88.01	2.02			
14	85.93	0.00			
15	85.46	-0.56			
16	90.71	4.68			
			AVERAGE	11.63	-13.00

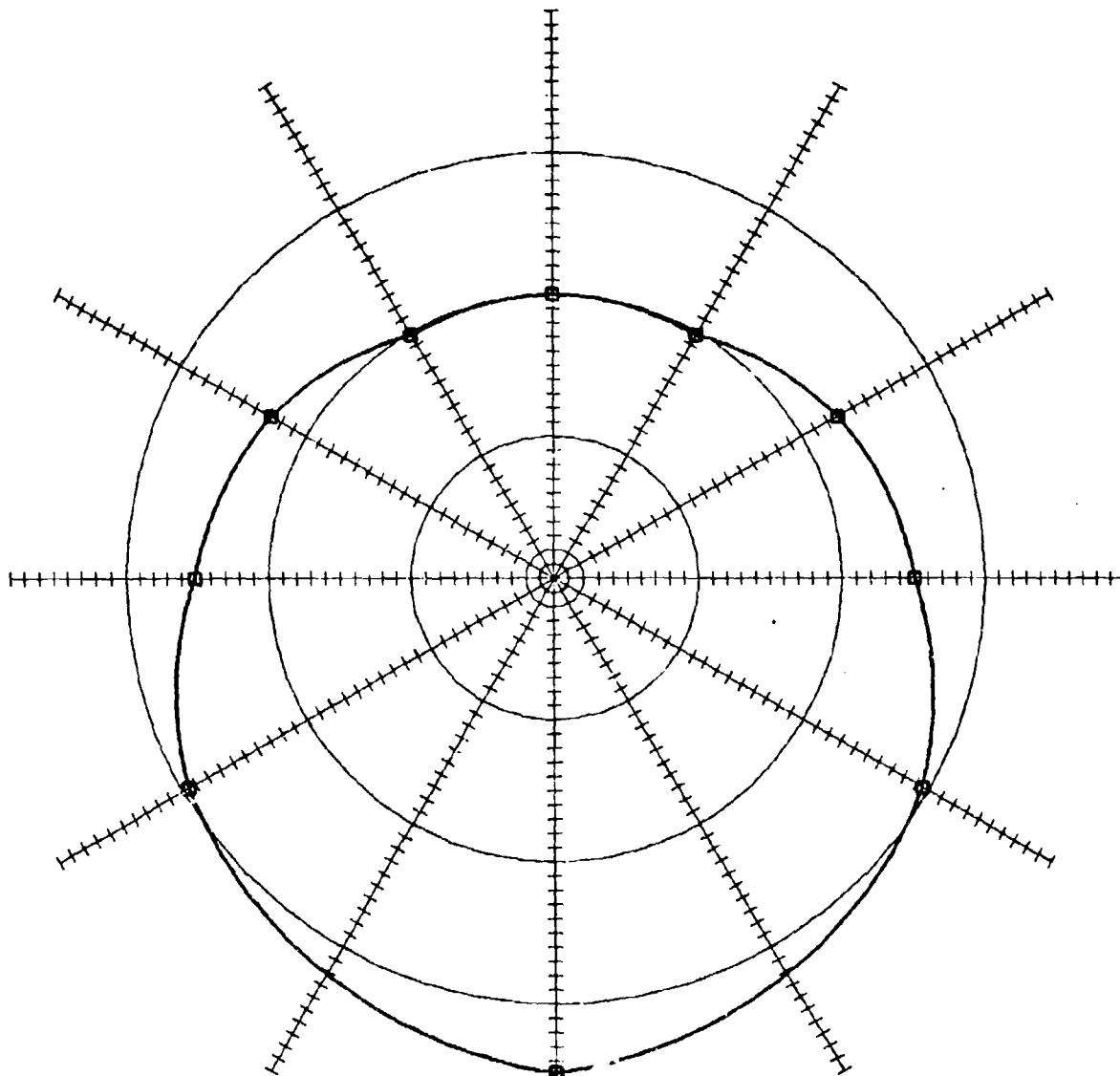

NAME 155 MM HOWITZER M114  
 ELEVATION 200  
 CHARGE SIZE 4 GREEN BAGS

CHANNEL	ENERGY	DIFFERENCE FROM REAR	ANGLE	DIFFERENCE FROM REAR	DIFFERENCE FROM C4
1	108.09	8.49	0°	14.81	-4.07
2	103.66	3.95	30°	12.15	-6.72
3	99.70	0.00	60°	9.50	-9.38
4	102.44	2.56	90°	5.06	-13.82
5	110.63	10.95	120°	2.80	-16.08
6	102.08	9.50	150°	-0.22	-19.11
7	94.76	2.80	180°	0.00	-18.89
8	96.29	5.06	210°	-0.22	-19.11
9	114.50	12.92	240°	2.80	-16.08
10	0.00	9.50	270°	5.06	-13.82
11	99.27	5.06	300°	9.50	-9.38
12	96.19	2.80	330°	12.15	-6.72
13	92.90	-0.22			
14	0.00	0.00			
15	93.63	-0.22			
16	97.64	5.06			
AVERAGE				8.94	-9.94

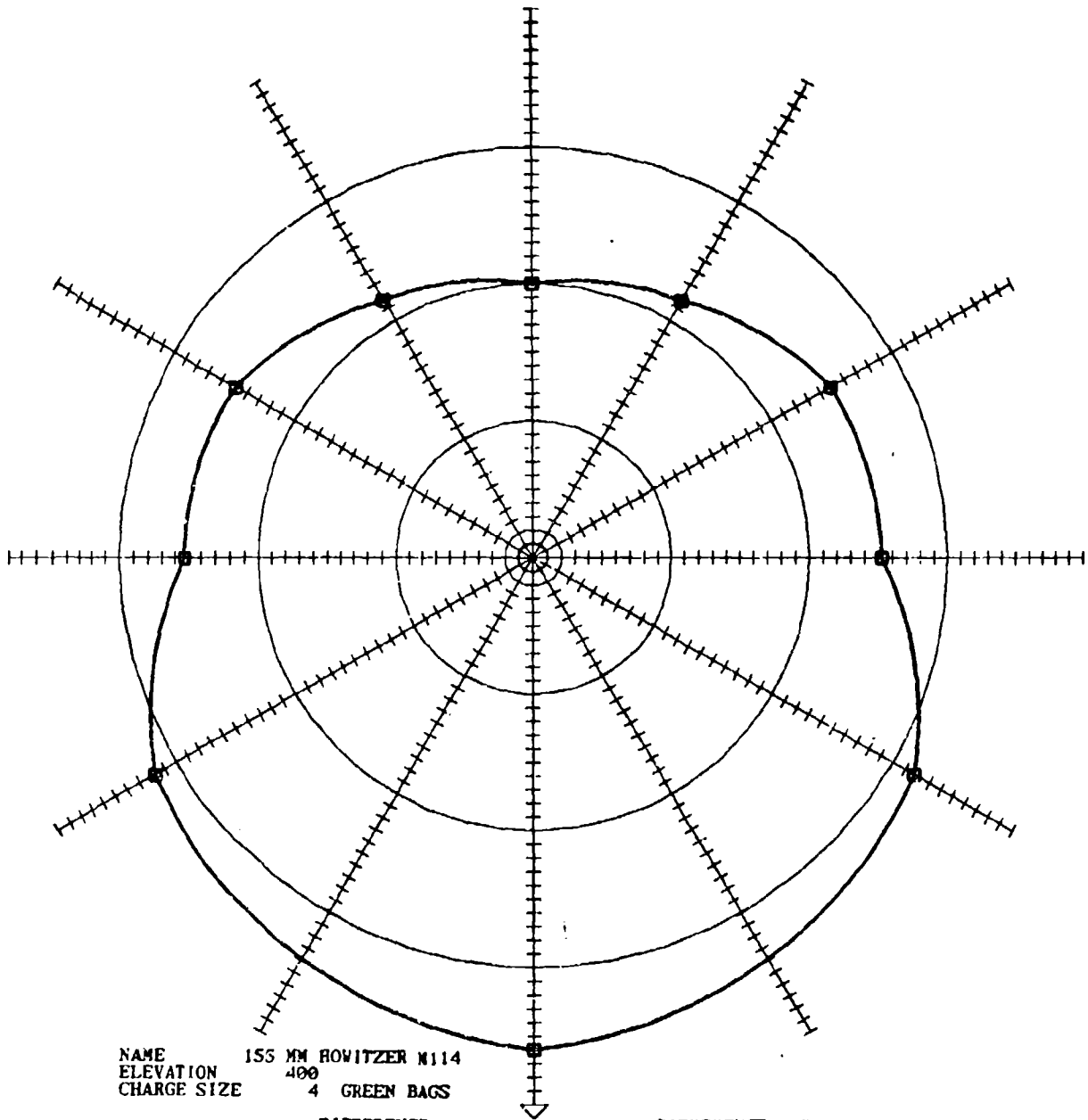

NAME 155 MM HOWITZER M114  
 ELEVATION 400  
 CHARGE SIZE 4 GREEN BAGS

CHANNEL	ENERGY	DIFFERENCE FROM REAR	ANGLF	DIFFERENCE FROM REAR	DIFFERENCE FROM C4
1	108.58	10.98	0°	15.96	-4.11
2	102.49	4.94	30°	13.85	-6.21
3	97.54	0.00	60°	11.75	-8.31
4	101.24	3.65	90°	5.24	-14.82
5	110.49	12.75	120°	4.91	-15.16
6	102.12	11.75	150°	1.66	-18.40
7	97.24	4.91	180°	0.00	-20.07
8	96.70	5.24	210°	1.66	-18.40
9	113.55	12.07	240°	4.91	-15.16
10	102.12	11.75	270°	5.24	-14.82
11	96.45	5.24	300°	11.75	-8.31
12	95.22	4.91	330°	13.85	-6.21
13	93.89	1.66			
14	91.15	0.00			
15	91.15	1.66			
16	96.26	5.24			
			AVERAGE	10.50	-9.56

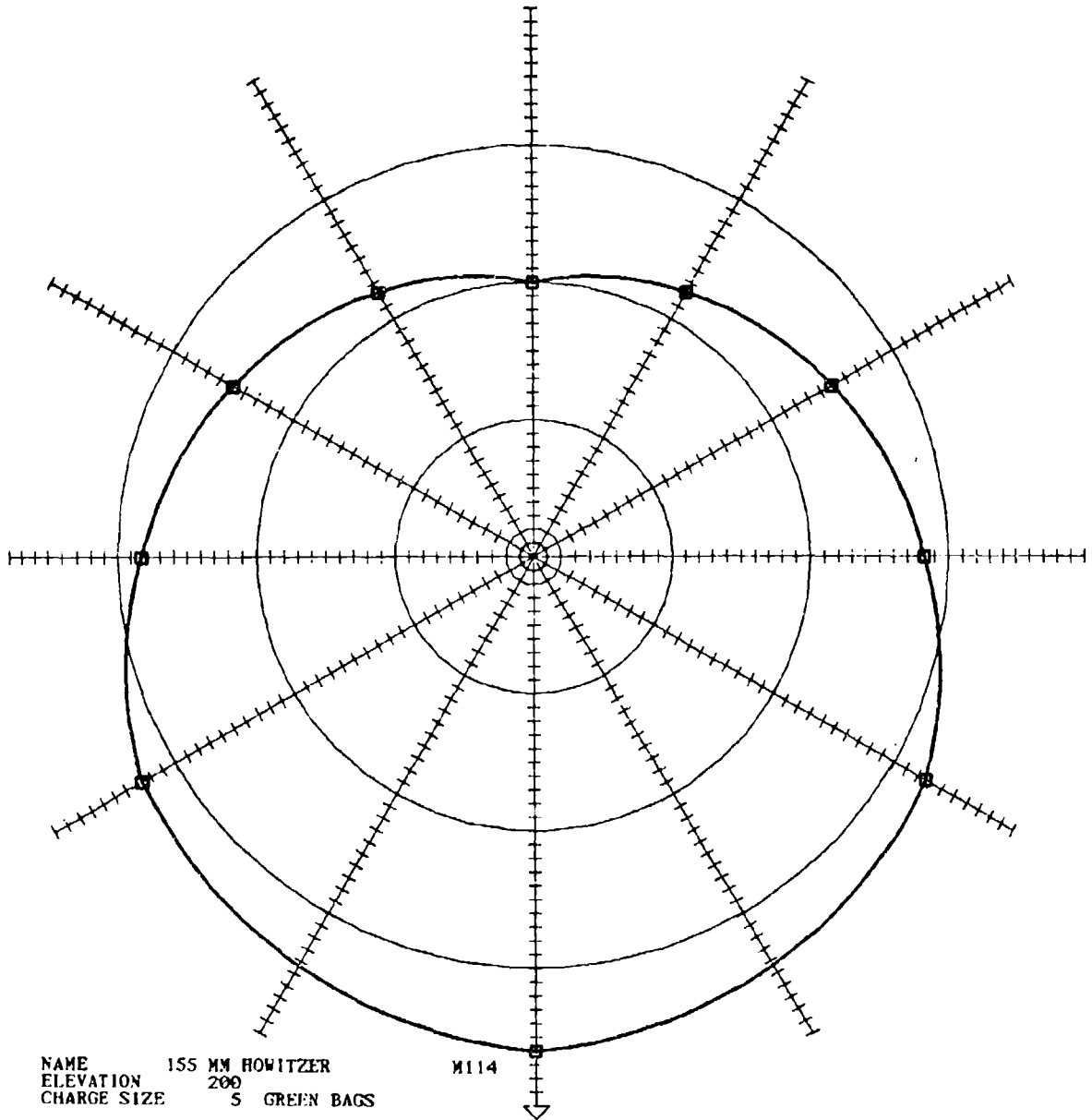

NAME 155 MM HOWITZER  
 ELEVATION 200  
 CHARGE SIZE 5 GREEN BAGS

M114

CHANNEL	ENERGY	DIFFERENCE FROM REAR	ANGLE	DIFFERENCE FROM REAR	DIFFERENCE FROM C4
1	112.23	13.22	0°	0.00	-19.61
2	104.66	5.68	30°	6.32	-13.28
3	99.30	0.00	60°	12.65	-6.96
4	103.03	4.08	90°	8.23	-11.37
5	111.74	12.74	120°	4.91	-14.70
6	104.07	11.23	150°	2.23	-17.38
7	96.54	4.19	180°	0.00	-19.61
8	92.23	6.59	210°	2.23	-17.38
9	0.00	16.07	240°	4.91	-14.70
10	105.88	12.96	270°	8.23	-11.37
11	101.89	9.56	300°	12.65	-6.96
12	98.17	5.73	330°	6.32	-13.28
13	96.72	4.66			
14	93.06	0.00			
15	92.95	-0.20			
16	99.06	6.89			
			AVERAGE	11.15	-8.51

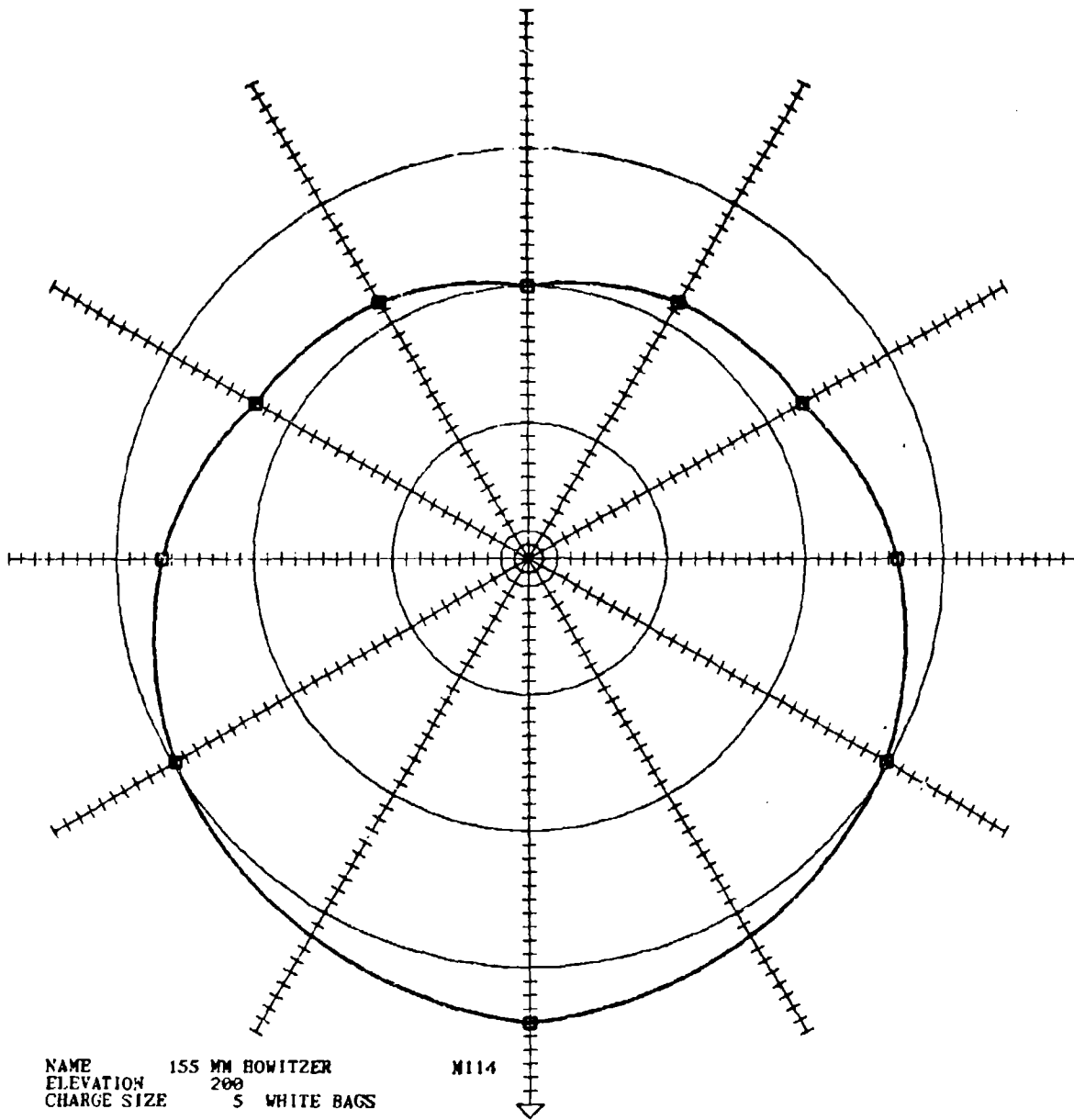

NAME 155 MM HOWITZER  
 ELEVATION 200  
 CHARGE SIZE 5 WHITE BAGS

M114

CHANNEL	ENERGY	DIFFERENCE FROM REAR	ANGLE	DIFFERENCE FROM REAR	DIFFERENCE FROM C4
1	113.34	8.40	0°	0.00	-14.50
2	106.27	1.38	30°	4.89	-9.61
3	104.88	0.00	60°	9.78	-4.71
4	107.92	2.87	90°	6.67	-7.82
5	115.45	10.52	120°	2.85	-11.65
6	109.05	11.83	150°	1.73	-12.77
7	102.34	3.74	180°	0.00	-14.50
8	103.95	6.65	210°	1.73	-12.77
9	0.00	16.07	240°	2.85	-11.65
10	105.49	8.39	270°	6.67	-7.82
11	103.65	6.52	300°	9.78	-4.71
12	100.58	3.39	330°	4.89	-9.61
13	97.90	0.79			
14	97.26	0.00			
15	99.87	2.67			
16	104.08	6.83			
			AVERAGE	8.85	-5.89



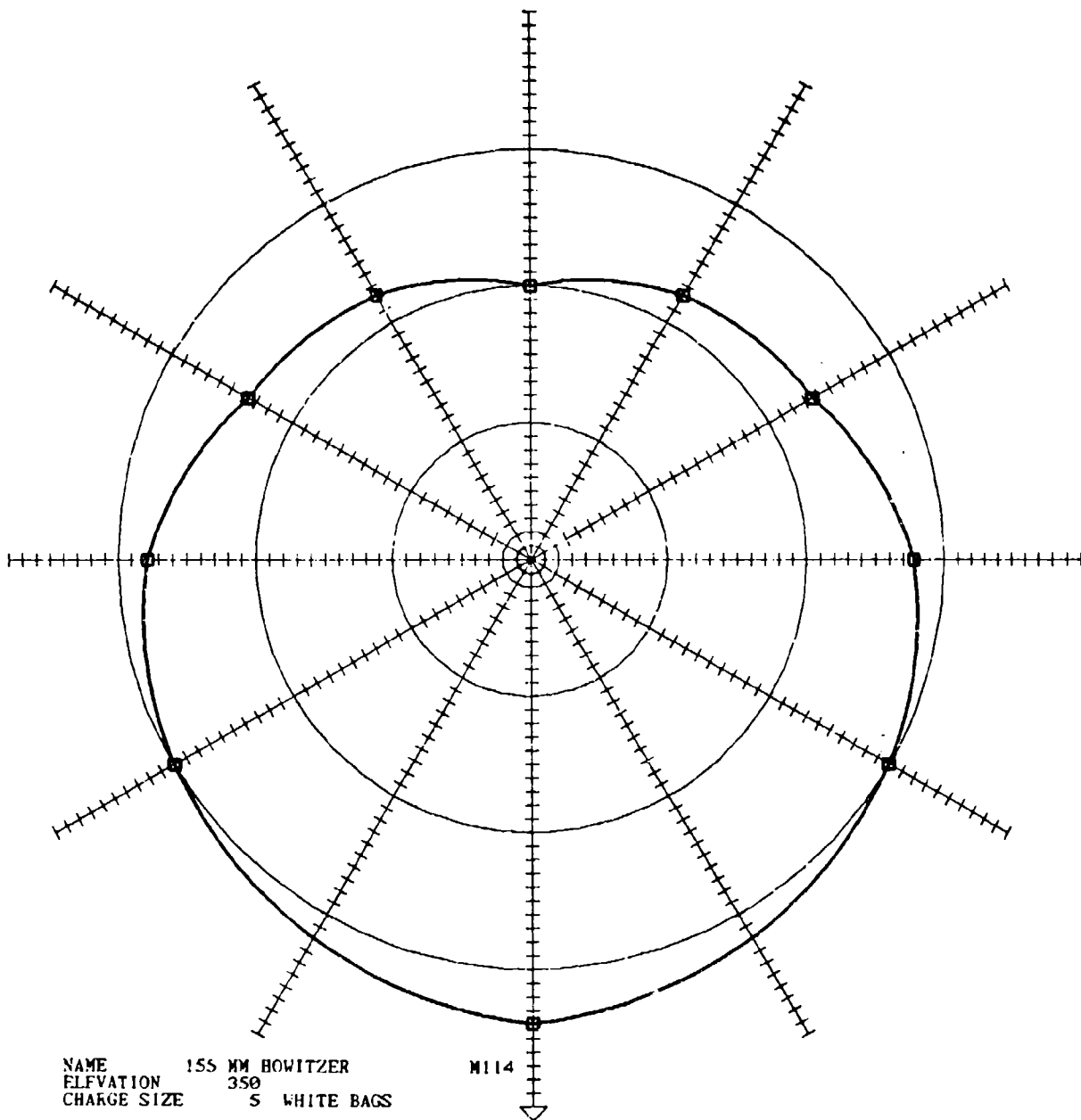

CHANNEL	ENERGY	DIFFERENCE FROM REAR	ANGLE	DIFFERENCE FROM REAR	DIFFERENCE FROM C4
1	112.76	8.79	9°	13.89	-0.96
2	106.62	2.66	30°	11.90	-2.96
3	103.98	0.00	60°	9.91	-4.95
4	107.18	3.13	90°	7.90	-7.06
5	113.08	9.11	120°	3.61	-11.25
6	107.47	11.58	150°	2.28	-12.58
7	100.85	4.74	180°	0.00	-14.86
8	104.75	8.50	210°	2.28	-12.58
9	117.77	13.89	240°	3.61	-11.25
10	105.94	10.14	270°	7.90	-7.06
11	103.13	7.26	300°	9.91	-4.95
12	99.83	3.91	330°	11.90	-2.96
13	97.24	1.38			
14	95.81	0.00			
15	99.01	3.18			
16	104.56	8.34			
			AVERAGE	9.03	-5.83

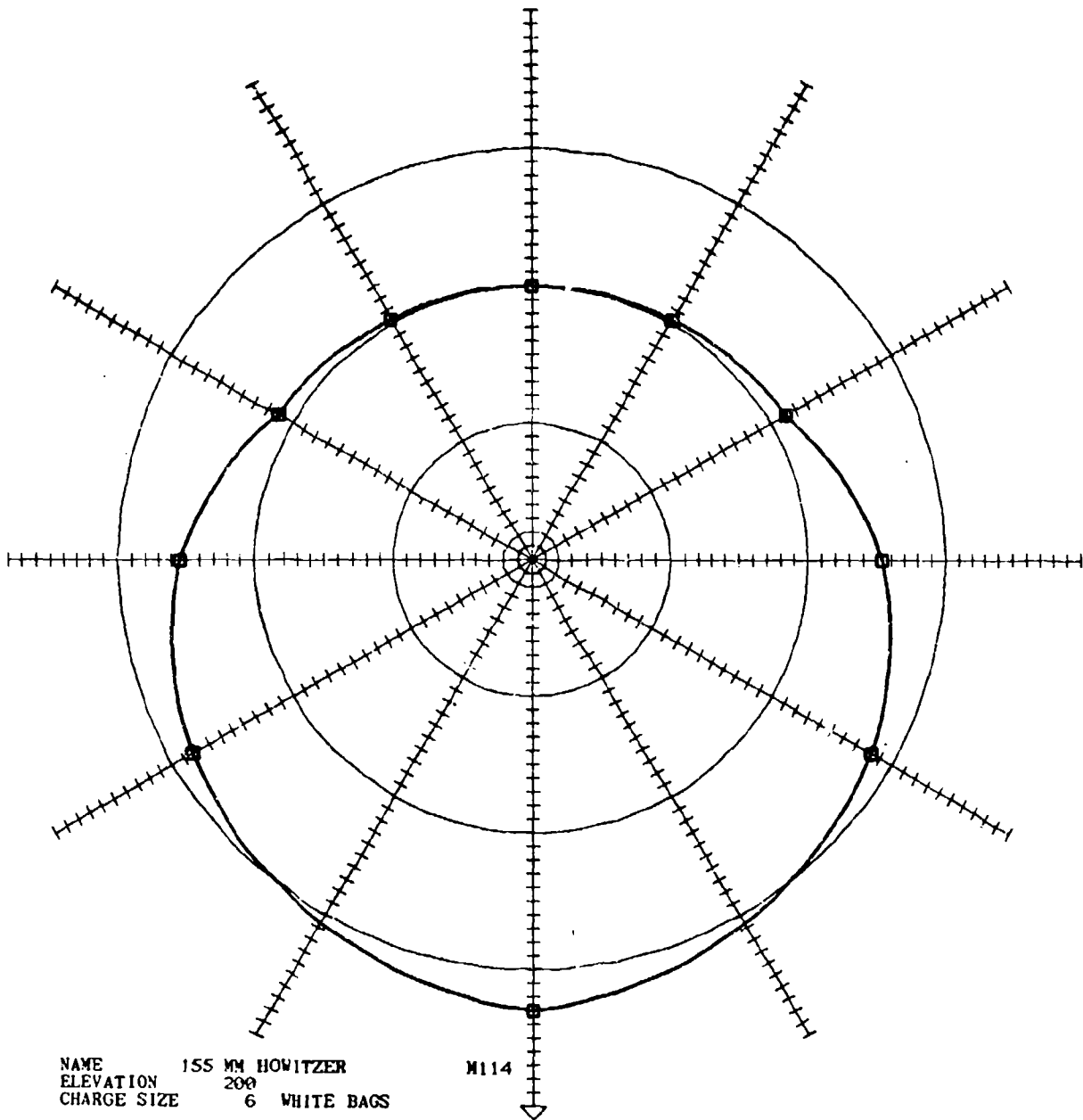

NAME 155 MM HOWITZER  
 ELEVATION 200  
 CHARGE SIZE 6 WHITE BAGS

M114

CHANNEL	ENERGY	DIFFERENCE FROM REAR	ANGLE	DIFFERENCE FROM REAR	DIFFERENCE FROM C4
1	115.76	8.93	0°	0.00	-12.00
2	108.55	1.84	30°	4.13	-7.87
3	106.76	0.00	60°	8.27	-3.73
4	107.71	0.90	90°	5.33	-6.66
5	114.91	8.17	120°	1.19	-10.80
6	107.03	6.87	150°	0.25	-11.74
7	100.12	0.11	180°	0.00	-12.00
8	103.29	3.42	210°	0.25	-11.74
9	0.00	13.89	240°	1.19	-10.80
10	108.88	9.10	270°	5.33	-6.66
11	107.44	7.22	300°	8.27	-3.73
12	101.70	1.93	330°	4.13	-7.87
13	100.24	0.45			
14	99.86	0.00			
15	99.97	0.06			
16	103.36	3.45			
			AVERAGE	7.60	-4.40

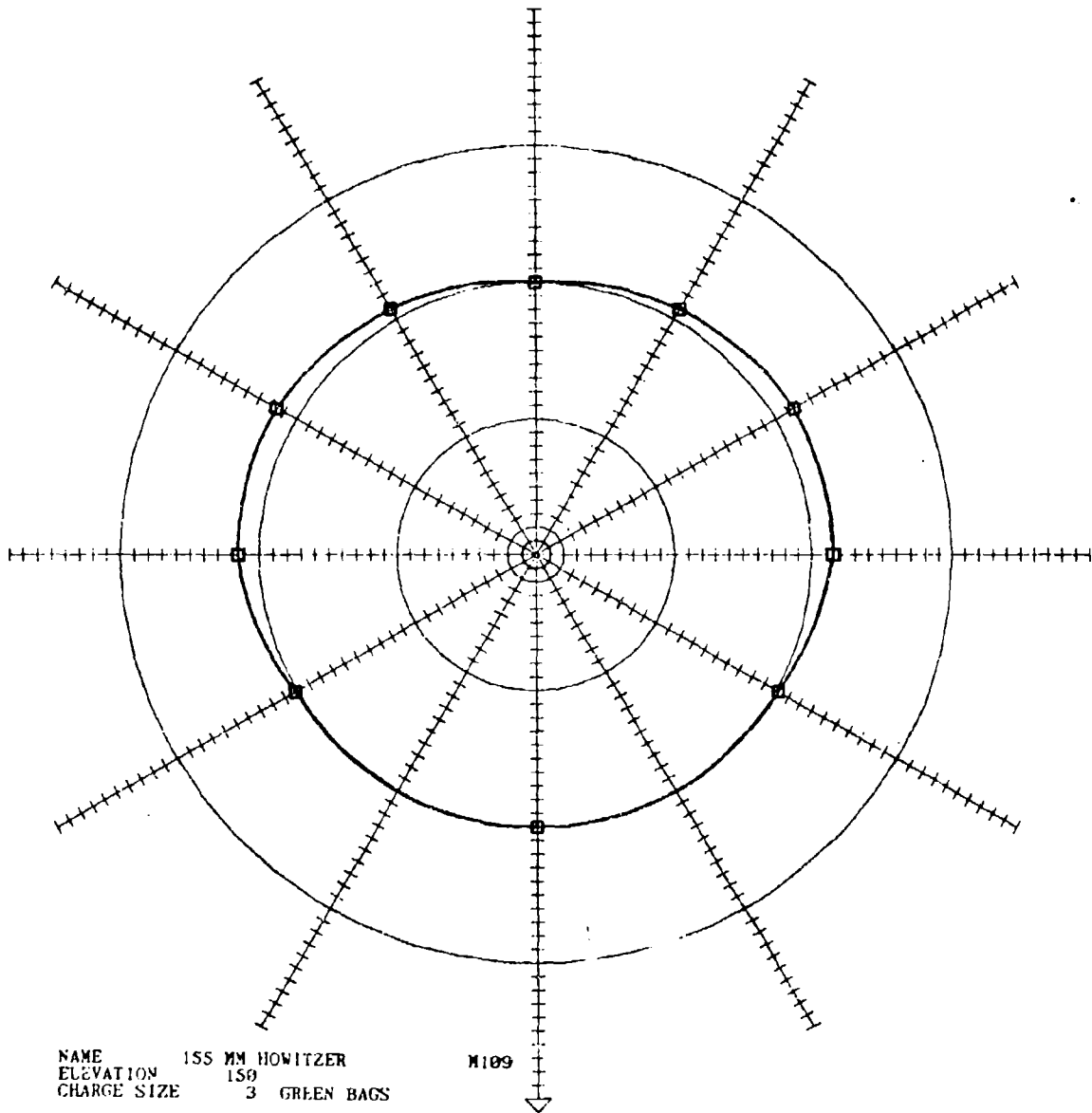

NAME 155 MM HOWITZER  
 ELEVATION 150  
 CHARGE SIZE 3 GREEN BAGS

M109

CHANNEL	ENERGY	DIFFERENCE FROM REAR	ANGLE	DIFFERENCE FROM REAR	DIFFERENCE FROM C4
1	108.15	1.95	0°	-0.01	-13.08
2	108.65	2.41	30°	0.05	-13.01
3	106.20	0.00	60°	0.12	-12.94
4	107.20	0.92	90°	1.49	-11.57
5	105.37	-1.04	120°	1.56	-11.50
6	97.06	-1.44	150°	0.83	-12.23
7	98.75	0.27	180°	0.00	-13.06
8	99.28	0.74	210°	0.83	-12.23
9	106.19	-0.01	240°	1.56	-11.50
10	99.51	1.01	270°	1.49	-11.57
11	100.79	2.76	300°	0.12	-12.94
12	101.17	2.64	330°	0.05	-13.01
13	99.39	0.88			
14	98.48	0.00			
15	99.35	0.78			
16	99.22	0.72			
			AVERAGE	0.72	-12.34

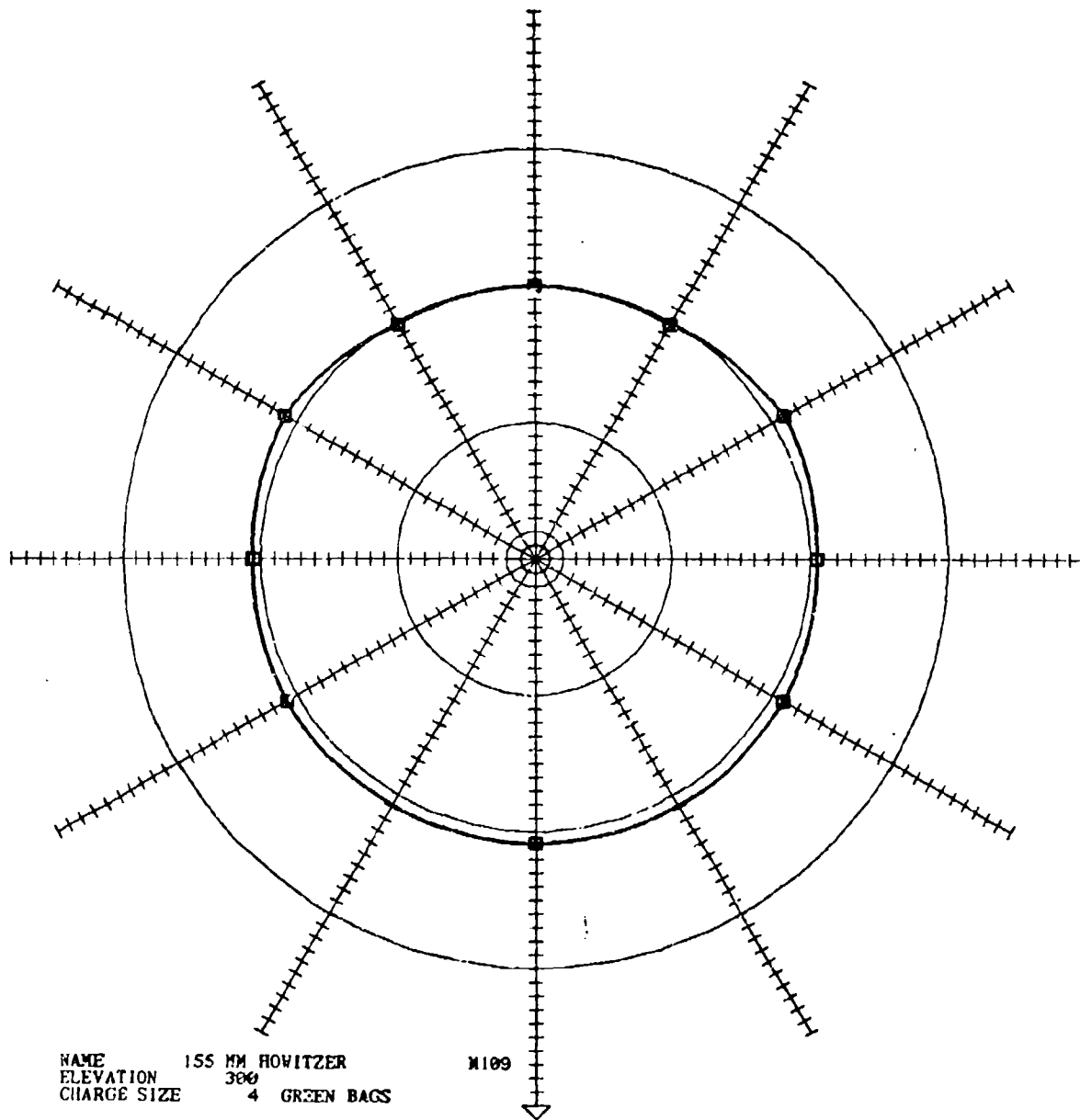

NAME 155 MM HOWITZER  
 ELEVATION 300  
 CHARGE SIZE 4 GREEN BAGS

M109

CHANNEL	ENERGY	DIFFERENCE FROM REAR	ANGLE	DIFFERENCE FROM REAR	DIFFERENCE FROM C4
1	110.24	2.29	0°	0.80	-10.35
2	110.64	2.58	30°	0.82	-10.33
3	108.81	0.00	60°	0.85	-10.30
4	107.91	-0.14	90°	0.46	-10.69
5	108.15	0.06	120°	0.95	-10.19
6	102.53	0.52	150°	-0.19	-11.35
7	99.56	-1.74	180°	0.00	-11.15
8	100.47	-1.53	210°	-0.19	-11.35
9	108.87	0.80	240°	0.95	-10.19
10	101.73	0.52	270°	0.46	-10.69
11	103.35	2.21	300°	0.85	-10.30
12	104.39	3.14	330°	0.82	-10.33
13	102.17	0.79			
14	101.27	0.00			
15	100.08	-1.18			
16	100.66	-1.28			
			AVERAGE	0.57	-10.58

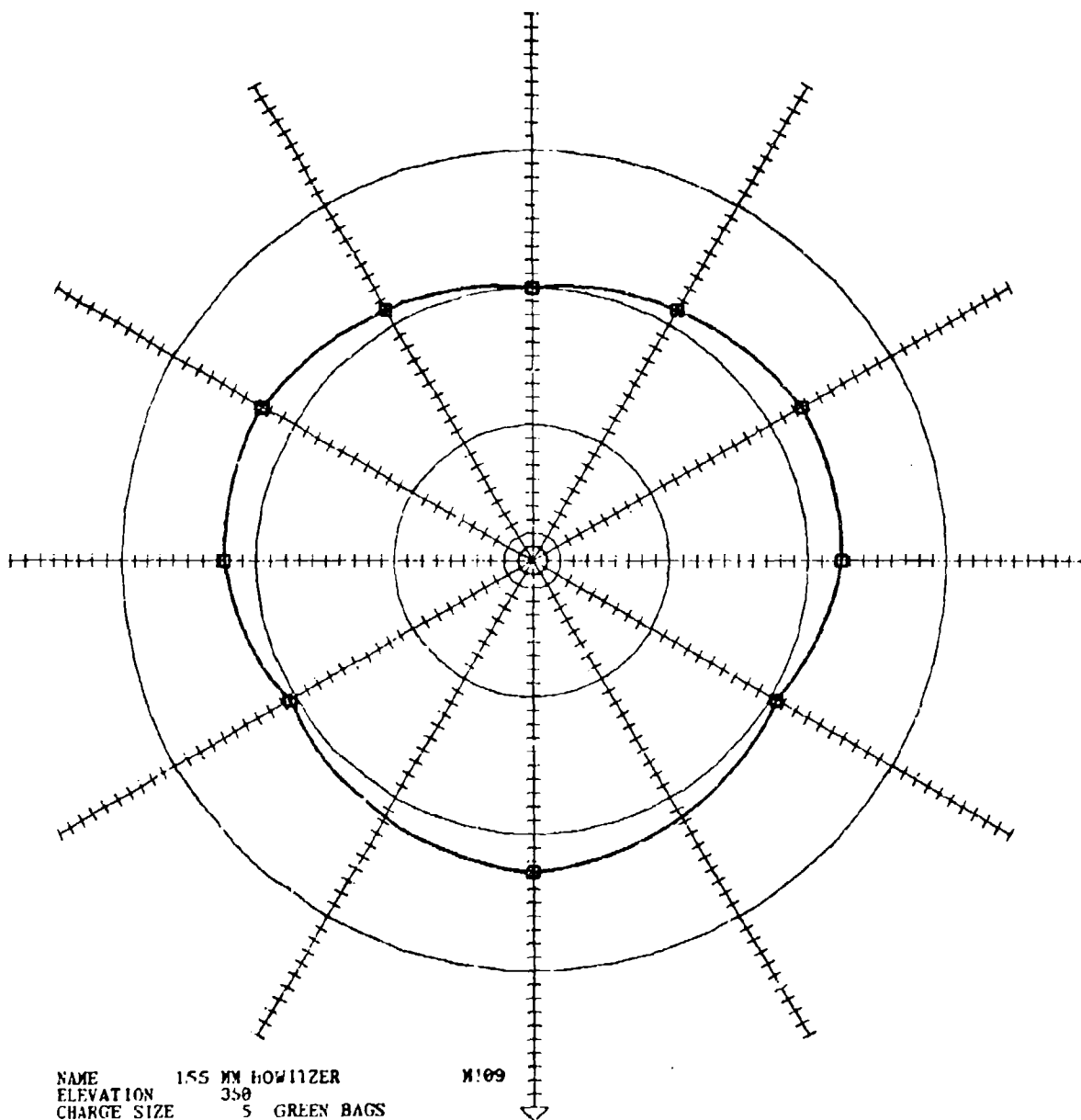

NAME 155 MM HOWITZER  
 ELEVATION 350  
 CHARGE SIZE 5 GREEN BAGS

M109

CHANNEL	ENERGY	DIFFERENCE FROM REAR	ANGLE	DIFFERENCE FROM REAR	DIFFERENCE FROM C4
1	111.72	1.52	0°	2.74	-6.48
2	112.77	2.52	30°	1.59	-7.62
3	110.22	0.00	60°	0.45	-8.76
4	112.33	2.02	90°	2.40	-6.81
5	110.15	-0.11	120°	2.57	-6.64
6	101.72	-1.09	150°	1.22	-7.99
7	105.34	2.36	180°	0.00	-9.22
8	106.06	3.20	210°	1.22	-7.99
9	112.94	2.74	240°	2.57	-6.64
10	104.24	1.52	270°	2.40	-6.81
11	104.52	1.81	300°	0.45	-8.76
12	106.05	3.40	330°	1.59	-7.62
13	104.53	1.88			
14	102.76	0.00			
15	103.22	0.56			
16	105.86	3.00			
			AVERAGE	1.69	-7.52

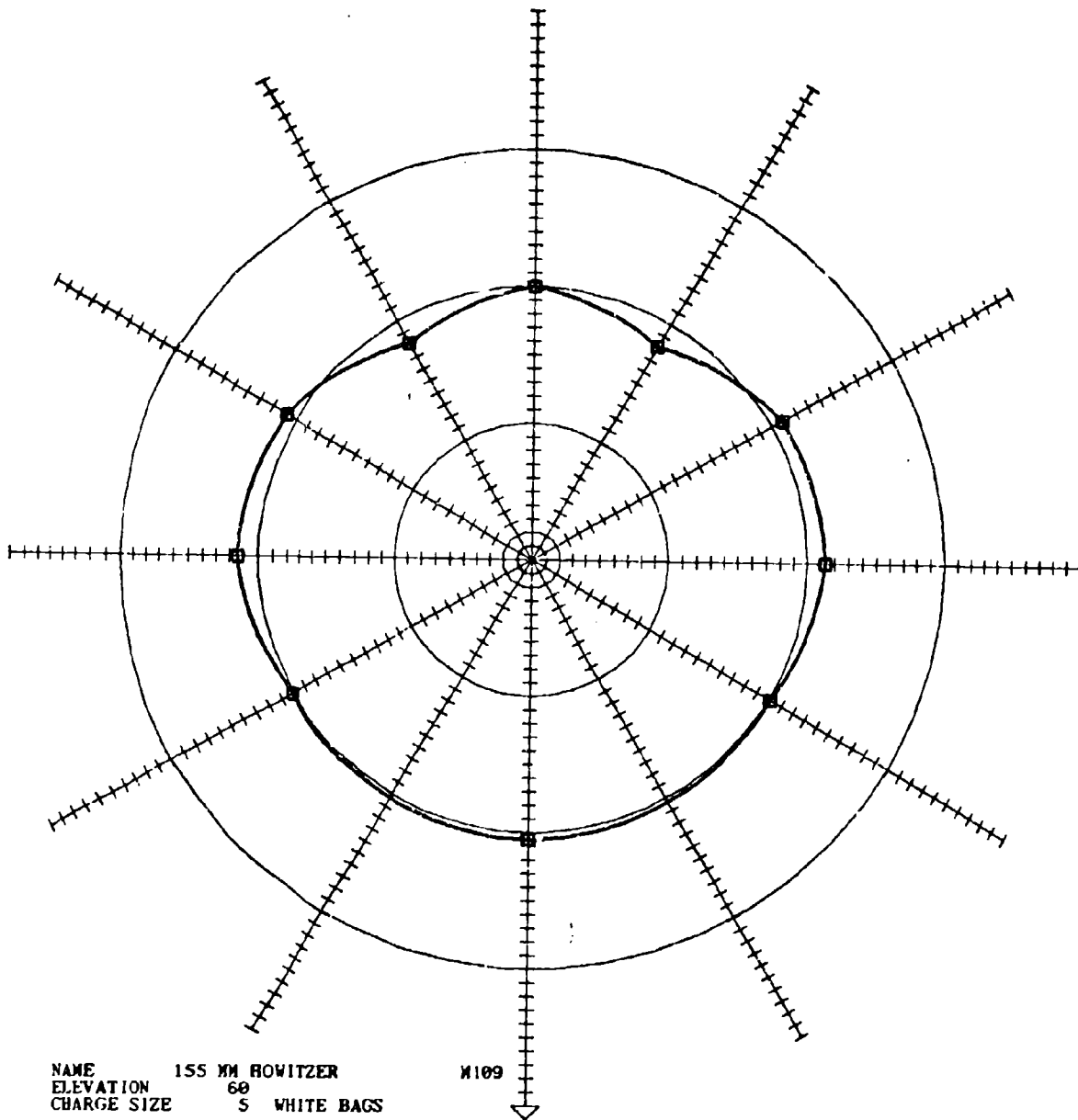

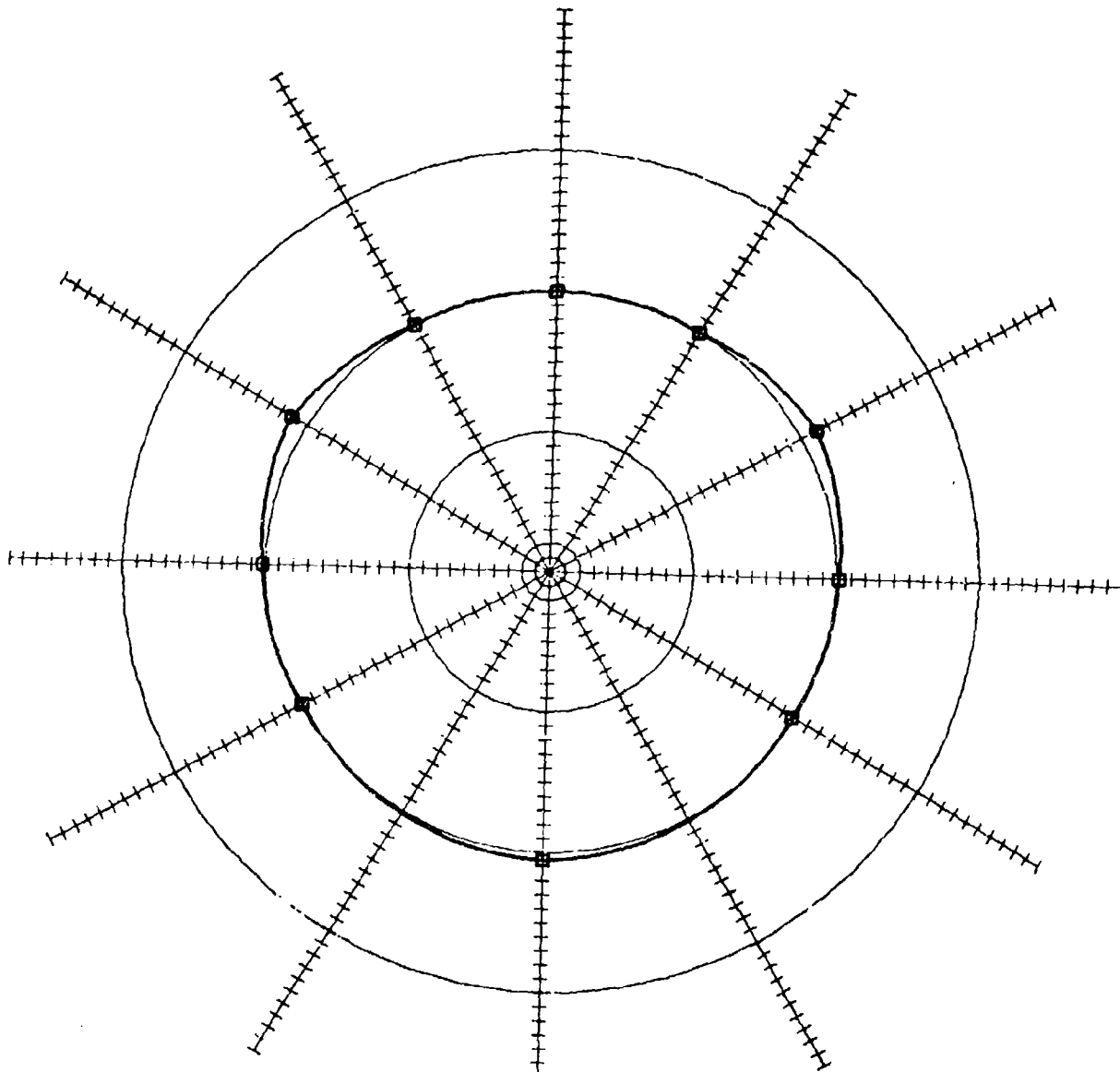

NAME 155 MM HOWITZER  
 ELEVATION 350  
 CHARGE SIZE 5 WHITE BAGS

M109

CHANNEL	ENERGY	DIFFERENCE FROM REAR	ANGLE	DIFFERENCE FROM REAR	DIFFERENCE FROM C4
1	113.52	1.48	0°	0.48	-5.80
2	114.36	2.34	30°	0.14	-6.13
3	112.07	0.00	60°	-0.18	-6.47
4	114.09	2.02	90°	0.15	-6.12
5	113.22	1.09	120°	1.17	-5.10
6	104.68	-2.36	150°	0.01	-6.26
7	105.51	-1.51	180°	0.00	-6.28
8	107.56	0.18	210°	0.01	-6.26
9	112.63	0.48	240°	1.17	-5.10
10	105.82	-0.97	270°	0.15	-6.12
11	107.18	0.46	300°	-0.18	-6.47
12	108.57	1.86	330°	0.14	-6.13
13	107.98	1.28			
14	106.74	0.00			
15	105.55	-1.25			
16	107.16	-0.15			
			AVERAGE	0.27	-6.00

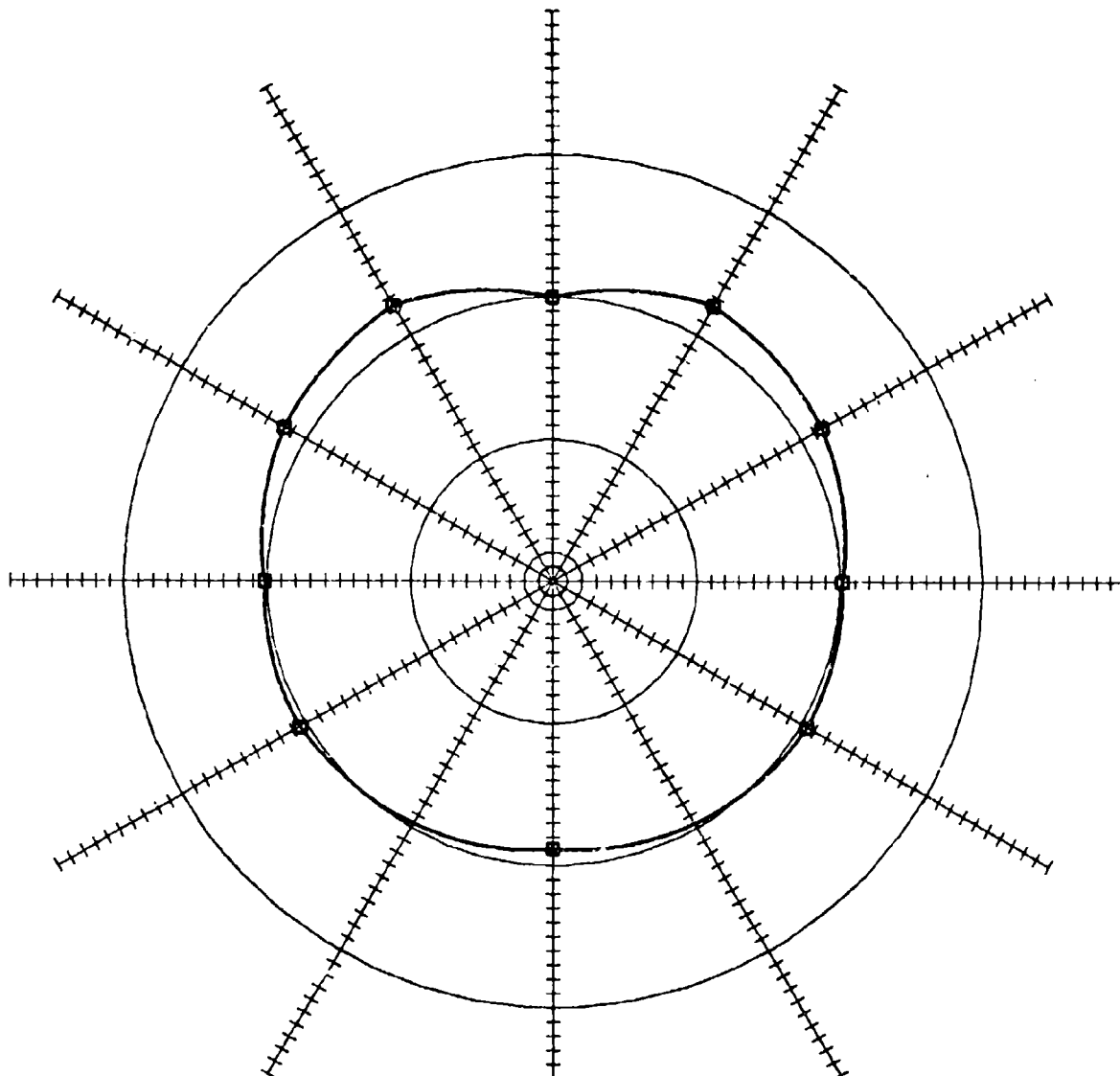

NAME 155 MM HOWITZER  
 ELEVATION 1275  
 CHARGE SIZE 5 WHITE BAGS

M109

CHANNEL	ENERGY	DIFFERENCE FROM REAR	ANGLE	DIFFERENCE FROM REAR	DIFFERENCE FROM C4
1	114.68	1.70	0°	-1.20	-8.21
2	116.42	3.40	30°	-0.36	-7.37
3	113.05	0.00	60°	0.46	-6.54
4	112.27	-1.92	90°	0.16	-6.85
5	113.10	0.04	120°	1.63	-5.37
6	105.48	-0.53	150°	2.39	-4.62
7	106.91	1.14	180°	0.00	-7.01
8	103.10	-2.65	210°	2.39	-4.62
9	111.77	-1.20	240°	1.63	-5.37
10	106.36	0.82	270°	0.16	-6.85
11	108.65	3.04	300°	0.46	-6.54
12	109.14	3.58	330°	-0.36	-7.37
13	108.85	3.36			
14	105.60	0.00			
15	107.07	1.41			
16	103.01	-2.71			
			AVERAGE	0.75	-6.25



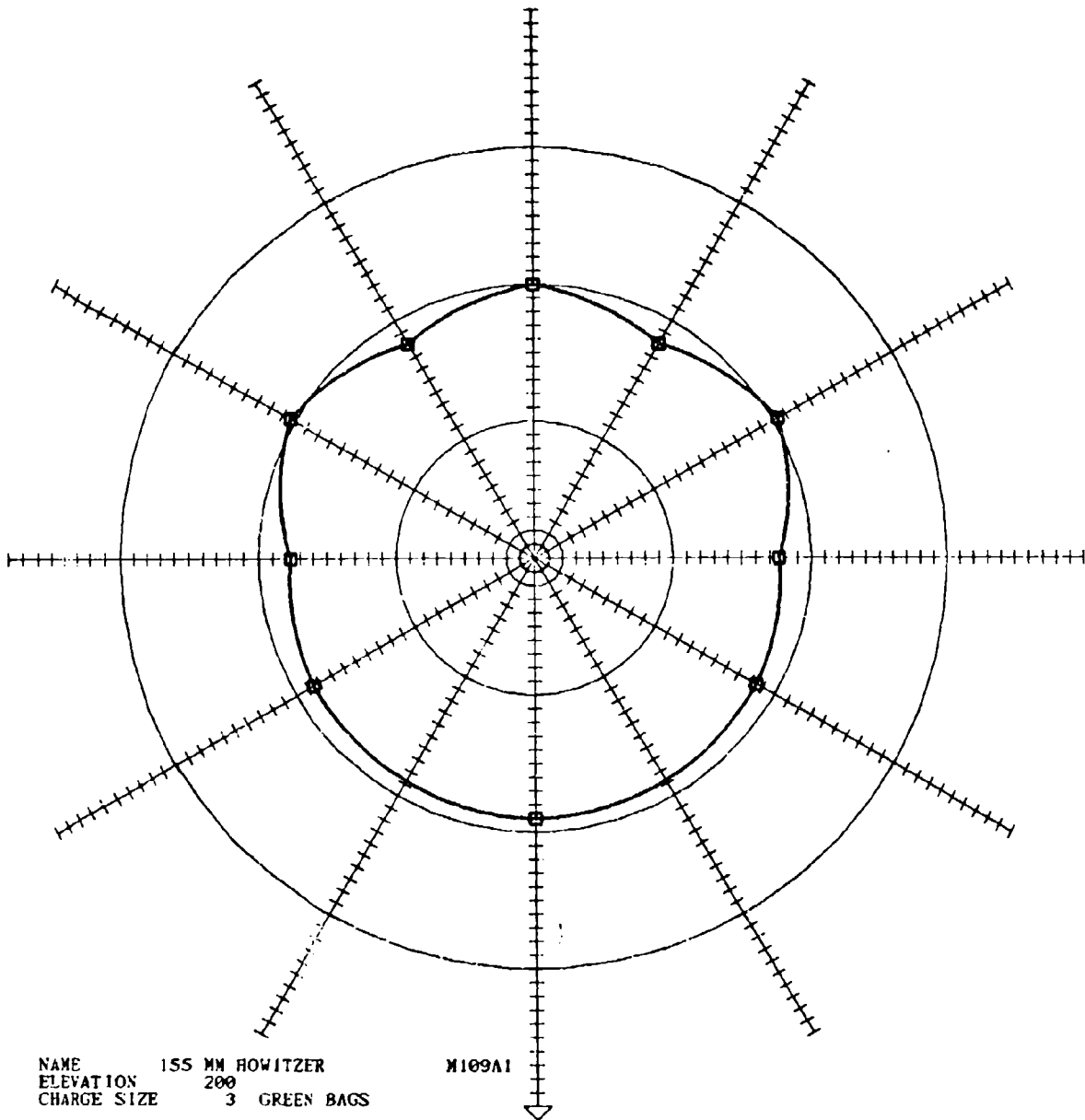

NAME 155 MM HOWITZER  
 ELEVATION 200  
 CHARGE SIZE 3 GREEN BAGS

CHANNEL	ENERGY	DIFFERENCE FROM REAR	ANGLE	DIFFERENCE FROM REAR	DIFFERENCE FROM C4
1	103.82	0.55	0°	-1.00	-17.26
2	105.17	2.15	30°	-1.26	-17.52
3	101.51	0.00	60°	-1.53	-17.79
4	102.49	-0.27	90°	-2.27	-18.53
5	101.63	-2.57	120°	0.40	-15.85
6	95.90	-4.18	150°	-1.91	-18.17
7	96.00	-0.92	180°	0.00	-16.26
8	94.48	-3.72	210°	-1.91	-18.17
9	101.16	-1.00	240°	0.40	-15.85
10	97.09	1.50	270°	-2.27	-18.53
11	97.24	-0.90	300°	-1.53	-17.79
12	98.09	0.87	330°	-1.26	-17.52
13	96.45	-1.52			
14	97.69	0.00			
15	95.56	-2.30			
16	95.24	-3.65			
AVERAGE				-1.07	-17.34

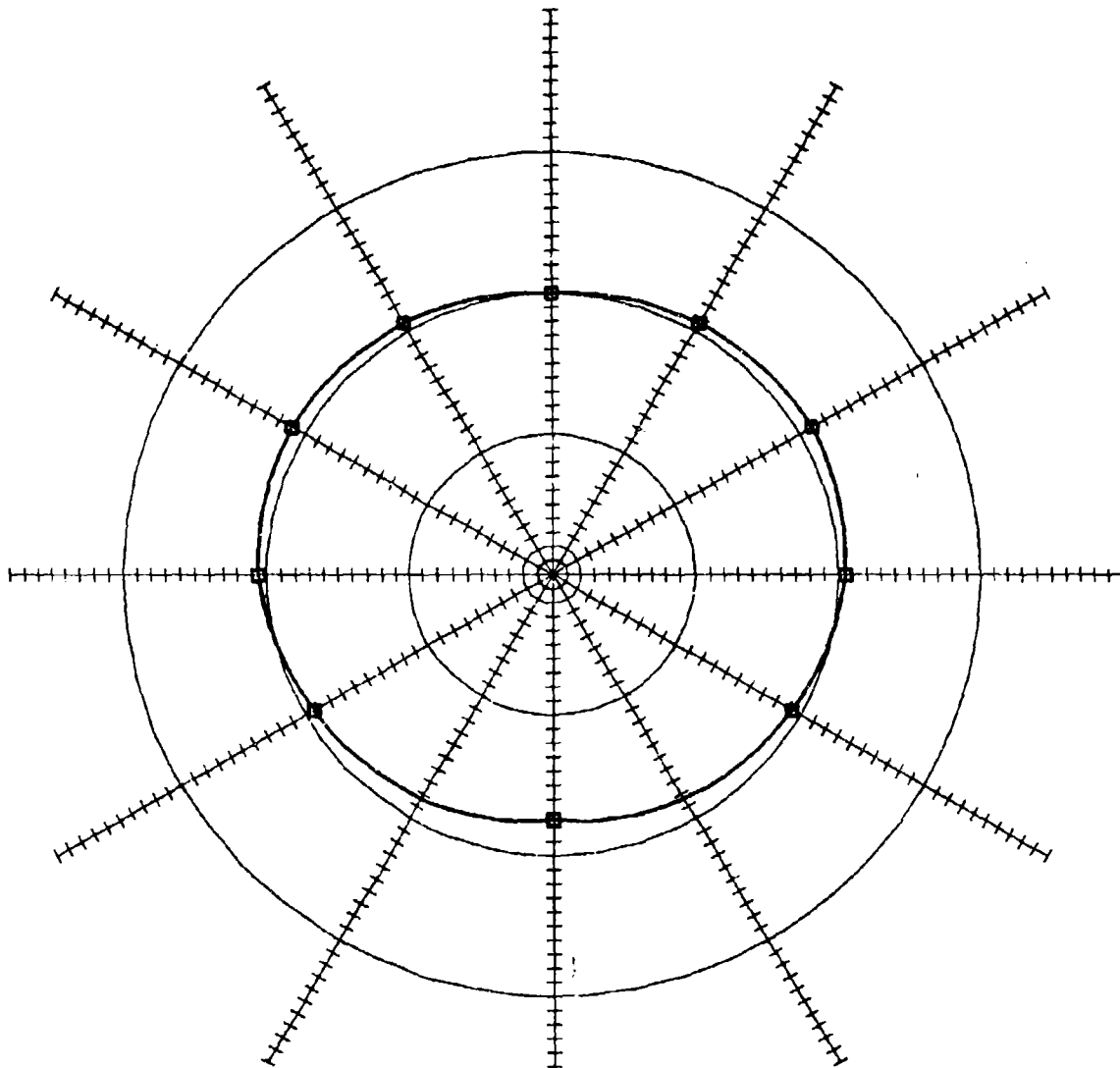

NAME 155 MM HOWITZER  
 ELEVATION 500  
 CHARGE SIZE 3 GREEN BAGS

M109A1

CHANNEL	ENERGY	DIFFERENCE FROM REAR	ANGLE	DIFFERENCE FROM REAR	DIFFERENCE FROM C4
1	102.10	-0.04	0°	-2.59	-19.10
2	104.05	1.88	30°	-1.65	-18.16
3	102.35	0.00	60°	-0.70	-17.21
4	103.38	0.72	90°	0.47	-16.02
5	101.84	-1.11	120°	1.00	-15.50
6	95.86	-1.76	150°	0.64	-15.86
7	97.16	1.08	180°	0.00	-16.51
8	96.06	0.07	210°	0.64	-15.86
9	93.44	-2.59	240°	1.00	-15.50
10	95.77	0.29	270°	0.47	-16.02
11	95.28	-0.27	300°	-0.70	-17.21
12	95.83	0.33	330°	-1.65	-18.16
13	96.87	1.24			
14	95.90	0.00			
15	96.34	-0.10			
16	99.11	1.23			
			AVERAGE	-0.11	-16.62

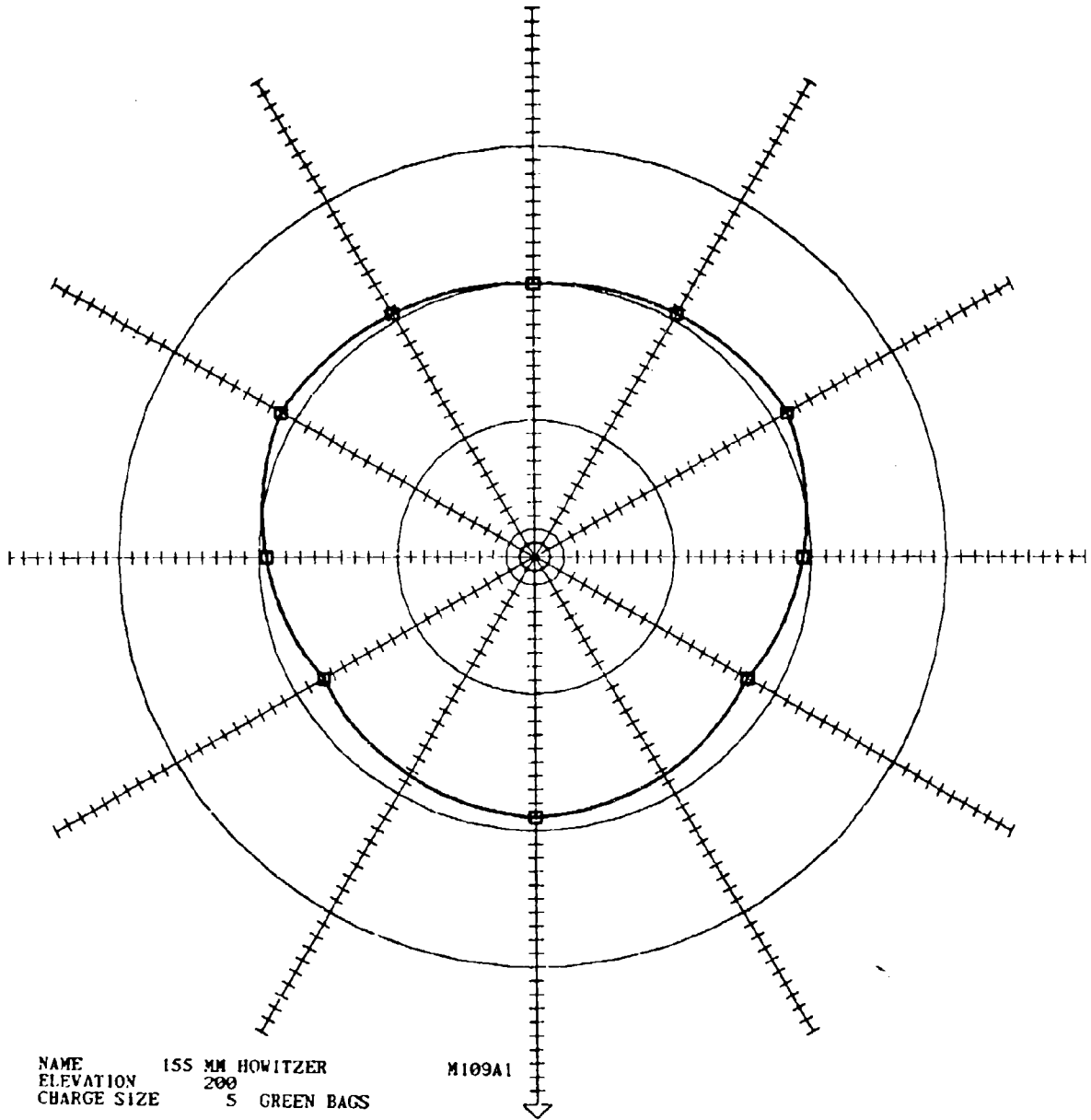

NAME 155 MM HOWITZER  
 ELEVATION 200  
 CHARGE SIZE S GREEN BAGS

M109A1

CHANNEL	ENERGY	DIFFERENCE FROM REAR	ANGLE	DIFFERENCE FROM REAR	DIFFERENCE FROM C4
1	106.89	-0.44	0°	0.00	-10.92
2	108.35	1.10	30°	-1.13	-12.06
3	107.13	0.00	60°	-2.27	-13.19
4	108.31	1.07	90°	-0.57	-11.50
5	103.82	-3.44	120°	1.13	-9.78
6	96.72	-4.37	150°	0.52	-10.39
7	102.49	-1.30	180°	0.00	-10.92
8	99.52	-1.72	210°	0.52	-10.39
9	0.00	-2.59	240°	1.13	-9.78
10	100.55	-0.82	270°	-0.57	-11.50
11	102.28	0.87	300°	-2.27	-13.19
12	102.45	1.07	330°	-1.13	-12.06
13	102.19	0.84			
14	101.17	0.00			
15	100.65	0.10			
16	99.21	-2.02			
			AVERAGE	-0.40	-11.31

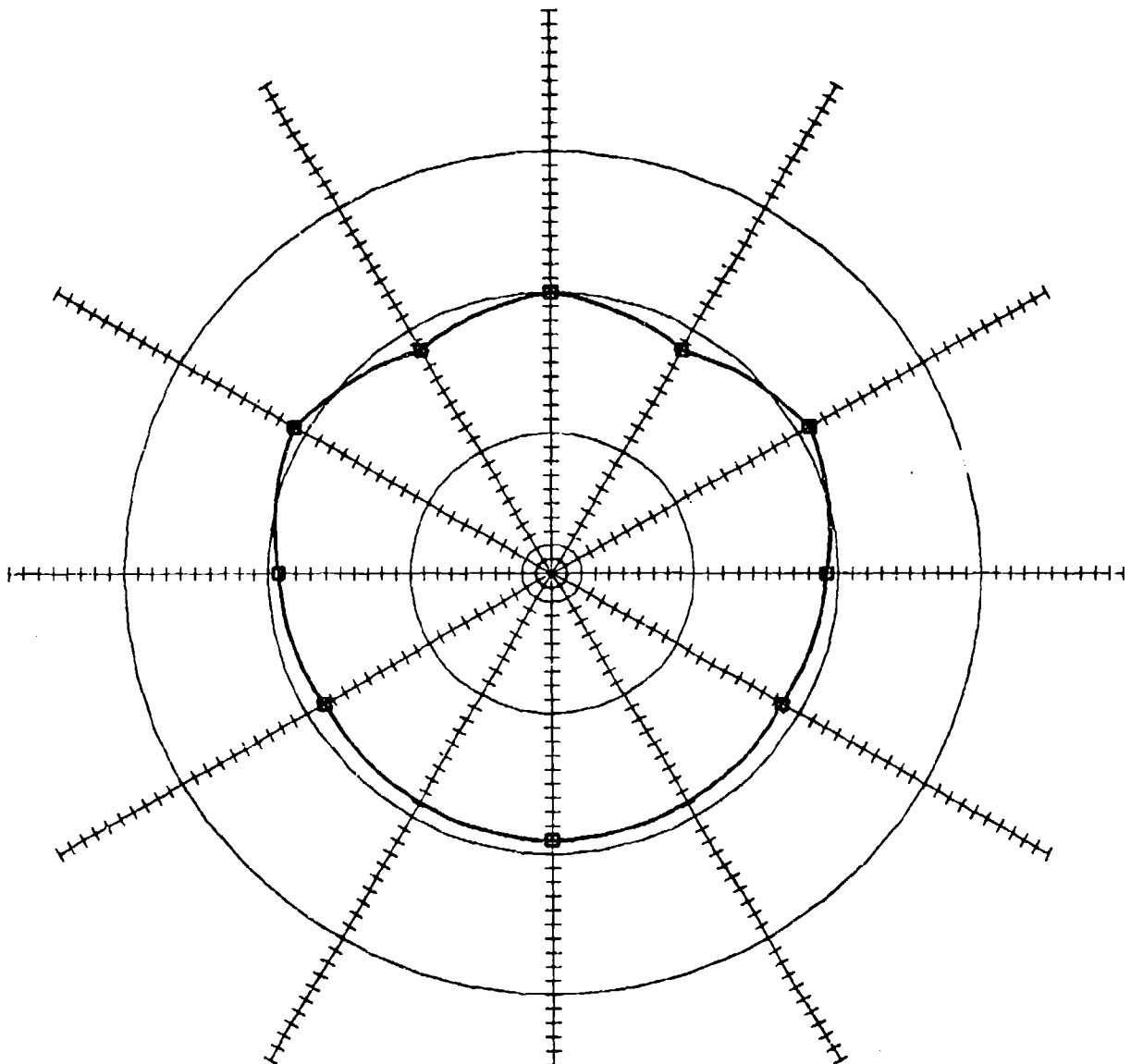

NAME 155 MM HOWITZER  
 ELEVATION 348  
 CHARGE SIZE 5 WHITE BAGS

M109A1

CHANNEL	ENERGY	DIFFERENCE FROM REAR	ANGLE	DIFFERENCE FROM REAR	DIFFERENCE FROM C4
1	110.49	1.24	0°	0.00	-8.51
2	110.31	1.30	30°	-0.69	-9.21
3	108.96	0.00	60°	-1.39	-9.91
4	110.63	1.63	90°	-0.80	-9.32
5	106.56	-2.74	120°	0.86	-7.65
6	100.43	-3.22	150°	-1.64	-10.16
7	103.77	0.14	180°	0.00	-8.51
8	103.18	-1.09	210°	-1.64	-10.16
9	0.00	-2.59	240°	0.86	-7.65
10	103.29	-0.04	270°	-0.80	-9.32
11	103.38	-0.05	300°	-1.39	-9.91
12	103.72	0.30	330°	-0.69	-9.21
13	102.12	-1.21			
14	103.34	0.00			
15	101.32	-2.07			
16	102.82	-1.55			
			<b>AVERAGE</b>	<b>-0.69</b>	<b>-9.20</b>

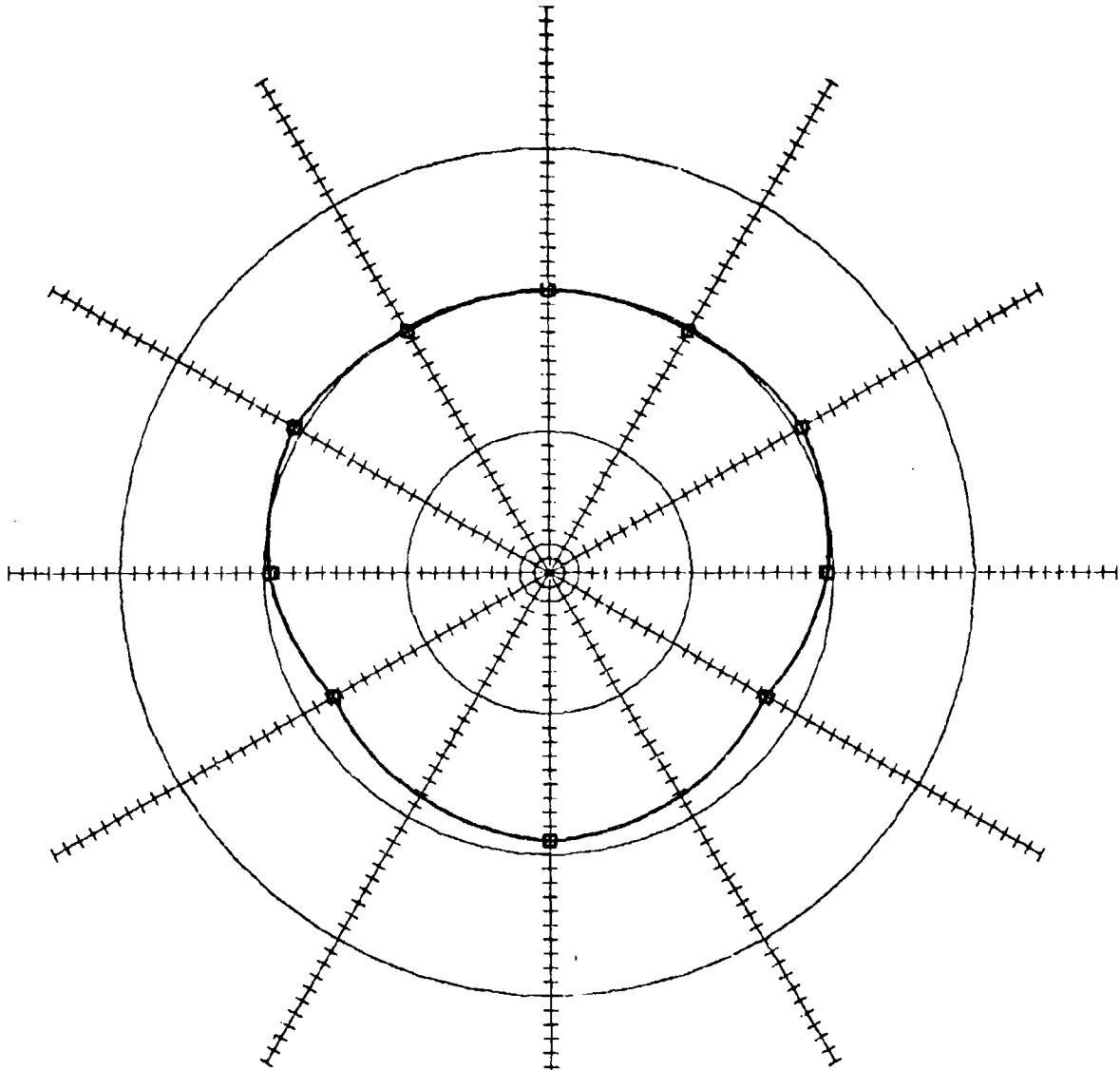

NAME 155 MM HOWITZER  
 ELEVATION 185  
 CHARGE SIZE 7 WHITE BAGS

M109A1

CHANNEL	ENERGY	DIFFERENCE FROM REAR	ANGLE	DIFFERENCE FROM REAR	DIFFERENCE FROM C4
1	112.02	-2.62	0°	0.00	-3.68
2	114.39	-0.28	30°	-1.23	-4.92
3	114.57	0.00	60°	-2.46	-6.15
4	115.39	0.00	90°	-0.40	-4.09
5	112.73	-1.92	120°	0.56	-3.11
6	106.53	-1.55	150°	-0.25	-3.94
7	110.72	2.39	180°	0.00	-3.68
8	107.29	-1.28	210°	-0.25	-3.94
9	0.00	-2.59	240°	0.56	-3.11
10	104.53	-3.76	270°	-0.40	-4.09
11	108.76	0.55	300°	-2.46	-6.15
12	107.43	-0.63	330°	-1.23	-4.92
13	107.14	-1.22			
14	108.02	0.00			
15	109.00	0.71			
16	107.20	-1.36			
			AVERAGE	-0.68	-4.36

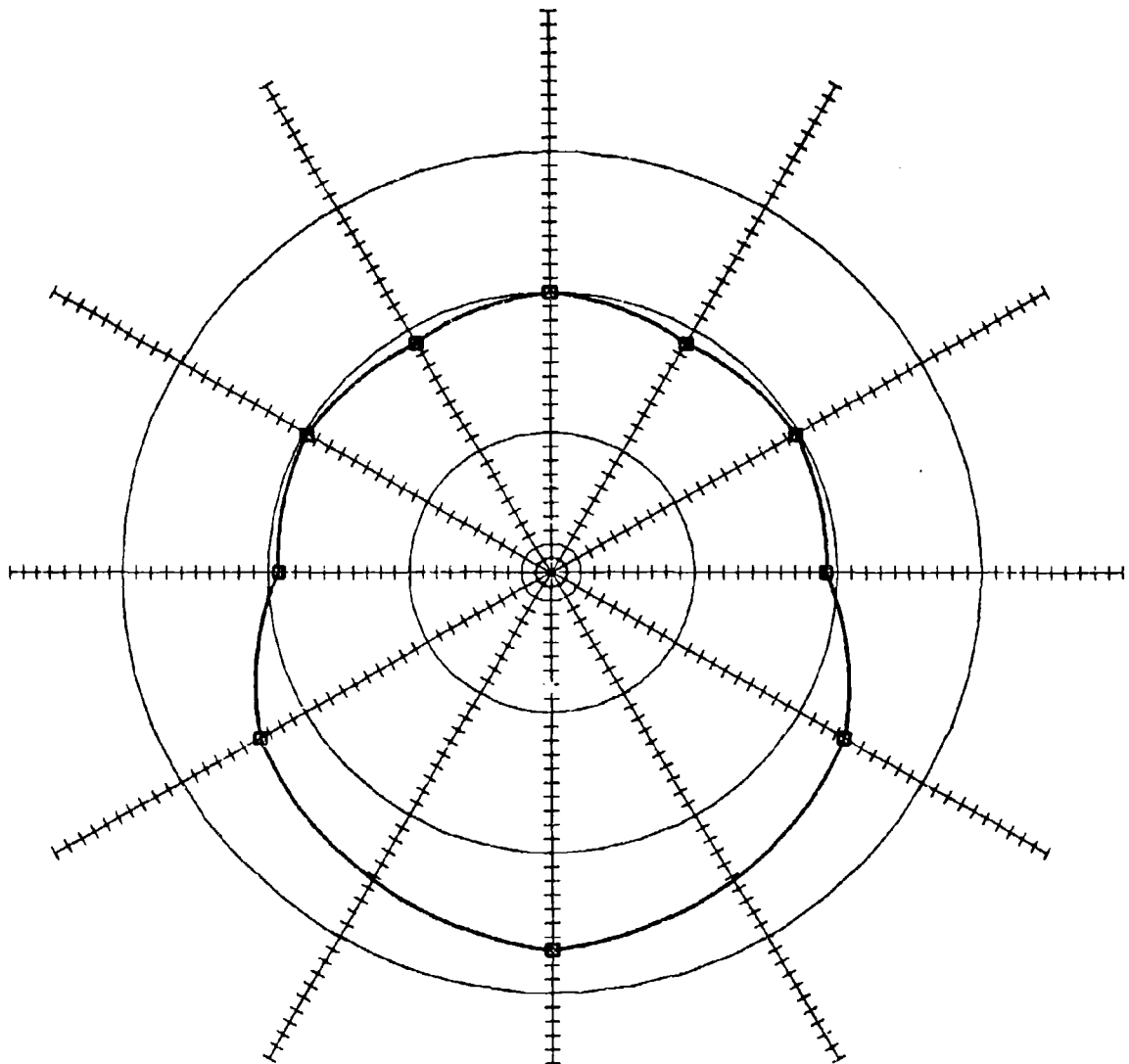

NAME 8 INCH HOWITZER  
 ELEVATION 100  
 CHARGE SIZE S WHITE BAGS

M110

CHANNEL	ENERGY	DIFFERENCE FROM REAR	ANGLE	DIFFERENCE FROM REAR	DIFFERENCE FROM C4
1	121.36	2.79	0°	6.88	5.90
2	118.60	-0.02	30°	5.28	4.30
3	118.59	0.00	60°	3.68	2.69
4	118.03	-0.56	90°	-0.78	-1.77
5	123.44	4.53	120°	-0.28	-1.27
6	117.78	4.48	150°	-1.11	-2.10
7	111.93	-1.10	180°	0.00	-0.98
8	112.82	-0.09	210°	-1.11	-2.10
9	125.47	6.88	240°	-0.28	-1.27
10	115.80	2.93	270°	-0.78	-1.77
11	111.72	-1.25	300°	3.68	2.69
12	113.88	0.56	330°	5.28	4.30
13	111.19	-1.84			
14	112.87	0.00			
15	112.65	-0.37			
16	112.67	-0.32			
			AVERAGE	2.71	1.72

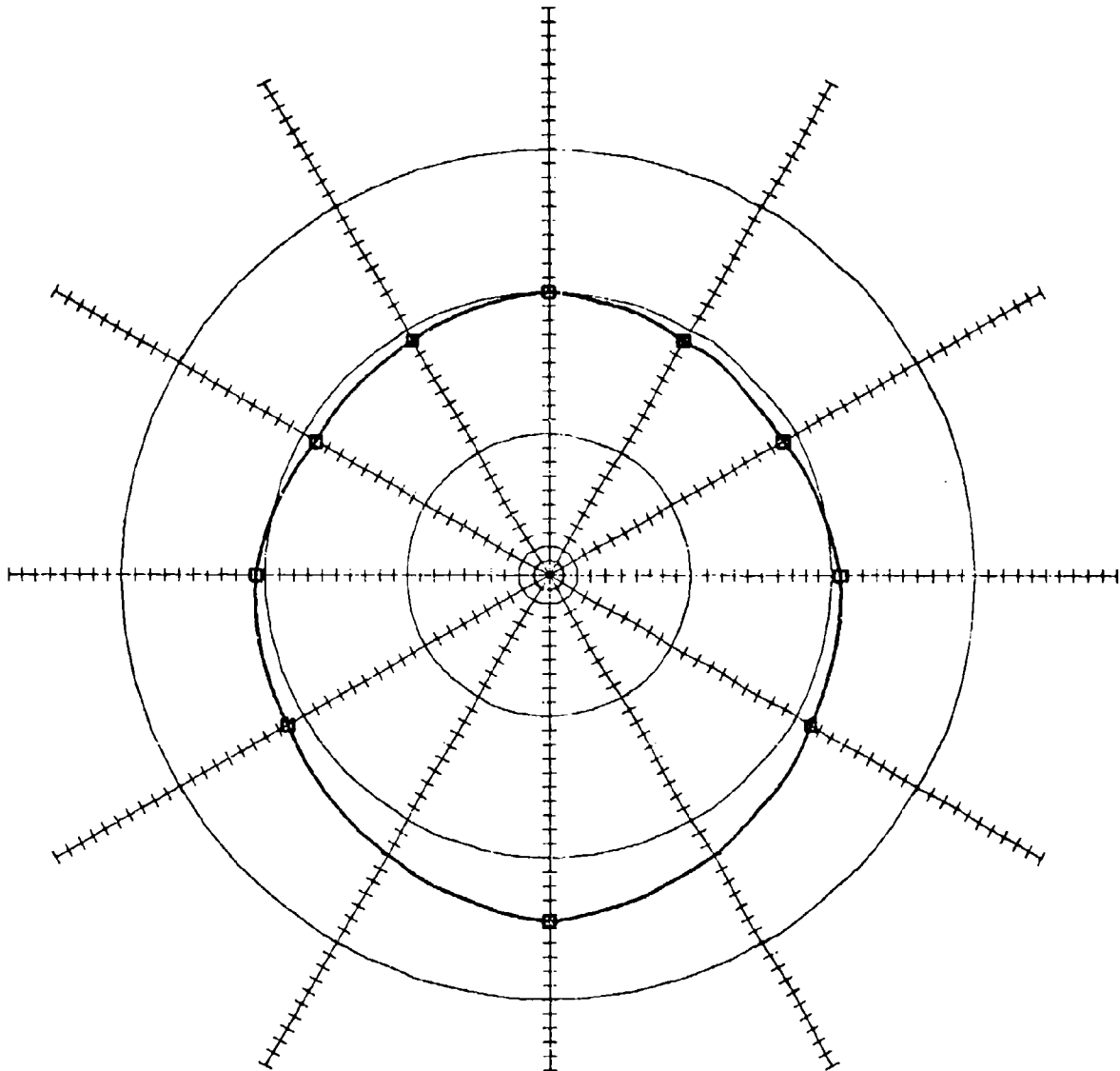

NAME 8 INCH HOWITZER  
 ELEVATION 290  
 CHARGE SIZE S WHITE BAGS

M110

CHANNEL	ENERGY	DIFFERENCE FROM REAR	ANGLE	DIFFERENCE FROM REAR	DIFFERENCE FROM C4
1	119.90	0.97	0°	4.45	4.06
2	118.00	-1.07	30°	2.85	2.46
3	119.02	0.00	60°	1.25	0.85
4	118.58	-0.65	90°	0.59	0.19
5	120.14	1.22	120°	-1.07	-1.46
6	113.76	0.25	150°	-0.85	-1.25
7	113.50	0.32	180°	0.00	-0.39
8	115.44	2.32	210°	-0.85	-1.25
9	123.47	4.45	240°	-1.07	-1.46
10	115.21	2.31	270°	0.59	0.19
11	111.66	-1.21	300°	1.25	0.85
12	110.32	-2.51	330°	2.85	2.46
13	111.55	-1.21			
14	112.79	0.00			
15	112.72	-0.49			
16	115.55	2.40			
			AVERAGE	1.20	0.80

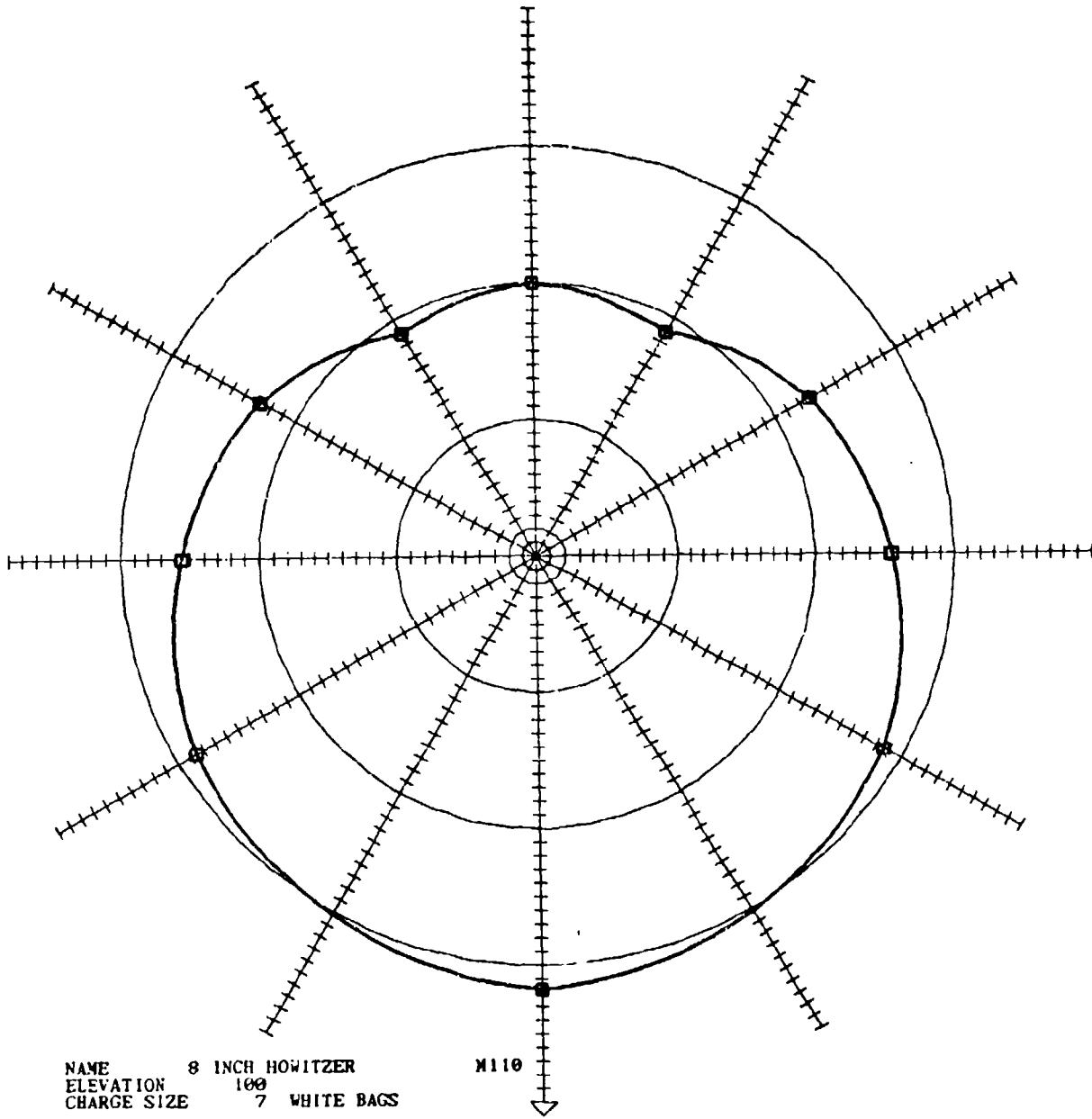

NAME 8 INCH HOWITZER  
 ELEVATION 100  
 CHARGE SIZE 7 WHITE BAGS

M110

CHANNEL	ENERGY	DIFFERENCE FROM REAR	ANGLE	DIFFERENCE FROM REAR	DIFFERENCE FROM C4
1	119.93	8.00	0°	11.75	3.56
2	114.03	2.20	30°	10.15	1.96
3	111.62	0.00	60°	8.55	0.36
4	114.26	2.00	90°	5.56	-2.62
5	119.36	7.65	120°	2.78	-5.40
6	113.27	8.36	150°	-1.15	-9.34
7	108.53	3.20	180°	0.00	-8.18
8	109.98	4.96	210°	-1.15	-9.34
9	123.25	11.75	240°	2.78	-5.40
10	113.90	9.42	270°	5.56	-2.62
11	112.33	7.96	300°	8.55	0.36
12	107.53	3.08	330°	10.15	1.96
13	103.30	-1.15			
14	104.55	0.00			
15	104.24	-1.16			
16	108.80	3.16			
			AVERAGE	7.23	-0.95



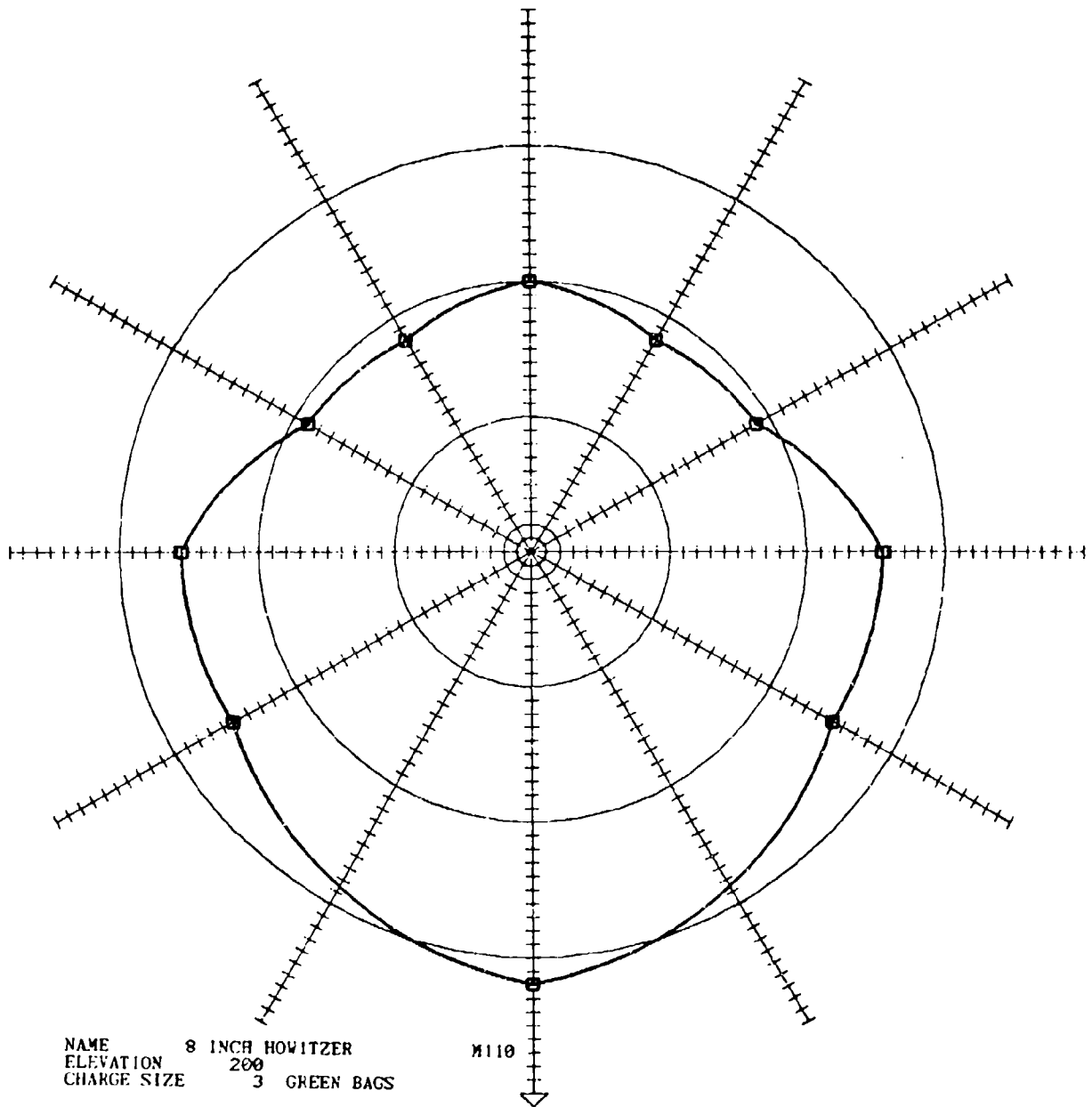

NAME 8 INCH HOWITZER  
 ELEVATION 200  
 CHARGE SIZE 3 GREEN BAGS

CHANNEL	ENERGY	DIFFERENCE FROM REAR	ANGLE	DIFFERENCE FROM REAR	DIFFERENCE FROM C4
1	111.56	6.40	0°	11.89	-2.83
2	107.02	2.33	30°	8.54	-6.18
3	104.74	0.00	60°	5.19	-9.53
4	101.78	-3.43	90°	5.42	-9.30
5	108.21	4.03	120°	-1.09	-15.82
6	100.32	2.22	150°	-1.92	-16.66
7	92.73	-5.07	180°	0.00	-14.73
8	99.22	1.27	210°	-1.92	-16.66
9	116.81	11.89	240°	-1.09	-15.82
10	104.64	7.54	270°	5.42	-9.30
11	103.03	5.80	300°	5.19	-9.53
12	98.73	1.44	330°	8.54	-6.18
13	94.69	-2.53			
14	97.76	0.00			
15	96.17	-1.31			
16	105.35	4.80			
			AVERAGE	5.94	-8.78

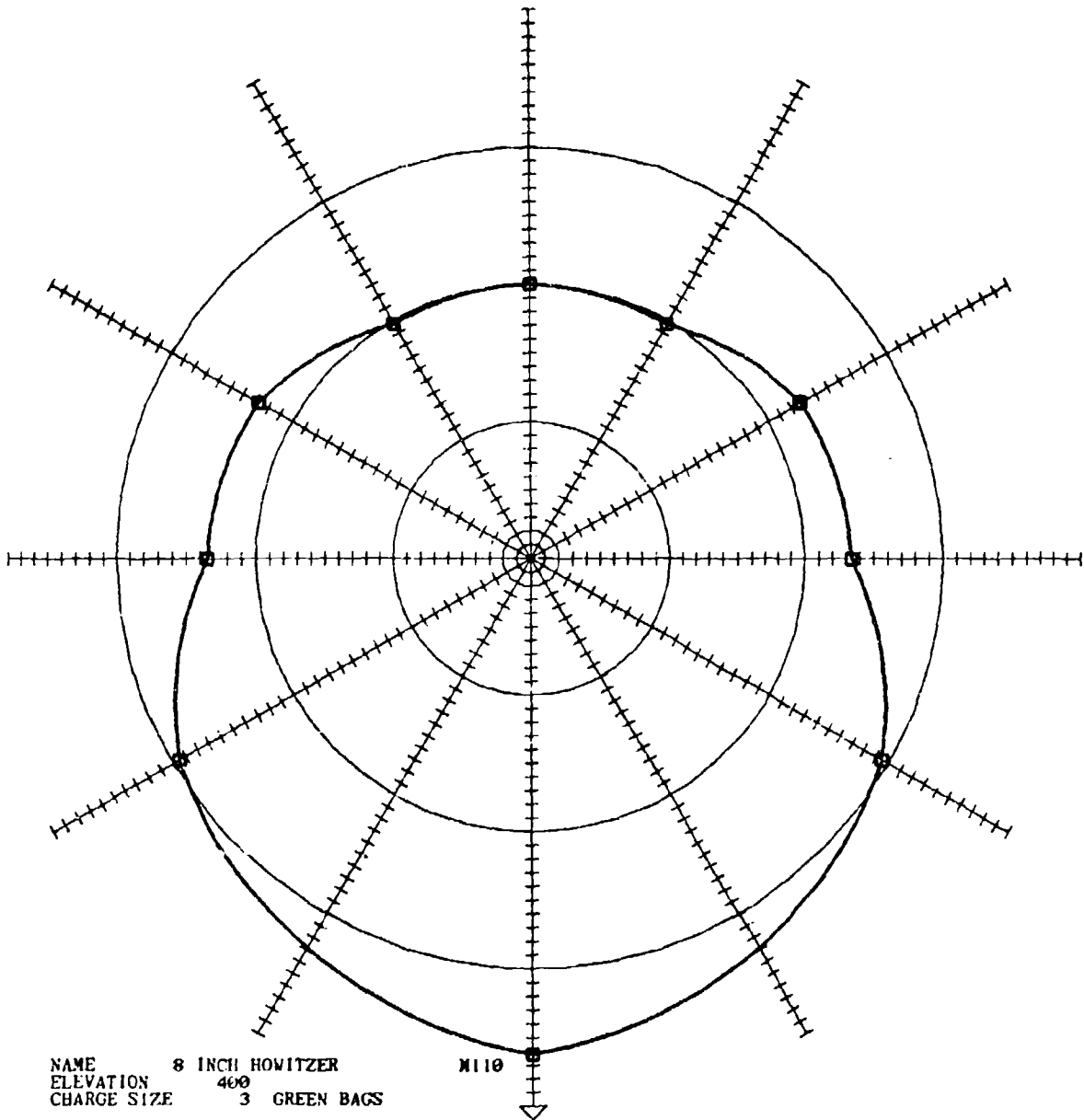

NAME 8 INCH HOWITZER  
 ELEVATION 400  
 CHARGE SIZE 3 GREEN BAGS

M110

CHANNEL	ENERGY	DIFFERENCE FROM REAR	ANGLE	DIFFERENCE FROM REAR	DIFFERENCE FROM C4
1	110.71	8.42	0°	16.20	-1.78
2	106.33	4.02	30°	12.84	-5.14
3	102.44	0.00	60°	9.48	-8.50
4	104.43	1.94	96°	3.37	-14.60
5	111.05	7.95	120°	2.76	-15.22
6	106.64	10.97	150°	-0.27	-18.26
7	97.25	1.66	180°	0.00	-17.98
8	97.72	1.77	210°	-0.27	-18.26
9	118.57	16.20	240°	2.76	-15.22
10	105.98	10.35	270°	3.37	-14.60
11	101.56	5.87	300°	9.48	-8.50
12	98.73	3.06	330°	12.84	-5.14
13	96.99	1.30			
14	95.63	0.00			
15	93.92	-1.85			
16	96.14	0.25			
			AVERAGE	9.57	-8.40

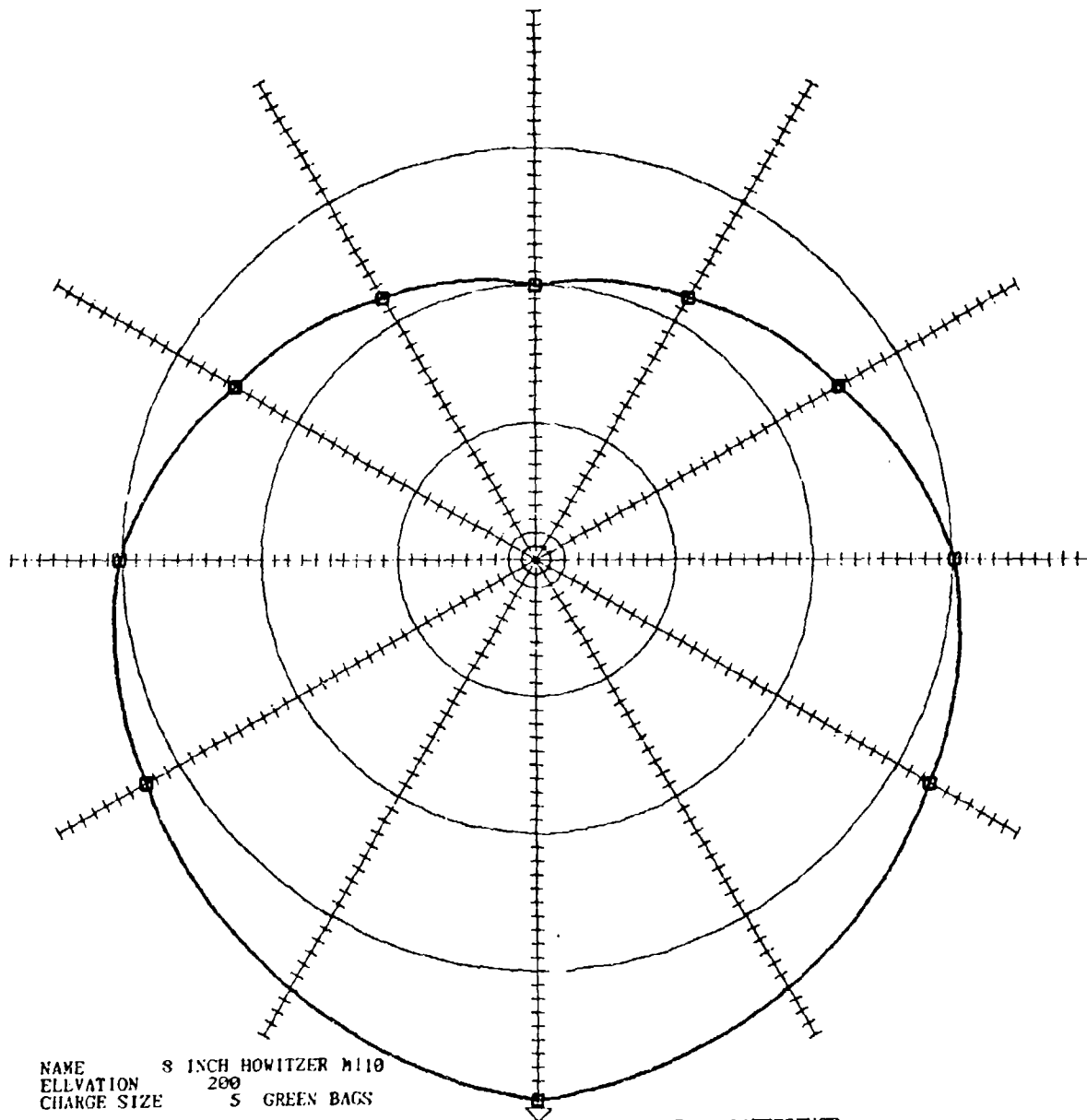

NAME 3 INCH HOWITZER M110  
 ELEVATION 200  
 CHARGE SIZE 5 GREEN BAGS

CHANNEL	ENERGY	DIFFERENCE FROM REAR	ANGLE	DIFFERENCE FROM REAR	DIFFERENCE FROM C4
1	116.87	12.18	0°	19.41	2.47
2	108.85	4.18	30°	16.05	-0.89
3	104.73	0.00	60°	12.69	-4.24
4	103.08	4.44	90°	10.13	-6.80
5	115.42	10.72	120°	5.24	-11.69
6	108.43	12.64	150°	2.00	-14.93
7	101.47	5.44	180°	0.00	-16.94
8	106.41	10.18	210°	2.00	-14.93
9	124.14	19.41	240°	5.24	-11.69
10	111.15	15.24	270°	10.13	-6.80
11	106.42	10.28	300°	12.69	-4.24
12	102.63	6.90	330°	16.05	-0.89
13	98.60	3.46			
14	95.80	0.00			
15	97.00	1.12			
16	106.34	9.98			
			AVERAGE	12.95	-3.99

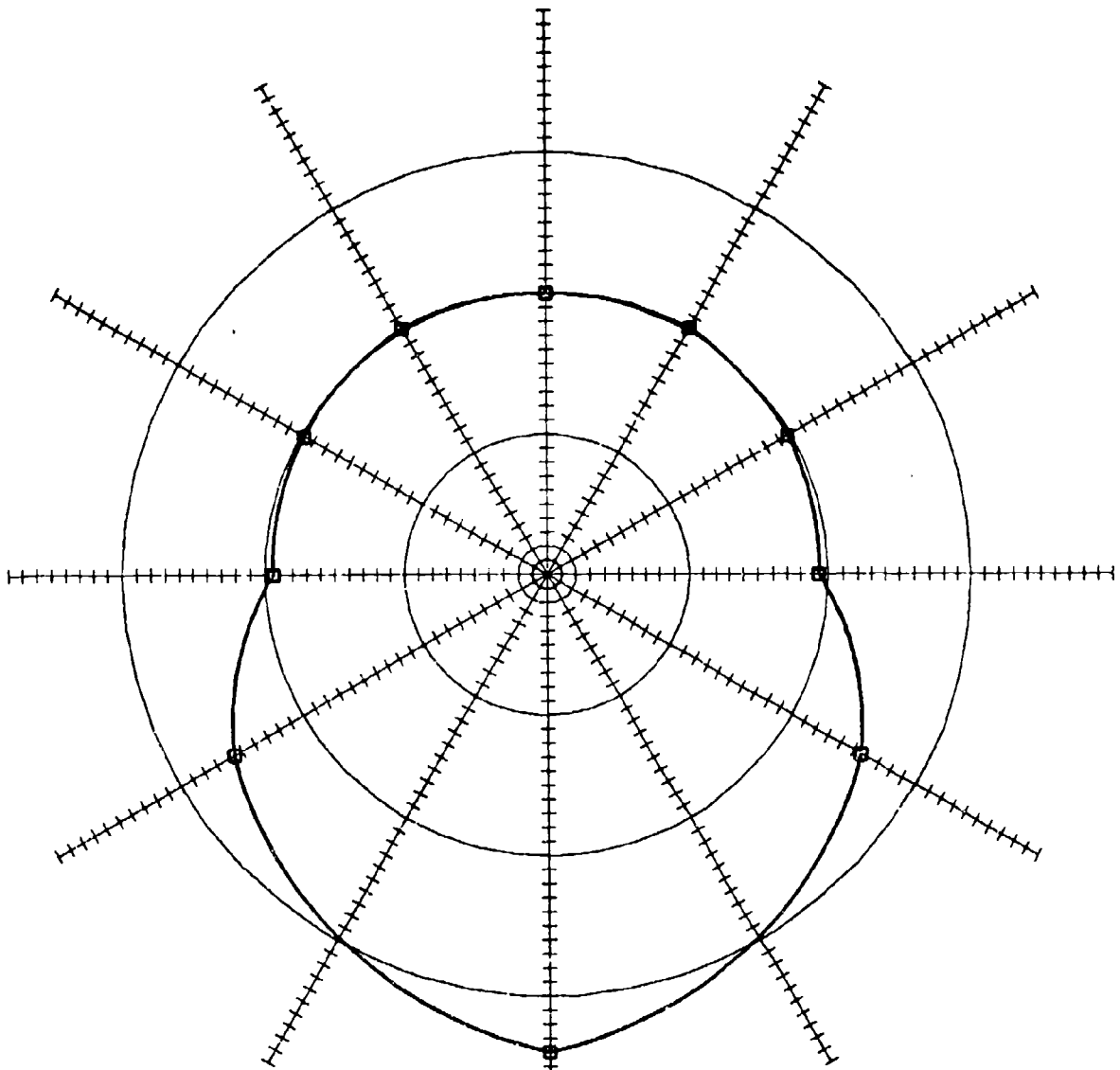

NAME 8 INCH SELF PROPELLED  
 ELEVATION 215  
 CHARGE SIZE 3 GREEN BAGS

M110A

CHANNEL	ENERGY	DIFFERENCE FROM REAR	ANGLE	DIFFERENCE FROM REAR	DIFFERENCE FROM C4
1	109.58	7.03	0°	13.93	-3.41
2	104.35	1.69	30°	9.77	-7.58
3	102.56	0.00	60°	5.60	-11.75
4	99.77	-3.02	90°	-0.62	-17.98
5	106.15	3.31	120°	-0.26	-17.62
6	97.36	3.28	150°	0.20	-17.16
7	92.48	-2.31	180°	0.00	-17.36
8	91.03	-3.13	210°	0.20	-17.16
9	116.72	13.93	240°	-0.26	-17.62
10	102.89	8.78	270°	-0.62	-17.98
11	97.77	4.30	300°	5.60	-11.75
12	97.51	3.32	330°	9.77	-7.58
13	94.72	0.60			
14	94.23	0.00			
15	94.04	-0.19			
16	92.01	-2.26			
			AVERAGE	6.82	-10.53

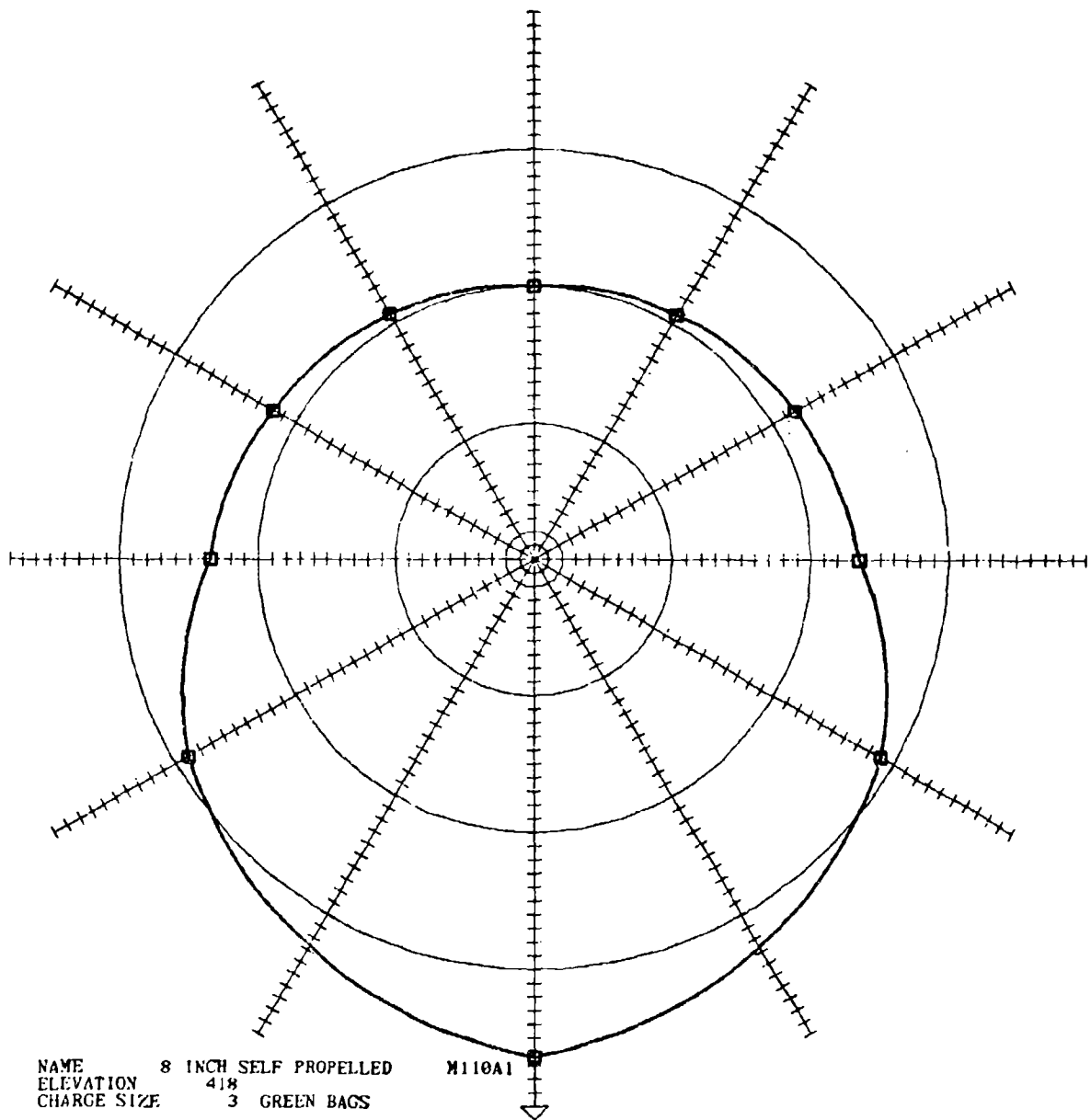

NAME 8 INCH SELF PROPELLED  
 ELEVATION 418  
 CHARGE SIZE 3 GREEN BAGS

M110A1

CHANNEL	ENERGY	DIFFERENCE FROM REAR	ANGLE	DIFFERENCE FROM REAR	DIFFERENCE FROM C4
1	109.39	9.40	0°	16.36	-3.70
2	102.61	2.56	30°	12.64	-7.42
3	100.18	0.00	60°	8.92	-11.14
4	100.98	0.58	90°	3.50	-16.57
5	108.12	7.30	120°	1.78	-18.28
6	102.60	8.47	150°	0.70	-19.36
7	97.80	2.46	180°	0.00	-20.07
8	95.54	2.62	210°	0.70	-19.36
9	116.44	16.36	240°	1.78	-18.28
10	102.77	10.42	270°	3.50	-16.57
11	96.77	4.30	300°	8.92	-11.14
12	94.35	1.66	330°	12.64	7.42
13	93.24	0.00			
14	92.47	0.00			
15	94.11	-0.19			
16	95.51	2.70			
			AVERAGE	9.43	-10.58

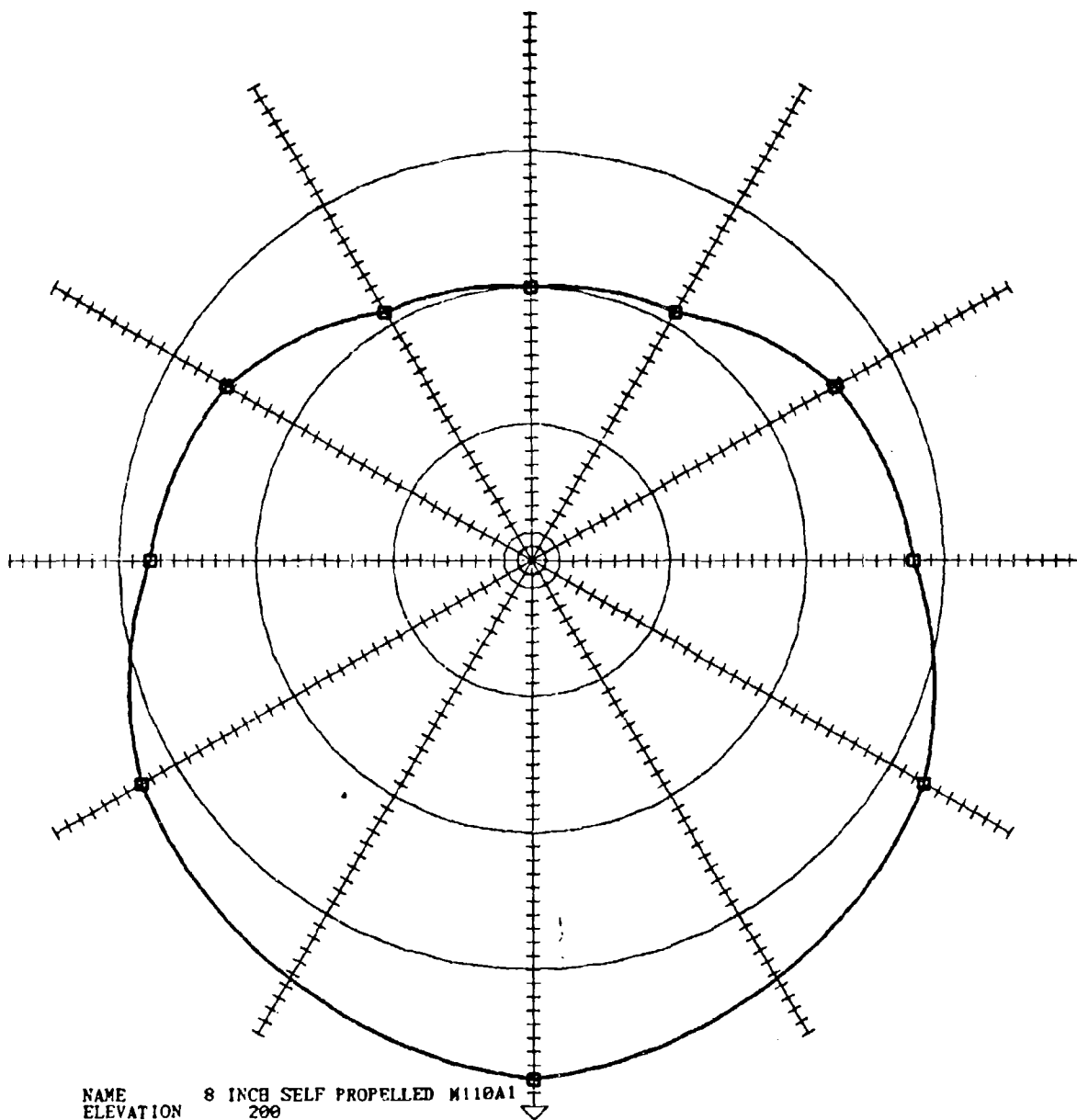

NAME 8 INCH SELF PROPELLED M118A1  
 ELEVATION 200  
 CHARGE SIZE 5 GREEN BAGS

CHANNEL	ENERGY	DIFFERENCE FROM REAR	ANGLE	DIFFERENCE FROM REAR	DIFFERENCE FROM C4
1	113.71	13.49	0°	17.99	-0.57
2	105.43	5.23	30°	15.38	-3.31
3	100.31	0.00	60°	12.77	-6.06
4	105.33	5.09	90°	7.71	-11.12
5	112.68	12.45	120°	5.50	-13.34
6	105.72	12.08	150°	0.98	-17.86
7	100.76	6.66	180°	0.00	-18.84
8	100.48	6.76	210°	0.98	-17.86
9	118.30	17.99	240°	5.50	-13.34
10	106.81	13.06	270°	7.71	-11.12
11	104.12	11.40	300°	12.77	-6.06
12	98.71	5.01	330°	15.38	-3.31
13	95.56	1.69			
14	93.84	0.00			
15	94.66	0.17			
16	100.73	6.89			
			AVERAGE	12.05	-6.64

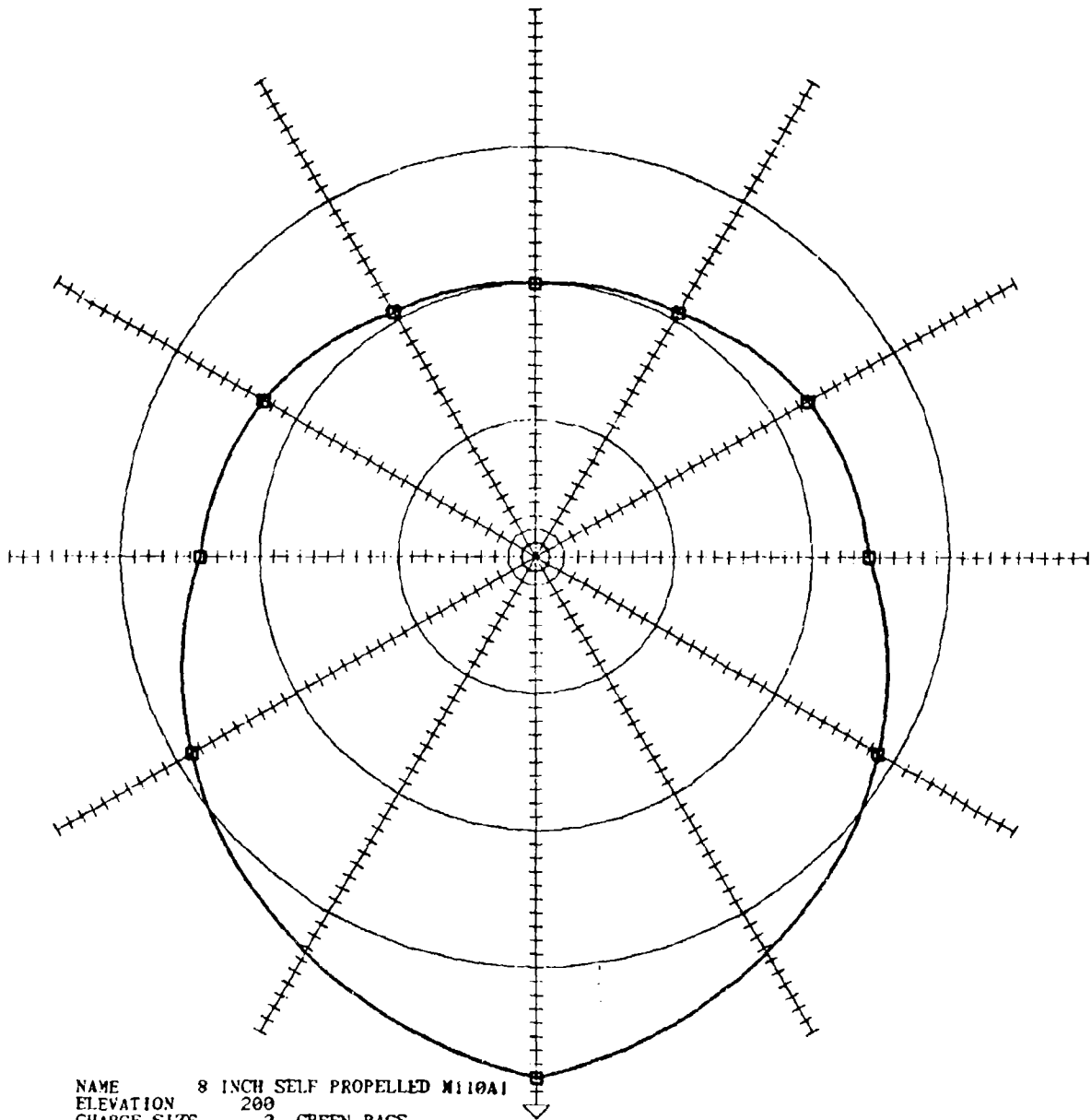

NAME 8 INCH SELF PROPELLED M110A1  
 ELEVATION 200  
 CHARGE SIZE 3 GREEN BAGS

CHANNEL	ENERGY	DIFFERENCE FROM REAR	ANGLE	DIFFERENCE FROM REAR	DIFFERENCE FROM C4
1	107.38	8.81	0°	17.99	-2.57
2	103.45	4.77	30°	13.35	-7.21
3	98.72	0.00	60°	8.70	-11.85
4	99.90	0.99	90°	4.20	-16.36
5	105.11	6.55	120°	2.74	-17.82
6	97.93	7.39	150°	0.62	-19.94
7	92.11	1.37	180°	0.00	-20.57
8	91.65	1.44	210°	0.62	-19.94
9	116.89	17.99	240°	2.74	-17.82
10	102.62	12.05	270°	4.20	-16.36
11	96.55	6.55	300°	8.70	-11.85
12	94.01	3.83	330°	13.35	-7.21
13	92.38	2.16			
14	90.48	0.00			
15	89.37	-0.92			
16	91.86	1.85			
			AVERAGE	10.46	-10.10

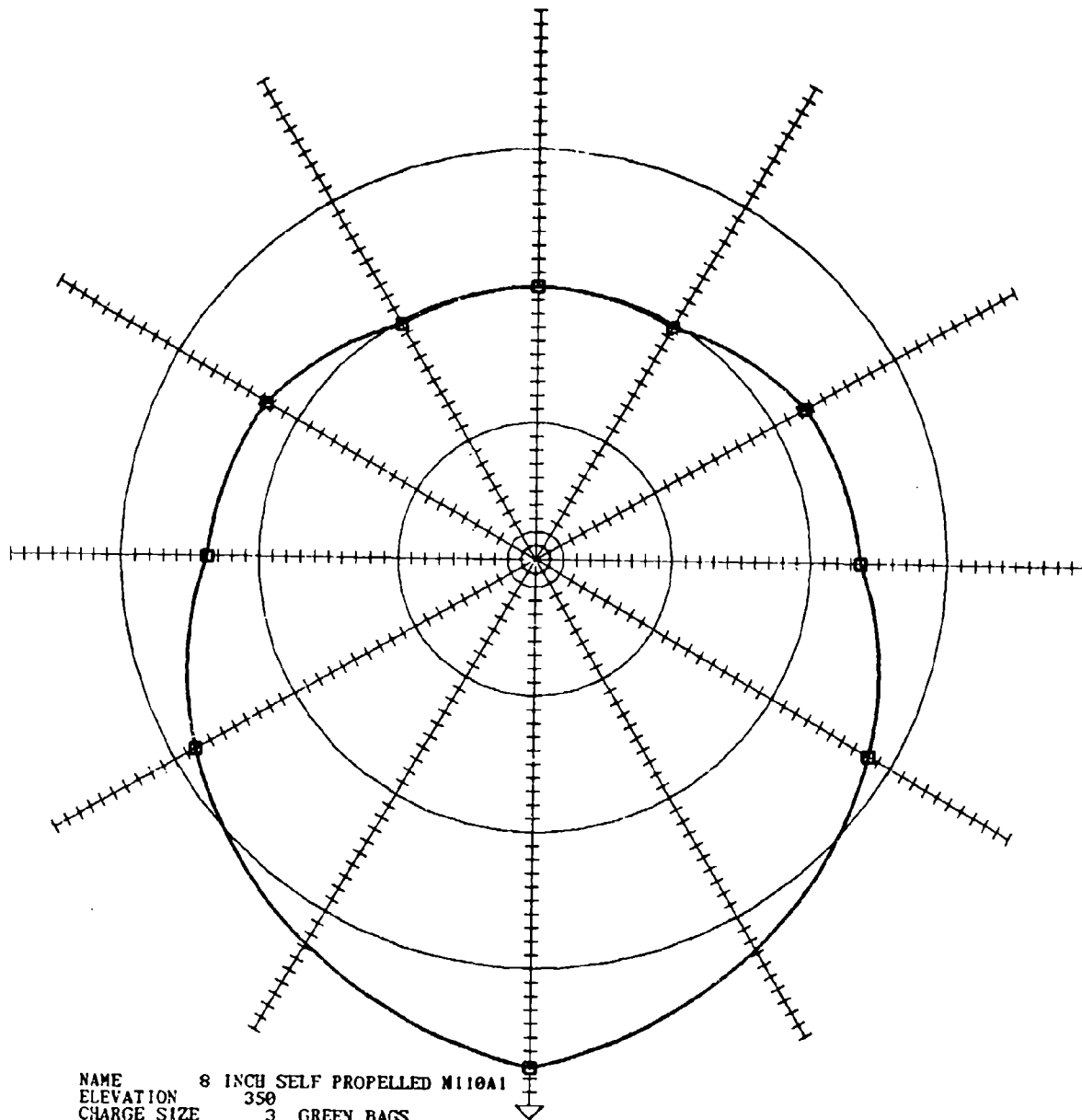

CHANNEL	ENERGY	DIFFERENCE FROM REAR	ANGLE	DIFFERENCE FROM REAR	DIFFERENCE FROM C4
1	107.52	9.39	0°	17.22	-3.16
2	103.29	5.19	30°	12.71	-7.66
3	98.21	0.00	60°	8.21	-12.17
4	99.86	1.72	90°	3.73	-16.65
5	105.22	6.64	120°	2.53	-17.85
6	99.56	6.36	150°	-0.25	-20.63
7	91.03	-0.66	180°	0.00	-20.38
8	90.89	-1.83	210°	-0.25	-20.63
9	115.41	17.22	240°	2.53	-17.85
10	101.84	10.56	270°	3.73	-16.65
11	95.44	3.73	300°	8.21	-12.17
12	94.62	3.26	330°	12.71	-7.66
13	92.56	1.53			
14	91.50	0.00			
15	89.30	-2.03			
16	93.50	1.85			
			AVERAGE	9.80	-10.58



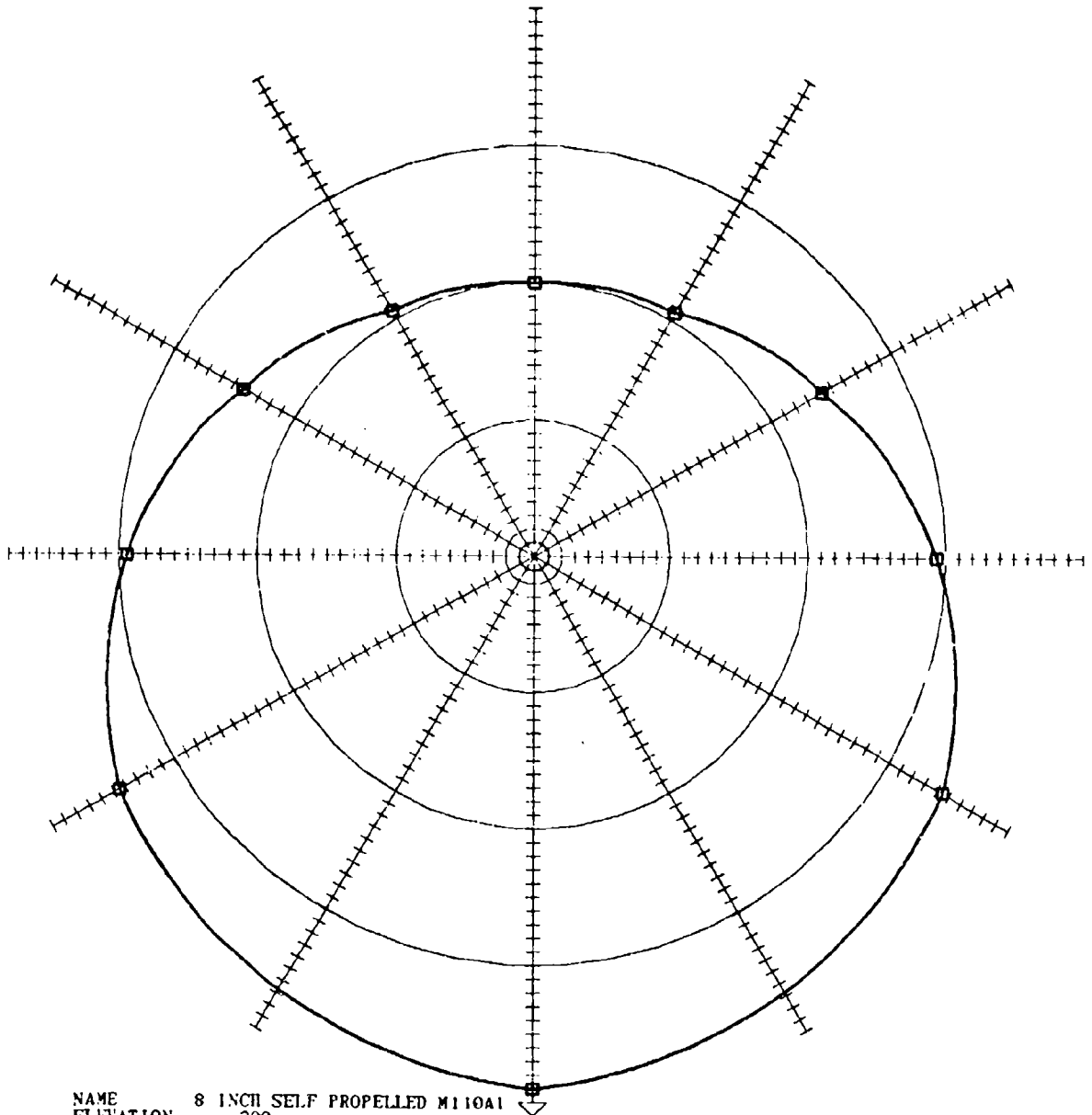

NAME 8 INCH SELF PROPELLED M110A1  
 ELEVATION 200  
 CHARGE SIZE 5 WHITE BAGS

CHANNEL	ENRGY	DIFFERENCE FROM REAR	ANGLE	DIFFERENCE FROM REAR	DIFFERENCE FROM C4
1	115.60	15.20	0°	0.00	-17.40
2	105.53	4.85	30°	7.22	-10.17
3	100.62	0.00	60°	14.45	-2.94
4	103.79	3.20	90°	9.34	-8.05
5	113.70	13.10	120°	4.23	-13.16
6	0.00	6.36	150°	0.62	-16.77
7	97.32	2.99	180°	0.00	-17.40
8	101.94	7.65	210°	0.62	-16.77
9	0.00	17.22	240°	4.23	-13.16
10	109.34	15.04	270°	9.34	-8.05
11	105.55	11.29	300°	14.45	-2.94
12	100.17	5.89	330°	7.22	-10.17
13	94.85	0.59			
14	94.26	0.00			
15	94.90	0.64			
16	101.69	7.39			
			AVERAGE	13.28	-3.79

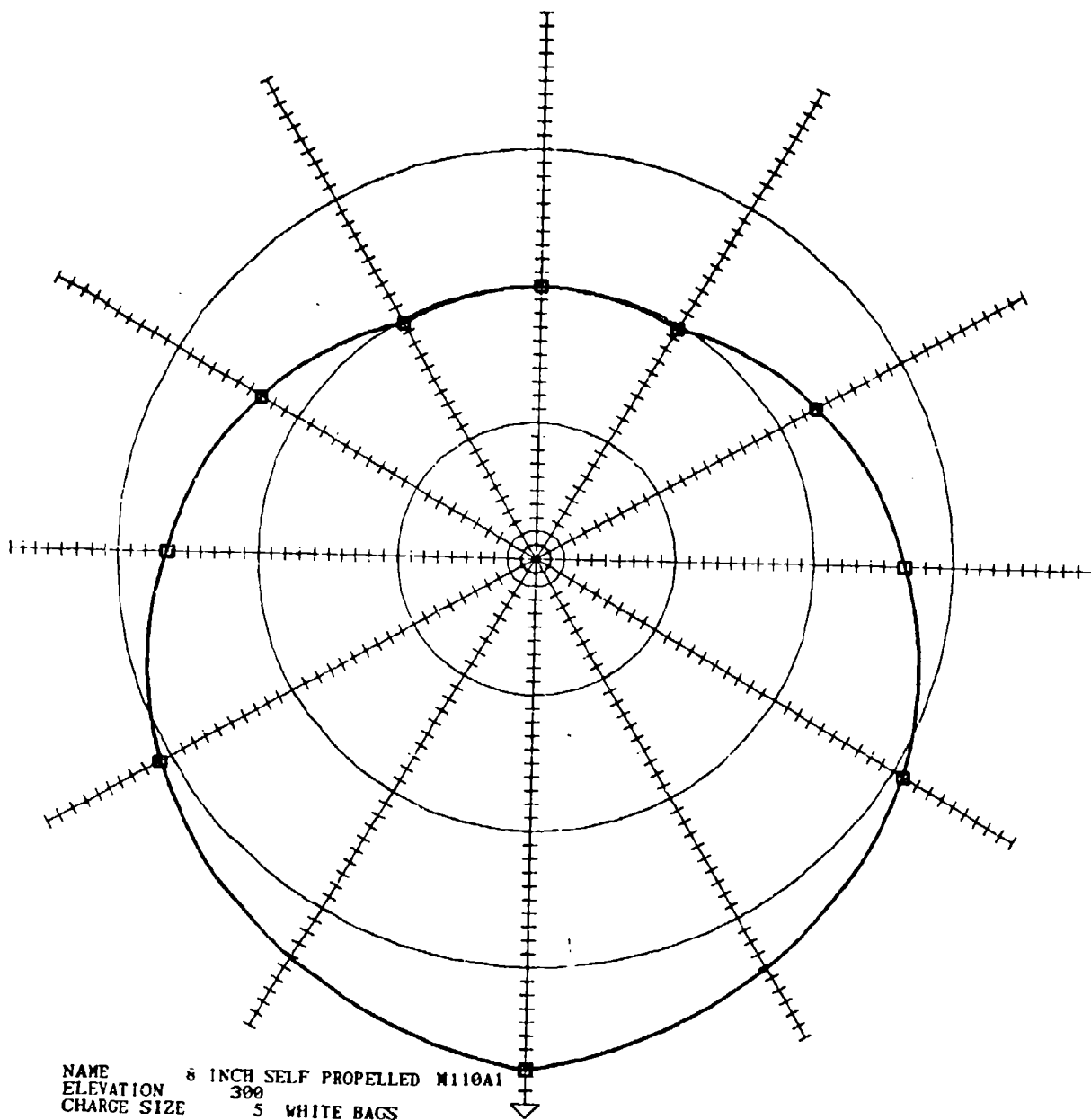

CHANNEL	ENERGY	DIFFERENCE FROM REAR	ANGLE	DIFFERENCE FROM REAR	DIFFERENCE FROM C4
1	114.95	11.43	0°	0.00	-14.68
2	107.12	3.70	30°	5.40	-9.28
3	103.54	0.00	60°	10.80	-3.88
4	106.26	2.88	90°	6.56	-8.11
5	113.56	10.16	120°	3.04	-11.64
6	0.00	6.36	150°	-0.26	-14.95
7	98.73	1.85	180°	0.00	-14.68
8	102.77	5.92	210°	-0.26	-14.95
9	0.00	17.22	240°	3.04	-11.64
10	107.88	10.82	270°	6.56	-8.11
11	104.37	7.33	300°	10.80	-3.88
12	100.53	3.74	330°	5.40	-9.28
13	96.91	0.12			
14	96.83	0.00			
15	96.00	-0.75			
16	102.61	5.79			
			AVERAGE	10.92	-3.76

APPENDIX D:

COMPOSITE DIRECTIVITY PATTERNS

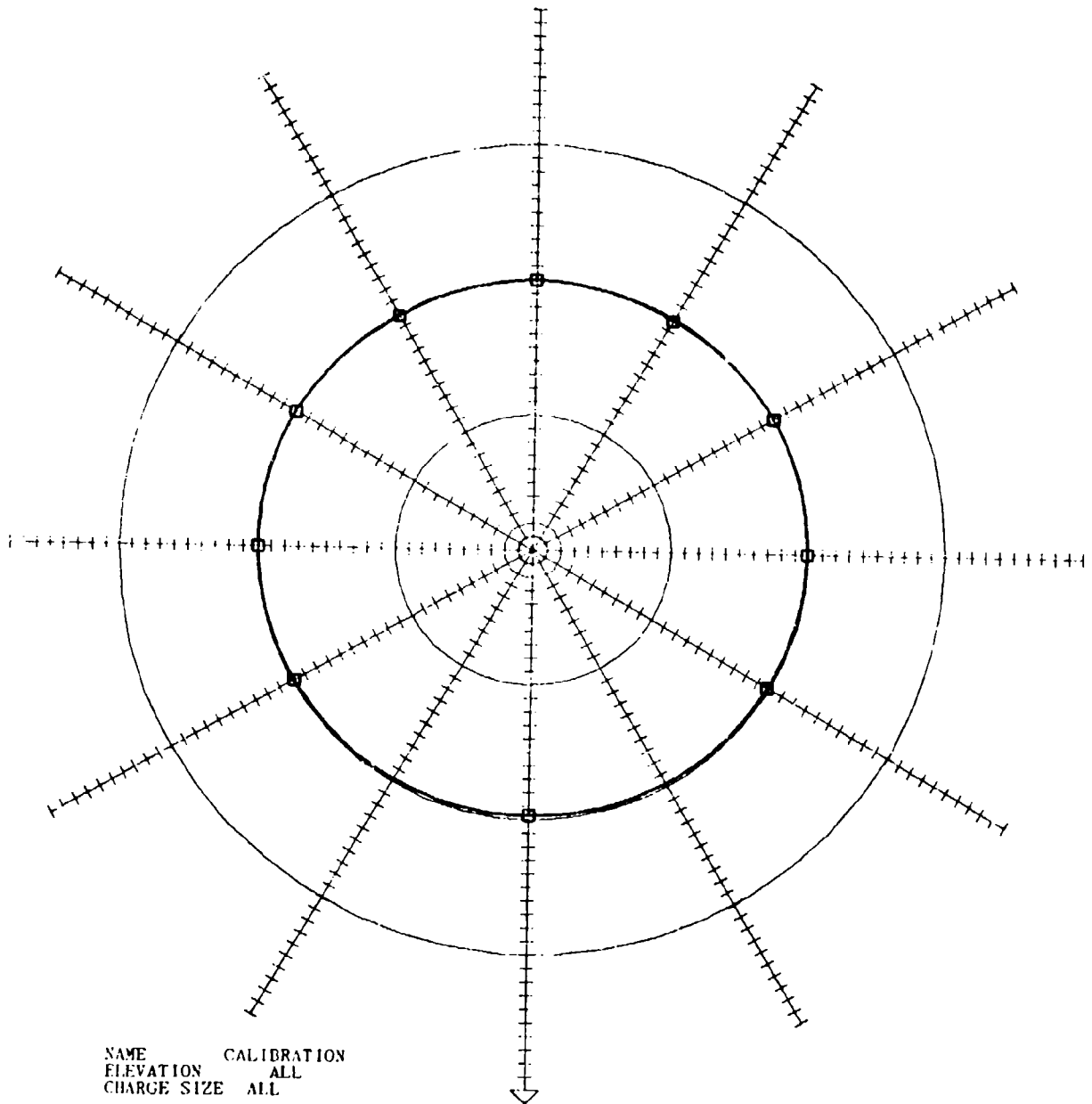

NAME CALIBRATION  
 ELEVATION ALL  
 CHARGE SIZE ALL

CHANNEL	ENERGY	DIFFERENCE FROM REAR	ANGLE	DIFFERENCE FROM REAR
1	118.62	-0.17	0°	-0.33
2	118.75	-0.08	30°	-0.27
3	118.78	0.00	60°	-0.20
4	118.93	0.08	90°	-0.09
5	119.22	-0.11	120°	-0.00
6	112.85	-0.29	150°	-0.16
7	113.16	0.10	180°	0.00
8	113.14	-0.25	210°	-0.16
9	118.56	-0.33	240°	-0.09
10	112.65	-0.25	270°	-0.09
11	112.95	0.19	300°	-0.20
12	112.58	-0.13	330°	-0.27
13	112.81	0.02		
14	113.00	0.00		
15	112.69	-0.35	AVERAGE	-0.15
16	112.77	-0.44		

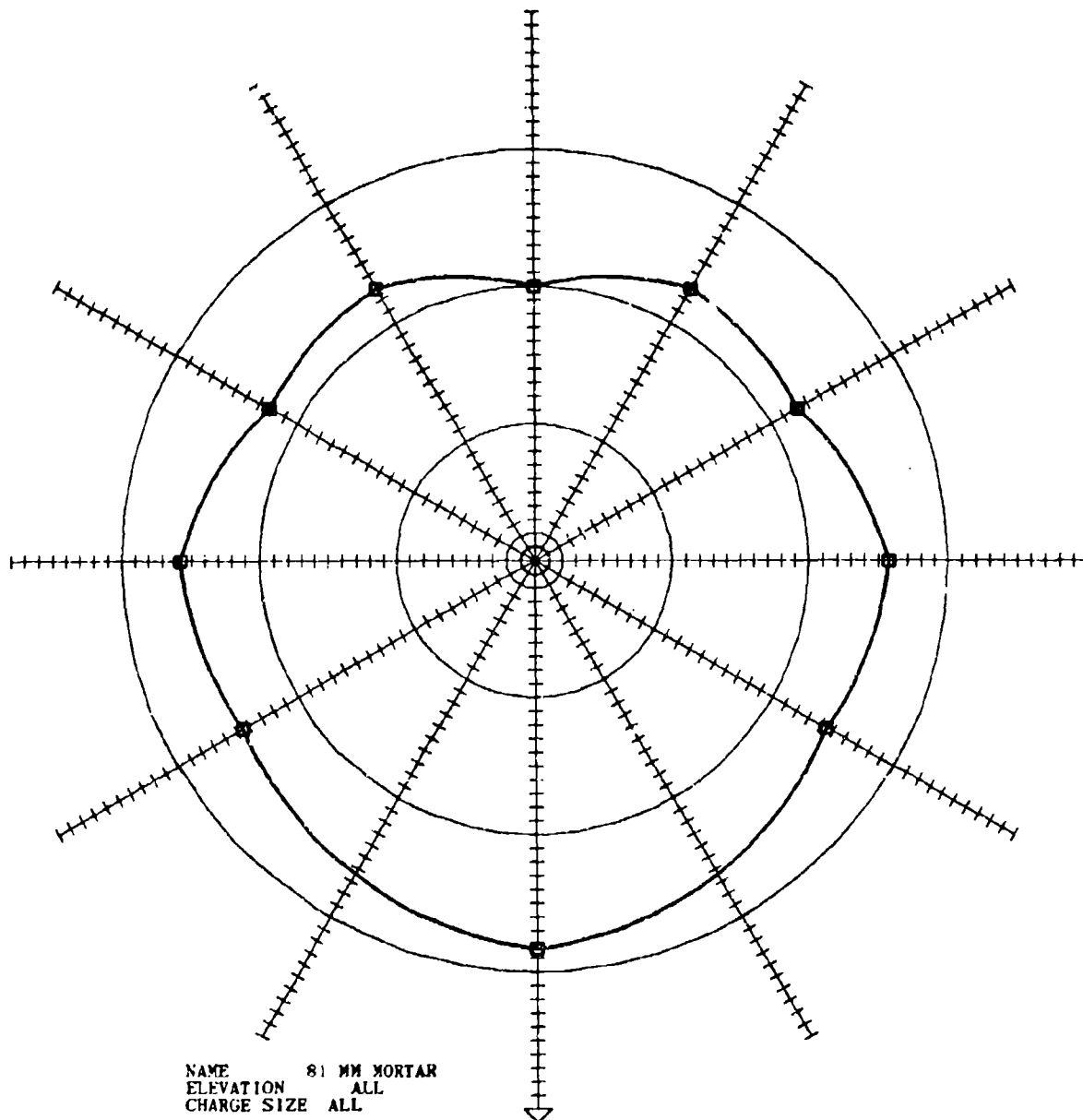

NAME 81 MM MORTAR  
 ELEVATION ALL  
 CHARGE SIZE ALL

CHANNEL	ENERGY	DIFFERENCE FROM REAR	ANGLE	DIFFERENCE FROM REAR
1	99.38	6.60	0°	8.29
2	97.15	4.05	30°	6.39
3	93.90	0.00	60°	4.48
4	94.29	0.42	90°	5.75
5	95.72	2.71	120°	2.20
6	88.19	2.25	150°	2.88
7	87.96	-0.11	180°	0.00
8	90.81	2.74	210°	2.98
9	101.12	8.29	240°	2.20
10	91.86	6.26	270°	5.75
11	91.22	5.75	300°	4.48
12	89.66	4.28	330°	6.39
13	83.83	2.82		
14	87.26	0.00		
15	92.00	3.00		
15	0.00	5.92		
			AVERAGE	4.86

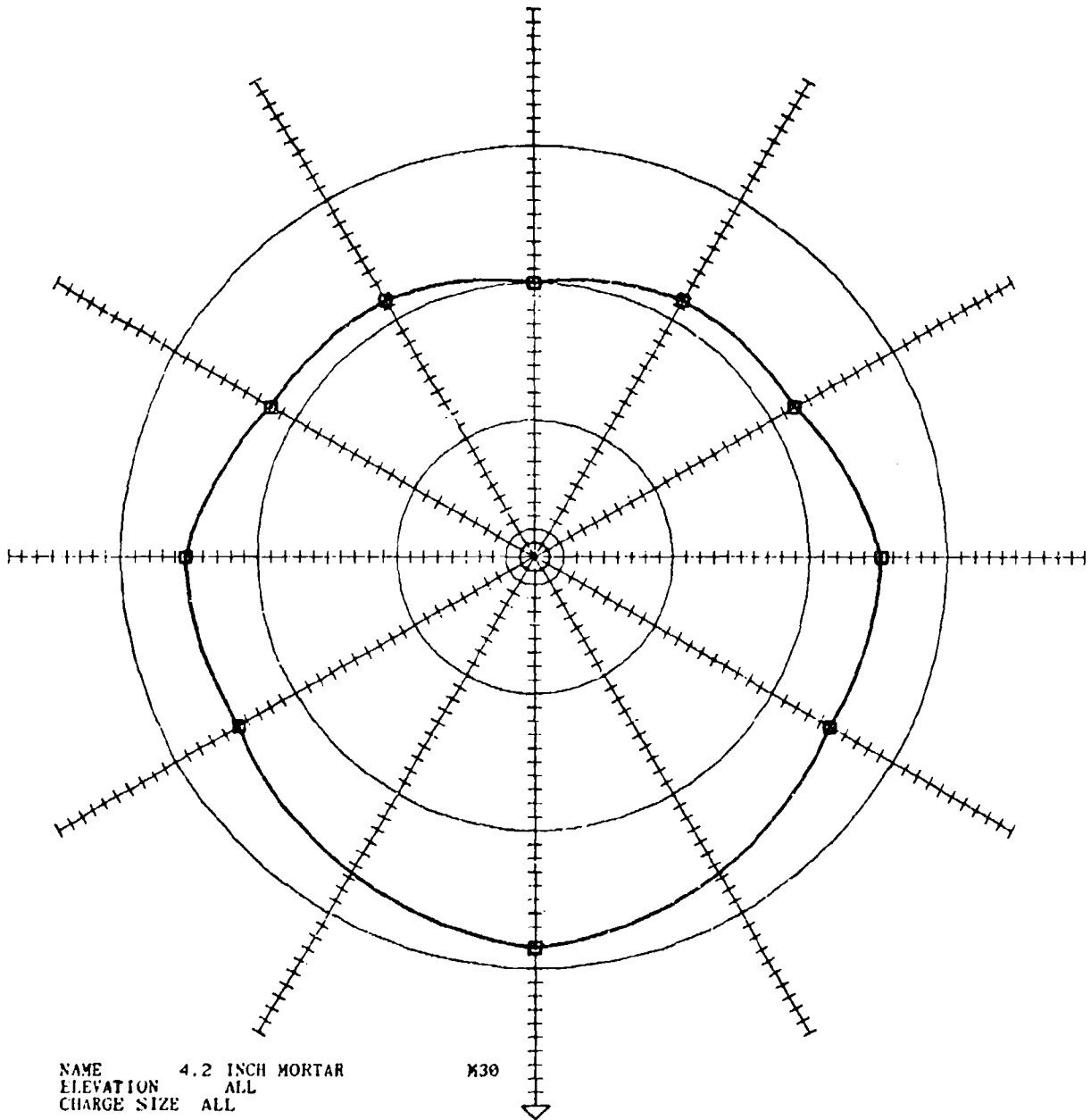

NAME 4.2 INCH MORTAR  
 ELEVATION ALL  
 CHARGE SIZE ALL

M30

CHANNEL	ENERGY	DIFFERENCE FROM REAR	ANGLE	DIFFERENCE FROM REAR
1	101.50	6.65	0°	8.15
2	98.74	3.92	30°	6.61
3	95.16	0.60	60°	4.78
4	95.74	0.73	90°	5.17
5	99.06	3.32	120°	1.89
6	92.13	2.57	150°	1.58
7	87.61	-0.88	180°	0.00
8	89.50	1.78	210°	1.58
9	103.97	8.45	240°	1.89
10	94.01	6.51	270°	5.17
11	92.47	5.17	300°	4.78
12	91.49	3.78	330°	6.61
13	89.45	1.98		
14	88.31	0.60		
15	89.24	1.16	AVERAGE	4.74
16	0.00	5.92		

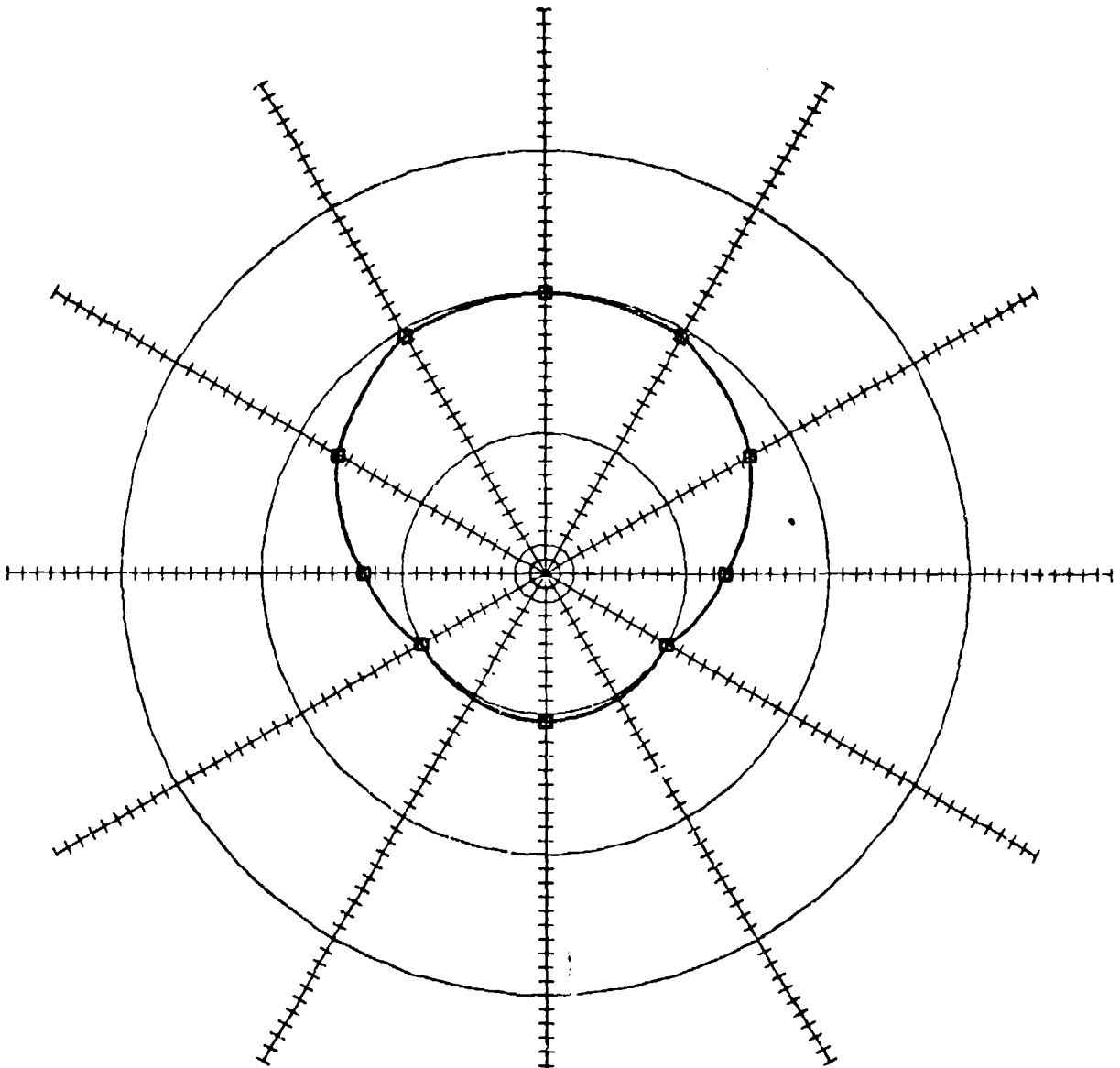

NAME 90 MM RECOILLESS RIFLE M67  
 ELEVATION ALL  
 CHARGE SIZE ALL

CHANNEL	ENERGY	DIFFERENCE FROM REAR	ANGLE	DIFFERENCE FROM REAR
1	102.66	-8.84	0°	-9.51
2	107.71	-3.71	30°	-9.75
3	111.26	0.00	60°	-9.98
4	108.44	-2.81	90°	-7.18
5	100.66	-10.59	120°	-3.17
6	94.20	-11.68	150°	-0.49
7	102.80	-3.37	180°	0.00
8	97.30	-8.45	210°	-0.49
9	102.01	-9.51	240°	-3.17
10	98.65	-8.80	270°	-7.18
11	98.97	-6.68	300°	-9.98
12	102.80	-3.00	330°	-9.75
13	105.64	0.04		
14	105.56	0.00		
15	104.57	-1.01		
16	99.33	-7.65		
			AVERAGE	-4.11

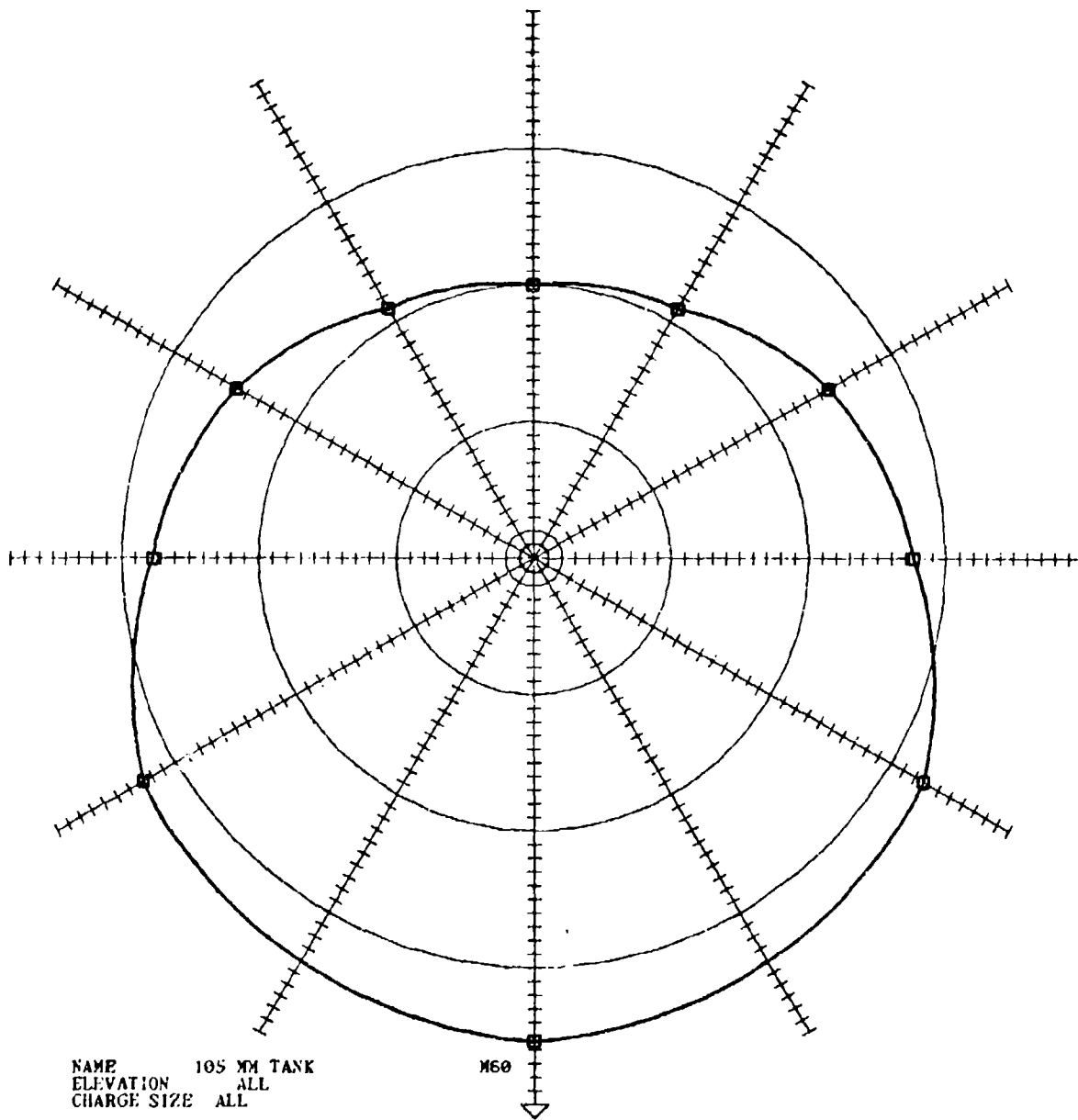

NAME 105 MM TANK  
 ELEVATION ALL  
 CHARGE SIZE ALL

M60

CHANNEL	ENERGY	DIFFERENCE FROM REAR	ANGLE	DIFFERENCE FROM REAR
1	113.04	13.09	0°	15.35
2	105.87	5.98	30°	14.04
3	100.07	0.00	60°	12.73
4	104.39	4.24	90°	7.61
5	113.07	12.68	120°	4.81
6	106.63	12.81	150°	1.09
7	97.68	3.36	180°	0.00
8	99.98	5.55	210°	1.09
9	115.47	15.35	240°	4.81
10	106.29	12.28	270°	7.61
11	103.08	9.06	300°	12.73
12	99.70	5.66	330°	14.04
13	96.08	1.97		
14	94.70	0.00		
15	94.43	0.33		
16	100.19	5.32		
			AVERAGE	10.78



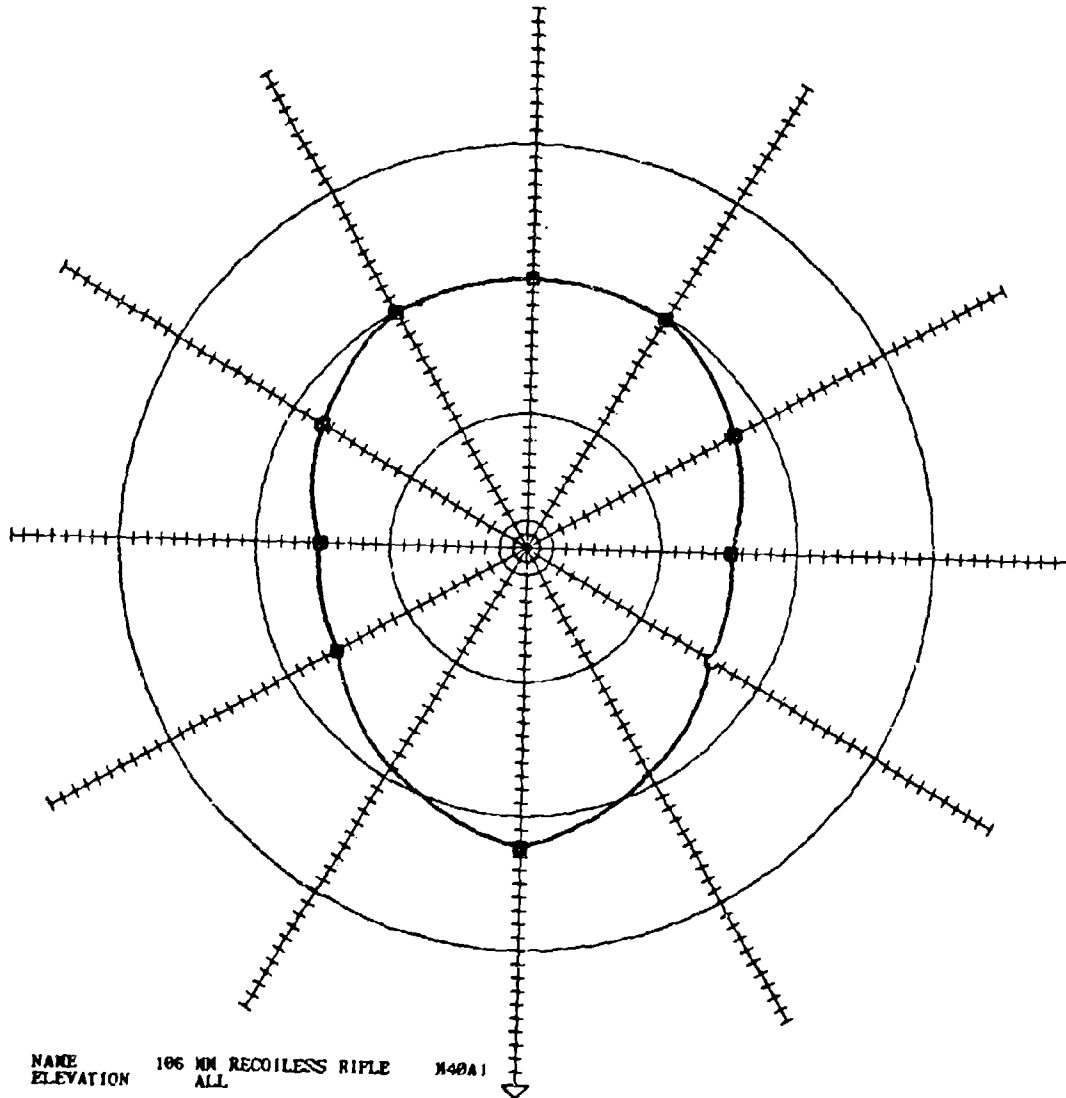

NAME 106 MM RECOILLESS RIFLE M40A1  
 ELEVATION ALL

CHANNEL	ENERGY	DIFFERENCE FROM REAR	ANGLE	DIFFERENCE FROM REAR
1	115.09	-4.06	0°	2.28
2	118.01	-3.41	30°	-0.87
3	119.17	0.00	60°	-4.02
4	117.23	-1.93	90°	-4.77
5	115.44	-3.79	120°	-2.40
6	108.98	-4.02	150°	-0.07
7	111.31	-2.40	180°	0.00
8	108.75	-4.77	210°	-0.07
9	120.73	2.60	240°	-2.40
10	108.51	-4.02	270°	-4.77
11	107.40	-4.77	300°	-4.02
12	109.81	-2.40	330°	-0.87
13	112.44	-0.07		
14	113.09	0.00		
15	113.09	-9.07		
16	108.81	-4.06	AVERAGE	-1.29

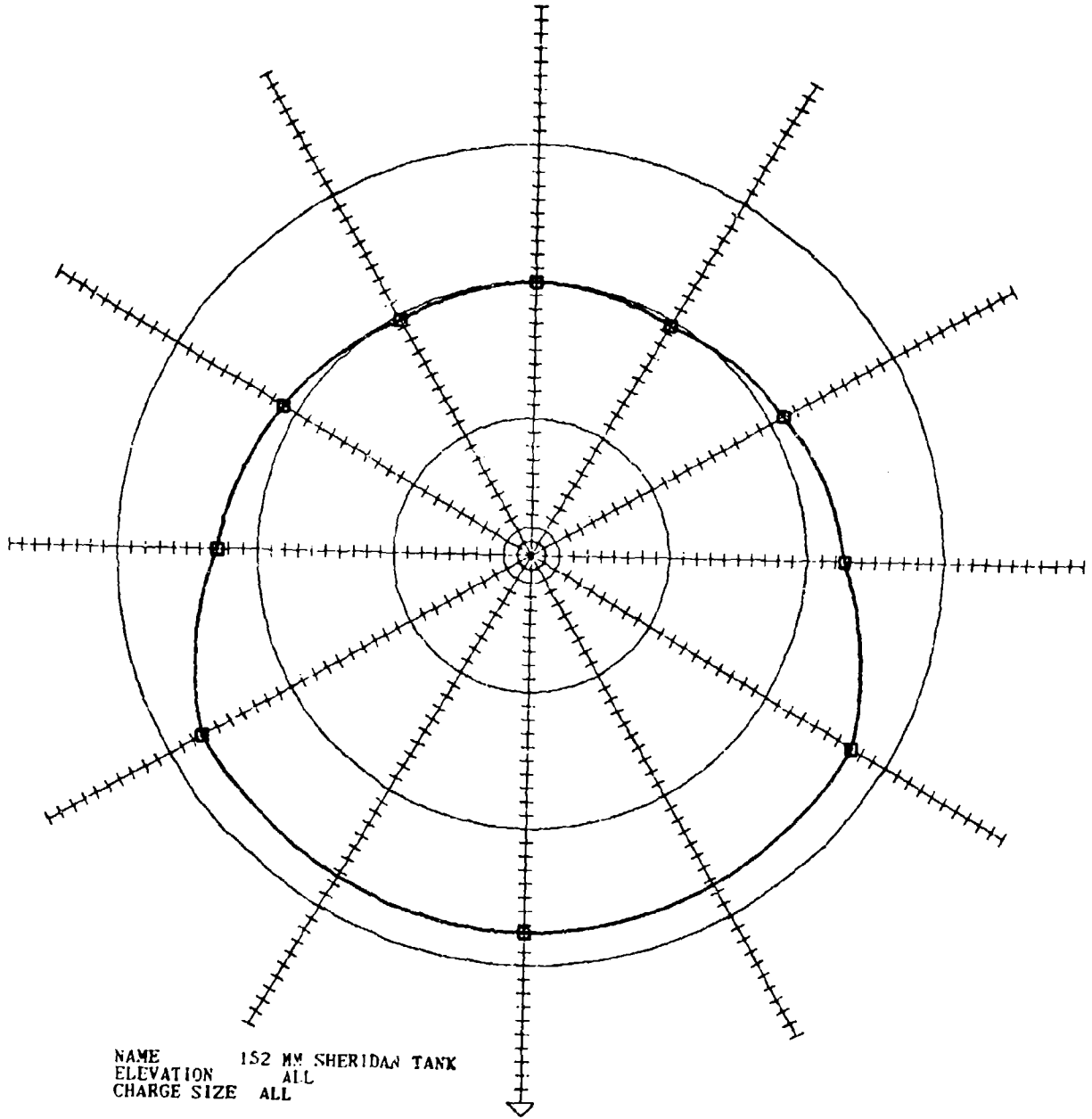

NAME 152 MM SHERIDAN TANK  
 ELEVATION ALL  
 CHARGE SIZE ALL

CHANNEL	ENERGY	DIFFERENCE FROM REAR	ANGLE	DIFFERENCE FROM REAR
1	119.19	8.43	0°	7.56
2	112.33	1.94	30°	7.38
3	110.09	0.00	60°	7.19
4	109.99	0.13	90°	2.73
5	116.73	5.95	120°	1.05
6	111.29	7.42	150°	-0.39
7	103.73	0.19	180°	0.00
8	105.41	1.03	210°	-0.39
9	117.66	7.56	240°	1.05
10	111.01	7.59	270°	2.73
11	107.02	3.60	300°	7.19
12	105.46	1.93	330°	7.38
13	103.83	0.38		
14	103.62	0.00		
15	102.34	-1.16		
16	105.57	1.87		
			AVERAGE	4.80

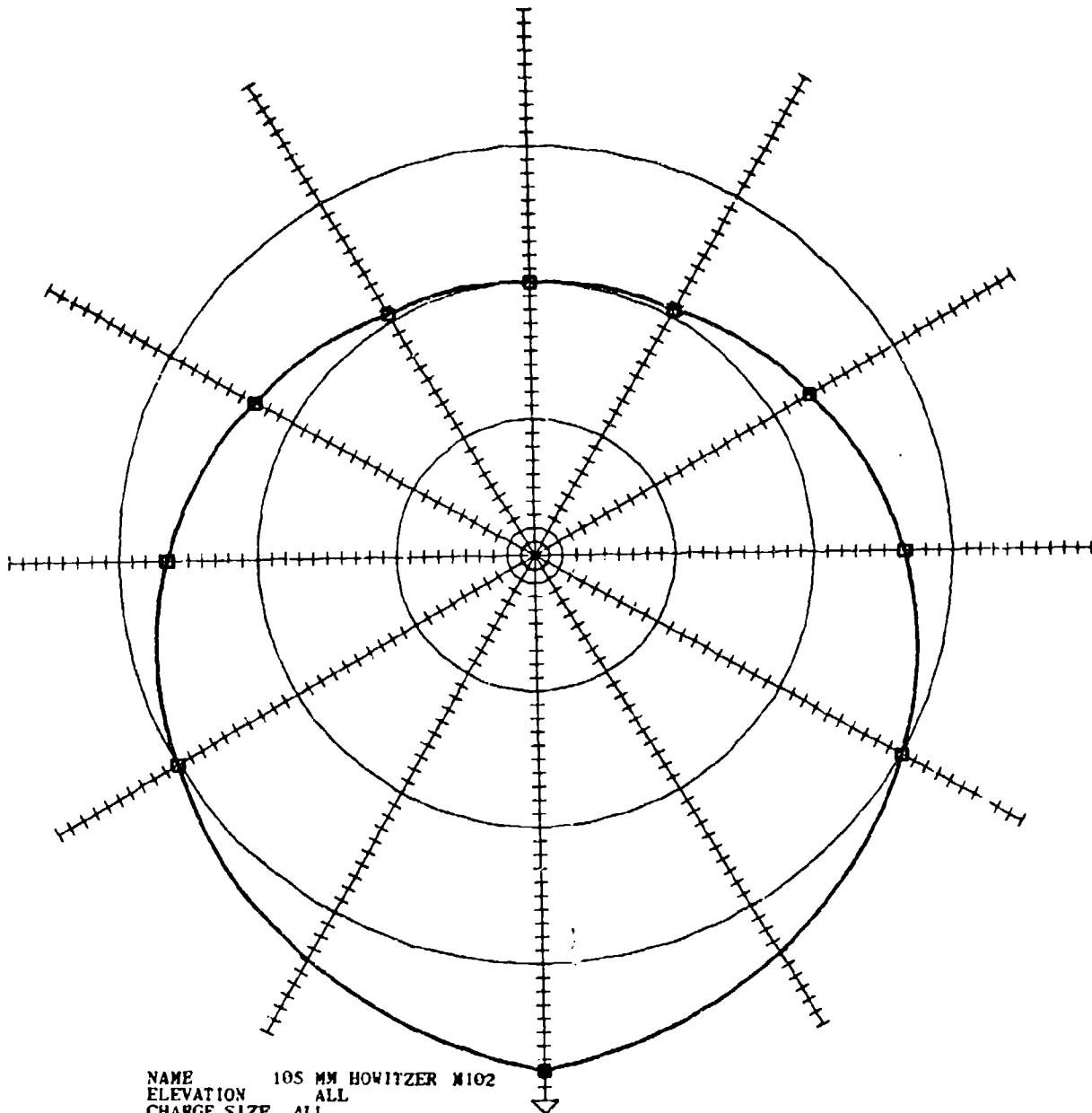

NAME 105 MM HOWITZER M102  
 ELEVATION ALL  
 CHARGE SIZE ALL

CHANNEL	ENERGY	DIFFERENCE FROM REAR	ANGLE	DIFFERENCE FROM REAR
1	101.22	10.73	0°	17.80
2	94.75	4.31	30°	13.91
3	90.14	0.00	60°	10.02
4	92.17	1.71	90°	6.46
5	99.24	8.84	120°	2.97
6	91.77	9.10	150°	0.53
7	84.78	1.86	180°	0.00
8	88.65	5.45	210°	0.53
9	107.36	17.80	240°	2.97
10	94.22	11.62	270°	6.46
11	90.68	7.72	300°	10.02
12	86.92	3.93	330°	13.91
13	84.59	1.47		
14	82.72	0.00		
15	82.42	-0.44		
16	88.42	5.15		
			AVERAGE	10.84

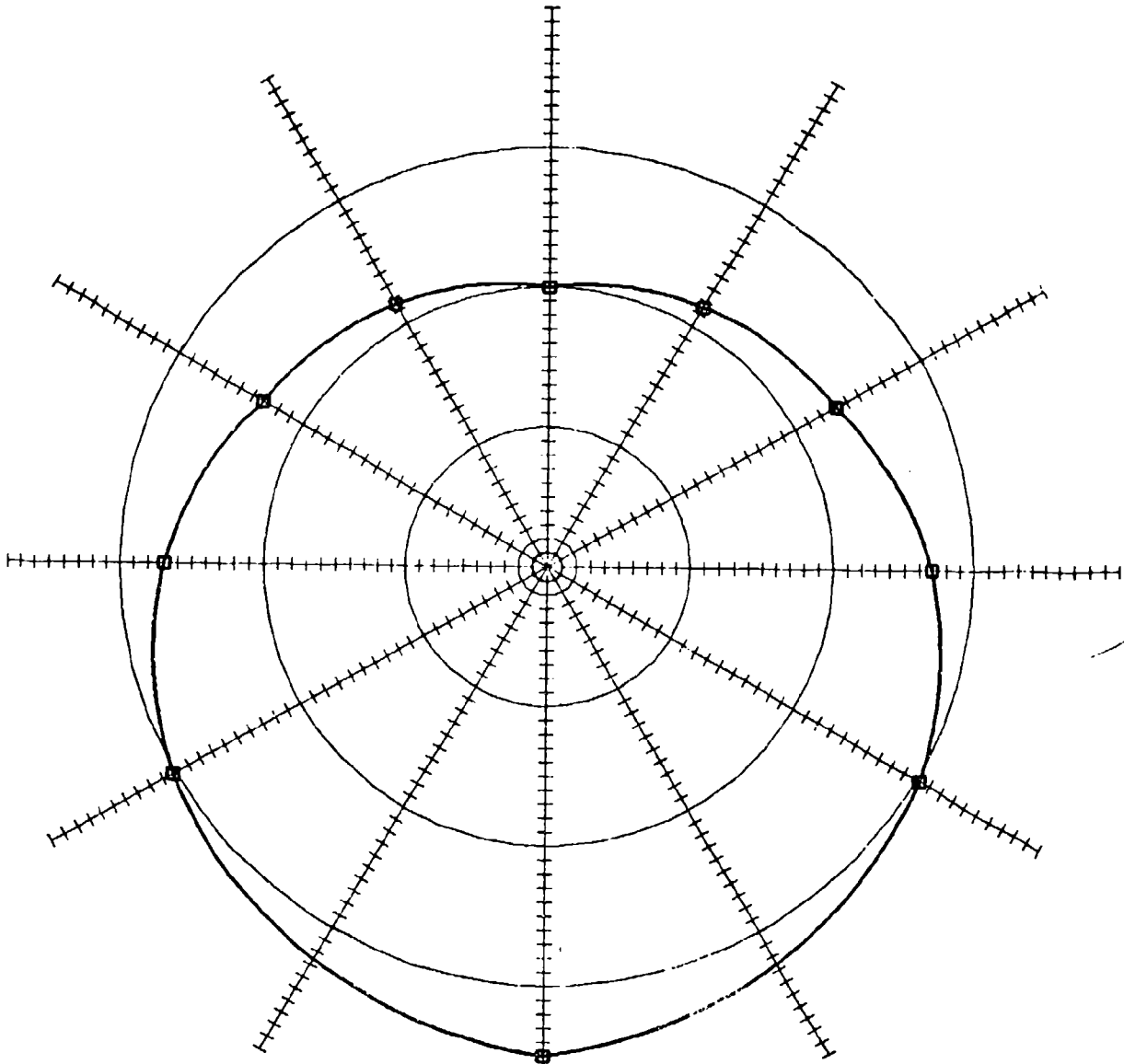

NAME 155 MM HOWITZER M114  
 ELEVATION ALL  
 CHARGE SIZE ALL

CHANNEL	ENERGY	DIFFERENCE FROM REAR	ANGLE	DIFFERENCE FROM REAR
1	112.57	9.80	0°	14.93
2	105.84	3.41	30°	12.55
3	103.24	0.00	60°	10.18
4	105.72	2.86	90°	6.87
5	113.15	10.71	120°	3.20
6	106.10	10.28	150°	1.56
7	99.41	3.09	180°	0.00
8	101.99	6.24	210°	1.56
9	115.59	14.93	240°	3.20
10	106.87	9.83	270°	6.87
11	103.64	7.42	300°	10.18
12	99.20	3.52	330°	12.55
13	97.15	1.51		
14	97.45	0.00		
15	97.43	1.61		
16	102.14	6.32		
			AVERAGE	9.45

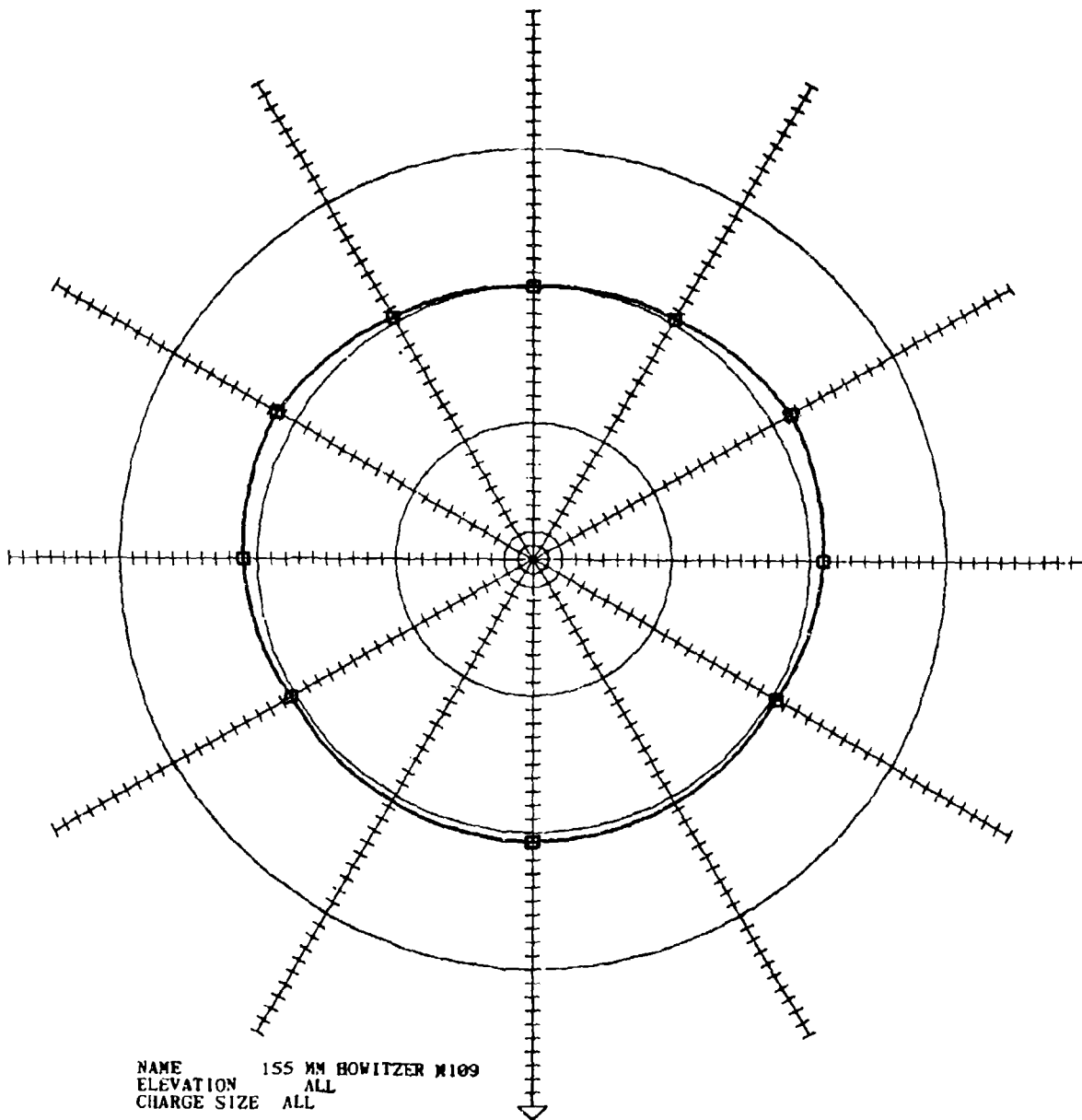

NAME 155 MM HOWITZER M109  
 ELEVATION ALL  
 CHARGE SIZE ALL

CHANNEL	ENERGY	DIFFERENCE FROM REAR	ANGLE	DIFFERENCE FROM REAR
1	112.39	1.71	0°	0.63
2	113.37	2.50	30°	0.46
3	110.80	0.00	60°	0.29
4	111.93	0.77	90°	1.00
5	111.16	0.05	120°	1.45
6	103.46	-1.10	150°	0.39
7	104.60	-0.08	180°	0.00
8	107.69	1.00	210°	0.39
9	111.11	0.63	240°	1.45
10	104.81	0.56	270°	1.00
11	105.98	1.74	300°	0.29
12	106.95	2.63	330°	0.46
13	105.85	1.25		
14	104.46	0.00		
15	103.95	-0.45		
16	105.28	0.26		
			AVERAGE	0.67

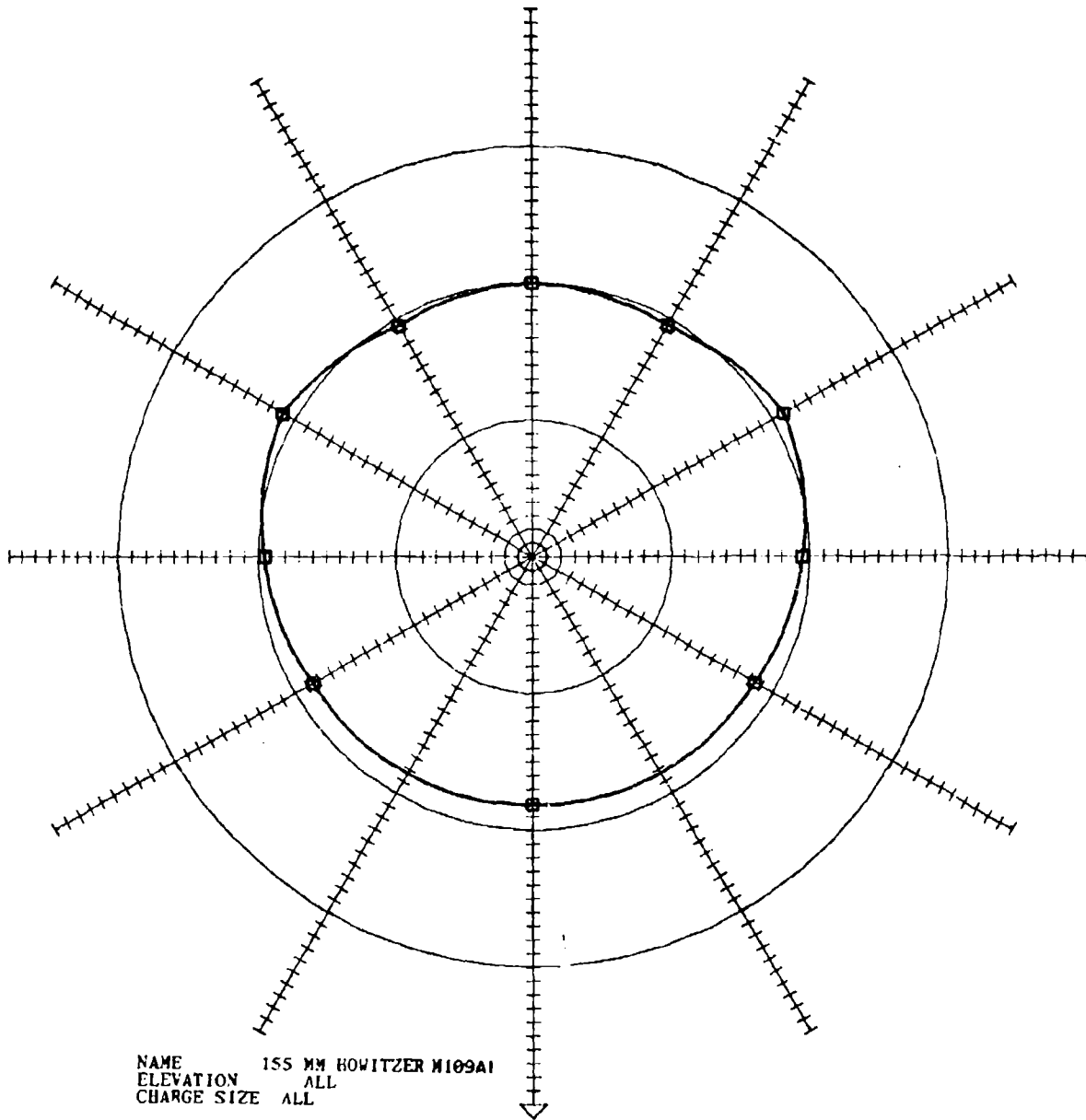

NAME 155 MM HOWITZER M109A1  
 ELEVATION ALL  
 CHARGE SIZE ALL

CHANNEL	ENERGY	DIFFERENCE FROM REAR	ANGLE	DIFFERENCE FROM REAR
1	108.66	-0.42	0°	-1.88
2	110.13	1.12	30°	-1.71
3	109.70	0.00	60°	-1.53
4	110.73	1.02	90°	-0.49
5	107.96	-1.97	120°	0.94
6	101.36	-2.80	150°	-0.52
7	105.42	1.08	180°	0.00
8	102.81	-1.31	210°	-0.52
9	100.38	-1.88	240°	0.94
10	101.81	-0.73	270°	-0.49
11	104.01	0.15	300°	-1.53
12	103.44	0.53	330°	-1.71
13	102.80	-0.29		
14	103.33	0.00		
15	103.57	-0.77		
16	102.83	-1.14		
			AVERAGE	-0.60

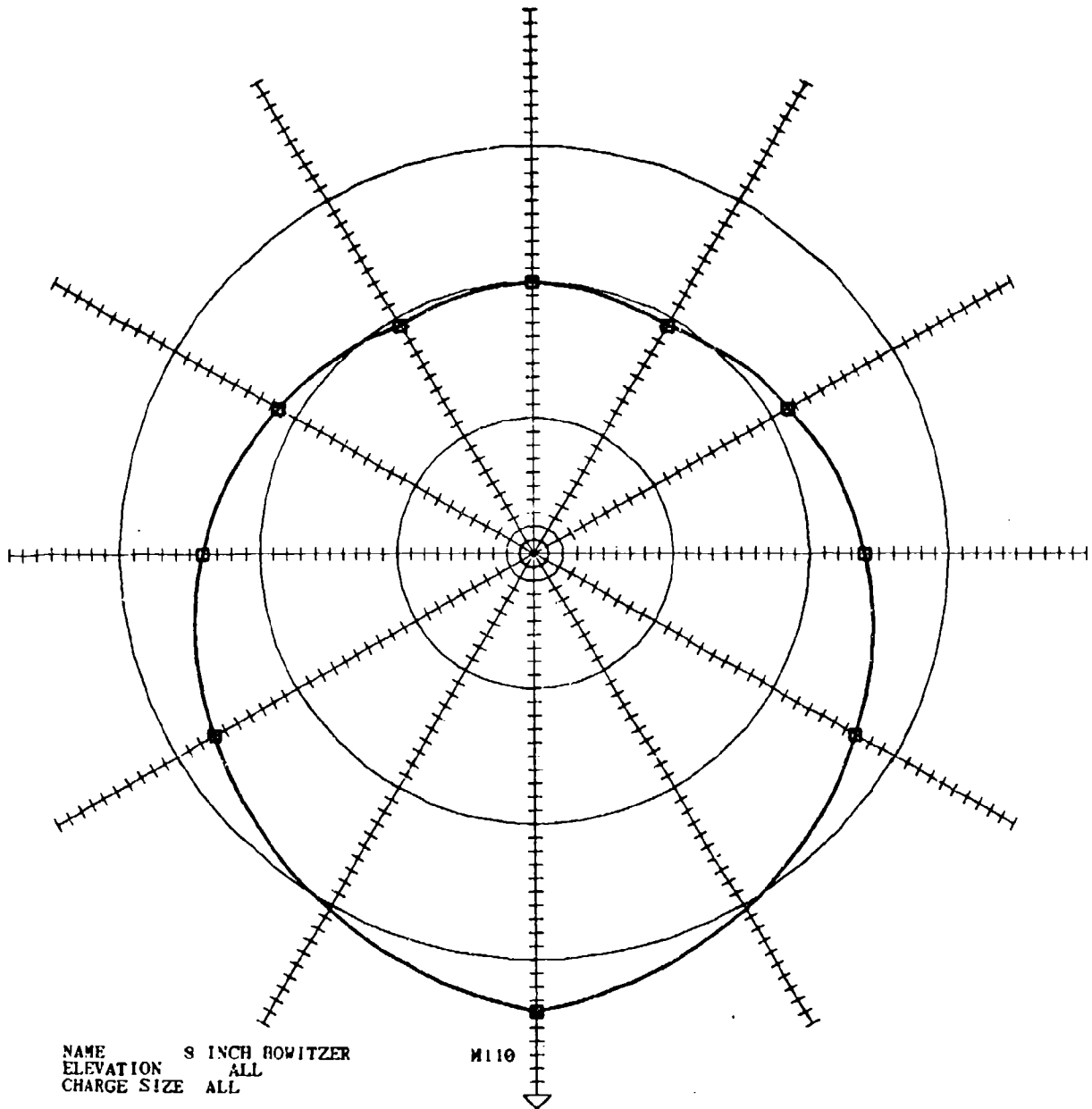

NAME 8 INCH HOWITZER  
 ELEVATION ALL  
 CHARGE SIZE ALL

M110

CHANNEL	ENERGY	DIFFERENCE FROM REAR	ANGLE	DIFFERENCE FROM REAR
1	118.37	6.42	0°	13.77
2	114.72	1.91	30°	10.29
3	115.08	0.00	60°	6.82
4	114.73	0.79	90°	4.01
5	119.09	6.10	120°	1.42
6	113.15	6.58	150°	-0.64
7	109.17	0.72	180°	0.00
8	110.69	3.47	210°	-0.64
9	119.55	13.77	240°	1.42
10	112.79	7.91	270°	4.01
11	109.58	4.57	300°	6.82
12	108.67	2.08	330°	10.29
13	107.41	-0.60		
14	108.51	0.00		
15	108.34	-0.68		
16	111.05	3.38		
			AVERAGE	7.36

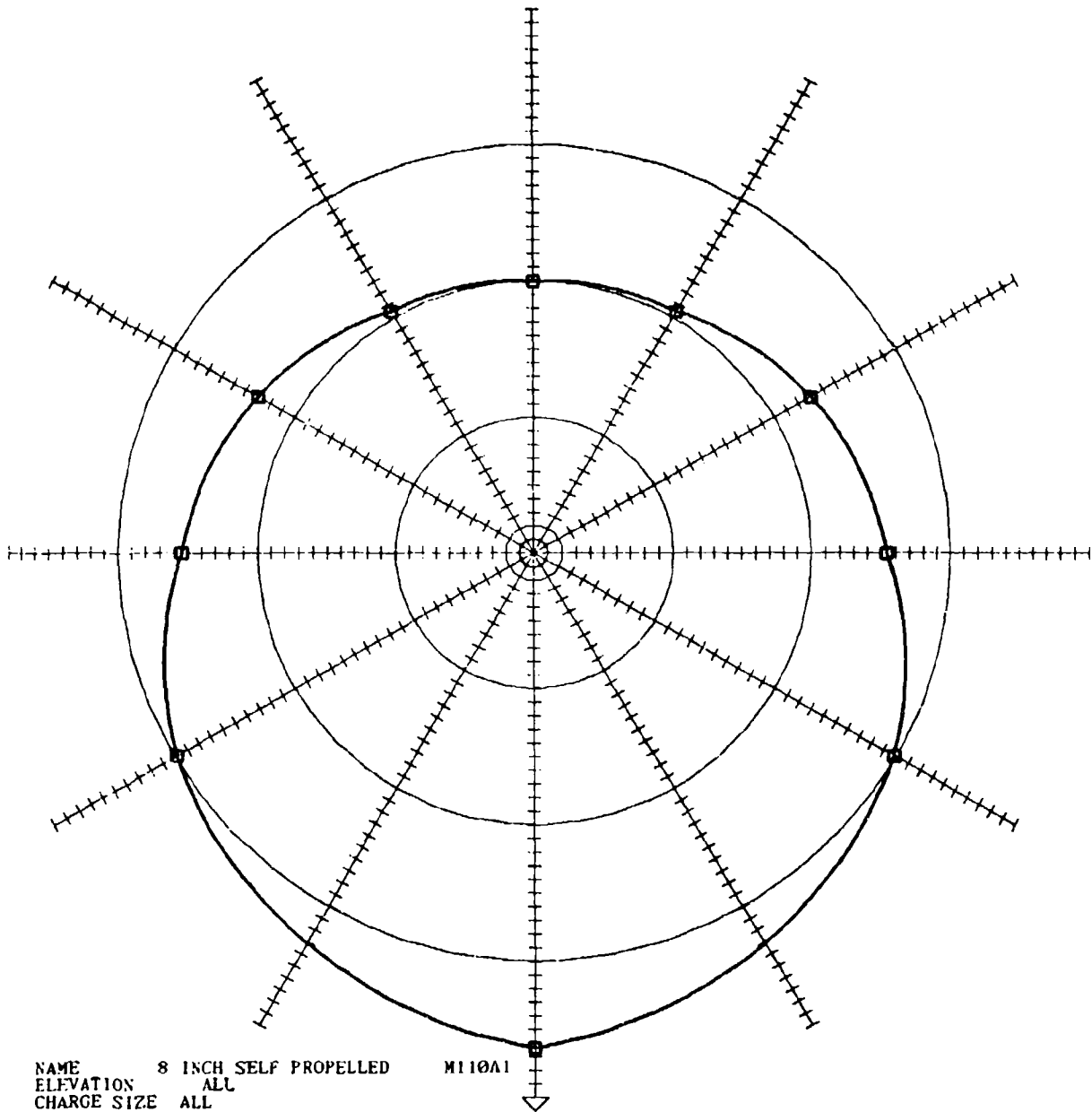

NAME 8 INCH SELF PROPELLED MI10A1  
 ELEVATION ALL  
 CHARGE SIZE ALL

CHANNEL	ENERGY	DIFFERENCE FROM REAR	ANGLE	DIFFERENCE FROM REAR
1	112.21	10.65	0°	16.33
2	104.84	4.03	30°	13.08
3	100.99	0.00	60°	9.84
4	103.39	1.89	90°	5.41
5	110.69	8.61	120°	3.03
6	102.70	8.27	150°	0.50
7	97.73	2.37	180°	0.00
8	98.76	2.98	210°	0.50
9	116.42	16.33	240°	3.03
10	105.55	11.46	270°	5.41
11	102.19	7.28	300°	9.84
12	97.79	3.82	330°	13.08
13	94.74	1.17		
14	93.88	0.00		
15	93.67	-0.48		
16	99.49	4.28		
			AVERAGE	9.90



APPENDIX E:  
WEIGHT EQUIVALENCY TABLES

<u>Weapon</u>	<u>Model</u>	<u>Charge Size &amp; Type</u>	<u>Weight (oz)</u>	<u>C-weighted SEL</u>	<u>F-weighted SFI</u>
81-mm mortar	--	4 CZ	1.56	93.7	95.2
		5 CZ	1.95	96.2	97.8
		7 CZ	2.72	99.5	101.2
		8 CZ	3.10	99.2	100.8
4.2-in. mortar	M30	11 CZ	2.92	94.1	95.9
		20 CZ	5.30	98.6	100.1
		24 CZ	6.36	100.2	101.8
		31 CZ	8.22	102.6	104.2
90-mm recoilless rifles	M67	NA	20.0	107.1	109.8
106-mm recoilless rifles	M40A1	NA	128.0	117.8	121.2
152-mm Sheridan tank gun	M551	NA	96.0	115.8	120.1
105-mm howitzer	M102	3 WB	12.5	99.2	101.3
		4 WB	16.3	100.6	103.0
		5 WB	22.1	102.0	104.2
		6 WB	30.8	104.8	107.8
155-mm howitzer	M114	4 GB	64.4	109.1	112.7
		5 GB	87.5	110.8	115.4
		5 WB	109.7	113.0	117.1
		6 WB	154.6	114.8	118.6
155-mm howitzer	M109	3 GB	49.4	107.1	109.7
		4 GB	64.4	109.1	111.8

Key: GB = green bag  
WB = white bag  
CZ = charge zone

<u>Weapon</u>	<u>Model</u>	<u>Charge Size &amp; Type</u>	<u>Weight (oz)</u>	<u>C-weighted SEL</u>	<u>F-weighted SEL</u>
8-in. howitzer	M110	5 GB	87.5	111.8	114.6
		5 WB	109.7	113.4	116.7
155-mm howitzer	M109A1	3 GB	120.3	111.8	116.0
		5 GB	210.5	117.8	121.0
		5 WB	270.9	119.2	127.4
		7 WB	450.2	118.9	124.0
8-in. self-propelled	M110A1	3 GB	49.4	102.7	106.1
		5 GB	87.5	106.9	109.9
		5 WB	109.7	109.7	113.1
		7 WB	210.4	113.9	117.2
105-mm tank	M60	3 GB	120.3	110.0	113.0
		5 GB	210.5	113.9	117.7
		5 WB	270.9	115.7	119.6
C-4 plastic explosive	NA	NA	192.0	111.4	114.5
		5.0		107.7	109.5
		10.0		110.6	112.9
		20.0		114.6	117.7
		40.0		118.3	121.5
		80.0		119.2	124.0
		160.0		121.3	127.1
320.0		125.1	131.2		

Key: GB = green bag  
WB = white bag  
CZ = charge zone

# CERL DISTRIBUTION

Pittsby Arsenal  
ATTN: SMOYA VPI

US Army, Europe  
ATTN: AIAEN

Director of Facilities Engr  
APO New York 09627

US Army Materiel  
Director  
ATTN: DRCPA-Lt. Prouhan  
ATTN: J. Pace  
501 Eisenhower Ave  
Alexandria, VA 22304

DIRCOM ST11-EUR  
APO New York 09710

HQDA (SGRD-EDE)

Chief of Engineers  
ATTN: DAEN-MPC-L, D. Spivy  
ATTN: DAEN-MPC-L (2)  
ATTN: DAEN-MPC-B  
ATTN: DAEN-MPC  
ATTN: DAEN-MPC-A  
ATTN: DAEN-PDC  
ATTN: DAEN-MPC-D/W. B. Holmes  
ATTN: DAEN-MPC-E/P. Van Parys  
ATTN: DAEN-MPC-L, P. Berk (2)  
ATTN: DAEN-MPC-S, J. Halligan  
ATTN: DAEN-ZFE-D/D. M. Benton (2)  
ATTN: DAEN-ZCF  
ATTN: DAEN-PMS (5)  
for forwarding to:  
National Defense HQDA  
Director General of Construction  
Ottawa, Ontario K1A0K2  
Canada

Canadian Forces Liaison Officer (4)  
U.S. Army Mobility Equipment  
Research and Development Command  
Ft. Belvoir, VA 22060

DFAR Envir Quality Section  
ATTN: Mike Halla  
Ft. Carson, CO 80542

US Training and Doctrine Command  
ATTN: ALEN-11-10, Dwyer  
Ft. Monmouth, VA 23051

Comuscom  
HQ EDCENOM  
Ft. Monmouth, VA 23030

US Army Aeronautical Research Lab  
ATTN: Robert T. Camp, Jr.  
ATTN: CPT J. Patterson  
Box 577  
Ft. Rucker, AL 36360

AFLSCORD  
Tyndall AFB, FL 32403

Director  
CSRD AMSL/BRF  
ATTN: Dr. H. Von Gierke  
Wright-Patterson AFB, OH 45433

Naval Undersea Center, Code 401  
ATTN: Bob Young  
San Diego, CA 92132

Naval Air Station  
ATTN: Ray Glass/Code 661  
Building M1  
Naval Air Rework  
North Island, CA 92135

US Naval Oceanographic Office  
WASH DC 20373

Naval Air Systems Command  
WASH DC 20360

NAVFAC  
ATTN: Code 04  
ATTN: David Kurtz/Code 2013C  
Alexandria, VA 22332

Fort Monmouth, CA 93043  
ATTN: Library (Code L03A)

Washington, DC  
ATTN: Building Research Advisory Board

Ardenne Proving Ground, MD 21005  
Human Engineering Laboratory  
ATTN: J. E. Weiss/AM7.0  
Army Environmental Hygiene Agency  
ATTN: CPT George Lutz/GIAcAcoustics

Federal Aviation Administration  
ATTN: H. R. Sabin, Chief  
Environ Policy Div

National Bureau of Standards  
ATTN: Don R. Flynn

Bureau of National Affairs  
ATTN: Fred Blosler, RA 402

Office of Noise Abatement  
ATTN: Gordon Beneman

Dept of Housing and Urban Development  
ATTN: George Winzer, Chief Noise  
Abatement Program

EPA Region III Noise Program  
ATTN: Pat Anderson

Illinois EPA  
ATTN: DNPC/Greg Zak  
ATTN: Bob Hellweg

Paul Borsky  
Franklin Square, NY 11610

USA Logistics Management Center  
Bldg 1202  
ATTN: MAJ K. Valentine

Federal Highway Administration  
Region 15  
ATTN: William Bowlby

Sensory Sciences Research Center  
ATTN: Karl Kryter  
ATTN: Jim Young

Society of Automotive Engrs  
ATTN: William J. Toth

Wyle Labs  
ATTN: L. Sutherland

Defense Documentation Center (12)

Schomer, Paul D

Acoustic directivity patterns for Army weapons / by P. D. Schomer, L. M. Little, A. B. Hunt.--Champaign, IL : Construction Engineering Research Laboratory ; Springfield, VA : available from NTIS, 1979.

127 p. : ill. ; 27 cm. (Interim report ; N-60)

1. Firearms-noise. 2. Noise-measurement. I. Little, Lincoln M. II. Hunt, A. B. III. Title. IV. Series: U.S. Construction Engineering Research Laboratory. Interim report ; N-60.