

AD A0 65234

# AGARD

ADVISORY GROUP FOR AEROSPACE RESEARCH & DEVELOPMENT

7 RUE ANCELLE 92200 NEUILLY SUR SEINE FRANCE

DDC FILE COPY

AGARD CONFERENCE PROCEEDINGS No. 255

## Operational Helicopter Aviation Medicine

DDC  
RECEIVED  
MAR 5 1979  
D

NORTH ATLANTIC TREATY ORGANIZATION



DISTRIBUTION AND AVAILABILITY  
ON BACK COVER

DISTRIBUTION STATEMENT  
Approved for  
Distribution of

79 03 05 055

**LEVEL II**

174  
AGARD-CP-255

1

NORTH ATLANTIC TREATY ORGANIZATION  
ADVISORY GROUP FOR AEROSPACE RESEARCH AND DEVELOPMENT  
(ORGANISATION DU TRAITE DE L'ATLANTIQUE NORD)

AGARD Conference Proceedings No. 255  
**OPERATIONAL HELICOPTER AVIATION MEDICINE**

Edited by  
Colonel S.C. Knapp MC  
Commander - US Army Aeromedical  
Research Laboratory (USAARL)  
P.O. Box 577  
Fort Rucker, AL 36362, USA

11/16/78  
11/600p.

ACCESSION NO.	
NTIS	Write Section <input checked="" type="checkbox"/>
DDC	Ref Section <input type="checkbox"/>
UNANNOUNCED	<input type="checkbox"/>
IDENTIFICATION	
BY	
CLASSIFICATION CODE	
SPECIAL	
A	

DDC  
RECEIVED  
MAR 5 1979  
D

**DISTRIBUTION STATEMENT A**  
Approved for public release;  
Distribution Unlimited

Papers presented at the Aerospace Medical Panel's Specialists' Meeting held at Fort Rucker, Alabama, USA, 1-5 May 1978.

400043  
79 02 05 055  
R



## THE MISSION OF AGARD

The mission of AGARD is to bring together the leading personalities of the NATO nations in the fields of science and technology relating to aerospace for the following purposes:

- Exchanging of scientific and technical information;
- Continuously stimulating advances in the aerospace sciences relevant to strengthening the common defence posture;
- Improving the co-operation among member nations in aerospace research and development;
- Providing scientific and technical advice and assistance to the North Atlantic Military Committee in the field of aerospace research and development;
- Rendering scientific and technical assistance, as requested, to other NATO bodies and to member nations in connection with research and development problems in the aerospace field;
- Providing assistance to member nations for the purpose of increasing their scientific and technical potential;
- Recommending effective ways for the member nations to use their research and development capabilities for the common benefit of the NATO community.

The highest authority within AGARD is the National Delegates Board consisting of officially appointed senior representatives from each member nation. The mission of AGARD is carried out through the Panels which are composed of experts appointed by the National Delegates, the Consultant and Exchange Programme and the Aerospace Applications Studies Programme. The results of AGARD work are reported to the member nations and the NATO Authorities through the AGARD series of publications of which this is one.

Participation in AGARD activities is by invitation only and is normally limited to citizens of the NATO nations.

The content of this publication has been reproduced directly from material supplied by AGARD or the authors.

Published December 1978

Copyright © AGARD 1978  
All Rights Reserved

ISBN 92-835-0226-4



*Printed by Technical Editing and Reproduction Ltd  
Harford House, 7-9 Charlotte St, London, W1P 1HD*

### **AEROSPACE MEDICAL PANEL**

**Panel Chairman:** Médecin Général G.Perdriel, FAF  
**Panel Deputy Chairman:** Air Commodore J.N.C.Cooke, RAF  
**Panel Executive:** Lt Colonel F.Monesi, IAF, MC

### **MEETING ORGANIZATION**

#### **Local Coordination**

**Host Nation Panel  
Coordinator:** Lt Col. G.S.Kush, USAF  
**Local Coordinator:** Col. S.C.Knapp, US Army  
**Project Officer:** Capt. R.T.Burden, US Army  
**Session Organizer:** Col. S.C.Knapp, US Army

## SESSION ORGANIZER

Colonel S.C.Knapp, MC  
Commander – US Army Aeromedical  
Research Laboratory (USAARL)  
P.O. Box 577  
Fort Rucker, AL 36362, USA

## SESSION CHAIRMEN

- Session I: Dr H.Burghart  
München-Harlaching Hospital  
Chirurgische Abteilung  
Sanatoriumsplatz 2  
D-8000 München 90  
FRG
- Session II: Dr I.C.Perry  
Aviation Medicine Consultant  
19 Cliveden Place  
London SW1W 8HD  
UK
- Session III: Dr K.A.Kimball  
US Army Aeromedical Research Laboratory  
P.O. Box 577  
Fort Rucker  
AL 36362  
USA
- Session IV: Dr M.Hofmann  
US Army Human Engineering Laboratory  
(Aviation Detachment)  
P.O. Box 476  
Fort Rucker  
AL 36362  
USA
- Session V: Col. R.W.Bailey, US Army (Ret.)  
Route 3, Box 241  
Enterprise  
AL 36330  
USA
- Session VI: Mr J.L.Haley, Jr  
US Army Aeromedical Research Laboratory  
P.O. Box 577  
Fort Rucker, AL 36362  
USA
- Wing Commander D.C.Reader, RAF  
RAF Institute of Aviation Medicine  
Farnborough  
Hants GU14 6SZ  
UK

## PREFACE

The 1978 Spring Aerospace Medical Panel Meeting of the NATO Advisory Group for Aerospace Research and Development met at Fort Rucker, Alabama, U.S.A., 1-5 May 1978. Hosts for this meeting were the United States Army Aeromedical Research Laboratory and the United States Army Aviation Center.

A single theme was chosen for the meeting--Operational Helicopter Aviation Medicine. This was the first panel meeting devoted entirely to the unique and special medical problems of helicopter flying. Aircraft inventories of NATO nations have been evolving from an almost totally fixed-wing fleet to a mixed fleet of fixed-wing and rotary-wing (helicopter) aircraft. There is a trend to increase the number of helicopters in direct support of the ground soldier to provide air mobility and firepower. The helicopters employed have become increasingly complex, and the operational missions have become extremely difficult and demanding for aircrews. The operational demand for combat flexibility provided by military helicopters assures their continuing importance to NATO in high mobility land warfare. Operations at sea involving long duration station holding, antisubmarine warfare, and foul weather search and rescue create entirely different problems. The helicopter will be indispensable to assure evacuation of the wounded to specialized care centers. In the civilian sector, the helicopter already has become a vital element in rescue missions of the wounded or the seriously ill. Experience has shown that helicopter operations present work environments, special stresses, and environmental demands on aircrews which are significantly different in type and/or degree from those in fixed-wing operations.

In order to give those attending the panel meeting a broad overview of the helicopter environment, the Army Aviation Center gave a tactical demonstration of the anticipated military use of the helicopter and a glimpse of the environment and the stresses faced by the aircrew. In addition, a series of in-depth operational briefings covering four major areas of helicopter operations were presented. One dealt with Soviet helicopters and what the Soviets are doing with rotary-wing aircraft. Topics of the other three operational briefings were medical evacuation in the NATO theater, antisubmarine warfare operations using the helicopter, and anti-tank and air-to-air operations with the helicopter. These briefings and demonstration caused panel members to be vividly aware of the daily and anticipated use of the helicopter. The urgency of the need to discuss the different medical aspects of helicopter use was made apparent.

Sixty-six papers were presented in six sessions. In addition, six poster papers were presented. These papers dealt with aviation medicine topics unique to helicopters, helicopter operations, and the aircrew who fly helicopters. The papers covered six major topic areas:

Medical Aspects of Evacuation and Search and Rescue Operations addressed helicopter inflight patient monitoring, resuscitation and support, hoist and rescue missions, special medical equipment requirements and developments, and design of helicopters specifically for medical evacuation.

Environmental Aspects of Helicopter Operations involved papers and discussions about the environmental effects and control of hot and cold climate operations, the acute and chronic effect and control of helicopter vibration, and cockpit toxicology.

Helicopter Operations Crew Fatigue Panel papers covered aviator fatigue and its causal effect on aviator performance and accidents.

Human Factors of Helicopter Design and Operations addressed cockpit design, instrument configuration, aircrew work load and its assessment, performance measures, combat operations under primitive or field conditions, sustained operations in support of ground combat operations, and related subjects.

Visual and Acoustic Aspects of Helicopter Design and Operations included cockpit lighting, aircraft conspicuity, visual displays, night vision equipment, communication noise, aircrew hearing loss, and weapons impulse noise.

Helicopter Safety and Crashworthiness covered crash injury analysis, designs for injury prevention, restraint systems, energy absorbing seats, helicopter escape, and postcrash fire.

The enthusiastic participation by the panel members and authors made this an open forum for the exchange of information on helicopter medicine. We did not receive answers to all our problems, to all our concerns, but we heard how others are looking at the same or similar problems. The information each member took back to his own field of work will help him meet and perhaps solve perplexing questions we all face.

## CONTENTS

	Page
PANEL AND MEETING OFFICERS	iii
SESSION CHAIRMEN	iv
PREFACE	v
TECHNICAL EVALUATION REPORT by S.C.Knapp	xi
KEYNOTE ADDRESS by J.C.Smith	xv
OPERATIONAL BRIEFING – SOVIET HELICOPTERS by R.P.Alex	xxiii
OPERATIONAL BRIEFING – ATTACK HELICOPTERS by J.C.Bahnsen	xxxi
OPERATIONAL BRIEFING – AEROMEDICAL EVACUATION, EUROPE by T.C.Scofield	xxxiii
OPERATIONAL BRIEFING – SEA, CARRIER, ANTISUBMARINE OPERATIONS by D.R.Bilicki	xxxix
 <u>SESSION I – MEDICAL ASPECTS OF MEDICAL EVACUATION AND SEARCH/RESCUE OPERATIONS</u>	
	Reference
RESCUE HELICOPTERS IN PRIMARY AND SECONDARY MISSIONS by B.Gorgass, G.Frey, W.Stotz, G.Kugler and I.Karger	1
AEROMEDICAL EVACUATION ON THE PREDICTED EUROPEAN BATTLEFIELD – A SCENARIO IN URGENT NEED OF ATTENTION by W.C.Wood	2
MARYLAND'S MED-EVAC HELICOPTER PROGRAM by R.A.Cowley	3
NIGHT RESCUE OPERATION PROCEDURE OVER SEA WITH BELL UH-1D HELICOPTERS by H.Knoche	4
COORDINATION OF MEDICAL ASPECTS OF THE AIR RESCUE SERVICE IN THE FEDERAL REPUBLIC OF GERMANY by H.J.Linde	5
MEDICAL ASPECTS OF HELICOPTER EVACUATION AND RESCUE OPERATIONS by D.S.Berliner	6
AN EVALUATION OF THE EFFECTS OF A STABILITY AUGMENTATION SYSTEM UPON AVIATOR PERFORMANCE/WORKLOAD DURING A MEDEVAC HIGH HOVER OPERATION by M.G.Sanders, R.T.Burden, Jr, R.R.Simmons, M.A.Lees and K.A.Kimball	7
THE BOAT THAT IS A RAFT by G.P.Gillespie	8
UH-60A MEDEVAC KIT by H.T.Hone	9
L'EVACUATION SANITAIRE PAR HELICOPTERE (CASUALTY EVACUATION BY HELICOPTER) par L.Vachon et W.Messens	10
DEVELOPMENT OF CASUALTY EVACUATION KIT FOR THE LIGHT OBSERVATION HELICOPTER (KIOWA) by R.M.Goede	11

	<b>Reference</b>
<b>HUMAN EXPOSURE TO MECHANICAL VIBRATION AT LYING POSTURE IN THE AMBULANCE HELICOPTER UH-1D</b> by H.Dupuis	12
<b>THE ORGANIZATION OF THE AIR RESCUE SERVICE IN THE FEDERAL REPUBLIC OF GERMANY</b> by G.Kugler	13
<b>DISCUSSION – Session I</b> Synopsis by H.Burghart	DI
<b><u>SESSION II – ENVIRONMENTAL ASPECTS OF HELICOPTER OPERATIONS</u></b>	
<b>CARBON MONOXIDE – A SIGNIFICANT AEROMEDICAL RISK (Abstract only)</b> by J.C.Denniston, F.S.Pettyjohn and J.K.Boyter	14
<b>NORTH SEA AND NORTH FLANK WINTER OPERATIONS</b> by E.P.Beck	15
<b>PROTECTIVE APPROACHES IN THE MODERATION OF THE PHYSIOLOGICAL EFFECTS OF EXTREME AMBIENT CONDITIONS IN HELICOPTER OPERATIONS</b> by L.J.SantaMaria	16
<b>MOBILE INTENSIVE CARE UNITS IN THE DANISH SEARCH AND RESCUE SERVICE</b> by K.Jessen	17
<b>IN-FLIGHT TOXICOLOGY OF FIXED AND ROTARY WING AIRCRAFT CREW STATIONS</b> by G.D.Pollard and D.W.Hirsch	18
<b>BACKACHE IN UH-1D HELICOPTER CREWS</b> by H.C.Schulte-Wintrop and H.Knoche	19
<b>DISCUSSION – Session II</b> Synopsis by I.C.Perry	DII
<b><u>SESSION III – HELICOPTER OPERATIONS CREW FATIGUE PANEL</u></b>	
<b>US ARMY AVIATION FATIGUE-RELATED ACCIDENTS, 1971–1977</b> by G.P.Krueger and Y.F.Jones	20
<b>EVALUATION OF AIRCREW FATIGUE DURING OPERATIONAL HELICOPTER FLIGHT MISSION</b> by C.Koch and F.Monesi	21
<b>CHANGES IN THE ROTARY WING AVIATOR'S ABILITY TO PERFORM AN UNCOMMON LOW ALTITUDE REARWARD HOVER MANEUVER AS A FUNCTION OF EXTENDED FLIGHT REQUIREMENTS AND AVIATOR FATIGUE</b> by M.A.Lees, R.R.Simmons, L.W.Stone and K.A.Kimball	22
<b>IMPLEMENTATION OF A DIVISIONAL AVIATION PROGRAM TO DECREASE FLIGHT CREW FATIGUE</b> by W.C.Wood	23
<b>DISCUSSION – Session III</b> Synopsis by K.A.Kimball	DIII
<b>SESSION IV – HUMAN FACTORS OF HELICOPTER DESIGN AND OPERATIONS</b>	
<b>ADVANCEMENTS IN HELICOPTER COCKPIT TECHNOLOGY</b> by H.P.Harper	24

	Reference
<b>VISUAL EFFECTS OF HELICOPTER MANOEUVRE ON WEAPON AIMING PERFORMANCE</b> by P.R.Michael, T.E.Jardine and M.K.Goom	25
<b>HUMAN FACTORS EVALUATIONS OF TODAY'S HELICOPTERS AS AN AID TO FUTURE SYSTEMS DESIGN</b> by E.J.Lovesey	26
<b>LIGHT EMITTING DIODE SYSTEM OF DARK ADAPTOMETRY FOR AVIATION SELECTION*</b> by L.Biggs	27
<b>TADRAP: A COMPUTER-AIDED TECHNIQUE FOR REDUCING AIRCREW TASK ANALYSIS DATA</b> by D.E.Gobuty	28
<b>UTILISATION D'UNE METHODE DE BIOSTEREOMETRIE DANS LA CONCEPTION D'UN POSTE DE PILOTAGE D'HELICOPTERE</b> par A.Coblentz, Y.Deloison, G.Ignazi et J.Prudent	29
<b>AN ANALYSIS OF HELICOPTER PILOT CONTROL BEHAVIOR AND WORKLOAD DURING INSTRUMENT FLYING TASKS</b> by J.Smit and P.H.Wewerinke	30
<b>DESIGN PROCEDURE FOR AN INFORMATION TRANSFER METHOD "CUBITS" FOR ALLOCATING PANEL AREA FOR AIRCREW STATION CONTROLS AND DISPLAYS</b> by P.M.Curran	31
<b>HUMAN FACTOR ENGINEERING TEST AND EVALUATION OF THE U.S. NAVY "LAMPS" HELICOPTER SYSTEM</b> by P.M.Curran, G.J.Laurent and P.M.Linton	32
<b>DESCRIPTION DE LA NOUVELLE SELECTION NEUROPSYCHOLOGIQUE DES PILOTES DE L'AVIATION LEGERE DE L'ARMEE DE TERRE</b> par E.J.Caille, D.Ziane, A.Goavec et A.Elzear	33
<b>EXAMEN RADIOLOGIQUE DU RACHIS ET APTITUDE A L'EMPLOI DE PILOTE D'HELICOPTERE</b> par R.P.Delahaye, R.Auffret et P.J.Metges	34
<b>A SYSTEM OF TRAINING IN AVIATION PHYSIOLOGY AND HUMAN FACTORS FOR ARMY AND NAVY HELICOPTER AIRCREW</b> by P.S.Ormerod	35
<b><u>SESSION V – VISUAL AND ACOUSTIC ASPECTS OF HELICOPTER OPERATIONS</u></b>	
<b>VISUAL REQUIREMENTS FOR THE HELICOPTER PILOT</b> by W.F.Lowe	36
<b>OBSERVATION OF NIGHT SHIPBOARD HELICOPTER OPERATIONS FROM A 210' U.S. COAST GUARD CUTTER</b> by W.W.Harvey, Jr	37
<b>OCULOMOTOR PERFORMANCE OF AVIATORS DURING AN AUTOROTATION MANEUVER IN A HELICOPTER SIMULATOR</b> by R.N.Armstrong, G.P.Krueger, J.H.Sapp and Y.F.Jones	38
<b>POUVOIR SEPARATEUR DE L'OEIL SUR TUBE CATHODIQUE COULEUR</b> par G.F.Santucci	39
<b>VISUAL PERFORMANCE/WORKLOAD OF HELICOPTER PILOTS DURING INSTRUMENT FLIGHT</b> by R.R.Simmons, M.A.Lees and K.A.Kimball	40

---

\* Not available at time of printing.

	Reference
<b>VISUAL POCKETS – A DESIGN PARAMETER FOR HELICOPTER INSTRUMENT PANELS</b> by R.W.Bailey and D.D.Glick	41
<b>VISUAL AND OPTICAL ASSESSMENT OF GAS PROTECTIVE FACE MASKS</b> by K.W.Welsh and J.A.Vaughan	42
<b>INTERNAL COCKPIT REFLECTIONS OF EXTERNAL POINT LIGHT SOURCES FOR THE MODEL YAH-64 ADVANCED ATTACK HELICOPTER</b> by C.C.Smyth	43
<b>SENSORIAL ASPECTS OF HELICOPTER OPERATIONS</b> by G.Rotondo	44
<b>THE EFFECTIVE ACOUSTIC ENVIRONMENT OF HELICOPTER CREWMEN</b> by R.T.Camp, Jr and B.T.Mozo	45
<b>A SURVEY OF COMMUNICATIONS IN THE HIGH NOISE ENVIRONMENT OF ARMY AIRCRAFT</b> by M.S.Mayer and A.W.Lindberg	46
<b>SOME ASPECTS OF HELICOPTER COMMUNICATIONS</b> by G.M.Rood and E.J.Lovesey	47
<b>DISORIENTATION IN ROYAL NAVAL HELICOPTER PILOTS</b> by A.P.Steele-Perkins and D.A.Evans	48
<b>OPERATIONAL CONSIDERATION OF AN/PVS-5 NIGHT VISION GOGGLES FOR HELICOPTER NIGHT FLIGHT</b> by W.C.Chiou	49
<b>TRAINING REQUIREMENTS FOR HELICOPTER OPERATION WITH NIGHT VISION GOGGLES</b> by I.Behar, D.M.Young and J.E.Johnson	50
<b>HEAD AIMING/TRACKING ACCURACY IN A HELICOPTER ENVIRONMENT</b> by R.W.Verona	51
<b>AVIATOR VISUAL PERFORMANCE: A COMPARATIVE STUDY OF A HELICOPTER SIMULATOR AND THE UH-1H HELICOPTER</b> by R.R.Simmons, M.A.Lees and K.A.Kimball	52
<b>DISCUSSION – Session V</b> Synopsis by R.W.Bailey	DV
<b><u>SESSION VI – SAFETY ASPECTS OF HELICOPTER DESIGN AND OPERATIONS</u></b>	
<b>OCCUPANT INJURY MECHANISMS IN CIVIL HELICOPTER ACCIDENTS</b> by R.G.Snyder	53
<b>COMPARATIVE INJURY PATTERNS IN US ARMY HELICOPTERS</b> by L.D.Sand	54
<b>ENGINEERING ANALYSIS OF CRASH INJURY IN ARMY AIRCRAFT</b> by J.E.Hicks	55
<b>LES ALGIES VERTEBRALES DES PILOTES D'HELICOPTERES</b> par R.Auffret, R.P.Delahaye, P.J.Metges et Vicens	56
<b>VERTEBRAL COLUMN INJURIES ASSOCIATED WITH HELICOPTER OPERATIONS (Abstract only)</b> by L.E.Kazarian	57



	<b>Reference</b>
<b>ASSESSMENT OF THE BENEFITS OF AIRCRAFT CRASHWORTHINESS</b> by A.E.Gilewicz	58
<b>CRASHWORTHY HELICOPTER SEATS AND OCCUPANT RESTRAINT SYSTEMS</b> by G.T.Singley and S.P.Desjardins	59
<b>SOME IMPROVEMENTS TO THE UK HELICOPTER COCKPIT</b> by D.C.Reader	60
<b>HELICOPTER CRASHWORTHY FUEL SYSTEMS AND THEIR EFFECTIVENESS IN PREVENTING THERMAL INJURY</b> by S.C.Knapp, P.Allemond and D.H.Karney	61
<b>A METHOD FOR SELECTING A CRASHWORTHY FUEL SYSTEM DESIGN</b> by S.H.Robertson and J.W.Turnbow	62
<b>BIOMEDICAL CONSTRAINTS ON THERMAL PROTECTIVE FLIGHT CLOTHING DESIGN: A BIOENGINEERING ANALYSIS</b> by F.S.Knox, III, T.L.Wachtel and S.C.Knapp	63
<b>CRASH SURVIVABILITY OF THE UH-60A HELICOPTER</b> by B.L.Carnell	64
<b>THE APPROACH TO CREW PROTECTION IN THE CRASH ENVIRONMENT FOR THE YAH-64</b> by J.M.McDermott	65
<b>HELICOPTER UNDERWATER ESCAPE TRAINER (9D5)</b> by W.F.Cunningham	66
<b>BAILOUT FROM AUTOROTATING HELICOPTERS</b> by H.D.Melzig, U.Schmidt and E.A.Bockemüller	67
<b>DISCUSSION – Session VI</b> Synopsis by J.L.Haley and D.Reader	DVI

## TECHNICAL EVALUATION REPORT (TER)

### SESSION I: MEDICAL ASPECTS OF EVACUATION AND SEARCH/RESCUE OPERATIONS

The importance of helicopters in sanitary evacuations has been particularly stressed in this session. However, civilian and military interventions may vary, for conditions are not identical.

Evacuations of the civilian wounded, especially those of road traffic, may profit by a technical and territorial organization, as our colleagues of West Germany have shown us.

The helicopter must be as quickly as possible at the place of the accident (optimal time is within 15 minutes after the accident).

It is also necessary that the wounded be transferred within an hour to a hospital specialized in the treatment of trauma.

We had the opportunity to appreciate the interest of a landing zone close to the hospitalization ward.

Highly trained personnel, when available including a doctor and/or a nurse, should be ready for every emergency helicopter.

The crew must be perfectly trained in hovering and winching techniques.

Such progress encounters financial difficulties; all the more that the personnel and the equipment must be permanently on alert.

It is also important to improve the conditions of night interventions, especially in the case of mountain accidents.

Military evacuations are more difficult to perform because the helicopter often becomes efficient only when operations are waning; there again, night interventions may seem desirable and may be facilitated by optical aids.

On the medico-physiological level and in any case of evacuation, the influence--sometimes adverse--of vibrations on the biological equilibrium of the wounded must be taken into consideration and all necessary steps must be taken.

Sea evacuations also set a particular problem and we have been quite interested in the approach techniques and the training of the personnel in charge of these missions.

### SESSION II: ENVIRONMENTAL ASPECTS OF HELICOPTER OPERATIONS

The session on Environmental Aspects of Helicopter Operations was introduced by outlining one of AGARD's missions--that of indoctrination and support of aircrew. A definition was given of the word environment, and the English and American definitions were very similar, that being surroundings mean those factors affecting the development of an organism or its behavior. To support this, a number of environmental factors were then outlined. Namely, that of what was the ideal environment and this normally taken as being the home situation. The pilot is taken from this ideal situation, given a sophisticated aircraft which has now become very fast, presented with a varying array of instruments and weapons, and then asked to go and operate in a variety of hostile outside environments such as hot and cold weather, poor visibility, mountainous areas, etc., and then in the more recent hostile ground environment--that of the anti-tank and anti-air.

The papers presented covered the operation of aircraft in the northern aspects of NATO with all their inherent cold problems not only for aircrew but for ground crew and soldiers as well. Complementing this, we then discussed certain rescue problems in high and cold sea states and the on-board equipment required to retrieve casualties in this particular situation.

On-board toxicology measuring systems were given in a first class paper. The question of on-board oxygen systems was raised, and it was generally considered that this was something requiring further investigation.

Methods of head and body cooling were described in an effort to reduce aircrew heat load. The effects of vibration and temperature variations from inside one particularly common helicopter model, the vibrations being transmitted through the seat resulting in backache, were given and a plea made for continuing work to be done in this area.

The session did not stimulate a great deal of discussion as one would have hoped and the reluctance to discuss the problems concerning air-to-air combat environment was probably due to the fact that most of the audience present had probably not thought much about it or never really considered it, and those who had probably were reluctant to discuss it because of security classification.

### SESSION III: HELICOPTER OPERATIONS CREW FATIGUE PANEL

In review of Session III, the panel on Helicopter Operations Crew Fatigue, we were able to review the problem of performance degradation and resultant effects or accidents as a function of aircrew fatigue and the potential increase in this problem due to the high reliability of future aircraft systems and the tactical requirement for sustained operations.

Presentations delineating methods which are proving to be useful in assessing the crew fatigue problem in the flight environment were also heard. Finally, an insight into an aviation program aimed at decreasing flight crew fatigue was provided. Thus, we were privileged to address not only the problem and a number of scientific methods to address certain aspects of it, but were provided information on a program which is attempting to apply scientific data and pilot education to decrease performance degradation and loss due to aviator fatigue.

In view of the operational briefings presented earlier in the week that discussed the capability of our aircraft to now out fly man, this area of research is in need of a much more concentrated effort and immediate solutions to these tactical flight related problems seem to be increasingly critical in light of the need for our joint continuous and sustained tactical operations to counter the potential enemy threat.

### SESSION IV: HUMAN FACTORS OF HELICOPTER DESIGN AND OPERATIONS

The session of Human Factors of Helicopter Design and Operations pointed out that the man-machine interaction with respect to the helicopter is indeed a complex one. Further, it pointed out that this complexity arises from the machine as well as from man himself.

The papers demonstrated that this complex interaction must be understood if the helicopter is to be maximally exploited. In general, the papers concentrated on three major areas with regard to this interaction. These areas included: concepts and methodologies for use in designing helicopters which will be more man compatible; selection and medical training of helicopter crews; and measurement and modeling of the helicopter man-machine system.

With regard to design concepts, we were provided many options for utilizing advanced technologies for achieving better man compatibility. These options included multiplexing, fly-by-wire, head-up displays, helmet mounted displays, and multifunction displays to mention some. With regard to methods to aid in crew station design, we were provided several avenues of approach for gaining information which would reduce the perpetuation of previous design errors. Also, methods were presented which will serve to aid in the design process. Such methods consider the aviator's sensory, motor, and cognitive tasks as well as his physical characteristics.

In the area of selection and medical training of helicopter crews, we were provided information about test batteries which incorporate cognitive, psychometric, and physiological data for predicting flight performance. We were told how certain physical characteristics such as spinal abnormalities may be used as selection criteria for helicopter pilots and why these pilots have unique aeromedical training requirements. In addition, we were told what these unique training requirements were, and how to establish a curriculum for teaching them.

Lastly, we were shown that a system's model is most desirable for explanatory, predictive, and evaluative purposes. Toward this end we were provided a model concerned with predicting flight difficulty as well as multivariate analyses which included aircraft, physiological, subject, and control input variables.

In summary, this session was a most rewarding session to chair. It demonstrated that much is being accomplished in an area where much needs to be done. I anticipate that together we will continue to make progress in this topical area.

### SESSION V: VISUAL AND ACOUSTIC ASPECTS OF HELICOPTER OPERATIONS

During the session on Visual and Acoustic Aspects of Helicopter Operations, problem areas were identified and defined. There was a consensus that the problems were detrimental to safe and effective helicopter operation. Papers were presented that proposed to better fit the man into this hostile environment by the application of existing knowledge in the behavioral and biological sciences. New developments in techniques and methodologies to extend and protect visual and auditory performance while performing aircrew duties were also presented.

A summary of the excellent work presented supported the self-evident conclusion that biomedical science can resolve almost every problem identified, either by the application of existing knowledge or by research programs directed toward the resolution of the problem. The major issue not resolved is the inescapable fact that even though man is the driving function of helicopter operations, sufficient priority and support are lacking to permit his optimal protection and function.

It was also well established during this session that there are cost effective operational advantages to be gained from biomedical science if given proper priority in the development, product improvement, and application of helicopter systems. In an earlier session, the threat briefing, information was provided concerning the priority and attention given to man in the helicopter operational environment by our potential enemy. We learned, unfortunately, that they are far superior to NATO in their attention to the biomedical requirements of the pilot. Hopefully, this conference may help to reverse this advantage.

## SESSION VI: SAFETY ASPECTS OF HELICOPTER DESIGN AND OPERATIONS

The last session was particularly rewarding because it had the unifying theme of crashworthiness, a relatively new word for the vocabulary of aerospace medicine. We first heard about the marked reduction of burns caused by crashworthiness principles as applied to fuel system design and the use of Nomex flight clothing. This was then followed by an engineering evaluation of fire suppression devices and their cost effectiveness. The lack of these features in civil helicopters was reported. Next came a useful demonstration of the effect of helicopter accidents on the vertebral column, and the ergonomics of and the injuries sustained in French helicopters were discussed. We then had two useful sessions from designers of U. S. helicopters, and we heard something about the work conducted by the U. S. Army looking at the effectiveness of seats and restraints and related test data. A brief outline of developments in the UK then followed. All these papers produced lively discussion periods which showed there was a considerable amount of interest in common which should enhance cooperation in helicopter design in the future.

KEYNOTE ADDRESS  
HELICOPTER TRAINING PROGRAM

Major General James C. Smith, US Army  
Commander  
United States Army Aviation Center and Fort Rucker  
Fort Rucker, Alabama 36362

This may be the only rudimentary presentation you are going to have during this week's conference. I scanned through the subjects to be presented to you and decided that you ought to know how we all came into this business of helicopter operations.

So for a few minutes, I am going to tell you what the Aviation Center is, what we do here and give you some increased sensitivity for the basis of helicopter operations.

We are doing some things at Fort Rucker now that we did not do last year. If you were to look at the developments over the years since 1954 when we moved the Aviation School from Fort Sill to Fort Rucker, you could understand why helicopter operations are continuing to be so dynamic. You are here at a good time and some of the points I will make will form the basis for a number of your presentations.

It started when a Piper Cub was launched off a carrier, if you want to call it that, in the North African invasion in World War II. Starting with that type of aviation in 1942, we progressed on to the Korean War where we first began our air helicopter aeromedical evacuation. The first time the helicopter was used extensively in war; at least a war of the United States.

Then we went into Viet Nam and the favorite picture I could show would be a gunship firing. But essentially it was a war in the ground environment, not the air environment. So I think the term aerospace has to be translated into some different terms when you start talking about helicopter operations and helicopter medicine. This is where we are today; hovering, attack helicopter firing a missile in the ground environment (Fig. 1).



Fig. 1

These are four primary missions of the Aviation Center. The training of aviators, mechanics and other specialists is our primary mission and is the standard mission of most schools adapted to aviation. This is the heart of all that we do in the way of analyzing the past and projecting to the future. Everything else we do at the Aviation Center stems from the development of doctrine, tactics and literature. We travel all over the world making sure that our aviation training is the type that we want it to be and that it meets the quality and the standards of that which we teach here. We also support reserve component training. We have about half of our Army aviation program in the National Guard and Reserves, so obviously we have to pay a lot of attention to them. All this is put together to perform the mission of Army aviation.

Now those of you who are from foreign nations, in many cases are aware that all your helicopter support is contained in your air force. Here we have it in the Army (Fig. 2), "to augment the capability of the Army to conduct prompt and sustained combat incident to operations on land." In fact, if you were to read a list of missions of our United States Air Force you would find one which is essentially like our mission--to support the Army.

Unique in our Army family is the fact that the Aviation Center team contains six separate identifiable agencies, all collocated here at Fort Rucker so that as a team we can produce with minimum resources a cohesive package on any subject related to Army aviation (Fig. 3).

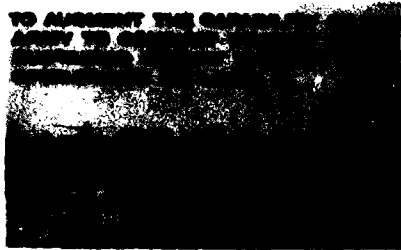

Fig. 2

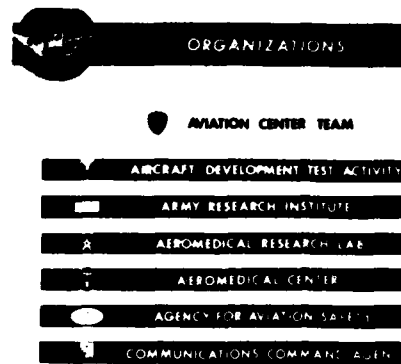

Fig. 3

We have two kinds of testing in the Army: developmental testing and operational testing. The Aircraft Developmental Test Activity belongs to another major command of the Army which is essentially the one that does all the developmental testing. The Test Activity is located here along with my Aviation Board which is the operational testing agency for aviation materiel in the Army. Obviously, we gain the benefits of having the two together. We are unique in that we are probably, for the major effort of development and testing, the only post in the Army that does have them collocated. It makes for a very cohesive effort.

The aviation element of the Army Research Institute located here is the scientific agency for human behavioral aspects of Army aviation deployment. Its presence here provides some tremendous advantages for us because this is where we do the course development for all our aviation training and we are very involved in this area.

I am not going to dwell on the Aeromedical Research Laboratory; you know what it is here for. Our Aeromedical Center, in addition to providing all our medical care, also conducts Army flight surgeon training. The Army flight surgeon school is part of the Aeromedical Center.

The US Army Agency for Aviation Safety, more commonly known as USAAAVS, is collocated here. Out of all the data that are developed as a result of our accident experience come many analyses which form the basis for new tactics, new techniques and new procedures, all of which are designed to conserve our resources in the future.

Our Army Communications Command Agency, in addition to providing all our electronic support and communications support, controls, commands and services all our air traffic control facilities throughout our training complex of 70 miles by 60 miles; all tower control at stagefields; our instrument procedures; instrument equipment; and all the personnel involved in that activity are part of this particular agency.

Just to give you some feeling for the environment that we have here, I will discuss our population and some of its composition (Fig. 4). We have a duty day population of approximately 17,000. Of this number approximately 2,000 are students. You can see that there are a lot of us here supporting these students, who we have as our most important product, in the school. We have a rather large population of both Department of the Army civilians and contractor personnel who instruct in our various training programs.

CATEGORY	TOTALS	COMMENTS
OFF AND	1,000	( 00)
UNEMPLOYED OFF	00	( 00)
COLLECTED	2,000	( 00)
DEPENDENTS	1,000	
DEPT OF DEFENSE	1,000	
CIVILIANS	1,000	
CONTRACTOR	1,000	
PERSONNEL	1,000	
OTHER	00	
ACTIVES	00	
<b>TOTAL</b>	<b>17,000</b>	<b>1,000</b>

Fig. 4



Fig. 5

Our primary arrival airfield is Cairns Army Airfield (Fig. 5). If you were to come in here in a fixed wing aircraft, this is where you would land. Most of the airspace in the vicinity of Fort Rucker is controlled by us (Fig. 6). In order to control this airspace and to make sure we can integrate military traffic with all the civilian traffic that might fly through it, we have a radar approach control center at Cairns manned by Department of the Army civilians (Fig. 7). But in order to do helicopter instrument training, recognizing how slow helicopters fly, we have within our controlled airspace developed our own airway system (Fig. 8). This system is operated by the Army using rated Army air traffic control personnel with Army air traffic control student participation. It is collocated with the radar approach control at Cairns Army Airfield.



Fig. 6



Fig. 7

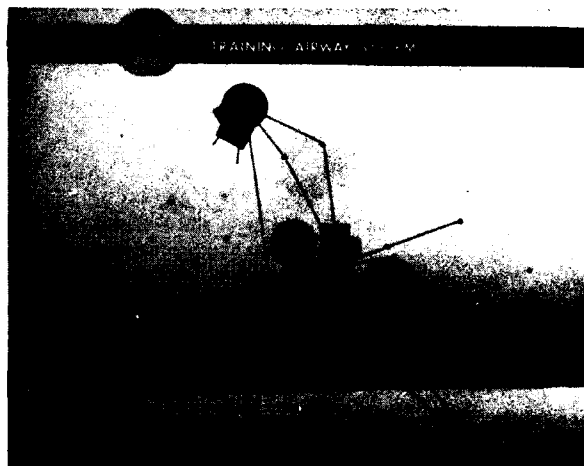

Fig. 8

Hanchey Army Heliport has extensive maintenance, classroom and administrative facilities (Fig. 9). It is currently the basefield for cargo, attack, light observation aircraft and the TH-55 which is our primary helicopter flight trainer. Hanchey is the largest heliport in the free world.

Lowe Army Heliport was originally a fixed wing airfield, but with the increased emphasis on helicopter training was converted to a helicopter basefield (Fig. 10). The UH-1 "Huey" is the only aircraft currently based there.

Our modern classroom buildings are the hub of our academic training (Fig. 11). They are equipped with the most up-to-date training aids which include detailed functional training devices and closed circuit television with both live and video tape production. Pilot training is essentially a half day on the flight line and a half day in the classroom.



Fig. 9

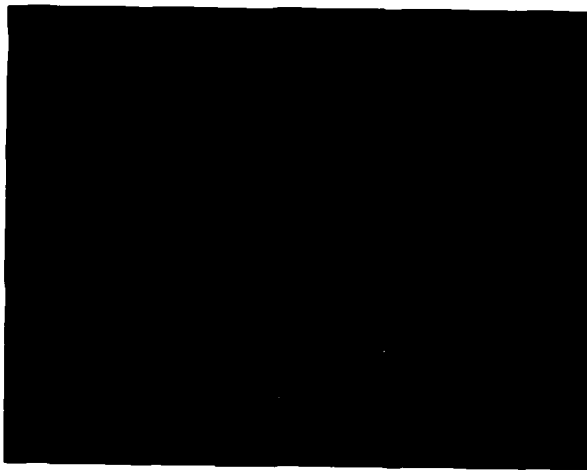

Fig. 10

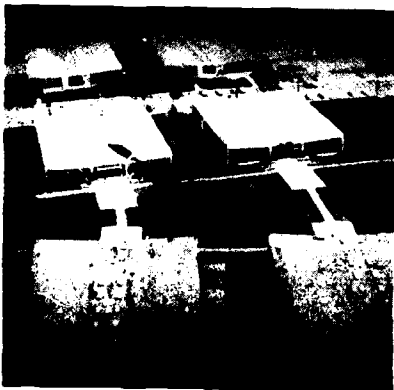

Fig. 11



Fig. 12



We train aircraft mechanics in both the UH-1 and OH-58 helicopters (Fig. 12). Our modern maintenance training facility contains 28 classrooms and 67,000 square feet of hangar space.

Aircraft to support our aviation training include 403 aircraft. Of these 29 are fixed wing and 374 are rotary wing. These aircraft, of course, are in the hands of an aircraft maintenance contractor which is unique, essentially unique throughout the service. You can see what I mean by unique when you consider our budget (Fig. 13). Out of our 245 million dollar budget for FY 78, a very large part is in major contracts. The 29 million dollar service contract for aircraft maintenance is probably the largest service contract in the Army.

Our training is divided into five general categories. These are: undergraduate training, which is initial entry type training for pilots; graduate training; specialty courses; and professional development (Fig. 14). Professional development, for example, consists of our two warrant officer courses. We have an aviation warrant officer advanced course and a branch immaterial warrant officer senior course. Our last category of training is nonresident instruction. We prepare all the materials for all the subjects we teach for worldwide distribution. Current enrollment is in excess of 7,000 students.

Undergraduate training or initial entry training is where the Army aviation program becomes very unique. We are the only service that takes individuals essentially out of high school and make pilots out of them. All the other services require at least four years of college. We take young people directly out of the civilian community, "off the street" if you will, and out of our military units and bring them into our initial entry program. We also bring commissioned officers from the Army into the pilot training program.

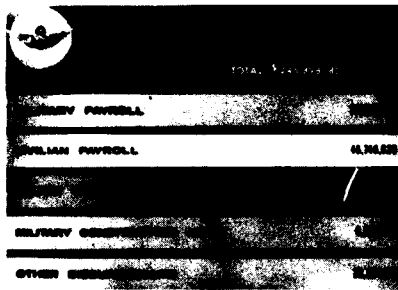

Fig. 13

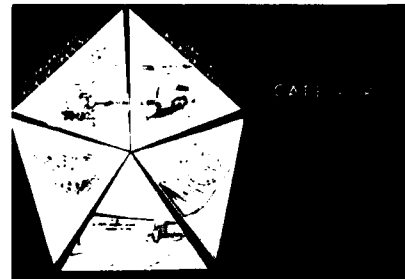

Fig. 14

The number of graduates we are programmed for in FY 78 will give you an idea of the scope of our operation (Fig. 15). Undergraduate training will have 879 graduates and graduate helicopter training will have over 2,000 graduates this year. In this number we have about 500 aviators who have been on extended ground assignments from 3-7 years. Ground duty is other than in an aviation position. We bring these aviators to Fort Rucker and refresh them before they go to their new aviation assignments.

We have a considerable output of enlisted students which this year should be over 4,000 students. The enlisted training consists of maintenance, air traffic control and flight operations courses.

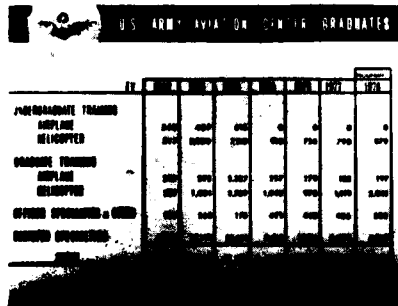

Fig. 15

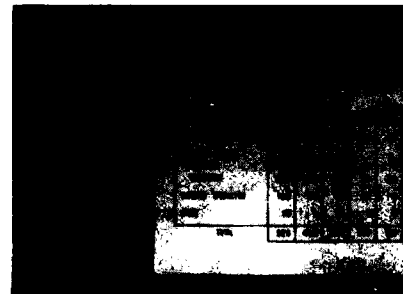

Fig. 16

We also have a very vigorous allied training program at our school (Fig. 16). Notable in this regard is our EURO/NATO course in which we have Germans, Danes, Norwegians and the Dutch. We have approximately 30 German students in training at all times with a small number from the other three countries. A relatively large number of Israeli students are also trained here along with students from numerous other nations. We have had students from 26 nations here at one time.

I am now to the point where I want to make some detailed explanations of the kind of training we do (Fig. 17). I would like to compare our present initial entry course which we started using in June 1977 to the previous course. The previous course consisted of 180 aircraft hours and 20 hours of UH-1 flight simulator. Our present course consists of 175 aircraft hours and 40 hours of UH-1FS time. I would now like to point out some comparisons between the two.



Fig. 17

Our primary training has been reduced from 85 hours to 50 hours. What we did was to eliminate most of the solo time except for the solo time in which very specific maneuvers are practiced by the students. In reality what we did was to eliminate those hours where we had student pilots going some place to have an accident.

Transition training in the UH-1 "Huey" has remained essentially the same. The major change in this phase is that we moved the cockpit procedures training into the academic portion of training instead of the flight portion.

In the instrument stage you can see one of our major changes--increasing simulator hours from 20 to 35. The Army in recent years has relied heavily on flight training simulation to the great advantage of proficiency and effectiveness in training as well as cost reduction.

We think we know how to train an instrument pilot best and here is how we do it. The student receives training first in the simulator for approximately two weeks. Then the simulator and aircraft are alternated until the last week of the course when all training is conducted in the aircraft. We are turning out better instrument pilots now than we ever had in the Army even though we have reduced this phase from ten to eight weeks and aircraft hours from 30 to 20. Overall, we think it is the best package effort anyone could put together on instrument flight training.

For the first time in the history of Army aviation, we have a night qualification course. Probably some of our more significant advances in overall combat capability of the Army lie right here. You know the type threat against which we will fly in a future war is that which we depict about the Soviet Union. A very mid to high intensity air defense environment, all kinds of lethal weapons many of which can be brought to bear against helicopters. We think we are going to have to operate much more at night. In our previous course a pilot at graduation had flown approximately 12 hours at night which was spread throughout the course. In the present course each student receives 20 hours of night just in the night qualification phase. If a student cannot fly at night he goes no further in this course. No one ever washed out in previous courses because they could not fly at night. There wasn't any way to define it; the hours were spread too thinly.

In the last four and one-half hours of the night qualification phase, every student receives training in night vision goggles. The students are taught the capabilities and limitations of the night vision goggles, a device in which the Aeromedical Research Laboratory has had great input.

For example, training with night vision goggles in order to make it safe requires increased emphasis in safety. The Aeromedical Research Laboratory developed filters which can be mounted on our night vision goggles which permit us to fly in the daytime as if it were night. We use the day filters to conduct our night vision goggles training in the combat skills phase of training. This is just one thing the Aeromedical Research Laboratory has done, and I think that by having the lab here at Fort Rucker as a member of our team has helped to facilitate that development.

Another new innovation in our initial entry course is the training of Aeroscout pilots. For the first time in Army aviation history we teach aeroscouts at Fort Rucker. In years past, all scouts were trained in their unit. An individual would go to flight school and learn to fly the Huey. When he reached his unit they would point to him and say you will be a scout pilot. Then the unit had to expend the time to train him to be a scout pilot. We are now taking ten students out of each IERW class and giving them 60 hours of aeroscout training in the combat skills phase to include transition into the OH-58 helicopter. The remainder of the class continues on to combat skills taught in the UH-1 aircraft. Students in both tracks receive five hours of UH-1 flight simulator training in tactical instruments.

What are tactical instruments? Well, it is basic instruments and it will teach you to fly in a stateside or European environment under whatever air traffic control system is in operation. Tactical instruments takes what a person learns in instrument training and applies the capabilities of the aviator and air crew to operate in the forward area of the combat zone. Whereas in our normal instrument training we are talking about taking an instrument flight from 4,000 feet above the ground on up within the capabilities of the aircraft versus tactical instruments where we are talking about being able to fly instruments 30 to 500 feet above the highest obstacle. Once the destination is reached, an approach, an instrument approach, to a small tactical beacon in the forward area of the combat zone is made.

The two areas which I would like to make sure you understand are that the frontiers of Army flight now lie in the night qualification phase and tactical instruments which we teach in combat skills. These are all based on a good basic instrument course.

For those of you who are sensitive to human behavior changes, let me now discuss some of the changes we have made since 1969 in our training program (Fig. 18). Primary training has been reduced from 100 hours to 50 hours. UH-1 transition has remained the same except for the cockpit procedures training which I mentioned earlier. Instruments has gone from 50 hours flight time to 20 hours now and from 7½ UH-1 flight simulator hours to 40 including five hours of tactical instrument training. Combat skills has increased significantly from 25 hours to 60. All this in a period of nine years.

I think you can see our emphasis has been on preparing the aviator while he or she is here in school for that environment in which the unit will fly against the Soviet threat.

I call it the ground environment; not the air environment.

COURSE DEVELOPMENT						
YEAR	PRIMARY	COPILOT	INSTRUMENTS	UH-1	COMBAT SKILLS	TOTALS
1969	100	0	50	7.5	25	182.5
1970	50	0	20	7.5	60	137.5
1971	50	0	20	7.5	60	137.5
1972	50	0	20	7.5	60	137.5
1973	50	0	20	7.5	60	137.5
1974	50	0	20	7.5	60	137.5
1975	50	0	20	7.5	60	137.5
1976	50	0	20	7.5	60	137.5
1977	50	0	20	7.5	60	137.5
1978	50	0	20	7.5	60	137.5
1979	50	0	20	7.5	60	137.5
1980	50	0	20	7.5	60	137.5

Fig. 18

OPERATIONAL BRIEFING  
SOVIET HELICOPTERS

Ralph P. Alex, President  
International Helicopter Committee of the Federation Aeronautique Internationale  
1037 Stratfield Road  
Fairfield, Connecticut 06432

Thank you, Colonel Knapp, for your very complimentary introduction. I enjoy coming to meetings like this where helicopters are the main topic and where fixed-wing aircraft will someday unfreeze and whirl their wings.

My discussion today will cover Soviet helicopter technology. I was introduced to Soviet technology in 1953. In 1959 as President of the American Helicopter Society and President of the International Helicopter Committee of the Federation Aeronautique Internationale, I visited the Soviet Union and was allowed to visit test bases, factories, and also to fly many of their helicopters and fixed-wing aircraft. This was the first time an American was allowed to do this. They also allowed me to take a great quantity of pictures. I returned to the U. S. with all this film undeveloped. The general comment on my return was, "I am sure they let you leave with undeveloped film because at some point they most likely x-rayed all of it and the result will be blank film,"--but it wasn't. Most amazing was the fact that every picture came out except the one roll where I forgot to remove the lens cover. It was also amazing that, while I am not a photographer, most all the pictures were of good quality.

Since this visit I have been continuously impressed by their progress in the rotary-wing art of helicopter production. They have been parallel with the U. S. since the development of the first successful helicopter--the Sikorsky XR-4 was delivered to the Army Air Corps in 1942. This helicopter is now in the Smithsonian Institute. The USSR began their helicopter development a few years later and over the past 33 years have become a major helicopter designer, producer, and user. Many different helicopters have been built and several in substantial production quantities. During the past 20 years that I have been President of the International Helicopter Committee of the FAI, the Russians have been members. Many years ago they told about the international helicopter competitions held in their country. These consisted of five events that comprised a training syllabus with pilots judged on points and precision flying. Finally in 1971, the Helicopter Committee had its first World Helicopter Competition in Buckeburg, Germany. The Russians were not able to enter. The Germans won the event. In 1973, a Second World Helicopter Competition was held at Middle Wallop in Great Britain. The Russians furnished a men's and women's team flying their Mi-1, a 20-year old helicopter. With their long experience training for the five events, they won the World Championship for men and women; and tied for first place in the team event with Great Britain.

I am now going to tell you a little about their development history and discuss some of their current and future plans which I was told about during our meeting in Paris in February of 1978. While understandably there is skepticism regarding some of their stated accomplishments and goals, I think that one must agree that they are well within the "state-of-the-art."

Fig. 1. Soviet Mi-1



Fig. 1 is a photograph of the Mi-1. This is the first of a design series by the Mikhail Mil Design Bureau. The helicopter is powered by a 525/575 hp radial piston engine which is a Russian version of the Pratt and Whitney R-1340. It has a three-blade rotor with steel tube-step tapered segmented spars with pin-joint splices; the leading edge is laminated wood; and the wood ribs are covered with fabric. This construction was progressively changed to eliminate splices and pinned attachments through the years; and finally, the blades used the same technology as in the U.S.--aluminum extruded leading edge spar and aluminum sheet pockets for the blade airfoil shape. This aircraft from the beginning of its development had anti-iced windshields, engine carburetor heat and rotor blade de-icing. The early versions used alcohol and the later versions used an electrical system. It has a scary starting system. It is a compressed air system with a storage tank. So, if the tank is empty, you

can't start. I asked, "Why don't you use an electrical system?" The reply was, "We can't afford it; and also, there is plenty of air everywhere. All you have to do is compress it." They have built over 3,000 of this model and trained over 9,000 pilots for their military and reserve forces. At present they are being used by their many aero clubs for proficiency training. Many are in extended storage. Gross weight of this helicopter is 4,200 lbs, cruise speed about 85 knots (100 mph).

Fig. 2. Soviet Mi-4  
"Hound"



Fig. 2 shows the Mi-4 which was Mil's next larger effort. The aircraft is very similar and slightly larger than the Sikorsky H-34 (S-58). It is powered by a USSR version of the Wright R-1820, 1450 hp engine. It has a four-blade rotor system and originally used steel tube spars and built-up wood leading edge and fabric covering. Subsequent models have aluminum extruded spars and aluminum pockets. The blades are electrically de-iced as is the windshield. The tail rotor is wood construction. A radar altimeter is standard equipment on this machine as it is on all helicopters operating in the Soviet Union. The climate in the USSR is so varied that there is a constant need to be prepared for icing, whiteout, IFR weather, and a minimum of navigation aids. Therefore, a radar altimeter is considered basic equipment. They also have a very simple navigation system. It consists of a basic three receiver ADF. It receives three signals from positioned transmitters in the field and it automatically computes position from these three fixed points. A continuous X and Y coordinate display instrument provides continuous position update. The instrument can be stopped to transfer position to a simple running map kneepad system. This navigation system is absolutely simple, very lightweight, and quite accurate. The radar altimeter has been there for years. They have built over 4,000 of these machines and they also have licensed other countries to build this machine. They have allowed Nationalist China to build them. Nationalist China has built about 80.

Fig. 3. Soviet Mi-6  
"Hook"



In 1957, they decided that the U. S. was coming along on big helicopters, and they went ahead and built this machine. It was built in 1957 and shown to the public and the western nations in 1959. Since then, they have built over 500 units. This helicopter holds several world speed records. It still holds the world speed record for 1,000 km closed course, 186 mph average speed set in 1959. It can carry up to 80 troops, it carries two six-by-six trucks and has two 5,500 hp flat-rated turbines. The turbines rating at sea level, for five

minutes, is 7500 hp. Again, dual radar altimeters, weapons systems mount in the nose, and quite a solid aircraft--one that they gave away to many of their satellite countries. They derated the machine for normal use to improve reliability. Instead of allowing it to fly at 97,000 gross, it flies at 83,000. They have very few spare parts. When the spares disappear, since there was no follow-on support promised, the satellite countries don't normally fly them very much after that. So, most of their friendly sister nations that have had the Mi-6's have flown them for a period and they go into storage and they stay there. What the Russians are going to do about that, I don't know. This 114-foot diameter rotor with 122 rotor rpm has flown on a 100 km closed course for an official world record at 211 mph. In the United States, the Black Hawk set the 15/25 km world's speed record at 220 mph. To break the 100 km USSR record of 211 mph would require flying for five or six minutes at very high speeds and would require boosting the engines to 40 or 50 percent over maximum power. The attempt was canceled. The feat of 211 mph for 100 km is still held by the Mi-6. Incidentally, all these machines have been produced in quantity. All these machines, even though they are in civilian dress, are military--it depends on what mission is assigned. As to the interior, it is quite a good interior; same type of construction as here. Today they have the biggest hydraulic presses for forging titanium, aluminum, and steel in the world. They have a 75,000 ton press and five 55,000 ton presses so they can make forgings for greatly increased production rates, and they are ready for it now.

Fig. 4. Mi-2



This machine was built from the Mi-1. It has two small turbines. What did they do? When they heard us discussing the facts and by reading our magazines and literature, they learned that when you have to have the helicopter operate in all weather, very low and slow, and near troops and people, you must have it multi-engine. This one has two 375 hp turbines. In 1956 they decided to develop a family of turbines. They built 375 hp turbines, 800, 1500, 2000, and 4000 hp sizes. They got them all to operate within a period of five years. Some of them not as successfully as others, but there were about 4,000 of these machines built. Production today is at a rate of 30 a month. The main manufacturing facility is in Poland. The Mi-2 flies a little faster than the Mi-1, but basically it is the Mi-1, turbinized. I asked what it was used for as it is completely outfitted inside as an exec luxury machine. I asked, "Why do you have plush interiors?" He said, "We have executives in Russia, too. Why do you think that we haven't?"

Fig. 5. Mi-10  
"Harke"



This is the Mi-10 which they built from the Mi-6. Fifty of these machines were built. We think it takes after the Sikorsky Crane, but it was developed about two years later. It has a rear-facing operator control with a sling that can carry 20 tons on the hook. It has no hoist. It has the same 114-foot rotor. It has flown 215 mph. Considered not too successful, because of each mission to transport missile components, it sort of fizzled.

Fig. 6. Kamov-25



Kamov is a coaxial man and he thinks tail rotors and tail cones and tail fuselages are a danger and not necessary. They contribute to parasitic power so he puts coax rotors and eliminates tail rotor losses. He has built five sizes so far. This had 800 hp engines, originally. Today these are rated at 1500 hp. The gondola, the belly nose section there, is for the rear-facing operator who crawls in there so that he can control the 3-ton load they can pick up on the sling from the carriers and, also, from the smaller missile ships that it has to supply from the carriers and from the supply ships. It can carry 11 troops; it has flown 175-185 mph at times, though officially the Russians say it won't fly over 125. It is carried on the Moskva helicopter carrier. It has anti-ship missiles on it now. It has dipping sonar and good radar out to line of sight. They tell me that with some of the IR equipment on board it can pick up line of sight up to 80 miles at about 12,000 feet. It can pick up a two degree surface temperature change on the water. This is what the Russians tell me, though they can't tell me much about what the two degree difference means. They built about 120 of this model.

Fig. 7. Kamov-25



You can see they have electric folding rotor blades. Now they are putting the blades closer together and making kneeling landing gear to have smaller hangar spaces on the deck, so they don't have to have such a high compartment or hangar space for the machine. The machine weighs about 16,000 pounds and has a 3-ton payload, and about 2½ hour endurance.

Fig. 8. Kamov-26



They built this small machine and it is called a Kamov-26. It has piston engines, carries about one-half ton of cargo. They built about 4,000 of these and it is used as a training machine and for agriculture and spraying. Also, in the farmlands, it is used for carrying minor supplies, cargo and spare parts.

Fig. 9. Mi-8  
"Hip"



The Mi-8 was built, we think, to match the U.S. Sikorsky S-61, a 24-30 passenger transport. They only built 110. They tried to market it in western Europe; they did not succeed too well. The machine has some world records. It was flown 180-190 mph by women for world records on long distances. Today it is used as a commercial transport and a later one as a troop transport. You will see pictures of some movies showing it in operation in East Germany, and I think it would be interesting to you. It has two 1500 hp flat-rated engines, weighs about 23,000 pounds, and carries 27-30 passengers and 22-25 troops. I said, "Why do you carry 25 when a squad is much less and why don't you have a squad carrier like the U.S.?" They said, "A squad must be very flexible. It might be required to be 20 or 10, but we have to have it large. You might want a Pathfinder crew or PR people to accompany a squad."

Fig. 10. V-12  
"Homer"



They went ahead and built the V-12 in 1970. They began building this machine in 1968. In 1970, they flew it. It has two Mi-6 rotor systems, one on each pylon on each wing panel, and each rotor can carry about 95,000 pounds, but they have improved them so this aircraft flies at a gross weight of a quarter million pounds. It will carry 300 troops. It is the equivalent of the Soviet An-22 transport. As a transport it goes into the theater, stays in the theater, and delivers the equipment the big airplane brings into the rear of the forward areas.



Fig. 11. V-12  
(In flight)



This is the V-12 in flight. Some of the flights it has had back from the Paris air show have been unusual. There is a man that sits way on top of the pilot's office in a little cupola and watches both rotors. When they get out of phase and begin to vibrate and cowlings begin to open and fall off, he advises the pilot and they land. I told them that it means the ship must be underdeveloped. They said it was very well developed except at times when it behaves that way. This is the type machine that can fly at 120-125 knots and probably faster, but they do have that unsymmetrical loading that causes a resonance, and they don't dare try to fly it too fast because they won't be able to slow down in time. They are building six more.

Fig. 12. Mi-24  
"Hind"



This is the Mi-24 gunship that they decided to build, and they built it basically from the Mi-8. It has a 72-foot diameter rotor, two 1500 hp derated engines that can put out at least 2500 hp each. It has wing stations for pods for 57 millimeter free (unguided) rockets, folding fin, and also, the outboard stations are for the bombs, missiles or other ordnance. In the front, the nose, is the gunner/copilot or he acts generally as copilot. He has a formation stick and he can take the aircraft over for some missions. In back, side by side, there are two pilots. In back of them in the cabin is a fire control or an artillery or a missile adjuster, and he acts like an artillery adjuster. He receives data from forward Pathfinder units; he gets information as to coordinates of enemy equipment, either tanks or armor of some kind; and he will then plot that information and transmit it to the gunner up forward who will then fire the missile. This capability has only been available within the last two or three years. This Mi-24 has been flying for four years now. These missiles that they are firing in this manner are not wire-guided; they are like the Hell Fire, fire and forget, up to 12-15 km. He gives them the coordinates, they fire in the general direction, and he can see the missile traveling on the CRT as he has a television sensor in the nose. In the last stages target approach, terminal guidance trajectory, he can watch the target, put the missile on target, activate the television recorder, watch the missile hit the target, and come home with that information, or rerun the tape on the screen and see what the missile really hit. They say it is wonderful for recording serial numbers of equipment they hit and they even look carefully at who is in the aircraft. I'm not sure they are telling the truth, but at least they have a good line. Basically, that is what they have now. The only other man they have in the aircraft most all the time is the crew chief. It is a five-man crew aircraft. In the movies, in this early model, you will see a cabin space big enough to carry 14-15 troops besides the ordnance and the five-man crew. It weighs 25,000-26,000 gross when it takes off for its mission. It has about 2½ hours of fuel. Some of the information that the Russians say we have erroneously gotten is that at that gross weight it has a range of about 80 km. They say, "Don't you believe that. We will never go anywhere without full tanks, it is uneconomical." The other thing they say, "with this machine, you must keep 12-15 km back of the MLR and back of the target because if the target is close enough to fire missiles at you, the Mi-24 is too big

a machine and any loss rate is unacceptable. We cannot lose our crews, they are few, and they are very important. They are very highly trained. We must keep them alive so we keep the aircraft far back and will not engage any targets close enough to where we might get return fire that might be effective from the other side." This is their philosophy. Initially, they built about 80 of the Mi-24. About 40 were in East Germany for the first couple of years and there are many more there now. They stopped production on this machine after about 200. The next ones that you will see are the machines that are in production now at rates up to 30 a month.

Fig. 13. Early version of Mi-24



This is the old machine, the early version of the Mi-24. The forward area mounts a nose chin turret; the landing gear is retractable. They said the gear must be retractable because they are going to have 360 degree fire from the turret. This is so they can sweep an azimuth of 360 degrees and fire at targets to the rear.

Fig. 14



This is a smaller machine with a 58-foot rotor and weighs about 15,000 to 16,000, same engines. Lately, in a clean version, it made world records in 1,000 km closed course at 200 mph and 500 km closed course at 207 mph. It carries anti-ship missiles and it has carried them in East Germany--in training maneuvers. I asked them why they do that; they are not flying at ships. Well, it is a good place to train, and we are amongst all the other gunships and gives them the type training we want. What type training is that? Mainly it is contour flying, absolutely in the nap-of-the-earth, in defilade for protection. So this is a smaller machine, very high speed. Incidentally, the women flew it and they made five records. They timed a climb to 6,000 meters (about 19,000 feet) in 4½ minutes. It is a climbing fool and reliable. I said, "Why do you have the women pilots fly it?" They answered, "They are perfectly competent, and we want to show you westerners that we don't need SAS and automatic flight stabilization; vibration is contained."

Fig. 15. Mi-24

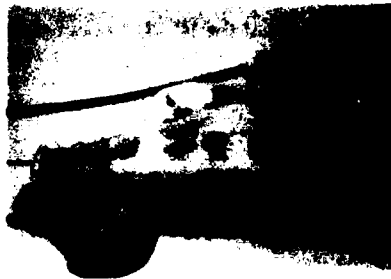

This is an underview of one of the latest machines with the bubble turrets--side view of the machine. This is one of the earlier versions, the number three version, and the side view changed somewhat. This is the earliest machine, that first Mi-24 with the side-by-side pilots and the forward observer. This is the squadron you will see in the movie, so we won't harp on it; but it has the big turret with the 20 mm cannon, gatling gun in the nose, and IR direction fire control, radar, and also a laser range finder with the turret. Once you find the target, the laser range finder will automatically hold on to it as an optical contrast seeker and sweep the target at very high rates of deflection. They claim it is very effective and they have used it. If you can look and see the cockpits, they have bubble canopies now instead of the flat non-glint glass that they had. They said non-glint doesn't work because it flares and glares too badly inside. So they now have canopies, which is the best of two worlds but still compromised, and right now they say they are testing a canopy that retracts in the hover or in the hover position where they pop up and fire. Under this condition, they have no canopy at all. That gives you three things: (1) no glint, no glare; (2) a feeling that you are out in the battlefield area, a more secure feeling; and the other (3) no weapon is going to hit them due to deflection of the round, either rifle fire or cannon fire, where even shrapnel might hit the cockpit canopy and that spall could incapacitate the pilot. If he has no structure or canopy the only time he can get incapacitated by a hit is if he is hit directly, which could happen even if the canopy was there. So, they think they have the best of three worlds, and it is an unusual concept.

#### COMMENTS BY SPEAKER

There are two other things I would like to tell you about the Russians. One is that they would like to tell you that everything is successful and everything they are doing is operational and with the long range missile keeping far away from the MLR, and I think that is a pretty valid one. The other basic thing that they just told me in February is that they are developing four RPV's because they cannot allow, in their way of thinking, the experienced crews of all their aircraft to be exposed to fire when they are going against sophisticated weapons. The losses will be untenable and totally unacceptable. They are making RPV's of the mini, the gunship, and will make them non-manned so that their gross weight will be about half of the present machines and the cost will be about a quarter. That is their goal. They have developed multi-fuel type engines in the small category, and it is very lightweight and will weigh less per pound horsepower, and they are now actively developing a 3,000 pound lift gunship, a 12-15 troop equivalent RPV remote power vehicle that would carry cargo, fuel and other supplies into forward areas. As for manned aircraft, they will only move forward when the area is sterile and it is safe to enter, and if it is safe they will put their manned aircraft into the area and their troops. These are the combat tactics they propose. It was explained to me quite in detail at their meeting, and it is pretty hard in two days to get any real feel for it, but that is their view. Right now they are building 30 gunships a month and 10 transports a month, and they say that they cannot build too many more than that a month. During last year's combat maneuvers, they experienced very large loss rates and came to the conclusion that they must develop these new tactics. The last thing to remember is that their aircraft is about the same as ours, a little more rugged, and with speeds of 200 miles an hour, with their combat performance as we saw in the short film, with some of the things we saw in our world championships and other places, that their combat performance is quite acceptable. Thank you very much. it was a pleasure to be here.

OPERATIONAL BRIEFING  
ATTACK HELICOPTERS

COL John C. Bahnsen  
TRADOC System Manager, Attack Helicopters  
United States Army Aviation Center  
Fort Rucker, Alabama 36362

My job is a very simple one--I am to insure that the American helicopter force takes very few losses and make sure the Russians have very high losses.

I am going to talk with you about some of the things we are doing in the attack helicopter business. The areas I will discuss with you are as follows:

- Total Attack Helicopter Weapon System Management
- NATO Battle
- Helicopter Air-to-Air Warfare
- Unique problems in Attack Helicopter Employment

"JAWS" is the acronym for the Joint Attack Weapons System (JAWS) tactics development and evaluation (TDE) conducted by the U. S. Army and U. S. Air Force utilizing the Air Force A-10 attack aircraft and Army attack helicopters. The film I will show you will depict how we integrated the A-10 close air support aircraft and attack and scout helicopters. I served as Army director of the Joint TDE.

(JAWS FILM SHOWN)

The tremendous stress placed on the Air Force pilots positioned in the nose of the A-10 was measured by the Air Force. The stress placed on the attack and scout helicopter pilots was not measured. I wish we had done so; it was a failing on our part.

Our job is attack helicopter total system management which includes personnel, tactics, hardware, training and logistics. We know less about the personnel area than the other areas just mentioned where we know a great deal. Herein lies the challenge to operational helicopter aviation medicine. We must learn the impact on human bodies and minds of our new weapon systems and employment thereof.

The principal attack helicopter missions are as follows:

- Anti-armor
- Cavalry
- Air Assault

Our primary mission, of course, is anti-armor. The traditional mission of cavalry includes the economy of force missions, reconnaissance and security. Air assault missions are supported by attack helicopters for security and suppression of enemy personnel and air defenses along the assault route.

My discussion of the NATO battlefield will include only the anti-armor mission. The NATO central battle scenario we will face looks like this--two US tank companies (approximately 30 direct fire anti-tank weapons systems) opposed by two enemy regiments with approximately 210 direct fire weapons systems, a 7-1 ratio. This is a most difficult situation at best. Each US weapon would have to destroy seven enemy weapons as they close within engagement range.

Reduction of enemy targets by engagement at longer ranges can be conducted by a platoon of attack helicopters each carrying 16 Hellfire missiles. If two attack helicopter platoons could be brought to bear on the force of 210 enemy systems with 90% effectiveness, we could attrit the enemy to a 3 or 4 to 1 ratio which is reasonable to defend against. This is a worse case actual example from a sector of the European battlefield. Herein lies the reason for having highly capable attack helicopters available on the battlefield.

Our Air Combat Engagement (ACE) tactics development evaluation (TDE) was initiated here at Fort Rucker. It was helicopter air-to-air development work, pure and simple. I have repeatedly stated that the first hero of the next war will be a helicopter pilot who encounters a flight of Hind helicopters (depicted in the film) and shoots a handful of them down. The ACE TDE was conducted to evaluate tactics required to counter the enemy helicopter air threat; to develop an attack helicopter counter air training program; and to examine weapons requirements for the air-to-air mission. Lessons learned in the training field were basic but important. Crew integrity proved to be vital. We cannot take any two pilots from the flight line or unit and do well at air to air. They have to be a team; they have to train together. Some pilots were paired up on a short notice basis and almost invariably they lost the air-to-air fight. A high degree of weapons and switchology proficiency is needed. Range estimation is a big problem. We need range finders to adequately employ our weapons. When

NOE flight was required, the pilots often lost track of the air-to-air mission or when pressed with the air engagement, they often lost track of their location. Trying to accomplish two distracting missions at the same time (air-to-air engagement and NOE navigation), human capability is challenged to the utmost. Common use terminology for the air-to-air mission does not exist and must be developed.

Tactically, we determined that the best flight mode is to remain at terrain/NOE flight. Combat action is very fast. If you skyline yourself you are much more vulnerable. The necessity for coordination with the air defense elements was examined and must be evaluated further. An evaluation of our current weapons available on the attack helicopter showed that the 7.62 mm gun and the current 2.75 inch rocket system were of little value. Some type of "heads up display" is required for fixed forward firing weapons. A fire control system for an on-board cannon will probably be required. Several fire control switches would have to be moved to other locations in the Cobra cockpit to facilitate air-to-air engagement. They have to be located where they can be felt by hand rather than requiring the pilot to bring his back into the cockpit. A simple protective coating on the helmet sight attachment is also required to keep the crew from scratching the canopy.

The attack helicopter employment problems of concern to the medical community include fatigue assessment and impact; day-night crew integration training and procedures; crew communication difficulties; laser protection; life support system adequacy; and requirements for night vision capabilities. The fatigue factor at the NOE environment is high but unknown and unmeasured. Will our new helicopters outfly our crews, especially when we have a day/night 24-hour mission? Integrating our crews for day and night missions will present problems. We need reliable but simple methods of communication in the NOE environment and during radio silence. The impact of dark adaptation on our crews and our night vision capabilities present a severe challenge to mission accomplishment.

Finally, I show you the list of aviation medicine concerns that are worrying the attack and scout helicopter force today:

- Personnel Fitness
- Man-Fighting Machine Interface
- Impact of Stress on Mission
- Night Vision Systems/Night Operations
- Aircrew Fatigue Aspects
- Human Factors Engineering

We are thinking seriously of using separate day crews and night crews and perhaps a manning ratio of up to two pilots to one cockpit seat for our new 24-hour capable attack helicopter. How we get these will depend to a great deal on the medical research identifying the fatigue and stress factors and other factors to be faced at NOE flight.

OPERATIONAL BRIEFING  
AEROMEDICAL EVACUATION, EUROPE

Thomas C. Scofield, Major, MSC  
Chief, Aviation/Operations Branch  
Headquarters, United States Army Medical Command, Europe  
APO New York 09102

INTRODUCTION

Distinguished AGARD panel members and guests, it is a pleasure for me to be here this afternoon to provide you with a brief picture of the United States Army Medical Command, Europe, and aeromedical evacuation within the European Theater 1978.

During the next few minutes, I would like to review some of the more significant actions and events that have taken place in Europe; review how we are organized for our mission in Europe; review the United States Army doctrine governing medical evacuation; and address two issues concerning the use of helicopters in a high intensity conflict in Europe.

For the purpose of this briefing, I will concentrate on the field medical evacuation units, which have the responsibility of patient evacuation.

The United States Army field medical assets in 1964 consisted of two hospital centers, three medical groups, six medical battalions, evacuation hospitals, surgical hospitals, ground ambulance companies, and several smaller medical units to support the U. S. Forces. Because of numerous studies, budget restraints, and congressional action, such as the Nunn Amendment, the medical capability in Europe has been greatly reduced (Fig. 1). From 1965 to 1967, one hospital center, three medical battalions, two evacuation hospitals, five ambulance companies, one clearing company, and one medical depot were eliminated as well as the two medical holding companies and the medical holding detachments. However, during this period we gained an air ambulance company and two helicopter medical detachments as well as one medical brigade (Fig. 2). From 1968 through 1971, a medical group, all of the medical battalions, and several evacuation hospitals, surgical hospitals, and ground ambulance companies were eliminated from the total force (Fig. 3). From 1972 through 1974, medical assets were further reduced. However, two helicopter medical detachments were added to compensate for the loss of the ground ambulance companies (Fig. 4). The years 1975 through 1978 were characterized by still further reduction in medical assets (Fig. 5).<sup>1</sup>

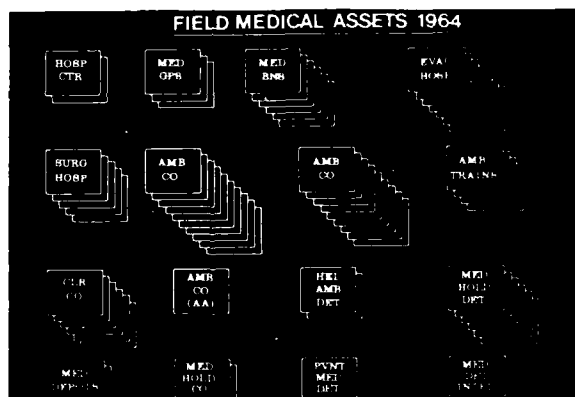

Fig. 1

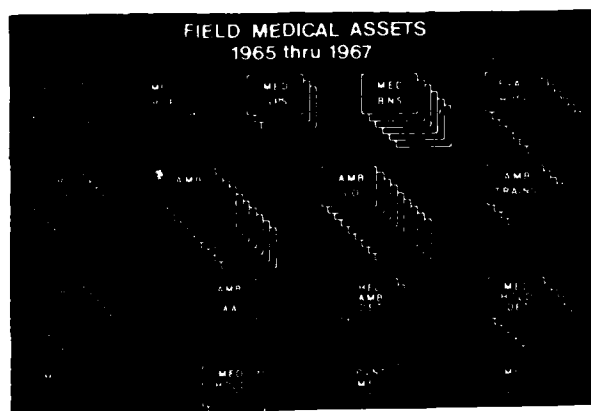

Fig. 2



In addition, outside the American sector, are five MEDDACs (Fig. 6). Various field units, under the command and control of the 30th Medical Group, a subordinate command of MEDCOM, provides the aeromedical evacuation capability within Europe. Today, within Europe, we have one air ambulance company and four air ambulance detachments.



Fig. 6

The air ambulances are stationed in seven permanent locations from which they provide support to all the MEDDACs within the Federal Republic of Germany. The Headquarters, 1st and 3d Platoons of the 421st Medical Company (Air Ambulance), are located at Nellingen. The 4th Platoon of the 421st Medical Company is located at Darmstadt. The 2d Platoon of the 421st Medical Company is located at Schweinfurt. The 159th Medical Detachment (HA) is located at Fuerth, Germany. The 15th Medical Detachment (HA) is located at Grafenwoehr. The 236th Medical Detachment (HA) is located at Landstuhl. This provides MEDCOM with a total of 49 UH-1H air ambulances (Fig. 7).

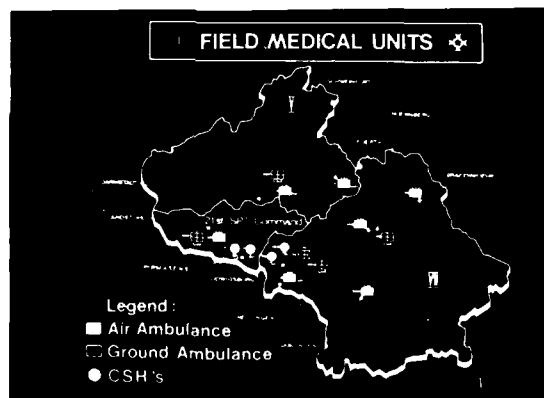

Fig. 7

There are four ground ambulance companies in Europe. The 651st Medical Company (AMB) is located at Ludwigsburg; the 42d Medical Company is at Nuernberg; the 557th Medical Company (AMB) is located at Darmstadt; and the 583d Medical Company (AMB) is located at Landstuhl (Fig. 7).

Aeromedical evacuation of patients in Europe follows basic U. S. Army doctrine, which governs the medical evacuation of patients from the most forward facility of the evacuation system--the battalion aid station or field site pick-ups to the hospitals in CONUS. There are three zones in the aeromedical evacuation system--the forward combat zone; the rear combat zone or communication zone (COMMZ); and the zone of interior (Fig. 8).

The Army is responsible for evacuation of patients within the combat zone. The primary means of evacuation for the U. S. Army within this zone is the UH-1H helicopter air ambulance. Patient evacuation is organized into four levels extending rearward in an integrated and continuous system. Each level, from unit to COMMZ, provides a greater treatment capability than does the preceding level (Fig. 8).

The organization of medical support is flexible and will be influenced principally by the tactical situation. Composition will vary widely with different situations and operational environments.

There are five levels of medical support:

- Unit level, which is an integral part of the 2d level division.



- Division level medical support.
- Corps level medical support.
- Communications zone level medical support.
- Zone of interior.

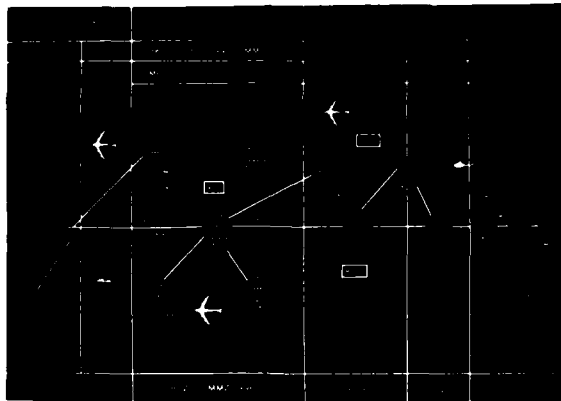

Fig. 8

Unit level medical support is the first level and is organic to division. These small medical units (platoons or sections) perform three primary functions. The first is to provide aidmen to the infantry, armor, or mechanized company of the battalions. The second is to establish and operate the company aid posts and battalion aid station, and the third is to provide evacuation from the point of injury back to the aid station, aid post, and/or battalion aid station.

The division level medical support is the second level and is provided to the entire division by its organic medical battalion. The medical battalion operates the division clearing stations and evacuates the patients from the forward battalion aid station.

The third level of medical support is corps level. The corps employs air and ground medical evacuation assets to evacuate patients from the divisional medical clearing stations to the hospitals located in the COMMZ. Of note here, the air ambulance may by-pass any level of medical support; for example, the battalion clearing station, and go directly to the combat support hospital if the condition of the patient is urgent. This decision is made by the pilot-in-command of the air ambulance in concert with the medic on board the air ambulance. This is an essential factor in rapidly moving the patient to the facility that can best treat the type of injury sustained by that patient.

The fourth level of medical treatment and evacuation is the communication zone. All medical units in the communication zone are assigned to the medical command. Presently in Germany, patients are evacuated from the corps area utilizing ground and air ambulances. Rail and U. S. Air Force tactical aeromedical aircraft may or could be used in time of war. These patients are moved to the general station or field hospitals located in the COMMZ.

The final level of support involves movement of patients from the COMMZ to the zone of interior--CONUS. This level of evacuation utilizes United States Air Force evacuation aircraft. These patients are taken to named general hospitals, named post hospitals, and other federal hospitals in CONUS. This completes the chain of medical evacuation.

Two of the issues expressed by critics of helicopter aeromedical evacuation in Europe are that the helicopters will not be able to survive on the battlefield because of the Warsaw Pacts anti-aircraft capabilities and fire power. The tactics developed here at Fort Rucker and the techniques employed and adopted insure that we can and will survive in this environment, if we train properly. Additionally, weather has been expressed as a factor that will prevent helicopter operations in Europe. Presently, we labor under peacetime weather restrictions which are there for safety. In time of war, these restrictions will be reduced or eliminated. Weather may well be a helpful factor to us--what the enemy can't see, he cannot hit. Further, weather may limit his tactical movement. Proper training and continuous evaluation of instrument efficiency will insure that we can safely perform in adverse weather conditions. I believe we can survive on the modern battlefield, if air ambulance assets are used properly, and that we will evacuate as far forward as the tactical situation dictates; however, mismanagement and improper employment of air ambulance assets will severely degrade our evacuation capability. The medical family must constantly review and reemphasize the proper use of air ambulance assets. Air ambulances should be utilized to evacuate emergency and priority cases which must be evacuated immediately to save life or limb. Air ambulances should not be used to evacuate minor illnesses. There is a continuous need to train tactical personnel and medical personnel in the proper and most effective method of evacuation.

All indications are that the next conflict will be highly lethal. The conflict may well be characterized by:

- Higher rate of casualties.
- Fewer hospital beds.
- Scarce medical evacuation assets.
- Longer distances for evacuation.
- Congested and interrupted main supply and evacuation routes by refugees and tactical units.
- Shortage of physicians and specialized surgical teams.
- Consumption of large amount of supplies.

These conditions dictate proper employment of air ambulance assets.

The keys to success for successful evacuation in this environment are:

- The proper utilization and the proper mix of air and ground evacuation vehicles.
- Evacuation of patients as far forward as the tactical situation permits by air. If the severity of the injury is such that air evacuation is warranted, then that option should be considered in concert with the tactical situation. If the injury is minor, ground evacuation is advisable.
- Mating the patient with the physician best capable of treating the patient's particular type injury as quickly as possible.
- Orchestrating patient flow to treatment facilities.
- Cycling medical aviation units in and out of combat regularly to maximize efforts without degradation of aircraft and crew availability rates.

Further, to meet the challenge of the modern day battlefield, we need helicopter aeromedical research. From the beginning of flight, man has experienced physiological problems which have limited his ability to operate his aircraft safely. Each new aerial development has created new problems. To survive and evacuate our patients, we need the aeromedical research scientists--we need answers to questions concerning:

- Fatigue.
- Night vision devices.
- Better instrumentation specifically designed for helicopters.
- New and better life support equipment designed for helicopter crews.
- New and better on-board medical equipment specifically designed for the helicopter environment for en route treatment.

The challenges are there. We need the aeromedical research scientist's help to solve these problems.

In the past few minutes, I have given you an overview of the Medical Command, Europe, discussed the medical evacuation doctrine, and addressed a few issues concerning the use and employment of helicopter air ambulances. We, in Europe, look forward to the next year with great anticipation, realizing that there will be new ideas, sweeping changes, and perhaps a reorganization or two.

Thank you for your interest and time. This concludes my briefing.

#### REFERENCES

1. George E. Chapin, Jr., "Medical Support" Briefing Presented to the Association of the United States Army, Garmisch, Germany, 17 April 1978.

OPERATIONAL BRIEFING  
SEA, CARRIER, ANTISUBMARINE OPERATIONS

Daniel R. Bilicki, CAPT, US Navy  
HS Wing One  
Naval Air Station, Jacksonville, Florida 32212

Helicopter Antisubmarine Wing One is located at the Naval Air Station, Jacksonville, Florida, and has administrative control of seven helicopter antisubmarine squadrons. In this capacity the wing controls approximately 65 SH-3, Sikorsky Sea King aircraft. These aircraft, assigned to the individual squadrons, deploy aboard the Atlantic Fleet attack aircraft carriers to provide antisubmarine warfare (ASW) protection for these ships.

The threat we are immediately concerned with is the Soviet attack submarine, be it nuclear or conventional powered. The quiet, elusive nature of the prodigious Soviet attack submarine is a constant threat to the CV, its associated task force, international merchant shipping, sea lanes, and harbors throughout the world. Only since 1959 has the Soviet Union placed sufficient emphasis on submarine production that this modern and powerful underwater weapon system has become the major strength of their Navy. Their submarine force presently consists of nearly 400 units, which when compared to the U. S. force is larger and more diversified. The versatility of the modern Soviet submarine poses a multiple sea going and land based threat. This includes: torpedoes from attack submarines at close range; cruise missiles from attack submarines at 15-300 miles; and ballistic missiles that could destroy a city such as Seattle, Washington, from an underwater firing position off the coast of New Jersey. It is evident that the Soviet submarine poses an immediate and formidable threat to national security and world peace.

Our mission specifically as Helicopter Antisubmarine Wing One is to nullify the awesome and everpresent threat by means of antisubmarine warfare tactics. Antisubmarine warfare presents a significant challenge in that 70% of the earth's surface is covered by water. Through systematic precision our highly trained professionals execute the four phases of ASW: search, detect, identify, and destroy with accuracy.

The CV, a vast and mobile floating arsenal, measuring over 1000' long and 90,000 tons, is a self-contained floating air station. It is home for over 5000 men and about 100 aircraft, which need to be fed, fueled, and maintained to do the task at hand. It is, however, an extremely vulnerable and highly prized target. The very noise it puts in the water is extreme and distinct, enabling the Soviet attack submarine to detect, identify, and track it with ease. The relatively small complement of capable ASW helicopters on board the CV provides it with superb ASW protection out to 50 miles. The range can be extended by in-flight refueling; however, other platforms prove to be more effective search vehicles at extended ranges. The SH-3's quick response, rapid localization and timely kill capability utilizing sonar, magnetic anomaly detection equipment, sonobuoys, and homing torpedoes are unprecedented.

The H-3 platform provides for compact placement of sensor and weapon packages. Mark 46 torpedoes can be mounted port and starboard. Marine markers, or smokes, are in the aft section of the port sponson. The dipping sonar is housed in a central well in the underside of the aircraft. The sonobuoy launcher is located in the after section of the cabin and can be operated electrically from the cockpit. The mad towed body and reeling machine are carried in the aft section of the starboard sponson and are particularly effective due to their trailed position below and aft of the aircraft, removing them from self-induced aircraft interference. Sonar evolutions are conducted from a hover. The sonar transducer can be positioned at various depths, has active and passive detection capabilities, can provide bathythermograph information and underwater communication.

The H-3 can launch an attack on information provided by its own sensors or on information gained by coordinated operations with other antisubmarine sensor platforms. The SH-3's versatility and unprecedented localization accuracy, coupled with its unique ability to launch an active homing torpedo from a hover, gives the helicopter a distinct advantage over other ASW platforms. It is able to flush the sinister hunter from his den and deliver a precise, timely attack on the enemy submarine. Crew coordination and discipline in the multipiloted aircraft are paramount in the safe and successful completion of all H-3 missions, especially the demanding night, all-weather ASW operations. Each member of the ASW team plays a significant role in the successful completion of the total ASW mission. As an integral member of the ASW team and in its unique fleet support role, the SH-3 provides an inexpendable service to the Navy's modern fleet. The versatility, vigilance, and valor displayed by the men of the antisubmarine helicopter squadrons have won the ASW helo a permanent place in the Navy's antisubmarine force.

## RESCUE HELICOPTERS IN PRIMARY AND SECONDARY MISSIONS

by

B.Gorgass, G.Frey, W.Stotz  
Rescue Center  
German Army Hospital  
Mähringer Weg 105/1  
7900 ULM, FRG

and

G.Kugler and I.Karger  
Allgemeiner Deutscher Automobil-Club-e.V (ADAC Zentrale)  
Baumgartnerstrasse 53  
8000 München 70, FRG

### A. INTRODUCTION

During the Vietnam War, the military medical service and the civilian rescue organizations in the Federal Republic of Germany noted with admiration that the US Army was able to fly every wounded person, with few exceptions, to the final unit for treatment within 40 minutes from the time the injury occurred. Thus the American soldier had the opportunity, under combat conditions, to be transported more rapidly and with more care to a place where he could receive clinical treatment than many of our civilian emergency patients in peacetime. The positive medical experience of the American medical service with its own ambulance helicopters were a decisive reason for starting to use helicopters in the civilian rescue service in the Federal Republic of Germany on a trial basis in 1967 and 1968 through the joint efforts of the various rescue organizations, the German automobile club (ADAC), public authorities and the Federal Army.

Despite many inadequacies, initial organizational problems, inappropriate medical equipment and insufficient space in the aircraft, the results of the experiments were so encouraging that in 1970, ADAC in Munich and in 1971 the Federal Army in Ulm began to set up permanent rescue helicopter bases. By now, the entire area of the Federal Republic of Germany is virtually covered by a network in which 24 rescue helicopters are operated.

### B. RESCUE HELICOPTER BASES IN THE FEDERAL REPUBLIC OF GERMANY

The size of the area of operations is determined primarily by the structure and geographical distribution of hospitals and special clinics as well as the population density and - which is also important - the airspeed of the helicopter. All rescue helicopters are stationed at well-equipped clinics. The experience of the various centers confirms that in a relatively densely populated country like the Federal Republic of Germany, regions with a 50 km radius are suitable and practical as areas of operation for rescue helicopters. This is because all aircraft can reach the periphery of the area within 10 minutes.

Some areas of operation overlap, but particularly in the southeastern part of our country, there are still gaps which for the most part will be filled in the near future.

The Federal Disaster Defence provides BO 105 helicopters at 16 bases. The Federal Army contributes to civilian air rescue at 5 fixed bases with BELL UH 1 D helicopters. Three bases are maintained by the German Air Rescue, a registered association, with Alouette III and Bell Long Ranger helicopters.

The crew consists of the following personnel, depending on the type of aircraft:

#### Technical crew:

BO 105: 1 pilot from the Border Patrol  
BELL UH 1 D: 1 pilot  
1 flight engineer/navigator

#### Medical crew:

The medical crew is standard for all aircraft.

1 emergency doctor  
1 emergency medical attendant

The emergency doctor is a doctor especially well-trained in emergency medicine from a hospital with a helicopter base whose emergency surgery and/or anaesthesia ward operates this service. The emergency medical attendants come from the various rescue organizations which also manage the ground rescue service. These emergency medical attendants have received special training in emergency medicine. However, for legal reasons they are not permitted to carry out themselves such important measures in emergency medicine as infusions, injections and defibrillation.

Nevertheless, these measures are frequently of utmost importance for the success of a rescue mission. For this reason, all rescue helicopters in the Federal Republic have a doctor on board. We are absolutely convinced that - at least in our country - the operation of such an expensive means of rescue as the helicopter is only justified if the patient is offered a maximum of medical care at the scene of the emergency and during the flight.

As chief promoter in the development of air rescue with helicopters, ADAC has assumed a particularly important function. It negotiates with the health insurance companies for almost all bases about the lump sums to be paid for each rescue mission, settles these amounts and is responsible for the statistical documentation.

Apart from this air rescue service system, there are 12 helicopter bases of the SAR service, operated by the Federal Army. The helicopters based there can in certain exceptional situations be requested in order to transport civilian patients.

The willingness of the health insurance institutions to pay approximately DM 850,- (about \$ 400) per mission was the most important requirement for establishing an air rescue service.

#### C. RANGE OF FUNCTIONS AND OPERATION TACTICS OF THE RESCUE HELICOPTER

As a supplement to and in support of the completely developed ground rescue service, the rescue helicopters fly primary, secondary and "other" missions.

PRIMARY MISSIONS are rapid flights to the scene of the emergency. Emergency medical care for the patient, if necessary air transport to a suitable hospital.

With SECONDARY MISSIONS, we distinguish between "urgent" and "non-urgent" flights. By secondary missions, we mean the transportation of an emergency patient from a hospital whose capacity does not suffice to provide the necessary treatment, to a clinic which is adequately equipped for final treatment, both medically and in terms of personnel and organization.

Urgent in this connection means that the danger to life is still acute and the entire mission must be carried out as rapidly as primary missions. Frequent causes for these urgent secondary missions are cranial injuries which can only be treated in a neuro-surgical clinic and severe respiratory disorders which can only be treated in large intensive care units with facilities for permanent artificial respiration.

Non-urgent secondary missions means that air transport to a special clinic offers advantages in terms of distance, transportation trauma and time. There is, however, no acute danger to life. The rescue means used in primary rescue service should, if possible, not be used for this type of transportation so that they remain available for acute emergencies.

Various, more infrequent types of missions fall in the category "Other Missions". They include:

- transportation of blood and organs
- transportation of medical equipment or special medical teams to smaller hospitals
- transportation of technical rescue teams, for example the fire brigade, with special equipment like hydraulic expanders to free persons who are wedged in, divers or mountain rescuers.

A particularly important function of rescue helicopters when used in disaster cases is transporting patients acutely in need of treatment both rapidly and carefully over greater distances to several key hospitals and special clinics.

The rescue helicopter is alarmed via the supra-regional rescue control center of the rescue service. Here the decision is made as to whether an ambulance, a rescue missions ambulance with doctor or a rescue helicopter should be sent, depending on the nature of the emergency alarm and in view of the distances, the traffic situation and weather conditions.

#### D. RANGE OF PATIENTS

In the early years when the air rescue service was being developed, bringing a trained doctor with an emergency medical attendant and suitable equipment to the scene of the accident as rapidly as possible was thought to be the rescue helicopter's most important task. After ensuring vital functions, transportation of the patient to the clinic with ground vehicles was possible in many cases. Operational tactics and medical equipment were for the most part oriented towards attending persons injured in road accidents. The public supported this procedure since the alarming increase of road accidents was visible to all daily in a particularly drastic way.

However, it was recognized increasingly that the less spectacular but similarly alarming increase of civilizational disorders which also represent an acute threat to life made it necessary to use helicopters for primary missions as well. Particularly in rural areas in which the family doctor cannot always be reached immediately and cannot reach the scene of the emergency fast enough, there are more and more cases in which the emergency doctor with the rescue helicopter is alarmed in order to treat and transport patients, for example those with myocardial infarctions, serious cases of poisoning or neonatal disorders.

<u>Urgent Primary Missions</u>	(n = 8740)
Traffic accidents	58.4 %
Accidents at work	5.7 %
Accidents at home	2.9 %
Burns	0.7 %
Accidents caused by sports	2.6 %
Accidents caused by water	0.8 %
Accidents in mountains	0.3 %
Rail accidents	0.7 %
Air emergencies	0.4 %
Gunshot injuries	0.6 %
Internal emergencies	19.7 %
Other emergencies	6.8 %

Quite typical examples of reasons for primary missions of rescue transport helicopters of the Disaster Defence for 1977 are given here. The rescue helicopter is alarmed in around 74 % of the cases for accidents. The predominance of such emergencies is partly due to the fact that there are practically always landing possibilities for the rescue helicopter where road accidents occur. Although helicopter landings in inhabited areas do present some navigational problems, acute disorders which usually occur in homes or at work make up a clearly defined percentage (approximately 20 %).

Below we give a breakdown of the 1,150 secondary missions flown by our Rescue Center in Ulm, based on other criteria:

<u>Reasons for Transport</u>	(n = 1150)
Diagnosis and therapy for cranial and brain traumata	30.01 %
Respiration and intensive therapy	25.13 %
Internal disorders	24.43 %
Operational care for surgical emergency patients	7.04 %
Neontal disorders	5.47 %
Burns	2.26 %
Poisoning	1.91 %
Transportation of blood and organs	2.34 %
(Death of patient before transportation)	1.14 %
(Death of patient during transportation)	0.27 %

The varying frequencies reflect the various reasons for transfer of the hospitals in our area. They are determined by the distribution of the hospitals, the types of clinics and the stage of development of the ground rescue service in each area of operations of the rescue helicopter. As far as the whole country is concerned, we find that with the improvement of the ground rescue service, in particular by making ambulances with doctors available, the ratio of primary to secondary missions changes so that there are proportionately more secondary flights. The greater the distance the patient must be transported, the more apparent the important advantage of the helicopter compared with ground rescue service becomes.

#### E. EQUIPMENT

The range of operations and the patients inevitably determine the nature and extent of the medical equipment in rescue helicopters. There are various basic principles:

- The medical equipment must be such as to meet the requirements for all branches of medicine, for example traumatology, toxicology and cardiology.
- It must make possible proper treatment of patients of all ages, from the premature infant to the aged person.
- All equipment for emergency diagnosis and elementary therapy must be easy to transport outside the helicopter as well so that it can be used at the scene of the emergency.
- All equipment must be adapted electrically to the helicopter so that use of the equipment does not present any problem during the flight and no disturbances occur.

An example of this is the equipment of the BELL UH 1 D from the Rescue Center in Ulm:

Portable equipment for treatment outside the helicopterBAG COMBINATION

- "RESPIRATION" Bag with medicine and equipment to treat isolated disturbances of the respiratory system
- "CIRCULATION" Bag with equipment to treat other emergency patients, particularly in case of cardiocirculatory emergencies
- portable ECG monitor with defibrillator
- 1 set for gastric irrigation and detoxication
- 2 stretchers, a vacuum mattress
- apparatus for rescuing persons wedged in (Force rescue axe)

Built-in equipment for observation of patients and treatment during the flight

- Anaesthesia apparatus for artificial respiration and for combined anaesthesia during the flight
- Cabinet with instruments, medicine and bandages
- Disaster kit with 20 liters of blood reserves, bandages, analgesics, etc. as anaesthetics for disasters
- Incubators of different sizes can be installed on short notice in order to transport newly born infants in all helicopters.

The stretcher used on these missions is placed lengthwise behind the pilot's seat and the substitute stretcher is placed directly above it in the same direction. This longitudinal position of the stretchers gives us around 60 % more space at the head of the patient so important emergency measures such as intubation and puncture of central veins can be taken in the aircraft and if necessary during the flight. Although space is limited, all the usual resuscitation methods can be employed at any time.

The second stretcher is used only in dire emergencies when a patient's life is in danger since the patient lies directly under the cabin roof when the stretcher is set in place in the upper stretcher lock. If the stretcher is locked in place in the middle, the patient would lie too close to the patient underneath.

In the BO 105 helicopters, the two stretchers on which the patients are transported are placed side by side. The medical equipment is for the most part similar to the equipment described above.

F. SUMMARY OF OUR EXPERIENCE1. Flight Experience

As doctors, we can only repeat statements made by experts in the field of helicopter flying. Pilots employed in the air rescue service stress unanimously that this activity requires great flying skill since in most missions, landings must be made on unfamiliar territory and many flights are flown in bad weather. In addition, this service involving work with patients requires an exceptional humanitarian commitment.

2. The Significance of the Air Rescue Service for Medical Care of the Public

As a result of the rapid transportation of a specially qualified doctor to the patient whose life is in danger and the possibility, if necessary, of transporting the patient to a suitable clinic further away at a warrantable risk, there has been a considerable improvement in medical attendance in general and in rural areas in particular. The period of rest required in the hospital is shortened by the fact that an emergency doctor is on board the helicopter and the extent of permanent damage is decreased. The use of the rescue helicopter has proven a lifesaver for many patients.

We hesitate to give exact figures for the number of human lives saved, since in many cases where the necessity of the flight is undisputed, attendance by the helicopter doctor is only the first decisive step towards saving a life. Without optimum clinical treatment, many patients would die afterwards.

We consider the rescue helicopter as a mobile intensive care unit which, as the extended tool of the hospital, cannot be replaced in certain emergencies by any other means of rescue. The rescue helicopter has now become an indispensable factor in the compound system of the rescue service of the Federal Republic of Germany.

## Bibliography

- AHNEFELD, F.W., BÖLL, H. :  
Der Einsatz von Hubschraubern bei der Versorgung von Notfallpatienten.  
Use of Helicopters in the Care of Emergency Patients.  
Wehrmed. M.schr. 13, 329-334 (1969)
- BURGHART, H.: Rettungshubschrauber - Konstruktive Voraussetzungen und  
Anforderungen an die Ausstattung.  
Notfallmedizin 3, 428-433 (1977)
- CLEVELAND, H.C., BIGELOW, D.B. et al:  
A Civilian Air Emergency Service: A Report of its Development, Technical  
Aspects, and Experience.  
Jour. of Trauma 6, 452-461 (1976)
- DANGEL, P: Die Bedeutung des Lufttransportes von Verwundeten und  
Kranken im Sanitätsdienst.  
Med. Diss. Juris Druck 1972 Zürich
- DRK - Schriftenreihe:  
Der Einsatz von Hubschraubern bei der Erstversorgung und dem Transport von  
Notfallpatienten.  
DRK-Schriftenreihe Nr. 42 (1970)
- DROH, R., DORTMANN, C:  
Der Hubschraubertransport von Notfallpatienten  
Anaesthesist 19, 66-71 (1970)
- GORGASS, B., FREY, G.:  
Der Rettungshubschrauber im Sekundäreinsatz  
Fortschritte der Medizin 95, 2460-2465 (1977)
- SCHIECHEL, F.A., KÖRNER, F.:  
Experimentelle Untersuchungen über die beim Hubschraubertransport auftretenden  
Schädigungen.  
Hefte Unfallheilkunde 99, 118-121 (1969)
- WING, J., E., ADDISON, J. A.:  
Helicopter Mobile Medical Companies.  
US Armed Forces Med. J. 7, 1802-1808 (1956)



**AEROMEDICAL EVACUATION ON THE PREDICTED EUROPEAN  
BATTLEFIELD - A SCENARIO IN URGENT NEED OF ATTENTION**

by

Dr William C. Wood  
5200 Oak Meadow  
Memphis  
Tennessee 38134  
USA

SUMMARY

The lifesaving efforts of American helicopter ambulances during this nation's involvement in the Republic of Vietnam conflict are legendary. In that war American forces maintained air superiority. MEDEVAC helicopters evacuated wounded from throughout the battle area. Due to the current antiaircraft capabilities of the Warsaw Pact nations, however, helicopters operating in the mid to high intensity predicted battlefield in Europe will be required to fly at lower altitudes and will frequently be denied access to contested airspace. A program of medical evacuation using primarily ground vehicle evacuation forward of the brigade trains area is presented in this paper. It is suggested that MEDEVAC helicopters be used on a "shuttle" basis, operating between the brigade trains area and the supporting combat support hospital. It is believed that this plan will accomplish the mutually supporting goals of increasing the number of lives saved and improving helicopter ambulance survivability on the predicted European battlefield.

The history of American involvement in the conflict in the Republic of Vietnam indicates that throughout active United States participation air superiority by American forces was maintained. The primary hazard to American aircraft operating over South Vietnam was enemy ground fire. A landmark achievement in the Vietnam War was the employment of a highly sophisticated medical evacuation system using helicopter ambulances. Never before in the history of warfare had medical evacuation been obtained so rapidly. Thousands of lives were saved by prompt helicopter evacuation, often under enemy fire. As Neel so well pointed out, the use of a helicopter ambulance evacuation system promoted centralization of better equipped, better staffed hospitals, and made specialty medical care more readily accessible to the combat casualty, often within minutes of actual wounding.<sup>3</sup>

However, the employment of the helicopter ambulance was contingent on the maintenance of air superiority. Superior communications must also exist to properly use helicopter evacuation. The Vietnam conflict was characterized by a fluid battlefield, with frequent "search and destroy" operations. Rear support areas were in many cases accessible only by air. The helicopter ambulance provided the ideal medical evacuation mode for this type of warfare.

In the more recent Yom Kippur War, or the War of Atonement, as some have called it, extensive antiaircraft capabilities of the Egyptian and Syrian forces compelled the Israeli Defense Force to modify aircraft tactical employment methods. Airspace over both the Golan Heights front and the Suez front was contested and aircraft losses by both parties on each front were considerable. It would appear from published accounts that the Israeli Defense Force was forced to rely primarily on ground evacuation of combat casualties in these areas. The use of tracked, armored personnel carriers as medical evacuation vehicles was shown to be an important, indeed a required, means of casualty evacuation in this intense period of fighting. The employment of helicopters in the contested airspace about the FEBA (forward edge of the battle area) was limited.<sup>1</sup> It is believed that this conflict more nearly approximates the predicted mid to high intensity battlefield which would occur in a European conflict than did the Republic of Vietnam engagements. It is obvious that, although many similarities between the predicted European battlefield and the October War are seen, there will likely be significant differences which will affect the techniques of medical evacuation.

Historically speaking, a combatant's perception of what will happen to him after wounding has and always will be a significant component of troop morale.<sup>2</sup> Medical evacuation doctrine must be applicable to the projected tactical environment and must consider the relevant factors of the enemy threat, the terrain, and the anticipated weather conditions. As the technique of modern warfare changes, a continuing reassessment of medical evacuation doctrine is essential.

The Predicted European Battlefield

Warsaw Pact forces are extensively equipped with an impressive array of anti-aircraft weapons. The fully tracked, highly mobile ZSU 23-4 quadruple antiaircraft system is a potent weapon against low flying aircraft. Forward troop units are equipped with vehicle launched and shoulder launched antiaircraft missiles. Just as in Vietnam, small arms fire will further endanger aircraft operating in the lower flight altitudes. The presence of this threat has placed increased reliance by

helicopter units on the use of NOE (nap-of-the-earth) low level flight and on the use of terrain features for masking.

European terrain differs markedly from that of the Sinai. The preeminent danger to rotorcraft in the European environment is the multitude of wire hazards. NOE flight techniques are a necessity, yet wire hazards remain an ever present threat to the aircraft operating at low altitudes, often only a few feet above the surface. Valleys provide protected approaches, and the use of such routes may allow access to units for casualty retrieval if no wire hazards are present.

Weather in Europe, particularly in the winter months, is notoriously poor, with snow, rain, and fog. Icing conditions may occur, further complicating medical evacuation.

American helicopter crews must be prepared to function in the CBR environment. Training with the M24 aviator protective mask is a crucial component of unit combat readiness and MEDEVAC units must be prepared to evacuate casualties under conditions in which use of this mask would be required. Night operations will play a role in future conflicts, just as they did in the Yom Kippur War. MEDEVAC will be more difficult under nighttime conditions, but these helicopter ambulance units must be prepared to function at any time of the day or night. The development and employment of the AN/PVS-5 night vision goggle holds great promise of improved night capability. Medical evacuation operations are a fertile field for extensive employment of these highly sophisticated night vision devices.

It is obvious that the European battlefield will be incredibly sophisticated, from tactical, threat, electronic, CBR, and logistic standpoints. Since the European battlefield would be predicted to be a mid to high intensity combat situation, casualty loads will be heavy. A premium will be placed on the prudent use of helicopter ambulances. The goal of medical evacuation is to provide the maximum lifesaving support as rapidly as possible. Use of medical evacuation helicopters in contested airspace where their survival is endangered might well result in aircraft losses. These aircraft must be properly used to ensure their survival and the performance of their mission in the most efficient manner. The luxury of air superiority can no longer be assured on day one of a European conflict. Ground evacuation must be used to evacuate casualties to a point in the brigade rear area where helicopter ambulances can more safely operate with greater chance of survival for rapid and more efficient casualty transportation. Before proceeding, a review of current United States Army medical evacuation doctrine is appropriate.

#### The Evacuation Sequence in Today's United States Army

In the current concept of medical evacuation from the forward edge of the battle area (FEBA), the unit battalion aid station contains an evacuation section which is sent forward from the battalion rear area to the FEBA for casualties. The wounded are then brought to the battalion aid station, where initial life-saving treatment is provided by the battalion physician's assistant. In support of each division is a medical battalion, composed of four medical clearing companies. Each medical clearing company contains a clearing section with physicians and an evacuation section, with wheeled vehicle ambulances. The medical clearing company sends the wheeled ambulances of its evacuation section forward to the battalion aid station to pick up casualties, who are then brought to the medical clearing company area. In general, one clearing company is collocated with the Division Support Command (DISCOM) trains in the division rear area. Employment of the remaining three medical companies is flexible, with at least one medical clearing company supporting each committed brigade of the division. The medical clearing company for each brigade is customarily located in the brigade trains area in the brigade rear. Supporting each committed division will be a combat support hospital with an increased complement of medical personnel and equipment. It is anticipated that the combat support hospital will be either in the corp area or in the division rear area. MEDEVAC helicopter ambulances are corp assets. In the Vietnam War MEDEVAC evacuation frequently bypassed the battalion aid station and flew to either a combat support hospital or an evacuation hospital. This provided specialty medical care much sooner than ground transportation and resulted in a tremendously improved chance of survival for the wounded individual. This evacuation system is of course somewhat more complicated than given above, but this brief outline will assist in understanding the changes to be suggested below.

The increased casualty load expected in a mid to high intensity conflict, coupled with finite helicopter ambulance resources and the tactical factors previously mentioned, indicate that increased reliance on ground transportation is essential for the predicted European battlefield. Particularly significant in casualty evacuation from the area about the FEBA (forward edge of the battle area) will be the use of tracked, armored vehicles, such as the M113 tracked ambulance, which will be required in many cases to safely move casualties from the forward battalion zone to a point of safe pickup by unarmored ground wheeled ambulances. Prudent use of all vehicles moving toward the rear areas will be absolutely essential to ensure timely evacuation of all wounded. It is proposed that the MEDEVAC helicopters not evacuate from locations forward of the medical clearing company position in the brigade rear area. NOE and low level flight techniques, including the use of protected approaches, may be necessary to enter this area.

The brigade commander should be given the option of personally permitting MEDEVAC missions forward of the brigade trains area. In this case he should be guided by tactical considerations, including local air superiority status, and by the advice of his brigade surgeon regarding the urgency of casualty evacuation as assessed from available medical information.

The use of the MEDEVAC helicopter to rapidly and efficiently transfer patients from the medical clearing company to the combat support hospital or evacuation hospital assures more efficient use of the physicians and facilities at the medical clearing company. Survivability of the MEDEVAC helicopters is improved, allowing their continued use. Use of this suggested system ensures that life-saving medical support by physicians at the medical clearing company will not be overflowed. Initial resuscitation by physicians in the medical clearing company with adequate treatment for shock, fractures, and hemorrhage, will improve the survival of patients being evacuated for specialty care in the larger supporting medical facilities.

Medical evacuation, just as military doctrine and tactics, cannot be planned from or based on a previous military conflict. The use of military evacuation assets must be continuously reassessed in light of changes in the projected battlefield environment. The United States Army has been a world leader in the employment of the helicopter ambulance, setting a precedent for concern for the wounded soldier that has saved countless lives. It remains for us to adapt the singular aspects of the predicted European battlefield to our helicopter capabilities. By approaching this problem and solving it we will increase our effectiveness in evacuating wounded, thus saving an increased number of lives and decreasing morbidity. At the same time we will enhance survivability of our helicopter ambulances which can then evacuate more casualties and save more lives. Evolution of the doctrine of MEDEVAC helicopter employment will pay rich dividends in lives saved on the predicted European battlefield. It will also maintain combat readiness of our units and minimize loss of combat effectiveness due to wounding. The predicted European battlefield represents a challenging area for implementing improved techniques of medical evacuation.

#### REFERENCES

1. Herzog, Chaim. The War of Atonement. Great Britain: Futura Books, 1975.
2. Keegan, John. The Face of Battle. New York: The Viking Press, 1976.
3. Neel, S. Major General. Medical Support of the U.S. Army in Vietnam 1965-1970. Washington, D.C.: Department of the Army, 1973.
4. Wood, William C. "Medevac on the European Battlefield." U.S. Army Aviation Digest, Vol. 23, No. 8 (August, 1977), p. 4.

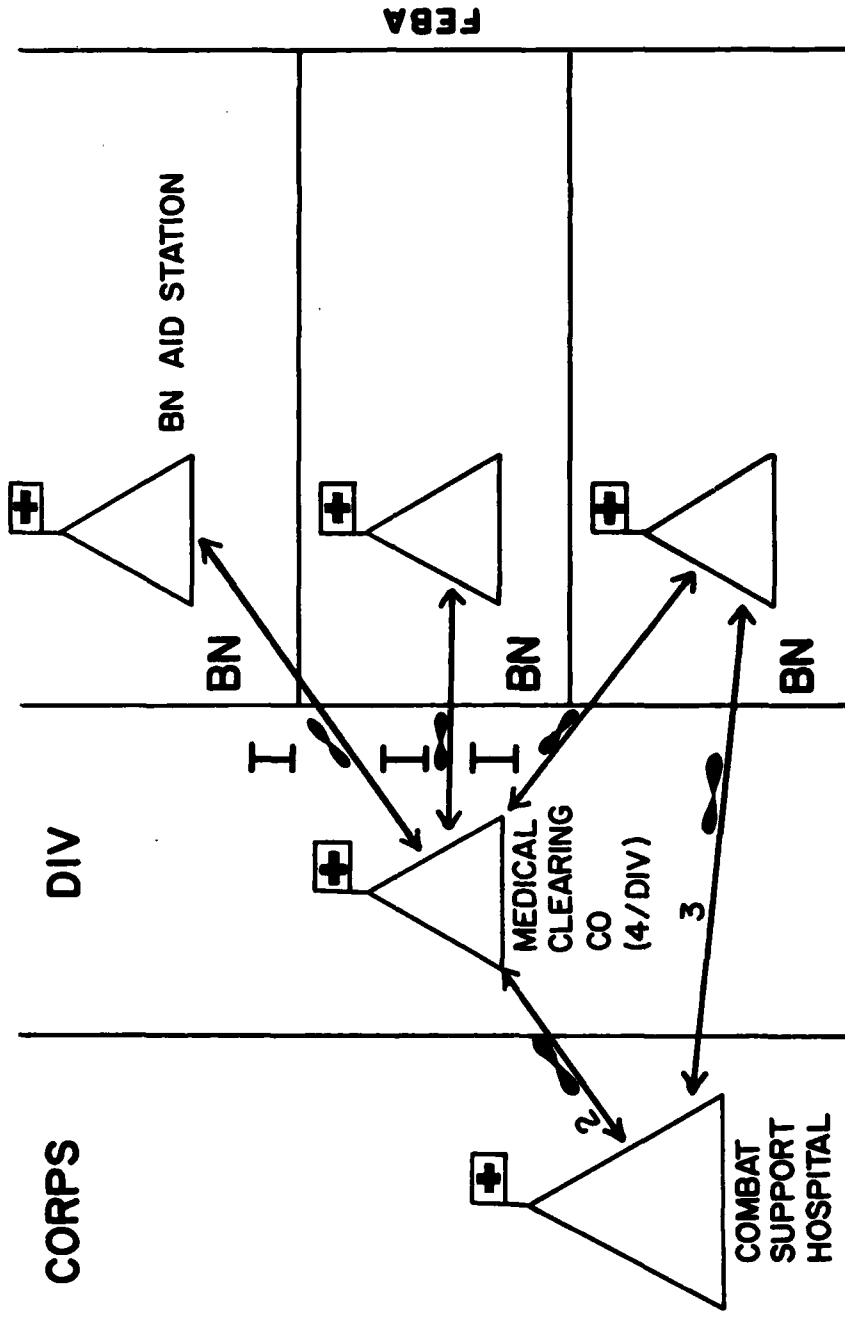

**MEDICAL SUPPORT OF A COMMITTED US ARMY DIVISION**

## MARYLAND'S MED-EVAC HELICOPTER PROGRAM

R Adams Cowley, M.D.  
Professor of Thoracic and Cardiovascular Surgery, and  
Director, Maryland Institute for Emergency Medical Services  
22 S. Greene Street  
Baltimore, Maryland 21201  
U.S.A.

A Med-Evac helicopter program, developed by the Maryland Institute for Emergency Medical Services in 1968 with the Maryland State Police Aviation Division, has been transporting patients to the Maryland Institute for Emergency Medical Services' Shock Trauma Center since 1970. The system was developed to reduce the high rural fatality rate. Helicopters pick up victims from the scene of accidents and speed them to special care centers which can manage severe multiple trauma and other medical problems. The helicopters are also used for interhospital transfer of critically ill and injured patients, physician emergencies, transport of premature or ill neonates, transport of medical personnel and supplies. By using the helicopters 90 percent of flight time for police work, the cost of Med-Evac transports has been kept down. The survival rate has improved since the beginning of the program to 82 percent of all transports.

The fatality rate in road traffic accidents is ten times greater in rural areas than in metropolitan areas. This may be accounted for by the higher speeds travelled on country roads, delay in discovery of accidents on little travelled roads, waiting for ambulance transportation, longer distances to be covered, sparsity of physicians and specialty resources and the fact that it is still general practice to transport the victim to the nearest hospital, regardless of its capabilities.

In military situations, helicopters have proven their value for medical evacuation from remote areas to treatment centers. But, although there have been experimental programs, helicopters have not been widely accepted in civilian operations as an arm of the emergency health care delivery system.

A Med-Evac Helicopter system was developed in 1967 by the Maryland Institute for Emergency Medical Services (MIEMS\*), in cooperation with the Maryland State Police (MSP) Aviation Division. The system has been transporting patients to the MIEMS Shock Trauma Center since 1970. It has proven to be economical and medically effective.<sup>(1)</sup>

The Center, established in 1960, had evolved by 1968 into a sophisticated clinical facility capable of providing definitive care to multiply injured patients. But a means was needed to get critically injured traffic accident victims from the state's rural counties to the treatment center in Baltimore.

After some preliminary trials with military helicopter transports, the Center approached the Maryland State Police to obtain helicopters to share between police work and patient transportation. In 1968, a Department of Transportation grant was awarded to develop the program. Bell 206B Jet Rangers with capacity for two litter patients in addition to the pilot and observer/medic were chosen. The helicopters were to be used mostly for police work, but Med-Evac transports were to have first priority. A large, all-weather heliport was built adjacent to the Center. The observer/medic completed the standard EMT-A 81-hour course and then took additional training at MIEMS.

The Air Med-Evac system was the first element added to the clinical Shock Trauma Center. Later, other specialty referral centers were added to build an integrated, complete emergency medical services system for Maryland. The whole system has grown tremendously since 1970, and is now responsible for planning, developing, coordinating and evaluating all aspects of emergency medicine in Maryland.<sup>(2, 3)</sup>

\*The MIEMS was established in 1960 as the country's first Shock Trauma Center. In 1968 it moved into its own building, containing an admitting area, operating rooms, critical care recovery unit, intensive care unit, clinical STAT laboratory, and research laboratory. The clinical hub of the state emergency medical services system, the center merged with the system in 1977 to become the Maryland Institute for Emergency Medical Services. System components in addition to the Med-Evac program include the MIEMS Shock Trauma Center, specialty referral centers, areawide trauma centers, a statewide communications system, research, evaluation, and educational programs for physicians, nurses, and EMT/paramedics. The system provides continuity of care from notification of an accident, resuscitation at the scene, transportation, definitive care and rehabilitation.

## EMS SYSTEM COMPONENTS

A communications system evolved from the need to coordinate helicopter transports. Now, through voice and telemetry communications, SYSCOM, the statewide system communications center, can link, county fire departments, central alarms, ambulances, hospitals, helicopters, consulting physicians and specialty referral centers to any other element anywhere in the state.

The specialty referral centers provide treatment for specific critical problems. The Med-Evac helicopters transport patients from the whole state to these centers in Baltimore.

The original center is the Adult Shock Trauma Center at MIEMS, which provides treatment for patients with:

- Severe injuries to two or more body systems
- Cardiac and major vessel injuries
- Uncontrolled shock from any cause
- Multiple injuries with complications such as shock, sepsis, respiratory, cardiac and liver failure, alcohol and drug overdose
- Severe facial and eye injuries
- Burns
- Gas gangrene
- Carbon monoxide and other poisoning.

Head and spinal cord injuries are treated in a special Central Nervous System program at MIEMS. The Johns Hopkins Hospital Pediatric Trauma Center provides services similar to those for adults at MIEMS for children, tailored to meet the specific and different needs of children. The Baltimore City Hospital Regional Burn Center provides the medical personnel, facilities and rehabilitation required by burn victims. A State Intensive Care Neonatal Program at Baltimore City, University of Maryland and Johns Hopkins Hospital manages critically ill and premature newborns referred from all over the state. The Curtis Hand Center at Union Memorial Hospital has special microsurgical facilities and personnel for the repair and reimplantation of severely injured and severed hands and arms and facilities for rehabilitation of these injuries.

These centers are the top level of care in the comprehensive EMS master plan for the state and are the only level of centers to receive helicopter transports. Other levels in the "Echelons of Trauma Care" system include the University Center level at Johns Hopkins Hospital and University of Maryland Hospital in Baltimore, and Areawide Trauma Centers in each of the state's five EMS regions. (Figure 1) Because of the geographical isolation and rural nature of Maryland's Eastern Shore, the Areawide Trauma Center there, Peninsula General Hospital, will receive helicopter admissions. At each level, strict requirements for facilities, equipment, staffing, clinical procedures and evaluation must be met before the center can be designated as part of the system. (Figure 2)

The foundation of the system continues to be local hospital emergency rooms, which handle 85 percent of the trauma cases. The Areawide Centers are prepared to handle the next, more critical 10 percent. The most critical 5 percent are transported by helicopter to the specialty referral centers.

The Maryland EMS system is voluntary and based on the understanding and participation of citizens, physicians, EMT's, hospitals and communities throughout the state. Public information and education programs for citizens explain how the system and its components relate to them and how to access the system. The medical community is involved through councils in each of five geographical regions and through medical control groups and advisory councils. Physicians are also contacted directly so that the function of the specialty referral centers, the type of patients appropriate for referral, the method of interhospital transfer, and available consultation may be explained.

## MED-EVAC OPERATION

The Maryland State Police Med-Evac helicopter fleet has grown to 14: four two-litter Bell Jet Rangers, eight three litter Hueys, and two eight-litter Sikorskys. Increased state funding within the last year provides for more manpower to be trained and to staff the service around the clock. Four bases, geographically distributed across the state are now staffed 24-hours a day. In the near future, helicopters will be based at four more locations to assure complete coverage of the state. (Figure 3)

**MIEMS**  
**■ REGIONAL TRAUMA CENTERS (AREA-WIDE)**



FIGURE 1

**ECHELONS OF CARE IN MARYLAND**

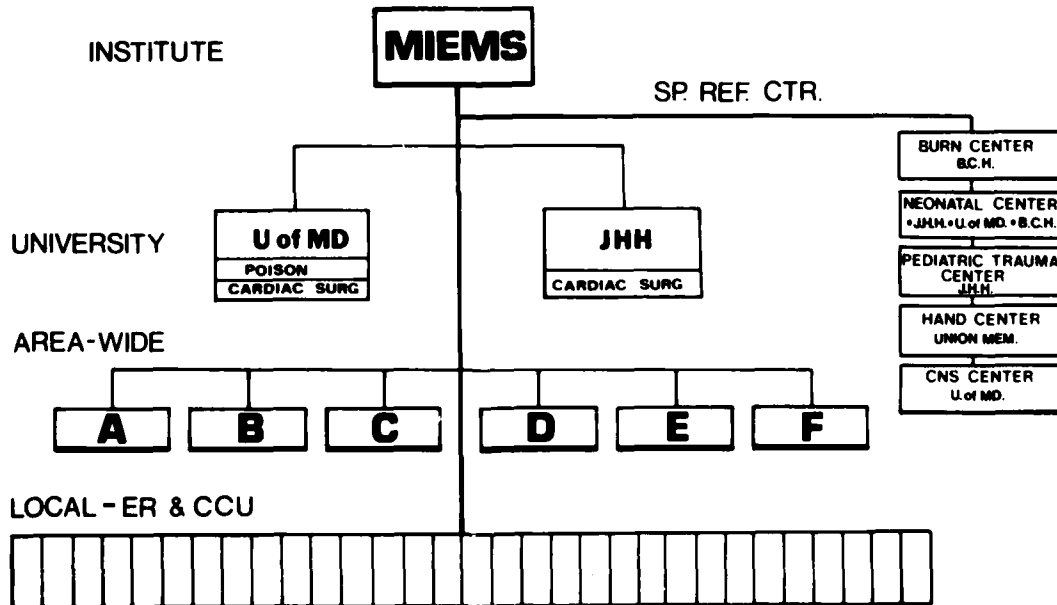

FIGURE 2

### MIEMS HELICOPTER DEPLOYMENT

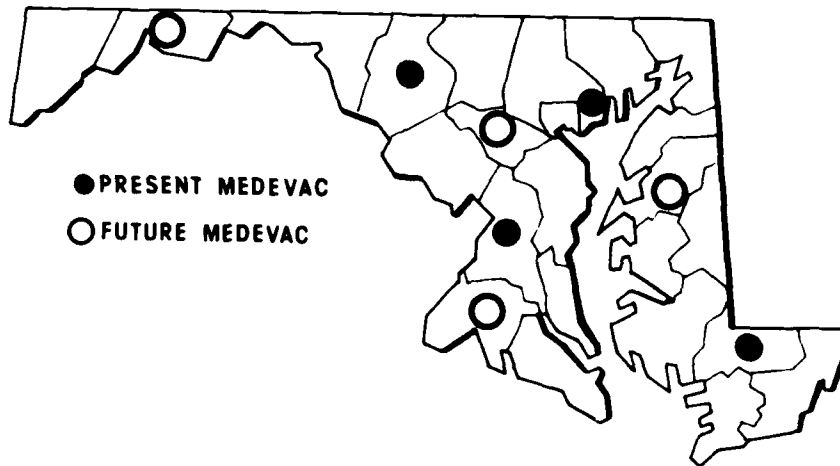

FIGURE 3



The Med-Evac system is used for six major purposes: 1) direct pickup of patients with life-threatening injuries from the scene of an accident; 2) interhospital transfers for critical multiple trauma victims; 3) transfer of any patient whom a local physician deems an emergency needing care and equipment which are unavailable in his hospital; 4) transport of premature infants from outlying hospitals to the State Intensive Care Neonatal Program hospitals; 5) transport of medical personnel to the scene of the accident or to other hospitals for emergency care or evaluation; 6) transport of medical supplies, blood or blood components, and organs for transplantations.

#### DIRECT PICKUP

Seventy percent of the Med-Evac transports come directly from the scene of an accident, usually a highway. Maryland's volunteer and paid ambulance and rescue squads cooperate with the State Police Med-Evac program to provide initial triage and facilitate rapid transportation to the appropriate care facility. The direct pickup at the scene of the accident involves the air med-evac helicopter by one of two methods. The helicopter crew, while on patrol, may see an accident or be alerted by monitoring emergency radio bands. In these instances, they would usually be the first paramedical assistance to arrive. Or a civilian or a highway patrolman may call the county central alarm for help, and the alarm dispatches an ambulance with a simultaneous request for helicopter support.

To coordinate the jurisdictional function and responsibilities at the scene of the accident, representatives from state police, local ambulance services, and physicians responsible for emergency health care delivery developed the following guidelines:

Whoever arrives first at the scene of the accident assesses the injury. If the injury is serious, he calls for both a helicopter and an ambulance. If the ambulance arrives first, the crew immediately administers first aid and resuscitation. If the injury is not life-threatening, the patient will be taken to the local hospital. A more serious injury will be taken by ambulance to an areawide trauma center. If the injury is life-threatening, the ambulance crew will continue resuscitation at the scene until the helicopter arrives to transport the patient to the Adult Shock Trauma Center or other specialty referral center. If the helicopter notifies those at the scene that it cannot reach the scene in a reasonable time or that the mission is not logistically possible, the ambulance crew will proceed immediately with the patient to the areawide trauma center. If the helicopter arrives at the scene first, the crew provides immediate first aid, resuscitation and injury assessment. If the victim does not require transport to a specialty referral center, they sustain the patient until the ambulance arrives for transport to the local hospital.

Mean response time for helicopters from call to pick up is 15 minutes. The helicopter crew spends no time at the scene stabilizing the patient, applying complex splints, G-suits, starting intravenous lines unless the victim is trapped in or under a vehicle. Instead, the medic/observer maintains the airway, administers oxygen, stops external bleeding with compression pads and practices cardiopulmonary resuscitation as needed. He is capable of inserting an esophageal obturator in comatose patients.

From most corners of the state, helicopters can reach the Baltimore centers within the critical "Golden Hour." (Research has shown that if patients reach definite care within one hour of a serious injury their chances for survival are much enhanced.) During this trip, the pilot contacts SYSCOM with the estimated time of arrival and the nature of the patient's injuries.

When the helicopter lands on the Shock Trauma Center heliport it is met by an anesthesiologist and a nurse who rapidly assess the patient during the five-minute ambulance ride to the center.

In the admitting area, a diagnostic operation room, the remainder of the multidisciplinary team is scrubbed and assembled, anticipating the injuries described by the pilot. Rapid, aggressive resuscitation and stabilization follows a predetermined protocol.<sup>(4)</sup> If necessary, the patient can be moved to an adjacent operating room for surgery.

Once stabilized, patients are taken to the Critical Care Recovery Unit (CCRU) where they are closely monitored. The average stay in the CCRU is five days, after which the patient is transferred to a step-down unit, the Intensive Care Unit. Average stay is again about five days. From the ICU, the patient may be transferred to the Intermediate Care Unit, a general hospital bed, a rehabilitation facility or home.

#### INTERHOSPITAL TRANSFERS

For interhospital transfers, a physician of an outlying hospital telephones SYSCOM at MIEMS to request assistance. A Shock-Trauma physician experienced in endotracheal intubation may be sent to accompany the transfer. All patients accepted for admission come directly to the Shock Trauma Center emergency receiving area where second triage is performed. They do not pass through the hospital emergency room.

Those admitted are stabilized, diagnosed, and transferred directly to the 12-bed Shock Trauma Recovery Unit, to the operating room, or to the Intensive Care Unit for further assessment, management, and treatment. Those patients not requiring the Center's facilities (4%) are referred to appropriate areas elsewhere in the hospital (e.g., ICU, CCU) or to a general hospital bed.

## PHYSICIAN EMERGENCY

When an emergency arises in the community and patient's survival is compromised because of inadequate facilities or a lack of specialized equipment, any physician may request assistance from the Shock Trauma Center by calling SYSCOM. Such patients automatically qualify for air med-evac transportation unless the Shock Trauma and the referring physician indicate that an ambulance would be the more suitable mode of transportation.

### TRANSPORT OF MEDICAL PERSONNEL

Physicians may be taken to the scene of an accident where victims are trapped or pinned under a vehicle, or if the emergency rescue crews suspect that certain medical procedures are required at the scene. Neurosurgeons, anesthesiologists, and thoracic surgeons have been flown to outlying hospitals to help evaluate and treat patients when the hospital involved did not have the physician staff to prepare the critically injured patient for transport.

### TRANSPORT OF MEDICAL SUPPLIES

Rapid helicopter transportation is of great value to convey unstable and perishable medical supplies, such as blood or blood components, and organs for transplantation, when these are required by other hospitals for both emergency and elective procedures. This especially pertains to distances exceeding 50 miles.

### TRENDS

Each year admissions to MIEMS Shock Trauma Center have increased an average of 7.89 percent. For the last few fiscal years the admissions have been as follows: 1972, 615; 1973, 782; 1974, 872; 1975, 920; and 1976, 1105.

Eighty-two percent of the admissions are delivered by helicopter, 70 percent from the scene of an accident. Admissions are highest in summer months. For example, in June, 1976, there were 130 admissions, compared with 73 in January, 1976. Saturday is the busiest day for admissions, with Sunday and Friday next. The largest number of admissions occur within several hours each side of midnight, with the fewest during morning hours. Sixty-five percent of MIEMS patients are 17 to 35 years old; 76 percent are males. Sixty-six percent are admitted as a result of traffic accidents, 10 percent because of assault.

In calendar year 1977, there were 1300 Med-Evac helicopter transports, 814 to Adult Shock Trauma Center at MIEMS, 120 to the Pediatric Trauma Center at Johns Hopkins, 180 to Baltimore City Hospital's Neonatal ICU, 77 to the University of Maryland Neonatal ICU, 54 to Johns Hopkins Neonatal ICU, 49 to the Baltimore Regional Burn Center at City Hospital, 29 to Union Memorial Hospital's Curtis Hand Center, 21 to Washington Burn Center, 9 to Peninsula General Hospital and 35 other Med-Evac transports.

In 1976, of those transported directly from the scene, 9.5 percent were discharged to home within 24 hours. The majority of this group had been intoxicated upon admission, which complicates the already difficult assessment and exclusion of head injury at the scene.

### SURVIVAL

In 1976, of patients admitted directly from the scene, 6 percent were dead on arrival, either from a rupture of a heart chamber, thoracic aorta or vena cava; severe head injuries; or fracture dislocations of upper cervical vertebrae.

Of those arriving alive, 2.1 percent died in the admitting area from hemorrhage from major vessels or irreversible brain injury. Fifty-six percent underwent immediate, total reparative surgical procedures, during which 2.8 percent died. Uncontrollable hemorrhage accounted for all but three of these deaths.

Ninety-five percent of all patients who arrived alive survived to be admitted to the Critical Care Recovery Unit. Irreversible brain damage caused therapy to be discontinued within 24 hours for 2.1 percent. Of those surviving beyond 24 hours, 6.7 percent died in the unit within seven days, the majority due to brain death, the others due to sepsis. (Table 1)

Comparison of statistics for highway traffic accidents transported by Med-Evac helicopter from the scene to MIEMS from 1972 to 1976 show improved survival rates. The percent discharged to home within 24 hours was cut in half: 19.2 percent in 1972 to 9.5 percent in 1976, reflecting improved triage at the scene. The number of patients dead on arrival decreased from 8.7 percent to 6.0 percent. The death rate in the admitting area fell from 5.3 percent to 2.1 percent and in the operating room from 6.3 to 2.8 percent. In the Critical Care Recovery Unit, the mortality of those who survived beyond the first 24 hours dropped from 8.0 to 6.7 percent. If the decreased early mortality can be attributed to more successful resuscitative and intra-operative care, more critically ill patients would be carried over to the Critical Care Recovery Unit, making these figures more impressive. Of all patients transported by Med-Evac, the percent surviving rose from 74.5 percent in 1972 to 82.1 percent in 1976, and of those who arrived alive, from 81.6 percent to 87.4 percent. (Table 2)

TABLE 1

## HELICOPTER TRANSPORTS TO MIEMS 1976

## ROAD TRAFFIC ACCIDENTS

	From Scene	Indirect
Transported	497	122
<u>Dead on arrival (DOA)</u>	<u>30 (6.0%)</u>	<u>6 (4.9%)</u>
Arrived alive	467	116
Died in admission area (AA)	10 (2.1%)	2 (1.7%)
<u>Died in operating room (OR)</u>	<u>13 (2.8%)</u>	<u>5 (4.3%)</u>
Admitted to Critical Care Recovery Unit (CCRU)	444	109
Died in CCRU within 24 hours	10 (2.1%)	6 (5.2%)
<u>Discharged home within 24 hours</u>	<u>47 (9.5%)</u>	<u>5 (4.3%)</u>
Admitted to CCRU longer than 24 hours	387	98
<u>Died in CCRU after 24 hours</u>	<u>26 (6.7%)</u>	<u>11 (11.2%)</u>
Total Survivors	408 (82.1%)	92 (74.4%)

TABLE 2

## HELICOPTER TRANSPORTS TO MIEMS 1976

## ROAD TRAFFIC ACCIDENTS

## Direct from Scene

	1972	1973	1974	1975	1976
Total transported	208	315	324	361	497
Dead on arrival (%)	8.7	5.4	3.7	7.8	6.0
Deaths in admission area (%)	5.3	5.7	3.5	3.3	2.1
Deaths in operating room (%)	6.3	6.0	4.5	1.8	2.8
Total deaths in first 24 hours (%)	12.6	14.8	9.0	6.6	7.1
Discharged home within 24 hours (%)	19.2	13.0	15.1	11.1	9.5
<u>Died in CCRU after 24 hours (%)</u>	<u>8.0</u>	<u>8.9</u>	<u>6.8</u>	<u>8.9</u>	<u>6.7</u>
Survived % all cases transported	74.5	74.6	82.7	79.5	82.1
Survived % those who arrived alive	81.6	78.9	85.9	86.2	87.4

## COST EFFECTIVENESS

The Med-Evac system remains cost-effective, because the helicopters are used for Med-Evac missions only ten percent of the total helicopter patrol time. The other 90 percent is used for routine police work: search and rescue for missing persons, aircraft and boats; criminal investigation support including search for escaped prisoners and persons fleeing crime scenes, general area searches for stolen cars and property that may be abandoned in rural, wooded, or isolated areas; surveillance and trailing of vehicles and persons suspected of involvement in criminal activity; aerial photography and area surveys in connection with murder, arson, etc.; route surveys and security; traffic control; security transports, support in disasters and civil disturbances and highway patrol. Med-Evac missions have first priority however. By using this sharing system, the cost of each transport has been held down to \$48 which is paid by the state. To keep the cost per transport down, the helicopters confine activities to an area which can be patrolled while maintaining an acceptable time-distance relationship with the specialty referral centers; are maintained on a full 24-hour alert and dispatched simultaneously with surface ambulance; and transport only patients with major life-threatening conditions to avoid competing with surface ambulances. To remain effective, helicopters maintain liaison and communications with state, county, and local police departments, ambulance units and treatment centers to assure maximum utilization and transport only to medical facilities which provide the necessary sophisticated level of treatment.

The Maryland Med-Evac Helicopter Program has thus proven that helicopters can be used successfully and efficiently to bring critically injured civilians to care. It has become an essential element in Maryland's integrated system of EMS care.

## REFERENCES

1. Cowley, R. A., Hudson, F., Scanlan, E., Gill, W., Lally, R. J., Long, W., and Kuhn, A. O.: An economical and proved helicopter program for transporting the emergency critically ill and injured patient in Maryland. Journal of Trauma, 13:1029, 1973.
2. Cowley, R. A.: A total emergency medical system for the state of Maryland. Maryland State Medical Journal, July, 1975.
3. Cowley, R. A.: Trauma center, A new concept in the delivery of critical care. The Journal of the Medical Society of New Jersey, 74 (11):979, 1977.
4. Cowley, R. A.: The resuscitation and stabilization of major multiple trauma patients in a trauma center environment. Clinical Medicine, 83:14, 1976.

NIGHT RESCUE OPERATION PROCEDURE  
OVER SEA WITH BELL UH- 1 D  
HELICOPTERS

By

Dr. Heinz Knoche, Maj. GAF  
Helicopter Transportation Wing 64  
1597 Ahlhorn, Postfach 300  
Germany

SUMMARY

Flight physiological aspects and disorientation problems of night rescue missions with Bell UH- 1 D helicopters are shown. Countermeasures which have proved to be successful in fighting disorientation are mentioned.

Night rescue missions over sea are in principle a task of the NAVY, however, when a SAR detachment was stationed at DECINOMANNU, it became necessary to establish procedures that would enable Bell UH- 1 D crews to conduct operations of this type under certain conditions. In particular the pilot had to be capable of recognizing and assessing the increased risks involved in a night rescue mission over sea in order to be able to decide on initiating a SAR mission, or its timely abortion, respectively. The crew normally comprises of: pilot, copilot, flight mechanic and air rescue specialist. Night search and rescue missions over sea are conducted roughly in the following manner:

After being scrambled the helicopter proceeds into the search area under IFR. In order to get into the range of the activated emergency transmitter as quickly as possible, it may initially be necessary, to operate at a higher altitude (s. fig. 1). As soon as the emergency transmitter is located a homing is carried out. The altitude may then be gradually reduced to 300 ft ASL on the radar altimeter. After overflying the target a flying pattern is initiated into the wind and the survivor is again approached. At a position 8 o'clock and a distance of about 20 - 25 m from the survivor a searker is dropped, while height is maintained at between 50 - 100 ft ASL and speed at between 30 - 50 KIAS. The following pattern is then flown at 60 KIAS and 300 ft ASL (s. fig. 2). The retracted landing light which points straight down is then turned on. Speed is then reduced and descent initiated.

During the final approach at 40 KIAS, descent is further continued down to 30 ft ASL. Depending on wind conditions speed is maintained between 20 - 40 KIAS. The searchlight is then turned on (s. fig. 3). Its use is at the discretion of the pilot. After visual contact is established with the survivor, who should - in his own interest - wear a reflecting helmet, the winch cable is lowered and speed is steadily reduced until the helicopter is hovering directly over or behind the target (s. below single winch, double winch). The helicopter is then directed to the target by the flight mechanic in such a way as to put the cable in the direction and reach to the survivor. On directions given by the flight mechanic to the pilot the survivor is kept at a 2 o'clock position to the helicopter until his rescue is effected (s. fig. 4).

Single Winch: The sling is moved to the survivor.

Double Winch: The air rescue specialist is moved to the survivor. In difficult conditions when the approach procedure is not exact, the air rescue specialist is let down into the water 2 - 3 m behind the survivor; the latter will then drift to the air rescue specialist.

While this maneuver is in progress the copilot controls the situation by dividing his attention between instrument reading and observation outside.

The description of this procedure sounds easy, however, it is bristling with flight physiological problems:

1. Night vision for example may be affected in many different ways, such as:

- a) Daily and seasonal variations
- b) Food

Our daily requirement is about 2000 I.U. of vitamin A. In the last war pilots engaged in night operations were provided with vitamin A, because normal rations did not contain enough. When normal night vision was obtained an additional increase by adding new doses of vitamin A was not possible.

- c) Metabolic diseases of the liver
- d) Intestinal malabsorption resulting in a vitamin A deficiency as under c)
- e) Nicotine, which diminishes the blood flow of the retina
- f) Adaptation to darkness and avoiding of dazzling
- g) Oxygen uptake.

2. Fixation of an object should be avoided since the macula is out of function at night.

3. Due to the lack of a horizon, stars are taken for lights on the ground and vice versa.

4. There is always the possibility of spatial disorientation induced by various factors such as the flashing anti-collision light during flight through clouds.

Some of these problems only briefly mentioned are of particular importance to night rescue operations such as dazzling and spatial disorientation.

Dazzling may result from

1. Instrument lights; they are adjustable
2. Full moon when survivor is approached and is inside reflecting strip of moonlight
3. Turning on the searchlight in misty weather; for this reason use of searchlight is at the discretion of pilot. Best results were obtained by turning on searchlight in intervals.

The considerably greater problem is disorientation. Disorientation is divided into the following grades:

- Mild - Pilot is in full control of helicopter
- Moderate - Pilot is not in full control of helicopter, adverse effects on helicopter control may be possible
- Severe - Pilot no longer has control over helicopter, definite wrong reactions in regard to helicopter control

The following list contains the most frequent situations likely to result in disorientation in helicopters in flight.

1. Sensation of not being straight and level after bank and return to normal attitude (the leans)
2. Low altitude hover over water at night
3. Reflection of anticollision light on clouds and fog outside of cockpit
4. Transition from IFR to VFR
5. Misinterpretation of relative position or movement of ship during night approach.
6. Head movement while in bank or turn.
7. Misperception of true horizon due to sloping cloud bank.
8. Inability to read instruments due to vibration
9. Awareness of flicker of rotors
10. Fatigue
11. Distraction by helicopter malfunction
12. Formation flying at night
13. Deception by faulty instruments
14. Vibrations
15. Enter VFR in snow, rain, haze in low altitude hover
16. Loss of night vision capability
17. Symptoms of cold or flu

Additional factors in connection with disorientation in helicopters are:

1. Flying into smoke signals
2. Task saturation
3. Wave motion interpreted as helicopter motion
4. Low level search mission at night
5. Lack of recent instrument flying
6. Communication difficulty, disturbing noise
7. Rotation around lateral axis during transition from descent to stationary hover.

The most critical situation of the rescue maneuver is without any doubt the hovering flight at about 30 ft altitude. In a study by F.R. Tormes and F.E. Guedry Jr., experience gained during this state in H-3 helicopters equipped with automatic hovering flight control was described as extremely hazardous. In this maneuver the crew of Bell UH-1D, a helicopter which is not equipped with automatic hovering flight control facilities, has at this point absolutely reached the limit of their capability. Only maximum teamwork can lead to success at this stage of the flight. The copilot having overall control of the situation is required to supervise the pilot who is under great strain and shows a tendency for overcontrolling the helicopter. Wrong reactions due to disorientation can have disastrous consequences. Increased tendency for overcontrol is indicated during transition from descent to stationary hovering. Due to the displacement of the center of gravity the helicopter rotates around its lateral axis and because there is a lack of reference points the pilot has the sensation of tilting backwards and upwards or backwards and downwards. (s. fig. 5)

The following factors adversely affect or make impossible hovering flights with Bell UH-1D under the above conditions.

1. Lack of reference points (survivor, seamarker, dinghi) make a flight over a fixed position impossible
2. Precipitation such as rain or snow will considerably affect or may make impossible assessment of speed.
3. Direction control is difficult in still air  
Salt spray around helicopter caused by rotor down-wash up to 50 ft may result in dazzling of pilot when searchlight is turned on (s. above).
4. Smooth water surface makes assessment of altitude difficult and leads to a further deterioration of the situation in connexion with 3.

Finally there are a number of potential countermeasures which have proved to be successful in fighting disorientation.

1. Believe the pages and scan them constantly
2. At first suspicion of disorientation let the second pilot know
3. Avoid sudden or extreme head movements
4. Learn to disregard physical sensations
5. "Talk yourself" through the instrument scan.
6. Transition to instruments early in deteriorating weather.
7. If flying under IFR make only small corrections.
8. If in hover, depart hover, and first gain altitude and then increase forward speed,

As long as the Bell UH-1D is in service all suggestions for improvement can only be concerned with the survival equipment. An emergency transmitter with maximum range and good signal quality as well as a reflecting helmet for the survivor will surely have a positive effect on operations.

#### REFERENCE

Tormes, F.R. and Guedry, F.E., Jr. Disorientation phenomena in naval helicopter pilots  
ASEMCG 46 (4) 387 - 393

Rose, H., Night Vision in: German Aviation Medicine in World War II Vol. I, Pelham Manor, N.Y., Scholicon International Inc., 1971

Reichweiten-Höhendiagramm

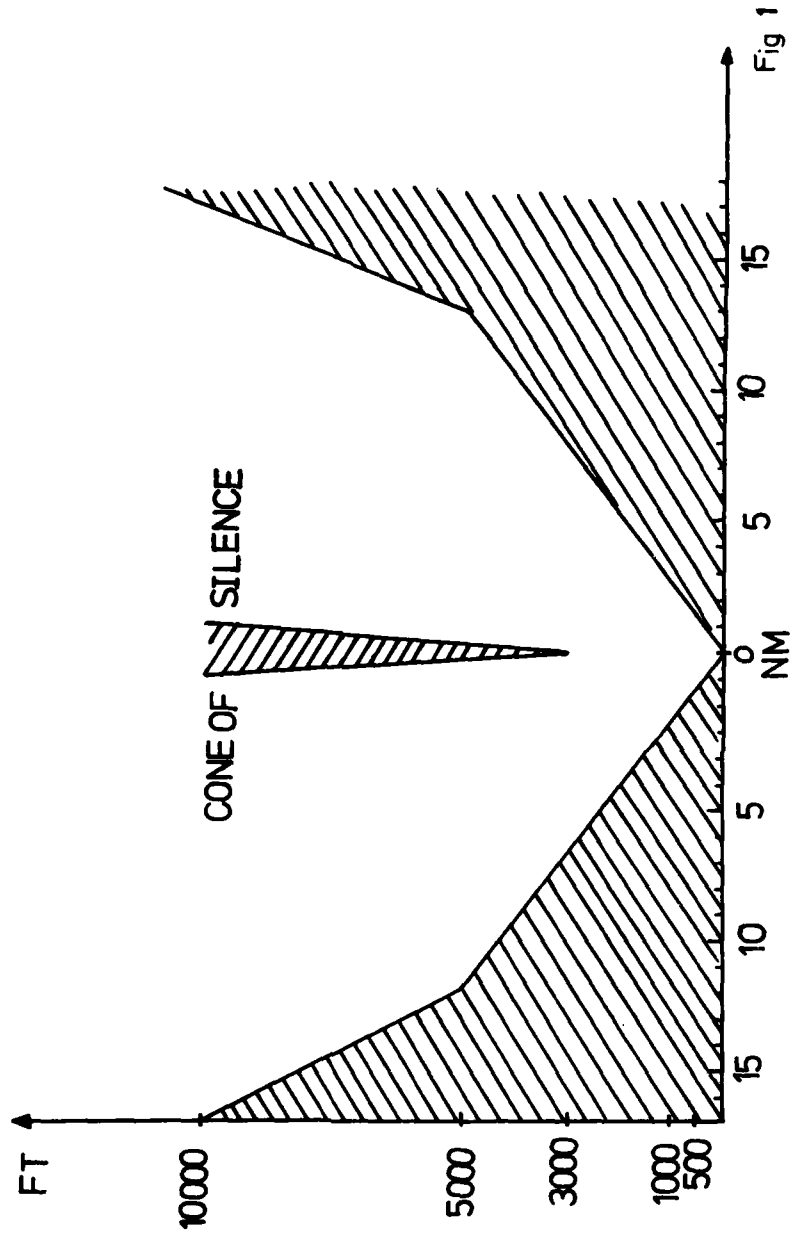

Fig 1



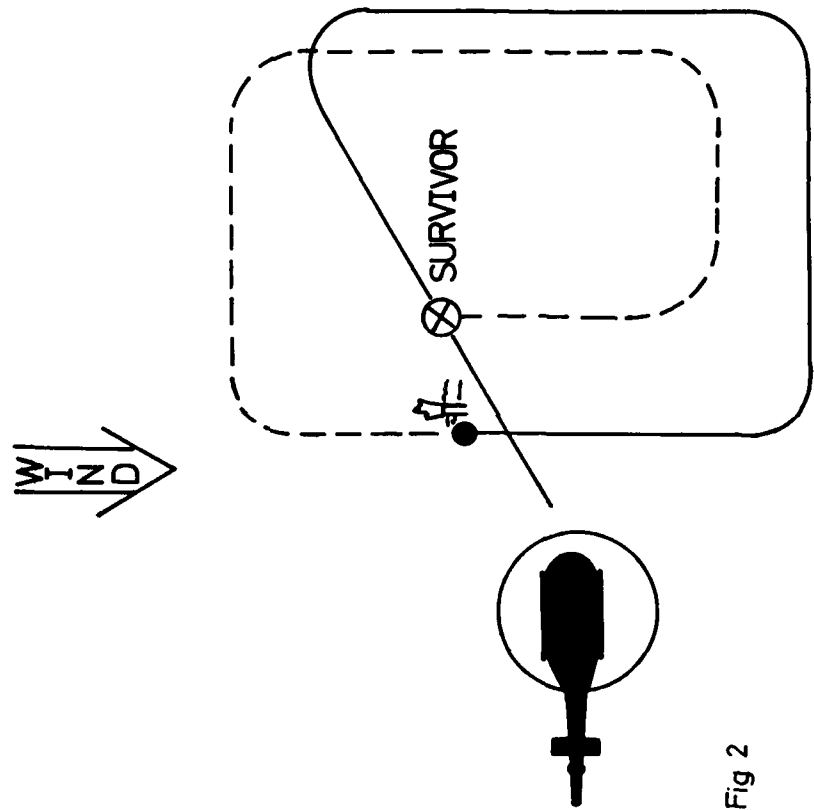
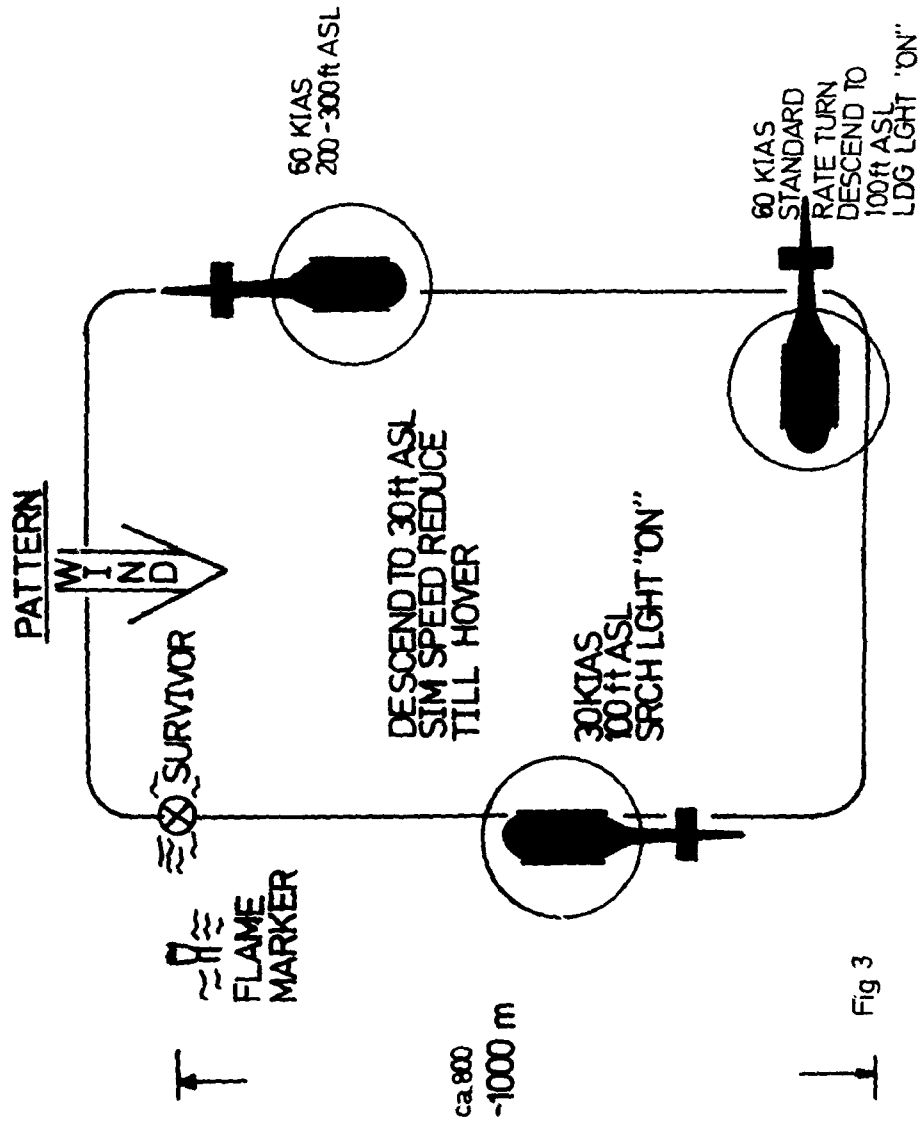
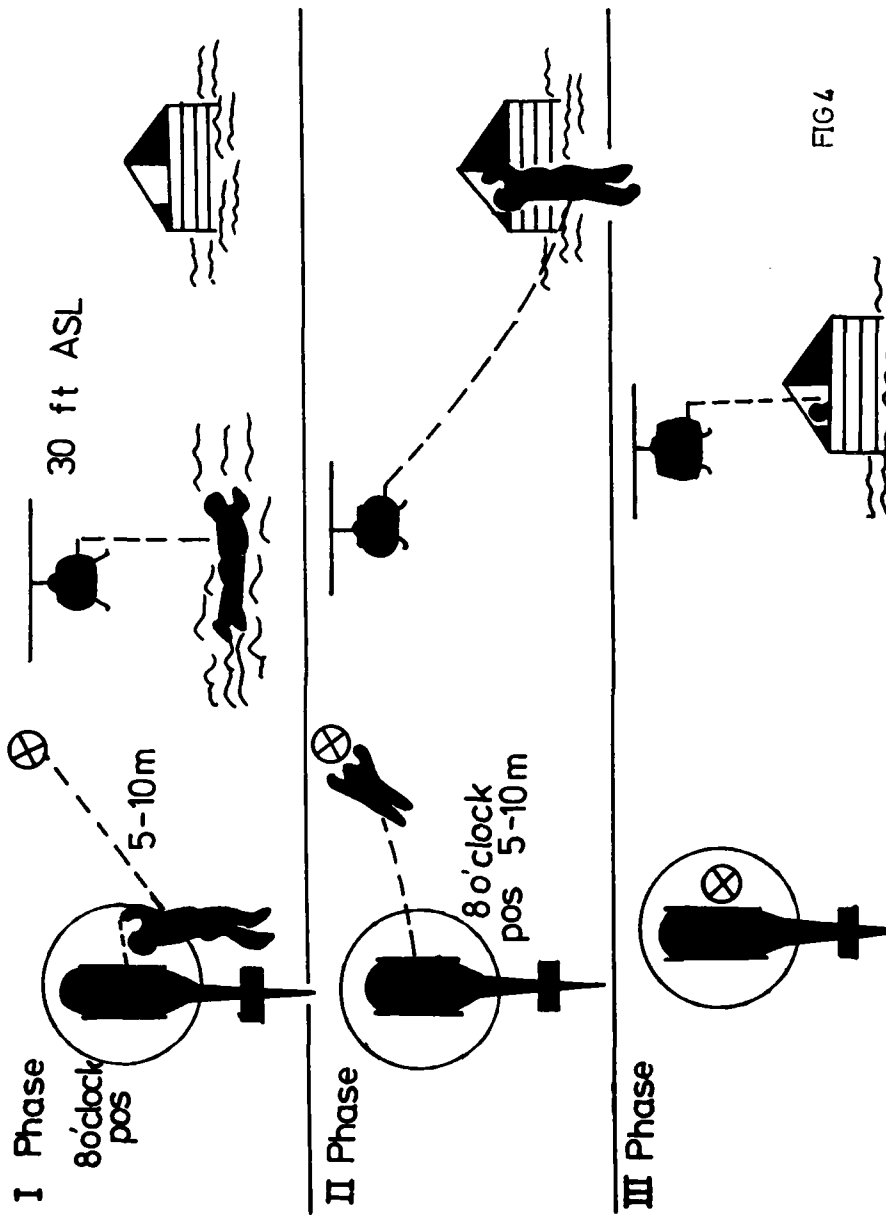

Fig 2





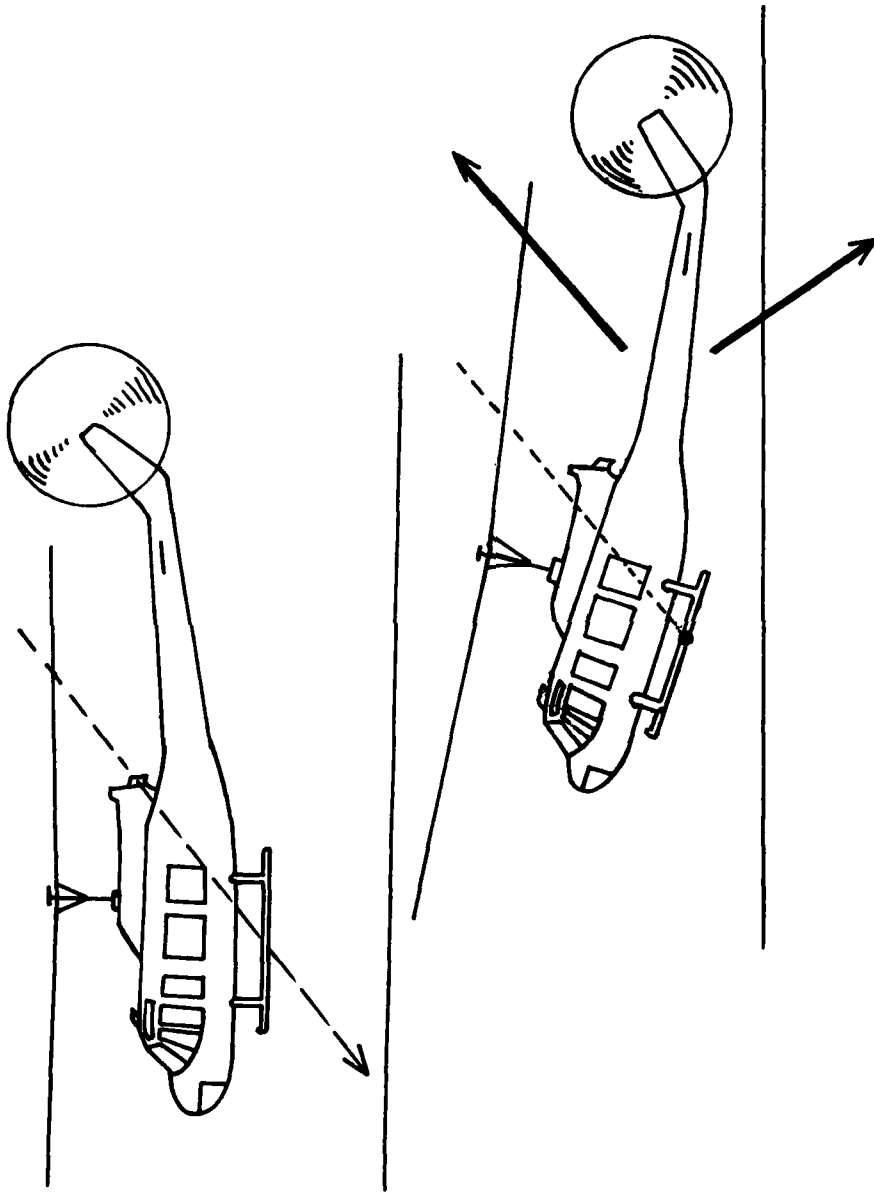

FIG 5

COORDINATION OF MEDICAL ASPECTS OF THE AIR RESCUE SERVICE  
IN THE FEDERAL REPUBLIC OF GERMANY

by  
Brig. General H.J. Linde, CAF (MD)  
Head - Committee on Aeromedical  
Aspects of the Air Rescue Services  
German Association for Aviation and  
Aerospace Medicine (DGLRM)  
Federal Armed Forces Medical College  
Infanteriestrasse 17  
8000 München 40  
Federal Republic of Germany

The ground rescue service in Germany has been supplemented by a helicopter rescue service since 1971 after it had become apparent that in the case of emergency patients requiring medical and surgical treatment the important factor was to get the doctor to the patient quickly. Before that time, the endeavors in Germany were directed at taking the patient from the scene of the emergency to a hospital for medical treatment as quickly as possible. Since then, it has been proved that a considerable reduction of the mortality rate could be achieved by taking the physician to the scene of the emergency. At the scene of the emergency, the physician, with appropriate equipment, can render suitable first aid directed primarily at restoration of the vital pulmonary and circulatory functions. When the patient's condition is restored so that he is transportable, he can be evacuated by ambulance or helicopter to a hospital while his vital functions are being maintained. In Germany this procedure permitted approximately 100 - 150 human lives per helicopter per year to be saved that would have been lost at the scene of the accident otherwise.

Secondly, it has become evident that evacuation by helicopter is suitable for all patients without exception and that the helicopter provides a means to fly to specialized hospitals within a short time which an ambulance might possibly need hours to reach.

The helicopter rescue service in Germany meanwhile is spread over the territory of the Federal Republic of Germany in 24 stations, forming a rescue network with individual radii of operation not exceeding 50 km. This arrangement at the same time permits reaching the patient within 10 minutes of flying time.

The majority of the helicopter belongs to the Federal Ministry of the Interior and is intended for employment in disaster operations. This means that they are first of all at the disposal of the Federal Government for supra-regional employment in disaster situations; for reasons of expediency, however, they are being utilized also in case of minor disasters such as represented by any serious traffic accident, grave industrial accident, or medical Emergency.

Thus the Federal Ministry of the Interior at the present time provides helicopters of the BO 105 type at 18 hospitals, the Federal Armed Forces have BELL UH 1 D's available

at 3 military hospitals, and a civilian organization has BELL 206 "Long Ranger" and BO 105 type helicopters available at 3 additional hospitals. All missions are paid for by the public or private health insurance organizations and trade cooperative or professional associations according to a uniform accounting procedure. These payments, however, cover only the operating costs and not the investment costs of the aircraft as such. Private airlines, therefore, cannot expect to recover their actual costs from the payments of the health insurance companies.

From the variety of types of aircraft initially there resulted also a variety of types of equipment carried by the helicopters. A committee of the Federal and Laender governments, with the technical advice of the "German Society of Aviation and Space Medicine" and other organizations involved in the emergency rescue service have developed standards to ensure uniformity of the aeronautical equipment of the rescue helicopters so far as possible, to adjust this equipment to the criteria of employment, and to ensure a mode of transportation affordin the best possible protection for the patient. In this respect, flying safety with the requirement for 2 independent rotors, low noise level, and diminished vibrations plays a decisive role. The question of absolute IFR capability for rescue helicopters is presently under investigation, without, however, any apparent results so far. This is one of the points of attack for criticism by opponents of the air rescue service.

In addition to the aeronautical equipment of the aircraft, the medical equipment is an essential element of the capability of successful employment: Standards corresponding to the medical equipment uniformly specified in the Federal Republic of Germany for rescue aircraft on long range missions have also been developed for rescue helicopters.

Every rescue helicopter stationed in Germany, therefore, carries the following medical equipment:

- Self-contained breathing system
- Fresh air breathing unit
- Suction unit/intubation set
- Sphygmomanometer
- Infusion solution and infusion set
- Puncture set for peripheral and central veins
- Surgical dressings including special dressings for burns
- Fixation material and splints
- Vacuum mattress
- Injection material
- Surgical pocket instrument case
- Stomach probes
- ECG display unit
- Defibrillator
- Otoscope
- Surgical dressings and general care equipment
- Pharmaceuticals

At the present time, there is no helicopter on the market that ideally meets the space requirement for physician, medical aid personnel, and patient; to achieve that, we would have to develop a flying operation theater.

The best aircraft and the best equipment would be useless, however, without an appropriately trained crew on board. German regulations, therefore, require that each aircraft must carry a physician trained in emergency medicine and a male ambulance nurse. Both must be fully trained in all measures dictated by emergency medicine and in the responsible operation of medical equipment on board. Beyond that they must have some aeromedical experience in order to meet all requirements peculiar to the air transport of emergency patients. All items of medical equipment are so installed as to permit their employment outside of the aircraft as well.

A number of special provisions applies to the mountain and sea rescue service, such as installation of a winch to permit rescuing injured persons in the mountains or at sea and hauling them on board. The winch has also proved valuable in rescue operations from burning sky-scrapers which did not offer any possibility for landing.

Basically, not every emergency patient must be evacuated by rescue helicopter. Depending entirely on the local conditions, evacuation by ground vehicle may frequently be more practical after restoration of the vital functions at the scene of the accident, however, the rescue helicopter must offer every opportunity for continued optimum medical care of the patient. Control of the pulmonary and cardiac functions, in particular, must be ensured, as well as infusion and intubation therapy.

The helicopters are alerted via the local control centers operated by welfare organizations, fire departments, or police. By 1979, there will be a uniform emergency telephone number - 110 - valid throughout Germany. Beyond that, the control centers directing rescue helicopter missions can also be reached by telephone directly.

The rescue helicopters made available by the Federal Armed Forces are part of the Search and Rescue (SAR) Service of the German Federal Armed Forces; they are integrated into the civil rescue network for special missions, but when a requirement arises they are at the disposal of the SAR Service in its primary mission.

For the German Federal Armed Forces, participation in the helicopter rescue service constitutes an essential aid in their training mission. In conjunction with the employment of ambulances equipped with facilities for rendering emergency treatment, the rescue centers of the German Armed Forces conduct courses on emergency medicine for physicians and male ambulance nurses in which medical officers and non-commissioned officers of the Medical Service receive appropriate training.

It should also be mentioned that, in addition to the short range emergency rescue missions flown by helicopters, there are 7 airlines in Germany engaged in long range aeromedical evacuation, so-called "repatriation flights"; these are primarily missions for the purpose of flying sick or injured tourists or employees from abroad back to Germany for hospital treatment. Presently there are efforts under way to coordinate this organization with the helicopter organization and the ground rescue service in order to provide for continuous transportation of the patients to the facility where they will ultimately receive treatment.



In conclusion, let me summarize the mission of the rescue helicopter:

1. Transportation of the physicians and male ambulance nurse to the scene of emergency.
2. Evacuation of the emergency patient.
3. Urgent transfer of emergency patients from the location providing initial hospital treatment to a specialized hospital.
4. Urgent transports of
  - organs,
  - units of blood from a blood bank,
  - pharmaceuticals.
5. Search for persons over water and in mountain areas.

Since the establishment of the helicopter rescue service in 1971, about 65.000 missions have been flown in Germany, over 18.000 missions in the last year alone. This constitutes a significant contribution to saving the lives of patients in acute distress. We have learned from medical statistics that every 6th mission was an absolutely life saving one.

With an annual death rate of between 15.000 and 18.000 persons killed in traffic accidents on the German highways and in the cities and a correspondingly high number of critically injured persons it is impossible today to imagine rescue operations without the use of helicopters.

The same applies to the rescue of emergency patients in cases such as cardiac infarction and poisoning.

In this context let me refer you to the experiences of the US and Israeli armed forces in their respective armed conflicts.

Although we can use the emergency rescue service in peacetime to train for a national emergency, may we all be spared the big test in a possible state of defense.

#### Summary

Specially equipped rescue helicopters have been used in the Federal Republic of Germany for six years now to provide emergency internal and surgical treatment to patients quickly at the scene of the accident and to evacuate them by helicopter to a special clinic, if required. About 65.000 missions have been flown.

For this purpose, 24 air rescue stations have been established in Germany ensuring almost complete coverage of the territory of the Federal Republic of Germany.

Since various government and private institutions are involved in the helicopter rescue service, coordination of the regulations governing the employment and equipment of all helicopters was necessary so that every patient would receive the best possible treatment under identical criteria.

Moreover, the number of cases requiring aeromedical evacuation by fixed-wing aircraft of tourists and employees of German firms involved in accidents in foreign countries has been increasing in the past years. The German Society of Aviation and Space Medicine has issued guidelines specifying minimum requirements for aeromedical evacuation of sick and injured persons and has initiated the standardization of the on-board equipment for these cases as well.

The SAR service of the German Federal Armed Forces has a considerable share in the emergency air rescue missions flown.

March 78

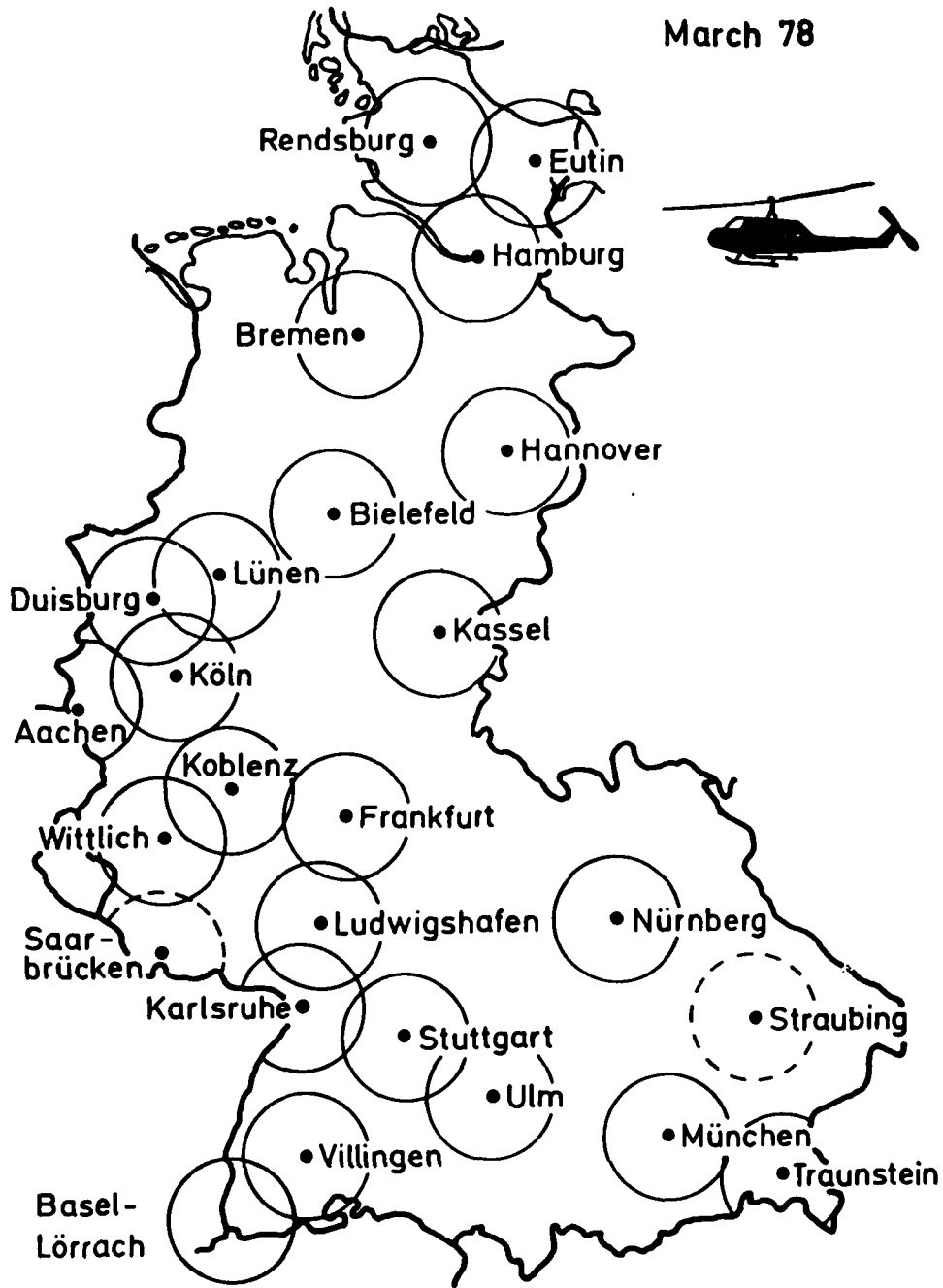

### Helicopter Rescue in Germany

Summary of missions  
1971 - 1977 = 64,171

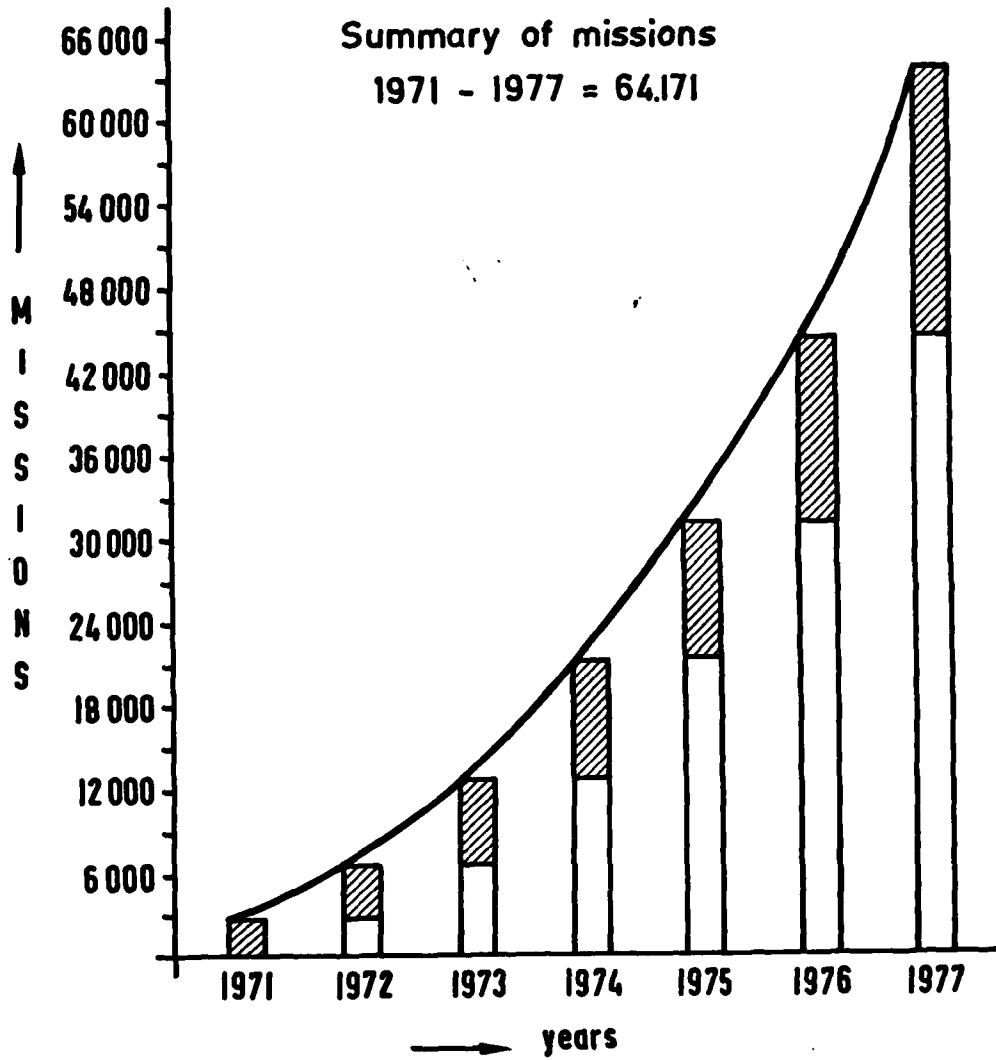

### Helicopter Rescue in Germany

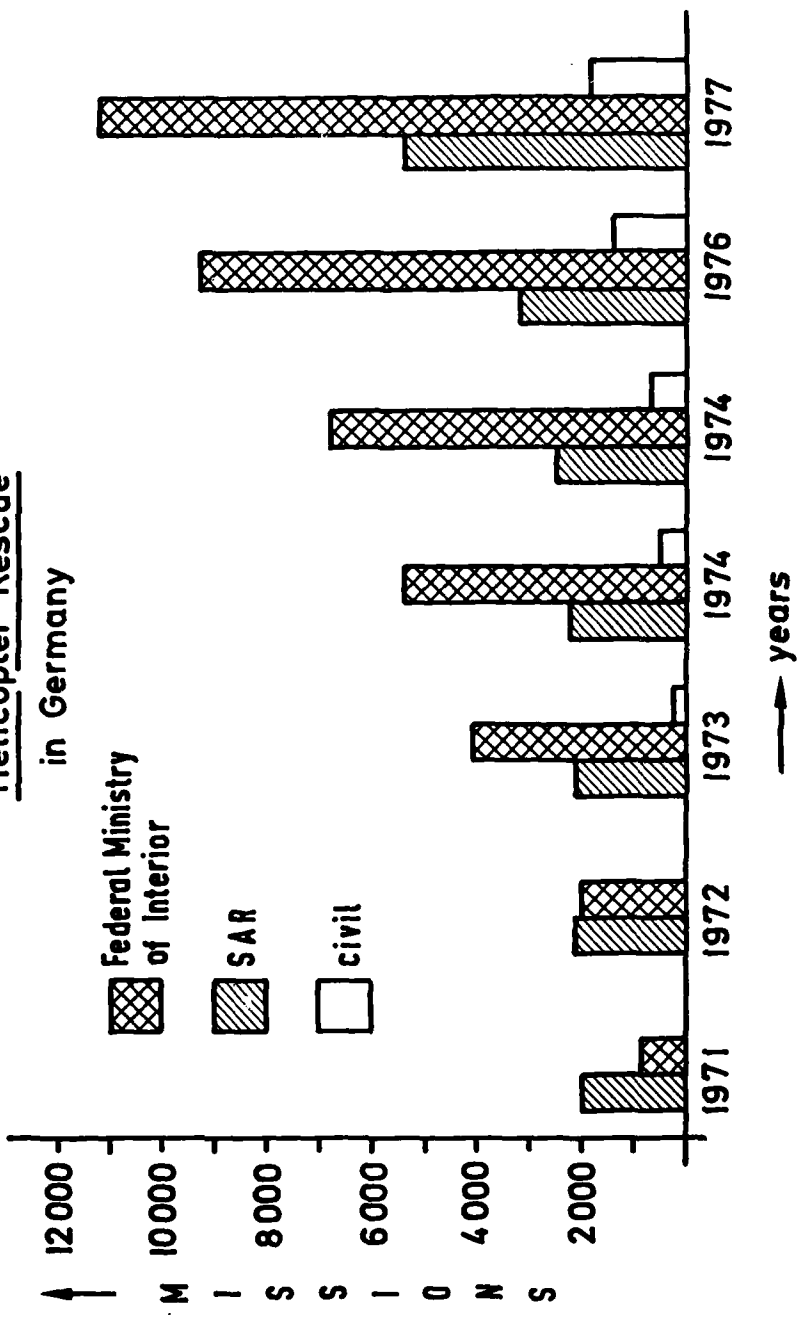

MEDICAL ASPECTS OF HELICOPTER EVACUATION  
AND RESCUE OPERATIONS

Daniel S. Berliner, M.D., LTC, MC, SFS  
Chief, Medical Division  
United States Army Agency for Aviation Safety  
Fort Rucker, Alabama 36362, USA

ABSTRACT

The use of helicopters in patient evacuation, both from site of incapacitation and between medical facilities is well known and its usefulness well documented. The special environment of the helicopter, however, is a continual cause of concern to the aerospace medicine specialist and the aviation medicine community. There are problems in using the current state-of-the-art helicopter for patient evacuation. While the best solution lies in redesign of patient care areas or production of new prototype aircraft, less costly solutions are possible. Education is a key to the success of an inflight patient care program. This applies to referring health care providers at all levels and onboard patient care attendants. With adequate training, standardization of inflight equipment, to isolate the patient from the vibrating and noisy rotary wing platform and to enhance continuation of care begun on the ground, is essential. The sophistication of inflight patient care and monitoring is limited only by imagination and funds, but care should be taken to insist on standardization of such equipment within and between medical evacuation helicopter units. To prevent helicopter evacuation aircraft from being utilized as air taxis, merely carrying patients, but providing little or no onboard patient care, continuing monitorship by the aerospace medicine specialist is required. Establishment of an operational heliborne patient evacuation system within the research and development community may prove to be the means to these goals.

The use of the helicopter in the evacuation of both military and civilian patients is the concern of all responsible members of the aerospace medicine community. The methodology with which patient movement by helicopter is accomplished varies considerably with location dependent upon the emphasis from and availability of physicians trained in the uniqueness of helicopter aviation medicine. While the helicopter is often the only available means of rapid patient evacuation, problem areas exist that must be considered when deciding to transport sick persons by this means.

The following case history demonstrates four areas of concern in helicopter patient movement.

Mrs. A. G., a 65-year old black female, had been burned in an apartment fire in a small town in Indiana, USA, at 1730 hours, 25 Nov 73. The local physician telephonically contacted a military medical evacuation unit some 45 flying minutes away at 1915 hours and requested patient transfer by helicopter to a burn center in Nashville, Tennessee, USA--a two-hour flight. His description of the patient's condition, when queried by the unit flight surgeon, was that of a somewhat debilitated lady, burned over 35 percent of her body, primarily over her trunk, and fully stabilized for helicopter flight. Inasmuch as no attendant from the local hospital was available to accompany the patient, the unit flight surgeon chose to fly this mission. On arrival at the requesting hospital at 2015 hours, the flight surgeon found a patient with upper trunk and neck, partial and full thickness burns covering approximately 40 percent of her body, in acute respiratory distress, having no tracheostomy accomplished, no urinary catheter, and a butterfly intravenous catheter in her left hand. The local physician expressed serious concern over the flight surgeon's request for tracheostomy, urinary catheter, and central venous pressure (CVP) intravenous catheter placement prior to helicopter evacuation. By 2200 hours, the patient had begun to be hydrated as per the Brooke burn formula, using a CVP line, had a Foley urinary catheter in place, and was being aerated through a tracheostomy on a portable Bird respirator. Her semicomatose state precluded adequate historical review prior to flight. While the patient remained alive en route, this status was not readily determined by the flight surgeon due to poor lighting in the helicopter and inadequate monitoring equipment for the vibrating, noisy helicopter (use of a hospital blood pressure cuff and stethoscope being impossible, as well as incompatible with the aircrew helmet). An inability to accurately communicate the condition of the

---

The opinions presented herein are those of the author's and in no way reflect Department of Defense or Department of the Army policy.

patient to the receiving burn center due to the monitoring difficulty as well as radio incompatibility between helicopter and hospital resulted in a less than enthusiastic welcome by the burn center staff regarding its readiness to deal with the severely ill patient. The requirement that the helicopter land at a local airport, necessitating a 30-minute ambulance ride to the burn center, further degraded the sequence of care to the patient. Her eventual survival of this ordeal might be considered to be in spite of her two-hour helicopter flight.

This appraisal clearly points out four problem areas of helicopter patient movement. These are:

1. The knowledge of the health care provider as to the suitability of helicopter evacuation for a particular patient, information based upon an understanding of the stresses and capabilities of helicopter patient movement.
2. The preparation and stabilization of patients prior to helicopter flight by the sending facility or field site.
3. The inflight protection of the patient from the vibratory and noise stresses of helicopter flight and the continuation of medical monitoring and treatment while flying.
4. The knowledge by the receiving facility as to the stresses and capabilities of helicopter patient movement.

Philosophically, while patient care is of utmost concern to patient evacuation by air, the capability to provide care in flight has been difficult at best. In some circles, policy decisions have yet to be made regarding the extent of aeromedical input to the mechanism of patient transportation by helicopter. The previous Vietnam era saw patients being moved by helicopter with little care being provided en route. The goal was speed of movement from injury site or field medical facility to a rearward hospital. This was not without merit and certainly saved numerous lives during that conflict. With the advent of the 1980's, however, ambulatory and emergency health care has become increasingly more recognized as a key element to the total health care system. Thus, pre-hospital care of the acutely ill or injured patient can be forecast to save many more lives than the modality of initiating care only after arrival at a fixed medical facility. In the interest of providing a continuum of health care to such a patient, the helicopter's role in today's and tomorrow's patient care system must be that of delivering high quality health care by trained medical attendants while rapidly transporting the patient between treatment sites.

In approaching helicopter evacuation of patients as a subsystem of both the health care delivery system and the rotary wing airframe, a number of substantive improvements must be made to continue the progression of helicopter aviation medicine such that health care is provided throughout heliborne patient movement. Two such areas are beyond the scope here. They are the systematized, standardized approach to aviation life support equipment for all crewmembers and a modular approach to design of patient care packages for new and proposed airframes. The current rotary wing fleet will be flyable for many more years, and the real world problems of caring for patients in such aircraft are within technical capabilities and are a necessity. The environment of helicopter flight in current equipment is hostile to the ill or injured patient, but is a necessary form of transport on the battlefield and in locales incapable of handling fixed wing aircraft. This need, coupled with stresses from vibration, noise, lack of space and lighting, lack of pressurization, and environmental factors of altitude, temperature, humidity, and air-borne contaminants (dust) produce a paradoxical, but tolerable situation. Such tolerance must not be based upon a philosophy that helicopters used for patient evacuation are transportation tools in which provision of health care is not required. Rather, the aerospace medicine community can tolerate the inadequacies of the helicopter in patient transport only if positive steps are taken to insure that quality health care is provided throughout the evacuation process.

Four areas of emphasis can accomplish this necessary goal. First, the aerospace medicine specialist must educate health care providers at all levels regarding the uniqueness of helicopter flight, the capabilities of the heliborne patient evacuation system, and the required preparation of the patient for helicopter movement. Physicians, nurses, and ground ambulance crews alike must be aware of their responsibilities as key members of the health care team providing pre-hospital and stabilizing care to a critically ill or injured patient. Emphasis on continuation of their efforts in the air is essential and can be provided through a military or civilian aviation medicine education program.

Second, the current helicopter evacuation system, whether military or civilian, must be continually monitored by aerospace medicine specialists. In the military, the helicopter evacuation unit requires input and monitoring by local flight surgeons. Regionalization of responsibility for the military system would serve to capitalize on slim resources of aerospace medicine specialists, while infusing timely and accurate input to planning, operations, after-action resumes, and critiques of missions flown by helicopter evacuation units.

A third area is that of training of all aircrewmembers involved in inflight patient care by the aerospace medicine specialist. The documentation and evaluation of such training must prove that even those who infrequently participate in this modality of care (as civilian nurse anesthetists and respiratory therapists) are capable to care for patient needs, can use and maintain necessary medical equipment, are familiar with the stresses of helicopter flying, and are professional in manner and attitude.

Finally, the aerospace medicine community must develop a single manager concept for all equipment used in helicopter evacuation of patients on as broad a scope as possible. The emphasis has to be on standardization, at least for each aircraft type and involving sister services within a defense establishment. Uniformity and interchangeability of equipment will further serve to reduce training cost as crews moving from one military unit to another will not have to deal with an orientation to differing, often locally procured medical equipment. The system can then approach the capabilities of fixed wing aircraft involved in patient evacuation with the goal being compatibility, especially when transfer of patients from helicopters to fixed wing aircraft becomes a necessity under combat conditions. Specific concerns are essential in the following areas:

1. Space - Modification of interior configuration may not be cost-effective in the current airframe, but continues to be a problem in maintaining unobstructed access to unstable patients.
2. Communication - Attendant-controlled, two-way capability between patient and aircrew is necessary, with requirement for built-in hearing protection and special design for conscious patients with head trauma. Attendant aircrew need to be able to talk to civilian and military receiving and sending health care facilities.
3. Fire Protection - Clothing for all medical attendants and covering for patients, all of fire retardant material, is needed, even in helicopters with crashworthy fuel systems.
4. Restraint Systems - Configuration of litters, attendant seats, restraining harnesses, and belts must protect patients and attendants in G-force survivable aircraft accidents.
5. Containment - Provision to protect patients from rotor blade downwash and dust on movement to and from aircraft, from vibration characteristics of the airframe, and capability to maintain constant cabin temperature in flight is necessary.
6. Medication Kits - Standardized pharmaceuticals and intravenous materials need to be unbreakable, easy-to-use, and single-dose type.
7. Lighting - Draping between cockpit crew and patient care area is required to prevent interference with pilot's ability to navigate at night, with patient care area lighting of adequate intensity to permit medical activities in a nighttime environment.
8. Oxygen and Suction (constant and intermittent) - Easily regulated built-in system with capability for humidification of medical oxygen is required. This must not interfere with aircraft electrical and navigational systems, but must be compatible with standard portable pressure respirator.
9. Monitoring - Compact, built-in, vibration-tolerant, readable vital-sign monitor (for temperature, pulse, respiration, and blood pressure) that does not interfere with aircraft electrical and navigational systems is necessary. This must be compatible with standard portable electrocardiographic and defibrillation equipment.
10. Aircrewmembers - Continual flight surgeon input to standardized training emphasizing an ability to handle dynamic patient situations, use and maintenance of medical equipment, and knowledge of stresses of helicopter flight is needed. The cockpit crew, the heliborne medical attendant, and the flight surgeon must work together as an inseparable team.

Such a prospective and operational approach to heliborne patient movement should prove to serve the needs of patient, aviator, and health care providers alike. With initiation or continuation of quality health care aboard a helicopter as a primary goal, a systems approach to the rotary wing patient movement platform can be the means to this end. Standardization, commonality, intuitiveness, and, the key ingredient, interpersonal teamwork can serve and benefit this visible gap in the military and civilian health care delivery system.



AN EVALUATION OF THE EFFECTS OF A STABILITY AUGMENTATION SYSTEM  
UPON AVIATOR PERFORMANCE/WORKLOAD DURING A MEDEVAC HIGH HOVER OPERATION

M. G. Sanders, R. T. Burden, Jr., R. R. Simmons  
M. A. Lees, & K. A. Kimball  
US Army Aeromedical Research Laboratory  
Fort Rucker, Alabama 36362

SUMMARY

Stability augmentation systems are purported to reduce pilot workload during hover, nap-of-the-earth, and IFR maneuvers. The current research project examines a method of aiding the MEDEVAC pilot in performing a hover maneuver while perhaps reducing workload. A modular, four-axis stability augmentation system (Ministab) with integrated rate attitude and heading retention was installed on the USAARL JUH-1H helicopter. Participating personnel for the project were nine US Army aviators with a total average of 1172 flight hours. The aviators hovered at 30 feet above ground level for five minutes under each of the three following flight control conditions: (1) Unaided--"normal" hover with visual flight rules conditions, (2) using Force Trim, and (3) using the Ministab. Continuous information from twenty pilot and aircraft monitoring points was recorded on an incremental digital recorder for all flights. Multivariate analyses were performed on both aircraft status variables and control input workload/activity measures. Under the conditions tested, the stability augmentation system evaluated did not provide a clear-cut improvement in flight performance and workload across all flight parameters.

INTRODUCTION

Successful completion of the Army medical mission often requires that the MEDEVAC helicopter pilot be capable of performing precise stabilized hovers during the extraction of injured personnel. The precision hover, required for hoist extractions, is one of the most difficult and taxing flight maneuvers. The potential severity of this mission essential maneuver, when high altitudes, adverse weather and immediate threat factors are considered, requires efficient execution. Thus, the "out-of-ground effect" hover maneuver contains two primary elements of concern--a need for a high degree of precision and a concomitant potential for excessive workload. These two areas also reflect the input and output of a multidimensional tracking task which is another way of describing the precision hover. A schematic of the control loop involved might be described as follows:

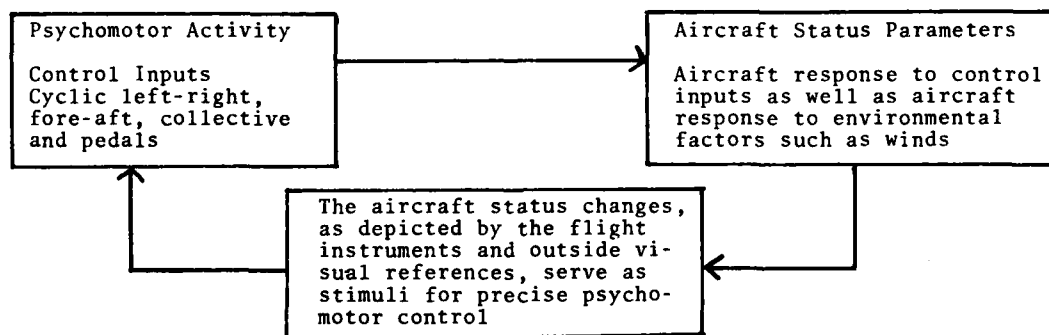

In a study by Anderson and Toivanen (1970),<sup>1</sup> pilot workload was evaluated relative to varying levels of autopilot assistance during an IFR formation flight using a UH-1 flight simulator. This evaluation "revealed that the increased autopilot capability enabled the pilot to perform considerably better under the highest workload condition tested." As well, "pilot control inputs and aircraft responses required for position control were significantly lower when the outer loop [heading, altitude, and heading and altitude] hold modes of the autopilot were engaged."

A four axes stability augmentation and altitude retention system (Ministab) was installed on the USAARL JUH-1H test vehicle for a comparative evaluation with other standard flight control conditions (Kaiser, 1976). The intent of the system was to augment the pilot's performance in pitch, roll, heading and altitude hold. The fourth axis (altitude hold) was not operated during the current evaluation. The objective of the current study was to evaluate aviator workload and aircraft status maintenance capability when using the stability augmentation and attitude retention system as compared to more typical flight control conditions.<sup>2</sup>

## METHOD

Subjects

Participating personnel for the project were nine US Army aviators with an average age of 27.7. Their rank varied from Chief Warrant Officer to Captain and their average total flight hours were 1172.2. The UH-1 helicopter was reported to be the aircraft in which they had logged the most flight time. The subjects were all currently in assignments which required flying and had been on flight status for an average of 3.8 years.

Apparatus

The Ministab was made available for testing by the US Army Air Mobility Laboratory at Fort Eustis, Virginia. The Ministab is a "modular stability augmentation system with integrated rate attitude and heading retention that can be applied to any helicopter having boosted flight controls." A computer with an integral rate gyro which senses motions of less than 1/100 of a degree/second is dedicated to each axis.

The test vehicle was a JUH-1H helicopter instrumented to measure and record pilot control inputs and aircraft position, rates and acceleration. This Helicopter In-Flight Monitoring System (HIMS) measures aircraft position in six degrees of freedom while simultaneously recording cyclic, collective and pedal inputs and aircraft status values. These data were recorded in real time on an incremental digital recorder. Continuous information from twenty pilot and aircraft monitoring points was recorded for all flights. Table 1 provides a list of these parameters along with a partial listing of measures that can be derived from the directly recorded information.

TABLE 1  
PARAMETERS MEASURED AND DERIVED

Parameters Measured	Derived Measures
Pitch	Pitch Rate
Roll	Roll Rate
Heading	Rate of Turn
Position X	Constant Error, Average Absolute Error, RMS Error
Position Y	Ground Speed, Constant Error Average Absolute Error, RMS Error
Acceleration X	
Acceleration Y	
Acceleration Z	
Roll Rate	Roll Acceleration
Pitch Rate	Pitch Acceleration
Yaw Rate	Yaw Acceleration
Radar Altitude	Rate of Climb, Average Absolute Error, Constant Error, RMS Error
Barometric Altitude	Rate of Climb
Airspeed	
Flight Time	
Rotor RPM	
Throttle	
Cyclic Stick (Fore-Aft)	Control Position, Absolute Control Movement Magnitude, Positive Control Movement Magnitude, Negative Control Movement Magnitude, Absolute Average Control Movement Rate, Average Positive Control Movement Rate, Average Negative Control Movement Rate, Control Reversals, Instantaneous Control Reversals, Control Steady State, Control Movement
Cyclic Stick (Left-Right)	
Collective	
Pedals	

Pilot inputs to controls were generally defined in the following manner. Control inputs on the cyclic fore-aft, cyclic left-right, and pedals were required to have the following characteristics: (1) seven successive samples of data (the data were sampled 20 times per second; therefore, .05 seconds per sample) were compared to data sampled .25 seconds later; (2) differences were obtained between these data occurring .25 seconds apart; (3) the average for three consecutive differences had to exceed .075 inches; (4) this difference had to be in the same direction for five consecutive comparisons. The same general requirements were made of the collective control inputs with the exception that six consecutive comparisons were required at .09 inch movements per comparison.

### Flight Testing

A Ministab training program of instruction used for system familiarization is provided in Appendix A. All in-flight evaluations took place at the Highfalls stagefield. A one-minute period was allotted just prior to the actual testing on each condition for practice on that condition. The aviators were tested under each of the three flight control conditions: (1) Unaided--"normal" hover during visual flight rules (VFR) conditions; (2) using Force Trim; (3) using Ministab. "Force Trim or Force Gradient enables the pilot to trim the control as desired for any condition of flight by means of springs and magnetic brake release assemblies. The Force Trim can be activated on the cyclic controls and the pedal controls. These devices are electro-mechanical units used to induce artificial control feeling and returns the cyclic to the desired initial position" (Operator's Manual, 1971).<sup>3</sup>

The aviators hovered at 30 feet above ground level (AGL) in essentially the same location (over the stagefield runway) for five minutes under each condition. Table 2 indicates the three flight conditions evaluated and controls (Con) required. The order of testing for the three experimental conditions was counterbalanced to minimize order effect bias. The direction of the wind was determined before the test of each flight condition and based on this information a heading was chosen that allowed the aircraft to face into the wind during the hover.

TABLE 2  
FLIGHT CONTROL CONDITIONS EVALUATED

<u>Flight Conditions</u>	<u>Flight Parameters</u>			
	Pitch	Roll	Heading/Yaw	Altitude
1. Unaided--"Normal" VFR Hover Conditions	Manual Con With Cyclic Fore-Aft	Manual Con With Cyclic Lateral	Manual Con With Pedals	Manual Con With Collective
2. Force Trim	Force gradients on with manual override for control changes with the cyclic.		Force gradients on with manual override for control with the pedals.	Manual control with collective.
3. Stability Augmentation Attitude Retention System (Ministab)	Monitor & make manual control inputs when conditions exceed the 10% control authority of the system.		Monitor & make manual control inputs when conditions exceed the 10% control authority of system.	Manual control with collective.

### Subjective Evaluation

After each flight condition was completed, a Cooper-Harper Handling Qualities Rating Scale was filled out by the subject (Cooper and Harper, 1969).<sup>4</sup> Post flight, the subjects completed a biographical data form and a questionnaire concerning aspects of their flight under the different experimental conditions.

### RESULTS AND DISCUSSION

Three primary analyses were performed on the data collected during the evaluation of the stability augmentation system. The first analysis to be reported concerned an examination of the existing wind conditions relative to the research helicopter during the evaluation. Again, the order of testing of the three flight conditions was counterbalanced across subjects to minimize order effect bias. Testing was continuous in that each condition evaluated was immediately followed by the next condition (approximately five-minute separations). The wind information collected during the testing periods was evaluated with the Versatile MANOVA program (Schori, 1976)<sup>5</sup> to determine if the wind direction, velocity, or aircraft heading relative to wind direction (crosswind component) varied among the three flight conditions. The results of this analysis are reported in Table 3.

TABLE 3  
MULTIVARIATE ANALYSIS OF VARIANCE WITH DISCRIMINANT ANALYSIS  
SUMMARY WIND DATA

Variable	Flight Condition Means			F <sup>1</sup>	Standardized Canonical Wts
	Unaided	Force Trim	Ministab		
Crosswind Component <sup>1</sup>	13.75	12.12	14.95	0.23	-0.278
Wind Direction Mean <sup>2</sup>	195.28	229.01	201.42	0.66	0.034
Wind Direction Std Deviation <sup>2</sup>	15.78	10.40	16.33	0.97	-0.171
Wind Velocity Mean <sup>3</sup>	8.85	9.50	9.07	0.29	-0.129
Wind Velocity Std Deviation <sup>3</sup>	1.72	1.47	1.90	2.97	-0.367
Overall Multivariate Test of Significance					
Wilks Lambda	F-Ratio	df(Num)	df(Den)	Prob	
0.580	0.750	10	24	0.67	

Total Discriminatory Power (Estimated Omega Squared) = 0.369

Significance Test, Individual Canonical Variables  
 Root I--88.64% Variance  
 Chi-Square = 6.11, df = 6, p < 0.41  
 Root II--11.36% Variance  
 Chi-Square = 0.96, df = 4, p < 0.91

<sup>1</sup>Univariate F-Ratio, df = 2/16. These F-Ratios were not significant at the .05 level of probability.  
<sup>2</sup>Unit of measurement--degree.  
<sup>3</sup>Unit of measurement--knot.

An examination of these data reveals that no significant differences were observed either univariately on any of the variables or overall in the multivariate test of significance. Indeed, the means listed in Table 3 indicate that very little difference did exist in wind direction variability, velocity and crosswind component across the three flight conditions. Therefore, performance and/or aircraft status differences found can be attributed to the flight conditions being evaluated and not extraneous wind variables impinging upon performance.

The second analysis pertained to an evaluation of aircraft status or stability variables. These variables are listed in Table 4 along with the findings of the analysis.

TABLE 4  
MULTIVARIATE DISCRIMINANT ANALYSIS OF VARIANCE  
WITH DISCRIMINANT ANALYSIS

Variable	Flight Condition Means			F <sup>1</sup>	Standardized Canonical Wts
	Unaided	Force Trim	Ministab		
Pitch Std Deviation <sup>2</sup>	0.69	0.80	0.83	2.05	0.069
Roll Std Deviation <sup>2</sup>	0.74	0.83	0.76	1.89	0.091
Heading Std Deviation <sup>2</sup>	2.70	3.55	2.44	1.82	0.058
Radar Altitude Std Deviation <sup>3</sup>	2.28	2.18	2.32	0.20	-0.051
Overall Multivariate Test of Significance					
Wilks Lambda	F-Ratio	df(Num)	df(Den)	Prob	
0.48	1.41	8	26	0.23	

Total Discriminatory Power (Estimated Omega Squared) = 0.46

Significance Test, Individual Canonical Variables  
 Root I--74.8% Variance  
 Chi-Square = 6.97, df = 5, p = 0.22  
 Root II--25.1% Variance  
 Chi-Square = 2.76, df = 3, p = 0.56

<sup>1</sup>Univariate F-Ratio, df = 2/16. These F-Ratios were not significant at the .05 level of probability.  
<sup>2</sup>Unit of measurement--degree.  
<sup>3</sup>Unit of measurement--feet.

It is indeed noteworthy that none of the variables examined (aircraft axis variation and rate measures) proved to be different to a significant degree across the three flight conditions. That is, the aircraft position variability and rate variability about each of the four axes did not change significantly when the stability augmentation system was activated as compared to the force trim and unaided flight conditions.

The third analysis to be described concerns the control input data which could relate to the activity requirements or workload of the operator. Table 5 contains the flight control variables which describe performance along each of the four primary flight control channels. The magnitude of control inputs was examined along with the number of inputs per second.

TABLE 5  
MULTIVARIATE ANALYSIS OF VARIANCE WITH DISCRIMINANT ANALYSIS  
CONTROL INPUT PARAMETERS

Variable	Flight Condition Means			F <sup>1</sup>	Standardized Canonical Wts
	Unaided	Force Trim	Ministab		
Cyclic Fore-Aft (CFA) Control Movement Magnitude <sup>3</sup>	0.35	0.38	0.27	11.71**	0.037 <sup>2</sup>
CFA Control Movements No of Occurrences/Sec	0.78	0.75	0.50	9.63**	0.018 <sup>2</sup>
Cyclic Left-Right (CLR) Control Movement Magnitude <sup>3</sup>	0.33	0.34	0.32	0.32	-0.025 <sup>2</sup>
CLR Control Movement No of Occurrences/Sec	0.73	0.68	0.74	0.40	-0.008
Collective Control Movement Magnitude <sup>3</sup>	0.27	0.34	0.43	0.98	0.007
Collective Control Mov No of Occurrences/Sec	0.02	0.06	0.04	2.40	-0.013
Pedals Control Movement Magnitude <sup>3</sup>	0.25	0.30	0.20	6.57**	0.012
Pedals Control Mov No of Occurrences/Sec	0.29	0.38	0.19	5.09*	-0.008

Overall Multivariate Test of Significance

Wilks Lambda	F-Ratio	df(Num)	df(Den)	Prob
0.084	2.73	16	18	0.02

Total Discriminatory Power (Estimated Omega Squared) = 0.90

Significance Test, Individual Canonical Variables

Root I--75.5% Variance

Chi-Square = 18.7, df = 9, p = 0.02

Root II--24.4% Variance

Chi-Square = 9.6, df = 7, p = 0.20

<sup>1</sup>Univariate F-Ratio, df = 2/16.

<sup>2</sup>Primary Contributor.

<sup>3</sup>Unit of measurement--inch.

\* p = .05

\*\* p = .01

Four of the variables examined univariately showed significant differences across the flight conditions ( $p < .05$ ) and are so designated in Table 5. Individually, the cyclic fore-aft flight control channel demonstrated that the Ministab did indeed reduce perceptual-motor workload in that 35% fewer inputs were required during the Ministab hovers as compared to the Unaided flight condition. As well, 33% fewer inputs were required during the Ministab hover as compared to the Force Trim hover. The average magnitude of cyclic fore-aft control inputs was also smaller for the Ministab hover as compared to the control inputs during the Unaided and Force Trim flight conditions.

Pedal control inputs also indicated a significant reduction in perceptual-motor workload by aviators when hovering with the Ministab. Thirty-four percent and forty-nine percent fewer pedal control inputs were made during the Ministab hover than during the

Unaided and Force Trim flight conditions respectively. As well, the average magnitude of the control movements was smaller for the Ministab flight condition.

An evaluation of the results of the control input multivariate analysis indicates that performance varied significantly across the three flight conditions ( $f = 2.73$ ,  $df = 16/18$ ,  $p = .02$ ). One root accounted for the significant discrimination ( $\chi^2 = 18.7$ ,  $df = 9$ ,  $p = 0.02$ ) and accounted for 75% of the variance. The total discriminatory power or estimated omega squared was 0.90. A review of the primary contributors among the standardized canonical scores depicted in Figure 1 that the flight performance displayed under the Ministab condition is characterized by fewer and smaller cyclic fore-aft control movements along with slightly smaller cyclic left-right control inputs as compared to the Unaided and Force Trim flights. Statistically, the variables utilized in the control input analysis produced a significant separation between the Ministab flight condition and the Unaided and Force Trim flights as witnessed by Figure 1. The scores plotted in Figure 1 represent mean canonical scores or a composite group mean for each flight condition.

#### Subjective Evaluations

The questionnaire utilized to obtain subjective/pilot opinion information about the flight evaluation provides several important points which impact the results of the study. The most important point made by several of the pilots was that the familiarization or instruction period given the pilots before flight testing (Appendix A) was not adequate for full proficiency with the system. This implies: (1) the stability augmentation system either requires greater experience than that described in Appendix A for adequate proficiency or the system is not automatically easy to master and may or may not be adequately understood and controlled with more experience with the system, and (2) the outcome of evaluation is more dependent upon level of experience with the system than was initially considered. It should be pointed out that the program of instruction received by each test subject was along the lines of that recommended by the system developers. The subjects were also equivocal about whether or not the Ministab aided or interfered with normal precision control while hovering. Five subjects stated that the system aided their hover while four considered the system an interference.

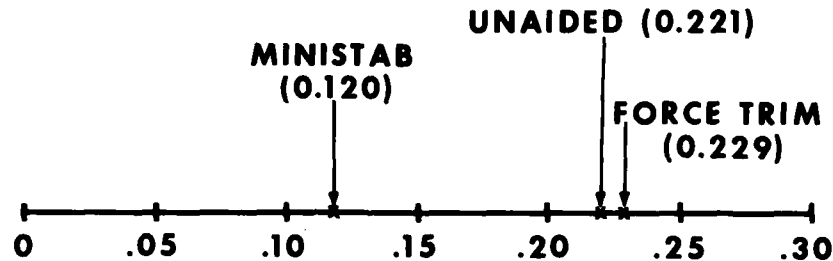

**FIGURE 1 CONTROL INPUT DATA  
MEAN CANONICAL SCORES**

The three flight conditions were ranked by the subjects as to which gave them their best hover performance. The outcome indicated that the Ministab provided the best hover performance (mean rank = 1.44) followed by 1.78 for the Unaided condition and 2.78 for the Force Trim hover condition. The Force Trim flight condition was not the familiar or normal mode of hover for the subjects and was considered undesirable because of control stiffness and reduction in control "touch."

The results of the Cooper-Harper Handling Qualities Rating Scale which was completed by each of the subjects after each of the flight conditions revealed the following ratings:

<u>Mean Pilot Rating</u>	<u>Flight Condition</u>
3.11	Unaided
3.33	Ministab
4.33	Force Trim

These subjective rating data again demonstrate the very slight perceived differences between the Unaided and Ministab flight conditions--the Unaided hover condition being the least demanding followed closely by the Ministab with a larger separation occurring between the Ministab and Force Trim conditions.

It should be noted that several months prior to the investigation reported in this article, the Ministab system was evaluated by a test pilot at Fort Rucker, Alabama. Several of the test pilot's written comments about the evaluation seem to support the objective and subjective results of the current investigation (Simon, 1976).<sup>6</sup>

In general, the test pilot made favorable comments about the system; however, it was noted that the "pure SAS [stability augmentation system] gain in the roll axis appeared to be higher than it should be.... This tendency was noted several times during the evaluation, usually occurring in a climbing turn." In addition, the test pilot stated that "the length of time required for the 'automatic fly-through' process or synchronization (where the controls are moved a small amount and held momentarily without depressing the mag brake button) was acceptable for up and away/cruising flights although a little learning was necessary to adapt to the time lag. However, this 'synchro time lag' was excessive in the hover regime probably due to the frequency of control inputs required for holding a position over the ground. It was noticed that a sizable number of corrective control inputs were made which did not cause or allow the system to synchronize itself."

The test pilot suggested a reduction in time lag "which should further reduce pilot workload." It is reported that this time lag reduction was accomplished before the current investigation. However, it is possible that the reduction was not sufficient and coupled with the excessive gain in the roll axis, which was mentioned earlier, these two factors could have produced the reduction in effectiveness of the Ministab (equivalence seen in the number of control inputs per second and magnitude of movement across the three flight conditions) along the cyclic left-right control dimension. No gain problems were noted by the test pilot along the pitch axis which corresponds to the reduced number of control inputs observed in the cyclic fore-aft control dimension for the Ministab condition relative to the Unaided and Force Trim conditions (Table 5).

#### CONCLUSION

In conclusion, under the set of conditions that existed during the evaluation, the stability augmentation system examined did not provide a significant change in aircraft stability. More completely, aircraft status maintenance was essentially equivalent across all three flight conditions.

The multivariate analysis data indicated that statistically the Ministab did reduce the overall control activity requirements for the aviators. However, performance on the collective control was essentially equivalent across the flight conditions in terms of both movement magnitude and number of inputs. This equivalence should be expected because, as mentioned earlier, the attitude hold mode was inoperative during the study. Although the aviators tested were aware of this, their opinion of the Ministab was based upon the total performance requirement which included collective control activity.

Another factor which could relate to the lack of perceived differences between the Ministab and the Unaided condition was the cyclic left-right control input data which indicated no differences in magnitude and number of inputs across the three conditions. Obviously control inputs made in the helicopter are a vector reflecting both left-right and fore-aft components, but because of measurement requirements the control inputs are described independently in terms of fore-aft and left-right activity. An integration of the fore-aft and left-right information could indicate whether or not more workload is experienced on the cyclic control under one or another of the flight conditions. However, the key issue here is that the stability augmentation system evaluation did not, under the conditions tested, provide a clear-cut improvement in flight performance and workload across all flight control parameters. This position is supported by the results of the questionnaire as well as the Cooper-Harper rating data. It is quite possible that given a much higher degree of experience on the part of the test pilots with the Ministab, along with more turbulent conditions, the Ministab could produce a more stable platform for hover operations, medical hoist, weapons delivery, etc., and provide a substantial reduction in control activity requirements for the pilot. Future research at the US Army Aeromedical Research Laboratory will examine state-of-the-art improvements in stability augmentation systems in order to provide information which will enable the pilot to maximize his capabilities, enhance mission accomplishment, and extend the pilot's effective performance range in continuous operations.

## REFERENCES

1. Anderson, P. A., & Toivanen, M. L. Effects of varying levels of autopilot assistance and workload on pilot performance in the helicopter formation flight mode (Honeywell Document No. 12543-FR4). Minneapolis, MN: Systems and Research Division, Honeywell Inc., March 1970. (AD 706001)
2. Kaiser Aerospace and Electronics. Ministab stability augmentation and attitude retention system. Palo Alto, CA: April 1976.
3. Operator's Manual: Army model UH-1D/H helicopters (TM 55-1520-210-10). Washington, DC: Department of the Army, August 1971.
4. Cooper, G. E., & Harper, R. P. The use of pilot rating in the evaluation of aircraft handling qualities (NASA TN D-5153). Washington, DC: National Aeronautics and Space Administration, April 1969.
5. Schori, T. R. Versatile MANOVA: Design and documentation (USAARL Rpt. No. 76-26). Fort Rucker, AL: US Army Aeromedical Research Laboratory, August 1976.
6. Simon, D. R. Pilot comments on the Kaiser "Mini"-Stab stability augmentation system in a USAARL UH-1 helicopter. Ft Eustis, VA: US Army Airmobility Research & Development Laboratory, April 1976.



## APPENDIX A

## Ministab Training (POI)

Time: 30-60 minutes

a. Preflight--Point out basic components of system associated with the preflight of test aircraft (static stops, computers, radar alt).

b. System Description--To familiarize pilot with internal (cockpit) controls of Ministab system, i.e., control head, circuit breakers, cyclic, and collective control surfaces (gray control box familiarization).

c. System Operation--To point out system capabilities and limitations. Explanations to include emergency procedures of (1) primary system, (2) yaw axis, and (3) LORAS (low airspeed indicator).

d. Pilot Familiarization and Technique--Purpose is to allow pilot to become comfortable in utilizing system.

## THE BOAT THAT IS A RAFT

George P. Gillespie  
 Mechanical Engineer  
 Aircraft and Crew Systems Technology Directorate  
 Naval Air Development Center  
 Warminster, Pennsylvania 18974

The Mini Boat, a life raft developed by the NAVAIRDEVCCEN (Naval Air Development Center) under the sponsorship of the Naval Air Systems Command (AIR-340B), has succeeded in placing the center of mass of the survivor below the center of buoyancy of the raft. This property enables the Mini Boat to be superior to traditional one man life rafts by possessing unique in-water characteristics and improved logistics.

The helo aircrewman experiences fatigue and related discomforts from his noisy, vibrating, and sometimes hot aircraft (1). These discomforts can degrade the performance required for normal flight duties as well as for emergency conditions. During an emergency the pilot usually can autorotate his helo to a relatively controlled landing, but the physiological problems stated above can compound the after effects of the crash, i.e., shock, panic, and disorientation (2). Furthermore, in an over water incident where impact has compromised the structural integrity of the helo, sinking will occur within one minute (3). The rapid rate of sinking and the physical and physiological effects of in-rushing water are great deterrents to the escape of any potential survivor.

Once the aircrewman escapes, a life raft adds greatly to his survivability; however, there is less than a 10% chance (4) that an aircrewman can release and remove the MPLR (Multiplace Life Raft) that is stowed within the sinking helo. A "quick fix" solution to the problem is to have a life raft for each aircrewman after emergency egress. This has been accomplished by packing an LR-1, the traditional one man life raft, into a "back pack" configuration and issuing it to all crewmembers as an add-on to required survival equipment. Although the "back pack" serves its intended function, its bulk and weight not only increase inflight discomfort, but it can also degrade the mobility of potential survivors.

The NAVAIRDEVCCEN has investigated these problems and is in the early stages of development of a "Helo Flotation System" and an "Automatically Expelled/Deployed Multiplace Life Raft System". The former is designed to actually float the helicopter with externally mounted inflatable spheres located around the helo to provide even and stable flotation. The latter will automatically expel and deploy a multiplace life raft containing a heater system and "blanket". These systems have the potential to allow helo aircrewmen to fly in a virtual "flight suit" environment. However, both efforts require airframe modification and are long term developments.

A short term solution involves the Mini Boat, a program sponsored by the Naval Air Systems Command (AIR-340). SAR (Search and Rescue) data obtained from the Naval Safety Center revealed that 97% of all helo aircrewmen downed over water are rescued within one hour. Based on this data, the NAVAIRDEVCCEN determined that in order to reduce weight and bulk, a minimum size life raft and mission specific aircrew survival equipment would be developed. This policy allowed for great flexibility and led to the development of the Mini Boat (5) and four mission specific helo aircrew configurations.

The Mini Boat is a one man life raft that demonstrates superior water survivability characteristics, improved logistics, and improved operational interfaces. The raft is made of a series of vertically aligned air tubes, divided into two distinct chambers. The primary compartment is inflated with a 56g (2 oz.) CO<sub>2</sub> cylinder, compared to a 224g (8 oz.) one for the LR-1, while the secondary compartment is inflated orally. The raft is heat sealed using two sheets of coated nylon fabric, 136g/m<sup>2</sup> (4 oz/yd<sup>2</sup>). Since oxygen in the atmosphere attacks cement, the problem of seam deterioration in cemented inflatables is eliminated with the use of heat sealing. Not only are maintenance and reliability characteristics greatly improved, but the stable seams permit the use of vacuum packaging to replace detailed inspection and maintenance with package inspection. The Mini Boat weighs 1.59 kg (3.5 lb) and can be packaged into a 1600 cm<sup>3</sup> (121 in<sup>3</sup>) volume, while the LR-1 weighs 3.41 kg (7.5 lb) and takes up 6900 cm<sup>3</sup> (522 in<sup>3</sup>) of space.

Although the Mini Boat comes in a small, lightweight package, its water characteristics are unique. The Mini Boat is commonly referred to as a raft; it is actually a boat because the center of mass of the survivor is below the center of buoyancy. Because of this feature the Mini Boat has excellent stability as verified in limited sea trials (6). After the primary chamber (Figure 1) is inflated the raft has shape and can be boarded (Figure 2) by depressing, with one hand, any portion of the raft and either sliding or rolling into the raft. The primary inflation chamber provides about 75 mm (3 in) of freeboard (height of the raft above the water), even though the survivor is sitting in a Mini Boat full of water. The survivor's recommended sequence of operation is to immediately obtain an additional 75 mm of freeboard (150 mm total) by orally inflating the secondary inflation chamber with five breaths (Figure 3). This air will remain in the uppermost cell since pressure of the water line restricts the air from entering the lower portion of the secondary chamber. At this time the survivor may evaluate his situation and decide when, and if, oral inflation and helmet bailing should be completed. Oral inflation will take less than 2.5 min. (about ten additional breaths), with an effort required similar to that required when inflating a balloon; helmet bailing will also take about 2.5 min., and all but .5 l (.53 qt.) can be removed from the raft. The Mini Boat will now display 300 mm of freeboard with very good stability (Figure 4). Sea water can be added to the raft for additional ballast at that time by depressing the side.

Besides providing a comfortable support for the body, the inflatable sides of the Mini Boat provide a thermal barrier between the sea and the body. This advantage is being extended in the development of an All Weather Mini Boat. An inflatable canopy is being developed that can be retrofitted to the current Mini Boat. Subjective cold temperature test data will be generated, then fabric changes, heat reflective laminates, inflation system changes, pumping systems (for removing sea water from the raft), and portable heating systems will be evaluated in a trade-off study.

Current plans consider introduction of the Mini Boat to the Naval Air Fleet in three modes, with vacuum packaging playing a significant role in each. The first mode is for man mounting as exemplified in a back pack for the Helo Pilot/Copilot Survival Vest. The Mini Boat will be packaged into a 280x280x20 mm shape and will be completely deployed upon inflation. The second mode consists of stowing individually packaged Mini Boats in the helo at convenient locations near exit ports, hatchways, or in seat systems. Priority in this mode is to make the Mini Boat readily accessible and easily attainable to the egressing aircrewman. Quantities and exact locations will be determined at a later date, but will depend, of course, on helo class, mission, and available space. The third mode is for packaging the All Weather Mini Boat into the Rigid Seat Survival Kit in the Fighter/Attack community.

If vacuum packaging is proven to be feasible in the above modes, periodic visual inspection will replace scheduled maintenance. As long as the package still has a vacuum, it is safe to assume that the Mini Boat has not been affected from external sources and is in the same state as the day it was packaged. The total use of heat sealing guarantees that the Mini Boat seams will not deteriorate in the package. Although the Mini Boats are completely sealed inside the vacuum package, the raft is completely deployed, ready for boarding, after jerking the inflation toggle. This action simultaneously breaks the vacuum and actuates the CO<sub>2</sub> inflation system.

The Mini Boat is amenable to wide and varied applications because it possesses superior in-water characteristics. It is a space and weight saver and it possesses superior logistic properties. Today the Mini Boat is being evaluated by the Royal Australian Air Force (RAAF), the United States Air Force (USAF), and the National Aviation and Space Administration (NASA).

#### REFERENCES

- (1) Tri-Service Review of Impact and Vibration, 9 January 1975
- (2) Rice, E. V., Green, J. F.; Underwater Escape From Helicopters, 1973
- (3) Naval Safety Center letter 3131 of 21 February 1974
- (4) Naval Safety Center letter 3750 of 28 May 1974
- (5) Gillespie, G. P.; The Mini Boat: A Life Boat For Helicopter Crewmen; ASME Publication, 1976
- (6) Evaluation of the Helicopter Pilot/Copilot Survival System; Pacific Missile Test Center, Pt. Mugu, CA; March 1976

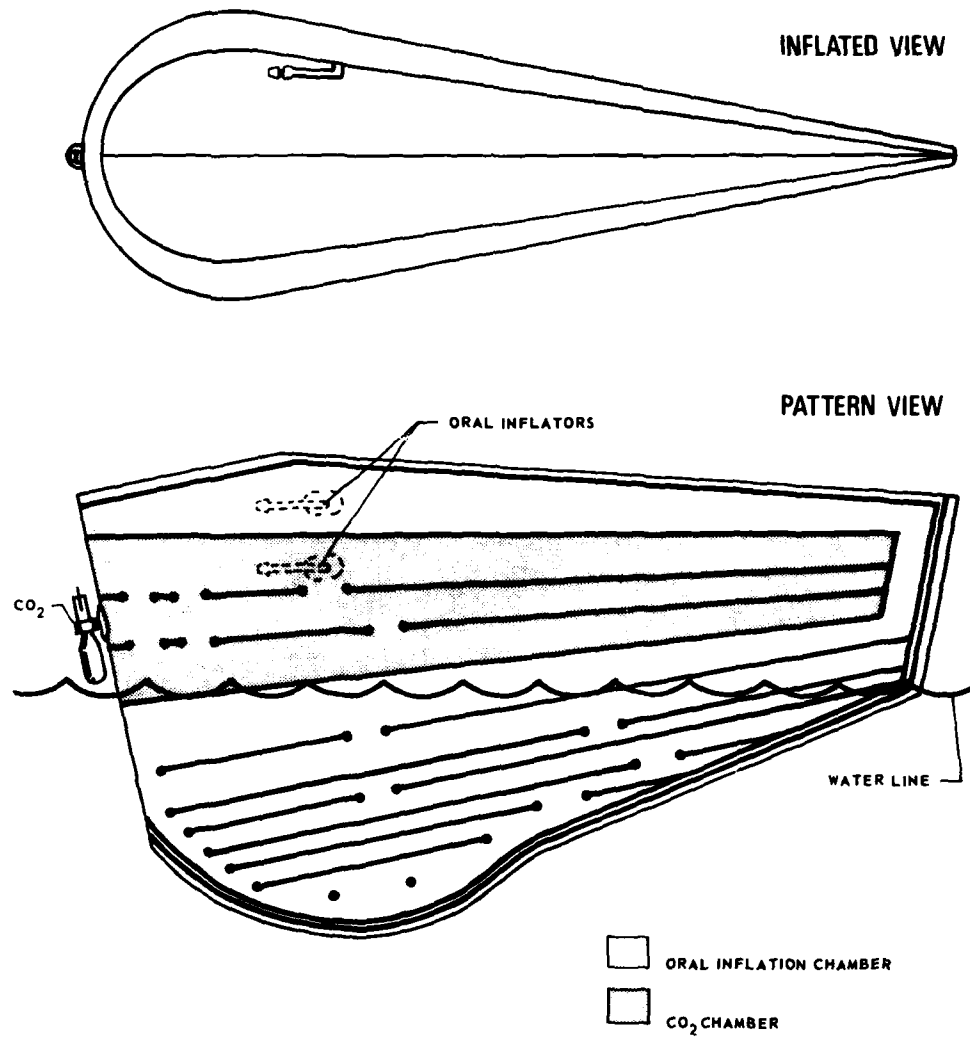

MINI BOAT: FINAL DESIGN

FIGURE 1 - SCHEMATIC



FIGURE 2 - BOARDING



FIGURE 3 - ORAL INFLATION



FIGURE 4 - FINAL CONFIGURATION

## UH-60A MEDEVAC KIT

Horace T. Hone  
 Systems Design & Development Branch  
 Engineering Department  
 Sikorsky Aircraft Division of  
 United Technologies Corporation  
 Stratford, Connecticut 06602  
 U.S.A.

## SUMMARY

The Sikorsky UH-60A or BLACK HAWK is the U. S. Army's next generation Utility Helicopter. A kit has been designed for converting the standard BLACK HAWK aircraft to medical evacuation configuration, after removal of eight troop seats. Four crash-attenuated litters are carried, plus a 60 Hz, 115 volt power pack that permits the use of regular hospital equipment by casualties in transit. Litters can be loaded transversely from either side of the aircraft. A lifting facility is provided for the upper litters.

## INTRODUCTION

The helicopter, in the early days of its military and civil applications, might have been classified as a luxury rather than a necessity; a luxury not in the sense that it provided an extravagant degree of comfort, but rather in the sense of being highly desirable yet not readily affordable or available. Today, the helicopter has achieved the status of a necessity, and we in the industry aim to make it a comfortable necessity, a readily affordable and available necessity. We believe that the enhanced performance achieved in every type of helicopter mission will be conspicuously evident in the UH-60A medevac operation.

## PRESENT SITUATION

Currently the UH-1 is still the U. S. Army's prime vehicle for the aerial evacuation of casualties from combat zones (Figure 1). It has an extensive and distinguished background of operational experience and is capable of carrying up to six litter patients in a remarkably compact configuration, accompanied by a medical attendant and sundry items of medical equipment. The litters, of regular folding pole type, are longitudinally stacked in tiers of three on either side of the aircraft. The attendant has partial access to one side of each patient, but has very little room to maneuver. The vertical clearance between patients is substantially less than the currently desired minimum of 18 inches (45.7 cm.).

The litters are secured by their handles to the bulkheads and poles on the inboard side and to webbing straps between ceiling and floor on the outboard side, in the classical manner. There is no deliberate crash-attenuation device, though the webbing straps provide some degree of vertical energy absorption, but with undesirable asymmetric and rebound characteristics. The crashworthiness of the system is governed by the strength limitation of the litters themselves, at about 13 g downward load factor.

The Army has been particularly concerned about improving the litter loading and unloading operations (Figure 2). The top litters are naturally the most difficult on the UH-1. A loading beam was developed to facilitate the procedure, but otherwise there is no mechanical lift-assisting device.

## FUTURE SITUATION

The vehicle which will replace the UH-1 is the UH-60A BLACK HAWK. This was designed by Sikorsky as model S-70 to the Army's specification for UTTAS (Utility Tactical Transport Aircraft System). The UTTAS program provided the opportunity to introduce a medical evacuation system that meets all the current U. S. Army medevac mission requirements and appreciably advances the state of the art from the point of view of the patient, the medical attendant and the loading crew (Figure 3).

## UTTAS REQUIREMENTS

BLACK HAWK is a larger machine than UH-1 and can take advantage of about 50% more effective cabin area. The UTTAS specification demanded a low profile for airtransportability reasons. Patient accessibility requirements dictated 18 inches (45.7 cm) clear space above the litter poles. Also, beneath the lower litter there should be sufficient



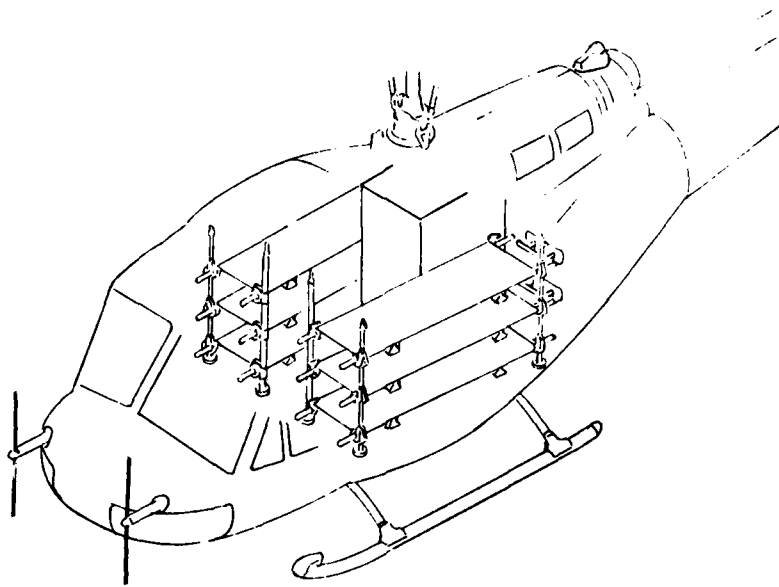

Figure 1. UH-1 Medevac Configuration.

vertical clearance to permit an energy-absorption stroke during a 42 feet (1280 cm) per second 95th percentile survivable downcrash; this aspect will be covered later, but the requirement works out at about 7.6 inches (19.30 cm). Collectively, these vertical dimension limitations prohibit a triple tier of litters in a 54 inch (137.16 cm.) cabin. An on-going study effort is underway on a 6 litter configuration; however, the Army's minimum capacity requirement can be met with a two-by-two litter configuration, with seating for two ambulatory patients and a medic utilizing existing crashworthy troop seats.

#### PATIENT ACCESSIBILITY

In addition to the top accessibility requirement, the UTTAS specification called for full length accessibility to all four patients by a 95th percentile medic. This precluded the possibility of transporting the patients in a lateral orientation since, although the

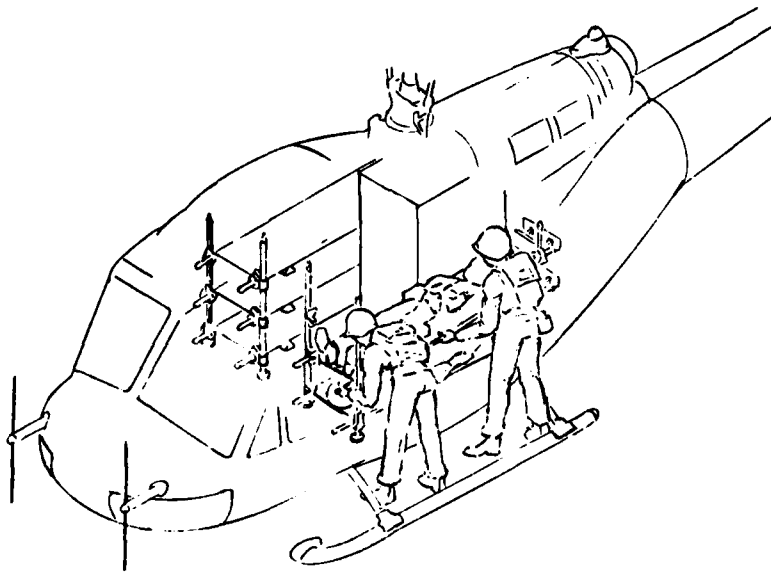

Figure 2. Loading Litters Into UH-1.

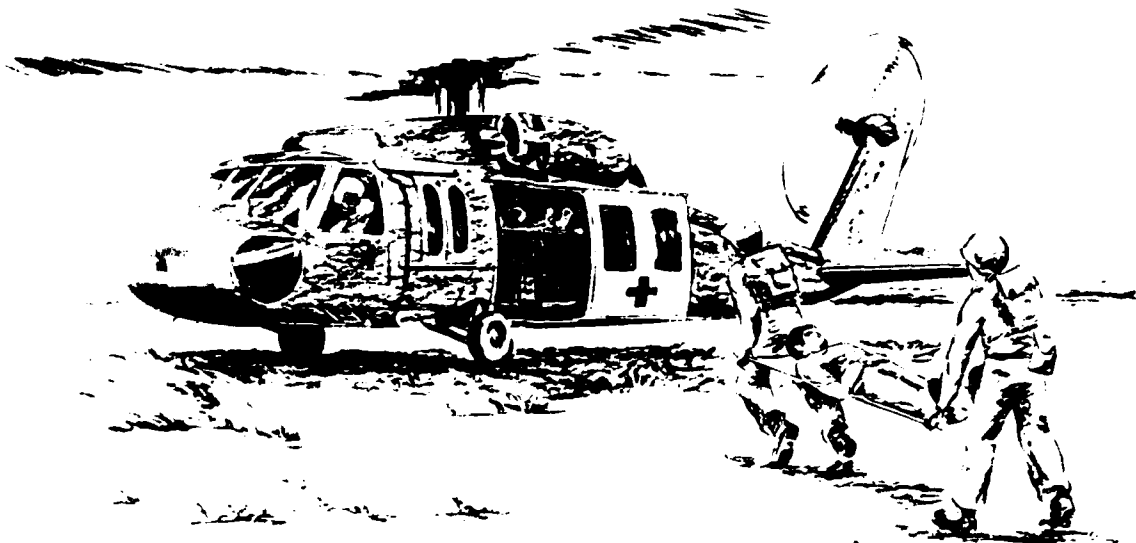

Figure 3. The UH-60A "BLACK HAWK."

cabin is wide enough to accommodate four litters sideways, there would be insufficient residual side clearance to permit longitudinal migration of the medic. Consequently, the litters are flown in a fore and aft attitude, as in the UH-1, but now the attendant has head to toe access to any patient (Figure 4). To further enhance accessibility, the traditional litter suspension arrangement has been replaced by a system in which all four litters are cantilevered from a central box-shaped pedestal. Thus, the attendant can minister to the needs of each patient with a minimum of vertical structural impediment.

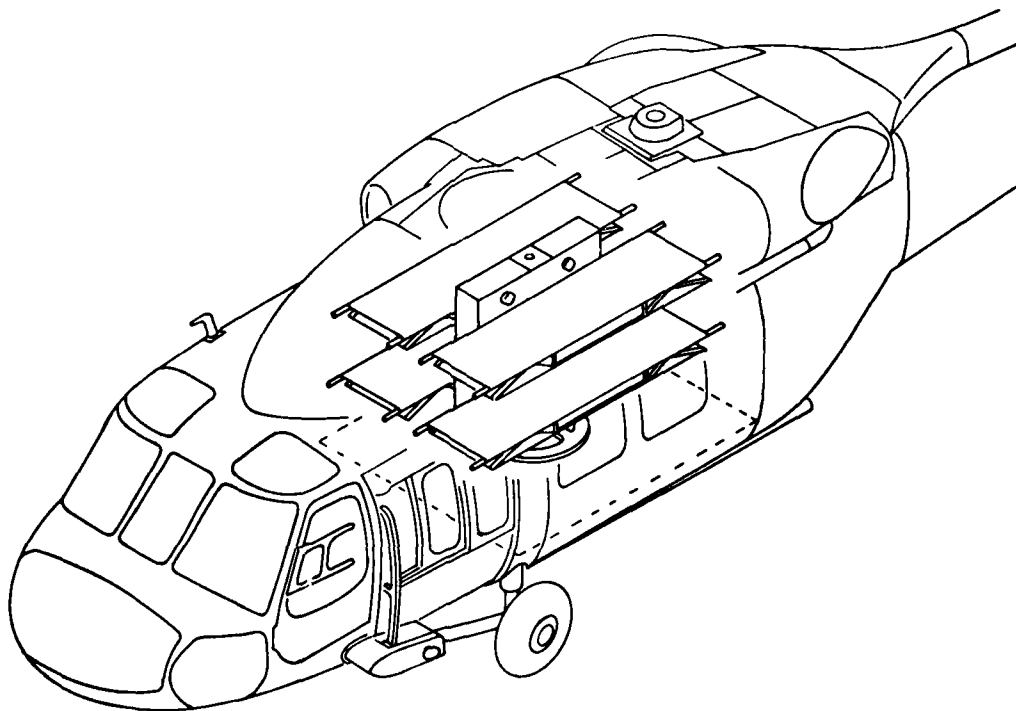

Figure 4. UH-60A Medevac Configuration.

### LITTER LOADING

The time and effort required to load and unload litters have been considerably reduced on the BLACK HAWK. The cabin has wide sliding doors on both sides and it would have been feasible to load the litters directly onto longitudinal racks, two from each side. However, there is a specification commitment for all litters to be loadable, in less than two minutes, from either side of the aircraft. This is a highly desirable facility in most combat situations, and in fact, it is quite essential in cases where, for various reasons, only unilateral access is available. The BLACK HAWK design achieves this by having the aforementioned pedestal from which the litter supports are cantilevered, rotatable about a vertical central axis, via pivot fittings in the floor and ceiling (Figure 5). Thus, the litter supports are oriented laterally for loading and unloading, permitting any of the four litters to be inserted or removed through either left or right door. The whole "carousel" assembly is rotated manually. A pinning mechanism operable from both ends of the pedestal locks the system in the lateral loading/unloading mode or the longitudinal flight mode.

It is physically possible to close the doors and take off with the litters lateral, but this configuration degrades accessibility and crashworthiness. In an emergency, the system could be rotated into flight mode during or after take-off by leaving the doors open until the system is locked into flight position.

### LITTER LIFT FACILITY

The ability to load a litter by a single transverse motion without any complex maneuvers represents a considerable advance, but there is another improvement which must now be mentioned. The upper litter supports can be lowered 19 inches (48.26 cm.) until they rest on top of the lower litter supports, and their height above ground is then only 3-1/2 feet (106.7 cm.) (Figure 6). The upper litter is then loaded and raised to its normal level so that the lower one can be loaded. In the event that there is no requirement for a lower litter, the upper litter support can be locked at an intermediate height selected by the medical attendant for maximum convenience and accessibility.

The lifting system utilizes hand-crankes which are available at both ends of the pedestal so that either of the upper litters can be moved using one crank or two, if an additional man is available. The controls which lock and unlock the lift system are duplicated at both ends.

With the lift system, four 95th percentile patients can be loaded and secured ready for take-off in less than two minutes from either side of the aircraft.

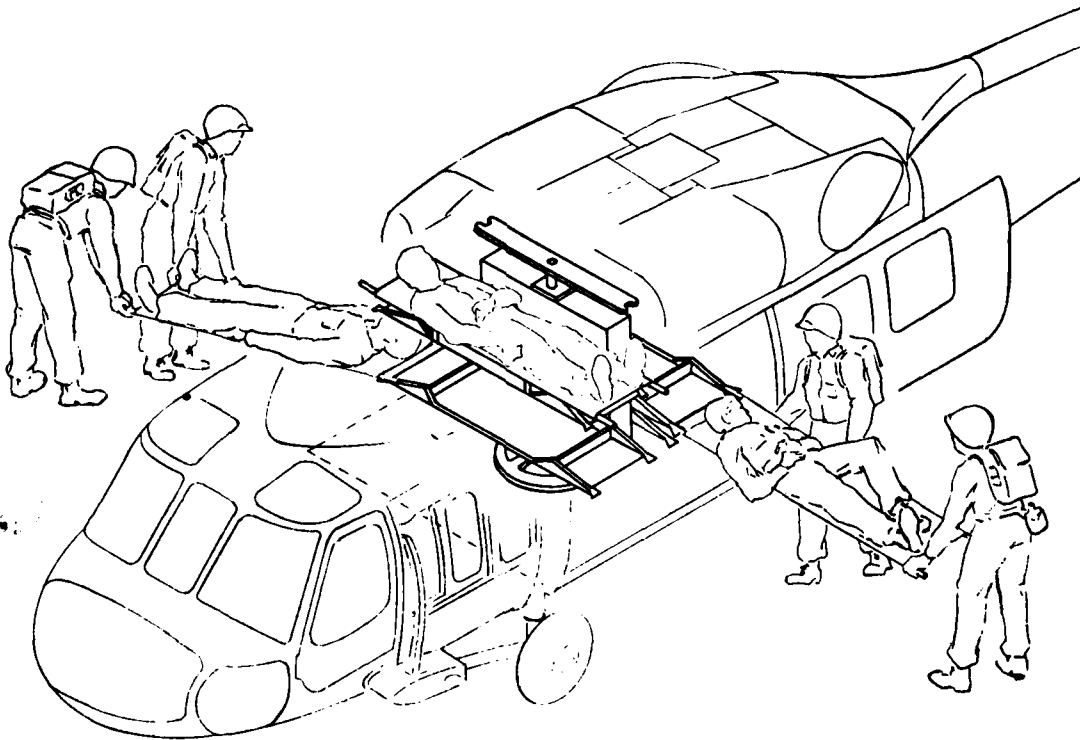

Figure 5. Loading Litters Into UH-60A.

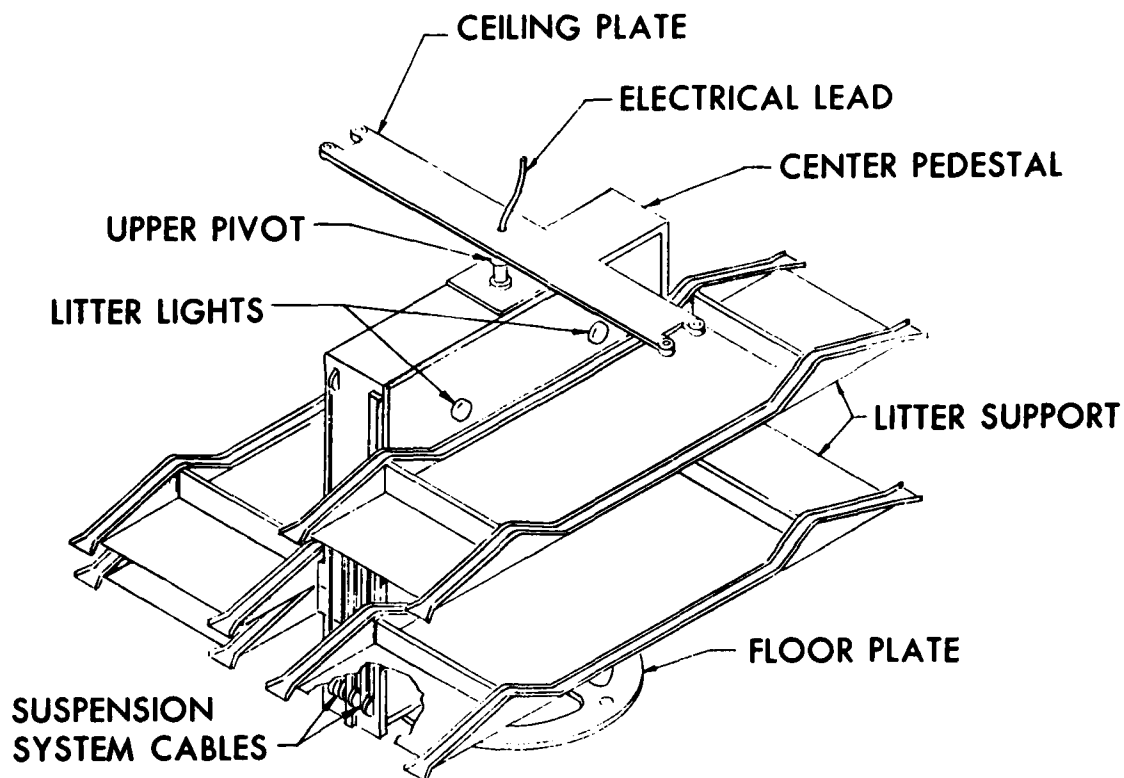

Figure 6. UH-60A Litter Support System.

#### CRASH ATTENUATION

Reference was made earlier to the downcrash energy-absorption feature. This is provided for each litter individually by means of an attenuator in its support system. A well-proven method of attenuation is employed, consisting of a solid wire passing between a trio of rollers so positioned that the wire is progressively deformed as it is drawn through. The system is calibrated to begin stroking at 13g for the weight of a 50th percentile patient (including splints, plaster casts, blankets, etc.). The designated stroke for this degree of attenuation is 7.6 inches (19.30 cm).

#### ADDITIONAL FEATURES

At each end of each litter support is a strap assembly that can be easily positioned, length-adjusted and fastened to secure the patient to the litter, and the litter to the litter support.

The litter supports are quickly detachable from their brackets on the central pedestal.

Removal of both right-side litter supports provides space for a rescue hoist to be mounted in the right doorway.

Each upper litter support can be used as a seat for three ambulatory patients when in its lowest position. In this configuration, a total of 8 ambulatory patients, 1 medic and a normal 3 man crew can be accommodated.

The following alternative combinations of litter patients, ambulatory patients and rescue hoist facility can be considered. In each case one medic and a normal crew of three are carried.

- a. 4 litter patients, 2 ambulatory patients, no rescue hoist.
- b. No litter patients, 8 ambulatory patients, no rescue hoist.
- c. 2 litter patients, 5 ambulatory patients, no rescue hoist.
- d. 2 litter patients, 2 ambulatory patients, plus rescue hoist.
- e. No litter patients, 5 ambulatory patients, plus rescue hoist.

Among other facilities are two 28 volt lights at each litter position and a pair of intravenous fluid hooks at each end of each litter support.

A 200 volt, 60 cycle power pack is included with the MEDEVAC kit to provide power for standard hospital equipment.

The whole kit, comprising the pedestal with litter supports and the power pack, can be removed or installed in the BLACK HAWK in less than 50 minutes.

## SUSPENSION SYSTEM

The litter suspension system is portrayed by the series of Figures 7 through 13.

The litter and patient are strapped to a litter support (Figure 7), which is socketed and pip-pinned on to L-shaped brackets (Figure 8), the vertical sections of which are grooved to slide on rails at each end of the central pedestal (Figure 9). The vertical motions of the brackets are synchronized by a crossed loop cable and pulley system (Figure 10), preventing the litter support from tilting and consequently jamming.

The attenuator, which works on the wire deformation principle, is incorporated in the cable system (Figure 11). In the lower litter suspension system, the attenuator housing is physically grounded to structure, but in the upper system it is movable, thereby providing the means of raising and lowering the upper litters. The housing can be grounded at a selected level by two pawls which lock onto one of the teeth on a rack, integral with the housing (Figure 12). The pawls will be locked on the topmost tooth if the lower litter is in use (Figure 12a); otherwise they can be locked on a lower tooth. The crash attenuation stroke of 7.6 inches (19.30 cm) is available (Figure 12b) whichever tooth is used, including the lowest one (Figure 12c). The attenuator housing is raised or lowered by a simple cable and drum system (Figure 13) operated by hand crank. A lightweight assembly is possible since it is isolated from crash loads by the rack and pawl device.

It will be noted that the crossed-loop cable and pulley arrangement, which forms the basis of the suspension system, permits a simple integration of the synchronizing, attenuating and (for the upper litters) the elevating facilities.

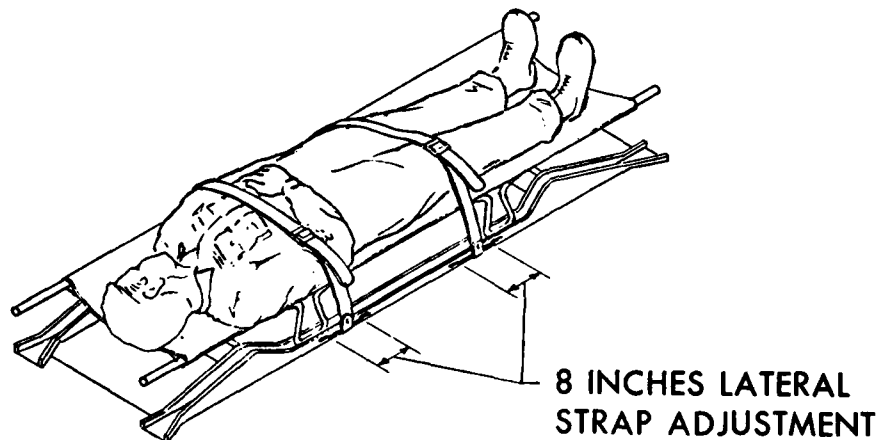

Figure 7. Patient on Litter, on Litter Support, Straps Secured.

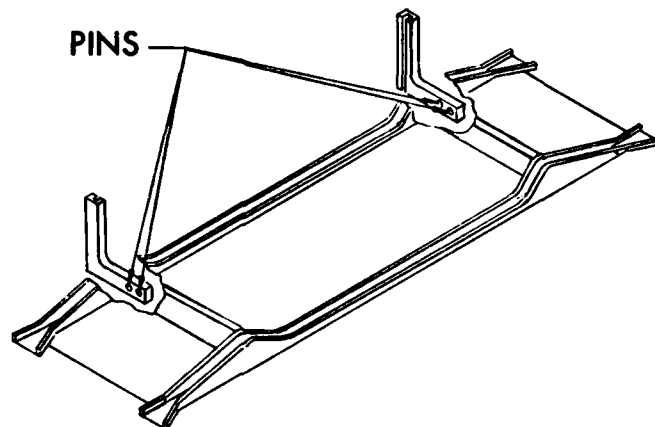

Figure 8. Litter Support is Semi-Permanently Socketed Onto L-Shaped Brackets.

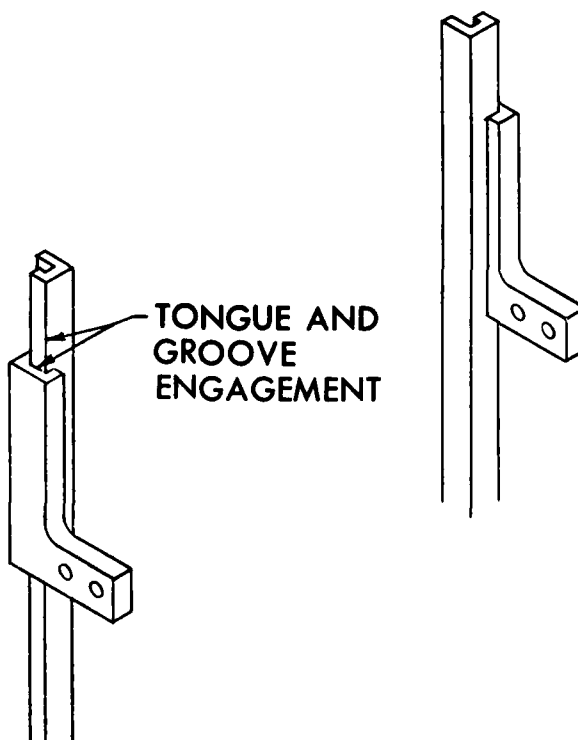

Figure 9. L-shaped Brackets Slide on End Rails of Central Pedestal.

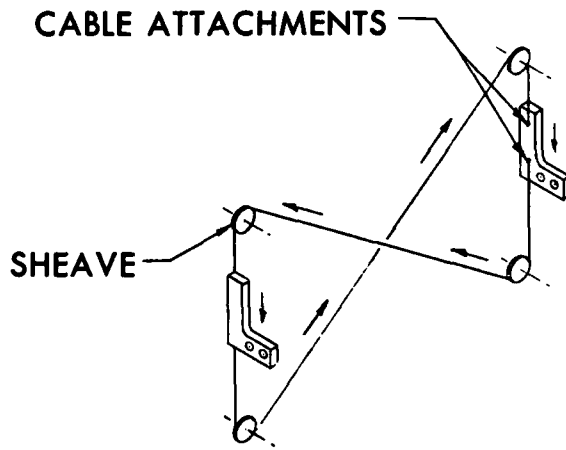

Figure 10. Vertical Motions of L-Shaped Brackets Synchronized by Crossed-Loop Cable System.

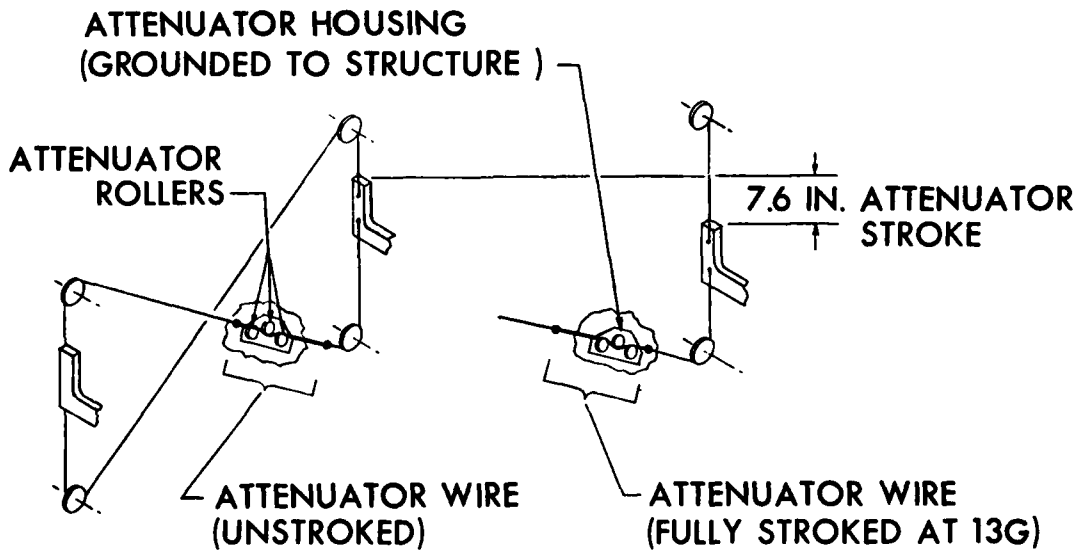

Figure 11. Wire-Bending Attenuator is Incorporated Into Crossed-Loop Cable System.

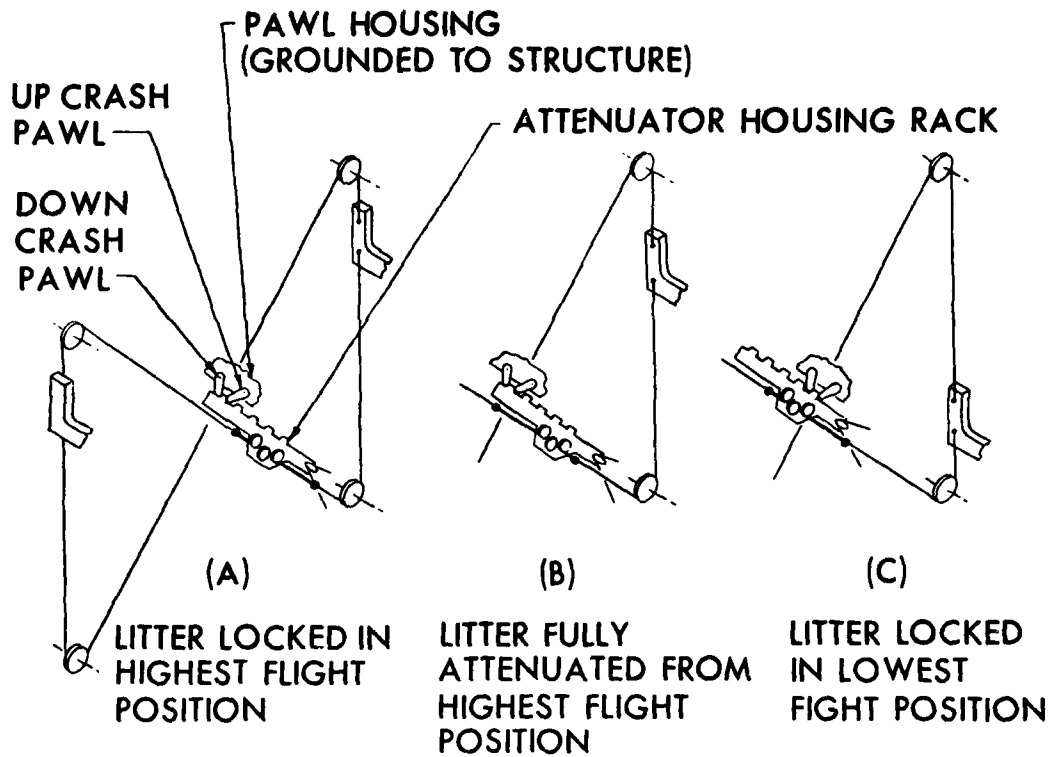

Figure 12. Attenuator Housing for Upper Litter is Movable to Facilitate Loading.

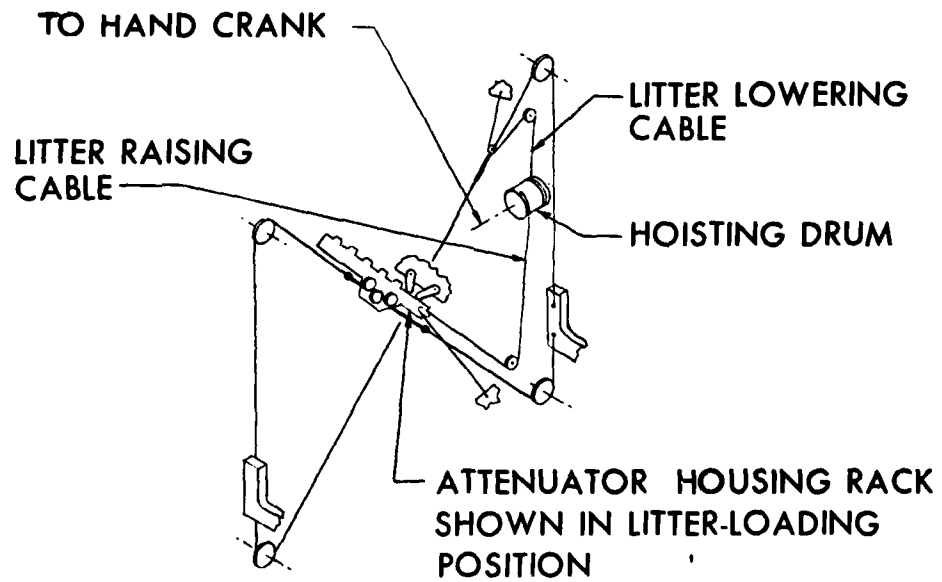

Figure 13. Complete synchronizing/Attenuating/Elevating System for Upper Litter.



## L'EVACUATION SANITAIRE PAR HELICOPTERE

par

Louis VACHON  
Ingénieur au Département Recherches  
Wilfrid MESSENS  
Ingénieur des Ventes  
Société Nationale Industrielle Aérospatiale  
Division Hélicoptères  
Boîte postale 13 - 13722 Marignane - France

### RESUME

L'évacuation sanitaire d'urgence peut se concevoir selon trois formules :

1. Transporter le blessé, dans l'état où il se trouve, le plus rapidement possible, du lieu de l'accident vers le centre hospitalier le plus proche.
2. Amener sur les lieux de l'accident les éléments d'une unité médicale de premier secours, et ne transporter le blessé qu'après lui avoir donné les premiers soins nécessités par son état.
3. Installer le blessé dans un véhicule équipé en unité médicale de secours et lui donner les premiers soins - en particulier réanimation - pendant le transport. L'évacuation devient alors partie intégrante du traitement. Le temps de transport est ainsi neutralisé.

Jusqu'à maintenant, l'exiguïté des cabines d'hélicoptères, ne permettait, du moins en primaire, que des évacuations dans le cadre de la première formule.

L'une des dernières productions de l'Aérospatiale - le Dauphin - tout en restant dans la gamme des hélicoptères légers, offre un volume utile de cabine et de soute suffisant pour envisager l'évacuation sanitaire évoluée, dans le contexte de la troisième formule.

En coopération avec le corps médical, l'Aérospatiale étudie pour le Dauphin une installation sanitaire très évoluée, permettant l'accomplissement en vol de tous les actes médicaux de réanimation et de petite chirurgie, ainsi que la télétransmission des données médicales au centre hospitalier d'accueil.

Une première installation probatoire a été réalisée et essayée, en vol, sur une reconstitution d'accident de la route. Simultanément, par suite d'un concours de circonstance tout à fait fortuit, l'appareil ainsi équipé a été utilisé en opération réelle sur un cas particulièrement grave. Un plein succès a démontré la validité de la formule.

### Un peu d'histoire

L'idée est déjà ancienne d'utiliser, au bénéfice des services de santé, la voie aérienne.

En 1870, au cours du siège de Paris, 160 malades ou blessés graves furent évacués par aérostats ! La technique du cadre "porte malade" amovible qu'on accrochait au ballon était en avance sur son temps. Cette technique se retrouve sur les premiers hélicoptères d'évacuation sanitaire.

La naissance de l'aviation sanitaire remonte à la fin de la première guerre mondiale, et l'on peut considérer cette innovation dans les transports sanitaires comme une idée d'origine française. Le Docteur Chassaing mérite à juste titre le nom de "Père de l'aviation sanitaire".

Il avait constaté en 1915 que les blessures des aviateurs évoluaient beaucoup plus favorablement que celles de leurs camarades de tranchées. Il avait attribué ce privilège au fait que les aviateurs étaient hospitalisés dès l'atterrissage, bénéficiant ainsi de soins précoces, sans avoir subi la choquante épreuve d'un long transport par route. Il pensa qu'il fallait faire profiter tous les blessés de ce moyen d'évacuation, rapide et confortable.

Rapidement, entre les deux guerres, la jeune aviation sanitaire acquerra ses lettres de noblesses. Au cours de la dernière guerre, ce furent surtout les américains qui employèrent ce transport. Entre le débarquement en Normandie et la capitulation de l'Allemagne, les Sky-Masters ont évacués vers la Grande-Bretagne ou les U.S.A. 385 576 blessés, dont 82 000 pendant le seul mois d'Avril 1945.

Le Général Eisenhower écrivait cette même année "Nous avons évacué, par air, la presque totalité de nos hôpitaux de l'avant, et cette méthode a sans doute sauvée des centaines, des milliers de vie". Un directeur du service de santé U.S.ARMY ajoutait : "parmi les moyens qui permettent de sauver le plus de vies humaines, l'évacuation aérienne est à placer sur le même plan que le plasma et la pénicilline".

Les hélicoptères n'ont fait réellement leur apparition dans ce domaine qu'à l'occasion de la guerre d'Indochine. Ils apparurent dans le ciel indochinois le 7 Avril 1950. C'était deux Hillers 360", capables d'évacuer chacun deux blessés. Leur première intervention eut un retentissement considérable sur le moral des troupes. Rapidement, par suite de sa maniabilité, et de sa possibilité de se poser pratiquement en tout terrain, l'hélicoptère a pris le pas sur l'avion, du moins pour les évacuations primaires.

Le conflit du Vietnam, mené par les américains a marqué la consécration de l'hélicoptère, comme engin de guerre et sanitaire.

Ce conflit a montré une révolution de la conception sanitaire par l'emploi généralisé de l'hélicoptère : on a assisté en réalité, non seulement au remplacement de l'ambulance par l'hélicoptère, mais bien à la substitution de la voie aérienne à la voie terrestre pour tout ce qui est transport des blessés ; 90 % en effet de toutes les évacuations sanitaires ont eu lieu par hélicoptère ou avion, ce qui donne des chiffres absolument énormes, tels que 25 000 évacuations aériennes pour les trois derniers mois de 1965 (500 000 hommes étant engagés au Vietnam).

L'avantage de ce système, sans parler du confort du blessé réside évidemment dans la vitesse d'évacuation. Pour fixer les idées, rappelons quelques chiffres :

- Vitesse utile moyenne de l'ambulance automobile au cours de la 2ème guerre mondiale : 10 km/h.
- Vitesse utile moyenne de l'hélicoptère au Vietnam : 130 km/h.

Le résultat concret fut que le délai s'écoulant entre la blessure et l'arrivée du blessé dans la formation hospitalière traitante a fondu dans les mêmes proportions. Le délai moyen qui était de 16 heures en 1945, était ramené à près de une heure.

Une constatation à faire est que de très nombreux blessés qui, avant l'hélicoptère, seraient morts entre le champ de bataille et l'hôpital, ont maintenant la possibilité de survivre.

La deuxième constatation est, qu'en dépit du pourcentage plus élevé de blessés gravissimes, la mortalité par blessure de guerre a été extrêmement abaissée par rapport aux conflits précédents.

- 1914 - 1918	8 %
- 1940 - 1945	4,5 %
- Corée	2,5 %
- Vietnam	1,5 % Army 1,2 % Marines

En 1973, pendant la guerre du Kippour, le Service de Santé Israélien utilisa aussi l'hélicoptère de façon intense, mais différemment des américains.

Contrairement au Vietnam où les hélicoptères ont été utilisés à partir des positions de combat des unités élémentaires, ce moyen de transport n'a guère été employé plus avant que les postes de secours des bataillons israéliens, et ceci pour deux raisons :

- Pour des considérations économiques "TSAHAL" ne disposait pas de la profusion d'hélicoptères de l'armée américaine.
- Ensuite, parce que la mobilité des formations de blindés sur les champs de bataille ne rappelait en rien la fixité relative des positions de la guerre du Vietnam. Dès lors, le poste de secours de bataillon constituait, de par sa moindre mobilité, le seul échelon de l'avant permettant d'amorcer une évacuation par hélicoptère.

Mais par contre, il a été fait appel dans 80 % des cas aux moyens aériens, pour les évacuations après mise en condition des blessés.

- Soit à partir des postes de secours de bataillon pour les blessés les plus urgents, par hélicoptères américains du type "Iroquois", vers les hôpitaux de campagne déployés à l'arrière des lignes,
- Soit à partir des points de rassemblement des brigades vers les hôpitaux, au moyen des "Iroquois" et des hélicoptères lourds français "Super-Frelon".

Le délai moyen entre la blessure et la table d'opération n'a jamais dépassé 4 heures pour ceux évacués du plus loin. Cette rapidité explique pour une large part le très faible taux de mortalité (1,3 %) enregistré dans les hôpitaux d'Israël.

Nous ne sommes plus, et par bonheur, en période conflictuelle. Les données mêmes du problème sont entièrement différentes :

- le nombre d'évacuations nécessaires est considérablement réduit.
- par contre la dispersion géographique des lieux d'accidents est beaucoup plus importante.
- enfin, et ceci pour des raisons économiques évidentes, la flotte possible d'hélicoptères sanitaires disponibles est sans commune mesure avec celle mise en oeuvre lors d'un conflit militaire.

Par contre, si la quantité d'évacuation à réaliser est très inférieure, il devient possible d'envisager d'augmenter la qualité des évacuations.

L'HELICOPTERE SANITAIRE, ANTENNE DE  
REANIMATION ET DE SOINS D'URGENCE

1. POSITION DE L'HELICOPTERE DANS LE CONTEXTE DES TRANSPORTS SANITAIRES

Dans les régions pourvues d'un réseau routier important et de structures médicales à forte densité, il n'est pas question d'envisager le remplacement total des ambulances automobiles par un véhicule aérien tel que l'hélicoptère et ceci pour plusieurs raisons :

- (a) Certaines conditions atmosphériques peuvent rendre le vol dangereux ou impossible.
- (b) La couverture totale par hélicoptères d'une nation exigerait un nombre de machines et une infrastructure - matérielle et humaine - démesurée.
- (c) La pénétration intégrale de l'hélicoptère en milieu urbain est loin d'être acquise et ne sera possible que dans les cités de l'avenir.

L'hélicoptère est donc un moyen d'évacuation sanitaire complémentaire.

Par contre il est irremplaçable dans bien des circonstances :

- (a) Blessés ou malades graves pour lesquels le facteur temps a une importance capitale.
- (b) Pénétration dans des zones dépourvues de réseau routier (sauvetage en mer, dans les fles, en montagne ...) ou dont l'accès par ambulance a été rendu momentanément impossible (accidents en chaîne sur autoroute).
- (c) Conditions météorologiques faisant obstacle aux véhicules terrestres (neige, verglas, inondations).

Dans les régions de grande étendue mais à faible densité d'installations hospitalières, il est bien évident que, dans tous les cas, l'hélicoptère est le moyen d'évacuation le mieux adapté.

2. MISSIONS DE L'HELICOPTERE SANITAIRE

A l'heure actuelle, compte tenu des appareils et des installations dont disposent nos organismes de secours (protection civile - gendarmerie), l'évacuation par hélicoptère se limite au simple transport d'un malade ou d'un blessé, sans possibilité d'intervention médicale pendant cette opération - les seuls avantages de cette formule étant d'une part la vitesse, et d'autre part la possibilité d'aller chercher le patient dans une zone non accessible à l'ambulance routière.

Pour son programme d'installation d'évacuation sanitaire de nouvelle génération par hélicoptère, la SNIAS a retenu le principe suivant :

"le transport doit faire partie intégrante du traitement"

Le blessé bénéficie ainsi, non seulement d'une intervention plus rapide et d'un transport plus court que par les moyens conventionnels, mais de soins dès le début de l'intervention. La durée du transport est ainsi neutralisée.

Les missions de l'hélicoptère sanitaire de nouvelle génération peuvent donc se définir succinctement comme suit :

(a) Transport primaire

- accès rapide et le plus près possible du lieu de l'accident,
- préparation du blessé au sol et conditionnement en vue du transport,
- soins pendant le transport et éventuellement interventions nécessitées par l'évolution de l'état du patient,
- transmission au centre hospitalier destinataire de toutes les informations utiles à la préparation du traitement et à la prise en charge dès l'arrivée.

(b) Transport secondaire

Le malade - ou blessé - étant déjà stabilisé et sous traitement dans une unité médicale doit être transporté dans une autre unité médicale, mieux équipée pour la poursuite des soins.

Il importe de pouvoir continuer pendant le vol une thérapeutique initiale dont l'arrêt, même de faible durée, pourrait être préjudiciable. En outre, comme dans le cas d'évacuation primaire, une intervention immédiate imposée par une évolution de l'état du patient pendant le vol doit être possible.

Ce concept a été développé par l'Aérospatiale avec la précieuse coopération de Monsieur le Professeur BOURRET, Directeur du Centre de Recherche de Traumatologie routière de Salon de Provence, et de Monsieur le Professeur SERRES de l'Université de Montpellier.

### 3. CARACTERISTIQUES DE L'APPAREIL

L'hélicoptère, implicitement défini par le concept exposé ci-dessus, a donc une double fonction :

fonction véhicule  
fonction antenne médicale

#### 3.1. Fonction véhicule

Les principales caractéristiques requises par cette fonction sont :

- . la disponibilité
- . la rapidité de mise en oeuvre
- . la possibilité d'atterrissage sur tous terrains et le plus près possible du lieu de l'accident
- . la fiabilité
- . un coût d'exploitation réduit
- . l'aptitude au vol de nuit et au vol tous temps.

Ces considérations nous orientent vers le choix d'un appareil léger, équipé d'un train à patins.

Ce choix limite donc, obligatoirement, le nombre de blessés transportables à chaque rotation. Les statistiques ressortant de l'analyse des accidents de la route montrent que le plus grand nombre d'accidents graves comporte deux blessés nécessitant une intervention et un transport d'urgence. Nous avons donc limité la capacité de transport à :

- . 2 blessés graves avec possibilité d'actes médicaux pendant le vol,
- . ou 1 blessé grave et 2 blessés légers, toujours avec assistance médicale,
- . ou 4 blessés légers, avec éventuellement accompagnement médical, mais pratiquement sans possibilité d'intervention pendant le vol.

#### 3.2. Fonction antenne médicale

##### 3.2.1. en évacuation primaire

(a) Amener sur le terrain :

- l'équipe médicale,
- le matériel nécessaire pour dégager le blessé : outillage de désincarcération pour accidents routiers - projecteurs, matériel spécialisé pour accidents de montagne, etc...
- le matériel médical permettant de conditionner le blessé en vue du transport - en particulier matelas coquille, attelles gonflables, immobilisateurs, matériel de premier secours.

(b) Permettre de charger aisément le blessé déjà installé sur brancard ou dans un matelas coquille.

(c) A bord de l'appareil et pendant le vol, permettre les actes médicaux nécessités par l'état du malade :

- réanimation respiratoire :  
ventilation pulmonaire  
intubation trachéale  
aspiration - tubage
- réanimation circulatoire :  
transfusion - perfusion
- surveillance électronique cardio-vasculaire :  
stimulation cardiaque - massage cardiaque  
défibrillation
- petite chirurgie

(d) Pendant le vol, transmettre à l'unité hospitalière destinataire toutes les informations nécessaires à la réception du malade et à la préparation des interventions nécessités par son état, soit par radio, soit par télétransmission de données.

##### 3.2.2. en évacuation secondaire

Le malade étant déjà stabilisé, il n'est plus question de préparation au sol. Par contre la poursuite pendant le vol de la thérapeutique en cours peut exiger l'emport d'équipements particuliers :

- réserves importantes d'air ou d'oxygène,
- source d'énergie pour assurer le fonctionnement d'appareillages spéciaux (couveuse, poumon artificiel),
- etc...

### 3.2.3. définition "architecturale" de l'appareil permettant l'accomplissement de la mission Antenne Médicale

Si du point de vue masse l'installation "antenne médicale" est peu pénalisante, il n'en est pas de même sur le plan des volumes nécessaires.

L'appareil devra comporter :

- une vaste soute, d'accès facile, susceptible de contenir l'ensemble des appareils nécessaires à l'intervention au sol, les batteries d'alimentation de l'appareillage électronique et électrique, les réserves d'air et d'oxygène, le respirateur volumétrique,
- une cabine de dimensions suffisantes pour
  - permettre l'installation de l'équipe médicale, des blessés, de l'appareillage médical et d'armoirs de rangement du petit matériel, des produits et médicaments divers,
  - permettre l'exécution des actes médicaux pendant le vol.
- un niveau de confort suffisant pour éviter au blessé des agressions d'ambiance préjudiciables à son état et permettre à l'équipe médicale l'accomplissement de sa tâche. En particulier :
  - stabilité de vol
  - faible niveau vibratoire
  - insonorisation
  - chauffage.

### 4. CHOIX DE L'APPAREIL - LE DAUPHIN 360



Dans la gamme des productions de l'Aérospatiale, le Dauphin 360 s'est révélé être particulièrement bien adapté à cette mission. Tout en restant dans la catégorie des hélicoptères légers, il présente des caractéristiques architecturales et dimensionnelles répondant en tous points aux nécessités évoquées ci-dessus.

Pour des dimensions extérieures à peine supérieures à celles de l'Alouette III, il offre un impressionnant volume de cabine de 5 m<sup>3</sup> sur un plancher plat de 4,2 m<sup>2</sup>, quatre larges portes d'accès, une soute indépendante de 1 m<sup>3</sup> dotée d'une porte très largement dimensionnée et d'un abord particulièrement aisé.

En outre, le confort offert par le Dauphin est exceptionnel, tant du point de vue vibratoire qu'acoustique. A noter également que le rotor anti-couple est du type fenestron, ce qui est un facteur de sécurité important au cours des opérations au sol.

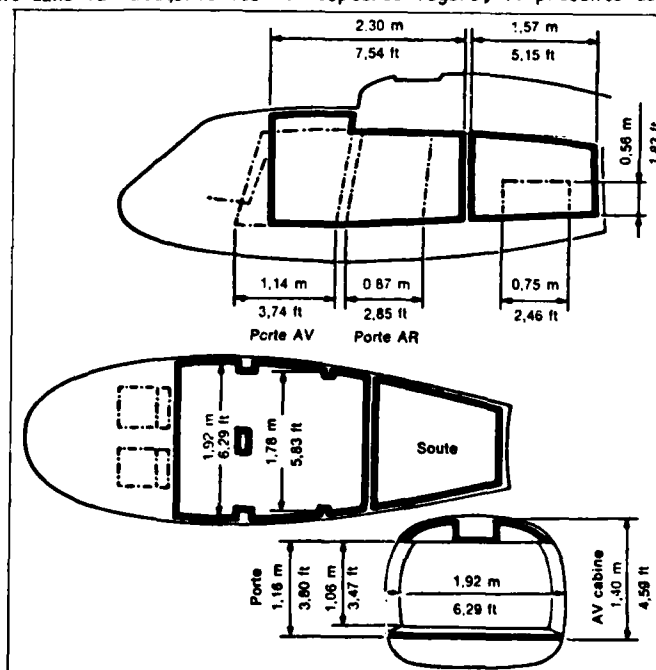

Mais, l'objet de notre exposé étant la présentation d'une installation sanitaire et non celle de l'appareil porteur, nous nous contenterons de rappeler très brièvement les principales caractéristiques du Dauphin :

Caractéristiques	Version 360 monomoteur
Masse maximum au décollage	3000 kg 6615 lb
Charge utile	1432 kg 3157 lb
Vitesse max. (VNE)	315 km/h 170 Kts
Vitesse de croisière rapide	270 km/h 146 Kts
Vitesse de croisière économique	247 km/h 133 Kts
Autonomie maxi, sans réserve à 130 km/h (70 Kts)	3 heures 42 minutes
Distance franchissable, en croisière économique, sans réserve	655 km/h 353 Nm
Rayon d'action, en croisière économique, avec 20 minutes de réserve	300 km 162 Nm

##### 5. INSTALLATION EXPERIMENTALE A BORD DU DAUPHIN

En étroite collaboration avec le corps médical et les SAMU, la SNIAS a réalisé une première installation expérimentale, le but n'étant pas d'optimiser l'appareil en tant qu'évacuation sanitaire, mais de s'assurer de la validité de la formule.

Cette installation est, en fait, un maquettage capable de voler.

Bien évidemment, l'aménagement que nous vous présentons ne saurait avoir un caractère imposé ou définitif. Il a seulement la valeur d'un exemple probatoire, démontrant :

- que l'espace disponible dans la cabine est nécessaire, mais suffisant pour réaliser l'installation définie par le corps médical, et que cette installation est parfaitement opérationnelle.
- que les qualités exceptionnelles de confort du Dauphin - tout particulièrement dans le domaine acoustique et vibratoire - permettent l'accomplissement des actes médicaux dans d'excellentes conditions, et que les conditions d'évacuation du patient sont exemptes de risques de traumatismes supplémentaires dus à des agressions d'ambiance.

Le plan trois vues ci-après expose schématiquement l'installation réalisée.

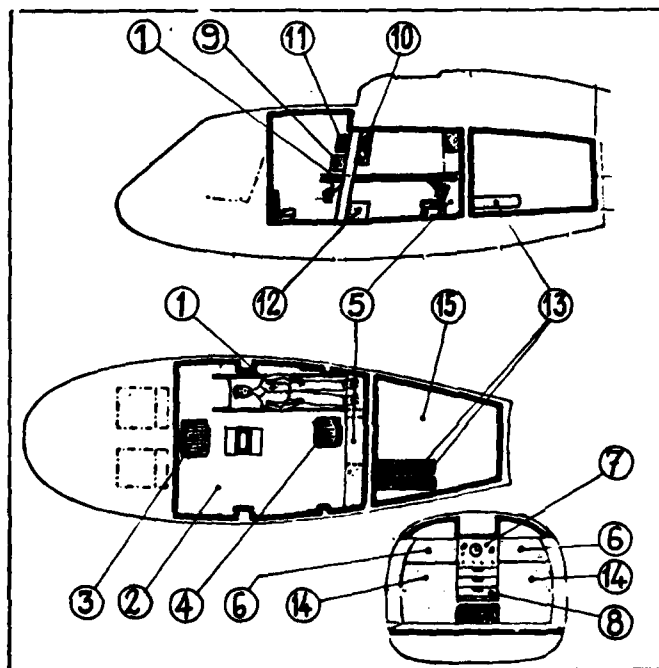

1. Brancard sur son support
2. Emplacement pour deuxième brancard (non installé)
3. Siège du médecin réanimateur
4. Siège de l'assistant ou infirmière (à dossier rabattable pour dégager les tiroirs du meuble)
5. Ensemble armoire, recevant l'instrumentation, les diverses trousse chirurgicales, et la pharmacie
6. Cardio-Secours
7. Respirateur volumétrique
8. Tiroirs de rangement pharmacie et matériels divers
9. Aspirateur de mucosité
10. Perfusion - Transfusion
11. Débit-mètre
12. Ensemble d'aspiration sur Venturi
13. Bouteilles d'air et d'oxygène
14. Emplacements disponibles pour l'installation d'autres appareillages médicaux
15. Soute de 1 m<sup>3</sup> pour rangement des matériels utilisables au sol (désincarcération, matelas immobilisateurs, attelles, etc...).

Ce schéma est assez explicite pour que nous n'entrions pas dans tous les détails de l'installation, d'autant plus que la définition de l'instrumentation médicale est du ressort de l'utilisateur et non de l'avionneur. Il est bien évident qu'elle est fonction des zones et des conditions d'exploitation. Le rôle de l'avionneur étant essentiellement de fournir un aménagement ayant la capacité nécessaire pour recevoir tel ou tel type d'appareillage.



La photo ci-contre montre l'installation telle que définie par les SAMU de Marseille et Montpellier, avec une instrumentation de leur choix. Mais l'on voit clairement que les appareils de réanimation et de surveillance peuvent être remplacés par du matériel de toute autre marque, sans aucune modification structurale, et qu'il reste une large place disponible pour l'installation d'autres appareillages complémentaires. (le deuxième brancard n'a pas été installé - il se positionne systématiquement au premier).

Un point très particulier de cette installation est le support de brancard. Profitant de la grande longueur de la cabine (2,30 mètres - 7,54 ft) il était souhaitable de pouvoir déplacer longitudinalement le patient pendant le vol pour faciliter l'accès du médecin aux différentes parties du corps. D'autre part, et ceci pour des impératifs médicaux, il était nécessaire de pouvoir donner au brancard des inclinaisons proclives ou déclives à la demande, toujours pendant le vol. Enfin, il est toujours malaisé d'introduire dans un véhicule un brancard par une porte latérale. Le porteur intérieur se trouvant dans des positions particulièrement inconfortables.

La solution retenue a été un système d'interface entre le brancard et l'appareil constitué par :

- un dispositif à rails avec blocage, assurant le déplacement longitudinal,
- un châssis en alliage léger destiné à recevoir le brancard et muni d'un dispositif d'inclinaison de  $\pm 10^\circ$ ,
- un ensemble mécanique de rotation de ce châssis, simultanément avec son déplacement longitudinal, permettant ainsi, par une cinématique très simple de le faire sortir par la porte arrière, pour recevoir le blessé sur sa civière. Des pieds télescopiques escamotables assurent la stabilité de l'ensemble en position sortie.



Opération d'embarquement  
d'un blessé

Le support de brancard présenté sur nos différentes photos a été conçu pour recevoir les civières du type utilisé par les SAMU. Une étude est en cours d'un dispositif adaptable à tous types de civières.

Simultanément des études de suspension visco-élastiques du brancard ont été lancées, pour filtrer les vibrations - d'un niveau déjà très bas - transmises par le plancher.

Sur la photo ci-contre, on peut constater que lorsque le brancard est en position extrême arrière l'espace libéré est suffisant pour que le réanimateur puisse s'agenouiller derrière la tête du malade, et effectuer aisément les opérations d'intubation.



Enfin, pour les transports secondaires à caractères très particuliers, le Dauphin est équipé des moyens d'arrimage nécessaire pour des équipements spéciaux tels qu'une couveuse artificielle, par exemple, et des sources d'énergie pour assurer leur fonctionnement pendant le vol.



D'autre part, un système de transmission radio des données physiologiques fondamentales est en cours de développement chez des équipementiers spécialisés. Ce programme reçoit l'aide des Services Officiels Français (D.R.E.T). L'expérimentation en est prévue au cours de l'année, à bord du Dauphin.



Le Dauphin, ainsi équipé, a été présenté au 2ème Congrès Mondial de la Réanimation à Paris, du 19 au 23 Septembre 1977, où il a été particulièrement apprécié par de nombreux médecins réanimateurs.

Plus récemment, il a été testé en conditions opérationnelles, sur la reconstitution d'un accident routier, par les équipes médicales des SAMU de Montpellier et de Marseille, et en particulier par Messieurs les Professeurs BOURRET et SERRE. L'excellence de son efficacité s'est trouvée démontrée par un incident fortuit survenu alors que se déroulaient les opérations de tournage d'un film à des fins didactiques et pédagogiques.

En début d'après-midi, alors que l'équipe de production cinématographique s'affairait sur le terre plein d'atterrissage de l'hôpital Saint Eloi à Montpellier, le standard du SAMU recevait un appel d'urgence de l'hôpital de Vaison-la-Romaine, petite ville située à 120 km à vol d'oiseau. Un quadragénaire venait d'être terrassé par un accident cardiaque et nécessitait un transport et son admission d'urgence dans un service cardio-vasculaire.

D'une part, par suite d'une situation conflictuelle, aucune ambulance routière n'était disponible, d'autre part, la durée du transport par route n'était pas compatible avec l'état du malade. Or, rappelons le, l'appareil n'était équipé que d'un maquettage, heureusement réalisé à l'aide d'un appareillage médical authentique.

10 minutes après l'appel et la mise à bord de l'appareillage de secours, l'appareil décollait de la DZ de l'hôpital, et l'équipage complétait pendant le vol les divers branchements électriques et pneumatiques nécessaires pour rendre le maquettage opérationnel et prêt à assurer la survie du malade durant son transport à Montpellier.

65 minutes plus tard, l'appareil était de retour sur l'aire d'atterrissage où l'équipe médicale du SAMU attendait le patient déjà largement tiré d'affaires puisque l'installation avait parfaitement fonctionné et permis, en vol, l'accomplissement de la réanimation et des actes médicaux d'urgence requis par son état.

Notons que la même intervention effectuée par une ambulance routière aurait demandé près de 4 heures.

#### Références

"Histoire des moyens de Transport et d'Evacuation des blessés en temps de guerre". Docteur PAYEN de l'Ecole de Santé des Armées de Bordeaux.

#### Remerciements

Nous tenons à remercier particulièrement pour l'aide qu'ils nous ont apporté à la conception et à la réalisation de l'installation d'évacuation sanitaire du Dauphin :

Monsieur le Professeur BOURRET, Directeur du Centre de Recherches en traumatologie routière de Salon de Provence.

Monsieur le Professeur SERRE de l'Université de Montpellier.

Monsieur le Docteur MOISAN, médecin réanimateur du centre hospitalier de Salon de Provence.

Les équipes des SAMU de Marseille et de Montpellier, et du centre hospitalier de Salon de Provence.

Le bataillon des Marins Pompiers de Marseille.

La Gendarmerie Nationale de Salon de Provence.

La Sécurité Civile.

La Section Ergonomie de la Direction des Recherches et des Etudes Techniques (DRET).

La Société ATM.

CASUALTY EVACUATION BY HELICOPTER  
by  
Louis VACHON  
Research Engineer  
Wilfrid MESSENS  
Sales Engineer  
Société Nationale Industrielle Aérospatiale  
Helicopter Division  
Boite Postale 13 - 13722 Marignane - France

ABSTRACT

Three different concepts may be applied to casualty evacuation :

1. Transport the casualty, as found and the quickest as possible, from the accident site to the nearest medical centre.
2. Send a first aid unit to the site and transport the casualty only after having given the first cares required by his condition.
3. Place the casualty in a vehicle, equipped as emergency medical unit, give him the first cares - in particular re-animation - during his transport. Then, evacuation becomes an integral part of the medical treatment. The transport time is thus neutralized.

Up to now, due to the small space available in helicopter cabins, only evacuations according to the first concept could be carried out, at least at the "primary" stage.

One of the latest AEROSPATIALE models - the "DAUPHIN" - while still being in the light helicopter class, offers, in its cabin and luggage hold, a useful volume which is sufficient to contemplate an improved casualty evacuation procedure according to the third concept.

In cooperation with medical services, AEROSPATIALE is designing, for the DAUPHIN, a very modern ambulance installation allowing in-flight performance of all medical actions required for reanimation and small surgery together with transmission of medical data to the hospital which will receive the patient.

A first trial installation was made and tested, in flight, on the occasion of a traffic accident simulation. At the same time, due to quite unpredictable circumstances, the aircraft so equipped was used for an actual evacuation mission, in a particularly serious case. A full success demonstrated the validity of this concept.

Some historical facts

The use of aerial transport, for the benefit of Medical Services, is a very old idea.

In 1870, during the siege of Paris, 160 seriously ill, or wounded persons were evacuated by balloons ! The technique of the removable "patient carrying" frame hooked to the balloon was well in advance of its time. The same principle is found on the first helicopters used for casualty evacuation.

The birth of the ambulance aircraft dates from the end of the First World War, and it can be considered that this innovation in casualty evacuation was initially a French idea. Doctor Chassaing rightly deserves the title of "Father of Medical Aviation".

In 1915, he had noted that the wounds of aviators were healing quicker than those of the men fighting in trenches. He thought this was due to the fact that airmen were taken to hospital immediately after landing, thus being cared for sooner, without having to go through the awful stressing period of a much too long road transport. He felt that all casualties should have the benefit of such fast and comfortable evacuation means.

Quickly, between the two wars, the young medical aviation will gain its nobility quarters. During the last world war, the U.S. Forces, in particular, made great use of this type of transport. In the period between the landing on Normandy beaches and the capitulation of Germany, the "Sky-Masters" transported to Great-Britain or to the United States 385576 casualties, 82000 of which during the sole month of April 1945.

The same year, General Eisenhower write : "We have air lifted nearly all the wounded people treated in our front line hospitals, and without any doubt this has saved hundreds, thousands of lives". One Director of the U.S. ARMY Health Service added : "Among the means allowing the saving of the greatest number of human lives, air evacuation is to be placed on the same rank as plasma and penicillin".

In this field, helicopters really made their appearance during the Indochina war only. It was on April 7th, 1950, that they were seen in the Indochina sky. They were two HILLERS 360, each capable of transporting two casualties. Their first action had a significant effect on the troop morale. Quickly, thanks to its manoeuvrability and ability to land practically anywhere, the helicopter has supplanted the aeroplane, at least for primary evacuations.

The Vietnam conflict, involving the United States, consecrated the helicopter both as a war machine and as an ambulance vehicle.

This conflict showed a complete revolution in the casualty evacuation concept through the general use of helicopters : in fact, we saw not only the replacement of the conventional ambulance car by the helicopter, but also the use of aircraft instead of ground vehicles for the transport of casualties. Indeed, 90 % of all casualty evacuations were carried out by rotary and fixed-wing aircraft, this giving fabulous figures, such as 25 000 air evacuations during the last quarter of 1965 (500 000 men being engaged in Vietnam).

The advantage of this system, besides the comfort offered to the wounded persons, is obviously the speed of evacuation. To give you some idea, let us recall some figures :

- Average useful speed of ambulance cars during World War II : 10 km/hour.
- Average useful speed of helicopters in Vietnam : 130 km/hour.

The concrete result was that the time elapsed between the moment the wound was inflicted and the arrival of the casualty in a hospital had been reduced in the same proportion. The average time of 16 hours, in 1945, had been reduced to 1 hour approximately.

A first thing to be noted is that numerous casualties, who, before the advent of the helicopter, would have died between the battlefield and the hospital, have now a good chance of survival.

A second noteworthy finding is that in spite of a higher percentage of serious casualties, fatality rate has decreased strongly compared with that of previous battles :

- 1914/1918	8 %
- 1940/1945	4.5 %
- Korea	2.5 %
- Vietnam	1.5 % (ARMY) 1.2 % (MARINES)

In 1973, during the Kippour war, the Israeli Medical Service also used the helicopter extensively, but not in the same manner as the U.S Forces.

Unlike in Vietnam, where helicopters were used right up to the fighting line, this means of transport was rarely used further forward than the battalion medical post, and this for two reasons :

- On economic grounds, "TSAHAL" did not have at its disposal the great number of helicopters available to the U.S. Army.
- Also, because the mobility of armoured units on the battlefield was, in no way, comparable to the relative immobility of positions during the Vietnam war. Therefore, the battalion medical post, due to its low mobility, was the sole forward unit allowing the initiation of evacuation by helicopter.

But, however, in 80 % of cases, aerial means were used for evacuation after the first cares had been given to wounded men.

- Either, for casualties requiring urgent care, using U.S. "IROQUOIS", helicopters, from the battalion medical post to field hospitals installed at the rear,
- Or, using "IROQUOIS" and French "SUPER FRELON" helicopters, from brigade collecting points to hospitals.

The average time elapsed between the wound and the operating table never exceeded 4 hours, for those evacuated from the farthest point. This rapidity clearly explains the very low fatality rate (1.3 %) recorded in Israeli hospitals.

Happily, we are no longer on a war footing. The problem fundamentals are widely different :

- the number of evacuations required is greatly reduced.
- however, the geographical scatter of accident sites is very much greater.
- at last, for obvious economic reasons, the possible fleet of available ambulance helicopters is far from having the size of that pushed into service during military operations.

Nevertheless, if the number of evacuations to be carried out is very much smaller, it becomes possible to contemplate the improvement in the quality of evacuations.

THE AMBULANCE HELICOPTER - A REANIMATION AND  
URGENT CARE UNIT

### 1. THE HELICOPTER POSITION IN THE AMBULANCE FIELD

In districts provided with an important road network and very dense medical structures, it is out-of-question to contemplate the complete replacement of ambulance cars by an aerial vehicle, such as the helicopter, and this for several reasons :

- (a) In some weather conditions, flying may be hazardous or even impossible.
- (b) Full coverage of a country by helicopters would require an excessive number of machines and an infrastructure - both in men and materials - largely out-of-measure.
- (c) The full penetration of helicopters in built-up areas is far from being accepted and shall be possible in future cities only.

Therefore, the helicopter is a complementary means of evacuation.

But, however, it cannot be replaced in many circumstances :

- (a) For seriously ill or wounded persons, when time becomes an essential factor.
- (b) Penetration in areas lacking road network (sea rescue, islands, mountains ...) or when accessibility by road is temporarily impossible (blocking of motor ways by successive accidents).
- (c) Weather conditions preventing road traffic (snow, ice, floods).

In large districts, but with a low density of medical facilities, it is obvious that, in all cases, the helicopter is the most suitable means of evacuation.

### 2. ROLE OF THE AMBULANCE HELICOPTER

At present, due to the aircraft and installations available to our assistance organisations (Civil Protection - Gendarmerie), evacuation by helicopter is limited to the simple transport of an ill or wounded person, without any possibility of medical action during this operation - the only advantages of this concept being speed and the possibility of collecting the patient in areas inaccessible by ambulance cars.

For an installation of a new generation, intended for the casualty evacuation by helicopter, AEROSPATIALE has retained the following principle :

"Transport must be an integral part of the medical treatment"

Thus, the casualty benefits, not only from a quicker action and a transport time shorter than with conventional means of transport, but he can receive cares right from the onset. Therefore, transport time is neutralized.

The roles of the new generation ambulance helicopter may be summarized briefly as follows :

- (a) Primary transport
  - quick access, in the immediate vicinity of the accident site,
  - preparation of the casualty and his conditioning for transport,
  - cares during transport and, if necessary, medical actions required by changes in the patient's condition,
  - transmission to the receiving medical centre of all the information which can be useful to prepare the treatment and on taking over the patient on his arrival.
- (b) Secondary transport

The patient having been stabilized and treated in a medical unit has to be transferred to another centre where more suitable equipment is available to continue the treatment.

It is important to be able to continue, in flight, the initial therapy which could be harmful if interrupted. Further, as in primary transport, an immediate medical action found necessary, in flight, by a change in the patient's condition should be possible.

This concept has been developed by AEROSPATIALE in cooperation with Professor BOURRET, Director of the Centre of Research in Traffic accident Traumatology, of Salon-de-Provence, and Professor SERRES of the Montpellier University.

### 3. AIRCRAFT CHARACTERISTICS

The helicopter, implicitly defined by the concept outlined above, has a dual role :

- . a vehicle function
- . a medical unit function

#### 3.1. Vehicle function

The main characteristics required for this function are :

- . Availability
- . Quick preparation for operation
- . Possibility of landing on any spot, in the immediate vicinity of the accident
- . Reliability
- . Low operating cost
- . Capability of night and all-weather flying

These considerations lead us to select a light helicopter, equipped with a skid type landing gear.

Therefore, this selection limits the number of casualties who can be transported on each flight. Statistics derived from traffic accident analysis show that in the majority of serious accidents, two casualties require urgent action and evacuation. Hence, transport capacity has been limited to :

- . 2 serious casualties, with possibility of medical action in flight.
- . or 1 serious casualty and 2 lightly wounded persons, always with medical assistance
- . or 4 lightly wounded persons, with a medical attendant, if necessary, but, practically, without possibility of medical action in flight.

#### 3.2. Medical unit function

##### 3.2.1. Primary evacuation

(a) Bring to the site :

- the medical team,
- the equipment required to clear the casualty : cutting tools in the case of traffic accidents - spotlights, special equipment in the case of mountain accidents, etc...
- the medical equipment required to prepare the casualty for transport, in particular shell type mattress, inflatable splints, immobilizing devices, first aid equipment.

(b) Allow easy loading of the casualty already installed on a stretcher or a shell type mattress.

(c) On board and during flight, allow the performance of medical actions required by the patient's condition :

- respirating reanimation
  - lung ventilation
  - tracheal intubation
  - suction - tubing
- circulatory reanimation
  - blood transfusion - perfusion
- cardio-vascular electronic monitoring
  - heart stimulation - heart massage
  - defibrillation
- small surgery

(d) During flight, transmit to the receiving hospital all the information required for the patient reception and the preparation of actions required by his condition, either by radio or by automatic data transmission.

##### 3.2.2. Secondary evacuation

The patient condition being stabilized already, ground preparation is no longer required. However, the in-flight continuation of the therapy may necessitate the carrying of specific equipment.

- large reserve of air or oxygen
- power source to ensure the operation of special equipment (incubator, artificial lung)
- and so on.

### 3.2.3. aircraft lay-out allowing the accomplishment of the "Medical unit" role

If from the weight aspect, the "medical unit" installation is not very penalizing, it is not quite the same as regards the volume required.

The aircraft should have :

- a large hold, easily accessible and capable of accommodating all the equipment required for ground action, the batteries powering the electronic and electric equipment, the air and oxygen reserve and the volumetric respirator,
- an amply dimensioned cabin :
  - to allow the installation of the medical team, the casualties, the medical equipment and stowage cupboards for small materials, various products and medicines,
  - to allow the performance of medical actions in flight.
- to give a comfort level sufficient to protect the casualty against any harmful effect from the ambient conditions and to allow the performance of the medical team task. In particular :
  - flight stability
  - low vibration level
  - sound proofing
  - heating.

### 4. SELECTION OF THE AIRCRAFT - THE SA 360 "DAUPHIN"



In the range of AEROSPATIALE helicopters, the SA 360 "DAUPHIN" appears to be particularly suited for this role. While still in the light helicopter class, it features a general lay-out and dimensions which fully meet the requirements stated above.

Although its overall dimensions are only slightly greater than those of the ALOUETTE III, it offers an impressive cabin volume of 5 cu.m., a flat floor of 4.2 sq.m., four wide access doors, a separate hold of 1 cu.m. provided with a large door and easily accessible.

Further, the comfort offered by the DAUPHIN is really exceptional, both from the vibration and noise level viewpoints. It is also to be noted that the tail rotor is of the shrouded type (FENESTRON), as it is an important safety factor during ground operations.

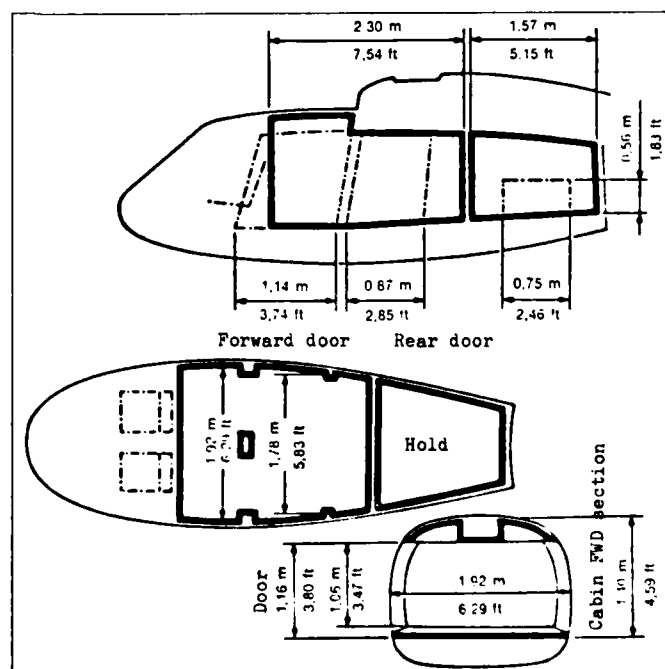

But, the subject of this lecture is to present an ambulance installation and not to describe the vehicle, so we shall restrict ourselves to a brief reminder of the DAUPHIN main characteristics.

Characteristics	SA 360 Single-engine
Maximum take-off weight	3000 kg 6615 lb
Useful load	1432 kg 3157 lb
Maximum speed (VNE)	315 km/hr 170 kt
Fast cruise speed	270 km/hr 146 kt
Best range speed	247 km/hr 133 kt
Maximum endurance, without fuel reserve, at 130 km/hr (70 kt)	3 hours 42 minutes
Range, without fuel reserve, at best range speed	655 km 350 n.m.
Radius of action, with 20 minute fuel reserve at best range speed.	300 km 162 n.m.

#### 5. TRIAL INSTALLATION ON "DAUPHIN"

In close cooperation with Medical Services and Emergency Medical units, AEROSPATIALE has designed a first trial installation, whose objective was not to optimize the aircraft for casualty evacuation, but to check the validity of the concept.

In fact, this installation is a flying mock-up.

Obviously, the lay-out, which we are presenting, can not be considered as imposed or final. It has only a proofing value, showing :

- that the space available in the cabin is necessary, but sufficient to realize the installation by the Medical Services, and that this installation is fully operational.
- that the DAUPHIN exceptional comfort qualities - particularly from the noise - and vibration level aspects - allow the performance of medical actions in excellent conditions and that the patient evacuation conditions are free from additional traumatism hazards resulting from ambient conditions.

The 3-view drawing below, shows the installation principle.

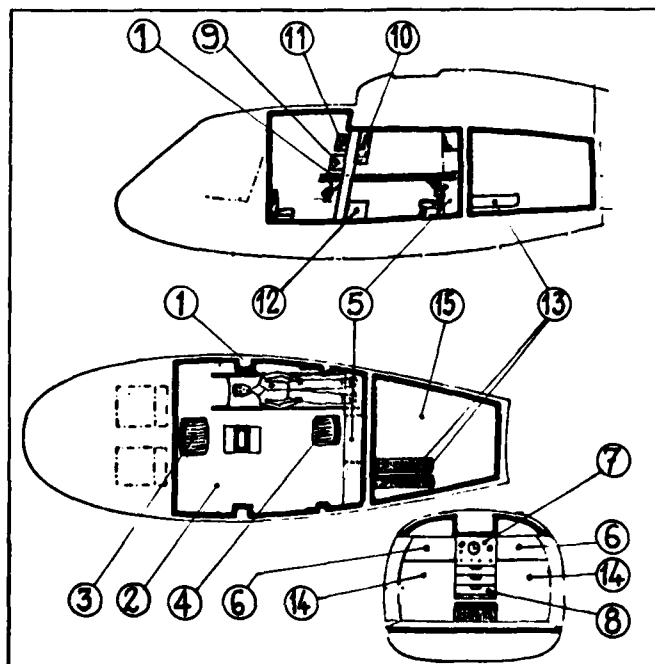

1. Stretcher on its support
2. Second stretcher location (not installed)
3. Seat for reanimator
4. Seat for medical attendant (with folding back to give access to cupboard drawers)
5. Cupboard for the storage of instruments, surgery kits and medicines
6. Cardiology equipment
7. Volumetric respirator
8. Drawers for the storage of medicines and miscellaneous items
9. Mucus suction device
10. Perfusion - Transfusion
11. Flowmeter
12. Suction equipment, operating from Venturi nozzle
13. Air and oxygen bottles
14. Space available for other medical equipment
15. Hold of 1 cu.m. for the storage of ground equipment (cutting equipment, mattress, immobilizing devices, splints, etc.)

This diagram is self-explanatory, so we shall not go into all the installation details, all the more as it is the user who has to define the medical equipment required and not the aircraft manufacturer. Obviously it depends on the operating areas and conditions. The role of the aircraft manufacturer is limited essentially to the provisions for accommodating the type of equipment required.



The photo, shown opposite, represents the installation as defined by the MARSEILLE and MONTPELLIER emergency medical units with equipment selected by them. But it can be seen clearly that reanimation and monitoring equipment may be replaced by that of any other make without any structural modification, and there remains a large space available for installing other complementary equipment. (The second stretcher has not been installed. It is located symmetrically to the first stretcher)

A very particular point regarding this installation is the stretcher support. Taking advantage of the great cabin length (2.30 m - 7.54 ft), it was desirable to have the possibility of moving the patient in the fore-and-aft direction, in flight, to facilitate the access to the various parts of the body. Further, on medical grounds, it was necessary to be able to tilt the stretcher, up or down, as required during flight. At last, it is always difficult to load a stretcher in a vehicle through a side door, as the man who carries the stretcher inside the vehicle has to take up particularly uncomfortable positions.

The solution retained is an interface system, between stretcher and aircraft, consisting in :

- a rail-borne locking support allowing fore-and-aft motion
- a light alloy frame accommodating the stretcher and tilting over  $\pm 10^\circ$ .
- a mechanical assembly, allowing the simultaneous rotation and fore-and-aft motion of the above frame. Thus, through a very simple movement, it is possible to push the frame through the rear door for loading the casualty. Retractable telescopic feet ensure the stability in the "out" position.





Loading a casualty

The stretcher support, shown in the various photos, has been designed to accommodate the stretcher of the type used by the emergency medical units. A support suitable for all stretcher types is being designed

At the same time, studies on stretcher visco-elastic suspension system have been initiated with a view to filtering the vibrations - already at a very low level - transmitted by the floor.

On the photo, shown opposite, it can be noted that when the stretcher is fully rearward, the space thus cleared is sufficient for the reanimator to kneel down behind the patient and perform the intubation operations easily.



At last, for very specific secondary transport, the "DAUPHIN" is provided with the necessary tie-down provisions for special equipment, such as an incubator, and the power sources required for their operation in flight.



In addition, a radio link system capable of transmitting fundamental physiological data is being developed by specialized equipment manufacturers. This programme is sponsored by the French Authorities (D.R.E.T.). Experimentation on the "DAUPHIN" is scheduled for this year.

The DAUPHIN, so equipped, was presented to the second World Forum of Reanimation, held in PARIS from September 19th to 23rd 1977, where it was well appreciated by many reanimators.

Quite recently, it was tested under operational conditions, during a traffic accident simulation, by the MONTPELLIER and MARSEILLES emergency medical units, and, in particular by Professors BOURRET and SERRE. Its real efficiency was proved by an unpredictable incident that occurred while a film was being taken for didactic and pedagogic purposes.

Early in the afternoon, while the filming team was busy on the landing area of SAINT ELOI hospital, in MONTPELLIER, the emergency medical unit received an urgent call from the hospital of VAISON LA ROMAINE, a small town 120 km away as the crow flies. A man, in his forties, just had a heart attack and his transfer to a specialized cardiology service was urgently required.

But, due to social troubles, no ambulance car was available and the road transport time was not compatible with the patient's condition. Moreover, let us remind you, the aircraft equipment was just a mock-up and - luckily enough - consisted of real medical equipment.

Ten minutes after the call and the loading of assistance equipment, the aircraft took off and, during flight, the crew completed the various electric and pneumatic connections required to make the mock-up operational and ready to ensure the patient's survival during his transport to MONTPELLIER.

Sixty-five minutes later, the aircraft was back to the landing area where the emergency medical team awaited the patient, who had somewhat recovered already as the installation had operated perfectly and allowed the performance, in flight, of reanimation and urgent medical actions required.

It should be noted that the same operation carried out by an ambulance car would have required 4 hours.

#### References :

"Histoire des moyens de transport et d'évacuation des blessés en temps de guerre" (History of casualty transport and evacuation in war time). Docteur PAYEN, Army Medical School, BORDEAUX.

#### Acknowledgements

We should like to extend our thanks, particularly for the help they gave us in the design and realization of the DAUPHIN ambulance installation, to :

Professor BOURRET, Director of the "Centre of Research in Traumatology", of Salon de Provence.

Professor SERRE, of the MONTPELLIER University.

Doctor MOISAN, reanimator at the Salon de Provence hospital

The MARSEILLES and MONTPELLIER emergency medical units, the Salon De Provence hospital teams.

The Marseilles fire brigade

The "Gendarmerie Nationale" brigade of Salon De Provence

The Civil Protection Service

The "Ergonomy" section of the "Directorate of Research and Technical studies" (D.R.E.T.)

The ATM Society.

## DEVELOPMENT OF CASUALTY EVACUATION KIT

for the

## LIGHT OBSERVATION HELICOPTER (KIOWA)

R. M. Goede, Major  
 Base Surgeon  
 Canadian Armed Forces  
 Base Hospital  
 Canadian Forces Base Moose Jaw  
 Bushell Park, Saskatchewan  
 Canada  
 SOH ONO

SUMMARY

In the late 1960's the Canadian Forces introduced the Beechcraft Musketeer, an "off the shelf" civilian light aircraft, for fixed wing pilot selection and primary training. This training was co-located with initial helicopter pilot training on the Kiowa helicopter at CFB Portage la Prairie.

The mission profile, coupled with the type of aircraft used, produced a probability that in the event of an aircraft crash, there would be a high survivability rate. These factors, along with the difficulty in reaching a crash site, especially on winter terrain, necessitated the development of air-borne evacuation capability.

The author was involved in the design and testing of a casualty evacuation kit utilizing the Kiowa helicopter. This kit consisted of a stretcher support frame, aluminum stretcher, and two rear doors with bubble extensions to ensure the necessary width to transport one patient across the rear passenger compartment. Flight testing was carried out at the Aerospace Engineering Test Establishment at CFB Cold Lake to determine the aerodynamic characteristics of the Kiowa aircraft with the kit installed.

This kit was designed to fit any Kiowa helicopter in the Canadian Forces fleet. In the event of an aircraft crash, this kit could be installed in the first available aircraft in approximately fifteen minutes.

TEXT

In the late 1960's the Canadian Forces introduced the Beechcraft Musketeer, and "off the shelf" civilian light aircraft for fixed wing pilot selection and primary training. This training is co-located with initial helicopter pilot training on the CH 136 (Kiowa) helicopter at Canadian Forces Base Portage la Prairie.

Both aircraft range up to seventy miles from base, some of it over fairly inaccessible terrain. During the winter months, both the CT 134 Musketeer and CH 136 Kiowa training areas cannot be reached by ground transport other than tracked vehicles. The speed of the tracked ambulance currently in use is approximately 4 mph. This would result in an unacceptable delay in reaching a crash site some distance from the base.

The mission profile, coupled with the type of aircraft used and the relatively low air speed, produced a probability that in the event of an aircraft crash, there would be a high survivability rate. As well, both aircraft are single engine. These factors necessitated the development of an airborne evacuation capability.

Development

There were a number of ways this capability could be provided:

- a. Use of the CH 135 (Iroquois) helicopter in a dedicated evacuation role;
- b. Refit two CH 136 (Kiowa) helicopters to accommodate the Bell Helicopter Company ambulance kit;
- c. Mount one litter across the back seat of the CH 136 (Kiowa) helicopter; or
- d. Attach two litter pods to the skids of the CH 136 Kiowa helicopter.

The advantages and disadvantages of each of the options were as follows:

a. Option (a) - CH 135 (Iroquois):

## (1) Advantages:

- (a) Well documented capability of CH 135 Iroquois helicopter as a casualty evacuation aircraft, including hoisting capability.

## (2) Disadvantages:

- (a) Cost of aircraft acquisition

(b) Aircraft dedicated to a single role.

b. Option (b) - Bell Helicopter Company Ambulance Kit:

(1) Advantages:

- (a) A proven kit
- (b) Medical personnel and life support equipment can be carried in the cabin
- (c) No restriction to the flight envelope
- (d) Pilots trained on aircraft type
- (e) Aircraft in Canadian Forces inventory and situated on base.

(2) Disadvantages:

- (a) Expensive retro fit required
- (b) Aircraft cannot be used in the training role and therefore would require dedication of aircraft to a single role

c. Option (c) - Litter across rear seat of CH 136:

(1) Advantages:

- (a) Patient carried inside aircraft
- (b) No extra heating required
- (c) Accessible to medical attendant
- (d) Rapid installation time, therefore no requirement for dedicated aircraft
- (e) Construction at base level

(2) Disadvantages:

- (a) Medical attendant working space limited
- (b) Restrictions to flight envelope
- (c) Limited space for carrying emergency medical equipment

d. Option (d) - Litter pods attached to skids of CH 136:

(1) Advantages:

- (a) Easy to construct at base level
- (b) Rapid installation time, therefore no requirement for dedicated aircraft

(2) Disadvantages:

- (a) Pods unheated
- (b) Restriction to flight envelope
- (c) Possible undesirable sympathetic vibrations

These options were assigned priority of desirability and submitted to higher headquarters. The proposals were studied both at Air Command and National Defence Headquarters. Canadian Forces Base Portage la Prairie was then authorized to prototype, install, and test a rear seat litter for the CH 136 Kiowa helicopter.

Planning and production was carried out using expertise provided by Base Aircraft Maintenance Engineering, Flight Safety, 3 Canadian Forces Flying Training School, Base Flight Surgeon, and Production workshops.

The final kit design provided for a stretcher in the transverse position across the rear seat of the CH 136 Kiowa helicopter. This necessitated a modification to both rear doors to increase the inside fuselage dimensions. Each door incorporated a "bubble" made of one-eighth inch thick glass reinforced plastic covered on the inside with one-half inch thick foam padding. With the modified doors installed, the maximum internal width of the fuselage was increased thirty inches to six feet ten and one-quarter inches.

The support frame for the stretcher was bolted to the centre of the rear seat platform using the bolt holes normally used for armament installation and rested on two legs that extended from the frame to the floor of the helicopter. The stretcher was designed to slide on the frame and secured by four removable pins. It was also designed to be compatible with the stretcher support rails in the military pattern ambulances. The stretcher, constructed of aluminum, is similar in dimensions to the supporting area of a folding litter used

by the Canadian Forces (21.6 X 72 inches for the Kiowa Kit versus 27 X 72 inches for the folding litter). The metal stretcher is designed to provide stronger support to the patient than the folding litter. The stretcher incorporates a one-half inch foam mattress which connects by velcro strips to the stretcher.

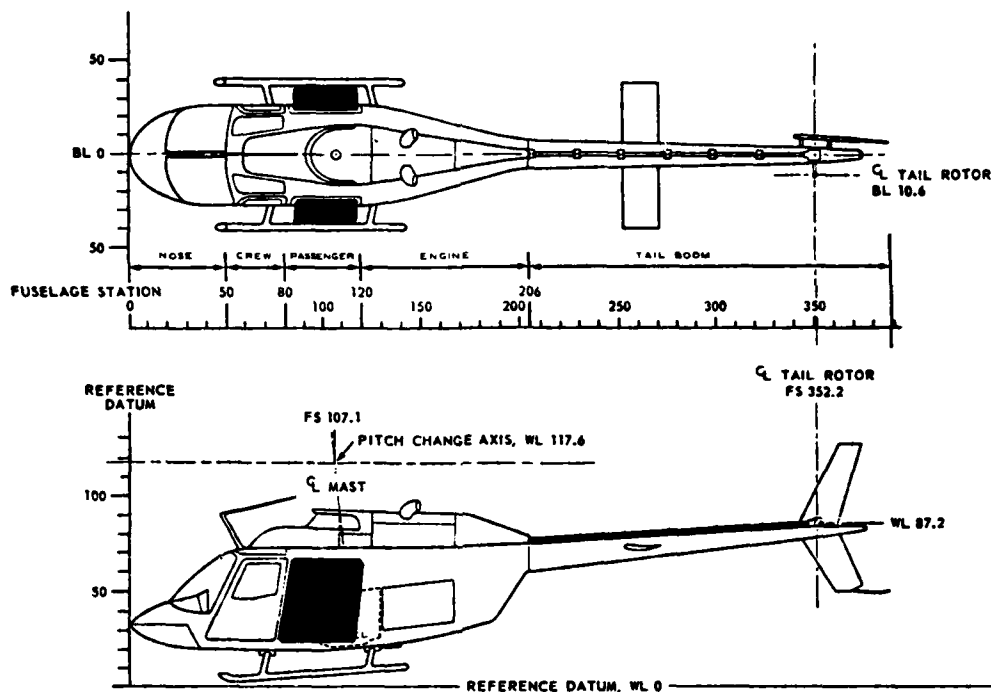

Figure # 1 - CH 136 with modified doors in place

#### Structural Analysis

The structural analysis of the litter kit was carried out by the Canadian Forces Engineering Test Establishment to determine the applicable limits for the kit when carrying a patient. A model of a frame bearing a 220 lb patient was analyzed. This analysis disclosed that in the event of a crash involving relatively low G loads, there would be a deflection of the front legs of approximately ten inches. This would result in a risk of injury to the medical attendant and the patient and minor risk to the other occupants of the aircraft.

The stretcher support frame was modified to provide a more rigid structure which could withstand the following "G" loads when bearing a 220 lb patient:

Nx	9 G
Ny	3 G
Nz	6 G

Although the modified frame did not meet the requirements outlined in the United States Army Aeromedical Research Development Laboratory Technical Report 71-22, Crash Survival Design Guide October 1971, and the Bell Helicopter Stress Report N-206-099-200, namely

Nx	20 G
Ny	10 G
Nz	20 G

The stretcher support frame was considered acceptable for a single production item to be used in an emergency evacuation role only.

The loading on the two bubble (doors) was found to be primarily aerodynamic. The loads on the bubble door which could be encountered at 120 knots (V<sub>ne</sub>) were calculated as follows:

	<u>Vertical</u>	<u>Radial Outward</u>	<u>Horizontal</u>
80 knots	up 1 lb	50 lb	aft 71 lb
120 knots	up 4 lb	110 lb	aft 160 lb

Figure # 2 - Aerodynamic loading on rear doors

It was determined that the two hinge pins and the latch on each door could easily bear the extra loads generated.

The CH 136 with the bubble doors installed was flown at air speeds up to 110 knots and in the sideways and rearward flight to aircraft operating limits to check the structural integrity of the doors. The modified doors remained firmly attached to the aircraft at all times. The general level of vibration of the aircraft, with the bubble doors installed, at air speeds greater than 80 knots was higher than had been experienced with the aircraft in the normal configuration. During manoeuvres at air speeds of 100 knots and above, the level of vibration was moderate. There was no reason to limit air speed on the basis of vibration alone.

#### Weight and Balance

The casualty litter kit weighs 80 lbs and increased the longitudinal moment by 7,770 in/lbs. It was installed symmetrically about the longitudinal axis of the aircraft. When placed on the stretcher, the patient's weight acted through a longitudinal arm of 97.5 inches. The lateral centre of gravity of the CH 136 shifted approximately 0.5 inches toward the side of the aircraft on which the trunk of the patient's body was lying because of the concentrated mass of the human body in that area. With the pilot and medical attendant sitting on the right side, the patient's head on the right side, the centre of gravity of the aircraft was close to the right lateral limit.

The centre of gravity for the kit installed ran from extreme aft position with only the pilot on board to the full forward position with addition of the patient and medical attendant. As a result of this shift in the centre of gravity and to enhance the in-flight handling characteristics, it was recommended that the aircraft with the litter kit installed should be flown with two front seat occupants at all times.

#### Aerodynamic Testing

Aerodynamic testing was carried out at the Canadian Forces Engineering Test Establishment at Canadian Forces Base Cold Lake. Trim control position tests indicated that there was a requirement for less forward cyclic, less right cyclic, and less right directional pedal displacement with the litter kit installed; as opposed to the clean configuration. Both the lateral and directional control displacement curve show a flattening and eventual reversal of control gradient commencing approximately 80 knots. The gradient reversal can be manifest by inadvertent over-controlling of the aircraft about both the longitudinal and vertical axis and result in frequent excitation of the lateral-directional oscillation.

The CH 136 Kiowa with the litter kit installed responded normally to all controls throughout most flight regimes. At speeds above 60 knots directional stability deteriorates and some dutch roll is evident. Lateral and directional stability decreased further in turns and at higher speeds. While all these characteristics were deemed acceptable they would most certainly demand more of a pilot's attention at night or when turbulence is encountered. During flight, it was noted that less forward cyclic is required for a given speed than in normal configuration.

It was found that there was a tendency for the nose of the aircraft to pitch up upon entry into autorotation. This moment increased in severity as the centre of gravity moves aft and as speed increases. Ski installation had a very pronounced and potentially dangerous effect on this manoeuvre, hence it was recommended that all flights with the litter kit installed should be with the skis removed and limited to 90 knots indicated air speed.

Control in hover, lateral and rearward flight was virtually unchanged. No noticeable difference in adverse yaw characteristics of the CH 136 was evident during qualitative testing in both configurations.

Addition of the litter kit to the CH 136 did not noticeably alter the handling characteristics of the helicopter in co-ordinated level turns to the right or left.

Forward speed power requirements are drastically higher due to drag. An aircraft with three persons on board may have a top speed of 80 knots and a flat out speed of less than 100 knots with only the pilot on board. The best range is accomplished at 92 knots and tests indicate a 15% deterioration in specific fuel consumption.

#### Human Engineering

Due to the fact that the kit installation requires no modification or major mechanical changes to existing aircraft, the installation is quick and efficient. A normal 3-man servicing crew installed the litter kit in a Kiowa in 12 minutes without problem.

The design of handles on the stretcher, the size and position of the support rack, the wide doors, and the quick release bayonet pins make for quick and safe loading and unloading of stretcher borne patients.

The functional design was reflected in loading and unloading trials. After one practice, two non-medical crewmen were able to unload the empty stretcher in 6 seconds, load a stretcher borne patient in 14 seconds, and unload a stretcher borne patient in 9 seconds.

The shoulder breadth of a 95th percentile man wearing winter flying gear (underwear, shirt and trousers or fatigues, boots and socks, jacket, helmet, and gloves) measures 20.7 inches. The width of the Kiowa litter, 21.6 inches, allows personnel with 95th percentile shoulder breadth to fit within the width of the stretcher. The stature or length of a 95th percentile man wearing winter flying gear including helmet and boots, is 75 inches. As with the standard folding litter, the length of the stretcher does not

allow 95th percentile personnel to be completely supported on the stretcher. As with the folding litter, some part of the boots or flight helmet may therefore extend beyond the edge of the stretcher. The inside width of the modified Kiowa allows the stretcher to extend into the glass-fibre bubbles. This new width of 80.25 inches allows the 95th percentile stretcher patient to fit the helicopter and allows sufficient clearance for the inevitable movements of the patient associated with turbulence, etc.

The physical layout of the litter in the helicopter restricted the personnel that can use the rear seat of the aircraft. Specifically, the area between the stretcher and the right seat back limits the waist depth available (7 inches); consequently, only medical attendants in the 50th percentile or less waist depth may fit comfortably. The medical attendant had some difficulty in getting in to the rear seat with the stretcher and patient in place and required assistance with strapping-in because of the cramped position. The pin which held the right side of the stretcher to the support frame impeded entry and exit and may cause injury if personnel do not move cautiously. When strapped-in, the observer had difficulty reaching both the door jettison handle and the normal door handle because the stretcher obstructed movement. A rear seat occupant with a short reach may be unable to jettison the right door. These features are unsatisfactory but they are considered acceptable for a kit having limited emergency use.

The space available also restricts the amount of medical equipment that could be carried and the ease of its use.

#### Conclusion

As a result of structural analysis, aerodynamic flight testing, and human engineering, numerous design deficiencies were elucidated.

Structural analysis of the stretcher support frame did not meet the structural load factors for personnel restraint equipment as specified in the USA AMRDL Report 71-22 or the Bell Helicopter Stress Report N-206-099-200. The modified support frame was considered acceptable for a single production item to be used in emergencies only.

The installation of the litter kit, with the pilot and medical attendant sitting on the right side and the patient's head to the right, the centre of gravity of the aircraft was close to the right lateral limits. The fore-aft centre of gravity with the kit installed ran from extreme aft position with only the pilot aboard to the full forward position with the pilot, medical attendant, and patient aboard. To enhance the in-flight handling characteristics, it is necessary that the two front seats of the aircraft be occupied at all times.

Aerodynamic testing disclosed that the CH 136 Kiowa helicopter with the litter kit installed responds normally to all controls throughout most flight regimes. There is a definite deterioration of directional stability above 60 knots. There is also a decrease in stability in turns. These decreases in aircraft handling characteristics were deemed acceptable. There is a tendency of the nose of the aircraft to pitch up upon entry into autorotation. This movement increases in severity as the centre of gravity moves aft and as speed increases. Ski installation has a very pronounced and potentially dangerous effect as full forward cyclic deflection is required to hold pitch attitude horizontal during entry into autorotations at 80 knots. As a result of this tendency to "pitch up" upon entry into autorotation, all flights with the litter kit installed were restricted to 90 knots indicated air speed, skis removed, and two front seat occupants.

Human engineering disclosed a major limiting factor in the working space for the medical attendant was extremely limited. Personnel with larger than 50th percentile waist depth (7.9 inches) were prevented from riding in the rear seat. This was considered acceptable as the medical attendants could be pre-selected, and the speed by which a casualty is evacuated from the crash site is the critical factor, not the comfort of the medical attendant.

These deficiencies outlined are significant enough to limit the casualty evacuation kit to a single production item; to be used at Canadian Forces Base Portage la Prairie in an emergency evacuation role only. Any other use of this kit would require extensive re-design and further aerodynamic testing, especially in the area of autorotation.

It is quite evident from this paper that there were numerous difficulties encountered in the design and production of this kit. There were unforeseen problems, especially in the area of changes to the flight characteristics of the helicopter. As previously mentioned, some of these changes to the autorotation performance could be potentially dangerous.

The purpose of presenting this paper is to demonstrate that there must be active involvement from multiple disciplines in the design and production of any medical item for use in aircraft, especially in helicopters. It is clearly demonstrated that changes of this significance to the structure and role of the aircraft should be attempted only after extensive design analysis and only after extensive design analysis and only if no other alternative is available.

#### REFERENCES

1. USA AMRDL Technical Report 71-22 Crash Survival Design Guide Oct 1971
2. Bell Helicopter Stress Report No. 206-099-200
3. CF AETE Report 76/43 Clearance For Service Use of CFB Portage la Prairie Manufactured Litter Kit on CH 136 Helicopter 4 Jan 1977
4. CF DCIEM Report 3600-1 (DCIEM/BchSc) Report on Human Engineering Assessment 26 Apr 1976
5. George H. Saunders, Dynamics of Helicopter Flight, U.S.A., John Wiley & Sons Inc, 1975

HUMAN EXPOSURE TO MECHANICAL VIBRATION AT LYING POSTURE  
IN THE AMBULANCE HELICOPTER UH-1D

Heinrich Dupuis, Dr.  
Chief, Anthropotechnics Working Group, Max-Planck-Institute, Am Kauzenberg  
655 Bad Kreuznach  
apl. Professor, Technical University 8 München and Johannes-Gutenberg-University  
65 Mainz FRG

SUMMARY

Experiments in advance have demonstrated the amount of vibration stress for man being transported in ambulances (wheeled vehicles). Further research should show vibration exposure of wounded or sick people during transportation by the helicopter UH-1D. Acceleration were measured at the mounting parts of the stretcher, at four points of transferring from the stretcher to the human body, and at two places upon the body. This was done under 11 flight situations: racing the engine, ground running, lifting up, suspense-flight, ascending-flight, horizontal-flight 60, 80, 100 and 116 kn, landing-flight and running out the engine. Effective values (rms) of acceleration and frequency analysis were used as a basis for evaluation.

Summarizing it was found the vibration stress to be about 90 % smaller when transported by helicopter than by wheeled vehicles. The middle of the three positions of the stretcher showed the relative lowest vibration comparing upper and ground position. From the mounting parts of the stretcher to the points of entrance into the body vibration decreases at about 90 % with exception of the situation at racing the engine. Besides low frequencies (5 to 10 Hz) high frequency vibration (30 to 50 Hz) was found.

For the psycho-physiological evaluation of the measured vibration recent results of laboratory research on the biomechanical behaviour and on the subjective sensitivity of man at lying posture can be used.

LIST OF SYMBOLS

a	acceleration ( $m/s^2$ )
$a_x, a_y, a_z$	acceleration in one of the three directions of the coordinate system (see lying posture in Fig. 2)
$a_w$	frequency weighted acceleration calculated by use of an electronic weighting network, up to now only valid for sitting and standing posture, ref. ISO 2631 [1]
K-value	"Wahrnehmungsstärke K", frequency weighted acceleration, ref. German Standard VDI 2057 [2]
KXL, KYL, KZL	K-value at lying posture in one of the three directions x, y and z of the coordinate system (see Fig. 2)
RMS	Root mean square = effective value
kn	flight speed (knots), 1 kn = 0,5144 m/s

1. INTRODUCTION

In connection with the general question on human exposure to mechanical vibration of soldiers driving or being transported in military vehicles we have reported on the man's vibration stress during AGARD CONFERENCE held at Oslo Norway 22-23 April 1974 [3]. There is also a high interest to know to which extend wounded soldiers or sick civilian people being transported in ambulances (wheeled vehicles) or helicopters may be exposed to mechanical vibration.

The aim of the following research was to find out human vibration stress at lying posture during transportation in the ambulance helicopter UH-1D. Several flight conditions had to be changed and acceleration measurements had to be carried out at three stretchers.

2. METHOD

For vibration measurements accelerometers (strain gauge principle, range  $\pm 100 m/s^2$ , natural frequency 250 cps) have been used in connection with amplifiers. A FM-Multiplex-System and a FM-tape-recorder served as recording system. Calibration of the complete measuring system was done before and after the experiments. The flight conditions during the field experiments were reported on an audiochannel of the tape recorder.



## 2.1 PLACES OF MEASUREMENT

For evaluation of vibration exposure the points of acceleration transmission between the stretcher and the human body are mostly important. Therefore accelerometers were fixed at these points of entrance E1, E2, E3 and E4 corresponding to Figure 1 and Table 1. These are the points of relativ high pressure between body and stretcher. Further more two points upon the body K2 and K4 and the fastening point T3 of the stretcher were choosen.

Measurements were carried out at all three stretchers (lower, middle and upper positions). Acceleration directions were generally x (vertical) and at the point T3 additionally y and z (horizontal) (Fig. 2).

Table 1: Points of acceleration measurements (see also Fig. 1)

Symbol	Measuring point
	point of <u>entrance</u> of vibration to the <u>body part</u> :
E1	heel
E2	pelvis
E3	shoulder-blade
E4	head
-----	
	<u>upon</u> the body part:
K2	abdominal wall
K4	forehead
-----	
T3	fastening point of stretcher

## 2.2 VIBRATION ANALYSIS AND EVALUATION

From the tape recordings RMS-values of acceleration for the duration of measurement were calculated. In addition the most important frequencies by the way of narrow-band-frequency-analysis [4,5] could be found.

## 2.3 FLIGHT CONDITIONS

For the field measurements the following 11 different flight conditions for the helicopter UH-1D were choosen:

- |                      |                            |        |
|----------------------|----------------------------|--------|
| 1. racing the engine | 6. horizontal flight       | 60 kn  |
| 2. ground running    | 7. " "                     | 80 kn  |
| 3. lifting up        | 8. " "                     | 100 kn |
| 4. suspense flight   | 9. " "                     | 116 kn |
| 5. ascending flight  | 10. landing flight         |        |
|                      | 11. running out the engine |        |

Because of the very short duration of measurement results of flight condition No. 3 and because of simular vibration behaviour of No. 1 and 11 running out the engine were not be considered.

## 3. RESULTS

The results of vibration measurements at the point T3 (stretcher fastening) are shown in Table 2 and in Figures 3 to 6. Vibration exposure data may be found in Table 3 and in Figures 7 to 14. Frequency-analyses are demonstrated in Figures 15-20.

### 3.1 INFLUENCE OF VIBRATION DIRECTION, STRETCHER POSITION AND FLIGHT CONDITION

For the transversally located stretchers with their different positions typical accelerations at point T3 are shown in Figures 3 to 6. From Table 2 one may find out, that the amplitudes of acceleration tend to be much smaller in both horizontal directions than in vertical direction with a ratio of about 1:3 to 1:4. That means that vertical acceleration - at least for that typ of helicopter - is the most important vibration direction.

In the average of all flight conditions and of the three directions the lowest vibration may be found at the middle stretcher position with the following ratio:

middle : upper : low (stretcher position)  
1 : 1,15 : 1,34 (acceleration)

The different flight conditions significantly show increase of acceleration at point T3 with increasing speed. At ground running and suspense flight acceleration tend to be smaller.

Table 2: Acceleration RMS in three patient-referred directions (Fig. 2) at stretcher fastening point T3  
 - L = low, M = middle, U = upper stretcher position -

flight condition	a c c e l e r a t i o n    RMS    [m/s <sup>2</sup> ]								
	horizontal    y			horizontal    z			vertical    x		
	L	M	U	L	M	U	L	M	U
ground running	0,87	0,82	0,70	0,65	0,47	0,62	3,00	2,60	2,90
suspense flight	1,22	0,85	0,72	0,70	0,50	0,75	3,20	2,00	2,50
ascending flight	1,15	0,85	0,95	0,85	0,60	0,77	3,50	2,20	2,80
horizontal flight									
60 kn	1,25	0,82	0,80	0,75	0,55	0,85	3,65	2,30	3,10
80 kn	1,25	0,97	0,80	0,85	0,60	0,87	3,65	2,80	3,00
100 kn	1,30	1,17	0,95	0,85	0,67	0,92	4,00	2,90	3,30
116 kn	1,45	0,95	1,05	0,85	0,55	1,15	4,10	3,30	3,90
landing flight	--	1,10	--	--	0,55	--	--	3,10	--

Table 3: Vertical acceleration RMS at point of entrance to the human body and at body points (see also Fig. 1)

flight condition	a c c e l e r a t i o n    RMS    [m/s <sup>2</sup> ]    at points							
	T3	E1	E2	E3	E3	K2	K4	
	(for com- parison)							
ground running	(2,60)	0,37	0,22	0,20	0,30	0,40	0,29	
suspense flight	(2,00)	0,37	0,20	0,24	0,22	0,35	0,20	
ascending flight	(2,20)	0,37	0,22	0,30	0,25	0,35	0,25	
horizontal flight								
60 kn	(2,30)	0,40	0,25	0,30	0,25	0,35	0,25	
80 kn	(2,80)	0,42	0,25	0,30	0,25	0,42	0,27	
100 kn	(2,90)	0,50	0,30	0,37	0,35	0,45	0,36	
116 kn	(3,30)	0,52	0,32	0,47	0,40	0,47	0,40	
landing flight	(3,10)	0,37	0,37	0,25	0,25	0,37	0,25	

### 3.2 INFLUENCES TO MAN'S VIBRATION EXPOSURE

From the typical vibration curves (Fig. 7-14) it may be seen, that accelerations from point T3 to all points E1-E4 decreases considerably. This also show the effective values in Table 3. For example at point E2 (pelvis) the effective value of vertical acceleration will be diminished to 0,27 m/s<sup>2</sup> from 2,65 m/s<sup>2</sup> at point T3 (average of all flight conditions). That means about 90 % damping by the elasticity of the stretcher. Generally increase of vibration exposure with speed also can be seen.

In comparison between the different points E1 to E4 from Figures 7-14 and Table 3 it may be found that vibration stress at pelvis E2 is relatively lowest, at shoulder-blade E3 and at head E4 about 8 %, at heel about 60 % higher (average of all flight conditions). Also the measuring point K2 (upon the abdominal wall) shows high values as a consequence of body resonances.

Specific situation may be demonstrated with racing the engine (Fig. 7). At about 200 cycles per min. typical resonances can be seen. Therefore amplitudes at points E1 and E4 - close to fastening points of the stretcher - increase considerably. This is also the case on the forehead (point K4). Patients therefore don't feel well subjectively during this situation of short duration.

### 3.3 FREQUENCIES

For measuring point T3 the frequency analyses of Figures 15-20 calculated important frequencies at 100-110 Hz, at about 70 Hz and lower. There was no frequency of importance over 110 Hz. But at the stretcher high frequency is much less important because of its elasticity. On the other hand at points E1 to E4 frequency analyses show generally maxima between 5 to 10 Hz. In this frequency range human being reacts very sensitiv because of body resonances.

#### 4. DISCUSSION AND EVALUATION

The vibration research with the helicopter UH-10 led to the following conclusions:

1. In comparison between the three stretcher positions relativ lowest acceleration on the middle one could be found.
2. Acceleration effective values at fastening points of stretcher in vertical direction x are as 3-4 times as high as in both horizontal directions y and z.
3. Flight conditions ground running, suspense flight, ascending flight and landing flight in general lead to some smaller vibration exposure at points of entrance to the human body than the horizontal flights with different speed.
4. With increasing speed acceleration values increase at all points of measurement.
5. When racing the engine at about 200 cycles per min. there is high resonance at the helicopter, at the stretcher and also at the patients head. From that point of view it would be a possibility of vibration protection to keep out the patient when racing the engine.
6. Under all flight conditions significant decrease of vibration to the points of entrance to the human body may be found. This diminution tends to be 90 % at pelvis.
7. In comparison with road vehicle transportation of lying people the helicopter UH-10 leads to vibration stress of only about 10 %.

Up to now there does not exist any official vibration testing and evaluation procedure considering frequency sensitivity of man in lying posture. The official document ISO 2631 "Guide for the evaluation of human exposure to whole body vibration" allows vibration evaluation of man ( $a_w$ ), but not yet when exposed in lying posture. But further recent research on biomechanic behaviour of the different body parts and on subjective vibration sensation carried out by our Institute [7] led to frequency-depending evaluation curves (Fig. 21 and 22) of the same K-value. From the calculated K-values in the diagram of Figure 23 the tolerable exposure time may be find out. This procedure really is valid for healthy people and it needs more knowledge on the vibration tolerance of sick and wounded people. But the evaluation guide in future may be helpful for analysis of vibration exposure in ambulance transportation.

#### 5. REFERENCES

- [1] ISO 2631: Guide for the evaluation of human exposure to whole body vibration (1974)
- [2] WVI 2057: Beurteilung der Einwirkung mechanischer Schwingungen auf den Menschen, Oktober 1963, Februar 1975, Januar 1976
- [3] Dupuis, H., Human exposure to whole-body vibration in military vehicles and evaluation by application of ISO/DIS 2631, AGARD CPP-145 B2-1 - B2-7 (1974)
- [4] Dupuis, H. und E. Hartung, Arbeitsphysiologische Untersuchungen zur Belastung von Fahrern auf Rad- und Kettenfahrzeugen durch mechanische Schwingungen, Forschungsbericht aus der Wehrmedizin BMVg-FBWM 72-2, 1-93 (1972)
- [5] see [4], BMVg-FBWM 73-6, 1-47 (1973).
- [6] Dupuis, H. und E. Hartung, Untersuchung zur Belastung durch mechanische Schwingungen beim Krankentransport im Hubschrauber UH-10, Forschungsbericht aus der Wehrmedizin BMVg-FBWM 74-3, 1-23 (1974)
- [7] Szameitat, P. und H. Dupuis, Über die Beeinflussung des liegenden Menschen durch mechanische Schwingungen, Arbeiten aus dem Max-Planck-Institut für Landarbeit und Landtechnik, Bad Kreuznach Heft A-76-1, 1-116 (1976)

#### 6. ACKNOWLEDGMENTS

These studies were performed as a research projet of the German ministry of defense (No. InSan 3871-V-072) [6]. The author is very thankful for assistance by members of Firma Dornier GmbH, Friedrichshafen in carrying out experimental flights and vibration measurements. Appreciation also is expressed to Mrs. J. Wadsack and W. Gilsdorf, Mr. E. Hartung, K. Matzanke and K. Adler for their assistance in processing and converting measuring data and preparing the paper.

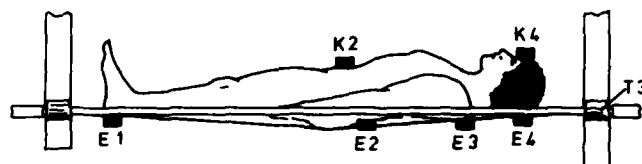

Figure 1: Points of acceleration measurements (see also Table 1)

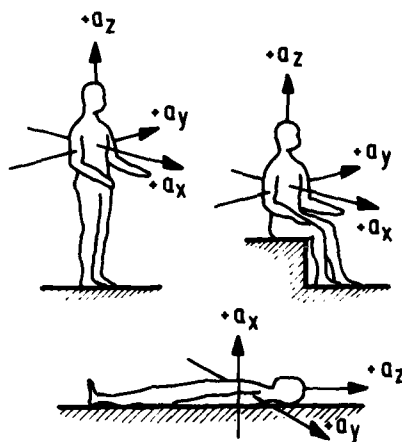

Figure 2: Coordinate systems for mechanical vibrations, ref. ISO 2631 [1]

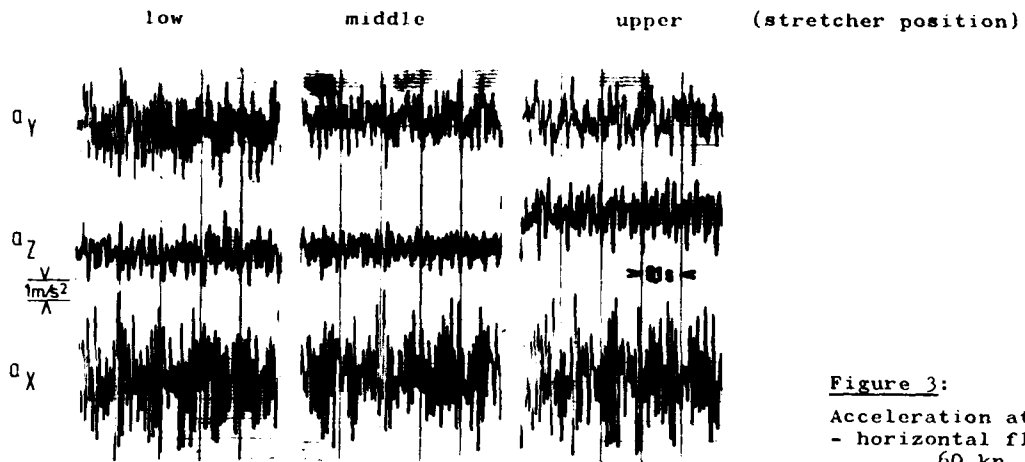

Figure 3:

Acceleration at point T3  
- horizontal flight -  
60 kn



Figure 4:

Acceleration at point T3  
- horizontal flight -  
80 kn

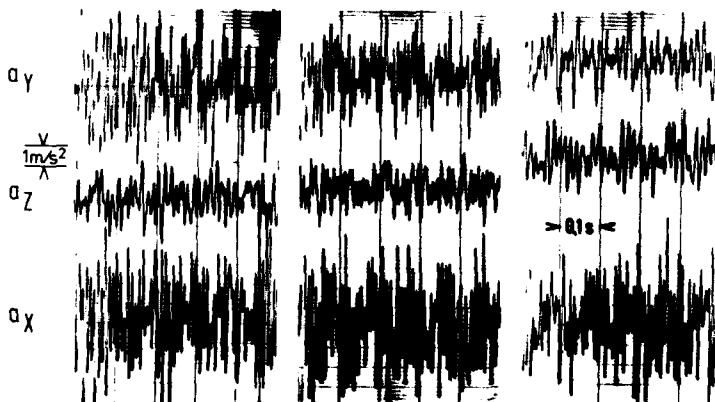

Figure 5:

Acceleration at point T3  
- horizontal flight -  
100 kn

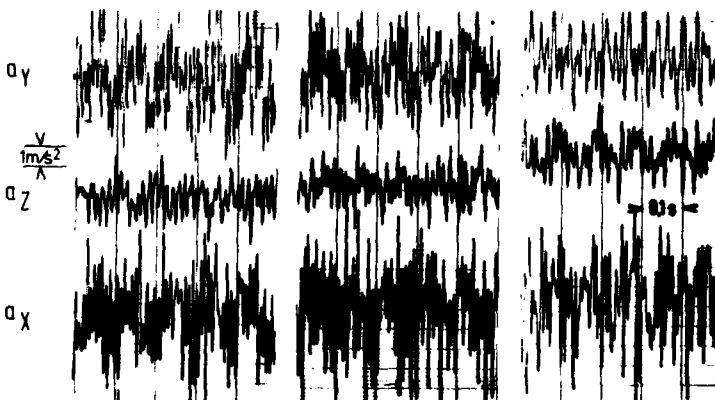

Figure 6:

Acceleration at point T3  
- horizontal flight -  
116 kn

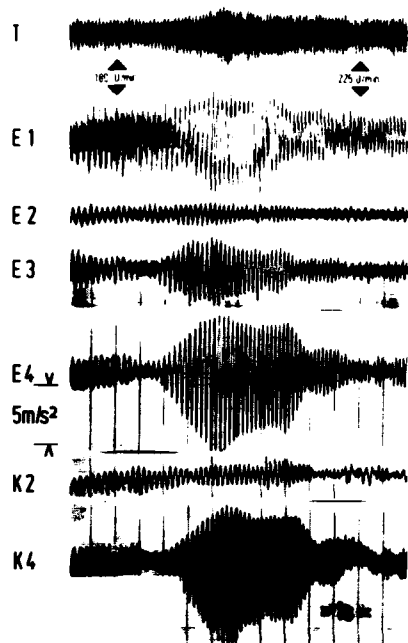

Figure 7: Vertical acceleration  $a_x$   
- racing the engine -

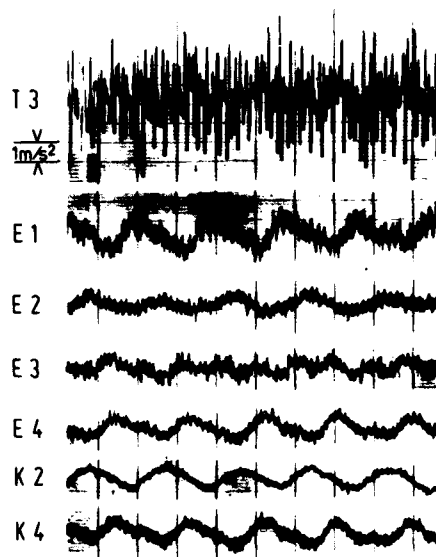

Figure 8: Vertical acceleration  $a_x$   
- ground running -

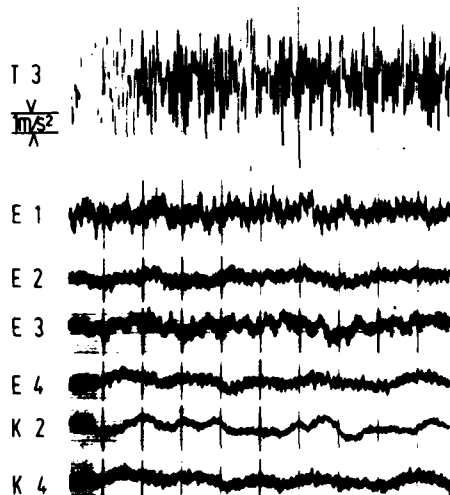

Figure 9: Vertical acceleration  $a_x$   
- suspense flight -

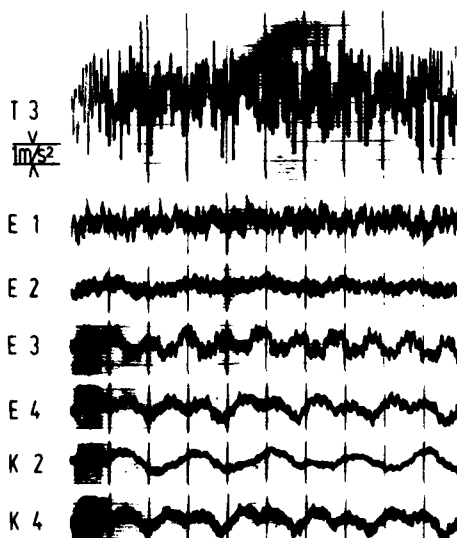

Figure 10: Vertical acceleration  $a_x$   
- ascending flight -

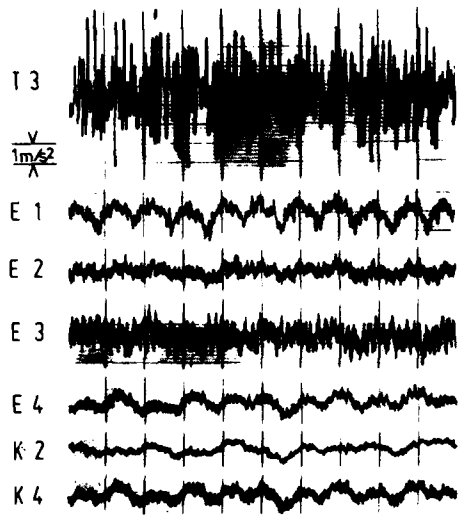

Figure 11: Vertical acceleration  $a_x$   
 - horizontal flight -  
 60 kn

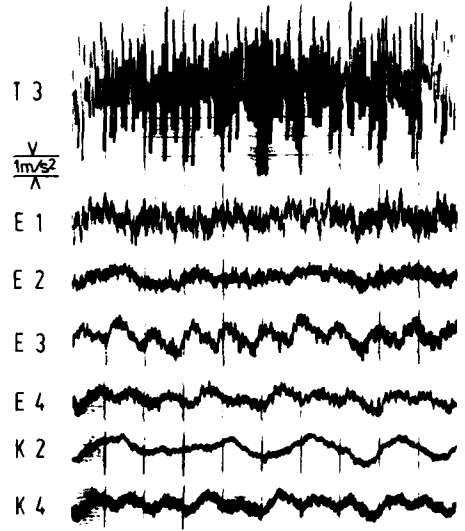

Figure 12: Vertical acceleration  $a_x$   
 - horizontal flight -  
 80 kn

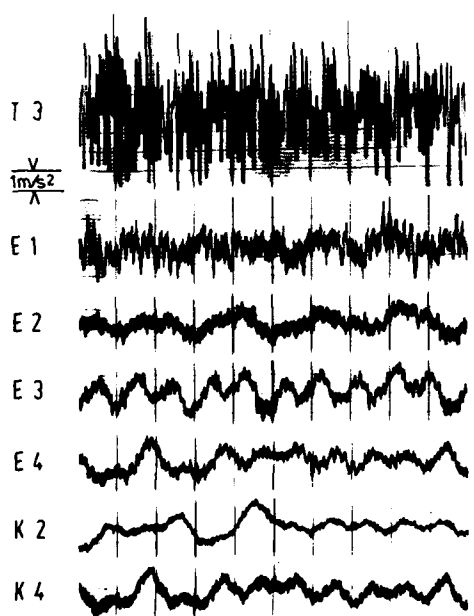

Figure 13: Vertical acceleration  $a_x$   
 - horizontal flight -  
 100 kn

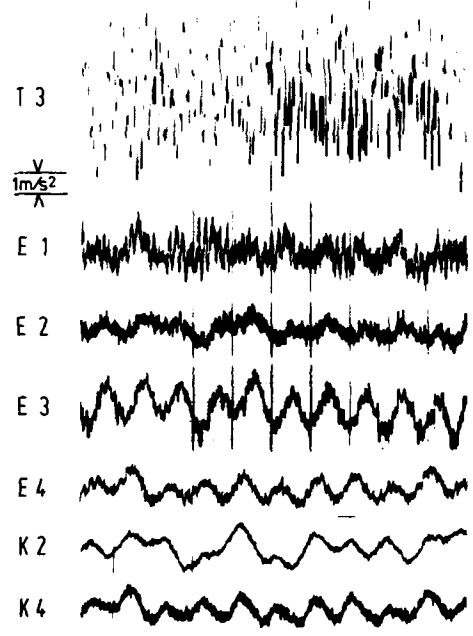

Figure 14: Vertical acceleration  $a_x$   
 - horizontal flight -  
 116 kn

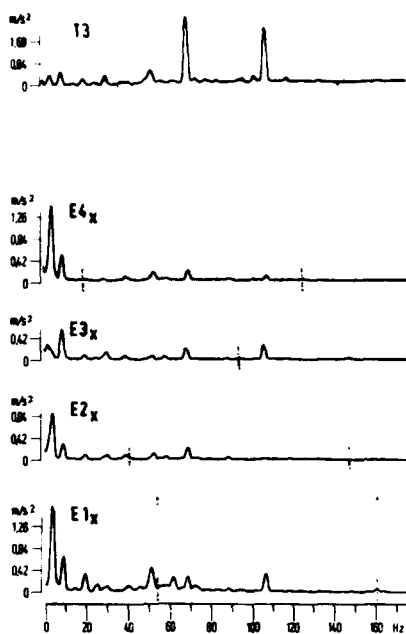

Figure 15: Frequency spectra  
- ground running -

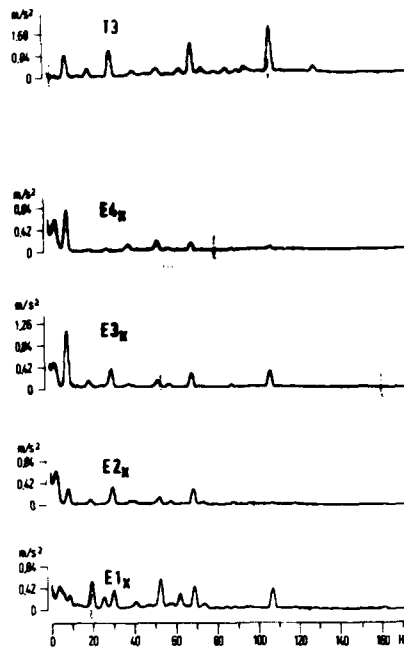

Figure 16: Frequency spectra  
- ascending flight -

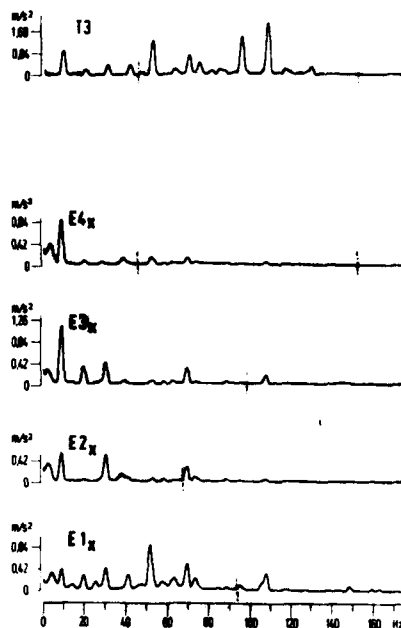

Figure 17: Frequency spectra  
- horizontal flight 60 kn



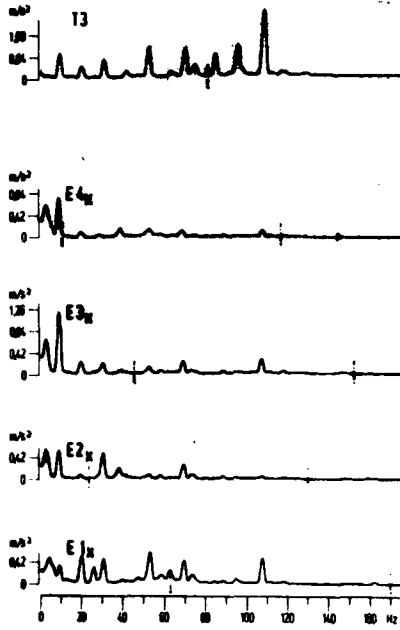

Figure 18: Frequency spectra  
- horizontal flight 80 kn

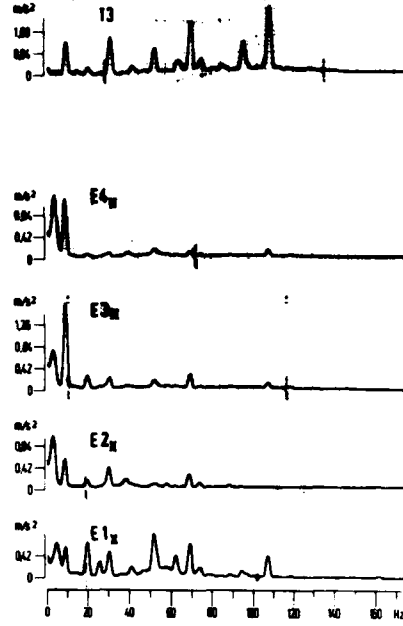

Figure 19: Frequency spectra  
- horizontal flight 100 kn

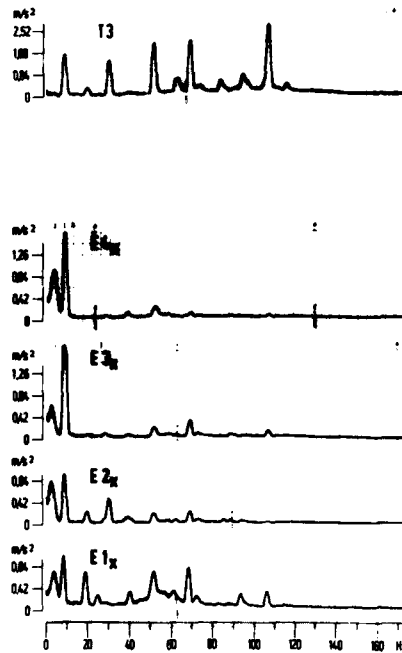

Figure 20: Frequency spectra  
- horizontal flight 116 kn

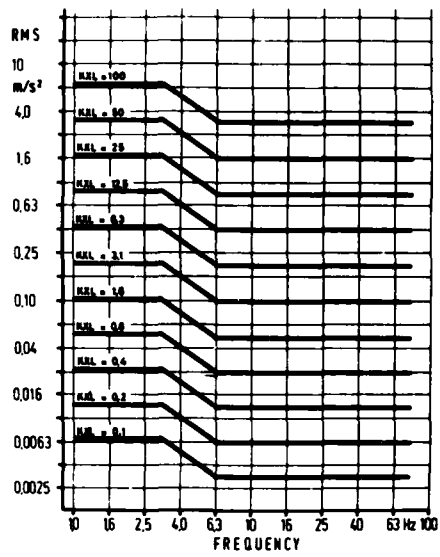

Figure 21: Vibration evaluation curves for lying posture (vertical x)

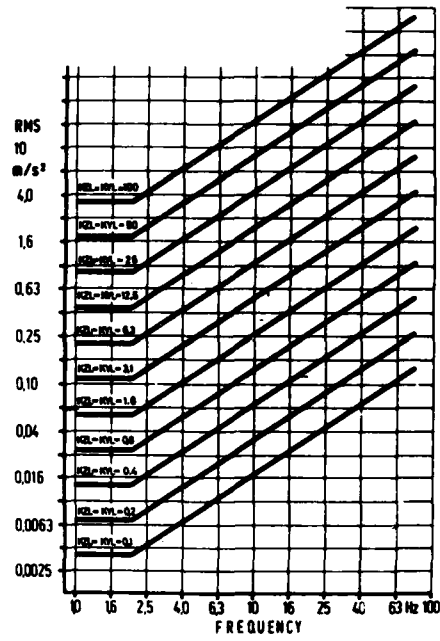

Figure 22: Vibration evaluation curves for lying posture (horizontal y and z)

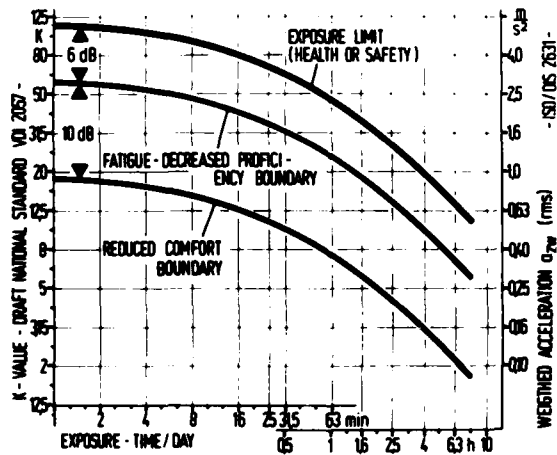

Figure 23: Time evaluation for K-values from figures 21 and 22 [2]

THE ORGANIZATION OF THE AIR RESCUE SERVICE IN THE  
FEDERAL REPUBLIC OF GERMANY

by

G.Kugler  
Allgemeiner Deutscher Automobil-Club-e.V  
(ADAC - Zentrale)  
Baumgartnerstrasse 53  
8000 München 70  
FRG

With the rapid increase of motorized road traffic, the number of accidents in the Federal Republic of Germany also escalated. From 1953 to 1976, 363,484 people died in accidents on our roads. 10,520,000 were injured. This trend necessitated the adoption of numerous technical safety measures and improvements in the emergency rescue service. Surveys revealed that 10 - 15 % of the persons killed would have had a chance of survival if better and more rapid aid had been rendered at the scene of the emergency. Thus saving human life is not merely a question of quantity but of the quality of the rescue means. It is not always rapid transportation to the nearest hospital which is decisive for the patient, but optimum care at the scene of the emergency and final treatment in a suitable hospital. If a person is seriously injured, his chances of survival decrease rapidly 10 minutes after the accident has occurred. Thus our goal must be to bring the best assistance to the patient in this period. The traffic density on our roads has proven to be an increasing obstacle for ground rescue service here.

At the beginning, we had no experience with the use of helicopters. It is true that military helicopters were requisitioned in exceptional cases for the rescue service, but these missions were limited for the most part to secondary transportation. In these cases, the diagnosis for the patient had already been made. Thus the criteria for requisitioning helicopters to be used in primary missions had to be developed first.

This was the purpose of the pilot test initiated 10 years ago as part of a wide-scale road safety program developed by ADAC (Allgemeiner Deutscher Automobil-Club). The pilot test was conducted at first with a chartered helicopter. In 1970, ADAC had its own BO 105 helicopter available for missions. It was the first civilian rescue helicopter in Germany equipped according to the latest knowledge in the field of emergency medicine. The tests soon revealed an important fact - namely that not every helicopter is suited for use in the rescue service. Aircraft with piston engines are not acceptable because warming up the engines involves a loss of time and the engine vibrations are transmitted to the cabin. Rescue work requires helicopters with turbine engines which have a sufficient margin of power, a noise level of less than 80 decibel and little vibration. Furthermore, it is advantageous to have small rotor diameters for landings where there is limited space only. Also, it must be possible to transport two patients in such a way that the doctor and the attendant are seated at the head of each stretcher.

Since the helicopters flying rescue missions almost always fly (with special permission) at a lower altitude than the safety altitude prescribed by law, helicopters with two engines are preferable, especially as the areas of operations are usually densely populated. Helicopters in the rescue service are subject to extreme wear and tear since they very often fly with a full load and almost invariably fly short distances. Another requirement is a minimum of technical maintenance since this means that helicopters are more likely to be ready for operation at any time.

With its "Munich Model", ADAC laid the cornerstone for the air rescue service in the Federal Republic of Germany. The experience acquired about technical, medical, organizational and financial requirements formed the basis for the use of other helicopters. In order to accelerate development of the rescue service, ADAC placed two helicopters at the disposal of the Disaster Relief. The Federal Ministry of the Interior set up a plan in 1972 for an air rescue network to cover the entire country.

Today there are 3 systems in Germany:

1. Disaster Relief with 16 stations
2. Federal Army with 5 stations
3. German Air Rescue with 3 stations.

All systems work according to the same organization plan.

The rescue helicopters which are stationed at clinics and have a doctor and a medical attendant on board can start within 1-2 minutes of the time the emergency alarm is received. Neither previous knowledge of the diagnosis nor confirmation that the patient will meet the costs for the flight is required in order for missions to be flown. Waiting for the diagnosis would mean an unnecessary delay which would negate the amount of time saved by using the helicopter. Such a delay is not in the interests of the patient.

Personnel in the rescue control centres is trained sufficiently in order to make a decision about the necessity of a flight on the basis of the information given in the emergency alarm by a layman. Special indication catalogues are available to the personnel for this purpose in addition. The quota of superfluous flights averages around 17.6 %.

One disadvantage which has not yet been overcome in air rescue should be mentioned. Missions are flown only in daylight hours, that is from 6:00 AM to 30 minutes after sunset. The helicopters have only VFR equipment and thus for safety reasons, only flights between hospitals from landing base to landing base are possible at night under conditions of visual flight rules. Primary missions in which the helicopter must land on roads or in extremely small areas present too great a risk in the dark. By now, there are various technical developments, for example the Night Sun System, infra-red or goggles to intensify the remaining sunlight, but even then, wires or small obstacles are still not perceptible enough. Since few secondary missions are flown between hospitals, helicopters from the Disaster Relief are not kept on stand-by at night. Furthermore, the noise problem would make stationing at the hospital difficult.

In the Federal Republic of Germany, we feel that the rescue service is the task of the Laender (Bavaria, North Rhine-Westphalia, Lower Saxony, etc.). The rescue service is governed by laws which are enacted by the Laender. It is supported by local governments (towns, districts). Due to the extent of the helicopters' areas of operation (50 km radius), towns and districts have joined together to form supporting associations. The Federal Ministry of the Interior places helicopters of the Disaster Relief at the disposal of these associations, and the Federal Ministry of Defence does likewise with army helicopters in return for reimbursement of costs. A sum of DM 900 is charged per flight hour. Administration of the rescue service was placed in the hands of ADAC which has the greatest know how in air rescue and also an organization covering the entire area of the country. Thus in Germany, private and public institutions work in close co-operation.

ADAC prepares special operations reports for all helicopters which are conceived as data carriers for a computer program. For each flight, the doctor makes a report containing medical data and the pilot makes a report with flight data. ADAC's computer processes these reports. 200 detail positions are evaluated for each flight. In 1977, the ADAC computer processed over 20,000 reports. The annual statistics for 1977 for all helicopters work out to about 300 printed pages. These figures help ADAC analyze the efficiency of operations and provide a basis for calculating costs.

In 1977, 12,589 missions were flown (24.2 % more than in 1976) with 7,000 flight hours. On the average, three missions are flown daily. The maximum number of missions flown is around 12. In conglomeration such as Munich, Frankfurt or Cologne, stationed rescue helicopters fly 1,000 - 1,200 rescue missions annually. In 50 % of the missions, injured persons are transported in the helicopter. In 30 % of the cases, the helicopter doctor treats the patient and then arranges for his transportation in the ambulance. This rendez-vous procedure makes it possible for the helicopter to remain available for serious, acute injuries or illnesses.

The average flight time for primary missions is 37 minutes and 74 minutes for secondary missions. The ADAC computer found that flight time between the helicopter station and the scene of the emergency is around 8-9 minutes. Patients flown in the helicopter are not always transported to the hospital at which the helicopter is normally stationed. It depends on the size of the intensive care unit at the hospital there and the capacity of other hospitals in the area. The percentage of patients delivered to hospitals at which the helicopters are normally stationed varies between 80 % and 20 %. As a general rule, the patient is flown to the nearest hospital equipped to provide treatment.

Another important result of the computer evaluation shows that the helicopters can usually land close to the patient, particularly when road accidents have occurred. The distance between the landing spot and the scene of the emergency was less than 50 meters in 70 % of the cases. However, the difference between smaller, manoeuvrable helicopters and larger ones which come off less well by comparison, is apparent here.

The rescue helicopter is undoubtedly the most expensive means of rescue. Despite its necessity, from a medical point of view, the air rescue service would not have had any future in the Federal Republic of Germany if it had not been possible to ensure that costs would be met. Direct operating costs for a helicopter in daily use amount to approximately DM 620,000 at a rate of about 1,000 flights annually. This amount can be broken down as follows:

500 flights à DM 900	=	DM 450,000
1 doctor		DM 80,000
2 medical attendants		DM 70,000
Insurance		DM 3,000
Medical equipment		DM 10,000
Maintenance costs for hangar and miscellaneous expenses		DM 7,000
		<hr/>
		DM 620,000

Costs for the doctor are refunded to the hospital and personnel costs for the medical attendants are paid to the aid organizations.

As long as a patient is covered by health insurance, he is not charged for the helicopter flight. After prolonged negotiations with the health insurance institutions, ADAC signed contracts for the refund of costs. These contracts stipulate that between DM 830 and DM 900 will be paid for a rescue flight in which a patient is transported

or is treated by a doctor. If 750 missions entailing medical attendance are flown annually, all costs would be met according to this scheme. The risk of flying superfluous missions is also covered here. However, 1,000 and more missions are flown in densely populated residential areas. In rural areas, this figure is considerably lower, namely between 400 and 500 missions annually. Since fixed costs for the doctor, medical attendants and insurance remain the same in any case, deficits occur in rural areas which must be offset by the Laender or local communities. ADAC meets all administrative costs which amount to over DM 1 million each year.

Air rescue is a public task. For this reason, the Federal Government finances investments for the helicopter (a rescue helicopter costs about 2,2 million), and the hangars at the hospitals at which the helicopters are usually based are paid for by the Laender. These costs need not be redeemed and this produces the advantage that the air rescue service can work more economically than a private enterprise.

Still, a rescue helicopter is always a compromise between what is necessary medically and feasible economically.

In the Federal Republic of Germany, long-distance missions (for example, transportation of vital organs or of patients to hospitals for treatment of paraplegia or burns) are also flown. These missions are flown by Federal Army aircraft and not by the rescue helicopters which only operate within a 50 km radius. The aircraft is requisitioned over the alarm centre of the SAR in Goch. ADAC uses special ambulance jets to repatriate tourists who have fallen ill abroad. These flights are financed by supplementary insurance. The inland insurance booklet which ADAC offers its members contains a guaranty sum of DM 25,000 for this purpose.

#### Summary:

The rescue helicopters stationed at hospitals serve primarily to transport the doctor to the patient in order to ensure optimum treatment at the scene of the emergency. The rescue helicopter is not a substitute for existing facilities offered by the ground rescue service, but rather it is the best possible supplement. In order to avoid competition between helicopters and rescue ambulances, operations must be co-ordinated by the emergency control centres. The helicopters must be ready for action within a very short time. Combining rescue tasks with others (for example the police or military) should be avoided. Increasing the density of the rescue network has proved its worth, as can be seen in the reduction of the number of deaths resulting from road accidents.

## DISCUSSION

- SPEAKER UNIDENTIFIED: Mr. Gorgass, where is the rescue helicopter stationed--on the airfield or at the hospital? Who alerts the rescue team for the mission?
- GORGASS:  
(Germany) We think the rescue helicopter should be stationed at the hospital for two reasons. First, the time for alarming the helicopter should be as short as possible. The helicopter should start with a medical crew within two minutes after getting the alarm. Second, the emergency doctor is a hospital doctor, and the whole time for the mission should be as short as possible because he has to work in the hospital, too.
- PERRY:  
(United Kingdom) What is the density of population that you work out for an area to cover? It would be nice to compare the American experience with your experience. Are you covering very similarly populated areas? Can you tell us the population of the area you serve?
- GORGASS:  
(Germany) Nearly 80% of the German population is served by this helicopter rescue service system. In the Munich area, which is a combination of several areas, one helicopter rescue station protects about three million people. Other stations covering more territory only protect 500-700,000 people. We think that inhabitants of rural areas should have nearly the same chance as the inhabitants of a city.
- STEINMAN:  
(United States) Have any of you experienced any difficulties or taken any special precautions for in-flight defibrillation on your helicopters?
- SPEAKER UNIDENTIFIED: We make defibrillations during the resuscitation of patients on secondary transport; but before installing the defibrillator, we made an investigation in a hovering helicopter. We then put it in as standard equipment for the helicopter. The same was done for civilian helicopters with no problems.
- KLEIN:  
(Germany) We have been presented two different systems. You have mentioned, Dr. Gorgass, the German system which insists that a doctor is on the helicopter. The American system does away with a doctor and says that it is enough to have fast transportation. The differences may be that a doctor is with a patient in 10 minutes or that the patient may be in a hospital within 20 minutes. It is a matter of a medical question and it is a matter of costs and cost effectiveness. I would like to discuss it a bit. My question to Dr. Cowley is, would he do away with his system and take over the German system if he could do so?
- COWLEY:  
(United States) First, I think you should qualify what you are doing. We are a small state. Most of our helicopter missions are flown in 20 minutes. So, these are the points I would like to make in relation to your [Germany] and our [United States] type of program. One, our paramedics are very highly trained and they can do, I think, most things that a doctor can do out in the field. Second, I would like to point out that I don't care whether you are riding in an ambulance or a helicopter, there isn't a great deal that you can do while in transport. If you don't believe it, go out and pick up one of your ambulances and go down the road at 15 miles per hour and try to resuscitate patients. It's difficult. Third, I would like to point out in relation to the physician versus the use of paramedics that our helicopters are stationed throughout the state. They don't have to be at a hospital, go out, and come back. They are generally out in the region. During traffic hours, in the mornings, and in the afternoons when people are going home, our helicopters are up flying. They are monitoring wave bands which means that any time they hear of an emergency they are in that vicinity and they simply drop down and begin resuscitation. If the patient doesn't need to come into the system that we have, the patient resuscitation continues until the ambulance arrives. And it's vice versa with the ambulance. If we had a larger state where there were two-hour transportation times and so forth, perhaps the physician would be of value, but not in our system. Lots of money has been spent in our state for developing large mobile vans with a doctor and a nurse on board. They are totally, in our opinion, non-cost effective because it is a waste of these people's talents and time when a well-trained paramedic will do.
- BURGHART:  
(Germany) It would be very interesting to combine the two systems more because of their principles and philosophies. We must have a trained man at the scene as quickly as possible, and you cannot translate the whole system from West Germany to America and vice versa. I think the most important thing is that there be a well-functioning system to save lives.
- KAPLAN:  
(United States) I would like to ask you, in your opinion, in your system, what is your reduction in mortality? Do you have a feedback close-looped with those central hospitals who are capable of treating all? How many intravenous things are infiltrated

during transportation? How are you evaluating and arresting internal abdominal hemorrhage from the scene to the hospital? Do you recognize the advantage of an anti-shock trouser in your system?

SPEAKER UNIDENTIFIED:

Last year we had more than 11,000 missions documented by the ADAC. Mr. Kugler will give some details later. We have transported more than 7,000 patients and from these 7,000 more than 6,000 got intravenous fluid for shock and about 3,000 people had intubation at the scene or during flight. I think that is tremendous. In our country the law says that all these things can be done only by a doctor; so we have to take the doctor to the scene. We say that we have had, in West Germany, about 200,000 emergency case fatalities. We could have saved more than 10% (more than 20,000 people) if we had had this system that we have seen today. So, we can lower by 10 or 15% the fatality rate. In my opinion, it is quite more than that. A victim who could become an emergency patient will not become an emergency patient because the first aid and the first treatment were so good that this patient does not become a statistic. An example--rupture of the spleen. A young boy is in a bicycle accident. The police alert the helicopter. The helicopter crew comes within 10 minutes. The medical doctor and the crew decide to bring this patient into the hospital--not to the nearest hospital but to a hospital specializing in the problem. They see at once that there is bleeding in the stomach or a rupture of the spleen, and so the young man will be operated on at once. He will never go into shock and be a real emergency patient. I think that it is a most important thing to give pre-clinical care not only to save human lives, but also to bring these possible emergency patients to help. This, in our opinion, is the most important thing, and you will never have this statistic.

GOEDE:  
(Canada)

In relation to a country like Canada that has a population of 22 million spread over a vast area, some of it very concentrated, some of it very sparse, what is the minimum concentration of population that makes this system cost effective? Second, what is the maximum radius of area to be covered by one helicopter?

SPEAKER UNIDENTIFIED:

Mr. Kugler's paper discusses costs and financial problems, so perhaps we can answer your question after that paper.

CAILLE:  
(France)

I have a question concerning night rescue operation procedure. Are your Bell helicopters equipped with forward looking infrared?

SPEAKER UNIDENTIFIED:

Up to now we have no experiences with infrared, but right now we are trying to find out whether this infrared will work. It is similar with the night vision goggles--we are studying their use now.

CAILLE:  
(France)

(Question directed to Dr. Sanders, United States) How can you talk about work load using a subjective evaluation--a self-rating scale and without referring to electrophysiological data (ECG, for example)? Don't you have any objective criteria? The only operating scale is a function of the pilot's psyche. The objective is limited to self-rating scales, to self-judgments by the pilot. Why didn't you make any evaluations that were electrophysiological--EMG or ECG?

SANDERS:  
(United States)

A self-rating scale wasn't the primary criteria. We used subjective ratings--both a questionnaire and a Cooper-Harper Scale only as adjuncts to the objective performance criteria values that we recorded in-flight during the evaluation. We have a helicopter in-flight monitoring system that records 20 channels of flight data, both pilot controlled inputs as well as aircraft status values. These were our primary criteria or primary sources of information. We used the subjective criteria only to add more information to the study so that we get a better and more complete picture of what is happening both as the pilots perceive those and as they operate during the hovers. We considered using EKG or EEG information. On some studies those types of data are obtained, but for this study, for the shortness of the period in which we were testing, it is difficult to relate specific physiological data to the kind of pilot performance information that we were looking for. We felt that the actual control activity in the aircraft status information was far more important for our purposes.

## CARBON MONOXIDE – A SIGNIFICANT AEROMEDICAL RISK

by

Joseph C. Denniston, Maj., VC  
 Frank S. Pettyjohn, Col., MC  
 James K. Boyter, Cpt., MSC  
 US Army Aeromedical Research Laboratory  
 Fort Rucker  
 AL 36362, USA

### ABSTRACT

Current concepts of the pathophysiology of low level exposure of humans to carbon monoxide (CO) will be presented. The review will include a discussion of endogenous and exogenous sources of CO and CO absorption, transport, and elimination. The toxic effects of acute and chronic CO exposure, CO effects on cognitive and cardiopulmonary function, equivalent physiologic altitudes by CO, and tolerable limits of CO exposure will be delineated. Emphasis will be placed not only on the factors that determine carboxyhemoglobin levels in the body but also on the impact to aviators of transient elevations in ambient CO within the combat operational environment.

The correlation of cigarette smoking, CO, and equivalent altitudes is exemplified by the following:

<i>Smoking History</i>	<i>Number of Cigarettes</i>	<i>% COHb</i>	<i>Actual Altitude (Feet)</i>	<i>Equivalent Altitude (Feet)</i>
Non-Smoker	1	2.39	5,000	8,000
Smoker	1	6.47	5,000	11,000

The COHb could increase even greater depending on smoking inhalation habits, type of cigarette, and a multi-factor effect of physiological variables. Examples demonstrating the importance of such physiological factors as temperature, ventilation, altitude and underlying cardiopulmonary disease on the resulting carboxyhemoglobin level will be presented.



## NORTH SEA AND NORTH FLANK WINTER OPERATIONS

by

Surgeon Commander E P Beck, Royal Navy  
 Royal Air Force Institute of Aviation Medicine  
 Farnborough, Hampshire, GU14 6SZ

## INTRODUCTION

The purpose of this paper is to provide a general review of the nature of problems which are encountered during helicopter operations in northernmost Europe where the winter climatic conditions range from sub-arctic to arctic.

It was a decade or so ago when a significant part of the UK contribution to NATO was committed to the defence of the north flank. At the time we had behind us many years of continuous experience of temperate, tropical and desert environments but little more than a dwindling memory of Korea 20 years previously and only a superficial knowledge of the problems to be faced during sustained operations in the far north. While the geographic location and climate were to be new, the operational objectives of Naval helicopter aviation remained unchanged. These objectives fall into two broad categories. The first concerns the search, identification and ability to attack surface or submarine vessels. This role is performed by a variety of helicopters (Wasp, Lynx, Wessex and Sea King) operating primarily from ships, ranging from a single aircraft carried on small ships to a full squadron on larger ships. The second category is the operation of the Commando Carrier which provides a mobile spearhead quick reaction force, either a Royal Marine Commando or British Army Unit, which is heliportable and self-sufficient<sup>1</sup>. It is in this latter category that the change to the arctic environment has had the greatest influence, gained through the experience of annual winter training periods based at Bardufoss in northern Norway.

## ARCTIC TRAINING IN THE COMMANDO ROLE

The objective of the periods of training at Bardufoss is to familiarize aircrew with the operation of their aircraft in an arctic environment and with the standard techniques of flying their aircraft in the Commando role including snow landings, troop and load lifting, navigation, mountain flying and night flying. The training periods include deployment of the force from the ship, operating from a fixed base ashore and periods operating from forward operating bases (FOB). The FOB is a mobile self-contained unit operating small numbers of aircraft in support of the ground forces. It operates from tented accommodation and without the benefits of permanent site utility services, ie power, water, heating, lighting etc. A FOB may be deployed for up to a month and the manning reflects the need for the servicing and maintenance of aircraft and for the temporary deployment of smaller sub-units in support of aircraft operating singly, grounded aircraft etc. It is evident therefore that it is necessary to place as much emphasis on the structure and efficient function of the ground support organisation as it is to develop the necessary techniques and skills in airmanship under arctic conditions. Since it is not possible to expose all aircrew and ground personnel to first-hand arctic experience each year, the philosophy has been to maintain continuity with an increasing nucleus of highly experienced personnel. Thus not only are these personnel qualified to carry out pre-deployment indoctrination and training in the UK but they ensure a minimum of necessary re-learning at each deployment and the continued progression in the development of new techniques and equipment.

## CLIMATE AND PROTECTIVE CLOTHING

A decade ago no specific provisions had been made in terms of aircraft modifications or personal equipment and clothing for general service use in the arctic. It was perhaps inevitable that for the first deployment to Norway the issue of additional clothing to combat the extreme cold weather included the Canadian parka, windproof trousers and mukluks. However, while this clothing is suitable for the consistently cold dry climate of northern Canada, the Norwegian climate is significantly different in one important respect. Although the average temperature throughout the coldest winter months remains well below freezing, the Norwegian climate is characterised by short sudden thaw periods due to a shift of the wind to a south-westerly direction. These warm periods are often associated with rainfall and they usually terminate by an equally sudden return to subzero conditions. Temperature variations as great as 15-20°C in a 24 hour period are therefore by no means uncommon. The Canadian clothing provides too much protection during the warmer spells but also it becomes saturated with water which promptly freezes with the return of the colder weather. A further important consequence of the warm spells and precipitation is the conditions underfoot which turn into a layer of ice covered with a film of water. These conditions are better suited to crampons and tracked vehicles than standard footwear and wheeled vehicles.

Following the recognition of the inadequacies of some of the items of clothing and footwear the opportunity has been taken over the past decade, under the auspices of the tri-service Mountain and Arctic Warfare Committee and the Aircrew Equipment Research and Development Committee, to rationalise all land winter clothing assemblies for both ground personnel and aircrew<sup>2</sup>. Aircrew clothing is based on a 3 layer clothing assembly with an additional supplementary outer layer drawn from the range worn by ground personnel. This layer is not worn in the cockpit or when flying. The inner layer of aircrew clothing consists of underwear, either cotton ribbed knit or acrilan pile; the intermediate layer consists of the aircrew jersey, shirt and trousers; the outer layer may be either the Cold Weather Flying Suit or the Combat Flying Suit. The supplementary layer, which is being phased in to replace the Canadian parka and trousers, provides a quilted jacket and quilted trousers with a windproof oversmock and trousers. The emphasis on footwear has shifted away from the routine use of mukluks to boots which may be worn with thermal or waterproof overboots as indicated by the conditions.

The aircrew clothing assembly provides a thermal insulation value of approximately  $0.36^{\circ}\text{C m}^2\text{W}^{-1}$  (2.4 Clo)<sup>3</sup>. With the addition of minor modifications to the cabin heating system for arctic based aircraft

this assembly enables aircrew to remain comfortable when in the aircraft and for survival purposes it is adequate for survival in conditions down to  $-40^{\circ}\text{C}$ . Although sockets are provided in the cockpit for electrically heated gloves and socks they are rarely used except by some rear crewmen whose duties require them to be at the open cabin door to supervise load lifting, during landing approaches, reloading external cameras etc. A second problem for these rear crewmen is the need for face protection particularly during recirculating snow conditions.

#### ARCTIC FLYING

The greatest limitation to flying Commando role aircraft in the arctic is the lack of visibility to navigate safely, either due to low cloud or snow fall and 'white out', rather than a temperature or icing limitation. This limitation remains the overriding factor despite the ability of aircraft to remain airborne in icing conditions. If the weather deteriorates to below visual flying conditions the procedure is to land and wait for the weather to clear. Aircrew therefore must be prepared to survive and for this reason carry in the aircraft the items of supplementary cold weather clothing, snowshoes, combat sleeping bag and an arctic survival pack. This procedure is less hazardous, particularly in mountainous areas, than climbing to above safety altitude and the possibility of encountering extreme icing conditions at altitude or the inability to penetrate down safely again.

The selection of suitable and safe landing sites requires pilot experience and training particularly when landing in virgin snow or on sloping or uneven sites where there is a shortage of good visual reference cues due to the lack of contrast in the panorama of snow. In soft dry snow some recirculation of snow is inevitable but in suitable landing sites it settles rapidly. However it does not follow that firm snow or frequently used sites are free from hazards. Special vigilance is necessary to avoid engine damage due to the ingestion of chunks of ice and other foreign objects, for example where crusted snow has been broken up by the movements of vehicles and around maintenance sites.

The pick-up and disembarkation of troops at remote landing sites is essentially a standard operating procedure in the Commando helicopter role. Nevertheless there are a number of simple but important points which illustrate the way in which operating in the arctic environment can affect these procedures. These points underline the dependence upon planning and co-ordination which can only be perfected by regular training.

- (i) As in any situation, the helicopter and troops are especially vulnerable to attack during the process of embarkation or disembarkation. Any snow cloud formed by recirculation as the helicopter comes in to land is very obvious from long distances so that a premium must be placed upon split-second timing and organised speed. Apart from tactical vulnerability, aircrew who are comfortable in their aircraft sometimes fail to appreciate the discomfort of troops outside the aircraft and they should make every effort that they are not responsible for unnecessary delays.
- (ii) The seating in the helicopter must be arranged to allow bundled skis and packs (pulks) to be carried such that they can be rapidly unloaded but do not pose an obstacle to the disembarking troops. The additional bulk causes an internal problem but underslung loads are unaffected. However, hooking on a load from the snow is a violently uncomfortable job.
- (iii) Internal communications with the troop leader are essential as he may need re-briefing on the way to the landing point. If the pre-arranged landing point is unsuitable the troop leader must know exactly where they are on the map as once on the ground orientation can be very difficult.
- (iv) When disembarking troops in fresh deep snow the pilot may have to remain at  $\frac{1}{2}$  power throughout. Not infrequently the troops will step out up to their waists in snow and their period of vulnerability will be increased up until the time they can don their skis or snowshoes.
- (v) Embarkation from predetermined rendezvous points requires split second timing to minimise the time for which troops are not wearing skis or snowshoes. If a marshaller is used he should be well clear of the recirculation snow cloud and wear goggles and face mask. The helicopter should make a first-time approach and land with its starboard wheels alongside the packs, bundled skis and men who lie face down until the helicopter has settled. Liquid fuel cookers should be empty. Again the priority is to get airborne again as quickly as possible and each man must know exactly what he has to do.
- (vi) As far as is possible the amount of snow carried into the aircraft should be kept to a minimum. If it is allowed to melt and then freeze the cabin floor can become treacherous. For this reason the cabin is usually maintained at low temperatures and the crew maintained in comfort by wearing the approved scale of clothing.

#### GROUND SUPPORT SERVICES

Consideration of the effects of operating in the arctic is inseparable from the difficulties faced by the aircraft maintainers and support groups on the ground. Much of their work must be carried out in the open under extremely unpleasant conditions and, unless man management techniques are good, men become unnecessarily cold and dispirited, morale flags and standards suffer. These effects are most noticeable among younger personnel who appear to lack the resilience of those a few years older. It is most important that all those in supervisory roles should have a full understanding of clothing discipline and the effects of cold on performance and of the recognition and prevention of hypothermia, frostbite and fatigue. In particular it has been found necessary to emphasise the relationships between wind speed, temperature and the net wind chill effect and to point out that rotor downdraught creates windspeeds of 25-40 kts or more.

In general the servicing and maintenance of aircraft takes approximately twice as long as under ideal temperate conditions. Some of the additional time is due to the inhibitory effect of extreme cold weather clothing on mobility and tactility rather than the effect of cold per se. Naturally this effect is most

noticeable in physical tasks such as the fitting or removal of aircraft covers. Covers are necessary on parked aircraft in certain weather conditions to reduce snow ingress through aircraft doors and hatches and to reduce direct deposits of snow and ice on the rotor blades and aircraft fuselage. The ease with which all tasks are done is also strongly influenced by other factors such as wind and the conditions underfoot. The problem of providing gloves or mittens which combine warmth, tactility and dexterity for skilled tasks however defies an ideal solution. Thus while it is relatively easy to maintain warmth of the body, feet and hands it is not possible to keep the fingers warm without sacrificing tactility and dexterity. The most efficient organisation for line maintenance and servicing has been found to be an arrangement of the team in relays in which each man works for a set period followed by a period for rewarming.

The actual time taken to perform any task is subject to two characteristic effects. The earliest effect is a progressive fall in the time taken over the first 2-4 days of the exposure of newcomers to the arctic environment. Presumably this is due to a combination of acclimatisation and familiarisation with the techniques of applying skills in the real, as opposed to simulated, conditions. Once over this period, the time taken for each task is relatively constant and independent of the temperature until the temperature is down to about  $-20^{\circ}\text{C}$ . Below  $-20^{\circ}\text{C}$  the time taken increases progressively with each increment of the fall in temperature.

#### SHIPBORNE OPERATIONS

Except for activities which take place on the flight deck the effect of the climatic conditions is much less severe at sea than on land. Aircrew are dressed for water survival and wear 'dry suit' immersion coveralls over appropriate layers of clothing which provide thermal insulation values from  $0.24^{\circ}\text{C m}^2 \text{W}^{-1}$  (1.6 Clo) to  $0.34^{\circ}\text{C m}^2 \text{W}^{-1}$  (2.2 Clo)<sup>3</sup>. This degree of protection is usual for survival in the North Sea where the water temperatures may be as low as those in the Arctic Circle. Thus even if a member of aircrew fails to use his liferaft and remains immersed in water at  $2.5^{\circ}\text{C}$  it would take an average of 12 hours for his deep body temperature to fall to  $33^{\circ}\text{C}$ , the temperature at which consciousness would be lost<sup>4</sup>. The construction of the aircrew liferaft incorporates an inflatable floor and canopy so that with the benefit of this additional insulation there should be no limit to the survival time.

At present no alternative to the aircrew immersion coverall is available for use by non-aircrew passengers in helicopters. Since the garment is individually fitted from a size roll and is designed to be worn over standard flying clothing it is not the ideal garment for use by casual passengers. Apart from the relative frequency of the overwater transfer of passengers in military helicopters, civilian operators are becoming increasingly involved in providing routine services to oil rigs and platforms, many of which are far offshore in the North Sea. The military services, and more recently industry, have recognised the requirement for a simplified, easily donned, multifit garment based on the "dry (or nearly dry) suit" principle. A number of such garments are becoming available for evaluation but it will be no easy task to produce a satisfactory garment.

As on land, the burden of the climatic conditions is felt not by the aircrew but by those working on the flight deck where the effects of windchill and freezing spray will penetrate any but the best protective clothing. A decade ago it was considered that the flight deck clothing should provide protection for exposures up to 2 hours. After exercises in 1974<sup>5</sup> it was demonstrated that flight deck personnel could be exposed for periods up to 6 hours under exceptionally severe conditions including the wind chill effects of rotor down draught. It was hardly surprising therefore that garments previously intended for a maximum of 2 hours exposure were found to be inadequate. Flight deck crews are now fully protected with what is essentially the ground forces arctic combat ensemble with the addition of a water and wind proof outer layer comprising foul weather jacket and trousers. The hood of the foul weather jacket has been designed to provide maximum protection of the face from wind.

#### CONCLUSIONS

Although the arctic is an extremely hostile environment it is evident that with careful planning and preparation, the provision of proven equipment and proper training, the disadvantages of the environment can be minimised. The operational tasks are therefore achieved to the maximum possible within the constraints imposed by the environment.

#### REFERENCES

1. Williams P.J. Royal Naval experience with helicopters operating from Commando Carriers and as plane guards. AGARD Conference Proceedings No 24. May 1967.
2. Waddell J.L. A review of cold weather clothing available to aircrew - 1976. RAF Institute of Aviation Medicine AEG Report 424. February 1977.
3. Marcus P., Griffin V. & Redman P. The thermal insulation of some current aircrew equipment assemblies. RAF Institute of Aviation Medicine AEG Report 316. May 1972.
4. Marcus P. & Richards S. Effect of clothing insulation worn beneath an immersion coverall on the rate of heat loss from the body in cold water. RAF Institute of Aviation Medicine AEG Report 403. August 1976.
5. Cold Weather Clothing. In Cockpit; Fleet Air Arm Safety Review, Issue No 81, Fourth Quarter 1977.

PROTECTIVE APPROACHES IN THE MODERATION OF THE PHYSIOLOGICAL  
EFFECTS OF EXTREME AMBIENT CONDITIONS IN HELICOPTER OPERATIONS

Louis J. SantaMaria, B.S.  
Aircraft and Crew Systems Technology Directorate  
Naval Air Development Center  
Warminster, Pennsylvania 18974 USA

#### SUMMARY

Protective measures in the moderation of the physiological effects of stressful environmental conditions for aircrew personnel is a concern for continuing research. The report is divided into two parts: (1) head cooling in a simulated warm environment with subjects at rest and exercising and (2) raft type in the emergency environment of cold water conditions.

To study the effectiveness of a head cooling system, three subjects were individually exposed to ambient temperature levels of 32.2°C and 40.6°C. Tests were conducted with and without head cooling under resting conditions. Under conditions of light activity simulating an increase in metabolic heat production of 150-200 KCAL/hr, only the cooling mode was used at each ambient temperature. The assessment was based on temperature and comfort sensation, skin and body temperature, heart rate and total weight loss. The moderating effects of head cooling were indicated in the setting-resting conditions; with exercise the advantages were less apparent, possibly as a result of system limitations.

In the cold water phase, the Encapsulating Life Raft (ELR) and the USN LR-1 raft were tested at three levels of air-water temperature conditions, i.e., 15.6°C/10°C, 7.2°C/1.6°C, and 2.8°C/-6.7°C, and a constant wind velocity of 25 km/hr. Two volunteer subjects were similarly equipped with minimal personal protective equipment. The advantages gained by the use of the ELR were indicated in terms of body temperatures and subjective reports even under the most stressful conditions of the program.

#### INTRODUCTION

The problem of designing adequate personal protection for use by aircrewmembers under adverse environmental conditions either in the normal operating envelope or in emergencies involving separation from the aircraft is one of continuing interest and concern. Probably from the very beginning of the development of protective suit assemblies and associated auxiliary equipment, the resolution of the complex problem includes the consideration of two diametrically opposed forces, i.e., adequate protection in the emergency environment for effective completion of the search and recovery maneuver, on the one hand, and the requirement that pilot and aircrewmembers be unstressed and unencumbered in the successful accomplishment of their mission, on the other. While the latter requirement is of paramount importance in normal flying conditions, it is none the less important that aircrew personnel be afforded the maximal level of environmental protection consistent with prevailing search and recovery operations. The onslaught of an emergency, for example, characterized by extremely low air and water temperatures, elevated wind velocity and hazardous sea states, reawakens in aircrew personnel who have opted for a quasi-comfortable suit configuration to the importance of a protective system leading to survival.

Protective measures in the moderation of the physiological effects of stressful environmental conditions for aircrew personnel is a concern of continuing research in the Applied Physiology Laboratory of the Naval Air Development Center. The subject matter for the present report is divided into two parts, the one considering head cooling as a protective approach in a simulated warm environment of the aircraft compartment and the other with protective measures in the simulated emergency of cold water conditions.

#### METHODS

##### 1. Head Cooling in Warm Environments

In the determination of the effectiveness of head cooling in a warm environment, a water-cooled helmet liner and its associated portable cooling unit designed by the Aerotherm/Accurex Corporation, Mountain View, California was used. Three volunteer subjects were individually exposed to ambient temperature conditions of 32.2°C (90°F) and 40.6°C (105°F) for trial periods not exceeding two hours in duration. The tests were conducted with and without head cooling while the subject was at rest or performing light activity to increase metabolic heat production to an approximate level of 150-200 KCal/hr. The pattern of exercise was as follows: standing (7 min.), marking time in place (4 min.), sitting (4 min.), and standing knee lift (5 min.). The timed sequence totalling a period of 20 minutes was repeated throughout the trial. The duration of each exposure was in the range of 1-2 hours depending upon the stabilization of resultant physiological effects or the life span of the effectiveness of the cooling capacity of the system. The evaluation was based on the following parameters: temperature sensation, comfort sensation, surface skin and oral temperature as indicated and recorded by a Digetec Temperature

Measuring System using thermistor sensors, pulse rate and total weight loss. Except for the latter, all other measurements were made at 10 minute intervals during each trial. The subjects were similarly clothed in standard flight equipment including Nomex underwear and flight suit, integrated torso harness, flying helmet and leather boots.

## II. Raft Study in Cold Water Conditions

The cold water exposures were conducted in an experimental chamber in which a 3.0 m. diameter pool containing water to a depth of 1.0 m. was located. The water was chilled to the desired temperature by means of wet ice; chamber temperature was controlled by means of the refrigeration system integrated with the chamber facility. Air and water temperatures were checked at regular intervals. A wind velocity level of about 25 km/hr was generated by two wall fans as part of the refrigeration system and by two 24" floor-mounted fans directed towards the experimental subject. Multiple surface skin and rectal temperatures were determined by means of thermistor sensors whose outputs were indicated and recorded by means of a Digetec Temperature Measuring System. The surface skin thermistors were 13 in number and were adhered to the following body areas: forehead, upper arm on the lateral aspect, lower arm on the anterior aspect, dorsum of the hand, pad of the index finger, chest, upper and lower back, lateral and medial aspects of the lower leg, dorsum of the foot and pad of the great toe. The rectal probe was inserted some 6-8 cm. and adhered at the sacral area with sufficient curvature of the thermistor lead wire to obviate the possibility of retraction. The aggregate of 13 surface skin and 1 rectal probes was directed from the suit assembly and connected by means of two common plugs to the Digetec System. By means of a time-controlling device, a full scan of all temperatures was made at regular intervals of 10 minutes duration throughout the course of exposure; in the same system, elapsed time was indicated by a digital clock. Mean skin temperature (MST) was derived from the segmental temperature readings according to the following weighting factors: torso, 35%; upper arm, 7%; lower arm, 7%; head, 7%; upper leg, 19%; lower leg, 13%; hand, 5%; and foot, 7%.

Upon completion of the process of adhesion of temperature sensors on the body surface and the insertion of the rectal probe, an initial scan of all the temperature readings was made to assure that all was in working order. Adjustments could be made at this time while the subject was exposed to a normal room environment. The subject was then equipped with a minimally protective suit configuration consisting of the following: Nomex underwear and coverall, anti-g suit, torso harness, survival vest and life preserver. The flight helmet, Nomex gloves and exposure mittens, wool socks and flight boots completed the personal protective system. Prior to entry into the experimental chamber, a second series of temperature recording was made to assure further that the temperature recording system was in proper order. Upon entry into the experimental chamber, the subject was instructed to demur only so long as to dissipate any body heat build-up attributable to the exertion of the dressing procedure. Following this interval which was a matter of minutes in duration, the subject climbed a ladder and exposed himself to the water environment.

As mentioned previously, the subject was monitored at 10 minute intervals and at the same time was interrogated by an inside observer regarding his sensations of comfort and temperature and shivering level. Sensations of comfort were noted according to a 4-point scale as follows: 1-comfortable, 2-slightly uncomfortable, 3-uncomfortable and 4-very uncomfortable. A 7-point scale was used for sensations of temperature as follows: 1-cold, 2-cool, 3-slightly cool, 4-neutral, 5-slightly warm, 6-warm and 7-hot. Shivering levels were indicated as slight, moderate or extreme.

The termination of a given trial was determined by the attainment of a pre-set time limit or of certain temperature levels as represented by a deep body temperature of 35.0°C or of an extremity temperature of 7.2-8.9°C. The subject could terminate the trial at any time by an expression of unwillingness to continue under the prevailing environmental conditions, even without the attainment of time and temperature limits just mentioned. Further, the test conductor reserved the right to terminate a trial exposure for any reason consonant with the safety and well-being of the volunteer subject. At the end of the exposure, the subject was immersed in a small tank containing water of 41-43°C temperature for rewarming purposes.

## RESULTS

### I. Head Cooling in Warm Environments

The results of the head cooling trials are presented in Table 1 as average values of the different measures employed in the program. At environmental temperatures of 32.2°C, mean skin temperature was only slightly affected in the resting mode, with or without cooling. In the exercise mode with cooling, an average increase of 1.6°C in MST was observed. Average head temperature was decreased by 1.6°C in the cooling mode at rest but only slightly affecting in the exercise mode. Under any condition at 32.2°C ambient temperature, oral temperature was only slightly affected.

As expected, the exercise mode resulted in an increase in heart rate by 22 beats/minute; the measure was only slightly affected in the resting mode with or without cooling. While weight losses were comparable in the resting modes, a reduced order of the measure was observed in the exercise mode at ambient temperatures of 32.2°C.

CONDITION	MEAN SKIN T(°C)	HEAD T(°C)	ORAL T(°C)	HEART RATE (B/min)	WT LOSS (g)	DURATION (min)
REST-32.2°C NO COOLING	+0.3	-0.3	+0.4	+4	310	120
REST-32.2°C COOLING	-0.1	-1.6	N.C.	N.C.	320	100
EXERCISE- 32.2°C COOLING	+1.6	+0.1	+0.2	+22	240	120
REST-40.6°C NO COOLING	+1.6	+0.7	+0.3	+19	470	110
REST-40.6°C COOLING	+0.6	-0.4	+0.1	+7	270	70
EXERCISE- 40.6°C COOLING	+1.4	+0.6	+0.3	+10	535	80

Table 1. Physiological Changes in Exposures to Warm Environmental Conditions with Head Cooling. Data represent average values.

At environmental temperatures of 40.6°C, MST increased by an average value of 0.6°C from starting levels in the resting-cooling altitude; average increase of the same measure under conditions of rest-no cooling and exercise-cooling were comparable at 1.6°C and 1.4°C respectively. Regarding head temperature, cooling with the subject at rest resulted in a slight decrease while with no cooling an average increase of 0.7°C was observed. With subjects exercising while being cooled at the higher ambient temperature, an increase in head temperature approximating the increase under resting-non-cooling conditions was observed. Oral temperature increased under all conditions of testing to values ranging from 0.1 to 0.3°C. Heart rate changes in the resting-cooling mode were slightly lower than in the resting-non-cooling mode; the order of heart rate change under conditions of exercise-cooling was slightly higher than in the rest-cooling mode but not higher than under conditions of rest and no cooling. For approximately equal time periods extrapolated from actual tests, an increasing order of weight loss was indicated as subjects were exposed to conditions of rest-no cooling, to rest-cooling and finally to the exercise-cooling mode.

Regarding subjective responses of comfort sensation at ambient temperatures of 32.2°C, the trials were characterized as uncomfortable to very uncomfortable under rest-no cooling conditions, ranging from comfortable to slightly uncomfortable under conditions of rest-cooling, and from comfortable to uncomfortable with exercise-cooling. In 40.6°C environments, rest-no cooling altitudes resulted in uncomfortable to very uncomfortable responses, rest-cooling effected slightly uncomfortable to uncomfortable comments and exercise-cooling responses ranged from slightly uncomfortable to very uncomfortable.

As for temperature sensation at 32.2°C, rest-no cooling trials resulted in responses ranging from warm to hot and slightly warm to warm in the cooling modes under conditions of rest and exercise. In 40.6°C environments, subjective responses were the same under all conditions of the experimental program.

## II. Raft Study in Cold Water Conditions

The results of tests using the encapsulating life raft (ELR) and the standard LR-1 are presented in Table 2 and described under each set of water and air temperature combination.

### 1. Conditions: 15.6°C Tw and 10.0°C Ta

#### A. Raft: ELR

In four tests conducted under conditions of 15.6°C Tw and 10.0°C Ta, each subject undergoing the experimental treatment with replication, the duration of exposure was the planned two hours. The order of decrease in Tr was 0.5°C in all tests except in the first exposure of the lesser experienced subject. In this case, Tr decreased by 0.9°C, but upon examination at the end of the trial it was noted that the sensor was slightly retracted possibly as a result of body movement in boarding the raft. Mean skin temperature (MST) was decreased by only 1.1°C (ave) in the one subject and by 3.4°C (ave) in the other less experienced subject. Both subjects characterized the tests under these conditions as "neutral" in regard to temperature sensation and "comfortable" in terms of comfort sensation.

#### B. Raft: LR-1

The four tests using the LR-1 raft under the same temperature conditions were also

of two-hour duration. The order of  $T_r$  decrease in two tests ranged between  $0.5^{\circ}\text{C}$  and  $1.0^{\circ}\text{C}$ ; the measure in the remaining two tests was lost as a result of subjective movements while in the raft. The MST was lowered by an average of  $5.2^{\circ}\text{C}$  (range of  $-3.6$  to  $-7.5^{\circ}\text{C}$ ) from starting levels. Under the prevailing temperature conditions, the two experimental subjects using the LR-1 raft described the exposures as "cool" and "slightly uncomfortable" in regard to temperature and comfort sensation, respectively.

2. Conditions:  $7.2^{\circ}\text{C}$   $T_w$  and  $1.6^{\circ}\text{C}$   $T_a$

A. Raft: ELR

In three of the four tests conducted under these conditions, the two-hour testing period was completed with no difficulty. The remaining test was terminated after a period of 1 hour 30 minutes in the interest of subjective comfort; the results of this test are not being reported. In the three two-hour exposures,  $T_r$  was decreased by an average of  $0.7^{\circ}\text{C}$  (range  $-0.5$  to  $-1.0^{\circ}\text{C}$ ) from initial levels; MST was lowered by  $4.4^{\circ}\text{C}$  (range  $-4.0$  to  $-4.7^{\circ}\text{C}$ ) within the same exposure period. In regard to temperature sensation, the subjects reported a "slightly cool to cool" condition; a report of "comfortable to slightly uncomfortable" was indicated in regard to comfort sensation.

B. Raft: LR-1

When the LR-1 raft was used under the same temperature conditions, the duration of four tests varied within a range of 1 hour 20 minutes to 1 hour 40 minutes. Three of the four tests were terminated because of subjective discomfort and shivering level; the remaining test was terminated as a result of the attainment of a critical core temperature of  $34.9^{\circ}\text{C}$ . The average decrease for the latter measurement in all tests was found to be  $1.2^{\circ}\text{C}$  (range  $-0.6$  to  $-2.3^{\circ}\text{C}$ ). The average decrease in MST among the four tests conducted with the LR-1 under these temperature conditions was of the order of  $6.8^{\circ}\text{C}$  (range  $-5.1$  to  $-7.9^{\circ}\text{C}$ ). The subjects characterized these tests as "cold" in regard to temperature sensation and "slightly uncomfortable" insofar as comfort sensation was concerned.

3. Conditions:  $2.8^{\circ}\text{C}$   $T_w$  and  $-6.7^{\circ}\text{C}$   $T_a$

A. Raft: ELR

Under these conditions of testing, the respective subjects were able to tolerate the exposure for the full two hours with no accompanying difficulties. The results represent the data from just two tests, one for each subject with no replication. It was considered that one valid exposure for each subject using either raft would suffice under the extreme temperature conditions considered in this program of work. With the ELR raft, MST was decreased by  $2.4^{\circ}\text{C}$  (range  $-2.1$  to  $-2.8^{\circ}\text{C}$ ); the  $T_r$  was lowered by  $0.8^{\circ}\text{C}$  (range  $-0.4$  to  $-1.1^{\circ}\text{C}$ ). In these tests, both subjects described the exposures as being "cool" and "comfortable."

B. Raft: LR-1

Both tests conducted using the LR-1 raft were terminated in advance of the expected 2-hour run. In the one test of 1 hour 20 minutes duration,  $T_r$  had decreased to the pre-set end point of  $35.0^{\circ}\text{C}$  necessitating the removal of the subject from the test environment. The other test was terminated at the end of 1 hour, 10 minutes at the subjects request. At the end of each run, the  $T_r$  was observed as having decreased by an average of  $2.2^{\circ}\text{C}$  (range of  $-2.0$  to  $-2.3^{\circ}\text{C}$ ) while MST decrease was of the order of  $7.2^{\circ}\text{C}$  (range  $-6.8$  to  $-7.6^{\circ}\text{C}$ ). The LR-1 tests at the coldest set of temperature conditions were described by the subjects as "cold" and "uncomfortable to very uncomfortable."

Water/Air Temp-C	Raft-No. of Tests	Duration Hr:Min	$\Delta$ MST $^{\circ}\text{C}$	$\Delta$ $T_r$ $^{\circ}\text{C}$	Comfort Sensation	Temp. Sensation
15.6/10.0	ELR-(4)	2:00	2.2	0.4	Comfortable	Neutral
	LR-1-(4)	2:00	5.2	0.8	Sl. Uncomf.	Cool
7.2/1.6	ELR-(3)	2:00	4.4	0.7	Comf. to Sl. Uncomf.	Sl. Cool to Cool
	LR-1-(4)	1:30	6.8	1.2	Sl. Uncomf.	Cold
2.8/6.7	ELR-(2)	2:00	2.4	0.8	Comf.	Cool
	LR-1-(2)	1:15	7.2	2.2	Uncomf. to Very Uncomf.	Cold

Table 2. Results of Tests Using the ELR and LR-1 Rafts in a Cold Water Environment. Data represent average values.

## DISCUSSION

### I. Head Cooling

As a personal protective system intended to alleviate the stressful effects of extreme environmental conditions, liquid conditioning has been the subject of considerable interest for the past twenty-five years. Early in its development, the advantages over gaseous ventilating system for full body protection were clearly outlined in terms of the reduced power requirements and increased effectiveness of the approach. As a result of the efficiency of liquid conditioning as a personal protective system under adverse thermal conditions, it was further developed by NASA for use in space flights involving periods of high energy expenditure during extra-vehicular activity (4,5). As a protective system for aircrew personnel of fixed or rotary-wing aircraft, the full-body liquid conditioning approach has not gained favor, possibly as a result of its restrictive characteristics in respect to conductive surface requirements, a condition aggravated in flights of longer duration.

From the full-body suit design, attention was drawn to the possible use of a liquid conditioning garment covering only the torso area of the body. Used in conjunction with a portable wet ice compartment as the heat sink, the abbreviated torso suit was successfully demonstrated for use in helicopter operations.

As an extension of the application of liquid conditioning to less generalized body surfaces, research in partitioned or differential body cooling was undertaken as a means of dissipating unacceptable levels of metabolic heat production (1,7). With increased interest in segmental cooling, attention was directed to the head area as the most effective avenue of heat transfer under adverse thermal conditions. In an investigation making use of a cooling hood, the potential uses of head cooling as a means of removing as much as 30% of the total body heat production were indicated (6). From an aspect even more specialized than the head area, a novel approach making use of neck cooling was shown to be effective in the improvement of subjective indices of thermal zones and comfort levels in environmental temperature conditions of 46°C (8). The approach made use of a small (7cm<sup>2</sup>) local heat flux applied to an area superficial to the carotid arteries.

In an evaluation of a water-cooled helmet liner, Kissen *et al.* (3) found that the magnitude of all physiological responses including skin and mean body temperature, mean heart rate, body heat storage, sweat loss and physiological index of strain were significantly reduced by head cooling at environmental temperature conditions of 46°C and 40% RH. The elevation of rectal temperature, however, was the same for both non-cooled and head-cooled conditions. The effect of head cooling on psychomotor performance tests was found to be negligible as a result of the heat loads imposed. The circulation of the conditioning system in this study made use of eight liquid-cooled neoprene patches covering the back and crown of the head, extending anteriorly to just below the hair line and laterally over the temples but excluding the ears, the jaw angles and upper part of the neck. Inlet water temperature and flow rate were maintained at 18°C and 1.0L/min. respectively.

Making use of a similar system in exposures at environmental temperatures of 95°F and 115°F, Williams *et al.* (9) reported a significant reduction in the elevation of rectal temperature, heart rate and sweat loss during head cooling at 115°F. and predicted that the helmet liner would be effective at much higher thermal loads including exercise or higher environmental temperatures.

In the design of a liquid conditioning system for the head of aircrew-personnel, the requirement that the protective and functional characteristics of the helmet system be not diminished is of primary importance. In an attempt to accomplish this, the conditioning channels, covering mainly the back and crown of the head as used in the present study, were made part of a cloth helmet over which the hard hat was worn. As such, it resulted in limited coverage of the head as compared to other systems where the forehead, sides of the head and neck were additionally covered by the patches through which the circulating medium flowed. The limited coverage of the system used in the present study may have accounted for the mild changes in some of the physiological measures of concern. In the absence of a sufficient data base from which to determine the significance of the effects of the experimental treatment on the pertinent physiological measures, the values were presented as average responses of the different subjects used in the study. Within the lesser order of magnitude indicated by the changes in the reported physiological measures, the moderating effect of head cooling is indicated in terms of mean skin temperature, head temperature, oral temperature and heart rate in the resting condition at both environmental temperatures of 90°F and 115°F. Weight loss under the same conditions was not so directly affected by head cooling as evidenced in tests of a lesser order of time in duration. With subjects undergoing light activity under conditions of the experimental program, the beneficial effects of head cooling regarding these measures was less obvious. In general, therefore, the findings under resting states sustain those of other researchers interested in head cooling as a protective measure for aircrew personnel in adverse thermal conditions of higher temperature. Under conditions of increased levels of metabolic heat production, increased coverage of the head and neck areas, increased flow-rate of the circulating medium over the one employed in the present system and possibly a lower order of inlet water temperature with an appropriate range of preferred temperatures may be necessary to realize the full advantages of head cooling.

## II. Raft Study in Cold Water Conditions

In the design of protective systems for cold weather operations, attention has been centered on personal garments and auxiliary equipment as constant-wear items for aircrew-personnel. This approach has resulted in a continuous search during the last



decades for protective suit systems which, while attempting to meet with current requirements of cold water survival, were adequate and acceptable to personnel during normal flying operations. It was considered that the development of a modular system composed of protective components actuated in the event of an emergency over cold water conditions would solve the perplexing problem presented by acceptability during flight and thermal protection in an emergency environment. In meeting this challenge, the encapsulating life raft was developed as the flotation platform supplying the additional thermal protection required on cold water impact (2).

In the actual operation of the encapsulating life raft during aircraft separation above 152 m. (500 ft), the aircrewman would be completely enveloped and virtually in a dry state even upon water entry. With the capability of low level separation, it is envisioned at least in concept, as being useful in helicopter operations. In separations below altitudes of 152 m, however, the encapsulating raft would be actuated in the water environment and be comparable to the conventional life rafts in terms of normal boarding procedures following the crewman's exposure to the water environment. The development of the encapsulating raft, therefore, would result in the transfer of the burden of cold water protection systems from the aircrewman's personal protective system as constant-wear equipment to the flotation platform in the emergency of cold water exposure.

Within the limits of the current investigation, the effectiveness of the encapsulating life raft in cold water environments, as compared with the standard USN LR-1 raft under similar conditions, regarding the lessening of the loss in body temperature and in evoking more acceptable levels of subjective sensation of temperature and comfort has been indicated. In actual 2-hour trials, average mean skin temperature losses were of the order of 2-4°C with the more protective raft, as opposed to losses ranging from 5-7°C with the standard raft in tests of approximately one-half duration under the most severe water and air temperature conditions employed in the study. Under these conditions, the duration of exposure was dictated by the attainment of subjective tolerance limits or of critical body temperatures. Subjective sensation of temperature and comfort in trials using the encapsulating raft ranged from "neutral" and "comfortable", respectively, to "cool" and "comfortable" as the ambient temperature conditions were lowered according to the experimental approach. When the standard LR-1 was used, the subjective responses regarding temperature and comfort ranged from "cool" and "slightly uncomfortable" respectively, to "cold" and very "uncomfortable" as the temperature conditions became more severe. As a result of the more acceptable subjective responses indicated in the program, the adequacy of the encapsulating life raft is further indicated.

As envisioned in the use of the encapsulating life raft, the total effect, both psychological and physiological, of remaining in a virtual dry state cannot be underestimated in the extension of survival in frigid water masses. Not only is the survivor protected from the debilitating effects of cold water exposure in the boarding of a standard raft, but he is also given the appropriate circumstances, protected thermally from the effects of severe ambient conditions upon aircraft separation prior to water impact. Although the latter maneuver may be a matter of minutes in duration, the former involving the boarding of a standard raft may be appreciably longer depending on the condition of the downed airman and the severity of the sea state. During this interval of time, the physiological state of the survivor may be so severely affected as to seriously compromise his efforts to regain a level of thermal balance in the raft environment. The proper use of the encapsulating raft would reduce the harmful effects of immersion and would effectively enhance the possibility of extended survival in cold water emergencies. In view of the cold water protection afforded by encapsulation as shown within the limits of the current study, it is concluded that the encapsulating life raft, of present or future design, should be considered as a major component in aircrew protective systems.

#### REFERENCES

1. Burton, D. R. Performance of Water Conditioned Suits. *Aerosp. Med.* 37: 501-504, 1966.
2. Jencks, Craig S. and DeSimone, D. N. The Encapsulating Life Raft System. AIAA Paper 73-1341, 1973.
3. Kissen, A. T.; Buehring, W. J.; O'Donnell, R. D.; Summers, W. C.; and Smedley, D. C. Evolution of a Water-Cooled Helmet Liner. AMRL-TR-74-135.
4. SantaMaria, L. J. and Radliff, M. H. Physiological Effects of Water Cooling during Elevated Work Loads in Pressure-Suited Subjects. NAVAIRDEVCON Report No. NADC-AC-7103.
5. SantaMaria, L. J. Determination of Skin Temperature under a Comfort-Controlled Liquid-Cooled Garment in Exercising Subjects. NAVAIRDEVCON Report No. NADC-CS-7118.
6. Shwartz, E. Effect of a Cooling Hood on Physiological Responses to Work in a Hot Environment. *J. Appl. Phys.* 29: 36-39, 1970.
7. Webb, Paul and Annis, J. F. Biothermal Responses to Varied Work Programs in Men Kept Thermally Neutral by Water Cooled Clothing. NASA CR-739, 1967.
8. Williams, B. A. and Chambers, A. B. Effect of Neck Warming and Cooling on Thermal Comfort. Second Conference on Portable Life Support Systems NASA SP-302, 1971.

9. Williams, B. A. and Shitzer, A. Modular Liquid-Cooled Helmet Liner for Thermal Comfort. *Aerosp. Med.* 45: 1030-1036, 1974.

MOBILE INTENSIVE CARE UNITS  
IN THE  
DANISH SEARCH AND RESCUE SERVICE

Knud Jessen, M.D., D.A. (Hafn.)  
Director Aeromedical Services  
Royal Danish Air Force  
P.O. Box 202  
DK-2950 Vedbaek  
Copenhagen, Denmark

The Sikorsky S-61 helicopter was introduced into the Danish Search and Rescue Service in 1966 and has been used for more than 3500 missions. More than 90% have been for civilian medical support, as a result of which the helicopter has evolved from a pure rescue vehicle to the point where it also should be considered a mobile intensive care unit. Much attention has been paid to the design of the helicopter cabin and to crew education, which now in 80% of the missions includes a specially trained physician. The experiences from more than 600 missions wherein the helicopter was employed as a mobile intensive care unit have demonstrated that the military has provided to the Public Health Service in Denmark a valuable means for patient evacuation.

Denmark has three unusual geographic features; it is almost completely surrounded by the sea, the coast is highly indented, and some 500 islands are included in its territory. An unusually large shipping volume passes through these waters, which at times are assaulted by violent storms.

A rescue service against disaster at sea has long existed (something on the order of five centuries), especially along the western coast of Jutland. Years ago this was carried out by fishermen combating the waves in small rowboats, often with the loss of the rescuers' lives. Later, the duties were taken over by special rescue ships home-berthed in the bigger harbours.

In 1951, a special squadron of the Royal Danish Air Force was formed to operate this service. The first aircraft were S-55 helicopters supported by the amphibious Catalina. But a new era began in 1966 when the unit was re-equipped with the S-61, a bigger, very sturdy and fast helicopter able to operate day and night, 365 days a year, far away from the Danish coast if necessary.

In the beginning, the mission was almost pure search and rescue; more than 3500 such operations have been carried out. One of the first and still most prominent was the rescue of sixty passengers and crew of the ill-fated ferry Skagerak which plied between Norway and Denmark. On September 21, 1966 the vessel was hit by massive waves during a hurricane and shipped between 150 and 200 tons of water. Shortly after Mayday was sent out, five helicopters and some ships were able to evacuate 145 passengers from lifeboats and dinghies. Only one man died, from a myocardial infarction.

This and subsequent similar airlift successes reflected great credit upon the skill and courage of the helicopter crews, as well as the competence with which the Rescue Coordination Centre (RCC) controlled it.

Manned 24 hours a day, the RCC always has a duty officer not only trained in coordination and management but who also has had practical experience in search and rescue. Within a few moments after a call for help is received, he has determined whether it could be supplied just as efficiently and quickly from another source such as the Salvage Corps. When responsibility for providing helicopter aid is accepted, the duty officer gives the necessary instructions and within a maximum of fifteen minutes the helicopter is airborne. The RCC is located in the middle of Jutland, but the Rescue Squadron operates from three widely dispersed bases so that a request for help can be answered with minimum flying time. One base is in the northern part of Jutland, another in the southern part, with the main one at the Vaerloese Air Force Base near Copenhagen.

More than 90 percent of the missions have been of civilian character, such as support to the fishing fleet, civil shipping, civil aviation, and to individuals distressed during recreational activities. But during the last years, support has also been given to the Public Health Services in the form of evacuation of sick or injured patients from isolated islands or from smaller hospitals to the bigger ones. This development meant that the helicopter was no longer only a rescue vehicle, but now had to evolve into a type of mobile intensive care unit since the transportation interval could very well be an hour or more.

The S-61 Sikorsky helicopter used is most suitable as the cabin provides not only ample space for patient observation and treatment, but also is so designed that a stretcher can be surrounded by apparatus for oxygen, suction, ECG with defibrillator, 12 volt incubators, and respirators, along with a wide variety of medical gear and drugs. Since we must have standardization in emergency medicine, this same equipment will be found in the civilian salvage corps vehicles and in most Danish hospitals. Supplies are stored in a transport container which contains smaller boxes, each having units for particular tasks, such as ventilation, suction, infusion, splints, drugs, and bandages. All assemblages can be hoisted from the helicopter to shipboard or the ground.

We have found the S-61 has an added important advantage, as the five-bladed rotors cause minimum vibrations and turbulence, insuring the best transport medium for the patients, since it is almost free

from positive or negative accelerative forces during takeoff and landing.

The crew ordinarily consists of two pilots, one radio operator, one flight engineer (who also serves the hoist operator), and a medical technician trained in land and sea rescue techniques. It is particularly noteworthy that although several helicopter services worldwide routinely operate without an on-board physician, in the Danish Search and Rescue Service a physician is an added supplement whenever a potential need for his skill is foreseen. This became policy at the request of the other crew members in spite of their well-demonstrated capabilities, since all wanted the best possible care for each patient. Presently approximately 80% of the missions carry a doctor.

Physicians allocated to this duty are usually those who have already completed their obligations in national service. Since they must perform alone in one of the most difficult and demanding disciplines, emergency medicine, each must have acquired practical experience after licensure. All are required to complete a post-graduate course in the Air Force medical school where their training, apart from military and aviation medicine, emphasizes acute and disaster medicine which involves supervised practice in anesthesiology, chest and abdominal traumatology, acute extremity surgery, treatment of acute central nervous system injury, and acute psychiatry. Furthermore, the pathophysiology and management of drowning and hypothermia are intensively reviewed. This education is provided by teachers from the university hospitals whenever the military physician faculty do not have the necessary expertise in some of the more highly specialized fields.

The training also included a few weeks of basic navigation, radio procedures, air control, meteorology, and the rudiments of flying. The physicians practice hoisting operations from land, sea, and rubber boats; participation in simulated survival exercises is required.

This preparation in flying and operational procedures is of tremendous importance, since the physicians are then able to descend onto a ship and there make an immediate appraisal of a patient's condition, and if necessary, to start treatment before evacuation to the helicopter.

Scarcely any two rescue or transport operations are the same. For this reason the helicopters must carry many different types of equipment ranging, for instance, from a single or double harness which amazingly does not increase the discomfort of even the severely injured, to a large flotation basket litter for hoisting litter patients. This latter combination was developed within the squadron as a modification of the normal Sikorsky stretcher and basket; it takes less cabin space, is easier to lower onto a ship in a high sea, and floats with an adult person should it be inadvertently detached from the mooring. The helicopter can even carry a patient in his own hospital bed, a method often used for burn cases or those with an injured spinal cord. All services are free of charge.

Since 1972 there have been more than 1000 missions in which a physician joined the crew. In over 600 of these the rescue helicopter had to act also as a mobile intensive care unit, as all the patients needed very close observation and treatment, such as I.V.-drips, artificial respiration, correction of cardiac disorders, and many surgical interventions. Only one patient has died during the evacuation, a too early born baby with severe respiratory distress syndrome; demise occurred just before arrival at the Copenhagen University Hospital.

Analysis of our detailed reports on each of the missions produces a rather startling observation. Unless trained in anesthesiology, aviation medicine, or emergency medicine, most physicians do not comprehend what patient movement may produce. The transport of patients who are physiologically decompensated, whether from disease or injury, must per se be considered a further trauma. One means of obtaining that evidence is to insure that there is effective communication between the receiving hospital and the flying unit, with feedback from the hospital. In this way we can demonstrate the uncritical rushing of patients to hospital is actually an emotional flight from professional responsibility. This must be emphasized and reemphasized. The only acceptable practice in emergency medicine is to stabilize the patient before transport and to prevent further deterioration during transit to definitive medical care. It is because the Search and Rescue adheres to this practice that the Danish success rate is so great.

Our experience in this area during peacetime has shown that there has been no special difficulty in performing these efforts within the helicopter--if the cabin of the vehicle is big enough and equipped to act as a mobile intensive care unit; if the crew is educated in advanced first aid; and if the rescue physician in addition to his education in emergency medicine also is trained as a crew member in helicopter flying under all conditions.

In this way, the use of an expensive but efficient military apparatus and organization provides the Public Health Services a supplementary means of patient evacuation from the sea and from isolated areas, in addition to secondary transportation between hospitals. All of these have been proven to be safe and easy on the patients. Further it provides realistic, professionally rewarding training for the Armed Forces in meeting their responsibilities in national disasters.

## IN-FLIGHT TOXICOLOGY OF FIXED AND ROTARY WING AIRCRAFT CREW STATIONS

Gary D. Pollard, CPT, MSC  
 Doris W. Hirsch, DAC  
 US Army Aeromedical Research Laboratory  
 Fort Rucker, Alabama 36362

SUMMARY

A system has been designed and developed for the measurement of toxic gases while in flight. The system is based on the use of several instruments including a multi-channel infrared spectrometer, a mass spectrometer as well as several other instruments and techniques. The techniques have been applied to the evaluation of weapons gases and contamination from engine exhaust in the Utility Tactical Transport Aircraft System (UTTAS) as well as other aircraft systems.

LIST OF SYMBOLS

UTTAS - Sikorsky YUH-60A Aircraft  
 ppm - Parts per million (1% = 10,000 ppm)  
 NBS - National Bureau of Standards  
 IR - Infrared  
 JEOL - Japan Electronic and Optical Limited  
 OSHA - Occupational Safety and Health Administration

INTRODUCTION

A system which was developed at the United States Army Aeromedical Research Laboratory (USAARL) uses a direct and immediate approach to the evaluation of toxic air contaminants occurring in in-flight helicopter aircraft and in the field at weapons firing sites.

Among the toxic chemicals encountered in the cabin atmosphere are hydrocarbons from the bleed air system, carbon monoxide contamination from the heating system (10) and exhaust products from the weapons system (7,8,9). The system can also be used for on-site testing of exhaust accumulations of weapons fired from fixed enclosed areas on the ground (11). The toxic chemical mixtures in the air from weapons firing are rapidly changing with often low (ppm) concentrations.

Acceptable ceiling concentration and time limits for exposure to atmospheric toxic chemicals in the in-flight helicopter are set by MIL-STD-800, 21 July 1958, and Code of Federal Regulations pt 29, July 1976 (OSHA Regulations). MIL-STD-800 and OSHA gives acceptable ceiling concentrations on the accumulation of chemical mixtures in the atmosphere such as from fixed ground weapons firing. These ceiling concentrations range from 0.02 to 5,000 ppm for various substances.

As previously stated, the atmospheric chemical mixtures have low, constantly changing concentrations. Therefore, collecting the sample on-site and performing the chemical analysis in the laboratory entails precautions and serious analytical problems. The sample collection method requires an enormous number of precisely timed samples because of the constantly changing atmospheric chemical mixture. In addition, certain compounds such as ammonia, nitrogen dioxide and hydrocarbon-free radicals react with each other and with trapping devices causing errors in the analysis.

The instrument must be contained in a limited space and operated from a minimum power supply. It must sustain operations while vibrating at a continuum of frequencies in the environment of impulse noise from weapons firing and frequently changing air pressure. Changing water vapor partial pressure may also be a source of interference. Because of the stringent requirements of the analytical instrument for in-flight analysis aboard the aircraft, the analytical instrument may be used for on-site ground weapons exhaust analysis also. The analytical capabilities of the instrument should be such that a chemical with concentrations in ppm can be measured directly even though it exists in a mixture of airborne chemicals and elements of much higher concentrations.

The MIL-STD-800, 21 July 1958, which remains as the military standard, though it is outdated, allows a ceiling concentration of carbon monoxide at 0.005 percent or 50 ppm. The standard (MIL-STD-800) recommends on-site sampling with subsequent analysis in the laboratory. The equipment used for on-site testing should conform to MIL-D-3945 or MIL-T-3948 which is carbon monoxide, colorimetric detector kit or NBS colorimetric indicating carbon monoxide.

Numerous other methods of analysis and instruments for sampling at timed sequences have been used since 1958. A rapid timing sequencer for toxic gas sampling (12), a carbon monoxide analyzer from Mine Safety Appliance Co. (MSA) carbon monoxide meter, Model 08-9141 (13), Geoscience Cadet carbon monoxide detector (14), and numerous other catalytic detectors (9) for carbon monoxide are manufactured by the Mine Safety Appliance Company and various other companies.

In September 1974 Kenneth G. Ikels published a Report (15) on a system for on-site oxygen contaminant detection. The system used a portable infrared (IR) analyzer which became commercially available in 1971 from the Wilks Scientific Corporation, South Norwalk, Connecticut.

The purpose of this study is to report an analytical system (utilizing a portable Wilks infrared instrument) that is capable of doing on-site analysis of air contaminants of in-flight helicopters. In addition, we will describe other systems including the Varian mass spectrometer, the JEOL gas chromatograph-mass spectrometer and others.

## METHODS

**Mass Spectrometry** - A Varian EM-600 mass spectrometer was purchased for use as a means of detecting gases that conceivably had not been previously identified. The project was to have an onboard, real time system that could detect gases before the various components could react together. This goal has not been realized with this instrument because of the numerous technical problems involved. The instrument is useful though and there is potential for further analytical ability.

The mass spectrometer is a low resolution instrument (approximately 200) and was designed as a teaching instrument. Its simplicity, however, increases the capacity for development of the system. There are no separating capabilities, i.e., the instrument is not coupled to a gas chromatograph and, therefore, a mixture placed in the inlet is analyzed as a mixture. The sensitivity has been found to be lacking. It can detect gases only in concentrations greater than about 0.03% or 300 ppm. This is a problem because many of the trace components are in a range much lower than this (i.e., 1 ppm). The difficulty is that one is trying to analyze 1 ppm of trace gas in the presence of 800,000 ppm nitrogen and 200,000 ppm oxygen. For this reason it would be highly desirable to have some means of separating or concentrating the sample. A sample concentrator was constructed which consisted of a series of valves and stainless steel tubing. The sample was allowed to enter the concentrator under vacuum. A short length of stainless steel tubing was packed with activated charcoal and stoppered at both ends with glass wool very similar to a chromatographic column. The charcoal column was cooled with liquid nitrogen to 73°K before the sample was applied. The column was then allowed to warm slowly while mass spectra was being taken. Some separation of N<sub>2</sub> and O<sub>2</sub> took place but when H<sub>2</sub>S was used as a trace gas, it was not detected. The technique is a promising one, though, and further development will be required to make the pre-concentrator useful. A major disadvantage of this system is the length of time required to analyze a sample and the cumbersome use of liquid nitrogen.

Another problem one encounters when using the mass spectrometer is the difficulty in controlling the inlet pressure accurately. The peak height is proportional to concentration but also the partial pressure of the gas in the inlet. If the pressure is not controlled accurately, no quantitative results can be obtained.

Electrical and vibration problems were also encountered. Initial attempts to isolate the system from vibration consisted of simply placing the instrument on a piece of 2 inch foam rubber. Vibration was still excessive so the mass spectrometer was bolted to a board which was suspended by springs from a frame which proved successful in removing the vibration. The electrical system in the helicopters of interest has a 28 volt DC system. An inverter is required to provide 110 volts AC for both the mass spectrometer and the vacuum pump. Since the mass spectrometer requires a regulated power supply, a Topaz inverter of sufficient capacity was used. The vacuum pump requires a considerable amount of current (about 4 amps at 110 volts). A Carter rotary inverter is used with the vacuum pump, and with the loss in power through the inverter, a 40 amp 28 volt circuit minimum is required. A 28 volt DC motor for the vacuum pump would save considerable weight and energy.

The sample of interest is air. Figure I shows a mass spectrum of a mixture of air. At m/e of 40 note the Argon (Ar) peak. This peak is equivalent to 940 parts per million (ppm). Argon can be used as an internal standard because of its fixed concentration in air. If one expands the sensitivity until the Argon peak is nearly off scale, then one could quantitate a gas in the 200-300 ppm range. In the harsh environment of flight, much noise is present which leads to some error even at this level. One can see that at concentrations below this the noise level would exceed the peak height of the compound of interest.

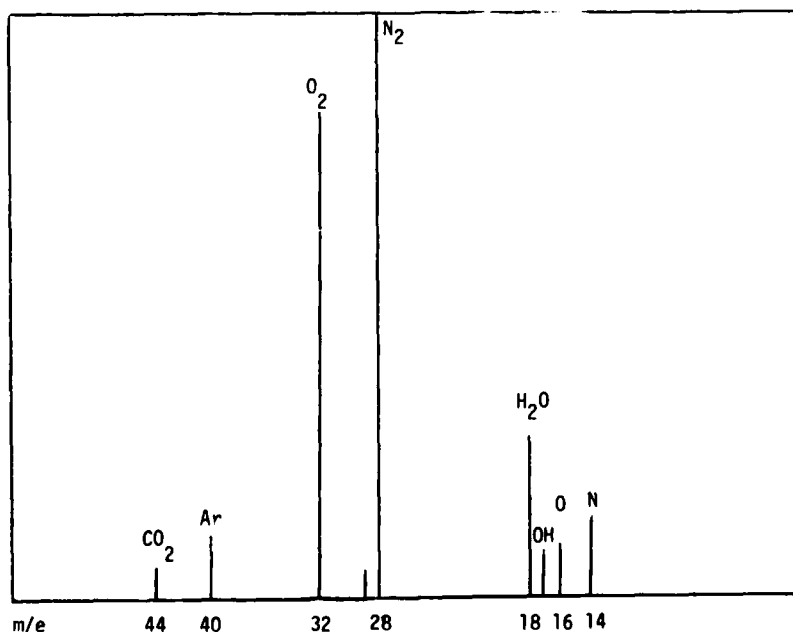

Figure I. Mass Spectrum of Air Using the Varian EM-600 Mass Spectrometer

Wilks Infrared Analyzer - This instrument was designed for monitoring of gases in the industrial environment. It is ideal though for use in an aircraft because of its portability, low power consumption and durability. A considerable amount of work has been done by Ikels et al. (6) with an earlier model of the same instrument. The Wilks Model 80 single beam infrared spectrometer has a 20 meter pathlength gas cell and is controlled by a microprocessor. It was connected to a Hewlett-Packard 700m XY recorder. The instrument is able to detect gases in the very low parts per million range ( $\pm 1$  ppm). The sensitivity of the instrument occurs because of the very long pathlength gas cell, i.e., there is a large number of molecules in the beam in order to accomplish a reasonable amount of infrared absorption. The microprocessor increases the power of the infrared analysis by allowing one to select and rapidly change specific wavelengths. It also allows one to program values for standards of several gases so that he can get an immediate printout of the concentrations of those gases.

A person might question the possibility of one compound absorbing at the wavelength that one is trying to measure another. This is indeed a possibility but the microprocessor can account for these interferences. For example,  $\text{NH}_3$  has some absorption at the  $\text{SO}_2$  wavelength. This is measured when the standards are being run. A matrix of all the wavelengths and all the absorptions at those wavelengths is created. A Fortran program supplied by Wilks when the instrument was purchased is used to solve the matrix. The results are entered into the instrument and the interferences are accounted for.

The XY recorder was used to record the infrared spectrum from 2.5 to 14.5 microns by connecting the absorption to the Y axis and the wavelength output to the X axis. The separation of wavelengths is accomplished with a novel system of variable wavelength filters. There are three filters and the infrared spectrum is divided into three sections because of the three filters. The filters do not have the resolution of a grating instrument but the filter system is very durable compared to a grating instrument which is an important factor in the portability of the instrument.

The instrument has been programmed to measure quantitatively the compounds at the wavelength described in Table I.

TABLE I  
COMPOUNDS AND THE WAVELENGTH AT WHICH MEASURED

Compound	Wavelength (Microns)	Range Calibrated
Reference	4.00	Not Applicable
H <sub>2</sub> O	2.689	Not Calibrated
Methane	3.275	0-50 ppm
Ethane	3.300	0-50 ppm
Ethylene	3.340	0-50 ppm
NO <sub>2</sub>	3.390	0-50 ppm
CO <sub>2</sub>	4.250	Not Calibrated
CO	4.761	0-50 ppm
SO <sub>2</sub>	8.905	0-50 ppm
NH <sub>3</sub>	10.834	0-50 ppm
Acetylene	13.750	0-50 ppm

The H<sub>2</sub>O and CO<sub>2</sub> were not measured quantitatively because of their natural presence in air and their strong infrared absorption. The 20 meter pathlength was used in this analysis. If one chooses to measure H<sub>2</sub>O and CO<sub>2</sub> quantitatively, he must reduce the pathlength. The cell does have the feature of variable pathlength. Also, a substance such as calcium chloride and ascarite can be used for removing the CO<sub>2</sub> and H<sub>2</sub>O in order to zero the instrument.

Ikels (6) reports that methane, ethane and ethylene can be separated quantitatively by pressurizing the cell to 10 atm. I have not found this to be possible at 1 atm, but have not pressurized the cell. Any hydrocarbon absorbs in the area of 3.2-3.4 microns and with possible interference in an unknown system such as bleed air or gun gases. A more appropriate way of reporting the result would be "hydrocarbons calibrated as methane" unless further identification could be made by mass spectrometry or some other technique.

A problem that has been discovered concerning the 20 meter cell is the length of time required to fill the cell. Figure II shows that 5 minutes of sampling is required in order for the cell to fill completely with a sample. This means that an underestimation of the concentration is possible. Work is underway to determine the extent of the underestimation if less than 5 minutes time is available in which to sample.

Single Channel Instruments - Several companies produce portable instruments for detecting various gases. Mine Safety Appliance Company, 600 Pennsylvania Center Boulevard, Pittsburgh, Pennsylvania 15235, produces a portable carbon monoxide indicator which is completely self-contained. The principle of operation is an electrochemical polarographic type cell which electro-oxidizes carbon monoxide to carbon dioxide. The carbon dioxide is detected and the resulting signal is monitored, temperature compensated and amplified to drive a meter or chart recorder. A small pump pulls an air sample into the inlet and through a flow indicator. The instrument is simple to use but does have its limitations. Some other gases interfere and give false readings so it is not entirely specific. Its response time is 90% of final reading 30 seconds which is better than the infrared analyzer as far as response time. One limitation that is a problem with this and all other gas analyzers is that changes in atmospheric pressure change the calibration of the instrument. This is particularly a problem in the helicopter in that all results must be corrected for altitude.

## CHARGING CURVES FOR 20 METER GAS CELL

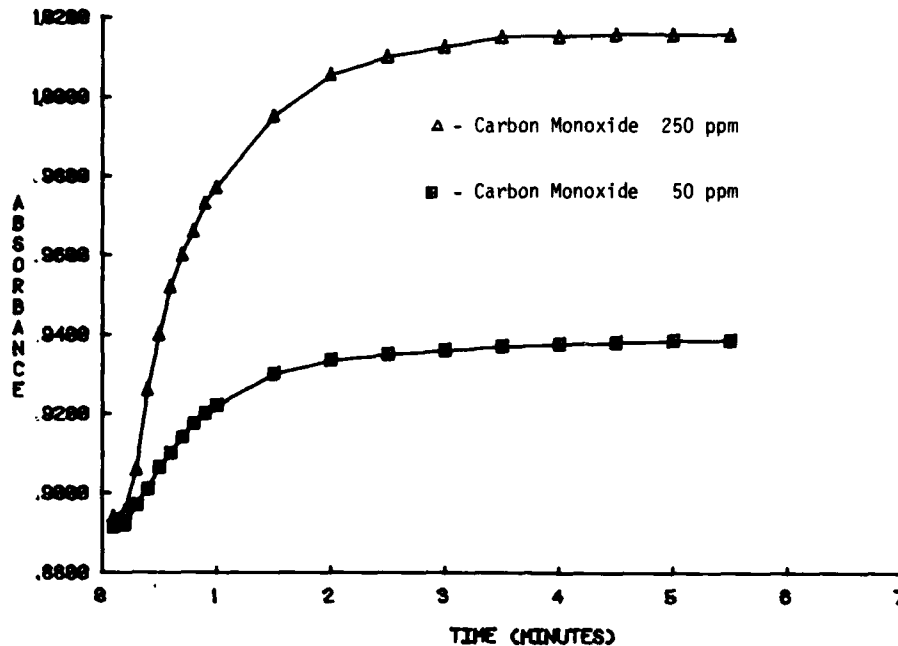

Figure II. Infrared Absorbance of Carbon Monoxide Versus Time of Gas Introduction

Another method of testing for unknown toxic gases is what is called "detector tubes" which are simply short glass tubes which contain chemicals on some solid support. A known quantity of air is drawn through the tube with a syringe type pump. The toxic gas reacts with the chemicals producing a color change in which the distance is proportional to the concentration of the gas present. Their advantage is their sensitivity as well as the wide variety of substances that can be tested. Their limitation is that they are not highly accurate and they do have some interferences. Detector tubes can be obtained from Mine Safety Appliance Company or Matheson Chemical Company.

Research Appliance Company, Gibsonia, Pennsylvania 15044, makes several analyzers including a  $\text{NO}_2\text{-NO}_x$  analyzer with recorder. The principle is a photometric cell and a chemical that reacts with the nitrogen oxides. Its sensitivity is good, less than .5 ppm, but it requires a fairly long period of time of sampling, i.e., 90% response in 2 minutes. They also have a  $\text{SO}_2$  analyzer that works on an electro-conductimetric principle and can detect concentrations to .01 ppm.

Energetics Science, Inc., 85 Executive Boulevard, Elmsford, New York 10523, makes small single and two channel instruments for monitoring carbon monoxide, hydrogen sulfide, nitrogen oxide and nitrogen dioxide. Their detection sensor is based on electrochemical oxidation or reduction. Again, each instrument has its limitations and interferences but sensitivity and portability are good.

The means of gathering samples can be quite complicated in themselves. One method used is that of bubbling the air (sample) through some solvent. The toxic gases then dissolve (hopefully) in the solvent which can be brought to the laboratory for analysis. Considerable error is likely here for many reasons such as rate of flow through the liquid, solubility of the compound in the liquid, temperature of the solvent, etc. This method though semi-quantitative can be used to detect very low level of gases and because of the sophistication of the instrumentation can be very specific.

Another technique would be the absorption of the gas on an inert material such as charcoal at very low temperatures. This technique has the problems associated with working with liquid nitrogen and a fairly complex system of flowmeters, pumps, etc., must be used. An advantage with this technique is that it minimizes changes in the composition of the sample while it is being returned to the laboratory.

A third method is the use of evacuated containers. The bulk of such a system is a problem of pressurization of the cylinder is required to obtain a sample large enough for a complete analysis. Also, the reaction of the gases and the absorption to the walls of the container are sources of error. Basically, the proper approach to gas analysis is an evaluation in the field or in flight where possible and then further investigation in the laboratory when some unknown toxic gas has been detected.



Other Methods of Analysis - Numerous other methods are available for gas analysis but most are not well suited to the helicopter environment. This instrumentation requires that the analysis not be made while in actual flight. There are advantages to both methods many of which have already been monitored. The advantage of a system in the laboratory, though, is that it can be much more complicated and therefore greater accuracy and sensitivity can be obtained. Our laboratory has a JEOL gas chromatograph-mass spectrometer with computer that can be used for gas analysis in the laboratory. Of course, such a system requires that some means of collecting the sample must be devised.

## RESULTS

During the period 12-14 April 1977, the US Army Aeromedical Research Laboratory (USAARL) Biochemistry Branch of the Aviation Medicine Research Division evaluated toxicologic gases related to the operation of the Sikorsky UTTAS (UH-60) aircraft at the request of the US Army Developmental Test Activity (USADTA).

As representative examples of toxic gases which would possibly accumulate in the aircraft during typical operational conditions, carbon monoxide (CO) and nitrogen dioxide/nitric oxide (NO<sub>2</sub>/NO) levels were monitored continuously and quantified during aircraft tests. In addition, an onboard mass spectrometer was used to produce immediate mass spectral data in order to analyze rapidly decaying toxic compounds. Samples were also taken in sealed nonreactive containers for later in-laboratory analysis using a high resolution, high sensitivity JEOL D100 mass spectrometer. The evaluation was divided into two phases: (1) accumulation of toxic gases from the aircraft engines and (2) generation of toxic gases as a result of weapons firing.

Both phases were conducted under a variety of conditions which, according to experimental design, would encompass as many operational procedures as the UTTAS would be anticipated to perform.

Aircraft Engine Evaluation - Tables II and III represent the gases detected in the aircraft as a function of selected aircraft maneuvers. The reference for this test was MIL-STD-800 which is the basic reference standard for carbon monoxide evaluation in military aircraft (1).

TABLE II  
CARBON MONOXIDE EVALUATION OF AIRCRAFT ENGINES (GROUND TESTS)

Heading Relative To Wind Direction	CO Measured Parts Per Million (ppm)	Maximum Standard Parts Per Million (ppm)
0°	<1	1200
90°	2	1200
180°	1	1200
270°	1	1200

Wind velocity was reported as 1 mph.

TABLE III  
CARBON MONOXIDE EVALUATION OF AIRCRAFT ENGINES (FLIGHT TESTS)

Condition	CO Measured (ppm)	Maximum Standard (ppm)
Normal Cruise Power	<1	1200
Full Military Power Climb	4	1200
Aircraft Circling	1	1200
Hovering	5	1200
Backward Flight	1	1200
Lateral Flight	1	1200

Gun Gas Evaluation - During the test series, airspeed (AS) was varied from 40 to 100 knots. Degree of offset by the right and left gunners was effected through a representative number of positions while conditions, such as number of rounds fired and status of the aircraft ventilation system, were varied. All tests were conducted at an altitude of 1,000 feet.

Carbon monoxide (CO) was monitored continuously during the test series and was found to vary from 0 to 20 parts per million (ppm). The worst case situation occurred at the slowest airspeed tested (40 knots) with both guns at maximum firing rate. However, the CO level did not exceed OSHA standards (2) in any combination of conditions. Nitric oxide and nitrogen dioxide (NO/NO<sub>2</sub>) were also monitored continuously and no detectable levels were found.

Mass spectrographic (MS) analysis revealed the gases presented in Table IV.

TABLE IV  
 MASS SPECTROGRAPHIC ANALYSIS OF GUN GASES\*

Gas	Sample 1 (ppm)	Sample 2 (ppm)	OSHA Standard Based on 8 Hr/ Day, 40 Hr/Week, Weighted Exposure Level (ppm)
NO	None detected	None detected	5
NO <sub>2</sub>	None detected	None detected	5
SO <sub>2</sub>	24	8.5	5
HCN	18	21	10
H <sub>2</sub> S**	126	63	50

\*Accuracy is  $\pm 25\%$ .

\*\*OSHA standards only allow one 10 minute exposure of 50 ppm H<sub>2</sub>S in any 8 hour period as opposed to the other gases in the table which are based on weighted averages.

The two samples analyzed were collected during the worst case situation described above. Trace quantities of other compounds were noted from the mass spectra generated but could not be positively identified due to the complex nature of the mixture. The only compound that was present in significant quantity is described as demonstrating a primary mass to charge (m/e) ratio peak at atomic mass units (amu) 57 and is probably Allyl alcohol, 2 Butane-1-ol or a product having a similar fragmentation pattern.

#### INTERPRETATION

Significant gas levels were identified according to current OSHA standards. All gases that were detected with the exception of hydrogen sulfide (H<sub>2</sub>S) were in the category of 8 hour weighted exposure compounds. This means that an individual may experience a maximum exposure level in a relatively short period of time as long as the average stated level is not exceeded in an 8 hour period. Also, several periods of exposure would be allowed as long as the cumulative dose did not exceed the average 8 hour value.

The other category which is identified as ceiling concentration is more restrictive in that a one time only exposure of a certain level for a stated number of minutes is allowed for any 8 hour period. H<sub>2</sub>S is in the latter category.

It is felt that the aircraft ventilation system could not be adequately evaluated because of safety considerations dictated by the firing range. The rapid forward movement of the aircraft and the accompanying forced air ventilation through the gunner's door probably created an override situation which could have masked any contribution by the aircraft's vent system. A low hover, maximum fire maneuver would probably have permitted a better evaluation in this case.

Mass spectrographic identification of low molecular weight compound mixtures was accomplished through peak matching and cracking patterns of known compounds. Quantification was achieved by using Argon, which has a known concentration in air (.94% or 940 ppm) as an internal reference, and comparing selected peak heights (3,4). The sensitivity of Argon and that of the unknown is used to establish a ratio correction factor. The sensitivities are usually referenced to n-butane and are found in the cornu compilation of mass spectral data (5). Fragmentation patterns are also determined from these tables. The formula for the general quantitation calculation is:

$$Cx = \frac{SA}{Sx} \times \frac{Px}{PA} \times CA$$

Where Cx = Concentration of unknown

S<sub>A</sub> = Sensitivity of Argon

S<sub>x</sub> = Sensitivity of unknown

P<sub>x</sub> = Peak height of unknown

P<sub>A</sub> = Peak height of Argon

CA = Concentration of Argon in air (940 ppm)

During the test series, no significant accumulation of carbon monoxide was experienced.

Although present in significant quantity, the levels of sulfur dioxide (SO<sub>2</sub>) and hydrogen cyanide (HCN) were not interpreted as excessive because they are in the OSHA 8 hour weighted exposure category (2). For example, a gunner would have to be exposed to over 100 minutes of continuous firing in one 8 hour period to exceed the stated safe level of SO<sub>2</sub> when the worst case is used as a model.

However, the situation is different with respect to H<sub>2</sub>S because this gas is in the OSHA ceiling concentration category. Due to the one time only exposure restriction imposed by this category, H<sub>2</sub>S concentrations were interpreted to have exceeded the safe limits as defined by OSHA regulations.

During the test series, there was no significant difference in gas concentration that could be attributed to the vent system being open or closed.

#### REFERENCES

1. "Procedure for Carbon Monoxide Detection and Control in Aircraft," Military Standard 800, United States Government Printing Office, Washington, D. C., 21 July 1958.
2. "Occupation's Safety and Health Standards," Part 1910, Subpart 2, Section 1910.1000, Table 21, pp 642.2-642.13, Government Printing Office, Washington, D. C., 1976.
3. Jeffery, P. G. and Kipping, P. J. "Gas Analysis by Gas Chromatography," p. 102, Macmillan Company, 1964.
4. Robox, John. "Introduction to Mass Spectrometry Instrumentation and Techniques," Interscience 312-320, 1968.
5. Cornu, A. and Massot, R. "Compilation of Mass Spectral Data," Heyden & Son Ltd., Presses Universitaires de France, 1966.
6. Ikels, K. G., Crow, W. L., Miller, R. L. "Contaminant Analyzer for Aircraft Oxygen Systems," Aerospace Medicine (1974).
7. Hody, G. L. and W. P. Schane. "Preliminary Carbon Monoxide Measurements in Armed Helicopters." USAARU Report No. 66-1, March 1966.
8. Littell, Delvin E. "Carbon Monoxide Measurements in the OH-58A Helicopter with the Heater in Operation." (Letter Report--Not for Publication), US Army Aeromedical Research Laboratory, Ft. Rucker, AL, December 1969.
9. Schane, William P. "Weapon Exhaust on the Tail Ramp of a JOH-47A During Firing of an XM-24 Machine Gun In Flight." (Letter Report--Not for Publication), US Army Aeromedical Research Laboratory, Ft. Rucker, AL, November 1966.
10. Hody, George L. "Air Contaminant Measurements in the Armed Chinook." (Letter Report--Not for Publication), US Army Aeromedical Research Laboratory, Ft. Rucker, AL, April 1966.
11. Littell, Delvin E. "Report of Analysis of Carbon Monoxide Data Obtained During Missile Firing Test of M551." (Letter Report--Not for Publication), US Army Aeromedical Research Laboratory, Ft. Rucker, AL, May 1969.
12. Hody, G. L. and H. W. Huffman. "A Rapid Timing Sequencer for Toxic Gas Sampling," USAARU Report No. 67-4, November 1966.
13. Hody, G. L. and W. P. Schane. "Preliminary Carbon Monoxide Measurements in Armed Helicopters," USAARU Report No. 66-1, March 1966.
14. Littell, Delvin E. "Carbon Monoxide Measurements in the OH-6A with XM-8 System." (Letter Report--Not for Publication), US Army Aeromedical Research Laboratory, Ft. Rucker, AL, March 1969.
15. Crow, Walter L. and Kenneth G. Ikels. "Oxygen Contaminant Detection: Procedures for Field Analysis of Aviator's Breathing Oxygen." SAM-TR-74-24, September 1974.

## BACKACHE IN UH-1D HELICOPTER CREWS

by

H.C.Schulte-Wintrop  
L.T.K.  
Manfried v Richthofenstr. 8  
4 Munster, FRG

and

H.Knoche  
Helicopter Transportation Wing 64  
4597 Ahlhorn  
Postfach 300, FRG

In aviation one can make the observation that progress in aircraft design and technical performance is not always accompanied by an improved ergonomical outlay. The development of helicopters with twobladed rotors meant a great step forward in the reduction of maintenance requirements. However, vibrational forces resulted which we are sure are one important cause of backache in helicopter crews flying this type of aircraft. Other factors like poor seat design and draughty cabin conditions attribute to the complaints. Seats by the way are also a problem in fixed wing aircraft even in modern airliners.

In the following we will not dwell on an explanation as to the pathology of spinal ailments in helicopter crews but rather on a practical way of dealing with this problem which we think has proved valuable. This is to say that we believe that more basic research on this topic is necessary. The fact that electronmicroscopy seems to be a promising tool in further investigations will be pointed out later. The important question of the recognition of vibration induced backache as an industrial disease depends on these studies.

The flight surgeon dealing with helicopter crews is of course interested in the etiology of backache in order that an effective treatment and prophylaxis can be instituted.

For this purpose a questionnaire was prepared and handed to the crews (6). Out of a total of 145 pilots, flight engineers and air rescue medics questioned 40 % complained of backache during flight and 51 % of backache after flight. The steady RPM setting during normal flight was marked to cause discomfort in 37 % of the cases as opposed to only 4 % when increasing RPM. In 39 % of the cases the pain was described as a lasting one. 29 % reported one of short duration. In 34 % it was felt in the middle of the back over the dorsal processi, in 54 % in the lumbar region, and in only 17 % in the neck (Fig. 1).

A study by Niethard (3) of the Orthopedic Clinic of the University of Heidelberg (Fig. 2) shows fairly well matching figures for objective and subjective findings for back complaints. As to our group one has to assume that the known dissimulation of flying personnel is in favour of our figures, in other words, the percentages given may rather be considered as too low. It may be added that 33 % of the personnel questioned returned their forms anonymously.

On the average 5 years of flying time elapsed since onset of discomfort or pain. 16 % of our volunteers had some vertebral abnormality prior to flying. This compares favourably with the percentage for all draftees born from 1946 through 1966 which is 62 %.

We have come to the conclusion that the following factors have to be considered as causative to backache in helicopter crews:

Vibration, seating posture, draft, lack of specific exercises and vertebral abnormalities.

Coming now to the factor vibration we can simply state that the vibrations caused by the two-blade rotor of the UH-1D and being transmitted to the body through an undampened seat are beyond the criteria set by US as well as German standards. The US Specification Mil A 8892 USAF (4) reads (Fig. 3) as follows:

The vibration of crew seats which can affect crew comfort during unaccelerated flight and from minimum to maximum cruising speed shall not exceed  $\pm 0,1$  g at frequencies below 22 Hz, 0,1 mm double amplitude at frequencies between 22 and 86 Hz and 1,5 g at frequencies above 86 Hz.

Unfortunately, the blade passing frequency which is the fundamental cause of obtrusive vibration ranges from 9 - 11 in the twobladed UH-1D.

We know that proper spinal support during flight relieves complaints of backache. Some of our

questioned pilots have found this out empirically. They use a cushion which is placed in the lumbar area.

The explanation for this effect lies in the shockabsorbing qualities of the double "S"-curved spine (Fig. 4). The UH-1D Pilot has to operate the stick with the right hand and the pitch with the other (Fig. 5). This gives rise to a leaning forward posture neutralizing the lordosis of lumbar spine (Fig. 6). In this way, more pressure is placed on the ventral parts of vertebral discs leading to narrowing of the vertebral distance and causing finally spondylotic changes.

We have tried an airbladder similar to a bloodpressure cuff (Fig. 7). This can be adjusted to different lumbar curvatures. The result of this trial was encouraging and has led to an improved seat design. A combination of a special vibration attenuating seat cushion plus a backsupport is ideal. In our new seat we have compromised by introducing a seat cushion and a noninflatable backsupport because the army felt that an airbladder might be too vulnerable through the wears and tears of daily flying.

The influence of cool air during open door manoeuvres or by way of structural leaks is another factor in the etiology of backache. This implies other models than the UH-1D as well. We all have come across with the effect of local cooling of muscular tissue. Even under warm weather conditions a cooling effect takes place when moist skin is exposed to a winddraft. This is called windchill. Rigidity, tenderness and myogelosis can develop. Unfortunately, the lumbar region which is most affected is not well protected by the flying suit worn in our service. Therefore we use a circular garment made out of wool to protect this area. So far this has proved very effective. Some of our volunteers remarked that special exercises were helpful.

Jumping esp. squad jumps, however, seem to do more harm than good. This is understandable since it causes additional pressure on the already strained vertebral discs. Vertical stretching or suspension from a horizontal bar alleviates backache.

In the treatment and prophylaxis of backache the following causal factors should be considered: Vibration, draft, seat design and lack of exercises and the symptoms of: painful and spastic muscles, myogelosis, tenderness of dorsal processi and paresthesia. It remains to be seen whether the latter findings are connected with an internal derangement of vertebral joints (Fig. 8) caused by vibratory acceleration and displacement (1).

Noxious vibration is inherent in twobladed rotors. Further developments will have to take this into consideration. In the meanwhile attenuation of these forces by special seat covers will be given first priority. A new seat with vibration absorber is expensive and takes much time to develop. Draft effects can be eliminated by proper protection esp. of the lumbar area. The backrest of the seat must be modelled to the vertebral curvature and finally a program of special exercises is certainly of value. The ideal would be a specially equipped gymroom near the crew stations where training can take place during standby times. Efforts should be made to strengthen the erector trunci muscles. Treatment consists of heat application, massages and other forms of physiotherapy.

With this program we feel that most of our helicopter crews can be kept on flying status without detrimental effects. Lastly a few words about the pathological findings:

Richter (2) has put rats on a vibrating table with 49 Hz and an effective acceleration of 2 G over 80-324 hrs. With scanning electronmicroscopy he was able to find a decrease of amorphous substance on the joint surface leading to an exposure of collagenous fibrous structures. The degree of damage was depending on the duration of vibration.

Perhaps one will submit rats to identical influence as humans in a UH-1D. This would be one possibility in finding out early pathological changes on the joint surface.

Myogelosis shows also a histology when muscular fibres are examined by electronmicroscopy. As Fassbender (5) of the Federal Armed Forces Medical and Hygiene Institute has pointed out the findings are identical with those found in hypoxic muscular tissue. We have learned that the "White finger syndrom" or Raynaud's phenomenon is one finding in workers operating vibrational tools (for instance pneumatic airhammer and percussion drills (1)). It seems quite possible that a diminished bloodflow is the primary cause for the myogelotic changes, in other words, a circulatory form of hypoxia.

It might be asked what our Xray findings are. Unfortunately, we have no routine Xray of vertebral spine prior to the flying career and therefore no way of comparing with radiological findings after say 1000 hrs of flying the UH-1D. For obvious reasons we are also hesitant in taking Xrays.

In cases of a more severe and chronic form of backache we have found spondylotic changes without a certain pattern. We have, however, seen differences in the height of helicopter pilots when on flying and when off flying. This, we feel, proves the assumption that flying the UH-1D poses an aggravated strain on the intervertebral discs leading to a narrowing of intervertebral distances.

References

- (1) Guignard, I.C. Vibration AGARD-A 6 151, P. 1 - 71
- (2) Richter I.E. Changes in amorphous substance on the joint surface in rats after their exposure to extended vibrations.  
Wehrmedizinische Monatschrift (monthly issue of military medicine) 6, 161 1977 P. 161 - 167
- (3) Niethard, F.U. Differential Diagnosis of backache. Monthly courses for graduate medical education 15, 726 1977 P. 128 - 131
- (4) MIL - A - 8892 (USAF) P. 5 - 6
- (5) Fassbender H.G. New morphologic data on rheumatic illness.  
Monthly courses for graduate medical education 2, 63 1978 P. 53 - 54
- (6) Schulte-Wintrop, H.C. Evaluation of questionnaires on backache.  
Not published 1977

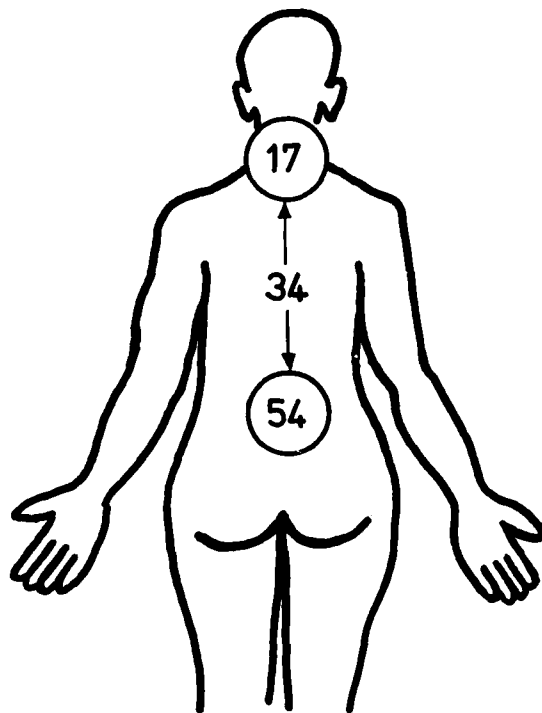

Figure 1

Evaluation of Backache in UH-1D Helicopter Crews  
(Schulte-Wintrop)



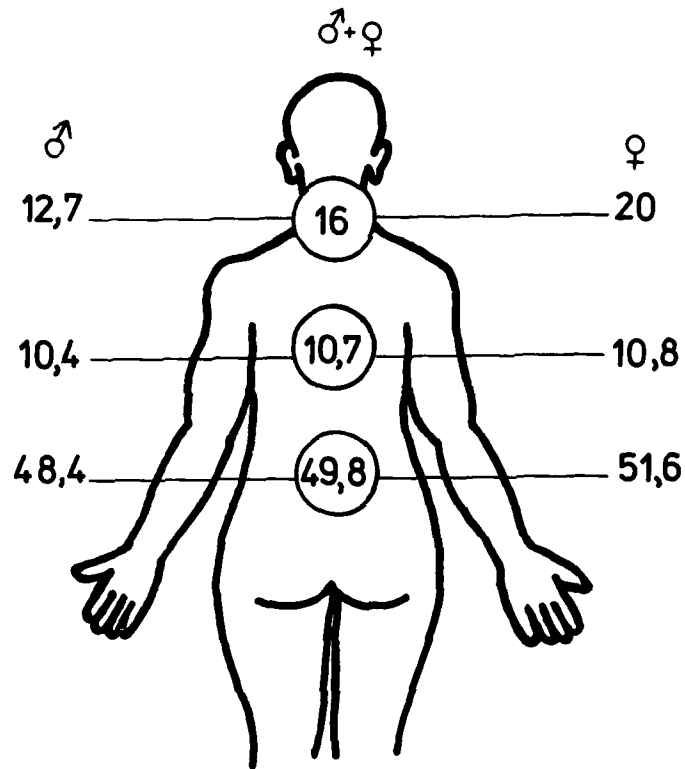

Figure 2

Comparison : Complaints of Backache and objective findings  
(Niethard)

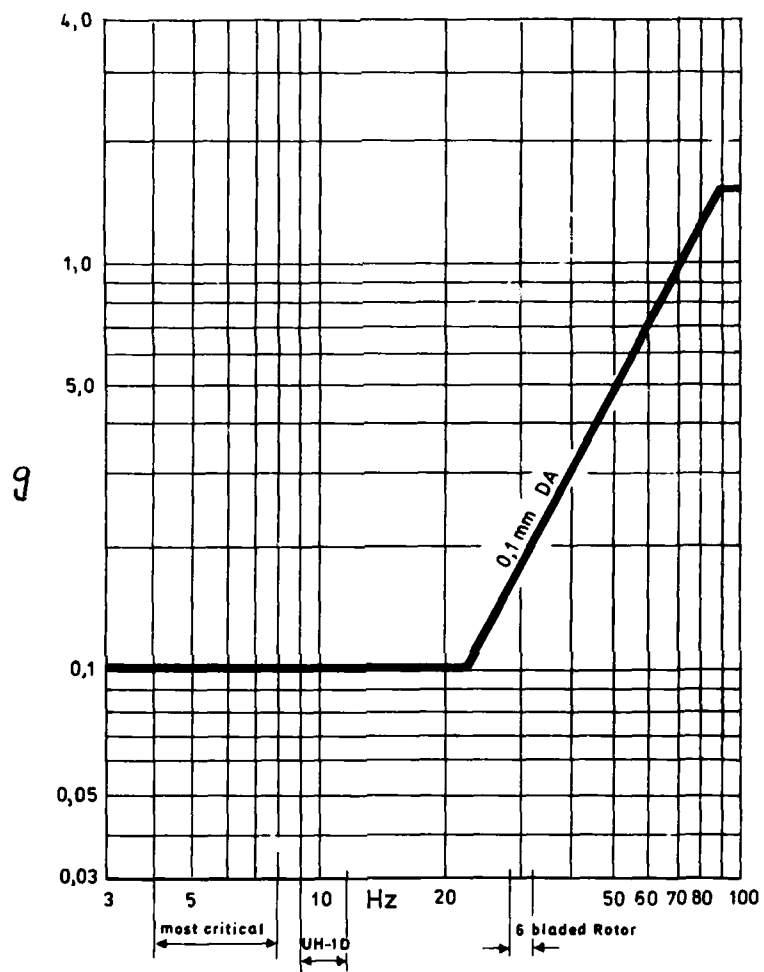

Figure 3

Vibration Requirements for Crew Comfort  
MIL-A-8892 (USAF)

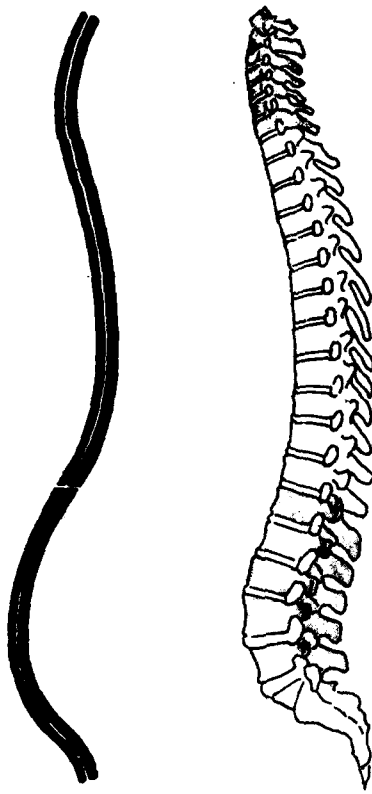

Figure 4

Vertebral: Column, lateral View ( double S-Form )

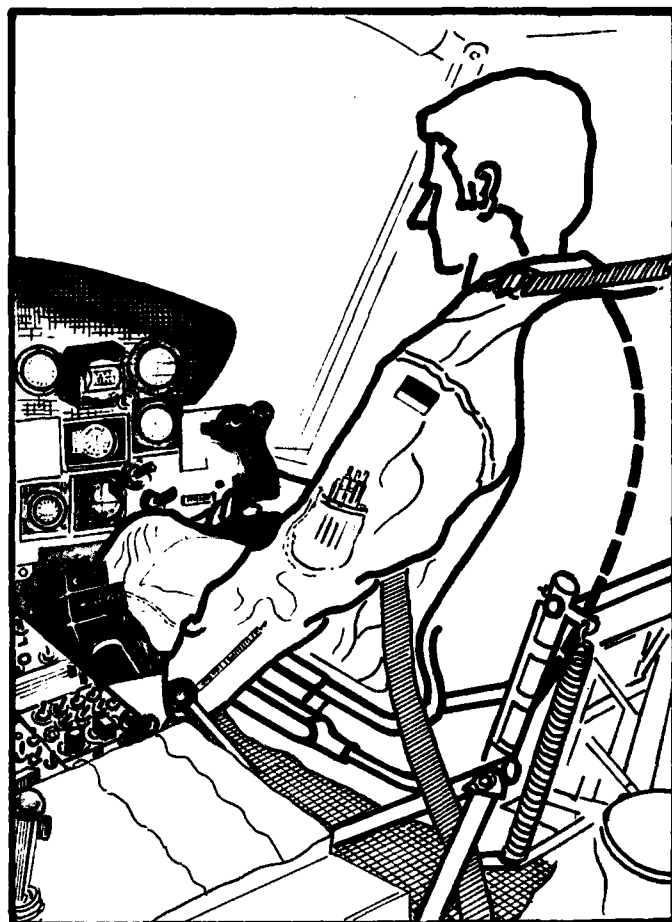

Figure 5

Pitch- and Stickcontrol in UH-1D

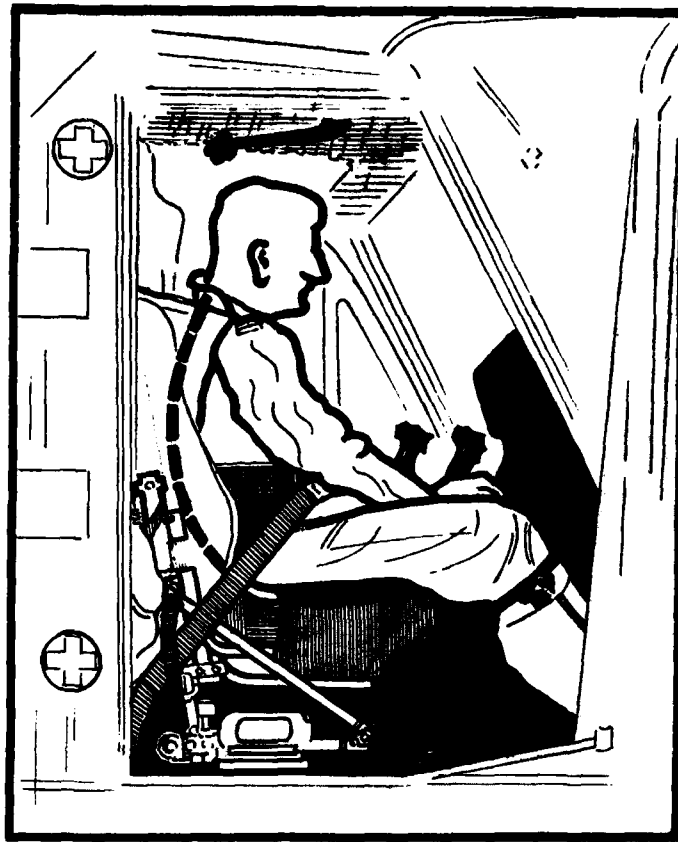

Figure 6

Lateral View of Helicopter Pilot in UH-1D  
without lumbar Support

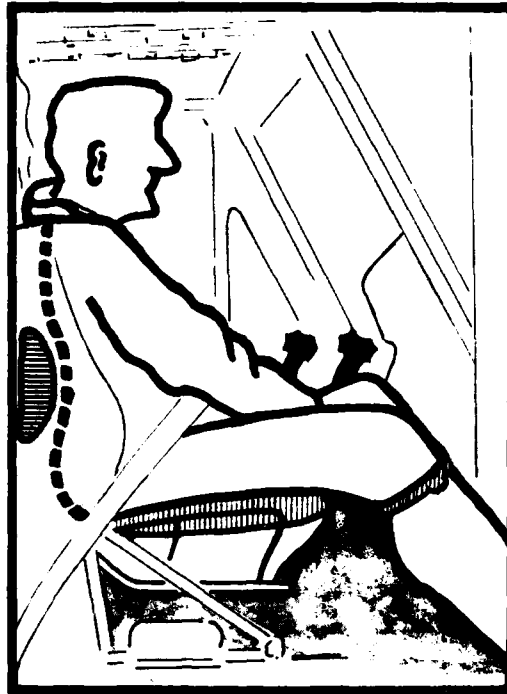

Figure 7

Lateral View of Helicopter Pilot in UH-1D  
with lumbar Support plus Vibration  
attenuating Seatcover

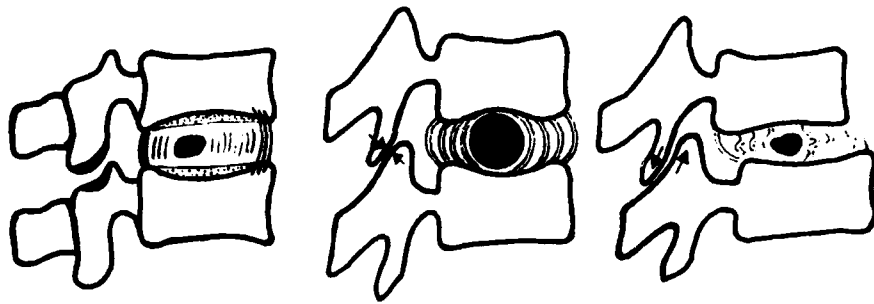

Figure 8

Spinal articular Unit and Model of  
internal Derangement

## DISCUSSION

- SPEAKER UNIDENTIFIED: In your honest, personal opinion, do you think that attack helicopters flying at night should be on an oxygen system of some sort?
- DENNISTON:  
(United States) This is something that is being argued. My personal opinion is that with night flying we should be on oxygen from the ground up despite the night vision devices. There is no doubt that oxygen will enhance visual acuity, depth perception, and other things.
- WENGER:  
(United States) Dr. Beck, you developed a full set of gear for your fully equipped troops? In other words, somebody with a pack and fully equipped in that regard?
- BECK:  
(United Kingdom) The development of the ground forces clothing is still underway. It has been a fairly slow one, probably a rapid learning process but financially a slow one. The biggest constraint has been financial and there has been as much rationalization as possible so there is still a certain amount of fluidity.
- PERRY:  
(United Kingdom) I think you should remember one or two points from this session. The points that have been trying to come through are that we have to look to having on-board oxygen systems for low level attack helicopters and that the stresses of these machines will go up, requiring more work on toxicology such as the work we have seen demonstrated here.



## US ARMY AVIATION FATIGUE-RELATED ACCIDENTS, 1971-1977

Gerald P. Krueger & Yvonna F. Jones  
 US Army Aeromedical Research Laboratory  
 P.O. Box 577  
 Fort Rucker, Alabama 36362

## SUMMARY

An accident data survey was made to determine how frequently aviator crew fatigue may have contributed to US Army aviation accidents from 1971 to 1977. All accident reports in the US Army Agency for Aviation Safety (USAAAVS) data base were reviewed. Aviator fatigue was deemed to be a contributing factor in 42 rotary wing accidents which resulted in a total of 51 fatalities and 63 personnel injuries. Fatigue contributed to 10 fixed wing accidents, resulting in three fatalities and five injuries. This paper categorizes these fatigue related accidents by aircraft and mission type and by time of day and day of week of the accident. It also describes pilot activities prior to the accidents which promote the likelihood of pilot fatigue contributions. The personnel and equipment costs of these accidents to the Army are estimated, and the relative importance of such accidents to the total US Army aviation accident picture is assessed.

## INTRODUCTION

One of the most plaguing aeromedical problems in Army aviation is that of aviator fatigue. Many stressors of military flight operations act in combination to fatigue the aviator. For example, the Army pilot routinely encounters such stressors as heat, noise, vibration, blowing dust, hazardous weather, reduced visibility at night, exhaust from engines or weapons and labyrinthine stimulation. In combat operations, additional stress may be caused by psychic elements such as fear, family separation, frustration and, of course, insufficient sleep.<sup>1</sup> Our present rotary wing training operations add to the list the increased stress found in low level and nap-of-the-earth flight and also flight while wearing various head-mounted sensors, displays or sighting systems. Some or all of these stressors may act on our aviators daily, and when they are combined with long hours of flying an aircraft in sustained flight operations, cause pilot fatigue.

Aviator fatigue is obviously a multifaceted phenomenon. The immediate or short-term workload of flying the aircraft, the duration and frequency of work/rest periods in a 24-hour duty day and the cumulative workload over several days or months all contribute to a pilot's state of alertness and operational efficiency.<sup>2</sup> Because of the multifaceted aspects of fatigue, it is very difficult to accurately determine its "true impact" on the safe performance of military flight missions.

Nevertheless, discussions of aviator fatigue continually arise in determining appropriate crew staffing ratios, planning military operations, and ensuring effective pilot performance and safety. Inevitably, these discussions get around to posing the question: "How many times has aviator fatigue been a contributing factor in aircraft accidents?"

For years fatigue has been cited as a causal factor in many military aviation accidents. For example, isolated studies have estimated that aviator fatigue was a major causal factor in at least 7% of the early Vietnam combat accidents<sup>3</sup> and in 15% of European peace time helicopter accidents over a five-year period.<sup>2</sup> Karney reported that in Fiscal Year 1976 aircrew fatigue was identified as a contributing causal factor in 10 US Army aviation accidents.<sup>4</sup>

Because of the recurring interest in this topic, this report presents summary data on US Army aviation accidents for which fatigue has been identified as a contributing factor. The relative contribution of these accidents to the total number of aviation accidents and their relative cost to the Army is estimated for the period 1971-1977.

## METHOD

Accident data described in this survey were obtained from the US Army Agency for Aviation Safety (USAAAVS) at Fort Rucker, Alabama. The USAAAVS computerized accident data base was searched for all Army aviation accident reports which identified "fatigue" or "sleep deprivation" as possible contributing factors. These accidents were labeled "fatigue-indicated." The year 1971 was chosen as a starting point for the search because by that year the Army's aviation accident reporting system added pilot work-rest history information on most of the accident reports entered in the USAAAVS data base. The search covered accidents from all three components of the US Army world-wide--Active, Reserve, and National Guard.

Computer printouts of the technical reports of the "fatigue-indicated" accidents were reviewed. The printouts included descriptive information on the accident, a narrative of events surrounding the accident, the investigation board's findings, relevant personal data for the crew involved in the accident, a chronological account of pilot activities 48 hours prior to the mishap, flight records, and cost data.

A two-fold approach was used in analyzing these data. First, the two authors independently reviewed all the information listed for 134 "fatigue-indicated" accident reports and gave each an overall subjective rating as to whether or not he or she thought aviator fatigue may actually have contributed to the accident. These accidents were labeled "fatigue-related." No predetermined decision rules were established for making these categorizations. The two independent sets of judgments were then compared and an index of reliability was calculated to determine the degree of agreement. Next, the two judges met to agree on a common classification for those accidents which they had classified differently. Summary statistics of important facts concerning the accidents judged to be "fatigue-related" were then calculated. The judges rank order listed the factors which they used in making such determinations.

Second, relevant data from all 134 fatigue-indicated accident reports were summarized by descriptive statistics. The reports were categorized based upon crew personal data provided in each accident investigation report. Categorizations such as amount of sleep, flying hours, etc., were predominately based on information listed for the piloting crewmember who was identified in the report as having played a definite primary causative role in the accident sequence. In the US Army accident reporting system an aviator is identified as having a primary role in the accident "when the factor(s) which made the event most likely or inevitable are attributed to him."<sup>5</sup> In some reports another individual, or factor (e.g., faulty maintenance or material failure), was listed as the primary cause while the fatigued aviator at the aircraft controls was listed as having a definite secondary role. Flight time and sleep data for this aviator were included in the statistical summaries. An aviator's role is considered secondary "when the factor(s) attributed to him were those which, when considered alone, did not cause the event but increased the likelihood of its occurrence."<sup>5</sup>

One important categorization in the accident reports is a determination by the accident investigator(s) as to whether or not the factors of "sleep deprivation" or "fatigue other" were definite or suspected contributors, or whether they were conditions merely present but which did not necessarily contribute to the cause. The data were summarized on these categorizations as well.

US Army aviation accident rates and relevant cost data were obtained from USAAAVS to show the relative importance of fatigue-related accidents in the overall accident picture.

## RESULTS AND DISCUSSION

Many of the complexities involved in the accident investigating and reporting process became apparent in the review of the accident reports. Making post hoc determinations of the state of alertness of the pilots at the time of an accident is a difficult task during the actual accident investigation process itself. It is an even more difficult task in the analysis of accident reports some months or years after the accidents. Some of the most perplexing problems were: (1) All accident investigations did not produce the same types and amounts of required information. (2) Crewmembers did not always live to "tell the tale." (3) Occasionally, the figures obtained in witness statements (e.g., numbers of hours of sleep or work, etc.) did not coincide with those obtained by accident investigators piecing the puzzle together. (4) Fatigue was usually only one of multiple factors which appeared to have contributed to the causes of many accidents. Nevertheless, this detailed analysis of a fairly large number of accident reports provides a rough indication of the scope of the problem of Army aviator fatigue.

### Fatigue Determinations

The USAAAVS accident report repository contained 134 accident reports listing sleep deprivation or fatigue indicators for one or more pilots during the years 1971 through 1977. Twenty-two reports were for fixed wing and 112 for rotary wing accidents.

The accident investigation reports listed "sleep deprivation" as being a definite causal factor in 4% of these accidents; as a suspected contributor in 19%; and as merely being a condition present at the time of the accident in 8% of them. "Fatigue other" was listed as a definite contributor in 7% of the accidents; as a suspected contributor in 71% and as a condition present in 5% of the accidents. Sleep deprivation and fatigue-other were indicated together in the same accident for 17% of the cases. Generally, these indicators were attributed to the pilot who was listed as having played a primary role in the accident.

In the accident investigation process it was left to the investigator(s) to determine whether "sleep deprivation" or "fatigue other" were factors in the accident. The indications of whether these factors were definite or suspected causes or merely conditions present, were assigned to the accidents by a large number of different accident investigators or teams of investigators. In the absence of any predefined guidelines

for making those determinations, it is likely that there were differences in the criteria used by each investigator.

The two judges (the authors) in this survey classified 39% (52 of 134) of these "fatigue-indicated" accidents as actually being "fatigue-related." That is, the judges felt that there was enough evidence in the accident report to lead them to believe that fatigue may have actually contributed to the accident. This judgmental position can be regarded as differing significantly from the mere indication that fatigue was a condition "present" at the time of the accident; and as being slightly more positive than the "suspected factor," but also as stopping short of the position that it "definitely" was a causal factor.

In the independent review of all the accident reports the two judges made a binary classification of each accident on a nominal scale: the accident either contained "fatigue-related" causes or it did not. A comparison of the two sets of classifications showed agreement on 119 of 134 reports, a proportion of 89%. When this figure was corrected to reflect only the proportion of agreement beyond that expected by chance, the index of agreement (Cohen's kappa)<sup>6</sup> was over .76 (confidence limits:  $.65 < k < .85$ ). Perfect agreement would have resulted in a kappa coefficient of 1.00. A reliability of .76 can therefore be considered fairly high.

The types of accident report information the judges considered to be important in determining whether fatigue was or was not a contributing causal factor in the accidents are listed in Table 1. Although the list rank orders the most important factors at the top, the judges agreed that the scalar distance between items was slight. That is, for analysis of some accidents the ordering of their importance may have been inverted. The judges usually considered a complex combination of several or all of the items of information in their deliberations.

TABLE 1  
ACCIDENT REPORT INFORMATION CONSIDERED IN MAKING AVIATOR FATIGUE  
CONTRIBUTION DETERMINATIONS

<u>ITEM</u>	<u>RANK ORDER</u>
Investigation Board's Findings and Recommendations	1
Narrative Account of the Accident	2
Chronological Account of Crew's Previous 72 Hours	3
No of Hours Duration of Last Sleep Period	4
No of Hours and Mission Types Flown in the Last 24 Hours	5
No of Hours Continuously Awake Prior to Event	6
No of Hours and Type of Work in Last 24 Hours	7
No of Hours Aviators Slept in the Last 24 Hours	8
No of Hours Slept in the Last 48 Hours	9
No of Hours Worked in the Last 48 Hours	10
No of Hours Flown by the Aviators in the Last 30 Days	11
Aviator's Unit & Command Response to Board Findings	12

#### Army Aviation Accidents

To place the number of fatigue-related accidents into perspective, it is useful to consider the scope of the overall Army aviation accident problem. The number of accidents, the accident rate per 100,000 flying hours and their relative cost to the Army worldwide for each of the seven calendar years are shown in Table 2.<sup>7</sup> The data show that there has been a steady decrease in the overall number of accidents and a slight decrease in the accident rate since 1971. Not shown in the table is the fact that the overall number of flying hours also decreased steadily from a high of 4,182,000 hours in 1971 to less than 1,500,000 hours in 1977. The number of fatalities, injuries and materiel cost varied as a function of the type of accident (e.g., type of aircraft, number of passengers and mission), the severity of the damage per accident and the escalation of materiel costs. It might also be useful to recall that the US Army began phasing out its involvement in Vietnam during 1971, and continued to do so throughout 1972 and into the early months of 1973.

#### Fatigue Accidents

The 134 fatigue-indicated accidents which occurred over the last seven years are listed in the middle two columns of Table 3. It can be seen that while the overall number of accidents declined from year to year, the percentage of accidents which were fatigue-indicated rose and fell variously, but in general, increased. Whether this general increasing trend is due to an actual change in the distribution of various causal factors for accidents or whether accident investigators have merely given increased attention to fatigue factors is not clear. The number of fatigue-indicated accidents constituted an overall average of 10.6% of all the aviation accidents over the seven-year period.

TABLE 2  
US ARMY AVIATION WORLDWIDE ACCIDENT RATES, 1971-1977

<u>Calendar Year</u>	<u>No of Accidents</u>	<u>Acdt Rate per 100,000 Hours</u>	<u>No of Fatalities</u>	<u>No of Injuries</u>	<u>Materiel Cost (\$ Thousands)</u>
1971	556	13.3	325	501	\$ 88,743
1972	217	9.1	136	184	33,055
1973	115	6.3	72	93	20,362
1974	113	7.2	7	77	14,472
1975	93	6.3	52	106	15,129
1976	90	6.2	28	94	22,539
1977 (11 mo)	86	6.1	29	56	19,636
<b>Total</b>	<b>1,270</b>	<b>8.9</b>	<b>649</b>	<b>1,111</b>	<b>\$213,936</b>

TABLE 3  
US ARMY AVIATION FATIGUE RELATED ACCIDENTS BY CALENDAR YEAR

<u>Calendar Year</u>	<u>All Accidents</u>	<u>Fatigue Indicated</u>		<u>Fatigue Related</u>	
	<u>No of Accidents</u>	<u>No of Accidents</u>	<u>% of Total</u>	<u>No of Accidents</u>	<u>% of Total</u>
1971	556	44	7.9	19	3.4
1972	217	20	9.2	9	4.1
1973	115	17	14.8	6	5.2
1974	113	12	10.6	5	4.4
1975	93	14	15.1	6	6.5
1976	90	16	17.8	4	4.4
1977	86	11	12.8	3	3.5
<b>Total</b>	<b>1,270</b>	<b>134</b>	<b>10.6</b>	<b>52</b>	<b>4.1</b>

The 52 accidents which were judged to be "fatigue-related" constituted an average of 4.1% of all the Army aviation accidents worldwide for the seven-year period. This figure seems to be a good descriptor of a fairly stable year-to-year distribution which only ranged from 3.4 to 6.5% of the totals as shown in the right side of Table 3.

#### Costs

Table 4 shows the number of fatalities, injuries and materiel costs for both the fatigue-indicated and the fatigue-related accidents by aircraft type, either fixed wing or rotary wing. The 112 fatalities and the 190 injuries in the fatigue-indicated accidents each represent over 17% of the respective total losses in all accidents during the seven-year period (112 of 649 fatalities and 190 of 1111 injuries). The \$27,724,000 total of materiel cost for these 134 fatigue-indicated accidents represents 13% of all the materiel losses for the seven years.

The fatigue-indicated accident rate for fixed wing aircraft was .15 per 100,000 flying hours. In terms of materiel cost, nine of the aircraft in the 22 fatigue-indicated fixed wing accidents were classified as total losses. These accidents included the loss of two significantly higher cost aircraft (OV-1's), accounting for over 73% of the total materiel costs (\$3,091,600 of \$4,244,000).

The fatigue-indicated accident rate for rotary wing aircraft was .78. Eighty-four percent of the accidents (112 of 134) involved rotary wing aircraft. The rotary wing

accidents accounted for 88% of the fatalities, 97% of the injuries and 85% of the materiel loss in all fatigue-indicated accidents over the seven years.

TABLE 4  
US ARMY AVIATION FATIGUE-RELATED ACCIDENTS AND THEIR COST BY CALENDAR YEAR

Calendar Year	Fatigue Indicated				Material Cost (\$ Thousands)	Fatigue Related			
	Accidents	Fatalities	Injuries			Accidents	Fatalities	Injuries	Material Cost (\$ Thousands)
1971	3	0	3	\$ 1,177	2	0	3	\$ 1,158	
1972	3	2	0	140	2	0	0	40	
1973	4	2	0	2,229	1	0	0	14	
1974	3	0	0	31	1	0	0	23	
1975	3	3	2	286	2	3	2	281	
1976	3	3	0	221	1	0	0	103	
1977	3	3	0	160	1	0	0	24	
<b>Total</b>	<b>22</b>	<b>13</b>	<b>5</b>	<b>\$ 4,244</b>	<b>10</b>	<b>3</b>	<b>5</b>	<b>\$ 1,643</b>	
1971	41	64	98	9,577	17	44	18	3,989	
1972	17	13	24	2,718	7	2	14	1,112	
1973	13	6	18	1,955	5	3	10	1,036	
1974	9	1	13	1,374	4	1	6	1,062	
1975	11	8	12	1,928	4	0	8	956	
1976	13	3	13	4,868	3	0	4	263	
1977	8	4	6	1,060	2	1	3	169	
<b>Total</b>	<b>112</b>	<b>99</b>	<b>185</b>	<b>\$23,480</b>	<b>42</b>	<b>51</b>	<b>63</b>	<b>\$ 8,587</b>	
<b>Grand Total</b>	<b>134</b>	<b>112</b>	<b>190</b>	<b>\$27,724</b>	<b>52</b>	<b>54</b>	<b>68</b>	<b>\$10,230</b>	

Thirty-five percent (39 of 112) of the fatigue-indicated rotary wing accidents occurred in Vietnam. These losses were not attributed directly to hostile fire but were categorized as combat zone accidents. They accounted for 58 deaths (34 of them in a single CH-47 accident), 96 injuries (50 of them in another CH-47 accident) and over \$10.5 million in materiel losses. Twenty-one of these Vietnam accidents resulted in total losses of the aircraft. All but one of the 39 accidents occurred in the years 1971-72.

The 54 fatalities resulting from the "fatigue-related" accidents account for over 8% (54 of 649) of all the fatalities in Army aviation accidents during the seven year period. The fatigue-related injuries made up over 6% (68 of 1111) of all injuries for the same period. The \$10.23 million in materiel cost for these 52 fatigue-related accidents represents 4.8% of all the materiel losses for the period.

The fatigue-related accident rate for fixed wing aircraft was .07 accidents per 100,000 flying hours; and for rotary wing aircraft it was .29. Eighty-one percent of the fatigue-related accidents (42 of 52) involved rotary wing aircraft. These accidents accounted for over 94% of the fatalities, almost 92% of the injuries and 85% of the materiel loss in all the fatigue-related accidents.

Thirty-three percent (14 of 42) of the fatigue-related rotary wing accidents occurred in Vietnam. These 14 accidents accounted for 40 fatalities (34 of them in the CH-47 accidents already mentioned above), 16 injuries and over \$4,160,000 in materiel costs. Eight of these Vietnam accidents resulted in total losses of the aircraft.

#### Model Aircraft

The fatigue-indicated and fatigue-related aviation accidents are categorized according to the model aircraft in Table 5.

The approximate number of flying hours, the overall accident rates, and the fatigue-indicated and fatigue-related accident rates for each of these same model aircraft are listed in Table 6.

TABLE 5  
US ARMY FATIGUE-RELATED AVIATION ACCIDENTS AND THEIR COST BY MODEL OF AIRCRAFT, 1971-1977

Aircraft Model	Fatigue Indicated			Material Cost (\$ Thousands)	Fatigue Related			Material Cost (\$ Thousands)	
	Accidents	Fatalities	Injuries		Accidents	Fatalities	Injuries		
O-1	1	0	1	\$ 19	-	-	-	\$ -	
OV-1	3	2	0	3,124	1	0	1	1,059	
T-42	6	6	0	270	2	0	0	43	
U-1	1	0	2	166	1	0	2	166	
U-3	1	0	0	6	-	-	-	-	
U-6	4	2	2	222	2	0	2	120	
U-8	2	3	0	140	2	3	0	140	
U-10	1	0	0	14	1	0	0	14	
U-21	3	0	0	285	1	0	0	103	
<b>Total</b>	<b>22</b>	<b>13</b>	<b>5</b>	<b>\$ 4,246</b>	<b>10</b>	<b>3</b>	<b>5</b>	<b>\$ 1,645</b>	
AH-1	14	4	8	3,226	4	2	4	1,636	
CH-47	3	40	50	4,413	1	34	0	1,675	
CH-54	1	2	2	3,025	-	-	-	-	
OH-6	4	1	1	188	-	-	-	-	
OH-13	2	0	2	21	2	0	2	21	
OH-58	31	12	31	2,683	14	3	16	1,165	
TH-55	3	0	3	79	-	-	-	-	
UH-1	54	40	88	9,846	21	12	41	4,090	
<b>Total</b>	<b>112</b>	<b>99</b>	<b>185</b>	<b>\$23,481</b>	<b>42</b>	<b>51</b>	<b>63</b>	<b>\$ 8,587</b>	
<b>Grand Total</b>	<b>1971-1977</b>	<b>134</b>	<b>112</b>	<b>190</b>	<b>\$27,727</b>	<b>52</b>	<b>54</b>	<b>68</b>	<b>\$10,232</b>

TABLE 6  
US ARMY AVIATION ACCIDENTS DURING THE YEARS 1971-1977 AS A FUNCTION OF AIRCRAFT MODEL

Model Aircraft	No of Flying Hours (Thousands)	Accidents	Overall Acct Rate Per 100,000 Hrs	Fatigue Indicated Accident Rate	Fatigue Related Accident Rate
O-1	198	28	14.1	.5	-
OV-1	208	25	12.0	1.4	.5
T-42	218	24	11.0	2.8	.9
U-1	29	11	37.7	3.4	3.4
U-3	61	5	8.3	1.7	-
U-6	204	19	9.3	2.0	5.9
U-8	341	35	10.3	.6	.6
U-10	11	6	54.9	9.2	9.2
U-21	396	20	5.1	.8	.3
Others	433	25	5.8	-	-
<b>Total</b>	<b>2,099</b>	<b>198</b>	<b>9.4</b>	<b>.1</b>	<b>.05</b>
AH-1	694	146	21.0	2.0	.6
CH-47	481	32	6.7	.6	.2
CH-54	64	5	7.9	1.6	-
OH-6	469	127	27.1	.9	-
OH-13	54	7	13.0	3.7	3.7
OH-58	2,206	181	8.2	1.4	.6
TH-55	932	79	8.5	.3	-
UH-1	6,664	443	6.7	.8	.3
Others	656	52	7.9	-	-
<b>Total</b>	<b>12,220</b>	<b>1,072</b>	<b>8.8</b>	<b>.9</b>	<b>.3</b>
<b>Grand Total</b>	<b>14,319</b>	<b>1,270</b>	<b>8.9</b>	<b>.9</b>	<b>.4</b>

On the basis of the numbers of aircraft in the inventory and the number of flight hours logged, four fixed wing aircraft are of special interest to today's Army: the OV-1 Mohawk, the T-42 Cochise, the U-8 Seminole, and the U-21 Ute. The overall accident rates for each of the first 3 of these was over 10 per 100,000 flying hours while for the U-21 it was considerably lower at only 5.1 (Table 6). Pilot fatigue did not stand out as an accident factor for any one of these four aircraft (Tables 5 and 6). Although fatigue-indicated accident rates varied somewhat, the fatigue-related rates for these four aircraft were all less than 1.0.

Some of these fixed wing aircraft are regularly flown by a single pilot while others are rarely flown with less than two pilots aboard. However, eight of the 22 (36%) fatigue-indicated accidents were single pilot flights. Four of the ten fatigue-related accidents were single pilot flights.

Nine of the 22 fatigue-indicated fixed wing accidents involved a total loss of the aircraft. Four aircraft were classed as total losses in the fatigue-related accidents.

In the rotary wing category, seven of the eight helicopters listed in Tables 5 and 6 are still of interest to the Army. The OH-13 and OH-6 helicopters are no longer found in the Active Army inventory, but the OH-6 is flown in many USA Reserve and National Guard units. Table 6 shows that the overall accident rate for the AH-1 Cobra, the OH-6 Cayuse and the OH-13 Sioux were each over 10 per 100,000 flying hours. The fatigue-indicated accident rates for all the aircraft models of interest were less than 2.0. The fatigue-related accident rates of interest were all less than .7.

Twenty-seven of the 112 (24%) fatigue-indicated rotary wing accidents were single pilot flights. Twenty of these involved the OH-58 Kiowa. Ten of the fatigue-related accidents (eight for the OH-58) were single pilot flights.

Sixty of the 112 (54%) aircraft in the fatigue-indicated rotary wing accidents were categorized as total losses. These total loss accidents included 29 of the 54 UH-1 Iroquois utility helicopters, 20 of 31 observation helicopters (18 OH-58's, 1 OH-6 and 1 OH-13), five of 14 AH-1 attack helicopters, all four cargo helicopters (CH-47 Chinook and CH-54 Tarhe) and two TH-55 Osage trainers. Fourteen of 21 UH-1's, eight of 14 OH-58's and three of four AH-1's involved in fatigue-related accidents were categorized as total losses.

In terms of the relative cost of fatigue accidents (Table 5), the OV-1 materiel losses were high. Both the human and material costs were high for the AH-1, CH-47, OH-58 and UH-1 accidents.

#### Time-of-Day

The fatigue accidents are listed in Table 7 according to the time-of-the-day of the occurrence. The 112 fatigue-indicated accidents were not evenly distributed over the eight three-hour periods of the day shown in Table 7 (Chi-square = 25.90, df = 7,  $p < .005$ ). In fact, 69% of them (93 of 134) occurred during the 12-hour period from 0700 to 1900 hours (Chi-square with Yates correction for discontinuity = 19.41, df = 1,  $p < .005$ ). This seems reasonable since the greatest number of Army flying missions is accomplished in daylight hours.

However, the 52 fatigue-related accidents were evenly distributed throughout the eight time periods listed (Chi-square not significant).

#### Day-Of-The-Week

The accidents are categorized by the day-of-the-week of the occurrence in Table 8. The fatigue-indicated accidents were not evenly distributed over the seven days of the week (Chi-square = 15.3, df = 6,  $.01 < p < .025$ ). It can readily be seen that most of the fatigue-indicated accidents occurred on the four busiest work days, Tuesday through Friday.

The occurrence of the 52 fatigue-related accidents was evenly distributed over the seven day week (Chi-square not significant).

TABLE 7  
FATIGUE-RELATED ACCIDENTS AS A FUNCTION OF TIME-OF-DAY OF OCCURRENCE

<u>Aircraft Type</u>	<u>Period of Day</u>	<u>Number of Accidents</u>	
		<u>Fatigue Indicated</u>	<u>Fatigue Related</u>
Fixed Wing	0400-0659	-	-
	0700-0959	2	1
	1000-1259	3	1
	1300-1559	2	-
	1600-1859	6	2
	1900-2159	8	5
	2200-0059	1	1
	0100-0359	-	-
<b>Total</b>		<b>22</b>	<b>10</b>
Rotary Wing	0400-0659	7	3
	0700-0959	19	3
	1000-1259	22	7
	1300-1559	22	7
	1600-1859	17	7
	1900-2159	9	4
	2200-0059	11	9
	0100-0359	5	2
<b>Total</b>		<b>112</b>	<b>42</b>
<b>Grand Total</b>		<b>134</b>	<b>52</b>

TABLE 8  
FATIGUE-RELATED ACCIDENTS AS A FUNCTION OF DAY-OF-THE-WEEK OF OCCURRENCE

<u>Aircraft Type</u>	<u>Day-of-Week</u>	<u>Number of Accidents</u>	
		<u>Fatigue Indicated</u>	<u>Fatigue Related</u>
Fixed Wing	Sun	2	0
	Mon	2	2
	Tues	3	2
	Wed	5	0
	Thur	3	2
	Fri	5	3
	Sat	2	1
<b>Total</b>		<b>22</b>	<b>10</b>
Rotary Wing	Sun	13	7
	Mon	9	3
	Tue	19	8
	Wed	24	7
	Thur	22	10
	Fri	16	5
	Sat	9	2
<b>Total</b>		<b>112</b>	<b>42</b>
<b>Grand Total</b>		<b>134</b>	<b>52</b>

#### Aviator Activity Levels

Table 9 lists the mean and the range of the number of hours the aviators spent in various activities prior to the accidents.



TABLE 9  
AVERAGE ACTIVITY LEVELS OF AVIATORS INVOLVED IN FATIGUE-RELATED ACCIDENTS

	Fatigue-Indicated		Fatigue-Related	
	Fixed Wing	Rotary Wing	Fixed Wing	Rotary Wing
Flight Time Last 24 Hr	Avg = 4.1 hr Range = (0-8 hr)	3.9 (0-10)	5.4 (0-8)	4.7 (0-16.5)
Work in Last 24 Hr	11.0 (7-15)	11.4 (2-21)	12.3 (10-15)	13.4 (3-21)
Work in Last 48 Hr	20.0 (7-24)	20.0 (2-40)	20.7 (20-24)	23.0 (6-40)
Continuously Awake Prior To Event	11.3 (3-16)	8.5 (1-19)	13.1 (5-16)	10.6 (2-19)
Sleep in Last 24 Hr	7.1 (4-9)	6.6 (2-11)	7.1 (4-8)	5.4 (2-10)
Sleep in Last 48 Hr	14.6 (4-18)	13.9 (8-21)	14.4 (4-18)	12.6 (8-21)
Duration of Last Sleep	6.9 (4-9)	6.0 (2-11)	7.1 (4-8)	4.7 (2-11)
Flight Time Last 30 Days	29.3 (0-62)	46.9 (0-138)	32.7 (7-55)	43.0 (0-133)

The numbers cited are those for aviators who were listed as having played a primary role in the accident. Row 1 of Table 9 summarizes the number of hours of flight time the aviators logged in the 24 hours immediately preceding the accidents. The grand mean for the pilots involved in all 134 fatigue-indicated accidents was 4.0 flight hours in the last 24 hours. The standard deviation (SD) was 2.8. The average number of flight hours for the pilots in the 52 fatigue-related accidents was slightly higher with a mean of 4.8 and a SD of 3.2 hours. The large standard deviations and the broad ranges cited in the table describe the wide variability of these measures. These data demonstrate that one cannot infer aviator fatigue solely by knowing the number of flight hours the pilot logged in the last 24 hours.

When making determinations about fatigue factors influencing aviator performance, it is important to consider both the pilot's duty and off-duty activities for several days prior to the accident. Rows 2 through 7 of Table 9 summarize work and sleep activities for the 48 hours preceding the accidents. The hours listed in Rows 2 and 3 represent military duty hours. On the average, the pilots worked over 11 hours in the last 24 hours and they worked over 20 hours in the last 48. Again, the variability in these data was high. Twenty percent of the pilots (26 of 129) worked 15 or more hours during the 24 hours preceding the accidents. Fifteen of these pilots were involved in accidents judged to be fatigue-related. As the ranges indicate, there were some pilots whose chronological histories listed a small number of duty hours prior to the accident. Unfortunately, the descriptions of their off-duty activities were not always complete. Some were very specific, for example, listing "four hours of reading" and some were quite vague, as "I went out for the evening." It was not easy to gauge the impact of some of the off-duty activities on these pilots.

How long a pilot was continuously awake prior to the accident (Row 4, Table 9) played an important part in making fatigue factor determinations. One-third of the pilots involved in fatigue-indicated accidents (45 of 129 case histories which included data on this question) had been awake for more than 12 hours. More importantly, fifty-six percent (28 of 50) of the pilots in the accidents judged to be fatigue-related had been awake longer than 12 hours; 12 of these pilots were awake longer than 15 hours; 7 of them longer than 17 hours.

The mean number of hours of sleep which pilots obtained in the 24 and 48 hours prior to the accident (Rows 5 and 6, Table 9) is not very informative by itself. The averages approximate the number of hours of sleep obtained by many adults on a regular basis. Examining the number of sleeping hours for each pilot on an individual basis is not much more informative. One fixed wing pilot slept only four hours in a 48 hour period. However, the next lowest amount of sleep for the fixed wing pilots was 13 hours. Of the 105 rotary wing aviators for whom data were available, only 12 slept less than four hours in the last 24 hours and only four slept less than eight hours in the 48 hours preceding the accidents. The data for the number of hours of sleep obtained during the 48 hours preceding the accidents clearly do not themselves as fatigue determiners.

Some of the explanations for the seemingly non-utility of knowing the number of hours of sleep in the last 48 hours become apparent in an examination of the data on the duration of the last sleep (Row 7, Table 9). Twenty-five percent of the pilots (31 of 126) involved in the fatigue-indicated accidents slept for less than four hours their last "sleep session" prior to the accidents. Forty-two percent of the pilots (20 of 48) in the fatigue-related accidents slept less than four hours at a time. Thus, although pilots were getting a total of six or more hours of sleep per 24-hour period, many were not getting sleep of adequate duration in a single sleep session. Their case histories cite "nap taking" frequently.

Man's sleep cycles usually alternate periods of light dreaming sleep necessary for psychological restoration with deep sleep needed for physiological recovery. One such cycle generally lasts on the order of 90 minutes.<sup>8</sup> It is very possible that the short duration sleep periods of many of the pilots involved in these accidents prevented them from getting enough "restful" REM sleep prior to the accidents.

The total number of flying hours a pilot accumulates during a 30-day period is usually considered in the interest of determining if chronic fatigue is involved (Row 8, Table 9). There has not been universal agreement as to how many hours per month a pilot should be allowed to fly. The policies regarding such limits have changed several times with increasing attention to combat fatigue losses. During the 1971-73 involvement in the Vietnam conflict the Army aviators who accumulated 90 flight hours in a 30 day period were to be monitored closely by both the unit commander and the flight surgeon. A certificate of the crew member's fitness to continue accumulating flight time above 110 hours had to be signed by the flight surgeon and the unit commander and placed in the crew member's flight records.<sup>9</sup> The present Army Regulation, AR 95-1,<sup>10</sup> says that "in combat, 140 hours per 30-day period has been considered a safe and effective performance ceiling and as a general rule aviators flying beyond 90 hours in a 30-day period must be observed frequently by a flight surgeon."

Sixteen percent of the pilots (21 of 134) involved in fatigue-indicated accidents, seven in the fatigue-related category, accumulated over 90 flight hours in the 30 days preceding the accident. All 21 of these accidents were in rotary wing aircraft, and all occurred in Vietnam. Since the Vietnam involvement, only 2 of 67 pilots accrued over 70 flight hours in the 30 days prior to their accidents. It seems that tracking the number of flight hours per 30-day period is not a very sensitive measure of aviator fatigue in peacetime operations.

Not shown in Table 9 are the data on missed meals. Irregularity of food ingestion and lack of hot meals may influence a pilot's capacity for sustained optimal performance and contribute to conditions of fatigue.<sup>3</sup> Seventeen percent of the pilots (23 of 134) in the fatigue-indicated accidents missed one or more meals during the workday of the accident. Nineteen percent of the pilots (10 of 52) involved in the fatigue-related accidents missed at least one meal.

#### Analysis of Errors

One of the implications of the search for pilot fatigue is that fatigue will somehow cause a pilot to modify his performance. Performance changes may come in the form of slower reaction times, lapses of attention, errors of omission or increased variability in performance of known tasks.<sup>11</sup>

Categorizing accidents into those which involve detrimental pilot performance changes is almost as difficult as making pilot fatigue determinations. Without elaboration as to how the decisions were made, 42 of the 52 fatigue-related accidents were categorized as involving pilot errors. Table 10 lists these pilot error situations. As examples of errors of omission and lapsed attention, two pilots landed fixed wing aircraft with the gear up, and one pilot failed to place the prop lever in position prior to takeoff. Four pilots allowed their aircraft to run out of fuel. Slowed reaction times were apparent in late attempts to take corrective action in degrading autorotation conditions. Variability in performance was exhibited in sloppy hovers and landings which resulted in accidents.

TABLE 10  
PILOT ERROR IN FATIGUE-RELATED ACCIDENTS, 1971-1977

<u>Error Situation</u>	<u>Fixed Wing</u>	<u>Rotary Wing</u>
Takeoff	1	1
Landing	4	8
Fuel Starvation	2	2
Hover		4
Autorotation		5
Poor Visibility/Weather		5
Wire Strikes		6
Low Level Flight		4
<b>Total</b>	<b>7</b>	<b>35</b>

## CONCLUSIONS

Pilot fatigue is very likely to have been a contributing factor in 4.1 percent of all US Army aviation accidents worldwide from 1971 through 1977. Fifty-four fatalities and 68 injuries resulting from the 52 fatigue-related accidents account for over 8 percent of all fatalities and for over six percent of all injuries suffered during the period. The \$10.23 million in materiel losses for the fatigue-related accidents amounted to over 4.8% of all materiel losses during the seven years.

On the basis of accident rates of .07 fixed wing and .29 rotary wing accidents per 100,000 flying hours, fatigue-related rotary wing accidents were four times more common during the seven year period. The 42 rotary wing accidents accounted for over 94 percent of the fatalities, almost 92 percent of the injuries and 85 percent of the materiel losses in the fatigue-related accidents.

Fatigue-related accidents did not occur in one model helicopter more than in another. However, one-fourth of these accidents (10) occurred in single pilot flights and eight of these involved the OH-58 Kiowa. Sixty percent (25 of 42) of fatigue-related rotary wing accidents resulted in a total loss of the aircraft.

Fatigue-related accidents were evenly distributed throughout the 24-hour day and the seven day week.

The chronological history of a pilot's activities prior to an accident was useful in determining whether or not pilot fatigue contributed to the accident. The duration of a pilot's last sleep and the number of hours he had been continuously awake prior to the accident seemed to be the indicators most relied upon. By themselves, the number of flight hours logged and the number of hours slept the 24 hours prior to the accident were not adequate determiners of pilot fatigue. An assessment of all the information contained in the case history was integrated into the rest of the accident investigation report in making determinations of fatigue factors.

## REFERENCES

1. Neel, S. Medical support of the US Army in Vietnam 1965-1970 (Vietnam Studies), Washington, D.C.: Department of the Army, 1973.
2. Perry, I. C. Helicopter aircrew fatigue (AGARD-AR-69). London: Harford House, NATO Advisory Group for Aerospace Research and Development, May 1974.
3. Fisher, K. S., & Carr, C. J. An interim report on factors that affect the performance of Army flight crew personnel. Bethesda, MD: Life Sciences Research Office, Federation of American Societies for Experimental Biology, July 1968.
4. Karney, D. H. Flight limits and crew rest. US Army Aviation Digest, 1976, 22(2), 1-6.
5. US Army. DA Form 2397 Series--Technical report of US Army aircraft accidents. Washington, D.C.: Department of the Army, September 1970.
6. Cohen, J. A. A coefficient of agreement for nominal scales. Educational and Psychological Measurement, 1960, 20, 37-46.
7. Spezia, E., & Davis, F. Z. Personal communication of data obtained from the computerized accident data base at the US Army Agency for Aviation Safety (USAAAVS) at Fort Rucker, Alabama, January 1978.
8. Kleitman, N. Sleep and wakefulness. Chicago: University of Chicago Press, 1963.
9. US Army in the Republic of Vietnam. Supplement 1 to Army Regulation 95-1. Vietnam: US Army Headquarters, 1970.
10. Headquarters, Department of the Army. Army aviation; General provisions and flight regulations (AR 95-1). Washington, D.C.: Department of the Army, November 1976.
11. Woodward, D. P., & Nelson, P. D. A user oriented review of the literature on the effects of sleep loss, work-rest schedules and recovery on performance (ONR-ACR-206). Arlington, VA: Office of Naval Research, December 1974.

## ACKNOWLEDGMENT

The authors gratefully acknowledge the assistance of Mrs. Frankie Davis in obtaining the data described in this report from the USAAAVS computerized data base.

The conclusions drawn from the data do not necessarily represent the official position of USAAAVS, USAARL, or the US Army unless so stated elsewhere.

## EVALUATION OF AIRCREW FATIGUE DURING OPERATIONAL HELICOPTER FLIGHT MISSION

Preliminary Report

by

Ten. Gen. C.S.A. Prof. C.Koch, IAF  
 Capo del Servizio Sanitario Aeronautico  
 Ispettorato Logistico A.M.  
 Via P.Gobetti 2  
 00185 Roma, Italy

Lt Col. F.Monesi, MC, IFA  
 Executive Aerospace Medical Panel  
 AGARD-NATO  
 7 rue Ancelle  
 92200 Neuilly sur Seine, France

## SUMMARY

Monitoring of physiological parameters is meant to be of value for the assessment of workload in laboratory and also field studies.

In-flight recordings of ECG, breathing rate and amplitude, EMG, EEG, EOG and Gz were transmitted telemetrically from the helicopter crew station to the ground receiving station.

The investigators were provided with some objective data on the increase in biological cost for an Agusta/Bell 204 helicopter pilot trying to maintain a given level of performance. In fact, the same task was performed by the pilot in two successive phases of an operational flight mission, the latter being more demanding.

However, it still remains that the attempt to assess aircrew's acute fatigue calls first for the solution of the methodological problem of the identification of parameters proving to be best adapted to encompass the biological impairment and weariness sometimes associated with flight profiles.

## INTRODUCTORY REMARKS

Fatigue is a global concept to denote those changes in bodily physiology, decrease in work output (either quantity or quality) and characteristic subjective feelings of tiredness or disinclination to work which are all associated with a continuous activity (Perry).

The range of operations which rotary wing aircraft have to perform has become more and more complicated. The helicopter has now become an all-weather vehicle in civil and military operations that involve, for example, the transport or placing of heavy suspended loads, landing and takeoff at high altitude in mountainous areas, rescue and research missions flying over inhospitable wooded or rocky land or heavy seas. This nerve-racking psychoemotive experience of the helicopter pilot in conditions of a continuous state of vigilant expectation and fear of danger, a tension that by itself is sufficient to wear out the psyche, is compounded by psychosensorial stimuli more or less specific to helicopter flying such as flickering lights and vibration phenomena caused by the rotation of rotor blades, and disorientation proving far more serious than in the case of fixed wing aircraft because accelerations may occur simultaneously along all three of the aerodynamic axes of the vehicle (Rotondo).

Recently, new low altitude terrain flight techniques (nap-of-the-earth, contour and low level flight) have become routine thereby further increasing the helicopter pilot's workload (Sanders).

## MATERIAL AND METHOD

Subject A pilot of the IAF, stationed in Milan, with about 4,000 hours of flight experience in both fixed and rotary wing aircraft, free from mental and physical disease at the last checkup made within the previous year and of normal behavioural patterns.

He was briefed about the general nature of the project and his role, then given a Bottlang Airfield Manual map (scale 1:200,000) on which the navigation course had been plotted.

3 Hellige electrodes were fixed on the heart region, 4 symmetrically on the mm erectores trunci, 2 on the forehead and 1 on the left suborbital region. A sensor was adapted to the microphone in front of the right nostril.

Task	120 min operational flight mission, VMC, VIS ≈ 5 NM, wind: variable 240 (#10), 5±1 KT, A: helicopter landing area
1st phase (20 min)	A→B : HDG 160°, IAS 90 KT, climb rate 300 ft/min, 3 min B : 1st 3 min hovering, 450' AGL B→D : zig-zag flight, 100' AGL, 8 min D : 2nd 2 min hovering, 90' AGL, 3 min winching operation D→A : straight flight, 1 min
2nd phase (50 min)	A→F : low level flight, HDG 115°, IAS 90 KT, 50' AGL, ≈ 13 NM -- Sarnico (lake of Iseo) 11 min F→F : following of lake contour anti-clockwise, ≈ 42 NM, 15' AGL, IAS 90 KT, 28 min, secondary task "identify all the boats on the lake" F→A : return flight - overflight of TWR, 30' AGL with 25° bank, 11 min
3rd phase (30 min)	A→C : map route flight, 100' AGL, IAS 40-80 KT, 30 min, secondary tasks "count the cable-cars operating on the slopes", "count the gliders flying in Valbrembana", "count the vehicles on the highway"
4th phase (20 min)	: identical to the 1st phase

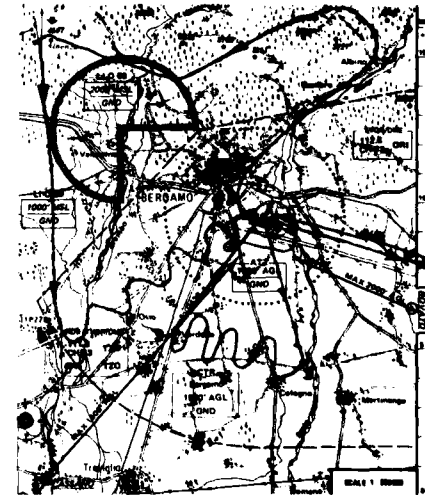

Fig.1 Navigation course utilized for the experiment  
 A. helicopter landing area  
 D. winching operation point

- Apparatus** - Messerschmitt-Bölkow-Blohm 8 channel PCM telemetry system  
 - Racall Store 7 FM tape recorder  
 - Galileo conventional 8 channel electrograph  
 - G-meter  
 - Agusta/Bell 204 helicopter as test vehicle

### RESULTS

The following physiological and flight parameters were recorded at the ground receiving station when the helicopter crew station was within a range of about 7.5 NM (some 14 Km).

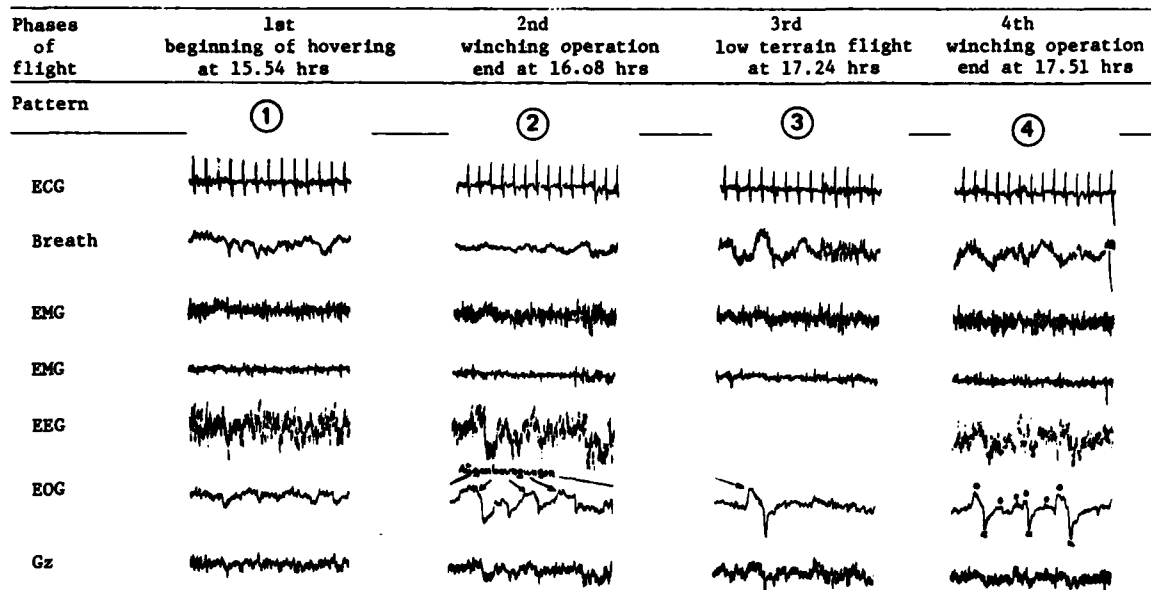

Fig. 2 - Physiological and flight parameters recorded in flight.

It is evident that in the 4th phase of the mission, at 17.51 hrs, the respiratory volume with irregular breathing rate, the amplitude of EMG patterns and the amount of eye movement and blinking recorded from the helicopter pilot showed an increase as compared with the same parameters recorded when the pilot was performing the same task (winching operation in hovering) in the 2nd phase, at 16.08 hrs. In fact, in the 4th phase the task was performed after 103 minutes of operational flight mission including, for most of the time, secondary high vigilance tasks such as identification of boats whilst flying along the meandering shore line of the lake, at 15' AGL, counting of cablecars on the slopes, gliders in the valley and cars on the highway.

### CONCLUSIONS

The pilot in command of the helicopter was a "desk pilot", experienced but out of practice.

During the low terrain flight he reached a state of high vigilance and alertness as shown by the rare blinking and reduced eye mobility whilst he was looking outside the vehicle (pattern No.3, EOG at 17.24 hrs).

During the winching operation in the 4th phase (pattern No.4, EOG at 17.51 hrs) in hovering following the performance of a 103 minute almost continuous vigilance task, the eye movements monitoring the winching are probably less complex as compared with those recorded in the 2nd phase (pattern No.2, EOG at 16.08 hrs).

This could be regarded as a sign of recollection of past skill, however the clear-cut increase in blinking gives probably a hint of the onset of fatigue. The physical exhaustion, in particular backache, of which the pilot complained, was not associated with feelings such as weariness and boredom, because of his high motivation.

The crucial question is which physiological parameters prove of practical value in revealing the onset of a state of acute fatigue. Undoubtedly, breathing rate and amplitude show relatively early changes with the increase in workload during helicopter flying (Pettyjohn) as well as EMG and EOG.

However, adequate computerized analysis of other physiological and behavioural parameters will possibly provide the investigator with more subtle tools for the identification of fatigue.

### ACKNOWLEDGEMENTS

The authors would like to thank Dr. Kurt Gratzl and Dipl.-Ing. Uwe Rimkus as well as the helicopter pilots of IAF without whose help this work would have not been possible.

### REFERENCES

- I C Perry "Helicopter Aircrew Fatigue" AGARD Advisory Report No.69, May 1974.
- F S Pettyjohn "Use of Respiratory Minute Volumes in Evaluation of Rotary and Fixed Wing Pilot Workload" AGARD CP 216, 1977.
- G Rotondo "Workload and Operational Fatigue in Helicopter Pilots" AGARD CP 217, 1977.
- M G Sanders and co-workers "Visual Workload of the Copilot/Navigator during Terrain Flight" AGARD CP 217, 1977.
- R R Simmons and K A Kimball "Methodological Considerations of Visual Workload of Helicopter Pilots" AGARD CP 216, 1977.

CHANGES IN THE ROTARY WING AVIATOR'S ABILITY TO PERFORM AN UNCOMMON  
LOW ALTITUDE REARWARD HOVER MANEUVER AS A FUNCTION OF EXTENDED  
FLIGHT REQUIREMENTS AND AVIATOR FATIGUE

M. A. Lees, R. R. Simmons, L. W. Stone, & K. A. Kimball  
US Army Aeromedical Research Laboratory  
P. O. Box 577  
Fort Rucker, Alabama 36362

#### SUMMARY

The US Army Aeromedical Research Laboratory (USAARL) has long recognized the importance of the aircrew as a critical component during extended operations of the man-helicopter system. To provide the local flight commander with information describing the effects of aviator fatigue on mission performance, USAARL has developed an in-flight research program which examined changes in man-helicopter system performance for a variety of flight maneuvers. The current report describes the system performance changes in the rearward hover maneuver across five days of an extended flight schedule. Observed system performance has been categorized into measures of the pilot's control performance, measures of the aircraft's stability, and combined measures of total system performance for each primary aircraft control channel. System performance changes across the five flight days and within the flight days were examined using multivariate analysis. Significant changes in each aircraft control channel are presented and the overall changes in system performance are discussed.

#### INTRODUCTION

The requirement to develop around-the-clock operational capability is well recognized within the US Army Aviation community.<sup>1 2</sup> To satisfy this requirement several major developmental efforts have been initiated to improve the effectiveness of various helicopter subsystems during tactical utilization including the development of night vision, navigation and communication devices. One component of the man-helicopter system that may be heavily affected by extended operations and the addition of tactical subsystems is the aircrew, and in particular the pilot. Determining the effect of extended flight requirements and aviator fatigue on mission performance is an area of major concern to the local flight commander who now has the responsibility to establish flight time limitations and crew rest requirements for his flight crews.<sup>3</sup>

The US Army Aeromedical Research Laboratory (USAARL) has long recognized the importance of the aircrew as a critical component of the tactical helicopter system. USAARL has also recognized the need to develop critical information regarding the aircrew's extended flight capability and the requirement to relay this type of information back to the local flight commander to aid in the effective management of aviation resources. In response, USAARL has developed an in-flight research program to examine realistic mission performance and to identify those changes in the man-helicopter system performance resulting from extended flight requirements and aviator fatigue. The goal of this research program is to provide the local flight commander with specific information that describes the critical time periods during extended flight missions where man-helicopter system performance will be degraded. In addition, this research is directed toward identifying those aspects of the mission performance that are most heavily affected by changes in the aviator's performance, what type of decrement can be expected, and to what degree the performance will be degraded. It is anticipated that these results which focus on the changes in the aircrew will complement other research and development efforts on helicopter subsystems in providing a comprehensive estimation of the man-helicopter system capability.

As a part of the ongoing aviation fatigue research program, USAARL has conducted an extensive field investigation to determine the effect of extended flight requirements on helicopter in-flight performance and on biomedical, physiological and psychological parameters which reflect the pilot's flight ability.<sup>4 5 6</sup>

This report presents an examination of the rearward hover--one of the maneuvers performed during five days of an extended flight schedule. This maneuver has several characteristics which make it particularly relevant in assessing changes in the pilot's flight control capability as a function of fatigue and extended flight requirements. The rearward hover is a demanding precision positioning maneuver used in avoiding obstacles. One possible application of this maneuver is in leaving or returning to a position of maximum terrain concealment. In addition, the rearward hover, as conducted in the research investigation, is not heavily practiced in the training environment and thus provides an opportunity to measure changes in the pilot's performance while engaged in a relatively unfamiliar maneuver.

The current report describes the system performance changes in the rearward hover maneuver across five days of extended flight requirements. The measures of the man-helicopter system performance have been categorized into measures of the pilot's control performance, measures of the aircraft's stability during the rearward hover and measures of changes in the total system performance as measured by values which reflect a combination of the pilot and aircraft performance.

The current report is the third in a series which examines the fatigue related changes in helicopter system performance observed during a large-scale fatigue investigation.<sup>4 5 6</sup> The major goal of the fatigue research program is to develop predictive indices which will enable the local flight commander to judge the existing level of aircrew fatigue and the potential impact on mission performance. The current report concentrates primarily on a description of system performance changes as a function of extended flight requirements. Future reports from the fatigue research program<sup>4 5 6</sup> will be used to determine the relationship between the measures of helicopter system performance, as presented in this report, and measures of pilot fatigue.

#### METHODS AND PROCEDURES

The major fatigue research investigation, which provided the data for the current report, was conducted at the USAARL field test facility located at Highfalls stagefield near Ft. Rucker, Alabama. The subjects for this investigation were six US Army aviators who had recently completed the Initial Entry Rotary Wing (IERW) flight training course at the US Army Aviation Center, Ft. Rucker, Alabama. The six aviators were divided into three pairs of test subjects and each pair of subjects participated in a 12-day research program. This research program included five flight days during which the subjects completed 13 one-hour flight periods per day performing as the aircraft commander or first pilot. The experimental schedule implemented during the five flight days and the list of maneuvers performed during each one-hour flight period are presented in Tables 1 and 2 respectively. A more complete description of the testing procedures and schedule is available in previous reports on the major fatigue investigation.<sup>4 5 6</sup>

TABLE 1  
SCHEDULE OF SLEEPING, EATING, AND TESTING

TIME FRAME	SUBJECT ACTIVITIES	EXPERIMENTAL MEASURES								
		Flight HIMS	Urine	Blood	IP Rating	Pupilo- meter	DVA	Reaction Time	Mood Scale	Fatigue Rating
0100 to 0430	Sleep Period		x							
0500 to 0600	Flight	x x	x	x	x					
0615 to 0800	Breakfast & Testing					x	x	x	x	x
0800 to 0945	Flight	x x	x		x					x x
1000 to 1145	Flight	x x	x	x	x					x x
1200 to 1400	Lunch & Testing					x	x	x	x	x
1400 to 1545	Flight	x x	x		x					x x
1600 to 1745	Flight	x x	x	x	x					x x
1800 to 2000	Supper & Testing					x	x	x	x	x
2000 to 2145	Flight	x x	x		x					x x
2200 to 2345	Flight	x x	x	x	x					x x
2400 to 0100	Snack & Testing					x	x	x	x	x

TABLE 2  
FLIGHT PROFILE

<u>Bad Weather</u>	
1.	3 ft. Hover - 1 minute (Measured)
2.	360° Pedal turn - left about mast (Measured)
3.	360° Pedal turn - right about mast (Measured)
4.	Slope - right skid (Measured)
5.	Slope - left skid (Measured)
6.	Hover taxi (Measured)
7.	Lateral hover
8.	360° Pedal turn - left about nose
9.	360° Pedal turn - right about nose
10.	360° Pedal turn - left about pilot
11.	360° Pedal turn - right about pilot
12.	360° Pedal turn - left about tail
13.	360° Pedal turn - right about tail
14.	Rearward hover (Measured)
<u>Marginal Weather</u>	
15.	10 ft. Hover - 1 minute (Measured)
16.	25 ft. Hover - 1 minute (Measured)
17.	50 ft. Hover - 1 minute (Measured)
18.	Simulated max-gross takeoff (Measured)
19.	Traffic pattern 300 ft. AGL (Measured)
	Crosswind (Measured)
	Downwind (Measured)
	Base (Measured)
	Final (Measured)
20.	Shallow approach (Measured)
<u>Good Weather</u>	
21.	Normal traffic pattern (Measured)
	Crosswind (Measured)
	Downwind (Measured)
	Base (Measured)
	Final (Measured)
22.	Normal approach (Measured)
23.	Max performance takeoff (Measured)
24.	Low level flight (Measured)
	Heading (Measured)
	Altitude (Measured)
	Airspeed (Measured)
25.	Confined area landing (Measured)
26.	Max performance takeoff (Measured)
	Heading (Measured)
	Altitude maintenance (Measured)
	Airspeed (Measured)
27.	Shallow approach (Measured)
<u>IFR (Hood)</u>	
28.	Standard rate climbing turn left to 180°
29.	Maintain straight and level flight 15 sec.
30.	Standard rate descending turn right to 180°
31.	Deceleration to 40 knots
32.	Acceleration to 90 knots

Objective measures of the pilot's control performance and the changes in the stability of the aircraft were measured through the use of the Helicopter In-Flight Monitoring System (HIMS). This research system provides for the real time acquisition of all major aircraft motion and pilot control parameters. HIMS monitors and records aircraft movement in six degrees of freedom as well as pilot control movements on the cyclic, collective and pedal controls. Measures of rates and accelerations along each aircraft axis are also obtained. An on-board radio ranging system is utilized to continuously track the research aircraft's position within the 100 square mile test range. HIMS continuously monitors and records 20 channels of information using an on-board incremental tape recorder. Complete processing of the HIMS data provided 440 direct or derived measures of aircraft and pilot performance. A more complete description of this system and the resulting system performance measures are available in USAARL Report No. 72-11.<sup>7</sup>

For the current investigation of man-helicopter system performance during the rearward hover maneuver, subsets of performance variables were selected for examination.



Each of these variable subsets (Table 3) examines one important aspect of the total system performance. These subsets are further categorized into variables which concentrate on the pilot's control performance (Set A through D), those which concentrate on the aircraft's stability during the rearward hover (Set E), and one set of variables which has been created to describe changes in the total helicopter system performance during the execution of the rearward hover (Set F).

TABLE 3  
EXPERIMENTAL MEASURES OF HELICOPTER SYSTEM PERFORMANCE

---

<u>Pilot Control Measures</u>	
SET A	<ol style="list-style-type: none"> <li>1. Cyclic Fore-Aft Average Control Movement Magnitude</li> <li>2. Cyclic Left-Right Average Control Movement Magnitude</li> <li>3. Collective Average Control Movement Magnitude</li> <li>4. Pedal Average Control Movement Magnitude</li> </ol>
SET B	<ol style="list-style-type: none"> <li>1. Cyclic Fore-Aft Average Control Movement Magnitude Standard Deviation</li> <li>2. Cyclic Left-Right Average Control Movement Magnitude Standard Deviation</li> <li>3. Collective Average Control Movement Magnitude Standard Deviation</li> <li>4. Pedal Average Control Movement Magnitude Standard Deviation</li> </ol>
SET C	<ol style="list-style-type: none"> <li>1. Cyclic Fore-Aft Average Number of Control Movements Per Second</li> <li>2. Cyclic Left-Right Average Number of Control Movements Per Second</li> <li>3. Collective Average Number of Control Movements Per Second</li> <li>4. Pedal Average Number of Control Movements Per Second</li> </ol>
SET D	<ol style="list-style-type: none"> <li>1. Cyclic Fore-Aft Percentage of Total Time in Control Movement</li> <li>2. Cyclic Left-Right Percentage of Total Time in Control Movement</li> <li>3. Collective Percentage of Total Time in Control Movement</li> <li>4. Pedal Percentage of Total Time in Control Movement</li> </ol>
<u>Aircraft Stability Measures</u>	
SET E	<ol style="list-style-type: none"> <li>1. Pitch Axis Standard Deviation</li> <li>2. Roll Axis Standard Deviation</li> <li>3. Heading Axis Standard Deviation</li> </ol>
<u>Combined System Performance Measures</u>	
SET F	<ol style="list-style-type: none"> <li>1. Cyclic Fore-Aft Combined Performance (Cyclic Fore-Aft Pitch Control, Cyclic Fore-Aft Percent of Time in Control Movement/Pitch Standard Deviation, Cyclic Fore-Aft Average Control Movement Magnitude)</li> <li>2. Cyclic Left-Right Combined Performance (Cyclic Left-Right/Roll Control, Cyclic Left-Right Percent Time in Control Movement/Roll Standard Deviation, Cyclic Left-Right Average Control Movement Magnitude)</li> <li>3. Pedal Combined Performance (Pedal/Heading Control, Pedal Percent Time in Control Movement/Heading Standard Deviation/Pedal Average Control Movement Magnitude)</li> </ol>

---

Variables in Sets A through D describe various aspects of the pilot's control inputs as determined through the processing of the changes in the aircraft's control positions.<sup>6</sup> Variable Set A describes the size of the control movements and Set B indicates the consistency or changes in the average distribution of these control inputs for each of the primary helicopter controls. Variable Set C measures the average number of control movements per second introduced by the pilots during the rearward hover. Set D describes the percentage of the total flight time used by the pilot in introducing control movements.

Each of the variable Sets A through D measures one aspect that is important in describing the quality of the pilot's control performance. Thus, the size of the control input as measured by the average control movement magnitude (Set A) is one dimension of control quality. Relatively small control movements represent precise control of the helicopter. Another important dimension, the consistency of the pilot's control performance, is reflected in the measures of control movement standard deviation (Set B), which describes the distribution of the pilot's control movements.

Measures of the number of control movements per second for each of the control channels (Set C) and the measures of the percentage of time spent in control movements

(Set D) both describe slightly different aspects of the control effort utilized by the pilot during the execution of the rearward hover.

Variable Set E describes the stability of the helicopter during the accomplishment of the rearward hover. These variables measure error from an absolutely stable helicopter attitude that could be expected from a hypothetically perfect rearward hover maneuver.

Variable Set F contains variables which are not directly obtained from the measurement of man-helicopter performance. These variables are ratios of objective performance measures created to assist in further describing the system relationship between the pilot's control performance and the resulting aircraft stability, as a function of extended flight requirements and aviator fatigue. These variables (combination performance) were constructed to adjust the measures of control effort by the measures of aircraft stability to more clearly describe changes in system performance. The combination variable for the cyclic fore-aft control channel is defined:

$$\frac{\text{(Cyclic Fore-Aft Percentage of Time in Control Movement/Pitch Standard Deviation)}}{\text{Cyclic Fore-Aft Average Control Movement Magnitude}}$$

This variable uses a description of the pilot's control effort (% time) and then adjusts it by dividing by the value of the system stability (Pitch SD). Thus, given a relatively constant value of control effort, an increase in system stability for this control axis (as reflected by a decrease in the Pitch SD) would result in a higher value for the numerator of this combination variable. The numerator of the variable is further adjusted by the average size of the control movements under the assumption that the use of relatively small control movements reflects more precise control of the helicopter's attitude. For the interpretation of this combination performance variable, and those which describe the other control channels, it is assumed that higher values reflect a higher quality of precision helicopter control. Although these combination variables have not been rigorously validated as measures of man-machine system performance, they have been useful to the authors in obtaining a clearer description of the relationship between the pilot's control performance and the aircraft's attitude stability for each of the primary helicopter attitude control channels. For the present investigation a combination variable for the collective control channel was not developed. It was felt that the dynamic resolution of the altimeters used to measure changes in the collective/altitude relationship did not afford the same precision as did the measures of pitch, roll and heading used to adjust the other control channel combination variables.

For the current investigation the in-flight performance on the rearward hover maneuver was examined across the first four complete flight days of the fatigue investigation. The in-flight performance for the morning, afternoon, and evening flight periods was also examined across the four flight days. In this manner changes in the man-helicopter system performance both across flight days and within the flight days was investigated. Each of the six sets of system performance variables were examined separately using multivariate analysis of variance techniques<sup>8</sup> to test for performance changes across flight days, performance changes within the flight days, and for a day by time of day interaction effect. Each of the six sets of performance variables were also tested using a multivariate analysis of covariance<sup>8</sup> to determine if the measured covariates, presented in Table 4, demonstrated a significant relationship to observed performance error. Any overall analysis which determined that a significant change in pilot or aircraft performance had occurred was further examined to determine the performance trend using orthogonal polynomial contrasts.<sup>8</sup>

TABLE 4

## COVARIATES MEASURING ENVIRONMENTAL AND EXPERIMENTAL EFFECTS

- 
1. Wind Speed
  2. Wind Gusts Speed
  3. Degrees of Crosswind
  4. Fuel Minutes (Measures Fuel Burn Off)
  5. Maneuver Sequence Number (An Index of Accumulated Daily Flight Time)
- 

## RESULTS AND DISCUSSION

Examination of Pilots' Control Inputs

The first characteristic of the pilots' control performance examined for changes both across and within the four flight days was the size of the control movements as measured by the variables in Set A. The results of these analyses are presented in Table 5 and demonstrate that there were no significant changes in the average size of the control movements during the execution of the rearward hover maneuver. In addition, the regression of the five covariates on each of the main effect error terms has indicated that there was no significant relationship between the measured covariates and the observed differences in size of the control movements. Examination of the other

pilot performance variables has shown that the covariates did not demonstrate a significant relationship with observed performance error for any of these analyses. In addition, it was found that there were no significant results for the day by time of day interaction term for the pilot performance variable sets. Thus, for the sake of brevity the results from each analysis of covariance regressions for variable Sets A, B, C, and D have not been presented. The results for the tests of performance change across flight days and within flight days have been combined in Table 5. The nonsignificant results for the interaction terms have also been eliminated from this table.

TABLE 5  
MULTIVARIATE ANALYSIS OF VARIANCE SUMMARY  
PILOT CONTROL PERFORMANCE VARIABLES

	F-Ratio <sup>1</sup>	Mean Squares Tested	Degrees of Freedom for Hypothesis	Degrees of Freedom for Error	P Less Than*	Root
Set A: Average Control Movement Magnitude						
1. Day Effect (D)	1.662	D/DS	12.00	32.04	.123	1
2. Time of Day Effect (T)	2.138	T/TS	8.00	14.00	.102	1
Set B: Average Control Movement Magnitude Standard Deviation						
3. Day Effect (D)	1.798	D/DS	12.00	32.04	.091	1
4. Time of Day Effect (T)	3.004	T/TS	8.00	14.00	.035*	1
Test of Trend for T						
5. Linear	5.712		4.00	61.00	.001*	1
6. Quadratic	1.760		4.00	61.00	.149	1
Set C: Number of Control Movements per Second						
7. Day Effect (D)	2.294	D/DS	12.00	32.04	.030*	1
Test of Trend for D						
8. Linear	22.338		4.00	61.00	.001*	1
9. Quadratic	.428		4.00	61.00	.788	1
10. Cubic	1.928		4.00	61.00	.117	1
11. Time of Day Effect (T)	5.653	T/TS	8.00	14.00	.002*	1
Test of Trend for T						
12. Linear	13.024		4.00	61.00	.001*	1
13. Quadratic	1.450		4.00	61.00	.229	1
Set D: Percentage of Time Spent in Control Movement						
14. Day Effect (D)	3.359	D/DS	12.00	32.04	.003*	1
Test of Trend for D						
15. Linear	22.716		4.00	61.00	.001*	1
16. Quadratic	1.433		4.00	61.00	.234	1
17. Cubic	3.981		4.00	61.00	.006*	1
18. Time of Day Effect (T)	2.048	T/TS	8.00	14.00	.115	1

<sup>1</sup>F-Ratios are an approximation using Wilks-Lambda criterion. Only significant roots or first roots are presented.

\*Significance test accepted if P less than .05.

When the standard deviations of the control movements were examined (Table 5.3 and 5.4) it was found that there was a significant difference between the morning, afternoon and evening flight periods although there was no significant change across the flight days.

The changes within the flight days on the measures of control movement standard deviation were also analyzed for trend information. The results of these analyses (Table 5.5, 5.6) demonstrate that there was a significant linear change within the flight days. Additional examination of the estimated mean values for each time period has shown that there was a modest decrease in the control movement standard deviation values for each of the control channels. The largest average change from the morning to the evening flight periods was less than .1 inches standard deviation. Further analyses of the changes in control movement standard deviation within the flight days are found in Table 6. The standardized discriminant function coefficients presented in this table reflect the relative contribution of each of the individual variables in describing the most important dimension of performance changes between the morning, afternoon and evening flight periods. These coefficients clearly show the cyclic fore-aft control movement magnitude standard deviation as being the most important variable in discriminating between flight periods. This finding is also supported by the univariate analysis results in Table 6 and in the correlations of this variable with the multivariate composite scores. These findings suggest that there was a gradual decrease

in the variability of the control movements from the morning to the evening flight periods and that this improvement in control movement consistency was observed primarily on the cyclic fore-aft control channel.

TABLE 6  
SET B VARIABLES--CONTROL MOVEMENT MAGNITUDE STANDARD DEVIATION  
FURTHER ANALYSIS OF THE TIME OF DAY EFFECT

Variables	Univariate F-Ratio	Mean Square	P Less Than	SDF Coefficient <sup>1</sup>	Correlations <sup>2</sup>
Time of Day Effect--No Covariates (df = 3, 15)					
1. Cyclic Fore/Aft Control Movement Magnitude Std Deviation	9.012	.037	.006*	1.466	.812
2. Cyclic Left/Right Control Movement Magnitude Std Deviation	2.044	.006	.180	-.866	.387
3. Collective Control Movement Magnitude Std Deviation	4.745	.010	.036*	.361	.578
4. Pedal Control Movement Magnitude Std Deviation	5.453	.016	.025*	-.109	.580

<sup>1</sup>Standardized Discriminant Function Coefficient.

<sup>2</sup>Correlations Between Variables and Composite Scores.

\*Significance test accepted if P less than .05.

The Set C variables were analyzed to determine changes in the number of control movements introduced by the pilots. The results (Table 5.7 and 5.11) demonstrate that there were significant changes both across days and within the daily flight periods. The tests of trend (Table 5.8 through 5.10, 5.12, 5.13) showed that there were significant linear changes in the number of control movements. The standardized discriminant function coefficients displayed in Table 7 identify the cyclic fore-aft control channel as showing the most important change across flight days. Examination of these coefficients and the estimated cell means for each flight day has determined that there was a gradual increase in the number of cyclic fore-aft control movements across the flight days, a decrease in the number of control movements on the collective and pedal controls and little change in the number of movements on the cyclic left-right control.

Examination of the standardized discriminant function coefficients for changes in the number of control movements within flight days (Table 7B) and the average number of control movements for the morning, afternoon and evening flight periods has determined that the cyclic fore-aft, cyclic left-right and the collective controls all showed important differences, with little change in the pedal control channel. Within the flight days the observed trend was for an increase in the number of cyclic fore-aft control movements per second and a progressive decrease in the control movements on the cyclic left-right and the collective control channels.

The findings on changes in the number of control movements per second strongly suggests that the pilots reallocated the usage of the four control channels as a function of increased flight time and the accompanying aviator fatigue. Within the flight days there is a trend toward increased utilization of the cyclic fore-aft control and decreased control effort on the cyclic left-right and the collective controls, with little observed difference in the pedal control. When the performance across the first four flight days is examined a clear trend again emerges suggesting an increased use of the cyclic fore-aft control and a decreased usage of the collective and pedal control. The above results show no substantial change in the number of the cyclic left-right control movements across flight days.

The results of the multivariate analysis on the Set D variables (percentage of the total flight time spent introducing control movements) are presented in Table 5.14 and 5.18. The only statistically significant change in this aspect of the pilots' performance was across the four flight days (Table 5.14). Further examination of these performance changes (Table 5.15 through 5.17 and Table 8) demonstrate a marked linear trend toward an increased percentage of time spent in control of the cyclic fore-aft channel. In addition there is an observable trend toward a reduction in the percentage of control time on the cyclic left-right control channel and the pedal control channel.

TABLE 7

MULTIVARIATE ANALYSIS OF VARIANCE SUMMARY  
 SET C VARIABLES--NUMBER OF CONTROL MOVEMENTS PER SECOND  
 FURTHER ANALYSIS OF DAY AND TIME OF DAY EFFECT

Variables	Univariate F-Ratio	Mean Square	P Less Than*	SDF Coefficient <sup>1</sup>	Correlations <sup>2</sup>
A. Day Effect--No Covariates (df = 3, 15)					
1. Cyclic Fore/Aft No of Control Movements Per Second (CM/Sec)	1.490	.037	.258	1.216	.275
2. Cyclic Left-Right CM/Sec	.765	.011	.531	-.420	.173
3. Collective CM/Sec	5.317	.160	.011*	-.771	-.586
4. Pedal CM/Sec	4.243	.522	.023*	-.586	-.448
B. Time of Day Effect--No Covariates (df = 2, 10)					
5. Cyclic Fore/Aft CM/Sec	1.135	.022	.360	2.498	.101
6. Cyclic Left-Right CM/Sec	.424	.004	.665	-2.297	-.021
7. Collective CM/Sec	6.327	.116	.017*	-2.253	-.329
8. Pedal CM/Sec	3.283	.443	.080	.578	-.233

<sup>1</sup>Standardized Discriminant Function Coefficient.

<sup>2</sup>Correlations Between Variables and Composite Scores.

\*Significance test accepted if P less than .05.

TABLE 8

MULTIVARIATE ANALYSIS OF VARIANCE SUMMARY  
 SET D VARIABLES--PERCENTAGE OF TIME SPENT IN CONTROL MOVEMENT  
 FURTHER ANALYSIS OF THE DAY EFFECT

Variable	Univariate F-Ratio	Mean Square	P Less Than*	SDF Coefficient <sup>1</sup>	Correlations <sup>2</sup>
Day Effect (df = 3, 15)					
1. Cyclic Fore/Aft Percentage of Time Spent on Control Movement (CM%)	.563	142.36	.648	-2.586	.003
2. Cyclic Left-Right CM%	1.769	472.38	.196	1.329	.222
3. Collective CM%	5.620	157.52	.009*	.636	.432
4. Pedal CM%	3.843	1715.56	.032*	1.143	.384

<sup>1</sup>Standardized Discriminant Function.

<sup>2</sup>Correlations Between Variables and Composite Scores.

\*Significance test accepted if P less than .05.

The series of analyses presented immediately above have examined four aspects of the pilots' control movement performance--the size (Variable Set A), the consistency (Set B), and two measures of control usage or effort (Sets C and D). The integration of the information obtained from each type of performance measure strongly suggests that the pilots reallocated some portion of their control effort in response to extended flight time and fatigue. Analyses of performance changes between the flight days and within the flight days have demonstrated that the cyclic fore-aft control channel tends to receive more of the pilot's effort and as a result, one or more of the remaining control channels are allocated less control activity. The lack of any significant differences in the size of the control movements serves to indicate that there were no drastic changes in the size of the control responses for any of the four primary control channels--a finding subjectively affirmed by the authors who observed

each flight. It is also interesting to note that the consistency of the cyclic fore-aft control movements improved (i.e., a smaller standard deviation) as the usage of this channel increased throughout the flight day.

#### Examination of Aircraft Stability Measures

The analyses of the aircraft stability measures are presented in Table 9. These results indicate no significant difference between flight days on the measures of attitude stability found in Set E. However, the results in Table 9.3 show that there were two dimensions of aircraft stability change within the flight days. Inspection of the standardized discriminant function coefficients in Table 10 and the average standard deviation values for the pitch, roll and heading axes (not presented in this report) has demonstrated that the first multivariate aircraft stability dimension describes an increased stability of the pitch channel from the morning to the evening flight periods accompanied by a less significant decrease in the heading stability.

TABLE 9  
MULTIVARIATE ANALYSIS OF VARIANCE SUMMARY  
AIRCRAFT STABILITY MEASURES - ATTITUDE STANDARD DEVIATION (SET E)

Source	F-Ratio <sup>1</sup>	Mean Squares Tested	Degrees of Freedom for Hypothesis	Degrees of Freedom for Error	P Less Than*	Root
A. Day Effect (D)						
1. D	1.540	D/DS	9.00	31.79	.177	1
2. D Adjusted for Five Covariates	2.032	D/DS	9.00	19.62	.091	1
B. Time of Day Effect (T)						
3. T	5.265	T/TS	6.00	16.00	.004*	1
T	4.751	T/TS	2.00	8.5	.041*	2
4. T Adjusted for Five Covariates	1.785	T/TS	6.00	6.00	.249	1
Test of Trend for T						
5. Linear	8.170		3.00	62.00	.001	1
6. Quadratic	2.707		3.00	62.00	.053	1
C. Day by Time of Day Interaction (DT)						
7. DT	1.247	DT/DTS	18.00	79.68	.246	1
8. DT Adjusted for Five Covariates	1.344	DT/DTS	18.00	65.54	.191	1
D. Regressions						
9. Five Covariates on Day by Subject Interaction (DS)	1.804		15.00	22.49	.100	1
10. Five Covariates on Time of Day by Subject Interaction (TS)	2.034		15.00	8.68	.146	1
11. Five Covariates on DTS Interaction	1.629		15.00	63.89	.091	1

<sup>1</sup>F-Ratios are an approximation using Wilks-Lambda criterion. Only significant roots or first roots are presented.

\*Significance test accepted if P less than .05.

The second multivariate dimension of change in aircraft stability is statistically unrelated to the first dimension and accounts for a significant but less important amount of the total performance change between the daily flight periods. Examination of the standardized discriminant function coefficients (Table 10) and the average standard deviation values has determined that this dimension portrays a gradual decrease in the stability of the aircraft's heading stability.

The combination of the analytical results from both multivariate performance dimensions suggests that during the course of the flight day both the pitch and roll attitude becomes more stable at the expense of the heading stability. It is appropriate to point out that the changes in aircraft stability was not exceedingly large, with the largest average change from morning to evening being approximately 0.25 degrees for pitch standard deviation (SD), 0.1 degrees for roll SD, and 0.5 degrees for heading SD. However, it is clear that there was a consistent change in the stability of the aircraft's pitch attitude between the flight periods. It is noteworthy that this finding

complements the trend toward increased usage of the cyclic fore-aft control found in the analyses of the pilot's control movement.

TABLE 10

MULTIVARIATE ANALYSIS OF VARIANCE SUMMARY  
SET E VARIABLES--ATTITUDE STANDARD DEVIATION  
FURTHER ANALYSIS OF THE TIME OF DAY EFFECT

Variable	Univariate F-Ratio	Mean Square	P Less Than*	SDF Coefficient <sup>1</sup>		Correlations <sup>2</sup>	
				Root 1	Root 2	Root 1	Root 2
Time of Day Effect (df = 2, 10)							
1. Pitch Standard Deviation	4.989	.668	.031*	2.207	.049	.555	-.126
2. Roll Standard Deviation	.416	.030	.670	-.747	1.724	.114	.194
3. Heading Standard Deviation	.956	1.494	.417	-1.174	-1.859	.120	-.361

<sup>1</sup>Standardized Discriminant Function.

<sup>2</sup>Correlations Between Variables and Composite Scores.

\*Significance test accepted if P less than .05.

One relationship that is surprisingly absent in the above analyses is the relationship between helicopter performance as reflected by the measures of pilot's control performance and aircraft stability and the effect of environmental conditions. Examinations of other maneuvers performed during the major fatigue investigation<sup>4 5 6</sup> have demonstrated a clear relationship between wind conditions and the resulting helicopter performance. For this investigation no aspect of pilot performance or aircraft stability has demonstrated any significant relationship between performance changes and the environmental effects. The lack of wind effects on performance may be due to the fact that this maneuver inherently contains some attitude instability due to the aerodynamic characteristics of a rearward moving helicopter and the fact that the pilot cannot directly see the upcoming flight path.

#### Examination of Combined System Performance Measures

The results of the examination of the combined system performance variables (Set F) are presented in Table 11 and show that there were significant changes both across flight days and within the flight days. The significant changes in overall performance were observed across flight days when the performance measures were considered alone and with covariates. However, the relationship between the five covariates and the appropriate performance error did not exceed the predetermined significance level (P less than 0.05). Therefore the analyses were again conducted using the two covariates which showed the highest relationship with the performance error, wind speed and the daily maneuver sequence number, which is an index of how many previous flight hours had been completed during that day of testing. The results of these analyses are found in Table 11.3 and 11.14, and again demonstrate a significant change between flight days as well as a significant relationship between the two covariates and the performance error. These latter tests (11.3 and 11.14) were used in the further description of the changes in system performance.

The standardized discriminant function coefficients, presented in Table 12, show that the predominant change in combined system performance across flight days occurred on the pedal/heading relationship. This finding is also supported by the univariate tests (Table 12.3). This significant change in pedal/heading control is presented graphically in Figure 1 which displays the average control performance quality value for each of the first four flight days. This figure portrays the predominately linear trend toward a reduction in the pedal/heading control relationship across flight days and also demonstrates a pronounced reduction in control quality from the third to the fourth flight days. The standardized discriminant function coefficients (Table 12.1 and 12.2) indicate that the cyclic fore-aft/pitch control relationship and the cyclic left-right/roll control relationship showed a relatively modest improvement in conjunction with the degraded performance on the pedal/heading relationship.

TABLE 11  
 MULTIVARIATE ANALYSIS OF VARIANCE SUMMARY  
 COMBINED PERFORMANCE MEASURES - SET E

Source	F-Ratio <sup>1</sup>	Mean Squares Tested	Degrees of Freedom for Hypothesis	Degrees of Freedom for Error	P Less Than*	Root
A. Day Effect (D)						
1. P	3.198	D/DS	9.00	31.79	.007*	1
2. D Adjusted for Five Covariates	4.194	D/DS	9.00	19.62	.004*	1
3. D Adjusted for Two Covariates <sup>2</sup>	3.312	D/DS	9.00	26.92	.008*	1
Test of Trend for D Adjusted for Two Covariates <sup>2</sup>						
4. Linear	24.763		3.00	60.00	.001*	1
5. Quadratic	.954		3.00	60.00	.421	1
6. Cubic	2.838		3.00	60.00	.045*	1
B. Time of Day Effect (T)						
7. T	5.336	T/TS	6.00	16.00	.003*	1
8. T Adjusted for Five Covariates	1.034	T/TS	6.00	6.00	.484	1
Test of Trend for T						
9. Linear	22.475		3.00	62.00	.001*	1
10. Quadratic	3.676		3.00	62.00	.017*	1
C. Test of Day by Time of Day Interaction (DT)						
11. DT	.952	DT/DTS	18.00	79.68	.521	1
12. DT Adjusted for Five Covariates	.830	DT/DTS	18.00	65.54	.660	1
D. Regressions						
13. Five Covariates on Day by Subject Interaction DS	2.076		15.00	22.49	.057	1
14. Two Covariates <sup>2</sup> on DS	3.693		6.00	22.00	.011*	1
15. Five Covariates on Time of Day by Subject Interaction (TS)	.442		15.00	8.68	.921	1
16. Five Covariates on DTS	.752		15.00	63.89	.732	1

<sup>1</sup>F-Ratios are an approximation using Wilks-Lambda criterion. Only significant roots or first roots are presented.

<sup>2</sup>The covariates (1) Maneuver Sequence Number and (2) Wind Speed were used in these analyses.

\*Significance test accepted if P less than .05.



afternoon to the evening flight periods the cyclic fore-aft control relationship continues to improve--this time at the expense of the cyclic left-right/roll control relationship and a continued deterioration of the pedal/heading relationship.

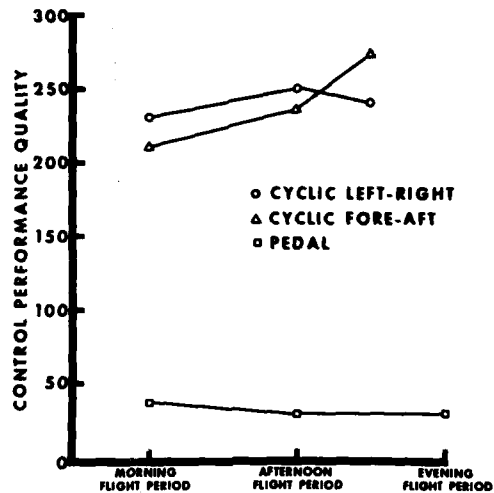

FIG. 2 CONTROL PERFORMANCE QUALITY BETWEEN DAILY FLIGHT PERIODS COMBINED PERFORMANCE MEASURES (SET E)

The analyses of the quality of system performance as defined by the combined performance variables in Set F have provided a useful tool in describing changes in man and machine components of the helicopter system. In the course of combining and integrating the pilot control and aircraft stability measures, a view of the comprehensive performance change is presented. The major finding in this investigation has been the evidence describing a shift in the amount of control effort allocated to each of the four primary control channels (cyclic fore-aft, cyclic left-right, collective, and pedals) as a function of extended flight and the corresponding aviator fatigue. In addition, results from this investigation strongly suggest that allocation of more control effort to any one control channel requires some reduction of control effort on one or more of the other control channels. Examination of the pilot's control performance has demonstrated that there was an increase in control effort on the cyclic fore-aft channel both across flight days and within the flight days. These findings were complemented by the analysis of the aircraft stability which demonstrated increased stability in the pitch axis. However, when the measures of the pilot's performance and the aircraft's stability are combined, it becomes apparent that the major changes across flight days was not only the allocation of more control effort to the cyclic fore-aft/pitch control relationship but also the cost of this allocation to the other control relationships; notably, the pedal/heading control relationship. System performance changes within the flight days clearly indicate that the stability of the pitch attitude is maintained and improved at the expense of the heading attitude and later the roll attitude. The authors would suggest that a similar relationship holds in system performance changes across the flight days, although this investigation has not presented direct support of this view.

#### CONCLUSIONS

In conclusion, this investigation has demonstrated that there are changes in pilot's control performance and aircraft stability as a function of extended flight requirements and the corresponding aviator fatigue. The separate and combined analyses of the primary man and machine components of the helicopter system strongly suggest that there is a reallocation of control effort in response to accumulation of extended flight time under a demanding schedule. These changes in control effort are highly consistent with previous research on fatigue and human performance and provide a classical indication of the degradation of secondary task aspects to maintain or improve primary task performance. These findings have demonstrated that the control of the pitch axis, using the cyclic fore-aft control, is maintained at the progressive expense of the remaining control channels. Precise control of the aircraft's heading is most heavily affected by the reallocation of control effort. In addition, these findings have demonstrated that there is a clearly accelerated decrease in heading control from the third to the fourth flight days under a rigorous flight schedule.

It must be noted that the changes in the pilot's performance measures and the aircraft stability measures were modest and clearly not life threatening to those pilots who participated in this investigation. However, the consistent changes in performance that are related to extended flight requirements may take on increased

TABLE 12  
 MULTIVARIATE ANALYSIS OF VARIANCE SUMMARY  
 SET F VARIABLES--COMBINED PERFORMANCE MEASURES  
 FURTHER ANALYSIS OF THE DAY AND TIME OF DAY EFFECT

Variable	Univariate F-Ratio	Mean Square	P Less Than*	SDF Coefficient <sup>1</sup>	Correlations <sup>2</sup>
A. Day Effect Adjusted for Two Covariates (df = 2, 13)					
1. Cyclic Fore/Aft Combined Performance	1.870	11840	.184	.184	-.582
2. Cyclic Left-Right Combined Performance	3.201	28805	.059	.259	-.228
3. Pedal Combined Performance	10.602	1003	.001*	-.907	-.037
B. Time of Day Effect (df = 2, 10)					
4. Cyclic Fore/Aft Combined Performance	5.815	47536	.021*	1.937	.442
5. Cyclic Left-Right Combined Performance	.956	4802	.417	-1.608	-.010
6. Pedal Combined Performance	1.750	616	.223	-.684	-.186

<sup>1</sup>Standardized Discriminant Functions.

<sup>2</sup>Correlations Between Variables and Composite Scores.

\*Significance test accepted if P less than .05.

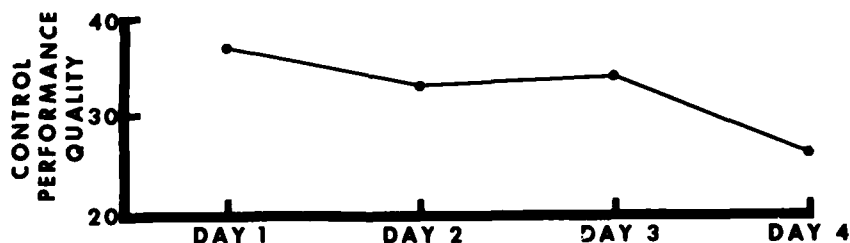

FIGURE 1 CONTROL PERFORMANCE QUALITY ACROSS FLIGHT DAYS COMBINED PERFORMANCE MEASURES (SET E) ADJUSTED FOR WIND SPEED AND ACCUMULATED HOURS OF FLIGHT PEDAL CONTROL CHANNEL

The changes in control performance quality within the flight days were also significant (Table 11.7) although there was again no relationship between performance error and the measured covariates (Table 11.15). Examination of the coefficients (Table 12.4, 12.5 and 12.6) clearly show that the major system performance changes within the flight days involved an improvement in the cyclic fore-aft/pitch control relationship, a reduction in the cyclic left-right/roll relationship of nearly the same magnitude, and a modest decrease in the pedal/heading relationship. The average control performance quality values for each of the daily flight periods are presented in Figure 2. This figure shows several interesting changes in the performance quality for each of the three control channels. These data suggest that both the cyclic fore-aft/pitch control relationship and the cyclic left-right/roll relationship improves from morning to afternoon flights while the pedal/heading relationship deteriorates. From the

importance when it is considered that the pilots in this investigation concentrated strictly on precision performance and had no auxillary duties such as navigation, communication, target acquisition, and weapons delivery. In addition, it is suggested that some aviators may not be as proficient, as were the recently graduated subject pilots, when their skills are urgently required.

## REFERENCES

1. Maddox, W. F. Where we are - where are we going. Aviation Digest, 1974, 11(20).
2. Merryman, F. H. Bringing Army aviation through the 70's into the 80's. Aviation Digest, 1974, 6(20).
3. Department of the Army. Army aviation: General provisions and flight regulations (AR 95-1). Washington, D.C.: Headquarters, Department of the Army, 1977.
4. Kimball, K. A., & Anderson, D. B. Aviator performance: Biochemical, physiological, and psychological assessment of pilots during extended helicopter flight. Proceedings (CP-180) of NATO/AGARD Conference, October 1975.
5. Lees, M. A., Kimball, K. A., & Stone, L. W. The assessment of rotary wing aviator precision performance during extended helicopter flights. Proceedings (CP-21) of NATO/AGARD Conference, November 1977.
6. Lees, M. A., Kimball, K. A., & Stone, L. W. Effect of prolonged flight on aviator performance: Hover maneuvers #1 (USAARL Tech. Rpt.). Ft Rucker, AL: US Army Aeromedical Research Laboratory, in press.
7. Hufman, H. W., Hofmann, M. A., & Sleeter, M. R. Helicopter in-flight monitoring system (USAARL Rpt. No. 72-11). Ft Rucker, AL: US Army Aeromedical Research Laboratory, March 1972.
8. Cramer, E. M. Revised MANOVA program. Chapel Hill, N.C.: The University of North Carolina at Chapel Hill, The L. L. Thurstone Psychometric Laboratory, May 1974.

## IMPLEMENTATION OF A DIVISIONAL AVIATION PROGRAM TO DECREASE FLIGHT CREW FATIGUE

by

Dr William C. Wood  
5200 Oak Meadow  
Memphis  
Tennessee 38134  
USA

### SUMMARY

Pilot error remains the leading cause of aircraft accidents. Pilot fatigue due to multiple stresses is a primary cause of pilot error. A vigorous and continuing program to recognize aviator fatigue has been implemented in the U.S. First Armored Division in Europe. Aviators are given lectures which review the various stresses inherent in aviation. The two types of aviator fatigue, acute skill fatigue and chronic skill fatigue, are discussed in detail. The emphasis is on recognition by the aviators themselves of symptoms and signs of fatigue. Flight hour limitation is an important part of a crew rest program, but does not replace the other elements as presented in this paper. Prevention of fatigue and recognition of fatigue which has developed is an essential component of an aviation safety program. Prevention of aircraft accidents will result in the saving of lives and increased combat readiness of aviation units.

The cause of most aircraft accidents remains "pilot error." Under the term "pilot error" are many different problems which have led to aircraft accidents. Doubtless, pilot fatigue is a problem which in many aircraft mishaps has either led to the accident directly or has contributed to other coexisting conditions which together resulted in an error in human judgement or performance. Since aviator fatigue is a factor which is amenable to recognition and treatment, it is a particularly crucial area for our attention.

In the U.S. First Armored Division a comprehensive program has been initiated to recognize aviator fatigue and to manage it medically to prevent aircraft accidents. Education of the aviator and of the non-aviator commander in the importance of fatigue as a factor in aircraft mishaps, the causes of fatigue, and in the recognition of fatigue are crucial components of the program. Each of these areas will be covered in detail in the following discussion. This material represents the factual basis for our stress and fatigue presentations. Although flight hour limitations will be discussed, it is essential for the reader to understand that flight hour limits are merely one component of a multifaceted program to prevent, recognize, and deal with stress and fatigue in the aviation environment.

Modern tactical doctrine emphasizes the all-weather, twenty-four hour a day combat capability of our armed forces. Today's U.S. Army is prepared to fight in all climates for prolonged periods of time in sustained high intensity combat. The tactical battlefield is more complex, more dangerous, more demanding, and more stressful than ever before. Fatigue, an ever-present component of combat since ancient times, will be a crucial factor in combat effectiveness, since modern military equipment has become more sophisticated. In particular, advanced airborne weapons systems such as the AH1S attack helicopter require considerable expertise to reach maximum combat effectiveness. Fatigue will degrade pilot performance, with consequent decline in combat effectiveness. Newer devices, such as the AN/PVS-5 night vision goggle, place increased demands on an aviator already beset by stresses due to tactical conditions and aircraft complexity. An increased emphasis on night operations has been essential, yet fatigue may well be a determining factor in these tactical exercises. Recognition of fatigue is essential to prevent aircraft accidents, to save life, and to maximize combat effectiveness. Lives saved through recognition of pilot and crewmember fatigue will return individuals to combat units who can then more effectively perform their mission. A crew rest program which is effective will increase combat readiness, preserve life, and decrease aircraft damage and loss due to accidents. Our present First Armored Division interest in crew rest has been strongly influenced by these considerations.

Limitation of flight hours has traditionally been a crucial component of crew rest programs. However, equally important is recognition of individual aviation crewmember variation and a unit commitment to close observation of individuals for signs of fatigue. Fatigue is frequently seen at flying hour limits well below those which will be given later, and fatigue does not follow our guidelines precisely. Furthermore, flight hour limits are to a certain degree arbitrary. Inadequate data exists on large groups of pilots to define the time of onset of fatigue. Data on aircraft accidents, collected in large volumes over the years, fails to define the limits of flight time beyond which fatigue predisposes to or results in an aircraft accident. Individual variation among aviators makes guidelines for fatigue difficult to apply unless we monitor each and every aviator individually.

We emphasize to our aviators that stresses are the cause of fatigue. We further emphasize that there is no laboratory test to detect fatigue, and that fatigue is only demonstrable through identification of a performance decrement.

It is important that aviators at the unit level be able to identify stresses in the aviation environment and that they become aware of which stresses can be decreased, which eliminated entirely, and which cannot be altered. Appropriate action for each identifiable stress should then be part of the crew rest program. Identification of the two types of fatigue, acute skill fatigue and chronic skill fatigue, by the individual aviators in the unit is a key to the success of the program. Management of each type of fatigue is then undertaken as will be discussed later. Non-aviator commanders who employ aviation units in their operations should also be familiar with these problems in order to employ aviation in the safest and the most efficient manner possible.

#### Historical Perspective

A review of pertinent experience in the field of stress and fatigue through aviation history is important to avoid repetition of previous errors. Aviators in the First World War flew aircraft with restricted performance capabilities, and were retained in active combat for prolonged periods of time without adequate rest away from duty. The vast majority of aviator losses in that war were related to aircraft accidents, many of which were fatigue related. In many cases, accidents occurred during the take-off or landing sequences of flight. Syndromes known now as chronic skill fatigue were reported then even among experienced aviators. Adequate corrective action to prevent aviator fatigue awaited increased knowledge in aviation medicine.

In the Second World War, global conflict placed climatological stresses on aviators which ranged from the extreme cold of the arctic area to the tropical heat of the Pacific and North Africa. Reverse cycle night training operations were undertaken prior to World War II and the night air war in Europe was particularly stressful to those aviators involved. Regular rotation from flight combat duty to non-combat assignments was a significant component of U.S. Army Air Force policy at that time.

During American involvement in the Republic of Vietnam conflict in recent times, work done by Dr. Philip Snodgrass showed the importance of days free from flight duty in reducing aviator fatigue.<sup>11</sup> This finding is used in current First Armored Division crew rest policies. Limited tours of duty were helpful in reducing aviator fatigue, as was regular rest from flying duty within the operational area of the unit.

The conflicts in the Syria-Israel-Egypt areas have demonstrated that modern warfare among highly mechanized armies may well be of considerable ferocity and of limited duration. Today most of our current crew rest problems occur during relatively short periods of training, usually seven to ten days. It is during these periods of time that crew rest guidelines, including flight hour limitation, are most crucial.

#### Stresses in the Army Aviation Environment

It is by approaching stresses in army aviation that we can best decrease fatigue. Many of the stresses in Army aviation are listed in Appendix I. Although army rotorcraft characteristically fly at flight altitudes below 10,000 feet above sea level, hypoxia can occur due to carbon monoxide poisoning or hyperventilation. The aviator who is a smoker has decreased night vision capability. Changes in aircraft speed and direction are stressful. The NOE (nap-of-the-earth) flight techniques now in use require almost constant pilot alterations in speed, heading, and altitude, creating a more stressful situation. Temperature and humidity factors can create additional stresses which are additive to other problems. Vibration is an ever present fatigue-producing component of helicopter operation.

Cockpit environment plays an increasingly important role in aviator stress. Complex weapons systems such as that in the AH1S Cobra attack helicopter place increased demands on aviators and increase cockpit workload. Marked differences exist between the cockpits of the OH58 scout helicopter, the UH-1H utility helicopter, and the AH1S Cobra attack helicopter. Significant differences in cockpit workload and comfort are present among these aircraft types and must be recognized in implementing flight time limitations. Dual pilot helicopters allow division of cockpit duties and reduction in stress, whereas single pilot helicopters do not allow this reduction in individual workload. Aircraft differ in their handling and flight characteristics. The OH 58 requires considerably more control movement than does the UH1H, and appropriate reduction in maximum flight hours allowable is therefore indicated. Weather and night flying place increased stress on the aviator and should receive reduced flight time maximum limits. Changes in work/rest cycle, poor meals, poor accommodations, command responsibility, and poor maintenance support all contribute significant stresses. Unit level aviation medicine support is absolutely necessary in treating psychological and medical problems in aviation personnel.

Self-imposed stresses are remediable stress factors. These include poor diet, fatiguing recreational pursuits, alcohol use and abuse, smoking, and improper use of drugs. It is important for unit level safety officers and flight surgeons to assess the mission of each aviation unit in determining fatigue factors and in locally tailoring crew rest recommendations. Units involved in VIP missions often have long stand-by periods which decrease crew rest. Aviator experience and level of training affect each individual's response to stresses. Less experience and inadequate training will result in increased stress upon that aviator, which will mandate lower flight hour limits for this individual until adequate training and experience have been obtained. Recognition of mission completion is an important morale factor.

As weapons systems increase in complexity, increased attention to human factors will be essential within our operational units. The increasing capabilities of the AH-1H and Advanced Attack Helicopters of the coming years will require new and innovative studies at the unit and individual level of crew rest and fatigue factors. Modern tactical training now includes the use of the M24 protective mask. The AN/PVS-5 night vision goggles is a highly stress-producing device whose employment must be coupled with meticulous observation of aviators for fatigue related problems. Aviator awareness of these stressful factors must be stressed again and again. Attempts to eliminate or reduce the effects of these stresses are a crucial component of a unit aviation safety program. These stresses acting on the aviator result in fatigue.

#### Types of Fatigue and Their Management

Operationally, we define fatigue as a state of decreased aviator performance due to stresses operant on the individual in the aviation environment. Only by recognition of performance decrement can the aviator discover the presence of fatigue. We emphasize in our crew rest program that it is the individual aviator who must detect fatigue in himself and in others. Aviation safety officers and flight surgeons are not present in units in adequate numbers to effectively make these identifications. The key factor is for the aviator himself to look for and recognize the signs and symptoms of fatigue in himself and in others.

Acute skill fatigue is the initial stage of fatigue seen in aviators. Its causes are multifactorial and almost always it is due to multiple stresses. It is the initial stage of performance decrement. Overcontrolling and irritability are easily recognized signs of acute skill fatigue. Errors in timing may occur, and are particularly common in the take off and landing sequences, the times of occurrence of many if not most of both military and civilian aircraft accidents. Pilot workload is highest at these times and the consequences of error are at their most critical point.

The fatigued aviator is prone to overlook important tasks in a series. Use of the checklist is essential at all times to prevent this occurrence and is particularly important during takeoff and landing periods. A decrease in control smoothness is a sign of performance decrement. The fatigued aviator is more likely to be distracted and has decreased attentiveness to cockpit and extra-cockpit tasks. This aviator is more likely to develop target fixation, which can be a lethal mistake for the aviator.

The fatigued aviator is often unaware of his performance deficiencies. He will frequently deny his fatigue and, due to "mission orientation," may attempt to fly missions in which he should not participate due to fatigue. A unit recognition of fatigue as a safety hazard will assist the fatigued aviator in verbalizing that his fatigue is indeed present, and will support him when he is allowed rest to restore his aviation performance. Fatigued aviators conduct poor instrument cross checks, and may ignore peripheral instruments and secondary tasks. Flight maneuvers may become less coordinated. A little emphasized effect of fatigue is the inability of the fatigued aviator to resist vertigo-inducing factors. Spatial disorientation is more readily induced in the fatigued aviation crewmember. This can occur at any flight altitude, from NOE to high level flight, and its consequences may be disastrous. Transition to instruments immediately if vertigo occurs is mandatory.

Prevention of acute skill fatigue should be a primary goal. Each stress factor should be addressed in a crew rest program. Adequate training is important. Sufficient time must be provided for aviators to allow them rest and natural sleep, the primary deterrents of acute skill fatigue. Limitation of flight hours is a helpful component of a crew rest program to prevent fatigue, but each individual must be monitored by other aviators to detect early signs of fatigue. Management of acute skill fatigue in aviation personnel is by the unit itself, and primarily consists of rest and natural sleep.

If acute skill fatigue is not recognized and adequately managed, a more severe form of performance decrement known as chronic skill fatigue will result. In this condition, poor judgment, poor appetite, weight loss, sleep difficulties, and alcohol abuse may be seen, along with any of the signs and symptoms of fatigue previously listed. The difference between acute skill fatigue and chronic skill fatigue is one of degree, for the two conditions are not qualitatively different. Both result in performance decrement. Acute skill fatigue is a step in the evolution of fatigue, which may further progress to chronic skill fatigue. Management of the aviator with chronic skill fatigue requires medical restriction from flying duty. Several weeks are usually necessary for recovery, during which time rest, removal from duty, and adequate sleep are required. Prevention of chronic skill fatigue includes the same elements as prevention of acute skill fatigue. Again it must be noted that limitation of flight hours is only one component, albeit a significant part, of a comprehensive crew rest program. Aviator monitoring of each other is a critical necessity. A listing of the signs and symptoms of fatigue is found in the Appendix.

#### CREW REST POLICY IN THE U.S. FIRST ARMORED DIVISION

The above material is presented in briefing form using slide presentations to our aviators, who are operationally organized as the 501 Combat Aviation Battalion of the U.S. First Armored Division. Crew rest guidelines have been provided which identify flight hour limitations for garrison conditions and also for tactical conditions, such as field exercises and actual combat. These flight hour limits are summarized in the

Appendix to this article. Because adequate baseline data for determination of flight hour limits is scant, the flight hour limits given here represent the best available estimates from our aviation safety officers, flight surgeon, aviation commanders, and the previously published data. The less stringent limitations on flight hours for tactical conditions allow unit commanders considerable flexibility in flight operations conducted during field exercises.

If flight hour limits are exceeded, the crew rest program requires that a written report of justification to be forwarded to the aviation battalion commander with an explanation of why flying hour limits were exceeded. This report will then be reviewed by the battalion aviation safety officer and the aviation medical officer to assess the impact of this action on aviation safety. These staff members will then report to the aviation battalion commander regarding their findings. Direct contact by these individuals with the aviators involved in the event could provide valuable background information and highlight aviation safety problems which could then be constructively approached to prevent further safety hazards. Each individual aviator is given the responsibility of employing his non-duty time to obtain adequate rest. Commanders dealing with the employment of aviators for missions must consider all pertinent stressful factors related to the flight, including flight duration, weather conditions, mission type, aircraft type, and opportunity for adequate rest at intermediate stops. Attention to rest facilities and adequate meals is a worthwhile aviation safety consideration.

The crew rest program emphasizes that the fatigued aviator should inform his unit commander if he feels that his fatigue may hazard a mission. Considerable responsibility rests on the aviation unit commander in weighing aviator fatigue against mission requirement. The crew duty day, listed under the heading in the Appendix of "Maximum Duty Hours," begins when the individual arrives at his duty station and ends when the individual leaves his designated duty station to return to his residence. Garrison duty days are limited to a maximum of 12 hours. Tactical condition duty days are limited to a maximum of 16 consecutive hours. Exceeding these time periods can only be authorized by the aviation unit commander, again weighing all applicable factors and with consideration for aviation safety.

The crew rest period is defined as the time in which an individual will be allowed to rest before assuming crew duties. For garrison duty, the minimum crew rest period is 10 hours. Under tactical conditions, the minimum crew rest period must include 8 hours sleep in a 24 hour period. It is particularly important that individuals who perform duty officer or other nighttime or after duty tasks receive compensatory time off to obtain 8 hours of uninterrupted sleep prior to performance of further flight duties.

Flight hour limits are shown for garrison conditions in the Appendix. Maximum duty hour limits for 7 days and for 30 days allow time for days off in order to reduce and prevent aviator fatigue. Specific limitations of flight times for particular mission types are also listed in the Appendix. NOE (nap-of-the-earth) day and night missions are particularly stressful and require limitation of flying hours to those given. Although not specifically listed in our current crew rest document, current recommendation in our units is for a limit of 45 minutes on use of the M24 protective mask, with one unmasked pilot always in a pilot or copilot position and prepared to assume control of the aircraft. Also, our current recommendation is for a maximum time for use of the AN/PVS-5 night vision goggle per evening to be one hour for non-instructor pilots.

Flight hour limits under tactical conditions are also given in the Appendix. These limits allow considerable flexibility for unit training under simulated combat conditions.

We consider these flight hour limits a rational initial program which will require meticulous monitoring and on-going reappraisal. These limits are consistent with the mission of the U.S. First Armored Division, which must maintain a high standard of combat readiness and training. Feedback from aviators and aviation units will be essential. Army aviation constitutes a magnificent capability for success on today's battlefield. Crew rest programs are life-saving and cost effective. Their development and implementation is an essential task for the army aviation team. By implementing an effective crew rest program in all its aspects we in the U.S. First Armored Division believe that we will save lives, increase unit effectiveness, and maintain combat readiness.

## REFERENCES

1. AGARD ADVISORY REPORT No. 69.ON HELICOPTER AIRCREW FATIGUE. NATO, May, 1974.
2. Barreca, Nicholas E. LTC. "Human Factors in Nap-of-the-Earth Flying. Part I: Perception of the External Environment." U.S.Army Aviation Digest. Vol.20, No.6(June,1974), p. 16.
3. Barreca, Nicholas E.LTC. "Human Factors in Nap-of-the-Earth Flying. Part II: Protection Against the External Environment." U.S.Army Aviation Digest. Vol.20, No.7(July,1974), p.15.
4. Barreca, Nicholas E.LTC. "Human Factors in Nap-of-the-Earth Flying. Part III: Flying Fatigue." U.S.Army Aviation Digest. Vol.20, No.8(August, 1974), p.14.
5. Barreca, Nicholas E.LTC. "Human Factors in Nap-of-the-Earth Flying. Part IV: Crew Selection, Training and Coordination." U.S.Army Aviation Digest.Vol.20, No.10(October,1974), p. 18.
6. Barreca, Nicholas E.LTC. "Flying Fatigue." U.S.Army Aviation Digest. Vol.18, No.1(January,1972), p.14.
7. Berliner, Daniel S. "Crew Rest and Nap-of-the-Earth Flying." Aviation, Space and Environmental Medicine. Vol.XLVI, No.10(October,1975), p.1267.
8. Clark, Alan. Aces High. Great Britain: William Collins Sons & Co.,1973.
9. Hurst, Ronald, Ed. Pilot Error: A Professional Study of Contributing Factors. London: Granada Publishing,Ltd.,1976.
10. Karney, David H.,LTC, and Thompson, Patsy. "Fatigue." U.S.Army Aviation Digest. Vol.22, No.2(February, 1976), p.28.
11. Neel, S.,Major General. Medical Support of the U.S.Army in Vietnam 1965-1970. Washington, D.C.: Department of the Army, 1973.
12. Wood, W.C.,Maj. "The Human Factor." Armor. Vol.LXXXVI, No.5(Sept.-Oct.,1977), p.20.
13. Wood, W.C.,Maj. "Operational Aspects of Stress and Fatigue." U.S.Army Aviation Digest. Vol.22, No.9(Sept.,1976), p.30.
14. U.S.Army Flight Surgeon's Manual. Special Text ST 1-105-8. Vol.I. U.S.Army Aviation School, Ft.Rucker, Al.,1970, p.16-1.



## APPENDIX I.

Table A. STRESSES IN ARMY AVIATION

1. Altitude stresses (including hypoxia)
2. Changes in speed (acceleration)
3. Temperature and humidity changes and extremes
4. Vibration
5. Cockpit environment
6. Aircraft handling and flight characteristics
7. Weather and night flying (including all IMC)
8. Circadian rhythm changes
9. Work/rest cycle changes
10. Meals and accommodations
11. Command responsibility
12. Ground organization and maintenance activity
13. Psychological problems
14. Medical conditions
15. Self-imposed stresses (diet, recreational activities, alcohol use and abuse, smoking, drugs)
16. Nap-of-the-earth flying
17. Anticipation, inactivity
18. A high accident and aircraft loss rate
19. Degree of aviator experience
20. Degree of recognition, praise and rewards to the individual and to the unit
21. Human factors problems related to weapons systems
22. Aviator performance in the CBR environment (including use of the M24 protective mask)
23. Stress related to human factors aspects of the AN/PVS-5 night vision goggle.

Table B. SIGNS AND SYMPTOMS OF FLYING FATIGUE

1. Overcontrolling
2. Irritability
3. Errors in timing (particularly during take off and landing sequences)
4. Overlooking important tasks in a series
5. Loss of accuracy and smoothness in control
6. Easy distraction
7. Preoccupation with one task component (including target fixation)
8. Decreased attentiveness
9. Unawareness of performance deficiencies
10. Loss of correct sequences
11. Neglecting peripheral instruments and secondary tasks
12. A tendency to split complicated tasks and maneuvers into component parts
13. A growing inability to correctly interpret sensory input and an increasing susceptibility to vertigo
14. Slowed reaction time
15. Poor judgment
16. Poor appetite
17. Weight loss
18. Sleeplessness (often manifested by arriving early for duty)
19. Overindulgence in alcohol.

APPENDIX II.  
FLIGHT HOUR LIMITS

A. GARRISON FLIGHT HOUR LIMITATIONS FOR AVIATION UNITS OF THE U.S. FIRST ARMORED DIVISION

Time Period	Maximum Duty Hours	Maximum Flight Hours		
		Day Dual/Solo	Night Dual/Solo	Day-Night Dual/Solo
24 hours	12	8/6	6/4	6/5
48 hours	24	16/12	8/6	11/9
72 hours	36	22/16	12/9	15/12
7 days	60	35/25	20/15	25/20
30 days	240	90/70	50/40	70/60

B. TACTICAL FLIGHT HOUR LIMITATIONS FOR AVIATION UNITS OF THE U.S. FIRST ARMORED DIVISION

Time Period	Maximum Duty Hours	Maximum Flight Hours		
		Day Dual/Solo	Night Dual/Solo	Day-Night Dual/Solo
30 days	320	140/100	70/70	100/100

C. MAXIMUM FLIGHT HOUR LIMITS BY MISSION TYPE UNDER GARRISON CONDITIONS

1. Night missions. Maximum of 6 hours total night flight during the duty day period.
2. NOE (nap-of-the-earth) Missions. 4 hours total flight time during the duty day period. Training period not to exceed 2 hours. At least 1 hour ground time between periods. During NOE training, the NOE segment of the total flight period should rarely exceed 75 minutes.
3. Instrument Missions and/or Instrument Training. Maximum of 4 hours per duty day period.
4. Night NOE flight. Maximum of 2 hours during duty day period. Night NOE flights are limited to 1 hour periods with at least 2 hours ground time between periods.

D. MAXIMUM FLIGHT HOUR LIMITS BY MISSION TYPE UNDER TACTICAL CONDITIONS

1. Eight flying hours per duty day is maximum allowed except when approved by the aviation unit commander.
2. Maximum flight hour limitations per crew duty day must be adjusted by the aviation unit commander when flight will be conducted in the proximity of unusual weather phenomena, hazardous terrain or while in high stress situations- formation flight, extreme hot weather or cold weather operations.

## DISCUSSION

- CAILLE:  
(France) I should like Dr. Kimball who is a psychologist, as I am, to pinpoint for us what he means by fatigue. Make explicit the word fatigue. Is it a question of a transitory state; is it operational fatigue; or is it a question of an asthenic syndrome that just occurs momentarily? Is it a question of the level of activation of the nervous system and vigilance or, on the other hand, is it a matter of a purely behavioral phenomenon and subjective phenomenon? In the way of criteria, we find that operational parameters are proposed coming from the machine itself; and, on the other hand, we have neurophysiological parameters. We're told nothing about the development of the neurophysiological parameters, in particular, the electroencephalogram.
- KIMBALL:  
(United States) We are defining fatigue as performance degradation. We are concerned here at the Aeromedical Research Laboratory in the performance aspects of pilot functioning because although we do feel there are many indicators of fatigue that can be used to address the flight environment, we are concerned with the output of the aviator. In other words, if we see a degradation in flight performance, we are in essence assuming that this is evident in fatigue in the aviator himself. We have used mood scales, fatigue scales; we have monitored the heart rate, looked at heart rate variability. We have not done EEG's. We have not found a successful way to utilize this technique in the helicopter environment. Perhaps you have one. This is a multifaceted problem. There are correlates in the physiological sense that can be helpful to mesh with the performance correlates to give us a better measure of what fatigue really is in the helicopter environment.
- GILLESPIE:  
(United States) Have you addressed the effects of aircrew equipment on fatigue; specifically, helmet, flight suit, survival vest, that type of thing?
- KIMBALL:  
(United States) No. The aviator in this particular study that Dr. Lees described came fitted with the normal gear. No survival vest was utilized. He wore the same SPH-4 helmet, etc.
- GILLESPIE:  
(United States) You mean all the aviators do wear the same equipment?
- KIMBALL:  
(United States) In this training environment, yes. Since we've completed this study, they have added a survival vest to their normal gear because of the NOE missions and the possibility of going down in trees where they couldn't be found quickly.
- GILLESPIE:  
(United States) Do you wear any cold water exposure suits?
- KIMBALL:  
(United States) No sir, not in Alabama.
- COOKE:  
(United Kingdom) Dr. Wood, you confine your recommendations, as far as I understand them, to limiting total flight hours. I haven't seen the handout and all may be evident in that, but are there recommendations in regard to other factors like the number of sorties flown and the total number of hours on standby and duty hours?
- WOOD:  
(United States) Sorties limitation in particular is discussed for night flight and for daytime nap-of-the-earth flight. The type of TOW missile missions that we might be called on to fly, a maximum time of about two to three sorties of NOE work per day, limiting the NOE time period to about 75 minutes per sortie--this is covered in detail in the handout. We've gone into a number of areas for both tactical and garrison conditions.
- KIMBALL:  
(United States) In summary of these papers, we've heard data which have demonstrated evidence of fatigue as an accident cause. We've discussed methods to evaluate aircrew fatigue and have been provided with research findings obtained in the helicopter environment relating aircrew fatigue to long hours of flight and pilot performance. And, we've had a description of a comprehensive program to describe fatigue symptoms to aviator personnel and to delineate work/rest cycles in the intent of increasing safety, pilot efficiency, and combat readiness.

ADVANCEMENTS IN HELICOPTER  
COCKPIT TECHNOLOGY  
by  
Howard P. Harper  
Human Factors Engineer  
Sikorsky Aircraft Division  
United Technologies Corporation  
100 N. Main Street  
Stratford, Conn. 06602

#### SUMMARY

This paper discusses the requirements of future missions in terms of the need for advanced controls and displays and improvements in cockpit vision, workload and comfort. A number of technological areas are reviewed as candidates for inclusion in an advanced cockpit. A cockpit design incorporating this technology is presented.

#### INTRODUCTION

Every two or three years a paper is published attempting to predict the future of the helicopter cockpit (References 1 and 2). This paper will continue that tradition, but with a slightly different emphasis. This will involve an examination of mission demands, a review of currently maturing technology, and a look at the constraints which must be overcome. The intent is to put forth a number of advanced concepts and to consider the cockpit integration implications of each. Nothing can change in a cockpit without reverberations which have a potential effect on all other systems. The intent is, therefore, to consider the most probable advances in terms of their effect on the total cockpit.

#### MISSION REQUIREMENTS

The increasing demands of future missions consistently pressure the cockpit designer to keep pace. Three mission categories are considered: land warfare, sea warfare and commercial operations. The intent is to discover whether efforts directed toward one of these areas would have beneficial applications in the others.

Land Warfare The Army is moving NOE flight out of the experimental stage. It is no longer the province of the test pilot - specially selected and trained - but the normal operational technique of every pilot. The problems of night operations, navigation, formation flight, and instrument flight have not been completely solved. Needless to say, the demands on the crew are extreme and it is equally obvious that a major part of the solution rests with improved cockpit design. The AAH and ASH mission, for example, mean more than just NOE flight between points. They require precision navigation, close coordination within and between aircraft, complex tactics and accurate weapons delivery.

Sea Warfare The Navy's anti-submarine warfare missions are demanding from the point of view of crew information processing, time on station (up to 8 hours with hovering in-flight refueling) and need to return IFR to a small destroyer flight deck under heavy sea conditions.

Civilian Usage Civilian usage has been, and will continue to be, a demanding operating environment. In particular, operations such as logging or ship off-loading which require precise hovers interspaced with short, low altitude dash segments are very fatiguing to crews. A recent article (Reference 3) described the rigors of helicopter logging where pilots are paid by the board foot of lumber transported. The record holder for one company moved 437 loads in one flight shift with 75 loads being transported in one 78 minute period. Profitability in these operations requires quick turnarounds and maximizing flight hours each day. IFR operations in high density air traffic areas are also high workload conditions. Landings on oil rigs and ship platforms require a high degree of maneuvering precision under adverse wind and visibility conditions.

Table I summarizes some of the most demanding tasks from these military missions and points out parallels in civilian helicopter usage. The mission requirements consistently show a need for sustained, precision aircraft control under extremely difficult environmental conditions. Long term successful performance of these tasks is questionable with today's cockpit technology. Table I relates these high demand mission situations to cockpit areas which are candidates for improvement. As shown here, the demands are similar across missions and thus efforts directed toward improved visibility, comfort, displays and controls and workload reductions will have applicability across the mission categories.

#### COCKPIT DESIGN CONSTRAINTS

In order to understand how we can get to an "advanced" cockpit from where we are now requires an understanding of the web of military specifications and standards which govern cockpit design. Helicopter cockpit geometry is governed by MIL-STD-1333 and MS-33575. They specify, for example, the location and clearance of controls, the seat height, the back angle, the height of the panel off the floor, and most of the other cockpit geometry parameters. Visibility is covered by MIL-STD-850. This defines the angles of up and down cockpit vision which must be available at each azimuth angle. A key requirement is the 25° over the nose vision. MIL-STD-250 locates different functional panels within the cockpit. MS-33785 describes the basic "T" arrangement of primary flight instruments. If the aircraft is to receive civilian certification for IFR flight, Part 91 of Civil Air Regulation tells us specifically which instruments must be available. All of this establishes the cockpit geometry rather firmly. In an IFR aircraft with a 5" (12.7 cm.) Vertical Situation Display and a 5" (12.7 cm.) Horizontal Situation Display the designer is pinched between keeping the panel lower edge 16" (40.6 cm.) off the floor and staying below the 25° over the nose vision line. Figure 1 shows visibility obstructions due to the pilot's arms,

hands, feet, pedals, sticks and the minimum package of conventional primary flight instruments when all of these specifications are adhered to. This shows that to improve over the nose visibility significantly, the primary instrument package must change in size or location. It also shows that the feet and rudder pedals are in an area where vision may be required. Therefore a significant improvement in vision will require a change in primary flight instrument concept and perhaps a change in cockpit seating geometry.

	SEA WARFARE	LAND WARFARE	CIVIL
VISIBILITY	<ul style="list-style-type: none"> <li>• STEEP APPROACHES &amp; VERTICAL LANDINGS ON SMALL SHIP PLATFORMS</li> </ul>	<ul style="list-style-type: none"> <li>• NOE OPERATION</li> <li>• RESTRICTED LZ'S</li> <li>• OBSERVATION &amp; AVOIDANCE OF AIR TO AIR THREAT</li> </ul>	<ul style="list-style-type: none"> <li>• ROOF TOP &amp; OIL RIG OPERATIONS</li> <li>• UTILITY OPERATIONS- FORESTRY , PRECISION LOAD PLACEMENT</li> <li>• AIR TRAFFIC AVOIDANCE</li> </ul>
WORKLOAD / COMFORT	<ul style="list-style-type: none"> <li>• IFR - TACTICAL SITUATION WORKLOAD IS HIGH</li> <li>• LONG MISSION DURATION WITH HIFR</li> </ul>	<ul style="list-style-type: none"> <li>• NOE NAVIGATION &amp; FLIGHT CONTROL WORKLOAD VERY HIGH</li> <li>• ROUGH AIR AND HIGH TEMPERATURE IMPACTS COMFORT</li> </ul>	<ul style="list-style-type: none"> <li>• HIGH DENSITY AIR TRAFFIC CONTROL PROCEDURES</li> <li>• LONG COCKPIT HOURS</li> </ul>
DISPLAYS	<ul style="list-style-type: none"> <li>• OVER WATER IFR</li> <li>• NIGHT RESCUE APPROACHES</li> <li>• TACTICAL SITUATION</li> <li>• ROUGH SEA APPROACH</li> </ul>	<ul style="list-style-type: none"> <li>• NIGHT VISION</li> <li>• NOE NAVIGATION</li> <li>• WEAPONS CONTROL</li> </ul>	<ul style="list-style-type: none"> <li>• AREA NAVIGATION IFR IN HIGH DENSITY TRAFFIC AREAS</li> </ul>
FLIGHT CONTROLS	<ul style="list-style-type: none"> <li>• PRECISION APPROACHES</li> <li>• ROUGH SEA LANDINGS</li> </ul>	<ul style="list-style-type: none"> <li>• NOE AGILITY TO AVOID TERRAIN</li> <li>• STABILITY WHILE READING MAPS ETC.</li> </ul>	<ul style="list-style-type: none"> <li>• PRECISION APPROACHES TO OIL RIGS , ROOFTOPS</li> <li>• PRECISION HOVER FOR SLINGLOAD OPERATION</li> </ul>

Table I. The Influence of Mission Requirements on the Cockpit.

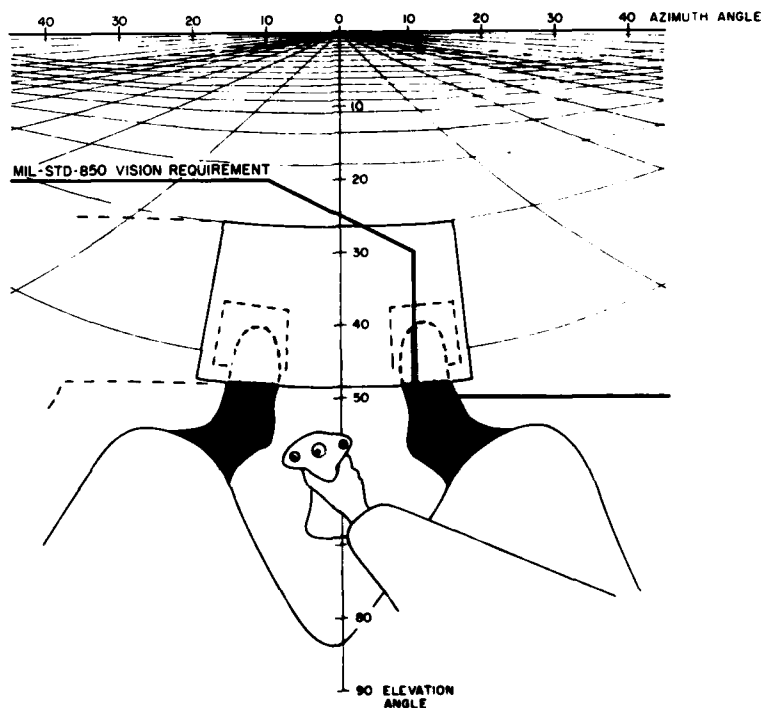

Figure 1. Cockpit Vision Constraints with Current Military Requirements.

## COCKPIT TECHNOLOGY

Many technological areas have matured to the point where they can have a significant impact in new helicopter cockpits. Among these are display media, display software, fly-by-wire, voice synthesis, on-board computation, and advanced seating concepts.

**Head-Up Displays (HUD).** Head-Up Displays have been widely used in fixed wing fighter and attack aircraft. Their primary usefulness is the ability to superimpose computer generated symbols onto fixed areas in space. This is particularly useful for forward firing weapons where the computer is generating a weapons trajectory solution or where the HUD superimposes symbols over a ground point as a landing aid (References 4 and 5).

The greatest potential for helicopter HUD's is in the weapons sighting role. Forward fired weapons generally stay within the HUD field of view. The use of a HUD for approach guidance in a helicopter poses genuine problems because of the need to keep the approach path within the HUD field of view. Helicopter flight paths can exceed the field of view of the widest angle HUDs. A 20° vertical and 35° horizontal field of view is considered to be an extremely wide field of view. A 20° crab angle in a helicopter low speed approach is not unusual.

The HUD display has several characteristics which affect the cockpit geometry. The combiner glass itself must overlay the portion of the real world where symbols will be superimposed on targets. The vertical dimensions will be centered on the horizon line or the aircraft longitudinal axis in some normal condition, i.e., cruise flight or approach. Typically, there is an area below the HUD, housing the CRT and optics, which blocks a large portion of prime display space. These displays require a rigidly held eye point to insure that both eyes are within the exit pupil. The increased field of view requires close mounting and therefore the display begins to approach the head strike zone.

**Helmet-Mounted Displays (HMD).** Conceptually the helmet-mounted display is ideal for a variety of helicopter display and control functions. As a weapons sighting system it can be used for forward firing weapons, for missile tracking, and for controlling turret mounted weapons. The instantaneous field of view can approach 45° (Reference 6) but can be increased to encompass all of the normal unrestricted head motion of the crewman (+ 90° of azimuth, + 90° of elevation). This is done by sensing helmet line of sight and driving a gimbaled sensor system to that position. In addition, symbology can be generated and superimposed on the visual image over the entire system field of view. This, of course, lends itself well to displaying FLIR imagery or Low Light Level Television. The HMD offers the possibility to create a visual display with all of the desired elements positioned and scaled appropriately for the full forward visual hemisphere. These systems have not yet achieved their full potential. However, there is enough on-going research in this area to provide reasonable confidence that current problems will be solved. Among the questions which remain are problems of monocular viewing of the display and of the cockpit with the other eye, the need for stabilization of the image in roll, the means of creating an aircraft oriented visual frame of reference, and the requirement for a head tracking system with a dynamic response which is both accurate (to insure precise superimposition) and quick and stable (to provide stability to the visual image to prevent vertigo and motion sickness). The additional helmet weight (about one (1) pound, .45 Kg.) reduces survivability in crash conditions due to the greater loads applied to the neck. The HMD opens the possibility for elimination of a large part of the conventional display space. This means using areas not required for external vision as locations for systems monitoring information. In the extreme, with a dependable HMD system, it is conceivable that normal cockpit windows could be reduced in area in favor of a greater dependence on HMD imagery.

**Panel Displays.** This category includes both vertical and horizontal situation displays. In the next cockpit generation we envision some form of electronic implementation. It appears that through the 80's displays with enough resolution to be used for FLIR or LLLTV imagery will be CRT's rather than solid state matrix displays. Color is desirable and is certainly available in penetration phosphor systems. These however, are not amenable to raster scanning to produce a high quality FLIR or LLLTV picture. Therefore, we can look for a CRT-type vertical situation display capable of portraying pictorial imagery with superimposed symbols to provide cueing for aircraft control in both marginal VFR and IFR flight.

If there is one area where technology can reduce workload, it is in eliminating paper maps from the cockpit. Map-type horizontal situation displays have been available for years but their cost, weight and size have precluded their use in production helicopters. The Sikorsky S-67 Gunship evaluated a system in 1972 and it exceeded all expectations. The moving map display may be considered merely a convenience when cockpit workload is low, and lighting is good, but it is a virtual necessity for NOE flight over unfamiliar terrain. One feature needed in a moving map display is the ability to annotate the map before and during the flight. The crew should be able to do such rudimentary things as draw a course line or note a destination or a target area on the map. The map display should be available to each crewman, it should smoothly transition from one map frame to another, and it should provide an image that is equivalent in detail to current paper maps.

**Systems Monitoring Displays.** Under this category we will cover engine and systems monitoring instruments and caution/advisory systems (discrete messages). With our current technology there is no reason why a flight crew should have to monitor the positions of pointers on scales in round instruments to evaluate the health of the aircraft systems. This approach is exactly that used in World War I. One approach to an improvement in this display system was taken by Sikorsky in providing a vertical scale instrument system for the BLACK HAWK. This system made use of vertical columns composed of a number of lighted elements. These elements were color-coded such that when parameters were in the normal operating range only green lights were lighted. When a parameter exceeded the green zone the lights would become amber or red depending on the magnitude of the deviation from normal. This provides a color cue to the pilot that one of the systems is operating out of tolerance. This is an approach to combining quantitative information with qualitative information in one display system. It has worked very effectively in the BLACK HAWK. In future developments one might eliminate the analog vertical

scale functions and replace them with green, amber, and red lights for each channel, supplemented by a digital readout which the pilot could call up if he desired to see it. The colored lights might be triggered by signals more sophisticated than merely a temperature or pressure which has exceeded a limit but perhaps by a rate of approach toward a limit which would produce an out of tolerance condition at some point in the future. Current caution, warning and advisory systems are candidates for major change. The current concept of reserved space for each potential message is being made obsolete by the number of systems we are monitoring. A survey of recent helicopters shows an average of 80 message capsules or about 39 square inches of primary panel space. The alternative is non-dedicated display space where a number of caution or advisory messages could be shown in a smaller area such as a CRT or flat panel display. This would require a computer based system to prioritize messages occurring simultaneously. An even better solution would use the computer to analyze the pattern of signals to determine a probable cause and present this processed information to the pilot along with a course of action. Such a system is clearly within the bounds of current technology.

Auditory Displays. The concept is certainly not new and, in fact, auditory displays are already used in almost every current aircraft. They are usually tones presented in conjunction with warnings such as gear up or low rotor RPM. Their usefulness is best determined by an analysis of the relative levels of visual and auditory workload. Generally visual workload becomes a problem before auditory. Data from the Army's NOE experience, however, seems to indicate that the crews are overloaded in both modalities. In those cases where auditory signals are deemed appropriate, the new development in voice synthesized displays would be considered. These systems are light, and can, with a reasonable computer interface, reproduce speech with high intelligibility, (Reference 6). In the past voice warning systems have often used a female voice to distinguish the warning message from normal interphone traffic. Since we are finding so many more women in cockpits, the robot voice quality found in these systems will be useful for discriminating between conversation and priority messages. Possible applications include voice warning, voice navigation commands, automatic checklists, and systems monitoring functions.

Controls. The current positions of the cyclic, the collective and the pedal controls all could use improvements. The current cyclic position impedes entrance and exit, blocks the view to the lower portion of the instrument panel and poses a crash hazard which has increased with the advent of stroking crash energy attenuating seats. In addition, the current position of the control is set low because pilots want to fly with their forearm resting on their thigh. This contributes to a forward leaning position in the seat which leads to lower back fatigue and discomfort. The current collective grip typically moves through about 10 inches of vertical travel. This often results in an uncomfortable position at its upper and lower extremes. The collective is also an obstacle to normal and emergency egress in the left hand seat of the side by side configured cockpit. The pedals and feet in typical current cockpit geometry are positioned such that they block vision in an important area.

There have been investigations of a number of advanced helicopter controller schemes over the past ten years. These have ranged from sidearm controllers with up to 4 control axes to 3 axes yoke controls. Among the most promising is the U. S. Army Human Engineering Laboratory's 3-axis yoke. This system, currently in developmental flight test, provides lateral and longitudinal cyclic and collective control so that the pilot can control all three axes with both hands or with either hand alone. This has the advantage of allowing the pilot to reach other controls in the cockpit with either hand and improves the crew's chances of flying home if the pilot is hit in either arm. Another advantage is the reduction in width of each pilot position by 5 or 6 inches and the resulting reduction in frontal profile of the aircraft due to eliminating the collective stick. The system has one of the disadvantages common to yokes in general: visual blockage of prime panel space.

Another promising scheme is the use of sidearm cyclic, collective, and yaw controls. Consideration has been given to both moveable controls and isometric (Pressure) controls. With either method a means of synchronizing the controls at two crew stations, must be provided. The problem is difficult with the moveable controls because of the need to keep the frictional forces low and yet back drive a second set of controls so that the second crewman can assume aircraft control without introducing transients into the system. With isometric controls the problem is worse because they cannot be mechanically back driven to a synchronized position. For this reason an electronic synchronization system is required. The proper installation for these controls requires an integration with the seat. Armrests are essential because the greater sensitivity and shorter travels requires firm forearm support. The controls would move with the seat when it was adjusted or when it stroked to attenuate crash loads thus avoiding the head strike hazard posed by a conventional cyclic with a stroking seat. In addition, the controls and armrests would hinge out of the way to allow good ingress and egress. With an escape system the controls would probably remain with the aircraft. Among the other advantages are improved panel visibility, easier ingress/egress and an extremely comfortable seating position. Each crew station width will be about 3 to 4 inches narrower than with a conventional collective control. The sensitivity of these controls is well-suited to vehicles with good handling qualities but further testing would be required to establish their capability with degraded AFCS modes. The vision blockage due to the pedals could be eliminated by adding the yaw control function to the collective sidearm control. This would allow the feet to be positioned further aft and flat on the floor thus opening the vision through the chin window.

Seats. Since the first generation of production crashworthy seats is just about to be introduced it is difficult to foresee what the next generation will look like. It does seem that in a cockpit with sidearm controls, the seat will become the focal point for cockpit integration. The seat will have a greater back angle, probably 170 - 200 which will, when combined with the sidearm control, provide a much more comfortable position than found in current helicopters. The next generation AH and OH helicopters have the technology available to include an escape system. The Sikorsky RSRA has now fully qualified its escape system out to a velocity of 160 kts. (258 Km./Hr.).

## ADVANCED COCKPIT

Figure 2 shows a generic side-by-side cockpit of the mid 1980's which has been put together from the concepts previously discussed. There are two CRT displays on each crewman's centerline. The upper unit is a vertical situation display and the lower a horizontal situation display. There is no instrument panel in the traditional sense. The lower console extends forward only as far as the knee and houses a smaller flat panel display and the controls for aircraft systems, navigation, and communication. The seats have a back angle of about 20° and incorporate sidearm controls integral with the adjustable armrests. On the right is a 2-axis cyclic control and on the left is a combined collective and yaw control. As a result there are no pedals to obstruct the lower forward vision.

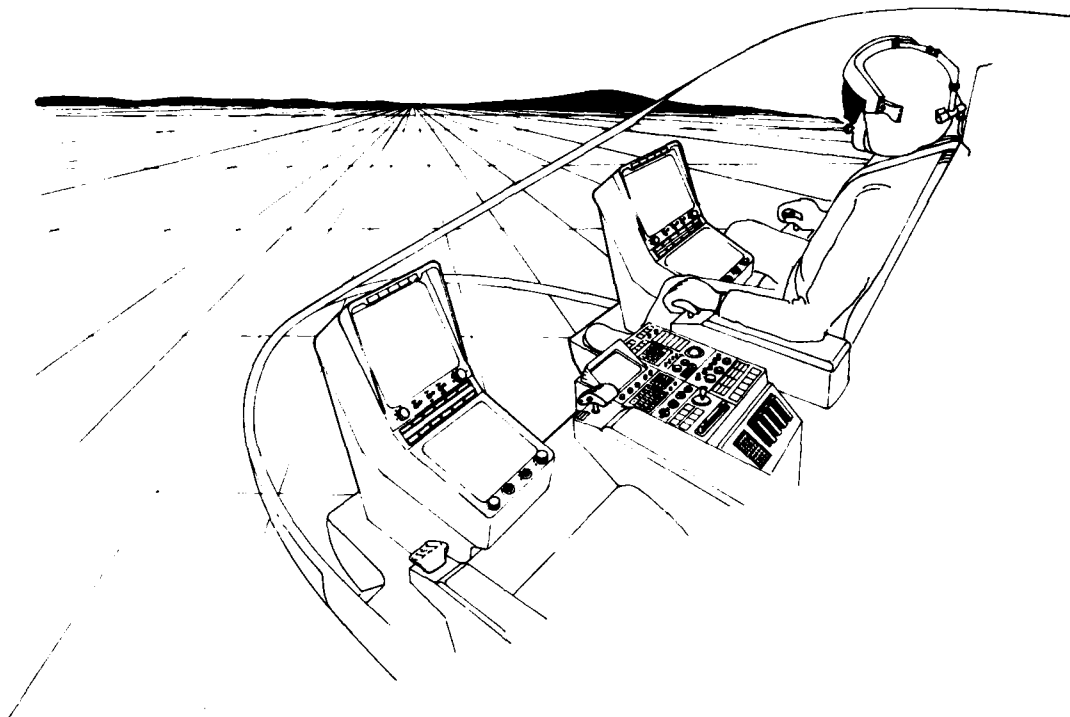

Figure 2. Advanced Cockpit Using Side Arm Controls, Helmet-Mounted Displays and Electronic Vertical, Horizontal, and Console Displays.

Figure 3 is a plot showing the visual obstructions resulting from this cockpit arrangement. The over the nose vision is 35° and the foot and pedal obstructions are eliminated. The sidearm controls allow an unobstructed view of the CRT displays. Table II summarizes the functions assigned to each of the display surfaces. The HMD will be required in AH and OH helicopters for all missions and in UH helicopters when operating in night NOE situations. When used, the HMD will display the night vision system imagery and supplementary symbology required for aircraft control. In addition, the HMD will be used for weapons control, navigation and high priority caution and warning information. The VSI primary function will be display of aircraft control symbology for flight in IFR or marginal VFR conditions. The map display will appear on the HSI. In-flight annotations will be recorded digitally and stored in a cassette located on the center console. The flat panel display will be used for systems monitoring, caution/advisory and communications functions.

## RECOMMENDATIONS

As can be seen, the advanced cockpit discussed here is quite different from the cockpit designed by rigidly following military specifications. It is recommended that the government review these requirements to determine whether they are unduly restrictive of technological advancement and design innovation. One approach might be the funding of preliminary cockpit designs with relaxed specification requirements. These could be evaluated in mock-up form to gain confidence in this design method. Then, in future procurement programs, the customer might just describe the mission, its performance requirements and the anthropometric range to be accommodated and let the airframe cockpit design teams apply, without unnecessary restriction, the best of available technology. This will, in the long run, greatly accelerate progress in crew station design.



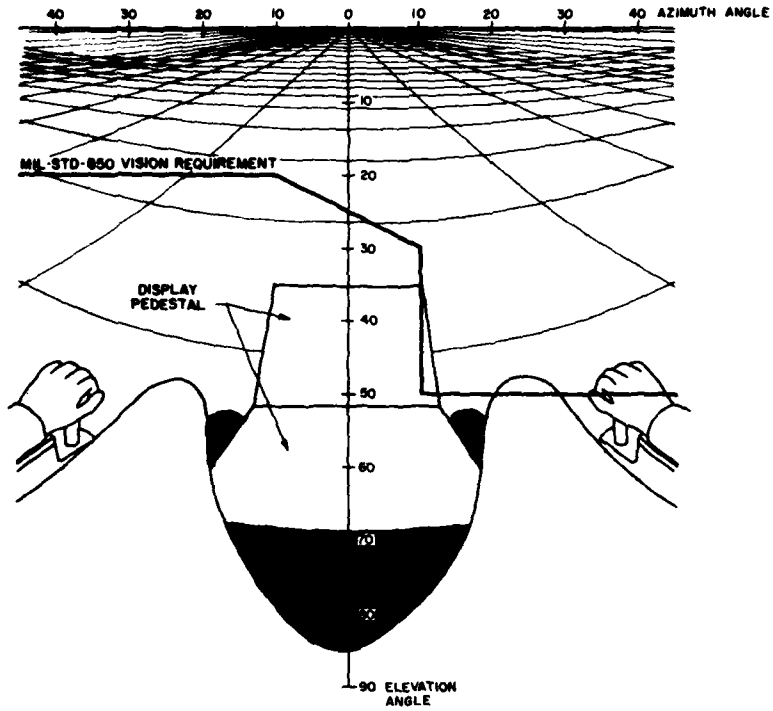

Figure 3. Cockpit Vision with Advanced Technology Cockpit.

DISPLAY FUNCTION	HELMET MOUNTED DISPLAY	VERTICAL SITUATION DISPLAY	HORIZONTAL SITUATION DISPLAY	CONSOLE DISPLAY
SYSTEM MONITORING				X
CAUTION / WARNING	X			X
NAVIGATION	X		X	
CONTROL	X	X		
COMMUNICATIONS				X
WEAPONS	X			

Table II. The Allocation of Display Functions.

## REFERENCES

1. Fry, Clarence A., The Helicopter Cockpit Configuration of the Future. Paper presented at Aircrew Performance in Army Aviation Symposium at Ft. Rucker, Alabama, November, 1973.
2. Moreland, Stephen, Future Concepts of Crew Station Integration. Paper presented at U.S. Army Aviation Center "Staying Power" Symposium, July, 1975.
3. Larson, George, Timber! Flying, Volume 102, November 4, April, 1978.
4. General Electric Company, Advanced Integrated Display System (AIDS) System Design Interim Report, November 23, 1976.
5. Walchli, R. M., Rauch, K. N., Halliday, W. and Gold, T., Flight Evaluation of a Head-Up Display with Real-World Overlay for Instrument Approach and Landing of V/STOL Aircraft. Naval Air Test Center Technical Report SY-23R-75, 28 October, 1975.
6. General Electric Company, Advanced Integrated Display System (AIDS) System Design Interim Report No. 3, October 31, 1977.

VISUAL EFFECTS OF HELICOPTER MANOEUVRE ON  
WEAPON AIMING PERFORMANCE

by

Mr P.R.Michael  
Senior Ergonomist - Research Dept.  
British Aerospace Dynamics Group  
Bristol  
UK

Mr T.E.Jardine  
Chief Systems Engineer - Anti-Tank  
British Aerospace Dynamics Group, Stevenage & Bristol Division  
P.O. Box 19, Six Hills Way  
Stevenage  
Herts SG1 2DA  
UK

Mr M.K.Goom  
British Aerospace Dynamics Group (16P)  
Bristol  
UK

SUMMARY

A helicopter is useful as a mobile platform for launching guided missiles but its high manoeuvrability presents problems for the missile operator. The aim of these studies was to identify and analyse the problem areas associated with the guidance of command-to-line-of-sight missiles from helicopters and to assess them experimentally. The weapon system considered employed a sight which was stabilized in pitch and yaw and which incorporated a manually operated servo control for moving the sight in azimuth and elevation.

Four interactions likely to degrade performance were studied. These were (1) The simultaneous use of sight and missile controls (2) Helicopter vibration (3) Helicopter forward motion and (4) Helicopter manoeuvre (roll, pitch and yaw). Results of a first series of simulation experiments established that, in general, helicopter vibration and forward motion did not degrade the operators' performance and that an operator could use the sight and missile guidance controls simultaneously without loss of accuracy. However, any helicopter manoeuvre which caused the field-of-view through the sight to roll was found to cause considerable degradation of performance, regardless of any previous flying experience of the subjects.

This effect of roll phasing (cross coupling) was investigated in a second series of simulations which contained some experiments where a system of roll compensation was used. This compensation caused the missile axes to appear and remain parallel to a graticule in the sight and the field-of-view retained its attitude at launch throughout the engagement. Provided the compensation was able to reduce roll phasing to less than  $20^{\circ}$  there was no degradation in performance.

The realism and validity of the simulations used and the possible value of operator training are discussed.

## 1. INTRODUCTION

### 1.1 General Scenario

The superior long range accuracy of modern anti tank missiles (A. T. G. W. ) gives them many advantages over conventional armament despite the longer flight time of a missile compared to a ballistic round and the higher cost per round. It was therefore inviting for the military decision makers to consider the helicopter as launching platform for A. T. G. W. systems in the late 1960's and early 1970's. The high mobility and manoeuvrability appeared to offer tremendous advantages over land vehicle systems which are normally static during an engagement. In theory at least the helicopter can use its mobility to seek out the enemy whilst staying out of range of conventional enemy armament. The high mobility would be useful also from the logistics viewpoint allowing a swift return to forward bases for servicing and replenishment or role change. The high manoeuvrability would also prove useful for evasive action when under enemy fire. Thus, several N.A.T.O. countries began development of A. T. G. W. for helicopters and produced systems such as AS11, HOT and TOW. In the U.K. also it was proposed to develop the In Service Swingfire system for helicopter usage.

However, it was recognised at an early stage in the development programme that to make full use of helicopter mobility it would create new problems which were not encountered in the land based systems. These problems largely centred upon the airgunner's ability to cope with weapon aiming in the helicopter environment.

This paper describes a programme of work which investigated important aspects of the air gunner's performance during an engagement for the helicopter borne variant of Swingfire, with particular reference to high manoeuvre effects.

### 1.2 Programme Objectives

In ATGW missile systems the operator has a high work load during an engagement; his full concentration is required to achieve good performance. Thus, there was some concern about the potential performance in weapon guidance from helicopters due to an increased task loading and the presence of additional environmental stressors caused by the high mobility and associated vibration. At the time this study commenced there was considerable emphasis on maintaining the weapon aiming performance in a wide operational envelope including fast forward speeds and high levels of roll and heading change.

The first programme objective was to highlight and assess the main factors which were potentially performance degrading. Four main potential factors were identified:-

- (i) Increased task loading due to the operation of a sight slew control in addition to the missile control.
- (ii) Relative motion of target and helicopter causing apparent motion or parallax between the missile and target.
- (iii) Visual effects due to rolling of the field of view about the sightline axis (the pitch and yaw sightline axes were to be gyro-stabilised).
- (iv) Performance degradation due to the vibration and accelerations experienced by the operator.

A preliminary experiment was set up to investigate the relative contribution of factors (i), (ii) and (iii) in degrading performance.

An examination of vibration effects was omitted at this stage in the programme as it was considered unlikely to have a significant effect at the levels encountered in helicopters. This experiment (which tested ten B.Ae. personnel as subjects using the simulator described in Section 3) found that factor (iii), the visual effects of roll, to be potentially the most important factor degrading performance. Thus the subsequent programme was oriented towards a quantitative assessment of the degradation in performance associated with these visual effects.

Four experiments were undertaken as described below. In brief, the first two aimed to demonstrate that visual roll could cause a significant degradation within the operational requirements. The final two experiments aimed to provide data for minimising this degradation.

Whilst the prime objectives were quite specific to the proposed weapon system; the findings have much broader implications to the understanding of human performance and the design of simulators.

To provide some background information an outline of the proposed weapon system is given in the following section.

### 1.3 An Outline of The Weapon System

Features of the Swingfire system and the proposed helicopter borne version which are relevant to this paper are outlined below. (Adapted from "Janes", Ref. 1). Swingfire is a long range command-to-line-of-sight (C.L.O.S.) anti-tank system. The missile is wire guided, command signals being generated by the operator's joystick control. Those commands are interpreted by the missile as demands for a change of heading referred to the roll and heading gyros in the missile autopilot; thrust vector control is employed. The operator uses a periscopic sight (alternative x1 and x10 magnifications) to maintain visual contact with the missile during the engagement. After launch the missile is gathered into the operator's field of vision by the automatic gathering phase in the guidance programme. In this way the missile is guided approximately onto the target sightline and final guidance is carried out by the operator. Swingfire has a velocity control system and maintaining the joystick stationary once the missile is framed in the target is sufficient to maintain the collision course.

The helicopter borne system (designated Hawkswing) was proposed to be a readily removeable system, primarily for installation in the Lynx and Gazelle helicopters. The main difference between this and the land based system lay in the use of the periscopic sight which was gyro stabilised in the pitch and yaw axes referenced to the sightline. A controller enabled the operator to slew the sight in azimuth and elevation in order to search out and maintain the target centrally in the field of view, compensating for the forward motion and change of heading of the helicopter.

A feature of the proposed system was that operational capability was to be maintained at high forward speeds and during evasive manoeuvres.

## 2. ROLLING FIELD OF VIEW EFFECTS

The concept of "up" and "down" (or left and right) is relative to a particular system at a particular time. This is known as the frame of reference of the system. In our everyday life we have few problems in deciding our vertical frame of reference since the cues from our visual and vestibular senses normally agree which way is "up". We have a little more trouble with left and right since they depend upon which way one is facing at the time and the bilateral symmetry of the body does not aid differentiation. On terra firma, frames of reference do not present much of a problem. However, this is not true for airborne situations where the frames of reference of the aircraft and crew may well be different from that of Earth. The best known example of this is the flying "inside-out" or "outside-in" (Johnson and Roscoe, Ref. 2) which occurs on the changeover from instrument flying in cloud to normal visual contact. Conflict of the visual cues in judging frames of reference has been examined by many scientists, Witkin in particular (Ref. 3).

However, the weapon aiming situation poses an additional problem, namely, the frame of reference of the missile in flight. Firstly it must be emphasised that this paper is concerned solely with the remote vision type of missile as opposed to the "on board" vision, type; the differences between which are illustrated below in Figure 1.

When the missile is launched its gyro axes are referenced to the helicopter. A helicopter manoeuvre after missile launch may introduce a misalignment between missile and helicopter axes, more particularly between the operator's reference axes (when tied to the helicopter) and those of the missile. It is those manoeuvres that roll his field of view which impair performance. This is illustrated below in Figure 2.

Thus, the missile does not respond to the operator's intention. The effect produced is for the path of the missile to spiral around the target sightline as it goes down range, despite the operator's best efforts. However, the consequences of helicopter manoeuvre are not so simple since it cannot be assumed that the operator's frame of reference is rigidly tied to the helicopter when outside visual cues clash with what his other senses tell him. Thus the effect depends upon the misalignment between the operator's frame of reference and that of the missile which is caused by

- (a) the relative rotation of the missile and helicopter after launch.
- (b) the operator's interpretation of the visual cues.

Although this effect is similar to cross coupling between the pitch and yaw axes there are several subtle differences. For this reason engineers who were working on the project coined the term 'visual roll phasing' to describe this phenomenon. Nordstrom (Ref. 4) was the first to study this phenomenon during manual guidance.

## 3. EXPERIMENT 1 - ELECTRONIC ROTATION OF CONTROL AXES

### 3.1 Introduction

This was a preliminary experiment to pave the way for a more detailed investigation. However, in the present context it enables a comparison to be made between the subjects' performance when the roll phasing was produced by rotating the control axes electrically rather than visually as in the later experiments.

### 3.2 Description of Simulation and Experiment

A closed circuit TV system was interfaced to the weapon aiming controls via an analogue computer to represent the air gunner's task.

The subject was seated in front of the display, with his preferred eye looking through an open eyepiece at the TV display which subtended a  $20^{\circ}$  f.o.v.

A scenic monochrome background (including a static target) was displayed on the C.C.T.V. which moved across the screen to represent the helicopters forward motion at 100 km/hr. This was achieved by signals directed onto the scan coils of the TV tube. The subject used a light joystick control, operated by his left hand, to keep the target area centralised on the screen.

A small bright square was electronically generated to represent the missile. A gather programme brought the missile close to the target sightline at the start of each trial after which the subject operated the weapon aiming control with his right hand to hold the "missile" on the target. The analogue programme simulated the basic flight characteristics of the missile (in the presence of wind gusting) at a given range in computing the position of the missile on the screen. Thus the control characteristics were similar to those of the Swingfire system which had a velocity (1st order) control with control demand shaping. The control/display ratio was not constant but diminished as the "missile" went down range.

Two weapon guidance joystick controls were tested:-

- (i) thumb operated displacement stick
- (ii) finger operated displacement stick

The former was the current In Service GM controller and the latter a modification of this, fitted with a longer shaft and held vertically in a pen-like grip by the index finger and thumb (see Figure 4). The sight slew control used was identical to the weapon aiming control; later tests revealed that a thumb operated sight control gave less interference with the weapon aiming task than the finger operated one but the effect was small enough not to invalidate the present experiment.

The simulation had no facility for rolling the field of view therefore the effects of roll phasing were produced by electrically rotating the joystick demand vector.

Joystick Demand	Output to missile
Yaw:- $-x$	$x \cos \theta + y \sin \theta$
Pitch:- $y$	$y \cos \theta - x \sin \theta$

where  $\theta$  is the angle of rotation of the control axes defining the level of roll phasing (or cross coupling). Four fixed values of  $\theta$ :-  $7.5^{\circ}$ ,  $15^{\circ}$ ,  $22.5^{\circ}$ ,  $30^{\circ}$  were used with zero roll as control condition.

Seven subjects were used in this part of the programme. Four were air gunners who were being trained for AS11 operations and the remaining three were BAe engineering apprentices.

All subjects were given a minimum of 100 training trials before commencing the experiment. In the experiment ten trials were undertaken by the subjects for each joystick/roll phasing combination; these were presented in a balanced order to minimise learning effects. Each trial was alternated with the control condition. At the end of each run the time on target score was given to the subjects. The trials were presented in blocks of thirty per session with a minimum 2 hour rest period between sessions. During the experiment the direction of phasing was set on alternate trials for clockwise, then anticlockwise, rotation of the control axes. The three BAe subjects undertook an extra set of trials in which the direction of rotation was changed twice during an engagement guidance (by the operation of a switch).

### 3.3 Results

For brevity only a summary of the results are presented here. The mean time on target scores are given in Figures 4a and b expressed as a percentage of the control condition scores. These graphs show clearly the linear degradation in performance associated with the phasing error level. A less significant quadratic trend was also observed. The differences between the two groups of subjects were small and within the limits of experimental error. The finger joystick control shows less susceptibility to roll phasing than the thumbstick (analysis of variance showed that this result was statistically reliable at  $p < 0.01$ ). The former, for example, showed a 10% performance degradation at  $19^{\circ}$  roll phasing whilst the thumbstick suffered the same degradation at  $7^{\circ}$  phasing error. The changing direction phasing caused a greater degradation than the fixed phasing and under the most severe roll phasing both joysticks had the same degradation.

### 3.4 Interim Conclusions

- (1) The results showed that roll phasing introduced electronically caused a degradation in performance.
- (2) Trainee airgunners were as susceptible as BAe personnel to roll phasing.
- (3) The finger joystick was less susceptible than the thumb control.

## 4. EXPERIMENT 2 - MOVING BASE STUDIES

### 4.1 Introduction

Experiment 1 had demonstrated that roll phasing had a significant effect. The question remained, however, whether the air gunner would be able to adapt to conditions of visual roll or not. If not, would the added stresses of the helicopter environment make manoeuvre impossible during an engagement.

The aim of this experiment was to reproduce the airgunner's task and environment as accurately as possible to determine the degradation effect, and to select the most suitable weapon aiming control.

### 4.2 Simulation Description and Experimental Procedure

The 5 Axis Manned Vehicle Motion Simulator at BAe Weybridge was used for this study. A scout helicopter cockpit, fitted with an APX-BEZO M250 gyro stabilised sight and weapon aiming controls was mounted onto the vibration rig (see Figure 5).

The visual environment was achieved by projecting a suitable 35mm colour slide onto the screen 5m in front of the subject. The slide projector was fitted with a zoom lens and mounted on a gimballed platform which was servo controlled in azimuth and elevation. The zoom lens and the servo controlled platform were controlled by an analogue computer to reproduce the visual effects of helicopter forward motion and change of heading.

The weapon aiming task was made as realistic as possible by utilising the Swingfire classroom trainer unit. This consisted of a high precision 2 axis servo controlled mirror which projected a circular spot of light onto the screen to represent the missile flare. The missile guidance programme and flight characteristics were generated by the analogue computer. A medium range engagement was simulated. Similarly to the previous experiment the thumbstick and the finger joystick were used as weapon aiming controls. The slew control for the M250 sight was a short horizontal stick mounted on the left handlebar.

The roll manoeuvres were achieved by rolling the helicopter about its longitudinal axis; in addition, vibration was applied in the vertical axis taken from inflight recordings of a Scout helicopter.

The following conditions were examined experimentally covering the range of expected operational manoeuvres.

Roll Amplitude	7.5, 15, 22.5, 30 deg.
Roll Period	23 sec.
Launch Attitude	Horizontal; Banked at 10°, 15°, 20°
Forward Speed	(1), 100 km/hr.

Zero roll was used as the control condition.

Three measures of performance were taken (a) "hit" rate (b) terminal radial error (c) time on target; these were obtained from direct telescopic observation or cine film analysis.

Six BAe apprentices were used as subjects in this experiment after a suitable period of training. The experimental conditions were presented in a balanced order with the control condition at the beginning and end of each block of ten trials. Each subject completed five replications of the manoeuvre.

### 4.3 Results

The three measures of performance were subjected to Analysis of Variance (see Table 2) backed by a non parametric test, namely Wilcoxon's Signed Ranks test, to test the statistical reliability of the results. The findings, which are illustrated graphically in Figure 6 a, b, c, are summarised below.

- (i) Effect of Forward Motion - the extra task loading caused by the forward motion of the helicopter did not impair performance.

- (ii) Effect of Roll - this showed a significant degradation ( $p < 0.01$ ) in performance as the roll amplitude increased. For the radial error this degradation was a linear function of the roll amplitude. The "hit" rate as (defined in the terms of this experiment) showed a marked degradation between the zero and  $7\frac{1}{2}^{\circ}$  roll cases.
- (iii) Effect of Launch Attitude - when the helicopter was banked at launch performance was impaired compared to the horizontal launch. This was due in part to the higher levels of phasing experienced with this manoeuvre.
- (iv) Differences Between Controls - the controls showed no overall differences, but a highly significant controller/roll interaction was observed ( $p < 0.01$ ). The thumb controller had a poorer relative performance under low roll phasing conditions (i.e. horizontal launch) but a better relative performance at higher levels. This was mainly due to differences between the two controls in the terminal pitch error. This is illustrated in Figure 7 where the maximum roll phasing angle shows an inverse relationship with performance.
- (v) Vibration - a comparison between vibration and static trials showed no significant differences between the two.

#### 4.4 Interim Conclusions

- (1) Although weapon aiming was feasible under high levels of manoeuvre performance was severely degraded.
- (2) Roll amplitude and launch attitude both contributed to the performance degradation.
- (3) The finger joystick was better than the thumb control under conditions of low manoeuvre with the situation reversed under conditions of high manoeuvre.

### 5. EXPERIMENT 3

#### 5.1 Introduction

The previous experiment had demonstrated that visual roll had a significant effect upon missile guidance performance. However, the question remained whether selected air crew would be susceptible to this effect after a suitable training period. This study aimed to examine this aspect.

#### 5.2 Description of Simulation and Experimental Procedure

The weapon aiming simulation was essentially similar to that of the previous study except that an Avimo Ferranti AF120 gyro stabilised sight was mounted in a cradle with a seat attached.

The visual effects of roll were achieved by modifying the Pechan prism assembly in the sight so that it could be rotated by a servo motor. This modification restricted the rotation in azimuth to  $\pm 2^{\circ}$ . A roll generator enabled the experimenter to select the required roll manoeuvre; a separate unit enabled the control axes of the missile to be aligned to the helicopter axes at the start of each run. A medium range engagement against static and moving targets was simulated. The visual effects of the following manoeuvres were reproduced:-

Roll Amplitude	20, 30, 40 <sup>o</sup>
Roll Period	20, 30, 40 Sec.
Launch Position	Horizontally Banked at 10 <sup>o</sup> , 20 <sup>o</sup> , 30 <sup>o</sup> .

Zero roll was used as the control condition.

Three measures of performance were taken (i) hit rate (ii) radial terminal error (iii) incidence of "grounding" (i.e. missile goes below the sightline). All three measures were judged by telescopic observation.

Ten subjects were used in this experiment, six of whom were experienced helicopter pilots, the remainder were ground crew. Each was given a minimum of 250 practice trials before commencing the experiment.

The experimental conditions were presented in a balanced order as in the previous experiments.

#### 5.3 Results

The first stage of the analysis of the results was to examine differences between the performance of the flying and non-flying personnel. No significant differences were found. In general the results were similar to those of the previous experiment despite the extra training and the lack of motion cues.\* Roll amplitude caused a significant degradation in performance (analysis of variance showed this to be statistically reliable,  $p < 0.01$ ); this is illustrated for radial error in Figure 9. "Hit" rate showed a similar trend but the



degradation was not significant at roll amplitudes less than  $20^{\circ}$ . The banked attitude at launch also degraded performance ( $p < 0.05$ ). However, the roll period did not reliably affect performance and there was only a marginal difference between the 20- 40 sec. periods, see (see Figure 9).

#### 5.4 Interim Conclusion

- (1) A performance degradation was observed when the operators were subjected to roll amplitudes greater than  $20^{\circ}$ , despite the increased training.
- (2) The roll period (or rate of roll) had no overall effect on performance.
- (3) There were no reliable differences between the flying and non flying personnel.

\* Although the overall performance was vastly improved due to the extra training and improvements to the simulation.

### 6. EXPERIMENT 4 - ROLL COMPENSATION

#### 6.1 Introduction

The previous experiment had shown that roll compensation was necessary to maintain the operational capability under the more severe conditions. Compensation could be achieved by roll stabilising the field of view through the sight or by electronic resolution of the joystick output. However, there were technical difficulties associated with the electronic method so the optical roll stabilisation was selected for testing.

#### 6.2 Simulation and Experimental Procedure

This simulation used the same equipment as previously except for a modification to the AF120 sight to reproduce the effect of roll compensation. This consisted of an illuminated graticule which was injected into the sight. This graticule remained fixed in the field of view and parallel to the missile control axis (although a  $10^{\circ}$  error was also represented). At the beginning of the trial the field of view was frozen at the launch attitude and the operator used the graticule as his frame of reference to guide the missile. See Figure 10). The same ten subjects were used from the previous experiment and the following conditions were tested:- launch attitude of  $0^{\circ}$ ,  $10^{\circ}$ ,  $20^{\circ}$ ,  $30^{\circ}$ ,  $40^{\circ}$ . In addition compensation errors between the missile axis and the graticule of zero and  $10^{\circ}$  were introduced.

#### 6.3 Results

The results showed that on all measures of performance the compensator enabled the operational capability to be maintained under all the roll conditions examined in Experiment 3. The terminal radial error scores are given in Table 1A. From this a small improvement is obtained at a launch attitude of  $20^{\circ}$  which is presumably due to the subjects trying harder under a marginally more difficult condition. At higher levels of launch angle,  $30^{\circ}$  and  $40^{\circ}$ , the tilting of the visual horizon appeared to distract the operator from the graticule and caused a degradation in performance. The incidence of missile "groundings", which was due to a momentary loss of control, was the most affected measure of performance in this case.

The  $10^{\circ}$  compensation error caused a small degradation in performance. This degradation was only significant when the compensation error was biased away from the visual horizon (see Table 1A and 1B).

TABLE 1A MEAN RADIAL ERROR - COMPENSATED TRIALS

	Attitude at Launch				
	$0^{\circ}$	$10^{\circ}$	$20^{\circ}$	$30^{\circ}$	$40^{\circ}$
Perfect Compensation	3.70	3.55	3.00	4.24	4.12
$10^{\circ}$ error towards horiz.	3.78	3.60	3.85	-	-
$10^{\circ}$ error away from horiz.	5.32	4.62	4.89	-	-

expressed in M. rads at eye.

TABLE 1B INCIDENCE OF MISSILE GROUNDING - COMPENSATED TRIALS

	Attitude at Launch				
	0°	10°	20°	30°	40°
Perfect Compensation	6.8	0	1.7	5.1	15.2
10° error towards horiz.	1.6	5.1	3.3	-	-
10° error away from horiz.	10.1	5.1	16.9	-	-

expressed as percentage grounding rate

#### 6.4 Interim Conclusions

The attitude compensator maintained operational capability for manoeuvres where the attitude at launch was 20° or less. Higher levels of launch attitude caused a degradation in performance, although the effect was less than that of the uncompensated case.

#### 7. A FURTHER ANALYSIS OF ROLL PHASING

In examining the degradation caused by roll phasing in more detail a distinction must be drawn between the actual roll phasing level (i.e. the rotation of the missile control axes with respect to those of the operator) and the degree of visual roll which is perceived by the operator: The latter cannot be measured easily whilst the former is defined mathematically for the sinusoidal manoeuvres used in the experiments:-

$$P_t = A \sin \frac{2\pi}{T} (t + a) \pm B$$

where  $P_t$  is the phasing error at time  $t$

$A$  is Amplitude of the roll and  $T$  the period

$B$  is the bank angle at launch

$a$  is a constant = 0,  $T/12$ ,  $T/4$  when  $B = 0$ .  $\frac{1}{2}A$ ,  $A$  respectively.

The degradation in performance was found to be related to the amplitude of the roll manoeuvre. This suggested that the degradation was a linear function of the mean roll phasing level during the simulated engagement. To examine this further a correction analysis was undertaken for Experiment 3 data between the radial terminal error and the mean phasing level,  $P$ , during

- the whole engagement
- the best 5 seconds of the engagement
- the best 2 seconds of the engagement

These correlations were found to be statistically reliable ( $p < 0.05$ ) but were not reliably different.

	Correlation Coefficient
$P_{15}$ (whole engagement)	+ 0.58
$P_5$ (last 5 seconds)	+ .77
$P_2$ (last 2 seconds)	+ .79

The mean phasing error during the last 5 seconds of the engagement,  $P_5$ , is an adequate description and was related to the radial error by the following empirical relationship

$$R = R_0 + 0.06 P_5$$

where  $R_0$  is the radial error in m. rads under zero roll (=3.5 m. rads). The highest value of  $P_5$  was 54° under a 30° roll amplitude, 20° launch attitude.

However, the prediction efficiency of  $P_5$  was only 62% and using  $P_{15}$  and  $P_2$  to give a weighted phasing level made only a marginal improvement in this efficiency. No other measure of phasing error gave a better predictive efficiency.

The period of the roll manoeuvre did not affect the performance of the subject. Thus the rate of change of phasing level had no effect, implying that the subject did not adapt to a given level of phasing error during an engagement.

The second major factor in the analysis was the bank angle at launch. For Experiment 3 the following empirical relationship between the roll parameters and the radial terminal error was derived.

$$R = k (A + 0.5B) + C$$

where  $R$  is the radial error in m. rad at the eye  
 $A$  is roll amplitude in degrees  
 $B$  is angle of bank at launch  
 $k$  had a value of 0.18 for this experiment

However, there is only a weak correlation between the mean phasing level  $P_5$  and the  $(A + 0.5B)$  factor ( $r = +0.32$ ). This indicates that the bank angle at launch causes the subject to adopt a different frame of reference, thus modifying the perceived phasing error. The attitude compensated trials in Experiment 4 showed a similar trend under high levels of roll. Thus it appears that the operator's response is a compromise between his own body frame of reference and that of the visual horizon as seen through the sight (which causes an induced phasing error).

These findings appear to agree with the work of Witkin on the personality trait known as "field dependency" (or psychological differentiation) mentioned in Section 2.

It was postulated that subjects who were more "field dependent" (as measured by a suitable test) would be more prone to the effects of visual roll. A previous study had measured the field dependency of R. A. F. pilots (Seale, Ref. 5) using the Embedded Figures Test in which under time pressure the subject has to search for a simple figure embedded in a more complex background presented on a card placed in front of him. This study had revealed that the R. A. F. pilots were at the extreme end of the range showing low "field dependency (or field independent)". This test was conducted on the Army Air Crew used as subjects in Experiments 3 and 4.

The results showed that the Army Air crew were closer to the population norm than the R. A. F. pilots in terms of their "field dependency". There was a trend for the more field dependent air crew to suffer higher degradation in performance under conditions of visual roll. This trend was statistically reliable (Spearman's rank correlation  $r = 0.81$ ,  $n = 9$ ) only after one of the ten subjects had been excluded from the analysis. Unfortunately the Embedded Figures Test seemed to be affected by differences in the educational attainment of the subjects and therefore was not suitable for rigorous comparison across air crew from commissioned and non-commissioned ranks. (This defect of the test was not documented at the time). It was tentatively concluded that the subjects susceptibility to visual roll phasing was related to the personality trait of "field dependency".

#### 8. A MODEL OF ROLL PHASING EFFECTS

The operator's tracking behaviour at any point during missile guidance can be represented by the schematic given below:-

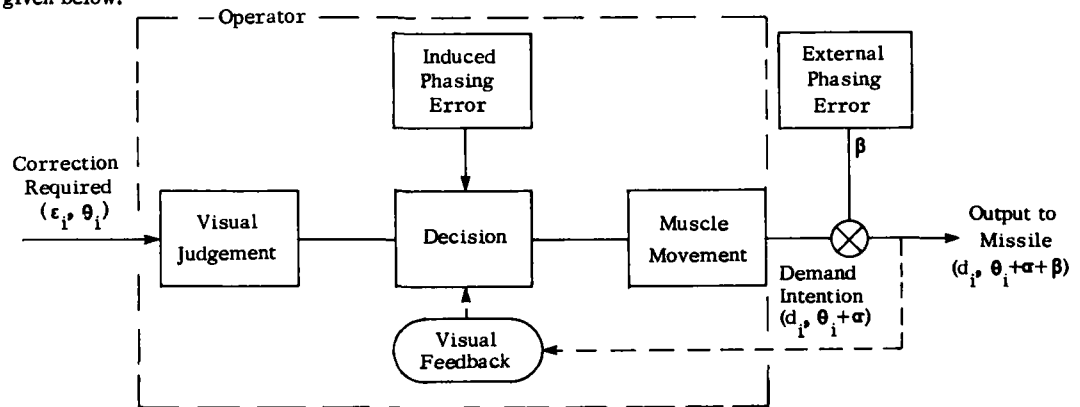

In this schematic  $(\epsilon_i, \theta_i)$  is the correction vector in magnitude and direction required to reduce the guidance error to zero at an instant in time,  $i$ . It is assumed that the operator makes discrete samples of the error and responds with the demand intention  $(d_i, \theta_i + \alpha)$  where  $i$  is the internal directional error (at the instant  $i$ ) within the operator caused by:-

- (i) induced phasing error produced by horizontal tilt.
- (ii) errors of visual judgement and muscle movement.

The external phasing error,  $\beta$ , due to the misalignment of the helicopter and missile axes by manoeuvre. The value  $\alpha$  will be variable, distributed about a mean which will be dependent upon the operator and his interaction with the control stick. The results of Experiment 1 showed the thumbstick to suffer an equal degradation in performance when subjected to  $7^\circ$  of phasing error against the  $19^\circ$  phasing error of the finger operated control. This suggested that the thumbstick had an internal phasing error whose mean was greater than  $12^\circ$ . This was partly due to the way in which the thumb articulates when making control demands.

How does the operator's strategy cope with phasing error? McLeod (Ref. 6) who undertook a similar investigation, suggested that the operator appeared to make no attempt to anticipate the direction of the phasing error but relied on making a sufficient number of corrections to eventually reduce his tracking error to zero.

Thus for this strategy to work effectively  $\epsilon_i > \epsilon_{i+1}$  where  $\epsilon_{i+1}$  is the correction required after  $d_i$  has been completed. If the operator makes no errors of magnitude (only of direction) this strategy will breakdown when  $\alpha + \beta \geq 60^\circ$  (from the properties of triangles). If errors are made in magnitude it can be shown simply that this strategy also breaks down when

$$\frac{d_i}{\epsilon_i} \geq 2 \cos(\alpha + \beta) \quad (\text{Eq. 1})$$

Thus the observed phenomenon of spiralling around the target can be explained by this model when  $\epsilon_i \approx \epsilon_{i+1}$   $0_i \approx 0_{i+1}$ .

However, even under conditions of high roll phasing nearly 40% of the trials achieved a good terminal error compared to 80% in the zero roll case. Thus there appears to be some strategy which enabled the operator to achieve a good performance. Returning to the model, if the operator attempts to minimise the internal error (i.e. by making  $\alpha \rightarrow 0$  and  $d_i < \epsilon_i$ ) then the effects of the roll phasing will be reduced. However, it did not appear to be easy for some subjects to adopt consciously a strategy which minimised the internal errors. Indeed, on several occasions the trials had to be interrupted when some subjects were so susceptible to the spiralling effect under high roll that they would not believe the simulation to be working properly.

The reason for this is fundamental to the functioning of man's psychomotor skills. It is widely recognised that any task involving hand-eye co-ordination may occur in one of two modes:

- (i) preprogrammed - without visual feedback
- (ii) "wait and see" - with visual feedback

(although authors may use differing nomenclature). Well learned tasks such as tracking are normally in the programmed mode and any visual feedback may be processed by the brain well after the subsequent demand has been executed. The "wait and see" mode is generally reserved for difficult or unpredictable tasks where the degree of control is more precise although slower, since the visual feedback is processed before the next demand is executed. McCallum and Cooper (Ref. 7) have identified brain activity patterns which can be associated with two types of motor control which they call categoric and scoputic. Thus in order to minimise internal phasing errors the operator must revert to the "Wait and See" mode particularly when the external phasing errors are high during a manoeuvre.

A similar effect has been observed in land based live firings when missiles have "barrel rolled" without any obvious defect. From an analysis of the operator's control demands it appeared that the fault was self induced by the operator when under stress by creating large internal errors. This was overcome by training the missile operators to stop momentarily making control demands.

## 9. IMPLICATIONS FOR SIMULATION, SELECTION AND TRAINING

This study has raised several aspects which are relevant to the design of simulators and the selection and training of personnel for air crew. Three entirely different simulations were utilised, yet the results were remarkably similar. The moving base simulation was in no way more effective than the fixed base one. The reason for this is not hard to find since, in contrast to pilot training, the helicopter motion cues are not intrinsic to the acquisition of skill in missile guidance but act merely as distractors.

The similarity between the effects of electronic rotation of the control axes in Experiment 1 and those of the visual effects in Experiments 2 and 3 can be explained by the non-adaptation of the subjects to the actual roll phasing level during weapon aiming. Thus, in designing simulators for skills training we must look closely at the relevant factors which are to be incorporated. Some skills cannot be easily acquired through training. Adaptation to visual roll is apparently one of these skills since it appears to be quite strongly related to personality traits (i.e. field dependency). What needed to be trained in this case was the remedial tracking strategy relying on a partial "wait and see" or scoputic mode of control. This could be equally well trained on the simulation used in Experiment 1 although merely giving repeated weapon guidance trials may not be the most efficient training programme. It is suggested that this categoric-scoputic aspect of training is also very relevant to other skills such as car driving and aircraft flying since it appears, on an experimental

basis, that many otherwise competent drivers find themselves in potentially dangerous situations merely because they do not revert to the "wait and see" mode rapidly enough when critical incidents occur.

Selection of missile operators is done on a very different basis from that of pilots and is based on attempting to detect and reject the poorest operators rather than select only the best men. At the present time, selection tests have proved to be of very limited use despite extensive research. However, this study has suggested two factors not covered by previous research in detail.

Firstly there is an indication that the best operators might be field independent as measured by the Embedded Figures Test. Further work using a more appropriate test (the Rod and Frame test) to measure field dependence - independence on Vigilant missile operators came up with similar indications. The second aspect is the facility to switch from preprogrammed to "wait and see" (i.e. catagoric to scoputic) mode when under skilled performance. Whilst this facility might be measured indirectly in existing psychomotor tests it might prove more effective to measure it directly. It is suggested therefore that further consideration of these two aspects of skilled performance might enhance future selection techniques.

#### 10. CONCLUDING REMARKS

The programme commenced by identifying four factors which were potentially performance degrading in weapon aiming from helicopters. The feasibility of the human operator is such that only one of these factors, namely visual roll phasing, affected performance greatly.

It was then thought that with a reasonable degree of selection and training the operator might be able to anticipate and compensate for the misalignment of the missile control axes with respect to the operator. However, this was not the case since horizon tilt affected performance even in the absence of any misalignment. Thus visual roll phasing was a complex effect and susceptibility appeared to be related to personality factors. However, several subjects managed to adopt a strategy which minimised the degradation due to visual roll phasing. This was achieved by utilising a slower, and more accurate tracking style which minimised over correction. Whilst some subjects did not readily learn this style on their own accord it appears to be skill which can be learned if presented during the early stages of skill acquisition. The acquisition of this style may be appropriate to many other psycho-motor tasks.

#### 11. REFERENCES

- |    |                               |   |
|----|-------------------------------|---|
| 1. | Pretty, and Archer D          | "Janes" Weapon Systems  |
| 2. | Johnson, S. L. and Roscoe, S. | "What Moves, the Airplane or the World" Human Factors 14 (2) 1972, P107-129.                                      |
| 3. | Witkin, H.                    | "Personality Through Perception - An Experimental and Clinical Study". Harpers Press Ltd 1954                     |
| 4. | Nordstrom, L.                 | "Effect of Banking of the Field of Vision on Manual Tracking Performance" Complex Vehicular Controls AD-604 1966. |
| 5. | Seale, S.                     |   |

#### ACKNOWLEDGEMENTS

The authors wish to thank the officers and men of the Army Air Corps at Middle Wallop, Hampshire who provided so much assistance during the experimental programme.

FIG. 1 TWO TYPES OF REMOTE CONTROL

1. "ON BOARD" VISION

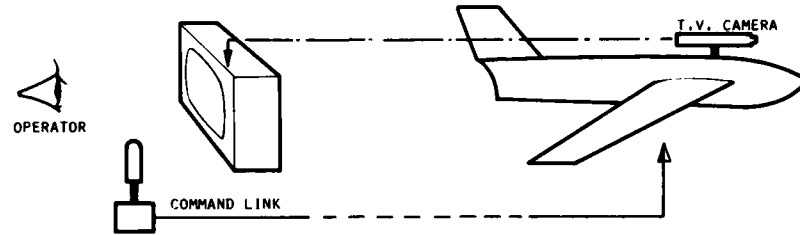

2. REMOTE VISION

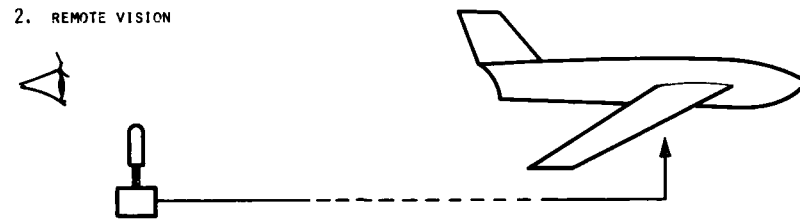

FIG. 2 THE ROLL PHASING EFFECT VIEW THROUGH THE OPERATOR'S SIGHT

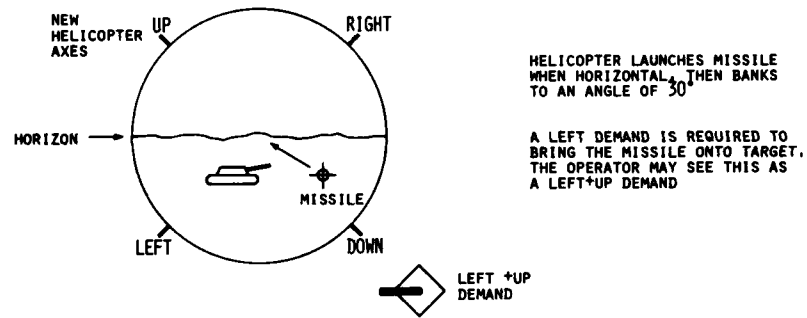

FIG. 3 TYPES OF JOYSTICKS

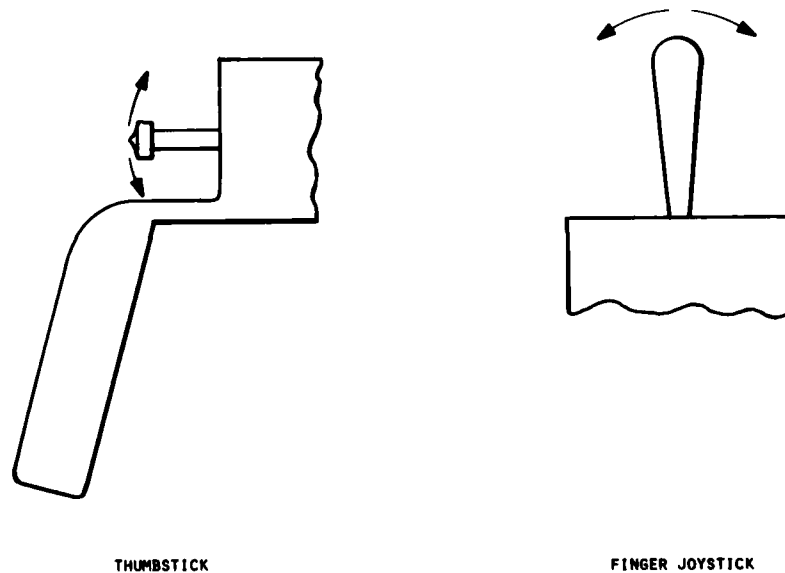

FIG. 4 PERFORMANCE DEGRADATION DUE TO ROLL PHASING MEAN TIME ON TARGET

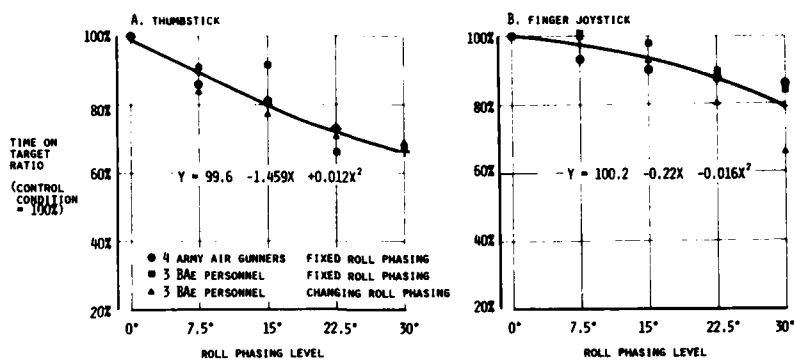
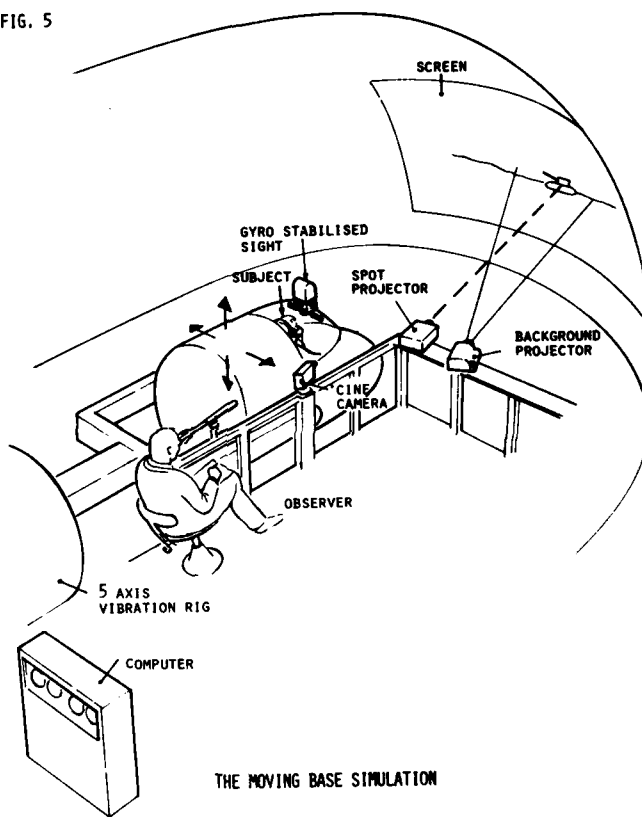

FIG. 5



EFFECT OF ROLL MANOEUVRE

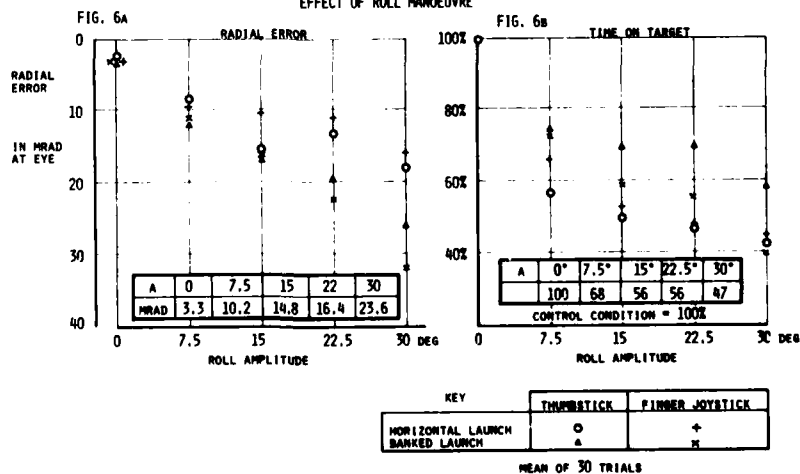

FIG. 6c

"HIT" RATE

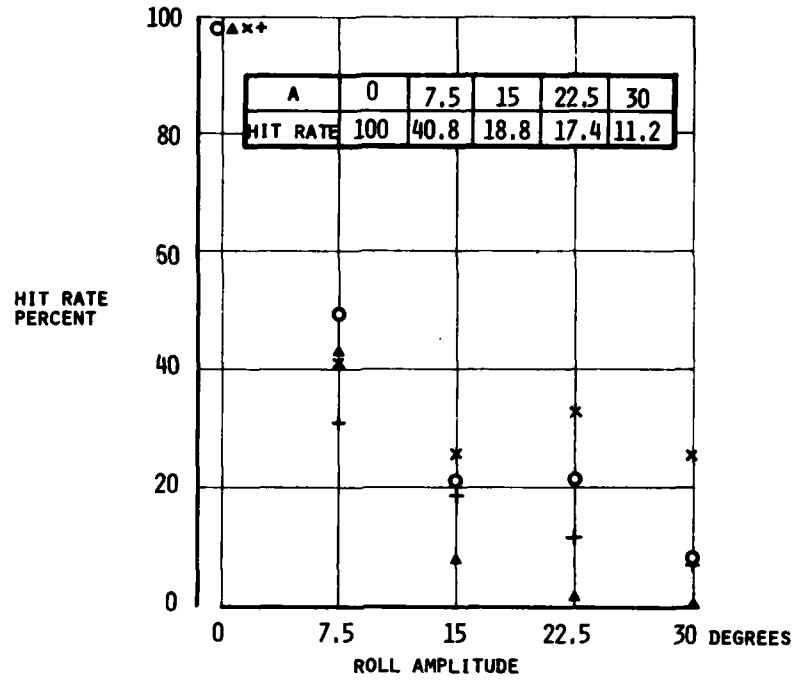

FIG. 7

PITCH ERRORS

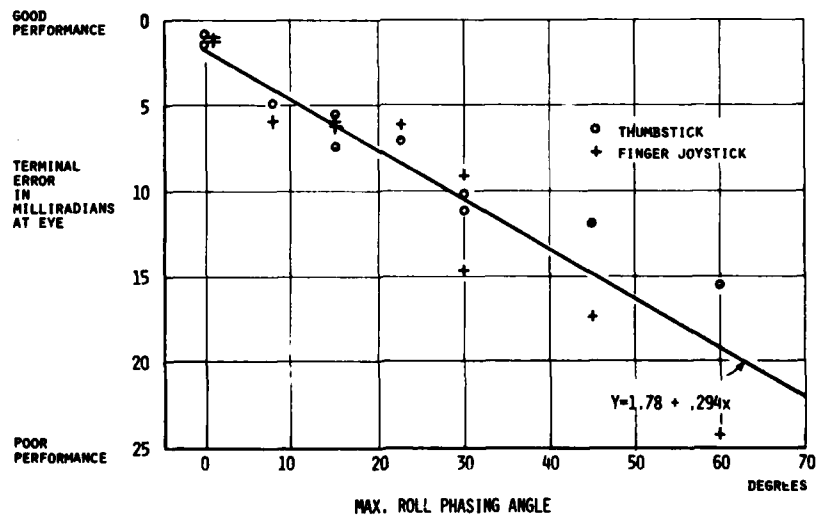



FIG. 8

EFFECT OF ROLL AMPLITUDE

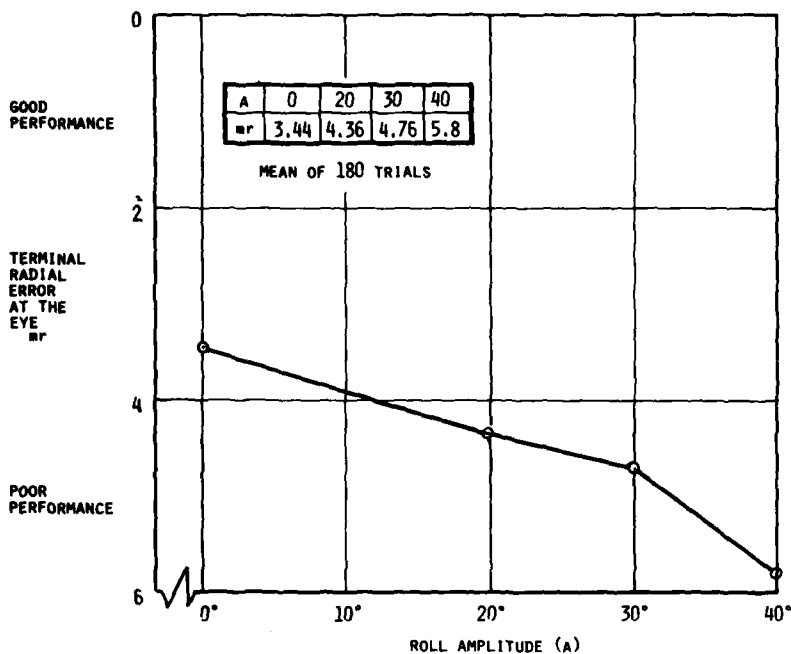

FIG. 9

EFFECT OF ROLL PERIOD

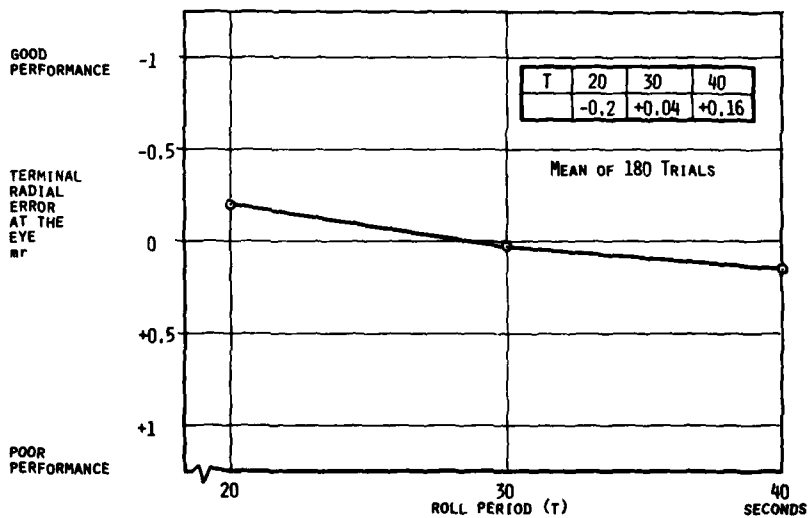
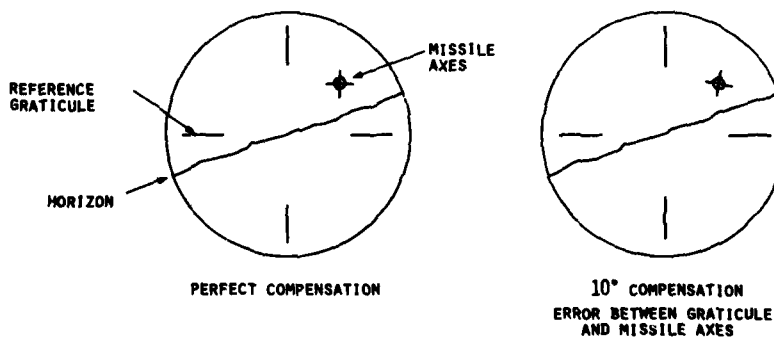

FIG. 10

THE ATTITUDE COMPENSATOR VIEW THROUGH THE OPERATOR'S SIGHT



THE FIELD OF VIEW IS FROZEN AT LAUNCH  
THE MISSILE AXES ARE SET PARALLEL TO  
THE GRATICULE

## HUMAN FACTORS EVALUATIONS OF TODAY'S HELICOPTERS AS AN AID TO FUTURE SYSTEMS DESIGN

by

E J Lovesey

Flight Systems Department  
 Royal Aircraft Establishment  
 Farnborough  
 Hants  
 England

## SUMMARY

Of the 3000 military aircraft in service in the United Kingdom, nearly one-third now are helicopters. With this increase in the proportion of helicopters also comes a growth in complexity in weapons systems and avionics. The requirement to operate, not just in daylight, but at night as well, increases still more the task difficulty of the helicopter crew. Combined, these factors indicate that more effort will be required to improve the helicopter human factors scene.

Until now, the helicopter crew have, in general, been able to cope with the situation, albeit at some cost to themselves. We have now reached the stage where we are asking the man to perform more and more difficult tasks with increasingly complex equipment. Unless this equipment is carefully matched to the man's requirements and his tasks are carefully designed to be within his capacity, the future man-helicopter systems will not meet the level of performance which is expected of them.

By examining problem areas now, we can at least prevent these being repeated in future helicopter weapon systems. Cine filming, eyemark and voice recording of crew during "Nap of the Earth" and other flight conditions are some of the ways in which present shortcomings can be highlighted. The future helicopter systems designer can also be made aware of present hardware shortcomings by conducting structured interviews and using other subjective methods with the operators of existing equipment. Questionnaires submitted to operators have proved to be very effective, if performed in a scientific manner. Often there seems to be little or no communication between system manufacturer and the customer. By showing the designer and manufacturer how their products are actually used by the operator, the latter's grievances will become meaningful and suitable action can be taken to prevent the present problems from being perpetuated in future designs.

## INTRODUCTION

Only by examining current helicopters to find out their good human factor features and shortcomings will it be possible to ensure the perpetuation of the good aspects and the eradication of the bad. To do this effectively will require us to proceed along several different routes which can be divided into the three broad categories of subjective evaluations, objective measurements and questionnaire/interview techniques.

## SUBJECTIVE EVALUATIONS

Firstly, and perhaps the easiest, is to physically examine the cockpit and cabin of helicopters when they are on the ground. A cursory glance will often reveal some incredibly bad design features due to poor engineering, inadequate equipment installation or just lack of consideration for the equipment user. Because of man's amazing adaptability he is usually able to cope for most of the time with these poor work-space and poor equipment layouts, albeit at some cost to himself and overall system efficiency. However, in difficult situations, such as during emergencies when the man has little or no spare capacity to overcome these shortcomings, he may be just unable to cope with the additional demands made upon him by the poorly designed equipment.

Examples of poor equipment design, which add to the helicopter crew's workload, range from single switches operating in the "wrong direction" (ie not in the recommended or accepted sense), to complete pieces of equipment badly installed such as the well-known Scout helicopter radio assembly<sup>1</sup>. (See Figures 1 and 2.) This radio was not only installed behind the front seats, requiring the pilot to remove his hand from the collective lever and turn around facing backwards to operate it, but had controls mounted in three different directions. This is such a clear example of how not to install equipment that all who have it demonstrated to them agree that they would never install anything as badly. However, someone at some time designed it and others no doubt approved the installation. Only by highlighting such poor design can others be made aware of the importance of considering the human factors aspect when designing or installing new equipment and preventing past errors from being perpetuated.

Having detected the obvious shortcomings, the less apparent deficiencies must be sought out. Sometimes the apparently well-designed cockpit can contain hidden snags. For example, Cressman<sup>2</sup> found that the COH58A Kiowa helicopter cockpit work space dimensions were such that 35% of all Canadian pilots would have difficulty in reaching and operating controls, or viewing certain consoles or be inconvenienced due to insufficient clearances between head, shoulders or limbs and the helicopter structure. In addition, the restricted clearance between the collective and cyclic controls under certain flight conditions was thought to constitute a flight safety hazard for the larger pilots, especially when wearing cold weather protective clothing. By constructing an adjustable anthropometer to represent the range of Canadian pilot personnel it was possible to evaluate the cockpit work space in this way. Only too often cockpits are assessed by a limited number of pilots who are extremely unlikely to represent the anthropometric ranges to be found

in the user population. Even if representatives of 5th and 95th percentile pilots in stature can be found, they are unlikely to have 5th and 95th percentile measurements in other critical dimensions, such as sitting eye height, reach, leg length, etc.

#### QUESTIONNAIRE/INTERVIEW TECHNIQUES

Questionnaires, if used sensibly, can yield information which would be extremely difficult to obtain by other methods. Often, once a helicopter or its equipment has been designed, manufactured and delivered to the operator there is little feedback of information to indicate either its faults or merits. A carefully designed and administered questionnaire can sometimes provide this feedback link, to the ultimate benefit of both user, manufacturer and R&D authority.

For a questionnaire to stand any chance of success a number of stages must be followed. Usually an initial study must take place, with visits to part of the population who will receive the final questionnaire. These visits will help to ensure that the correct questions are asked in a form which is readily understandable by the population concerned. All too often human factors engineers ask questions in their own jargon which are either ambiguous or misunderstood (or both) by the recipient. On the other hand, if questions can be phrased in the recipient's terminology it shows that the latter is not dealing with someone completely out of touch with reality but with someone who has made some effort in trying to understand the user's problems and who is open to suggestions. At this stage in the design of the questionnaire, the means of analysis should be considered. All too often the questionnaire analyst is confronted with a mass of almost unclassifiable and meaningless data which cannot be correlated with other data. The correctly designed questionnaire will yield data that can be quickly and simply extracted and, if necessary, processed by computer and correlated with other data. This can be accomplished by the use of forced choice questions constructed around a decision tree.

Finally, even if the questionnaire has been designed to ask the correct questions in the right way, such that the responses can be readily analysed, it will not achieve its potential if it is poorly administered.

A questionnaire needs to be distributed personally with an explanation of its purpose. Another problem often encountered is that the equipment user has been complaining for years about its shortcomings but nothing has been done to improve it. If a questionnaire arrives without explanation, the user may doubt if it is worth bothering to complete it as nothing has happened in the past. If the questioner is available to explain that the user's objections to the equipment have not reached him, and that this is an attempt to remedy the situation, his chance of receiving completed questionnaires will be very much improved. The distributor should be available to help anyone who still has difficulty in understanding any of the questions. Similarly there should be someone detailed to collect the questionnaires when completed and to return them to the originator.

Frequently there are complaints that a very low proportion of completed questionnaires have been returned. This is usually due to some or all of the following reasons as follows

- 1 Questionnaires were sent to a Unit Commander by post for distribution without any personal contact by the originator.
- 2 No explanation was given of the purpose of the questionnaire.
- 3 The questionnaire was ambiguous or poorly designed.
- 4 There was no one to collect the completed forms.
- 5 The Unit has already received a number of poorly designed questionnaires recently and is getting bored at completing them.

However, if the questionnaires are designed and administered in a sensible and scientific way they can provide the equipment designer with information which is invaluable and often unobtainable by other means.

Even with a well-produced and administered questionnaire, difficulty is sometimes encountered with, for example, pilots who are quite willing to discuss equipment, etc but uneasy at writing comments down on paper. For this situation the structured interview might offer the best approach. The same procedure should be followed as is required for a questionnaire except that the subjective responses are recorded by the questioner rather than the subject. This technique has been used successfully on several occasions by Howells, of Flight Systems Department RAE<sup>4</sup>. The procedure used was for the helicopter pilots to read through sequentially structured general questions which led to forced choice branching questions. Having done this and registered the preferred choice category the pilots went on to explain verbally the detailed reasons for so choosing. The verbal response was then noted down by the questioner or discussed in greater detail for clarification. Sometimes, if no objection was raised, the dialogue between pilot and questioner was recorded on tape for later analysis.

This technique of a structured interview was developed initially for a trial to supplement radar plots of a helicopter's position during an evaluation of a helicopter guidance approach aid. It was found to be acceptable to the test pilots concerned and yielded information of both sufficient generality and detail for use by the equipment designers. The latter were able to assess more fully the system performance than they had previously, by reference to radar records alone.

Since this use of the structured interview, it has been usefully employed in the evaluation of helicopter seating and helicopter workload studies. It would be equally applicable for assessing electro-optical aids and other equipment for helicopter use.

In general, if performed in a sensible manner, subjective techniques using questionnaires or interviews can yield much information which is unobtainable by other objective measurement techniques. It can also

give the designer insight into why objective data result in the way they do. Most important, subjective information provides the feedback link between the equipment operator and the designer or manufacturer.

#### OBJECTIVE EVALUATIONS OF THE HELICOPTER CREW

Having devoted some effort to promote the use of subjective techniques for the investigation of the merits and shortcomings of helicopters, it should be realised that objective measures are also required for the evaluation of particular aspects of helicopter operations.

The use of radar plots<sup>5</sup> of aircraft flight path and recordings of air speed, cyclic and collective control movements<sup>6</sup> are often used as objective methods for assessing pilot activity. However, these are not always available or convenient to use, requiring extensive ground facilities or modification to the aircraft under investigation and other objective assessment methods must be used.

Since much of the information that the pilot requires is acquired visually, it can be argued that study of eye movements or scanning patterns<sup>7</sup> (Lovesey) may indicate the difficulty of the task being performed at the time. This can be achieved using "Eyemark" cameras or cine filming, both of which require little or no interference with the helicopter or its systems.

Figures 3 and 4 show typical pilot scanning patterns recorded by cine filming of Scout, Gazelle or Puma pilots during different stages of flight. The directions in which the pilots are looking have been divided into the inside the cockpit categories of maps and instruments and the outside categories of to the left, front and right. Time spent looking in these directions are shown column by column in Figures 3 and 4. Each set of columns represents about a minute's record for a particular flight condition. The typical patterns of pilots head activity shown here have been found to be more a function of flight condition than of the aircraft's type or of the individual pilot<sup>7</sup>. For example, the cruise pattern shows relatively few (17 per minute) long looks of several seconds to the front or at instruments. Cruising flight can be considered as a comparatively leisurely task, unlike "Nap of the Earth" flight which is perhaps the most demanding form of flight close to the ground.

"Low level" flight is somewhere between the above two conditions. Low level activity shows that the pilot is glancing more frequently (28 per minute) and for shorter periods than he did during cruise. "Nap of the Earth" shows even shorter and even more frequent glances (39 per minute). During this type of flight very close to both the ground and potentially hazardous objects, the pilot simply cannot spare more than a second or so looking in any one direction. He is constantly scanning both inside and outside of the cockpit during this period of high workload; some glances taking only a quarter of a second or less.

A GCA produces a different pattern altogether. In this case a single pilot spends almost all his time looking at instruments with a very few short glances outside. Similarly circle around, approach, descent, hover and climb out from a small wooded clearing has yet another set of activity patterns. In general, the more frequent the pilot glances, the higher the workload of the pilot. There are of course, exceptions to this, such as during descent, when for the final stages, the pilot fixates on a point in the clearing and does not take his eyes away from it until he is within a few feet of the ground.

Thus some measure of pilot workload can be gained by studying pilot head and eye movements. It can also reveal some surprising facts. For example, at "Nap of the Earth" height it was expected that a pilot would spend almost all his time looking outside the cockpit to detect and avoid trees, wires and other potential hazards. However, cine films of pilot activity have shown that the closer the pilot flies to the ground, the more time he spends looking inside the cockpit. The reasons for this are that he is constantly scanning his instruments to check engine power etc and to detect engine and system changes which might indicate failures. If he has no crew to help him, he may be map reading and changing radio frequency. At low level the view ahead may be only a few hundred yards or even less. This requires constant checking of the map with the few identifiable ground features in view. At a height of several hundred feet, the pilot can see for miles around and thus identify his position on the map quickly and with little difficulty. Similarly, at low level, radio signals may be masked by ground features and this will require additional tuning or frequency changing which would not be required at higher altitude.

Although cine filming of a pilot's activity pattern can provide some useful general objective data, it is a relatively crude method of investigating helicopter pilots scanning patterns. A more precise method used in the United Kingdom and elsewhere<sup>8</sup> is that of the "Eyemark" camera. This method uses a head mounted recording system which incorporates a beam of light reflected from the cornea of one of the eyes of the pilot. It provides a picture record of where the pilot's head is pointing together with a spot of light superimposed on the picture of at what his eye is actually pointing. This enables the observer to determine exactly where the pilot is looking. It is thus possible to calculate the amount and number of times that a pilot looks at a particular instrument, or where outside he is looking during flight.

Figure 5 shows the more detailed "Eyemark" activity chart obtained for a Gazelle pilot during low level and climbing flight. Helicopter pilots glances of less than a tenth of a second have been recorded during peaks of high level activity by this method. The "Eyemark" technique reveals similar but more detailed and sensitive pilots visual activity patterns than does the simpler cine filming method. However, the "Eyemark" is a much more costly technique and gives no indication of pilot manual activity in the cockpit as does the cine film.

Often, visual activity recordings can be supplemented by tape recordings of the intercom during flight. These not only aid in the analysis of the visual record, but can also give an indication of pilot and crew workload. Voice recordings can directly inform the observer of the task difficulty by their content, or in certain situations, by their quantity and frequency of occurrence. For example if the pilot is constantly having to use his radio or intercom, it is an indication that his flying task still allows some spare mental capacity to take on verbal tasks. If these secondary tasks are then interrupted and the pilot temporarily ceases speaking, it is likely that the primary task of flying has increased in difficulty and the secondary verbal task has had to be dropped.

This method of detecting a high workload in a flight situation was the starting point of an investigation by Howells and Rogers<sup>9</sup> and a method of detecting changes in the speech spectrum to indicate stress is now under development.

#### CONCLUSIONS

Only by ensuring that the manufacturers and equipment designers are aware of the shortcomings and merits of existing helicopters and their systems, will it be possible to help future designs to be optimised. This paper briefly lists some methods which have been used by the Human Engineering Division at Farnborough to provide this feedback link.

In the past, investigators have tended to be polarised towards either subjective evaluation using questionnaires etc or objective measures. Rarely have both objective and subjective measures been used simultaneously. Only by using various subjective and objective measures together will the full picture of the helicopter user and his requirements be built up and better future designs ensured.

Copyright © Controller HMSO, London, 1978.

#### REFERENCES

- 1 E J Lovesey. The Helicopter - Some Ergonomic Factors. Applied Ergonomics, Volume 6, Part 3. September 1975, pages 139-146.
- 2 P W Gressman. Anthropometric Survey of the COH58A Kiowa Helicopter. DCIEM Toronto Technical Memorandum 879, 1972.
- 3 N M Hawkins and M J Griffin. Helicopter Pilot Opinion Questionnaire. ISVR Memorandum No 458, April 1972.
- 4 E J Lovesey, R Gray, G M Rood, H Howells et al. Vibration and other Measurements in RN Sea King Helicopter. Unpublished RAE Report, February 1976.
- 5 J W Buckle. Instrument Approach Trials using a Sea King HAS Mk 1 Helicopter. RAE Report TR 74147, November 1974.
- 6 A Winn and R B Lewis. Pilot Workload during Instrument Flight. 30th Annual National Forum of the American Helicopter Society, 1974.
- 7 E J Lovesey. In-Flight Recording of Helicopter Pilot Activity. AGARD Conference Proceedings No 217. Studies on Pilot Workload, April 1977.
- 8 M G Sanders, M A Hofmann, R R Simmons and J N De Bonis. Visual Workload of the Co-Pilot/Navigator during Terrain Flight. AGARD Conference Proceedings No 217. Studies on Pilot Workload, April 1977.
- 9 H Howells and R Rogers. Exploratory Use of Verbalised Strategies as Indices of Task Induced Stress. Ergonomics Volume 17 No 4, July 1974, Page 561.



Fig.1. Scout pilot operating poorly positioned radio.

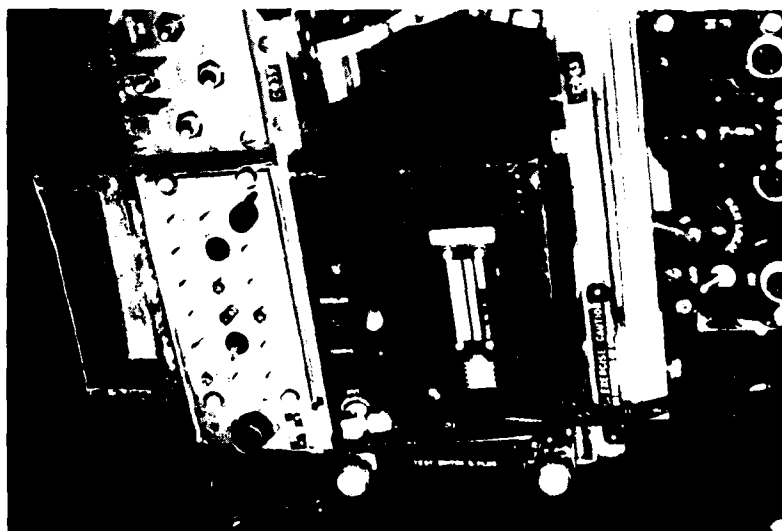

Fig.2. Close-up of radio showing the three orientations.

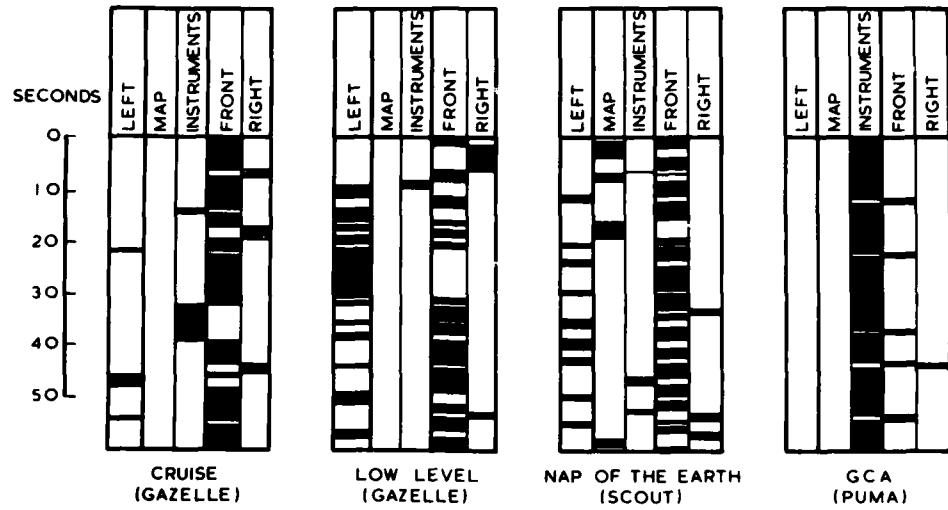

Fig.3. TYPICAL PILOT'S HEAD ACTIVITY PATTERNS FOR CRUISE, LOW LEVEL, NOE AND GCA FLIGHT

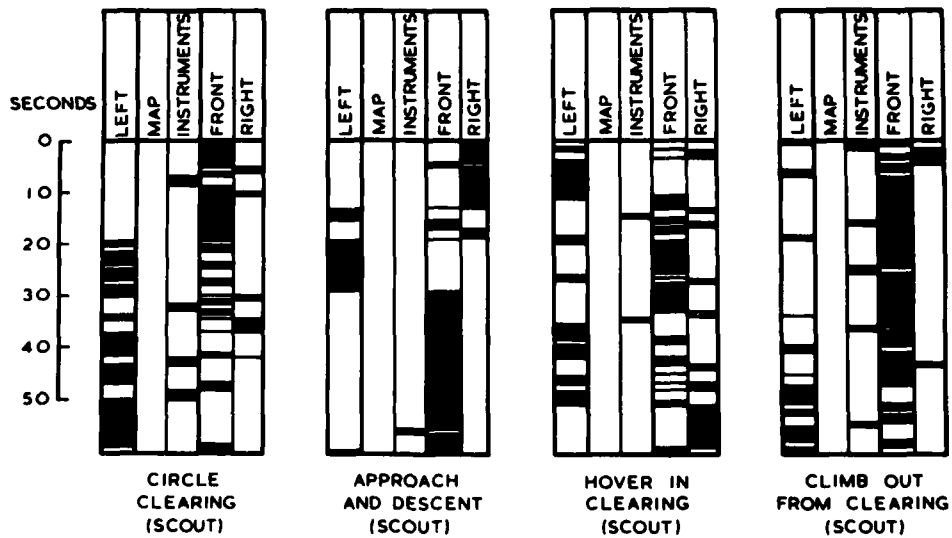

Fig.4. TYPICAL PILOT'S HEAD ACTIVITY PATTERNS FOR OPERATIONS IN AND OUT OF WOODED CLEARINGS

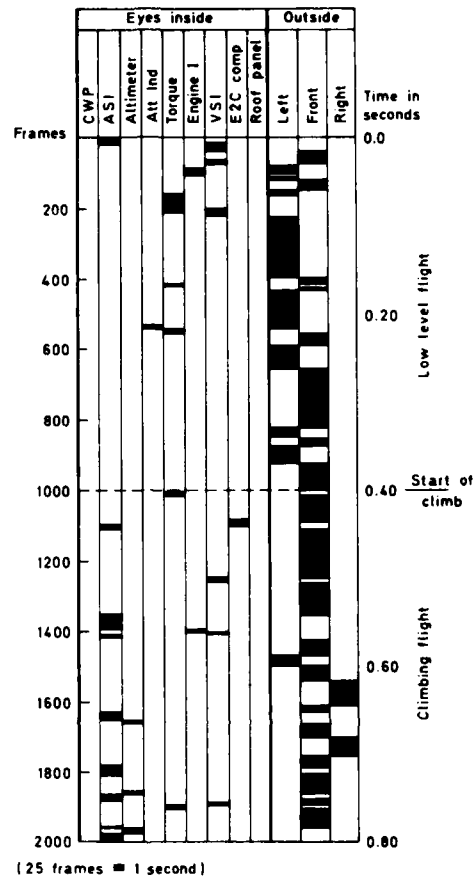

Fig.5. Gazelle pilot's visual activity during low level and climbing flight from 'Eyemark' record



**TADRAP: A COMPUTER-AIDED TECHNIQUE FOR  
REDUCING AIRCREW TASK ANALYSIS DATA**

By

David E. Gobuty, Chief  
Human Factors Engineering  
Hughes Helicopters  
Centinela Avenue at Teale Street  
Culver City, California 90230  
U. S. A.

**SUMMARY**

As part of the Human Factors Engineering activity during design of the Hughes Helicopters YAH-64 Advanced Attack Helicopter, a technique has been developed for the computer-aided reduction of aircrew task analysis data. Called TADRAP, for Task Analysis Data Reduction and Analysis Program, the system begins with the processing of raw data from a classical task analysis which was structured around a five-tiered pyramidal scheme for mission description. Once coded and keypunched, TADRAP converts the task analysis data into estimates of operator workload based upon expected task completion time, plus weighted values representing the complexity factors of action cycle, sensory modality, and task position. TADRAP facilitates task analysis validation and presents workload data in tabular form. Future plans include expanding TADRAP routines to provide computer-graphics illustrations of analyzed mission profiles.

**1. INTRODUCTION**

TADRAP, for Task Analysis Data Reduction and Analysis Program, is a FORTRAN computer program designed to reduce raw aircrew task analysis (TA) data into meaningful numbers. These numbers represent operator workload. The lower the workload, the less demanding is the task on the operator.

TADRAP was developed to handle the TA effort for Hughes Helicopters' entry into the U. S. Army's Advanced Attack Helicopter (AAH) competition, the YAH-64. Hughes' AAH is a twin engine helicopter featuring a fully articulated rotor system and a tandem crew station arrangement. The pilot occupies the rear crew station, some 20 inches (508 mm) higher than the copilot/gunner's forward crew station location. Chosen the winner of a competitive flyoff in late 1976, the YAH-64 is currently in full scale Phase 2 engineering development.

As a tool in the engineering process, TADRAP calculates and displays an operator workload index. Knowledge of expected operator workload is valuable to system designers. As workload increases, so too does system complexity and, perhaps, operator errors. Error frequency is a measure of system efficiency. Therefore, early knowledge of workload data can have the effect of creating a more simple-to-use-design. As a result, error frequency is lower, and the system is proven more efficient.

In training, TADRAP workload numbers are useful in planning course curricula. Equipments requiring relatively high workload are those which would benefit from training emphasis. Therefore, TADRAP data spotlights equipments and operating sequences requiring more thorough training.

For the task analyzer, TADRAP provides a clue concerning candidate tasks for task sharing. Should TADRAP show that one pilot is highly loaded while the other is idle or moderately busy, an attempt at dividing labor between the crew members could be considered. The result, where task sharing is possible, would be a more even distribution of tasks.

The net result of TADRAP workload data, applied early in system design, is a savings of money. In the first place, time and energy consumed during the initial phases of system design could be concentrated toward increasing operator efficiency. Secondly, training programs could be designed with insight concerning complexity of the training task itself. A training program might be tailored to provide greater depth of instruction to high TADRAP-predicted workload tasks. Thirdly, an aircraft system designed to minimize crew workload could result in greater accuracy and time-on-the-target values. More efficient use of aircraft systems could result in fewer accidents and savings of increasingly scarce manpower and material resources.

**2. GOALS**

From the beginning, TADRAP was designed with three basic goals in mind. First, TADRAP should provide computer-calculated values for YAH-64 operator workload based upon a typical mission scenario. The scenario would also be time based, and together crew workload at any given time during the "mission" would be available to the task analyzer.

Second, TADRAP should provide a means whereby the inescapable subjective bias brought to the TA by the analyst could be controlled. Utilizing the inherent "balancing" qualities of the computer, TADRAP processing of raw (manuscript) task analyses should eliminate such subjective problems as fatigue and data sorting errors which will occur with human processing of multi-thousand entry task analysis information.

Thirdly, the TADRAP system should provide flexibility to the task analyzer. Without software changes, TADRAP should allow for changes in the time interval used as a flag for printing routines, freedom in choosing segments of a mission for TADRAP processing, and relieve the analyst of some of the mechanical chores associated with TA data interpretation. The TADRAP system developed to date has met all of these goals.

### 3. ASSUMPTIONS

Ground rules were established at the outset of the TA effort to permit machine calculation of workload data. These ground rules, or assumptions, form the frame work around which the TADRAP system is built.

#### 3.1 Task Analysis Structure

Basic to TADRAP is a classical TA. The analysis, once structured, was performed by skilled human factors engineers working with knowledgeable military helicopter aviators.

The TA began with development of a tiered, pyramidal approach to mission description. Beginning at the most general, at the top of the pyramid, and ending at the most specific, at the bottom of the pyramid, five TA levels were developed:

1. Mission
2. Phase
3. Segment
4. Function
5. Task

Mission. The MISSION describes the overall goal of the system in the configuration being analyzed. Examples of YAH-64 missions are Anti-Tank and Aircraft Ferry, to name two.

Phase. PHASE divides the mission into its first cut elemental parts. For the YAH-64, typical phases are: Preflight, Enroute, Engagement, Return, and Postflight, to name five.

Segment. At the SEGMENT level, scenario-dependent events are identified. Examples include: Start Engines, Fly VFR, Perform Postflight, and Exit Forward Crew Station, to name four.

Function. Segments are divided into one or more FUNCTIONS. Each function identifies a serial set of tasks which must be further analyzed to completely describe crew activity. Function examples are: Tune Radio, Adjust Cabin Temperature, and Maintain Altitude, to name three.

Task. Finally, all functions are divided into their sequential TASKS. For TADRAP, the task level represents the basic unit of operator work. Task examples are: Operate Toggle Switch, Adjust Collective Control Lever, and Apply Wheel Brakes, to name three.

#### 3.2 Segment Library

Probably the single most important aspect of TADRAP is its ability to produce workload data structured from the segment level down. TADRAP, in essence, formulates a library of workload-analyzed mission phase segments. Once a detailed, five-level TA is completed, a task analyst is provided the option of varying the structure of his task analyzed mission by recombining segments in a different order. In addition, as each new mission is task analyzed, new mission segments are identified. These segments are then added to the existing library of workload-analyzed segments.

This segment-basic structure of TADRAP provides flexibility and eventually reduces TA effort. When the library becomes filled with the various workload analyzed segments, future TAs need not reach five levels of complexity. The analyst need only TA to the third level, the segment level, and stop. His next step would normally be to continue analysis down to the task level. However, with a complete workload-analyzed segment library, he need only select those segments identified in his three-level TA from the existing library, and then go directly to TADRAP for workload printout.

#### 4. WORKLOAD MODEL

In essence, four facets of a task were determined meaningful for calculation of crew workload. Therefore, at the task level, comparative workload can be expressed, in part, as a numerical index equal to the sum of three weighted primary workload determinants - Action Cycle, Sensory Modularity, and Task Position with weighting factors ranging from one to five. Time is considered a fundamental concomitant of task load, and has the desirable feature of being easily manipulated within an experimental environment. It is also one of the easiest variables to measure, assuming that the minimum interval to be measured is of greater duration than a few seconds. For this reason, it appeared desirable to develop a crew loading model wherein the validation criteria could be expressed in terms of time limits.

Intuitively the most practical, and therefore the most acceptable approach to developing an analysis of AAH Crew Workload seemed to require the development of a mathematical model. The model approach has several desirable features. Being expressed in mathematical relationships, it is relatively easy to program the elements for machine processing. Once programmed, it is possible to manipulate the input data, and derive the effect of changes in crew tasks, function reassignment, and mission reorganization.

A model has one further feature that is especially desirable. By using a model one can essentially reduce the workload analysis to a counting procedure for the analyst. In turn, demand upon a limited manpower base is reduced and the reliability of the analysis is improved by eliminating a certain degree of subjective judgement. This, however, does not eliminate all the effects of analyst subjectivity from the workload conclusions. Input data to the model are all taken from the AAH Crew Task Analysis, and within the present state-of-the-art TA is still largely a matter of expert judgement.

In accordance with the foregoing constraints, and the practical considerations involved, a TADRAP Crew Task, Function and Segment Loading Model was developed as summarized in Figure 1. TADRAP programming was accomplished such that data can be extracted directly from the Task Analysis, input to TADRAP and the resultant crew workload can be machine displayed for one or more tasks, functions or segments. One essential characteristic of the model is that in addition to the computational flexibility provided by any model, the TADRAP model produced loading values which are expressed relative to an allowable bandwidth of upper and lower time limits. Thus, a series of tasks or functions can be graphically portrayed as a rising and/or falling band of varying width. The centerline of the band is a line "t" which traces the base time estimate, and a line "t<sub>w</sub>" which traces the weighted time. The weighted time "t<sub>w</sub>" is a function of inherent task load based upon the parameters of Sensory Modality, Action Cycle and Task Position (all defined later in the text). The deviation of "t<sub>w</sub>" from "t" graphically displays either (or both) the effect of inherent load and/or the "queuing" effects of serial tasks.

The particular bandwidth concept described above was incorporated in the TADRAP model for two reasons. First, all time estimates available within the state-of-the-art are derived from either past intuitive studies, empirical measurements of specific tasks in past development programs, or generalized estimates such as those of the American Institute for Research (AIR) (1962). While the AIR studies are a praiseworthy attempt to develop an index extensible to other programs, they are still highly particularistic. Although the index represents an averaging, or normative approach to data developed on several different pieces of equipment, it still is considered to be limited in scope of equipment covered, and possibly somewhat optimistic when applied to an airborne weapon system program. As a rough estimator, the index is probably "not too bad"; but as a predictor, it's probably "not too good".

It was determined therefore, that to make use of existing time estimates, it would be necessary to establish some form of confidence limits within which time could vary and still be considered acceptable. The bandwidth chosen was established as  $t + (2t)^{1/2}$ . For time estimates greater than 10 seconds and less than 25 seconds, the acceptable bandwidth will be as great as  $\pm 1/2$  sigma and as small as  $\pm 1/4$  sigma. As time exceeds 50 seconds, the bandwidth limits will approach zero deviation from the estimate.

The second reason for incorporating the bandwidth concept in the TADRAP model was that once the bandwidth was established for any given event, or series of events, the time data derived from real time simulation could be immediately accepted if it lay within the bandwidth, or rejected if it lay outside the bandwidth. This makes it possible to consider a practical method for validating workload data computed by the TADRAP model.

Based on the foregoing discussion, the TADRAP Crew Task, Function and Segment Loading Model of Figure 1 satisfies all primary objectives. The model assures reliability in the analysis. It is flexible enough to allow consideration of different mixes of tasks, functions and segments within a minimum effort. It is sensitive enough to differences in load to reflect changes at the task level. And finally, it is capable of validation.

#### 5. TASK ANALYSIS

The TA forms the basic data source for TADRAP processing of crew workload. The format of the TA was engineered with three goals in mind. First, the TA should be complete. That is to say, it should be structured in such a way that the task analyst is encouraged to provide detail descriptions of subtask and gross task elements. Second, the TA should be designed to reduce task analyst subjective bias. It is

## TADRAP T, F &amp; S Loading Model

$$L = L_c + L_d$$

Five basic expressions are necessary to compute load -

$$1. L_c = \frac{t_{w_c} - t_c}{t_{2_c} - t_{1_c}}, L_d = \frac{t_{w_d} - t_d}{t_{2_d} - t_{1_d}}$$

$$2. t_1 = t - (2t)^{1/2}, t_2 = t + (2t)^{1/2}$$

$$3. w^* = x + \left(1 - (1/n)^{1/2}\right)x$$

$$4. R = t_2 - t_1$$

$$5. t_w = t_1 + \left[R - \left((1/w)^{1/2}R\right)\right]$$

Ten designations are used:

The first three represent raw data from the Task Analysis:

1.  $t$  = Estimated task time based on empirical data.
2.  $x$  = The sum of weights given to a task, function or segment considering Action Cycle, Sensory Mode, Task Position.
3.  $n$  = The number of steps in a task, tasks in a function or functions under evaluation.

The remaining seven are calculated:

4.  $w$  = The calculated weighting factor.
5.  $t_1$  = The lower limit of the time estimate.
6.  $t_2$  = The upper limit of the time estimate.
7.  $R$  = The numerical range from  $t_1$  to  $t_2$ .
8.  $t_w$  = Calculation of weighted time.
9.  $L_c$  = Calculation of continuous loads at any given point.
10.  $L_d$  = Calculation of discrete load at any given point.

---

\*When considering an individual task containing only a single step will always be equal to  $x$ .

Figure 1. TADRAP task, function and segment loading model.

fully recognized that TA is a highly subjective art form. However, techniques aimed at reducing the breadth of subjective interpretation should be designed into the analysis from the beginning. Lastly, the TA should allow easy conversion of manuscript TA entries into TADRAP keypunch input. Therefore, once the TA is completed by the professional analyst, reduction of the TA data into TADRAP-meaningful input can become a clerk function.

### 5.1 Form

The Task Analysis Worksheet, illustrated in Figure 2, was developed to satisfy the goals described above. Briefly, the form contains a heading which identifies the name and TADRAP key numbers for the mission phase, segment, and function being analyzed. Note that each row on an analysis worksheet represents one task, and each sheet represents one function. A collection of sheets describe a segment.

On the left hand side, the first column contains a task number. All tasks are numbered with a seven digit unique identifier consisting of three digits for the segment, two for the function and two for the task. The next six columns are reserved for the TADRAP verb, object, modifier (VOM) triad and their two-character identifiers. In partial fulfillment of the goal to reduce subjective bias, TADRAP requires the task analyst to force-fit the task being analyzed into a VOM format. The verb describes the action, the object is the object of the action, and the modifier provides for greater task generalization. The two character VOM identifiers are utilized by TADRAP in a table look-up routine for subsequent display. The following is an example of a VOM triad:

POSITION PO CONTROL CN ROTARY SWITCH RS

TASK ANALYSIS																
MISSION PHASE						SEGMENT										
FUNCTION						OPERATION										
NO.	TASK		DESCRIPTION	O	CONTROL/DISPLAY		OPERATOR ACTION			TASK TYPE		STIMULUS INPUT		FEEDBACK		OPERATOR
										C	D	1	2	1	2	

Figure 2. Task analysis worksheet.

The column headed "O" designates the operator performing the task; whether P (pilot), C (copilot/gunner), B (both), or E (either). Under "Control/Display" are entered the nomenclature of the control or the display with which the task is associated, as well as a narrative definition of the control or display options (such as: ON/STBY/OFF).

In the center portion of the worksheet, a brief narrative description of the crew member's task is entered in the "Operator Action" column. The "Task Type" column codes whether or not the task is of a continuous (C) or discrete (D) type. Continuous tasks are those associated with omnipresent crewmember activity, such as scanning the flight instruments and operating the flight controls. Discrete tasks refer to those tasks performed over and above the continuous ones, such as tuning to a specific radio frequency while in flight. "Feedback" entries indicate the primary sensory modality stimulated as a result of the task having been completed. The "Stimulus Input" provides for a brief narrative of that act which resulted in the present task.

On the right side of the worksheet, the first four columns are provided for future growth when it may become possible to predict the criticality of a task response, and describe accuracy requirements and delay tolerance. The "A/C" column is reserved for the action cycle weighting, chosen from a standardized list. The next two columns permit entry of weightings for sensory modality ("SM") and task position ("TP"), also chosen by the analyst from standardized lists. Time estimated necessary to perform the task being analyzed is chosen from the AIR Data Store (Munger, 1962). The last column provides room for a narrative comment.

### 5.2 Action Cycle

The action cycle represents an attempt to define tasks in terms of their subtask elements. A weighting scale of one to five was assigned to each of the currently identified fifteen action cycles. The lower the weight, the fewer the subtask steps. Table I identifies the TADRAP action cycles and their weightings.

TABLE I. ACTION CYCLE WEIGHTING

Action Cycle	Weight
Locate - Act	1
Locate - Return	1
Locate - Act - Return	2
Locate - Observe - Return	2
Act - Feedback - Return	2
Act - Feedback - Act	2
Feedback - Act - Feedback	2
Locate - Act - Feedback - Return	2
Locate - Select - Act - Return	2
Locate - Observe - Process - Return	2
Locate - Act - Feedback - Act - Return	3
Locate - Select - Act - Feedback - Return	3
Locate - Observe - Process - Act - Return	3
Locate - Observe - Process - Act - Feedback - Return	4
Locate - Observe - Process - Act - Feedback - Act - Return	5

### 5.3 Sensory Modality

The SM column permits the analyst to describe primary sensory modality or modalities utilized by the operator in performing the task. For example, it is assumed that tasks which require auditory attention only, such as receipt of a radio message, consume less "energy" as compared to tasks which require both visual and auditory attention; therefore, tasks of the former type are assigned weights of one, and of the latter, weights of five. Sensory modality weightings are presented in Table II.

TABLE II. SENSORY MODALITY WEIGHTING

Sense Mode	Weight
Auditory	1
Cutaneous	2
Visual	3
Visual and Cutaneous	4
Visual and Auditory	5

### 5.4 Task Position

Changing attention from task-to-task between inside the aircraft and outside the aircraft causes operator "energy" consumption to increase. This is the premise behind the task position weightings presented in Table III. In selecting a task position weight from the table, the analyst first examines the previous task in the current series. He then concentrates on the task which is the subject of task analysis. Understanding the position of the current task, with respect to the previous task, he then selects the appropriate weight from the table.

TABLE III. TASK POSITION WEIGHTING

Task Position		Weight
Previous Task	Present Task	
Inside	Inside	1
Outside	Inside	2
Inside and Outside	Inside	3
Inside	Outside	4
Outside	Outside	5

### 5.5 Key Punching

TADRAP input consists of a deck of punched cards containing important elements from the task analysis. Essentially, each individual card contains data describing one task. To facilitate conversion of the manuscript task analysis, the worksheet is designed as a keypunch load sheet. Keypunch operators may directly convert the manuscript analysis to card format without an intermediate step.

## 6. TADRAP PROCESSING

The TADRAP system performs four basic functions, using "raw" task analysis data as input. First, the data is formatted and stored on a random access peripheral device. Next, under control of the task analyst, TADRAP searches the data for selected segments. Once a selected segment is located, the system calculates task workload and time bandwidths. Finally, TADRAP displays the resulting analysis by outputting it on a high speed printer. A copy of the analysis is stored in the machine for future use.

### 6.1 Variables

TADRAP permits the task analyst to select the report increment, as well as individual segment(s) from the segment library to be processed.

Report Increment. The TADRAP system computes workload data on a second-by-second basis throughout the entirety of the segment(s) selected for analysis. However, it may not be desirable to print the analysis in second-by-second increments, especially when many segments are being processed at one time. A second-by-second printout of task analysis data may be useful when many short duration tasks are encountered, in order to provide hardcopy data describing workload on each task. Typically, however, to save output time and expense, the analyst might select a once-in-five or once-in-ten second report increment. In this way, noncritical segments, which may consume large amounts of time, do not consume overwhelming amount of output space. Critical segments may be re-run, at a later date, in a second-by-second format, as needed.

Segment Selection. Out of the vast library of mission phase segments, an analyst may be interested, at any one time, in only a limited number. TADRAP allows the analyst to preselect only those segments of interest for workload analysis.

### 6.2 Discrete and Continuous Tasks

TADRAP is sensitive to the fact that some tasks performed while an aircraft is in flight are of a continuous nature, while others are discrete, occurring at specific points throughout a mission. In order to provide a workload figure that takes into account these important factors, TADRAP is first used to compute workload values for the continuous tasks performed by the two AAH crewmembers. These values, the continuous task load constants, are used in additive fashion during airborne segments in the computation of discrete workload. Should discrete tasks be performed without the presence of continuous tasks, TADRAP avoids adding the continuous load constant, printing instead just the discrete workload values.

## 7. TADRAP OUTPUT

Output from TADRAP currently consists of a workload analysis document produced on a computer-controlled high speed printer. Figure 3 presents a sample of the TADRAP workload analysis format as well as a key for interpreting the data contained therein.

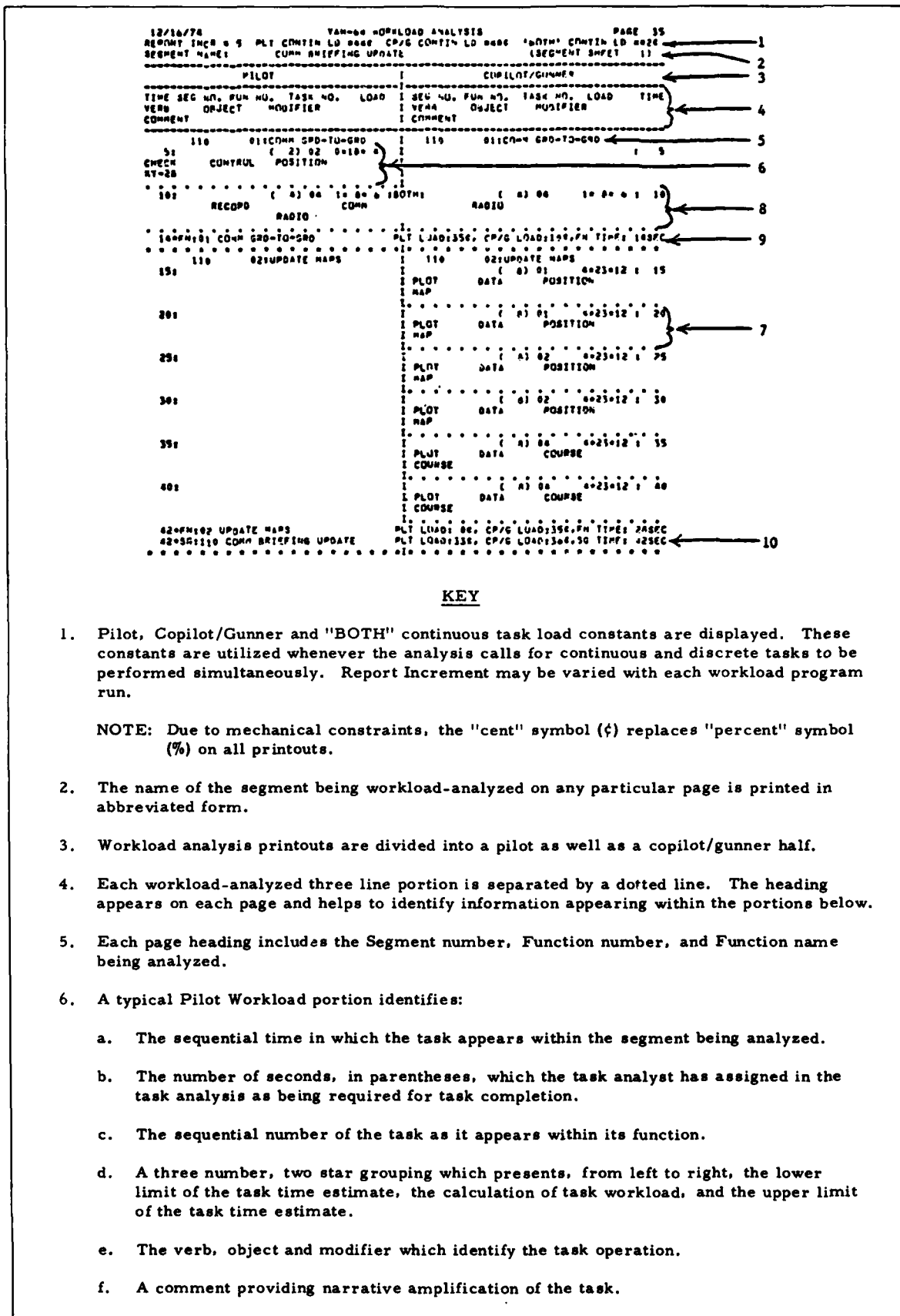

Figure 3. Sample workload analysis format (sheet 1 of 2).



KEY (CONT)

7. A typical copilot/gunner workload portion provides exactly the same information as a pilot workload portion, but on the opposite side of the page.
8. A "BOTH" workload portion appears whenever the pilot and copilot/gunner are simultaneously performing the same task. The information presented is identical to that in a pilot or copilot/gunner portion.
9. The program computes pilot and copilot/gunner workload for the function as a whole when the last task within a function has been processed. The printout includes, from left to right, the time elapsed from the beginning of the segment, the function identification number and its name, pilot and copilot/gunner workload and the time required for performance of the function.
10. After processing the last task and function within the segment being workload-analyzed, the program computes workload values for the segment as a whole. From left to right, the total time elapsed from the beginning of the segment is displayed, as are the segment identification number and its name. Values for pilot and copilot/gunner workload are presented with the number of seconds required for segment completion.

Items 6d, 9, and 10 are major significant TADRAP outputs.

Figure 3. Sample workload analysis format (sheet 2 of 2).

#### 8. FUTURE PLANS

Current utilization of TADRAP data is limited. Because TADRAP produces workload report documents, instead of graphic representations, a significant portion of analyst time is consumed in data extraction. Modern techniques utilizing the digital computer as a graph generator are adaptable to TADRAP. Currently, each workload analysis run is saved in precisely defined format.

With time, a computer program could be written to cause TADRAP to generate workload-over-time plots for each crewmember. Reduction of manual plotting chores will permit TADRAP data to be available to design and training decision makers in a timely and easy to interpret format. When workload data is available to those in a position to influence system design, improvements in the crew station man-machine interface will be easier to implement.

#### 9. REFERENCE

Munger, S.J., et al., An Index of Electronic Equipment Operability. American Institute for Research, Report No. AIR-C43-1/62-RP (2), 31 January 1962.

#### 10. ACKNOWLEDGEMENTS

The writer wishes to acknowledge the individual support to TADRAP development provided by Messrs Charles A. Gainer and Richard L. Harrison, both of whom were formerly professionally associated with Hughes Helicopters and the YAH-64 Program. Mr. Gainer is currently Chief of the Fort Rucker, Alabama, Field Unit of the U. S. Army Research Institute for the Behavioral and Social Sciences. Mr. Harrison is an Engineering Psychologist with the U. S. Army Aviation Test Board, Fort Rucker.

# UTILISATION D'UNE METHODE DE BIOSTEREOMETRIE DANS LA CONCEPTION D'UN POSTE DE PILOTAGE D'HELICOPTERE

par

A.Coblentz, Y.Deloison, G.Ignazi et J.Prudent  
Laboratoire d'Anthropologie et d'Ecologie Humaine  
Université René Descartes  
45 rue des Saints-Pères  
75270 Paris Cedex 06  
France

## 1 - OBJECTIFS DE L'ETUDE -

Les cabines de pilotage des hélicoptères français furent conçues jusqu'en 1975, à partir des normes américaines résumées sur la fiche MS. 33575 : "*Dimensions, Basic, Cockpit, Helicopter*", éditée en juin 1969. Ces normes figuraient dans la documentation de référence aussi bien pour ceux qui concevaient les nouveaux types d'appareils que pour ceux qui les réalisaient.

Les Etats-Majors ainsi que la Direction des Recherches Etudes et Techniques ont estimé que les normes américaines répertoriées dans cette fiche devaient être adaptées, pour des raisons ergonomiques, à la population utilisatrice française. En effet, une bonne adaptation dimensionnelle du poste de pilotage aux caractéristiques anthropométriques des sujets appelés à les occuper contribue à accroître le confort d'un poste de travail faisant déjà l'objet de nombreuses critiques.

La notion d'inconfort peut, en particulier, être illustrée par certains modèles anciens d'hélicoptères, dans lesquels, pour compenser l'absence de réglage du siège, certains pilotes d'une taille inférieure à 1,70 m. sont obligés d'installer des coussins supplémentaires sur l'assise du siège et derrière leur dos pour atteindre les palonniers et les autres instruments de vol. Il en résulte que le pilotage, sur ce type d'appareil, et parfois sur d'autres modèles, plus récents, entraîne au terme d'un certain nombre d'heures, variable selon la fréquence et le type de vol, des douleurs cervicales, dorsales et lombaires, stigmatisées par les pilotes et confirmées par les Services de Santé des Armées.

Ces douleurs semblent provoquées par les multiples contraintes auxquelles sont soumis les pilotes. On y trouve associées, de mauvaises attitudes en posture assise (hyper extension du cou et asymétrie liée au maniement concomitant des manches des pas cyclique et collectif au cours des différentes phases de vol) et des contraintes mécaniques liées à l'environnement (vibrations ou trépidations).

Le but de notre étude consistait à définir, grâce à la connaissance des caractéristiques anthropométriques fonctionnelles de la population française de pilotes d'hélicoptères de l'Armée de Terre (ALAT), de nouvelles normes ergonomiques d'aménagement des postes de pilotage adaptées aux besoins des opérateurs.

## 2 - DEROULEMENT DE L'ETUDE -

Au cours d'une première phase, nous nous sommes rendus sur 4 bases d'hélicoptères situées en des zones géographiques différentes. A l'aide des informations recueillies auprès des pilotes et de documents bibliographiques, nous avons analysé :

- la fonction de pilotage, le rôle et l'action des commandes de vol,
- les conditions d'environnement à bord et les différentes contraintes du poste de pilotage pour des appareils de types différents,
- les caractéristiques de la population utilisatrice :
  - . âge,
  - . qualification professionnelle dans l'armée,
  - . caractéristiques biométriques.

Au cours d'une deuxième phase, nous avons réalisé :

- un appareil de mesure permettant de relever, pour chaque point anatomique et pour chaque point choisi sur le matériel équipant une maquette du poste de pilotage d'hélicoptère, les trois coordonnées X, Y et Z, obtenues dans un système géométrique de référence fixe;
- une maquette de simulation du poste de pilotage, tenant compte des résultats précédemment obtenus et intégrant l'ensemble des connaissances ergonomiques et dimensionnelles à cette étude.

Grâce à ce système de mesures tridimensionnelles et à la maquette, nous avons pu mesurer les réglages à donner pour satisfaire les différents sujets et analyser les positions ainsi que les variations d'attitudes de ces pilotes au cours des séances de simulation de pilotage d'hélicoptère.

## 3 - POPULATION UTILISATRICE -

### 3.1 - Présentation des échantillons servant à déterminer les caractéristiques anthropométriques de la population utilisatrice -

- . Le pilotage des hélicoptères représentant un type très particulier de poste de travail, nous avons cherché à définir les caractéristiques anthropométriques de la population utilisatrice.

- . Dans ce but, 54 mensurations ont été relevées sur un échantillon de 115 pilotes devêtus, puis équipés en tenue de vol.

Il faut remarquer que cet échantillon se trouvait constitué de deux séries :

- la première, composée de 50 pilotes d'hélicoptères, dont l'âge moyen était de 30 ans et demi, a été subdivisée pour des raisons de méthodologie, en deux groupes :
  - . l'un constitué de 35 pilotes d'hélicoptères sur lesquels seules les mesures biométriques ont été relevées,
  - . l'autre, formé de 15 pilotes sur lesquels les mesures anthropométriques furent relevées et qui en plus ont effectué une simulation sur maquette;
- la seconde, comprend 65 pilotes de l'Armée de l'Air, susceptibles de piloter des hélicoptères, examinés lors d'une précédente enquête effectuée au cours des années 1972-1973.

Afin de savoir s'il était possible de rassembler ces deux séries, composées en fait de trois groupes, en un échantillon jugé représentatif de la population des pilotes d'hélicoptères, nous avons effectué une analyse statistique. Nous avons adopté comme méthode l'analyse de la variance. Cette méthode répondait à deux finalités :

- Le regroupement des mesures biométriques individuelles des deux séries, pilotes d'hélicoptères (N = 50) et pilotes d'avions (N = 65), permettait de définir les caractéristiques anthropométriques de l'échantillon.
- La comparaison du groupe des 15 pilotes ayant effectué une simulation sur maquette, avec l'ensemble de la population utilisatrice, ainsi que l'étude de la répartition des mesures biométriques individuelles de ces pilotes au sein de cette même population utilisatrice.

### 3.2 - Comparaisons statistiques par la méthode d'analyse de la variance des trois groupes constituant la population utilisatrice -

Pour comparer ces trois groupes, l'analyse de la variance a porté sur les huit mesures biométriques caractéristiques présentées dans le tableau n°1.

L'analyse du tableau n°2 fait ressortir que pour aucune des huit mesures biométriques étudiées, la valeur du *F* de Snédécour ne se révèle significative. Cette observation permet d'affirmer la similitude des trois groupes qui peuvent donc être rassemblés en un seul échantillon.

Les 115 sujets de l'échantillon ainsi formé représentaient un effectif statistiquement suffisant pour donner une image réelle de la population concernée.

### 3.3 - Caractéristiques biométriques de la population utilisatrice -

#### 3.3.1 - Mesures biométriques et technique de mesures :

Certaines mensurations ont été relevées en utilisant les techniques habituelles de l'anthropométrie. L'homogénéité de la méthode de mesure a permis ainsi de rendre ces mesures comparables aux données françaises et étrangères recueillies antérieurement.

A ces mensurations traditionnelles s'ajoutait un certain nombre de mesures originales qui représentaient un ensemble de données complémentaires indispensables au but particulier de cette étude.

#### 3.3.2 - Choix des mensurations : Ce choix a permis :

##### - Sur le sujet devêtu :

- . de caractériser biométriquement la population utilisatrice et en particulier de déterminer la longueur des chaînons interarticulaires,
- . d'apporter les données nécessaires à l'élaboration de l'équipement individuel,
- . d'évaluer l'évolution anthropométrique probable, au terme d'une décennie, de la population des pilotes d'hélicoptères.

##### - Sur le sujet équipé :

- . de préciser l'encombrement du sujet dans son poste de travail,
- . de connaître les distances et les hauteurs fonctionnelles d'atteinte.

A partir de ces 54 mensurations sélectionnées, nous avons recueilli 67 informations biométriques dont :

- . 33 sur le sujet devêtu,
- . 34 sur le sujet équipé.

MESURES BIOMETRIQUES Exprimées en millimètres (Sujet éveillé)	PILOTES DE CHASSE Groupe n° 1			PILOTES D'HELIPTERE					
				Groupe n° 2			Groupe n° 3		
	*n	m	σ	n	m	σ	n	m	σ
- POIDS (kg.) .....	65	74,0	8,1	35	72,94	9,42	15	71,87	10,46
- Stature .....	65	1756,0	53,0	35	1755,80	62,49	15	1733,80	56,58
- Taille assis (redressé) .....	65	931,7	30,3	35	927,36	30,02	15	923,06	24,31
- Distance acromion - siège (redressé) ...	65	617,4	27,0	35	617,06	26,25	15	612,00	24,45
- Distance acromion - épicondyle .....	65	322,2	16,8	35	327,88	16,58	15	316,20	13,27
- Distance épicondyle - styloïde radiale .	65	263,7	10,2	35	267,17	12,38	15	261,86	12,85
- Distance condyle fémoral externe - pointe de la malléole externe .....	65	434,5	18,1	35	432,0	21,82	15	421,33	20,85
- Distance E.I.A.S. gauche - sol .....	65	990,3	43,2	35	993,06	50,02	15	972,13	46,09

\*n = nombre de sujets.  
m = moyenne du groupe.  
σ = écart-type

**Tableau n°1 : PRESENTATION DES PARAMETRES STATISTIQUES CONCERNANT HUIT MESURES BIOMETRIQUES CARACTERISTIQUES.**

CARACTERES	Nombre de sujets	Degré de liberté	Carré moyen entre groupes	Degré de liberté	Carré moyen à l'intérieur des groupes	Rapport F de Snédécour au seuil de 0,05	signifi- cation.
Poids .....	65 + 35 + 15 = 115	3 - 1 = 2	32,96	115 - 3 = 112	78,11	F (2,112) = 0,42	n.s.
Stature .....	65 + 35 + 15 = 115	3 - 1 = 2	314,39	115 - 3 = 112	3190,75	F (2,112) = 1,00	n.s.
Taille assis (redressé) .....	65 + 36 + 15 = 116	3 - 1 = 2	546,74	116 - 3 = 113	872,39	F (2,113) = 0,63	n.s.
Distance acromion-siège (redressé) .....	65 + 35 + 15 = 115	3 - 1 = 2	183,19	115 - 3 = 112	694,20	F (2,112) = 0,26	n.s.
Distance acromion-épicondyle (redressé) .....	65 + 35 + 15 = 115	3 - 1 = 2	783,12	115 - 3 = 112	266,74	F (2,112) = 2,94	n.s.
Distance épicondyle - sty- loïde radiale .....	65 + 23 + 15 = 103	3 - 1 = 2	157,93	103 - 3 = 100	123,42	F (2,100) = 1,28	n.s.
Distance condyle fémoral ex- terne - pointe malléole ext..	65 + 35 + 15 = 115	3 - 1 = 2	1056,97	115 - 3 = 112	386,08	F (2,112) = 2,74	n.s.
Distance E.I.A.S. gauche - sol .....	65 + 35 + 15 = 115	3 - 1 = 2	2474,82	115 - 3 = 112	2091,49	F (2,112) = 1,18	n.s.

**Tableau n°2 : ETUDE BIOMETRIQUE COMPARATIVE DES TROIS GROUPES DE PILOTES, EFFECTUEE PAR LE TEST DE SNEDECOR.**

### 3.3.3 - Principales mensurations définissant l'encombrement du sujet assis :

Nous avons sélectionné à l'intérieur de la liste des mensurations, celles qui apparaissent comme les plus représentatives de l'encombrement de l'homme assis. Ces mesures principales nous ont permis, à partir de diverses attitudes fonctionnelles adoptées par le sujet assis, de schématiser, sous forme de volumes d'encombrement, les différents éléments segmentaires du corps humain (Cf. figure n°1).

Mesure  
n°

- 4 - Taille assis redressé
- 50 - Longueur maximale de la tête
- 51 - Largeur de la tête
- 33 - Largeur des épaules
- 39 - Profondeur du thorax
- 40 - Profondeur de l'abdomen
- 38 - Largeur coude à coude
- 26 - Distance olécrane - articulation métacarpo-phalangienne
- 14 - Hauteur coude - siège
- 9 - Hauteur acromion - siège
- 36 - Largeur des fesses assis
- 20 - Longueur fesses - genoux
- 37 - Largeur des deux genoux non serrés
- 41 - Epaisseur des cuisses (1/3 supérieur)
- 21 - Longueur fesses - creux poplité
- 16 - Hauteur genoux - sol
- 18 - Hauteur creux poplité - sol
- 43 - Longueur du pied
- 46 - Largeur du pied
- 47 - Hauteur malléole externe - sol.

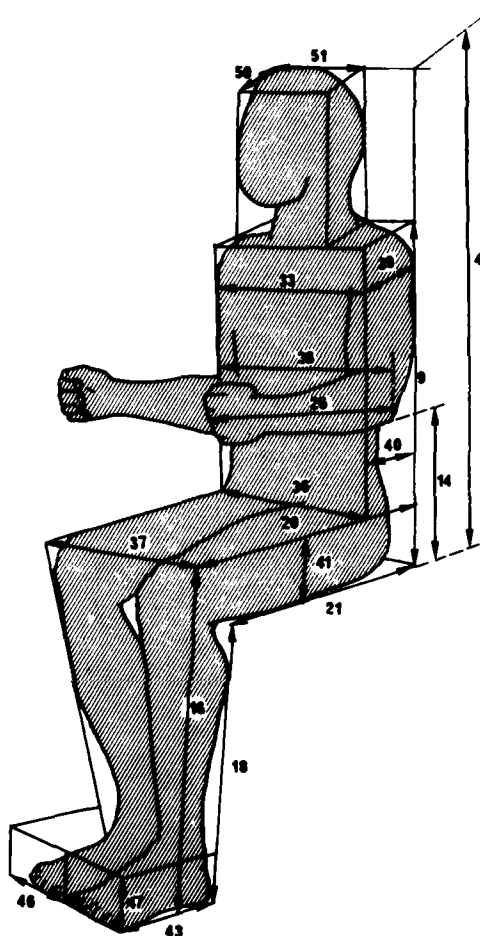

Figure n°1 : PRINCIPALES MENSURATIONS DEFINISSANT L'ENCOMBREMENT DU SUJET ASSIS.

#### 4 - METHODE -

La méthode utilisée a consisté, grâce à un relevé de coordonnées tridimensionnelles (X, Y, Z) de points anatomiques d'une part et de commandes d'autre part, à découper l'espace en une série de plans horizontaux, sagittaux et frontaux dont l'ensemble reconstitue le volume réel dans lequel sont situées les aires d'atteintes extrêmes et préférentielles des membres supérieurs et inférieurs.

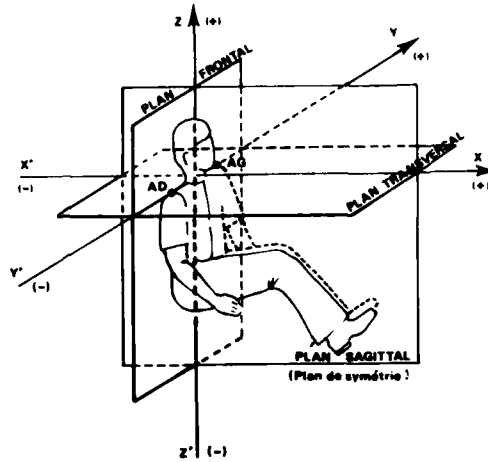

Figure n°2 : SITUATION RELATIVE DE L'OPERATEUR ET DES AXES SERVANT DE REFERENCE AUX SERIES DE PLANS :  
 - TRANSVERSAUX,  
 - SAGITTAUX,  
 - FRONTAUX.  
 (AD = ACROMION DROIT - AG = ACROMION GAUCHE).

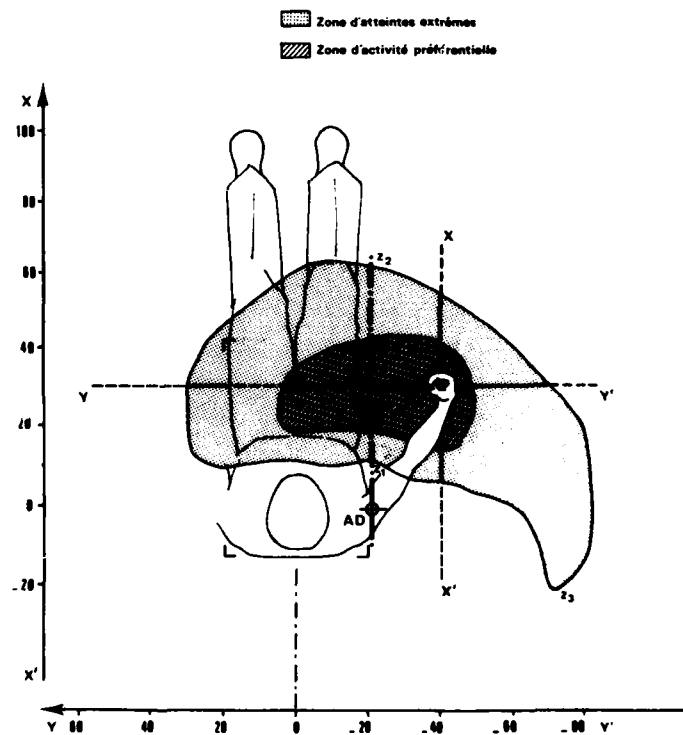

Figure n°3 : ZONES D'ATTEINTES EXTREMES ET D'ACTIVITE PREFERENTIELLE PASSANT PAR UN PLAN TRANSVERSAL SITUÉ A 10 CM. AU-DESSUS DE L'ACROMION.

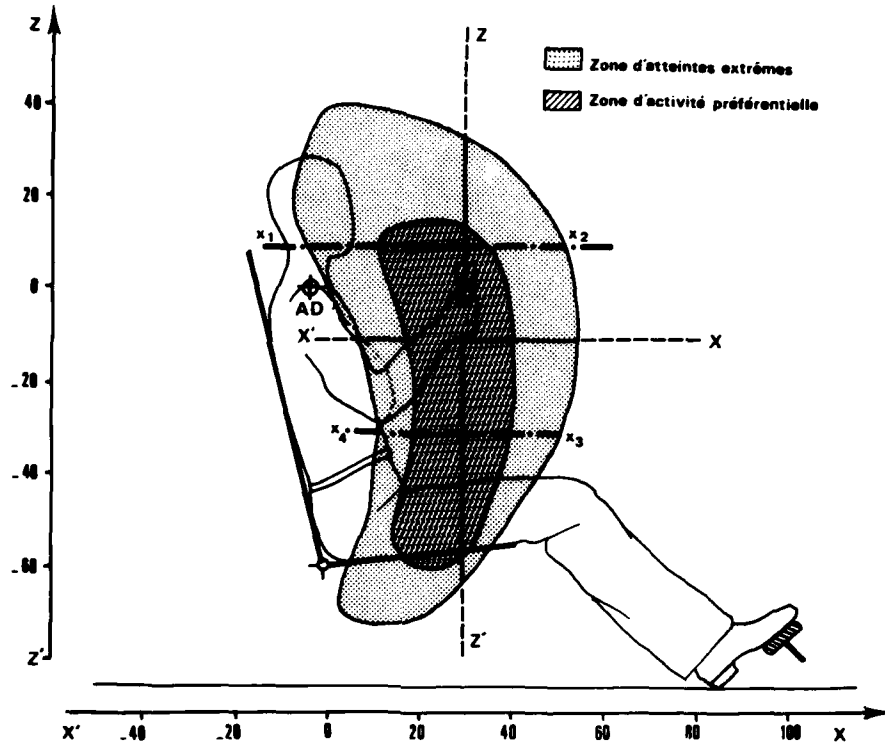

Figure n°4 : ZONES D'ATTEINTES EXTREMES ET D'ACTIVITE PREFERENTIELLE PASSANT PAR UN PLAN SAGITTAL SITUE A 10 CM. DU PLAN DE SYMETRIE.

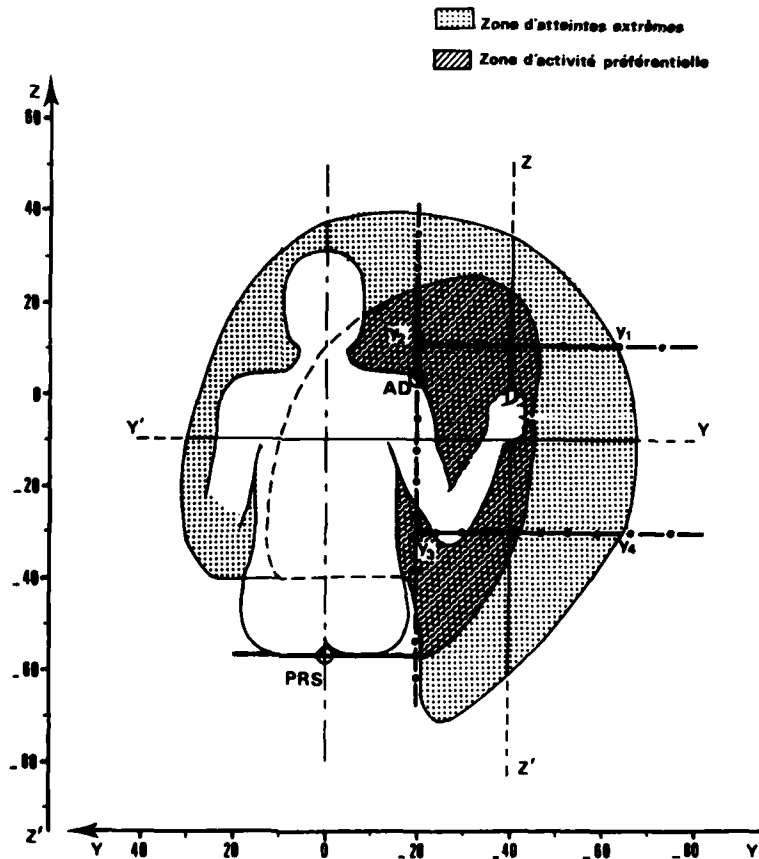

Figure n°5 : ZONES D'ATTEINTES EXTREMES ET D'ACTIVITE PREFERENTIELLE PASSANT PAR UN PLAN FRONTAL SITUE A 30 CM. EN AVANT DE L'ACROMION.

## - MEMBRE SUPERIEUR -

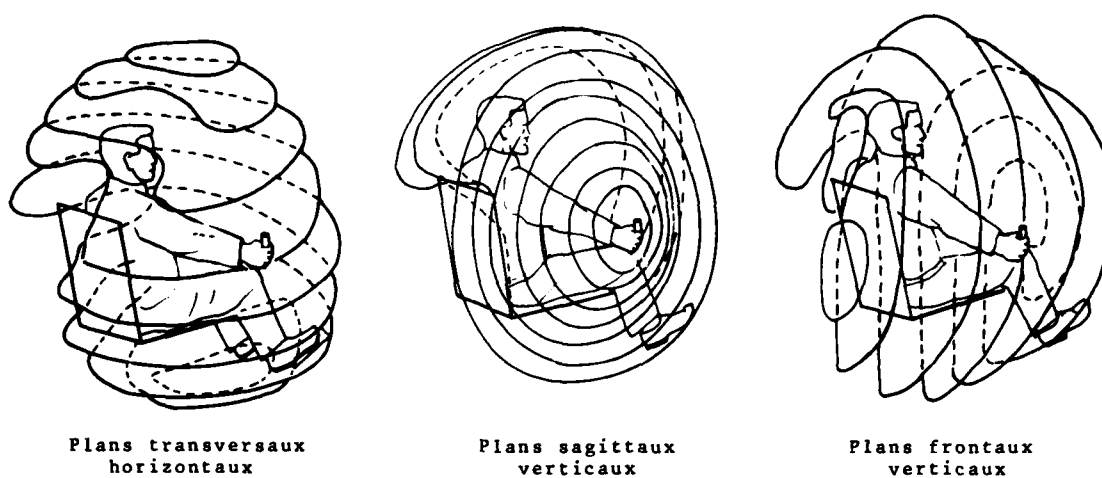

FIGURE n°6 : SUBDIVISION TRIDIMENSIONNELLE DE L'ESPACE DE TRAVAIL D'UN OPERATEUR ASSIS.

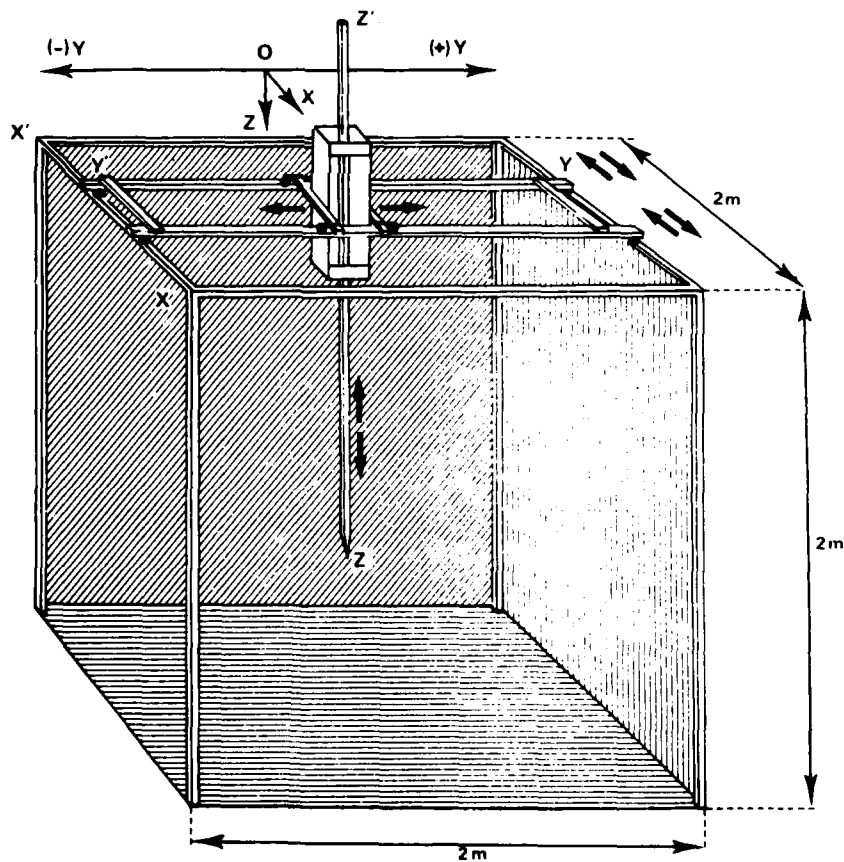

Figure n°7 : SYSTEME DE MESURES STEREOMETRIQUES. (LE CHASSIS ET LE SYSTEME DES CHARIOTS).



4.1 - Matériel permettant le relevé des mesures stéréométriques -4.1.1 - Système de mesures stéréométriques :

Afin de connaître la position dans l'espace d'un point fixe, ou la position à un moment donné d'un point mobile, nous avons réalisé un appareil permettant d'obtenir rapidement et directement des coordonnées tridimensionnelles.

- Description de l'appareil :

Cet appareil (Figure n°7 ci-avant) est constitué :

- d'un chassis métallique matérialisant les arêtes d'un cube de deux mètres de côté. Trois faces de ce cube sont concrétisées par des panneaux pleins : le premier constitue la base du cube, les deux autres panneaux sont verticaux et perpendiculaires entre-eux; ils constituent l'arrière et le côté gauche de l'appareil.

A l'intérieur de ce volume, délimitant un référentiel, tous les points sont identifiables en coordonnées tridimensionnelles.

- d'un système de mesure comprenant :

- . 2 toises parallèles situées entre les deux arêtes supérieures latérales permettent les lectures des mesures postéro-antérieures selon l'axe  $X'X$ ,
- . 1 toise placée perpendiculairement entre les deux précédentes permet une lecture selon l'axe  $Y'Y$ , et
- . 1 toise mobile verticale portée par un système de chariots, permet une mesure selon l'axe  $Z'Z$ .
- . le système des chariots permet, en amenant l'extrémité inférieure de la toise verticale "au contact" du point à coter, de lire directement les coordonnées  $X, Y, Z$ . Il est constitué de deux éléments :
  - un petit chariot portant la toise verticale, cette dernière fournit une lecture directe de la coordonnée  $Z_0$ . Ce petit chariot mobile se déplace sur des rails matérialisant l'axe  $Y'Y$ . Nous obtenons ainsi une lecture directe de la coordonnée  $Y_0$  (Figure n°8).
  - les rails de ce petit chariot constituent les éléments d'un second chariot qui se déplace dans le sens antéro-postérieur, soit selon l'axe  $X'X$ . La position de ce second chariot permet de connaître la coordonnée  $X_0$  (Figure n°8).

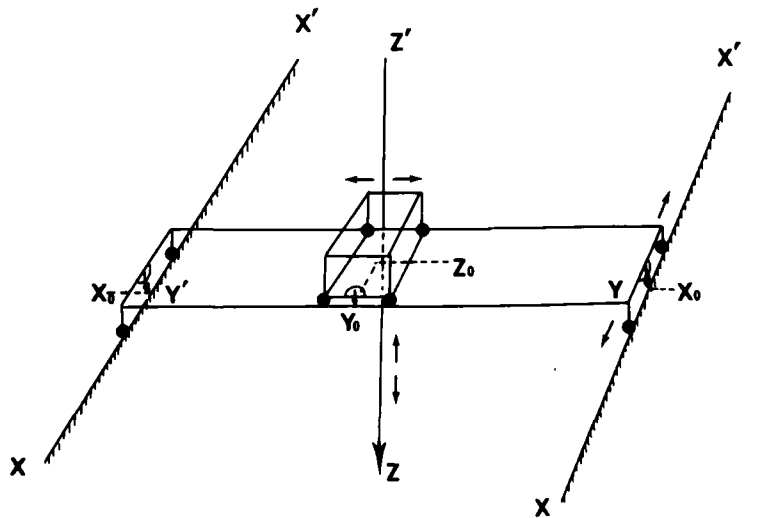

Figure n°8 : LE SYSTEME DES CHARIOTS

- Système géométrique de référence :

Un système de coordonnées tridimensionnelles permet de connaître la position de tous les points situés dans le volume déterminé par l'appareil.

Nous avons choisi un système d'axes trirectangle (Figures n°9 et 10) dont l'origine  $O$  se situe en arrière et en haut du plan sagittal de l'appareil, c'est-à-dire que :

- la coordonnée  $X_0$  de l'axe  $X'X$  précise la position postéro-antérieure du point coté. Par construction, les valeurs de  $X_0$  sont toujours positives;
- la coordonnée  $Y_0$  de l'axe  $Y'Y$  précise la position droite, gauche ou sagittale de ce point. Par convention nous avons choisi  $Y_0$  négatif du côté droit du sujet assis dans l'appareil.

Ces deux axes  $OX$  et  $Y'Y$  sont donc perpendiculaires et situés dans un plan horizontal. L'axe  $Z'Z$  est perpendiculaire à ce plan. La coordonnée  $Z_0$  mesure la "hauteur" du point. Les valeurs de  $Z_0$  sont toujours positives par construction (Figure n°10).

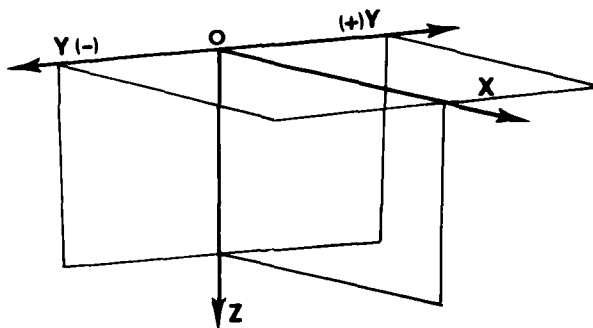

Figure n°9 : AXES ET PLANS DE REFERENCE.

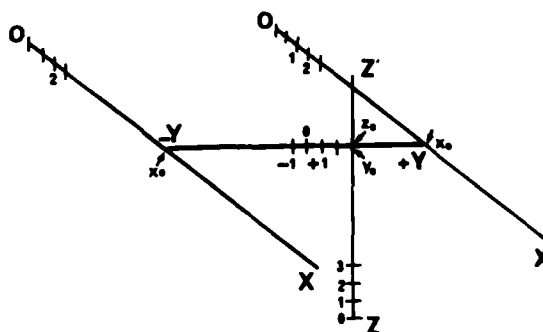

Figure n°10 : SCHEMA DU SYSTEME TRIDIMENSIONNEL DE LECTURE DES COORDONNEES.

#### 4.1.2 - Maquette du poste de pilotage :

Sur cette maquette, les commandes de vol, fidèlement reproduites, permettraient grâce à un large éventail de réglages, d'adapter aux dimensions de chaque pilote les différents éléments du poste de pilotage. Ainsi, tout en recréant au cours de la simulation de leur tâche, les attitudes ainsi que les mouvements propres à chacun d'entre eux, les pilotes pouvaient, grâce à la multiplicité des réglages, rechercher les conditions d'exécution optimales et ainsi définir de façon subjective leur meilleure position de confort.

Signalons également que nous avons fixé, par convention, l'angle formé par l'horizontale et l'azimut zéro à  $25^\circ$  (Cf. Figures n°12 et 13), afin de posséder un repère fixe valable pour l'ensemble des pilotes. En effet, tous les éléments du poste étant réglables, indépendamment les uns des autres, aucun ne pouvait nous servir de référence. Il nous est paru plus simple et plus satisfaisant d'amener le centre de vision des pilotes sur un axe virtuel commun à tous et parfaitement défini.

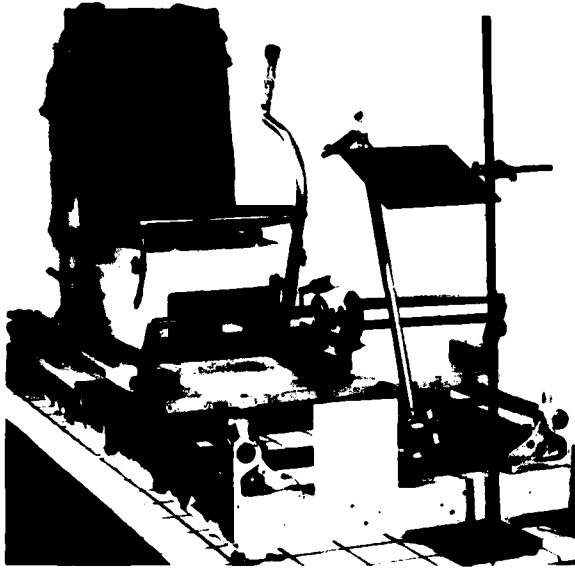

Figure n°11 :  
VUE D'ENSEMBLE DES DIFFERENTS ELEMENTS  
COMPOSANT LA MAQUETTE DU POSTE DE PILO-  
TAGE.

Figure n°12 :  
REPRESENTATION SUR LA VUE  
DE PROFIL D'UN PILOTE, DE  
L'ANGLE DE VISION HORIZON-  
TALE - AZIMUTH ZERO DE 25°.

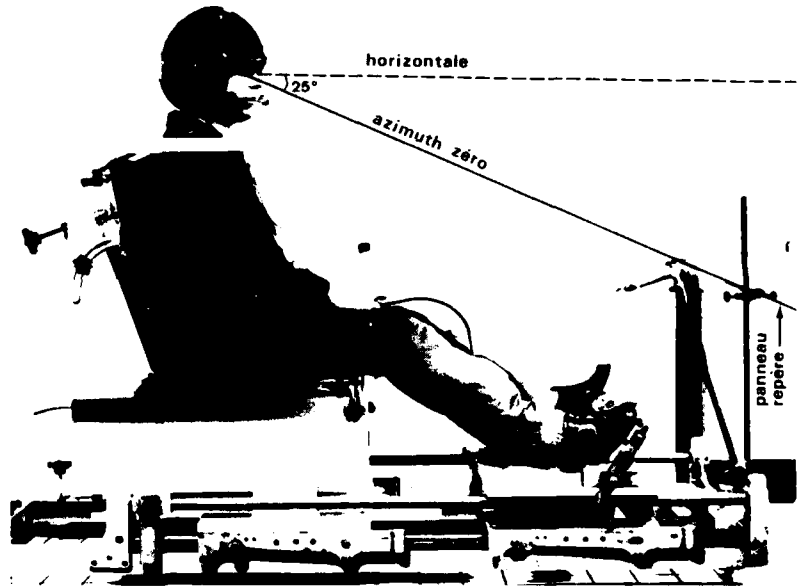

Figure n°13 :  
VUE DE FACE REPRESENTANT L'ALIGNEMENT DU  
CENTRE DE VISION DU PILOTE (C.V.P.) AVEC  
LE PANNEAU INCLINE SERVANT DE REFERENCE  
DANS LA DETERMINATION DE L'ANGLE DE VI-  
SION HORIZONTALE - AZIMUTH ZERO DE 25°.

## 4.2 - Mesures stéréométriques -

## 4.2.1 - Utilisation de la maquette : différents réglages :

Dans un premier temps, le sujet en tenue complète de vol s'installait dans la maquette et, grâce aux différentes possibilités de réglages, modifiait les divers éléments du poste en fonction de sa morphologie et de son appréciation personnelle du confort. Ces réglages étaient exécutés par un opérateur, sur les conseils du pilote et dans l'ordre suivant :

- fixation des harnais de sécurité,
- réglage du siège en hauteur et d'avant en arrière par rapport aux palonniers, afin de posséder une assise et une position de jambes, confortables,
- réglage des palonniers en hauteur et inclinaison des pédales, leur course étant appréciée par le sujet (Cf. Figure n°15),
- réglage du champ visuel : l'ensemble siège-palonniers étant ensuite déplacé dans le but d'amener le centre de vision du pilote sur l'axe horizontale-azimut zéro de 25°,
- vérification des réglages du siège par rapport aux palonniers, compte tenu du déplacement précédent,
- réglage du manche du pas collectif (Cf. Figure n°16),
- réglage du manche du pas cyclique (Cf. Figure n°14).

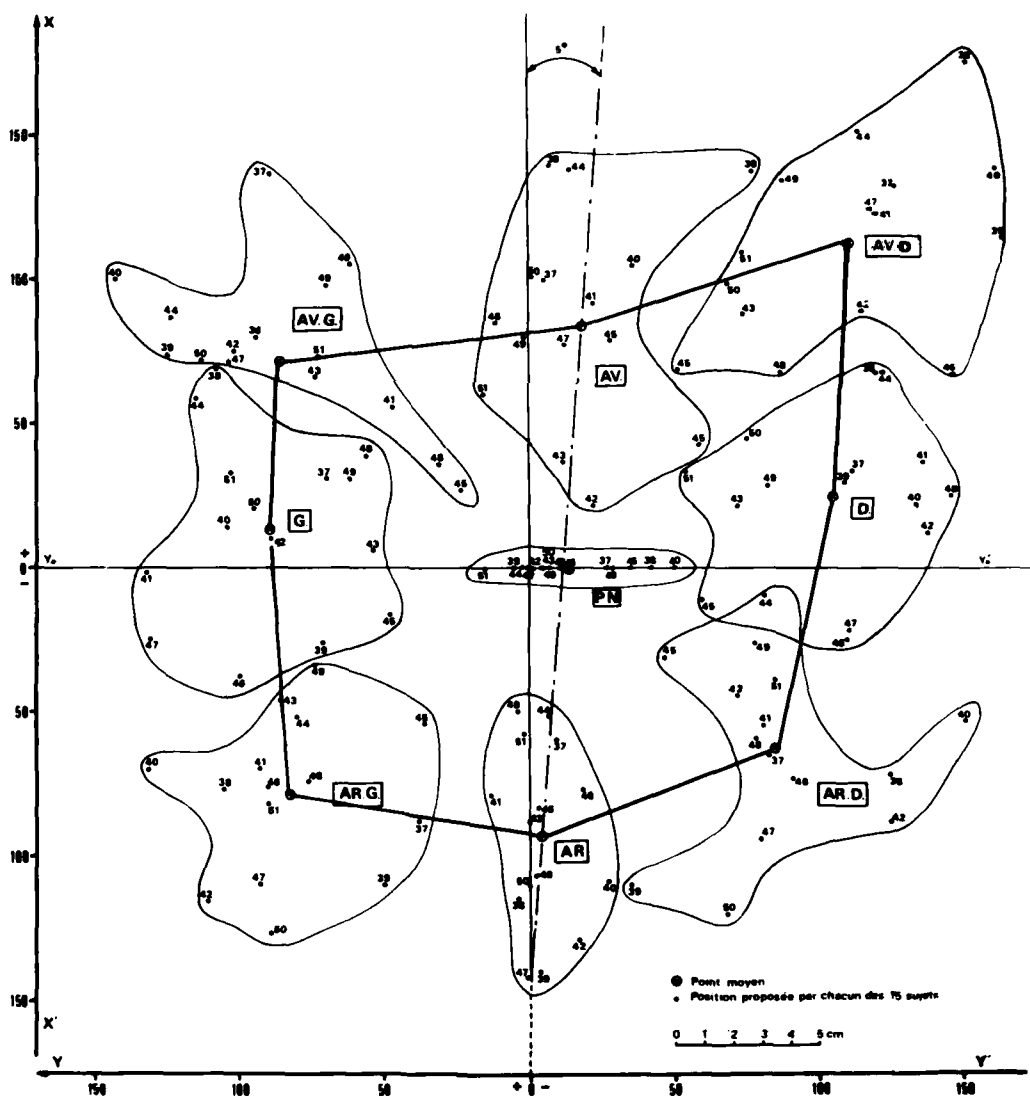

Figure n° 14 : PROJECTION SUR UN PLAN HORIZONTAL DES POSITIONS CARACTERISTIQUES DU DEBATTEMENT DU MANCHE DU PAS CYCLIQUE PROPOSEES PAR LES 15 PILOTES ET REGROUPEES EN DIFFERENTES AIRES DE REPARTITION. TOUTES CES POSITIONS SONT CONSTRUITES A PARTIR D'UNE LIGNE COMMUNE DE REFERENCE  $Y'o - Y_0$  SUR LAQUELLE SONT ARBITRAIREMENT PLACES LES POSITIONS NEUTRES (P.N.) DES 15 PILOTES.

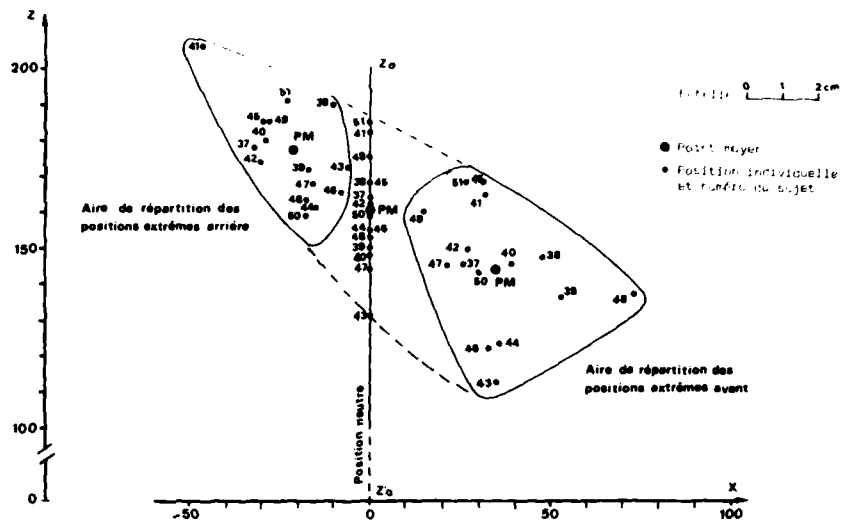

Figure n°15 : PROJECTION SUR UN PLAN SAGITTAL DES POSITIONS EXTREMES DU DEBATTEMENT DES PALONNIERS CONSTRUITES A PARTIR D'UNE LIGNE COMMUNE DE REFERENCE ( $Z'0 Z0$ ) SUR LAQUELLE SONT ARBITRAIREMENT PLACES LES POSITIONS NEUTRES DES 15 PILOTES.

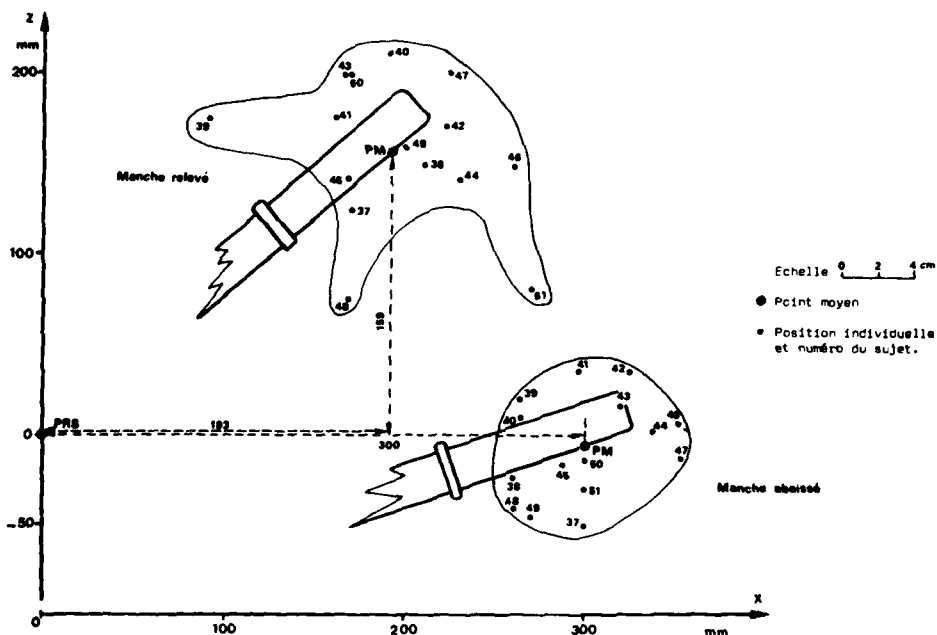

Figure n°16 : PROJECTION DANS UN PLAN SAGITTAL DES POSITIONS EXTREMES DU DEBATTEMENT DU MANCHE DU PAS COLLECTIF, PROPOSEES PAR LES 15 PILOTES.

LES POSITIONS SONT CONSTRUITES A PARTIR D'UN P.R.S. COMMUN AUX 15 PILOTES.

Dans un deuxième temps, nous avons relevé une série de mesures ayant pour but de définir, d'une part les réglages effectués par le sujet, les positions, les courses, les débattements des différents éléments du poste de pilotage et d'autre part d'apprécier l'encombrement du sujet à ce poste de travail.

\* P.R.S. : Point de référence du siège.

## 4.2.2 - Choix des points mesurés (Cf. Figure n°17) :

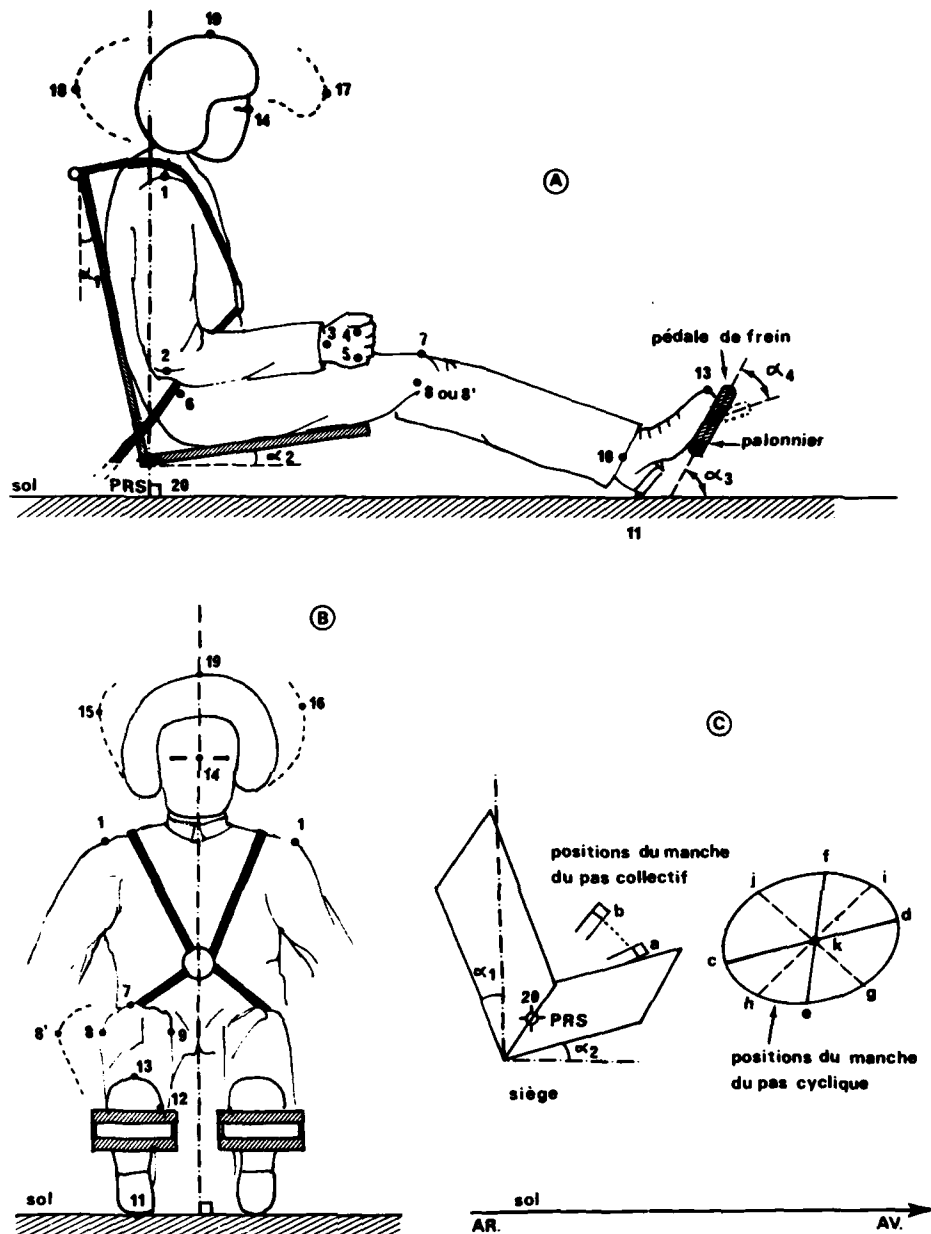

Figure n°17 : SCHEMAS ILLUSTRANT LES POINTS MESURES PAR LA METHODE STEREOMETRIQUE.

5 - EXEMPLES DE RESULTATS EXPERIMENTAUX -

Afin d'illustrer les possibilités de la méthode stéréométrique, nous donnons ici les représentations graphiques construites à partir des résultats expérimentaux et illustrant deux cas particuliers : celle du sujet le plus petit et celle du sujet le plus grand, rencontrés dans notre échantillon.

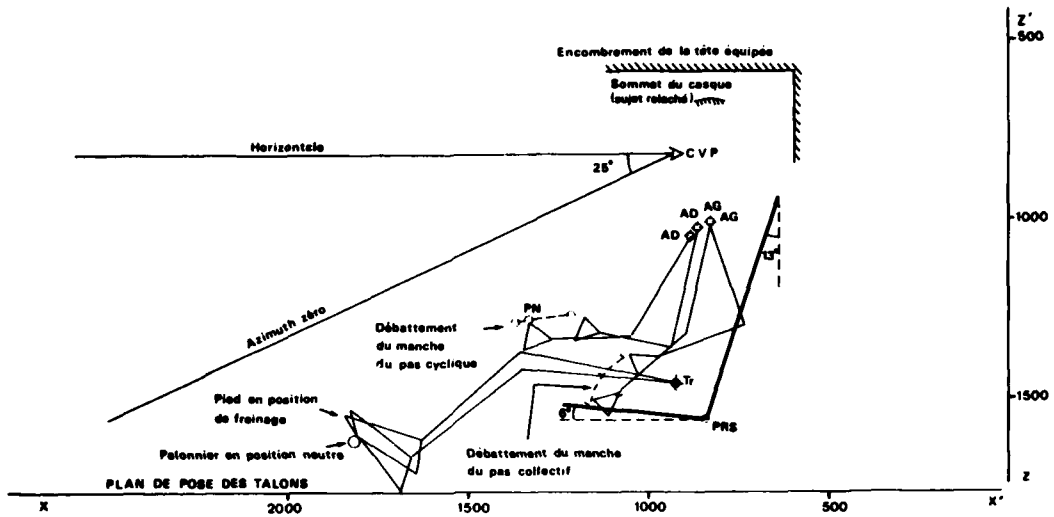

Figure n°18 : VUE DE PROFIL DU POSTE DE PILOTAGE - REPRESENTATION GRAPHIQUE  
DU PLUS PETIT PILOTE RENCONTRE DANS NOTRE ECHANTILLON -  
SUJET n°42 : - STATURE ..... 1,64 M.  
- POIDS ..... 61 KG.

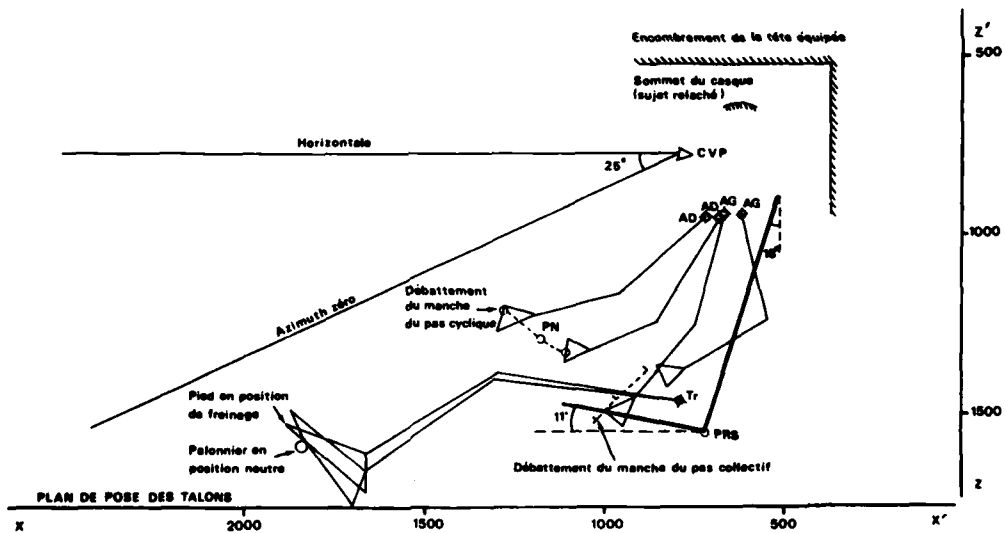
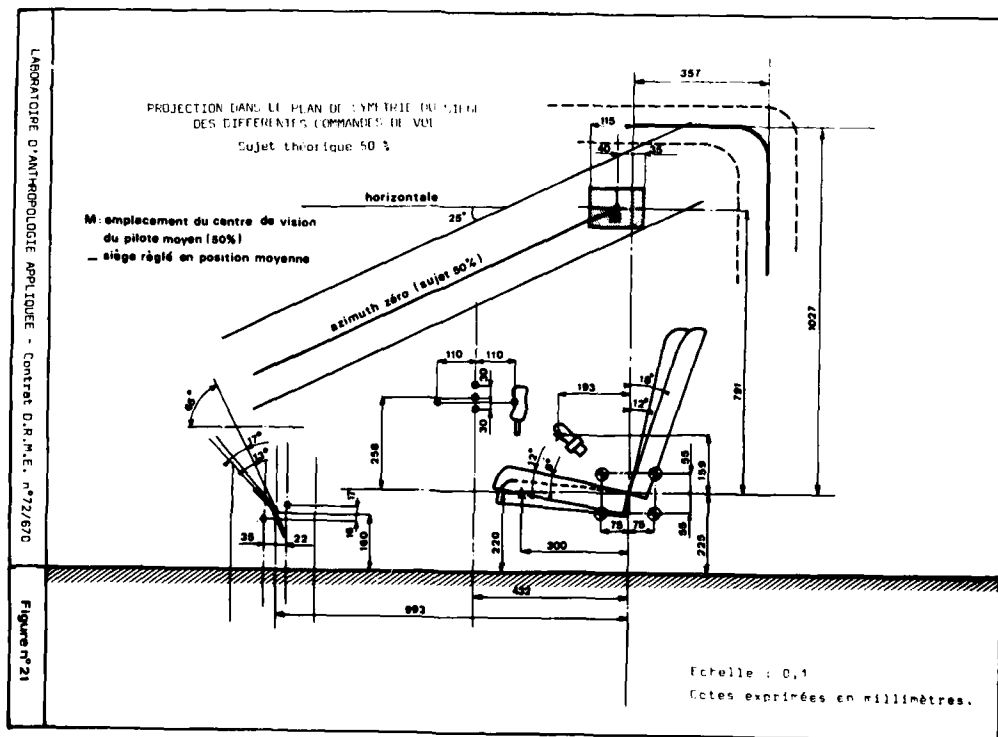
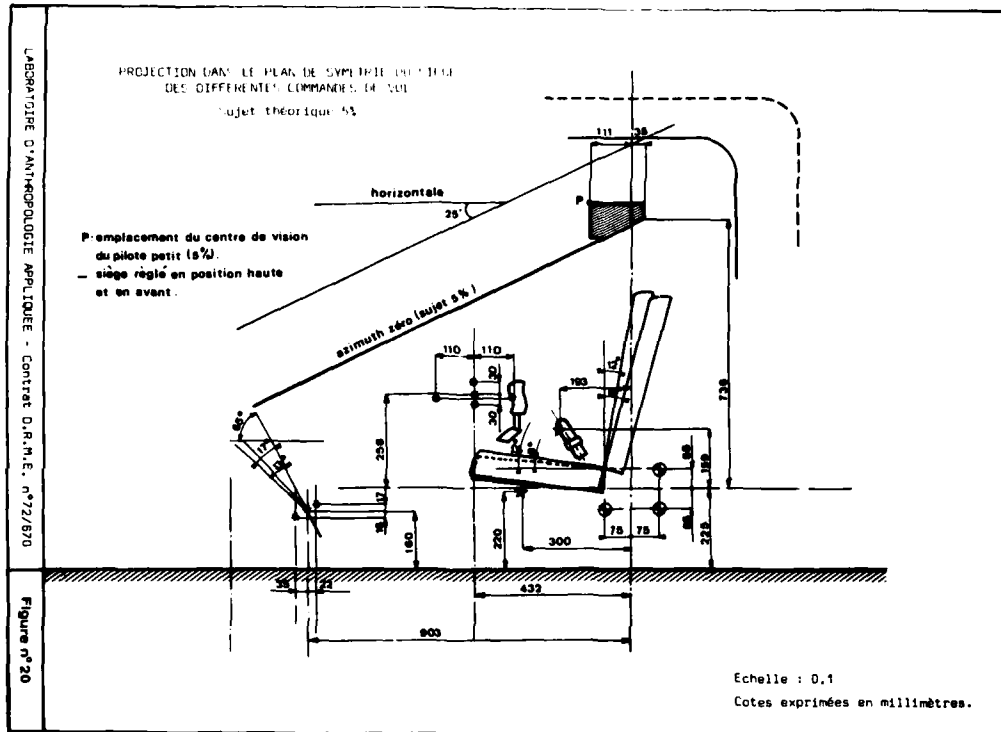

Figure n°19 : VUE DE PROFIL DU POSTE DE PILOTAGE - REPRESENTATION GRAPHIQUE  
DU PLUS GRAND PILOTE RENCONTRE DANS NOTRE ECHANTILLON -  
SUJET n°41 : - STATURE ..... 1,84 M.  
- POIDS ..... 92 KG.

## 6 - REALISATION DES FICHES TECHNIQUES -

### 6.1 - Construction graphique des zones d'atteintes des sujets théoriques : 5%, 50% et 95% :

L'analyse des mesures anthropométriques relevées sur les 115 pilotes nous a permis de construire les sujets théoriques : petit 5%, moyen 50% et grand 95%.





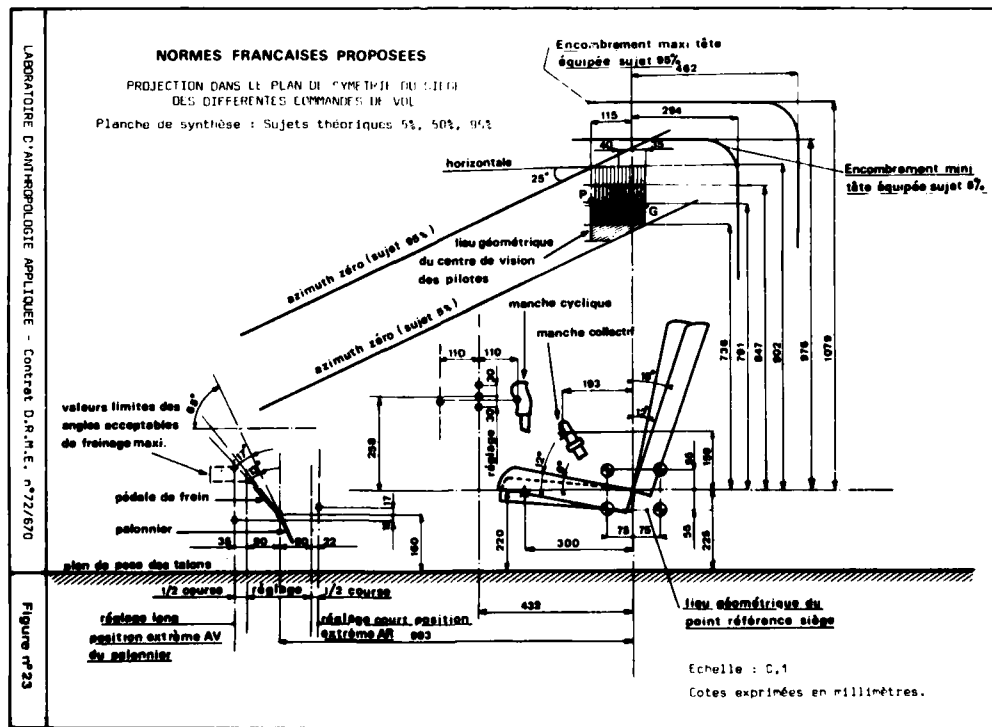
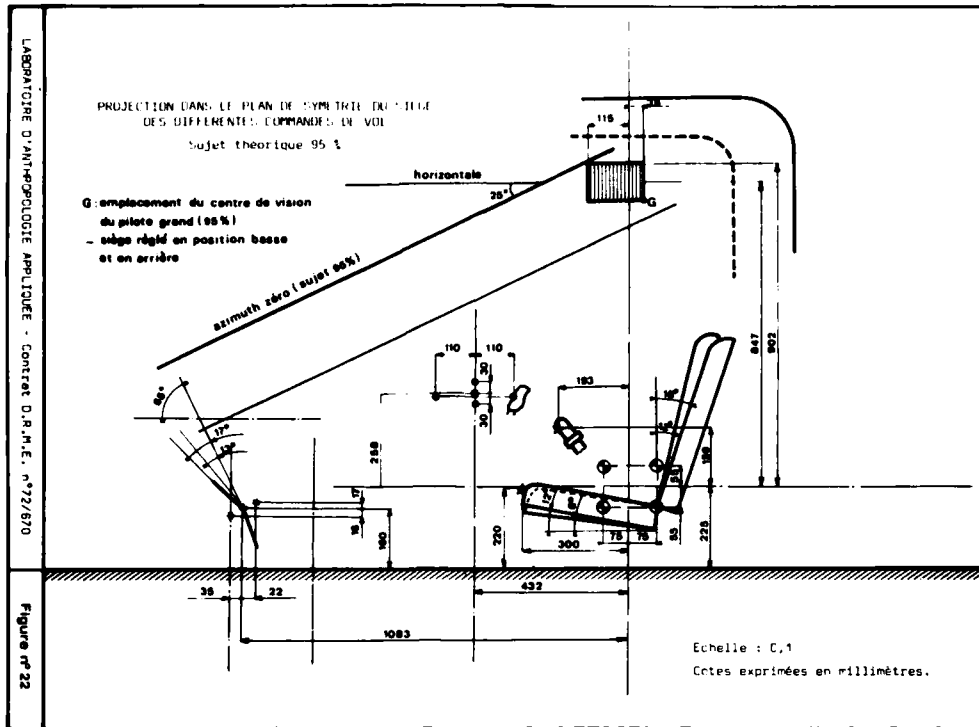

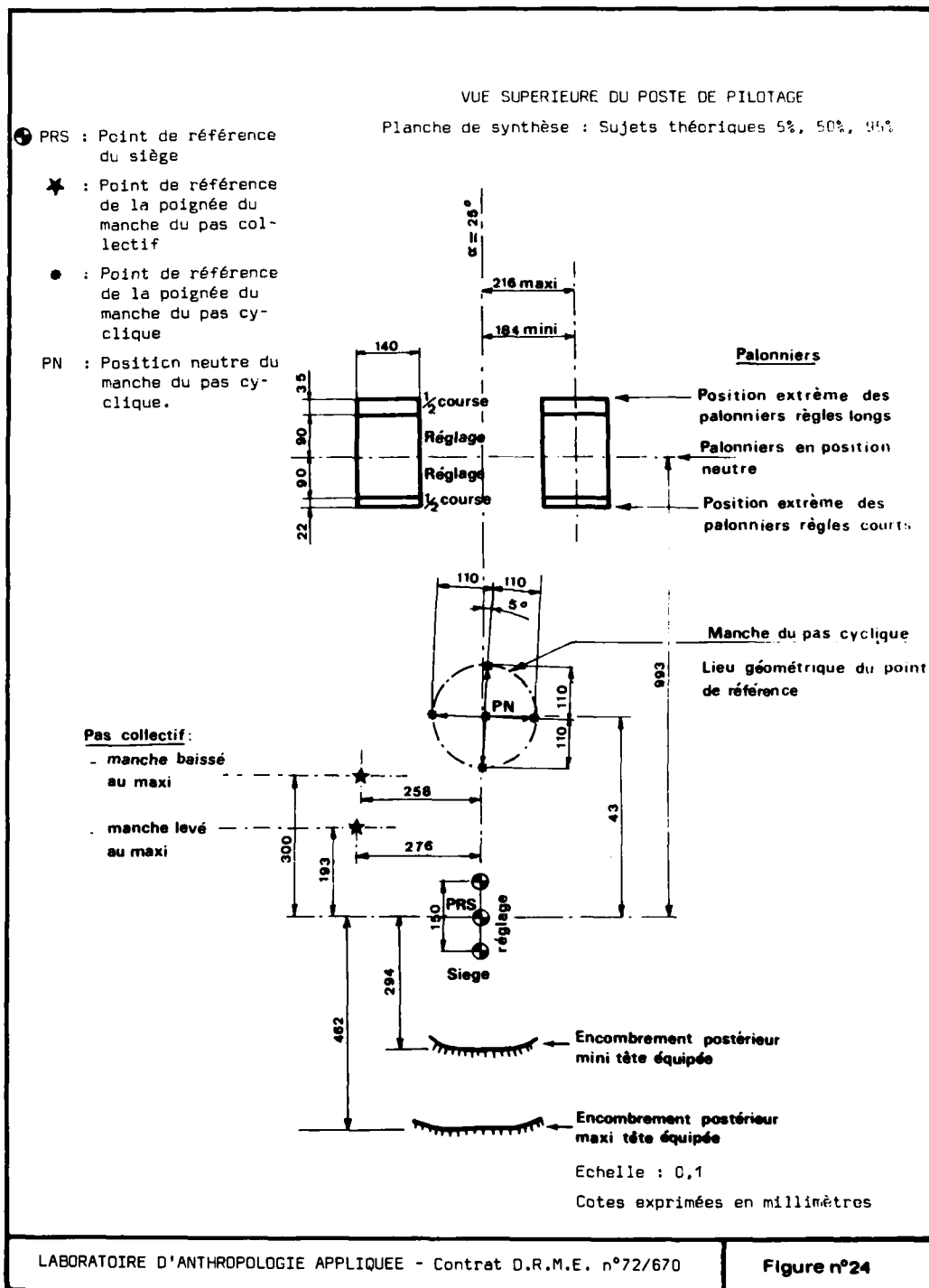

Il faut insister sur le fait que ces sujets théoriques ont été respectivement constitués de la somme des éléments anatomiques segmentaires 5%, 50% et 95% composant le corps humain (buste, cuisse, jambe, pied, bras, avant-bras, main, hauteur des yeux et taille du sujet assis redressé, puis relâché). Dans ces conditions, le sujet théorique 5% (1,64 m.) est plus petit que le sujet réel représentant le 5ème percentile de la stature (1,66 m.); le sujet théorique 95% (1,87 m.) est plus grand que le sujet réel représentant le 95ème percentile de la stature (1,85 m.).

Le principe de ces constructions théoriques permet de couvrir toutes les possibilités de combinaisons des éléments segmentaires, quelle que soit la valeur des percentilages. En effet, il existe toujours des différences individuelles. Ainsi par exemple, pour des individus de même stature, le rap-

port entre la hauteur du buste et la longueur du membre inférieur n'est pas constant; les uns peuvent avoir un petit buste et des membres inférieurs relativement longs; d'autres peuvent avoir un grand buste et des membres inférieurs relativement courts.

Les sujets théoriques 5% et 95% déterminent donc *les limites inférieure et supérieure* des diverses possibilités réelles et théoriques des combinaisons entre les divers éléments anatomiques et qui peuvent ainsi refléter les variations des rapports corporels.

De plus, nous avons été amenés à étudier pour ce poste particulier de travail et les postures qu'il impose, la variabilité des *angles de confort* (ou plus exactement de moindre inconfort) des segments interarticulaires. Ces angles précisent les attitudes des pilotes et permettent de déterminer leurs zones d'atteintes.

## 6.2 - Présentation des résultats -

Les fiches techniques figurant ci-avant représentent la synthèse de cette étude. Nous présentons sur les figures n°20, 21, 22, 23 et 24, les dispositions relatives des commandes de vol et du siège étudiées en fonction d'une visibilité minimale de 25° dans l'axe pilote.

Ces fiches sont présentées de la façon suivante :

### - Projection dans le plan de symétrie du siège du pilote :

A partir de l'ensemble des mesures caractérisant les sujets petits 5%, moyens 50% et grands 95%, nous avons défini un poste de pilotage adapté à chacun de ces sujets théoriques (figures n°20, 21 et 22).

La figure n°23 présente la conception du poste de pilotage adaptable à 90% de la population utilisatrice.

### - Vue supérieure du poste de pilotage d'hélicoptère :

La figure n°24 présente en vue supérieure la conception du poste adaptable à 90% de la population utilisatrice.

## 7 - CONCLUSIONS -

Les problèmes posés par la réalisation d'un poste d'activité aussi complexe que le poste de pilotage d'un hélicoptère sont multiples. Nous venons de mettre en évidence comment, par les moyens d'une méthode de biostéréométrie, il nous avait été possible d'apporter aux ingénieurs de conception et aux constructeurs, les éléments qui, compte tenu des impératifs biométriques et techniques leur permettraient de répondre aux besoins de sécurité et de confort de ce poste de travail particulier.

Au-delà de cet exemple, il est bon de retenir que si l'on veut aborder *l'étude dynamique* de l'utilisation d'un poste de travail, quel qu'il soit, il s'avère nécessaire d'aller au-delà de la simple description statistique de la morphologie et de la connaissance du volume d'encombrement de l'utilisateur potentiel. L'emploi de la méthode stéréométrique constitue un progrès en ce sens.

Lorsqu'on utilise la méthode traditionnelle de mesures anthropométriques à l'aide des instruments habituels (toise, pied à coulisse, céphalomètre, ruban métrique,...) les dimensions sont relevées indépendamment les uns des autres, et il n'est jamais possible de préciser leurs positions relatives dans l'espace. Après que le calcul des principales caractéristiques et les développements corrélationnels aient été établis, l'exploitation et l'interprétation ne portent que sur des valeurs numériques brutes et non sur des segments orientés dans l'espace.

En utilisant le système de référence simple, que représente un trièdre trirectangle, les points de repères anatomiques ne sont plus indépendants les uns des autres et il suffit dès lors de déterminer les trois coordonnées (X, Y, Z) de chacun des points anatomiques retenus.

L'utilisation de la géométrie analytique pour traiter mathématiquement les données tridimensionnelles, permet la résolution de nombreux problèmes, ce qui augmente considérablement la richesse de l'exploitation des données. En effet, les coordonnées relevées par cette méthode peuvent fournir de nombreuses déterminations qu'il serait difficile, voire impossible d'obtenir autrement. C'est le cas en particulier :

- des distances entre points anatomiques et les dispositions précises dans l'espace de chaque segment, pour un geste donné,
- des distances entre points anatomiques et les plans définis par trois autres points d'un segment anatomique,
- les angles entre droites joignant deux points quelconques qu'elles aient ou non un point commun,

- l'angle entre une droite et un plan,
- l'angle formé par deux plans, etc...

Au total, le relevé des mesures stéréométriques, à condition qu'il soit associé à un type d'exploitation approprié, trouve certainement sa place parmi les méthodes actuelles d'étude de poste de travail. On peut, en opérant ainsi, répondre aux principales préoccupations des bureaux d'études qui doivent, en permanence, rechercher des compromis entre les contraintes techniques liées à l'élaboration de postes de travail de plus en plus complexes et les impératifs biomécaniques des utilisateurs.

## AN ANALYSIS OF HELICOPTER PILOT CONTROL BEHAVIOUR AND WORKLOAD DURING INSTRUMENT FLYING TASKS

by

J. Smit  
 P.H. Weverinke  
 National Aerospace Laboratory NLR  
 Amsterdam  
 The Netherlands

## SUMMARY

During helicopter instrument hover- and navigation (tracking) tasks a number of flight data, physiological measures and subjective ratings were collected. Mathematical models were used to describe and analyze the pilot's control behaviour and attentional workload. The optimal control model seems to offer a suitable framework for the description of control tasks as complex as helicopter instrument flying. A control effort model, which was formulated in terms of the optimal control model, describes the relationship between performance and attention paid to the task. The physiological variables and subjective ratings in general reflected the variations in control effort connected with the various tasks.

## 1. INTRODUCTION

Apart from the stresses connected with military helicopter operations, as there are: perceived threat, time stress, discomfort by heat, vibration, protecting clothes etc., there is an attentional workload, inherent to the control of a helicopter. The flight characteristics of an unstabilized helicopter during certain mission phases require a fair amount of control effort from the pilot. This certainly interferes with other duties assigned to the pilot. In order to be able to predict mission effectiveness it is therefore mandatory to have insight in the complex interactions of the various workload constituents and mission performance.

This paper describes an exploratory experiment in which task analysis methods and workload estimation techniques were used to assess the potential of these methods in the case of complex control tasks.

With respect to the description and the analysis of a task it is desirable to formulate the functioning of the pilot in terms commensurate with those used for the description of the other elements of the complex man-machine system. The resulting conceptual framework can serve two purposes. Firstly, it can be used as a diagnostic tool. This concerns the analysis of experimental results and the "explanation" of system characteristics. The influence of human operator characteristics on total system performance can be estimated. Secondly, the framework can be used to predict the behaviour of systems in the design stage and to give an insight in the complex interactions between the various system elements. A promising contribution in this respect is provided by the state space optimization-, estimation- and decision theory. The mathematical model of pilot controlling based on these concepts is known as the optimal control model developed by Kleinman and Baron (Refs 1 and 2).

A control effort model formulated in terms of the optimal control model has been developed by Weverinke (Ref. 3). This model offers the possibility to estimate the trade-off between system performance and workload (equivalent with invested effort). Another approach is the use of physiological measurements and subjective ratings to obtain an estimate of the pilot's state in terms of level of arousal, signs of stress responses, perceived workload-level etc. The objective of the experiment was to analyze control behaviour and to estimate the attentional workload connected with the performance of tasks of different levels of difficulty. For this purpose it was decided to choose instrument flying tasks, although instrument flying is not a standard part of the task inventory of the type of helicopter used in this experiment. The advantage of the use of instrument flying tasks is that it offers the possibility to describe the pilot's input in terms of displayed variables. This would be much more difficult to accomplish with the use of outside world information. The description of the pilot's input as attained and the synchronous measurement of relevant flight data, pilot's control behaviour, subjective ratings and physiological variables offered the opportunity to analyze the data in a multi-variate way. This potentially renders a more appropriate kind of representation of the complex interactions occurring with realistic in-flight conditions than an uni-variate approach.

## 2. METHOD

## Experimental program

Four military pilots participated in the experiment. An instructor-pilot acted as safety pilot. The pilots had only little helicopter instrument flying experience (they had an average flying experience of 1200 hours of which 60 hours instrument flying). The Alouette III helicopter used was modified and equipped for the instrument flying tasks and for the measurement and recording of the relevant flight- and physiological parameters. Figures 1 and 2 show the modified instrument panel and the position of the crew. The tasks to be performed were an instrument hover flight of approximately 3 minutes duration and two navigation (tracking) tasks. The hover task comprised stabilizing the helicopter at a height of 600 ft AGL with minimal horizontal velocities. The aircraft attitude angles were displayed on a three-axis attitude director indicator, ADI, as shown in figure 1. The horizontal velocity components were presented via the flight director roll and pitch bars of the ADI. For instance, an "up" position of the pitch bar designated a backward velocity, a "left" position of the roll bar a lateral velocity to the right. For all ADI indicators the "fly-to" principle was applied. The deviation from the prescribed height was displayed via a vertical pointer at the left side of the ADI instrument. A height error indication of two dots corresponded with a height error of 100 ft.

The instrument navigation (tracking) tasks consisted of flying along a track (defined by an Inertial Navigation System output) with an indicated airspeed of 60 kts, at a prescribed height of respectively 600 and 150 ft AGL and minimizing the deviations from this track as indicated by the flight director roll bar of the ADI. Full deflection of the bar corresponded with a cross track deviation of 200 ft. The sensitivity of the height error indicator for the low level navigation was set at 60 ft height error for a deviation of two dots, for the navigation at 600 ft it was the same as for the hover task (100 ft). By including the low level navigation task it was intended to induce a higher attentional workload, forcing the pilot to a tighter height control.

A standard sortie (of approximately 30 minutes) consisted of two hover tasks (of 3 min.) and the two navigation tasks (of 5 min.). The visual navigation to and from the trial area served as a low-workload

reference task for the evaluation of the physiological responses.

#### Measurements

All performance measures (aircraft attitudes, velocities, positions with respect to the desired track, height), physiological measures and aircraft control positions were recorded digitally and processed with the aid of a digital computer. The following physiological variables were derived from the recorded data:

- . Heart rate, the instantaneous heart rate, derived from the measured time intervals between successive ventricular contractions (R-waves of the cardiogram) expressed as beats per minute
- . Heart rate root mean square successive difference (RMSSD); this is a heart rate variability descriptor which takes into account the trend of mean heart rate and minimizes its effect by considering the observation order through difference scores (Ref. 4)

$$\text{RMSSD} = \sqrt{\sum_{i=1}^{N-1} (X_{i+1} - X_i)^2 / (N-2)}$$

- . Heart rate average band power, ABP, in the frequency band .06 to .21 Hz. Average band power refers to the area under the power spectral density curve between these frequencies. It represents the contribution of the autonomic processes which regulate the blood pressure (vascular regulation) to the total heart rate variability (Ref. 5).
- . Respiration frequency, the number of inhalations per minute.
- . Skin resistance level, SRL, the mean value of the slowly changing resistance as measured between two electrodes attached to the subjects left foot. The low-pass filtered resistance signal is transformed to a conductance measure, SCL, expressed in units of conductivity ( $\mu\text{Mho}$ ).
- . Skin resistance response, SRR, the rapid fluctuations of the skin resistance signal. As a measure of SRR the standard deviation of the high-pass-filtered skin resistance signal was taken.

Subjective ratings were collected after each flight segment from the safety pilot (effort rating on a non-adjectival rating scale) and from the evaluation pilot (effort ratings, demand ratings and controllability and precision ratings, see table 1). Control activity measures (RMS values) were derived from the recordings of longitudinal and lateral cyclic control inputs ( $\delta_e$  and  $\delta_a$ ), tail rotor pedal control inputs ( $\delta_r$ ) and collective pitch control inputs (CP).

As an overall performance measure, the index "J" was calculated from the recorded display parameters:

$$J_{\text{hover}} = (\text{RMS } h/h_L)^2 + (\text{RMS } v_h/v_{hL})^2$$

$$J_{\text{nav}} = (\text{RMS } h/h_L)^2 + (\text{RMS } y/y_L)^2$$

wherein:  $h$  is the height deviation,  $v_h$  is the horizontal velocity vector (composed of the longitudinal and lateral velocity) and  $y$  is the cross-track deviation. These scores are weighed by their corresponding display limits (denoted by the subscript L).  $J$  is analogous to the cost functional of the optimal control model, this performance criterion is assumed to be minimized by the pilot (denoting his control strategy).

#### Mathematical models

For the analysis of the complex control tasks and for the formulation of control effort involved, a theoretic framework was chosen provided by the state space optimization-, estimation- and decision theory. It consists of several submodels, corresponding with pertinent human operator characteristics (functions). One submodel describes the way in which the operator will process the information available to him, to generate an estimate of the system state. This can be associated with an internal representation of the task (internal model) and allows a systematic investigation of a variety of information processing aspects. Combined with a submodel for human control behaviour, this model is known as the optimal control model, OCM (Ref. 1). It can be used to describe multivariable linear control situations and, because it is formulated in the time-domain, it can deal with time varying processes. The model is based on the assumption that the well-motivated, well-trained human operator will act in a near optimal manner subject to his inherent limitations and constraints and the extent to which he understands his task. The model can be considered as normative because it formulates the human control behaviour as it should be, given the human limitations and the task situation. The following human limitations are dealt with in the model:

1. The various internal time delays associated with the processing of information. These are represented by a lumped equivalent perceptual time delay  $\tau$ , which has been found to be relatively constant (0.20 sec).
2. The various sources of human randomness are represented by errors in observing system outputs and executing control inputs by including observation noise and motor noise.

Other human operator related parameters which have to be assumed in the model are:

- . The objectives of the task (instructions) resulting in an optimal control strategy (minimizing a cost functional).
- . The overall level of attention dedicated to the task. The optimal (minimal cost functional) allocation of attention among the various displayed variables is assumed (computed) in the model.

The following task characteristics are formulated in the model:

- . the helicopter dynamics
  - . the disturbance environment (moderate atmospheric gust)
  - . the information available to the pilot to perform the task (via the flight instruments).
- The displayed information is for the hover task: pitch, roll and heading (angles and rates), horizontal velocity vector and acceleration, height error and vertical velocity. For the navigation tasks: pitch-, roll- and heading angles and rates, cross-track deviation, height error, forward-, vertical- and lateral velocity. The pilot's control strategy is assumed to be such that a cost functional is minimized. The weightings of the cost functional are selected on the basis of allowable deviations or limits: each variable which is included in the cost functional is normalized by the inverse of the limit. Values for the limits of the displayed guidance variables (horizontal velocity and height error for the hover task, and cross-track deviation and height error for the navigation tasks) are taken equal to the display limits. Values for the limits of attitude angles and control deflections are determined partly from structural limitations and partly from a knowledge of pilot preferences and task instructions. For a more detailed description of the models and assumptions the reader is referred to the literature (Refs 6 and 7).

Based on the fore-going, performance scores of the variables of interest are obtained using digital computer programs. These model predictions are compared with the experimental results.

For a complete description and prediction of human operator behaviour and its influence on system reliability also the aspect of human controller's effort should be incorporated (apart from system performance). Because the pilot is highly adaptive, system performance will be maintained over a wide range of task difficulty. But the effort invested by the pilot may vary considerably. In this context a control effort model is developed in terms of the afore-mentioned optimal control model parameters. The model predicts a workload index (control effort) based on the overall level of attention and the sensitivity of task performance (cost functional,  $J$ ) to the momentary attention paid by the subject. This model has been shown to correlate very well with subjective effort ratings for a wide range of single-axis control tasks (Ref. 3).

### 3. RESULTS AND DISCUSSION

A total number of 24 sorties were flown by the evaluation pilots. (Pilots A, B, C and D flew respectively 9, 7, 5 and 3 sorties.) During the familiarization trials it became obvious that especially the instrument hover task was very difficult to perform for most of the pilots. Sometimes the safety pilot had to interfere because of too large deviations from the prescribed flight conditions (height error, horizontal velocities, vertical speed).

#### Physiological measures and subjective ratings

The values of the physiological measures and subjective ratings, averaged over the four subjects are shown in table 2. (The results are given in more detail in reference 8.) In order to normalize the various measures and make them comparable between the four tasks, a conversion was carried out in which every value was related to the sortic mean and expressed as a deviation percentage score. The means and standard deviations (averaged over runs and pilots) of these deviation percentage scores are also given in table 2. For the case of comparison with the other measures the deviation percentage scores for the heart rate variability measures (RMSSD and log average band power) are reflected. So, high values of these scores correspond with a relative suppression of the heart rate variability. The relatively large inter- and intra individual variability of some of the measures is reflected in the large standard deviations. To test the significance of the observed differences between the four tasks of the mean values of the deviation percentage scores, multiple comparisons were made. (Duncan's New Multiple Range test.) The results of the multiple comparisons are given in table 3.

It can be concluded that the physiological measures (except the skin resistance measures) and the subjective ratings reflected the differences between the tasks considered (visual navigation, instrument navigation and instrument hover) with respect to the required level of attention and effort. There was no indication of any influence of the lower height above the terrain (150 ft) during the low navigation trials in terms of emotional reactions connected with perceived risk. Probably, the presence of a safety pilot was, in this respect, quite reassuring. Of the physiological measures the heart rate variability scores (RMSSD and log ABP) did discriminate best between the various tasks (yielded the highest difference scores). Also the various subjective ratings did discriminate very well between the tasks, which is of course not so surprising, considering the range of the tasks in terms of effort and demand.

#### Results of a multi variate analysis

In this experiment data were collected and processed of which, for a multi-variate analysis, the following variables, classified into four groups, were chosen:

- physiological measures
  - . heart rate
  - . RMSSD
  - . log ABP
  - . respiration frequency
  - . skin conductance level
  - . skin resistance response
- the overall performance index ( $J$ )
- subjective ratings
  - . safety pilot rating
  - . effort rating
  - . demand rating
- control activity indicators
  - . longitudinal cyclic control activity ( $\sigma_{\delta e}$ )
  - . lateral cyclic control activity ( $\sigma_{\delta \beta}$ )
  - . directional (pedal) control activity ( $\sigma_{\delta \gamma}$ )
  - . collective pitch control activity ( $\sigma_{CP}$ )<sup>r</sup>

Every trial yielded a set of these more or less correlated variables. To get insight in the relations between the different variables and groups of variables some multi-variate analysis techniques were applied (Ref. 8). Because of the relatively small sample size and the varying experimental conditions inherent to this type of field experiments the results should be interpreted with a fair amount of caution, keeping in mind that these results tell only something about this particular set of variables and experimental conditions. Multiple correlation is used to show the relationship between a linear combination of a set of variables and one other variable. This analysis has been executed to determine the relationship between three groups of variables (respectively: the six physiological variables, two subjective ratings, four control activity indicators and the overall performance index,  $J$ ). The canonical analysis has been chosen in order to get an impression of the relationships between the various groups of variables. The results of the multiple and canonical correlation analysis is given in table 4. All correlation coefficients for the hover tasks are significant. For the navigation tasks there is a significant correlation between the physiological variables (a linear combination) and the other groups of variables (linear combinations of the subjective ratings, control activity measures and the overall performance index  $J$ ). These outcomes indicate that a group of physiological measures potentially has a greater predictive power with respect to other task and effort related measures than a single physiological parameter. These significant linear relationships explain 40-75 % of the observed variance. The results are in general more conclusive for the relatively high-workload situation (hover), as far as the correlations between the (groups of) non-physiological variables are concerned, than for the relatively low-workload situation (navigation tasks).

## Mathematical model results

Optimal control model predictions were obtained using the following assumptions:

- . the cost functional weightings selected via the maximum allowable limits were chosen on the basis of the available understanding of the task requirements and physical- and display limits
- . the indifference thresholds were zero and the overall level of attention was obtained by determining the "optimum" trade-off between system performance and attention.

The predicted system performance scores and the optimum allocation of attention (an equal division of attention between longitudinal and lateral control has been assumed) are given in table 5 for the hover task and in table 6 for the high-level navigation task. Also the corresponding measurements are given. The results in table 4 indicate that there is a substantial difference in hover performance between the three subjects considered. The model predictions concerning the guidance variables (height error,  $h$ , and horizontal velocity,  $v_h$ ) are clearly too optimistic. However, the model predictions may reflect the "limit" (optimum) of human control behaviour (of the well-trained, well-motivated pilot). This also holds for the high navigation task. For this task the inter-subject variability is considerably less than for the hover task; therefore, also the average performance is given in table 6. The experimental results of the low-navigation task differ only from those of the high-navigation task with respect to the height performance. The model did (exactly) predict this performance improvement for the low-navigation task.

The assumption that no thresholds are involved in observing the display information is reasonable to the extent it is related to the quality of the displays involved in the experiment. This was the consideration for neglecting the thresholds. However, the assumption is not in accordance with pilot's control behaviour in real flight: within certain limits the pilots tolerate display deviations (and do not take any control actions). Thus, a second "prediction" was made assuming an indifference threshold of 1/6 of the full display deflections of the guidance variables. The resulting scores are given (between parentheses) in tables 5 and 6. In summary, it can be concluded from the foregoing that the optimal control model predictions seem to reflect optimal control behaviour, i.e., the model results can be used to predict the "best attainable" performance (this is in accordance with the "normative" character of the model).

By changing some parameters in the model (details are given in reference 6) a better agreement between model and experimental results was obtained. The resulting model scores are compared with the measured scores for two subjects for the hover task in table 7. Apart from the substantial difference in heading scores (possibly due to an inaccuracy in the description of the helicopter dynamics) all the important performance scores match well. One of the subjects performed the hover task with various horizontal velocity display sensitivities (5 and 25 kts full display deflections). He maintained a surprisingly constant level of horizontal velocity performance in terms of display deviations and not in units of knots. This excellently supports the assumption involved in the optimal control modelling that the pilot's control strategy is such that the display deviations are within an "acceptable" region. It can be concluded from the foregoing that for all the tasks considered a good agreement between measured scores and model results could be obtained on the basis of reasonable assumptions and basically two model parameters: the indifference threshold ratio and the overall level of attention. The latter is mainly dictated by the demand of the task while the first parameter may reflect the pilot's level of skill and motivation.

The model results are used to compute the corresponding control effort. Because of the limited data this analysis can only be rather speculative. For subject A control effort has been computed for the hover and navigation tasks. Also the theoretical curves of system performance versus control effort have been established by varying the overall level of attention. The result is shown in figure 3. The model predicts that the hover task is more demanding than the navigation tasks. Furthermore, it is shown that the hover performance is more sensitive to attention (or effort) than the navigation performance. This may explain why the inter-subject variability (in performance) is much larger for the hover task than for the navigation tasks. The control effort model results are compared with subjective ratings and physiological variables (Tab. 8). In general almost all parameters indicate that the hover task is the most demanding. Furthermore, on the average there is no marked difference between the high and low level navigation tasks. In summary, it can be concluded that the control effort model yields effort predictions which are in good accordance with other indicators of control effort. This provides additional validating evidence for the control effort model which, so far, only has been tested against data obtained for laboratory tasks.

## 4. REFERENCES

1. Kleinman, D.L. and Baron, S.: Manned vehicle system analysis by means of modern control theory. NASA CR-1753, June 1971.
2. Baron, S. et al.: Application of optimal control theory to the prediction of human performance in a complex task. AFFDL-TR-69-81, Wright-Patterson Air Force Base, Ohio, March 1970.
3. Wewerinke, P.H.: Human operator workload for various control situations. Tenth Annual Conference on Manual Control, Wright-Patterson Air Force Base, Ohio, April 1974.
4. Varni, J.G. et al.: Analysis of cyclic heart rate variability. Psychophysiology, Vol.8, no.3, (1971), 406-413.
5. Hyndman, B.W. and Gregory, J.R.: Spectral analysis of sinus arrhythmia during mental loading. Ergonomics, Vol.18, no.3, (1975), 225-270.
6. Wewerinke, P.H.: Performance and workload analysis of in-flight helicopter missions. Thirteenth Annual Conference on Manual Control, Massachusetts Institute of Technology, Cambridge, June 1977.
7. Wewerinke, P.H.: An analysis of in-flight helicopter pilot control behaviour and workload. NLR TR 76146 C, December 1976.
8. Smit, J.: Physiological measurements and subjective ratings obtained during instrument flying with an Alouette III helicopter. NLR TR 77073 C, June 1977.
9. Cooley, W.W. and Lohnes, P.R.: Multivariate data analysis. John Wiley & Sons, Inc., New York (1971).

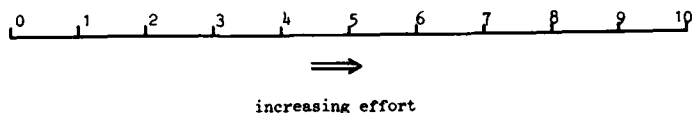

TABLE 1  
Rating scales

Name:

Task:

Using the scale below, indicate the degree of effort you spend on performing the task



Rating scale for  
Controllability and Precision

- 0 - Extremely easy to control with excellent precision
- 1 -
- 2 - Very easy to control with good precision
- 3 -
- 4 - Easy to control with fair precision
- 5 -
- 6 - Controllable with somewhat inadequate precision
- 7 - Controllable, but only very imprecisely
- 8 - Difficult to control
- 9 - Very difficult to control
- 10  Uncontrollable
- Not applicable

Rating Scale for  
Demands on Pilot

- 0 -
- 1 -
- 2 - Completely undemanding, very relaxed and comfortable
- 3 - Largely undemanding relaxed
- 4 -
- 5 -
- 6 - Mildly demanding of pilot attention, skill, or effort
- 7 - Demanding of pilot attention, skill, or effort
- 8 - Very demanding of pilot attention, skill, or effort
- 9 - Completely demanding of pilot attention, skill, or effort
- 10  Uncontrollable
- Not applicable

TABLE 2  
Means and standard deviations (within brackets) of the physiological variables, subjective ratings and the corresponding deviation percentage scores for the various tasks (averaged over all pilots)

Variable	Visual navigation		High navigation		Low navigation		Hover	
	M(s)	Deviation percentage score	M(s)	Deviation percentage score	M(s)	Deviation percentage score	M(s)	Deviation percentage score
Heart rate (beats/min)	74.8 (8.3)	94.1 (5.8)	77.8 (7.9)	98.0 (4.1)	77.7 (7.8)	97.8 (3.9)	87.4 (9.2)	110.1 (6.6)
RMSD	3.3 (2.2)	65.0(27.9)*	2.0 ( .9)	109.9(17.6)*	2.1 ( .8)	108.1(17.9)*	1.8 ( .7)	122.5(16.4)*
log ABP	1.3 ( .3)	50.8(28.2)*	.8 ( .2)	111.7(15.3)*	.8 ( .2)	105.9(17.2)*	.7 ( .4)	131.6(30.2)*
Respiration frequency (inh/min)	15.6 (3.3)	87.0(10.5)	18.0 (2.7)	101.4 (5.2)	18.3 (2.4)	103.3 (5.4)	19.8 (3.4)	108.3 (6.4)
Skin conductance level (µmho)	37.8(11.5)	100.1 (6.2)	36.8(11.9)	97.0 (5.5)	38.1(11.5)	100.9 (4.9)	34.2(13.9)	102.1 (3.4)
Skin resistance response (kΩ)	.22(.15)	89.8(35.9)	.28(.15)	111.2(46.1)	.22(.12)	89.9(35.7)	.28(.12)	109.1(16.4)
Safety pilot	1 (0)	29.1 (8.5)	3.5 (1.1)	92.8(13.7)	4.8 (1.3)	129.2(17.7)	5.6 (1.8)	148.9(19.0)
Effort rating	2.4 (1.4)	48.0(19.7)	4.9 (1.6)	102.9(13.8)	5.4 (1.8)	113.6(18.0)	6.2 (1.6)	135.6(28.1)
Demand rating	2.3 (1.4)	42.9(22.1)	5.5 (1.5)	108.7(20.7)	5.7 (1.4)	113.8(22.7)	6.6 (1.2)	134.7(30.8)

\*Reflected values

TABLE 3  
Results of the multiple comparisons

Variable	COMPARISONS					
	Hover - Vis. nav.	Hover - High nav.	Hover - Low nav.	Low nav. - High nav.	Low nav. - Vis. nav.	High nav. - Vis. nav.
Heart rate	S.	S.	S.	N.S.	S.	S.
RMSSD	S.	S.	S.	N.S.	S.	S.
log ABP	S.	S.	S.	N.S.	S.	S.
Respiration frequency	S.	S.	S.	N.S.	S.	S.
Skin conductance level, SCL.	N.S.	S.	N.S.	N.S.	N.S.	N.S.
Skin resistance response, SRR.	N.S.	N.S.	N.S.	N.S.	N.S.	N.S.
Safety pilot rating	S.	S.	S.	S.	S.	S.
Effort rating	S.	S.	S.	N.S.	S.	S.
Demand rating	S.	S.	S.	N.S.	S.	S.

S : Significant ( $p < .05$ )  
N.S.: Not significant

TABLE 4  
Canonical and multiple correlation coefficients for the navigation  
( $N = 42$ ) and hover trials ( $N = 33$ )

Groups of variables		Canonical or multiple correlation coefficients	
		Navigation (42 runs)	Hover (33 runs)
Physiological variables	Subjective ratings (effort and demand)	.87**	.85**
	Control activity measures	.82**	.76*
	Overall performance index (J)	.73**	.71**
Subjective ratings (effort and demand)	Control activity indicators	.44	.71**
	Overall performance index (J)	.30	.65**
Control activity indicators	Overall performance index (J)	.33	.62**

\*  $p < .05$

\*\*  $p < .01$

TABLE 5  
Model predictions and experimental results for the hover task

PARAMETER	MODEL PRED.	MEASURED		
		SUBJECT		
		A	B	C
$\sigma_{\theta}$ (pitch attitude) (deg)	1.6	1.7	1.6	1.4
$\sigma_{\phi}$ (roll attitude) (deg)	1.0	1.6	1.3	1.6
RMS $\psi$ (heading) (deg)	4.3	2.5	4.8	4.5
RMS h (height) (ft)	13.1(16.3)	21.3	55.1	100.4
RMS u (long. velocity) (kts)	0.8(1.0)	1.5	2.5	2.8
RMS v (lateral velocity) (kts)	0.4(0.7)	1.2	1.6	2.2
RMS $v_h$ (horizontal velocity) (kts)	0.9(1.2)	1.9	3.0	3.5
$\sigma_{\delta_e}$ (long. cyclic) (deg)	1.1	1.1	1.0	0.7
$\sigma_{CP}$ (coll. pitch) (deg)	1.1	1.1	0.8	0.4
$\sigma_{\delta_a}$ (lateral cyclic) (deg)	0.2	0.6	0.5	0.6
$\sigma_{\delta_r}$ (tail rotor pedal) (deg)	1.7	1.1	0.6	0.7
Overall performance $J_m$	0.05(0.09)	0.20	0.66	1.49
Replications	-	15	5	3

(.): predictions with thresholds

TABLE 6  
Model predictions and experimental results for the high level navigation task

PARAMETER	MODEL PRED.	MEASURED				AVERAGE
		SUBJECT				
		A	B	C	D	
$\sigma_{\theta}$ (pitch attitude) (deg)	0.9	2.6	1.9	2.2	1.8	2.2
$\sigma_{\phi}$ (roll attitude) (deg)	2.8	2.8	2.4	3.1	2.4	2.7
$\sigma_{\psi}$ (heading) (deg)	3.6	4.9	6.2	6.6	3.6	5.5
RMS h (height) (ft)	12.5(15.4)	25.4	41.3	39.3	35.6	35.9
RMS u (airspeed) (kts)	0.8(1.4)	5.2	6.5	7.3	7.0	6.6
RMS y (cross track deviation) (ft)	38.7(43.2)	43.0	84.5	66.3	76.8	69.4
RMS $\dot{y}$ (cross track rate) (kts)	4.1	3.7	4.7	4.6	4.0	4.3
$\sigma_{\delta_e}$ (long. cyclic) (deg)	0.7	0.8	0.7	0.6	0.5	0.7
$\sigma_{CP}$ (coll. pitch) (deg)	0.9	1.2	1.2	0.5	0.3	0.9
$\sigma_{\delta_a}$ (lateral cyclic) (deg)	1.5	0.4	0.4	0.4	0.3	0.4
$\sigma_{\delta_r}$ (tail rotor pedal) (deg)	1.2	0.9	1.0	0.6	0.4	0.8
Overall performance, $J_m$	0.05(0.07)	0.11	0.35	0.26	0.27	0.25
Replications	.	9	7	5	3	24

(.): predictions with thresholds

TABLE 7  
Model "match" and experimental results of the hover task

	SUBJECT A		SUBJECT B	
	MODEL	MEASURED	MODEL	MEASURED
$\sigma_{\theta}$ (pitch attitude) (deg)	2.1	1.7	2.1	1.6
$\sigma_{\phi}$ (roll attitude) (deg)	1.4	1.6	1.5	1.3
RMS $\psi$ (heading) (deg)	6.8	2.5	7.8	4.8
RMS h (height) (ft)	22.3	21.3	54.5	55.1
RMS u (long. velocity) (kts)	1.5	1.5	2.1	2.5
RMS v (lateral velocity) (kts)	1.2	1.2	1.7	1.6
RMS $v_h$ (horizontal velocity) (kts)	1.9	1.9	2.7	3.0
$\sigma_{\delta_e}$ (long. cyclic) (deg)	1.0	1.1	1.0	1.0
$\sigma_{CP}$ (coll. pitch) (deg)	0.8	1.1	0.8	0.8
$\sigma_{\delta_a}$ (lateral cyclic) (deg)	0.2	0.6	0.14	0.5
$\sigma_{\delta_r}$ (tail rotor pedal) (deg)	1.6	1.1	1.7	0.6
Overall performance, $J_m$	0.20	0.20	0.58	0.66
$f_{LONG}$	0.57		0.57	
$P_O$	-16 dB		-15 dB	
Threshold ratio TH	1/6 display limit		1/2 display limit	

TABLE 8  
Comparison of control effort model results, subjective ratings and physiological variables

SUBJECT	TASK	COMPUTED EFFORT	SUBJECTIVE RATING		PHYSIOLOGICAL VARIABLES					
			EFFORT	DEMAND	Heart rate	RMSSD	log ABP	Resp. freq.	SCL	SRR
A	Hover	17.0	5.0	5.5	85.4	2.0	1.0	17.6	41.5	.26
	Low navigation	15.9	4.5	5.4	71.0	1.9	.9	16.9	41.9	.22
	High navigation	15.9	4.3	4.8	72.1	1.8	.9	16.4	39.4	.25
B	Hover	16.5	7.5	7.4	84.5	2.5	.7	19.5	22.5	.40
	Low navigation	15.1	6.4	6.4	78.8	3.1	.9	19.3	22.1	.32
	High navigation	14.9	6.7	6.7	78.1	3.2	.8	19.2	21.0	.40
Average of 4 subjects	Low navigation	15.0	5.2	5.5	77.7	2.1	.8	18.3	38.1	.22
	High navigation	15.1	5.2	5.7	77.8	2.0	.8	18.0	36.8	.28

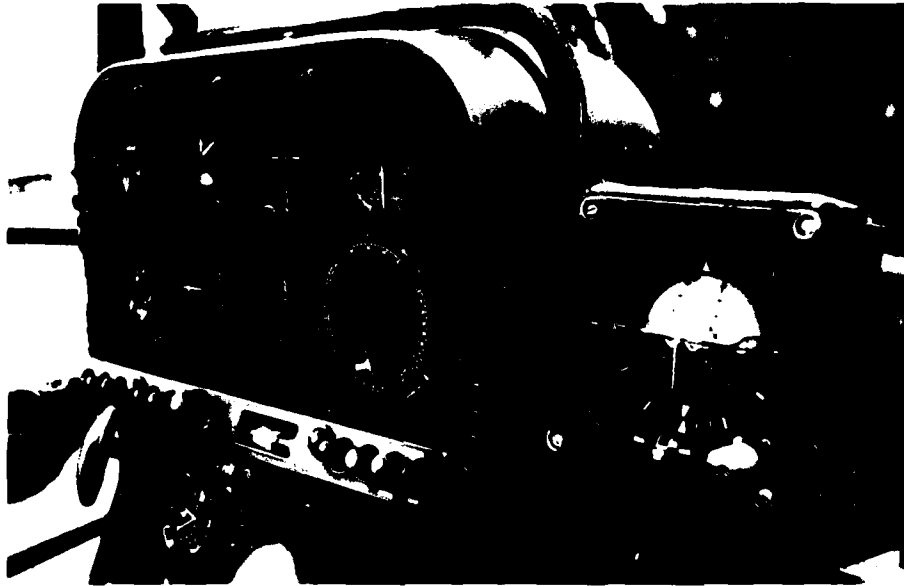

Figure 1 Alouette III instrument panel



Figure 2 Safety pilot, evaluation pilot (with respiration sensor and blue goggles) and NLR observer in the Alouette III helicopter

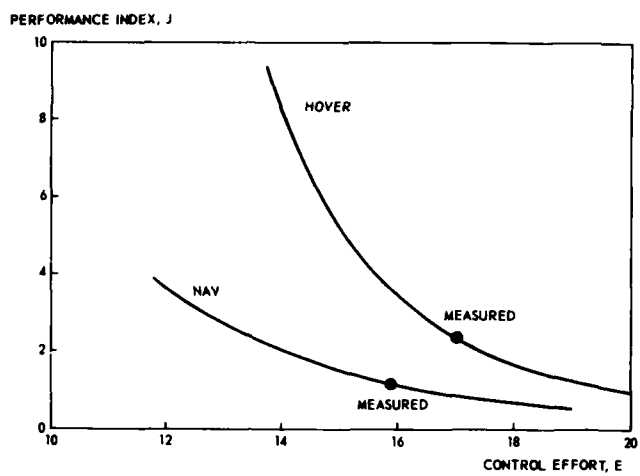

Figure 3 Performance versus control effort for subject A

DESIGN PROCEDURE FOR AN INFORMATION TRANSFER METHOD "CUBITS"  
FOR ALLOCATING PANEL AREA FOR AIRCREW STATION CONTROLS AND DISPLAYS\*

Patrick M. Curran, Ph.D.  
Commander, MSC, USN  
Aircraft and Crew Systems Technology Directorate  
Naval Air Development Center  
Warminster, Pennsylvania 18974 USA

#### SUMMARY

Current design procedures for the determination and allocation of panel space for the controls and displays of the various systems integrated into aircrew stations do not involve adequate consideration of operator capabilities and critical interface requirements.

The primary goal of this effort was to develop a systematic and objective method for the allocation of panel areas in aircrew workspaces. The developed procedure is based on: 1) the criticality of the control or display on crew safety and mission effectiveness; 2) the frequency of utilization; and 3) the amount of information which is conveyed by the operator to the system through control actuation or which is conveyed to the operator by the display presentation. This procedure utilizes an computational method called "CUBITS" to establish a single figure of merit for the allocation of panel space. This method also deals with the number of control settings and accuracy required in the computation of the amount of information being transferred.

#### INTRODUCTION

The panel area for controls and displays which is available to aircrew in their workstations is severely constrained by functional anthropometric limitations and space available in the airframe. The great increase in the amount of controls and displays resulting from weapon system technology advances (but man's reach and visual capability remain constant) mandates that a logical and systematic approach be used to allocate panel space.

The various military specifications and standards which are cited in procurement documents provide requirements and guidance for the design of knobs, switches, and other controls and displays, including minimum spacing between controls for operator manipulative ease. There are specifications for numerical readouts and other displays, and for style and dimensions of alphanumeric for display/labeling usage and detailed requirements for abbreviations. Most of these specifications and standards specify a minimum control size or a range of sizes. This leaves the system designer many alternative choices of device and labeling sizes without providing criteria for making the selection or without guidance on when to allow additional space above a minimum size. These current design deficiencies too often result in the selection and arrangement of crewstation controls and displays which are later found to directly contribute to degraded system performance and a decreased probability of mission success. Accordingly, the system and operator performance related factors deemed to be most influential in the development of effective criteria/requirements for control and display selection and panel space determination should receive major consideration in this design and development process.

#### DEFINITIONS

For the purpose of this paper, the following definitions apply:

Information - A dictionary definition: "the communication or reception of knowledge or intelligence." This paper considers a display as a device which transfers information to the operator and a control as a device through which the operator transfers information to the aircraft system or subsystem.

Information "BITS" - The units in which information is measured or expressed quantitatively (Fano, Ref. 1). The amount of information associated with the known occurrence of an event  $x$ ; is:

$$I(x_1) = \log_a [P(x_1)]^{-1}$$

where  $P(x_1)$  is the probability of an event occurring and  $\log_a$  is the logarithm to the base  $a$ . If logarithms are taken to the base two, the units are bits. When the number of possible events or choices is  $N$ , and each has an equal probability of occurrence, the above equation reduces to:

$$I = \log_2 N \text{ bits}$$

\* Opinions or conclusions contained in this paper are those of the author and do not necessarily reflect the views or endorsement of the Navy Department.



Criticality - The rating of the importance of a control or display for the successful accomplishment of a mission and for flight safety.

Utilization - The frequency of use of a control or display.

CU - An acronym for criticality-utilization and used in this paper as a weighting (i.e., multiplying) factor to reflect importance of various degrees of criticality and frequency of use in allocating panel area.

Packing Factor - The ratio of the sum of the "CUBITS" area allocations of individual controls or displays mounted on a panel to the total area of the panel.

Target Area - This is the area for a panel (or control group) which results from the summation of the "CUBITS" area allocations of the individual controls and displays to be mounted on the panel.

#### RATIONALE

The design procedure set forth in this paper for allocating panel space for controls and displays takes into consideration the following two major aspects of man's performance:

a) As influencing control location and size--

The time involved in actuating a control may be subdivided sequentially into the time to extend the aim to the general region of the control and the time to aim at or actuate the control. If the control to be actuated is small and is closely surrounded by other controls, the aim/actuate time will be longer than if the control was larger, or was allocated more panel space so that less concern would be required to prevent inadvertent actuation of adjacent controls. This last phase of time, the aim time, is shown in Figure 1 below as a function of the area surrounding the control device.

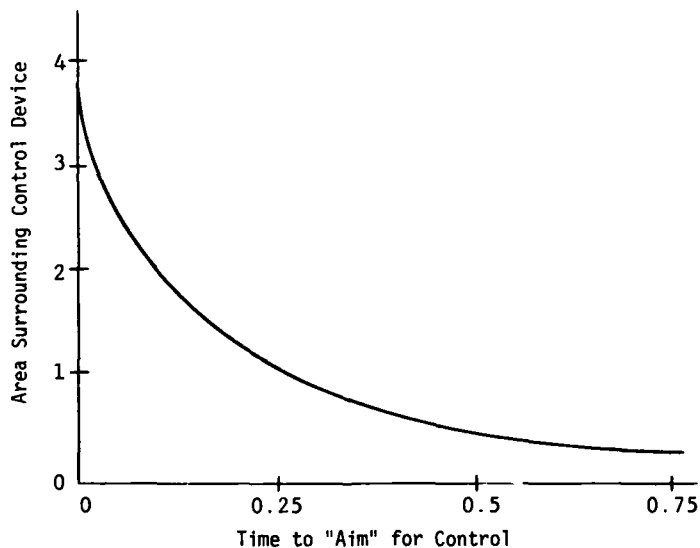

Figure 1. Effect of Area Around a Control Device on Time to Reach the Control

b) As influencing display location and size--

The time required to read the message of a display can be subdivided into the sequential time phases of traversing the eyes to the display and reading or comprehending the display. Experimental (unpublished) tests show that the time to read a number, letter, or dial decreases (over the range of practical interest here) as the size of the character is increased as shown in Figure 2.

The "time-to-aim" and "time-to-read" factors presented in Figures 1 and 2 are influenced by panel area allocations in the manner described below. The aircrew performs many tasks to perform, and most of these tasks are repetitive. Therefore, to reduce the task time, the controls that are manipulated frequently and the displays that are read frequently are allocated more panel area than the infrequently-used ones. However, the infrequently-used control/display devices are so vital to crew safety that operator reaction time should be minimized by allocating more panel area to these controls/displays. The above factors led to the development of a criticality-utilization (CU) weighting factor, which was defined previously. Following para-

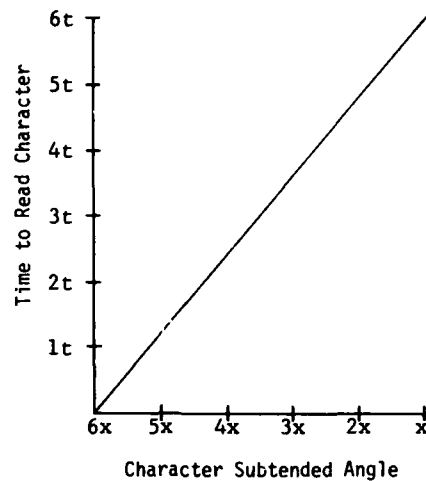

Figure 2. Effect of Character Size on Time to Read Character

graphs will describe procedures for developing "normal usage" panel area allocations for controls and displays. Multiplying these area allocations by the CU weighting factor thus increases or decreases area allocation to reflect criticality and frequency of use factors.

A display which has a number of characters or symbols to be read by the operator obviously requires more display area than one which displays but a single symbol. Similarly, a control which offers the capability of multiple selection choices requires more panel area than one which offers but two choices (e.g., ON or OFF). These differences are expressible as the information content or the amount of information transferred between man and the system. The units of information representing information content or amount of information transferred are "BITS" defined previously. The design procedure accommodates the informational transfer capability of a control or display by allocating a "normal usage" panel area in proportion to the number of bits of information of the control/display. The term "normal usage" is used to distinguish this area allocation from the one which results after multiplying by the CU weighting factor to obtain a CUBIT area allocation.

In discussing "time-to-aim" and "time-to-read," it was mentioned that the initial time phase was that for traversing the eye to the display, or the hand to the general region of the control. In laying out the entire crew station, the systems designer should give preference to locating in close proximity to the operator those control/displays or groups or panels which are most frequently used or most critical.

The basic objective of the design procedure for allocating area for controls and displays is to achieve a more optimum crew station design, with the premise that panel area within easy reach and view of the operator is valuable "real estate." Any procedure which reduces the number of controls and displays which the operator must actuate may therefore also be a desirable step. Thus, combining controls which are mutually exclusive will also save panel area. For example, instead of providing an OFF-ON switch and providing a separate switch to select modes when "ON," the two switches may often be combined. The elimination of dedicated panels in favor of integrated controls/displays and time-sharing techniques in general may save panel real estate, but practically always at the price of reducing rate of information transfer between the crewman and the system. Thus, tradeoffs have to be thoroughly considered. For the purpose of this design procedure, it is assumed that such tradeoffs have been carefully considered, and have resulted in a specific list of controls and displays which are to be located on a panel.

## DESIGN PROCEDURE

### Criticality and Utilization Weighting Factors

The CU weighting factor is a multiplying factor for increasing or decreasing the panel area for a control or a display to achieve an area allocation which reflects the frequency of use during flight and the criticality for flight safety or mission success. The choice of the numbers to be used for the CU weighting multipliers was the subject of much trial and error experimentation. Controls and displays not used in flight are obviously demotable by a considerable extent as compared to controls/displays which are used in flight. The CU weighting multipliers which resulted from the investigation are given in Table I.

The frequency of use of a control or display should be selected from the results of a time base analysis of operator tasks (e.g., the analysis required by reference 2 in new aircraft development programs). The four frequency-of-use classification categories are given the codes N, I, F, V shown in Table I. These will be used when tabular listings

TABLE I  
CRITICALITY AND UTILIZATION (CU) WEIGHTS

UTILIZATION			CRITICALITY		
			Routine	Critical For Flight Safety or Mission Success	Emergency (e.g., Avoidance of Enemy Action, Preparation for Crash Landing)
Frequency of Use	Probable Use Per Hour	Codes	R	C	E
Not Used In Flight	0	N	.2	.3	.4
Infrequent or Rare*	2 or less	I	.8	1.2	1.8
Frequent	3 to 15	F	1.0	1.5	2.2
Very Frequent	16 or Greater	V	1.2	1.8	2.6

\* Backup equipment panels are included in this category.

are made of all the controls and displays which are to be accommodated on a panel or control grouping.

The selection of the category of criticality should also be made from the results of a time-based Analysis of Tasks. The following notes will also provide guidance on selection of the appropriate category of Criticality. Routine is an average rating of the importance of controls and displays and serves to give area preference in accordance with frequency of use for the purpose of reducing operator time in performing all of his tasks. The two columns to the right of routine are concerned with shortening reaction time on actions where elapsed time from receipt of an indication requiring action is important. Critical for mission success would include launching times of torpedos, sonobuoys, missiles, and associated communications affecting such launching times. Critical for flight safety would include communications and navigation required for returning to base, or required for notification of aircraft malfunction requiring aborting a flight. The right-hand column, Emergency, would include events/actions required in which direct threats to the aircraft or aircrew would exist (e.g., fire, engine malfunction, avoidance of enemy actions, aircrew escape).

In selecting the weighting multipliers, unity was chosen for the combination of frequent usage but not critical as to operator reaction time from an emergency class of signal. It is thus the usual condition, and results in the CUBITS area allocation being equal to the "normal usage" areas for controls and displays described in the following paragraphs. The small multiplying factors of 0.2, 0.3, and 0.4 are applied to controls not used in flight. These small weighting factors thus encourage the not-used-in-flight controls and displays to be located outside of normal reach, or the use of subminiature devices.

#### Normal Usage Area - Controls

A control is a device through which the operator issues instructions or transfers information to the system. The panel area assigned to a control must take into account: 1) the physical size of available controls as required for the number of alternate control selections (choices); 2) the manipulative ease of control actuation; 3) the clearance needed from adjacent controls; and 4) the labeling associated with the control. The effect on required panel area of the above four factors is described in the following paragraphs.

a) Number of Control Selections - It has been found that an efficient panel area allocation for a control is obtained when panel area is made proportional to the amount of information available through the control. The information units to be expressed in bits as defined previously. Section A in Table II provides the information content of a discrete control which corresponds to the number of choices (selections) available on the control. The information content of a continuous control may be established by analyzing the control to answer the question: If the continuous control were to be replaced by a discrete control, what would be the minimum number of selection choices which would adequately perform the function of the continuous control? Section A of Table II can then be used to obtain the bits of information. If N is the number of discrete selections which

may be adequately substituted for the continuous control,  $1/N$  is the resolution needed of the continuous control. Section B of Table II provides the information content in bits which correspond to a number of values of required resolution. A continuous control may offer almost an infinite number of control steps. It is important therefore to make certain that only the minimum adequate number of steps or selections be considered in attaching an information content to the continuous control. Where the continuous control is a qualitative one, a radio volume control for example, it is suggested that a resolution of 1 part in 16 be used, if no satisfactory derivation can be made of the substituted number of discrete steps. In the case of control panel light dimmer controls, it is known that a 9-step selection is adequate. Light dimmers are therefore rated as transferring 3.2 bits of information.

TABLE II  
INFORMATION CONTENT OF CONTROLS

A. DISCRETE CHOICE

<u>Number of Choices</u>	<u>Number of Bits</u>
2	1.0
3	1.6
4	2.0
5	2.3
6	2.6
7	2.8
8	3.0
9	3.2
10	3.3
11	3.5
12	3.6

B. CONTINUOUS CHOICE

<u>Resolution Required</u>	<u>Number of Bits</u>
1/9	3.2*
1/16	4.0**
1/20	4.3
1/50	5.6
1/100	6.6

FOR VALUES NOT LISTED:

Amount of information in bits =  $3.32 \log_{10}$  (number of choices)

\* for light intensity controls (dimmers)

\*\* for continuous qualitative

b) Area of Controls for Manipulative Ease and Clearance - The previous section proposed that the space allocated to a control be proportional to its information transfer capability in bits. The next step toward establishing a design procedure is to determine the panel area to be assigned to a control rated as a single bit. The major amount of such area is established by the joint requirements that a control be of such size that it can be conveniently actuated and that it be reasonably spaced from adjacent controls to minimize their inadvertent operation. Panel area allocations being discussed at this juncture are for normal usage (i.e., neither too high or too low in frequency of usage or criticality). A control having an information transfer capability of one bit is a control for selecting between two choices. Either a pushbutton or a toggle switch would normally be selected. Using the pushbutton minimum diameter and clearances from adjacent pushbuttons specified in a major US regulatory document (reference 3), the pushbutton will occupy  $0.77 \text{ in.}^2$  ( $19.6 \text{ mm}^2$ ) of panel space. The rectangular toggle switch occupies  $1 \text{ in.}^2$  ( $25.4 \text{ mm}^2$ ) of toggle space when in a group of other toggle switches, but can occupy as little as  $0.55 \text{ in.}^2$  ( $13.97 \text{ mm}^2$ ) if other adjacent controls are of a different type (e.g., thumb-wheels). Thus, approximately 0.8 square inches (5.16 sq. cm.) appears to be an average value of panel area to assign to a single bit control, in the absence of labeling considerations.

c) Labeling on Area Allocation - Controls normally require labeling for identification of their function and of their selection positions. The effect of such labeling on area allocation was determined by examining a typical selection of adequately labeled controls for which the labeling met the character size specified in reference 3 and the controls met the control size specified in reference 4. This survey concluded that  $1.1 \text{ sq. in.}$  ( $7.097 \text{ sq. cm.}$ ) per bit of panel space is required as an average value to accommodate the size of the control, its clearance from adjacent controls, and its labeling.

### Normal Usage Area - Displays

Displays, in the context of this paper, are visual dynamic indicators of equipment, system, or situation conditions. They range from the simplest of indicators, such as an advisory light, upward through displays of considerable sophistication and information transfer capability, such as heading and attitude indicators and larger cathode ray tube displays. Displays transmit information by being visible or readable to the operator. The sizes of characters and the spacing and sizes of graduation marks are specified in US regulatory documents (reference 3, 4, and 5). The documents also provide the criteria for the area needed for readability of display data under military airborne conditions. To this area needed for readability of display data must be added the panel area of the devices which hold and mount the small areas needed for readability, and these panel areas for mounting are often the predominant factors in establishing total needed panel area. The labeling for identification also adds to the panel area needed for a display.

A display device which transmits one bit of information is a two-choice device, exemplified by a mechanical flag or by an advisory light which is either on or off. The typical panel area requirement for such a device is 0.7 square inches (4.516 sq. cm.). This panel area includes the identifying label. Displays, however, come in so many different generic forms that the 0.7 square inches per bit should be tested for applicability to the particular generic type of display being considered. Numerical readouts, because of their mounting requirements, require a panel space per digit window which is dependent upon the number of digit windows. For a wide class of display devices, the size of the information display area is covered by US regulatory documents and the package size in which these devices are mounted is fairly consistent between qualified suppliers. For example, a US document (reference 6) specifies warning, caution, and advisory lights to the point that the designer has little option on the panel area needed except for the choice of legends and their abbreviations.

Numerical readouts are normally assembled with a module for each digit display window and a retaining bezel (reference 7). In the absence of the bezel, the length would increase directly proportional to the number of digits to be displayed. The presence of the bezel, with hold-down screws at each end, adds a fixed length which makes the panel area required per digit window decrease as the number of digit windows increases. The following Table III of panel area versus number of digit windows follows a design which is in general accordance with specified designs (reference 7) but decreased in size for numerals of 1/4-inch height.

TABLE III

<u>Number of Digits</u>	<u>Panel Area (sq. in.)</u>
1	0.7
2	0.9
3	1.0
4	1.2
5	1.3
6	1.5
7	1.7
8	1.8
9	2.0
10	2.2
11	2.3
12	2.5

### APPLICATION OF CUBITS METHODOLOGY

#### Area Allocation Procedure

The design procedure for establishing a design objective or "target" panel area of a group of associated controls and displays (which may be the entire panel) requires these major steps:

- a) Determination of the information content in bits for each control and each display as described previously.
- b) 1. The bit rating of each control is multiplied by 1.1 square inches (7.097 sq. cm.) to give the "normal usage" panel area allocation.  
2. The bit rating of each display is multiplied by an appropriate square inches per bit selected from Table III to give the "normal usage" panel area.
- c) Each "normal usage" panel area is multiplied by its CU weighting factor, selected from Table I. This gives the CUBITS area allocation for each control and display device.
- d) The CUBITS area allocations for the controls/displays are added. To



The most frequently met with situations of prescribed panel width are those in which the panel width must be 5.75 inches (14.6 cm.) to meet the requirements of the applicable US specification (reference 8). The rear dimension of the control box within such panels cannot exceed 4.75 inches (12.1 cm.) of width. Although all of the behind panel components must be within the 4.75 inches (12.1 cm.), most of the extra width on the top of the panel is available for labeling and also for clearance required around controls. An effective panel width of 5 inches (12.7 cm.) has been found to be practicable for panels meeting the US specification (reference 8) when calculating panel height from target panel area.

Appendix A provides an example of applying the CUBITS panel area allocation methodology to analyze a panel which contains two control groupings. The complete panel was found to have a packing factor of 75 percent. The top control grouping (radar) has a packing factor of 70 percent. This can be improved by layout changes mentioned in Appendix A. The lower grouping of controls has a packing factor of 77 percent. With the requirement to accommodate four selector switches, the panel height must be sufficient to locate one selector switch above the other with clearance between them in accordance with the US specification (reference 4) for manipulation without interference. There is thus no practical way of reducing the panel area of the bottom grouping of controls.

Panel areas are also subject to statistical variations of the individual devices from their assumed "normal usage" panel areas, and of the number of devices which must be fitted on a panel. If a panel is to accommodate a relatively large number of differently sized controls and displays, the probability is greater that a packing factor close to unity can be achieved than if but a few devices must be accommodated. In the latter case, giving consideration to placing a small group of controls/displays along with other groups on a panel may result in an overall saving of panel space in the crew station.

It should be noted that panel area allocations for controls are not based upon the size of the device being controlled. Remote control should be used on devices being controlled which otherwise would require additional panel area beyond that allocated by the CUBITS method.

#### REFERENCES

1. Fano, R. M., Transmission of Information, MIT Press and John Wiley and Sons, Inc., New York 1961.
2. U.S. Military Specification, MIL-H-46855, "Human Engineering Requirements for Military Systems, Equipment and Facilities."
3. U.S. Military Specification, MIL-M-18012, "Markings for Aircrew Station Displays, Design and Configuration of."
4. U.S. Military Specification, MIL-C-81774, "Control Panel, Aircraft, General Requirement for."
5. U.S. Military Standard, MIL-STD-1472, "Human Engineering Design Criteria for Military Systems, Equipment and Facilities."
6. U.S. Military Standard, MIL-STD-411, "Aircrew Station Signals."
7. U.S. Military Specification Sheet, MIL-R-39077/3B, "Readouts, Incandescent Type, Style RPO2 (Twelve Message Unit)."
8. U.S. Military Standard, MS 25212, "Control Panel, Console Type, Aircraft Equipment, Basic Dimensions."

#### ACKNOWLEDGMENT

The author wishes to thank the originators of the CUBITS approach upon whose efforts this presentation is based. They include: Dr. Robert J. Wherry, Jr.,; Dr. Lloyd Hitchcock; Mr. George Laurent; and Mr. John Lazo.

## APPENDIX A

Figure A-1 shows a panel for a developmental airborne system which combines on one panel two different control groupings. The top group of controls and displays all relate to selection of a radar's parameters and advisory lights as to the radar's status. The bottom group of controls/displays serve to select what is to be displayed on a CRT display, radar being one of these options.

Table A-1 shows the computations for this panel as required by the CUBITS method. The target panel area allocations are:

	Area (in. <sup>2</sup> )	(cm. <sup>2</sup> )
Radar Control/Display Group	11.6	(29.5)
Display Selection Group	16.6	(42.2)
	<u>28.2</u>	<u>(71.6)</u>

Using 5 inches (12.7 cm.) as the effective panel width, a panel height of 5.6 inches (14.2 cm.) would give the panel an area equal to its target area, and the US specifications (reference 8) would then require the panel length to be 5 5/8 inches (14.29 cm.). The actual panel height is 7.5 inches (19.1 cm.) or about 2 inches (5.1 cm.) higher than that possible if all devices could be neatly packed in with no odd spaces left over. As pointed out previously, achieving unity packing factor is practically never possible. It does appear that the top (radar) portion of the panel could be reduced in height about 1 inch (2.54 cm.) by relocating the Emission toggle switch between the two selector switches and running the four advisory light indicators in a row across the top of the panel.

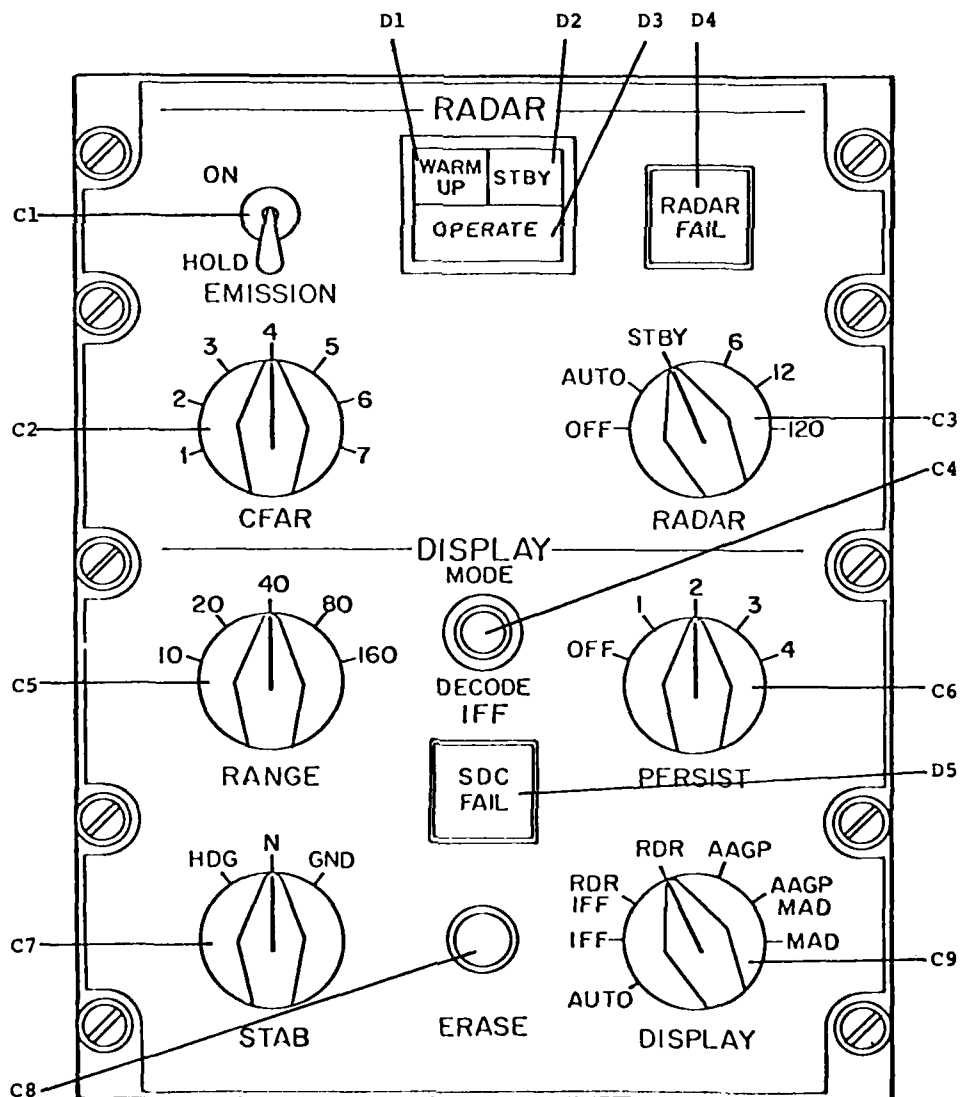

Figure A-1. Combined Radar and Display Selection/Control Panel



TABLE A-1

SYSTEM				SUBSYSTEM					
Identification of Control/Display	Settings or Range	No. of Alts.	Bits	Normal Usage Area per Bit	Normal Usage Area	Level of Criticality		CU Weighting Factor	CUBITS Area Allocation
						Criticality	Utility		
Radar Subgroup									
		2	1	0.7	0.7	R	I	0.8	0.6
D2		2	1	0.7	0.7	R	I	0.8	0.6
D3		2	1	0.7	0.7	R	I	0.8	0.6
D4		2	1	0.7	0.7	R	I	0.8	0.6
C1		2	1	1.1	1.1	C	I	1.2	1.3
C2		7	2.8	1.1	3.1	R	V	1.2	3.7
C3		6	2.6	1.1	2.9	R	F	1.0	2.9
									10.3
		Allowance for subgroup				labeling			1.3
									11.6
Display/Select									
C4		3	1.6	1.1	1.8	C	F	1.5	2.7
C5		5	2.3	1.1	2.5	R	F	1.0	2.5
C6		5	2.3	1.1	2.5	R	F	1.0	2.5
D5		2	1.0	0.7	0.7	R	I	0.8	0.6
C7		3	1.6	1.1	1.8	R	I	0.8	1.4
C8		2	1.0	1.1	1.1	R	I	0.8	0.9
C9		7	2.8	1.1	3.1	C	F	1.5	4.7
									15.3
		Allowance for subgroup				labeling			1.3
									16.6
Summary/Total									

HUMAN FACTOR ENGINEERING TEST AND EVALUATION  
OF THE U.S. NAVY "LAMPS" HELICOPTER SYSTEM\*

Patrick M. Curran, Ph.D., Commander, MSC, USN  
George J. Laurent, M.S., P.E.  
Paul M. Linton, B.S.E.E.  
Aircraft and Crew Systems Technology Directorate  
Naval Air Development Center  
Warminster, Pennsylvania 18974 USA

SUMMARY

This paper presents the human factors engineering (HFE) planning, implementation, and contributions in the evaluation of the U.S. Navy Light Airborne Multi-purpose System (LAMPS) during calibrated range and open-sea operations. The major purpose of this test and evaluation program was to exercise and evaluate a short-range and extended mission version of the entire integrated LAMPS system in both a controlled range and flight operational environment. Human factor engineering participation in this overall program was directed to the critical evaluation of the interfaces among the various system operators and their equipments in the two LAMPS system versions. The major HFE objective in this program was to assess the adequacy of the air and ship crews and their station designs in the two LAMPS system versions and to identify what changes in software, hardware, and operator task assignments should be recommended for future LAMPS preproduction equipments.

The major sources of HFE data in this program were subjective; primarily operator questionnaires, structured observations, and tape-recorded interviews. Objective data included mission key-event printouts, internal communication system (ICS) voice tapes, and aircraft and shipboard display photographs. As a result of this test program, the following conclusions were made:

a. For the short-range LAMPS, a two-man aircrew can effectively perform the two primary missions during normal operations. The Air Tactical Control Officer (ATACO) is occasionally overloaded, while the Remote Radar Operator (REMRO), Electronic Support Measures Operator (ESMO), and Acoustic Sensor Operator (ASO) can adequately perform their assigned tasks.

b. For the extended mission LAMPS, the three-man aircrew can effectively perform the primary missions during normal operations in daylight. Nighttime operations (not tested) are expected to be degraded from daytime operations by an undetermined extent because the on-topping operation with instruments is less accurate than the visual on-topping procedure used in daylight operations.

Two of the aircrew, the Air Tactical Officer (ATO) and Sensor Operator (SO), were occasionally task overloaded but not to an extent which was considered serious enough to jeopardize mission success. Of the four LAMPS shipboard operators, only the Acoustic Sensor Operator (ASO) required too much time to perform his tasks. It was considered that this was due to the poor software/hardware implementation of his station which would be alleviated by the adoption of the design and task procedural recommendations resulting from this study.

c. The voice intelligibility of the UHF communications set was good and the data link voice channel was considered excellent.

d. The effectiveness of future LAMPS preproduction systems would be significantly enhanced by the adoption of the specific recommendations resulting from this HFE test and evaluation program.

INTRODUCTION

System Description

LAMPS is an integrated ship and air system in which a helicopter, based aboard a ship, serves as an extension of the shipboard surveillance and attack systems. The helicopter provides an elevated platform for radar surveillance and electronic listening, and a means for deployment of sonobuoys, detection of magnetic anomalies associated with submarines and the delivery of weapons. The helicopter thus provides the means for redetection, localization and classification of surface and sub-surface targets.

The normal mode of operation is with the ship in control of the helicopter. A full duplex data link between the helicopter and the ship makes available for shipboard processing and display the radar, countermeasure receivers for the electronic (warfare) support measures (ESM) and acoustic sonobuoy signals which were received by the helicopter. The data link also transmits magnetic anomaly detection (MAD) marks to the ship. Through the command channel of the data link, the ship may control the airborne radar, countermeasures receiver, selection of sonobuoys, and fly-to-point directions for helicopter flight. The Air Tactical Control Officer (ATACO) aboard the parent ship directs the aircraft's tactics, utilizing both helicopter-transmitted data and ship-derived data. Should the data link be unavailable for use because of failure, emission control (EMCON)

or line-of-sight propagation effects, the helicopter is equipped to perform its primary missions independently of the ship. However, the helicopter does not have as extensive sensor processing capabilities as does the ship.

The LAMPS system has two primary missions: anti-submarine warfare (ASW) and anti-surface ship targeting defense. The LAMPS concept includes the secondary missions of medical evacuation, vertical replenishment, radio relaying and gunfire spotting. The secondary missions were not exercised in this test and evaluation program and consequently HFE evaluations were conducted solely for performance assessment of the primary missions.

#### ASW

In the ASW mission, the LAMPS helicopter serves as an extension of the shipboard surveillance and attack systems, thus permitting greater speed of closing on the submarine, and permitting sonobuoy and weapon deployment without the increased hazards to the ship of enemy attack which would accompany closer approach by the ship to the submarine. Until the time that active sonar is used, the submarine may not be forewarned that localization of his position is imminent. In the typical ASW mission, the helicopter would be maintained in a state of readiness on the deck. Once a detection is made by the ship or some other fleet element, the helicopter is launched and vectored to the expected position of the target where localization and target classification are performed. If the contact is lost, the helicopter will attempt to redetect. When the target is localized, the ship's commanding officer will decide whether or not to attack the contact.

#### ASST

As in ASW, the ship is faced with the prospect of relatively close-in attacks while itself being relatively restricted in its capability to maneuver clear of the threat or to combat the threat with its own defensive armament. The role of the LAMPS helicopter is to provide sufficient early warning of attack to enable the parent ship to initiate appropriate evasive or retaliatory measures. In ASST operations, the altitude of the helicopter and its standoff capability permits obtaining this early warning to the ship. The helicopter's radar and electronic support measures set are the prime ASST sensors for accomplishing this primary mission.

#### Crew Functions

In the short-range and extended mission versions of the LAMPS the shipboard crew is composed of the Air Tactical Control Officer (ATACO), the Acoustical Sensor Operator (ASO), the Remote Radar Operator (REMRO), and the Electronic Support Measures Operator (ESMO). It is expected that the specific task assignments for these shipboard operators used in this test program will change in future operational LAMPS system design due to the likelihood of LAMPS tasks being combined with similar functions for other non-LAMPS shipboard equipments.

On the premise that performance of the LAMPS primary missions could be accomplished effectively, the short-range version of the LAMPS utilized a two-man aircrew [Pilot and Air Tactical Officer (ATO)] while the extended mission LAMPS version had the following three-man aircrew: Pilot, Air Tactical Officer (ATO), and Sensor Operator (SO). The task assignments for the LAMPS aircrew are expected to apply closely to the crew tasks for the future LAMPS operational system.

Detailed summaries of the air and shipboard crew task assignments are contained in References 1 and 2.

#### Program Rationale

The total program of engineering and functional testing to validate the LAMPS system consisted of three broad phases: 1) testing in the laboratory environment, 2) local flights at the Naval Air Development Center, and 3) extended over-water tests on a calibrated range followed by open-sea tests. Due to program scheduling and funding limitations, adequate HFE testing was not included in the laboratory and local flight tests. As a result, HFE problems/issues that may have been identified during these initial tests had to be considered in the at-sea test phase.

The major purpose of the HFE participation in the at-sea tests was to determine HFE adequacy in terms of impacts on overall systems performance (i.e., hardware, software, and human operators) with such questions as: Are the airborne and shipboard operators able to adequately perform these jobs? Do the controls and displays allow effective accomplishment of the required operator interfaces? Are there identifiable mission segments which consistently require excessive operator interactions? etc.

Ideally, this man-system performance assessment should be obtained from direct HFE investigative involvement in the flight tests with data derived from objective measurement of appropriate human and systems functions. Such tests would require precise measurement of operator actions in their multi-varied procedural forms, and accurate identification of inputs of the various initiating operational sources which would dictate the required operator response in prescribed time frames. In such tests dedicated HFE flights for the various types of missions would have to be conducted to allow close control and measurement of the specific tactical situations and the resultant operator actions. In this way operators could be tasked to execute a predetermined sequence of actions within the established time frame imposed by the tactical situation to provide explicit informa-

tion on operator capability to effectively accomplish the required tasks.

An analysis of the LAMPS system design, the variability of the predicted tactical situations, and the limited LAMPS program scheduling/funding revealed that operator performance could not be evaluated with strictly objective measures and that primary reliance would have to be placed on subjective measures. The LAMPS system requirements do not specify target or maximum allowable time for the accomplishment of specific operator actions. Due to complex, interacting and relatively unpredictable display and control initiating variables from airborne, shipboard, and target sources predetermined sets of operator tasks could not be established for the various missions. Accordingly, subjective methods consisting of HFE personnel observations, operator questionnaires, and tape recorded operator interviews were employed during these tests.

## TEST PROCEDURES

### Aircrew Composition

The adequacy of the two-man aircrew for the short-range version and the three-man aircrew for the extended mission version of LAMPS was primarily an issue of task loading. In the absence of any formal definition, these crew compositions were to be considered adequate if the operators were consistently able to perform all assigned functions in a correct and timely manner. In the case of the short-range version, this issue was originally raised since it was suspected that certain LAMPS mission phases, particularly ASW localization during restricted operations, could not be conducted in a timely manner by only two airborne operators. For example, during the time an ATO had selected and managed sensors, examined sensor returns, translated sensor data into tactical data, and finally converted to attack data it was possible that a present generation submarine could have escaped. If the aircrew performance impeded mission effectiveness in any way, the aircrew composition would be judged inadequate.

### Short-Range Version Tests

The testing program for this short-range LAMPS version is presented in Figure 1. Detailed information on the specific procedures and questionnaires employed are included in Reference 1.

#### Controlled Range and OPEN-SEA

As may be noted in Figure 1, the aircrew and ship crew were tasked to record their observations whenever events of HFE significance occurred. To facilitate the gathering of this information, the operators were provided brief, generalized, questionnaires at the completion of each flight. In flight, pilots and ATO's recorded their answers to specific questions furnished on knee-pad cards. These knee-pad questions, prepared for ASW, navigation, and Radar/ASMO flights, were brief and related to operation of controls and appearance of displays specific to the mission of that flight. In addition the ATO was tasked to record any HFE related in flight problem occurring on the multi-purpose display (MPD) with a hard-mounted, pre-aimed 35 mm camera. An additional data source consisted of ICS tape recording for each flight.

All of the operators completed detailed questionnaires concerning lighting, control location/actuation, display location/appearance, procedural adequacy, observed operator overloads, etc., after each second, tenth and last day of test operations. The test program questionnaires used during the controlled range phase were reviewed, modified, and expanded for the open-sea tests.

The responses to the questionnaires and the knee-pad cards as well as the information from the MPD photographs and ICS tapes provided the basis for structuring interviews and the debriefing formats.

#### Voice Intelligibility

The purpose of the voice intelligibility tests was to quantitatively assess the performance of the UHF communications set and data link voice channel. The test method selected was a variation of Egan's 1000 phonetically-balanced monosyllabic word test. This test procedure includes a sender whose task is to read the list of monosyllabic words over the communications net, and a listener who records each word as he hears it. The listeners score sheet is then graded against the transmitted list. In order to maintain consistency across all tests the word lists were pre-recorded on cassette tapes. Tape players were provided to airborne and shipboard operators. The details of this test and word lists used are included in Reference 3.

### Extended Mission Version Tests

As may be noted in Figure 2, general and detailed questionnaires were used for both the controlled range and open-sea tests. Detailed information on the specific procedures and questionnaires employed are included in Reference 2.

Short questionnaires were available after each flight for use by the ATO, SO, and ATACO. A longer, more detailed questionnaire was completed by each of the LAMPS operators at the conclusion of the test.

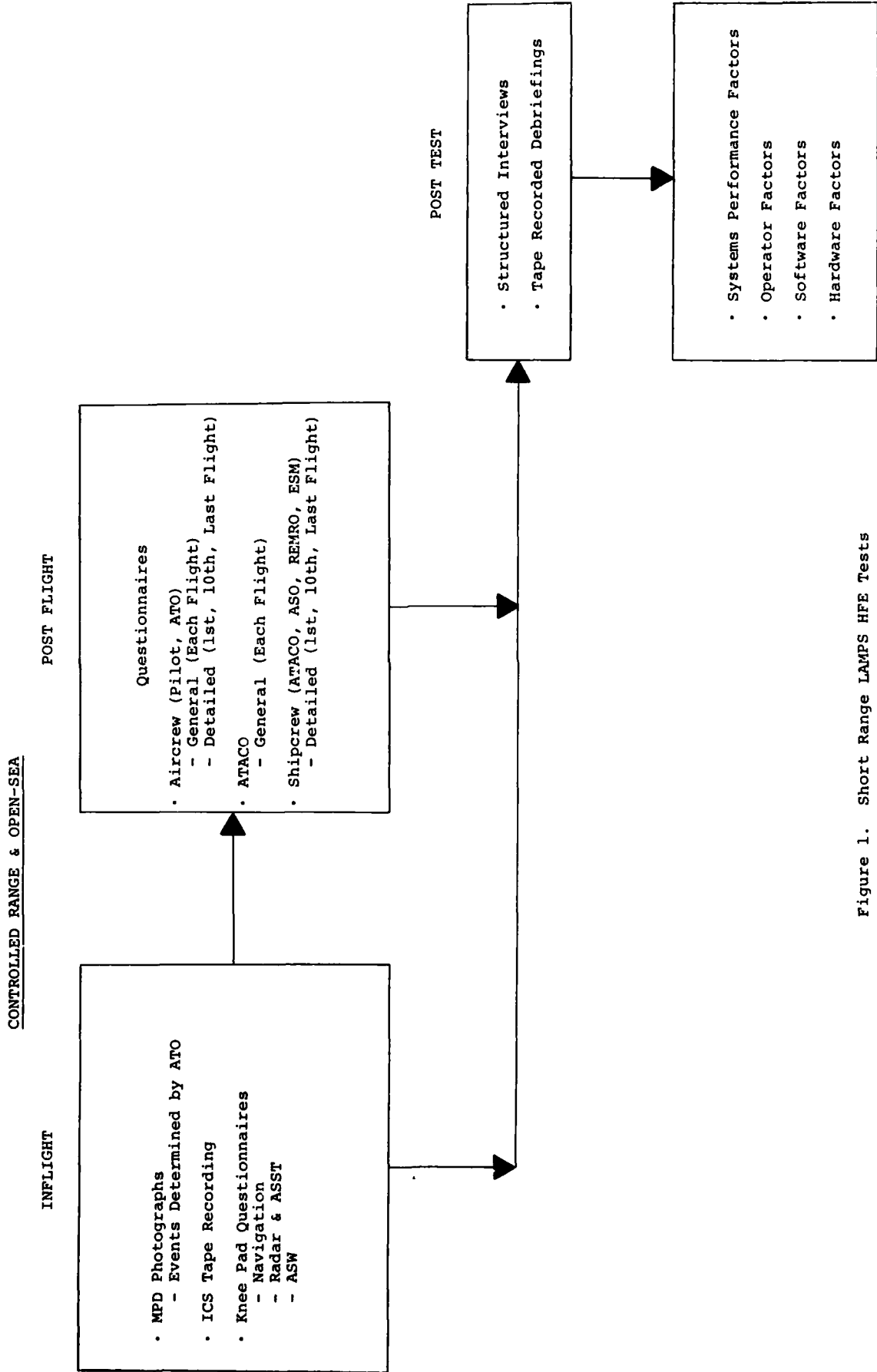
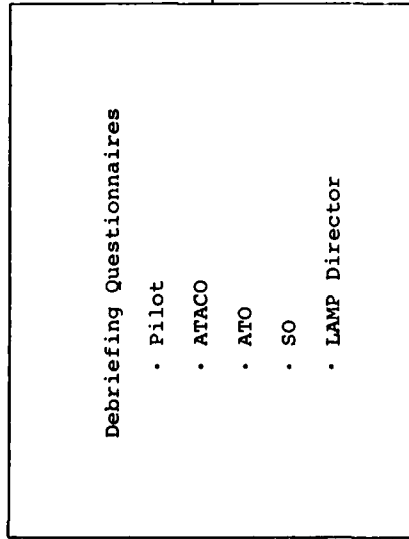

Figure 1. Short Range LAMPS HFE Tests

CONTROLLED RANGE & OPEN-SEA

POST EACH FLIGHT



POST FLIGHT

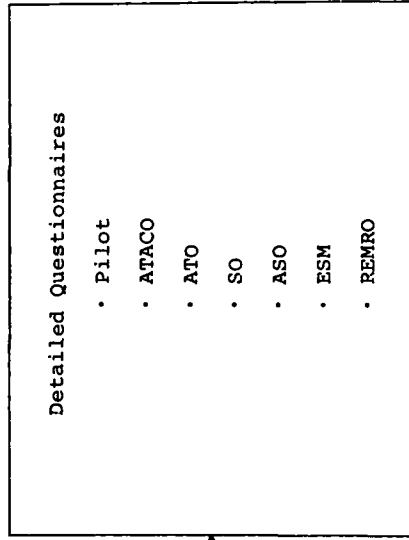

POST TEST

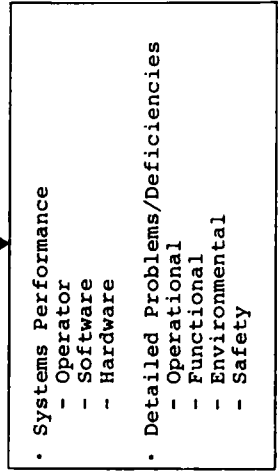
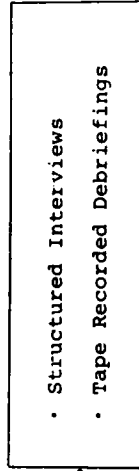

Figure 2. Extended Mission LAMPS HFE Tests

The questionnaire responses were employed to structure the operator interviews and debriefings.

## RESULTS

### Short Range Version Test

The human factors engineering data collected during these tests strongly suggests that a two-man aircrew can adequately execute both LAMPS primary missions. All pilots, ATOs and ATACOs, were confident that the aircrew would not be overloaded utilizing a full-up system. No instances were observed or reported where the inability of a pilot or ATO to perform assigned functions in any way jeopardized mission success. However, the data is only valid for the environment in which it was collected and may not be applicable to operational LAMPS mission scenarios. For example, the most demanding situation for the aircrew is ASW localization, classification, and attack during restricted operations, i.e. helo control. These tests were by definition normal operations, i.e., operations with the ship in control. Each of the flights were preplanned and directed toward the exercising of specific sub-systems.

Most of the comments concerning task loading and two-man aircrew adequacy were obtained from tape-recorded interviews with pilots, ATOs and ATACOs. All operators emphasized that the pilot was not overloaded. All pilots agreed that they never experienced overload. It is interesting to note that all pilots primarily performed their own assigned tasks, and were reluctant to provide assistance to the ATO during "busy" periods. This may be partially attributed to the fact that at no time did any of the ATOs become so overloaded that pilot intervention was mandatory. Some instances were noted where pilots took over certain communications, usually between the helicopter and calibrated range command and control, when the ATO was very busy. One pilot did perform some keyset functions, but in general, the pilots didn't want to become involved in ATO duties. An opinion, generally shared among the pilots was that there were "... too many hands down there for one keyset" when the pilot attempted to intervene.

The ATOs were also very consistent in their comments. All of their comments can be summarized as: "There are periods of very heavy task loading. These periods are always brief and almost invariably due to equipment malfunctions. Operationally the ATO should not be overloaded with a full-up system." All the ATOs mentioned that the periods during which they felt busiest were those times when equipment was failing or dropping off-line, and they were required to reinitialize the operational program or re-cycle the equipment. It was often during these periods when additional communications to the ship or range control were required to explain or discuss the difficulties. The extra voice communications only added to the ATO's problems. The ATACOs interviewed were also in agreement regarding the adequacy of a two-man aircrew. They believed that two men were sufficient in the aircraft and reported ATO overloads only during periods of equipment malfunction.

Voice intelligibility testing was conducted on a single flight during the controlled range exercises with the ATACO reading the 100 monosyllabic word list to the helicopter. All 100 words were received and 73 percent were recorded correctly by the ATO. Only four of the 27 incorrect responses indicated that the ATO totally misunderstood the word. The subjective responses were definite and unanimous; voice communications were considered to be consistently excellent with the data link voice channel being the preferred mode. Without exception, all operators interviewed reported no deficiencies in the area of voice communications and offered only favorable comments. Operators were especially enthusiastic about the data link voice channel is inherently secure due to data link directionality. Unlike the UHF antennas the data link antenna is directional; aimed at, and continuously corrected to, the ship position. A second feature of the data link voice channel is that it provides an audio indication of overall data link performance: i.e., when voice transmissions begin to fade the command and control and sensor information will probably also be breaking up. This indication may provide the ATO or ATACO time to evaluate the problem and take corrective action. The third advantage attributed to the data link voice channel was that it was considered superior to UHF communication at all ranges, and especially at long ranges. No quantitative evaluations were performed to confirm this finding, but again operators were unanimous in their agreement.

### Extended Mission Tests

In the primary mission of ASST, none of the LAMPS operators was task overloaded. In the ASW mission, the pilot, ESMO, and the REMRO were not overloaded, the ATACO was fully loaded, and the ASO was task overloaded to a degree of jeopardizing mission success. The ASO was appreciably overloaded because of the many actions he had to perform to achieve a desired result. These steps comprised successive button depressions as sequences of cues were displayed on his CRTs. There was simply too much button pushing required to perform often repeated tasks such as creating verniers or selecting sonobuoys for audio monitoring. Many of the recommendations resulting from this study on redesign of the ASO Station are aimed at reducing the number of button pushings. However, there is no assurance that the ASO would not be task overloaded even if all the recommendations were followed. The future LAMPS system is expected to have double the number of sonobuoy receivers, which will certainly increase the ASO workload. The number of tasks which the ASO must perform in the projected redesign should be analyzed very carefully to ensure

that a satisfactory man-machine interface will result.

In all of the tests the pilot was not task overloaded. However the ATO and SO were task overloaded during certain times of the ASW localization phase of operations under helicopter control. The task overload condition of the ATO and SO was judged to be not so serious as to jeopardize the mission. A number of the recommendations resulting from our study have as their objective a streamlining of the ATO and SO operations and decreasing the need for communications between the two of them.

In the ship-helicopter communication system, the data link voice channel was found to be superior to high frequency (HF) radio in clarity and superior to ultra-high frequency (UHF) radio in both clarity and range. However, a serious deficiency was noted due to the lack of provisions for ATACO and ATO use of this channel. Although the narrow beam width of the data link antenna provided some measure of security, it was not up to the desired standards of secure voice. Also, the HF radio was not used much because it was subject to interference and was not a secure system. At extended ranges data link was lost as the helicopter descended for Magnetic Anomaly Detection (MAD) usage.

#### Identified Problems

Even though the major purpose of the HFE test program was directed to aircrew size adequacy and questions of voice intelligibility, the numerous questionnaires which were administered and the extensive debriefs which were conducted identified many HFE problems and deficiencies related to system/subsystem design and operation. The HFE data obtained from these sources allowed total system performance, i.e., hardware, software, and the human operator to be examined. Many specific recommendations involving changes in operator tasks/procedures, crew station geometry/configuration, control and display design/location, interior lighting and crew station habitability, life support and escape design resulted from these tests.

### CONCLUSIONS AND RECOMMENDATIONS

#### HFE Testing

A major conclusion reached as a result of the HFE involvement in this new LAMPS system testing program is that human factors engineering testing should be initiated as early as possible in the overall test program and continued for the program's duration. The importance of undertaking human factors testing in an integration laboratory, or on a system simulator, or even earlier cannot be overemphasized. If a total human factors engineering test program is properly administered, the bulk of HFE testing should be completed prior to arrival at the "operational" test site. Any issue which can be investigated prior to integrated system testing should be. This concept is vital since experience has shown that once operational testing is underway human factors issues receive low priority. As soon as hardware problems, weather problems, or any other unexpected delays occur, human factors testing is pushed lower and lower down the priority list.

Equally important as a strong and early human factors engineering effort is the development of a comprehensive and detailed test plan. This test plan should be more than an unrelated collection of specific test procedures for investigating specific subsystems, displays, and controls. The comprehensive test plan should be generated by working from the general to the specific. First, the very general issues to be examined must be identified. Then, the general areas can be subdivided into more identifiable elements. This sub-division continues until specific test plans and procedures are defined. The human factors engineer must know exactly the purpose of each test, what types and amounts of data are required, and the most appropriate data collection and data analysis techniques. The test plan should be completed prior to any actual testing. Lastly, the test plan must be flexible enough to allow investigation of unanticipated problems in successive test stages.

#### Crew Size

Based on the data collected during the controlled range and open-sea tests, it is concluded that the two man aircrew in the short-range version and the three-man aircrew in the extended mission version of LAMPS can adequately perform the primary missions during normal operations.

In the short-range version tests, there was no evidence to suggest that either the pilot or ATO were overloaded when utilizing a full-up system. There were no instances observed or reported where the inability of the pilot or ATO to perform assigned functions in any way jeopardized mission success.

In the extended mission version tests, the pilot was never task overloaded while the ATO and SO encountered task overloads during ASW localization operational phases which were not considered to jeopardize mission success. Specific recommendations to reduce the ATO and SO tasks and decrease the need for communication between the two of them should considerably reduce these overload conditions.

During the short-range version tests the ATACO was occasionally overloaded at certain times while the REMRO, ESMO, and ASO operators adequately performed their assigned



tasks. The scope of the ATACO's comments, particularly those with regard to task overload and confusion during times of high rates of information transfer indicated a need for a complete system review of the LAMPS shipboard implementation.

#### Communications

In the short-range version tests, it was concluded that the voice intelligibility of the UHF communications set was good and the data link voice channel was excellent. The single reason that voice intelligibility did not receive an overall rating of excellent was the 73 percent UHF intelligibility score recorded during the single inflight voice test conducted. Absolutely no statistical significance can be attributed to this score. Data link voice was the unanimous choice of all operators for voice communications.

In the extended mission version tests, communications between all LAMPS operators had considerable shortcomings as noted previously. Recommendations resulting from these studies have been made to: provide secure HF and secure data link voice; expand the number of operators who can use the data link voice channel; use powered inter communications systems (ICS) on the ship instead of sound-powered; increase audio volume available; and, in the helicopter, eliminate the possibility of transmitting simultaneously on more than one radio.

#### HFE Problems/Deficiencies

During these tests many of the HFE problems related to systems performance were identified as primarily due to system/subsystems design or operational deficiencies. Approximately 200 recommendations for improving man-machine interfaces at all seven of the LAMPS operator stations resulted from this study. The specific recommendation covering operator tasks/procedures, crewstation geometry/configuration, display/control design/arrangement, and life support/escape design are delineated in References 1 and 2.

#### REFERENCES

1. Curran, P.M., Linton, P.M., and Laurent, G.J. "Human Factors Engineering Test and Evaluation of LAMPS MK III H-2/SR" Preliminary Report No. NADC-76032-40, Naval Air Development Center, Warminster, PA, 30 January 1976.
2. Laurent, G.J., and Curran, P.M. "Human Factors Engineering Evaluation of LAMPS MK III H-3/EM At-Sea Test" Preliminary Report No. NADC-77065-40, Naval Air Development Center, Warminster, PA, 15 February 1977.
3. Webster, J.C. "Compendium of Speech Testing Material and Typical Noise Spectra for Use in Evaluation Communications Equipment", Naval Electronic Laboratory Center, San Diego, Calif., September 1972.

\*Opinions or conclusions contained in this paper are those of the author and do not necessarily reflect the views or endorsement of the Navy Department.

**DESCRIPTION DE LA NOUVELLE SELECTION NEUROPSYCHOLOGIQUE  
DES PILOTES DE L'AVIATION LEGERE DE L'ARMEE DE TERRE**

E.J.Caille  
Médecin Chef des Services  
Maître de Recherches du Service de Santé des Armées  
Directeur du CERPA  
83800 Toulon Naval, France

D.Ziane  
Médecin en Chef  
Assistant de Recherches du Service de Santé des Armées  
Commandement de l'Aviation Légère de l'Armée de Terre  
78129 Villacoublay Air, France

Médecin Principal A.Goavec et Lieutenant - Observateur pilote A.Elzear  
Antenne-ALAT  
Fort Neuf de Vincennes  
94300 Vincennes, France

**RESUME**

Une nouvelle batterie expérimentale a été étalonnée entre 1974 et 1977 sur 165 moniteurs et 800 pilotes d'hélicoptère; elle comporte des épreuves psychométriques classiques (Matrix, MMPI, RTS, ANX...), des questionnaires de motivation, une épreuve de pilotage (programmée et dépouillée sur microprocesseur), une polygraphie EEG et ECG analysée suivant les algorithmes AMC de Hjorth.

La validité de ces prédicteurs est démontrée sur 200 pilotes opérationnels. Une analyse factorielle des correspondances permet de réduire cette batterie.

Depuis 1956, le personnel navigant de l'Aviation Légère de l'Armée de Terre française (ALAT) faisait l'objet d'une sélection psychotechnique mise au point par le Centre d'Etudes et de Recherches psychologiques de l'Armée de l'Air (C.E.R.P. Air) à partir d'une batterie US de Flanagan et des travaux de PLACIDI, MALMEJAC et leurs successeurs.

En 1973, par suite de l'évolution de l'ALAT vers l'usage exclusif de l'hélicoptère et la tactique du combat aéromobile, il a paru nécessaire de la doter d'une batterie de sélection des pilotes construite à partir de sa nouvelle physionomie.

Une commande de la Direction des Recherches, Etudes et Techniques de l'Armement (DRET) confia l'élaboration de cette sélection à l'un de nous. L'étude préliminaire s'appuya sur l'examen de 165 moniteurs et 400 élèves-pilotes "ab initio".

Dans le cadre de commandes ultérieures de la DRET, un matériel à base de microprocesseurs a été construit au Centre d'Etudes et de Recherches de Psychologie Appliquée (CERPA) de la Marine à TOULON, d'une part pour l'administration systématique des questionnaires de motivation et de personnalité, d'autre part pour l'analyse automatique des tracés électro-encéphalographiques et électrocardiographiques ainsi que pour l'étude de la perfectibilité psychomotrice sur plateforme Alouette II (tracking et attention diffusée).

Cette batterie élaborée de 1974 à 1976, mise en service le 10 mai 1977, comporte :

- 1.- des tests cognitifs classiques : niveau de culture, facteur G, facteur S.
- 2.- six épreuves psychométriques préparatoires à l'entretien psychologique de dépistage des névrotiques et des caractériels :

a) Questionnaire de motivation (MOT), de 48 items regroupés en cinq clusters : qualité des antécédents, motivation militaire, motivation aéronautique, "leadership", style de vie. Ce questionnaire a été validé sur 160 instructeurs et 165 officiers et sous-officiers en service dans les anciens groupes de l'aviation légère de Corps d'Armée (GALCA) et de division (GALDIV),

b) Questionnaire d'anxiété latente (ANX) de 50 items, inspiré du MAS de TAYLOR,

c) Questionnaire de dépistage des tendances autoagressives (RTS) de 21 items,

d) Questionnaire introversion-extraversion (QI/E) d'EYSENCK, de 50 items,

e) Forme abrégée du MMPI, inspirée de FASCHINGBAUER de 166 items,

f) Questionnaire de dépistage des troubles psycho-somatiques (QC1) de 100 items, inspiré du Cornell-Index.

Prochainement, ces six questionnaires seront émis sur consoles de visualisation individuelles avec réponse sur clavier. Le dépouillement des réponses tiendra compte non seulement du contenu de celles-ci, mais également de la stratégie adoptée par le candidat : temps de latence, corrections. L'entretien psychologique s'appuiera donc, comme auparavant sur les réponses finales fournies par le candidat et il sera en outre éclairé par le comportement de ce dernier devant chaque question.

Il gagnera, de ce fait, en objectivité et en profondeur, comme cela a été vérifié sur d'autres catégories de personnel soumises à des questionnaires analogues administrés par un dispositif automatisé construit au CERPA autour d'un calculateur HEWLETT-PACKARD. Ces personnels étaient des nageurs de combat, des plongeurs démineurs et des infirmiers.

### 3.- Épreuve de pilotage simulé

Le candidat prend place sur une plateforme d'hélicoptère Alouette II dont les commandes (palonniers, cyclique, pas général) agissent sur deux segments de droite visibles sur un écran de télévision et rendant compte des changements d'assiette et des déplacements verticaux de l'hélicoptère. Au cours de l'épreuve, ces segments lumineux reçoivent du microprocesseur des modifications programmées aléatoirement et simulant les changements de position de l'hélicoptère. Le candidat corrige les écarts en agissant sur les commandes de l'appareil.

Simultanément, le candidat-pilote doit comptabiliser un symbole lumineux significatif désigné à l'avance parmi cinq symboles apparaissant dans une succession aléatoire et dans des sites programmés au hasard sur un écran parabolique occupant le champ visuel.

Après une séance de familiarisation de cinq minutes avec l'installation et l'action des commandes (directives verbales diffusées à partir d'un enregistrement sur cassette), le candidat est soumis à deux séquences de pilotage simulé avec comptabilisation de symboles. Les deux séquences, comportant chacune trois essais de cinq minutes, sont séparées par une nuit de repos.

Au cours de chaque essai, les écarts en X (palonniers), en Y et A (cyclique) et en Z (pas général), non corrigés instantanément par le candidat, sont calculés en moyenne et variance. Une courbe de perfectibilité est établie sur l'ensemble des six essais.

Un indice de coordination du tracking sur quatre axes (D) est calculé en temps réel à partir de la somme des carrés des écarts en X, Y, Z et A : il exprime la capacité du candidat à contrôler les quatre paramètres de manière synchrone (perfectibilité moyenne : 25 à 17). Le score de comptabilisation du symbole lumineux est pris en compte séparément.

Pendant l'épreuve, un moniteur observe le comportement du sujet, enclenche les séquences successives et contrôle les données éditées par l'imprimante.

Le coefficient de corrélation multiple actuel de cette épreuve synthétique atteint .66 avec le contrôle en vol des 23 premières heures d'école de pilotage.

### 4.- Etude de la vulnérabilité neuro-physiologique

La principale originalité de la nouvelle sélection, mise au point d'après l'examen de 3000 sujets (pilotes de l'ALAT et également nageurs de combat de la Marine), réside dans l'étude objective de la vulnérabilité manifestée au cours de situations contrôlées (hyperpnée volontaire, stimulation lumineuse intermittente, calcul mental, exercice musculaire) sur des tracés électro-encéphalographiques et électro-cardiographiques.

La mise en évidence d'indices de vulnérabilité à partir de tracés polygraphiques recourt à l'analyse harmonique des signaux (FOURIER, HJORTH) et à leur traitement en temps réel sur micro-processeurs.

- l'électrocardiogramme est analysé en fréquence et en arythmie (FC et Ar)
- l'analyse de l'électroencéphalogramme permet de dégager trois paramètres :

- \* l'activité (A) ou amplitude en microvolts du signal
- \* la mobilité (M) ou fréquence de giration de l'autospectre en hertz
- \* la complexité (C) ou richesse en harmoniques en hertz

L'EEG est enregistré en dérivation rolando-occipitale droite et gauche dans six situations :

- Yeux fermés (YF) au repos allongé : 3 minutes
- En hyperventilation volontaire (HPN) : 3 minutes
- Sous stimulation lumineuse intermittente (SLI), yeux clos : 3 minutes à la fréquence de 6,4 hertz choisie comme la plus discriminante pour dépister la photosensibilité,
- Sous compression oculaire (ROC : réflexe oculo-cardiaque) : 60 secondes
- Au cours d'une épreuve de calcul mental (CM), yeux clos : 2 minutes suivies, pour comparaison, d'une minute de tracé sans calcul mental, yeux ouverts,
- Au cours de la phase de récupération après 40 flexions - extension des genoux et des hanches (accroupi - debout) exécutées en 40 secondes.

Le calcul de la variance des paramètres FC et Ar d'une part, A, M, C droites et gauches d'autre part permet d'établir un indice de vulnérabilité côté de 1 à 5 et un indice d'asymétrie en amplitude et en fréquence entre le cerveau droit et le cerveau gauche côté de 1 à 5 également.

Les relations de phase et la cohérence du spectre croisé (zones homotopes droites et gauches) ne peuvent pas être calculées en temps réel avec notre équipement, mais les rapport d'activité et de complexité D/G sont des prédicteurs valides de réussite de toutes les tâches psychomotrices.

La candidature des individus vulnérables, présentant une majoration des ondes EEG lentes theta (paramètre M abaissé) ou une forte réactivité à l'épreuve du ROC et de la SLI, ainsi que celle des candidats à forte asymétrie est à décourager, compte tenu des difficultés du vol opérationnel (vol tactique, vol de nuit avec ou sans aide à la vision nocturne) dans une machine bruyante et vibrante. Le bon pilote présente une avance du cerveau gauche directeur sur le cerveau droit spécialisé dans la reconnaissance des formes et des alignements.

### 5.- Entretiens et synthèse

Le passage à l'antenne de sélection se termine pour le candidat par un entretien avec le médecin psychologue attaché au Centre (aspect caractériel et neuro-psychologique) et un entretien

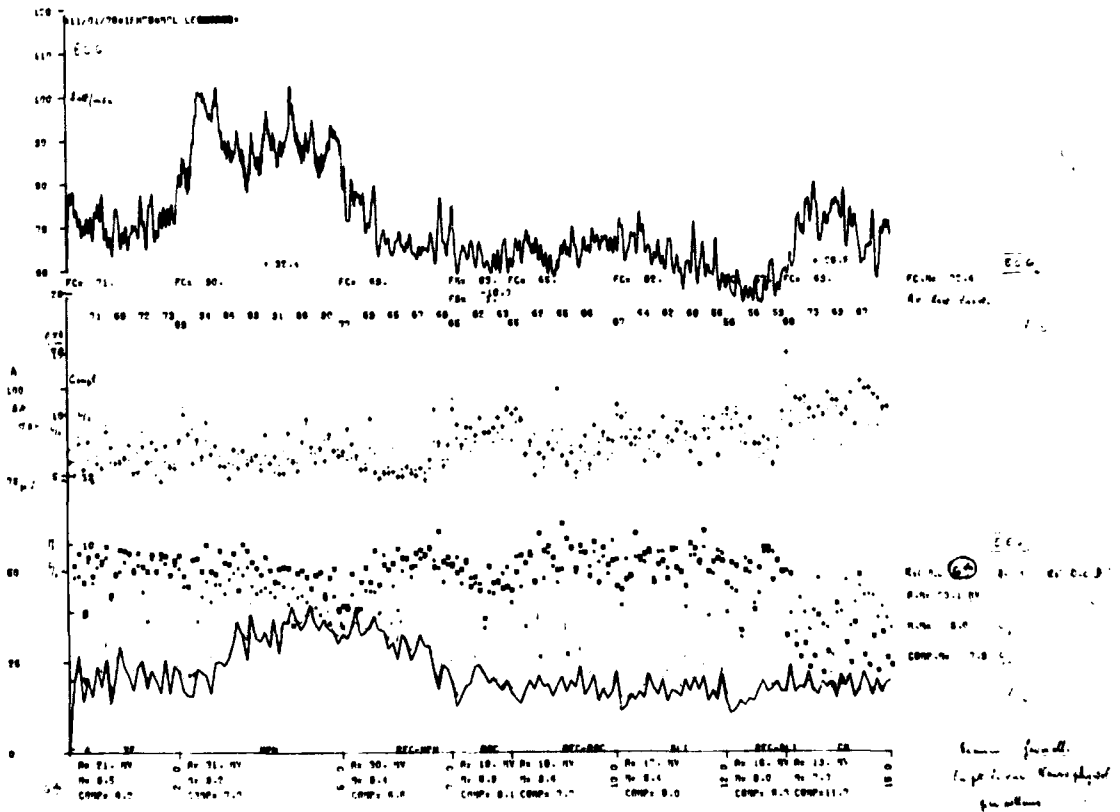
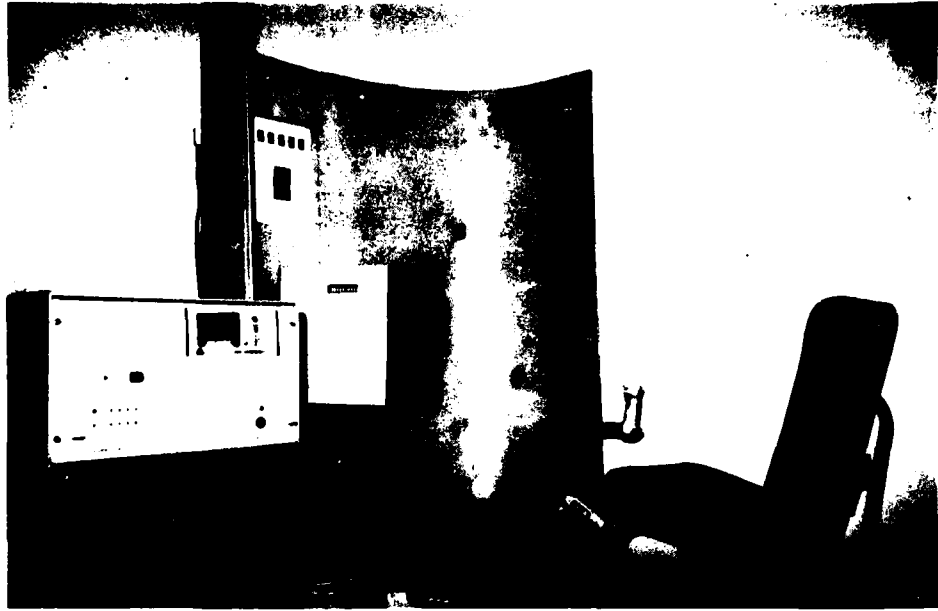

avec l'officier observateur pilote de l'ALAT, chef du Centre (aspect motivationnel et psychomoteur). Ces entretiens s'appuient sur les résultats des épreuves décrites plus haut : niveau culturel, niveau intellectuel, motivation, stabilité caractérielle, vulnérabilité neurophysiologique, perfectibilité à l'épreuve de pilotage simulé.

Il est procédé ensuite à une synthèse de ces résultats à l'occasion d'une réunion du médecin et de l'officier ALAT. Le candidat est alors classé dans l'une des sept fractions de la courbe de GAUSS représentant la population sélectionnée. Ces fractions sont cotées en allant des meilleurs aux plus mauvais résultats au sens du pronostic de réussite :

A = 5 % de la population  
 B = 15%  
 C+ = 20%  
 Co = 20%  
 C- = 20%  
 D = 15%  
 E = 5 %

Ce classement différentiel est la seule donnée communiquée au commandant qui reste maître du niveau exigé à l'admission en fonction de la ressource et des besoins de l'ALAT. Toutefois l'admission des candidats classés D et E ne doit pas être envisagée.

#### VALIDATION

Mise au point de 1974 à 1976, cette nouvelle batterie n'est utilisée comme outil exclusif de sélection des pilotes d'hélicoptère de l'ALAT que depuis mai 1977.

Environ 10 à 15% des candidats sélectionnés seront admis en école de pilotage. Les candidats sélectionnés en mai 1977 doivent au préalable s'engager au titre de l'Ecole Nationale des Sous-officiers d'active de l'Armée de Terre qui leur dispensera une formation militaire de neuf mois commençant au début de l'année 1978. Leur séjour en Ecole de pilotage est prévu de décembre 1978 à juillet 1979. Un lot de 100 candidats issu de la nouvelle sélection sera disponible pour une validation définitive au 2ème semestre 1980.

Cependant, les éléments de la batterie ont subi au cours de la phase expérimentale et continuent à subir une validation partielle a posteriori à l'occasion de leur application aux pilotes admis en école de pilotage depuis 1973 et aux nageurs de combat de la Marine.

En ce qui concerne la validation au sein de l'ALAT, la batterie des tests psychométriques est appliquée chaque année à environ 150 pilotes admis depuis 1973 et actuellement en service dans les unités opérationnelles. Les résultats des tests sont confrontés avec un critère constitué par la notation gaussienne attribuée à l'intéressé en tant qu'homme (H), par son entourage militaire, en tant que militaire (M), par ses chefs, en tant que pilote ( $P_u$ ) par ses moniteurs.

En mars 1978, nous avons procédé au contrôle de l'adaptation en unités opérationnelles de l'ALAT : près de 200 pilotes ont été examinés. Nous en avons extrait les validations suivantes :

- l'indice de coordination du 3ème essai du pilotage simulé est corrélé avec la notation  $P_u$  exprimant la valeur du pilote dans son unité : cette corrélation s'exprime par un coefficient  $r$  de PEARSON = .41, significatif à  $P > .01$ .

- le pourcentage d'accroissement de la fréquence cardiaque (paramètre FC) sous l'action des différents stimuli est également corrélé avec la notation  $P_u$  :  $r = .28$ ,  $P = .05$  pour l'épreuve d'hyperpnée (HPN).

- le pourcentage de diminution de la fréquence cardiaque sous compression oculaire (paramètre ROC) est corrélé avec le critère  $P_u$  à  $r = .37$ ,  $P = .01$ .

A l'occasion de cette même étude, la validité de la pédagogie de base de notre école de DAX (enseignement pratique du pilotage) a pu être démontrée : on note entre l'adaptation du pilote en unité (critère  $P_u$ ) et le test correspondant aux 45 premières heures de pilotage, un coefficient  $r = .27$ , significatif à  $P = .05$ . Le test en école aux 84 premières heures de pilotage est corrélé avec le même critère  $P_u$  ( $r = .28$ ,  $P = .05$ ) et enfin la valeur du pilote est corrélée avec la moyenne de sortie de stage ( $r = .39$ ,  $P > .01$ ). Sans cette étude, le commandement n'aurait pas pu disposer de cette information.

#### CONCLUSION

S'appuyant sur des techniques modernes de recueil et d'analyse automatique, explorant tous les secteurs de la personnalité du futur pilote (motivation, efficacité intellectuelle, perfectibilité psychomotrice, vulnérabilité neurophysiologique, profil psychologique), faisant appel à des situations-tests concrètes, proches de la situation réelle du pilotage, cette nouvelle batterie de sélection fournit à l'officier et au médecin chargé d'établir le bilan du candidat, au cours de l'entretien individuel, des éléments d'appréciation objectifs et différentiels.

Elle se propose d'être un premier pas vers l'adéquation indispensable et qui doit demeurer permanente entre la sélection, la formation militaire et technique et le critère final constitué par la réussite dans la carrière.

NOTE CONCERNANT L'ANALYSE  
DES CORRESPONDANCES DE LA BATTERIE ALAT - CS1

L'analyse factorielle des correspondances (BENZECRI) permet d'obtenir une représentation réduite de la réalité multidimensionnelle : chaque candidat pilote est ici décrit par :

- un paramètre d'âge
- cinq paramètres de motivation (cinq clusters du questionnaire de motivation)
- un paramètre "Préoccupations psychosomatiques" : QC1
- un paramètre intellectuel (3 condensés en 1)
- un paramètre "Anxiété latente" de Taylor
- un paramètre RTS (tendance auto-agressive)
- un paramètre Introversiion/Extraversiion, inspiré d'Eysenck
- 14 paramètres MMPI (4 validité, 9 cliniques, 1 introversiion sociale)
- quatre FC et Ar (16 paramètres condensés en 4)
- trois paramètres EEG : A, M, C (48 paramètres condensés en 3)
- deux paramètres de pilotage (tracking), 6 essais - 66 paramètres condensés en DV4 et mémoire
- une catégorie synthétique de personnalité : VGP

La réduction (calculée sur IBM 360/44) opère la recherche des axes d'inertie du nuage et permet sa représentation en projection (axe ou plan). Le premier axe, explicite 8% de l'inertie totale et peut être interprété comme un axe clinique (caractériel et de normalité psychique).

Le deuxième axe (7% de l'inertie) peut être nommé : axe structurel (tempéramental). Les sujets actuellement retenus à la sélection (catégories psychologiques A, B, C+) et les mieux notés en Ecole (B1, B2, P) et en Unités (Homme, Militaire, Pilote) sont :

- les plus extravertis, mais aussi les plus sérieux (autocontrainte), présentant une bonne capacité mnémonique en attention diffusée, du "leadership" et du point de vue neurophysiologique, un niveau d'activation élevé,
- les moins anxieux, les moins déprimés, ayant moins tendance à se dévaloriser et à se préoccuper de leur santé,
- ils sont généralement plus âgés, présentant des meilleurs antécédents et une prédominance tempéramentale du système sympathique,
- les sujets mal adaptés accusent une forte vulnérabilité cardiaque et électroencéphalographique et un manque certain de capacité de coordination au tracking sur quatre dimensions (DV4 forte).



EXAMEN RADIOLOGIQUE DU RACHIS  
ET APTITUDE A L'EMPLOI DE PILOTE D'HELICOPTERE

Médecin Chef des Services R.P. DELAHAYE (1) (3),  
Médecins en Chef AUFFRET (2) et P.J. METGES (1) (3).

En 1971 (3), nous proposons la définition d'un standard spécifique d'aptitude à l'admission à l'emploi de pilote d'hélicoptère. Nous pensions qu'aux nuisances spécifiques de ce poste de travail devraient correspondre des conditions particulières d'aptitude. Pour diverses raisons, ce projet ne fut pas entièrement retenu.

- 1° Les données actuelles du problème des lombalgies des pilotes d'hélicoptère  
Les années ont passé. De nouveaux modèles d'appareils sont entrés en service. Les lombalgies des pilotes d'hélicoptère existent toujours comme le montrent deux études inspirées par R.P. DELAHAYE et R. AUFFRET (1) (2).  
En 1974, C. COLLEAU (2) rapporte les résultats d'une enquête menée près des pilotes de la Base Aéronavale de LANVEOC-POULMIC. Il met bien en évidence l'importance du type de mission sur la survenue des lombalgies. Il insiste sur la nocivité à ce point de vue, des missions RESCUE P.A. des hélicoptères qui imposent des vols, les vibrations engendrées par l'hélicoptère sont particulièrement importantes.  
En 1977, VICENS (1) rend compte des conclusions tirées de la surveillance clinique et radiologique effectuée sur une courte série de personnel navigant. Il s'agit de celui de la section des voilures tournantes du Centre d'Essais au vol de Brétigny sur Orge. C'est un personnel hautement qualifié, motivé et entraîné.
- 2° Caractère des lombalgies  
Leur origine est due d'une part à la position de pilotage et d'autre part aux vibrations engendrées par l'hélicoptère.  
La clinique montre que ces lombalgies ont une intensité variable allant de la simple gêne à la douleur pénible. Elles évoluent sous forme chronique entrecoupée ou non de poussées aiguës apparaissant pendant ou après le vol. Ces douleurs sont liées au pilotage d'hélicoptère. Aucun pilote n'a connu de tels symptômes en vol sur avion. Ces lombalgies commencent à apparaître après 1000-1500 heures de vol (Colleau, Vicens) délai plus long que celui des statistiques anciennes (SLIODSBERG) (4) 300-500 heures. Ces délais varient en fait selon les individus et diminuent chez les pilotes porteurs d'anomalies rachidiennes pré-existantes (anomalies transitionnelles lombosacrées en particulier).  
Après ces délais d'apparition, les rythmes de vol correspondant à l'apparition, ou à l'entretien des phénomènes douloureux sont en moyenne de 30 à 40 heures par mois, 3 à 4 heures par jour, 1 H 30 en vol continu. Ces seuils s'abaissent pour les missions en vol stationnaire ou à faible vitesse.
- 3° La prophylaxie des lombalgies des pilotes d'hélicoptère  
se situe à plusieurs niveaux :
- lors de la conception de l'hélicoptère, c'est la recherche d'une meilleure filtration des vibrations. Les sièges doivent offrir une position se rapprochant des angles de confort de WISNER-SWEARINGEN. L'utilisation des stabilisateurs automatiques et du pilote automatique améliore les conditions de pilotage.
  - lors de l'emploi des appareils en formation, il est possible d'imaginer un plan de charge en vol des pilotes, inférieur au seuil d'apparition des lombalgies.
  - le médecin du personnel navigant (flight surgeon) joue un rôle important dans la surveillance médicale et l'endoctrinement du personnel navigant. Il intervient comme conseiller du commandement pour les respects des règles d'hygiène, la pratique des sports et l'importance de la charge de vol.
  - l'adoption d'un standard d'aptitude particulier à l'admission du pilote d'hélicoptère permettrait de sélectionner les candidats et d'éliminer ceux qui se révèlent les plus fragiles dans toutes les statistiques.

(1) Service de Radiologie de l'Hopital d'Instruction des Armées BEGIN,  
69 avenue de Paris 94160 Saint Mandé.

(2) Laboratoire de Médecine Aérospatiale du Centre d'Essais en vol de Brétigny  
sur Orge 91220

(3) Chaire d'Electro-Radiologie et de Biophysique Aérospatiales de l'Ecole d'Application du Service de Santé pour l'Armée de l'Air.  
26 Boulevard Victor 75996 PARIS ARMEES



#### 4° Le standard d'admission des pilotes d'hélicoptère

La mise au point de ce standard nécessite la définition du segment rachidien critique.

Le segment rachidien critique. Les arguments cliniques et physiopathologiques sont significatifs. Le rachis lombaire et la charnière lombosacrée constituent principalement le segment critique spécifique lors du pilotage des hélicoptères. Par contre, pour les pilotes d'avions de combat, le segment rachidien critique est différent : c'est le rachis dorsal et la charnière dorsolombaire qui constituent pour l'essentiel les segments les plus sensibles lors de l'éjection. En effet, c'est là essentiellement que sont observées les lésions vertébrales (fractures surtout) après éjection.

Puisque les segments critiques sont différents, on ne peut donc pas concevoir un standard d'aptitude commun à ces 2 postes de travail (pilote d'avions de combat, pilote d'hélicoptère).

#### 5° Le standard d'aptitude des pilotes d'hélicoptères

Sont aptes : les candidats chez qui les examens cliniques et radiologiques ne révèlent pas d'anomalies statique, morphologique, susceptibles de fragiliser son segment critique : la charnière lombosacrée et le rachis lombaire. Ainsi, il existe des causes communes d'inaptitude au pilotage d'avions de combat et des hélicoptères et des causes d'inaptitudes spécifiques à chacun de ces postes de travail.

#### 6° Causes d'inaptitudes communes

Ce sont : les affections évolutives (Mal de Pott, mélitococcie, spondylo-arthrite ankylosante).

Les séquelles de fractures autres que les fractures-tassements cunéiformes antérieures sans lésions discales adjacentes.

Les troubles de la statique vertébrale dans le plan frontal quand la scoliose a un angle supérieur à 15°.

Les anomalies congénitales complexes (agénésie pédiculaire, articulaire, hypogénésie du corps vertébral, etc ...).

#### 7° Causes d'inaptitudes spécifiques au pilotage d'hélicoptère

C'est essentiellement l'existence d'une anomalie transitionnelle lombosacrée telle qu'elle s'accompagne d'un désencastré de la nouvelle vertèbre-pivot ou charnière.

Si cette vertèbre se projette au dessus de la ligne horizontale unissant les bords supérieurs des 2 crêtes iliaques, elle est désencastrée. Dans ces conditions cette vertèbre-pivot, mobile, mal arrimée au bassin, va favoriser le surmenage du nouveau disque charnière.

Il y a là une prédisposition de ce disque à toutes les lésions dégénératives traumatiques ou microtraumatiques.

L'existence de néo-articulations transverso-sacrées fréquemment le siège de lésions dégénératives (Schmorl et Junghans) est une cause d'inaptitude.

C'est également le cas des malformations asymétriques de la charnière lombosacrée qui ont d'ailleurs souvent un retentissement sus-jacent.

La lyse isthmique bilatérale d'une vertèbre lombaire généralement L5 ou L4 avec spondylolisthésis qui est une cause de fragilisation du disque adjacent, devrait également justifier l'inaptitude.

Les séquelles d'épiphysose de croissance (Maladie de Scheuermann) n'entraînent l'inaptitude que si elles intéressent le segment lombaire avec des modifications morphologiques cunéiformes et des irrégularités des plateaux vertébraux marquées, atteignant plusieurs vertèbres. Ces aspects sont très rarement réalisés au niveau du rachis lombaire.

Il faut insister sur la nécessité d'une bonne musculature rachidienne.

#### 8° Causes d'inaptitudes spécifiques au pilotage d'avions de combat

Les anomalies transitionnelles lombosacrées, les lyses isthmiques sans spondylolisthésis sont compatibles avec ce poste de travail. Les séquelles d'épiphysose de croissance responsables d'une accentuation de la cyphose dorsale physiologique, de déformation en coin antérieur des corps vertébraux et d'irrégularités marquées des plateaux atteignant plusieurs vertèbres, entraînent l'inaptitude.

En somme, à segment rachidien critique différent pour les pilotes d'hélicoptère (lombosacrée) et pour les pilotes d'avions de combat (dorsolombaire et dorsal), il est logique d'envisager l'utilisation de standards d'aptitude différents à ces 2 postes.

Nous ne traitons pas du problème des pilotes d'avions de transport pour lesquels la tolérance en matière d'aptitude rachidienne nous paraît devoir être très large.

#### 9° Conclusion

Nous proposons, en ce qui concerne l'aptitude rachidienne au pilotage des standards adaptés aux segments rachidiens critiques propres aux différents postes de travail. Il s'agit surtout des pilotes d'avions de combat et des pilotes d'hélicoptères. L'aptitude à l'un de ces 2 emplois ne signifie pas forcément l'aptitude à l'autre.

BIBLIOGRAPHIE SIMPLIFIEE

- 1 : AUFFRET R. ; DELAHAYE R.P. ; METGES P.J. ; VICENS J.L.  
Les algies vertébrales des pilotes d'hélicoptère.  
Operational Helicopter Aviation Medicine.  
Fort Rucker 1 - 5 May 1978 -6 - 8 - 1 et suivantes.
- 2 : COLLEAU C. (1974)  
Colonne vertébrale et pilotage des hélicoptères. Travail du Service de  
Radiologie de l'Hopital BEGIN à St Mandé et du Laboratoire de Médecine  
Aérospatiale du Centre d'Essais en Vol de Brétigny sur Orge.  
Thèse Médecine LYON  
1974, 1 vol in 4°, 102 pages.
- 3 : DELAHAYE R.P. ; SERIS H. ; AUFFRET R. ; GUEFFIER G. ; METGES P.J. (1971)  
L'examen radiologique du rachis et l'aptitude à l'emploi du pilote  
d'hélicoptère.  
Revue Médecine Aéronautique et Spatiale 1971  
10 (38) p 99 - 1102
- 4 : DELAHAYE R.P. ; PANNIER R. ; SERIS H. ; AUFFRET R. ; MANGIN H.  
CARRE R. ; TEYSSANDIER M/J. (1970)  
Physiopathology and Pathology of affection of the Spine  
in Aerospace Medicine.  
AGARDOGRAPHE 1970 80 pages

A SYSTEM OF TRAINING IN AVIATION PHYSIOLOGY AND HUMAN  
FACTORS FOR ARMY AND NAVY HELICOPTER AIRCREW

P S ORMEROD  
RN Air Medical School  
Seafield Park  
Hillhead  
Fareham  
Hampshire UK.

SUMMARY

Helicopter aircrew are employed in widely varying roles and situations, facing entirely different sets of aeromedical problems. There are fundamental differences in their aeromedical training requirements, especially from those of fixed-wing aviators. A method of designing courses of training is described.

NOTE

The views expressed in this paper are those of the author and although examples have been based on the teaching given at the RN Air Medical School, literal extracts of RN methods have not been used. The paper should not be regarded as a description or commentary on the training methods used in the Royal Navy.

INTRODUCTION

Aeromedical training designed specifically for helicopter aircrew is a relatively recent development. Helicopter pilots were, and frequently still are, given either physiology training intended to fulfil the needs of a fixed-wing situation or worse still, given no training at all.

The early helicopters were relatively simple in construction and equipment, having a very limited payload, endurance and flight envelope. Despite their spectacular VTOL and hovering capabilities, their fixed-wing contemporaries, the second generation, transonic jets, held much more interest for the aviators of the day and for their medical advisors. Helicopters were without oxygen equipment or ejection seats, flew at modest speeds and stayed low.

The prevailing attitude was that helicopters present to their pilots few of the traditional physiological burdens of flight and the need for aeromedical training was therefore left undiscovered or ignored. More than thirty years after the arrival on the military scene of the first helicopters, this attitude can still be found although the changes in the helicopters, their equipment and the roles in which they are operated could not be more dramatic. Even the light helicopters of today, in the role of battlefield reconnaissance in which the early machines were used, would hardly be recognised by those who flew thirty years ago. The low-light vision systems which permit such delicate and difficult flying as that involved in darkened approaches to unprepared and unfamiliar sites and the anti-tank missiles which can be deployed, would be as surprising to the veteran aviator as the spectacular improvements which have come about in the available engine power and the flight envelope. Larger helicopters are used to carry a remarkable range of sensors, on-board processing equipment and weapons in a variety of military settings. These developments have led to recognition, at last, of the considerable range of human factors problems in helicopter flying, the severity and significance of which are evidenced by the close attention being given to them in recent years by the research laboratories.

Flight in the hovering and VTOL modes is a source of so different a set of spatial orientation problems that special training is immediately justified. An even more pressing indication for purpose-designed, effective aeromedical and human factors training for helicopter aircrew is however the high proportion of helicopter accidents attributed to aircrew error and the implications which the helicopter environment can be shown to have for the overall effectiveness of the weapon and sensor systems which they carry.

There is no indication however, for aeromedical 'education' of aircrew, indeed with the increasing complexity, and hence practice-dependence, of the skills they are expected to maintain, the time taken up on gaining knowledge which is genuinely 'background' in character must be minimised. The requirement is for purposeful, economic aeromedical 'training'. It should provide the aircrew with the knowledge necessary to anticipate and avoid difficulties and it should contain the clearest possible advice on how to deal with problem situations. It is not enough to teach the scientific principles which are the keys to solving the problems, the aircrew are busy enough at their jobs to be in need of pre-digested and dogmatic advice on aeromedical matters. They are not fools but neither are they so super-intelligent and quick-thinking that they can apply complex physiological principles - such as the interaction of the visual, vestibular, kinaesthetic and proprioceptive senses in the overall perception of balance in a hovering helicopter - in the short time available to them to solve the problems of controlling the machine in an emergency situation. Much better to circumvent the clever physiology so beloved by the teacher, tempting though it is to regard it as a preliminary step. At the end of the day the student needs only the ability to apply, reliably, the practical implications of the medical problems.

A TRAINING SYSTEM

It is this direct relationship between the specific requirements of the student and the content of the training given which constitutes a training system. If the training is to be effective, it must be designed so as to be easily and reliably absorbed by the students. The bare facts must therefore be sufficiently embellished with explanation and presented in such a way as to appear convincing and relevant. Hopefully it can also be made interesting and enjoyable.

A successful system will have the following characteristics:

1. A clear training objective - a statement of the nature and standard of the ability of the student is to be given at completion of training.
2. A basis of thorough examination of the students working situation to reveal the problems he faces and hence his training needs.
3. A training content which reflects the range and relative seriousness of the aeromedical problems in the particular flying task and the best available advice on how to deal with them.
4. A standard of instructional method and control which ensures that the training content is purposefully and economically presented.
5. A provision for review and correction or improvement of the training system. This will include monitoring the standard of knowledge in the population of aviators throughout the time scale in which the training is required to be effective - which is normally throughout employment on flying duties.

Aeromedical training courses for helicopter aircrew have been held at the Royal Navy Air Medical School since 1970. All RN helicopter aircrew and British Army pilots attend for initial and refresher training. This paper is not a description of a particular syllabus of training however but a commentary on the methods used to devise the present courses and the factors considered to be important in determining the usefulness to aircrew of aeromedical training.

#### COURSE DESIGN

This is achieved in five stages:

1. Job analysis.
2. Production of an Instructional Specification.
3. Definition of training content.
4. Production of Instructional material.
5. Provision for feedback and System Control.

#### Job Analysis

Whilst some of the medical problems to be included in the training are common to all helicopters, and some are common to all flying machines, it is as shallow and inaccurate to refer to helicopter problems in general as it is to couple fighter aircraft with transports. Given the objective, to optimise 'personal' performance, it is the 'personal' problem which must be defined. The Army pilot of the battlefield utility has a very different set of problems from those of the pilot of a large helicopter such as the Super-Frelon in the anti-submarine search and attack role, operating his dipping sonar from the deck of a carrier. The Army pilot spends much of his time flying visually and his skills are tested by the need for tactical 'hedge-hopping' flying and difficult landings at unfamiliar sites. The ASW pilot spends a lot of time instrument flying and doing procedural manoeuvres such as the approach to his ship's deck or into the hover over the sea. His skills are tested by the need to monitor the complex systems of his aircraft and the capability which he must maintain for prompt action in difficult emergency situations.

Even when the airframe and role in which aircrew do their flying are apparently similar, the range and relative importance of problems will not necessarily be the same. The American SH3 series are superficially the same as the British Sea King and the Canadian CH34. They all hover over the water with a dipping sonar at night but the flying techniques used to do this, especially the emergency techniques, create situations offering opportunities for spatial disorientation which reflect quite different priorities. They have a similar flight envelope but spend quite different proportions of their time in different parts of it. The SH3 is operated exclusively from big through-deck ships, the Sea King also embarks in cruisers and fleet support ships, the CH34 with its bear-trap landing system is operated from destroyers.

Within the same air force, a particular helicopter may be operated entirely differently by separate units. They may be due to geographical or climatic variation or simply a change in demand for one or other of the tasks which constitute the role. One squadron may spend most of its time doing anti-submarine operations, another with the same aircraft does mostly coastal shipping searches or long-range Search and Rescue.

Surveys of the incidence of particular aeromedical problems, such as those of Felix et al (1) and Evans (2), can be extremely useful but because of the variations described above there is no substitute for a direct approach to the aviators doing the job concerned. It may be possible to make use of questionnaires, it may be necessary if the training system is on a large scale but it will often be sufficient to interview a small sample of the aircrew concerned in the manner of taking a clinical history. As the aviator describes the practical flying situations he finds himself in, including the emergencies which arise and how they are dealt with, the doctor questions him in more detail to explore possible opportunities for visual illusion, vestibular misrepresentation of true orientation, environmental variables such as atmospheric pressure, temperature, unusual vibration and so on. Needless to say this process of communication is made easier if the doctor has some personal experience of flying to ease his understanding of the aviator's jargon and to identify more easily with the situation described, but this brings with it the danger that the job analysis will be coloured too much by the doctor's personal flying experience, which is generally limited and narrow.

Enquiries should cover the following sources of job variations; the list is far from exhaustive and it will be apparent that considerable initiative is necessary to collect a realistic picture.

**Flight Profile** - What type of flying occupies most of the aviators time? What sort of altitude and speed ranges, what special manoeuvres, mostly day or night? What sort of landing sites, types of flight deck? How does he judge his range and height whilst approaching a landing or hover in these situations? What are the emergencies which can arise and how does he cope with them? Are there any situations which are particularly difficult to deal with in his type of helicopter? Has he or anyone he knows ever experienced difficulties or unusual sensations during any phase of flight? Does it make a lot of difference if the aircraft is in a particular configuration of payload or wind conditions, does this type of aircraft or that role have a reputation for being difficult or marginal in any special situation? Does the way in which it is operated present any difficulties for the crewman or navigator? Do they have to conduct winching operations in any special way? Does the crewman show difficulty or inaccuracy in judging range and relative movement in any particular situation where his assistance is important?

**Displays and Instruments** - What range of avionics is carried and how are they used? What proportion of flying is instrument-based and how are instrument failures dealt with in critical flight situations? What sort of displays are used for other information, where in the cockpit is it located, does anything he might use in a turn demand head movement to be seen? How are the radar and sonar monitored? Are there any situations in which he expects to have poor results or difficulties and why?

**Physical Environment** - Is the aircraft pleasant or unpleasant to operate and which situations are subjectively worse than others? Does any phase of flight, climatic variation or geographical location produce particular difficulty or distress? Does any particular situation produce exceptional levels of noise, vibration or thermal stress? Do the seats and personal equipment present any disadvantages? What is the procedure for strapping in and does this present difficulties doing the job, is there any conflict between staying well strapped in and achieving the mission?

**Operational Environment** - Does it make a difference to the difficulty of the job or any of the factors mentioned so far if he is in a busy air traffic or tactical situation? How does this affect his workload, how does he achieve a visual lookout and fulfil his duties in the cockpit? Does his pattern of employment give him plenty of practice in this sort of setting or is it unusual to meet anything on this scale?

**Psychological Factors** - What motivates him toward (and away from) this type of flying? Are any aspects of it elating or frightening? What sort of pressures are applied through crew relationships, the social and command structure of the squadron, competition for promotion, demands from above, ambiguity or conflict in regulations and so on?

It will be apparent that this enquiry, if it is thorough, approximates to a full ergonomic survey of the job and indeed if such a survey has been done the results should certainly be consulted. But the purpose here is different. If significant design shortcomings are revealed they should obviously be acted upon but for training application what is needed is a realistic appraisal of the practical difficulties of doing the job with the present equipment and in the present physical and psychological climate. There are many disincentives in military aviation to the frank reporting of difficulties experienced and failures achieved. The pragmatic aviator is well aware that considerations of blame and retribution feature prominently in the minds of formal boards of inquiry and that even a casual admission to his contemporaries as well as his superiors can have profound effect on his personal future. The doctor has the enormous advantage of the umbrella of medical confidence under which information can be solicited although it must be realised that the medical profession generally is regarded with as much suspicion by military aviators as by civil licence-holders and this barrier can be broken down only by a special effort to do so. Questionnaires will achieve results only if there is provision for genuine anonymity of reply. The most useful stories of aeromedical near-disaster may only be revealed by personal interview however since the underlying aeromedical significance of an incident will frequently be inapparent to the aviator. His view of the event and especially his rationalisation afterwards is likely to be in terms of a straightforward misfortune, adverse circumstances or mistake and he will therefore ignore or discount as irrelevant when completing a questionnaire, an item in which the history-taker will be able to detect underlying aeromedical causes.

The training course itself may be the most fruitful source of the anecdotal problem situations which are so rich in instructional value. Aviators will talk amongst themselves about common problems given the right surroundings and there is considerable merit in a teaching system which encourages dialogue, such as in tutorials, as well as using formal lectures and demonstrations.

#### Production of an Instructional Specification

The course designer is likely to emerge from the job analysis phase with the beginnings of a range of topics which portends a training marathon if high standards of awareness and ability are to be achieved in the aircrew population. It will be necessary however to contain evangelical zeal and to devise a practical compromise between the ideal and that which can be achieved in the context of the time and resources available. Aeromedical training must take its place in the queue of many other worthy demands on aircrew time for ground training and to attempt to represent any other cause to the military commanders is likely to be counter-productive. These gentlemen are likely to have developed themselves as aviators at a time when aeromedical training, especially for helicopters, was primitive or non-existent and the very fact of their survival tends to diminish in their eyes the need for such 'education'. It is part of the medical course designer's task to present them with an accurate perspective of the value of aeromedical training for aircrew.

Nevertheless it is useful at this stage to keep to the straight and narrow of an idealised solution because it is the only sure way of avoiding the neglect of important topics. The technique used is the writing of the Scalar, a logical statement in diagrammatic form of what is expected of the aviator in achieving his flying task. If the overall requirement is for him to be able to peak his personal performance in the face of the physiological and psychological obstacles which his helicopter world presents, then the first line of the Scalar states this: 'Optimises personal performance'.

In order to do this he will have to be able to identify certain situations in which problems exist or threaten and react appropriately. These constitute subordinate 'abilities' which he must have if he is to succeed in the overall objective. The wiring diagram of the Scalar is then developed into more and more branches of these subordinate abilities until each branch end is a unit which depends on knowledge of a few facts or a particular technique rather than calling for further subdivision. The distinction is not crucial since the function of the Scalar is purely to explore the logical consequences of the top line so that nothing is missed. All the terminal 'abilities' and their key points will eventually be included in the instructional specification.

The example given in Figure 1, at first sight perhaps forbidding, demonstrates the value of this exhaustive approach by presenting on the right hand side a list of abilities (with implications for topics to be covered in training) which, assembled any other way, would be liable to omissions. It matters little what the shape of the wiring diagram becomes or the terminology of the intermediate 'abilities'; the end product is the range of 'abilities' which if he does not already possess, the aviator must be trained in if he is to be properly equipped to do his job.

This list of desirable abilities can then be used to write an instructional specification of items which must be included in the course. For each topic a list of 'key points', the facts or techniques which must be taught if the ability is to be conveyed, is assembled. The order in which these key points are taught is determined later, according to instructional convenience; at this stage the concern is to ensure that everything which needs to be taught, and the standard of knowledge which the student must achieve, is contained in the specification. A sample page of such a list is given in Figure 2.

In practice the contents of this specification will often be unattainable and it will be necessary, as implied earlier, to aim for a less ambitious training objective because of the constraints of time and resources. Nevertheless any shortfall from the training requirement defined by the methods described above carries with it the irrefutable implication that the aviators at large will be deficient to that extent in the skills deemed necessary to perform their task. This may or may not show measurable consequence, for example as a higher incidence of accidents or of operational failure, but logically it must have some effect, measurable or otherwise. The instructional specification is a useful starting point for the inevitable process of compromise however and a valuable document on which to base argument for allocation of sufficient training time, equipment, and facilities. Military Commanders (or Company Managers) are more likely to respond sympathetically to proposals based on logical argument and threats of specific consequences if training is denied than to emotive claims for aeromedical teaching based on unspecified flight safety requirements.

#### Definition of Training Content

The bare list of facts and techniques to be taught must now be turned into a workable plan of lessons in the context of the constraints of time and resources available to teach them. Among the more important points to be decided early on during this phase of planning is the timing of the lessons in the overall sequence of flying training and employment of the aircrew population. The aim is to attain and maintain a certain standard of ability throughout employment on flying duties. It is likely that a system which includes elements of formal initial training and follow-up instruction, formal or otherwise, will be necessary in order to achieve this.

Ab Initio Training - Aviation medicine is a difficult subject to assimilate, especially to the standards aspired to in this system, without personal flying experience to relate problems toward. On the other hand there is a distinct risk in allowing a student to proceed to a stage of flying training when he will fly solo without warning him at least of the more spectacular physiological problems which may be encountered.

A case in point involved a student pilot who was sent off solo to practice steep turns during the light fixed-wing training which precedes basic helicopter training. He had an hour for this sortie which took him some distance from the airfield in clear sunny skies. After a while he got bored with steep turns at the briefed altitude and began to explore the flight envelope further. He enjoyed himself enormously with this new found freedom and it was sometime later when, finding himself at 16,000 feet and about to become overdue to return, he was faced with the problem of a rapid descent and transit back to the field. He decided that spinning down to 2,000 feet would solve the problem and promptly did so. This story would not have emerged if he had not been so incredibly lucky as to survive this descent, despite an aircraft which was notoriously unreliable in protracted spins. The student, whilst not reporting the incident formally for obvious reasons, was perceptive enough to realize afterwards that something unusual must have happened to lead him to choose such a dangerous manoeuvre. He knew himself to be a cautious fellow and would not have dreamt of spinning from 6,000 feet, let alone 16,000 feet. It was some time later that he learned that hypoxia affects confidence and judgement at much lower altitudes than those which produce tangible symptoms such as light-headedness. This student had in fact attended a course of training in aviation medicine at the very beginning of flying training in which he did well enough. On completion of this initial course however, this student at once began the exciting, consuming business of his first ground training on aircraft systems and navigation, his first real flying lessons - even if the ideal training had been given, if it was remembered at all, it would have been at the back of his mind on such an occasion as this.

An attempt to teach aeromedical 'abilities' to the full standard and to expect retention of knowledge into and beyond the later stages of flying training is therefore unlikely to be successful. The first experience of aviation medicine training can be wasted unless it is consolidated as flying training proceeds. An attractive alternative is to divide the ab initio training into two stages: a simple but convincing acquaintance with the more obvious and dangerous problems at the very beginning of training and a more thorough training to meet the objective proper at a later stage.

If this method is adopted, it is particularly important to ensure that what is taught in the first brief visit to the aeromedical classroom is confirmed rather than confused by what is taught in the air in basic flying training. The medical course designer must satisfy himself that this is so by taking an interest in the flying school's training methods. This will probably result in the discovery that even if the formal syllabus has no medical ingredient, the flying instructors will have their own ideas about important aeromedical points to demonstrate to their students. Tactful negotiation may be necessary to agree a common line, especially if the flying instructor's ideas are in need of correction, either in factual content or in method of teaching.

A dramatic example of this came to light when an instructor lost control of his aircraft whilst demonstrating the dangerous consequences of violent head movements during aircraft turns in a spare moment or two during an early night flying familiarisation sortie in a helicopter. His technique involved rapid shaking around of his own head whilst on the controls, the consequences of which terrified the student who barely succeeded in gaining control from the completely disabled instructor in time to prevent a crash. This incident is typical of the type which are not formally reported. Misconceptions and ill-contrived, incomplete knowledge instilled in the impressionable student at this stage can be difficult to replace with a true perspective of aeromedical problems later on, even if he survives the initial teaching session.

Other factors may influence the form of training given to student aircrew. In the Royal Navy these include a requirement to train non-pilot aircrew, tactical navigators and winch men, to the equivalent standard and at the same time and on the same course as the pilots. Their duties place a different emphasis on a knowledge of such topics as spatial perception and vigilance performance on sensor displays, but there are advantages too in bringing crew members together at this early stage. The crewman needs to be able to judge range and height reliably if he is to successfully conn the pilot in a hover over a survivor in the water or into a confined landing space. He will be expected to assist in visual lookout; he may spend hours staring at his radar or sonar or his duties may involve weapon aiming or release in circumstances where aeromedical factors affect his performance. Whilst common training complicates attainment of the individual instructional specifications, the extra knowledge of each other's problems is far from wasted. Job analysis, the writing of the Scalar and an instructional specification should still be done separately for each crew job before any attempt is made to combine the training programme.

Continuation Training - It must not be assumed that the desired level of knowledge achieved on completion of the initial training will be maintained by virtue of the flying experience gained in the normal course of flying duties. In a written test used to assess the knowledge of ab initio students at the end of their course the average score for Navy students was 67%, whilst the experienced aviators averaged only 37% in the same written test, given in their case before the refresher training began. The interval between initial and refresher training varied but was not less than four years.

Continuation training in one form or another is probably indispensable to satisfactory standards of aeromedical ability among aviators but many factors influence the way in which it can be most expediently conducted. The extra demands on aircrew time and the difficulties which may be caused by the undesirability of having them assemble from their flying stations at some central location will often be an important consideration and it may be necessary to consider as an alternative providing touring instructors from a central source or making use of Flight Surgeons at the flying stations to give the instruction instead. Both of these options have disadvantages; touring instructors implies a requirement for touring or multiple provision of equipment such as rotating chairs and even decompression chambers. Use of local specialist labour implies difficulties in standardising and monitoring training and, not least, the additional problem of teaching the Flight Surgeons what and how to teach. It would be wrong to assume that purposeful, economic training can be delegated easily, by virtue of the specialist knowledge which the Flight Surgeon's own training has given him, unless he is given specific briefing on the conduct of this particular training system and has acquired instructional skills in addition to his medical powers. The individual Flight Surgeon is unlikely to be doing enough of this type of work to achieve the professional instructional standards which are possible in a central school.

An important ingredient, but not the sole source of continuation training, can be a programme of articles on aeromedical subjects in flight safety and other journals and magazines which the 'target' aircrew are known to read. A successful programme, covering the necessary range of topics, repeated with a suitable periodicity and with sufficient freshness of style to recapture the interest of the non-captive audience, can be useful in maintaining standards of knowledge which long intervals between formal training will erode. A propaganda campaign of this type is inevitably a one-way conversation however, and although a valuable means of providing centralised teaching support to the local Flight Surgeon, if used as the sole means of continuation training it is difficult to ensure effectiveness. Such a system would also rob the central school responsible for the initial training of the opportunity for the regular feedback which refresher courses have been found to be so good at providing. Refresher courses are an invaluable source of the otherwise unreported anecdotes which are so useful in teaching the subject effectively, examples of which have already been described.

The course designer must bear in mind through the process of defining the content of his training course, the very real temptation to include matters which concern or interest him professionally but are either peripheral or irrelevant to the students true needs. Every course of training will bear the imprint of the designers personal interest or attitudes to the subject just as every teacher's classroom style is

similarly affected. One of the advantages of using the Scalar is that it helps the designer to focus his mind and direct his efforts towards the real objective of the training and the production of a detailed instructional specification containing all the key points to be conveyed is of similar value to the teacher.

#### Production of Instructional Material

An important factor in the standard of training eventually achieved is the calibre and consistency of the teaching. Teaching (and course design) are skills which are separate from expertise in aviation medicine. If professional instructional assistance is available it will often be profitable to seek advice, especially on matters of instructional technique. If the instructional package which the student receives is to be effective it will be:

1. Credible - This is a function of the teachers status, which must clearly entitle him to speak authoritatively on the subject. An aviation physician should be acceptable in this role, especially to impressionable trainee aircrew, but in facing experienced aircrew, credibility is quickly sacrificed if the doctor proves unable to identify with their particular situation or if he appears to be trotting out the same old generalisations and platitudes which they heard last time around. A realistic, sympathetic rapport is necessary. Aviators are chosen to be self-reliant and will readily ignore advice which is not delivered with real authority. It helps in achieving credibility for the teacher to have personal flying experience, ideally to be himself a qualified aviator with practical knowledge of the students own flying task. This is not an absolute requirement however, indeed it should not be assumed that doctors and medical laymen are the only suitable teachers. The subject matter of the training is, in reality, applied aviation skills and only incidentally and superficially involves academic physiology and psychology. In suitable circumstances an aviator, perhaps one who is no longer eligible for flying duties and who has learned the subject well, could do the instructing or some of it, well enough.
2. Relevant - The importance of relevance *in the student's eyes* cannot be overstated if he is to be expected to learn, retain and use the aeromedical training throughout his flying hours, especially during difficult moments when his mind will be fully occupied, with no time to work out his own solutions from physiological first principles. Problems must be brought to his attention using examples taken from known incidents directly connected with his future flying tasks and if necessary situations which are at once plausible and relevant to his future needs must be invented in preference to using genuine, but irrelevant, stories. For example it is of little value explaining the 'breakaway' phenomenon by citing the case of the high flying solo jet pilot - a description of the sensory isolation experienced by helicopter pilots whilst wearing hoods for instrument flying practice will be much more pertinent. If real accident details of a case of particular illusion of depth perception in a helicopter are not available, invent one rather than use a story of an accident to a DC3 in the 1940s. The plausibility of the invented accident must be carefully checked however.
3. Convincing and Memorable - The impact value of a practical demonstration, especially a personal demonstration is high. It excludes the possibility of the 'it can't happen to me' response which can be expected when attempting to teach almost anything implying a human limitation, especially to aviators. Rotating chairs and demonstrations of visual limitations and illusions are easily constructed and it would be almost unthinkable not to use them. Practical demonstration of altitude effects may be more of a problem since a chamber will be required. There is however, no effective substitute for a personal experience, at least once in a flying career, of the insidious and inexorable effects of hypoxia on confidence and judgement before the development of tangible symptoms, if the sort of incident described earlier is to be avoided.
4. Uncomplicated - Some of the topics to be covered are necessarily involved and difficult, perhaps even controversial in their true cause, mechanism or application. These are matters to be settled in the medical forum and certainly not to be reviewed as part of an initial training course for aviators. Students attending for refresher courses may relish a deeper analysis and welcome background information, especially on developments in research, but in the main the policy should be to simplify and further simplify the subject. Medical terminology can be largely ignored, even at the expense of inventing simple names which are easy to remember and relate to the problem even if they do not enjoy general recognition. The temptation for an instructor to pursue in extra detail those aspects of the subject which interest him has already been mentioned, it can be extremely difficult to resist adding a few words to highlight the marvellous symmetry or subtlety of a physiological mechanism or mentioning in passing the part played by the instructor himself in discovering or explaining a particular problem. But unless there is a genuine reason to include such material, perhaps to add interest or conviction to the key point being taught, the teacher is merely cluttering the students mind and may well be confusing the issue.
5. Positive - The aim of the training is to enable aviators to *deal* with problems and not to create more problems for him by cataloguing situations which he must find his own way out of. Certain areas of the subject matter can take on an air of gloom and despondency entirely unsuited to the students best interests, unless the teaching is contrived to avoid it. The problems which the aviator may face must be stated clearly and convincingly, but in each case equally clear recommendations on the best course of action should be made too. The subject of proper use of seat harnesses for example



should be dealt with as a constructive technique for minimising or prevention of crash injury rather than a macabre parading of the teacher's knowledge of the anatomical consequences of crashes involving extreme and unsurvivable violence. The knowledge that the cause of death with high GX forces may be mediastinal tearing and rupture of the major vessels, if of little practical value to the aviator himself. Much better to emphasise the potential benefits of careful adjustment of the harness every time he straps in and the value of adopting a particular posture in the seat in the event of an emergency. Especially with ab initio students, care must be taken not to add to the psychological pressures of flying training or to sow in any aviator the seeds of an unnecessary anxiety condition. If the problem raised has no known solution which can be explained in the classroom the aviator is unlikely to be able to think one up in the heat of the problem situation and the subject is perhaps best left alone.

6. Interesting - Fortunately it is not a difficult task, especially if the material is genuinely relevant to the students needs, to make aviation medicine interesting to aviators who are generally highly motivated and intensely inquisitive professionals. Practical demonstrations add interest as well as impact. It may be useful to emphasise a central theme and purpose for the training, for example by referring individual topics back to the fundamental problem of optimising human performance in the particular working situation. The evolutionary context in which the sensors and cerebral faculties developed is one way of explaining the limitations - with the counterpoint that the two million or so years since stone age man appeared is too short a time scale for major biological improvements in response to the short term demands of helicopter flying. The aviator is stuck with the problem of exploiting his cave-man equipment and must learn to live with its limitations in a space-age job.

#### Provision for Feedback and System Control

The end product of this training system is, hopefully, a beneficial effect on accident rates and operational effectiveness. Many other variables influence these quantities however and in the case of operational effectiveness measurement or even establishing criteria of success may be difficult. The course manager is left with little alternative to direct measurements of the level of ability in aeromedical matters among the aircrew population which he serves.

Techniques of measurement, whether by questionnaire, written examination or other means, are another aspect of instructional skill in which the doctor will benefit from seeking advice. It can be difficult to ensure reliability or validity of measurement unless the questions used are carefully chosen and arranged. Multiple choice techniques offer great convenience in processing results but present extra difficulties in achieving a balanced factual coverage which is also unambiguous to the reader. Further discussion of these matters is beyond the scope of this paper.

#### Sources of Reference for Students and Teachers

There is at present no handbook or text which is written to fit the special needs of helicopter aircrew. The handbook by Dobie (3) may be of some value if it is not possible to produce material which parallels the course contents exactly. The review by Hartman et al (4) may provide the course designer and instructors with useful information which is not covered by standard aviation medicine texts.

#### CONCLUSION

This paper has set out to establish that devising an effective training programme for helicopter aircrew is far from a simple task if the training is to be both effective and economic. Helicopter aircrew have special requirements, often unique to their aircraft type and role as well as being quite different from those of fixed-wing aviators. Traditional methods of demonstrating practical difficulties which aircrew may encounter must be adapted and new ones invented to cater adequately for these requirements. Training methods in aeromedicine and human factors is not well covered in the literature and so the subject matter of the paper has been deliberately kept as broad as possible, at the expense of exhaustive treatment of any particular aspect, in the hope that comment and suggestion will be provoked from other teachers of aeromedicine.

#### References

1. Tormes, F R and F E Guedry Jr. Disorientation phenomena in Naval Helicopter Pilots. Aviation Space Environment Medicine 46(4): 387-393, 1975.
2. Evans A. Unpublished results of a survey of Disorientation in Royal Navy Helicopter Pilots after Tormes and Guedry 1976.
3. Dobie T G Aeromedical Handbook for Aircrew AGARDograph No. 154 1972.
4. Hartman B O et al Operational Aspects of Variations Alertness. AGARDograph No. 189 1974.

FIGURE 1. THE SCALAR

FIGURE 2. SAMPLE PAGE FROM INSTRUCTIONAL SPECIFICATION

LESSON TITLE: Health Hazards	LESSON No: 6	DURATION: 0.45	LOCATION/INST. Lecture Room
ENABLING OBJECTIVE/STANDARD	KEY POINTS		METHOD/AIDS
<p>1. Protects eyes - Identifies dangerous circumstances from options in written test.</p>	<ol style="list-style-type: none"> <li>1. Importance of good eyesight to an aviator's career.</li> <li>2. Sources of possible injury:               <ol style="list-style-type: none"> <li>a. Foreign Objects. Dust in turbulent air, chiselling and grinding in workshops.</li> <li>b. Aviation fuels and other fluids.</li> <li>c. Direct exposure to rapid airstreams; birdstrike on windscreen, conning for winch transfer.</li> <li>d. Intense U/V light. Snow blindness, welding flash.</li> <li>e. Intense visible light. Direct sunlight, lasers, weapon flash.</li> </ol> </li> <li>3. Appropriate use of clear and tinted visor or safety glasses.</li> <li>4. Avoidance of unsuitable coloured or pigmented shades.</li> </ol>		<p>Lesson Vufoil Issue helmet visor Issue goggles Issue safety glasses Aircrew sunglasses</p>
<p>2. Avoids Noise-induced Deafness identifies risk sources and degree from options in a written test.</p>	<ol style="list-style-type: none"> <li>1. Noise induced deafness is insidious and irreversible.</li> <li>2. Deaf aids offer little benefit.</li> <li>3. Damage relates to:               <ol style="list-style-type: none"> <li>a. Frequencies and intensity of sound levels at the ear.</li> <li>b. Duration of exposure.</li> <li>c. Cumulation of exposure.</li> </ol> </li> <li>4. Average exposure due to normal helicopter flying duties is borderline for significant damage.</li> <li>5. Need for scrupulous protection on duty.</li> <li>6. Avoidance of other sources:               <ol style="list-style-type: none"> <li>a. Gunnery, rifle clubs.</li> </ol> </li> </ol>		<p>Film: "Dangerous Noise" (20 minutes)</p> <p>Lesson Damage Risk Graphs Standard ear defenders Helmet ear muffs.</p>

NOTE: This example page does not constitute a complete lesson. Although the topic of health hazards has in this case formed a self contained lesson because of the time taken, it might in other circumstances have been coupled with other topics under a broader lesson title such as 'PERSONAL HEALTH'.

## VISUAL REQUIREMENTS FOR THE HELICOPTER PILOT

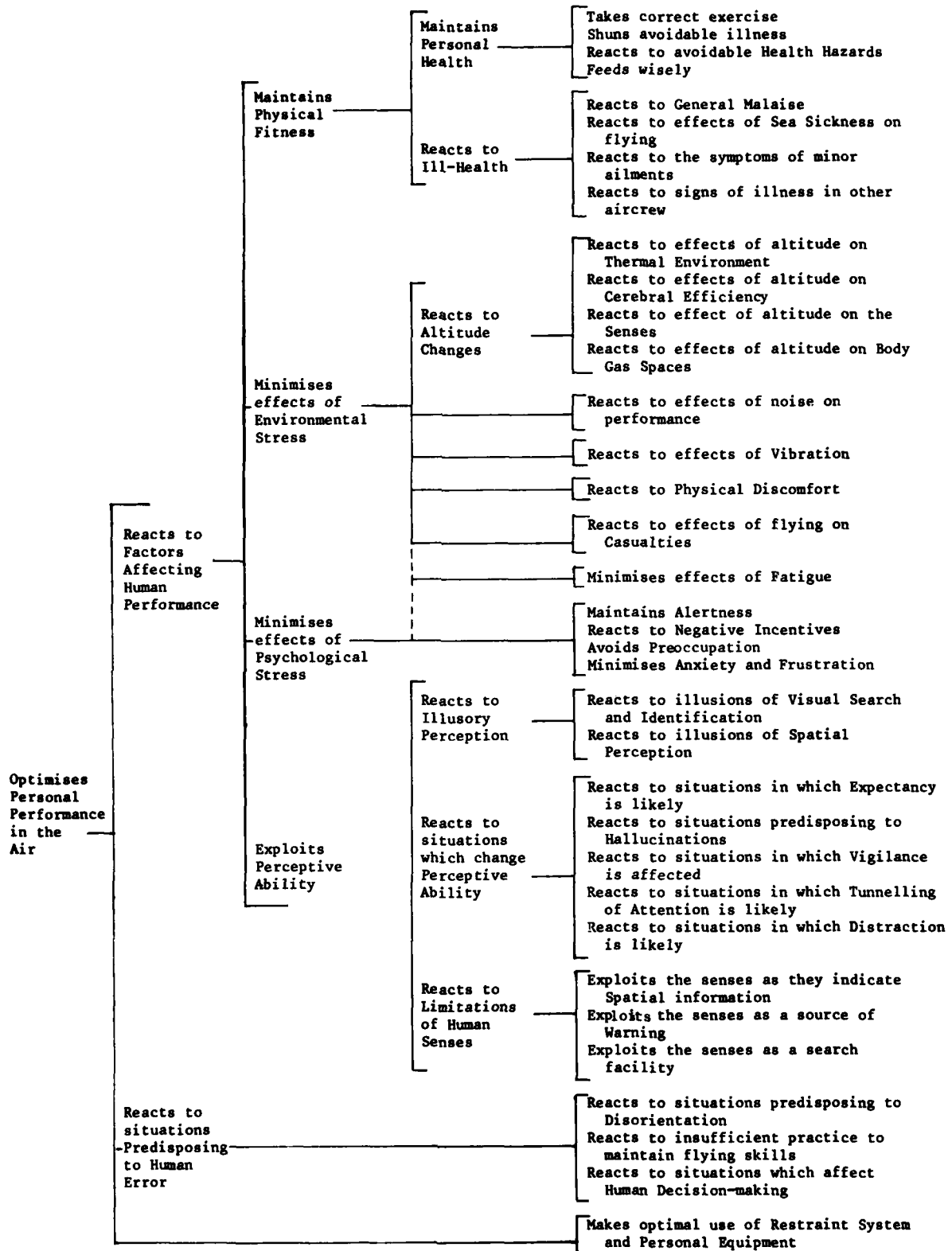
William F. Lowe, Ph.D.  
Human Factors and Cockpit Arrangement Group  
Bell Helicopter Textron  
P. O. Box 482  
Fort Worth, Texas 76101

## SUMMARY

This paper discusses the 1978 effort of the Human Factors Engineering group at Bell Helicopter Textron relating to the definition of the helicopter pilot external visual requirements. The paper outlines the original goals that were planned and describes the tasks accomplished so far. The major part of the paper is devoted to the discussion of the flight test results of pilots flying obstacle avoidance maneuvers. Prediction that pilots would maneuver closer to obstacles on their side of the aircraft as opposed to obstacles on the copilot/observer side and that as speed of fly-by maneuvers increased the distance required for safe clearance would increase were not completely supported by the data. Explanation of these contradictory results are offered. The remainder of the paper discusses a survey of commercial operators to determine the unique requirements of their operations. A vision plot of a new commercial twin turbine helicopter is included and its excellent visibility is discussed.

## INTRODUCTION AND BACKGROUND

Early this year our Human Factors Engineering group requested and received company research and development funding to study helicopter pilot vision requirements. The total effort originally involved three specifically defined tasks. One task was to obtain additional data pertaining to an earlier exploratory study of visual free time. This research was initiated about five years ago and reported by Dr. Strother.<sup>1</sup> The second task was to investigate vision requirements specific to obstacle avoidance flights. A previous test flight evaluation of this problem had been made at Bell Helicopter Textron (BHT) about two years ago. The third task was to survey the unique vision requirements of commercial operations such as logging, off shore oil, tower/pole setting and other commercial work.

Due to the high workload in the Human Factors group, a decision was subsequently made to limit the effort to only the obstacle avoidance flight tests and to compile questionnaire responses from our larger commercial operators to determine their unique requirements. This paper discusses the results of the flight tests and summarizes the responses received from the questionnaires.

The study discussed here was actually started about two years ago. The objective was to test the ability of pilots to maneuver safely, yet in close proximity to obstacles as a function of crew seating arrangements (side by side vs. tandem, for example). Results from this type of study would allow us, hopefully, to relate helicopter pilot vision requirements to design concepts for vehicles committed to flying nap-of-the-earth (NOE) missions. In NOE flight the pilot typically maneuvers close to obstacles and even between obstacles. This allows the helicopter to be masked from detection while approaching as close as necessary to enemy positions in the accomplishment of the mission; for example, scouting or weapon delivery. Thus, natural obstacles, such as trees, are used for cover from enemy detection and protection from enemy fire. A major problem in this type of flight is the pilot's ability to judge the size of the opening between obstacles and the maneuvering area required to reach favorable positions for accomplishing the mission without striking obstacles with the rotor tip. There are at least two factors which influence the pilot's ability to make this judgment. One is the technique in which the pilots estimate the position of the center line of the aircraft as a point midway between two obstacles. This is the desired manner of flying between two obstacles (See Position A on Fig. 1). Actual performance, however, may be based on the pilot's seated position within the aircraft with respect to the center line of this aircraft which can cause him to leave a wider margin on the copilot/observer side than on his side. Thus, he would require more clearance between obstacles or conversely reduce his perceived margin of safety. (See Position B on Fig. 1.)

A second factor which may affect his ability to make a sound obstacle avoidance judgment is the visibility available to him to see the obstacle in relation to the main rotor tip. On his side of the helicopter he generally has adequate vision of the obstacle and the rotor tip path at 90° to his flight path. When the obstacle is on the copilot/observer side, the pilot's vision may be obscured by door posts, door frames, and the observer. It may be even further reduced by observer sighting systems equipment, such as scope boots and telescopic sight units.

So, two years ago, we commenced to do an exploratory test of these concepts. One pilot flying an OH-58 helicopter with a side-by-side cockpit hovered and air-taxied past a hard obstacle, and then a tree, as close as he felt safe. A total of 18 measurements was taken. These represented 8 trials with the obstacles on his side of the OH-58 and 10 trials with the obstacles on the observer/copilot side. His single trial performance and the mean ( $\bar{x}$ ) of his performance is shown in Table I.

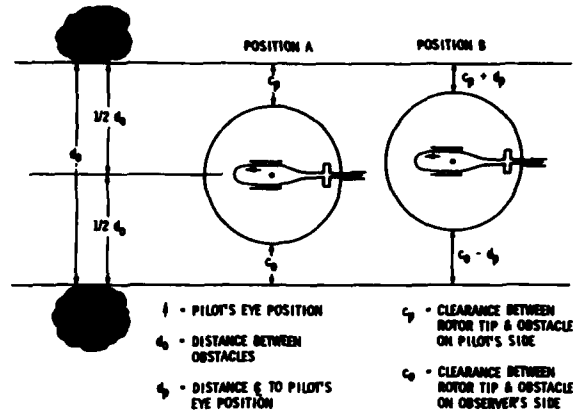

Fig. 1. Estimating Clearance of Rotor

TABLE I  
DATA ON MEAN ( $\bar{X}$ ) PERFORMANCE

		OBSTACLE ON OBSERVER'S SIDE		OBSTACLE ON PILOT'S SIDE	
		DISTANCE ROTOR TIP TO OBSTACLE	$\bar{X}$	DISTANCE ROTOR TIP TO OBSTACLE	$\bar{X}$
OBSTACLE (SOLID OBJECT)	HOVER	40"	34"	37.0"	23.0"
	AIR TAXI	22"		7"	
	HOVER	94"	82"	57"	29.5"
OBSTACLE (TREE)	AIR TAXI	94"	82"	7"	8.5"
	HOVER	22"		37"	

As can be seen from Table I, the pilot did hover and air taxi closer to both the solid obstacle (concrete pillar) and the tree when the obstacles were on his side. It is interesting to note that he, generally, came closer to the solid obstacle than he did to the tree. This result we believe can be attributed to the fact that in comparison with the tree the concrete pillar presented a much more sharply defined obstacle (even though considerably more dangerous). Fig. 2 shows the difference in the distance required in the worst case (air-taxi) condition. When the obstacle was on the observer's side of the aircraft the pilot required almost 10 times the amount of separation from the obstacle.

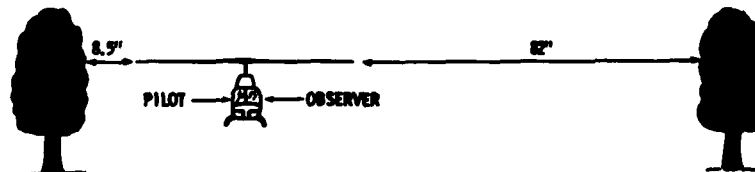

Fig. 2. Worst Case Clearance

## TEST PLAN

It was decided to obtain more data of the same nature, by additional testing, in the overall vision requirements effort.

The test plan called for the use of a Bell 206B (with a side-by-side cockpit and a 33.4 foot rotor diameter), a Bell Model 212 (side-by-side cockpit and a rotor diameter of 48.0 feet), and a Bell Model AH-1 Cobra (tandem cockpit, pilot in the rear seat and a rotor diameter of 44.0 feet). The pilot's task would be to hover, make 10Kt fly-bys, and 30Kt fly-bys. They were to do each of the three maneuvers twice with the obstacle (tree) on their right and twice with it on their left. We predicted the results of the test flights to be as follows:

1. Pilots would be closer with obstacle on his right (as had been demonstrated in the earlier flights with the OH-58 Scout helicopter).
2. Pilots would fly closer to obstacles with the 206 than with the 212 (increased rotor diameter and cockpit width would force the pilot to increase his margin of safety).
3. There should be no difference which side the obstacle is on for the AH-1 Cobra pilot because of the tandem cockpit arrangement.
4. Speed would cause the distance from the obstacle to increase up to an asymptotic level.

That was the plan. Unfortunately, extensive bad flying weather earlier this year caused us to curtail the flight tests considerably. The workload for both our Production and Experimental Pilot staffs was so great that we were ultimately limited to the use of eight pilots and only one aircraft, a Model 206B. Neither the Model 212 nor the Cobra could be made available. So with the use of one aircraft and eight pilots, we set out to study vision requirements at NOE. The instructions to the pilots were again "come as close to the tree as you feel safe." When the pilot indicated he was as close as he felt was safe, a marker was dropped by an observer in the aircraft to mark the position. The experimenter sat in the cabin behind the pilot and dropped the marker (a 5 pound shot bag) down between the side of the ship and the right skid. Measurements from the positions of the markers to the base of the tree were taken and recorded. The raw data was adjusted by +2.5 feet to account for the distance from the outer skin (drop point) to the  $C_L$  of the 206B. The rotor blade radius (16.66 feet) was then subtracted from the total distance measured in order to determine the calculated distance of the rotor blade tip to the tree trunk. At the hover and fly-by rotor blade altitude, the tree branches were estimated to extend about 10 feet from the tree trunk.

## TEST RESULTS AND DISCUSSION

It is always very satisfying when the results of your study clearly support your predictions or hypotheses. It is equally satisfying if your results completely negate the prediction or hypotheses of a fellow experimenter. However, it is somewhat disappointing to report that our results did not clearly and obviously confirm the predicted performance. An explanation for this will be offered later.

Table II shows the individual pilot performance (mean distance of two trials) and the mean distance of the sample of pilots. Fig. 3 shows the same information graphically. As you can see, there is considerable variability in the pilot's performance. You can also see that the predicted effect of speed not only is not supported, but is in fact contradicted. The prediction that pilots would be closer when the obstacle was on their side of the aircraft is not completely supported by the data.

TABLE II  
INDIVIDUAL AND SAMPLE MEANS OF ROTOR  
TIP TO OBSTACLE CLEARANCE IN FEET.\*

PILOT	HOVER		10 KT FB		30 KT FB	
	RIGHT	LEFT	RIGHT	LEFT	RIGHT	LEFT
1	18.59	17.34	19.09	17.09	17.04	15.04
2	11.59	15.04	6.34	12.09	5.04	11.04
3	16.04	16.59	16.04	19.04	10.04	12.34
4	13.59	13.59	13.59	14.59	10.04	10.34
5	21.04	20.04	27.09	25.59	29.09	32.09
6	26.09	26.34	18.59	18.04	19.09	20.59
7	24.59	19.59	18.09	18.34	19.09	18.34
8	25.09	26.34	19.09	21.34	25.04	21.34
$\bar{x}$	19.77	19.50	17.30	18.49	17.31	18.09

\* (RAW DATA ADJUSTED FOR DISTANCE TO APC CENTER LINE AND ROTOR BLADE RADIUS.)

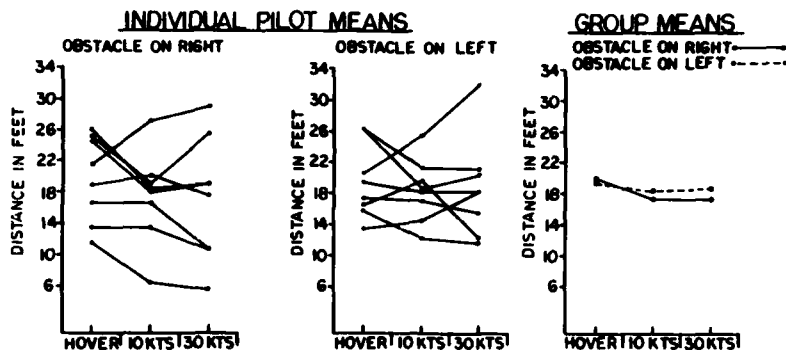

Fig. 3. Rotor Tip Distance from Obstacle

The contradictory effect of speed seems quite easily explained. The prediction made was based on the concept that the pilot's task would be referenced to the obstacle represented as a single tree in an open field. The actual target tree was, however, the tallest and largest tree in a row of ten trees. As a result, on the 10 and 30Kt fly-by trials, the pilots would back off a considerable distance before starting their run. Thus, they estimated their clearance on the row of trees (instead of a single target tree) and maintained this clearance as they flew past. In the hover tests, however, they approached the target tree in sideward flight.

The data show that the pilots hovered slightly closer when the obstacle was on the left. Obviously the magnitude of the difference is of no practical use. The result was, however, unexpected. This is somewhat more difficult to explain than the effect of speed. Four of the pilots flew on days when the atmospheric conditions were ideal with winds of 0-10 knots. On the last day of data collection the wind was 18 knots, gusting to 25 knots. We wanted data on four more pilots so we decided to continue the test flights. Flying under this gusty condition meant that when the target tree was on the right the pilot had an 18-25 knot tailwind. When the obstacle was on the left side, he was headed into the wind--a much safer condition--and he was not as concerned about the tail rotor getting into the branches. The difference in the performance under calm and gusty conditions is shown in Fig. 4. The wind effect does not seem to be a factor in the fly-by trials since the aircraft is basically more stable with speed. On both the 10 and 30 knot trials the pilots were closer with the obstacle on the right side of the aircraft.

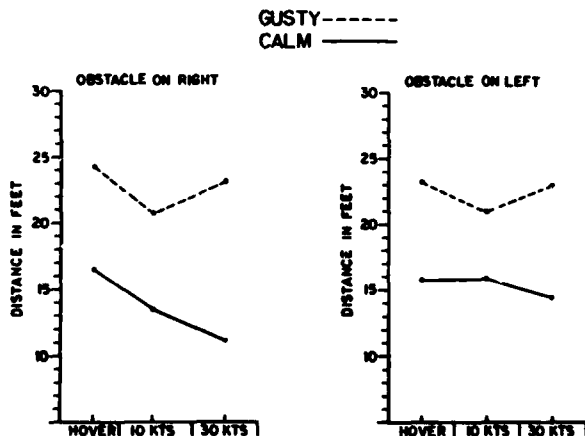

Fig. 4. Means: Gusty (18-25 Kts) vs. Calm (0-10 Kts)

The results, based on a sample of these eight pilots, do not agree with the one pilot exploratory test. Fig. 2 shows that in the Air Taxi trial (worst case) he required almost 10 times the clearance distance when the obstacle (tree) was on the copilot/observer side of the helicopter. The results of this study indicate that the pilots required less than 10% more clearance.

#### SURVEY RESULTS

Considerably more knowledge has been gained about the military's visual requirements in helicopters than those of commercial operators. A questionnaire was prepared and forwarded to some of the larger operators asking for their visual requirements. Each of these were known to operate from 10 to over 150 helicopters. At the time the paper was prepared we had received completed questionnaires from 36 pilots.

Table III shows the results based on this sample of pilots. Major criticism was directed to "up through the

green house" (referring to the tinted overhead window) and "to the rear" (referring to the aft view). Many design suggestions and comments were received. Through a very concerted effort, the BHT Engineering Department has greatly improved the pilot vision in our new, commercial, twin turbine Model 222. Fig. 5 shows the improvement in the vision Forward and Up, To The Side and Up, and To The Side and Down categories.

TABLE III  
QUESTIONNAIRE RESPONSE  
IS SUFFICIENT VISION SUPPLIED FOR OPERATION AND SAFETY ?

AREA	YES	NO	RATIO-NO
OVER THE NOSE	33	3	1/12
FORWARD AND UP	28	8	2/9
TO SIDE AND UP	27	9	1/4
TO SIDE AND DOWN	28	8	2/9
ACROSS COCKPIT	24	11	11/35
DOWN THRU CHIN BUBBLE	27	9	1/4
UP THRU GREEN HOUSE	17	19	19/36
TO REAR	12	23	23/35

Fig. 5 shows the pilot's vision available in the Model 222. The heavy black line is the Mil Std 850B required vision for side-by-side seating. At 0° the over-the-nose vision available meets the required 25° of downward vision. The forward and up vision is considerably better than the 850B requirements.

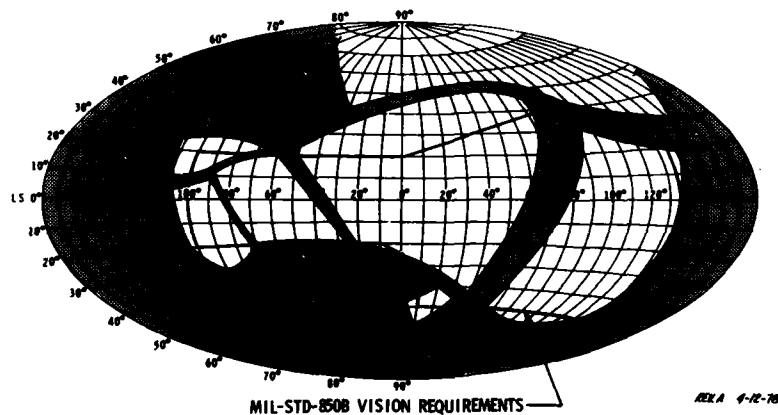

Fig. 5. Model 222 Pilot Visibility Plot

The vision to the side, up and down, is excellent, exceeding all the military requirements. The usual vision blockage caused by the windshield post and door post has been greatly reduced compared to earlier models.

#### CONCLUSIONS

We feel that additional flight test evaluation of the effects of limiting the helicopter pilot's vision, both in time and by obscuration due to structure, should be performed. We plan to perform additional studies but strongly recommend more research be devoted to examining these problems. In the area of vision restrictions we hope to see studies on the effect of several variables on the ability to avoid obstacles, particularly,

- Increased rotor blade diameter
- Speed
- The pilot sitting on the aircraft center line (such as in a Bell Cobra)
- Well defined as opposed to ill defined obstacles
- Intermittent illumination of the obstacle and in the cockpit

We are also anxious to increase the data available in other areas, that of visual time available to, or required by the pilot, and the attitudes the pilots have subjectively, toward the vision available from their cockpits.

We feel the pilot's vision is a critical design factor and the improved cockpits of the future will reflect a careful consideration of this important feature.



REFERENCES

1. Strother, Dora Dougherty, Ph.D., "Visual Activities of the Helicopter Pilot During Low Altitude, VFR Flight," Paper Presented at Aircrew Performance in Army Aviation Conference, November 27-29, 1973, Fort Rucker, Alabama.

OBSERVATION OF NIGHT SHIPBOARD HELICOPTER OPERATIONS  
FROM A 210 FOOT U.S. COAST GUARD CUTTER \*

CAPTAIN W. W. HARVEY, JR, USPHS (R) FLIGHT SURGEON  
USCG TRAINING CENTER, ALAMEDA, CALIFORNIA 94501

A COAST GUARD AVIATOR NEEDS A TAPETUM LUCIDUM, SIMILAR TO THE MEMBRANE BEHIND THE RETINA OF A CAT'S EYE WHICH ACTS AS A MIRROR TO REFLECT LIGHT RAYS BACK ONTO THE RETINA, FOR NIGHT TIME SHIPBOARD HELICOPTER OPERATIONS. ALSO A CAT'S GYRO SYSTEM WOULD BE HELPFUL.

This thought occurred to me while conducting night helicopter operations to observe the effectiveness of flight deck lighting aboard the U.S. Coast Guard Cutter Dependable. During these observations I also gathered additional data from the pilot, the LSO (landing signal officer), and other members of the ship's crew.

My intention is to outline these observations, add a simple review of visual perception and attempt to stimulate all personnel involved in night helicopter operations in concentrating more effort in improving all safety aspects of this concept.

From discussion with our more experienced pilots assigned to the "Shipboard Helicopter Operations Division", at AVTRACEN Mobile, it appears that these pilots feel relatively secure in night shipboard landings. This feeling is prevalent especially with those who have the most experience in icebreaker operations and many months of shipboard deployments.

The inexperienced pilot, though HB qualified as a first pilot-flying AAH52A had this to say:

"Liftoff from the flight deck caused no great amount of undue stress, strange but acceptable, as the cutter moved from under and away, as departure was to the left at an altitude even with the cutter's superstructure and stack. There is apparently a visual sensation of the tail rotor swinging dangerously close to the ship's abovedeck structure as the helo turns into the wind.

Instant darkness envelopes the aircraft on leaving the visual reference of the ship, requiring immediate attention to instrument flying conditions, in a turn at low altitude away from the ship."

The pilot is on instruments until turning thru the dark void to a crosswind leg to sight the lights of the ship, causing an instrument/visual reference situation.

In this particular flight, the pilot experienced vertigo and alerted the copilot/instructor. He requested that the instructor pilot assume control of the aircraft, which he did and subsequently performed a smooth roll out, recovered the lost altitude, and corrected the aircraft's altitude, with confidence and without incident.

After a short period of straight and level flight, controlled by the instructor pilot, the junior pilot resumed control of the aircraft and landed on the ship's flight deck with good and "comfortable" control.

This all illustrates a good, mature training experience which was appreciated by the instructor pilot and the junior pilot.

Three principal areas for night helo operations were selected for observation in an attempt to better evaluate the total lighting effect. These three were from the boat deck just above the helo shelter, from behind the LOS on the flight deck, and from the cockpit of the aircraft. The findings of these observations are presented in outline.

The shipboard flight deck lighting configuration is outlined in the schematic at the back of the paper. Briefly, it consists of two wing-mounted side cargo lights on the boat deck deflected downward into the water, and three specially mounted red-lensed flood lights. The aft third of the flight deck is illuminated by two hooded white lights mounted in loose or freely moving brackets for ease of positioning.

\* Opinions or conclusions contained in this paper are those of the author and do not necessarily reflect the views or endorsement of the United States Coast Guard or of the United States Public Health Service

**A. Observing from after boat deck:**

1. Forward 2/3 of flight deck illuminated by two (2) wing mounted cargo lights and three (3) specially mounted red-lensed flood lights.
2. After 1/3 of flight deck lighted by two (2) hooded white floods specially mounted but loose in the mounting brackets for positioning.
3. The above lighting created satisfactory outlining of flight deck from this area of observation.
4. This lighting produced a dark transition visual perception:
  - a. Forward 2/3 flight deck red/rose.
  - b. Dark transition light perception zone between red-white.
  - c. After white lights meshed into brown/red-white.

**B. Observing from behind LSO standing on flight deck:**

1. Forward flooding with light of grid and flight deck adequately perceived.
2. No distracting lights.
3. White aft floods did not shine at or blind LSO.
4. Aft white lights apparently of minimal benefit.
  - a. Possibly a green or green/white combination.
  - b. Possibly green/yellow combination.
  - c. Above may give sharper contrast to grid and aft flight deck.
  - d. Darkened transition color area between white-red.
5. Grids on 210 have poor contrast and outline for positioning of aircraft with present lighting from LSO position.
6. Present illumination makes determination of wheels-down difficult on approach over after-deck, i.e. LSO cannot tell whether wheels in well or extended due to approach altitude.

**C. Observing from aboard the aircraft:**

1. On short final 500-800 feet out, 200-150 feet altitude and closing:
  - a. Complete after section of ship red-brown/black-black in appearance from above sequence but all with relative definition of perception.
  - b. Ship's white side lights arranged to aid pitch-roll definition relatively good.  
(Grid 7 degree pitch permitted 10 degree roll.)  
(Non Grid 4 degree pitch, 5 degree roll.)
  - c. Too much light might create halo effect; too little light will not provide adequate ship visual reference definition.
2. Prior to touch down:
  - a. Pilot attention concentrated on LSO.
  - b. No blinding or distracting lights noted.
  - c. Flight deck prominent as faded rose/red.
  - d. Grid poorly visualized.
  - e. White deck markings tend to grey out.
  - f. Touch down made by LSO signal.

DISCUSSION:

On lift off from the flight deck at night the pilot leaves visual reference to go on instruments which creates the ideal condition for vertigo-visual reference turns.

During practice touch-and-go to a flight deck, the pilot remains on instruments until base-leg (and the ship becomes visible). Again visual-instrument reference flying establishes the setting for disorientation, visual illusions and vertigo.

Visual reference to the ship, i.e. ship-sea movement, pitch, roll, and forward movement is aided by the side white lights and sea reflection which visually displays the ship and flight deck as a multiphasic moving target and the usual references for judging height and closure are changed. Prior to touchdown, the flight deck appears either too high or too low and it is necessary to fix on the LSO. Do not fly up and down movement of the ship.

Night operations present, to both the experienced and inexperienced pilot, many night visual illusions. Dim light on the flight deck causes an apparent sensation of being high and farther out; visual restrictions of darkness create night myopia. The small target of the flight deck on a 210 foot Coast Guard Cutter, which is a 24 foot diameter white circle with a center lineup line and a center four foot solid white diameter circle, compounds illusionary sensations on final approach over the stern. Again, creating the illusion too high and too far out makes for a low to short approach.

In general most pilots feel the present lighting system is adequate, providing the proper amount of contrast definition and illumination on the aft part of the ship and flight deck and grids for safe operation as well as providing enough illumination for the tie-down crews, firefighters, rescuer and LSO with talker.

Despite this feeling of comfort re visual aspects of approach and touch down, all who fly with the Radar Altimeter Warning System (RAWS) are further comforted by the "beep to a hover" provided by this instrument.

Finally, on any approach always be prepared for a go around or wave off.

SUMMARY AND RECOMMENDATIONS:

1. What started as a lighting effectiveness observation again emphasized the ever present problem of disorientation.
2. Disorientation frequently occurs during approach and take-off.
3. Visual illusions commonly occur on approach and can be disastrous.

Recommendation - that counter measures be constantly stressed in all helicopter training for both experienced and inexperienced pilots.

4. Helicopter flight deck lighting presently used on Coast Guard 210 foot cutters is satisfactory for night shipboard operations.

Recommendation - constant feed back from commanding officers, LSO's, pilots and ship crewmen in an attempt to improve flight deck lighting.

Request comments from others not directly involved but knowledgeable in illumination and visual perception.

5. Concur with all pilots that there is no substitute for frequent inflight training program for training of pilots, aircrewmembers, and ships' crew in actual flight operations.
6. REPEAT: All should note visual and somatic illusions are a frequent cause of disorientation.

## VISION - REVIEW OF FUNCTION OF THE EYE

A. Visual Reception - Retina:1. Rods

a. Take over at level of 0.1 ft. candle about the level of full moonlight (night vision).

b. Perception of color is not possible.

(1) It is possible to distinguish between light and dark colors at night only in terms of intensity.

(2) If intensity (brightness) is above cone threshold, color can be perceived.

(3) At 0.1 ft candle (moonlight), vision is on 1/7 as good as during average daylight.

2. Cones

a. Concerned with day vision

b. Concerned with color vision.

3. Visibility of an object

a. Angular size of object.

b. Quantity and direction of illumination.

c. Contrast between object and background.

d. Length of time seen.

e. Atmospheric separation.

f. Moving or stationary.

g. Retinal adaptation.

B. Visibility and illumination:

1. No gain in visibility above 1000 foot candles.

2. Prolonged exposure to glare and illumination, i.e. brilliant light:

a. May cause temporary blindness.

b. Photophobia.

c. Discomfort.

d. May affect night vision up to five (5) hours.

Recent experimental work has shown exposure to bright sunlight has a cumulative and adverse effect on dark adaptation. Individuals exposed to intense sunlight for two to five hours show a definite decrease in their sensitivity at low brightness levels. Persistent sunlight exposure retards dark adaptation and loss of night visual acuity for several days. Visual acuity reduces rapidly (photopic) as the image moves rapidly away from the center of the visual field. A target will be perceived at maximum stance only if observer happens to look within a degree or so of its position.

Review of function of the Eye - Continued.

C. Night Myopia:

1. Light shift to myopia under conditions of dark adaptation-- Purkinje affect. (Under conditions of light adaptation, the retina is more sensitive to orange and red hues; when dark adapted, more sensitive to the blues, i.e. the eye seeks the blue end of the spectrum at night. White light broken into spectrum components.)

2. A hyperop (far sighted) can relax the accommodation and possibly see better. An emmetrop (normal) or myop (near sighted) may become more myopic.

3. The situation can become critical for an aviator especially if mildly myopic. He might have a -0/25 D and still read 20/20 daylight, but at night may "effectively" become -0/50 or -0.75 because of the retina trying to focus the blue lights. Add a little tension for night carrier landings which cranks in a bit of ciliary spasm, he may become -1.00 or -1.25, which effectively makes him 20/50 or 20/60 vision.

REFERENCES

1. Army Flight Surgeons Manual
2. Special text ST 1-105-8 - U.S. Army Aviation School, Ft. Rucker, AL
3. Shipboard Helicopter Operational Procedures - CG-429
4. RANDEL, Hugh W. M.D. - Aerospace Medicine, 2nd Edition
5. National Search and Rescue Manual
6. ALLEN, James H., M.D. - Mays Diseases of the Eye, 24th Edition

Personal Communications:

1. Dr. TRAINER, Flight Surgeon - Ft. Rucker, AL
2. LCDR ADDISON, Don - U.S. Coast Guard

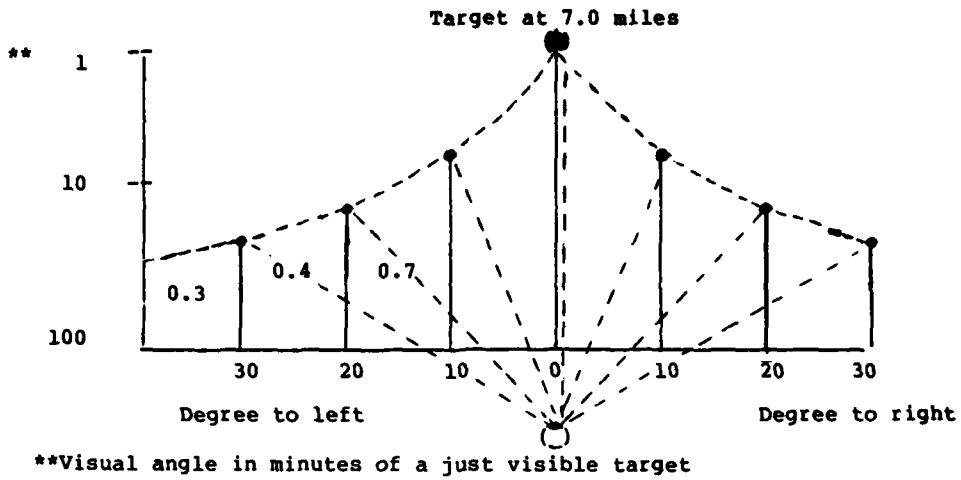

FIGURE A

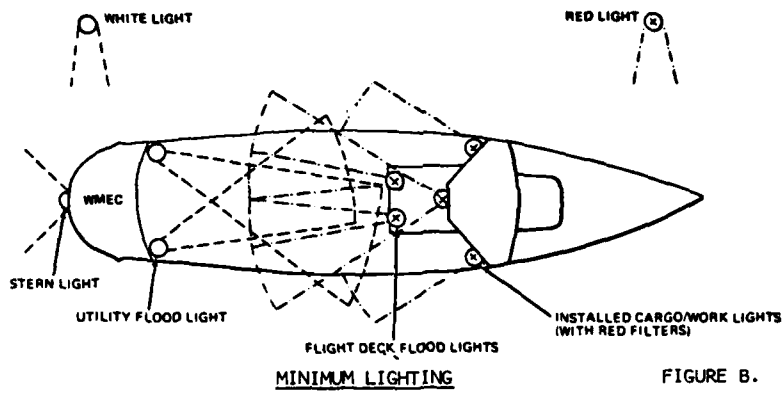
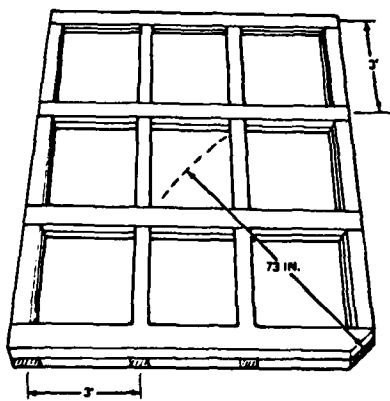
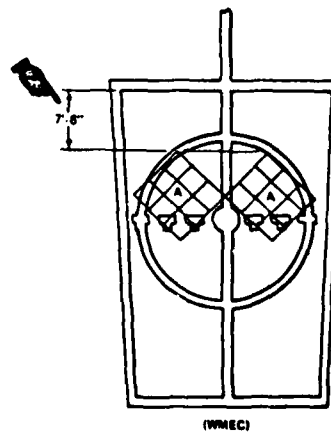

FIGURE B.



NOTE:  
FOR BEST CHOCKING OF HELICOPTER INBOARD  
CORNERS SHOULD BE CUT OFF TO CREATE A  
73-INCH RADIUS TO CENTER OF GRID.

FIGURE C. - Grid Construction



OPTIMUM LANDING SPOT

FIGURE D.

## OCULOMOTOR PERFORMANCE OF AVIATORS DURING AN AUTOROTATION MANEUVER IN A HELICOPTER SIMULATOR

Richard N. Armstrong, Gerald P. Krueger,  
John H. Sapp, & Yvonna F. Jones  
US Army Aeromedical Research Laboratory  
Fort Rucker, Alabama 36362

### SUMMARY

The oculomotor performance of ten US Army pilots, a group of five experienced and a group of five newly graduated aviators, was filmed during helicopter simulator flights conducted under precision instrument flight conditions. Each pilot flew a one-hour precision instrument flight in a simulator on each of four days. On the fourth day, the flight scenario included a simulated engine failure that required the pilot to execute an autorotation maneuver. Oculomotor performance, pilot control, and aircraft flight dynamic measures were recorded during the fourth flight. The allocation of pilot visual activity to various instruments was observed to differ as a function of two phases of the autorotation maneuver. Pilots controlled rotor speed and airspeed closer to desired limits in the second phase than they did in the initial phase of the autorotation. Few differences of pilot visual activity were exhibited as a function of the experience level of the pilots.

### INTRODUCTION

The utilization of autorotation techniques to safely land rotary wing aircraft during certain airborne emergencies, e.g., engine failures, has contributed much toward minimizing the loss of equipment and human life. However, accidents in which pilots do not successfully complete attempted autorotations continue to be a problem in US Army aviation. During fiscal years 1973-1976, 710 reported mishaps involving autorotations resulted in 15 fatalities and 91 injuries. The cost of aircraft damage for those mishaps exceeded 15 million dollars.<sup>1</sup>

Knowing how to correctly perform the autorotation maneuver takes on increased importance when one considers that the Army is currently preparing for the conduct of flight operations during periods of adverse weather and low visibility in 24-hour mission scenarios. These flight conditions make the conduct of autorotations more difficult. They also increase the need for reliance upon the aircraft instruments in accomplishing the maneuver.

The successful completion of a forced landing via autorotation depends on many variables. They include the type of helicopter, the particular system failure encountered, environmental conditions, terrain features, time of day, aircraft flight dynamics, and especially the aviator's ability to quickly and accurately analyze failure situations and to perform the correct emergency flight procedure(s). If the present safety record in the use of the autorotation maneuver is to be improved, even under the additional 24-hour mission requirements, a better understanding of pilot performance during the maneuver is imperative.

How well an aviator responds to emergency situations is much dependent upon his acquisition of aircraft status information through perceptual cues, his processing of the perceived information and his resultant control action. Although aviators utilize all their senses during flight, a major portion of the information a pilot requires to fly a helicopter is obtained through the visual sensory modality. Effective aviator visual activity in the use of cockpit instruments is especially important in the performance of an autorotation under instrument flight conditions.

To optimize a pilot's visual activity during performance of an autorotation, the information the pilot needs during the maneuver must first be identified. Once the informational requirements have been established, alternative methods of presenting this information can be evaluated and effective visual scan strategies determined.

One useful way of studying the information requirements is to examine what information pilots presently use in performing autorotations. Pilot oculomotor activity has been studied in helicopter flight maneuvers under visual flight rules (VFR)<sup>2,3</sup> and instrument flight rules (IFR) conditions.<sup>4</sup> However, for the most part these studies were concerned with the visual performance of pilots under normal flight conditions. There are no published data concerning pilot visual activity during the execution of emergency flight maneuvers. The study reported here explored the relationship between oculomotor activity and aviator proficiency in the execution of an autorotation maneuver during instrument flight conditions in a helicopter simulator.



## METHODOLOGY

### Overview

Each of ten US Army aviators, a group of five new graduates and a group of five experienced pilots, flew four precision instrument flight profiles in a moving base helicopter simulator. A 50-minute flight scenario was repeated once on each of three consecutive days of the test. It included an instrument takeoff (ITO), climbs and descents while maintaining assigned headings, climbing and descending turns, level flight, navigation enroute, an instrument landing system (ILS) approach and execution of a missed approach (Figure 1). On the fourth day the flight scenario was shortened somewhat for the last of the four flights. An unannounced engine failure was introduced on the climb-out segment of the missed approach immediately after the simulator reached an altitude of 1500 feet. The pilots responded to the engine failure by entering autorotation.

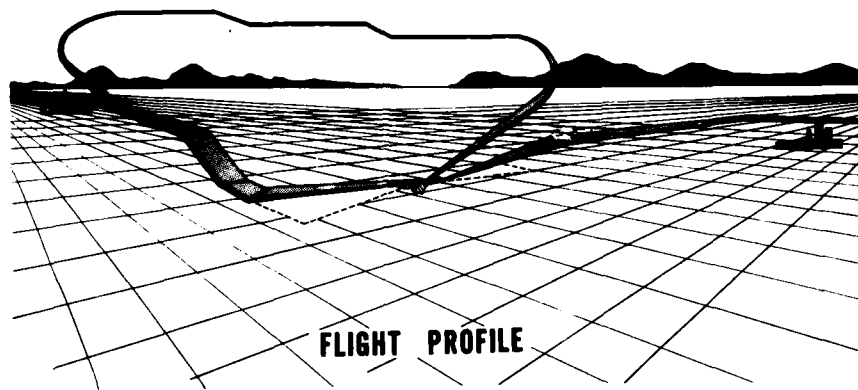

Figure 1. IFR Flight Profile

During all flights, pilot control movements and aircraft flight dynamic measures were recorded on magnetic tape by means of a digital computer. Visual performance data were collected on 16mm film using a corneal reflection technique during each pilot's fourth flight. Both sets of data were analyzed to evaluate aviator and aircraft performance. This paper presents some of the results obtained from the autorotation segment of the fourth flight.

### Subjects

The subjects were ten rated US Army aviators. Five were recent graduates of the Army's Initial Entry Rotary Wing Flight Course and had an average of 197 hours of rotary wing flight experience. The other five were more experienced pilots with an average of 2300 hours of rotary wing flight experience. Three of these more experienced pilots were current instructor pilots while the other two had served in that capacity in the past. All were current in the Army's UH-1 helicopter. The average age of the recent graduates was 24 years and that of the more experienced aviators was 29.

### Apparatus

Research Simulator Facility. The research simulator (Figure 2) used in this investigation is a replica of the US Army's utility helicopter cockpit with a two degree-of-freedom motion system. The cockpit switches, flight controls, instruments, navigation aids and power management gauges are the same as those found in a standard UH-1 helicopter (Figure 3). The flight dynamics are controlled by a closed loop analog computer and are patterned after the aerodynamics of the UH-1. The motion system provides the

flight crew with kinesthetic sensations much like those of real flight. The major difference between the dynamics of the simulator and those of the helicopter is that the antitorque pedals in the simulator are more sensitive than those in an actual helicopter. This difference requires the aviator to be more attentive to those controls and their associated flight parameters during flight.

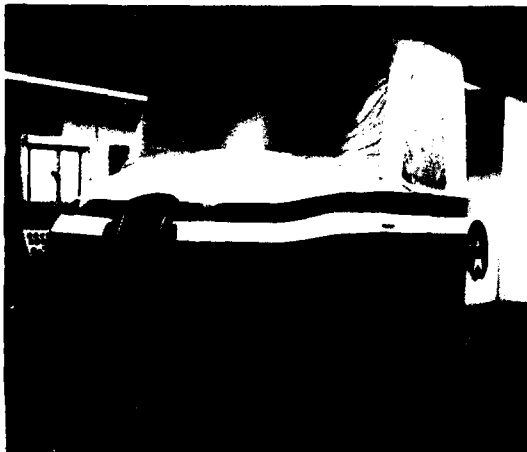

Figure 2. Research Simulator



Figure 3. Simulator Cockpit

On-line data collection is provided through a data acquisition system consisting of a multipurpose acquisition and control system interface, a Systems Engineering Laboratory (SEL) 8500 hybrid analog/ digital computer and associated computer programs. The data acquisition system provides the capability of real-time monitoring and recording of 22 different flight parameters during actual simulator flights. These parameters include aircraft control movements, navigation and position information, flight instrument indications and aircraft flight dynamics (Table 1). Each parameter is sampled 20 times per second and recorded on both magnetic disc and tape.

TABLE 1  
RECORDED FLIGHT PARAMETERS

1. Altitude	12. Pedal Movement
2. Rate of Climb	13. Rate of Turn
3. Heading	14. Torque
4. Pitch Rate	15. Gas Producer RPM
5. Roll Rate	16. Pitch Attitude
6. Airspeed	17. Roll Attitude
7. Ground Position N/S	18. Throttle Position
8. Ground Position E/W	19. Rotor RPM
9. Left/Right Cyclic Movement	20. Longitudinal Velocity
10. Fore/Aft Cyclic Movement	21. Lateral Velocity
11. Collective Movement	22. Aircraft Trim

Eye Movement Recorder and Analyzer. Visual performance of all subjects was recorded by means of a modified NAC Eye Mark Recorder in conjunction with a LOCAM high-speed motion picture camera and special 16mm Kodak Ektachrome film. Figure 4 shows the NAC Eye Mark Recorder mounted on an aviator's head.

The optical scene in the pilot's forward field of view, in this case the instrument panel, is obtained through the image lens on the front of the device and transmitted through a fiber optic bundle to the 16mm camera where it is recorded on the film. A small light located slightly below and to the right of the subject's right eye, produces an optically focused, wedge-shaped image which is reflected off the cornea of the eye through a series of mirrors and prisms to the optic bundle where it is superimposed on the optical scene being filmed. A series of adjustments on the device allow for calibration of the corneal reflection image so that it appears on the recorded visual scene at the exact point at which the subject is looking. Figure 5 shows one frame of the movie film taken during this investigation. The white wedge-shaped image indicates the viewing point of the pilot at a specific moment in time.

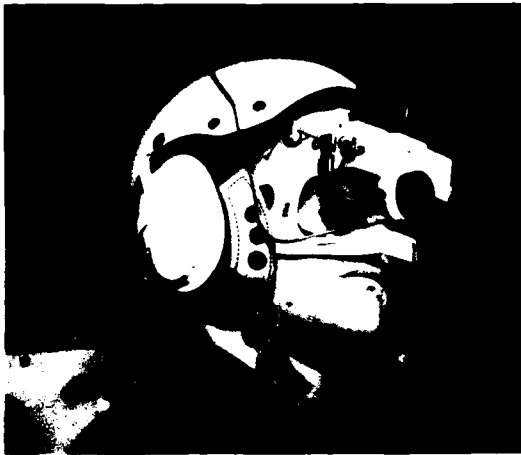

Figure 4. NAC Eye Mark Recorder

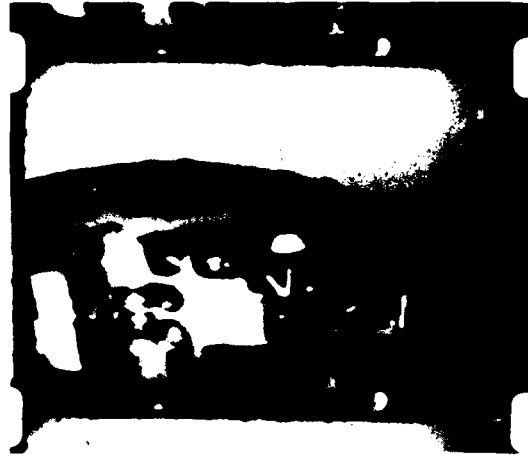
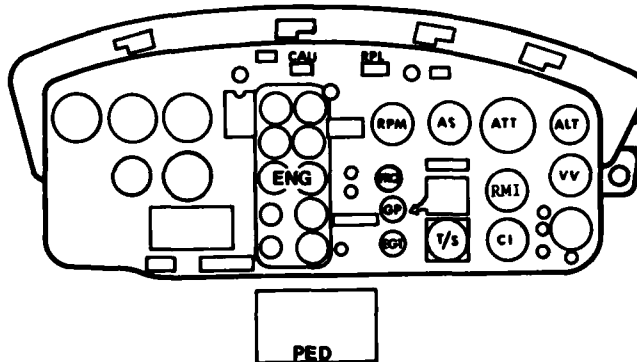

Figure 5. Pilot's View Recorded on Film

All film recordings were made in real time during the simulator flights. This equipment allowed the experimenters to determine where the pilots were looking each 1/16 of a second.

A schematic diagram of the instrument panel and the 15 instruments and display areas analyzed in this study are shown in Figure 6.



ALT: Altimeter  
 VV: Vertical Velocity Indicator  
 CI: Course Indicator (OMNI)  
 T/S: Turn and Slip Indicator  
 RMI: Radio Magnetic Indicator  
 ATT: Attitude Indicator  
 AS: Airspeed Indicator  
 TRQ: Torquemeter Indicator  
 GP: Gas Producer Tachometer Indicator  
 EGT: Exhaust Gas Temperature Indicator

RPM: Dual Tachometer (Engine & Rotor RPM Indicator)  
 CAU: Master Caution Light  
 RPL: RPM Warning Light  
 PED: Pedestal Panel  
 ENG: Engine Instruments:  
 Fuel Quantity and Pressure  
 Engine Oil Temperature and Pressure  
 Transmission Oil Temperature and Pressure  
 Electrical Voltmeters and Loadmeter  
 OTH: Areas Other Than Those Listed Above

Figure 6. Instrument Panel Layout

Since the engine status gauges are monitored infrequently during an autorotation they were grouped together for purposes of reporting the data. The controls and displays located in the center pedestal console were grouped together for the same reason.

The eye movement data were time-scored by projecting the film on a screen one frame at a time with an 16mm projector analyzer. The pilot's viewing time on each of the 15 instruments or display groups was summarized utilizing the SEL 8500 computer system.

### Oculomotor Activity Measures

Three separate measures were used in the analysis of visual performance:

- a. Percent viewing time--the percentage of time spent looking at a specific visual area during the maneuver.
- b. Dwell time--the mean fixation time spent looking at a specific visual area.
- c. Scan rate--the rate at which each visual area is viewed per minute.

The equations for these measures are shown in Table 2.

TABLE 2  
VISUAL PERFORMANCE MEASURES

Percent Viewing Time	$\% VT = \frac{t_i}{t_t} \times 100$
Dwell Time	$DT = \frac{t_i}{n_i}$
Scan Rate	$SR = \frac{n_i}{t_t} \times (60 \text{ sec})$
$t_i$	Total time spent looking at a specific visual area "i" in seconds
$t_t$	Total flight time in seconds
$n_i$	Number of looks at a specific visual area "i" during the flight

### Procedure

Prior to the first of the four simulator flights each pilot was briefed on the experiment and the flight profile he was expected to fly. He was told to fly the profile according to standard instrument flight rules (IFR) and to hold assigned altitudes, airspeeds and headings "as closely as he could" while keeping the aircraft in trim. Cruise speed was to be 90 knots, rates of climb and descent were to be made at 500 feet/minute and all turns were to be executed at a standard rate, 3°/second. Each pilot was also informed that emergency situations identical to those experienced in the actual aircraft could occur in the simulator. If this were to happen, he was to carry out the same emergency procedures he would perform under actual flight conditions.

After the initial briefing the pilot moved into the simulator where he was shown the basic operation of the device. He then took over the controls, performed an ITO, some level flight, a few turns, climbs and descents, and then landed. This initial training period lasted from 20 to 30 minutes.

The flight profile was then flown with one of the investigators acting as the copilot and on-board observer. The copilot assisted the pilot in tuning radios and navigation aids but did not take over the controls or make radio calls. Both the pilot and the copilot wore standard Army flight suits, helmet and gloves during flight. The flight itself was under the continual direction of another experimenter acting as an air traffic controller outside the cockpit. A total flight lasted 50-60 minutes.

Prior to the second, third, and fourth flights each subject was provided feedback as to how precisely he flew on the preceding flight(s). This feedback consisted of showing the pilot a graph of his performance on each of the flight parameters he was requested to maintain as well as graphs of his aircraft control movements. The graphs were reviewed in detail with the pilot, and goals of increasing precision in holding to the requested parameters were stressed.

The first three flights were training flights to bring the aviators up to an optimal level of proficiency in the simulator. Three flights were selected as the optimum number for transition based on prior evaluations conducted in the simulator. The fourth flight was conducted as described in the overview section above. The data collected during the fourth flight provided the basis for this analysis.

### Autorotation Performance Criteria

The objective of performing an autorotation maneuver in response to an aircraft emergency is to land the aircraft, preferably without damage to the equipment or injury to the flight crew and passengers. The accomplishment of that task involves a number of complex aerodynamic tradeoffs between potential and kinetic energies and pilot control measures.

The autorotation maneuver in response to an emergency condition can be considered in three phases. In the initial phase (Phase 1) the aircraft will tend to deviate from previously controlled conditions in response to the specific system failure(s) encountered. The pilot must first diagnose the nature of the emergency to determine what action is to be taken. Once he has determined that an autorotation is necessary, he must take steps to set up the aircraft conditions necessary to maintain positive aircraft control. This is accomplished by smoothly reducing collective pitch to maintain rotor speed, adjusting the antitorque pedals to maintain coordinated flight, and adjusting the aircraft attitude to control the heading, airspeed and the rate of descent.

During the second phase (Phase 2), after the pilot has established the desired aircraft control there will be less of a tendency for the aircraft to deviate from the established flight conditions than there was during the initial phase and the aircraft aerodynamics will stabilize for a relatively smooth descent toward the ground. The desired autorotation flight parameters for a UH-1 helicopter are described in the US Army's Aircraft Operator's Manual<sup>5</sup> and the Rotary Wing Instrument Guide.<sup>6</sup> The prescribed rotor speed is to be in the range of from 294 to 324 rpm (339 maximum). Under visual conditions, the recommended indicated airspeed is from 70 to 80 knots with a minimum of 53 knots and a maximum of 99. During IFR flight an aircraft attitude should be established such that the airspeed is reduced to 60 knots and maintained until visual contact is made with the ground. Heading deviation is to be within  $\pm 10^\circ$  and the aircraft must be held in proper trim. The aviator strives to maintain the balance of these conditions during the descent portions of flight.

The final deceleration and termination phase (Phase 3) of the maneuver begins at approximately 100 feet above the ground. Cyclic control is used to reduce excessive forward speed and then collective pitch is applied to cushion the landing. This last phase must be completed using visual cues from outside the aircraft because present instrumentation in US Army helicopters does not provide accurate absolute altitude and angle of deceleration information necessary to initiate the proper control actions without outside cues.

During autorotation exercises in the US Army's UH-1 synthetic instrument flight trainer the pilot is expected to control the simulator according to these same criteria for airspeed, heading and trim.<sup>6</sup> The synthetic flight trainer is considered to have crashed when the rotor speed exceeds 341 rpm or drops below 259 rpm. The pilots who flew in this investigation were likewise expected to control the research simulator within these limits. It should be noted that the above limits have been established as guidelines. The exact limits to which flight parameters can deviate and a successful autorotation still be accomplished have not been specifically defined under actual emergency conditions.

Since the research simulator was not equipped with a visual system, the data analyzed in this study was limited to Phases 1 and 2 of the autorotation or to that portion of the maneuver above 100 feet in altitude. A review of the data indicated that, in general, the initial phase of the maneuver was completed within the first twenty seconds after the onset of the simulated engine failure. The two flight segments analyzed were therefore established as:

Phase 1--Beginning with the introduction of the engine failure and up to 20 seconds into performance of the autorotation maneuver.

Phase 2--From 20 seconds into the maneuver until the simulator reached an altitude of 100 feet above ground.

The design of this experiment specifically precluded discussing autorotation maneuvers with the aviators prior to the initiation of an unannounced engine failure. Therefore, exact performance requirements were not discussed with the aviators before they performed the autorotation.

The parameters selected to represent aircraft performance in the analysis were those defined in the UH-1 operator's manual: airspeed, rotor speed, heading and aircraft trim. The pilots' control of heading was evaluated by analysis of root mean square (RMS) variation around the  $060^\circ$  heading which the aviators were instructed to maintain during the execution of the ILS missed approach prior to the introduction of the engine failure. Rotor speed was evaluated with respect to the RMS variation from the average rotor speed at the time of the initiation of the engine failure (317 rpm). Aircraft trim was considered in light of the RMS deviation of the inclinometer (the ball of the turn and slip indicator) from the centered or null position. Since the operator's manual does not specify a single airspeed requirement for autorotations, airspeed variation was evaluated with respect to the standard deviation about the mean airspeed maintained by the individual aviator.

## RESULTS AND DISCUSSION

Oculomotor Activity

A description of how the aviators allocated their visual time is presented in Figures 7 through 12. These charts summarize the visual activity directed to each instrument during Phases 1 and 2 of the performance of the autorotation. The mean percent viewing times for all instruments monitored are shown in Figures 7 and 8. The mean dwell times allocated to these same instruments are shown in Figures 9 and 10 and the average scan rates in Figures 11 and 12.

Examination of the visual measures concerning the aircraft status and warning displays (torquemeter, gas producer tachometer, exhaust gas temperature, engine instruments, master caution light, RPM warning light and the pedestal panel) reveals very little overall usage of these displays. However, it should be noted that the amount of visual activity directed to these displays was higher during the first phase of the maneuver than it was during the second phase. The majority of that activity occurred during the first few seconds of Phase 1--the time period during which the aviators had to diagnose the nature of the emergency. During Phase 2 of the autorotation many of these instruments were not even looked at. Since these displays are not directly related to the control of the aircraft, and since they were viewed infrequently, they were excluded from the analysis reported here. The course indicator was also excluded from the analysis due to its low rate of usage during the autorotation.

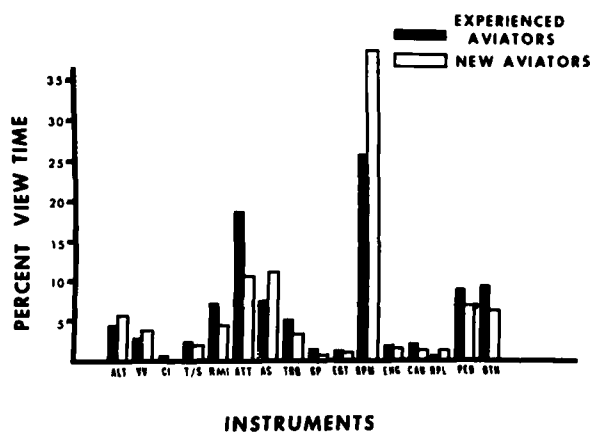
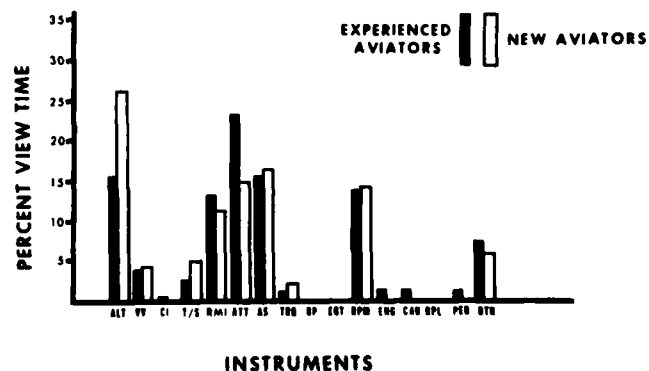

Figure 7. Percent Viewing Time Allocated to Flight Instruments During Phase 1 of the Autorotation Maneuver

Figure 8. Percent Viewing Time Allocated to Flight Instruments During Phase 2 of the Autorotation Maneuver



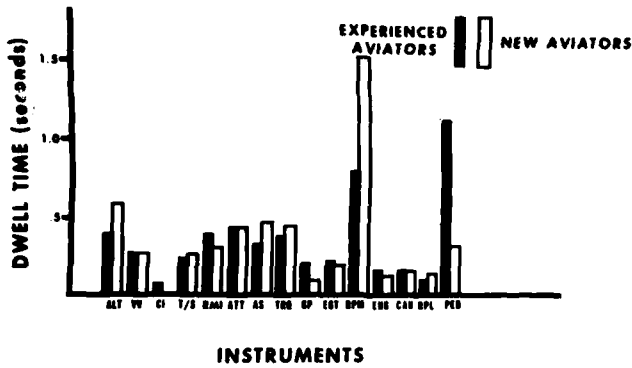

Figure 9. Mean Dwell Time on the Flight Instruments During Phase 1 of the Autorotation Maneuver

Figure 10. Mean Dwell Time on the Flight Instruments During Phase 2 of the Autorotation Maneuver

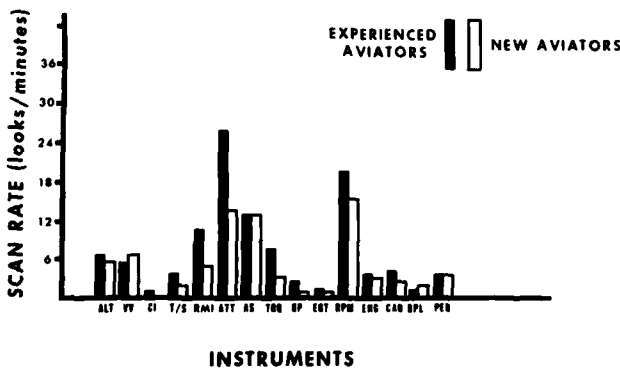
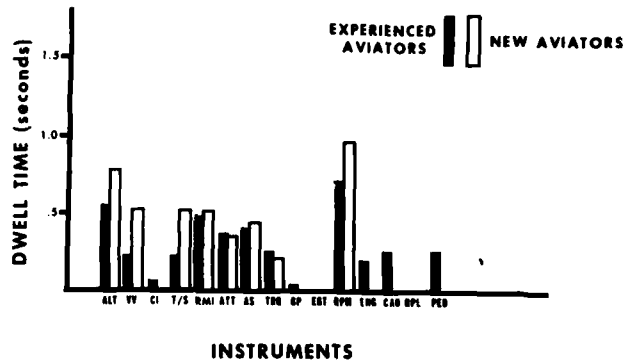
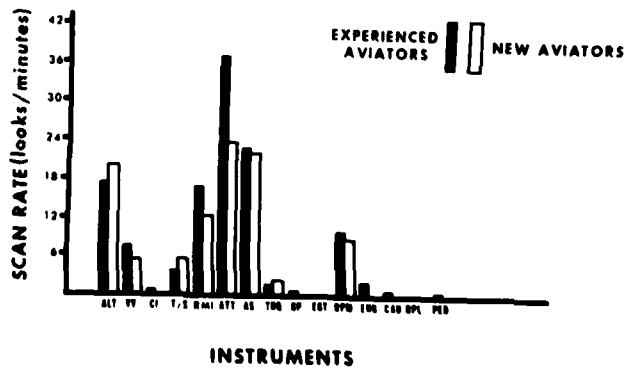

Figure 11. Scan Rate to the Flight Instruments During Phase 1 of the Autorotation Maneuver

Figure 12. Scan Rate to the Flight Instruments During Phase 2 of the Autorotation Maneuver



The percent viewing time, scan rates, and dwell times were each analyzed separately using an analysis of variance which treated the aviator's experience level as one factor and the two phases of the autorotation as repeated measures. The analysis was limited to the visual activity directed toward the instruments that are normally associated with the control of altitude, heading, attitude, airspeed, and rotor speed. The significant results of these analyses are shown in Table 3. Since this investigation was an initial exploration of the relationship between visual activity and performance, corrections for multiple F-test comparisons were not conducted and significance levels of  $p < .10$  were considered.

TABLE 3  
SUMMARY OF VISUAL PERFORMANCE MEASURES ANALYSES

Dependent Variables	Between Pilots Experience Level	Within Pilots	
		Flight Phase	Flight Phase X Experience Level
<u>% Viewing Time</u>			
Altimeter	.025	.001	
Radio Magnetic Indicator		.005	
Attitude Indicator		.10	
Airspeed Indicator		.025	
RPM Indicator		.05	
Vertical Velocity Indicator			
Turn/Slip Indicator			
<u>Dwell Time</u>			
Altimeter	.10	.01	
Radio Magnetic Indicator		.10	
Attitude Indicator		.025	
Airspeed Indicator			
RPM Indicator	.05		
Vertical Velocity Indicator	.10		.10
Turn/Slip Indicator			
<u>Scan Rate</u>			
Altimeter		.001	
Radio Magnetic Indicator		.005	
Attitude Indicator	.10	.01	
Airspeed Indicator		.005	
RPM Indicator		.01	
Vertical Velocity Indicator			
Turn/Slip Indicator			

NOTE: 1.  $p$  values are those of the upper limit of the intervals:  
 $p < .001$ ,  $.001 < p < .005$ ,  $.005 < p < .01$ ,  $.01 < p < .025$ ,  
 $.025 < p < .050$ ,  $.050 < p < .10$

2.  $df = 1/8$

As shown in Table 3, significant differences were found in all three measures of visual activity between the two phases of the autorotation for the altimeter, attitude and radio magnetic indicators. The scan rate and the percent viewing time for the airspeed and RPM indicators were also found to differ between the two phases of the autorotation. The significant mean visual activity levels allocated by the ten pilots to each of these five instruments are graphed as a function of the phase of the autorotation in Figure 13. In general, the aviators increased their visual activity on four of the instruments (altimeter, attitude, airspeed, and radio magnetic indicators) during Phase 2 of the autorotation. The increase in visual activity on these instruments was in part balanced by decreased utilization of the RPM indicator.

The dwell time on the altimeter, RPM, and vertical velocity indicators, along with the scan rate on the attitude indicator and the percent viewing time for the altimeter, were found to differ as a function of the group experience level. On the average, the new aviators tended to dwell on the altimeter, RPM, and vertical velocity indicators for longer periods of time than did the more experienced aviators (Figures 9-10). The newer aviators also spent a significantly greater percentage of time viewing the



altimeter (Figures 7-8). In addition, they looked at the attitude indicator less frequently (Figures 11-12) than did the experienced aviators.

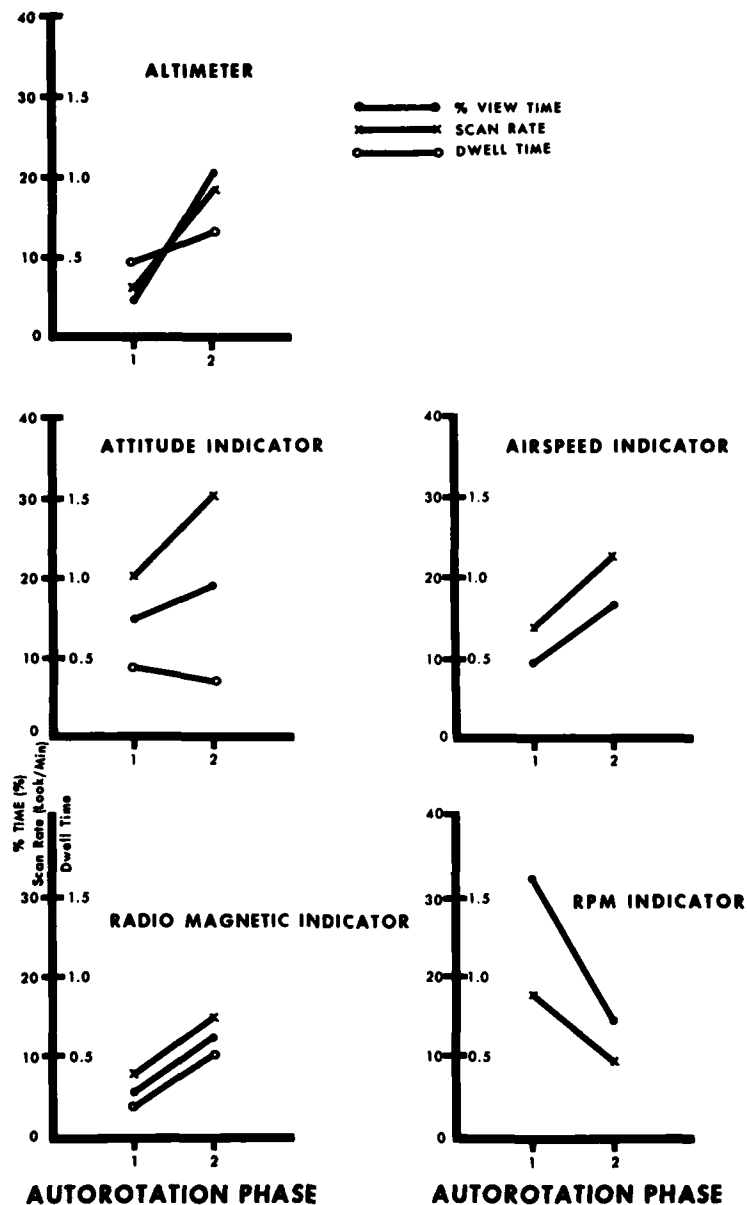

Figure 13. Pilot Visual Activity as a Function of Autorotation Phase

There was only one significant interaction between the experience level and the autorotation phase variables on the oculomotor activity measures--that for the dwell time on the vertical velocity indicator. As indicated in Figure 9, the dwell time on the vertical velocity indicator was about equal for both groups of pilots during Phase 1 of the autorotation; but, on the average, the newer pilots dwelled on that indicator longer during Phase 2 of the autorotation (Figure 10).

### Aircraft Flight Performance Measures

Each of the performance measures selected was assessed by the analysis of variance with repeated measures on the two phases of the autorotation. The results of that analysis are shown in Table 4.

TABLE 4  
SUMMARY OF CONTROL PERFORMANCE MEASURES ANALYSES

Dependent Variables	Between Pilots	Within Variables Pilots	
	Experience Level	Flight Phase	Flight Phase X Experience Level
RMS Aircraft Trim (Ball)			
RMS Heading			
SD Airspeed		.001	
RMS Rotor RPM		.10	

NOTE: 1. p values are those of the upper limit of the intervals:  
p < .001, .05 < p < .10

2. df = 1/8

The standard deviation of airspeed and the RMS of rotor speed were both found to differ as a function of the two phases of the autorotation. The overall means depicting the significant decrease in the pilots' control variations of rotor speed and airspeed in Phase 2 of the autorotation are shown in Figure 14. Both the rotor speed and airspeed variability were less during the second phase.

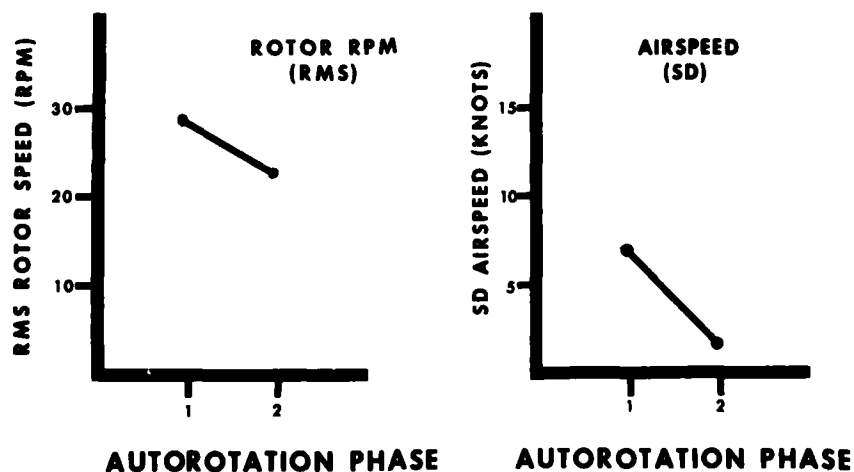

Figure 14. Performance Measure Variability as a Function of Autorotation Phase

There were no significant differences between experience levels nor were there any significant interactions between the experience level and the autorotation phase variables for the pilot control performance measures.

### Visual Activity and Flight Performance

The relationships between visual activity measures and the flight performance measures during the autorotation maneuvers are not straightforward. When the visual

activity measures which were significant (Figure 13) are compared with the significant control performance variables (Figure 14), direct one-to-one relationships do not seem apparent. For example, during Phase 1, the visual activity toward the RPM indicator was higher than it was during Phase 2. Likewise, the variability of the rotor speed was higher during Phase 1. This would indicate that relatively higher levels of visual activity during a given flight phase are in some way related to higher variability of a pilot's control of the flight parameter. If this were true, the variability of the airspeed performance measure would be expected to be lower during the first phase of the autorotation because of the relatively low visual activity directed to the airspeed indicator during that period. However, examination of the data in Figure 14 does not support that assumption. The airspeed variability was actually less during the second phase of the autorotation. Another example would be the fact that significant differences were found between autorotation phases for the percent of time, dwell time and scan rate on the radio magnetic indicator; however, the aircraft heading did not differ significantly between the two phases of the autorotation.

In a similar manner, even though the analyses did not indicate significant differences between aviator experience levels on flight performance measures, there were differences between experience levels with respect to the visual activity directed to various instruments (Table 3).

The data do support the theory that pilots visually attend to the flight parameter of most concern until it is brought under control and then shift their attention elsewhere. As an example, both the rotor speed variability and the visual activity toward the RPM indicator decreased from Phase 1 to Phase 2. The visual activity on the other four instruments increased during that same interval. It appears that as the pilots stabilized their rotor speed control, they also began to reduce the level of visual activity devoted to the RPM indicator and to shift their visual activity to other instruments.

It is apparent that the relationships between visual activity and the performance measures in this study are more complex than mere direct one-to-one relationships.

Relating the visual activity on an individual instrument to the pilot's control of the flight parameter associated with that instrument is partially precluded by the fact that the information provided on certain instruments is redundant. For example, in this study some of the aviators reported they were not concerned with airspeed as a separate entity. Their reported technique of stabilizing the airspeed was to place the simulator into the proper attitude and then the airspeed would "take care of itself." Airspeed stability could therefore be achieved through use of various combinations of visual activity to the airspeed indicator and the attitude indicator. The attitude indicator itself is a multifaceted instrument which presents aircraft pitch and roll information. These parameters are in turn related to airspeed, heading and altitude. Therefore, a single look at this instrument could mean many things.

Thus far we have looked at the pilots' visual and simulator control performance separately and have compared them over the two flight phases of approximately 20 seconds each. These comparisons point out that the relationships between visual behavior and control performance are not related in a straightforward manner. What appears to be needed is a time link approach to analyzing both sets of data simultaneously and sequentially. An example of the sequential time link between visual scan behavior and pilot control performance is illustrated for a single aviator in Figure 15. The horizontal axis of the graph represents cumulative time as the autorotation maneuver progresses. The solid markings in the parallel tracks depict the sequence of the pilot's visual activity in the form of the time spent viewing each instrument during individual fixations. The individual aircraft control parameters are shown by the solid lines which vary in amplitude over time.

During the initial phases of the maneuver this pilot spent a considerable amount of time viewing the RPM indicator at the expense of other instruments. He appears to have done so because the rotor speed was rapidly decreasing from the initial value of 317 rpm to a value lower than that desired. During this same period heading and airspeed were both decreasing, but at a slower rate.

At approximately six seconds into the flight a control movement was introduced which changed the rotor speed from a decreasing trend to one that was increasing toward the desired level. The aviator then appears to have shifted his visual attention toward other instruments but had not yet checked the radio magnetic indicator (RMI). The heading continued to move toward the lower limit of 050°. At approximately 7.5 seconds, the aviator monitored his radio magnetic indicator for the first time. Shortly after he checked the RMI, the direction of heading movement reversed indicating a control change on the part of the aviator. This relationship between the pilot's visual scans and his aircraft control performance continues through the rest of the maneuver. It should be noted that not all fixations resulted in a change to the associated performance measure. For example, the pilot looked at his airspeed indicator numerous times during the maneuver, but the downward trend of the airspeed measure continued. Presumably, these fixations on the airspeed indicator informed the pilot that the airspeed was decreasing at an acceptable rate and a control correction was not necessary.

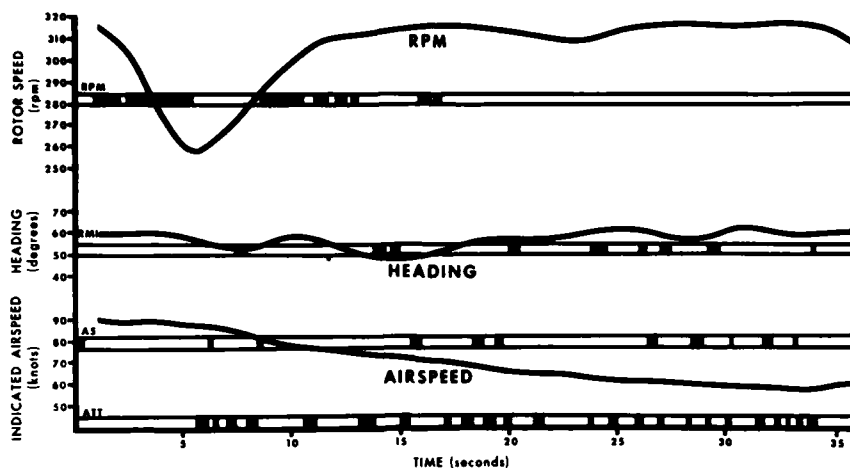

Figure 15. Sequential Time Link Between Pilot Visual Scan Behavior and Control Performance Measures

Similar trends were noted in the data of other aviators tested in this investigation. We are presently evaluating a time sequence approach to analyzing the performance measures as they are time linked to the visual activity. That analysis should provide a more comprehensive quantification of the relationship between aviator visual activity and aircraft control performance.

#### CONCLUSIONS

The objective of this exploratory study was to investigate the relationship between aviator oculomotor activity and pilot control of a simulator during performance of an autorotation maneuver under instrument flight conditions. This maneuver differs from the standard or normal flight conditions in that the aviator is concerned with one objective--successfully landing the aircraft. Oculomotor activity should therefore be directed toward those instruments that will aid in reaching this objective.

A number of general conclusions can be drawn from the data presented here with respect to aviator oculomotor activity during autorotation to a simulated engine failure.

- a. After a few initial glances at the aircraft status and warning displays to diagnose the emergency situation, the majority of the aviators' visual activity was devoted toward the RPM, attitude and the airspeed indicators during the initial phase of the autorotation.
- b. After the rotor speed variability was reduced, the aviators decreased their visual activity toward the RPM indicator and simultaneously increased visual attention to the attitude, radio magnetic, altimeter and airspeed indicators.
- c. Throughout the autorotation the newer aviators exhibited longer dwell times to the altimeter, vertical velocity and RPM indicators than the experienced aviators. They also spent a greater percent of viewing time on the altimeter and looked at the attitude indicator less often than did the more experienced pilots.
- d. In terms of aircraft control performance, both groups of pilots exhibited more control of both rotor speed and airspeed in the second phase of the autorotation than they did in the first phase.
- e. The relationships between oculomotor activity and specific aircraft performance measures during autorotations are more complex than can be made by direct one-to-one comparisons. An analysis of the simultaneous and time sequential links between pilot visual scans and flight parameter control seems to be required to provide a more definitive understanding of the complex ties between aviator visual activity and aircraft control performance.

The data obtained from this exploratory investigation add to the existing data base concerning visual performance in helicopter flight and should assist in future work directed toward the optimization of pilot visual activity during emergency situations.

## REFERENCES

1. Forbes, D. US Army autorotation accidents. Ft Rucker, AL: Unpublished manuscript. US Army Agency for Aviation Safety, July 1977.
2. Frezell, T. L., Hofmann, M. A., Snow, A. C., & McNutt, R. P. Aviator visual performance in the UH-1 (USAARL Rpt No 75-11). Ft Rucker, AL: US Army Aeromedical Research Laboratory, March 1975.
3. Barnes, J. A. Analysis of pilots' eye movements during helicopter flight (HEL TM 11-70). Aberdeen Proving Ground, MD: US Army Human Engineering Laboratory, April 1972.
4. Simmons, R., Lees, M., & Kimball, K. Visual performance/workload of helicopter pilots during instrument flight (USAARL Rpt No 78-6). Ft Rucker, AL: US Army Aeromedical Research Laboratory, January 1978.
5. Department of the Army. Operators manual, Army model UH-1D/H helicopters (TM-55-1520-210-10, C17). Washington, D.C.: Headquarters, Department of the Army, April 1977.
6. US Army Aviation Center. Rotary wing instrument guide. Ft Rucker, AL: US Army Aviation Center and Fort Rucker, February 1977.

**POUVOIR SEPARATEUR DE L'OEIL SUR TUBE CATHODIQUE COULEUR**

par

Médecin en Chef G.F. SANTUCCI  
 Chef de la Division Psychophysiologie  
 de la Perception Visuelle

Centre de Recherches de Médecine Aéronautique  
 5bis, Avenue de la Porte de Sèvres  
 75996 - PARIS ARMEES  
 FRANCE

**RESUME**

Grâce à une méthodologie et un appareillage originaux l'acuité visuelle angulaire en contraste coloré simultané a été étudiée sur écran de télévision RVB. Les couleurs testées sont le rouge, le vert, le bleu, le pourpre, le cyan, le jaune et le blanc à égalité de luminance pour l'ensemble. Le contraste de brillance a également été étudié.

Ce travail effectué sur une population de 60 membres du personnel navigant âgés de 20 à 50 ans a permis :

- de définir la taille optimum de caractère assurant une reconnaissance de forme avec une bonne probabilité.

- de préciser les contrastes colorés assurant une meilleure rapidité de perception.

Les données ainsi recueillies peuvent permettre l'optimisation de la lecture d'informations sur tube cathodique.

**INTRODUCTION**

Pilotes, ingénieurs et médecins s'accordent pour reconnaître que l'évolution des missions et des performances des aéronefs de combat futurs nécessite l'élaboration de nouveaux modes de présentation des données de vol. En effet, on admet que le niveau de saturation tant du point de vue physiologique que technologique est sur le point d'être dépassé.

La maîtrise technologique du tube cathodique autorise maintenant la conception de nouveaux tableaux de bord et de nouveaux modes de présentation de l'information.

Afin d'optimiser cette nouvelle interface homme/machine, il est nécessaire d'approfondir nos connaissances de certains paramètres physiologiques de la perception visuelle.

Parmi les nombreuses questions qui peuvent se poser nous avons choisi l'étude de l'acuité visuelle angulaire en contraste coloré sur écran de télévision observé en vision lointaine.

Le rôle important de la couleur dans la présentation d'informations a été démontré par de nombreux travaux ainsi que l'attestent les revues bibliographiques de COOK (1974) et de SEMPLE (1971). Très récemment CHRIST (1975) a effectué un certain nombre de recherches sur la couleur dans les systèmes de présentation visuelle d'informations.

L'étude des conclusions de l'ensemble de ces travaux conduit à préconiser l'emploi de la couleur parce que les performances sont, la plupart du temps, améliorées et en aucun cas dégradées.

Cette notion étant admise, il convient d'optimiser la présentation et de définir une hiérarchisation des couleurs permettant une prise d'information plus rapide. Des études ont été faites et l'on trouve les références chez les auteurs cités ci-dessus. Il est à noter que ces études ont été faites pour la plus grosse part en présentant une couleur sur un fond noir ou blanc. Or, la technologie des visualisations électroniques est suffisamment avancée pour permettre des présentations en contraste coloré simultané.

**I - POSITION DU PROBLEME**

Les phénomènes de perception en contraste coloré sont étudiés depuis longtemps (Chevreul, Pieron, Helmholtz, Land...). L'attention des auteurs s'est portée surtout sur les modifications de sensation colorée induite par la présentation simultanée de deux plages de couleurs différentes.

Dans le domaine ergonomique, le contraste coloré doit être abordé selon deux voies, soit que la couleur porte en elle-même le message (lampe allumée/éteinte) soit qu'elle est supportée par une forme qui participe aussi au message. Il faut alors reconnaître une forme colorée sur fond coloré. L'acuité visuelle est une fonction qui correspond à un tel schéma.

L'étude des publications portant sur le sujet ne permet pas de dégager comme nous allons le voir, des données cohérentes. Ceci est dû pour une part aux nombreux paramètres qui régissent la perception des couleurs et l'acuité visuelle. Le problème se complique par ailleurs du fait de la terminologie et de la métrique qui n'ont été codifiées que récemment par la C.I.E. Pour notre part nous utilisons la terminologie et la métrique correspondant aux normes C.I.E.

Les données de la littérature que nous présentons peuvent être classées en deux groupes : le 1er groupe correspond aux résultats les plus anciens qui se rapportent à des expériences effectuées avec des systèmes de présentation colorés faisant appel à la projection de plages colorées, à partir de lampes avec filtres ou de sources spectrales, à l'utilisation de stimulus pigmentaire (en général papier) éclairés par une lampe. Le deuxième groupe se rapporte à des travaux plus récents utilisant des visualisations électroniques de type tube cathodique (le plus fréquent) ou bien diodes électroluminescentes etc...

**1.1. - Les systèmes d'affichage à base de lampes**

Mac ADAM (1949) a mesuré l'acuité visuelle en présentant des optotypes de différentes couleurs sur fond gris isolumineux. A chaque fois il cherchait avec des stimulus achromatiques le contraste de brillance donnant la même performance. Il montre ainsi que plus la couleur est saturée meilleure est l'acuité visuelle puisqu'elle devient équivalente à celle obtenue avec des contrastes de brillance de plus en plus grands. Par ailleurs il pense que l'acuité visuelle en contraste coloré est étroitement corrélée au seuil différentiel chromatique.

MERCIER, en 1957 rapporte les résultats de FERREE et RAND selon lesquels à luminosité égale

les couleurs donneraient une meilleure acuité visuelle dans l'ordre suivant : jaune, vert jaune, orange, vert, rouge, vert-bleu, bleu. Alors que ROUX (1958) rapporte des résultats de ARNULF et FLAMENT selon lesquels si les luminances sont bien égales les acuités sont identiques pour toutes les couleurs et la lumière blanche.

LEGRAND en 1956, dans son livre, rapporte les résultats de nombreux auteurs qui sont contradictoires : "en somme, ce problème de l'acuité en lumière colorée est extrêmement confus".

En 1966, CAVONIUS et SCHUMACHER ont étudié, chez deux sujets, l'acuité visuelle colorée avec un réseau dont les barres alternantes sont équilumineuses, mais dont les longueurs d'onde diffèrent, ce qui revient à présenter un test coloré sur un fond coloré. Leur dispositif expérimental permet d'obtenir des tests colorés très fortement saturés. Une longueur d'onde est attribuée, fixe, à une série de barres, l'autre série de barres est illuminée successivement par tout le spectre visible. Plus le rapport entre la longueur d'onde du test et celle du fond est grande meilleure est l'acuité. Mais résultats très intéressants, l'effet de cette différence de longueur d'onde n'est pas identique pour tout le spectre. L'acuité est bonne pour un faible rapport, si le test et le fond sont illuminés avec de courtes longueurs d'onde alors que le rapport devra être beaucoup plus important pour obtenir le même niveau d'acuité avec les grandes longueurs d'onde du spectre visible.

POKORNY et Coll. en 1968 ont mesuré avec un réseau l'acuité visuelle en faisant varier la longueur d'onde du test chez cinq sujets, et à différents niveaux de luminances. L'acuité visuelle augmente asymétriquement avec la luminance du test. Elle est plus basse pour le bleu chez quatre sujets, un sujet montre aussi une acuité visuelle demeurant plus basse lorsque la luminance augmente, et ceci dans le rouge.

### 1.2. - Contraste coloré et visualisation électronique

PUIG (1976) rapporte dans sa revue bibliographique un certain nombre de travaux qui se sont attachés à étudier l'apport de la couleur dans la détection et la reconnaissance de cible sur des écrans de télévision. Ces recherches ont porté sur des études globales de simulation et aucune ne rapporte d'étude de l'acuité visuelle.

Les travaux se rapportant à la lisibilité d'informations sur écran de TV ont eu pour thème la comparaison des performances obtenues avec différents systèmes d'affichages et la vue directe (HENNESY 1973, LONG 1969, PUIG 1976).

Il faut noter deux publications concernant la perception de la couleur sur écran de télévision : HAUSING (1976) a cherché à connaître le nombre de couleurs pouvant être reconnues sans confusion sur un système TV trichrome Shadow Mask. Il a montré que 6 couleurs pouvaient être discriminées avec une bonne probabilité : le rouge, le vert, le bleu, le jaune, cyan et pourpre.

DUPONT-HENIUS (1977) a déterminé les seuils différentiels chromatiques sur écran de télévision trichrome Shadow Mask. Son étude sur vingt sujets ne lui a pas permis de confirmer les résultats donnés par MACADAM en 1942. Les points mesures ne se trouvent pas sur une ellipse mais dessinent une figure ovoïdale accidentée.

Ainsi nous n'avons pas trouvé dans la littérature de travaux qui puissent donner des éléments de réponse précis au problème qui nous était posé.

Les données que nous avons rapportées en 1.1. ne peuvent être transposées directement car elles n'ont pas été établies sur des tubes cathodiques.

Or, les mécanismes mis en jeu dans la perception visuelle d'images présentées sur tube cathodique sont très probablement différents de ceux utilisés lorsque le stimulus est "stable".

En effet particulièrement avec les tubes à balayage TV, l'image reçue par l'œil est une image construite séquentiellement dans le temps et dans l'espace.

Nous avons donc été conduits à concevoir et réaliser un appareillage pour étudier les points suivants :

- Quel est le rôle du contraste de brillance dans l'acuité visuelle angulaire mesurée sur un écran de télévision ?
- En contraste coloré simultané existe-t-il des différences d'acuité visuelle selon les couleurs utilisées si on réalise l'égalité de luminance entre le test et le fond ?
- Quelle est la plus petite taille du détail significatif d'un test assurant une bonne perception ?
- Existe-t-il une influence prépondérante de la couleur du fond ou du test ?

## II - METHODOLOGIE EXPERIMENTALE

Pour des raisons techniques nous avons été amenés à effectuer deux expérimentations qui diffèrent l'une de l'autre par les couleurs testées et l'écran de télévision testé. Au cours de l'expérimentation nous les désignerons par A et B.

### A) L'appareillage

#### 1) Les moniteurs de télévision

##### Expérimentation A

Un téléviseur couleur Schlumberger RC6 V3 de type RVB équipé d'un tube vidéocolor A67150X de 63 cm de diagonale. Ce moniteur est du type Shadow Mask trichrome à balayage 625 lignes.

##### Expérimentation B

Elle a été conduite sur un moniteur Sony PVM 1300E/AS équipé d'un tube trinitron de 33 cm de diagonale.

#### 2) Système générateur d'image

Il permet l'incrustation électronique d'un test coloré sur fond d'une autre couleur. Le balayage TV ne permettant pas la réalisation d'une image circulaire suffisamment précise pour obtenir un anneau, nous avons choisi un E construit selon les règles de l'anneau de Landolt. L'épaisseur des barres est égale à l'épaisseur des lacunes. Le E est inscrit dans un carré de 5 unités de base, l'unité étant définie par l'épaisseur de la barre. Le détail significatif est donc la lacune que l'œil doit percevoir.

Ce E peut être orienté vers le haut, le bas, la gauche, la droite de l'écran en étant toujours centré sur celui-ci.

Il peut être présenté selon 9 tailles.

### Caractéristiques des tailles présentées

N°taille	0	1	2	3	4	5	6	7	11
Valeur angulaire du détail significatif	1'25"	1'46"	2'08"	2'30"	2'51"	3'13"	3'34"	3'55"	5'21"

Le système offre une palette de 6 couleurs pour le test et le fond. On dispose de 3 fois 6 canaux. Chaque canal permet la constitution d'une couleur par mélange des trois fondamentales : rouge, vert, bleu.

#### 3) Le système de commande

Il est piloté par un ruban perforé généré par un ordinateur à partir d'un programme établi en fonction du type d'expérimentation choisi. Sur le ruban sont définis : l'image, le temps de présentation et l'ordre de succession.

#### 4) Le système de réponse

Le sujet répond par l'intermédiaire d'un manipulateur à 4 positions correspondant aux 4 orientations de l'optotype. On obtient ainsi la nature de la réponse et le temps de réponse du sujet. Ces résultats sont enregistrés sur ruban perforé en même temps que sont repris les caractéristiques de l'image ayant provoqué la réponse.

Trois types de réponses sont possibles :

- le sujet reconnaît ou pense avoir reconnu l'orientation du symbole et l'indique
- il ne l'a pas reconnue et il appuie sur un interrupteur signifiant "je ne sais pas"
- il s'abstient de répondre.

Dans tous les cas, l'image reste affichée pendant la durée fixée par le programme.

### B) L'expérimentation

#### 1) Les couleurs

##### Expérimentation A

Nous avons étudié les 3 couleurs fondamentales du téléviseur : rouge (R), vert (V) et bleu (B) et deux mélanges : le jaune (J) et le blanc (W), ainsi que le pourpre et le cyan. La colorimétrie effectuée avec un spectrophotomètre "Gamma Scientific" type 3000 A, a permis le calcul des coordonnées trichromatiques dans le système X Y Z.

	R	V	B	J	W
x	0,67	0,34	0,15	0,44	0,28
y	0,33	0,57	0,08	0,42	0,29

Avec ces 5 teintes était testé le noir. Au total nous avons donc 6 possibilités pour le fond et 6 pour le test. Compte tenu que lettres et fonds de même couleur n'étaient pas programmés, cela donne 30 possibilités de contrastes simultanés.

##### Expérimentation B

Outre les trois fondamentales rouge, vert, bleu, ont été étudiés le blanc, le pourpre et le cyan dont les coordonnées trichromatiques sont : - pourpre x 0,40 y 0,22  
- cyan x 0,24 y 0,34

Il y a donc également 30 possibilités de contrastes simultanés.

#### 2) Les sujets

Trente membres du Personnel Navigant de l'Aéronautique ont été examinés à chacune des expérimentations soit 60 sujets au total. Leur âge était compris entre 20 et 50 ans, en trois groupes de 10 sujets, par tranche de 20 à 29, 30 à 39, 40 à 50 ans.

Ces sujets présentaient une vision normale puisque membres du Personnel Navigant. Nous avions connaissance de leur dossier de visite systématique et pouvions éliminer toute anomalie même légère.

#### 3) Les conditions de présentation du test

Nous avons étudié l'acuité visuelle en vision de loin. Le téléviseur était situé à 8 m (expérience A) et à 4 m (expérience B) du sujet à l'extrémité d'un grand tunnel en toile grise. Ceci permettait d'avoir une ambiance neutre au point de vue couleur. Ce tunnel était éclairé par des tubes fluorescents qui permettaient d'obtenir un éclairage uniforme de 300 lux à 1 m du sol (hauteur des yeux du sujet installé dans un fauteuil à positions multiples).

#### 4) La luminance de l'écran

Elle demeure constante pour toutes les couleurs. Elle a été fixée à 15 nits, mesurée avec un radio-photomètre équipé d'une cellule corrigée CIE, sur laquelle est monté un télescope avec une ouverture de 2°. La plage test étant supérieure à 2°, nous étions dans des conditions photopiques. La luminance de l'environnement immédiat du téléviseur était de 12 à 13 nits.

### C) Organisation d'une séance

Pour mesurer l'acuité visuelle nous devons montrer au sujet une gamme de tailles de caractères telle qu'il y ait au moins une taille toujours perçue correctement et une taille non perçue.



La définition offerte par l'écran de télévision ne nous a pas permis d'obtenir des tailles non perçues pour certaines couleurs. Dix tailles furent présentées.

Afin d'éviter les réponses dues au hasard, chaque taille était montrée 4 fois (haut, bas, droite et gauche).

Pour chaque couple coloré, toutes les tailles et positions étaient présentées. Au total, nous devons montrer 900 images. Chaque image était construite en définissant le temps de présentation (1500 ms), la taille et l'orientation de la lettre, la couleur du fond et la couleur de la lettre.

L'ordre de présentation était randomisé par un programme sur ordinateur. Entre chaque image le calculateur insère l'ordre de présentation pendant une seconde d'une plage blanche isoluminescente aux couleurs, afin d'éliminer les effets de contraste coloré consécutif.

La durée de chaque séance était approximativement de 45 minutes.

### III - RESULTATS

Deux types d'analyses ont été effectués :

- . analyse qualitative portant sur le pourcentage de bonnes réponses,
- . analyse quantitative reposant sur l'étude des délais de réponses.

Les traitements statistiques utilisés pour cela (analyse de la variance et comparaison des moyennes consécutives) ont été faits séparément pour les deux expériences, les résultats sont présentés pour chacune des manipulations.

#### 3.1. - Expérimentation A

Elle concerne les couples colorés formés à partir des couleurs rouge, vert, bleu, jaune, blanc et noir.

##### 3.1.1. - Etude des couples colorés

###### 3.1.1.1. - Etude quantitative

La comparaison des moyennes consécutives selon la méthode de NEWMANS et KEULS, permet de construire le tableau I qui présente les délais de réponses en fonction de la couleur du fond, toutes tailles confondues.

On peut, sur ce tableau, différencier deux groupes de couleurs, le bleu et le rouge d'une part, le blanc jaune et vert d'autre part.

Le bleu et le rouge donnent des temps de réponses moyens groupés et bons ; alors que les délais de réponses moyens sont plus dispersés sur les fonds jaune blanc et vert.

Le fond noir donne les meilleurs résultats avec des valeurs moyennes égales pour toutes les couleurs de caractère sauf pour le bleu. Ceci s'explique parce qu'il y a contraste de luminance. Cette donnée était attendue et confirme l'hypothèse de départ.

Si l'on considère les délais de réponses en fonction de la couleur de la lettre avec des fonds colorés différents, les résultats sont identiques à ceux énoncés ci-dessus et ne sont donc pas exposés.

###### 3.1.1.2. - Analyse qualitative

Le tableau II présente sous forme synthétique le pourcentage moyen de réponses justes pour un fond de couleur donné en fonction de la couleur du caractère. Le classement des couleurs se fait de façon très parallèle à celui obtenu en considérant les délais de réponses moyens. On peut noter que tous les délais de réponses compris entre 590 et 633 ms correspondent à un taux de réponses justes supérieur à 95 %. Les mêmes observations ont été faites si l'on considère la performance pour une couleur de lettre en fonction des diverses couleurs du fond.

##### 3.1.2. - Analyse de l'acuité visuelle angulaire selon les couleurs

La figure III présente le temps de réponse moyen pour une couleur de fond en fonction de la taille du caractère (toutes couleurs de caractère confondues).

On note que lorsqu'il y a contraste de luminance (fond noir) la performance est la meilleure pour toutes les tailles.

Pour la plus petite taille correspondant au détail significatif vu sous un angle de 1'25", les fonds rouge, bleu et jaune provoquent les délais de réponse les plus longs. Mais dès la taille 2 on note que les couleurs rouge et bleu permettent la meilleure rapidité de perception pour toutes les tailles.

Cependant, les différences entre couleurs vont s'amenuisant au fur et à mesure que la taille du caractère croît pour permettre une performance égale au niveau de la taille la plus grande (5'21").

##### 3.1.3. - L'analyse de la variance

L'étude de la variance a permis de mettre en évidence une plus grande dispersion des délais de réponse si l'on considère la couleur du fond et au contraire une homogénéité plus grande pour les couleurs de lettre. Ceci peut permettre de conclure que la couleur d'un fond a un rôle plus important dans la perception et permet de mieux différencier les couples colorés que ne le permet la couleur de la lettre.

Ce résultat se conçoit bien lorsqu'on envisage les proportions relatives de l'important rayonnement engendré par le fond et la plus faible quantité émise par le caractère.

#### 3.2. - Expérimentation B

Cette expérimentation avait pour but l'étude de l'acuité visuelle angulaire selon les contrastes colorés obtenus à partir des couleurs rouge, vert, bleu, cyan et pourpre.

La méthodologie a été en tout point comparable à celle appliquée lors de l'expérimentation A.

Cependant, contrairement à la manipulation A deux couples de couleurs (vert/cyan et rouge/pourpre) donnent des résultats se distinguant trop nettement des autres. Aussi, pour certains traitements statistiques, ils ont été extraits afin de ne pas perturber les résultats généraux.

### 3.2.1. - Etude des couples colorés

#### 3.2.1.1. - Etude qualitative

Le tableau IV montre les délais de réponses moyens (toutes tailles confondues) des couleurs de lettres pour un fond damé.

Comme pour l'expérimentation A, on note que la couleur de fond bleu donne des résultats les plus groupés et les meilleurs.

Le fond blanc donne des résultats légèrement plus dispersés que le fond bleu, mais nettement plus homogène que lors de l'expérimentation A.

Pour les fonds rouge et pourpre, les résultats sont groupés sauf lorsque ces couleurs sont présentées ensembles dans un couple coloré.

Le même phénomène se remarque pour les couleurs vert et cyan.

Dans ces couples colorés il faut noter l'allongement très important des délais de réponse.

Si l'on envisage pour une lettre l'effet de la couleur du fond on retrouve une hiérarchie similaire à celle énoncée ci-dessus et les résultats détaillés ne sont pas exposés.

#### 3.2.1.2. - Analyse qualitative

Le tableau IV présente le pourcentage moyen (toutes tailles confondues) de réponses justes selon la couleur du fond pour les diverses couleurs de lettres. Il met bien en évidence les effets des couples vert/cyan et rouge/pourpre, qui ne permettent qu'un pourcentage très faible de bonnes réponses.

Les couples colorés utilisés lors de l'expérimentation A donnent des résultats identiques. On remarque que les deux nouvelles couleurs testées : le pourpre et le rouge, lorsqu'elles ne sont pas opposées donnent les performances les meilleures.

#### 3.2.2. - Acuité visuelle angulaire et couleur

L'étude des résultats présentés ci-dessus nous a conduit à éliminer, car trop défavorables, les couples vert/cyan et rouge/pourpre pour étudier l'effet de la taille du caractère.

Aussi sur la figure 5 on peut voir l'évaluation du délai moyen de réponses (toutes couleurs de caractères confondues) pour un fond donné en fonction de la taille de l'optotype.

Compte tenu de l'élimination des couples colorés défavorables, on peut donc noter l'amélioration rapide du délai de réponse avec l'augmentation de la taille de l'optotype. Ce résultat est identique à celui trouvé lors de l'expérimentation A.

3.2.3. - L'analyse de variance indique la prépondérance du fond sur la lettre pour l'expérimentation B comme pour l'expérimentation A.

Cette analyse n'est pas aussi fine que pour l'expérimentation A du fait des dispersions introduites par les couples particuliers déjà mentionnés.

## DISCUSSION

Les résultats que nous venons de présenter sont difficilement confrontables aux travaux antérieurs car le stimulus utilisé est très différent. En effet, l'image télévisuelle est construite séquentiellement dans le temps et l'espace et s'oppose en cela aux systèmes de stimulation type "boîte à lumière".

Du point de vue colorimétrique pur, on peut cependant considérer les résultats obtenus par Mac ADAM. Cet auteur a montré que parmi les trois paramètres de la stimulation colorée (tonalité, luminosité, saturation) la saturation était un élément important de l'acuité à luminosité constante. Il souligne aussi la notion de liaison entre l'acuité visuelle et le seuil différentiel chromatique. Nos résultats laissent à penser également que plus une couleur est saturée, meilleure est l'acuité.

De même, si l'on considère les coordonnées trichromatiques de nos stimulus on peut considérer que ces derniers sont équidistants dans le triangle CIE x, y, z, 1931 (fig. 7) et les différences de performances constatées s'expliquent mal dans ce diagramme. Les mêmes paramètres, reportés sur un triangle UCS 1964 (fig. 8), montrent qu'en fait l'équidistance n'est pas respectée, surtout pour les mélanges comportant du bleu (pourpre et cyan).

Notre protocole d'étude a été construit de façon à minimiser les influences psychosociologiques de la couleur, de la nature de la tache, de la fatigue éventuelle pour tenter de n'observer que le phénomène le plus pur possible.

Ainsi, nous avons utilisé un échantillon de population homogène constitué par des membres du Personnel Navigant de l'aéronautique. Le système de réponse était conçu pour éviter entre autre toute verbalisation de la part du sujet.

La tache était aussi élémentaire que possible compte tenu que l'on ne peut, dans une étude ergonomique, dissocier la réponse motrice de la perception.

La durée de l'expérimentation et le protocole de présentation des images ont été conçues de telle sorte qu'une éventuelle fatigue ne perturbe pas les résultats. Bien que nous n'ayons pas donné précédemment ces résultats nous avons pu vérifier qu'aucune dégradation de la performance ne se produisait au cours de l'examen.

Toujours dans cette perspective de réduire les sources de fatigue, l'environnement lumineux de l'écran était tel qu'il ne comportait aucun contraste excessif. Il est certain que ce ne sont pas là des conditions opérationnelles où des contrastes violents peuvent être rencontrés. Il est donc nécessaire de vérifier ces données en haute et basse luminance.

La forme du stimulus nécessaire pour une étude précise de l'acuité était relativement neutre quant au contenu informationnel.

Aussi, il faut considérer que les résultats que nous avons présentés ne sont que des éléments de base pour l'étude nécessaire des divers paramètres de la lisibilité d'une information en saturation réelle.

D'un point de vue technologique, il faut remarquer que parmi les couleurs donnant les meilleurs résultats figurent le bleu et les mélanges où il participe. Or, actuellement les systèmes cathodiques embarquables reposent sur le principe du tube à pénétration variable qui ne permet que les couleurs autorisées par un mélange de rouge et de vert. A ce propos, on peut se demander cependant si cet handicap ne peut pas être pour une part compensé par la meilleure définition que permet le balayage cavalier ou aléatoire qui est associé au tube à pénétration. Aussi nous menons

une étude physiologique sur ce système d'affichage.

### CONCLUSION

Afin de préciser certains paramètres physiologiques de la perception visuelle sur tube cathodique, une méthodologie et un appareillage originaux ont été conçus et mis au point.

Le premier thème d'application a été l'étude de l'acuité visuelle en contraste coloré simultané sur écran de télévision.

Les contrastes testés ont été obtenus à partir des couleurs rouge, vert, bleu, jaune, cyan et pourpre ainsi qu'à partir du blanc et du noir.

Les résultats montrent que lorsqu'on crée un contraste de brillance la performance est la meilleure quelle que soit la couleur utilisée. Par contre, si l'on réalise une égalité de luminance les délais de réponse les plus rapides sont observés avec les couleurs rouge, bleu. Le pourpre autorise également une bonne perception sauf s'il est opposé au rouge.

L'influence de la couleur du fond est plus importante que celle de la couleur de la lettre.

Ces résultats constituent des données de base permettant l'élaboration de systèmes de présentation de l'information en couleur sur tube cathodique.

### BIBLIOGRAPHIE

- 1 - CAVONIUS (C.R.) - SCHUMACHER (A.W.)  
Human Visual Acuity Measured with Colored Test Objects.  
Science, vol. 152, May 1966 : 1276-1277.
- 2 - COOK (T.C.)  
Color coding - A review of the literature.  
U.S. Army Human Engineering Laboratory, Aberdeen Proving Ground, MD 21005, November 1974,  
pp 19.
- 3 - HAEUSING (M.)  
Color coding of information on electronic displays.  
Forschungsinstitut fuer Anthropotechnik, Meckenheim, W. Germany, 1976 : 210-17.
- 4 - HENNESSY (R.T.) - BORDEN (G.J.)  
Color perception in the transitional zones of tricolor glide-slope indicators (GSI'S).  
Final Technical Report 29 June/29 November 1973.  
Human Factors Research  
Naval Air Engineering Center, Department of the Navy, PHILADELPHIA, PENNESYLVANIA, 19112.
- 5 - LE GRAND (Y.)  
Optique physiologique.  
L'espace visuel.  
PARIS, Ed. de la "Revue d'Optique", 1956, T. 3, pp. 391.
- 6 - LONG (E.R.) - LONG (S.A.T.)  
The visual acuity in viewing scaled objects on television compared with that in direct viewing.  
Report NASA-TN-D5534, November 1969.
- 7 - MERCIER (A.)  
Exploration clinique de l'acuité visuelle.  
L'Année Thérapeutique et Clinique en Ophtalmologie, VII, 1957 : 383-394.
- 8 - POKORNY (J.) - GRAHAM (C.H.) - LANSON (R.N.)  
Effect of Wavelength on Foveal Grating Acuity.  
Journal of the Optical Society of America, 1968, 58 (10) : 1410-1414.
- 9 - PUIG (J.A.)  
Requirements for Color in Television Displays.  
Human Factors Laboratory, Naval Training Equipment Center, ORLANDO, FLORIDA, 32813, June 1976,  
pp. 23.
- 10 - ROUX (M.)  
Acuité visuelle brute, absolue, relative, naturelle, mesure de l'acuité clinique.  
Conférence LYON ophtalmologie, 2, Octobre 1958 : 5-27.
- 11 - SEMPLE (C.A.) & Al.  
Analysis of Human factors data for electronic flight display systems.  
Air Forces Systems Command., Wright-Patterson Air Force Base, OHIO, April 1971.
- 12 - DUPONT HENIUS (G.J.)  
Differential chromaticity perception thresholds. Color 77.  
Ed. Adam Hilger, BRISTOL : 492-94.

### REMERCIEMENTS

- . A la Direction des Recherches Etudes et Techniques qui apporte son soutien à cette étude.
- . Au Médecin en Chef NATHIE qui a effectué le traitement informatique et statistique des résultats.



TABLEAU N° 1 - RESULTATS EXPERIMENTATION A



TABLEAU N° 2 - RESULTATS EXPERIMENTATION A

**DELAI DE REPONSES MOYENS EN MILLISECONDES**

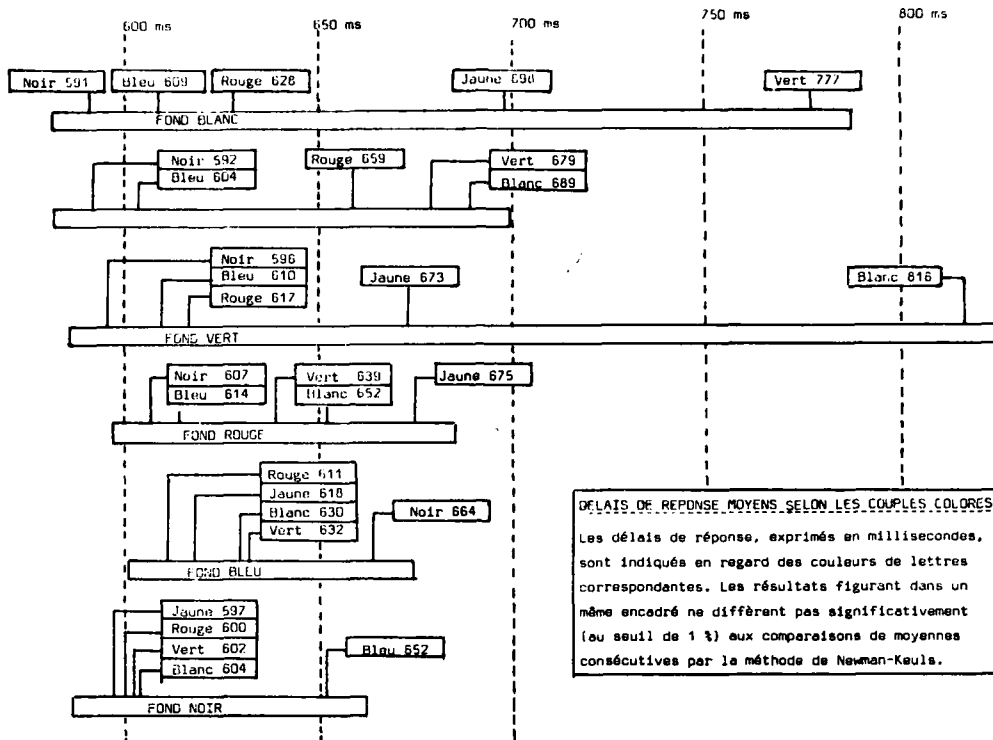

**TABLEAU N° 4 - RESULTATS EXPERIMENTATION B**

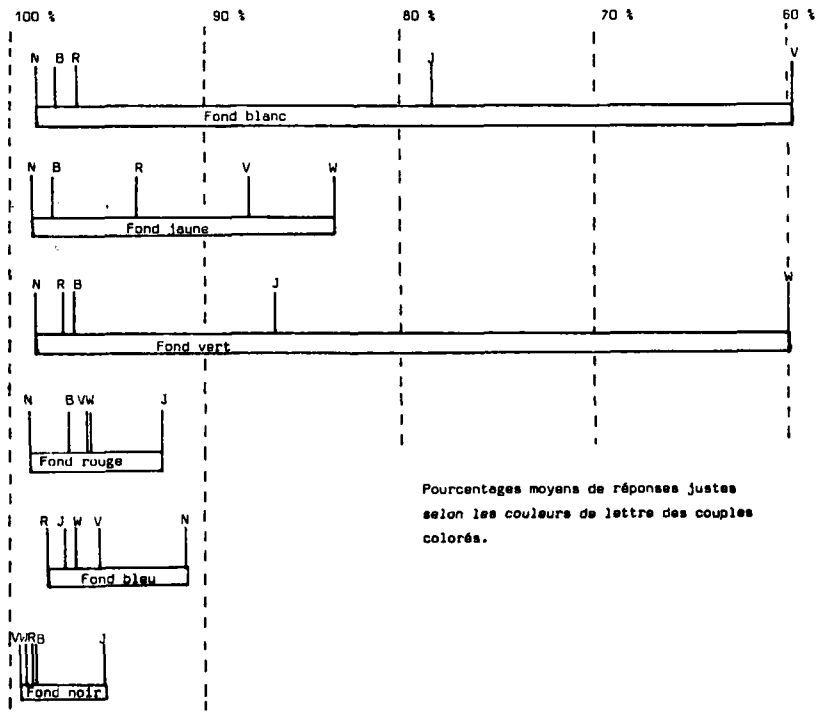
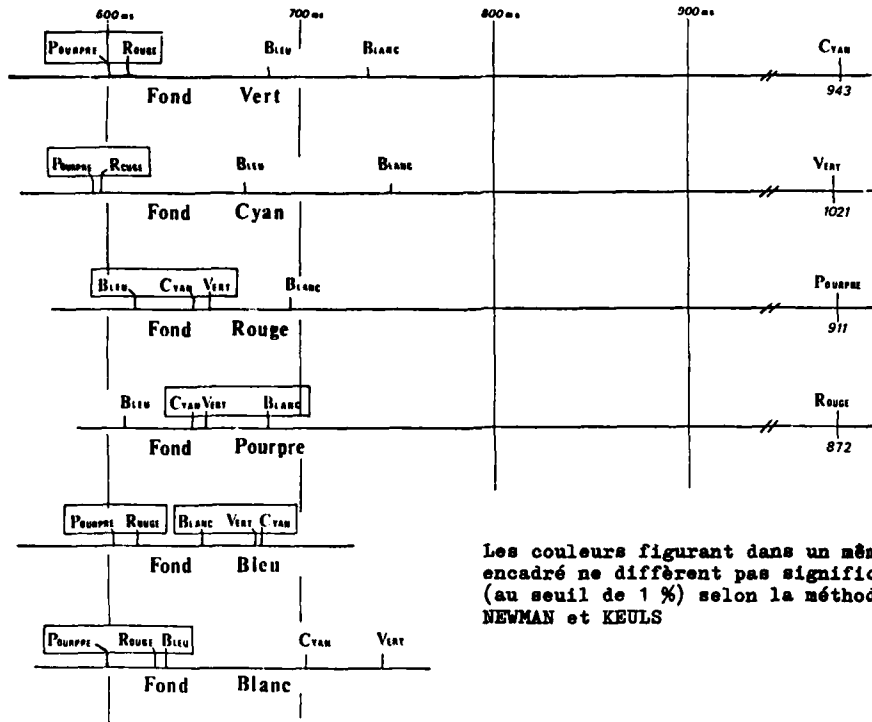
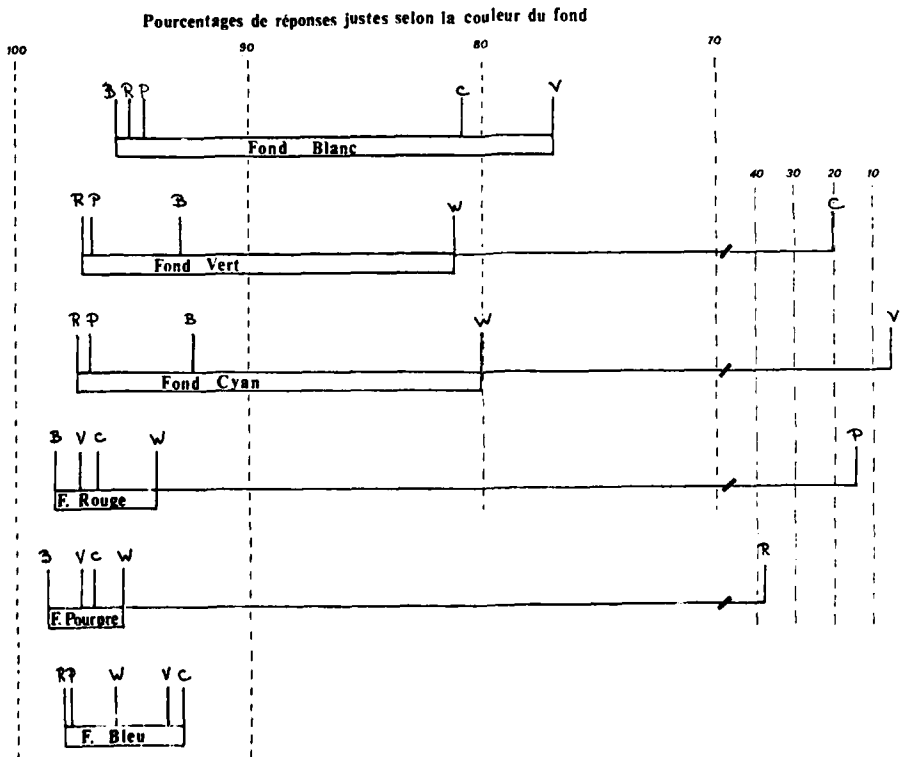

**TABLEAU N° 5 - RESULTATS EXPERIMENTATION B**

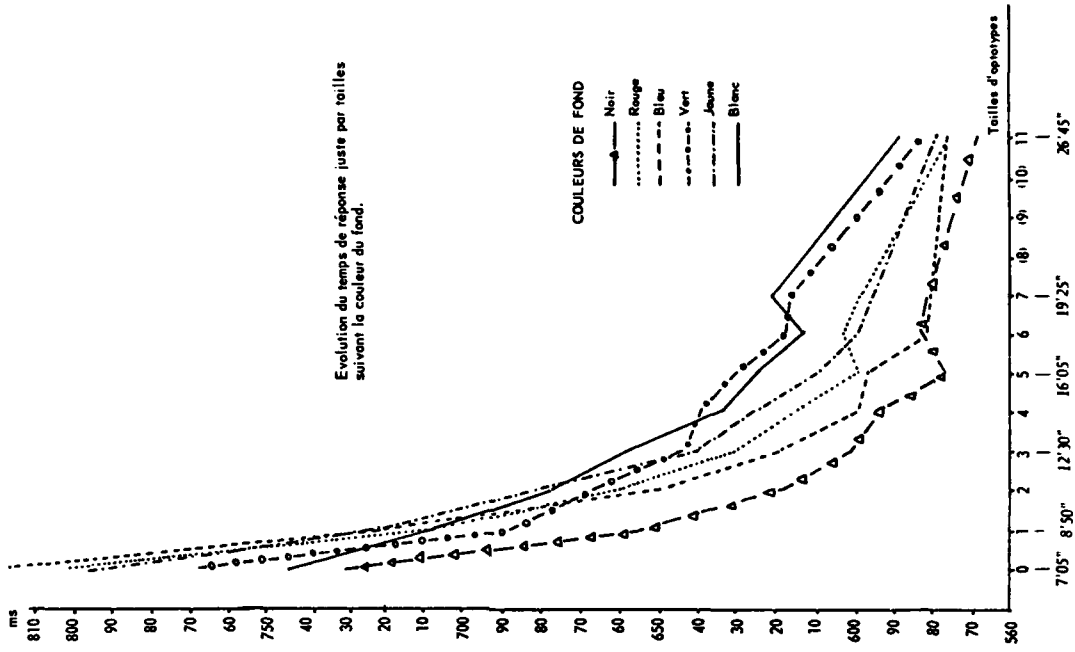

FIGURE N° 3 - RESULTATS EXPERIMENTATION A

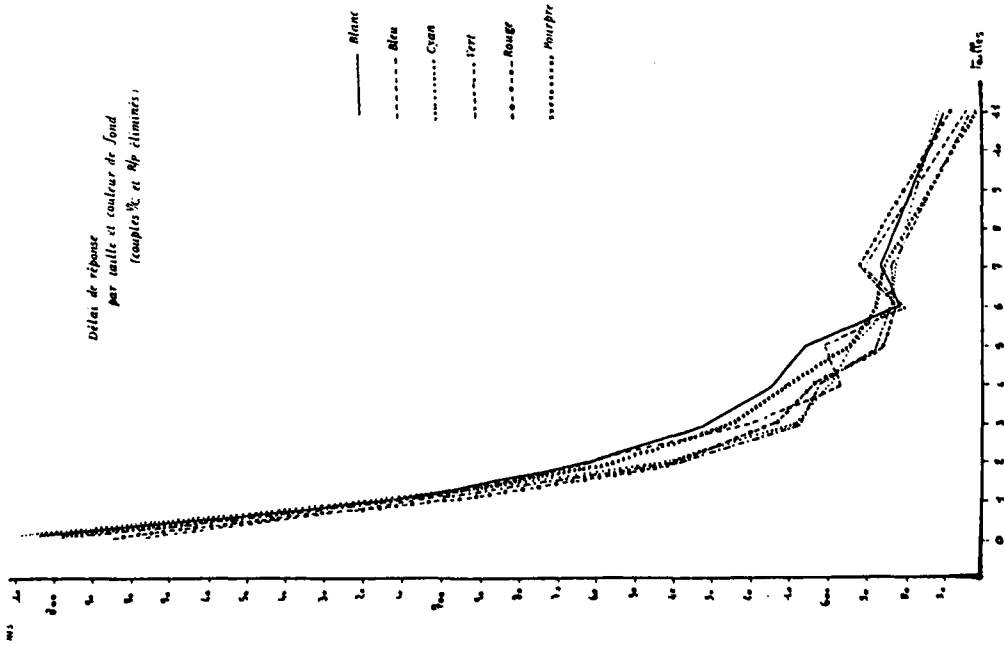

FIGURE N° 6 - RESULTATS EXPERIMENTATION B

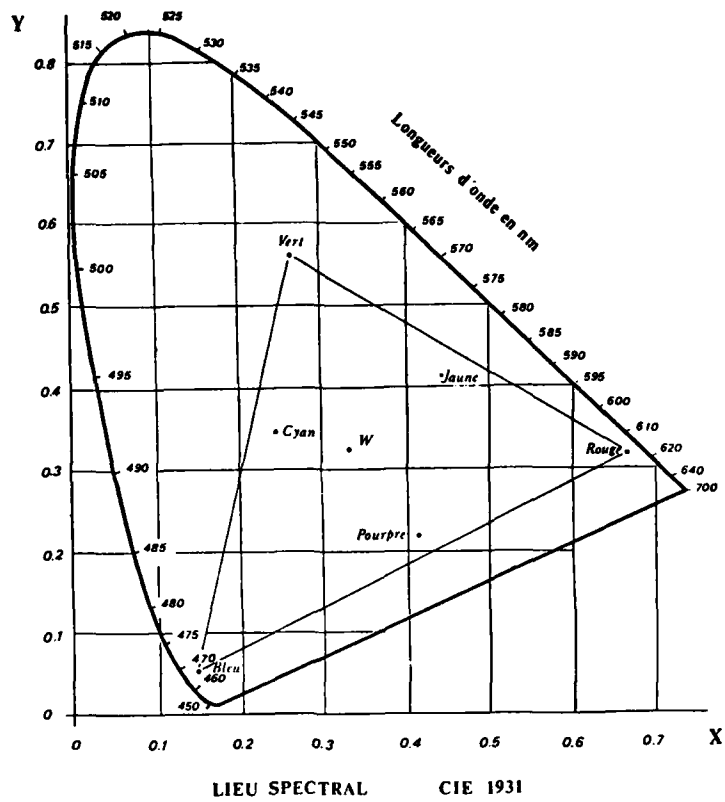

FIGURE N° 7 - POSITION DES STIMULUS UTILISES POUR L'EXPERIMENTATION SUR LE TRIANGLE X Y Z

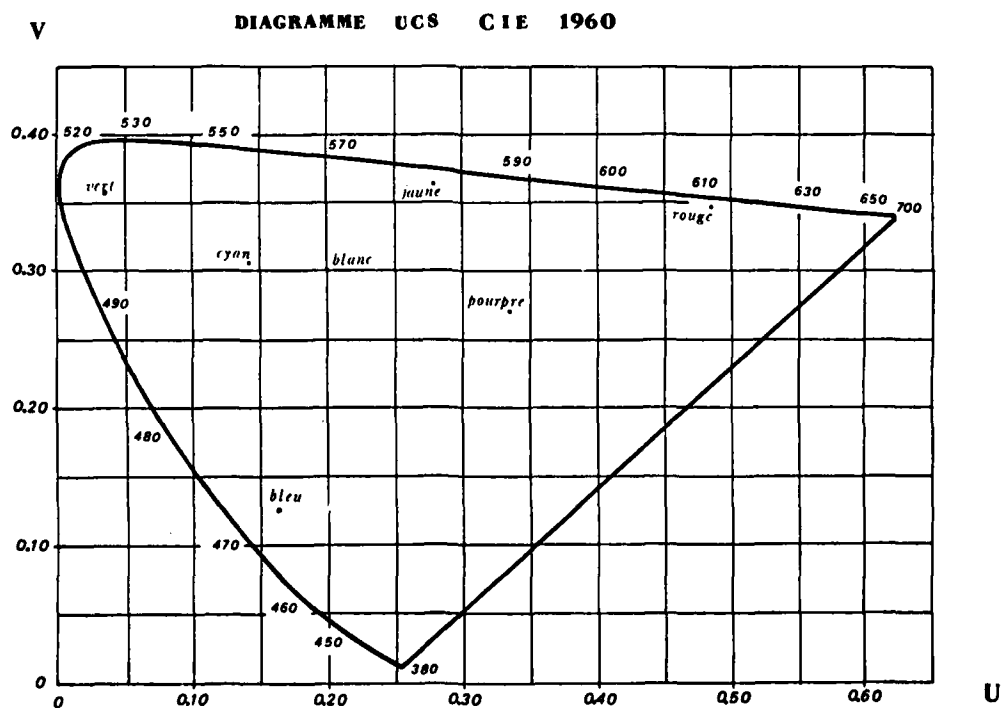

FIGURE N° 8 - POSITION DES STIMULUS UTILISES AU COURS DE L'EXPERIMENTATION SUR TRIANGLE UCY

VISUAL PERFORMANCE/WORKLOAD OF HELICOPTER PILOTS  
DURING INSTRUMENT FLIGHT

R. R. Simmons, M. A. Lees, & K. A. Kimball  
US Army Aeromedical Research Laboratory  
P. O. Box 577  
Fort Rucker, Alabama 36362

SUMMARY

Flight under instrument flight rules (IFR) is reported to be one of the most important factors contributing to aviator fatigue during helicopter operations. This study was initiated to collect visual and psychomotor performance data in an attempt to investigate and study the general visual performance of aviators during IFR conditions. Two groups of aviators, with varied experience levels, were the subjects. A NAC Eye Mark Recorder and the Helicopter In-Flight Monitoring System were utilized to collect the required data. The results indicated, among other findings, that pilot subjective opinion does not agree with objective data. Additionally, the attitude indicator and radio compass comprised over 60% of the pilots' total visual workload, while the aircraft's status gauges were monitored less than 10% of the total time. These data should provide invaluable information concerning the visual requirements of pilots for safe helicopter operations.

INTRODUCTION

The airmobility concept can be defined as the utilization of aerial vehicles organic to the Army to assure the balance of mobility, firepower, intelligence, support, and command and control. The aerial vehicle which has proven to best provide the support for this concept has been the helicopter. Army aircrews, utilizing the helicopter to support the ground fighting forces with rapid transportation, supplies, and medical evacuation, fly under any and all weather conditions. To accomplish these missions, Army aviators are required to fly through meteorological conditions during which they are unable to identify any outside references to aid in the control of their aircraft. This necessitates that they receive all visual cues from cockpit instruments which artificially represent their aircraft's relative spatial and geographical position. This type of flight, which is performed utilizing instruments to fly the aircraft, is referred to as flight under instrument flight rules (IFR).

This IFR flight condition has been referred to in AGARD Advisory Report No. 69<sup>1</sup> as being the most important contributing factor to aviator fatigue during helicopter operations with a possible exception of nap-of-the-earth flight. Additionally, in light of the reported accidents during IFR flights or reduced visibility conditions,<sup>2</sup> it can be concluded that either relevant perceptual cues which exist outside the cockpit are not adequately represented within the cockpit or the information is present but cannot be used effectively. It must be pointed out that optimal rotary wing flight during IFR and reduced visibility conditions is not likely to be achieved by merely representing the outside world in the cockpit via an instrument display. The basic questions of what cues are required for safe flight and how to correctly display them must still be answered.

Several studies have been devised to collect data related to visual performance. These investigations can be divided into three categories: (1) subjective opinions of visual performance, (2) objective visual performance data during fixed wing flight, and (3) objective data during helicopter flight. Studies by Siegel and MacPherson,<sup>3</sup> Clark and Intano,<sup>4</sup> Simmons, et al,<sup>5</sup> have analyzed the opinions of aviators as to which instruments they felt were utilized to fly selected maneuvers. However, these findings do not agree with research results of Frezell, et al;<sup>6</sup> Sanders;<sup>7</sup> and Simmons, et al.<sup>5</sup> These investigators have reported a very poor agreement between subjective data and actual pilot visual performance. Additional studies by Milton, Jones, and Fitts;<sup>8</sup> Fitts, et al;<sup>9</sup> and Diamond<sup>10</sup> have utilized test equipment to obtain objective visual performance data of aviators during flight maneuvers in several fixed wing aircraft. Although these investigations provided useful information as to visual performance during fixed wing flight, data obtained during this work cannot be easily generalized to rotary wing flight because of the extreme aerodynamic differences between airplanes and helicopters.

Sunkes, et al;<sup>11</sup> Stern and Bynum;<sup>12</sup> Frezell, et al,<sup>6</sup> have recorded visual performance in helicopters during selected visual flight rules (VFR) flights. Additionally, two reports<sup>13 14</sup> investigated a number of maneuvers utilizing both the interview technique as well as in-flight recordings of visual performance of two aviators during IFR flight. These efforts have provided some needed information as to the frequency, duration, and sequence of fixations during helicopter operations. Although all of these studies have provided useful information for the visual performance data base, much investigation remains to be accomplished before a reliable visual performance/workload model can be established for safe helicopter flight.



The purpose of this investigation was to measure the visual performance of helicopter pilots during IFR conditions in an attempt to provide a data base which would not only answer some of the basic questions about visual workload during instrument flight, but would also provide a means of comparing simulated IFR, VFR, night, and nap-of-the-earth flights in helicopters with respect to their varying visual performances and workloads. This information will be invaluable when applied to the development of more efficient training techniques, procedures, and aircraft instrumentation in that a significant reduction in the overall visual performance/workload of the aviator during helicopter operations will be realized.

## METHOD

### Subjects

Subjects for this investigation were selected from a group of volunteer Army pilots stationed at Fort Rucker, Alabama. For design purposes subjects were assigned to two general groups of aviators. The first group consisted of five rated helicopter aviators who had no visual problems which would be incompatible with the NAC Eye Mark system, possessed an Army standard instrument rating, were currently on flight status, and had logged less than 250 hours of flight time. For comparisons to past reports this group was designated as student qualified aviators (SQA).

The second group of five subjects possessed the same qualifications as the first with the exception that they had logged over 2400 hours of flight time and were instrument instructor pilots. Again, for comparative reasons, this group was referred to as instrument qualified aviators (IQA).

### Equipment

Equipment utilized to record visual performance included a NAC Eye Mark Recorder, a LOCAM high speed motion picture camera, and Kodak 4X negative black and white film (ASA 500/400 ft. X 16mm).

### NAC Eye Mark Recorder

The basic device employed to study visual performance/workload was the NAC Eye Mark Recorder which utilizes the corneal reflection technique. Through the application of this technique, foveal fixation points as well as other oculomotor behavior can be detected and recorded. An illuminated reticle is focused on the cornea and reflected by the mirrors on the NAC such that the reticle is superimposed on the pilot's actual field of view. The pilot's eye movement and fixation points are then recorded on 16mm film. The complete description, specifications, and operating procedures for the NAC system are outlined in USAARL Report No. 77-4.<sup>15</sup>

### Camera System

The camera arrangement consisted of a LOCAM Model 51-0002 high speed motion picture camera with decoder and time code generator. The NAC/camera arrangement is illustrated in Figure 1.

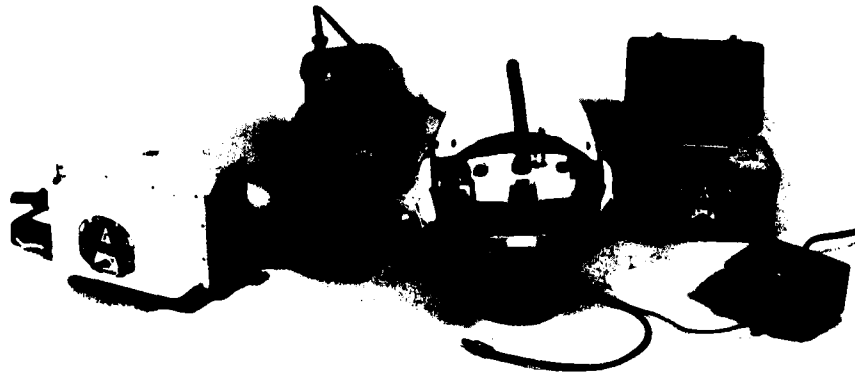
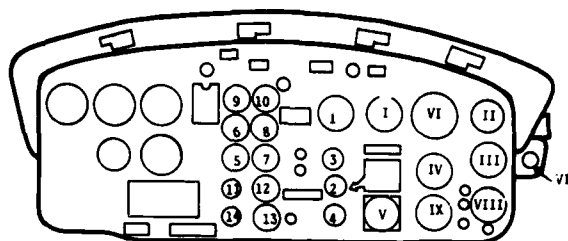

FIGURE 1. TOTAL NAC RECORDING SYSTEM

The LOCAM camera with decoder is located to the far left of the picture. The recording adapter and optic bundle link the NAC mask to the camera. Directly behind the camera is a 30 Vdc battery which provides power for the time code generator located to the right of the NAC. The smallest box is a variable power supply which was designed and fabricated by the laboratory to provide a constant power supply for the reticle light of the NAC.

#### Aircraft (JUH-1H)

Subjects for this investigation flew in an Army JUH-1H helicopter modified to provide inputs to the HIMS. The aircraft was dual instrumented with the pilot's panel arrangement being standard with the exception of an AAU-32/A Altitude Encoder/Pneumatic altimeter. Figure 2 provides a schematic representation of the UH-1 instrument panel.



#### MONITORING GAUGES

##### ENGINE PERFORMANCE

1. Engine RPM
2. Gas Producer
3. Torque
4. Exhaust Temperature

##### FUEL STATUS

9. Fuel Pressure
10. Fuel Quantity

##### OIL STATUS

5. Trans. Oil Pressure
6. Engine Oil Pressure
7. Trans. Oil Temperature
8. Engine Oil Temperature

##### ELECTRICAL SYSTEM STATUS

11. Main Generator
12. DC Voltmeter
13. AC Voltmeter
14. Standby Generator

#### FLIGHT DISPLAYS

- I. Airspeed Indicator
- II. Altimeter
- III. VSI
- IV. RMI
- V. Turn & Bank

- VI. Artificial Horizon
- VII. Magnetic Compass
- VIII. Clock
- IX. VOR

FIGURE 2. UH-1H INSTRUMENT LAYOUT

#### PROCEDURES

##### Initial Briefing

The selected subject pilots initially visited the laboratory and were interviewed. During these sessions, subjects were fitted with the NAC mask, briefed about their general responsibilities during the study, and scheduled for the research flight to be initiated from Cairns Army Airfield, Fort Rucker, Alabama.

##### In-Flight Investigation

On the designated date each subject met the research team at the USAARL Aviation Section at Cairns AAF. During this time the subject pilot was briefed. He was to be the pilot in command during an instrument flight which would be initiated from Runway 36, where the pilot was to perform an instrument takeoff, track in-bound to the Enterprise nondirectional beacon, perform some basic IFR flight maneuvers at the command of the safety pilot, and finally perform an ILS approach to Runway 06 at Cairns. After this briefing the subject was fitted with the NAC and the system was calibrated. The subject then proceeded to the aircraft where he was seated and the normal safety procedures of fastening restraints and checking communications were accomplished. The NAC system was connected to the camera system and fine adjustment of the NAC performed.

Before starting the test profile, the helicopter was hovered from three to five minutes to allow the NAC time to settle on the subject's head. This time was utilized to move the aircraft from its parking location to the taxiway short of the designated runway. The NAC was adjusted for the final time and the camera turned on.

The profile, as described, consisted of requiring the subject pilot to fly under instrument conditions toward the Enterprise nondirectional beacon. During this enroute phase, the subject was to perform, on command, a variety of basic instrument flight maneuvers to include level flight, climbs, turns, climbing turns, descending turns, and straight descents. For purposes of this investigation, these maneuvers are defined in Table 1.

TABLE 1  
FLIGHT MANEUVERS FOR THE UH-1 AND UH-1FS STUDIES

Instrument Takeoff (ITO) - Is defined from complete stop on the active runway through lift off to 450 ft., maintaining runway heading.

Climb - Is defined as straight ascent of at least 1000 ft. maintaining a constant heading with standard school procedures ( $\pm 10$  knots airspeed and 500 FPM). No separate navigation task was assigned.

Cruise - Is defined in this study as level flight for at least one minute, maintaining standard school procedures with no additional task assigned other than maintaining constant heading.

Descent - Is defined as the intentional loss of altitude of at least 1000 ft., maintaining a constant heading following school procedures with no additional task assigned.

Climbing Turn - Was performed by simultaneously changing direction of 180 degrees and climbing 500 ft. No other task assigned.

Descending Turn - Was the simultaneous descending and turning 500 ft. at 180 degrees. No other task assigned.

Level Turn - Was performed by banking the aircraft and turning while maintaining constant altitude and airspeed. No other task assigned.

Instrument Landing (ILS) - Is defined in this study as the published ILS approach RWY6 to Cairns Army Airfield. The maneuver began at Cairns outer marker (OM) and ended at Cairns middle marker (MM). This maneuver differed from all other maneuvers in that the additional task of monitoring the OBS gauge was required.

Figure 3 demonstrates the mission profile. Average time for these research flights was 30 minutes. Because of the limitation of film capacity, cameras were changed about midway through the profile and calibration of the NAC was checked. This calibration check was again performed after the completion of the profile.

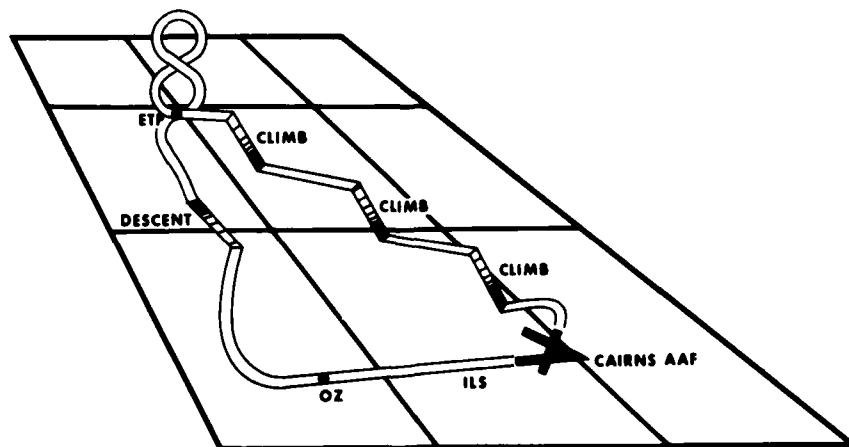

FIGURE 3. MISSION PROFILE

After mission termination the subject was debriefed and given a short questionnaire which requested his impressions of his visual performance during the various maneuvers.

#### Measurements

Continuous information was recorded pertaining to the ten subject pilots' visual performance. Oculomotor behavior was collected at 16 data points per second. Twelve areas were selected which best described the pilots' visual performance. A thirteenth area was labeled "all other areas." If the percentage of time spent monitoring this area was significantly low it could be assumed that the other twelve areas accurately represented the total visual performance of the subjects. A list of these areas is presented in Table 2.

TABLE 2  
THE THIRTEEN VISUAL DATA POINTS

1. REST	All other areas not included in the following twelve areas:
2. ALT	AAU-32/A Altitude Encoder/Pneumatic Altimeter
3. VSI	Standard UH-1 Vertical Velocity Indicator
4. OBS	Standard UH-1 Omni Indicator
5. T&B	Standard UH-1 Turn and Slip Indicator
6. RMI	Standard UH-1 Radio Magnetic Compass
7. AH	Standard UH-1 Pilot's Attitude Indicator
8. AS	Standard UH-1 Airspeed Indicator
9. TORQ	Series of instruments including the Torquemeter, Gas Producer Tachometer, and Exhaust Gas Temperature Indicator
10. RPM	Dual Rotor and Engine Tachometer
11. ELEC	The electrical gauges which include AC and DC Voltmeters and the main and standby Generator Loadmeters
12. OIL	The oil monitoring gauges to include Engine and Transmission Oil Temperature and Pressure gauges
13. FUEL	The Fuel Pressure and Fuel Quantity gauges

#### ANALYSIS AND RESULTS

##### Visual Performance

Visual Performance was analyzed for each of the eight maneuvers described in Table 1. Reduction of the film data provided seconds per maneuver that fixations were recorded within each of the thirteen areas described in Table 2. From these values, the percentage of time spent within each area per maneuver was computed as well as mean dwell time and scan rate per minute for each area. The definitions and formulas utilized for these measures are found in Table 3.

TABLE 3  
DESCRIPTION OF BASIC AND DERIVED VISUAL MEASURES

UNIT	DEFINITION	SYMBOL/FORMULA
1. Fixation	The stationary eye movement within a designated area for at least 100 milliseconds	F
2. Number	The sum of fixations on a designated area (instrument)	N
3. Time	The sum of time spent fixated on a designated area (instrument)	T
4. Link Values	The visual path traveled from one area (instrument) to another	LV
5. Dwell Time	Mean time fixated per area	$DT = T/N$
6. Percent of Time	The percentage of lapse time during a maneuver which was allotted to each area	$\%T = T/\Sigma T \times 100$
7. Percent of Number	The percentage of fixations during a maneuver allotted to each area	$\%N = N/\Sigma N \times 100$
8. Scan Rate	The rate that each area was fixated	$SR = N/\Sigma T \times 60$

These visual data for each subject were combined into appropriate groups and the results are reflected by Tables 4 through 7.

TABLE 4  
PERCENT OF VISUAL FIXATIONS (%N)

	ITO		TURN		ILS	
	SQA	IOA	SQA	IOA	SQA	IOA
AH	40.5 (6.2)	38.4 (10.0)	31.9 (8.0)	34.9 (8.1)	18.9 (7.5)	27.7 (8.1)
RMI	28.8 (5.2)	25.1 (5.8)	22.4 (7.5)	22.2 (4.8)	30.0 (2.1)	24.1 (2.7)
T-B	4.0 (1.6)	8.4 (5.8)	2.9 (2.2)	7.2 (4.8)	1.9 (1.3)	4.2 (1.3)
ALT	8.6 (5.3)	6.4 (2.6)	12.3 (2.8)	9.8 (2.7)	6.1 (2.5)	7.2 (1.7)
A/S	9.5 (3.9)	11.0 (3.)	13.7 (3.7)	13.8 (5.3)	7.6 (3.3)	9.4 (2.4)
VSI	4.9 (2.9)	4.6 (4.7)	8.5 (5.6)	3.6 (3.5)	8.8 (5.0)	4.6 (3.2)
OBS	0.3 (0.5)	0	3.3 (5.7)	3.1 (3.1)	24.3 (4.1)	18.6 (3.5)
TRQ	1.8 (1.6)	3.6 (2.5)	3.5 (2.3)	3.3 (1.5)	1.3 (1.2)	2.0 (1.3)
RPM	0 0	0	0 0	0 0	0.1 (0.2)	0.2 (0.8)
ELEC	0	0	0	0	0	0
OIL	0	0	0	0	0	0.1 (0.2)
FUEL	0	0	0	0	0	0
REST	1.2 (2.4)	2.3 (2.3)	1.0 (2.6)	1.9 (2.7)	0.9 (1.2)	1.9 (1.6)

TABLE 5  
PERCENT OF VISUAL FIXATIONS (%N)

	CLIMB		CRUISE		DESCENT	
	SQA	IQA	SQA	IQA	SQA	IQA
AH	40.5 (6.2)	38.4 (10.0)	31.9 (8.0)	34.9 (8.1)	18.9 (7.5)	27.7 (8.1)
RMI	28.8 (5.2)	25.1 (5.8)	22.4 (7.5)	22.2 (4.8)	30.0 (2.1)	24.1 (2.7)
T-B	4.0 (1.6)	8.4 (5.8)	2.9 (2.2)	7.2 (4.8)	1.9 (1.3)	4.2 (1.3)
ALT	8.6 (5.3)	6.4 (2.6)	12.3 (2.8)	9.8 (2.7)	6.1 (2.5)	7.2 (1.7)
A/S	9.5 (3.9)	11.0 (3.)	13.7 (3.7)	13.8 (5.3)	7.6 (3.3)	9.4 (2.4)
VSI	4.9 (2.9)	4.6 (4.7)	8.5 (5.6)	3.6 (3.5)	8.8 (5.0)	4.6 (3.2)
OBS	0.3 (0.5)	0	3.3 (5.7)	3.1 (3.1)	24.3 (4.1)	18.6 (3.5)
TRQ	1.8 (1.6)	3.6 (2.5)	3.5 (2.3)	3.3 (1.5)	1.3 (1.2)	2.0 (1.3)
RPM	0 0	0	0 0	0 0	0.1 (0.2)	0.2 (0.8)
ELEC	0	0	0	0	0	0 0
OIL	0	0	0	0	0	0.1 (0.2)
FUEL	0	0	0	0	0	0
REST	1.2 (2.4)	2.3 (2.3)	1.0 (2.6)	1.9 (2.7)	0.9 (1.2)	1.9 (1.6)

TABLE 6  
VISUAL DWELL TIME IN MILLISECONDS (X)

	ITO		TURN		ILS	
	SQA	IQA	SQA	IQA	SQA	IQA
AH	920 (850)	840 (580)	570 (340)	790 (580)	510 (370)	680 (460)
RMI	600 (370)	550 (270)	580 (310)	670 (420)	680 (490)	620 (390)
T-B	520 (130)	670 (160)	560 (200)	590 (210)	410 (170)	620 (350)
ALT	450 (170)	420 (180)	480 (210)	450 (180)	550 (230)	520 (270)
A/S	580 (380)	400 (190)	480 (250)	410 (160)	480 (260)	490 (280)
VSI	530 (70)	440 (120)	470 (160)	260 (80)	470 (200)	410 (190)
OBS	250 (20)	0	270 (60)	330 (90)	750 (460)	720 (350)
TRQ	260 (110)	460 (150)	710 (130)	660 (190)	300 (140)	600 (320)
RPM	0 (0)	0	0 0	0 0	0	510 (40)
ELEC	0	0	0	0	0	70 (0)
OIL	0	0	0	0	0	290 (30)
FUEL	0	0	0	0	0	0
REST	300 (180)	130 (50)	160 (40)	170 (30)	310 (100)	500 (320)

TABLE 7  
VISUAL DWELL TIME IN MILLISECONDS ( $\bar{x}$ )

	CLIMB		CRUISE		DESCENT	
	SQA	IQA	SQA	IQA	SQA	IQA
AH	660 (470)	740 (420)	670 (440)	790 (480)	630 (400)	690 (440)
RMI	730 (430)	680 (370)	750 (450)	690 (390)	602 (330)	760 (410)
T-B	510 (200)	740 (240)	650 (370)	670 (240)	650 (300)	670 (270)
ALT	660 (330)	530 (250)	590 (280)	550 (230)	540 (230)	620 (300)
A/S	540 (270)	510 (250)	520 (270)	490 (200)	570 (320)	440 (180)
VSI	620 (250)	500 (180)	550 (210)	480 (260)	580 (220)	500 (180)
OBS	240 (100)	260 (50)	240 (100)	300 (80)	370 (150)	330 (150)
TRQ	740 (250)	570 (320)	630 (350)	700 (260)	520 (210)	800 (390)
RPM	410 (70)	140 (20)	360 (100)	110 (30)	260 (100)	140 (0)
ELEC	0	0	0	0	0	190 (20)
OIL	0	120 (10)	0	0 (0)	0	160 (30)
FUEL	0	0	170 (60)	0	0	220 (10)
REST	290 (90)	300 (70)	210 (50)	370 (100)	350 (80)	550 (230)

Tables 4 and 5 denote the percentages of fixations along with the standard deviation for each group for each of the flight segments during which the thirteen areas were fixated. The data depicted in Tables 6 and 7 represent the mean dwell time spent viewing each instrument. The presentation of the data in percentages and rates allows the results to be compared across maneuvers and subject groups regardless of subject variance in time required to complete the maneuvers.

Figures 4 through 6 graphically illustrate the percentage of lapsed time each group spent within each area. The solid bar represents values for the IQA group and the broken bar those of the SQA group. Scan rate and lapsed time differences were minimal across groups; therefore, scan rate data are not presented.

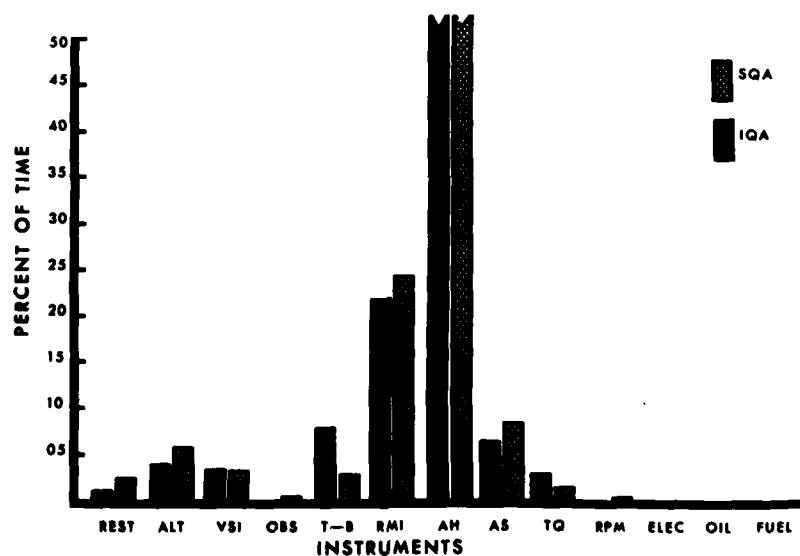

FIGURE 4. FREQUENCY OF FIXATIONS DURING ITO

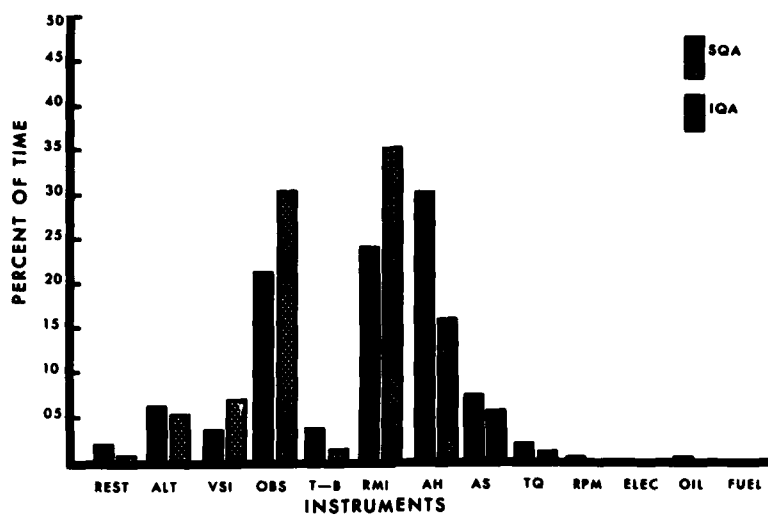

FIGURE 5. FREQUENCY OF FIXATIONS DURING ILS

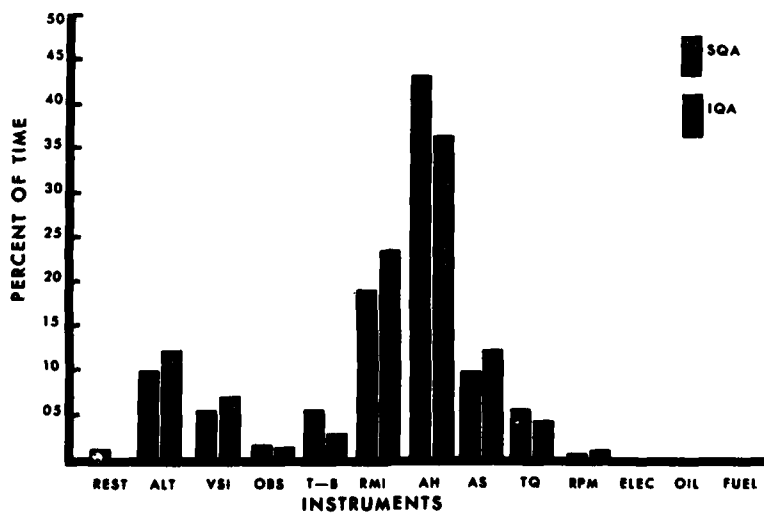

FIGURE 6. FREQUENCY OF FIXATIONS DURING CRUISE



From inspection of the mean values, it was determined that the RPM, electrical, oil, and fuel gauges comprised less than one percent of the scan rate or percentage of lapse time measures obtained during most of the maneuvers. Because these values were extremely low, and at times zero, they were eliminated from the statistical analyses. Additionally, the visual area labeled "all other areas" typically comprised only one percent of the total lapsed time and was deleted. Finally, the gauges described in the "torque" area were noted; but because this area represented three gauges which confounded the results and because it was not homogeneous with the remaining flight gauges, it too was excluded from the remaining tests. The statistical analysis was performed utilizing the remaining seven areas. These areas were the altimeter, vertical speed indicator, radio magnetic compass, attitude indicator, airspeed indicator, turn and bank indicator, and omni indicator. These instruments could best be described as aircraft flight displays, and those gauges which were excluded, as aircraft monitoring gauges. The final analyses were performed between two groups of subjects across the eight flight maneuvers. The visual performance measures of the seven flight instruments were utilized as dependent variables for these analyses.

Multivariate and univariate analyses were performed employing group scan rates, dwell times, and percentage of lapse times, to determine if one of these measures was superior in describing visual performance differences between subject groups or maneuvers. Initially, a multivariate analysis of variance test (MANOVA) of the percentage of time was performed between the two groups of subjects, eight maneuvers, and seven flight gauges. The results are shown in Table 8.

TABLE 8  
MULTIVARIATE ANALYSIS OF VARIANCE SUMMARY:  
PERCENT OF LAPSE TIME FOR ALL MANEUVERS

SOURCE	F-RATIO	HYPOTHESIS df	ERROR df	P LESS THAN	CANONICAL R
GROUPS	8.427	7.0	2.0	.110	.983
MANEUVERS	7.386	49	258.26	.001	.967
	2.951	36	240.973	.001	.771
	1.849	25	217.761	.011	.613
GROUP-MANUEVER INTERACTION	1.255	49	258.26	.135	.614

Significant test uses Wilks-Lambda criterion. The third factor was subjects and was used in creating appropriate error terms for the primary comparisons.

The group and group-maneuver interactions were not significant; however, as was expected, there were differences across maneuvers. Next, the climb, cruise, and descent portion of the flight profile appeared to contain similar visual fixation data. The performance during these three maneuvers was tested by MANOVA and no significant differences were found between groups, the group-maneuver interaction, or across the three maneuvers (Table 9).

TABLE 9  
MULTIVARIATE ANALYSIS OF VARIANCE SUMMARY:  
PERCENT OF LAPSE TIME FOR CLIMB, CRUISE, DESCENT

SOURCE	F-RATIO	HYPOTHESIS df	ERROR df	P LESS THAN	CANONICAL R
GROUPS	2.683	7.0	2.0	.224	.918
MANEUVERS	.639	14.0	20.0	.804	.700
GROUP-MANUEVER INTERACTION	1.882	14.0	20.0	.096	.848

Significant test uses Wilks-Lambda criterion. The third factor was subjects and was used in creating appropriate error terms for the primary comparisons.

Because these three maneuvers demonstrated no significant differences they were tested, in turn, against the remaining maneuvers. The results of these three maneuvers compared to the ITO, the ILS, climbing turns, descending turns, and level turns only reflect differences on the maneuver main effects ( $p < .05$ ).

The MANOVA was utilized next to test the difference between group dwell times during each maneuver. Again, comparisons between visual dwell time during climb, cruise, and descent demonstrated no significant differences. These three maneuvers were compared in turn with each of the remaining maneuvers. Significant differences were found when data from these maneuvers were compared against the ILS ( $p < .009$ ). When the scan rate data were submitted to an identical test, significant differences were observed among the three maneuvers, the ITO ( $p < .001$ ) and the ILS ( $p < .001$ ).

It may be noted in the above multivariate comparisons that the degrees of freedom for the test were relatively few in number, resulting in an extremely conservative test of the experience level and maneuver main effects. However, since the main purpose of these comparisons was to determine if there were any major differences between visual performance on these factors, this conservatism is considered appropriate.

Because of the results of the MANOVA, univariate F tests associated with significant visual performance variables were examined as an aid in describing changes in visual performance across maneuvers. The groups differed in performance during climb, cruise, and descent only in the percent of time fixated on the turn and bank indicator ( $F = 11.087$ ,  $df = 1/8$ ,  $p < .01$ ). This same group difference was found testing each of the remaining maneuvers as illustrated in the test of the three maneuvers against the ITO ( $F = 21.222$ ,  $df = 1/8$ ,  $p < .002$ ). There were no other group differences noted during the univariate tests of the percentage of time, scan rate, or the dwell times.

The significant results of the univariate F test of the maneuvers utilizing percentage of lapsed-time measure are presented in Table 10 and the results of the same test of the maneuvers with the scan rate measure are shown in Table 11.

TABLE 10  
UNIVARIATE F TEST OF MANEUVERS/PERCENT OF TIME

		ALT	VSI	T&B	RMI	AH	AS	OBS
CLIMB, CRUISE, DESCENT	F							
	P							
CLIMB, CRUISE, DESCENT AND ITO	F	9.61	13.44			8.53		
	P	.001	.001			.001		
CLIMB, CRUISE, DESCENT AND ILS	F	14.05	3.84	5.41	7.80	7.66		146.75
	P	.001	.02	.005	.001	.001		.001
CLIMB, CRUISE, DESCENT AND DESCENDING TURNS	F			4.02	11.73	3.14		
	P			.02	.001	.04		
CLIMB, CRUISE, DESCENT AND CLIMBING TURNS	F		3.60	7.38				
	P		.03	.001				
CLIMB, CRUISE, DESCENT AND LEVEL TURNS	F	3.43	6.57					
	P	.03	.002					

TABLE 11  
UNIVARIATE F TEST OF MANEUVERS/SCAN RATE

		ALT	VSI	T&B	RMI	AH	AS	OBS
CLIMB, CRUISE, DESCENT	F	4.98						
	P	.02						
CLIMB, CRUISE, DESCENT AND ITO	F	6.45	8.75		5.40			
	P	.002	.001		.006			
CLIMB, CRUISE, DESCENT AND ILS	F	11.94		3.14	9.26	16.67		128.73
	P	.001		.04	.001	.001		.001
CLIMB, CRUISE, DESCENT AND DESCENDING TURNS	F			4.71	6.64			
	P			.01	.002			
CLIMB, CRUISE, DESCENT AND CLIMBING TURNS	F			4.78				
	P			.009				
CLIMB, CRUISE, DESCENT AND LEVEL TURNS	F		3.28					
	P		.04					

A stepwise discriminant analysis was performed utilizing the scores of the seven instrument flight displays which had previously been chosen. Separate analyses were performed for the percent of lapse time, scan rate, and dwell time. A stepwise discriminant analysis was utilized to determine if the variables could effectively define changes in visual performance between groups and maneuvers. The two subject groups were tested to determine if they could be classified by the 39 variables. Table 12 reflects the results of this test. From these results, it can be demonstrated that dwell time was not a good discriminator of groups.

TABLE 12  
STEPWISE DISCRIMINANT ANALYSIS CLASSIFICATION  
OF SUBJECT GROUPS

VARIABLE USED	GROUP	CLASSIFIED AS:		PERCENT
		SQA	IQA	
Dwell Time	IQA	11	27	71
	SQA	26	12	68
Scan Rate	IQA	7	31	81
	SQA	32	6	84
Percent of Time	IQA	7	31	84
	SQA	33	5	86

Finally, the same stepwise discriminant analysis, utilizing the seven variables simultaneously, was performed to determine if the maneuvers could be correctly classified. Only the ITO and ILS could be classified with any accuracy (89%).

#### Questionnaire

Following each test flight, subjects were provided a pilot's opinion questionnaire which had been prepared for USAARL Report No. 76-18, "Pilot Opinion of Flight Displays and Monitoring Gauges in the UH-1 Helicopter."<sup>16</sup> The sections of the questionnaire which closely relate to the objective data are the frequency of use and importance which each aviator rated the flight instruments during climb, cruise, and descent. Current aviator responses were compared to responses of the original group of aviators who had answered these same questions. For each section and display category, a Kendall's Coefficient of Concordance (W) was computed to determine the relationship between ranks for the two subject groups. The coefficient of concordance (W) for the two groups for the frequency of use of the flight display during climb, cruise, and descent as well as the order of importance were significant at the .01 level indicating a high level of agreement between the two groups. Current and past aviator opinions are presented in Table 13.

TABLE 13  
PILOT OPINION: FREQUENCY OF USE OF INSTRUMENTS

MONITORING GAUGES	FREQUENCY OF USE					
	RUN UP	HOVERING	PRE-TAKEOFF	CLIMB	CRUISE	DESCENT
<b>ENGINE PERFORMANCE</b>						
Engine RPM	1	1	1	1	1	1
Gas Producer	7	2	7	2	2	2
Torque	9	3	10	3	3	3
Exhaust Temp.	3	4	8	4	4	4
<b>TREND INFORMATION</b>						
Trans. Oil Press.	4	5-7	3-4	5	5	6
Eng. Oil Press.	2	5-7	2	7-8	9	5
Trans. Oil Temp.	6	5-7	5	6	7-8	7-8
Eng. Oil Temp.	5	8	3-4	7-8	7-8	7-8
<b>FUEL MANAGEMENT</b>						
Fuel Pressure	10	10	9	9	10	10
Fuel Quantity	8	9	6	10	6	9
<b>ELECTRICAL SYSTEMS</b>						
Main Generator	13	11	11-12	11-12	11	11
DC Voltmeter	11	12	11-12	13	12	12
AC Voltmeter	12	13	13	11-12	13	13
Standby Gen.	14	14	14	14	14	14
$\chi^2$ <	.01	.001	.05	.01	.001	.001
$W^r$ <	.01	.001	.01	.001	.01	.001
<b>FLIGHT GAUGES</b>						
Airspeed Indicator				1	1	1
Altimeter				2	2	2
VSI				3	3	3
RMI				4	4	5
Turn & Bank		NA		5	6	4
Artificial Horizon				6	5	6
Magnetic Compass				7	7	7
Clock				8	8	8
VOR				9	9	9
$\chi^2$ <				.01	.01	.01
$W^r$ <				.01	.01	.01

## DISCUSSION

The visual data which have been reported to this point were collected to develop a pilot visual performance data base during helicopter flight. The maneuvers were flown under instrument flight rules, and varied from an ITO through climbs, cruise, descents, and turns, which are basic IFR maneuvers with no navigation tasks, and finally included an ILS. Aviator visual performance during these maneuvers is quite complicated.

The data base is essential however, because there appears to be no other method to determine what cues are required for safe helicopter flight. The questionnaire data demonstrate that aviators' opinions do not agree with their own objective visual data. Although subjectively aviators feel that the attitude indicator and radio magnetic compass ranked very low in priority of use, visually they depended very heavily on these same two instruments. The visual performance related to these two instruments combined accounted for two-thirds of their total visual lapse time across all maneuvers.

Utilization of the attitude indicator and radio magnetic compass seems to indicate that pilots place a high priority on maintenance of the aircraft's stability about its major axes (pitch, roll, and yaw). The data of the present study would support this assumption in that before a pilot can utilize fine detailed information about his flight, he needs to determine that the aircraft is positioned spatially about these three axes. Only after this is ascertained would the pilot scan other instruments for fine detail.

Projecting this line of thought, the instrument panel can be divided into three separate zones. The first zone which could be labeled "aircraft stability management" would include the attitude indicator for pitch and roll information, and both the radio magnetic compass and turn and bank indicator for yaw information. To gain this stability information from these instruments would require the pilot to perform simple visual tracking tasks in contrast to reading quantitative information from other instruments such as the altimeter or airspeed indicator.

The second zone provides the finely detailed information about current aircraft status such as exact altitude or airspeed. This zone could be labeled "quality flight management" and would include the altimeter, airspeed indicator, and vertical speed indicator. Instruments in this zone would be utilized only when the monitoring of zone one was not critical.

The final zone would be comprised of the remaining instruments which include special navigation instruments and aircraft monitoring gauges. This third zone could be termed "special requirement gauges." These gauges are not vital for normal flight but are monitored or used only on as-time-allows or on a need-to-know basis. These zones are illustrated in Table 14.

TABLE 14  
INSTRUMENT CLUSTERS WITHIN EACH ZONE

ZONE I	1. ATTITUDE INDICATOR 2. RADIO MAGNETIC COMPASS 3. TURN AND SLIP INDICATOR	AH RMI T&B
ZONE II	1. ALTIMETER 2. AIRSPEED INDICATOR 3. VERTICAL VELOCITY INDICATOR	ALT AS VSI
ZONE III	1. AIRCRAFT MONITORING GAUGES 2. SPECIAL NAVIGATION INSTRUMENTATION 3. ALL OTHER VISUAL AREAS	TORQ, RPM, ELEC OIL, FUEL OBS REST

If these zones adequately describe aviator visual performance during IFR flight in a helicopter, the twenty-three instruments utilized by the pilot have been reduced to three zones. The visual performance data from this investigation describe the percentage of lapse time, scan rate, and dwell time. However, the importance or cost of a zone or gauge can be described by the sum of the frequency that an area is visually fixated and the average time fixated in that area (dwell time). The lapse time and number of fixations on the gauges can be utilized to derive this single value. The formula would appear as:  $CF_z = (T/\sum T + N/\sum N)/2$ . CF represents the "cost factor" of each zone, "T" is in seconds, and "N" is number. If this value is divided by two, the CF is in percentage of workload.

If the above formula is utilized, the data in this study can be reduced to a single value for each of the three zones across eight flight maneuvers. The CF value reflects the percentage of time, scan rate, and dwell time as one value. A summary graph for the three zone/cost factor approach is represented by Figure 7. The solid line represents the SQA aviators and the broken line the IQA.

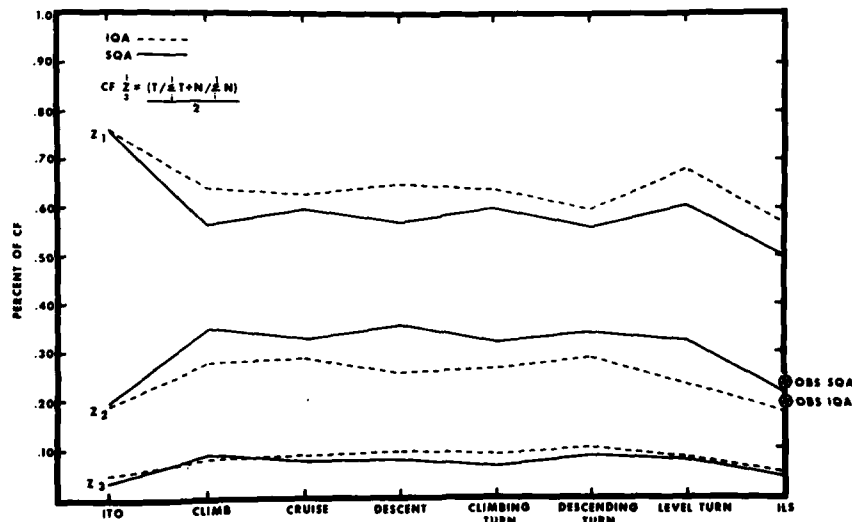

FIGURE 7. GRAPH OF CF/ZONE

Each zone represented on the graph has a distinct level of visual work cost. Zone 1 utilizes approximately 60% of the total effort; Zone 2, 30%; and Zone 3 less than 10%. Zone 2 effort is increased only as Zone 1 decreases and Zone 3 remains fairly constant with the exception of the ILS maneuver. The reason for this observation could be that the ILS was different from all the other maneuvers in that it included not only basic flight but also a navigation problem. Zones 1 and 2 have distinct workload

points for the ITO and ILS maneuvers with the rest of the maneuvers requiring some effort allotted between these two maneuvers. The ITO appears to be the least stable maneuver requiring maximum work cost within Zone 1 while during the ILS the utilization of Zone 1 is at its lowest point. Since both maneuvers are considered to be high workload situations, these values in Zone 1 could represent a maximum and minimum workload required in the zone to afford stability management of a helicopter. Notice that during these same two maneuvers Zones 2 and 3 are at the same workload levels from one maneuver to the other. This demonstrates that as workload increases, both of these areas are sacrificed.

The fact that all maneuvers other than the ITO and ILS are at a level of less than maximum effort, and more than minimum effort in Zone 1, could represent some rest time that is not essential to flight.

The statistical analysis which was previously completed supports the Zone/CF theory to a large degree. The values which comprise the CF were tested separately. The MANOVA and univariate F of the percent of lapse time, scan rate, and dwell time (CF value) demonstrated no differences between the climb, cruise, and descent maneuvers and demonstrated minimal differences when these were compared with the turn maneuvers. The major differences were found when comparing CF values of the ITO and ILS maneuvers to the "flight" maneuvers; likewise, the stepwise discriminant analysis utilizing the same three criteria could classify only the ILS and ITO with any accuracy.

The univariate F test demonstrated differences in the percent of lapse time and scan rate of altimeter, vertical speed indicator, radio magnetic compass, and the attitude indicator when comparing the climb, cruise, and descent maneuvers with the ITO. Reviewing the mean values demonstrates that the usage of the gauges in Zone 2 (ALT and VSI) was depressed while Zone 1 (AH and RMI) required more attention during the ITO. The OBS gauge was significant only during the comparison of the three flight maneuvers with the ILS. Finally, the turn's CF values were significantly different from climb, cruise, and descent because of the rearrangement of usage of the instruments within Zone 2. These conclusions are also supported by the graph in Figure 7.

The univariate F test revealed the only significant difference between subject groups was their use of the turn and slip indicator. The stepwise discriminant analysis also was able to discriminate groups mainly by their usage of this same instrument. Therefore, Zone 1 for the two groups was expanded and the results appear in Figure 8.

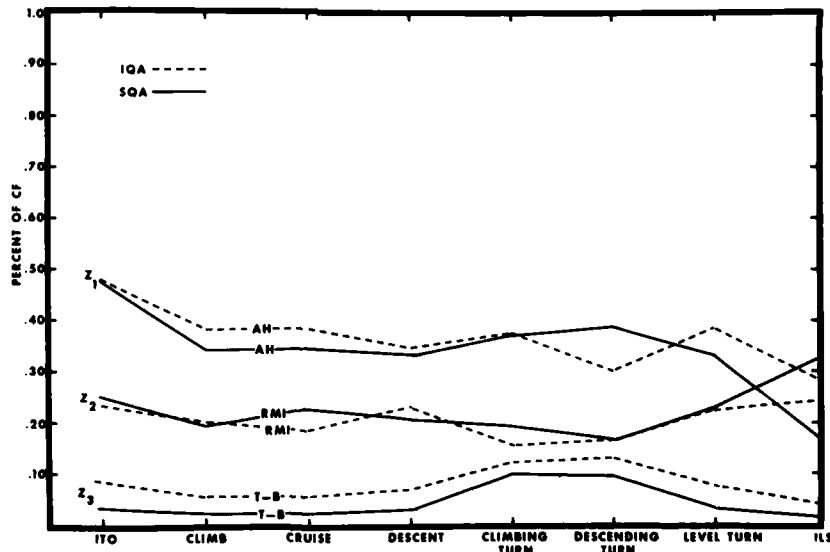

FIGURE 8. GRAPH OF CF/ZONE 1

The visual performance on the radio magnetic compass has varying results across groups. However, the attitude indicator (with the exception of descending turns) and the turn and bank indicator do show distinct level differences between groups. Finally, it should be noted that with the exception of the difference of the two groups within Zone 1, their CF performance paralleled one another (Figure 7). The total visual workload of the SQA was lower in Zone 1 than the IQA, allowing the SQA more time for Zone 2. This usage of Zone 1, as other data are indicating, could reflect a major difference of proficiency levels with the SQA being the more currently proficient.

## CONCLUSIONS

This study was initiated to investigate the visual performance of pilots flying during helicopter IFR maneuvers. The study of IFR maneuvers was unique because the aviators were forced by conditions to receive any and all of their visual cues to manipulate the aircraft from an instrument panel. This limited visual field allowed investigators to analyze which cues were fixated and derive what information was visually obtained by the pilot. During VFR this extraction of visual performance would be very difficult because of lack of precise definitions as to the quality of possible VFR cues.

The data reflected in Tables 4 through 7 and Figures 4 through 6 represent pilot visual performance during the various maneuvers of this project. This information is useful in itself in describing general visual performance during helicopter flight. Some conclusions can be noted from this data.

- a. When compared to Fitts, Jones, and Milton's visual studies<sup>9</sup> in fixed wing aircraft during IFR maneuvers, it is readily apparent that the percentage of utilization of the RMI and AH are reversed during helicopter flight with the AH being utilized the most.
- b. During helicopter flights the AH and RMI comprised over 50% of the total visual performance with no other instrument being utilized one-half the time of either instrument with one exception--the ILS maneuver.
- c. The mean dwell time for instruments with simple pointer systems such as the AS, ALT, and VSI was 400 to 500 milliseconds while more complex instruments such as the RMI and AH required 500 to 600 milliseconds.
- d. Oil, fuel and electrical gauges were each observed less than one percent of the time. If consideration is given to this fact, it can be interpreted in the sense that each aviator has less than a one percent chance of detecting any malfunction reflected by these gauges.
- e. Subject opinion data did not agree with the objective visual data.

The above results have a basic application in describing visual performance during helicopter operations. However, because of the numerous tables and figures involved it becomes extremely difficult to attempt to predict or model visual performance/workload in other aircraft or during other operational missions. To attempt to combine all the useful information into a more concise package, the visual zone/cost factor was introduced. The zones were ranked as to their visual importance to the pilot with the aircraft stability management zone being the most important. The cost factor accounted for the frequency and duration of the pilot's fixation to describe his total visual requirements. This formula provides some possible useful alternatives.

- a. The usage of Zone 1 between groups of subjects could describe current proficiency differences as described in the discussion section.
- b. It could also be predicted that a significant reduction in Zone 1 could be accomplished by providing a more stable helicopter platform as in fixed wing aircraft. Such a reduction would provide more visual time for other tasks such as monitoring of other gauges or attending to other mission needs. Additionally, because Zone 1 comprises over 55% of the visual workload, any visual performance reduction in this area would have significant savings in visual workload.
- c. With the minimum and maximum visual workloads in Zone 1 noted for the ITO and ILS maneuvers, perhaps accidents during inadvertent instrument flight could be explained as exceeding the minimum visual workload in this zone for aircraft stability management.

This study should not conclude visual performance/workload but should assist in developing a data base for predicting visual performance/workload during flights in aircraft of varying stability and during adverse weather missions dictated by military requirements. The application of this and similar information to aircraft panel design could ultimately provide the significant factor which determines safe tactical mission accomplishment.

## REFERENCES

1. Perry, I. C., Ed. Helicopter aircrew fatigue (AGARD-AR-69). London: Harford House. Advisory Group for Aerospace Research & Development, May 1974.
2. Ricketson, Darwin S., Johnson, S. A., Branham, L. B., & Dean, R. K. Incident, cost and factor analysis of pilot error accidents in U.S. Army aviation (AGARD-CP-132). London: Harford House. Advisory Group for Aerospace Research & Development. Paper presented at Aerospace Medical Panel Specialists Meeting, Soesterberg, Netherlands, September 1973.

3. Siegel, A., & MacPherson, D. Pilot opinion of the optimum arrangement of primary flight instruments in Naval aircraft (Report No. NADA-AC-6910). Warminster, PA: Naval Air Development Center, September 1969.
4. Clark, William, & Intano, Gabriel. Helicopter display improvement study (IFC-TN-75-1). Randolph AFB, TX: USAF Instrument Flight Center, May 1975.
5. Simmons, R., Hofmann, M., & Lees, M. Pilot opinion of flight displays and monitoring gauges in the UH-1 helicopter (USAARL Rpt. No. 76-18), Ft Rucker, AL: US Army Aeromedical Research Laboratory, April 1976.
6. Frezell, T., Hofmann, M., & Snow, A. C. Aviator visual performance in the UH-1H, Study II (USAARL Rpt. No. 75-11). Ft Rucker, AL: US Army Aeromedical Research Laboratory, March 1975.
7. Sanders, M. G. Personal communication based on data being prepared for publication. November 1976.
8. Milton, J. L., Jones, R. E., & Fitts, P. M. Eye fixations of aircraft pilots: Frequency, duration, and sequence fixations when flying the USAF instrument low approach system (ILAS) (USAF Tech. Rpt. No. 5839). Dayton, Ohio: Wright Patterson Air Force Base, October 1949.
9. Fitts, Paul M., Jones, Richard E., & Milton, John L. Eye fixations of aircraft pilots: Frequency, duration, and sequence fixations when flying Air Force ground controlled approach system (GCA) (USAF Tech. Rpt. No. 5967). Dayton, Ohio: Wright Patterson Air Force Base, November 1949.
10. Diamond, S. Time, space and stereoscopic vision: Visual flight safety considerations at supersonic speeds. Aerospace Medicine, 1970, 41, 300-305.
11. Sunkes, J. A., Pazera, E. E., & Howell, W. D. A study of helicopter pilots' eye movements during visual flight conditions (Task Assignment No. 59-205-10). Atlantic City, N.J.: Test and Experimental Division, September 1960.
12. Stern, J. A., & Bynum, J. A. Analysis of visual search activity in skilled and novice helicopter pilots. Aerospace Medicine, 1970, 41, 300-305.
13. Barnes, J. A. Tactical utility helicopter information transfer study (Tech. Memo. 7-72). Aberdeen Proving Grounds, MD: Human Engineering Laboratory, April 1972.
14. Barnes, J. A. Analysis of pilots' eye movements during helicopter flight. (Tech. Memo. 11-72). Aberdeen Proving Grounds, MD: Human Engineering Laboratory, April 1972.
15. Simmons, Ronald, Kimball, Kent, & Diaz, Jamie. Measurement of aviator visual performance and workload during helicopter operations (USAARL Rpt. No. 77-4). Ft Rucker, AL: US Army Aeromedical Research Laboratory, December 1976.
16. Simmons, Ronald R., Hofmann, Mark A., and Lees, Michael A. Pilot opinion of flight displays and monitoring gauges in the UH-1 helicopter (USAARL Rpt. No. 76-18). Ft Rucker, AL: US Army Aeromedical Research Laboratory, April 1976.



VISUAL POCKETS - A DESIGN PARAMETER FOR HELICOPTER  
INSTRUMENT PANELS

R. W. Bailey, COL (Ret)  
Consultant

United States Army Aeromedical Research Laboratory  
Fort Rucker, Alabama 36362

and

David D. Glick, MAJ

United States Army Aeromedical Research Laboratory  
Fort Rucker, Alabama 36362

ABSTRACT

The concept of fixation points between instruments ("Visual Pockets") for instrument flight of helicopters has been proposed as a new concept to reduce pilot work load and improve performance. It has also been proposed that this concept be applied to cockpit instrument panel design. In view of the significance attached to this revolutionary concept of "Visual Pockets," a review and perspective of helicopter pilot visual information requirements are presented with special emphasis on the impact of "Visual Pocket" concepts.

INTRODUCTION

In a presentation to this group at Koln by Barnes<sup>1</sup> entitled "Use of eye-movement to establish design parameters for helicopter instrument panels," it was proposed that data from previous studies<sup>2,3</sup> provide the basis for a new concept in instrument panel design. In summary, it was reported that, "the point of greatest fixation time was often found to be a point from which it was possible to peripherally monitor instruments the pilot considered important." Because of basic physiological function limitations of the visual system, classic and accepted perceptual information processing mechanisms, as well as a great deal of data collected at this laboratory, this concept was and is radical and suspect. One might first believe Barnes' conclusion was predicated upon errors in calibration; however, the author was careful to explain, "the spacing of the instruments was such that we were easily able to determine that the pilots were fixating on blank portions of the panel rather than these seemingly useless fixations being caused by loss of calibration in the eye movement measurement system." In view of the fact that this new concept was proposed as the basis for future cockpit design and thereby could play a key role in survivability and operational success a review of some of the key findings, data base of the Barnes paper, as well as a review of the functional limitations and capabilities of the visual system are in order lest we compromise an already marginal and difficult task.

To provide a quick review, the Barnes paper reported three areas that were non-instrument fixation points: The "Pocket," a point midway between the Attitude Indicator, Remote Magnetic Indicator, Altimeter and the Vertical Velocity Indicator, identified in this photo by the arrow on the far right. A visual pocket called "power" located between the Airspeed Indicator, Dual Tachometer and the Torquemeter identified by the upper left-hand arrow, and another visual pocket called "Temp-slip" located at a point between the Gas Producer Tachometer, Exhaust Gas Temperature Indicator and the Turn and Slip Indicator identified by the arrow in the lower left of Figure 1.

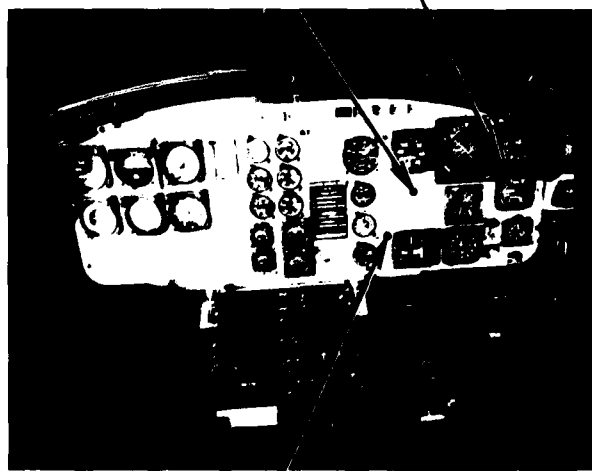

Figure 1

Four in-flight eye movement data segments were reported that are documented in a previous study.<sup>1</sup> These data, according to the report appear to be from a single aviator of unknown skill level and the following conditions:

Cruise IFR - Four runs totaling 618 seconds of recording with 793 fixations recorded and 504 fixations not identified "because of blinks, movement, movement beyond the system limits, etc.," leaving a total of 479 seconds of data.

180° Standard Rate Turn (three degrees per second) - Data were reported based upon three turns lasting 154 seconds during which 191 eye fixations were recorded and 94 eye fixations lost, leaving a total of 125.5 seconds of data.

IFR Hover in ground effect data was based upon one flight lasting 77 seconds during which 85 eye fixations were recorded and 20 eye fixations lost, leaving a total data time of 70 seconds.

Low Level Cruise IFR - These data were not a part of the original design, but "were flown to utilize film which remained when the scheduled mission was accomplished," which is the Cruise IFR described above.

This portion of the experimental design is presented to shed some light on the differences in data that we have collected during real IFR flights of ten fixed- and rotary-winged aviators of much longer duration (3.7 hours of data) employing the same methodology. To date, we have been unable to identify visual pockets or peripheral vision employed to monitor instruments other than those fixated by the pilot.

### Visual Search

Visual search is not usually covered in physiologic or psychological textbooks on visual perception, although it represents the most important process in the extraction of information from visual displays. To better understand how this function is performed, it is necessary to consider those functions that are critical to this extracting of information from visual displays.

### Acuity

The decrement in visual acuity from the fixation point to the periphery of the retina results in a severe penalty if we try to use the periphery to analyze visual stimulation in detail as shown in this data plot by Alpern.<sup>4</sup>

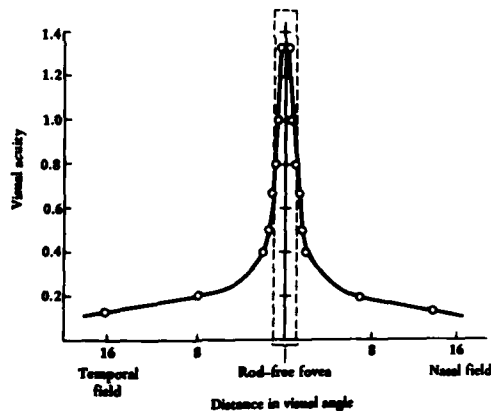

Figure 2

According to the visual pocket technique while fixating the "Pocket" location, the pilot should monitor the Attitude Indicator, Altimeter, and Vertical Velocity instruments. As a result of cockpit distances and layout, we find the most one could expect to perceive by such a technique would be "trend" information since the alphanumeric portions of these displays require 20/140 acuity, 100% contrast and greater than 10 footlamberts of luminance. The peripheral retina is capable of only 20/50 at the near edge of the instruments but rapidly drops to 20/200 prior to reaching the far side of any instruments in this cluster.

If we apply the "visual pocket" technique to the pocket identified as "Power," the fixation point for peripheral monitoring of Rotor RPM, Torquemeter and Air Speed, we again find the peripheral retina is incapable of providing the kind of quantitative information that is necessary. For example: The Rotor RPM instrument requires at least 20/60 acuity, but peripheral retinal acuity at this angular distance away from the foveal fixation point is 20/200. It might be possible to detect needle movement produced by catastrophic engine failure (runaway or loss of power), but other clues resulting from such an event would have already been perceived. (See Figure 1.)

The Torquemeter would also be impossible to read since it demands 20/80 acuity and the peripheral retina again is capable of only 20/200 at the visual angle separating the instrument from the fixation point. (See Figure 1.)

The Air Speed instrument has large letters requiring only 20/160, but again the visual angle from the reported "Power" fixation point results in 20/100 acuity at the closest point of the instrument dropping rapidly to 20/200 before reaching the other side. Perhaps trend information could be obtained from needle movement perceived in this portion of the periphery especially sensitive to moving objects, but movement of the needle would have to be fairly rapid. (See Figure 1.)

Fixation of the visual pocket called Temp-Slip was identified as the fixation point used to monitor the adjacent Gas Producer Tachometer Indicator, Exhaust Gas Temperature Indicator and the Turn and Slip Indicator. Quantitative information would again be impossible to acquire from peripheral vision because the alphanumeric information display in this group requires 20/40 acuity for the Gas Producer Tach (EGT) to a 20/60 requirement for the remaining two instruments. Maximum peripheral acuity at the nearest point of the instruments is 20/70 for the EGT and 20/100 for the other two instruments. (See Figure 1.)

#### ATTENTION

We should consider the size of the useful visual field (the area surrounding the fixation point from which information can be perceived and processed during a fixation) in terms of its response to more than one stimulus if we propose to monitor more than one instrument during a single fixation. Mackworth<sup>5</sup> has shown that too much information considered in a single fixation causes the field to constrict, i.e., results in a priority to the foveal portion. In a research task requiring correct response in identifying three letters presented for 100 milliseconds, one in the center as a fixation point, the other two adjacent, scores were virtually perfect, but when the test letters added to the fixation letter were moved greater than three degrees from the fixation point, accuracy of identification dropped to about 10%. Although not quantified in any of the in-flight data we have seen to date, the accuracy of any alphanumeric information supplied by the peripheral retina must be suspect of being incorrect.

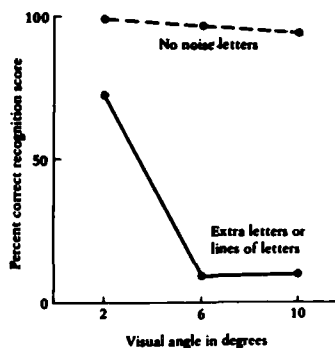

Figure 3

This is not to say the peripheral retinal information is not important. It is certainly important to provide information for the next fixation, lower thresholds for light detection and the detection of movement. Gainer and Obermayer<sup>6</sup> in a paper, Pilot Eye Fixations While Flying Selected Maneuvers Using Two Instrument Panels, were quoted in support of the peripheral visual use by the visual pocket technique. Their study, however, was done using vertical tape instruments adjacent to an Attitude Director Indicator. The Altimeter had a relatively thick horizontal bar to display altitude. The study was done in an M B-5 Simulator providing flight characteristics of a YF-102. One task was maximum climb out and level off which was skillfully done without fixating rate of climb, altimeter or an altitude planning scale. The movement and relative position in the parafoveal field of the bars on these instruments did no doubt provide adequate peripheral stimuli. To extrapolate this singular and unique situation to round dials in a different environment is to make an apple from an orange.

#### Lighting

In addition, we should also remember the critical effect of cockpit lighting on acuity. As seen on this graph by Chalmers, Goldstein and Koppany, levels below .01 fl will produce a rapid rise in error probability.

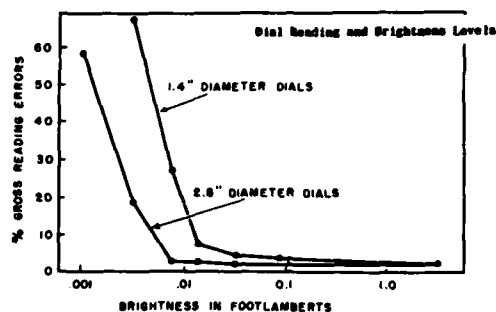

Figure 4

### Vibration

Teare and Parks<sup>8</sup> reported decrements in acuity for vibration above 12 hertz and amplitudes of .1 inches in their study of Visual Performance during whole body vibration.

Increased dwell times for instrument fixation in helicopters vs fixed wing aircraft in a paper to be published by Simmons at the US Army Aeromedical Research Laboratory (USAARL) has considered vibration as a possible cause for this result.

### SUMMARY

The role of the peripheral retina is very important but not as the final perceptive path. Perhaps the most succinct description of role of the peripheral retina is given by Sanders<sup>9</sup> in a monograph, *Studies in Perception*, dedicated to M. S. Bouman and published by the Institute for Perception, Soesterberg, Netherlands. Sanders' data show peripheral retina can provide sufficient information to develop expectancy for pointer position later verified by fixation. The peripheral retina's high sensitivity to movement and detection of relevant signals is the key to understanding the functional visual field, but not as a final processor. Sanders says it best, "peripheral information can be very important for the human operator who is inspecting a multi-source display." The expectancy principle guarantees continuity of successive perceptual samples and provides order and plan in the visual scanning process.

### REFERENCES

1. Barnes, John A., Use of eye movement measures to establish design parameters for helicopter instrument panels. AGARD-CPP-216, Neuilly-Sur-Seine, France, 1977.
2. Barnes, John A., Analysis of pilots' eye movements during helicopter flight, Tech Memorandum 11-72, Human Engineering Lab, Aberdeen Proving Ground, MD, 1972.
3. Barnes, J. A., Tactical utility helicopter information transfer study, Tech Memorandum 7-70, Human Engineering Laboratory, Aberdeen Proving Ground, MD, 1970.
4. Alpern, M., Muscular Mechanisms, In H. Dawson (Ed), *THE EYE*, Vol 3, p 2, New York Academic Press, 1962.
5. Mackworth, N. H., Visual noise causes tunnel vision, *Psychonomic Science* 3, 67-68, 1965.
6. Gainer, C. A. and Obermayer, R. W., Pilot eye fixations while flying selected maneuvers using two instrument panels, *Human Factors* 6(5), p 485-501, 1964.
7. Chalmers, E. L., Goldstein, M., and Koppany, W. E., The effect of illumination on dial reading. USAF Technical Report No. 6021, 1950.
8. Teare, R. J. and Parks, D. L., Visual performance during whole-body vibration, Tech Report 4, The Boeing Co., Wichita, Kansas, 1963.
9. Sanders, A. F., Peripheral viewing and cognitive organization, studies in perception, Institute for Perception RVO-T40, Soesterberg, The Netherlands, 1966.

## VISUAL AND OPTICAL ASSESSMENT OF GAS PROTECTIVE FACE MASKS

K. W. Welsh, MS, OD, and J. A. Vaughan, BS  
 Aviation Physiology Laboratory, Civil Aeromedical Institute  
 Federal Aviation Administration, P. O. Box 25082  
 Oklahoma City, Oklahoma 73125

## SUMMARY

This study was conducted to evaluate the visual characteristics of and specify ophthalmic design requirements for smoke/gas protective face masks for pilots and aircrew members. Visual tests with the mask in place include: (i) peripheral field of vision, (ii) visual acuity, (iii) stereoscopic depth perception, (iv) color vision, and (v) spectacle frame displacement.

Measurements were made on five adult males (age range 35 to 54 years) while wearing each of the 26 devices and again without the masks.

Reduction in the temporal and inferior field was found with some of the goggle-mask (two-piece) combinations. These data indicate that 30.8 percent of the test items degraded visual acuity below 20/20 at the 0.4 m (16.0 in) distance, 15.4 percent at 0.76 m (30.0 in), and 7.6 percent at 6.0 m (20.0 ft). Mean values of depth perception ranged from 2.4 percent to 404.4 percent over control (no mask) values. The three goggles with tinted facepieces created no alterations in color perception. Spectacles worn with the two-piece protective masks were displaced upward on the face. Full-face (one-piece) masks displaced the spectacles downward. Suggested criteria for an acceptable protective mask are discussed.

Introduction.

Protection of helicopter pilots and aircrew members from toxic gases and smoke remain essential for effective helicopter operations. This postulate is verified by the U.S. Army's current program to develop a new generation protective face mask for both ground and airborne personnel.

This study, conducted at the Federal Aviation Administration (FAA) Civil Aeromedical Institute, Oklahoma City, Oklahoma, was designed to evaluate the visual and optical properties of 26 commercially available protective masks. The 26 masks were evaluated because they passed, or indicated a potential to pass, a minimum acceptable level of gas protection as determined in the Protection and Survival Laboratory at the FAA Civil Aeromedical Institute.

Tests conducted on each of the 26 test items include five visual tests and six purely optical tests. However, this paper will be limited to a discussion of only the visual tests. Tests conducted using five volunteer male subjects included: (i) visual acuity at three angles and distances, (ii) changes in the normal peripheral field of vision, (iii) stereoscopic depth perception, (iv) color vision for test items with tinted facepieces, and (v) the effect of the masks on proper positioning of eyeglasses.

Methods.

Visual performance was evaluated for the 26 test items shown in Table 1. The 26 items consisted of five fullface (one-piece) and eight two-piece (goggles and oxygen mask) units. As shown in Table 1, five of the eight goggles were tested with two or more oxygen masks.

The five test subjects ranged in age from 35 to 54 years (mean 43 years). Three had uncorrected visual acuity of 20/20 or better at 6.0 m, 0.76 m, and 0.4 m, and the remaining two subjects wore corrective lenses to attain these acuity levels. Either nonprescription or corrective lenses were worn with each test item by each subject throughout the experiment with the exception of the visual field measurements.

To minimize experimental variability, all the tests were conducted with the subject's head in the Frankfort Plane, a standard reference plane for head positioning. It is defined as the position of the head when the upper border of the auditory meatus is horizontally aligned with the lowest point on the orbital margin of the maxillary bone. The device for positioning the head in the Frankfort Plane is shown in Figure 1. It consists of a metal ear bar inserted about 1.0 cm into the auditory meatus and adjusted to apply slight pressure on the upper surface of the ear canal. A curved bar in a horizontal plane with the ear bar is swiveled forward to touch the lower orbital margin of the maxillary bone. The pitch of the head was pivoted around the ear canal by an adjustable chinrest to align the tip of the curved bar with the lower orbital margin. The chinrest together with two cupped occipital supports, formed a rigid 3-point craniostat.

The wear angle of each test item is the angle between the frontal plane of the head and the transparent facepiece. This plane was recorded by marking two points along a plumbline - one on the upper part and the other on the lower part of a card attached to the test item as shown in Figure 2. The subject's head could then be repositioned in the Frankfort Plane by realigning the two points on the card with the plumbline.

A. Peripheral Field of Vision. Measurements were taken on a Ferree-Rand arc perimeter designed to measure the peripheral field 95.0 arc degrees on each side of a central fixation point. Luminance across the arc of the perimeter was 6.45 mL (6.0 fL). The test subject was instructed to keep his gaze on the central fixation point while the experimenter slowly moved a circular white test target (12.0 mm in diameter) from the periphery toward the fixation point and to signal when he became aware of the

moving target. The peripheral field was measured both with and without the test items along 12 equally spaced meridians around the subject's visual field.

B. Visual Acuity. Tests were conducted at distances of 6.0, 0.76, and 0.4 meters. The test symbols were Landolt "C" figures that varied in size to equate visual acuity levels of 20/40, 20/30, 20/25, and 20/20 at the three distances. The subject was asked to indicate the position of the break in the Landolt "C" (either left, right, up, or down) beginning with the top row of figures (20/40) and to read from left to right toward the bottom row (20/20). The test card containing the Landolt "C" figures was positioned approximately 5 and 10 arc degrees below the subject's line-of-sight (horizontal) for the intermediate (0.76 m) and near (0.4 m) tests, respectively. Measurements were made at an ambient luminance level of 53.8 mL (50.0 fL). Incorrect responses were recorded at each of the three distances. Subjects wearing bifocal lenses were allowed to look through the distant portion of the lenses if the bifocal portion interfered with testing at 6.0 m.

C. Stereoscopic Depth Perception. Stereopsis was measured at 6.0 m with the standard Howard-Dolman apparatus. After donning a test item, each subject made five rod alignments by pulling a looped cord attached to a movable rod to align the rod with a stationary rod. The final separation between the two rods was read on a millimeter scale. Each subject, as his own control, made two series of five alignments without the test items. Ambient luminance was controlled at 53.8 mL (50.0 fL).

D. Color Vision. For test items with tinted facepieces, Dvorine Pseudo-Isochromatic Plates were used to detect changes in normal color vision. A Macbeth easel lamp produced luminance of 23.7 mL (22 fL) on the plates. Subjects read numbers on the 14 test plates presented in a random sequence, and errors were recorded.

E. Spectacle Frame Displacement. Physical displacement of the spectacle frame by the test item was quantitatively determined. The subjects wore zylonite frames selected to fit their facial features. A strip of paper tape (1.0 x 35.0 mm) was placed on each subject's spectacle lens 4.0 mm below the center of the pupil. After the subject donned the test item over the spectacles, his head was positioned in the Frankfort Plane and a fullface photograph was taken at eye level with a Nikon 35-mm camera at a distance of 1.0 m. Each photograph was analyzed by measuring the distance from the center of the pupil to the edge of the tape with an optical reticle. The displacement, either up (+) or down (-) was multiplied by a magnification factor of 7.71 to represent real displacement values.

#### Results.

Mean values of the peripheral visual field tests show that the superior field remained normal or only slightly reduced for all 26 test items. The temporal or lateral field was also normal when the subjects wore the one-piece masks or goggles with transparent side shields. Reduction in the temporal and inferior field with two-piece items was caused primarily by the opaque material surrounding the transparent facepiece of some of the goggles or by the upper portions of the oxygen masks. The inferior field was further decreased by oxygen masks with prominent nasal cups that elevated the goggles on the face. The graph of the mean visual field of test item 08 (Figure 3) is an example of the impairment of both the temporal and inferior field. One-piece test items generally provided a larger inferior field of vision than did the goggles/oxygen mask combinations (Figure 4).

The data in Table 2 indicate that 8 of the 26 test items (31 percent) degraded visual acuity below 20/20 at the 0.4 m distance. Acuity was somewhat less impaired at 0.76 m (4 of 26 test items, or 15 percent) and at 6.0 m (2 of 26 test items, or 8 percent). In all other cases, visual acuity was 20/20 (denoted by dashes in Table 2). The most likely reason for degraded acuity at the near distance (0.4 m) and to some extent at the intermediate distance (0.76 m) was the visual distortion created when the goggles were pushed upward by the oxygen mask. This displacement caused the subject's line of sight to pass through the peripheral, rather than through the central, portion of the facepiece.

Results of the Howard-Dolman test for depth perception, shown in Table 3, were calculated in terms of the percentage of change from control values. Mean scores ranged from 2.4 percent for test item 17 (a goggles/oxygen mask combination) to 404.4 percent for test item 23 (a polyurethane hood). A close relationship was noted between test items that created high alignment disparities and those that degraded visual acuity (compare test items 02, 03, 04, 05, and 23).

Results of the color vision evaluation indicated that the three goggles with tinted facepieces (test items 06, 09-18) and the tinted fullface hood (test item 26) caused no alteration in color perception.

Bifocal displacement for the 26 test items is given in Table 4. Results show that bifocal displacement was upward with the 21 goggles/oxygen mask combinations (mean +6.62 mm, range +2.20 to +10.33 mm) but was consistently downward when the five full-face devices were worn (mean -7.66 mm, range -5.09 to -12.18 mm).

#### Discussion.

As indicated by these data, visual performance is frequently altered by wearing gas/smoke protective masks. The wearer's peripheral field of vision is reduced in proportion to the relative size of the transparent facepiece. With two-piece combinations, the prominent nasal portion of the mask can also restrict vision in the lower field. Compensatory head movements when wearing the test items would tend to enlarge the useful field of vision but may be time consuming and disruptive to other cockpit duties. Also, excessive head movements may result in unacceptable leakage from the mask and/or possible influx of toxic gases. One-piece (full-face) masks provide a larger visual field than two-piece items and would presumably enhance spatial perception and object detection during hovering and landing operations. Alterations in normal stereoscopic depth perception caused by distortions within the transparent facepiece may also degrade flying performance.

Displacement of a spectacle frame after donning the mask may reduce visual acuity, especially for objects in the lower field. Frame displacement with respect to the individual's line-of-sight can create prismatic deviation of the spatial world or change an astigmatic correction factor of the spectacle lens. Also, if bifocal lenses are worn, the position of the lenses can be elevated or depressed after donning the face mask.

The authors recognize that further testing including appropriate field evaluations are necessary to assess the operational effectiveness of current or future mask designs. The authors suggest the following minimum visual and design requirements for protective face masks:

1. Create no impairment in distant, intermediate, or near visual acuity when worn by a normal-sighted individual or an individual wearing prescription spectacle lenses.
2. Cause minimal reduction in the wearer's peripheral field of vision. The device should provide a peripheral vision envelope of at least  $120^{\circ}$  ( $60^{\circ}$  on each side of the central point) in the horizontal meridian, and  $80^{\circ}$  ( $40^{\circ}$  above and below the central point) in the vertical meridian.
3. Create no significant stress and/or change in the integrity of the binocular system. Significant alterations include diplopia, suppression of vision in one eye, or a marked degradation of stereoscopic depth perception.
4. Cause no changes in color perception, including the addition of color to a neutral surface (white or gray) by tinted facepiece or the reduction in normal color perception by selective absorption.
5. Be designed and constructed to fit snugly but also allow adequate space for corrective lenses to be worn comfortably at the normal wear angle without being displaced upward or downward.

TABLE I. Test Items

<u>Test Item</u>	<u>Goggle</u>	<u>Respirator</u>
01	Sierra 322-01	Puritan 114120-01
02	Sierra 322-01	Sierra 358-1030
03	Sierra 322-01	Sierra 358-1002
04	Sierra 322-01	Sierra 232-37
05	Sierra 322-20	Sierra 520-120
06	Puritan 118071	Puritan 114020-20
07	Robertshaw 595-900	Puritan ZM401-M36
08	Robertshaw 595-900	Puritan 114020-20
09	American Allsafe G202-13R	Sierra 358-1030
10	American Allsafe G202-13R	Sierra 520-120
11	H. L. Bouton 1970	Puritan 114020-20
12	H. L. Bouton 1970	Puritan 114120-01
13	H. L. Bouton 1970	Sierra 358-1030
14	H. L. Bouton 1970	Sierra 358-1002
15	H. L. Bouton 1970	Sierra 358-62
16	H. L. Bouton 1970	Sierra 520-120
17	H. L. Bouton 1970	Sierra 232-37
18	H. L. Bouton 1970	Eros Scott Intertech
19	Welsh 1083	Puritan 114020-20
20	Welsh 1083	Sierra 520-120
21	H. L. Bouton 552	Sierra 520-120
22	Robertshaw 900-002-066	
23	Robertshaw 900-700-062-01 (Hood)	
24	Scott 10100C2A	
25	Sierra 651-100-1	
26	Robertshaw 900-700-062-02 (Hood)	

TABLE II. VISUAL ACUITY

<u>Test Item</u>	<u>Test Distance</u>		
	<u>6.0 m</u>	<u>0.76 m</u>	<u>0.40 m</u>
01	-*	-	-
02	-	1/5**	3/5
03	1/5	-	1/5
04	-	1/5	1/5
05	-	-	2/5
06	-	-	-
07	-	-	1/5
08	-	-	-
09	-	-	-
10	-	-	-
11	-	-	-
12	-	-	-
13	-	-	-
14	-	-	-
15	-	-	-
16	-	-	-
17	-	-	-
18	-	-	2/5
19	-	-	-
20	-	-	-
21	-	-	-
22	-	-	-
23	5/5	5/5	5/5
24	-	-	-
25	-	-	-
26	-	1/5	2/5

\* All test subjects (n = 5) had 20/20 visual acuity.

\*\* Numerator of fraction indicates number of subjects with less than 20/20 visual acuity.



TABLE III. DEPTH PERCEPTION

<u>Test Item</u>	<u>Mean Alignment Disparity (mm)</u>	<u>Change From Control (%)</u>	<u>Test Item</u>	<u>Mean Alignment Disparity (mm)</u>	<u>Change From Control (%)</u>
01	34.6	146.8	14	21.6	9.3
02	42.6	195.4	15	19.2	5.6
03	49.8	246.8	16	19.2	31.6
04	30.8	100.4	17	17.6	2.4
05	48.5	211.9	18	24.1	16.7
06	20.2	20.7	19	18.8	22.2
07	31.4	77.6	20	21.0	4.8
08	27.4	95.3	21	23.2	47.9
09	20.3	19.4	22	18.8	14.4
10	23.6	35.7	23	67.9	404.4
11	20.0	17.0	24	20.9	8.6
12	21.7	23.5	25	24.4	30.5
13	17.2	9.2	26	36.8	119.2

TABLE IV. BIFOCAL DISPLACEMENT

<u>Test Item</u>	<u>Mean Displacement (mm)</u>	<u>Standard Deviation (mm)</u>
01	+5.86*	3.63
02	+8.79	3.80
03	+9.17	1.60
04	+3.16	6.73
05	+2.78	3.29
06	+8.40	1.82
07	+2.20	3.18
08	+5.94	5.73
09	+10.33	3.64
10	+3.16	4.13
11	+8.02	4.56
12	+7.86	5.02
13	+8.94	4.32
14	+8.56	3.08
15	+3.08	4.85
16	+7.40	1.20
17	+7.09	5.48
18	+8.79	3.38
19	+7.25	3.24
20	+6.71	4.52
21	+5.47	5.28
22	-6.25	1.17
23	-5.47	3.00
24	-9.33	5.62
25	-12.18	8.51
26	-5.09	2.12

\* With reference to the center of the pupil (+) indicates an upward displacement and (-) indicates a downward displacement.

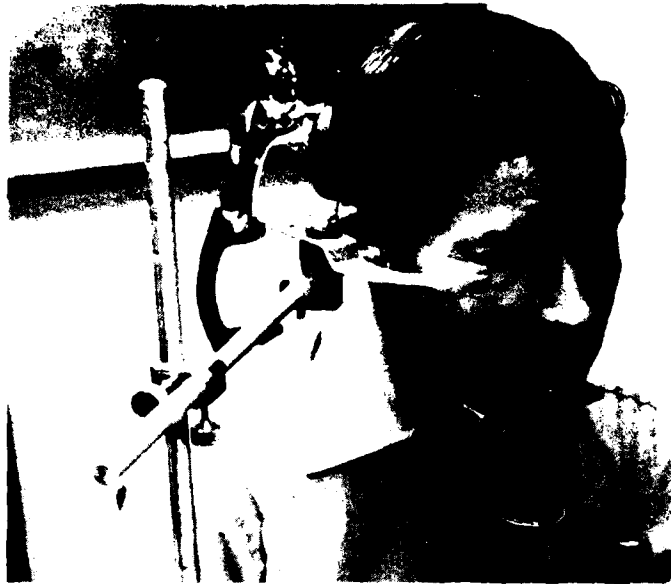

Figure 1. Test subject with head positioned in Frankfort Plane.



Figure 2. Subject wearing goggle/oxygen mask combination; wear angle is marked by two points on the card attached to the side of the goggles.

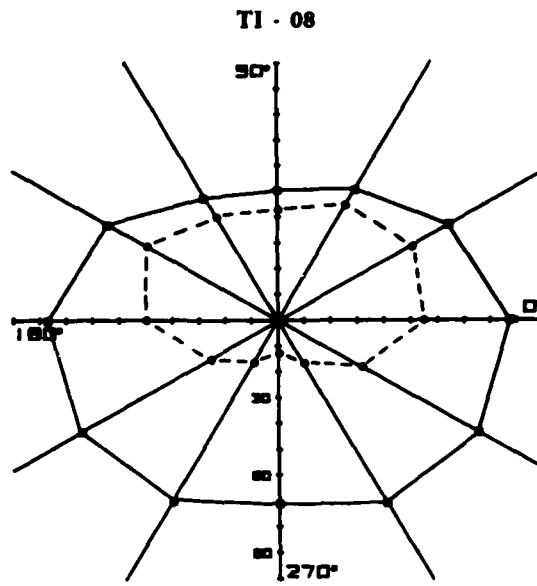

Figure 3. Mean values of peripheral visual field for two-piece combination test item. Broken and solid lines are values with and without the test item, respectively.

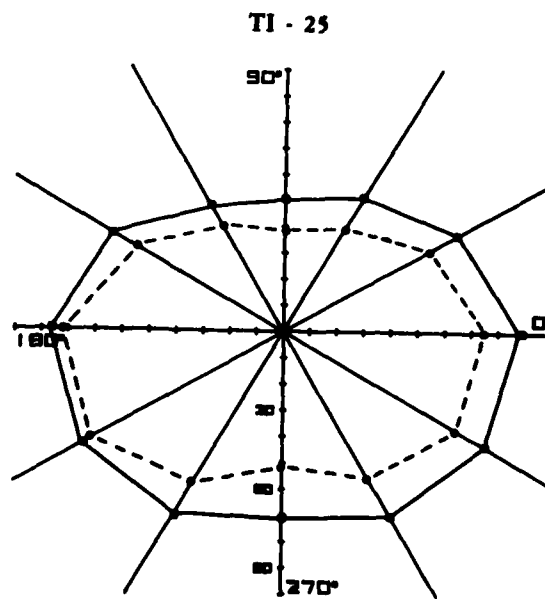

Figure 4. Mean values of the peripheral visual field for one-piece (full-face) test item. Broken and solid lines are values with and without the test item, respectively.

INTERNAL COCKPIT REFLECTIONS OF EXTERNAL POINT LIGHT  
SOURCES FOR THE MODEL YAH-64 ADVANCED ATTACK HELICOPTER

by  
Christopher C. Smyth  
Human Factors Engineer  
US Army Human Engineering Laboratory  
Aberdeen Proving Ground, Maryland 21005

#### SUMMARY

The US Army Human Engineering Laboratory (HEL) has developed a computer program for computing the internal cockpit reflections on the transparent canopy surfaces of external point light sources. Computations have been completed for the Model YAH-64 Advanced Attack Helicopter (low glare canopy design). The results show that primary reflections as seen from the pilot's position are possible on (1) the upper rear corners of the forward side canopy surfaces, (2) the upper edges of the rear sides, and (3) the sides of the top surface. Computations have also been completed for the copilot's position and show possible reflections on the front and side surfaces. A computer graphics output is used to show reflection points on canopy layouts and perspectives of the cockpit.

#### INTRODUCTION

The US Army Human Engineering Laboratory (HEL) has developed a computer program for computing internal cockpit reflections on the transparent canopy surfaces of external point light sources. This work is part of a three-stage effort to determine optimum canopy designs for the Model 209 AH-1S Cobra Helicopter and the Model YAH-64 Advanced Attack Helicopter (AAH). This work was undertaken at the request of the Project Manager's Office, USA Aircraft Survivability Equipment. The low glare canopy design presently used on both models consists of flat, transparent panels on the front surfaces and simple cylindrical panels on the sides and top. The design is a reasonable choice for reducing both solar glint to outside observers during daytime operations and internal reflections of outside light sources during nighttime operations.

A flat plate canopy (FPC) design was originally developed for the Cobra and AAH to reduce daytime solar glint to a momentary flash at certain observer-aircraft-sun angles. A moving aircraft no longer produced the continual solar glint which was present on the earlier compound-shaped canopy designs. The continual presence of solar glint had increased the range of visual detection by ground observers.

However, in certain lighting situations during nighttime operations, the internal surfaces of the FPC performed as mirrors reflecting virtual images of external light sources that were visible to the pilot. HEL has shown by computer analysis that these reflections are possible on most of the transparent surfaces and for a wide range of source locations (1). These virtual images of ground-level lights were disorienting to the pilot and he could not easily discriminate between the light sources on the ground and their reflections from the canopy surfaces. This problem was a potential safety hazard during flight.

The present low glare canopy design was developed to reduce these two conflicting problems to manageable levels. The design incorporates front planar transparent surfaces and simple cylindrical surfaces for the sides and top. HEL recommended a similar design with, however, novel features (2). The present work effort is directed toward a closer study of the two problems of glint and reflections, and developing an optimum design for the canopy's transparent surfaces.

#### METHOD

A ray-tracing program was written to trace in three dimensions the straight-line rays from the nominal position of the pilot's eye backwards to visible points on the internal surfaces of the cockpit. Each ray is traced between transparent surface points until a nontransparent surface is reached. These surfaces are assumed to be diffusive without specular reflectances and the ray is considered absorbed. At each reflection point on a transparent surface, the reflectance and transmittance are computed along with the directional cosines of the corresponding transmitted and reflected rays. In this way, a reflected ray reaching the pilot's eye is traced backwards to all possible external sources that can generate that ray.

The transparent surfaces of the low glare canopy design are specified as a set of planar and cylindrical surfaces and their corresponding edge vertices. Each planar surface is specified by the coordinates of its edge vertices and the consecutive order in which adjacent vertices are listed. A cylindrical surface is specified by cylindrical parameters and the consecutive sequence of the edge vertices and their coordinates. The cylindrical parameters are (1) origin point on the cylindrical axis, (2) directional cosines of the axis, and (3) the radius of the cylinder. The edges of the cylindrical surface are assumed for simplicity to be curvilinear lines which become straightened when the cylinder is transformed into a flat plane.

Given directional cosines and an origin point of a straight-line ray, the program computes, in turn, the intersection point of the ray with each surface. The program tests the intersection point against the surface edges. The reflection point for the ray is that intersection point which is contained within the edges of the corresponding surface segment. The angle of incidence between the surface normal and the ray at this point is computed along with the corresponding values of reflections and transmittance and the directional cosines of the transmitted and reflected rays. Tracing backwards, the reflected ray becomes the incident ray for the next set of computations. (See Appendix A of reference (1) for ray tracing on planar surfaces and computation of transmittance and reflectance values, and Appendix B of reference (3) for derivation of equations used in ray tracing on cylindrical surfaces.)

The program includes internal and external obstructing surfaces and the internal blast barrier of the YAH-64 between the pilot and copilot, as well as the transparent surfaces of the canopy in the computation. The obstructing surfaces are those that either obstruct the pilot's vision or block incident rays from external sources. The internal surfaces are (1) the pilot's seat, display panel and side armor, (2) the copilot's seat, gunner-sight and side armor, and (3) the sides and floor of the cockpit. The external surfaces are (1) aircraft nose section, (2) gun pods and wheel wells, (3) wing stubs, (4) rocket pods, (5) engine intakes, and (6) rotary housing. These surfaces are specified as planar segments in the same manner as are the canopy surfaces. The intersection computations are performed first for all obstructing surfaces and computation of a reflection point for a ray on an obstructing surface renders the computation complete since the backwards traced ray is considered absorbed.

The transparent blast barrier, which separates the copilot and pilot, is treated first as a reflecting surface and then as a transmitting surface for reflection points on surfaces beyond it.

This computation process is repeated for pilot-viewing directions indexed at equal increments over a quarter sector. The sector is bounded by vision directly to the front, to the side, top and bottom. In this way, a table is constructed which lists at discrete intervals all possible internal reflection points and the corresponding external light directions. This approach generates a large amount of data and a computer-graphics routine is included for output. The primary reflection points and the corresponding incident ray entry points are shown on side, top and front views of the canopy and on perspective drawings of the cockpit as seen from the pilot's position. Similar comments apply to computations for the copilot's position. (See Appendix C of reference (1) for a discussion of perspective drawings.)

#### DISCUSSION

The results of this application are shown in Figures 1 through 19. These figures are hard copies of the computer graphics output. Figure 1 shows side, top and front views of the canopy frame, blast barrier and obstructing surfaces. The pilot's nominal eye position is shown in each view. The blast barrier and obstructing surfaces are sketched in with broken lines. The aircraft fuselage and tail assembly are not included in this sketch.

Figure 2 shows side, top and front views of the canopy frame and blast barrier, sketched with broken lines, separated from the obstructing surfaces. Figure 3 is a perspective drawing of the cockpit as seen from the pilot's position. The pilot's nominal viewing direction is shown by the small cross near the top center of the upper front canopy surface. The drawing covers a 60-degree field-of-view and shows that the lower portions of the front and forward side canopy surfaces are blocked from view by the pilot's instrument panel.

The frame edges for the canopy sides are drawn as straight lines connecting adjacent corner vertices. This is done for convenience in the computer graphics routines. The computations assume that the frame edges for the cylindrical surfaces are curvilinear lines (see Method).

Figures 4 through 13 show "dots" for the entry positions of external rays generating primary reflections on the right-hand side of the canopy for the pilot's position. Also shown are the corresponding primary reflections spaced at two degrees by two degrees increments. The number shown at each reflection point is equal to the negative value of the logarithm (base 10) of the light reflectance. The numbers are truncated to their integer values by dropping the fractional parts. The numerical "zero" corresponds to those reflectances which are greater than 0.1 in value. The numerical "one" corresponds to those values equal to or less than 0.1 but greater than 0.01.

Figure 4 shows that entry points are possible over much of the lower front panel and the side surfaces. Figure 5 shows that primary reflection points can occur on (1) the upper rear corner of the front side panels, (2) the upper edge of the rear side panels, and (3) the side edges of the top panel. The front side panel reflections have reflectance values in the 0.1 to 1.0 range, while those on the rear sides and top are in the 0.01 to 0.1 range.

Figures 6 and 7 are perspective drawings of the cockpit as seen from the pilot's nominal viewing position and direction. Figure 6 shows entry points on the lower front and front side surfaces. Figure 7 shows primary reflections on the right-hand side of the canopy. Figure 8 shows reflection points where the pilot has shifted his viewing direction 20 degrees to the right. (Note that some reflection points are shown on the canopy frame. This is because the structure outline is drawn as straight line members between the corner vertices instead of the curvilinear members used in the computations. See Methods.)

Figures 9 through 13 show reflection points generated on one canopy surface by external rays entering another surface. Figure 9 shows reflection points on the top surface generated by entry points on the right rear side surface. Figure 10 shows reflections on the top surface generated by entry points on the right forward side surface. Figure 11 shows reflections on the right rear side due to entry points on the left rear side. Figure 12 shows reflections on the right forward side due to entry points on the lower front surface. Finally, Figure 13 shows reflections on the right rear side due to entry points on the left forward side.

Figures 14 through 19 are similar drawings for the copilot's position. Figure 14 shows "dots" for the entry points of external rays generating primary reflections seen from the copilot's position. The figure shows that entry points occur on the forward side surfaces. Figure 15 shows that the corresponding primary reflections occur on (1) the upper corner of the lower front surface, (2) the upper edge of the forward side surfaces, and (3) the upper front surface. The associated reflectance values range in value from 0.01 to 0.1. Figure 16 is a perspective drawing of the cockpit from the copilot's position. The drawing shows reflection points where the copilot has shifted his viewing direction 45 degrees to the right.

Figures 17 through 19 show pairings between entry points and reflection points by canopy surfaces. Figure 17 shows reflections on the upper front surface generated by entry points on the right forward side surface. Figure 18 shows reflections on the lower front surface due to entry points on the right forward side. Finally, Figure 19 shows reflections on the right forward side due to entry points on the left forward side.

#### CONCLUSION

A computer program developed by HEL to show internal cockpit reflections of external point light sources has been applied to the Model YAH-64 Advanced Attack Helicopter (low glare canopy design). The results show that during nighttime operations, ground-light reflections are possible on the transparent surfaces of the canopy. Reflections are possible from the top and side canopy surfaces for the pilot and the front and forward side surfaces for the copilot. The results are an improvement over the flat plate canopy design since reflections are limited to certain portions of these surfaces. Where reflections actually occur depends upon the particular lighting situation and flight scenario.

#### REFERENCES

1. Smyth, C.C. Computing internal cockpit reflections of external point light sources for the Model 209 AH-1S Cobra helicopter flat plate canopy design. Technical Memorandum 20-77, US Army Human Engineering Laboratory, Aberdeen Proving Ground, MD, 1977.
2. Stowell, H.R., & Smyth, C.C. Investigation of inside light reflection problem on the flat plate canopy (FPC) for Model 209 AH-1S helicopter. Technical Memorandum 13-77, US Army Human Engineering Laboratory, Aberdeen Proving Ground, MD, 1977.
3. Smyth, C.C. Computing Internal Cockpit Reflections of External Point Light Sources for the Model YAH-64 Advanced Attack Helicopter (Low Glare Design), Technical Memorandum 24-77, US Army Human Engineering Laboratory, Aberdeen Proving Ground, MD, 1977.

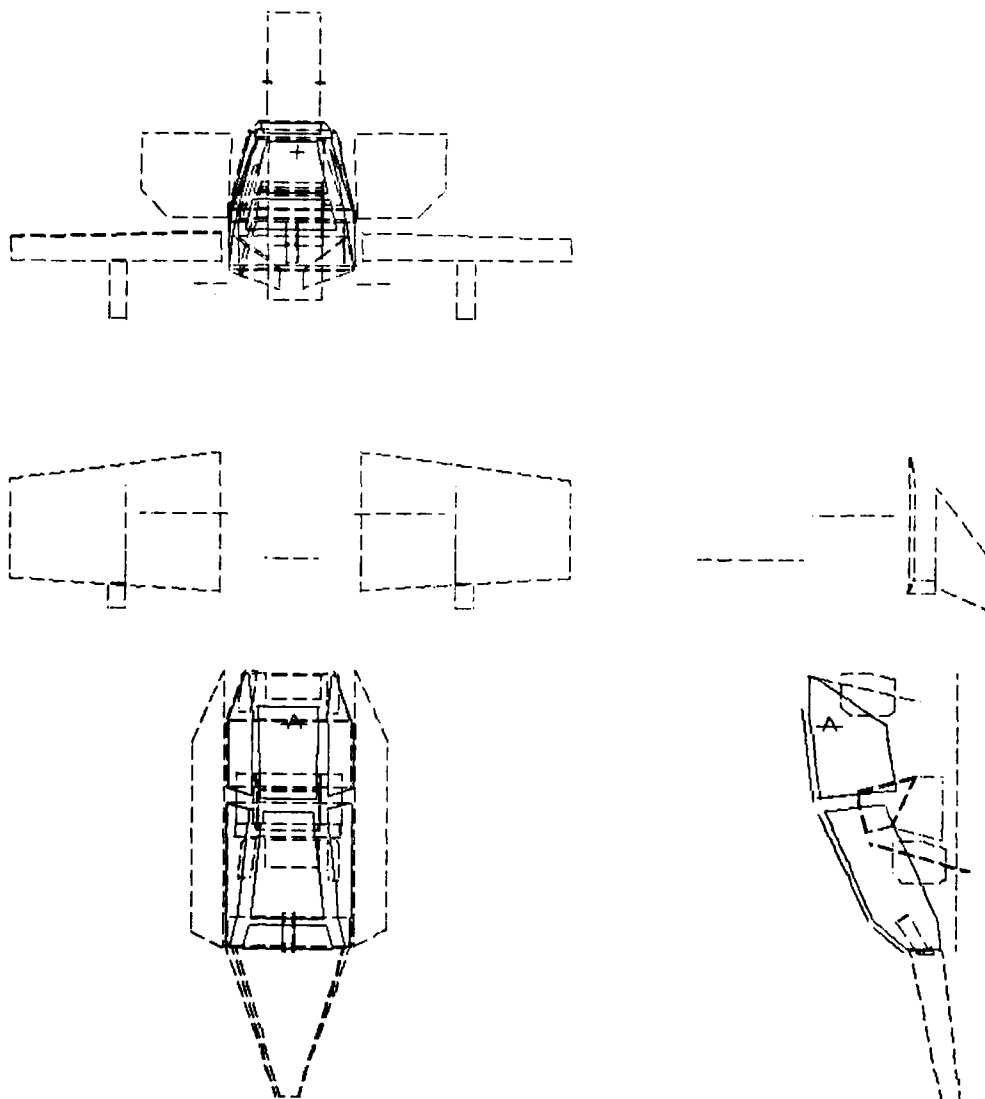

Figure 1. Top, side and front views of canopy frame and obstructing surfaces.

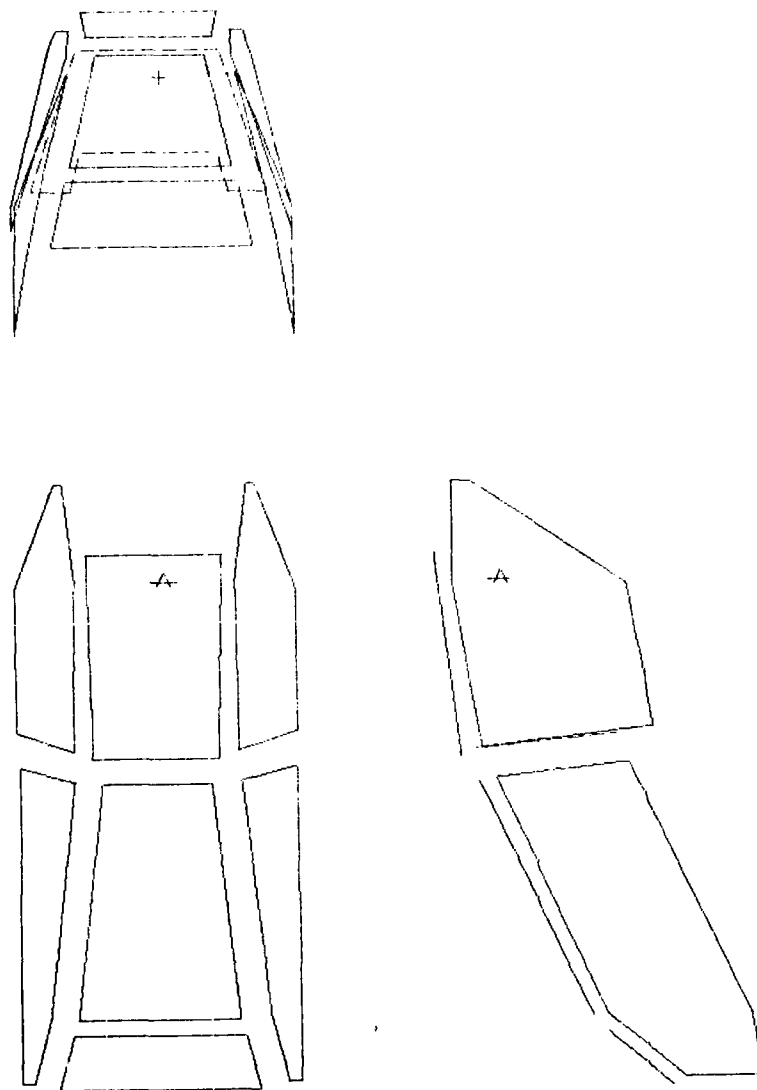

Figure 2. Top, side and front views of canopy frame.



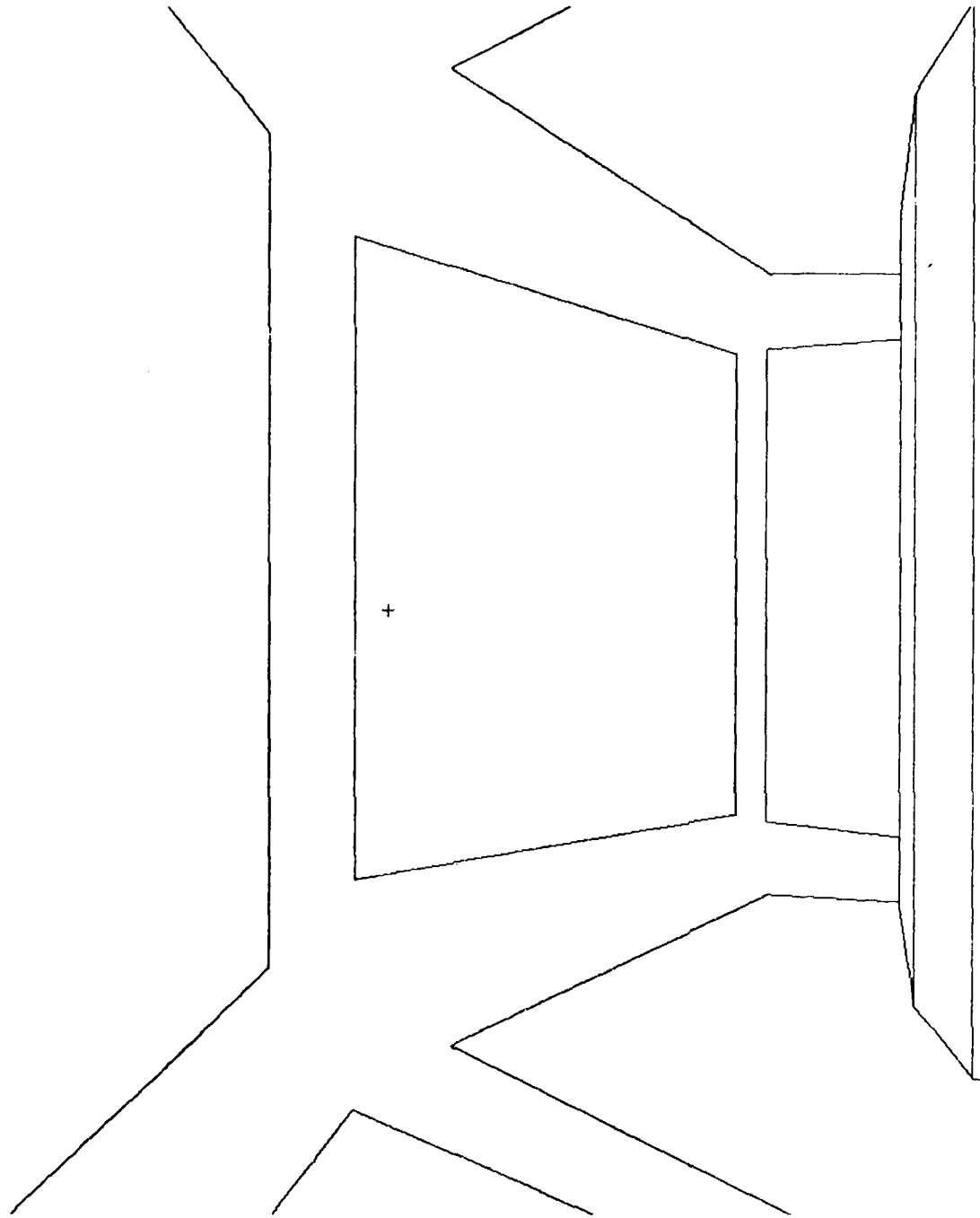

Figure 3. Perspective view of the cockpit interior from the pilot's nominal viewing position and direction.

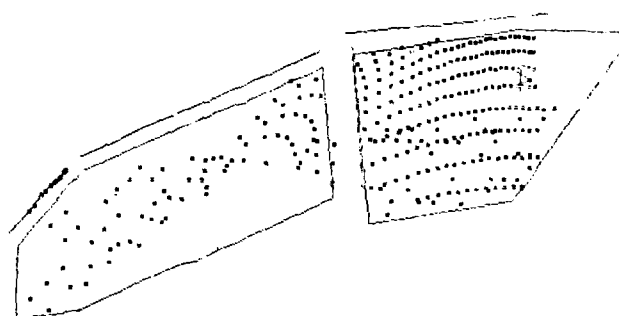
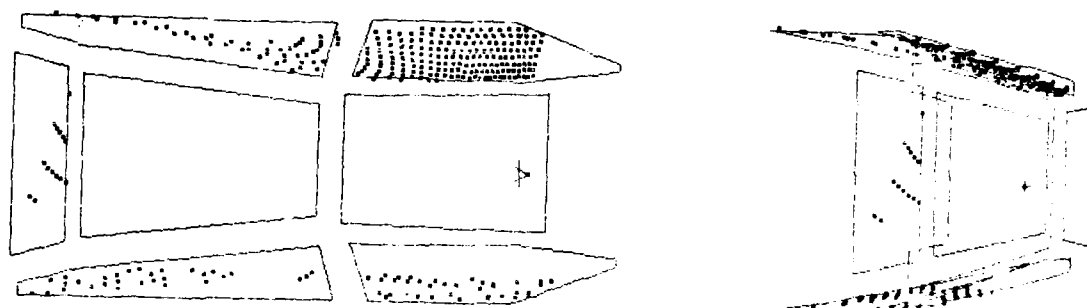

Figure 4. Entry ray positions generating primary reflections on the right-hand side of the canopy as seen from the pilot's position.

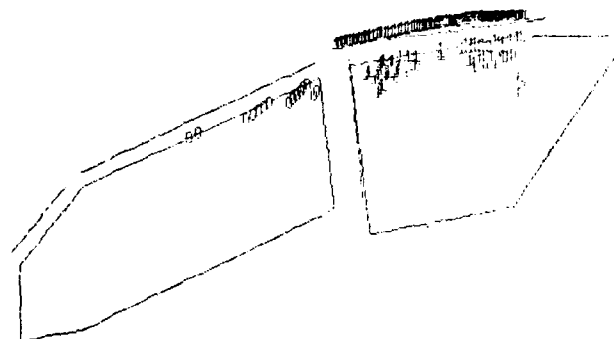
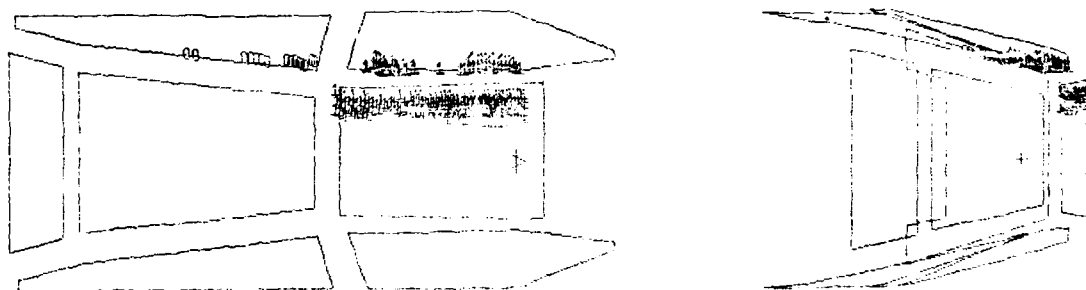

Figure 5. Primary reflection points on the right-hand side of the canopy and their associated reflectance values for the pilot's position.

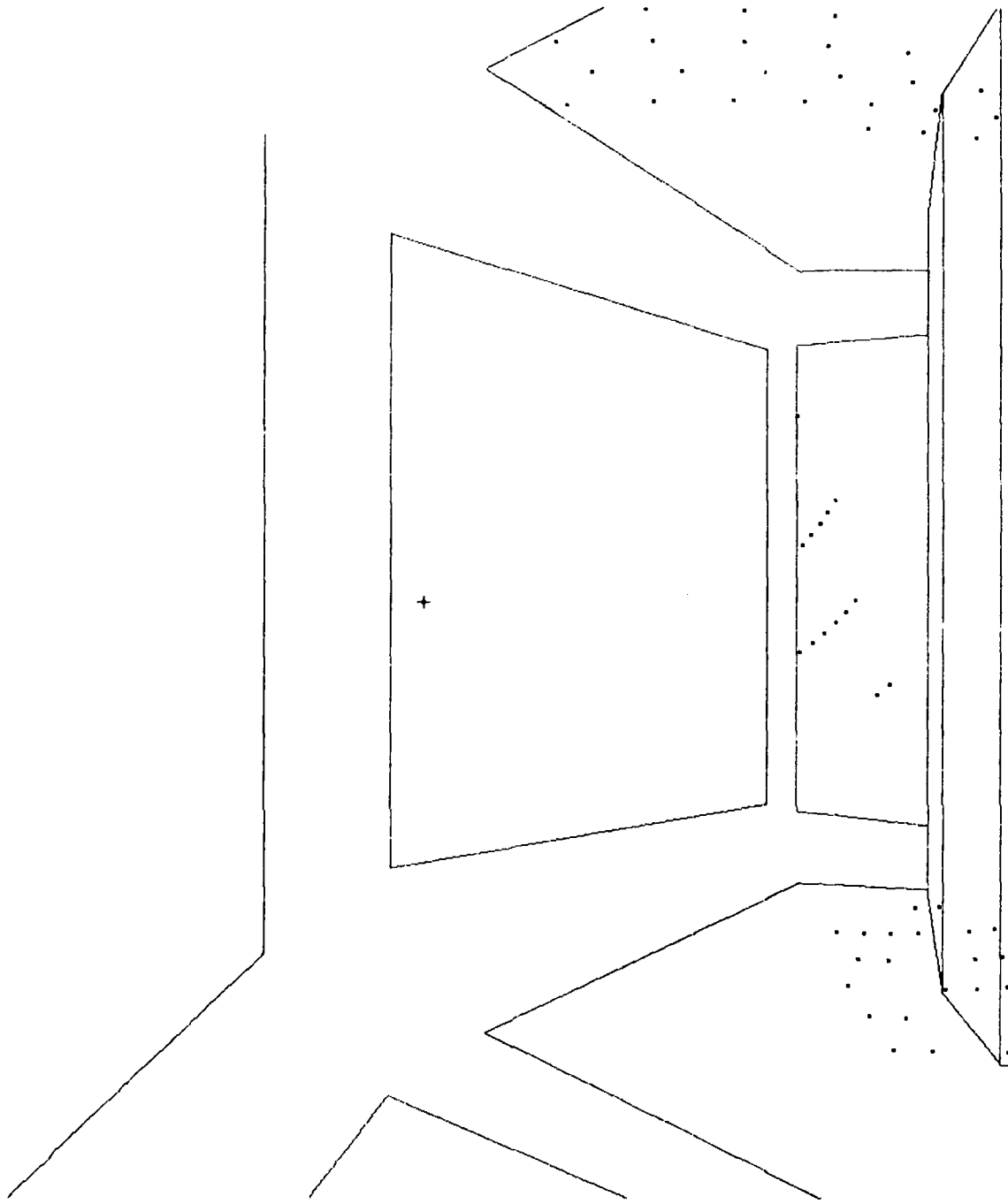

Figure 6. Perspective view of entry ray positions for the pilot's nominal viewing direction and position.

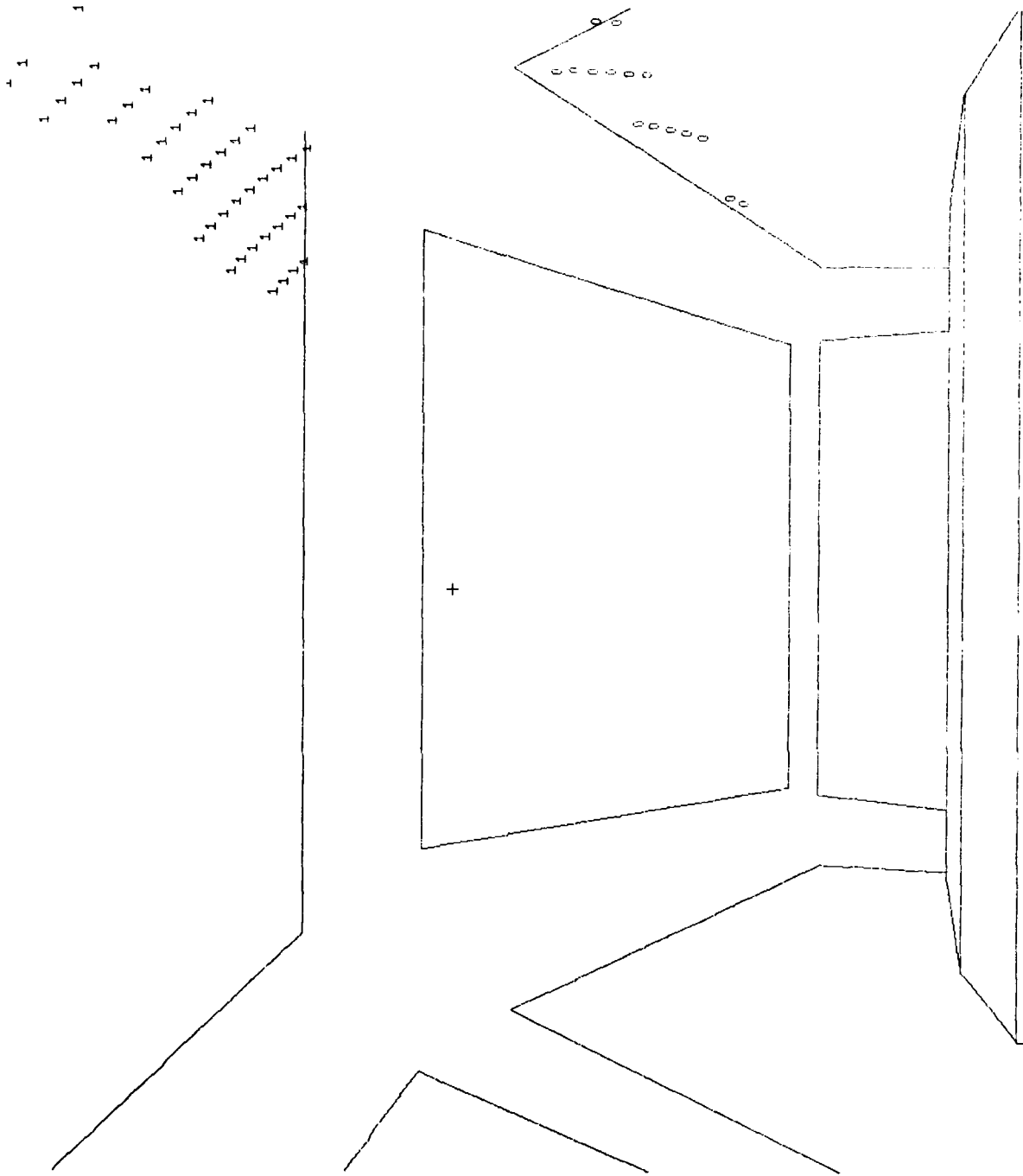

Figure 7. Perspective view of primary reflection points for the pilot's nominal viewing direction and position.

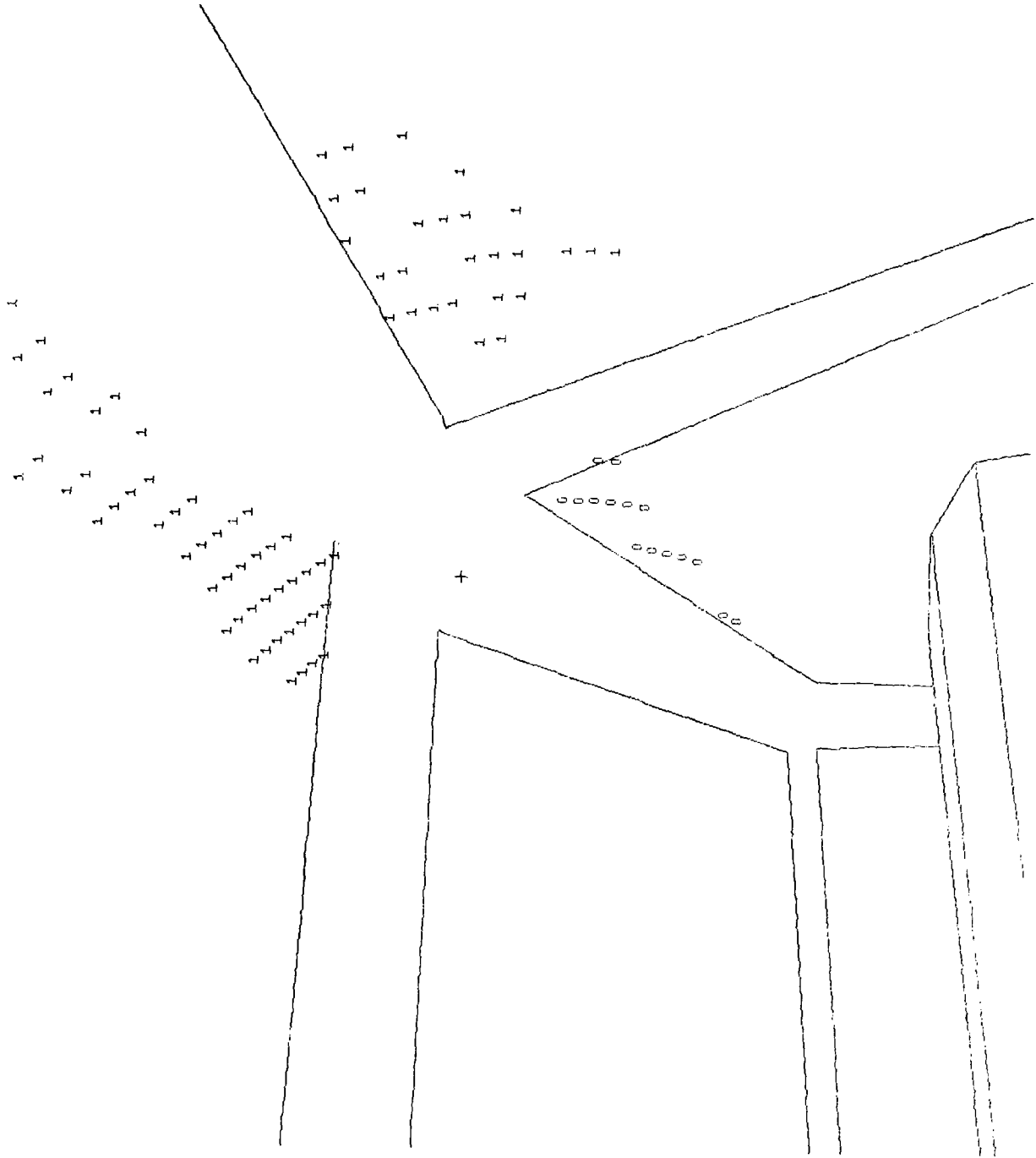

Figure 8. Perspective view of primary reflection points for the pilot viewing 20-degrees to the right side.

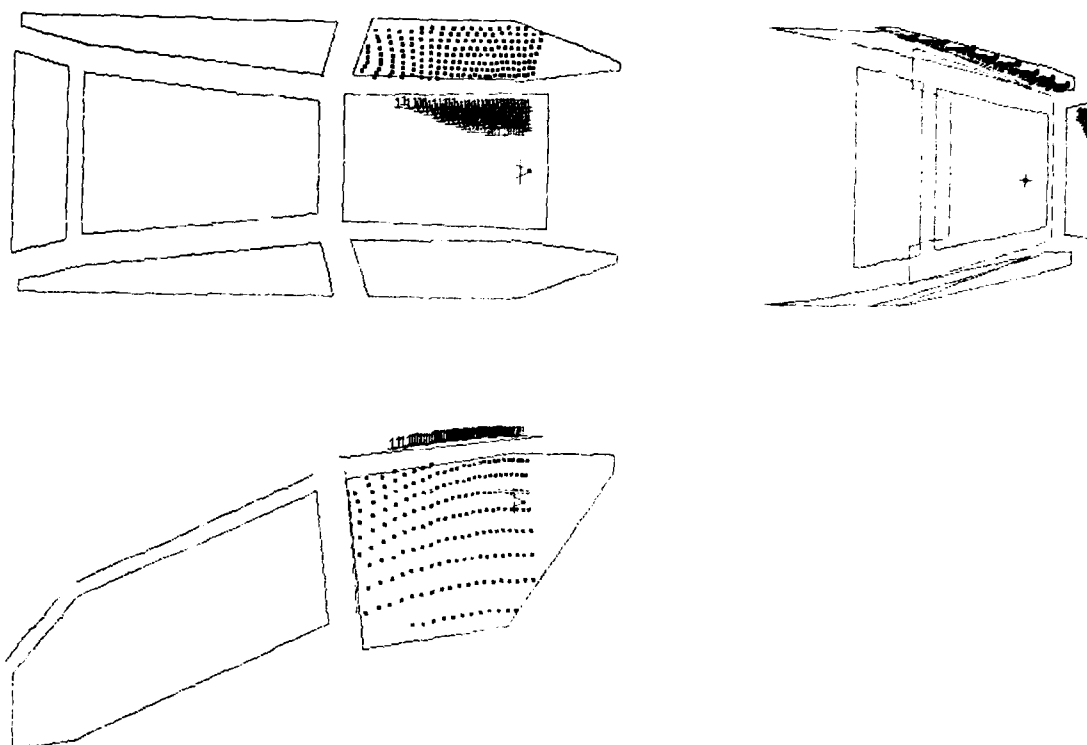

Figure 9. Entry ray positions on the right rear side canopy surface and their corresponding reflection points on the right side of the top surfaces.

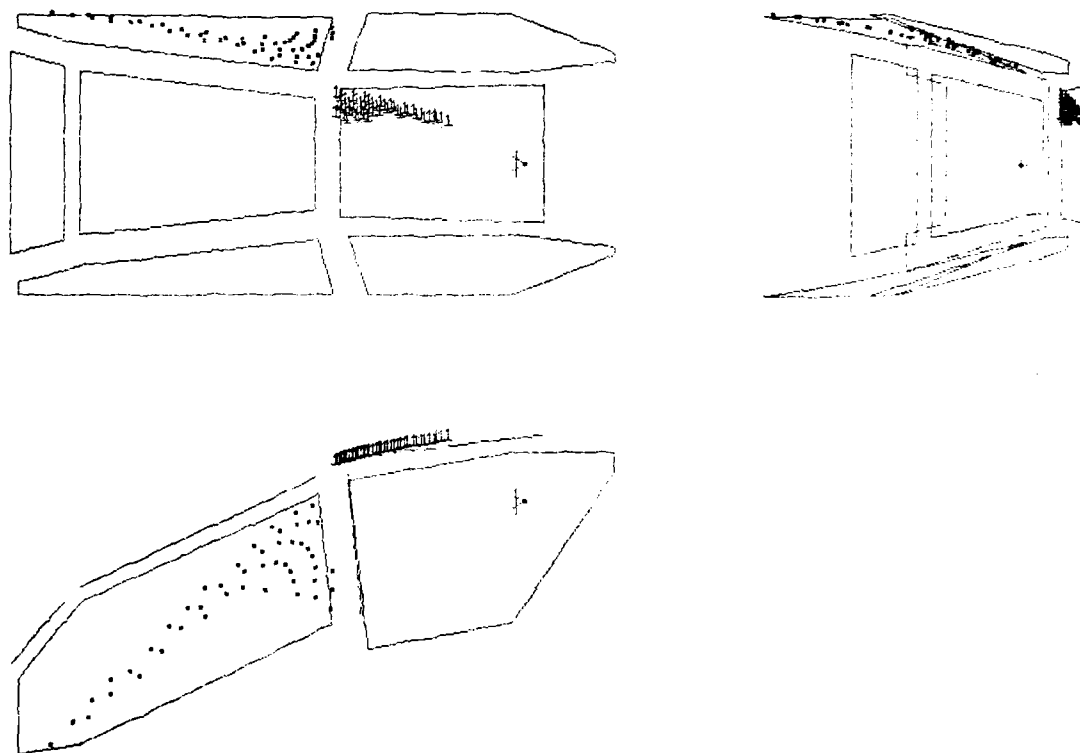

Figure 10. Entry ray positions on the right forward side canopy surface and their corresponding reflection points on the right front of the top surface.

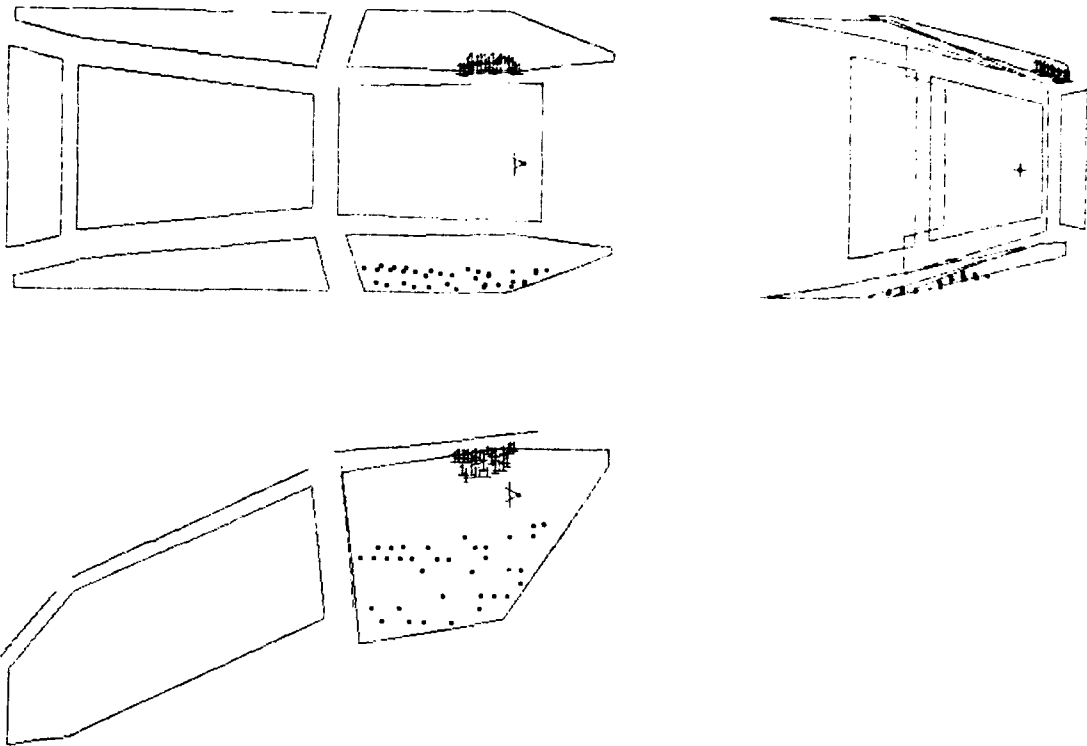

Figure 11. Entry ray positions on the left rear side canopy and their corresponding reflection points on the top edge of the right rear surface.

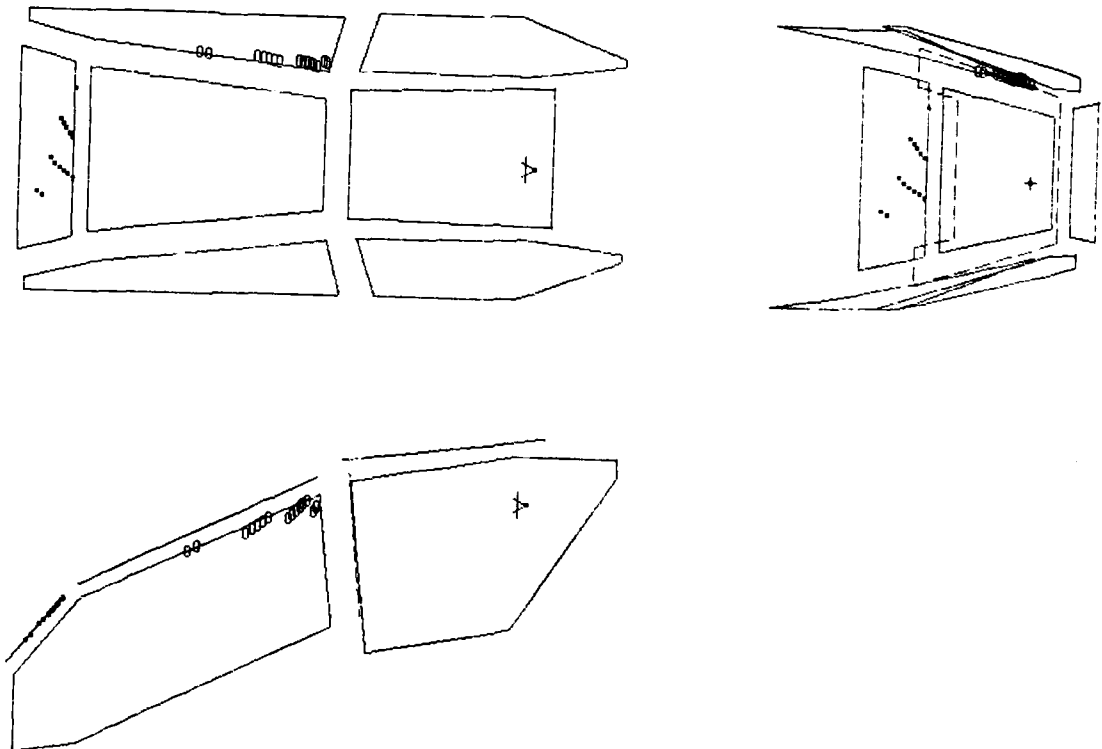

Figure 12. Entry ray positions on the lower front canopy surface and their corresponding reflection points on the upper rear corner of the right forward side surface.

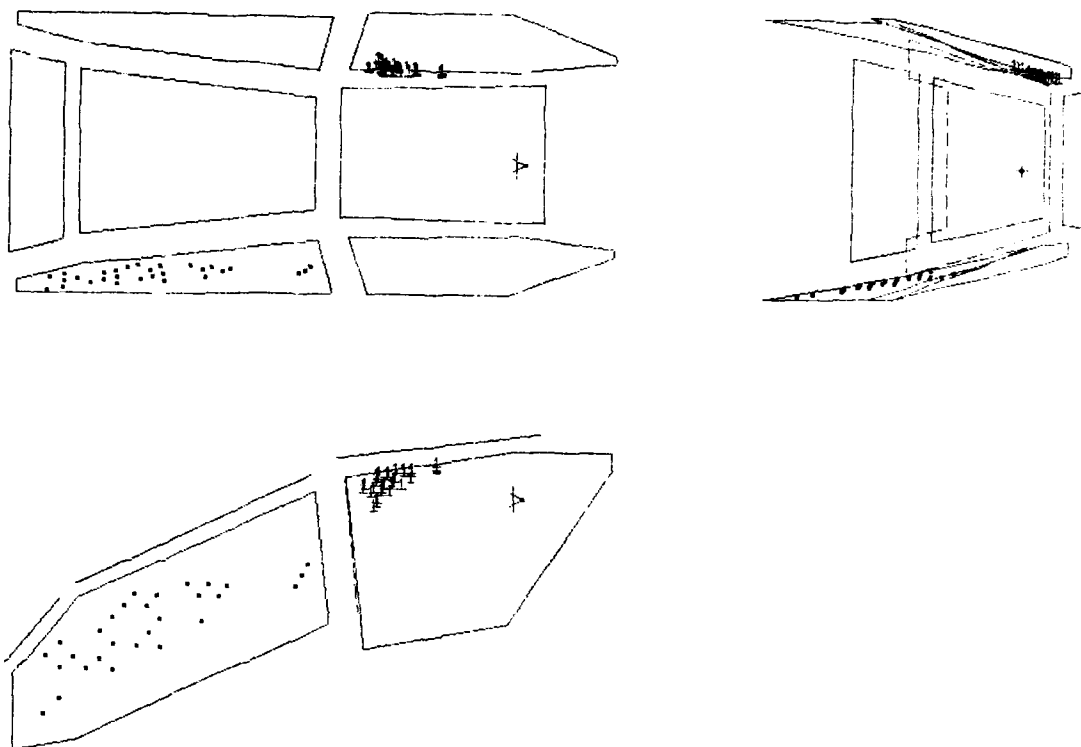

Figure 13. Entry ray positions on the left forward side canopy surface and their corresponding reflection points on the upper front edge of the right rear side surface.

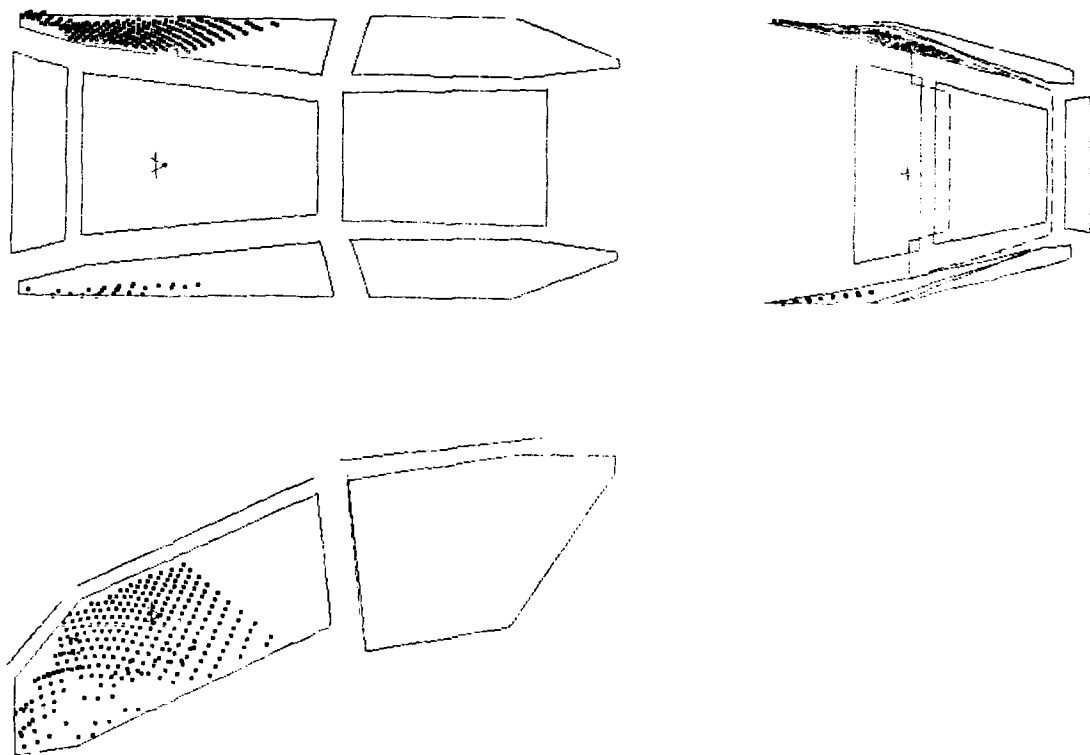

Figure 14. Entry ray positions generating reflections on the right hand side of the canopy as seen from the copilot's nominal position.



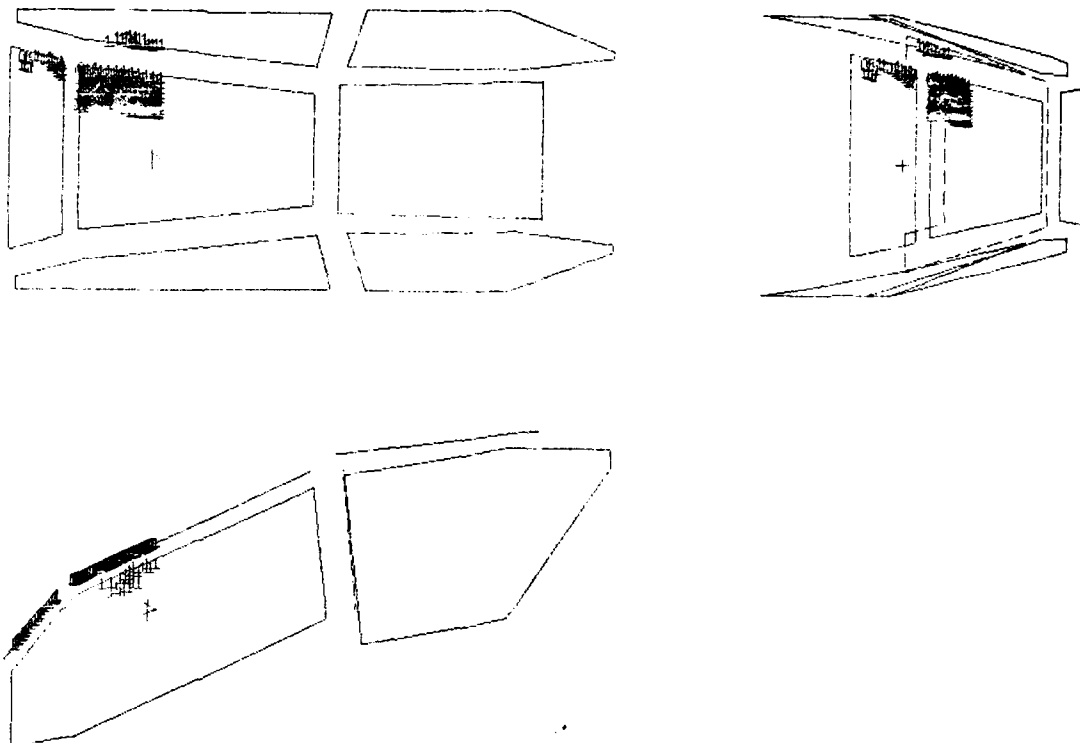

Figure 15. Primary reflection points on the right hand side of the canopy and their associated reflectance values for the copilot's position.

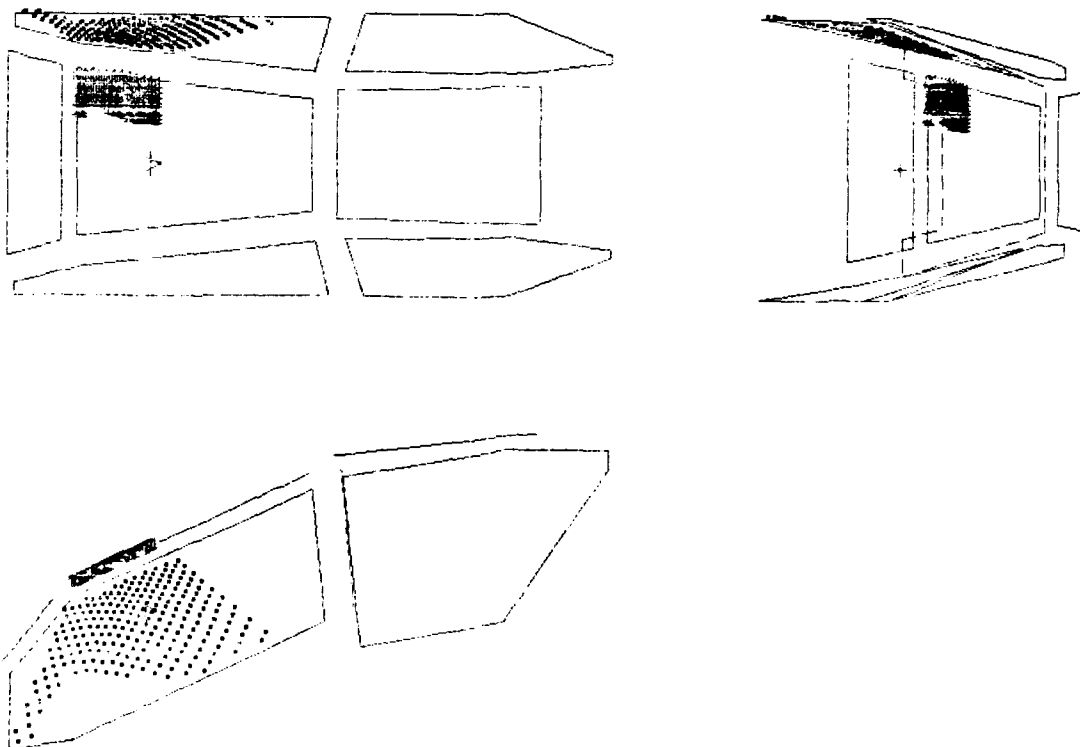

Figure 17. Entry ray positions on the right forward side canopy surface and their corresponding reflection points on the right side of the upper front surface.

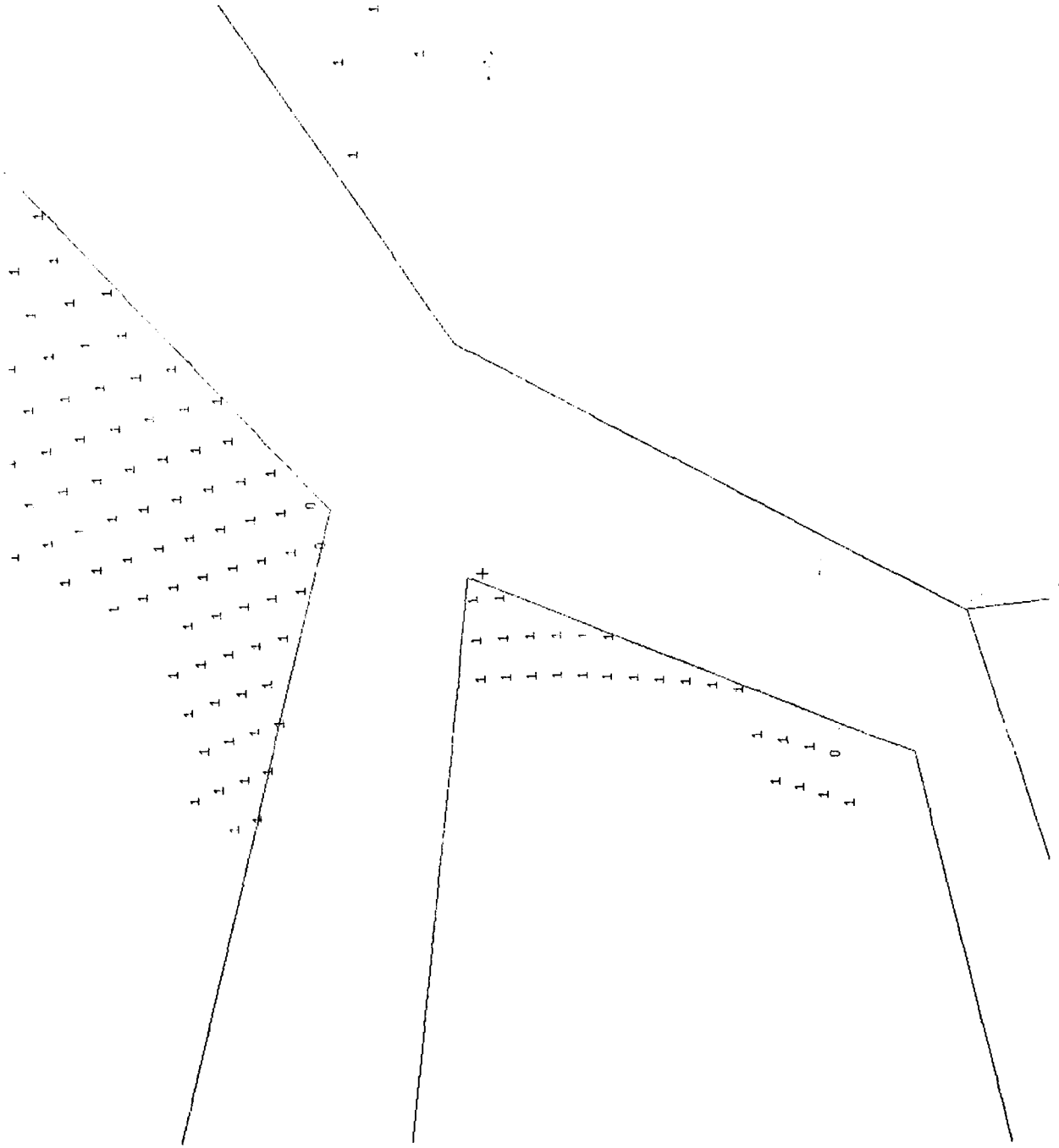

Figure 16. Perspective view of primary reflection points for the copilot's viewing 45-degrees to the right side.

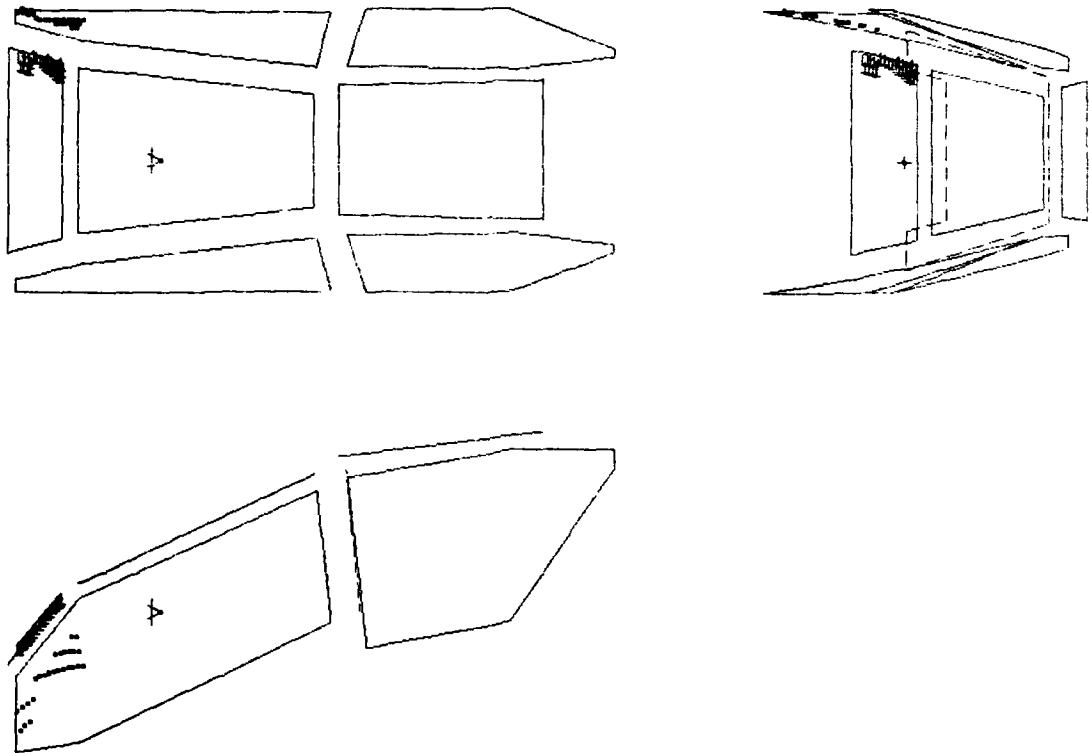

Figure 18. Entry ray positions on the right forward side surface and their corresponding reflection points on the upper right corner of the lower front surface.

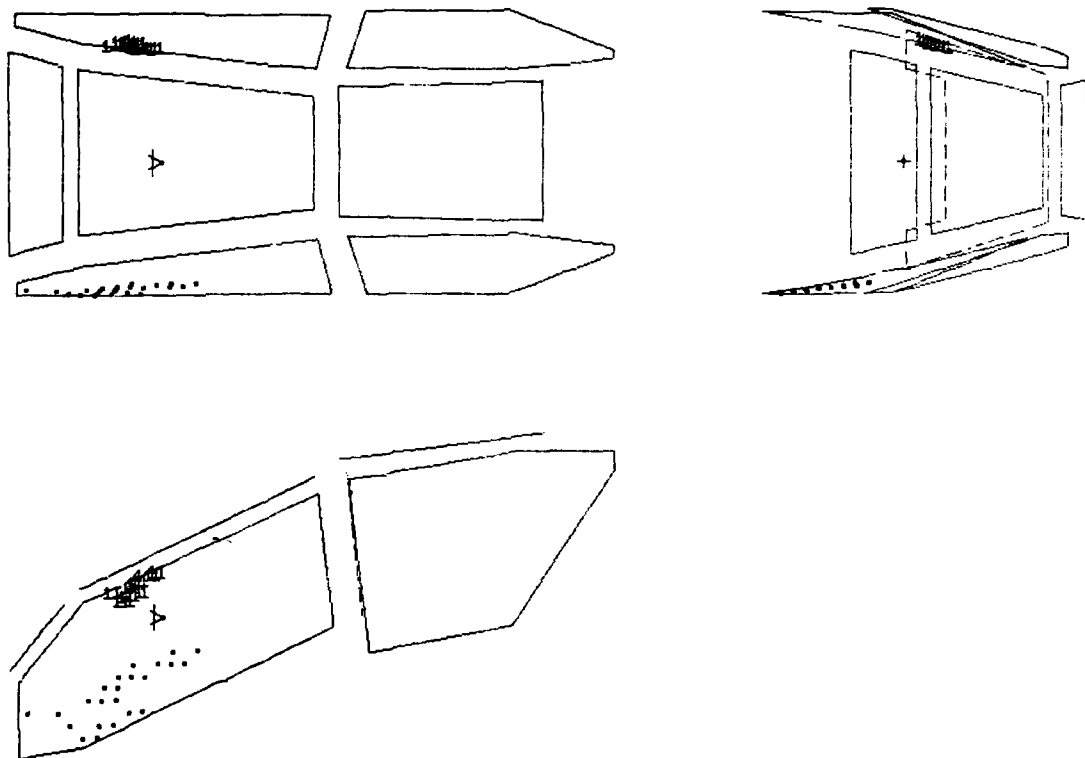

Figure 19. Entry ray positions on the left forward side surface and their corresponding reflection points on the upper edge of the right forward side.

## SENSORIAL ASPECTS OF HELICOPTER OPERATIONS

by

Brig.Gen.Prof.Gaetano ROTONDO, IAF (M.C.)  
Italian Air Force Medical Service H.Q.  
Via P.Gobetti 2 - 00185 ROME - ITALY

### SUMMARY.

As components of physical and psychic workload in the piloting of helicopters, and therefore as possible pathogenetic concurrent factors of operational fatigue in helicopter aircrews, Author examines and analyzes the effects of some sensorial phenomena related to the use of such rotor-powered aircraft.

Particularly acoustic and non-acoustic vibrations associated with flying this type of vehicle are discussed in their action not only on auditory apparatus, but also on the function of other apparatuses and central nervous system, with special reference to the effects exerted by vibratory motions on visual function.

Another problem taken into consideration is the disorientation that, particularly during helicopter flights, pilot may experience whenever there is a conflict between his own sensorial evaluations and the information supplied by the instruments. In helicopter operations this problem becomes far more serious than in the case of conventional fixed-wing aircraft, since accelerations may occur simultaneously along all three of the aerodynamic axes of the vehicle ; so that it is possible for the pilot to experience more frequently environmental and coenesthetic situations that are ambiguous from both the visual and vestibular standpoint ; this may sometimes produce flight accidents.

Finally Author examines the means that might be employed for the purpose of ascertaining and individuating functional changes and possibly preventing negative effects produced by the above-mentioned sensorial phenomena, in order to attain an ever higher degree of flight safety in helicopter operations as a result of the prevention of flight accidents due to the human factor.

### PRELIMINARY REMARKS.

In the study of physical and psychic workload and in the analysis of possible causes of operational fatigue in helicopter pilots, considerable importance may be attached to the effects of some sensorial phenomena related to the use of the rotor-powered aircrafts, such as vibrations, noise, and other specific fatiguing factors of a psycho-sensorial nature involved in carrying out of this type of flying activity.

### EFFECTS OF VIBRATIONS.

As regards acoustic and non-acoustic vibrations, we are concerned with an extremely complex problem. In particular, helicopter vibrations are characterized by a frequency that, depending on the type, may range from 280 to 320 Hz and an amplitude that varies as a function of the balancing of the rotor blade or, as this is normally put in technical language, the proper tracking of the two halves of the rotor. This type of vibration is vertical and becomes more accentuated when the two halves of the rotor are not in perfect track. Although there exist many other vibrations of a cyclic type and several frequencies, including horizontal vibrations and the variable vibrations that depend upon the relative wind and ground resonance, the vertical vibrations undoubtedly remain the most important ones as regards repercussions on pilot's body.

The ultimate effect of prolonged and repeated exposures to vibratory motions of various frequencies, amplitudes and directions may take the form of a wide range of troubles that consist essentially of headache, buzzing, general discomfort, a feeling of numbness, generalized weakness, irritability, deterioration of will power and the capacity to concentrate, reduction in reflex time, psychic depression, and tiring of the eyes and ears. These disturbances, given their intensity and persistence, may well be said to contribute in a decisive and preponderant manner to the genesis of operational fatigue in helicopter pilots (9,10,13) and of helicopter accidents (7).

Particularly troublesome and fatiguing is the effect that vibrations will eventually exert on visual perception of the pilot and, more particularly, on his visual acuity (4, 7). The veil that drops in front of his eyes as a result of continuous vibrational motions at frequencies above about 15-20 Hz will make it practically impossible for him

to read panel instruments or flying charts. It is well known that prolonged visual fatigue leads inevitably to general fatigue within a short period of time.

Particular practical interest may also be attached to the effects exerted on visual acuity by sinusoidal vibrations (i.e. frequency of approximately 10 Hz and amplitude exceeding 2.5 cm). This may be particularly obvious during low-altitude flights in perturbed atmospheric conditions. In fact, it has been experimentally demonstrated (4) that vibrations of 2.7 cm amplitude caused a 10% drop in visual acuity when the frequency was 1 Hz, a 12% drop at 2 Hz, and a 30% reduction at 3 Hz. Furthermore, with an amplitude of 5.5 cm, visual acuity is reduced by 12% at 1 Hz and by 20% at 2 Hz. And lastly, when vibrations have an amplitude of 11.25 cm, visual acuity diminishes by 15% at frequencies of 1.5 Hz. These results may also be valid for those cases in which the pilot, subjected to vibrations, fixes his eyes on an immobile object at infinity (a distant reference point on the horizon, for example). On the other hand, if the object is fixed but close to the pilot (eg. dial on the instrument panel) the reduction in visual acuity will be accentuated.

Motor activity is also compromised by vibrations. In a helicopter, it becomes particularly difficult to perform the small movements needed for the control operations, especially when the oscillations are intense, of variable strength, and make themselves felt at irregular intervals. Very intense vibrations may also provoke chest anginal pain, visceral pain, and even occasional diarrhoea with discharges of blood. Slow oscillations cause a feeling of depression.

#### EFFECTS OF NOISE.

The action on the auditory function of the noises due to the helicopter engines is almost as disturbing and fatiguing as the effects of vibrations. In fact, no matter what the origin of the noise in the helicopter (engine power, thrust, number and type of rotor blades, speed of the rotor tips, number of H.P. per rotor blade, etc.), there can be no doubt that prolonged and repeated exposure to the noises of such rotor-powered flying vehicles, just like exposure to the noises of other types of aircrafts, will lead to auditory fatigue and, thus, exert a considerable influence on the origin and subsequent aggravation of general fatigue (16). Indeed it is well known that noises, depending on duration and intensity of stimulation, may provoke states of adaptation, auditory fatigue, deafness, as well as other general effects on many physiological systems. When noises attain a certain level (about 80 db) and act for a certain length of time (12-16 hours), they at first produce a state of adaptation that consists in a raising of the threshold of acoustic perception (TTS = Temporary Threshold Shift). If noise persists, such threshold shift remains constant (ATS = Asymptotic TTS) and continues at this level even after noise exposure has ceased (20); however, if the interruption of noise exposure persists for a few days, threshold value will return to its normal level. Following repetition and prolongation of noise exposure, on the other hand, the initial state of adaptation may give way to auditory fatigue, which may be defined as a reduction of perceptible sensitivity due to continuous stimulation of the auditory apparatus. Such reduction persists for some time after the cessation of the noise that has brought it about. It is followed by a period of recovery, rather rapid at first, then markedly slower, possibly even with interruptions or brief reversals. There is a clear correlation between fatigue and intensity of the stimulus, and this becomes particularly obvious above 60 db. An equally clear correlation exists between fatigue and the duration of the stimulus.

If noise exposure becomes customary, subjects having a special predisposition may, in the absence of adequate protection, reach an ultimate stage consisting of occupational deafness properly. In that case, the TTS is transformed into a PTS (Permanent Threshold Shift) and hence an irreversible form of acoustic damage (18). The various times for the onset of permanent damage are influenced by a variety of causal and concurrent factors that may be either endogenous (individual susceptibility, age, previous ear affections) or exogenous (intensity, frequency and rhythm of the noise, and working conditions).

Apart from the local effects on the auditory apparatus, it is well known that noises may also exert general actions on other systems (6,16) such as: 1) the central nervous system, with modifications of chronaxia, reflexes, reaction times, and endocranial pressure, and with electroencephalographic, neuromuscular, and psychic disturbances; 2) the circulatory system, with variations of the cardiac rhythm, arterial pressure, and electrocardiographic patterns anomalies; 3) the respiratory apparatus, with modifications of depth and frequency of the breath, and sometimes with apnea, followed by polypnea; and 4) the digestive apparatus, with variations of the secretion of saliva, gastric motility and secretions, motor activity of bowels, etc.

Therefore, a considerable influence may be exerted - through a state of auditory

fatigue - by prolonged and repeated exposure to aircraft and helicopter noises in general, on the genesis and evolution of flight general fatigue. According to COERMANN et al. (2), the phenomenon of fatigue induced by noise can, in fact, be explained as the final outcome of a struggle of noise against the other impulses that reach the encephalon at the same time. The greater concentration needed to capture such desirable impulses implies an excessive expenditure of energy and leads rapidly to a nervous fatigue. The observable manifestations of such nervous fatigue are the previously mentioned neurological phenomena, which include the reduction of the chronaxia of motor nerves (6), the lengthening of simple reaction time and the increase of the "average variation" of the reaction itself, i.e. the number of errors and the inconstancy of the motorial reaction (15), and lastly the attenuation of the patellar reflex (1). The latter phenomenon is not observed in subjects exposed to the noise while protected by means of ear muffs; this may be interpreted as an exhaustion phenomenon that is secondary to an earlier phase of nervous hyperexcitability and suggests that noise exerts its fatiguing action on the nervous system, primarily through the mediation of the ear. Indeed, TIZZA-NO (16) affirms the concept that "the ear is not a closed vessel that merely gathers and dissolves noises it receives. Somewhat similarly to a transformer, it converts sound vibrations into neuron vibrations that will transmit the perceived sensations to the brain".

#### EFFECTS OF PSYCHO-SENSORIAL FACTORS : SPATIAL DISORIENTATION.

Another phenomenon of a psycho-sensorial nature that must be taken into consideration is the spatial disorientation that, particularly during helicopter flights, pilot may experience whenever there is a conflict between his own sensorial evaluations and the information supplied by the instruments. This conflict may induce him, if his critical faculty has not been sufficiently trained or if it has been compromised by fatigue, to commit manoeuvring errors due to failure to correct the trim of the aircraft (or an instinctive but erroneous correction) in situations that call for manoeuvres absolutely opposite to pilot's instinct.

In helicopter pilots, this problem of disorientation in flight may become far more serious than in the case of conventional fixed-wing aircraft, since accelerations may occur simultaneously along all three of the aerodynamic axes of the vehicle. In these conditions, it is possible for the pilot to experience more frequently environmental and coenesthetic situations that are ambiguous from both the visual and vestibular standpoint, so that the interaction of sensorial information frequently leads to conflicts. This may sometimes contribute to produce flight accidents.

Generally speaking, however, the types of disorientation to which the helicopter pilot is subject are, for the most part, similar to those reported in fixed-wing aircraft. But there are some particular types of disorientation which are peculiar to rotary-wing aircraft and are most apt to occur in the helicopter's flight envelope, at low altitudes and slow airspeeds, or in a hover. Not only, in fact, is the helicopter capable of roll, pitch, and yaw movements (i.e., rotational acceleration about the x, y, and z axes) like conventional aircraft, but in a controlled hover it is capable of linear acceleration along the three axes. Thus, the pilot in a hover experiences a mixture of vestibular and proprioceptive stimuli which may be more difficult to interpret than those experienced in fixed-wing aircraft.

According to TORMES and GUEDRY (17), with minimum visual cues, forward (+G<sub>x</sub>) acceleration is less conducive to disorientation than backward (-G<sub>x</sub>), lateral (+G<sub>y</sub>, -G<sub>y</sub>), or vertical (+G<sub>z</sub>, -G<sub>z</sub>) acceleration. In fact, a common maneuver employed by helicopter pilots when disoriented is increasing forward airspeed and flying straight and level long enough to regain spatial orientation. It is not surprising, then, that the sensation of backward (-G<sub>x</sub>) motion, especially in a night low-altitude hover over water, is so disorienting. This sensation of "backing down" usually results in incorrect control input which leads to unusual aircraft attitudes.

Particularly in operations conducted by naval helicopter pilots disorientation is often experienced while in low-altitude hovers at sea in IFR conditions, and at night. Factors which contribute to disorientation in this setting include relative motion illusions and somatic sensations while in the hover configuration. Disorientation is also frequently reported during approaches and takeoff from aviation ships at night (17). The nature of many helicopter missions, e.g., night search and rescue operations, may mean that the helicopter pilot is involved in situations requiring shifts between IFR and VFR more frequently than the fixed-wing pilot. Such shifts facilitate and potentiate disorientation.

Characteristics of helicopters which are recognized as playing a role in disorientation include the helicopter's capacity not only for above-mentioned angular and linear acceleration along three axes, but also for occasional high-vibration levels. Since a

large component of vibration in helicopters is a function of the basic propulsion system and the aerodynamic properties of rotary wings, vibration is a very important problem ; particularly, its effect on the vestibular and proprioceptive senses, which chronically and acutely in certain phases of flight are causally related to disorientation, may be due to excessive translational lift vibrations ; also vibration dampeners on inadequate instrument panel allow blurring of instruments. Vibration can also degrade visual acuity for instruments at critical times in some helicopter operations.

A helpful countermeasure against the blurring of vision for cockpit instruments during critical flight movements may be a temporary increase of luminance level which improves vision when there is relative vibratory motion between the eye and flight instruments (5), and which may be an effective countermeasure against other forms of disorientation (14). The frequency of disorientation may be also reduced by changes in cockpit instrumentation which include reducing the area of the instrument scan by combining flight instruments and providing command information, thereby reducing both data processing time and the amount of head motion required to monitor the instruments.

### CONCLUSIONS.

After having examined the effects of sensorial and psycho-sensorial phenomena related to the use of helicopters, it would certainly be interesting and important if it were possible to define the degree and limits of the psychophysical workload they involve. Numerous methods have been proposed for the purpose of obtaining a measure of workload by quantitatively evaluating the functional changes produced by these stressing and fatiguing factors on the single organs and apparatuses and/or the whole body. As it is known, such changes may consist of : an increase of the latency time of the pupillar reflex ; a diminution of the capacity for rapid binocular fusion ; an increase of the accommodation time for near and distant vision ; a reduction of the critical flicker fusion frequency (8,19), and changes of other ophthalmic indexes ; variations in the duration of the central nervous time of the orbicular blinking reflex under light stimulation ; an increase of the duration and inconstancy of the psychomotorial reaction times ; increased instability in neuromuscular coordination ; audiometric changes ; electrocardiographic changes, and variations in the Ruffier and Dickson index of cardiac resistance (9) ; urinary and haematic changes, etc.

Quite obviously, it is extremely difficult to find a precise differential criterion that could be used to obtain a quantitative graduation of the workload, because of the numerous and extremely variable individual, environmental, and circumstantial factors conditioning the reaction to any kind of stimulus. However, the individuation of some of the above-mentioned functional changes may often give an approximative idea on the harmful effects of the sensorial and psycho-sensorial phenomena specifically related to the use of helicopters.

As regards the means that might be employed for the purpose of possibly preventing negative effects produced by such phenomena, it is certainly very important the use of constructional and functional measures which are able to reduce the production of acoustic and non-acoustic vibrations and increase the protection from their general and local effects.

Also the above-mentioned countermeasures against the various forms of disorientation in flight (temporary increase of the luminance level of the instrument during some critical flight movements, adequate changes in cockpit instrumentation including reduction of the area of instrument scan and incorporation of a flight director system in helicopters, reduction of extreme head movements, etc.) can be very helpful and effective in counteracting disorientation and preventing possible flight accidents. It is also necessary to recommend that all known disorientation countermeasures be stressed in basic and secondary helicopter training, with special emphasis on those situations which are particularly troublesome in helicopters. Besides, rotary-wing pilots should be trained to be especially alert in those phases of flight where disorientation is most likely to occur, and should learn to recognize and disregard visual and vestibular phenomena which may lead to disorientation.

In this way, it will be possible to attain an ever higher degree of flight safety in helicopter operations as a result of the prevention of flight accidents due to the human factor.

REFERENCES.

1. CAPORALE, R. 1959 : "Some acoustic and non-acoustic effects of exposition to noise and vibrations of jet-engines". Riv.Med.Aeron.Spaz., 22 : 17.
2. COERMANN, R.R., G.H. ZIEGENRUECKER, A.L. WITTWER and H.E. Von GIERKE. 1960. Aerospace Med., 31 : 443.
3. DOBIE, T.G. 1972 : "Aeromedical Handbook for Aircrew". AGARDograph No.154.
4. DRAZIN, D.H. 1959 : "Effects of low-frequency high-amplitude whole-body vibration on visual acuity". Air Ministry, Flying Personnel Research Committee, Memo No.128.
5. GILSON, R.D., F.E. GUEDRY, and A.J. BENSON. 1970 : "Influence of vestibular stimulation and display luminance on a compensatory tracking task". Aerospace Med., 41 : 1231.
6. GRANDPIERRE, R., and L. LEMAIRE. 1947 : noticed by GROGNOT in : "Bruit et vibrations ressentis en aviation". Méd.Aéron., 6 : 327.
7. GRIFFIN, M.J. 1974 : "A study of vibration, pilot vision and helicopter accidents". AGARD Conference Proceedings No.145, B.16.
8. KRUGMAN, H.E. 1947 : "CFF as a function of anxiety reaction : an exploratory study". Psychosom.Med., 9 : 269.
9. LE ROUX, R. 1960 : "La fatigue opérationnelle des pilotes d'hélicoptères". Revue des Corp de Santé, 1 : 493.
10. PERRY, I.C. 1974 : "Helicopter aircrew fatigue". AGARD Advisory Report No.69.
11. ROTONDO, G. 1969 : "Experimental contribution to preventive and therapeutic treatment of flight fatigue". Riv.Med.Aeron.Spaz., 32 : 231.
12. ROTONDO, G. 1976 : "Spatial disorientation, as a possible cause of flight accidents". Min.Med., 67 : 158.
13. ROTONDO, G. 1977 : "Workload and operational fatigue in helicopter pilots". AGARD Conference Proceedings No.217, B.1.
14. STEELE, J.R. 1974 : "Spatial disorientation". Approach, Naval Safety Center, Norfolk, Va.
15. STROLLO, M., and F.O. DEBARNOT. 1957 : "Influence of noise, produced in flight, on readiness and constancy of motor reaction". Riv.Med.Aeron., 20 : 601.
16. TIZZANO, A. 1958 : "Biological effects of noise". Proceedings XXth National Hygiene Congress, Rome.
17. TORMES, F.R., and F.E. GUEDRY. 1975 : "Disorientation phenomena in naval helicopter pilots". Aviat.Space Environmental Med., 46 : 387.
18. TRIBEL, W. 1955 : "Considérations sur la surdité professionnelle des pilotes d'avions à moteurs à pistons et des pilotes d'avions à réaction". Méd.Aéron., 367.
19. VOZZA, R. 1955 : "Flicker fusion frequency as a test of operational fatigue in jet-pilots". Riv.Med.Aeron., 18 : 771.
20. WARD, W.D. 1975 : "Studies of Asymptotic TTS". AGARD Conference Proceedings No.171, C.4.



## THE EFFECTIVE ACOUSTIC ENVIRONMENT OF HELICOPTER CREWMEN

Robert T. Camp, Jr. and Ben T. Mozo  
 Bioacoustics Division  
 US Army Aeromedical Research Laboratory  
 Fort Rucker, Alabama 36362

## SUMMARY

Internal and external noise levels of helicopters are usually measured to determine the acoustic environment of the crewmen. These types of measurements alone are inadequate for assessing the real acoustic hazards of personnel. The attenuation characteristics of helmets and hearing protectors and the variables of the physiology of the human ear must be taken into account in determining the effective acoustic environment of Army helicopter crewmen. Also, the acoustic hazards of voice communications systems noise may influence the overall acoustic environment of the personnel. The composite acoustic environment can be determined only with complex acoustic measurements that are necessary to quantify the effective acoustic environment of the crewmen.

## INTRODUCTION

Noise characteristics of helicopters should be given consideration in the design and purchase of aircraft for several reasons. The high sound pressure levels associated with the operation of military aircraft are hazardous to hearing by most damage risk criteria. Also, the high level sounds may interfere with communications and operational efficiency of crewmen.

The traditional approach to the task of ascertaining the acoustic environment that may affect the personnel is to measure sound pressure levels at various crewmen's positions under various operational conditions. In discussions of helicopter noise problems in popular and scientific articles it is often assumed that the sound pressure levels within the aircraft are the actual pressure level values that impinge on the ears of the personnel who operate the aircraft. It is assumed that the ambient sound pressure levels are the same as the effective acoustical environment of the crewmen. The effective acoustical environment is defined as the actual acoustic energy that is received by the hearing system.

Measuring the effective acoustic environment of helicopter crewmen is a complex process. The purpose of this paper is to discuss the differences between the ambient acoustic level environment of the aircraft and the actual acoustic levels that affect the aircraft crewmen's ears.

## HUMAN AUDITORY SYSTEM EFFECTS

The human ear is divided into three sections: the external, middle, and inner ear. The inner ear contains a complex system of membranes, nerves, and hair cells that may be damaged by noise. The amount of noise induced hearing loss is determined by the effective acoustic environment or the actual energy transmitted into the inner ear.

The middle ear is a pathway to the inner ear and is equipped with certain protective mechanisms that affect the acoustic input. It contains two muscles that limit the input to the inner ear.

The external canal is shaped as an irregular tube. There are various forms and sizes. The variations of sizes and shapes may produce various amounts of protection, especially in the high frequencies. Unpredictable limiting characteristics of the middle ear plus the variations of sizes and shapes of the external ear canal make it difficult to measure the actual acoustic stimuli travelling through the system to the inner ear.

## HEARING PROTECTOR AND VOICE COMMUNICATIONS SYSTEMS EFFECTS

The human auditory system just discussed is not the only source of variables that may affect the actual sound transmitted to the ear. Hearing protective devices, earplugs, headsets, and helmets contribute to the transformation of the acoustic environment to sound spectrum characteristics and sound pressure levels that may be vastly different from the values obtained using free field measurements in the cockpit. In general, all types of hearing protectors, both insert and circumaural, attenuate high frequencies much more efficiently than they attenuate low frequencies.

Let us take, for example, the case of a typical pilot flying an Army CH-47 helicopter wearing the standard SPH-4 helmet. One would expect that the change of sound characteristics beneath the helmet when fitted on the head of the aircrewman would be the original sound spectrum on the outside of the helmet minus the attenuation characteristics of the helmet. If the pilot were flying with no voice communication system or warning signals activated, the resultant spectrum at the external ear would be approximately the values as determined by this method. One must remember that the helmet earcups are sealed tightly over the ears of the crewmen and contain earphones that generate a sound source beneath the helmet. One normally does not associate very high sound pressure levels with an earphone. Coupled to small volumes such as the canal of the human ear, earphones are capable of generating up to 120 dB sound pressure level. Our investigations of sound sources from communication systems, warning signals, navigation signals, have revealed that a very significantly high sound pressure level may be transmitted from the earphone. These levels are much greater than the ambient noise that is transmitted through the helmet.

Another source of noise that may enter in the total effective acoustic environment is the distortion created by the design of voice communications electronic systems. It is well-known that military voice communication systems are designed with distortion. Some military specifications require only 70% intelligibility and specify certain various amounts of peak clipping which yield harmful distortion harmonics. The effects of peak clipping have been thoroughly discussed in some of my previous presentations to this group. Peak clipping may cause a decrement of intelligibility and also creates unnecessary harmonics that add to the total excessive energy that is transmitted to the ears and thereby the contributor to hearing loss. Added to these harmonics, often we have found inverter power line noise that yields very high acoustic signals through the earphones and therefore is a significant source of acoustic hazard.

#### TRANSDUCER CHARACTERISTICS EFFECTS

Another aspect of the problem that one should note is the characteristics of transducers. Microphones and earphones should have flat response within the audio range, ideally. If either the microphone or the earphones have peaks the crewmen may set gains of voice communications and other signals emitted through the earphones that are unnecessarily high level. By some evaluations the M-87 microphone has been considered one of the best military type noise cancelling microphones available. The response characteristics contain a very large peak in the 4000 Hz range. So when one receives messages transmitted through this microphone, there is an unnecessarily high emphasis of the 4000 Hz range. With our present-day knowledge of hearing loss causes, it is well established that this is the most vulnerable portion of the audio spectrum for hearing damage. If this microphone were used in low ambient noise conditions and if the reception were in quiet environments, there would probably be no significant amounts of hearing loss. However, in its application in high noise environments, where gain settings are very high, the net result is that the ear is subjected to large quantities of energy which for long periods of time may cause significant hearing loss for some personnel.

Earphones should also have flat response. If they produce peak response one would expect the same potential hearing damaging spectra when listening in high level noise much for the same reason that peak microphones cause problems. The recent trend to change to lighter earphones should be watched carefully to avoid the regression of headphone response. Some of the small earphones may produce high distortion when driven at the levels required in the noisy military environment.

With the excess energy caused by variables of transducer response plus the many other signals such as voice communication messages, warning signals, navigation signals, and special instrumentation, there are significantly high acoustic levels generated beneath the helmet earcups.

#### SPECIAL PROBLEMS OF LOW FREQUENCY NOISE

One other aspect of the helicopter noise problem that may affect the effective acoustic environment of the crewmen is extremely low rotary blade passing frequency which is usually below the octave bands traditionally given in the analyses of survey data. In this region of the audio spectrum, measurement is seldom made of the aircraft noise spectra. The attenuation characteristics of the hearing protectors worn also in helicopters is not usually reported. The question arises: Are these low frequencies passing through the helmets? Do they cause high frequency harmonic distribution that contributes to the total noise in the effective acoustic environment?

Our laboratory is presently engaged in the investigation of the effects of low frequencies on animal ears. We have found significant temporary threshold shift in the high frequencies when the animals were exposed to long periods of low frequency band centered at 63 Hz.

#### CONCLUDING REMARKS

In summary, the purpose of our presentation is to call attention to the fact that the ambient sound pressure level measurements often made in helicopter cockpits with sound level meters will not yield essential information about the noise characteristics that truly affect the helicopter crewmen. We should be aware of the difference between these levels and the actual effective acoustic environment that must be determined by other means. We have shown how the ambient acoustics level transmitted through the helmets is transformed by the attenuation characteristics of the helmet or other hearing protective devices that the crewmen may be wearing. In addition to these transformations, there are added signals caused by the design of microphones, earphones, hearing protective devices and electronic systems. In a word, the actual acoustic energy at the eardrums of the crewmen is usually totally different from the acoustic environment measured around the various positions inside the aircraft. We have also discussed the variables of the middle ear that limit and modify the acoustic spectrum that is produced at the eardrum. All of these variables and unknowns make it very difficult to assess the real energy that reaches the inner ear, the locale of hearing damage. We have methods by which we measure the output of earphones and the magnitudes of various warnings and navigation signals necessary in the operation of helicopters.

Precise narrow band measurements are necessary and in addition, standard real-ear attenuation characteristics of helmets and hearing protective devices must be accomplished. A better estimate of the total acoustic input to the crewmen is made by the insertion of a tiny microphone in the ear with small wires that will not affect the attenuation characteristics of the helmets. Also, we have developed a portable cement chamber that is very useful in estimating the output of earphones as used in the helicopter operations.

It is recommended in future helicopters voice communication systems, auditory warning systems, and other special instrumentation with auditory signals be designed with consideration for the total systems output so as to minimize the acoustic hazards that presently exist. This approach is necessary for realizing the most efficient operation of the crewmen. The evaluation of this low frequency problem can be done only after sufficient research has been accomplished. The recent findings about the significance of low frequency noise spectra cast doubt about the present universal application of dBA for reporting helicopter noise measurements. It is also recommended that as more sophisticated instrumentation is obtained for the measurement of helicopter noise that more attention be given to the extremely low frequency of the rotary blade.

A SURVEY OF COMMUNICATIONS IN THE HIGH NOISE ENVIRONMENT  
OF ARMY AIRCRAFT

MITCHELL S. MAYER  
AND  
ARTHUR W. LINDBERG

US ARMY AVIONICS RESEARCH AND DEVELOPMENT ACTIVITY  
FORT MONMOUTH, N.J. 07703

ABSTRACT

In Army aircraft, the noise environment consists of a continuous noise level comprised of a mixture of random (broadband) and periodic frequencies (the aircraft noise signature or "whine") and in the case of gunships, transient high-level noise bursts generated by the weapons systems. The noise environment reaching the aviator's ear is comprised of direct ambient noise penetration and communications systems processed noise (during periods of communications use, or "open mike operations").

The most insidious impact of the high noise levels is the long-term permanent hearing threshold shift, or hearing loss, that the aviator may incur from his prolonged exposure to the aircraft's interior sound pressure levels.

Improvement of speech intelligibility under all flight conditions will improve the aviator's effectiveness by reducing the number of transmission repetitions necessary to assure that a message is correctly conveyed, thus reducing the distraction level during critical mission phases. Reducing the ambient aircraft noise processed by the communications system will further improve speech intelligibility and reduce this particular increased noise contribution to pilot stress.

1. INTRODUCTION

Noise may be defined as an undesired sound level reaching one's ear. The noise may vary from a low level tape "hiss" during a quiet musical passage on a stereo system to the sound generated by a pneumatic drill at a short distance. The effect of noise upon the human physiology will range from a simple annoyance, through efficiency reducing stress, to actual permanent damage of the inner ear.

In Army aircraft, the noise environment consists of a continuous noise level comprised of a mixture of random (broadband) and periodic frequencies (the aircraft noise signature or "whine") and in the case of gunships, transient high-level noise bursts generated by the weapons systems. The noise environment reaching the aviator's ear is comprised of direct ambient noise penetration and communications system processed noise (during periods of communication, or "open mike" operation). The continuous noise characteristic of the aircraft may represent an enjoyable sound to the aviator during a routine flight, much as the throaty exhaust system on a sports car contributes to its appeal for an automobile buff. However, this same noise characteristic will become a source of annoyance during moments of high stress on a critical mission involving communication, and will actually contribute to the pilot stress condition, reducing the functional effectiveness of the aviator to perform his mission assignment safely and in the minimum time.

The potential stress-producing perceived noise levels of selected Army aircraft are:

<u>Aircraft</u>	<u>dba (SPL)</u>
AH-1( )	90-100
UH-1( )	92-98
OH-58A	90-101
CH-47C	105-115
OV-1D	100-110

NOTE: Levels are perceived noise levels without hearing protection. Data from tests conducted by US Army Avionics R&D Activity at Fort Hood, Texas (September 76 to March 77).

In addition to the contribution of these perceived noise levels to aviator stress, they also represent a flight safety hazard due to their communications "masking" and/or attention distraction effects, even when the aviator employs some form of hearing protection.

The most insidious impact of the high noise levels is the long-term permanent hearing threshold shift, or hearing loss, that the aviator may incur from his prolonged exposure to the aircraft's interior sound pressure levels. Recent personnel hearing loss studies by the US Army Medical Research and Development Command conservatively estimated that from 30 to 80 percent of all Army personnel develop some degree of noise-induced hearing loss while on active duty. This is particularly true of Army

aviation crew members and aircraft ground personnel, who are exposed to the intensity and frequency spectra of typical Army aircraft. The distressing fact concerning the noise-induced hearing loss experienced by aviators is that it is a true perceptible, or nerve, deafness for which prosthetic compensation (i.e., electronic hearing aids) is not possible.

Improvement of speech intelligibility under all flight conditions will improve the aviator's effectiveness by reducing the number of transmission repetitions necessary to assure that a message is correctly conveyed, thus reducing the distraction level during critical mission phases. Reducing the ambient aircraft noise processed by the communications system will further improve speech intelligibility and reduce this particular noise contribution to pilot stress. We at the Avionics R&D Activity are currently pursuing technological advances and/or improvements to the Army aircraft communications system to further reduce the ambient noise levels at the aviator's ear and improve speech intelligibility.

The development of solutions for the joint problems of speech intelligibility and hearing loss are made difficult through the involvement of the disciplines of aircraft noise source control, acoustics and vibrational physics, and communications electronics. In the succeeding sections, we will define the system and hardware performance parameters which contribute to the overall intelligibility/hearing loss problems, the difficulties in analyzing and testing the communications system performance, the development of laboratory test techniques and our current understanding of the communications contributory effects, which may be eliminated through system/equipment improvements.

## 2. ANALYSIS OF THE AIRCRAFT NOISE ENVIRONMENT

Before a discussion of the communication system can commence, an understanding of the noise environment in which the communication system will operate is necessary.

The helicopter ambient environment is inherently noisy due to the weight/performance design trade-offs which must be made in rotary-wing design. Military aircraft, especially are susceptible to this problem because the addition of noise-control devices would increase the weight of the aircraft, reducing mission effectiveness and flight performance parameters. The airframe designer must trade off noise reduction improvement costs against those costs associated with the operationally desirable design elements of performance and payload.

Each Army aircraft possesses a different and distinct noise "signature". The typical aircraft ambient noise environment consists of an aperiodic broadband noise spectrum generated by the turbine drive train, rotor system and general shell structure, that is loudest in the low frequency range and gradually diminishes in intensity as the frequency increases. In addition, periodic noise peaks may exist in the spectrum of interest that are the result of transmission gear meshing, turbine rotation, drive train shaft vibration and acoustic resonances of the cabin cavity. The noise levels within the aircraft interior will vary with the sample position and angle, due to the reverberant nature of the interior. In other words, the sound pressure level (SPL) at the co-pilot position may be greater than that measured at the pilot's location and slight variations in head position and angle may dramatically change the perceived noise levels. Also, variations in aircraft operational performance (i.e., takeoff, cruise, climbing turns, etc.) will effect slightly the intensity of the perceived noise environment. The noise environment spectrum is unaffected, however, by flight maneuver variations.

## 3. LABORATORY SIMULATION OF THE AIRCRAFT NOISE SPECTRUMS

The vagaries of in-flight testing, encountered during our Army aircraft noise investigations have led us to develop improved in-flight and laboratory analysis techniques, that permit us to more readily investigate and understand the particular noise environment of an Army aircraft. Also, we have devised laboratory noise environment simulation techniques, which eliminate the variables encountered in flight testing, such as different aircraft and crews, atmospheric interference, weather conditions, availability of aircraft and the cost of the flight time itself, that can result in both test repeatability and financial problems.

Originally developed to simulate the CH-47 helicopter, the noise environment simulation facility has been refined to allow for the simulation of any vehicle noise environment (to include all aircraft and ground vehicular sources). Figure 1 shows the simulation system structure. The major sub-systems are:

- a. The noise generation system.
  - (1) Crown dual-channel tape recorder and preamplifier,
  - (2) A dual-channel octave equalizer
  - (3) A dual-channel 700 watt RMS amplifier
  - (4) Two Electro-Voice Sentry IVB speaker systems

## AIRCRAFT NOISE SIMULATION/INTELLIBILITY TESTING

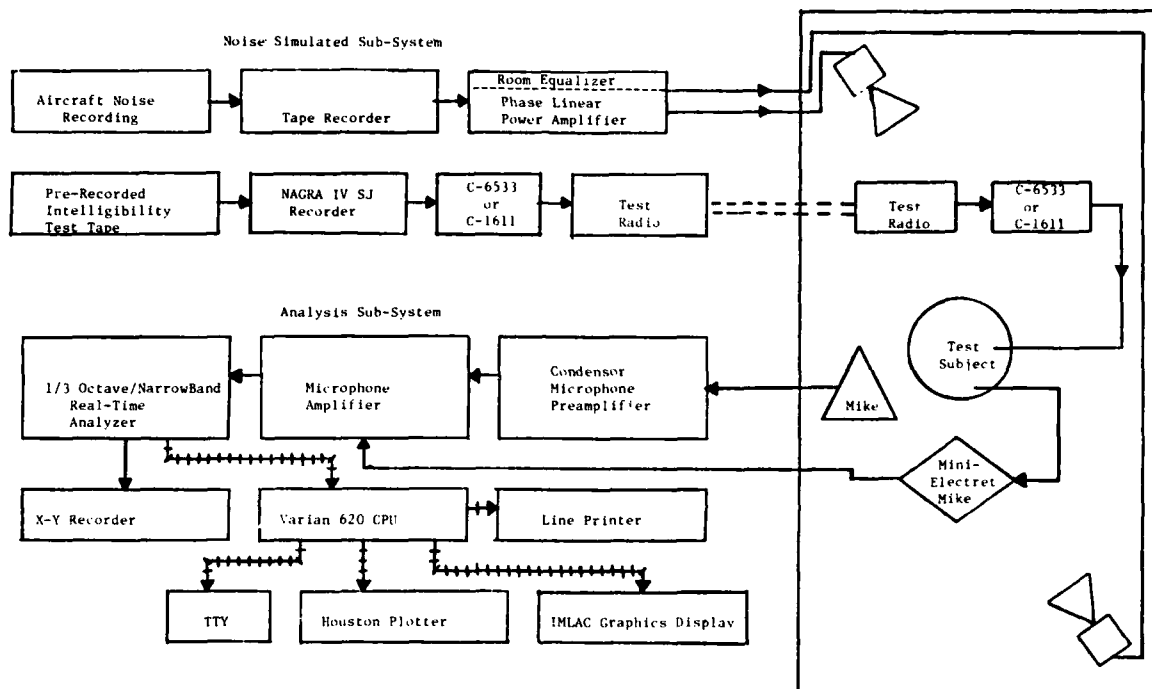

FIGURE 1

- b. A double-walled, semi-reverberent sound isolation chamber.
- c. An audio/acoustic/noise analysis system
  - (1) Real time 1/3 octave analyzer
  - (2) Real time narrow-band analyzer
  - (3) A precision sound pressure level measuring amplifier
  - (4) A video monitor/display
  - (5) A minicomputer for data reduction and formatting
  - (6) A digital plotter

For aircraft simulation, a short flight series is required to obtain a calibrated composite tape recording of the actual noise environment and an analysis (1/3-octave and narrowband) of the aircraft noise using a precision sound level analyzer with hard copy output. The tape recorder and analyzer are the portable equivalents of the systems used in the laboratory simulation and analysis system and possess comparable accuracies.

The noise recording is reproduced in the sound isolation chamber using the noise generation system. The dual-channel equalizer is used to match the sound isolation chamber acoustical spectrum to the actual recorded aircraft noise spectrum and intensity. A human test subject is positioned in the chamber and his helmet communications system is connected to the aircraft communication hardware under test. The test subject then may record speech intelligibility test results, while sound pressure levels, at the subject's ear, are automatically measured and recorded. Accurate, statistical rating of the voice processing performance of a communications device/system may be obtained through the use of numerous test subjects. Simultaneously, direct measurements of the helmet earcup noise penetration and communications system noise susceptibility may be performed.

The test results obtained with the simulator are comparable to flight test results. However, the simulator tests may be repeated upon demand, regardless of weather and atmospheric conditions, aircraft availability, and at a very low cost compared to flight tests. The test variables may be precisely controlled and manipulated to determine their effect upon the communication device under test.

The aircraft noise environment simulator has enabled us to obtain certain basic performance data on the component devices of; and the overall, aircraft communications system. The following discussions describe our findings on the individual device and system performance parameters.

#### 4. ANALYSIS OF THE AIRBORNE COMMUNICATION SYSTEM

The current airborne communications system is composed of:

- a. A noise-cancelling microphone (M-87)
- b. A noise-attenuating helmet or headset (SPH-4, David Clark 19LB-87)
- c. An intercommunication control system (C-6533/ARC, C-1611/AIC)
- d. A VHF-FM radio set (AN/ARC-114, AN/ARC-54)
- e. A VHF-AM radio set (AN/ARC-115, AN/ARC-134)
- f. A UHF-AM radio set (AN/ARC-164, AN/ARC-116, AN/ARC-51BX)
- g. An HF-SSB radio set (optional) AN/ARC-102

##### 4.1 M-87/AIC Microphone

4.1.1 General Description: The M-87 microphone is a dynamic, moving coil, noise-cancelling microphone. It is sound powered (does not require external DC power) and exhibits a 5ohm output impedance. The microphone is a common pressure gradient microphone which derives its noise cancelling capability (far field response) from the presence of "equal and opposite" sound pressure levels (SPL) impinging on either side of the microphone diaphragm.

The noise cancellation of this microphone provides the "first line of defense" in the prevention of aircraft noise processing through the communications system and contributing to the high levels at the aviator's ear. The near field response (voice reproduction) provides the basic transmitting interface of the communications system with the aviator.

4.1.2 Performance Analysis: Figure 2 shows the nearfield frequency response of the M-87. Note the sharp roll-off below 1KHz and the peak in the 3KHz to 4KHz region. The low frequency roll-off of the microphone response causes a reduced electrical reproduction of the speech energy level in that region where the majority of the voiced speech frequencies are located. The peak at 3-4KHz generates undesirable voice and noise levels in the frequency band where the ear is most susceptible to hearing damage. Overall, the modified speech reproduction of the current microphone degrades speech intelligibility and speaker identification.

The above speech reproduction problems are compounded by the ineffective far field response (noise cancelling) of the microphone, also shown in Figure 2. Broadband and periodic ambient noise enters the communications system, through the microphone, and is processed to both the listener and the talker (through his sidetone), adding to the speech-masking noise level at the aviator's ear.

#### 4.2 SPH-4 Earcup Assembly

4.2.1 Description: The SPH-4 helmet's earcup/transducer assemblies consist of two H-143 earphones (transducers) mounted in two circumaural, noise-attenuating earcups. These assemblies link the aviator with the communications system, and serve as the sole attenuation devices to protect him from the potentially damaging sound pressure level (SPL) present in the aircraft.

4.2.2 Performance Analysis: The earcup assembly of the SPH-4 helmet is effective in protecting the wearer from the aircraft ambient noise environment, however, this protection is minimal (80-85dba penetration) in certain Army aircraft, such as the OV-1D and CH-47C. There is an insufficient margin of hearing protection provided to permit communications without exceeding the maximum 85 dba safe sound pressure level, established by the Surgeon General.

The above remarks are in direct opposition to previously published statements concerning the noise attenuating effectiveness of the helmet and result from the differing test methods of the environmental protection and the communications engineering disciplines. It is our determination that the device or system must be tested in a controlled approximation of the environment in which it must function, to effectively evaluate the expected performance capabilities of the equipment. The standard test methods for hearing protection, although readily repeatable, use unrealistically low ambient noise intensities, and consequently, yield different test results. Figure 3 shows that the attenuation characteristic of the earcups measured in a high SPL aircraft noise environment is typically less than that measured using low-intensity standard threshold (ANSI Z24.1957) techniques. The upper curve more closely approximates actual earcup attenuation measurements made in various Army aircraft samples at Fort Hood, Texas during the 1976-77 time frame. The actual attenuation obtained by an individual is very dependent upon the helmet fit and hair style.

This higher level ambient noise appearing within the earcups results from direct penetration, poor earcup sealing, and a complex waveform regeneration phenomenon, commonly called "pumping". Pumping action occurs when the high-level acoustic wavefront strikes the earcup and causes it to move in resonance. Suspended in a resilient seal, the earcup will effectively regenerate the forcing waveform at its interior, in much the same fashion that a speaker cone regenerates a waveform, when driven by the voice coil action against the magnet. The pumping effect increases in a logarithmic manner as the noise level is increased, accounting for the higher levels of penetration recorded in our simulated environment tests.

The high-intensity noise penetration generates an immediate communications problem. Although the speech and communications system processed noise is transient in nature and contributes minimally to the long-term ambient at the ear, the requirement to overcome the ambient noise by at least 10db, in order to achieve proper intelligibility, may generate distortion in the communication system and even within the aviator's ear, contributing to general pilot fatigue.

In addition, the frequency response of the earcup/transducer assembly is inadequate for a high-noise environment communications system. Figure 4 shows the adequate frequency response of the standard H-143 transducer, when measured external to the earcup. The mounting of the transducer into the earcup radically modifies its frequency response, causing high communications/noise peaks in the 3-4KHz region to be presented to the user's ear (also shown in Figure 4). This is precisely the frequency range where the ear is most susceptible to hearing damage.

#### 4.3 Intercommunication Control System

4.3.1 Description: The intercommunication control system (ICS), or intercom, contains a microphone amplifier, a headset amplifier, a radio set transmitter switching and control section, and a receiver input and isolation matrix. The salient characteristics of the microphone and headset amplifiers are:

Frequency Range: 300 to 6000Hz, (+1.0, -2.0db)  
Distortion: 3% to 10% normal (12.5% Max)

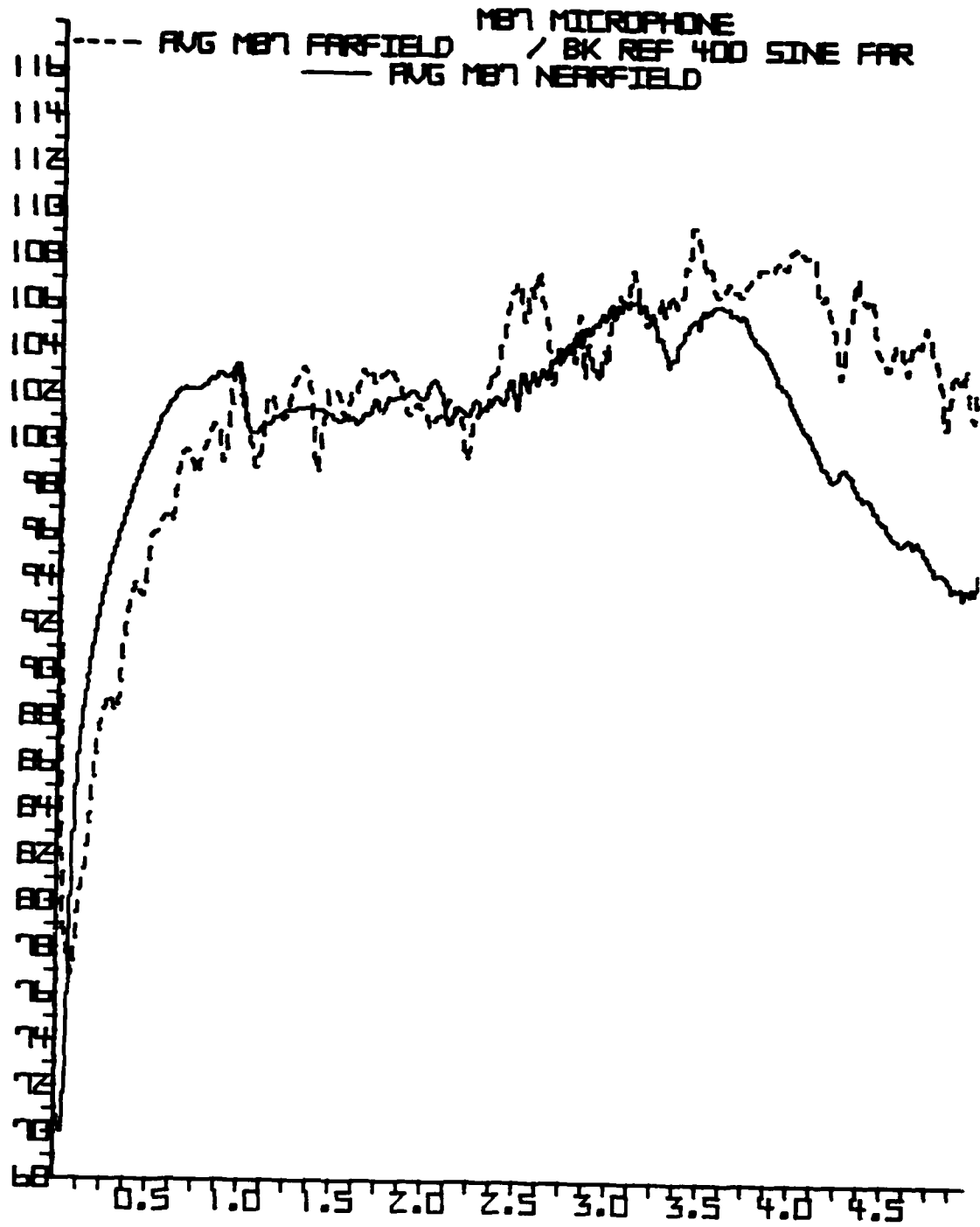

FIGURE 2



NO 340 L310 DIETZGEN GRAPH PAPER  
SEM-LOGARITHMIC  
3 CYCLES X 10 DIVISIONS PER INCH

EUGENE DIETZGEN CO  
MADE IN U.S.A.

SPH-4 Real-Ear and Simulator Attenuation

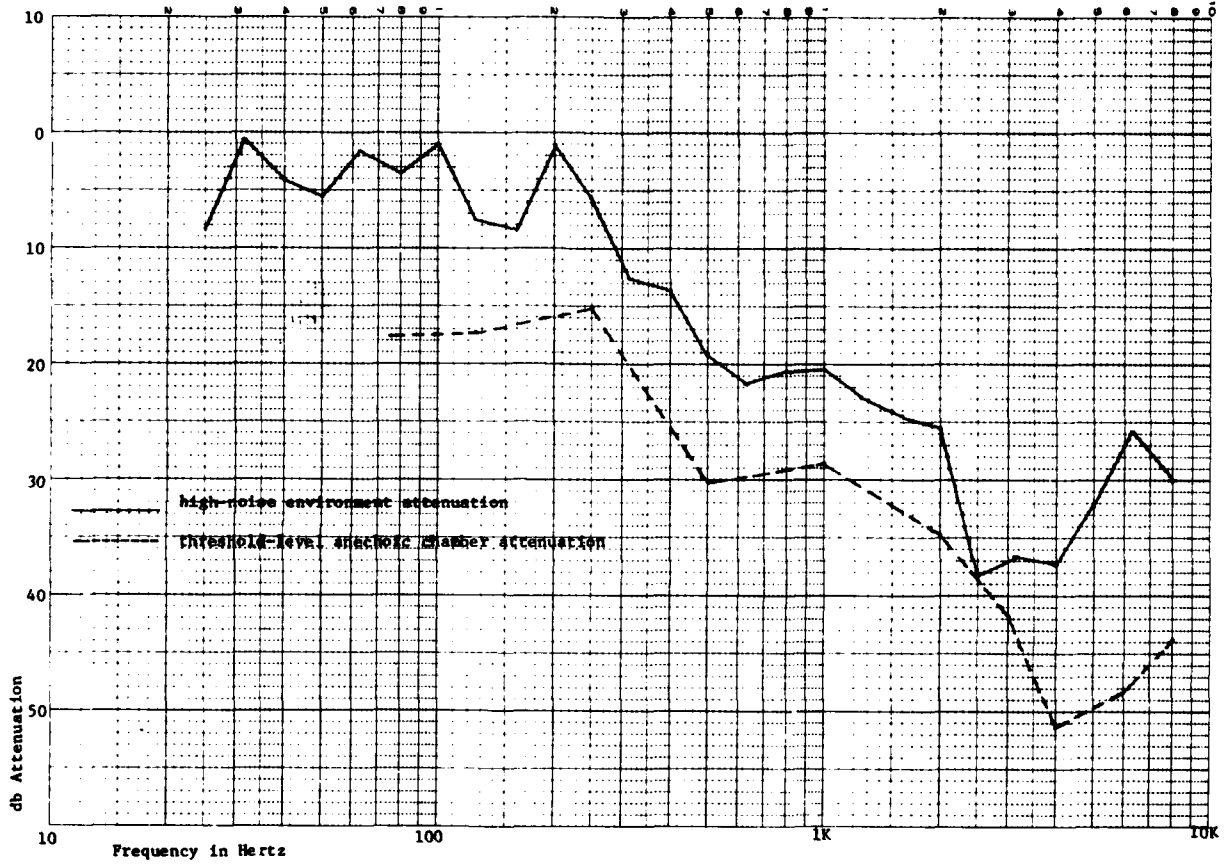
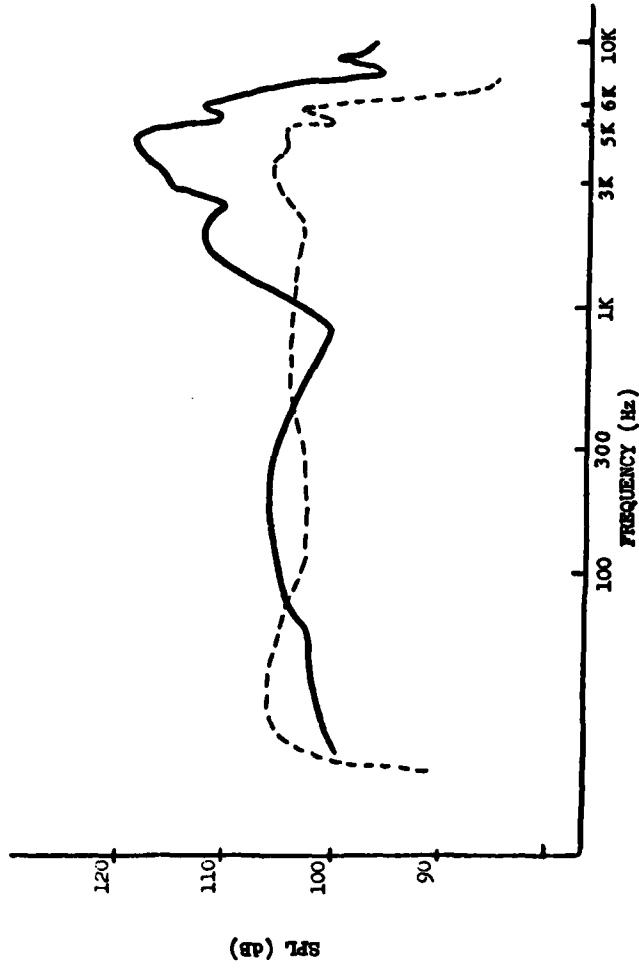

FIGURE 3



----- Frequency response of an H-143 AIC earpiece

———— Frequency response of the H-143 in a SPH-4 earcup

FIGURE 4

4.3.2 Performance Analysis: (See Figure 5) The frequency response, or bandpass of the intercom is comparable to the average frequency range of the adult male speech spectrum (200Hz to 6100Hz). The distortion levels range from virtually unperceptible to definitely noticeable. The dynamic range and AGC parameters are generally adequate for voice communications, however, improvements would be beneficial to meeting our basic goals of low distortion speech processing and peak noise reduction. In the older intercoms, such as the C-1611/AIC, a certain amount of "peak-clipping" is employed to improve speech intelligibility. Studies preceding the design of the earlier intercoms indicated that speech intelligibility, in the presence of high atmospheric noise could be improved by introducing a controlled amount of "clipping", or square wave limiting, of the speech peaks. The effect was to increase the "talk power", or signal-to-noise ratio by enhancing the transmitted energy in the voice spectrum. More recent studies (succeeding the intercom development) indicate that, in the high acoustic noise environment, the effects of peak clipping on speech intelligibility range from marginal improvement to extreme degradation as a function of the processed noise in the communications system. We now are aware that more significant and repeatable intelligibility improvement results may be obtained merely by limiting the system generated and processed noise floor.

#### 4.4. VHF-FM Radio Set

4.4.1 Description: The VHF-FM radio set (30-76MHz) is the prime tactical line-of-sight (LOS) radio of the Army. Airborne versions provide the basic communications link between the ground and airborne forces. The VHF-FM has the potential to be the most "high fidelity" airborne communications radio in the Army inventory.

Frequency modulation techniques yield superior voice intelligibility, due to the inherent random noise and interference rejection properties. The use of higher carrier frequencies (i.e., 30MHz and above), where atmospheric and cosmic noise intensities are low when compared to man-made interference and receiver noise, improves the signal intelligibility (in both FM and AM radio sets). The audio bandpass capability of FM transceivers is generally greater than a comparable AM radio set for the same effective spectrum usage (due to complex wave form modulation effects and low frequency concentration of the voice spectrum).

4.4.2 Performance Analysis: The airborne VHF-FM has a voice bandpass capability of 6KHz, however, the use of audio pre-emphasis and de-emphasis circuitry limits the effective response of the radio set transmitter-to-receiver link to about 3500Hz. In other words, the transmitted audio high frequencies are emphasized (increased in amplitude) to provide uniform modulation of the transmitter. At the receiver, a de-emphasis network is employed to restore the normal speech roll-off characteristic and generate a perceived audio output comparable to other Army transceivers. Also, the 150Hz tone used for squelch de-activation (tone squelch mode) is not sufficiently suppressed by the audio bandpass filter and may supply a masking effect for voice under certain cumulative system parameter situations. Consequently, the monosyllabic single word intelligibility of the VHF-FM is essentially the same (80% to 90%) as that measured for the standard AM radio sets. In general, this intelligibility level (under low system-processed noise conditions) is adequate for voice communications.

#### 4.5. VHF-AM Radio Set

4.5.1 Description: The VHF-AM radio set (116 to 150MHz) serves as a line-of-sight (LOS) communications link between military aircraft and air traffic control operations in and around civilian airfields. The major noise interference results from man-made sources and internal receiver noise generation.

4.5.2 Performance Analysis: This radio set has a 3500Hz bandwidth and contributes typically 3% to 5% distortion to the system processed signal under operational conditions. The radio set noise contribution (from atmospheric and internal receiver noise generation) is adequately low.

#### 4.6. UHF-AM Radio Set

4.6.1 Description: The VHF-AM radio set (225-400MHz) is the prime military air traffic control radio set and is used for air-to-air inter-military and military airfield traffic control communications. Noise interference sources are essentially the same as those of VHF-AM radio set.

4.6.2 Performance Analysis: The performance parameters of the UHF-AM radio set are essentially the same as those of the VHF-AM radio set.

#### 4.7. HF-SSB Radio Set (optional)

4.7.1 The high frequency single side-band radio set (HF-SSB) is the only beyond line-of-sight airborne radio set currently available in the Army inventory. The radio set operates in the 2 to 30 MHz frequency range, a portion of the RF spectrum that is heavily used, throughout the world, for long range communications. Very narrow IF and audio filters are employed to reduce the spectrum usage, in an effort to reduce the crowding experienced as a result of global traffic and extreme propagation ranges. This radio set is a candidate for the non-line-of-sight communication link requirement of low level, Nap-of-the-Earth airborne operations. The radio set is generally an optional installation on the larger utility and heavy lift helicopters.

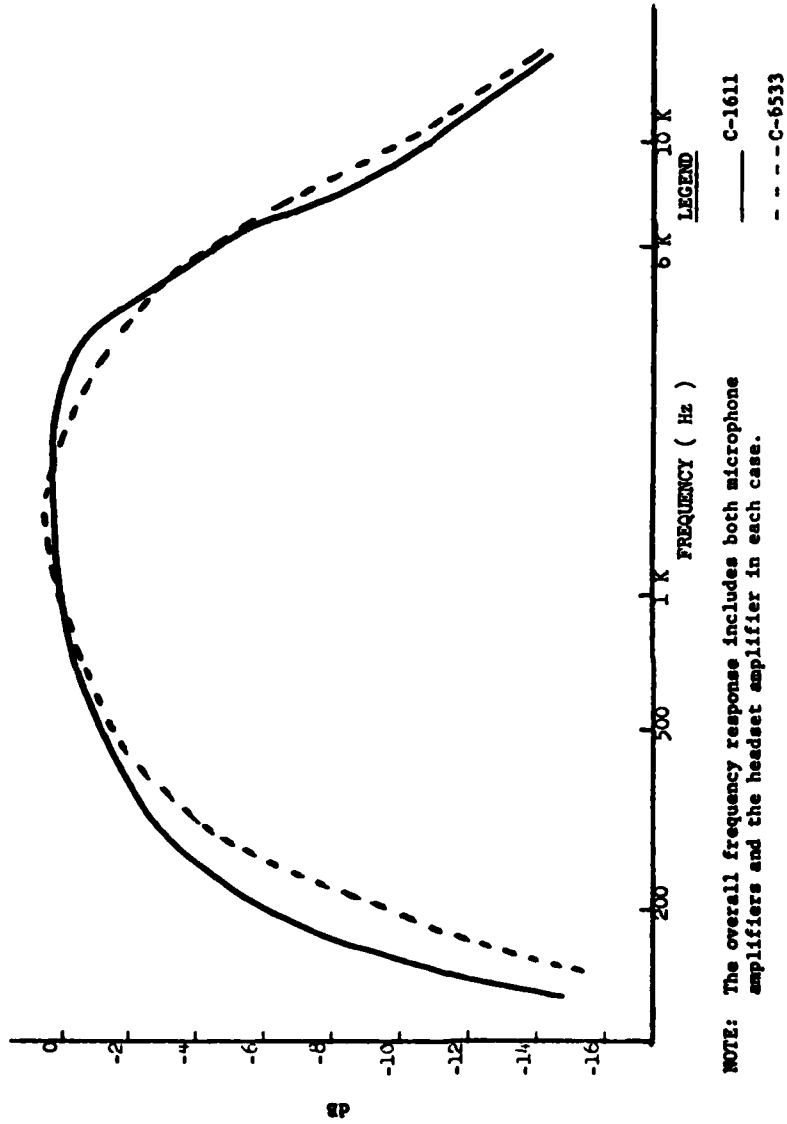

FIGURE 5

Comparison of the overall frequency responses of a C-1611 and a C-6533 intercommunication control set

4.7.2 Performance Analysis: The basic disadvantage of HF communications is the high levels of man-made, cosmic and atmospheric noise interference present throughout the frequency spectrum, with atmospheric noise (i.e., lightning discharges) being the principle contributor to communications interference. The performance levels of HF-SSB versus VHF-AM are comparable to the performances of an automobile AM radio versus an FM radio; the reception range is very good, but the static lightning discharges and general noise susceptibility can spoil the range advantage. The non-line-of-sight communications capability is dependent upon sky waves reflected from ionized air layers (generated by the sun's ultraviolet output) in the ionosphere, and will vary dramatically on essentially a daily basis, as the altitude and ionization intensity of the reflecting layer changes. A complex prediction process has been developed to compensate for these variations by providing frequency effectiveness information, to be used for channel selection during daylight, day-to-night transition periods, night, and seasons of the year. There are periods, however, when even short-range communications cannot be reliably accomplished (i.e., in the vicinity of intense thunderstorm activity). The radios generally employ a very sharp 300-3500Hz bandwidth and produce 3% to 5% distortion under operational conditions (discounting atmospheric distortion effects).

## 5. THE OVERALL RESPONSE OF THE AIRCRAFT COMMUNICATION SYSTEM

The overall response of the system consists of the combined operating characteristics of each of its components. Figure 6 shows the resultant response when swept tone (generated by an artificial voice) is used as an input signal to an M-87 microphone. This signal was processed by the microphone amplifier of an interphone to the headset amplifier of a second interphone and finally to the H-143 earphone inside an SPH-4 earcup assembly. The output was measured using an artificial ear with an attached flat plate (for circumaural earcups). The SPH-4 earcup assembly is firmly positioned on the flat plate by a 1Kg force. This particular experiment does not include any radio transceivers nor the atmospheric link between them. The frequency response of the RF linked system is similar, however, the increased system and atmospheric noise will result in a slight additional reduction in speech intelligibility. A comparison of the overall response curve (Figure 6) with the previously introduced individual response curves of the microphone, the earcup/transducer assembly, the interphone and the radio sets indicates quite readily that the majority of the audio frequency response modification (speech coloring) originates in the microphone and headset.

The microphone and headset interact unfavorably in the processing of noise to the aviator's ear. Figure 7 shows the noise level inside the earcup during level flight in a UH-1H helicopter. It is immediately obvious that an interaction breakpoint occurs at approximately 1000Hz. Below this breakpoint, earcup penetration is the primary contribution to the aircraft ambient noise level at the ear. Above 1000Hz, the ineffective farfield response (noise cancelling) of the microphone surpasses the earcup penetrating noise level and becomes the main source of aircraft ambient noise at the ear.

We have conducted high-noise environment tests of a simulated low noise communications system ( $S+N/N=40$  db), using standard Army transceivers, intercoms and helmets. An ideal noise cancelling, flat response microphone was simulated by recording messages with a high quality 1/2 inch microphone in a quiet environment. These tests demonstrate that, by essentially eliminating the communications system processed noise and using more of the available system bandwidth (provided by the simulated microphone), speech intelligibility may be improved by as much as 50%. By similarity, improvement of the earcup/transducer assembly frequency response and attenuation characteristic will yield further intelligibility enhancement and provide some marginal noise intensity relief (2-6db) to the aviator.

As a result of these initial findings, we engaged in a series of improvement and development programs, to provide the necessary increase system performance.

## 6. MICROPHONE IMPROVEMENT PROGRAM

As discussed, our test programs indicate that speech intelligibility in the aircraft noise environment may be significantly enhanced by improving the frequency response and noise cancelling capabilities of the Army airborne microphone. We have generated a specification requirement for a new improved high gain microphone, M-162( )/AIC, with a flat (+3db) nearfield frequency response from 200Hz to 6000Hz and state-of-the-art noise cancellation. Two potential candidates for the new microphone are:

- a. A militarized piezo-electric ceramic microphone.
- b. A militarized electret condenser microphone.

During the 4Q, FY-77, and 1Q FY-78 we conducted extensive classical (anechoic chamber) tests of the above microphones. Psychoacoustic testing of these microphones will begin in FY-78. The respective nearfield and farfield frequency responses of these microphones are shown in Figures 8 and 9.

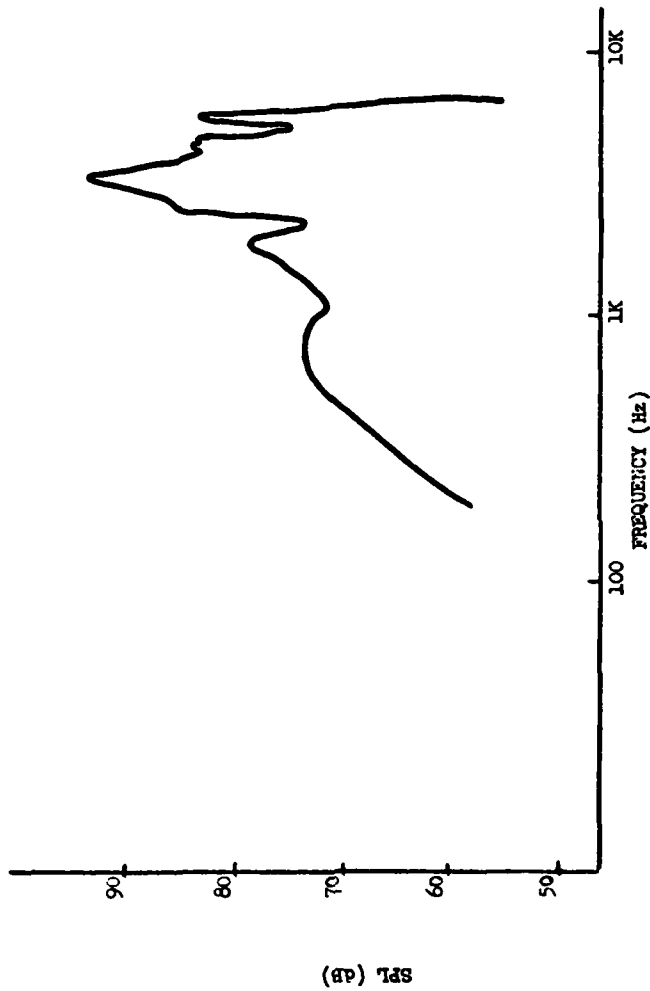

FIGURE 6  
Overall communication system response

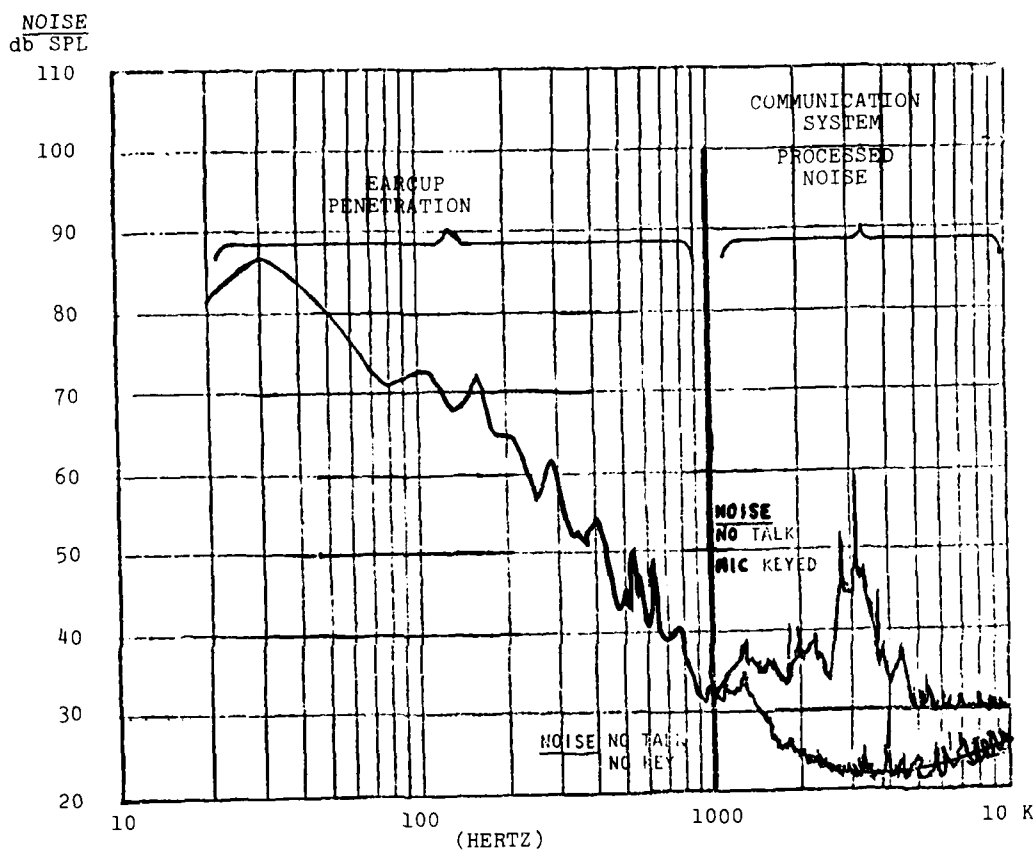

Figure 7. NOISE INSIDE THE EARCUP  
AT LEVEL FLIGHT

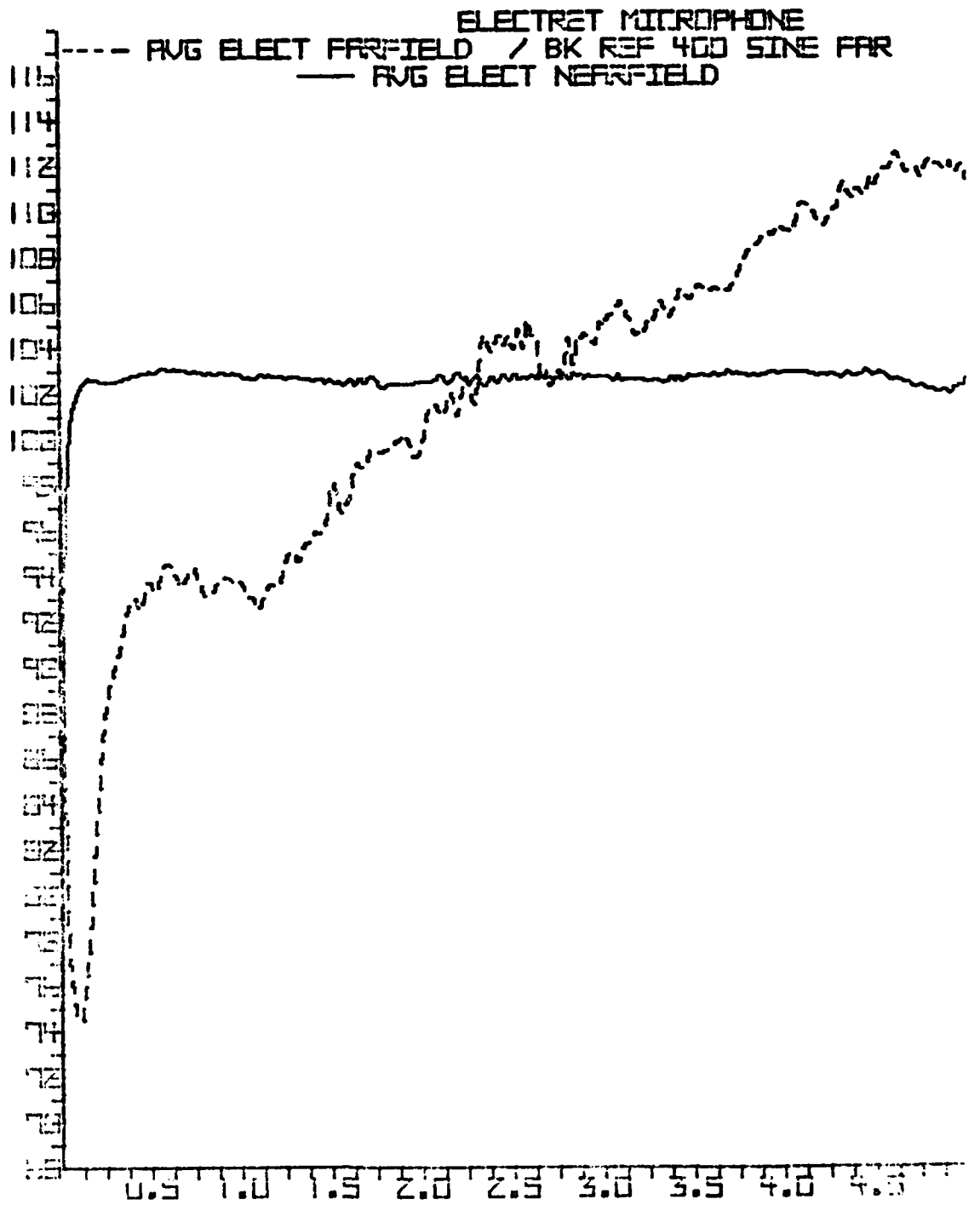

FIGURE 8



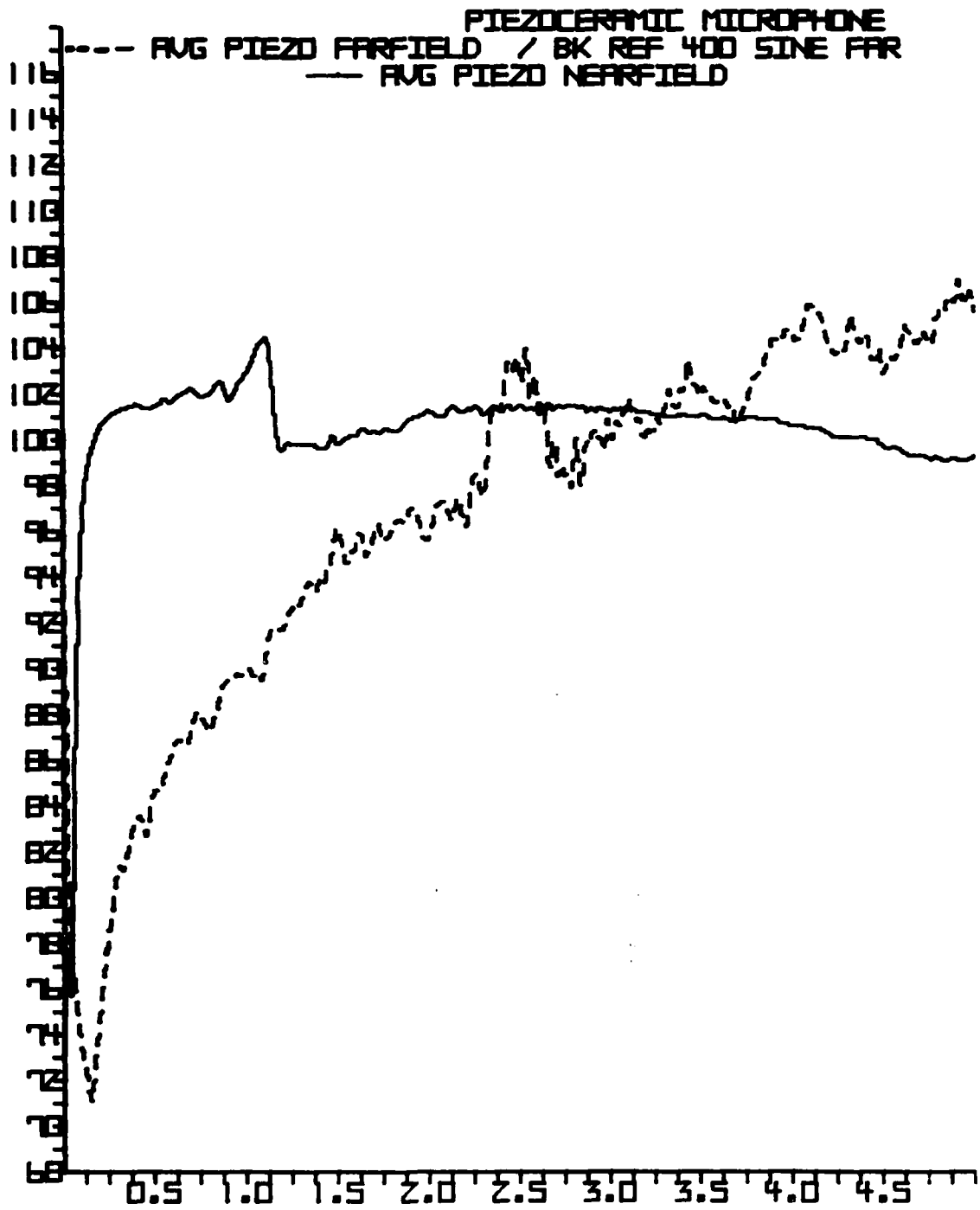

FIGURE 9

We note that the piezo-electric ceramic and electret microphones require 10 volts at 8MA DC power to operate internal FET impedance matching amplifiers. Present Army aircraft and avionics do not have provisions for providing power to these microphones. We have a concurrent intercom improvement program, which will provide the requisite power on the same lines presently used only for audio interconnection. (This technique of supplying power is known as "phantom power"). The high gain of the microphones is required to improve audio isolation in the airborne communications system by providing greater equalization of the microphone and headset audio levels in the common helmet inter-connection cable.

#### 7. HEADSET IMPROVEMENT PROGRAM

Articulation Index prediction techniques and our simulated system tests indicate that further improvement of airborne speech intelligibility and slight reductions in the system-processed noise levels can be accomplished through improvements of the headset (earcup/transducer assembly).

We have recently completed a program to improve the design compatibility of the earcup/transducer assembly and provide a flat frequency response (+6db) from 200Hz to 6000Hz. See Figure 10. The flat frequency response reduces the undesirable voice and noise peaks present in the current assembly, however, the overall "talk power" will be increased by providing more broad spectrum voice information, improving consonant and unvoiced speech recognition.

The noise attenuating capability of the earcup/transducer assembly represents an improvement over the current SPH-4 helmet earcup performance limits. Attenuation is increased by approximately 5db from 100Hz to 500Hz and approximately 10db from 2500Hz to 10KHz. Additional test and evaluation of this earcup/transducer assembly will be required prior to its introduction to the field.

#### 8. INTERCOM IMPROVEMENT PROGRAM

The product-improvement program for the C-6533/ARC inter-communication control system was structured primarily to improve the universal use capability and audio isolation of this device. However, during the initiation of the contractual effort, we determined that the incorporation of an audio limiter will enhance our ability to control the voice/noise levels at the aviator's ear by suppressing high modulation levels and noise bursts to a set limit. As previously mentioned, a DC power regulator has been incorporated in these engineering test models, to provide power to the candidate improved noise-cancelling microphones.

We have incorporated individual volume controls for the numerous receiver inputs to the intercom. The necessity for this improvement developed from a totally unrelated program for the development of a multi-function avionics control system. In this configuration, the radio sets (and their audio controls) will be located remotely from the control panel, precluding priority volume level adjustment by the aviator. Incorporation of the individual controls into the intercom will permit this adjustment technique to be accomplished (by each aviator) from a single point, and allows each individual to adjust the radio set volumes to his particular needs (in terms of hearing sensitivity). Due to the magnitude of these "improvements" we have changed this effort to a development program and re-designated the intercoms as C-10414( )/ARC.

#### 9. RADIO SET IMPROVEMENTS

We are planning to conduct baseline radio systems tests in a simulated aircraft environment to investigate the feasibility of increasing the voice bandwidth beyond 3500Hz. The candidate radio set for this study will be the AN/ARC-114 VHF-FM, since the bandwidth may be increased easily by disabling the de-emphasis circuit. If significant improvement in intelligibility is obtained, additional investigations of the impact on spectrum usage and proximate receiver de-sensitization will be conducted to ascertain the feasibility of incorporating such changes into the new production radios. A considerable development effort may be required to improve receiver filter circuitry and minimize transmitter spectral emissions to reduce the impact on frequency allocation requirements.

Other improvement areas include the improvement of transceiver linearity (to reduce total harmonic distortion) and the investigation of enhanced modulation techniques, for increased speech intelligibility and audio isolation. Some interesting new modulation schemes employing voice bandwidth compression have recently been developed. Application of such a technique would permit us to increase the effective transmittal speech bandwidth while maintaining (or possibly reducing) the RF spectrum usage, minimizing the previously mentioned emissions problems. The improvements, where deemed necessary, will be accomplished within the intent of MIL-STD-188( ), which is mandatory for use by DOD Agencies in the design, installation and operation of new communications systems and equipment.

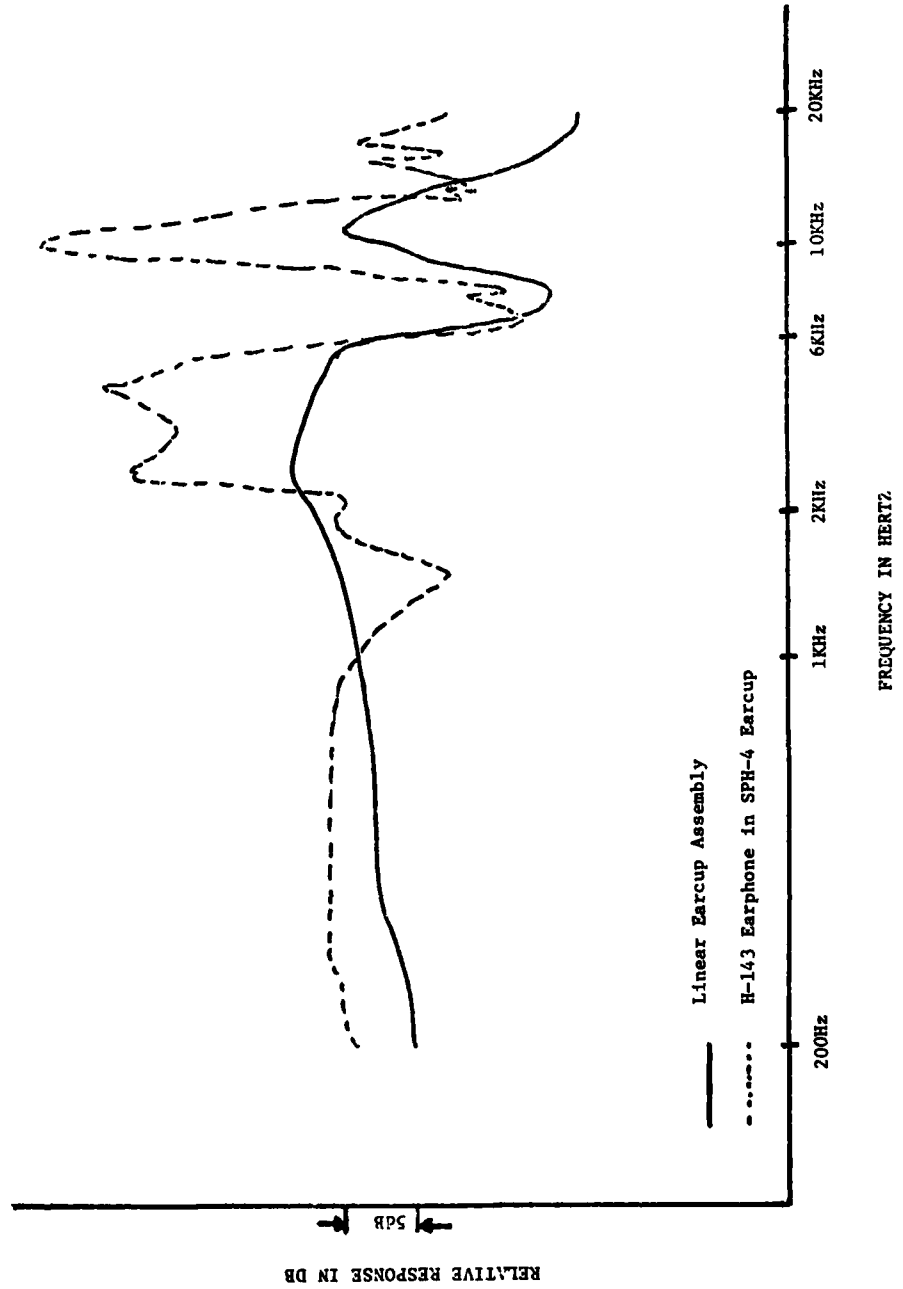

COMPARISON OF LINEAR EARCUP TRANSDUCER TO SPH-4 EARCUP TRANSDUCER

FIG 10

For the current family of radio sets, the processed external and internal receiver noise level will vary from 10db to 40db (assuming a low ambient noise environment) below the desired voice signal level and is dependent upon the degree of signal attenuation resulting from the separation between the transmitting and receiving stations. This signal-to-noise ratio (S+N/N) range represents the normal physical limitations of conventional analog audio processing and modulation techniques.

At the system level, digital speech processing techniques will be investigated as a long term solution to the speech intelligibility, system-processed noise and audio isolation problem areas.

Finally, we are investigating an electronic approach to noise reduction within the helmet earcup. Briefly, the earcup/ambient noise level is sampled, processed through an adaptive filter which inverts and adjusts the amplitude of the noise signal, and re-introduces it to the earcup through the existing headset transducer. The inverted waveform should cancel (or minimize) acoustically the penetrating ambient noise wave form, resulting in an artificially quiet environment at the ear. Early investigations of this technique indicate that it is effective for low frequencies (below 1000Hz). Fortunately, this is the frequency range where earcup penetration is the primary contributor to the ambient level. (See Figure 7). A problem associated with this technique is the speed of adaptation to variations in the ambient environment. If the adaptation occurs too rapidly, portions of the speech waveform may be cancelled or altered; if the adaptation is too slow, the technique may prove ineffective in reducing transitory elements of the noise environment.

#### 10. SUMMARY

One will note that the majority of the improvement efforts on the aircraft communications systems will result mainly in speech intelligibility increases. This improvement will increase the survivability of the aviator in a tactical low-level flight situation, by reducing the communications period exposure requirement, mission profile workload and, to some degree, pilot fatigue and stress. In addition, flight safety should be enhanced for those aircraft accident situations, which have been linked to poor or faulty communications systems.

However, the total effect of the improvements on the reduction of noise levels reaching the aviator's ear, will be minimal, unless the adaptive filter/acoustic canceller technique proves to be completely successful. As previously stated, the desired voice signal must be about 10db (average) above both the electronically processed and earcup penetrating aircraft noise, to achieve some measure of reliable speech intelligibility. Due to the acoustical combinational effects within the earcup, it is immediately obvious that the communications system processed voice plus noise will contribute slightly to the long-term average noise level at the aviator's ear, particularly at the extreme transmitter/receiver separation condition, and during Nap-of-the-Earth flight operations. As an example, if the ambient noise level is 85dbA, the addition of voice communications will raise the perceived average level to 88-92dbA. Total elimination of the communications system-processed noise will not reduce the overall noise level by more than 2dbA to 6dbA. The aircraft noise environment will remain at levels which contribute to human fatigue and stress and, in the worst situations, pilot error, emergency declarations and aircraft accidents. Further, the risk of hearing damage due to equipment degradation (i.e., helmet earcup seal hardening) will remain.

Therefore, technological breakthroughs in the areas of aircraft noise source control and reduction, and helmet earcup attenuation techniques are necessary to effectively reduce the noise impinging on the aviator's ear. Currently available aircraft noise control approaches, such as noise-attenuating structural panels and sub-chassis isolation of engines and transmissions, must be incorporated into new production and modernized aircraft to provide short-term relief from the currently unacceptable noise conditions. Such approaches, while more costly than the present airframe fabrication techniques, will minimize the impact on the aircraft mission and performance parameters and eliminate the need for electronic appliques, with their resultant impacts upon system space, weight and power requirements. Long term development programs, to provide the aforementioned technological advances in both aircraft noise control and helmet attenuation are required to permit the needed noise reduction in aircraft that will meet the Army's need for increased performance and mission effectiveness in the battlefield scenarios of the future.

#### 11. REFERENCES

1. Giordano, T. and Keane, G. United States Army Electronics Command, The Effect of Helicopter Noise on Communication and Hearing, 1973, ECOM-4140.
2. Mayer, M., United States Army Avionics Laboratory, Acoustic Noise Suppression in Airborne Communications, 1975, ECOM-4336.
3. Lindberg, A. and Mayer, M. Army Aviation Association of America; Communication in the Aircraft (High Noise) Environment, 1976, Proceedings of Aviation Electronics Symposium, Volume 2.
4. Lindberg, A. and Mayer M. Department of the Army, Laboratory Testing Techniques for High-Noise Environment Communications Systems, 1976, AD-A026062, Army Science Conference Proceedings, Volume II, Pages 373-387.

## SOME ASPECTS OF HELICOPTER COMMUNICATIONS

by

G M Rood and E J Lovesey

Human Engineering Division  
 Flight Systems Department  
 Royal Aircraft Establishment  
 Farnborough  
 Hants  
 England

## SUMMARY

There are many factors that influence helicopter radio communications. These can be divided, roughly, into three groups. Firstly, there are the characteristics of the signal transmitters and receivers and their siting. Secondly, there are the effects of noise and distortion of the signals and finally there is the ability of the operator to perceive the signals while performing other tasks. In the past, considerable effort has been devoted to optimise the size and siting of aerials on the helicopter. Rather less effort has been extended to interface the various equipments associated with these aerials with other systems, with the helicopter environment or with the human operator. As the helicopter's radio and other systems have become both more complex and greater in number, this has resulted in the crew being required to perform more tasks in more difficult circumstances, so that now there is the danger that the crew are overloaded and unable to operate the helicopter satisfactorily as a weapon system.

Although the effort devoted to correct aerial siting etc has not been reduced, the importance of the man and the effect of the helicopter environment upon his ability to receive and process audio signals is, at last, receiving attention. In particular, helicopter cockpit noise levels, helmet attenuation, signal masking, total operator noise dose and crew task difficulty are all being studied with the purpose of improving the overall helicopter/crew efficiency.

## INTRODUCTION

Noise levels in modern helicopters generally are much higher than one would like to accept. Noise reduces communications efficiency and can, if sufficiently high, produce temporary and permanent hearing loss.

There are a number of ways in which noise may be reduced and communications improved; depending upon the helicopter and its systems characteristics and also upon the time in the helicopter's life at which improvements are initiated. If the problem of noise is considered at an early stage in the design of a helicopter and its systems, much of the noise can be "engineered out". This can be achieved by thoughtful positioning of engine, gearboxes etc and careful installation of aerials to reduce interference and selection of a systems audio frequencies which do not correspond with noise peaks from other equipment. If it is too late to alter the basic engineering then one is forced to consider other methods of reducing noise and improving communications. These might include Active Noise Reduction, voice operated switching, adaptive noise cancelling, improved noise attenuating helmets and minor re-shaping of audio signals which coincide with predominant noise peaks caused mechanically by gear meshing etc.

## THE INFORMATION LOAD

Before considering the systems which generate signals and noise at the men's ears, one should examine man's ability to receive and process information. Man can be considered as a multi-sensor device with a single channel between sensor and processor. This concept is depicted in Figure 1. If it is assumed that the human operator receives and processes information in this way, it can be argued that information from different senses must be time shared. There must also be a limit to the quantity of information which can be carried by the single channel. It is therefore important that too much information is not presented to the man. For example he cannot be expected to perform separate visual and auditory tasks simultaneously, (although he might be able to cope with these tasks sequentially if their difficulty is within his mental capacity). If the signals reaching the sensors are degraded by noise or other environmental effects, then his workload will be increased and his ability to process the information presented will be still further reduced. Figure 2 depicts both the information sources and some of the factors which degrade man's ability to sense and process signals. Only by carefully matching information sources to the man's processing capacity will the optimum man-machine system be produced.

This is a simple theory but difficult to achieve in practice. Figure 3 shows a typical modern ASW helicopter's audio signal and noise sources and their routes to the operator's ears. Starting with the incoming signals from external sources, apart from atmospheric distortion of the signals between transmitters and receivers, there can be interference between receiving aerials. There may also be RF interference and airframe shielding of signals. Once the signals have been received they are processed by the appropriate electronics, amplified and fed via the intercomm to the crew's head sets. During this part of the process the signals may be still further distorted and subject to electrical noise pick-up. Still further noise may be picked up through each crew member's microphone each time someone speaks, or in the case of the United Kingdom "hot mic" system, all of the time.

In addition, since protective headgear can provide only limited noise attenuation, the hearer will be subjected to cabin noise, which may mask the already degraded signal coming through the intercomm. This is particularly a problem at the lower frequencies (see Figure 4) where helmet attenuation is

particularly poor yet helicopter cabin noise levels are relatively high. Consequently it is important not to present audio signals to the man at these low frequencies since they will either be masked by helicopter cabin noise, or will have to be of a sufficiently high level to be heard that they may cause discomfort and hearing damage to the listener. Improved attenuation at low frequencies on the British Mk 4 protective helmet has eased the problem and work is in progress on a helmet with further improved low frequency attenuation.

Figure 3 illustrates another problem which confronts the helicopter crew. It is the quantity of audio information to which they may be subjected. Even in an ideal situation where there is no distortion or noise masking of signals, it could still be impossible to complete the audio task, simply because of the number of simultaneous conflicting signals which have to be heard and processed by the operator. In large fixed wing aircraft the problem is sometimes overcome by using a relatively large number of operators, each dedicated to listening to a particular audio signal. In the smaller helicopter with its limited crew size this is not possible and one operator may have many audio tasks to do. Only by presenting signals clearly and using careful operating procedures, which minimise the chance of generating simultaneous conflicting signals, will it be possible for one man to perform several audio tasks efficiently.

The danger of presenting too much information to the man can be illustrated by the current audio warning problem. In some present aircraft there are as many as fourteen different audio warnings. (The internationally agreed limit is 24!) Even with fourteen warnings there are the problems of (i) learning to what each warning sound refers; (ii) recognising the sound correctly when under stress, in an emergency situation. Additionally, in emergency situations several audio warnings often occur simultaneously. This adds to the problem since the warnings are likely to mask one another and make the specific identification of each warning sound difficult. In other words, each signal has to be detected against a background of other signals, classified and then responded to, all in as short a time as possible and under stressful conditions, when the operator's mental capacity may be less than normal. A possible alternative to this unsatisfactory situation might be to have a single audio warning which alerts the operator. He would then determine the nature of the problem and possibly the corrective action required, from a visual display. This could be in the form of a centralised warning panel or alpha numeric-CRT display.

#### SIGNAL FREQUENCY CHOICE

Equipment which has an audio output often works perfectly in the laboratory but is far from satisfactory in the real life environment of a helicopter cabin. Figure 5 illustrates a typical ESM or sonics situation in a helicopter. The audio signal ranges from about one hundred to one thousand Hz. A signal of 80 dB can be readily detected and interpreted in a benign environment. Conversely, when heard in a helicopter cabin much of the audio signal is masked by rotor and gear noise, despite the increase in signal level to 90 dB. Additionally, the noise level together with the higher signal level may cause temporary hearing loss.

Both the problems of the noise masked signal and the hearing loss would be largely overcome if the audio signal frequency range was changed. Figure 5 shows that by choosing a part of the frequency spectrum free of noise peaks, yet still within the normal range of hearing, a reshaped and/or heterodyned audio signal can be presented to the listener, which is not masked by noise. In addition to the improved signal to noise ratio, the signal magnitude is lower and unlikely to add significantly to the noise dose and to cause any temporary hearing loss.

#### CONTRIBUTION OF SIGNALS TO NOISE EXPOSURE

As mentioned above in section 3, the signal can contribute to the noise dose of the operator. Figure 4 and Figure 6 show, respectively, how the helmet attenuates the cabin noise to an acceptable level at the ear and then the communication signal increases the overall sound level at the ear again. Glen and Moore<sup>1</sup> showed that the communications signals at the ear, averaging 40% of the sortie time, are a major contributor to the total noise dose, and, without the signals the dose averaged about 6 dB less.

Current research into noise dose on RAF, RN and AAC aircraft also shows that the signal may contribute significantly to the noise dose. An indication of some of the variables associated with the noise problem, in this case concerning noise dose<sup>2</sup> (although the principles apply equally well to communications and other problems) is shown in Figure 7. Present research is looking into distributions of noise in each of these particular areas and investigating inter and intra aircraft variations. This will enable statistical models to be built up of the noise for each type of helicopter. In helicopters, in particular, the distribution of the bands of noise which cause interference with listening tasks is being found, which, with similar statistical distributions for helmet attenuation, will allow adequate statistical cover to be made. Further progress is being made in determining the acceptable noise level at the ear, taking into account sonar listening or detecting tasks, ESM, noise dose etc and then working outwards via the helmet to provide acceptable helicopter cabin environments for new helicopters.

#### ALLEVIATION OF THE NOISE PROBLEM

The problems of internal helicopter cabin noise and audio signals upon crew performance can be tackled in several ways. Firstly every effort should be made at the start of a helicopter design process to minimise cabin noise by sensible engine and airframe layout. Engines and gearboxes must not be allowed to intrude into the cabin area, as they have on some past helicopters. The cabin should be isolated as much as possible from the vibration and noise sources, by use of nodal beam suspension and similar techniques.

Aerials must be sited to reduce interference and shielding by parts of the airframe as far as possible. Equipment should be integrated both within a system and between systems. All too often different pieces of equipment appear to have been designed separately so that when the system has been finally put together there have been incompatibilities between its component parts. This has resulted in the final signal becoming virtually unintelligible.

Similarly, the environment in which the equipment has to be operated must be known early in the design stage. Audio signal frequencies must be chosen which are free from expected noise peaks generated by rotors, gearboxes etc.

If, despite the measures listed above, noise levels at the operator's ears are still unacceptably high, electronic techniques such as voice operated switches and active noise reduction must be employed. Mechanical attenuation of noise by ear defenders or helmets may also be used, but as shown by Figure 4, these methods are of limited value at the lower noise frequencies of a few hundred Hz, typical of the helicopter cabin, although active noise reduction techniques are giving considerable gains in attenuation at low frequencies, ie up to 1 kHz.

#### CONCLUSIONS

In present helicopters, both the number and magnitude of audio signals are often too great to permit efficient and safe crew operations.

Cabin noise needs to be reduced to improve the signal to noise ratio and to reduce the crew's noise dose. Signals also need to be reduced both (i) in magnitude to reduce noise dose and (ii) in quantity to reduce workload and to remain within man's processing capacity.

Only by carefully integrating all aspects of the helicopter and its systems with the crew who have to operate them will the total man/machine system realise its full potential.

© Copyright Controller HMSO, London, 1975

#### REFERENCES

- |   |                                |   |
|---|--------------------------------|---|
| 1 | Sqn Ldr M C Glen<br>S A Moorse | The contribution of communications signals to noise exposure.<br>RAE TR 77027, February 1977. |
| 2 | G M Rood<br>Sqn Ldr M C Glen   | A survey of noise doses received by military aircrew.<br>RAE TR 77080, June 1977.             |

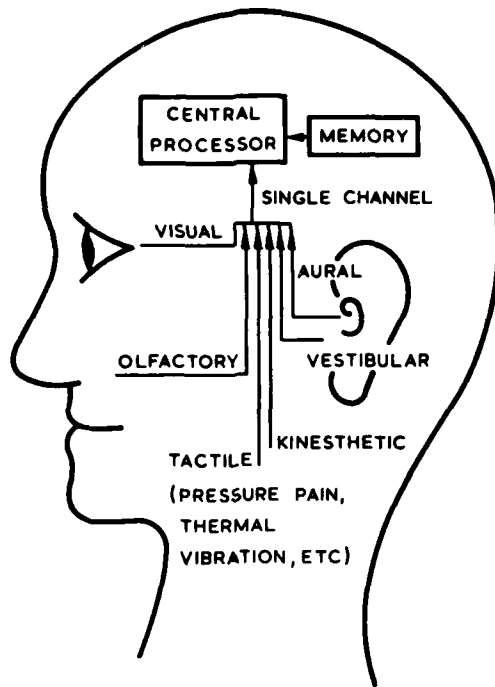

**Fig1 MAN'S SINGLE CHANNEL FOR SENSORY INPUTS**

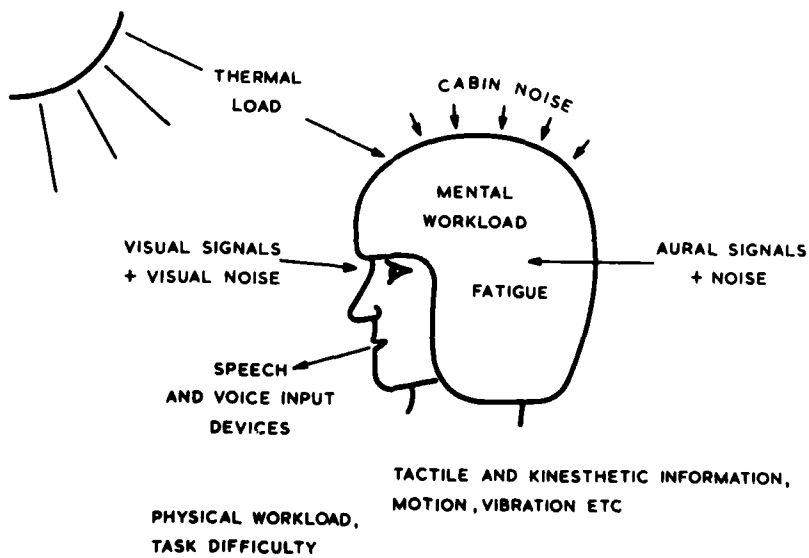

**Fig2 CONTRIBUTORS TO CREW WORKLOAD**



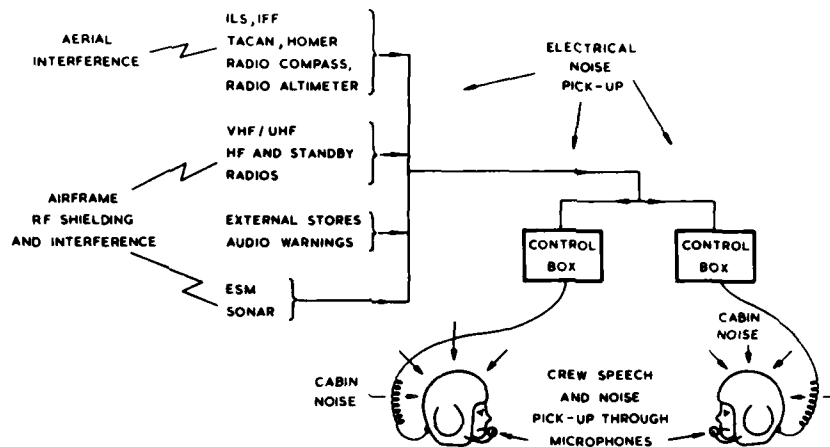

Fig. 3. SOME AUDIO SIGNALS AND NOISE SOURCES IN A HELICOPTER

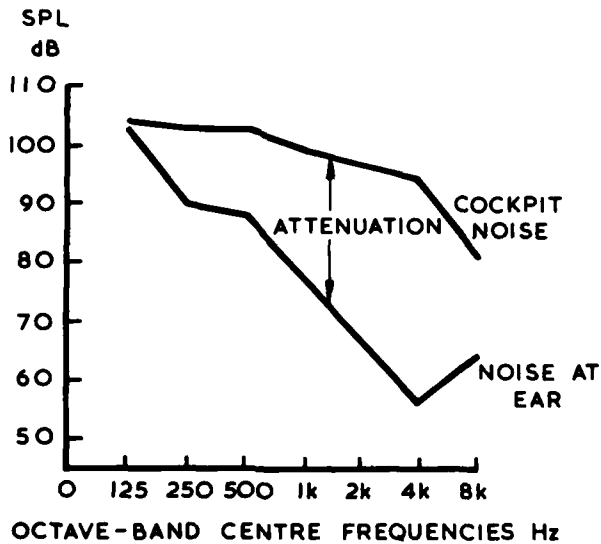

Fig. 4. ALLOWANCE FOR HEADGEAR ATTENUATION

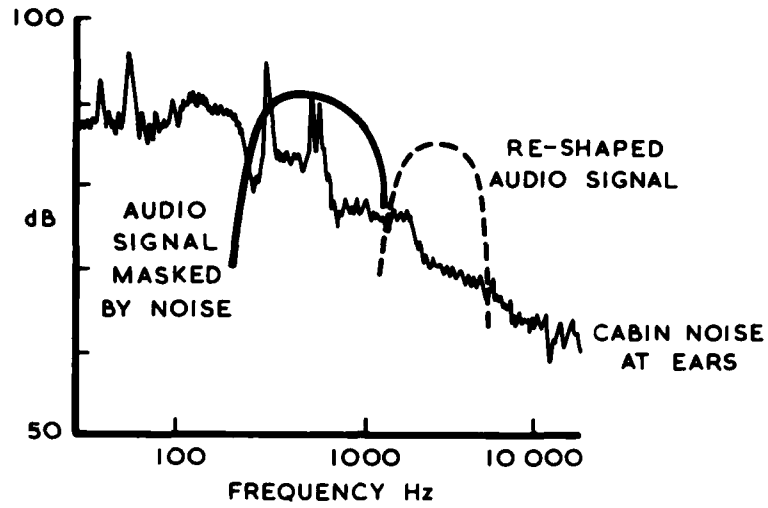

Fig. 5. RE-SHAPING OF AUDIO SIGNAL TO REDUCE MASKING BY CABIN NOISE

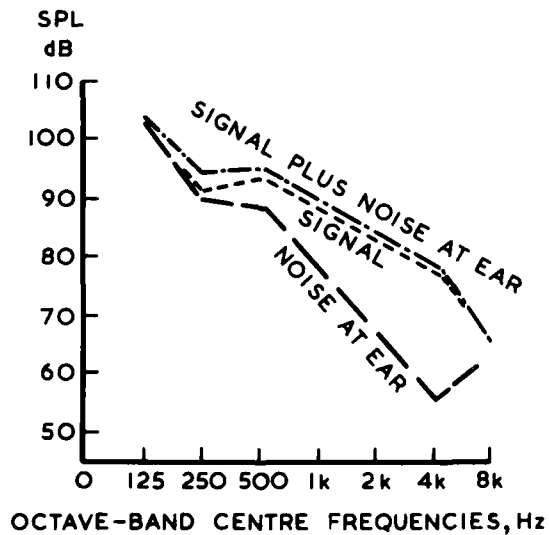

Fig. 6. NOISE AND SIGNAL COMBINED TO GIVE TOTAL EXPOSURE

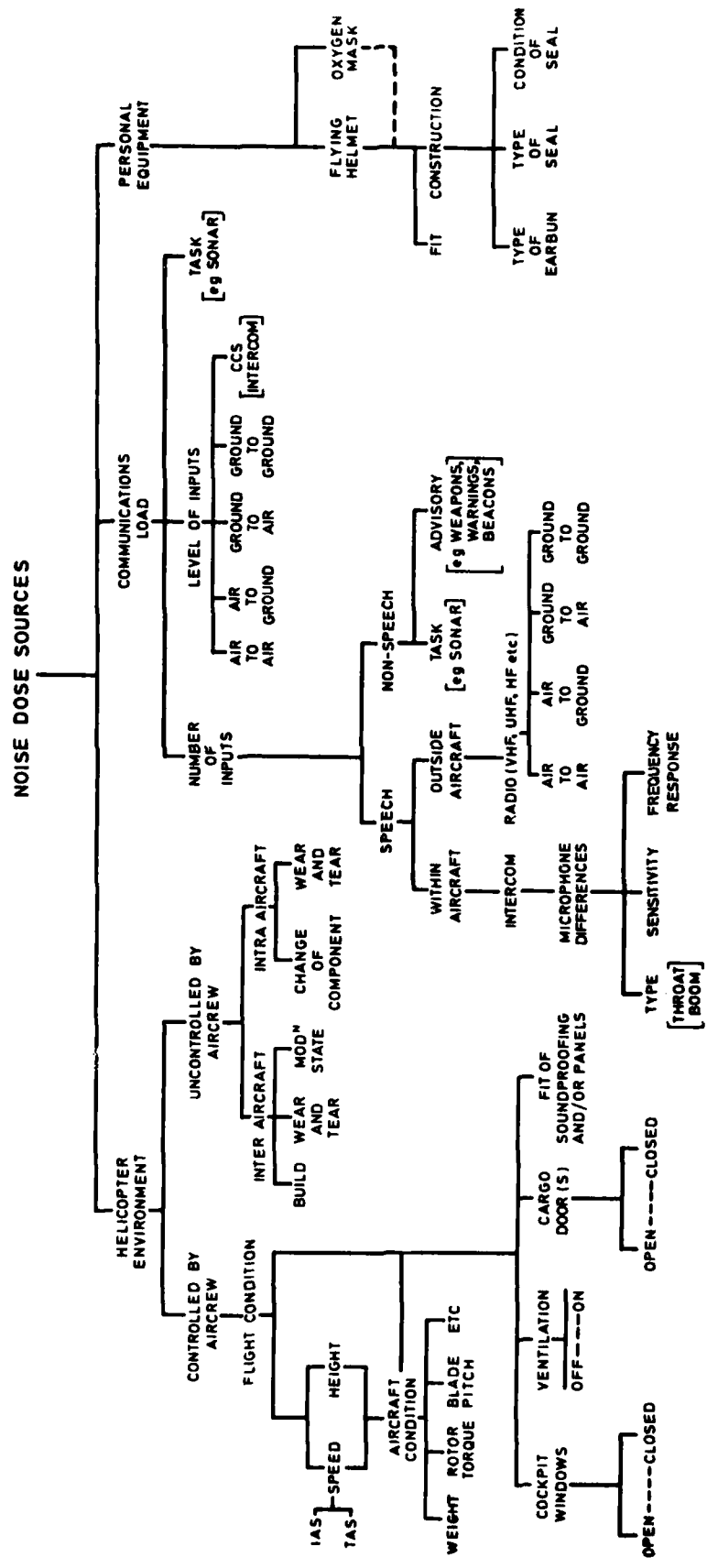

Fig 7 Noise dose variables - helicopter aircrew

DISORIENTATION IN ROYAL NAVAL HELICOPTER PILOTS

By

A P Steele-Perkins  
 Royal Air Force Institute of Aviation Medicine  
 Farnborough  
 Hants

and

D A Evans  
 Royal Naval Air Medical School  
 Seafield Park  
 Hillhead  
 Hants

Summary

The incidence of pilot disorientation in fixed and rotary wing aircraft has been previously investigated, but information regarding special orientation problems of naval helicopter pilots engaged in operations at sea and landing on moving platforms was not obtained until 1974 when a survey of 104 active USN pilots was reported (1). This questionnaire was adapted and distributed to RN helicopter pilots.

The aims of the survey were that useful information would be obtained on aircraft manning, cockpit and instrument design for future helicopters generations, and instruction to helicopter pilots regarding disorientation and thus a possible improvement in flight safety.

Findings

Disorientation continues to be a factor in the loss of crews and aircraft. A complete review of US Naval Safety Centre records over a 5 year period 1969-1973 disclosed 23 naval helicopter accidents in which pilot disorientation or vertigo was a definite or suspected factor. 29 deaths resulted from 12 of these helicopter accidents. No similar study has been completed for RN helicopter accidents.

Disorientation in helicopters has been previously studied in US Air Force and Army pilots. (2,3,4,5,6,7). However disorientation experienced by Naval helicopters, especially while engaged in operations at sea, was first reported by Tormes F R Lt Cdr MC USNR and Fred E Guedry, Jnr in 1974 (1). In shipboard operations, the aviator is confronted with new factors conducive to disorientation, and often with fewer visual cues and more complex relative motion problems than with land-based aircraft.

This study was undertaken in order to elucidate the frequency and types of spatial disorientation experienced by RN helicopter pilots. The helicopter has become increasingly prominent in anti-submarine warfare (ASW), Search and Rescue (SAR), and as a general utility platform in modern naval operations. This prominence is reflected in the percentage of operational RN aircraft which are helicopters, i.e. 66% in 1976. This compares with 40% in 1965 and 37% in 1961. Comparable USN figures were 18.7% in 1973, 12.7% in 1963, and 7.4% in 1958 (8).

A questionnaire concerning disorientation was answered anonymously and individually by 182 RN (USN 104) helicopter pilots. 52% (USN 56%) indicated one or more episodes of severe disorientation and 9% indicated having experienced severe disorientation 10 or more times while piloting helicopters (USN 5 times or more 8.6%). A number of factors conducive to disorientation were identified. Some precipitating factors appear to be specific to operations over water or over a moving deck, although some of these may well have their counterparts in special operations over land. Other factors are common to land and sea-based operations and some are common to fixed-wing as well as rotary wing aircraft.

The most common phenomenon reported by respondents was the "leans" (96%) and the most common conditions reported as leading to disorientation were:-

1. Misinterpretation of relative position or movement of ship during night approach.
2. Take off from carrier or other aviation ship, night.
3. Head movement whilst in bank or turn.
4. Reflections of anti-collision lights on cloud and fog outside the cockpit.
5. Misperception of true horizon due to sloping cloud bank.

A surprisingly high figure (35%) was inability to read instruments due to vibration. The USN survey revealed an even higher percentage (45%).

PROCEDUREMethod

The USN questionnaire was adapted and approximately 300 were distributed through Squadron Staff Officers to active RN helicopter pilots, 182 questionnaires (60%) were completed individually and returned anonymously through Squadron Staff Officers.

Disorientation was defined in instructions as "an incorrect or seat of your pants" impression of the attitude, position, or movement of the pilot and/or aircraft relative to the horizon or other stable reference. The flight deck of a moving ship was considered a "stable reference". Vertigo was defined as "a sensation that the pilot or environment is spinning". Navigational error was not considered true disorientation.

The degree of disorientation was to be subjectively graded by the responding aviator as follows:

- "mild" - pilot felt disorientated and uncomfortable but always felt in control of the aircraft.
- "moderate" - pilot felt disorientated and concerned and there may have been adverse effect on aircraft control.
- "severe" - pilot felt disorientated, mentally stressed and/or there was definite interference with aircraft control.

All questions applied only to experience as pilot or co-pilot in RN helicopters. Fixed wing experiences were specifically excluded.

Pilots involved in the RN survey were serving with anti-submarine, Commando and training squadrons at the time the study was undertaken.

RESULTS

A list of factors and flight conditions which have been associated with disorientation in helicopters was presented in the questionnaire. Table I lists in decreasing order the percentage of 182 aviators reporting disorientation under each described circumstance, according to the aviator's recall, during his career as a helicopter pilot. Additional factors not listed in the questionnaire but felt related to disorientation by the respondent were elicited and are listed in Table II.

The aviators involved in the study had accumulated a total of over 234,000 helicopter flight hours (Mean 1285) including 36,000 actual or simulated instrument hours (Mean 195).

Of 182 pilots involved in the study one (0.5%, USN 0.96%) denied any degree of disorientation. 42 pilots (RN 36%, USN 23%) reported situations where both pilots became disorientated simultaneously or during the same flight. Four (RN 2.2%) had been involved in accidents or incidents as a consequence of disorientation. 3.8% of USN pilots had been involved in accidents as a consequence of disorientation.

When specifically queried about severe disorientation as described above, 48% (USN 33%) denied any episode of disorientation as helicopter pilots, while 52% (USN 56%) admitted one or more episodes of severe disorientation. 9% had experienced severe disorientation 10 or more times. 9 USN pilots (8.6%) had experienced severe disorientation five or more times.

Degree of Disorientation experienced by 182 RN Helicopter Pilots

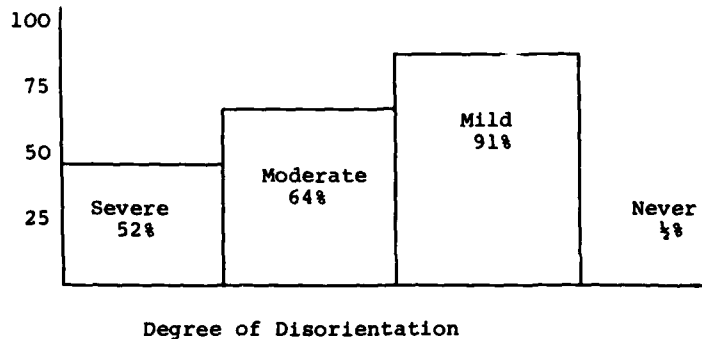

Distribution of 182 RN Helicopter Pilots by Degree and Degree of Disorientation (with USN figures in brackets)

Degree of Disorientation	Number of Occurrences		
	0	1 - 9	10+
Severe	87 (48%)	79 (43%)	16 (9%)
Moderate	65 (36%)	77 (42%)	40 (22%)
Mild	16 (9%)	52 (29%)	114 (63%)

TABLE I

Percentage of 182 RN Pilots who have Experienced Disorientation under Described Circumstances While Piloting Helicopters

(USN Percentage alongside RN results)

	<u>RN</u>	<u>USN</u>
1. Sensation of not being straight and level after bank and turn ("the leans")	96	91
2. Misinterpretation of relative position or movement of ship during night approach	73	58
3. Take-off from carrier or other aviation ship	52	39
4. Head movement while in bank or turn	51	56
5. Reflection of anti-collision light on clouds and fog outside the cockpit	48	70
6. Misperception of true horizon due to sloping cloud bank	46	47
7. Reflection of lights on windshield	44	36
8. Landing on carrier or other aviation ship, night	44	51
9. Transitioning from IMC to VMC and vice versa	43	62
10. Fatigue	38	33
11. Distraction by aircraft malfunction	36	29
12. Inability to read instruments due to vibration	35	45
13. Night transition from hover over flight deck to forward flight	35	49
14. Misjudgement of altitude following take-off from carrier or other aviation ship	34	21
15. Low altitude hover over water, night	29	81
16. Misperception of true horizon due to ground lights	28	33
17. Misled by faulty instrument	25	25
18. Vibration	24	24
19. Symptoms of cold or flu	11	22
20. Loss of night vision	20	15
21. Sensation of being suspended in space, detachment from aircraft	19	-
22. Awareness of flicker of rotors	18	35
23. Low altitude hover over water, day	16	10
24. Formation flying, day	13	8.6
25. Going IMC in dust, snow, water, in low hover	12	19
26. Formation flying, night	11	25
27. Landing on carrier or other aviation ship, day	5	0.96
28. Take-off or landing in strong cross winds	4	13
29. Low altitude hover over land	3	6.7
30. Self-medication with over-the-counter drugs	2	1.9
31. In flight refuelling from moving ship	1	2.8

As noted in Table I, the most common type of disorientation reported was "the leans". It is of interest that this phenomenon appears to be the most frequently encountered type of disorientation, exclusive of geographic disorientation, in both rotary and fixed wing aircraft. "The leans" has remained the most frequently observed orientation problem for several decades regardless of aircraft type or performance capabilities.

## TABLE II

Additional Factors associated with Disorientation in Helicopters

1. Marker flares illuminating cabin
2. Insufficient planning night sortie brought forward
3. Banked turns at night over moving lights
4. Cloud flying (day or night) with side doors off (Wasp helicopter)
5. Low ambient temperature affecting visual acuity
6. Lack of recent instrument flying
7. Shoulder straps of different tightness

Many incidents occurred during IF training and simulated IF.

The "breakoff phenomenon" (95) was described by one pilot as his most memorable episode of disorientation. 19% of the RN pilots in the survey reported sensations of being suspended in space or detached from the aircraft. This question was asked in the survey directly (following advice from the USN researchers).

During interviews many USN pilots reported sensations of being "Suspended in Space" while flying helicopters but no feelings of estrangement, detachment from the aircraft, or unreality as described by Benson (9) were elicited.

Case No. 69

Helicopter Type Sea King HAS Mk 1; Mission-Intensive Instrument Flying during an instrument rating instructor's course (which I passed); weather - day; pilot hours - 950. Having marshalled for GCA and on final run in before descending onto the glide slope I had an impression of being completely "dissociated" from myself and looking down at myself flying the aircraft. It was a feeling of being crouched over the controls and looking down on everything. It was a most odd feeling which occurred at first because of a mild disorientation but it occurred many times (approximately 6-10 times) later because, I am sure, of awareness and concern of the first occasion. It always happened at the top of GCA glide path before descending.

An extremely prevalent type of disorientation in USN Helicopter pilots, not previously described, occurs at night in a 40 ft hover over water while "dipping" sonar, a common submarine detection technique during which a sonar dome is lowered well below the ocean surface. An apparent discrepancy in the comparative results was that 81% of USN helicopter pilots in the survey had experienced disorientation in these circumstances but only 29% of RN helicopter pilots had experienced this. This can be explained by the number of Commando role pilots who would not have carried out night hovers.

A common predisposing factor in this cause of disorientation is the use of localising of position light aids such as hover lights or flame marker floats. Whilst not specifically asked in the questionnaire all Anti-submarine Warfare pilots questioned thought that this was one of the most potent disorientating factors.

Case No. 130

... At the time of the incident I was practicing dropping position markers, and to note the position of the marker usually involved looking over one's shoulder. On this particular night I looked towards the 'lights' of my contact to assess range and bearing. But when I turned back to my instruments everything went. I did not seem able to recover anything. I remember the Radar Altimeter height bug (set at 150 feet) coming on and then pulling in power until I heard the overtorque bells ringing. I eventually fully regained control in a spiralling turn at 1100 feet.

The Role of Aircraft Instruments

In this demanding flying environment, flight instruments must be designed to give clear unambiguous interpretation in the minimum time under vibration (which may exceed 0.2g peak-to-peak). Instrument space is at a premium as those helicopters with systems capable of automatic hovering require extra instruments to give the information required. Indeed the situation has been reached where there is no more space available, and it may be argued that cramming instruments into a small space leads to clutter and difficulty in instrument scanning. Any improvements in instrument design must reflect this philosophy. A new device which could have considerable potential is the Malcolm horizon (10). This projects a thin beam of light across the cockpit and gives peripheral pitch and roll information. Reported trials in Canada have been encouraging and the UK is about to carry out an assessment.

Head Up Displays (HUDs) are at present difficult to install in helicopters because of the space needed for the hardware. Unlike a fixed wing pilot who is normally viewing the HUD as a matter of course, the distance of the windscreen from the helicopter pilot would force the pilot to concentrate his visual scan over too small an area.

A flexible response display involving cathode ray tubes (CRTs) has many advantages. It can be located in the primary instrument area and is able to give the pilot the information he desires for any given role. In addition the space normally taken up by instrument surrounds or casings is now available, and therefore more information can be presented in a smaller display area, without clutter.

### Conclusion

This paper had described the frequency of disorientation and factors contributing to it in a survey of Royal Naval helicopter pilots. It is planned to carry out a similar survey by questionnaire in Royal Air Force helicopter pilots which will provide further information on the factors leading to disorientation in the specific role of operating support helicopters in the United Kingdom and Germany.

### REFERENCES

1. TORMES, F.R. Lt Cdr MC USNR and GUEDRY Jnr. F.E. - Disorientation Phenomena in Naval Helicopter Pilots - NAMRL - 1205. Pensacola, Fla. Naval Aerospace Medical Research Laboratory.
2. BARNUM F and BONNER RH - Epidemiology of USAF spatial disorientation aircraft accidents, 1 Jan 1958 - 31 Dec 1968. Aerospace Med, 42:896 898, 1971.
3. BERRY CA and EASTWOOD HK - Helicopter problems: Noise, cockpit contamination and disorientation. Aerospace Med, 31:179-190, 1960.
4. CLARK B - Pilot reports of disorientation across 14 years of flight. Aerospace Med: 42 : 708-712, 1971.
5. EASTWOOD HK and BERRY CA - Disorientation in helicopter pilots. Aerospace Med, 31: 191-199, 1960.
6. HIXSON WC, NIVEN JI and SPEZIA E - Major orientation-error accidents in regular Army UH-1 aircraft during fiscal year 1969: Accident factors. NAMRL-1169. Pensacola, Fla: Naval Aerospace Medical Research Laboratory and US Army Aeromedical Research Laboratory, October 1972.
7. OGDEN FW, JONES QW and CHAPPELL HR - Disorientation experiences of Army helicopter pilots. Aerospace Med, 37: 140-143, 1966.
8. Anon, Flight Activity of Naval Aircraft. OPNAV Notice C-3700, Fiscal Years 1958, 1963 and 1973.
9. BENSON AJ - Spatial disorientation and the "break-off" phenomenon. Aerospace Med, 44: 944-952, 1973.
10. MONEY KE, MALCOLM RE and ANDERSON PJ - The Malcolm Horizon AGARD Conference Proceedings No 201. Visual Presentation of Cockpit Information including special devices used for particular conditions of flying.



OPERATIONAL CONSIDERATION OF AN/PVS-5 NIGHT VISION  
GOGGLES FOR HELICOPTER NIGHT FLIGHT

Wun C. Chiou, Ph.D.  
United States Army Aeromedical Research Laboratory  
P.O. Box 577  
Fort Rucker, AL 36362

A potential hazard exists in helicopter night training with the second generation night vision goggles (AN/PVS-5) when less than twenty percent moon illumination is available or when the moon is beyond 60° azimuthal position. This paper reports experimental results and discusses operational problems in which artificial illumination is being utilized to increase helicopter night vision goggle training duration when ambient illumination is insufficient.

Two types of artificial illumination have been evaluated. The first type utilizes the existing helicopter landing light as an illumination source. The second type uses auxillary external illumination sources such as a searchlight. Results indicate that the third method is the most desirable one for operational considerations. As for the second type of artificial illumination source, two kinds of illuminators were evaluated. A modified one kilowatt AN/VSS-4 (XG-4) armored illuminator and the fire-fly lighting system were flight tested. Results reveal that the former provides a far better illumination pattern than the latter. Spectral transmission characteristics and optical quality of these artificial illumination sources will be given in detail. Various advantages and disadvantages of using one kind versus the other will also be discussed in detail. In this paper, it has been shown that an artificial illumination source or a combination of various sources can be utilized to increase the helicopter NVG training time at night.

#### INTRODUCTION

Current scheduling of AN/PVS-5 night vision goggles (NVG) training conducted by the US Army Aviation Center here at Fort Rucker depends greatly upon the level of available night sky illumination. The second generation NVG require a minimum of quarter moon illumination in order to perform certain landing and hovering maneuvers for helicopter night training. At the present time, the NVG night training unit uses photometric measurements to monitor the night sky illumination. When the illuminance value falls below certain critical values, the training has to be terminated. This critical dependence of ambient light levels creates a major difficulty for the night training program to fulfill its training schedule within a preassigned time frame.

In order to provide an active training schedule, it is necessary to circumvent the fluctuating night sky illumination by introducing a steady illumination from an artificial illumination source (AIS). Two major types of AIS are evaluated in this study. The first type utilizes the existing helicopter landing light (hereafter abbreviated as type AIS I). The second type is to make use of available external illumination devices such as a searchlight (AIS II).

Three major modification alternatives are provided for the AIS I. The reason for the modification is that the landing light is usually too bright and does not diffuse to a broader and useful illumination area. The first modification method is to add a voltage control device in the aircraft electric circuitry such that the landing light level can be controlled externally. However, this requires a considerable hardware modification. It is excluded from the present study. The second method for the AIS I is to apply an appropriate heat-absorbing filter in front of the landing light such that the output illumination spectral energy of the landing light falls within the NVG photocathode response wavelength range (approximately 200 to 1000 nm). Two kinds of filters are used in this study. The first kind, termed dark-pink filter, was originally used in the US Army INFANT system. The second kind, called light-pink filter was from a US Army tank searchlight filter. The dark-pink filter cost ten times more than that of the light-pink filter. However, the former can sustain higher thermal energy radiating from the landing light than the latter.

The third modification alternative is to apply an appropriate filter in front of the NVG instead of the landing light filter. Although the spectral energy response characteristics of the NVG photocathode tube is constant, the second and third methods are not necessarily the same. The reason is that the second method only filters the landing light while the third method filters any light source which falls into the photocathode tube of the NVG.

For the AIS II, two kinds of searchlights were evaluated. The first kind is called the Modified 1.0 KW AN/VSS-4 (XE-4) Searchlight (hereafter abbreviated as MSL

or System A). The second kind is the Fire-Fly Light System (FFLS or System B). The MSL was provided by the US Army Night Vision Laboratory, Fort Belvoir, VA. It was a modified version of a US Coast Guard searchlight. The FFLS which was utilized quite frequently in medical search/rescue mission in Vietnam consists of seven helicopter mounted searchlight systems.

Since the present study contains two distinct substudies, the following description of the study will be divided into two subsessions for each session. Substudy I will describe the Artificial Illumination source Type I (AIS I). Substudy II will be for the Type II (AIS II)

#### Substudy I (AIS I)

#### METHODOLOGY (AIS I)

##### a. Sample

Figures 1 and 2 show the front and back sides of the dark-pink filter when mounted on a circular alloy casting. The configuration is the same for the light-pink filter except the latter is about one-third thinner. A glass ground with parallel cylinders is placed in front of the filter in order to uniformly diffuse the light. The diameter of the filter is about 12 centimeters (or 4.72 inches). Only the filter itself without the ground glass was spectrophotometrically evaluated. In actual flight test, the ground glass was included in the total system.

##### b. Apparatus

(1) Macbeth Transmission Densitometer TD-504 made by Macbeth Color and Photography Division of Kollmorgen Corporation, Newburgh, New York was used to measure the optical density of the filter.

(2) The spectral transmission characteristics and power spectral distribution were performed by a Tektronix Digital Processing Oscilloscope - Rapid Scan Spectrometer (DPO-RSS System). The light source was a GE-100 watt tungsten light bulb. The data acquisition unit was a minicomputer PDP 11/05 with various input/output (I/O) accessories. The DPO unit digitizes the waveform from the RSS optical unit which is capable of scanning the optical spectrum from 300 nm (ultraviolet) to 1100 nm (near infrared). The spectrometer utilizes a Czerny-Turner grating monochromator without an exit slit. The spectral response of the monochromator from the light source is focused onto the target of a vidicon tube in which the signal is being discharged by a sequential scanning electronic gun. Thus the vidicon target converts the charge image into an electronic signal that is received by the plug-in unit of the DPO for CRT display. The processes described above can be controlled by software programming.<sup>1</sup>

#### RESULTS AND DISCUSSION (AIS I)

Since the optical characteristics of the dark-pink filter and the light-pink filter are essentially identical, the following description involves only the dark-pink filter. Results from the optical densitometry measurement show very interesting optical properties of the filter. When the more reflective side of the filter is placed in a face-up position, it has an average optical density (O.D) of 5.90. However, if it is placed face-down, its value is reduced to 4.41 O.D. It is obvious that the filter has an optical characteristic of directional sensitivity. A second unusual observation has also been noted. When the filter with the more reflective side is face-up, the O.D. value increases from 5.64 at the center to 6.35 at the edge. When the other side is up, the reading is approximately uniform across the radial direction of the device which has the O.D. value of 4.41. One possible explanation is that the multi-layer infrared coating materials at the filter surface were "baked" by the light or the heat generated from the light. As a consequence, the coating materials become nonuniform across the surface of the filter. Thus, toward the center, the coating materials were gradually dissolved or evaporated away as a function of exposure duration of the filter to the thermal energy.

The spectral power distribution of the filter within a wavelength range of 400 to 800 nm has been obtained. It is noted that the filter transmits virtually no light at all in the spectral region except a small amount at the end of the red spectrum. Following an execution by the automatic reference from the computer program, the spectral transmittance of the filter is obtained (Shown in Figure 3). In general, the obtained spectral characteristics curve implies that the filter transmits the light from 770 nm onward to the near infrared region. The spectral energy provides approximately one-third of the useful energy readily available to the NVG photocathode spectral response envelope. It contains very little energy to the naked-eye.

Flight test results indicate an overall acceptance of the system for night flight training although complaints have been made that some backscattering from the light source was present. The backscattering problem may be due to several anomalous optical characteristics. After this flight test, it was suggested that the filter be cut and fitted directly into the goggles with tube outserts instead of placing it directly in front of the landing light. This was the third modification method. The subsequent flight test showed that the device did not provide adequate illumination

since it reduces spectral energy sources other than the landing light which are needed for a normal NVG operation.

#### CONCLUSION (AIS I)

Three kinds of filters with essentially the same optical characteristics were used in this substudy to provide an artificial illumination source for NVG training at night. It was found that there were three anomalous optical properties of the infrared-coated filter: (1) there existed a difference of about 1.5 optical density when the light incident was shined through from the highly reflective side versus from the coated side, (2) at the highly reflective side, the optical density increased radially from 5.64 to 6.33, while at the other side, it was uniformly distributed across the radial direction with an average value of 4.41 O.D., and (3) the transmittance of light through the filter was dependent upon the angle of incidence. Results from the flight performance evaluation showed the dark-pink filter coupled with the landing light is the most satisfactory artificial illumination source to be used for NVG training at night. The other two types present additional operational problems.

#### SUBSTUDY II (AIS II)

##### METHODOLOGY (AIS II)

###### a. Test Samples:

(1) Modified 1.0 Kw AN/VSS-4(XE-4) Searchlight system (MLS or briefly System A). This system uses 28VDC. It draws 70 amperes transient current and 50 amperes steady state current. Beam width range is from five to thirteen degrees. The output illumination of this system is from 500,000 to 1,000,000 candlepower. Figure 4 shows System A.<sup>2</sup>

(2) Fire-Fly Light System (FFLS - hereafter called System B). Figure 5 shows System B.<sup>2</sup> This system consists of seven aircraft landing lights in which one is at the center and the other six form the circular configuration. The system also uses 28VDC power source from the aircraft power generator. Each landing light draws 36 amperes steady state current and 1000 watt power output. The total illumination of this system is about 350,000 candlepower.

b. Apparatus - The photometric equipment was the Spectra Spotmeter, Model UB/UBD serial #B409 manufactured by Photo Research, a division of Kollmorgen Corporation. The illuminance sensitivity range of the spotmeter with a cosine receptor CR-100 is from  $10^{-3}$  to  $10^1$  footcandle (fc.) The cosine receptor, which mounts on the front of the objective lens of the spotmeter, measures the integrated illuminance from all sources in the hemisphere above it. Since it is cosine-corrected, the correct illuminance reading will be obtained from a source, regardless of where it is located in the forward hemisphere.

c. Procedures - This study was conducted from 2000 to 2400 hours on 15 June 1977 at High Bluff Stagefield, Fort Rucker, Alabama, USA. At this date and time, there was no moon, which was ideal for this evaluation. High Bluff has five runways. In this study, only the first runway was used. The remaining runways were used for takeoff and landing of test helicopters.

Test System A and System B were mounted in two separate UH-1D helicopters. The test helicopters flew around the target at altitudes of 1000 and 3000 feet. The radius of the flight path was approximately one-half mile. The light was supposed to shine at the target as steadily as possible. Nevertheless at 3000 feet or above, the target was barely visible, and the light cone moved around the target rather than on the target.

Three test positions were used (shown in Figure 6). Location I was at the end of the first runway. Location II was situated at the center of the first quarter of the runway which was 400 feet away from Location I. Location III was at the very center of the runway which was 800 feet from Location I and 400 feet from Location II. The symmetric configuration of the light cone allows us to apply results from three test locations to the whole runway.

In each test location, four or five of the highest readings were recorded. Since the light cone fluctuated due to the unstable condition of the target fixation and due to the circulating nature of the flight path, the light readings also fluctuated from a minimum to a maximum reading. In addition to the highest reading, the light measurements were also taken within each quadrant of the flight path. This provides a reference curve to determine the overall uniformity and variability of the surface illumination.

##### RESULTS AND DISCUSSION (AIS II)

Table I shows data of the ambient light measurements. Data are average values of four readings in each measurement position. (All numerical values are to multiple  $10^{-3}$  footLamberts (fL.)) It also shows the equivalent percent moon condition. For example in system A, i.e., the AN/VSS-4(XE-4) searchlight at 1000 feet and at the end of the runway, the available average luminance is  $2.08 \times 10^{-3}$  fL. which is equivalent to about 86% moon illumination.

A conversion formula is also attached in Table I. Since the measurement was obtained in illuminance (footcandle) by the spotmeter with the cosine receptor, the rule of thumb to convert the available luminance (in footLamberts) is to multiply the former by the surface reflectance of the object to be measured (In this case, the average reflectance of the paved runway is assumed to be 55%).

#### CONCLUSION (AIS II)

Figure 7 is the one-dimensional luminance intensity profile of the runway. Notice that the upper curve is for the altitude 1000 feet and the lower curve is for 3000 feet. Since only four data points are available in the lower curve due to the weather conditions and the allowable flight time, results at this altitude are rather incomplete. Nonetheless, in view of the similar shape of the profile between the two altitudes, one should be able to infer that the general shape could be extrapolated if needed.

From the profile, one notices that System B provides a brighter and steeper light intensity distribution on the runway. In other words, it is less uniformly distributed. In comparison, System A provides a smooth light intensity distribution over the runway.

From Figure 7, it should be noted that at a 1000 feet altitude, both systems produce ambient light at the center of the runway in the range of 150% of the full moon illumination. From observations through the night vision goggles, one noticed that the supplemental light was too bright. A simple solution is to install a variable voltage control device into the system such that any desirable moon condition can be readily provided.

A final word of caution is that the data presented here was based on the cloudy night sky condition with no ambient moon illumination. In the actual night to night operation, the presence of the natural ambient moon illumination has to be taken into consideration in order to compute the availability of the total actual percentage of ambient illumination (i.e., the natural as well as the artificial ambient light) for the night vision goggles (NVG). A photometric instrument is needed to continuously monitor the ambient light level in order to assure the minimum amount of ambient light which is required for safe night flight training using the NVG.

Since the present searchlight systems which were mounted in a helicopter with a circular flight path did not provide a stable illumination condition for the test field, several alternative methods have been explored, but no acceptable method has yet been determined. Nonetheless, further research and development efforts are needed in order to improve the current method for providing a stable and controllable ambient illumination.

#### REFERENCES

1. Chiou, Wun C., US Army Aeromedical Research Laboratory, "Infrared Power Spectral and Transmission Characteristics of Windscreens in Army Aircraft," August 1975, USAARL-LR-76-2-7-2.
2. Hannan, M.J., US Army Aviation Board, "Final Report of Concept Evaluation of Increased Night Flight Training Time," July 1977, TPN # 7-37-7-CEP 084-08.

TABLE I. AMBIENT LIGHT LEVEL

ALTITUDE		<u>Unit X 10<sup>-3</sup> fL.</u>			
		System A		System B	
		ILLUMINATION	EQUIVALENT	ILLUMINATION	EQUIVALENT
		(L)	% MOON	(L)	% MOON
1000 ft	Location I	2.08	86%	1.64	68%
	II	2.25	93%	2.98	124%
	III	4.49	135%	3.59	158%
3000 ft	Location I	--	--	--	--
	II	0.64	26%	--	--
	III	1.34	55%	2.06	85%

Formula  $L = 0.55 \times I$

where I = illuminance in fc.

L = luminance in fL.

0.55 is average runway reflectance<sup>1</sup>

<sup>1</sup>IES Lighting Handbook, Waverly Press Inc., Baltimore, MD, 1966, p 7-9



FIGURE 1. Pink Filter Front View



FIGURE 2. Pink Filter Back View

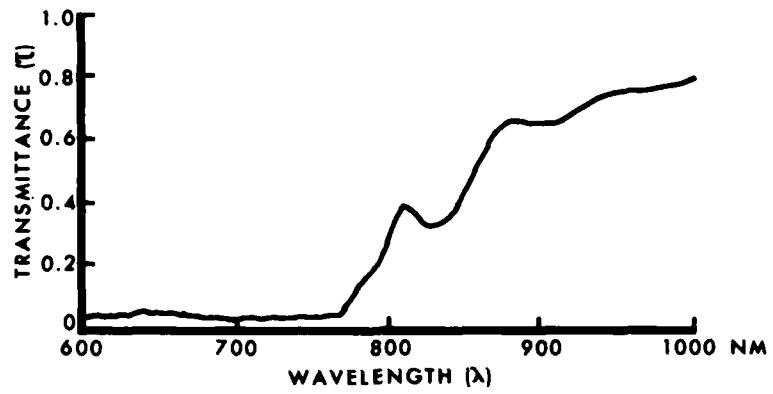

FIGURE 3 SPECTRAL TRANSMITTANCE (600-1000NM)  
OF NVL FILTER FOR NVG



FIGURE 4. AN/VSS-4 (XG-4) Light



FIGURE 5. Fire-Fly Light System

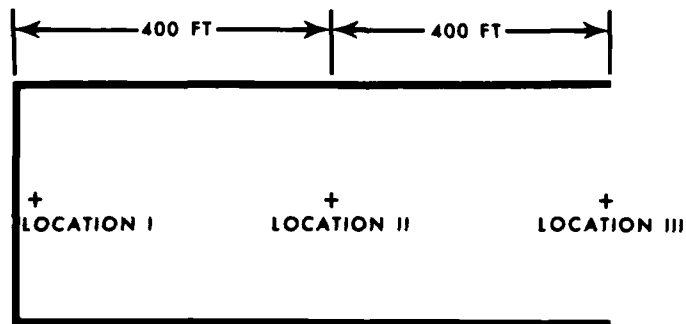

FIGURE 6 TEST LOCATION ON THE RUNWAY





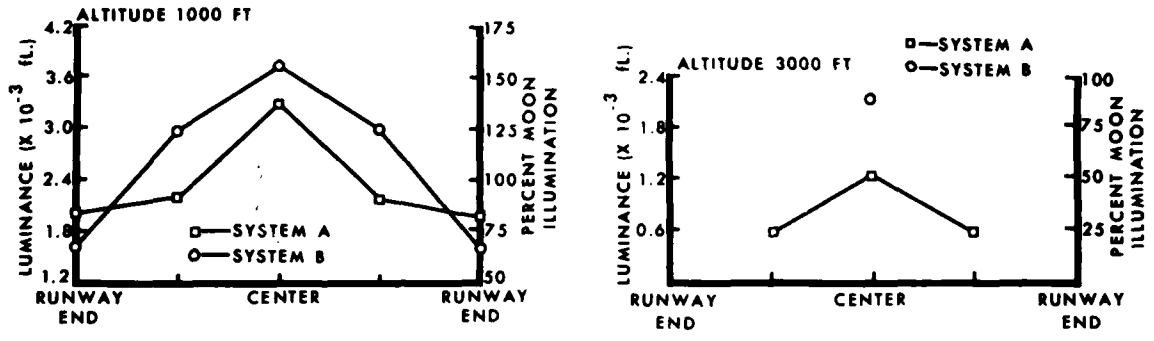

FIGURE 7 ONE-DIMENSIONAL INTENSITY PROFILE

TRAINING REQUIREMENTS FOR HELICOPTER OPERATION  
WITH NIGHT VISION GOGGLES

Isaac Behar, Ph.D.  
United States Army Aeromedical Research Laboratory  
P.O. Box 577  
Fort Rucker, Alabama 36362

¶

CPT Dana M. Young  
Directorate of Training  
Fort Rucker, Alabama 36362

¶

CPT James E. Johnson  
Directorate of Training Developments  
Fort Rucker, Alabama 36362

Abstract

Confident, safe, and effective helicopter operation with the aid of the AN/PVS-5, Night Vision Goggles (NVGs) may be acquired only during a period of training. The Army Aviation Center experience in NVG stagefield training at night identified numerous problem areas and their remediation, which are described in this report. An evaluation of an approach to circumventing many of these problems as well as providing an added margin of safety by providing the initial part of the NVG training during the daytime using appropriate filters for the goggles is also described.

INTRODUCTION

The tactics of recent and projected military operations have focused upon two requirements: first, the suspension of operations at dusk is now only history -- continuous, all weather, 24-hour/day operational capability, in daylight and darkness, characterizes the mid-intensity, high threat battlefield environment of the immediate future. Second, the peculiar strengths and weaknesses of rotary-wing flight dictate concealment and rapid, surreptitious mission accomplishment, which means terrain or nap-of-the-earth flight profiles. Meeting the demand for low-level helicopter flight at night maximally taxes all of the pilot's capabilities and skills. Indeed, with respect to the acquisition of needed visual information, the capability of the visual system may be exceeded, particularly when there is less than full-moon sky illuminance. Considerable success in augmenting visual information for helicopter guidance under the conditions of scotopic vision is afforded by the image intensification characteristic of the AN/PVS-5, Night Vision Goggles.<sup>1</sup> However, the goggles do not provide imagery which approaches the capability of the photopic system for spatial, temporal, and chromatic resolution.<sup>2</sup> It is, perhaps, this enigmatic visual experience -- imagery qualitatively resembling scotopic vision but at photopic luminance -- which underlies the interpretative reorientation necessary when the night vision goggles are used.

Specifically, the aviator must learn the significance for visual guidance of the reduced (40°) field of view (e.g., loss of streaming movement in the visual periphery for velocity estimation), reduced acuity (e.g., poorer recognition of targets, navigational landmarks, obstacles, and other hazards), lack of color discrimination (e.g., airport color-coded lights, color-coded information on navigational maps), poor stereoscopic vision (no appreciation, for example, of slow backward drifting in hover position), and the requirement for manual refocusing from distant to instrument viewing.

In view of these drastic alterations of the visual information available via the night vision goggles, confident, safe, and effective NVG helicopter operation may be acquired only during a period of training. The Fort Rucker Army Aviation Center experience in NVG training, both with Initial Entry Rotary Wing (IERW) students and qualified pilots, as well as some training innovations still in the development stages will be summarized in this paper.

NIGHT VISION GOGGLE TRAINING

Academic Training

NVG training for IERW students is presented as part of a general night operations program and is preceded by a two-week course of night flying with unaided eye ("Night Hawk" training). The academic syllabus includes night terrain identification, hemispherical illumination, and the psychophysiology of vision with an emphasis on night vision performance enhancement. Ancillary NVG training proffered at this stage includes:

proper attachment of the goggles to the flight helmet, providing adaptation to the added weight and shifted center of gravity; and the operation of the four adjustments of the goggles which are critical for optimum performance: dioptric correction, focus for distance, interpupillary spacing, and eye relief. Procedures for coping with battery failure (which occurs without warning) are also covered. Finally, the requirements for modifications of the helicopter external and instrument lighting systems for NVG compatibility are presented.

#### Stagefield Training

The limits of light intensification gain of the NVGs determine the constraint on NVG training to those nights when ambient, sky illuminance exceeds approximately  $2.5 \times 10^{-3}$  footcandles. This occurs when there is some 20 percent moon exposure at sufficient elevation above the horizon and without a heavy cloud cover. With full moon, under equivalent conditions, ambient illuminance is about  $1.7 \times 10^{-2}$  footcandles, and at this level most aviators would prefer to fly with the naked eye. Within this range, the absolute illuminance is a critical variable influencing NVG operating and training problems. If the total ambient level is high, the NVG imagery is superior, and the effect of a discrete, bright artificial light source on the NVGs is negligible. As the ambient level decreases, the quality of the imagery is reduced and the effect of the light source on NVG performance is greatly increased. Thus, for example, interior lighting in the control tower may have no effect on training on a high ambient night, but the same tower interior lighting configuration on a low ambient level night may prevent the NVG wearer from seeing the intended landing area. Because of this dependence upon sky illuminance level, only some twenty nights per month provide ample moonlight, and of these, moonrise may occur between early evening and early morning which forces an irregular training schedule.

#### NVG Operating Problem Areas

The helicopter internal lighting is normally the first problem encountered when conducting NVG training. There are several aircraft modifications that must be made for satisfactory NVG operation, including increasing the range of dimming of all instrument and caution lights to  $10^{-5}$  footlamberts, and painting the cockpit interior black to minimize reflections. Any light source that comes on automatically, that cannot promptly be turned off, must be attenuated. An example of this type of lamp would be any caution, advisory or warning light. A pilot may receive a 20-minute-fuel-warning light. If the master caution light is not attenuated to the NVG level and the ambient illuminance is low, he probably will have very poor visibility outside the helicopter. If this happens during a critical maneuver, it could be catastrophic. As a rule of thumb, if the light can be seen with the unaided eye, it is too bright for NVG compatibility.

The external aircraft lighting may have the same effect on the NVG user as has the internal aircraft lighting. If a position light is in the field of view of the NVG pilot, he may not be able to see beyond it. Visibility may also be reduced by backscatter from a position light that is not in his direct view. This characteristic of the NVGs to adjust to the highest luminance level is analogous to the rapid loss of dark adaptation of the naked eye.

The selection of a stagefield training area cannot be arbitrary since it engenders the same basic lighting problems encountered with the aircraft lighting. Any light source that could cause reductions in visibility while training with the goggles needs to be eliminated, including tower, barrier, and fire crew station lighting, street lights on civilian property off the end of the runway, and automobile headlights. Automobile traffic with headlights is a problem for the naked eye pilot, but is much more critical during NVG flight training. Consideration must be given to the same lighting problems when selecting nap-of-the-earth routes, confined areas, and pinnacles. The impact on the local community also should be considered in selecting these areas as very few people are completely indifferent to a helicopter operating over their home late at night.

The support requirements for NVG training define the logistical problems for night training in the school situation, where training must be conducted on schedule in order that a constant student flow and a level demand on available resources be maintained. This can be illustrated with a theoretical class of 40 students being trained to use the NVGs as pilot aids. Given the lunar illumination requirements, conditions are adequate to conduct only one NVG training period per night. For NVG training, the student pilot to instructor pilot (IP) ratio is 2 to 1. The maximum time period the student may spend using the goggles is 1.5 hours, and the IP may instruct with NVGs for a maximum period of three hours. Safety considerations presently prohibit more than four aircraft using a stagefield simultaneously and further restrict the operation to only one type of aircraft per stagefield. Our hypothetical class of 40 students would require 20 aircraft and 5 stagefields. Each stagefield has the following staffing: 3 aircraft control personnel using NVGs in the tower, a crash crew of 4 people with equipment, a refueling truck and operator, and an A.P.U. with operator to start the aircraft. While performing selected NVG training requirements, a chase/safety/observation helicopter is required. This increases the aircraft requirement to 25 and adds 10 pilots to the logistical requirement. Finally, the Federal Aviation Administration and local regulatory agencies have rules and regulations that must be waived or amended to enable the conduct of NVG training.

The psychological stress that emerges in the night NVG training regimen will be alluded to briefly. In part, it derives from the reversal of the diurnal pattern of work and rest. In addition to its psychophysiological significance, there is in the school situation the added administrative inconvenience that the required training coordination be done during the day while training is conducted at night. Add to this the conflict of availability at night of eating, medical, and entertainment facilities, as well as the disruption of normal family living patterns, and it is evident that the NVG IP and his students frequently experience considerable stress.

To insure safe flight operations during NVG training, each student receives academic safety training on NVG operation, and crew rest requirements and maximum NVG utilization times are established. Flight safety is further enhanced by operating only when sky illumination exceeds the minimal level, by utilizing chase aircraft, limiting stagefield density, restricting to one the type of helicopter at any stagefield, and modifying stagefield and aircraft to enhance NVG visibility.

#### Daytime NVG Training

The efficiency of training helicopter operation with the Night Vision Goggles has been improved in two ways. First, the dependency upon sufficient natural night sky illumination has been mitigated through the use of augmenting artificially produced illumination, as described in a companion paper.<sup>3</sup>

The second approach consisted of developing a set of filter outserts so that NVG training could be conducted during daytime.<sup>4</sup> Such training would drastically reduce the logistical problems and cost, while adding a significant margin of safety since the IP would have unobstructed, daytime vision. Quite satisfactory NVG imagery - approximating that obtained with 25% moon exposure - is obtained without compromising NVG tube life by using Shade 14 welders lenses during sunny days and Shade 12 during cloudy days. A lower shade number (Shade 10) combined with appropriate polarizers permits variable adjustment to a broad range of meteorological conditions. The two transmissivity characteristics that are critical in choice of filter are the total density and the near IR blocking capability. If the latter is insufficient, given the high near IR reflectance of foliage and the high near IR sensitivity of the NVGs, false contrast is obtained such that from the air, trees appear white and merge in the distance with the sky. Under these conditions, no clearly defined horizon is visible and spatial orientation is disturbed. Welders lenses combine the desired characteristics of high density and near IR blocking, and in addition, are readily available and inexpensive.

Two adjunct devices enhance the quality of imagery obtained with the daytime NVG filters. The first is a tight fitting filter holder with sunshade which has all internal surfaces blackened. The other item is a set of soft, pliable eyepieces which couple the eyes directly to the eye lenses, thus excluding stray light which would reduce image contrast. It should be mentioned that while the filters provide good imagery for viewing beyond the cockpit, the imbalance in daytime illumination prevents the instruments from being visible.

The transfer value of training IERW students with the daytime filters to NVG guided helicopter operation at night was assessed in a small study using four students. Following Night Hawk training two students received one week of NVG training entirely at night, while the other two received an equivalent duration of training with another IP but entirely during the day using filtered NVGs. At the end of this training, all four students were evaluated in NVG helicopter operation at night by another IP who did not have prior knowledge of the type of NVG training that the students had received. All four of the students were judged to be capable of flying with the goggles. The two students that received daytime NVG training with filters lacked some of the perceptual experience unique to night flying (particularly momentary blooming to bright lights), but the IP evaluator estimated that a single night training period would be sufficient to bring the daytime trained students to the performance level of the others. The basic skills of NVG operation transferred without any noticeable difference in performance.

While this test was being conducted in the school setting, three sets of daytime filters were provided to a unit in the field, the Air Cavalry Combat Brigade at Fort Hood, Texas, to determine their value to NVG training in a representative tactical unit training environment. The results of that experience were reported to be extremely favorable. In all applications, stagefield and tactical, and in various aircraft, the transfer from daytime, filtered NVG experience to the actual goggle environment was reported to be successful. It should be noted that the unit had gone into a reverse training cycle to begin NVG training and welcomed the opportunity to go back to a normal training day. This undoubtedly contributed to their positive response to the daytime filtered NVGs. Even at the unit level, though there remain problems with the daytime filters, their advantages seem to far outweigh their disadvantages.

#### Summary

The alteration by the Night Vision Goggles of the visual information used for helicopter guidance and control necessitates a program of training before safe, confident, and effective NVG operation is acquired. It is recommended that NVG training be preceded by a course of instruction in unaided night flying. Problems associated with

night NVG stagefield training include internal and external aircraft lighting, stagefield lighting, aircraft density, personnel stress, and logistical support.

An approach to circumventing many of these problems, and affording an added margin of safety, consists of providing the initial NVG training during the daytime using appropriate filters for the NVGs. So equipped, the goggles constitute their own simulator.

#### References

1. Sanders, M.G., Kimball, K.A., Frezell, T.L., and Hofmann, M.A. Helicopter flight performance with the AN/PVS-5, Night Vision Goggles. Paper presented at the Aerospace Medical Panel Meeting, AGARD/NATO, October 1975, Ankara, Turkey.
2. Wiley, R.W., and Holly, F.F. Vision with the AN/PVS-5 Night Vision Goggle. Paper presented at the Aerospace Medical Panel Meeting, AGARD/NATO, May 1976, Copenhagen, Denmark.
3. Chiou, W.C. Operational consideration of AN/PVS-5 Night Vision Goggles for helicopter night flight. Paper presented at the Aerospace Medical Panel Meeting, AGARD/NATO, May 1978, Fort Rucker, Alabama, USA.
4. Behar, I. Night Vision Goggle, AN/PVS-5, modification for daytime training. USAARL LR-77-7-7-2, June 1977.

## HEAD AIMING/TRACKING ACCURACY IN A HELICOPTER ENVIRONMENT

CPT Robert W. Verona  
 United States Army Aeromedical Research Laboratory  
 P.O. Box 577  
 Fort Rucker, Alabama 36362

## SUMMARY

This experiment was conducted to measure man's head aiming/tracking capability using a helmet mounted sighting device. The influences of target speed, helmet suspension types, sighting eye dominance and helmet weighting parameters on head aiming/tracking were investigated. If the aiming/tracking accuracy was sensitive to manipulation of the man-machine interface parameters, then it would seem to indicate that improved aiming/tracking accuracy could be obtained by improving the interface.

The factors analyzed were: eye dominance, helmet weighting, target speed and helmet suspension. The eye dominance and target speed factors were statistically significant. However, the only factor of practical significance was target speed. A subject aiming at a static target with his head has an RMS error of about 3.5 milliradians. If the target begins to move 4°/sec the error increases to about 10.5 milliradians. When the subject begins to vibrate too, the error increases to 13 milliradians. If the target speed doubles as he is vibrating, the error increases to 16.8 milliradians.

## INTRODUCTION

Much interest has been generated in the aerospace community during recent years concerning Visually Coupled Systems (VCS). A VCS can be defined as a closed-loop technique utilizing the natural visual and motor skills of the operator to control a system function. The development of methods to accurately and remotely measure head position has enabled engineers to use the head as a control device. When the head tracker is used to orient an electro-optical (E-O) sensor whose video information is being viewed on a display also mounted on the head, a VCS is achieved.

In airborne applications of VCS some of the head-tracker and display hardware must be mounted on the crewmember's helmet; thus, the terms Helmet Mounted Display (HMD) and Helmet Mounted Sight (HMS) are used to identify the display and tracker respectively. Since the helmet alone introduces considerable weight to the operator's head, the additional weight contributed by the VCS hardware must be kept to an absolute minimum. This restriction is not only necessary so the aviator's safety is not compromised, but also so his performance is not encumbered.

Purpose

This experiment was conducted to measure man's head aiming/tracking capability using a helmet mounted sighting device. The influences of target speeds, helmet suspension types and sighting eye dominance, helmet weighting parameters on head aiming/tracking accuracy were investigated. If the aiming/tracking accuracy was sensitive to manipulation of these man-machine interface parameters, then it would seem to indicate that improved aiming/tracking accuracy could be obtained by improving the interface.

Literature Review

The only systematic perceptual-motor experiment conducted to measure the ability of the neck and shoulder muscles to effect head aiming/tracking was performed by Honeywell Systems and Research Division. The purpose of this study, conducted in 1965 by R. Nicholson,<sup>1</sup> was to investigate the feasibility of using the HMS as a means of aiming an armament system. A three-phase experiment was conducted. In Phase I, a laboratory experiment measured static sighting accuracy. In Phase II, tracking accuracies were obtained using moving targets. The last phase was conducted to obtain field test data for high-speed, low-altitude flights. The series of tests indicated that the accuracy of the sighting process can be expected to vary between a fraction of a degree and four degrees depending on the target angular rate and the target sighting angle.

Other tests have been conducted to ascertain the performance characteristics of specific HMS systems under specific conditions.<sup>2,3</sup> Bench tests were conducted at the Aerospace Medical Research Laboratory, Wright-Patterson Air Force Base (WPAFB), Ohio, using the Volna Test Station to obtain aiming performance data without the man in the system. Flight tests were conducted in high performance aircraft to obtain tracking/aiming performance data during tactical operating conditions (Grossman, 1974).<sup>5</sup>

An analysis of the previously referenced bench tests indicate that aiming accuracies are a function of the off-boresight angle and can be expected to vary from 0.01 degree for the forward quadrant to 1° for the rear quadrant (Polhemus, 1975).<sup>6</sup> An analysis of the flight test data indicates a median radial error of 0.8° and that 90% of the time the radial error was less than 2.2° over all off-boresight angles, g-loads and angular rates. However, rather than the performance of specific systems, the measures of interest in the present experiment were the limitations imposed by the man and man-machine interface.

The results of Nicholson's experiment indicate that the head can be used as a very effective aiming device. However, Nicholson used a very limited range of target motion parameters which highlighted the capabilities rather than the limitations of the aiming functions. The maximum off-boresight angle for targets during the static aiming tests was only 10°. The reaction times vary among the three subjects, the average being 2.04 seconds with .81 second standard deviation. This indicates that, given sufficient time, a target can be held within a cross hair over small angular ranges with much less than 1° circular error probability (CEP). However, if targets appear greater than 10° from boresight, which would be a less restrictive and more realistic situation, the CEP is not known. During the dynamic portion of the testing, constant errors were introduced due to tracking/aiming bias errors of the observer and alignment errors of the measurement equipment. The author removed these errors from the data before analyzing it. The technique used to remove this error also tended to smooth the data.

#### METHODOLOGY

##### Sight System

A thorough analysis of the empirical data obtained from flight tests and static bench tests of HMS devices indicated head aiming/tracking accuracies with a mean radial error of 13.6 milliradians (mr) had been obtained. In order to measure the man's capabilities alone, a device was designed which would measure static aiming accuracies to within 1.6 mr using a cooperative target. This device consists of a 32 X 32 photocell array. The photocells were positioned with their centers on 1/2" increments in X and Y. Each photocell had two sensing elements, one activated the X axis and the other activated the Y axis. When a photocell was activated it turned on CMOS switches, one for X position and the other for Y position. The switches activated voltage dividers and the position of the activated photocell was uniquely determined by the X, Y voltages. If the two photocells were activated simultaneously, the arithmetic mean of the two cells was determined. This means the resolution of the array was 1/4" as long as the activating source was approximately 3/4" in diameter. (The actual diameter was determined empirically.)

The activating source was a PBL 150 watt quartz iodide lamp with an IR 740 nm high pass filter. The energy from the lamp passed through a light weight non-coherent fiber-optic light guide to a lightweight telescope mounted on the subject's helmet. The emerging beam of infrared (IR) light was boresighted with the subject's reticle. The beam of light was 5/8 + 1/8" in diameter as it impinged on the photocell array. The configuration of this aiming/tracking system is illustrated in Figure 1. The IR beam was not visible to the subject. Also mounted on the subject's helmet was a

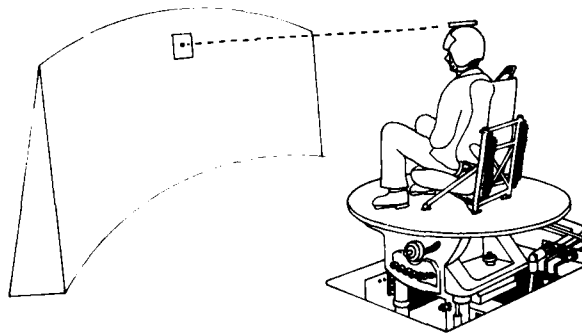

FIGURE 1. Sketch Shows Target Board Being Illuminated by Infrared Spot Projector Mounted on Subject's Helmet.

Sperry Rand sight reticle generator. This device generated an illuminated reticle of adjustable intensity; the collimated reticle could be viewed by either the right or left eye. Prior to starting each testing session the subject's reticle and the spot of light from the helmet mounted projector were boresighted at 80". As the subject aligned his reticle with the illuminated target, the experimentors adjusted the spot projector until it was centered on the illuminated target. The accuracy of the boresight was checked by observing the X, Y monitor and displayed voltage levels. Corrections to the mechanical adjustment were made electrically and statistically.

### Target

A miniature lamp with a translucent white filter was installed in the center of the photocell array. This lamp was the target. The intensity of the lamp was controllable. The computer turned on the lamp to indicate the initiation of a tracking/aiming trial and turned off the lamp to indicate the conclusion of a trial. The photocell board with the lamp/target firmly affixed to its center was moved in a quasi-random direction at pre-determined constant velocities. The speeds of the target were 0°/second, 4°/second, and 8°/second. The target moved at a constant velocity throughout each 30 second tracking trial, but the direction and magnitudes of the acceleration vectors were constantly changing. The target transversed a spherical path + 50° in azimuth and +30° to -15° elevation with a radius of 80" from the crewmembers' design eye. The device that moved the array was called the moving target system (MTS). The hybrid computer generated commands for the MTS servos to follow. The same quasi-random path was used for each subject since the same random numbers (therefore quasi-random) were generated each experimental session.

### Data Acquisition

The X and Y channels coming from the voltage dividers on the photocell array were observed on an X, Y monitor. These signals were simultaneously recorded for historical purposes on a 14 channel FM instrumentation recorder and fed to the hybrid computer.

Since the beam was constantly in motion, even when the target and the cockpit were in a static condition, some noise was introduced into the analog channels from the photocell array. To compensate for the noise generated in the photocell array and lines from the array to the analog portion of the hybrid computer, a series of threshold levels were used by the computer to improve the signal to noise ratio. These threshold levels also compensated for non-linearities in the voltage dividers. As a penalty, the static resolution of the photocell array was degraded, but the dynamic accuracy was not seriously effected. Thirty-two threshold levels were established in the X and Y channels (3.2 mr). The output of the photocell board was compared to the threshold levels and the result recorded at 1,000 Hz. A probability density histogram was generated from the 30,000 data points obtained in each axis during the 30 second tracking period. The statistics presented in this report were obtained from the analysis of these histograms.

The subject response switches, target servo position feedbacks, time code, intercom, target drive commands, and simulator accelerations were simultaneously displayed on oscilloscopes and recorded on the 14 channel recorder. The subject response switches, target servo position feedbacks and time code were also sampled and recorded by the computer. At the conclusion of each 30 second tracking trial, the computer would analyze 10% of the tracking data and provide its analysis within seconds to the test director on a CRT and hard copy. This procedure proved also to be an invaluable tool in troubleshooting the data acquisition hardware.

### Vibration Environment

A 45-minute tactical scenario was flown in an attack helicopter (AH-1G) with three orthogonally mounted accelerometers secured to the copilot/gunners floor panel. Simulated TOW and live 7.6 mm, 40 mm and 2.5" rockets were fired. The accelerations measured at the copilot/gunners floor panel were recorded as X, Y and Z vibration components. The crew's communications were also recorded. This 45-minute program was recorded twice on each of three 90-minute master tapes to be used throughout the test sequence. A time code was added to the tapes so the USAARL Hybrid Computer could synchronize the aiming/tracking tasks with the vibration according to a predetermined schedule. Small sections of the vibration tapes were blanked since the accelerometers overload during gun firing. Master tape I was played for all data collection tests so that the Multi-Axis Helicopter Vibration System (MAHVS) replicated the helicopter vibrations experienced by the copilot/gunner during the actual flight and each subsequent simulator flight. Each tracking sequence and target movement was also repeated at the same time based on the time code information synchronized with the vibration signals.

### Subjects

Six Army aviators were used as subjects. Three were instructor pilots for the Cobra Transition Course at US Army Aviation Center and two were US Army Aeromedical Research Laboratory pilots. The sixth aviator had more than 1000 hours of gunship experience in Republic of Vietnam. All six subjects passed the standard static acuity and the dynamic acuity tests administered by an optometrist and research psychologist respectively. The subjects were also given an eye dominance test. One of the aviators wore glasses.



### Helmets

The six aviator subjects were fitted for form-fit helmets by Protection Incorporated personnel. Wax molds were made of the aviators' heads and plaster head forms were made from the molds. The foam liners for each SPH-4 light weight helmet were then fitted to a particular individual's headform. The hard foam liners were covered with soft foam and leather and the backs were reinforced with fiberglass. The fiberglass reinforcement enabled the helmet technician to remove and insert the foam liners in the test helmet without damage to the delicate foam inserts. Absorbent cotton skull caps were worn by the subjects to reduce possible heat discomfort.

The weight and center of gravity (cg) of the test helmet were adjusted to conform to the weight and center of gravity of the standard issue SPH-4 during the symmetrically weighted condition and the projected integrated helmet display/sight system (IHADSS) weight and cg with the display during the asymmetrically weighted condition.

### Cockpit

A metal mock-up of an AH-1G copilot/gunner crewstation (less canopy), shown in Figure 2, was fabricated and installed on the MAHVS. The crewstation geometry, seat,



FIGURE 2. A Metal Mock-Up of an AH-1G  
Cockpit Secured to the Multi-Axis  
Helicopter Vibration Simulator.

instrument panel, and pedals were authentic. The cyclic control, however, was mounted on the floor, as in the pilot's crewstation instead of its normal location. The trigger switch on the cyclic was used by the pilot to indicate when he began to track the target and his tracking confidence. The pilots were directed to squeeze the trigger switch on the cyclic to the first detent as soon as they saw the target illuminate. The computer began taking and scoring data at this time. The subjects were also directed to squeeze the trigger to the second detent as long as they had enough confidence to "fire" a point fire weapon at the target. The computer graded this data as "high confidence" data. The information contained in this report is based on the sum of all the data without regard to tracking confidence.

### Safety

A multitude of precautions were taken to insure the subjects' safety during the experiment. The MAHVS, shown in Figure 3, is equipped with a sophisticated fail-safe system that shuts down the hydraulic systems at the slightest irregularity. The subject held a fail-safe switch closed during the periods the MAHVS was operating. If the subject released the switch the system would immediately shut down.

The inter-communications systems provided the subject with a "hot mike" so that all personnel in the area could monitor him. A closed-circuit low light level television camera was trained on the subject so that his actions could be viewed by the MAHVS operator and be recorded on video tape. These tapes were retained for historical documentation.

A sophisticated radio communications system was also installed so the MAHVS operator could notify an on-call flight surgeon and the hospital emergency room if an accident occurred.



FIGURE 3. The Multi-Axis Helicopter Vibration Simulator (MAHVS) Operator Monitors System Performance. In the Event of A System Malfunction Operator Must disarm Hydraulic Systems, Correct Deficiency and Reinitialize Simulator. Controller, Timekeeper and Subject Stations Are Shown in Background.

## RESULTS

### Data

The independent variables in this study were eye dominance, helmet suspension, target speed, and helmet weighting. The dependent variable was aiming/tracking accuracy expressed in milliradian (mr) root mean squared (RMS) error. There were two levels of eye dominance, dominant and non-dominant eye used for aiming/tracking; two levels of helmet suspension, form fit and sling; and two levels of helmet weighting, symmetrical and asymmetrical. There were four levels of target speed; high (target moving  $8^\circ/\text{second}$ ; subject vibrating), low (target moving  $4^\circ/\text{second}$ , subject vibrating), static (target static in one of three locations, subject static), and test (target moving  $4^\circ/\text{second}$ , subject static).

Six combinations of the eye dominance, helmet weighting and helmet suspension variables were administered to the six subjects; each combination was considered a separate treatment. The six treatments were:

- A. Dominant eye, symmetric helmet weighting, and form fit helmet suspension.
- B. Dominant eye, asymmetric helmet weighting, and sling helmet suspension.
- C. Non-dominant eye, symmetric helmet weighting, and form fit helmet suspension.
- D. Non-dominant eye, asymmetric helmet weighting, and form fit helmet suspension.
- E. Dominant eye, symmetric helmet weighting, and sling helmet suspension.
- F. Dominant eye, asymmetric helmet weighting, and form fit helmet suspension.

The treatments were administered in the order indicated in Table I. The 6 X 6 Latin Square order of presentation was used to minimize the learning effects.

The aiming/tracking data collected during this study are analyzed as though two separate experiments had been conducted. In Case I, eye dominance data are analyzed in addition to helmet weighting and target speed. The form fit suspension is a constant factor for the Case I analysis. The data for the Case I analysis are obtained from treatments A, C, D, and F. The raw data for Case I analysis are shown in Table II.

In Case II, helmet suspension data are analyzed in addition to helmet weighting and target speed. The dominant eye is a constant factor for the Case II analysis. The data for Case II analysis are obtained from treatments A, B, E and F. The raw data for Case II analysis are shown in Table III.

TABLE I. EXPERIMENTAL DESIGN\*

Treatments	DOMINANT EYE				NON-DOMINANT EYE	
	FORM FIT		SLING		FORM FIT	
	SYM (A)	ASY (F)	SYM (E)	ASY (B)	SYM (C)	ASY (D)
Ss						
S <sub>1</sub>	1	6	3	4	5	2
S <sub>2</sub>	2	5	6	1	3	4
S <sub>3</sub>	3	4	2	5	1	6
S <sub>4</sub>	4	3	5	2	6	1
S <sub>5</sub>	5	2	1	6	4	3
S <sub>6</sub>	6	1	4	3	2	5

\*Four target speeds for each treatment not shown

The figures in Tables II and III were calculated from the line-of-sight (LOS) data obtained from photocell board X and Y output voltages; the position of the light beam on the photocell board produced the output voltages. These outputs were sampled and recorded each millisecond during the 30-second aiming/tracking trial. The mean and standard deviation of the 30,000X and 30,000Y photocell coordinates were calculated using the following equations:

$$(1) \bar{X} = \frac{\sum_{i=1}^{\xi} X_i}{30000}$$

$$(2) \bar{Y} = \frac{\sum_{i=1}^{\xi} Y_i}{30000}$$

$$(3) \alpha_x^2 = \frac{\sum_{i=1}^{\xi} (X_i - \bar{X})^2}{30,000}$$

$$(4) \alpha_y^2 = \frac{\sum_{i=1}^{\xi} (Y_i - \bar{Y})^2}{30,000}$$

The standard deviation ( $\alpha$ ) of the photocell coordinates were then converted to subtended visual angles using the following equation:

$$(5) \tan^{-1} \frac{s}{d} = \theta$$

For:  $d = 80$  inches subject to target distance  
 $s = 0.5$  inches distance between photocell centers  
 $\theta = 0.358^\circ = 6.088\text{mr}$

The x and y standard deviations were then converted into radial values. The photocell coordinates were transformed into subtended visual angles by multiplying the photocell coordinates by 6.088 mr/photocell. Since the  $\bar{X}$  and  $\bar{Y}$  were approximately equal to zero:

$$(6) r^2 = \alpha_r^2 = (\bar{X} - \alpha_x)^2 + (\bar{Y} - \alpha_y)^2 = (\alpha_x^2 + \alpha_y^2)$$

The  $\alpha_r$  values were then averaged over the number of replicates on the same condition; the mean and standard deviation of  $\alpha_r$  are listed in Tables II and III. The resulting values of  $\alpha_r$  are somewhat inflated by using the equations and techniques discussed above. The x and y values are treated independently rather than as paired values, i.e.,  $X_1, Y_1$ . For comparison purposes, however, the data techniques used are considered generally acceptable.

#### STATISTICS

In Case I and Case II the factors were completely crossed and the treatments were counterbalanced. Analysis of Variance (ANOVA) computer programs and manual techniques were used to analyze the data. The two computer statistical analysis packages used were "Revised MANOVA Program" by Elliot M. Cramer<sup>7</sup> and "Biomedical Statistical Programs"<sup>8</sup> from the University of California, Los Angeles. The same results were obtained from each method of analysis.

TABLE II. RAW AIMING/TRACKING DATA CASE I

SUBJECT	STATIC (n=6)		TEST (n=2)		LOW (n=10)		HIGH (n=10)	
	DOM SYM	NON DOM ASY	DOM SYM	NON DOM ASY	DOM SYM	NON DOM ASY	DOM SYM	NON DOM ASY
1. M	2.40	2.49	11.14	9.56	14.50	12.44	17.54	17.88
SD	0.97	0.53	0.05	2.80	2.94	1.79	1.54	1.89
2. M	3.25	3.55	8.63	12.45	11.56	11.47	11.24	11.01
SD	0.53	0.43	0.08	1.54	1.00	1.81	1.26	0.95
3. M	2.56	2.47	8.51	9.10	10.82	11.57	11.68	12.20
SD	0.66	1.10	1.09	1.86	0.93	1.11	1.76	1.18
4. M	1.34	2.73	7.98	9.89	11.36	11.60	11.52	11.45
SD	1.03	0.92	0.60	0.15	1.33	1.88	1.07	0.97
5. M	2.108*	3.84	12.84	10.44	15.97	12.63	13.60	15.42
SD	1.580	0.65	5.79	3.19	3.32	1.60	0.97	2.19
6. M	3.16	3.65	13.08	12.57	15.34	13.97	15.32	17.45
SD	0.80	0.647	2.66	0.91	1.89	1.92	1.05	2.12

\* (n=5)

TABLE III. RAW AIMING/TRACKING DATA CASE II

SUBJECT	FORM FIT		SLING		ASY		FORM FIT		SLING		ASY		FORM FIT		SLING		ASY	
	SYM	ASY	SYM	ASY	SYM	ASY	SYM	ASY	SYM	ASY	SYM	ASY	SYM	ASY	SYM	ASY	SYM	ASY
1. M	2.40	2.49	1.68	2.92	11.14	9.56	13.06	11.48	14.50	12.44	13.01	16.37	17.54	17.88	18.13	19.74		
SD	0.97	0.53	0.53	0.52	0.05	2.80	3.25	3.34	2.94	1.79	1.35	2.87	1.54	1.89	1.59	1.73		
2. M	3.25	3.55	2.45	2.51	8.63	12.45	7.90	10.18	11.56	11.47	11.14	11.01	15.08	13.63	13.30	16.00		
SD	0.53	0.43	0.63	1.09	0.08	1.54	0.81	1.05	1.00	1.81	0.82	1.69	1.25	1.13	1.06	1.20		
3. M	2.56	2.47	2.43	3.20	8.51	9.10	9.38	8.66	10.82	11.57	11.29	10.87	15.82	14.61	15.51	13.88		
SD	0.66	1.10	1.33	0.71	1.09	1.86	2.64	0.78	0.93	1.11	0.78	1.24	1.77	1.25	1.48	1.63		
4. M	1.34	2.73	2.62	2.18	7.98	9.89	7.45	7.54	11.36	11.60	11.55	11.20	13.30	16.73	13.47	14.20		
SD	1.03	0.92	0.67	1.32	0.60	0.15	0.22	0.63	1.33	1.88	1.03	1.19	1.29	1.30	1.31	1.55		
5. M	2.108*	3.84	2.24	2.30	12.84	10.44	13.31	10.41	15.97	12.63	13.45	13.14	18.96	15.93	16.87	16.90		
SD	1.580	0.65	0.49	1.35	5.79	3.19	1.17	0.26	3.32	1.60	1.33	1.18	1.92	1.48	1.28	2.29		
6. M	3.16	3.65	3.09	3.39	13.08	12.57	9.60	12.23	14.14	15.34	14.13	13.72	17.45	18.00	16.99	17.51		
SD	0.80	0.64	1.18	0.62	2.66	0.91	1.10	1.75	1.89	1.92	1.20	1.65	1.04	1.76	2.02	1.35		

\*(n=5)

## Case I Analysis

The ANOVA was applied to the Case I data using aiming/tracking accuracy as the criteria measure (univariate). The factors tested were eye dominance, helmet weighting and target speed. Each subject received all treatments. The ANOVA Summary Table is shown in Table IV. The p values less than 0.1 are considered statistically significant ( $p < 0.1$ ).

TABLE IV. ANALYSIS OF VARIANCE CASE I

SOURCE OF VARIATION	SS	df	MS	F*	p
Eye Dominance	45.722	1	45.722	6.859	0.009
Helmet Weight	0.908	1	0.908	0.136	0.712
Target Speed	16299.598	3	5433.199	815.090	0.001
Eye Dominance X Helmet Weight	0.947	1	0.947	0.142	0.706
Eye Dominance X Target Speed	0.837	3	0.279	0.042	0.989
Helmet Weight X Target Speed	11.656	3	3.885	0.583	0.626
Eye Dominance X Helmet Weight X Target Speed	7.897	3	2.632	0.395	0.757
Within Cells	4352.746	653	6.666		

\*Since the majority of the data variability is accounted for in a consistent manner by the target speed factor, the F values for the interactions are less than one.

The eye dominance factor is statistically significant ( $p < 0.009$ ), but the helmet weighting factor is not statistically significant. The target speed factor has overwhelming statistical significance ( $p < 0.001$ ). None of the interactions are statistically significant.

## Case II Analysis

The ANOVA was applied to the Case II data using aiming/tracking accuracy as the criterion measure (univariate). The factors tested were helmet suspension, helmet weighting and target speed. Each subject received all treatments. The ANOVA Summary Table is shown in Table V. The p values less than 0.1 are considered statistically significant.

TABLE V. ANALYSIS OF VARIANCE CASE II

SOURCE OF VARIATION	SS	df	MS	F*	p
Suspension	4.587	1	4.587	0.986	.321
Helmet Weighting	6.903	1	6.903	1.483	.224
Target Speed	16475.348	3	5491.781	1179.940	0.001
Suspension X Helmet Weight	6.881	1	6.881	1.478	.224
Suspension X Target Speed	2.082	3	0.694	0.149	0.930
Helmet Weight X Target Speed	11.574	3	3.858	.829	0.478
Suspension X Helmet Weight X Target Speed	9.574	3	3.191	0.686	0.561
Within Cells	3048.560	655	4.654		

\*Since the majority of the data variability is accounted for in a consistent manner by the target speed factor, the F values for the interactions are less than one.

The helmet suspension factor is not statistically significant ( $p < 0.32$ ), and neither is the helmet weighting factor ( $p < 0.224$ ). Again, the target speed factor is statistically significant ( $p < 0.001$ ). None of the interactions are statistically significant.

#### DISCUSSION

The experimental data were obtained to allow hardware decisions to be made based on objective data rather than speculation. With this thought in mind, the discussion section will emphasize the practical significance of the experimental results.

##### Case I

The aiming/tracking performance of the subjects, although statistically better with the dominant eye, is only improved on the average 6.1% when the dominant rather than the non-dominant eye was used. (Figure 4) The effect of eye dominance on aiming/tracking performance has important hardware implications. Different configurations are needed if the right or left eye viewing option is provided to the HMS user. The manufacturing and

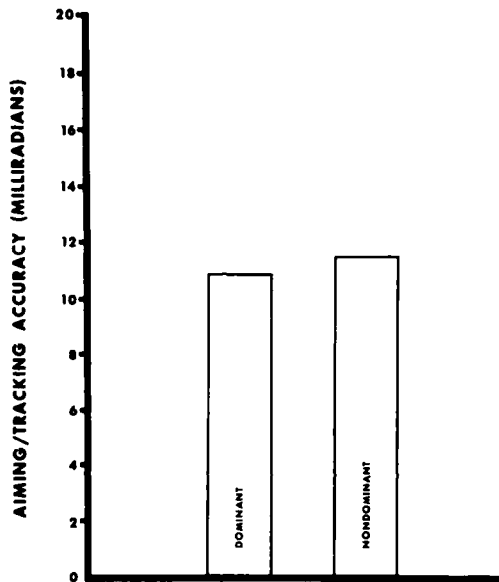

FIGURE 4. Eye Dominance

logistics support costs of the HMS are reduced if only one configuration (right or left) is manufactured and stocked. The 6.1% difference in aiming/tracking performance, although reliable, is not considered of sufficient practical importance to insure the cost penalties associated with separate right and left eye viewing. This position was influenced by the much larger performance differences among the four levels of the target speed factor.

The mean performances using the symmetrically and the asymmetrically weighted helmets were essentially the same (Figure 5); no statistically significant difference was observed. The subjects complained the asymmetrical weighting caused "hot spots" and headaches. There were usually red marks on the forehead and around the left ear (weight was over right ear) at the end of a day's testing when the subject wore the asymmetric helmet. However, this discomfort did not deteriorate aiming/tracking performance.

The performance changes with target speed levels are much more profound (Figure 6).

When the target was static and the subject was static, the average RMS error was 3.5 mr. As the target began to move at  $4^\circ/\text{sec}$ , the error increased to 11 mr. When the subject began to experience vibration too, the error increased to 13.3 mr. An increase of target speed to  $8^\circ/\text{sec}$  caused the accuracy to further decline to 16.5 mr. The changes were 2.2, 2.8, and 3.7 fold, respectively, from the static condition. The target speed factor accounted for such an overwhelming portion of the variation that interactions involving target speeds have F ratios less than the expected value.

The target speed x eye dominance data (Figure 7) show the dominant eye performance is better than the non-dominant eye performance at all target speed conditions. The improvement seems to be absolute rather than a constant percentage across all target speed conditions.

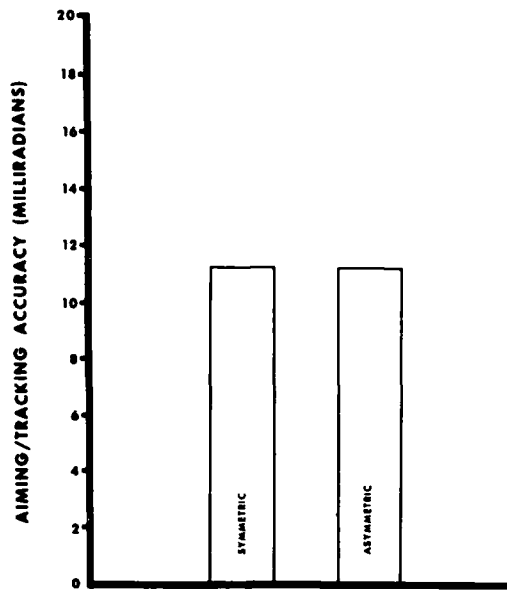

FIGURE 5. Case I Helmet Weighting

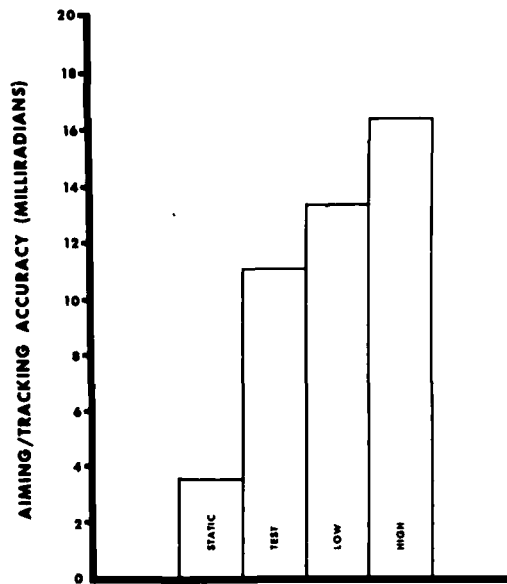

FIGURE 6. Case I Target Speed



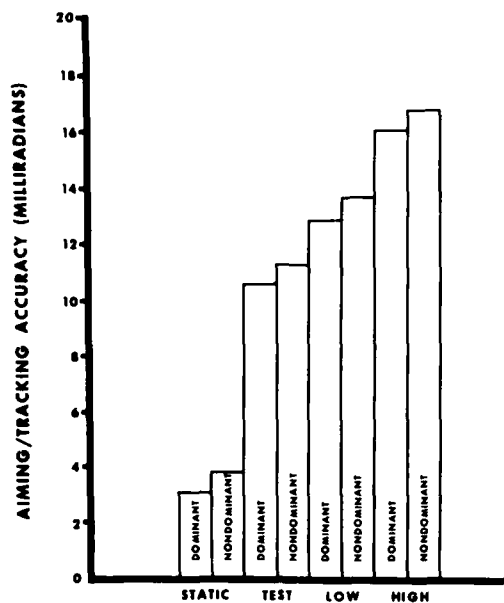

FIGURE 7. Case I Target Speed X Eye Dominance.

The target speed x helmet weighting data (Figure 8) shows less consistency.

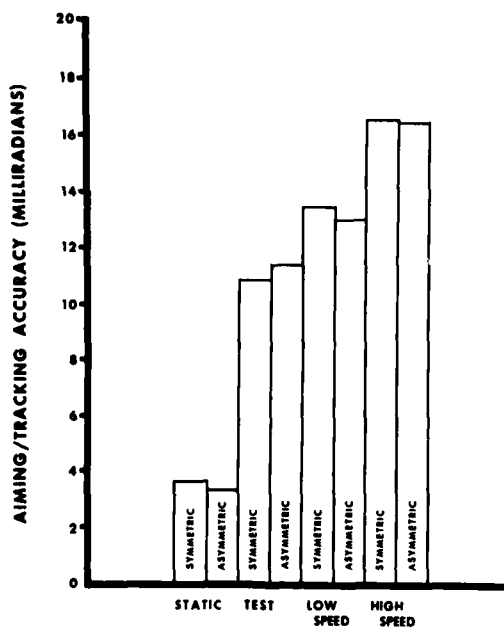

FIGURE 8. Case I Target Speed X Helmet Weighting.

The subjects performed better with the asymmetric helmet weighting in the static and low speed conditions, better with the symmetric helmet weighting in the test condition, and about the same in high speed condition.

The helmet weighting x eye dominance data (Figure 9) shows performance differences of about 10% from the best to worst case, dominant asymmetric to non-dominant asymmetric respectively. Very small differences were obtained.

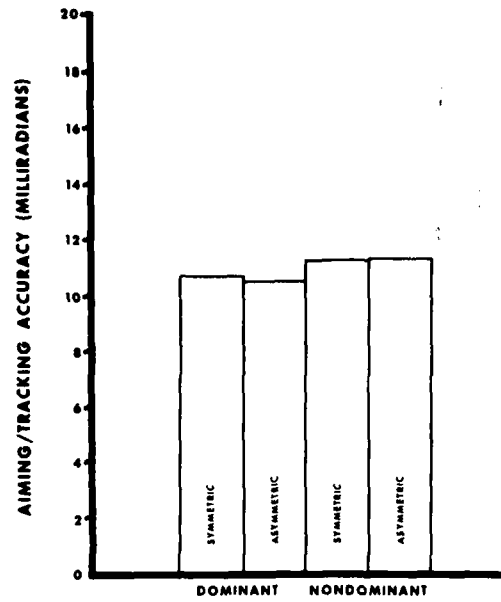

FIGURE 9. Case I Helmet Weight X Eye Dominance.

The three way interaction of target speed x eye dominance x helmet weighting is not statistically significant ( $p < 0.76$ ); the data (Figure 10) shows the target speed variability overshadowing any differences. The eye dominance differences are somewhat less obvious, but nevertheless seem to exist.

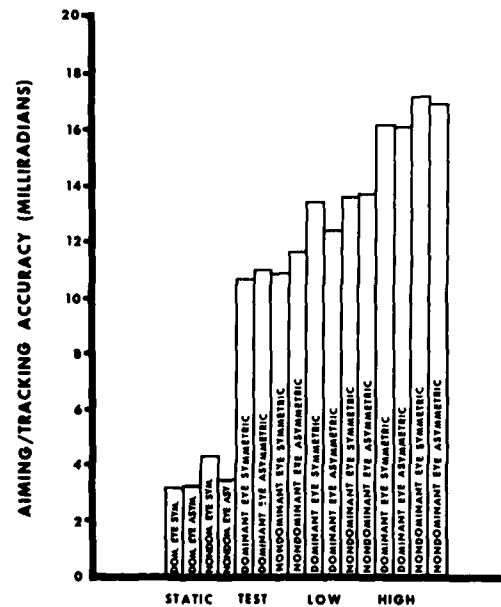

FIGURE 10. Target Speed X Eye Dominance X Helmet Weight.

## Case II

The aiming/tracking performance was statistically different for the four levels of the target speed factor ( $p < 0.001$ ) (Figure 11). The same results were obtained from the target speed data in Case I. When the subject and the target were static and the subject simply aimed at the target, the average RMS error was 2.9 mr. The subject's accuracy degraded to 10.5 mr. as the target moved at  $4^\circ/\text{sec}$ . When the subject began to vibrate in addition to the target moving  $4^\circ/\text{sec}$  the accuracy degraded to 13.0 mr. The increase of the target speed to  $8^\circ/\text{sec}$  caused the accuracy to further deteriorate to 15.5 mr. The changes were 2.6, 3.4, and 4.3 fold respectively from the static condition. The Case I data showed changes of 2.2, 2.8, and 3.7 from the static condition. In both cases, the target speed factor accounted for an overwhelming portion of the data variability.

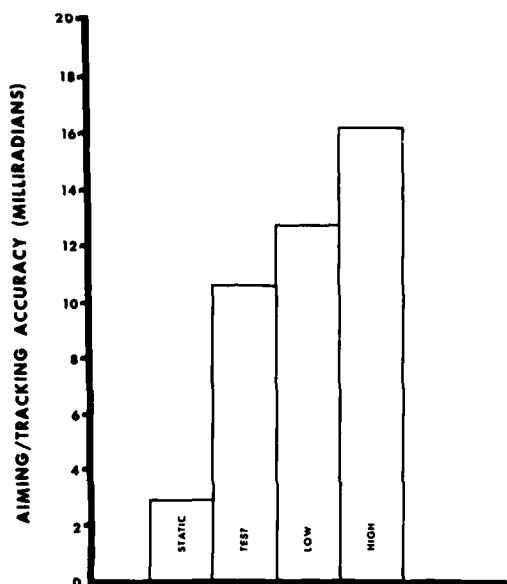

FIGURE 11. Case II Target Speed.

The aiming/tracking performance was not statistically different for the sling and form fit helmet suspensions ( $p < 0.32$ ) (Figure 12). The subjects seemed to think they

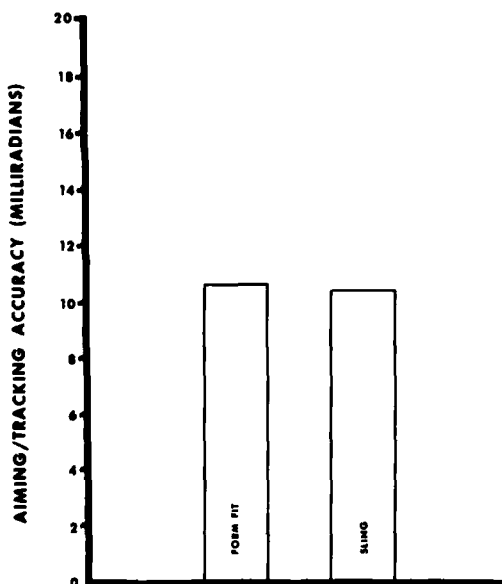

FIGURE 12. Suspension Types.

were performing better with the form fit but the newness and uniqueness of the form fit may have influenced their comments. In the field, when a life support equipment specialist is not available to insure optimum fit of the helmet, the sling suspension is more susceptible to a tenuous fit than the form fit suspension.

The effect of symmetrical or asymmetrical helmet weighting ( $p < 0.22$ ) was not statistically significant (Figure 13). The same results were obtained in the Case I analysis.

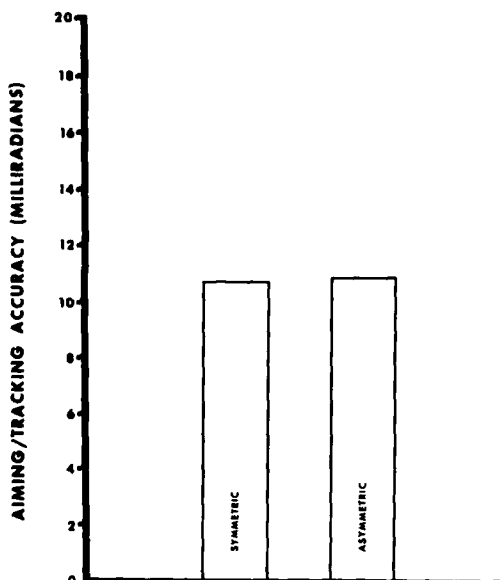

FIGURE 13. Case II Helmet Weighting.

The target speed x suspension data (Figure 14) shows a reduction in accuracy as target speed increases. The sling suspension seems to be better than form-fit, but the difference in suspension was not statistically significant. The interaction of the target speed X suspension factors was not considered statistically significant ( $p < .99$ ).

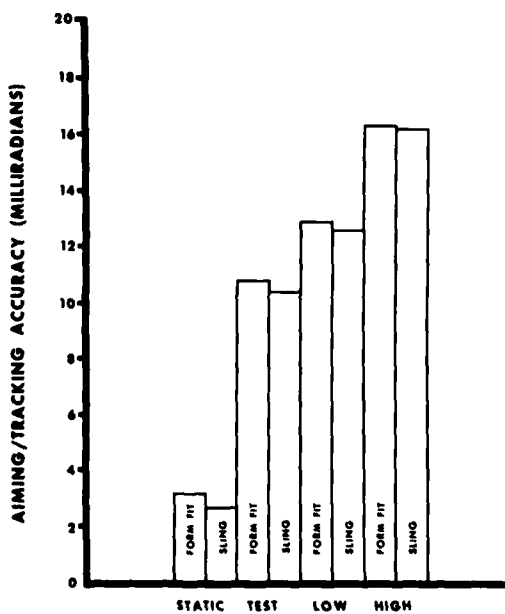

FIGURE 14. Case II Target Speed X Suspension.

The target speed x helmet weighting data (Figure 15) also shows a reduction in accuracy as target speed increases. The symmetric performance appears to be better than the asymmetric performance, but the difference was not statistically significant.

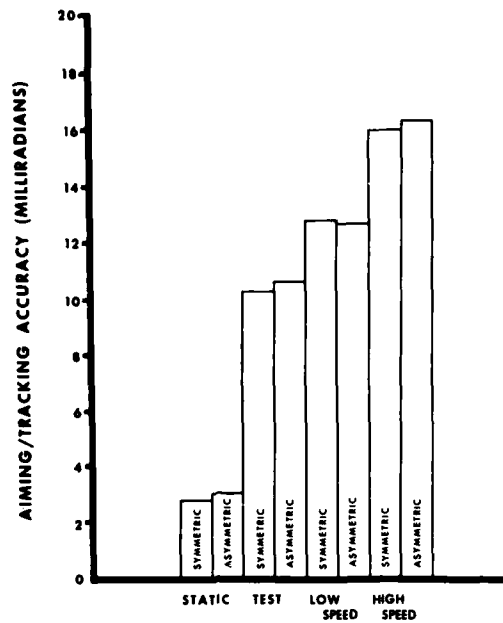

FIGURE 15. Case II Target Speed X Helmet Weighting.

The helmet weighting x helmet suspension data (Figure 16) shows the accuracy about the same for the symmetric and asymmetric form-fit sling suspensions. The interaction is not statistically significant ( $p < 0.22$ ).

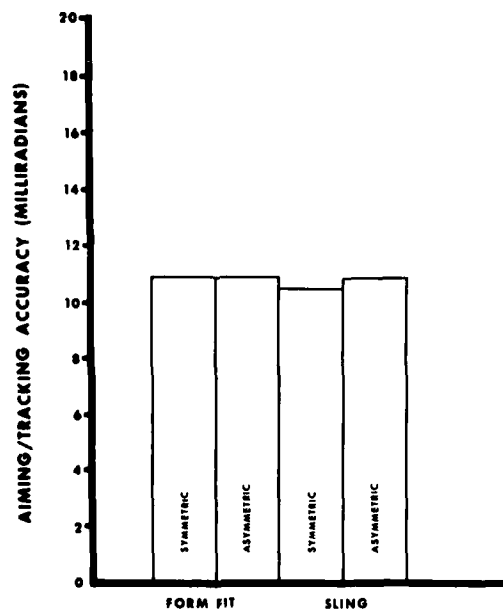

FIGURE 16. Case II Helmet Weight X Suspension.

3. Haywood, Wesley J., Jr., "Advanced helmet mounted sight study program," Raytheon Company, Bedford, MA, AMRL-TR-73-10, Jan 75.
4. Polhemus, William, "An advanced helmet mounted sight(AHMS) system Nov 71-Apr 73," Polhemus Navigation Sciences, Inc., Burlington, VT, AMRL-TR-73-47, Jun 76.
5. Grossman, Jeffrey D., "Flight evaluation of pilot sighting accuracy using a helmet-mounted sight," Naval Weapons Center, China Lake, CA 93555, TR NWC TP 5638, Apr 74.
6. Polhemus, William L., "Micro-tracker," Second Advanced Aircrew Display Symposium, 23 Apr 1975.
7. Cramer, Elliot M., "Revised MANOVA program," The L.L. Thurstone Psychometric Laboratory, The University of North Carolina at Chapel Hill, Chapel Hill, NC 27514, May 1974.
8. Dixon, Edward W., Biomedical Statistical Programs, Health Sciences Computing Facility, Department of Biomathematics, School of Medicine, University of California, Los Angeles, University of California Press, Jan 1, 1973.

AVIATOR VISUAL PERFORMANCE: A COMPARATIVE STUDY OF  
A HELICOPTER SIMULATOR AND THE UH-1 HELICOPTER

R. R. Simmons, M. A. Lees, & K. A. Kimball  
U. S. Army Aeromedical Research Laboratory  
P. O. Box 577  
Fort Rucker, Alabama 36362

SUMMARY

Simulator instrument flight provides several advantages to both the training and research community. These advantages include decreased cost of operation, increased safety, and enhanced flexibility for tailoring each flight profile to mission requirements. This research project was initiated to compare the visual performance/workload of pilots during helicopter and simulated helicopter instrument flights (IFR). The corneal reflection technique was utilized to obtain the visual data. Although pilot performance in the Army's UH-1FS simulator and the UH-1H helicopter were similar, several differences were noted. Additionally, the zone/cost factor theory from previous studies was expanded. The overall purpose of such research has been to provide information concerning pilots' visual requirements for safe mission accomplishment.

INTRODUCTION

"The most important aspect of the Army's helicopter flight simulator program is credibility. The user must be given a system that he accepts as the best--one that he says, 'flies like the aircraft'." In 1972 the UH-1 flight simulator (UH-1FS) was developed for the US Army to duplicate the flight, engine, and system characteristics of the UH-1 helicopter (Figure 1). The flight deck of the simulator is mounted on a five-degree-of-freedom motion and the interior is configured such that it is an authentic replica of the UH-1H helicopter to the extent that the hardware is identical in appearance, feel, and function to its aircraft counterpart. This UH-1FS is primarily utilized for instrument and emergency flight training.

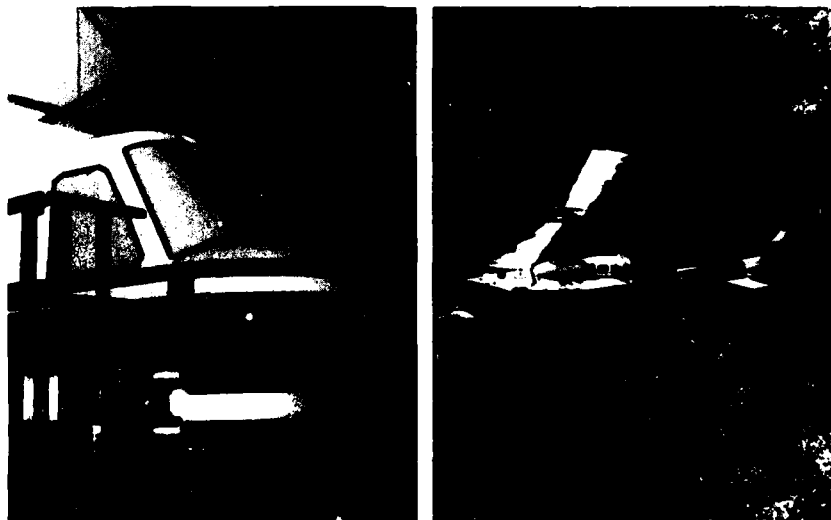

FIGURE 1. UH-1FS AND UH-1H AIRCRAFT

Simulated instrument flight training provides several advantages to the military. These advantages include decreased cost of operation, increased safety during training, and enhanced flexibility for tailoring each flight profile to mission requirements.

The fidelity of the simulation system does not require exact duplication of aircraft aerodynamic characteristics to provide excellent flight training.

Although the research community shares the same advantages as the military training staff in simulator utilization, to assure that their research data will generalize to actual aircraft application, the fidelity quality of the simulation system must be known. This study describes a visual performance/workload comparison between pilots performing instrument flights in the UH-1FS simulator and the UH-1 helicopter. The objective of this research was two-fold. First, such visual data provided an expansion of the current helicopter visual data base collected by the US Army Aeromedical Research Laboratory in that it provided a preliminary examination of the Zone/Cost Factor (CF) theory outlined in USAARL Report No. 78-6.<sup>2</sup> Second, this visual data permitted an objective comparison of the differing visual performance/workload of aviators during simulator and helicopter instrument flight.

#### METHODS

Initially an investigation had been completed concerning the visual performance of pilots during instrument flights (IFR) in the UH-1 helicopter. The results of this study were presented in USAARL Report No. 78-6. To assure the best possible comparison between aircraft, the methodology which was utilized for this helicopter instrument study was also applied in collecting the visual performance data in the UH-1FS. Subjects for both studies consisted of ten rated helicopter pilots who were free of visual problems which might compromise the visual recording system, possessed an Army instrument rating, were currently on flight status, and had logged less than 250 hours of flight time. This group of aviators was labeled student qualified aviators (SQA).

The second group of ten aviators possessed the same qualifications as the first with the exception that they had logged over 2400 hours of flight time and were instrument instructor pilots. For comparison, this group was referred to as instrument qualified aviators (IQA).

Equipment utilized to record visual performance included a NAC Eye Mark Recorder, which employs the corneal reflection technique, and a LOCAM high speed motion picture camera with negative black and white film. A static illustration of the total system is provided in Figure 2. The complete description and specifications of the system along with operating procedures have been outlined in USAARL Report No. 77-4.<sup>3</sup>

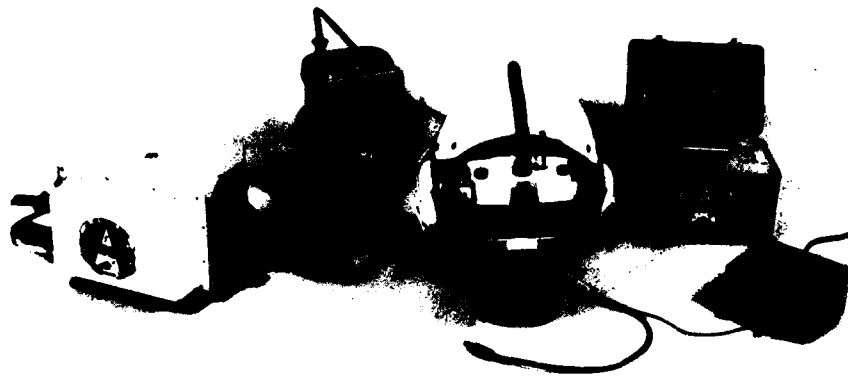

FIGURE 2. TOTAL NAC RECORDING SYSTEM

The flight profile for both the simulator and helicopter investigations consisted of an instrument takeoff (ITO), and basic instrument flight maneuvers to include climbs, level flights, descents, and turns. Finally, each subject performed an instrument landing (ILS) back to the originating airfield. A brief description of these maneuvers



is provided in Table 1; and an illustration of the total profile is provided in Figure 3. Because data were lost during climbing and descending turns in the UH-1FS, these maneuvers will not be compared.

TABLE 1  
FLIGHT MANEUVERS FOR THE UH-1 AND UH-1FS STUDIES

Instrument Takeoff (ITO) - Is defined from complete stop on the active runway through lift off to 450 ft., maintaining runway heading.

Climb - Is defined as straight ascent of at least 1000 ft. maintaining a constant heading with standard school procedures (+ 10 knots airspeed and 500 FPM). No separate navigation task was assigned.

Cruise - Is defined in this study as level flight for at least one minute, maintaining standard school procedures with no additional task assigned other than maintaining constant heading.

Descent - Is defined as the intentional loss of altitude of at least 1000 ft., maintaining a constant heading following school procedures with no additional task assigned.

Climbing Turn - Was performed by simultaneously changing direction of 180 degrees and climbing 500 ft. No other task assigned.

Descending Turn - Was the simultaneous descending and turning 500 ft. at 180 degrees. No other task assigned.

Level Turn - Was performed by banking the aircraft and turning while maintaining constant altitude and airspeed. No other task assigned.

Instrument Landing (ILS) - Is defined in this study as the published ILS approach RWY6 to Cairns Army Airfield. The maneuver began at Cairns outer marker (OM) and ended at Cairns middle marker (MM). This maneuver differed from all other maneuvers in that the additional task of monitoring the OBS gauge was required.

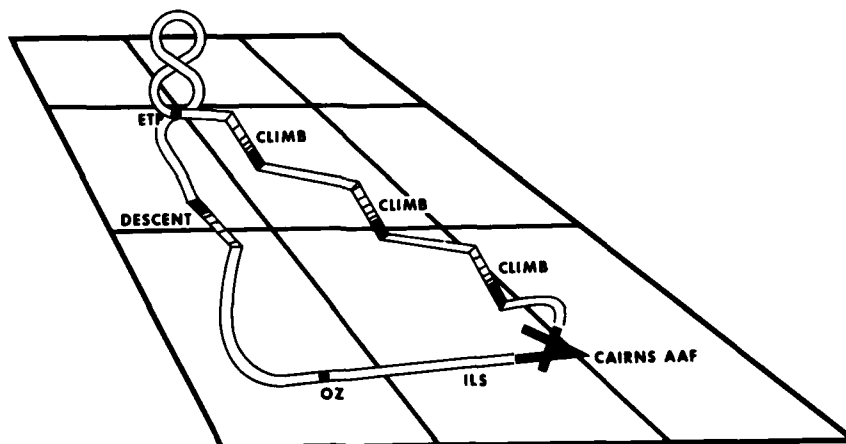

FIGURE 3. MISSION PROFILE

#### Measurements

Continuous oculomotor behavior was recorded during the flight profile at a rate of 16 data points per second. Because the flights were performed under IFR conditions the subjects' visual performance was limited to the cabin area and instrument panel. From these available visual areas, twelve instruments were selected which best described the total visual performance of the subjects. A thirteenth area was labeled "all other areas." If the percent of time spent monitoring this area was significantly low it could be assumed that the other twelve areas accurately represented the total visual

performance of the subjects. A list of these areas is provided in Table 2 and illustrated as arranged on the aircraft instrument panel in Figure 4. Both aircraft had identical instrument panels with the exception of the particular type of altimeters.

TABLE 2  
THE THIRTEEN VISUAL DATA POINTS

1. REST	All other areas not included in the following twelve areas:
2. ALT	AAU-32/A Altitude Encoder/Pneumatic Altimeter
3. VSI	Standard UH-1 Vertical Velocity Indicator
4. OBS	Standard UH-1 Omni Indicator
5. T&B	Standard UH-1 Turn and Slip Indicator
6. RMI	Standard UH-1 Radio Magnetic Compass
7. AH	Standard UH-1 Pilot's Attitude Indicator
8. AS	Standard UH-1 Airspeed Indicator
9. TORQ	Series of instruments including the Torquemeter, Gas Producer Tachometer, and Exhaust Gas Temperature Indicator
10. RPM	Dual Rotor and Engine Tachometer
11. ELEC	The electrical gauges which include AC and DC Voltmeters and the main and standby Generator Loadmeters
12. OIL	The oil monitoring gauges to include Engine and Transmission Oil Temperature and Pressure gauges
13. FUEL	The Fuel Pressure and Fuel Quantity gauges

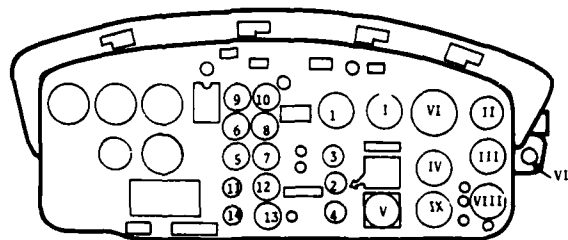

#### MONITORING GAUGES

##### ENGINE PERFORMANCE

1. Engine RPM
2. Gas Producer
3. Torque
4. Exhaust Temperature

##### OIL STATUS

5. Trans. Oil Pressure
6. Engine Oil Pressure
7. Trans. Oil Temperature
8. Engine Oil Temperature

##### FUEL STATUS

9. Fuel Pressure
10. Fuel Quantity

##### ELECTRICAL SYSTEM STATUS

11. Main Generator
12. DC Voltmeter
13. AC Voltmeter
14. Standby Generator

#### FLIGHT DISPLAYS

- |                       |                        |
|-----------------------|------------------------|
| I. Airspeed Indicator | VI. Artificial Horizon |
| II. Altimeter         | VII. Magnetic Compass  |
| III. VSI              | VIII. Clock            |
| IV. RMI               | IX. VOR                |
| V. Turn & Bank        |                        |

FIGURE 4. UH-1H INSTRUMENT LAYOUT

Visual performance was analyzed for each of the six maneuvers described in Table 1. Reduction of the data from the films provided seconds per maneuver that fixations were recorded within each of the thirteen areas described in Table 2. Additionally, the number of fixations per area were recorded. From these values, the percentage of lapse time spent within each area per maneuver was computed as well as mean dwell time and scan rate per minute for each area. The definitions and formulas utilized for these computations are found in Table 3.

TABLE 3  
DESCRIPTION OF BASIC AND DERIVED VISUAL MEASURES

<u>UNIT</u>	<u>DEFINITION</u>	<u>SYMBOL/FORMULA</u>
1. Fixation	The stationary eye movement within a designated area for at least 100 milliseconds	F
2. Number	The sum of fixations on a designated area (instrument)	N
3. Time	The sum of time spent fixated on a designated area (instrument)	T
4. Link Values	The visual path traveled from one area (instrument) to another	LV
5. Dwell Time	Mean time fixated per area	$DT = T/N$
6. Percent of Time	The percentage of lapse time during a maneuver which was allotted to each area	$\%T = T/\Sigma T \times 100$
7. Percent of Number	The percentage of fixations during a maneuver allotted to each area	$\%N = N/\Sigma N \times 100$
8. Scan Rate	The rate that each area was fixated	$SR = N/\Sigma T \times 60$

#### ANALYSES

Raw data were compiled and are presented in summary form in Figures 5 through 10. Figure 5 through Figure 7 represent the graphic differences of the subjects' scan rates during three maneuvers.

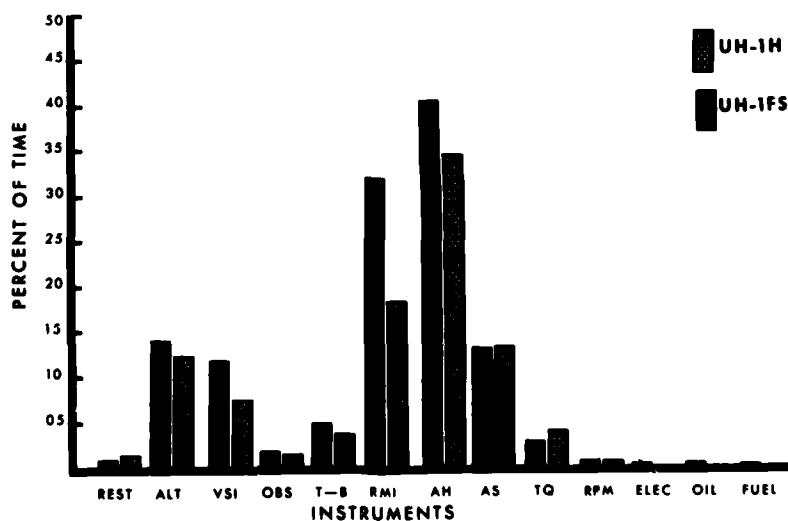

FIGURE 5. SCAN RATE COMPARISONS OF AIRCRAFT DURING IN-FLIGHT MANEUVERS

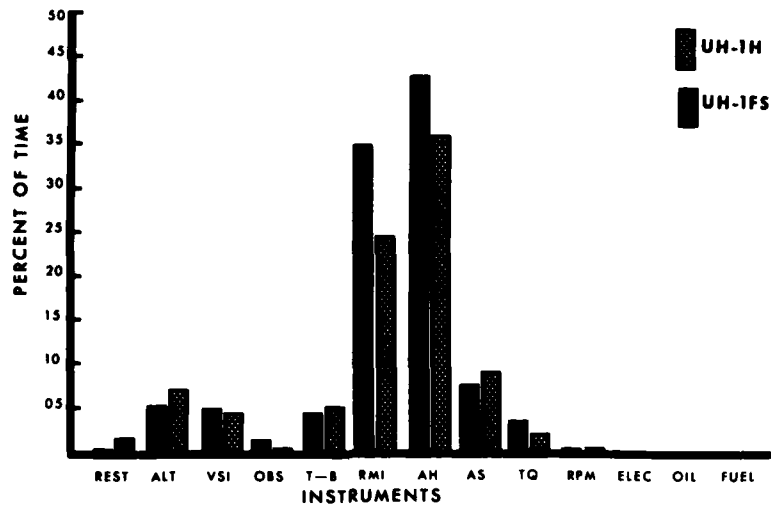

FIGURE 6. SCAN RATE COMPARISONS OF AIRCRAFT DURING ITO MANEUVERS

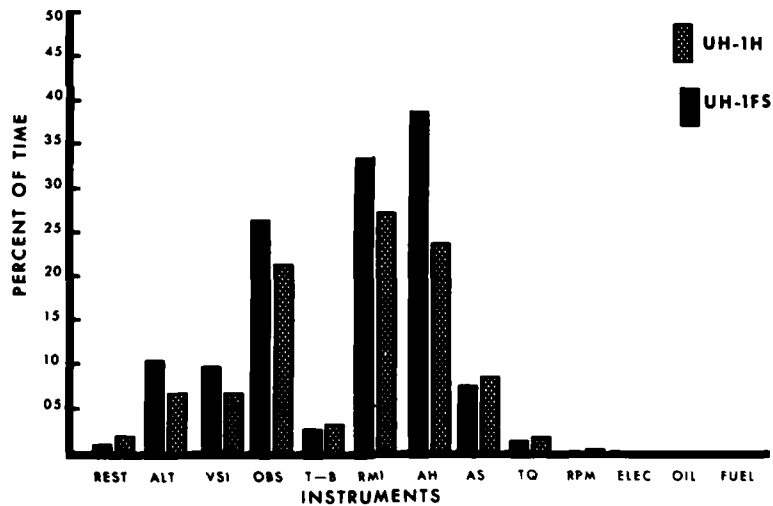

FIGURE 7. SCAN RATE COMPARISONS OF AIRCRAFT DURING ILS MANEUVERS

Figures 8 and 9 depict mean dwell time differences while Figure 10 illustrates subjects' visual performance as to their percentage of lapse time per area. These figures are presented as examples of the three preliminary data sets. A more homogeneous combination will be presented in the Results and Discussion section.

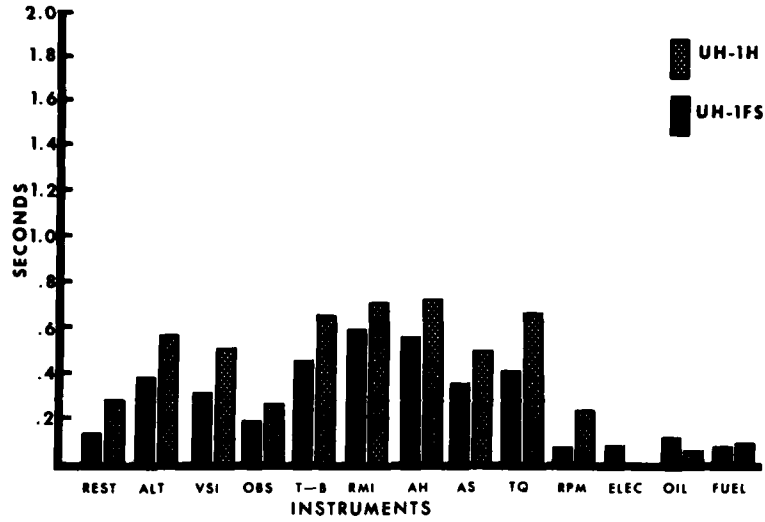

FIGURE 8. DWELL TIME COMPARISONS OF AIRCRAFT DURING IN-FLIGHT MANEUVERS

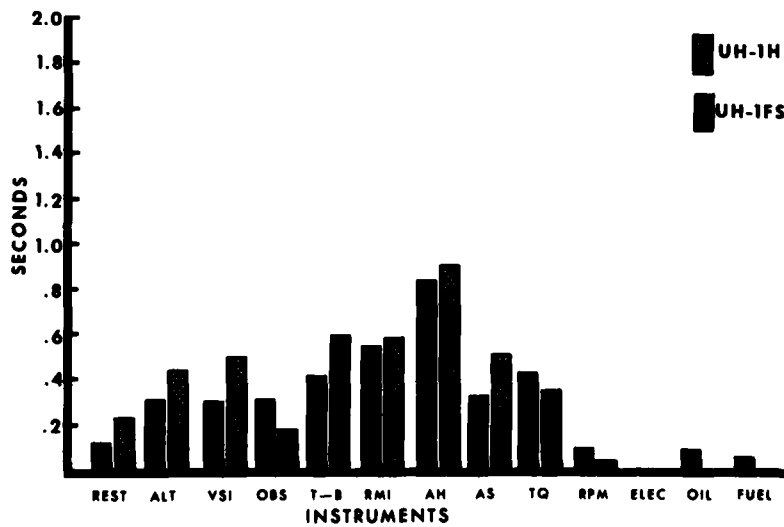

FIGURE 9. DWELL TIME COMPARISONS OF AIRCRAFT DURING ITO MANEUVERS

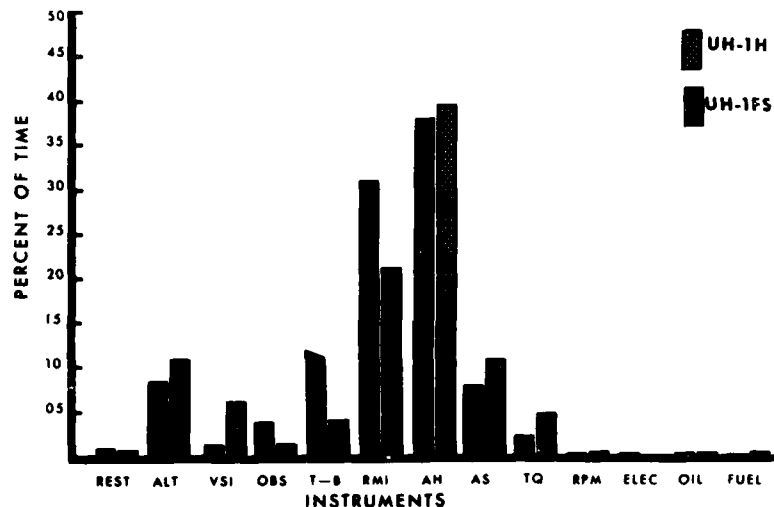

FIGURE 10. PERCENT LAPSE TIME COMPARISONS OF AIRCRAFT DURING IN-FLIGHT MANEUVERS

The visual performance from the UH-1 helicopter data had been previously analyzed and reported in USAARL Report No. 78-6. From inspection of the simulator data it was concluded that the data should be arranged in the same format as the UH-1 data. Therefore, because the percentage of lapse time for the RPM, electrical, oil, fuel, and torque gauge clusters as well as the area labeled "all other areas" comprised less than 10% of the total visual percent of lapse time, all were excluded from the final analyses. The seven remaining gauges were the altimeter, vertical speed indicator, radio magnetic compass, attitude indicator, airspeed indicator, turn and bank indicator, and omni indicator. These gauges could best be described as the aircraft's flight display while those which were deleted as the monitoring gauges.

The data from the remaining seven instruments of the UH-1FS were separated into zones to correspond with the instruments zones utilized in the UH-1 investigation. Zone 1, "aircraft stability management," was comprised of the artificial horizon, radio magnetic compass, and turn and bank indicator. Zone 2, "quality flight management," included the altimeter, vertical speed indicator, and the airspeed indicator. The last zone, "special requirement gauges," was comprised of the omni indicator, and all other gauges which had been excluded. The omni indicator was utilized only during the IIS maneuver. Thus, none of the Zone 3 instruments were included in the analyses of the five remaining maneuvers--climb, level flight, descent, turns, and ITO.

The final analyses were conducted to determine changes in visual performance between two separate aircraft, between two subject experience levels, and across six maneuvers. The visual performance measures (scan rate, dwell time, and percentage of lapse time) of the seven flight instruments within the three zones were utilized as dependent variables for these tests.

#### Multivariate Analysis of Variance and Univariate F Test

A multivariate analysis of variance (MANOVA) and an univariate F test were selected to define significant visual performance changes across various types of maneuvers. First, a full analysis (aircraft, groups, and maneuvers) was utilized to test only three maneuvers--climb, level, and descent. These maneuvers had previously been identified as being representative of a standard in-flight maneuver; and as requiring similar visual performance. The results of these analyses revealed significant differences in visual performance between the types of aircraft and also the two pilot experience levels. No significant differences were observed in visual performance across maneuvers; and there were no significant interactions of these main effects.

The results of the analyses of the group differences for the two significant sets of visual measures are presented in Table 4. The standardized discriminant function coefficients which show the relative contribution of each variable to the multivariate dimension of performance change are also presented. In addition, the univariate F ratios are presented as an additional aid in describing the visual performance changes for each major variable in the multivariate analysis.

TABLE 4  
 MULTIVARIATE ANALYSIS OF VARIANCE: GROUP MAIN EFFECT  
 DURING CLIMB, LEVEL, AND DESCENT MANEUVERS

TEST	VARIABLE	F-RATIO	HYPOTHESIS df	ERROR df	P LESS THAN	A*	B**
Group Eff	Zone 1 Scan Rate	6.428	3.00	14.00	0.006(Root I)***		
Univariate F	T-B Scan Rate	8.747	1.00	16.00	0.009	1.441	0.630
	RMI Scan Rate	0.014	1.00	16.00	0.908	-0.433	0.025
	AH Scan Rate	0.255	1.00	16.00	0.621	0.958	0.108
Group Eff	Zone 1 Per- cent Time	8.031	3.00	14.00	0.002(Root I)***		
Univariate F	T-B % Time	10.891	1.00	16.00	0.005	1.282	0.629
	RMI % Time	1.013	1.00	16.00	0.329	0.416	-0.192
	AH % Time	1.221	1.00	16.00	0.286	1.298	0.211

\*--Standard Discriminant Function Coefficients

\*\*--Correlation Between Variables and Composite Score

\*\*\*--Significant test uses Wilks-Lambda criterion. Only significant roots are present.  
 The subject factor was used in creating appropriate error terms for the primary comparisons.

The results of the analyses comparing visual performance between the UH-1 and the UH-1FS are presented in Table 5. The standardized discriminant function coefficients and univariate F ratios are again presented to aid in describing the major visual performance changes.

The second, third, and fourth sets of multivariate analyses compared visual performance during the ITO, ILS, and turn maneuvers with the set of three standard in-flight maneuvers (climb, level, and descent). The comparisons of visual performance on the ITO maneuver and the in-flight maneuvers reflected significant changes between the experience levels (groups), the type of aircraft, and between the maneuvers. These analyses showed no significant interactions of the main effects. The significant visual performance changes between groups and aircraft types were highly similar to those changes presented in Tables 4 and 5, the analyses of the main three in-flight maneuvers. Thus, for the sake of brevity, these results have not been included. Analyses of visual performance, from the ILS and turn maneuvers when compared to the three main maneuvers, indicated aircraft-maneuver and group-maneuver interactions. Although the main effects compared similarly to the previous test, simple main effect tests were required. These results are reflected by previous figures of scan rate, dwell time and percent of time, and will be discussed in the remaining sections.

Changes in visual performance across all the flight maneuvers were similar to the results reported in USAARL Report No. 78-6. Since the primary purpose of this report is to describe differences between aircraft, these significant changes across maneuvers are not presented.

#### Stepwise Discriminant Analysis

A stepwise discriminant analysis was completed utilizing the scores of the seven instrument flight displays which had previously been selected. Separate analyses were performed for the percentage of lapse time, scan rate and dwell time. The results reflected which visual performance measures were most important in discriminating between the two types of aircraft and to what degree of accuracy the aircraft could be discriminated between. Table 6 is a tabulation of the results.

TABLE 5  
MULTIVARIATE ANALYSIS OF VARIANCE: AIRCRAFT MAIN EFFECT  
DURING CLIMB, LEVEL, AND DESCENT MANEUVERS

TEST	VARIABLE	F-RATIO	HYPOTHESIS df	ERROR df	P LESS THAN	A*	B**
Aircraft Eff	Zone 2 Dwell Time	12.670	3.00	14.00	0.001 (Root I)***		
Univariate F	ALT Dwell Time	31.159	1.00	16.00	0.001	0.766	0.847
	VSI Dwell Time	18.607	1.00	16.00	0.001	0.546	0.654
	AS Dwell Time	10.179	1.00	16.00	0.006	-0.012	0.484
Aircraft Eff	Zone 1 Scan Rate	9.110	3.00	14.00	0.001 (Root I)***		
Univariate F	T-B Scan Rate	00.731	1.00	16.00	0.405	-0.019	0.153
	RMI Scan Rate	25.749	1.00	16.00	0.001	0.995	0.908
	AH Scan Rate	1.798	1.00	16.00	0.199	0.415	0.240
Aircraft Eff	Zone 1 Per- cent Time	6.194	3.00	14.00	0.007 (Root I)***		
Univariate F	T-B % Time	0.002	1.00	16.00	0.969	-0.409	0.009
	RMI % Time	7.531	1.00	16.00	0.014	-1.633	-0.596
	AH % Time	0.009	1.00	16.00	0.926	-1.516	-0.020
Aircraft Eff	Zone 2 Per- cent Time	4.601	3.00	14.00	0.019 (Root I)***		
Univariate F	ALT % Time	7.338	1.00	16.00	0.015	0.910	0.682
	VSI % Time	0.001	1.00	16.00	0.917	0.461	0.027
	AS % Time	3.221	1.00	16.00	0.092	0.812	0.452

\*--Standardized Discriminant Function Coefficients

\*\*--Correlation Between Variables and Composite Score

\*\*\*--Significant test uses Wilks-Lambda criterion. Only significant roots are present.

TABLE 6  
STEPWISE DISCRIMINANT ANALYSIS OF AIRCRAFT

VARIABLE	ACFT	CLASSIFIED AS:			MAJOR CONTRIBUTING VARIABLES FOR CLASSIFICATION OF AIRCRAFT				
		UH-1FS	UH-1H	% CORRECT	1	2	3	4	
Scan Rate	UH-1FS	104	28	79	Inst	RMI	AH	VSI	AS
	UH-1H	20	100	83	F Value	122.69	14.46	18.72	9.39
Dwell Time	UH-1FS	107	25	81	Inst	ALT	AS	AH	RMI
	UH-1H	31	89	74	F Value	88.14	34.08	6.50	1.25
Percent Time	UH-1FS	101	31	77	Inst	RMI	AH	VSI	ALT
	UH-1H	36	84	70	F Value	36.37	22.71	9.32	6.91

#### RESULTS AND DISCUSSION

The analyses of the visual data reflected significant differences between subject groups as to their scan rate and percentage of lapse time on the turn and bank indicator. Additionally, both the turn and bank indicator and the attitude indicator were major contributors to the MANOVA significance tests of subject groups. The tests between aircraft revealed significance in all of the Zone 2 instrument dwell times, and the scan rate of the radio magnetic compass. However, to better illustrate these



independent distinctions of the aircraft into a single plane of reference, the zone/cost factor (CF) theory which has been outlined in the UH-1 report was utilized.

Briefly, this theory states that the instruments located on conventional aircraft instrument panels could be grouped into three zones. The first zone, labeled "aircraft stability management," would include the attitude indicator, radio magnetic compass, and turn and bank indicator. This zone would be the primary zone for instrument flight, providing aircraft stability information about the three axes of the vehicle. The second zone would be utilized only when monitoring of Zone 1 was not critical. These Zone 2 instruments would include the altimeter, airspeed indicator, and the vertical speed indicator. This zone could be termed "quality flight management." The final zone would be comprised of the remaining instruments which include special navigation instruments and aircraft monitoring gauges. This third zone could be referred to as "special requirement gauges." These gauges are not vital for basic flight but are monitored or used on an "as time allows" or "need to know" basis.

In addition to grouping the instruments into three major classifications, under the zone/CF theory, the visual performance measurements are combined into one variable labeled "cost factor" for each instrument or zone. Visual performance is a combination of the time spent viewing a point (dwell time) and the frequency that the area is fixated (scan rate). Therefore, the lapse time and number of fixations of an area or gauge can be utilized to derive this single CF value. The formula would appear as:  $CF_z = (T/ET + N/EN)/2$ . CF represents the "cost factor" of each zone. "T" is in seconds, and "N" is number of fixations. If this value is divided by 2 the CF can be considered in percentage of workload.

If the above zone/CF theory is utilized the data from both the UH-1 and UH-1FS can be reduced to single values for each of the three zones across six flight maneuvers. The CF value is a reflection of the combined values of scan rate, dwell time, and percentage of lapse time. A summary graph for the three zone/cost factor approach is represented by Figure 11. The solid bar represents the visual data from the UH-1 study and the broken bar that of the UH-1FS. The fact that the UH-1FS CF values in Zone 1 are elevated above the UH-1 performance reflects more visual performance/workload during UH-1FS flights was required to maintain basic aircraft stability. This allows UH-1FS pilots less time on Zone 2 instruments. The MANOVA and univariate F tests (Table 5) support this statement.

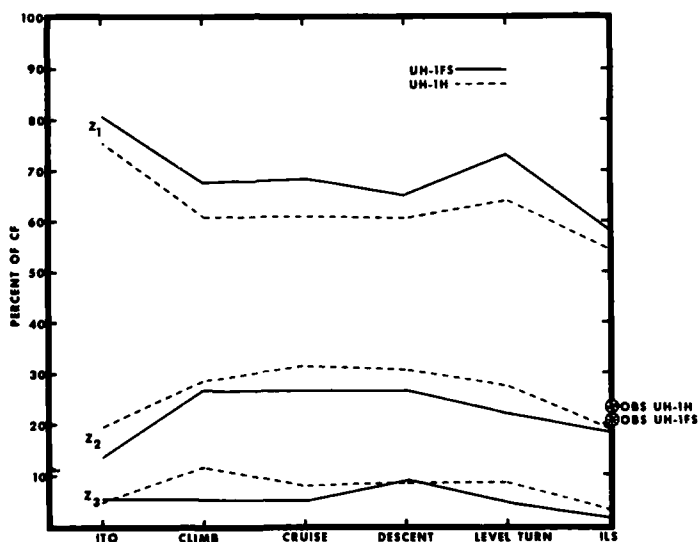

FIGURE 11. GRAPH OF CF/ZONE

Figure 12 is a breakdown of the individual instrument CF values within Zone 1, and Figure 13 is the same breakdown for Zone 2. Differences in the visual workload of the radio magnetic compass and the attitude indicator which was described by the multivariate comparisons of visual performance are readily apparent. Additionally, the aircraft-maneuver interaction during the ILS for the radio magnetic compass can be identified.

The results described by the MANOVA of aircraft main effects are also valid for instruments within Zone 2. The pilots who flew the UH-1 experienced more visual workload on the airspeed indicator and altimeter within this area than did the pilots in the UH-1FS.

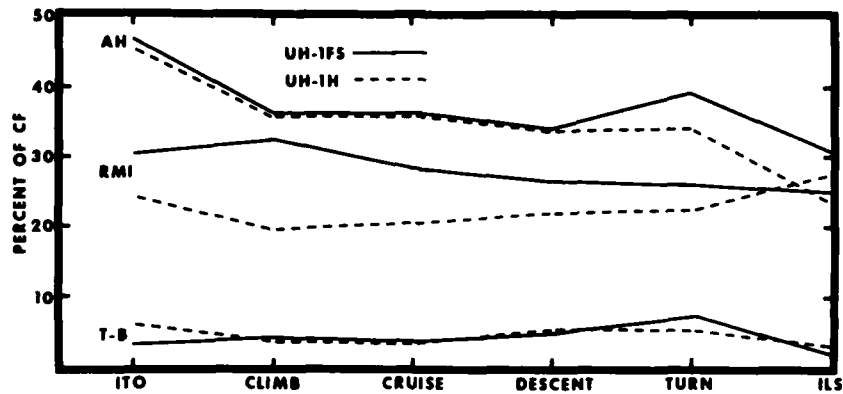

FIGURE 12. GRAPH OF CF/ZONE 1

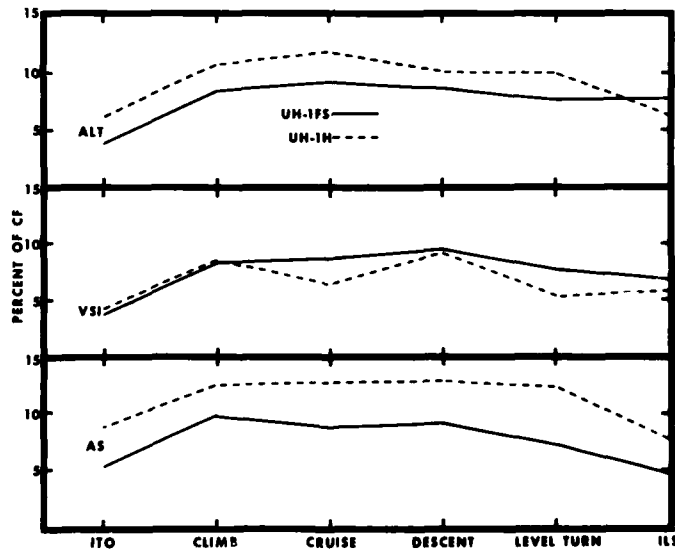

FIGURE 13. GRAPH OF CF/ZONE 2

## CONCLUSIONS

Maximum visual performance of an instrument or zone of instruments as reflected by increased scan rate or dwell time could indicate high visual workload. On the other hand this same performance could reflect a high percentage of low workload, free time in which the particular zone was fixated because it was centrally located. By reviewing the data in Figure 11 it is readily apparent that the ITO maneuver requires the maximum visual performance within Zone 1. This maneuver could also be classified as the least stable maneuver, requiring high pilot psychomotor performance to attain and maintain stability of the vehicle. The ILS, by contrast, is basically a general in-flight maneuver, similar to a descending maneuver, coupled with a high navigation workload to maintain the ILS course. This maneuver had the least aviator visual performance within Zone 1. Thus, through these two maneuvers, the ITO and ILS, the maximum time required

and the minimum time needed to maintain aircraft stability can be relatively established. It also can be assumed that the level of usage for Zone 1 instruments in the remaining in-flight maneuvers reflect a certain amount of "low workload" time.

From the graphic illustration in Figure 11 a general UH-1 helicopter visual workload pattern can be developed. This pattern is not necessarily that of a general helicopter IFR flight but would vary as a function of stability and aerodynamics of the vehicle. This same pattern is quite different when compared to fixed wing flight.<sup>4 5</sup> These differences will be discussed in future reports.

The visual workload pattern of the UH-1 helicopter flight can also be observed in the UH-1FS data (Figure 11). This would indicate that the UH-1FS does simulate the UH-1 helicopter IFR flight to some degree. Differences are observed for the level of workload in the Zone 1 instruments with UH-1FS pilots requiring the most time. This characteristic probably reflects a stability differential between vehicles which, from the results of the other tests, is most predominant on measures of the vertical or yaw axis gauges. Additionally, the dwell time on the instruments in the UH-1FS (Figures 8 and 9) are 100 to 200 milliseconds less than the dwell times in the UH-1. This could reflect different vibration levels for each of the aircraft.

The zone/CF theory is not complete. However, through the addition of more visual data to our current data base, such a theory could aid in predicting proficiency levels of aviators as is outlined in USAARL Report No. 78-6 and perhaps provide a means for differentiating visual workload as a function of vehicle stability.

Visual performance data has traditionally been numerous blocks of independent evaluations of a number of differing variables such as scan rate, dwell time, and percentage of lapse time. The zone/CF theory attempts to combine these blocks of visual information into one concise picture and thereby provide a tool to enhance instrument panel design, training and proficiency requirements, and, in general, provide safe helicopter flight regimes for mission accomplishment.

#### REFERENCES

1. Catron, R. L. Flight simulator acceptance. Aviation Digest, April 1976, 22.
2. Simmons, R., Lees, M., & Kimball, K. Visual performance/workload of helicopter pilots during instrument flight (USAARL Rpt. No. 78-6). Ft Rucker, AL: US Army Aeromedical Research Laboratory, January 1978.
3. Simmons, R., Kimball, K., & Diaz, J. Measurement of aviator visual performance and workload during helicopter operations (USAARL Rpt No. 77-4). Ft Rucker, AL: US Army Aeromedical Research Laboratory, December 1976.
4. Milton, J. L., Jones, R. E., & Fitts, P. M. Eye fixations of aircraft pilots: Frequency, duration, and sequence fixations when flying the USAF instrument low approach system (ILAS) (USAF Tech. Rpt. No. 5839). Dayton, Ohio: Wright Patterson Air Force Base, October 1949.
5. Fitts, Paul M., Jones, Richard E., & Milton, John L. Eye fixations of aircraft pilots: Frequency, duration, and sequence fixations when flying Air Force ground controlled approach system (GCA) (USAF Tech. Rpt. No. 5967). Dayton, Ohio: Wright Patterson Air Force Base, November 1949.

## DISCUSSION

- CAMP:  
(United States) I want to make a comment about the flat-plate canopy. We measured the noise environment--the noise inside the helicopter--after the flat-plate was installed, and we found that we had traded a headache for a stomachache. This design has disastrous effects on the acoustic control.
- SMYTH:  
(United States) Do you remember what the differences between the flat-plate and the round-plate were in the Cobra system?
- CAMP:  
(United States) No, I don't have the exact values. The Cobra is ideally designed. It is one of the best designed helicopters in terms of noise spectrum. The flat-plate made it the worst.
- STEELE-PERKINS:  
(United Kingdom) We are obviously very concerned about the same problem in England with communications. One idea which I might put forward for consideration is with the new generation flat-response microphones and the problem of getting power across to them. An idea we have carried out at Farnborough in an experimental microphone, a Knoles noise-cancelling microphone, was to make an extra little box fitting into the actual helmet. In that box we put two little Mallory cells, two batteries matched in parallel for the extra safety factor. From two very small Mallory cells we had two months of continual flying with no problem at all.
- BAILEY:  
(United States) Very good. I think that we would agree that we've always considered power to be our cheapest, most easily obtained commodity in communications.
- LINDBERG:  
(United States) We did look at battery systems. We were a little concerned that in recording to meet some of the environmental characteristics of operating at low ambient temperatures and at high ambient temperatures that you would get a very strong fluctuation in the voltage coming out of the battery and that could affect the sensitivity in the microphone to such a degree as to affect communications. We were lucky to have Black Hawk, AH, CH-47 MOD programs coming forth at this time. So while we were looking at the design of a new intercom, we decided to add the capability to the intercom itself. The power is phantom up the line to the microphone without requiring any additional wiring or wiring changes to the aircraft. If a pilot is interfacing into a new aircraft and has his SPH-4 helmet, all he would need would be a new microphone and he would be able to operate.
- BAILEY:  
(United States) The Black Hawk represented a tremendous improvement in some of our aircraft noise factors. The low band pass frequencies were much lower in terms of energy.
- CAILLE:  
(France) CPT Verona, I was very interested by the methodological excellence, the Latin square in six positions, in your study. It is a study that is methodologically indisputable, but the criteria are more arguable. Why haven't you detected the theta waves of the EEG which must be associated to this vibration study, especially in the area of 6 to 8 hertz? The calculation of spectral energy between theta and beta one would have given you an additional criterion that would have been, possibly, more significant.
- VERONA:  
(United States) In the original study, as it was planned, we did intend to use electrophysiological data. However, because of the complexity of the systems, we had to run two different studies. CPT Johnson did the electrophysiological study.
- JOHNSON:  
(United States) The overwhelming reason we did not do the electrophysiological study concurrently with CPT Verona's study was that in order to obtain reliable electromyographic data in the vibration environment would require that we use either implantable fine wire electrodes or use skin abrasion techniques with surface electrodes in order to get adequate electrical contact. Since the subjects quite often were required to participate all afternoon on several consecutive afternoons, we felt this would be impractical from the standpoint of a man's comfort and well being. It was decided that we would do a separate experiment using electrophysiological techniques under conditions that were more amenable to the subjects.
- CAILLE:  
(France) Can you tell me the axes of vibration and the levels that you used?
- VERONA:  
(United States) We used the X, Y, and Z as recorded aboard an AH-1 aircraft flying the same scenario. The X, Y, and Z were orthogonal axes; we did not use roll, pitch, and yaw. I believe the peak negative G was about 3.1. We had some gross movements of probably six inches displacement in the simulator. We did roll

DV-2

off at five hertz. We recorded the signals aboard the aircraft, brought that same tape in, and went through the same scenario on the ground.

CAILLE:  
(France)

You said you used a high level and a low level. So, one was what--a ratio of the other; or did you just turn the vibration down; or was it a terribly different vibration level?

VERONA:  
(United States)

Vibration was a one-to-one recording from the aircraft. The high and low levels refer to target speed rather than vibration levels.

OCCUPANT INJURY MECHANISMS  
IN CIVIL HELICOPTER ACCIDENTS

by

Richard G. Snyder, Ph.D.  
Head, Biomedical Department & Research Scientist  
Highway Safety Research Institute  
Institute of Science and Technology  
The University of Michigan  
Ann Arbor, Michigan 48109 USA

SUMMARY

The 1977 U.S. civil fleet numbers some 7160 helicopters, and (as of 1975) 27,872 active helicopter pilots. However, helicopters comprise only four per cent of the general aviation fleet. During the period 1964-1977, 3575 helicopter accidents were reported, including three air carriers. This averages 255 accidents per year, but varies by year, with no distinct trend. Of 7064 individuals reported to be in these accidents, 82.7% received only minor or no injury. Where crew fatality occurred autopsies were obtained in 39.4% of the cases, but in only 7.1% were toxicological findings determined. From 1964 through 1976, 339 individuals were involved in post-impact fire, resulting in 28 fatalities. However, an important finding is that when an impact causes greater than minor injury, the chances are equal that a fatality will result. Detailed investigations of impact injuries have not been conducted in civil helicopter accidents, whereas they have been on military helicopter accidents. Because of this lack of attention to occupant protection and crashworthiness, no large body of statistical data is available for analysis of the nature, site, and frequency of injuries. Rather, information is available for only a small number of accidents. This paper discusses mechanisms incurred in several selected accidents involving roll-over, rotor blade strike, and seat and restraint system failures. The present injury and fatality rate could be reduced in civil accidents by improved restraints, including use of upper-torso belts, energy-absorbing seats, crashworthy fuel systems, and increased use of protective helmets.

THE CIVIL HELICOPTER FLEET

The civil helicopter/rotorcraft fleet has increased steadily since 1946, when a Bell Model 47 was granted the world's first commercial helicopter license (1). Helicopter use has expanded into many new areas, including, agriculture, law enforcement patrol and rescue operations, construction work, logging, offshore oil rig transportation, medical evacuation, pipeline inspection, overland oil and mineral exploration, mining, training, and personal transportation.

By the end of 1977, the number of helicopters in active service had risen to 7160 (Table I), not including seven in air carrier use (2-6). In 1977, 1,219 U.S. corporations operated 1578 helicopters, an increase of 13.4% over 1975 in the number of corporate helicopters. An additional 1288 helicopters were utilized by 369 federal, state, and local civil government users, and 959 commercial operators flew 4294 helicopters in 1977. In comparison, a decade earlier (1967) the corporate helicopter fleet numbered only 487 helicopters (7). The three categories of helicopter operators (commercial, corporate, and governmental) total 2547 operators flying 7160 helicopters. This amounts to an increase over 1976 of 9.3% in the number of operators, and 15.8% in the number of active helicopters (2-6). As of December 21, 1975, the most recent date for which FAA data are available, there were 27,872 active U.S. helicopter pilots (8).

A detailed breakdown of the 1977 civil helicopter fleet for the United States and Canada is shown in Table II (2,p.285). Worldwide, there are currently estimated to be about 10,000 civil helicopters operational, with over 7,000 in North American and 1450 in Europe. The world inventory has been projected to total 12,000 helicopters by the end of 1979 (9).

While there were only 357 heliports in the U.S. in 1960 (and some 19 states lacked even a single heliport), by 1977 3,433 were listed (2), 417 for public use and 3,016 for private use. Of these, 299 are rooftop and 3,134 are ground-level facilities. There are heliports on the 80 mobil oil rigs and 2,060 oil platforms in the Gulf of Mexico, and others off Alaska and California--and, as of last month --the Atlantic coast. The U.S. Forest Service alone maintains some 300 heliports and "several thousand" unimproved helistops. There are also presently 699 hospital heliports (2).

U.S. civil helicopters range in size from the single-seat Rotorway Scorpion 204 kg (450 lb) empty wgt., with a cruising speed of 59 knots (or 78 knots max. level speed

TABLE I

## ACTIVE U.S. CIVIL ROTORCRAFT

Year	General Aviation* Rotorcraft		Air Carrier Rotorcraft	Commercial Production
	AIA	FAA		
1977	7,160			
1976	6,181	4,505 <sup>P</sup>	7 <sup>P</sup>	755
1975	5,222	4,073	7	864
1974	4,819	3,610	10	828
1973	4,601	3,143	13	770
1972	4,185	2,787	14	575 <sup>b</sup>
1971	3,874	2,352	16	469 <sup>ab</sup>
1970		2,255	18	482 <sup>ab</sup>
1969	3,433	2,557	16	534 <sup>ab</sup>
1968		2,350	22	522 <sup>ab</sup>
1967	2,438	1,899	22	455 <sup>ab</sup>
1966	2,318	1,622	21	583 <sup>a</sup>
1965	2,053	1,503	21	598
1964	1,767	1,306	20	579
1963	1,497	1,171	-	-
1962	1,319	967	-	-
1961	1,179	798	-	432
1960	936	634	-	294

\* Includes autogiros; excludes air carrier helicopters

p Preliminary data

a Excludes three Fairchild "Porters" in 1966; nine in 1967; five in 1968; 13 in 1969; one in 1970

b Excludes foreign licensees of Bell

- Data not found

Sources: Refs. 2, 4-8

at S/L) and range (standard fuel) of 91 nm (105 mi) (10), to the Sikorsky CH-53 converted under NASA contract as a 16-seat demonstration prototype of the projected S-65C commercial inter-city transport (14,536 kg (32,048 lb) empty wgt.) (11).

New-generation helicopters also include the Sikorsky S-76 5-13 passenger executive transport (2242 kg, 145 ktas normal cruise - 161 ktas sea level maximum speed; range 401 nm at 125 k with 30 min. reserve), which has certification pending (FAR 29, Cat. A.) (11, pp. 392-393; 12). The Bell 222, featuring the first civil helicopter use of crash-resistant fuel tanks and 8 g seats, is presently scheduled for first delivery in September, 1979. The Bell 222 was designed primarily as an executive transport helicopter (1, pp. 284; 13-16).

Since there is a significant difference between the Federal Aviation Administration (FAA) figures and those of the Aerospace Industries Association (AIA) relative to numbers of helicopters in operation, Table I and III presents both FAA and AIA totals. The AIA data were developed from survey responses from operators, the FAA data from "active aircraft" (e.g., must have a current registration and been flown during the previous calendar year). But why this should be such a large discrepancy is not clear. For example, the FAA lists 4504 helicopters in 1976 while the AIA lists 6181 that year, a difference of 1676, or 27.1%. The major types of helicopter uses are listed in Table IV.

The 7160 helicopters (excluding seven air carriers) in operation (AIA data) in the U.S. currently represent approximately four percent of the total 1977 general aviation fleet of 186,000 aircraft (preliminary FAA data). If the current ratio continues through 1985, when the FAA has forecast 262,000 aircraft (17), this would represent over 10,480 helicopters in U.S. civil operation.

#### OVERALL ACCIDENT STATISTICS

Unfortunately, it is not yet possible to provide a precise overview of the nature, frequencies, and severity of trauma in civil helicopter accidents. To date very little attention has been given to such analysis for civil helicopter accidents, possibly because they are such a small part of the total civil accidents. In contrast, military helicopter accident investigations have resulted in a large body of excellent injury data being collected, evaluated, and utilized in making the new-generation military helicopter a much more crashworthy product. The Army's Crash Survival Design Guide, presently under revision, reflects the attention the Army has given to military helicopter crash protection (18), and there is a relatively large literature dealing with military helicopter

TABLE II  
CIVIL HELICOPTER FLEET  
U.S. AND CANADA 1977

State	Commercial		Corporate and Executive		Civil Government		TOTAL ALL HELICOPTERS
	Operators	Helicopters	Operators	Helicopters	Operators	Helicopters	
Alabama	7	14	22	27	8	191	232
Alaska	31	243	12	13			256
Arizona	30	159	11	27	7	23	209
Arkansas	14	18	12	14			32
California	121	438	90	125	54	170	733
Colorado	15	56	9	12	7	12	80
Connecticut	9	13	13	15			28
Delaware	3	4	2	4	1	1	9
Dist. of Col.	2	2	3	5	7	22	29
Florida	63	205	39	58	27	75	338
Georgia	11	21	15	18	5	20	59
Hawaii	15	18	6	10	4	5	33
Idaho	21	56	20	27	6	12	95
Illinois	22	55	34	45	12	26	126
Indiana	24	54	23	26	10	19	99
Iowa	14	19	18	19	8	22	60
Kansas	9	17	10	11	6	9	37
Kentucky	9	19	45	47	2	5	71
Louisiana	16	391	13	38	13	24	453
Maine	4	10	4	4	2	8	22
Maryland	2	10	14	15	3	20	45
Massachusetts	11	36	26	31	3	3	70
Michigan	20	45	50	58	9	35	138
Minnesota	13	39	14	14	3	6	59
Mississippi	5	10	6	7	8	14	31
Missouri	14	62	12	12	9	20	94
Montana	8	18	4	5	3	4	27
Nebraska	12	35	11	14	5	10	59
Nevada	7	19	8	11	6	14	44
New Hampshire	2	3	9	10			13
New Jersey	16	27	39	47	4	11	85
New Mexico	7	14	9	10	1	1	25
New York	39	193	52	67	16	36	296
North Carolina	11	18	13	27	2	3	48
North Dakota	6	8	7	7	1	1	16
Ohio	23	58	44	49	9	25	132
Oklahoma	10	76	9	15	2	3	94
Oregon	15	200	51	54	6	14	268
Pennsylvania	27	123	89	103	5	13	389
Rhode Island	2	4	3	3	1	1	8
South Carolina	10	36	19	22	1	5	63
South Dakota	1	2	1	1	2	2	5
Tennessee	9	21	17	17	6	36	74
Texas	50	148	70	135	20	46	329
Utah	11	106	9	10	2	4	120
Vermont	1	1	5	5			6
Virginia	10	15	23	28	8	22	65
Washington	43	123	52	69	7	25	217
West Virginia	3	8	45	48	4	12	68
Wisconsin	6	34			2	2	36
Wyoming	4	15	5	6			21
Puerto Rico	2	8	2	2	3	6	16
Canada	119	967	100	131	31	250	1348
Commercial Operators ....	840				Commercial Helicopters....	3,327	
Corporate Operators ....	1,119				Corporate Helicopters ....	1,447	
Government Operators ....	338				Government Helicopters....	1,038	
TOTAL .....	2,297	U.S. Operators*			TOTAL.....	5,812US Helicopters*	
Commercial Operators ....	119				Commercial Helicopters ...	967	
Corporate Operators .....	100				Corporate Helicopters ....	131	
Government Operators ....	31				Government Helicopters ...	250	
		250 Canadian Operators				1,347Canadian Heli	
GRAND TOTAL .....	2,547 Operators				GRAND TOTAL .....	7,160 Helicopters	

\* Includes Puerto Rico

Source: Ref. 2



TABLE III  
 BREAKDOWN OF HELICOPTER OPERATIONS BY  
 TYPE AND NUMBER OF OPERATORS  
 (Courtesy Aerospace Industries Association, Ref. 1)

YEAR	TOTAL	HELICOPTER FLIGHT SCHOOLS	COMMERCIAL	CORPORATE AND EXECUTIVE	CIVIL GOVERNMENT AGENCIES
<b>Operators</b>					
1960	318	50	193	94	31
1961	400	55	265	106	35
1962	503	85	322	145	36
1963	600	106	405	150	45
1964	710	121	451	212	47
1965	860	156	508	299	53
1966	933	183	519	353	61
1967	1023	144	522	427	74
1968	-	-	-	-	-
1969	1379	148	689	596	94
1970	-	-	-	-	-
1971	1424	137	672	590	162
1972	1491	162	758	566	167
1973	1532	218	752	599	181
1974	1536	211	725	608	203
1975	1891	165	779	833	279
1976	2330	218	911	1082	337
1977	2547	224	959	1219	369
<b>Helicopters Operated</b>					
	<b>AIA</b>	<b>FAA</b>			
1960	936	634	705	134	97
1961	1179	798	882	173	124
1962	1319	967	994	213	112
1963	1497	1171	1157	218	122
1964	1767	1306	1333	311	123
1965	2053	1503	1537	401	115
1966	2318	1622	1699	475	144
1967	2438	1899	1764	487	187
1968	-	2350	-	-	-
1969	3433	2557	2390	770	273
1970	-	2255	-	-	-
1971	3874	2352	2605	802	467
1972	4185	2787	2992	745	448
1973	4601	3143	3295	780	526
1974	4819	3610	3418	778	623
1975	5222	4023	3342	1056	824
1976	6181	4505	3702	1392	1987
1977	7160	-	4294	1578	1288

\*1968 and 1970 not included as no AIA surveys those years.  
 Totals include some helicopters on order.

crash tests, crashworthiness and results of accident investigations.

The primary source of civil data are accident reports of the National Transportation Safety Board (NTSB) records. However, detailed injury information has seldom been included. The only data uniformly provided for each occupant is a category of injury ("no injury/minor", "severe", "fatal"). Similarly, no detailed injury data are generally listed in the NTSB computerized files, which go back to 1964. These data have been searched, utilizing the University of Michigan Automated Data Access and Analysis System (ADAAS), for the NTSB individual files for some 3335 helicopter accidents (through 1976) stored on magnetic tape.

Detailed biomedical accident investigation studies, with emphasis upon human factors and occupant injury causation, have been conducted by the Civil Aeromedical Institute (CAMI) of FAA, at Oklahoma City, and by HSRI, the University of Michigan, for a number of years. But even these studies have involved few helicopter investigations.

TABLE IV  
HELICOPTER OPERATOR SERVICES

(Ref. 1)

Agriculture	Exploration	Mechanic Training School (G.I. Approved)
Air Carrier (Part 127)	External Load	Offshore
Air Taxi/Charter	Fire Control/Support	Patrol (Power-Cable-Pipe)
Ambulance	Forestry, General	Photo
Bank Paper	Government Agency (Not for Hire)	Pilot Training School (G.I. Approved)
Transportation	Herding (Cattle & Stock)	Pollution Detection/Monitoring
Certified Repair Station	Herding (Wildlife)	Private (Personal)
Commuter Air Carrier (Scheduled)	Law Enforcement Agency	Sightseeing
Construction	Law Enforcement (For Hire)	Traffic Reporting
Corporate (Part 91 Not for Hire)	Logging	
Executive Transport (For Hire)		

Several air carrier helicopter accidents have had major NTSB team investigations. However, examination of these has shown that the circumstances of the accidents precluded obtaining useful impact injury information. Both of the Los Angeles Airways Sikorsky S-61L accidents, at Paramount, California, 22 May, 1968 (19), and at Compton, California 14 August, 1968 (20) were non-survivable, and the aircraft were destroyed by post-impact fire. The first was fatal to all 23 occupants, the second was fatal to three crew and 18 passengers when a main rotor blade separated in flight at 1200-1500 feet attitude. In a more recent case, on 16 May, 1977, a New York Airways Sikorsky S-61L rolled over on its right side. Its landing gear failed while it was parked on the rooftop heliport of the Pan Am Building in New York. Substantial damage resulted (21). The four passengers outside were killed and one seriously injured, and one pedestrian on a street below was killed and another seriously injured by falling debris. None of these air carrier accidents thus provide useful impact injury data.

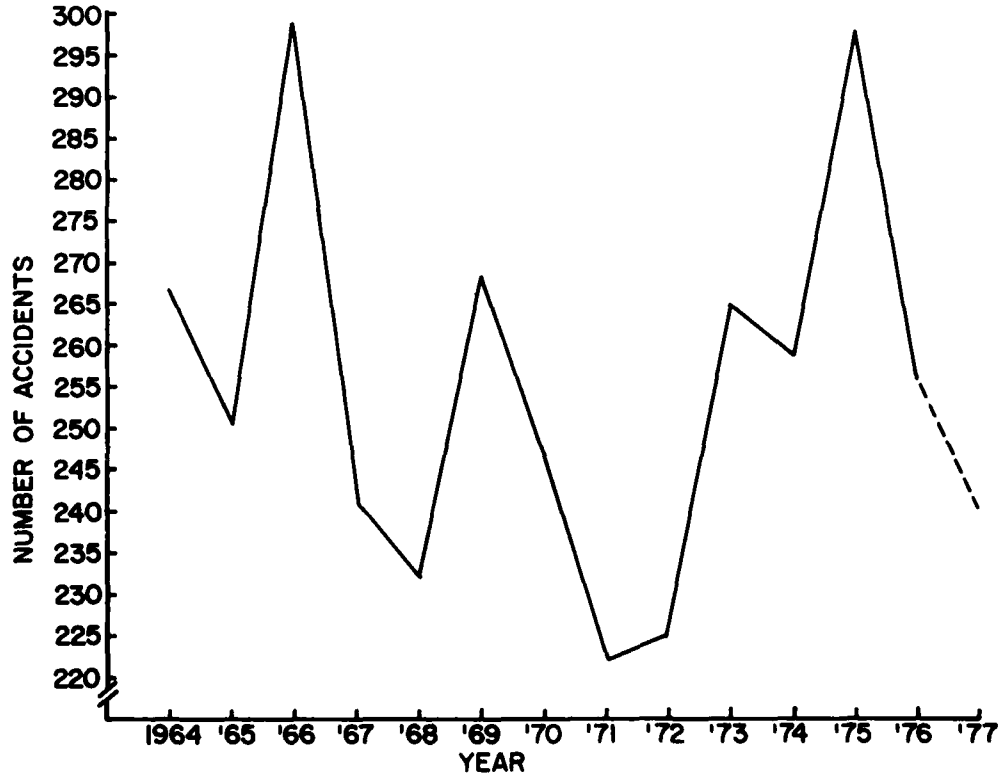

Fig. 1 U.S. CIVIL HELICOPTER ACCIDENTS 1964-1977

Fig. 1 graphs civil U.S. helicopter accidents for the fourteen-year period 1964-1977. No clear trend is shown. A more complete compilation is provided in Table V. During this period there have been a total of 3575 helicopter accidents, averaging 255 per year. While there has been some decrease in total accidents for the past three years, this is due to the large number recorded in 1975. Totals for 1973 (265), 1974 (259), and 1976 (256) remaining relatively stable. Data for 1977 are still preliminary and may well end up close to the 1976 figure.

TABLE V  
COMPARISON OF U.S. CIVIL HELICOPTER  
ACCIDENTS WITH INJURY CLASSIFICATIONS  
1964 - 1977

Year	No. of Accidents	Crew			Pass.			Crew & Pass.			Totals
		M/N	S	F	M/N	S	F	M/N	S	F	
1977 <sup>(1)</sup>	240	212	32	19	107	22	25	319	54	44	417
1976	256	235	38	21	143	30	34	378	68	55	501
1975	298	285	31	22	205	19	24	490	50	46	586
1974	259	244	25	34	152	17	16	396	42	50	488
1973	265	269	30	21	190	20	17	459	50	38	547
1972	225	231	18	24	186	18	34	417	36	58	511
1971	222	218	22	14	121	11	11	339	33	25	397
1970	247	254	19	16	202	5	10	456	24	26	506
1969	268	248	21	29	204	13	22	452	34	51	537
1968	232	220	20	28	158	13	52	378	33	80	491
1967	241	228	24	21	157	18	23	385	42	44	471
1966	304	293	36	19	200	26	27	493	62	46	601
1965	251	246	24	14	136	16	9	382	40	23	445
1964	267	266	28	17	229	16	10	495	44	27	566
Means	255	246	26	21	170	17	22	417	44	44	505
Totals	3575	3449	368	299	2390	244	314	5839	612	613	7064

(1) Preliminary data, probably incomplete. Does not include 13 pilots and 12 passengers for which injury data unknown. Does not include fatalities and 9 injuries to ground personnel.

Although some 7064 individuals were reported to be in these accidents, 5839 or 82.7% received only minor or no injury, similar to the proportion (78.8%) found to occur for fixed-wing aircraft accidents over the period 1967-1976 (22).

A comparison of the fatality rate is shown in Fig. 2. This is the ratio of annual fatalities divided by the total annual accidents. In addition, the fatality rates for pilots and passengers may be compared. Passengers have had a higher rate for six years, including the past three years, and pilots have had a higher rate for seven years, with one year having equal fatality rates. Two years, 1968 (.34) and 1972 (.26), have had much higher fatality rates. Although the rates have varied from .09 in 1965 to .34 in 1968, there seems to have been a slight upward trend during the past five years.

A similar comparison of the ratio of severe injuries per accident is provided in Fig. 3. Pilots appear to incur severe injury only slightly more frequently than passengers. However, the total index for severe injuries per accident per year has not varied a great deal, ranging from .10 (1970) to .27 (1976). During the past two years severe injuries have been reported more often than previously.

One point, however, deserves particular consideration, since it reflects upon an important aspect of helicopter crash safety. For the total 3575 accidents reported during this 14-year period, the number of severe injuries (612), combined for both crew and passengers, and fatalities (613) are nearly identical. This indicates that in any civil helicopter accident where greater than minor injury to an occupant occurs, the chances are equal that a fatality will result. In comparison, in general aviation fixed-wing aircraft, annual fatalities are about twice the number of occupants severely injured, therefore, the chances of a fatality over severe injury are about two in three, as compared to receiving more than minor injury (22-24). For perspective, in an automobile, the chances of receiving a severe injury in an accident are 25.4 times that of being killed, given that the impact is severe enough to cause at least serious injuries (25,26). Considering, therefore, only accidents that result in at least severe injuries, helicopter accidents appear to be less dangerous to life than fixed wing, but considerably more dangerous than automobile accidents.

Injuries to pilots and passengers for each category are compared in Fig. 4. These

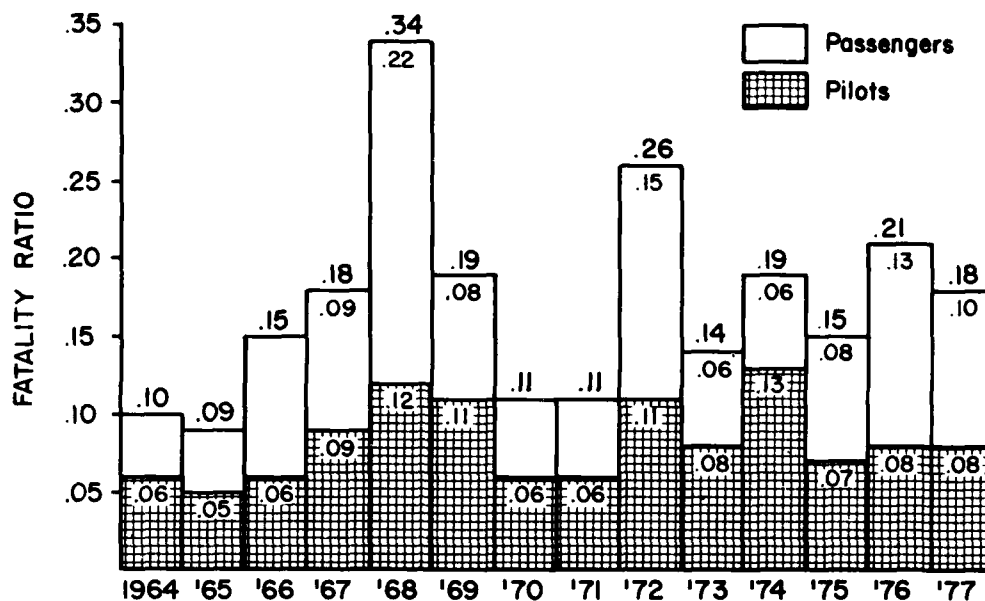

Fig. 2 ANNUAL INDEX OF FATALITY PER ACCIDENT  
(Ratio of Annual Fatalities / Total Annual Accidents)

data reflect the mean values for the past 14 years. The 293 mean annual total for pilots exceeds the 209 average for passengers, since many accidents have occurred with no passenger aboard. While the proportion of serious injuries is similar for both groups, 10.5% of the passengers received a fatality but only 7.1% of the pilots.

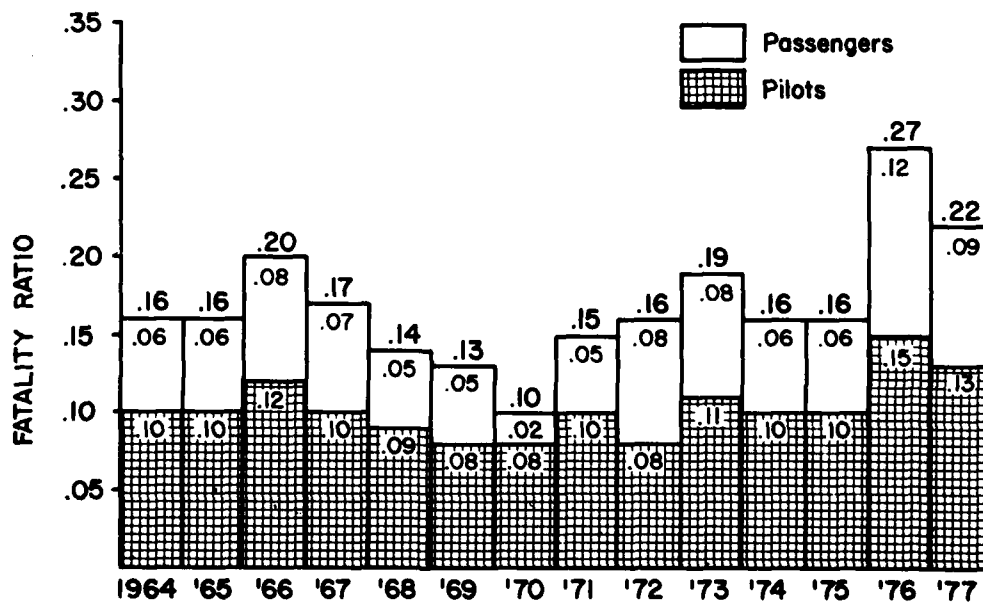

Fig. 3 ANNUAL INDEX OF SEVERE INJURY PER ACCIDENT  
(Ratio of Annual Severe Injuries / Total Annual Accidents)

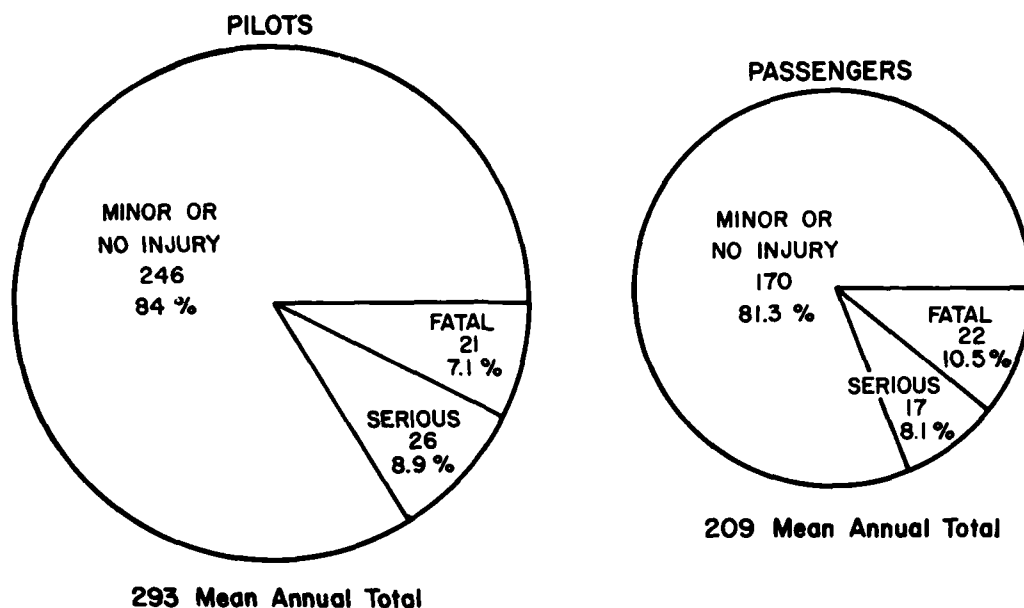

Fig. 4 COMPARISON OF OCCUPANT TRAUMA (ANNUAL AVERAGE)  
1964—1977

#### SELECTED INJURY MECHANISMS

The previous section has reviewed various general categories of injury recorded for the period 1964-1977. Since data are not available to analyze the site, frequency, and specific nature of trauma for these accidents, and thus provide an overview of the injury mechanisms, selected accidents will be briefly reviewed. These are not intended to indicate statistically significant problems and mechanisms, but rather to show some of the causes of trauma documented in selected civil accident investigations and insight into the resulting biomechanics/kinematics.

##### 1. Roll-Over

During hard landings or emergency autorotations it is not unusual for the main rotor blades to contact the tail boom as they hyperextend downwards in the impact, and may sever the tail. Subsequently, the cabin usually rolls to the side and severe disintegration may occur as the blades strike the ground. This mechanism was identified by the FAA in 1962 when three different FAA test pilots inadvertently crashed while conducting routine autorotation during certification test flights (27). Since each of these flights were being recorded on high-speed movie film, the exact sequence was clear during stop-motion playback.

Case No. 1. An example of this type of accident is shown in Fig. 5. In this case engine failure in a Brantly B2 occurred about 1000 feet above the terrain and the pilot executed an emergency power-off autorotation into a farmyard. Touchdown deceleration was light, but due to the uneven sloping hillside terrain, main rotor blade deflection severed the tail boom aft of the cabin. The aircraft rolled to the left and was destroyed. Despite the disintegration of the cabin plexiglass and violent lateral motion, the pilot escaped with no injury except for a minor facial laceration caused by flying plexiglass. In this instance, impact forces were insignificant, although in many such power-off emergency autorotations vertical impact force could be a major factor.

The tendency to roll about the longitudinal axis was reported in an analysis of U.S. Army helicopter accidents by Haley, who found that at least one roll occurred in two of three light observation helicopter accidents, five of eight utility helicopter accidents, and in one of two cargo helicopter accidents (28).

While no roll-over was reported, the tail rotor drive shaft was cut by the main rotor, of the Bell Model 222 during a test flight on 1 December, 1977 when an emergency autorotation was made into a plowed field (29). Although damage was substantial there was no fire and no reported injuries to the pilot or engineer passenger.

##### 2. Seat Failure

Helicopters are considerably more prone to vertical impact in landings than fixed-

wing aircraft. This is especially true in crash landings where the primary force vector is usually vertical, although lateral and forward horizontal forces may also be a factor. However, in many accidents injury has been attributed to failure of the seat tiedown, seat pan, or other seat structure. Cases have been investigated where the lack of adequate energy-absorption devices in the seat or seat cushion have resulted in significant vertebral trauma. In some cases "dynamic overshoot" has probably occurred, in which the seat cushion has yielded and compressed rapidly without absorbing energy, resulting in amplification of the force on the occupant as his buttocks are decelerated abruptly by the underlying structure. In other cases the seat collapses without providing adequate force limiting or energy attenuation.

Case No. 2. A Bell 47J-2A upon return from a local sightseeing trip passed over the heliport and while making a 180° turn, the tail rotor pinion gear failed, causing the aircraft to rotate. It came to rest on a down slope wooded area in a near level attitude, with the left side slightly low. The pilot and two passengers received serious trauma, and two passengers were fatally injured. There were four passengers on the rear bench seat, a common practice in that model, even though only two lap belts were provided. The seating arrangement is shown in Fig. 6, showing the pilot seat in front. The pilots' seat was extensively damaged (Fig. 7). The rear bench seat (Fig. 8) is supported only by four detachable tubular legs in front and is hinged at the rear. This collapsed (Fig. 9), the left outboard belt being torn out. Note that the double belt utilized a metal-to-webbing release mechanism, which will be discussed in Case 4.

Fatal injuries to two passengers included multiple fractures with one receiving a fractured neck. Major injuries to one passenger included compression fractures of the fourth and fifth thoracic vertebrae, concussion, fracture of the left pubis and ischium, multiple fractured ribs, and abdominal trauma with laceration of liver, ruptured spleen, and chest pneumothorax. These injuries reflect the failure of both the pilot seat and passenger bench type of seat to provide adequate impact protection to occupants.



Fig. 5. Brantly B2 subsequent to emergency power-off autorotation into hillside and main rotor blade severance of tail.



Fig. 6. View of Bell 47J-2A single pilots' seat structure.



Fig. 7. Pilots' seat framework after impact.

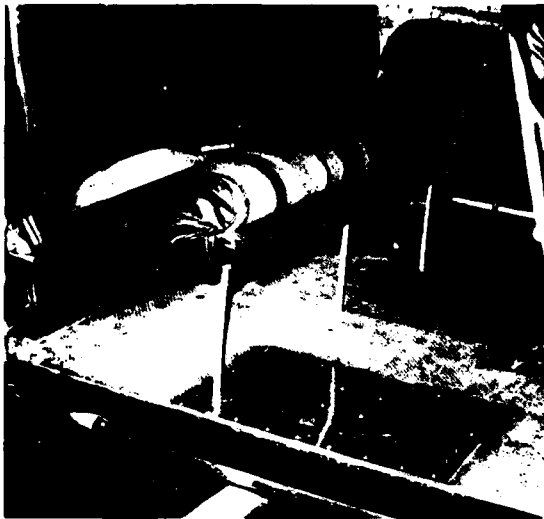

Fig. 8. Typical Bell 47J-2A rear seat configuration. Support elements consist of four tubular supports in front and a hinged rear.



Fig. 9. Four persons were occupying this Bell 47J-2A rear bench seat which completely collapsed in impact (cushions removed to show structure).

Not only were there only two belts for four occupants, but one belt utilized a deficient metal-to-webbing construction with protruding release mechanism, there was no upper torso restraint, and the bench seat provided insufficient energy absorption mechanisms.

Case No. 3. A Bell Jet Ranger 206B suffered a mechanical failure and subsequent loss of power at about 800 feet altitude, and impacted in a grove of pine trees, sliding down one tree. The fuselage came to rest upright with the right skid collapsed. The cabin environment was not subjected to intrusion, extensive collapse, nor significant structural failure. The pilots' panel was intact, the floor had minor deformations, and no significant damage occurred to the rear seat and baggage area. However, injuries subsequently fatal to the instructor pilot in the left seat, and disabling paraplegia to the pilot in the right seat, resulted primarily from inadequate energy absorption characteristics of the seat structure and lack of upper torso restraint.

Major impact trauma to the instructor pilot included fracture-dislocation of the first lumbar vertebra with compression of spinal cord and lower extremity paralysis, multiple transverse process fractures, right second lumbar vertebra and left first, third, and fourth lumbar vertebrae, compression fracture of twelfth thoracic vertebra, compression fracture of left lateral second lumbar vertebra, and concussion. Among major injuries to the right-seat pilot were multiple vertebral fractures (marked compression of the body of the third lumbar, fractures to the left and right transverse processes of second, third, and fourth lumbar vertebrae), ruptured diaphragm, herniation of the fundus of the stomach and splenic tearing, and subsequent paraplegia.

Fig. 10 shows an external view of the seats, which were equipped with additional padding for comfort, but which probably provided little if any energy absorption. The forward portions of both seat structures had collapsed forward (Fig. 11), and both seat pans were deformed and gashed where contact and penetration with underlying control and boost structures occurred, and contact on the right side by the top of the inverter box, two inches below the seat pan.

The injuries received reflect substantial lack of crashworthy seat-restraint protection. The extreme vertebral trauma, involving compression, multiple bilateral transverse process fractures, and spinal cord damage indicate that the primary direction of loading was vertical, but that the body spinal seated posture at impact was not entirely perpendicular to the force direction. Lack of upper torso restraint allowed the body to contact structures causing upper torso and head trauma as well.

The injuries incurred by both occupants were far more severe than would be the case had adequate energy absorption devices and upper torso restraint been employed. The Army's Crash Survival Design Guide, for example, notes concerning seat strength and deformation characteristics that the load-limiter minimum stroke distance should be 8" for rotary wing (18), while a 1962 Army troop seat design study recommended that the seat-restraint system should be capable of maintaining 25G + 5G in the pelvic area while deforming through at least 12 inches of vertical travel (30).

#### 4. Lack of Upper Torso Restraint

Case No. 4. The pilot of an Enstrom F-28A, subsequent to suspected mechanical malfunction and impact landing, received fatal injuries which were attributed to an intruding blunt object, probably as a result of a rotor blade strike when the rotor mast



Fig. 10. View of Bell Jet Ranger 206B seats post-impact, with seat cushions in place.

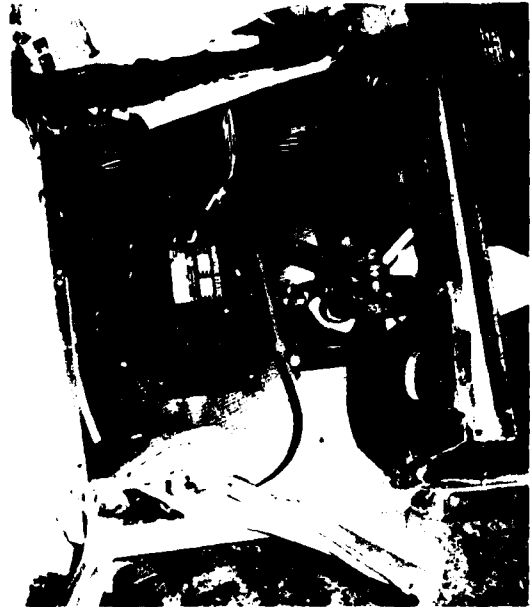

Fig. 11. Right front seat with cushion and seat pan removed, showing structural collapse. The occupant received severe vertebral fractures and spinal damage resulting in paraplegia.

failed. Neither of the two passengers were reported to be injured. However, the pilot's lower face was almost obliterated, and major injuries included transection of the sternum, comminuted fracture of the humerus with extensive left shoulder lacerations, left rib fractures, laceration of the spleen and aorta with hemopericardium. It was determined that had an upper torso restraint been available and worn this pilot would not have flexed forward sufficiently to have been in the strike zone. Fig. 12 shows that blade intrusion into the cabin area was very limited.

Blade intrusion (in-flight) was also reported in the Los Angeles Airways Sikorsky S-61L accident at Compton, where one crew member was reportedly decapitated and received slashing type injuries to the right torso.

#### 4. Restraint Failure

The seat-restraint system should be considered as a single system, since adequate occupant protection is dependent upon both. This is especially true in cases where the seat belt tie downs are attached to the seat. A strongly attached seat belt is of little use if the seat itself fails. Failure of any component, attachment, the webbing, buckle mechanism, or the seat itself may result in injury to the occupant. In the following accident, fatal ejection of the pilot was directly caused by release of a fabric-to-metal type lap belt.

Case No. 5. A student pilot was practicing a running takeoff from a salt-flat sandbar in a Hughes 269B. The right skid dug through the crust into the softer terrain below, pitching the helicopter down and rolling to the right. The student pilot, seated in the left seat, was ejected through the canopy and fatally injured. The instructor pilot in the right seat was uninjured. Investigation disclosed that although the pilot's seatbelt had been secure previously, it loosened inadvertently as he was attempting to regain control and allowed him to be thrown from

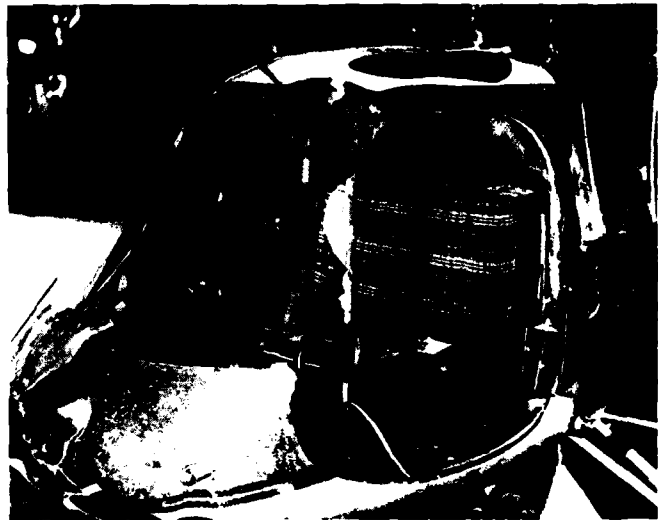

Fig. 12. Enstrom 27A in which pilot fatally injured when lack of shoulder harness allowed head flexion into probable blade strike in emergency landing.



his seat unrestrained at impact.

Deficiencies in the design of this belt (shown in Fig. 13), which have also been previously noted in fixed-wing aircraft, were found by the NTSB. In the impact sequence, as the right skid dug in, the pilot probably applied left and aft cyclic control, causing his right arm to contact and lift the seatbelt locking lever. The seatbelt release lever, which protrudes above the release mechanism, when snagged on clothing or when contacted by the arm during deceleration, can be lifted and cause this belt to loosen and slip through. The location of the protruding release lever, near the pilots' right forearm, also increased the possibility of inadvertent loosening of the seatbelt during normal arm motions in cyclic control. NTSB analysis resulted in a recommendation to the FAA for an amended TSO (31).

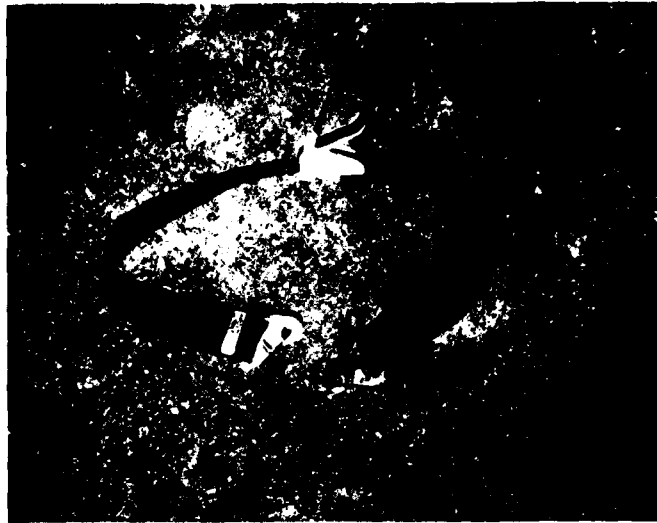

Fig. 13. Metal-to-fabric lap belt used in Hughes 269B accident in which the release mechanism inadvertently opened, allowing pilot to be fatally ejected.

#### DISCUSSION

In view of findings reported by Haley at a 1971 AGARD Conference, that in Army helicopters for the period 1967-1969, 40 percent of all occupant fatalities occurred in survivable accidents with fire the single largest fatality cause (followed by head injury) (28), a search of civil helicopter accidents records was made to determine the incidence and injury effect of post-impact fire. From 1964 through 1976, 339 individuals were associated with post-impact fire. However, only 28 deaths were attributed to this cause in civil helicopter accidents. Of 280 fatalities to helicopter pilots, autopsies were obtained in 111 cases (39.4%), but toxicology was only determined in 20 cases (7.1%) according to NTSB data.

The selected cases noted in the preceding section indicate that there is a serious need for detailed investigation of helicopter accidents to determine the nature and extent of occupant protection and impact injury causation. However, it is evident that data are presently insufficient to determine the extent to which such deficiencies have contributed to fatal and serious injuries.

A number of accident investigations have clearly shown that upper-torso restraints are not often installed, and this has been confirmed by a survey of manufacturers installations 1972-1978 (32). Although at first glance it may seem that an upper-torso restraint is of less value in a helicopter than in fixed-wing aircraft, it is at least as important in occupant protection. In any impact, including the cases noted above, considerably improved protection can be provided by an upper-torso restraint. Such restraints should utilize an inertia reel to allow freedom of motion of the pilot but include sensing and automatic locking of the device during impact.

The upper-torso restraint serves to keep the occupant from flexing and flailing against interior structure in an impact deceleration. In a helicopter an upper-torso restraint serves an additional important function, in that it can keep the occupant's vertebral column in better position to resist vertical impact injuries. This is because if the back is allowed to flex forward during vertical impact, one effect is that distribution of the loading on the vertebral bodies is decreased, and with more concentrated loading failure can occur at less load than if the back is more erect. The complexities involved has been discussed in detail by Kazarian (33), and the role of the articular facets described by King, et al. (34).

An example of greatly improved protection over case no. 4 is illustrated by Fig. 14, a Hughes 269C operated by the San Mateo, California Sheriffs Department. Instead of the standard civil seat, they utilize the optional military seat, offering additional occupant crash protection. Both pilots utilize Y-yoke dual shoulder harnesses, attached to inertia reels, and which stow above when on the ground for easy donning. The use of military helmets is also mandatory, an item which could prevent much head injury in civil use.

A combination of well designed and installed restraints, including upper-torso restraint, seats designed to provide adequate crush space and energy absorption by a number of force-limiting techniques, and use of protective helmets are measures which can offer improved occupant impact protection in civil helicopters.

#### CONCLUSION

Civil helicopter accidents have not had the same degree of evaluation and attention as military accidents. Relatively little is known concerning the mechanisms of impact

injury causation except for a few cases which have had biomedical investigation. This may be because helicopter accidents make up only about four percent of the total civil accidents.

During the past 14 years there have been a total of 3575 helicopter accidents reported, averaging 255 a year. An average of 505 individuals are involved in helicopter accidents per year, and approximately 82% receive only minor injury or none at all. However, when an accident is severe enough to result in greater than minor injury, the chances are equal that a fatality will occur. This suggests that civil helicopters require improved occupant impact protection. From 1964 through 1976, 339 occupants in helicopter accidents were exposed to fire, and 28 deaths were reported from this cause.

A serious effort should be made to obtain and record injury information in future helicopter accidents to provide a basis for further evaluation.



Fig. 14. Hughes 269C equipped with upper torso restraint, helmets, and military-style seat.

#### REFERENCES

1. Aerospace Industries Association of America, Inc. 1977/78 Directory Heliports in the United States, Canada, Puerto Rico. Washington, D.C., 1978, p.27.
2. Aerospace Industries Association of America, Inc. 1977 Directory of Helicopter Operators in the United States, Canada and Puerto Rico. Washington, D.C., 1978.
3. North, David M., "Selected Helicopter Growth Forecast" Aviation Week and Space Technology, January 30, 1978, pp. 49-53.
4. Aerospace Industries Association of America, Inc., Aerospace Facts and Figures 1972/73. Washington, D.C., 1973.
5. Aerospace Industries Association of America, Inc., Aerospace Facts and Figures 1977/78. Washington, D.C., 1978.
6. Federal Aviation Administration Flight Standards Service. Technical Analysis Branch. Unpublished data, February, 1978.
7. Aerospace Industries Association of America, Inc., Aerospace Facts and Figures 1962. Washington, D.C., 1962
8. Federal Aviation Administration FAA Statistical Handbook of Aviation, Calender Year 1975. Department of Transportation, Washington, D.C., 31 December, 1975.
9. Anon. "Europe Gears for Helicopter Surge", Aviation Week and Space Technology. pp. 51-53, January 30, 1978.
10. Taylor, J.W.R. (ed) Janes' All the World's Aircraft, 1972-73, London, pp. 413-414, 1973.
11. Taylor, J.W.R. (ed) Janes' All the World's Aircraft, 1976-77, London, pp. 388-389, 1977.
12. Anon. "Inflight Report: Sikorsky S-76", Business and Commercial Aviation, pp. 71-75, January, 1978.
13. Garrison, J.R. and H.H. Waldrup, The Bell Model 222, Society of Automotive Engineers, Inc., Technical Paper No. 770951, November, 1977.
14. Lambert, M., "Helicopter Meeting Highlights New Trends" Flight International, pp. 356-357, February 11, 1978.
15. Bulban, E.J., "Helicopter Sales Increase Predicted", Aviation Week and Space Technology, pp. 42-47, January 30, 1978.

16. Anon. "Light Turbine Helicopter Growth Predicted", Aviation Week and Space Technology, p. 20, February 13, 1978.
17. Federal Aviation Administration, The National Aviation System Plan Fiscal Years 1976-1985, March, 1975, pp. 2-1.
18. U.S. Army Air Mobility Research and Development Laboratory., Crash Survival Design Guide, Eustis Directorate, Ft. Eustis, VA., USAAMRCL Technical Rept. 71-22, October, 1971.
19. National Transportation Safety Board, Aircraft Accident Report. Los Angeles Airways, Inc., Sikorsky S-61L, N303Y, Paramount, California, May 22, 1968. File No. I-0005. Adopted 18 Dec., 1969, Washington, D.C. Report SA-404.
20. National Transportation Safety Board, Aircraft Accident Report. Los Angeles Airways, Inc. S-71L Helicopter, N300Y, Compton, California, August 14, 1968. File No. I-0016. Adopted 27 August, 1969. Washington, D.C. Report SA-407.
21. National Transportation Safety Board. Aircraft Accident Report. New York Airways, Inc. Sikorsky S-61L, N619PA, Pan Am Building Heliport New York, New York. May 16, 1977, Washington, D.C., Report No. NTSB-AAR-77-9, 13 October, 1977.
22. Snyder, R.G., General Aviation Crash Survivability Society of Automotive Engineers, Inc. Warrendale, PA. Paper No. 780017, February, 1978.
23. National Transportation Safety Board, Safety Information Release, "Accidents, Fatalities, Rates. U.S. General Aviation 1967-1977", SB78-6, January 17, 1978.
24. Snyder, R.G. Crashworthiness Investigation of General Aviation Accidents Society of Automotive Engineers, Inc., Warrendale, PA., Paper No. 750537, April, 1975.
25. National Safety Council "Accident Facts" 1977 Edition. Chicago, Illinois, 1977.
26. National Transportation Safety Board Safety Information: Transportation Fatalities 49,575 in 1976, May 14, 1977.
27. Staples, J.C., Personal Communication, Federal Aviation Agency, Washington, D.C., November 5, 1962.
28. Haley Jr., J.L., "Analysis of U.S. Army Helicopter Accidents to Define Impact Injury Problems", Linear Acceleration of Impact Type, AGARD Conference Proceedings No. 88, Report AGARD-CP-88-71, pp. 9-1 to 9-12, June, 1971.
29. National Transportation Safety Board. Bell Helicopter, N9992K, Model 222. Preliminary accident/incident resume report, 1 December, 1977.
30. Turnbow, J.W., V.E. Rothe, G.M. Bruggink, and H.F. Roegner Military Troop Seat Design Criteria Aviation Crash Injury Research of Flight Safety Foundation TCREC Technical Report 62-79. U.S. Army Aviation Material Laboratories, Fort Eustis, VA, November, 1962.
31. Lawson, N.D., Memorandum recommendation regarding Hughes 269B accident May 6, 1974, National Transportation Safety Board, 1974.
32. Snyder, R.G. Civil Aircraft Restraint Systems: State-of-the-Art Evaluation of Standards, Experimental Data, and Accident Experience Society of Automotive Engineers, Inc., Warrendale, PA. Report No. 770154, Appendix D, February, 1977.
33. Kazarian, L.E., D.D. Boyd, and H.E. von Gierke "The Dynamic Biomechanical Nature of Spinal Fractures and Articular Facet Derangement" AGARD Conference Proceedings No. 88 Linear Acceleration (Impact Type), AGARD-CP-88-71, pp. 19:1-9, June, 1971.
34. King, A.I., P. Prasad, and C.L. Ewing "Mechanism of Spinal Injury Due to Caudoccephalad Acceleration" Orthopedic Clinics of North America. 6:19-31, 1975.

#### ACKNOWLEDGEMENTS

The author would like to acknowledge the generous assistance provided in the preparation of this paper, by Thomas J. Collins, Technical Analysis Branch, Flight Standards Service, FAA, Washington, D.C. and Matthew M. McCormick, Human Factors Division, National Transportation Safety Board, Washington, D.C. In addition Dr. Richard J. Kaplan, Systems Division, provided advice in Data Analysis, Leigh S. Peck assisted with accident data retrieval, Kathy Jackson with illustrations, Jean Brindamour with photo reproduction and Beverly Creviston, with manuscript assistance.

## COMPARATIVE INJURY PATTERNS IN U. S. ARMY HELICOPTERS

by

Laurel D. Sand  
Air Safety Specialist  
U.S. Army Agency for Aviation Safety  
Fort Rucker, Alabama 36362

## Summary

This paper examines the type of injuries, body area injured, and cause of injuries to 740 U.S. Army aviators involved in 388 rotary wing accidents from 1 January 1972 through 30 September 1977. Considerations were given to two main areas: (a) relationship to injury regarding the aviator's height, weight, and location aboard the aircraft, cockpit condition, and aircraft altitude; and (b) comparison of present injury experience with previous injury studies. The results, through statistical analyses, show that not one or even combinations of those factors listed in (a) above were significant in injury causation. Further, comparison of injuries shows that the overall injury pattern has not changed significantly in the past 20 years. For example, injuries to the extremities, the head, and the spine continue to be among the leading body areas to be injured. Also, 94 percent of all accidents from 1957 to present were classified as survivable but produced 33 percent of all fatalities.

## Introduction

The first U.S. fatal military aircraft accident occurred at 5:18 PM on September 17, 1908, at Fort Myer, Virginia.<sup>1</sup> In that accident First Lieutenant Thomas E. Selfridge received fatal head injuries. Mr. Orville Wright, also aboard the aircraft, sustained a broken leg, fractured ribs, and facial lacerations. The injuries incurred by Selfridge and Wright are similar to those injuries aviators receive today. Since 1957 our data shows that head injuries have been a leading cause of death and that extremities have been one of the most injured body areas. Each year the Army experiences an unacceptable number of rotary wing accidents in which injuries or fatalities occur even though the accidents are considered survivable.

The purpose of this paper is to present a comparison of the injuries to occupants of pilot or copilot seats in U.S. Army helicopter accidents from 1 January 1972 through 30 September 1977 with previous injury studies.<sup>2,3,4</sup> Injury data were gathered for each individual involved from the Technical Reports of U.S. Army Aircraft Accidents stored at the U.S. Army Agency for Aviation Safety, Fort Rucker, Alabama.

## Discussion

Accident Experience. From July 1960 through September 1977 the Active Army had 7,903 aircraft accidents with 6,382 people injured and 3,046 people killed. The cost of these accidents totaled more than \$912 million.

Figure 1 shows the U.S. Army aircraft accident injury and fatality rates per 100,000 flying hours from FY 61 through FY 77. Significant increases in these rates are evident in 1962, 1964, 1967, 1972 and 1976. The reason for the sharp rise in 1962 is that there were more than three times as many people killed compared to the previous year without a significant increase in flying hours. In 1972 there was a significant rise which surpassed the fatality experience of the Vietnam era. This peak was due to five helicopter accidents that produced 127 fatalities and 50 injuries. The increase in 1964 reflects the introduction of the airmobility concept which brought about a significant increase in exposure to situations that cause accidents. A similar pattern is seen in the 1966-1970 time frame during the Vietnam war. The rapid decline in the injury and fatality rates after Vietnam is indicative of a post-war era with reduced demands on aviation. In 1976 a large number of accidents involving weather and wire strikes resulted in nearly twice as many fatalities as the previous and following years. The trend of the injury and fatality rates is on the decline as shown in Figure 1. The accident rate has dropped 84 percent since 1961.

Accident Survivability. The U.S. Army criteria taken from Army Regulation 95-5<sup>5</sup> to classify an aircraft accident in respect to survivability is:

"a. An accident is survivable if the crash forces imposed upon the occupants are, in your best judgment, within the limits of human tolerance and all portions of the inhabitable area of the aircraft remain reasonably intact; i.e., are not collapsed sufficiently to impinge upon, or crush vital areas of a person seated in a normal position.

"b. Fatal injuries or occupancy of an inhabitable area are not criteria for determining survivability of an accident. For example, if the front seat area of a tandem seat aircraft was completely demolished but the structure of the rear seat was virtually intact, the accident would be classified as partially survivable even though the rear seat occupant was fatally injured. The accident would still be classified as partially survivable if the rear seat was unoccupied. Thus, occupancy or nonoccupancy is irrelevant to survivability.

"c. An accident is nonsurvivable when the impact forces exceed human tolerance and/or all inhabitable areas are collapsed or disintegrated by impact to a degree where all occupants would sustain crushing injuries of vital body areas."

Table 1 shows the Army's aircraft accident experience, by survivability classification, as reported in previous studies since 1957, i.e., Bezreh 1957-1960<sup>2</sup>, Mattox 1961-1965<sup>3</sup>, Berner and Sand 1965-1969<sup>4</sup>, and the present. Hereafter, these studies will be referred to as Bezreh, Mattox, Berner and Sand when comparing findings.

It should be noted that even though more than 90 percent of all accidents are considered survivable they account for a significant percentage of the total fatalities. In the FY 57 through FY 69 time frame, 35 percent of the fatalities occurred in survivable accidents compared to 33 percent for this period.

Table 2 shows the accident experience for the four categories of helicopters reviewed. Observation, utility, and cargo helicopters each had more accidents with injuries and fatalities than without injuries and fatalities. The reverse was true for attack helicopters, which had fewer accidents with injuries and fatalities.

Patterns of Injury. The lower extremities, the head, and the upper extremities continue to be among the most injured body area (see Figure 2). During the periods examined by Bezreh and Mattox and for the period of this study, it was found that these body areas were the recipients of more than 50 percent of all injuries. Bezreh's study shows that the number of injuries to the head are significantly greater when compared to Mattox and the present study. One explanation for the greater number of head injuries is that protective helmets for aircrewmembers were not available until mid-1959. Injuries to the face, neck, pelvis and lower extremities tend to remain constant. There is a slight increase in injuries to the chest and abdomen, while the upper extremities and spine show a decrease. Figure 2 also shows that for this period more fatal injuries occurred to the head than all other body areas combined.

The preponderance of major injuries occurs to the lower extremities, spine, chest and head. The major injuries that occur to the lower extremities, spine and head are primarily fractures, while the chest receives injuries such as hemorrhage, lacerations and contusions of internal organs. Minor injuries are generally lacerations, contusions, abrasions and sprain/strain which require less than five days in the hospital or quarters. The legs head the list for these injuries followed by the arms and then the face.

Table 3 shows that certain injury types tend to remain constant. Bezreh and Mattox reported that wounds, fractures and burns accounted for 85 and 86 percent respectively of all injuries compared to 81 percent for this time period. Lacerations, contusions and abrasions are the most frequent types of injury, accounting for 50.4 percent of the total injuries, while fractures account for 27.2 percent. Sprain/strain injuries account for 7.6 percent and all other injuries occur less than four percent.

Injury Causation. Injuries to the legs, arms and head occur frequently because these parts are most distant from the restraint system and are free to flail during a crash. Head injuries are caused primarily by contact with aircraft structures, particularly in accidents in which the aircraft rolls over. High impact forces generally cause concussion, laceration or contusions of the brain and rebound injuries when the head strikes the seat back or other structures. In three cases fatal head injuries occurred when the main rotor blade entered the cockpit.

Since 1969 the extremities have received more injuries than other body areas. The injuries generally occur as a result of impact forces which cause structures to deform and impinge upon them or cause the extremities to rebound into surrounding structures. Rare injuries to the legs played a major role in the death of two occupants. One occurred when an OH-58 pilot was severely lacerated in the thigh by the main rotor blade. The leg became infected from contaminated water and the aviator died of septicemia. The other was the front seat occupant of an AH-1G. The aircraft struck wires across a river and crashed in trees. A branch penetrated the cockpit and caused below-the-knee amputation and the occupant bled to death before help arrived.

Seventy-four percent of the injuries to the spine are compression fractures of the vertebrae. Sprain/strain injuries of the paraspinal muscles account for 24 percent and transection of the spinal cord 2 percent. The cause of these injuries is often vertical deceleration, i.e., the lack of energy attenuation in the restraint system, landing gear and fuselage. A methodology for the analysis of injury causes is discussed in "Engineering Analysis of Crash Injury in Army Aircraft" by Dr. J. E. Hicks. Injuries to internal organs also occur for these reasons. The thermal injuries shown include fatal thermal injuries, thermal injuries to persons who died from other causes and all nonfatal thermal injuries. Because of the high incidence of thermal injuries, the Army spearheaded the development of the crashworthy fuel system. This system and its effectiveness will be presented in this conference.

Causes of Death. For the past 20 years multiple extreme injuries, head injuries, and burns have been called the "big three" causes of death as shown in Table 4. Bezreh, Mattox, and Berner and Sand found these three injuries were responsible for more than 70 percent of the causes of death. Drowning was the fourth leading cause of death during the 1965-1969 time frame. At present, drowning and hemorrhage tie in fourth place. Three of the four drownings occurred in 1975 and in each case the individual was reported as not knowing how to swim. The six thermal fatalities (6 percent) shown in Table 4 are explained as follows: Two were in an aircraft not equipped with a crashworthy fuel system and four were in four separate non-survivable accidents in which burns were listed as cause of death. Two of the aircraft were equipped with the crashworthy fuel system and two were not. The dramatic drop in thermal fatalities is due mainly to the success of the crashworthy fuel system and partly to the fire retardant Nomex flight uniform. In contrast, "multiple extreme" injuries as cause of death for this time period is the result of the five catastrophic helicopter accidents in which 127 people were killed.

Finally, a correlation analysis was performed to determine (a) if there was any difference in where an individual sat, i.e., left or right seat or front or rear seat, (b) if the individual's height and weight influence his receiving or avoiding injuries, and (c) if there were any relationships of any of these combinations to the attitude of the aircraft and condition of the cockpit by type of aircraft. The smallest aviator was 64 inches tall and weighed 110 pounds. The largest aviator was 77 inches tall and weighed 223 pounds. The average was 70.4 inches and 173 pounds. The analysis showed that none of the

variables were significant even in accidents in which one individual was injured and the other was not. The study showed that statistically it makes no difference how big you are or where you sit. A separate crash injury study being conducted by USAAAVS concerning the AH-1 series also verified that the relationship of injuries to seat location was not significant. A Ridit<sup>6</sup> analysis was performed to determine if the severity of injuries was associated with type of aircraft. This analysis showed that the probability of injury was highest in observation helicopters, followed by utility helicopters. The attack helicopter was the lowest of the group. Cargo helicopters were not analyzed because of their small number of accidents and injuries.

#### Final Remarks

The trend in rotary wing accidents which produce injuries or fatalities is on the decline, as shown in Figure 1. In addition, the overall accident rate has dropped 84 percent since 1961. Several important factors have contributed to this trend, i.e., an increasing awareness in aviation safety to include an active safety educational program, improved life support equipment such as the SPH-4 helmet and Nomex flight clothing, and the incorporation of the crashworthy fuel system.

It is predicted that the patterns of injury occurring in future accidents involving the Army's present family of aircraft will compare closely with those in the past. Little has been done to improve the overall injury picture in these aircraft. However, due to past injury studies, a great deal of time and money have been spent developing today's state-of-the-art in lifesaving crashworthy features. The next generation of aircraft will be crashworthy to the extent that all fatalities should be prevented and injuries minimized in 95 percent of all survivable accidents.<sup>7</sup> The Utility Tactical Transport Aircraft System (UTTAS) and the Advanced Attack Helicopter (AAH) are designed in accordance with the Army's "Crash Survival Design Guide."<sup>8</sup> The crash safety design criteria of this document were the basis of the Army's Military Standard MIL-STD-1290 (AV)<sup>9</sup> which requires that all future Army helicopters be crashworthy during crash impacts up to the 95th percentile survivable accident. The Army is spearheading the drive towards aircraft that are not only safe to fly in but safe to crash in as well. For these reasons the overall injury picture of the future should change significantly by reducing mortality and morbidity in Army aircraft accidents.

#### References

1. First U. S. Military Aircraft Accident. United States Army Agency for Aviation Safety, May 1973.
2. Bezreh, Anthony A., Helicopter Versus Fixed Wing Crash Injuries. Aerospace Medicine, Vol. 34, No. 1, January 1963.
3. Mattox, Kenneth L., Injury Experience in Army Helicopter Accidents. U. S. Army Board for Aviation Accident Research, Fort Rucker, Alabama, HF 68-1.
4. Berner, William H., and Sand, Laurel D., Deaths in Survivable Aircraft Accidents, Aerospace Medicine, Vol. 42, No. 10, October 1971.
5. Army Regulation 95-5, Aircraft Accident Prevention, Investigation, and Reporting, 1 July 1975.
6. Bross, I. D. J., and Feldman, R., Ridit Analysis of Automotive Crash Injuries. New York: Division of Automotive Crash Injury Research, Cornell University Medical College, 1956.
7. Singley, G. T., III, and Sand, L. D., U. S. Army Helicopter Accident Experience. AGARD Proceedings No. 212 on Aircraft Operational Experience and its Impact on Safety and Survivability AGARD-CP-212, p. 1-1, June 1976.
8. USAAMRDL TR-71-22, Crash Survival Design Guide, U. S. Army Mobility R & D Laboratory, Fort Eustis, Virginia, October 1971.
9. Military Standard MIL-STD-1290 (AV), Light Fixed and Rotary Wing Aircraft Crashworthiness, 25 January 1974.

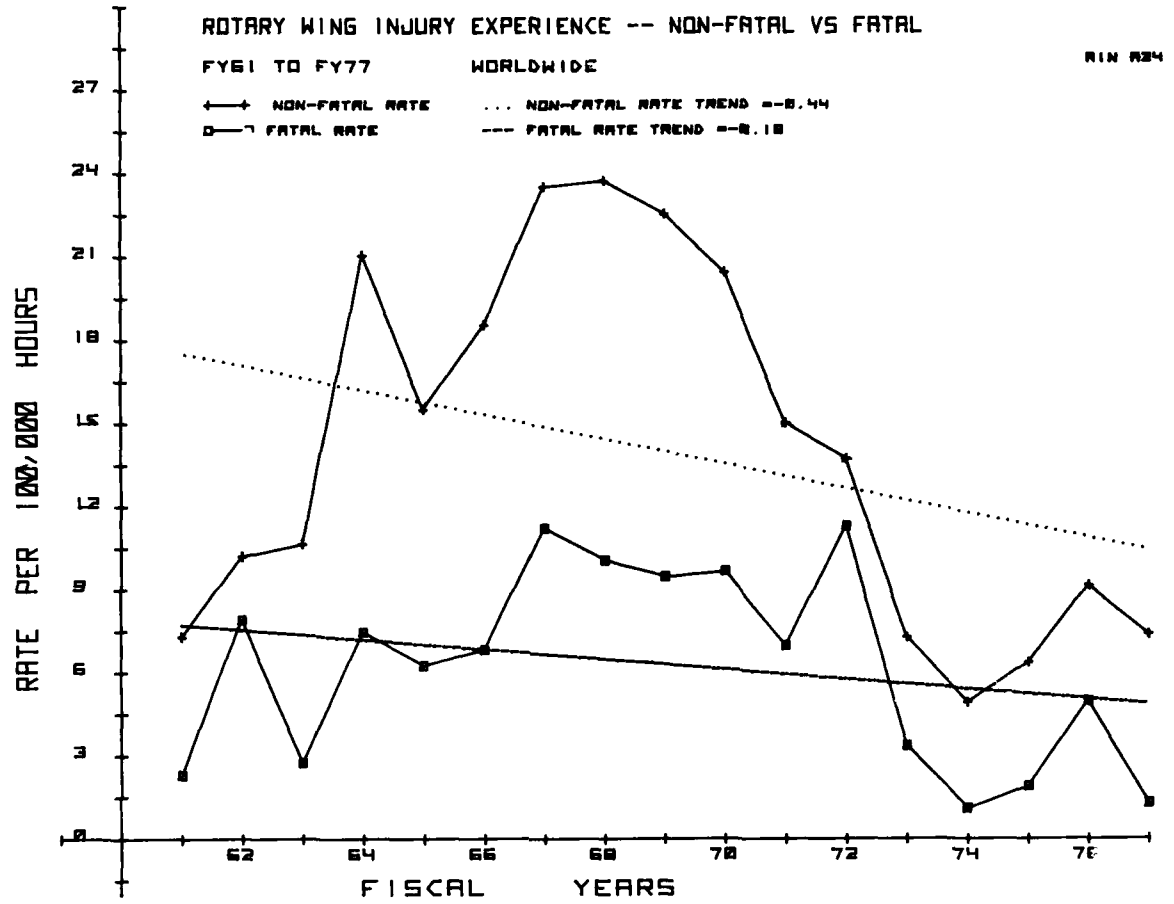

Injuries to Body Areas by Degree of Injury  
 U.S. Army Helicopter Injury Experience by  
 Body Area and Degree  
 1 January 1972 through 30 September 1977

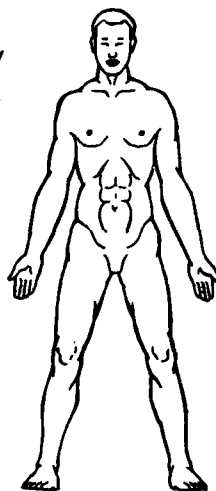

	PRESENT	BEZREM <sup>2</sup>	MATTOX <sup>3</sup>
HEAD	13.4%	21%	11%
FACE	10.6%	7%	10%
NECK	3.3%	2%	4%
UPPER EXTREMITIES	14.5%	16%	22%
CHEST	10.5%	7%	9%
ABDOMEN	5.0%	1%	3%
PELVIS	1.3%	2%	1%
SPINE	10.1%	6%	13%
LOWER EXTREMITIES	22.7%	25%	21%
BODY AREA NOT REPORTED	8.7%*	12%	6%

DEGREE OF INJURY	HEAD	FACE	NECK	UPPER EXTREMITIES	CHEST	ABDOMEN	PELVIS	SPINE	LOWER EXTREMITIES	BODY AREA NOT REPORTED	TOTAL
FATAL	45	0	3	0	15	8	0	2	2	58*	133
MAJOR	52	22	3	28	63	27	5	71	73	7	351
MINOR	28	77	25	107	20	12	7	21	137	16	450
TOTAL	125	99	31	135	98	47	12	94	212	81	934

\*Generally classified as Multiple Extreme Injuries

FIGURE 2



TABLE 1  
U.S. Army Aircraft Accident Experience by Survivability  
1 July 1960 through 30 September 1977

	Jul 57 - Dec 60* (Bezreh)	Jan 61 - Dec 65* (Mattox)	Jul 65 - Jun 69** (Berner/Sand)	Jan 72 - Sep 77**
Survivable	97%	95%	94%	84%
Partially Survivable	0	0	0	6
Nonsurvivable	<u>3</u>	<u>5</u>	<u>6</u>	<u>10</u>
TOTALS	100%	100%	100%	100%

\*Partially Survivable accidents were not a classification for these time periods.

\*\*Survivable and Partially Survivable accidents were reported together as survivable.

TABLE 2  
U.S. Army Helicopter Injury Experience Per Accident  
1 January 1972 through 30 September 1977

	NUMBER OF ACCIDENTS	ACCIDENTS WITHOUT INJURY	ACCIDENTS WITH INJURY	ACCIDENTS WITH FATALITIES
Attack AH-1	84	47	27	10
Observation OH-6/OH-58	123	52	54	17
Utility UH-1	172	81	63	28
Cargo CH-47/CH-54	9	2	3	4

TABLE 3  
U.S. Army Helicopter Injury Experience by Injury Type and Degree  
1 January 1972 through 30 September 1977

INJURY TYPES	TOTAL INJURIES	% MINOR	% MAJOR	% FATAL	PERCENT OF TOTAL INJURIES		
					Present	Bezreh '57-'60	Mattox '60-'65
Lacerations Contusions Abrasions	471	83.6	18.6	22.6	50.4	58	60
Fractures	254	2.4	62.5	18.0	27.2	20	17
Sprain/Strain	71	13.6	2.8	0.0	7.6	5	7
Multiple Extreme	34	0.0	0.0	25.5	3.6	1	2
Concussion	29	0.0	8.4	0.0	3.1	4	1
Burns	27	0.4	0.9	16.5	2.9	8	10
Crushing Rupture Hemorrhage	27	0.0	5.4	6.0	2.9	4	1
Decapitation	7	0.0	0.0	6.8	0.8	0	0
Miscellaneous	6	0.0	1.2	1.4	0.7	0	2
Drowning	4	0.0	0.0	3.0	0.4	0	0
Traumatic Amputation	4	0.0	0.2	0.2	0.4	0	0
Total	934	100.0	100.0	100.0	100.0	100	100

TABLE 4  
Helicopter Causes of Death

	BEZREH %	MATTOX %	BERNER/SAND %	1 JAN 72 - 30 SEP 77 %
Multiple Extreme	24	53	14	51
Head Injuries	24	15	22	27
Burns	24	15	41	6
Hemorrhage	9	2	3	4
Drowning	6	0	9	4
Ruptured Aorta	3	8	3	2
Transection of Spinal Cord	0	3	2	2
Asphyxia	0	0	1	2
Other	<u>10</u>	<u>4</u>	<u>5</u>	<u>2</u>
TOTALS	100	100	100	100

## ENGINEERING ANALYSIS OF CRASH INJURY IN ARMY AIRCRAFT

by

James E. Hicks, Ph.D.  
Aerospace Engineer  
U.S. Army Agency for Aviation Safety  
Fort Rucker, Alabama 36362

Summary

A methodology for identification of crashworthiness deficiencies in Army aircraft is discussed. The methodology provides for injury and impact data to be extracted from accident reports using a specially-developed injury coding system. Personnel injuries are costed through a technique which provides for consideration of each injury based on its relative severity as determined by medical examination. Crash injury causes are identified and ranked according to the magnitude of their effect and probability of occurrence. The technique is designed to provide recommendations as to the most urgent crashworthiness research/development/procurement efforts for consideration by aircraft systems managers and aviation research laboratories.

An application of the methodology to an operational Army aircraft is shown. Preliminary results as to the more significant crash hazards in this aircraft are discussed. Recommendations are made as to the use of the methodology and to additional investigation aids which would improve the future identification of crash hazards.

Introduction

For a number of years, the U.S. Army has taken the lead in the prevention of aircraft crash injury. This is due to the continuing research in this area and has led to the incorporation of crashworthiness improvements into both current and future Army aircraft.

Because of currently dwindling resources and diminishing funds for crashworthiness research, however, the need has become greater than ever for an improved direction to crashworthiness R&D planning. This is needed to insure that the funds available are placed against the most pressing needs. This paper discusses a methodology for the analysis of aircraft crash injury which has been developed to identify their underlying engineering design causes and focus on the most pressing R&D requirements. An application of this methodology to an operational Army helicopter is discussed in order to show the output available.

Assumptions

The major assumptions of this technique are as follows:

- a. Past aircraft accident data provides a valid baseline for establishment of future crashworthiness design criteria.
- b. The economic loss to the Army due to injuries of various degree in aircraft accidents is as specified in Reference [1].
- c. The rates of injury occurrence and cost as identified in the baseline study period will prevail for a future 20 year period.

Objectives

The overall objectives of this technique are to (1) identify the most significant injury causes, (2) determine the extent of losses attributable to each and (3) establish under what crash mechanisms and impact conditions each becomes a problem. Emphasis was to be placed on not merely documenting the types and frequency of injuries sustained but also on identifying their underlying engineering causes. The analysis of the engineering causes of crash injury was to consider the biological limitations of the human body as presently contained in such investigation tools as the Dynamic Response Index (Reference [2]). It was envisioned that a primary output of this effort would be an improved direction for crashworthiness research and development including identification of follow-on research required to define specific design changes necessary to reduce the identified hazards in current and future aircraft designs.

MethodologyDATA SOURCE

The primary data source for this analysis is the case files of Army aircraft accidents (Department of the Army 2397-series forms). Appendix A contains definitions of an Army aircraft accident and additional terms used in other sections of this report.

Another data source was the pathology data bank maintained by the Armed Forces Institute of Pathology. This source provided additional data beyond that available in the USAAAVS accident files for certain fatal injury cases.

A final data source was a description of currently available technology in the aircraft crashworthiness and life support equipment areas. This information was derived primarily from research and development studies by U.S. Army Applied Technology Laboratory. Representative information available in the open literature is contained in References [2], [3] and [4].

#### OVERALL STUDY METHODOLOGY

Each step in the analysis sequence is shown in Figure 1. The overall scheme is one in which analyses of individual accident case histories establishes a data base of crashworthiness-related hardware deficiencies and related injuries. This data base is then analyzed to determine the most urgent crash hazards and the impact conditions under which they occur. Details of the procedure used in each of these overall steps are discussed below and are referenced back to Figure 1.

#### ACCIDENT REPORT ANALYSIS

The study of each accident involved two efforts: an analysis of the impact conditions and a medical analysis of the impact trauma and causal factors. A system of classification and coding was developed to aid in recording these findings. (The impact conditions were studied and coded but will not be discussed in detail here.) This system took components of similar codes now in use within the USAAAVS automatic data processing system as well as portions of codes in use in other crash safety investigations. The objective was a system which was sufficiently descriptive to lead to meaningful findings and recommendations but not so detailed that the analysis was made cumbersome.

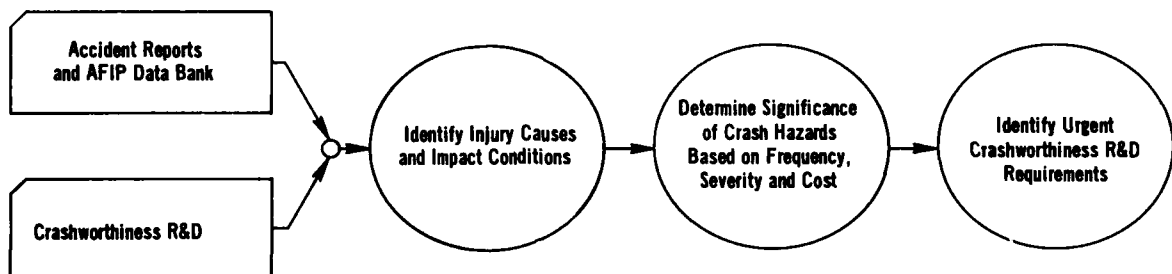

FIGURE 1.—Overall Sequence of Analysis

The coding system which resulted provided for a systematic classification of each injury in terms of (1) its medical description of trauma, (2) the mechanism by which it occurred, (3) the underlying deficiency which caused it, and (4) its resulting cost. Details of the code and its use are discussed below.

#### Medical Description of Trauma

All of the trauma incurred by each occupant was recorded in terms of a medical description of what kind of injuries resulted and their severity. The following characteristics of each injury were established.

- Location of injury by overall body region
- Aspect of injured region
- Type of lesion
- Body system involved
- Injury severity

The actual codes used for this analysis are available from USAAAVS. These codes were the result of a combined opinion of the agencies concerned as to what portions of previous codes were useful. These codes had one unique aspect in that the "injury location" was determined in terms of an overall body region rather than an exact anatomical site. This procedure was used because the primary emphasis was placed on the identification of injury causes and their remedies rather than a medical "cataloging" of the injuries themselves. The determination of injury location by overall body region facilitated the engineering analysis of the injury causes.

#### Mechanism of Injury Occurrence

The mechanism of injury occurrence described the process through which each injury occurred. The following mechanism parameters were established for each injury:

- Mechanism action
- Mechanism qualifier

These two parameters, in conjunction with the Injury Location description above, were used to comprise a subject-verb-qualifier combination. This described how the injury occurred by use of a simple sentence construction, such as "pilot's face struck cyclic."

### Injury Cost

The economic loss to the Army due to each injury was calculated based on Reference [1]. Reference [1] was applied herein based on the overall injury classification to each casualty and resulted in an estimate of the loss for each casualty taken as a whole. In cases in which multiple injuries occurred to one casualty, the cost of each individual injury was calculated as a portion of this total. A flight surgeon determined the severity of each individual injury in these cases to identify the proportionate cost of each individual injury. The proportion of the total cost which was due to each injury was weighted based on the loss which would have occurred had that injury occurred alone relative to the costs of the other injuries. The mathematical procedure used to calculate the cost of each injury is shown in equation (1):

$$\text{Individual Cost of Injury} = \text{Total Cost of Casualty} \times \frac{\text{Cost of individual injury acting alone}}{\text{Sum of costs of all injuries, each acting alone}} \quad (1)$$

Use of this equation insures that (1) all injuries which occurred receive proper economic consideration based on their relative severity and (2) that the sum of all the weighted injury costs is equal to the "book value" for the cost of that casualty.

In fatal cases, all of the injuries were recorded on a frequency basis, but costs were apportioned only among the fatal injuries. This distinction was made because the multiple extreme injuries in these severe cases precluded a credible assessment of the economic benefits of preventing the less severe injuries.

### Combined Injury Code

The components of the injury code discussed above were established for each casualty and then combined to provide a description of his injuries, their causes and costs, in a format and level of detail which permitted analysis of the critical trends (discussed below). Thus, an injury code such as the hypothetical example shown in Table I below was established for each casualty.

TABLE I  
Hypothetical Example of Use of Injury Code for Casualty Suffering Major Injuries

INJURY NUMBER	Location	INJURY DESCRIPTION				MECHANISM		CAUSE FACTOR			Cost
		Aspect	Type	System	Severity	Action	Qualifier	Subject	Action	Qualifier	
1	Spine	Inferior	Fracture	Skeletal	Major	Received	Excessive Decelerative Force	Seat	Allowed	Excessive Loading	\$45,405
2	Face	Anterior	Laceration	Skin	Major	Struck	Gunsight	Design	Provided	Inadequate Clearance	\$4,541
3	Hand	Right	Contusion	Skin	Minor	Struck	Structure	Extremities Flailed		On Impact	\$54

After the analysis of the impact conditions and the medical analysis of the injuries was completed for each casualty in a given accident, the results of these two analyses were cross-checked to assure consistency and completeness of the overall analysis.

### ANALYSIS OF CRASH HAZARDS

#### Identification of Hazards

The results of the analysis discussed above form a data base of crash injuries, their causes and the conditions under which they occur. This data base was further analyzed to determine the most serious crash hazards and ways of reducing them.

As used herein, a crash hazard consists of the combination of an injury location, its mechanism and its associated cause factor. Thus, the first injury listed within the hypothetical example above is an occurrence of the crash hazard "spine received excess decelerative force because the seat allowed excessive loading." The extent of the excessive decelerative loading and the conditions under which it occurred are provided by the results of the impact analysis for the example accident.

#### Rank-Ordering of Hazards

The crash hazards identified through the above analyses were rank-ordered according to their overall significance. The criteria which were used to rank the hazards were (1) the frequency of the hazard, (2) the severity of the resulting injuries and (3) the cost of the injuries. The procedure used to rank the hazards consisted of two steps: first, the hazards were placed into groups of significance according to their frequency and severity. Next, the hazards within each significance group were ranked according to their cost. These hazards were considered in identifying urgent crashworthiness research and development programs for both current and future helicopters.

#### Ranking According to Frequency

Each hazard was evaluated according to the frequency of its occurrence and was placed into frequency groups as shown in Table II. The format and rationale for this frequency ranking was modeled after Reference [5].

TABLE II  
Crash Hazard Frequency Ranking

Frequency Index	Descriptive Nomenclature	Mathematical Definition
A	Frequent	$0.5 < f^*$
B	Reasonably probable	$0.1 < f \leq 0.5$
C	Occasional	$0.05 < f \leq 0.1$
D	Remote	$0.01 < f \leq 0.05$
E	Improbable	$f \leq 0.01$

\*f is defined as the relative frequency of occurrence of a hazard and is calculated as

$$f = \frac{\text{Frequency of occurrence of crash hazard}}{\text{Number of accidents studied}}$$

#### Ranking According to Severity

Each crash hazard was evaluated relative the severity of the resulting injuries and was placed into severity groups as shown in Table III. The rationale and format for this severity ranking procedure was taken from Reference [5].

Table III  
Crash Hazard Severity Ranking

Severity Index	Descriptive Nomenclature	Definition**
I	Life-threatening	Results** in fatal or critical injury
II	Serious	Results in major injury
III	Marginal	Results in minor injury
IV	Negligible	Results in no more than minimal injuries

\*\*Worst credible result

#### Overall Ranking of Crash Hazards

The results of evaluating each crash hazard according to its frequency and severity as described above were used together to place the hazards into overall significance groups. The frequency and severity rankings of each hazard were weighted equally in this process. Table IV indicates how all hazards were placed into one of eight groups as determined by the combination of frequency and severity indices.

TABLE IV  
Hazard Significance Groups Based on Frequency & Severity Indices

Significance Group	Frequency Index-Severity Index
1	A.I
2	A.II, B.I
3	A.III, B.II, C.I
4	A.IV, B.III, C.II, D.I
5	B.IV, C.III, D.II, E.I
6	C.IV, D.III, E.II
7	D.IV, E.III
8	E.IV

The crash hazards within each significance group were then rank-ordered according to the cost of the resulting injuries. The resulting ordered list comprises a "totem pole" of the most serious crash hazards.

#### Results

Results of an application of the methodology discussed above to a typical Army helicopter are discussed below. Since the intent of this paper is primarily to discuss the study methodology, only representative

examples of the analysis results are shown in order to indicate the validity of the approach. The accident data used in this application were the aircraft accidents which occurred to an operational aircraft in a recent five year period. This period is judged to represent a statistically valid sample of the peace-time operation of this aircraft.

#### STATISTICAL DESCRIPTION OF IMPACTS

##### Combined Velocity Components

Figure 2 depicts the longitudinal and vertical components of the change in velocity of the aircraft center of gravity during its major impact for each of the accidents studied. The resulting impact survivability is indicated.

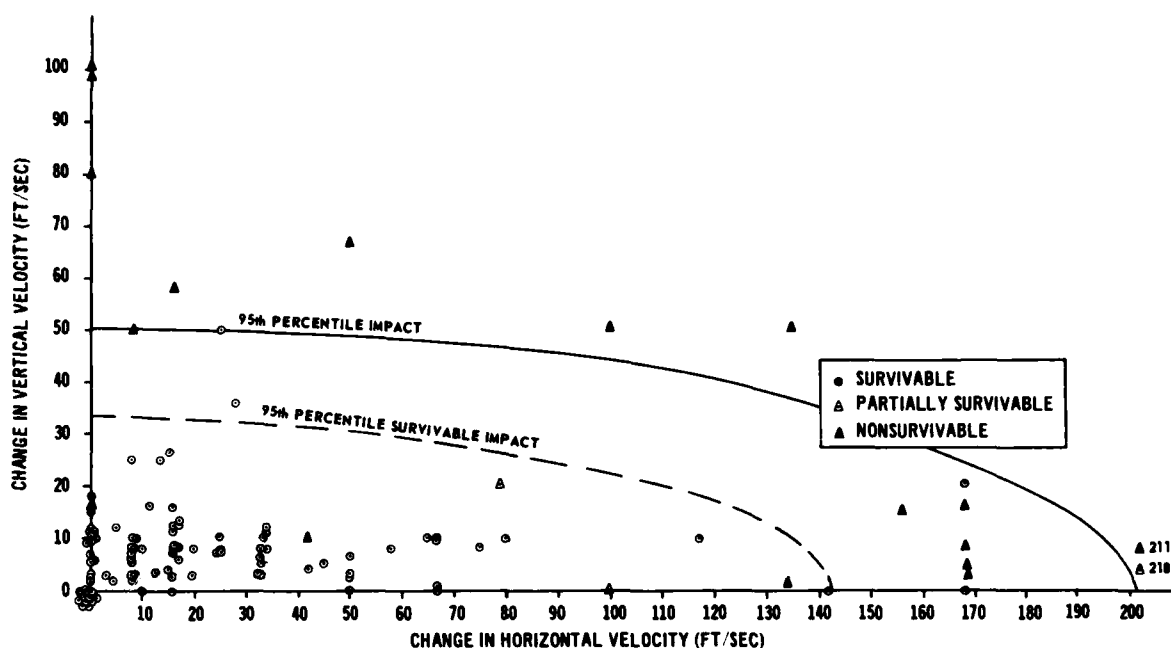

FIGURE 2.—Vertical and Horizontal Components of Impact Velocity Change

Statistically derived curves for the 95th percentile impact and for the 95th percentile survivable impact are superimposed on the individual data points. The 95th percentile survivable impact curve indicates a "design space" for improvements within the existing aircraft design. The 95th percentile impact is analogous information for design and evaluation of crashworthiness features in future helicopters of similar type. This distinction is made because the strength and crushability of the existing airframe forming the "container" for the occupants limits the improvements which can be reasonably proposed for the current aircraft. However, for new aircraft designs, this limitation is not as severe due to potential improvements in the container itself. Thus, crashworthiness improvements for future helicopters should be based on what impacts are expected (the 95th percentile curve) and not on what impacts were survivable in current aircraft (the 95th percentile survivable curve).

##### Combined Force Components

In contrast to the velocity data, the estimates for the crash force did not lend themselves to statistical derivation of cumulative distributions and percentile curves. This was the result of the way in which the data grouped around certain "reasonable" estimates. Satisfactory investigation/analysis techniques were not available for accurate determination of the crash forces.

#### INJURY CAUSE FACTORS

##### Influence of Impact Conditions on Injury

The influence of impact velocity on injuries was most strongly evident with regard to the vertical velocity component. Figure 3 depicts the relative frequency of back injuries versus impact vertical velocity change. Figure 3 indicates that significant numbers of back injuries occur even in impacts of less than 20 feet per second vertical velocity change. Analysis of these individual cases revealed that factors other than the vertical impact had significant influence on the incidence of spinal injury. These other influences included the longitudinal and lateral components of the impact velocity and the occupant's seating position at time of impact. Evaluation of the influences of these parameters is not possible using currently available investigation tools such as the Dynamic Response Index (Reference [2]).

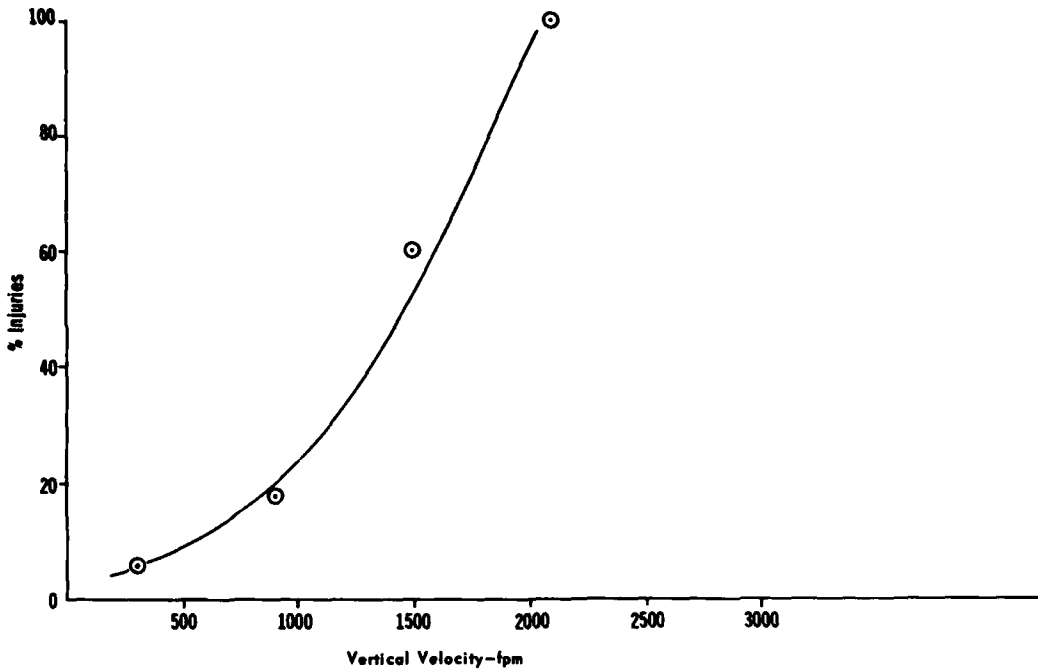

FIGURE 3.-Relative Frequency of Spinal Injuries versus Change in Vertical Velocity

Frequency of Occurrence and Costs of Injury Mechanisms

Figure 4 depicts the frequency of occurrence and cost associated with the most prevalent crash injury mechanisms. All accidents regardless of survivability and all injuries regardless of severity are included in Figure 4. A breakdown of the more significant injury mechanisms by underlying cause factor is discussed below. Figure 4 indicates that the most frequent injury mechanism was "Body struck structure" while the mechanism resulting in the largest injury cost was "Body received excessive decelerative force." After these two, the mechanisms of "Body struck by external object" and "Body exposed to fire" produced the next largest frequency and costs of injuries.

Cause Factors Resulting in Injury Mechanism "Body Struck Structure"

As discussed above, the mechanism "Body struck structure" resulted in the highest frequency of injuries (126 instances). The engineering factors which caused this mechanism to occur are depicted in Figure 5. Figure 5 indicates that excessive collapse of the aircraft structure was the cause factor resulting in both the highest frequency and cost of these "body struck structure" injuries. The next most significant factor was that the aircraft design provided inadequate clearance, resulting in significant injuries due to occupant flailing during the impact and striking structure. The third most significant cause factor resulting in body strike injuries was determined to be that the occupants seat failed under crash loading resulting in the occupant, to varying extents, becoming a freely moving object inside the aircraft. It is worthy of note that correction of any one of these cause factors in a new aircraft design may require a "systems" consideration of all the factors. However, the evidence in the individual accident reports was used to determine the primary injury cause factors in each case in order to identify specific improvements for current aircraft.

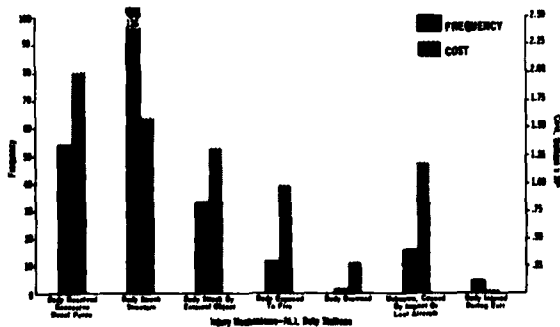

FIGURE 4.-Frequency and Cost of Injury Mechanisms

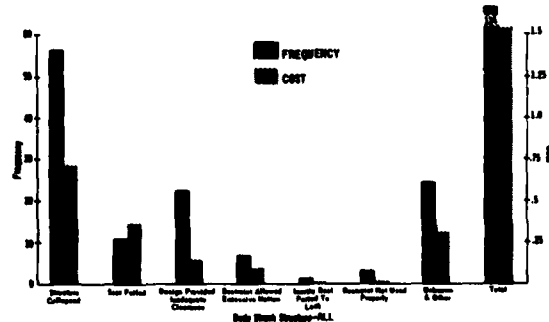

FIGURE 5.-Frequency and Cost of Cause Factors Resulting in "Body Struck Structure"



Cause Factors Resulting in Mechanisms "Body Received Excess Force"

The engineering factors which caused the 55 instances of the mechanism "Body received excessive decelerative force" are shown in Figure 6. Figure 6 indicates that a large majority of the instances and the associated costs of these injuries was caused by the aircraft and seat allowing excessive loading of the occupant: i.e., during the major impact, the aircraft and seat transmitted peak forces to the occupant which were beyond human tolerance. The energy absorption of the landing gear, airframe and seat failed to protect these occupants.

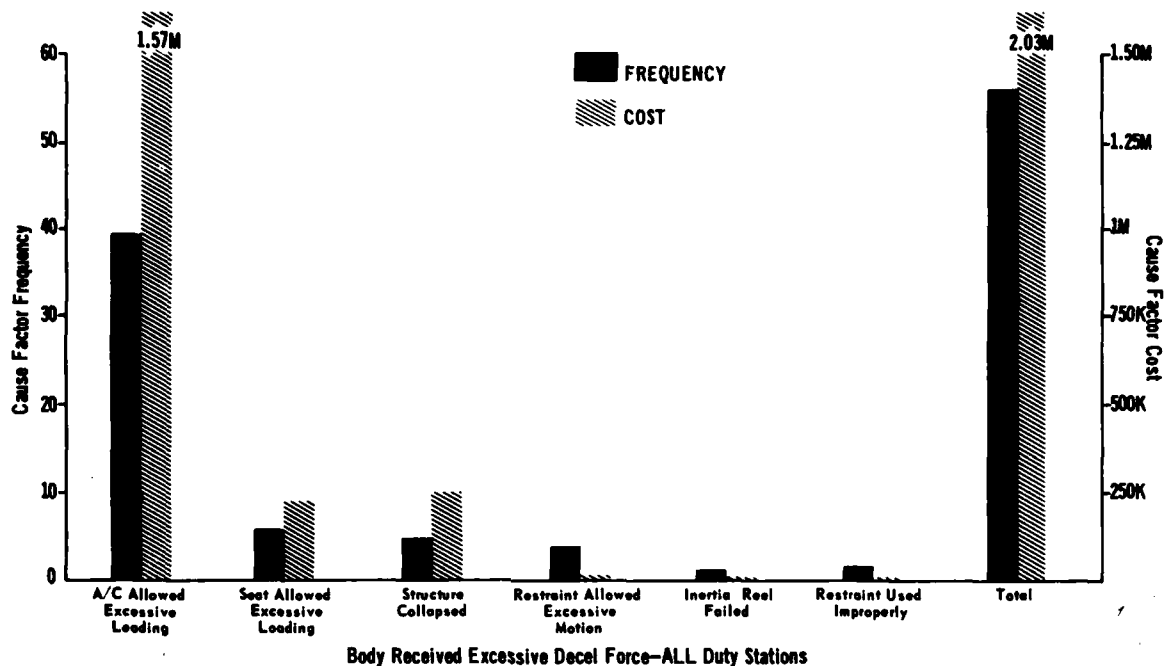

FIGURE 6.—Frequency and Cost of Cause Factors Resulting in "Body Received Excessive Decelerative Force"

Most Significant Crash Hazards

The combinations of the above injury mechanisms and engineering cause factors comprise the crash hazards identified through analysis of the aircraft accident data. A total of 22 crash hazards were identified for this aircraft type. These crash hazards were ranked according to the procedure discussed above to identify the most significant hazards for possible remedial action. The results of the ranking process are shown in Table V. The frequencies and costs shown in Table V include all accidents and injuries studied, regardless of severity. The hazards are listed in decreasing order of significance (based on frequency, severity and cost). The injury costs associated with each hazard were computed for a 20-year period of aircraft operation, with the rates and types of accidents assumed the same as in the base study period (CY 71-76) and the projected aircraft flying hour program.

TABLE V

Rank-Ordered Listing of Crash Hazards, Operational Army Aircraft, CY 71-76

Hazard No.	Significance Group	Description	Frequency Index	Severity Index	20-Year Cost
1	2	Body rec'd excessive decel. force when A/C and seat allowed excessive loading	B	I	\$6,676K
2	2	Body struck by external object when main rotor blade entered occupiable space	B	I	4,324K
3	2	Body struck structure when structure collapsed excessively	B	I	2,585K
4	2	Body struck structure because of unknown causes	B	I	1,150K
5	2	Body struck structure because design provided inadequate clearance	B	I	531K

Hazard No.	Significance Group	Description	Frequency Index	Severity Index	20-Year Cost
6	3	Body exposed to fire when fuel system failed on impact	C	I	\$3,639K
7	3	Body injured by unknown or unclassified mechanisms	C	I	3,008K
8	3	Body struck structure when seat failed	C	I	1,316K
9	3	Body struck by external object when external object (other than main rotor blade) entered occupiable space	C	I	201K
10	4	Aircraft missing	D	I	1,504K
11	4	Body rec'd excessive decel. force when structure collapsed	D	I	940K
12	4	Upper body struck structure because restraint allowed excessive motion	D	I	407K
13	5	Body drowned due to unknown causes	E	I	752K
14	5	Body drowned because injuries prevented escape from A/C	E	I	376K
15	5	Body rec'd excessive decel. force when restraint allowed excessive motion	D	II	8K
16	5	Upper body struck structure because restraint was not used properly	D	II	7K
17	5	Head struck by external object when helmet displaced excessively	E	I	188K
18	6	Body injured during exit	D	III	1K
19	7	Body rec'd excessive decel. force when inertia reel failed	E	III	4K
20	7	Body rec'd excessive decel. force because restraint was not used properly	D	IV	1K
21	7	Body struck structure because inertia reel failed to lock	E	III	<1K
22	8	Body struck by external objects due to unknown causes	E	IV	<1K

Table V indicates that the most significant crash hazards were identified as Significance Level 2. Five hazards were identified in this group and each was determined to be reasonably probable (but not frequent) and life-threatening (worst credible result). Of these five, the hazard "body received excessive decelerative force when the aircraft and seat allowed excessive loading" resulted in the largest injury cost and is thus ranked as the most significant crash hazard for this aircraft.

#### Identification of Crashworthiness R&D Requirements

The above rank-ordered listing of crash hazards was analyzed to identify pressing research and development requirements to remedy the significant crashworthiness deficiencies. Because the strength and crushability of the existing airframe limits the cost-effective improvements which could be made to the existing aircraft, a distinction was made between the R&D requirements for current and future helicopters.

Based on the above medical and engineering analysis of crash injury data and engineering judgment as to the crashworthiness improvements which can be reasonably expected within the existing airframe, Table VI below is a rank-ordered listing of pressing crashworthiness R&D requirements for the aircraft studied.

TABLE VI

## Crashworthiness R&amp;D Requirements for Current Aircraft

<u>Priority*</u>	<u>Hazards Addressed by this Requirement (Reference Table V)</u>	<u>R&amp;D Requirement</u>
1	#1, #8,	Develop and procure replacement crew seats which will attenuate vertical loading on occupant to survivable levels.
2	#2	Develop and procure rollbar/main rotor blade deflector similar in function to that incorporated into the design of certain developmental Army helicopters.
3	#5, #12, #15, #19, #21	Develop and procure replacement crew restraint systems which provide more effective longitudinal and lateral restraint to upper body.
4	#6	Complete installation of approved crash-worthy fuel system.

Crashworthiness R&D for future helicopters must consider each of the hazards listed in Table V. The present designs of both the UH-60A Blackhawk and YAH-64 Advanced Attack Helicopter contain a number of design features intended to reduce previously-identified deficiencies. Table V should be considered an indication of the priority of those design features which provide an increase in crashworthiness beyond that of the current aircraft. This priority should be considered within any future design decision in which it is necessary to tradeoff crashworthiness features against each other or against other design requirements.

Additional R&D Requirements

Two additional research efforts were suggested by the results of the application of this methodology to the study aircraft. These suggested efforts are intended to provide additional investigation aids to improve the future identification of crash injury hazards. The first of these is the requirement for a more accurate system of determining the impact conditions in all Army aircraft accidents. Presently, these conditions (velocities, angles and forces) are estimated by the accident investigation board based on witness statements and physical evidence such as aircraft and terrain damage. The inaccuracies in this method are evidenced by the fact that accurate estimates of the crash impact forces were impossible to obtain using information presently available in the aircraft accident report. These data were seen to cluster around certain "typical, reasonable" values and precluded any valid estimate of their actual distribution (such as their 95th percentile values). An onboard crash data recorder is required for proper analysis of the impact conditions against which crashworthiness improvements must be designed and evaluated. Such a system is included as a portion of the Accident Information Retrieval System (AIRS) which is under development at the Army's Applied Technology Laboratory (Reference [6]).

The second of these research efforts is a requirement for a more reasonable method of judging the influence of multi-directional impact forces upon spinal injury. The present data shows that the currently used method (Reference [2]) of evaluating the probability of spinal injury based on a one-dimensional Dynamic Response Index (DRI) is inadequate because this method considers only the vertical component of the crash impact load. As previously discussed, Figure 3 indicates that spinal injuries were found to occur in impacts involving vertical decelerations within human tolerance but which involved decelerations in other directions. A number of personnel suffering back injuries appeared to be injured by the combination of crash loads in multiple directions, rather than by the vertical component alone. Others suffered back injuries in impacts in which even the vector summation of the crash load components did not appear significant. In these cases, other factors such as seating position may have influenced the incidence of back injury. A system of evaluating all influences on back injury and determining future crashworthiness design criteria requires an improved spinal injury model which considers crash loading along multiple directions as well as other pertinent factors.

Conclusions

Based on this study of a typical Army aircraft, it is concluded that the methodology discussed provides a useful system for the identification of crashworthiness design deficiencies and the research necessary to reduce them. Use of the technique allows the following:

- (1) Summary of the medical analysis of accident trauma using a coding system based on general body location.
- (2) Identification of the underlying mechanical causes of injuries which considers the bioengineering limits of the human body.

\*The overall priority of these requirements within the Army safety program can be established only after similar analysis of other major aircraft types.

(3) Identification of the costs of individual injuries.

(4) Identification of the most significant crash hazards based on frequency, severity and cost.

Application of this technique has identified the most significant crash hazards and the remedial research for both current and future helicopters of the type studied. In addition, requirements have been identified for two systems/techniques of wide application to all Army aircraft accidents. These are (1) an improved spinal injury model which considers multidirectional crash loadings and (2) a crash data recording system such as included as a portion of the developmental Accident Information Retrieval System (Reference [6]).

In addition, application of this technique to the accidents studied has demonstrated a distinct difference in the 95th percentile impact and the 95th percentile survivable impact. It is concluded that crashworthiness improvements for future helicopters should be based on what impacts are expected (the 95th percentile impact) and not on what impacts were survivable in current aircraft (the 95th percentile survivable impact). The usefulness of the 95th percentile survivable impact is considered to be a definition of a design space for improvements to existing aircraft only.

#### Future Efforts and Recommendations

As a result of this study and the successful application of the methodology discussed to a typical Army helicopter, USAAVS will coordinate the study of all major operational Army aircraft types. Results of these studies will be provided to appropriate Army research organizations and aircraft system managers for guidance in future R&D expenditures. In addition, the following recommendations are made:

(1) Recommend that the technique discussed be considered for use of other aircraft users, providing a basis for effective exchange of crashworthiness information and injury data.

(2) Recommend the development of an improved spinal injury model which considers multidirectional crash loading.

(3) Recommend continued development of the Accident Information Retrieval System.

(4) Recommend that crashworthiness improvements for future helicopters be based on the 95th percentile impact, not the 95th percentile survivable impact.

#### References

1. Headquarters, Department of Defense, Table for Computing Cost of Injuries and Occupational Illness of DOD Personnel, November 18, 1976, Department of Defense Instruction 1000.19 (Incl 9).
2. U.S. Army Air Mobility Research and Development Laboratory, Crash Survival Design Guide, October 1971, USAAMRDL Technical Report 71-22.
3. U.S. Army Air Mobility Research and Development Laboratory, Aircrew Restraint System - Design Criteria Evaluation, February 1975, USAAMRDL Technical Report 75-2.
4. Saczalski, K, et al, Aircraft Crashworthiness, University Press of Virginia, Charlottesville, VA, 1975.
5. Headquarters, Department of Defense, System Safety Program Requirements, 28 June 1977, Military Standard 882A.
6. Hamilton Standard, Division of United Technologies, Accident Information Retrieval System, Final Technical Report, 31 August 1977, submitted to Eustis Directorate, U.S. Army Air Mobility R&D Laboratory under Contract DAAJ02-76-C-0058.

Appendix A

## Definitions and Terminology

Aircraft Accident - Damage which occurs to one or more aircraft while flight was intended. Damage as a direct result of hostile fire is not an accident but a combat loss.

Crash Force - The maximum value of an assumed triangular crash pulse, determined at the aircraft center of gravity, which occurs during the major impact.

Crash Hazard - A condition due to the design or configuration of an aircraft or life support equipment which may result in injuries to occupants in aircraft accidents.

Crashworthiness - The ability of a vehicle to sustain a crash impact and reduce occupant injury and hardware damage.

Injury Cause Factor - The design deficiency which caused a specific injury mechanism to occur.

Injury Classification - A designation of the medical significance of all of the injuries incurred by a given casualty taken as a whole.

Injury Cost - The economic loss to the Army due to accidental injuries to servicemembers, as calculated according to DODI 1000.19.

Injury Mechanism - The mechanical process through which a specific injury was determined to have occurred, i.e., "what happened."

Injury Severity - A designation of the medical significance of a specific injury.

Major Impact - That impact of the aircraft which results in the largest decelerative forces being transmitted to the aircraft and occupants.

Survivability - An accident in which the following statements are satisfied for at least one occupant aboard the aircraft:

- a. The forces transmitted to the occupant through his seat and restraint system do not exceed the limits of human tolerance to abrupt accelerations.
- b. The fuselage structural container maintains a livable volume around the occupant.

## Les algies vertébrales des pilotes d'hélicoptères

Médecin en Chef R. AUFFRET (1)  
 Médecin Chef des Services R.P. DELAHAYE (2) (3)  
 Médecin en Chef P.J. METGES (2) (3)  
 Médecin VICENS (1)

### INTRODUCTION

Il y a plus de 40 ans que le pilote d'essais Maurice CLAISSE, après un vol d'endurance sur un hélicoptère Bréguet-Dorand, soulignait le caractère désagréable des vibrations se répercutant dans toute la machine : "Secoué sur une monture inconfortable pendant une heure de vol, le pilote se hâte d'atterrir et de rentrer au hangar pour soigner ses courbatures".

Malgré les immenses progrès technologiques accomplis depuis le vol du premier gyroplane en 1907 cette remarque rapportée par le Vice-Amiral JUBELIN, reste malheureusement en grande partie encore valable actuellement.

La diminution des agressions et nuisances et l'amélioration de l'hygiène du poste de pilotage n'ont en effet pas suivi le perfectionnement technique des appareils et se sont constituées ainsi de véritables affections professionnelles créées par le fait du vol et à l'occasion de la pratique aéronautique.

Ces manifestations pathologiques et leur relation avec le pilotage de l'hélicoptère ont été très étudiés en France depuis 1950, date à laquelle les premiers appareils ont été utilisés dans les formations de l'Armée de l'Air Française.

De nombreux travaux leur ont été consacrés parmi lesquels il faut citer ceux de MISSENERD et TERNEAU (1957), FABRE et GRABER (1959), MONTAGNARD et COLL (1961), SLIOSBERG (1962) et plus récemment ceux de DELAHAYE, AUFFRET, SERIS, GUEFFIER, METGES, COLLEAU et VETTES.

Nous avons entrepris une étude systématique clinique et radiologique portant sur la totalité du personnel navigant de la section Voilures tournantes du C.E.V. de Brétigny. Cette section comprend 12 sujets dont l'âge s'échelonne de 28 à 53 ans avec une moyenne de 38 ans et le nombre d'heures de vol sur hélicoptères varie de 400 à 7000 heures (moyenne : 2600 heures).

Soumis à une surveillance médicale semestrielle stricte, pratiquant pour la plupart un entraînement sportif régulier, ces pilotes d'essais, ingénieurs ou mécaniciens navigants présentent un bon état physique général et leur seule symptomatologie fonctionnelle est rachidienne.

### I Etude clinique :

- 1) Sur le plan clinique la lombalgie prédomine, pouvant revêtir ses deux formes habituelles, aiguë ou chronique, celles-ci alternant le plus souvent dans le temps chez un même sujet.

#### \* Fréquence :

La fréquence retrouvée dans notre étude est de 8 cas sur 12 ; bien qu'un échantillon réduit ne puisse donner lieu à l'élaboration de statistiques significatives, ce chiffre rejoint ceux publiés par MONTAGNARD et COLL (60 %) et SLIOSBERG (75 %) portant sur de grandes séries ; le pourcentage élevé trouvé par ce dernier vient probablement du fait que son enquête concernait des pilotes opérationnels en Afrique du Nord soumis à un véritable surmenage.

#### \* Circonstances d'apparition :

Tous les auteurs s'accordent à mettre en évidence un délai d'apparition aux phénomènes douloureux : de 300 heures pour SLIOSBERG et VON GIERKE, 500 à 1000 heures pour MONTAGNARD du même ordre pour COLLEAU.

(1) Laboratoire de Médecine Aérospatiale du Centre d'Essais en Vol, B.P. No.2, 91220 Brétigny Air, France.

(2) Service de Radiologie de l'Hôpital d'Instruction des Armées BEGIN, 94160 St. Mandé, France.

(3) Chaire d'Electroradiologie et de Biophysique Aérospatiales de l'Ecole d'Application du Service de Santé pour l'Armée de l'Air, 5 bis Avenue de la Porte de Sèvres, 75996 Paris Armées, France.

Ce délai paraît actuellement être plus long (1000 à 1500 heures dans notre étude) et surtout soumis à ces variations individuelles très importantes ; il est diminué par la présence de lésions rachidiennes préexistantes ou d'anomalies congénitales : c'est ainsi qu'un pilote porteur d'une anomalie transitionnelle de la charnière lombosacrée a accusé des douleurs lombaires dès la 20<sup>ème</sup> heure de vol. Quant au rythme de vol, ce facteur reconnu d'entretien de la symptomatologie, nous avons retrouvé des valeurs voisines de celles publiées dans la littérature. Les seuils propices à l'apparition de phénomènes douloureux sont en moyenne de :

- 30 à 40 heures de vol par mois
- 3 à 4 heures par jour
- 1H30 de vol à la suite.

\* Symptomatologie :

a) La lombalgie chronique est la plus fréquente (7 cas sur 12). Son tableau est celui d'une douleur peu intense à type de fatigue, de pesanteur, de gêne, siégeant dans la région lombaire, parfois plus bas située (lombosacralgie) ; elle est transversale médiane, prédominant souvent d'un côté, pouvant irradier vers la région fessière, les crêtes iliaques et plus rarement les aines en avant. Cet endolorissement est rythmé par les vols, aggravé par les efforts de soulèvement et les longs trajets en voiture, calmé par le repos en décubitus et les séances de kinésithérapie. L'examen met parfois en évidence une discrète attitude antalgique scoliotique avec raideur et une légère contracture paravertébrale ; mais le plus souvent la statique est correcte et l'examen ne révèle que des signes dynamiques : légère diminution de l'indice de Schobert, retard du redressement du segment lombaire.

b) Les lombalgies aiguës ont été retrouvées chez 6 sujets, 5 étant survenues sur un fond de lombalgie chronique, de façon isolée.

Leur mode de survenue est variable : on relève souvent un début progressif sans effort initial précis mais après un surmenage inhabituel ou une apparition en deux temps la douleur ne se manifestant que quelques heures après le vol ; parfois le début est brusque mais l'effort ou le faux-mouvement déclenchants sont alors indépendants de la pratique aéronautique (jardinage, sport, etc ...).

Ces lombalgies aiguës revêtent le tableau du classique : tour de rein constitué par une douleur très vive, intense, réveillée au moindre mouvement, limitant tout déplacement ; cette douleur siège dans la région lombosacrée, souvent plus vive d'un côté mais irradiée habituellement à toute la région lombaire et fessière et souvent même dans les cuisses.

L'examen, rendu difficile par l'intensité de l'algie, révèle des points douloureux latérovertébraux à hauteur des derniers disques, la contracture paravertébrale et surtout l'inflexion antalgique cyphoscoliotique qui se maintient identique dans les divers mouvements rachidiens. Il met en outre en évidence un signe de Lasègue lombaire bilatéral.

Sous l'effet du repos en décubitus de préférence sur un plan dur, du traitement antalgique anti-inflammatoire et décontracturant l'évolution est en règle favorable en quelques jours mais la lombalgie aiguë se reproduit souvent à intervalles variables sur un fond de douleurs chroniques (5 cas sur 6).

c) Enfin la sciatique, complications majeures de la discopathie dégénérative, a été retrouvée dans 2 cas, frappant les pilotes ayant plus de 4000 heures de vol et souffrant depuis plusieurs années de lombalgies. Sur 128 sujets effectuant un travail intensif, SLIOSBERG en dénombre 11.

L'examen clinique met en évidence l'inflexion antalgique directe ou croisés, les classiques points de VALLEIX et surtout le signe de LASEGUE. La sciatique affecte indifféremment la racine L5 ou S1, souvent accompagnée alors d'une abolition du réflexe achilléen. On note en général l'absence de signes neurologiques déficitaires importants ; un de nos deux cas s'est cependant manifesté sous forme paralysante de type L5, due à une très volumineuse hernie discale ayant nécessité une intervention.

2) Les dorsalgies

Il s'agit classiquement plus d'une gêne ou d'un endolorissement que d'une véritable douleur, siégeant dans la région moyenne du dos (D6-D7) et cédant à des mouvements d'extension du tronc, elles sont souvent associées à des douleurs lombaires. SLIOSBERG et COLLEAU en retrouvent environ 40 %. Pour notre part, nous n'avons dénombré aucune véritable dorsalgie ; cette différence s'explique en partie par

l'amélioration de la position de pilotage et du confort dorsal des sièges, mais surtout par le fait que l'étude de COLLEAU concernait des pilotes de l'Aéronavale portant fixé sur le dos un dinghy plié et sa bouteille de gonflage d'un poids total de 8 Kg ; ce harnachement constitue un dossier inconfortable et inadapté aux sièges de série, ces contraintes étant encore accentuées par le port de la Mae-West.

### 3) Les cervicalgies :

Dans son enquête, SLIOSBERG note que 30 % des sujets présentent des douleurs cervicales basses, médianes, pouvant parfois irradier vers l'épaule ou le membre supérieur revêtant alors la forme d'une névralgie cervico-brachiale. Elles sont exceptionnellement isolées, le plus souvent associées à des lombalgies ; COLLEAU en retrouve 2 cas (sur 29), interprétant cette diminution par une amélioration de la visibilité aux commandes des appareils modernes.

Pour notre part nous avons mis en évidence 1 cas de cervicalgies aiguës répétées chez un pilote ayant 7000 heures de vol se présentant sous l'aspect classique du torticolis avec contracture musculaire intense et scoliose antalgique : ces épisodes aigus surviennent sur fond douloureux chronique.

D'autres pilotes ont signalé simplement une gêne de la nuque ou du cou réveillée aux mouvements extrêmes de la tête dont le rythme évolutif est variable ; elle est aggravée par le port du casque.

## II Etude radiologique :

Nous avons fait pratiquer un examen radiologique complet en position debout comportant 8 clichés : colonne cervicale, dorsale et lombaire face et profil, disque L5 S1 face et profil.

Les résultats de cette étude sont les suivants :

### 1) Au niveau de la colonne lombaire :

- sur le plan de la statique vertébrale : 2 cas d'attitude scoliotique
- 2 cas d'anomalies transitionnelles avec désencastrement partiel de la vertèbre charnière
- chez 5 pilotes des signes arthrosiques ont été notés consistant essentiellement en une ostéophytose marginale antérieure atteignant les corps vertébraux de L2 à L5 avec une certaine prédominance pour les 3 dernières vertèbres.

Cette ostéophytose s'accompagne 2 fois d'un pincement de l'interligne L4L5 dont l'un correspond probablement à un aspect post-opératoire (cure de hernie hiatale).

Les corrélations radiocliniques sont relativement satisfaisantes dans ce groupe (4 sujets sur 5 souffrent de lombalgies), ainsi que pour les pilotes porteurs d'une anomalie transitionnelle ; dans ce dernier cas est admise depuis longtemps la prédisposition, élective, à l'égard d'atteintes dégénératives, traumatiques ou microtraumatiques (DE SEZE).

Par contre dans 2 cas de lombalgies avérées, dont une forme sévère compliquée de sciatique, on ne retrouve pas de correspondance radiologique. Ce fait n'est pas surprenant puisque dans toutes les grandes statistiques publiées il apparaît qu'au minimum 25 % des lombalgies et des sciaticques n'ont aucune traduction radiologique sur les clichés standards (G. VIGNON).

Enfin, depuis les travaux de DELAHAYE, METGES, MANGIN et GUEFFIER montrant l'existence d'une attitude scoliotique chez 20 % de la population dite "normale", il apparaît que ce trouble isolé de la statique dans le plan frontal ne peut être reconnu comme le témoin d'une manifestation pathologique en dehors des cas où il s'agit d'une inflexion d'origine antalgique avec contracture paravertébrale.

### 2) Au niveau du rachis dorsal :

De discrets signes arthrosiques ont été relevés dans 6 cas, consistant essentiellement en une ostéophytose marginale antérieure atteignant les corps vertébraux de D8 à D11 avec une prédominance pour D9 D10, le plus souvent associée à une atteinte lombaire.

Des troubles de la statique frontale pour lesquels les réserves précédentes restent valables ont été retrouvés 3 fois sans corrélation avec la clinique.

### 3) Au niveau du rachis cervical :

Chez tous les sujets examinés ont été mises en évidence des déformations de type arthrosique des apophyses unciformes de C5 C6 et à un moindre degré C7, associées



dans 5 cas à des troubles de la statique sagittale à type de rectitude sur le cliché de profil. On relève également une ostéophytose marginale antérieure C5C6 (dans 2 cas) et un pincement de l'interligne C6 C7 (1 cas) ; chez le seul pilote accusant des antécédents de cervicalgies importantes, on note des signes de type discarthrosique avec pincement des interlignes C5 C6 et C6 C7, ostéophytose marginale antérieure C5 C6 C7 et postérieure C6 C7.

Il est actuellement admis que la cervicarthrose représente une entité anatomoradiologique dont l'apparition peut être précoce et dont l'extrême fréquence au-delà de 40 ans (50 %) (de la population) contraste avec son incidence clinique souvent absente ou tout au moins intermittente. Cependant la présence de signes radiologiques identiques chez tous les pilotes examinés, dont la plupart n'ont pas atteint la quarantaine, nous paraît être significative.

### III Approche physio-pathologique

Toutes les études réalisées jusqu'ici s'accordent à admettre que la pathologie rachidienne des pilotes d'hélicoptères est le résultat de l'action synergique de deux facteurs :

- un facteur postural : la mauvaise position de pilotage,
- un facteur mécanique microtraumatique dû aux vibrations de l'hélicoptère.

#### 1) Le facteur postural :

Bien décrit par SLIOSBERG il résulte du fait que le pilotage d'un hélicoptère requiert une utilisation constante et coordonnée des 4 membres ; le membre supérieur droit manoeuvre le manche de pas cyclique responsable du mouvement de translation, le membre supérieur gauche agit sur le levier de pas collectif réglant la sustentation de l'appareil, les pieds enfin actionnent le palonnier qui, par l'intermédiaire du rotor de queue (rotor anti-couple), permet de faire pivoter la machine et de choisir un cap de vol.

La disposition de la commande de pas collectif oblige le pilote à se pencher à gauche tandis que les impératifs du vol à vue nécessitent une flexion du tronc en avant, la tête en hyperextension. On conçoit bien que une telle position aille à l'encontre de tous les critères de confort établis jusqu'ici ; SWEARINGEN et WISNER ont défini la valeur des angles devant exister entre les pièces squelettiques adjacentes pour permettre, chez un individu assis, un bon relâchement des groupes musculaires antagonistes, traduction physiologique de la notion subjective de confort.

Ces valeurs diffèrent notablement de celles mesurées sur les pilotes, surtout dans les appareils d'un modèle ancien (SIKORSKY H 34 par exemple).

Cette attitude dissymétrique et permanente va ainsi engendrer une contraction tonique des muscles paravertébraux et sus tentateurs du rachis.

Or comme le montrent les modèles analogiques décrits par DIECKMANN et COERMANN, le corps humain est assimilable à un ensemble de masses suspendues reliées entre elles par des systèmes de ressorts et d'amortisseurs (disques intervertébraux, ligaments, muscles) ; les muscles jouent un rôle d'amortisseurs limitant les mouvements du squelette et protégeant ainsi les disques intervertébraux. Contracturés, leur efficacité va rapidement diminuer avec la fatigue et cet amortisseur sera forcé, livrant ainsi vertèbres et disques à l'action directement nocive des vibrations.

En outre KEEGAN a démontré qu'au niveau du rachis lombaire, la position assise efface la lordose, les corps vertébraux tendent à se rapprocher en avant et l'espace intervertébral à bailler en arrière ; la pression nucléaire augmente (10 à 15 Kg / Cm<sup>2</sup> soit 30 % de plus qu'en position debout) et le nucléus pulposus est refoulé en arrière vers la partie périphérique de l'annulus et surtout le capsulo-ligamentaire innervé.

C'est donc sur une colonne préalablement fragilisée, sensibilisée, que vont agir les microtraumatismes vibratoires.

#### 2) Les vibrations

Résultat du rendement imparfait de tout système mécanique en mouvement, les vibrations représentent, au même titre que la chaleur, une forme dégradée d'énergie que l'opérateur humain récupère directement à son poste de travail sous forme de nuisances. Leur caractère universel et leur importance ergonomique expliquent que de nombreux chercheurs aient essayé d'en déterminer les effets physiologiques et physiopathologiques (COERMANN ; DIECKMANN ; WISNER, BERTHOZ).

Le domaine aéronautique est loin d'être épargné par les agressions vibratoires et en particulier l'hélicoptère qui, parmi tous les moyens de transport utilisés est de ceux qui engendrent les vibrations de plus haut niveau.

D'importants travaux ont été consacrés à la mesure de ces phénomènes et à l'étude de leur action sur le personnel navigant parmi lesquels il faut citer ceux de GOLDMAN, VON GIERKE, GUIGNARD, et en France ceux de SERIS, AUFFRET, DEMANGE, VETTES.

#### A) Origine et mesure des vibrations

Les vibrations enregistrées à bord des hélicoptères sont d'origine mécanique et aérodynamique ; elles sont décrites dans le système de coordonnées rectangulaires et référence (X, Y, Z) relié au squelette humain.

##### - les vibrations d'origine mécanique :

- . De basse fréquence, elles sont provoquées par le rotor principal tournant à la fréquence  $\Omega$  et par les N pales de ce rotor ; ses causes sont multiples, nous retiendrons parmi les principales :
  - \* le fonctionnement des dispositifs articulés (pas cyclique, battement) ; liés à la technologie même de l'appareil ils engendrent des vibrations de fréquence  $N\Omega$  principalement sur l'axe Z (siège-tête).
  - \* la différence de traînée des pales avançantes et reculantes
  - \* le mauvais réglage en incidence d'une pale par rapport aux autres entraînant une vibration de fréquence  $\Omega$  selon l'axe Z
  - \* éventuellement un défaut d'équilibrage statique des pales (balourd) créant une oscillation de fréquence  $\Omega$  perpendiculaire à la précédente.
- . De moyenne et haute fréquence, elles ont pour origine :
  - \* le fonctionnement des moteurs ou turbines
  - \* le rotor de fréquence  $\omega$  et ses N pales (fréquence  $N\omega$ )
  - \* les organes mobiles de transmission

##### - Les vibrations d'origine aéronautique

De très basse fréquence, elles sont dues aux réponses de la cellule aux excitations aérodynamiques et aux actions du pilotes à travers les servocommandes (SERIS ; AUFFRET) ; elles sont importantes dans les évolutions à grande ou faible vitesse, lors du survol de zones accidentées à basse altitude ou en vol stationnaire près du sol.

La mesure des vibrations par analyse spectrale ou analyse de fréquence qui donne la répartition des énergies mises en jeu en fonction de la fréquence a été réalisée au CEV pour différents types d'hélicoptères ; elle a permis de retrouver pour chaque appareil deux pics de basse fréquence caractéristiques correspondant à (3,7 à 8,5 Hz) et N (15 à 20 Hz).

Si le premier pic, dû à un réglage défectueux peut être considérablement réduit, le second, inhérent au fonctionnement même de l'hélicoptère, est inévitable.

La réponse du corps humain à ces vibrations a pu être évaluée en vol au moyen d'accéléromètres placés sur le siège et les principales masses corporelles ; on peut également l'étudier au laboratoire grâce à des tables vibrantes. Le laboratoire de Médecine Aérospatiale possède un générateur de vibrations électro-hydraulique qui peut être actionné soit par un programme régulier (sinusoïde), soit par une bande magnétique reproduisant les vibrations enregistrées à bord des appareils.

#### B) Résultats :

Les effets physiologiques des vibrations sont dus aux déformations et aux déplacements relatifs importants que subissent les organes ou les tissus à certaines fréquences.

Les travaux de DIECKMANN puis de COERMANN ont permis par le biais de modèle analogiques simples d'étudier et d'expliquer l'action des vibrations d'axe Z sur l'organisme et en particulier sur le rachis.

Ces modèles permettent de rendre compte de l'existence pour chaque segment du corps d'une fréquence de résonance, c'est-à-dire une fréquence à laquelle la transmission du mouvement appliqué au support est maximale ; au delà de cette fréquence la transmissibilité diminue : il y a effet filtre.

Les actions physiopathologiques des vibrations dépendent donc de la fréquence de résonance des différentes masses corporelles et de la fréquence imposée au support.

Les principales fréquences de résonance étudiées par GOLDMANN et VON GIERKE sont : de 4 à 6 Hz pour le thorax dans son ensemble, de 12 à 14 Hz pour la partie supérieure du thorax avec flexion en avant du rachis, de 20 à 30 Hz pour la tête.

D'une façon globale, entre 2 et 10 Hz l'amplitude de la réponse est supérieure à celle de l'excitation, au-delà elle diminue ; cependant entre 20 et 30 Hz du fait de sa résonance la tête possède une amplitude de vibration trois fois plus grande que le segment adjacent.

Il est facile de constater que toutes ces valeurs sont du même ordre que celles des vibrations enregistrées à bord des hélicoptères ; les masses corporelles ainsi excitées vont subir des mouvements d'une relative indépendance sollicitant activement les disques intervertébraux et les masses musculaires paravertébrales qui constituent le système ressort-amortisseur.

Il faut souligner ici le rôle joué par le siège assurant la transmission au pilote des mouvements de l'appareil ; en règle générale, les sièges actuels amplifient les vibrations jusqu'à une fréquence de 10-15 Hz puis tendent à les amortir pour des fréquences supérieures. Cette amplification aux basses fréquences, parfois considérable (rapport de 2,5 ou plus) va contribuer à augmenter les contraintes rachidiennes.

A cet égard, il faut insister avec WISNER et BERTHOZ sur l'importance des déphasages que peuvent présenter entre elles des différentes masses suspendues et qui seraient particulièrement nocifs pour le rachis, en particulier les changements de phase thorax-bassin. Outre ces mouvements axiaux, les vibrations d'axe Z produisent sur la colonne vertébrale des oscillations d'avant en arrière : entre 12 et 14 Hz par exemple, la colonne dorsale fléchit en avant ; ce phénomène est particulièrement net au niveau de la tête qui répond aux sollicitations verticales par des oscillations horizontales.

On conçoit bien que ce mouvement d'avant en arrière, aggravé par la position en hyperextension et par le port du casque qui ajoute une certaine inertie au système puisse engendrer des lésions au niveau de la zone charnière représentée par la colonne cervicale basse.

La physiopathologie des vibrations d'axe X et Y sur le rachis est plus mal connue mais elle est certainement loin d'être négligeable agissant par le biais de forces de cisaillement, souvent là encore amplifiées par le coussin du siège.

Au total, toutes ces données physiopathologiques permettent de mieux comprendre le mécanisme d'action des vibrations sur le rachis sensibilisé par une mauvaise posture : une fois l'amortisseur musculaire forcé, le surmenage du système discoligamentaire va se traduire sur le plan anatomique par l'apparition d'une discopathie dégénérative, à l'origine du tableau clinique et radiologique rencontré.

#### IV Moyens de prévention :

Comme dans toute la pathologie à caractère professionnel, deux objectifs simultanés sont à poursuivre ; adapter l'homme à son travail et la machine à son opérateur humain

En ce qui concerne les hélicoptères, des progrès considérables peuvent être constatés au plan du niveau vibratoire dans les appareils de nouvelle génération ; ce fait a été mesuré sur GAZELLE, il a pu être apprécié subjectivement par les pilotes sur le DAUPHIN et l'ECUREUIL derniers-nés de la production aéronautique française. Il est dû au perfectionnement technologique qui permet de remplacer des systèmes métalliques articulés par des pièces monobloc en matériau plastique, à l'installation d'amortisseurs (cylind-blocks) diminuant les vibrations engendrées par les rotors et les transmissions en mouvement.

Par contre hormis le Super-Frelon pour lequel la position de pilotage est relativement satisfaisante des progrès restent encore à réaliser dans ce domaine ainsi que dans celui des sièges qui trop souvent encore amplifient les vibrations de basse fréquence nocives pour le rachis.

Il faut cependant noter ici l'amélioration apportée en matière de confort postural par l'utilisation des stabilisateurs automatiques (Gazelle ; Alouette III) et du pilote automatique (Puma ; Super-Frelon).

En ce qui concerne l'adaptation de l'homme à son poste de travail, elle doit commencer par une sélection soignée des futurs pilotes d'hélicoptères comportant un examen radiologique complet du rachis en position debout ; cet examen permet d'éliminer d'emblée de la profession les sujets présentant des troubles statiques importants, des anomalies transitionnelles avec désencastrement total de la vertèbre-pivot ou très asymétriques, certaines autres anomalies congénitales ou séquelles d'affections acquises (arthrite, ostéoarthrites). Il faudra ensuite veiller, au cours de la pratique aéronautique, au respect des seuils de durée et de rythme de vol propices à l'apparition de douleurs vertébrales.

Enfin l'observation de règles hygiéno-diététiques simples : alimentation saine et équilibrée, pratique régulière d'un entraînement physique (gymnastique, natation en particulier) permettra d'éviter l'apparition d'une surcharge pondérale et d'un relâchement de la musculature paravertébrale sensibilisant le rachis aux micro-traumatismes professionnels.

Il faut souligner ici le rôle important que joue, par ses conseils et sa surveillance le médecin du personnel navigant dans le domaine de cette prévention individuelle.

Toutes ces mesures prophylactiques doivent permettre d'éviter l'apparition de phénomènes douloureux invétérés avec le retentissement socio-professionnel et psychologique qu'ils comportent, ce dernier pouvant aller au maximum jusqu'à la névrose décrite par BERGOUIGNAN en 1961 (névrose lombalgique).

### CONCLUSION

En dépit des progrès accomplis dans le domaine des techniques aéronautiques les rachialgies engendrées par le pilotage des hélicoptères constituent toujours une pathologie d'actualité :

Sur le plan fonctionnel, la lombalgie reste le principal sujet de doléances affectant le type chronique, entrecoupée de poussées aiguës, parfois compliquée de sciatique, son délai d'apparition paraît actuellement retardé, sans doute en raison du ralentissement des rythmes de vol. Radiologiquement elle se traduit souvent par l'existence de signes arthrosiques, parfois par la découverte d'une anomalie congénitale prédisposante, enfin dans un certain nombre de cas (30 % pour DELAHAYE) l'examen radiologique standard est normal.

La pathologie rachidienne dorsale se résume en la présence dans un pourcentage non négligeable de cas (50 % environ) de discrets signes d'arthrose frappant électivement D8 D9 D10 dont l'incidence clinique est pratiquement nulle dans la population étudiée.

Il a été mis en évidence enfin, chez tous les pilotes examinés l'existence d'image de type arthrosique des apophyses unciformes de C5 C6 C7, associées souvent à une rectitude cervicale dans le plan sagittal.

Ces anomalies radiologiques dorsales et surtout cervicales survenant avec une grande fréquence chez des sujets relativement jeunes méritent d'être prises en considération ; dans les statistiques précédemment publiées les dorsalgies et les cervicalgies rencontrées chez les pilotes opérant dans des conditions différentes étaient plutôt rattachées à une contracture musculaire paravertébrale. Il semble en fait qu'à l'ombre des lombalgies qui restent au premier plan du tableau clinique puissent se développer précocement de manière insidieuse des lésions plus haut situées surtout cervicales n'apparaissant cliniquement que dans des conditions particulières (vol intensif par exemple).

Seule une étude à long terme clinique et radiologique comportant des examens répétés dans les mêmes conditions pourrait indiquer de façon précise le devenir de ces lésions et leur évolution par rapport à la population générale.

Le développement de la recherche dans le domaine des effets physiologiques et physiopathologiques des vibrations permettra sans doute également de mieux appréhender ces problèmes.

Pour l'instant on ne peut fournir que des hypothèses.

## VERTEBRAL COLUMN INJURIES ASSOCIATED WITH HELICOPTER OPERATIONS

by

Dr Ing. Leon E. Kazarian  
6570th Aerospace Medical Research Laboratory  
Air Force Systems Command  
Wright-Patterson Air Force Base  
Ohio 45433, USA

### ABSTRACT

The human spinal column is a flexible rod whose geometry varies with every movement of the body. The column possesses in combination, a number of means to attenuate, transmit, and absorb mechanical loads. These actions are achieved by a variety of mechanisms and, as a consequence, have impact on the severity and mode of hard and soft tissue spinal injuries. In this paper, the USAF spinal injury experience for rotary wing aircraft is reviewed over the past ten years. The data collected are based upon an indepth review of accident investigation reports along with a review of radiographic records. For convenience, spinal injury types are categorized according to radiological appearance and mechanism. Hard tissue spinal injuries range in severity from anterior wedge compression fractures to compressed impacted centrum fractures. Traumatic disk injuries have been classified according to

- disk space narrowing
- vertebral end plate rupture and intraspongious disk herniation
- disk prolapse.

In this paper the various mechanisms of force attenuation, transmission, and absorption in the vertebral body and intervertebral disk are delineated from experimental data and related to observed modes and severities of spinal injury. The spinal injuries experienced by USAF aircrews and passengers are partially attributed to the structural inadequacy and geometry of the support system, and the ineffectiveness of the restraint system to minimize torso rotation following crash deceleration.

## ASSESSMENT OF THE BENEFITS OF AIRCRAFT CRASHWORTHINESS

by

Major Andrew E. Gilewicz  
Aerospace Engineer  
U.S. Army Agency for Aviation Safety  
Fort Rucker, Alabama 36362

Summary

An assessment is made of the economic benefits of providing crashworthiness improvements within future Army helicopters, as outlined in MIL-STD-1290 "Light Fixed-and Rotary-Wing Aircraft Crashworthiness." The discussion is based on two separate studies of Army helicopter aircraft accident reports. The first study projects from a cost-effectiveness standpoint the crashworthiness features which would be most worthwhile in preventing or reducing injury and hardware damage. The second study addresses itself specifically to the current utility helicopter, UH-1, and to the prediction of future accident losses for a number of candidate utility helicopter replacements. Projections were derived based on each helicopter's crashworthiness design features and the effectiveness in injury and hardware damage prevention. The net results of these studies demonstrates the cost effectiveness of MIL-STD-1290. Additionally, the technical adequacy of the design requirements is verified based on typical Army helicopter crash impacts.

Introduction

Historically, aircraft crashworthiness has been a product difficult to sell to the aviation community. Dollar costs and weight penalties have been considered unacceptable. Operational expediency and a philosophy of "build them to fly, not to crash" have resulted in the development of aircraft which perform their mission but fail to provide adequate crash protection for their occupants in the event of an accident. From such accidents, design deficiencies have been identified, but the cost of retrofitting a large existing fleet of aircraft with major improved crashworthiness features has generally been considered prohibitive.

The rapid expansion of rotary wing aviation in military operations during the 1960's produced a requirement for a new generation of helicopters for the U.S. Army. This requirement provided the opportunity for those concerned with crashworthiness to interject their design concepts into the early developmental stages of the new aircraft systems. This was accomplished by including the requirements of Military Standard 1290 (Reference [1]) into the aircraft design specifications. This MIL-STD, adopted by the Department of Defense in 1974, represents one of the most significant recent milestones in aviation safety. This document specifies crashworthiness features required in the construction of future U.S. military light fixed and rotary wing aircraft. These specifications are based primarily on the recommended aircraft design criteria contained in USAAMRDL Technical Report 71-22, Crash Survival Design Guide (Reference [2]).

The recognition of the desirability of including crashworthiness design concepts into new aircraft systems does not automatically remove the cost considerations. New aircraft are becoming more costly with improved technology. The need for economic justification of crashworthiness has become an important part of the overall justification for new aircraft systems. The primary objective of this paper is to discuss a proposed methodology for performing the economic justification of crashworthiness.

Definitions

Aircraft Accident - Damage which occurs to one or more aircraft while flight was intended. Damage as a direct result of hostile fire is not an accident but a combat loss.

Major Accident - An aircraft accident is classified major when the aircraft is destroyed, or damage sustained is in excess of prescribed limits as to required repair manhours or the aircraft is lost or abandoned.

Survivable /ccident - An accident in which the following statements are satisfied for at least one occupant aboard the aircraft:

- a. The forces transmitted to the occupant through his seat and restraint system do not exceed the limits of human tolerance to abrupt accelerations.
- b. The fuselage structural container maintains a livable volume around the occupant.

Nonsurvivable Accident - An accident in which neither of the above statements is satisfied for all occupants aboard the aircraft.

Major Injury. Any injury requiring five days of hospitalization or any of the following symptoms without regard to hospitalization:

- a. Unconsciousness due to head trauma.
- b. Fracture (open or closed) of any bone, other than closed fractures of the phalanges or nasal bones.
- c. Traumatic dislocation of any joint, excluding phalanges, or internal derangement of the knee.

- d. Injury to any internal organ.
- e. Moderate-to-severe lacerations which cause extensive hemorrhage or require extensive surgical repair.
- f. Third-degree burns.
- g. First- and second-degree burns involving more than five percent of the body surface.

#### Discussion

With the development of the Utility Tactical Transport Aircraft System (UTTAS) the replacement for the Army's primary helicopter, it became necessary to assess the costs and benefits of the crashworthiness features of the system. Two recent studies by the U.S. Army address the economics of the crashworthiness specifications of that standard. These studies represent an approach to the continuing system safety program of assessing the benefits of safety design features. They compare the costs of past Army aircraft accidents with the predicted costs of similar accidents in generic type aircraft, equipped with the crashworthiness design features of MIL-STD-1290. Table 1 compares the typical design characteristics of the aircraft studied with the crashworthiness features of MIL-STD-1290 and their potential benefits.

TABLE 1.--Crashworthiness Requirements of MIL-STD-1290 Compared to Current Army Aircraft

ITEM	TYPICAL CURRENT DESIGN	MIL-STD-1290	POTENTIAL INJURY OR HARDWARE DAMAGE REDUCTION/ELIMINATION
Landing Gear	Sink speed capacity (zero fuselage deformation) = 12-15 ft/sec with zero-degree roll and pitch.	Sink speed capacity = 30 ft/sec with 10-degree roll and pitch.	<ul style="list-style-type: none"> <li>■ Vertical crash force injury</li> <li>■ Reduces rollovers which reduces hardware damage and flail injury.</li> </ul>
Personnel Restraint Harness	Shoulder straps not used on seats other than pilot seats, except OH-6 and OH-58.	<ul style="list-style-type: none"> <li>■ Shoulder straps required</li> <li>■ Convenient ingress-egress</li> <li>■ Low-stretch webbing</li> </ul>	<ul style="list-style-type: none"> <li>■ Head and upper torso "flail" injuries</li> </ul>
Seating	Ultimate loads (total restraint system): <ul style="list-style-type: none"> <li>■ Pilot-12-20 <math>g_x</math>, 6-10 <math>g_y</math>, 15 <math>g_z</math></li> <li>■ Other-10 <math>g_x</math>, 5 <math>g_y</math>, 11 <math>g_z</math></li> </ul>	<ul style="list-style-type: none"> <li>■ Pilot-30 <math>g_x</math>, 30 <math>g_y</math>, 15 <math>g_z</math></li> <li>■ Other-24 <math>g_x</math>, 30 <math>g_y</math>, 15 <math>g_z</math></li> <li>■ "Limits" g loads to survivable levels</li> </ul>	<ul style="list-style-type: none"> <li>■ Spinal column compression fractures and other internal injury</li> <li>■ Torso ejection from fuselage</li> </ul>
Fuselage Integrity	<ul style="list-style-type: none"> <li>■ Rollover integrity is fair.</li> <li>■ Large side openings reduce strength and integrity of some aircraft.</li> </ul>	<ul style="list-style-type: none"> <li>■ Rollover strength is better.</li> <li>■ Cockpit structure sustains 4 times aircraft weight at any loading angle.</li> </ul>	<ul style="list-style-type: none"> <li>■ Injuries caused by inward fuselage buckling.</li> </ul>
Main Transmission Integrity	Tiedown strength, applied separately: <ul style="list-style-type: none"> <li>■ OH-6-17 <math>g_x</math>, 17 <math>g_y</math>, 20 <math>g_z</math></li> <li>■ OH-58-15 <math>g_x</math>, 10 <math>g_y</math>, 20 <math>g_z</math></li> <li>■ Remainder-8 <math>g_x</math>, 8 <math>g_y</math>, 8 <math>g_z</math></li> </ul>	<ul style="list-style-type: none"> <li>■ Tiedown strength, applied in selected combinations: 20 <math>g_x</math>, 18 <math>g_y</math>, 20 <math>g_z</math></li> </ul>	<ul style="list-style-type: none"> <li>■ Injuries caused by transmission/rotor penetration of cabin.</li> <li>■ Structural damage due to displaced transmission.</li> </ul>
Tail Rotor	Tail rotor vulnerable to impact by trees and other obstacles.	<ul style="list-style-type: none"> <li>■ Tail rotor protected from impact by location and shielding.</li> <li>■ Blades are impact tolerant.</li> </ul>	<ul style="list-style-type: none"> <li>■ Eliminates many accidents caused by tail rotor strikes.</li> <li>■ Eliminates loss of anti-torque control after blade strike.</li> </ul>
Main Rotor Blade	Rotor hub-to-mast integrity for flight loads only, except OH-6 static mast which provides good crash integrity.	Better hub-to-mast integrity. (Rotor must not displace excessively when outer 10% span torn off.)	<ul style="list-style-type: none"> <li>■ Injuries caused by blade penetration.</li> <li>■ Structural damage due to displaced rotor.</li> </ul>

#### Study of Army Helicopter Fleet Crashworthiness

In the first study (Reference [3]), 299 U.S. Army helicopter accidents in which major hardware damage was sustained and at least one occupant suffered major injuries were reviewed for the 1970-71 period (Table 2). Personnel injuries and hardware damage considered probably preventable by crashworthiness design features of MIL-STD-1290 were isolated. Identifiable hardware deficiencies caused 356 potentially preventable injuries (Figure 1) and 160 potentially preventable fatalities (Figure 2). Had the aircraft been equipped with the crashworthy features outlined in Table 1, the potential dollar savings during the 2-year span of the study would have been \$20,000,000. The potential hardware savings over the same period would have been \$18,500,000 or about 32 percent of the total hardware losses.

Table 2 - Summary of CY 70-71 Injuries in Army Aircraft Accidents, Five Aircraft Types

Aircraft	Total Major Crashes	Total Aboard	Total Casualties	Occupants in Severe, Survivable Crashes
AH-1	154	303	137	48
CH-47	43	457	356	151
OH-6	217	516	182	110
OH-58	77	190	64	31
UH-1	522	3,106	1,085	714
<b>Total, CY 70-71</b>	<b>1,013</b>	<b>4,572</b>	<b>1,824</b>	<b>1,054</b>
<b>Total in this study</b>	<b>299</b>	<b>1,054</b>	<b>818</b>	<b>1,054</b>

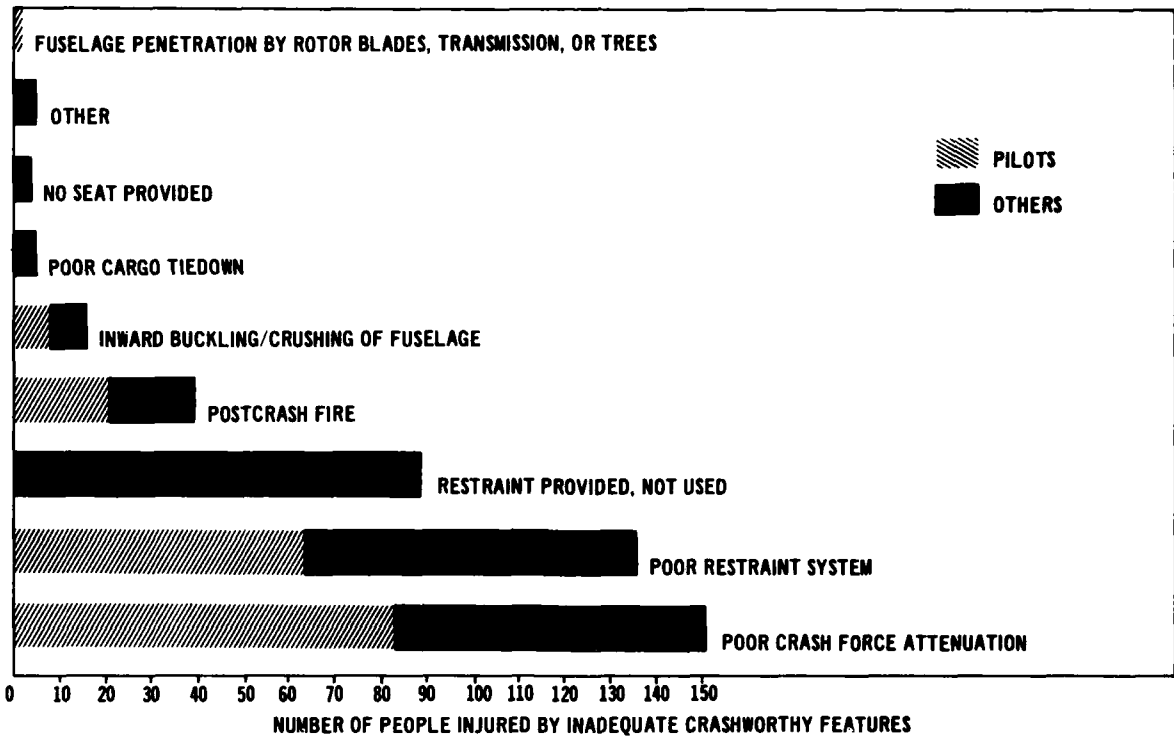

FIGURE 1.—Identity of Hardware Deficiencies Causing 356 Potentially Preventable Injuries, CY 70-71

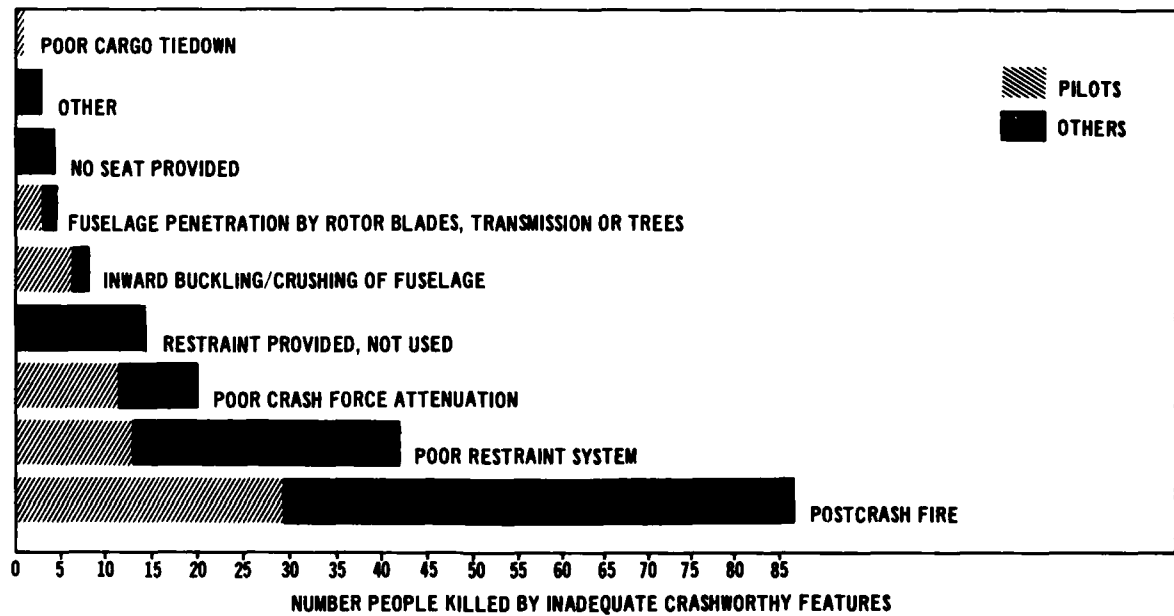

FIGURE 2.—Identity of Hardware Deficiencies Causing 160 Potentially Preventable Fatalities, CY 70-71

A cost effectiveness analysis compared the total benefits with the total costs over the life cycle of a utility aircraft. The total life cycle crash safety benefits were estimated as the sum of the personnel and hardware savings. These savings were compared to the projected costs of the increased crashworthiness features in the generic UTTAS based on Army planning figures for acquisition costs and usage rates. Crash safety benefits were projected using a range of anticipated accident rates. The cost of increased crashworthiness was estimated as a ratio of the weight of crashworthiness features to the aircraft empty weight. This ratio was used to estimate the increase in the generic UTTAS life cycle costs, including both acquisition and operating costs, to provide MIL-STD-1290 crashworthiness features.

The cost of crashworthy improvements was compared to the personnel and hardware benefits to determine the time required for the crashworthiness to "pay for itself." The point at which this would occur was



predicted to be 3 to 10 years, depending on the accident rate (Figure 3). The 1970-71 accident rate was assumed to be applicable.

From a cost-effectiveness standpoint, the individual crashworthy features which would be most worthwhile in preventing or reducing injury and hardware damage were determined to be:

#### REDUCTION OF OCCUPANT INJURY

1. Improved occupant restraint, especially upper torso, to prevent flailing injuries.
2. Fuselage rollover capability without collapse.
3. Improved landing gear to prevent snagging/gouging and resultant rollover, as well as greater absorption of sink speed energy.
4. Increased "load-limiting" capacity of seats and fuselage structure to prevent back injury.
5. Crashworthy fuel system.

#### REDUCTION OF HARDWARE DAMAGE

1. Protected tail rotor with tolerant blade will prevent many accidents.
2. Improved landing gear to prevent rollover, as well as greater absorption of sink speed energy.
3. Impact-tolerant main rotor blade tips and transmission integrity to sustain unbalanced loads from bent/broken missing tips.
4. Crashworthy fuel system.

#### Study of Crashworthiness Improvements to the Generic UTTAS

The second study (Reference [4]) was done by the U.S. Army Agency for Aviation Safety (USAAAVS) with support of a number of other Army agencies for the U.S. Army Training and Doctrine Command (TRADOC) for use in the Cost and Operational Effectiveness Analysis (COEA) of the UTTAS. The study consisted of analyzing 138 major aircraft accidents which occurred in the time period 1972-75 (Table 3) and predicting which accidents, injuries, and fatalities might have been prevented had the same missions been flown using a number of UTTAS candidate utility type aircraft (Table 4).

The major advantage of the study was the realistic peacetime accident rate based on more recent data. Additionally, specific aircraft types and missions were addressed. The steps in the crashworthiness and accident analysis are depicted in Figure 4. The initial effort was to establish an accident rate for each of the UTTAS candidate aircraft. Design features which would influence rate were taken into account.

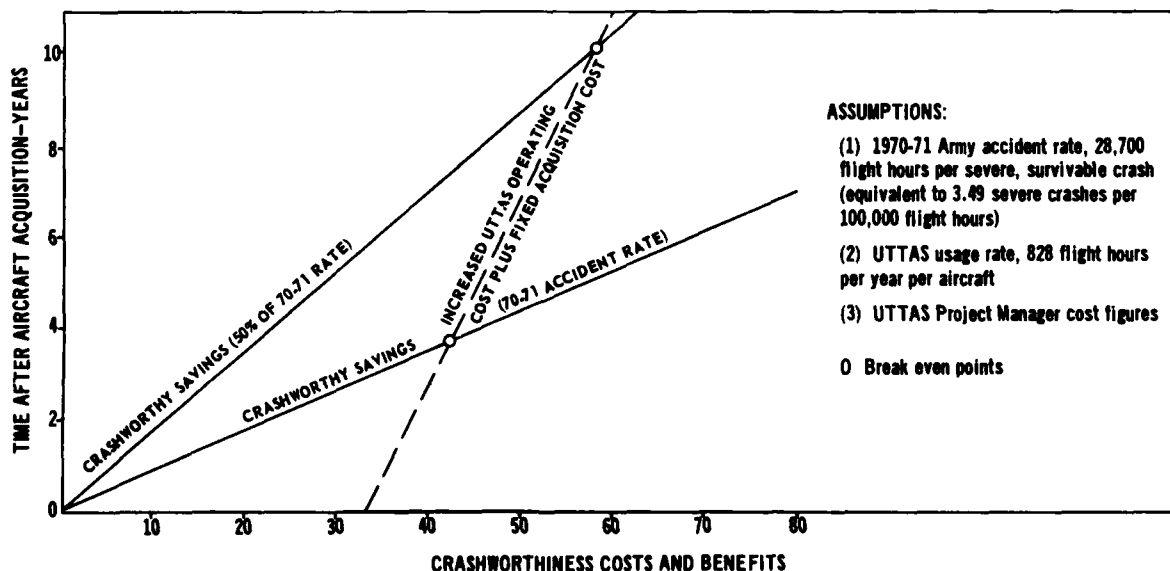

FIGURE 3.—Crashworthy Feature Savings and Costs As A Function of Usage Time

Table 3 - UH-1H Major Aircraft Accidents, CY 72-75

Number of Survivable Accidents	120
Number of Nonsurvivable Accidents	19
Number of Major Accidents	139
Number of Accidents Analyzed in this Study	138
Number of Aircraft Flight Hours:	2,837,653
Accident Rate:	4.86 per 100,000 flight hours
Number of Occupants Aboard	683
Number of Occupants Killed or Injured	304 or 44.5% of total

Table 4 - Candidate Utility Aircraft and Pertinent Fleet Parameters

Aircraft Type	Unit Acquisition Cost (1975 Dollars)	Projected Fleet Size	Flying Hours Per Aircraft Per Year
UH-1H	\$ 591K	1695	324
UH-1H(PIP)	\$ 708K	1695	324
UH-1N	\$1,042K	1695	324
UH-1N(MOD)	\$1,134K	1695	324
Mode 214A(MOD)	\$1,280K	1769	324
UTTAS (Generic)	\$1,792K	1107	324

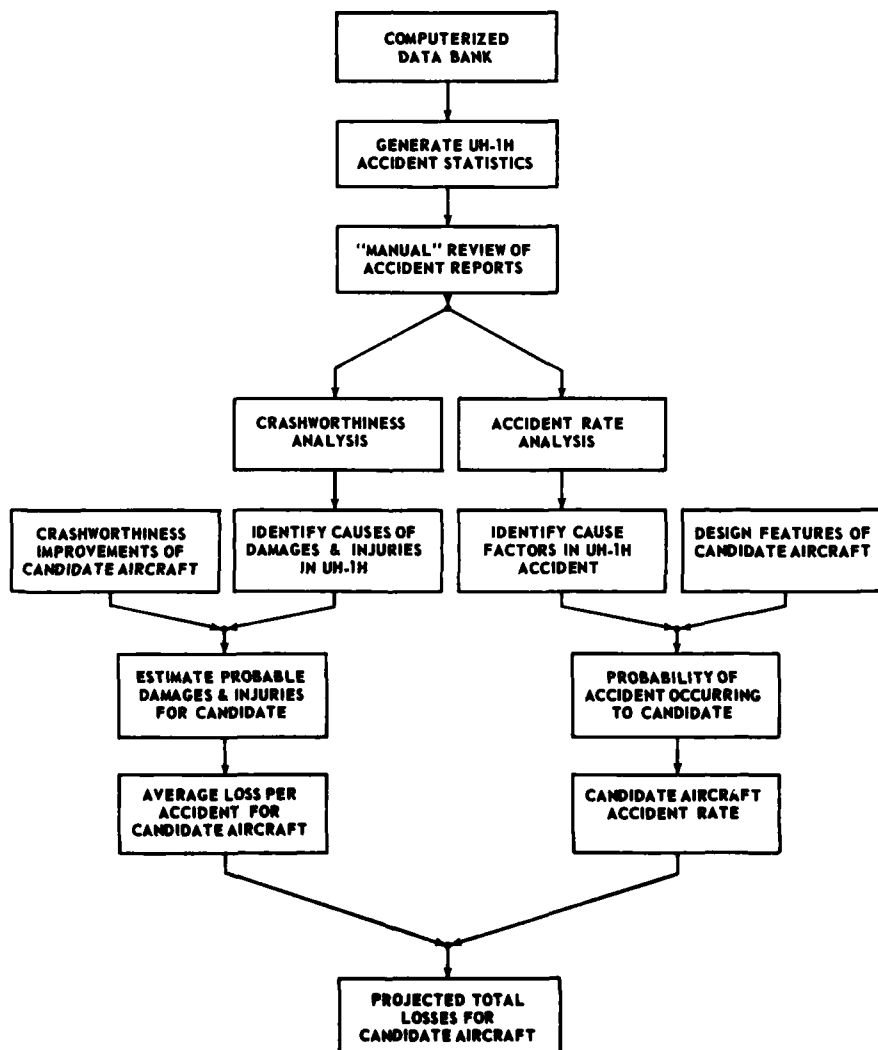

FIGURE 4.-Sequence of Analysis

Second, a mean economic loss due to hardware damage and personnel injury was established for each of the UTTAS candidates, taking into account its particular crashworthiness features. Finally, the accident costs for each candidate were derived by multiplying accident rates by the respective mean loss per accident. Accident costs were derived for an assumed 20-year life (Figure 5).

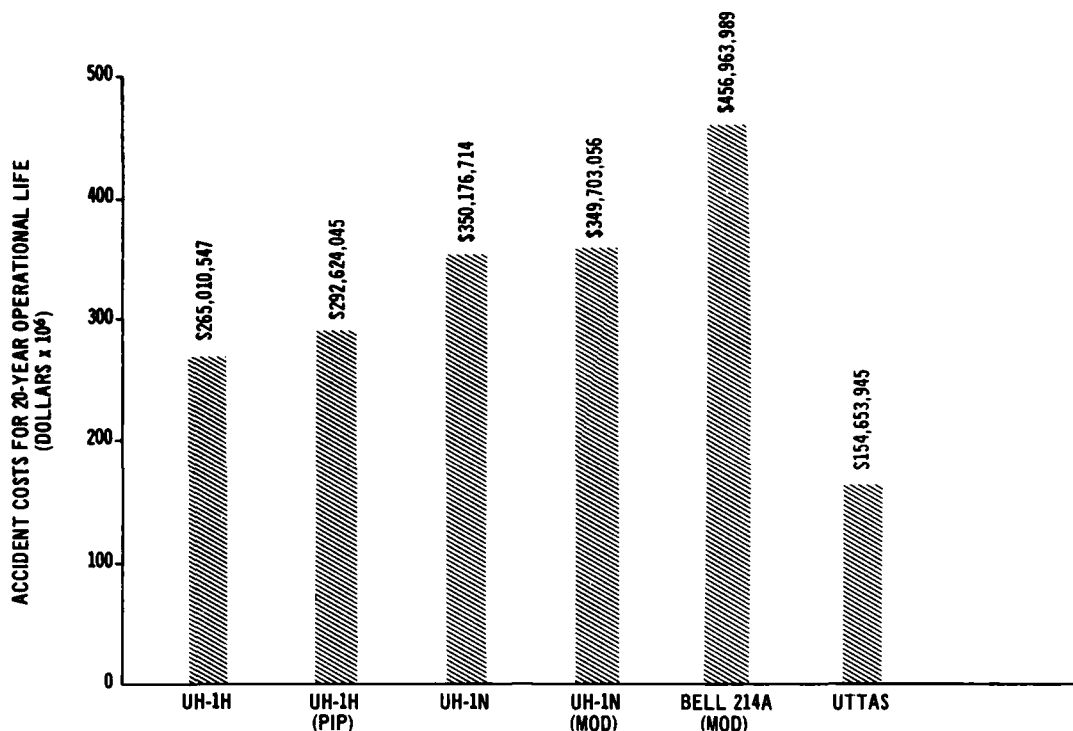

FIGURE 5.—Total Accident Costs for 20-Year Operational Life

The study predicted that the accident rate (Figure 6) itself might be reduced by 40 percent by design features such as the twin-engine design with single-engine capability. In addition to the savings expected from the reduced accident rates, the percent of total occupants killed or injured could be reduced from 45 percent to 29 percent, a 16 percent improvement (Figure 7). The hardware savings, per aircraft due to crashworthiness, are estimated to be a reduction from 65 percent to 38 percent of acquisition cost (Figure 8).

This second study supports the following major conclusions:

- a. Accidents constitute a significant portion of aircraft life cycle costs. Crashworthiness improvements reduce these losses in spite of increased initial acquisition costs.
- b. Crashworthiness improvements and other safety features are most cost effectively included in an aircraft as integral system requirements in the conceptual design stage. This technique provides the most dramatic reductions in accident losses.

#### Conclusions

The net result of the two studies demonstrates the cost effectiveness of MIL-STD-1290. In addition, the level of crashworthiness improvements in MIL-STD 1290 was judged sufficient relative to the crash impact conditions in the accidents studied. Therefore, these studies have verified the technical adequacy of the design requirements based on typical Army helicopter crash impacts.

In a larger sense, both studies represent a reasonable approach to the continuing problem of adequate assessment of the benefits of safety design features because the methodology used identifies these benefits in the language of management—cost, performance, and time. This approach does not ignore the humanitarian aspects of safety, but places major emphasis on a systematic, unemotional dedication of limited resources to the most critical problems.

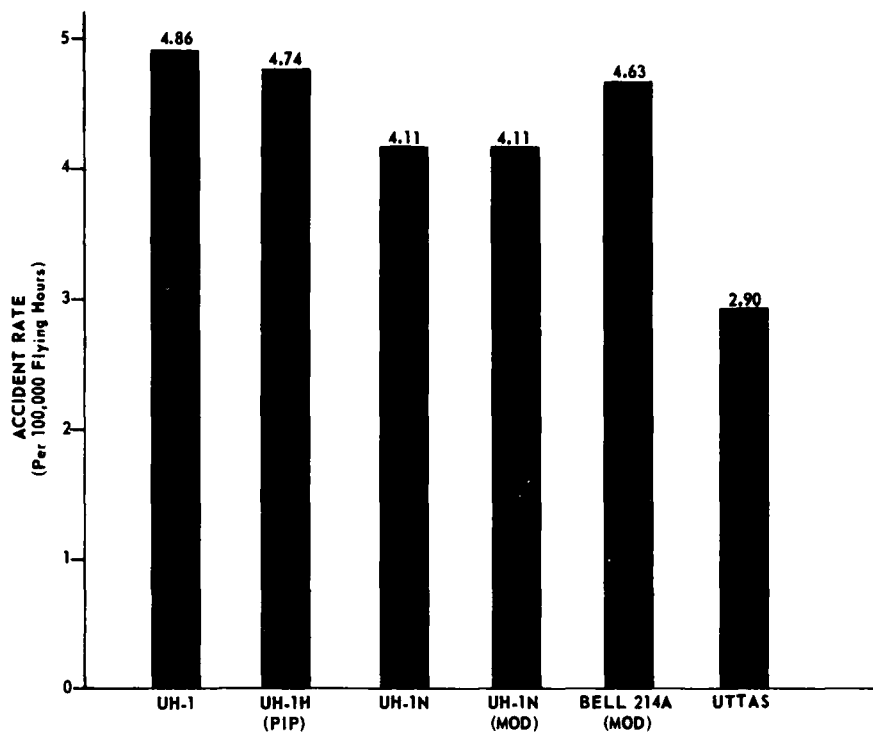

FIGURE 6.—Projected Peacetime Accident Rates for Candidate Aircraft

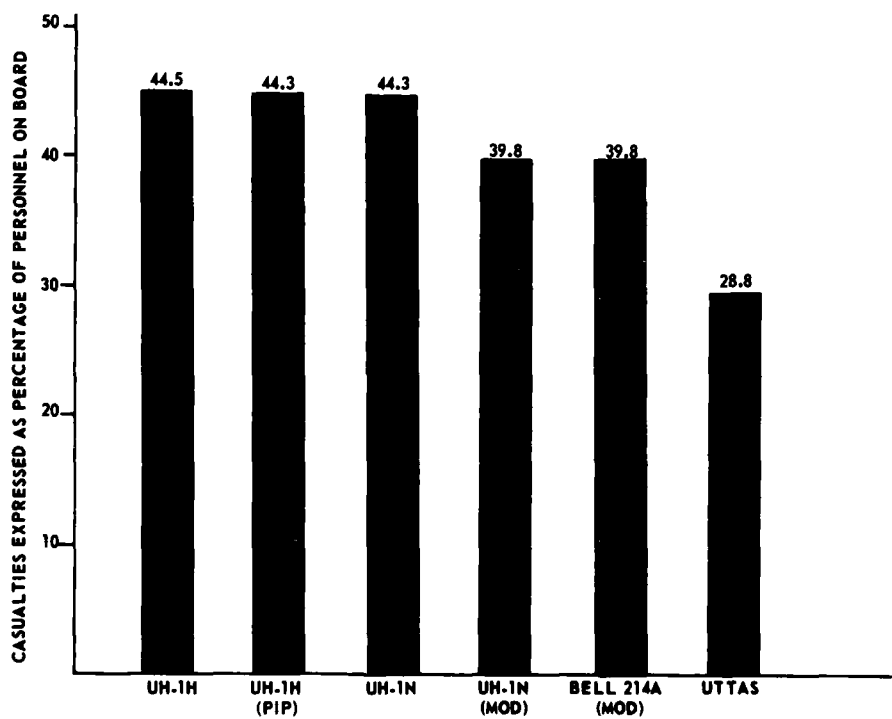

FIGURE 7.—Projected Casualties for Candidate Aircraft

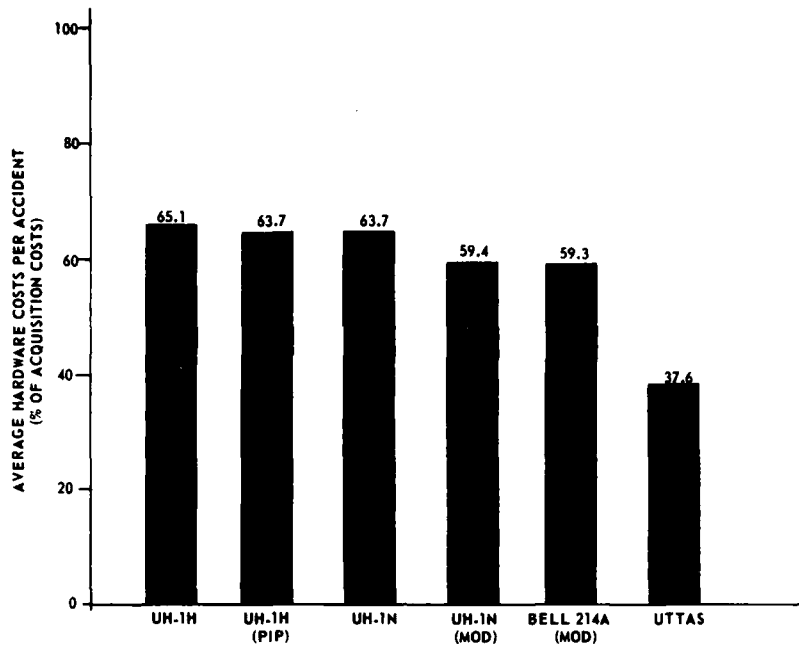

FIGURE 8.—Projected Mean Loss Per Accident as a Percentage of Unit Acquisition Costs

References

1. MIL-STD-1290(AV), Light Fixed- and Rotary-Wing Aircraft Crashworthiness, 25 January 1974.
2. USAAMRDL Technical Report 71-22, Crash Survival Design Guide, Eustis Directorate, October 1971.
3. Haley, J. L., and Hicks, J. E., Crashworthiness Versus Cost: A Study of Army Rotary Wing Aircraft Accidents in Period January 70 Through December 71, joint technical report (unpublished) of the U.S. Army Aeromedical Research Laboratory and U.S. Army Agency for Aviation Safety, Fort Rucker, Alabama, presented at Aircraft Crashworthiness Symposium, University of Cincinnati, 6-8 October 1975.
4. Hicks, J. E., Technical Report 76-2, Economic Benefits of Utility Aircraft Crashworthiness, U.S. Army Agency for Aviation Safety, July 1976.

## CRASHWORTHY HELICOPTER SEATS AND OCCUPANT RESTRAINT SYSTEMS

by

George T. Singley, III  
Aerospace Engineer  
Applied Technology Laboratory, USARTL (AVRADCOM)  
Ft Eustis, Virginia 23604

and

Stanley P. Desjardins  
President, Simula, Inc.  
2211 South 48th Street, Suite C  
Tempe, Arizona 85282

## SUMMARY

The next generation of US Army aircraft, currently under development, will possess unprecedented crashworthiness. This achievement is a direct result of almost two decades of aircraft crashworthiness R&D, adherence to crashworthiness military specifications, and the Army's commitment to reducing loss of life and costs associated with helicopter crashes. These helicopters are equipped with seats and restraint systems offering substantial improvements in comparison to existing helicopters with respect to strength, body restraint, and crash force attenuation. These seat and restraint systems are capable of retaining the seated occupant in the same relative position within the aircraft throughout the 95th percentile potentially survivable accident without the occupant being subjected to conditions in excess of human tolerance.

Cockpit and cabin seat and restraint systems retention strengths have been demonstrated to withstand drop and sled tests with velocity changes of 50 ft/sec and peak accelerations of 48G for drop tests and 30G for sled tests. This increased strength is achieved with lightweight designs and is made possible by the application of load limiting principles. This crash force attenuation characteristic limits the impact loading not only of the seat structure but also of the seat occupant. It is the design requirement to reduce the probability of occupant injury due to decelerative loading which most deserves increased attention. Optimally, one would like to be able to determine the statistical probability of occupant injury for a given seat design and impact pulse. At present, this is not possible.

## INTRODUCTION

For a helicopter to be efficiently designed to be crashworthy, the effort must be accomplished beginning with the early design stages, as was the case during the US Army's Utility Tactical Transport Aircraft System (UTTAS) and Advanced Attack Helicopter (AAH) development programs (1, 2, 3, and 4). The fuselage must be designed to provide a protective shell around the occupants during crashes as severe as the 95th percentile potentially survivable accident defined in Table I. This means that the fuselage must have sufficient strength, stiffness, and crash energy absorption characteristics to prevent either collapse of the structure or loss of retention of high mass items around the occupants. In addition to this crash impact structural integrity requirement, the landing gear, airframe, and seating systems must attenuate crash impact decelerations input to the occupant in the headward direction (see Figure 1) to humanly tolerable levels to avoid spinal injury. Except for lateral loading of side-facing seats, deceleration levels in the other directions during the 95th percentile potentially survivable accident are within defined human tolerance levels assuming adequate occupant restraint. In addition to reducing decelerative loading of the seat occupant, crash force attenuation features in a seat also reduce the loads which the seat structure must withstand, thereby permitting a lower weight structure than would be needed if one were to design for sufficient strength to withstand the nonattenuated crash loads.

Ideally, it would seem most efficient to simply specify human tolerance requirements and an array of vehicle crash impact conditions and develop the helicopter as a crashworthy system with that mix of crashworthiness features that is most efficient for the particular helicopter being designed. Unfortunately, the necessary validated structural and/or human tolerance analytical techniques to perform and evaluate such a maximum design freedom approach to crashworthiness are not available. Furthermore, testing fuselages sufficiently early in the development cycle to permit evaluation of systems concepts is not practical. Consequently, a balance must be struck between (1) the pure system approach and (2) a total definition of necessary performance on a component level.

Current helicopter crashworthiness criteria require that the aircraft be designed as a system to meet specified vehicle impact design conditions; however, minimum criteria are also specified for a few crash critical components. For example, crash tiedown load factors are specified for high mass items. The landing gear must be able to decelerate the helicopter from a vertical impact velocity of 20 ft/sec on a level rigid surface without the fuselage contacting the ground, and seat/restraint system strengths and minimum crash energy absorption requirements are specified. Mandatory minimum crashworthiness design criteria for US Army light fixed- and rotary-wing aircraft are stated in MIL-STD-1290 (5).

This paper reviews helicopter crashworthy seat and restraint system design principles, presents recent R&D results, and discusses areas deserving additional R&D.

#### INJURY DATA

As part of a current effort to update the Army's Crash Survival Design Guide (6), data from the US Army Agency for Aviation Safety (USAAAVS) for Army aircraft accidents occurring in the period January 1971 to November 1977 have been reviewed. Injury data have been related to various segments of the body and specific classes of helicopters, and are presented in Tables II, III, and IV. Helicopters are divided into four classes: utility, observation, cargo, and attack. Percentages for each body segment for each class of aircraft, including total helicopters are presented. Further, the injury data are for all aircraft occupants, not just crew members or passengers. Table II presents injuries to body segments as a percent of major and fatal injuries as defined by USAAAVS.\* Table III presents injuries to three critical body segments including the head, thorax, and vertebral column as a percent of major injuries. Table IV presents the same information as a percent of fatal injuries.

It is apparent from the data presented in Table II that there are five body segments which sustain the greatest percentage (each above 10%) of injuries in this category. These include head, upper extremities, thorax, vertebrae, and lower extremities. Improving the crash protection for these segments of the body should therefore be emphasized in efforts to improve the crashworthiness of aircraft and to reduce the probability of serious injury in crashes.

A few more observations can be made concerning the data contained in Table II. First, it can be seen that the percentage of head injuries does not vary significantly between helicopter types. This implies that head impact with surrounding structure, including bulkheads, instrument panels, and glare screens, is of frequent occurrence. It simply means that the motion envelopes of the head in all these aircraft include the mentioned obstacles. The high percentage of injuries to the upper and lower extremities probably also relates to the motion envelope of these members of the body and their overlap with aircraft equipment and structure. The injury data also show that the percentage of head injuries in cargo helicopters is higher than for other types of helicopters. The percentage of vertebral injuries is lower. This probably relates to the increased structural depth of these larger helicopters, which produces increased energy absorption. The attack helicopter produces the larger percentage of vertebral injuries, although the observation helicopter is relatively close. These data simply emphasize the fact that the smaller aircraft necessarily have less energy-absorbing structure and therefore produce higher acceleration loads on the occupant than do the larger aircraft.

Several interesting trends can be noted by comparing Tables III and IV. First, remember that Table III compares injuries to head, thorax, and vertebral column as a percent of major injuries, whereas Table IV presents them as a percent of fatal injuries. It is interesting to note that vertebral injury is a high percent of major injuries, whereas it is a relatively low percent of fatal injuries. Vertebral injury, however, can debilitate the subject and minimize his chances of escaping the crashed aircraft. This, of course, can reduce his chances for survival. Further, vertebral injury can often permanently disable the subject through paralysis. Another trend that is apparent from these two tables is that a much higher percentage of thorax injuries are related to fatal injuries than to major injuries.

#### CRASHWORTHY SEAT/RESTRAINT SYSTEM PARAMETERS

Because the seat/restraint system is so critical to occupant survival and because its crashworthiness can be demonstrated relatively inexpensively, extensive seat/restraint system crashworthiness design and test criteria have been developed in the last 18 years. MIL-S-58095(7) has been the Army's crashworthy pilot/copilot seat/restraint system criteria document since 1971. Draft military specifications for troop and cabin gunner seat/restraint system criteria have been validated and are in the coordination stage (9, 23). Table V contains a brief summary of the crashworthiness criteria contained in MIL-S-58095 and MIL-STD-1290 and compares this criteria with the older, superseded seat criteria.

The factors (excluding postcrash factors such as fire) that determine a seat occupant's probability of survival during a crash impact are outlined in Figure 2. The airframe should provide a protective shell around the occupants such that the landing gear and airframe absorb a portion of the crash impact energy while an inhabitable volume is maintained in which structural components do not penetrate and high mass items are restrained. Within the protective container, structure should not entrap occupant extremities. Any structure or objects within the strike envelope of flailing body parts should be de-lethalized; e.g., removed, padded, or made frangible. The structural response, including deformation, at the seat attachment points must be withstood by the seat. The seat and occupant restraint system should be

\*Major Injury - Any injury requiring five or more days of hospitalization or quarters or combination of both or any of the following without regard to hospitalization:

- a. Unconsciousness due to head trauma.
- b. Fracture (open or closed) of any bone other than closed fractures of the phalanges or nasal bones.
- c. Traumatic dislocation of any joint excluding phalanges or internal derangement of the knee.
- d. Injury to any internal organ.
- e. Moderate-to-severe lacerations which cause extensive hemorrhage or require extensive surgical repair.
- f. Third-degree burns.
- g. First- and second-degree burns, involving more than five percent of the body surface.

designed not only to withstand the input deceleration/time pulse and restrain the occupant but also to minimize the occupant's strike envelope. The importance of this last point is borne out by the previous discussion of injury data. The occupant's motion envelope during energy absorbing movement must be investigated to ensure that the occupant will not strike an object, e.g., cyclic stick.

The occupant restraint system should be as full-bodied as operational, cost, and weight considerations will permit. Current minimum configuration criteria are shown in Figure 3; however, it should be noted that the next version of the Crash Survival Design Guide will not recommend the side strap for the pilot/copilot restraint system. The method for releasing the restraint system must be familiar, obvious, and easy-to-operate. Inadvertent release such as might occur when clothing snags on the release buckle, or due to inertial forces, or if the buckle is struck by the cyclic stick, must be avoided. High elongation restraint system webbing not only increases the occupant strike envelope, but has been shown to be a significant factor in amplification of occupant loading (see Figure 4) (10, 11).

A review of human tolerance data collected by Eiband and presented in the Crash Survival Design Guide indicates that energy-absorbing seat stroke must be provided to reduce the vertical loads imposed on the occupant in the 95th percentile survivable accident. Loads imposed on forward- and aft-facing seats in the lateral and longitudinal direction, however, are tolerable without energy-absorbing stroke, given adequate restraint.

Figure 5 shows the current human tolerance criteria for decelerative loading in the headward direction. This curve shows that if the deceleration plateaus measured at the seat pan are less than 23G for time durations longer than 0.006 second and higher for time durations less than 0.006 second, the environment should be tolerable. It is the crash force attenuation function of crashworthy seats that most challenges the designer, analyst, and test engineer today. The basic problem is how to minimize the energy-absorbing stroking force to prevent spinal injury while being limited by the amount of available stroking distance imposed by the aircraft geometry. This is an aircraft system energy-absorption problem.

To illustrate this point, assume the aircraft to be a rigid body where

$$\begin{aligned}
 F &= \text{force at aircraft center of mass (lb)} \\
 M &= \text{aircraft mass (lb-sec}^2/\text{ft)} \\
 \ddot{z}_{\text{avg}} &= \text{aircraft average acceleration (ft/sec}^2\text{)} \\
 \dot{z}_i &= \text{initial velocity (ft/sec)} \\
 \dot{z}_f &= \text{final velocity (ft/sec)} \\
 Z &= \text{total vertical displacement of aircraft center of mass with respect to ground (ft)} \\
 g &= 32.2 \text{ ft/sec}^2 \\
 G &= \text{average deceleration in G units} = \frac{\ddot{z}_{\text{avg}}}{g}
 \end{aligned}$$

Then by Newton's law of motion,  $F = M \ddot{z}$

The kinetic energy (KE) is  $KE = M \left( \frac{\dot{z}_i^2}{2} - \frac{\dot{z}_f^2}{2} \right)$

The work (U) done by bringing the impact mass to rest ( $\dot{z}_f = 0$ ) from the initial velocity ( $\dot{z}_i$ ), assuming an average force ( $F_{\text{avg}}$ ) is

$$U = F_{\text{avg}} Z = M \ddot{z}_{\text{avg}} Z$$

From the principle of work and kinetic energy,

$$U = KE \Rightarrow Z = \frac{\dot{z}_i^2}{2Gg} \quad (1)$$

The vertical velocity component in 95 percent of all Army helicopter survivable accidents is 42 ft/sec or less. For an average deceleration of 14.5G, equation (1) yields

$$Z = \frac{\dot{z}_i^2}{2Gg} = \frac{(42)^2}{2(14.5)(32.2)} = 1.89 \text{ ft} = 22.68 \text{ in}$$

Obviously, 22.68 inches of seat stroke is impractical, so the crash energy absorption function must be a combination of energy absorbing landing gear, crushable airframe structure, and seat energy absorption. Figure 6 illustrates how the seat and airframe (including the landing gear) combine to limit decelerative loading of the occupant assuming rigid body mechanics, a triangular deceleration input pulse, and a seat energy absorber load-deflection curve with the same rise time as the input pulse and a square wave once the limit load is achieved. For this system, the seat stroke is



$$S = G_m g t_m^2 \left( -\frac{K^3}{24} + \frac{K}{2} + \frac{1}{2K} - 1 \right) \quad (2)$$

Once again, using the 95th percentile survivable vertical triangular input pulse from Table I as measured at the seat floor,

$$G_m = 48$$

$$t_m = .027 \text{ sec}$$

$$K = \frac{G}{G_m} = \frac{14.5}{48} = .302$$

$$S = (48)(386)(0.027)^2 \left[ -\frac{(.302)^3}{24} + \frac{(.302)}{2} + \frac{1}{2(.302)} - 1 \right] = 10.87 \text{ in}$$

Figure 7 shows the test results upon which the current energy-absorber limit load criteria are based (12). The data show that for a peak limit load of 4,650 pounds, the vertical component of deceleration in combined dynamic loading tests, as well as that resulting from uniaxial loading tests, would be below the 23G limit. Dividing the 4,650 pounds by the effective weight of the movable part of the seat with the occupant effective weight (318 pounds in this case) yields 14.62G for a limit load factor for the vertical energy-absorbing system. It was also shown in the reference 12 program that with the limit load factor of the energy-absorbing system set at 14.5G, a minimum of 12 inches of vertical stroke would be required to absorb the residual energy remaining after stroking of the landing gear and fuselage as defined by the 95th percentile survivable accident pulse in Table I (see Test Nos. 3 and 4 in Table VI). Since the seat pan is normally located only on the order of 8 inches above the floor in most aircraft, it is apparent that the seat must stroke below floor level into a well in the aircraft floor to achieve the additional stroke as shown in Figure 8.

A limited analysis has been performed to further investigate seat system sensitivity to several variables. The analytical method chosen to compute the response of the seat and occupant system was a computer program called SEAT (12). The Dynamic Response Index (DRI) was chosen as a probability of injury indicator for this analysis. SEAT is a five-degree-of-freedom lumped parameter model that represents a seated occupant subjected to vertical crash pulses. Variables were input to SEAT and the response of the seat pan was calculated. The response of the seat pan was then input to the Dynamic Response Index (DRI) model and the DRI was calculated. A physical representation of the SEAT/DRI model is shown in Figure 9. The DRI is used by the US Air Force for establishing acceptable ejection seat acceleration performance (13).

The variables chosen for analysis were: (1) shape of input deceleration pulse at the base of the seat, (2) shape of the energy-absorber/deformation characteristic, (3) shape of the cushion load-deformation characteristic, and (4) occupant size. The eleven cases analyzed are summarized in Table VII. Input pulse shapes included triangular, sinusoidal, and an irregular one from a crashworthy troop seat test program. In cases 1 through 10, the peak deceleration, as well as the velocity change, was kept constant. These various input pulses were analyzed to establish the effect of the various shapes that might be used within existing criteria. The first three shapes are triangular, and are permitted by both the Crash Survival Design Guide and MIL-S-58095. It will be noted that the rate of onset is varied in these pulses and is therefore used as the correlating parameter.

Several separate energy absorber force versus deformation characteristics were analyzed. The first was the trapezoidal shape which provides the most energy absorption per length of stroke. The case 8 energy absorber included a softer rate of onset simulating, to some extent, the characteristic obtainable from elongation of work hardening material such as a stainless steel tube like that used in the reference 12 program. This shape is referred to as a variable limit load energy absorber by some researchers. The case 9 energy absorber simulates a seat 'bottoming' because of inadequate stroke distance. The shape is trapezoidal and is identical to the energy absorber in case 1 within the first 8 inches of stroke. At 8 inches of stroke, the load resisting the stroking of the seat is increased rapidly to represent the 'bottoming' effect. Case 10 represents a seat having energy-absorber characteristics identical to that in case 1 except for an increase in resistive load after an 8-inch stroke. This increase in load may be caused by rubbing of the seat bucket against the side of a well that is provided under the seat to permit additional stroke distance in systems with inadequate distance between the seat pan and the floor.

Column 4 of Table VII presents the cushion characteristics. The case 6 cushion is twice as thick as the case 1 cushion, and the case 7 cushion is double that. Column 5 indicates the occupant weight percentile used in the analysis. Occupants ranging from the 5th to the 95th percentile were analyzed in this study. The remaining columns in the table are results of the analysis and include the seat stroke in inches and the maximum DRI for the various combinations.

The results of the analysis are qualified by the fact that it was run as a sensitivity analysis. In other words, the results are to be used simply as comparative measures of the sensitivity of the system to the described variables. No attempt to tune the model was made prior to the analysis to match, for example, seat stroke with that measured in tests of similar systems; consequently, the actual values calculated, such as seat stroke, should not be used as quantitative predictions.

Table VII shows that the DRI decreases with increased rate of onset. In other words, the steeper the initial slope of the input pulse, the lower the probability of injury, according to the DRI. This trend contradicts established human tolerance data; i.e., tolerance should decrease with increase in the rate of onset if all other variables are held constant (6). The sinusoidal input pulse also produced a slightly lower DRI than did the triangular-shaped pulses. Reducing the rate of onset of the load-deformation characteristic of the energy-absorbing system had a significant effect on the DRI. The trapezoidal shape

produced a DRI of 21.07 for case 2, whereas the case 8 energy absorber with a more gradual increase in load produced a DRI of 18.00. It can be seen, however, that the trapezoidal pulse required only 10.86 inches of stroke; case 8 energy absorber required 11.4 inches.

Allowing the seat to bottom out, of course, produces undesirable effects; however, it is surprising that the effect is not as acute as might be expected. The trapezoidal energy absorber produced a DRI of 21.07, whereas the seat that bottomed out after 8 inches of stroke produced a DRI of 23.04. This DRI increase, as will be pointed out later, is appreciably less than the increase associated with the lighter 5th percentile occupant in the same seat.

In case 10, the load was increased from 3000 pounds to 3600 pounds to simulate the bucket striking the seat well with a glancing blow. It can be seen that there is no effect on the DRI, peak pelvic deceleration, or peak seat deceleration in comparison to case 2. The reason for this is that the peak values occur much earlier in time than the increased load that occurs at 8.0 inches of stroke. This would indicate that some frictional input at this point in the pulse is not detrimental if the maximum DRI criterion is valid. In fact, the stroke for case 10 was 8 percent less than that for case 2.

The effect of the softness of the cushion is well illustrated in the three cases which evaluated this variable. The relatively hard cushion produced a DRI of 21.07 in case 2; the cushion which is half as hard produced a DRI of 23.97; and the softest cushion produced a DRI of 32.76. Thus, the effect of a soft, thick cushion can equal the effect of a seat bottoming out due to inadequate stroke, assuming, again, that the DRI provides a valid measure of evaluating crash injury potential. Similar studies using DRI to evaluate the effect of cushion properties on ejection seat protection also show the importance of the cushion (14).

The 5th percentile occupant was exposed to a DRI of 26.65. This value should be compared with the 21.07 computed for the 95th percentile occupant. This is a rather large increase due simply to the weight of the occupant, and for ejection seats, it would equate to a probability of injury of 90 percent. The lighter 5th percentile occupant can be exposed to a higher probability of injury during the standard operation of the seat than can a heavier percentile occupant who bottoms out. The last point sheds some light on a frequent question associated with retrofitting crashworthy seats to existing aircraft. The question has to do with whether it is better to set the limit load of the energy-attenuating system per the established criteria or whether to increase the load to keep heavier occupants in more severe crash environments from bottoming out. The last point would indicate that it would be better to maintain the limit load criteria and provide a softer ride to most occupants in most crashes as long as the occupant is restrained in the seat even after all stroke is expended. The others would bottom out, but it would appear that their probability of injury would not be as high as might be imposed on occupants if the limit load of the system were raised. This analysis needs to be conducted in considerably more depth before a great deal of confidence can be placed in the above observations.

For the vertical energy-attenuation system to operate as required, the frame must limit lateral and longitudinal excursions and guide the seat into the well. For some helicopters, seats which allow energy-absorbing stroke in directions other than vertical are not acceptable, as they reduce or eliminate the ability of the seat to perform its principal energy-absorbing function -- that of providing energy attenuation in the vertical direction -- and/or increase the chances for the occupant to strike surrounding structure. If the seat moves laterally or longitudinally, its vertical stroke may be blocked entirely or cause a deceleration spike. Therefore, since the lateral and longitudinal strokes are not required for human tolerance considerations, depending on the application, it may be desirable to provide vertical crash force attenuation only.

Another significant consideration in crashworthy seat design is the seat's structural tolerance to warping of the airframe structure to which the seat is attached. Floor warping is produced by crash loads and distortions of the airframe. If the seat frame is too rigid, members might fracture or be overloaded by the distortions. Criteria have therefore been established to require that the seat be designed to accept full static test loads while being distorted. Bulkhead mounting of the seat is one method of avoiding the floor warpage problem, which generally allows a lighter weight seat; however, any bulkhead distortion must also be withstood.

#### COCKPIT SEAT/RESTRAINT SYSTEMS

Table VIII is a tabulation of all major crashworthy pilot/copilot seat R&D efforts in the last 13 years. The weight of crashworthy seats is noticeably on the decline for the same ballistic protection criteria. Crashworthiness technology has advanced to the point that a crashworthy design can be achieved with little or no weight increase. Another notable occurrence in the history of crashworthy crew seat design is the frequent attempt to achieve the standard seat design. References 15, 17, and 21 were such programs for helicopters and fixed-wing aircraft. Experience has shown that the typical differences in cockpit design between aircraft prevent the design of one seat to fit in several aircraft models without unacceptable weight, cost, and/or crashworthiness penalties. As long as a particular seat design is not specified before the airframe is designed, experience indicates that only seat components such as the restraint system, cushion, and perhaps the seat bucket may be standardized. For example, the UH-60A and YAH-64 seats are floor mounted and bulkhead mounted respectively. Pilot/copilot seat/restraint systems currently being developed to comply with MIL-S-58095 include those for the UH-60A BLACK HAWK (see Figure 8) and the YAH-64 Advanced Attack Helicopter (see Figure 10). These seats are similar concepts; however, they differ in method of attachment, stroking characteristics, and ballistic protection.

The basic BLACK HAWK pilot/copilot seat assembly consists of an armored bucket and a seat frame. The bucket is equipped with bottom and back cushions, headrest, and restraint system. The bucket is attached to the seat frame through four carrier bearings. The seat frame is attached to four fittings mounted on top of tracks on the aircraft floor, thus providing the aircraft attachment interface. The seat bucket is formed from a state-of-the-art armor system comprised of a hot pressed boron carbide/Kevlar-49 ceramic composite. Occupant retention within the seat is provided by an improved five-strap restraint system.

This system provides lap belts, two shoulder straps with an inertial reel, lap belt tiedown strap, and a single point of attachment buckle. To ensure against occupant submarining under the lap belt, the buckle is permanently affixed to the lap belt tiedown strap which requires its use at all times. A seat cushion with low rebound potential and which minimizes relative motion between occupant and seat is also incorporated in the design to preclude occupant dynamic overshoot through "bottoming out" on the seat pan. The two inversion tube energy absorbers (see Figure 8) attenuate the energy of a vertical crash pulse to a survivable level by allowing the seat assembly to stroke downward relative to the supporting frame under impact loading. Limit loads are sized using a 14.5G load factor and the effective weight of the 50th percentile occupant. Depending on vertical seat adjustment position, between 12 and 17 inches of vertical stroke are available. The energy-absorbing devices have been isolated from the seat structure so that they will not be subjected to excessive transverse or bending loads. This separation of functions, structure and energy absorption, ensures that the energy-absorbing system will perform satisfactorily under the MIL-S-58095 dynamic loading conditions. The seat has been designed with sufficient lateral and longitudinal rigidity, relative to the specification loads, to assure that it will stroke into the well on the UH-60A, thus providing additional stroke beyond that available between the seat pan and floor. Provision to withstand the seat racking specified in MIL-S-58095 without structural or attachment failure during a crash is provided by several structural load release devices in the frame. For emergency situations, the seat can be tilted back by disengaging spring-loaded pins. The seat then tilts back by rotating about spherical bearings in the lower crossmember end fittings so the incapacitated occupant can be pulled from the seat.

Five dynamic tests were conducted in accordance with cockpit seat test number 1 of Table XII on an early prototype BLACK HAWK armored crew seat at the Naval Air Development Center (NADC), Warminster, Pennsylvania, during the last part of 1976 and 1977. Analyses of these test data are not complete, and several obstacles to interpretation of the data exist. The testing conducted was not sufficient to permit isolation of the effects of the several variables; consequently, only tentative conclusions and observations have been made.

The same seat test article experienced five consecutive 95th percentile survivable crash pulses with only replacement of the energy-absorbing devices being necessary. In each case, the seat stroked into the well, or depression in the aircraft floor under the seat, providing an additional stroke capability of 4 to 5 inches beyond that which would be allowed if the seat did not stroke into the well. The additional stroke permitted by the well is necessary to provide the degree of protection required, and the tests conducted have demonstrated the feasibility of the seat system concept including the well. However, the seat bucket responses to the input pulses differed somewhat from those obtained in the previous testing conducted in 1970 in support of the Army's criteria development (12). The initial decelerative spike, following negative spike (notch), and eventual second spike that characterize the NADC input pulse are more pronounced and their amplitudes are higher than the triangular pulse required by MIL-S-58095. The effect of this, particularly the magnitudes of the second spike, makes meeting the established criteria more difficult. Effort is now being expended to select the best energy-absorber load setting to meet the design criteria and to provide the most overall protection for the occupants.

In one test, the seat's vertical crash energy attenuation limited the deceleration of the 194 pound occupant to tolerable levels. Peak decelerations did not exceed 23G for time durations in excess of 6 milliseconds. Also, in this test, the DRI was calculated to be 15.27. Figure 11 shows the headward deceleration history measured on the seat bucket and dummy during this test. It also shows the input pulse measured on the drop platform deck and corrected to the vertical, or Z, axis of the seat. A weighted average deceleration of the dummy and moving seat weight elements is also presented. It was developed by multiplying each estimated mass in the system by the deceleration measured on that mass, summing these values, and dividing the total by the total weight. This plot shows that the energy-attenuating system limited the weighted average deceleration imposed on the system to 13 to 14G. Figure 12 shows the energy-absorber limit load together with the vertical seat pan deceleration/time histories and the DRI plot overlaid on the seat pan deceleration/time history. Figure 8 shows the seat in the post-test configuration in the drop test facility at NADC.

#### CABIN SEAT/RESTRAINT SYSTEMS

There has been considerably less crashworthiness R&D on cabin seats than cockpit seats. Until the two programs described in references 23 and 24, an operationally suitable, affordable, low weight cabin seat had not been demonstrated to be crashworthy. Because of the number of cabin seats in a typical troop transport helicopter and the low weight of existing noncrashworthy cabin seats (some less than 6 pounds each), the need to minimize weight in a crashworthy seat is essential. Also, in designing cabin seats, the following factors must be considered: folding, stowing, the occupant's unfamiliarity with helicopter hardware, ease of ingress/egress, avoidance of snagging on occupant equipment/clothing, ease of restraint system hook-up and release both in daylight and at night, and the wide range of occupants, clothing, and equipment to be accommodated. It would be inappropriate to discuss all of these in this paper. The reader interested in these design factors should consult references 6, 8, 9, 23, and 24. Although aft-facing seats are the preferred orientation from a crashworthiness standpoint, operational considerations often dictate that some seats be forward- or side-facing; for example, in the BLACK HAWK there are four aft- and seven forward-facing troop seats. There are also two side-facing seats, one for the crew chief/gunner and the other for any additional passengers.

The most thoroughly tested and promising troop seat design to date is that described in reference 23 and shown in Figure 13. This seat is the result of a US Army program to develop a draft crashworthy troop seat specification based on the Crash Survival Design Guide and has been selected for the BLACK HAWK. Pertinent seat characteristics are listed in Table IX. Both forward- and aft-facing seats were designed, subjected to ingress/egress/human factors engineering mock-up evaluation, statically tested, and dynamically crash tested. These seats have two energy-absorbing diagonal struts beneath the seat pan and two energy absorbers that connect the seat to the ceiling attachment hardware. All of these energy absorbers employ the wire-through-roller, wire-bending concept shown in Figure 14. In addition to being lightweight, low in cost and immune to environmental degradation, these devices are reliable and efficient in the sense that their load-deflection curve is predictable and flat during stroking. Another important

feature of this seat concept is that the crash force attenuators stroke in tension, which avoids the stability problems that plague compression struts. Because vertical crash forces are attenuated by the upper energy absorbers and transverse crash forces are attenuated by the diagonal energy-absorbing struts and steel cables beneath the seat pan, the seat pan tends to maintain its parallel-to-the-floor attitude during seat stroking. This is important because it not only makes the seat's kinematics more predictable, but it makes the vertical crash force attenuation limit load more predictable for the system. The stroking behavior of a seat with vertical energy absorbers in series is sensitive to occupant center-of-gravity location and therefore is variable and sometimes unpredictable.

The operational suitability of this design concept was demonstrated by the use of a similar design in the Boeing Vertol YUH-61A during the UTTAS competition and by the two ingress/egress human factors engineering mock-up evaluations documented in reference 23. These evaluations revealed how necessary it is to pay attention to restraint system design details if one is to have an operationally suitable design. Both three- and four-strap restraint systems were evaluated. Shoulder strap retractors and automotive-type strap stand-ups for the lap belt and shoulder straps were shown to greatly facilitate restraint system hook-up. Although strap retractors make the restraint system easier to hook up and therefore increase the chances that the occupant will use the restraint system, available retractors have been shown to be prone to jamming and fouling by the Army environment.

Following demonstration of the troop seat's strength and load/deflection characteristics by static testing, a series of 11 dynamic crash tests were performed, the results of which are summarized in Table X. Although MIL-STD-1290 requires two dynamic assembly crash tests, and despite the extensive component and assembly static testing of these seats, it is significant that 11 tests were found to be necessary. The fact that no crashworthy seat developed to date has passed the required crash criteria the first time is worth remembering when planning a crashworthy seat development program. Tests 3A and 4A demonstrated the ability of the forward- and aft-facing troop seats to withstand test number 2 of the dynamic test criteria shown in Table XII. Seven tests were performed to trade off conflicting seat vertical crash force attenuator factors.

In 1975, the Army crash tested a CH-47C to obtain data pertaining to the dynamic behavior of large troop/cargo carrying helicopter structures and eight seats (25). Seven of these seats were of the crash-force attenuating type, three were armored crew seats and four were troop seats. The Crash Survival Design Guide contains dynamic design and test criteria which, for practical reasons, assume a triangular pulse shape. Consequently, testing these seats in a full-scale crash test added a realistic method of evaluation since the airframe structural deformation attenuates the crash forces imparted to the seat and the seat forcing function is no longer a simplistic shape. It was not the purpose of the crash test to qualify any of these seats; rather, the intent was to observe seat behavior during an actual aircraft crash. Pilot and copilot seats must comply with all of the static and dynamic test provisions of MIL-S-58095 (AV) and cabin seats must comply with the static and dynamic test provisions of the Crash Survival Design Guide in order to be qualified as crashworthy. One forward-facing crashworthy troop seat of the reference 23 type was located in the aft portion of the aircraft. The aircraft impact conditions were severe but potentially survivable: Aircraft pitched 10 degrees nose up, resultant velocity of 50 ft/sec, vertical velocity component of 40 ft/sec, and a horizontal velocity component of 30 ft/sec. The peak vertical acceleration measured on the floor beneath the crashworthy troop seat was 62.95G. The seat's vertical energy absorbers stroked 6.75 inches as designed, thereby limiting the vertical decelerations on the dummy to tolerable levels as shown in Figure 15. Throughout the crash sequence, the dummy was restrained in an upright position.

There are several differences between cockpit and cabin seats that significantly affect design. Weights for cockpit and cabin seat occupants are listed in Table XI. The wide range of occupant weights for cabin seats, the many possible occupant clothing and equipment combinations, the lack of any basis for predicting the frequency with which the variously equipped occupants will occupy these seats, and the finite seat vertical stroke available prevent the seat from absorbing all of the 95th percentile survivable vertical impact pulse. Based on the dynamic test program of Table X, the cabin seat dynamic test criteria of Table XII were selected as offering the best protection. Note that the 95th percentile survivable accident resultant velocity change must be withstood by all seats; however, the peak deceleration for cabin seats is less than for cockpit seats. The draft criteria resulting from this program call for a 50th percentile clothed and equipped anthropomorphic dummy weighing 197 pounds to be used for test number 1 of Table XII. The energy-absorption mechanism is supposed to limit the measured accelerations to values within the acceptable pulse duration of Figure 5. This last criterion addresses the crashworthy seat R&D area most needing attention -- analytical and testing techniques for the determination of the probability of seat occupant injury due to crash impact loading.

There is a need for the aviation R&D community to develop and validate an anthropomorphic dummy capable of simulating human response to three-dimensional impact, and in particular, impulsive loading of the crash impact type parallel to the spine. Although extensive effort has been expended by the automotive R&D community on anthropomorphic dummies, these simulators have been designed and tested for accurate response to loading normal to the spine, not parallel. Furthermore, the anthropometry of the soldier population varies from that of the civilian population. The need for such a validated, repeatable, standard dummy is illustrated by the crashworthy troop seat test criteria. The injury criteria of Figure 5 are based on acceleration history measured at the seat pan of a crew seat; however, the typical troop seat is fabric over a tubular frame, thereby preventing meaningful seat pan acceleration measurements. This necessitates the use of dummy accelerometer data to show compliance with Figure 5. A high fidelity dummy is required for such compliance testing.

Of no less importance is the need for better criteria for human tolerance to crash impact decelerative loading. Specifically, the seat designer and evaluator need an analog that will predict the statistical probability of injury. If the seat crash force attenuation behavior is to truly be designed to minimize injury, then an analytical tool is needed which the designer can use to determine the sensitivity of the cumulative probability of injury of the potential occupant population as a function of seat variables. The cumulative probability of injury analyses documented in references 27 and 28 are examples of the type of analysis needed; however, the DRI was used in these studies. The DRI was developed and validated for

ejection seat injury analysis. Because of the combined loading, varying pulse shapes, multiple impact pulses during a crash, difference between ejection seat and helicopter seat occupant population, and difference in helicopter and fixed-wing occupant body restraint, the probability of crash injury predicted by the DRI must be considered suspect pending validation for the seat crash impact application.

Proposed design and test criteria for side-facing crew chief/gunner seats have also been verified in a parallel program similar to the above-mentioned troop seat program. Both fixed-base and swiveling versions of the seat shown in Figure 16 were successfully tested. There are advantages and disadvantages to both types. Some gunners prefer the mobility and ease of egress of the swivel type and the swiveling feature permits a favorable orientation of the occupant during a crash; however, the swivel feature adds complexity and weight to the basic seat design. The fixed side-facing gunner seat is approximately 30 percent lighter than the swiveling type; however, the occupant is oriented such that the 95th percentile potentially survivable crash loading in the lateral direction with respect to the occupant exceeds human tolerance in this direction. Because of the nearness of structure that typically surrounds the gunner station, the amount of stroking distance in the forward direction is limited. References 9 and 24 provide a detailed discussion of the crashworthy side-facing crew chief/gunner seat program.

#### CONCLUSION

Design and test criteria for practical crashworthy seat and restraint systems have been verified. Both the Army's AAH and BLACK HAWK are equipped with crashworthy seats and occupant restraint systems designed in accordance with the Crash Survival Design Guide. These features will significantly reduce the incidence and severity of crash impact injuries. Notwithstanding these unprecedented crashworthiness achievements, there is a need for validated anthropomorphic dummies for crashworthy seat testing and for a validated crashworthy seat occupant probability-of-injury model.

#### REFERENCES

1. Bainbridge, R.E., et al, "Crashworthiness of the Boeing Vertol UTTAS," Aircraft Crashworthiness, University Press of Virginia, Charlottesville, VA, 1975, pp. 66-80.
2. Carnell, Brian L., "Crashworthiness Design Features for Advanced Utility Helicopters," Aircraft Crashworthiness, University Press of Virginia, Charlottesville, VA, 1975, pp. 51-63.
3. McDermott, J.M., and Vega, E., "The Effects of Latest Military Criteria on the Structural Weight of the Hughes Advanced Attack Helicopter - YAH-64," Proceedings from The American Helicopter Society Conference on Helicopter Structures Technology, NASA-Ames Research Center, Moffett Field, CA, 16-18 Nov 1977.
4. Fox, R.G., et al, "Designing Crashworthiness Into the YAH-63," presented at the Aircraft Crashworthiness Symposium, Cincinnati, OH, 3 Oct 1975.
5. Military Standard MIL-STD-1290 (AV), "Light Fixed- and Rotary-Wing Aircraft Crashworthiness," 25 Jan 1974.
6. Turnbow, J.W., et al, "Crash Survival Design Guide," USAAMRDL Technical Report 71-22, Eustis Directorate, US Army Air Mobility Research and Development Laboratory, Ft Eustis, VA, Oct 73.
7. Military Specification MIL-S-58095 (AV), "Seat System: Crashworthy, Nonejection, Aircrew, General Specification for," Aug 1971.
8. Carr, Richard W., "Helicopter Troop/Passenger Restraint Systems Design Criteria Evaluation," USAAMRDL Technical Report 75-10, Eustis Directorate, US Army Air Mobility Research and Development Laboratory, Ft Eustis, VA, Jun 1975.
9. Reilly, M.J., "Crashworthy Helicopter Gunner's Seat Testing Program," USAAMRDL Technical Report 78-7, Applied Technology Laboratory, US Army Research and Technology Laboratories (AVRADCOM), Ft Eustis, VA, Dec 1977.
10. Carr, R.W., and Desjardins, S.P., "Aircrew Restraint System-Design Criteria Evaluation," USAAMRDL Technical Report 75-2, Eustis Directorate, US Army Air Mobility Research and Development Laboratory, Ft Eustis, VA, Feb 1975.
11. Kourouklis, G., et al, "The Design, Development, and Testing of an Aircrew Restraint System for Army Aircraft," USAAMRDL Technical Report 72-26, Eustis Directorate, US Army Air Mobility Research and Development Laboratory, Ft Eustis, VA, Jun 1972.
12. Desjardins, S.P., and Harrison, H.D., "The Design, Fabrication, and Testing of an Integrally Armored Crashworthy Crew Seat," USAAMRDL Technical Report 71-54, Eustis Directorate, US Army Air Mobility Research and Development Laboratory, Ft Eustis, VA, Jan 1972.
13. Brinkley, James W., "Development of Aerospace Escape Systems," Air University Review, Vol XIX(5), 34-49, Jul-Aug 1968.
14. Payne, P.R., "Injury Potential of Ejection Seat Cushions," Journal of Aircraft, Vol 6, Number 3, May-Jun 1969, American Institute of Aeronautics and Astronautics, New York, NY.
15. Mazelsky, Bernard, "Preliminary Design of Armored Crashworthy Crew Seats for Future Army Helicopters," ARA Report 174, Aerospace Research Associates, Inc., West Covina, CA, Aug 1975.
16. Mazelsky, Bernard, "A Crashworthy Armored Pilot Seat for Helicopters," USAAVSCOM Technical Report 73-34, US Army Aviation Systems Command, St Louis, MO, Jan 1974.

17. Hammer, E.W., Jr., and Peterson, R.L., "Design and Mockup Evaluation of a High-Strength Armored Crew Seat for Transport/Cargo Aircraft," US Air Force Flight Dynamics Laboratory, Wright-Patterson AFB, OH, Jun 1974.
18. Reilly, M.J., "Crash Attenuating Armored Crew Seat Development Report," DB-2431-1, The Boeing Company, Vertol Division, Philadelphia, PA, May 1969.
19. Anderson, L.R., Grimes, G.R., and Rogers, O.A., "Study and Design of Armored Aircrew Crash Survival Seat," USAAVLABS Technical Report 67-2, US Army Aviation Materiel Laboratories, Ft Eustis, VA, Mar 1967.
20. Thompson, D.F., and Harper, P., "Armored Protection for Pilot/Copilot Seat with Crash Safety Features for CH-47A Helicopter," USATRECOM Technical Report 64-73, US Army Transportation Research Command, Ft Eustis, VA, Dec 1964.
21. Hackenberger, G.K., and Mattenson, W.O., "Development of a Crashworthy, Armored, Universal Crew Seat for US Army Aircraft," USATRECOM Technical Report 65-2, US Army Transportation Research Command, Ft Eustis, VA, Feb 1965.
22. Dupstadt, J.R., "Integrated Crew Survivability Seat for the UH-1B Helicopter," USATRECOM Technical Report 65-7, US Army Transportation Research Command, Ft Eustis, VA, Feb 1965.
23. Reilly, M.J., "Crashworthy Troop Seat Testing Program," USAAMRDL Technical Report 77-13, Applied Technology Laboratory, US Army Research and Technology Laboratories (AVRADCOM), Ft Eustis, VA, Nov 1977.
24. Reilly, M.J., "Crashworthy Helicopter Gunner's Seat Investigation," USAAMRDL Technical Report 74-93, Eustis Directorate, US Army Air Mobility Research and Development Laboratory, Ft Eustis, VA, Jan 1976.
25. Singley, G.T. III, "Full Scale Crash Testing of a CH-47C Helicopter," Preprint No. 1082, 32nd Annual National V/STOL Forum of the American Helicopter Society, Washington, DC, May 1976.
26. Churchill, E., et al, "Anthropometry of US Army Aviators - 1970," USANL Technical Report 72-52-CE, US Army Natick Laboratories, Natick, MA, Dec 1971.
27. Phillips, N.S., et al, "A Statistical Evaluation of the Injury Potential of a 'Square Wave' Energy Absorber," USAAMRDL Technical Report 72-9, Eustis Directorate, US Army Air Mobility Research and Development Laboratory, Ft Eustis, VA, Jun 1972.
28. Carr, R.W., and Phillips, N.S., "Definition of Design Criteria for Energy Absorption Systems," NADC Report AC-7010, US Naval Air Development Center, Johnsville, Warminster, PA, Jun 1970.

Table I. Design Environment (5)

SUMMARY OF DESIGN PULSES FOR ROTARY-WING AIRCRAFT*			
IMPACT DIRECTION	VELOCITY CHANGE (FT/SEC)	PEAK G	PULSE DURATION 'T' (SEC)
LONGITUDINAL (COCKPIT)	50	30	0.104
LONGITUDINAL (PASSENGER COMPARTMENT)	50	24	0.130
VERTICAL	42	48	0.054
LATERAL	30	18	0.104

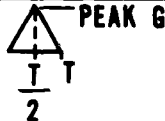
\* PULSE SHAPE: 

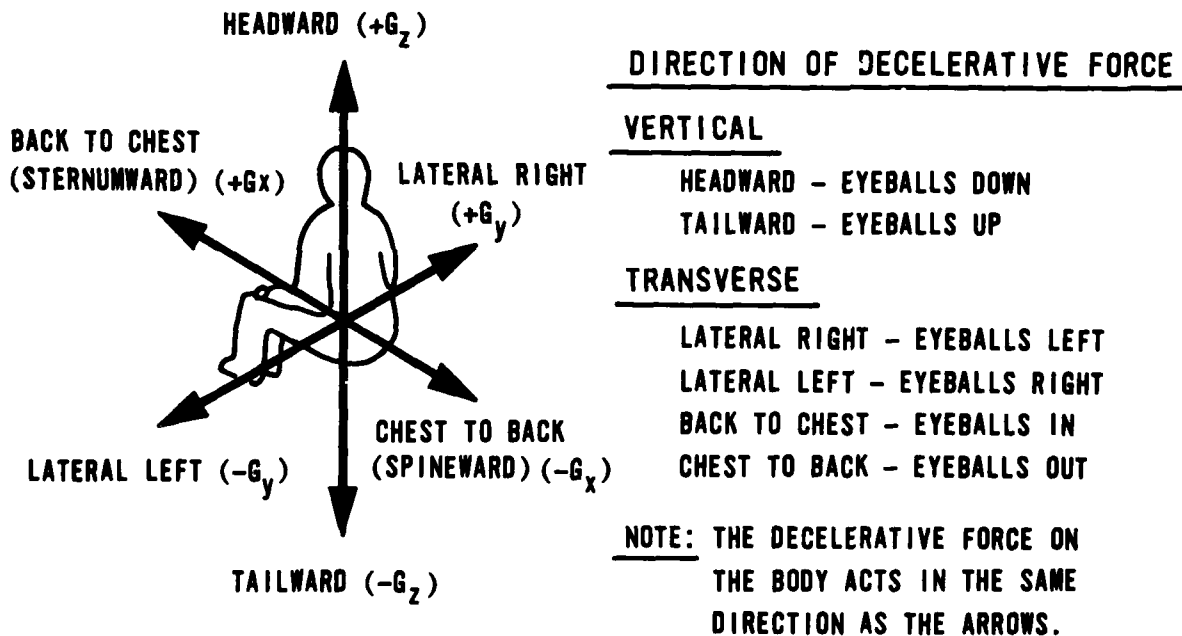

Figure 1. Decelerative Forces on the Body

Table II. Injuries to Body Segments as a Percent of Major and Fatal Injuries

BODY SEGMENT	PERCENTAGE OF MAJOR & FATAL INJURIES				
	UTILITY (UH)	OBSERVATION (OH)	CARGO (CH)	ATTACK (AH)	TOTAL HELICOPTERS
HEAD	19.6	18.5	22.9	21.5	19.7
FACE	9.1	9.2	10.0	11.8	9.4
NECK	2.5	3.0	1.4	3.2	2.6
UPPER EXTREMITIES	10.9	12.9	17.1	15.1	12.1
THORAX	13.7	12.2	7.1	8.6	12.5
ABDOMEN	7.8	5.9	10.0	3.2	7.1
PELVIS	3.8	2.6	0	1.0	3.1
VERTEBRAE	15.3	19.2	8.6	21.5	16.5
LOWER EXTREMITIES	17.1	16.6	22.9	14.0	17.1
TOTAL NUMBER OF INJURIES	678	271	70	93	1112

Table III. Injuries to Head, Thorax, and Vertabral Column as a Percent of Major Injuries

BODY SEGMENT	PERCENTAGE OF MAJOR INJURIES				
	UTILITY (UH)	OBSERVATION (OH)	CARGO (CH)	ATTACK (AH)	TOTAL HELICOPTERS
HEAD	11.5	15.8	11.1	14.8	13.0
THORAX	7.7	8.2	5.6	3.3	7.3
VERTEBRAE	20.4	24.0	11.1	32.8	22.0
TOTAL NUMBER INJURIES	417	186	38	61	710



Table IV. Injuries to Head, Thorax, and Vertabral Column as a Percent of Fatal Injuries

BODY SEGMENT	PERCENTAGE OF FATAL INJURIES				
	UTILITY (UH)	OBSERVATION (OH)	CARGO (CH)	ATTACK (AH)	TOTAL HELICOPTERS
HEAD	32.4	25.3	35.3	34.4	31.5
THORAX	23.3	22.7	8.8	18.8	21.6
VERTEBRAE	7.3	6.7	5.9	0	6.5
TOTAL NUMBER OF INJURIES	261	75	34	32	402

Table V. Crashworthy Seat Ultimate Static Load Factors

LOAD DIRECTION WITH RESPECT TO AIRCRAFT	CREW SEAT LOADS (G)		TROOP SEAT LOADS (G)	
	MIL-S-5822 * (1957)	MIL-S-58095 (1971)	MIL-S-27174 * TYPE 1 (1960)	MIL-STD-1290 (1974)
FORWARD	8.0	35.0	1.1	30.0
A T F	5.0	12.0	-	12.0
DOWN	15.0	48.0	10.0	48.0
UP	7.5	8.0	-	8.0
SIDE	10.0	20.0	3.0	20.0

\* FOR COMPARISON PURPOSES, THE ULTIMATE STATIC LOADS PRESENTED IN MIL-S-5822 AND MIL-S-27174 HAVE BEEN CONVERTED TO LOAD FACTORS IN TERMS OF G, BASED ON A 199.7LB OCCUPANT .

**AIRFRAME RELATED:**

- . PROTECTIVE SHELL
- . STRIKE HAZARDS
- . STRUCTURAL HARDPOINTS
- . CRASH FORCE ATTENUATION

**SEAT/RESTRAINT SYSTEM RELATED:**

- . ORIENTATION
- . STRENGTH
- . STIFFNESS
- . KINEMATICS
- . RESTRAINT SYSTEM CONFIGURATION & STRAP WIDTH
- . RESTRAINT SYSTEM ATTACHMENT/RELEASE MECHANISM
- . CRASH FORCE ATTENUATION

**OCCUPANT:**

- . EFFECTIVE & TOTAL WEIGHT
- . MECHANICAL PROPERTIES
- . BODY POSITION

Figure 2. Seat Occupant Crash Impact Survival Factors

### Cockpit Seats

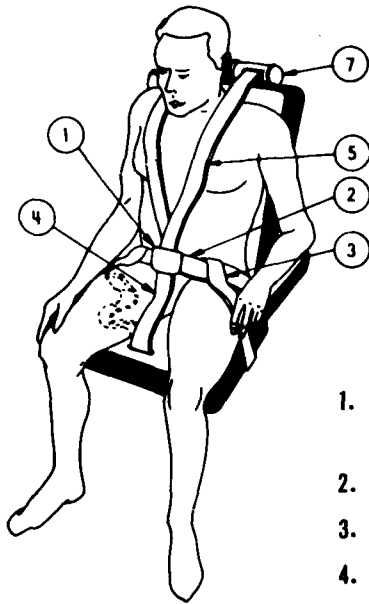

MIL-S-58095

- ITEM IDENTIFICATION**
1. SINGLE POINT ATTACHMENT  
RELEASE BUCKLE
  2. LAP BELT
  3. SIDE STRAP
  4. LAP BELT TIEDOWN STRAP
  5. SHOULDER STRAP
  6. ADJUSTER
  7. INERTIA REEL

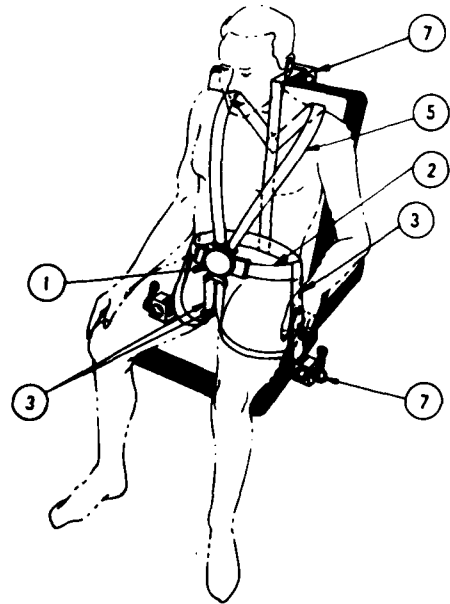

GUNNER/CREW CHIEF

### Cabin Seats

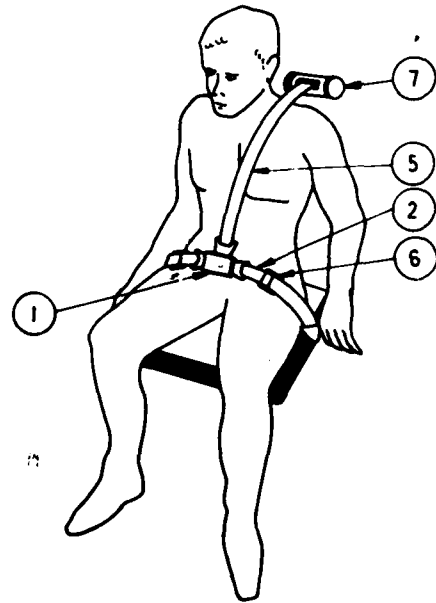
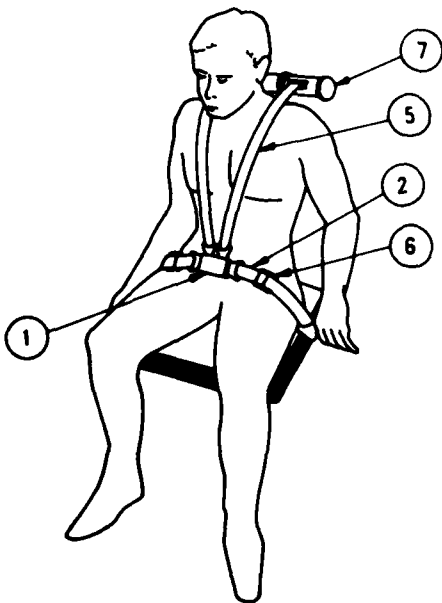

**Figure 3. Occupant Restraint System Configuration**

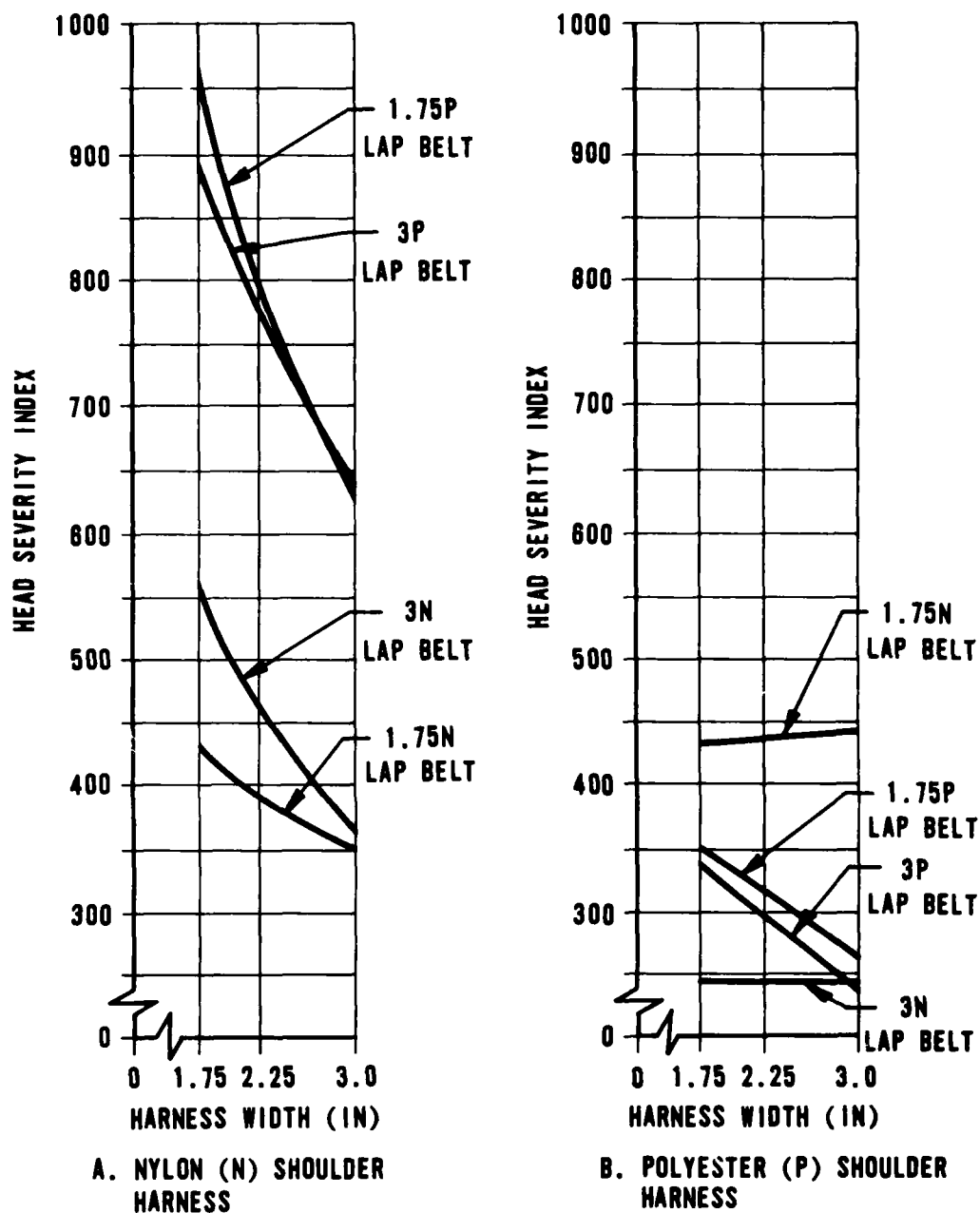

Figure 4. Head Severity Index Versus Material Stiffness (Calculated for a longitudinal crash pulse  $V = 50$  ft/sec, Peak Deceleration of 30G and a 95th Percentile Occupant (11))

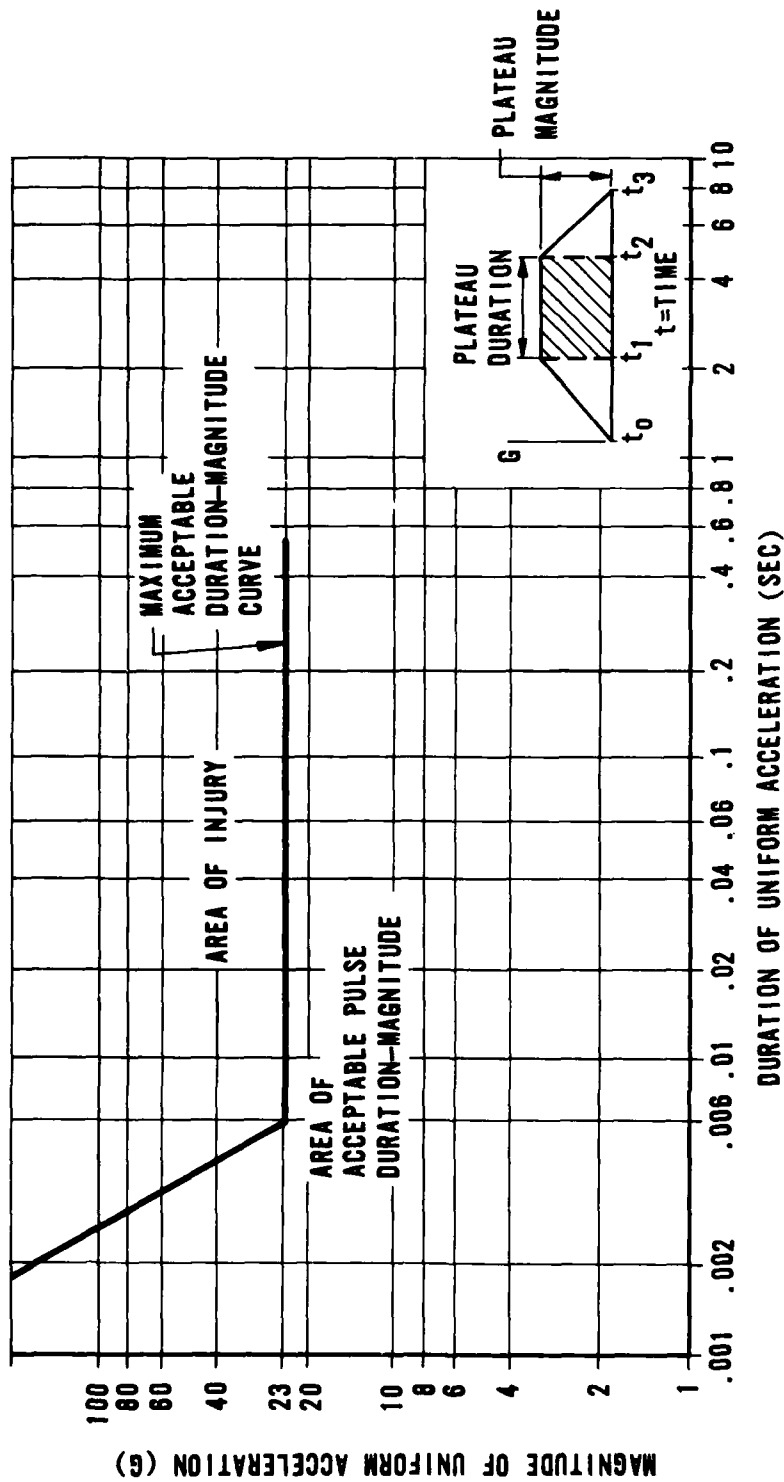

Figure 5. Maximum Acceptable Vertical Pulse Acceleration and Duration Values (6)

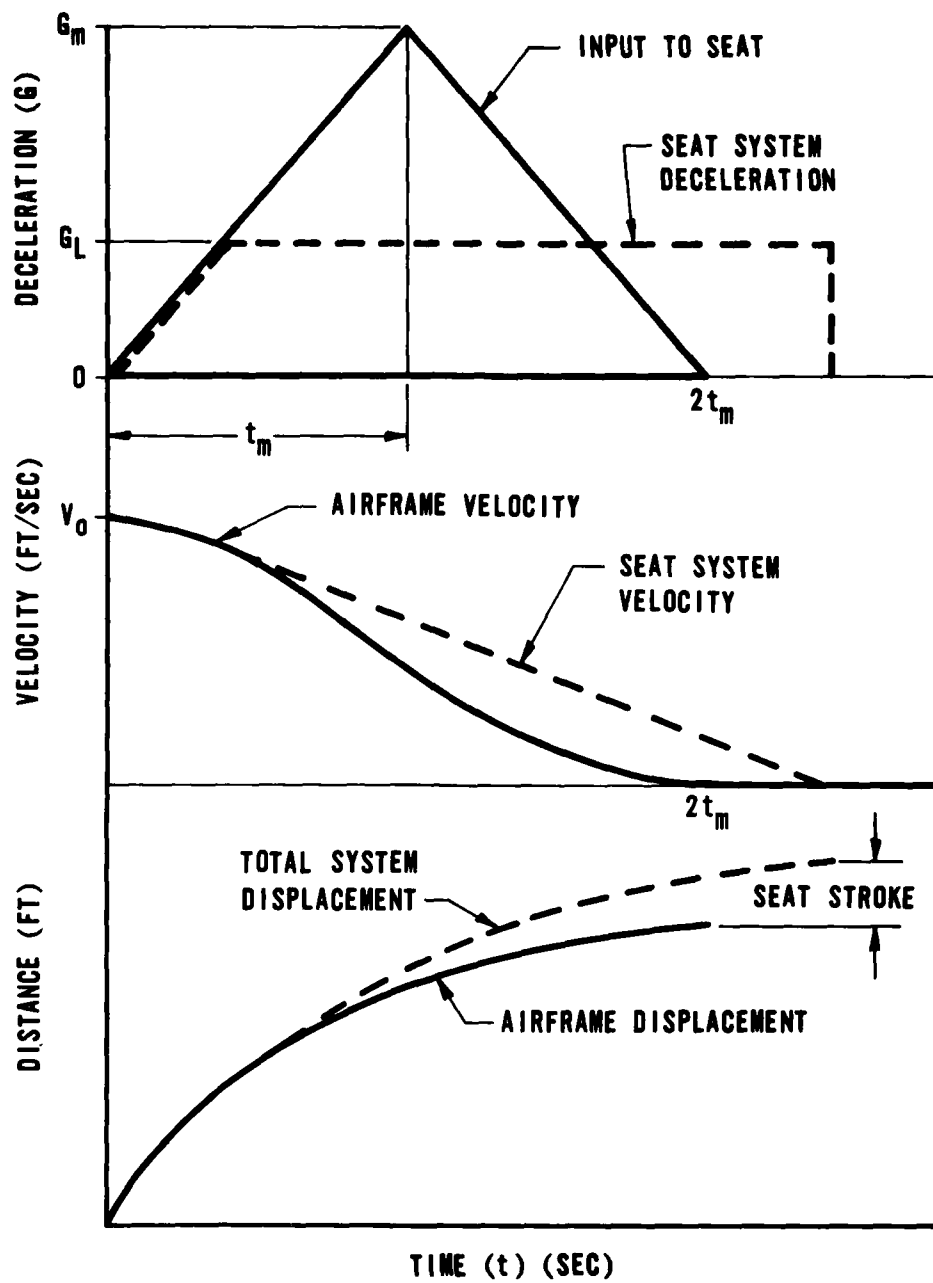

Figure 6. Airframe and Seat Deceleration-Time, Velocity-Time, and Distance-Time Curves (6)

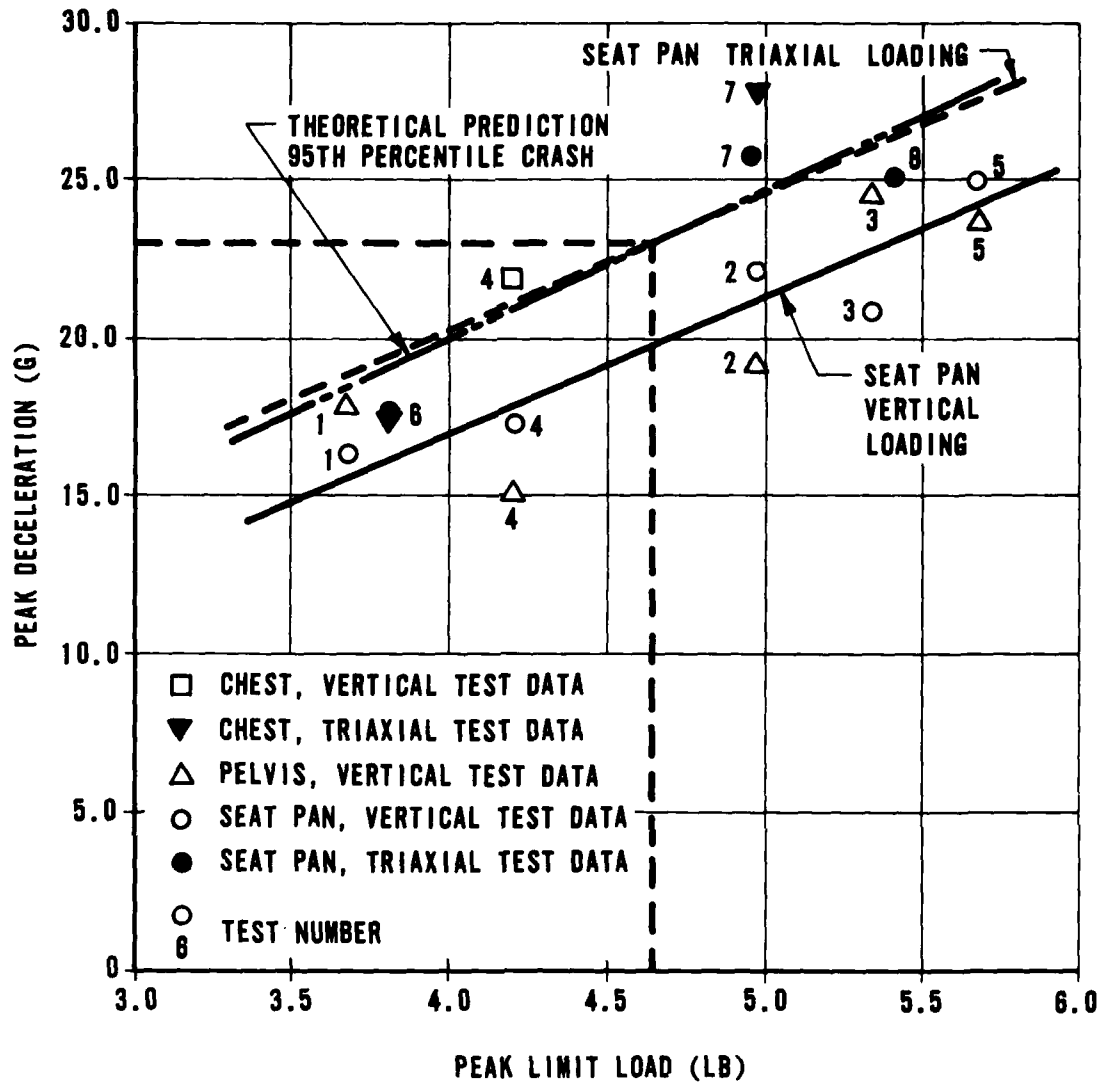

Figure 7. Peak Vertical Deceleration of Chest, Pelvis, and Seat Versus Corrected Peak Limit Load (12)

Table VI. Seat Stroke as a Function of Test Number (12)

TEST NO.	CORRECTED VERTICAL LIMIT LOAD (LB)	MEASURED STROKE (IN.)	VERTICAL STROKE (IN.)	PERCENTILE VERTICAL PULSE *
1	3,695	10.0	9.7	92.0
2	4,988	10.0	9.7	92.0
3	5,347	11.4	11.1	95.0
4	4,208	13.9	13.5	94.0
5	5,696	13.2	12.9	97.5
6	3,818	11.5	11.2	90.0
7	4,977	11.5	11.2	92.0
8	5,419	12.5	12.2	95.5

\* BASED ON CHANGE IN VELOCITY.



Figure 8. Prototype Armored Pilot/Copilot Seat After Drop Test



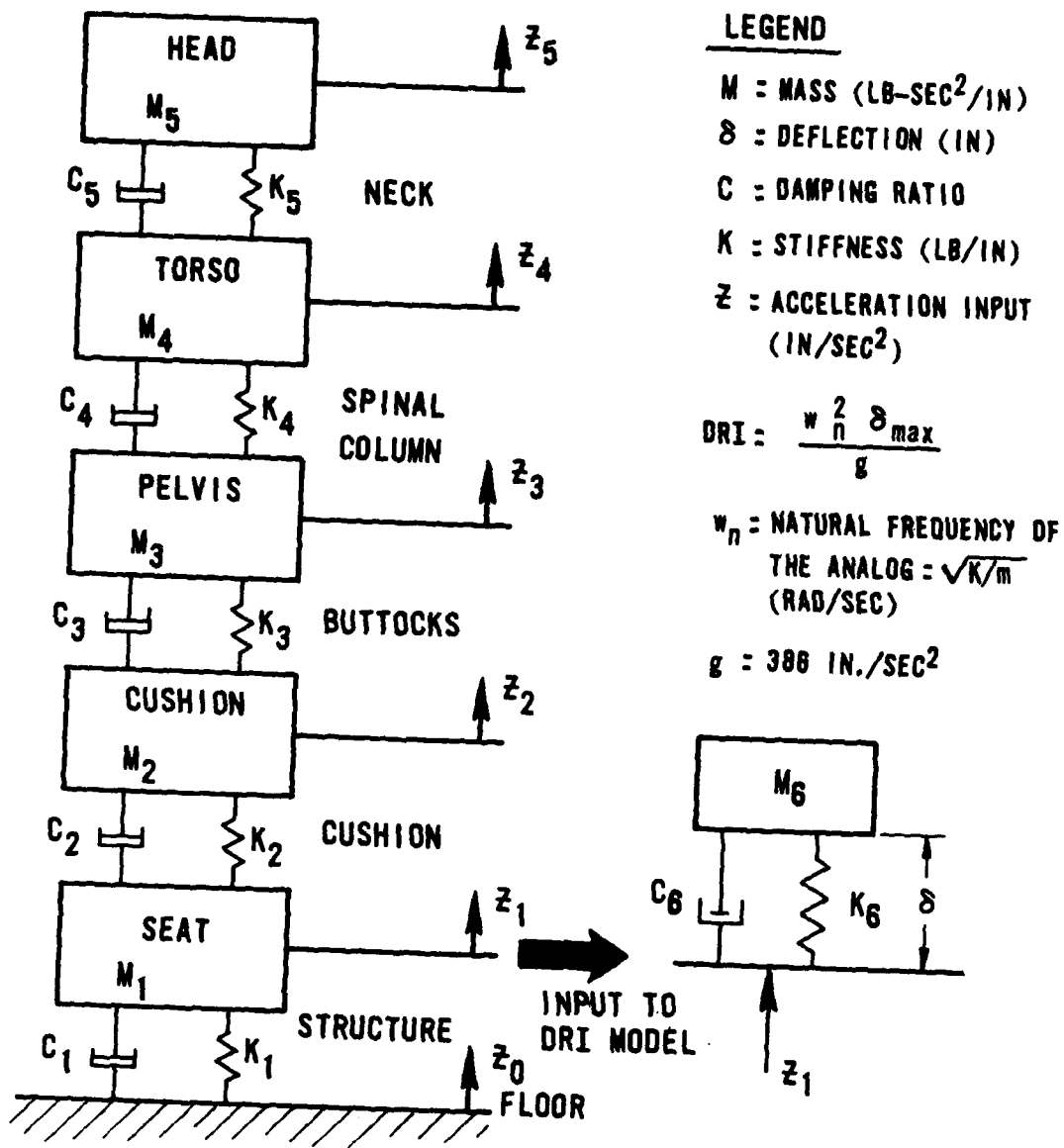
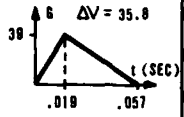
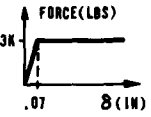
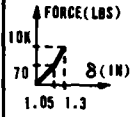
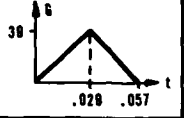
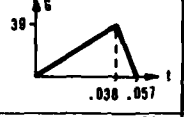
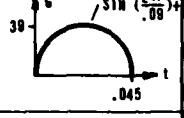
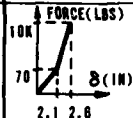
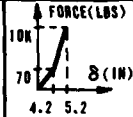
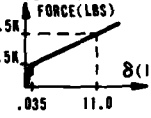
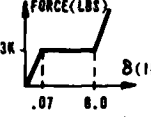
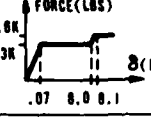
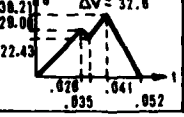
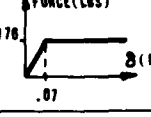

Figure 9. SEAT/DRI Model

Table VII. Summary of Seat/DRI Sensitivity Analysis

CASE	INPUT PULSE	ENERGY ABSORBER	CUSHION	OCCUPANT % TILE	$W_s$ (LBS)	$W_c$ (LBS)	SEAT ACCEL (G)	PELVIS ACCEL (G)	STROKE (IN)	DRI
1				95TH ( $W_E = 147.5$ )	60.8	5.0	42.0	44.5	10.67	20.92
2		SAME AS CASE 1	SAME AS CASE 1				47.5	41.8	10.86	21.07
3							43.6	40.3	10.73	21.33
4							44.0	43.6	9.45	20.89
5	SAME AS CASE 2			5TH ( $W_E = 102.04$ )			47.5	50.6	5.88	26.65
6				95TH			47.9	54.2	10.46	23.97
7							48.2	66.3	9.57	32.76
8			SAME AS CASE 1				23.8	33.8	11.40	18.00
9							181.7	70.8	8.27	23.04
10							47.5	41.8	10.01	21.07
11				50TH ( $W_E = 139.05$ )	10	1	17.9*	22.70	8.90	19.75**

\* PEAK ACCELERATION OF CHEST  
\*\* DRI USING PELVIC ACCELERATION HISTORY

$W_s$  = WEIGHT OF STROKING SEAT MASS LESS CUSHION  
 $W_c$  = WEIGHT OF SEAT CUSHION  
 $W_E$  = EFFECTIVE OCCUPANT WEIGHT

Table VIII. Recent Crashworthy Armored Pilot Seats

YEAR	CONFIGURATION	DESIGNER	SPONSOR	ARMOR MAT'L	TOTAL SEAT WT (LB)*	ENERGY ABSORBER TYPE	MULTI- (M) OR UNI-AXIAL (U) E/A SYSTEM	VERTICAL E/A	
								STROKE (IN) **	REF NO. ***
1978	UH-60A	Sikorsky/Norton/Simula	USA	B <sub>4</sub> C	105	Inversion Tube	U	12	2
1978	YAH-64	Hughes/Norton/Simula	USA	B <sub>4</sub> C	140	Inversion Tube	U	7	3
1978	Prototype	ARA Assoc, Inc.	USN & USA	ESR/KEVLAR	110	Rolling Helix	M	12	15
1976	YUH-61	Boeing-Vertol	USA	B <sub>4</sub> C	148	Wire Bending	M	11	1
1976	YAH-63	Bell Helicopter/Dynamic Science	USA	B <sub>4</sub> C	123	Inversion Tube	U	12	4
1974	HLH	Boeing-Vertol	USA	B <sub>4</sub> C	136	Rolling Helix	M	12	-
1973	UH-1	ARA Assoc, Inc.	USN & USA	AL <sub>2</sub> O <sub>3</sub>	156	Rolling Helix	M	9	16
1972	CH-3, CH-53, UH-1N	Dynamic Science/Norton	USAF	B <sub>4</sub> C	212	Rolling Helix	U	6	-
1972	Transport FW Acft	Budd Company	USAF	B <sub>4</sub> C	175	Rolling Helix	M	4.5	17
1971	CH-54	Sikorsky/Carborundum	USA	B <sub>4</sub> C	168	Rolling Helix	U	8	-
1971	Experimental Prototype	Dynamic Science	USA	B <sub>4</sub> C	212	Steel Tube and Cable	U	12	12
1969	CH-46/47	Boeing-Vertol	-	DHS	131	Peeling Tube	M	6	18
1967	UH-1B	Hayes Int'l	USA	AL <sub>2</sub> O <sub>3</sub>	198	Steel Cable	M	7	19
1965	CH-47	Boeing-Vertol	USA	AL <sub>2</sub> O <sub>3</sub>	159	Honeycomb	M	5.25	20
1965	Universal	Kaman	USA	AL <sub>2</sub> O <sub>3</sub>	161	Steel Straps	U	5	21
1965	UH-1B	Bell Helicopter	USA	AL <sub>2</sub> O <sub>3</sub>	197	Cable Sheave	U	10	22
1965	CH-34	Sikorsky	USA	AL <sub>2</sub> O <sub>3</sub>	200	Honeycomb	U	12	19

LEGEND:

- USA - US Army
- USAF - US Air Force
- USN - US Navy
- B<sub>4</sub>C - Boron Carbide
- AL<sub>2</sub>O<sub>3</sub> - Aluminum Oxide
- ESR - Electro Slag Remelt Steel
- DHS - Dual Hardness Steel
- E/A - Energy Absorber
- \* - Armor areal coverage varied among seats
- \*\* - Vertical stroking distance measured with seat in down position of adjustment range
- \*\*\* - Reference numbers are those in list of references



Figure 10. AAH Crashworthy Armored Crew Seat

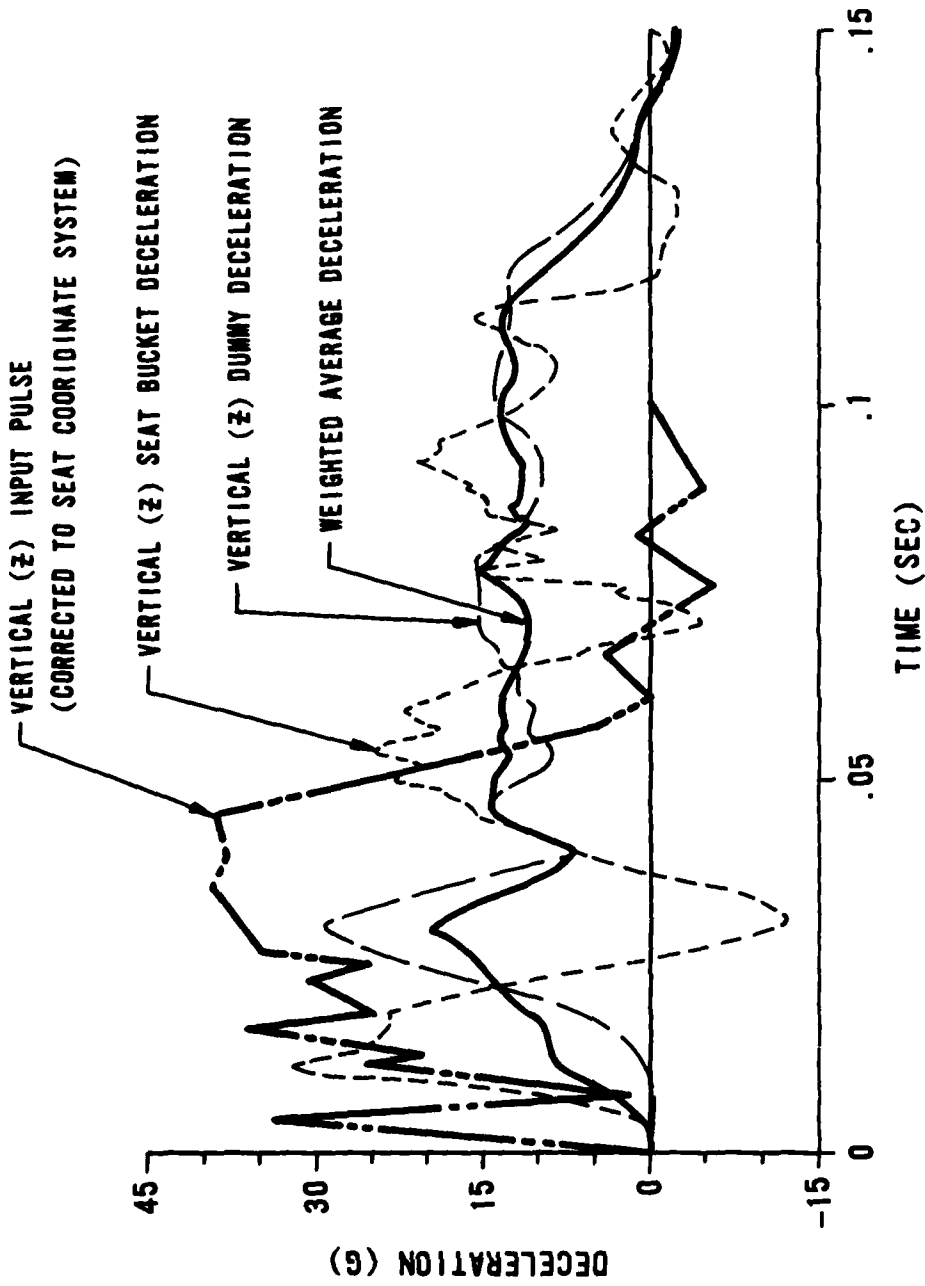

Figure 11. Decelerations Versus Time of Seat Bucket, Dummy, Weighted Average of Bucket and Dummy, and Input Pulse

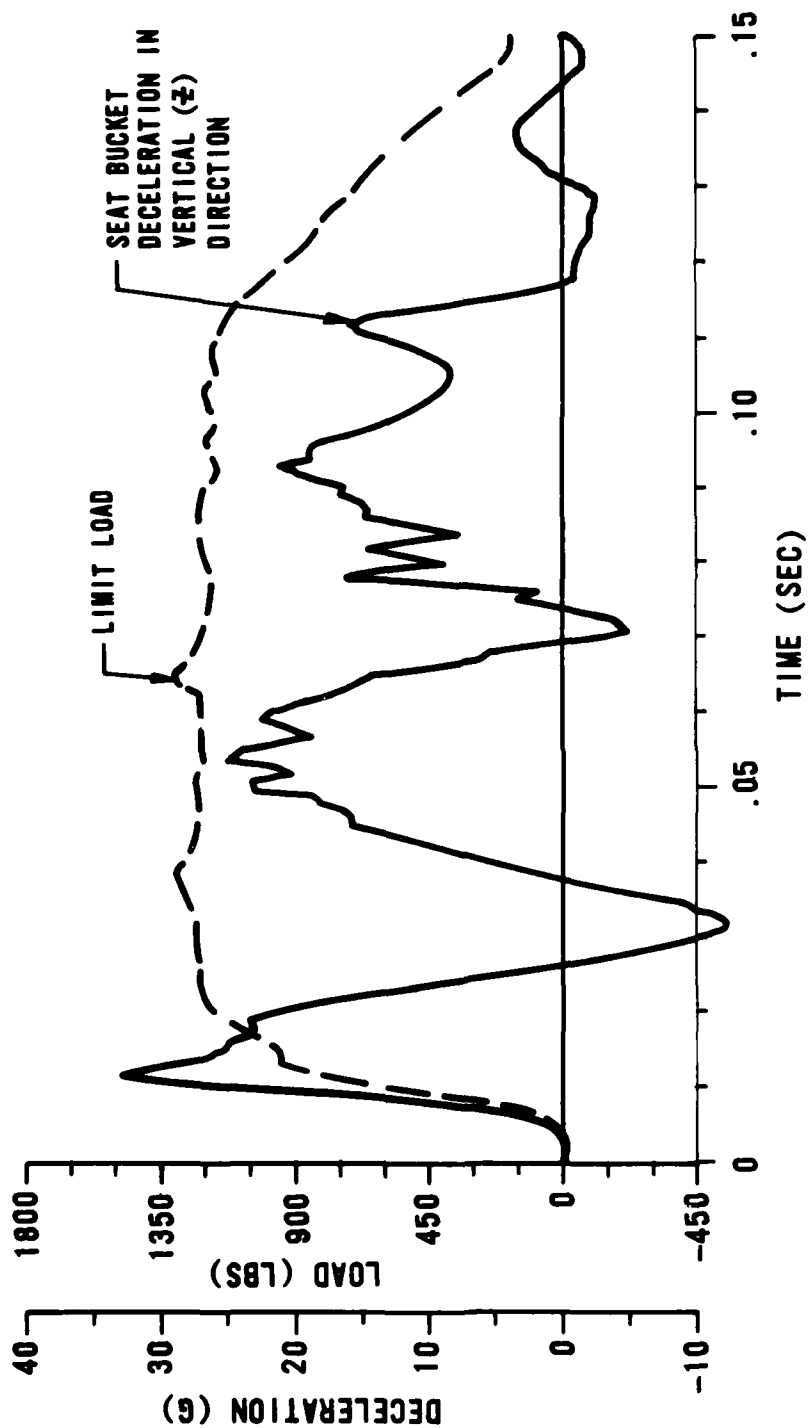

Figure 12. Deceleration of Seat Bucket and Limit Load of Energy Absorbers Versus Time

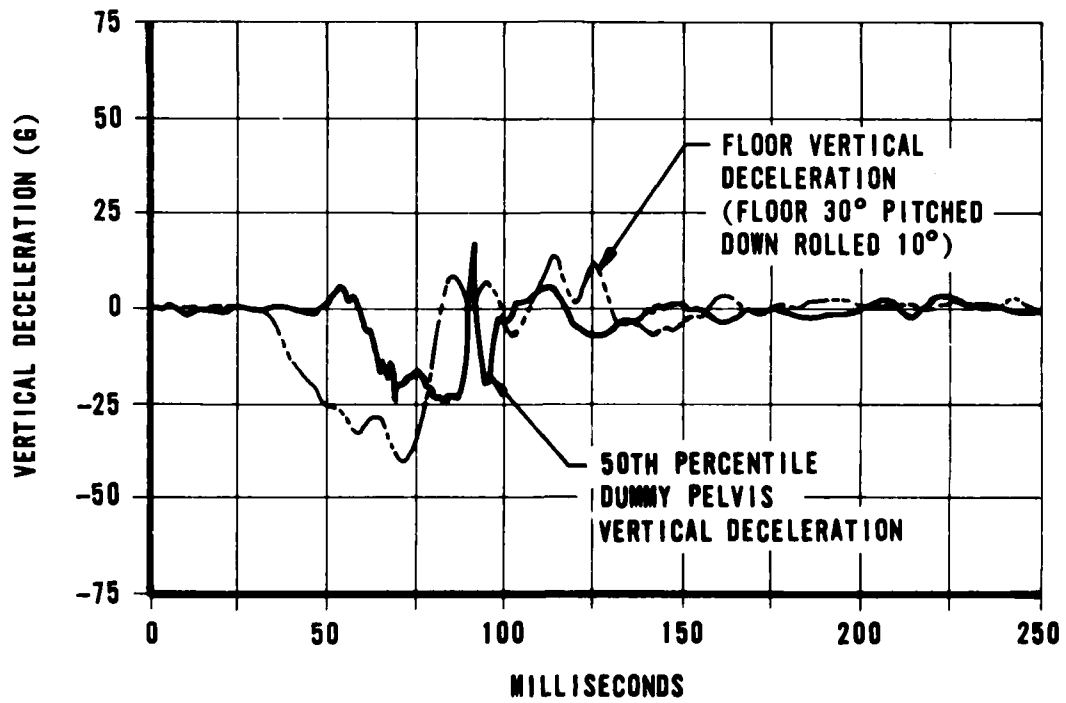
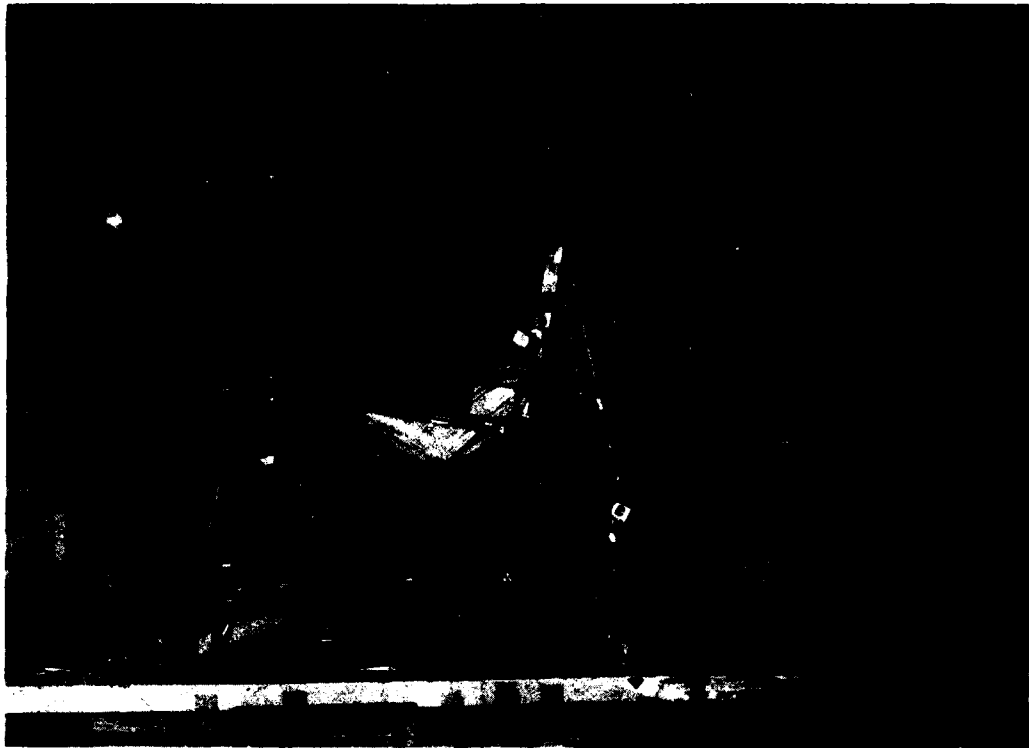
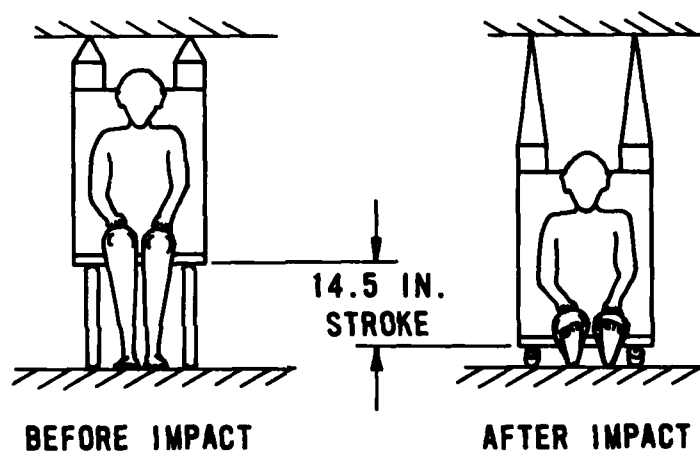

Figure 13. Crashworthy Helicopter Troop Seat After 48G, 42 ft/sec Dynamic Test

Table IX. Crashworthy Troop Seat Characteristics

- LIGHT WEIGHT: 15 LBS PER ONE-MAN SEAT/RESTRAINT SYSTEM
- LOW COST: APPROXIMATELY \$300 PER SEAT
- OPERATIONAL SUITABILITY DEMONSTRATED DURING UTTAS PROGRAM & BY HFE MOCK-UP EVALUATION USING 1ST TO 99TH PERCENTILE SOLDIERS.
- HIGH STRENGTH DEMONSTRATED BY STATIC & DYNAMIC TESTS
- 14.5 INCHES OF VERTICAL CRASH FORCE ATTENUATION STROKE USING 2 WIRE-THROUGH-ROLLER ENERGY ABSORBERS



- VERTICAL CRASH FORCE ATTENUATION NOT AFFECTED BY OCCUPANT C.G. SHIFTS. DESIGNS WITH ATTENUATORS IN SERIES ARE EFFECTED AS SHOWN BELOW:

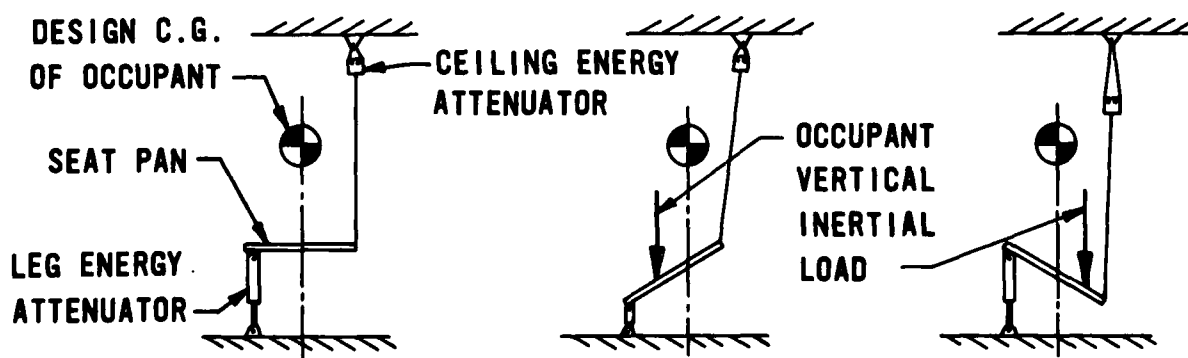



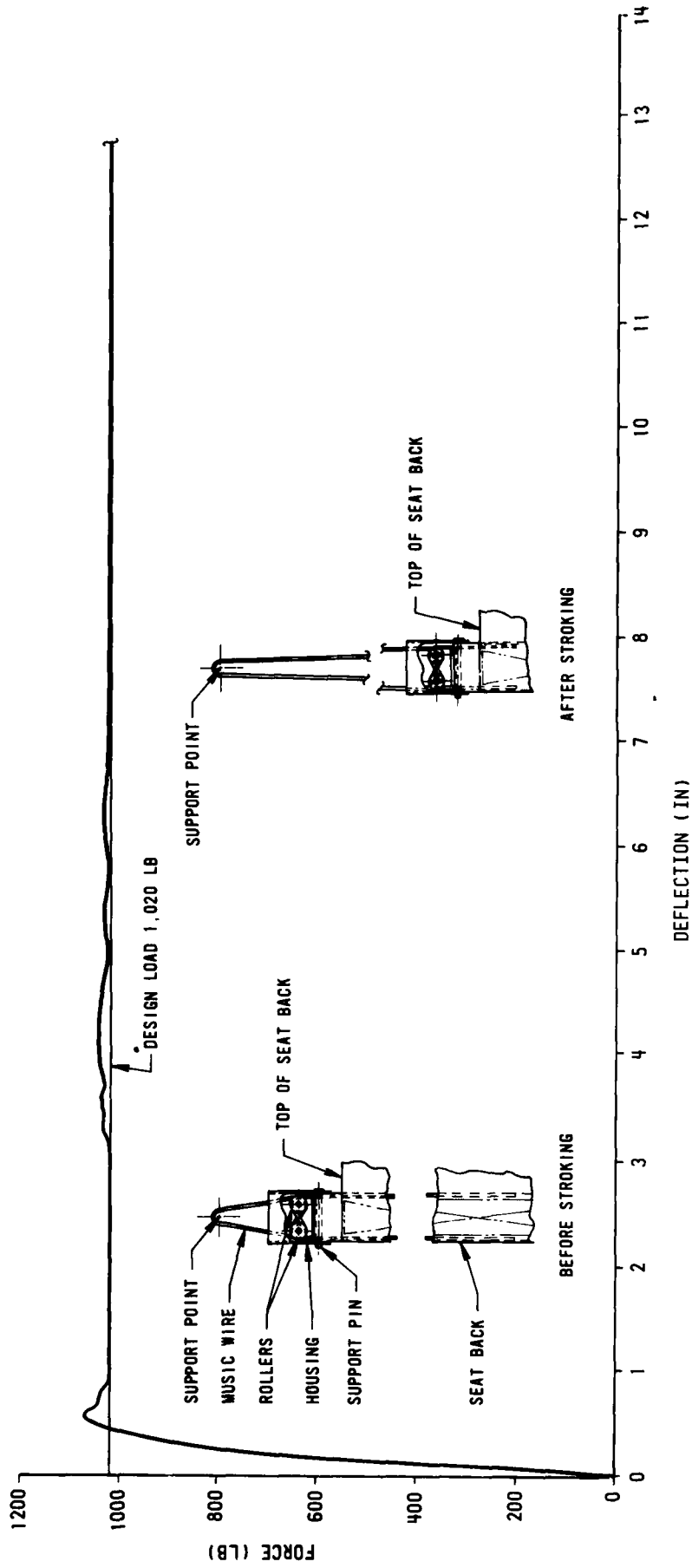

Figure 14. Wire-Through-Roller Energy Absorber

Table X. Summary of Troop Seat Dynamic Test Conditions (23)

TEST NO.	SEAT TYPE	IMPACT ATTITUDE	DUMMY PERCENTILE	TOTAL WEIGHT (LB)	IMPACT VELOCITY (FT/SEC)	PEAK G	SEAT STROKE (IN.)	DUMMY RESPONSE (G)		DRI @ TIME		SLED STROKE (IN.)	RESTRAINT LOAD (LB)	
								PLATEAU	OVER-SHOOT	DRI (MS)	DRI (MS)		LAP	SHOULDER
1	fwd	3 axis	95th	243	49.3	48.6	10.75	14	67	37.6	120	23.5	400	700
2	aft	3 axis	95th	220	49.4	51.2	14.87	15	78	9.5	151	23.5	400	80
3	fwd	fwd yaw	95th	243	50.0	24.0	Lapbelt failure				246	40.0	750	2000
4	aft	fwd yaw	95th	243	50.0	44.9	Seat back failure			24.8	139	45.0	--	3000
1A	fwd	3 axis	95th	212	41.9	23.6	10.00	12	32	32.8	120	27.0	780	400
3A	fwd	fwd yaw	95th	243	49.5	26.2	6.80	15	23	11.7	155	45.0	2450	1320
4A	aft	fwd yaw	95th	243	48.5	52.5	8.00	19	21	18.0	129	43.0	--	--
2A	aft	3 axis	95th	220	42.3	52.4	11.00	12	25	8.0	162	25.5	--	--
2B	aft	3 axis	50th	170	42.2	52.4	11.00	14.5	25	19.4	109	25.5	--	--
2C	aft	3 axis	50th	204	49.0	60.9	12.10	19	25	24.5	109	--	--	--
1B	fwd	3 axis	50th	204	46.6	54.2	6.10	17	28	37.8	123	--	650	550

Notes: Vertical attenuator load setting - 1450 lb.

Diagonal attenuator load setting - 1100 lb.

Total weight includes dummy, clothing, and equipment weights.

50th percentile dummy - Alderson Research Laboratory model VIP-50A.

95th percentile dummy - Sierra model 895.

Dummy response is chest acceleration except for test 1., which is pelvis acceleration.

Dummy response is vertical acceleration for 3-axis tests and longitudinal acceleration for fwd yaw tests.

Seat stroke is for vertical attenuator in 3-axis tests and longitudinal attenuator in fwd yaw tests.

Table XI. Seat Occupant Weights

Item	Percentile Weight (Lbs)					
	5th		50th		95th	
	Soldier (23)	Aviator (26)	Soldier	Aviator	Soldier	Aviator
Man	126.3	133.1	156.3	170.5	201.9	211.6
Total Weight - Clothed & Equipped	166.6	144.3	196.6	181.7	242.2	222.8
Vertical Effective Weight - Clothed	103.4	113.0	127.4	142.4	163.9	174.8
Vertical Effective Weight - Clothed & Equipped	136.7	113.0	160.7	142.4	197.2	174.8

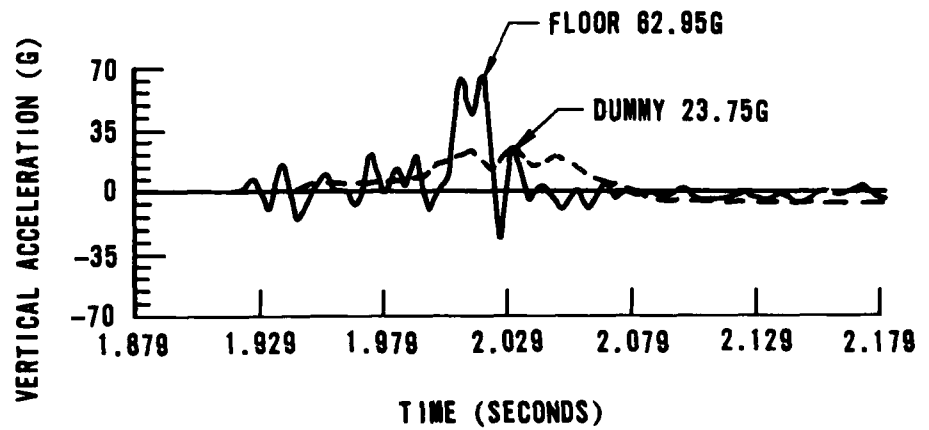

Figure 15. Crashworthy Troop Seat

TABLE XII. DYNAMIC TEST CONDITIONS FOR AIRCRAFT SEATS

SEAT ORIENTATION	
<b>TEST 1</b> DOWNWARD, FORWARD, AND LATERAL LOADS	<b>TEST 2</b> FORWARD AND LATERAL LOADS
<b>TEST PULSE FOR COCKPIT SEATS (7)*</b>	
<b>TEST PULSE FOR CABIN SEATS (23)*</b>	
<p>* THE RISE TIME FOR THE TRIANGULAR PULSES MAY VARY BETWEEN THE TWO VALUES ILLUSTRATED.</p>	

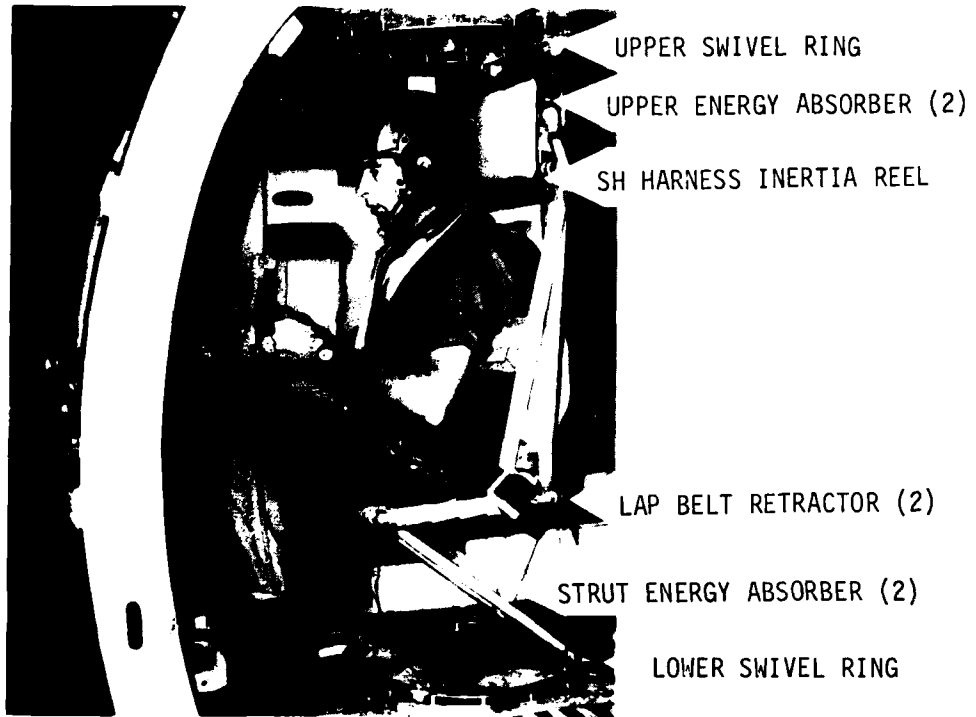

Figure 16. Swivel Gunner Seat Mock-Up

## SOME IMPROVEMENTS TO THE UK HELICOPTER COCKPIT

by

Wing Commander D C Reader  
 Royal Air Force Institute of Aviation Medicine  
 Farnborough  
 Hampshire  
 UK

## SUMMARY

The importance of helicopters to military forces cannot be denied, yet moves to improve the human-factor aspects of helicopters have been late in appearance and partly ineffectual in application. In the UK, however, there have been improvements to the restraint harnesses; the location and methods of stowage of the survival aids; the strength, adjustment and anti-vibration properties of the crew seats; and experiments have been conducted to investigate the feasibility of different configurations of flight controls.

## INTRODUCTION

Whilst helicopters have been in military use for more than 30 years, there is no doubt that from an aeromedical aspect they lack many of the newer features that have been incorporated in fixed wing aircraft. Cabin conditioning systems and ejection seats for instance are two major advances which enhance respectively human performance and survivability, yet have not been extended to helicopters. The requirement to minimise the all-up-weight of the helicopter is often used as an excuse against all innovation in the cockpit, yet there is much that can be done that involves neither weight increase nor large sums of money. This paper describes some of the improvements to the UK helicopter cockpit that are being sought and some of these may be appropriate in other helicopters of the NATO alliance.

## Harnesses

One of the most important developments has been the introduction of a negative G strap, between the legs, to make the 4 point harness (double lap and shoulder straps) into a 5 point harness. The case for a negative G strap has been made before (Reader, 1971) but briefly, the advantages of a negative G strap for a helicopter restraint harness are as follows:

The negative G strap prevents the other elements of the harness from moving during impact. As the upper torso moves forward in  $-G_x$  accelerations (eye balls out), the tension in the shoulder straps tends to elevate the central point of the harness and lift the forward end of the lap straps. This moves the lap straps away from the pelvis and onto the soft abdomen. In addition, it allows the pelvis to "submarine", or move under the lap straps. This in turn flexes the spine and reduces its tolerance to  $+G_z$  (vertical, eye balls down) accelerations. The negative G strap prevents this movement, it carries small loads itself, but ensures that adequate pelvic restraint is present at all times. As the pelvis cannot move forward, there are no additional risks to the genitalia.

During nap-of-the-earth flying, where vertical vibration is likely, the negative G strap fulfils the same function as it does when fitted to harnesses in fixed wing aircraft. It functions as the forward end of loops over each thigh and over each shoulder ensuring that under  $-G_z$  (vertical, eye balls up) acceleration the body cannot move and displace the harness upwards. This function accounts for the name by which this element of the 5 point harness is normally known, the negative G strap, although it has been referred to variously as a stabilizing, crutch or controlling strap.

The 5 point harness is now fitted to all new UK military helicopters, all Royal Navy and most Royal Air Force helicopters. The harness has been well accepted and has already been tested in actual crash impacts. One of the areas for concern was whether the additional complication of the harness would restrict underwater egress. A sample of the 5 point harness together with a 4 point harness has been fitted to the cockpit of the Royal Navy underwater egress trainer ("the dunker") for almost 2 years. All aircrew undergo training in this device with both the 4 point and the 5 point harness and they report little difference between them in terms of egress times underwater.

Together with the 5 point harness, a new quick release fitting (QRF) has been introduced. Earlier forms of the QRF had two main disadvantages, inadvertent and impact release. The QRFs could be released inadvertently because one continuous action e.g. turning the operating head through  $120^\circ$ , would release the QRF and all its attached straps. Flailing objects have struck the QRF during impact, so turning the operating head and releasing it with fatal results to the occupant. Most QRFs have some spring mechanism to lock the lugs of the straps in position. Violent blows to the QRF can dislodge the internal locking mechanism, compress the springs by inertia forces and unlock the QRF. The new QRF in use with the 5 point harness overcomes these difficulties by the introduction of a thumb catch which must be depressed before the operating head can be turned and by special locking pins which lock the lugs positively in the QRF until the operating head is turned.

## Personal Survival Packs

During impact tests of various helicopter seats, it was observed that collapse of the seat was more likely if the dummies slumped forwards onto the front of the seat. When the dummies were prevented from slumping or moving forwards, collapse only occurred at high levels of impact. Efficient harness design can reduce the amount of slumping but the elimination of compressible seat cushions is much more effective.

The substitution of a rigid sitting platform in place of a conventional cushion spreads the impact forces over the whole seat structure and makes seat failure less likely. Furthermore, the platform can be contoured for comfort and the contours themselves provide some additional pelvic restraint. Earlier platforms were hollow structures made from glass reinforced plastic (GRP), but it was soon realised that the enclosed space could be used for the stowage of flotation and survival aids normally carried in fabric packs worn on the back. These packs were heavy, bulky and uncomfortable, but any other method of stowage could not guarantee that the aids would always be available after underwater egress. In addition to the discomfort of these packs, their flexible nature led to premature deterioration of the contents through chafing which, therefore, required frequent inspection. The packs had to be worn to and from the aircraft and gave rise to persistent complaints of backache in flight. However, stowage of the survival and flotation aids in a rigid pack used as a sitting platform overcomes all these complaints. The pack is not a personal issue, it remains in the aircraft until used on emergency escape. The rigid pack prevents chafing and can be sealed against the elements. A layer of natural sheepskin, cool in summer and warm in winter, is used as a cushion on the pack for added comfort. Differently shaped packs are required for differing shapes of seats, but the same top contour is used for all, moreover the operating and servicing drills are identical. Trials in "the dunker" have proved that egress underwater with the rigid pack poses no more problems than did the larger flexible back pack. These rigid packs are now either in use, or in production, for all Royal Navy and most RAF helicopters. They are also under trial in Canada, Denmark and Holland.

#### Seats

A major source of aircrew fatigue in helicopters is vibration. Aerodynamic engine and gearbox vibration together with atmospheric turbulence combine to produce an environment in the helicopter far from conducive for efficient performance, especially at high speeds. The frequency of vibration which causes the human body to resonate is normally well below that seen in most helicopters, but parts of the body, e.g. arms, hands and face, do resonate at about 20 Hz, a frequency of vibration often detected in modern helicopters. Whilst the elimination of the vibration at source is the ideal solution, careful choice of cushion materials can isolate much of the vibration from the man. However, a more satisfactory solution is to isolate the seat and occupant mechanically from the airframe. The production crew seat for the Anglo-French Lynx helicopter demonstrates this feature. The seat pan which contains the rigid survival pack is spring mounted in a seat support structure. The seat pan and seat back are in effect doubled, the supporting structures being connected to a separate seat pan and seat back plate by coil springs. Small metal stays limit the movement of the sprung portion. The restraint harness is connected to the supporting framework of the seat and so encompasses both occupant and spring mounted seat portions. Trials of the system have been encouraging. The seat subjectively improves the comfort in flight, and vibration in the major axes is markedly reduced.

Vibration measurements (Rowlands, 1976) show that the system isolates well at about 20 Hz, as designed, both in the vertical and fore and aft planes. In the lateral plane the springs do not isolate to any great extent because the coil springs are mainly uni-directional in function, and are mounted in the vertical and fore and aft planes. Impact testing has shown that the coil springs become fully compressed early in the deceleration, and then both parts of the seat move together. In the inverted position, the restraint harness and the metal stays prevent the two parts of the seat from separating. Later versions of this system will incorporate elastomeric vibration isolators which have the advantage of acting in all three planes simultaneously. They also incorporate built in stops to limit excessive movement.

Considerable progress has been made recently towards the incorporation of the principles of crashworthiness in UK seats and helicopter cockpits. Although the UK requirements for crash resistance are considerably lower than current US military specifications, the principles of crashworthiness are well accepted. Later versions of the UK helicopter crew seat will incorporate energy attenuating units to limit the force transmitted from the airframe during impact. The energy attenuating system used should be maintenance free, have high specific energy absorption, be multi-directional in use and have a predictable performance under a wide range of temperature conditions. Several types of energy attenuating units have been examined. Cylindrical devices which utilize the deformation of a plastic inner component are simple and cheap to install and have the advantage that they are widely used in the car industry. However, they will require heavy supporting structure. A newer type of unit utilises the simple principles of wire bending but is incorporated into a cylindrical unit to provide bi-directional function, not normally associated with wire bending devices. This unit has been developed in the USA and has the merits of reported low price and weight. It remains to be seen whether this type of unit can be satisfactorily incorporated in the seat under development in the UK.

Modern helicopters are highly manoeuvrable and agile and are capable of high forward speed. This usually results in a pronounced nose down attitude in forward flight and aircrew have asked to be able to compensate for this attitude by seat adjustment. The ability to tilt the seat back  $10^{\circ}$  would enable crew to adopt a similar position to that in the hover and this should improve comfort as the crewman's back is better supported by the seat as he no longer leans forward away from it. To maintain adequate functional reach in the cockpit and external view, the degree of tilt must be limited, but early trials have shown that subjectively this feature does provide additional comfort. Provided the ability to vary the angle of the seat back is incorporated early enough in the design phase, it need not add to its complexity. Preferably, it should permit continuously variable adjustment of the seat angle, but to ensure system safety together with adequate structural strength under impact conditions, two positions (normal and reclined) will be used initially.

#### Control Configurations

The flight controls for helicopters consist of a cyclic pitch stick, a collective pitch lever, a tail rotor pitch control (foot pedals) and in some aircraft, an engine power twist grip control on the lever. When automatic flight systems are not employed, all these controls require manipulation and, under many conditions, work load is high. Adverse environmental conditions, especially vibration, increase the work load still further. Most helicopter pilots rest the right forearm on the right thigh to enable a firmer control to be obtained, and to limit undemanded inputs to the cyclic stick. This requires the pilot to lean forward and to the left, and usually denies him much of the support offered by the seat back.

Modern helicopters usually incorporate some form of automatic stabilization or flight control, and a fuel metering computer to simplify engine handling. Despite this automation, the current configuration of controls usually follows the older designs. In these, long levers and sticks with large control deflections were employed so that the pilot could exert the considerable forces needed to control the helicopter in the event of loss of hydraulic power assistance. Few large helicopters of recent design can be controlled in this way without power assistance, thus the design of the controls has become somewhat inappropriate.

An alternative approach is to re-engineer the controls so that small forces and deflections are required, and to fit the controls directly onto the crew seat. In this way the cyclic control could be placed on the right hand side of the seat in front of an arm rest and the collective lever could be placed on the left. Positioning of the controls on the seat would enable the pilot to maintain a more comfortable position, it would simplify the problem of control and seat adjustment because of anthropometric variation, and would abolish the central stick which obstructs egress from the cockpit and interferes with internal view of the instruments.

Experiments have been conducted in the UK to see whether helicopters can be controlled by non-conventional controls positioned in this way. Necessary preliminaries to any flight trials are simulator studies, and these are now well advanced. Force transducer type controls were used in the initial assessments and, in the absence of a full scale helicopter simulator, a stylized helicopter pursuit task generated by a digital computer was used. A variety of subjects, both trained and untrained in helicopters, took part in the assessments. The experiments showed that a fair measure of close control could be obtained in this way and that cyclic and collective controls could be combined if necessary. This would leave one hand available for the many other tasks which occur in flight.

The next step is to introduce this type of control into a full helicopter simulator prior to flight trials. Such a radical departure from conventional controls requires a considerable amount of validation before flight trials can start. However, the advantages from the point of view of human factors are so great that the move should not be resisted for long. Side arm or seat mounted controls are under consideration in the UK for the helicopter to replace the Sea King.

#### REFERENCES

- Reader, D.C. (1971). A case for the negative G strap. AGARD Conference Proceedings 88 (Paper C4), 1971.
- Rowlands, G.F. (1976). Lynx helicopter pilots seat - vibration tests. RAE Informal Report YSG/307/06/GFR, May 1976.



## HELICOPTER CRASHWORTHY FUEL SYSTEMS AND THEIR EFFECTIVENESS IN PREVENTING THERMAL INJURY

Stanley C. Knapp and Pierre Allemond  
Bioengineering and Evaluation Division  
United States Army Aeromedical Research Laboratory  
Fort Rucker, Alabama 36362

and

David H. Karney  
Medical Division  
United States Army Agency for Aviation Safety  
Fort Rucker, Alabama 36362

### SUMMARY

In 1968, the United States Army committed itself to a goal of eliminating postcrash fires in survivable helicopter accidents. New helicopters manufactured after 1970 were equipped with a crashworthy fuel system, and an extensive retrofit program of older aircraft was begun. This paper reviews all Army helicopter accidents during the period 1968-1976 and classifies them by survivability and whether or not the aircraft was equipped with a crashworthy fuel system. Accident associated fatalities and injuries were reclassified as to the primary injury involved and its relationship to the existence of any postcrash fire. The direct costs involved in the care of thermal fatalities and thermal injuries were calculated using the most conservative estimates. It is shown that the helicopter crashworthy fuel system essentially eliminated postcrash fatalities and injuries in accidents involving helicopters equipped with the new system.

### INTRODUCTION

Aircraft postcrash fire injuries are emotionally hideous. The victims risk permanent disfigurement and are often socially crippled. Many never return to flying. Physical and emotional handicaps prevent, for some, any gainful employment. The clinical care of burn patients is expensive, long term, and logistically difficult. A social, occupational, financial, and medical responsibility is incurred. Employers, insurance underwriters, and a tax-burdened public carry this responsibility. Public money pays for most military or government service related injuries.

The prevention of aircraft postcrash fire related injury and death has been a long sought goal of physicians, airframe designers, manufacturers, and safety conscious management. Although crash impact forces have always been the primary etiologic factor in aircraft accident morbidity and mortality, postcrash fires create disproportionate suffering when associated with large fixed wing transport and rotary wing accidents. This is particularly true for accidents classified as survivable\* or partially survivable.\* Failure to escape or inability to escape because of momentary incapacitation, partial entrapment, or indecision are important secondary factors that contribute to thermal injury.

Ironically, large transport aircraft and helicopters greatly differ as to the nature of a postcrash fire, survival time, and usual cause of fire related death. Transports tend to slide away from the impact site and area of initial fuel spillage. Fuel is largely contained in wings that break apart or burn external to the main inhabited space. Large interior volumes allow time to egress of up to 90 seconds. Cause of death or primary incapacitation is smoke and toxic fuel inhalation from burning polymeric structures used in furnishings, insulation, wiring, and non-load bearing interior structures.

Helicopter crashes have a high vertical acceleration component that crush fuel cells located beneath the cockpit and passenger compartments. Misting of fuel in the cockpit is common. Rotor action causes the aircraft to roll over or beat itself apart structurally. Fire is immediate and rapid spreading. Small internal volumes surrounded by large areas of plexiglass that usually break open on impact dictate a maximum time to egress and be outside the fireball of 17 seconds.<sup>1</sup> Cause of death is flame contact and superheated air or flame inhalation.

The purpose of this paper is to report the operational effectiveness of the U. S. Army Crashworthy Fuel System (CWFS) for helicopters in eliminating helicopter postcrash fire mortality and reducing morbidity.

\*Survivability is a generic classification dependent on habitable postcrash cockpit structural space and/or crash acceleration forces at the floor under the seat that are within human tolerance irrespective of the influence of fire or water (drowning).<sup>2,3</sup>

## BACKGROUND

In March of 1968, the Army Chief of Staff, General Harold K. Johnson, made a decision to allocate three million dollars in emergency research and development funds for the development of a crashworthy fuel system (CWFS) for Army helicopters. General Johnson's decision was based on a visit to Vietnam in early 1968, where Army field commanders expressed their concern for the increasing number of personnel being killed or injured from burns received in helicopter postcrash fires and who would have otherwise survived.

Acting upon the decision of General Johnson, the U. S. Army Materiel Command awarded contracts to several companies for the development of a crashworthy fuel system for the UH-1 helicopter. The result of this developmental work was a fuel system designed to reduce fuel spillage by means of impact resistant fuel cells, fuel cells which were self-sealing (ballistic capability), and fuel lines including valves with break-away and non-leak features. Fig. 1 is a schematic of the UH-1D/H fuel system.

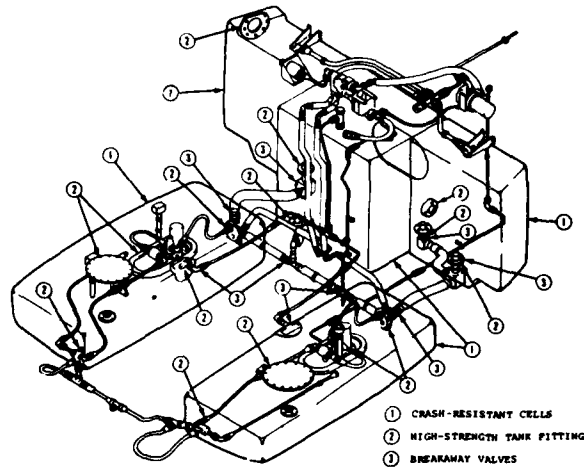

Fig. 1. Schematic of the Crashworthy Fuel System installed on the UH-1D/H helicopter fleet. The basic features are the same in systems installed in other aircraft types.

During the month of April 1970, following a period of intensive testing and evaluation, the first UH-1D equipped with a crashworthy fuel system came off the production line.

The original concept was to install the system only on new aircraft. Not all Army aircraft were to be outfitted. As early accident data from CWFS equipped aircraft were compiled by the U. S. Army Agency for Aviation Safety, a dramatic conclusion was evident. There were no thermal injuries in CWFS equipped aircraft. Decisions were rapidly made to incorporate the CWFS in other new Army helicopters during factory assembly. Human cost data by Zilioli and Bisgard<sup>2</sup> were used by the Army Safety Agency, Eustis Directorate, Army Air Mobility Laboratory, and the Army Aviation Systems Command to demonstrate that a systematic retrofit program in the Army's utility helicopter fleet could be cost effective from a human cost standpoint. A retrofit program was then instituted.

Table I outlines the rate at which the US Army has equipped its helicopters with the CWFS.

TABLE I  
ARMY HELICOPTER CONVERSION RATE TO CRASHWORTHY FUEL SYSTEM

Aircraft	1971	1974	1975	1976
UH-1D/H	44%	93%	100%	100%
UH-1B/C/M	--	26%	76%	90%
AH-1G	--	66%	100%	100%
OH-58	--	70%	95%	99%
OH-6A	--	--	0	63%
CH-47A/B	--	--	0	5%
CH-47C	--	17%	100%	100%
CH-54		Conversion not planned		
UTTAS*		Will be CWFS equipped		
AAH**		Will be CWFS equipped		
ASH***		Will be CWFS equipped		

\*Utility Tactical Transport Aircraft System

\*\*Advanced Attack Helicopter

\*\*\*Advanced Scout Helicopter

## METHOD

To determine the operational effectiveness of the crashworthy fuel system, accident data compiled by the U. S. Army Agency for Aviation Safety were reviewed. Accidents occurring during two time periods were examined. The first, 1967-1969, represents an interval during which no crashworthy fuel systems were installed. Accident data prior to 1967 were not computerized and were considered statistically unreliable; thus, not used. The second interval studied began in 1970, coincident with the installation of the first crashworthy fuel system, and extended through 30 June 1976. No combat related accidents were included, primarily because of the incomplete nature of combat accident reporting.

All accidents were classified as survivable or nonsurvivable as defined by Army regulation<sup>3</sup> and the Army Crashworthiness Design Guide.<sup>4</sup> This classification does not consider effects of fire or drowning. Hence, a further classification was necessary to identify thermal and non-thermal crash events and their relationship to the primary cause of death or injury. It is possible under this classification for an individual to survive the impact of a nonsurvivable accident and die a thermal death. But the authors' analyses also identify those individuals who for some reason died from impact forces in survivable accidents and then were exposed to a postmortem fire.

It is important for the reader to clearly understand this classification. The initial impression of lay persons or persons unfamiliar with postcrash accident analysis techniques when viewing the burned wreckage and victims of an accident is to make a wrong judgment that death was caused by fire. In fact, none of the victims may have died as a result of fire. Only a careful reconstruction of the accident sequence and a thorough autopsy examination of all deaths will assign cause of death and place the injuries seen in their proper sequence of occurrence.

It would be advantageous to assume that individuals involved in accidents classified as survivable without fire would all live. Unfortunately, the assumption is not valid. Factors such as time to rescue, drowning, cockpit intrusion, restraint failures, inadequate or absent protective equipment, and other unusual events contribute to fatalities in survivable accidents. These factors were not examined in this study. Only the event primarily responsible for the individual's death or injury was determined. A judgment was then made prior to final classification as to whether the individual would have survived or escaped injury had that event not occurred, be it fire or impact related.

## RESULTS AND DISCUSSION

Table II presents fatalities and injuries from 68 nonsurvivable accidents classified as to their thermal and non-thermal etiologies. Data from accidents involving the three primary fleet helicopters being flown during the 1967-1969 time frame are presented. No aircraft were equipped with the crashworthy fuel system.

TABLE II  
1967-1969 FATALITIES AND INJURIES IN NONSURVIVABLE ARMY HELICOPTER CRASHES\*

Aircraft	Fatalities		Injuries	
	Thermal	Non-Thermal	Thermal	Non-Thermal
UH-1D	64	108	2	8
UH-1H	31	148	1	0
AH-1G	1	14	0	0
TOTAL	96	270	3	8

\*68 accidents, no crashworthy fuel systems, 57 postcrash fires

Table III presents the same data on 1000 accidents classified as survivable. Elimination of fatalities and reduction of injury in survivable accidents are more realistic goals than trying to make nonsurvivable accidents survivable. It should be noted that postcrash fires occurred in 13.3 percent of survivable crashes and contributed 95 thermal injuries or 59.7 percent of the 159 fatalities produced in 1967-1969 by 1000 survivable accidents. Sixty-four thermal injuries account for 4.7 percent of the 1361 persons injured. These thermal injuries represent a fortunate group of aviators. Thermal protective flying suits were available but were still not universally used by all units. Considering all factors that can mitigate rapid egress from a crashed and burning helicopter, the 64 survivors with thermal injury are operationally significant. The senior author of this paper concluded from interviewing hospitalized postcrash fire survivors in 1971 that accident victims who survive the impact aspects of helicopter crashes and then encounter an ensuing postcrash fire (listed in order of decreasing frequency of occurrence) either do not know how they got outside the fireball, were thrown clear of the aircraft and/or fireball, or were rescued from the aircraft/fireball by other aircrew. Rarely is rescue accomplished by formal rescue techniques.

TABLE III  
1967-1969 FATALITIES AND INJURIES IN SURVIVABLE ARMY HELICOPTER CRASHES\*

Aircraft	Fatalities		Injuries	
	Thermal	Non-Thermal	Thermal	Non-Thermal
UH-1D	47	106	32	718
UH-1H	47	49	25	530
AH-1G	1	4	7	49
<b>TOTAL</b>	<b>95</b>	<b>159</b>	<b>64</b>	<b>1297</b>

\*1000 accidents, no crashworthy fuel systems, 133 postcrash fires

A comparison of injuries and fatalities, both thermal and non-thermal, for survivable and nonsurvivable accidents during the 1970-1976 time frame is depicted in Table IV. There were 1160 survivable accidents involving aircraft not equipped with the crashworthy fuel system. Of these, 3.7 percent resulted in fire. This represents a 72 reduction in fire occurrence as compared to the 1967-1969 data. A major factor in this reduction was the rapid crashworthy fuel system retrofit program of fleet aircraft considered to be at highest risk. See Table I. Though the 1970-1976 reporting period is longer, the net yearly accident rate has been steadily declining. This has been especially true since the military "phase down" after the Southeast Asia withdrawal. There has been an overall reduction in all injuries and death regardless of etiology. Factors contributing to this reduction include introduction of better restraint systems, more crashworthy seats, Nomex<sup>®</sup> aramid flight clothing, the SPH-4 helmet, fewer old high-fire-risk aircraft (See Table I), and introduction of crashworthy airframe improvements.

TABLE IV  
1970-1976 ARMY HELICOPTER CRASH FATALITIES AND INJURIES

Classification	Survivable		Nonsurvivable	
	w/o CWFS	with CWFS	w/o CWFS	with CWFS
Thermal Injuries	20	5	5	0
Non-Thermal Injuries	529	386	13	28
Thermal Fatalities	34	0	31	1
Non-Thermal Fatalities	120	44	229	85
Accidents	1160	1258	61	32
Postcrash fires	43	16	42	18

Table IV also shows that during the period 1970-1976, 1258 survivable accidents occurred involving aircraft equipped with a crashworthy fuel system. Sixteen fires occurred and resulted in five thermal injuries, but no thermal fatalities. This represents a 75 percent reduction in thermal injuries and elimination of thermal fatalities when compared to survivable accidents during the same period in aircraft not equipped with the crashworthy fuel system.

Table V shows the sources of flammable fluid spill causing postcrash fires in crashworthy fuel system equipped aircraft accidents.

TABLE V  
SOURCES OF FLAMMABLE FLUID SPILL CAUSING POSTCRASH FIRE, 1970-1976

Source	Survivable	Nonsurvivable	Other
	Accident*	Accident*	
Ruptured fuel cell or lines	10	12	---
Hydraulic fluid	1	1	---
Transmission fluid	1	1	---
Fuel vent	9	0	---
Auxiliary tank	0	1	---
Engine	0	0	1
Unknown	1	1	---
<b>TOTAL</b>	<b>22</b>	<b>16</b>	<b>1</b>

\*Accidents involving CWFS equipped aircraft

The system is not crash proof. It is only crashworthy. Fuel vent leakage can be indicated in nine survivable accidents. The fuel vent does not have crashworthy or non-leak characteristics and may be expected to cause fires in roll over accidents. Ruptured fuel cells and fuel lines contributed another 10 fires. Though the fuel lines are coiled or looped to allow considerable deformation before rupture, line fracture does occur. If fuel boost pumps are running at the time of line fracture, raw fuel can be pumped onto hot engine surfaces or exposed to sparks. Some retrograde flow can also occur, especially if all one-way valves fail to function properly. It is nearly impossible to reconstruct the exact sequence of events from the study of an aircraft consumed by fire. Tank rupture can occur secondary to intrusion by cargo hooks, tree trunks, or other objects external to the airframe. Fig. 2 depicts

an unburned crashed aircraft classified as partially survivable that has literally torn itself apart from roll over during fuselage deceleration after impact with the ground. The intact and non-leaking main fuel cell can be seen in the foreground where it was found by the accident investigation team.



Fig. 2. This UH-1H crashed at night in instrument meteorological conditions (IMC). The pilot and copilot survived with injuries. The crashworthy fuel system functioned as designed. Note the right forward fuel cell in the foreground, which tore loose from the aircraft and prevented fuel spillage. There was no postcrash fire.

It should be noted that one thermal fatality listed in Table IV occurred in a nonsurvivable accident. The individual may have survived had there not been a fire. Non-lethal facial injury possibly rendered the individual unconscious and thus unable to egress. Severe fire enveloped the aircraft postcrash and before any rescue could be attempted.

Tables VI and VII break down injuries and fatalities respectfully by aircraft type for the 1970-1976 reporting period. The majority of deaths and injury occurs in UH-1H accidents. The UH-1H is not necessarily less crashworthy. It is the workhorse of the Army helicopter fleet and the most flown aircraft; thus, exposing it to the greatest accident risk.

TABLE VI  
1970-1976 INJURIES BY AIRCRAFT TYPE

Aircraft	Thermal		Non-Thermal	
	w/o CWFS*	with CWFS**	w/o CWFS*	with CWFS**
UH-1D	1	0	39	26
UH-1H	18	5	352	345
AH-1G	3	0	75	17
OH-58A	3	0	76	26
TOTAL	25	5	542	414

\*1221 accidents, without CWFS, and 85 postcrash fires

\*\*1290 accidents, with CWFS, and 34 postcrash fires

TABLE VII  
1970-1976 FATALITIES BY AIRCRAFT TYPE

Aircraft	Thermal		Non-Thermal	
	w/o CWFS*	with CWFS**	w/o CWFS*	with CWFS**
UH-1D	8	0	10	5
UH-1H	49	1	263	107
AH-1G	3	0	36	12
OH-58A	5	0	40	5
<b>TOTAL</b>	<b>65</b>	<b>1</b>	<b>349</b>	<b>129</b>

\*1221 accidents, without CWFS, and 85 postcrash fires

\*\*1290 accidents, with CWFS, and 34 postcrash fires

With this review of the fatalities and injuries caused by postcrash fires, it is of value to examine the human costs of these fires. Table VIII depicts fatality and injury costs. These figures are very conservative in that they are based on military medical facility care and not civilian facility care. These figures represent direct costs to the Army and do not include Veteran's Administration benefits, Social Security benefits, or other factors. They include a pro rata estimation of medical evacuation costs and average all active duty Army burn injury or fatality expenses. They do not reflect costs of retraining. They do not take into consideration grade, rank, or seniority. These figures do not reflect the intangible but considerable costs associated with personal and family suffering, alterations in life style, and home care. The significantly higher figure for thermal fatalities probably is derived from the fact that so many thermal fatalities are preceded by extended hospital care involving heroic measures.

TABLE VIII  
FATALITY AND INJURY COSTS\*

	Estimated cost for each
Thermal fatality	\$155,000
Thermal injury	15,000

\*DA Circular 385-48, 1974

Table IX depicts the human costs for accidents involving noncrashworthy fuel system equipped aircraft for the period 1967-1969. It is to remember that these figures are considered conservative, and they take into consideration only those injuries and fatalities directly related to fire. If the primary cause of death was impact injury with associated thermal injury, the statistic would not appear in Table IX. It is interesting to note that the total number of individuals involved and their associated fatality costs for both survivable and nonsurvivable accidents were approximately the same. However, for those accidents classified as survivable, the number of individuals who sustained thermal injuries but apparently escaped some of the effects of the postcrash fire is 20 times the number of thermal injuries reported for nonsurvivable accidents. This difference may be attributable to the severity of the accident and not the severity of the fire.

TABLE IX  
HUMAN COSTS\* FOR NON-CWFS ACCIDENTS, 1967-1969

	Survivable		Nonsurvivable	
	Individuals	Cost	Individuals	Cost
Thermal fatality	95	\$14,725,000	96	\$14,880,000
Thermal injury	64	992,000	3	46,500
<b>Total</b>	<b>159</b>	<b>\$15,717,000</b>	<b>99</b>	<b>\$14,926,500</b>

\*Calculated using data Tables II, III, and IV.

Table X depicts thermal injury and thermal fatality costs associated with noncrashworthy fuel system helicopter accidents for the period 0-1976. The significant reduction in the number of individuals involved in both survivable and nonsurvivable accidents over the period 1967-1969 is attributable to the gradual attrition of older high-fire-risk aircraft (See Table I) and the introduction of effective fire resistant clothing.

TABLE X  
HUMAN COSTS\* FOR NON-CWFS ACCIDENTS, \*\* 1970-1976

	Survivable		Nonsurvivable	
	Individuals	Cost	Individuals	Cost
Thermal fatality	34	\$5,270,000	31	\$4,705,000
Thermal injury	20	310,000	5	77,500
<b>Total</b>	<b>54</b>	<b>\$5,580,000</b>	<b>36</b>	<b>\$4,782,500</b>

\*Calculated using data Tables IV, VI, and VII.

\*\*1,221 accidents.

Table XI represents the direct human costs for thermal injuries and fatalities in survivable and nonsurvivable accidents involving Army helicopters equipped with a CWFS for the period 1970-1976. The reduction is dramatic.

TABLE XI  
HUMAN COSTS\* FOR CWFS ACCIDENTS, \*\* 1970-1976

	Survivable		Nonsurvivable	
	Individuals	Cost	Individuals	Cost
Thermal fatality	0	0	1	\$155,000
Thermal injury	5	\$77,500	0	0

\*Calculated using data Tables VI and VII.

\*\*1,290 accidents.

The introduction of any safety device, especially if it means modification to an aircraft, involves trade offs of payload, fuel consumption, power, weight, and a host of others. These trade offs involve real dollars and perceived or actual reduction in operational capability. Table XII reviews the operational penalties and cost factors for installation of the helicopter CWFS in new and retrofitted aircraft.

TABLE XII  
CRASHWORTHY FUEL SYSTEM OPERATIONAL PENALTIES AND COST FACTORS

Aircraft	Added weight pounds	Fuel penalty gallons	Development costs dollars	Hardware costs dollars	Aircraft modified	Aircraft net cost dollars
UH-1D/H	160	11	362,000	7,400	3,077	7,517
UH-1B/C/M	93	18	214,000	9,500	900	9,737
AH-1G	130	6	250,000	4,600	769	4,925
OH-58A	67	1.5	320,000	4,200	2,065	4,354
OH-6A	70	6	631,000	6,900	244	9,486
CH-47A/B/C	610	54	2,215,000	20,000	426	25,200

#### CONCLUSION

The introduction of the helicopter CWFS into the United States Army helicopter fleet as an integral part of a long-range program to eliminate crash fatalities and reduce crash injury has been shown to be a highly successful and operationally effective mechanism. As more aircraft are retrofitted with the CWFS and improvements are made in crashworthiness design for hydraulic systems and other potential sources of postcrash fire, the goal of eliminating postcrash fire as a significant hazard in survivable accidents seems to be within our grasp.

#### REFERENCES

1. Schrunk, D. G., Knapp, S. C., McCahan, G. R., et al. USAARL Evaluation of the Life Saving Capabilities of the Heliborne Crash/Rescue Fire Suppression System, Annex A. US Army Aviation Test Board Report 4ES 825 000 001, Military Potential Test of the Heliborne Crash Rescue Fire Suppression System, Apr 70.
2. Zilioli, A. E. and Bisgard, J. C. "Crash Injury Economics: Injury and Death Costs in Army UH-1 Accidents in Fiscal Year 1969." USAARL Report No. 71-18, US Army Aeromedical Research Laboratory, Fort Rucker, Alabama, Dec 71.
3. US Army Regulation 95-5, "Aircraft Accident Prevention, Investigation, and Reporting," 1 Jul 75.
4. "Crash Survival Design Guide," USAAMRDL Technical Report 71-22, Eustis Directorate, US Army Air Mobility Research and Development Laboratory, Fort, Virginia. Contract DAAJ02-69-C-0030, Oct 71.

## A METHOD FOR SELECTING A CRASHWORTHY FUEL SYSTEM DESIGN

by  
S. Harry Robertson, P.E.,  
and  
James W. Turnbow, Ph.D.  
Engineering Safety Center  
Arizona State University  
Tempe, Arizona 85281

### SUMMARY

A complete crashworthy fuel system (CRFS) involves many design considerations as well as an abundant use of specialized hardware. By necessity, design tradeoffs are involved in the evolution of each fuel system design. Since the successful incorporation of the CRFS design into U.S. Army aircraft, much interest has been focused on the overall concept.

Presently, there is no single system which is universally adaptable to all aircraft. Consequently, each fuel system designer is confronted with the problem of deciding how much CRFS hardware he should incorporate into his fuel system design, to achieve the desired safety level.

This paper discusses a rating method that a CRFS designer can use to help determine the amount of hardware and special design considerations needed to obtain a desired reduction in the fuel system "Fire Hazard Level". It uses as its basis, man's tolerance to the thermal environment, and deals particularly with changes in the escape times available to the aircraft occupants.

### INTRODUCTION

When an aircraft crashes, its occupants are exposed to many hazards which affect survival, one of which is fire. The fuel system is the major fire threat, however, cargo and other flammable fluids such as lubricating and hydraulic oils can also be a factor.

Now that truly crashworthy fuel systems exist in some U.S. military aircraft, and crashworthy hardware is available from many aerospace manufacturers, the fuel system designer is confronted with the problem of trying to determine how much fire safety can (or needs to) be obtained from any given fuel system design.

An evaluation technique has been developed which can allow a fuel system designer to rate a given fuel system design to determine the relative "Fire Hazard Level" for each component and/or hazardous area. Proposed crashworthy design changes can then be integrated into the original non-crashworthy design and the system be re-evaluated to determine the "Fire Hazard Level" reductions.

For the evaluation to be performed, several assumptions must be made to establish a baseline or starting point. They are:

1. The only fire threat being evaluated is the one from the fuel system. (The cargo, oils, etc. are not included in this evaluation, although they, too, could be evaluated if they were included in the evaluation process to be discussed later.)
2. That the fire threat associated with the original, or non-crashworthy, fuel system design, is the basis from which the fuel system improvements are to be measured. As an example, the overall fire threat associated with the original non-crashworthy fuel system is assumed to be 100%. Improvements in fuel system design are measured in percentage of reduction from the original 100% "Fire Hazard Level".
3. In order to evaluate the behavior of various fuel system designs, a crash environment which is typical of the serious, marginally survivable accident must be used as the basic reference point.
4. That the evaluator be familiar with accident reconstruction, fuel system behavior during crash situations, and that he have some formal accident investigation training such as that offered by Arizona State University's "Crash Survival Investigators School", a two week concentrated course devoted exclusively to the study of human and system survival during the aircraft crash environment.

### DISCUSSION

The evaluation process is performed in the following manner:

1. The original non-crashworthy fuel system is defined, and the various components and/or hazardous areas are denoted, as shown in Figure 1.
2. Each identified component or hazardous area in the non-crashworthy fuel system is evaluated in accordance with the Rating System (defined later), to determine its relative "Fire Hazard Level".

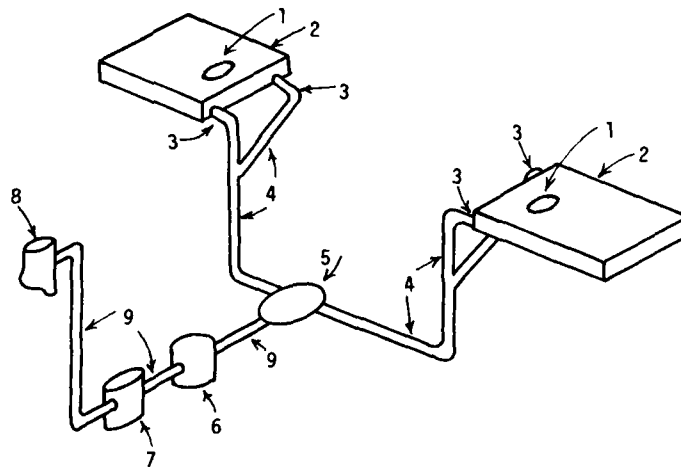

NON-CRASHWORTHY FUEL SYSTEM

<u>Item</u>	<u>Description</u>	<u>Item</u>	<u>Description</u>
1	Fillers	6	Filter
2	Tanks	7	Pump
3	Outlets	8	Carburetor
4	Fuel Lines (Upper)	9	Fuel Lines (Lower)
5	Selector Valve		

Figure 1. The Non-Crashworthy Fuel System With The Components and/or Hazardous Areas Identified.

3. The non-crashworthy fuel system design is modified to incorporate various crashworthy hardware and/or design changes, and then re-evaluated in accordance with the Rating System to determine the "Fire Hazard Level" reductions attributable to the improved design.

Note: The non-crashworthy fuel system can be upgraded by the addition of only one crashworthy item, or by the addition of many crashworthy items. Each upgraded system must be evaluated as a complete system to determine the "Fire Hazard Level" reduction attributable to separate design changes. The reason for the complete re-evaluation of each upgraded system is that the changing of one or more component and/or hazardous areas can, and usually does, influence the behavior of the remaining components and/or hazardous areas.

RATING SYSTEMS (General)

The rating system evaluates the following four items:

1. The likelihood of fuel spillage occurring from the designated Items (Component and/or hazardous areas) during the serious, marginally survivable crash.
2. The likelihood of fuel spillage from the designated Items catching fire.
3. The likelihood of an existing fire which started at a designated Item functioning as an ignition source for other probable spillages in other designated areas. (The chain reaction situation.)
4. The probable escape time available to occupants if a fire occurs at a designated Item.

RATING SYSTEM (Specific)Failure of a Component to Cause Spillage

When rating the fuel system components and/or hazardous areas for the likelihood of fuel spillage during the serious, marginally survivable crash the following items should be included in the evaluation.

• Vulnerability of the component and/or area during impact.

• Corrosion

(b) Specific component or area design

2. Probability that a destructive impact will occur. Each designated area is rated in each specific system configuration. The rating is given in the form of a percentage of probable spillage occurrence. Example: If the designated item will cause spillage during every serious crash, it is given a 100% rating, whereas if it will cause spillage in only one out of every four accidents it is given a rating of 25%.

#### Likelihood of Spillage Catching Fire

When rating the fuel system components and/or hazardous areas for the likelihood of fuel spillage catching fire, the following items should be included in the evaluation.

1. Availability of ignition sources.
  - (a) Type
  - (b) Available energy and duration
  - (c) Location
2. Size of fuel spill
3. Probable spillage paths

Spillage occurring at each designated item is rated in each specific system configuration. The rating is given in the form of percentages of probable ignition. Example: If the spillage will catch fire every time during the serious crash environment, it is given a 100% rating. If it will ignite in only one out of every four accidents it is given a rating of 25%.

#### Fire Starting Other Fires

When rating the fuel system components and/or hazardous areas for the likelihood of an existing fire serving as an ignition source for other spillages, the following items should be included in the evaluation.

1. Location of fire
2. Size of fire
3. Location of other ignitable material
4. Possible spillage paths
5. Possible flame spread paths

Each fire is rated in each specific system configuration. The rating is given in the form of points. If an existing fire is 90 to 100% likely to ignite surrounding spillages, a rating of 10 is given. If the likelihood of an ignition chain reaction is 80% to 90%, a rating of 9 is given. The point rating decreases at the rate of 1 point for each 10% decrease in likelihood of occurrence, as shown below.

<u>RATING POINTS</u>	<u>LIKELIHOOD OF CHAIN REACTION OCCURRENCE</u>
10	90 - 100%
9	80 - 90%
8	70 - 80%
7	60 - 70%
6	50 - 60%
5	40 - 50%
4	30 - 40%
3	20 - 30%
2	10 - 20%
1	0 - 10%

#### Estimated Escape Time

When rating the fuel system components and/or hazardous areas for the probable escape time available to occupants if a fire occurs, the following items should be included in the evaluation.

1. Location of initial fire relative to the occupants.
2. Growth potential of the fire.
  - (a) Initial spillage quantity
  - (b) Sustained spillage quantity

## 3. Egress considerations.

- (a) Location of occupants relative to escape routes
- (b) Complexity of the escape (doors, hatches, handles, cargo and other potentially delaying problems)

Each fire is rated in each specific system configuration. The rating is given in the form of points. If the escape time is estimated to be less than 20 seconds, the fire is given a rating of 10. If the escape time is more than 20 seconds, but less than 40 seconds, the fire is rated 9. The point rating decreases at the rate of one point for each 20 second increase in escape time as shown below.

<u>RATING POINTS</u>	<u>AVAILABLE ESCAPE TIME</u>
10	0 - 20 Seconds
9	20 - 40 Seconds
8	40 - 60 Seconds
7	60 - 80 Seconds
6	80 - 100 Seconds
5	100 - 120 Seconds
4	120 - 140 Seconds
3	140 - 160 Seconds
2	160 - 180 Seconds
1	180 -

For a discussion of why 180 seconds is chosen as the maximum time duration, see Appendix I.

HAZARD UNITS

"Hazard Units" are arbitrary numbers derived by the following formula.

$$(FCS \times LSCF) \times (FSOF + EET)$$

FCS = Rating in percent for each Item when evaluated for the likelihood of "Failure of a Component to Cause Spillage".

LSCF = Rating in percent for each Item when evaluated for the "Likelihood of Spillage Catching Fire".

FSOF = Rating in points for each fire when evaluated for the likelihood of "Fire Starting Other Fires".

EET = Rating in points for each fire when evaluated for "Estimated Escape Time" for occupants.

FIRE HAZARD LEVEL

The "Fire Hazard Level" is 100% for the complete, non-crashworthy fuel system design. For a specific component and/or designated area it is derived by the following formula.

$$FHL = \frac{\text{Component and/or area "Hazard Units"}}{\text{Total System "Hazard Units"}} \times 100$$

SAMPLE PROBLEM

To assist the reader in understanding how the rating system works, assume that the fuel system depicted in Figure 1 was evaluated in accordance with the procedures defined under "Rating System" and that the totals derived are shown in Table 1.

It can be noted from the Table that the non-crashworthy fuel system has a total "Fire Hazard Level" of 100%. Further, it can easily be seen that Item 3, the tank outlet area, is the largest contributor to the fuel system fire problem. Obviously Items 2, 4, 6, 7, and 9 are also major contributors, whereas Items 1, 5, and 8 are of a much lesser hazard.

If, for example Item 3 were modified so that it would greatly resist spilling fuel during a crash (like using crashworthy, high strength fittings in the tanks; self-sealing breakaway valves at the coupling between the tank and the fuel line; and the fuel line was made flexible to accommodate fuel system displacement), the rating for Item 3 might be as follows:

Item	Description	% FCS	% LSCF	POINTS FSOF	POINTS EET	HAZARD UNITS	FIRE HAZARD LEVEL
3	Outlets	10	10	2	1	.03	.04

If all other Item ratings remained the same, which may or may not be the actual case, depending upon the influence on them due to the design change, the new "Fire Hazard Level" would be 77.94 or a 22.06 per-cent reduction in the original, non-crashworthy fuel system "Fire Hazard Level" of 100%.

This can be shown as follows:

Item 3, Outlet (original component design) "Hazard Unit" 16.20

Item 3, Outlet (crashworthy design) "Hazard Unit" .03

Total Original System "Hazard Units" 73.4

Component "Fire Hazard Level" =  $\frac{.03}{73.4} \times 100 = .04$

Total non-crashworthy system "Fire Hazard Level" = 100%

Total crashworthy system "Fire Hazard Level" = 77.94

"Fire Hazard Level" Reduction = 22.06%

BASIC, UNMODIFIED FUEL SYSTEM							
Item	Description	% FCS	% LSCF	POINTS FSOF	POINTS EET	HAZARD UNITS	FIRE HAZARD LEVEL
1	Fillers	.50	.50	8	8	4.00	5.45
2	Tanks	.50	.80	10	10	8.00	10.90
3	Outlets	.90	.90	10	10	16.20	22.07
4	Fuel Lines (Upper)	.50	.90	10	10	9.00	12.26
5	Valve	.80	.30	8	8	3.84	5.23
6	Filter	.80	.75	10	7	10.20	13.90
7	Pump	.75	.75	10	7	9.56	13.02
8	Carburetor	.20	.75	10	6	2.40	3.27
9	Fuel Lines (Lower)	.80	.75	10	7	10.20	13.90
TOTALS						73.4	100.00

Table 1. Tabulation of Points Obtained From Rating The Typical Fuel System Shown in Figure 1.

#### CONCLUSION

In any given crash, there are many hazards to man's survival. Fire is usually one of the major threats.

The rating system presented provides a way for fuel system designers to evaluate an original non-crash-worthy fuel system in terms of "Fire Hazard Level", and then evaluate an improved fuel system, to determine its "Fire Hazard Level" reduction.

## APPENDIX 1

The length of time required for evacuation from a crashed aircraft can differ for a variety of reasons. Examples include ratio of occupants to usable exits; ease of exit operation; interference problems, such as cargo, fire, etc.; degree of occupant injury, and obviously the availability of rescue personnel.

Studies, by the authors, of aircraft crash fire growth rates and of evacuation times used by survivors in some 3,500 air crashes, have shown that most evacuations fall into one of two categories. Either the occupants are out of the aircraft within a few seconds to a minute or so, or they are in the aircraft for a much longer period of time - in some cases hours or days.

The growth rates of typical post crash fires are such that they usually start out small, grow in intensity for several minutes, then start to subside. Man's ability to survive these fires is usually predicated on the clothing he is wearing; the air he is breathing; the temperature to which he is being exposed; and the duration of his exposure.

A summary of actual crash data, as well as experimental crash test data, indicates that three minutes is about as long as one can expect to survive in a major crash fire. In fact, his survival time will be much less in many crashes, due primarily to the close proximity of the fuel to the occupants.

For further study of the subject, the reader is referred to the scientific literature, much of which is summarized in the U.S. Army "Crash Survival Design Guide, USAAMRDL TR 71-22. This document coauthored by the authors of this article, is the basic handbook in the field, and is available from the U.S. National Technical Information Service. It is currently being updated for release in early 1979.

BIOMEDICAL CONSTRAINTS ON THERMAL PROTECTIVE FLIGHT CLOTHING DESIGN:  
A BIOENGINEERING ANALYSIS

Francis S. Knox, III, Ph.D.  
Louisiana State University Medical Center  
School of Medicine in Shreveport  
P. O. Box 33932  
Shreveport, Louisiana 71130

Thomas L. Wachtel, M.D.  
Assistant Professor of Surgery  
University Hospital, University of California Medical Center  
Regional Burn Treatment Center  
San Diego, California 92103

and

Stanley C. Knapp, M.D.  
Commander, US Army Aeromedical Research Laboratory  
P. O. Box 577  
Fort Rucker, Alabama 36362

SUMMARY

Current design standards for flight clothing worn by military aircrew members in rotary wing aircraft specify that the flight suit must provide protection against the thermal energy of a postcrash fire. The duration for which this protection must last is usually from 3 to 10 seconds based on the observed evacuation times of uninjured crews from upright, intact, nonburning aircraft or helicopters.

The level of protection (acceptable burn injury) is not specified, which, if taken literally and to extreme, would mean that any test uniform or fabric that allowed sufficient heat transfer to cause even a first degree burn when subjected to the worst credible postcrash fire for ten seconds would be unacceptable. Moreover, a precise description of the postcrash fire is left unspecified.

From studies of the dynamics of large JP-4 fuel fires and of instrumented helicopter hulks immersed in such fires, the worst credible postcrash fire environment (WCE) was defined.<sup>2,3</sup> Data from these fires allowed the construction and calibration of a JP-4 fueled postcrash fire simulator. This simulator was used to expose 95 domestic white pigs (animal model for human skin) to simulated postcrash fires of various intensities (0.70 to 3.92 cal/cm<sup>2</sup>/sec) and various durations (0.55 to 14.29 sec). In some instances fabrics (e.g., Nomex) were placed between the fire and the pig. The resultant burns were graded on surface appearance and on depth of damage. The relationship between thermal energy and burn depth is complex and depends on, among other things, initial skin temperature, skin color, length of hair stubble, exposure time, and amount and rate of tissue water boiling. Fabrics tend to lower the amount of energy transmitted to the skin provided they remain intact and maintain an insulating air layer. Multiple layers enhance protection.<sup>4</sup>

Increased protection, measured in terms of burn area and depth, requires the use of multiple fabric layers, heavy weight fabrics, and more thermally stable polymers. However, the resultant textile and flight suit design requirements for thermal protection often conflict with other desirable qualities such as comfort (including heat stress), durability, appearance, and cost.

The experimental burn data presented here and survival data from the Natural Burn Information Exchange can form the basis of a rational consideration of the biomedical constraints on thermal protective flight clothing design when compared with textile engineering and cost factors. Finding the proper balance among the biomedical, textile, engineering, and cost factors will facilitate the selection of new flight suit materials and designs, and will help determine the allocation of resources between flight clothing and other protective devices such as crashworthy fuel systems.

INTRODUCTION

There are many factors which influence the design of flight clothing. Among these are: appearance, durability, comfort, functionality, cost, and thermally protective capability. The need to provide aircrew members with thermal protection is well documented,<sup>1</sup> but the optimization of a design which provides thermal protection while meeting other design goals is not simple. Rational judgments regarding the advisability of purchasing a new uniform fabric or design can only be made when the proper data upon which to make such a decision are available.

Since the object of thermal protective clothing is to protect the aircrew member from a postcrash fire, how

can fabrics and flight suits be evaluated in a way which will quantitatively measure the improved medical prognosis of the wearer in the operational environment? Formulation of such a quantitative test method must take into account the answers to five major questions. 1) what is the thermal environment against which the garment is expected to insulate the wearer? 2) what are appropriate exposure times? 3) from what is the garment protecting? pain? burn? smoke? toxic gases? 4) what is the clinical endpoint? threshold pain? epidermal burn? partial thickness burn? time of useful function? survivability? 5) how are the fabrics to be applied? in contact with the skin? spaced away from the skin? with underwear? . . . or without?

Clearly, the present standards fail to answer these questions thereby making any decisions regarding the cost effectiveness of some slight improvement in protection (however defined) fraught with potential error.

The U. S. Army Aeromedical Research Laboratory (USAARL) Thermal Analysis Program was initiated in order to develop a clinically valid algorithm for fabric evaluation.

The following rationale has guided these studies. Thermally protective clothing should be evaluated in a manner which is readily understood by physicians, textile engineers, and managers. To do so, it must provide a quantitative estimate of the severity of burn injury which the wearer would suffer when exposed to a worst credible postcrash fire for a variety of times up to ten seconds. If possible, the burn severity should be related to survivability. Survival of a burn patient depends on area burned, amount of full thickness burn, age, sex, treating facility, and associated injuries. Minimizing area and depth of burn increases survival of all groups.

The USAARL bioassay method is such a method for evaluating fabrics which provides the unequivocal endpoint of burn depth in a human skin analog, pigskin.<sup>5</sup> This method has been used successfully to evaluate fabrics<sup>4,5</sup> but is too logistically cumbersome and costly for routine fabric screening.

This paper discusses the collection of a large data base using the bioassay method and of the constraints imposed on the clothing designer by the biophysics of burn formation.

#### METHODS

An instrumented UH-1 helicopter hulk was burned with 473 liters of JP-4<sup>3</sup> (Figs. 1 and 2), and an instrumented 1893 liter JP-4 pool fire was studied to arrive at a working definition of the worst credible postcrash fire environment (WCE).<sup>2</sup> A new postcrash fire simulation furnace was built based on a NASA designed furnace.<sup>5</sup> This furnace (Fig. 3) consists of a JP-4 fueled, firebrick lined box and a water cooled, pneumatically actuated shutter system mounted in a movable animal holding table. This furnace can be set to deliver heat fluxes of 0.7 to 3.9 calories per square centimeter per second with furnace wall temperatures of 870 to 2450° F. At low heat fluxes, the exposure was from 95 to 100% radiative while at high heat fluxes, more typical of postcrash fires, the heat fluxes were 65 to 90% radiative consistent with observed values for large JP-4 fuel fires.

Details of the following bioassay procedures can be found elsewhere.<sup>4</sup> To summarize, domestic white pigs were anesthetized, closely clipped to remove the long hair, placed on the pig carrying table over an asbestos template containing six circular holes and exposed to the controlled fire for controlled but variable lengths of time. The resulting burns were photographed, graded on a 1 to 16 scale by clinical observation, biopsied at 24 hours, and subsequently graded by a pathologist as to general burn severity (microscopically graded on a 1 to 10 scale), and burn depth in microns. In some instances, fabrics were placed between the pig and the fire, either in contact with the skin or as single and double layers with space between the fabric and the skin.<sup>4</sup> Likewise, heat sensors were exposed to the fire either bare or protected by fabrics.

The furnace wall temperature was monitored continuously as was the heat flux in one of the template holes using a slug calorimeter. In all, 95 pigs were used and more than 1500 burns evaluated. For each exposure of a pig to the fire, the computerized data base currently contains the pig number; the burn site location; indication of the smokiness of the fire; the duration of exposure, corrected for the time of travel of the shutter; two values for the heat flux, one derived from the slug calorimeter, digitized once per second and hand calculated and one value from the slug calorimeter digitized at 100 per second and calculated by computer; the furnace wall temperature; the skin surface temperature; the presence or absence of fabrics; the condition of the skin, i.e., natural or painted with black paint; the gross grade on a 1 to 16 scale; the microscopic grade on a 1 to 10 scale; the epidermal thickness in microns; the dermal thickness in microns and the depth of the burn measured from the epidermal border to the deepest extent of the burn; the length of the hair; the date; the time of day; a new micrograde based on a second reading of the biopsy specimens; a new epidermal depth, a new dermal depth; a new burn depth measured from the fat/dermal border up to the deepest extent of the burn; the total depth of the dermis at the burn site; the total depth of the skin at the burn site; a corrected burn depth which takes into account for the shrinkage or swelling of the burns (see discussion following); and a quality indication on a 1 to 9 scale indicating the general reliability of the data for that burn site.

The quality of the data was downgraded if some of the values, for instance, skin temperature, were calculated as opposed to measured, if some of the pathology data were missing or were ungradable and the like.

Several small studies were performed while collecting the data base. For instance, the data collected from natural and blackened pigskin indicate that natural pigskin in these studies absorbed 60% of the incident energy while blackened skin absorbed 90%. In another study, skin samples of various thicknesses were obtained using an air powered dermatome. Skin samples were divided and alternate strips sent to the pathology section for thickness measurement and the other samples were weighed, dried, and reweighed in order to determine the distribution of water as a function of depth within the skin. This latter information is required for the incorporation of a subroutine in the mathematical models to account for tissue water and blister formation.



Fig. 1. Instrumented UH-1 Helicopter Hulk surrounded by 473 liters of JP-4.



Fig. 2. Same as above approximately 60 seconds after ignition. Tailboom burned off in 44 seconds.

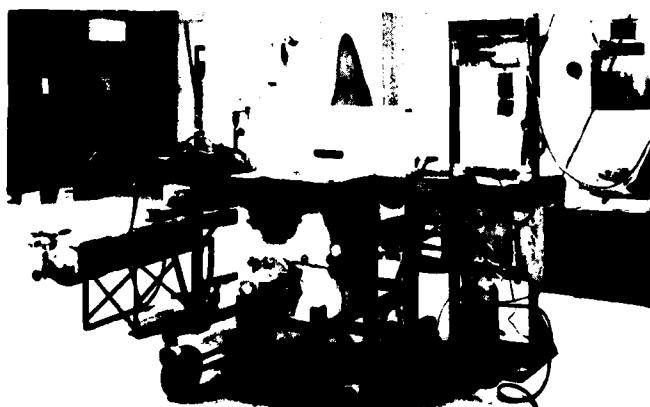

Fig. 3. Postcrash fire simulation furnace with water cooled shutter mounted in movable animal holding table.



Four high temperature fabrics were studied, both singularly and in conjunction with jersey knit t-shirt material to simulate standard underwear.<sup>4</sup>

In another study, subsuperficial, mid-dermal, deep dermal and dermal fat border temperature measurements were obtained using small (.002 to .005 inches) copper-constantan thermocouples during thermal exposures.

## RESULTS

### Definition of WCE

Postcrash fires of any vehicle, helicopters included, can be extremely variable. The amount of fuel available, its distribution on the ground and in the air subsequent to impact, the time of ignition, the buildup to a steady state, the total duration of the fire, the presence or absence of wind and the like are all complicating factors in describing a "typical postcrash fire."

How then do we define a typical JP-4 postcrash fire? Fig. 4 summarizes our current operating definition along with some values from previous studies. The shaded area represents the extent of the variability generally associated with large fuel fires. Small momentary excursions above and below this region are often experienced but these usually occur in unfavorable conditions where the wind velocity is above 1 or 2 miles per hour. The dashed line is a time-temperature tracing from one thermocouple in a JP-4 fire conducted at Fort Rucker.<sup>2</sup> Notice that there is a transient buildup of less than 20 seconds during which the fire is spreading over the pool and developing to its full height. Beyond this initial transient portion there is a "steady state" portion during which the temperatures are generally in the region of 1900 to 2100° F. These temperatures yield heat fluxes which are 80 to 90% radiative and total 3 to 4 calories per square centimeter per second.

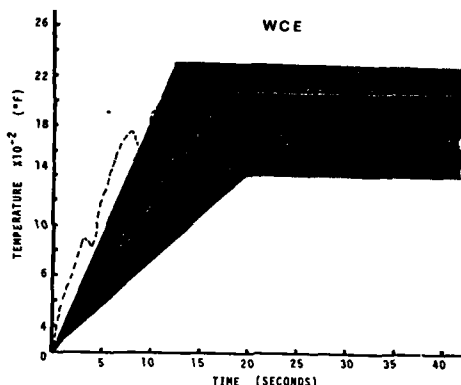

Fig. 4. Working Definition of Worst Credible Postcrash Fire Environment (WCE) derived from large scale JP-4 fires. Dotted line is the output from one thermocouple in a 1893 liter JP-4 fire. Solid line is the temperature profile of WCE. Shaded area represents general region of variability seen in large scale fires.

The fire oscillates every 5 seconds or so, as oxygen is alternately consumed and entrained into the fire. This pulsation is visible on 16 mm color movies taken of the fire. The solid line depicts our working definition of a "worst credible steady state" fire. A 15 to 20 second buildup period is followed by a "steady state fire" of 2100° F which delivers about 4 calories per square centimeter per second.<sup>2</sup>

It should be stressed that this is a working definition and that no particular fire would be expected to duplicate this profile over its entire course. The steady state temperature of 2100° F is 250° hotter than the suggested temperature of 1850° F for a JP-4 fire over a water base.<sup>6</sup> The duration of the steady state period will be variable depending on the amount of fuel available. Fire subsequent to fuel spills of 473 liters, for instance, will last well beyond 50 seconds followed by a gradual decrease in fire intensity as fuel is consumed.

### DATA BASE

The data base contains over 45,000 entries and is represented here by one page, Table 1. As a way of visualizing some of the relationships within the new data base, Figs. 5 to 12 are presented. Fig. 5 shows the surface appearance of a burn graded 4 on the gross burn scale. Fig. 6 shows the surface appearance of a severe burn graded as a 16. Fig. 7 shows a section of pigskin stained with hematoxylin and eosin. The burn grade is 1 with a corrected burn depth of 74 microns, i.e., epidermal damage only. Fig. 8 shows a section of a more severe burn, grade 8, with a corrected burn depth of 996 microns. Fig. 9 is a plot of Burn Depth vs. New Micro Grade in which vertical bars indicate mean values and dots are individual data points. Fig. 10 shows the relationship between total heat flux (cal/cm<sup>2</sup>) and micro burn grade. Fig. 11 shows the relationship between total heat flux and surface appearance (gross burn grade). Fig. 12 relates total flux and corrected burn depth

as a function of exposure time. Exposure times are indicated as numbers on the plot which signify the following categories: 1 for 0 to 2 seconds; 3 for 2 to 4 seconds; 5 for 4 to 6 seconds; and 7 for 6 seconds or greater.

Table II shows the relationship between burn severity and the amount of shrinkage or swelling seen in the biopsy specimens. Table III shows the results of a regression analysis which indicates that correction for shrinkage did not significantly alter the relationship between burn severity (gross grade) and depth.

Two representative intraskin time temperature histories are plotted in Fig. 13 along with the output of a preliminary version of the analytical model currently being developed.

TABLE I

FIG	MOLE	* TEMP	FLUX	WALL	T.	FAB	GROSS	EPI	DERM	BURN	DATE	TIME	EPI	BURN	SKIN	GROUP										
		SPOKE		SKIN		COND	MIC						N	T	COR	BD										
225RR	1	21	1	4.03	0.00	1225.	96.7	0	1	0	6	70.	1840.	269.	3.20	7200	9	1050	4	70.	1750.	1375.	1375.	1450.	94.	9
225RR	2	22	1	4.09	0.00	1225.	96.7	3	1	3	4	00.	1930.	0.	3.20	7200	9	1050	3	70.	1750.	1875.	1875.	1950.	79.	9
225RR	3	23	1	4.13	0.00	1225.	96.7	5	1	3	4	00.	1960.	0.	3.20	7200	9	1050	3	70.	1750.	1875.	1875.	1950.	70.	9
225RR	4	24	1	4.04	0.00	1225.	96.7	0	1	0	0	70.	2110.	200.	3.20	7200	9	1050	3	90.	1750.	1875.	1875.	1950.	67.	9
225PR	4	25	1	4.02	0.00	1225.	96.7	5	1	1	4	70.	2000.	0.	3.20	7200	9	1050	4	70.	2000.	2000.	2000.	2075.	75.	9
225RR	6	26	1	4.13	0.00	1225.	96.7	5	1	3	4	00.	1740.	0.	3.20	7200	9	1050	3	60.	1625.	1750.	1750.	1825.	69.	9
221LF	1	1	1	0.05	0.72	1220.	97.4	0	0	5	7	00.	1490.	510.	3.20	7200	9	1050	6	75.	1500.	1625.	1875.	1875.	210.	4
221LF	2	2	1	0.15	0.72	1220.	97.4	0	0	6	6	70.	2360.	300.	3.20	7200	9	1050	4	100.	2000.	2250.	2250.	2325.	68.	4
221LR	3	3	1	0.39	0.72	1216.	97.4	0	0	7	7	70.	1960.	1840.	3.20	7200	9	1050	6	75.	2000.	2000.	2000.	2075.	75.	4
221LF	4	4	1	0.10	0.72	1220.	97.4	0	0	10	0	00.	1740.	1540.	3.20	7200	9	1050	7	75.	1500.	875.	1750.	1825.	80.	4
221LF	5	5	1	0.15	0.72	1220.	97.4	0	0	8	6	70.	1440.	1450.	3.20	7200	9	1050	3	100.	1375.	1375.	1375.	1450.	76.	4
221LF	6	6	1	0.19	0.72	1220.	97.4	0	0	6	6	100.	1410.	550.	3.20	7200	9	1050	4	100.	1375.	1750.	1750.	1825.	61.	4
221LR	7	7	1	0.39	0.72	1216.	97.4	0	0	6	6	70.	2330.	370.	3.20	7200	9	1050	4	100.	2375.	2250.	2250.	2325.	68.	4
221LR	2	0	1	0.50	0.72	1218.	97.4	0	0	3	6	70.	2600.	300.	3.20	7200	9	1050	3	75.	2750.	2750.	2750.	2825.	75.	4
221LR	3	9	1	0.03	0.72	1216.	97.4	0	0	5	6	70.	2330.	410.	3.20	7200	9	1050	4	100.	2250.	2325.	2325.	2400.	73.	4
221LR	4	10	1	0.54	0.72	1216.	97.4	0	0	10	0	70.	2030.	1340.	3.20	7200	9	1050	6	100.	1625.	1800.	1500.	1575.	630.	4
221LR	5	11	1	0.59	0.72	1216.	97.4	0	0	6	6	70.	2330.	370.	3.20	7200	9	1050	4	100.	2375.	2250.	2250.	2325.	68.	4
221LR	6	12	1	0.03	0.72	1216.	97.4	0	0	6	6	70.	2230.	500.	3.20	7200	9	1050	4	75.	2500.	2625.	2625.	2700.	72.	4
221RF	1	27	1	0.10	0.72	1212.	97.4	0	0	10	0	00.	2060.	1330.	3.20	7200	9	1120	6	75.	2125.	1750.	2750.	2000.	825.	4
221RF	2	20	1	0.16	0.72	1212.	97.4	0	0	6	6	70.	2100.	550.	3.20	7200	9	1120	5	100.	2250.	2000.	2500.	2500.	46.	4
221RF	3	29	1	0.20	0.72	1212.	97.4	0	0	6	6	60.	2110.	450.	3.20	7200	9	1120	4	100.	2000.	2250.	2250.	2300.	46.	4
221RF	4	30	1	0.11	0.72	1212.	97.4	0	0	9	0	60.	2360.	1120.	3.20	7200	9	1120	6	100.	2250.	1875.	1875.	2200.	347.	4
221RF	3	31	1	0.16	0.72	1212.	97.4	0	0	3	4	70.	1800.	0.	3.20	7200	9	1120	3	100.	1875.	2125.	2125.	2200.	67.	5
221RF	6	32	1	0.20	0.72	1212.	97.4	0	0	6	6	60.	2130.	250.	3.20	7200	9	1120	3	125.	2250.	2250.	2250.	2325.	77.	4
221RR	1	21	1	0.13	0.72	1225.	97.4	0	0	10	6	50.	2400.	750.	3.20	7200	9	1120	5	75.	2500.	2125.	2125.	2125.	0.	4
221RR	2	22	1	0.19	0.72	1225.	97.4	0	0	7	6	70.	2230.	350.	3.20	7200	9	1120	4	75.	2125.	2125.	2125.	2200.	73.	4
221PR	3	23	1	0.23	0.72	1225.	97.4	3	0	4	6	80.	2400.	400.	3.20	7200	9	1120	4	100.	2625.	2375.	2375.	2450.	81.	4
221RR	4	24	1	0.14	0.72	1225.	97.4	0	0	10	7	00.	2360.	1120.	3.20	7200	9	1120	5	100.	2375.	2000.	2000.	2090.	0.	4
221RR	5	25	1	0.19	0.72	1225.	97.4	3	0	9	6	80.	2350.	350.	3.20	7200	9	1120	4	100.	2750.	2250.	2375.	2450.	233.	4
221RR	6	26	1	0.23	0.72	1225.	97.4	3	0	9	6	80.	1930.	510.	3.20	7200	9	1120	4	100.	2250.	2500.	2575.	2650.	133.	4
236LF	1	1	1	0.15	0.80	1250.	97.4	1	0	9	6	70.	2080.	550.	3.20	7200	10	950	4	31.	2200.	2063.	2063.	2130.	81.	4
236LF	2	2	1	0.21	0.80	1250.	97.4	1	0	6	6	70.	2090.	350.	3.20	7200	10	950	4	62.	2100.	2200.	2200.	2363.	67.	4
236LF	3	3	1	0.25	0.80	1250.	97.4	1	0	6	6	80.	1490.	400.	3.20	7200	10	950	4	62.	1300.	1463.	1463.	1330.	71.	4
236LF	4	4	1	0.16	0.80	1250.	97.4	0	0	9	7	70.	1410.	940.	3.20	7200	10	950	5	46.	1350.	1200.	1600.	1703.	446.	4
236LF	5	5	1	0.21	0.80	1250.	97.4	0	0	9	9	70.	1660.	740.	3.20	7200	10	950	7	46.	1763.	750.	1913.	1950.	1113.	4
236LF	6	6	1	0.25	0.80	1250.	97.4	0	0	0	0	60.	1260.	1360.	3.20	7200	10	950	6	31.	1200.	1125.	1350.	1425.	250.	4
236LR	1	7	1	0.17	0.80	1246.	95.1	1	0	6	6	70.	1980.	300.	3.20	7200	10	952	4	62.	1500.	1725.	1725.	1830.	96.	4
236LR	2	8	1	0.23	0.80	1246.	95.1	1	0	6	6	70.	2230.	500.	3.20	7200	10	952	5	77.	2100.	1463.	1463.	1575.	155.	4
236LR	3	9	1	0.27	0.80	1246.	95.1	1	0	6	6	60.	1890.	350.	3.20	7200	10	952	5	62.	1875.	1425.	1425.	1500.	97.	4
236LR	4	10	1	0.18	0.80	1246.	95.1	0	0	9	9	50.	1710.	1800.	3.20	7200	10	952	7	62.	1725.	1125.	1000.	1875.	715.	4
236LR	5	11	1	0.23	0.80	1246.	95.1	0	0	9	9	70.	1860.	870.	3.20	7200	10	952	6	77.	1875.	1875.	2100.	2175.	269.	4
236LR	6	12	1	0.27	0.80	1246.	95.1	0	0	7	7	90.	1740.	600.	3.20	7200	10	952	3	62.	1800.	2025.	2025.	2100.	65.	4
236RF	1	27	1	0.19	0.80	1270.	95.1	0	0	9	7	70.	2080.	990.	3.20	7200	10	952	6	77.	2100.	1930.	2200.	2363.	370.	4
236RF	2	20	1	0.21	0.80	1270.	95.1	0	0	7	7	60.	2060.	1120.	3.20	7200	10	952	6	62.	2003.	2063.	2400.	2550.	406.	4
236RF	3	29	1	0.25	0.80	1270.	95.1	0	0	9	0	60.	2160.	870.	3.20	7200	10	952	6	77.	2213.	1680.	2025.	2175.	513.	4
236RF	4	30	1	0.16	0.80	1270.	95.1	1	0	9	6	70.	1960.	250.	3.20	7200	10	952	4	46.	1650.	1600.	1680.	1800.	106.	4
236RF	5	31	1	0.21	0.80	1270.	95.1	1	0	3	6	60.	2010.	300.	3.20	7200	10	952	4	62.	2130.	1950.	1950.	2100.	157.	4
236PR	6	32	1	0.25	0.80	1270.	95.1	1	0	6	6	70.	2060.	400.	3.20	7200	10	952	4	62.	1725.	2063.	2063.	2175.	52.	4
236PR	1	21	1	0.15	0.80	1250.	95.1	1	0	9	6	50.	1790.	450.	3.20	7200	10	952	4	46.	1350.	1800.	1800.	1875.	56.	4
236PR	2	22	1	0.21	0.80	1250.	95.1	1	0	8	6	70.	2030.	350.	3.20	7200	10	952	6	46.	1830.	1690.	1875.	1980.	204.	4
236PR	3	23	1	0.25	0.80	1250.	95.1	1	0	6	6	70.	2030.	500.	3.20	7200	10	952	6	77.	2400.	2025.	2250.	2363.	354.	4
236PR	4	24	1	0.16	0.80	1250.	95.1	1	0	9	7	60.	1710.	990.	3.20	7200	10	952	6	77.	1800.	1425.	1830.	1913.	480.	4
236PR	5	25	1	0.21	0.80	1250.	95.1	1	0	9	6	60.	2110.	740.	3.20	7200	10	952	6	62.	1350.	2100.	2430.	2500.	266.	4
236PR	6	26	1	0.25	0.80	1250.	95.1	1	0	9	0	70.	2230.	1310.	3.20	7200	10	952	0	62.	1350.	362.	1830.	1980.	1012.	4
220LF	1	1	1	0.13	0.71	1270.	96.2	1	0	0	6	00.	2100.	300.	3.20	7200	10	1020	3	40.	1750.	1750.	1750.	1800.	50.	4
220LF	2	2	1	0.19	0.71	1270.	96.2	1	0	0</																

Fig. 6. Gross burn  
Grade 16



Fig. 7. Micro burn  
Grade 1. See  
text for depth.

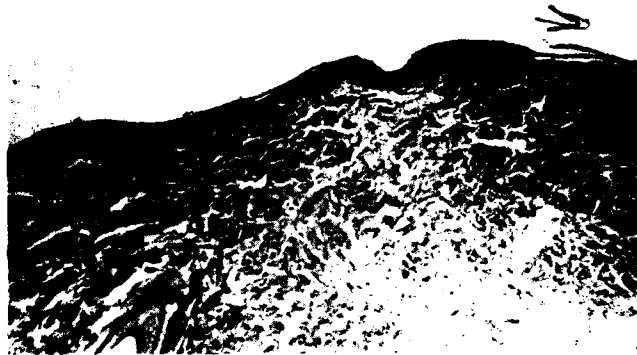

Fig. 8. Micro burn  
Grade 8. See  
text for depth.

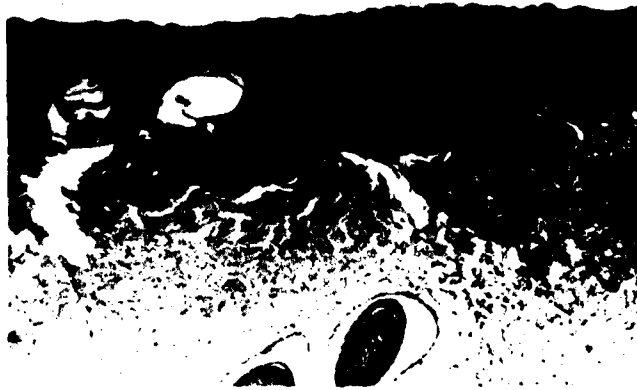

Fig. 9

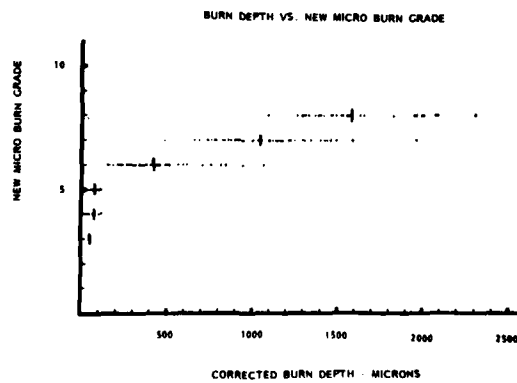

Fig. 10

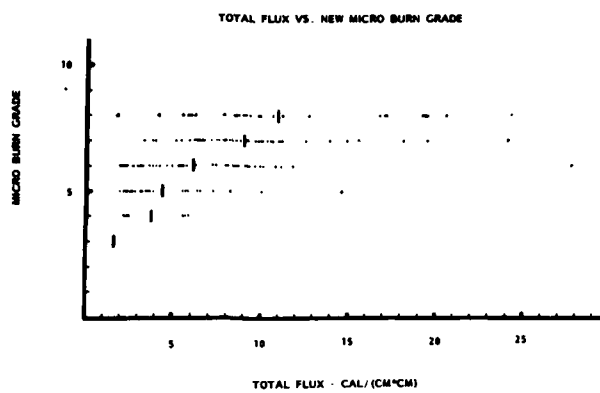

Fig. 11

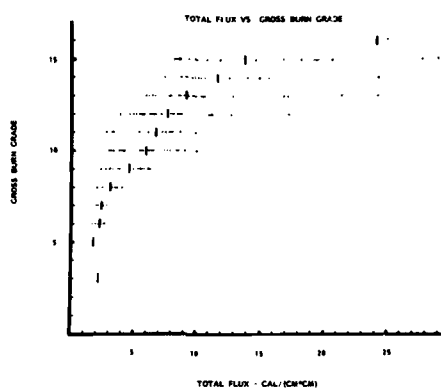

Fig. 12. Burn depth as a function of Total Heat Flux ( $\text{cal}/\text{cm}^2$ ) and exposure time. Individual data points are identified with exposure times as follows:  
 1 = 0 to 2 seconds; 3 = 2 to 4 seconds;  
 5 = 4 to 6 seconds; 7 = greater than 6 seconds.

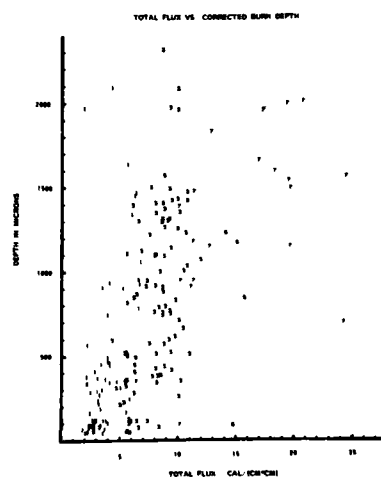

TABLE II

Gross Grade	N	Depth	Corr. Depth	Corr. Depth Depth
1	5	87.5	74.2	1.10
2	5	97.5	104.5	1.07
3	4	78.1	82.4	1.06
4	1	37.5	43.3	1.15
5	7	355.4	305.9	1.09
6	21	87.9	86.8	.98
7	16	135.9	131.1	.96
8	24	147.9	144.9	.98
9	129	320.8	312.1	.97
10	146	550.9	549.5	1.00
11	30	488.3	544.9	1.12
12	74	670.6	871.3	1.30
13	56	691.3	957.4	1.38
14	41	784.2	1148.6	1.46
15	67	901.3	1180.7	1.31
16	2	537.5	754.0	1.40

628

TABLE III

Exposure Time (Sec)	N	Total Flux	Depth Corr. Depth	b		SE(b)		t	
				b	a	SE(b)	SE(b)		
1	76	3.88	348.5	133.3	-63.3	23.9	5.58	(P<.001)	
			379.9	161.8	-117.8	26.7	6.06	(P<.001)	
3	94	7.91	385.3	76.4	-18.8	15.0	5.10	(P<.001)	
			818.4	122.4	-148.9	24.1	5.07	(P<.001)	
5	85	13.12	845.8	50.8	178.4	12.3	4.13	(P<.001)	
			981.5	64.7	-133.0	14.7	4.40	(P<.001)	
7	9	18.83	1018.7	45.9	253.4	15.9	2.89	(P<.05)	
			1448.0	101.4	-238.1	21.2	4.78	(P<.01)	
9	17	15.97	739.0	18.8	1004.6	19.9	-.84	---	
			1088.7	12.0	1208.3	27.4	-.44	---	
240									
All	260	8.65	506.5	43.4	231.0	4.2	10.4		
			766.9	59.8	249.8	5.6	10.7		

Regression Analysis showing the effect of correcting the burn depth, e.g. at 1 second exposure the "t" statistic improved with depth correction from 5.58 to 6.06.

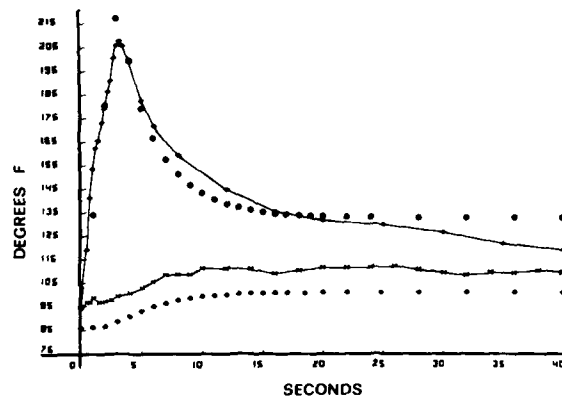

Fig. 13. Tissue temperature as a function of time at two different depths. Observed temperatures are shown as symbols connected by straight lines for depths of approximately 200 microns (above) and 2000 microns - fat/c'ermal border (below). The output of a computer model (solid circles) which did not take into account water boiling or tissue cooling by blood. The 9° F offset between the lower two curves is due to assuming that the starting surface temperature and the initial temperature at a depth of 2000 microns are identical.

## DISCUSSION

The initial objective of this project was to correct certain perceived deficiencies in the postcrash fire simulation source and in fabric application methodologies and then to use the bioassay method to collect a substantial data base upon which to develop analytical and empirical models with which to generate clinically valid burn predictions. The development of this data base was necessitated by the fact that previous data used primarily hot water conductive heating or purely radiating heating such as would be experienced in the flash burns caused

by atomic weapon detonation. There was no large data base generated with a JP-4 fuel fire as the input and pig-skin (the best available animal model for human skin) as the biological sensor.

We now have such a data base and common to all such data bases there is considerable scatter in the data as evidenced by the high Figs. 9 through 12. One of the more likely sources for this scatter could be fluctuations in exposure time due to inconsistent shutter performance. An attempt was made to correct for the dynamics of the water cooled shutter system based on a limited number of calibration tests, but this correction does not allow for day to day variation. A second source of variation might be the variation in initial skin temperature at sites other than the one measured. A University of Rochester study<sup>7</sup> showed that skin temperature can have a significant effect on the degree of burn experienced for a given exposure and that there is a slow decrease in skin temperature following induction of anesthesia.

Early in the experiment, the pigs were clipped four to five days prior to exposure, resulting in rather longer hair stubble than in later pigs which were shaved or clipped on the morning of the exposure. Data on hair length are available in the data base but have not been used in these figures to correct the total incident heat flux.

Some of the scatter is due to the judgmental process involved in gross grading and grading the biopsy specimens. Another study, not yet completed, is directed toward describing the nature and extent of this variability. In this study, selected burn biopsies from our data base and from the University of Rochester studies were re-graded by a senior pathologist in an attempt to uncover the places in the grading system where confusion regarding criteria and sources of variability in making depth measurements might exist. The finding which emerges from this study is that depending on the pathologist's judgment about involvement of the upper dermis subsequent to blister formation, the micrograde can change from a four (epidermal/dermal separation, partial) to a six in which superficial dermal damage less than 500 microns is involved. In many cases it appears that some pathologists have chosen to ignore slight damage to the dermis and call a burn in which blister formation is in process either a four or a five, while others have chosen to call the same burn a six because it involves minor damage to the dermis. Likewise, for the very deep burns which involve the dermis up to the adipose tissue border but do not involve the underlying adipose tissue, there is often disagreement and inconsistency on whether to include the dermal appendages which reach down into the adipose tissue in certain skin sections. The data base is currently under intensive review in order to quantify, as best is possible, these and other sources of variability so that the models which are being and will be developed from these data will present a clear and unequivocal picture of the burn process.

Recently, Takata<sup>8</sup> published a model assuming first order reaction kinetics based on the preliminary data base collected in this project. Since Takata's analysis it has become apparent that there is a need to correct the measured burn depths in moderate burns to account for some slight swelling due to edema and in more severe burns to account for the shrinkage and desiccation which accompanies these burns (See Table II). This correction for deep dermal burns can be as much as 40%. Thus, a measured depth of 1000 microns in some instances should be 1400 microns when referred to normal tissue.

Takata's model did, for the first time, include water boiling and a factor to account for attenuation of the radiation by the hair of the pig. The importance of including water boiling can be shown by Figure 13 which shows the recorded skin temperature at a depth of approximately 200 microns (superficial) in which the tissue temperature never reaches boiling while output from the computer model, which did not include a subroutine to account for water boiling, overshoots this temperature by 4 or 5 degrees. In more severe exposures, this overshoot would be considerably greater. Since in these models, tissue damage is logarithmically related to skin temperature, the maintenance of skin temperature below the boiling point of water until that skin has been desiccated is an important factor in tuning the model to reflect what is really happening in the skin.

Notice, too, that while the current preliminary model follows quite well in the ascending, heating portion of the recorded temperature, except for the overshoot, it cools off too rapidly at first during the cooling phase and then maintains a tissue temperature which is too high at longer times. The result of this prolonged predicted high tissue temperature is a severe over prediction of the resulting burn damage. Model optimization will require the addition of water boiling, tissue cooling, and a consideration of those sources of variation that can be identified in the data base in adjusting the model to predict the observed burns.

Next, consider the performance of the sample fabrics which were evaluated using the bioassay technique as previously reported.<sup>4</sup> Statistical analysis of these data showed that none of the fabrics in any combination sufficiently attenuated the heat flux to make it clinically significantly better than any of the other fabrics. The largest improvement as measured by burn depth was seen, not between fabrics, but between the way in which the fabrics were applied to the skin. That is, the introduction of spaces or underwear or underwear with spaces increased the protection, i.e., decreased the burn depths. However, the minimal burn depth observed was slightly more than 200 microns which is still clinically a second degree burn, just as were the unprotected control burns of 1200 to 1400 microns. The current state of the art in predicting burn survivability is such that burns are categorized as first, second, or third degree and the total area of burn (second and third degree lumped together) or the total of area of third degree burn alone is used in computing burn survivability as a function of age and sex. There are no clinical data currently available which allow the judgment to be made that the improvement of protection manifested by a change in burn depth from, say, 1200 microns, changes the survivability assuming that the areas of the two burns are equal.

Intuitively, one feels that such an improvement may well improve the survivability but the data are not yet available. It is important to note, however, that these data reflect the performance of some of the best fabrics available when exposed for five seconds to a worst credible steady state fire.

If we could assume for the moment that 50% of the 81% body surface area covered by the uniform, excluding head, hands, and feet, i.e., 40% total body area, receives the average burn for these fabric combinations (between 1200 and 200 microns) and assume, for the sake of argument, that there is no clinical difference between a burn depth of 200 microns, i.e., superficial dermal and a burn depth of 1200 microns, i.e., mid to deep dermal, then according to Feller, et al.<sup>9</sup> for male pilots under 34 years of age, survivability would be projected at 87%, female pilots in the same age category at 78 or 79%. Pilots in the 35 to 49 age group would have a 72% survival closely followed by females of the same group at 68% survival. For senior pilots age 50 to 59, survivability with the same burn would be predicted to decrease to 62% for male and 56% for females, while for pilots just prior to retirement, age 60 and above, the figures drop to 18% for males and 5% for females. Fortunately, most of the Army helicopter pilots are in the under 34 age group and thus have the highest natural chance for survival.

It should be pointed out that the survivability statistics would vary depending on the general state of health of the individual including other injuries and would probably be biased upward in the case of pilots who would be expected to exceed the general population in health and physical fitness. Survivability will also vary somewhat from treatment center to treatment center.

Given the current survivability data then, and assuming no difference between burns of 200 microns and 1200 microns in depth, the survivability for a given area of burn, for example, 40%, will vary tremendously depending on the age of the pilot, the sex and the general health of the pilot. The second complicating factor is the total area burned which is a dominant factor in survivability. The area burned will depend on not only the thermal input experienced at a given location, which in a postcrash fire will, in all likelihood, not be the same over the entire body, but will also depend a great deal on the construction of the uniform. Thus, single layered uniforms which are worn a half size too small in order to look "military" would be more likely to result in the most severe burns whereas uniforms worn slightly large would be expected to result in lesser burns, both in area and in depth.

There is great variability inherent in the response of tissue to a reasonably well defined thermal input. Our hope lies in producing a generally accepted data base with sources of error reasonably well documented and to develop mathematical models which predict burn damage consistent with these data. Better clinical survivability data are needed in order to facilitate judgments concerning the change in prognosis resulting from a change in fabric or uniform design which is shown to decrease burn depths from 1000 microns to 200 microns.

To circumvent this problem, there have been systems developed to classify fabrics based on the time to threshold blister as an endpoint.<sup>10</sup> One problem with this limited clinical criterion is that in those instances where fabric combinations are shown to exceed such a threshold there has been no way of quantifying the clinical importance of the more severe damage. It can be shown, for instance, that third degree, i.e., full thickness burns, are several times more effective in reducing survivability than second degree, i.e., partial thickness burns. What is needed is a better understanding of the relationship between burn depth and survivability. Hopefully, these data will become available as the burn demonstration projects funded by the federal government are completed over the next several years.

In the meantime, the present study indicates that single layered uniforms, while providing some protection for a few seconds in a fully developed postcrash fire, do not appear, from the medical standpoint, to significantly increase the chances of survival for longer exposures, i.e., five seconds or greater. The data also support the contention that increasing the number of layers in uniforms and the addition of underwear can increase the insulating qualities of these uniforms but still may not provide what one might define as adequate protection. Further, this discussion of dermal burns completely ignored the question of the ability of a pilot to escape through a fire which would result in excruciating pain while wearing any of these uniforms in any mode of application in much less than five seconds. Fortunately for the U. S. Army helicopter pilots of UH-1 aircraft, the introduction of the crashworthy fuel system has reduced, to a great extent, the need for increased thermal protection via thermal protective clothing.

Finally, it was observed<sup>11</sup> that the application of one centimeter of shaving cream to the palm of the hand is sufficient to provide in excess of 45 seconds of protection from a 3000° F propane torch. From the engineering standpoint, if one insists upon protecting aviators with flight clothing, which, in the tropical environments, must be relatively lightweight and therefore nonprotective, the ability to rapidly introduce a water based foam between the skin and such a uniform during a crash sequence has intriguing possibilities.

## CONCLUSIONS

This report describes the biomedical constraints in designing thermal protective flight clothing. 1) Thermally protective flight clothing must protect the aviator from burns in a highly variable thermal environment. As a design criterion, a worst credible environment has been defined as a steady state fire of 2000 to 2100° F which reaches this level in approximately 15 to 20 seconds after ignition and remains in the steady state so long as there is sufficient fuel. 2) It has been possible using the USAARL bioassay technique to assemble a large data base relating thermal input from a simulated postcrash fire using a JP-4 fuel furnace to burns in pigs as a human skin analog. This data base contains information relating thermal input to healthy bare skin and skin protected by various standard fabrics. In addition, there is a data base relating the same thermal input to the response of various thermal sensors. 3) The data base can be used in the formulation of mathematical models which will predict burn damage given thermal input. Current models need to be revised to take into account potential sources of error in the data base and complicating factors such as tissue water boiling and heat removal by blood. 4) There is a pressing need to develop an adequate relationship between burn depth and

patient survivability so that the clinical effectiveness of decreasing burn depths by insulating materials can be rationally assessed.

#### REFERENCES

1. Department of the Army Approved Small Development Requirement (SDR) for Clothing System for Army Aircrew Members, Par 26 (2), February 9, 1966.
2. Albright, J. D., F. S. Knox, III, D. R. DuBous, and G. M. Keiser. The Testing of Thermal Protective Clothing in a Reproducible Fuel Fire Environment, A Feasibility Study. USAARL Report No. 71-24, Fort Rucker, Alabama, June 1971.
3. Lum, Calvin B. Instrumented Helicopter Burn. Letter Report USAARL-LR-73-6-3-2. January 1973.
4. Knox, Francis S., III, Stanley C. Knapp, Thomas L. Wachtel, George R. McCahan. Bioassay of Thermal Protection Afforded by Candidate Flight Suit Fabrics. Tenth Scientific Session of the Joint Committee on Aviation Pathology, Halton, England, September 6-12, 1976.
5. Knox, Francis S., III, George McCahan, Jr., Thomas L. Wachtel. Use of the Pig as a Bioassay Substrate for Evaluation of Thermal Protective Clothing and Physical Sensor Calibration. Aerospace Medicine 45(8): 933-938, 1974.
6. Bader, B. E. Heat Transfer in Liquid Hydrocarbon Fuel Fires. Chemical Engineering Progress Symposium Series, Vol. 61, No. 56, pp. 78-79, 1965.
7. Berkley, K. M., H. E. Pearse, T. P. Davis. Studies of Flash Burns: The Influence of Skin Temperature in the Production of Cutaneous Burns in Swine. The University of Rochester Atomic Energy Project UR-338, August 5, 1954.
8. Takata, A. Development of Criterion for Skin Burns. Aerospace Medicine 45(6): 634-637, 1974.
9. Feller, Irving, Javius D. Flora, Richard Bawol. Baseline Results of Therapy for Burned Patients. JAMA 236(17): 1947-1957, 1976.
10. Stoll, A. M. and M. A. Chianta. Method and Rating System for Evaluation of Thermal Protection. Aerospace Medical Research Department, Naval Air Development Center, Johnsville, Warminster, PA, 18974, Aerospace Medicine 40(11): 1232-1237, 1969.
11. William Schane, Personal Demonstration, 1971.

#### ACKNOWLEDGEMENTS

In conducting this research, the investigators adhered to the "Guide for the Care and Use of Laboratory Animals," as promulgated by the Committee on Revision of the Guide for Laboratory Animal Facilities and Care of the Institute of Laboratory Animal Resources, National Research Council.



## CRASH SURVIVABILITY OF THE UH-60A HELICOPTER

By

Brian L. Carnell  
Systems Engineering Branch  
Engineering Department  
Sikorsky Aircraft Division of  
United Technologies Corporation  
Stratford, Connecticut 06602  
U.S.A.

## SUMMARY

The Sikorsky UH-60A or BLACK HAWK is the U. S. Army's next generation Utility Helicopter. It has been designed from the outset to minimize the hazards found in the many accidents that occurred in the combat environment of Southeast Asia.

Its many crash survivability design features combine to meet five basic requirements:

1. A protective shell is maintained around the occupants; the energy-absorbing landing gear cushions the crash impact and the structure is designed to minimize penetration by rotor blades, transmissions and engines.
2. The loads on the occupants are limited to non-injurious levels; all seats are energy-attenuating.
3. Major post-crash fires are prevented; a complete crash survivable fuel system is installed.
4. The interior is non-injurious; no hard structure is in the head strike zones. Padding and shielding in the cockpit protect the aircrew from injury and entrapment.
5. Adequate emergency escape capability is provided; jettisonable cockpit doors and cabin windows allow rapid emergency egress.

Two special equipment kits, one for extended range ferry flights, the other for MEDEVAC missions with litter patients, are also designed to be crash survivable.

## INTRODUCTION

The use of large numbers of U. S. Army helicopters in the combat environment of Southeast Asia caused a large increase in the number of accidents, injuries and fatalities. The Army's concern at these losses of men and material resulted in the Eustis Directorate of the U. S. Army Air Mobility Research and Development Laboratory contracting with the Aviation Crash Injury Research (AVCIR) Group of the Flight Safety Foundation. They were to define the Army aircraft crash environment and develop design concepts and criteria to improve their crash survivability. The many accidents investigated, full-scale aircraft crash tests, aircraft crashworthiness evaluations, and design concepts developed culminated in USAAMRDL Technical Report 71-22, "Crash Survival Design Guide".

From the beginning of the Sikorsky UH-60A Helicopter Program, now called BLACK HAWK, TR-71-22 was used as a design guide. Together with other specific crash survivability criteria, it set the basic requirement that the BLACK HAWK be capable of protecting all its occupants from injury in the 95th percentile combat survivable crash.

## DISCUSSION

The Sikorsky BLACK HAWK helicopter is a twin-engined single main rotor and canted tail rotor helicopter, able to carry a crew of three and eleven troops. The pilot and copilot sit side by side in the cockpit. Immediately behind them are two sideward-facing gunner's seats with sliding windows, which when open, allow the gunners to aim and fire their weapons. The remaining ten cabin seats are arranged in a row of three forward-facing seats, a row of three aft-facing seats and, at the rear of the cabin, a row of four forward-facing seats. Large sliding doors are provided on each side of the cabin to allow very rapid loadings and unloading of troops on either side of the helicopter.

The major crashworthiness features of the BLACK HAWK are shown in Figure 1. They include:

- A cabin superstructure that retains the engines and transmission at high load factors.
- An energy-absorbing landing gear.
- Crashworthy self-sealing fuel tanks and lines.
- An inertial crash switch that activates the fire extinguishing system.
- Crashworthy load-limiting crew seats.
- Crashworthy load-limiting troop seats.
- Extra emergency exits on both sides.
- A tail wheel that protects the tail rotor in high flare landings.

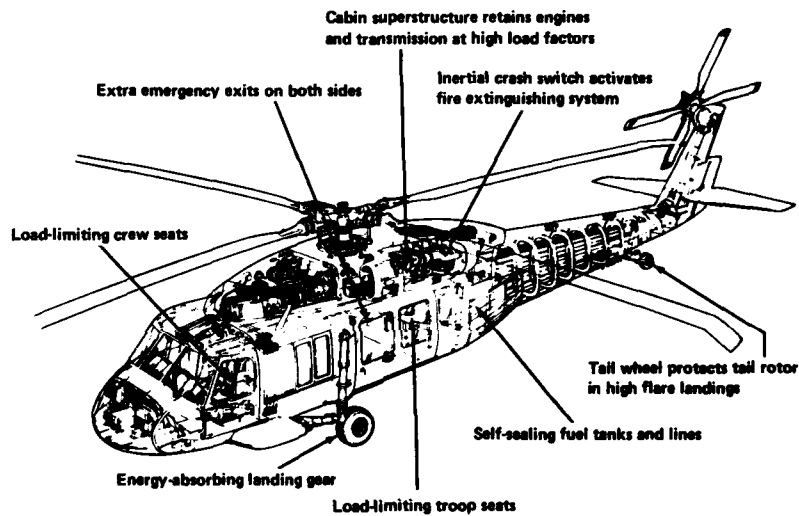

Figure 1. UH-60A Major Crashworthiness Design Features.

In designing the BLACK HAWK helicopter, the objective was to provide a well-balanced mix of design features which, in combination, would achieve five basic crash survivability goals:

1. Maintenance of a protective shell around occupants.
2. Limitation of the loads on the occupants to non-injurious levels.
3. Prevention of post-crash fires.
4. Provision of a non-injurious interior.
5. Provision of adequate emergency escape capability.

At the inception of the design, the basic components that make up the helicopter were arranged, as shown in Figure 2, to provide a high level of crash survivability. For example, a main wheel - tail wheel layout was chosen so that a nose wheel would not be mounted under the cockpit. The tail wheel also protects the tail structure and the tail rotor in high flare landings.

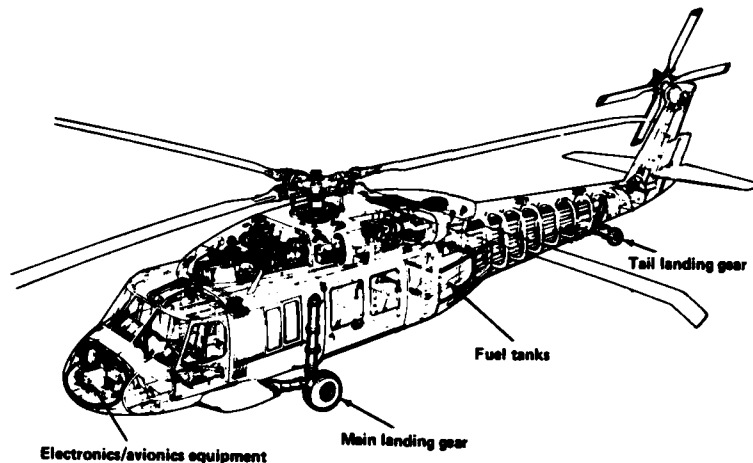

Figure 2. Sikorsky UH-60A Component Layout.

The main landing gear is of the swinging arm type with support struts attached above and outside the cabin. The two fuel cells are installed in the fuselage aft of the cabin, well away from the landing gear, and also well separated from the electronics and electrical equipment installed in the nose of the helicopter. These basic features minimize the hazards caused by penetration of the cockpit, cabin and fuel tanks by a collapsing landing gear, and by separating the areas of potential fuel spillage and the ignition sources, the likelihood of a crash fire is reduced.

Of particular importance in the first basic goal, maintenance of a protective structural shell around the occupants, are the following features. Each landing gear support strut is made up of two oleos, one above the other, which, in high sink speed ground impacts, act as emergency energy absorbers and cushion the impact of the fuselage with the ground. Spring-loaded orifice valves open, allowing the oleos to stroke through a distance of 23 inches (58.4 cm.) while decelerating the fuselage at an average of 9g. This capability is sufficient to prevent the fuselage from contacting the ground at sink speeds up to 35 fps (10.67 meters/sec.). The fuselage structure also contributes to the helicopter's crash survivability. It is designed to retain the high mass items above the cabin such as the main transmission and rotor and the engines to 20g forward, 20g downward, and 18g sideward load factors (and other combinations) and prevent their breaking through the cabin ceiling. It is also designed to prevent displacement of the main gearbox with a forward tilt which would allow the main rotor blades to slice into the cockpit. The structure is shown in Figure 3.

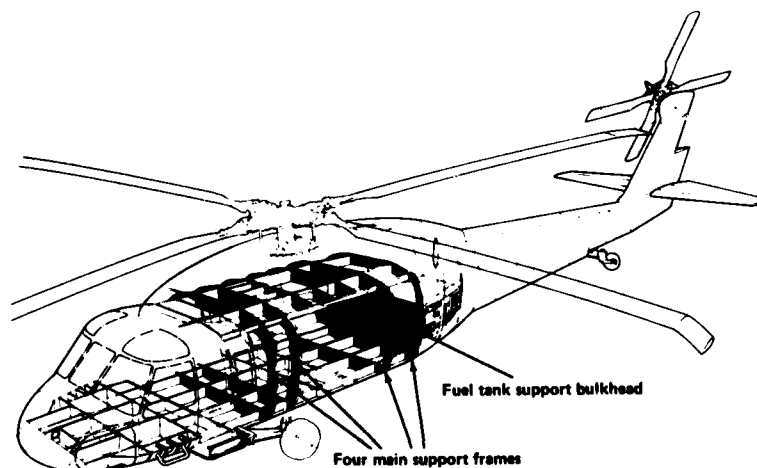

Figure 3. High Mass Item Support Structure.

The structure consists of pairs of main frames forward and aft of the cabin doors with longitudinal roof beams to support the main rotor gearbox and the engines. The fuel tanks are also prevented from entering the cabin when subjected to high forward inertia loads by the bulkhead shown in Figure 3.

The structure is aluminum in order to provide the highest ductility and energy-absorbing capacity. This is particularly important because of the location of the main transmission and engines above the cabin. The ductility allows the kinetic energy of these items to be absorbed without building up very high load factors. The energy absorption minimizes structural damage and injuries due to the effects of dynamic spring-back.

This fuselage capability, when combined with the energy absorption of the landing gear, enables the helicopter to meet the requirement to maintain 85% of the cabin living space in the 42 fps (12.80 meters/sec.) vertical impact crash.

In crashes with significant forward speed, the landing gear, with its large main wheels, significantly reduces both the tendency to dig into soft ground and the resultant longitudinal loads.

The smooth rounded shape of the forward fuselage minimizes plowing in nose down crash impacts. Its design to resist high earth pressures reduces the tendency to scoop earth. The ability of the fuselage to skid along the ground is aided by four underfloor keel beams, shown in Figure 4, that run longitudinally from behind the fuel tanks right up to the nose.

The continuation of the cockpit structure forward to the nose of the helicopter allows its crushing to absorb the energy of longitudinal impacts into a wall or abutment and to meet the velocity levels of 20 fps (6.10 meters/sec.) and 40 fps (12.19 meters/sec.) for protection of the cockpit and cabin occupants respectively.

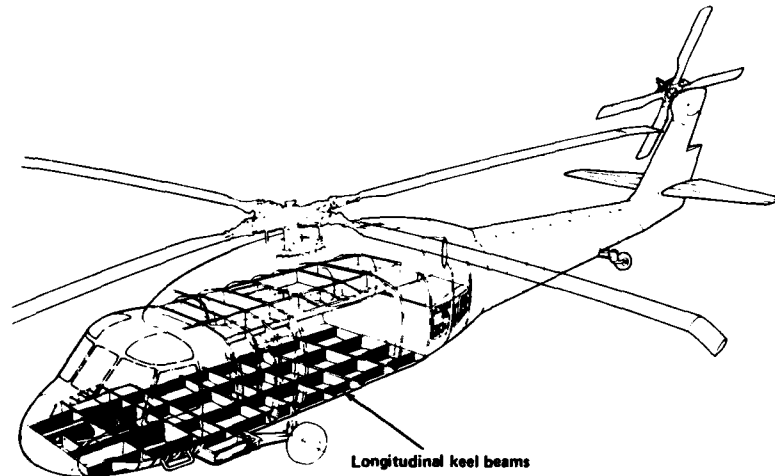

Figure 4. Longitudinal Keel Beams.

The underfloor structure forms a grid of fuselage frames and longitudinal beams. This construction minimizes the deformation of the cockpit and cabin floors and resultant hazards to the crew and troops.

Even though the cabin sidewalls have large door and window openings, the structure is designed to prevent parallelogramming, being able to resist simultaneous 20g forward and 10g downward inertia loads acting between the roof-supported components and the lower nose structure.

To maintain at least 85% of the living space when the fuselage impacts the ground laterally at 30 fps (9.14 meters/sec.), the cabin sidewalls are curved outward to allow progressive energy absorption. This shaping also assists in maintaining the fuselage protective shell in rollover accidents.

The second basic crash survivability requirement is the limitation of the loads on the occupants to non-injurious levels. To meet this goal, it is necessary that:

1. The occupant be retained in his seat.
2. The seat be retained in place in the helicopter.
3. When the fuselage floor decelerations exceed the injury limits of the occupant, the seat be able to limit the loads to a safe level by stroking and attenuating the impact energy.

The BLACK HAWK seats meet these requirements. The aircrew seat is shown in Figure 5.

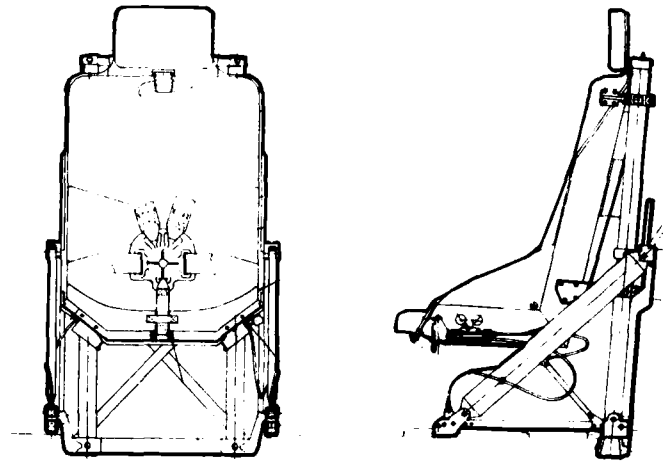

Figure 5. Air Crew Seat.

The pilots are protected by armored buckets and wings. Each seat bucket is mounted on four bearing assemblies on two vertical support tubes. The seat height may be adjusted by moving the seat up and down the support tubes. In high sink speed accidents, the seats move down the support tubes, the motion being controlled by two inverting-tube type energy attenuators. The seats provide the required 12 inches (30.48 cm.) of stroke from the lowest adjusted position at a load factor on the average crew member of  $14 \frac{1}{2}g$ . A cavity in the cockpit floor structure is provided to accommodate this long seat stroke as shown in Figure 6.

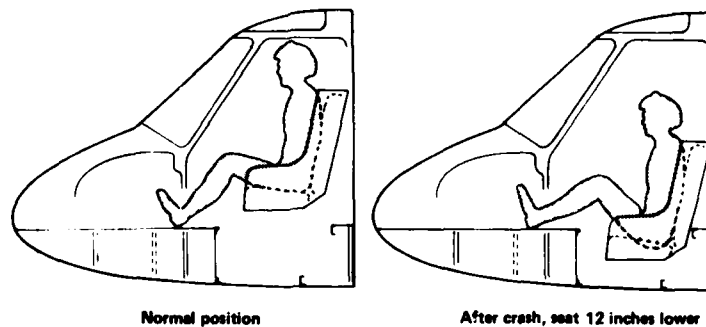

Figure 6. Crew Seat Stroking Capability.

The attachment of the seat to the floor structure is designed to meet high load factors even when the floor structure is warped and the support track rolled, thus preventing premature seat separation due to floor distortions.

The seats are equipped with improved restraint systems with lap belts, shoulder harnesses with inertia reels, and lap belt tie-down straps. High-strength, low stretch webbing is used. The single-motion rotary type buckles are at the ends of the tie-down straps, requiring the use of these straps at all times. Adjustors are provided on each lap belt section and on the two shoulder straps. The seat cushion design is close to the optimum for reducing dynamic overshoot. It is quite thin when the man is sitting on it. However, it is carefully contoured and allows some ventilation and is surprisingly comfortable. The improvements in the retention of the seat and the man under high crash load factors will prevent the man from submarining under the lap belt, while allowing rapid release from the seat when required for emergency escape.

The arrangement of the troop and gunner's seats in the cabin is shown in Figure 7.

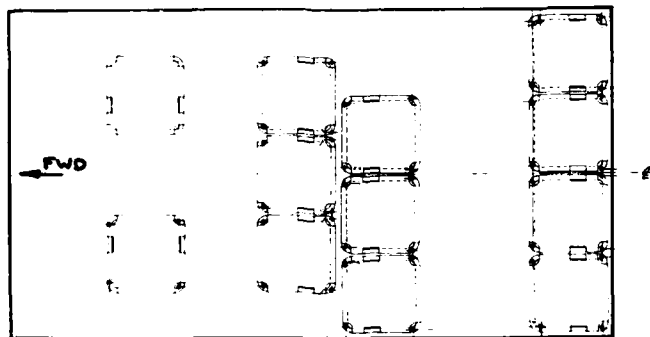

Figure 7. Cabin Seating Arrangement.

All the seats, forward, aft, and sideward facing, are designed to provide a high level of combat crash survivability. The seats, similar to those designed, developed and tested under Army funding by the Eustis Directorate, are floor and ceiling mounted and attenuate the loads on the occupant in both horizontal and downward directions. The basic seat design is shown in Figure 8.

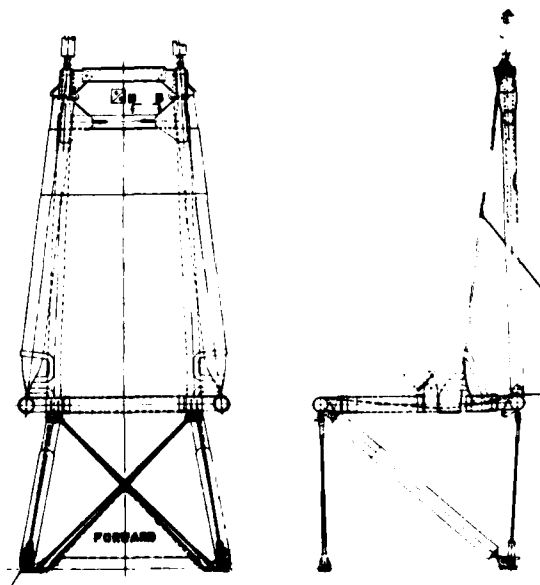

Figure 8. Troop Seat Design.

Two separate attenuation systems are used. Each seat is suspended from the ceiling on two wire-bending type energy absorbers which limit the loads in crashes with predominately vertical decelerations. These attenuator devices absorb energy by pulling preformed wires through rollers, causing it to bend, first one way then the other.

Two more wire-bending type energy absorbers, installed inside aluminum struts, are installed below the seat frame. For all the cabin seats, regardless of seating direction, these attenuators are positioned diagonally between the forward edge of the seat frame and the floor fitting under the aft edge of the seat frame, one on each side of the seat. Thus, in crashes with high forward inertia loads, the attenuators stroke in tension and allow the loads to attenuate in the forward direction.

The troop seats are equipped with improved retention systems that include both lap belts and dual shoulder straps. The two side-facing gunners need to be able to move from their seats to aim and fire their machine-guns through the windows. They wear body harnesses that are attached to the seats by three straps, each with an inertia reel. They are able to extend about 40 inches (101.6 cm.), more than double the usual crew seat inertia reel. Straps from the reels at each side of the seat frame are attached to each side of the waistband of the body harness, while the third strap reaches from a reel on the back of the seat to the body harness behind the gunner's shoulders. All the cabin seat restraint systems are also made from low-stretch webbing, and where appropriate, are equipped with adjusters.

The third basic requirement is the prevention of major postcrash fires. This is accomplished in the BLACK HAWK by designing the fuel and other flammable fluid systems to minimize spillage in crashes and by minimizing potential ignition sources in areas of anticipated fuel spillage. Army experience with helicopters equipped with crashworthy fuel systems has already clearly demonstrated the effectiveness of this dual approach in preventing major crash fires and thermal fatalities and injuries.

To minimize ignition sources, the electrical wiring is routed away from the underfloor area as much as possible. The underbelly lights are designed to displace into the structure to prevent exposure of the hot bulb filaments and are equipped with extra length wires to prevent breaking and sparking of the wires. All the electrical equipment is adequately restrained to prevent the shorting and sparking of pulled and broken wires and is, where possible, located well away from the fuel system.

The antennas on the aircraft underside are both multi-function and flush with the airframe structure to minimize damage and the risk of sparks. Other type antennas, mostly of low power, are located away from the fuel tanks.

Another source of ignition is friction sparking, caused when a helicopter slides on the ground. The underside and wheels of the BLACK HAWK are aluminum which does not spark. In accidents where the helicopter rolls on its side the engines become a serious potential ignition source. Rollover may displace the engine nacelles and expose the engine hot metal parts. This hazard is reduced in the BLACK HAWK by the use of ductile titanium firewalls and the activation of the fire-extinguishing system by a crash activated omni-directional inertia switch set at a 5g load factor. The ingestion of spilled fuel into the engine will be minimized by the use of a suction feed which prevents the continued pumping of fuel from broken fuel lines. Major emphasis has been placed on the design of the fuel system to minimize fuel spillage from the tanks and lines. The arrangement of the system is shown in Figure 9.

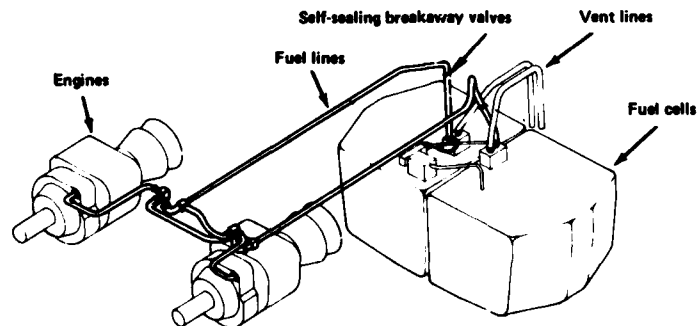

Figure 9. Crashworthy Fuel System.

The fuel cells are of crashworthy design per specification MIL-T-27422B and have successfully passed the required 65 foot (19.8 meters) high drop test with no subsequent leakage. Each cell is essentially rectangular and will not snag or tear on the structure. The attachments of the cells to the structure are frangible to allow their displacement without tearing the fittings out of the cell wall. The fuel quantity probe is of low flexural strength and is equipped with a rounded shoe at the end to prevent its spearing the tank. The structure is designed to crush without spearing the tank and, in this regard, the use of void-filling polyurethane foam provides some additional protection. The fuel lines, of crashworthy self-sealing flexible hose, will, with large component displacement, activate the flapper-type self-sealing breakaway valves installed in the lines. The vent lines are also equipped with poppet-type valves to prevent draining of fuel through the vent lines.

The length of all the fuel lines is minimized by the position of the fuel tanks and engines and they are placed close to the major structural members wherever possible. The fuel lines are routed away from those areas of the fuselage most likely to suffer damage in a crash; the fuselage underside and sidewalls.

The fourth basic survivability goal is the provision of a non-injurious or delathalized interior. Of first concern are heavy items of equipment that would be very hazardous if loose under high g loads. All such equipment in the BLACK HAWK is restrained to 25 g loads acting in any direction.

Secondly, the crew and troops are positioned, when properly restrained, to prevent head strikes. The head strike envelopes of the pilot and copilot are free of hard structural members, but come close to the upper windshield frame if they are thrown forward and upward. It consists of a rounded box beam of fiberglass material and does not present a significant hazard to a helmeted crewmember. Strike envelopes developed for the troops in the cabin show that in one area the heads of the occupants can come close to a major fuselage frame. The edges of this door frame are therefore protected by shaped, rounded shields.

In the cockpit, leg injuries are minimized by padding of the lower edge of the instrument panel. Similar padding is also provided on the outstanding edge of the instrument panel glare shield. The foot pedals have been extended downward and fairings have been added to prevent foot entrapment under the pedals and between the pedals and the side of the console between the pilots.

The third and last survivability feature for a non-injurious interior is the choice of interior materials. In the BLACK HAWK they are, as far as practicable, non-flammable and do not give off toxic smoke and fumes when burned.

The fifth, and last of the basic requirements, is the provision of adequate emergency escape capability. Since structural deformations can jam the sliding doors, extra emergency exits, shown in Figure 10, are provided on each side of the helicopter.

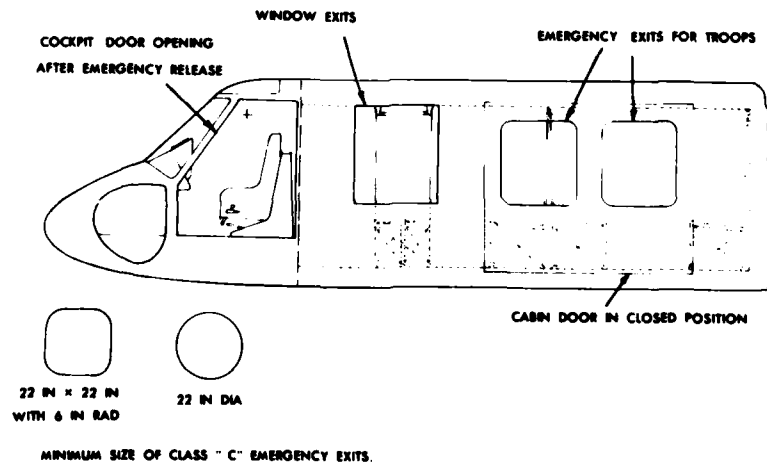

Figure 10. Emergency Exits.

The cockpit doors are jettisonable, as are two large windows in each cabin door. The minimum size recommended for emergency exits is shown in Figure 10 for comparison. The crewchief/gunner's windows, although not emergency exits, can also be used as exits. All the emergency exits are clearly marked.

Although the fuselage is wide and, on its side, presents a more difficult escape problem, the seats can be used to climb up and out of both the cockpit and the cabin. The emergency exit release handles are designed to leave the opening clear after actuation in order not to hinder rapid escape.



One feature, normally considered a requirement for rapid emergency egress, is the installation of emergency lighting with its own battery power system. The U. S. Army, however, deleted their requirement for such lighting for the following reasons:

1. All occupants are close to emergency exits.
2. Removable lights are subject to unauthorized removal; unavailable when needed.
3. Crash actuation of lights detrimental if in enemy territory.
4. Weight, cost and complexity are reduced.

#### SPECIAL EQUIPMENT

In addition to the basic aircraft features just described, there are two special equipment kits which will at times be used in BLACK HAWK operations. The range extension fuel system kit is designed to allow long-range ferry flights. Two auxiliary fuel cells, of simple rectangular shape are installed in the BLACK HAWK cabin. Figure 11 shows their relationship to the main fuel cells and other components.

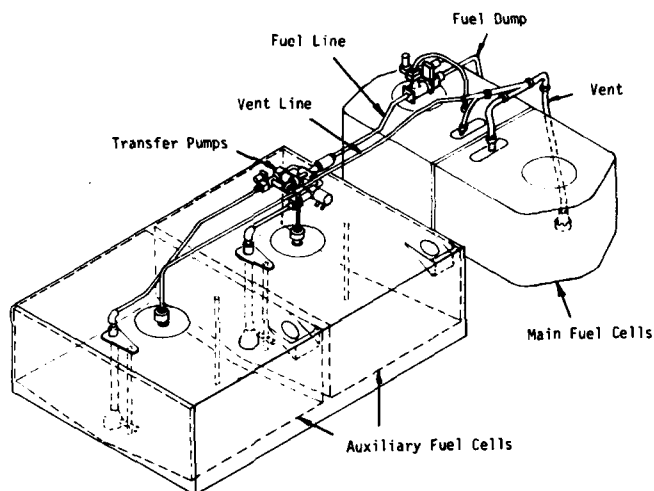

Figure 11. Range Extension and Primary Fuel Systems.

This complete system is designed to be crash survivable and meets the same standards as the primary fuel system, except that the fuel cells are not of self-sealing construction. They are, however, designed to meet the requirements of MIL-T-27422B in all other respects. All the fittings in the tank are designed to meet the pull-out strength requirements and are designed to break away from the support structure rather than pull out of the cell wall.

The fuel and vent lines are equipped with self-sealing breakaway valves. The two fuel cells are installed in structural boxes of aluminum/honeycomb sandwich construction. The flooring of the boxes is fastened directly to the cargo tie-down fittings in the cabin floor. The fuel cells are retained to the same high mass item load factors as the other major components. The range extension system is designed to provide the same high degree of crash survivability as the primary fuel system.

The MEDEVAC kit is another special piece of equipment that may be installed in the BLACK HAWK cabin. It is designed to carry four patients in standard Army litters. It may be pivoted to a position across the aircraft for loading of the patients from either side of the helicopter. In flight, the litters are rotated into a longitudinal position to allow access by a medical attendant, as shown in Figure 12.

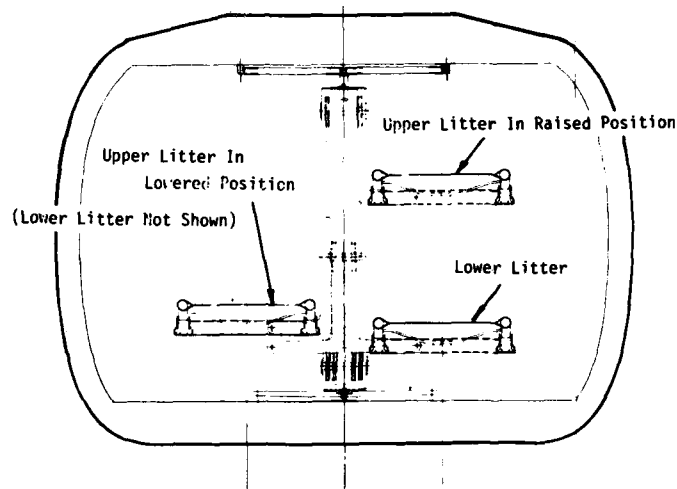

Figure 12. MEDEVAC Kit - Litter Arrangement.

Support frames for the four litters are mounted on pairs of arms which project laterally from the corners of the box structure, with two litters on each side of the box, one above the other.

The arms supporting the litters are mounted in vertical slides and are interconnected by cables so that the two arms supporting a litter move up and down together.

The cable system of the two upper litters is also used to raise and lower them by means of a simple handcrank mechanism to facilitate loading and unloading of the litter patients.

The cable systems of all four litters also include wire-bending type energy attenuators which allow the litters to move vertically downward when a predetermined load on the litter is reached. The stroking load corresponds to a load factor of 13g on the occupant. The design of the system provides a stroking distance of 7.6 inches (19.30 cm.) for each of the litters.

Two adjustable straps are provided on the litter support structure to hold the occupants and their litters on the support structure. The MEDEVAC kit will provide the same high level of crash survivability as the basic aircraft.

In summary, the BLACK HAWK and its special equipment has many design features to overcome the hazards found in accidents involving earlier utility helicopters. They combine to meet the basic crash survivability objectives; the reduction of damage, injuries and fatalities in accidents, particularly those in combat.

THE APPROACH TO CREW PROTECTION IN THE CRASH ENVIRONMENT FOR THE YAH-64

John M. McDermott, Manager  
 Structural Analysis Section  
 Hughes Helicopters  
 Centinela Avenue at Teale Street  
 Culver City, California 90230

SUMMARY

The paper deals with the approach to crashworthiness in protecting the crew of the AAH. Basic requirements of crash criteria specified by the Army are presented. Impact modes and impact velocities are discussed. The means used to meet these requirements using a total systems approach (i.e., landing gear, plus fuselage crushing and energy absorbing seats all in series) are presented. Crash pulses felt by the occupants during the various crash impacts are presented. Design of energy absorbing seats is discussed. Protection of the crew by use of turnover structure and by means of high load factors on heavy mass items which could penetrate the cockpit is illustrated. Maintaining living space during crash barrier impacts, and protection against blade strikes using the roll over structure are discussed.

INTRODUCTION

The beginning of the 1970's saw the introduction into the military requirements, of criteria in many areas which previously had not been strictly defined. The first aircraft to be designed to these criteria were the UTTAS and the AAH. For these two helicopters, the Army defined requirements<sup>1</sup> which listed criteria for crashworthiness. This paper deals with the approach to the problems of crew protection for the crashworthiness standards specified by the Army for the Advanced Attack Helicopter.



Fig. 1. YAH-64 Advanced Attack Helicopter.

CRASHWORTHINESS REQUIREMENTS

The requirements for crashworthiness on the YAH-64 were laid down in the RFP which was issued in 1972. This stated in terms of impact criteria, crash velocity and load factor capability the latest requirements for an advanced attack helicopter operating in the modern Army. Table I shows the criteria as laid down for the YAH-64 in terms of longitudinal impact, longitudinal nose down impact, vertical impact, and lateral impact.

TABLE I  
 CRASHWORTHINESS IMPACT CRITERIA

Direction	Impact Velocity	Criteria
Longitudinal	20 ft/sec	Safe evacuation
Longitudinal - 15 degrees nose down	60 ft/sec	95% cockpit space
Vertical	42 ft/sec	85% cockpit space
Lateral	30 ft/sec	85% cockpit space

In addition, there are high load factors which are specified for the strength of the heavy items which might prove to be a hazard to the crew during the crash environment. These are shown as follows:

	Applied Separately		Applied Simultaneously		
	(a)	(b)	(c)	(d)	
Longitudinal	+20	+20	+10	+10	
Vertical	(20*) 20/-10	(13*) 10/-5	(26*) 20/-10	(13*) 10/-5	
Lateral	+20	+10	+10	+20	

NOTE: (\*) indicates alternate value to be used in conjunction with 1 g rotor lift, if more critical.

Also, there is a requirement that turnover structure shall be incorporated:

Turnover Structure

Turnover structure shall be provided. The turnover structure shall withstand the following independently applied loads:

- a. 4W perpendicular to a waterline
- b. 4W longitudinally parallel to a waterline
- c. 2W laterally

W is defined as a basic structural design gross weight. For this condition the aircraft shall be resting on the ground in an attitude after turning over and shall be that which is the most critical for the safety of the occupants. The canopy shall be assumed to be buried to a depth of two inches in soil for distribution of turnover loads.

The crash conditions are illustrated by Figs. 2 through 6.

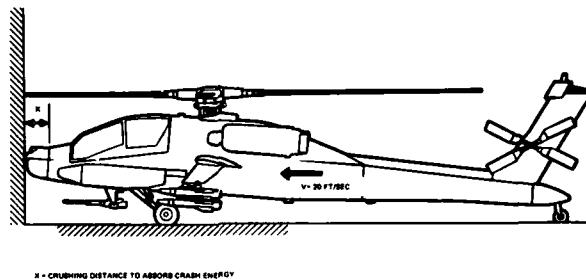

Fig. 2. Longitudinal rigid barrier impact at 20 ft/sec.

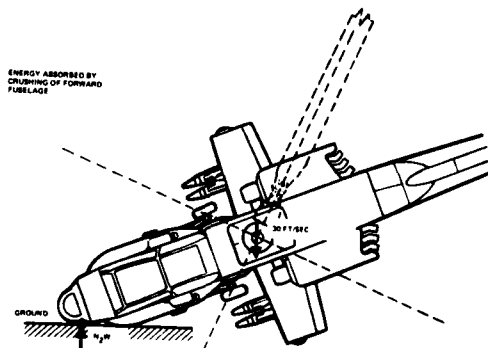

Fig. 3. Lateral impact, nose first at 30 ft/sec.

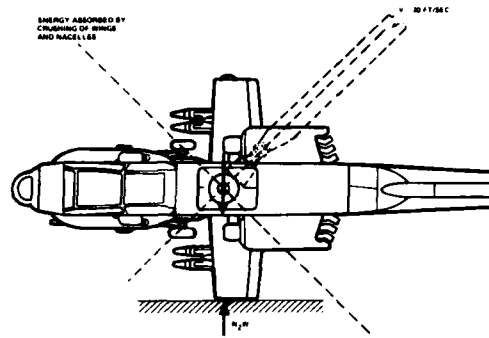

Fig. 4. Lateral impact, wing first at 30 ft/sec.

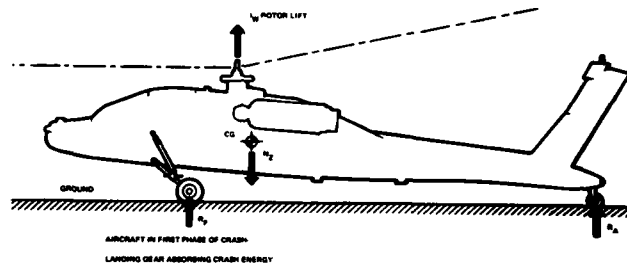

Fig. 5. Vertical impact, crash I condition at 45 ft/sec.

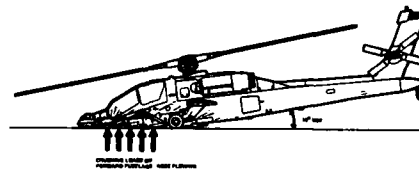

Fig. 6. Vertical impact - crash II condition nose down at 45 ft/sec.

#### DESIGN APPROACH

In approaching the problems of crashworthiness there are three basic rules of concepts which must be observed. These are:

- a. It is essential to maintain living space for the occupants of the vehicle. Excessive crushing must be avoided, and the restraint system must be such that the occupants do not strike the inside of the vehicle with any kind of secondary collision.

- b. The acceleration levels which are experienced by the occupants of the vehicle must be kept down to the limits of human tolerance.
- c. Postcrash fire, which is one of the biggest hazards, should be avoided by the use of a crashworthy fuel system.

#### Crashworthy Features

- High strength and energy absorbing crew seat
- Redundantly supported static mast
- Structural deformation
- Cockpit roll bar
- Crashworthy fuel system
- Energy absorbing main gear
- Collapsible gun turret
- Collapsible optical turret

The overall approach to crashworthiness in the YAH-64 is not to consider any one particular element as more vital in providing crash protection than the others, but instead to adopt the systems approach in which each element is regarded as a link in a chain, each link being as important as every other link, and the whole providing the total safety required during the crash.

The first element in this chain is the landing gear. During most of the helicopter crash attitudes, the landing gear is the first element to come on contact with the ground. A fairly large proportion of all helicopter crashes are with the helicopter in a nearly vertical descent mode. The particular criterion for the YAH-64 is a 42 feet per second vertical crash. It is assumed that the helicopter contacts the ground, and that the ground is infinitely rigid.

The landing gear is of a trailing arm type (Fig. 7) which means that it is relatively insensitive to side loads from the point of view of absorbing energy. The landing gear is designed to react to this 42 feet per second vertical impact load by the use of an auxiliary stroking device. The normal, or design landing condition, has a conventional oleo stroking mechanism. However, the crash condition makes use of the kneeling capability of the landing gear, which is provided to fulfill another design requirement, that of air transportability. In the crash condition, a pressure relief valve is activated. This pressure relief valve opens up the auxiliary stroke (which is primarily there for kneeling) and provides another energy absorbing mechanism in series with the main oleo. Essentially, the landing gear in this mode is a load sensitive device, rather than velocity sensitive. The load stroke curve is relatively flat and the energy absorption capability of the gear is very good. Efficiencies of between 85 and 90 percent have been obtained with preliminary drop test results.

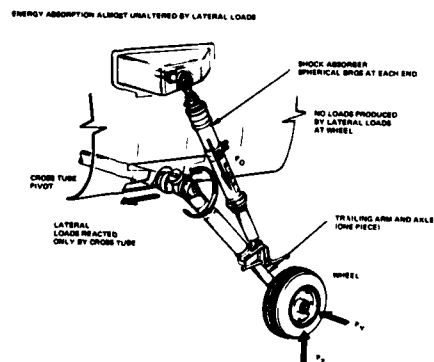

Fig. 7. Crashworthiness landing gear trailing arm type.

The landing gear portion of the energy absorption takes up about 57 percent of the total kinetic energy of the vertical impact. When the landing gear portion of the energy absorption is complete, the fuselage belly contacts the ground. Up until that time, load factors have been relatively small; the design load factor for the crash condition being 5.5 g. However, upon the fuselage contacting the ground, the load factor increases rapidly and builds up to a high enough level to cause crushing of the lower fuselage structure. The crushing

stroke of the lower fuselage is of the order of 5 inches and during this phase when the load factors are built up, the occupant protection now passes over to the energy absorbing mechanism of the crew seats. The crew seat consists of an armored seat bucket which is free to slide on bulkhead-mounted rails. It is supported by dual energy absorbers which keep the load factors on the occupant to survivable levels during a crash. The most critical condition for the seat is with the 95th percentile occupant and with the seat in its most down position at the beginning of the crash. This provides for the least amount of stroke and obviously for the heaviest occupant we require the greatest amount of energy absorption. Hence, the combination of short stroke and heavy occupant provides the most critical condition. It should also be pointed out that in order to protect the lightest occupant, it is necessary to set the energy absorber stroking load so that it is based on a light occupant. This is because the heaviest person has the lowest g force and the longest stroke, while the lightest occupant has the highest g force combined with the shortest stroke. Thus, the maximum survivable g level on the lightest occupant determines the energy absorber load level, and this, in turn, then determines the minimum stroke required for the heaviest occupant. The crash pulse for the vertical impact is shown in Fig. 8, and, as can be seen, it is divided into the phases mentioned. That is, the portion containing the landing gear stroking phase, the crushing of the fuselage, and the stroking of the crew seat.

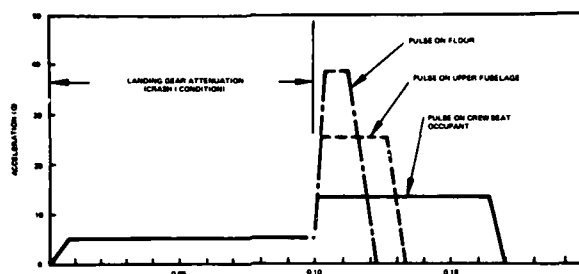

Fig. 8. Crash pulses for vertical impact, at 42 ft/sec.

For the provision of turnover structure refer to Fig. 9 where there is an illustration of the ship in the turned over condition. The criteria as laid down is that it should take  $4W$  vertical,  $4W$  longitudinal, and  $2W$  lateral acting separately where  $W$  is considered to be the structural design gross weight of the aircraft. The protection of the crew in this condition is achieved by means of the static rotor mast, the blast shield, and rollover bar.

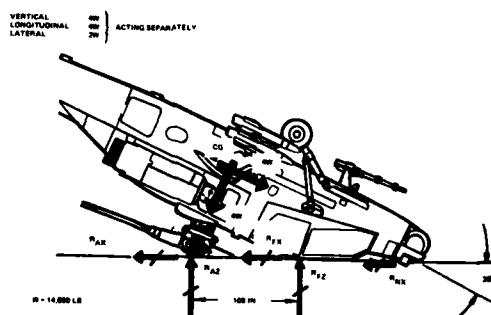

Fig. 9. Crashworthiness - turnover structure.

The crash load factors on the rotor system are shown in Fig. 10 which presents a table for the load figures for heavy mass items. These apply mainly to the rotor support structure. One of the foremost hazards during a crash is the danger of penetration of the cockpit area by the main rotor. On the YAH-64, very good protection is provided in this respect, because of the unique design of the rotor support structure. The rotor is supported upon a static mast with the drive shaft going up through the middle and the main rotor supported on bearings on the outside. The static mast is connected to a mast base which is supported on a truss structure which connects to the deck of the helicopter (Fig. 11). With the high load factors specified for this crash condition, it is assured that in most crashes the rotor support structure would not break off and cause a possible blade strike. In addition to providing structural integrity to preclude such occurrence, there is also a blade

strike deflector which doubles as a blast shield for survivability. The blast shield protects the pilot and copilot gunner from an explosive projectile in either area. In addition, the rigid structure formed by this blast shield acts as a blade strike deflector. It also acts as turnover structure, which is necessary to meet the requirements that are specified above. The maintenance of the living space in the cockpit area is a vital requirement for the crash condition. It would be of no use to preserve the occupants by keeping the g levels on them to those within human tolerance, only to have them crushed by the collapse of the living space within the cockpit.

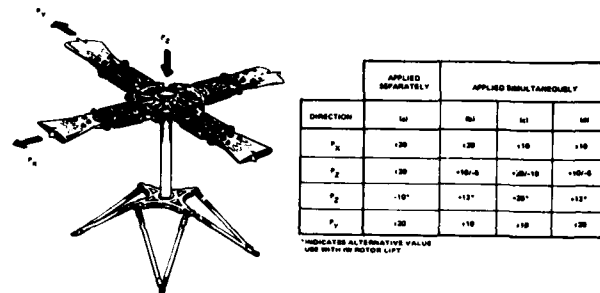

Fig. 10. Crashworthiness load factors on rotor support structure.

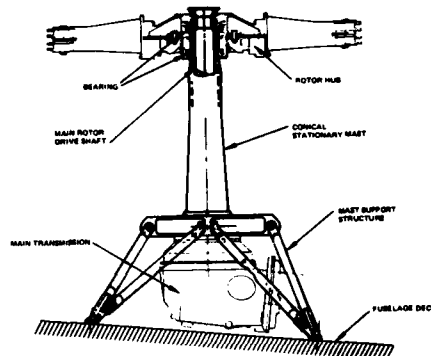

Fig. 11. Rotor support structure.

## CONCLUSION

The approach taken in the crash protection for the crew of the YAH-64 is as follows:

The use of a systems concept in which energy is first absorbed by the landing gear. The second phase is taken by crushing on the fuselage; and the third phase by energy absorbing crew seats. In addition, the high strength static rotor mast prevents the blades from deflecting downwards, possibly striking the crew. The cockpit roll bar is an additional protection in this area, and also resists the overturn case. The crashworthy fuel system is of a type proven from long experience in the Army to prevent postcrash fires.

The sum total of these approaches is to provide the crew with the most advanced concept of crash survival in any helicopter to date.

## REFERENCES

1. Gormont, Ron, and Wolfe, Robert, "The U. S. Army UTTAS and AAH Programs." AAVSCOM, presented at AGARD Meeting, NASA Ames, May 1977.
2. "Crash Survival Design Guide," TR 71-22.
3. Carnell, Brian, "Crashworthiness Design Features for Advanced Utility Helicopters," Sikorsky Aircraft, presented at the Symposium of Aircraft Crashworthiness, University of Cincinnati, October 1975.



4. Smith, H. G., and McDermott, J. M., "Designing for Crashworthiness and Survivability," AHS Forum, May 1968.

5. "Light Fixed and Rotary Wing Aircraft Crashworthiness," MIL-STD-1290.

## HELICOPTER UNDERWATER ESCAPE TRAINER (9D5)

WILLIAM F. CUNNINGHAM, LCDR, USN

NAVAL TRAINING EQUIPMENT CENTER  
ORLANDO, FLORIDA 32813

The drowning of helicopter aircrewmembers has long been a major concern. Although most military helicopters are designed to float upright after water touch down, very often, either because of airframe damage or blade motion on water entry, they roll right or left making escape extremely difficult. Naval Safety Center records show that during the period from July 1963 to February 1975, 234 helicopters with 1,093 occupants ditched or crashed in water. Almost half of the survivors were forced to escape from a submerged or partially submerged aircraft. The success rate of survival was 91.5 percent for those trained in underwater escape while the success rate for those who has not been trained was only 66 percent. It is evident that a need exists to train helicopter aircrews and passengers in the correct procedures for underwater escape.

To aid in such training the Navy contracted for the procurement of a Helicopter Underwater Escape Trainer (9D5). This trainer is a helicopter equivalent of the Navy "Dilbert Dunker" long used as an underwater escape procedures trainer. The same principles of the "Dilbert Dunker" apply to the helicopter escape trainer. Aircrews ride the trainer from different seat positions, thoroughly gaining confidence in their ability to successfully escape from anywhere in the helicopter. This training reflects the belief that successful escape from a ditched/sinking helicopter depends largely on spontaneous action achieved through repetitive drills. The results tend to prove this true.

The first production of the Helicopter Underwater Escape Trainer (9D5) is in operation at Naval Aviation Schools Command at Pensacola, Florida. Exact operating procedures are being determined during an evaluation period. It is anticipated that eventually all aircrew personnel will be required to complete training in the helicopter underwater escape trainer. In addition, personnel who may have occasion to ride in helicopters will also be required to receive this training. Following evaluation of the first trainer, additional units are anticipated for Naval Air Station, Jacksonville, Florida; Naval Regional Medical Centers at San Diego, California and Portsmouth, Virginia; and Marine Corps Air Stations at Cherry Point, North Carolina and El Toro, California.

Since its inception the helicopter has never been fully appreciated. Although an extremely versatile machine it is often looked upon with contempt or sullen disinterest by many in the aviation community. This, in addition to its vernal quality, may account for the relative low priorities in development of helicopter systems. This is particularly true in the area of life support where until recently the helicopter pilot and aircrews have been virtually ignored. Some of that is perhaps due to their own indifference as indicated by the failure to carry parachutes or in some cases personal safety equipment. Nevertheless there are indications that helicopter pilots and crewmen are greatly concerned with one specific area of helicopter life support--that is underwater escape, a concern shared by most, if not all, involved in helicopter operations, both crew and passengers alike.

Statistics from the Naval Safety Center show that from July 1963 to February 1975, 234 helicopters with a total of 1,093 occupants either crashed or were ditched at sea; 196 persons died in those accidents, 130 were listed as lost/unknown, and 29 suffered either a fatal injury or an unjury which caused drowning. The remaining 37 victims were not injured, but drowned nonetheless. Of the 897 survivors, 437 (49%) egressed under water! The success rate for aviators trained for underwater egress was 91.5%. The success rate for those who had not been trained was only 66%. Major problems encountered by survivors were: intrushing water, disorientation, confusion, panic, entanglement with debris, and unfamiliarity with existing release mechanisms. Difficulty in operating release mechanisms on emergency exits was frequently encountered during actual underwater egress. Among the most widely deployed Navy helicopters (H-2, H-3, H-46), there are fifteen different types of external rescue handles.

Evidence shows that aircrewmembers who have received training in underwater egress using the "dilbert dunker" underwater escape trainer are more apt to survive a helicopter ditching. It seems probable that underwater egress training in a device representative of an operational helicopter would serve to increase those survival chances. Low survivability rates highlight the definite need for underwater egress training for passengers. Perhaps even the pilot survival rate can be increased with the use of a helicopter dunker.

The need for helicopter underwater egress training has long been realized in the Royal Navy, which has utilized a device for such demonstration since 1962. Since the trainer's inception, drowning fatalities during ditching incidents have been reduced to near zero. The training is mandatory for all aircrews, and is repeated at two-year intervals. Aircrews ride the trainer in different seat positions, thoroughly gaining confidence in their ability to successfully egress from anywhere in the helicopter. Their training reflects the belief that successful egress from a ditched/sinking helicopter depends largely on spontaneous action achieved through repetitive drills. The results tend to prove their hypothesis.

Because of our own difficulties experienced with helicopter underwater egress in 1972 the Navy established a project team of fleet representatives to determine what type of training could or would increase the survival rate. Drawing from the Royal Navy's experience this team developed a set of Military Characteristics for a helicopter underwater escape trainer now known as the 9D5. The device was not designed as a mock-up of any specific helicopter, although that may change with future models. The final design called for a cockpit portion in the shape of a large cylinder with seats for six occupants. The interior and exterior are constructed of heavy fiberglass with the ends made of wire and steel mesh. The "cockpit" is suspended by cables from a stainless steel support structure. The support structure spans the width of a 24 ft x 34 ft x 15 ft deep swim tank, contains the hydraulic up/down winches and roll actuators, and supports one end of the loading platform in addition to the operator's console. The hydraulic power supply is located in an attached pump room.

The 9D5 was designed to lower its occupants at a controlled descent rate ranging from 0 to 10 feet per second from the uplock position to the water surface, followed by a sink rate of up to one foot per second. After impact, the trainer is capable of rolling 180 degrees in either direction. Each of these actions is operator controlled. Egress can be practiced with the trainer floating upright, inverted underwater, or any position in between. The uncertainty of exactly what occurs after water impact adds realism and thus substantially enhances the value of the training. Egress from the trainer is via open windows and doorways. Prior to egress, the trainee is required to operate the latch release mechanism and move a slide bar above the exit, simulating the required operations to remove a window or doors from a real helicopter. The release handle on the present device is not peculiar to those of any current operational helicopter. Rather, it is capable of being positioned in any one of four quadrants. It can be pulled and moved left or right dependent upon the specific setting of the operator. A slide bar over each door exit will simulate the act of clearing a passage (solid doors and windows will not be used). The release mechanism and slide bar enable practice of escape techniques but are not intended to prevent the trainee from escaping. For trainee safety an independent emergency system is capable of retracting the fuselage and occupants to the water surface in less than ten seconds from any attitude.

The interior of the fuselage simulates the pilot (2 seats) and passenger (4 seats) compartments of a helicopter. Although capable of training six students at one time, it is anticipated that no more than four will be trained during any one cycle, to assure that adequate assistance can be given to any individual encountering difficulty. During the training cycle, two trainees may ride in the pilot compartment and two in the passenger compartment, or all four may ride in the passenger section. Once in the water and the motion of the device ceases, the trainee must perform three distinct actions:

1. Release the seat belt.
2. Operate the release mechanism properly (handle).
3. Clear the exit (operate slide bar).

Once these operations are complete the trainee swims clear of the fuselage and to the surface.

The training sequence begins with a verbal training brief for the students concerning water survival and underwater escape techniques. The students don appropriate flight equipment, climb the ladder to the loading platform and enter the fuselage section. They are then strapped in and are ready to begin the escape exercise.

To assure student safety two experienced divers are in the water during device operations. They utilize a full face and head compressed air supply mask which also permits voice communication with surface observers. The diving equipment is purchased as a part of the 9D5 device procurement. An additional two observers and the device operator make up the surface crew.

At present only one 9D5 is in operation. The device was constructed by Burtek, Inc., of Tulsa, Oklahoma and installed in a specially constructed indoor swim tank at the Naval Aviation Schools Command, Pensacola, Florida. Naval Aviation Schools Command is conducting training classes with the device to evaluate its operational capabilities and determine if safe but realistic helicopter underwater escape training can be provided.

The evaluation which is nearly complete is considering the following factors:

1. Determine number of students per training cycle.
2. Determine safe, maximum student load per hour.

3. Evaluate escape handle realism.
4. Determine potential for night escape training.
5. Evaluate realistic water impact angle.
6. Develop appropriate classroom aids.
7. Determine device's potential for survival equipment evaluations.
8. Evaluate gain from training non-aircrew personnel.
9. Determine if device is satisfactory for new helos entering fleet.
10. Determine number of divers required for safe device operation.
11. Determine pool depth for realistic escape effort.
12. Determine degree of swimming skill needed for device operation.
13. Determine number of cycles required per student.
14. Determine if the device is capable of providing training compatible with helicopters presently in the fleet or programmed for introduction in the near term.

Once the evaluation is completed, a fleet project team, much like the one which planned the first 9D5, will use the data to plan possible future procurements. From the data gathered to date, the anticipated increase in the confidence of aircrews to overcome the disorientation caused by inrushing water of a flooded compartment and to successfully egress underwater has been realized. Although many confess apprehension about their first exposure in the dunker, after several rides nearly all express supreme self-assurance about their abilities to egress successfully.

#### REFERENCES

- Doege, A. G. Put Parachutes Back in Helicopters, APPROACH. Naval Safety Center, Norfolk, VA February 1975 pp 1-3.
- Lucasey, R. Helicopter Crews Have Their Own Dunker, TESTER. NAS Patuxent River, Maryland, April 30, 1976 p 3.
- Rosenbaum, B. Universal Helicopter Underwater Escape Trainer 9D5, NAVTRADEV P-1300-67. Naval Training Equipment Center, Orlando, Florida. June 1977 pp 4-5.
- Shoemaker, B. H. Helicopter Escape, APPROACH. Naval Safety Center, Norfolk, VA. September 1974 pp 15-18.

# BAILOUT FROM AUTOROTATING HELICOPTERS

by

H.D. Melzig

U. Schmidt

E.A. Bockemüller

Deutsche Forschungs- und Versuchsanstalt für Luft- und Raumfahrt e. V. (DFVLR)  
3300 Braunschweig, Flughafen  
Germany

## SUMMARY

Parachute jumps were conducted from an autorotating helicopter to prove the possibility of bailout with a parachute as a means of rescue in emergency cases. The tests were conducted at glide angles of  $17^{\circ}$  proving by their good agreement with the computed results the general applicability of the computational method to glide angles up to  $90^{\circ}$ . The results show that bailout from autorotating helicopters is possible for all glide angles. It is recommended, however, that crew members are taught to perform the ball attitude and give a delay of 3 sec before releasing their parachute.

## 1. INTRODUCTION

There is no rescue system existing for helicopters which offers a chance of successful survival comparable to the ejection seat of a fighter aircraft. The development of a special rescue system for helicopters has not been undertaken for a long time for several reasons.

First it was the possibility of autorotation, which was thought to be a comprehensive rescue system for all emergency cases. However statistics have shown that autorotation can only be applied in about 30 % of the emergency cases, since certain predictions have to be fulfilled like an intact rotor, intact control and sufficient height and visibility. A number of accidents happen even after a successfully conducted autorotation during impact on uneven ground by tilting over of the helicopter.

When rescue measures were considered eventually, the existence of the rotor was the great obstacle which prohibited the simple application of the approved ejection seats. A further handicap proved to be the additional weight of the rescue system which deducts from the pay load, an already critical factor for a combat helicopter.

A valuable rescue system for helicopters with a wide range of performance requires the separation of the rotor blades and an upward ejection or extraction. Such a solution, however, requires the consideration of the rescue system in an early phase of planning of a new helicopter.

For all helicopters already in service a simple easy to introduce rescue possibility can only be the rescue parachute. Statistics show that in some emergency cases a rescue parachute had or could have led to a safe rescue. These are cases where autorotation by damage of main or tail rotor or loss of control or heavy icing could not be conducted or had to be considered as no successful means because of low visibility or uneven terrain.

This investigation had to prove the possibility to safely bail out from an autorotating helicopter, and further to work out proposals for the best way of controlled bail out, which means the best flight attitude of the jumper after bail out to fly safely clear from the sinking helicopter for an unhindered inflation of the parachute.

Measured flight paths for 4 different flight attitudes of the free falling jumpers at an autorotation glide angle of  $17^{\circ}$  agreed with the theoretical method for the computation of general flight paths which showed that even at vertical autorotation a successful bail out can be possible.

## 2. MODES OF AUTOROTATION

For bailing out the jumpers used a Bell UH-1D of the German Air Force.

Fig. 1 shows the modes of autorotation, possible for this type of helicopter. The upper diagram describes the flight path velocity versus sink rate, the lower diagram the horizontal velocity versus sink rate. It can be seen that autorotations with flight velocities between 100 kts (flat autorotation) and 0 kts (vertical autorotation) are possible. The sink rate is varying between 1500 ft/min and 3500 ft/min (vertical autorotation). Autorotations with a horizontal velocity of 65 kts with minimum sink rate and with a glide path angle of about  $14^\circ$  on one hand and - to obtain a maximum range - autorotations with 100 kts horizontal velocity with a glide path angle of  $12^\circ$  on the other hand are the most important and often applied ones. If possible, pilots will avoid vertical autorotation, because of the difficulty to flare the helicopter near the ground out of this flight path.

The precise location of the autorotation curve is a function of the mass of the helicopter and of the air density. Due to these circumstances the bailout tests had to be conducted with the following autorotation conditions:

$$v_x = 65 \text{ kts (horizontal velocity)}$$

$$v_z = 2000 \text{ ft/min (vertical velocity = sink rate)}$$

$$\gamma = 17^\circ \text{ (glide angle)}$$

Fig. 2 shows the horizontal velocity depending from inclination of the helicopter fuselage. This attitude is important for the separation of the jumper from the helicopter. The maximum pitch angle ( $\theta = 3^\circ$ ) corresponds with the horizontal velocity of 65 kts. This is the point at which conditions the bailout tests were conducted.

## 3. CONTROLLED BAILOUT FLIGHT PATH

For the bailout tests the 4 jump attitudes described in fig. 3 were chosen.

Attitude 1 represents the minimum drag, attitude 4 the maximum drag configuration. In the latter case the body axis of the jumper is perpendicular to the wind blast. It is difficult even for the experienced test jumpers to control this attitude.

Attitude 2, the frog attitude, produces drag and lift. Attitude 3, the sphere or ball attitude was selected as a most stable position. This attitude can easily be controlled and kept by a jumper for a long time.

The  $C_D$ -S data [1] shown in this fig. were used for the trajectory calculation.

## 4. FLIGHT PATH COMPUTATION FOR THE BAILED OUT JUMPER

For flight path computation of the jumper at different attitudes after bail out a special form of equations of motion is used.

For this purpose new dimensionless variables are introduced by

$$\bar{x} = \frac{g}{v^2} x$$

$$\bar{z} = \frac{g}{v^2} z$$

$$\tau = \frac{g}{v} t$$

Furthermore 2 dimensionless parameters are introduced:

$$\mu = \frac{\rho C_D S v^2}{2 mg}$$

$$\kappa = \frac{C_L}{C_D}$$

If differentiation with respect to  $\tau$  is marked by a dot the equations of motion are written as follows:

$$\ddot{\bar{x}} = -\mu \dot{\bar{x}}^2 + \dot{\bar{z}}^2 \cdot \left( \dot{\bar{x}} - \kappa \dot{\bar{z}} \right)$$

$$\ddot{\bar{z}} = -\mu \dot{\bar{x}}^2 + \dot{\bar{z}}^2 \cdot \left( \dot{\bar{z}} + \kappa \dot{\bar{x}} \right) + 1$$

The initial conditions follow from:

$$\bar{x}(0) = \bar{z}(0) = 0$$

$$\dot{\bar{x}}(0) = \cos \gamma$$

$$\dot{\bar{z}}(0) = \sin \gamma$$

The computed results for different glide path angles ( $\gamma = 15, 30, 60, 90^\circ$ ) and different values of drag coefficient of the free falling body ( $C_D$ ) and gliding number ( $\kappa = 0$  and 1) are shown in figures 4 to 11 in earth fixed and in helicopter fixed coordinates. The terminal point of the flight paths in fig. 4 - 7 corresponds to 3 sec after bailout.

Fig. 8 - 11 show the initial phase of 1 sec after bailout.

For the computations  $C_D$  values from windtunnel tests [1] were used. The measured flight paths correspond satisfactorily with the computed ones for attitudes 3. The deviations in attitude 1, 2 and 4 are due to the difficulty to perform and hold these attitudes over the period of 3 sec.

## 5. MEASUREMENT OF FLIGHT PATH

A total of 20 bailouts with two jumpers were made from an autorotating helicopter at an altitude of 4000 ft. The exit and separation of the parachutist from the helicopter was documented by 2 cinetheodolite ground stations and by 16 mm motion pictures taken at 64 frames per second and by 35 mm pictures taken at 6 frames per second by a motorized camera. The photo platform was a chase airplane flying formation with the helicopter.

The helicopter and jumper trajectories were obtained with frame by frame analysis of the cinetheodolite motion pictures measuring the centers of gravity of man and helicopter. During the test the helicopter pilot tried to keep the flight path constant. The correct attitude of the jumpers could be checked by the motion pictures.

The jumpers left the helicopter from the right cargo door. In the moment of bail out an impuls produced by the jumper was recorded to get an exact coordination for data reduction. The demanded attitude was kept for 3 sec. After 10 sec the jumper released his parachute.

The test results are shown in fig. 12. The trajectories demonstrate that for the allowed initial conditions ( $v_x = 65$  kts,  $v_z = 2000$  ft/min) the dangerous area of the helicopter had been overcome after the 3 sec. This is also valid for the most unfavourable maximum drag attitude. In reality the jumpers will not fly exactly in the same direction as the helicopter but deviate to the side, most of all if they try to do so, thus getting safe clearance from the helicopter flight path.

## 6. COMPARISON OF COMPUTATION AND MEASUREMENT

Measured and computed flight paths show relatively good agreement, regarding that it is impossible to perform and hold the idealized attitudes during free fall as well as in a windtunnel. This was especially difficult with the maximum drag attitude which is a rather unstable flying configuration even for an experienced jumper, but also for the minimum drag and the frog attitude, since the jumper has no good orientation how his body axis is positioned to the direction of wind. In addition gusts cause further deviation from the ideal flight path. A very good agreement has resulted for the ball position, which is easy to perform and insensitive to wind and gusts. The experimental curve is slightly more curved but the position after 3 sec is exactly the same. The deviated curves 1, 2 and 4 are all on the safe side and it can be assumed that sideward deviation will further contribute to safe clearance from the helicopter.

With this explanation and the good agreement of the stable ball position it can be concluded that the  $C_{D.S}$  values from the windtunnel test can be used in the computation. The computed trajectories for  $30^\circ$ ,  $60^\circ$ , and  $90^\circ$  can be valued as idealized extreme cases which are difficult to perform in practice for a specific attitude, but it can be assumed that the practical trajectories will lie in between the band of curves close to the ball trajectory, which is the recommended attitude for unexperienced jumpers.

## 7. THE STRESS LOADING OF JUMPERS JUDGED FROM THEIR HEART AND BREATHING RATES

Heart rate and breathing rate are indicators for the psychic stress of parachute jumpers. In this investigation this measurement was used to find out if any of the different attitudes causes more stress than the other, but this suggestion was not certified by the results.

The heart rate is, as usually watched at all parachute jumpers, already 120 bpm or higher while sitting in the aircraft before jump. The figure 13 relates to 2 experienced test jumpers for 10 jumps each. There is a wide spreading for the two, while sitting in the aircraft but the one individual lies always close to the upper borderline, the second close to the lower one. So the individual spreading is much less.

Values rise at the point of jump and rise further at the point of parachute opening which is initiated about 10 sec after jump. The spreading diminishes almost at that point indicating that heart rate reaches the upper limit with 180 bpm and each individual is in maximum stress in the phase of free fall concentrating to hold a stable attitude.

This minimum spreading also indicates that each of the attitudes brought maximum stress, not showing any preference.

Hanging on the parachute brings only little ease, probably because of the concentration steering the parachute to reach the landing point. Another maximum occurs before landing which is the phase of highest stress for the experienced parachute jumper using a steerable gliding parachute.

## 8. RECOMMENDATIONS FOR BAIL OUT

The parachute test jumpers experienced no dangerous situations during any of the different attitudes they performed after jumping out of the helicopter autorotating with an glide angle of  $17^\circ$ . As the computations show, this will not change significantly even at  $90^\circ$  vertical descent. As the test jumpers report, a sideward separation takes always place after jumping out of the side door. In theory the separation will only take place in vertical direction, which is no position to release the parachute. Here only the frog attitude can lead to a clearance from the helicopter flight path.



Since vertical descent is avoided in practice and the high possibility of sideward deviation of the jumpers flight path, it is recommended that the untrained emergency jumper tries to perform the ball attitude, which means that he controls his arms and legs by pressing them to his body like in a squatting posture with the right hand on the parachute release handle close to the left shoulder and the left arm respectively to the right. He should also wait for 3 sec after jump before he releases his parachute if altitude is sufficient.

It has been proven at DFVLR that with a rescue parachute consisting of a cluster of 3 small parachutes a rescue from relatively low altitude is possible. Since in the majority of cases there will be a forward speed of about 50 kts this parachute will lead to a safe landing when it is released in 100 ft altitude [2].

## 10. CONCLUSIONS

It was proven that bail out from an autorotating helicopter can be performed even by crew members untrained in parachute jumping. This fact should make easy the decision to bail out in situations where a safe termination of the autorotation is doubtful.

## 11. LITERATURE

- |                                 |  |
|---------------------------------|--|
| [1] Hoerner, S.F.               | Fluid Dynamic Drag<br>Published by the author, 1965  |
| [2] Fu, K.-H<br>Koch, R.        | Altitude Loss of Parachute-Load Systems using Clustered Parachutes<br>Journal of Aircraft, Vol. 14, No. 1, Jan. 1977 |
| [3]                             | Escape Measures for Combat Helicopter Crews<br>AGARD-AR 62, 1973   |
| [4] Melzig, H.D.<br>Schmidt, U. | Escape Measures for Combat Helicopter Crews<br>AGARD-CP-134, 1973  |
| [5] Schmidt, U.                 | Recent Research in Combat Aircraft and Helicopter Rescue Systems<br>AGARD-CP-212, 1976                               |

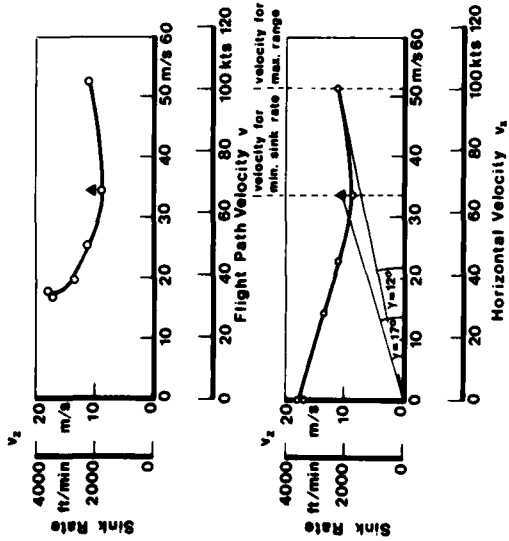

Fig. 1: Velocity vs sink rate during autorotation of UH-1D with 320 rpm (▲ bailout test condition)

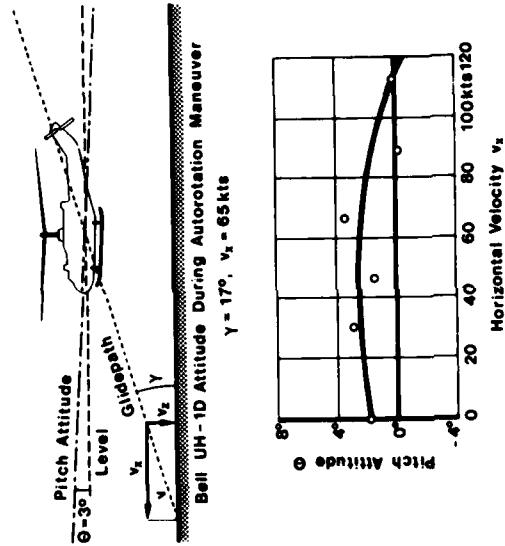

Fig. 2: Helicopter pitch attitude vs horizontal velocity

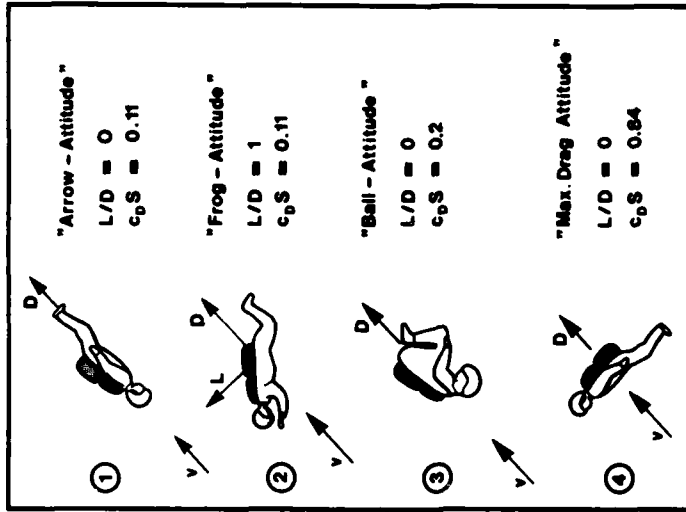

Fig. 3: Attitudes of parachutist jumpers after bailout

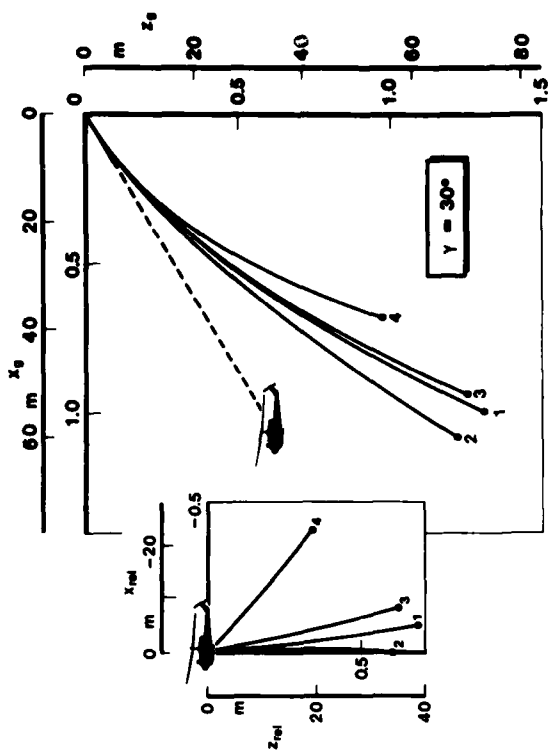

Fig. 5: Computed flight paths for jumpers ( $\gamma = 30^\circ$ ,  $v = 24$  m/sec)

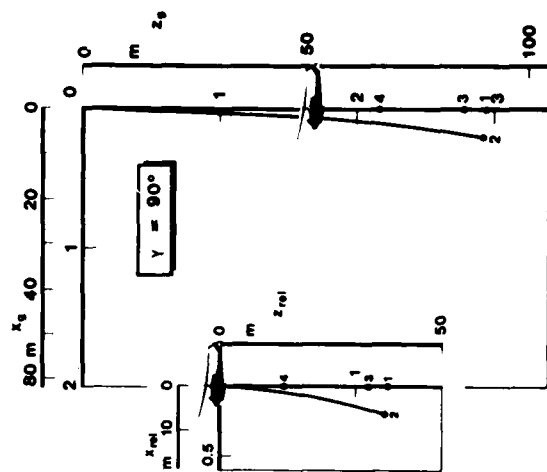

Fig. 7: Computed flight paths for jumpers ( $\gamma = 90^\circ$ ,  $v = 17$  m/sec)

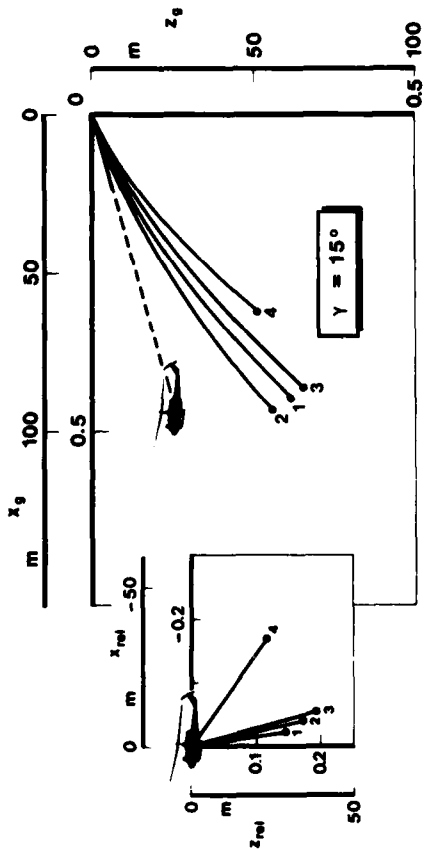

Fig. 4: Computed flight paths of jumpers from autorotating helicopter for the first 3 seconds after bailout and 4 different attitudes ( $\gamma = 15^\circ$ ,  $v = 33$  m/sec)

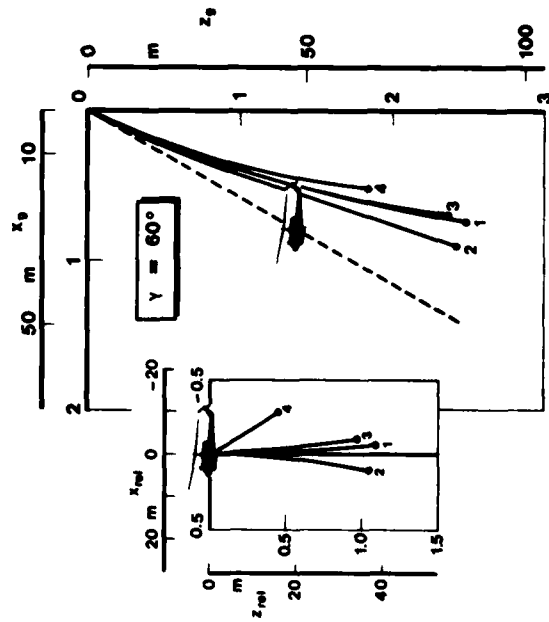

Fig. 6: Computed flight paths for jumpers ( $\gamma = 60^\circ$ ,  $v = 19$  m/sec)

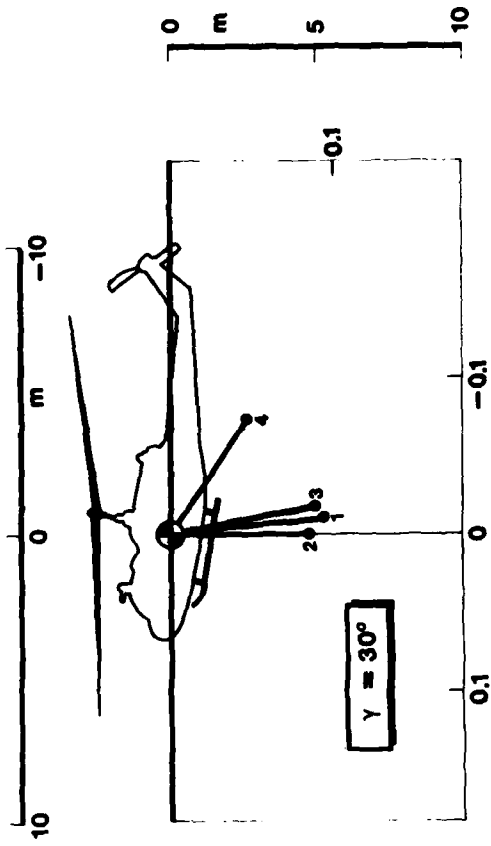

Fig. 9: Computed flight path for jumpers for the first second after bailout

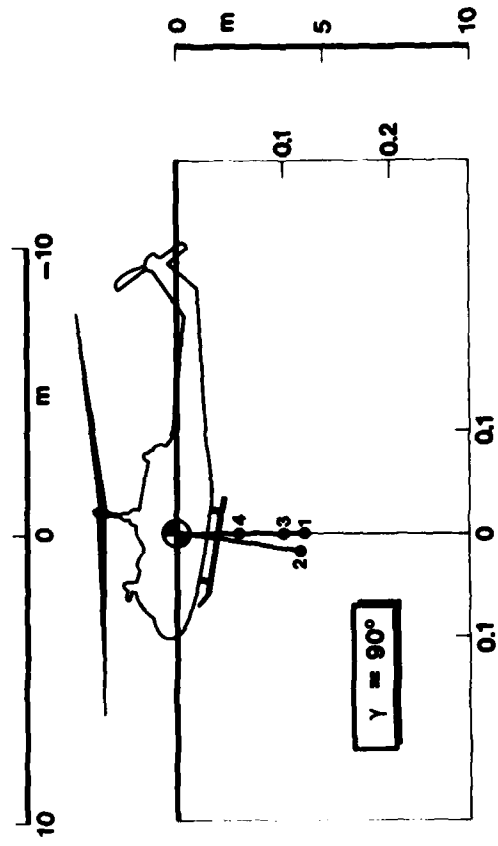

Fig. 11: Computed flight path for jumpers for the first second after bailout

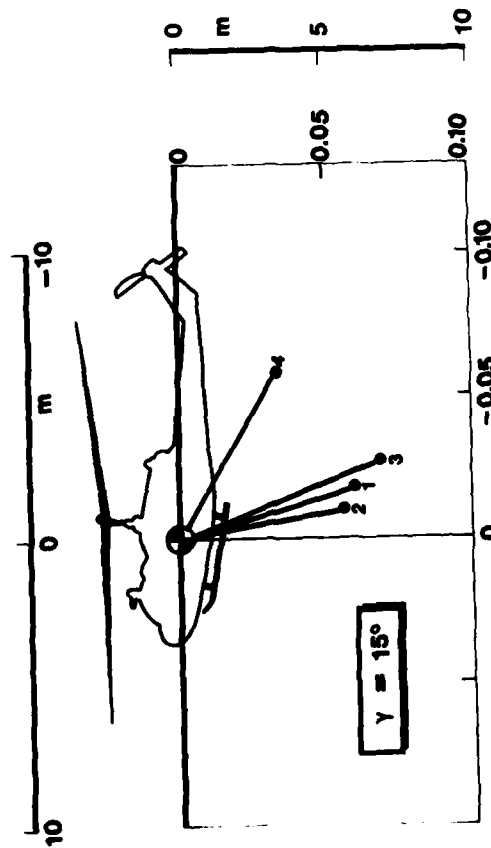

Fig. 8: Computed flight path for jumpers for the first second after bailout

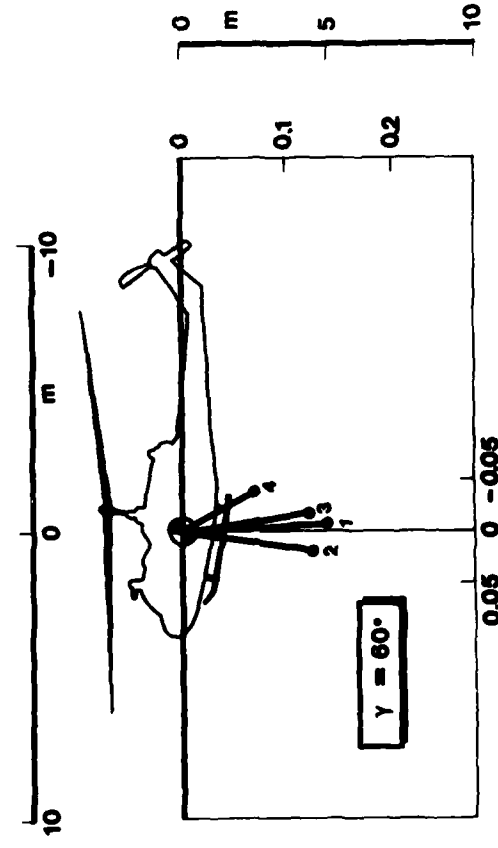

Fig. 10: Computed flight path for jumpers for the first second after bailout

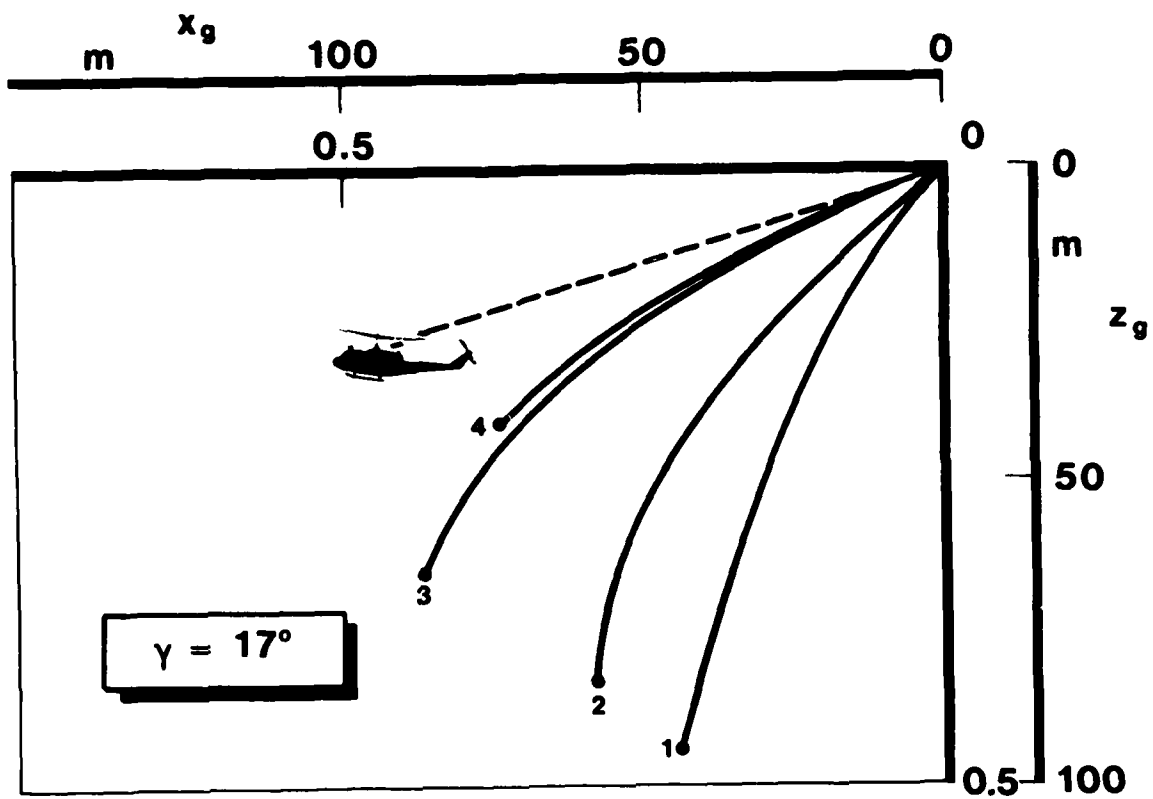

Fig. 12: Measured flight paths of jumpers

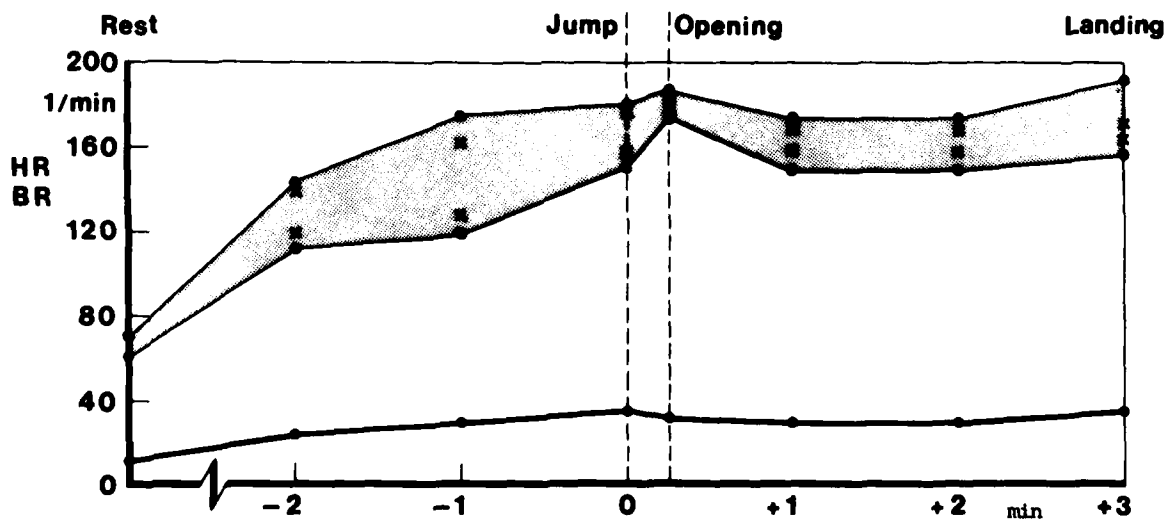

Fig. 13: Heart rate HR and breathing rate BR of parachute jumpers

## DISCUSSION

- READER:  
(United Kingdom) MAJ Gilewicz spoke very highly of the new military standard 1290AV on military crashworthiness standards. We will be producing, soon, a UK version of this standard to go into our own classifications. I would recommend any of you who are from other nations other than the U. S. who have not seen this standard 1290AV, military standards of crashworthiness, to obtain a copy.
- SPEAKER UNIDENTIFIED: We heard about the military standard 1290 which is being applied to the military helicopters. Do you know if there is any study going on at the moment to bring into the civilian field some of the criteria which are being applied in the military field as regards building, crashworthiness, and safety for civilian applications?
- SNYDER:  
(United States) I know of nothing along these lines.
- SINGLEY:  
(United States) (Addressing Dr. L. Kazarian, United States) A number of investigators have proposed using a dynamic response index as a probability of injury model. Would you care to comment on the use of the DRI as a probability of injury model in light of your results?
- KAZARIAN:  
(United States) The Air Force is responsible for putting the dynamic response index into being. For those of you who are not familiar with the DRI, it is a single degree of freedom model with a spring and a dash pot and somehow it's supposed to give you some sort of a probability of injury. I don't understand how the DRI works.
- AUFFRET:  
(France) Should one, after each airplane crash or helicopter crash, have a systematic radio exam of the spinal column?
- KAZARIAN:  
(United States) In the F111 group, our injuries are primarily in the area of T5, T6, and T7. What we see in the F111 aircrewman over long-term follow-up is fusion at about four vertebral levels. In the F4's we're seeing a loss in intervertebral disc space height, and this is combined with a spinalosis deformance. The long-term consequences seem to be vertebral body breaking with a loss in range of motion. Paralleling these efforts, we've been impacting both baboons and Rhesus monkeys in the same mode that we see the injuries being produced, and we're seeing similar findings in the animals. I would recommend serial radiographs, usually one right after the accident has occurred, one in approximately six weeks. On the F111's we're going at nine months, and then at one year after that nine months, and approximately a year and half later. What we have now with the F111 aircrewman is a very nice sequential series showing how we're getting vertebral body fusion within the system. And, of course, the question is should we allow the aircrewman to fly? Currently, the F111 is out of spec; the support and restraint system is out of spec; and, if an aircrewman has an increased thoracic kyphosis along with vertebral body fusion, there is a very high probability that on powered inertial reel retraction (and this is where we're getting our hyperextension injuries in the thoracic spine) there will be vertebral body subluxation and nerve root and cord involvement. We're recommending an aircrewman who has sustained this type of an injury to be taken out of the crew escape system; and, of course, you can't put him into the ejection seat either.
- PERRY:  
(United Kingdom) You've mentioned about how soon you take the first or second x-ray. Over the years and again recently I've been x-raying helicopter pilots' backs who have impacted, some severely, some not so severely. We have, in fact, not demonstrated fractures using good radiographic techniques until some three weeks after the incident, although some had severe pain and some had minor pain. So this would possibly be the forum where we could actually come to a plan or an idea of a plan for just exactly how we should do this. In fact, I've got nine cases in whom we didn't discover it until nine years later.
- KAZARIAN:  
(United States) I should have told you about our radiographic techniques; I failed to do so. We take routine AP and lateral films. After we take the AP and laterals, depending upon where we think the injury may be located, we'll go ahead and take serial linear tomograms and that's done in a rather precise manner. We're hoping that we'll be able to use a cat scanner, but currently we're using serial linear tomographic techniques to follow up the injury. Once we determine the slice that we're interested in, that is the distance we will stay with; and we usually go one centimeter above and one centimeter below and take x-rays. That's the sequential series after.
- SPEAKER UNIDENTIFIED: I was very impressed with the work that you've been doing with the Air Force data. Would it be true to say that the Army data are looked at as thoroughly as

DVI-2

you look at it?

KAZARIAN:  
(United States)

I don't think so.

WENGER:  
(United States)

Did I understand you to say that the Puma, which had close to the ideal sitting arrangement, had a great deal of complaints regarding vertebral pain and trauma?

AUFFRET:  
(France)

I think that perhaps I was misunderstood. The Puma is currently a very well regarded helicopter by flight crews in a number of different countries, and I should like to pinpoint this fact. I think that the improvement of the subjective feeling of the pilot (of Puma pilots) is more linked to an improvement of the pilot's posture than to a great deal of reduction in vibration.

STEELE-PERKINS:  
(United Kingdom)

First, were the vibration measurements on the floor of the aircraft or at the man-seat interface because the Lynx has an antivibration seat which attenuates to at least 50% the levels of vibration. Second, with most helicopters flying in cruise flight with a nose down attitude with an occupant taking up a nose forward seating position, how do you consider this affects the vibration of the occupant?

AUFFRET:  
(France)

It's quite obvious, as far as the Puma is concerned, that the vibration level that I showed on the slide was vibration levels that have been recorded on the helicopter floor. I didn't want to go into all the details about the various measurements that have been made about the head and the thorax in the Puma seats or other helicopters; but we can't say that the reduction is considerable, particularly when the movement goes from the floor to the different parts of the human body. When a Lynx pilot is in a very leaning forward position, he will undergo at the top of the superior vertebral column a very bad vibrational level. Mr. Kazarian showed this in what he presented. We saw that the fragility of the column is linked to a forward flex. As far as arthrosis is concerned in the cervical and dorsal column--without being able to give you any particular statistics today because I don't have them--nevertheless, I am led to think that we are going to see these arthroic manifestations increase as a result of the posture that I have described.

**REPORT DOCUMENTATION PAGE**

<b>1. Recipient's Reference</b>	<b>2. Originator's Reference</b>	<b>3. Further Reference</b>	<b>4. Security Classification of Document</b>								
	AGARD-CP-255	ISBN 92-835-0226-4	UNCLASSIFIED								
<b>5. Originator</b>	Advisory Group for Aerospace Research and Development North Atlantic Treaty Organization 7 rue Ancelle, 92200 Neuilly sur Seine, France										
<b>6. Title</b>	OPERATIONAL HELICOPTER AVIATION MEDICINE										
<b>7. Presented at</b>	the Aerospace Medical Panel's Specialists' Meeting held at Fort Rucker, Alabama, USA, 1-5 May 1978.										
<b>8. Author(s)/Editor(s)</b>	Various	Edited by Col. S.C.Knapp, MC	<b>9. Date</b> December 1978								
<b>10. Author's/Editor's Address</b>	Various	Commander - US Army Aeromedical Research Laboratory (USAARL) Fort Rucker, AL 36362, USA	<b>11. Pages</b> 656								
<b>12. Distribution Statement</b>	This document is distributed in accordance with AGARD policies and regulations, which are outlined on the Outside Back Covers of all AGARD publications.										
<b>13. Keywords/Descriptors</b>	<table> <tr> <td>Helicopters</td> <td>Stress (physiology)</td> </tr> <tr> <td>Airborne operations</td> <td>Stress (psychology)</td> </tr> <tr> <td>Pilots (personnel)</td> <td>Human factors engineering</td> </tr> <tr> <td>Aerospace medicine</td> <td></td> </tr> </table>			Helicopters	Stress (physiology)	Airborne operations	Stress (psychology)	Pilots (personnel)	Human factors engineering	Aerospace medicine	
Helicopters	Stress (physiology)										
Airborne operations	Stress (psychology)										
Pilots (personnel)	Human factors engineering										
Aerospace medicine											
<b>14. Abstract</b>	<p>Helicopters have become increasingly complex. Their operational missions can be extremely demanding for aircrews and significantly differ from those of fixed wing aircraft.</p> <p>Rotary wing operations are compounded by specific stresses and environments, special safety and workload aspects, unique performances and goals.</p> <p>Combat flexibility and air mobility in land and sea warfare, medical evacuation, search and rescue, fatigue related accidents, human factors of helicopter design, visual and acoustic aspects of helicopter operations, and crashworthiness of fuel systems and aircraft, are some of the elements of the scenarios staged by the authors.</p> <p>The papers presented in the 6 sessions of the Specialists' Meeting, held by the Aerospace Medical Panel at Fort Rucker, USA, 1-5 May 1978, highlight the medical problems of operational helicopter flying in an exhaustive review.</p>										



<p>AGARD Conference Proceedings No.255 Advisory Group for Aerospace Research and Development, NATO OPERATIONAL HELICOPTER AVIATION MEDICINE Edited by Colonel S.C.Knapp, MC Published December 1978 656 pages</p> <p>Helicopters have become increasingly complex. Their operational missions can be extremely demanding for aircrews and significantly differ from those of fixed wing aircraft.</p> <p>Rotary wing operations are compounded by specific stresses and environments, special safety and workload aspects, unique performances and goals.</p> <p>P.T.O.</p>	<p>AGARD-CP-255</p> <p>Helicopters Airborne operations Pilots (personnel) Aerospace medicine Stress (physiology) Stress (psychology) Human factors engineering</p>	<p>AGARD Conference Proceedings No.255 Advisory Group for Aerospace Research and Development, NATO OPERATIONAL HELICOPTER AVIATION MEDICINE Edited by Colonel S.C.Knapp, MC Published December 1978 656 pages</p> <p>Helicopters have become increasingly complex. Their operational missions can be extremely demanding for aircrews and significantly differ from those of fixed wing aircraft.</p> <p>Rotary wing operations are compounded by specific stresses and environments, special safety and workload aspects, unique performances and goals.</p> <p>P.T.O.</p>	<p>AGARD-CP-255</p> <p>Helicopters Airborne operations Pilots (personnel) Aerospace medicine Stress (physiology) Stress (psychology) Human factors engineering</p>
<p>AGARD Conference Proceedings No.255 Advisory Group for Aerospace Research and Development, NATO OPERATIONAL HELICOPTER AVIATION MEDICINE Edited by Colonel S.C.Knapp, MC Published December 1978 656 pages</p> <p>Helicopters have become increasingly complex. Their operational missions can be extremely demanding for aircrews and significantly differ from those of fixed wing aircraft.</p> <p>Rotary wing operations are compounded by specific stresses and environments, special safety and workload aspects, unique performances and goals.</p> <p>P.T.O.</p>	<p>AGARD-CP-255</p> <p>Helicopters Airborne operations Pilots (personnel) Aerospace medicine Stress (physiology) Stress (psychology) Human factors engineering</p>	<p>AGARD Conference Proceedings No.255 Advisory Group for Aerospace Research and Development, NATO OPERATIONAL HELICOPTER AVIATION MEDICINE Edited by Colonel S.C.Knapp, MC Published December 1978 656 pages</p> <p>Helicopters have become increasingly complex. Their operational missions can be extremely demanding for aircrews and significantly differ from those of fixed wing aircraft.</p> <p>Rotary wing operations are compounded by specific stresses and environments, special safety and workload aspects, unique performances and goals.</p> <p>P.T.O.</p>	<p>AGARD-CP-255</p> <p>Helicopters Airborne operations Pilots (personnel) Aerospace medicine Stress (physiology) Stress (psychology) Human factors engineering</p>

<p>Combat flexibility and air mobility in land and sea warfare, medical evacuation, search and rescue, fatigue related accidents, human factors of helicopter design, visual and acoustic aspects of helicopter operations, and crashworthiness of fuel systems and aircraft, are some of the elements of the scenarios staged by the authors.</p> <p>The papers presented in the 6 sessions of the Specialists' Meeting, held by the Aerospace Medical Panel at Fort Rucker, USA, 1-5 May 1978, highlight the medical problems of operational helicopter flying in an exhaustive review.</p> <p>ISBN 92-835-0226-4</p>	<p>Combat flexibility and air mobility in land and sea warfare, medical evacuation, search and rescue, fatigue related accidents, human factors of helicopter design, visual and acoustic aspects of helicopter operations, and crashworthiness of fuel systems and aircraft, are some of the elements of the scenarios staged by the authors.</p> <p>The papers presented in the 6 sessions of the Specialists' Meeting, held by the Aerospace Medical Panel at Fort Rucker, USA, 1-5 May 1978, highlight the medical problems of operational helicopter flying in an exhaustive review.</p> <p>ISBN 92-835-0226-4</p>
<p>Combat flexibility and air mobility in land and sea warfare, medical evacuation, search and rescue, fatigue related accidents, human factors of helicopter design, visual and acoustic aspects of helicopter operations, and crashworthiness of fuel systems and aircraft, are some of the elements of the scenarios staged by the authors.</p> <p>The papers presented in the 6 sessions of the Specialists' Meeting, held by the Aerospace Medical Panel at Fort Rucker, USA, 1-5 May 1978, highlight the medical problems of operational helicopter flying in an exhaustive review.</p> <p>ISBN 92-835-0226-4</p>	<p>Combat flexibility and air mobility in land and sea warfare, medical evacuation, search and rescue, fatigue related accidents, human factors of helicopter design, visual and acoustic aspects of helicopter operations, and crashworthiness of fuel systems and aircraft, are some of the elements of the scenarios staged by the authors.</p> <p>The papers presented in the 6 sessions of the Specialists' Meeting, held by the Aerospace Medical Panel at Fort Rucker, USA, 1-5 May 1978, highlight the medical problems of operational helicopter flying in an exhaustive review.</p> <p>ISBN 92-835-0226-4</p>

583  
4

AGARD

NATO + OTAN

7 RUE ANCELLE · 92200 NEUILLY SUR SEINE  
FRANCE

Telephone 745.08.10 · Telex 610176

DISTRIBUTION OF UNCLASSIFIED  
AGARD PUBLICATIONS

AGARD does NOT hold stocks of AGARD publications at the above address for general distribution. Initial distribution of AGARD publications is made to AGARD Member Nations through the following National Distribution Centres. Further copies are sometimes available from these Centres, but if not may be purchased in Microfiche or Photocopy form from the Purchase Agencies listed below.

NATIONAL DISTRIBUTION CENTRES

**BELGIUM**

Coordonnateur AGARD VSL  
Etat-Major de la Force Aérienne  
Quartier Reine Elisabeth  
Rue d'Evere, 1140 Bruxelles

**CANADA**

Defence Scientific Information Service  
Department of National Defence  
Ottawa, Ontario K1A 0Z2

**DENMARK**

Danish Defence Research Board  
Østerbrogades Kaserne  
Copenhagen Ø

**FRANCE**

O.N.E.R.A. (Direction)  
29 Avenue de la Division Leclerc  
92 Châtillon sous Bagneux

**GERMANY**

Zentralstelle für Luft- und Raumfahrt-  
dokumentation und Information  
c/o Fachinformationszentrum Energie,  
Physik, Mathematik GmbH  
Kernforschungszentrum  
7514 Eggenstein-Leopoldshafen 2

**GREECE**

Hellenic Air Force General Staff  
Research and Development Directorate  
Holargos, Athens, Greece

**ICELAND**

Director of Aviation  
c/o Flugrad  
Reykjavik

**UNITED STATES**

National Aeronautics and Space Administration (NASA)  
Langley Field, Virginia 23365  
Attn: Report Distribution and Storage Unit

THE UNITED STATES NATIONAL DISTRIBUTION CENTRE (NASA) DOES NOT HOLD STOCKS OF AGARD PUBLICATIONS, AND APPLICATIONS FOR COPIES SHOULD BE MADE DIRECT TO THE NATIONAL TECHNICAL INFORMATION SERVICE (NTIS) AT THE ADDRESS BELOW.

PURCHASE AGENCIES

*Microfiche or Photocopy*

National Technical  
Information Service (NTIS)  
5285 Port Royal Road  
Springfield  
Virginia 22161, USA

*Microfiche*

Space Documentation Service  
European Space Agency  
10, rue Mario Nikis  
75015 Paris, France

*Microfiche*

Technology Reports  
Centre (DTI)  
Station Square House  
St. Mary Cray  
Orpington, Kent BR5 3RF  
England

Requests for microfiche or photocopies of AGARD documents should include the AGARD serial number, title, author or editor, and publication date. Requests to NTIS should include the NASA accession report number. Full bibliographical references and abstracts of AGARD publications are given in the following journals:

Scientific and Technical Aerospace Reports (STAR)  
published by NASA Scientific and Technical  
Information Facility  
Post Office Box 8757  
Baltimore/Washington International Airport  
Maryland 21240, USA

Government Reports Announcements (GRA)  
published by the National Technical  
Information Services, Springfield  
Virginia 22161, USA



Printed by Technical Editing and Reproduction Ltd  
Harford House, 7-9 Charlotte St, London W1P 1HD

ISBN 92-835-0226-4