

AD A O 6 0 8 3 3

DDC FILE COPY

⑨ **LEVEL II** (2) <sub>B.S.</sub>  
**QUARTERLY SUMMARY** *part. no. 3,*  
**Number Three**

⑪ **30 June 1978**

⑫ 477 p

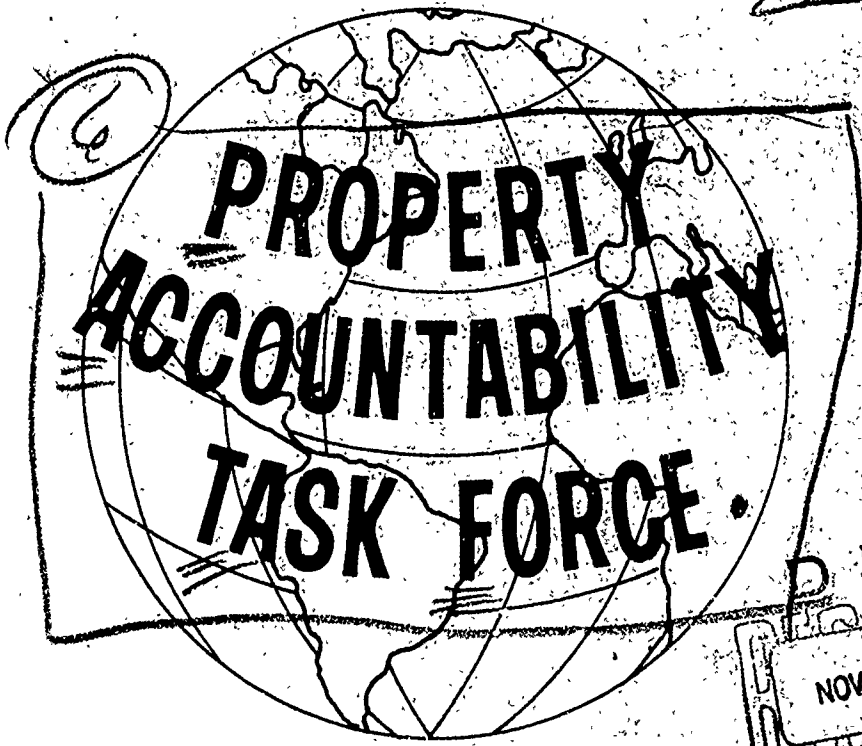

DDC  
 NOV 2 1978  
 F

This document has been approved for public release and sale; its distribution is unlimited.

Department of the Army  
 Office of the Deputy Chief of Staff for Logistics  
 Washington, D.C. 20310

78 09 14 069

110 300

# DISCLAIMER NOTICE

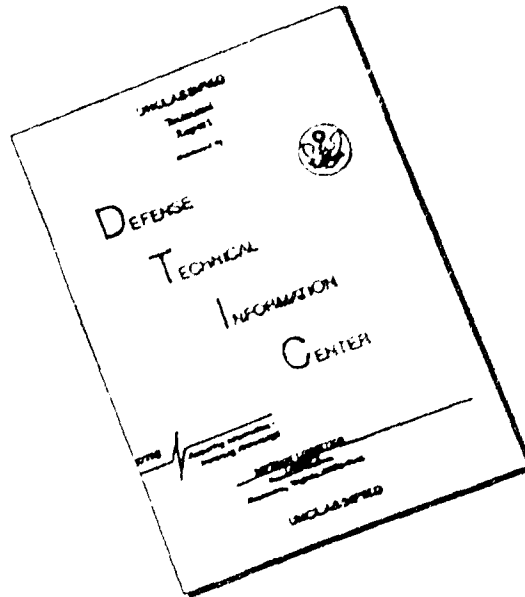

THIS DOCUMENT IS BEST  
QUALITY AVAILABLE. THE COPY  
FURNISHED TO DTIC CONTAINED  
A SIGNIFICANT NUMBER OF  
PAGES WHICH DO NOT  
REPRODUCE LEGIBLY.



DEPARTMENT OF THE ARMY  
OFFICE OF THE DEPUTY CHIEF OF STAFF FOR LOGISTICS  
WASHINGTON, D.C. 20310

2

DALO-ZX1

SUBJECT: Property Accountability Progress

1. The Department of the Army Property Accountability Task Force has now been in full operation for over eight months. Significant progress has been made in accounting for property throughout the Army. Although much of the initial thrust emanated from the Task Force, I am proud to state that the Army, worldwide, has accepted the challenge of improving property accountability. Many organizations have initiated innovative changes. I can assure you that the procedures being put into effect will not be "quick fixes" but will be the framework by which we will build a viable accountability system for the long term.
2. I would like to give a capsulized report of the status of several important actions. Strict inventory procedures have been established which designate company commanders as hand receipt holders or property book officers and require a 100 percent physical inventory prior to change/assumption of command. The report of survey system has been overhauled and simplified, and the new system will become effective 1 January 1979. The officer education program has been modified to include mandatory training in property accountability for all basic and advanced courses. The programs of instruction for enlisted supply clerks have been updated to ensure that all required tasks are being taught. Supply publications are being revised in understandable and easy to read terms, and overprinted hand receipts are being included in catalogs and technical manuals to assist in inventorying property. New procedures are being published to provide improved physical security of Army property at organizational/installation level.
3. I am confident that the men and women of today's Army will continue to rise to the task of accounting for and making proper use of all items entrusted to us.

OREN E. DeHAVEN  
Major General, GS  
Director, DA Property Accountability  
Task Force

i  
110 300

This document has been approved  
for release to the public  
distribution is unlimited

ACCESS	
NTIS	Section <input checked="" type="checkbox"/>
ODC	Section <input type="checkbox"/>
UNANNOUNCED	<input type="checkbox"/>
JUSTIFICATION	<input type="checkbox"/>
<i>Part 1</i>	
<i>on file</i>	
INDEX BY	DISTRIBUTION/AVAILABILITY CODES
TITLE	SPECIAL
<b>A</b>	

FOREWORD

i

INDEX

iii

Part One

DAPATF ACTIONS

Chapter 1	General	1
Chapter 2	Flasher Messages	
Section I	Summaries	3
Section II	Messages	5
	1. Shop Equipment Automotive Maintenance and Repair, Organizational Maintenance No. 1 Common, and Other PAA Funded SKO's (Flasher No. 13)	6
	2. Accountability of Organizational Clothing and Individual Equipment (CTA 50-900, Interim Change to AR 710-2, w/C4, Number 5-2; AR 700-84 w/C4, Number 5-2; AR 210-10, Number 1-1; and AR 640-10, Number 1-1 (Flasher No. 14)	8
Chapter 3	Proper Count Messages	
Section I	Summaries	11
Section II	Messages	17
	1. Review of the Equipment Survey Process	18
	2. Equipment Authorization Policies and Procedures Review	20
	3. Proper Count Flasher Message No. 10	23
	4. Crime Prevention Message - Training and Accountability	24
	5. DA Property Accountability Task Force (DAPATF) Telephone Numbers	26

18 09 14 19



	TITLE	PAGE
	6. Acceleration of Current Program to Simplify Supply Publications	27
	7. Essential Instruction in the Management and Accountability of Army Materiel	28
	8. Property Accountability Training	30
	9. Supply Publications Change Procedures	32
	10. Organizational Clothing and Equipment (OCE)	34
	11. Acceleration of Current Program to Simplify Supply Publications	35
	12. Supply Publication Change Procedures	36
	13. Guidelines for Individual Issue of Discretionary Items, CTA 50-900	37
	14. Property Accountability Working Conference III	38
	15. Property Accountability Working Conference III	40
	16. DAPATF Working Conference III	42
	17. Property Accountability Working Conference III	45
	18. Request for Clarification	46
	19. Crime Prevention Message - Turning In Property to Defense Property Disposal Office (DPDO)	47
	20. SKO Moratorium, Flasher No. 13	49
	21. DA Property Accountability Task Force (DAPATF)	50
	22. Revision of AR 710-2 to Include Instructions on Use of Hand Receipts	51
	23. DAPATF Working Conference III Agenda	52
	24. SKO Moratorium	55
	25. DAPATF Working Conference III	56
	26. Accounting for Damaged Property	57
	27. Distribution of DD Form 200	58
Chapter 4	Correspondence and Publications	
Section I	Summaries	59
Section II	Correspondence	67
	1. Property Accountability - Enforcement of Supply Discipline	68

TITLE	PAGE
2. 761A, Unit Supply Technician	69
3. USACIDC Property Accountability Recommendations	71
4. Property Accountability Training	72
5. Supply Publications Management of Change Study IPR	73
6. TEC/Exportable Training Packages	74
7. Tool Kit Inventory	75
8. Quick Inventory Automotive Tool Boxes	79
9. Quick Inventory Aviation General Mechanics Tool Kit	82
10. Validation of DA Directed and Emphasized Training Subjects	84
11. Implementation of Approved DAIG Recommendation - Consumption Standards	85
12. Shop Equipment, Contact Maintenance, NSN 4940-01-016-2262	86
13. Revision of CTA 50-900 and Consolidation with CTA 50-906	87
14. Annual Evaluation of the USACIDC Quarterly Crime Prevention Report	90
15. Recategorization of Supplies and Equipment	92
16. Approval of TRADOC Supplement 1 to AR 710-1 (Draft)	95
17. Logistics Service Awards Program	97
18. Request for 12-hour Training Packet	98
19. Property Accountability Training Material	99
20. Reports of Survey and Cash Collection Vouchers	100
21. Request for Waiver of Property Accountability	102
22. Fort Leonard Wood Reports of Survey #182-78 and #189-78 (USAR)	106
23. Proper Count Impact on Personnel (USAR)	111
24. Draft AR 190-51, Security of Army Property at Unit and Installation Level	112
25. USACIDC Property Accountability Recommendations	115
26. Army's Request for Deviation from DOD 7200.10M	119
27. Secure Storage Space for Organizational Clothing and Equipment (OCE)	121

	TITLE	PAGE
	28. Logistics Service Awards Program	123
	29. LOG Services Awards Program	125
	30. Tool Kit Inventories	126
	31. Surveying Officer's Guide	128
	32. Draft AR 735-11	130
	33. Component Listings of Integral Components of End Items, DA Forms 2062	132
	34. TM Operators' Manual Consolidation List	134
	35. Draft AR 672-XX, Logistics Services Awards Program	136
	36. Logistics Services Awards Program	137
	37. Draft AR 190-51, Security of Army Property at Unit and Installation Level (MACOM's)	139
	38. Draft AR 190-51, Security of Army Property at Unit and Installation Level (Army Staff)	141
	39. Department of the Army Property Accountability Task Force DAPATF Working Conference III	142
Section III	Publications	145
	1. Property Accountability (Commander Call, May-June 1978)	146
	2. Proper Count Message (Army Logistician, July-August 1978)	147
	3. Self-Help in Property Accountability (Army Logistician, July-August 1978)	151
Part Two	MACOM RESPONSES	
Chapter 5	Recommendation 6A, Command Emphasis	155
Chapter 6	Recommendation 6B, Management Information System	164
Chapter 7	Recommendation 6C, Audit Trail	180
Chapter 8	Recommendation 6D, Turn-in Procedures	188
Chapter 9	Recommendation 6E, Uniform Allowances	190

	TITLE	PAGE
Chapter 10	Recommendation 6F, Supply Publication Change	255
Chapter 11	Recommendation 6G, Accountability Regulation Change	287
Chapter 12	Recommendation 6H, Supply Publication Simplicity	289
Chapter 13	Recommendation 6I, IAR Reductions	304
Chapter 14	Recommendation 6J, Droppage Allowance	307
Chapter 15	Recommendation 6K, Equipment/Component Recategorization	309
Chapter 16	Recommendation 6L, Equipment Authorization System	313
Chapter 17	Recommendation 6M, Cash Collection	361
Chapter 18	Recommendation 6N, Medical Supply Accountability	362
Chapter 19	Recommendation 6O, Report of Survey System	367
Chapter 20	Recommendation 6P, CMF 76 Management	379
Chapter 21	Recommendation 6Q, Officer Education	397
Chapter 22	Recommendation 6R, Consumption Standards	405
Chapter 23	Recommendation 6S, DAPATF Establishment/Operations	407
Chapter 24	Implied Recommendation, Security of Army Property	423
Chapter 25	Related Actions	432
Chapter 26	Lessons Learned	471

PART ONE, DAPATF ACTIONS

CHAPTER 1

GENERAL

1. Purpose. This booklet summarizes messages, correspondence, and other information released by the Department of the Army Property Accountability Task Force (DAPATF) since 1 April 1978. These publications provide the direction for improvement of property accountability within the US Army.

2. Background.

a. On 11 October 1977, the Chief of Staff, Army approved the Report of the Audit Survey and Special Inspection of Management and Accountability of Army Materiel prepared by the Department of the Army Inspector General. This report, based on a four-month inspection of 118 company size units, indicated significant problems in the area of property accountability. It noted that although there was an extrapolated value of excess property of 89 million dollars, extension of the report losses amounted to 118.5 million dollars.

b. The Department of the Army Property Accountability Task Force was established on 14 October 1977 to implement the report recommendations. Its charter is to take appropriate measures to make regulatory changes and policy announcements required to correct the deficiencies noted. Organized to address supply management, supply publication change, equipment authorization essentiality, training, legal simplification, and security, the task force has developed a number of policy changes during the last quarter. These actions have been forwarded to the MACOM's for implementation. This correspondence has been compiled and presented in this booklet for your use.

3. Assistance. Comments involving the contents of this booklet may be forwarded to HQDA, ATTN: DALO-ZXT, Pentagon, Washington, DC 20310. Direct contact is encouraged through the use of AUTOVON numbers listed on the rear cover of the booklet.

CHAPTER 2

FLASHER MESSAGES

Section I. Summaries

1. Proper Count Flasher Message No. 13, DTG 171632Z Apr 78, Shop Equipment Automotive Maintenance and Repair, Organizational Maintenance No. 1 Common, and Other PAA Funded SKO's.

Summary: Directs all MACOM's not to take any further requisition action on any changes to SKO's that are PAA funded except for absolute mission essential items or changes that have safety implications, pending the DARCOM development of procedures for processing changes.

Action Officer: LTC Stalcup

2. Proper Count Flasher Message No. 14, DTG 091910Z May 78, Accountability of Organizational Clothing and Individual Equipment (CTA 50-900), Interim Change to AR 710-2, w/C4 number 5-2, AR 700-84 w/C4 Number 5-2, AR 210-10, Number 1-1, AR 640-10, Number 1-1.

Summary:

- Standardizes the procedures for the issue, turn-in, transfer, and accountability of CTA 50-900 OCIE.

- Requires that the individual's organizational clothing record be transferred with the individual upon PCS.

Section II  
Flasher Messages

*Preceding Page BLANK*

R 171632Z APR 78  
FM DA WASH DC //DALO-ZXT//  
TO AIG 7405  
AIG 7406  
AIG 7446  
ARSTAF  
INFO RUEADWD/DA WASH DC //DAIG-IS/AI//  
RUEADWD/DA WASH DC //NGB-ARL//  
RUEADWD/DA WASH DC //DAAR-LO//  
RUCLAHA/DRXMC-AL FT LEE VA  
BT

UNCLAS E F T O

THIS IS A PROPER COUNT FLASHER MESSAGE NO. 13

SUBJECT: SHOP EQUIP AUTO MAINT AND REPAIR ORGN MAINT NO 1 COMMON,  
AND OTHER PAA FUNDED SKO'S

A. FORSCOM AFLG-SMS, 102144Z FEB 78, SUBJ: SHOP EQUIP AUTO MAINT AND  
REPAIR ORGN MAINT NO 1 COMMON, LIN W32593.

B. DA MSG DALO-ZXT, 231923Z FEB 78, SUBJ: SHOP EQUIP AUTO MAINT AND  
REPAIR, ORGN MAINT NO 1 COMMON, LIN W32593.

C. FORSCOM MSG AFLG-SMS, 222015Z MAR 78, SUBJ: SHOP EQUIP AUTO MAINT  
AND REPAIR ORGN MAINT NO 1 COMMON, LIN W32593.

D. DARCOM MSG DRCMM-RX, 102021 APR 78, SUBJ: SHOP EQUIP AUTO MAINT  
AND REPAIR, ORGN MAINT NO 1 COMMON, LIN W32593.

1. REF A REQUESTED GUIDANCE ON REQUESTING AND FUNDING FOR CHANGES  
TO SUBJECT SET.

2. REF B ADVISED DARCOM TO PROVIDE FUNDING INFORMATION TO ALL MACOMS  
IN VIEW OF THE APPLICABILITY OF OMA FUNDS ARMY-WIDE.

3. REF C REQUESTED STATUS OF RESPONSE TO REF A.

4. REF D NOTAL, ADVISED FORSCOM THAT AN IN-DEPTH ANALYSIS IS CURRENTLY  
UNDERWAY TO DEVELOP DEFINITIZED PROCEDURES FOR PROCESSING CHANGES ON  
A NON-REIMBURSABLE BASIS FOR PAA FUNDED SKO'S. REQUISITIONING AND  
FUNDING INFORMATION IS EXPECTED APPROXIMATELY 60-90 DAYS.



5. THIS IS TO DIRECT ALL MACOMS NOT TO TAKE ANY FURTHER REQUISITION ACTION ON ANY CHANGES TO SKO'S THAT ARE PAA FUNDED EXCEPT FOR ABSOLUTE MISSION ESSENTIAL ITEMS OR CHANGES THAT HAVE SAFETY IMPLICATIONS, PENDING THE DARCOM DEVELOPMENT OF PROCEDURES FOR PROCESSING CHANGES. REQUISITIONING AND FUNDING INFORMATION WILL BE PROVIDED BY DARCOM WHEN PROCEDURES ARE DEVELOPED AND FINALIZED.

6. THIS HAS NO EFFECT ON ROUTINE REPLACEMENT ACTION FOR COMPONENTS TO SKO'S.

BT

ACTION ADDRESSEES  
080 ARSTAF A (DAMEMO 105-1 APPLIES)

R 091910Z MAY 78  
FM DA WASH DC //DALO-ZXT//  
TO AIG 7405  
AIG 7406  
AIG 7446  
ARSTAF  
INFO RUEADWD/DA WASH DC //DAIG-IS/AI//  
RUEADWD/DA WASH DC //NGB-ARL//  
RUEADWD/DA WASH DC //SAAR-LO//  
RUCLAHA/DRSMC-AL FT LEE VA  
RUEMANA/DALO-LER NEW CUMBERLAND AD PA  
BT

UNCLAS E F T O

THIS IS PROPER COUNT FLASHER MESSAGE NO. 14.

SUBJECT: ACCOUNTABILITY OF ORGANIZATIONAL CLOTHING AND INDIVIDUAL EQUIPMENT (CTA 50-900), INTERIM CHANGE TO AR 710-2, W/C4 NUMBER 5-2, AR 700-84 W/C4 NUMBER 5-2, AR 210-10, NUMBER 1-1, AR 640-10, NUMBER 1-1.

A. DAMO-FDU 191950Z APR 78, SUBJ: TRANSFER OF ORGANIZATIONAL ISSUE ITEMS (CTA 50-900).

1. REF A IS A LISTING OF THE CTA 50-900, ORGANIZATIONAL CLOTHING AND INDIVIDUAL EQUIPMENT (OCIE) WHICH WHEN AUTHORIZED, WILL BE RETAINED/ TRANSFERRED WITH THE INDIVIDUAL UPON PCS/TDY.

2. IN ORDER TO STANDARDIZE THE PROCEDURES FOR THE ISSUE, TURN-IN, TRANSFER, AND ACCOUNTABILITY OF OCIE, THE FOLLOWING ACTION WILL BE FULLY IMPLEMENTED BY 1 JULY 1978:

A. DURING RECEPTION CENTER PROCESSING (RCP), ITEMS OF CTA 50-900 OCIE ISSUED TO ENLISTED INDIVIDUALS WILL BE TEMPORARILY RECORDED ON DA FORM 3078, PERSONAL CLOTHING REQUEST. DA FORM 3078 WILL BE RETAINED UNTIL THE INDIVIDUAL COMPLETES SIX MONTHS SERVICE, HAS BEEN ISSUED A COMPLETE ALLOWANCE OF PERSONAL CLOTHING ITEMS, OR UNTIL THE INDIVIDUAL HAS IN-PROCESSED AT HIS/HER INITIAL PERMANENT DUTY STATION, WHICHEVER DATE IS LATER.

B. WHEN IN-PROCESSING AT INITIAL PERMANENT DUTY STATION, ALL OCIE ISSUED DURING RCP WILL BE TRANSFERRED TO DA FORM 3645.

C. ALL FUTURE ISSUES AND TURN-INS OF OCIE MADE TO INDIVIDUALS WILL BE RECORDED ON DA FORM 3645.

D. CTA 50-970 EXPENDABLE ITEMS ISSUED DURING RCP WILL NOT BE RECORDED ON DA FORM 3645.

E. OCIE AUTHORIZED FOR RETENTION/TRANSFER IAW REF A, AND PRESENTLY ON INDIVIDUALS DA FORM 3645, WILL NOT BE PICKED UP ON THE CIF OR UNIT/ORG PROPERTY BOOK (PB).

3. ABSTRACTING OF OCIE TO/FROM UNIT/ORG PROPERTY BOOK FOR UNITS NOT SUPPORTED BY A CIF IS AUTHORIZED FOR THE ISSUE OF THOSE OCIE ITEMS WHICH ARE AUTHORIZED TO BE RETAINED/TRANSFERRED IAW REF A.

4. ABSTRACTING FROM THE CIF PB AND UNIT/ORG PB WILL BE ACCOMPLISHED IN THE FOLLOWING MANNER:

A. DA FORM 3645 WILL BE PREPARED IN TWO COPIES.

(1) ONE COPY FORWARDED TO UNIT.

(2) ONE COPY RETAINED BY CIF OR UNIT/CONSOLIDATED SUPPLY IF NO CIF. NOTE: IF NO CIF AND CONSOLIDATED SUPPLY - FILE BOTH COPIES IN UNIT SUPPLY.

B. INDIVIDUAL ISSUES AND TURN-INS WILL BE RECORDED ON A CONSOLIDATED DA FORM 3645, REFLECTING THE INDIVIDUAL'S NAME, SSN AND QUANTITY ISSUED. THE CONSOLIDATED 3645 WILL ACCOMMODATE TWENTY-FIVE INDIVIDUALS. THE CONSOLIDATED 3645S WILL THEN BE TOTALED, ATTACHED TO A SEPARATE DA FORM 3645 AND POSTED TO THE PROPERTY BOOK AT LEAST WEEKLY. THE SEPARATE DA FORM 3645 WILL SHOW THE TOTAL QUANTITY ISSUED OR TURNED-IN, THE TRANSACTION AND THE NOTATION. "SEE SUPPORTING 3645(S) ATTACHED."

5. THE FOLLOWING PROCEDURES WILL BE FOLLOWED WHEN AN INDIVIDUAL DEPARTS ON PCS:

A. UPON CLEARANCE OF THE CIF/UNIT SUPPLY - ENSURE THE INDIVIDUAL RETAINS THOSE ITEMS OF OCIE AUTHORIZED TO BE TRANSFERRED WITH HIM/HER.

B. THE CIF COPY (ORGANIZATION COPY, IF NO CIF) OF DA FORM 3645 REFLECTING THOSE ITEMS WHICH WILL BE RETAINED/TRANSFERRED WITH THE INDIVIDUAL WILL BE FILED IN THE CIF OR UNIT/ORGANIZATION SUPPLY (IF NO CIF) FOR A PERIOD OF SIX MONTHS AFTER THE INDIVIDUAL DEPARTS ON PCS.

C. THE UNIT COPY OF DA FORM 3645 REFLECTING THOSE ITEMS WHICH WILL BE TRANSFERRED WILL BE INCLOSED IN THE MILITARY PERSONNEL RECORD JACKET (MPRJ) EVEN IF ALL ITEMS ARE AT ZERO (O) BALANCE.

D. THE CUSTODIAN OF THE INDIVIDUAL'S PERSONNEL RECORDS WILL AUTHENTICATE THAT THE DA FORM 3645 IS INCLOSED DURING THE OUT-PROCESSING WHEN CLOSING OUT THE MPRJ.

E. PROCESSING OF THE DA FORM 3645 WILL BE INCLUDED IN THE INSTALLATION CLEARANCE PROCEDURES, WITH THE DA FORM 3645 BEING LISTED ON DA FORM 137, THE INSTALLATION CLEARANCE FORM.

6. IF AN INDIVIDUAL ARRIVES AT THE NEW DUTY STATION WITHOUT A COPY OF DA FORM 3645 IN THE MPRJ, THE NEW CUSTODIAN OF THE INDIVIDUAL'S MPRJ WILL IMMEDIATELY REQUEST A COPY OF THE INDIVIDUAL'S DA FORM 3645 FROM THE OLD CUSTODIAN OF THE INDIVIDUAL'S MPRJ.

7. THIS INTERIM CHANGE IS BEING DISSEMINATED BY ELECTRICAL MESSAGE TO AVOID WASTE OF ARMY FUNDS THROUGH LACK OF ACCOUNTABILITY OF OCIE. THIS MESSAGE EXPIRES SIX MONTHS FROM DATE OF MESSAGE, IF NOT SUPERSEDED BY A FORMAL NUMBER CHANGE. DEVIATIONS FROM CURRENT POLICIES AND PROCEDURES NOTED IN THIS MESSAGE WILL BE INCORPORATED INTO AR 710-2, AR 700-84, AR 210-10, AND AR 640-10.

8. DAPATF POC IS LTC PHILIP J. SAULNIER, AUTOVON 224-3264.

9. REPORT CORRELATION: RECOMMENDATION 6E.

BT

ACTION ADDRESSEES  
080 ARSTAF A (R) (DAMEMO 105-1 APPLIES)

CHAPTER 3

PROPER COUNT MESSAGES

Section I. Summaries

1. Proper Count Message, DTG 051852Z Apr 78, Review of the Equipment Survey Process.

Summary: Message indicated that a review of AR 310-34 and AR 570-7 was being made with emphasis on length of time between equipment surveys, readiness reporting elements, makeup of survey teams, and establishment of teams at levels other than, and in addition to, HQDA/MACOM. MACOM's were requested to provide comments by 30 Apr 78.

Action Officer: MAJ Roberts

2. Proper Count Message, DTG 051854Z Apr 78, Equipment Authorization Policies and Procedures Review.

Summary: Requests MACOM's to review and provide comments on AR 310-34 and AR 310-49 as part of the analysis of the equipment authorization system to ensure that units receive and retain only that materiel that is mission essential for mission accomplishment at a specific time and place.

Action Officer: MAJ Roberts

3. Proper Count Message, DTG 121410Z Apr 78, Proper Count Flasher Message No. 10.

Summary: Message confirms TRADOC's inquiry that Proper Count Flasher Message No. 10 constituted an interim change to CTA 50-900.

Action Officer: LTC Saulnier

4. Proper Count Message, DTG 141914Z Apr 78, Crime Prevention Message - Training Aid Accountability.

Summary: Refers to conditions contributing to vulnerability of Training and Audiovisual Support Centers (TASC) property to theft and pilferage. Outlines procedures to assist in reducing TASC vulnerability to losses.

Action Officer: MAJ Pitcher

5. Proper Count Message, DTG 141920Z Apr 78, DA Property Accountability Task Force (DAPATF) Telephone Numbers.

Summary: Provides current telephone numbers for the DAPATF by primary areas of interest.

Action Officer: MAJ Fitzpatrick

6. Proper Count Message, DTG 172040Z Apr 78, Acceleration of Current Program to Simplify Supply Publications.

Summary: Requests DARCOM to give an IPR on 1 May 78 to the Director, DAPATF as to the status of the CL supply catalog and TM hand receipt program.

Action Officer: LTC O'Hara

7. Proper Count Message, DTG 251615Z Apr 78, Essential Instruction in the Management and Accountability of Army Materiel.

Summary: TRADOC was requested to provide direction to all service schools on the use of the logistics baseline curriculum. TRADOC provided information in message 031705Z Apr 78. This message requested further clarification of the TRADOC response and asked for plans concerning certain points.

Action Officer: MAJ Fitzpatrick

8. Proper Count Message, DTG 251618Z Apr 78, Property Accountability Training.

Summary: Announces the availability of a 12-hour training packet on unit level supply procedures prepared by the US Army Quartermaster School and correspondence and technical extension courses applicable to property accountability.

Action Officer: MAJ Fitzpatrick

9. Proper Count Message, DTG 011325Z May 78, Supply Publications Change Procedures.

Summary: Provides clarification of Flasher Message No. 11 and AR 310-3 regarding issuance of interim changes to AR 725-50 by the Materiel Readiness Support Activity. Requests the Logistics Evaluation Agency to review procedures for transmission of identifier, distribution and designator codes to the field as part of the supply publication change study.

Action Officer: MAJ Roberts

10. Proper Count Message, DTG 012015Z May 78, Organizational Clothing and Equipment (OCE).

Summary: Advises Eighth Army that their proposed new concept for management and accountability for OCE at a central issue facility was forwarded to the Logistics Evaluation Agency which is preparing an update of AR 710-2.

Action Officer: LTC Waters

11. Proper Count Message, DTG 081930Z May 78, Acceleration of Current Program to Simplify Supply Publications.

Summary: Message clarifies prior correspondence regarding the inclusion of printed CL supply catalogs in sets, kits, and outfits issued to the field. Also provides instructions concerning preparation of hand receipt publications.

Action Officer: LTC O'Hara

12. Proper Count Message, DTG 101652Z May 78, Supply Publication Change Procedures.

Summary: Request MACOM include the number of publications reviewed, changed, and rescinded in addition to the information requested in Flasher Message No. 11.

Action Officer: MAJ Roberts

13. Proper Count Message, DTG 101654Z May 78, Guidelines for Individual Issue of Discretionary Items, CTA 50-900.

Summary: Request status of TRADOC effort to develop guidelines for authorizing minimum essential discretionary CTA 50-900 items that a soldier would require during peacetime, tailored to the type of unit, category, and climatic conditions.

Action Officer: LTC Saulnier/MAJ Roberts

14. Proper Count Message, DTG 151500Z May 78, Property Accountability Working Conference III.

Summary: Message advises MACOM's that the Property Accountability Working Conference III will be held at Fort Lee, VA on 27-29 Jun 78. Request names of attendees by 2 Jun 78. TRADOC is requested to give consideration for service school representatives to attend as observers.

Action Officer: MAJ Fitzpatrick

15. Proper Count Message, DTG 181347Z May 78, Property Accountability Working Conference III.

Summary: Requests that FORSCOM attendees at working conference include four captains who assumed command after 16 Jan 78 of an armor, mechanized infantry, infantry, and maintenance company. Company commanders should be prepared to discuss:

- a. Procedures utilized during change of command inventory.
- b. Inventory adjustment actions and turn-in of excess resulting from change of command inventory.
- c. Any other property accountability subject they would like to surface.

Action Officer: MAJ Fitzpatrick

16. Proper Count Message, DTG 191955Z May 78, DAPATF Working Conference.

Summary: Provides a list of issues to be resolved at working conference and presents a number of topics for which commands/agencies are requested to furnish the status.

Action Officer: MAJ Fitzpatrick

17. Proper Count Message, DTG 231327Z May 78, Property Accountability Working Conference III.

Summary: Explains that TDY costs for command representatives attending DAPATF working conferences must be borne by each attendee.

Action Officer: MAJ Fitzpatrick

18. Proper Count Message, DTG 241449Z May 78, Request for Clarification.

Summary: Message states that commanders of a company/detachment equivalent size activity serving in an O5 or lower position will fully comply with Flasher No. 2. Change 5, AR 710-2, soon to be staffed, will permit commanders of such organizations serving in an O6 or higher position to appoint an individual to conduct the change of command inventory.

Action Officer: LTC Stalcup



19. Proper Count Message, DTG 241450Z May 78, Crime Prevention Message - Turning In Property to Defense Property Disposal Office (DPDO).

Summary: Furnishes information that a large number of thefts of Government property have occurred while property was en route to DPDO from the generating unit/activity. Message provides procedures to help prevent the diversion of property between the unit and DPDO.

Action Officer: MAJ Pitcher

20. Proper Count Message, DTG 311403Z May 78, SKO Moratorium, Flasher No. 13.

Summary: Requests DARCOM take action on paragraphs 3A-3F of CINCUSAREUR message DTG 100739Z May 78, subject: SKO Moratorium, Flasher No. 13.

Action Officer: LTC Stalcup

21. Proper Count Message, DTG 082017Z Jun 78, DA Property Accountability Task Force (DAPATF).

Summary: Message again outlines the DAPATF primary areas of interest and the appropriate telephone numbers.

Action Officer: MAJ Fitzpatrick

22. Proper Count Message, DTG 092013Z Jun 78, Revision of AR 710-2 to Include Instructions of Use of Hand Receipts.

Summary: Advises Materiel Readiness Support Activity that Change 5, AR 710-2 is targeted for publication in early FY 79. Specific instructions on the use of preprinted DA Form 2062 will be incorporated in the change.

Action Officer: LTC O'Hara

23. Proper Count Message, DTG 141305Z Jun 78, DAPATF Working Conference III Agenda.

Summary: Provides the agenda of the DAPATF Working Conference III to be held at Fort Lee, VA on 27-29 Jun 78.

Action Officer: MAJ Fitzpatrick

24. Proper Count Message, DTG 151640Z Jun 78, SKO Moratorium.

Summary: Furnishes information as to the status of the tool kit inventory aids program, including hand tool layout mats.

Action Officer: LTC O'Hara

25. Proper Count Message, DTG 161820Z Jun 78, DAPATF Working Conference III.

Summary: Requests name of USAREUR attendee at working conference and additional issues/problems; if any, to be presented.

Action Officer: MAJ Fitzpatrick

26. Proper Count Message, DTG 231332Z Jun 78, Accounting for Damaged Property.

Summary: Provides information that damage to military vehicles and/or major military equipment caused by an accident which are economically repairable, being turned in for repair and return to the user, will be repaired based on a work order. If the amount of the damage caused by the accident exceeds \$500 or sufficient negligence is involved, a report of survey will be utilized.

Action Officer: LTC Saulnier/CW2 Wright

27. Proper Count Message, DTG 231330Z Jun 78, Distribution of DD Form 200.

Summary: Provides instructions for disposition of copy 3, DD Form 200.

Action Officer: LTC Saulnier/CW2 Wright

Section II  
Proper Count Messages

R 051852Z APR 78  
FM DA WASH DC //DALO-ZXT//  
TO AIG 7405  
AIG 7406  
AIG 7446  
ARSTAF  
INFO RUEADWD/DA WASH DC //DAAG-PA//  
RUEADWD/DA WASH DC //DRCS-S  
RUEADWD/DA WASH DC //NGB-ARL//  
RUEADWD/DA WASH DC //DAAR-LO//  
RUEADWD/DA WASH DC //DAIG-IS/AI//  
RUCLAHA/DRXMC FT LEE VA  
RUEMANA/DALO-I.ER NEW CUMBERLAND AD PA  
BT

UNCLAS E F T O

THIS IS A PROPER COUNT MESSAGE

SUBJECT: REVIEW OF THE EQUIPMENT SURVEY PROCESS (S: 30 APR 78)

A. HQDA, CSA LETTER, DATED 11 OCTOBER 1978, SUB. MANAGEMENT AND ACCOUNTABILITY OF ARMY MATERIEL.

B. AR 310-34, WITH CHANGES 1 AND 2, EQUIPMENT AUTHORIZATION POLICIES AND CRITERIA, AND COMMON TABLES OF ALLOWANCE, 22 APRIL 1977.

C. AR 570-7, EQUIPMENT MANAGEMENT: EQUIPMENT SURVEY PROGRAM, DATED 30 JUNE 1975.

1. REFERENCE A FORWARDED THE DAIG REPORT ON MANAGEMENT AND ACCOUNTABILITY OF ARMY MATERIEL. THIS REPORT AND ADDITIONAL COMMENTS BY MEMBERS OF THE DAIG INSPECTION TEAM INDICATED MTOE/TDA UNITS HAD ON-HAND EQUIPMENT FOR WHICH MISSION REQUIREMENTS NO LONGER EXISTED. FURTHER, IT NOTED THAT THERE WAS A WIDESPREAD RETENTION OF EXCESS EQUIPMENT WITHOUT AUTHORITY.

2. REFERENCE B PROVIDES GUIDANCE FOR THE EQUIPMENT AUTHORIZATION PROCESS.

3. REFERENCE C PRESCRIBES POLICIES AND PROCEDURES FOR CONDUCTING THE ARMY EQUIPMENT SURVEY PROGRAM. IT INDICATES THAT ON-SITE EQUIPMENT SURVEYS WILL BE CONDUCTED FOR ACTIVE ARMY TOA INSTALLATIONS/UNITS, ACTIVE ARMY MTOE GENERAL SUPPORT FORCE/NONREADINESS REPORTING (GSF/NRR) MILITARY POLICE UNITS, AND GSF SCHOOL SUPPORT UNITS AT LEAST EVERY THREE YEARS. THE GUIDANCE DOES NOT COVER REVIEW NOR

SURVEY PROCEDURES FOR OTHER CATEGORIES OF UNITS.

4. AS THE DAPATF HAS BEEN TASKED TO REVIEW THE EQUIPMENT AUTHORIZATION SYSTEM TO ENSURE THAT UNITS RECEIVE AND RETAIN ONLY THAT MATERIAL THAT IS CONSIDERED ESSENTIAL FOR MISSION ACCOMPLISHMENT AT A SPECIFIC TIME AND PLACE, A REVIEW OF REFERENCE B AND C IS BEING CONDUCTED. THIS REVIEW WILL INCLUDE, BUT WILL NOT BE LIMITED TO, THE FOLLOWING AREAS:

A. LENGTH OF TIME BETWEEN SURVEYS.

B. SURVEY OF READINESS REPORTING ELEMENTS (SURVEY LIMITED TO NON-TOE REQUIRED, AUTHORIZED EQUIPMENT).

D. MAKEUP OF SURVEY TEAMS.

D. ESTABLISHMENT OF TEAMS AT LEVELS OTHER THAN, AND IN ADDITION TO HQDA/MACOM.

E. OTHER AREAS AS REQUIRED.

5. MACOM'S ARE REQUESTED TO PROVIDE RECOMMENDATIONS ON 4A THROUGH E, ABOVE, NLT 30 APR 78. ADDITIONALLY, COMMAND ORIENTED SUPPLEMENTAL MATERIAL SHOULD BE FORWARDED ALONG WITH COMMENTS TO ENSURE PROPER CONSIDERATION AND INTEGRATION OF FIELD POLICIES AND PROCEDURES.

6. REPORT CORRELATION: RECOMMENDATION 6L.

7. POC IS MAJOR(P) JAMES T. ROBERTS, JR., AUTOVON 224-4782.

BT

ACTION ADDRESSEES

080 ARSTAF A (DAMEMO 105-1 APPLIES)

R 051854Z APR 78  
FM DA WASH DC //DALG-ZXT//  
TO AIG 7405  
AIG 7406  
AIG 7446  
ARSTAF  
INFO RUEADWD/DA WASH DC //DAAG-PA//  
RUEADWD/DA WASH DC //DRCIS-S//  
RUEADWD/DA WASH DC //NGB-ARL//  
RUEADWD/DA WASH DC //DAAR-LO//  
RUEADWD/DA WASH DC //DAIG-IS/AI//  
RUCLAHA/DRXMC FT LEE VA  
RUEMANA/DALO-LER NEW CUMBERLAND AD PA  
BT

UNCLAS E F T O

THIS IS A PROPER COUNT MESSAGE

SUBJECT: EQUIPMENT AUTHORIZATION POLICIES AND PROCEDURES REVIEW  
(S: 30 APR 78)

A. HQDA, CSA LETTER, DATED 11 OCT 77, SUBJECT: MANAGEMENT AND ACCOUNT-  
ABILITY OF ARMY MATERIEL.

B. HQDA, DALO-ZXT PROPER COUNT MESSAGE, DTG 131752Z JAN 78, SUBJECT:  
REVIEW OF MTOE/TDA AUTHORIZED SECONDARY ITEMS.

C. AR 310-34, W/C 1 AND 2, EQUIPMENT AUTHORIZATION POLICIES AND  
CRITERIA AND COMMON TABLES OF ALLOWANCE, 22 APR 77.

D. AR 310-49, THE ARMY AUTHORIZATION DOCUMENTS SYSTEM (TAADS), W/C 1,  
7 NOV 75.

1. REFERENCE A FORWARDED THE DAIG REPORT ON MANAGEMENT AND ACCOUNT-  
ABILITY OF ARMY MATERIEL. THIS REPORT AND ADDITIONAL COMMENTS BY  
MEMBERS OF THE DAIG INSPECTION TEAM INDICATED THAT UNITS HAD ON-HAND  
AUTHORIZED MATERIEL AND EQUIPMENT FOR WHICH MISSION REQUIREMENTS NO  
LONGER EXISTED.

2. REFERENCE B REQUESTED MACOM'S TO REEMPHASIZE PRESENT TAADS POLICIES AND PROCEDURES, CONSIDER MISSION ESSENTIALITY DURING INVENTORY PROCESS, ENCOURAGE COMMAND REVIEW OF CURRENT AUTHORIZATION AND LETTER REQUESTS, AND PROMPT TURN-IN OR CANCELLATION OF REQUISITIONS FOR MTOE/TDA PROPERTY DEEMED EXCESS TO UNIT NEEDS.

3. REFERENCES C AND D PRESENT GUIDANCE ON THE EQUIPMENT AUTHORIZATION PROCESS. THIS GUIDANCE INDICATES PROCEDURES FOR REQUESTING ADDITIONAL EQUIPMENT, GUIDELINES FOR AUTHORIZATION AND TURN-IN, JUSTIFICATION NEED, AND CRITERIA FOR DOCUMENTATION.

4. AS THE DAPATF HAS BEEN TASKED TO LOOK AT THE EQUIPMENT AUTHORIZATION SYSTEM TO ENSURE THAT UNITS RECEIVE AND RETAIN ONLY THAT MATERIEL THAT IS MISSION ESSENTIAL FOR MISSION ACCOMPLISHMENT AT A SPECIFIC TIME AND PLACE, A REVIEW OF REFERENCES C AND D IS BEING MADE. THIS REVIEW WILL INCLUDE, BUT WILL NOT BE LIMITED TO, THE FOLLOWING AREAS:

A. LETTER REQUEST REVIEW PROCEDURES AT INSTALLATION, MACOM, AND HQDA LEVEL.

B. COMMANDER AWARENESS OF TYPE, NUMBER, AND COST OF EQUIPMENT REQUESTED.

C. CHANGES IN COMMAND CHANNEL REVIEW AND APPROVAL PROCEDURES.

D. ESTABLISHMENT OF REVALIDATION PROCEDURES FOR APPROVED LETTER REQUESTED EQUIPMENT AFTER A SPECIFIC PERIOD OR TOE SERIES CHANGE.

E. JUSTIFICATION CRITERIA.

F. COST ANALYSIS PROCEDURES.

G. STORAGE CENTRALIZATION OF SUBORDINATE UNIT ITEMS USED ONLY PERIODICALLY.

H. ADEQUACY OF OTHER POLICIES IN AR 310-34/310-49.

I. OTHER AS REQUIRED.

5. MACOM'S ARE REQUESTED TO PROVIDE COMMENTS ON 4A THROUGH I, ABOVE, NLT 30 APR 78. ADDITIONALLY, COMMAND ORIENTED SUPPLEMENTAL MATERIAL CONCERNING AR 310-12/310-49 SHOULD BE FORWARDED ALONG WITH COMMENTS TO ENSURE PROPER CONSIDERATION OF FIELD METHODOLOGY.

6. REPORT CORRELATION: RECOMMENDATION 6L.

7. POC IS MAJOR JAMES T. ROBERTS, JR., AUTOVON 224-4782.

BT

ACTION ADDRESSEES

001 DALO



R 121410Z APR 78  
FM DA WASH DC //DALO-ZXT//  
TO RUCLAIA/CDRTRADOC FT MONROE //ATLG-MS, -SP  
BT

UNCLAS E F T O

THIS IS A PROPER COUNT MESSAGE

SUBJECT: PROPER COUNT FLASHER MESSAGE NO. 10.

A. TRADOC ATLG-MSP-SP, 262227Z JAN 78 (U)

B. TRADOC ATLG-MSP-SP, 080246Z APR 78 (U)

1. REF MSGS REQUESTED ADVICE ON WHETHER OR NOT PROPER COUNT FLASHER MESSAGE NO. 10 CONSTITUTES AN INTERIM CHANGE TO CTA 50-900.

2. THIS MSG CONFIRMS FONECON 27 JAN 78 BETWEEN SGM SIMPSON, HQ, TRADOC, AND LTC SAULNIER, DALO-ZXT. PROPER COUNT FLASHER MESSAGE NO. 10 DOES CONSTITUTE AN INTERIM CHANGE TO CTA 50-900.

BT

ACTION ADDRESSEES  
006 DALO

R 141914Z APR 78  
FM DA WASH DC //DALO-ZXT//  
TO AIG 7406  
AIG 7446  
INFO RUEADWD/DA WASH DC //DAIG-IS/AL//  
RUEADWD/DA WASH DC //NGB-ARL//  
RUEADWD/DA WASH DC //DAMO-ODU  
RUEADWD/DA WASH DC //DAAR-LO//  
RUEADWD/DA WASH DC //DAPE-HRE//  
RUKGCID/CDRUSACIDC WASH DC//CIOP-CP  
BT

UNCLAS E F T O

THIS IS A PROPER COUNT MESSAGE

SUBJECT: CRIME PREVENTION MESSAGE - TRAINING AID ACCOUNTABILITY

A. AR 108-2, ARMY TRAINING AND AUDIOVISUAL SUPPORT, 26 JUL 76.

B. AR 710-2, MATERIEL MANAGEMENT FOR USING UNITS, SUPPORT UNITS,  
AND INSTALLATIONS, 1 AUG 71 W/C1-4.

1. TRAINING AND AUDIOVISUAL SUPPORT CENTERS (TASC) ARE VULNERABLE  
TO SUBSTANTIAL LOSS OF GOVERNMENT PROPERTY THROUGH THEFT AND PILFERAGE.  
LOOSE MANAGEMENT AND ACCOUNTABILITY PRACTICES PROVIDE THE CONDITIONS  
THAT ALLOW THE FOLLOWING CRIMINAL ACTS TO OCCUR:

A. THEFT OF LOCALLY FABRICATED ITEMS THAT CAN BE ADAPTED TO A  
NONMILITARY USE. IF NOT PLACED ON THE TASC ACCOUNT AT THE TIME OF  
FABRICATION, IT IS DOUBTFUL IF THE LOSS WOULD BE IDENTIFIED.

B. PILFERAGE OF EXPENDABLE/CONSUMABLE SUPPLIES USED IN THE  
FABRICATION OF TRAINING DEVICES. SUPPLIES MAY BE DIVERTED AFTER  
ORDERING FOR A NONEXISTENT WORK REQUIREMENT OR AFTER PROCURING  
EXCESSIVE QUANTITIES IN ORDER TO STEAL THE EXCESS. THE FORMER  
MEANS WAS USED TO DIVERT 144 SHEETS OF PLYWOOD AT ONE LOCATION.

2. TO REDUCE TASC VULNERABILITY TO CRIMINAL LOSS:

A. POSITIVE CONTROL MUST BE ESTABLISHED AND MAINTAINED OVER  
ALL TRAINING DEVICES RECEIVED OR FABRICATED AT THE TASC. SEE  
PARA 4-9 REFERENCE ALFA.

B. JOINT PHYSICAL INVENTORIES MUST BE CONDUCTED UPON CHANGE OF  
PROPERTY BOOK OFFICERS AND/OR HAND RECEIPT HOLDERS.

C. TIMELY INVENTORY ADJUSTMENTS MUST BE ACCOMPLISHED FOR LOST OR STOLEN PROPERTY.

D. COMPLETE ITEM DESCRIPTIONS AND SERIAL NUMBERS MUST BE INCLUDED ON DA FORM 4103-R, TRAINING AND AUDIOVISUAL SUPPORT LOAN ORDER OR HAND RECEIPT AND TRANSFERRED TO A PERMANENT HAND RECEIPT AND/OR UPDATED AS REQUIRED BY REFERENCES.

E. A JOB ORDER SYSTEM SHOULD BE ESTABLISHED TO ACCOUNT FOR THE AMOUNT OF CONSUMABLE/EXPENDABLE SUPPLIES USED FOR EACH PROJECT. LOCAL PROCEDURES SHOULD ALSO ENSURE THAT A REASONABLE CORRELATION EXISTS AMONG REQUIREMENTS FOR A PROJECT, QUANTITIES OF MATERIALS PROCURED AND QUANTITIES ULTIMATELY USED FOR THE PROJECT.

BT

ACTION ADDRESSEES

006 DAAR  
001 DAIG  
006 DALO  
012 DAMO  
003 DAPE  
002 NGB

R 141920Z APR 78  
FM DA WASH DC //DALO-ZXT//  
TO AIG 7406  
AIG 7405  
AIG 7446  
ARSTAF  
BT

UNCLAS E F T O

THIS IS A PROPER COUNT MESSAGE

SUBJECT: DA PROERTY ACCOUNTABILITY TASK FORCE (DAPATF) TELEPHONE  
NUMBERS

A. DALO-ZXT MSG, 081845Z MAR 78

1. REF A ANNOUNCED THE CURRENT PHONE NUMBERS AND PENTAGON ROOM NO.  
FOR THE DAPATF. HOWEVER, NUMEROUS CALLS TO THE ORIGINAL PHONE NUMBERS  
HAVE BEEN RECEIVED. SUCH CALLS CREATE UNNECESSARY CONFUSION AND ARE  
DETRIMENTAL TO THE MISSION OF THE ARMY OPERATIONS CENTER.

2. THE FOLLOWING LIST OUTLINES THE DAPATF PRIMARY AREAS OF INTEREST  
AND THE PHONE NUMBER THAT SHOULD BE USED FOR CALLS ON THESE SUBJECT  
AREAS.

PROPERTY ACCOUNTABILITY (GENERAL)	224-3264/65
PROPERTY ACCOUNTABILTIY (MEDICAL)	224-3238/39
REPORT OF SURVEY	224-3264/65
PERSONNEL AND TRAINING	224-3264/65
AUTHORIZATIONS	224-3238/39
PUBLICATIONS	224-3238/39
PHYSICAL SECURITY/CRIME PREVENTION	224-3238/39

3. REQUEST MACOM'S DISSEMINATE THIS INFORMATION TO THE LOWEST UNIT  
LEVEL.

BT

ACTION ADDRESSEES  
080 ARSTAF A (DAMEMO 105-1 APPLIES)

R 172040Z APR 78  
FM DA WASH DC //DALO-ZXT//  
TO RUKLDAR/CDRDARCOM ALEX VA //DRCIS-S//  
INFO RUCLENB/CDRMRSA LEX KY //DRXMD-MP//  
BT

UNCLAS E F T O

THIS IS A PROPER COUNT MESSAGE

SUBJECT: ACCELERATION OF CURRENT PROGRAM TO SIMPLIFY SUPPLY PUBLICATIONS

- A. LETTER, ODCSLOG, DALO-ZXT, 7 DEC 77, SAB
  - B. 1ST IND, DARCOM, DRCMM (7 DEC 77), 20 JAN 78, SAB
  - C. LETTER, DARCOM, DRCMM-MP, 8 MAR 78, SUBJECT: USE OF DA FORM 2062 (HAND RECEIPT) WITH OPERATORS' MANUAL.
  - D. LETTER, ODCSLOG, DALO-ZXT, 10 MAR 78, SAB
1. REF B PROVIDED MILESTONES FOR UPDATING AND PUBLISHING 142 CL SUPPLY CATALOGS WITH PREPRINTED HAND RECEIPTS OF WHICH 28 WERE SCHEDULED FOR SUBMISSION FOR PRINTING BY END OF APR 78.
  2. REF C INDICATED THAT PREPRINTED HAND RECEIPTS WOULD BE ADDED TO 82 OPERATOR'S TM'S (NOW APPROX 77) AS AN INITIAL INCREMENT.
  3. REQUEST AN IPR BE GIVEN TO THE DIRECTOR, DAPATF AS TO THE STATUS OF THE CL AND TM HAND RECEIPT PROGRAM. IN ADDITION TO THOSE CL'S AND TM'S TO BE COMPLETED BY END OF SEP 78, REQUEST PLANS BE PROVIDED AT THE IPR FOR ADDING A PREPRINTED HAND RECEIPT TO THE REMAINDER OF CL'S AND OPERATOR'S TM'S. THE FOLLOWING TIME AND DATE HAS BEEN RESERVED ON THE DIRECTOR'S CALENDAR - 1000-1100 HOURS, 1 MAY 1978. LTC O'HARA, 694-3238/9 IS THE ACTION OFFICER.

BT

ACTION ADDRESSEES  
006 DALO

R 251615Z APR 78  
FM DA WASH DC //DALO-ZXT//  
TO RUCLAIA/CDRTRADOC FT MONROE VA //ATLG-MSP/ATTNG-TD//  
BT

UNCLAS E F T O

THIS IS A PROPER COUNT MESSAGE

SUBJECT: ESSENTIAL INSTRUCTION IN THE MANAGEMENT AND ACCOUNTABILITY  
OF ARMY MATERIEL

A. DALO-ZXT MSG, DTG 08184Z MAR 78

B. TRADOC MSG, DTG 031705Z APR 78, SAB

1. REF A REQUESTED THAT YOU PROVIDE DIRECTION TO ALL SERVICE  
SCHOOLS ON THE USE OF THE LOGISTICS BASELINE CURRICULUM. YOUR  
DIRECTIVE WAS TO ENCOMPASS THE FOLLOWING POINTS.

A. MANDATORY INSTRUCTION OF THE SUPPLY PROCEDURES ESSENTIAL  
TRAINING SUBJECTS IN ALL ADVANCE AND BASIC COURSES.

B. ESTABLISHMENT OF AN EVALUATION PLAN TO ENSURE THAT EACH  
STUDENT MASTERS THE SPECIFIED TASK TO THE STANDARDS PRESCRIBED IN  
THE BASELINE CURRICULUM. MASTERY OF THE SUPPLY PROCEDURES ESSENTIAL  
TRAINING SUBJECTS SHOULD BE A PREREQUISITE FOR SUCCESSFUL COMPLETION  
OF THE BASIC AND ADVANCE COURSES.

C. USE OF THE SUPPLY PROCEDURES ESSENTIAL AND ENHANCEMENT  
TRAINING SUBJECTS IN ALL BRANCH SCHOOLS PROVIDING REFRESHER/ORIENTA-  
TION TRAINING FOR BATTALION AND BRIGADE COMMANDER COURSES.

D. MANDATORY INSTRUCTION OF THE SUPPLY PROCEDURES ESSENTIAL  
TRAINING SUBJECTS AND USE OF THE NEW EVALUATION PLAN SHOULD BEGIN  
NOT LATER THAN 1 MAY 1978.

2. YOUR MSG, REF B, IS NOT CLEAR REGARDING POINTS OUTLINED IN 1B  
THROUGH D ABOVE.

3. REQUEST YOU INFORM DAPATF OF YOUR PLANS CONCERNING THE FOLLOWING  
POINTS:

A. ENSURING THAT ALL STUDENTS MASTER THE SUPPLY PROCEDURES  
ESSENTIAL TRAINING SUBJECTS AS A PREREQUISITE FOR GRADUATION FROM  
THE OFFICER BASIC AND ADVANCE COURSES.

B. USE OF SUPPLY PROCEDURES ESSENTIAL AND ENHANCEMENT TRAINING SUBJECTS IN ALL BATTALION/BRIGADE COMMANDER COURSES. THIS INSTRUCTION IS ABSOLUTELY ESSENTIAL IN VIEW OF THE POLICY REQUIRING A JOINT PHYSICAL COUNT INVENTORY BETWEEN INCOMING AND OUTGOING COMPANY COMMANDERS. THE GUIDANCE ON HOW TO CONDUCT AN INVENTORY MUST BE PROVIDED BY THE BATTALION COMMANDER. BDE COMMANDERS SHOULD ALSO BE FAMILIAR WITH THE NEW INVENTORY PROCEDURES.

C. ALTHOUGH THE LOGC LETTER DISSEMINATING THE LOGISTICS BASELINE CURRICULUM STATED THAT INSTRUCTIONS ON THOSE SUBJECTS SHOULD BEGIN ON 1 MAY, IT SHOULD BE CLEARLY REITERATED THROUGHOUT THE TRADOC COMMUNITY THAT THIS MANDATORY INSTRUCTION MUST NOT BE DELAYED.

4. REQUEST THIS INFORMATION AND ANY OTHER DIRECTIVES YOU MAY PROVIDE TO THE SERVICE SCHOOLS CONCERNING USE OF THE LOGISTICS BASELINE CURRICULUM BE FORWARDED TO DAPATF NLT 2 MAY. REQUESTED INFORMATION WILL BE INCORPORATED INTO THE PROPERTY ACCOUNTABILITY IPR SCHEDULED FOR 4 MAY 1978.

BT

ACTION ADDRESSEES  
006 DALO

R 251618Z APR 78  
FM DA WASH DC //DALO-ZXT/  
TO AIG 7405  
AIG 7406  
AIG 7446  
ARSTAF  
RUEADWD/DA WASH DC //DAIG-IS/AI//  
RUEADWD/DA WASH DC //NGB-ARL//  
RUEADWD/DA WASH DC //DAAR-LO//  
RUCLAHA/DRXMC-AL FT LEE VA  
RUEMANA/DALO-LER NEW CUMBERLAND AD PA  
BT

UNCLAS E F T O

THIS IS A PROPER COUNT MESSAGE

SUBJECT: PROPERTY ACCOUNTABILITY TRAINING

A. HQDA LETTER, DATED 11 OCT 77, SUBJECT: MANAGEMENT AND ACCOUNTABILITY OF ARMY MATERIEL.

B. DALO-ZXT MSG, DTG 241645Z FEB 78.

C. FM 21-6, HOW TO PREPARE AND CONDUCT TRAINING.

D. DA PAM 351-20, ANNOUNCEMENT OF ARMY CORRESPONDENCE COURSES.

E. TC 21-5-4, CATALOG OF TRAINING EXTENSION COURSE LESSONS.

1. THE DAIG SPECIAL INSPECTION OF THE MANAGEMENT AND ACCOUNTABILITY OF ARMY MATERIEL HIGHLIGHTED A NEED FOR IMPROVING THE PROFICIENCY OF UNIT LEVEL PERSONNEL RESPONSIBLE FOR PROPERTY ACCOUNTABILITY. ADDITIONAL, ON THE JOB TRAINING OF ALL UNIT LEVEL PERSONNEL WILL ASSIST IN OVERCOMING MANY OF THE ORGANIZATIONAL SUPPLY PROBLEMS EXPERIENCED AT THE COMPANY AND BATTALION LEVEL. TRAINING IN THE PROCEDURES FOR MANAGING AND ACCOUNTING FOR EQUIPMENT AND SUPPLIES WILL ASSIST THE UNIT IN BETTER CONTROL AND UTILIZATION OF TOOLS, TA 50 EQUIPMENT, AND OTHER ARMY EQUIPMENT/MATERIEL.

2. TO ASSIST IN UNIT LEVEL TRAINING EFFORTS, THE US ARMY QUARTER-MASTER SCHOOL HAS DEVELOPED A TWELVE-HOUR TRAINING PACKET ON UNIT LEVEL SUPPLY PROCEDURES. THE PACKET PROVIDES TRAINING ON SUPPLY PUBLICATIONS, ISSUE AND TURN-IN REQUIREMENTS, PROPERTY RECORD PROCEDURES, ETC., AND CONTAINS LESSON PLANS, PRACTICAL EXERCISES, FACSIMILE VIEWGRAPHS AND HANDOUTS THAT MAY BE REPRODUCED LOCALLY.



REQUESTS FOR THIS MATERIAL SHOULD BE SUBMITTED TO THE US ARMY QUARTERMASTER SCHOOL, FORT LEE, VA, ATTN: ATSM-TNG-TM-ET, AUTOVON 687-3561. TO ENSURE EQUITABLE DISTRIBUTION OF THE MATERIAL AVAILABLE, REQUESTS SHOULD BE COORDINATED AND SUBMITTED FROM THE HIGHEST LEVEL FEASIBLE, I.E., BATTALION, BRIGADE, OR INSTALLATION LEVEL.

3. ALSO AVAILABLE FROM THE US ARMY TRAINING SUPPORT CENTER ARE VARIOUS PROPERTY ACCOUNTABILITY CORRESPONDENCE COURSES FOR USE BY INDIVIDUAL SOLDIERS OR IN GROUP STUDY PROGRAMS TO IMPROVE KNOWLEDGE OR EXPERTISE IN THESE AREAS. THESE CORRESPONDENCE COURSES ARE OUTLINED IN DA PAM 351-20, ANNOUNCEMENT OF ARMY CORRESPONDENCE COURSES, AND ENROLLMENT MAY BE ACCOMPLISHED BY FILLING OUT A DA FORM 145, ARMY CORRESPONDENCE COURSE ENROLLMENT APPLICATION AND SUBMITTING IT THROUGH PROPER CHANNELS.

4. TRAINING FOR SUCH SPECIALIZED SKILL JOBS AS PLL AND TAMMS CLERKS MAY BE ACCOMPLISHED USING TECHNICAL EXTENSION COURSES (TEC) AVAILABLE FROM LOCAL LEARNING CENTERS. TEC IS A SERIES OF SERVICE SCHOOL PRODUCED LESSONS THAT CONCENTRATE ON PREPARING SOLDIERS TO PERFORM SPECIFIC TASKS REQUIRED BY THEIR JOBS. TC 21-5-4, CATALOG OF TRAINING EXTENSION COURSE LESSONS, LISTS THE LESSONS WHICH APPLY TO DIFFERENT UNITS.

5. AS THE PROPERTY ACCOUNTABILITY IMPROVEMENT ACTIONS CONTINUE, THEIR SUCCESS WILL BE DIRECTLY AFFECTED BY THE PROFICIENCY OF ALL SOLDIERS IN MANAGING AND ACCOUNTING FOR ARMY EQUIPMENT AND SUPPLIES. THIS ADDITIONAL TRAINING IN PROPERTY ACCOUNTABILITY PROCEDURES AND RESPONSIBILITIES IS ENCOURAGED, AND WILL PROVIDE DIRECT BENEFITS TO INDIVIDUAL SOLDIERS, THEIR UNIT, UNIT READINESS AND OVER THE LONG HAUL THE ENTIRE US ARMY.

BT

ACTION ADDRESSEES  
080 ARSTAF A (DAMEMO 105-1 APPLIES)

R 011325Z MAY 78  
FM DA WASH DC //DALO-ZXT//  
TO RUCLBNB/CDRMRSA LEXINGTON KY //DRXMD-SS//  
RUEMANA/CDRUSALEA NEW CUMBERLAND AD PA //DALO-LER  
INFO RUKLDAR/CDRDARCOM ALEXANDRIA, VA //DRCMM-SP/DRCMM-IS-S//  
RUEBDSA/CDRLA ALEXANDRIA VA //DLA-LMM//  
BT

UNCLAS E F T O

THIS IS A PROPER COUNT MESSAGE

SUBJECT: SUPPLY PUBLICATIONS CHANGE PROCEDURES

A. YOUR MESSAGE, DTG 241930Z APR 78

B. HQDA, DALO-ZXT FLASHER MESSAGE NO. 11, DTG 012007Z FEB 78, SUBJECT:  
SUPPLY PUBLICATIONS CHANGE PROCEDURES.

C. AR 310-3, CHANGE 11, PREPARATION, COORDINATION, AND APPROVAL OF  
DA PUBLICATIONS (PARA 1-12, 1-12.1, AND 1-12.2), SUBJECT: SUPPLY  
PUBLICATIONS CHANGE PROCEDURES.

THIS MESSAGE IS IN TWO PARTS.

PART ONE FOR MRSA.

1. REF B AND C DO NOT PRECLUDE MRSA FROM UTILIZING THE ELECTRICAL  
MESSAGE SYSTEM IN FORWARDING CHANGES TO THE FIELD, REF C, PARA 1-12,  
STATES THAT IN RARE INSTANCES WHEN INSTRUCTIONS MUST BE ISSUED  
IMMEDIATELY AND A PUBLISHED CHANGE CANNOT REACH USERS BEFORE A  
MANDATORY REQUIRED DATE, INTERIM MESSAGE CHANGES ARE PERMITTED.

2. REF C, PARA 1-12, ALSO PERMITS MRSA TO USE INTERIM ELECTRICAL  
MESSAGES, WHERE NECESSARY, TO MEET A MANDATORY EFFECTIVE DATE  
IMPOSED BY DOD DIRECTIVES AND/OR OTHER AGENCIES, ETC. IN ADDITION,  
INTERIM PINPOINT MESSAGE CHANGES MAY BE USED WHEN A CHANGE IS URGENT  
AND WOULD HAVE A DIRECT AND IMMEDIATE IMPACT ON THE INDIVIDUAL  
SOLDIER. THE LATTER METHOD IS PREFERABLE BECAUSE OF THE WIDER  
DISTRIBUTION SCHEME AND RELATIVE PERMANENCY FOR REREQUISITIONING  
PURPOSES.

3. REVIEW OF FORMAL NUMBERED CHANGES TO AR 725-50 INDICATES THAT MRSA IS COMPLYING WITH THE GENERAL GUIDANCE CONTAINED IN REF B AND C PERTAINING TO PUBLICATION OF CHANGES. BASED ON CRITICALITY AND VOLUME OF CHANGE, MRSA MAY DEVELOP FORMAL NUMBERED CHANGES ON A FREQUENCY OTHER THAN AS INDICATED. HOWEVER, THE BASIC GUIDANCE CONTAINED IN REF B STILL APPLIES TO NORMAL PUBLICATION CHANGE PROCEDURES.

PART TWO FOR USALEA.

4. AS PART OF THE SUPPLY PUBLICATION CHANGE STUDY EFFORT, REQUEST THAT YOU REVIEW PROCEDURES PERTAINING TO TRANSMISSION OF IDENTIFIER, DISTRIBUTION, AND DESIGNATOR CODES TO THE FIELD IN SUPPORT OF CCSS. SAILS, DS-4, AND OTHER INTERNAL ARMY SYSTEMS AND MAKE APPROPRIATE RECOMMENDATIONS AS NEEDED.

5. DIRECT COORDINATION WITH THE DEFENSE LOGISTICS AGENCY (DLA-LMM), MR. HENDRIX, COMMERCIAL 274-7861 AND MSRA (DRXMD-SS) MR. LOY, AUTOVON 745-3688/3893 IS AUTHORIZED.

6. POC IS MAJOR JAMES T. ROBERTS, AUTOVON 694-4782.

7. REPORT CORRELATION: RECOMMENDATION 6F.

BT

ACTION ADDRESSEES

006 DALO

00006 TOTAL NUMBER OF COPIES REQUIRED

#0507

R 012015Z MAY 78  
FM DA WASH DC //DALO-ZXT//  
TO RUAGAAA/CDR USAEIGHT SEOUL KOREA //DJ-MS-SM//  
INFO RUEMANA/DALO-LFR NEW CUMBERLAND AD PA  
BT

UNCLAS E F T O

THIS IS A PROPER COUNT MESSAGE

SUBJECT: ORGANIZATIONAL CLOTHING AND EQUIPMENT (OCE)

A. USA EIGHT, DJ-MS-SM MSG, 260500Z APR 78, SUBJECT: SAB.

1. YOUR PROPOSED, NEW CONCEPT FOR MANAGEMENT AND ACCOUNTABILITY FOR OCE AT A CENTRAL ISSUE FACILITY WAS PROVIDED TO THE LOGISTICS EVALUATION AGENCY FOR FURTHER REVIEW.

2. LEA PLANS TO REWRITE PROCEDURES FOR CIF OPERATIONS IN THE UPDATE REVISION OF AR 710-2.

3. POC IS LTC WATERS, AUTOVON 224-3238.

4. REPORT CORRELATION: RECOMMENDATION 6E.

BT

ACTION ADDRESSEES  
006 DALO

R 081930Z MAY 78  
FM DA WASH DC //DALO-ZXT//  
TO RUKLDAR/CDRDARCOM ALEXANDRIA VA //DRCIS-S//  
INFO RUCLBNB/CDRMRSA LEXINGTON KY //DRXMD-SE//  
RUEMANA/CCDA NCAD NEW CUMBERLAND PA //DRXCA-M//  
BT

UNCLAS E F T O

THIS IS A PROPER COUNT MESSAGE

SUBJECT: ACCELERATION OF CURRENT PROGRAM TO SIMPLIFY SUPPLY PUBLICATIONS  
(S: 19 MAY 78)

- A. LETTER, DALO-ZXT, 31 JAN 78, SAB.
  - B. DARCOM MSG, DRCMM-SP, 101845Z MAR 78, SAB.
  - C. MRSA MSG, DRXMD-SE, 312015Z MAR 78, SAB.
1. REF A REQUESTED THAT APPROPRIATE CLS BE INCLUDED AS PART OF ALL SETS, KITS, AND OUTFITS (SKO) ISSUED TO THE FIELD. THE INTENT OF REF LETTER WAS TO ENSURE THAT ALL SKO BEING INITIALLY ISSUED TO THE FIELD FROM DEPOTS OR OTHER SUPPLY SOURCES CONTAIN THE CURRENT CL SUPPLY CATALOG AND THE COMPANION HAND RECEIPT PUBLICATION AS AN INTEGRAL PART OF THE SKO. THIS SHOULD BE DONE AS THE PREPRINTED HAND RECEIPT PUBLICATIONS BECOME AVAILABLE FOR THE 142 SUPPLY CATALOGS TARGETED FOR COMPLETION BY 1 OCT 78 AND ALL SUCCEEDING ONES.
  2. ALL HAND RECEIPT PUBLICATIONS WILL INCLUDE THE INITIAL QUANTITY OF ISSUE ALLOWANCE IN COLUMN T, DA FORM 2062.
  3. THE NUMBERING, CONTENTS OF THE INTRODUCTION, AND OTHER FORMAT REQUIREMENTS OF THE HAND RECEIPT PUBLICATIONS WILL CONFORM TO DRAFT MILITARY SPECIFICATION MIL-M-63007(TM).
  4. REQUEST YOUR RESPONSE AS TO THE PLANNED ACCOMPLISHMENT OF PARAGRAPHS 1, 2, and 3 ABOVE BY 19 MAY 78.
  5. POC IS LTC O'HARA, 694-3238.
  6. REPORT CORRELATION: RECOMMENDATION 6H.

BT

ACTION ADDRESSEES  
006 DALO

R 101652Z MAY 78 .  
FM DA WASH DC //DALO-ZXT//  
TO AIG 7406  
INFO RUEMANA/CDR USALEA NEW CUMBERLAND AD PA //DALO-LER//  
BT

INCLAS E F T O

THIS IS A PROPER COUNT MESSAGE

SUBJECT: SUPPLY PUBLICATION CHANGE PROCEDURES

1. HQDA, DALO PROPER COUNT MESSAGE NO. 11, DTG 012007Z FEB 78,  
SUPPLY PUBLICATION CHANGE PROCEDURES.

.. MACOM'S ARE TO BE COMMENDED FOR INFORMATION FORWARDED IN RESPONSE  
TO PARA 6, REF A ABOVE. THAT REF REQUESTED COMMENTS PERTAINING TO  
THE EXECUTION OF FLASHER NO. 11 AND THE RESULTS OF MACOM MONITORING  
OF TURBULENCE REDUCTION.

2. PARA 3, REF A REQUESTED THAT MACOM'S:

A. REVIEW POLICIES CONCERNING DEVELOPMENT AND PUBLICATION OF  
SUPPLEMENTARY GUIDANCE TO ENSURE PREVIOUS AR'S IAW AR 310-2.

B. REVIEW SUPPLEMENTS TO ENSURE INFORMATION IS MINIMUM ESSENTIAL  
FOR EFFECTIVE IMPLEMENTATION AND THAT THE INFORMATION CONTAINED  
THEREON IS CURRENT AND APPLICABLE.

C. RESCIND THOSE SUPPLEMENTS THAT ARE DEEMED INEFFECTIVE.

3. IN COMPILING COMMENTS ON THE ABOVE, MACOM SHOULD ALSO INCLUDE  
THE NUMBER OF PUBLICATIONS REVIEWED, CHANGED AND RESCINDED. FOR  
MACOM WHO HAVE FORWARDED THE REPORT INDICATED, A TELEPHONIC TRANS-  
MISSION OF THE NUMBERS REQUESTED MAY BE ACCOMPLISHED. TRADOC, MDW,  
JSARJ, AND DARCOM ARE EXEMPT FROM THIS REQUIREMENT.

4. POC IS MAJOR(P) JAMES T. ROBERTS, AUTOVON 224-4782.

5. REPORT CORRELATION: RECOMMENDATION 6L

BT

ACTION ADDRESSEES

006 DALO

INFORMATION ADDRESSEES

012 DAMO

R 101654Z May 78  
FM DA WASHDC //DALO-ZXT//  
TC RUCLAIA/CDRTRADOC //ATLC-MSP//  
INFO RUEADWD/HQDA WASHDC //DALO-FDU//  
BT

UNCLAS E F T O

THIS IS A PROPER COUNT MESSAGE

SUBJECT: GUIDELINES FOR INDIVIDUAL ISSUE OF DISCRETIONARY ITEMS,  
CTA 50-900

A. LETTER HQDA, DALO-ZXT, SUBJECT AS ABOVE, 19 JAN 78.

1. ABOVE REF REQUESTED TRADOC DEVELOP GUIDELINES FOR AUTHORIZING MINIMUM ESSENTIAL DISCRETIONARY CTA 50-900 ITEMS THAT A SOLDIER WOULD REQUIRE DURING PEACETIME, SPECIFICALLY TAILORED TO THE TYPE UNIT/ ORGANIZATION, CATEGORY AND CLIMATIC CONDITIONS. THESE GUIDELINES, WHEN DEVELOPED, WILL BECOME AN APPENDIX TO CTA 50-900 WHICH IS CURRENTLY UNDER REVISION.

2. AS THE CTA REVISION IS NEARING COMPLETION, REQUEST THE STATUS OF THE TRADOC EFFECT TO DEVELOP THOSE GUIDELINES.

3. POC IS LTC SAULNIER OR MAJ(P) ROBERTS, AUTOVON 224-4782.

4. REPORT CORRELATION: RECOMMENDATION 6E.

BT

	ACTION ADDRESSEES
006	DALO
	INFORMATION ADDRESSEES
012	DAMO

R 151500Z MAY 78 ZDS  
FM DA WASHDC //DALO-ZXT//  
TO AIG 7406  
RUEADWD/DA WASHDC //NGB-ARL//  
RUEADWD/DA WASHDC //DAAR-LO//  
RUEADWD/DA WASHDC //DAPC-EP-MS//  
RUEMANA/DALO-LER NEW CUMBERLAND AD PA  
RUCLAHE/CDRUSALOGC FT LEE VA //ATCL-T//  
RUCLAHA/CDRUSAQMS FT LEE VA //ATMS-TD/CD//  
RUEADWD/DA WASHDC //DAIG-IS/AI//  
BT

UNCLAS E F T O

THIS IS A PROPER COUNT MESSAGE

SUBJECT: PROPERTY ACCOUNTABILITY WORKING CONFERENCE III (S: 2 JUN 78)

A. TELEPHONE CONVERSATION, 11 MAY 1978, BETWEEN LTC(P) KELLY, DAPATF AND COL PHILBROOK, HQ TRADOC.

THIS MESSAGE IS IN TWO PARTS.

PART I FOR ALL.

1. PLANS ARE BEING FORMULATED FOR THE PROPERTY ACCOUNTABILITY WORKING CONFERENCE III TO BE HELD 27-29 JUNE. TRADOC AGREEMENT TO HOST THIS CONFERENCE AT QUARTERMASTER SCHOOL, FT LEE, VA IS APPRECIATED.
2. CONFERENCE FACILITIES FOR APPROXIMATELY 35 ATTENDEES WILL BE REQUIRED. REQUEST THAT ON-POST BILLETING ACCOMMODATIONS BE ARRANGED AND THAT CLERICAL AND REPRODUCTION SUPPORT BE PROVIDED.
3. THE CONFERENCE AGENDA AND REQUIREMENTS FOR ATTENDEE PRESENTATIONS WILL BE PROVIDED BY SEPARATE MESSAGE.
4. REQUEST NAMES OF ATTENDEES BE SUBMITTED TO DALO-ZXT, NLT 2 JUN 78 (AUTOVON 224-3264).
5. DAPATF POC IS LTC SAULNIER AND MAJ FITZPATRICK.

PART II FOR TRADOC.

6. REQUEST CONSIDERATION BE GIVEN FOR SERVICE SCHOOL REPRESENTATIVES TO ATTEND THE CONFERENCE AS OBSERVERS. THE INFORMATION TO BE PRESENTED/ DISCUSSED WILL BE BENEFICIAL FOR UPDATING APPROPRIATE INSTRUCTIONAL MATERIAL. THE NAME OF SCHOOL REPRESENTATIVES THAT CAN ATTEND SHOULD ALSO BE PROVIDED DALO-ZXT NLT 2 JUN 78.



ACTION ADDRESSEES

006 DAAR

001 DAIG

EE3 DAPC

002 NGB

INFORMATION ADDRESSEES

006 DALO

R 181347Z MAY 78  
FM DA WASHDC //DALO-ZXT//  
TO RUCLHTB/CDRFORSCOM FT MCPHERSON GA //AFLG-SMS//  
INFO RUCLBFA/CDRIICORPS FT HOOD TX  
RUWTBDA/CDR4THINFDIV(MECH) FT CARSON CO  
RUCLBPA/CDR24THINFDIV FT STEWART GA  
RUCLAKA/CDR821ABNDIV FT BRAGG NC  
RUCLAHA/CDRQMSCH FT LEE VA //ATMS-TD-CD//  
BT

UNCLAS E F T O

THIS IS A PROPER COUNT MESSAGE

SUBJECT: PROPERTY ACCOUNTABILITY WORKING CONFERENCE III

A. HQDA, DALO-ZXT 151500Z MAY 78.

1. REF MESSAGE PROVIDED INFORMATION CONCERNING PROPERTY ACCOUNTABILITY WORKING CONFERENCE III TO BE HELD AT FT LEE, VA, DURING THE PERIOD 27-29 JUNE.

2. REQUEST FORSCOM ATTENDEES INCLUDE FOUR CAPTAINS PRESENTLY IN COMMAND AND WHO ASSUMED COMMAND AFTER 16 JAN 78 OF THE FOLLOWING TYPE UNITS:

A. ARMOR CO.

B. MECH INF CO.

C. INF CO.

D. MAINT CO.

3. FURTHER REQUEST DESIGNATED COMPANY COMMANDERS ARRIVE AT LARKIN HALL (BLDG 11101), FT LEE, VA, NLT 261300 JUNE 1978. COMMANDERS WILL RECEIVE A DETAILED BRIEFING ON DA PROPERTY ACCOUNTABILITY ACTIONS TO DATE.

4. COMPANY COMMANDERS SHOULD BE PREPARED TO DISCUSS THE FOLLOWING AREAS DURING SEMINAR DISCUSSION:

A. PROCEDURES UTILIZED DURING CHANGE OF COMMAND INVENTORY.

B. INVENTORY ADJUSTMENT ACTIONS AND TURN-IN OF EXCESS RESULTING FROM CHANGE OF COMMAND INVENTORY.

C. ANY OTHER PA SUBJECT THEY WOULD LIKE TO SURFACE, DISCUSS, RECOMMEND.

NOTE: NO FORMAL PRESENTATION IS REQUIRED.

5. REQUEST NAMES OF ATTENDEES BE SUBMITTED TO DALO-ZXT, NLT 2 JUN 78  
(AUTOVON 224-3264).

6. DAPATF POCS ARE LTC SAULNIER AND MAJ FITZPATRICK.

BT

ACTION ADDRESSEES  
006 DALO

R 191955Z MAY 78  
FM DA WASHDC //DALO-ZXT//  
TO AIG 7406  
RUEADWD/DA WASHDC //NGB-ARL//  
RUEADWD/DA WASHDC //DAAR-LO//  
RUEADWD/DA WASHDC //DAPC-ZA/EP/MS//  
RUEADWD/DA WASHDC //DAIG-IS/AI//  
RUEMANA/DALO-LER NEW CUMBERLAND AD PA  
RUCLAHE/CDRUSALOGC FT LEE VA //ATCL-DP-TG//  
RUEORDE/CDR USA MEDICAL MATERIEL AGENCY FT DETRICK MD  
RUCLAHA/CDR USAQMS FT LEE VA //ATMS-TD/CD//  
BT

UNCLAS E F T O

THIS IS A PROPER COUNT MESSAGE

SUBJECT: DAPATF WORKING CONFERENCE III (S: 9 JUN 78)

A. DALO-ZXT, MSG 151500Z MAY 78, SUBJECT: PROPERTY ACCOUNTABILITY WORKING CONFERENCE III.

B. TELEPHONE CONVERSATION, 19 MAY, BETWEEN LTC WATERS, DAPATF AND CPT CHURCHMAN, USAMMA.

1. ALTHOUGH OUTSTANDING PROGRESS HAS BEEN MADE IN IMPLEMENTING THE DAIG RECOMMENDATIONS FOR IMPROVING PROPERTY ACCOUNTABILITY, SEVERAL ISSUES REMAIN TO BE RESOLVED.

2. REQUEST MACOM POC'S BE PREPARED TO PROVIDE COMMAND POSITIONS ON THE FOLLOWING ISSUES.

- A. MANAGEMENT INFORMATION SYSTEM (MIS)  
AN ARMY-WIDE AUTOMATED STANDARD SYSTEM OR REMAIN AS IS.
- B. CENTRAL ISSUE FACILITY (CIF)  
ISSUE OF CTA 50-900  
STANDARDIZATION OF PROCEDURES  
CENTRALIZED OR DECENTRALIZED
- C. CASH COLLECTION VOUCHER  
DO WE ELIMINATE THE CASH COLLECTION VOUCHER EXCEPT FOR  
THE CASH SALE OF HAND TOOLS?
- D. POST, CAMP AND STATION (PCS) PROPERTY  
HOW DO WE IMPROVE THE ACCOUNTABILITY OF PCS PROPERTY?

3. REQUEST EACH MACOM PROVIDE DALO-ZXT ANY ADDITIONAL ISSUES/PROBLEMS THAT NEED TO BE RESOLVED AT THE WORKING CONFERENCE.

4. REQUESTED INFORMATION SHOULD BE PROVIDED NLT 9 JUN 78. NEGATIVE REPLIES ARE REQUESTED.

5. THE FOLLOWING MACOM/AGENCIES ARE REQUESTED TO PRESENT THE STATUS OF THE TOPICS SPECIFIED BELOW:

A. DARCOM

(1) AVIATION COMPOSITE TOOL KIT PROGRAM.

(2) AMDF IMPROVEMENT ACTIONS.

(3) CL SUPPLY CATALOGS AND TM'S WITH ACCOMPANYING PRE-PRINTED HAND RECEIPTS. MILESTONE FOR THE CL'S AND HAND RECEIPTS REMAINING TO BE PUBLISHED. REQUEST 15 COPIES OF EACH PUBLISHED CL SUPPLY CATALOG WITH ACCOMPANYING PRE-PRINTED HAND RECEIPT BE PROVIDED FOR DISTRIBUTION TO THE MACOM POC'S AT THE CONFERENCE.

B. TRADOC

(1) IMPLEMENTATION OF THE LOGISTICS BASELINE CURRICULUM IN THE OFFICER BASIC AND ADVANCE COURSES.

(2) THE SERVICE SCHOOLS APPROACH TO ENSURING THAT ALL STUDENTS MASTER THE REQUIRED TASKS AS A PRE-REQUISITE FOR SUCCESSFUL COMPLETION OF THE COURSE.

(3) BN/BDE COMMANDER REFRESHER TRAINING BEING CONDUCTED BY BRANCH SCHOOL.

(4) PROGRAM TO DEVELOP/IDENTIFY TOOL SET/KIT INVENTORY AIDS TO INCLUDE INSERTS FOR TOOL BOXES AND SILHOUETTE LAYOUT MATS.

C. US ARMY MEDICAL MATERIEL AGENCY (USAMMA)

(1) MEDICAL MATERIEL CL SUPPLY CATALOGS WITH ACCOMPANYING PRE-PRINTED HAND RECEIPTS.

D. MILPERCEN

(1) ACTIONS TO IMPROVE THE 76Y GRADE STRUCTURE INVERSION.

(2) RECLASSIFICATION PROCEDURES TO BE PUBLISHED IN CHANGE 60 TO AR 600-200.

E. LOGISTICS EVALUATION AGENCY (LEA)

(1) CHANGE 5 TO AR 710-2.

(2) LOGISTICS EXCELLENCE AWARD.

(3) SUPPLY PUBLICATION MANAGEMENT OF CHANGE STUDY.

6. THE COMPLETE CONFERENCE AGENDA WILL BE PROVIDED AT A LATER DATE.

BT

ACTION ADDRESSEES

006 DAAR

001 DAIG

EE3 DAPC

002 NGB

INFORMATION ADDRESSEES

006 DALO

0015 TNCR

R 231327Z MAY 78  
FM DA WASHDC //DALO-ZXT//  
TO RUFDAAA/CINCUSAREUR HEIDELBERG GERMANY//AEAGD-SM-F//  
BT

UNCLAS E F T O

THIS IS A PROPER COUNT MESSAGE

SUBJECT: PROPERTY ACCOUNTABILITY WORKING CONFERENCE III

A. USAREUR, AEAGD-SM-F MESSAGE, DTG 180729Z MAY 78, SAB.

1. THE DAPATF SHARES YOUR CONCERN OVER UNPROGRAMED TDA REQUIREMENTS AND THEIR ACCOMPANYING BUDGET IMPACT; HOWEVER, IN ORDER TO ACCOMMODATE PRIORITY PROGRAMS SUCH REQUIREMENTS ARE AN INEVITABLE ASPECT OF OPERATIONS.
2. THE DAPATF WORKING CONFERENCES ARE AN INTEGRAL ASPECT OF THE PROPERTY ACCOUNTABILITY IMPROVEMENT ACTIONS AND VITAL TO THE CROSS-FERTILIZATION AND COORDINATION OF ARMY-WIDE ACTIONS TO IMPROVE THE MANAGEMENT AND ACCOUNTABILITY OF ARMY MATERIEL.
3. AS EXPLAINED DURING THE PREVIOUS DAPATF WORKING CONFERENCES, TDY COSTS MUST BE BORNE BY EACH CONFERENCE ATTENDEE.
4. USAREUR'S ACTIVE PARTICIPATION IN THE FORTHCOMING CONFERENCE WILL ENSURE THAT THE PLANNED IMPROVEMENT ACTIONS ARE IMPLEMENTED IN A MANNER THAT IS CONSISTENT WITH THE ENTIRE ARMY'S MISSION ACCOMPLISHMENT.

BT

ACTION ADDRESSEES  
006 DALO

R 241449Z MAY 78  
FM DA WASHDC //DALO-ZXT//  
TO RUCLHTB/CDR FORSCOM FT MCPHERSON GA //AFLG-SMS//  
INFO RUCLAIA/CDR TRADOC FT MONROE VA //ATLG-MSP-SP//  
BT

UNCLAS E F T O

THIS IS A PROPER COUNT MESSAGE

SUBJECT: REQUEST FOR CLARIFICATION

- A. DALO-ZXT MSG, 011350Z NOV 77, SUBJECT: INVENTORIES.
- B. FORSCOM MSG, 151315Z MAY 78, SUBJECT: REQUEST FOR CLARIFICATION.
  - 1. THIS IS IN RESPONSE TO PARAGRAPH 2 OF REFERENCE B.
  - 2. COMMANDERS OF A COMPANY/DETACHMENT EQUIVALENT SIZED ACTIVITY SERVING IN AN O5 OR LOWER POSITION WILL FULLY COMPLY WITH REFERENCE A.
  - 3. CHANGE 5 TO AR 710-2, SOON TO BE STAFFED WITH YOUR HEADQUARTERS, WILL OFFER SOME LATITUDE FOR COMMANDERS OF COMPANY/DETACHMENT EQUIVALENT SIZED ACTIVITY SERVING IN AN O6 OR HIGHER POSITION. SPECIFICALLY, AN INDIVIDUAL MAY BE APPOINTED BY THE COMMANDER SERVING IN AN O6 OR HIGHER POSITION TO CONDUCT THE CHANGE OF COMMAND INVENTORY.
  - 4. DAPATF POC IS LTC STALCUP, AUTOVON 224-3264.
  - 5. REPORT CORRELATION: RECOMMENDATION 6A.

BT

ACTION ADDRESSEES  
006 DALO



R 241450Z MAY 78  
FM DA WASHDC //DALO-ZXT//  
TO AIG 7406  
AIG 7446  
INFO RUEADWD/DA WASHDC //DAIG-IS/AL//  
RUEADWD/DA WASHDC //NGB-ARL//  
RUEADWD/DA WASHDC //DAAR-LO//  
RUEADWD/DA WASHDC //DAPE-HRE//  
RUKGCID/CDRUSACIDC WASHDC //CIOP-CP//  
RUEMANA/DALO-LER NEW CUMBERLAND AD PA  
BT

UNCLAS E F T O

THIS IS A PROPER COUNT MESSAGE

SUBJECT: CRIME PREVENTION MESSAGE - TURNING IN PROPERTY TO DEFENSE  
PROPERTY DISPOSAL OFFICE (DPDO)

A. AR 710-2, MATERIEL MANAGEMENT FOR USING UNITS, SUPPORT UNITS, AND  
INSTALLATIONS, 1 AUG 71 W/C1-4.

B. DOD 4160.21-M, DEFENSE DISPOSAL MANUAL, 1973 W/C1-6.

1. THE DA PROPERTY ACCOUNTABILITY TASK FORCE (DAPATF) HAS BEEN ADVISED THAT A LARGE NUMBER OF THEFTS OF GOVERNMENT PROPERTY HAVE OCCURRED WHILE THE PROPERTY WAS EN ROUTE TO THE DEFENSE PROPERTY DISPOSAL OFFICE (DPDO) FROM THE GENERATING UNIT/ACTIVITY. IMPROPER ACCOUNTABILITY PROCEDURES FREQUENTLY MADE THE STOLEN ITEMS PARTICULARLY VULNERABLE TO THEFT AND DETECTION OF THE LOSS MORE DIFFICULT. IN A NUMBER OF CASES THE GENERATING UNITS DROPPED ACCOUNTABILITY FOR THE PROPERTY WHEN THE TURN-IN DOCUMENT (DD FORM 1348-1) WAS INITIATED AT DPDO INDICATING RECEIPT. IN OTHERS, ACCOUNTABILITY WAS DROPPED AT THE TIME THE TURN-IN DOCUMENT WAS PREPARED AT THE UNIT AND THE ITEM(S) WERE DESIGNATED FOR SHIPMENT TO DPDO (PRIOR TO TRANSFER).

2. THE PROPERTY DISPOSAL OFFICER (PDO) DOES NOT BECOME ACCOUNTABLE FOR PROPERTY UNTIL IT HAS BEEN INSPECTED, CLASSIFIED AND QUANTITY DETERMINED. AFTER PROCESSING IS COMPLETE, A SECOND COPY OF THE TURN-IN DOCUMENT IS VALIDATED BY THE PDO AND RETURNED TO THE GENERATING UNIT. BASED ON THE INFORMATION CONTAINED ON THE VALIDATED DD FORM 1348-1 (THE SECOND COPY RETURNED TO THE UNIT) ACCOUNTABILITY MAY THEN BE DROPPED.

3. COMMANDERS MAY PREVENT DIVERSION OF PROPERTY BETWEEN THE UNIT AND DPDO BY:

A. ENSURING PROPERTY DESIGNATED FOR TRANSFER TO DPDO IS ADEQUATELY SECURED WHILE IN THE UNIT.

B. HAVING A RESPONSIBLE INDIVIDUAL ACCOMPANY THE PROPERTY TO DPDO.

C. CHECKING FIRST AND SECOND COPIES OF UNIT TURN-IN DOCUMENTS AGAINST EACH OTHER AND INITIATING ACTION IF ANY DISCREPANCIES ARE NOTED.

D. DROPPING PROPERTY FROM ACCOUNTABILITY ONLY AFTER RECEIPT OF THE SECOND COPY OF DD FORM 1348-1 WHICH HAS BEEN VALIDATED BY DPO.

4. HQDA POC IS MAJ PITCHER, AUTOVON 224-3238/9/4782.

5. REPORT CORRELATION: IMPLIED RECOMMENDATION TO IMPROVE SECURITY OF ARMY PROPERTY.

BT

ACTION ADDRESSEES

006 DALO

INFORMATION ADDRESSEES

006 DAAR

001 DAIG

003 DAPE

002 NGB

R 311403Z MAY 78  
FM EA WASHDC//DALO-ZXT//  
TO RUKLDAR/CDR DARCOM ALEX VA //DRCIS-S//  
INFO RUFDAAA/CINCUSAREUR, HEIDELBERG, GERMANY//AEAGD-SM-F//  
BT

UNCLAS E F T O

THIS IS A PROPER COUNT MESSAGE

SUBJECT: SKO MORATORIUM, FLASHER NO. 13

A. CINCUSAREUR MSG 100739Z MAY 78, SUBJECT: SKO MORATORIUM,  
FLASHER NO. 13.

1. REQUEST YOUR HQ TAKE ACTION ON PARAGRAPH 3A-3F OF REFERENCE MESSAGE.
2. PROVIDE DIRECT RESPONSE TO CINCUSAREUR WITH INFORMATION COPY TO HQDA, ATTN: DALO-ZXT.
3. DAPATF POC IS LTC STALCUP AUTOVON 224-3264.
4. REPORT CORRELATION: RELATED ACTIONS.

BT

ACTION ADDRESSEES  
006 DALO

R 82017Z JUN 78  
FM DA WASHDC //DALO-ZXT//  
TO AIG 7405  
AIG 7406  
AIG 744 ,  
ARSTAF

UNCLAS E F T O

THIS IS A PROPER COUNT MESSAGE

SUBJECT: DA PROPERTY ACCOUNTABILITY TASK FORCE (DAPATF)

1. THE FOLLOWING LIST OUTLINES THE DAPATF PRIMARY AREAS OF INTEREST AND THE PHONE NUMBERS THAT SHOULD BE USED FOR CALLS ON THESE SUBJECT AREAS:

CHIEF, DAPATF	224-3264/227-4753
PROPERTY ACCOUNTABILITY (GENERAL)	224-3264
PROPERTY ACCOUNTABILITY (MEDICAL)	224-3238
REPORT OF SURVIV	224-3238
PERSONNEL AND TRAINING	224-3264
AUTHORIZATIONS	224-3238
PUBLICATIONS	224-3238
PHYSICAL SECURITY/CRIME PREVENTION	224-3238

2. ALL CALLS SHOULD BE TO THESE NUMBERS AND NOT TO THE DAPATF ORIGINAL NUMBERS IN THE ARMY OPERATIONS CENTER. CALLS TO THE ORIGINAL NUMBERS CREATE UNNECESSARY CONFUSION AND ARE DETRIMENTAL TO THE MISSION OF THE ARMY OPERATIONS CENTER.

3. REQUEST THIS INFORMATION BE DISSEMINATED TO ALL UNITS.

ACTION ADDRESSEES

006 DALO

R 092013Z JUN 78  
FM DA WASHDC //DALO-ZXT//  
TO RUCLBNB/CDRMRSA LEX KY //DRXMD-SE//  
INFO RUEMANA/CDRUSALEA NEW CUMBERLAND AD PA //DALO-LER//  
BT

UNCLAS E F T O

THIS IS A PROPER COUNT MESSAGE

SUBJECT: REVISION OF AR 710-2 TO INCLUDE INSTRUCTIONS ON USE OF HAND RECEIPTS

A. YOUR MSG 011700Z JUN 78 (U)

1. REF A REQUESTED THE ANTICIPATED DATE FOR COMPLETION OF THE REVISION OF AR 710-2.

2. CHANGE 5 TO AR 710-2 IS TARGETED FOR PUBLICATION IN EARLY FY 79. SPECIFIC INSTRUCTION ON THE USE OF PREPRINTED DA FORM 2062 WILL BE INCORPORATED IN THE CHANGE.

3. REPORT CORRELATION: 6F.

4. POC IS LTC O'HARA, AUTOVON 224-3238.

ACTION ADDRESSEES  
006 DALO

R 141305Z JUN 78  
FM DA WASHDC //DALO-ZXT//  
TO AIG 7406  
RUEADWD/DA WASHDC //NGB-ARL//  
RUEADWD/DA WASHDC //DAAR-LO//  
RUEADWD/DA WASHDC //DAPC-ZA/EP/MS//  
RUEADWD/DA WASHDC //CAPE-MP//  
RUEADWD/DA WASHDC //DAIG-IS/AI//  
RUEADWD/DA WASHDC //DAAG-PA//  
RUEMANA/DALO-LER NEW CUMBERLAND AD PA  
RUCLAHE/CDRUSALOGC FT LEE VA //ATCL-DP-TG//  
RUEORDA/CDRUSA MEDICAL MATERIEL AGENCY FT DETRICK MD  
RUCLAHA/CDRUSA QMS FT LEE VA //ATMS-TD-CD//  
RUCLBPA/CDR24TH INF DIV & FT STEWART GA //AFZP-DIO//  
BT

UNCLAS E F T O

THIS IS A PROPER COUNT MESSAGE

SUBJECT: DAPATF WORKING CONFERENCE III AGENDA

A. DALO-ZXT MSG, 151500Z MAY 78, SUBJECT: PROPERTY ACCOUNTABILITY WORKING CONFERENCE III.

B. DALO-ZXT MSG, 191955Z MAY 78, SUBJECT: DAPATF WORKING CONFERENCE III.

1. THE DAPATF WORKING CONFERENCE III WILL BEGIN AT 0900, 27 JUNE, IN LARKIN HALL, BUILDING 11101, FORT LEE, VA. THE TENTATIVE AGENDA FOR THE CONFERENCE IS AS FOLLOWS:

TUESDAY - 27 JUNE

SUBJECT	TIME
ADMIN REMARKS	0900-0910
OPENING REMARKS	0910-0925
DAPATF BRIEFING	0925-0945
DAIG PERCEPTIONS	0945-1005
BREAK	1005-1020
COMPANY COMMANDERS BRIEFINGS	1020-1050
SEMINAR	1050-1130
LUNCH	1130-1300
DAPATF STATUS UPDATES	1300-1600
BREAK	1600-1800
NO-HOST COCKTAIL PARTY/DINNER	1800

WEDNESDAY - 28 JUNE

SUBJECT	TIME
ISSUE RESOLUTION/DISCUSSION	
6A - INVENTORY PROCEDURES HOW DO WE IMPROVE THE ACCOUNTABILITY OF POST, COMP AND STATION PROPERTY?	0900-0930
6B - ESTABLISH A MANAGEMENT INFORMATION SYSTEM A STANDARD ARMY-WIDE AUTOMATED SYSTEM OR REMAIN AS IS	0930-1000
BREAK	1000-1010
6E - ESTABLISH UNIFORM ALLOWANCES FOR CTA 50 ITEMS CENTRAL ISSUE FACILITIES STANDARDIZATION OF PROCEDURES CENTRALIZED OR DECENTRALIZED	1010-1040
6M - ELIMINATE CASH COLLECTION VOUCHER EXCEPT FOR THE CASH SALES OF HAND TOOLS	1040-1110
6R - ESTABLISH CONSUMPTION STANDARDS AT INSTALLATION AND SUBORDINATE LEVELS	1110-1130
LUNCH	1130-1300
TRADOC BRIEFING LOG BASELINE CURRICULUM IMPLEMENTATION ENSURING THAT ALL STUDENTS MASTER REQUIRED TASKS AS PREREQUISITE FOR GRADUATION BN/BDE COMMANDER REFRESHER TRAINING PROGRAM TO DEVELOP TOOL SET/KIT INVENTORY AIDS	1300-1330
DARCOM BRIEFING AVIATION COMPOSITE TOOL KIT PROGRAM AMDF IMPROVEMENT ACTIONS SUPPLY CATALOGS AND TMS WITH ACCOMPANYING PREPRINTED HAND RECEIPTS	1330-1400
MILPERCEN BRIEFING 76Y GRADE STRUCTURE INVERSION RECLASSIFICATION PROCEDURES FOR CMF 76	1400-1430
BREAK	1430-1445
TAG BRIEFING IMPLEMENTATION OF THE PUSH DISTRIBUTION SYSTEM	1445-1515

SUBJECT	TIME
USAMMA BRIEFING MEDICAL MATERIEL CL SUPPLY CATALOGS	1515-1535

LOGISTICS EVALUATION AGENCY (LEA) LOGISTICS EXCELLENCE AWARD SUPPLY PUBLICATION MANAGEMENT OF CHANGE STUDY CHANGE 5 TO AR 710-2	1535-1600
--	-----------

THURSDAY - 29 JUNE

SUBJECT	TIME
AUDIT TRAIL - FORT STEWART F&AO	0900-0930
QMS - PROPERTY ACCOUNTABILITY INITIATIVES	0930-1000
DAPATF SUMMARY WRAP-UP	1000-1015
76Y TRAINING BRIEFING & TOUR	1015-1130
QMS LUNCHEON - MACOM PRINCIPAL REP'S	1130

2. REQUEST EACH MACOM/AGENCY BRING A COPY OF BRIEFING MATERIAL (SCRIPT, CHARTS, ETC.) SUITABLE FOR REPRODUCTION BY DAPATF, FOR DISTRIBUTION TO THE MACOM POC'S.

3. MACOM RECOMMENDED SUBJECTS/ISSUES FOR DISCUSSION WILL BE ADDRESSED IN THE DAPATF STATUS UPDATES.

4. LIMITED ON-POST BILLETING ACCOMMODATIONS HAVE BEEN ARRANGED. OVERSEAS ATTENDEES WILL BE GIVEN PRIORITY FOR ON-POST BILLETS. REQUEST ATTENDEES CONTACT MSG THOMAS TODD, AUTOVON 687-3319/4582, ON 20-21 JUNE, TO CONFIRM FINAL BILLETING ARRANGEMENTS. THOSE ATTENDEES NOT PROVIDED ON-POST BILLETS WILL BE BILLETED IN MOTELS IN PETERSBURG, VA.

5. DAPATF POC IS MAJOR FITZPATRICK.

6. FT LEE POC IS LTC BARRETT AND MSG TODD.

BT

ACTION ADDRESSEES  
006 DALO  
INFORMATION ADDRESSEES  
EE4 DAAG  
006 DAAR  
001 DAIG  
EE3 DAPC  
003 DAPE  
002 NGB



R 151640Z JUN 78  
FM DA WASHDC //DALO-ZXT//  
TO RUFDAAA/CINCUSAREUR HEIDELBERG GERMANY //AEAGD-SM-F//  
INFO RUKLDAR/CDRDARCOM ALEX VA //DRCIS-S//  
BT

UNCLAS E F T O

THIS IS A PROPER COUNT MESSAGE

SUBJECT: SKO MORATORIUM

- A. YOUR MSG DTG 100739Z MAY 78, SAB.
  - B. DALO-ZXT MSG 311403Z MAY 78, SUBJECT: SKO MORATORIUM FLASHER NO 13.
    1. REF A REQUESTED INFORMATION BE FURNISHED TO FACILITATE DEVELOPMENT OF PROCEDURES IN REFERENCE TO THE MORATORIUM ON SKO COMPONENT REQUISITIONS.
    2. REF B TASKED DARCOM TO FURNISH INFORMATION REQUESTED IN REF A WITH EXCEPTION OF (G) DIRECT TO CINCUSAREUR WITH INFO TO DAPATF.
    3. IN REFERENCE TO PARAGRAPH (G) REF A, NO TARGET DATE HAS BEEN ESTABLISHED FOR DISTRIBUTION OF HAND TOOL LAYOUT MATS AND ALSO NO SPECIFIC SETS HAVE BEEN IDENTIFIED FOR THE DEVELOPMENT OF MATS. DARCOM HAS BEEN TASKED TO ASSUME THE DEVELOPMENT AND FIELDING OF INVENTORY AIDS. AN IMPLEMENTATION PLAN IS DUE DAPATF BY 17 JUL 78. STATUS OF THE TOOL KIT INVENTORY AIDS WILL BE PRESENTED BY DARCOM AT THE DAPATF WORKING CONFERENCE SCHEDULED FOR 27-29 JUN 78 AT FT LEE, VA.
    4. REPORT CORRELATION IS RELATED IMPROVEMENT ACTIONS.
    5. POC IS LTC O'HARA, AUTOVON 224-3238.
- BT

ACTION ADDRESSEES  
006 DALO

R 161820Z JUN 78  
FM DA WASHDC //DALO-ZXT//  
TO RUFDAAA/CINCUSAREUR HEIDELBERG GERMANY //AEAGD-SM-F//  
BT

UNCLAS E F T O

THIS IS A PROPER COUNT MESSAGE

SUBJECT: DAPATF WORKING CONFERENCE III

A. DALO-ZXT MSG, DTG 151500Z MAY 78, SUBJECT: PROPERTY ACCOUNTABILITY WORKING CONFERENCE III.

B. DALO-ZXT MSG, DTG 191955Z MAY 78, SUBJECT: DAPATF WORKING CONFERENCE III.

1. REF A ANNOUNCED THE DAPATF WORKING CONFERENCE III, SCHEDULED FOR 27-29 JUNE AT FT LEE, VA AND REQUESTED THE NAMES OF MACOM ATTENDEES BE PROVIDED DALO-ZXT.
2. REF B OUTLINED THE MAJOR ISSUES THAT THE MACOM'S SHOULD BE PREPARED TO DISCUSS/RESOLVE AT THE CONFERENCE AND REQUESTED THAT EACH MACOM PROVIDE DALO-ZXT ANY ADDITIONAL ISSUES/PROBLEMS THAT NEED TO BE RESOLVED.
3. AS OF THIS DATE, DAPATF HAS NOT RECEIVED THE USAREUR RESPONSE TO THESE REQUESTS. USAREUR'S ACTIVE PARTICIPATION IN THE DAPATF WORKING CONFERENCE WILL ENSURE THAT THE PROPERTY ACCOUNTABILITY IMPROVEMENT ACTIONS RECEIVE THE BENEFIT OF ARMY-WIDE COORDINATION AND ARE IMPLEMENTED IN A MANNER CONSISTENT WITH THE TOTAL ARMY'S MISSION ACCOMPLISHMENT.
4. IN ORDER TO FINALIZE THE CONFERENCE AGENDA AND ARRANGEMENTS, REQUEST THE NAME OF THE USAREUR ATTENDEE AND ADDITIONAL ISSUES/PROBLEMS, IF ANY, BE PROVIDED DALO-ZXT AS SOON AS POSSIBLE.

BT

ACTION ADDRESSEES  
006 DALO

R 231332Z JUN 78  
FM DA WASHDC //DALO-ZXT//  
TO AIG 7406  
INFO AIG 7405  
AIG 7406  
ARSTAF  
DA WASHDC //DAIG-IS-AI//  
DA WASHDC //NGB-ARL//  
DA WASHDC //DAAR-LO//  
DALO-LER NEW CUMBERLAND AD PA  
DRXMC-AL FT LEE VA

UNCLAS E F T O

THIS IS A PROPER COUNT MESSAGE

SUBJECT: ACCOUNTING FOR DAMAGED PROPERTY

- A. HQDA, DALO-ZXT MSG, 251818Z OCT 77, PROPER COUNT FLASHER NO 1,  
SUBJECT: INVENTORY ADJ RPT (DA FORM 444).
- B. HQ, FORSCOM, AFLG-SMS MESSAGE, 261346Z MAY 78, SUBJECT: ACCOUNTING  
FOR DAMAGED PROPERTY.
1. PARA 4 OF REF A ESTABLISHED REQUIREMENT FOR A REPORT OF SURVEY FOR  
ALL DAMAGED PROPERTY WHERE THE AMOUNT EXCEEDS \$250.00 OR SUFFICIENT  
NEGLIGENCE IS INVOLVED.
  2. REF B REQUESTED CLARIFICATION AND INTERPRETATION OF PARA R, REF A.
  3. TO ENSURE UNIFORM APPLICATION, PARA 4, REF A IS CHANGED TO READ:  
DAMAGE TO MILITARY VEHICLES AND/OR MAJOR MILITARY EQUIPMENT CAUSED  
BY AN ACCIDENT WHICH ARE ECONOMICALLY REPAIRABLE, BEING TURNED IN FOR  
REPAIR AND RETURN TO THE USER, WILL BE REPAIRED BASED ON A WORK ORDER.  
IF THE AMOUNT OF THE DAMAGE CAUSED BY THE ACCIDENT EXCEEDS \$500 OR  
SUFFICIENT NEGLIGENCE IS INVOLVED A REPORT OF SURVEY WILL BE UTILIZED.
  4. THIS MESSAGE EXPIRES SIX MONTHS FROM DATE OF MESSAGE, IF NOT  
SUPERSEDED BY A FORMAL NUMBER CHANGE. DEVIATIONS FROM CURRENT POLICIES  
NOTED IN THIS MESSAGE WILL BE INCORPORATED INTO AR 735-11.
  5. DAPATF POCS ARE LTC PHILIP SAULNIER AND CW2 WILLIAM WRIGHT.
  6. REPORT CORRELATION: RECOMMENDATION 6 O.

R 231330Z JUN 78  
FM DA WASHDC //DALO-ZXT//  
AIG 7406

UNCLAS E F T O

THIS IS A PROPER COUNT MESSAGE

SUBJECT: DISTRIBUTION OF DD FORM 200

- A. REFERENCE FORSCOM MSG 141355Z JUN 78
- B. REFERENCE PARA 5-13B(3) and C. AR 735-11
1. FORSCOM REQUESTED CLARIFICATION OF REF B ABOVE, AS TO THE DISTRIBUTION OF COPY THREE OF DD FORM 200, WHEN PECUNIARY CHARGES ARE NOT BEING COLLECTED.
2. COPY THREE OF DD FORM 200 WILL BE FORWARDED TO THE FINANCE AND ACCOUNTING OFFICE FOR COLLECTION OF PECUNIARY CHARGES. IF PECUNIARY CHARGES ARE NOT BEING COLLECTED, COPY THREE MAY BE DISCARDED.
3. DAPATF POCS ARE LTC SAULNIER OR CW2 WRIGHT, AUTOVON 224-3238.
4. REPORT CORRELATION: NA.

## CHAPTER 4

### CORRESPONDENCE AND PUBLICATIONS

#### Section I. Summaries

1. Letter to HQDA, Office of The Surgeon General, dated 24 Mar 78, Property Accountability - Enforcement of Supply Discipline.

Summary: Letter requests OTSG to incorporate in the rewrite of AR 40-61 the guidance contained in DA Circular 735-5, 10 Feb 78.

Action Officer: MAJ Pitcher

2. Letter to MACOM's, dated 24 Mar 78, 761A, Unit Supply Technician.

Summary: Requests MACOM's to provide comments, recommendations, and alternatives concerning assignment of 761A, Unit Supply Technicians to MTOE battalions.

Action Officer: MAJ Fitzpatrick

3. Letter to Commander, US Army Logistics Evaluation Agency, dated 5 Apr 78, USACIDC Property Accountability Recommendations.

Summary: Letter requests evaluation of the USACIDC recommendations for property accountability improvements. The suggestions that are adopted will be in the rewrite of AR 710-2.

Action Officer: LTC Stalcup

4. Memorandum for Deputy, The Surgeon General, dated 21 Apr 78, Property Accountability Training.

Summary: Requests assistance in expediting the approval and implementation of the 76-J Program of Instruction.

Action Officer: MAJ Fitzpatrick

5. DF to LEA (DALO-LER), dated 21 Apr 78, Supply Publications Management of Change Study IPR.

Summary: Requests LEA make an analysis of the ADCSLOG's comments at the Supply Publications Management of Change IPR on 20 Apr 78.

Action Officer: MAJ Roberts

6. Letter to Commander in Chief, US Army, Europe and Seventh Army, dated 21 Apr 78, TEC/Exportable Training Packages.

Summary: Provides a list of exportable training material available for needed subject areas identified by USAREUR.

Action Officer: MAJ Fitzpatrick

7. Letter to Commander, US Army Training and Doctrine Command (ATLG-MSP-SP), dated 21 Apr 78, Tool Kit Inventory.

Summary: Provides a copy of correspondence from FORSCOM indorsing the toolbox insert program and offering the 82d Airborne Division as the sponsoring unit and Fort Bragg as the test site for further development efforts.

Action Officer: LTC O'Hara

8. Letter to Commander, US Army Forces Command (AFLG-SMS), dated 21 Apr 78, Quick Inventory Automotive Tool Boxes.

Summary: Expresses appreciation for support of FORSCOM HQ and Fort Bragg in developing quick inventory tool boxes. Provides information as to the status of the instant inventory and control program.

Action Officer: LTC O'Hara

9. Letter to MG Richard H. Thompson, Commander, US Army Troop Support and Aviation Materiel Readiness Command, dated 21 Apr 78, Quick Inventory Aviation General Mechanics Tool Kit.

Summary: Advises MG Thompson that the DAPATF fully supports the efforts of the Transportation Center and requests any assistance in expediting the project.

Action Officer: LTC O'Hara

10. Comment to Deputy Chief of Staff for Personnel (DAPE-MPT), dated 24 Apr 78, Validation of DA Directed and Emphasized Training Subjects.

Summary: Emphasizes the importance of property accountability instruction in providing officers the basic fundamental knowledge necessary to manage and account for Army materiel at unit level.

Action Officer: MAJ Fitzpatrick

11. Memorandum for Director of Management, dated 4 May 78, Implementation of Approved DAIG Recommendation - Consumption Standards.

Summary: States that a proposed study of Performance Evaluation of Installation Resource Management, being considered by the Management Directorate, includes within its scope the theme of DAIG recommendation 6R. Recommends, therefore, that the Management Directorate study group include the accomplishment of recommendation 6R.

Action Officer: LTC Stalcup

12. Indorsement to Commander, US Army Armament Materiel Readiness Command (DRSAR-MM), dated 9 May 78, Shop Equipment, Contact Maintenance, NSN 4940-01-016-2262.

Summary: Equipment Improvement Recommendation surfaced a problem of adequately securing items stored in subject shop equipment. As a possible solution, a modification that provides an individually keyed lock set for compartments of each vehicle was offered. Command was requested to review problem and take appropriate action.

Action Officer: MAJ Pitcher

13. Letter to HQDA Staff Agencies and selected MACOM's, dated 10 May 78, Revision of CTA 50-900 and Consolidation with CTA 50-906.

Summary: Incloses quick reference CTA 50-900 discretionary guidelines developed by TRADOC and HSC which identify the recommended minimum essential issue for the individual soldier. Requests the guidelines be reviewed and provide comments to DAPATF.

Action Officer: MAJ Roberts

14. Letter to Commander, US Army Criminal Investigation Command (CIOP-CP), dated 15 May 78, Annual Evaluation of the USACIDC Quarterly Crime Prevention Report.

Summary: Suggests that the Quarterly Crime Prevention Report be given a wider distribution. Also points out the need for continuing liaison between ODCSLOG and USACIDC after completion of the DAPATF's mission.

Action Officer: MAJ Pitcher

15. Letter to MACOM's and selected HQDA Staff Agencies, dated 17 May 78, Recategorization of Supplies and Equipment.

Summary: Provides proposed new expendability code definitions, the type accountability required, and other related actions. Requests comments on the proposals.

Action Officer: LTC Stalcup

16. DF, DALO-ZXT, 19 May 78, Approval of TRADOC Supplement 1 to AR 710-1 (Draft).

Summary: DF requested DALO-LER to review draft AR 710-1 and reply to TRADOC.

Action Officer: MAJ Roberts

17. Letter to USALEA, 24 May 78, Logistics Service Awards Program.

Summary: Letter requested additional information be included in IPR scheduled for 31 May 78.

Action Officer: LTC O'Hara

18. Indorsement to Commandant, US Army Quartermaster School (ATSM-TNG-TM-ET), 31 May 78, Request for 12-hour Training Packet.

Summary: Forwards request of Senior Army Advisor, Rhode Island ARNG for training material to Quartermaster School for action.

Action Officer: MAJ Fitzpatrick

19. Letter to Senior Army Advisor (ARNG-US), Rhode Island, 31 May 78, Property Accountability Training Material.

Summary: Informed ARNG-US that 12-hour training packet request was forwarded to US Army Quartermaster School.

Action Officer: MAJ Fitzpatrick

20. Indorsement to Commander, Tooele Army Depot, 31 May 78, Reports of Survey and Cash Collection Vouchers.

Summary: Indorsement clarified questions asked about the Cash Collection Voucher.

Action Officer: CW3 Wright



21. Indorsement to Commander, US Army, Europe and Seventh Army, 31 May 79, Request for Waiver of Property Accountability.

Summary: Indorsement clarified action that could be taken on Reports of Survey.

Action Officer: Mr. Miskovich

22. Indorsement to Commander, US Army Training and Doctrine Command, 31 May 78, Fort Leonard Wood Reports of Survey #182-78 and #189-79 (USAR).

Summary: Indorsement both clarified and directed action in reference to Reports of Survey.

Action Officer: Mr. Miskovich

23. DF to OCAR, 1 Jun 78, Proper Count Impact on Personnel (USAR).

Summary: DF requested OCAR to take action on FORSCOM request.

Action Officer: LTC Stalcup

24. Letter to Commander, Military District of Washington, 5 Jun 78, Draft AR 190-51, Security of Army Property at Unit and Installation Level.

Summary: Letter clarified question referencing Draft AR 190-51.

Action Officer: MAJ Pitcher

25. Letter to USACIDC, 7 Jun 78, USACIDC Property Accountability Recommendations.

Summary: Letter forwarded status of actions planned on recommendations submitted by USACIDC.

Action Officer: LTC Stalcup

26. Memorandum for Office Assistant Secretary of Defense (Comptroller), 8 Jun 78, Army's Request for Deviation from DOD 7200.10M.

Summary: Memo responded to request for DAPATF to review DOD memorandum.

Action Officer: LTC Saulnier

27. DF to DAEN-MCE, 9 Jun 78, Secure Storage Space for Organizational Clothing and Equipment (OCE).

Summary: DF requests DAEN ensure all new construction include adequate secure storage space for Government property.

Action Officer: MAJ Pitcher

28. Memorandum for CDR LEA, 9 Jun 78, Logistics Service Awards Program.

Summary: Memo summarized results of IPR conducted on 8 Jun 78 for Director DAPATF.

Action Officer: LTC O'Hara

29. Information Paper for DCSLOG, 12 Jun 78, LOG Services Awards Program.

Summary: Paper briefly gave past, present, and future actions of the Awards Program.

Action Officer: LTC O'Hara

30. Letter to CDR DARCOM, 13 Jun 78, Tool Kit Inventories.

Summary: Letter tasked DARCOM to take lead in the development of tool box inserts and layout mats for hand tools.

Action Officer: LTC O'Hara

31. Letter to Commandant, Quartermaster School, 15 Jun 78, Surveying Officer's Guide.

Summary: Letter forwarded suggestion from Fort Huachuca which suggested incorporating "The Surveying Officer's Guide" into Army-wide Training Literature Program.

Action Officer: MAJ Fitzpatrick

32. Letter to CDR DARCOM, 15 Jun 78, Draft AR 735-11.

Summary: Letter requested review of Draft with specific emphasis on chapter 6.

Action Officer: CW2 Wright.

33. Letter to CDR DARCOM, 23 Jun 78, Component Listings of Integral Components of End Items.

Summary: Letter requested the developing of an additional hand receipt for end items and their integral components.

Action Officer: LTC O'Hara

34. Letter to CDR DARCOM, 23 Jun 78, TM Operators' Manual Consolidation List.

Summary: Letter requested specific information concerning a newly developed printout along with a copy of the printout. Also requested information on programmed actions to resource the TM simplification effort.

Action Officer: LTC O'Hara

35. DF to Army Staff, 23 Jun 78, Draft AR 672-XX, Logistics Services Awards Program.

Summary: DF requested addressee to review Draft regulation.

Action Officer: LTC O'Hara

36. Letter to MACOM's, 26 Jun 78, Logistics Services Awards Program.

Summary: Letter requested MACOM's review Draft AR 672-XX.

Action Officer: LTC O'Hara

37. Letter to MACOM's, 1 Apr 78, Draft AR 190-51, Security of Army Property at Unit and Installation Level.

Summary: Requests comments/concurrence in proposed regulation.

Action Officer: MAJ Fitzpatrick

38. DF to Army Staff, 1 Apr 78, Draft AR 190-51, Security of Army Property at Unit and Installation Level.

Summary: Requests comments/concurrence in proposed regulation.

Action Officer: MAJ Pitcher

39. DAPATF Working Conference III.

Summary: Agenda for Working Conference hosted by Quartermaster School, Fort Lee, VA.

Action Officer: Members DAPATF

Publications

40. Article in Commanders Call, May-Jun 78 issue, Property Accountability.

Summary: Article discussed the enforcement of supply discipline by the Commander through disciplining and administrative measures.

41. Article in Army Logistician, Jul-Aug 78 issue, Proper Count Message.

Summary: MG DeHaven discusses the problems and numerous actions being taken to correct property accountability within the Army.

42. Article in Army Logistician, Jul-Aug 78 issue, Self-Help Available in Property Accountability.

Summary: Article discusses various correspondence subcourses, training extension course lessons, and Field Manuals available for individual or group learning on property accountability.

Action Officer: MAJ Fitzpatrick

Section II  
Correspondence



DEPARTMENT OF THE ARMY  
OFFICE OF THE DEPUTY CHIEF OF STAFF FOR LOGISTICS  
WASHINGTON, D.C. 20310

24 DEC 1978

DALO-ZXT

SUBJECT: Property Accountability - Enforcement of Supply Discipline

Headquarters  
Department of the Army  
Office of The Surgeon General  
Washington, DC 20310

1. The Inspector General Report of Audit Survey and Special Inspection of Management and Accountability of Army Materiel revealed a lack of command efforts to enforce supply discipline and property accountability.
2. Recommendation 6 0(3) was of particular importance which said in part: Prescribe in applicable regulations that failure to maintain supply discipline, in matters more serious than those appropriately handled under the report of survey system, be disposed of through administrative action.
3. DA Circular 735-5 (Incl 1) was written by the DA Property Accountability Task Force to comply with the above recommendation. It contains specific guidance on the enforcement of supply discipline. This guidance outlines the disciplinary and administrative measures that are available to assist the commander in providing the required emphasis that is essential to the implementation of an effective supply discipline and supply management program. The guidance will be included in AR's 710-2, 735-5, 735-11 and other appropriate regulations.
4. In furtherance of the approved recommendation, it is requested that you incorporate in the rewrite of AR 40-61, the guidance found in the inclosed circular.

FOR THE DEPUTY CHIEF OF STAFF FOR LOGISTICS:

SIC 111

1 Incl  
*as wn*

OREN E. DeHAVEN  
Major General, GS  
Director, DA Property Accountability  
Task Force



DEPARTMENT OF THE ARMY  
OFFICE OF THE DEPUTY CHIEF OF STAFF FOR LOGISTICS  
WASHINGTON, D.C. 20310

DALO-ZXT

24 MAR 1978

SUBJECT: 761A, Unit Supply Technician

Commander  
US Army Forces Command  
ATTN: AFLG-SMS  
Fort McPherson, GA 30330

1. Reference HQDA letter, dated 11 October 1977, subject: Management and Accountability of Army Materiel.
2. An important aspect of the Army's ability to properly manage and account for materiel is the utilization of trained personnel. The DAIG report emphasized that many of the supply problems currently being experienced by field units may be attributed to an absence or inadequate knowledge of supply and accountability procedures on the part of supervisory personnel.
3. The DAPATF has received numerous recommendations that the 761A, Unit Supply Technician, be authorized and assigned to TOE battalions. The knowledge and expertise provided by a supply warrant officer would undoubtedly enhance the management and accountability of supplies and equipment at the battalion level. However, coordination with ODCSFER and ODCSOPS identified a major manpower and budgeting constraint that must be addressed.
4. There are 312 battalion/squadron-size units not presently authorized a Unit Supply Technician. If 312 Unit Supply Technicians were allocated to these battalions an adverse impact on force structure authorizations would result. Warrant officer allocations currently exceed budgeted force structure resources by approximately 600 in FY 78 and 630 in FY 79. Allocating 312 Unit Supply Technicians, without a corresponding trade-off in other warrant officer MOS's, would not be feasible at this time.
5. One possible alternative would be to trade-off the 761A authorizations in the Divisional Materiel Management Centers in order to establish warrant officer positions at the divisional TOE battalion level. Even then, approximately 175 additional positions would have to be created or traded-off from other warrant officer authorizations to satisfy the remaining requirements.

DALO-ZXT

SUBJECT: 761A, Unit Supply Technician

6. Request you consider the constraints of this recommendation, and provide DAPATF your comments, recommendations and alternatives concerning the assignment of a 761A, Unit Supply Technician, to TOE battalions. Of particular interest is what warrant officer space-for-space trade-offs might be effected, and what is a viable "price" that should be paid to effect the assignment of Unit Supply Technicians to TOE battalions. Will the trade-off or "price" that must be paid be worth the expert knowledge gained by assigning supply warrant officers at the TOE battalion level of operations?

7. Request comments/recommendations be provided DAPATF NLT 17 April.

ES.00

OREN E. DeHAVEN  
Major General, GS  
Director, DA Property Accountability  
Task Force

DISTRIBUTION:

CDR TRADOC (ATLG-MSP)  
CDR DARCOM (DRCIS-S)  
CINCUSAREUR (AEAGD-SM-F)  
CDR EUSA (DJ-MS-SM)  
CDR USARJ (AJGD-S)  
CDR USACC (ACSLOG-SMT)  
CDR USAHSC (HSLO-S)  
CDR USAINSCOM (IALOG-S)





DEPARTMENT OF THE ARMY  
OFFICE OF THE DEPUTY CHIEF OF STAFF FOR LOGISTICS  
WASHINGTON, D.C. 20310

5 APR 1978

DALO-ZXT

SUBJECT: USACIDC Property Accountability Recommendations

Commander  
US Army Logistics Evaluation Agency  
New Cumberland Army Depot  
New Cumberland, PA 17070

1. At the request of the DAPATF the United States Army Criminal Investigation Command (USACIDC) were asked to take a look at improving accountability from the view point of their crime prevention role. Worldwide surveys were conducted as well as detailed analysis made of logistics regulations from the standpoint of tightening up "Loop Holes" that allows for criminal activity. The results of these efforts are attached.
2. Request you evaluate for inclusion in AR 710-2, paragraphs 2a(1), and 2a(4) to 2a(11), of the attached report. Paragraph 2a(2) and 2a(3) are being considered for AR 703-1.
3. Request you provide a summary of the USACIDC recommendations adopted for inclusion in AR 710-2. To facilitate our response to USACIDC, a brief explanation for recommendations not accepted, would be appreciated.
4. POC this headquarters is LTC Billy J. Stalcup, 224-3264.

FOR THE DEPUTY CHIEF OF STAFF FOR LOGISTICS:

1 Incl

as

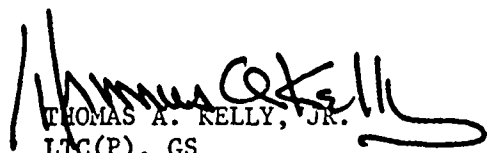

(USACIDC letter  
shown on pages  
498-501, Vol. II)

  
THOMAS A. KELLY, JR.  
LTC(P), GS  
Chief, DA Property Accountability  
Task Force



DEPARTMENT OF THE ARMY  
OFFICE OF THE DEPUTY CHIEF OF STAFF FOR LOGISTICS  
WASHINGTON, D.C. 20310

DALO-ZXT

21 APR 1978

MEMORANDUM FOR: DEPUTY SURGEON GENERAL

SUBJECT: Property Accountability Training

1. A major effort of the DAPATF in improving the property accountability procedures has been in the field of education and training of both officers and enlisted men. The officer education efforts have centered around the logistics baseline curriculum developed by the LOGC for use by all Service Schools. The Health Services Command (HSC) letter of 29 March (Incl 1), providing direction on the use the Logistics Baseline Curriculum is outstanding and typifies the excellent support and backing that the property accountability improvement actions have received.

2. The enlisted training efforts centered on a review of the 76Y and 76J task analysis to ensure that the training shortfalls identified by the DAIG have been incorporated into the Service School training courses. The task analysis review has been completed and DAPATF was advised by message from HSC (Incl 2) that the 76J Program of Instruction (POI) is currently out for staffing and approval by OTSG, and should be on-line within six months. I would appreciate your assistance in expediting the approval and implementation of this POI so that instruction may begin in the June/July time frame. This would be in keeping with the changes made in the training courses of other supply MOS's and be of definite assistance in providing knowledgeable, well trained soldiers to manage and account for equipment and supplies in field units and activities.

3. The DAPATF is available to provide any assistance you may desire and I am sure that, together, we can effect changes in Army property accountability procedures that will enable us to better accomplish our mission.

SIGNED

2 Incl  
as

OREN E. DeHAVEN  
Major General, GS  
Director, DA Property Accountability  
Task Force

# DISPOSITION FORM

For use of this form, see AR 340-13, the proponent agency is TAGCEN.

REFERENCE OR OFFICE SYMBOL DALO-ZXT	SUBJECT Supply Publications Management of Change Study IPR
--	---

TO DALO-LER FROM DALO-ZXT DATE 21 APR 1978 CMT 1  
MAJ Roberts/ss/44782

1. During the Supply Publications Management of Change IPR on 20 April 1978, the ADCSLOG commented on:

- a. The need to keep in mind, based on LEA research and analysis, whether or not change is truly needed.
- b. The identification of the period of time between changes to the regulations being used for study analysis.
- c. The requirement that the Vice Chief of Staff, Army approve the recommendations of the study group prior to publication and implementation.

2. It is requested that the DAPATF be informed of your analysis of the ADCSLOG's comment noted in 1b above, NLT 30 April 1978. Other comments are for information only.

## SIGNED

THOMAS A, KELLY, JR.  
LTC(P), GS  
Chief, DA Property Accountability  
Task Force



DEPARTMENT OF THE ARMY  
OFFICE OF THE DEPUTY CHIEF OF STAFF FOR LOGISTICS  
WASHINGTON, D.C. 20310

DALO-ZXT

21 APR 1978

SUBJECT: TEC/Exportable Training Packages

Commander in Chief  
US Army Europe and 7th Army  
ATTN: AEAGD-SM-F  
APO New York 09403

1. Reference DAPTF Working Conference II, 14 - 16 February 1978.
2. Inclosure 1 lists the areas in need of exportable training material that you presented at the February working conference. This list has been staffed with TRADOC and the appropriate Service School to determine if training packages are available and in what form.
3. A list of the training material available for these subject areas is provided with the Quartermaster School letter of 23 March 1978 (Incl 2). As outlined in paragraph 3 of the QM School letter, recommend you effect direct contact with the School to identify SHIPREP and define the depth of training needed in ROID and SHIPREP.
4. Use of these correspondence courses, TEC packages, and other available training material will provide a valuable assistance in improving the knowledge and proficiency of all personnel involved in the management and accountability of Army materiel.

FOR THE DEPUTY CHIEF OF STAFF FOR LOGISTICS:

SIGNED

2 Incl  
as

OREN E. DeHAVEN  
Major General, GS  
Director, DA Property Accountability  
Task Force



DEPARTMENT OF THE ARMY  
OFFICE OF THE DEPUTY CHIEF OF STAFF FOR LOGISTICS  
WASHINGTON, D.C. 20310

DALO-ZXT

SUBJECT: Tool Kit Inventory

Commander  
US Army Training and Doctrine Command  
ATTN: ATLG-MSP-SP  
Fort Monroe, VA 23651

1. References:

a. Letter, ODCSLOG (DALO-ZXT), dated 23 February 1978, subject as above, and 1st indorsement, TRADOC (ATLG-MSP-SP) (23 Feb 78) to LOGC.

b. Letter, TRADOC (ATLG-MSP-SP), dated 23 March 1978, subject as above.

c. Letter, XVIII Airborne Corps and Fort Bragg, dated 6 March 1978, subject: Quick Inventory Automotive Tool Boxes and 1st indorsement, FORSCOM, dated 27 March 1978 (Incl 1).

2. A copy of reference 1c is forwarded for your information and appropriate action. Direct communication between your headquarters and FORSCOM is authorized. It is requested that a copy of any correspondence be furnished this office, ATTN: DALO-ZXT.

FOR THE DEPUTY CHIEF OF STAFF FOR LOGISTICS:

SIGNED

1 Incl  
as

CF:  
CDR DARCOM (DRCIS-S)  
CDR USALOGC (ATCL-DP)

OREN E. DeHAVEN  
Major General, GS  
Director, DA Property Accountability  
Task Force

AFLG-SMS (6 Mar 78) 1st Ind  
SUBJECT: Quick Inventory Automotive Toolboxes

HQ, FORSCOM, Ft McPherson, GA 30330 27 Mar 78

TO: HQDA (DALO-ZXT/Major General O. E. DeHaven) Wash DC 20310

1. Several FORSCOM units have been active in improvising methods to improve the control and accountability of hand tools. One method is the use of a toolbox insert which was briefed to the DA Property Accountability Task Force by FORSCOM in November 1977 and by the 82d Airborne Division in February 1978. It is understood this procedure is under consideration by the DA Task Force and that TRADOC/DARCOM have been directed to develop and field the concept on a priority basis.
2. Request the 82d Airborne Division be designated as the official sponsoring unit and Fort Bragg as the test site for the current TRADOC/DARCOM development effort.

FOR THE COMMANDER:

1 Incl  
nc

  
JOHN K. SINGLEAUB  
Major General, GS  
Chief of Staff

CF:  
Cdr, XVIII Abn Corps & Ft Bragg  
Ft Bragg, NC



DEPARTMENT OF THE ARMY  
HEADQUARTERS XVIII AIRBORNE CORPS AND FORT BRAGG  
FORT BRAGG, NORTH CAROLINA 28307

6 MAR 1978

AFZA-GD-S

SUBJECT: Quick Inventory Automotive Toolboxes

Commander  
United States Army Forces Command  
ATTN: AFCS  
Fort McPherson, Georgia 30330

1. On-going actions within the 82d Airborne Division in conjunction with the United States Army Transportation School to test and evaluate aviation related toolboxes indicate that improvements can be made in tool accountability and control through the use of polyvinylchloride (PVC) inserts and an organized tool control program. An internal test in the 82d Airborne Division indicates like improvements in tool control can be accomplished by the expansion of the PVC insert concept to automotive general mechanics' toolkits.
2. In February of this year, MG DeHaven, the Chief of the DA Property Accountability Task Force, was briefed by the Division on the PVC insert concept and shown the aviation and automotive toolboxes configured using PVC inserts. MG DeHaven expressed an interest in the program and requested a copy of the briefing and pictures of the boxes.
3. Initial efforts by the 82d Airborne Division have shown that 70 of the tools in the general mechanics' toolset will fit in the general mechanics' toolbox when configured with PVC and spring clip inserts (Inclosure 1). All 88 tools will fit in an aviation mechanics' toolbox when configured with PVC inserts.
4. Due to the potential increase in tool accountability and subsequent savings in reduced replacement tool costs, this command is vitally interested in testing and adopting the PVC insert concept. To this end, this command stands ready to provide a testing ground for testing of a PVC insert for Army-wide adoption.

AFZA-GD-S

SUBJECT: Quick Inventory Automotive Toolboxes

6 MAR 1972

5. Request FORSCOM assistance in acquiring approval for expanded testing of a general automotive mechanics' toolbox insert and formal DARCOM/TRADOC sponsorship of this test.

FOR THE COMMANDER:

1 Incl  
as WD

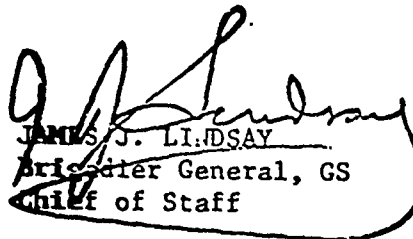
  
JAMES J. LINDSAY  
Brigadier General, GS  
Chief of Staff





DEPARTMENT OF THE ARMY  
OFFICE OF THE DEPUTY CHIEF OF STAFF FOR LOGISTICS  
WASHINGTON, D.C. 20310

DALO-ZXT

21 APR 1978

SUBJECT: Quick Inventory Automotive Tool Boxes

Commander  
US Army Forces Command  
ATTN: AFLG-SMS  
Fort McPherson, GA 30330

1. References:

a. 1st indorsement, FORSCOM (AFLG-SMS) (6 Mar 78), dated 27 March 1978, subject as above.

b. Letter, ODCSLOG (DALO-ZXT), dated 23 February 1978, subject: Tool Kit Inventory, and 1st indorsement, TRADOC (Incl 1).

2. The interest and support of your headquarters and the XVIII Airborne Corps and Fort Bragg in developing quick inventory tool boxes for improved tool accountability is appreciated. During a conference at Fort Bragg in February, the Director and members of the DA Property Accountability Task Force were briefed on the testing program of tool boxes with inserts by the 82d Airborne Division.

3. By reference 1b, TRADOC was requested to expand the development of the instant inventory and control program to cover tool kits supporting all Army equipment. In addition, it was recommended that consideration be given to the development of tool layout mats. TRADOC tasked the US Army Logistics Center to pursue the program. Your headquarters will be kept informed by this office as to the progress made by TRADOC.

4. A copy of your correspondence (reference 1a) has been sent to TRADOC for information and appropriate action regarding the offer of the 82d Airborne Division and Fort Bragg as a sponsoring unit and test site. Direct communication between TRADOC and your headquarters is authorized.

FOR THE DEPUTY CHIEF OF STAFF FOR LOGISTICS:

SIGNED

1 Incl  
as

CF:  
CDR DARCOM (DRCIS-S)  
CDR USALOGC (ATCL-DP)

OREN E. DeHAVEN  
Major General, GS  
Director, DA Property Accountability  
Task Force

ATLG-MSP-SP (23 Feb 78) 1st Ind  
SUBJECT: Tool Kit Inventory

HQ TRADOC, Fort Monroe, VA 23651

TO: Commander, US Army Logistics Center, ATTN: ATCL-DP, Fort Lee, VA  
23801

1. Inventory and accounting for components of tool kits has long been recognized as a problem. The TRADOC supports any methodology that would allow rapid conduct of accurate tool kit inventories.
2. It appears that there are at least four ways of identifying the components and completeness of tool kits. These are:
  - a. Silhouette layout mats proposed in basic correspondence.
  - b. Preformed inserts for tool containers which are shaped and sized to components of the kit.
  - c. Data plates affixed to the container listing the type and quantity of components of the kit. The data plate concept may have applicability to the Tool Kit, Carpenter's, Engineer Squad.
  - d. Supply catalogues containing a components list along with the description and photographs of the components and the kit.
3. Some informal coordination regarding the development of inventory aids has already occurred between members of the Department of the Army Property Accountability Task Force (DAPATF) and personnel at the Ordnance and Transportation Schools. The Ordnance School has provided a silhouette type layout mat of the General Mechanic Automotive Tool Set to DAPATF. Some information on the work done by the Transportation School on various aircraft tool kits has also been provided to DAPATF.
4. Request US Army Logistics Center determine what efforts and progress have been made by TRADOC Service Schools towards development of tool set/kit inventory aids. Further request the following be accomplished:
  - a. Identify four more tool sets/kits in addition to the General Mechanic Automotive Tool Set, that are adaptable to the silhouette type inventory aid.
  - b. Determine when a sample inventory aid for the selected tool sets/kits will be available for inspection.

ATLG-MSP-SP (23 Feb 78)  
SUBJECT: Tool Kit Inventory

c. Recommend whether these silhouette inventory aids should be reproduced for immediate distribution or should be first field tested.

d. Recommend distribution ratio (i.e., one per set/kit, one per squad, etc.) or scope of field test, as applicable.

e. Develop field test evaluation questionnaire/plan to obtain meaningful user comment and a basis for cost analysis.

f. Evaluate the appropriateness of using preformed inserts, data plates, etc., in instances where the number and/or size of set/kit components renders the silhouette approach impractical.

5. By separate correspondence, the DAPATF is being advised of this approach to develop viable tool set/kit inventory aids. This correspondence will also note that funds have not been programmed for contractual reproduction of the inventory aid models to be developed.

6. Response to the requirements enumerated in paragraph 4 should be addressed to this headquarters, ATTN: ATLG-MSP-SP, to arrive NLT 25 Apr 78. In the event that all evaluations cannot be adequately addressed within this time period, estimated completion dates should be provided.

2 Incl  
nc

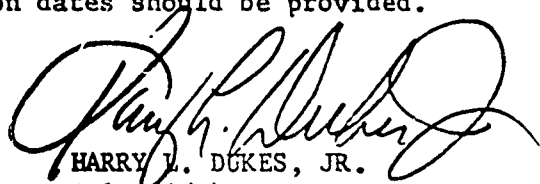

HARRY L. DUKES, JR.  
Colonel(P), GS  
Deputy Chief of Staff for Logistics



DALO-ZXT

DEPARTMENT OF THE ARMY  
OFFICE OF THE DEPUTY CHIEF OF STAFF FOR LOGISTICS  
WASHINGTON, D.C. 20310

21 APR 1978

Major General Richard H. Thompson  
Commander  
US Army Troop Support and  
Aviation Materiel Readiness Command  
4300 Goodfellow Boulevard  
St. Louis, MO 63120

Dear General Thompson:

General Post sent me a copy of his letter to you, dated 3 April, concerning the quick inventory aviation general mechanics tool kit. You may recall that you wrote me on 29 December 1977, urging support for the program.

Even before receipt of your letter, the DA Property Accountability Task Force had been actively involved in this project. As you found on your trip to Europe, the troops we have talked to during field visits also want better tool boxes to help them in their inventories.

Initially we assumed that DARCOM should take the lead in developing a modified tool box. However, as a result of a meeting between personnel of the Transportation Center, DARCOM, and the Task Force, it was determined that TRADOC, as representative of the user, should take over the project. TRADOC was so tasked on 23 February and requested to expand the program to include tool kits associated with other Army equipment. They, in turn, asked the Logistics Center to consider various alternatives and to provide milestones for proposed actions by 23 April.

The XVIII Airborne Corps and FORSCOM also back the program and have offered the 82d Airborne Division as the official sponsoring unit, and Fort Bragg as a site for further testing. TRADOC has been advised of the offer. I was briefed on the PCV insert for aviation and automotive tool boxes by the 82d Airborne Division during a conference at Fort Bragg in February.

DALO-ZXT

Major General Richard H. Thompson

The DA Property Accountability Task Force fully supports the efforts of the Transportation Center as outlined in General Post's letter. Anything your command can do to expedite the project will undoubtedly benefit the field user in maintaining better tool accountability and control.

Sincerely,

SIGNED

OREN E. DeHAVEN  
Major General, GS  
Director, DA Property Accountability  
Task Force

DALO-ZXT (13 Apr 78)

SUBJECT: Validation of DA Directed and Emphasized Training Subjects

TO DAPE-MPT

FROM DALO

DATE 24 APR 1978 CMT 2  
MAJ Fitzpatrick/kp/43264

1. Reference HQDA letter, dated 11 Oct 77, subject: Management and Accountability of Army Materiel.
2. Referenced letter outlines the approved recommendations for overcoming the DAIG identified deficiencies in the management and accountability of Army materiel. Recommendation 6Q addresses the requirement to "modify programs of instruction in the officer education system so as to eliminate the lack of knowledge about supply procedures that is currently displayed by the officer corps."
3. The property accountability instruction, listed in inclosure 1 to your DF, was developed and implemented as a result of the DAIG recommendation cited above. This instruction is absolutely essential in order to provide officers with the basic fundamental knowledge necessary to manage and account for Army materiel at the unit level. Its mandatory use in the basic and advance courses will be a direct assistance in enabling officers to manage and account for supplies and equipment in an efficient and economical manner.
4. The DA directive requiring this mandatory instruction is DALO-ZXT message, DTG 081848Z Mar 78, subject: Logistics Baseline Curriculum.

FOR THE DEPUTY CHIEF OF STAFF FOR LOGISTICS:

LIKED

Incl  
nc

THOMAS A. KELLY  
LTC(P), GS  
Chief, DA Property Accountability  
Task Force



DEPARTMENT OF THE ARMY  
OFFICE OF THE DEPUTY CHIEF OF STAFF FOR LOGISTICS  
WASHINGTON, D.C. 20310

DALO-ZXT

4 MAY 1978

MEMORANDUM FOR: DIRECTOR OF MANAGEMENT

SUBJECT: Implementation of Approved DAIG Recommendation - Consumption Standards

1. References:

- a. Report of Audit Survey and Special Inspection of Management and Accountability of Army Materiel, dated 6 October 1977.
- b. Draft Chief of Staff memorandum, subject: Performance Evaluation of Installation Resource Management.

2. Paragraph 6r, of the special inspection on property accountability (reference 1a), identified the need to establish consumption standards at installation and subordinate organization level.

3. The concept of a proposed study of Performance Evaluation of Installation Resource Management Study, which is being considered by your office (reference 1b), encompasses, within its scope, the theme of the above DAIG recommendation. In order to focus on the total installation resource management task by a single group, the pursuit of action to accomplish the above DAIG recommendation could best be incorporated into your study effort which I fully support. It is, therefore, recommended that your study group, as identified in reference 1b, include the accomplishment of recommendation 6r of reference 1a.

4. This has been discussed by the DAPATF and a member of your study effort, who agree. The DAPATF and the other elements of the Office of the Deputy Chief of Staff for Logistics stand ready to provide assistance to the group on this or any other area.

5. OTIG concurs in this recommendation.

FOR THE DEPUTY CHIEF OF STAFF FOR LOGISTICS:

SIGNED

OREN E. DeHAVEN  
Major General, GS  
Director, DA Property Accountability  
Task Force

DALO-ZXT (24 Apr 78) 1st Ind  
SUBJECT: Shop Equipment, Contact Maintenance, NSN 4940-01-016-2262

DA, ODCSLOG, Washington, DC 20310

TO: Commander, US Army Armament Materiel Readiness Command,  
ATTN: DRSAR-MM, Rock Island, IL 61299

1. The attached letter and Equipment Improvement Recommendation (EIR) surface the problem of adequately securing items stored in subject shop equipment. Since locking mechanisms on compartments of all M-880 series contact vehicles are activated by a common key (master key), it is obvious that little real security is provided to items stored therein. As these vehicles continue to enter the inventory and additional keys are issued, it is reasonable to expect increasing problems in managing and accounting for Government property stored on board unless positive action is taken.
2. Request your command review this problem and take action deemed appropriate to improve security of subject shop equipment. A modification that provides an individually keyed lock set for compartments of each vehicle would appear to offer the best solution to the problem.
3. The HQDA POC for this action is Major Pitcher, AUTOVON 224-3238/4782.
4. Report correlation: Implied recommendation to improve security of Army property.

FOR THE DEPUTY CHIEF OF STAFF FOR LOGISTICS:

1 Incl  
~~as~~ *W.P.*  
CF:  
HQDA (DAPE-HRE)

THOMAS A. KELLY, JR.  
LTC(P), GS  
Chief, DA Property Accountability  
Task Force





DEPARTMENT OF THE ARMY  
OFFICE OF THE DEPUTY CHIEF OF STAFF FOR LOGISTICS  
WASHINGTON, D.C. 20310

DALO-ZXT

10 MAY 1978

SUBJECT: Revision of CTA 50-900 and Consolidation with CTA 50-906

SEE DISTRIBUTION

1. References:

a. HQDA (DAMO-FDU) letter, 1 May 1978, Revision of CTA 50-900 and Consolidation with CTA 50-906.

b. VCSA letter, 11 October 1977, Management and Accountability of Army Materiel.

c. HQDA (DALO-ZXT) Proper Count Flasher Message No. 10, DTG 091625Z Jan 78, Organization Clothing and Equipment (CTA 50-900).

2. Reference a forwarded a revision and consolidation of CTA 50-900 and CTA 50-906 for your review.

3. Reference b stated that the Chief of Staff, Army had approved the accompanying DAIG Report of Audit Survey and Special Inspection of Management and Accountability of Army Materiel. This report indicated substantive deficiencies in accountability and recommended corrective action. One such recommendation pertained to the establishment of uniform allowances for CTA 50-900 specifically tailored to organization, mission, and climatic conditions. This recommendation evolved from the DAIG finding that commands inspected had a wide divergence of CTA 50-900 individual issue policies and that subordinate units had a diversity of individual issue among their soldiers. In many cases units had extensive CTA issue in excess of individual soldier minimum essential requirements and which created an accountability burden on unit personnel.

4. Reference c reiterated Army policy and directed that review procedures be established at division, separate brigade and installation level to ensure that only minimum essential CTA 50-900 are authorized. Accountability procedural changes were also noted to ensure increased control over initial issue, individual maintenance, and turn-in.

DALO-ZXT

SUBJECT: Revision of CTA 50-900 and Consolidation with CTA 50-906

5. As a further step to assist field commanders, the quick reference CTA 50-900 discretionary guidelines at inclosures 1 and 2 have been developed by TRADOC and HSC for their use. These guidelines identify what is the recommended minimum essential issue for the individual soldier. This concise listing takes into account the type unit he may be assigned, by category, under varying climatic conditions. In addition to fostering easy identification of baseline requirements by nonlogistically oriented personnel, the guidelines may be used by the logistics community for budget and planning purposes. It will assist commanders at all levels in establishing uniform listings for units under their command while permitting them latitude in selectively adding to or deleting items based on mission unique requirements.

6. Request that you review the attached inclosures, for sufficiency and comment as to the utility of the listings NLT 15 June 1978 to this office.

7. POC is Major(P) James T. Roberts. Report correlation: Recommendation 6E.

FOR THE DEPUTY CHIEF OF STAFF FOR LOGISTICS:

SIGNED

- 2 Incl
- 1. TRADOC Ltr,  
18 May 78, w/incl
- 2. HSC 3d Ind,  
28 April 78, w/incl

OREN E. DeHAVEN  
Major General, GS  
Director, DA Property Accountability  
Task Force

DALO-ZXT

SUBJECT: Revision of CTA 50-900 and Consolidation with CTA 50-906

DISTRIBUTION:

HQDA (DAAR-OL)  
HQDA (DACA-OMO)  
HQDA (DAIG-SD)  
HQDA (DALO-TST)  
HQDA (DAMA-CSS)  
HQDA (DAMO-FDU)  
HQDA (DAMO-ODO)  
HQDA (DAMO-RQR)  
HQDA (DAMO-SSC)  
HQDA (DAPE-HRL)  
HQDA (DASG-HCD)  
HQDA (NGB-ARL)

COMMANDERS

US ARMY FORCES COMMAND  
US ARMY COMMUNICATIONS COMMAND  
US ARMY INTELLIGENCE AND SECURITY COMMAND  
US ARMY EQUIPMENT AUTHORIZATION REVIEW ACTIVITY  
EIGHTH US ARMY  
COMMANDER IN CHIEF  
US ARMY, EUROPE AND SEVENTH ARMY



DEPARTMENT OF THE ARMY  
OFFICE OF THE DEPUTY CHIEF OF STAFF FOR LOGISTICS  
WASHINGTON, D.C. 20310

15 MAY 1978

DALO-ZXT

SUBJECT: Annual Evaluation of the USACIDC Quarterly Crime Prevention Report

Commander  
US Army Criminal Investigation Command  
ATTN: CIOP-CP  
5611 Columbia Pike  
Falls Church, VA 22041

1. Reference letter, CIOP-CP, dated 9 May 1978, subject as above (distributed with HQ USACIDC Quarterly Crime Prevention Report for First Quarter, CY 78).
2. The Quarterly Crime Prevention Report (QCRP) provides an excellent, easy-to-read summary of crime prevention information. It is undoubtedly a valuable tool for crime prevention activities. The publication would be of even greater value if it received widespread distribution rather than limiting it to Army law enforcement activities, as stated in reference letter. The QCPR should be distributed to installations down to unit/activity level which is, after all, the "first line of defense" for crime prevention programs.
3. Much of the information contained in the QCPR would also be of value to the logistics community. If it were provided to appropriate Army staff and subordinate command staff elements on a regular basis, voids and weaknesses in existing policies and procedures could be more readily identified and eliminated.
4. Special Agent Hambrick's participation in the DA Property Accountability Task Force (DAPATF) has proved to be an excellent beginning in ensuring that pertinent crime prevention information is introduced into the logistics community in a timely manner. The DAPATF is a temporary organization, however, and a need exists to have continuing liaison between ODCSLOG and USACIDC after completion of the DAPATF's mission.

DALO-ZXT

SUBJECT: Annual Evaluation of the USACIDC Quarterly Crime Prevention  
Report

This could be accomplished by providing a desk in DALO-SM for Mr. Hambrick, or other representative from HQ USACIDC, and continuing the part-time liaison relationship that has existed between USACIDC and the DAPATF since last October. In addition to providing crime prevention information to ODCSLOG, the CI Logistics Specialist Program would also be abreast of proposed changes to logistics policy. Such an arrangement would appear to be mutually beneficial to both organizations.

FOR THE DEPUTY CHIEF OF STAFF FOR LOGISTICS:

SIGNED

THOMAS A. KELLY  
LTC(P), GS  
Chief, DA Property Accountability  
Task Force



DEPARTMENT OF THE ARMY  
OFFICE OF THE DEPUTY CHIEF OF STAFF FOR LOGISTICS  
WASHINGTON, D.C. 20310

DALO-ZXT

17 MAY 1978

SUBJECT: Recategorization of Supplies and Equipment

Deputy Chief of Staff for  
Operations and Plans  
Headquarters, Department of the Army  
Washington, DC 20310

1. References:

a. HQDA letter, dated 11 October 1977, subject: Management and Accountability of Army Materiel.

b. AR 310-34,

c. AR 735-5.

2. Reference 1a indicated confusion existed concerning the expendability code assigned to items in the Army Master Data File (AMDF). It was found that items coded "X" (expendable) were treated as consumables regardless of whether they were true consumables or nonconsumables. Since 95 percent of the items in the AMDF are coded "X", the need to improve or change attitudes towards the accountability of these items is apparent.

3. Recommendation 6K of the DAIG special report addresses the need to recategorize equipment and components into more realistic expendability codes. This recategorization should include simple definitions which differentiate between items that are truly consumed and those which must be accounted for until worn out or turned in.

4. A review of present definitions has led to the conclusion that an additional code is needed to avoid the recoding of many items as nonexpendable, which would then require property book accounting.

5. Following are the proposed new expendability code definitions.

a. Nonexpendable - "N". Items which are not consumed in use, retain their original identity during the period of use, and require that accountability be maintained throughout the life of the item.

DALO-ZXT

SUBJECT: Recategorization of Supplies and Equipment

This includes all nonconsumable end items coded nonexpendable in the AMDF and authorized by TO&E, MTOE, JTA, TDA, or CTA (except for CTA 50-970/8-100). Commercial and fabricated items similar to items coded as nonexpendable in the AMDF or authorization media are considered nonexpendable.

b. Durable - "D". Items which retain their original identity, are not consumed in use, and are not categorized as nonexpendable. Included are nonconsumable components of all sets, kits, outfits and assemblages; all tools (Federal Supply Classes 5110, 5120, 5130, 5133, 5136, 5140, 5180, 5210, 5220, and 5280); and any other nonconsumable item with a unit value in excess of \$50.00.

c. Expendable - "X". Items, regardless of value or type classification, which are consumed in use. This includes all Class IX (repair parts) and other items, with a unit value of \$50.00 or less, that do not fit the criteria of a nonexpendable or durable item.

6. The Surgeon General will develop procedures for coding and accounting for Class VIII, Medical Supplies and Equipment, used at fixed treatment facilities. These procedures will be coordinated with ODCSLOG and published in AR 40-61.

7. The following designates the type accountability required for the specified category of items:

<u>Category</u>	<u>Accountability</u>
Nonexpendable	Stock record, property book, and hand receipt
Durable	Stock record and hand receipt/hand receipt annex (user level)
Expendable	Stock record and no accounting required upon issue

This does not infer that expendable items are not to be used efficiently. Commanders should institute local controls as necessary.

8. The document register for expendable items will be renamed Expendable/Durable Document Register. The Expendable/Durable Register will be retained for two years after the last supply action and then destroyed IAW AR 340-2. This will provide an audit trail for durable items and will also provide information on the consumption of expendable items.

DALO-ZXT

SUBJECT: Recategorization of Supplies and Equipment

9. There have been numerous misinterpretations concerning the application and use of expendability and recoverability codes. This is particularly true when an item is coded expendable, as well as recoverable. This misinterpretation results from a failure to look beyond the AMDF expendability column. The expendability code denotes the method to be used in accounting for the property; the recoverability code indicates disposition action to be taken with each item, including the organization level to which the item will be returned. It is proposed that the AMDF be restructured to move the recoverability column along side the expendability column to more easily draw user attention to the recoverability codes.

10. Your comments/concurrences on proposals in paragraphs 5-9, above, by 16 June 1978 would be appreciated.

FOR THE DEPUTY CHIEF OF STAFF FOR LOGISTICS:

**SIGNED**

OREN E. DeHAVEN  
Major General, GS  
Director, DA Property Accountability  
Task Force

DISTRIBUTION:

Commander, US Army Forces Command  
Commander, US Army Training and Doctrine Command  
Commander, US Army Materiel Development and Readiness Command  
Commander, US Army Health Services Command  
Commander in Chief, US Army, Europe and Seventh Army  
Commander, US Army Communications Command  
Commander, US Army, Japan  
Commander, US Army Intelligence and Security Command  
Commander, Eighth US Army  
Commander, US Army Logistics Center  
HQDA (DALO-SMS)  
HQDA (DAMA)  
HQDA (DASG)  
Commander, US Army Logistics Evaluation Agency



# DISPOSITION FORM

For use of this form, see AR 340-15, the proponent agency is TAGCEN.

REFERENCE OR OFFICE SYMBOL	SUBJECT
DALO-ZXT	Approval of TRADOC Supplement 1 to AR 710-1 (Draft)

~~XX~~ THRU DALO-SM  
TO DALO-LER

FROM DALO-ZXT

DATE 19 MAY 1978 CMT 1  
MAJ Roberts/ss/44782

1. References:

a. DAIG Report, dated 6 October 1977, Report of Audit Survey and Special Inspection of Management and Accountability of Army Materiel.

b. HQDA Msg, DTG 012007Z Feb 78, Supply Publication Change Procedures (Proper Count Flasher 11).

2. Reference a stated that a majority of commanders surveyed did not feel additional supplemental guidance was necessary for effective field operation. This survey placed the use of the current supplement process in doubt as an effective tool for issuing implementing instructions.

3. Reference b stated that, effective 1 June 1978, all of the MACOM supplements to supply publications, developed in accordance with AR 310-2, will be forwarded to the appropriate HQDA proponent agency for review and approval prior to publication.

4. As proponent for AR 710-1, it is requested that you review the attached supplement for applicability and relevance and reply directly to TRADOC.

FOR THE DEPUTY CHIEF OF STAFF FOR LOGISTICS:

SIGNED

THOMAS A. KELLY, JR.  
LTC(P), GS  
Chief, DA Property Accountability  
Task Force



DEPARTMENT OF THE ARMY  
HEADQUARTERS UNITED STATES ARMY TRAINING AND DOCTRINE COMMAND  
FORT MONROE, VIRGINIA 23651

ATLG-MSP-SP

15 MAY 1978

SUBJECT: Approval of TRADOC Suppl 1 to AR 710-1 (Draft)

HQDA (DALO-ZXT)  
WASH DC 20310

Subj draft is forwarded for your approval prior to publication IAW message, DA, DALO-ZXT, 012007Z Feb 78.

FOR THE COMMANDER:

1 Incl  
as wd

  
DOREATHA MANGRUM  
DAC  
Asst AG



DEPARTMENT OF THE ARMY  
OFFICE OF THE DEPUTY CHIEF OF STAFF FOR LOGISTICS  
WASHINGTON, D.C. 20310

DALO-ZXT

24 MAY 1978

SUBJECT: Logistics Service Awards Program

Commander  
US Army Logistics Evaluation Agency  
ATTN: DALO-LEZ-A  
New Cumberland Army Depot  
New Cumberland, PA 17070

1. Reference DALO-ZXT letter, dated 31 January 1978, subject as above.
2. At a meeting of the Army Logistics Policy Council at Fort Lee, 26-27 April 1978, the proposed logistics awards program was briefly discussed. Several attendees suggested the Association of the United States Army (AUSA) as a likely candidate for sponsorship of the award. It is requested that you explore this possibility. The address of the AUSA is 1529 18th Street, NW, Washington, DC 20009; telephone number is 202-483-1800.
3. Status of the sponsorship of the award should be included in the IPR for the Director, DA Property Accountability Task Force which is scheduled for 31 May 1978.

FOR THE DEPUTY CHIEF OF STAFF FOR LOGISTICS:

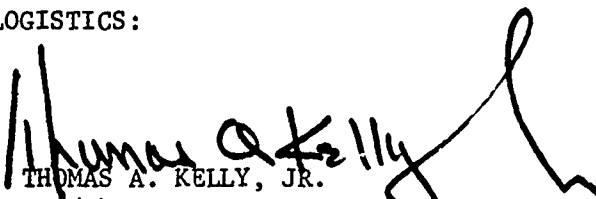
  
THOMAS A. KELLY, JR.  
LTC(P), GS  
Chief, DA Property Accountability  
Task Force

DALO-ZXT (19 May 78) 1st Ind  
SUBJECT: Request for 12-hour Training Packet

DA, ODCSLOG, Washington, DC 20310 31 May 1978

TO: Commandant, US Army Quartermaster School, ATTN: ATSM-TNG-TM-ET,  
Fort Lee, VA 23801

1. Forwarded for appropriate action.
2. Your assistance in this request is greatly appreciated.

FOR THE DEPUTY CHIEF OF STAFF FOR LOGISTICS:

SIGNED

THOMAS A. KELLY, JR.  
LTC(P), GS  
Chief, DA Property Accountability  
Task Force



DEPARTMENT OF THE ARMY  
OFFICE OF THE DEPUTY CHIEF OF STAFF FOR LOGISTICS  
WASHINGTON, D.C. 20310

DALO-ZXT

31 MAY 1978

SUBJECT: Property Accountability Training Material

Senior Army Advisor (ARNGUS), Rhode Island  
Armory of M united Commands  
1051 N. Maine Street  
Providence, Rhode Island 02904

1. Reference UR letter, dated 19 May 1978, subject as above.
2. Your request for the 12-hour training packet on unit level supply procedures has been forwarded to the US Army Quartermaster School, Fort Lee, Virginia. You should receive the training packet in the near future.

FOR THE DEPUTY CHIEF OF STAFF FOR LOGISTICS:

(SIGNED)

THOMAS A. KELLY, JR.  
LTC(P), GS  
Chief, DA Property Accountability  
Task Force

DALO-ZXT (10 May 78) 1st Ind  
SUBJECT: Reports of Survey and Cash Collection Vouchers

DA, ODCSLOG, Washington, DC 20310

31 MAY 1978

TO: Commander, Tooele Army Depot, ATTN: SDSTE-COU, Tooele, UT 84074

1. References:

a. Paragraph 2-11a of AR 735-11, dated 1 May 1974.

b. DACA-FA message, DTG 252059Z Nov 74, subject: AR 735-11, Property Accountability - Accounting for Lost, Damaged and Destroyed Property - 1 May 1974.

c. DACA-FAL-S message, DTG 270104Z Feb 76, subject: Application to Simple Negligence to Hand Tool Losses.

d. DACA-FAL-S message, DTG 131926Z May 76, subject: Cash Sales of Hand Tools to Individuals from Self Service Supply Centers.

2. Reference 1b and 1c did not intend to eliminate the use of the Cash Collection Voucher, as prescribed in reference 1a, as a means to account for hand tool losses.

3. In addition, reference 1d allows an individual to replace a lost hand tool by making a cash purchase at the local self service supply center.

FOR THE DEPUTY CHIEF OF STAFF FOR LOGISTICS:

SIGNED

THOMAS A. KELLY  
LTC(P), GS  
Chief, DA Property Accountability  
Task Force

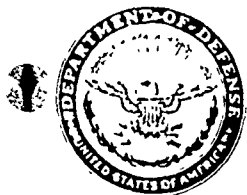

DEPARTMENT OF THE ARMY

TOOELE ARMY DEPOT  
TOOELE, UTAH 84014

10 May 1978

SDSTE-COU

SUBJECT: Reports of Survey and Cash Collection Vouchers

Department of the Army  
ATTN: DACA-FAL-S  
Washington, D.C. 20310

1. Here at Tooele Army Depot property accountability is foremost among priorities of our Commander, Colonel Burbules. The combination of Cash Collection Voucher, Statement of Charges and Report of Survey generally allows us to establish and enforce accountability and responsibility in a manner satisfactory to both the Government and the employee.
2. Unfortunately, it has been suggested that your Messages 270104Z Feb 76 and 252059Z Nov 78, Subject: Application of Simple Negligence to Hand Tool Losses, stand for the proposition that, in cases of hand tool loss Cash Collection Vouchers will not be used. This interpretation stems from the language in 252059Z Nov 74 to the effect that "a report of survey will be processed... unless the loss is admitted and a statement of charges is processed..."
3. Is this interpretation correct? Does this message remove the cash collection voucher as an alternative for enforcement of accountability? If so, it would seem that any motivation for an employee to accept monetary responsibility without a costly report of survey is diminished. If negligence must be admitted via a statement of charges or ascertained by Report of Survey, there is no question that the employee will put the government to the task of proving negligence. Of course, on the other hand if an employee can pay without a record of negligence by signing a cash collection voucher his motivation to admit liability is a little greater.
4. I understand that communicating directly with your office informally may be extraordinary, perhaps even improper, but I have exercised the other options available to me and now turn to you for help, because the other answers I have received conflict. Any information which your office, as the font of knowledge with respect to Reports of Survey can provide, would be greatly appreciated.

  
VINCENT J. FAGGIOLI  
CPT JAGC  
Office of Chief Counsel

DALO-ZXT (undated) 3d Ind  
SUBJECT: Request for Waiver of Property Accountability

DA, ODCSLOG, Washington, DC 20310

TO: Commander in Chief, United States Army, Europe and Seventh Army,  
ATTN: AEAGC, APO New York 09403

1. Reference DACA-FAL-S message, DTG 141558Z Feb 75, subject: Interim Change to AR 735-5.
2. Reference provided all major Army commands final approval authority on property accountability waivers up to \$1M. Consequently, your headquarters may take action if a waiver on attached reports of survey is warranted.
3. If a waiver is granted, necessary corrective actions should be taken to preclude the occurrence of similar situations in the future.

FOR THE DEPUTY CHIEF OF STAFF FOR LOGISTICS:

**SIGNED**

3 Incl  
nc

THOMAS A. KELLY, JR.  
LTC(P), GS  
Chief, DA Property Accountability  
Task Force



TO: Department of the Army  
HQ DA (DACA-CSS-FL)  
Washington, D.C. 20310

THRU: ~~Community Commander  
USMCA Bamberg  
APO 09139~~

*Recommend approval  
Shepherd Klavitz  
LTC Inf  
Deputy Community Cdr  
25 Aug 77*

FROM: Property Book Officer  
14th Finance Section  
APO 09139

IAW AR 735-5, a request for waiver for accountability  
is submitted.

Incl  
as

  
MICHAEL K. LAMB  
CPT, FI  
Property Book Officer

AETSBBG-F-CDR 1st Ind  
SUBJECT: Request for Waiver of Property Accountability

DA, Commander, 14th Finance Section, APO 09139 13 October 1977

THRU: Commander, VII Corps, ATTN: AETSDIO-SM, APO 09154

TO: Department of the Army, HQ DA (DACA-CSS-FL), Washington, D.C. 20310

1. It appears from all available evidence that accountability for the 14th Finance Section property was properly maintained up until the move of the Finance Office from Nurnberg to Bamberg in January 1976. It was during this move that accountability for the property became questionable.

2. The three reports of survey have been completed and copies of the findings are attached as Exhibit A, B and C.

3. I recommend that this request for waiver of accountability be favorably considered.



L.J. ANCHOR  
MAJ, FI  
Commanding

**Inclosures**

1. Exhibit A: Report of Survey 2-77
2. Exhibit B: Report of Survey 3-77
3. Exhibit C: Report of Survey 4-77

AETSGD-BD-S (undated) 2d Ind  
SUBJECT: Request for Waiver of Property Accountability

DA, Headquarters VII Corps, APO 09107 27 January 1978

THRU: ~~Commander in Chief, United States Army, Europe and  
Seventh Army, ATTN: AEAGG, APO 09403~~ *CTJ* FEB 1978

TO: Department of The Army, HQ DA (DACA-CSS-FL), Washington,  
D.C. 20310

1. Recommend approval.
2. As a result of findings made during follow-up visits by members of the VII Corps staff, it is recommended that the period of the Waiver of Property Accountability be extended through 4 August 1977.
3. Additional assistance is being provided to the 14th Finance Section to insure that property accountability is restored.

1 Incl  
as

Telephone: KLY (2723-)351

  
GEORGE S. PATTON  
Major General, USA  
Acting Commander

DALO-ZXT (24 Jan 78) 4th Ind  
SUBJECT: Fort Leonard Wood Reports of Survey #182-78 and #189-78 (USAR)

DA, ODCSLOG, Washington, DC 20310 31 JAN 78

TO: Commander, US Army Training and Doctrine Command, ATTN: ATRM-FFI,  
Fort Monroe, VA 23651

1. References:

a. DACA-FAL-S message, DTG 141558Z Feb 75, subject: Interim Change to AR 735-5.

b. Telephone conversation between LTC Ippilito (TRADOC) and Mr. Miskovich (DALO-ZXT).

2. As discussed during reference 1b, reference 1a provided all Army major commands final approval authority on property accountability waivers up to \$1M. Consequently, your headquarters may take action if a waiver on subject reports of survey is warranted.

3. If a waiver is granted for subject reports of survey, request a copy of the waiver and attached documentation be provided FORSCOM so that necessary corrective actions may be taken to preclude the occurrence of similar situations in the future.

FOR THE DEPUTY CHIEF OF STAFF FOR LOGISTICS:

2 Incl  
nc

THOMAS A. KELLY, JR.  
LTC(P), GS  
Chief, DA Property Accountability  
Task Force



DEPARTMENT OF THE ARMY  
HEADQUARTERS  
US ARMY TRAINING CENTER ENGINEER AND FORT LEONARD WOOD  
FORT LEONARD WOOD, MISSOURI 65473

ATZT-DI-OSC

24 JAN 1978

SUBJECT: Ft Leonard Wood Reports of Survey #182-78 and #189-78 (USAR)

Commander  
TRADOC  
ATTN: ATRM-FFI  
Fort Monroe, VA 23651

1. Attached is Report of Survey #182-78 with 43 inclosures and #189-78, received at Ft Leonard Wood from the 281st AVN Co. (USAR). You will note the prices have been changed on copy 2 of Report of survey 182-78 to reflect the current prices of the items.
2. Your comments/recommendations concerning the attached reports of survey are requested, prior to processing at this station. It appears that supervisory personnel were grossly negligent in the accountability of Government property as well as negligent in the maintenance of records relation to the company operation and the security of the equipment.

FOR THE COMMANDER:

2 Incl  
as

  
W. R. LIGHTFOOT  
ADMIN OFFICER

ATRM-FFI (24 Jan 78) 1st Ind AUTOVON 680-4221  
SUBJECT: Ft Leonard Wood Reports of Survey #182-78 and #189-78 (USAR).

HQ TRADOC, Fort Monroe, VA 23641 0 3 5 1978

TO: HQDA (DALO-ZXT) WASH DC 20310

1. The attached documents amply attest to a serious supply accountability problem existing in the 281st Avn Co (USAR). Although it appears obvious that negligence is involved, it is doubtful that any survey officer or board could piece together a seven-year puzzle and expect to have sufficient evidence to levy pecuniary charges.

2. It appears that a waiver of property accounting provisions UP Chapter 13, AR 735-5 would be more appropriate in this case. However, it appears that in lieu of final action being taken by TRADOC, it would be in the best interests of all concerned that final action remain in command channels. This would insure that appropriate disciplinary/administrative actions could be taken. In this regard, request an exception be granted for the above mentioned course of action so that Fifth Army and FORSCOM be directed to take final approval action.

FOR THE COMMANDER:



ARTHUR E. YORK  
CPT, AGC  
Asst AG

2 Incl  
nc

Copy furnished: (W/O incl)  
Cdr, USATC Engr &  
Ft L. Wood  
ATTN: ATZT-DI-OSC

DALO-ZXT (24 Jan 78) 2d Ind

SUBJECT: Ft Leonard Wood Reports of Survey #182-78 and #189-78 (USAR)

DA, ODCSLOG, Washington DC 20310

15 MAR 1978

TO: Commander, TRADOC, ATTN: ATRM-FFI, Fort Monroe, VA 23641

Subject reports of survey should be processed in accordance with FORSCOM/  
TRADOC Supplement 1 to AR 735-11 (para 4-2a), dated 27 February 1975.

FOR THE DEPUTY CHIEF OF STAFF FOR LOGISTICS:

2 Incl  
nc

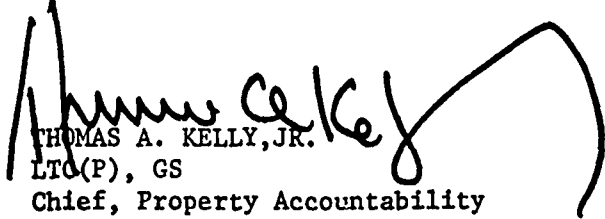
  
THOMAS A. KELLY, JR.  
LTC(P), GS  
Chief, Property Accountability  
Task Force

ATRM-FFI (24 Jan 78) 3d Ind

AUTOVON 680-4221

SUBJECT: Ft Leonard Wood Reports of Survey #182-78 and #189-78 (USAR)

HQ TRADOC, Fort Monroe, VA 23651 20 MAR 1978

TO: HQDA (DALO-ZXT) WASH DC 20310

1. Request reconsideration to recommendation made in preceding comment based upon verbal guidance received from your headquarters (LTC Ippolito and Mr. Wright) 17 March 1978, concerning a similar survey.

2. Action under Chapter 13, AR 735-5 appears more appropriate since exact losses cannot be determined.

FOR THE COMMANDER:

2 Incl  
nc

  
DORATHA MANGRUM  
DAC  
Asst AG



# DISPOSITION FORM

For use of this form, see AR 340-15; the proponent agency is The Adjutant General's Office.

REFERENCE OR OFFICE SYMBOL	SUBJECT
DALO-ZXT	Proper Count Impact on Personnel (USAR)

TO: OCAR  
ATTN: DAAR-LO

FROM: DALO

DATE: 1 JUN 1978  
CMT: LTC Stalcup/lch/43264

1. References:

- a. FORSCOM message 181900Z May 78, subject as above.
- b. Discussion between Mr. Frigon, OCAR and LTC Stalcup, DALO-ZXT, 1 Jun 78.

2. Request you take the lead for action as deemed necessary on the FORSCOM proposals outlined in reference 1a.

3. If the DA Property Accountability Task Force can be of assistance in your effort, please advise.

FOR THE DEPUTY CHIEF OF STAFF FOR LOGISTICS:

  
THOMAS A. KELLY, JR.  
LTC(P), GS  
Chief, DA Property Accountability  
Task Force

CF:  
CDR FORSCOM  
ATTN: AFLG-SMS

111

DA FORM 2496  
1 FEB 68

REPLACES DD FORM 2496, EXISTING SUPPLIES OF WHICH WILL BE  
ISSUED AND USED UNTIL 1 FEB 68 UNLESS SOONER EXHAUSTED.

U.S. GPO: 1974-549-843/8686



DEPARTMENT OF THE ARMY  
OFFICE OF THE DEPUTY CHIEF OF STAFF FOR LOGISTICS  
WASHINGTON, D.C. 20310

5 JUN 1978

DALO-ZXT

SUBJECT: Draft AR 190-51, Security of Army Property at Unit and  
Installation Level

Commander  
US Army Military District  
of Washington  
ATTN: ANLOG  
Fort Lesley J. McNair  
Washington, DC 20319

1. References:

- a. DCSLOG letter, DALO-ZXT, 1 Apr 78, subject as above, with inclosure, Draft AR 190-51, subject as above, undated.
- b. MDW letter, ANLOG, 8 May 78, subject as above.
- c. DA report, DAIG-IS, 6 Oct 77, subject: Report of Audit Survey and Special Inspection of Management and Accountability of Army Materiel.

2. Reference paragraph 2 of your letter (reference 1b):

- a. The requirement to maintain an informal serial number control ledger for office machines contained in paragraph 3-11c(2)h of Draft AR 190-51, cited in your letter, is a Level II security measure. It is an additional recommended security measure to be implemented at the discretion of the local commander if Level I safeguards have proven inadequate to stem thefts/unexplained losses of such items from bulk stocks. It is not a mandatory (Level I) physical security measure.
- b. A change has been made to paragraph 1-3a of Draft AR 190-51 deleting the reference to annual physical security inspections and simply referring to requirements for such inspections as outlined in AR 190-13. A revision to AR 190-13 will incorporate the changed inspection requirements.

DALO-ZXT

SUBJECT: Draft AR 190-51, Security of Army Property at Unit and  
Installation Level

3. All comments from Army staff agencies and the major Army commands, as well as from a few large CONUS installations, were reviewed and incorporated in Draft AR 190-51 as appropriate. Major changes were made in some areas, most notably with regard to security lighting at airfields and security of items designated as pilferable in the Army Master Data File (AMDF). The purpose for some of these changes was to reduce costs and the burden associated with implementing certain provisions of the regulation when the added risk trade-off appeared acceptable and reasonable.

4. Paragraph 1-5, Waivers or Exceptions, of the draft regulation was also changed to broaden and clarify the major Army commanders' authority to provide exceptions to Level I requirements. Specifically cited as a basis for exception is a Level I physical security measure clearly not in the best interest of the US Government. A location with negligible criminal history and local criminal threat is noted as an example of when such an exception might be appropriate. Costs of a particular measure should, of course, be considered when making this determination.

5. The DAIG report (reference 1c), based on inspection of 118 company-size units, noted that "inadequate safeguarding of materiel resulted in a portion of the losses discovered during the inspection" (paragraph 4a(4), reference 1c). The report further indicated that a sizeable number of commanders felt that inadequate storage facilities of organizational clothing and equipment (OCE) had contributed to losses. It was also found that numerous reports of survey for OCE cited security problems as a basis for the losses. A review of existing directives revealed that little specific guidance was available to commanders on protecting their assets, although a number of them (AR 190-13, AR 210-10, AR 710-2, etc.) charged the commander with responsibility for safeguarding property within their commands. Draft AR 190-51 was developed, not to impose more stringent standards, but to provide basic standards for various types of common Government supplies and equipment for which there were no security standards.

DALO-ZXT

SUBJECT: Draft AR 190-51, Security of Army Property at Unit and  
Installation Level

6. In view of the above stated need for security guidance in this area, the additional flexibility provided to major Army commanders in allowing exceptions to Level I requirements, and the delay that was experienced in obtaining comments from the field, resource impacts for Draft AR 190-51 will not be requested. Responses from the Army Staff and major Army commands indicate common agreement that Level I measures delineated in Draft AR 190-51, with the changes that have been incorporated, are basic, essential, and reasonable for the protection of US Government property.

7. The POC for this action is Major Pitcher, AUTOVON 224-4328/9. (Commercial 694-3238/9). Report correlation: Implied recommendation to improve security of Army property.

FOR THE DEPUTY CHIEF OF STAFF FOR LOGISTICS:

SIGNED

THOMAS A. 1  
LTC(P), GS  
Chief, DA Property Accountability  
Task Force



DEPARTMENT OF THE ARMY  
OFFICE OF THE DEPUTY CHIEF OF STAFF FOR LOGISTICS  
WASHINGTON, D.C. 20310

DALO-ZXT

7 JUN 1978

SUBJECT: USACIDC Property Accountability Recommendations

United States Army Criminal  
Investigation Command  
5611 Columbia Pike  
ATTN: CIOP-CP (CWO Hambrick)  
Falls Church, VA 22041

1. Reference letter, your headquarters, undated, subject, USACIDC Support to the DA Property Accountability Task Force.
2. Attached for your information is the status of actions planned on recommendations submitted by reference letter.
3. Your support of the DA Property Accountability Task Force efforts is appreciated.
4. Report Correlation: Implied recommendations. POC this headquarters is LTC Billy J. Stalcup, 224-3264

FOR THE DEPUTY CHIEF OF STAFF FOR LOGISTICS:

1 Incl  
as

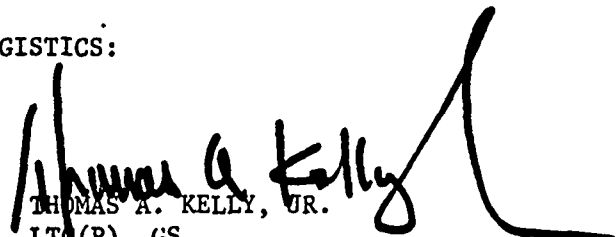
  
THOMAS A. KELLY, JR.  
LTC(P), GS  
Chief, DA Property Accountability  
Task Force

DALO-LER (5 Apr 78) 1st Ind  
SUBJECT: USACIDC Property Accountability Recommendations

DA, ODCSLOG, US Army Logistics Evaluation Agency, New  
Cumberland Army Depot, New Cumberland, PA 17070 2 JUN 1978

TO: HQDA (DALO-ZXT), WASH DC 20310

1. Basic correspondence requested our evaluation of Inclosure 1 for possible inclusion in AR 710-2. Paragraph 2 is a brief summary of those recommendations adopted for inclusion in AR 710-2. Paragraph 3 is an explanation of those recommendations not accepted. Responses are keyed to the specific paragraphs in Inclosure 1 to basic letter.

2. Adopted recommendations:

a. Paragraph 2a(1). Concur in part. AR 710-2 presently contains a glossary. A review of the terms contained in this glossary indicates that there are numerous terms that require further definition. There are also several terms used in AR 710-2 that are not defined. The terms in the glossary will be reviewed for further definition or additions/deletions, as applicable. However, updating the terms in AR 710-2 is only a partial solution to the problem identified. All terms used by the Army logistics community should be reviewed. Logistics terms should be standardized and included in AR 310-25, Dictionary of United States Army Terms.

b. Paragraph 2a(5). Concur in part.

(1) Change 5, AR 710-2, proposes that only sensitive items are required to be inventoried quarterly. Ammunition and arms are coded as sensitive and are, therefore, required to be inventoried.

(2) The requirement to inventory pilferable items quarterly is not feasible. There are too many items coded as pilferable in the ARMS AMDF. DSU/GSUs are required to conduct a 100 percent inventory of all items semiannually. This requirement provides sufficient control.

(3) The term "adjustment research" has been eliminated and replaced with the term "causative research" in the draft change 5, AR 710-2. This is in consonance with terminology used in AR 735-5, Property Accountability - General Principles, Policies, and Procedures.

2 JUN 1978

c. Paragraph 2a(6). Concur. AR 735-11 and change 5, AR 710-2 (both in draft), no longer permit the use of DA Form 444, Inventory Adjustment Report, for loss of sensitive items. Ammunition and arms are both coded as sensitive in the ARMS AMDF.

d. Paragraph 2a(7). Concur. See b above.

e. Paragraph 2a(8). Concur. The definitions of components of end items are presently under review by the Materiel Readiness Support Activity. The new terms and definitions will be included in change 5, AR 710-2.

f. Paragraph 2a(9). Concur in part. Change 5, AR 710-2, requires that excess items be turned in within 10 days.

3. Explanation of those recommendations not accepted for adoption:

a. Paragraph 2a(4). This Agency agrees with the finding that control in the utilization of DA Form 1687, Delegation of Authority - Receipt for Supplies, is lacking. The problem, however, is not the system but one of command emphasis and attention.

b. Paragraph 2a(10). The draft change 5 to AR 710-2 outlines the requirements for inventory of organization clothing and individual equipment (OCIE). Inventories are required upon assignment to, and prior to departure from, a unit. These inventories will be conducted prior to the individual reporting to the OCIE issue point for issue or turn in. Inventories prior to, and immediately after, a field exercise are encouraged. Other inventories are at the discretion of the commander. Diverse geographical locations and varying missions of the units make it extremely difficult to establish more stringent criteria in AR 710-2.

c. Paragraph 2a(11). This Agency agrees that procedures for obtaining items from the cannibalization point need to be clarified. The "can" point is a source of supply to the DSU/GSU supply support activity and not the source of supply for using units for organizations. Requests should be submitted to the DSU/GSU. Using units should not deal directly with the "can" point. Establishing controls at the

DALO-LER (5 Apr 78) 1st. Ind  
SUBJECT: USACIDC Property Accountability Recommendations

2 JUN 1978

battalion level, as proposed by USACIDC. would make the battalion a source of supply. Demand data could not be captured by the DSU/GSU using these procedures. Clarification of present procedures should resolve this problem.

FOR THE COMMANDER:

1 Incl  
nc

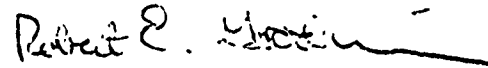

ROBERT E. GOODWIN  
Colonel, GS  
Chief, Logistic Operations  
and Readiness Division





DALO-ZXT

DEPARTMENT OF THE ARMY  
OFFICE OF THE DEPUTY CHIEF OF STAFF FOR LOGISTICS  
WASHINGTON, D.C. 20310

1979

MEMORANDUM FOR: OFFICE, ASSISTANT SECRETARY OF DEFENSE (COMPTROLLER)

ATTN: MR. CREHAN

SUBJECT: Army's Request for Deviation from DOD 7200.10M

1. This responds to your request of the DA Property Accountability Task Force to review the attached DOD, Office of the General Counsel memorandum (Tab A).
2. The Army strongly believes that liability for damage or loss to other Government property should be limited to an amount equal to one month's pay for the following reasons:
  - a. The Army has not collected for catastrophic losses.
  - b. It is the Army's belief that it is unreasonable to collect total liability for catastrophic losses.
  - c. The use of a simple negligence standard versus a gross/simple negligence standard would result in increased findings of pecuniary liability.
  - d. The DAIG found that of the 640 reports of survey in inspected units, property losses were valued at \$549,806, only \$33,506 (6.1 percent) of liability was approved.
  - e. The proposed deviation provides for a reasonable, realistic, and believable level of pecuniary liability for loss or damage to Government property.
  - f. Provides a deterrent to careless loss or damage to Government property.
  - g. Procedure will be simpler to administer and can be supplemented with punitive actions under the Uniform Code of Military Justice.

DALO-ZXT

SUBJECT: Army's Request for Deviation from DOD 7200.10M

h. This procedure will be more equitable than the use of a standard dollar criterion, which is applicable to all grades.

i. A standard of one month's base pay would not require changes to the DOD manual necessitated by inflationary adjustments.

3. After careful review of the DOD, General Counsel memorandum, and the Comptroller General of the United States Decision of 5 December 1963, (B-152699) (Tab B), the Army desires to change its request to establish a blanket remission of indebtedness for enlisted personnel when losses involving personal arms and equipment exceed one month's basic pay. The present system for damage or losses of personal arms and equipment will remain in effect. This change will require both officer and enlisted personnel to pay for the full loss of personal arms and equipment. However, the Army will pursue a course of action through legislative change to allow blanket remission of indebtedness for enlisted personnel for losses of personal arms and equipment.

FOR THE DEPUTY CHIEF OF STAFF FOR LOGISTICS:

**SIGNED**

THOMAS A. KELLY  
LTC(P), GS  
Chief, DA Property Accountability  
Task Force

2 Incl  
as

# DISPOSITION FORM

For use of this form, see AR 340-15, the proponent agency is TAGCEN.

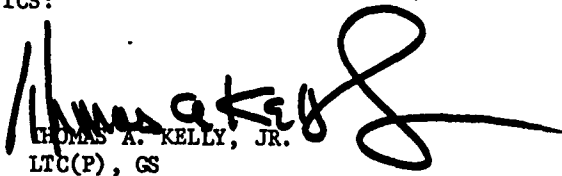
REFERENCE OR OFFICE SYMBOL	SUBJECT		
DALO-2XT	Secure Storage Space for Organizational Clothing and Equipment (OCE)		
TO DAEN-MCE	FROM DALO	DATE 9 JUN 1970 MAJ Pitcher/ss/43238	CMT 1
<p>1. Reference DAIG Report, DAIG-IS, 6 October 1977, subject: Report of Audit Survey and Special Inspection of Management and Accountability of Army Materiel.</p> <p>2. Referenced DAIG Report cited inadequate storage facilities of OCE as contributing to losses of Government property and noted that review of numerous reports of survey substantiated that lack of protection was the basis for substantial losses (paragraph 4a(4), reference 1). Conversations between members of the DA Property Accountability Task Force (DAPATF) and commanders during trips to the field have also indicated that inadequate secure storage space for unit supplies and equipment is a major problem at many locations.</p> <p>3. Request your office take the action deemed appropriate to ensure all new construction includes adequate secure storage space for safeguarding Government property of units/activities that will occupy them. Recommended security standards for facilities used to store and protect <u>unclassified</u> and <u>nonsensitive</u> Government supplies and equipment are at inclosure 1 (Sensitive items are identified in Appendix N, AR 710-2).</p> <p>4. The HQDA POC for this action is Major Pitcher, 694-3238/9. Report correlation: Implied recommendation to improve security of Army property.</p> <p>FOR THE DEPUTY CHIEF OF STAFF FOR LOGISTICS:</p> <p>1 Incl as CF: DAPE-HRE-PS</p> <p> THOMAS A. KELLY, JR. LTC(P), GS Chief, DA Property Accountability Task Force</p>			

121

DA FORM 2496  
1 FEB 62

REPLACES DD FORM 96, WHICH IS OBSOLETE.

## STORAGE STRUCTURE SECURITY

Buildings and rooms used for the storage of unclassified and nonsensitive US Army supplies and equipment are considered secure structures if they meet or exceed the following standards:

a. Walls and floor of new construction are of masonry and/or concrete. Walls and floors of existing structures, and ceilings of existing structures and new construction are of at least 1/2 inch (1.27 cm) plywood, 1 inch (2.54 cm) tongue-in-groove boards or equivalent.

b. Doors provide a degree of security comparable to that provided by the walls of the basic structure.

c. Door hinge mounting screws are not exposed to the exterior of the facility. If screws are exposed they will be spot welded, covered, or filled with material in a fashion to prevent their easy removal. Nails will not be used to mount hinges.

d. Door hinge pins exposed to the exterior of the facility are of a design or modified to prevent their easy removal.

e. Doors to the exterior locked from the inside are secured with a dead bolt locking device, cross bar, or similar locking device that is resistant to jimmying and manipulation from the outside as opposed to a latch style door lock.

f. Windows have individual locking devices.

g. All first floor openings, except doors, in excess of 96 square inches (619.4 square cm) which are located less than 12 feet (3.7m) from ground level are barred, grilled, or covered with chain link material in a manner to preclude easy removal. Installed metal framed windows which do not provide an opening in excess of 96 square inches (619.4 square cm) with the glass broken out and when fully open are exempt from this requirement.

h. Doors which are secured from the outside have locking devices conforming with appropriate Corps of Engineer guide specifications for the type of structure or with US Government tumbler-type, key operated padlocks.



DEPARTMENT OF THE ARMY  
OFFICE OF THE DEPUTY CHIEF OF STAFF FOR LOGISTICS  
WASHINGTON, D.C. 20310

DALO-ZXT

11 JUN 1978

MEMORANDUM FOR: COMMANDER, LOGISTICS EVALUATION AGENCY

ATTN: COLONEL TOUSLEY

SUBJECT: Logistics Service Awards Program

1. The results of the IPR, conducted on 8 June 1978 for the Director, DAPATF, subject as above, are listed below:

a. Selection of the combat service support units and combat/ combat support unit by the local commanders will be accomplished through the use of the evaluation annexes of AR 672-XX, results of Inspector General Inspections, and CLRTX visits if available.

b. MACOMs will establish a logistics awards board to select the best units in the seven categories as applicable.

c. MACOMs will submit their nominees to Logistics Evaluation Agency who will categorize the nominees from all MACOMs.

d. The DCSLOG unit logistics awards board chaired by the ADCSLOG will evaluate and nominate one unit per category.

e. The final approval will rest with the DCSLOG.

2. Sponsors for the program were discussed and prioritized. They will be contacted during the time frame that the regulation is being staffed with MACOMs. The agencies discussed were:

a. American Defense Preparedness Agency (ADPA).

b. Association of the United States of America (AUSA).

c. Society of Logistics Engineer (SOLE).

DALO-ZXT

SUBJECT: Logistics Service Awards Program

3. The draft regulation will be briefed during the upcoming DAPATF Working Conference III at Fort Lee, Virginia, 27-29 June 1978. The regulation will be distributed at the conference to all MACOM representatives for coordination. The cover letter will be signed by General DeHaven. During the time of the conference Mr. Ted Stanley and LTC O'Hara will visit TSA to discuss the Connelly Award and its similarities with the LOG Awards Program.

4. Additional coordination prior to the conference will be conducted by telephone between Mr. Stanley and LTC O'Hara.

THOMAS A. KELLY  
LTC(P), GS  
Chief, DA Property Accountability  
Task Force

INFORMATION PAPER

DALO-ZXT

SUBJECT: LOG Services Awards Program

FACTS.

1. Results of IPR conducted on 8 June 1978 for Director, DAPATF, subject as above, are as follows:
  - a. Selection of CSS units and C/CS units will be accomplished by evaluation using AR 672-XX, Results of IG Inspections and CLRTX Visits.
  - b. MACOM's will establish logistics awards boards to select.
  - c. MACOM's will submit nominees to LEA, who will categorize.
  - d. DCSLOG will establish a unit logistics awards board, chaired by the ADCSLOG to nominate one unit per category.
  - e. Final approval rests with the DCSLOG.
2. Sponsors were prioritized as follows:
  - a. American Defense Preparedness Agency (ADPA).
  - b. Association of the United States Army (AUSA).
  - c. Society of Logistics Engineers (SOLE).
3. The regulation will be briefed at the DAPATF Working Conference III, 27-29 June 1978.
  - a. MACOM's will receive the regulation at the Conference for staffing within their commands.
  - b. Cover letter will be signed by Director, DAPATF.

LTC O'Hara/44782



DEPARTMENT OF THE ARMY  
OFFICE OF THE DEPUTY CHIEF OF STAFF FOR LOGISTICS  
WASHINGTON, D.C. 20310

DALO-ZXT

13 JUN 1978

SUBJECT: Tool Kit Inventories

Commander  
US Army Materiel Development  
and Readiness Command  
ATTN: DRCIS-S  
5001 Eisenhower Avenue  
Alexandria, VA 22333

1. References:

a. The Inspector General Report of Survey and Special Inspection of Management and Accountability of Army Materiel, 6 October 1977.

b. Letter, DALO-ZXT, ODCSLOG to DARCOM, 23 December 1977, subject: Improved Composite Tool Kit (CTK) Inventory, and 1st Ind, DARCOM, 26 January 1978.

c. Letter, DALO-ZXT, ODCSLOG to TRADOC, 23 February 1978, subject: Tool Kit Inventory, and 1st Ind, TRADOC, 23 May 1978 (Incl 1).

2 Reference 1a stated that problems existed in the identification, inventorying, and security of hand tools. The overprinted hand receipt (DA Form 2062) and illustration of all items in sets, kits, and outfits, which are being included in CL supply catalogs, should assist in identifying and inventorying of hand tools. However, comments from the field recommend that other quick inventory methods such as tool box inserts and silhouette layout mats also be adopted.

3. As a result of your reply to letter from this office, 23 December 1977 (reference 1b), TRADOC was requested to expand initial efforts in developing instant inventory aids. The response from TRADOC indicating the evaluation and views of that headquarters and the comments of the Logistics Center and several of the associated schools are included in reference 1c. A tool box insert program for aircraft maintenance which shows promise, was initiated by the US Army Transportation Center and is currently being evaluated by TSARCOM. However, similar efforts for other types of equipment are desirable.



DALO-ZXT

SUBJECT: Tool Kit Inventories

4. As the representative of the user, TRADOC recommends that your headquarters assume the development and fielding of inventory aids in view of your responsibility for review and materiel management of sets, kits, and outfits under the provisions of AR 708-1. TRADOC will advise and assist DARCOM as required. Request appropriate action be taken to review high density SKO's for the possible immediate application of a tool kit inventory method, and the remaining SKO's be programed for a similar review according to the master review schedule. An implementation plan is requested by 17 July 1978.

5. It is further requested that the status of this project be briefed at the DAPATF Working Conference scheduled for 27-29 June 1978.

FOR THE DEPUTY CHIEF OF STAFF FOR LOGISTICS:

**SIGNED**

1 Incl

as

CF:

CDR, TRADOC

OREN E. DeHAVEN

Major General, GS

Director, DA Property Accountability

Task Force



DEPARTMENT OF THE ARMY  
OFFICE OF THE DEPUTY CHIEF OF STAFF FOR LOGISTICS  
WASHINGTON, D.C. 20310

15 JUN 1977

DALO-ZXT

SUBJECT: Surveying Officer's Guide

Commandant  
US Army Quartermaster School  
ATTN: ATSM-TB  
Fort Lee, VA 23801

1. The attached suggestion from Fort Huachuca is forwarded for appropriate action.
2. Request you consider incorporating the QMS publication entitled "The Surveying Officer's Guide" into the Army-wide training literature program. A guide on the procedures and requirements for processing a report of survey will be an invaluable assistance in improving the timely, efficient processing of reports of survey. This guide should reflect the procedures of the revised report of survey system to be outlined in the new AR 735-11, scheduled for implementation in the Fall of 1978.
3. Request you provide DAPATF your comments on this recommendation and, if appropriate, a milestone schedule outlining the revision, publication, and distribution of the surveying officer's guide as part of the Army-wide training literature program.

FOR THE DEPUTY CHIEF OF STAFF FOR LOGISTICS:

1 Incl  
as

THOMAS A. KELLY  
LTC(P), GS  
Chief, DA Property Accountability  
Task Force

SUGGESTION EVALUATION		
<small>For use of this form, see AR 672-20; the proponent agency is Office of the Deputy Chief of Staff for Personnel.</small>		
<b>TO:</b> (Include ZIP code) CDR, USACC ATTN: CC-PA-PT Fort Huachuca, AZ 85613	<b>FROM:</b> (Include ZIP code) HQDA DALO-ZXT WASH DC 20310	
<b>1. SUGGESTION TITLE</b> Training for Report of Survey Officers	<b>2. SUGGESTION NUMBER</b> 7-3-151	
<b>3. ACTION TAKEN OR RECOMMENDED</b>		
<input type="checkbox"/> a. APPROVED FOR ADOPTION <input type="checkbox"/> TOTALLY <input type="checkbox"/> PARTIALLY OR WITH MODIFICATION (Explain in item 4) <small>DATE SUGGESTION WAS OR WILL BE PUT INTO EFFECT</small>		
<input type="checkbox"/> ALSO RECOMMEND CONSIDERATION FOR WIDER APPLICATION AS INDICATED IN ITEM 4		
<input type="checkbox"/> b. ALREADY IN USE OR UNDER CONSIDERATION (Explain in item 4 indicating whether this suggestion contributed to the action in any way)		
<input type="checkbox"/> c. NOT APPROVED FOR ADOPTION FOR REASONS SHOWN IN ITEM 4		
<input checked="" type="checkbox"/> d. RECOMMEND ADOPTION, BUT APPROVAL NOT WITHIN JURISDICTION OF THIS OFFICE. REASONS FOR RECOMMENDATION ARE CONTAINED IN ITEM 4.		
<input type="checkbox"/> e. NOT RECOMMENDED FOR ADOPTION FOR REASONS SHOWN IN ITEM 4		
<input type="checkbox"/> f. OTHER (Specify in item 4)		
<b>4. REASONS FOR ACTION TAKEN OR RECOMMENDED (If more space is needed, continue on reverse)</b>		
<p>The suggestion to establish a training lesson to orient officers on the requirements for performing a report of survey has considerable merit. To be of maximum Army-wide benefit and facilitate the widest distribution and utilization, development of this training aid may best be accomplished through the Army Training Literature program. A pamphlet that is available for repeated reference and study by report of survey officers and distributed through publication channels will provide an economical means of orienting and educating officers on the procedures and requirements for processing a report of survey.</p> <p>A pamphlet entitled The Survey Officers Guide, available from the US Army Quartermaster School, provides guidelines and instruction for processing reports of survey. A copy of your suggestion is being forwarded to the US Army QMS so that consideration may be given for incorporating the Surveying Officers Guide into Army-wide literature program.</p>		
<b>5. BENEFITS (Complete for all suggestions adopted or recommended for adoption)</b>		
<input type="checkbox"/> a. TANGIBLE (Show actual or estimated dollar savings in terms of man-hours or personnel spaces, estimated savings based on increased output; and/or materials, equipment or other resources saved, for the first year subsequent to adoption. Indicate cost of conversion and net first year savings)		
<input type="checkbox"/> b. INTANGIBLE (Describe effect on operations, health, safety, welfare, or morale, and number of people and specific organizations affected. Based on criteria in AR 672-20, indicate whether significance is considered moderate potential value, substantial potential value, high potential value, or exceptional potential value and whether application is limited, extended, broad, or general)		
<b>6. DATE</b> 15 JUN 1978	<b>7. NAME, TITLE, &amp; TELEPHONE EXT OF EVALUATOR</b> Henry H. Fitzpatrick/MAJ/43264	<b>8. SIGNATURE &amp; TITLE OF RESPONSIBLE OFFICIAL</b> <i>[Signature]</i>



DEPARTMENT OF THE ARMY  
OFFICE OF THE DEPUTY CHIEF OF STAFF FOR LOGISTICS  
WASHINGTON, D.C. 20310

DALO-ZXT

15 JUN 1978

SUBJECT: Draft AR 735-11

Commander  
US Army Materiel Development  
and Readiness Command  
ATTN: DRCPP-SP  
5001 Eisenhower Avenue  
Alexandria, VA 22333

1. Subject draft Army regulation is forwarded pursuant to the FONECON between Mr. Eadinger, of your office, and Captain Varo on 26 May 1978.
2. Review of chapter 6 of the draft reveals that it has remained substantially unchanged since 1962. Request your office review the draft with specific emphasis toward necessary revisions in chapter 6. The inclosed draft contains pencil changes to be added to chapter 6. Also inclosed is recommended language modifying para 6-1b.
3. It is also requested that you advise this office regarding any perceived need to staff this chapter through DLA and/or MTMC. In this regard, it should be noted that, in accordance with suggestions received from MTMC, the current chapter 7, AR 735-11, has been deleted.
4. The draft regulation should be sent out for publication within a matter of days. As chapter 6 has minimal impact on the policy changes in the report of survey system, if comments are not received before the regulation is sent out, any revisions will be included in the followup revision to be completed after an approximate six-month test period of the new regulatory standards.

FOR THE DEPUTY CHIEF OF STAFF FOR LOGISTICS:

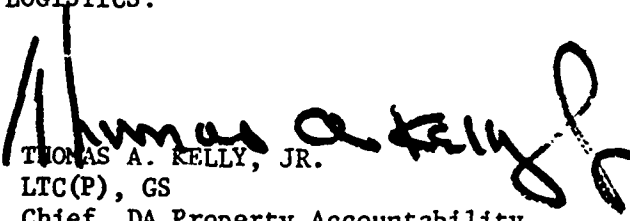
  
THOMAS A. KELLY, JR.  
LTC(P), GS  
Chief, DA Property Accountability  
Task Force

~~2 Incl~~

as

Draft w/d

New para 6-1b:

All losses involving vendor or contractor liability shall be referred to the contracting officer for a determination as to the contractor's liability in accordance with the particular contract involved. He is obligated to make a comprehensive finding of fact in each instance. The decision of the contracting officer is final and conclusive unless the contractor makes a timely appeal under the disputes clause. If such a dispute is considered by the Armed Services Board of Contract Appeals, pursuant to the provisions of the contract, the decision of the Board is final and conclusive unless determined by a court of competent jurisdiction to have been fraudulent, or capricious, or arbitrary, or so grossly erroneous as to imply bad faith, or not supported by substantial evidence.



DEPARTMENT OF THE ARMY  
OFFICE OF THE DEPUTY CHIEF OF STAFF FOR LOGISTICS  
WASHINGTON, D.C. 20310

23 JUN 1978

DALO-ZXT

SUBJECT: Component Listings of Integral Components of End Items,  
DA Forms 2062

Commander  
US Army Materiel Development  
and Readiness Command  
ATTN: DRCIS-S  
5001 Eisenhower Avenue  
Alexandria, VA 22333

1. References:

- a. FORSCOM message, DTG 191850Z Jun 78, subject as above.
  - b. DALO-ZXT letter, 7 December 1977, subject: Acceleration of Current Program to Supply Publications.
  - c. DA conference, 14-15 June 1978, subject: Standardization of Definitions and Titles (BII and AAL).
2. Referenced message stated that all components in operator manuals must be brought under control by the use of hand receipts.
3. Reference b was the initial tasking letter requesting preprinted, reproducible DA Form 2062, Hand Receipts (HR's), be included in the -10 TM operator manuals.
4. The initial thrust of the tasking letter was to ensure all items of equipment and operator manuals were covered by reproducible hand receipts.
5. In view of the results of referenced meeting, request your headquarters take necessary actions to notify Materiel Readiness Commands to develop an additional hand receipt for the end item and its integral components for proper property accountability.

DALO-ZXT

SUBJECT: Component Listings of Integral Components of End Items,  
DA Forms 2062

6. Request your response on actions be furnished DAPATF by 14 July 1978.

FOR THE DEPUTY CHIEF OF STAFF FOR LOGISTICS:

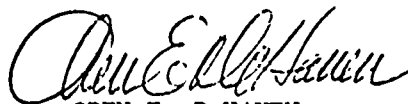

OREN E. DeHAVEN  
Major General, GS  
Director, DA Property Accountability  
Task Force



DEPARTMENT OF THE ARMY  
OFFICE OF THE DEPUTY CHIEF OF STAFF FOR LOGISTICS  
WASHINGTON, D.C. 20310

DALO-ZXT

23 JUN 1978

SUBJECT: TM Operators' Manual Consolidation List

Commander  
US Army Materiel Development  
and Readiness Command  
ATTN: DRCIS-S  
5001 Eisenhower Avenue  
Alexandria, VA 22333

1. References:

a. HQDA (DALO-ZXT) message, DTG 172040Z Apr 78, subject:  
Acceleration of Current Program to Simplify Supply Publications.

b. DARCOM/MRSA/DAPATF meeting, 15 June 1978.

2. Reference 1a established a requirement for IPR, which was accomplished, and also requested that plans be developed to add preprinted hand receipts to remainder of operator TM's after initial priority list was accomplished.

3. The meeting referenced in 1b, surfaced efforts by MRSA to develop a computer print-out which would accomplish the following:

a. Complete listing of all operator TM manuals which would require accompanying hand receipt documents for equipment (approximately 7,000 manuals).

b. List would be broken out by readiness command.

4. Request the following information be furnished DAPATF concerning the print-out:

a. When will above mentioned list be accomplished?

b. What sequence numbering will the list be in?



DALO-ZXT

SUBJECT: TM Operators' Manual Consolidation List

c. In what priority will the list be stratified?

d. What will determine this priority, e.g., maintenance significant items, high density items, or a combination of both?

e. Once the priority is established, what is the target date for completion of hand receipts for manuals?

5. Request information as to what program action has been or is planned to resource the TM simplification effort.

6. Request information be furnished DAPATF by 24 July 1978. Further, request one copy of print-out be furnished DAPATF upon its compilation.

FOR THE DEPUTY CHIEF OF STAFF FOR LOGISTICS:

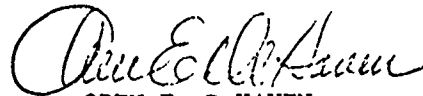

OREN E. DeHAVEN  
Major General, GS  
Director, DA Property Accountability  
Task Force

# DISPOSITION FORM

For use of this form, see AR 340-15, the proponent agency is TAGCEN.

REFERENCE OR OFFICE SYMBOL

DALO-ZXT

SUBJECT

Draft AR 672-XX, Logistics Services Awards Program

TO SEE DISTRIBUTION

FROM DALO

DATE 23 JUL 1978

CMT 1

LTC O'Hara/kp/44782

1. As a result of increased command emphasis on property accountability and a concerted effort at unit level to improve supply discipline, the establishment of an award to recognize excellence in all areas of logistics is being considered by this office. These areas include supply, maintenance, transportation, petroleum, and ammunition. Food service will be excluded, since it is represented by the Philip A. Connely Award. The Awards Program will be applicable to all active Army units.

2. A draft Army regulation to implement the Logistics Services Awards Program is inclosed. It is requested that the draft be reviewed and your comments and concurrence be forwarded on DA Form 2028 to Director, DAPATF (DALO-ZXT), by 31 July 1978.

3. The POC for this action is LTC W. D. O'Hara, Jr., Room 1A256, Pentagon, 694-3238/4782.

FOR THE DEPUTY CHIEF OF STAFF FOR LOGISTICS:



OREN E. DeHAVEN

Major General, GS

Director, DA Property Accountability  
Task Force

1 Incl  
as

DISTRIBUTION:

DAAG-ZX  
DAAR-ZX  
DACA-ZX  
DAEN-ZC  
DAPE-ZX  
DAIG-ZX  
DAJA-ZX  
NGB-ZA  
DAMA-ZX  
DAMI-ZX  
DAMO-ZX  
DASG-ZX  
DALO-SMS  
DALO-TSZ-X  
DALO-AV  
DALO-SMM



DEPARTMENT OF THE ARMY  
OFFICE OF THE DEPUTY CHIEF OF STAFF FOR LOGISTICS  
WASHINGTON, D.C. 20310

DALO-ZXT

26 JUN 1978

SUBJECT: Logistics Services Awards Program

SEE DISTRIBUTION

1. As a result of increased command emphasis on property accountability and the concerted effort at unit level to improve supply discipline, the establishment of an award to recognize excellence in all areas of logistics is being considered by this office. These areas include supply, maintenance, transportation, petroleum, and ammunition. Food service will be excluded since it is represented by the Philip A. Connelly Award. The award program will be applicable to all Active Army units.
2. A draft Army regulation to implement the Logistics Services Awards Program is inclosed. It is requested that the draft be reviewed and your comments and concurrence be forwarded on DA Form 2028 to Commander, US Army Logistics Evaluation Agency, ATTN: DALO-LEP, New Cumberland Army Depot, New Cumberland, Pennsylvania 17070 by 31 July 1978.
3. The Department of the Army Property Accountability Task Force project officer for this action is LTC W. D. O'Hara, Jr., AUTOVON 224-3238 and the LEA POC is Mr. Ted Stanley, AUTOVON 977-6744.

FOR THE DEPUTY CHIEF OF STAFF FOR LOGISTICS:

THOMAS A. KELLY, JR.  
LTC(P), GS  
Chief, DA Property Accountability  
Task Force

1 Incl  
~~as~~  
WO Incl

DALO-ZXT

SUBJECT: Logistics Services Awards Program

DISTRIBUTION:

Commander in Chief, US Army Europe and Seventh Army, ATTN: AEAGD-SM-F,  
APO New York 09403

Commander, US Army Forces Command, ATTN: AFLG-SMS, Fort McPherson,  
GA 30330

Commander, US Army Training and Doctrine Command, ATTN: ATLG-MSP,  
Fort Monroe, VA 23651

Commander, Eighth US Army, ATTN: DJ-MS-SM, APO San Francisco 96301

Commander, US Army Japan, ATTN: AJGD-S, APO San Francisco 96343

Commander, US Army Communications Command, ATTN: ACSLOG-SMT,  
Fort Huachuca, AZ 85613

Commander, US Army Intelligence and Security Command, ATTN: IALOG-S,  
Arlington Hall Station, Arlington, VA 22212

Commander, US Army Health Services Command, ATTN: HSLO-S, Fort Sam  
Houston, TX 78234

Commander, Military Traffic Management Command, ATTN: MT-SS,  
Washington, DC 20315

Commander, US Army Criminal Investigation Command, ATTN: CIOP-CP,  
5611 Columbia Pike, Falls Church, VA 22041

Commander, Military District of Washington, ATTN: DCS-TSI, Fort  
Lesley J. McNair, Washington, DC 20319



DEPARTMENT OF THE ARMY  
OFFICE OF THE DEPUTY CHIEF OF STAFF FOR LOGISTICS  
WASHINGTON, D.C. 20310

DALO-ZXT

1 APR 1978

SUBJECT: Draft AR 190-51, Security of Army Property at Unit and Installation Level

SEE DISTRIBUTION

1. Reference HQDA (DALO-ZXT) message, DTG 112035Z Nov 77, subject: Security of Army Property at Installation/Organizational Level (a Proper Count Message).
2. Subject regulation provides guidance on safeguarding unclassified, nonsensitive supplies and equipment at unit and installation level. It is intended that the proposed regulation will provide the unit/installation commander:
  - a. A single source reference document that interfaces property management and accountability and physical security, which are inter-related, by broad category of property.
  - b. Definitive guidance on what are considered to be minimum "reasonable precautions" to be taken to safeguard various kinds of property (Level I physical security measures, chapter 3).
  - c. A workable methodology and flexibility for developing a physical security program tailored to the local security environment (chapter 2 and Level II physical security measures, chapter 3).
  - d. A concise document (less than 30 pages when published) that outlines this information in an easily readable and ready reference format.
3. Addressees are requested to provide command concurrence/nonconcurrency in the proposed regulation and any comments to HQDA (DALO-ZXT), Washington, DC, not later than 3 May 1978. Comments should be forwarded on DA Form 2028. It is not anticipated that the draft AR will be restaffed with field commands after consideration/incorporation of comments provided.

DALO-ZXT

SUBJECT: Draft AR 190-51, Security of Army Property at Unit and  
Installation Level

4. The HQDA POC for this action is MAJ Pitcher, AUTOVON 224-3238/  
9/4782.

1 Incl  
as

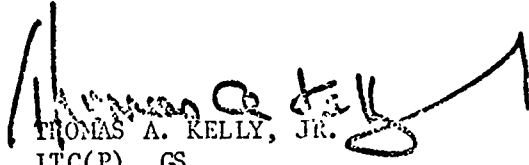
  
THOMAS A. KELLY, JR.  
LTC(P), GS  
Chief, DA Property Accountability  
Task Force

DISTRIBUTION:

HQDA (NGB-ZA)  
Commanders

US Army Materiel Development and Readiness Command, ATTN: DRCIS-S,  
5001 Eisenhower Avenue, Alexandria, VA 22333

US Army Communications Command, ATTN: ACSLOG-SMT, Fort Huachuca,  
AZ 85613

US Army Security and Intelligence Command, ATTN: IALOG-S, Arlington  
Hall Station, Arlington, VA 22212

Military Traffic Management Command, ATTN: MT-SS, Washington,  
DC 20315

US Army Military District of Washington, ATTN: DCS-TSI, Fort Lesley  
J. McNair, Washington, DC 20319

US Army Criminal Investigation Command, ATTN: CIOP-CP, 5611 Columbia  
Pike, Falls Church, VA 22041

US Army Health Services Command, ATTN: HSLO-S, Fort Sam Houston,  
TX 78234

US Army Forces Command, ATTN: AFLG-SMS, Fort McPherson, GA 30330

US Army Training and Doctrine Command, ATTN: ATLG-MSP, Fort Monroe,  
VA 23651

US Army Japan, ATTN: AJGD-S, APO San Francisco 96301

Eighth US Army, ATTN: DJ-MS-SM, APO San Francisco 96301

US Army Recruiting Command, ATTN: CRFM-SS, Fort Sheridan, IL 60037

Commander in Chief

US Army Europe and Seventh Army, ATTN: AEAGD-SM-F, APO New York 09403

Commandant

US Army Military Police School, ATTN: ATZN-TDE, Fort McClellan,  
AL 36205

PROPERTY ACCOUNTABILITY PROPERTIES

For use of this form, see AR 340-15, the proponent agency is TAGCFM.

REFERENCE OR OFFICE SYMBOL

SUBJECT

DALO-ZXT

Draft AR 190-51, Security of Army Property at Unit and Installation Level

TO SEE DISTRIBUTION

FROM DALO

DATE 1 APR 1978

CMT 1

MAJ Pitcher/dvw/43238

1. Reference HQDA(DALO-ZXT) message, DTG 112035Z Nov 77, subject: Security of Army Property at Installation/Organizational Level ( Proper Count Message).

2. Subject regulation provides guidance on safeguarding unclassified, nonsensitive supplies and equipment at unit and installation level. It is intended that the proposed regulation will provide the unit/installation commander:

a. A single source reference document that interfaces property management and accountability and physical security, which are interrelated, by broad category of property.

b. Definitive guidance on what are considered to be minimum "reasonable precautions" to be taken to safeguard various kinds of property (Level I physical security measures, chapter 3).

c. A workable methodology and flexibility for developing a physical security program, tailored to the local security environment (chapter 2 and Level II physical security measures, chapter 3).

d. A concise document (less than 30 pages when published) that outlines this information in an easily readable and ready reference format.

3. Addressees are requested to provide concurrence/nonconcurrence in the proposed regulation and any comments to DALO-ZXT not later than 21 April 1978. Comments should be forwarded on DA Form 2028.

4. The POC for this action is MAJ Pitcher, Room 1A256, the Pentagon, 694-3238/9/4782.

FOR THE DEPUTY CHIEF OF STAFF FOR LOGISTICS:

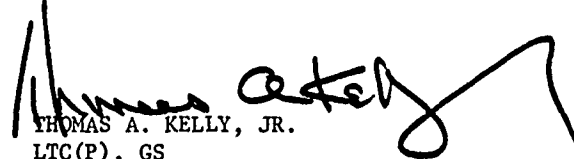
  
THOMAS A. KELLY, JR.  
LTC(P), GS  
Chief, DA Property Accountability  
Task Force

1 Incl  
as

DISTRIBUTION:

DAAG-ZX      DAMA-ZX  
DAAR-ZX      DAMI-ZX  
DACA-ZX      DAMO-ZX  
DAEN-ZX      DASG-ZX  
DAIO-ZX      DALO-SMS  
DAIG-ZX      DALO-TSE  
DAJA-ZX      DALO-AV

CF:  
DAPE-ZX

DEPARTMENT OF THE ARMY PROPERTY ACCOUNTABILITY TASK FORCE  
DAPATF

WORKING CONFERENCE III  
27-29 JUNE 1978  
FORT LEE, VIRGINIA

AGENDA

TUESDAY - 27 JUNE

<u>SUBJECT</u>	<u>TIME</u>
Admin Remarks	0900-0910
Opening Remarks	0910-0925
DAPATF Briefing	0925-0945
DAIG Perceptions	0945-1005
Break	1005-1020
Company Commanders Briefings	1020-1050
Seminar	1050-1130
Lunch	1130-1300
DAPATF Status Updates	1300-1600
Break	1600-1800
No-host Cocktail Party/Dinner	1800



WEDNESDAY - 28 JUNE

<u>SUBJECT</u>	<u>TIME</u>
Issue Resolution/Discussion	
6A - Inventory Procedures How do we improve the accountability of Post, Camp and Station Property?	0900-0930
6B - Establish a Management Information System A standard Army-wide automated system or remain as is.	0930-1000
Break	1000-1010
6E - Establish Uniform Allowances for CTA 50 items Central Issue Facilities Standardization of Procedures Centralized or Decentralized	1010-1040
6M - Eliminate Cash Collection Voucher Except for the Cash Sales of Hand Tools	1040-1110
6R - Establish Consumption Standards at Installation and Subordinate Levels	1110-1130
Lunch	1130-1300
TRADOC BRIEFING Log Baseline Curriculum Implementation Ensuring that all students master required tasks as prerequisite for graduation. Bn/Bde Commander refresher training Program to develop tool set/kit inventory aids.	1300-1330
DARCOM BRIEFING Aviation Composite Tool Kit Program AMDF Improvement Actions Supply Catalogs and TM's with accompanying preprinted hand receipts	1330-1400
MILPERCEN BRIEFING 76Y Grade Structure Inversion Reclassification procedures for CMF76	1400-1430

WEDNESDAY - 28 JUNE (CONT.)

<u>SUBJECT</u>	<u>TIME</u>
Break	1430-1445
TAG BRIEFING Implementation of the PUSH Distribution System	1445-1515
USAMMA BRIEFING Medical Materiel CL Supply Catalogs	1515-1535
Logistics Evaluation Agency (LEA) Logistics Excellence Award Supply Publication Management of Change Study Change 5 to AR 710-2	1535-1600

THURSDAY - 29 JUNE

<u>SUBJECT</u>	<u>TIME</u>
Audit Trail - Fort Stewart F&AO	0900-0930
QMS - Property Accountability Initiatives	0930-1000
DAPATF Summary Wrap-up	1000-1015
76Y Training Briefing and Tour	1015-1130
QMS Luncheon - MACOM Principle Rep's	1130

Section III  
Publications

# PROPERTY ACCOUNTABILITY

## enforcement of supply discipline

Various disciplinary and administrative measures are available to the commander to enforce supply discipline and reduce the loss, damage or destruction of government property.

A commander's usual reaction is to reach for AR 735-11 and start a report of survey. This may be appropriate or, in some cases, required. But, the report of survey is a supply-oriented document; it is not intended to be used as corrective action or punishment for negligence or misconduct which may have contributed to the loss.

Commanders must recognize that military discipline goes hand in hand with supply discipline. There are disciplinary and administrative tools available for use in conjunction with the report of survey:

- An oral reprimand has an immediate impact on everyone. In more serious cases, a formal letter of admonition or reprimand may be used and, when appropriate, may be filed in the member's official military personnel file in accordance with AR 600-37.

- Noting demonstrated inefficiency in OERs and EERs is a must. If a member continually displays a lack of ability or desire to meet command supply discipline requirements, consideration may be given to MOS reclassification, bar to reenlistment, reduction for inefficiency under chapter 7, AR 600-200, or separation as set down in chapter 5 or 13, AR 635-200.

- Cases of misconduct or neglect resulting in damaged or lost military property are subject to Article 15 or court-martial under the Uniform Code of Military Justice (UCMJ). For example, disciplinary action under the UCMJ may be taken under Article 92 for dereliction of duty or for failure to obey orders or punitive regulations.

Disciplinary action may also be taken under Article 108 for loss or damage to military property or for the wrongful sale or disposition of such property. In many instances, AR 735-11 requires a finding that the member's gross negligence was the proximate cause of the loss before he may be held pecuniarily liable.

However, disciplinary action under

the UCMJ often is permissible based on simple negligence. In addition, disciplinary action may be taken for misconduct which was not the direct cause of the loss.

The argument is often heard that "This soldier has been punished enough by the report of survey, and I don't want to give him an Article 15." This indicates a misunderstanding of the purpose of both the report of survey and nonjudicial punishment.

The report of survey is not a form of punishment nor has it proved to be effective as a deterrent. Nonjudicial punishment is both, though it is resorted to only when less severe measures either have failed to correct the situation or are inappropriate in view of the seriousness of the violation.

Use of administrative and disciplinary alternatives discussed above need not be limited to cases involving the standards prescribed by AR 735-11 for pecuniary liability. Even where no pecuniary liability is found, the facts may warrant some form of command action. Further, these measures may be appropriate not only for personnel directly causing a loss but also for those who fail to supervise properly.

There is little doubt that strong measures should be taken against the supply sergeant whose stocks were found by a command inspection to be \$10,000 short due to his misconduct or neglect. But similar action also would be appropriate against supervisors and commanders in the chain of command if investigation revealed that required inventories had never been made or verified.

At present, the report of survey all too frequently is successfully appealed, or the pecuniary liability remitted as a morale factor. It's then too late to take action of any kind. Supply discipline and with it military discipline suffer.

Obviously, each case must be judged on its own facts. Commanders have adequate means available to ensure a vigorous program of supply discipline and a full proper count in addition to the report of survey.

**EDITOR'S NOTE:** *COMMANDERS CALL* plans to do an in-depth story on reports of survey, upon receipt of the revised regulation.

## Proper Count Message

"Proper Count" has become a watchword in the Army in recent months. It is, of course, a contraction of the words "property accountability" and labels the concerted, intensive effort underway, Army-wide, to make much needed and overdue improvements in the management and accountability of our materiel. It also connotes each soldier's and civilian employee's personal responsibility for insuring that maximum lifespan and utility are obtained from all Government property entrusted to them.

The Army Chief of Staff directed, last year, a special Department of the Army Inspector General's inspection of management and accountability of Army materiel. Results of that inspection left little doubt that substantial improvements were needed in the way we look after and take care of Government property. General Rogers, after reviewing the inspector general report, stated his position lucidly, "We simply are not going to tolerate this type of mismanagement in our Army." He also provided clear-cut guidance on the approach to be taken in ameliorating the property accountability problems that exist.

"I expect each commander to become involved, for most of the problems associated with control of supplies in the Army can be attributed to a lack of involvement at all levels of command. The greatest improvements will result from a high level of command interest; I expect that level to be reached by all of us."

After reviewing the inspector general report, the initial, logical question is usually, "What happened to the stringent property controls of the 1950's and 1960's?" A complete answer to this question is difficult since a number of factors have combined to attenuate the effectiveness of the Army's supply economy program during the last decade.

Active involvement in combat operations frequently has resulted in a shift of emphasis away from strict accountability for property. Our prolonged experience in Southeast Asia was certainly no exception. We must also realize that advancing technology, as well as preparation for multiple contingency missions, have also had an influence. We must keep track of, as well as care for, an ever increasing density of equipment, supplies, components, and parts in a typical unit. The threat of relatively brief, high intensity conflict situations has also necessitated a proliferation of pre-positioned war reserve and backup stocks throughout the world. These must be managed and accounted for.

Numerous changes in the logistics system itself have also had a substantial impact. The advent of the computer provided the means for more responsive logistics support, but it has not been an unmixed blessing. Increasing sophistication requires personnel with additional skills and, hence, training; and they are not always available in desired numbers or at the most propitious times. Change, whether resulting from doctrinal innovation or system sophistication, all too frequently results in periods of turbulence and uncertainty when items may "fall through the cracks" that temporarily exist while property control procedures are being modified.

Finally, it must be recognized that sociological changes in American society at large sooner or later are manifest in the Army as well. Civilian experts in assets protection have pointed out the diminishing effectiveness of traditional ethical standards and employee goodwill as restraints against criminal or antisocial behavior toward the "company." It is reasonable to expect that some of our personnel view the Army as a nonpersonal, faceless entity that is ripe for ripping-off since "nobody's hurt" and "the Government can afford it." Ever notice how many US Government ballpoint pens you see in use in homes and businesses offpost?

The next logical question is, "What can we do to get better?" The key to a sound asset control program is, of course, the active involvement of commanders at all levels, as the Chief of Staff has stated. It is difficult to argue with the maxim "that gets done which the boss checks." A commander must be fully cognizant of his property accountability responsibilities; be knowledgeable of the policy, procedures, and requirements contained in pertinent directives; and take the time to inspect, question, and review his command's performance.

At company level there are four basic property accountability functions that must be properly performed to adequately control Government supplies and equipment. Every item on the property book or on hand receipts should be hand receipted and subhand receipted to a responsible individual at the lowest practicable level. All individual clothing records must be accurate and up to date. Change-of-command and periodic inventories have to be conducted in accordance with existing directives and at any other time that the commander perceives a need.

Another function the company commander must perform is to insure that appropriate inventory adjustment and disciplinary actions are taken in a timely manner in incidents involving lost, damaged, or destroyed property. Finally, the commander must take all reasonable precautions to safeguard supplies and equipment that arrive in or depart from his command. In essence, the company commander is responsible for implementing a comprehensive unit asset protection program through the integration of sound management techniques, personal accountability, and physical controls.

Though command emphasis can be expected to result in the greatest improvement in accounting for the Army's property, there are numerous other actions underway to assist in this endeavor. These are being coordinated by the Department of the Army Property Accountability Task Force. The task force was established on 25 October 1977 under the Deputy Chief of Staff for Logistics, based on a recommendation contained in the inspector general report. The mission of the task force is to execute the remaining recommendations contained in the report, that were approved by the Chief of Staff, and to take any other actions deemed necessary to improve the management and accountability of supplies and equipment.

Task force membership consists of representatives from various Headquarters, Department of the Army, and field organizations who have expertise in personnel and training, supply, physical security, logistics systems, property accountability, management of change and authorizations, publications, medical supply, military law, and criminal investigation. The multidisciplinary organization of the task force allows for a unified approach to the multifaceted and complex problems associated with our sophisticated logistics system and for expeditious coordination of actions among the Army Staff. To facilitate interchange of information and implementation of the inspector general recommendations, points of contact have been established at all major Army commands and they, in turn, have established similar "stovepipe" communication channels with their subordinate commands.

Department of the Army Staff actions that can be implemented immediately are announced to the field by separate messages. Increased visibility is provided to these property accountability messages through the use of an identifying statement in the passing and delivery instructions. Messages transmitting information are labeled "This is a Proper Count Message." Those that are directive in nature are prefaced with the statement, "This is a Proper Count Flasher Message Number . ." These are numbered sequentially. Policy changes contained in "flasher" messages will ultimately be incorporated in appropriate regulations.

The task force is working on a broad spectrum of actions to improve the Army's property management and accountability system. Some highlights of ongoing projects are summarized in the box on page 5. These efforts are being closely coordinated with the major commands to ensure that all proposed changes to the logistics system are reasonable and practical. In addition to the "stovepipe" property accountability structure between Department of the Army and the major commands to facilitate communications, extensive personal contact is used by the task force so that policy and procedural changes are not developed in a vacuum. Members make frequent TDY trips to continental United States installations. A trip through US Army, Europe, has just been completed and there are plans to visit Japan, Hawaii, and Korea this Spring. Periodic working conferences of points-of-contact in the major commands have also provided input from the field to the task force.

Indications are that the tactical commanders have taken up the property accountability banner and are moving out aggressively to improve control of their assets. The logistics community is particularly challenged to provide the tools and expertise necessary to assist them in doing their jobs more efficiently. Directives, technical manuals, supply catalogs, and component listings must be made simple and understandable, with changes published much less frequently. Policies and procedures pertaining to property accountability - as well as relief from accountability - have to be reasonable, yet comprehensive and "close the loop" to ensure that no property or collection actions to reimburse the Government for lost, damaged, or destroyed items "fall through the cracks." Policies and procedures must also be simple, practical, affordable, and effective over the long haul. Thought must also be given to aids or concepts - such as tool set inserts and layout sheets - that facilitate taking inventories at the user and unit levels.

Many of the improvements under consideration by the task force are not new. Some "tried and true" procedures, from years past, may well be reaffirmed and again implemented. Any ideas that you may have, whether original or based on experience, are earnestly solicited and would be appreciated. They should be directed to HQDA (DALO-ZXT), Washington, DC 20310.

Our problems have evolved over a period of years and we cannot expect miracles to solve them overnight. However, if we all become as professionally knowledgeable in logistics as we should be, pull together as a team to make the system work as it was intended, and methodically correct the shortcomings, substantial progress can be made in a matter of months. Possession of authorized levels of equipment by units and habitual exercise of supply discipline by all personnel are essential to readiness, particularly during these times of severely constrained funding. We owe this much to our country, our Army and, most of all, to ourselves.



## Self-Help Available in Property Accountability

Soldiers can increase their knowledge of property accountability procedures by means of the correspondence subcourses, training extension course (TEC) lessons, and field manual listed in the accompanying chart. These exportable training materials are available for individual or group training.

All Army personnel may apply for correspondence subcourses by mailing a completed and approved DA Form 145, Army Correspondence Course Enrollment Application, to - Army Correspondence Course Program, Newport News, Virginia 23628. Supervisors may enroll groups of soldiers in courses that parallel on-the-job training.

If TEC lessons are not available from battalion S3's, commanders may address requests to - Commander, US Army Training Support Center, ATTN: ATTSC-TP-TECSPT, Fort Eustis, Virginia 23604.

Field Manuals may be obtained at company libraries or requisitioned through publications channels.

### Correspondence Subcourses:

IS0277, Small-Unit Administrative Supply Operations  
QM0012, Unit and Organizational Supply, Part I  
QM0013, Unit and Organizational Supply, Part II  
QM0063, Packaging and Packing  
QM0129, Supply Procedures at Unit and Organizational Levels  
QM0173, Clothing Sales Store and Self-Service Supply Centers  
QM0346, Introduction to Division Logistics System (DLOGS)  
QM0374, Repair Parts Supply Records and Procedures, Part I  
QM0375, Repair Parts Supply Records and Procedures, Part II  
QM0418, Hand Tools  
QM0569, Automated Property Records at Unit and Organizational Levels  
QM0622, Supervisory Aspects of Unit and Organizational Supply

### Field Manual:

FM 10-30, Central Issue Facility

### Training Extension Course Lessons:

TEC Lessons 551-101-7901-F through 7905-F, PLL (DLOGS)  
TEC Lessons 551-101-7915-F through 7927-F, PLL (Non-DLOGS)

Part II

Major Command Input

NOTE: Items noted in paragraph 3 of each chapter input listing are annotated with the tasking document referred to in paragraph 2 of the same chapter. DAPATF actions listed in paragraph 2 may be found on the page identified in the volume noted.

## Chapter 5

### Command Emphasis

1. Recommendation 6A. Institute a system of review at major command level which will ensure that unit of command emphasis, at installation level, necessary to correct the deficiencies uncovered by this inspection. Specifically, it is a system for strict inventory procedures that will provide unit commanders with the assistance and time to properly account for unit property and assign responsibility for individual items, down to the user level.

	<u>Volume</u>	<u>Page</u>
2. DAPATF actions:		
a. Proper Count Flasher Message No. 2, DTG 011350Z Nov 77, Inventories.	1	9
b. Proper Count Message, DTG 011326Z Dec 77, USAR Interface with Property Accountability Program.	1	51
c. Proper Count Message, DTG 211605Z Dec 77, Maintaining Accountability During Transfer of Property.	1	54
d. Proper Count Message, DTG 271344Z Feb 78, USAR Interphase with Property Accountability Program.	2	48
e. Proper Count Message, DTG 222035Z Mar 78, Inventory Adjustment and Loss Reporting System.	2	57
f. Letter, 18 Jan 78, Modification to Inventory Adjustment Documents and Related Summary Data Needs of Managers.	2	86
g. Indorsement, 18 Mar 78, Request for Extension of Waiver to Appoint Accountable Officers.	2	213
h. Letter, 24 Mar 78, Property Accountability - Enforcement of Supply Discipline.	2	234
i. Letter, HQDA, DALO-ZXT, 14 Dec 77, Inventory Procedures.	2	258
j. Proper Count Message, DTG 241449Z May 78, Request for Clarification.	3	46

3. MACOM responses:	<u>Page</u>	<u>Tasking Ref</u>
a. Message, CDR USALEA, DTG 141845Z Apr 78, Request for Assistance.	158	
b. Message, CDR USASCH, Ft Shafter, DTG 081930Z May 78, Maintenance of Property Book Pages.	159	
c. Message, CDR FORSCOM, DTG 151315Z May 78, Request for Clarification.	160	2a
d. Message, CDR FORSCOM, DTG 181900Z May 78, Proper Count Impact on Personnel (L R).	161	2d
e. Message, CDR FORSCOM, DTG 021145Z Jun 78, Inventories.	163	2a

INSTITUTE SYSTEM FOR CMD REVIEW AND IMPROVE INVENTORIES :

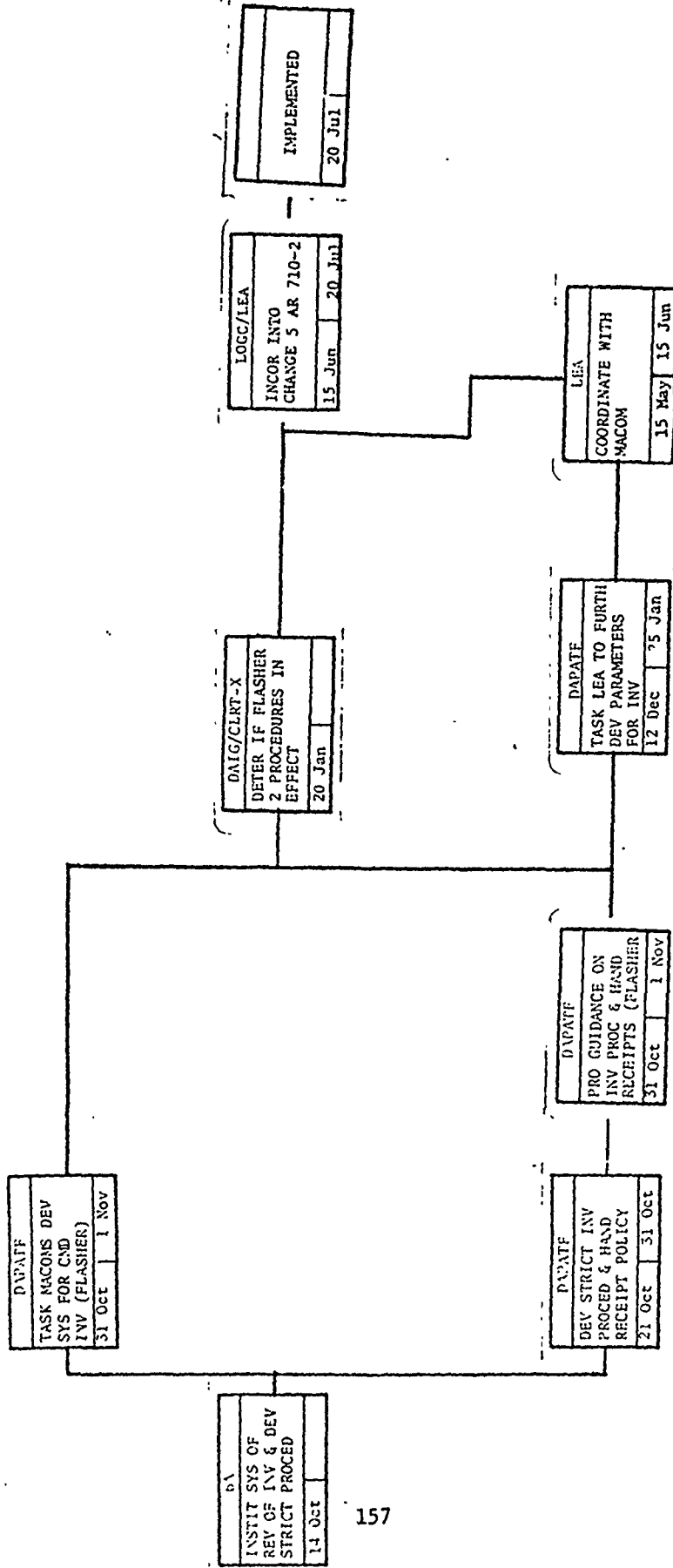

\* UNCLASSIFIED \*  
\*\*\*\*\*

DEPARTMENT OF THE ARMY  
PENTAGON TELECOMMUNICATIONS CENTER

CDSN = SCC969    MLN = 73105/03847    TOR = 781050210  
RTTUZYUW RUEANAC772 1042005-LLLL--RUEADWC.  
ZNR L0000  
R 141845Z APR 78  
FM CDR USAEA NEW COMB PA //CALC-LEF//  
TO RUCCPRA/CCRJSAE SHAPE DE //FC S//  
INFC RUEADWC/HQDA WASH DC //CALC-ZXT//  
BT

JNCLAS

SUBJ: RECLEST FOR ASSISTANCE

1. YOUR MSG 110900Z APR 78
1. AF 710-2 CURRENTLY CONSISTS OF THE BASIC REG EITH FOUR CH. CH 4 IS DTD 1 APR 77. AN INTERIM FINPCINT DISTR MSG CH WAS PUB WITH DATE TIME GROUP 231430Z SEP 77. NONE OF THESE CH AFFECT HANCTOCL ACCOUNTABILITY METHODS.
2. AS A RESULT OF THE DAIG SPECIAL INSP OF ARMY UNITS IN 1977, THE DA ECSLOG PROPERTY ACCOUNTABILITY TASK FORCE (DA PATF) & THIS AGCY ARE WORKING ON CH TO INVT, TURN-IN, & HAND RECEIPT PRO. POSSIBLY SOME OF THESE REVISED PRO WILL APPEAR IN CH 5 TO AR 710-2, WHICH WILL BE FIELDED IN THE NOV 78 TIMEFRAME.
3. DA PATF HAS PUB ARTICLES OF INTEREST IN CA SPOTLIGHT AND IN CDRS' CALL. IN ADDITION, THE PATF HAS PUB A SERIES OF PROPER COUNT MSG. & LTRS. THEY WILL FURNISH YOU A SUMMARY OF THEIR ACTIONS UNDER SEPARATE COVER.
4. YOU WILL BE INCLUDED ON DISTR FOR FUTURE MSG CH TO SUPPLY POLICIES AND PRO. IF WE MAY BE OF FURTHER ASST, PL CONTACT US.

BT

ACTION ADDRESSEES

JO6 DALO

00006    TOTAL NUMBER OF COPIES REQUIRED  
#0772

PLS	PLM	SI
ZX	TA	SMT
ZXA	TS	SMS
ZXA-C	TSM	SMM
AV	TST	SNV
PL	TSE	SML
PLS	TSP	SMD
PLW	TTC	SMI
PLR	TUB	SMB
PLF	SAA	SMC
PEO	SA	SMI
		RMP

\*\*\*\*\*  
\* UNCLASSIFIED \*    PAGE CI  
\*\*\*\*\*    141845Z APR 78  
\*\*\*\*\*    RUEANAC/772

\*\*\*\*\*  
\* UNCLASSIFIED \*  
\*\*\*\*\*

DEPARTMENT OF THE ARMY  
PENTAGON TELECOMMUNICATIONS CENTER

1A	
ZKA	
ZXA	
ZAX	
AV	
PLG	

CDSN = SCD089 MCN = 78129/01975 TOR = 781290128  
RTTUZYUW RUHHHMA3025 1290110-UUUU--RUEADWD.  
ZNR UUUUU  
R 081930Z MAY 78  
FM CDRUSASCH FT SHAFTER HI //AFZV-DI-HD//  
TO RUCLHTD/CDRFORSCCM FI MCFHERSEN GA //AFLG-SMS//  
INFO RUEADWD/DA WASH DC //DALO-ZXT//  
BT

JNCLAS  
THIS IS A PROPER CCNT MESSAGE  
SUBJ MAINTENANCE OF PROPERTY BOOK PAGES  
A. AR 710-2, MATERIAL MANAGEMENT FOR USING UNITS, SUPPORT UNITS,  
AND INSTALLATIONS, AUG 71, W/C 1-4 (U)  
1. IAW REF A, PARA 2-7, C (6) REQUIRES THE RECORDING OF ALL SERIAL  
NUMBERED END ITEMS ON THE REVERSE SIDE OF THE PROPERTY BOOK PAGE.  
2. IAW REF A, FIG 2-2, INSTRUCTIONS FOR DA FORM 3329 STATES WHEN  
SPACE IS INSUFFICIENT FOR LISTING ALL SERIAL NUMBERS ON ONE PAGE  
BUT ARE RECORDED ON HAND RECEIPTS A SEPARATE DA FORM 3329 WILL  
BE UTILIZED PER HAND RECEIPT.  
3. THIS COMMAND RECORDS THE SERIAL NUMBERS FOR THE ABOVE ASSETS  
ON THE HAND RECEIPTS BUT NOT ON THE DA FORM 3329. ON HAND ASSET  
EQUATE TO SOME BCCC HAND RECEIPTS. THESE ASSETS ARE SERVICED/  
REPAIRED AND EXCHANGED BY CONTRACT SERVICES. IT IS VIRTUALLY  
IMPRACTICAL TO MAINTAIN THESE SERIAL NUMBERS ON THE REVERSE SIDE  
OF THE DA FORM 3329 BY HAND RECEIPTS, DUE TO THE FREQUENT EXCHANGES  
INVOLVED BY CONTRACT REPAIR SERVICES.  
4. REQUEST EXEMPTION FROM RECORDING SERIAL NUMBERS OF RANGES,  
REFRIGERATORS, WASHERS AND DRYERS TO THE REVERSE SIDE OF DA FORM  
3329. THIS COMMAND WILL CONTINUE TO MAINTAIN SERIAL NUMBER OF  
THESE ASSETS ON HAND RECEIPTS.  
BT

ACTION ADDRESSEES  
006 DALO  
00036 TOTAL NUMBER OF COPIES REQUIRED  
#3025

\*\*\*\*\*  
\* UNCLASSIFIED \*  
\*\*\*\*\*  
PAGE 01  
081930Z MAY 78  
RUHHHMA/3025

\* UNCLASSIFIED \*  
\*\*\*\*\*

TRCL	
TA	
LS	
TSW	
PL	
PLR	
PLF	
PLC	

DEPARTMENT OF THE ARMY  
PENTAGON TELECOMMUNICATIONS CENTER

CDSN = SC0088 MCN = 78135/08591 TOR = 781351651  
RTTUZYUW RUCLHTA7386 1351636-UUUU--RUEADWD.  
ZNR UUUUU  
R 151315Z MAY 78  
FM CDR FORSCCM FT MCFFERSON GA //AFLG-SMS//  
TO RUEADWD/DA WASH DC//DALG-ZXT//  
INFO RUCLAIA/CDR TRACCC FT MONROE VA //ATLG-MSP-SP//  
RUWMBHA/JR USASIX SFRAN CA //AFKC-LG-MRP//  
RUEOPIA/CDR USAGNE FT MEADE MD  
RUWTFNA/CDR USAFIVE FT SAM HOUSTON TX  
BT

UNCLAS

THIS IS A PROPER CCLNT MSG  
SUBJECT; REQUEST FOR CLARIFICATION

- A. DALG-ZXT MSG, 011350Z NOV 77, SUBJ; INVENTORIES.
- 1. SUB PARA C, PARA 1 OF REF A STATES COMMANDERS AT COMPANY/DETACHMENT OR EQUIVALENT ELEMENT SIZE WILL BE THE HAND RECEIPT HOLDER.
- 2. THIS HQ HAS RECEIVED NUMEROUS INQUIRIES FROM THE FIELD QUESTIONING THE INTENT OF 1 ABOVE. IS THE INTENT FOR DETACHMENT OR EQUIVALENT LEVEL COMMANDERS IN THE GRADES LTC (05) AND COL (06) TO BE HAND RECEIPT HOLDERS OR PROPERTY BOOK OFFICERS.
- 3. YOUR EARLIEST REPLY WILL BE APPRECIATED.

BT

ACTION ADDRESSEES

006 DALG

INFORMATION ADDRESSEES

001 AFLO/ATLG

00007 TOTAL NUMBER OF COPIES REQUIRED

#7386

\*\*\*\*\*  
\* UNCLASSIFIED \*  
\*\*\*\*\*

PAGE 01  
151315Z MAY 78  
RUCLHTA/7386



\*\*\*\*\*  
 \* UNCLASS E F T C \*  
 \*\*\*\*\*

PENTAGON TELECOMMUNICATIONS CENTER

2XS		
2XAT	LG	SMS
2XA	TSN	SM
2X81382133		SM
AV		SM
PL	TSP	SM
PLS	SAC	SM
PLM	SAB	SM
PLRG//	SAA	SM
PLF	SA	SM
PLO		SM

CDSN = SCD770 PCN = 78138/20205 TGR =  
 RTTEZYUW RUCLHTA7822 1382104-EEEE--KLEADWD  
 ZNY EEEEE  
 R 181900Z MAY 78  
 FM CDR FORSCOM FT MCPIERSON GA //AFLG-SMS//  
 TO RJEADWD/DA WASH DC //CALL-ZXT//  
 INPC RUEOPIA/CDRLSACNEFT MEALE MD //AFKA-LG//  
 RJWTFNA/CDR USAFIVE FT SAM HOUSTON TX //AFK  
 RJWMBHA/CDR USASIX SFFAN CA //AFKC-LG/  
 BT

UNCLAS E F T C

THIS IS A PROPER COUNT MESSAGE  
 SUBJECT: PROPER COUNT IMPACT ON PERSONNEL (USAR)

1. IMPLEMENTATION OF PROPER COUNT DIRECTIVES, COUPLED WITH INCREASED COMMAND EMPHASIS ON SUPPLY MANAGEMENT PROCEDURES, HAS REEMPHASIZED A PROBLEM THAT CONTINUOUSLY PLAGUES THE USAR AND WILL NOT IMPROVE. THIS IS THE ABILITY OF USAR UNITS TO MANAGE, ACCOUNT FOR, AND CONTROL EQUIPMENT AND SUPPLIES WITHIN CURRENT MANPOWER RESOURCES.
2. IN USAR UNITS THE SUPPLY FUNCTION IS ACCOMPLISHED LARGELY BY PART-TIME PERSONNEL. IN SOME CASES, UNIT TECHNICIANS ATTEMPT TO PERFORM SOME OF THESE FUNCTIONS; HOWEVER, THEY ARE LIMITED DUE TO THE PRESSURE OF OTHER DUTIES AND LACK OF QUALIFICATIONS. SIXTH ARMY STUDIES HAVE REVEALED THE UNIT ASST CURRENTLY SPENDS ONLY 10 - 15 PERCENT OF HIS TIME ON SUPPLY RELATED FUNCTIONS. THE REMAINDER OF HIS TIME IS SPENT ON NON-LOGISTICS RELATED TASKS.
3. THE DA IG REPORT ON MANAGEMENT AND ACCOUNTABILITY OF ARMY MATERIEL IDENTIFIED THE MAGNITUDE OF PROBLEMS THAT ACTIVE COMPONENTS WITH FULL-TIME, TRAINED PERSONNEL ARE EXPERIENCING IN MANAGEMENT PROBLEMS; THESE PROBLEMS ARE THREEFOLD IN USAR UNITS. THE USAR CANNOT ACCOMPLISH ALL THE TASKS REQUIRED TO MANAGE, ACCOUNT FOR AND CONTROL UNIT PROPERTY. THE TIME REQUIRED IS JUST NOT AVAILABLE. THIS IS COMPOUNDED BY THE PERSONNEL SHORTAGES CURRENTLY BEING EXPERIENCED IN THE MAJORITY OF USAR UNITS. PROBLEMS ARE FURTHER EXAGGERATED BY MANUAL SYSTEMS AND PROCEDURES; INADEQUATE SPACE; CHANGES IN SKO'S; AND FREQUENT REQUISITIONING CAUSED BY INVALID REQUESTS. THE PROBLEM WILL PERSIST IN THE USAR UNTIL ADEQUATE NUMBERS OF QUALIFIED, FULL-TIME PERSONNEL ARE AUTHORIZED AND/OR ASSIGNED TO USAR UNITS.
4. TO MEET THE OBJECTIVES OF THE DA PROPERTY ACCOUNTABILITY TASK

\*\*\*\*\*  
 \* UNCLASS E F T C \*  
 \*\*\*\*\*

PAGE 01  
 181900Z MAY 78  
 RUCLHTA/7822

\*\*\*\*\*  
\* UNCLASS E F T O \*  
\*\*\*\*\*

PENTAGON TELECOMMUNICATIONS CENTER

FORCE AND TO ASSIST IN THE IMPROVEMENT OF SUPPLY PROCEDURES OVER-ALL, IT IS PROPOSED THAT:

A. ADDITIONAL SUPPLY ORIENTED ACTIVE COMPONENT AUGMENTEES (OFF/WO/ENL) BE ASSIGNED TO CENTERS AND BDE/OP/BN-SIZE UNITS THAT HAVE SIGNIFICANT AMOUNT OF EQUIPMENT ON HAND.

B. ADDITIONAL FULL TIME SUPPLY ORIENTED ARMY RESERVE TECHNICIANS (ART) AND/OR NON-DUAL STATUS PERMANENT CIVILIANS BE ASSIGNED TO MUSARC AND SEPARATE COMPANIES POSSESSING A PROPERTY BOOK, E.G., FA/ENG/SIC/ACFT/CAV TRPS/ ETC. AS AN ALTERNATIVE RESERVISTS CAN BE ASSIGNED ON A 2-YEAR EXTENDED ADT TOUR (SAME AS THE RESERVE RECRUITERS), 175 DAY ADT AND/OR ON A TWO-WEEK AT TOUR (WHICH WILL SATISFY THEIR AT REG.)

C. ONE ADDITIONAL PLTA 4 EACH YEAR TO BE UTILIZED TO CONDUCT ANNUAL INVENTORIES.

D. ADDITIONAL SEPARATE ADMIN CHILL PERIODS BE AUTHORIZED TO UNIT COMMANDERS AND STAFF OFFICERS TO IMPROVE THE "PROPER COUNT" PROGRAM AS PART OF THE UNIT'S ANNUAL TRAINING PROGRAM (ATP). (THIS WILL INSURE THAT THE COMMANDERS AND STAFF OFFICERS DEVELOP COMMAND INTEREST AND ARE FULLY INVOLVED IN THE "PROPER COUNT" PROGRAM).

E. MUSARC BE AUTHORIZED ADDITIONAL FULL-TIME SUPPLY ORIENTED ARTS TO PERFORM DUTIES AS "EXAMINERS" WOULD CONDUCT STAFF INSPECTION/ASSISTANCE VISITS TO UNITS AT LEAST ONCE EACH YEAR TO AUDIT THE PROPERTY BOOKS AND EVALUATE THE IMPLEMENTATION OF THE "PROPER COUNT" PROGRAM. THE NUMBER OF EXAMINERS REQUIRED WOULD DEPEND UPON THE NUMBER OF SUBORDINATE UNITS TO BE EXAMINED IN THE MUSARC.

5. TO RESOLVE THIS PROBLEM RECOMMEND THAT DA AND OAR INITIATE A JOINT STUDY ON THE FEASIBILITY OF THE ABOVE PROPOSALS. IT WOULD APPEAR THAT THE MONETARY SAVING THROUGH TIGHTENED ACCOUNTABILITY AND IMPROVED MANAGEMENT WOULD MORE THAN JUSTIFY THE ADDED PERSONNEL COSTS AND MOVE US CLOSER TO THE "TOTAL ARMY" CONCEPT. HOWEVER, PERSONNEL SHORTAGES BOTH CURRENT AND PROJECTED MUST BE RECOGNIZED IN CONSIDERATION OF THIS CONCEPT. THE CURRENT "FAVORED" POSITION OF OVERSEAS COMMANDS IN FILL OF EXPERIENCED SUPPLY PERSONNEL WOULD PROBABLY RESULT IN THE CLNUS (THUS FORSCOM) EXPERIENCED SUPPLY PERSONNEL BASE BEING FURTHER DEGRADED.

BT

ACTION ADDRESSEES

006 CALO

00006 TOTAL NUMBER OF CCPJES REQUIRED

#7822

\*\*\*\*\*  
\* UNCLASS E F T O \*  
\*\*\*\*\*

PAGE 02  
181900Z MAY 78  
RUCLHTA/7822

\*\*\*\*\*  
 \* UNCLASSIFIED \*  
 \*\*\*\*\*

DEPARTMENT OF THE ARMY  
 PENTAGON TELECOMMUNICATIONS CENTER

CDSN = SCD064 MCN = 78154/0959J TOR = 781541  
 RTTUZYUW RUC LHTA911) 1541743-JUUU--RUEADWD.  
 ZNR UUUUU  
 R 021145Z JUN 78  
 FM CDR FORSCOM FT MONROE VA //AFLG-SMS//  
 TO RUWMBHA/CDR USASIX SFRAN CA //AFKC-LG-MRP//  
 RUEPFA/CDR USAONE FT MEADE MD//  
 RUWTFNA/CDR USAFIVE FT SAM HOUSTON TX//  
 INFO RUEADWD/DA WASH DC //DALO-ZXT//  
 RUC LAIA/CDR TRADOC FT MONROE VA //ATLG-MSP-S2//  
 BT

BKS	TA	SM
ZX	LE	SMT
ZXT A	TSM	GMS
ZXA	TST	GMM
THCL	TSE	SMW
AV	TSP	SML
PL	TS	SMD
PLW	SAC	FM
PLS	SAB	RMB
PLR	SAA	RMO
PLF	SA	RMI
PLO		RMP

UNCLAS

THIS IS A PROPER CCMT MESSAGE

SUBJECT: INVENTORIES

- A. REF, USASIX MSG, AFKC-LG-MRP, 101700Z MAY 78, SAB.
- B. REF, FORSCOM MSG, AFLG-SMS, 151315Z MAY 78, SUBJECT: REQUEST FOR CLARIFICATION.
- C. REF, DA MSG, DALO-ZXT, 241449Z MAY 78, SBJ; REQUEST FOR CLARIFICATION.
- D. REF, FORSCOM FLASHER MSG NO. 2, AFLG-SMS, 111945Z NOV 75, SAB.
- 1. REF A REQUESTED THAT DET OR EQUIVALENT LEVEL COMMANDERS IN THE GRADES LTC (O5) AND COL (O6) BE EXEMPT FROM THE REQUIREMENTS OF REF D.
- 2. REF B REQUESTED DA CLARIFICATION OF THEIR INTENT FOR O5/O6 COMMANDERS TO BE THE HAND RECEIPT HOLDER/PROPERTY BOOK OFFICER.
- 3. REF C IS DA RESPONSE TO REF B, WHICH STATES THAT O5/O6 COMMANDER WILL FOLLOW THE PROVISIONS OF FLASHER NO. 2 WITH O6 COMMANDERS GIVEN THE LATITUDE OF APPOINTING AN INDIVIDUAL TO CONDUCT THE CHANGE OF COMMAND INVENTORY. THIS POLICY WILL BE INCLUDED IN CHANGE 5 TO AR 710-2.

BT

ACTION ADDRESSEES

006 DALO

INFORMATION ADDRESSEES

001 AFLO/ATLO

0007 TOTAL NUMBER OF COPIES REQUIRED

#9110

\*\*\*\*\*  
 \* UNCLASSIFIED \*  
 \*\*\*\*\*

PAGE 01  
 021145Z JUN 78  
 RUC LHTA/9110

## Chapter 6

### Management Information

1. Recommendation 6B. Establish, at MACOM and installation levels, a management information system that maintains stratified visibility of supply accountability adjustment actions.

2. DAPATF actions:

DALO-ZXT Message, DTG 281905Z Mar 78,  
requests status of implementation of MIS  
system at MACOM's and installations -  
Suspense: 17 Apr 78.

Volume      Page

2              282

3. MACOM responses:

a. Message, CDR FORSCOM, DTG 051530Z Apr 78,  
Management Information System For Loss Adjustment  
actions.

Page              Tasking Ref

167              2

b. Message, CDR EUSA, DTG 100802Z Apr 78,  
Management and Accountability of Army Materiel.

168              2

c. Message, CDR MTMC, DTG 111405Z Apr 78,  
Management and Accountability of Army Materiel.

169              2

d. Message, CDR FORSCOM, DTG 131315Z Apr 78,  
Management Information System for Loss Adjustment  
Actions.

170              2

e. Message, CDR USARJ, DTG 140655Z Apr 78,  
Management and Accountability of Army Materiel.

171              2

f. Message, CINCUSAREUR, DTG 141309Z Apr 78,  
Management and Accountability of Army Materiel.

173              2

g. Message, CDR TRADOC, DTG 141544Z Apr 78,  
Management and Accountability of Army Materiel.

175              2

h. Message, CDR USACIDC, DTG 171405Z Apr 78,  
Management and Accountability of Army Materiel.

176              2

	<u>Page</u>	<u>Tasking Ref</u>
i. Message, CDR USACC, DTG 172251Z Apr 78, Management and Accountability of Army Materiel.	177	2
j. Message, CDR INSCOM, DTG 172004Z Apr 78, Management and Accountability of Army Materiel.	178	2
k. Message, CDR HSC, DTG 172050Z Apr 78, Management and Accountability of Army Materiel.	179	2

ESTABLISH A MANAGEMENT INFORMATION SYSTEM

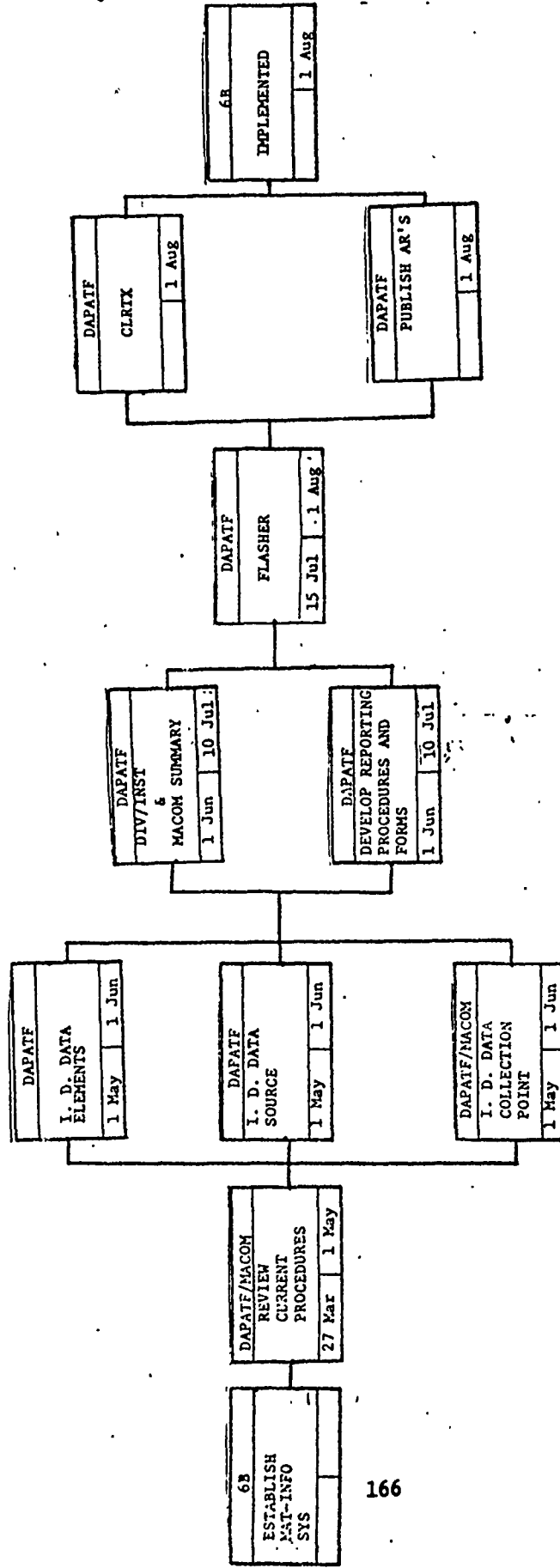

\*\*\*\*\*  
 \* UNCLASSIFIED \*  
 \*\*\*\*\*

DEPARTMENT OF THE ARMY  
 PENTAGON TELECOMMUNICATIONS CENTER

DNS	THCL	SM
ZX	MA	SMT
ZXT A	LE	SMS
ZXA	TSM	SMM
ZXA-C	TST	SMV
AV	TSE	SML
PL	TSP	SMD
<del>T9095220</del>	SAC	TM
PLW	SAB	TMB
PLR	SAA	TMC
PLF	SA	RMI
<del>PLQ</del>	<del>LC</del>	RMP

CDSN = SCC389 MCN = 78095/22449 TCR =  
 RTTUZYUW RUCLHTA3853 095200C-UUUU--RUEADWD.  
 ZNR UUUUU  
 R 051530Z APR 78  
 FM CDR FCRSCCM FT MCPHERSON GA//AFLG-SMS//  
 TO AIG 7433  
 INFO RUEADWD/DA WASH DC //DALC-ZXT/CALO-PLS/  
 BT

UNCLAS  
 SUBJ: MANAGEMENT INFORMATION SYSTEM FOR LOSS ADJUSTMENT ACTIONS  
 A. DA, VICE CHIEF OF STAFF LETTER, 11 OCT 77, SUBJ: MANAGEMENT  
 AND ACCOUNTABILITY OF ARMY MATERIEL  
 1. A REQUIRES THE ESTABLISHMENT, AT THE MACCM AND INSTALLATION  
 LEVEL, OF A MANAGEMENT INFORMATION SYSTEM THAT WILL MAINTAIN VISI-  
 BILITY OF ALL SUPPLY ACCOUNTABILITY ADJUSTMENT ACTIONS.  
 2. VISIBILITY OF LOSS DATA IS ENVISIONED EVENTUALLY THROUGH A DA  
 STANDARD SYSTEM, HOWEVER, THIS SYSTEM MAY NOT BE AVAILABLE FOR  
 SEVERAL YEARS. SUCH A SYSTEM IS INTENDED TO PROVIDE THE COMMANDER  
 WITH VISIBILITY AND MANAGEMENT DATA OF RELIEF FROM ACCOUNTABILITY  
 DOCUMENTS SUCH AS REPORTS OF SURVEY, IARS, STATEMENT OF CHARGES  
 AND CASH COLLECTION VOUCHERS.  
 3. IN ACCORDANCE WITH A, REQUEST THIS HC BE ADVISED OF THE TYPE  
 MANAGEMENT INFORMATION SYSTEM CURRENTLY UTILIZED TO PROVIDE MANAGE-  
 MENT INFORMATION REQUIREMENTS ON ALL LOSS ADJUSTMENT ACTIONS.  
 THIS INFORMATION IS REQUIRED TO ENABLE THIS HC TO EVALUATE ALL  
 REQUIREMENTS AND DETERMINE THE MOST APPROPRIATE METHODS TO SATISFY  
 THOSE REQUIREMENTS THROUGH STANDARD AUTOMATED MEANS.  
 4. RESPONSE REQUESTED NLT 24 APR 78.  
 BT

- ACTION ADDRESSEES  
 006 CALC  
 INFORMATION ADDRESSEES  
 006 CAAR  
 009 DACS  
 012 DAMO  
 001 AFLO/ATLG  
 00034 TOTAL NUMBER OF COPIES REQUIRED  
 #3853

\*\*\*\*\*  
\* UNCLASSIFIED \*  
\*\*\*\*\*

DEPARTMENT OF THE ARMY  
PENTAGON TELECOMMUNICATIONS CENTER

TO	
FM	
INFO	
FILE	
SEARCHED	
SERIALIZED	
INDEXED	
FILED	

CDSN = SCD235 MCN = 78100/04420 TOR = 781001245  
RTTUZYUW RUAGAAA1037 1001154-LLUL--RUEADWD.  
ZNR UUUUU  
R 100802Z APR 78  
FM CDR USAEIGHT SEOUL KOREA//DJ-MS-SM//  
TO AIG 7826  
INFO RUEADWD//DA WASH DC//DALC-ZXT//  
BT

UNCLAS

THIS IS A PROPER COUNT MESSAGE  
SUBJ; MANAGEMENT AND ACCOUNTABILITY OF ARMY MATERIEL (S; 17 APR 78)  
A. PROPER COUNT MSG DALU-ZXT 281905Z MAR 78 (U) PASLP  
B. DALU-ZXT 251818Z OCT 77, SUBJ; INVENTORY ADJUSTMENT REPORT  
(DA FORM 444) (U)  
C. LTR, EUSA GCJ-FP, 22 NOV 77, SUBJ; REVISION OF SUMMARY OF  
PROPERTY ADJUSTMENT ACTIONS (U)  
1. REF ALFA REQ STATUS OF IMPLEMENTATION OF MANAGEMENT INFO  
SYSTEM THAT MAINTAINS VISIBILITY OF SUPPLY ACCOUNTABILITY ADJUST-  
MENT ACTIONS AT MACOM AND INSTALLATION LEVEL. REF BRAVO WAS PROPER  
COUNT FLASHER MSG NO 1. REF CHARLIE WAS THIS HQ IMPLEMENTATION  
OF REF BRAVO.  
2. IT IS BELIEVED THAT ALL SUBCOMDS ESTABLISHED A SYSTEM FOR COLLEC-  
TION AND REPORTING OF ADJUSTMENT ACTIONS AS A RESULT OF REF BRAVO  
AND CHARLIE ALTHOUGH IT MAY NOT HAVE BEEN CALLED A QUOTE  
MANAGEMENT INFO SYSTEM UNQUOTE. IF AFFIRMATIVE, REQ APPROX  
DATE OF ESTABLISHMENT BE PROVIDED THIS HQ NLT 13 APR 78, T  
TOGETHER WITH NAME OF ACTION OFFICE. INFO MAY BE TELEPHONED TO  
293-8641/8770/6044, WITH CONFIRMATION IN WRITING.

BT

ACTION ADDRESSEES

006 DALU

00006 TOTAL NUMBER OF COPIES REQUIRED

#1037

168

\*\*\*\*\*  
\* UNCLASSIFIED \*  
\*\*\*\*\*

PAGE 01  
100802Z APR 78  
RUAGAAA/1037



\*\*\*\*\*  
\* UNCLASSIFIED \*  
\*\*\*\*\*

EKS	TWCG	...
ZXT	TA	...
ZXT	TA	...
AV	...	...
PT	...	...
PLW	...	...
PLR	SMA	...
PLF	SA	...
PLD	...	...

DEPARTMENT OF THE ARMY  
PENTAGON TELECOMMUNICATIONS CENTER

CDSN = SCD33) MCL = 73102/04046 TCR = 781020426  
 RTTZYUW RUKGCVF0003 1020+24-66UL--RUEADWD  
 ZNR 00000  
 R 111405Z APR 78  
 FM CDR MTMC WASHDC //MT-SPI//  
 TO RUEADWC/HQ DA WASHDC //JALO-ZXT//  
 INFO RUECPMA/CDR MTC EA DAYCNE NJ //MTE-SV//  
 RUAACMA/CDR MTC WA JAKLAND CA //MTC-SV//  
 RUDCRCA/CDR MTC TTGE KHAM NL //MTC-SV//  
 RUCLEJA/DIR MTC TEA FT EUSTIS VA  
 BT

UNCLAS

SUBJ: MANAGEMENT AND ACCOUNTABILITY OF ARMY MATERIEL  
 A. DALG-ZXT MSG 281900Z MAR 78, SAB. (PROPER COUNT MESSAGE)  
 B. DALG-ZXT MSG, 201818Z OCT 77, SUBJ: INVENTORY ADJUSTMENT REPORT

- (DA FORM 444) (PROPER COUNT FLASHER MESSAGE NUMBER 1)
1. A SYSTEM TO MAINTAIN VISIBILITY OF SUPPLY ACCOUNTABILITY ADJUSTMENT ACTIONS (REF A) WAS IMPLEMENTED AS OF 1 OCT 77.
  2. PER REF B IAR DATA IS REVIEWED AT INSTALLATION, MTC MAJOR SUBORDINATE COMMANDS AND AT THIS HQ.

BT

ACTION ADDRESSES

006 DALG  
 00006 TOTAL NUMBER OF COPIES REQUIRED  
 #0038

\*\*\*\*\*  
 \* UNCLASSIFIED \*  
 \*\*\*\*\*

PAGE 01  
 111405Z APR 78  
 RUKGCVF/0038

*Rick*

\*\*\*\*\*  
 \* UNCLASSIFIED \*  
 \*\*\*\*\*

DEPARTMENT OF THE ARMY  
 PENTAGON TELECOMMUNICATIONS CENTER

BVS	THCL	SM
7X	TA	SPT
ZXT	LE	SRE
ZXA	TST	SPT
ZXA-C	TST	SPT
AV	TST	SPT
PL	TST	SPT
1032035		
PLW	SAA	
PLR	SAA	
PLF	SM	
PLS	AI	

CDSN = SCC369 MCM = 73103/15563 TCR = 78  
 RTTUZYUW RLCLHTA4679 1032023-LLLL--RUEADWC.  
 ZNR UUUUU  
 R 131315Z APR 78  
 FM CDR FORSCOM FT MCPHERSON GA //AFIG-SMS//  
 TO RUEADWC/DA WASH DC //DALO-ZXT//  
 INFO RUEADWC/DA WASH DC //DALC-PLS/CAAR-IC/DAIG  
 BT

UNCLAS

THIS IS A PROPER COUNT MESSAGE  
 SUEJ; MANAGEMENT INFORMATION SYSTEM FOR LOSS ADJUSTMENT ACTIONS  
 A. DA MSG, DALO-ZXT, 2819J5Z MAR 78 SUBJ; MANAGEMENT AND ACCOUNTABILITY OF ARMY MATERIEL.  
 B. DA LETTER, DALO-ZXT, MFR ON 15 - 16 DEC 77 CONFERENCE, FT LEE VA.  
 C. FORSCOM MSG, AFAG-SMS, 051530Z APR 78.  
 1. REFERENCE A REQUESTS STATUS OF IMPLEMENTATION OF A MACOM/INSTALLATION MANAGEMENT INFORMATION SYSTEM FOR MAINTAINING VISIBILITY OF ACCOUNTABILITY ADJUSTMENT ACTIONS.  
 2. THIS HEADQUARTERS BY REF C HAS TASKED EACH INSTALLATION TO IDENTIFY THE TYPE OF MANAGEMENT INFORMATION SYSTEM CURRENTLY UTILIZED FOR MANAGEMENT/MONITORING OF LOSS ADJUSTMENT ACTIONS. RESPONSE DATA WILL BE EVALUATED WITH THE ACTUAL REQUIREMENTS FOR AN MIS.  
 3. GUIDANCE PRESENTED AT PARAGRAPH 6 OF REF E INDICATES THAT IT IS NOT IN THE BEST INTEREST OF GOOD MANAGEMENT TO INTRODUCE A NEW AUTOMATED MIS DEVELOPMENT EFFORT UNTIL ALL REQUIREMENTS HAVE BEEN IDENTIFIED. ONCE REQUIREMENTS HAVE BEEN ESTABLISHED, USALC AND CSC SHOULD DETERMINE THE FEASIBILITY AND LOGIC IN DEVELOPMENT OF A SUPPORTING AUTOMATED SYSTEM. IN KEEPING WITH THE PROVISIONS PRESCRIBED BY AR 18-1, THIS HEADQUARTERS TO DATE HAS NOT ENCOURAGED THE DEVELOPMENT OF A MACOM UNIQUE OR CLASS C FOR MIS. AFTER EVALUATION OF THE VARIOUS METHODS FOR OBTAINING LOSS ADJUSTMENTS DATA AND ACTUAL REQUIREMENTS HAVE BEEN IDENTIFIED, FORSCOM WILL IDENTIFY ALL REQUIREMENTS AND IF APPROPRIATE, PROVIDE DA WITH RECOMMENDATIONS FOR A STANDARD ARMY WIDE AUTOMATED MIS NOT EARLY MAY 1978.  
 BT

ACTION ADDRESSEES  
 006 DALC  
 INFORMATION ADDRESSEES  
 006 CAAR  
 001 DAIG  
 001 AFLO/ATCO  
 00014 - TWR

\*\*\*\*\*  
 \* UNCLASSIFIED \*  
 \*\*\*\*\*

PAGE C1  
 131315Z APR 78  
 RUCLHTA/4679

\*\*\*\*\*  
 \* UNCLASSIFIED \*  
 \*\*\*\*\*

B.	THCL	SM
ZX	TA	SMT
ZXT A	TE	SMS
ZXA	TSI	SMW
ZXA-C	TTD	SMW
AV	TTT	SMW
PLS	TTT	SMW
PLW	TTT	SMW
PLR	TTT	SMW
PLF	TTT	SMW
PLO	TTT	SMW

DEPARTMENT OF THE ARMY  
 PENTAGON TELECOMMUNICATIONS CENTER

CDSN = SC0306 MCN = 78104/06659 TCR = 778104C919  
 RTTUZFDY RJAQJHA4668 1040702-LLUL--RUEADWD.  
 ZNR UUUUU  
 R 140655Z APR 78  
 FM CDRUSARJ CPLAMA JAPAN//AJGD-SD//  
 TO DA WASHCC//DALU-ZX1//  
 BT

JNCLAS

THIS IS A PROPER COUNT MESSAGE.  
 SUBJ MANAGEMENT AND ACCOUNTABILITY OF ARMY MATERIEL

1. DA DALU-ZXT 231052 MAR 78 (U)

2. DA DALU-ZXT 251813Z OCT 77 (U)

3. AR 735-11 (U)

1. A SYSTEM OF REVIEW HAS BEEN ESTABLISHED AT THIS HQ AND SUBCOMMAND LEVEL TO MAINTAIN VISIBILITY ON ALL SUPPLY ACCOUNTABILITY ADJUSTMENT ACTIONS. IT INCLUDES

A. REVIEW OF ALL IAR ADJUSTMENTS AT SUBCOMMAND LEVEL BY DESCRIPTION OF PROPERTY, IDENTIFICATION OF UNIT ADJUSTING PROPERTY, ITEM QUANTITY, TOTAL ADJUSTED VALUE OF ITEM, AND REASON FOR ADJUSTMENT. REVIEW IS CONDUCTED QUARTERLY TO DETERMINE TREN IN ADJUSTMENTS, FREQUENCY OF ADJUSTMENTS, AND TO TAKE CORRECTIVE ACTION AS REQUIRED.

B. COLLECTION OF DATA ON IAR ACTIONS TO PROVIDE USARJ (MACOM) WITH VISIBILITY ON EXTENT OF INVENTORY ADJUSTMENTS. THIS DATA PLUS INFO ON REPORTS OF SURVEY, STATEMENT OF CHARGES, ETC. ARE BEING REVIEWED QUARTERLY AS PART OF THE USARJ REVIEW AND ANALYSIS PROGRAM.

2. THE SYSTEM (MANUAL) CURRENTLY USED BY THIS COMMAND IN COLLECTING DATA ON ADJUSTMENT ACTIONS IS ADEQUATE AND CONFORMS WITH REQUIREMENTS UNDER PARAS 2-8/2-9, REF C.

3. FOLLOWING RECOMMENDATIONS ARE MADE TO IMPROVE CURRENT SYSTEM OF REVIEW.

A. ESTABLISH DA PERFORMANCE STANDARD ON IAR ADJUSTMENTS FOR USE AT MAJOR COMMAND LEVEL. A TARGET OF NOT MORE THAN 2 PCT (NET ADJUSTMENT) OF AVERAGE INVENTORY VALUE AS SPECIFIED IN PARA 7-7D, AR 710-2 IS RECOMMENDED. FORMULA SPECIFIED, HOWEVER, REQUIRES CHANGE TO INCLUDE PERIOD OF ADJUSTMENT, I.E., QUARTERLY OR ANNUALLY. FORMULA IS INEFFECTIVE WITHOUT A TIME FRAME.

B. CHANGE RQMT FOR PREP OF INV ADJ REPTS FOR STK REC ACCTS OPERATING UNDER AUTOMATED SYSTEM TO CONFORM WITH

\*\*\*\*\*  
 \* UNCLASSIFIED \*  
 \*\*\*\*\*

PAGE 01  
 140655Z APR 78  
 RLADJHA/4668

\*\*\*\*\*  
\* UNCLASSIFIED \*  
\*\*\*\*\*

DEPARTMENT OF THE ARMY  
PENTAGON TELECOMMUNICATIONS CENTER

PARA 2-4E(2), REF C WHICH REQ CAUSATIVE RESEARCH WHEN EXTENDED  
LINE ITEM VALUE EXCEEDS \$200 OR ITEM COST IS A CONTROLLED ITEM.  
PARA 3-68, AR 710-2 STIPULATES THAT IAR'S ARE NOT REQUIRED FOR  
ITEMS WITH VALUE OR COST \$25 OR LESS. THE \$25 CRITERIA IS  
APPROPRIATE FOR A MANUAL SYSTEM, BUT SHOULD BE WAIVED UNDER  
THE AUTOMATED SYSTEM AS IAR'S ARE PREPARED SEPARATELY FOR  
ADJUSTMENTS \$200 AND UNDER REQUIRING NO RESEARCH AND THOSE  
OVER \$200 REQUIRING CAUSATIVE RESEARCH. A SEPARATE LISTING OF  
ADJUSTMENTS \$25 OR LESS IS NOT REQUIRED.

BT

ACTION ADDRESSEES

006 CALO

00006 TOTAL NUMBER OF COPIES REQUIRED

#4668

NNNN

\*\*\*\*\*  
\* UNCLASSIFIED \*  
\*\*\*\*\*

PAGE C2  
140655Z APR 78  
RUADJHA/4668

\*\*\*\*\*  
 \* UNCLASSIFIED \*  
 \*\*\*\*\*

DEPARTMENT OF THE ARMY  
 PENTAGON TELECOMMUNICATIONS CENTER

CD\$N = SCD295 MCN = 78111/17011 TOR  
 RTTUZYUW RUFDAAA1364 1112138-UUUU--RUEADWD  
 ZNR UUUUU  
 R 141309Z APR 78  
 FM CINCUSAREUR HEIDELBERG GERMANY//AEAGD-SM  
 TO DA WASH DC//DALU-ZXT//  
 BT

BKS#	THCL	SM
ZX	TC	
ZXT	TC	
ZXA	TC	
ZXA-C	TC	
AV	TC	
PL	TC	
PLS	TC	
PLW	TC	
PLR	TC	
PLF	TC	
PLO	TC	

UNCLAS

SUBJ: MANAGEMENT AND ACCOUNTABILITY OF ARMY MATERIEL  
 A. LTR, OFFICE OF THE CHIEF OF STAFF, 11 OCT 77, SAB.

B. HQCA, DALU-ZXT, 281900Z MAR 78.

1. REF A REQUIRES THE ESTABLISHMENT OF A MANAGEMENT INFORMATION SYSTEM THAT MAINTAINS VISIBILITY OF SUPPLY ACCOUNTABILITY ADJUSTMENT ACTIONS. REF B REQUESTS STATUS OF IMPLEMENTATION OF REF A.

2. INFORMATION REQUESTED IN REF B FOLLOWS:

A. IMPROVED VISIBILITY OF ADJUSTMENT DOCUMENTS IN EXISTING INFORMATION DATA BASE WAS ACHIEVED BY:

(1) REQUIRING INVENTORIES TO BE PERFORMED IAW AR 710-2 AND SURVEYS, STATEMENTS OF CHARGES, CASH COLLECTION VOUCHERS AND INVENTORY ADJUSTMENT REPORTS (IAR) BE PROMPTLY SUBMITTED FOR REVIEW AND APPROVAL.

(2) MODIFYING THE RESOURCE MANAGEMENT/EXPENDITURE REPORT TO REFLECT SSSC SALES OF HAND TOOLS. THE RESULTING INFORMATION IS USED BY SUBORDINATE COMMANDERS, USAREUR IG, CLRT AND CLAIT TEAMS TO ASSESS PROGRAM EFFECTIVENESS DURING THEIR REVIEWS OF ADJUSTMENT DOCUMENTS.

(3) REQUIRING USAREUR F&AU TO INFORM ADJUSTMENT DOCUMENT APPROVING AUTHORITIES IN WRITING OF COLLECTION ACTION ACTUALLY TAKEN.

(4) CONDUCTING INTERNAL REVIEW AUDITS TO IDENTIFY POTENTIAL POLICY PROBLEMS AND COMPLIANCE VIOLATIONS. THE RESULTS OF AUDITS ON SSSC HAND TOOL CASH SALES, TOOL CONTROLS, AND USE OF ADJUSTMENT DOCUMENTATION IN FINANCIAL PLANNING WERE FORMALLY PROVIDED TO THE AUDITED UNITS.

B. INCREASED COMMAND INTEREST IN AND EMPHASIS ON USE OF THIS INFORMATION WAS ACHIEVED BY:

(1) ENFORCING AR 735-11 QUARTERLY COMMAND REVIEW REQUIREMENTS AND REQUIRING USAREUR SUBORDINATE UNIT COMMAND REVIEWS TO BE SUBMITTED TO HQ USAREUR FOR REVIEW.

(2) PUBLISHING A SAMPLE REPORT OF SURVEY COMMAND REVIEW. A COPY WAS PROVIDED TO HQCA ON 31 MAR 78. A SAMPLE IAR COMMAND REVIEW IS NOW BEING PREPARED FOR DISTRIBUTION.

\*\*\*\*\*  
 \* UNCLASSIFIED \*  
 \*\*\*\*\*

PAGE 01  
 141309Z APR 78  
 RUFDAAA/1364

\*\*\*\*\*  
\* UNCLASSIFIED \*  
\*\*\*\*\*

DEPARTMENT OF THE ARMY  
PENTAGON TELECOMMUNICATIONS CENTER

- (3) MAKING ADJUSTMENT DOCUMENTS A MATTER OF INTEREST DURING USAREUR IG VISITS AS EVIDENCED BY THE USAREUR IG REQUEST FOR CLARIFICATION OF IAR APPROVAL PROCEDURES.
- (4) HIGHLIGHTING THE OCCURRENCE OF ARTIFICIAL LOSSES APPEARING IN IAR AND SURVEYS BECAUSE OF UNIT LEVEL OVERSIGHTS.
3. RELATED ADJUSTMENT PROCEDURE OBSERVATIONS ARE PROVIDED FOR YOUR INFORMATION.
- A. PAST FAILURES TO PERFORM REQUIRED REVIEWS APPEAR TO BE CAUSED BY MISUNDERSTANDING. NOW ADJUSTMENT DOCUMENTS ARE BEING REVIEWED FOR MANAGEMENT PURPOSES AS WELL AS ADMINISTRATIVE COMPLETENESS.
- B. INITIAL COMMAND REVIEWS ESTABLISHED BASE LINES TO IDENTIFY RELATIVE MAGNITUDES OF PROBLEM AREAS AND TO EVALUATE EFFECTS OF MANAGEMENT ACTIONS. SUBSEQUENT REVIEWS TEND TO BE MORE USEFUL BECAUSE DATA IS COLLECTED TO SOLVE LOCAL PROBLEMS. THIS VERSATILITY IS ESSENTIAL FOR THE 1300 UNIT PROPERTY BOOKS AND 350 DS/GS ACCOUNTS.
- C. RESULTS OF COMMAND REVIEWS ARE MORE IMPRESSIVE WHEN THE UNIT/COMMAND IS PROVIDED SEVERAL SAMPLES OF EXCELLENT REVIEW SUMMARIES AND THESE ARE THEN LOCALLY ADAPTED FOR USE. THE COMMAND REVIEW LEARNING CURVE IS EXPECTED TO CONTINUE TO GO UP.
- D. CONSIDERATION SHOULD BE GIVEN TO USE OF UNIT CLASS A AGENT SERVICES AS AN OPTION TO CURRENT HQDA SSSC HAND TOOL SALES PROCEDURES. THIS MIGHT OVERCOME PROBLEMS BECAUSE LOST TIME MAYBE REDUCED AND MAY ENCOURAGE UNIT COMMANDERS TO CONDUCT MORE INVENTORY SPOT CHECKS.
- E. SOME UNITS ARE MAKING GREATER USE OF STATEMENTS OF CHARGES NOW THAN PREVIOUSLY. THIS REDUCES THE RELIANCE ON SSSC PROCEDURES AND MAY BE MISINTERPRETED TO INDICATE LACK OF PROGRAM SUPPORT.
4. USAREUR CONTINUES TO PLACE COMMAND EMPHASIS ON VISIBILITY AND USE OF ADJUSTMENT DOCUMENT INFORMATION.

BT

ACTION ADDRESSEES

006 DALO  
00006 TOTAL NUMBER OF COPIES REQUIRED  
#1364

\*\*\*\*\*  
\* UNCLASSIFIED \*  
\*\*\*\*\*

PAGE 02  
141309Z APR 78  
RUFDAAA/1364

\*\*\*\*\*  
 \* UNCLASSIFIED \*  
 \*\*\*\*\*

SM	
CT	
MS	<input checked="" type="checkbox"/>
PLO	<input checked="" type="checkbox"/>

DEPARTMENT OF THE ARMY  
 PENTAGON TELECOMMUNICATIONS CENTER

CDSN = SCC869 MCN = 78104/12276 TOR = 781041655  
 RTTUZYUW RUCLAIA1732 10415+8-LLUL--RUEACWC  
 ZNR UUUUU  
 R 141544Z APR 78  
 FM CDTRADCC FT MONROE VA //ATLG-MSP-SP//  
 TO RUEACWC/HQDA WASH DC //DALG-ZXT//  
 INFC RUCLHTE/CDRFRSCOM FT MCPHERSON GA //AFLC-SM//  
 BT

UNCLAS

THIS IS A PROPER COUNT MESSAGE

- SUBJ: MANAGEMENT AND ACCOUNTABILITY OF ARMY MATERIEL
1. THIS RESPONDS TO MESSAGE, CA, DALG-ZXT, 281905Z MAR 78.
  2. THE REQUIREMENT FOR INSTALLATIONS, SCHOOLS, AND SPECIAL ACTIVITIES TO ANALYZE AND MAINTAIN INFORMATION ON ACCOUNTABILITY ADJUSTMENTS WAS ESTABLISHED BY FURSCOM/TRADCC SUPPLEMENT 1, 27 FEB 75, TO AR 735-11. SUBMISSION OF ADJUSTMENT INFORMATION TO THIS HQS, ON QUARTERLY BASIS, WAS DIRECTED IN TRADCC, ATLG-MSP-SP, PROPERTY COUNT FLASHER MESSAGE #1 12242Z DEC 77.
  3. SUBORDINATE COMMAND 1ST QTR FY 78 SUBMISSIONS HAVE BEEN REVIEWED. SECOND QTR REPORTS ARE BEING RECEIVED/REVIEWED AT THIS TIME.
  4. TRADCC CONTINUES TO EVALUATE THE UTILITY AND AFFORDABILITY OF EXTENDING THE MANUAL MANAGEMENT INFORMATION SYSTEM BEYOND THE INSTALLATION, SCHOOL OR SPECIAL ACTIVITY LEVEL. FINAL DETERMINATION AND CORRESPONDING RECOMMENDATIONS WILL BE FORMULATED AS THE REVISED AR 735-11 IS RECEIVED AND THE NEXT HEADQUARTERS MANPOWER REDUCTION BECOMES APPARENT.

BT

ACTION ADDRESSEES

OO6 DALG

INFORMATION ADDRESSEES

OO1 AFLC/ATLC

CGCC7 TOTAL NUMBER OF COPIES REQUIRED

#1732

\*\*\*\*\*  
 \* UNCLASSIFIED \*  
 \*\*\*\*\*

PAGE 01  
 141544Z APR 78  
 RUCLAIA/1732

\*\*\*\*\*  
 \* UNCLASSIFIED \*  
 \*\*\*\*\*

DEPARTMENT OF THE ARMY  
 PENTAGON TELECOMMUNICATIONS CENTER

CDSN = SCD478 MCN = 78108/C3172 TOR =  
 RTTUZYUW RUKGCVA0014 1080400-UUUU--RUEADWD.  
 ZNR UUUUU  
 R 171405Z APR 78  
 FM CDR USACIDC WASH DC //CILO-ST//  
 TO HQ DA WASH DC //DALO-ZXT//

S	TYPE	SY
ZX		ENT
ZXT <i>A</i>		ENT
ZXA		ENT
ZXA-C		ENT
78108C418		ENT
PL		ENT
PLS		ENT
PLW		ENT
PLR	SA	ENT
PLF	SA	ENT
PLQ		ENT
MATERIEL		ENT

UNCLAS

SUBJ: MANAGEMENT AND ACCOUNTABILITY OF ARMY  
 A. HQDA MSG DALO-ZXT 281905Z MAR 78.

1. REF A REQUESTS STATUS OF MACOM MANAGEMENT INFORMATION SYSTEMS THAT MAINTAIN VISIBILITY OF SUPPLY ACCOUNTABILITY ADJUSTMENT ACTIONS.
2. HQUSACIDC PRESENTLY RECEIVES COPIES OF THE QUARTERLY ASSET CONTROL SYSTEM (ACS) FEEDER REPORT FROM USACIDC FIELD ELEMENTS. THIS REPORT PROVIDES MACOM VISIBILITY OF AUTHORIZED AND ON HAND QUANTITIES OF RICC 1, 2, 3 AND SELECTED CTA ITEMS. THE USACIDC FIELD ELEMENTS ALSO ANNOTATE ON THE ACS REPORT CONDITION CODES ON SELECTED ITEMS OF EQUIPMENT CRITICAL TO THE USACIDC MISSION. THE CONDITION CODES AND THE ON-HAND QUANTITIES OF AUTHORIZED EQUIPMENT PROVIDE HQUSACIDC WITH ITS LOGISTICS READINESS POSTURE.
3. TO IMPROVE THE MANAGEMENT AND VISIBILITY OF USACIDC EQUIPMENT ON HAND, HQUSACIDC IS DEVELOPING AN AUTOMATED ASSET VISIBILITY

PAGE 2 RUKGCVA0014 UNCLAS  
 PROGRAM.  
 BT

ACTION ADDRESSEES  
 006 DALO  
 00006 TCTAL NUMBER OF COPIES REQUIRED  
 #0014

\*\*\*\*\*  
 \* UNCLASSIFIED \*  
 \*\*\*\*\*

PAGE 01  
 171405Z APR 78  
 RUKGCVA/0014



\* UNCLASSIFIED

\*\*\*\*\*

PKG	UNIT	CH
ZX		ONE
ZXF		TWO
ZYA		THREE
ZYA-C		FOUR
AV		FIVE
PZ81080316		SIX
PLS		SEVEN
PLW		EIGHT
PLR		NINE
PLF		TEN
PLD		ELEVEN
PLO		TWELVE
MATERIEL (U)		

DEPARTMENT OF THE ARMY  
PENTAGON TELECOMMUNICATIONS CENTER

CDSN = SCD437 MCN = 78108/02512 TOR =  
RTTUZYUW RUWJHRA4667 1080311-UUUU--RUEADWD  
ZNR UUUUU  
R 172251Z APR 78  
FM CDRUSACC FT HUACHUCA AZ //CC-LEG-SMT-SD/  
TO DA :ASHDC //DALO-ZXT//  
BT

UNCLAS

SUBJ MANAGEMENT AND ACCOUNTABILITY OF ARMY

A. YOUR DALO-ZXT 281905Z MAR 78 (U)

1. REF REQUESTED STATUS OF IMPLEMENTATION OF MANAGEMENT INFORMATION SYSTEM TO MAINTAIN VISIBILITY OF SUPPLY ACCOUNTABILITY ADJUSTMENT ACTIONS.

2. MANY USACC ACTIVITIES FUNCTION IN DUAL CAPACITIES IN OTHER MACOMS AND/ER RELY ON HOST-TENANT AGREEMENTS FOR SUPPLY AND ADMINISTRATIVE SUPPORT. ESTABLISHMENT OF PROCEDURES, WHICH AVOID CONFLICTING INSTRUCTIONS AND PREVENT DUPLICATIVE REPORTING TO THIS HQ AND THE HOST MACOM, WILL BE COMPLICATED.

3. SINCE IMMINENT EXTENSIVE MODIFICATION OF AR 735-11 AND RESOLUTION OF FAC PARTICIPATION IN THE COLLECTION OF LOSS DATA WOULD CAUSE MAJOR CHANGES OF ANY DATA COLLECTION PROCEDURES BASED ON THE CURRENT AR 735-11 AND EXISTING STATEMENTS OF CHARGE AND CASH COLLECTING PROCEDURES, INTERIM PROCEDURES HAVE BEEN ESTABLISHED ONLY AT MAJOR SUBCOMDS SUCH AS HQ 5TH SIGNAL COMMAND AND HQ FORT HUACHUCA, WHERE LOSS DATA COLLECTION IS RELATIVELY UNCOMPLICATED.

BT

ACTION ADDRESSEES

006 DALO

00006 TOTAL NUMBER OF COPIES REQUIRED

#4667

\*\*\*\*\*  
\* UNCLASSIFIED \*  
\*\*\*\*\*

PAGE 01  
172251Z APR 78  
RUWJHRA/4667

\*\*\*\*\*  
 \* UNCLASS E F T O \*  
 \*\*\*\*\*

*Reading File*

DEPARTMENT OF THE ARMY  
 PENTAGON TELECOMMUNICATIONS CENTER

CDSA = SCD201 MCN = 78108/10425 TCR = 781081627  
 RTTEZYUW RUDHAAA1411 1081629-EEEE--RUEADWD.  
 ZNY EEEEE  
 R 172004Z APR 78  
 FM CDRINSCOM AHS VA //IARM-F//  
 TO RUEADWC/CA WASHDC //DALO-ZXT//  
 BT

UNCLAS E F T O  
 SUBJ MANAGEMENT AND ACCOUNTABILITY OF ARMY MATERIAL  
 A. YOUR DALO-ZXT 281905Z MAR 78 (U)  
 1. THIS COMMAND HAS HAD A REPORTING SYSTEM IN EFFECT FOR A  
 NUMBER OF YEARS THAT WAS DESIGNED TO IDENTIFY PROPERTY  
 ACCOUNTABILITY PROBLEMS AND KEEP THE HQ APPRAISED OF ACCOUNTABILITY  
 ADJUSTMENT TRENDS.  
 2. ONLY A SLIGHT MODIFICATION TO THIS REPORT WAS NECESSARY TO  
 ACHIEVE COMPLIANCE WITH THE 11 OCT 77 CHIEF OF STAFF LETTER BY  
 REQUIRING SEPARATE DATA FOR PROPERTY BOOKS AND SUPPLY ACCOUNTS.  
 BT

ACTION ADDRESSEES  
 006 DALC  
 00006 TOTAL NUMBER OF COPIES REQUIRED  
 #1411

BKS	THCL	SM
ZX	TA	SMT
ZXT	IE	SYS
ZXA	TCM	SVI
ZXA-C	TEP	SMI
AV	TSI	SML
PL	TSP	SMO
PLS	SAC	SMI
PLW	SAB	SMB
PLR	SAA	SMC
PLF	SA	SMI
PLO		SMR

\*\*\*\*\* PAGE 01  
 \* UNCLASS E F T O \* 172004Z APR 78  
 \*\*\*\*\* RUDHAAA/1411

\*\*\*\*\*  
 \* UNCLASSIFIED \*  
 \*\*\*\*\*

DEPARTMENT OF THE ARMY  
 PENTAGON TELECOMMUNICATIONS CENTER

CDSN = SCD#66 MCN = 78108/14477 TOR = 781082059  
 RTTUZYUW RUWTFNFA1912 10816+4-UUUU--RUEADWD.  
 ZNR UUUUU  
 R 172050Z APR 78  
 FM CDR HSC FT SAM HOUSTON TX //HSLO-S//  
 TO DA WASH DC //DALO-ZXT//  
 BT

UNCLASO

SUBJ: MANAGEMENT AND ACCOUNTABILITY OF ARMY MATERIEL  
 A. MSG, DALO-ZXT, 281905Z MAR 78.

1. VISIBILITY OF SUPPLY ACCOUNTABILITY ADJUSTMENT ACTIONS HAS BEEN ESTABLISHED WITHIN US ARMY HEALTH SERVICES COMMAND AS DIRECTED BY LETTER, OFFICE OF THE CHIEF OF STAFF, DATED 11 OCT 77.
2. A MANUAL SYSTEM TO INCLUDE DATA FROM INVENTORY ADJUSTMENT REPORTS, CASH COLLECTION VOUCHERS, STATEMENT OF CHARGES, AND REPORTS OF SURVEY FROM SUBORDINATE ELEMENTS IS SUBMITTED TO HQ HSC ON A QUARTERLY BASIS. THIS DATA IS DISPLAYED TO PROVIDE VISIBILITY TO ADJUSTMENT ACTIONS FROM EACH SUBORDINATE ELEMENT AND THE TOTAL COMMAND.

BT

ACTION ADDRESSEES

006 DALO

00006 TOTAL NUMBER OF COPIES REQUIRED  
 #1912

BKS		
ZX		
ZXT		
ZXA		
ZXA-C		
AV		
PL		
PLS		
PLW		
PLR		
PLF		
FLO		

\*\*\*\*\*  
 \* UNCLASSIFIED \*  
 \*\*\*\*\*

PAGE 01  
 172050Z APR 78  
 RUWTFNFA/1912

## Chapter 7

### Audit Trail

1. Recommendation 6C. Establish effective procedures and an audit trail at the Finance and Accounting Office which will ensure that assessed pecuniary liability is, in fact, collected from the responsible individual's pay.

	<u>Volume</u>	<u>Page</u>
2. DAPATF actions:		
Letter, 15 Mar 78, Audit Trail Procedures.	2	285

	<u>Page</u>	<u>Tasking Ref</u>
3. MACOM responses:		
a. Message, ADC 24th Inf Div, DTG 191747Z Jun 78, Report of Survey and Statements of Charges Audit Trail Test (1 Apr-31 May 78).	182	2
b. Letter, 24th Inf Div, 23 Jun 78, Report of Survey and Statement of Charges Audit Trail Test (1 Apr-31 May 78).	183	2

AUDIT TRAIL

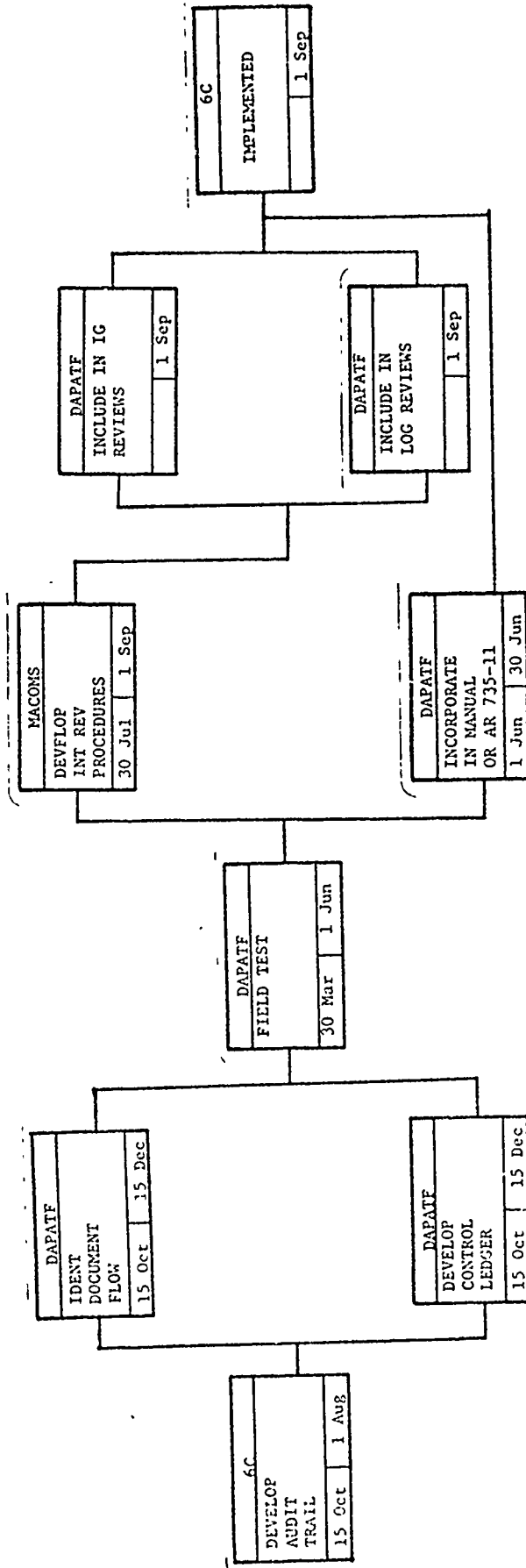

\*\*\*\*\*  
\* UNCLASSIFIED \*  
\*\*\*\*\*

DEPARTMENT OF THE ARMY  
PENTAGON TELECOMMUNICATIONS CENTER

CDSN = SCD597 MLN = 78170/11362 TOR = 781701952  
RTTUZYUW RUCLBPA5212 1701817-UUUU--RLEADWD.  
ZNR UUUUU  
R 191747Z JUN 78  
FM ADC 24TH INF DIV FT STEWART GA //AFZP-ADC//  
TO DA PROPERTY ACCOUNTABILITY TASK FORCE WASH DC //DALO-ZXT//  
BT

UNCLAS

8G MARINE SENDS

SUBJECT: REPORTS OF SURVEY AND STATEMENTS OF CHARGES AUDIT TRAIL  
TEST (1 APR - 31 MAY 78)

A. LETTER, DALO-ZXT, MG DEHAVEN TO MG VAUGHT, 15 MAR 78.

1. SUBJECT TEST HAS BEEN CONCLUDED WITH RESULTS PASSED TO YOUR  
TASK FORCE. IN CLR VIEW, THE TEST HAS BEEN A SUCCESS. IT HAS ALSO  
POINTED OUT AREAS WHERE IMPROVEMENT CAN BE MADE. WITHIN THIS DIVISION

THE PROCESS HAS ALREADY BEGUN.

2. THE 24TH INFANTRY DIVISION AWAITS THE OPPORTUNITY TO BE OF FURTHER  
ASSISTANCE.

BT

ACTION ADDRESSEES

006 DALO

00006 TOTAL NUMBER OF COPIES REQUIRED

#5212

\*\*\*\*\*  
\* UNCLASSIFIED \*  
\*\*\*\*\*

PAGE 01  
191747Z JUN 78  
RUCLBPA/5212

DEPARTMENT OF THE ARMY  
HEADQUARTERS, 24TH INFANTRY DIVISION AND FORT STEWART  
FORT STEWART, GEORGIA 31313

AI ZP-VDF

23 June 1978

SUBJECT: Reports of Survey and Statements of Charges Audit Trail Test  
(1 April - 31 May 1978)

Director  
DA Property Accountability Task Force  
ATTN: DALO-ZXT  
The Pentagon  
Washington, DC 20310

1. Reference letter, DALO-ZXT, Major General Dellaven to Major General Vaught, dated 15 March 1978.
2. The 24th Infantry Division Finance Office was pleased to have had the opportunity of conducting the Audit Trail Procedures Test for DD Forms 200 and DD Forms 362 during April and May of 1978.
3. I feel that the test was a success and proved to be a means of enhancing efficiency in processing collection actions in this finance office.
4. Through participating in the Audit Trail Procedures Test, the 24th Infantry Division Finance Office has become aware of the need for improved control measures in the processing of DD Forms 200 and 362. I believe that the conscientious application of the following recommendations will lead to a substantial increase in the collection of Reports of Survey and Statements of Charges:
  - a. To prevent Statements of Charges from being returned to the files room before collection action has been confirmed, both copies of the "E" Block Ticket will have printed in red ink in the remarks section of the Block Ticket: RETURN TO PAY ADJUSTMENTS. (Incl 1)
  - b. To enhance collections on Statements of Charges, the pay adjustment clerk will pull one copy of the DD Form 362 and annotate the block ticket number and the date. Then, this copy will be filed in a 3-day suspense file awaiting the return of the collected DD Form 362. (Incl 1)

AFZP-YDF

23 June 1978

SUBJECT: Reports of Survey and Statements of Charges Audit Trail Test  
(1 April - 31 May 1978)

c. Inclosure 2 is a proposed Pay Adjustment Log for DD Forms 200 and 362. This form contains sufficient space to record all of the entries required by the Audit Trail Procedures Test. In addition, this control log also has a column to record the date that the Report of Survey or the Statement of Charges was received at Finance, and a column to record the service member's unit. The date received column enables supervisors to determine the amount of time required to complete the collection action within the finance office. The unit column serves as an additional control measure.

FOR THE COMMANDER:

2 Incl  
as

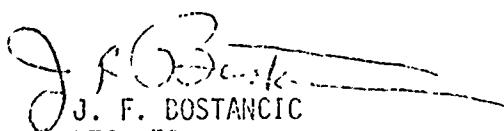
  
J. F. BOSTANCIC  
LTC, FC  
Division Finance Officer



STATEMENT OF CHARGES DD FORM 362  
REPORT OF SURVEY DD FORM 200  
SOP

1. Centralized control of DD Forms 362 and 200 will be maintained at the following levels of responsibility:

- a. Housing Division: Government property issued by or charged to that office.
- b. CIF: (Fort Stewart) Government property issued by or charged to that office.
- c. CIF (Hunter Army Airfield) Government property issued by or charged to that office.
- d. DIO: Government property issued by or charged to that office.

2. If the DD Form 362/200 is given to a soldier for items issued by or charged to the offices listed in para 1a,b,c,d above; and if the member is not in a departing, PCS, or ETS status, then:

- a. Forward to appropriate office.
- b. Appropriate office will check correctness of DD Form 362.
- c. Appropriate office will forward to the Division Finance Officer, ATTN: PAY ADJUSTMENTS, Ft Stewart, GA 31313:
  - (1) Four copies of DD Form 362.
  - (2) One extra copy for each additional individual listed on the DD Form 362.
  - (3) Attach the DD Form(s) 362/200 to two copies of DA Form 200 (Unit Transmittal Letter). Annotate the name and the SSAN of each individual on the Unit Transmittal Letter.

If the member is departing on PCS or ETS, he/she must handcarry the DD Form 362/200 to the appropriate office for corrective action and to the Finance Office for collection.

3. Upon receipt of DD Form 362/200 in the Finance Office:

- a. Insure all annotated documents are attached to the UTL. Sign and date the UTL. If the UTL and the document do not correspond, annotate the UTL and call the appropriate office to correct the discrepancy.
- b. Date stamp all documents as received.
- c. Check BOTH copies of the "E" block ticket to insure that the block control clerk has printed in RED INK in the remark section of the block ticket: RETURN TO PAY ADJUSTMENTS.

d. Review the PFR to insure that no previous collection for the same DD 362/200 has been initiated or collected.

e. Pull one copy of DD 362/200 and annotate the block ticket number and the date. Then file this copy in the 3-day suspense.

f. Route the block as follows:

- (1) 1 PFR
- (2) 2 QE
- (3) 3 Control (Pay Adjustments)

g. Pull the suspense copy and match it with the PFR. Pull the copy to be returned to the originating activity.

h. Have DD Form 362/200 certified to the effect that the collection action has been made.

i. Log the DD Form 362/200 action and the date forwarded back to the originating activity.

PAYMENT ADJUSTMENT LOG FOR  
 DD FORM 362 AND DD 200

UTL	TRANS	NAME AND SSN	UNIT	DEBT AMOUNT	PROP VOL NO.	REPORT OF SUBV NO.	DATE		ACTION	DATE FWD
							ORIG. DATED	REC/DATE SUP DATE		

Incl 2



Chapter 8

Turn-in Procedures

1. Recommendation 6D. Improve and simplify procedures for the turn-in of excess property with the objective of returning the material to its intended use and eliminating the unauthorized but implicit incentives for hoarding excesses for later "scrounge-trades."

2. DAPATF actions:

Volume      Page

a. Proper Count Message, DTG 161825Z Dec 77,  
Turn-in of Excess Material.

1              52

b. Letter, 16 Dec 77, Turn-in Procedures.

1              88

3. MACOM responses:

Page              Tasking Ref

SIMPLIFY TURN-IN PROCEDURES

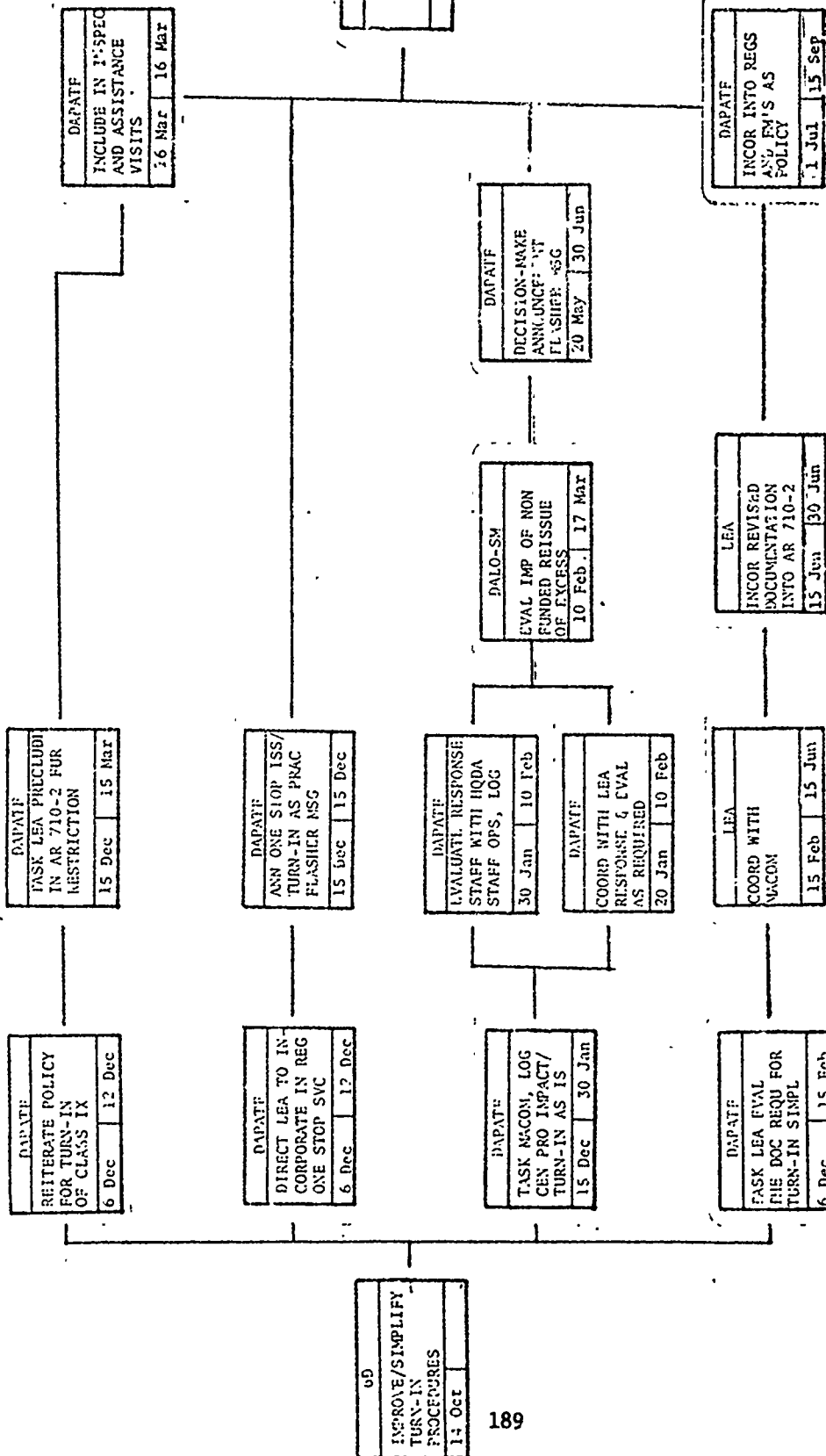

## Chapter 9

### Uniform Allowances

1. Recommendation 6E. Establish, at installation level, uniform allowances for CTA 50 and troop installed items specifically tailored to the organization, mission, and local climatic conditions.

2. DAPATF actions:	<u>Volume</u>	<u>Page</u>
a. Proper Count Flasher Message No. 9, DTG 221900Z Dec 77, Property Accountability for Discretionary Components of End Items.	1	21
b. Proper Count Flasher Message No. 10, DTG 091625Z Jan 78, Organizational Clothing and Equipment (CTA 50-900).	2	6
c. Proper Count Message, DTG 230238Z Mar 78, Abandoned Clothing of Enlisted Personnel Dropped from the Rolls, Interim Change to AR 700-84 w/C4, No. 5-1.	2	60
d. Letter, 31 Jan 78, Guidelines for Individual Issue of Discretionary Items, CTA 50-900.	2	101
e. Letter, 31 Jan 78, Guidelines for Individual Issue of Discretionary Items, CTA 50-900.	2	104
f. Letter, 31 Jan 78, Guidelines for Individual Issue of Discretionary Items, CTA 50-900.	2	107
g. Letter, 31 Jan 78, Standardization of Definitions and Titles.	2	123
h. Letter, 5 Feb 78, Personal Clothing Requirements for Commissioned and Warrant Officers.	2	136
i. Letter, 13 Feb 78, Review of Initial Clothing Allowance (Clothing Bag).	2	140
j. Letter, 15 Feb 78, Identification of Mandatory and Discretionary Items.	2	145

	<u>Volume</u>	<u>Page</u>
k. Proper Count Message, DTG 121410Z Apr 78, Proper Count Flasher Message No. 10.	3	23
l. Proper Count Message, DTG 012015Z May 78, Organizational Clothing and Equipment (OCE).	3	34
m. Proper Count Flasher Message No. 14, DTG 091910Z May 78, Accountability of Organizational Clothing and Individual Equipment (CTA 50-900), Interim Change to AR 710-2, w/C4 Number 5-2, AR 700-84 w/C4, Number 5-2, AR 210-10, Number 1-1, AR 640-10, Number 1-1.	3	8
n. Proper Count Message, DTG 101654Z May 78, Guidelines for Individual Issue of Discretionary Items, CTA 50-900.	3	37
o. Letter, 10 May 78, Revision of CTA 50-900 and Consolidation with CTA 50-906.	3	87
3. MACOM responses:	<u>Page</u>	<u>Tasking Ref</u>
a. Letter, HQ DARCOM, 17 Mar 78, Standardi- zation of Definitions and Terms.	195	2j
b. Message, NGB Wash, DC, DTG 031320Z Apr 78, Property Accountability for Discretionary Components of End Items.	197	2a
c. Letter, USAINSCOM, 4 Apr 78, Property Accountability for Discretionary Components of End Items.	199	2a
d. Message, CDR DARCOM, DTG 072100Z Apr 78, Standardization of Definitions and Titles.	202	2g
e. Message, DAMO-FDU, DTG 042142Z Apr 78, Interim Change to CTA 50-900 for all Purpose Lightweight Individual Carrying Equipment (ALICE).	203	
f. Message, CDR TRADOC, DTG 080246Z Apr 78, Request for Information.	205	2b
g. Message, CDR DARCOM, DTG 132030Z Apr 78, Standardization of Definitions and Titles.	206	2j

	<u>Page</u>	<u>Tasking Ref</u>
h. DF, DALO-SML, 14 Apr 78, Standardization of Definitions and Titles.	208	2g
i. Message, CINCUSAREUR, DTG 141439Z Apr 78, Central Issue Facilities.	209	2b
j. Ind, HQ, Academy of Health Sciences, 20 Apr 78, Guidelines for Individual Issue of Discretionary Items, CTA 50-900.	212	2e
k. Message, CDR FORSCOM, DTG 281450Z Apr 78, Standardization of Definitions and Titles.	213	2g
l. Letter, HQ MDW, 1 May 78, Property Accountability for Discretionary Components of End Items.	215	2a
m. Message, CDR USASCH, DTG 050110Z May 78, Property Accountability for Discretionary Components of End Items and Organizational Clothing and Equipment (OCE).	216	2j
n. Message, CDR FORSCOM, DTG 151500Z May 78, Accountability of Organizational Clothing and Individual Equipment (CTA 50-900), Interim Change to AR 710-2 w/C4 No. 5-2, AR 210-10 No. 1-1, AR 640-10, No. 1-1.	217	2m
o. Message, CDR FORSCOM, DTG 171835Z May 78, Accountability of Organizational Clothing and Individual Equipment (CTA 50-900).	218	2m
p. Letter, HQ TRADOC, 18 May 78, Guidelines for Individual Issue of Discretionary Items, CTA 50-900.	219	2d
q. Message, CDR INSCOM, DTG 191424Z May 78, Accountability for Clothing and Equipment.	227	2m
r. Message, CINCUSAREUR, DTG 230859Z May 78, Message Change to CTA 50-900.	229	
s. Message, CDR TRADOC, DTG 232123Z May 78, Wash and Wear Fatigues.	230	
t. Message, CDR TRADCC, DTG 252200Z May 78, Accountability of Organizational Clothing and Individual Equipment (CTA 50-900).	231	2m



	<u>Page</u>	<u>Tasking Ref</u>
u. Message, DALO-SML, DTG 261947Z May 78, Standardization of Definitions and Titles.	232	2g
v. DF, DAMO-RQR, 30 May 78, Revision of CTA 50-900 and Consolidation with CTA 50-906.	233	2o
w. DF, DALO-TST, 31 May 78, Revision of CTA 50-900 and Consolidation with CTA 50-906.	235	2o
x. Message, CDR EUSA, DTG 310805Z May 78, Command Storage of MTOE Required and Authorized Differences.	236	
y. Ind, DAMO-ODO, 9 Jun 78, Revision of CTA 50-900 and Consolidation with CTA 50-906.	237	2o
z. Message, DALO-SML, DTG 091514Z Jun 78, Standardization of Definitions and Titles.	238	2g
aa. Ind, USACC, 14 Jun 78, Revision of CTA 50-900 and Consolidation with CTA 50-906.	239	2o
bb. Message, CDR EUSA, DTG 160401Z 78, Revision of CTA 50-900 and Consolidation with CTA 50-906.	240	2o
cc. Ind, HQ RSCOM, 16 Jun 78, Revision of CTA 50-900 and Consolidation with CTA 50-906.	241	2o
dd. Message, CDR EUSA, DTG 190805Z Jun 78, Requirement Allowance for CTA Items.	242	
ee. Message, CDR FORSCOM, DTG 201150Z Jun 78, USAR Deviation to Proper Count Flasher Message No. 14.	243	2m
ff. Message, CDR INSCOM, DTG 201759Z Jun 78, Revision of CTA 50-900 and Consolidation with CTA 50-906.	244	2o
gg. Ind, HQ DAAR, Wash, DC, 20 Jun 78, Revision of CTA 50-900 and Consolidation with CTA 50-906.	245	2o
hh. Message, CDR TRADOC, DTG 212101Z Jun 78, Accountability of Organizational Clothing and Individual Equipment (CTA 50-900), Interim Change to AR 710-2 w/C4 No. 5-2.	246	2m
ii. Ind, DA OTSG, Wash, DC, 26 Jun 78, Revision of CTA 50-900 and Consolidation with CTA 50-906.	247	2o

UNIFORM ALLOWANCE ESTABLISHMENT

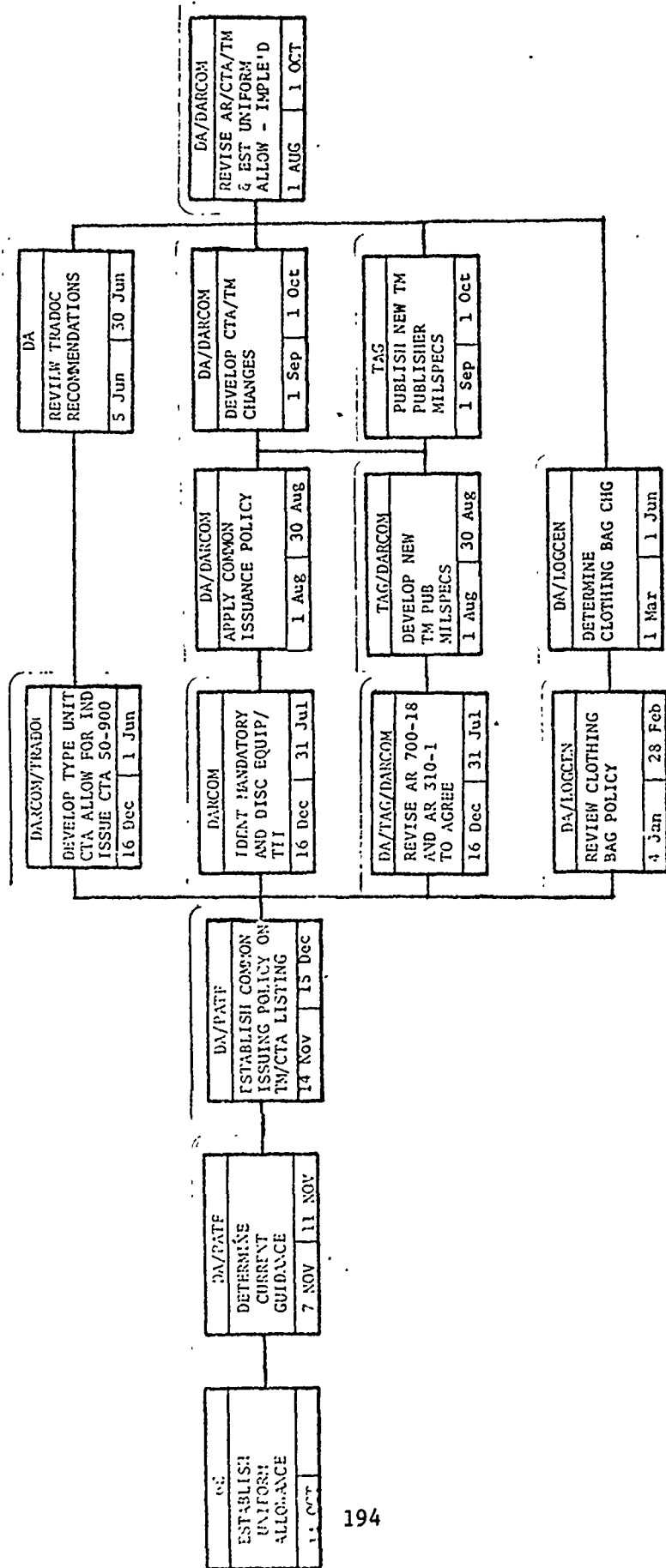



DEPARTMENT OF THE ARMY  
HEADQUARTERS US ARMY MATERIEL DEVELOPMENT AND READINESS COMMAND  
5001 EISENHOWER AVE., ALEXANDRIA, VA. 22333

17 MAR 1978

DRCMM-MP

SUBJECT: Standardization of Definitions and Terms

THRU: HQDA (DALO-SML)  
WASH DC 20310

TO: HQDA (DALO-ZXT)  
WASH DC 20310

1. References:

- a. Letter, DALO-SML, dated 14 February 1978, subject as above.
- b. Letter, DALO-ZXT, dated 15 February 1978, subject as above.
- c. Phone conversation between LTC W. O'Hara, DALO-ZXT, and Mr. R. Graves, DRCMM-MP, 10 March 1978.
- d. Letter, DRCMM-MP, dated 8 March 1978, subj: Use of DA Form 2062 (Hand Receipt) with Operators' Manuals (copy inclosed).

2. Reference 1a requests that the DARCOM response to the DA Property Accountability Task Force (PATF), on inclusion of preprinted, reproducible hand receipts in -10 operators' manuals, be submitted to HQDA (DALO-SM), the proponent of the affected Army regulations and military specifications, prior to submission to HQDA (DALO-ZXT), the PATF. In addition, this reference requests that a review be made of definitions and terms currently used to identify the various lists of support items within the COEI (e.g., BII, AAL, ICOEI, and ES&ML's) for the purpose of improving clarity and simplification.

3. Reference 1b requested that DARCOM take action to identify mandatory and discretionary items for end items/systems on a priority basis and within the framework of definition changes to be made in AR 310-3, AR 700-18, and MIL-M-63050. It also requests that this action be correlated with the DARCOM actions to provide preprinted, reproducible, DA Form 2062 (Hand Receipt) with component lists (CL's) and operators' manuals.

DRGM MP

17 MAR 1978

SUBJECT: Standardization of Definitions and Terms

4. In response to the requirements stated in paragraphs 2 and 3 above, action was initiated in the hand receipt work group meeting 22-24 February 1978 (incl 1 to ref 1d) to review all definitions currently used to identify the various support item lists (BII, AAL, etc.) identified in AR 700-18, AR 310-3, and MIL-M-63050, and make recommendations for their simplification. This is included as a part of the plan for providing preprinted, reproducible DA Forms 2062 with -10 operators' manuals provided DA PATF by above reference 1d. DARCOM recommendations will be submitted through HQDA proponent (DALO-SM) by July 1978.

5. When the determination is made as to the precise definitions and terms to be used for the various support item lists in the -10 operators' manuals, action will be taken to identify the items contained within these listings, based upon the revised definitions and criteria. The plan for implementation of the hand receipt concept will be adjusted depending on the extent of changes required to these support item lists.

FOR THE COMMANDER:

1 Incl  
as



E. A. VIERECK, JR.  
Colonel, GS  
Associate Director of Maintenance

CF:  
Cdr, MRSA, ATTN: DRXMD-MP/DRXMD-SE,  
Lexington, KY 40511  
Cdr, TRADOC, ATTN: ATCD-SP/ATLG-MSP,  
Fort Monroe, VA 23651  
Cdr, Logistics Center, ATTN: ATCL-DPE,  
Fort Lee, VA 23801

\*\*\*\*\*  
 \* UNCLASSIFIED \*  
 \*\*\*\*\*

BWS /	THCL	SM
ZX	TA	SMT
ZXT A	LF	SIG
ZXA		
ZXA-C		
V		
PL		
PLZ		
PLR		
PLP		
PLO /		

DEPARTMENT OF THE ARMY  
 PENTAGON TELECOMMUNICATIONS CENTER

CDSN = SCD667 MCN = 78J93/07002 TOR = 78D931548  
 RTTUZYUW RUEAUSA0538 0931546-UUUU--RUEADWD.  
 ZNR UUUUU  
 R 031320Z APR 78 ZEX  
 FM NGB WASHDC//NGB-ARL-P//  
 TO AIG 7300  
 RULGSAA/TAG VI ST CROIX VI  
 INFO RUEACWD/HQDA WASHDC//DALO-ZXT//  
 RUEOPIA/CDR USAONE FT MEADE MD//AFKA-IG//  
 RUHTNFA/CDR USAFIVE FT SAM HCUSTON TX//AFKB-IG//  
 RUWMBHA/CDR USASIX PRESIDIO SANFRAN CA//AFKC-IG//  
 RUEAUSA/NGB WASHDC//NGB-ARL-P//  
 BT

UNCLAS

PROVIDE COPIES TO USPFOS ABOVE  
 THIS IS A NGB PROPER COUNT MESSAGE  
 SUBJ: PROPERTY ACCOUNTABILITY FOR DISCRETIONARY COMPONENTS OF END  
 ITEMS.

1. COMMANDERS ARE REMINDED THAT DISCRETIONARY COMPONENTS OF END ITEMS  
 ARE ACCOUNTABLE ITEMS AND SHOULD BE BROUGHT UNDER HAND/RECEIPT/HAND-  
 RECEIPT ANNEX ACCOUNTABILITY AT UNIT LEVEL. DISCRETIONARY COMPONENT  
 OF END ITEMS ARE FOUND IN THE OPERATORS TECHNICAL MANUALS (-10) AND  
 ARE LISTED UNDER THE FOLLOWING CATEGORIES.

- A. ITEMS TROOP INSTALLED OR AUTHORIZED LIST (ITAL).
  - B. ADDITIONAL AUTHORIZED ITEMS OR;
  - C. EXPENDABLE CONSUMABLE MAINTENANCE SUPPLIES AND MATERIELS.
- NONCONSUMABLE ITEMS ARE LISTED IN THE SAME CATEGORY WITH CONSUMABLE  
 ITEMS.

2. TO INSURE ACCOUNTABILITY AND CONTINUITY FOR DISCRETIONARY ITEMS  
 THE FOLLOWING POLICY IS IN EFFECT:

- A. THE APPROVING AUTHORITY WILL IDENTIFY WHICH DISCRETIONARY  
 COMPONENTS OF END ITEMS ARE AUTHORIZED FOR THEIR UNITS. APPROVAL  
 WILL BE BASED ON MINIMUM ESSENTIAL MISSION REQUIREMENTS.
- B. DISCRETIONARY COMPONENTS OF END ITEMS WILL BE BROUGHT UNDER  
 HAND-RECEIPT/HAND-RECEIPT ANNEX ACCOUNTABILITY AT UNIT LEVEL SIMILAR  
 TO ACCOUNTABILITY FOR MANDATORY COMPONENTS (BASIC ISSUE ITEMS/BII/  
 OF END ITEMS).
- C. DISCRETIONARY COMPONENTS IDENTIFIED BY APPROVING AUTHORITY  
 AS MANDATORY FOR THEIR UNITS WILL BE EITHER ON HAND OR ON ORDER AS  
 IN THE CASE OF BII.

\*\*\*\*\*  
 \* UNCLASSIFIED \*  
 \*\*\*\*\*

PAGE 01  
 031320Z APR 78  
 RUEAUSA/0538

\*\*\*\*\*  
\* UNCLASSIFIED \*  
\*\*\*\*\*

DEPARTMENT OF THE ARMY  
PENTAGON TELECOMMUNICATIONS CENTER

D. DISCRETIONARY COMPONENTS WILL BE INVENTORIED AT THE SAME TIME THAT END ITEMS AND THEIR BASIC ISSUE ITEMS COMPONENTS ARE INVENTORIED.

3. APPROVING AUTHORITY FOR DISCRETIONARY COMPONENTS OF END ITEMS BY INSTALLATION, DIVISION OR SEPARATE BRIGADES. IN THOSE INSTANCES WHERE SEPARATE COMPANIES, BATTALIONS ARE NOT ATTACHED OR ASSIGNED THE APPROVING AUTHORITY WILL BE THE CONTROL HEADQUARTERS.

4. PROPOSED HAND RECEIPT FORMAT CHANGE TO TM ANNEXES CONCERNING

INITIAL IS BEING DEVELOPED TO CLARIFY AND SIMPLIFY REQUIREMENT AUTHORIZATIONS AND ACCOUNTABILITY. IMPLEMENTATION IS EXPECTED BY

5. POC FOR NGB-ARL IS MAJ MCREAL AUTOVCN 225-4068.

BT

ACTION ADDRESSEES

006 DALC

INFORMATION ADDRESSEES

000

\*\*\*\*\* AMRO \*\*\*

00-006 , TOTAL NUMBER OF COPIES REQUIRED

#0538

NNNN

\*\*\*\*\*  
\* UNCLASSIFIED \*  
\*\*\*\*\*

PAGE 02  
031320Z APR 78  
RUEAUSA/0538



DEPARTMENT OF THE ARMY  
UNITED STATES ARMY INTELLIGENCE AND SECURITY COMMAND  
ARLINGTON HALL STATION  
ARLINGTON, VIRGINIA 22212

IALOG-SS

04 APR 1978

SUBJECT: Property Accountability for Discretionary Components of  
End Items

HQDA (DALO-ZXT)  
WASH DC 20310

1. Reference your message DALO-ZXT 221900Z Dec 77, subject as above.
2. Specific procedures for the hand receipting and control of discretionary components have been transmitted to INSCOM units. Group, field station, separate company and MI detachment commanders have been appointed as the approving authority for discretionary components of end items. The major thrust of the INSCOM program is to require only those components needed to accomplish the mission to be on hand in the units.
3. Major subordinate units of the INSCOM have established procedures at the approving level for the accountability of discretionary components of end items.
4. The property accountability for discretionary components of end items will be the subject of continuing review in subordinate units during this Headquarter's component of the Command Supply Inspection and Command Logistics Review Team.
5. A copy of the INSCOM implementing procedures is attached.
6. POC this headquarters is Major A. Hoyer, Autovon 222-5563/5641.

FOR THE COMMANDER:

1 Incl  
as

*J. J. Kraynak*  
Asst AG

(Use in file area only)

01 LOG242 RR RR TT EEEE JAN 31 311157-2 Jan 78

FM CDRINSCOM AHS VA //IALOG-SS// 3554  
TO AIG 7538  
UNCLAS E F T O

QQQQ  
SUBJ PROPERTY ACCOUNTABILITY FOR DISCRETIONARY ITEMS

A. DA MSG DALOZ\*-ZXT DTG 221900Z DEC 77 (SAB).  
1. EFFECTIVE IMMEDIATELY ALL CMDRS ABOVE CO LEVEL, CMDRS OF MI  
DET AND SEPARATE CO CMDRS WILL BE THE APPROVING AUTHORITY FOR  
AUTHORIZATION OF DISCRETIONARY COMPONENTS OF END ITEMS. DISCRET  
IONARY ITEMS ARE THOSE COMPONENTS AUTHORIZED BY TECH MANUALS BUT  
NOT REQUIRED UNLESS MISSION DICTATES. IN OPERATORS MANUALS (-10),  
DISCRETIONARY ITEMS ARE LISTED UNDER THE FOLLOWING CATEGORIES:  
(1) ITEMS TROOP INSTALLATION OR AUTHORIZED LIST (ITAL) (2)  
ADDITIONAL AUTHORIZED ITEMS (3) EXPENDABLE CONSUMABLE MAINTENANCE  
SUPPLIES AND MATERIALS.  
2. THE APPROVING AUTHORITY WILL IDENTIFY WHICH DISCRETIONARY COMPO  
NENTS OF END ITEMS ARE AUTHORIZED FOR THEIR UNITS. APPROVAL WILL  
BE BASED ON MINIMUM ESSENTIAL MISSION REQUIREMENTS. ONLY THOSE ITEMS  
REQUIRED TO ACCOMPLISH THE MISSION WILL BE RETAINED. THOSE ITEMS  
THAT

COPY

PROPOSED

TABLE  
NOPE

STAFF COORDINATION  
CG  
DEPUTY CG  
Colt  
COMD PROG  
DCSPER  
DCSSEC  
DCSOPS  
DCSLOG  
DCSFOR  
DCSRBD  
DCSCOM  
DCSTEL  
DCSMIS  
AG  
IG  
SJA  
SAS&CA  
USASA CDEA  
USASA CDA  
  
READING FILE  
 YES  NO  
OFFICE OF RECORDS  
IALOG-SS  
Name, Tel. No. of Ac. Officer and Date  
MR. HILL/JS/  
25563  
27 JAN 78

MR. HILL/IALOG-SS/25563/27 JAN 78  
J.M. CHAFFIN, Col GS, DCCLOG  
PAUL-D-MAHALIK, MAJ-CH-MATL DIV, 25768

SIGNATURE OF RELEASING OFFICER  
*J.M. Chaffin*

IA(HQ) FORM 55 1 OCT 73

REPLACES IA(HQ) FORM 55, 11 SEPTEMBER 1969. MAY BE USED UNTIL SUPPLY IS EXHAUSTED.

UNCLASSIFIED E F T O

Incl



UNCLASSIFIED E F T O

02 02 LOG242 RR -- TT EEEE

THAT THE APPROVING AUTH DEEMS NOT MISSION ESSENTIAL, WILL BE TURNED IN AS EXCESS.

3. DISCRETIONARY COMPONENTS OF END ITEMS WILL BE BROUGHT UNDER HAND RECEIPT, HAND RECEIPT ANNEX CONTROL. HAND RECEIPT ANNEX ACCOUNTABILITY AS THE UNIT LEVEL WILL BE SIMILAR TO ACCOUNTABILITY FOR MANDATORY COMPONENTS. (BASIC ISSUE ITEMS)

4. DISCRETIONARY COMPONENTS IDENTIFIED BY APPROVING AUTHORITY AS MANDATORY FOR THEIR UNITS WILL EITHER BE ON HAND OR ON ORDER AS IN THE CASE OF BII.

5. DISCRETIONARY ITEMS WILL BE INVENTORIED AT THE SAME TIME THAT END ITEMS AND THEIR BASIC ISSUE ITEM COMPONENTS ARE INVENTORIED.

6. THE POLICY AND PROCEDURES ESTABLISHED BY THE ABOVE STATED APPROVING AUTHORITY WILL BE FORWARDED TO THIS HQ NLT 20 MAR 78 FOR CONSOLIDATION AND FORWARDED TO THE DA PROPERTY ACCOUNTABILITY TASK FORCE.

201

UNCLASSIFIED E F T O

\*\*\*\*\*  
\* UNCLASSIFIED \*  
\*\*\*\*\*

*LTC Cowden*  
*Info*

DEPARTMENT OF THE ARMY  
PENTAGON TELECOMMUNICATIONS CENTER

CDSN = SC0816 MON = 78.08/C1475 TCR = 730930122  
PTTUZYUJ RUKLDAR/971 0972112-0000--RLEADWD.  
ZNR 0000  
P R 072100Z APR 78  
FM CCKCARCCM ALEX VA//ORCA1-MP//  
TO RUEADWD/DA WASHDC//DALO-SML//  
INFO RUEBNA/COMARSA LEXINGTON KY//ORXMD-MP//  
BT

UNCLAS  
SUBJ: STANDARDIZATION OF DEFINITIONS AND TITLES  
A. H. DA (DALO-SML) ISG 311342Z MAR 78 (U), SAG.  
DRAFT PROPOSED NEW/REVISED TERMS AND REDEFINITIONS REQUESTED BY  
REF A ARE IN PROCESS OF DEVELOPMENT AND ARE EXPECTED TO BE READY  
FOR STAFFING BY 11 APR 78. STAFFING WILL BE ACCOMPLISHED BY MAIL  
AND IS EXPECTED TO BE COMPLETED BY 28 APR 78. REVISED TERMS AND  
REDEFINITIONS, ALONG WITH PLAN FOR THEIR IMPLEMENTATION REQUESTED  
BY REF A, WILL BE PROVIDED BY 5 MAY 1978.

BT  
ACTION ADDRESSEES  
006 DALO  
INFORMATION ADDRESSEES  
EE4 DAAG  
004 CASG  
0010 TOTAL NUMBER OF COPIES REQUIRED  
0971

\*\*\*\*\*  
\* UNCLASSIFIED \*  
\*\*\*\*\*

PAGE 01  
072100Z APR 78  
RUKLDAR/0971

\*\*\*\*\*  
 \* UNCLASSIFIED \*  
 \*\*\*\*\*

DEPARTMENT OF THE ARMY  
 PENTAGON TELECOMMUNICATIONS CENTER

ERS		
E		
PL		
PLS		
PLW		
PLR		
PLF		
PLO		

CDSN = SCD038 MCN = 78094/21762 TOR = 780971901  
 RTTUZYUW RUEADWD0711 0942328-UUUU--RUEAPPA RUEADWD.  
 ZNR UUUUU  
 R 042142Z APR 78  
 FM DA WASHDC //DAMU-FDU//  
 TO AIG 7406  
 AIG 7405  
 RUEADWD/DA WASHDC //NGB-ARL//  
 INFO AIG 7300  
 RULGSAA/TAG VI ST CROIX VI  
 AIG 7446  
 RUKLDAR/DIR USAEARA ALEX VA  
 RUEDEBE/CDR USASPTAP PHILA PA  
 RUEADWD/DA WASHDC //DAMO-RQD/DALO-TST-E/DALO-ZXT/CACA  
 -OM/DAMA-CSS//  
 BT

UNCLAS  
 STAFAC  
 SUBJECT: INTERIM CHANGE TO CTA 50-900 FOR ALL PURPOSE LIGHTWEIGHT  
 INDIVIDUAL CARRYING EQUIPMENT (ALICE).  
 A. CTA 50-900, W/C1, 29 AUG 75.  
 1. PENDING PUBLICATION OF REVISION TO REF A, CHANGES TO THE TYPE OF  
 ALLOWANCE FOR THE ALICE ARE AS FOLLOWS:  
 (NOTE: ALICE CONSISTS OF LIN 859567/D11812/D64043/D70550/F28401/  
 F30391/H39825 OR H39835/H90705/S94991/U48674 AND U73323).  
 A. LIN859567 BELT INDIVIDUAL EQUIPMENT:  
 (1) DELETE FIRST BOI: PER INDIVIDUAL.../-/1/-/1/-/1/-/1/M.  
 (2) ADD QUANTITY OF 1 IN AA-MOB COLUMN OF SECOND BOI AS  
 DISCRETIONARY ALLOWANCE.  
 B. LIN F28401 COVER FIELD PACK: CHANGE BOI TO READ: PER  
 INDIVIDUAL ISSUED FIELD PACK LIN H39825 OR H39835 IN SNOW COVERED  
 AREAS.../1/1/1/1/1/1/-/D.  
 C. LIN H39835 FIELD PACK MEDIUM:  
 (1) DELETE FIRST BOI: PER INDIVIDUAL ASSIGNED CATEGORY I AND  
 II TOE UNITS.../-/1/-/1/-/1/-/1/M.  
 (2) ADD QUANTITY OF 1 IN AA-MOB COLUMN OF SECOND BOI AS  
 DISCRETIONARY ALLOWANCE.  
 (3) ADD LIN H39825 TO FIELD PACK LARGE; DELETE THE WORD  
 "MALE" FROM FIRS. BOI AND CHANGE TYPE OF ALLOWANCE FROM MANDATORY TO  
 DISCRETIONARY.

\*\*\*\*\*  
 \* UNCLASSIFIED \*  
 \*\*\*\*\*  
 PAGE 01  
 042142Z APR 78  
 RUEADWD/0711

\*\*\*\*\*  
\* UNCLASSIFIED \*  
\*\*\*\*\*

DEPARTMENT OF THE ARMY  
PENTAGON TELECOMMUNICATIONS CENTER

- D. LIN H90705 FRAME PACK:  
(1) CHANGE THE TYPE OF ALLOWANCE FROM MANDATORY TO DISCRETIONARY FOR FIRST BOI PARAGRAPH.  
(2) ADD ADDITIONAL BOI: PER INDIVIDUAL ISSUED FIELD PACK  
LIN H39825...../1/1/-/-/-/-/1/M.  
E. LIN S94991 SHELF CARGO:  
(1) DELETE FIRST BOI: PER 10 INDIVIDUALS IN ALASKA ISSUED  
FRAME PACK LIN H94745...../-/3/-/-/-/-/1/M.  
(2) ADD QUANTITY OF 3 IN AA-MOB COLUMN OF SECOND BOI AS  
DISCRETIONARY ALLOWANCE AND CHANGE LIN H94745 TO READ LIN H90705.  
F. LIN U73323 SUSPENDERS:  
(1) CHANGE NOMENCLATURE TO READ SUSPENDER BELT INDIVIDUAL  
EQUIPMENT.  
(2) DELETE FIRST BOI: PER INDIVIDUAL ISSUED BELT LIN  
859567...../-/1/-/-/-/-/1/M.  
(3) ADD QUANTITY OF 1 IN AA-MOB COLUMN OF SECOND BOI AS  
DISCRETIONARY ALLOWANCE.  
G. LIN 011812/064043/070550/F30391 AND U48674: NO CHANGES  
REQUIRED.

BT

ACTION ADDRESSEES

012 DAMO

INFORMATION ADDRESSEES

003 DACA

006 DALO

002 DAMA

002 NGB

00025 TOTAL NUMBER OF COPIES REQUIRED

#0711

\*\*\*\*\*  
\* UNCLASSIFIED \*  
\*\*\*\*\*  
204

PAGE 02  
042142Z APR 78  
RUEADWD/0711

\*\*\*\*\*  
\* UNCLASSIFIED \*  
\*\*\*\*\*

DEPARTMENT OF THE ARMY  
PENTAGON TELCOMMUNICATIONS CENTER

CDSN = SCDF 2 MCN = 78098/10280 TOR = 780981648  
RTTUZYUW RUCLAIA/1193 0980247-UUUU--RUEADWD.  
ZNR LULUU  
R 080246Z APR 78  
FM CCRTRADCC FT MGNRUE VA //ATLG-MSP-SP//  
TO HQDA WASHDC //DALU-ZXT//  
BT

UNCLAS  
THIS IS A PROPER COUNT MESSAGE  
SUBJ: REQUEST FOR INFORMATION  
A. TRADOC ATLG-MSP-SP 262227Z JAN 78 (U)  
1. REF REQUESTED ADVICE ON WHETHER OR NOT PROPER COUNT FLASHER  
MESSAGE #10 CONSTITUTES AN INTERIM CHANGE TO CTA 50-900.  
2. DUE TO POSSIBLE MISROUTING, YOUR RESPONSE NOT RECEIVED TO  
DATE. REQUEST RETRANSMISSION.  
BT

ACTION ADDRESSEES  
006 CALG  
INFORMATION ADDRESSEES  
J12 DAMJ  
CO1 AFLO/ATLO  
00019 TOTAL NUMBER OF COPIES REQUIRED  
#1198

\*\*\*\*\*  
\* UNCLASSIFIED \*  
\*\*\*\*\*

PAGE 01  
080246Z APR 78  
RUCLAIA/1198

\*\*\*\*\*  
\* UNCLASSIFIED \*  
\*\*\*\*\*

DEPARTMENT OF THE ARMY  
PENTAGON TELECOMMUNICATIONS CENTER

CDSN = SCD740 MCN = 78104/00461 TCR = 781040029  
PTTUZYUW RUKLDAR1553 1032032-UUUU--RUEADWD.

ZNR UUUUU

P R 132030Z APR 78

FM CERDARCCM ALEX VA//DRCMM-MP//  
TO RUCLAIA/CDRTRADOC FT MONFCE VA  
RUEADWD/DA WASHDC //DASG//  
RUEADWD/DA WASHDC//DAEN//  
RUCLAHA/CDRLOGC FT LEE VA  
RUCLHTB/CDRFORSCOM FT MCPHERSON GA  
RUDHAAA/CDRINSCOM AMS VA  
RUMJHRA/CDRACC FT HUALHUCA AZ  
RUEDEIA/CDRCERCOM FT MONMOUTH NJ//DRSEL-MA//  
RUCIAMA/CDRTARCOM WARREN MI//DFSTA-M//  
RUCIFRA/CDRTSARCOM STL MO//DRSTS-M//  
RUCDGD/CDRMIRCOM REDSTONE ARS AL//DRSMI-N//  
RUCIAFB/CDRARRCOM ROCK ISLAND IL//DRSAR-MA//  
RUCLBNB/CDRMRSA LEXINGTON KY//DRXND-MP//  
INFO RUEADWD/DA WASHDC //DALO-SML//  
RUEDBIA/CDRCERCOM FT MONMOUTH NJ//DRSEL-MM//  
RUCIAMA/CDRTARCOM WARREN MI//DRSTA-F//  
RUCIFRA/CDRTSARCOM STL MO//DRSTS-S//  
RUCDGD/CDRMIRCOM REDSTONE ARS AL//DRSMI-S//  
RUCIAFB/CDRARRCOM ROCK ISLAND IL//DRSAR-MM//  
BT

ACTION  
SND  
INFO  
PLS  
EN

UNCLAS

SUBJ: STANDARDIZATION OF DEFINITIONS AND TITLES

THIS MSG IN TWO PARTS. PART I FOR ALL.

- A. HQDA(CALO-SML) MSG 311842Z MAR 78(U), SAB(NOTAL).
- B. HQDARCCM MSG (DRCMM-MP)072100 APR 78(U), SAB(NOTAL).
- C. HQDARCCM(DRCMM-MP)LTR 17 MAR 78(U), SUBJ: STANDARDIZATION OF DEFINITIONS AND TERMS (NOTAL).

1. REF A REQUESTED THIS HQ TO DEVELOP NEW/REVISED TERMS AND REDEFINITIONS FOR BASIC ISSUE ITEMS(BII)AND ADDITIONAL AUTHORIZATION LIST(AAL)ITEMS TO REPLACE THOSE CURRENTLY DELINEATED IN AR 700-18. REF A FURTHER DIRECTED THAT THE USE OF THE TERMS COMPONENTS OF END ITEMS(COEI)AND INTEGRAL COMPONENTS OF END ITEMS(ICOEI)WAS TO BE DISCONTINUED. CA GUIDANCE ALSO REQUIRED THAT THE NEW DEFINITIONS BE STATED IN CLEAR, SIMPLE TERMS (SIXTH GRADE COMPREHENSION LEVEL). THE TERM MANDATORY WAS TO BE

\*\*\*\*\*  
\* UNCLASSIFIED \*  
\*\*\*\*\*  
206

PAGE 01  
132030Z APR 78  
RUKLDAR/1553

DEPARTMENT OF THE ARMY  
PENTAGON TELECOMMUNICATIONS CENTER

USED WITH BII AND THE TERM DISCRETIONARY WITH AAL.

2. IN COMPLIANCE WITH THE DA GUIDANCE DISCUSSED ABOVE, THIS HQ DEVELOPED THE FOLLOWING DEFINITIONS OF BII AND AAL:

A. BII: BASIC ISSUE ITEMS (BII) (MANDATORY ITEMS) ARE THOSE MINIMUM ESSENTIAL ITEMS, TOOLS, TMDE, REPAIR PARTS, PUBLICATIONS, FIRST AID, AND SAFETY RELATED EQUIPMENT REQUIRED BY THE OPERATOR/CREW TO PLACE THE END ITEM IN OPERATION TO ACCOMPLISH ITS ASSIGNED MISSION TO PERFORM EMERGENCY REPAIRS UNTIL COMPLETION OF THE MISSION. BII (EXCEPT FOR PUBLICATIONS) ARE STOCK NUMBERED ITEMS WHICH ARE LISTED IN AND AUTHORIZED BY THE OPERATOR'S MANUAL TO BE ISSUED WITH THE END ITEM. BII ARE SEPARATELY PACKED FOR SHIPMENT AND MUST ACCOMPANY THE END ITEM WHEN IT IS ISSUED, TRANSFERRED BETWEEN PROPERTY ACCOUNTS, OR TURNED IN.

B. AAL: ADDITIONAL AUTHORIZATION LIST (AAL) (DISCRETIONARY) ITEMS ARE THOSE ADDITIONAL ITEMS, SEPARATE FROM BII, RECOMMENDED TO SUPPORT THE END ITEM DURING OPERATION BUT NOT REQUIRED TO PLACE THE END ITEM IN OPERATION OR TO PERFORM EMERGENCY REPAIRS. AAL ITEMS NEED NOT ACCOMPANY THE END ITEM DURING OPERATION AND WILL NOT BE ISSUED OR TURNED IN WITH THE END ITEM. THE AAL IS AN INFORMATIONAL LISTING IN THE OPERATOR'S MANUAL, PREPARED BY THE PROPONENT COMMAND, AND IDENTIFIES THE PARTICULAR ITEMS AND RECOMMENDED MINIMUM QUANTITY OF EACH NEEDED TO SUPPORT ONE END ITEM. THE SELECTION OF THE PARTICULAR ITEMS AND THEIR QUANTITIES FROM THE AAL WILL BE DETERMINED BY THE USER COMMAND. AAL ITEMS MUST BE AUTHORIZED BY A CTA, MTOE, TDA, OR JTA OR MUST BE ADDED TO THE APPROPRIATE AUTHORIZATION DOCUMENT PRIOR TO ISSUE.

3. REQUEST EACH ADDRESSEE REVIEW THE ABOVE DEFINITIONS FOR ACCURACY AND APPLICABILITY AND PROVIDE COMMENTS AND/OR CONCURRENCE TO CDR, MRSA, LEXINGTON, KY, ATTN: DRXMD-MP, BY 21 APRIL 1978. PART II FOR MRSA.

4. REQUEST MRSA, DRXMD-MP, SERVE AS HCCARCOM POINT OF CONTACT TO REVIEW AND COMPILE THE COMMENTS/CONCURRENCES FROM ABOVE ADDRESSEES. BASED UPON THE RESPONSES, MRSA WILL FINALIZE CLEARLY UNDERSTANDABLE DEFINITIONS FOR BII (MANDATORY) ITEMS AND AAL (DISCRETIONARY) ITEMS. BY 1 MAY 1978, MRSA WILL SUBMIT TO THIS HQ (DFCMM-MP) FINAL DEFINITIONS FOR BII AND AAL AND CORRESPONDING DRAFT LETTERS OF INSTRUCTION FOR DISSEMINATION ARMY-WIDE. IN ADDITION, MRSA WILL PROVIDE TO THIS HQ PLANS INCLUDING MILESTONE DATES FOR RECOMMENDED CHANGES TO THE APPROPRIATE AR'S AND SPECIFICATIONS BASED ON THESE NEW/REVISED DEFINITIONS.

BT

Action  
EEY DAEN  
006 INFO  
004 DA10  
00010 - TWCR

# DISPOSITION FORM

For use of this form, see AR 340-15, the proponent agency is TAGCEN.

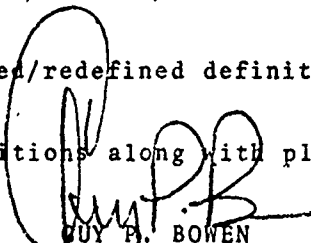
REFERENCE OR OFFICE SYMBOL	SUBJECT		
DALO-SML	Standardization of Definitions and Titles		
TO DALO-ZXT	FROM DALO-SML	DATE 14 APR 1978	CMT 1
Mr. Hudson/ejt/72458			
1. References:			
a. Letter, DALO-ZXT, 31 Jan 78, subject as above.			
b. Letter, DALO-SML, 14 Feb 78, subject: Standardization of Definitions and Terms.			
c. Letter, DALO-ZXT, 15 Feb 78, subject: Identification of Mandatory and Discretionary Items.			
d. Letter, DRCMM-MP, DARCOM, 8 Mar 78, subject: Use of DA Form 2062 (Hand Receipt) with Operators' Manuals.			
e. Letter, DRCMM-MP, DARCOM, 17 Mar 78, subject: Standardization of Definitions and Terms (Incl 1).			
f. MSG, draft, DALO-SML, undated, subject as above.			
g. DF, DALO-ZXT, 23 Mar 78, subject as above.			
h. Fonecon, 30 Mar 78, between LTC Bowen, DALO-SML, and MAJ Roberts, DALO-ZXT, subject as above.			
i. MSG, DALO-SML, DTG 311842Z Mar 78, subject as above (Incl 2).			
j. MSG, DRCMM-MP, DARCOM, DTG 072100Z Apr 78, subject as above (Incl 3).			
2. In accordance with references 1a and 1h, appropriate actions have been initiated and milestones established.			
3. The milestones contained in reference 1j which supersede those identified in reference 1e are:			
a. DARCOM development of new/revised/redefined definitions and terms by 11 Apr 78.			
b. Completion of new/revised/redefined definitions staffing by 28 Apr 78.			
c. Revised terms and definitions along with plan for their implementation to HQDA by 5 May 1978.			
 GUY H. BOWEN LTC, GS Chief, ILS and Maintenance Engineering Division			

DA FORM 2496  
1 FEB 62

REPLACES DD FORM 36, WHICH IS OBSOLETE.

208

GPO-1975-665-422/1063



\*\*\*\*\*  
 \* UNCLASS E F T C \*  
 \*\*\*\*\*

DEPARTMENT OF THE ARMY  
 PENTAGON TELECOMMUNICATIONS CENTER

BSS	TRCL	EM
TA	TA	SNS
IS	IS	ST
ISM	ISM	ST
IS	IS	ST
IS	IS	ST
IS	IS	ST
IS	IS	ST

CDN = SC0379 MCN = 78109/15667 TGR = 731092007  
 RTTEZYUW RUFDAAA6897 1092004-EEEE--RUEADWD  
 ZNY EEEEE  
 R 141439Z APR 78  
 FM CINCUSAREUR HEIDELBERG GERMANY//AEAGC-SM-F//  
 TO RIFTFRA/CDR V CORPS FRNAKFURT GERMANY//AETVGD//  
 RUFLOWA/CDR VII CORPS MOEHRINGEN GERMANY//AETSGD-S&S//  
 RUFLLCA/CDR 21ST SUPCOM KAISERSLAUTERN GERMANY//AERLO-  
 SM//  
 RUDOEVA/CDR USAB BERLIN GERMANY//AEBA-SX//  
 RUFLEJA/CDR USASETAF VICENZA ITALY//AESE-GOL-SM//  
 RUFTMAA/CDR 32D AADCOM DARMSTADT GERMANY  
 //AETL-GEL//  
 ZEN CDR USAMEDCGMEUR HEIDELBERG GERMANY//AEMLO//  
 RUFTOVA/CDR 42D MP GP (CUSTOM) MANNHEIM GERMANY  
 RUFTSKA/CDR 56TH FA BDE SCHWAEBISCH GMUEND GERMANY  
 //AELAT-LG//  
 RUFDAAA/CDR USAMILPERCENEUR SCHWETZINGEN GERMANY//AEUPE-  
 E//  
 RUFTSFA/CDR 1ST SP BN 10TH SFG (ABN) BAD TOELZ GERMANY  
 //AEUSP-CD//  
 RUFTSJA/CDR 4TH TRANS BDE OBERURSEL GERMANY//AEUTR-SVC//  
 RUFTOVA/CDR 7TH SIG BDE SANDHOFEN GERMANY//AEUSC-R//  
 RUFZTPA/CDR 11TH AVN GP SCHWAEBISCH HALL GERMANY//AEUAV-  
 D//  
 RUFLMMA/CDR 66TH MI GP MUNICH GERMANY  
 RUFTFBA/CDR 59TH ORD BDE PIRMASENS GERMANY//AEUSA-DM//  
 RUF1FDC/CDR 60TH ORD GP ZWEIBRUECKEN GERMANY//AERCD-L//  
 RUFTFMA/CDR 18TH ENGR BDE KARLSRUHE GERMANY//AEUEG-S//  
 RUFLETA/CDR SEVENTH ARMY TNG COMD GRAFENWOEHR GERMANY  
 //AETTIG-SD//  
 RUFTFRA/CDR U;AEAGSC ROEDELHEIM GERMANY//AEUAS-S//  
 INFO RUEADWD/DA WASH DC//DALG-ZXT//  
 BT

UNCLAS E F T O  
 SUBJ: CENTRAL ISSUE FACILITIES  
 A. CHAPTER 2, SECTION IV, AR 710-2.  
 B. PARAS 3-149 TO 150, AR 710-2.  
 C. HQDA, DALG-ZXT, 091625Z JAN 78.  
 D. FM 10-30, CENTRAL ISSUE FACILITY.

\*\*\*\*\*  
 \* UNCLASS E F T O \*  
 \*\*\*\*\*

PAGE 01  
 141439Z APR 78  
 RUFDAAA/6897

\*\*\*\*\*  
\* UNCLASS E F T C \*  
\*\*\*\*\*

DEPARTMENT OF THE ARMY  
PENTAGON TELECOMMUNICATIONS CENTER

1. REF A ESTABLISHES HQDA POLICIES AND PROCEDURES FOR ISSUING AND ACCOUNTING FOR PERSONAL CLOTHING AND EQUIPMENT AT UNIT AND ORGANIZATION LEVEL. REF B ESTABLISHES HQDA POLICIES AND PROCEDURES FOR ESTABLISHMENT OF AN INSTALLATION CENTRAL ISSUE FACILITY (CIF) INCLUDING STOCKAGE POLICIES AND ISSUE PROCEDURES. REF C RESTATES REQUIREMENTS IN REFS A AND B AND IMPLIES THAT ALL CTA 50-900 IS ISSUED/RECEIVED BY INSTALLATION CIF IAW REF B. REF C ALSO REQUIRES IDENTIFICATION OF DISCRETIONARY CTA 50-900 ITEMS NLT 1 MAY 78. REF D PROVIDES USEFUL INFORMATION FOR LAYING OUT CIF OPERATIONS, DETERMINING STOCKAGE LEVELS AND SETTING UP CIF RECORDS IAW REF B.
2. USAREUR EFFORTS TO IMPROVE CTA 50-900 PROPERTY ACCOUNTABILITY CONTINUES BUT IS HINDERED BY MISUNDERSTANDING OF UNIT/ORGANIZATION PROCEDURES (REF A) AND INSTALLATION/DIVISION CIF PROCEDURES (REF B AND D).
3. TO ASSIST USAREUR UNITS AND TO IMPROVE THE APPLICATION OF HQDA POLICIES AT APPROPRIATE ACTIVITIES, THE FOLLOWING INFORMATION IS PROVIDED.
  - A. ONLY USAREUR APPROVED SUPPLY ACTIVITIES ARE AUTHORIZED TO OPERATE CIF IAW REF B AND D. USE OF ABSTRACT ACCOUNTING PROCEDURES IS LIMITED TO USAREUR APPROVED CIF ONLY. ALL OTHER NON-DLOGS CLOTHING EXCHANGE ACTIVITIES MUST OPERATE UNDER PROPERTY BOOK ACCOUNTING PROCEDURES (REF A) AND WILL NOT USE ABSTRACT ACCOUNTING PROCEDURES.
  - B. WHILE PROPERTY BOOK CLOTHING ISSUE/EXCHANGE/TURN-IN POINTS PROVIDE MANY OF THE SAME SERVICES AS CIF, THEY ARE NOT AUTHORIZED TO STOCK CTA 50-900 OR USE REPAIR CYCLE, RESUPPLY AND LAUNDRY CYCLE FORMULAS AUTHORIZED IN REF B AND SHOWN IN REF D. UNIT/ORGANIZATION PROPERTY BOOKS ARE AUTHORIZED TO MAINTAIN UP TO FIVE PERCENT OF THEIR AUTHORIZATION FOR SIZED ITEMS ON HAND BUT THIS IS NOT CONSIDERED AS A STOCKAGE LEVEL. THIS QUANTITY IS AN AUTHORIZATION CEILING ONLY.
  - C. THE OBJECTIVE OF REF C IS TO IMPROVE CTA 50-900 CONTROLS IN UNITS AND ATTEMPTS TO CLARIFY THE USE/UNIT/CIF PROCEDURES TO BE FOLLOWED. WHERE A APPROVED CIF (REF B) IS NOT ESTABLISHED, NON-DLOGS UNIT PROPERTY BOOKS (REF A) WILL PERFORM ISSUE, EXCHANGE, TURN-IN AND CLOTHING RECORDS MAINTENANCE FUNCTIONS IAW REF A AND C.
  - D. UNITS OPERATING UNDER DLOGS PROVISIONS (TC 38 SERIES) MAY ESTABLISH A SINGLE CIF (REFS B AND D) WITH ANNEXES OR REQUIRE UNIT COMMANDERS TO SIGN FOR ALL CTA 50-900 ON THEIR HAND RECEIPT AND CONDUCT REQUIRED TRANSACTIONS THROUGH THE UNIT PROPERTY BOOK. THE POLICIES AND PROCEDURES IN REF A APPLY TO THE UNIT COMMANDERS' HAND RECEIPT ALTERNATIVE. THE POLICIES OF REFS B AND D APPLY WHEN A CIF

\*\*\*\*\*  
\* UNCLASS E F T C \*  
\*\*\*\*\*

PAGE 02  
141439Z APR 78  
RUFDAAAA/6897

\*\*\*\*\*  
\* UNCLASS E F T C \*  
\*\*\*\*\*

DEPARTMENT OF THE ARMY  
PENTAGON TELECOMMUNICATIONS CENTER

IS ESTABLISHED. EXCEPT FOR DIVISION CIF OFFICERS, UNIT PROPERTY BOOKS ARE NOT AUTHORIZED TO USE ABSTRACT ACCOUNTING PROCEDURES. E. REFERENCES TO DIRECT TRANSACTIONS IN REF C BETWEEN THE USER AND THE CIF DO NOT PROHIBIT DIRECT TRANSACTIONS BETWEEN USERS AND UNIT SUPPLY PERSONNEL IF AN APPROVED CIF IS NOT ESTABLISHED. ON THE CONTRARY, DIRECT ISSUE/TURN-IN TRANSACTIONS ARE ENCOURAGED SO THAT RESPONSIBILITIES FOR CTA 50-900 ARE CLEARLY ESTABLISHED AND FILLED.

F. CONUS INSTALLATIONS TYPICALLY ESTABLISH A SINGLE CIF FOR CENTRALIZED CTA 50-900 OPERATIONS. USAREUR SUPPLY PERSONNEL MAY ERRONEOUSLY BELIEVE THAT EACH INSTALLATION COMMANDER OPERATES A CIF IAW REF B AND D. THIS MISUNDERSTANDING EXISTS EVEN AT SOME USAREUR SUB POSTS AND SUB COMMUNITIES. THESE ACTIVITIES, UNLESS APPROVED BY USAREUR, MUST OPERATE IAW REF A. WHERE COMMUNITIES OR OTHER PROPERTY BOOK ACTIVITIES HAVE MEMORANDUM OF UNDERSTANDING OR AGREEMENTS BECAUSE OF UNIT SEPARATION FROM PARENT UNITS, PROPERTY BOOK PROCEDURES (REF A) CAN CONTINUE TO BE USED. WHILE USAREUR DOES NOT ENCOURAGE SUCH MEASURES OVER THE LONG TERM, THIS SUPPORT TECHNIQUE IS AUTHORIZED UNTIL MORE ACCEPTABLE SUPPORT ALTERNATIVES ARE AVAILABLE.

3. REQUEST USAREUR MACOM INSURE THAT THIS INFORMATION IS WIDELY DISSEMINATED SO THAT EFFORTS TO IMPROVE PROPERTY ACCOUNTABILITY CAN CONTINUE.

BT

ACTION ADDRESSEES

006 DALO

00006 TOTAL NUMBER OF COPIES REQUIRED

#6897

211

\*\*\*\*\*  
\* UNCLASS E F T C \*  
\*\*\*\*\*

PAGE 03  
141439Z APR 78  
RUFDAAA/6897

HSA-COM (31 Jan 78) 2d Ind  
SUBJECT: Guidelines for Individual Issue of Discretionary Items.  
CTA 50-900

HQ, Academy of Health Sciences, US Army, Fort Sam Houston, TX 78234

APR 20 1978

TO: Commander, US Army Health Services Command

1. Attached as Inclosures 1 and 2 are the recommended discretionary CTA 50-900 individual items of issue for AMEDD TOE by unit category and climatic condition.

2. Recommendations for each individual MTOE unit were not identified. AHS can only recommend discretionary individual items of issue for type units by unit category and climatic zone. Allowances for discretionary individual items of issue must be a judgemental decision on the part of the commander based on the units mission and contingency plans.

FOR THE SUPERINTENDENT:

2 Incl  
wd incl 1  
Added incl 1 and 2

WD



KEITH L. DAVIS  
CPT, MSC  
Chief, Admin Sv Div

\*\*\*\*\*  
 \* UNCLASS E F T O \*  
 \*\*\*\*\*

DEPARTMENT OF THE ARMY  
 PENTAGON TELECOMMUNICATIONS CENTER

BKS	
EZ	
ZXA	
ZXA-C	
PL	
PLW	
PLF	
PLD	

COSN = SCD766 MCN = 78119/01331 TOR = 781190116  
 RTTEZYUW RUGLHTA6110 1190118-EEEE--RUEADWDV  
 ZNY EEEEE  
 R 281450Z APR 78  
 FM CDR FORSCOM FT MCPHERSON GA //AFLG-SMS//  
 TO DA WASH DC //DALO-ZXT//  
 R 212025Z APR 78  
 CDR FORSCOM FT MCPHERSON GA //AFLG-SMS//  
 CDR MRSA LEXINGTON KY //DRXMD-MP//  
 CDR TRADOC FT MONROE VA //ATLG-MSP-SP//  
 BT

UNCLAS E F T O

SUBJ: STANDARDIZATION OF DEFINITIONS AND TITLES

A. CDRDARCOM MSG, DRCMM-4P, DTG 132030Z APR 78, SAB.

1. REQUESTED RESPONSE TO REFERENCE A IS SUBMITTED BELOW. RE-  
 SPONSES ARE KEYED TO REF A.

2. PARA 2A; RECOMMEND DEFINITION OF BII BE AMENDED AS FOLLOWS;

"BII; BASIC ISSUE ITEMS ARE THOSE MINIMUM ESSENTIAL, MANDATORY  
 ITEMS REQUIRED TO OPERATE THE EQUIPMENT AND TO ENABLE IT TO  
 PERFORM THE MISSION AND FUNCTION FOR WHICH IT WAS DESIGNED OR IN-  
 TENDED. BII ARE NATIONAL STOCK NUMBERED (NSN) ITEMS WHICH ARE  
 LISTED AT AND AUTHORIZED BY APPENDIX OF THE OPERATIONS MANUAL  
 TO BE ISSUED WITH THE END ITEM. THESE ITEMS WILL BE ISSUED WITH THE  
 EQUIPMENT (UNDER ITS NSN), BE KEPT WITH IT AND ACCOUNTED FOR AS A  
 PART OF IT ON THE UNIT PROPERTY BOOK/HAND RECEIPT. IT MUST  
 ACCOMPANY THE END ITEM WHEN IT IS ISSUED, TRANSFERRED BETWEEN  
 PROPERTY ACCOUNTS, OR TURNED IN."

SAFETY ITEMS SHOULD INCLUDE FIRE EXTINGUISHERS REQUIRED IAW AR  
 385-55.

3. PARA 2.A; RATIONALE FOR ABOVE DEFINITION IS BASED UPON  
 GUIDANCE FOR CLEAR, SIMPLE TERM DEFINITIONS. ADDITIONALLY, TMDE,  
 REPAIR PARTS, AND PUBLICATIONS SHOULD NOT BE INCLUDED AS COMPONENTS  
 OF THE BII FOR THE FOLLOWING REASONS:

A. TMDE - TEST, MEASURING AND DIAGNOSTIC EQUIPMENT (TMDE)  
 SHOULD BE AUTHORIZED BY APPROPRIATE SUPPLY CATALOGS AND/OR REPAIR  
 PARTS MANUALS (FOR SPECIAL PECULIAR EQUIPMENT) FOR USE BY QUALIFIED  
 MAINTENANCE PERSONNEL NOT OPERATOR/CREW.

B. REPAIR PARTS. APPROPRIATE -20P MANUALS LIST THE AUTHORIZED  
 REPAIR PARTS FOR AN ITEM OF EQUIPMENT AND REQUIRED CONTROL BY PLL  
 PERSONNEL. ANY ATTEMPT TO PLACE ADDITIONAL REPAIR PARTS WITH THE

212

\*\*\*\*\*  
 \* UNCLASS E F T O \*  
 \*\*\*\*\*

PAGE 01  
 212025Z APR 78

\*\*\*\*\*  
\* UNCLASS E F T O \*  
\*\*\*\*\*

DEPARTMENT OF THE ARMY  
PENTAGON TELECOMMUNICATIONS CENTER

ITEM OF EQUIPMENT AS BII WOULD BE COUNTER-PRODUCTIVE AND CREATE A CONTROL PROBLEM. THE REPAIR PARTS (-20P) MANUALS SHOULD CONTINUE AS THE SINGLE SOURCE OF AUTHORIZATION FOR REPAIR PARTS.

C. PUBLICATION - IT IS RECOMMENDED THAT OPERATORS MANUALS LIST THE APPROPRIATE APPLICABLE PUBLICATIONS FOR THE ITEM OF EQUIPMENT IN A SEPARATE APPENDIX AND THAT AR 700-18 CONTINUE TO REQUIRE THAT THEY BE SHIPPED WITH THE ITEM. INCLUSION TO BII MAY PRECLUDE ANY UPDATING OF PUBLICATIONS WHICH HAVE BEEN PREPACKED WITH THE BII AS MAJOR CHANGES OCCUR.

4. THE TERM "REQUIRED TO PERFORM EMERGENCY REPAIRS" MAY APPLY TO MANY ITEMS AUTHORIZED BY BOTH BII AND AALIT'S NOT CLEAR WHAT THE INTENT IS; AN ADJUSTABLE WRENCH MAY PERFORM EMERGENCY REPAIRS. WILL THIS NOW BE INCLUDED IN BII?

5. PARA 2B. A. AUTHORIZATION DOCUMENTS SHOULD INCLUDE TM'S.

B. CHANGE 3RD SENTENCE TO READ; THE AAL IS AN INFORMATIONAL LISTING IN THE OPERATOR'S MANUAL, APPENDIX \_\_\_\_\_, WHICH IDENTIFIES THE PARTICULAR ITEMS AND RECOMMENDED MINIMUM QUANTITY WHICH MAY BE USED TO SUPPORT ONE END ITEM.

6. WHAT CATEGORY WILL ITEMS CURRENTLY LISTED AS COMPONENTS OF THE END ITEM BE LISTED UNDER THE PROPOSED DEFINITIONS?

BT

ACTION ADDRESSEES

006 DALO

00006 TOTAL NUMBER OF COPIES REQUIRED

#6110

214

\*\*\*\*\*  
\* UNCLASS E F T O \*  
\*\*\*\*\*

PAGE 02  
212025Z APR 78  
RUCLHTA/6110



DEPARTMENT OF THE ARMY  
HEADQUARTERS U.S. ARMY MILITARY DISTRICT OF WASHINGTON  
FORT LESLEY J. MCNAIR  
WASHINGTON, D.C. 20310

ANPAT

MAY 01 1978

SUBJECT: Property Accountability for Discretionary Components of End  
Items

DA (DALO-ZXT)  
Washington, DC 20310

1. Reference is made to message DALO-ZXT, 221900Z Dec 77, Subject as above.
2. This commands implementing procedures for discretionary components of end items are contained at inclosures 1 and 2.

FOR THE COMMANDER:

- ~~2 Incl~~  
1. PAI 27  
2. PAI 33

WD

  
DONALD L. BURT  
Colonel, GS  
Chief, MDW Property Accountability  
Task Force

\*\*\*\*\*  
 \* UNCLASSIFIED \*  
 \*\*\*\*\*

DEPARTMENT OF THE ARMY  
 PENTAGON TELECOMMUNICATIONS CENTER

*(Handwritten routing slips and administrative markings, including 'PLN' and 'PLC' in boxes)*

CDSN = SCD094 MCN = 78125/J2760 TOR = 781250517  
 RTTUZYUW RUHHMA3057 125C203-UUUU--RUADWD.  
 ZNR UUUUU  
 R 050110Z MAY 78  
 FM CORUSASCH FT SHAFTER HI //AFZV-DI-SU//  
 TO RUCLHTD/CDR FCRSCCM FT MCPHERSON GA //AFLG-SMS//  
 INFO RUEADWD/; CA WASH DC //DALO-ZXT//  
 RUHH8HA/CDR 25TH INF DIV SCHOFIELD BKS HI //AEVG-LGS//  
 RUHH8HA/CDR 45TH SPT GP SCHOFIELD BKS HI //AFZV-FF-EGL//  
 ZEN/CDR IX CORPS (AUG) FT DEKUSSY HI  
 //AFZV-IX-SM// (CCURIER)  
 BT

UNCLAS

THIS IS A PROPER COUNT MSG  
 SUBJ PROPERTY ACCOUNTABILITY FOR DISCRETIONARY COMPONENTS OF END  
 ITEMS AND ORGANIZATIONAL CLOTHING AND EQUIPMENT (OCE)

- A. UR 082528Z MAR 78 (U)  
 B. UR 062040Z FEB 78 (U)  
 C. UR 131820Z JAN 78 (U)
1. REVIEW OF DISCRETIONARY ITEMS REQUIRED BY REF A HAS BEEN COMPLETED. WHILE NO ADDITIONAL FUNDING REQUIREMENTS WERE GENERATED, SOME EXCESSES WERE IDENTIFIED FOR TURN IN.
  2. REQUEST CLARIFICATION OF PARA 3, REF B AND PARA 5, REF C, PERTAINING TO APPROPRIATE LEVEL OF DETERMINATION OF DISCRETIONARY ITEMS. SPECIFICALLY, DOES DELEGATION OF AUTHORITY APPLY EQUALLY TO COMMANDERS OF INSTALLATIONS, DIVISIONS AND SEPARATE BRIGADES? CLARIFICATION IS REQUIRED SINCE THE ARMY ELEMENTS IN HAWAII INCLUDE COMMANDERS AT INSTALLATION (USASCH), DIVISION (25TH INF) AND SEPARATE BRIGADE(S) (45TH SPT GP AND IX CORPS (AUG) LEVELS AND EACH WOULD HAVE THIS AUTHORITY. FURTHER, WRITTEN DELEGATION WOULD BE REQUIRED ONLY BELOW THESE LEVELS OF COMMAND.
  3. YOUR EARLIEST REPLY WILL BE APPRECIATED.

BT

ACTION ADDRESSEES

006 DALO

INFORMATION ADDRESSEES

000

\*\*\*\*\* AMRD \*\*\*

00006 TOTAL NUMBER OF COPIES REQUIRED  
 #3057

\*\*\*\*\*  
 \* UNCLASSIFIED \*  
 \*\*\*\*\*

PAGE 01  
 050110Z MAY 78  
 RUHHMA/3057



\* UNCLASS E F T O \*  
 \*\*\*\*\*

PLS	THCL	SM
ZLA	TA	SMT
ZXT <i>A</i>	IE	SNS
ZXA	TSM	SMM
ZXA-C	TST	SMW
AV	TSE	SML
PL	TSP	SMD
PLS	SAC	RM
PLW	SAB	RMB
PLR	SAA	RMC
PLF	SA	RMI
PLO		RMP

DEPARTMENT OF THE ARMY  
 PENTAGON TELECOMMUNICATIONS CENTER

CDSN = SCD279 MCA = 78135/11097 TOR = 781351918  
 RTTEZYUW RUCLHTA74CS 1351851-EEEE--RUEADWD.  
 ZNY EEEEE  
 R 151500Z MAY 78  
 FM CDR FORSCOM FT MC PHERSON GA //AFLG-SMS//  
 TO AIG 7433  
 AIG 7435  
 AIG 7570  
 INFO RUEADWD/DA WASH DC //DALO-ZXT//  
 RUCLAIA/CDR TRACCC FT MCGRCE VA //ATLG-MSP-S  
 BT

UNCLAS E F T O

THIS IS FORSCOM PROPER COLAT FLASHER MSG NO. 14.  
 SUBJECT: ACCOUNTABILITY OF ORGANIZATIONAL CLOTHING AND INDIVIDUAL  
 EQUIPMENT (CTA 5C-9CG), INTERIM CHANGE TO AR 710-2 W/C4 NUMBER 5-2,  
 AR 210-10, NUMBER 1-1, AR 640-10, NUMBER 1-1.

- A. DALO-ZXT MSG, 091910Z MAY 78, SAB.
- 1. REFERENCE MSG IS YOURS FOR ACTION.
- 2. PARA A OF REF A SHOULD BE CHANGED TO READ:
  - A. DAMO-FDU 191950Z APR 78, SUBJ: TRANSFER OF ORGANIZATIONAL  
 ISSUE ITEMS (CTA 5C-9CG) AS CHANGED BY DAMO-FDU MESSAGES, 031440Z  
 MAY 78 AND 041155Z MAY 78 WITH THE SAME SUBJECT.

BT

ACTION ADDRESSEES

006 DALO

INFORMATION ADDRESSEES

001 AFLO/ATLD

00007 TOTAL NUMBER OF COPIES REQUIRED

#7409

\*\*\*\*\*  
 \* UNCLASS E F T O \*  
 \*\*\*\*\*

PAGE 01  
 151500Z MAY 78  
 RUCLHTA/7409

\*\*\*\*\*  
 \* UNCLASSIFIED \*  
 \*\*\*\*\*

ORG	THCL	SM
ZX	TA	SMT
ZXT /	LR	SMS
ZXA	TSM	SMM
ZXA-C	TST	SMW
AV78137	TSB	SNL
PL	TSP	SND
PLS	SAC	SN
PLW	SAB	SMB
PLR	SAA	SNC
PLF	SA	SNI
PLO /		SNP

DEPARTMENT OF THE ARMY  
 PENTAGON TELECOMMUNICATIONS CENTER

CDSN = SC0937 MCA = 72137/20314 TGR  
 PTTUZYUR RUCLHTA773C 1572109-0000--RUADWD  
 ZNR UUUUU  
 R 171835Z MAY 78  
 FM CDR FORSCOM FT MCFFERSON GA //AFLG-SMS/  
 TO RUEOPIA/CDR USALAE FT MEADE MD//  
 RUMTFXA/CDR USAFIVE FT SAM HOLSTON TX//  
 RUWABHA/CDR USASIX SFRAN CA  
 INFO RUHEADW/DA WASH DC //DALL-ZXT//  
 BT

UNCLAS

THIS IS A PROPER COUNT MESSAGE (USAR)  
 SUBJECT: ACCOUNTABILITY OF ORGANIZATIONAL CLOTHING AND  
 INDIVIDUAL EQUIPMENT (OTA 50-90J)

- A. PROPER COUNT FLASHER MSG NO. 14, DALL-ZXT, 091910Z MAY 78, SAR
  - B. FORSCOM PROPER COUNT FLASHER MSG NO. 14, AFLG-SMS, 151500Z  
MAY 78, SAB
  - C. AFLG-SMS MSG 021740Z NOV 77, SUBJ: SECTION VI, AR 710-2,  
USAR SUPPLY PROCEDURES
- REFERENCED MESSAGES DO NOT CHANGE THAT REQUIREMENT OF PARA 2-29B,  
 AR 710-2. FOR USAR, THE DA FORM 3078 WILL BE PLACED ON FILE IAW  
 REF C WHEN THE CRITERIA OF PARA 2-29E ARE MET RATHER THAN BE  
 DESTROYED.

BT

ACTION ADDRESSEES

006 DALD

00006 TOTAL NUMBER OF COPIES REQUIRED

#773C

\*\*\*\*\*  
 \* UNCLASSIFIED \*  
 \*\*\*\*\*

PAGE 01  
 171835Z MAY 78  
 RUCLHTA/773C



DEPARTMENT OF THE ARMY  
HEADQUARTERS UNITED STATES ARMY TRAINING AND DOCTRINE COMMAND  
FORT MONROE, VIRGINIA 23651

18 MAY 1978

ATCD-S-A

SUBJECT: Guidelines for Individual Issue of Discretionary Items,  
CTA 50-900

HQDA (DALO-ZXT)  
WASH DC 20310

1. Reference letter, DALO-ZXT, HQDA, 19 Jan 78, subject as above.
2. Based on our understanding of the problem, the desired solution appears to be the development of effective procedures to insure compliance with existing guidelines, rather than publication of more guidelines. Appendix A of CTA 50-900 explains the term "discretionary allowances." It states in part: "Items of clothing and equipment authorized on a discretionary basis . . . governed by procedures established in AR 710-2. These items will not be requisitioned by, nor issued to, organizations unless required for the necessary operation of the unit, military mission, or for discharge of assigned military duties, including climatic and geographical requirements, and then only in the quantities as necessary and required. Paragraph I-A-7f of CTA 50-900 states: "It is essential that appropriate commanders use extreme care in authorizing discretionary allowances indicated herein, to insure limitation qualitatively and quantitatively to those items which are essential to the mission of their commands. Too liberal an interpretation of what is necessary will generate excessively large requirements and adversely affect the supply situation Army-wide."
3. Any discretionary item which the appropriate commander determines to be required for the accomplishment of his unit's mission can be considered mission essential to that unit, be it required by one or all soldiers of the unit. Since the terms "mission essential" and "minimum essential" appear to be used interchangeably in the referenced letter, the following definitions of these terms were used in developing the inclosed guidelines:
  - a. Minimum essential discretionary allowances - Clothing and equipment items issued at the discretion of appropriate commanders which meet all of the following criteria:
    - (1) Must be essential to the health, comfort and efficient functioning of personnel within a given climatic zone.

*Incl 1*

ATCD-S-A

SUBJECT: Guidelines for Individual Issue of Discretionary Items,  
CTA 50-900

(2) Must be required for the accomplishment of the unit's TOE/TDA mission.

(3) Must be required by all personnel within a given type unit/organization regardless of MOS, status or duty assignment.

b. Mission essential discretionary allowances - Clothing and equipment items which, in addition to mandatory items, are essential to the accomplishment of all missions assigned to a unit/organization, to include training which is necessary to enable that unit to be prepared to accomplish any of its assigned missions. This includes items authorized on the basis of MOS, status or duty assignment.

4. In developing the inclosed minimum essential guidelines, we considered only those items in the CTA which met the criteria prescribed by paragraph 3a above. Specifically, we did not include those mission essential items which are required exclusively by selected unit personnel based on MOS or duty assignment (e.g., Pocket Ammunition Magazine, LIN P13051). This determination must remain the prerogative of authorized commanders. The procedures for exercising this discretionary authority are clearly specified in CTA 50-900 and appropriate publications referenced in Appendix C.

5. The value of the requested guidelines is recognized only as a general guide to assist commanders at all levels in determining the minimum allowances required for efficient functioning of personnel engaged in peacetime military operations under specific climatic conditions. Such guidelines should clearly state that the items shown constitute the basic allowance for all personnel assigned to a given unit; that allowances based on individual MOS, position or duty assignment are not included; that allowances required to support specific contingencies or missions other than the unit's normal TOE/TDA mission are not included; and that these guidelines do not relieve commanders of their responsibility to determine that these items are actually required.

6. Detailed review of all discretionary allowances contained in CTA 50-900 revealed that most items which meet the criteria in paragraph 3a above are required for environmental protection within specified climatic zones by all personnel regardless of type unit, MOS, duty assignment or any other consideration. Consequently, these items were compiled into guidelines for individual issue of items common to all units/organizations which are at Inclosure 1.

7. Inclosure 2 contains those items which, in addition to those listed in Inclosure 1, are considered minimum essential for Category I Infantry units.

ATCD-S-A

**SUBJECT: Guidelines for Individual Issue of Discretionary Items,  
CTA 50-900**

**8. Inclosure 3 contains those items which, in addition to those listed in Inclosure 1, are considered minimum essential for Airborne, Ranger and Special Forces units.**

**FOR THE COMMANDER:**

*J. M. Laekins*

3 Incl  
as

J. M. LAEKINS  
LTC, AGC  
Asst. AG

GUIDELINES FOR INDIVIDUAL ISSUE

ITEMS COMMON TO ALL UNITS/ORGANIZATIONS

The following allowances are established as guidelines to assist commanders in authorizing minimum essential *discretionary* organizational clothing and equipment to all individuals of all units for health, comfort and efficient functioning under given climatic conditions.

CATEGORY	LINE NO. AND ITEM	CLIMATIC ZONE/ALLOWANCES							REMARKS
		I	II	III	IV	V	VI	VII	
I-II-III	B13907 - Bag Barracks:	1	1	1	1	1	1	1	
I-II	B15825 - Bag Water-proof Clothing	1	1	1	1	1	1	1	
I-II	C07440 - Boots Hot Weather	1	1						
I-II-III	C08119 - Boots Cold Weather			1	1	1	1		
I-II-III	C08256 - Boots Extreme Cold Weather							1	
I-II	C96399 - Canteen Water: Collapsible 2 Qt	1	1						
I-II-III	C96536 - Canteen Water: Plastic 1 Qt	1	1	1	1	1	1		Note 1.
I-II-III	B59567 - Belt Individual Equipment	1	1	1	1	1	1	1	
I-II-III	C96810 - Canteen Water: Cold Climate					1	1	1	Note 1.
I-II-III	D64043 - Case Field First Aid Dressing	1	1	1	1	1	1	1	
I-II-III	F29980 - Cover Water Canteen Cold Climate					1	1	1	Note 1.
I-II-III	E43851 - Coat Cold Weather			1	1	1	1	1	

NOTE: Because of wide variations in temperatures within Zones V and VI, the determination to authorize issue of cold climate canteen with cup and cover must be based on local climatic conditions.

Page 1

*J. C. C. 1*

GUIDELINES FOR INDIVIDUAL ISSUE  
ITEMS COMMON TO ALL UNITS/ORGANIZATIONS

Cont.

CATEGORY	LINE NO. AND ITEM	CLIMATIC ZONE/ALLOWANCES							REMARKS
		I	II	III	IV	V	VI	VII	
I-II-III	F54680 - Cup Water Canteen Cold Climate					1	1	1	Note 1.
I-II-III	F54817 - Cup Water Canteen Steel	1	1	1	1	1	1		Note 1.
I-II-III	K34733 - Helmet Ground Troops	1	1	1	1	1	1	1	Except parachutist
I-II-III	K71200 - Liner Grnd Troops Helmet	1	1	1	1	1	1	1	Except parachutist
I-II-III	K46058 - Hood Ex- treme Cold Weather					1	1	1	
I-II-III	L70172 - Liner Cold Weather Coat			1	1	1	1	1	
I-II-III	L70720 - Liner Ex- treme Cold Weather Parka					1	1	1	
I-II	L70789 - Liner Wet Weather Poncho	1	1						
I-II-III	L72022 - Liner Cold Weather Trousers					1	1	1	
I-II-III	M52555 - Mitten Inserts					1	1	1	
I-II-III	M53240 - Mitten Shells					1	1	1	
I-II-III	N39848 - Overshoes Mens			1	1	1	1	1	

Page 2

GUIDELINES FOR INDIVIDUAL ISSUE

ITEMS COMMON TO ALL UNITS/ORGANIZATIONS

Cont.

CATEGORY	LINE NO. AND ITEM	CLIMATIC ZONE/ALLOWANCES							REMARKS
		I	II	III	IV	V	VI	VII	
I-II-III	N69904 - Parka Extreme Cold Weather					1	1	1	
I-II-III	P17415 - Poncho	1	1	1	1	1	1	1	
I-II-III	T00150 - Shelter Half Tent	1	1	1	1	1	1		
I-II-III	T04205 - Shirt Cold Weather Wool			2	2	2	2	2	
I-II	T71673 - Sleeping Bag: Intermediate Cold			1	1				
I-II	T71706 - Sleeping Bag: Extreme Cold					1	1	1	
I-II-III	U73597 - Suspenders Trousers			1	1	1	1	1	
I-II-III	X36109 - Trousers Extreme Cold Weather			2	2	2	2	2	
I-II-III	X37180 - Trousers Cold Weather Wool			2	2	2	2	2	
I-II-III	X86839 - Undershirt Mans: 50 Cotton/ 50 Wool			2	2	2	2	2	
I-II-III	G49350 - Drawers Cold Weather, 50 Cotton/50 Wool			2	2	2	2	2	
I-II-III	F30391 - Cover Water Canteen	1	1	1	1	1	1		Note J.



GUIDELINES FOR INDIVIDUAL ISSUE

INFANTRY UNIT/ORGANIZATION

The following allowances are established as guidelines to assist commanders in authorizing minimum essential *discretionary* organizational clothing and equipment to all individuals of infantry units/organizations.

CATEGORY	LINE NO. AND ITEM	CLIMATIC ZONE/ALLOWANCES							REMARKS
		I	II	III	IV	V	VI	VII	
I	D11812 - Carrier Intrenching Tool	1	1	1	1	1	1	1	
I	H39835 - Field Pack Medium	1	1	1	1	1	1		
I	H39835 - Field Pack, Large							1	
I	H90705 - Frame Pack w/Straps							1	
I	U48674 - Strap Tie Down Cargo			2	2	2	2	2	
I	U73323 - Suspenders Belt Ind Eqpt	1	1	1	1	1	1	1	
I	L00210 - Intrench- ing Tool	1	1	1	1	1	1	1	

u 2

GUIDELINES FOR INDIVIDUAL ISSUE

AIRBORNE, RANGER & SPECIAL FORCES UNITS/ORGANIZATIONS

The following allowances are established as guidelines to assist commanders in authorizing minimum essential *discretionary* organizational clothing and equipment to individuals of Airborne, Ranger and Special Forces units/organizations.

CATEGORY	LINE NO. AND ITEM	CLIMATIC ZONE/ALLOWANCES							REMARKS
		I	II	III	IV	V	VI	VII	
I-II	D11812 - Carrier Intrenching Tool	1	1	1	1	1	1	1	
I-II	H39835 - Field Pack, Medium OR Field Pack, Large	1	1	1	1	1	1	1	Size issued based on bulk and weight of indiv. combat load
I-II	H90705 - Frame Pack w/Straps	1	1	1	1	1	1	1	Per individual issued large pack
I-II	U48674 - Strap Tie Down Cargo	2	2	2	2	2	2	2	
I-II	U73323 - Suspenders, Belt; Individual Equipment	1	1	1	1	1	1	1	
I-II	F43234 - Coat Camouflage.	3	3	3	3	3	3		
I-II	L00210 - Intrench- ing Tool	1	1	1	1	1	1	1	
I-II	F28747 - Cover Helmet Camouflage	1	1	1	1	1	1		
I-II	K35092 - Trousers Camouflage	3	3	3	3	3	3		
I-II	K34870 - Helmet Parachutists	1	1	1	1	1	1	1	Parachutists o..ly
I-II	L71337 - Liner Para- chutist Helmet	1	1	1	1	1	1	1	Parachutists only
			226						

Incl 3

\*\*\*\*\*  
 \* UNCLASS E F T O \*  
 \*\*\*\*\*

DEPARTMENT OF THE ARMY  
 PENTAGON TELECOMMUNICATIONS CENTER

BKS	FA	GM
ZX	LE	SAT
ZY	TSM	SMS
ZXA	TST	SMM
THCL	TSE	SMW
AV	TSP	SML
PL	TSC	CMD
PLW	SAC	PM
PLS	SAB	PMB
PLR	SAA	PMD
PLF	SA	PMI
PLO		PMR

CDSN = SC0091 MCN = 76139/12824 TGR = 781391532  
 RTTEZYUW RUDHAAA1680 1391534-EEEE--RUEADWD.  
 ZNY EEEEE  
 R 191424Z MAY 78  
 FM CORINSCOM AHS VA //IALLC-SS//  
 TO AIG 7567  
 INFO RUEADWD/DA WASHDC //CALD-ZXT//  
 BT

UNCLAS E F T O

SUBJ ACCOUNTABILITY FOR CLOTHING AND EQUIPMENT

- A. DALOZXT 09191CZ MAY 78, SAB (FLASHER NO 14)
- B. DAMO-FDU 191950Z APR 78, TRANSFER OF CTA 50-900
- C. DALO-SMS 281412Z SEP 77, ABSTRACTING OF EQUIP
  1. TO ENSURE STANDARDIZED PROCEDURES FOR THE ISSUE, TURN-IN, TRANSFER, AND ACCOUNTABILITY OF ORGANIZATIONAL CLOTHING AND INDIVIDUAL EQUIPMENT, THE FOLLOWING ACTION WILL BE FULLY IMPLEMENTED BY 1 JUL 78:
    - A. DURING RECEPTION CENTER PROCESSING, (1) OCIE WILL BE RECORDED ON DA FORM 3078.
    - B. INITIAL PERMANENT DUTY STATION:
      - (1) ALL OCIE WILL BE TRANSFERRED FROM DA FORM 3078 TO DA FORM 3645.
      2. ALL FUTURE ISSUES/TURN-INS WILL BE RECORDED ON THE DA FORM 3645.
      3. EXPENDABLE ITEMS WILL NOT BE RECORDED ON THE DA FORM 3645 (EX: DCG TAGS, PATCHES, STRIPES)
      4. ALL OCIE AUTHORIZED FOR RETENTION/TRANSFER WILL NOT BE PICKED UP ON UNIT, ORGANIZATION OR CIF PROPERTY BOOKS. (EX: HOSPITAL WHITES, COOK WHITES, AVIATION CLOTHING, ATHLETIC UNIFORM) IAW DA MSG 191950Z APR 78.
      5. ABSTRACTING WILL BE ACCOMPLISHED IN THE FOLLOWING MANNER:
        - A. DA FORM 3645 WILL BE PREPARED IN (2) CYS.
          - (1) ONE CY TO UNIT
          - (2) ONE CY RETAINED BY CIF
        - B. INDV ISSUES/TURN-INS WILL BE RECORDED ON A CONSOLIDATED 3645, REFLECTING THE INDIVIDUALS NAME, SSN, AND QUANTITY ISSUED. THE CONSOLIDATED 3645'S WILL THEN BE TOTALED, ATTACHED TO A SEPARATE 3645 FOR ISSUE AND TURN-IN AND POSTED TO THE PROPERTY BOOK AT FAST WEEKLY. THE SEPARATE 3645'S WILL SHOW THE TOTAL QUANTITY ISSUED OR TURNED IN, THE TRANSACTION AND THE NOTATION: "SFE SUPPORTING 3645(S) ATTACHED".

\*\*\*\*\*  
 \* UNCLASS E F T O \*  
 \*\*\*\*\*

PAGE 01  
 191424Z MAY 78  
 RUDHAAA/1680

\*\*\*\*\*  
\* UNCLASS L F T O \*  
\*\*\*\*\*

DEPARTMENT OF THE ARMY  
PENTAGON TELECOMMUNICATIONS CENTER

6. OCIE THAT MAY BE TRANSFERRED/RETAINED THAT IS ALREADY ON THE PROPERTY BOOKS WILL BE DELETED THRU ATTRITION. EQUIPMENT WILL REMAIN ON PROPERTY BOOKS UNTIL INDIVIDUAL DEPARTS ON PCS, THEN ABSTRACTED OFF.
- C. DEPARTURE ON PCS
  1. ENSURE INDV RETAINS THESE ITEMS OF OCIE AUTH TO BE TRANSFERRED WITH HIM/HER. (SEE DA MSG 251950Z APR 78)
  2. THE CIF/ORG CY OF 3645 REFLECTING THOSE ITEMS WHICH WILL BE RETAINED/TRANSFERRED WITH THE INDV WILL BE FILED IN THE CIF OR ORG SUPPLY (IF NO CIF) FOR A PERIOD OF SIX MONTHS AFTER THE INDV DEPARTS ON PCS.
  3. THE GAINING UNITS COPY OF THE 3645 REFLECTING ITEMS TRANSFERRED WILL BE INCLUDED IN THE MILITARY PERSONNEL RECORDS JACKET (MPRJ) EVEN IF ALL ITEMS ARE AT ZERO (0) BALANCE.
  4. THE CUSTODIAN OF THE INDV PERSONNEL RECORDS WILL AUTHENTICATE THAT THE 3645 IS INCLUDED DURING OUT-PROCESSING WHEN CLOSING OUT THE MPRJ.
  5. PROCESSING THE 3645 WILL BE INCLUDED IN THE INSTALLATION CLEARANCE PROCEDURES, WITH THE 3645 BEING LISTED ON DA 137, IN STALLATION CLEARANCE FORM.
  6. IF INDV ARRIVES AT NEW DUTY STATION WITHOUT A CY OF THE 3645 IN THE MPRJ, THE NEW CUSTODIAN OF RECORDS WILL IMMEDIATELY REQUEST A CY OF THE INDV 3645 FROM THE OLD CUSTODIAN OF THE INDV MPRJ.
  7. INDV WILL BE ISSUED CLOTHING ON A "TEMPORARY" BASIS UNTIL THE DA 3645 IS REC'D. IF CY IS NOT AVAILABLE, A 100% INVENTORY WILL BE CONDUCTED AND A NEW DA 3645 PREPARED.
2. POC THIS HQ IS HQ HILL, AUTOVON 222-5563/5641.

BT

ACTION ADDRESSEES

706 DALO  
012 DAMO  
00018 TOTAL NUMBER OF COPIES REQUIRED  
41680

228

\*\*\*\*\*  
\* UNCLASS L F T O \*  
\*\*\*\*\*

PAGE 02  
191424Z MAY 78  
R:DHAAA/1680

\*\*\*\*\*  
 \* UNCLASSIFIED \*  
 \*\*\*\*\*

MCC

PENTAGON TELECOMMUNICATIONS CENTER'S

KS	TA	SM
ZK	LE	SMT
ZXT	TSM	SMS
	T730	SMM
THOL	TGE	SMW
AV	TOP	SML
PL	TS	SMD
PLA	SAC	SM
PLS	S/E	SMB
PLR	SAA	SMC
PLF	SA	SM
PLG		

CDSN = SCD071 PCA = 78144/15261 TOR = 778144/1730  
 RTTUZYUW RUFDAAA2575 1441731-UULL--RUEADND  
 ZNR UUUUU  
 R 230859Z MAY 78  
 FM CINCUSAREM HEICELBERG GEMANY//AEAGU-SM-F//  
 TO RUEADND/HQDA WASH DC//LARG-FDU//  
 INFO RUEADND/INCCA WASH DC//DALC-ZX1//  
 BT

UNCLAS

SUBJECT: MESSAGE CHANGES IL LTA 50-900

- A. CTA 50-900 W/CF 1, AUG 78.
- B. MSG, DAND-FCL, 021854Z JUL 78, SUBJ: CHANGES TO COMMON TABLES OF ALLOWANCES (C1A).
- C. MSG, DAND-FDU, 211920Z JULY 78, SUBJ: CHANGES TO CTA 50-900 AS A RESULT OF CHANGES TO EXISTED M/MAR CLOTHING BAG (FY 77).
- D. MSG, DAND-FCL, 021430Z AUG 77, SUBJ: STANDARDIZATION OF COLORS OF FIVE PIECE ATHLETIC UNIFORM ENSEMBLES.
- E. MSG, DAND-FCL, 241652Z AUG 77, SUBJ: AUTHORIZATION OF ADDITIONAL BLACK LEATHER FIRST AID CASE FOR FEMALE MP.
- F. MSG, DAND-FCL, 051845Z JAN 78, SUBJ: INTERIM AUTHORIZATION FOR FIRE RETARDANT GLOVES FOR GREAT VEHICLE CREWMEN.
- G. MSG, DAND-FDU, 141651Z MAR 78, SUBJ: AUTHORIZATION FOR BARBED TAPE WIRE HANDLES GLOVES BY CTA 50-900.
- H. MSG, DAND-FDU, 151550Z APR 78, SUBJ: TRANSFER OF ORGANIZATIONAL ISSUE ITEMS (CTA 50-900).
- I. MSG, DAND-FDU, 031444Z MAY 78, SUBJ: TRANSFER OF ORGANIZATION ISSUE ITEMS (CTA 50-900).
- J. MSG, DAND-FDU, 041155Z MAY 78, SUBJ: TRANSFER OF ORGANIZATION ISSUE ITEMS (CTA 50-900).
- K. REFS B-J PROVIDE MESSAGES CHANGING BASIC CTA IN REF A.
- L. ABOVE REFS (EXCEPT MESSAGES NOT CURRENTLY ON FILE AT USAREUR PROPONENT), AS PUBLICATIONS REFERENCE LIBRARY OR AT OTHER USAREUR RESOURCE PARAGRAPHS. USAREUR UNITS ARE EXPERIENCING DIFFICULTY IN DETERMINING WHAT THEY ARE AUTHORIZED TO ISSUE AND WHAT THE BASICS OF ISSUE ARE.
- M. REQUEST YOUR ASSISTANCE IN IMPROVING SUPPLY PUBLICATIONS IN USER UNITS BY PROVIDING HQ USAREUR A CONSOLIDATION OF MESSAGE AND LETTER CHANGES CURRENTLY IN EFFECT.
- N. HQ USAREUR FCL IS MAJ GEN. KAPKE, AEAGU-SM-F HRG AIL 6760/8142 APO C9403.

\*\*\*\*\*  
 \* UNCLASSIFIED \*  
 \*\*\*\*\*

PAGE 01  
 230859Z MAY 78  
 RUFDAAA/2575

\*\*\*\*\*  
\* UNCLASSIFIED \*  
\*\*\*\*\*

DEPARTMENT OF THE ARMY  
PENTAGON TELECOMMUNICATIONS CENTER

CDSN = SCD982 MCM = 78144/02418 TOR = 781440233  
RTTUZYUW RUCLAIA4934 1432124-0000--RLEADWD.  
ZNR UUUUU  
R 232123Z MAY 78  
FM COMTRADOC FTLANGLE VA //A1LG-MSP-SP//  
TO RUEOFTA/CDRUS/TC & FT DIX NJ //ATZCGC//  
INFO RUEADWD/HQDA WASHDC //CALL-ZXT//  
BT

UNCLAS

SUBJ: WASH AND WEAR FATIGUES

A. FT DIX ATZCGC 10 MAY 78 REQUEST FOR EXCEPTION TO POLICY FOR ISSUANCE OF FATIGUES DURING BASIC TRAINING. (U)

1. REF REPORTED A HIGH INCIDENCE OF WASH AND WEAR FATIGUE DAMAGE DURING RIGOROUS EXERCISES OF BASIC TRAINING. ESTABLISHMENT OF A PROCEDURE FOR FREE EXCHANGE/REPLACEMENT/REPAIR OF DAMAGED FATIGUES FOR BASIC TRAINEES WAS REQUESTED.

2. IMPLEMENTATION OF THE RECOMMENDATION FOR FREE EXCHANGE/REPLACEMENT/REPAIR OF FATIGUES DAMAGED DURING BASIC TRAINING CANNOT BE SUPPORTED IN VIEW OF FISCAL RESTRAINTS. THIS HEADQUARTERS HAS, HOWEVER, RECOMMENDED TO HOLD THAT FATIGUES RECOVERED FROM PERSONNEL AT DISCHARGE BE AUTHORIZED FOR USE AS SUPPLEMENTAL CLOTHING BY BASIC TRAINEES. SPECIFICALLY, TWO SETS OF FATIGUES WOULD BE ISSUED TO EACH BASIC TRAINEE BY THE SUPPORTING PROPERTY BOOK OFFICER FOR THE DURATION OF THE TRAINING PERIOD.

3. YOUR HEADQUARTERS WILL BE ADVISED OF DEVELOPMENTS. POC THIS HEADQUARTERS IS LTC KURGVEL, ACTUATOR 680-2710.

BT

ACTION ADDRESSEES

006 DALO

00006 TOTAL NUMBER OF COPIES REQUIRED

4934

\*\*\*\*\*  
\* UNCLASSIFIED \*  
\*\*\*\*\*

PAGE C1  
232123Z MAY 78  
RUCLAIA/4934

\*\*\*\*\*  
\* UNCLASSIFIED \*  
\*\*\*\*\*

DEPARTMENT OF THE ARMY  
PENTAGON TELECOMMUNICATIONS CENTER

CDSN = SCD002 MCA = 78146/03132 TCR = 781460330  
RTTUZYUW RUCLAIA/5140 1452Z01-ULLU--RLEADWD.  
ZNR UUUUU  
R 252200Z MAY 78  
FM CERTRADOC FT MCNELE VA//ATLG-MSP-SP//  
TO AIG 7573  
INFO RUEADWD/CA WASH DC//CALC-ZXT//  
BT

UNCLAS

SUBJ: ACCOUNTABILITY OF ORGANIZATIONAL CLOTHING AND INDIVIDUAL  
EQUIPMENT (CTA-5C-9CC), INTERIM CHANGE TO AR 710-2, W/C4 NUMBER 5-2  
THIS IS A PROPER COLM MESSAGE

A. DA DALO-ZXT 091510Z MAY 78 (U)

1. SOME PARTS OF REF MSG NEED CLARIFICATION PRIOR TO THE 1 JULY  
IMPLEMENTATION DATE.

2. THIS CLARIFICATION WILL BE PROVIDED ON OR ABOUT 6 JUNE.  
INTERIM QUESTIONS, IF ABSOLUTELY NECESSARY, WILL BE ADDRESSED  
TO ATLG-MSP-SP, ATTN: MR NURTH, AUTUVEN 680-2702/3703.

BT

ACTION ADDRESSEES

006 CALO

00006 TOTAL NUMBER OF COPIES REQUIRED

#5140

\*\*\*\*\*  
\* UNCLASSIFIED \*  
\*\*\*\*\*

PAGE 01  
252200Z MAY 78  
RUCLAIA/5140

\*\*\*\*\*  
 \* UNCLASSIFIED \*  
 \*\*\*\*\*

DEPARTMENT OF THE ARMY  
 PENTAGON TELECOMMUNICATIONS CENTER

CDSN = SCD719 MCA = 7E14E/227E1 TOR = 781102322  
 RTTUZYUW RUEADWD1340 1462303-UULU--RUEAPP?  
 ZNR UUUUU  
 R 261947Z MAY 78  
 FM DA WASHDC //D/LC-SPU//  
 TO RUKLDAR/CDRDARCCP ALEX VA //DRCMM-MP//  
 INFO RUCLHTB/CDR FGFSCCM FT MCPHERSON  
 RUCLAIA/CDRTRACCC FT MCNELE VA //ATLG-MSP-SP//  
 RUCLAHA/CDRLOGC FT LEE VA //ATCL-MT//  
 RUCLBNB/CDRMRSA LEXINGTON KY //CRXMC-MP//  
 BT

BKS	TA	SM
ZX	LE	SMT
ZXT	TSM	SMS
ZXA	TST	SMM
AV	TSE	SMW
PL	TSP	SML
PLW	TS	SMD
PLS	SAC	RM
PLF	SAB	RMB
PLO	GA	RMO
		RMI
		RMP

UNCLAS

SUBJECT: STANDARDIZATION OF DEFINITIONS AND TITLES

A. MSG, DRCMM-MP, DARCCM, 222115Z MAY 78. B. FONECON BETWEEN MR. HUD

SON, DALC-SML, AND AF. GRAVES, DRCMM-MP, 23 MAY 78, SAB.

1. THIS MSG CONFIRMS, PER REF B, THE DESIRABILITY OF A MEETING, PER REF A, TO DEVELOP FINAL FULLY COORDINATED DEFINITIONS FOR BII AND AAL

AS FURTHER DISCUSSED IN REF B, THE DATES 14 AND 15 JUN 78 INSTEAD OF 1-2 JUN 78 ARE CONCLUDED IN.

BT

ACTION ADDRESSEES

006 DALO

00006 TOTAL NUMBER OF COPIES REQUIRED

#1340

\*\*\*\*\*  
 \* UNCLASSIFIED \*  
 \*\*\*\*\*

PAGE 01  
 261947Z MAY 78  
 RUEADWD/1340



# DISPOSITION FORM

For use of this form, see AR 340-16; the proponent agency is The Adjutant General's Office.

REFERENCE OR OFFICE SYMBOL

DAMO-RQR

SUBJECT

Revision of CTA 50-900 and Consolidation with  
CTA 50-906

TO DALO-ZXT

FROM DAMO-RQR

DATE 30 May 78

CMT 1

Mr. Braswell/vt/76063

1. Reference Ltr (undated) subject as above, with two inclosures.
2. Referenced letter has been reviewed and comment is furnished on inclosure 1.

FOR THE DEPUTY CHIEF OF STAFF FOR OPERATIONS AND PLANS:

1 Incl  
DA Form 2028

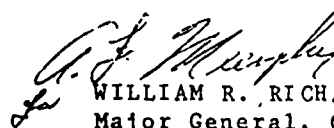
  
WILLIAM R. RICHARDSON  
Major General, GS  
Director of Requirements,  
ODCSOPS

CF:  
DAMO-RQA  
DAMO-"Q"

A. F. MURPHY  
Colonel, GS  
Chief, Requirements Programs  
and Priorities Division  
Requirements Dir, ODCSOPS

233

DA FORM 2496  
1 FEB 62

REPLACES DD FORM 96, EXISTING SUPPLIES OF WHICH WILL BE  
ISSUED AND USED UNTIL 1 FEB 63 UNLESS SOONER EXHAUSTED.

<b>RECOMMENDED CHANGES TO PUBLICATIONS AND BLANK FORMS</b> For use of this form, see AR 310-1; the proponent agency is the US Army Adjutant General Center.						Use Part II (reverse) for Repair Parts and Special Tool Lists (RPSTL) and Supply Catalogs/Supply Manuals (SC/SM).		DATE <b>30 May 78</b>	
TO: (Forward to proponent of publication or form) (Include ZIP Code)						FROM: (Activity and location) (Include ZIP Code)			
DALO-ZXT						DAMO-RQR			
<b>PART I - ALL PUBLICATIONS (EXCEPT RPSTL AND SC. SM) AND BLANK FORMS</b>									
PUBLICATION/FORM NUMBER						DATE		TITLE	
ITEM NO.	PAGE NO.	PARA-GRAPH	LINE NO.*	FIGURE NO.	TABLE NO.	RECOMMENDED CHANGES AND REASON <i>(Exact wording of recommended change must be given)</i>			
						<p style="text-align: center;"><u>GENERAL COMMENT</u></p> <p>Recommend reference to TOE/TDA (Incl 1) be changed to MTOE/TDA</p> <p>Reason: MTOE/TDA are the correct documents that authorize personnel and equipment. MTOE mission may vary from the TOE mission statement.</p>			
<i>*Reference to line numbers within the paragraph or subparagraph.</i>									
TYPED NAME, GRADE OR TITLE						TELEPHONE EXCHANGE AUTOVON, PLUS EXTENSION		SIGNATURE	
Bill Braswell						76063			

DA FORM 2028 Incl 1  
1 FEB 74

REPLACES DA FORM 2028, 1 DEC 66, WHICH WILL BE USED.  
234

# DISPOSITION FORM

For use of this form, see AR 340-15, the proponent agency is TAGCEN.

REFERENCE OR OFFICE SYMBOL	SUBJECT
DALO-TST-B	Revision of CTA 50-900 and Consolidation with CTA 50-906

TO DALO-ZXT FROM DALO-TST DATE 31 MAY 1978 CMT 1  
Mr. Dudding/71411/bc

1. Reference your undated letter subject as above.
2. In response to paragraph 6 referenced letter the attached inclosures have been reviewed for sufficiency and are concurred in by this division.

FOR THE DEPUTY CHIEF OF STAFF FOR LOGISTICS:

1 Incl  
as

  
ROBERT A. STRATI  
Colonel, GS  
Chief, Troop Support Division

DA FORM 2496  
1 FEB 62

REPLACES DD FORM 96, WHICH IS OBSOLETE.

\*\*\*\*\*  
 \* UNCLASSIFIED \*  
 \*\*\*\*\*

DEPARTMENT OF THE ARMY  
 PENTAGON TELECOMMUNICATIONS CENTER

CDSN = SCD174 MCN = 78151/08304 TOR = 78151/304  
 RTTUZYUW RUAGAAA4506 1511153-0000--RUEADWD.  
 ZNR UUUUU  
 R 310805Z MAY 78  
 FM CDR USAEIGHT SECLL KOREA //DJ-MS-SM//  
 TO RUEADWD/DA WASH DC //DALC-SMS/DAMG-FDU/DALO-  
 INFO RUKLDAR/CDR LSALACLP ALEX VA  
 RUAKRFA/CDR 15TH SLFCCMD TAEGU KOREA //EANC-GM-  
 BT

BKS	TA	SM
ZX	LE	SMT
ZXT	TSM	SMS
ZXA	TST	SMM
THCL	TSE	SMW
PL	TSP	SML
PLW	T3	SMD
PLS	SAC	RM
ZXY	SAB	RMB
PLF	SAA	RMC
	SA	RMI
		RMD

UNCLAS

SUBJ: COMMAND STORAGE OF MICE REQUIRED AND AUTHORIZED DIFFERENCES

A. LAST SENTENCE IN PARA 2-5b, AR 710-2, 1 AUG 71 (U)

1. AR 310-34 AND AR 310-45 ALB CLASSIFY MNY ITEMS IN CTAS AS BEING ORGANIZATIONAL PROPERTY. ALSO ALL ITEMS CONTAINED IN CTA 50-900 ARE ORGANIZATIONAL.

2. THE QUESTION HERE IS SHOULD ACT CITED REF BE CHANGED TO PROVIDE FOR COMD STORAGE OF DIFFERENCES BETWEEN REQUIRED AND AUTHORIZED QUANTITIES ( ALL ORGANIZATIONAL PROPERTY AND NOT JUST THAT PROPERTY LISTED IN MICE)

3. PLEASE ADVISE ASAP.

BT

ACTION ADDRESSEES

006 DALO

INFORMATION ADDRESSEES

003 DAPE

012 DAMO

00021 TOTAL NUMBER OF COPIES REQUIRED

#4506

\*\*\*\*\*  
 \* UNCLASSIFIED \*  
 \*\*\*\*\*

PAGE 01  
 310805Z MAY 78  
 RUAGAAA/4506

DAMO-ODO (Undated)

1st Ind

SUBJECT: Revision of CTA 50-900 and Consolidation with CTA 50-906

HQDA, Deputy Chief of Staff for Operations and Plans, Washington, DC 20310

TO: HQDA, Office of the Deputy Chief of Staff for Logistics,  
ATTN: MAJ(P) Roberts, Washington, DC 20310

9 JUN 1978

Reviewed and concur with inclosure to basic correspondence.

FOR THE DEPUTY CHIEF OF STAFF FOR OPERATIONS AND PLANS:

2 Incl  
wd

*for John A. Keutmann*  
JOHN C. FAITH  
Major General, GS  
Director of Operations  
and Readiness

JOHN A. KEUTMANN  
COL, GS  
Assistant Director

\*\*\*\*\*  
 \* UNCLASSIFIED \*  
 \*\*\*\*\*

DEPARTMENT OF THE ARMY  
 PENTAGON TELECOMMUNICATIONS CENTER

WKS	TA	SM
LY	LE	SMT
XI	TCM	SMS
ZXA	TST	SMM
THCL	TTF	SMW
W06	TS	SML
PL	TS	SMD
PLW	SAC	RM
PLS	SAB	RMB
PLR	SAA	RMO
PLF	SA	RMI
PLC		RMP

CDSN = SCD665 MCN = 70100/13530 TCR = 78160  
 RTTUZYUW RUEADWDJ125 16J1659-JUUL--RUEAPP.  
 ZNR UUUUU  
 R 091514Z JUN 78  
 FM DA WASHDC //DALO-SML//  
 TO RUCLAIA/CDRTRADCC FT MONROE VA //ATLG-MSP-SP//  
 RUCLHTB/CDRFORSCOM FT MONROE VA //AFLG-SMS//  
 INFO RUKLCAR/CDRARCOCY ALEX VA //DRUMM-MP//  
 RUCLAHA/CDRLOGC FT LEE VA //ATCL-MT//  
 RUCLBNA/CDRMRSA LEXINGTON KY //LRXMD-MP//  
 BT

UNCLAS

SUBJECT: STANDARDIZATION OF DEFINITIONS AND TITLES

A. MSG, DRCM4-MP, DARCOM, 132030Z APR 78, SUBJ AS ABOVE. B. MSG, ATLG-MSP-SP, TRADCC, 261557Z APR 78, SUBJ AS ABOVE. C. MSG, AFLG-SMS, FORSCOM, 212025Z APR 78, SUBJ AS ABOVE. D. MSG, DRCM4-MP, DARCOM 222115Z MAY 78, SUBJ AS ABOVE. E. MSG, DALO-SML, HQDA, 261947Z MAY 78, SUBJ AS ABOVE.

1. REF A REQUESTED REVIEW OF PROPOSED DEFINITIONS FOR BASIC ISSUE ITEMS (BII) AND ADDITIONAL AUTHORIZATION LIST (AAL). REFS B AND C NONCONCURRED JTF DEFINITIONS PROPOSED IN REF A. REF D SO ADVISED HQDA AND RECOMMENDED DARCOM HOST MEETING 1-2 JUN 78 TO RESOLVE DIFFERENCES/COMMENTS. REF E CONFIRMED DESIRABILITY OF A HQDA, DARCOM, FORSCOM AND TRADCC MEETING AND CHANGED DATES OF 1-2 JUN TO 14, 15 JUN 78.

2. THE PURPOSE OF THIS MSG IS TO REITERATE THE HQDA DESIRE THAT IN ADDITION TO REPRESENTATION BY DARCOM AT THE 14-15 JUN 78 MEETING D; SUBJECT, THAT FORSCOM AND TRADCC PROVIDE REPRESENTATIVES FOR THIS MEETING. THIS MEETING WILL BE CHAIRED BY HQDA DDCSLOG (DALO-SMU FOR THE PURPOSE OF DEVELOPING THE DEFINITIONS FOR BII AND AAL TO BE STAFFED WITH THE POLA STAFF PRIOR TO TAG PRINTING. THIS MEETING WILL CONSTITUTE THE FINAL DA STAFFING WITH MACOMS. YOUR PARTICIPATION IS CONSIDERED ESSENTIAL FOR PREPARATION OF APPROPRIATE DEFINITIONS FOR BII AND AAL FOR HQDA STAFFING.

BT

ACTION ADDRESSEES

006 DALO  
 00006 TOTAL NUMBER OF COPIES REQUIRED  
 #0125

\*\*\*\*\*  
 \* UNCLASSIFIED \*  
 \*\*\*\*\*

PAGE 01  
 091514Z JUN 78  
 RUEADWD/J125

CC-LOG-SMT-SK (25 May 78) 1st Ind  
SUBJECT: Revision of CTA 50-900 and Consolidation with CTA 50-906

Headquarters, US Army Communications Command, Ft. Huachuca, AZ 85613

TO: HQDA (DALO-ZXT) WASH, DC 20310

14 UN 19

The discretionary guidelines are sufficient for general use by commanders and should be utilized.

FOR THE COMMANDER:

wd all incl

  
WILLIAM J. WINDER  
Chief, Supply, Maintenance and  
Transportation Division

\*\*\*\*\*  
 \* UNCLASSIFIED \*  
 \*\*\*\*\*

DEPARTMENT OF THE ARMY  
 PENTAGON TELECOMMUNICATIONS CENTER

CDSN = SCD171 MCN = 78167/08277 TOR = 781671157  
 PTTUZYUW RUAGAAA2286 1670955-UUUU--RLEADWD.  
 ZNR UUUUU  
 P 16J401Z JUN 78  
 FM CDR USAEIGHT SEOLL KOREA//DJ-MS-SM//  
 TO DA WASH DC//CALC-ZXT//  
 BT

UNCLAS

SUBJ; REVISION OF CTA 50-900 AND CONSOLIDATION WITH CTA 50-906  
 A. YOUR LTR CALC-ZXT DATED REC 1 JUN 78 WITH INCL LTR, TRADOC  
 ATCD-S-A, 18 MAY 78, SUBJ; GUIDELINES FOR INDIVIDUAL ISSUR OF  
 DISCRETIONARY ITEMS, CTA 50-900 (U)

1. CONCUR WITH REVISION OF CTA 50-900 AND CONSOLIDATION WITH IN  
 ESTABLISHING BASIC UNIT REQUIREMENTS.
2. ADDITIONALLY, AGREE WITH NEED FOR A STRONG USAGE STATEMENT  
 SIMILAR TO PARA 5 OF TRADOC LTR.

BT

ACTION ADDRESSEES

006 CALO  
 00006 TOTAL NUMBER OF COPIES REQUIRED  
 #2286

BKS	TA	SM
ZX	LE	GMT
ZXT	ISM	GMS
ZXA	TST	SMY
THOL	TSE	SMY
AV	TSP	SMY
HL	TS	SMO
PLW	SC	SM
PLS	SB	SM
PLR	SA	SMO
PLF	SA	SM
PLC	SA	SM

\*\*\*\*\*  
 \* UNCLASSIFIED \*  
 \*\*\*\*\*

PAGE 01  
 160401Z JUN 78  
 RUAGAAA/2286



AFLG-SMS (undated) 1st Ind  
SUBJECT: Revision of CTA 50-900 and Consolidation with CTA 50-906

HQ FORSCOM, Ft McPherson, GA 30330

16 JUN 1978

TO: HQDA (DALO-ZXT), Washington, DC 20310

1. This HQ concurs in the recommended approach outlined in inclosures to basic letter.
2. Recommend the listings at inclosures be further reviewed for climatic zone authorizations, i.e., rationale for cold weather boots recommended in Zone III.

FOR THE COMMANDER:

2 Incl  
nc

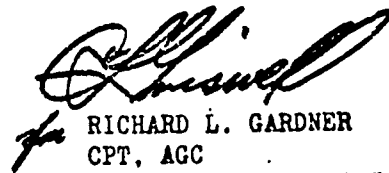

RICHARD L. GARDNER  
CPT, AGC  
Assistant Adjutant General

\*\*\*\*\*  
\* UNCLASSIFIED \*  
\*\*\*\*\*

DEPARTMENT OF THE ARMY  
PENTAGON TELECOMMUNICATIONS CENTER

CDSN = SCD470 MCA = 781701831 TOR = 781701831  
RTTUZYUW RUAGAAA26J3 17J153C-UUUU--KLEADWD.  
ZNR UUUUU  
R 190805Z JUN 78  
FM CDR USAEIGHT SECUL KS//CJ-MS-SM//  
TO RUEMANA/CDR USALEA MAC NEW CUMBERLAND PA//DALC-LER//  
INFO RUEADWD/CA WASH DC//LALO-SMS/DALG-ZXT/DAMO-FDU//  
BT

UNCLAS  
SUBJ: RQR ALW FOR CTA ITEMS  
A. YOUR DALC-LER 09193JZ JUN 78  
B. SUG NO 5A-33-78 W/FIFTH ARMY & FORSCOM EVAL (U)  
1. THIS COMD CONCURS WITH BASIC IDEA OF REF BRAVO. ONE EUSA  
UNIT SURVEYED REGARDING REF BRAVO IS CURRENTLY COMPUTING TOTAL  
CTA REQUIREMENTS.  
2. ONE TRADEOFF TO BE CONSIDERED FOR TOTAL ADOPTION WOULD BE  
ESTABLISHMENT AND MAINTENANCE OF PROPERTY BOOK PAGES FOR TDA AND  
RC UNITS WHICH DO NOT ISSUE ANY CTA ITEMS. FOR THESE UNITS  
PROPERTY BOOK PAGES WOULD BE FOR FUTURE REQUIREMENTS ONLY (NO ON-  
HAND/DUE-IN QUANTITIES).  
BT

ACTION ADDRESSEES  
006 DALC  
INFORMATION ADDRESSEES  
J12 DAMO  
00018 TOTAL NUMBER OF COPIES REQUIRED  
#26J3



\*\*\*\*\*  
\* UNCLASSIFIED \*  
\*\*\*\*\*  
PAGE 01  
190805Z JUN 78  
RUAGAAA/26J3  
242

\*\*\*\*\*  
\* UNCLASS E F T O \*  
\*\*\*\*\*

DEPARTMENT OF THE ARMY  
PENTAGON TELECOMMUNICATIONS CENTER

CDSN = SCD442 MCA = 78172/J1875 TOR = 781720211  
RTTEZYUW RUCLHTA1662 172J101-EEEL--RUEADWD.  
ZNY EEEEE  
R 201150Z JUN 78  
FM CDR FORSCGM FT MC PHERSON GA //AFLG-SMS//  
TO RUEOPIA/CDR USALNE FT MEADE MD//  
RUWTFNA/CDR USAFIVE FT SAM HOUSTON TX//  
RUWMBHA/CDR SASIX SFRAN CA//  
RUHHMA/CDR USASCF FT SHAFTER HI//  
RUWMAEA/CDR 172C INF BDE (AK) FT RILFAR DSON AK//  
INFO RUEADWD/DA WASH DC //DALC-ZXT/DAAR//  
BT

UNCLAS E F T O

THIS IS A PROPER COUNT MESSAGE

SUBJECT: USAR DEVIATION TO PROPER COUNT FLASHER MESSAGE NO. 14.  
A. DALO-ZXT MSG, 091910Z MAY 78, SUBJECT: ACCOUNTABILITY OF  
ORGANIZATIONAL CLOTHING AND INDIVIDUAL EQUIPMENT (CTA 50-900),...  
NUMBER 1-1.

1. REF MESSAGE REQUIRED THAT PROPERTY BOOK ACCOUNTS ABSTRACTING  
CTA 50-900 ITEMS ON CONSOLIDATED DA FORMS 3645 MUST POST THE  
PROPERTY BOOK AT LEAST WEEKLY.

2. EXCEPTION TO THIS WEEKLY REQUIREMENT IS AUTHORIZED FOR USAR  
UNITS. USAR PROPERTY BOOK ACCOUNTS WILL BE POSTED FROM CONSOLI-  
DATED DA FORM 3645 AT LEAST EVERY 60 DAYS.

BT

ACTION ADDRESSEES

006 DALO

INFORMATION ADDRESSEES

006 DAAR

00012 TOTAL NUMBER OF COPIES REQUIRED

#1662

\*\*\*\*\*  
\* UNCLASS E F T O \*  
\*\*\*\*\*

PAGE 01  
201150Z JUN 78  
RUCLHTA/1662

\*\*\*\*\*  
\* UNCLASS E F T O \*  
\*\*\*\*\*

DEPARTMENT OF THE ARMY  
PENTAGON TELECOMMUNICATIONS CENTER

CDSN = 50081 MCA = 78171/14890 TOR = 781712105  
RTTEZYUW RUDHAAA1281 1712015-EEEE--RUEADWD.  
ZNY EEEEE  
R 201759Z JUN 78  
FM CDRINSCOM AHS VA //IALOG-SS//  
TO RUEADWD/DA WASHDC //DALO-2XT//  
BT

UNCLAS E F T O  
SUBJ REVISION OF CTA 50-900 AND CONSOLIDATION WITH CTA 50-906  
A. LTR HQDA, DALO-2XT, DATED 25 MAY 78, SAB.  
1. CONCUR WITH PROPOSALS OUTLINED IN REF ALPHA.  
2. YOUR IDEA OF A SPECIAL SECTION OF CTA 50-900 BREAKING OUT  
DISCRETIONARY ITEMS BY TYPE OF UNIT IS OUTSTANDING.  
BT

ACTION ADDRESSEES

006 DALO  
00036 TOTAL NUMBER OF COPIES REQUIRED  
#1281

NNNN

\*\*\*\*\*  
\* UNCLASS E F T O \*  
\*\*\*\*\*

PAGE 01  
201759Z JUN 78  
RUDHAAA/1281

DAAR-OLP (Undtd) 1st Ind  
SUBJECT: Revision of CTA 50-900 and Consolidation with  
CTA 50-906

HQDA (DAAR) WASH DC 20310 20 JUN 1978

TO: HQDA (DALO-ZXT) WASH DC 20310

Concur. Allowing commanders the latitude to determine minimum essential CTA 50-900 discretionary allowances provides the Army Reserve the necessary equipment to accomplish peacetime training.

FOR THE CHIEF, ARMY RESERVE:

wd incl

  
WALTER TROESCHEL, JR.  
Colonel, GS  
Chief, O & L Division

\*\*\*\*\*  
 \* UNCLASSIFIED \*  
 \*\*\*\*\*

DEPARTMENT OF THE ARMY  
 PENTAGON TELECOMMUNICATIONS CENTER

BKS	TA	BY
ZX	FE	
ZY	FSM	
ZXA	FSM	
ZYB	FSM	
ZYC	FSM	
ZYD	FSM	
ZYE	FSM	
ZYF	FSM	
ZYG	FSM	
ZYH	FSM	
ZYI	FSM	
ZYJ	FSM	
ZYK	FSM	
ZYL	FSM	
ZYM	FSM	
ZYN	FSM	
ZYO	FSM	
ZYP	FSM	
ZYQ	FSM	
ZYR	FSM	
ZYS	FSM	
ZYT	FSM	
ZYU	FSM	
ZYV	FSM	
ZYW	FSM	
ZYX	FSM	
ZYY	FSM	
ZYZ	FSM	

CDSN = SCD837 NCM = 78173/02343 TCR = 781730320  
 RTTUZYUW RUCLAIA/7137 172210Z-0000--KLEADWD.  
 ZNR UUUUU  
 R 212101Z JUN 78  
 FM CDRTRADOC FT MCNRCE VA //ATLG-MUP-S//  
 TO AIG 7573

INFO: RUEADWD/HQDA WASHDC //DALC-TSE//  
 THIS IS PROPER CCNT MESSAGE.  
 SUBJ: ACCOUNTABILITY OF ORGANIZATION OF ORGANIZATIONAL CLOTHING AND I  
 INDIVIDUAL  
 EQUIPMENT (CTA 50-900), INTERIM CHANGE TO AR 710-2 W/C4 NUMBER  
 5-2

- A. DA DALO-ZXI 0919ICZ MAY 78.
- B. TRADOC ATLG-MSP-MSP-SP 252200Z MAY 78
- C. FONECCN LTC SAULNIER HQDA AND MK NORTH TRADOC 7 JUN 78
- 1. THE CLARIFICATION/IMPLEMENTATION TO REF A BY REF B IS PROVIDED AS FOLLOWS.
- 2. REF A IS YCLRS FOR ACTION WITH THE FOLLOWING CHANGES\*  
 A. PARA 2A CHANGE "... ENLISTED INDIVIDUALS WILL...."  
 TO "...ENLISTED INDIVIDUALS MAY...."  
 B. PARA 6, CHANGE"...THE NEW CUSTODIAN...OLD CUSTODIAN  
 ...." TO...THE NEW COMMANDER...OLD COMMANDER...."
- 3. THE PROCEDURES OF THIS MESSAGE WITH CHANGES WILL BE MADE PERMANENT WITH THE EFFECTIVE PUBLICATION OF CG, AR 710-2 AND DA PAM 600-8-10.
- 4. THE INTENT OF REF A IS THAT THE FOUR ITEMS OF CTA 50-900 EQUIPMENT ISSUED BY THE CIIP WILL NOT BE ENTERED ON THE ORGANIZATION PROPERTY BOOK BUT WILL BE ENTERED ONCE AND WILL REMAIN ON THE INDIVIDUAL'S JA FORM 3645. THESE FOUR ITEMS ARE THE BARRACKS BAG, COLD WEATHER CAP, COLD WEATHER COATS, AND ANODIZED BELT BUCKLE.
- 5. TRADOC POC IS MR. JAMES NORTH, ATLG-MCP-S, AUTOVON 680-3589/2974.

BT

ACTION ADDRESSEES  
 006 CALO  
 INFORMATION ADDRESSEES  
 001 AFLO/ATLU  
 0007 TOTAL NUMBER OF COPIES REQUIRED  
 #7137

DASG-HCD (Undtd) 1st Ind  
SUBJECT: Revision of CTA 50-900 and Consolidation with CTA 50-906

DA, OTSG, WASH DC 20310 26 JUN 1978

TO: HQDA (DALO-ZXT), WASH DC 20310

1. The proposal to include in CTA 50-900 lists of minimum essential discretionary organizational clothing and equipment for individuals by unit category and climatic zone has merit.
2. Recommend the inclosed HSC guidelines for individual issue medical units/organizations be consolidated with TRADOC guidelines for individual issue items common to all units/organizations. This list will establish guidelines to assist commanders of all units in authorizing minimum essential discretionary organizational clothing and equipment.
3. The HSC and TRADOC lists do not include female clothing. Therefore, proposed lists of clothing and equipment for women in medical units/organizations are attached (Incl 3, 4 and 5).

FOR THE SURGEON GENERAL:

- 5 Incl  
Added 3 incl
3. Indiv issue to women  
(excluding nurses)
  4. Indiv issue (nurses) -  
discretionary
  5. Indiv issue (nurses) -  
mandatory

  
QUINN H. BECKER, M.D.  
Brigadier General, MC  
Director, Health Care Operations

GUIDELINES FOR INDIVIDUAL ISSUE TO MEN (INCLUDING NURSES)  
MEDICAL UNITS/ORGANIZATIONS

The following allowances are established as guidelines to assist commanders in authorizing minimum essential discretionary organizational clothing and equipment to individuals to medical units/organizations.

CATEGORY	LINE NO. AND ITEM	Climatic Zone Allowances						
		I	II	III	IV	V	VI	VII
II &	B59567 Belt Individ Equip: Webbing OD	1	1	1	1	1	1	1
III	D64043 Case Field First Aid Dressing	1	1	1	1	1	1	1
	D73323 Suspenders Field Pack (Used with B59567)	1	1	1	1	1	1	1
	C08119 Boots Cold Weather			1	1	1		
	C07440 Boot Hot Weather	1	1					
	C08256 Boots Extreme Cold Weather							1
	B15825 Bag Waterproof Clothing: Coated Cotton	1	1	1	1	1	1	1
	C96536 Canteen Water: Plastic	1	1	1	1	1	1	1
	C96810 Canteen Water: Steel							1
	D01695 Cap Garrison: Wool Serge OB 108			1	1	1	1	1
	D01857 Cap Cold Weather: Cotton Nylon			1	1	1	1	1
	D03750 Cap Hot Weather	1	1					
	E45563 Coat Womens: Wool Serge OG 108			1	1	1	1	1
	F29980 Cover Water Canteen: Cold Climate							1
	G49350 Drawers Cold Weather Mens 50 Cotton 50 Wool Knit ankle length			2	2	2	2	2
	F30391 Cover Water Canteen: Webbing OD 7	1	1	1	1	1	1	1
	F54680 Cup Water Canteen: Cold Climate					1	1	1
	F54817 Cup Water Canteen: Steel	1	1	1	1	1	1	1
	H93071 Fork Field Mess	1	1	1	1	1	1	1
	K34733 Helmet Ground Troops: Steel OG	1	1	1	1	1	1	1

*File 13*



GUIDELINES FOR INDIVIDUALS AND UNITS TO ASSIST COMMANDERS IN AUTHORIZING MINIMUM ESSENTIAL DISCRETIONARY ORGANIZATIONAL CLOTHING AND EQUIPMENT TO INDIVIDUALS TO MEDICAL UNITS/ORGANIZATIONS

The following allowances are established as guidelines to assist commanders in authorizing minimum essential discretionary organizational clothing and equipment to individuals to medical units/organizations

CATEGORY	LINE NO. AND ITEM	Climate Zone Allowances							
		I	II	III	IV	V	VI	VII	
II & III	K71200 Liner Ground Troops Helmet	1	1	1	1	1	1	1	
	K35007 Helmet Sun: Adjustable Chin Strap	1	1	1					
	K46058 Hood Extreme Cold Weather					1	1	1	
	L70172 Liner Cold Weather Coat: Nylon Quilted			1	1	1	1	1	Note
	L70720 Liner Extreme Cold Weather Parka: Mans Nylon Quilted					1	1	1	
	L72022 Liner Cold Weather Trousers Nylon					1	1	1	Note
	M17642 Mattress Pneumatic: Nylon Coated	1	1						
	M52555 Mitten Inserts: Wool and Nylon					1	1	1	
	M53240 Mitten Shells					1	1	1	
	M52829 Mitten Set Arctic					1	1	1	Note
	M52966 Mitten Shells Cotton White					1	1	1	Note
	M53240 Mitten Shells: Trigger Finger Leather Palm					1	1	1	Note
	N37752 Overalls Wet Weather: Coated Nylon Green			1	1	1	1	1	Note
	N40396 Overshoes: High Black Vinyl Plastic			1	1	1	1	1	
	N53095 Pan Mess Kit	1	1	1	1	1	1	1	
	N69836 Parka Snow Camouflage: White					1	1	1	Note
	N69904 Parka Extreme Cold Weather: Man's Cotton Nylon					1	1	1	
N70110 Parka Wet Weather: Coat Style			1	1	1	1	1	Note	

GUIDELINES FOR INDIVIDUAL ISSUE TO WOMEN (EXCLUDING RESERVE)  
IN MEDICAL UNITS/ORGANIZATIONS

The following allowances are established as guidelines to assist commanders in authorizing minimum essential discretionary organizational clothing and equipment to individuals to medical units/organizations:

CATEGORY	LINE NO. AND ITEM	Climate Zone Allowances							
		I	II	III	IV	V	VI	VII	
II & III	P17415 Poncho: Coated Nylon OG	1	1	1	1	1	1	1	
	T05575 Shirt Cold Weather, Wool Flannel OG 108			2	2	2	2	2	
	T67108 Shirt Womens: Wool Serge OG 108			1	1	1	1	1	
	T71673 Sleeping Bag: Universal Type 1	1	1	1	1	1	1	1	
	T71706 Sleeping Bag: Universal Size Type 2					1	1	1	
	T68519 Slacks Utility Wool Serge OG 108			2	2	2	2	2	
	U06645 Spoon Field Mess: Unplated C25	1	1	1	1	1	1	1	
	U73597 Suspender Trousers: Scissors Back Type					1	1	1	
	X35057 Trousers Camouflage: Cotton Nylon White					1	1	1	Note 1
	X36109 Trousers Extreme Cold Weather: Cotton Nylon					1	1	1	
	X37180 Trouser Cold Weather, Wool			2	2	2	2	2	Note 1
	X86839 Undershirt Mens: 50 cotton 50 wool full sleeve			2	2	2	2	2	
**	E45090 Coat Cold Weather	1	1	1	1	1	1	1	
	K46083 Hood Cold Weather (Coat LIN E45090)			1	1	1	1	1	
	L70378 Liner Cold Weather (Coat LIN E45090)			1	1	1	1	1	
**	Substitution of another Coat for this one should be coordinated with TSG.								

Note 1: Because of the assignment of women to different type of medical activities, the determination to issue white mittens, Parkas and trousers, Parka wet weather coat, over-all wet weather, trouser and liners cold weather must be based on local climatic conditions. Note 2: To be issued only if men's cold weather coat has been issued.

GUIDELINES FOR INDIVIDUAL ISSUE (NURSES)  
MEDICAL UNITS/ORGANIZATIONS

The following allowances are established as guidelines to assist commanders in authorizing minimum essential discretionary organizational clothing and equipment to individuals in medical units/organizations.

CATEGORY	LINE NO. AND ITEM	Climatic Zone Allowances							REMARKS
		I	II	III	IV	V	VI	VII	
I & III	B59567 Belt Individ Equip: Webbing OD	1	1	1	1	1	1	1	
	D64043 Case Field First Aid Dressing	1	1	1	1	1	1	1	
	U73323 Suspenders Field Pack (Used with B59567)	1	1	1	1	1	1	1	
	B15825 Bag Waterproof Clothing: Coated Cotton	1	1	1	1	1	1	1	
	C08119 Boots Cold Weather			1	1	1	1		
	C07440 Boot, Hot Weather	1	1						
	C08256 Boots Extreme Cold Weather							1	
	C96536 Canteen Water: Plastic	1	1	1	1	1	1	1	
	C96810 Canteen Water: Steel							1	
	D01857 Cap Cold Weather: Cotton Nylon			1	1	1	1	1	
	D03750 Cap Hot Weather	1	1						
	F29980 Cover Water Canteen: Cold Climate							1	
	F30391 Cover Water Canteen: Webbing OD 7	1	1	1	1	1	1	1	
	F54680 Cup Water Canteen: Cold Climate							1	
	F54817 Cup Water Canteen: Steel	1	1	1	1	1	1	1	
	H93071 Fork Field Mess	1	1	1	1	1	1	1	
	K34733 Helmet Ground Troops: Steel OG	1	1	1	1	1	1	1	
	VK71200 Liner Ground Troops Helmet	1	1	1	1	1	1	1	
	K33007 Helmet Sun: Adjustable Chin Strap	1	1	1					
	K46058 Hood Extreme Cold Weather					1	1	1	
	L70172 Liner Cold Weather Coat: Nylon Quilted			1	1	1	1	1	Note 2

Incl 4

GUIDELINES FOR AUTHORIZING (AR 600-10)  
MEDICAL UNITS/ORGANIZATIONS

The following allowances are established as guidelines to assist commanders in authorizing minimum essential discretionary organizational clothing and equipment to individuals to medical units/organizations.

CATEGORY	LINE NO. AND ITEM	Climatic Zone Allowances							REMARKS
		I	II	III	IV	V	VI	VII	
II & III	L70720 Liner Extreme Cold Weather Parka: Mans Nylon Quilted					1	1	1	
	✓L72022 Liner Cold Weather Trousers Nylon					1	1	1	Note 1
	M17642 Mattress Pneumatic: Nylon Coated	1	1						
	M52555 Mitten Inserts: Wool and Nylon					1	1	1	
	M53240 Mitten Shells					1	1	1	
	M52829 Mitten Set Arctic					1	1	1	Note 1
	M52966 Mitten Shells Cotton White					1	1	1	Note 2
	M53240 Mitten Shells: Trigger Finger Leather Palm					1	1	1	Note 2
	N53095 Pan Mess Kit	1	1	1	1	1	1	1	
	N69836 Parka Snow Camouflage: White					1	1	1	Note
	N69904 Parka Extreme Cold Weather: Man's Cotton Nylon					1	1	1	
	P171415 Poncho: Coated Nylon OG	1	1	1	1	1	1	1	
	T71673 Sleeping Bag: Universal Type 1	1	1	1	1	1	1	1	
	T71706 Sleeping Bag: Universal Size Type 2					1	1	1	
	U06645 Spoon Field Mess: Unplated C25	1	1	1	1	1	1	1	
	U73397 Suspender Trousers: Scissors Back Type					1	1	1	
X35057 Trousers Camouflage: Cotton Nylon White					1	1	1	Note	
X36109 Trousers Extreme Cold Weather: Cotton Nylon					1	1	1		

Note 1: Determination of the issue of these articles must be based on local climatic condition.

Note 2: To be issued if men's field jacket has been issued in place of women's.

SUPPLIES FOR INDIVIDUAL ELEMENT ISSUE (NURSES)  
MEDICAL UNITS/ORGANIZATIONS

The following allowances are established as guidelines to assist commanders in authorizing minimum essential mandatory organizational clothing and equipment to individuals to medical units/organizations.

CATEGORY	LINE NO. AND ITEM	Climatic Zone Allowances						
		I	II	III	IV	V	VI	VII
I & III	B14729 Bag Duffel: Cotton Duck	2	2	2	2	2	2	2
	D01969 Cap Nurse: Cotton Broadcloth White	2	2	2	2	2	2	2
	D01695 Cap Garrison: Wool Serge OG 108			1	1	1	1	1
	D01857 Cap Cold Weather: Cotton Nylon			1	1	1	1	1
**	F45090 Coat Cold Weather: Women's GIN /Nylon with Resistant Sateen OG 107	1	1	1	1	1	1	1
	E45563 Coat Womens: Wool Serge OG 108			1	1	1	1	1
	K46083 Hood Cold Weather (Coat lin E45090)			1	1	1	1	1
	L70378 Liner Cold Weather (Coat lin E45090)			1	1	1	1	1
	N40396 Overshoes High Black			1	1	1	1	1
	O5575 Shirt Womens: Wool Flannel OG 108			2	2	2	2	2
	P67108 Shirt Womens: Wool Serge OG 108			1	1	1	1	1

GUIDELINES FOR INDIVIDUAL MANDATORY ISSUE (NURSES)  
MEDICAL UNITS/ORGANIZATIONS

The following allowances are established as guidelines to assist commanders in authorizing minimum essential mandatory organizational clothing and equipment to individuals to medical units/organizations.

CATEGORY	LINE NO. AND ITEM	Climatic Zone Allowances							REMARKS
		I	II	III	IV	V	VI	VII	
II & III	T68519 Slacks Utility-Wool Serge OG			2	2	2	2	2	
	X86702 Undershirt Mens Cotton White Pullover Quarter Length Sleeves			2	2	2	2	2	
	X86839 Undershirt Mens 50 Cotton 50 Wool Full Sleeves			2	2	2	2	2	
	G49350 Drawers Cold Weather: Mens 50 Cotton 50 Wool Knit Ankle Length			2	2	2	2	2	
	G51857 Dress Womens: CTN/Poly Bengaline White Hospital Duty and 85909N Pantsuit: Womens Poly White	8	8	8	8	8	8	8	
**	Substitution of another coat for this one should be coordinated with TSG.								

## Chapter 10

### Supply Publication Change

1. Recommendation 6F. Implement a management of change system which brings supply publications under the same discipline as that recently established for TAADS changes.

	<u>Volume</u>	<u>Page</u>
2. DAPATF actions:		
a. Proper Count Flasher Message No. 11, DTG 012007Z Feb 78, Supply Publication Change Procedures.	2	9
b. Proper Count Message, DTG 272020Z Mar 78, Supply Publication Change Procedures.	2	62
c. DF, 3 Feb 78, Project Proposal: Supply Publication Management of Change Study.	2	133
d. Letter, 15 Feb 78, DLOGS Program Review.	2	141
e. Letter, 23 Feb 78, Revision to AR 310-1, AR 310-2, and AR 310-3.	2	163
f. Letter, 24 Feb 78, Administrative Control of Supply Publication Change.	2	175
g. Indorsement, 7 Mar 78, Project Proposal: Supply Publication Management of Change Study.	2	183
h. Proper Count Message, DTG 011325Z May 78, Supply Publications Change Procedures.	3	32
i. Proper Count Message, DTG 101652Z May 78, Supply Publication Change Procedures.	3	36
j. DF, 19 May 78, Approval of TRADOC Supplement 1 to AR 710-1 (Draft).	3	95

3. MACOM responses:	<u>Page</u>	<u>Tasking Ref</u>
a. Message, CDR DARCOM, DTG 051915Z Apr 78, Supply Publication Management of Change Study.	259	2g
b. Message, CDR TRADOC, DTG 080254Z Apr 78, Supply Publications Change Procedure.	260	2a
c. Message, CDR EUSA, DTG 140803Z Apr 78, Supply Publication Management of Change Study.	261	2g
d. Message, CDR MRSA, DTG 241930Z Apr 78, Supply Publications Change Procedures.	262	2a
e. CMT 2, USALEA, 26 Apr 78, Supply Publications Management of Change Study IPR.	263	2c
f. Letter, FORSCOM, 27 Apr 78, Supply Publications Change Procedures.	264	2a
g. Letter, Health Services Command, 28 Apr 78, Supply Publication Change Procedures.	266	2a
h. Message, CDR USARJ, DTG 280808Z Apr 78, Supply Publication Change Procedures.	268	2a
i. Letter, CDR EUSA, 2 May 78, Supply Publication Change Procedures.	269	2a
j. Letter, Deputy C/S MDW, 3 May 78, Supply Publications Change Procedures.	270	2a
k. Message, CDR TRADOC, DTG 041839Z May 78, Supply Publications Change Procedures.	271	2a
l. Message, CDR MRSA, DTG 041745Z May 78, Supply Publication Change Procedures.	272	2a
m. Message, CDR DARCOM, DTG 051910Z May 78, Supply Publication Change Procedures.	274	2a
n. Message, CDR MTMC, DTG 121245Z May 78, Supply Publication Change Procedures.	275	2a



	<u>Page</u>	<u>Tasking Ref</u>
o. Letter, HQ USAREUR, 16 May 78, Supply Publication Change Procedures.	276	2a
p. Message, CINCUSAREUR, DTG 231349Z May 78, Interim Change to 710-1.	284	2a
q. Letter, DARCOM, 14 Jun 78, Draft TRADOC Supplement 1 to AR 710-1.	285	2j

SUPPLY PUBLICATION CHANGE CONTROL

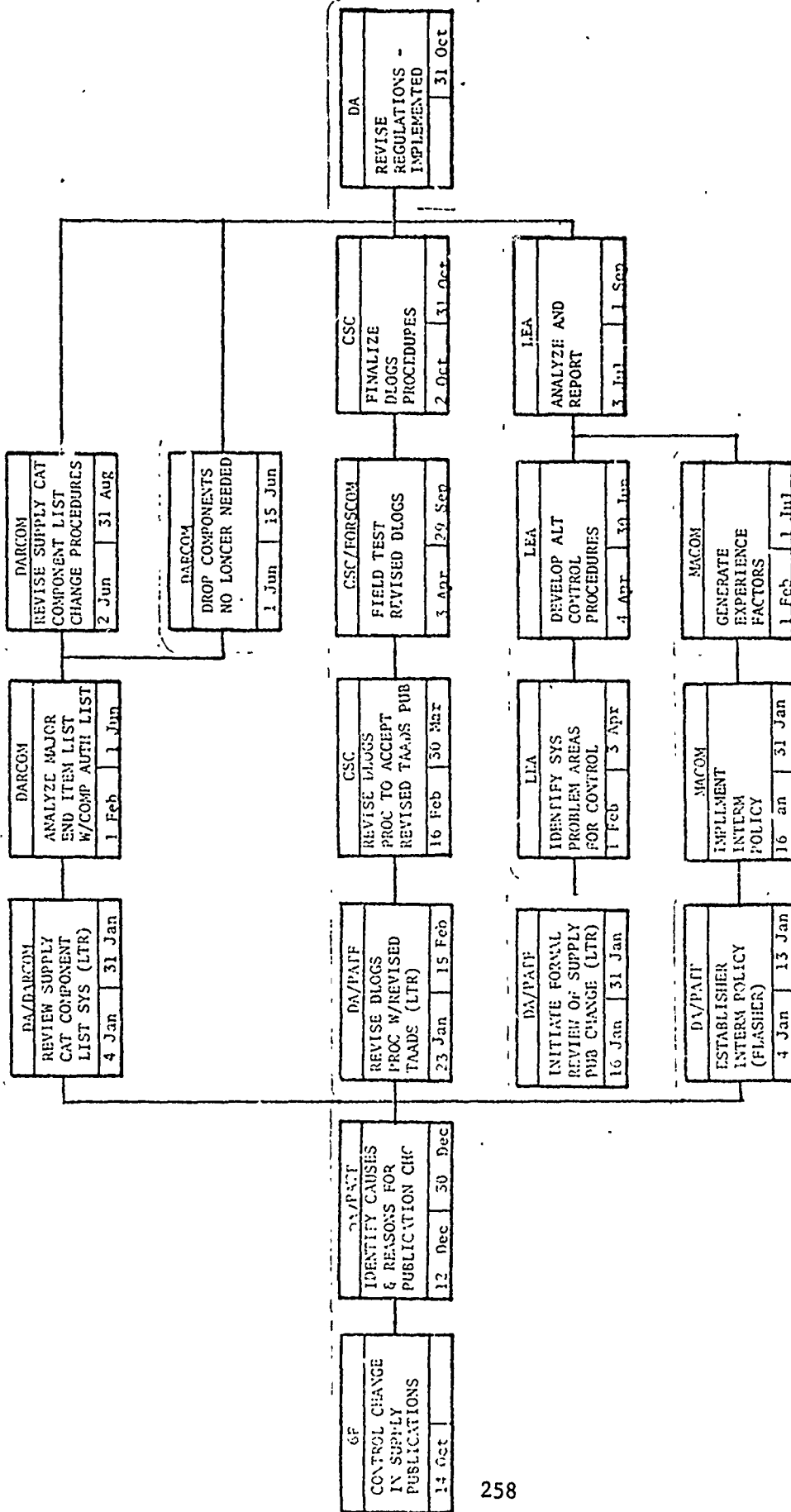

DEPARTMENT OF THE ARMY  
PENTAGON TELECOMMUNICATIONS CENTER

CDSN = SC0023 MCN = 73006/C2861 TOR  
RTTUZYUW RUKLDAR0482 0951019-UUUU--RUEADW  
ZNR UUUUU  
R 051915Z APR 78  
FM CDRDARCCM ALEX VA//DRCMM-SP//  
TO RUEMANA/CORUSALEA (CJ) PA//CALC-LER//  
INFO RUEADWC/DA WASHDC//CALC-SMZ/CALC-ZX1  
BT

ZXA	TRM	SMI
ZXA-C	TRM	SMI
AV	TRM	SMI
PLS	TRM	SMI
PLW	SAI	SMI
LR	SAI	SMI
LF	SA	SMI
LO		RMP

UNCLAS

SUBJ: SUPPLY PUBLICATION MANAGEMENT OF CHANGE STUDY

A. DALG-LER MSG JTD 222005Z MAR 78 (U).

B. FCNECCN BETWEEN MR. CHRISTENSEN OF YOUR AGENCY AND MRS. CARYL VETH THIS HEADQUARTERS ON 4 APRIL 1978.

1. PARA 1 OF REF A CITED PERTINENT ARMY REGULATIONS TO BE ANALYZED IN DETAIL UNDER SUBJ STUDY. FOL INFO IS PROVIDED FOR YOUR GUIDANCE IAW REF B:

A. AR 700-120. ALTHOUGH NOT OFFICIAL AS YET, DARCCM IS NO LONGER THE PROPONENT FOR THIS AR. THE PROPONENT IS DALG-SMD. A COMPLETE REVISION OF THIS AR IS CURRENTLY BEING STAFFED BY DALG-LER LET 3 DATED 17 FEB 78, SUBJ: SECOND DRAFT REVISION OF AR 700-120. PL AT LEA IS MAJOR THOMAS HICKS, EXTENSION 6930.

B. AR 708-7. PROVISIONS OF THIS REGULATION HAVE BEEN INCORPORATED INTO CHAP 4, DOD 4140.26-M, VOL 1, DEFENSE INTEGRATED MATERIEL MANAGEMENT MANUAL FOR CONSUMABLE ITEMS, WHICH IS SCHEDULED FOR PUBLICATION ON 1 MAY 1978. THIS AR WILL BE SUPERSEDED AND CANCELLED WITH THE PUBLICATION OF DOD 4140.26-M.

C. SAR 755-2. CHAPTER 2 HAS BEEN CANCELLED AND THE TEXT HAS BEEN INCLUDED IN AR 700-99. CHAP 4 IS THE ONLY CHAP LEFT. DALG-SMS, BY 1ST IND DTD 27 MAR 78 HAS CONCURRED IN DARCCM RECOMMENDATION FOR A SEPARATE AR TO ENCOMPASS POLICY NOW CONTAINED IN CHAP 4. IN ADDITION, DA REQUESTED ACTION BE INITIATED TO REPRINT AR 755-2, WITH CONTENTS TO CONSIST OF POLICY NOW CONTAINED IN CHAP 4. CHAP 5 ALREADY COVERED BY PARA 5-139 OF AR 710-2. A LETTER WAS SENT TO TAGEN 9 FEB 78 RECOMMENDING THAT CHAP 5 BE RESCINDED.

2. IN RESPONSE TO PARA 2 OF REF A, COPIES OF CITED ARS WHERE DARCCM WAS SHOWN AS THE PROPONENT WILL BE FORWARDED THIS DATE UNDER SEPARATE COVER, EXCEPT FOR AR 708-1. AR IS NOT AVAILABLE AT PUBLICATIONS; HOWEVER, REQUEST IS ON ORDER AND WILL BE FORWARDED UPON RECEIPT FROM AG PUBLICATIONS CENTER.

BT

\*\*\*\*\*  
\* UNCLASSIFIED \*  
\*\*\*\*\*

PAGE 01  
C51915Z APR 78  
RUKLDAR/C482

\*\*\*\*\*  
\* UNCLASSIFIED \*  
\*\*\*\*\*

DEPARTMENT OF THE ARMY  
PENTAGON: TELECOMMUNICATIONS CENTER

QJDN = SCDS . MLN = 78098/10M5E TOR = 780981634  
RTTCZYUW RUCLAIA1200 0980255-UUUU--RUEADWD.  
ZNR UUUUU  
R 080254Z APR 78  
FM CONTRADCC FT MONROE VA //ATLG-MSP-SP//  
TO HQDA WASHDC //DALO-ZXT//  
BT

REC'D  
P.L.  
P.L.O.

UNCLAS

THIS IS A PROPER COUNT MESSAGE  
SUBJ: SUPPLY PUBLICATIONS CHANGE PROCEDURE  
A. HQDA DALO-ZXT 012007Z FEB 78 (U)  
B. HQDA CAMO-FDU 042142Z APR 78 INTERIM CHANGE TO CTA 50-906 FOR  
ALL PURPOSE LIGHTWEIGHT INDIVIDUAL CARRYING EQUIPMENT (ALICE)(U)  
1. REF A ESTABLISHED NEW GROUND RULES FOR CHANGES TO SUPPLY  
PUBLICATIONS. REF B IS THE LATEST ELECTRICAL MESSAGE CHANGE TO  
A COMMON SUPPLY PUBLICATION.  
2. SEVERAL RECENT HQDA MESSAGE CHANGES TO SUPPLY PUBLICATIONS  
HAVE NOT CONFORMED TO INSTRUCTIONS OF REF A. THIS HAS RESULTED IN  
DEROGATORY FIELD COMMENTS. REQUEST YOUR ASSISTANCE IN UPHOLDING  
CREDIBILITY OF THE IMPORTANT "PROPER COUNT" INITIATIVE.  
BT

ACTION ADDRESSEES .

- 006 DALO
- INFORMATION ADDRESSEES
- 003 DACA
- 002 DAMA
- 012 DAMC
- 002 NGB
- 001 AFLC/ATLG
- 00026 TOTAL NUMBER OF COPIES REQUIRED
- #1200

\*\*\*\*\*  
\* UNCLASSIFIED \*  
\*\*\*\*\*  
260

PAGE 01  
080254Z APR 78  
RUCLAIA/1200

\*\*\*\*\*  
 \* UNCLASSIFIED \*  
 \*\*\*\*\*

DEPARTMENT OF THE ARMY  
 PENTAGON TELECOMMUNICATIONS CENTER

CDSN = SCC524 MCM = 78104/C8875 TOR = 781041307  
 RTTUZYLW RLAGAAA2055 1041+0C-LLLL--RUEACWC.  
 ZNR UUUUU  
 R 140803Z APR 73  
 FM CDR USAEIGHT SEJUL KOREA//DJ-MS-SM//  
 TO RUEMANA/CCR USALEA NCAD NEW CUMBERLAND PA//DALC-LER//  
 INFO RUEACWC/DA WASHDC//CALC-ZXT//  
 BT

UNCLAS  
 SUBJ: SUPPLY PUBLICATION MANAGEMENT OF CHANCE STUDY (S: 14 APR 78)  
 A. YOUR DALC-LER 222000Z MAR 78 (L)  
 SUPPLEMENTS, DIRECTIVES, AND CORRESPONDENCES AFFECTING ARS IN PARA 1  
 OF CITED REF WILL BE DISPATCHED VIA FIRST CLASS MAIL NLT 17 APR 78.  
 BT

ACTION ADDRESSEES

006 DALC

00006 TOTAL NUMBER OF COPIES REQUIRED

#2065

BKS	THCL	SM
ZX	TA	SMT
ZXT	LE	SMS
ZXA	TSM	STM
ZXA-C	TST	STV
AV	TTM	TMU
PL	TTT	TUW
PLS	TTU	TUX
PLV	TTV	TUY
PLR	TTW	TUZ
PLF	TTX	TVA
PLO	TTY	TVB

NNNN

\*\*\*\*\*  
 \* UNCLASSIFIED \*  
 \*\*\*\*\*

PAGE C1  
 140803Z APR 73  
 RUAGAAA/2065

\*\*\*\*\*  
 \* UNCLASS. IED \*  
 \*\*\*\*\*

BND	TUCI	
ZX		
ZY		
ZXA		
PLS		
PLW		
PLR		
PLF		
PLO		

DEPARTMENT OF THE ARMY  
 PENTAGON TELECOMMUNICATIONS CENTER

CDSN = SCD653 MCN = 78114/10710 TORAL 781142013  
 RTTUZYUW RUCLBNA3490 1141957-UUUU--RUEADWD  
 ZNR UUUUU  
 R 241930Z APR 78  
 FM CCR MRSA LEX KY //DKXMD-SS//  
 TO RUEADWD/DA WASH DC //DALO-ZXT/DALO-SMS//  
 INFO RUKLDAR/CDR DARCOM ALEX VA //DRCMM-SP//  
 BT

UNCLAS  
 SUBJ: SUPPLY PUBLICATIONS CHANGE PROCEDURES.

- A. YCUR 012007Z FEB 78 (U).
1. REFERENCED MESSAGE PROVIDES GUIDANCE PERTAINING TO REGULATORY CHANGES AND IS PROPER COUNT FLASHER MESSAGE NR 11.
  2. THE RESTRICTIONS IMPOSED BY THIS MESSAGE DOES NOT ALLOW THIS ACTIVITY TO PERFORM ITS MISSION PERTAINING TO CODE ASSIGNMENTS THAT WILL EVENTUALLY BE PUBLISHED IN AR 725-50.
  3. CCDES SIGNIFICANT TO INTRA ARMY REQUIREMENTS AS INDICATED BY REFERENCED MESSAGE ARE TO BE PUBLISHED WITH A MINIMUM FREQUENCY OF SEMI-ANNUALLY. THIS IS TO BE ACCOMPLISHED UTILIZING FORMAL CHANGES TO REGULATIONS.
  4. THE ABOVE POLICY PREVENTS THIS ACTIVITY FROM ASSIGNING DOCUMENT IDENTIFIER CODES, ROUTING IDENTIFIER CODES, DISTRIBUTION CODES, AND WEAPONS SYSTEMS DESIGNATOR CODES ON AN AS REQUIRED BASIS TO SUPPORT CCSS, SAILS, DS-4 AND OTHER INTERNAL ARMY SYSTEMS. ADDITIONALLY THIS LIMITS OUR ABILITY TO SUPPORT MATERIEL READINESS REQUIREMENTS AND INTURN LIMITS DARCOM MRC'S ABILITY TO DETERMINE WHAT ITEMS OF SUPPLY ARE HAVING ON ADVERSE EFFECT ON THE ARMY'S OPERATIONS READINESS GOALS.
  5. REQUEST THAT A REVIEW OF THE POLICY AND GUIDANCE CONTAINED IN REFERENCE MESSAGE BE MADE AND THAT THIS ACTIVITY BE GIVEN THE AUTHORITY TO CONTINUE MAKING MESSAGE CHANGES TO AR 725-50 AND AR 710-2, AS REQUIRED OF THE CODES INDICATED ABOVE.
  6. THIS ACTIVITY'S POINT OF CONTACT CONCERNING THE ABOVE ACTION IS MR EDWIN LUY, AUTOVON: 745-3686/3893.

BT  
 ACTION ADDRESSEES  
 006 DALO  
 00006 TOTAL NUMBER OF COPIES REQUIRED  
 #3490

\*\*\*\*\* PAGE 01  
 \* UNCLASSIFIED \* 241930Z APR 78  
 \*\*\*\*\* RUCLBNA/3490

DALO-LER (21 Apr 78)

SUBJECT: Supply Publications Management of Change Study IPR

TO DALO-ZXT

FROM USALEA

DATE 26 APR 1978 CMT 2  
Mr. Christensen/jcn/6930

Data requested in paragraph 2, Comment 1, follows:

<u>AR</u>	<u>No. of Changes</u>	<u>Date of Basic</u>	<u>Date of Last Change</u>	<u>Elapsed Period (Months)</u>	<u>Mean Time (Months)</u>	<u>EST. NO. AVG</u>
700-84	4	Jan 74	Sep 76	32	8	.7
700-120	2	Mar 74	Feb 75	11	6	1
708-1	18	Dec 70	Jan 77	73	4	1.5
708-7	1	Oct 74	Feb 76	16	16	.3
710-2	4	Aug 71	Apr 77	68	17	.4
710-3	6	Sep 72	Nov 77	62	10	.6
725-1	1	Jun 77	Oct 77	4	4	1.4
725-50	3	Jun 74	Jun 77	36	12	.5
755-2	2	Jul 70	Mar 74	44	22	.4

FOR THE COMMANDER:

  
ROBERT E. GOODWIN  
Colonel, GS  
Chief, Logistic Operations  
and Readiness Division



DEPARTMENT OF THE ARMY  
HEADQUARTERS, UNITED STATES ARMY FORCES COMMAND  
FORT MCPHERSON, GEORGIA 30330

AFAG-ASP

27 APR 1978

SUBJECT: Supply Publications Change Procedures

HQDA (DALO-ZXT)  
Washington, DC 20310

1. Reference DA message, 012007Z February 1978, subject as above (Proper Count Flasher Message No. 11).
2. The following comments are provided in accordance with above reference.
  - a. Prior to the dispatch of above reference, the system of changing supply publications was inadequate and caused confusion at unit/activity supply areas. The number of message and letter changes when implemented by installations and other intermediate headquarters, resulted in a volume of correspondence that fell on the unit/activity supply accounts. This called for undue and numerous changes in supply records, many of which were minor and unimportant in nature.
  - b. General consensus of field commanders is that the proposed policy of distributing interim message changes through the pinpoint distribution system is excellent.
3. Specific comments of interest made by field commanders follow:
  - a. Supplements to Supply AR's below the MACOM level should be prohibited. Reason being that all units/activities under command of a MACOM should be following the same procedures.
  - b. The supply field is not the only message change offender. MILPERCEN sends out many message type interim changes to AR's requesting "widest possible dissemination." This requires a "shotgun" approach to reach the holders of a basic AR.
  - c. The current procedure of disseminating information by the "Proper Count, Proper Count Flasher" and interim change message formats have resulted in confusion at the unit level. Each communication from a higher



AFAG-ASP  
SUBJECT: Supply Publications Change Procedures

headquarters results in subsequent implementation by subordinate headquarters. USAADCENFB indicates it has received 33 DA Proper Count Messages, 39 FORSCOM Proper Count Messages, 24 TRADOC Proper Count Messages, and numerous messages from USAFIVE, USASIX, 504th ASA Group, and the 31st ADA Brigade.

d. The 5th Infantry Division (M) and Ft Polk indicates it has a problem similar to c above. Currently, to find an answer to an accountability question, the unit supply representative must research messages, letters, regulations, circulars, supply bulletins, supply catalogs, and local SOP's. In addition, he must consult pamphlets, bulletins and message files to determine if the on-hand publications are current with the appropriate changes.

e. Ineffective distribution of publications changes is reported as being the single most problematic area in attempting to remain current on supply procedures. On occasion this can be attributed to incorrect publications procedures at unit level. However, much of the problem remains in the methods used to by-pass the pinpoint distribution system.

f. Fort Sheridan reports that messages issued to "clarify" policy regulations have the same effect as a change, i.e., they must be disseminated to all holders of appropriate publications and must be posted to and filed with the appropriate directives. The following messages were identified as being in this category.

(1) DALO-ZXT, 312105Z Feb 78 (Proper Count), subject: Items Not Authorized in Quick Supply Stores (QSS).

(2) DALO-ZXT, 152028Z Mar 78 (Proper Count), subject: Marking of Tools.

(3) DALO-ZXT, 230238Z Mar 78 (Proper Count), subject: Abandoned Clothing of Enlisted Personnel Dropped From the Rolls.

FOR THE COMMANDER:

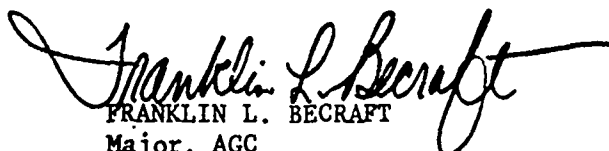
  
FRANKLIN L. BECRAFT  
Major, AGC  
Assistant Adjutant General

Copies furnished:  
HQDA (DAAG-PA)  
Cdr, USA LEA New Cumberland Army  
Depot, New Cumberland, PA 17070

2

265



DEPARTMENT OF THE ARMY  
HEADQUARTERS, UNITED STATES ARMY HEALTH SERVICES COMMAND  
FORT SAM HOUSTON, TEXAS 78234

28 APR 1978

HSLO-S

SUBJECT: Supply Publication Change Procedures

HQDA (DALO-ZXT)  
WASH DC 20310

1. Reference is made to message, DALO-ZXT, 012007Z Feb 78, subject as above.
2. Headquarters, US Army Health Services Command (HSC) and subordinate units have implemented the procedures outlined in referenced message. Review of all supply publications have been accomplished and rescissions and changes have been made where indicated. The DCSLOG in Headquarters, US Army Health Services Command monitors supply publication change turbulence within the command.
3. The limitations imposed on supply publication changes by referenced message are considered realistic. This policy should be helpful in reducing turbulence and confusion in supply functional areas.
4. Numerous message changes to CTAs are continuing to be published. These message changes do not follow the format prescribed by your 1 Feb 78 message. A recent example is at inclosure 1. Although authorization documents such as CTAs are not published by DA DCSLOG, they are considered to be a supply publication by field users. Recommend the supply publication change procedures be followed in publishing changes to CTAs.

FOR THE COMMANDER:

R. E. TRACKWELL  
CPT, AGC  
Asst AG

1 Incl  
Msg, DAMO-FDU, 202100Z Apr 78

CF:  
Cdr, Logistics Evaluation Agency, New Cumberland Army Depot,  
New Cumberland, PA 17070



ROUTINE

PT 07183 110/2131Z

*MYS*

PAGE 01

ACT <u>PI</u> <u>TNG</u>	ACT _____	PI <u>DPTSEC</u>	<u>OP</u> <u>PI</u>	ACT <input checked="" type="checkbox"/> <u>PI</u> <input checked="" type="checkbox"/>
5TH US ARMY	FT SAN HOUSTON	HEALTH SERVICES	OTHER COMMANDS	
<input checked="" type="checkbox"/> C/S PAO	DC PAO DRSC	CS HI VS	BAMC ArEES	
<input checked="" type="checkbox"/> PA SJA	JA CPO MISO	DS <u>XLO</u> JA	CID 92FO	
<input checked="" type="checkbox"/> RH <input checked="" type="checkbox"/> OIS	IG <input checked="" type="checkbox"/> AGA MWFO	IG MS ZA	AHS INSCOM	
<input checked="" type="checkbox"/> LOG ORR	PH <input checked="" type="checkbox"/> ADJ CHAPLAIN	PE CH ZB	SWRC CPSTAN	
TNG <input checked="" type="checkbox"/> PM	41MG DPCA JPPSO	SE CH EO	545 NMRC	
OPS CHAP	<input checked="" type="checkbox"/> DIO COMP HQCMD	HC AG IO	90TH SARPMA	
<input checked="" type="checkbox"/> IG AMA	DCE DFAE DPTSEC	OP <input checked="" type="checkbox"/> PA CE	XARR7 OSI	

RTTUZYUW RUEADWD0146 1102119-UUUU--RUWTNFA.

ZNR UUUUU

R 202100Z APR 78

FM DA WASHDC //DAMO-FDU//

TO AIG 7406

AIG 7405

RUEADWD/DA WASHDC //NGB-ARL//

INFO AIG 7300

RULCSAA/TAG VI ST CROIX VI

AIG 7446

RUKLDAR/DIR USAEARA ALEX VA //DRXEA-MC//

RUCIAFB/CDR ARRCOM ROCK ISLAND IL //DRSAR-MMP-S//

BT

UNCLAS

STAFAC

SUBJECT: AUTHORIZATION OF M58 TRAINING AID SKIN DECONTAMINATING BY CTA 5G-970

A. DAMO-FDU MSG 071523Z MAR 78 SAB.

B. CTA 5G-970, W/C2, 1 AUG 77.

REFERENCE A WHICH CHANGED REFERENCE B IS MODIFIED AS FOLLOWS:

(DELETE) PER 4 STUDENTS ATTENDING AIT AND CBR OFFICER AND NCO COURSE AT CBR SCHOOL OR OCCS....1

PAGE 2 RUEADWD0146 UNCLAS

(SUBSTITUTE) PER 4 STUDENTS ATTENDING BASIC TRAINING OR ONE STATION UNIT TRAINING, CBR OFFICER AND NCO COURSE AT CBR SCHOOL OR OCCS....1

BT

#0146

NNNN

ROUTINE *Incl 1*

UNCLASSIFIED  
\*\*\*\*\*

DEPARTMENT OF THE ARMY  
PENTAGON TELECOMMUNICATIONS CENTER

BKS	TRCL	CH
ZX	SA	10
ZXT		
ZXA-C		
AV		
PL		
PLW		
PLZ	SA	10
PL7		
PL0		

CDSN = SCD469 MCN = 73113/07078 TUR 81131106  
RTTUZYUW RUADJHAJ0804 1180013-JUUU--RUEADWD  
ZNR UUUUJ  
R 280808Z APR 78  
FM CDUSARJ CPZAMA JAPAN//AJGD-SD//  
TO RUADWD/DA WASHDC//DALO-ZXT//  
INFO RUEMANA/CDK USALEA IGAO NEW CJ BERLAND  
BT

UNCLAS

THIS IS A PCKPER COUNT MESSAGE  
SUBJ SUPPLY PUBLICATION CHANGE PROCEDURES

- A. DA DALO-ZXT 012007Z FEB 78 (U)
- B. LTR AJGD-SD HQ USARJ 27 FEB 78 (U)
  1. RESULTS OF DA DIRECTED ACTION ON REVIEW OF PUBLICATION CHANGE PROCEDURES FOLLOW (TYPE ACTION - NUMBER).
    - A. MACOM SUPPL REVIEWED - 13
      - (1) RESCINDED - 4
      - (2) REVISED/UNDER REVISION - 6
      - (3) STILL CURRENT/RETAINED - 3
    - B. SUBCOMD SUPPL REVIEWED - 3
      - (1) REVISED/UNDER REVISION - 1
      - (2) STILL CURRENT/RETAINED - 2
    - C. MACOM SUPPLY RELATED REGS REVIEWED - 8
      - (1) RESCINDED - 1
      - (2) REVISED/UNDER REVISION - 2
      - (3) STILL CURRENT/RETAINED - 5
    - D. SUBCOMD SUPPLY RELATED PUB REVIEWED - 26
      - (1) RESCINDED - 9
      - (2) REVISED/UNDER REVISION - 6
      - (3) STILL CURRENT/RETAINED - 11
  2. SUBJECT ACTION HAS BEEN HIGHLY BENEFICIAL TO USARJ PROPER COUNT PROGRAM. COMMAND EMPHASIS CONTINUES IN REDUCING NUMBER OF SUPPLY RELATED PUBLICATIONS TO MINIMUM ESSENTIALS.

BT

ACTION ADDRESSEES

006 DALO  
00006 TOTAL NUMBER OF COPIES REQUIRED  
#0864

\*\*\*\*\*  
\* UNCLASSIFIED \*  
\*\*\*\*\*

PAGE 01  
280808Z APR 78  
RJADJHA/0864



DEPARTMENT OF THE ARMY  
HEADQUARTERS, EIGHTH UNITED STATES ARMY  
APO SAN FRANCISCO 96301

AGJ-AP

2 May 1978

SUBJECT: Supply Publication Change Procedures

HQDA(DALO-ZXT)  
WASH DC 20314

1. Reference is made to Message, HQDA(DALO-ZXT), DTG 012007Z Feb 78, subject as above.
2. The current policy with regard to monitoring supply publication change procedures is an effective and efficient way to control changes to publications. It assures that only those changes that are absolutely necessary are distributed to subordinate commands at the lower echelons.
3. Within this command, supplements to supply regulations are being reviewed for conformity with current policy. Only that supplementary information deemed essential is set forth in a supplement. Likewise, those supplements already in existence are being reviewed for essentiality.

FOR THE COMMANDER:

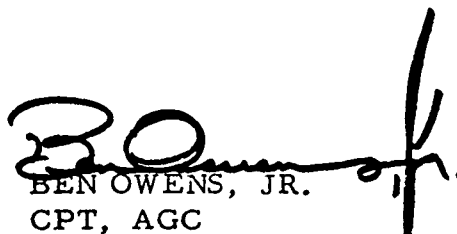
  
BEN OWENS, JR.  
CPT, AGC  
Asst AG

CF:  
Cdr, USALEA  
New Cumberland Army Depot  
New Cumberland, PA 17070



DEPARTMENT OF THE ARMY  
HEADQUARTERS U.S. ARMY MILITARY DISTRICT OF WASHINGTON  
FORT LESLEY J. MCNAIR  
WASHINGTON, D.C. 20319

ANLOG

MAY - 3 1978

SUBJECT: Supply Publications Change Procedures

HQDA (DALO-ZXT)  
Washington, DC 20310

1. Reference is made to HQDA message 012007Z Feb 78, subject as above. This command has experienced no turbulence attributable to the policy stated in the message. This is primarily due to the fact that all MDW units are in the National Capital Region (NCR) and, for supply, MDW operates as essentially one installation. Therefore the constraints of interim message/letter changes do not apply.

2. The two supply publication supplements MDW has will be revised during this FY to incorporate policy and procedure changes resulting from the Proper Count Flasher Messages. The DA proponent review requirement is expected to impact only to the extent of slowing publication and implementation.

FOR THE COMMANDER:

DONALD L. BURT  
Colonel, GS  
Deputy Chief of Staff, Logistics

CF:  
USA Logistics Evaluation Agency  
New Cumberland Army Depot  
New Cumberland, PA 17070

UNCLASSIFIED

DEPARTMENT OF THE ARMY  
PENTAGON TELECOMMUNICATIONS CENTER

CDSN = SCD063 MCN = 76125/01642 TOR = 781250200  
RTTUZYUW RUCLAIA34CC 1241840-0000--RUEADWD.  
ZNR UUUUU  
R 041839Z MAY 78  
FM CDTRADOC FT MGNRCE VA//ATLG-MSP-SP//  
TO RUEADWD/DA WASHDC//DALG-ZXT//  
INFO RUEMANA/CDRLSALEA NCAD NEW JERSEY//DALG-LER//  
BT

JNCLAS

SUBJ: SUPPLY PUBLICATIONS CHANGE PROCEDURES

A. DA DALG-ZXT 012007Z FEB 78

1. THIS MSG IS AN INTERIM RESPONSE TO REF MSG.

2. STATUS OF ACTIONS TAKEN AT HQ TRADOC IS/

A. TRADOC SUPPL 1 TO AR 710-1 IS CURRENTLY BEING REVISED. A DRAFT COPY OF THIS SUPPL WILL BE FORWARDED TO DALG FOR APPROVAL PRIOR TO PUBLICATION.

B. PROCEDURES TO CONTROL INTERIM CHANGES TO SUPPLY PUBLICATIONS ARE BEING ESTABLISHED THROUGH TRADOC AG.

3. PROGRESS REPORT ON REVIEW OF TRADOC INSTALLATIONS/ACTIVITIES PUBLICATIONS FOLLOWS/

A. OF 38 TRADOC INSTALLATIONS/ACTIVITIES TASKED TO REPLY TO REF MSG, 29 HAVE REPLIED, AND REVIEW IS COMPLETE ON ALL BUT TWO.

B. THUS FAR 40 PUBLICATIONS HAVE BEEN REVIEWED. THERE WERE 22 APPROVED, 16 CHANGED AND TWO RESCINDED.

4. A FINAL REPORT WILL BE FORWARDED WHEN THE REVIEW IS COMPLETE.

BT

ACTION ADDRESSEES

006 DALG

INFORMATION ADDRESSEES

001 AFLO/ATLG

00007 TOTAL NUMBER OF COPIES REQUIRED

#3400

UNCLASSIFIED

PAGE 01  
041839Z MAY 78  
RUCLAIA/3400

\* UNCLASSIFIED \*  
\*\*\*\*\*

DEPARTMENT OF THE ARMY  
PENTAGON TELECOMMUNICATIONS CENTER

CDSN = SCD399    MCN = 78124/17297    TOR = 78124  
RTTUZYUW RUCLBNA3854 124174E-UUUU--RUEADWD.  
ZNR UUUUU  
R 041745Z MAY 78  
FM COR MRSA LEX KY //DRXMD-SS//  
TO RUEADWD/DA WASH DC //DALE-ZXT//  
INFO RUKLDAR/COR DARCOM ALEX VA //DRXAM-ABE/DRCHM

BKS	THCL	SM
ZX	TA	SMT
ZYT	LE	SIS
ZXA	TSM	SPI
ZXA-C	TST	SPT
AV	TSE	SM
PL	TSP	SND
PLS	SAC	SM
PLW	SAB	SM
PLR	SAA	SM
PLF	SA	SM
PLO		RMP

UNCLAS

SJBJ: SUPPLY PUBLICATION CHANGE PROCEDURES.

- A. YOUR 012007Z FEB 78 (U) NLTAL
  - B. MY 241030Z APR 78 (U). NLTAL
  - C. DARCOM DRXAM-ABE 262015Z APR 78 (U) NLTAL
  - D. YOUR 011325Z MAY 78 (U) NLTAL.
1. REF A WAS PROPER COUNT FLASHER MESSAGE NR. 11 AND REQUIRED THAT ACTIVITIES PROVIDE COMMENTS PERTAINING TO THE CURRENT POLICY AND THE RESULTS OF THE MONITORING PROCEDURES IMPLEMENTED TO CONTROL CHANGE AND TURBULANCE TO SUPPLY REGULATIONS.
  2. THIS ACTIVITY BY REF B REQUESTED DEFINITIVE GUIDANCE PERTAINING TO CODE ASSIGNMENTS IN SUPPORT OF ARMY MAJOR AUTOMATIC DATA PROCESSING (ADP) SYSTEMS.
  3. REF C REQUESTED A COPY BE FURNISHED DARCOM, DRXAM-ABE, OF INFORMATION FURNISHED DA PERTAINING TO PARAGRAPH 6 OF REF A.
  4. ~~REF D HAS THE REPLY TO REF B AND REQUESTED THE~~ FOR CONFORMING WITH GENERAL GUIDANCE CONTAINED IN REF A.
  5. AS REQUIRED BY PARA 6 OF REF A THIS ACTIVITY HAS INITIATED THE FOLLOWING PROCEDURES.
    - A. ALL REQUESTS FOR CHANGE TO SUPPLY PUBLICATIONS UNDERGO A THOROUGH REVIEW AND ONLY THOSE REQUESTS REQUIRING IMMEDIATE ACTION ARE PUBLISHED. ALL OTHER REQUESTS ARE HELD FOR SEMI/ANNUAL FORMAL CHANGE.
    - B. ALL REGULATIONS REQUIRING UPDATING ARE REVIEWED BY A SELECT GROUP OF PERSONNEL FREE TO REQUEST FOR PUBLICATION. BASED ON THE RECOMMENDATIONS OF THIS GROUP THE REGULATIONS ARE EITHER SUBMITTED FOR PUBLICATION OR HELD PENDING ADDITIONAL UPDATING REQUIREMENTS.
    - C. MESSAGE CHANGES ARE BEING HELD TO AN ABSOLUTE MINIMUM AND ARE INCLUDED IN THE NEXT FORMAL CHANGE TO THE APPLICABLE REGULATION.
    - D. DOD DIRECTED CHANGES ARE PROVIDED TO ALL MAJOR COMMANDS, LAOS AND IMPLEMENTING ACTIVITIES UPON RECEIPT NORMALLY BY A NUMBERED FUTURE CHANGE LETTER INDICATING EFFECTIVE DATE AND FORMAL CHANGE

\*\*\*\*\*  
\* UNCLASSIFIED \*  
\*\*\*\*\*

PAGE 01  
041745Z MAY 78  
RUCLBNA/3854



\*\*\*\*\*  
\* UNCLASSIFIED \*  
\*\*\*\*\*

DEPARTMENT OF THE ARMY  
PENTAGON TELECOMMUNICATIONS CENTER

NUMBER OF APPLICABLE PUBLICATION.  
6. ALL FUTURE REQUESTS FOR INFORMATION REGARDING SUPPLY PUBLICA-  
TIONS THAT ARE THE RESPONSIBILITY OF THE MATERIEL READINESS SUPPORT  
ACTIVITY (MRSA) SHOULD BE ADDRESSED TO THE ATTENTION OF DRXMD-S.  
7 THIS ACTIVITY'S POINT OF CONTACT CONCERNING THE ABOVE ACTION  
IS MR EDWIN LOY, AUTOVON 745-3686/3893.

BT

ACTION ADDRESSEES

006 DALD

00006 TOTAL NUMBER OF COPIES REQUIRED

#3854

NNNN

\*\*\*\*\*  
\* UNCLASSIFIED \*  
\*\*\*\*\*

PAGE 02  
041745Z MAY 78  
RUCLBNA/3854

\*\*\*\*\*  
 \* UNCLASSIFIED \*  
 \*\*\*\*\*

DEPARTMENT OF THE ARMY  
 PENTAGON TELECOMMUNICATIONS CENTER

	TRCL	SM
ZX	TA	TAT
ZXT	TD	TMT
ZXA	TD	TMM
ZXA-C	TD	TMM
AV	TD	TML
PL	TD	TMD
PLS	TD	TMI
PLM	TD	TMB
PLR	TD	TMC
PLF	TD	TMI
PLD	TD	TMP

CDSN = SCD886 MCN = 78126/02063 TOR = 781260232  
 RTTUZYUW RUKLDARC80C 1251905-UUUU--RUEADWD.  
 ZNR UUUUU  
 R 051910Z MAY 78  
 FM CORDARCOM ALEX VA//DRCIS//  
 TO RUEADWD/DA WASHDC//DALU-ZXT//  
 BT

UNCLAS

SUBJ: SUPPLY PUBLICATION CHANGE PROCEDURES

A. YOUR 012007Z FEB 78, SA2.

THE FOLLOWING REPORT ON SUPPLY PUBLICATION CHANGE TURBULENCE  
 ATTRIBUTABLE TO THE PROPERTY ACCOUNTABILITY PROGRAM DURING THE PERIOD  
 1 FEB 5#47 30 APRIL 1978 IS FURNISHED IN ACCORDANCE WITH PARA 6 OF  
 REFERENCE:

- A. NUMBER OF SUPPLY PUBLICATIONS REVIEWED 41
- B. NUMBER RESCINDED 3
- C. NUMBER CONSOLIDATED 0
- D. IMPACT ACCELERATED/INCREASED WORKLOAD

E. REMARKS. THE ABOVE FIGURES INCLUDE THE COMPONENT LISTS,  
 TECHNICAL MANUALS, AND SPECIFICATIONS REVIEWED TO MEET MILESTONES OF  
 THE PROGRAM TO "ACCELERATE THE CURRENT PROGRAM TO SIMPLIFY SUPPLY  
 PUBLICATIONS" ASSIGNED DARCOM BY THE DA PROPERTY ACCOUNTABILITY TASK  
 FORCE.

BT

ACTION ADDRESSEES

006 DALO

00306 TOTAL NUMBER OF COPIES REQUIRED

#0800

\*\*\*\*\*  
 \* UNCLASSIFIED \*  
 \*\*\*\*\*

PAGE 01  
 051910Z MAY 78  
 RUKLDAR/0800

\*\*\*\*\*  
 # UNCLASSIFIED #  
 \*\*\*\*\*

PENTAGON TELECOMMUNICATIONS CENTER

CDSN = SCD633 MCN = 78132/16160 TOR = 781321840  
 RTTUZYUW RUKGC CC5CS 1321827-0000-RUEADWD.  
 ZNR UUUUU  
 R 121245Z MAY 78  
 FM CDRMTMC WASHDC //MT-SPI//  
 TO RUEADWC/HQDA WASHDC //DALC-ZXT//  
 INFO RUEOBMA/CDRMTMCEA BAYCNE NJ //MTE-SV//  
 RUWADMA/CDRMTMCA CARLAND CA //MT-SV//  
 RUDOROA/CDRMTMCTTGE ROTTERDAM NETHERLANDS //MTG-SV//  
 RUCLEJA/DIRMTMCTEA FT EUSTIS VA  
 RUEMANA/CDRUSALEA NEW CUMBERLAND ARMY DEPOT PA //DALO-LER//  
 BT

UNCLAS

SUBJ. SUPPLY PUBLICATION CHANGE PROCEDURES

- A. DALC-ZXT MSG, 012007Z FEB 78, SAB (PROPER COUNT FLASHER MSG NO. 11).
- B. MT-SPI MSG, 162100Z FEB 78, SAB.
- C. DALO-ZXT MSG, 101652Z MAY 78, SAJ (NOTAL) (PROPER COUNT MSG).
  - 1. INITIAL RESPONSE TO REF A WAS FORWARDED BY REF B.
  - 2. DURING THE PAST THREE (3) MONTHS SUPPLY PUBLICATION CHANGE TURBULANCE HAS BEEN MINIMAL; HOWEVER, THERE HAVE BEEN AT LEAST 15 ELECTRICAL MESSAGES IN THE AUTHORIZATIONS AREA.
  - 3. PER REF C ONLY 2 SUPPLEMENTS WERE ON HAND. ONE HAS BEEN

PAGE 2 RUKGCVGC5CS UNCLAS  
 PESCINDED.

BT

ACTION ADDRESSEES

006 DALO

00006 TOTAL NUMBER OF COPIES REQUIRED

#0509

BKS	THCL	SM
ZX	TA	SMT
ZXT <i>B</i>	LE	SMS
ZXA	TSM	SMB
ZXA-C	TST	SM7
AV	ASE	SML
PL	TFP	SMO
PLS	SAJ	SM1
PLW	SAD	SM3
PLP	SAV	SMC
PLF	SA	SMI
PLO <i>/</i>		RMP

\*\*\*\*\*  
 # UNCLASSIFIED #  
 \*\*\*\*\*

PAGE 01  
 121245Z MAY 78  
 RUKGCVG/0509



DEPARTMENT OF THE ARMY  
HEADQUARTERS, UNITED STATES ARMY, EUROPE and SEVENTH ARMY  
APO NEW YORK 09403

AEUPE-AMD-AC

16 May 1978

SUBJECT: Supply Publication Change Procedures

HQDA (DALO-ZXT)  
WASH DC 20310

1. Reference is made to your messages, subject as above, DTG 012007Z Feb 78 and 101652Z May 78.
2. Attached as inclosure 1 is letter implementing interim guidance contained in your February message. This action itself detracts from the intent of your program to furnish definitive long-term guidance. Suggest procedures be documented in official publication soon.
3. Inclosure 2 is a copy of current action at this headquarters to update all command publications. An indication of significant changes to or elimination of publications containing supply procedures will be furnished your headquarters when project is completed.

FOR THE COMMANDER IN CHIEF:

2 Incl  
as

  
R. L. SCHENCK  
Colonel, AGC  
Asst AG

CF:  
HQDA (DAAG-PA), WASH DC 20314  
HQ USAREUR (AEAGD-SM) (CSDP)



**DEPARTMENT OF THE ARMY**  
**HEADQUARTERS, UNITED STATES ARMY, EUROPE and SEVENTH ARMY**  
APO New York 09403

AEUPE-AMD-AC

26 April 1978

SUBJECT: Supply Publication Change Procedures

Commanders of USAREUR Major Commands and Assigned Units (to Division Level)  
Heads of Staff Offices, This Headquarters

This letter expires 1 year from date of publication.

1. HQDA (DALO-ZXT) message, DTG 012007Z February 1978, subject above, is partially quoted as follows for information and action:

"This is a Proper Count Flasher Message No. 11

SUBJ: Supply Publication Change Procedures

A. AR 310-1, Publications, Blank Forms, and Printing Management, 1 Dec 76.

B. AR 310-2, w/Ch 1, Identification and Distribution of DA Publications and Issue of Agency and Command Administrative Publications, 12 Jul 76.

C. AR 310-3, w/Ch 11, Preparation, Coordination, and Approval of Department of the Army Publications, 26 Jul 77.

1. The DAIG report on management and accountability of Army materiel indicated that the number of supply publication changes/supplementary instructions issued by various headquarters, was unmanageable at unit level. Many changes were transmitted by electrical means and were minor in nature. In one instance, one regulation was changed by the electrical message method 25 times since August 1974 without initiation of formal revision as required by AR 310-3. In addition, the Army distribution system was noted as unresponsive. Message initiators were relying on AIG distribution, rather than utilizing pinpoint distribution procedures.

2. Effective immediately, the following policy will be reiterated and enforced by applicable headquarters' staff agencies concerned with supply publication change.

a. Publications will be amended or added to by publication of formal numbered changes. Serious errors will be corrected immediately by published changes, while minor changes will be allowed to accumulate and be published in the next significant change or revision to the publication. Except for changes required for immediate correction of serious errors, numbered changes should be issued no more than semiannually, with annual issue preferable

b. Interim electrical message changes will be utilized only to:

(1) Meet a mandatory effective date imposed by law, Executive Order, an order from another executive agency, court order, or DOD directive.

(2) Eliminate or modify a policy, procedure, or other specifications that:

(a) Could result in loss of life, personal injury, or destruction of property.

(b) Is wasting Army funds, man-hours, or other critical resources.

(3) Forestall the issuance of anticipated adverse judicial rulings.

c. Interim pinpoint message changes will be used whenever possible when a change is urgent and when widespread distribution is desired.

d. Preparation of messages will include: (Para 1-12.1, Change 11, AR 310-3).

(1) A two-part number noting the first part as the number of the next regular change, followed by a hyphen, and when the second part indicating the sequence number of the interim change.

(2) The subject indicating the information as an interim change.

(3) The expiration date of the message, six months from the date of transmission, with a statement in the text that "This message expires six months from the date of the message, if not superseded by a formal numbered change."

e. The number of interim electrical messages will be limited to three changes, as in the case of the interim pinpoint message changes. After a maximum of three changes are issued, or within six months of the first message change, the proponent agency of the supply publication must supersede those changes through issuance of a formal numbered change (para 1-12.2, Change 11, AR 310-3).

3. In regard to the use of supplements to AR, the DA report stated that a majority of commanders surveyed did not feel that the additional guidance was necessary for effective unit operations. This places the use of the supplement process as an effective tool for issuing implementing instructions in doubt. Therefore with regard to supply publications, MACOMS will:

a. Review policies concerning development and publication of supplementary guidance to ensure policies are IAW AR 310-2.

b. Review supplement to ensure information is minimum essential for effective implementation and that the information contained therein is current and applicable.

c. Rescind those supplements that are deemed ineffective.

4. Effective 1 June 1978, all MACOM supplements to supply publications developed IAW AR 310-2, will be forwarded to HQDA proponent agencies for review and approval prior to publication. Supplements may clarify DA policy, but will not deviate from that policy. MACOMS will establish similar procedures for subordinate elements.

5. It must be emphasized that, although logistics management is a dynamic process, unnecessary changes to clarify or provide interim policy guidance

AEUPE-AMD-AC

26 April 1978

SUBJECT: Supply Publication Change Procedures

by the electrical message method creates tremendous turbulence and/or doubtful receipt at user level. Commanders who authorize such changes must ensure that the review and approval process is such that only the most urgent are transmitted."

2. Particular attention is directed to paragraph 4 of quoted message. Proponents of proposed supply publications will insure required coordination and approval have been made before releasing document for publication.
3. These procedures will be incorporated into USAREUR Supplement 1 to AR 310-2 upon publication of change to basic AR.

FOR THE COMMANDER IN CHIEF:



R. L. SCHENCK  
Colonel, AGC  
Asst AG

Telephone: HDG Mil (2121-)7914

DISTRIBUTION: C, plus  
10 - AEUPE-AMD-AC



DEPARTMENT OF THE ARMY  
HEADQUARTERS, UNITED STATES ARMY, EUROPE and SEVENTH ARMY  
APO 99483

S: 28 April 1978

AEUPE-AMD-AC

10 April 1978

MEMORANDUM FOR: HEADS OF STAFF OFFICES

SUBJECT: USAREUR Command Publications

1. In January 1977, I provided a summary of publications policies and other guidance intended to reduce the length and volume of our directives and to avoid wasting time on needless activity. That guidance has been incorporated into USAREUR Supplement 1 to AR 310-2, 1 December 1977.

2. We have made some progress in reducing the number of our publications, but much remains to be done, as evidenced by the large number of publications listed in USAREUR Pam 310-1 that remain outdated. I reiterate my personal interest in this matter and solicit your personal support to accomplish this purpose. I have asked the AG to prepare specific administrative guidance to insure that this project is a coordinated effort. His guidance, attached as Inclosure 1, is approved for implementation.

1 Incl  
as

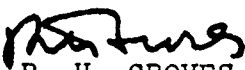
  
R. H. GROVES  
Major General, GS  
Chief of Staff

DISTRIBUTION:

3 - Ea Head of Staff Office  
11 - AG (AEUPE-AMD-AC)



# DISPOSITION FORM

For use of this form, see AR 340-15, the proponent agency is TAGCEN.

S: 28 April 1978

S: 26 May 1978

REFERENCE OR OFFICE SYMBOL

SUBJECT

AEUPE-AMD-AC

Command Publications

TO Heads of Staff Offices

FROM AG

DATE 3 Apr 78

CMT 1

MAJ Smith/sb/8373

1. During January 1977, the Chief of Staff issued specific guidance on publications policies to reduce the volume and improve the quality of USAREUR directives. Since then, the coordinated efforts of the staff have had the following results:

- a. 167 command publications were eliminated.
- b. 395 complete revisions or changes were published.
- c. 69 new or revised posters were published.
- d. Current total of 872 long-term publications and 151 posters represents nearly a 20% reduction.

These results are commendable and mean resource savings throughout the command. The obvious paper and printing savings are great but the intangible savings are even greater. Coordination with higher and lower level commands has significantly reduced the need to publish supplementary guidance. Commanders and staff officers have fewer publications with which to be familiar, thus allowing more time for other worthwhile activities. The greatest impact is here in the headquarters staff. Once essential guidance is placed in a well coordinated long-term publication, it becomes unnecessary to duplicate our efforts to republish each year. The annual review permits an opportunity to publish changes as necessary.

2. The posted copy of USAREUR Pam 310-1 at inclosure 1 indicates a large number of our publications remain outdated. The Publications Control Officer has dealt with you on many of these and a significant number are now being revised. To continue our progress and insure this large undertaking is a coordinated effort, request you accomplish the following:

a.. Personally review inclosures to gain an appreciation for the currency of your publications.

b. Designate an individual knowledgeable in staff procedures (UM 1-10 and UM 310-10) concerning command publications to be your staff publications control officer. This individual should be charged with the following specific duties:

- (1) Determine current status and continued essentiality of each publication within your proponentcy.
- (2) Determine a realistic date for submitting appropriate coordinated draft revisions. Assign a point of contact for each such publication.
- (3) Determine which publications are truly essential for distribution to REFORGE units.
- (4) Prepare a consolidated reply encompassing all above actions to this office

NLT 26 May 1978.

Incl 1, CofS Memo, 10 Apr 78

DA FORM 2496

REPLACES DD FORM 24, WHICH IS OBSOLETE.

281

AEUPE-AMD-AC  
SUBJECT: Command Publications

3. Additional guidelines and policy that will influence your actions are:

a. Each supplement preceded by a plus (+) sign and followed by date of current AR must be revised or rescinded before 1 February 1979. See paragraph 4-25b.1, AR 310-2, as supplemented. All such supplements not acted upon earlier will be rescinded automatically.

b. STAFF 77 and other directed revised relationships must be considered and incorporated into essential publications. Any publication dated before January 1977 is candidate for revision.

c. Command program guidance concerning functional responsibilities transferred to subordinate commands must remain within your proponentcy. For example, if Cdr, 4th Trans Bde is assigned responsibility for the Terminal Facilities Guide, then DCSLOG retains responsibility for internal headquarters coordination and publication of USAREUR guidance. You should insure subordinate units responsible for preparing draft USAREUR publications have necessary directives (USAREUR Memorandums) to do so.

d. REFORGER units automatically receive publications designated by an asterisk (\*) in USAREUR Pam 310-1.

e. When an AR is superseded or rescinded, the corresponding USAREUR supplement must be revised immediately. USAREUR Supplement 1 to AR 310-2 provides procedures.

f. The workload spread of your staff and the AG editorial staff must be considered when proposing revision dates. Obviously, all publications requiring revision cannot be accomplished in the last months of this year.

g. Publication of a change is the preferred method to update guidance. This office will determine whether a complete revision or change will be published based on costs, convenience to user, and complexity of the subject.

h. The Chief of Staff tasked this office to develop a policy that will significantly reduce the number of interim message changes to command publications. AR 310-3 established similar policy which has not been sufficiently implemented. Message at inclosure 2 indicates the gravity involved with losing control of such changes.

4. In summary, we must insure our subordinate commanders have necessary guidance to do their jobs while assuring we do not waste their time with superfluous details. USAREUR directives will be published, when essential, in concise language. Few USAREUR programs are so unique that special detailed guidance must be published. Departmental guidance is written in terms that generally can be applied without further supplementation. A well coordinated and written command publication provides a basis for long-term planning and mission accomplishment and considers the impact on our individual soldiers.

AEUPE-AMD-AC  
SUBJECT: Command Publications

Specific requirements of this paper are enumerated again, as follows, to insure initiation of a coordinated effort:

- a. Designate a publications control officer to accomplish this project.
- b. A 100% review of all publications will be accomplished.
- c. Nonessential publications will be eliminated.
- d. Outdated guidance will be revised.
- e. REFORGER units will be provided essential USAREUR publications.
- f. Provide by 26 May 1978 a reply to the AG, ATTN: AEUPE-AMD-AC, that includes the following:
  - (1) A copy of inclosure 1, posted in red ink, with updated or corrected status as follows:
    - (a) Line thru those that should be rescinded and mark with the letter "R".
    - (b) Those containing current guidance and requiring no revision, mark with a letter "C".
    - (c) Those requiring revision mark with "REV" and proposed revision date.
    - (d) Delete or add REFORGER designation as necessary.
  - (2) A separate listing of POC and telephone number of each publication that will be revised.
  - (3) Provide POC information by 28 April 1978 to the USAREUR Publications Control Officer (Major W. H. Smith), telephone 6267/8392/7914.

2 Incl  
as

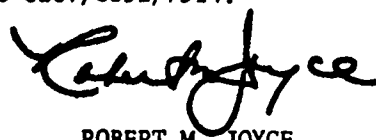

ROBERT M. JOYCE  
Colonel, AGC  
Adjutant General

DISTRIBUTION:  
3 - Ea Head of Staff Office  
11 - AG (AEUPE-AMD-AC)

\* UNCLASSIFIED \*  
\*\*\*\*\*

DEPARTMENT OF THE ARMY  
PENTAGON TELECOMMUNICATIONS CENTER

CDSN = SCD604 MCM = 78144/09503 TGR = 781441211  
RTTUZYUW RUFDAAA2370 1441212-LLLL-KLEADWD.  
ZNR UUUUU  
R 231349Z MAY 78  
FM CINCUSAREUR HEIDELBERG GERMANY//AEAGD-SM-F//  
TO RUKLDAR/CDR DARCLM ALEX VA//CRCCP-FW//  
INFO RUEADWD/HQDA WASH DC//DALL-ZXT//  
BT

UNCLAS

SUBJ: INTERIM CHANGE 1L AR 710-1

- A. CDR, DARCLM, CRCCP-FW, 161811Z JAN 78, (U) (NOTAL).
- B. CDR, DARCLM, CRCCP-FW, 181812Z MAY 78, (U) (NOTAL).
- C. HQDA, DALG-ZJT, C12001Z FEB 78.
  1. REF A WAS NOT RECEIVED. REF B CITES CHANGE TO REF A AND BASIC AR. REF C ESTABLISHES PROCEDURES FOR CONTROL OF SUPPLY PUBLICATION CHANGES INCLUDING REF A AND B.
  2. REQUEST REF A AND B BE CONSOLIDATED PER REF C AND PROVIDED TO THIS OFFICE.
  3. USAREUR DCSLLG-SM-F FLC IS MAJ J.H. KAPKE, HBG (2121-) 6760.

BT

ACTION ADDRESSEES

006 DALG

00006 TOTAL NUMBER OF COPIES REQUIRED

#2370

\*\*\*\*\*  
\* UNCLASSIFIED \*  
\*\*\*\*\*

PAGE 01  
231349Z MAY 78  
RUFDAAA/2370

14 JUN 1979

DRCM-SP

SUBJECT: Draft TRADOC Supplement 1 to AR 710-1

Commander  
US Army Training and Doctrine Command  
ATTN: ATLC-HSP  
Fort Monroe, VA 23651

1. Subject draft supplement was referred to this headquarters by the DA Property Accountability Task Force for review and approval since DARCOM is the proponent agency for AR 710-1.

2. This headquarters interposes no objection to the publication of this supplement; however, AR 710-1 is currently under complete revision with a proposed publication date of 30 April 1979. Accordingly, the US Army DARCOM Materiel Readiness Support Activity, ATTN: DRXMD-SS was tasked by this headquarters for maintaining this regulation in a current status, including the preparation and staffing of changes and revisions. In addition, the following recommended changes are provided:

a. Page 1, paragraph 2-5. The addition of "and TRADOC" to current paragraph 2-5c appears to be in error.

b. Page 6, paragraph 3-32h. Change paragraph 3 32h to read "3-32g" since paragraph 3-32f is the last paragraph in current AR.

c. Page 24, paragraph 5-47d(2)(c). Change "ACMA" to read "SICC". The term "ACMA" is no longer used.

d. Page 31, paragraph 5-47i. Change reference to "AR 735-7" to read "AR 37-69". AR 37-69 superseded AR 735-7 effective 1 July 1978.

e. Page 22, paragraph 5-47i(3)(a)2. AR 700-59 is cited. However, DA Pamphlet 310-1 reflects the AR as being rescinded by DA Circular 310-1 with no replacement.

↓  
HQDA (DALO-ZXT)

14 JUN 1978

DRCM-SP

SUBJECT: Draft TRADOC Supplement 1 to AR 710-1

3. In addition to the above and in view of a DAIG survey, which placed the use of the current supplement process in doubt as an effective tool for issuing implementing instructions, the TRADOC supplement should include sufficient information to minimize the need for further supplementation.

FOR THE COMMANDER:

1 Incl  
Draft TRADOC Suppl 1

*for*

OTTO C. GRUMMT  
Colonel, GS  
Associate Director  
of Supply & Distribution

CF:  
→ HQDA (DALO-ZXT) WASHDC 20310

*signed*

ROGER J. SNOWDON  
Assistant for Supply Policy  
and Distribution

HQDA (D: ZXT)

## Chapter 11

### Accountability Regulation Transfer

1. Recommendation 6G. Transfer the proponency for all supply and supply accountability regulations to DCSLOG.

	<u>Volume</u>	<u>Page</u>
2. DAPATF actions:		
a. Proper Count Message, DTG 291624Z Nov 77, Transfer of the Proponency of Supply and Supply Accountability Regulations to DCSLOG.	1	43
b. Proper Count Message, DTG 301930Z Nov 77, Transfer of the Proponency of Supply and Supply Accountability Regulations to DCSLOG.	1	48
c. DF, 23 Feb 78, Transfer of the Space and Proponency for Accountability Regulations.	2	161
3. MACOM responses:	<u>Page</u>	<u>Tasking Ref</u>
Message, CDR EUSA, DTG 260412Z May 78, Exception to Regulation.	288	2a

\*\*\*\*\*  
 \* UNCLASSIFIED \*  
 \*\*\*\*\*

BKS	TA	SM
ZX	LE	SMT
ZXT	TSM	SMS
ZXA	TST	SMM
THCL	TSE	SMW
AV	TSP	SML
PL	TS	SMD
PLW	SAC	RM
PLS	SAB	RMB
PLR	SAA	RMO
PLF	SA	RMI
PLO		RMP

DEPARTMENT OF THE ARMY  
 PENTAGON TELECOMMUNICATIONS CENTER

CDSN = SCD506 MCN = 7E146/U9094 TOR = 781401154  
 RTTUZYUW RUAGAA/3945 1461145-0000--KUEACKD.  
 ZNR UUUUU  
 R 260412Z MAY 78  
 FM CDR USAEIGHT SECLL KOREA //LJ-MS-SM/  
 TO DA WASH DC //LA;F-SMS//  
 INFO ZEN USAGY SECLL KOREA//EAGY-CIC// (COURIER)  
 ZEN CDR USAFEA-K SECLL KOREA //EAFE-S// (COURIER)  
 BT

UNCLAS

SUBJ; EXCEPTION TO REGULATION

A. PARA 5-4B, AR 735-5, 22 MAY 74 (U)

- B. YOUR DALO-ZXT 291624Z NOV 77, SUEJ; TRANSFER OF PROPONENCY OF SUPPLY AND SUPPLY ACCOUNTABILITY REGULATIONS OF DCSLOG (U)
1. REF ALFA PROHIBITS FOREIGN INDIGENOUS PERSONNEL FROM SIGNING PROPERTY VOUCHERS. REF BRAVO CHANGED PROPONENCY FOR AR 735-5 FROM DACA TO DALO ALTHOUGH SPECIFIC OFFICE WAS NOT IDENTIFIED.
  2. REDUCED ALO.S, REPLACEMENT OF US PERSONNEL WITH INDIGENOUS PERSONNEL, AND RESTRICTION OF REF ALFA, ALL COMBINED, ARE SERIOUSLY HAMPERING MANY ACTIVITIES IN CARRYING OUT ASSIGNED MISSIONS. MOST SERIOUSLY AFFECTED ARE TLA ACTIVITIES IN MAINTENANCE SHIPS, RECREATION SERVICES ACTIVITIES, AND FACILITIES ENGINEERING ACTIVITIES. THERE ARE NUMEROUS ACTIVITIES THAT ARE COMPRISED ENTIRELY OF INDIGENOUS PERSONNEL AND SUPPORTED BY STOCK RECORD ACCOUNT. THERE ARE ALSO 23 KOREAN SERVICE CORP COMPANIES COMPRISED ENTIRELY OF INDIGENOUS PERSONNEL. IN ORDER TO COMPLY WITH REF ALFA, IT IS NECESSARY TO ASSIGN US INDIVIDUALS SPECIFICALLY TO SIGN PROPERTY VOUCHERS. SUPPLIES ARE THEN SIMPLY GIVEN TO SHOP/ACTIVITY PERSONNEL (INDIGENOUS) FOR MISSION PERFORMANCE.
  3. IT IS BELIEVED THAT REF ALFA POLICY IS A CARRY-OVER FROM PREVIOUS MULTILINE DOCUMENT SYSTEM WHERE ONE SIGNATURE SUFFICED FOR NUMEROUS LINE ITEMS. BELIEVE THAT REF ALFA SHOULD NOT BE APPLICABLE TO PRESENT SINGLE LINE DOCUMENT SYSTEM OR THAT IT SHOULD BE CHANGED ECSSILY TO APPLY TO ONLY NON-EXPENDABLE OR HIGH DOLLAR-VALUE ITEMS.
  4. REQ THIS HQ BE AUTHORIZED EXCEPTION TO REF ALFA UNDER CIRCUMSTANCES DESCRIBED IN PARA 2 ABOVE TO PERMIT INDIGENOUS PERSONNEL TO SIGN PROPERTY VOUCHERS FOR EXPENDABLE ITEMS.

BT

ACTION ADDRESSEES

006 DALO

006 TVCR

\*\*\*\*\*  
 \* UNCLASSIFIED \*  
 \*\*\*\*\*

PAGE 01  
 260412Z MAY 78  
 RUAGAA/3945



## Chapter 12

### Supply Publication Simplicity

1. Recommendation 6H. Accelerate the current program to simplify supply publications. Consider issuance of two levels of user manuals; one for the operator and a more sophisticated one for technical support personnel. Include standard inventory "tear-out" forms as annexes to publications referring to sets, kits, and outfits so that components can be brought under control without resort to cumbersome "shortage annex" procedures.

2. DAPATF actions:	<u>Volume</u>	<u>Page</u>
a. Proper Count Message, DTG 301556Z Nov 77, Distribution of Supply Publications.	1	46
b. Letter, 7 Dec 77, Acceleration of Current Program to Supply Publications (DARCOM).	1	64
c. Letter, 7 Dec 77, Publications Support Under CABL.	1	66
d. Letter, 7 Dec 77, Distribution of Publications.	1	67
e. Letter, 7 Dec 77, Review and Revise Supply Field Manuals and Training Circulars.	1	59
f. Letter, 7 Dec 77, Acceleration of Current Program to Simplify Supply Publications (OTSG).	1	70
g. Letter, 7 Dec 77, Simplify Supply Publications (DCSLOG).	1	71
h. Letter, 7 Dec 77, Acceleration of Current Program to Simplify Supply Publications (DARCOM).	1	72
i. Letter, 28 Dec 77, Acceleration of Current Program to Simplify Supply Publications.	1	84
j. Letter, 31 Jan 78, Acceleration of Current Program to Simplify Supply Publications.	2	100

	<u>Volume</u>	<u>Page</u>
k. Letter, 31 Jan 78, Publication to Identify Components for Proper Count.	2	135
l. Letter, 13 Feb 78, Use of DA Form 2026 (Hand Receipt) In Operators Manuals.	2	133
m. Indorsement, 16 Feb 78, Proper Count Posters.	2	152
n. Letter, 10 Mar 78, Acceleration of Current Program to Simplify Supply Publications.	2	200
o. Suggestion Evaluation, 21 Mar 78, Supply Catalog Freeze.	2	216
p. Proper Count Message, DTG 172040Z Apr 78, Acceleration of Current Program to Simplify Supply Publications.	3	27
q. Proper Count Message, DTG 081930Z May 78, Acceleration of Current Program to Simplify Supply Publications (S: 19 May 78).	3	35
r. Proper Count Message, DTG 092013Z Jun 78, Revision of AR 710-2 to Include Instructions on Use of Hand Receipts.	3	51
s. Letter, 23 Jun 78, Component Listings of Integral Components of End Items, DA Forms 2062.	3	132
t. Letter, 23 Jun 78, TM Operator's Manual Consolidation List.	3	134
3. MACOM responses:	<u>Page</u>	<u>Tasking Ref</u>
a. Message, CDR DARCOM, DTG 111340Z Apr 78, Acceleration of Current Program to Simplify Supply Publications.	294	2n
b. Message, CDR DARCOM, DTG 101715Z May 78, Acceleration of Current Program to Simplify Supply Publications.	295	2b

	<u>Page</u>	<u>Tasking Ref</u>
c. Message, CDR DARCOM, DTG 101720Z May 78, Acceleration of Current Program to Simplify Supply Publications.	296	2q
d. Message, CDR DARCOM, DTG 181613Z May 78, Acceleration of Current Program to Simplify Supply Publications.	297	2b
e. Message, CDR DARCOM, DTG 181500Z May 78, Acceleration of Current Program to Simplify Supply Publications.	299	2q
f. Message, CDR MRSA, DTG 011710Z Jun 78, Acceleration of Current Programs to Simplify Supply Publications.	301	2j
g. Message, CDR MRSA, DTG 011700Z Jun 78, Revision of AR 710-2 to Include Instructions on Use of Hand Receipts.	302	2b
h. Message, CDR FORSCOM, DTG 191850Z Jun 78, Component Listings of Integral Components of End Items DA Forms 2062.	303	2h



IMPROVE DISTRIBUTION PROCEDURES

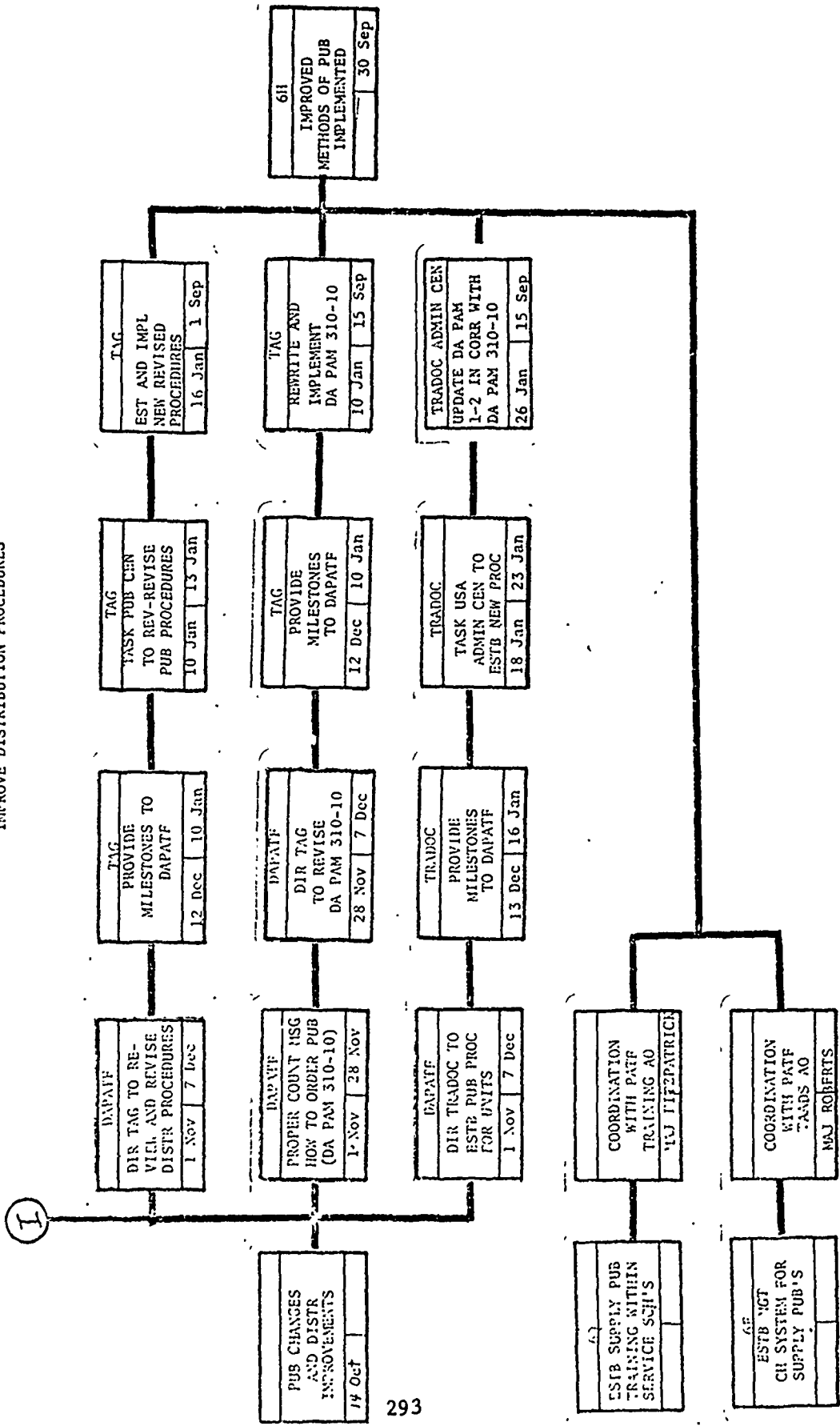

DEPARTMENT OF THE ARMY  
PENTAGON TELECOMMUNICATIONS CENTER

DDSN = SCD313 MON = 73101/12004 TCR = 73111745  
RTTZYUW RUKLJAK1177 10115+7-0000--RUEADWC.  
ZNR 00000  
R 111340Z APR 78  
FM CDRDARCOM ALEX VA //DRCMM-SL//  
TO RUCIAFE/CDRARRCOM ROCK ISL IL  
RUEDEIA/CDRCERCOM FT MUMFOUTH NJ//  
RUCGGCA/CDRMIRCOM KEESSTONE ARSENAL AL  
RUCIFRA/CDRTSARCOM STE MC  
RUCIAMA/CDRTARCOM WARREN MI  
RUCLENB/CDRUSAMRSA LEXINGTON KY  
INFC RUEYANC/CDARCOM JDA NEW CUMBERLAND PA  
RUEHANA/CDRGMPA NCAD NEW CUMBERLAND PA  
RUEADWC/EA WASHDC //JALC-ZXT//  
BT

BKS	TACL	CV
ZX	TA	---
ZXT	TA	---
ZXA	TA	---
ZXA-C	TA	---
AV	TA	---
PL	TA	---
PLS	TA	---
PLW	TA	---
PLR	TA	---
PLF	SA	---
PLO	SA	IMP

JNCLAS  
SUBJ: ACCELERATION OF CURRENT PROGRAM TO SIMPLIFY SUPPLY PUBLICATIONS  
A. DRCMM-SL LTR DTD 15 DEC 77 SAE (U)  
B. DRCMM-MP LTR DTD 8 MAR 78 SUBJ: USE OF CA FORM 2062 (HAND RECEIPT) WITH OPERATOR'S MANUALS (U) (INCL)  
C. DALG-ZXT LTR DTD 10 MAR 78, SAE (U) (INCL)  
1. REF A TASKED MRSA TO COORDINATE A SCHEDULE FOR UPDATING 142 CLS TO INCLUDE A HAND RECEIPT AND TO MONITOR PROGRESS IN COMPLETING THE TASK. REF B PROPOSED TO DA THAT THE HAND RECEIPT FOR THE CLS BE PUBLISHED AS A SEPARATE DOCUMENT BUT CROSS REFERENCED TO THE EASIC NUMBER. REF C APPROVED THE PROPOSAL IN REF B.  
2. IN ACCORDANCE WITH THE ABOVE, REQUEST SUBSEQUENT ACTIONS TO PRODUCE HAND RECEIPTS FOR CLS EMPLOY THE CONCEPT OF THE HAND RECEIPT BEING A SEPARATE DOCUMENT. MRSA WILL PROVIDE ADDITIONAL DETAIL GUIDANCE AS REQUESTED TO IMPLEMENT THIS CONCEPT.  
BT

ACTION ADDRESSEES  
C06/CAAC  
INFORMATION ADDRESSEES  
EE4 CAAG  
O12 CAMC  
UCC18 TOTAL NUMBER OF COPIES REQUIRED  
41177

\*\*\*\*\*  
\* UNCLASSIFIED \*  
\*\*\*\*\*

PAGE 01  
111340Z APR 78  
RUKLCAR/1177

\*\*\*\*\*  
\* UNCLASSIFIED \*  
\*\*\*\*\*

DEPARTMENT OF THE ARMY  
PENTAGON TELECOMMUNICATIONS CENTER

EX	
EX	
EX	
EX	
EX	
EX	
EX	
EX	
EX	
EX	
EX	
EX	

CDSN = SCD665    MCN = 78131/01371    TOR = 781310M12  
RTTUZYUW RUKLDAR 1200 1301728-UUUU--RUEADWD.  
ZNR UUUUU

R 101715Z MAY 78  
FM CDRDARCOM ALEX VA //DRCMM-SL//  
TO AIG 7536  
RUEMANI/CDRGMPA NCAD NEW CUMBERLAND PA  
INFO RUCLBNB/CDRUSAMRSA LEXINGTON KY  
RUEOPEA/CDREMRA VHFS WARRENTON VA  
RUEORDB/CDRMMA FT DETRICK MD  
RUEDEBE CDRUSASPTA PHILA PA  
RUEMANA/CDARCOM CGA NEW CUMBERLAND PA  
RUEADWD/DA WASHDC //DALU-ZXT//  
RUWJHRA/CDRUSACSLA FT HUAFUCA AZ//  
BT

UNCLAS  
SUBJ: ACCELERATION OF CURRENT PROGRAM TO SIMPLIFY SUPPLY PUBLICATIONS

- A. DRCMM-SL LTR DTD 16 DEC 77 (U) (NOTAL)
  - B. DRXMD-SE LTR DTD 24 APR 78 (U) (NOTAL)
  - C. AR 710-2 (U)
1. IT HAS BEEN BROUGHT TO OUR ATTENTION THAT SOME HAND RECEIPTS (DA FORM 2062) HAVE BEEN PUBLISHED UNDER PROGRAM ESTABLISHED BY REF A. WITHOUT THE AUTHORIZED QUANTITY BEING PREPRINTED ON THE FORM. THE REASON FOR THIS IS THAT REF C STATES THAT THIS WILL BE A PENCIL ENTRY.
2. REF B PROVIDED A DRAFT MIL-M-63007 (TM) WHICH COVERS THE PUBLICATION OF THE PREPRINTED HAND RECEIPT AS A SEPARATE PUBLICATION. THIS DRAFT REQUIRES THE AUTHORIZED QUANTITY TO BE PREPRINTED ON THE HAND RECEIPT. REF B TAKES PRECEDENCE OVER REF C FOR ALL HAND RECEIPTS FOR CLS BEING PREPRINTED UNDER SUBJECT PROGRAM. REQUEST ADDRESSEES ESTABLISH THE NECESSARY CONTROLS TO ASSURE THAT ALL OVERPRINTED HAND RECEIPTS PRODUCED BY YOUR ACTIVITY INCLUDE THE PREPRINTED AUTHORIZED QUANTITY.

BT  
ACTION ADDRESSEES  
006 DALO  
INFORMATION ADDRESSEES  
EE4 DAAG  
012 DAMO  
*00018 TRER  
NANA*

\*\*\*\*\*  
\* UNCLASSIFIED \*  
\*\*\*\*\*

PAGE 01  
101715Z MAY 78  
RUKLDAR/1200

\*\*\*\*\*  
 \* UNCLASSIFIED \*  
 \*\*\*\*\*

DEPARTMENT OF THE ARMY  
 PENTAGON TELECOMMUNICATIONS CENTER

CDSN = SCD821 MCN = 78131/02598 TOR = 781310239  
 RTTUZYUW RUKLDAR1278 1302002-UUUU--RUEADWD.  
 ZNR UUUUU  
 R 101720Z MAY 78  
 FM CORDARCOM ALEX VA//DRXMM-SP//  
 TO RUCLBNB/CDRMRSA LEXINGTON KY//DRXMC-SE//  
 INFO RUEAMND/CDRARCCH CDA NCAD PA//DRXCA-M//  
 RUEADWD/DA WASH DC//CALG-ZXT//  
 BT

UNCLAS  
 THIS IS A PROPER COUNT MESSAGE  
 SUBJ: ACCELERATION OF CURRENT PROGRAM TO SIMPLIFY SUPPLY  
 PUBLICATIONS (S: 19 MAY 78)  
 A. DALO-ZXT MSG CTD 081930Z MAY 78 (U)  
 REF A YOURS FOR ACTION AS REQUIRED BY PARA 4.  
 BT

ACTION ADDRESSEES  
 006 DALO  
 00006 TOTAL NUMBER OF COPIES REQUIRED  
 #1278

BKS	THCL	SM
ZX	TA	SMT
ZXT-A	LE	SMS
ZXA	TSM	SM
ZXA-C	TST	SM
AV	...	...
PL	...	...
PES	...	...
PIV	...	...
PIR	...	...
PIF	...	...
PLO	...	...

\*\*\*\*\*  
 \* UNCLASSIFIED \*  
 \*\*\*\*\*

PAGE 01  
 101720Z MAY 78  
 RUKLDAR/1278



\*\*\*\*\*  
 \* UNCLASSIFIED \*  
 \*\*\*\*\*

PENTAGON TELECOMMUNICATIONS CENTER

CDSN = SCD515 MCA = 78138/17257  
 PTTUZYUW RUKLDAR2167 1381614-UUUU--RUEADWD  
 ZNR UUUUU  
 R 181613Z MAY 78  
 FM CDRDARCOM ALEX VA//DRCMM-SL//  
 TO AIG 7536  
 RUEMANI/CDRGMPA NCAD NEW CUMBERLAND PA  
 RUEOPEA/CDREMRA VFES WARRENTON VA  
 RUEDEBE/CDRUSASPTA PHILA FA  
 RUEORDA/CDRMMA FT GETRICK MD  
 RUWJHRA/CDRUSACSLA FT HUACHUCA AZ  
 INFO RUCLBNA/CDRLSAMRSA LEXINGTON KY  
 RUEMANA/CDRARCUMCEA NEW CUMBERLAND PA  
 RUEADWD/DA WASHDC//CALC-ZXT//  
 BT

BKS	THCL	SM
ZX	TA	SWT
ZXA	TSM	SWS
ZXA-C	TST	SXM
AV	TSE	SNL
FL	TSP	SND
PLS	SAC	RM
PLW	SAB	RMB
PLR	CAA	RMC
PLF	SA	RMT
PLQ		RMP

UNCLAS

SUBJ: ACCELERATION OF CURRENT PROGRAM TO SIMPLIFY SUPPLY PUBLICATIONS

1. IT HAS BEEN BROUGHT TO OUR ATTENTION THAT SOME HAND RECEIPTS (HR) (DA FORM 2062) FOR CL(S) HAVE BEEN PRINTED AND RELEASED TO THE FIELD WITHOUT AN ENTRY TO INDICATE THE DATE OF THE CL TO WHICH THE HR APPLIES.
2. DRAFT MIL-M-63007(1M) DISTRIBUTED BY DRXMD-SE LTR DTD 24 APR 78, SUBJ: IMPLEMENTATION OF DA FORM 2062 (HAND RECEIPT) FOR SUPPLY CATALOGS FOR COMPONENT LIST GIVES AN EXAMPLE ON PAGE 12 OF HOW THE CURRENT DATE OF THE CL SHOULD BE SHOWN.
3. IN THE EVENT YOU HAVE ANY CLS/HRs CURRENTLY IN THE APPROVAL AND/OR PRINTING STAGES OF PRODUCTION WHICH DO NOT CONTAIN THE PRE-PRINTED DATE OF THE APPLICABLE CL ON THE HR, REQUEST THE FOLLOWING ACTION(S) AS APPLICABLE:
  - A. IF THE PUBLICATION(S) WERE FORWARDED TO TAG FOR APPROVAL AND PRINTING PLEASE CONTACT MS HAVERSTICK ON AUTOVON 223-7556 AND PROVIDE THE REQUIRED DATE(S) TO HER. IF POSSIBLE SHE WILL GET THE DATE ADDED TO THE HR BEFORE PRING AND DISTRIBUTION.
  - B. IF YOU WENT TO TAG AND OBTAINED APPROVAL TO PRINT THE CL/HR LOCALLY THROUGH CONTRACTORS PLEASE CONTACT THEM AND HAVE THE DATE ADDED TO THE HR IF IT CAN BE DONE WITHOUT DELAYING THE PRODUCTION.
4. REQUEST YOU ASSURE THAT ALL HR FORWARDED FOR PRINTING SINCE SEQUENT TO RECEIPT OF THIS MESSAGE ARE PREPARED IN ACCORDANCE

\*\*\*\*\*  
 \* UNCLASSIFIED \*  
 \*\*\*\*\*  
 PAGE 01  
 181613Z MAY 78  
 RUKLDAR/2167

\*\*\*\*\*  
\* UNCLASSIFIED \*  
\*\*\*\*\*

PENTAGON TELECOMMUNICATIONS CENTER

WITH DRAFT MIL-M-63007(TM).  
BT  
ACTION ADDRESSEES  
006 DALO  
00006 TOTAL NUMBER OF COPIES REQUIRED  
#2167

NNNN

\*\*\*\*\*  
\* UNCLASSIFIED \*  
\*\*\*\*\*

\*\*\*\*\*  
\* UNCLASSIFIED \*  
\*\*\*\*\*

DEPARTMENT OF THE ARMY  
PENTAGON TELECOMMUNICATIONS CENTER

CDSN = 5CD125 MCN = 781387/2597 TOR = 781381533  
RTTUZYUW RUCI BNA4215 1381504-0000--RUCIADWD,  
ZNR 0000  
R 181500Z MAY 78  
FM CDR MRSA LEXINGTON KY //DRXME-SE//  
TO RUEADWD/DA WASH DC //LALC-ZX1//  
INFO RUEKLDAR/CDR DARCOM ALA VA //DRCOM-SP/DRCOM-SU//  
RUCIAPB/CDR ARKCOLM BUCK ISL ILL //DRSER-PAS/DRSAA-MA-TADP//  
RUEDEIA/CDR CERCEM FT MON NJ //DRSEI-PA-LT//  
RUCDODA/CDR MIRCOP MEDSTEN ARS AL //DRSMI-SUB/DRSMI-NPS//  
RUCIEMM/CDR FARCOM WAREH MI //DRSOM-1/DRSOM-RVD//  
RUCIFRA/CDR ISARCOM SIL MI //DRSIS-SXP-C/DRSIV-Q//  
RUEMANI/CDR GMPA NCAD PA //SISGP-17//  
RUEMAND/CDR CDA NCAD PA //DRXCA-C//  
RUEADWD/DA WASH DC //LALC-PAF//  
BT

UNCLAS

SUBJ: ACCELERATION OF CURRENT PROGRAM TO SIMPLIFY SUPPLY PUBLICATIONS  
(S 19 MAY 78)

A. LTR MRSA DRXME-SE 24 APR 78 (U)

B. YOUR 081930Z MAY 78 (U)

1. PLANNED ACCOMPLISHMENTS REQUESTED IN REF B ARE AS FOLLOWS:

A. PARAGRAPH 1: CONTACT HAS BEEN MADE WITH VARIOUS MPCs CONCERNING  
OVERPACKING SCs AND HAND RECEIPT WITH PHYSICAL SKOS IN FUTURE ISSUES.

B. CONSENSUS OF OPINION IS THAT THIS IS NO PROBLEM.

C. MRSA WILL PROVIDE GUIDANCE TO ISSUING COMMANDS TO INCLUDE IN THE  
FIR

PACKING LIST OR PROCUREMENT PACKAGE THE APPROPRIATE SC AND HAND RECEIPT  
BT

WHEN SHIPPING SKOS TO RECIPIENTS. TARGET DATE 5 JUNE 78.

D. APPROPRIATE CHANGES TO AR 310-3, CHAPTER 12, AND DARCOM-R 750-4

5

WILL BE RECOMMENDED BY MRSA. TARGET DATE 30 MAY 78.

F. PARAGRAPHS 2 AND 3: QUANTITIES FOR COLUMN T, DA FORM 2062 AND  
PARAGRAPH 3, FORMAT FOR HAND RECEIPT: INSTRUCTIONS TO PROPONENTS HAS  
BEEN ISSUED VIA REFERENCE A.

2. REQUEST THE LATEST ADVERTISE ACTION TO BE TAKEN IN IC AND ID. USA  
POINT OF CONTACT FOR THIS SUBJECT IS MR. ANDY DALLAK, AUTOVON 745-413

7.

BT

\*\*\*\*\*  
\* UNCLASSIFIED \*  
\*\*\*\*\*

PAGE 01  
181500Z MAY 78  
RUCI BNA/4215

\*\*\*\*\*  
\* UNCLASSIFIED \*  
\*\*\*\*\*

DEPARTMENT OF THE ARMY  
PENTAGON TELECOMMUNICATIONS CENTER

ACTION ADDRESSES  
106 DALO  
INFORMATION ADDRESSES  
1E4 DAAG  
00006 TOTAL NUMBER OF COPIES REQUIRED  
44215

NNNN

300

\*\*\*\*\*  
\* UNCLASSIFIED \*  
\*\*\*\*\*

PAGE 02  
1 297 MAY 78  
VAL 3NA/4215

\* UNCLASSIFIED \*

DEPARTMENT OF THE ARMY  
PENTAGON TELECOMMUNICATIONS CENTER

CDSN = SCD342    MCN = 78152/15701    TOR = 781521742  
 RTTUZYUW RUCLBNA46J4 1521724-UUUU--RUEADWD.  
 ZNR UUUUU  
 R 011710Z JUN 78  
 FM CDR MRSA LEX KY //DRXMD-SE//  
 TO RUKLDAR/CDR DARCOM ALEX VA //DRCMM-MS//  
 INFO RJKLDAR/CDR CARCOM ALEX VA //DRCMM-SP/DRCMY-SL//  
 RUEADWD/DA WASH DC //CALG-ZXT//  
 BT

UNCLAS  
 SUBJ: ACCELERATION OF CURRENT PROGRAMS TO SIMPLIFY SUPPLY PUBLICATION S

1. YOUR 101845Z MAR 78 (U).
2. REF A DIRECTED MRSA TO ESTABLISH A PROCEDURE FOR OVERPACKING SUPPLY CATALOG AND HAND RECEIPTS FOR COMPONENT LIST PRIOR TO ISSUE TO USER.
3. MRSA HAS QUERIED PERSONNEL AT PROPONENT MRCS ABOUT THE FEASIBILITY OF THIS REQUIREMENT AND HAS DETERMINED IT IS FEASIBLE.
4. REQUEST THAT DARCCM-R 750-45, 17 NOV 77, BE UPDATED TO INCLUDE OVERPACKING AS CITED IN PARA 1 ABOVE.
5. YOUR IMMEDIATE RESPONSE TO THIS REQUEST IS URGENTLY REQUIRED TO SUPPORT THE EFFORTS OF THE DA PROPERTY ACCOUNTABILITY TASK FORCE RELATIVE TO COMPONENT PARTS ACCOUNTABILITY WITHIN THE ARMY IN THE FIELD.
6. MRSA POC IS MR ANDY DALLAK, AUTOVON 745-4137. A REPLY IS EXPECTED BY COB 12 JUN 78.

BT  
 ACTION ADDRESSEES  
 006 DALO  
 00006 TOTAL NUMBER OF COPIES REQUIRED  
 #46J4

BKS	TA	SM
ZX	LE	CMT
ZXA	TSM	SMS
THCL	TST	SMM
AV	TSE	SNW
PL	TSP	SML
PLW	TS	SMD
PLS	SAC	RM
PLR	SAB	PMB
PLF	SAA	RMO
PLO	SA	RMI
		RMP

\*\*\*\*\*  
 \* UNCLASSIFIED \*  
 \*\*\*\*\*

PAGE 01  
 011710Z JUN 78  
 RUCLBNA/46J4

\* UNCLASSIFIED \*

DEPARTMENT OF THE ARMY  
PENTAGON TELECOMMUNICATIONS CENTER

DDSN = SCD34J MCN = 78152/15698 TOR = 781521742  
RTTUZYUW RUCLBNA4603 1521725-UUUU--RUEADWD.  
ZNR UUUUU  
R 011700Z JUN 78  
FM CDR MRSA LEX KY //CRXMD-SE//  
TO RUEADWD/CDR DA WASH DC //DALO-ZXT//  
INFO RUEMANA/CDR USALEA NEW CUMBERLAND PA //DALO-LER//  
BT

*FAW*  
✓

UNCLAS

SUBJ: REVISION OF AR 710-2 TO INCLUDE INSTRUCTIONS ON USE OF HAND RECEIPTS.

1. FONECON, 25 MAY 1978, BETWEEN LTC O'HARA, DAPATF, AND MR. DALLAK, MRSA, SUBJECT AS ABOVE.

1. DURING REFERENCED FONECON IT WAS DETERMINED THAT YOUR OFFICE HAS TASKED LEA TO UPDATE AR 710-2 SO THAT INSTRUCTIONS TO THE FIELD ON THE PROPER USE OF THE DA FORM 2062 HAND RECEIPT PUBLICATIONS IN RELATIONSHIP TO COMPONENT LIST SUPPLY CATALOGS ARE COMPLETE AND IN ACCORDANCE WITH DA POLICY.

2. REQUEST THAT MRSA BE ADVISED OF THE ANTICIPATED DATE FOR COMPLETION OF THE REVISION OF AR 710-2 IN ORDER TO COMPLETE IN-HOUSE PLANNING FOR RELEASE OF A PS MAGAZINE ARTICLE ON SAME SUBJECT.

BT

ACTION ADDRESSEES

006 DALO

00006 TOTAL NUMBER OF COPIES REQUIRED

#4603

BKS	TA	SM
ZX	LE	SMT
ZXT	TSM	SMS
ZXA	TST	SMM
THCL	TSE	SMW
AV	TSP	SML
PL	TS	SMD
PLW	SAC	RM
PLS	SAB	RMB
PLR	SAA	RMO
PLF	SA	RMI
PLO		RMP

\*\*\*\*\* UNCLASSIFIED \*\*\*\*\*

PAGE 01  
011700Z JUN 78  
RUCLBNA/4603

\*\*\*\*\*  
\* UNCLASS E F T O \*  
\*\*\*\*\*

DEPARTMENT OF THE ARMY  
PENTAGON TELECOMMUNICATIONS CENTER

CDSN = SCD120 MCN = 78171/C2442 TOR = 781710317  
RTTEZYUW RUCLHTA1514 1710z2C-EEEE--RUEADWD.  
ZNY EEEEE  
R 191850Z JUN 78  
FM CDR FORSCCM FT MCPIERSON GA //AFLG-SMS//  
TO RUEADWD/DA WASH DC //CALC-ZXT//  
RUKLDAR/CDR CARCCM ALEX VA //CRCIS-S//  
BT

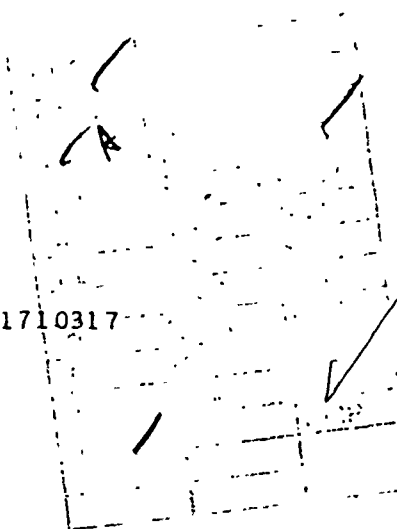

UNCLAS E F T O  
THIS IS A PROPER CCUNT MESSAGE  
SUBJECT; COMPONENT LISTINGS OF INTEGRAL COMPONENTS OF END ITEMS,  
DA FORMS 2062.  
A. DA CONFERENCE, 14-15 JUN 78, SUBJECT; STANDARDIZATION OF  
DEFINITIONS AND TITLES (BII AND AAL)  
B. CALD-ZXT LETTER, 7 DEC 77, SUBJECT; ACCELERATION OF CURRENT  
PROGRAM TO SUPPLY PLEICATIONS.  
1. REF CONFERENCE IDENTIFIED A MAJOR PROBLEM WHICH WILL SURFACE  
IN REVISED TECHNICAL MANUALS, -10 SERIES, IN COMPLIANCE WITH REF B.  
2. REF B DIRECTED CARCGM TC REVIEW AND TAKE ACTION TO REVISE  
OPERATOR'S MANUALS TO INCLUDE THE DA FORM 2062, HAND RECEIPT, AS  
A COMPONENT LISTING IN A REPRODUCIBLE FORMAT. REF B DIRECTED THIS  
COMPONENT LISTING TO INCLUDE BASIC ISSUE ITEMS AND DISCRETIONARY  
ITEMS (NONCONSUMABLE).  
3. REF A INDICATED CARCCM WAS PROCEEDING ON THIS GUIDANCE AND  
THAT THOSE ITEMS PRESENTLY IDENTIFIED AS INTEGRAL COMPONENTS OF  
END ITEMS WOULD NOT BE IDENTIFIED/LISTED ON THE REPRODUCIBLE  
DA FORMS 2062.  
4. FORSCOM CONTENDS THAT COMPLIANCE WITH RECOMMENDATION 6H OF  
THE SPECIAL IG REFCRT ON PROPERTY ACCOUNTABILITY REQUIRES THAT  
"ALL" COMPONENTS MUST BE BROUGHT UNDER CONTROL WITH OUT THE USER  
HAVING TO OBTAIN THE COMPONENT LISTING FOR BII AND AAL FROM THE  
MANUAL AND HAVING TO TYPE THOSE LISTING THE INTEGRAL COMPONENTS  
OF THE END ITEM.  
5. REQUEST CA REVIEW OF REQUIREMENTS OF REF B TO INCLUDE  
INTEGRAL COMPONENTS OF END ITEM.

BT

ACTION ADDRESSEES

J06 DALO

INFORMATION ADDRESSEES

J00

00006 TNR

\*\*\*\*\* AMRD \*\*\*

303

\*\*\*\*\*  
\* UNCLASS E F T O \*  
\*\*\*\*\*

PAGE 01  
191850Z JUN 78  
RUCLHTA/1514

## Chapter 13

### IAR Restrictions

1. Recommendation 6I. Restrict the inventory adjustment report system to those administrative transactions which are needed to adjust stock record accounts and automated property book records, but do not represent actual loss or consumption of material.

2. DAPATF actions:	<u>Volume</u>	<u>Page</u>
a. Proper Count Flasher Message No. 1, DTG 251818Z Oct 77, Inventory Adjustment Report (DA Form 444).	1	5
b. Proper Count Message, DTG 101520Z Nov 77, Inventory Adjustment Report (IAR)(DA Form 444).	1	36
c. Proper Count Message, DTG 211857Z Nov 77, Conference to Identify Modifications to Inventory Adjustment Procedures, Documents, and Related Summary Data Needs for Managers.	1	42
d. Proper Count Message, DTG 081702Z Dec 77, Conference to Identify Modifications to Inventory Adjustment Documents and Related Summary Data Needs for Managers.	1	49
e. Letter, 22 Mar 78, Requested Deviation to DOD 7200.10-M.	1	225
f. Letter, 31 Mar 78, Clarification of AR 710-2, Paragraph 2-12d.	2	245
g. Proper Count Message, DTG 231332Z Jun 78, Accounting for Damaged Property.	3	57
3. MACOM responses:	<u>Page</u>	<u>Tasking Ref</u>
Message, CDR USACC, DTG 181541Z May 78, Inventory Adjustment Report (DA Form 444).	306	2a



RESTRICT INVENTORY ADJUSTMENT REPORT (IAR)

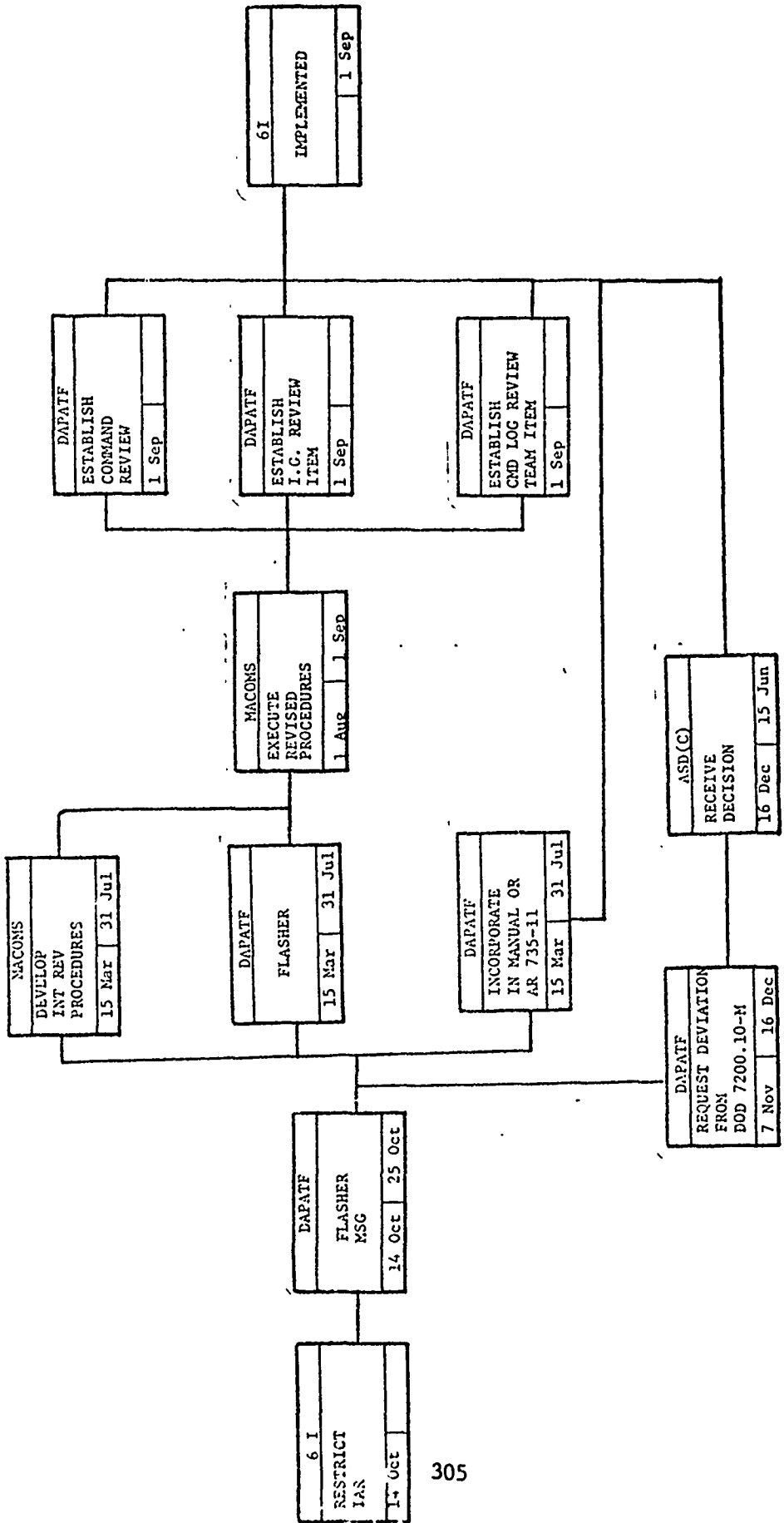

\*\*\*\*\*  
 \* UNCLASSIFIED \*  
 \*\*\*\*\*

PENTAGON TELECOMMUNICATIONS CENTER

CDSN = SCD670 MCM = 78136/19180 TCR = 781382020  
 RTTUZYUW RUWJHRA1734 1381932-0000--KLEADWD.  
 ZNR UUUUU  
 P 181541Z MAY 78  
 FM COMUSACC FT FLACFUCA AZ //CC-LOG-SMT-SD//  
 TO AIG 899  
 INFO RUEADWD/OA WASHDC //CALC-ZXT//  
 BT

UNCLAS

SUBJ INVENTORY ADJUSTMENT REPORT (DA FORM 444) (U)

A. DA WASHDC CALC-ZXT 251818Z OCT 77 (U)

3. AR 735-11 (U)

1. PARA 6 OF REF A PLACED SPECIFIC REQUIREMENTS ON MACOMS IN COMPLYING WITH PARA 2-S, REF B. THIS HQ HAS DELAYED REQUIRING SUBCOMDS TO SUBMIT DATA TO MEET THIS REQUIREMENT BECAUSE OF INFORMATION INDICATING IMMINENT MAJOR REVISION OF REF B.

2. ADDITIONAL INFORMATION RECENTLY RECEIVED INDICATES NEW AR 735-11 WILL BE IMPLEMENTED 1 JUL 78 AND WILL INCLUDE GREATLY EXPANDED LOSS REPORTING AND ANALYSIS REQUIREMENTS.

3. PENDING RECEIPT OF THE REVISED REGULATION, THIS HQ WILL PLACE NO REPORTING REQUIREMENT ON SUBCOMDS IN CONNECTION WITH REF A.

BT

ACTION ADDRESSEES

006 DALO

00006 TOTAL NUMBER OF COPIES REQUIRED  
 #1734

BKS	THCL	SM
ZX	TA	SMT
ZXT	TE	SMS
ZXA	TF	SMM
ZXA-C	TG	SML
AV	TH	SML
PL	TI	SMD
PLS	TJ	SMD
PLW	TK	SMD
PLR	TL	SMD
PLF	SA	SMT
PLD		RMP

\*\*\*\*\*  
 \* UNCLASSIFIED \*  
 \*\*\*\*\*

PAGE 01  
 181541Z MAY 78  
 RUWJHRA/1734

Chapter 14

Droppage Allowance

1. Recommendation 6J. Establish a reasonable periodic allowance for droppage of property accountability at the unit level which recognizes the inevitability of loss, damage, or destruction of material in the course of realistic peacetime readiness training.

2. DAPATF actions:

Volume

Page

Covered under Recommendation 60,  
Report of Survey.

3. MACOM responses:

Page

Tasking Ref

ESTABLISH PERIODIC ALLOWANCE FOR DROPPAGE

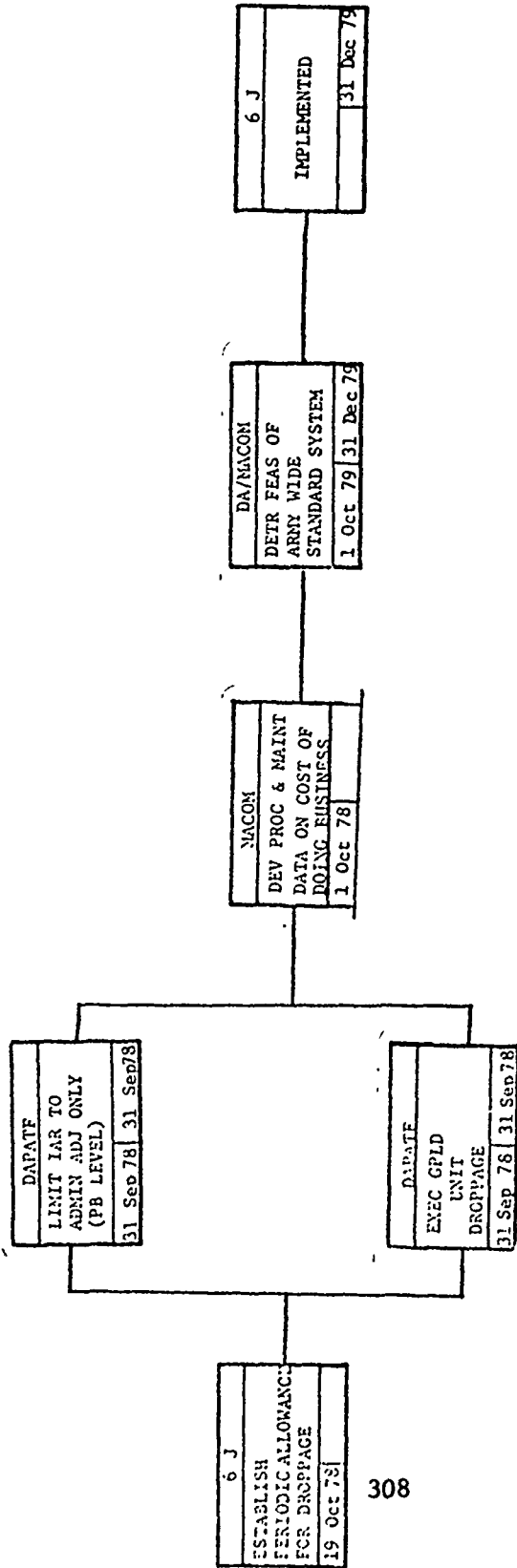

## Chapter 15

### Equipment/Component Recategorization

1. Recommendation 6K. Recategorize equipment and components as expendable and nonexpendable under definitions which simply and realistically differentiate between those items which are consumable in training and garrison operations and those items which must be accounted for until worn-out or obsolete.

2. DAPATF actions:

Letter, 17 May 78, Recategorization of Supplies and Equipment.

Volume      Page

3              92

3. MACOM responses:

a. Message, CINCUSAREUR, DTG 131429Z Jun 78, no subject.

Page              Tasking Ref

311              2

b. Message, CDR USARJ, DTG 140558Z Jun 78, Recategorization of Supplies and Equipment.

312              2

REALISTICALLY RE-CATEGORIZE EQUIPMENT AND COMPONENTS AS EXPENDABLE OR NON-EXPENDABLE

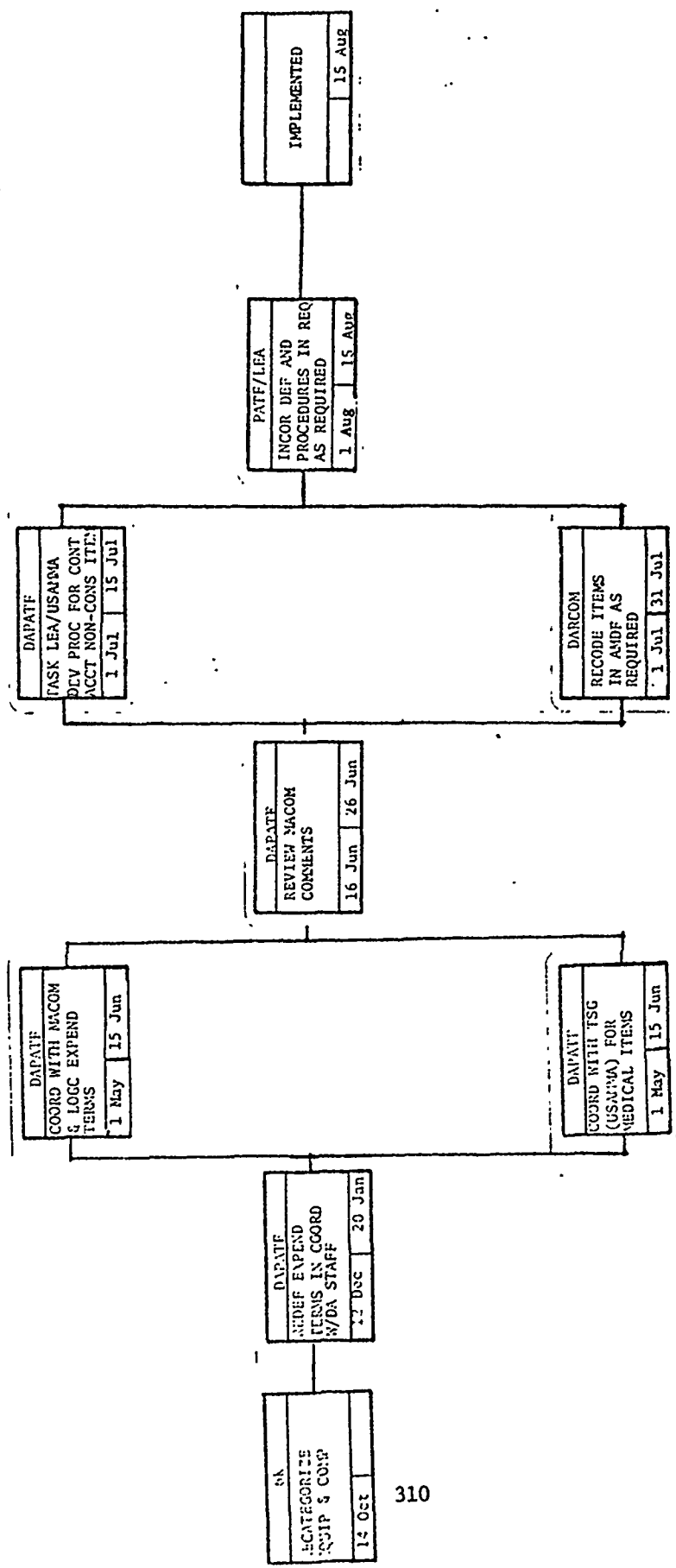

\*\*\*\*\*  
 \* UNCLASSIFIED \*  
 \*\*\*\*\*

DEPARTMENT OF THE ARMY  
 PENTAGON TELECOMMUNICATIONS CENTER

BKS	TA	SM
ZX	LE	SMT
ZXT	TSM	SMS
ZXA	TST	SMM
THCL	TSE	SMW
AV	TSP	SML
PL	TS	SMD
PLW	SAC	SM
PLS	SAB	SMB
PLR	SAA	SMA
PLF	SA	SMI
PLQ		SMP

CDSN = SCD732 MCA = 78166/1JJ89 TOR = 78161242  
 RTTUZYUW RUFDAAA1C94 1661234-UUUU--RUEADWD.  
 ZNR UUUUU  
 R 131429Z JUN 78  
 FM CINCUSAREUR HEIDELBERG GERMANY//AEAGD-SM-F//  
 TO DA WASH DC//DALO-ZXT//  
 BT

UNCLAS

1. REF REQUESTS COMMENTS/CONCURRENCE ON PROPOSAL TO ADD A NEW EXPENDABILITY CRITERIA.
2. CONCUR WITH PROPOSAL IN REF. USAREUR FIELD UNITS ALSO RECOMMEND CONSIDERATION OF THE FOLLOWING RECOMMENDATIONS:
  - A. THE 50 DOLLAR UNIT VALUE LIMITATION SHOULD BE INCREASED TO 100 DOLLARS TO BE REPRESENTATIVE OF EQUIPMENT VALUE TO BE SAFEGUARDED AND APPROXIMATE THE BREAK POINT BETWEEN STATEMENTS OF CHARGES VERSUS REPORT OF SURVEYS.
  - B. COMMODITY COMMANDS SHOULD BE ADVISED NOT TO RECLASSIFY NON-CONSUMABLE COMPONENTS OF ALL SETS, KITS AND OUTFITS ON A BLANKET BASIS. THIS WILL ENSURE THAT THE INCREASED ADMINISTRATIVE COSTS ARE NOT OUTWEIGHED BY THE EXPECTED SAVINGS.
  - C. DURABLES SHOULD BE SPECIFICALLY AUTHORIZED FOR STOCKAGE IN SELF MADE ONLY TO PROPERTY BOOK OFFICER REPRESENTATIVES.
  - D. EXPENDABILITY CODE TITLE APPEARS TO BE OUTDATED AND SHOULD BE RETITLED "ACCOUNTABILITY CODE" IN AMDF. ADOPTION OF THIS RECOMMENDATION MAY ALLOW FOR ELIMINATION OF TERMS "CONSUMABLE" AND "NONCONSUMABLE."
  - E. CHANGES TO AUTOMATED SYSTEMS (I.E. SALES AND LOGS) SHOULD BE DIRECTED CONCURRENT WITH CATALOG CHANGE BROADCASTS.
  - F. MOVEMENT OF RECOVERABILITY CODE ALONG SIDE EXPENDABILITY CODE IS PARTICULARLY NOTeworthy TO AMDF USERS.
3. HQ USAREUR ACTO IS MAJ KAPKE HBG MIL 676J.

BT

ACTION ADDRESSEES

006 DALO  
 0006 TOTAL NUMBER OF COPIES REQUIRED  
 #1094

\*\*\*\*\*  
 \* UNCLASSIFIED \*  
 \*\*\*\*\*

PAGE 01  
 131429Z JUN 78  
 RUFDAAA/1094

\*\*\*\*\*  
\* UNCLASSIFIED \*  
\*\*\*\*\*

DEPARTMENT OF THE ARMY  
PENTAGON TELECOMMUNICATIONS CENTER

CDSN = SC0J51 MCN = 78165/0000 TOR = 781650954  
RTTUZYUW RUADJHA1188 1050002-0000--RUEADWD.  
ZNR UUUUU  
R 140558Z JUN 78  
FM CDRUSARJ CPZAMA JAPAN//ALGO-SE//  
TO DA WASHDC//LALC-ZXT//  
BT

UNCLAS

THIS IS A PROPER COUNT MESSAGE.

SUBJ RECATEGORIZATION OF SUPPLIES AND EQUIPMENT

A. LTR DALO-ZXT HQDA 17 MAY 78 (U).

B. AR 710-2 (U)

C. AR 735-5 (U)

1. COMMENTS/RECOMMENDATIONS TO REF A, KEYED TO APPL  
PARA, ARE PROVIDED AS FOL

A. PARA 5 - CONCLR

B. PARA 7 - PROPOSED POLICY EXEMPTS DURABLE ITEMS FROM  
PROPERTY BOOK ACCOUNTABILITY WITH CONTROL LIMITED TO  
HANDRECEIPT/HANDRECEIPT ANNEX. DETAILED GUIDANCE WILL  
BE REQUIRED FOR THIS INFORMAL ACCOUNTING PROCEDURE TO  
INSURE COMPLIANCE WITH ACCOUNTING STANDARDS. INCREASE IN  
WORKLOAD IS ANTICIPATED AT PROPERTY BOOK/HANDRECEIPT LEVEL  
IF ALL DURABLE ITEMS REQUIRE HANDRECEIPT CONTROL.

C. PARA 8 - A SEPARATE DOCUMENT REGISTER SHOULD BE  
MAINTAINED FOR DURABLE ITEMS TO FACILITATE IDENTIFICATION  
OF ITEMS REQUIRING HANDRECEIPT CONTROL.

D. PARA 9 - CONCLR.

2. RECOMMEND NEW EXPENDABILITY CODE TO INCLUDE DETAILED  
ACCOUNTING PROCEDURES FOR DURABLE ITEMS BE INCORPORATED  
IN REF B AND C PRIOR TO IMPLEMENTATION

BT

ACTION ADDRESSEES

006 DALO

00006 TOTAL NUMBER OF COPIES REQUIRED

#1188

\*\*\*\*\*  
\* UNCLASSIFIED \*  
\*\*\*\*\*

312

PAGE 01  
140558Z JUN 78  
RUADJHA/1188



## Chapter 16

### Equipment Authorization System

1. Recommendation 6L. Redesign the equipment authorization system to restrict issue of material to the user to the minimum essential for mission accomplishment at a specific time and place. Maintain centralized control at the highest level feasible of material that is needed only periodically.

2. DAPATF actions:

	<u>Volume</u>	<u>Page</u>
a. Proper Count Message, DTG 131752Z Jan 78, Review of MTOE/TDA Authorized Secondary Items.	2	22
b. Proper Count Message, DTG 051852Z Apr 78, Review of the Equipment Survey Process.	3	18
c. Proper Count Message, DTG 051854Z Apr 78, Equipment Authorization Policies and Procedures Review.	3	20

3. MACOM responses:

	<u>Page</u>	<u>Tasking Ref</u>
a. Message, CDR USARJ, DTG 140045Z Apr 78, Review of the Equipment Survey Process (S: 30 Apr 78).	317	2b
b. Message, CDR HSC, DTG 181712Z Apr 78, Review of the Equipment Survey Process.	319	2b
c. Letter, MTMC, 18 Apr 78, Equipment Authorization Policies and Equipment Survey Process.	320	2b and 2c
d. Message, CDR Admin Cen, DTG 201450Z Apr 78, Review of the Equipment Survey Process.	322	2b
e. Message, CDR Admin Cen, DTG 211247Z Apr 78, Equipment Authorization Policies and Procedures Review.	323	2c
f. Letter, USA Recruiting Cmd, 24 Apr 78, Review of Equipment Survey Process.	324	2b
g. Letter, USA Japan, 24 Apr 78, Equipment Authorization Policies and Procedures Review.	325	2c

	<u>Page</u>	<u>Tasking Ref</u>
h. Message, CDR TOAD Tobyhanna, DTG 251905Z Apr 78, Review of the Equipment Survey Process.	327	2b
i. Message, CDR TOAD, Tobyhanna, DTG 251910Z Apr 78, Equipment Authorization Policies and Procedures Review.	328	2c
j. Message, CDR FORSCOM, DTG 261836Z May 78, Accounting for Rental/Leased Equipment in TAADS (Change to AR 310-49).	329	
k. Message, CDR USACC, DTG 262215Z Apr 78, Equipment Authorization Policies and Procedures Review.	330	2c
l. Letter, HQ Recruiting Command, 26 Apr 78, Equipment Authorization Policies and Procedures Review.	332	2c
m. Letter, HQ FORSCOM, 27 Apr 78, Equipment Authorization Policies and Procedures Review.	334	2c
n. Letter, HQ Computer Systems Cmd, 27 Apr 78, Review of the Equipment Survey Process.	336	2b
o. Message, CDR NCAD, DTG 271830Z Apr 78, Revision of Equipment Survey Process and Authorization Policy and Procedures.	337	2b
p. Message, CDR HSC, DTG 272149Z Apr 78, Equipment Authorization Policies and Procedures Review.	338	2c
q. Letter, West Point, 28 Apr 78, Equipment Authorization Policies and Procedures Review.	339	2c
r. Letter, HQ FORSCOM, 28 Apr 78, Review of the Equipment Survey Process.	341	2b
s. Message, CDR USACIDC, DTG 282030Z Apr 78, Equipment Authorization Policies and Procedures Review.	343	2b and 2c
t. Letter, West Point, 28 Apr 78, Review of Equipment Survey Process.	346	2b

	<u>Page</u>	<u>Tasking Ref</u>
u. DF, NGB-ARL, 2 May 78, Review of the Equipment Survey Process.	347	2b
v. DF, NGB-ARZ-A, 2 May 78, Equipment Authorization Policies and Procedures Review.	348	2c
w. Letter, HQ USACC, 3 May 78, Review of the Equipment Survey Process.	350	2b
x. Letter, DARCOM, 3 May 78, Equipment Authorization Policies and Procedures Review.	351	2c
y. Message, CDR DARCOM, DTG 031430Z May 78, Review of the Equipment Survey Process.	353	2b
z. Message, CDR USASCH, DTG 050110Z May 78, Property Accountability for Discretionary Components of End Items and Organizational Clothing and Equipment (OCE).	354	2a
aa. Message, CDR INSCOM, DTG 051915Z May 78, Review of the Equipment Survey Process.	355	2b
bb. Letter, HQ Computer Systems Command, 8 May 78, Equipment Authorization Policies and Procedures Review.	356	2c
cc. Letter, HQ MDW, 9 May 78, Department of the Army Property Accountability Task Force (DAPATF) Request for Comments.	358	2b and 2c
dd. Message, CDR INSCOM, DTG 091350Z May 78, Equipment Authorization Policies and Procedures Review.	359	2c
ee. Message, CDR EUSA, DTG 310131Z May 78, Accounting for Leased/Rental Property.	360	

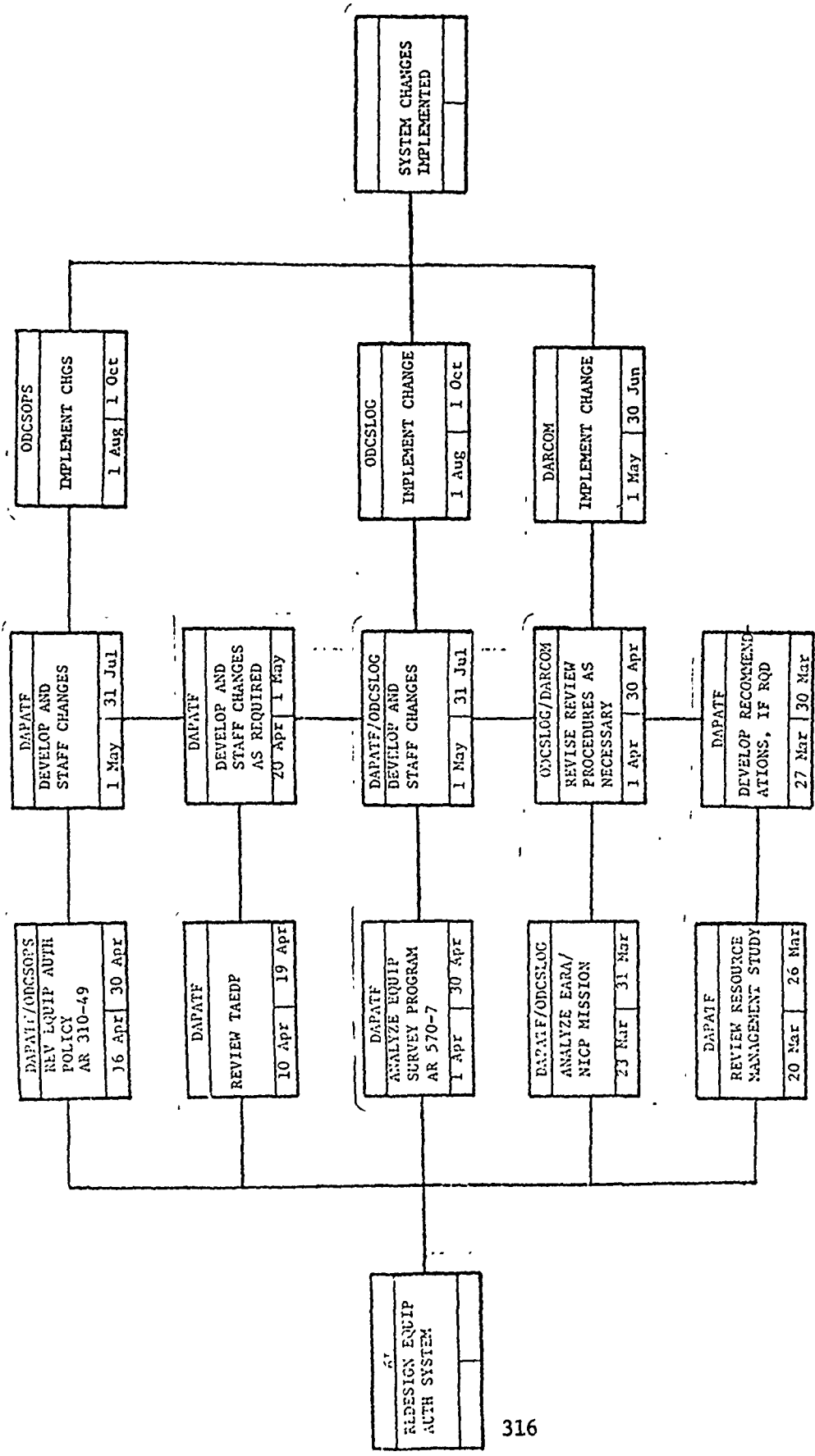

\*\*\*\*\*  
 \* UNCLASS E F T  
 \*\*\*\*\*

ZXT	AE	SIS
ZXA	AE	SIS
ZYA-G	TST	SIT
ZYB-G	TST	SIT
PL	TST	SIS
PLM	SIB	SIB
PLR	SAA	SIC
PLF	SA	SIC
PLO		SMP

DEPARTMENT OF THE ARMY  
 PENTAGON TELECOMMUNICATIONS CENTER

CDSN = SCDC37    MCN = 78104/03539    TCR = 78104C424  
 RTTEZYUW RUACJHA4593 1040054-EEEE--RUEADW  
 ZNY EEEEE  
 R 140045Z APR 78  
 FM CDRUSARJ CPZAMA JAPAN//AJGC-FC//  
 TO DA WASHDC//DALU-ZXT//  
 BT

UNCLAS E F T D

THIS IS A PROPER COUNT MESSAGE  
 SUBJ REVIEW OF THE EQUIPMENT SURVEY PROCESS (S 30 APR 78)

- A. YOUR 051852Z APR 78 (U)
- B. AR 310-34, 24 FEB 75 W/CH 1 AND 2 (U)
- C. AR 570-7, 30 JUN 75 (U)
- 1. FOL COMMENTS KEYED TO PARA 4 SUBPARA OF REF A, ARE PROVIDED IN COMPLIANCE WITH PARA 5 THEREIN.
  - A. FREQUENCY OF SURVEYS AS CONTAINED IN PARA 2-1 OF REF C IS CONSIDERED ADEQUATE. HOWEVER, PARA 2-1A SHOULD BE AMENDED TO PERMIT INDIVIDUAL UNIT SURVEY TO BE RESCHEDULED WHEN REQUIRED, WITHOUT CAUSING SLIPPAGE OF OTHER SCHEDULED UNIT EQUIPMENT SURVEYS.
  - B. CURRENTLY THERE IS ONLY ONE (1) READINESS REPORTING UNIT IN THE COMMAND AND NO PROBLEMS HAVE BEEN ENCOUNTERED. EXPERIENCE FACTOR IN THIS AREA HAS BEEN SUCH THAT NO COMMENTS ARE OFFERED.
  - C. MAKEUP OF SURVEY TEAM HAS BEEN ON AN AD HOC BASIS WITH SELECTION OF MEMBERS IAW CRITERIA OUTLINED IN PARA 2-4 OF REF C. PROCEDURE CAN BE PROBLEMATIC IN CASES OF INDIVIDUAL SURVEYORS, IN THAT BOTH TECHNICAL KNOWLEDGE AND EXTENSIVE MANAGEMENT OF EQUIPMENT DO NOT ALWAYS GO HAND-IN-HAND. TECHNICAL KNOWLEDGE AND APPLICATION/UTILIZATION IS CONSIDERED TO BE OF FIRST IMPORTANCE IN THAT THE TEAM CHIEF SHOULD BE ABLE TO PROVIDE NECESSARY EXPERTISE FOR EQUIPMENT MANAGEMENT.
  - D. PARA 2-2D REF C SHOULD BE AMENDED. INSTEAD OF ENCOURAGING INSTALLATION/UNIT COMMANDERS TO CONDUCT EQUIPMENT REVIEWS PRIOR TO TAADS SUBMISSION, REVIEWS SHOULD BE MADE MANDATORY WITHIN ONE (1) YEAR FROM THE DATE OF THE MACOM SURVEY. RESULTS OF THE INSTALLATION/UNIT SURVEY SHOULD BE AVAILABLE TO THE MACOM EQUIPMENT SURVEY TEAM FOR REVIEW.
  - E. THREE SUCCESSIVE DRAFTS OF CHANGE TO AR 310-34 EQUIPMENT UTILIZATION MANAGEMENT PROGRAM, DATED 15 DECEMBER 75, 30 NOVEMBER

\*\*\*\*\*  
 \* UNCLASS E F T D \*    PAGE C1  
 \*\*\*\*\*    140045Z APR 78  
 \*\*\*\*\*    RUACJHA/4593

\*\*\*\*\*  
\* UNCLASS E F T O \*  
\*\*\*\*\*

DEPARTMENT OF THE ARMY  
PENTAGON TELECOMMUNICATIONS CENTER

76 AND 21 SEPTEMBER 77 WERE REVIEWED AND COMMENTS WERE FURNISHED. CONTENTS OF DRAFT CHANGE TO REF B IN SOME INSTANCES OVERLAP GUIDANCE IN REF C. PROPOONENT FOR REF E IS CAMG-FCU AND PROPOONENT FOR REF C IS DALO-PLR. IT IS RECOMMENDED THAT FEASIBILITY OF COMBINING BOTH PROGRAMS INTO ONE BE TAKEN INTO CONSIDERATION. 2. METHODOLOGY AS PROVIDED IN APPENDIX A TO REF C HAS BEEN USED IN CONDUCTING EQUIPMENT SURVEYS WITHOUT FURTHER LOCAL SUPPLEMENTATION. GUIDANCE AS OUTLINED IN REF C HAS BEEN MORE THAN ADEQUATE FOR USE BY INDIVIDUAL SURVEYORS DURING THE COURSE OF A SURVEY.

BT

ACTION ADDRESSEES

006 DALO

00006 TOTAL NUMBER OF COPIES REQUIRED

#4593

NNNN

318

\*\*\*\*\*  
\* UNCLASS E F T O \*  
\*\*\*\*\*

PAGE 02  
140045Z APR 78  
RUACJHA/4593

\*\*\*\*\*  
\* UNCLASSIFIED \*  
\*\*\*\*\*

DEPARTMENT OF THE ARMY  
PENTAGON TELECOMMUNICATIONS CENTER

ZTA-C
PL
PLS
PII
PIR
PIP
PIV

CDSN = SCD568 MCN = 78108/14481 TOR = 78108-2100  
RTTUZYUW RUWTNFA1926 1081842-UUUU--RUEADWD.  
ZNR UUUUU  
R 181712Z APR 78  
FM CDRHSC FT SAM HOUSTON TX //HSOP-FI//  
TO DA WASH DC //DALO-ZXT//  
BT

UNCLAS

SUBJ: REVIEW OF THE EQUIPMENT SURVEY PROCESS

A. YOUR 051852Z APR 78, SA3.  
B. AR 570-7, EQUIPMENT MANAGEMENT: EQUIPMENT SURVEY PROGRAM DTD  
30 JUNE 1975.

1. THE FOLLOWING COMMENTS ARE KEYDT TO PARA 4A THRU 4E REF A  
ABCVE:

A. RECOMMEND FREQUENCY OF SURVEYS AS SET FORTH IN PARA 2-1 AND  
2-1A REF B, ABOVE, NOT BE CHANGED. PARA 2-1A PROVIDES THE MACOM  
WITH DESIRED FLEXIBILITY, FURTHER RECOMMEND PARA 2-1B BE CHANGED  
TO PERMIT DESK AUDIT FOR UNIT/ACTIVITIES WHOSE TDA VALUES DO NOT  
EXCEED 150,000 DOLLARS REGARDLESS OF LOCATION.

B. SURVEY OF READINESS REPORTING ELEMENTS WOULD BE DESIRABLE;  
HOWEVER, IT IS QUESTIONABLE WHETHER THE ADDITIONAL ASSETS (MAN-  
POWER AND TOY FUNDS) REQUIRED TO INCLUDE THESE UNITS IN THE  
EQUIPMENT SURVEY PROGRAM WOULD PROVE ECONOMICALLY SINCE MAJOR POR-  
TION OF MTOE UNITS IS STRUCTURED FROM TDE WHICH IS AN AUTHORIZATION  
DOCUMENT IN ITSELF. IT SHOULD BE POINTED OUT THAT THIS COMMAND  
DOES NOT HAVE ANY READINESS REPORTING UNITS.

C. MAKEUP OF SURVEY TEAMS REMAIN AS RECOMMENDED IN REF  
B, ABCVE.

D. ESTABLISHMENT OF SURVEY TEAMS BELOW THE MACOM LEVEL IS NOT  
RECOMMENDED. THESE TEAMS ARE APT TO BE MORE SUBJECTIVE THAN  
OBJECTIVE IN THEIR SURVEY. PARA 2-17.1, AR 710-2 PROVIDES FOR  
RECONCILIATION OF PB AND AUTHORIZATION DOCUMENTS. CONTROL OF A  
DETAILED AND THOROUGH RECONCILIATION OF THE PB AND AUTH DOC  
WOULD PROVIDE THE COMMANDER NECESSARY DATA TO DETERMINE IF EQUIP  
ON HAND WERE AUTH AND REQUIRED TO CARRY OUT HIS MISSION.

E. N/A

2. POC FOR EQUIPMENT SURVEY IS MR M MOSKOWITZ, AUTOVON 471-  
6218/6219.

BT

ACTION ADDRESSEES

006 DALO  
00006 TNCR

\*\*\*\*\*  
\* UNCLASSIFIED \*  
\*\*\*\*\*

PAGE 01  
181712Z APR 78  
RUWTNFA/1926



DEPARTMENT OF THE ARMY  
HEADQUARTERS  
MILITARY TRAFFIC MANAGEMENT COMMAND  
WASHINGTON, D.C. 20315

REPLY TO  
ATTENTION OF:

18 APR 1978

MT-SPI

SUBJECT: Equipment Authorization Policies and Equipment Survey Process

HQDA (DALO-ZXT)  
WASH DC 20310

1. References:

- a. DALO-ZXT message, 051854Z Apr 78, subj: Equipment Authorization Policies and Procedures Review (Proper Count Message).
- b. DALO-ZXT message, 051852Z Apr 78, subj: Review of the Equipment Survey Process (Proper Count Message).
- c. MTMCR 715-2, Resources Review Boards (Incl 1).
- d. MTMCR 750-1, Utilization of Equipment Reports (Incl 2).
- e. MTMC Suppl 1 to AR 710-1 (Incl 3).
- f. MTMC Suppl 1 to AR 570-7 (Incl 4).

2. Comments to para 4, a thru h, reference a follow:

- a. Letter requests are used for both proponent approved and HQDA controlled TDA equipment. All TDA equipment authorizations must be approved by this HQ.
- b. Commander awareness is accomplished in several ways, such as: through letters, messages, review and analysis meetings, annual capital equipment budget submissions, and submission of economic analyses UP AR AR 235-5. Examples of MTMC regulatory media include references c thru f:
  - c. Not applicable.
  - d. Revalidation is an on-going action.
  - e. Statement of need must be conclusive. Doubtful items are returned to the originator for additional information or disapproved.



MT-SPI

SUBJECT: Equipment Authorization Policies and Equipment Survey Process

f. Provisions of AR 235-5 are followed. Also see reference c.

g. Not required. This headquarters approves administrative storage when justified.

h. Generally adequate.

3. Comments/recommendations to para 4a thru e, reference b follows:

a. Recommend that the length of time between surveys be as determined by the major command. MTMC is a staunch supporter of the Equipment Survey Program and for several years installation surveys were accomplished on an annual basis. As TDAs were purified annual surveys were eliminated. Between surveys, command visibility and control include utilization management (ref b) and economic analyses; e.g. barge derrick and tug services at Military Ocean Terminal, Bayonne are furnished from commercial sources and personnel and equipment authorizations have been deleted from the TDA. The foregoing is not to say that equipment surveys are no longer required; however, it is felt that the need for a survey with the attendant TDY expenditures can best be determined by the major command.

b. Not applicable.

c. Para 2-4, AR 570-7 is adequate.

d. Recommend the teams remain at HQDA/MACOM level; however, augmentation from subordinate command/installation levels should be used if personnel constraints exist.

e. Recommend that para 2-1b, AR 570-7 be deleted and replaced by: "On-site equipment surveys of units/activities with few TDA equipment authorizations will be made at the discretion of the major command." The figure of \$150,000 in para 2-1b, AR 570-7 could equate to two, three or four items and is not recommended as a criteria in determining the need for an equipment survey. In this connection, this HQS received verbal approval from DALO-PLR over two years ago to deviate from the \$150,000 criteria.

FOR THE COMMANDER:

4 Incls

ss

WR

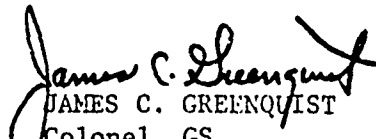
  
JAMES C. GREENQUIST  
Colonel, GS  
Director of Services

\*\*\*\*\*  
\* UNCLASSIFIED \*  
\*\*\*\*\*

DEPARTMENT OF THE ARMY  
PENTAGON TELECOMMUNICATIONS CENTER

CD SN = SCD545 MCN = 78111/19161 TGR = 781112334  
RTTUZYUW RUCNAAA1135 1111+46-UUUU--RUEADWD.  
ZNR UUUU  
R 201450Z APR 78  
FM CCRADMINCEN FT BENJ HARRISON IN//ATZI-DI-P8  
TO HQDA WASH DC//DALG-ZXT//  
BT

ZL
ZY A
ZXA
ZXA-C
AV
PLS
PLR
PLF
PLQ

UNCLAS  
THIS IS A PROPER COUNT MESSAGE.  
SUBJECT: REVIEW OF THE EQUIPMENT SURVEY PROCESS  
A. URMSG DALG/ZXT 051052Z APR 78.  
THE FOLLOWING EQUIPMENT REVIEW IS SUBMITTED IN COMPLIANCE WITH  
PARA 4 OF ABOVE REFERENCE.  
A. AN EQUIPMENT SURVEY SHOULD BE MADE ANNUALLY.  
B. THE EQUIPMENT SURVEY SHOULD INCLUDE ALL UNITS (TOA AND  
TOE) AND ALL ESSENTIAL EQUIPMENT.  
C. NO CHANGE REQUIRED FOR THE TEAM CONFIGURATION.  
D. EQUIPMENT SURVEY TEAMS AT HQDA AND MACOMS ARE ADEQUATE AND  
NO CHANGES ARE REQUIRED.

BT  
ACTION ADDRESSEES  
006 DALG  
00006 TOTAL NUMBER OF COPIES REQUIRED  
#1135

\*\*\*\*\* PAGE 01  
\* UNCLASSIFIED \* 201450Z APR 78  
\*\*\*\*\* RUCNAAA/1135

\*\*\*\*\*  
\* UNCLASSIFIED \*  
\*\*\*\*\*

DEPARTMENT OF THE ARMY  
PENTAGON TELECOMMUNICATIONS CENTER

OSV = SCD121 MCN = 78112/05873 TCR = 781120942  
RTTUZYUW RUCNAAA1200 1112009-UUUU--RUEADWD.  
ZNR UUUUU  
R 211247Z APR 78  
FM CDR ADMINLEN FT BENJAMIN HARRISON IN//ATZI-DI//  
TO HQDA WASHDC //DALG-ZXF//  
BT

UNCLAS

SUBJ: EQUIPMENT AUTHORIZATION POLICIES AND PROCEDURES REVIEW  
THIS IS A PROPER COUNT MESSAGE:

- A. YOUR MESSAGE, DALG-ZXF, 051854Z APR 78.  
1. CURRENT EQUIPMENT AUTHORIZATION POLICIES AND PROCEDURES  
HAVE BEEN REVIEWED AND INFORMATION IS PROVIDED IAW PARA 4 OF ABOVE  
REFERENCE.  
A. INTERIM EQUIPMENT AUTHORIZATION SHOULD BE AUTHORIZED TO  
BE GRANTED AT THE INSTALLATION LEVEL FOR CONTROLLED AND NON-CON-  
TROLLED AND COMMERCIAL.  
B. THE REQUEST SHOULD INCLUDE COST AND PERSONNEL REQUIREMENTS  
AND BE REVIEWED BY THE INSTALLATION COMMANDER OR HIS DESIGNEE.  
C. CHANGE AS LISTED IN 2 A & B ABOVE.  
D. THE REVALIDATION PROCEDURES SHOULD BE COMPLETED ANNUALLY.  
E. THE JUSTIFICATION CRITERIA SHOULD INCLUDE A BREAKDOWN OF  
THE ADDITIONAL COST FOR PERSONNEL, MAINTENANCE AND EQUIPMENT.  
F. AS STATED IN E ABOVE.  
G. NO CHANGE.  
H. NO CHANGE.

BT

ACTICA ADDRESSEES

006 DALG  
00006 TOTAL NUMBER OF COPIES REQUIRED  
#1200

\*\*\*\*\*  
\* UNCLASSIFIED \*  
\*\*\*\*\*

PAGE 01  
211247Z APR 78  
RUCNAAA/1200



DEPARTMENT OF THE ARMY  
HEADQUARTERS UNITED STATES ARMY RECRUITING COMMAND  
FORT SHERIDAN, ILLINOIS 60037

USARCRFM-PB

24 APR 1978

SUBJECT: Review of Equipment Survey Process

HQDA (DALO-ZXT)  
WASH DC 20310

1. Reference is made to:

a. Message, DALO-ZXT, HQDA, 051352Z Apr 78, subject as above.

b. Telephone conversation between Major(P) Roberts, HQDA, and Mr. Lewis, HQ USAREC, 24 April 1978.

2. Due to the wide geographical dispersion of USAREC units, the small size and similarity of equipment authorized, on-site equipment surveys are not scheduled in this Command. Desk audits are performed on a continuing basis as outlined in paragraph 2-1, b, Chapter 2, AR 570-7.

FOR THE COMMANDER:

*for* *John A. Foster, LTC*  
JOHN A. FOSTER  
Colonel, GS  
Director, Recruiting Force Management

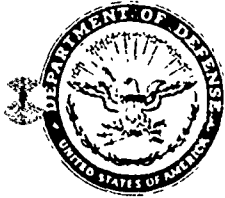

DEPARTMENT OF THE ARMY  
HEADQUARTERS, UNITED STATES ARMY JAPAN/IX CORPS  
APO SAN FRANCISCO 96343

REPLY TO  
ATTENTION OF

AJGC-FDA

24 APR 1978

SUBJECT: Equipment Authorization Policies and Procedures Review

HQDA (DALO-ZXT)  
WASH DC 20310

1. References:

- a. DA message, DALO-ZXT DTG 051854Z Apr 78, subject as above.
- b. AR 310-34, 27 Feb 75, w/changes 1 and 2.
- c. AR 310-49, 10 Jun 75, w/change 1.

2. Following comments keyed to subparagraphs of paragraph 4 of reference a, are provided in compliance with paragraph 5 therein.

a. Letter Requests (LR) are reviewed at Directorate, Garrison Force Development Activity and MACOM ACofS, G3, Force Development Division. Since the inception of LR procedures by Letter of Instructions and subsequent inclusion in Appendix H to reference b, it has been proven to be timely and effective in reducing TDA document turn-around time for documenting equipment.

b. LR are required to be reviewed and approved for submission through Directors/Unit Commanders via command channels to HQ, US Army Japan, ACofS, G3 for review and approval. In some instances requests are forwarded to appropriate MACOM staff offices for review and concurrence for acquisition of equipment on LR that is of high dollar value and/or mission peculiar.

c. Processing LR through this command and DA agencies has posed no problems. Current LR procedures and processing time frames are more than adequate and as such no changes in command channel review and approval procedures are recommended.

d. In consideration of the fact approved LR equipment is included in the first update of activity TDA subsequent to receipt of approved LR, a separate revalidation of LR is not considered necessary. Command Letter of



24 APR 1978

AJGC-FDA

SUBJECT: Equipment Authorization Policies and Procedures Review

Instructions (LOI) makes it mandatory that a review of equipment authorizations be conducted in conjunction with annual inventories and/or upon change of command or responsible property book officers.

e. Justification for equipment must be in accordance with guidelines provided in Appendix C of reference c. Additional guidance as outlined in AR 310-34 for communication equipment, materials handling equipment, aircraft and motor vehicles must be considered in preparing justification for such equipment. Data as to personnel reductions, labor saving equipment, workloads, size and dispersion of work areas, cost savings etc., should be used in supporting statements. Recommend that an expanded criteria for equipment justification be included as an appendix to either reference b or c.

f. A full economic analysis, per AR 11-18 is made in accordance with Appendix A thereto, as pertains to programs, projects and activities to which the concept of economic analysis or program evaluation applies. A cost analysis providing comparison as to cost of owning equipment, as opposed to cost of not owning equipment is applied on a case by case basis for high dollar value mission peculiar items of equipment.

g. Storage centralization of subordinate unit items used only periodically is currently practiced for one TOE unit. Central pool for Facility Engineer equipment is also operated to support four activities at separate geographical locations.

h. Other policies contained in AR 310-34/310-49 are considered adequate inasmuch as AR 310-34 provides detailed guidance while AR 310-49 provides summary guidance. These publications interface and can be used without difficulty.

i. No further comments are offered.

FOR THE COMMANDER:

  
S. NOZAKI  
SGM  
Asst AG

2

326

\* UNCLASSIFIED \*  
 \*\*\*\*\*

DEPARTMENT OF THE ARMY  
 PENTAGON TELECOMMUNICATIONS CENTER

CDSN = SCC429 MCN = 78115/14125 TDR = 781151922  
 RTTLZYUW RHECRFA1655 1151920-UUUU--RUEACWC.  
 ZNR UUUUU  
 R 251905Z APR 78  
 FM CDR T3AD TUDYMANNA PA//SDSTC-AE//  
 TO CDR CA WASH DC//DALC-ZXT//  
 BT

UNCLAS  
 SUBJ REVIEW OF THE EQUIPMENT SURVEY PROCESS  
 REF DA MSG 051822Z APR 78, DALC-ZXT, SAB, THIS INSTALLATION  
 HAS NO COMMENTS OR RECOMMENDATIONS RELATIVE TO AREAS OF REVIEW  
 LISTED IN REF MSG.  
 BT

ACTION ADDRESSEES

G06 CALC  
 C0006 TOTAL NUMBER OF COPIES REQUIRED  
 #1655

BKS		✓
EX		
ZXT	✓	✓
ZXA		
ZXA-C		
AV		
PL		
PLS		
PT7		
PLR		
PLF		
PLO	✓	

AAAA

\*\*\*\*\*  
 \* UNCLASSIFIED \*  
 \*\*\*\*\*

PAGE 01  
 251905Z APR 78  
 RHECRFA/1655

\*\*\*\*\*  
\* UNCLASSIFIED \*  
\*\*\*\*\*

DEPARTMENT OF THE ARMY  
PENTAGON TELECOMMUNICATIONS CENTER

CDSA = SCD439 MCM = 78115/14473 TOR = 781151947  
RTTUZYUW RHECRFA1856 1151925-LLUL-RUEADWC.  
ZNR UUUUU  
R 251910Z APR 78  
FM CDR TQAD TUBYHAINNA PA//SDSTC-AE//  
TO CDR DA WASH DC//DALO-ZX1//  
BT

UNCLAS  
SUBJ EQUIPMENT AUTHORIZATION POLICIES AND PROCEDURES REVIEW  
IN COMPLIANCE WITH PARA 4 OF DA MSG 051854Z APR 78, DALO-ZXT, SAB,  
THE FOLLOWING COMMENTS ARE SUBMITTED BY THIS INSTALLATION:

- A. LETTER REQUEST REVIEW PROCEDURES AT INSTALLATION LEVEL IS CONDUCTED BY RECEIPT OF SOURCE DOCUMENT
  - (1) REVIEW OF PRESENT EQUIPMENT POSSIBLE ON HAND.
  - (2) UTILIZATION OF EQUIPMENT.
  - (3) FIVE YEAR MODERNIZATION PROGRAM(SUBMITTED ON A YEARLY BASIS
  - (4) EMERGENCY SUBMISSION REQUIREMENTS
- B. POST AUDIT TRAIL OF REQUEST OF NON-DA CONTROLLED ITEMS
  - (1) MONTHLY WALK THRU BY EQUIPMENT MANAGEMENT PERSONNEL
  - (2) COMMANDER'S WALK THROUGH
  - (3) LOCAL OPERATION POLICIES, I.E., OPERATION FERRET
  - (4) REVIEW OF UTILIZATION REPORTS
- C. COMMANDER APPROVES ALL NON-DA CONTROLLED ITEMS OF REQUEST.
- D. NO COMMENT.
- E. USER FURNISHES JUSTIFICATION CRITERIA (AW AR 310-49.
- F. ECONOMIC ANALYSIS REPORT INITIATED BY USER, REVIEWED BY COMPTROLLER IAW AR 11-28.
- G. NO COMMENT.
- H. NO COMMENT.
- I. NO COMMENT.

BT  
ACTION ADDRESSEES  
006 DALO  
00006 TOTAL NUMBER OF COPIES REQUIRED  
#1656

RRC	DA	CH
ZX	EA	MT

\*\*\*\*\*  
\* UNCLASSIFIED \*  
\*\*\*\*\*

PAGE 01  
251910Z APR 78  
RHECRFA/1856



\*\*\*\*\*  
 \* UNCLASSIFIED \*  
 \*\*\*\*\*

DEPARTMENT OF THE ARMY  
 PENTAGON TELECOMMUNICATIONS CENTER

CDSN = SCD595 PCN = 78146/21449 TGR = 781462220  
 RTTUZYUW RUC LH TA E595 1462101-UUUU--RUEADWD.  
 ZNR UUUUU  
 R 261836Z MAY 78  
 FM CDR FORSCOM FT MC PHERSON CA //AFLE-SMS//  
 TO RUEADWD/DA WASH DC //DANC-FDL/DALC-ZXT/DALC-SMS//  
 INFO AIG 7433  
 AIG 7570  
 RUCLAIA/CDR TRADOC FT MONROE VA //ATLG-MSP-SP//  
 BT

BKS	TA	GM
ZX	LE	SMT
ZXT	TSM	SMS
ZXA	TST	SMM
FOL	TSE	SMW
AV	TSP	SML
PL	TS	SMD
PLW	BAC	SM
FIP	SAP	SMB
DF	SAA	SMD
FLO		SMP

UNCLASSIFIED  
 SUBJ; ACCOUNTING FOR RENTAL/LEASED EQUIPMENT IN TAADS  
 (CHANGE TO AR 310-49).

- A. REF DA MSG, DANC-FDU, 172155Z MAY 78.
- B. PARA 1-9, AR 735-5.
  1. REF A PRESCRIBES CHANGE TO AR 310-49 AND STATES THAT RENTAL/LEASE NONEXPENSIBLE EQUIPMENT SHOULD NOT BE RECORDED ON THE PROPERTY BOOK. THIS IS IN CONFLICT WITH REF B.
  2. REQUEST CLARIFICATION OF PROPERTY ACCOUNTING POLICY FOR RENTAL/LEASED NONEXPENSIBLE PROPERTY.

BT  
 ACTION ADDRESSEES  
 012 CAMD  
 INFORMATION ADDRESSEES  
 001 AFLO/ATLO  
 EE4 DAAG  
 003 DACA  
 006 DALO  
 003 CAPE  
 00025 TOTAL NUMBER OF COPIES REQUIRED  
 #8595

\*\*\*\*\*  
 \* UNCLASSIFIED \*  
 \*\*\*\*\*  
 PAGE 01  
 261836Z MAY 78  
 RUC LH TA /8595

\*\*\*\*\*  
 \* UNCLASSIFIED \*  
 \*\*\*\*\*

BNS	THCL	GH
ZX	TA	CF
ZXA	LE	CS
ZXA	TM	CM
ZXA-C	TF	CM
AV	TS	CM
PLS		
PLW		
PLR		
PLF		
PLO		

DEPARTMENT OF THE ARMY  
 PENTAGON TELECOMMUNICATIONS CENTER

CDSN = SCD108 MCN = 78117/03742 TOR = 78117135  
 RTTUZYUW RUWJHRA5662 11/0353-UUUU--RUEADWD.  
 ZNR UUUUU  
 R 262215Z APR 78  
 FM CDRUSACC FT HUACHUCA AZ //CC-FD-0AUA//  
 TO DA WASHDC //DALU-ZXT//  
 BT

UNCLAS

SUBJ EQUIPMENT AUTHORIZATION POLICIES AND PROCEDURES REVIEW

A. YOUR DALU-ZXT 051854Z APR 78 (U)

1. THE FOLLOWING IS IN RESPONSE TO REFERENCE A AND IS KEYED TO PARAGRAPH 4.

A. PARA 4A--LETTER REQUESTS REVIEW PROCEDURES ARE ADEQUATE.

B. PARA 4B--THIS FACET OF COMMAND RESPONSIBILITY MUST BE EMPHASIZED BOTH IN REGULATION AND THRU INSPECTIONS.

C. COMMAND CHANNEL REVIEW AND APPROVAL PROCEDURES APPEAR ADEQUATE.

D. ESTABLISHMENT OF REVALIDATION PROCEDURES FOR APPROVED LETTER REQUESTED EQUIPMENT AFTER A SPECIFIC PERIOD OR TSE CHANGE IS DESIRABLE BUT THE COST OF ADDITIONAL MANPOWER AND TDY FUNDS THAT WOULD BE REQUIRED TO PUT THIS INTO EFFECT MUST BE CONSIDERED IF IT IS GOING TO BE ACCOMPLISHED EARLIER THAN THE EQUIPMENT SURVEY 3 YEAR CYCLE.

E. JUSTIFICATION CRITERIA REQUIRES REINFORCEMENT. AR 310-49 IS ESPECIALLY IN NEED OF REVISION IN THIS AREA TO PROVIDE MORE SPECIFIC AND DETAILED GUIDANCE ON JUSTIFYING EQUIPMENT.

F. COST ANALYSIS PROCEDURES SHOULD APPLY TO EQUIPMENT REQUESTS. THE REQUESTOR SHOULD BE REQUIRED TO SHOW HOW THE ADDITIONAL EQUIPMENT OR NEW EQUIPMENT WILL SAVE MONEY IN THE PERFORMANCE OF HIS MISSION. A SYSTEM TO ACCOMPLISH IMMEDIATE BUY OF EQUIPMENT THAT WOULD SAVE SPACES OR DELETE PRESENTLY AUTHORIZED EQUIPMENT ON A 2 FOR 1 OR GREATER QUANTITY IS REQUIRED. AUTHORIZING THE ITEM DOES NOT PHYSICALLY GIVE THE UNIT THE ASSET TO EFFECT THE SAVING. (THE FACILITY ENGINEER AREA IS A GOOD EXAMPLE WHERE THE LATEST STATE OF THE ART EQUIPMENT COULD SAVE SPACES.)

G. STORAGE CENTRALIZATION IS PRACTICAL AT MAJOR INSTALLATIONS. USACC IS USUALLY A TENANT ON AN INSTALLATION. THE

\*\*\*\*\*  
 \* UNCLASSIFIED \*  
 \*\*\*\*\*

262215Z APR 78  
 RUWJHRA/5662

\*\*\*\*\*  
\* UNCLASSIFIED \*  
\*\*\*\*\*

**DEPARTMENT OF THE ARMY  
PENTAGON TELECOMMUNICATIONS CENTER**

SYSTEM OF POOLING EQUIPMENT WITH HOST INSTALLATIONS DOES NOT GIVE APPROPRIATE SUPPORT OF POOLED EQUIPMENT TO TENANT UNITS. ALTHOUGH THE TENANT UNIT HAS THE PERSONNEL TO OPERATE THE EQUIPMENT, THE HOST WILL NOT LET THE TENANT OPERATOR USE IT. THE HOST REQUIRES HIS OPERATOR TO OPERATE THE EQUIPMENT AND THEN CHARGES THE TENANT FOR THE JOB. THIS GENERALLY OCCURS IN THE FACILITIES ENGINEERING AREA.

H. OTHER POLICIES IN AR 310-34/310-49 WOULD BE MORE EFFECTIVE IF ALL REGULATIONS WHICH PROVIDE EQUIPMENT AUTHORIZATION GUIDANCE WERE CONSOLIDATED INTO A SINGLE GOVERNING AR; FOR EXAMPLE, AR 570-7. THIS CONSOLIDATED REGULATION SHOULD SUPERSEDE PORTIONS OF ALL REGULATIONS RELATING TO AUTHORIZATION IN MTOE/TDA AND BECOME A SINGLE AUTHORITATIVE SOURCE.

I. THE REQUIREMENT TO REQUEST LINE ITEM NUMBERS (LIN) FOR INCORPORATION IN CHAPTER 6 OF SB 700-20 SHOULD BE REVIEWED FURTHER. THESE ITEMS ARE NOT SUPPORTED BY THE ARMY WHOLESALE SYSTEM AND HAVE BEEN PROCURED FOR SPECIFIC FUNCTIONS FROM COMMERCIAL SOURCES. COSTS INCURRED IN MAINTAINING THIS DATA IN AUTHORIZATION DOCUMENTS IS QUESTIONABLE IN LIGHT OF HISTORICAL ACTION TAKEN BY HQDA TO ELIMINATE SECTIONS VI, V, AND IV OF TDA SINCE 1956. THESE TDA EQUIPMENT SECTIONS WERE BUILT AT ENORMOUS COST TO THE ARMY ONLY TO BE DISCONTINUED WHEN THE TRUE VALUE FOR MANAGEMENT WAS ESTABLISHED. THE RECENT ACTION TO TRANSFER LIN FROM CHAPTER 7 TO CHAPTER 6 OR CHAPTER 2 HAS RESULTED IN A STRAIGHT FORWARD REASSIGNMENT OF INDIVIDUAL CHAPTER 6 LIN BASED ON EXTENSIVE SUBMISSION OF REQUESTS FOR TYPE CLASSIFICATION EXEMPTION.

2. THIS COMMAND HAS NO SUPPLEMENTAL MATERIEL CONCERNING AR 310-34/310-49.

BT

**ACTION ADDRESSEES**

006 DALO  
00006 TOTAL NUMBER OF COPIES REQUIRED  
45662

\*\*\*\*\*  
\* UNCLASSIFIED \*  
\*\*\*\*\*  
331

PAGE 02  
262215Z APR 73  
RUWJHRA/5662



DEPARTMENT OF THE ARMY  
HEADQUARTERS UNITED STATES ARMY RECRUITING COMMAND  
FORT SHERIDAN, ILLINOIS 60037

USARCRFM-PB

26 APR 1978

SUBJECT: Equipment Authorization Policies and Procedures Review

HQDA (DALO-ZXT)  
WASH DC 20310

1. Reference is made to:

- a. Message, DALO-ZXT, HQDA, 051854Z Apr 78.
- b. Appendix H, AR 310-34.
- c. Appendix D, AR 310-49.
- d. USAREC/MEPCOM Supplement 1 to AR 310-49 (Inclosure 1).

2. All requests for equipment authorization within this Command are processed in accordance with reference 1b through 1d. Each command level is required to review equipment authorization requests to insure they comply with the above regulations.

3. The following comments are furnished in accordance with paragraph 5, reference 1a and are relative to this Command's review procedures.

a. Review of letter requests for authorization within this Command begin with the requesting activity commander, they are then forwarded through regional/sector commanders to HQ USAREC/HQ MEPCOM. The review at each echelon is performed to insure that the request is in proper format and compliance with reference 1b through 1d. This review includes research as to availability of a standard item determination as to controlled/noncontrolled item, type, cost, quantity, and justification. Additionally, at all levels a review is required to be made by the logistics personnel and the staff element controlling the function requiring the item.

b. Justification is in accordance with paragraph 3-18, AR 310-49 and reference 1d. The need for the item in relationship to mission accomplishment is a primary factor.

d. Items authorized are reviewed on an annual basis to insure continuous need through IG inspection, Command Logistics inspection, and the Command Supply Discipline Program reviews team.

USARCFM-PB

SUBJECT: Equipment Authorization Policies and Procedures Review

d. During the cost analysis procedures the commander is made fully aware of type, number, and cost of equipment requested due to the indepth economical review made in relationship to leasing versus purchasing, possible selection of a standard adopted item in lieu of a commercial item, or the initiation of a new method or discontinuance of an old at the same time satisfying mission requirements.

4. This Command has no items that are used only periodically, therefore, no centralized storage.

5. Policies as established by AR 310-34/310-49 are adequate for this Command.

6. Inclosure 1 is furnished in accordance with paragraph 5, reference 1a.

FOR THE COMMANDER:

1 Incl  
as

*An Victor A. Foster, LTC*  
JOHN A. FOSTER  
Colonel, GS  
Director, Recruiting Force Management



DEPARTMENT OF THE ARMY  
HEADQUARTERS, UNITED STATES ARMY FORCES COMMAND  
FORT MCPHERSON, GEORGIA 30330

27 APR 1978

AFLG-SMS

SUBJECT: Equipment Authorization Policies and Procedures Review

HQDA (DALO-ZXT)  
WASH DC 20310

1. References:

- a. DA message 051854Z Apr 78, SAB.
- b. AR 310-34.
- c. AR 310-49.
- d. FORSCOM Suppl 1 to AR 310-49 (Incl 1).
- e. FORSCOM message AFOP-MD, 132123Z Aug 76, subject: MTOE/TDA Changes (Incl 2).
- f. FORSCOM message AFOP-DDO, 311240Z Jan 78, subject: TAADS/TOE Personnel/Equipment Change Requests (Incl 3).
- g. Letter, FORSCOM AFLG-PO/AFLG-DD, 27 Mar 78, subject: Authorization for and Accountability of Commercial Non-Standard Equipment (Incl 4).
- h. FORSCOM message AFLG-SMS, 081528Z Mar 78, subject: Property Accountability for Discretionary Components of End Items and Organizational Clothing and Equipment (Incl 5).

2. In compliance with reference 1a, the following comments are provided. Comments are keyed to para 4, ref 1a:

- a. LETTER REQUEST REVIEW PROCEDURES AT INSTALLATION, MACOM AND HQDA LEVEL. Letter request review procedures are those contained in Section II, Appendix H, ref 1b and Section II, ref 1c as implemented by references 1d and 1f.

27 APR 1978

AFLG-SMS

SUBJECT: Equipment Authorization Policies and Procedures Review

b. COMMANDER AWARENESS OF TYPE, NUMBER AND COST OF EQUIPMENT REQUESTED. Ref 1e (WALKER) requested commanders screen request for change from subordinate units and examine critically proposed additions and deletions.

c. CHANGES IN COMMAND CHANNEL REVIEW AND APPROVAL PROCEDURES. No changes in review and approval procedures are recommended at this time.

d. ESTABLISHMENT OF REVALIDATION PROCEDURES FOR APPROVED LETTER REQUESTED EQUIPMENT AFTER A SPECIFIC PERIOD OR TOE SERIES CHANGE. The letter request procedure for approval of equipment addresses a specific MTOE number and CCNUM, upon reorganization to a different series TOE or reorganization under the same TOE all equipment must be rejustified before authorization in the new MTOE can be accomplished.

e. JUSTIFICATION CRITERIA. Guidance for justification of equipment is as contained in references 1b, 1c and 1d.

f. COST ANALYSIS PROCEDURES. No cost analysis procedures are in effect at this time. This area is being explored as to the best and easiest manner in which to produce this information.

g. STORAGE CENTRALIZATION OF SUBORDINATE. Guidance was provided in ref 1h to screen items required for climatic and/or contingency requirements for centralized storing.

h. ADEQUACY OF OTHER POLICIES IN AR 310-34/310-49. Inclusion of changes disseminated by messages take too long in being incorporated into the regulations, e. g., Audio-Visual equipment messages from February 1977.

FOR THE COMMANDER:

5 Incl  
as WD

  
RICHARD L. GARDNER  
CPT, AGC  
Assistant Adjutant General

335

2



DEPARTMENT OF THE ARMY  
HEADQUARTERS  
UNITED STATES ARMY COMPUTER SYSTEMS COMMAND  
FORT BELVOIR, VIRGINIA 22060

27 APR 1978

CSCS-SLL

SUBJECT: Review of the Equipment Survey Process

HQDA (DALO-ZXT)  
WASH DC 20310

1. Reference your MSG (U) 051852Z Apr 78, subject as above.
2. Recommendations below are keyed to paragraphs of referenced message as follows:
  - a. Length Of Time Between Surveys: The present three-year interval is satisfactory providing there are no substantive and/or frequent changes in manpower levels or organization missions. Sporadic increases/decreases in manpower levels, due to changes in assigned missions, simultaneously increase/decrease the types and density of equipment. It may be advisable to require equipment surveys to be conducted within 90 to 120 days preceding such changes of manpower levels and missions. This will avoid the possibility of having equipment in some organizations/activities and not in use, or of having equipment required in other organizations but not available for use, and in some instances of causing needless acquisition of equipment.
  - b. No comment.
  - c. No comment.
  - d. Establishment Of Teams At Levels Other Than, And In Addition To, HQDA/MACOM: Establishment of teams at lower levels may prove beneficial. Caution should be exercised to avoid Equipment Survey Teams being authorized at levels where Man-power Survey Teams are not authorized. The Equipment Survey Team must coordinate its efforts with the Man-power Survey Team. This may be very difficult or impossible if both functions are not authorized at the same level.

FOR THE COMMANDER:

AARON G. REAMES  
LTC, GS  
ACoFS, G4



\*\*\*\*\*

DEPARTMENT OF THE ARMY  
PENTAGON TELECOMMUNICATIONS CENTER

CDSN = SC0308 MCN = 73117/15711 TOR = 781172009  
PTTUZYUW RUEJMANA1901 1771353-UUUU--RUEADWD.  
ZNR UUUUU  
P 271830Z APR 78  
FM CDRNCAD NEW CUMBERLAND PASDSNC-SM//  
TO RUEADWD/DA WASHDC/DALO-ZXT/MAJ (P) J T ROBERTS  
INFO RUEPABE/CDRDESCOM CHAMBERSBURG PA//DRSDS-S//  
BT

UNCLAS

SUBJ: REV OF EQUIP SURV PROC AND AUTH PLCY AND PRGC

A. MSG DRSDS-S 141525Z APR 78, SAME SUBJ.

1. DUE TO SHORT FUSE SUSPENSE DATE, AND ON GOING ACT WI EQUIP  
MGT DIV, I.E., INTERNAL REV WALL-TO-WALL INVENT, PREP FOR  
CEMPR VISIT, ETC, AN IN-DEPTH REV COULD NOT BE ACCOMP AT THIS  
TIME.

2. THE FOL RECM IS FURN: CH 1 TO AR 310-49 WAS PUB IN NOV 75.  
SINCE THAT TIME, SEVERAL MSG HAVE BEEN PUB INCORPORATING ADD  
CH TO THE REG. RECM THAT A LIST OF MSG THAT ARE STILL IN EFF  
BE PUB AND FWD TO ALL ACTY ON AN ANL BASIS.

BT

ACTION ADDRESSEES

006 DALO

00006 TOTAL NUMBER OF COPIES REQUIRED

#1901

ACTS	TIME	
ZZ	EA	
ZXT	LB	
ZZA	CS	
ZXA-C	TS	
AV	CS	
PL	CS	
PLS	CS	
PLT	CS	
PLR	CS	
PLP	CS	
PLQ	CS	

\*\*\*\*\*  
\* UNCLASSIFIED \* PAGE 01  
\* 271330Z APR 78 \*  
\*\*\*\*\* RUEJMANA/1901

\*\*\*\*\*

DEPARTMENT OF THE ARMY  
PENTAGON TELECOMMUNICATIONS CENTER

CDSN = SCD486 ACN = 73118/07354 TOR =  
RTTUZYUW RUMT #FA2041 1172209-JUUU--R'JEADWD.  
ZNR UUUUU  
R 272149Z APR 78  
FM CDR HSC FTSA-HOUSTON TX //HSCP-FT//  
TO DA WASHDC //DALO-ZAT//  
BT

HKS /	INCD	OR
ZX	TA	SMT
ZXT/1	LE	SMS
ZXA	TSM	SFM
ZXA-C	TST	SFW
AV	TSE	SVL
PL	TSP	SW
PLS	SAC	SY
PLH	SAR	SZ
PLR	SAA	TH
PLF	SA	THI
PLO		THP
REVIEW		

UNCLAS  
SUBJ: EQUIPMENT AUTH POLICIES AND PROCEDURES

1. YOUR 051854Z APR 78.  
THE FOLLOWING COMMENTS ARE KEYED TO PARAGRAPH 4A THRU I, ABOVE  
REF:
- A. REVIEW PROCEDURES FOR LTR REQUESTS AS AUTH IN AR 310-49 ARE ADEQUATE.
  - B. CDRS OF HSC ACTIVITIES ARE REQUIRED TO SIGN LTR CJB-MITTING PRIORITY LISTING OF EQUIP REQUIREMENTS NEEDED TO SUPPORT THEIR MISSION ACCOMPLISHMENT.
  - C. ALL REQUESTS FOR EQUIP HAVING A COST VALUE OF \$100 OR MORE IS REVIEWED BY A COMMITTEE COMPOSED OF MEMBERS FROM DEPUTY CHIEF OFFICES OF HSC. APPROVAL OF EQUIP REQUIREMENTS ARE CONTINGENT UPON JUSTIFICATION SUBMITTED AND MISSION TO BE SUPPORTED. EQUIP APPROVED FOR AUTH AND ACQUISITION BY THIS COMMITTEE ARE PROVIDED HSC PBAC FOR APPROVAL PRIOR TO ADVISING HSC ACTIVITIES.
  - D. LONG TERM CHANGES IN MISSION REQUIREMENTS DICTATE REVIEW OF EQUIP FOR LATERAL TRANSFER OR TURN IN.
  - E. JUSTIFICATION CRITERIA MUST BE CONSISTENT WITH NEED OF MISSION ACCOMPLISHMENT.
  - F. COST ANALYSIS IS REQUIRED FOR ALL REQUESTS FOR AUTH TO LEASE EQUIP. THESE ARE REVIEWED ON AN ANNUAL BASIS.
  - G. NOT APPLICABLE
  - H. POLICIES GOVERNING AUTH AND DOCU IN AR 310-34 AND 310-49 ARE ADEQUATE.
  - I. NCNE

BT  
ACTION ADDRESSEES  
006 DALO  
00006 TOTAL NUMBER OF COPIES REQUIRED  
#2641

THIS PAGE IS BEST QUALITY PRACTICABLE  
FROM COPY FURNISHED TO DDC

\*\*\*\*\* PAGE 01  
\* UNCLASSIFIED \* 272149Z APR 78  
\*\*\*\*\* RUWTFNA/2641



DEPARTMENT OF THE ARMY  
UNITED STATES MILITARY ACADEMY  
WEST POINT, NEW YORK 10996

MACO-M

ADD 28 1978

SUBJECT: Equipment Authorization Policies and Procedures Review

HQDA (DALO-ZXT)  
WASH DC 20310

1. Reference your message, 051854Z Apr 1978, subject as above.
2. The following comments are provided in response to your request:
  - a. Procedures for review of letter requests for equipment are not so much in need of change as is the criticality of the reviews which are given. The responsibility for justifying requests for equipment rests with the originator. Where insufficient information or justification is included such requests should not be honored.
  - b. Regulations should include a requirement that Commanders emphasize the importance of restricting equipment requests to the minimum necessary to accomplish the mission efficiently and effectively.
  - c. Stricter controls should be established on the acquisition of commercial equipment. Reasons why standard items are not considered satisfactory should be required. In addition, a recommendation should be required as to whether an item should be adopted in lieu of an already adopted item or in addition thereto.
  - d. Requirements for items and/or quantities which exceed those authorized by basic TOE's should be required to be revalidated at not more than two year intervals for items with an initial cost of \$1,000 or over.
  - e. Justification for equipment should include detailed reasons why each item is needed, what necessary function it will serve, how this function has been accomplished (if not a new mission), and exactly how the item will be used.
  - f. A simplified format for use in cost analyses should be developed.

MACO-M

SUBJECT: Equipment Authorization Policies and Procedures Review

g. Centralized storage of TOE field equipment, particularly mechanical/electrical items would provide greater assurance of availability in working condition in the event of deployment, provided inspection, testing and servicing, as applicable, would be accomplished periodically.

h. Where there is a question as to the length of time an item will be needed and the economics of the situation are not readily apparent, a loan from another activity at the installation or from the NICP should be considered. If a loan is not possible, rental of the item for not more than one year should be considered. If the requirement for a rented item will continue beyond one year, an economic analysis should be made to determine whether continued rental or procurement would be most advantageous to the Government.

i. Regulations governing equipment surveys should require that Common Tables of Allowances (CTA) items be included if time permits. The survey should cover whether the CTA items on-hand are in fact authorized by the CTA.

j. Defense Disposal Activities should be required to obtain written assurance that requests for release of materiel include an approval from the Accountable Officer of the installation placing the request and that the requestor has authority by TDA or CTA for the equipment. The same should apply to transfers between installations.

2. Inclosed is copy of draft supplement to AR 310-49 submitted for review. This draft was prepared some time ago but was not published when it was learned that a complete revision of AR 310-49 was about ready for publication. Portions of this draft are considered applicable to the present effort.

FOR THE SUPERINTENDENT:

1 IncX  
As stated

WP

*f* *Cheryl D. Geyer, LTC*  
T. M. PARTIN  
LTC, AGC  
Adjutant General



DEPARTMENT OF THE ARMY  
HEADQUARTERS, UNITED STATES ARMY FORCES COMMAND  
FORT MCPHERSON, GEORGIA 30330

AFLG-SMS

28 APR 1978

SUBJECT: Review of the Equipment Survey Process (S: 30 Apr 78)

HQDA (DALO-ZXT)  
WASH DC 20310

1. Reference, HQDA MSG, DALO-ZXT, DTG 051852Z Apr 78, SAB.
2. The following comments are furnished keyed to those areas as requested in paragraph 4 of reference message.
  - a. Paragraph 4A - The length of time between Equipment Surveys established as once every three years is adequate. Recommend however, that authority for out-of-cycle Equipment Surveys be granted. Out-of-cycle Surveys could be necessitated by significant changes to the installation/activity TDA, due to reorganizations, restructuring of authorization document, inactivations, etc.
  - b. Paragraph 4B - The surveying of Readiness Reporting Elements (limited to non-TOE required, authorized equipment) is currently only being accomplished, if the unit activity is identified as an augmentation paragraph to the installation TDA. Recommend however, a selective sampling of installation TOE/MTOE units not identified as augmentation paragraphs, be considered during on site equipment surveys. A spot check of these selected unit property accounts would be conducted to preclude duplication of equipment authorizations and identify possible excesses. If the recommendation to survey TOE/MTOE units is adopted a requirement would exist for the staffing of two each additional Equipment Specialist General.
  - c. Paragraph 4C - The recommended makeup of the FORSCOM Equipment Survey Team is as follows:

1 each O-6	Equipment Survey Control Officer/Team Chief
*3 each GS-12	Equipment Specialist General
5 each GS-11	Equipment Specialist General
1 each GS-9	Logistics Specialist/Analyst (TAADS)
1 each GS-5	Administrative Asst/Clerk Typist

28 APR 1978

AFLG-SMS

SUBJECT: Review of the Equipment Survey Process (S: 30 Apr 78)

\*One of these positions is to maintain overall responsibility of Equipment Survey Program for U. S. Army Reserve Components.

d. Paragraph 4D - The establishment of teams at levels other than, or in addition to HQDA/MACOM would not provide any significant benefits. An Equipment Specialist is available in the staffing of Installation Force Development Offices and is able to perform on-the-spot analysis of activity TDA requirements.

e. Paragraph 4E - The problem of equipment retention following loss of mission, continues to be an area of concern. A recommended solution is when a mission is discontinued or a reorganization of a unit/activity takes place, actions (by P.O., Command Letters, etc.) should be synonymous regarding personnel and equipment strengths. Equipment determined excess based on reorganization/inactivation should be identified and directed turn-in. At inclosure 1 is a copy of Permanent Orders where exact personnel strength is given but equipment is mentioned in general.

FOR THE COMMANDER:

1 Incl  
as

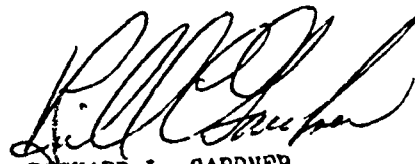

RICHARD L. GARDNER  
CPT, AGC  
Assistant Adjutant General

\*\*\*\*\*  
 \* UNCLASSIFIED \*  
 \*\*\*\*\*

ZI	TA	TI
ZC	TC	TD
ZD	TD	TE
ZE	TE	TF
ZF	TF	TG
ZG	TG	TH
ZH	TH	TI
ZI	TI	TJ
ZJ	TJ	TK
ZK	TK	TL
ZL	TL	TM
ZM	TM	TN
ZN	TN	TO
ZO	TO	TP
ZP	TP	TQ
ZQ	TQ	TR
ZR	TR	TS
ZS	TS	TT
ZT	TT	TU
ZU	TU	TV
ZV	TV	TV
ZW	TV	TV
ZX	TV	TV
ZY	TV	TV
ZZ	TV	TV
ZZ	TV	TV

DEPARTMENT OF THE ARMY  
 PENTAGON TELECOMMUNICATIONS CENTER

CDSN = SCD757 MCN = 78119/01222  
 R7TUZYUW RUKGCV30079 1190J49-UUUU--RUEADWD.  
 ZNR UUUUU  
 R 282030Z APR 78  
 FM CDR USACIDC WASH DC //CILO-ST//  
 TO HQ DA WASH DC //DALO-ZXT//  
 BT

UNCLAS  
 SUBJ: EQUIPMENT AUTHORIZATION POLICIES AND PROCEDURES REVIEW

A. HQDA MSG DALO-ZXT 051852Z APR 78  
 B. HQDA MSG DALO-ZXT 051354Z APR 78

- REFERENCES A AND B REQUESTED COMMENTS ON EQUIPMENT SURVEYS AND EQUIPMENT AUTHORIZATION POLICIES AND PROCEDURES. COMMENTS ARE MADE TO THOSE PARAGRAPHS IN REFERENCES A AND B THAT ARE APPLICABLE TO USACIDC.
- THE FOLLOWING COMMENTS PERTAIN TO REFERENCE A:
  - REFERENCE PARAGRAPH 4A. THE LENGTH OF EQUIPMENT SURVEYS SHOULD REMAIN AT A MINIMUM OF ONE EVERY THREE YEARS.
  - REFERENCE PARAGRAPH 4C. SURVEY TEAMS SHOULD CONSIST OF PERSONNEL FROM THE MACOM HQ AND EACH SUBORDINATE ELEMENT UNDER THE MACOM WITH ASSISTANCE FROM TRADOC WHEN REQUIRED.
  - REFERENCE PARAGRAPH 4D. SUBORDINATE ELEMENTS UNDER A MACOM SHOULD BE ENCOURAGED TO CONDUCT EQUIPMENT SURVEYS, RESOURCES

PAGE 2 RUKGCVB0079 UNCLAS  
 PERMITTING. COMMANDERS SHOULD MAKE PERIODIC REVIEW ON THE MISSION ESSENTIALITY OF EQUIPMENT. THIS CAN BE ACCOMPLISHED THROUGH USE OF EQUIPMENT SURVEY TEAMS AS SPECIFIED IN AR 570-7.

- THE FOLLOWING COMMENTS PERTAIN TO REFERENCE B:
  - REFERENCE PARAGRAPH 4A. LETTER REQUESTS FOR EQUIPMENT ARE SUBMITTED THROUGH USACIDC COMMAND CHANNELS TO HQUSACIDC. IF THE ITEM IS NOT DA CONTROLLED, HQUSACIDC WILL STAFF THE REQUEST WITHIN THE HQUSACIDC STAFF AND PROVIDE INSTRUCTIONS ON ACQUISITION OF THE ITEM UPON COMPLETION OF THE STAFF REVIEW. LETTER REQUESTS FOR EQUIPMENT THAT IS DA CONTROLLED ARE SUBMITTED BY HQUSACIDC TO THE DA PROPONENT AS SPECIFIED IN AR 310-49.
  - REFERENCE PARAGRAPH 4B. COMMANDERS AT ALL LEVELS SHOULD

343

\*\*\*\*\*  
 \* UNCLASSIFIED \*  
 \*\*\*\*\*

PAGE 01  
 282030Z APR 78  
 RUKGCVB/0079

\*\*\*\*\*  
\* UNCLASSIFIED \*  
\*\*\*\*\*

DEPARTMENT OF THE ARMY  
PENTAGON TELECOMMUNICATIONS CENTER

BE DIRECTLY INVOLVED IN THE TYPE, NUMBER AND COST OF EQUIPMENT REQUESTED. BOTH AR 310-34 AND AR 310-49 SHOULD SPECIFY COMMANDER RESPONSIBILITIES BELOW MACOM LEVEL IN REVIEWING, MONITORING, AND APPROVING EQUIPMENT AUTHORIZATIONS. THIS IS PARTICULARLY PERTINENT TO CTA EQUIPMENT (AR 310-34) WHERE THE AUTHORIZED ON-HAND QUANTITY IS BASED ON A BOI AND NOT TAADS.

C. REFERENCE PARAGRAPH 4C. AS MENTIONED IN PARAGRAPH 3B ABOVE, ALL COMMANDERS MUST BE DIRECTLY INVOLVED WITH REVIEW AND

PAGE 3 RUKGCV80079 UNCLAS  
APPROVAL PROCEDURES. REVIEW AND APPROVAL GUIDELINES FOR COMMANDERS AT UNIT LEVEL (COMPANY AND DETACHMENT SIZE), BATTALION LEVEL AND ON UP THE CHAIN OF COMMAND SHOULD BE SPECIFIED IN AR 310-34 AND AR 310-49.

D. REFERENCE PARAGRAPH 4D. REVALIDATION OF LETTER REQUESTS FOR EQUIPMENT SHOULD BE AN ON-GOING REVIEW. WHEN A REQUEST IS SUBMITTED THROUGH CHANNELS, THE EQUIPMENT REQUESTED SHOULD BE MATCHED AGAINST THE CURRENT AUTHORIZATION DOCUMENT. IF THE MACOM HAS AUTHORIZATION, ACCORDING TO 310-49, TO MAKE TAADS CHANGES, THEN THE UNIT SHOULD BE NOTIFIED BY THE MACOM TO EFFECT SUCH CHANGES TO THEIR TAADS DOCUMENTS. FOR ITEMS WHICH ARE DA CONTROLLED, PROCEDURES OUTLINED IN CHAPTER 2 OF AR 310-49 WILL APPLY.

E. REFERENCE PARAGRAPH 4E. JUSTIFICATION CRITERIA SHOULD INCLUDE IN ADDITION TO CRITERIA LISTED IN AR 310-49, STATEMENTS TO SUPPORT THE ABSOLUTE NECESSITY FOR THE ITEM. IT SHOULD BE STATED IN DETAIL WHY THE UNIT'S MISSION WILL NOT BE MET IF THE ITEM IS NOT ON HAND.

F. REFERENCE PARAGRAPH 4G. USACIDC CENTRALLY STORES EQUIPMENT USED PERIODICALLY. EQUIPMENT IN THIS CATEGORY IS SPECIAL

PAGE 4 RUKGCV80079 UNCLAS  
INVESTIGATIVE TYPE EQUIPMENT FOR MISSION UNIQUE REQUIREMENTS. ITEMS ARE RETAINED AT PBO LEVEL AND HAND RECEIPTED TO SPECIAL AGENTS ON AN AS REQUIRED BASIS. CENTRAL STORAGE OF PERIODICALLY

344

\*\*\*\*\*  
\* UNCLASSIFIED \*  
\*\*\*\*\*

PAGE 02  
282030Z APR 78  
RUKGCVR/0079



\*\*\*\*\*  
\* UNCLASSIFIED \*  
\*\*\*\*\*

DEPARTMENT OF THE ARMY  
PENTAGON TELECOMMUNICATIONS CENTER

USED SPECIAL INVESTIGATIVE EQUIPMENT PROVIDES FOR CENTRALIZED CONTROL AND DISTRIBUTION AND MAXIMUM EQUIPMENT UTILIZATION.

4. POLICIES AND PROCEDURES IN AR 310-34 AND 310-49 AS THEY PERTAIN TO USACIDC ARE ADEQUATE. THERE ARE NOT USACIDC SUPPLEMENTS TO AR 310-34 AND 310-49.

5. RECOMMEND CONSIDERATION BE GIVEN TO INCORPORATE INTO A SEPARATE CTA, COMMON ITEMS OF EQUIPMENT REQUIRED TO SUPPORT THE LAW ENFORCEMENT COMMUNITY. ALSO RECOMMEND THAT HIGH COST ITEMS OF EQUIPMENT REQUIRED TO SUPPORT THE LAW ENFORCEMENT COMMUNITY BE STANDARDIZED AND REFLECTED IN SB 700-20. THIS INCLUDES EQUIPMENT SUCH AS THE NEW STATE OF THE ART CAMERA EQUIPMENT, CONCEALABLE PROTECTIVE CLOTHING, PERSONNEL ELECTRONIC WARNING DEVICES, NIGHT VISION EQUIPMENT, VARIOUS TYPES OF KITS REQUIRED TO SUPPORT THE INVESTIGATIVE MISSION.

BT.

ACTION ADDRESSEES

006 DALO

00006 TOTAL NUMBER OF COPIES REQUIRED

#0079

NNNN

345

\*\*\*\*\*  
\* UNCLASSIFIED \*  
\*\*\*\*\*

PAGE 03

28239Z APR 78

PUK3CVB/0079



DEPARTMENT OF THE ARMY  
UNITED STATES MILITARY ACADEMY  
WEST POINT, NEW YORK 10996

MACO-M

APR 28 1978

SUBJECT: Review of Equipment Survey Process

HQDA (DALO-ZXT)  
WASH DC 20310

1. Reference your message, 051852Z April 78, subject as above.
2. Per your request, the following comments are provided:
  - a. It is recommended that equipment surveys be required at not greater intervals than two years.
  - b. Survey teams should include personnel who are technical experts or have sufficient expertise to identify equipment.

FOR THE SUPERINTENDENT:

*for Cheryl D. Gregor, LT*  
T. M. PARTIN  
LTC, AGC  
Adjutant General

# DISPOSITION FORM

For use of this form, see AR 340-15, the proponent agency is TAGCEN.

REFERENCE OR OFFICE SYMBOL

SUBJECT

NGB-ARL-P

Review of the Equipment Survey Process

TO

DALO-ZXT

FROM

NGB-ARL

DATE

2 MAY 1978

CMT 1

CPT Reeder/adr/54068

1. References:

- A. DALO-ZXT msg 051852Z Apr 78, SAB
- B. AR 570-7

2. Reference B is not applicable to the Army National Guard. However, ARNG has requested an equipment survey team from FORSCOM on two occasions. The second FORSCOM survey is scheduled for 14-23 May at Fort Irwin, CA and will be attended by a representative of the ARNG Logistics Division. Following this survey, an evaluation to determine if the Equipment Survey Program has applicability to the ARNG will be conducted.

FOR THE CHIEF, NATIONAL GUARD BUREAU:

*Raymond M. Booth*  
RAYMOND M. BOOTH

Colonel, GS

Chief, Army Logistics Division

347

DA FORM 2496  
1 FEB 62

REPLACES DD FORM 96, WHICH IS OBSOLETE.

GPO-1975-665-422/1063

# DISPOSITION FORM

CPT R. J. J. R.

For use of this form, see AR 340-15, the proponent agency is TAGCEN.

REFERENCE OR OFFICE SYMBOL	SUBJECT
NGB-ARL-P	Equipment Authorization Policies and Procedures Review

TO DALO-ZXT FROM NGB-ARZ-A DATE 2 MAY 1978 CMT 1  
MAJ Sempek/njj/54068

1. Reference DALO-ZXT message 051845Z April 1978, subject as above.
2. The referenced message requested comments on nine areas relative to equipment authorizations under the Army Authorization Documents System (TAADS). NGB in its role as a MACOM TAADS proponent, reviews, approves and publishes changes to ARNG authorization documents. Currently, NGB manages 540 MTOE and 320 TDA authorization documents.
3. Specific comments were requested on the following areas:
  - a. Letter requests review procedures at installation, MACOM and DA level.

COMMENTS: Letter requests for changes in equipment authorization originate at unit level. These requests are reviewed at State level by the TAG and the USPFO. NGB reviews approximately 15 to 20 equipment changes weekly. Each request is subjected to a complete logistical review for justification and compliance with DA and NGB equipment authorization policies.
  - b. Changes in command channel review and approval procedures.

COMMENTS: None.
  - c. Command awareness of type, number and cost of equipment requested.

COMMENTS: The Army Logistics Division maintains internal data on the type and frequency of requests for changes in TAADS equipment authorizations. Costs are considered for TDA equipment changes; the least expensive equipment that will perform the function is selected for TDA equipment applications. For MTOE equipment changes, NGB approves requests that are in agreement with the DA published Base TOE. Where possible, ARNG MTOE equipment authorizations are closely aligned with the Base TOE. Exceptions in this policy are dictated by the availability of certain types of equipment such as communications and high mobility vehicles. In some cases, the preferred item is not available to the ARNG; therefore, an alternate type of equipment is documented in the MTOE.
  - d. Establishment of revalidation procedures for approved letter requests for equipment after a specific period or TOE series change:

COMMENTS: NGB distributes updated MTOE and TDA documents to the field on an annual basis. Letters of Authorization are invalid upon receipt of the updated authorization documents.
  - e. Justification criteria:

COMMENTS: Justification for equipment changes is the most important but least understood aspect of the letter request procedure. The requestor is guided by the general information in paragraph 3 of Chapter 3, AR 310-49 and by Appendix C of this same regulation. For specific equipment authorization policies the requestor and

DA FORM 2496  
1 FEB 62

REPLACES DD FORM 96, WHICH IS OBSOLETE.

348

\*GPO-1975-565-422/1063

NGB-ARL-P

SUBJECT: Equipment Authorization Policies and Procedures Review

analyst refer to AR 310-34. The general criteria on "how-to" justify equipment could be clarified in the regulation. NGB has updated its supplemental instructions to include "how-to-justify" guidance. An improved edition of this guidance will be published later this year as a NGB TAADS Handbook.

f. Cost Analysis Procedures

COMMENTS: Requests for additional equipment are analyzed for validity of the requirement. The established requirement "drives" the authorization system. Cost analysis is not used in the decision process. Within the parameters of this viewpoint, the least expensive equipment is selected to meet the requirement.

g. Storage centralization of subordinate unit items used periodically.

COMMENTS: Selected major end items and weapons systems are prepositioned and maintained at Mobilization and Training Equipment Sites (MATES) for use of by owning and other units during Annual and Inactive Duty Training. This concept would be difficult to implement for other authorized equipment as most ARNG units are located in self-contained but widespread unit armories. In some cases an MTOE battalion has subordinate units in several armories throughout the State. All equipment, other than equipment at the MATES, is positioned and accounted for by the unit (s) in the armories.

h. Adequacy of other policies in AR 310-34 and AR 310-49.

COMMENTS: None.

4. Published supplemental material referred to above is not available for submission with this reply. Copies will be submitted upon publication of updated material to the field.

FOR THE CHIEF, NATIONAL GUARD BUREAU:

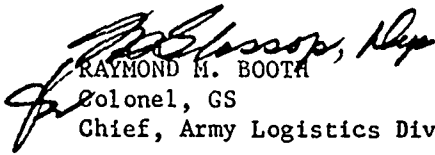
  
RAYMOND M. BOOTH  
Colonel, GS  
Chief, Army Logistics Division



DEPARTMENT OF THE ARMY  
U. S. ARMY COMMUNICATIONS COMMAND  
FORT HUACHUCA, ARIZONA 85613

Mr. Glassman/ls/879-6941

03 MAY 1978

CC-FD-OAUA

SUBJECT: Review of the Equipment Survey Process

HQDA (DALO-ZXT)  
WASH DC 20310

1. Reference is made to message, DALO-ZXT, your headquarters, 051852Z Apr 78, subject as above. Following is this command's response to paragraphs 4a through 4e as requested in cited reference.

a. Paragraph 4a. The 3-year length of time between surveys is adequate. Out of cycle surveys are authorized to be conducted when required due to reorganizations, identifiable equipment problems, etc.

b. Paragraph 4b. Survey of MTOE units other than General Support Forces (GSF) is being accomplished if they have an augmentation TDA. The MTOE equipment is considered to be sure that there are no duplications between what is authorized in the MTOE and augmenting TDA.

c. Paragraph 4c. The USACC equipment survey team consists of one GS-12.

d. Paragraph 4d. The establishment of teams below MACOM level would require additional manpower and would not provide any significant benefits.

e. Paragraph 4e. No input to other areas has been gathered.

2. At inclosure 1 is USACC Supplement to AR 570-7 as requested in paragraph 5 of referenced message.

FOR THE COMMANDER:

1 Incl  
as

*for Marshall*  
SAMUEL G. CONLEY, JR.  
Colonel, GS  
ACCS for Force Development



DEPARTMENT OF THE ARMY  
HEADQUARTERS US ARMY MATERIEL DEVELOPMENT AND READINESS COMMAND  
5001 EISENHOWER AVE., ALEXANDRIA, VA. 22333

DRCIS-S

3 May 1978

SUBJECT: Equipment Authorization Policies and Procedures Review (S: 30 Apr 78)

HQDA (DALO-ZXT)  
WASH DC 20310

1. References:

a. Message, DALO-ZXT, R051854Z Apr 78, subject as above.

b. Telephone conversation, Major J. T. Roberts, DALO-ZXT, and Mr. E. Sprague, DRCIS-S, 27 April 1978, subject as above.

2. Forwarded in accordance with the above references. Comments keyed to paragraph numbers of referenced message follow:

a. 4A. The letter request review procedures at installation/MACOM and HQDA level are considered adequate. The feature that was particularly advantageous to the user prior to implementation of the management of change study was the authorization for procurement as soon as the item appeared in an approved IAR-B. This command had experienced 60 day turn-around time. The present system of procuring only after receipt of an approved TDA (restricted to two updates per year) improves the Army programming and budget functions, but causes the user to attempt to circumvent the regulatory requirement. Recommend that the letter request procedures be continued. This method allows for a more detailed review of the justifications, as the workload is spread throughout the year, and it facilitates the TDA semi-annual update.

b. 4B. DARCOM commanders have centralized equipment management, which assists them in keeping abreast of equipment authorization, acquisition, accountability, utilization and maintenance. DARCOM Installation and Services Activity and major subordinate commands conduct surveys and reviews, which result in command letters from headquarters advising performance. DARCOM installation commanders make semi-annual walk-through reviews to ascertain utilization and maintenance of equipment.

DRCIS-S

SUBJECT: Equipment Authorization Policies and Procedures Review (S: 30 Apr 78)

c. 4C. Command channel and approval procedures, although adequate, were more responsive to the customer when an approved IAR-B could be used as authorization to procure.

d. 4D. Revalidation Procedures. DARCOM equipment utilization management provides for revalidation through Command Equipment Surveys (CES), Command Equipment Management Program Reviews (CEMPR), and the yearly authorization property book reconciliation.

e. 4E. Recommend that justification criteria for equipment be contained in AR 310-34 rather than in both AR 310-34 and AR 310-49 (DA Forms 2028 attached).

f. 4F. The cost analysis requirement in paragraph 3-15a, AR 310-49, is interpreted as consideration of cost prior to establishing the authorization for the least expensive item that will satisfactorily perform the function. Formal cost analysis documentation required only if specified by another regulation (e.g.; AR 235-5 and AR 340-22). Staffing is insufficient to perform formal cost analysis on each letter request (DA Form 2028 attached).

g. 4G. DARCOM has established central equipment pools, which enables greater visibility and reduction of this type asset. These items are reviewed by CES/CEMPR teams and during Commander/Equipment Manager walk-through reviews.

h. 4H. Policies in AR 310-34 and AR 310-49 are considered adequate.

FOR THE COMMANDER:

2 Incl  
as  
WD

  
U. H. SANDWEN  
Chief, Services Division  
Directorate for Installations  
and Services



\*\*\*\*\*  
 \* UNCLASSIFIED \*  
 \*\*\*\*\*

DEPARTMENT OF THE ARMY  
 PENTAGON TELECOMMUNICATIONS CENTER

ZTS	TRCL	GM
ZX	TA	JRE
ZYT	TE	CS
ZYA	TF	FM
ZYA-C	TH	TT
PL	TI	UD
PLS	TJ	VA
PLW	TK	VB
PLX	TL	VC
PLY	TM	VD
PLZ	TN	VE

CDSN = SCD128 MCN = 78123/17898 TOR = 781232227  
 RTTUZYUW RUKLDAR0386 123143E-UUUU--RUEADWD.  
 ZNR UUUUU  
 R 031430Z MAY 78  
 FM CORDARCOM ALEX VA //DRCIS-S//  
 TO DA WASHDC //CALC-ZXT//  
 BT

UNCLAS

THIS IS A PROPER COUNT MESSAGE

SUBJ: REVIEW OF THE EQUIPMENT SURVEY PROCESS

A. PROPER COUNT MESSAGE CALC-ZXT 051852Z APR 78, SUBJECT AS ABOVE. COMMENTS KEYED TO SUB-PARAGRAPHS IN PARA 4 REFERENCED MESSAGE. FOLLOW.

A. LENGTH OF TIME BETWEEN SURVEYS. NO CHANGE IS RECOMMENDED AS RESOURCES WILL NOT PERMIT MORE FREQUENT SURVEYS.

B. SURVEY OF READINESS REPORTING ELEMENTS (SURVEY LIMITED TO NON-TOE REQUIRED, AUTHORIZED EQUIPMENT). NOT APPLICABLE TO DARCOM AS MP COMPANIES, CALIBRATION, AND US ARMY BAND ARE ONLY TOE'S ASSIGNED.

C. MAKEUP OF SURVEY TEAMS. TEAM COMPOSITION SHOULD BE AT THE DISCRETION OF THE MACOM AND BASED ON EQUIPMENT DENSITIES AND TYPES OF EQUIPMENT. EQUIPMENT/SUPPLY/AUTHORIZATION SPECIALISTS SHOULD BE INCLUDED.

D. ESTABLISHMENT OF TEAMS AT LEVELS OTHER THAN, AND IN ADDITION TO HQDA MACOM. TEAMS AT MAJOR SUBORDINATE COMMAND/INSTALLATION LEVELS WERE MSC/IL INITIALLY ESTABLISHED AND PROVED INADEQUATE. THE MSC/IL PERSONNEL ARE CALLED UPON TO PROVIDE MEMBERSHIP TO SUBJECT SURVEY TEAMS.

E. OTHER AREAS. THE CHANGE IN PROCEDURES CAUSED BY THE MANAGEMENT OF CHANGE STUDY IMPLEMENTATION ALLOWING ONLY TWO SUBMISSIONS PER ACTIVITY DURING A ONE YEAR PERIOD MAKES IT IMPERATIVE THAT SCHEDULING OF CES BE CLOSELY MONITORED TO ACHIEVE MINIMUM DELAY IN TOA UPDATE. IT IS RECOMMENDED THAT AN EXCEPTION TO THE TWICE YEARLY UPDATE BE GIVEN FOR CES PROCESSING SO THAT CES RESULTS ARE TIMELY AND EFFECTIVE. SINCE THE SURVEYS ARE CONDUCTED TRI-ANNUALLY, WORK-LOAD WOULD NOT BE EXCESSIVE.

BT

ACTION ADDRESSEES

006 DALO

00006 TOTAL NUMBER OF COPIES REQUIRED

40386

\*\*\*\*\*  
 \* UNCLASSIFIED \*  
 \*\*\*\*\*

PAGE 01  
 031430Z MAY 78  
 RUKLDAR/0386

UNCLASSIFIED  
 \*\*\*\*\*

DEPARTMENT OF THE ARMY  
 PENTAGON TELECOMMUNICATIONS CENTER

PLF		
PLC		

CDSN = SCD094 MCN = 78125/02760 TOR = 781250317  
 RTTUZYUW RUHHHMA3057 125C203-0000--RUEADWD  
 ZNR UUUUU  
 R 050110Z MAY 78  
 FM CORUSASCH FT SHAFTER HI //AFZV-DI-SJ//  
 TO RUCLHTD/CDR FCRSCCM FT MCPHERSON GA //AFLG-SMS//  
 INFO RUEADWD/: CA WASH DC //DALU-ZXT//  
 RUHHBHA/CDR 25TH INF DIV SCHOFIELD BKS HI //AFV3-EGS//  
 RUHHBHA/CDR 45TH SPT GP SCHOFIELD BKS HI //AFZV-FF-EGL//  
 ZEN/CDR IX CORPS (AUG) FT DEKUSSY HI  
 //AFZV-IX-SM// (CCURIER)  
 BT

UNCLAS  
 THIS IS A PROPER CCINT MSG  
 SUBJ PROPERTY ACCOUNTABILITY FOR DISCRETIONARY COMPONENTS OF END  
 ITEMS AND ORGANIZATIONAL CLOTHING AND EQUIPMENT (OCE)  
 A. UR 082528Z MAR 78 (U)  
 B. UR 062040Z FEB 78 (U)  
 C. UR 131820Z JAN 78 (U)  
 1. REVIEW OF DISCRETIONARY ITEMS REQUIRED BY REF A HAS BEEN  
 COMPLETED. WHILE NO ADDITIONAL FUNDING REQUIREMENTS WERE GENERATED,  
 SOME EXCESSES WERE IDENTIFIED FOR TURN IN.  
 2. REQUEST CLARIFICATION OF PARA 3, REF B AND PARA 5, REF C, PER-  
 TAINING TO APPROPRIATE LEVEL OF DETERMINATION OF DISCRETIONARY  
 ITEMS. SPECIFICALLY, DOES DELEGATION OF AUTHORITY APPLY EQUALLY TO  
 COMMANDERS OF INSTALLATIONS, DIVISIONS AND SEPARATE BRIGADES?  
 CLARIFICATION IS REQUIRED SINCE THE ARMY ELEMENTS IN HAWAII INCLUDE  
 COMMANDERS AT INSTALLATION (USASCH), DIVISION (25TH INF) AND  
 SEPARATE BRIGADE(S) (45TH SPT GP AND IX CORPS (AUG) LEVELS AND  
 EACH WOULD HAVE THIS AUTHORITY. FURTHER, WRITTEN DELEGATION WOULD  
 BE REQUIRED ONLY BELOW THESE LEVELS OF COMMAND.  
 3. YOUR EARLIEST REPLY WILL BE APPRECIATED.  
 BT

ACTION ADDRESSEES  
 006 DALO  
 INFORMATION ADDRESSEES  
 000 \*\*\*\*\* AMRD \*\*\*  
 00006 TOTAL NUMBER OF COPIES REQUIRED  
 43057

\*\*\*\*\*  
 \* UNCLASSIFIED \*  
 \*\*\*\*\*  
 PAGE 01  
 050110Z MAY 78  
 RUHHHMA/3057

\*\*\*\*\*  
 \* UNCLASS E F T O \*  
 \*\*\*\*\*

DEPARTMENT OF THE ARMY  
 PENTAGON TELECOMMUNICATIONS CENTER

CDSN = SCD168 MCN = 7E12E/02352 TGR = 781281622  
 RTTEZYUW RUDHAAA0671 1281545-EEEE--KLEADWD.  
 ZNY EEEEE  
 R 051915Z MAY 78  
 FM CORINSCOM AFS VA //IARM-SA//  
 TO RUEADWD/DA WAFSEC //CALL-ZXT//  
 BT

UNCLAS E F T O

SUBJ: REVIEW OF THE EQUIPMENT SURVEY PROCESS

- A. HQDA MSG DALC-ZXT 051852Z APR 78 (U)
- 1. IAW REF THE FOLLOWING RECOMMENDATIONS ARE PROVIDED:
  - A. IN THE INTEREST OF EFFICIENCY AND OBTAINING MAXIMUM UTILIZATION OF ASSIGNED PERSONNEL THIS COMMAND HAS FOUND IT COST EFFECTIVE TO COMBINE EQUIPMENT AND MANPOWER SURVEYS WHERE AND WHEN FEASIBLE. TO PERMIT MAXIMUM FLEXIBILITY RECOMMEND THAT THE TIME FRAME BETWEEN EQUIPMENT SURVEYS BE BROUGHT IN LINE WITH THAT FOR MANPOWER SURVEYS (PARAGRAPH 3-10, AR 57C-4 APPLIES).
  - B. AGREE WITH SURVEYING READINESS REPORTING ELEMENTS (LIMITED TO NON-TOE REQUIRED, AUTHORIZED EQUIPMENT).
  - C. COMPOSITION OF SURVEY TEAM SHOULD BE AT THE DISCRETION OF THE MACOM COMMANDER IAW PARA 2-4, AR 57U-7.
  - D. ESTABLISHMENT OF TEAMS AT LEVELS OTHER THAN MACOM SHOULD BE AT THE DISCRETION OF THE MACOM COMMANDER.
- 2. THIS HQ HAS ELECTED NOT TO ISSUE ANY SUPPLEMENTAL MATERIAL TO AR 57U-7.
- 3. PARAGRAPH 2-12C OF AR 57C-7 SHOULD BE DELETED SINCE US ARMY SECURITY AGENCY REDESIGNATED USA INTELLIGENCE AND SECURITY COMMAND NO LONGER MANAGES B-46 ITEMS.

BT  
 ACTION ADDRESSEES  
 006 DALD  
 00006 TOTAL NUMBER OF COPIES REQUIRED  
 #0671

BKS	INCL	SM
ZX	TA	SMT
ZXT	IE	SMS
ZXA	TSM	SMM
ZXA-C	TST	SMW
AV	TSE	SML
PL	TSP	SMD
PLS	SAC	RM
PLW	SAB	RMB
PLR	SAA	RMC
PLF	SA	RMI
PLO		RMP

\*\*\*\*\*  
 \* UNCLASS E F T O \*  
 \*\*\*\*\*

PAGE 01  
 051915Z MAY 78  
 RUDHAAA/0671



DEPARTMENT OF THE ARMY  
HEADQUARTERS  
UNITED STATES ARMY COMPUTER SYSTEMS COMMAND  
FORT BELVOIR, VIRGINIA 22060

8 MAY 1978

CSCS-SLL

SUBJECT: Equipment Authorization Policies and Procedures Review

HQDA (DALO-ZXT)  
WASH DC 20310

1. Reference your message, DTG 051854Z Apr 78, subject as above.
2. Our response is keyed to paragraph 4 of referenced message.
  - a. Paragraph 4a through 4g and paragraph 4i: No comments.
  - b. Paragraph 4h (Adequacy of other policies in AR 310-34/310-49).

(1) After having read the DAIG Report of the Special Inventory conducted during 1977 and the separate Proper Count messages of the DAPATF, it appears that CTA property accountability, or the lack thereof, poses inventory problems at all levels.

(a) Controlled equipment is documented by individual LIN in Section III of the TAADS document and usually is adjusted (or should be) when personnel levels are adjusted.

(b) Property Book Officers are required to reconcile the authorized allowances recorded on property book pages with the authorized allowances in the applicable HQDA approved authorization documents, annually IAW para 2-17.1, AR 710-2. There are indications that if these reconciliations are being performed properly, the results are still less than satisfactory.

(2) Recommend consideration be given to establishing a policy that requires reconciliation of all property on the property book whenever the TAADS Document is changed, but at least annually. BOI for CTA property is normally associated with individuals by skill or MOS and excesses may be generated by personnel adjustments. Thus, both personnel and equipment levels should be adjusted simultaneously.

CSCS-SLL

SUBJECT: Equipment Authorization Policies and Procedures Review

3. A copy of our USACSC Supplement 1 to AR310-49 is at Incl 1 for your information.

FOR THE COMMANDER



AARON G. REAMES  
LTC, GS  
ACofS, G4

1 Incl  
as



DEPARTMENT OF THE ARMY  
HEADQUARTERS U.S. ARMY MILITARY DISTRICT OF WASHINGTON  
FORT LESLEY J. MCNAIR  
WASHINGTON, D.C. 20319

ANLOG

MAY 09 1978

SUBJECT: Department of the Army Property Accountability Task Force  
(DAPATF) Requests for Comment

HQDA (DALO-ZXT)  
Washington, DC 20310

1. References:

a. HQDA message //DALO-ZXT//, subject: Review of the Equipment Survey Process (S: 30 Apr 78), 051852Z Apr 78.

b. HQDA message //DALO-ZXT//, subject: Equipment Authorization Policies and Procedures Review (S: 30 Apr 78), 051854Z Apr 78.

2. The following comments/recommendations are forwarded pertaining to referenced messages:

a. It is considered unnecessary to establish more teams at any level for the purpose of property accountability. At the present time the DAIG, MDWIG, Equipment Survey Team, Command Logistics Review Team and Maintenance Assistance and Instruction Teams are all involved in inventories, inspections and surveys at command authorization through user levels. More teams would place an additional burden on user personnel as well as tax the command's resources of personnel knowledgeable in this area. There are no identifiable property accountability gains that would accrue from the infusion of more teams.

b. It is recommended that the DA approved letter request be accepted as authority to requisition equipment. This action is imperative now that authorization documents are only updated bi-annually.

3. AR 310-34, AR 310-49 and AR 570-7 furnish sufficient guidance for authorizing and documenting equipment and conducting equipment surveys. No changes are recommended.

FOR THE COMMANDER:

  
DONALD L. BURT  
Colonel, GS  
Deputy Chief of Staff, Logistics

\* UNCLASS E F T O \*  
\*\*\*\*\*

DEPARTMENT OF THE ARMY  
PENTAGON TELECOMMUNICATIONS CENTER

DSN = SCD210 MCN = 7813C/18581 TOR = 781302018  
.TTEZYUW RUDHAAACS52 1302016-EEEE--RUEADWD.  
ZNY EEEEE  
R 091350Z MAY 78  
FM CDRINSCOM AHS VA //IARM-SA//  
TO RUEADWD/DA WASHCC //CALO-ZXT//  
BT

UNCLAS E F T O

SUBJ: EQUIPMENT AUTHORIZATION POLICIES AND PROCEDURES REVIEW

A. DA MSG, CALO-ZXT, 051854Z APR 78 (U).

1. IAW REFERENCE THE FOLLOWING COMMENTS ARE PROVIDED:

A. CONCUR IN CURRENT REVIEW PROCEDURES. THIS HQ STAFFS ALL REQUESTS WITH THE STAFF ELEMENT HAVING THE TECHNICAL EXPERTISE IN A PARTICULAR AREA OTHER THAN NATIONAL SECURITY AGENCY DIRECTED MISSION ITEMS.

B. COMMANDER AWARENESS CAN BE ACCOMPLISHED BY HAVING THE UNIT COMMANDER, BELGW MACCM, INITIATING THE REQUEST TO PERSONALLY SIGN LETTER.

C. COMMAND CHANNEL REVIEW PROCEDURES SHOULD BE AT THE DISCRETION OF THE MACCM COMMANDER.

D. A VIABLE EQUIPMENT UTILIZATION SURVEY WOULD NEGATE THE REQUIREMENT FOR REVALIDATION OF APPROVED LETTER REQUESTS FOR OTHER THAN READINESS REPORTING ELEMENTS.

E. AGREE WITH JUSTIFICATION CRITERIA AS ESTABLISHED IN AR 310-34.

F. CHANGE FIGURE H-1, APPENDIX H, AR 310-34 TO INCLUDE A COLUMN FOR UNIT COST. THIS WOULD ASSIST THE COMMANDER IN AWARENESS AND COST ANALYSIS.

G. ITEMS USED PERIODICALLY SHOULD BE CENTRALLY STORED.

H. AGREE WITH POLICY AND PROCEDURES AS CURRENTLY STATED IN AR 310-34/310-49.

2. PARA D-3E2, APPENDIX D, AR 310-49 SHOULD BE DELETED SINCE US ARMY SECURITY AGENCY REDESIGNATED USA INTELLIGENCE AND SECURITY COMMAND IS NO LONGER A MISSION ASSIGNEE AGENCY.

BT

ACTION ADDRESSEES

006 DALD

INFORMATION ADDRESSEES

012 DAMD

00018 TOTAL NUMBER OF COPIES REQUIRED

\*\*\*\*\*  
\* UNCLASS E F T O \*  
\*\*\*\*\*

PAGE 01  
091350Z MAY 78  
RUDHAAA/0952

\*\*\*\*\*  
\* UNCLASSIFIED \*  
\*\*\*\*\*

SRG	TA	SM
ZX	IE	DMT
ZYM	LM	AY
OMA	JNT	MMI
DN	LO	VW
AV		PO
		IO
		IO
		IO
		AP

DEPARTMENT OF THE ARMY  
PENTAGON TELECOMMUNICATIONS CENTER

CDSN = SCD018    PCN = 78151/06423    TCR = 781511019  
RTTUZYUW RUAGAAA4359 1511C11-UULL--RLEACWO.  
ZNR UUUUU  
R 310131Z MAY 78  
FM CDR USAEIGHT SECILL KS//D.-AS-SM//  
TO CA WASH DC//CALC-SMS/LALC-ZXT/DAMC-FDL//  
BT

UNCLAS  
SUBJ: ACCOUNTING FOR LEASED/RENTAL PROPERTY  
A. PARA 1-9A, AR 735-5, 22 MAY 74, SUEJ; PROPERTY ACCOUNTABILITY,  
GENERAL PRINCIPLES, POLICIES, AND BASIC PROCEDURES (U)  
  . YOUR DAMO-FDL 172155Z MAY 78, SUEJ; POLICY CHANGE FOR  
DOCUMENTING RENTAL/LEASED EQUIPMENT IN TAADS (CHANGE TO AR 310-49)  
1. THERE APPEARS TO BE SOME CONFLICT BETWEEN CITED REFS. DOES REF  
BRAVC MEAN THAT RENTAL/LEASE CONTRACT WILL NOT BE RECORDED ON  
PROPERTY BOOK OR THAT RENTAL/LEASE PROPERTY WILL NOT BE RECORDED ON  
PROPERTY BOOK OR THAT NEITHER WILL BE RECORDED ON PROPERTY BOOK?  
2. IF PROPERTY BOOK IS NOT APPROPRIATE ACCOUNTING METHOD FOR DRENTAL  
RENTAL/LEASEEQUIPMENT IN USE, WHAT IS APPRIOPRIATE ACCOUNTING  
METHOD, AND WHAT IS DIRECTIVE THAT SETS FORTH APPROPRIATE  
PROCEDURES? NEITHER REF CITES APPROPRIATE DIRECTIVE NOR  
ACCOUNTING METHCD.

BT  
  ACTION ADDRESSEES  
006 CALC  
  INFORMATION ADDRESSEES  
012 DAMO  
00018    TOTAL NUMBER OF COPIES REQUIRED  
#4359

\*\*\*\*\*  
\* UNCLASSIFIED \*  
\*\*\*\*\*

PAGE 01  
310131Z MAY 78  
RUAGAAA/4359



Chapter 17

Cash Collection

1. Recommendation 6M. Eliminate the cash collection voucher except for the cash sale hand tools program because of its redundancy to the more effective statement of charges system.

2. DAPATF actions:

Volume      Page

3. MACOM responses:

Page      Tasking Ref

Covered under Recommendation 6o,  
Report of Survey.

## Chapter 18

### Medical Supply Accountability

1. Recommendation 6N. Bring medical supply accountability under a tighter system of control that more closely parallels that of the rest of the Army, while recognizing the circumstances peculiar to hospital operations.

2. DAPATF actions:	<u>Volume</u>	<u>Page</u>
a. Proper Count Flasher Message No. 5, DTG 301406Z Nov 77, Accountability of Hospital Duty White Uniforms (Male).	1	13
b. Proper Count Message, DTG 232000Z Dec 77, Hospital Duty White Uniforms.	1	56
c. Proper Count Message, DTG 232001Z Dec 77, Accountability of Hospital Duty White Uniforms.	1	58
3. MACOM responses:	<u>Page</u>	<u>Tasking Ref</u>
a. Message, CDR USAMEDCOMEUR, DTG 281400Z Apr 78, Hospital Duty White Uniforms.	364	2a
b. Message, CDR USANMA, DTG 161500Z May 78, Accountability of Hospital Duty Uniforms.	365	2a
c. Message, CDR HEC, DTG 121625Z Jun 78, Issue and Control of Hospital Duty White Uniforms.	366	2a

IMPROVE PROPERTY MANAGEMENT OF MEDICAL SUPPLIES AND EQUIPMENT

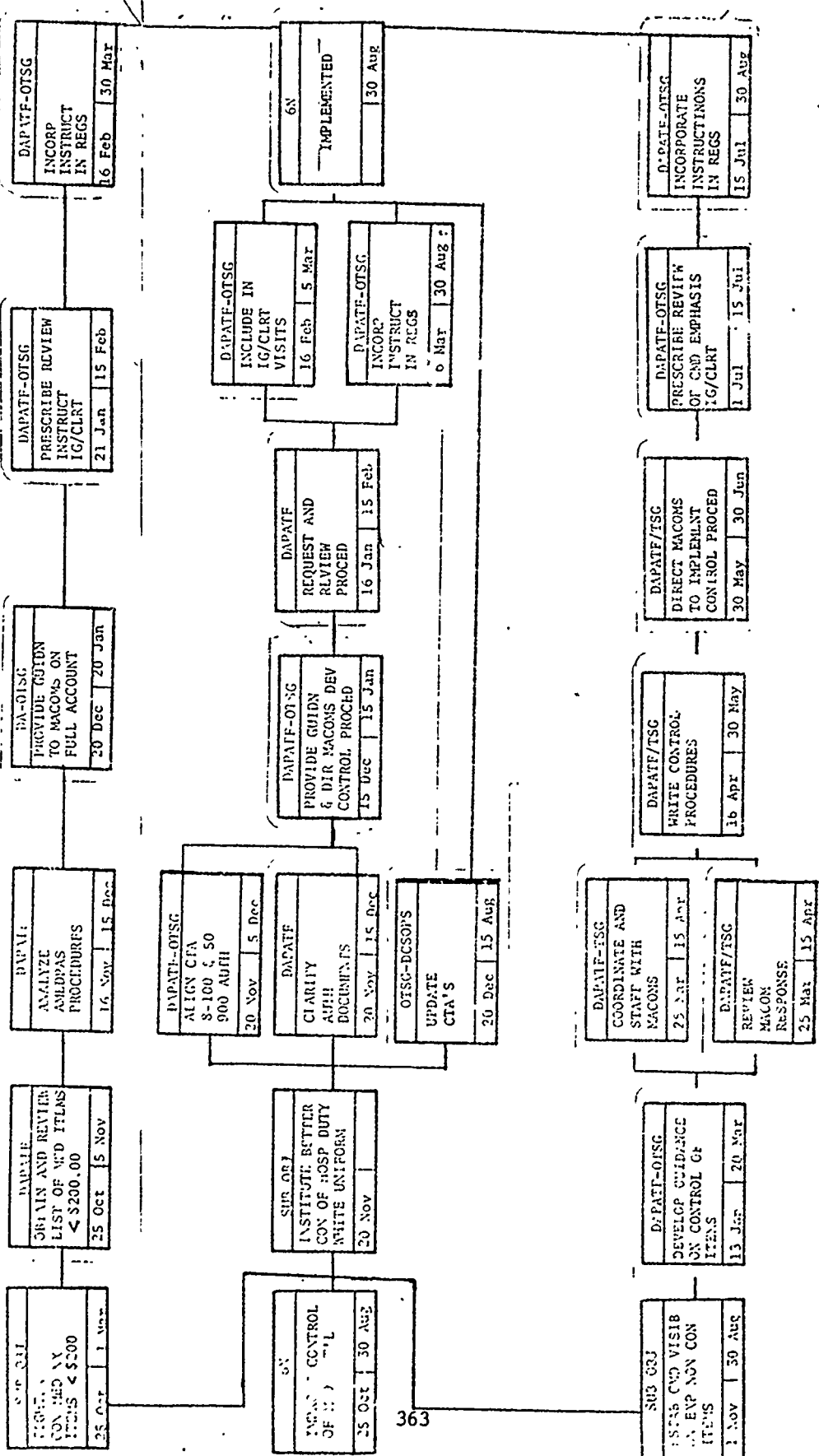

\*\*\*\*\*  
\* UNCLASSIFIED \*  
\*\*\*\*\*

DEPARTMENT OF THE ARMY  
PENTAGON TELECOMMUNICATIONS CENTER

CDSN = SCD285 MCN = 78118/15513 TOR = 781182041  
RTTUZYUW RUFDAAA4323 1182043-UUUU--RUEADWD.  
ZNR UUUUU  
R 281400Z APR 78  
FM CDR USAMEDCJMEUR HEIDELBERG GERMANY //AEMLO-SO//  
TO RUEADWD/HQDA WASH DC //DASG-HCD//  
INFO RUEADWD/HQDA WASH DC //DASG-HCL//  
BT

UNCLAS

SUBJECT: HOSPITAL DUTY WHITE UNIFORMS

A. DA MSG, DALO-ZXT, DTG 301406Z NOV 77, SUBJ: ACCOUNTABILITY OF  
HOSPITAL DUTY WHITE UNIFORMS.

B. CTA 8-100

1. THE NEW CTA 8-100, DTG 23 MAR 78 STILL LISTS SUBJ ITEMS AS EX-  
PENDABLE WHICH SEEMS IN CONTRAVENTION TO DA POLICY ANNOUNCED IN REF  
ALPHA.

2. PLEASE CLARIFY.

BT

ACTION ADDRESSEES

004 DASG

INFORMATION ADDRESSEES

006 DALO

00010 TOTAL NUMBER OF COPIES REQUIRED

#4323

364

\*\*\*\*\*  
\* UNCLASSIFIED \*  
\*\*\*\*\*

PAGE 01  
281400Z APR 78  
RUFDAAA/4323

\*\*\*\*\*  
\* UNCLASSIFIED \*  
\*\*\*\*\*

*Review File*

DEPARTMENT OF THE ARMY  
PENTAGON TELECOMMUNICATIONS CENTER

CDSN = SCD044 MCN = 78136/17845 TOR = 781362054  
RTTUZEXW RUECRDE2252 1361542-LLLL--RUEADWD.  
ZNR UUUUU  
R 161500Z MAY 78 ZEX  
FM CDR USAMMA FT DETRICK MD//SGMMA-LDT//  
TO AIG 7485  
AIG 7486  
AIG 7487  
AIG 7488  
INFO RUEADWD/RJCA WASH DC //DALU-TST/DALU-ZXT//  
BT

UNCLAS  
SGMMA-LDT 7547  
SUBJ: ACCOUNTABILITY OF HOSPITAL DUTY WHITE UNIFORMS  
A. PROPER COUNT FLASHER MSG NO 5 DTG C71936Z DEC 77 SUBJ AS ABOVE.  
B. AR 40-2.  
C. AR 710-2.  
D. HSC REG 700-7 (1 OCT 77)  
1. EFF 1 JUN 78 THE ARMY MASTER DATA FILE (AMDF) WILL REFLECT THE HOSPITAL DUTY WHITE UNIFORM (HDWU) AS NONEXPENDABLE (NX). THE HDWU ARE IDENTIFIED IN THE FEDERAL SUPPLY CATALOG 6532-IL DATED 1 NOV 77 AS:  
SMOCK, MED ASST MEN'S - INDEX NUMBER 1010 THRU 1035  
TROUSERS MED ASST MEN'S - INDEX NUMBER 1160 THROUGH 1340  
2. ACTIVITIES SHOULD INSURE HDWU ARE ACCOUNTED FOR AS NX IAW ABOVE REFERENCES.  
3. THIS INFO SHOULD BE DISSEMINATED TO ALL PROPERTY BOOK OFFICERS AND MEDICAL SUPPLY OFFICERS.  
BT

- ACTION ADDRESSEES  
J04 DASG
- INFORMATION ADDRESSEES  
J06 DALO
- 00010 TOTAL NUMBER OF COPIES REQUIRED  
#2252

\*\*\*\*\*  
\* UNCLASSIFIED \*  
\*\*\*\*\*  
PAGE 01  
161500Z MAY 78  
RUECRDB/2252

\*\*\*\*\*  
 \* UNCLASSIFIED \*  
 \*\*\*\*\*

DEPARTMENT OF THE ARMY  
 PENTAGON TELECOMMUNICATIONS CENTER

BKS	TA	SM
ZX	LE	SMT
ZXT A	TSM	SMS
ZXA	TST	SMM
THCL	TSE	SMW
AV	TSP	SML
PL	TS	SMD
PLW	SAC	RM
PLS	SAB	RMB
PLR	SAA	RMO
PLF	SA	RMI
PLG		RMP

CDSN = SCD527 MCN = 78164/J2616 TOR = 7816403  
 RTTUZYUW RUWTNFA2280 163180E-UUUU--RLEADWD,  
 ZNR UUUUU  
 R 121625Z JUN 78  
 FM CDRHSC FT SAM HOLSTON TX //HSLJ-SC//  
 TO AIG 7468  
 INFO RUEADWD/DA WASHDC //CASG-HCL//  
 BT

UNCLAS

SUBJ: ISSUE AND CONTROL OF HOSPITAL DUTY WHITE UNIFORMS

- A. MSG, DALO-ZXT, 122003Z MAY 78
- B. AR 712-2, WITH C 4
- C. HSC REG 700-7, 9 SEP 77
- D. MSG, DAMO-FDU, 152226Z AUG 77
- 1. REF A CHANGED THE ACCOUNTING SYSTEM FOR ORGANIZATIONAL CLOTHING AND INDIVIDUAL EQUIP (OCIE) ITEMS CONTAINED IN CTA 50-900. CLOTHING ITEMS ARE NOW TO BE DROPPED FROM THE PB UTILIZING THE CONSOLIDATED DA FORM 3645, ORGANIZATION CLOTHING AND EQUIPMENT RECORD, ON AN ABSTRACT BASIS, WEEKLY.
- 2. THE ABOVE IS APPLICABLE TO ALL OCIE EXCEPT THE HOSPITAL DUTY WHITE UNIFORMS (HDWU). CTA 50-900 LINE ITEM NO: 8590N AND N8591N, PANTSUITS: WOMEN'S COTTON/POLYESTER; LIN 651857, DRESSES: COTTON/POLYESTER; LIN DC1969, CAP NURSES; LIN F33046, COVERALLS, MAN'S ARE CONSIDERED BY THIS FC TO BE CONTROLLED ITEMS. CONSEQUENTLY, THESE ITEMS WILL BE MAINTAINED ON THE PB AND ACCOUNTED FOR IAW THE PROCEDURES SET FORTH IN HSC REG 700-7, ISSUE AND CONTROL OF HDWU, 9 SEP 77.
- 3. THE HDWU INCLUDED IN CTA 8-100, ARMY MED DEPARTMENT EXPENDABLE SUPPLIES, 23 MAR 78, NSN 6532-00-110-8290 THRU 6532-00-113-5418, TROUSERS AND NSN 6532-00-117-7487/7542/7543/7546 SMOCK, ARE ALSO CONSIDERED TO BE CONTROLLED ITEMS AND ARE TO BE MAINTAINED ON THE PB AND ACCOUNTED FOR IAW HSC REG 700-7.
- 4. NSN 6532-00-149-0464/0465/0466/0467/0472/0473, DRESSES: COTTON/POLYESTER ARE LISTED IN CTA 8-100 AS EXPENDABLE. ACTION IS BEING TAKEN AT THIS TIME TO ELIMINATE THESE ITEMS FROM CTA 8-100. REF D INDICATES THAT ACTION IS ALSO BEING TAKEN TO MOVE NSN 6532-00-117-7137/7542/7543/7546 SMOCK AND NSN 6532-00-110-8290 THRU 6532-00-113-5418 TROUSER FROM CTA 8-100 TO CTA 50-900.

BT

ACTION ADDRESSEES

004 DASSG  
 IN 6  
 06 DACO  
 012 DAMO  
 022 TNCR.

366

\*\*\*\*\*  
 \* UNCLASSIFIED \*  
 \*\*\*\*\*

PAGE 01  
 121625Z JUN 78  
 RUWTNFA/2280

## Chapter 19

### Report of Survey System

#### 1. Recommendation 60.

a. Recognize that catastrophic losses cannot feasibly be accounted for by holding individuals pecuniarily liable for large dollar amounts, irrespective of the degree of negligence involved.

b. Provide for a swift and sure assessment of reasonable level of pecuniary responsibility and deterrent to carelessness. As a point of departure, examine the feasibility of redefining "negligence" in a simple statement of that lack of prudence which the Government has the right to expect, limit pecuniary liability for lost property to an amount equal to an individual's basic pay for one month, establish report of survey approval authority at the special Courts-Martial convening authority level, and designate the General Courts-Martial convening authority as the officer authorized to act for the Secretary of the Army on final appeals for relief from pecuniary liability.

c. Prescribe, in applicable regulations, that failure to maintain supply discipline, in matters more serious than those appropriately handled under the Report of Survey system described above, be disposed of through administrative action. Specifically, adverse efficiency reports, reduction-in-grade, relief from duty, and, in extreme cases, punishment under the UCMJ or elimination from the Service would be possible and appropriate.

#### 2. DAPATF action:

	<u>Volume</u>	<u>Page</u>
a. Proper Count Message, DTG 152100Z Nov 77, Accounting for Lost, Damaged, and Destroyed Property.	1	41
b. Proper Count Message, DTG 012115Z Feb 78, Request for Clarification of Installation Commander Authority.	2	34
c. Proper Count Message, DTG 091440Z Feb 78, Accounting for Lost, Damaged, and Destroyed Property, AR 735-11.	2	42
d. Proper Count Message, DTG 091610Z Feb 78, Accounting for Lost, Damaged, and Destroyed Property, AR 735-11.	2	43

	<u>Volume</u>	<u>Page</u>
e. Proper Count Message, DTG 271848Z Feb 78, Revision of AR 735-11, Paragraph 4-15.	2	52
f. Indorsement, 30 Jan 78, Approval Authority for Reports of Survey.	2	95
g. Indorsement, 31 Jan 78, Approval of Reports of Survey, 2d Bn 52d ADA.	2	110
h. Indorsement, 31 Jan 78, Recommended Change to AR 735-11 and AR 210-50.	2	119
i. Letter, 16 Feb 78, Requested Deviations to DOD 7200.10-M.	2	147
j. Indorsement, 16 Feb 78, Proposed Revision to AR 735-11.	2	157
k. Indorsement, 16 Feb 78, Report of Survey for Damaged Privately-Owned Vehicle (POV).	2	178
l. Indorsement, 13 Mar 78, Report of Survey 46-76.	2	202
m. Indorsement, 13 Mar 78, Report of Survey 25-78.	2	204
n. Indorsement, 14 Mar 78, Property Adjustment Procedures.	2	208
o. Letter, 15 Mar 78, Requested Change to AR 735-11.	2	212
p. Memorandum, 21 Mar 78, Visit to DLA on 20 Mar 78.	2	226
q. Memorandum for: Office, Assistant Secretary of Defense (Comptroller), ATTN: Mr. Crehan, 8 Jun 78, Army's Request for Deviation from DOD 7200.10M.	3	119



3. MACOM responses:	<u>Page</u>	<u>Tasking Ref</u>
a. Message, CDR EUSA, DTG 170502Z Apr 78, Lost, Damaged, and/or Destroyed Property.	371	2c
b. Message, CDR TRADOC, DTG 012030Z May 78, Adjustment to Property Books, DD Form 362 (Statement of Charges for Government Property Lost, Damaged or Destroyed), AR 735-11.	372	2o
c. Message, CINCUSAREUR, DTG 041019Z May 78, Draft AR 735-11.	373	2j
d. Message, CDR FORSCOM, DTG 261345Z May 78, Accounting for Damaged Property.	374	2k
e. Message, CDR FORSCOM, DTG 261346Z May 78, Accounting for Damaged Property.	376	2k
f. Message, CDR FORSCOM, DTG 141355Z Jun 78, Distribution of Reports of Survey.	377	2j
g. Message, CDR FORSCOM, DTG 201155Z Jun 78, Improvements in Reports of Survey Processing Time.	378	2j



\*\*\*\*\*  
 \* UNCLASSIFIED \*  
 \*\*\*\*\*

THCL	CM
ZX	ENT
ZXT	SMS
ZXA	SMT
ZXB	SMT
ZXC	SMT
ZXD	SMT
ZXE	SMT
ZXF	SMT
ZXG	SMT
ZXH	SMT
ZXI	SMT
ZXJ	SMT
ZXK	SMT
ZXL	SMT
ZXM	SMT
ZXN	SMT
ZXO	SMT
ZXP	SMT
ZXQ	SMT
ZXR	SMT
ZXS	SMT
ZXT	SMT
ZXU	SMT
ZXV	SMT
ZXW	SMT
ZXZ	SMT

DEPARTMENT OF THE ARMY  
 PENTAGON TELECOMMUNICATIONS CENTER

CDSN = SCD153 MON = 78107/02888 TCR 781070919  
 PTTUZYUW RIAGAAA2236 1070356-0000-3LEADWDEL  
 ZNR 0000  
 P 170502Z APR 78  
 FM CDR USAEIGHT SEOUJL KOREA //DJ-MS-SM//  
 TO CA WASH DC //JALC-LAT//  
 BT

UNCLAS

SUBJ: LOST, DAMAGED, AND/OR DESTROYED PROPERTY  
 A. VERBAL REC MR. MISHOVICH, DURING DAPATF VISIT TO KOREA, REGR  
 REVIEW AND COMMENTS RELATIVE TO DRAFT REVISION OF AR 735-11 (U)  
 1. THE PRINCIPLES AND POLICIES IN DRAFT REVISION OF AR 735-11 WILL  
 SIMPLIFY AND IMPROVE REPORT OF SURVEY SYSTEM AND PROCEDURES  
 CONSIDERABLY.  
 2. A COMPARISON OF DRAFT REVISION WITH CURRENT AR 735-11, HOWEVER,  
 REVEALS THAT CERTAIN PERTINENT AREAS ARE NOT COVERED, THAT IS:  
 A. APPOINTING SURVEY OFFICERS.  
 B. SAMPLE REPORTS OF SURVEY IN DETAIL.  
 C. REVIEWING AUTHORITY.  
 D. APPEALS PROCESS.  
 E. DESIGNATION OF STAFF AUTHORITY.  
 F. DISCREPANCIES INCIDENT TO SHIPMENT.  
 3. THERE ARE, ALSO, NO PROVISIONS FOR COLLECTING AND SUMMARY  
 REPORTING (COMMAND VISIBILITY) OF PROPERTY ADJUSTMENTS AS DELINEATED  
 IN PROPER CCNT FLASHER MESSAGE NO 1.  
 BT

ACTION ADDRESSEES

CC6 CALC  
 00006 TOTAL NUMBER OF COPIES REQUIRED  
 #2236

\*\*\*\*\* PAGE C1  
 \* UNCLASSIFIED \* 170502Z APR 78  
 \*\*\*\*\* RIAGAAA/2236

\*\*\*\*\*  
\* UNCLASSIFIED \*  
\*\*\*\*\*

DEPARTMENT OF THE ARMY  
PENTAGON TELECOMMUNICATIONS CENTER

CDSN = SCD543 MCN = 78123/00876 TOR = 781230105  
RTTUZYUW RUCLAIA3170 1222031-UUUU--RUEADWD.  
ZNR UUUUU  
R 022030Z MAY 78  
FM CDTRADOC FTMONROE VA //ATLG-MSP-SP//  
TO AIG 7573  
INFO RUEADWD/HQDA WASHDC //DALG-ZXT//  
RJCLHTB/CDRFORSCOM FT MCPHERSON GA //AFLG-SMS//  
BT

UNCLAS

SUBJ: ADJUSTMENT TO PROPERTY BOOKS, DD FORM 362 (STATEMENT OF CHARGES FOR GOVERNMENT PROPERTY LOST, DAMAGED OR DESTROYED) AR 735-11

A. FONECON BETWEEN HQDA DAPATF, WO4 WRIGHT AND TRADOC DCSLOG MR SHARKEY 1 MAY 78

1. REF ABOVE PROVIDED GUIDANCE REGARDING POSTING DD FORM 362 TO PROPERTY BOOKS FOR LOSS OR DESTRUCTION OF GOVERNMENT PROPERTY, THE DD 362 WILL BE POSTED TO THE PROPERTY BOOK AT TIME THE FORM IS INITIATED IN ACCORDANCE WITH PROVISIONS OF PARA 2-11B, AR 735-11. PROPERTY BOOK OFFICERS WILL TAKE ACTION TO OBTAIN COPY OF DD FORM 362 WHEN COLLECTION OF CHARGES IS COMPLETED.

2. REQUEST WIDEST DISSEMINATION OF THIS POLICY AND PROCEDURE TO ALL SUPPORTED UNITS.

BT

ACTION ADDRESSEES

006 DALD

INFORMATION ADDRESSEES

001 AFLO/ATLD

00007 TOTAL NUMBER OF COPIES REQUIRED

#3170

\*\*\*\*\*  
\* UNCLASSIFIED \*  
\*\*\*\*\*

PAGE 01  
022030Z MAY 78  
RUCLAIA/3170

\*\*\*\*\*  
\* UNCLASSIFIED \*  
\*\*\*\*\*

DEPARTMENT OF THE ARMY  
PENTAGON TELECOMMUNICATIONS CENTER

217		
ZXA		
ZYA		
AV		
PL		
PLS		
PLT		
PLR		
PLF		
PLO		

CDSN = SCD058    MCN = 78125/01497    TOR = 781250150  
RTTUZYUW RUFDAAA2204 1250151-UUUU--RUEADWD.  
ZNR UUUUU  
R 041019Z MAY 78  
FM CINCUSAREUR HEIDELBERG GERMANY//AEAGD-SM-  
TO HQDA WASH DC//DALG-ZXT//  
BT

UNCLAS  
SUBJECT: DRAFT AR 735-11  
1. PER PREVIOUS DISCUSSIONS WITH DAPATF MEMBERS, A FINAL DRAFT OF AR 735-11 WAS PLANNED FOR MAY 78 AND PUBLICATION OF REVISED AR 735-11 WAS SCHEDULED FOR JULY 78.  
2. TO ENSURE CURRENT USAREUR POLICIES AND IMPLEMENTATION PROGRAMS ARE CONSISTANT WITH PLANNED HQDA POLICIES, REQUEST ONE COPY OF PROPOSED DRAFT AR 735-11 BE PROVIDED FOR INFORMATION PURPOSES.  
3. HQUSAREUR POC IS MAJ J.H. KAPKE, RLG MIL 6760/8142.  
BT

ACTION ADDRESSEES  
006 DALG  
00006    TOTAL NUMBER OF COPIES REQUIRED  
#2204

**THIS PAGE IS BEST QUALITY PRACTICABLE  
FROM COPY FURNISHED TO DDC**

\*\*\*\*\*  
\* UNCLASSIFIED \*  
\*\*\*\*\*  
PAGE 01  
041019Z MAY 78  
RUFDAAA/2204

\*\*\*\*\*  
 \* UNCLASSIFIED \*  
 \*\*\*\*\*

DEPARTMENT OF THE ARMY  
 PENTAGON TELECOMMUNICATIONS CENTER

CDSN = SCD971 MCA = 78147/01935 TOR = 78147/0148  
 RTTUZYUW RUCLHTA8614 146222C-LUUL--KLEADWD.  
 ZNR UUUUU  
 R 261345Z MAY 78  
 FM CDR FORSCOM FT MCFFERSON GA //AFLG-SMS//  
 TO CA WASH DC //CALC-ZXT//  
 R 221515T MAY 78  
 FM CDR 5TH INF DIV (M) & FTCLK FTPLK LA//AFZ-OT-GC//  
 TO CDR FORSCOM FTMCFFERSON GA//AFLG-SMS//  
 BT

BKS	TA	SM
ZX	LE	SMT
ZXT	TGM	SMS
ZXA	TST	SMM
147/0148	TSE	SMW
AV	TSP	SML
PL	TS	MD
PLW	SAC	SM
PLB	SAB	SM
PLR	SAA	SMO
PLC		SMI
		SMF

UNCLAS

SUBJECT: ACCOUNTING FOR DAMAGED PROPERTY

- A. FORSCOM MESSAGE, 12124CZ MAY 78, SUBJECT: REQUEST FOR CLARIFICATION.
- B. FCNECON, MAJCF CHAFIN, FPATF, AND MR GREENE THIS HEADQUARTERS, 17 MAY 78, SAB.
- C. FCNECON, MAJCF CHAFIN, FPATF, AND CAPT PROCTOR THIS HEADQUARTERS, 1 APRIL 1978, SAB.
- D. FCNECON, CMC WRIGHT, CAPATF, AND CAPT PROCTOR, 14 APRIL 1978, SAB.
- 1. REFERENCE A INTERPRETED CA AND FORSCOM GUIDANCE TO REQUIRE A REPORT OF SURVEY FOR ALL DAMAGED PROPERTY WHERE THE AMOUNT OF DAMAGE EXCEEDS \$250.00.
- 2. AR 735-11 AND CONVERSATIONS, REFERENCES B, C, AND D, SUPPORT THE CONCLUSIONS THAT SOME EXCEPTIONS TO THE ABOVE BLANKET POLICY SHOULD BE CONSIDERED. EXPLANATION FOLLOWS:
  - A. PARA 1-8I, AR 735-11 RECOGNIZES THAT DAMAGE CAN RESULT FROM OTHER THAN FAULT OR NEGLIGENCE BY QUALIFYING THE DEFINITION OF DAMAGE, I.E., "THE TERM USUALLY IMPLIES THAT DAMAGE IS THE RESULT OF SOME ACT OR COMMISSION." PARA 1-6D, AR 735-11 STATES "HOWEVER, LOSS, DAMAGE, OR DESTRUCTION OF PROPERTY MAY RESULT FROM NORMAL OPERATIONS OF THE ARMY. IN SUCH CASES, IT IS OFTEN DESIRABLE TO RELIEVE INDIVIDUALS FROM PROPERTY RESPONSIBILITY WITH A MINIMUM OF EXPLANATION IN VIEW OF THE DISPROPORTIONATE COST....."
  - B. NORMAL OPERATIONAL COST ARE A DAILY OCCURRENCE AND IN A FIELD TRAINING ENVIRONMENT THE COST CAN BE SIGNIFICANT. SOME OF THESE WOULD INCLUDE:
    - (1) TRAILERS DAMAGED BY ROUGH TERRAIN.

THIS PAGE IS BEST QUALITY PRACTICABLE  
 FROM COPY FURNISHED TO DDC

\*\*\*\*\*  
 \* UNCLASSIFIED \*  
 \*\*\*\*\*

PAGE 01  
 221515Z MAY 78  
 RUCLHTA/8614

\*\*\*\*\*  
\* UNCLASSIFIED \*  
\*\*\*\*\*

DEPARTMENT OF THE ARMY  
PENTAGON TELECOMMUNICATIONS CENTER

- (2) HEAVY VEHICLE DAMAGE TO BRIDGES AND ROADS.
  - (3) TANKS THROWING/BREAKING A TRACK.
  - (4) FAULTY PARTS CAUSING ENGINE DAMAGE.
  - (5) A DRAIN PLUG FALLS OUT RESULTING IN ENGINE DAMAGE.
4. THE BLANKET POLICY INCREASES THE REQUIREMENT FOR REPORTS OF SURVEY AND ASSOCIATED COSTS, ELIMINATES COMMAND PREROGATIVE AND ELIMINATES THE OPTION OF AN AR 15-6 INVESTIGATION. IN ADDITION, DELAYS IN REPAIRS OF OPERATIONAL DAMAGES, CAUSED BY AWAITING SURVEY OFFICER RELEASE, IMPACT ON UNIT OPERATIONAL READY RATES.
5. RATHER THAN REQUIRING A R/S ON ALL JCB ORDERS INVOLVING REPAIRS OF OVER \$250.00, REPAIR FACILITIES COULD BE PROVIDED THE OPTION OF INITIATING AN ECCO WHEN A PIECE OF EQUIPMENT APPEARS TO HAVE BEEN DAMAGED THROUGH NEGLECT OF THE OPERATOR. THE UNIT COMMANDER COULD THEN DETERMINE THROUGH INVESTIGATION IF THERE WAS NEGLIGENCE AND INITIATE A R/S, AS APPROPRIATE. REQUEST RECONSIDERATION.

BT

ACTION ADDRESSEES  
006 CALO  
INFORMATION ADDRESSEES  
001 AFLO/ATLL  
0007 TOTAL NUMBER OF COPIES REQUIRED  
#8614

THIS PAGE IS BEST QUALITY PRACTICABLE  
FROM COPY FORWARDED TO DDC

\*\*\*\*\*  
\* UNCLASSIFIED \*  
\*\*\*\*\*

PAGE 02  
221515Z MAY 78  
RUC/LHTA/8614

\* UNCLASS E F T O \*  
 \*\*\*\*\*

DEPARTMENT OF THE ARMY  
 PENTAGON TELECOMMUNICATIONS CENTER

CDSN = SCD925 MCA = 78146/14311 TCF = 78146/1855L  
 RTEZYUW RUCLHTA8546 1461555-EEEE--KLEADWD.  
 ZNY EEEEE  
 R 261346Z MAY 78  
 FM CDR FORSCLM FT MCFFERSLN GA //AFLG-SMS//  
 TO RUEADWD/DA WASH DC //LALC-ZXT//  
 INFO RUCLDGA/CDR 51F INF DIV FT POLK LA //AFZX-DI-  
 BT

BKS/	TA	SM
ZX	LE	SMT
ZXT/	TSM	SMS/
ZXA	TST	SMM
1855L	TSE	SMW
AV	TTF	SML
PL	TS	SMD
PLW	SAC	RM
PLS	SAB	RMB
PLR/	SAA	RMO
PLF	SA	RMI
FLO/		RMP

UNCLAS E F T O

THIS IS A PROPER CCINT MESSAGE  
 SUBJECT: ACCOUNTING FOR DAMAGED PROPERTY

- A. REF, CDR, 51F INF DIV (M) & FT POLK MSG, 221515Z MAY 78, SAB.
- B. REF, FONECCN, MAJ CHAPIN, FPAIF, AND MR. WRIGHT, DAPATF, 24 MAY 78, SAB.
- 1. REF A REQUESTS CLARIFICATION OF BLANKET POLICY REQUIREMENT FOR A REPORT OF SURVEY FOR ALL DAMAGED PROPERTY WHERE THE AMOUNT EXCEEDS \$250.00. REF A CITES EXAMPLES OF NORMAL OPERATIONAL COSTS WHICH MAY EXCEED \$250.00.
- 2. AR 750-1 DIRECTS A TECHNICAL INSPECTION TO DETERMINE IF THE CONDITION OF THE EQUIPMENT IS THE RESULT OF OTHER THAN NORMAL WEAR. THIS SHOULD BE THE BASIS FOR DETERMINING IF A REPORT OF SURVEY OR AR 15-6 INVESTIGATION IS REQUIRED. IF IT IS DETERMINED TO BE ATTRIBUTABLE TO FAIR WEAR AND TEAR, EQUIPMENT FAILURE OR ACTS OF GOD (OR WEATHER, SUCH AS FROZEN WATER PIPES BURSTING AND CAUSING DAMAGE TO FEEL PROPERTY), WHERE ABSOLUTELY NO NEGLIGENCE IS INVOLVED, A WORK ORDER REQUEST OR A TURN-IN SLIP IS ALL THAT SHOULD BE REQUIRED.
- 3. REF B CONCLUDES WITH INTERPRETATION OF REF A AND PARA 2 ABOVE.
- 4. REQUEST CONFIRMATION OF REF B AND SUBSEQUENT CHANGE, IF APPROPRIATE, TO FLASHER MESSAGE NO. 1 WORLD WIDE AS THIS IS NOT A SINGLE INSTALLATION PROBLEM.

BT

ACTION ADDRESSEES

006 DALO

INFORMATION ADDRESSEES

001 AFLG/ATLC

00007 TOTAL NUMBER OF COPIES REQUIRED

#8546

\*\*\*\*\*  
 \* UNCLASS L F T O \*  
 \*\*\*\*\*

PAGE 01  
 261346Z MAY 78  
 RUCLHTA/8546



\*\*\*\*\*  
 \* UNCLASSIFIED \*  
 \*\*\*\*\*

DEPARTMENT OF THE ARMY  
 PENTAGON TELECOMMUNICATIONS CENTER

CDSN = SCD485 MCA = 78165/12716 TOR = 781651637  
 RTTUZYUW RUCLHTA1031 1651539-UUUU--RUEADWD.  
 ZNR UUUUU  
 R 141355Z JUN 78  
 FM CDR FORSCOM FT MCPHERSON GA //AFLG-SMS//  
 TO RUEADWD/DA WASH DC //CALG-ZXT//  
 INFO RUCLAIA/CDR TRADOC FT MONROE VA //ATRM-FFI//  
 BT

UNCLASSIFIED

SUBJECT: DISTRIBUTION OF REPORTS OF SURVEY

A. PARAS 5-13B(3) AND C, AR 735-11.

1. WAS IT INTENDED, AS STATED IN ABOVE REFERENCES, THAT THE TRIPPLICATE COPY OF ALL REPORTS OF SURVEY BE FORWARDED TO THE FINANCE AND ACCOUNTING OFFICE. THIS HEADQUARTERS HAS THE OPINION THE COPY WOULD SERVE NO USEFUL PURPOSE UNLESS THERE ARE APPROVED PECLNIARY CHARGES TO BE COLLECTED.

2. CLARIFICATION IS REQUESTED.

BT

ACTION ADDRESSEES

006 DALO

00006 TOTAL NUMBER OF COPIES REQUIRED

#1031

BKS ✓	DA	SM
ZX	LF ✓	SMT
ZXT ✓	TCN	SMS ✓
ZXA	ZST	SMM
THCL	TNI	SNW
AV	TEP	SNL
PL	TS	STB
ELW	SBC	SM
PLS	SAB	SMC
PLR	SAA	SMO
PLF ✓	SA	SMI
PLO ✓		SMP

377

\*\*\*\*\*  
 \* UNCLASSIFIED \*  
 \*\*\*\*\*

PAGE 01  
 141355Z JUN 78  
 RUCLHTA/1031

\*\*\*\*\*  
\* UNCLASSIFIED \*  
\*\*\*\*\*

DEPARTMENT OF THE ARMY  
PENTAGON TELECOMMUNICATIONS CENTER

CDSN = SCD125 MCM = 78171/15477 TOR = 781712129  
RTTUZYUW RUCLHTA1612 17121CC-UUUU--RLEADWD.  
ZNR UUUUU  
R 201155Z JUN 78  
FM CDR FORSCOM FT MCPHERSON GA //AF LG--SMS//  
TO AIG 7433  
INFO RUEADWD/DA WASH DC //DALO-ZXT/LG//  
RUCLAIA/CDR TRAFCC FT MONROE VA //ATRM-FF1//  
BT

UNCLASSIFIED

THIS IS A PROPER COUNT MESSAGE.

SUBJECT: IMPROVEMENTS IN REPORTS OF SURVEY PROCESSING TIME.

1. AS YOU ARE AWARE, PROCESSING TIME FOR REPORTS OF SURVEY HAS BEEN AN AREA OF CONTINUING INTEREST TO THE DAIG, AS WELL AS TO THIS HEADQUARTERS. ON NUMEROUS OCCASIONS YOU HAVE BEEN ADVISED THAT ALTHOUGH IMPROVEMENTS HAD BEEN MADE, THAT FORSCOM WIDE, THE AREA REMAINED UNSATISFACTORY.

2. THIS HEADQUARTERS IS PLEASED TO HAVE THE OPPORTUNITY TO ADVISE YOU THAT THE AVERAGE PROCESSING TIME FOR REPORTS OF SURVEY REVIEWED AT THIS HEADQUARTERS DURING SECOND QUARTER FY 78, THAT WERE INITIATED BY THE ACTIVE COMPONENT, REACHED AN ALL-TIME LOW OF 3.4 MONTHS. AVERAGE PROCESSING TIME FOR THE ACTIVE COMPONENT DURING FIRST QUARTER WAS 6.1 MONTHS.

3. YOU ARE TO BE COMMENDED ON THIS ACHIEVEMENT.

THIS ACCOMPLISHMENT IS INDICATIVE OF THE RESULTS THAT CAN BE OBTAINED BY COMMAND INTEREST, AND THROUGH COOPERATION AND TIMELY PERFORMANCE OF ASSIGNED DUTIES ON THE PART OF ALL INDIVIDUALS CONCERNED.

BT

ACTION ADDRESSEES

006 DALO

INFORMATION ADDRESSEES

001 AFLO/ATLO

0007 TOTAL NUMBER OF COPIES REQUIRED

#1612

378

\*\*\*\*\*  
\* UNCLASSIFIED \*  
\*\*\*\*\*

PAGE 01  
201155Z JUN 78  
RUCLHTA/1612

## Chapter 20

### CMF 76 Management

1. Recommendation 6P. Improve and discipline the distribution of CMF 76 personnel. Ensure the prompt reclassification of the inept or dishonest individual. Provide improved training at the entry level and ready access to MOS qualifying training for those who have shown promise in on-the-job training. Develop authorizations and management procedures to ensure that qualified personnel are sufficient in number to guarantee that they will actually be available at the unit level.

2. DAPATF actions:	<u>Volume</u>	<u>Page</u>
a. Proper Count Flasher Message No. 8, DTG 211525Z Dec 77, Improvement of Entry Level Training.	1	19
b. Proper Count Message, DTG 211955Z Oct 77, Management of Supply Personnel, CMF 76.	1	31
c. Letter, 14 Dec 77, Personnel Distribution Procedures.	1	86
d. Letter, 21 Dec 77, MOS Prerequisites.	1	89
e. Proper Count Message, DTG 181803Z Jan 78, Mobile Training Teams (MTT).	2	28
f. Proper Count Message, DTG 241645Z Feb 78, Property Accountability Training Material.	2	46
g. Letter, 9 Jan 78, 76Z Skill Qualification Test.	2	80
h. Letter, 13 Jan 78, Authorization for Supply Warrant Officers (DCSPER).	2	82
i. Letter, 13 Jan 78, Authorization for Supply Warrant Officers (DCSOPS).	2	84
j. Letter, 18 Jan 78, Personnel Management Procedures.	2	91
k. Letter, 18 Jan 78, to MG Smith on Tool Box Issuance.	2	93

	<u>Volume</u>	<u>Page</u>
l. Letter, 13 Feb 78, Prerequisites for Reclassification into CMF 76.	2	143
m. Letter, 8 Mar 78, TEC/Exportable Training Packages.	2	194
n. Letter, 24 Mar 78, 761A, Unit Supply Technician.	2	230
o. Proper Count Message, DTG 171650Z Mar 78, Entry Level Training.	2	
p. Letter, 24 Mar 78, 761A, Unit Supply Technician.	3	69
q. Memorandum for: Deputy Surgeon General, 21 Apr 78, Property Accountability Training.	3	72
3. MACOM responses:	<u>Page</u>	<u>Tasking Ref</u>
a. Indorsement, HQ Academy of Health Services, 13 Apr 78, 761A, Unit Supply Technician.	382	2p
b. Indorsement, HQ DARCOM, 11 Apr 78, 761A, Unit Supply Technician.	383	2p
c. Letter, USA INSCOM, 12 Apr 78, 761A, Unit Supply Technician.	384	2n
d. Letter, J4, CDR EUSA, 12 Apr 78, 761A, Unit Supply Technician.	386	2p
e. Msg, CDR USARJ, DTG 140600Z Apr 78, 761A, Unit Supply Technician.	387	2p
f. Indorsement, HQ USACC, 19 Apr 78, 761A, Unit Supply Technician.	388	2p
g. Letter, HQ USAREUR, 21 Apr 78, 761A, Unit Supply Technician.	389	2p
h. Letter, CDR Log Ctr, 2 May 78, 761A, Unit Supply Technician.	391	2p
i. Indorsement, HQ FORSCOM, 24 May 78, 761A, Unit Supply Technician.	395	2p
j. Memorandum, from OTSG, 15 Jun 78, Property Accountability Training.	396	2q

DISTRIBUTION OF CMF 76 PERSONNEL

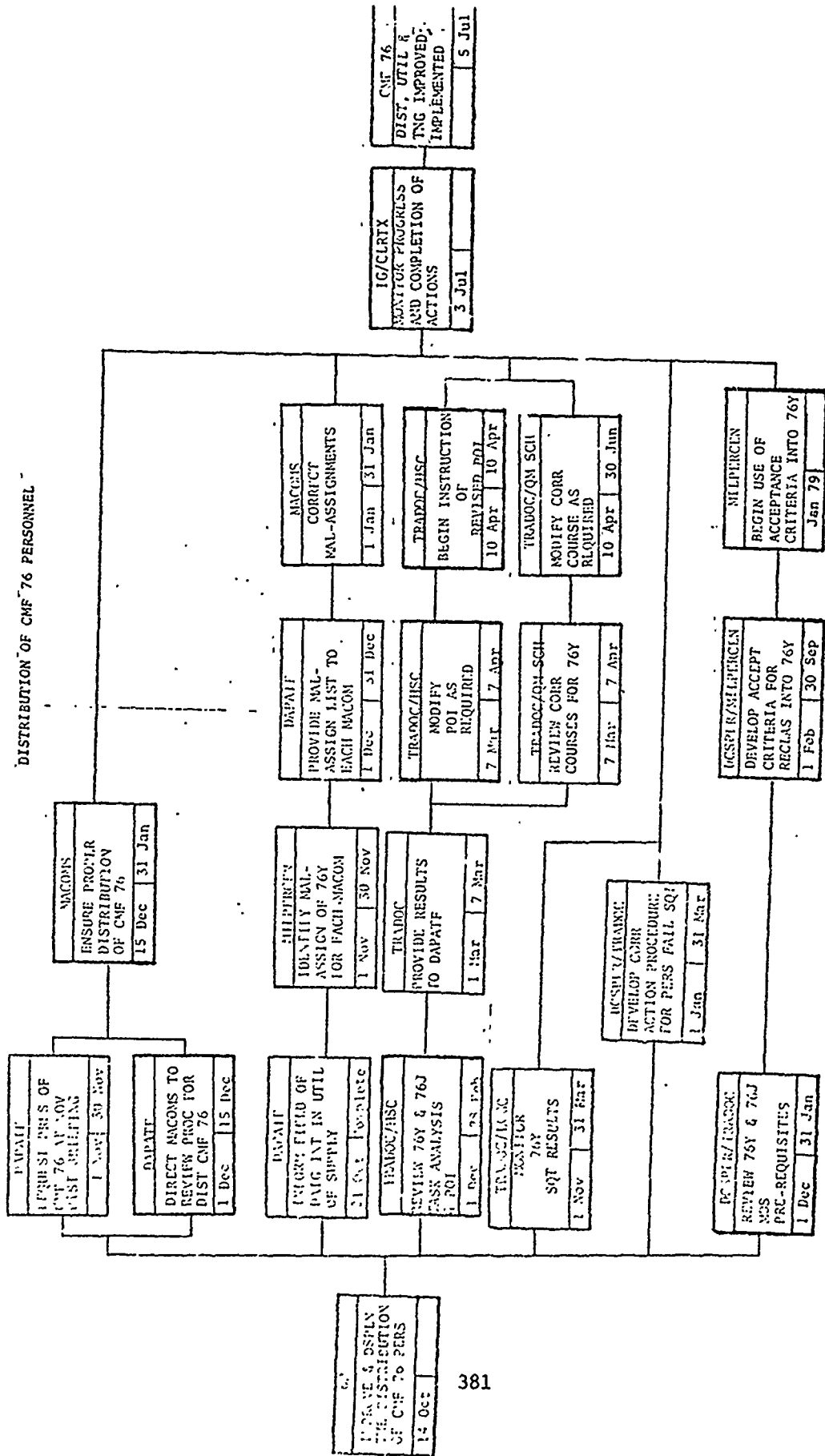

HSA-COM (24 Mar 78) 2d Ind  
SUBJECT: 761A, Unit Supply Technician.

HQ, Academy of Health Sciences, US Army, Fort Sam Houston, TX 78234

~~APR 13 1978~~  
THRU: ~~Commander, US Army Health Services Command, ATTN: HSLO-S~~  
~~Fort Sam Houston, TX 78234 14 APR 1978~~

TO: HQDA (DALO-ZXT), Washington, DC 20310

1. The assignment of a 761A, Unit Supply Technician, to all TOE medical battalions - divisional as well as separate medical battalions is highly desirable.
2. This assignment would permit more effective management and control of TOE equipment and would also permit the Health Services Materiel Officer to deal primarily with the management of medical supplies for the division.
3. The Unit Supply Technician would be the battalion property book officer. As such, he will ensure that authorized items are on hand in sufficient quantities to accomplish unit mission, that request and on-hand quantities do not exceed authorized levels, and that excess property is reported for timely disposition. In addition, he will inspect supply procedures throughout the battalion and the storage of basic loads of ammunition and rations.
4. A review of all Warrant Officer requirements in Army Medical Department TOE has been conducted in order to identify possible trade-off spaces. The review included the following Warrant Officer MOS's: 041AO, Food Service Technician; 100B, Aviation Operations and Maintenance; 202AO, Biomedical Equipment Repair Technician; 310AO, Utilities Operation and Maintenance Technician; 630AO Automotive Repair Technician; 713AO, Legal Administrative Technician; 011AO, Military Physicians Assistant. Results of this review confirm that all of the Warrant Officer positions are critical to the mission of the medical TOE to which authorized and a space-for-space trade-off for any of these positions would be an inappropriate course of action, i.e., a "price" too high to justify authorization of Unit Supply Technicians.

*Kenneth R. Dirks*

KENNETH R. DIRKS, M. D.  
Major General, MC  
Superintendent

DCRPS-P (24 Mar 78) 1st Ind  
SUBJECT: 761A, Unit Supply Technician

APR 11 1978

HQs, US Army Materiel Development and Readiness Command, 5001 Eisenhower Ave.,  
Alexandria, VA 22333

TO: HQDA, ATTN: DALO-ZXT/DAPATF, WASH DC 20310

This command has no mission responsibility concerning the assignment of  
Unit Supply Technicians in TOE battalions. Recommend your request for  
comments, as reflected in basic letter, be sent to TRADOC.

FOR THE COMMANDER:

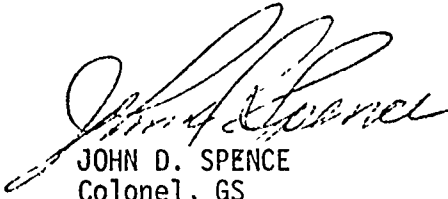

JOHN D. SPENCE  
Colonel, GS  
Associate Director for  
Plans and Doctrine



DEPARTMENT OF THE ARMY  
UNITED STATES ARMY INTELLIGENCE AND SECURITY COMMAND  
ARLINGTON HALL STATION  
ARLINGTON, VIRGINIA 22212

IALOG-SS

12 APR 1978

SUBJECT: 761A, Unit Supply Technician

HQDA  
(DALO-ZXT)  
WASH DC 20310

1. Reference HQDA Letter, DALO-ZXT, dated 24 March 1978, subject as above.
2. This Headquarters agrees wholeheartedly that the proper training, knowledge, and assignment of supply personnel directly effects property accountability.
3. The priority should be to place 761A's in non-DLOGS units. Units operating under DLOGS have access to the expertise of the 761A even though a geographic problem may exist. Furthermore, manual property book units have a greater requirement for the expertise of the unit supply technician due to the nature of the task. Many TDA units also fit into this classification of working with the manual property book system. It is recommended that the primary focus of any realignment of unit supply technicians should be to provide the 203 TOE units working under the manual system with the expertise required to perform their supply functions.
4. An alternative proposal is to convert selected 761A slots located in TDA units to DA civilian employee positions. No degradation of unit/activity efficiency would be anticipated. The inherent problem with this proposal is the ability to fund the hiring of additional DA civilians. However, if DA funding were made available several 761A's could be released from the TDA slots for reassignment to TOE units designated for receipt of a unit supply technician. However, DA must not lose sight of the fact that a loss of unit supply technicians at the TDA level without a corresponding replacement by DA civilians would have a detrimental effect on materiel management. If this alternative approach is undertaken the cost factor must be overcome and the TDA conversion slots must be identified.



IALOG-SS  
SUBJECT: 761A, Unit Supply Technician

12 APR 1978

5. The proposal of adding 312 unit supply technicians is valid from the standpoint of adding to the capabilities of units to accomplish their property accountability mission on a long-term basis. Without the assignment of the unit supply technician the recent efforts of the DAIG and DAPATF in highlighting and correcting property accountability problems would not be completed. Personnel assignment is one of the basic problems addressed in the DAIG report. The cost of correcting the personnel deficiency cannot be eliminated. There is no cheap way out. The US Army has placed considerable emphasis on property accountability over the last year and any attempt to save money on personnel will not in-turn help eliminate lost dollars through faulty unit property accountability. The investment in additional unit supply technicians would add creditability to the entire study of property accountability and be a major factor in the elimination of unit supply problems. The addition of the unit supply technicians would have a positive effect on the Army's ability to manage materiel. Increased funding, personnel allocations, and personnel authorizations are mandatory for the proper implementation of the DA program on a long-term basis. The "price" paid to upgrade unit capabilities with unit supply technicians is warranted based on the DAIG's report and the concept of placing the personnel expertise at the level that will have the most direct impact on upgrading the units' capability to perform the property accountability mission.

6. This Headquarters concurs with the authorization and corresponding additional allocation of 761A's to battalion/squadron sized units. Specific comments on space trade-offs in the DMMC is intentionally omitted due to the nature of the INSCOM organization. It is recommended that the US Congress be appraised of the Army's increased requirement for the Warrant Officers.

FOR THE COMMANDER:

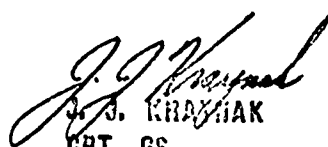

J. J. KRAYNAK  
CPT, GS  
Asst AG



DEPARTMENT OF THE ARMY  
HEADQUARTERS, EIGHTH UNITED STATES ARMY  
APO SAN FRANCISCO 96301  
OFFICE OF THE ASSISTANT CHIEF OF STAFF, J4

DJ-MS-SM

APR 12 1978

Dear General DeHaven: *Re PATE*

Reference your letter, DALO-ZXT, 24 Mar 78, subj: 761A, Unit Supply Technician.

This command fully concurs with recommendations that the 761A, Unit Supply Technician, should be authorized and assigned to TOE battalions. A telephonic survey disclosed that EUSA Unit Supply Technicians believe they would be more effective at the organizational level.

Eighth Army additionally agrees with the "trade-off" as proposed in paragraph 5 of the cited reference. Presently, each supply technician serves as a property book team chief and has responsibility for 16-20 separate company hand receipts. This is excessive and results in ineffective supply control. Additionally, 4 of the 5 property book team chiefs are not assigned to the brigade command to which they are responsible; consequently, they are not rated by the commanders they actually work for.

Assigning supply technicians to TOE battalions brings control to the battalion commander. The technician will then be responsible for the battalion property (4-6 companies). Significantly improved supervision will be brought to the unit supply rooms.

It is recognized that the approximately 175 new warrant officer allocations which are needed are costly and presently unprogrammed. However, the greater expertise should more than offset costs/trade-offs in other areas by improved property control and fewer asset losses.

Sincerely,

*Francis J. Toner*

FRANCIS J. TONER  
Brigadier General, USA  
Assistant Chief of Staff, J4

Major General Oren E. DeHaven  
Director, DA Property Accountability Task Force  
Office of the Deputy Chief of Staff for Logistics  
Washington, DC 20310

\*\*\*\*\*  
 \* UNCLASSIFIED \*  
 \*\*\*\*\*

BKS	THCL	SM
ZX	TA	SMT
ZXT A	IR	SMS
ZXA	TS	SMT
ZXC	TR	SMT
AV	TS	SMT
PLS	TR	SI
PLT	TR	SI
PLR	TR	SI
PLF	SI	SMT
PLO		RMP

DEPARTMENT OF THE ARMY  
 PENTAGON TELECOMMUNICATIONS CENTER

COEN = SCD222 MCN = 73104/06153 TCR = 1781040823  
 RTTUZYUW RUADJHA4643 1040001-LLLL--RLEADWD.  
 ZNR UUUUU  
 R 140600Z APR 78  
 FM CDUSARJ CPZAMA JAPAN//A JGO-SD//  
 TO DA WASHDC//DALO-LX//  
 BT

UNCLAS

THIS IS A PROPER JOINT MESSAGE  
 SUBJ 761A, UNIT SUPPLY TECHNICIAN  
 A. LTR DALO-ZXT HQDA 24 MAR 78 (U)  
 1. REALISTIC ON-SITE APPRAISAL CANNOT BE MADE AS THERE ARE  
 NO TCE BN'S ASSIGNED TO HQ USARJ/IX CORPS. COMMENTS/  
 RECOMMENDATIONS ARE AS FOLLOWS.  
 A. SPACE-FCR-SPACE TRADE-OFF FROM OTHER WARRANT  
 OFFICER AUTHORIZATION CANNOT BE APPRAISED/JUSTIFIED AS  
 THERE ARE NO TCE BN ASND.  
 B. ASSIGNMENT OF UNIT SUPPLY TECHNICIANS TO TCE BN WILL  
 GREATLY CONTRIBUTE TO ELIMINATION OF MOST SUPPLY  
 PROBLEMS AT TCE BN LEVEL. PRICE OF CHANGE/VER CAN BEST  
 BE ASSESSED BY LOSS OF PROPERTY UNDER CURRENT SYSTEM  
 AT DIVISION LEVEL.  
 C. NOT CONSIDERING TRADE-OFF/FCRCE STRUCTURE AUTH-  
 ORIZATION CHANGE, FOLLOWING SHOULD BE CONSIDERED.  
 (1) ASSIGNMENT OF SENIOR SUPPLY WARRANT OFFICERS AS  
 BN S-4 RATHER THAN CAPTAINS. THIS WOULD ALLOW TCE BN  
 TO HAVE A PROFESSIONAL STAFF LOGISTICS OFFICER IN ADDITION  
 TO EXPERTISE REQUIRED FOR SUPPLY PROBLEMS.  
 (2) ANOTHER ALTERNATIVE IS TO ASSIGN TOP GRADE SUPPLY  
 NCO ILC OF WARRANT OFFICERS. MOST TOP GRADE NCO'S  
 POSSESS ESSENTIALLY SAME DEGREE OF EXPERTISE AND  
 KNOWLEDGE AS UNIT SUPPLY TECHNICIANS.  
 (3) CONSIDERATIONS SHOULD BE GIVEN TO A MIX OF WARRANT  
 OFFICERS AND SENIOR SUPPLY NCO'S TO FILL 312 SPACE FCMTS.  
 THOSE UNITS THAT REQUIRE TECHNICAL EXPERTISE, SUCH AS  
 SIGNAL, ARMOR, ORDNANCE, AIRCRAFT, ETC. SHOULD HAVE  
 A WARRANT OFFICER. INFANTRY, CONVENTIONAL ARTY, MF,  
 TRANS, ETC. SHOULD BE HANDLED BY A SENIOR SUPPLY NCO.  
 BT

ACTION ADDRESSEES

006 DALO  
 006 - TNCR-

\*\*\*\*\* PAGE C1  
 \* UNCLASSIFIED \* 140600Z APR 78  
 \*\*\*\*\* RLADJHA/4643  
 387

CC-LOG-SMT-SD (24 Mar 78) 1st Ind  
SUBJECT: 761A, Unit Supply Technician

Headquarters, US Army Communications Command, Ft. Huachuca, AZ 85613

19 APR 1978

TO: HQDA (DALO-ZXT), Washington, D.C. 20310

1. The experience of this HQ has been that assignment of a unit supply technician, 761A, is supportable at the battalion level only when considerable quantities of technical mission equipment are authorized and substantial levels of operational and maintenance supplies are required. It is believed that providing unit supply technicians for any less demanding logistical support situations would cause overstaffing. This is particularly probable since more effective command involvement is certain to result from the recent reestablishment of unit/detachment commanders as property book officers and hand receipt holders.
2. This command could not contribute to the suggested redistribution of warrant officer spaces and, considering the above evaluation, it is recommended that authorizations for unit supply technicians, 761A, at battalion level be provided only where volume of recurring supply activity thoroughly justifies the position.

FOR THE COMMANDER:



A.C. FRENCH  
Acting Chief, Supply, Maintenance  
and Transportation Division



DEPARTMENT OF THE ARMY  
HEADQUARTERS, UNITED STATES ARMY, EUROPE and SEVENTH ARMY  
APO NEW YORK 09403

21 APR 1978

AEAGD-SM-F

SUBJECT: 761A, Unit Supply Technician

HQDA (DALO-ZXT)  
Washington, DC 20310

1. Reference:

a. Ltr, HQDA, 11 Oct 77, subject: Management and Accountability of Army Materiel.

b. Ltr, HQDA, 24 Mar 78, subject: 761A, Unit Supply Technician.

2. Ref a forwards CSA approved DAIG recommendations to improve property accountability. Ref b requests comments on HQDA proposal to trade-off Division Maintenance Management Center 761A authorizations to establish warrant officer positions in divisional TOE battalions.

3. Interested USAREUR unit comments are incorporated in this response to reference b.

a. The 761A, General Supply Technician requirement and authorization has been deleted from the battalion MTOEs in USAREUR. To a large extent, these manpower spaces were transferred to the divisions or corps to establish automated Materiel Management Centers. At this point in time, USAREUR could not provide the manpower space trade-offs (by proper identity) to fully reconstitute the 761A requirements in divisional battalions.

AEAGD-SM-F

21 APR 1978

SUBJECT: 761A, Unit Supply Technician

b. The 761A, Unit Supply Technician Career program covered in DA Pam 600-11, Warrant Officer Professional Development, Jul 77 encourages understanding of but does not require training in DLOGS automated property accountability. Outstanding technicians are selected to move from 761A into the 762A Support Supply Technician career series where DLOGS training is required. The proposed reallocation initially appears to provide a few battalion positions but may not provide 761A incumbents with either the necessary training or progression opportunities and will not satisfy all divisional and nondivisional requirements.

c. Normally, enlisted personnel qualify for MOS 761A by doing an outstanding job in 76 series enlisted MOS. This talent is available in the enlisted grades and should be considered for augmenting Bn level PBO requirements. Once an EM is selected for warrant officer status MOS 761A, the newly appointed MOS 761A should perform in PB maintenance activities.

d. MOS 761A is the entry MOS and MOS 762A (Spt Supply Tech) positions frequently occupied are by newly appointed MOS 761A. Reassigning MOS 761A people occupying 762A slots to fill Bn slots would be detrimental to SSA operations. It appears a trade-off has already been made in which continuity of support for readiness was enhanced at the cost of peacetime administration.

e. Since the number of MOS 761A are limited, they are of more value at DMMC or higher HQ, than out in Bn. Rather than waste this scarce talent, their monitoring of property accountability from a higher level, with occasional inspecting/assistance visits to the Bn/Co level, is more prudent.

3. In summary, the trade-off of 761A Unit Supply Technicians in Division MMC for staffing unit level property book activities does not appear to be a viable alternative because of personnel authorization ceilings and current personnel assignment/progression practices.

FOR THE COMMANDER IN CHIEF:

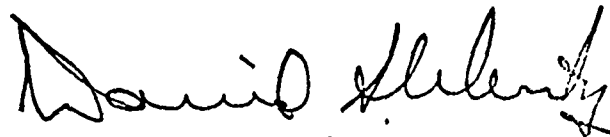

DAVID A. WENTZY  
CPT, AGC  
Asst Adjutant General

2



DEPARTMENT OF THE ARMY  
UNITED STATES ARMY LOGISTICS CENTER  
FORT LEE, VIRGINIA 23801

MAY 2 1978

ATCL-CFS

SUBJECT: 761A, Unit Supply Technician

HQDA (DALO-ZXT)  
Wash, DC 30310

1. Reference letter, DALO-ZXT, HQDA, 24 March 1978, subject as above.
2. This Center and the Quartermaster School have carefully reviewed the proposal outlined in referenced letter. Due to current limitations on warrant officer strength levels, it is not recommended that the 761A warrant officer be returned to battalions supported by a nonorganic (central) property book activity. The USALOGC feels there are more practical approaches that can be undertaken to strengthen battalion supply operations.
3. At Inclosure 1 is an analysis of the proposal made in referenced letter and a number of suggested alternatives and general comments for consideration.
4. Request this Center be informed of the recommendations made by other organizations what your final recommendation will be.

1 Incl  
as

*for H. D. Smith*  
H. D. SMITH  
Major General, USA  
Commanding

CF:  
Cdr, TRADOC, ATLG-MSP  
Comdt, USAQMS, ATSM-CD-C

## EVALUATION

### ASSIGNMENT OF 761A, UNIT SUPPLY TECHNICIAN, TO TOE BATTALIONS

1. Do not recommend trading off the 761A authorizations in the DMMC or BMMC in order to establish warrant officer positions at the divisional or brigade TOE battalion/squadron level. The supply personnel assigned to the DMMC/BMMC should provide training assistance, supervision, and guidance to the battalion/squadrons and separate elements.

a. The alternative to trade off the 761A supply technician authorization at the DMMC to the battalions within divisions and separate brigades would not provide sufficient quantities of the 761A supply technician for all division and separate brigade battalions. In addition, there are still a number of non-battalion units within the division/ separate brigade (e.g., MPCO, Brigade Headquarters). Even though there have been numerous recommendations by units in the field to assign the 761A to TOE battalions, as reported by the DAPATF, this would not necessarily become a panacea for all supply accountability problems. In effect, this would only move the doctor closer to the patient, and would be difficult to afford at this time.

b. Given the availability of adequate numbers of trained 76Y personnel to fill TOE spaces at battalion/squadron level, there should not necessarily be a requirement for additional 761A Unit Supply Technicians at the battalion level. The assignment of warrant officers to the battalion/squadron level, without those trained 76Y personnel, may not solve the current property accountability problems.

c. The authorized location of the 761A, as a minimum, should be with the location of the property book. This dictates that within the divisions and separate brigades, the 761A should remain assigned to the DMMC/BMMC; however, in nondivisional units, this normally means assignment at the battalion level. The larger question centers around where the property book should be located to effect maximum management of accountability of supplies and equipment; and, it was determined through the Division Logistics Study Test which evaluated the DMMC, that centralization at the DMMC/BMMC was the most efficient and economical with relation to scarce personnel resources (i.e., 761A).

d. The assignment of a Supply Warrant Officer at the divisional TOE battalion, should it eliminate the requirement for the Captain currently authorized as the S-4, may impact on the rating scheme for the Support Platoon Leader.



e. The creation of additional 761A Unit Supply Technicians for use in the DMMC/BMMC may have an adverse impact on the 76Y career field. The additional warrant officer candidates would, in all probability, come from the ranks of the 76Y career field and further dilute the expertise available at the level where the problem exists (i.e., hand receipt level).

f. The quantity of school trained enlisted supply personnel with MOS 76Y filling battalion and company/battery supply billets needs accurate assessment. For example, in FY 77, 362 MOS 76Y were gains to the MOS through reenlistment and 2,025 were losses through reenlistment in other MOS. These figures represent a sizeable loss of skill, while at the same time generating a significant requirement for training.

2. There is a general consensus both from the field, and within the US Army Quartermaster School, that the 761A would be a valuable asset in the battalion/squadron level regardless of property book location. However, the primary deficiency in property accountability procedures rests not at the property book level but at the hand receipt level (i.e., company level). Other alternatives considered to correct this deficiency in addition to locating a 761A at battalion level were:

a. Authorize a 761A at brigade/division artillery/DISCOM/Regiment/group level to provide supervision and assistance to the assigned battalions as necessary. This proposal would provide much needed command emphasis and establish the expertise offered by a 761A in the property accountability link at command level between the DMMC/BMMC and the hand receipt holder that is presently lacking. The current shortfall of warrant officer authorizations mitigates against this approach. Additionally, the aggressive application of existing brigade S-4 personnel may have the same desired result.

b. Designate the S-4 position at the battalion/squadron level a 92 primary SSI. This approach is similar in logic and adapted from the recognized need to authorize a Signal Officer to supervise, plan, and control the battalion communications needs and a Medical Corps Officer to attend to the needs of the unit in the medical area.

c. Conduct a detailed "scrub" of warrant officer positions that could be effectively filled with DA civilians or commissioned officers as possible trade offs for 761A positions.

d. The S-4 officer could be traded for additional MOS 761A personnel. This alternative was discarded since this action would be counter-productive by increasing the workload assigned the 761A and thereby decreasing the overall improved conditions desired in the property accountability area. This also disregards the need for S-4 attention to maintenance, transportation, and logistics services.

NOTE: Some of the above alternatives have an adverse impact on the commissioned officer base, due to the Officer Grade Limitation Act (10 USC 3202) which requires a decrease in commissioned officer authorization if warrant officer authorizations are increased.

e. Insure the proper utilization of all 76Y personnel within both the divisional and nondivisional organizations. All attempts should be made to staff these positions with adequately trained, experienced personnel. Also, the 76Z personnel assigned at the division/brigade level, should be used to the maximum extent possible to assist and advise the junior NCOs at the battalion/squadron level. However, not all 76Z will have a 76Y background.

3. As stated in AR 570-2, and within the confines of strength levels 761A Unit Supply Technicians may be authorized and assigned to all nondivisional battalions and squadrons not supported by a Division Materiel Management Center (DMMC) or Brigade Materiel Management Center (BMMC) currently operating under an automated property book system. It is believed, however, that in TOE organizations not supported by a DMMC or BMMC, and where no 761A Unit Supply Technicians are authorized, property accountability problems result from the detailing of and frequent rotation of junior officers to the PBO function.

4. Additional comments:

a. Encourage the use by field commanders of exportable training packages to upgrade the level of proficiency of assigned supply personnel.

b. The logistics baseline curriculum for officer basic and advanced courses has been revised with increased emphasis on supply subjects. This will provide at least more supply awareness and command emphasis.

c. There is no doubt that assignment of 761A Unit Supply Technicians to TOE battalions would be beneficial, but the luxury may not be affordable due to current resource constraints.

AFLG-SMS (24 Mar 78) 1st Ind  
SUBJECT: 761A, Unit Supply Technician

HQ, FORSCOM, Ft McPherson, GA 30330

24 MAY 1978

TO: HQDA (DALO-ZXT) WASH DC 20310

1. A comprehensive review was made of the requirement to authorize and assign 761A Unit Supply Technicians to TOE battalions and the feasibility of trade-off spaces being utilized to fill these positions.
2. This HQ nonconcurrs with the proposed trade-off of 761A authorizations in the Division Materiel Management Centers (DMMC) to gain warrant officer spaces for use as battalion Supply Technicians.
3. Although this expertise would greatly enhance battalion level management and accountability of supplies and equipment, this reduction in the DMMC would seriously impact on the efficiency of logistics support within the divisions.
4. In view of force structure constraints for warrants, a viable alternative would be to up grade authorized positions, add an assistant Supply Sergeant (E5) at unit level, and better train the existing unit supply NCO. Specific training on management and accountability of property at unit level concurrent with existing tenured knowledge possessed by senior supply sergeants can provide the technical expertise required.
5. In this regard, force structure impact would be minimal, the "price" insignificant, and the desired expertise gained. Therefore, serious consideration should be given realignment of senior supply NCO authorizations to preclude degradation of current 761A authorizations, particularly those assigned to DMMC positions.
6. However, additional 761A positions should be authorized at the Support Command Brigade/Div Arty staffs to provide command supply assistance to subordinate units. The benefits in terms of supply discipline, property accountability and expertise at the "working level" are considerable. Those 761As would have no direct responsibilities for property accountability but provide instruction and assistance to the battalion supply personnel. Recommendations received from FORSCOM units varied as to how additional supply expertise would be provided to the units, but all comments indicated a definite requirement for additional assistance in terms of personnel and expertise.

FOR THE CO. MANDER:

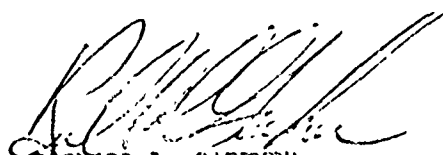

RICHARD L. GARDNER  
CPT, AGC

395 Assistant Adjutant General



DEPARTMENT OF THE ARMY  
OFFICE OF THE SURGEON GENERAL  
WASHINGTON, D.C. 20310

REPLY TO  
ATTENTION OF:

SGPE-EDP

15 JUN 1978

MEMORANDUM FOR DIRECTOR, DA PROPERTY ACCOUNTABILITY TASK FORCE,  
OFFICE OF THE DEPUTY CHIEF OF STAFF FOR LOGISTICS

SUBJECT: Property Accountability Training

1. Reference is made to your memorandum, DALO-ZXT, subject as above, dated 21 April 1978.
2. The 76J POI has been staffed within OTSG and has been approved for immediate implementation. Telephonic approval was transmitted by the Education and Training Division, U.S. Army Medical Department Personnel Support Agency to the Academy of Health Sciences, U.S. Army on 2 May 1978 and a written affirmative response was signed by the Director of Personnel on 18 May 1978.
3. Conversation with the Director of Training at the Academy of Health Sciences, U.S. Army indicates that the POI change will be implemented with the class that is currently in session.

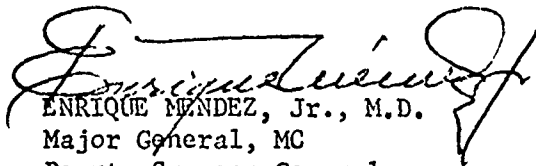
  
ENRIQUE MENDEZ, Jr., M.D.  
Major General, MC  
Deputy Surgeon General

## Chapter 21

### Officer Education

1. Recommendation 6Q. Modify programs of instruction in the officer education system so as to eliminate the lack of knowledge about supply procedures that is currently being displayed by the officer corps.

2. DAPATF actions:

	<u>Volume</u>	<u>Page</u>
a. Proper Count Flasher Message No. 3, DTG 231845Z Nov 77, Essential Instruction in the Management and Accountability of Army Materiel.	1	9
b. Proper Count Flasher Message No. 4, DTG 292025Z Nov 77, Essential Instruction in the Management and Accountability of Army Materiel.	1	11
c. Proper Count Flasher Message No. 6, DTG 301554Z Nov 77, Logistics Baseline Curriculum.	1	15
d. Proper Count Flasher Message No. 7, DTG 121815Z Dec 77, Supply Primer.	1	17
e. Proper Count Flasher Message No. 12, DTG 081848Z Mar 78, Logistics Baseline Curriculum.	2	12
f. Proper Count Message, DTG 181615Z Jan 78, Requests for Change of Suspense Date.	2	25
g. DAPATF Letter, 18 Jan 78, Subject: Personnel Management Procedures.	2	91
h. Proper Count Message, DTG 081548Z Feb 78, Status of Property Accountability Instruction.	2	41
i. CMT 2, 24 Apr 78, Validation of DA Directed and Emphasized Training Subjects.	3	84
j. Proper Count Message, DTG 251615Z Apr 78, Essential Instruction in the Management and Accountability of Army Materiel.	3	28
k. Proper Count Message, DTG 251618Z Apr 78, Property Accountability Training.	3	30

3. MACOM responses:	<u>Page</u>	<u>Tasking Ref</u>
a. Message, CDR FORSCOM, DTG 082000Z Apr 78, Property Accountability in NCO Academy Curriculum.	400	2b
b. Message, CDR TRADOC, DTG 241349Z Apr 78, Property Accountability in NCO Academy Curriculum.	401	2b
c. Message, CDR USACC - Japan, DTG 010802Z May 78, Property Accountability Training.	402	2k
d. Message, CDR TRADOC, DTG 052114Z May 78, Essential Instruction in the Management and Accountability of Army Materiel.	403	2j

OFFICER EDUCATION SYSTEM

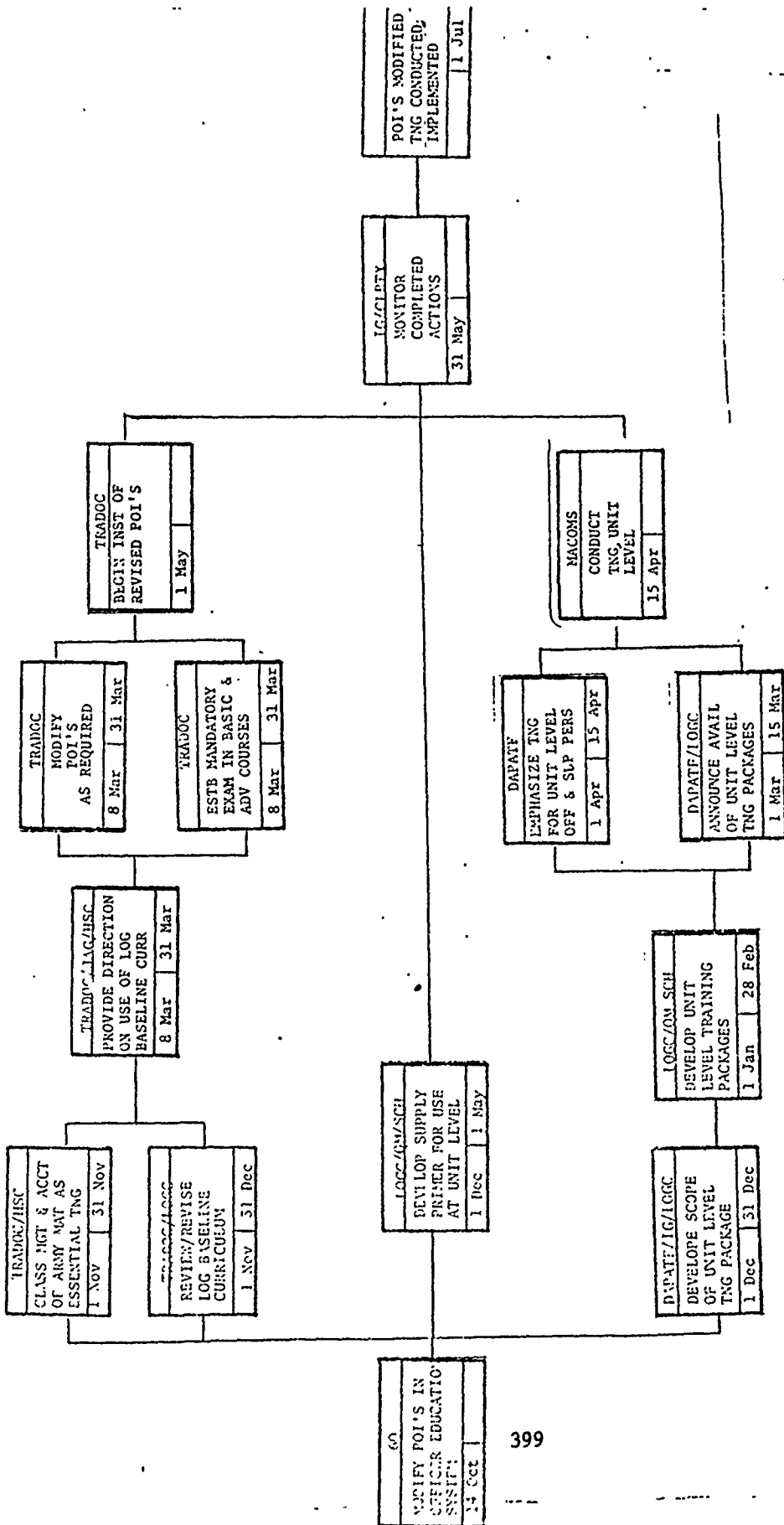

\*\*\*\*\*  
 \* UNCLASS E F T O \*  
 \*\*\*\*\*

PKS	TRCL	SM
EX		

DEPARTMENT OF THE ARMY  
 PENTAGON TELECOMMUNICATIONS CENTER

CDSN = SCD100 MCN = 73094/15332 TOR = 780941807  
 RTTEZYUW RUCLHTA3695 0941742-EEEE--RUJADWD.  
 ZNY EEEEE  
 P 082000Z APR 78  
 FM CDR FORSCOM FT MCPHERSON GA //AFIG SMS//  
 TO AIG 7433  
 AIG 7435  
 AIG 7570  
 INFO RUFACWD/DA WASH DC //DALO-ZXT//  
 BT

UNCLAS E F T O  
 THIS IS A PROPER COUNT MSG  
 SUBJ: PROPERTY ACCOUNTABILITY IN NCO ACADEMY CURRICULUM  
 A. HQ DAIG REPORT, 6 OCT 77, SUBJ: REPORT OF AUDIT SURVEY AND  
 SPECIAL INSPECTION OF MANAGEMENT AND ACCOUNTABILITY OF ARMY MATERIEL.  
 1. REFERENCED REPORT REFLECTED THE MAGNITUDE OF A FAILURE TO UNDER-  
 STAND SUPERVISOR RESPONSIBILITY IN MANAGING AND ACCOUNTING FOR ARMY  
 MATERIEL.  
 2. DA HAS TAKEN STEPS TO IMPROVE BASIC ENTRY SKILL AND OFFICER  
 COURSES OF INSTRUCTION BY INCREASING ESSENTIAL SUBJECTS ON SUPPLY  
 PROCEDURES.  
 3. RECOMMEND COMMANDERS REVIEW CURRICULUM FOR NCO ACADEMIES FOR  
 POSSIBLE INCLUSION OF BASIC SUBJECTS ON SUPPLY PROCEDURES, (I.E.,  
 HAND RECEIPT/SUPERVISOR'S RESPONSIBILITY, INVENTORY PROCEDURES) TO  
 INCREASE NCO AWARENESS OF SUPPLY MANAGEMENT AND ACCOUNTABILITY  
 RESPONSIBILITIES.  
 BT

ACTION ADDRESSEES  
 006 DALC  
 00076 TOTAL NUMBER OF COPIES REQUIRED  
 43695

\*\*\*\*\* PAGE 01  
 \* UNCLASS E F T O \* 032000Z APR 78  
 \*\*\*\*\* RUCLHTA/3695



\*\*\*\*\*  
 \* UNCLASSIFIED \*  
 \*\*\*\*\*

DEPARTMENT OF THE ARMY  
 PENTAGON TELECOMMUNICATIONS CENTER

CDSN = SCD515 MCN = 78114/09032 TOR = 781141812  
 RTTUZYUW RUCLAIA2459 1141350-UUUU--RUEADWD.

ZNR UUUUU

R 241349Z APR 78

FM CORTRADC FT MONROE VA//ATTNG-TD-NCO//  
 TO RUCLAE/CDRLOGCEN FT LEE VA//ATCL-TD//  
 INFO RUEADWD/HQ DA WASH DC//DALO-ZXR//  
 RUCLHTB/CDRFORSCOM FT MCPHERSON GA//AFLG-SMS//  
 BT

UNCLAS

SUBJ: PROPERTY ACCOUNTABILITY IN NCO ACADEMY CURRICULUM  
 A. HQ DAIG REPORT, 6 OCT 77, SUBJECT: REPORT OF AUDIT SURVEY AND  
 SPECIAL INSPECTION OF MANAGEMENT AND ACCOUNTABILITY OF ARMY MATERIAL.  
 B. MSG HQ FORSCOM., 032000Z APR 78 SAB.  
 1. REF A INDICATED THAT MANY SUPERVISORS FAIL TO UNDERSTAND THEIR  
 RESPONSIBILITY FOR MANAGEMENT AND ACCOUNTABILITY OF ARMY MATERIAL.  
 2. REF B RECOMMENDED THAT CDR REVIEW NCO CURRICULUM FOR POSSIBLE  
 INCLUSION OF BASIC SUBJECTS ON SUPPLY PROCEDURES TO INCREASE NCO  
 AWARENESS OF SUPPLY MANAGEMENT.  
 3. REQUEST YOU DETERMINE THE FEASIBILITY AND NECESSITY OF INCLUDING  
 SUCH SUBJECTS IN THE ADD-ON TRAINING PORTION OF THE NCOA CURRICULUM.  
 4. TRADOC POC IS LTC BECWITH, ATVN 680-4129.

BT

ACTION ADDRESSEES

006 DALO

00006 TOTAL NUMBER OF COPIES REQUIRED  
 #2459

BKS	TRCL	SM
ZX	TA	SMT
ZXT	LE	SMS
ZXA	TSM	SXM
ZXA-C	TST	STW
AV	TSE	SNL
PL	TSP	OND
PLS	SAC	IM
PLW	SAB	IMS
PLR	SAA	ENC
PLF	SA	EMI
PLO		EMP

\*\*\*\*\*  
 \* UNCLASSIFIED \*  
 \*\*\*\*\*

PAGE 01  
 241349Z APR 78  
 RUCLAIA/2459

\*\*\*\*\*  
 \* UNCLASSIFIED \*  
 \*\*\*\*\*

DEPARTMENT OF THE ARMY  
 PENTAGON TELECOMMUNICATIONS CENTER

CDSN = SCD414 MCN = 73121/04313 TCR = 781211233  
 ?TTUZYUW RUADJHA1011 1210316-UUUU--RUEADWD.  
 ZNR UUUUU  
 R 010802Z MAY 78  
 FM CDR USACC-JAPAN CP 241A JAPAN //CCJ-LO//  
 TO RUCLAHA/USACMS F. VA //ATSM-TNG-TM-ET//  
 INFO RUEADWD/DA WASH DC //DACO-ZXT//  
 RUWJHRA/CDRUSACC FT HUACHUCA AZ//CC-LOG-SMT-S//  
 RUHHHMA/CDRUSACC ACTPAC FT SHAFTER HI //CCP-LG//  
 RUAGAAA/CDR 1ST SIG BDE (USACC) SEOUL KOREA //CCK-LG//  
 BT

BKS	TRCL	CM
ZX	TA	SMT
ZXA	LE	SMT
ZXA	TSM	SMT
ZXA-C	TST	SMT
AV	TSE	SMT
PL	TSP	SMT
PLS	SAC	SMT
PLW	S.P.	SMT
PLR	SAA	SMT
PLF	SA	SMT
PLO		SMT

UNCLAS

SJBJ PROPERTY ACCOUNTABILITY TRAINING

- A. HQ DA LTR, 11 OCT 77 SJBJ MGT AND ACCOUNTABILITY OF ARMY MAT (U)
- B. DACO-ZXT 241645Z FEB 78 (U)
- C. DACO-ZXT 251618Z APR 78 (U)
- D. FM 21-6, HOW TO PREPARE AND CONDUCT TNG (U)
- E. DA PAM 351-20, ANNOUNCEMENT OF ARMY CORRESPONDENCE COURSE (U)

1. REQ TWO (2) EA TWELVE-HR TNG PACKETS ON UNIT LEVEL SJP PROCEDURES BE PROV CDR USACC-JAPAN ATTN CCJ-LO. FOR REC THAT USAQMS PRODUCE THIS 12 HR PACKET ON TV VIDEOTAP CASSETTES TO STD INSTR AND TO PRECLUDE INSIR IN THE FLD FROM INTRODUCING THEIR OWN OPINIONS INTO WHAT IS SUPPOSED TO BE A DA STD PACKAGE. USACC ELM HAVE VIDEOTAP CASSETTE PLAY-BACK EQUIP AVAIL TO USE FOR INST.  
 2. REC FOR INSTR TO BE ON VIDEOTAP CASSETTE WAS ALSO MADE DURING MEETINGS HELD IN JAPAN ON 12 APR WITH MEMBERS OF PROPER JOINT TASK FORCE FROM JCSLCS, DA.

BT

ACTION ADDRESSEES

006 DALO  
 00006 TOTAL NUMBER OF COPIES REQUIRED  
 #1011

\*\*\*\*\*  
 \* UNCLASSIFIED \*  
 \*\*\*\*\*

PAGE 01  
 010802Z MAY 78  
 RUADJHA/1011

\*\*\*\*\* \*  
\* UNCLASSIFIED \*  
\*\*\*\*\*

DEPARTMENT OF THE ARMY  
PENTAGON TELECOMMUNICATIONS CENTER

CDSN = SCD649 MCN = 78125/18626 TOR = 781252312  
PTTUZYUW RUCLAIAJ521 1252115-UUUU--RUEADWD.  
ZNR UUUUU  
P 052114Z MAY 78  
FM CDR TRADOC FT MONROE VA//ATTNG-TD-CS/CSS//  
TO CDRUSALC FT LEE VA//ATCL-TG/ATCL-DPE//  
RUWTFHA/CDRUSACAC&FT LEAVENWORTH KS//ATZL-TDA-AD//  
RUEADWD/DA WASHDC//DALO-ZXT/DAPE-MPT//  
AIG 891  
XMT: COMDT USAIMA FT BRAGG NC  
COMDT USACGSC FT LEAVENWORTH KS  
COMDT DINFOS FT BEN HARRISON IN  
DIR DLI PRESIDIO OF MONTEREY CA  
COMDT SGM ACADEMY FT BLISS TX

BT

UNCLAS

THIS IS A PROPER COUNT MESSAGE

SUBJECT: ESSENTIAL INSTRUCTION IN THE MANAGEMENT AND ACCOUNTABILITY OF ARMY MATERIAL

THIS MESSAGE IN TWO PARTS.

- A. LTR HQ USALC ATCL-TG DTD 13 MAR 78 LOGISTICS BASELINE CURRICULA
- B. MY 031705Z APR 78
- C. DALO-ZXT 251615Z APR 78 (NOTAL)

PART ONE FOR ALL.

1. THE INSTRUCTIONAL MATERIALS PROVIDED IN A ABOVE AND FURTHER IMPLEMENTED BY B ABOVE IS TO BE INCLUDED IN ALL OFFICERS BASIC AND ADVANCED COURSES THAT BEGIN AFTER 1 MAY 78.
2. ALL STUDENTS MUST MASTER THE REQUIRED TASKS TO THE STANDARDS IN THE BASELINE CURRICULUM PRIOR TO GRADUATION FROM THEIR COURSE. TO INSURE TASK MASTERY IN ACCORDANCE WITH THE STANDARDS IN THE LOGISTICS BASELINE CURRICULUM AN EVALUATION PLAN WILL BE ESTABLISHED.
3. REQUEST ALL SERVICE SCHGCLS PROVIDE PROPERTY ACCOUNTABILITY MATERIAL TO ALL BN/BDE COMMANDERS DURING CURRENT REFRESHER/ ORIENTATION TRAINING.

PART TWO FOR DALO-ZXT.

4. THE REFRESHER/ORIENTATION TRAINING COURSE FOR BN AND BDE COMMANDERS IS AT CAPE-MPT FOR CONCEPT APPROVAL OF A REVISED PROGRAM OF INSTRUCTION. IMPLEMENTATION OF THE REVISED COURSE IS PROGRAMMED FOR 4TH QTR FY 78.
5. MANAGEMENT AND ACCOUNTABILITY OF ARMY MATERIAL WILL BE INCLUDED

403

\*\*\*\*\* \*  
\* UNCLASSIFIED \*  
\*\*\*\*\*

PAGE 01  
052114Z MAY 78  
RUCLIAJ521

\*\*\*\*\*  
\* UNCLASSIFIED \*  
\*\*\*\*\*

DEPARTMENT OF THE ARMY  
PENTAGON TELECOMMUNICATIONS CENTER

IN THE REVISED COURSE.  
BT

ACTION ADDRESSEES  
006 DALO  
003 DAPE  
INFORMATION ADDRESSEES  
001 AFLO/ATLO  
0010 TOTAL NUMBER OF COPIES REQUIRED  
#3521

NNNN

404

\*\*\*\*\*  
\* UNCLASSIFIED \*  
\*\*\*\*\*

PAGE 02  
052114Z MAY 78  
RUCLAIA/3521

Chapter 22

Consumption Standards

1. Recommendation 6R. Determine and establish consumption standards at the installation and subordinate organizational level so that the efficiency and cost effectiveness of readiness training can be accurately measured.

2. DAPATF actions:

a. Letter, 22 Dec 77, Consumption Standards for Selected Items.

b. Memorandum for: Director of Management, 4 May 78, Implementation of Approved DAIG Recommendation - Consumption Standards.

3. MACOM responses:

	<u>Volume</u>	<u>Page</u>
	1	93
	3	85
	<u>Page</u>	<u>Tasking Ref</u>

DETERMINE CONSUMPTION STANDARDS FOR SELECTED ITEMS

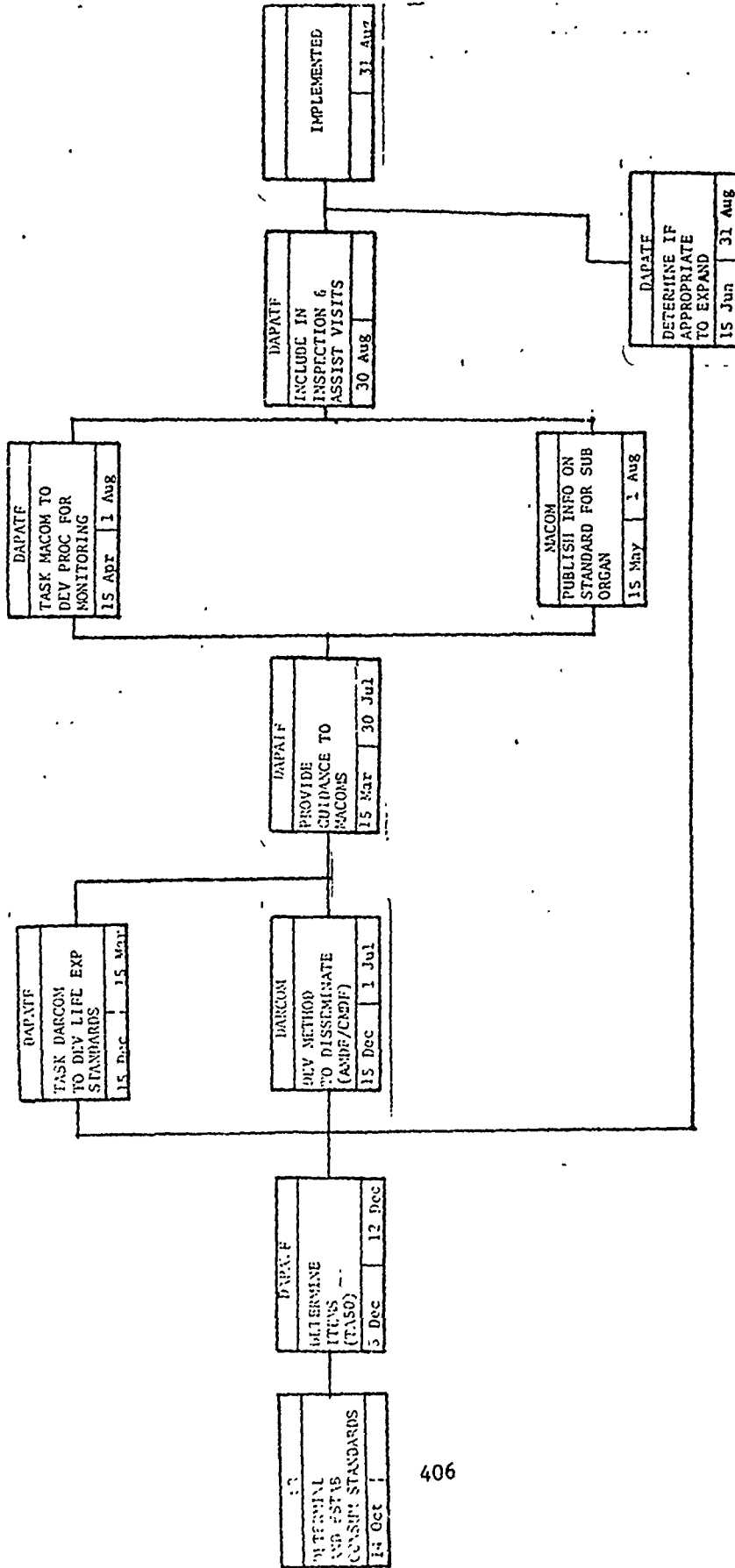

Chapter 23

DAPATF Establishment/Operation

1. Recommendation 6S. Establish a task force at DA level, under the leadership of the DCSLOG, to make the regulatory changes and policy announcements required to correct the deficiencies revealed by this inspection and to effect the recommendations herein.

2. DAPATF actions:	<u>Volume</u>	<u>Page</u>
a. TAG Letter, 25 Oct 77, subject: Department of the Army Property Accountability Task Force.	1	
b. Rogers sends, DTG 131545Z Oct 77, Property Accountability.	1	28
c. Proper Count Message, DTG 171830Z Oct 77, Property Accountability Task Force (DAPATF).	1	29
d. Proper Count Message, DTG 201910Z Oct 77, Designation of Points of Contact (POC) for Property Accountability Actions.	1	32
e. Proper Count Message, DTG 021820Z Nov 77, Property Accountability Task Force Working Conference.	1	35
f. Proper Count Flasher Message, DTG 111921Z Nov 77, Property Accountability Task Force Working Conference.	1	37
g. Proper Count Message, DTG 291809Z Nov 77, Property Accountability Task Force Membership.	1	45
h. Proper Count Message, DTG 181801Z Jan 78, Property Accountability Working Conference.	2	27
i. Proper Count Message, DTG 272005Z Jan 78, Property Accountability Working Conference.	2	30
j. Proper Count Message, DTG 012005Z Feb 78, DA Property Accountability Task Force (DAPATF) Briefing.	2	33

	<u>Volume</u>	<u>Page</u>
k. Proper Count Message, DTG 031955Z Feb 78, DAPATF Working Conference Agenda.	2	35
l. Proper Count Message, DTG 061848Z Feb 78, Request for Area Clearance.	2	37
m. Proper Count Message, DTG 061850Z Feb 78, DA Property Accountability Task Force Visit.	2	40
n. Proper Count Message, DTG 271345Z Feb 78, DA Property Accountability Task Force Visit.	2	49
o. DF, 21 Mar 78, Reserve Component Committee Actions.	2	223
p. DF, 22 Mar 78, Priority of USALEA Projects.	2	230
q. Proper Count Message, DTG 141920Z Apr 78, DAPATF Telephone Numbers.	3	26
r. Proper Count Message, DTG 151500Z May 78, Property Accountability Working Conference III.	3	38
s. Proper Count Message, DTG 181347Z May 78, Property Accountability Working Conference III.	3	40
t. Proper Count Message, DTG 191955Z May 78, DAPATF Working Conference III.	3	42
u. Proper Count Message, DTG 231327Z May 78, Property Accountability Working Conference III.	3	45
v. Proper Count Message, DTG 141305Z Jun 78, DAPATF Working Conference III Agenda.	3	52
w. Proper Count Message, DTG 161820Z Jun 78, DAPATF Working Conference III.	3	56
3. MACOM responses:	<u>Page</u>	<u>Tasking Ref</u>
a. Message, CDR TRADOC, DTG 192243Z May 78, Property Accountability Working Conference III.	410	2r
b. Message, CDR FORSCOM, DTG 221935Z May 78, Property Accountability Working Conference III.	411	2r



	<u>Page</u>	<u>Tasking Ref</u>
c. Message, CDR USACIDC, DTG 231915Z May 78, DAPATF Working Conference.	412	2r
d. Message, Deputy Commandant, USA Intel Sch, DTG 261232Z May 78, Property Accountability Working Conference III.	413	2r
e. Message, CDR XVIII ABN Corps, DTG 262323Z May 78, Property Accountability Working Conference III.	414	2r
f. Message, CDR XVIII ABN Corps, DTG 302020Z May 78, Property Accountability Working Conference III.	415	2r
g. Message, Commandant, USAMMCS, DTG 311719Z May 78, Property Accountability Working Conference III.	416	2r
h. Message, Commandant, USAQMS, DTG 021320Z Jun 78, Property Accountability Working Conference III.	417	2r
i. Message, CDR HSC, DTG 081717Z Jun 78, DA Property Accountability Task Force (DAPATF) Working Conference III.	418	2t
j. Message, CDR FORSCOM, DTG 082027Z Jun 78, DAPATF Working Conference III.	419	2t
k. Message, CINCUSAREUR, DTG 191309Z Jun 78, DAPATF Working Conference III.	421	2t

\*\*\*\*\*  
\* UNCLASSIFIED \*  
\*\*\*\*\*

DEPARTMENT OF THE ARMY  
PENTAGON TELECOMMUNICATIONS CENTER

CDSN = SCD793 NCA = 7814C/09054 TOR = 781401025  
RTTUZYUW RUCLAIA4722 1392247-UUUU--RUEADWD.  
ZNR UUUUU  
R 192243Z MAY 78  
FM CDTRADOC FT MONROE VA//ATLG-MSP-SP//  
TO RUWTFHA/CDRUSACAC8 FT LEAVENWORTH KS//ATZL-TDA-AD//  
RUCLAHE/CDRUSALC FT LEE VA//ATCL-TG/ATCL-DPE//  
AIG 891  
INFO RUEADWD/CA WASHDC//DALC-ZXT/DAPE-MPT//  
XMT: COMDT USAIMA FT BRAGG AC  
COMDT USACGSC FT LEAVENWORTH KS  
COMDT DINFOS FT BEN HARRISON IN  
DIR DLI PRESIDIO OF MONTEREY CA  
COMDT SGM ACADEMY FT ELISS TX  
BT

UNCLAS

SUBJ: PROPERTY ACCOUNTABILITY WORKING CONFERENCE III (S: 2 JUN 78)  
A. DA DALO-ZXT 151500Z MAY 78 (NOTAL)  
B. FONECON BETWEEN LTC KURGVEL, TRADOC AND LTC BARRETT, USAQMS,  
18 MAY 78  
1. REF A ANNOUNCED PLANS TO CONDUCT SUBJ CONFERENCE AT THE USAQM  
SCHOOL, FT LEE, VA, 27-29 JUN 78. ATTENDANCE OF SERVICE SCHOOL  
REPRESENTATIVES WAS SUGGESTED. REF B ESTABLISHED THAT USAQMS IS  
PREPARED TO HOST SUBJECT CONFERENCE.

PAGE 2 RUCLAIA4722 UNCLAS

2. REQUEST ADDRESSEES PARTICIPATE IN THE THIRD PRIORITY ACCOUNTABILITY WORKING CONFERENCE, 27-29 JUN 78 AT USAQMS, FT LEE, VA WITH ONE OBSERVER. PREFERABLY THE SCHOOL REPRESENTATIVES SHOULD BE INDIVIDUALS DIRECTLY INVOLVED IN THE MANAGEMENT/PRESENTATION OF PROPERTY ACCOUNTABILITY/SUPPLY MANAGEMENT INSTRUCTION.
3. CONFERENCE AGENDA WILL BE PROVIDED BY SEPARATE MESSAGE. TDY COSTS WILL BE BORNE BY ADDRESSEES.
4. REQUEST THE NAME AND GRADE OF SCHOOL REPRESENTATIVES BE SUBMITTED TO COMDT QMSCH, FT LEE, VA, ATTN: ATMS-TD/CD WITH INFO CY TO HQ DA, ATTN: DALC-ZXT, NLT 2 JUN 78. QMSCH POC IS LTC BARRETT, ALTERNATE MR. NEELAN, AUTOCEN 687-4582/2194.

\*\*\*\*\*  
\* UNCLASSIFIED \*  
\*\*\*\*\*

PAGE 01  
192243Z MAY 78  
RUCLAIA/4722

\*\*\*\*\*  
 \* UNCLASSIFIED \*  
 \*\*\*\*\*

DEPARTMENT OF THE ARMY  
 PENTAGON TELECOMMUNICATIONS CENTER

DKS	TA	SM
ZX	LE	SMT
ZXT	TSM	SMS
ZXA	TST	SMM
THO	TSE	SMW
AV	TSP	SML
PL	TS	SMD
PLW	SAC	SM
PLS	SAB	SMB
PLR	SAA	SMA
PLF	SA	SMI
PLO		SMAP

CDSN = SCD173 MCA = 76143/15139 TGR = 781430819  
 RTTUZYUH RUCLHTA8133 1431808-UUUU--RUEADWD.  
 ZNR UUUUU  
 R 221935Z MAY 78  
 FM CDR FORSCOM FT MCHERSON GA //AFLG-SMS//  
 TO RUCLBFA/CDR III CORPS & FT HOOD TX//  
 RUWTBDA/CDR 4TH INF DIV (MECH) FT CARSON CO//  
 RUCLBPA/CDR 24TH INF DIV FT STEWART GA//  
 RUCLAKA/CDR XVIII ABN CORPS FT BRAGG NC//  
 RUWTKDA/CDR 3D ACR FT BLISS TX//  
 INFO RUEADWD/DA WASH DC //DALG-ZXT//  
 RUCLAKA/CDR 82D ABN DIV FT BRAGG NC//  
 BT

UNCLASSIFIED

THIS IS A PROPER COUNT MESSAGE  
 SUBJECT: PROPERTY ACCOUNTABILITY WORKING CONFERENCE III  
 (S; 31 MAY 78)

- A. HQDA MSG; DALG-ZXT 161347Z MAY 78
- B. FONECON LTC AKIA, FORSCOM, AND LTC TATE, 3RD ACR, 19 MAY 78, SAB.
- 1. REF MSG REQUESTED FORSCOM INFO ADDRESSEES PROVIDE COMPANY COMMANDERS TO ATTEND SUBJECT CONFERENCE.
- 2. REQUEST ADDRESSEES PROVIDE THE FOLLOWING COMPANY COMMANDERS AS INDICATED TO SATISFY THIS REQUIREMENT:
 

INSTL (FCC)	TYPE UNIT COMMANDER
FT CARSON (LTC LITTLE)	MECH INF COMPANY
FT BRAGG (LTC PCTTS)	DIVISIONAL MAINT COMPANY
FT HOOD (COL FINKBINER)	ARMORED COMPANY
FT STEWART (LTC PERRY)	INFANTRY COMPANY
- 3. THE 3RD ACR MAY SEND ONE REPRESENTATIVE PER REFERENCED FONECON.
- 4. ATTENDEES SHOULD BE PREPARED TO COMPLY WITH REQUIREMENTS OF REF A.
- 5. REQUEST NAMES OF ATTENDEES BE SUBMITTED THIS HQ, ATTN: AFLG-SMS, AND INFO HQDA, ATTN: DALG-ZXT, NLT 31 MAY 78.
- 6. BILLETING INFORMATION WILL BE PROVIDED BY SEPARATE MESSAGE.
- 7. FORSCOM POC, MAJ CHAFIN, AV 588-3926/2713.

BT  
 ACTION ADDRESSEES  
 006 DALG  
 INFORMATION ADDRESSEES

*001 AFLO/ATLO*  
*0007 TACT*

\*\*\*\*\*  
 \* UNCLASSIFIED \*  
 \*\*\*\*\*

PAGE 01  
 221935Z MAY 78  
 RUCLHTA/8133

\*\*\*\*\*  
\* UNCLASSIFIED \*  
\*\*\*\*\*

DEPARTMENT OF THE ARMY  
PENTAGON TELECOMMUNICATIONS CENTER

CDSN = SCD658 MCN = 78143/20683 TOR = 781432248  
RTTUZYUW RUKGCVB0116 1432245-UUUU--RUEADWD.  
ZNR UUUUU  
R 231915Z MAY 78  
FM CDR USACIDC WASH DC//CILO-ST//  
TO HQDA WASH DC//DALG-ZXT//  
BT

UNCLAS

SUBJ: DAPATF WORKING CONFERENCE

A. HQDA MSG DALG-ZXT 191955Z MAY 78.

1. REF A ADVISED OF SUBJECT CONFERENCE AND REQUESTED ADDITIONAL ISSUES THAT NEED TO BE RESOLVED AT THE WORKING CONFERENCE.
2. THE USACIDC HAS NO ADDITIONAL ISSUES TO BE ADDRESSED. THE USACIDC WILL NOT BE ABLE TO SEND A REPRESENTATIVE TO THE WORKING CONFERENCE. HOWEVER, IF AFTER THE CONCLUSION OF THE CONFERENCE A WRITTEN SUMMARY IS PREPARED, REQUEST A COPY BE PROVIDED HQ USACIDC, ATTN: CILO-ST.

BT

ACTION ADDRESSEES

006 DALG

00006 TOTAL NUMBER OF COPIES REQUIRED

#0116

412

\*\*\*\*\*  
\* UNCLASSIFIED \*  
\*\*\*\*\*

PAGE 01  
231915Z MAY 78  
RUKGCVB/0116

\*\*\*\*\*  
 \* UNCLASS E F T C \*  
 \*\*\*\*\*

DEPARTMENT OF THE ARMY  
 PENTAGON TELECOMMUNICATIONS CENTER

CDSA = SCD869 PCF = 78146/13502 TCR = 781461631  
 RTEZYUW RUEGGEA3429 1461304-EEEE--KLEADWD.

ZNY EEEEE

R 261232Z MAY 78

FM DEPUTY COMDT US ARMY INTEL SCH FT DEVENS MA//ATSIF-DT-ES//

TO RUCLAHA/CLMGT GMSCH FT LEE VA//ATMS-TC/CD//

INFO RUEADWD/HCLA WASH DC//LALL-ZX1//

RJWJHRA/CDR USAICS FT FLORHLLA AZ

BT

UNCLAS E F T C

SUBJ: PROPERTY ACCOUNTABILITY WORKING CONFERENCE III

A. CDR TRADUC FT BELLE VA MSG 192243Z MAY 78, ATLG-MSP-SP, SAB

B. FCNECON MAJ FOLEY, USAISL, AND MK NEELAN, QMSCH, 25 MAY 78

1. USAISD WB UNABLE TO SEND A REP TO SUBJ CONF. ONLY ONE MGT/  
 PROP ACCT/SUP MGT INSTR IS ASSIGNED AND HE WNB PRESENT FOR DUTY  
 27-29 JUN.

2. REQ USISD BE FURN COPY OF CONF MINUTES.

BT

ACTION ADDRESSEES

J06 DALC

03006 TOTAL NUMBER OF COPIES REQUIRED

#3429

BKS	TA	SM
ZX	ILE	ISMT
ZXT	ATSM	SMS
ZXA	IST	SAM
THCL	IE	SNV
AV	IE	SL
PL	IE	SD
PLW	IE	SM
PLS	IE	MB
PLR	IE	MO
PLF	IE	MI
PLO	IE	MP

\*\*\*\*\*  
 \* UNCLASS E F T U \*  
 \*\*\*\*\*

PAGE 01  
 261232Z MAY 78  
 RUEGGEA/3429

\*\*\*\*\*  
 \* UNCLASSIFIED \*  
 \*\*\*\*\*

DEPARTMENT OF THE ARMY  
 PENTAGON TELECOMMUNICATIONS CENTER

BKS	TA	SM
ZX	LE	SMT
ZXT/H	TSM	SMS
ZXA	TST	SMM
THCL	TSE	SMW
AV	TSP	SML
PI	TS	SMD
PLW	SAC	RM
PLS	SAB	RMB
PLR	SAA	RMO
PLF	SA	RMI
PLQ		RMP

CDSN = SCD033 ACN = 78147/G2678 TCR :: 781470230  
 PTTUZYUW RUCLAKA3478 1462323-UULL--RUEADWD.  
 ZNR UUUUU  
 P 262323Z MAY 78  
 FM CDR XVIII ABN CORPS FT BRAGG NC//AFZA-DI-LI//PLF  
 TO RUCLHTB/CDRFORSCOM FT MCPHERSON GA//AFIG-SMS7//PLF  
 INFO RUEADWD/HQ LA WASH DC//CALC-ZXT//  
 BT

UNCLAS

SUBJ: PROPERTY ACCOUNTABILITY WORKING CONFERENCE II

REFERENCES:

- A. FORSCOM MSG, AFIG-SMS, LTG 221935Z MAY 78.
- B. FONECON, LTC MARCUS, THIS HEADQUARTERS AND MAJ CHAPIN, FORSCOM, 25 MAY 78.
- 1. THIS HEADQUARTERS DESIRES TO SEND CPT ROBERT D. STARNES, 467-90-2514, COMMANDER, 835TH TRANS CO, 1ST CORPS SPT CMD, TO SUBJECT CONFERENCE.
- 2. IT IS NOTED THAT ALL OF THE CURRENT UNITS TO BE REPRESENTED ARE DIVISIONAL UNITS WORKING WITH THE DLOGS SYSTEM. NON-DIVISIONAL, NON-DLOGS UNITS SUCH AS 1ST CORPS SPT CMD HAVE EXPERIENCED SOME UNIQUE PROPERTY ACCOUNTABILITY PROBLEMS BECAUSE OF VARIOUS PORPER COUNT FLASHER MESSAGES. IT IS IMPERATIVE THAT THESE EXPERIENCES BE AIRED FOR CONSIDERATION ALONG WITH THOSE OF DLOGS UNITS IN ORDER THAT THE DA TEAM BE ABLE TO ASSESS THE TOTAL IMPACT ON THE FIELD.
- 4. POC, THIS HQ, IS LTC CLAPP, AUTOVON 236-8315; 1ST CORPS SPT CMD, IS LTC MARCUS, ALTVCN 236-3678.

BT

ACTION ADDRESSEE.

006 DALG

00006 TOTAL NUMBER OF COPIES REQUIRED

#3478

\*\*\*\*\*  
 \* UNCLASSIFIED \*  
 \*\*\*\*\*

PAGE 01  
 262323Z MAY 78  
 RUCLAKA/3478

\* UNCLASSIFIED \*  
\*\*\*\*\*

380  
4  
1  
2  
3  
4  
5  
6  
7  
8  
9  
10  
11  
12  
13  
14  
15  
16  
17  
18  
19  
20  
21  
22  
23  
24  
25  
26  
27  
28  
29  
30  
31  
32  
33  
34  
35  
36  
37  
38  
39  
40  
41  
42  
43  
44  
45  
46  
47  
48  
49  
50

DEPARTMENT OF THE ARMY  
PENTAGON TELECOMMUNICATIONS CENTER

CDSN = SCD53G PCN = 78150/17474 TCR = 781502341  
RTTUZYUW RUCLAKA3575 1502020-LLLL--RLEADWD.  
ZNR UUUUU  
R 302020Z MAY 78  
FM CDR XVIII ABN CORPS FT BRAGG NC//AFZA-D1-D//  
TO RUCLHTB/CDRFORSCOM FT MCPIERSON GA//AFLG-SMS//  
INFO RUEADWD/DA WASHDC//DALC-2X1//  
BT

UNCLAS  
SUBJ: PROPERTY ACCOUNTABILITY WORKING CONFERENCE III  
A. FORSCOM MESSAGE AFLG-SMS, 221935Z MAY 78, SAB.  
ATTENDEE AT SUBJECT CONFERENCE FROM THE 82D AIRBORNE DIVISION WILL  
BE CPT DAVID J. FOWLER, 255-76-4652, COMMANDER, COMPANY A, 782D  
MAINTENANCE BATTALION.  
BT

ACTION ADDRESSEES  
006 DALC  
00006 TOTAL NUMBER OF COPIES REQUIRED  
#3575

NNNN

\*\*\*\*\*  
\* UNCLASSIFIED \*  
\*\*\*\*\*

PAGE 01  
302020Z MAY 78  
RUCLAKA/3575

\*\*\*\*\*  
\* UNCLASSIFIED \*  
\*\*\*\*\*

DEPARTMENT OF THE ARMY  
PENTAGON TELECOMMUNICATIONS CENTER

COSN = SCD545 MCN = 78151/13132 TOR = 781511742  
RTTUZYUW RUCDGMJJ2J 151171E-UUUU--RUEADWD.  
ZNR UUUUU  
R 311719Z MAY 78  
FM COMDTUSAMMCS REDSTONE ARSENAL AL //ATSK-DS-LS//  
TO RUELAHE/COMDT CMCCH FT LEE VA //ATMS-TD/CD//  
INFO RUEADWD/DA WASH DC //DALO-ZXT//  
BT

UNCLAS  
FOR LTC BARRETT/MR. NEELAN  
SUBJ: PROPERTY ACCOUNTABILITY WORKING CONFERENCE III  
A. TRADOC 192243Z MAY 78, SAB.  
USAMMCS REPRESENTATIVE TO CONFERENCE WILL BE FRANK M. MERRIMAN,  
GS-11.  
BT

ACTION ADDRESSEES  
0006 DALO  
00006 TOTAL NUMBER OF COPIES REQUIRED  
#0000

DA	DA	SM
DA	DA	SM
DA	DA	SM
DA	DA	SM
DA	DA	SM
DA	DA	SM
DA	DA	SM
DA	DA	SM
DA	DA	SM
DA	DA	SM
DA	DA	SM
DA	DA	SM
DA	DA	SM
DA	DA	SM
DA	DA	SM

\*\*\*\*\*  
\* UNCLASSIFIED \*  
\*\*\*\*\*

PAGE 01  
311719Z MAY 78  
RUCDGM/0020



\*\*\*\*\*  
\* UNCLASSIFIED \*  
\*\*\*\*\*

DEPARTMENT OF THE ARMY  
PENTAGON TELECOMMUNICATIONS CENTER

CDSN = SCD869 MCN = 78153/150J7 TOR = 781531825  
RTTUZYUW RUCLAHA0113 1531547-UUUU--RUEADWD.  
7NR IUJUU  
R 021320Z JUN 78  
FM COMDT USAQMS FT LEE VA//ATSM-TD-CD//  
TO RUEADWD/DA WASH DC//DALO-ZXT//  
INFO RUCLAIA/CDR TRADCC FT MONROE VA//ATTNG-TD-CS/CSS//  
BT

UNCLAS  
THIS IS A PROPER COUNT MESSAGE.  
SBJ: PROPERTY ACCOUNTABILITY WORKING CONFERENCE III  
A. MSG, HQDA, DALC-ZXT, 151500Z MAY 78.  
B. MSG, HQ TRADOC, ATLG-MSP-SP, 192243Z MAY 78.  
1. REFERENCE A REQUESTED NAMES OF ATTENDEES FOR THE PROPERTY  
ACCOUNTABILITY WORKING CONFERENCE III.  
2. FOLLOWING ARE QM SCHOOL PROPER COUNT REPRESENTATIVES AND  
SERVICE SCHOOL REPRESENTATIVES:  
LTC ROBERT C. BARRETT PROPER COUNT  
MR. OLIVER K. NELAN PROPER COUNT  
CW3 CARLISS E. NCE QMS  
CW3 MALORY MINTER QMS  
SFC DONALD HALL QMS  
MISS BETTY SLAUGHTER QMS

BT  
ACTION ADDRESSEES  
006 DALO  
00006 TOTAL NUMBER OF COPIES REQUIRED  
#0113

EKS	FA	SM
ZX	LE	SWT
ZY	ISM	QMS
ZXA	ISF	SM
	ISG	SM
	ISJ	SM
	ISK	SM
	ISL	SM
	ISM	SM
	ISN	SM
	ISO	SM
	ISP	SM
	ISQ	SM
	ISR	SM
	ISU	SM
	ISV	SM
	ISW	SM
	ISX	SM
	ISY	SM
	ISZ	SM

\*\*\*\*\*  
\* UNCLASSIFIED \*  
\*\*\*\*\*

PAGE 01  
021320Z JUN 78  
RUCLAHA/0113

\*\*\*\*\*  
\* UNCLASSIFIED \*  
\*\*\*\*\*

PENTAGON TELECOMMUNICATIONS CENTER

CDSN = SCD58J MCA = 78159/20197 TOR = 781592227  
RTUZYUW RUWTFNA212C 1591537-LUUU--KUEADWD.  
ZNR UUUUU  
R 081717Z JUN 78  
FM CORHSC FT SAM HOLSTEN TX //HSLD-S//  
TO DA WASH DC //CALC-ZXT//  
BT

UNCLAS

SUBJ DA PROPERTY ACCOUNTABILITY TASK FORCE (DAPATF) WORKING  
CONFERENCE III

A. YOUR 191955Z MAY 77.

1. NUMEROUS QUESTIONS CONCERNING THE REWRITE OF AR 735-11 SAND PROPOSE  
D CHANGES TO PROCEDURES FOR ACCOUNTING FOR LOST, DAMAGE,  
OR DESTROYED PROPERTY HAVE BEEN RECEIVED FROM THE FIELD.

2. SUGGEST INFORMATION CONCERNING PROPOSED CHANGES AND PLANNED  
TIME FRAMES BE DISSEMINATED AT THE CONFERENCE.

BT

ACTION ADDRESSEES

006 DALO

00006 TOTAL NUMBER OF COPIES REQUIRED

#2120

THIS PAGE IS UNCLASSIFIED  
FROM COPY FURNISHED BY SIG

\*\*\*\*\*  
\* UNCLASSIFIED \*  
\*\*\*\*\*  
418

PAGE 01  
081717Z JUN 78  
RUWTFNA/2120

\*\*\*\*\*  
\* UNCLASS E F T O \*  
\*\*\*\*\*

DEPARTMENT OF THE ARMY  
PENTAGON TELECOMMUNICATIONS CENTER

CDSN = SCD895 MCN = 7816C/C2281 TCR = 781600228  
RTTEZYUW RUCLHTA9551 16JUN28-EEEE--RUEADWD.  
ZNY EEEEE  
R 082027Z JUN 78  
FM CDR FORSCGM FT MCPHERSON GA //AFLG-SMS//  
TO DA WASH DC //CALC-ZXT//  
BT

THIS PAGE IS BEST QUALITY PRACTICABLE  
FROM COPY FURNISHED TO DDC

UNCLAS E F T C

THIS IS A PROPER COUNT MSG

SUBJ: DAPATF WORKING CONFERENCE III (S; 9 JUNE 78)

- A. DALO-ZXT MSG, 191955Z MAY 78, SAB
1. REF MSG REQUESTED MACOM PROVIDE ANY ADDITIONAL ISSUES/PROBLEMS FOR RESOLUTION AT SUBJECT CONFERENCE.
2. THE FOLLOWING RECOMMENDED TOPICS ARE PRESENTED FOR POSSIBLE DISCUSSION AT SUBJECT CONFERENCE:
  - A. REQUEST ATTENDEES BE PROVIDED A CURRENT STATUS OF ALL IG RECOMMENDED ACTIONS IN ORDER TO INSURE THAT ATTENDEES MAY PROVIDE A COMPLETE UPDATE TO COMMANDERS ON THE PROPER COUNT PROGRAM.
  - B. DISCUSSION OF THE RATIONALE FOR THE DECISION NOT TO DIVIDE AR 710-2 INTO TWO (2) REGULATIONS.
  - C. EXPAND DISCUSSION OF CASH COLLECTION VOUCHERS TO INCLUDE INCENTIVES TO IMPROVE FREQUENCY OF USE IN PURCHASING TOOLS FROM SSSC. PRESENT SYSTEM IS PAYING FEW DIVIDENDS.
  - D. ATTENDEES SHOULD BE PROVIDED WITH ANY ADDITIONAL ACTIONS PENDING AT DA ON THE CABL CONCEPT AS IT IMPACTS HEAVILY ON PROPERTY ACCOUNTABILITY PROGRAMS AND REWRITE OF AR 710-2.
  - E. 761A AUTHORIZATIONS VS UPGRADING CURRENT 76CMF POSITIONS.
  - F. MANAGEMENT OF CHANGE STUDY SHOULD BE EXPANDED TO INCLUDE A DISCUSSION OF THE STATUS OF THE "PUSH" DISTRIBUTION SYSTEM AND WHAT ACTIONS ARE ENVISIONED TO BRING ALL PUBLICATIONS UNDER THE RESTRICTIVE PROCEDURES OF FLASHER NO. 11.
  - G. TIMELINESS IN ASSIGNMENT OF STANDARD LINE NUMBERS AND AUTHORIZATIONS FOR AUGIC VISUAL AND TRAINING AIDS.
  - H. INTENT OF DA LETTER OF 11 OCT 77 AS IT RELATES TO CROSS LEVELING OF EXCESSES FROM BCTTCM TO TCP. DOES THE MACOM CROSS LEVEL BETWEEN INSTALLATION/RESERVE COMMANDS OR UTILIZE THE ESTABLISHED WHOLESALE SYSTEM FOR THIS PURPOSE?
  - I. REIMBURSEMENT OF MONIES COLLECTED FROM ADJUSTMENT DOCUMENTS AT THE INSTALLATION VS DEPOSITED TO GENERAL FUND.
  - J. WHAT ACTIONS SHOULD BE TAKEN TO IMPROVE PROPERTY ACCOUNTA-

\*\*\*\*\*  
\* UNCLASS E F T O \*  
\*\*\*\*\*

PAGE 01  
082027Z JUN 78  
RUCLHTA/9551

\*\*\*\*\*  
\* UNCLASS E F T O \*  
\*\*\*\*\*

DEPARTMENT OF THE ARMY  
PENTAGON TELECOMMUNICATIONS CENTER

BILITY AT THE INSTALLATION LEVEL?

BT

ACTION ADDRESSEES

006 DALD

0006 TOTAL NUMBER OF COPIES REQUIRED

#9551

NNNN

\*\*\*\*\*  
\* UNCLASS E F T O \*  
\*\*\*\*\*

PAGE 02  
082027Z JUN 78  
RUCLHTA/9551

\*\*\*\*\*  
\* UNCLASSIFIED \*  
\*\*\*\*\*

DEPARTMENT OF THE ARMY  
PENTAGON TELECOMMUNICATIONS CENTER

CDSN = SCD209 MCN = 76171/17052 TOR = 781712252  
RTTUZYUW RUFDAAA3244 1712254-UUUU--RUEACWD.  
ZNR UUUUU  
R 191309Z JUN 78  
FM CINCUSAREUR FEIDELBERG GERMANY//AEAGC-SM-F//  
TO RUEADWD/DA WASH DC//DALC-ZXT//  
INFO RUEOAGA/CDR USA CMS FT LEE VA//ATMS-TD-CD//  
BT

UNCLAS

SUBJ: DAPATF WORKING CONFERENCE III

A. HQDA, DALC-ZXT, 191955Z MAY 78.

B. CINCUSAREUR, AEAGC-SM-F, (21309Z JUN 78 (NOTAL)).

C. HQDA, DALC-ZXT, 161820Z JUN 78.

THIS MSG IS IN THREE PARTS. PART 1 FOR ALL.

1. REF A REQUESTS ADDITIONAL TOPICS FOR CONFERENCE BE PROVIDED.  
REF B PROVIDES COMMENTS AND NAME OF ATTENDEE. REF C REQUESTS NAME  
OF USAREUR ATTENDEE.

PART 2 FOR DALC-ZXT.

2. RELEVANT PORTIONS OF REF B REQUESTED IN REF C FOLLOW:

QUOTE

2. NO ADDITIONAL ISSUES HAVE BEEN IDENTIFIED FOR DISCUSSION;  
HOWEVER, USAREUR UNITS ARE NOW REVIEWING POSSIBLE ISSUES FOR USAREUR  
ATTENTION. WHERE APPROPRIATE, THESE WILL BE DIRECTED TO CONCERNED  
STAFF OFFICES WITH INFO COPIES PROVIDED TO DAPATF.

3. REFERENCE PARA 2 YOUR MESSAGE, THE FOLLOWING IS PROVIDED:

(A) INFORMATION NOW AVAILABLE INDICATES USAREUR PREFERS AN ARMY-  
WIDE STANDARD MIS SYSTEM TO BE TAUGHT BY CONUS SCHOOLS RATHER THAN  
LOCALLY DEVELOPED PROCEDURES.

(B) USAREUR CIF OBJECTIVES AND FLASHER MESSAGES 10 AND 14 IMPLI-  
MENTATION WERE PROVIDED TO DAPATF AND REPRESENT THE USAREUR POSITION  
(C) CASH COLLECTION VOUCHERS SHOULD NEITHER BE ELIMINATED NOR  
RESTRICTED TO HAND TOOLS UNLESS CURRENT POLICIES ARE IN CONFLICT WITH  
STATUTORY REQUIREMENTS.

(D) SUGGESTIONS FOR IMPROVING POST, CAMP, AND STATION (PCS) PRO-  
PERTY ACCOUNTABILITY INCLUDE:

(1) MAKING AR 31C-34, ESPECIALLY PARA 32-2, MORE READABLE. FIELD  
PERCEPTIONS OF PCS ITEMS VARY WIDELY AND INCLUDE CATEGORIES SUCH AS  
BASOPS, SUPPLIES, INSTALLATION PROPERTY, RECREATION SERVICES, DAY  
ROOM, UNIT FUND, CIPEC, LUXURY ITEMS, COMMERCIAL TYPE ITEMS, AND TDA  
PROPERTY LESS EXCEPTIONS TO THESE CATEGORIES;

\*\*\*\*\*  
\* UNCLASSIFIED \*  
\*\*\*\*\*

PAGE 01  
191309Z JUN 78  
RUFDAAA/3244

\*\*\*\*\*  
\* UNCLASSIFIED \*  
\*\*\*\*\*

DEPARTMENT OF THE ARMY  
PENTAGON TELECOMMUNICATIONS CENTER

- (2) SOME ITEMS MAY BE BOTH AUTHORIZED BY CTA OR TOE AND NEED CLARIFICATION; #NE  
(3) PERSONNEL ARE UNFAMILIAR WITH SPECIFIC PCS PROPERTY AND THE ASSOCIATED NSN AND CORRECT NOUN NOMENCLATURE FOR THAT PROPERTY. THIS SUBJECT REQUIRES CONTINUAL SUPERVISION BY SENIOR EXPERIENCED PERSONNEL.  
4. USAREUR ACTG AND ATTENDEE AT SUBJECT CONFERENCE IS MAJOR J.H. KAPKE, HBG MIL 6760/6142.  
UNQUOTE  
3. MAJ KAPKE WILL ALSO ATTEND RETURN OF SECONDARY ITEMS MEETING, DA DCSLOG ON 23 JUN 78.  
PART 3 FOR MSG THEPAS, CMS.  
4. ON POST BILLETS ARE REQUESTED FOR MAJ KAPKE FOR PERIOD 24-29 JUN 78.  
5. USAREUR ACTG IS MAJ KAPKE, HBG MIL 6760.

BT  
ACTION ADDRESSEES  
006 DALD  
0006 TOTAL NUMBER OF COPIES REQUIRED  
#3244

\*\*\*\*\*  
\* UNCLASSIFIED \*  
\*\*\*\*\*

PAGE 02  
191309Z JUN 78  
RUFDAAA/3244

## Chapter 24

### Security of Army Property

1. Implied Recommendation. Improve security of Army property at unit and installation level.

	<u>Volume</u>	<u>Page</u>
2. DAPATF actions:		
a. USACIDC Message, DTG 261200Z Oct 77, USACIDC Support to the DA Property Accountability Task Force.	1	33
b. Proper Count Message, DTG 112035Z Nov 77, Security of Army Property at Installation/Organizational Level.	1	38
c. Proper Count Message, DTG 131710Z Feb 78, Crime Prevention Message - Cannibalization Point Requisition.	2	44
d. Proper Count Message, DTG 312105Z Feb 78, Items Not Authorized in Quick Supply Stores (QSS).	2	53
e. Proper Count Message, DTG 222110Z Mar 78, Crime Prevention Message, Individual Clothing and Equipment Losses.	2	55
f. Indorsement, 31 Jan 78, Tool Kit, General Mechanics: Automotive (FSN 5180-00-177-7033).	2	128
g. Letter, 24 Mar 78, Property Accountability - Enforcement of Supply Discipline.	3	68
h. Letter, 1 Apr 78, Draft Ar 190-51, Security of Army Property at Unit and Installation Level (MACOM).	3	139
i. DF, 1 Apr 78, Draft AR 190-51, Security of Army Property at Unit and Installation Level (HQDA Staff).	3	141
j. Proper Count Message, DTG 141914Z Apr 78, Crime Prevention Message - Training Aid Accountability.	3	24

	<u>Volume</u>	<u>Page</u>
k. Ind, 9 May 78, Shop Equipment, Contract Maintenance, NSN 4940-01-016-2262.	3	86
l. Proper Count Message, DTG 241450Z May 78, Crime Prevention Message - Turning In Property to Defense Property Disposal Office (DPDO).	3	47
m. Letter, 5 Jun 78, Draft AR 190-51, Security of Army Property at Unit and Installation Level.	3	112
n. Letter, 7 Jun 78, USACIDC Property Accountability Recommendations.	3	115
o. DF, 9 Jun 78, Secure Storage Space for Organizational Clothing and Equipment (OCE).	3	121
3. MACOM responses:	<u>Page</u>	<u>Tasking Ref</u>
a. Message, CDR INSCOM, DTG 311438Z May 78, Turning in Property to Defense Property Disposal Office (DPDO).	426	2i
b. Message, CDR TRADOC, DTG 271858Z Jun 78, Crime Prevention Message - Turning In Property to Defense Property Disposal Office (DPDO).	427	2i
c. Message, CDR USACC, DTG 052105Z May 78, Draft AR 190-51, Security of Army Property at Unit and Installation Level.	428	2h
d. DA Form 260, Thru: HQDA (DAPE-ZXM), Request for Printing of Publication, AR 190-51.	430	2h and 2i



SECURITY OF ARMY PROPERTY

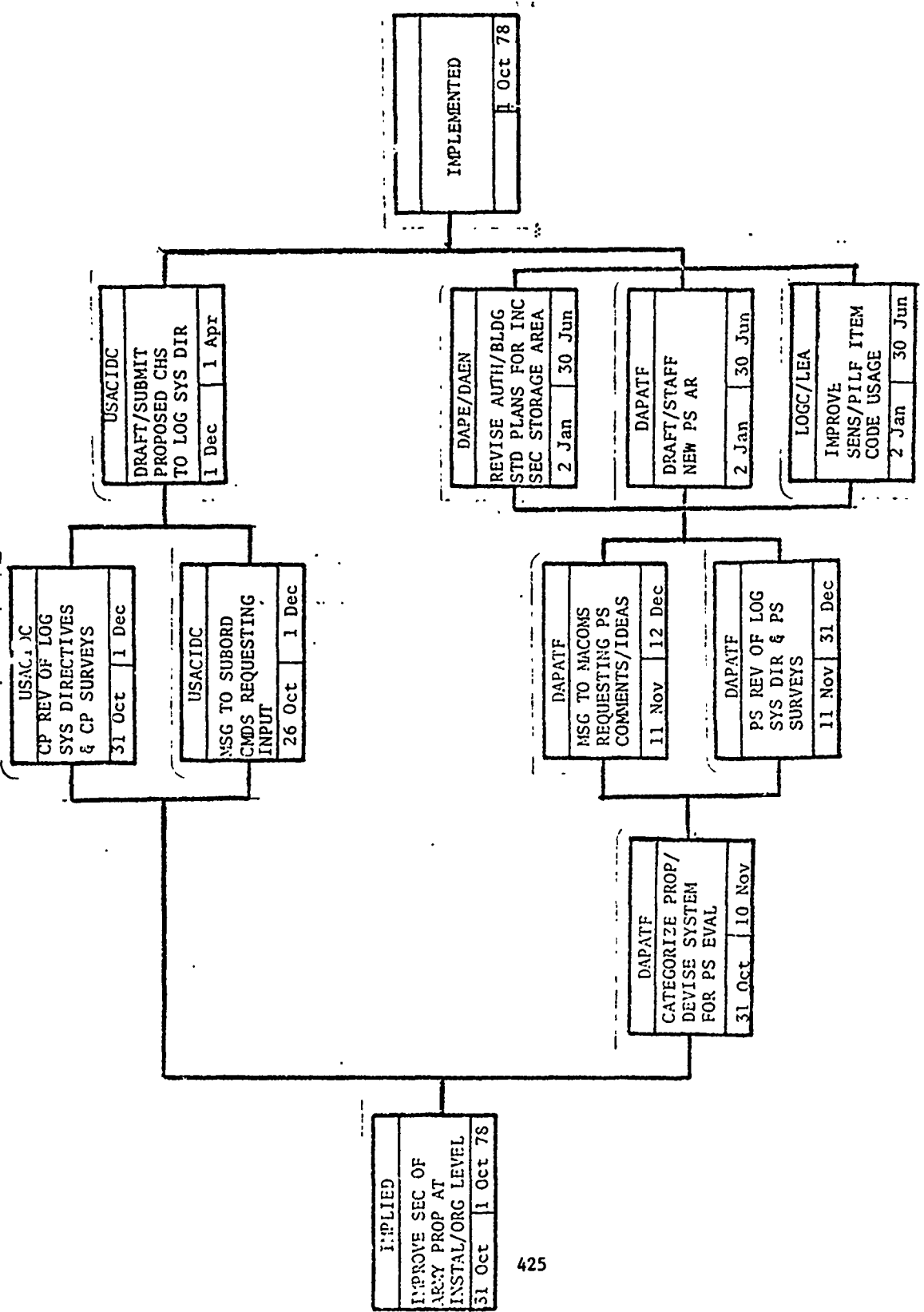

\*\*\*\*\*  
 \* UNCLASS E F T O \*  
 \*\*\*\*\*

DEPARTMENT OF THE ARMY  
 PENTAGON TELECOMMUNICATIONS CENTER

BKS	TA	SM
ZX	LE	SMT
ZXT	TSM	SMS
ZXA	TST	SMM
THCL	TSE	SMW
AV 2055	TSP	SML
PL	TS	SMD
APLWOTH	SAD	RM
PLS	SAB	RMB
PLR	SAA	RMO
PLF	SA	RMI
PLO		RMP

CDSN = SC0416 MCN = 78152/J3235 TOR = 78152055  
 RTTEZDKW RUDHAAA/2521 1512212-EEEE--RUEADWD.  
 ZNY EEEEE 7UI RUEADWD/DA WASHDC //DALG-ZXT//  
 R 311438Z MAY 78  
 FM CORINSCOM AHS VA //IALCG-SS//  
 TO AIG 7567  
 INFO RUEADWD/DA WASHDC //DALG-ZXT//  
 BT

UNCLAS E F T O

SUBJ TURNING IN PROPERTY TO DEFENSE PROPERTY DISPOSAL OFC (DPDO)  
 A. DALG-ZXT 241450Z MAY 78, SAB (U).

1. ALL INSCOM CCRS SHOULD ENSURE THE BELOW LISTED ACTIONS ARE FOL  
 TO PREVENT UNAUTHORIZED DIVERSION OF PROPERTY BETWEEN THE UNIT AND  
 DPDO:

A. ENSURE PROPERTY DESIGNATED FOR TURN-IN/TRANSFER TO DPDO IS  
 ADEQUATELY SECURED WHILE IN THE UNIT.

B. HAVE RESPONSIBLE INDIV ACCOMPANY THE PROPERTY TO DPDO.

C. CHECK FIRST AND SECOND COPIES OF UNIT TURN-IN DOCUMENTS  
 AGAINST EACH OTHER AND INITIATE ACTION IF ANY DISCREPANCIES ARE  
 NOTED.

D. DROPPING PROPERTY ACCOUNTABILITY ONLY AFTER RECEIPT OF THE  
 SECOND COPY OF DD FORM 1348-1 WHICH HAS BEEN VALIDATED BY DPDO.

2. THE PROPERTY DISPOSAL OFFICER (PDO) DOES NOT BECOME ACCOUNTABLE  
 FOR PROPERTY UNTIL IT HAS BEEN INSPECTED, CLASSIFIED AND QUANTITY  
 DETERMINED. AFTER PROCESSING IS COMPLETE, THE SECOND COPY OF THE  
 TURN-IN DOCUMENT IS VALIDATED BY THE PDO AND RETURNED TO THE  
 GENERATING UNIT. BASED ON THE INFO CONTAINED ON THE SECOND COPY,  
 UNIT ACCOUNTABILITY MAY THEN BE DROPPED.

3. CONSIDERATION SHOULD BE GIVEN TO INCLUDING THESE PROCEDURES IN  
 THE NEXT SCHEDULED UPDATE OF UNIT STANDARD OPERATING PROCEDURES.  
 IMPLEMENTATION SHOULD BEGIN IMMEDIATELY.

4. POC THIS HQ IS MC HILL, AUTOVON 222-5553/5641.

BT

ACTION ADDRESSEES

006 DALG

00006 TOTAL NUMBER OF COPIES REQUIRED

42521

\*\*\*\*\*  
 \* UNCLASS E F T O \*  
 \*\*\*\*\*

PAGE 01  
 311438Z MAY 78  
 RUDHAAA/2521

\*\*\*\*\*  
\* UNCLASSIFIED \*  
\*\*\*\*\*

DEPARTMENT OF THE ARMY  
PENTAGON TELECOMMUNICATIONS CENTER

CDSN = SCD711 MCN = 78179/J3271 TOR = 781790224  
RTTUZYUW RUCLAIA7540 1781859-0000--RUEADWD.  
ZNR 00000  
R 271858Z JUN 78  
FM CDRTRADOC FT MCNAKE VA//ATLG-MUP-S//  
TO RUEADWD/DA WASHDC//DALC-ZXT/DALO-SMS//  
INFO: RUEADGE/CERUSALCG CEN FT LEE VA  
RUCLHTB/CDRFORSCEM FT MCPHERSON GA  
AIG 7432  
BT

UNCLAS  
SUBJ: CRIME PREVENTION MESSAGE - TURNING IN PROPERTY TO DEFENSE  
PROPERTY DISPOSAL OFFICE (DPDO)  
A. DALO-ZXT 241450Z MAY 78  
1. REF ADVISED THAT THEFTS ARE OCCURRING WHILE GOVERNMENT PROPERTY  
IS ENROUTE TO THE DPDO FROM THE GENERATING ACTIVITY AND OUTLINED  
PROCEDURES WHICH MAY PREVENT DIVERSIONS.  
2. METHODOLOGY SPECIFIED PARA 3D OF REF IS NOT COMPATIBLE WITH NOR  
FEASIBLE IN SAILS AUTOMATED PROCESSES UTILIZED THROUGHOUT TRADOC.  
GENERATION OF SHIPPING DOCUMENTS (DD FORM 1348-1) WITHOUT DROPPING  
PROPERTY FROM ACCOUNTABILITY WILL REQUIRE EXTENSIVE REVISION TO  
THESE AUTOMATED PROCESSES. DUE TO ACTUAL AND PROJECTED REDUC-  
TIONS IN PERSONNEL/RESOURCES MANUAL OFF-LINE PROCESSING CANNOT BE  
ACCOMPLISHED.  
3. IN VIEW OF THE FOREGOING, THIS COMMAND CANNOT IMPLEMENT THIS  
ASPECT UNTIL SUCH TIME AS AN AUTOMATED PROCESS HAS BEEN FIELDDED.  
BT

ACTION ADDRESSEES  
006 DALO  
INFORMATION ADDRESSEES  
001 AFLO/ATLO  
00007 TOTAL NUMBER OF COPIES REQUIRED  
#7540

\*\*\*\*\* PAGE 01  
\* UNCLASSIFIED \* 271858Z JUN 78  
\*\*\*\*\* RUCLAIA/7540

\*\*\*\*\*  
\* UNCLASSIFIED \*  
\*\*\*\*\*

DEPARTMENT OF THE ARMY  
PENTAGON TELECOMMUNICATIONS CENTER

CDSN = SCD935 MCN = 78126/02553 TOR = 781260321  
RTTUZYUW RUWJHRA6521 1260251-UUUU--RUEADWD.  
ZNR UUUUU  
R 052105Z MAY 78  
FM CDRUSACC FT HUACHUCA AZ //CG-1S//  
TO DA WASHDC //DALG-ZXT//  
BT

UNCLAS

SUBJ DRAFT AR 190-51, SECURITY OF ARMY PROPERTY AT UNIT AND  
INSTALLATION LEVEL

- A. YOUR DALG-ZXT LTR 1 APR 78 (U)
1. PAGE 1-2, PARA 1-3A, LINE 12 - CONDUCTED ANNUALLY OR BIENNIALY. REASON - CURRENT CHANGE TO AR 190-13.
  2. PAGE 1-3, PARA 1-4C - ADD THAT DISPATCHERS OR OTHER PERSONNEL ON DUTY WITH OTHER PRIMARY FUNCTIONS ARE NOT DEDICATED GUARDS.
  3. PAGE 1-5, PARA 1-4J - CHANGE TO NONCOMBAT AREA. REASON - AR 310-25 DEFINES COMBATANT AS INDIVIDUAL MEMBERS AND SOLDIER OR UNIT; THEREFORE, NONCOMBATANT WOULD ALSO BE DEFINED AS PERSONS RATHER THAN IN CONNECTION WITH AN AREA.
  4. PAGE 1-6, PARA 1-5C - ADD THAT ACTIVITIES OF ONE MACOM LOCATED ON THE INSTALLATION OF ANOTHER MACOM WILL REQUEST WAIVERS FROM THEIR PARENT MACOM AND NOT FROM THE INSTALLATION MACOM.
  5. PAGE 1-7, PARA 1-5E - DELEGATE EXCEPTION AUTHORITY AT THE SAME LEVEL AS WAIVER AUTHORITY WITH THE FOUR YEAR REVIEW BY THE MACOM.
  6. PAGE 2-4, PARA 2-4B, LINE 1 - CHANGE TO FM 19-30.
  7. PAGE 2-7, PARA 2-7B - DELETE IN ENTIRETY AS THE LEGAL RAMIFICATIONS INVOLVED IN CONDUCTING VEHICLE SEARCHES WITHOUT PROBABLE CAUSE WOULD FAR OUTWEIGH ANY MATERIAL RECOVERED.
  8. PAGE 2-9, PARA 2-8I - RECRATE AND BAND ITEMS UNTIL OPERATIONALLY NEEDED. REASON - IAW AR 710-3 ITEM AND SHIPPING DISCREPANCY REPORTS ARE REQUIRED TO BE INITIATED UPON RECEIPT OF MATERIEL THEREBY NECESSITATING THAT ITEMS BE OPENED ON RECEIPT.
  9. PAGE 3-5, PARA 3-4B(1)(A), LINE 2 - DELETE "CLOSE." REASON - REDUNDANT.
  10. PAGE 3-8, SUBPARA (11), LINE 3 - CHANGE TO AIRFIELD COMMANDER. REASON - HE HAS RESPONSIBILITY FOR THE TOTAL PHYSICAL SECURITY AND THE INSTALLATION COMMANDER WOULD HAVE TO RELY ON THE RECOMMENDATION OF THE AIRFIELD COMMANDER.
  11. PAGE 3-8, SUBPARA C(1) - DELETE IN ENTIRETY. REASON - EXPENDING FUNDS FOR PERIMETER BARRIERS AND LIGHTING IS NOT FEASIBLE SINCE

\*\*\*\*\*  
\* UNCLASSIFIED \*  
\*\*\*\*\*

PAGE 01  
052105Z MAY 78  
RUWJHRA/6521

\*\*\*\*\*  
\* UNCLASSIFIED \*  
\*\*\*\*\*

DEPARTMENT OF THE ARMY  
PENTAGON TELECOMMUNICATIONS CENTER

- LEVEL 1 WILL STILL REQUIRE GUARDS IF SIX OR MORE AIRCRAFT ARE PARKED.
12. PAGE 3-10, PARA 3-5B(1) - CHANGE TO NONCOMBAT AREAS. REASON - SEE ITEM 3.
13. PAGE 3-12, SUBPARA (A), LINE 4 - CHANGE TO APPROXIMATING. REASON - GRAMMATICAL. THAT SAME CORRECTION SHOULD BE MADE THROUGHOUT THE DRAFT, WHEREVER IT APPEARS.
14. PAGE 3-14, SUBPARA (B), LINE 2 - CHANGE TO RESPONSIBLE COMMANDER REASON - INSTALLATION COMMANDER TOO FAR REMOVED FROM COMMAND/GROUP/BATTALION MOTOR POOL AND AUTHORIZATION SHOULD BE AT RESPONSIBLE LEVEL.
15. PAGE 3-18, PARA 3-6B(1) - ADD DEPLOYED SIGNAL MAINTENANCE VANS HOUSING TMDE ARE EXEMPT. REASON - SIGNAL UNITS WITH TACTICAL MISSIONS ARE NOT USUALLY IN AN ENVIRONMENT THAT COULD PROVIDE DOUBLE BARRIER PROTECTION WHEN DEPLOYED.
16. PAGE 3-38, SUBPARA C(1)(A) - CHANGE TO BUILDINGS OR ROOMS AND OFFICES. ADD THAT BUILDINGS HAVING DEDICATED GUARD PERSONNEL AT ENTRANCES/EXITS ARE EXEMPT.
17. PAGE D-1, PARA D-2 - ADD KEYS WILL NOT BE ISSUED FOR PERSONAL RETENTION AND WILL BE RETURNED TO A UNIT/FACILITY KEY DEPOSITORY FOR SAFEKEEPING AND ACCOUNTABILITY AT THE END OF EACH DUTY DAY/SHIFT.
18. GENERAL COMMENTS.
- A. LEAVING THE IDENTIFICATION OF AREAS STORING ANY OF THE PROPERTY ADDRESSED AS MISSION ESSENTIAL/VULNERABLE AREAS AT LEVEL 2 NEGATES THE NEED FOR PHYSICAL SECURITY INSPECTIONS. UNDER PARA 1-3, RESPONSIBILITIES ADD THAT ALL AREAS ADDRESSED IN THIS DRAFT REGULATION WILL BE DESIGNATED AS VULNERABLE AREAS AND WILL RECEIVE PHYSICAL SECURITY INSPECTIONS.
- B. MANY PARAGRAPHS USE THE WORDS "SHOULD" OR "MAY" WHICH ARE GUIDANCE BUT NOT REGULATORY. CHANGE TO "WILL."
- C. THE REGULATION AS DRAFTED WOULD PROVIDE A COMMANDER OPTIMUM PROTECTION FOR MATERIEL BUT TO IMPLEMENT AT UNIT AND USER LEVEL WOULD REQUIRE ADDED MANPOWER AND RESOURCES. IT, THEREFORE, LEAVES A COMMANDER A GCCD PROGRAM WITHOUT VIABLE MEANS TO ENFORCE IT.

BT

ACTION ADDRESSEES  
006 DALO  
00006 TOTAL NUMBER OF COPIES REQUIRED  
#6521

\*\*\*\*\*  
\* UNCLASSIFIED \*  
\*\*\*\*\*

PAGE 02  
052105Z MAY 78  
RUWJHRA/6521

REQUEST FOR PRINTING OF PUBLICATION		DATE
For use of this form, see AR 310-3, the proponent agency is The US Army Adjutant General Center.		
TO: (Include ZIP Code)		FROM: (Originating Agency)
THRU: HQDA (DAPE-ZXM) WASH DC 20310		HQDA (DAPE-HRE-PS) WASH DC 20310
TO: HQDA (DAAG-PAP) WASH DC 20314		PERSON TO CONTACT MAJ James T. Roberts
		TEL/AUTOVON NO. 44782/43239
PART I - COMPLETED BY ORIGINATING AGENCY		
1. TYPE AND TITLE OF PUBLICATION (On Confidential or higher classified publications, indicate title which can be listed in the indexes (DA Pamphlet 310 series).)		
AR 190-51, Security of Army Property at Unit and Installation Level. (Number was initially reserved for proposed AR, "Security of Army Aircraft, Vehicles and Associated Components, Parts and Tools." Material from that draft was subsequently incorporated in attached AR, which is broader in scope.)		
2. JUSTIFICATION (Indicate why publication is needed, such as statutory requirement, DOD Directive, etc. Use reverse side for additional space if necessary.)		
<p>a. The DAIG Report of Audit Survey and Special Inspection of Management and Accountability of Army Materiel, 6 Oct 77, was completed by CSA directive. This AR resulted from efforts of DA Property Accountability Task Force to implement CSA approved recommendations in DAIG Report.</p> <p>b. This is a new AR which fills an existing policy void.</p> <p>c. Recommend this AR: (1) be published without classification; and (2) become effective 1 Oct 78.</p> <p>d. No ADP implications.</p> <p>e. Local supplementation prohibited except upon approval of HQDA (DAPE-HRE).</p>		
3. RELATED PUBLICATIONS		4. PUBLICATIONS TO BE SUPERSEDED
AR 190-13      AR 735-11 AR 710-2		NONE
5. COPYRIGHT MATERIAL		6. SALE BY SUPERINTENDENT OF DOCUMENTS
a. INCLUDED IN MANUSCRIPT (If "YES" copy of copyright release must be attached.)	b. HELD BY (Name and address, include zip code, of copyright owner)	<input checked="" type="checkbox"/> MAY BE SOLD <input type="checkbox"/> NOT TO BE SOLD
<input type="checkbox"/> YES <input checked="" type="checkbox"/> NO	N/A	
7. RECOMMENDED DISTRIBUTION (Include statement as to whether or not distribution to National Guard and USAR is required.)		
To be distributed in accordance with DA Form 12-9, Requirements for Army Regulations. Distribution A to Active Army, ARNG, and USAR Military Police and Supply+Maintenance Organizations. Forward additional 15 copies each to HQDA (DAPE-HRE)/HQDA (DALO-ZXT) WASH DC 20310		
8. CONCURRENCES		
LIST AGENCY AND NAME AND GRADE OF CONCURRING OFFICER		
DAMI-CI: LTC J. D. Fink	SAPA: COL C. D. Bussey	DAMO: BG N. C. Lighton
DACA-FAL: Mr. J. J. Barry	DAAG: COL L. J. Harmon	DAIG-AI: LTC W. R. Moser
DALO-SMS: COL K. A. Jollimore	DAMA-PPM: COL A. F. Dorris	DAAR: COL J. A. Thomas
DAJA-ALG: LTC P. J. Rice	DALO-AV: Ms. C. L. Chapman	(Contd on back)
THIS PUBLICATION, FOR WHICH PRINTING IS REQUESTED, DOES NOT UNNECESSARILY DUPLICATE EXISTING PUBLICATIONS AND IS ESSENTIAL TO THE EFFECTIVE, EFFICIENT, AND ECONOMICAL CONDUCT OF OFFICIAL BUSINESS.		
TYPED NAME AND GRADE OF AGENCY HEAD (His Deputy, or one of his Division Chiefs)		SIGNATURE OF AGENCY HEAD (His Deputy, or one of his Division Chiefs)
PATRICK R. LOWREY, COL, GS Chief, Law Enforcement Division, ODCSPER		

DA FORM 260  
1 JAN 75

EDITION OF 1 NOV 54 WILL BE USED.  
430

<b>PART II - COORDINATION</b> (To be used by general staff or high level agencies when submitted thereto for approval)		
LIST AGENCY AND NAME AND GRADE OF COORDINATION OFFICER		
<b>PART III - APPROVING AUTHORITY</b> (To be used by general staff or higher level agencies when submitted thereto for approval)		
APPROVED FOR PUBLICATION.		
<b>PART IV - REPORTS CONTROL ACTION</b>		
APPROVED IN ACCORDANCE WITH AR 335 15. REPORTS CONTROL SYMBOL ASSIGNED _____		
DATE	TYPED NAME AND GRADE	SIGNATURE
DAEN-PM: COL C. O. Swanson DASG-ZX: COL C. A. Mateer DALO-ZXT: COL Kelly FORSCOM: MAJ Chapin USAREUR: COL R. K. Cornell MIMC: COL D. R. Holt DARCOM: Mr. E. Sprague MDW: COL D. L. Burt USARJ: COL B. T. White NGB-DAE: Mr. Bray HSC: COL Berger USINSCOM: CPT J. J. Kraynak USAEIGHT: CPT Comer TRADOC: Mr. J. M. North USAMPS: CPT Michaels USACC: Mr. TEMPLETON		

	<u>Page</u>	<u>Tasking Ref</u>
b. MACOM responses:		
(1) Message, CDR DARCOM, DTG 102021Z Apr 78, Shop Equip Auto Maint and Repair Orgn Maint No. 1, Common, LIN W32593.	448	2a(2)
(2) Message, CDR TRADOC, DTG 202234Z Apr 78, Shop Equip Auto Maint and Repair Orgn Maint No. 1, Common and Other PAA Funded SKO's.	449	2a(4)
(3) Message, CDR FORSCOM, DTG 241920Z Apr 78, Shop Equip Auto Maint and Repair Orgn Maint No. 1, Common and Other PAA Funded SKO's.	450	2a(4)
(4) Message, CDR DARCOM, DTG 091555Z May 78, Funding of Tool Sets and Test Sets.	451	2a(4)
(5) Message, CINCUSAREUR, DTG 100739Z May 78, SKO Moratorium (Flasher Msg No. 13).	453	2a(4)

3. Army Master Data File.

	<u>Volume</u>	<u>Page</u>
a. DAPATF actions:		
(1) Proper Count Message, DTG 242050Z Jan 78, Need to Improve Army Master Data File (AMDF).	2	29
(2) DF, 27 Mar 78, Input for AMDF Improvements.	2	238
b. Macom responses:		
Message, CCDA NCAD NEWCUMB, DTG 041940Z Apr 78, Need to Improve Army Master Data File (AMDF).	455	3a(1)

4. Logistics Services Awards Program.

	<u>Volume</u>	<u>Page</u>
a. DAPATF actions:		
(1) Letter, 31 Jan 78, Logistics Services Award Program.	2	117
(2) 1st Ind, 10 Mar 78, Logistics Services Awards Program (to LEA).	2	198



	<u>Volume</u>	<u>Page</u>
(3) Letter, 24 May 78, Logistics Services Awards Program.	3	97
(4) Memorandum for CDR LEA, 9 Jun 78, Logistics Services Awards Program.	3	123
(5) Info Paper, 12 Jun 78, Logistics Services Awards Program.	3	125
(6) DF, 23 Jun 78, Draft AR 672-XX, Logistics Services Awards Program.	3	136
(7) Letter, 26 Jun 78, Logistics Services Awards Program.	3	137
b. MACOM responses:	<u>Page</u>	<u>Tasking Ref</u>
Responses due 4th Qtr.		
5. AR 710-2 actions:		
a. DAPATF actions:	<u>Volume</u>	<u>Page</u>
Monitor AR and Draft AR 710-2 information flow.		
b. MACOM actions:	<u>Page</u>	<u>Tasking Ref</u>
(1) Message, CINCUSAREUR, DTG 191329Z Apr 78, Temporary Hand Receipt Form (DA Form 3122).	457	
(2) Message, CDR EUSA, DTG 240809Z Apr 78, Wartime Unit Level Property Accounting.	459	
(3) Message, CDR TRADOC, DTG 270044Z Apr 78, Authorization Edit.	460	
(4) Message, CDMT USAQMS, DTG 221800Z May 78, Request for Working Conference on Supply Policy and Procedure Changes.	462	
(5) Message, CDR EUSA, DTG 240800Z May 78, Property Book Accounting For Nonexpendable Property.	464	

	<u>Page</u>	<u>Tasking Ref</u>
(6) Message, CDR USATSC, DTG 061800Z Jun 78, Request for Working Conference on Supply Policy and Procedure Changes.	465	
(7) Message, CDR USALOGC, DTG 062020Z Jun 78, Policy and Procedure Changes.	466	
(8) Message, CDR USALOGC, DTG 071945Z Jun 78, Policy and Procedure Changes.	468	

\*\*\*\*\*  
\* UNCLASSIFIED \*  
\*\*\*\*\*

*Hand Tools*

UNCL	SM
SMT	
MS	
PL	
PLI	
PLQ	

DEPARTMENT OF THE ARMY  
PENTAGON TELECOMMUNICATIONS CENTER

CDSN = SCC667 MCN = 78095/C1622 TCR = 78095C123  
RTTUZYUW RUCLATA0781 0942113-UUUU--RUFAGLD.  
ZNR UUUUU  
R 042112Z APR 78  
FM CERTRADCC FT MCNRDE VA//ATLG-MSP-SP//  
TO RUFCAAA/CINCUSAREUR HEIDELBERG GERMANY//AEAGC-SM-F//  
INFO RUCLAPA/CDRUSALOGC FT LEE VA//ATCL-DP//  
RUEAGWC/FSCA WASHDC//DALG-ZXT//  
BT

THIS IS A PROPER COUNT MESSAGE  
UNCLAS

SUBJ: PROPERTY ACCOUNTABILITY TRAINING AIDS

1. DA DALG-ZXT 301938Z MAR 78 (U)
1. REF INDICATES NINE DISPLAY MAT TYPE TOOL KIT/SET INVENTORY AIDS HAVE BEEN DEVELOPED/ARE AVAILABLE IN USAREUR. REF ALSO STATES TRADOC HAS BEEN TASKED TO DEVELOP LIKE ITEMS.
2. TO PRECLUDE DUPLICATION OF EFFORT, REQUEST YOU ADVISE CDR, USA LOGC, FT LEE VA, ATCL-DP, WITH INFO CY THIS PG, ATTN: ATLG-MSP-SP, TO WHICH SKC THE DISPLAY MATS PERTAIN. FURTHER REQUEST YOUR ASSESSMENT ON WHETHER THESE DISPLAY MATS ARE READY FOR ARMY-WIDE USE OR NEED FURTHER REFINEMENT. ANY ADDITIONAL PERTINENT INFORMATION, SUCH AS FIELD TEST DATA, USER COMMENT, ETC., WILL BE APPRECIATED.
3. ALSO REQUEST YOU FWD ONE CY OF THE USAREUR TNG SPT CATALOG TO CDR, USA LOGC.

BT

ACTION ADDRESSEES

706 DALC

0006 TOTAL NUMBER OF COPIES REQUIRED

9C781

\*\*\*\*\*  
\* UNCLASSIFIED \*  
\*\*\*\*\*

PAGE 01  
042112Z APR 78  
RUCLATA/C781

\*\*\*\*\*  
 \* UNCLASSIFIED \*  
 \*\*\*\*\*

*Hand Text*

*Fit2*

DEPARTMENT OF THE ARMY  
 PENTAGON TELECOMMUNICATIONS CENTER

BKS	TICL	SM
ZX	TA	SMT
ZXT <i>A=</i>	TD	SMS
ZXA	TD	SMT
ZXA-C	TD	SMT
AV	TD	SMT
PL	TD	SMT
PLS	TD	SMT
PLW	SAB	SMT
PLR	SAA	SMT
PLF	SA	SMT
PLO		RMP

USN = SCD751 MCN = 78104/CC5C9 TCR = 781040031  
 RTTUZYUW RUFDAAA3892 1040032-UUUU-RUEADWD.  
 ZNR UUUU  
 R 110929Z APR 78  
 FM [REDACTED] HEIDELBERG GERMANY//AEAGD-SM-F//  
 TO RUEADWD/DA WASH DC//DALG-ZXT//  
 RUCLAIA/CDR TRADOC FT MONROE VA//ATLG-MSP-SP//  
 INFO RUCLAFE/CDR USALOGC FT LEE VA//ATCL-DR//  
 BT

UNCLAS

SUBJ: [REDACTED]  
 A. CINCUSAREUR, AEAGD-SM-F, 101309Z MAR 78, (NGTAL).  
 B. HCDA, DALG-ZXT, 301938Z MAR 78.  
 C. CDR, TRADOC, ATLG-MSP-SP, 042112Z APR 78.

1. REF A ADVISES USAREUR UNITS OF AVAILABILITY OF LIMITED SUPPLY OF TOOL SET AND BASIC ISSUE ITEM (BI) TRAINING AID DISPLAY MATS. REFS B AND C REQUEST SAMPLE MATS BE PROVIDED FOR EVALUATION. REF B ALSO EXPRESSES UNFOUNDED CONCERN THAT UNNECESSARY DUPLICATION OF EFFORT MAY OCCUR. REF C ASKS IF THESE ARE READY FOR ARMY-WIDE USE AND REQUESTS FIELD TEST DATA.

2. REQUESTED SAMPLES ARE BEING FORWARDED SEPARATELY. TO CLEAR UP POSSIBLE MISUNDERSTANDING THE FOLLOWING INFORMATION IS PROVIDED:  
 A. THESE PAPER DISPLAY MATS WERE DESIGNED PRIOR TO JULY 1977 AND WERE INTENDED TO BE TRAINING AIDS RATHER THAN DURABLE FIELD UNIT INVENTORY LAYOUT MATS. USAREUR ADVISED SUBORDINATE MACOM OF THE AVAILABILITY OF OFF THE SHELF AIDS TO MAINTAIN PROGRAM MOMENTUM.  
 B. SAMPLES COVER A VERY LIMITED NUMBER OF LINE ITEMS REQUIRING INVENTORY AND ARE RESTRICTED TO VERY HIGH DENSITY ITEMS. AVAILABILITY WAS EXTREMELY LIMITED (LESS THAN 200 EACH AND THREE ARE NOW AT ZERO BALANCE). CURRENT STOCKS WILL BE DEPLETED. USERS WERE ENCOURAGED TO UPDATE THESE TRAINING AIDS BECAUSE OF SUPPLY CATALOG CHANGES AFTER PUBLICATION. ADDRESSEES ARE STRONGLY ENCOURAGED TO DEVELOP DURABLE DISPLAY MATS FOR DISTRIBUTION.  
 C. DEVELOPMENT OF SIMILAR TRAINING AIDS WAS CONSIDERED BUT DETERMINED TO BE AN INEFFECTIVE SOLUTION BECAUSE OF OUR LIMITED PRODUCTION CAPABILITIES, COSTS, LARGE NUMBER OF AIDS REQUIRED AND THE NUMBER OF SUPPLY CATALOG CHANGES ANTICIPATED.

3. IN VIEW OF THE ABOVE, TRAINING AIDS ARE NOT CURRENT ENOUGH FOR ARMY-WIDE USE AS TRAINING AIDS, REQUIRE UPDATING PRIOR TO USE, AND ARE NOT DURABLE ENOUGH FOR DAILY UNIT INVENTORIES. FIELD USER COM-

\*\*\*\*\*  
 \* UNCLASSIFIED \*  
 \*\*\*\*\*

PAGE 01  
 110929Z APR 78  
 RUFDAAA/3892

\*\*\*\*\*  
\* UNCLASSIFIED \*  
\*\*\*\*\*

DEPARTMENT OF THE ARMY  
PENTAGON TELECOMMUNICATIONS CENTER

MENTS AND NEEDS ARE THE BASIS FOR USING AVAILABLE AIDS UNTIL DARCCM  
AND TRADCC PRODUCE NEEDED DURABLE USER INVENTORY AIDS.  
4. USAREUR COMMANDERS RESPONSIBLE FOR DAILY PROPERLY  
ACCOUNTABILITY ENTHUSIASTICALLY LOOK FORWARD TO USING THE COMJS  
INVENTORY MATS.

BT

ACTION ADDRESSES

006 CALD

00006 TCTAL NUMBER OF COPIES REQUIRED

#3892

NNNN

\*\*\*\*\*  
\* UNCLASSIFIED \*  
\*\*\*\*\*

PAGE 02  
110929Z APR 78  
RU-DAAA/3892

\*\*\*\*\*  
\* UNCLASSIFIED \*  
\*\*\*\*\*

*RF IN  
Handbook*

DEPARTMENT OF THE ARMY  
PENTAGON TELECOMMUNICATIONS CENTER

CDSN = SCD682 MCN = 7813001139 TOR # 781300104  
RTTUZYUW RUWTFFA4430 1292003-0000--RUEADWD.

ZNR UUUUU

R 092000Z MAY 78

FM CDR TSARCOM STL MC //DRSTS-WG//

TO RUEADWD/HQDA WASH DC //DALG-AV//JALC-ZXT//

RUKLDAR/CDR GARCLM ALEX VA //LRCLM-MS (MR ELSASSER)//

RUCLEJA/CDR USATSCH FT ELSIIS VA //ATSP-CD-MS (LTC JOYCE)

ATSP-CD-TE (MR EDWARDS)//

RUCLHTA/CDR FCRSCLM FT MCFFERSON GA //AFCP-AV (SFC COHEA)//

AFCL-REA (MR JESILS)//

RULNAPG/CDR NG ELREAL AVN LCG CTR APG MD //JAC-AVN-L (MR R

LINDSAY)//

RUCLDQA/CDR USAAVNC FT RUCKER AL //ATZQ-D-MS (MAJ CLAY)//

RUCIPFA/CDR 101ST AEN DIV FT CAMPBELL KY //AFZS-DE (CPT RYAN)//

RUCLAKA/CDR 18TH ABN CORPS 6 FT BRAGG NC //AFZA-GD (CPT ROGERS)//

RUCLAHA/CDR LUG CTR FT LEE VA //ATCL-MA (MR G EVERHART)//

RUCLENB/CDR USACMSA LEXINGTON KY //CRXMC-E//

RUKLDAR/DIR USA EARA ALEX VA //DRAEA-MC//

RUCLATA/HQ TRADOC FT MONROE VA //ATLG-MST//

BT

*ACT AVNFO FLD ZXT*

UNCLAS

SUBJ COMPOSITE TOOL KIT (CTK) SPECIAL PROGRAM REVIEW

A. TSCH LTR, ATSP-CD-TE, 3 APR 78, SLEJ COMPOSITE TOOL KIT TEST (INLAY VS INSERT)

B. OUR DRSTS-WG 271535Z APR 78 (U), SUBJ QUARTERLY MEETING OF THE READINESS PANEL LF THE FCRSCLM/DARCLM/TRADOC MATERIEL DEVELOPMENT AND READINESS COUNCIL (FOTMDRC) FOR AVIATION GROUND SUPPORT EQUIPMENT (AGSE)

1. REF A PROVIDED SUMMARY AND RESULTS OF THE USATSCH COMPARISON TESTING OF THE INLAY VS INSERT CTR EFFORTS AND SUGGESTED IMPLEMENTATION OF THE INSERT TYPE MODIFICATION.

2. REF B ADVISED THAT THE QUARTERLY MEETING OF THE READINESS PANEL OF THE FOTMDRC FOR AGSE WILL BE HELD AT TSARCOM 17-18 MAY 1978. THE CTK WAS INCLUDED AS A PROPOSED AGENDA ITEM.

3. SINCE RECEIPT OF REF A LETTER TSARCOM HAS BEEN INVESTIGATING IMPLEMENTATION ALTERNATIVES AND DEVELOPING COST AND SCHEDULE ESTIMATES. AS A RESULT IT IS DEEMED ESSENTIAL THAT A SPECIAL PROGRAM REVIEW BE HELD TL:

A. REVIEW THE USATSCH'S PROCEDURES FOR THE INSERT TYPE MODI-

\*\*\*\*\*  
\* UNCLASSIFIED \*  
\*\*\*\*\*

PAGE 01  
092000Z MAY 78  
RUWTFFA/4430

\*\*\*\*\*  
\* UNCLASSIFIED \*  
\*\*\*\*\*

DEPARTMENT OF THE ARMY  
PENTAGON TELECOMMUNICATIONS CENTER

- FICATION OF THE AVIATION GENERAL MECHANIC'S TOOL KIT.
- B. EVALUATE IMPLEMENTATION ALTERNATIVES AND DISCUSS RELATED RAMIFICATIONS OF COST AND SCHEDULE.
- C. DEVELOP A UNIFIED CA, LAFCOM, TRACCC, FORSCOM POSITION FOR IMPLEMENTATION.
- 4. THE REVIEW WILL BEGIN AT 0830, 18 MAY 1978 IN CH-47M CONF ROOM, 9TH FLOOR, FEDERAL (MART) BLDG, 12TH G SPRUCE, ST. LOUIS, MO. IT IS SCHEDULED AS FOLLOW-ON TO THE REF E MEETING IN AN EFFORT TO CONSERVE TDY AND TRAVEL COSTS.
- 5. POC FOR THIS COMMAND IS LTC BUELL R. POWELL, DRSTS-WG(2), AUTOVON 698-5808, COMMERCIAL (314) 268-5808.

3T  
ACTION ADDRESSEES  
006 DALD  
INFORMATION ADDRESSEES  
003 CACA  
002 DAMA  
012 DAMO  
00023 TOTAL NUMBER OF COPIES REQUIRED  
#4430

\*\*\*\*\*  
\* UNCLASSIFIED \*  
\*\*\*\*\*  
PAGE 02  
092000Z MAY 78  
RUWFFFA/4430



DEPARTMENT OF THE ARMY  
HEADQUARTERS US ARMY MATERIEL DEVELOPMENT AND READINESS COMMAND  
5001 EISENHOWER AVE., ALEXANDRIA, VA. 22333

JUN 1 1978

DRCRE

SUBJECT: Quality of Common Hand Tools

SEE DISTRIBUTION

1. Reference message, DRCQA-PD, DTG 042025Z Mar 78, subject as above.
2. The referenced message requested that selected LAO's survey their activities and provide failure/demand data on common tools. This data has been reviewed along with data provided by the DARCOM depots. Generally, these data indicated that the field user was satisfied with the quality of common tools and that the tools were adequate to meet mission requirements. A summary of field replies is provided at Inclosure 1 for your information.
3. As a special effort, this headquarters will closely monitor all reports pertaining to the quality of common tools for the next six months. To assure the effectiveness of our effort, addressees are requested to emphasize the importance of accurate and complete reporting of tool failures to personnel at their respective activity. Care should be taken to properly segregate the types of failures, i.e., quality, fair wear and tear, design deficiencies, etc., and report them through the proper channels.

FOR THE COMMANDER:

1 Incl  
as

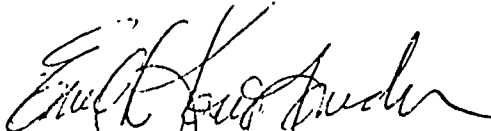
  
EMIL L. KONOPNICKI  
Major General, USA  
Director of Readiness



DFCRE

SUBJECT: Quality of Common Hand Tools

DISTRIBUTION:

C, LAO-FORSCOM, Ft. McPherson, GA 30330  
C, LAO-Ft. Bragg, Bldg 2-1731, Ft. Bragg, NC 28307  
C, LAO-Ft. Campbell, Bldg 7603, Ft. Campbell, KY 42223  
C, LAO-Ft. Carson, Bldg 7603, Ft. Carson, CO 80913  
C, LAO-Ft. Hood, Ft. Hood, TX 76544  
C, LAO-Ft. Lewis, Bldg 9505, Ft. Lewis, WA 98433  
C, LAO-Ft. Ord, Bldg 2073, Ft. Ord, CA 93941  
C, LAO-Ft. Polk, PO Drawer AE, Ft. Polk, LA 71459  
C, LAO-Ft. Riley, Bldg 137, Ft. Riley, KS 66442  
C, LAO-Ft. Stewart, Ft. Stewart, GA 31313  
C, LAO-Ft. Richardson, PO Box 5507, Ft. Richardson, AK 99505  
C, LAO-Canal Zone, PO Box 919, Albrook AFS, Canal Zone  
C, LAO-Hawaii, Ft. Shafter, HI 96858  
C, LAO-TRADOC, Ft. Monroe, VA 23651  
C, LAO-Ft. Benning, Bldg 35, Ft. Benning, GA 31905  
C, LAO-Ft. Bliss, PO Box 6054, Ft. Bliss, TX 79906  
C, LAO-Ft. Dix, Bldg 5401, Ft. Dix, NJ 08640  
C, LAO-Ft. Knox, PO Box 59, Ft. Knox, KY 40121  
C, LAO-Ft. Leonard Wood, Bldg 2333, Ft. Leonard Wood, MO 65473  
C, LAO-Ft. Rucker, PO Drawer L, Bldg 411, Ft. Rucker, AL 36362  
C, LAO-Ft. Sill, PO Box 3127, Ft. Sill, OK 73503  
C, LAO-ACC, Ft. Huachuca, AZ 85613  
C, LAO-Europe, c/o ODCSLOG USAREUR, APO NY 09403  
C, LAO-Korea, APO ST 96301

CF:

HQDA (DALO-ZXT)

DRCMM

C, DARCOM QAFA

DRCOA REVIEW

0 FIELD

0 ADEQUACY FOR MISSION REQUIREMENTS

<u>INSTL</u>	<u>ADEQUATE</u>	<u>INADEQUATE</u>
BENNING	X	
BRAGG	X	
CAMPBELL	X	
CARSON	X	
HOOD	X <sup>1</sup>	
KNOX	X <sup>2</sup>	
LEWIS	X	
POLK	X	
RUCKER	X	
STEWART		X <sup>2</sup>

1 - MARGINAL  
2 - DELAYS

DRCGA REVIEW  
(SURVEY)

0 DEPOTS

0 ADEQUACY FOR MISSION REQUIREMENTS

<u>INSTL</u>	<u>ADEQUATE</u>	<u>INADEQUATE</u>
ANNISTON	X	
CORPUS CHRISTI	X	
LETTERKENNY	X	
LEX-BLUE GRASS	X	
NAVAJO	X	
NEW CUMBERLAND	X	
RED RIVER	X	
SACRAMENTO	X	
SHARPE	X	
SIERRA	X	
TOBYHANNA	X	
TOOELE	X	
UMATILLA	X	
WINGATE	X	

\*\*\*\*\*  
\* UNCLASSIFIED \*  
\*\*\*\*\*

LTC O'HARA

DEPARTMENT OF THE ARMY  
PENTAGON TELECOMMUNICATIONS CENTER

ACT. AV INFO FLO  
ZK

CDSN = SCD638 MCN = 78172/19592 TOR = 781722333  
PTUZYUW RUCLHTA1758 172224E-UUUU--RUEADWD.  
ZNR UUUUU  
P 211735Z JUN 78  
FM CDR FORSCOM FT MCPHERSON GA //AFLG-REA//  
TO RUEADWD/DA WASH DC //ALO-AV/DALO-ZXT//  
INFO RUKLDAR/CDR DARCOM ALE. VA //DRCMM-MS//  
RUCIFRA/CDR TSARCOM STL MD //DRSTS-WG(2)/DRSTS-S(2)//  
RUWTFFC/CDR AVRADCCM STL MD //DRDAV-EQA/DRDAV-EOG(2)//  
RUCLAIA/CDR TRADCC FT MONROE VA //ATLG-MST//  
RUCLEJA/CDR USATC FT EUSTIS VA //ATSP-CD-MS/ATSP-CD-TE//  
RULNAPG/CHIEF NGB ABERDEEN PROVING GROUND MD  
//NGB-AVN-L//  
RUCLDQA/CDR AVN CTR FT RUCKER AL  
//ATZQ-D-MS//  
RUCLBNA/CDR MATERIEL READINESS SUPPORT ACTIVITY,  
LEXINGTON KY //CRXMD-ED//  
RUKLDAR/DIR EQUIP AUTH REVIEW ACTIVITY, ALEX VA  
//DRSEA-MC//  
RUEJAGE/CDR USALOGC FT LEE VA //ATCL-MA//  
RUCIPFA/CDR 101ST ABN DIV AIR ASLT FT CAMPBELL KY  
//AFZB-GD//  
RUCLAKA/CDR XVIII ABN CORPS & FT BRAGG NC//AFZA-GD-S//  
BT

UNCLAS

SUBJ: AVIATION MAINTENANCE COMPOSITE TOOL KIT (CTK) PROGRAM  
A. TSARCOM LTR, DRSTS-WG(2), DATED 9 JUN 78, SUBJ: MINUTES OF  
COMPOSITE TOOL KIT (CTK) SPECIAL PROGRAM REVIEW.  
1. FORSCOM RECOMMENDS CA PROVIDE AUTHORITY AND GUIDANCE TO MACOMS  
FOR IMPLEMENTATION OF THE COMPOSITE TOOL KIT (CTK) PROGRAM IN ALL  
AVIATION UNITS (TO INCLUDE THE COLOR CODING AND TOOL CONTROL MANAGE-  
MENT PROGRAM) AS SOON AS REQUIRED ACTIONS IN REF A ARE COMPLETED.  
THESE ACTIONS SHOULD INCLUDE IDENTIFICATION OF A PLASTIC FOR USE IN  
THE INLAY METHOD (WHICH FORSCOM PREFERENCES) TO REPLACE THE EXHAUSTED  
STOCK OF PLASTIC (NSN 8030-00-582-4598) USED IN THE TEST AT FT CAMP-  
BELL AND FT BRAGG. THIS PLASTIC EXHIBITS UNDESIRABLE ODOR AND RE-  
SIDUE CHARACTERISTICS WHICH WOULD BE DETRIMENTAL TO A SUCCESSFUL  
AVIATION MAINTENANCE TOOL CONTROL PROGRAM.  
2. IT IS ALSO RECOMMENDED THAT ALL ACTIONS IN REF A BE EXPEDITED,  
AS THE DEVELOPMENT AND TESTING OF THE CTK HAS BEEN AN ONGOING PROGRA

\*\*\*\*\*  
\* UNCLASSIFIED \*  
\*\*\*\*\*

PAGE 01  
211735Z JUN 78  
RUCLHTA/1758

\*\*\*\*\*  
\* UNCLASSIFIED \*  
\*\*\*\*\*

DEPARTMENT OF THE ARMY  
PENTAGON TELECOMMUNICATIONS CENTER

IN EXCESS OF THREE (3) YEARS.  
3. POC THIS HQ IS JOHN JESTUS, AV 588-2912/2913.  
BT

ACTION ADDRESSEES  
006 DALO  
00006 TOTAL NUMBER OF COPIES REQUIRED  
#1758

NNNN

447

\*\*\*\*\*  
\* UNCLASSIFIED \*  
\*\*\*\*\*

PAGE 02  
211735Z JUN 78  
RUCLHTA/1758

\*\*\*\*\*  
 \* UNCLASSIFIED \*  
 \*\*\*\*\*

*skd*

BKS	DTGL	SK
ZX	DL	SK
ZXT	DL	SK
ZXA	DL	SK
ZXD	DL	SK
ZXE	DL	SK
ZXF	DL	SK
ZXG	DL	SK
ZXH	DL	SK
ZXI	DL	SK
ZXJ	DL	SK
ZXK	DL	SK
ZXL	DL	SK
ZXM	DL	SK
ZXN	DL	SK
ZXO	DL	SK
ZXP	DL	SK
ZXQ	DL	SK
ZXR	DL	SK
ZXS	DL	SK
ZXT	DL	SK
ZXU	DL	SK
ZXV	DL	SK
ZXW	DL	SK
ZXX	DL	SK
ZXY	DL	SK
ZXZ	DL	SK

DEPARTMENT OF THE ARMY  
 PENTAGON TELECOMMUNICATIONS CENTER

CDSN = 50743 MCN = 73101/04727 TCR = 781010622  
 RTTUW RUKLDAR112+ 1012022-0000--RUEADWD.  
 ZNR 0000  
 R 102021Z APR 78  
 FM CDR DARCCM A-EX VA//DRCM-RS//  
 TO LTR/COMFORSCOM FT MCDONNELL GA//AFLG-SMS//  
 INFO RUEADWD/OA WASHDC//DALO-ZXT/DALO-SMS//  
 RUCIAFB/CDRARRCOM ROCK IS IL//CRSAR-MA//  
 BT

UNCLAS

SUBJ: SHCP EQUIP AUTO MAINT AND REPAIR ORGN MAINT NO 1 COMMON  
 LIN W32593

- A. FORSCOM MSG, AFLG-SMS 102144Z FEB 78, SUBJ AS ABOVE (U)
- B. CA MSG DALO-ZXT 231923Z FEB 78, SUBJ AS ABOVE (U)
- C. FORSCOM MSG AFLG-SMS 222015Z MAR 78, SUBJ AS ABOVE (U)
- 1. HQ DARCCM RECOGNIZES THE REQUIREMENTS TO UPDATE PAA FUNDED (FORMALLY PEMA) SKO'S AND THAT THESE COMPONENTS SHOULD BE ISSUED ON A NON-REIMBURSABLE BASIS. HOWEVER, THERE ARE MANY ALTERNATIVES TO ACCOMPLISHING THIS MISSION AND AN IN-DEPTH ANALYSIS IS CURRENTLY UNDER WAY TO DEVELOP DEFINITIZED PROCEDURES FOR PROCESSING CHANGES WITHIN THE WHOLESALE SYSTEM AND STILL BE RESPONSIVE TO CUSTOMER NEEDS. APPROX 60-90 DAYS ARE REQUIRED TO DEVELOP AND COORDINATE THESE PROCEDURES.
- 2. YOU WILL BE ADVISED OF REQUISITIONING AND FUNDING INFORMATION WHEN PROCEDURES ARE DEVELOPED AND FINALIZED.

BT  
 ACTION ADDRESSEES  
 OCG CALC.  
 00006 TOTAL NUMBER OF COPIES REQUIRED  
 #1124

*Reading File*

\*\*\*\*\*  
 \* UNCLASSIFIED \*  
 \*\*\*\*\*

PAGE 01  
 102021Z APR 78  
 RUKLDAR/1124

\*\*\*\*\*  
\* UNCLASSIFIED \*  
\*\*\*\*\*

(over 500)

DEPARTMENT OF THE ARMY  
PENTAGON TELECOMMUNICATIONS CENTER

CO SA = SC0123 M CN = 731.1/03840 TOR = 781110414  
RTTUZYJW RUCLAIA2265 1102255-0000--RUEACWO.  
ZNR 00000  
R 202234Z APR 78  
FM CDTRADOC FT MONROE VA//ATLG-MSP-SP//  
TO AIG 7573  
INFC RUCLHTB/CDRFORSCOM FT MCPHERSON GA//AFLG-SMS//  
RUEACWO/HQCA WASHDC//DALU-ZXT//  
BT

JNCLAS  
THIS IS TRADOC PROPER JOINT FLASHER MSG NO 13  
SUBJ: SHOP EQUIP AUTO MAINT AND REPAIR ORGN MAINT NO 1 COMMON AND  
OTHER PAA FUNDED SKU'S  
A. CA CALC-ZXT 171622Z APR 78  
REF MSG IS YOURS FOR INFORMATION AND APPROPRIATE ACTION  
BT

ACTION ADDRESSEES

006 DALU

INFORMATION ADDRESSEES

001 AFLC/ATLU

00007 TOTAL NUMBER OF COPIES REQUIRED

#2265

449

\*\*\*\*\*  
\* UNCLASSIFIED \*  
\*\*\*\*\*

PAGE 01  
202234Z APR 78  
RUCLAIA/2265

\* UNCLASS E F T O \*  
 \*\*\*\*\*

*Central Sec*

DEPARTMENT OF THE ARMY  
 PENTAGON TELECOMMUNICATIONS CENTER

CDSA = SCC215 MCN = 7315/12469 TOR = 781151740  
 RTTEZYUW RUCLHTA5640 11517J3-EEEE--RUEADWD.  
 ZNY EEEEE  
 R 241920Z APR 78  
 FM CDR FORSCOM FI MCPHERSON GA //AFLG-SMS//  
 TO AIG 7433  
 AIG 7435  
 AIG 7570  
 INFC RUEADWD/DA WASH DC //DALD ZXI//  
 BT

UNCLAS E F T O  
 THIS IS A PROPER COUNT MSG; FORSCOM FLASHER MESSAGE NO. 13  
 SUBJ; SHOP EQUIP AUTO MAINT AND REPAIR CRG MAINT NO. 1 COMMON AND  
 OTHER PAA FUNDED SKU'S.  
 A. DA DALC-ZXT MSG, 171632Z APR 78, DA FLASHER NO. 13., SAB.  
 1. REF MSG IS YOURS FOR INFORMATION AND APPROPRIATE ACTION.  
 2. THIS HQS WILL KEEP YOU ADVISED OF STATUS OF DARCOM'S  
 DEVELOPMENT OF REQUISITIONING AND FUNDING INFORMATION.  
 BT

ACTION ADDRESSEES  
 006 DALC  
 INFORMATION ADDRESSEES  
 001 AFLG/ATLU  
 00007 TOTAL NUMBER OF COPIES REQUIRED  
 #5640

BKS	THCL	SM
ZX	TA	SMT
ZXA	TS	SMS

\*\*\*\*\*  
 # UNCLASS E F T O #  
 \*\*\*\*\*  
 PAGE 01  
 241920Z APR 78  
 RUCLHTA/5640



\*\*\*\*\*  
\* UNCLASSIFIED \*  
\*\*\*\*\*

RF-11

DEPARTMENT OF THE ARMY  
PENTAGON TELECOMMUNICATIONS CENTER

Handwritten table with columns and rows, containing a circled 'A' and other markings.

CDSN = SCD612    PCN = 78130/00501    ICR = 781300045  
RTTUZYUW RUKLDAR1020 1291604-UUUU--RUEADWD.  
ZNR UUUUU  
R 091555Z MAY 78  
FM CDRDARCOM ALEX VA //DRCMM-RS//  
TO RUCIWMA/CDRTRCCM WARREN MI //DRSTA-MX//  
INFO RUCIAFB/CDRARRCOM RUCK ISLAND IL //DRSAR-IMP-P/ DRSAR-MA-TMDE//  
RUEADWD/DA WASHDC //CALC-FM1/LALL-ZXT/ CALO-SMS//  
BT

UNCLAS

SUBJ: FUNDING OF TOOL SETS AND TEST SETS  
A. TARCOM MSG DRSTA-MX 051330Z APR 78, SUBJ AS ABOVE (U) NOTAL  
B. DRAGCM MSG LRCMM-RS 281800Z MAR 78, SUBJ AS ABOVE (U) NOTAL  
1. AR 37-100-78 CLEARLY OUTLINES POLICY ON FUNDING OF SPECIAL TOOLS AND TEST SETS THAT ARE INTENDED TO BE DEPLOYED WITH NEW WEAPON SYSTEM TO EQUIP USING UNITS AND REPAIR FACILITIES. PRINCIPAL ITEM PROCUREMENT APPROPRIATION FUNDS WILL BE USED AS PART OF THE COST OF THE WEAPON SYSTEM.  
2. HOWEVER, SETS, KITS, AND CUTFITS ARE CLASSIFIED (FUNDED) IN TWO CATEGORIES: (1) PROCUREMENT APPROPRIATION ARMY (PAA) MAJOR END ITEMS, AND (2) STOCK FUND END ITEMS. NORMAL REPLACEMENT OF LOSSES AND BREAKAGES IS THE RESPONSIBILITY OF THE USER. THE USER IS REQUIRED TO PROGRAM, BUDGET, AND EXPEND COMA FUNDS FOR THIS PURPOSE.  
3. PERIODICALLY TOOL SETS, KITS, AND CUTFITS ARE REVIEWED TO EVALUATE THEIR FUNCTIONAL CAPABILITY AS COMPARED TO THE END ITEMS THEY ARE TO SUPPORT. ADDITIONS OF TOOLS IN THE (PAA) SETS ARE SUPPOSED TO BE CENTRALLY FUNDED AND FREE ISSUED TO THE FIELD.  
4. ARRCOM HAS BEEN ADDING TO THE CONFIGURATION OF PAA TOOL SETS AND NOT CENTRALLY FUNDED AND FREE ISSUED TO THE FIELD.  
4. ARRCOM HAS BEEN ADDING TO THE CONFIGURATION OF PAA TOOL SETS AND NOT CENTRALLY FUNDING THE ADDITIONS. THEY HAVE REQUIRED THE FIELD TO SUBMIT FUNDED (COMA DOLLARS) REQUISITIONS FOR THE NEW ITEMS. THIS HAS CREATED A FINANCIAL PROBLEM FOR THE FIELD. (WE SHOULD HAVE BEEN CENTRALLY FUNDING THESE ITEMS AND FREE ISSUING THEM TO THE FIELD.)  
5. THE PROBLEM WAS IDENTIFIED DURING THE DA DIRECTED PROGRAM PROJECT COUNT. CARCLP WAS TASKED BY EA LTR, 30 DEC 77, TO DEVELOP A PROGRAM FOR CENTRALLY FUNDING THE ITEMS REQUIRED BY ADDITIONS IN TOOL SETS CONFIGURATION. BASED ON THE LETTER, THIS HQ INITIATED AN ANALYSIS OF THE PROBLEM AND RESPONDED TO DA.

THIS PAGE IS BEST QUALITY PRACTICABLE FROM COPY FURNISHED TO DDC

\*\*\*\*\*  
\* UNCLASSIFIED \*    # PAGE 01  
\*\*\*\*\*                                  # 091555Z MAY 78  
   # RUKLDAP/1020

\*\*\*\*\*  
\* UNCLASSIFIED \*  
\*\*\*\*\*

DEPARTMENT OF THE ARMY  
PENTAGON TELECOMMUNICATIONS CENTER

6. SUMMARY OF OUR FINDINGS:

A. DARCOM SHOULD FREE ISSUE COMPONENTS REQUIRED TO MEET ADDITIONS IN TOOL SETS, KITS, AND OUTFITS WHICH WERE ORIGINALLY FUNDED BY PAA.

B. ADDITIONS IN TOOL SETS, KITS, AND OUTFITS THAT ARE ORIGINALLY FUNDED BY THE STOCK FUND SHOULD CONTINUE TO BE FUNDED WITH O&MA. THE FIELD SHOULD BE ADVISED OF ADDITIONS TO THIS SETS IN SUFFICIENT TIME TO ALLOW THEM TO PROGRAM FUNDS.

C. NEED EXISTS TO DEVELOP DETAILED PROCEDURES TO FORECAST AND COMPUTE REQUIREMENTS, PROGRAM FUNDING AND CONTROL ISSUES TO THE FIELD.

7. BASED ON OUR ANALYSIS, THE FOLLOWING ACTION HAS BEEN TAKEN:

A. ARRCOM HAS BEEN DIRECTED TO DEVELOP PROCEDURES TO COMPUTE REQUIREMENTS, PROGRAM FUNDS AND FREE ISSUE TO THE FIELD AS OUTLINED ABOVE. (ARRCOM IS A SINGLE MANAGER FOR SKO'S. OTHER COMMANDS MANAGE SKO'S ON AN EXCEPTION BASIS.) PROCEDURES ARE TO BE DEVELOPED AND PROMULGATED TO THE FIELD AND MRC'S BY MID-JULY.

B. RECONFIGURATION OF SKO'S ON A CENTRAL FUNDED BASIS AND SUBSEQUENT FREE ISSUE WILL HAVE TO BE DEFERRED UNTIL FUNDS ARE OBTAINED THROUGH REPROGRAMMING ACTION OR UNTIL INCLUDED IN THE FY 80 APPROPRIATION AND APPROVAL. EXCEPTIONS TO THIS DEFERRAL WILL BE ITEMS DETERMINED TO BE ABSOLUTELY MISSION ESSENTIAL OR CHANGES THAT HAVE SAFETY IMPLICATIONS.

C. WE ARE PURSUING THIS ISSUE AND WILL CONTINUE TO WORK WITH ARRCOM.

D. IN SUMMARY, THE MACOM'S SHOULD NOT BE REQUIRED TO FUND ADDITIONS TO PAA FUNDED SKO'S. WE WILL PROVIDE GUIDANCE TO THE FIELD BY MID-JULY. AS AN INTERIM ACTION, DA ISSUED A MESSAGE 17 APRIL 1978 ADVISING THE FIELD NOT TO TAKE ACTION TO UPDATE SKO'S FUNDED WITH PAA MONEY PENDING RECEIPT OF FURTHER GUIDANCE.

3. THIS MSG IS IN RESPONSE TO REF A AND CLARIFICATION POLICY FURNISHED IN REF E.

BT

ACTION ADDRESSEES

006 DALD

INFORMATION ADDRESSEES

003 DACA

012 DAMC

00021 TOTAL NUMBER OF COPIES REQUIRED

\*1020

**THIS PAGE IS BEST QUALITY PRACTICABLE  
FROM COPY FURNISHED TO DDC**

\*\*\*\*\*  
\* UNCLASSIFIED \*  
\*\*\*\*\*

PAGE 02  
C91552Z MAY 78  
RUKLDAR/1020

\*\*\*\*\*  
 \* UNCLASSIFIED \*  
 \*\*\*\*\*

WKS	TRCL	SU
ZX	TA	SA
ZXA	TB	SM
ZXA-C	TC	SN
54725	TSE	SO
PL	T.P	SP
PLS	SAC	PM
PLW	SAB	PN
PLR	SAA	PO
PLP	SA	PI
PLO		PK

DEPARTMENT OF THE ARMY  
 PENTAGON TELECOMMUNICATIONS CENTER

CDSN = SCD989    MCN = 78135/07036    TOR = 78135  
 9TTUZYUW RUFDAAA552C 1351514-0000--RUEADWD.  
 ZNR UUUUU  
 R 100739Z MAY 78  
 FM CINCUSAREUR HEIDELBERG GERMANY //AEAGC-SM-F//  
 TO RUEADWD/DA WASH DC //CALC-ZXT//  
 INFO RUKLDAR/CDR DARCCM ALEX VA //DRCCM-RA//  
 RUCLBNB/CDR DARCCM LEXINGTON KY //DRXMD-SS//  
 BT

UNCLAS

SUBJECT: SKO MORATORIUM (FLASHER MSG NO. 13)  
 A. DA, DALO-ZXT, 171632Z APR 78, SUBJECT: SHOP EQUIP AUTO MAINT.  
 1. REF PLACED A MORATORIUM ON SKO COMPONENT REQUISITIONS UNTIL  
 DARCOM PROCEDURES FOR PROCESSING PAA FUNDED SKO CHANGES ON A NON-  
 REIMBURSABLE BASIS ARE PUBLISHED.  
 2. REF WAS FORWARDED TO USAREUR UNITS FOR ACTION WITH INFO TO  
 ADDRESSEES. USAREUR IMPLEMENTATION STRESSES CONTINUING USAREUR  
 EFFORTS FOR REDISTRIBUTION TO MINIMIZE TOTAL REQUIREMENTS AND IM-  
 PROVE READINESS OF USING UNITS.  
 3. TO FACILITATE DEVELOPMENT OF PROCEDURES CITED IN REF A, TO INSURE  
 CONTINUITY OF SUPPORT DURING THIS MORATORIUM AND TO ASSURE USAREUR  
 IS PREPARED TO IDENTIFY ACTUAL (RATHER THAN MERELY AUTHORIZED)  
 REQUIREMENTS, REQUEST THE FOLLOWING INFO BE FURNISHED:  
 (A) DATE OF END OF MORATORIUM.  
 (B) PROBABLE PERIOD FOR CONVERSION FROM CURRENT FUNDING OF  
 CATALOG CHANGES TO CENTRALIZED FUNDING.  
 (C) A PROJECT CODE TO BE USED TO IDENTIFY USER NON-RECURRING  
 (CATALOG CHANGES) AND RECURRING DEMANDS (ROUTINE REPLACEMENTS) FOR  
 ITEMS ADDED BY RECENT CATALOG CHANGES DURING THIS CONVERSION.  
 (D) A LIST OF CATALOG CHANGES SUBJECT TO THIS MORATORIUM THAT ARE  
 NOT IDENTIFIED IN DA FAM 310-6, JULY 77.  
 (E) SUGGESTED USAREUR INVENTORY AND FINANCIAL ACTIONS TO BE TAKEN  
 FOR ITEMS DELETED IN ABOVE CATALOGS THAT WILL NOT BE REDISTRIBUTED  
 IN USAREUR BECAUSE OF OBSOLESCENCE OR REDUCED NEED.  
 (F) SUGGESTED USAREUR ACTIONS FOR REQUISITIONS TO CONUS FOR ADDED  
 ITEMS IN ABOVE CATALOGS THAT WERE PROCESSED PRIOR TO THIS MORATORIUM  
 AND THAT WILL NOT BE IDENTIFIED BY THE REQUESTED PROJECT CODE.  
 (G) TARGET DATE FOR DISTRIBUTION OF HAND TOOL LAYOUT MATS FOR  
 SKO CATALOGS NOW UNDER REVISION AND THAT ARE SUBJECT TO THIS  
 MORATORIUM.

THIS PAGE IS BEST QUALITY PRACTICABLE  
 FROM COPY FURNISHED TO DDC

\*\*\*\*\*  
 \* UNCLASSIFIED \*  
 \*\*\*\*\*

PAGE 01  
 100739Z MAY 78  
 RUFDAAA/552C

\*\*\*\*\*  
\* UNCLASSIFIED \*  
\*\*\*\*\*

DEPARTMENT OF THE ARMY  
PENTAGON TELECOMMUNICATIONS CENTER

4. USAREUR DCSLCG-SM-F PLC IS MAJ J. H. KAPKE, HBG MIL 6760/8142.

BT

ACTION ADDRESSEES

006 DALO

00006 TOTAL NUMBER OF COPIES REQUIRED

#5520

NNNN

\*\*\*\*\*  
\* UNCLASSIFIED \*  
\*\*\*\*\*

PAGE 02  
100739Z MAY 78  
RUFDAAAA/5520

\*\*\*\*\*  
\* UNCLASSIFIED \*  
\*\*\*\*\*

DEPARTMENT OF THE ARMY  
PENTAGON TELECOMMUNICATIONS CENTER

SMSA

UN = SCD261 M.N = 78098/06993 TOR = 780980921  
RUZYUW RUEMANA8995 09 71257-0000--RUCAAD  
? UUUUU  
041940Z APR 78  
OCCDA NCAD NEWCOMB PA//DKXCA-DS//  
RUECBNB/COR7THSISCOMAD FT RITCHIE MD//CCV-LOG-SM-S//  
FO RUEADWD/HQDA WASH DC//DALO-SMS/DALO-ZXT//  
RKLDR//CDRCARCOM ALEX VA//DRCMM-SL//  
RBNJHRA//CDRUSASAC FT HUACHUCA AZ//CC-LOG-SMT-S//  
BT

FILE  
PIF  
FILE (AMDF)

JNCLAS  
SUBJ: NEED TO IMPROVE ARMY MASTER DATA FILE (AMDF)  
A. UJ P241344Z FEB 78.  
FOLLOWS SPENSES ARE KEYED TO RECOMMENDATIONS CONTAINED IN PARA 2 OF REF:

- A. RECOMMENDATIONS IMPACTING THE CURRENT AMDF EXPENDABILITY CODE DATA ELEMENT EXPLANATION AND STRUCTURE ARE BEING HELD IN ABEYANCE BECAUSE A THIRD CODE IS BEING CONSIDERED BY DA AND DARCOM FOR IMPLEMENTATION WITHIN THE NEXT SIX MONTH TIME FRAME. THIS NEW CODE WILL BE APPLICABLE TO INDIVIDUAL ITEMS THAT ARE COMPONENTS OF A LARGER ACCOUNTABLE ITEM SUCH AS TOOL KIT, TOOL SET, SET, ECT, AND WILL BE IDENTIFIED AS CODE "D" MEANING DURABLE.
- B. AMDF DATA INPUT TO CDA IS SUBJECT TO EXTENSIVE EDITS AND VALIDATIONS, HOWEVER, CDA COMPUTER EDITS CANNOT DETECT, FOR EXAMPLE, THAT EXPENDABILITY CODE SHOULD BE "X" OR "N" ON ANY GIVEN ITEM. RELIANCE IS PLACED ON THE AMDF USER TO REPORT ANY SUSPECT DATA ELEMENT VALUES TO THE AMDF FILE ORIG AND/OR CDA. EXAMPLES CITED IN PARA 2B OF REFERRED TO THE MISSILE (MIRCOM) AND COMMUNICATIONS & ELECTRONICS (CERCOM) MATERIEL READINESS COMMANDS RESPECTIVELY FOR REVIEW, ANALYSIS, AND APPROPRIATE ACTION.
- C. INFORMATION PERTAINING TO A STOCK NUMBER CHANGE, DELETION OR REPLACEMENT IS PROVIDED IN THE ARMS AMDF MONTHLY MICROFICHE PUBLICATION FOR A MINIMUM OF TWO YEARS. IDENTIFICATION AND EXPLANATION OF THOSE STOCK NUMBERS THAT APPLY TO ABOVE POLICY IS PROVIDED IN USACDA PAMPHLET 18-1, PARAS 30, 3R, AND 3I, OF THE GENERAL INFORMATION SEC.
- D. DEPENDING UPON TYPE ITEM, THE AMDF NOMENCLATURE VALUE ON FILE MAY RANGE FROM A MINIMUM OF 35 TO A MAXIMUM OF 105 CHARACTERS, E.G.,
  - (1) 64 FOR LINS
  - (2) 105 FOR SUBSISTENCE AND MEDICAL ITEMS.
  - (3) 35 FOR ALL OTHER ITEMS.

THIS PAGE IS SECURITY CLASSIFIED  
FROM COPY FURNISHED TO DDC

\*\*\*\*\*  
\* UNCLASSIFIED \*  
\*\*\*\*\*

PAGE 01  
041940Z APR 78  
RUEMANA/8995

\*\*\*\*\*  
\* UNCLASSIFIED \*  
\*\*\*\*\*

DEPARTMENT OF THE ARMY  
PENTAGON TELECOMMUNICATIONS CENTER

1. DUE TO SPACE LIMITATIONS, THE ARMS AMDF MONTHLY MICROFICHE PUBLICATION PROVIDES A MAXIMUM OF 21 CHARACTERS OF BASIC NOUN/NOMENCLATURE FOR ALL ITEMS.

2. FOR ANY GIVEN EFFECTIVE DATE, AMDF DATA ELEMENT VALUES DISSEMINATED BY MEANS OF VARIOUS CDA PRODUCTS AND SERVICES ARE CURRENT AS OF THAT DATE AND HAVE PRECEDENCE OVER ANY CONFLICTING DATA ELEMENT VALUES PUBLISHED IN OTHER AUTHORIZED DA PUBLICATIONS.

F. EMPHASIS IS CURRENTLY PLACED ON AMDF QUANTITY UNIT PACK AND UNIT PACKAGE QUANTITY DATA ELEMENTS BEING AVAILABLE IN ARMY USED STOCK ITEMS. EFF ON/ABO CUT 1 OCT 78, EMPHASIS WILL BE EXPANDED TO COVER BOTH ARMY USED STOCKED AND ARMY USED NONSTOCKED ITEMS.

G. THE WEIGHT VALUE ON MAJOR ITEMS OF EQUIPMENT IS PROVIDED VIA THE AMDF WHENEVER INPUT BY THE AMDF FILE ORIG. RECOMMEND REFERENCE TO TECHNICAL BULLETIN 55-46-1, STANDARD CHARACTERISTICS FOR TRANSPORT-

ABILITY OF MILITARY VEHICLES AND OTHER OUTSIZE/OVERWEIGHT EQUIPMENT. WHENEVER THE WEIGHT DATA ELEMENT IS MISSING FROM THE AMDF.

BT

ACTION ADDRESSEES

006 DALO

INFORMATION ADDRESSEES

000

\*\*\*\*\* AMRD \*\*\*

00006 TOTAL NUMBER OF COPIES REQUIRED

#8995

THIS PAGE IS NOT TO BE REPRODUCED  
FROM COPY FURNISHED TO YOU

\*\*\*\*\*  
\* UNCLASSIFIED \*  
\*\*\*\*\*

PAGE 02  
041940Z APR 78  
RUEMANA/8995

\*\*\*\*\*  
\* UNCLASS E F T O \*  
\*\*\*\*\*

DEPARTMENT OF THE ARMY  
PENTAGON TELECOMMUNICATIONS CENTER

CJSM = SCD484 MCN = 73110/15594 TCR = 781102132  
RTTEZYJW RUFDAAA0595 1102152-EEEE--RUEADAD.  
ZNY EEEEE  
R 191329Z APR 78  
FM CINCUSAREUR HEIDELBERG GERMANY //AEAGD-SM-F//  
TO RUFTFRA/CDR V CORPS FRANKFURT GERMANY //AETVGD//  
RJFLOWA/CDR VII CORPS MUEHNINGEN GERMANY //AETSGD-S&S//  
RJFLICA/CDR 21ST SUPCOM KAISERSLAUTERN GERMANY //AERLO-  
SM//  
RUCDEVA/CDR USAB BERLIN GERMANY //AEBA-SX//  
RUFLEJA/CDR USAS&TAF VICENZA ITALY //AESE-GDL-SM//  
RUFTMAA/CDR 320 AADLGM DARAISTADT GERMANY //AETL-GD//  
ZEN CDR USAMEDCOMEUR HEIDELBERG GERMANY //AEMLO//  
RUFTFDC/CDR JMMC ZWEIBRUECKEN GERMANY //AEAGD-MMC//  
RUFTOVA/CDR 420 MP GP (CJSTOM) MANNHEIM GERMANY  
RUFTSKA/CDR 50TH FA BDE SCHWAEBISCH GMUEND GERMANY  
//AELAT-LG//  
RUFTSFA/CDR 1ST SF BN 10TH SFG (ABN) BAD TCELZ GERMANY  
//AEUSP-CD//  
RUFTSJA/CDR 4TH TRANS BDE UBERURSEL GERMANY //AEUTR-SVC//  
RUFTOVA/CDR 7TH SIG BDE SANDHOFEN GERMANY //AEUSC-R//  
RUFZTPA/CDR 11TH AVN GP SCHWAEBISCH HALL GERMANY //AEUAV-  
D//  
RUFLMMA/CDR 66TH MI GP MUNICH GERMANY  
RUFTFBA/CDR 59TH ORD BDE PIRMASENS GERMANY //AEUSA-DM//  
RUFTFDC/CDR 60TH ORD GP ZWEIBRUECKEN GERMANY //AERCD-L//  
RUFTFMA/CDR 18TH ENGR BDE KARLSRUHE GERMANY //AEUEG-S//  
RUFLFTA/CDR SEVENTH ARMY TNG CCMD GRAFENWDEHR GERMANY  
//AETTG-SD//  
RUDORRA/CDR NSSG (US) SHAPE BELGIUM //AEUSG-LOG//  
RUEODJA/CDR USSA IRAN TEHRAN IRAN //AEUI-LG//  
RUFTFRA/CDR USAPAE FRANKFURT GERMANY //AEUPC-MS//  
RUFTFRA/CDR USAREUR ENGR REAL ESTATE AGCY FRANKFURT  
GERMANY  
RUFLMMA/CDR 1SGEUR MUNICH GERMANY //IAINTA-GPE-L//  
INFO RUEACWD/DA WASH DC //OALO-ZXT//  
RUCLAIA/CDR TRADLC FT MONRJE VA //ATLG-MSP-SP//  
RUCLAHE/CDR USALOGC FT LEE VA //ATCL-DP//  
BT

UNCLAS E F T O

END PAGE

YOUR COPY FILE

\*\*\*\*\*  
\* UNCLASS E F T O \*  
\*\*\*\*\*

PAGE 01  
191329Z APR 78  
RUFDAAA/0595

\*\*\*\*\*  
\* UNCLASS E F T O \*  
\*\*\*\*\*

DEPARTMENT OF THE ARMY  
PENTAGON TELECOMMUNICATIONS CENTER

SUBJECT: TEMPORARY HAND RECEIPT FORM (DA FORM 3122)

A. BALTIMORE PUBLICATIONS BULLETIN NO 3, DATED 6 FEB 78.

B. AR 710-2.

1. ITEM NO. 3, SECTION 1 OF REFERENCE A PROVIDED INFORMATION THAT THE DA FORM 3122 HAS BEEN REPLACED BY DD FORM 1150. CHAPTER 2 OF REFERENCE B PROVIDED THAT THE DA 3122 COULD BE USED AS A TEMPORARY HAND RECEIPT.

2. IN USAREUR, DA FORM 3121 WILL BE USED TO REPLACE DA FORM 3122 AS A TEMPORARY HAND RECEIPT.

3. USAREUR UNITS MAY CONTINUE TO USE DA FORM 3122 AS A TEMPORARY HAND RECEIPT UNTIL STOCKS ARE DEPLETED. UPON DEPLETION OF STOCK, THE POLICY IN PARAGRAPH 2 ABOVE WILL BECOME EFFECTIVE.

BT

ACTION ADDRESSEES

006 CALO

00006 TOTAL NUMBER OF COPIES REQUIRED

#0595

UNCLAS E F T O



*Readme File* *710-2* *1N*

\*\*\*\*\* UNCLASSIFIED \*\*\*\*\*

DEPARTMENT OF THE ARMY  
PENTAGON TELECOMMUNICATIONS CENTER

CDSN = SCD211 MCN = 78114/05209 TGR = 781141332  
RTTUZYUW RUAGAAA3504 1141311-0000--RUEADWD.  
ZNR UUUUU  
R 240809Z APR 78  
FM CDR US8EIGHT SEUL KOREA //DJ-MS-SM//  
TO DA, WASH DC //DALG-SMS/DALO-ZXT//  
BT

ZXT	
ZYA	
ZYA-C	
ZY	
PI	
PLS	
PIW	
PIR	SM
PLF	SA
PLO	

UNCLAS  
SUBJ: WARTIME UNIT LEVEL PROPERTY ACCOUNTING  
A. LTR, DALG-SMS 8039580, 20 MAR 78, (U)  
1. WITH EXCEPTION TO PARA 2-83C, THIS HQ CONCURS IN DRAFT SECTION X OF CHAPTER 2 TO AR 710-2.  
2. PARA 2-83C TENDS TO NEGATE INTENT OF BALANCE OF SECTION X. IT IMPLIES THAT UNIT COMMANDERS/PROPERTY BOOK OFFICERS HAD BETTER HAVE DOCUMENTED PROOF THAT PROPERTY WAS CHARGED TO CERTAIN INDIVIDUALS AND THAT LOSS WAS DUE TO NEGLIGENCE ON PART OF A PARTICULAR INDIVIDUAL. IN OTHER WORDS, THEY MUST MAINTAIN NEARLY ALL RECORDS REQUIRED BY SECTION II, AR 710-2.  
3. RECOMMEND PARA 2-83C BE REWRDED AS FOLLOWS AND INCLUDED AS LAST SUBPARA OF PARA 2-83; QUOTE. RELIEF FROM RESPONSIBILITY WILL NOT BE AUTOMATIC WHEN NEGLIGENCE FOR LOSS OR DAMAGE OF PROPERTY IS SUSPECT CIRCUMSTANCES SURROUNDING THE LOSS WILL BE REPORTED AS PART OF LOG-STAT REPORT ALONG WITH STATEMENTS/AFFIDAVITS COLLECTED FROM KNOWLEDGEABLE PERSONNEL. WHEN COMBAT EXIGENCIES LESSEN, SUCH LOSS OR DAMAGE WILL BE TAKEN UNDER CONSIDERATION EITHER BY A BOARD OF OFFICERS ORGANIZED FOR SUCH PURPOSE, OR PROCESSED IN ACCORDANCE WITH UCMJ.  
UNQUOTE.  
BT

ACTION ADDRESSEES  
006 DALG  
INFORMATION ADDRESSEES  
012 DAMD  
00018 TOTAL NUMBER OF COPIES REQUIRED  
#3504

\*\*\*\*\* UNCLASSIFIED \*\*\*\*\* PAGE 01  
\* UNCLASSIFIED \* 240809Z APR 78  
\*\*\*\*\* RUAGAAA/3504

**DEPARTMENT OF THE ARMY  
PENTAGON TELECOMMUNICATIONS CENTER**

CDSN = SCD256 MCN = 73117/05130 TOR = 781170603  
 RTTUZYUW RUCLAIA2755 1170045-UUUU--RUEADWD.  
 ZNR UUUUU  
 R 270044Z APR 78  
 FM CDTRADOC FT MONROE VA//ATLG-MSP-SP//  
 TO RUEADWD/HQDA WASHDC//DALO-SMS//  
 INFO RUCLHTB/CDRFORSCOM FT MC PHERSON GA//AFLG-SMS//  
 RUFMANA/CDRUSALEA NCAD NEA CUMBERLAND PA//DALO-LER//  
 RUEADWD/DA WASHDC//DALO-LXT//  
 BT

BKS	
ZY-C	
AV	
PL	
PLR	
PLF	
PLO	

UNCLAS

SUBJ: AUTHORIZATION EDIT

- A. ITEM 64A, TABLE 1-2, AR 710-2
- B. PARA 2-2C, AR 710-2
- C. ITEM 20A, TABLE 1-1, AR 710-2

1. REF A REQUIRES CONDUCT OF REQUISITION AUTHORIZATION EDITS. REF B REQUIRES COMMANDERS OF REQUESTING UNITS/ACTIVITIES TO PERFORM THE AUTHORIZATION EDIT AND TO INSURE FUND AVAILABILITY ON REQUESTS WITH AN IPU 01-08. REF C REQUIRES MACOM TO ESTABLISH PROCEDURES FOR AUTHORIZATION EDIT OF REQUISITIONS.

2. REQUEST THAT THE NEXT PUBLISHED CHANGE TO AR 710-2 PLACE RESPONSIBILITY FOR AUTHORIZATION EDIT ONTO THE COMMANDER OF THE UNIT/ACTIVITY INITIATING THE SUPPLY REQUEST. PENDING PUBLICATION OF THE NEXT CHANGE TO 14 710-2, THIS HEADQUARTERS WILL ISSUE INTERIM INSTRUCTIONS TO THAT EFFECT UNDER PROVISIONS OF REF C.

3. RATIONALE FOR THIS ACTION IS AS FOLLOWS:

A. REQUESTING UNITS/ACTIVITIES HAVE THE CAPABILITY TO PERFORM AUTHORIZATION EDITS. AS SUBMISSION OF A SUPPLY REQUEST CONSTITUTES CERTIFICATION THAT FUNDS ARE AVAILABLE FOR THIS PURCHASE, UNIT/ACTIVITY COMMANDERS/CHIEFS SHOULD REVIEW ALL SUCH REQUESTS TO ASCERTAIN THAT FUNDS ARE EXPENDED ONLY FOR AUTHORIZED SUPPLIES AND EQUIPMENT.

B. TRADOC INSTALLATION SUPPLY DIVISIONS OPERATE IN AN AUTOMATED MODE UTILIZING THE STANDARD ARMY INTERMEDIATE LEVEL SUPPLY SUB-SYSTEM (SAILS). CORRESPONDINGLY, THEY ARE ORGANIZED AND STAFFED FOR AUTOMATED OPERATIONS AS OUTLINED IN TM 38-711 SERIES. MANPOWER FOR SUPPLEMENTAL MANUAL OPERATIONS IS EXTREMELY LIMITED NOW AND WILL BE UNAVAILABLE UPON EXECUTION OF ASSESSED FY 79 RESOURCE REDUCTIONS.

\*\*\*\*\*  
\* UNCLASSIFIED \*  
\*\*\*\*\*

DEPARTMENT OF THE ARMY  
PENTAGON TELECOMMUNICATIONS CENTER

C. SAILS DOES NOT PROVIDE UNIT/ACTIVITY AUTHORIZATION INFORMATION OR UPDATED ON HAND/ON ORDER ASSET DATA IN AN AUTOMATED MODE. TO CONDUCT A VIABLE AUTHORIZATION EDIT WITHIN THE INSTALLATION SUPPLY DIVISION, AUTHORIZATION DOCUMENT FILES FOR ALL CUSTOMERS WOULD HAVE TO BE MANUALLY ESTABLISHED, MAINTAINED AND RESEARCHED. FURTHER, A PHYSICAL REVIEW OF REQUESTING UNIT/ACTIVITY PROPERTY BOOK AND DOCUMENT REGISTER WOULD BE REQUIRED TO ASCERTAIN THAT AUTHORIZED QUANTITIES OF SUPPLIES/EQUIPMENT WOULD NOT BE EXCEEDED.

4. ODCSLOG FORSCOM CONCURS IN THE CONCEPT THAT CONDUCT OF AUTHORIZATION EDITS SHOULD BE MADE A RESPONSIBILITY OF REQUESTING UNIT/ACTIVITY COMMANDERS.

BT

ACTION ADDRESSEES

006 DALD

00006 TOTAL NUMBER OF COPIES REQUIRED

#2755

NNNN

\*\*\*\*\*  
\* UNCLASSIFIED \*  
\*\*\*\*\*

PAGE 02  
27JJ44Z APR 78  
RUCLAIA/2755

\*\*\*\*\*  
\* UNCLASSIFIED \*  
\*\*\*\*\*

*Richardson*

DEPARTMENT OF THE ARMY  
PENTAGON TELECOMMUNICATIONS CENTER

CDSN = SCD154 MCN = 78143/02888 TGR = 781430343  
RTTUZYUW RUCLAH/1805 1422025-UUUU--RUEADWD.  
ZNR UUUUU  
R 221800Z MAY 78  
FM CMT USAQMS FT LEE VA//ATSM-ID-TA//  
TO ZEN/CDRUSALCGL FT LEE VA  
INFO RUCLEJA/CDRLSATSC FT EUSTIS VA//ATYSC-IT//  
RUEMANA/CDRLEA NEW CUMBERLAND PA//DALC-LER//  
RUEADWD/DA DCSLEG WAFSEC  
BT

UNCLAS

SUBJECT: REQUEST FOR WORKING CONFERENCE ON SUPPLY POLICY AND  
PROCEDURE CHANGES

1. THE QUARTERMASTER SCHOOL HAS REACHED THE POINT WHERE THE PRODUCTION OF SOLDIER'S MANUALS AND SQT'S IS IMPOSSIBLE DUE TO PENDING CHANGES TO ARMY REGULATIONS, ESPECIALLY CHANGE 5 TO AR 710-2. REPRESENTATIVES FROM THE QUARTERMASTER SCHOOL VISITED THE LOGISTICS EVALUATION AGENCY, NEW CUMBERLAND, PA ON 9-10 MAY 78 TO REVIEW PROPOSED CHANGE 5 TO AR 710-2. ~~ONLY PART OF CHAPTER 2 CHANGES TO BE REVIEWED FOR REVISION. THE IMPACT OF THIS SMALL PORTION IS SIGNIFICANT HOWEVER, AN ANALYSIS OF THE IMPACT ON THE PLAN II 76Y SOLDIER'S MANUAL DELIVERED TO TRADOC FOR PRINTING AND DISTRIBUTION ON 8 MAY 78 AND THE CURRENT SQT IS SUMMARIZED BELOW. USING THE IMPACT OF CHAPTER 2 REVISIONS, IT IS ANTICIPATED THAT OTHER CHAPTER REVISIONS WILL SIMILARLY IMPACT ON MOS'S 76D, P, AND A.~~

A. SUMMARY OF 76Y SM CHANGES:

SL 10 33 PERCENT  
SL 20 25 PERCENT  
SL 30 16 PERCENT  
SL 40

B. SUMMARY OF 76Y SQT CHANGES:

SQT 2 10.4 PERCENT  
SQT 3 11.4 PERCENT  
SQT 4 7.0 PERCENT  
SQT 5 1.0 PERCENT

2. THE PLAN II 76Y SOLDIER'S MANUAL JUST DELIVERED TO TRADOC IS NOW UNUSABLE AND MUST BE REVISED. THE CURRENT 76Y SQT IS NO LONGER VALID. FURTHER, THE SQT FOR ADMINISTRATION IN OCTOBER 1979 CANNOT BE PROVIDED AS REQUIRED BY TRADOC AND DA. THE QMS

\*\*\*\*\*  
\* UNCLASSIFIED \*  
\*\*\*\*\*

PAGE 01  
221800Z MAY 78  
RUCLAH/1805

\*\*\*\*\*  
\* UNCLASSIFIED \*  
\*\*\*\*\*

DEPARTMENT OF THE ARMY  
PENTAGON TELECOMMUNICATIONS CENTER

HAS REACHED THE POINT WHERE SOMETHING MUST BE DONE. THE CHOICE IS BETWEEN NO SM CR SCT CR ESTABLISHING A COORDINATED PLAN THAT WILL WORK.

3. RECOMMEND THE US ARMY LOGISTICS CENTER CONVENE A WORKING CONFERENCE ATTENDED BY HIGH LEVEL REPRESENTATIVES OF DCSLOG, LEA, ATSC, LOGC, AND GMS. THE PURPOSE OF THE CONFERENCE WOULD BE TO PRESENT POLICY AND PROCELURE CHANGE PROBLEMS FOR ALL POINTS OF VIEW AND DEVELOP A PLAN THAT WILL ACCOMMCDATE THESE CHANGES AND DEVELOPMENT OF SOLDIER'S MANUALS AND SKILL QUALIFICATION TESTS. THE CONFERENCE SHULLD BE CONVENED ASAP BUT NLT 16 JUN 78.

BT

ACTION ADDRESSEES

006 DALG

00006 TOTAL NUMBER OF COPIES REQUIRED

#1805

NNNN

\*\*\*\*\*  
\* UNCLASSIFIED \*  
\*\*\*\*\*

PAGE 02  
221800Z MAY 78  
RUCLAH/1805

\*\*\*\*\*  
\* UNCLASSIFIED \*  
\*\*\*\*\*

DEPARTMENT OF THE ARMY  
PENTAGON TELECOMMUNICATIONS CENTER

CDSN = SCD663 MCM = 76144/10255 TLR = 761441306  
RTTUZYUW RUAGAAA3591 1441123-LLLL--RLEADWD.  
ZNR UUUUU  
R 240800Z MAY 78  
FM CDR USAFIGHT SELL KS//DJ-MS-SM//  
TO RUEADWD/DA WAFB IC//CALL-SMS/CALL-ZXT//  
INFO RUEMANA//CDR USALEA NCAD NEW CUMBERLAND PA//DALC-LER//  
BT

UNCLAS

SUBJ: PROPERTY BOOK ACCOUNTING FOR NON-EXPENDABLE PROPERTY

A. PARA 2-64(B), AR 710-2, 1 AUG 71 (U)

B. UR DAMD-FDL 172155Z MAY 78 (C)

1. REF ALFA AS WORDED IS AN ALL INCLUSIVE STATEMENT WHEREAS IN REALITY THERE ARE NUMEROUS TYPES OF NON-EXPENDABLE PROPERTY THAT SHOULD NOT BE ACCOUNTED FOR IN PROPERTY BOOKS. SOME EXAMPLES ARE COMMISSARY EQUIPMENT, INSTALLED EQUIPMENT, AND LEASED/RENTAL EQUIPMENT (REF BRAVC).

2. RECOMMEND REF ALFA BE REVISED TO SHOW THESE EXCLUSIONS.

BT

ACTION ADDRESSEES

006 DALD

00006 TOTAL NUMBER OF COPIES REQUIRED

43591

BKS	TA	SM
ZX	LE	SMT
ZXT	TSM	SMS
ZXA	TST	SMM
THOL	TSC	TGW
AV	TTP	TSC
PL	TB	TAD
FLW	TAD	TAD
PL	TAD	TAD

\*\*\*\*\*  
\* UNCLASSIFIED \*  
\*\*\*\*\*

PAGE C1  
240800Z MAY 78  
RUAGAAA/3591

\*\*\*\*\*

DEPARTMENT OF THE ARMY  
PENTAGON TELECOMMUNICATIONS CENTER

CDSN = SCD811 MCN = 78157/21865 TOR = 781572254  
RTTUZYUW RUCLEJA6535 157194C-UUUU--R LEADWD.  
ZNR UUUUU  
R 061800Z JUN 78  
FM CDR USATSC FT ELSTIS VA//ATTSC-IT//  
TO RUCLAHA/COMDT USACMS FT LEE VA//ATSM-TD-TA//  
RUEADWD/DA WASHDC//CAPE-ZA//  
RUCLAHE/CDR USALCCEN FT LEE VA  
INFO RUEMANA/CORLEA NEW CUMBERLAND PA//DALC-LER//  
RUEADWD/DA WASHDC//DALC-ZA//  
RUEAHDF/CDRUSAMILPERCEN ALEX VA//DAPC-ZA//  
BT

BKS	JA	SM
ZX	LE	SMT
ZXT	TSM	SMS
ZXA	EST	SMH
	EE	SMW
AV	TSP	SML
PL	TS	SMO
PLW	SAC	SMA
PLS	SAG	SMB
PLR	SAA	SMD
PLE	SA	SME
PLO		SMP

UNCLAS  
SUBJECT: REQUEST FOR WORKING CONFERENCE ON SUPPLY POLICY AND  
PROCEDURE CHANGES

- A. USAQMS MSG 221800Z MAY 78, SAB.
1. REF A STATED THAT QMS CANNOT PRODUCE SOLDIER'S MANUALS (SM) AND SQT BECAUSE OF CHANGES TO ARMY REGULATIONS, ESPECIALLY CHANGE 5 TO AR 710-2. MOREOVER, SM AND SQT NOW IN THE FIELD HAVE BEEN RENDERED INVALID.
2. ATSC STRONGLY SUPPORTS QMS DESIRE TO ESTABLISH A PLAN FOR COORDINATING DEVELOPMENT OF REGULATORY AND TRAINING MATERIALS. LACK OF SUCH A PLAN EFFECTIVELY REMOVES LARGE NUMBERS OF SOLDIERS FROM THE EVALUATION SUBSYSTEM OF THE ENLISTED PERSONNEL MANAGEMENT SYSTEM (EPMS). MORE IMPORTANTLY, SOLDIERS THROUGHOUT THE ARMY ARE ATTEMPTING TO CONTEND WITH CONFLICTING INSTRUCTIONS, WITH DELETERIOUS CONSEQUENCIES FOR OPERATING SYSTEMS, MISSION ACCOMPLISHMENT, AND COMBAT READINESS.
3. ATSC ALSO SUPPORTS QMS RECOMMENDATION THAT USALCCEN CONVENE A HIGH LEVEL WORKING CONFERENCE TO DEVELOP A COORDINATION PLAN. SINCE EPMS IS HEAVILY AFFECTED, RECOMMEND REPRESENTATIVES BE INVITED FROM DA DCSPER AND MILPERCEN EPMS TASK FORCE.
4. FOR DA DCSPER: REQUEST THE FOLLOWING ITEM BE ADDED TO THE JULY MEETING OF THE EPMS STEERING COMMITTEE: COORDINATING DEVELOPMENT OF REGULATORY AND TRAINING MATERIALS.
5. ATSC POC AND CONFERENCE PRINCIPAL IS COL EDWARD R. RAUPP, DIRECTOR, INDIVIDUAL TRAINING AND EVALUATION DIRECTORATE (ITE), AUTOVON 927-5397/5567.

BT  
ACTION ADDRESSEES  
03 DHP  
INFO ADDRESSES  
06 DALC  
03 DHP  
0009 TNR

\*\*\*\*\*  
\* UNCLASSIFIED \*  
\*\*\*\*\*

PAGE 01  
061800Z JUN 78  
RUCLEJA/57

\*\*\*\*\*  
 \* UNCLASSIFIED \*  
 \*\*\*\*\*

DEPARTMENT OF THE ARMY  
 PENTAGON TELECOMMUNICATIONS CENTER

BKS	TA	SM
ZX	LE	SMT
ZXT	TSM	SMS
THCL	TST	SMM
AV	TSE	SMW
PL	TSP	SML
PLW	TS	SMD
PLS	SA	SM
PLR	SA	SMO
PLF	SA	SMI
PLQ		SMP

CDSN = SCDJ17 MCN = 78158/03453 TOR = 781580334  
 RTT ZYUW RUCLAHJ427 1572J36-UUUU--RUEADWD.  
 ZNR UUUUU  
 R 062020Z JUN 78  
 FM CDRUSALOGC FT LEE VA//ATCL-SPC//  
 TO RUCLAIA/CDRTRADCC FT M. NRGE VA//ATCD-S/ATING-TD//  
 INFO RUCLEJA/CDRTNGSPICEN FT EUSTIS VA//ATTSC-IT//  
 RUEMANA/CDRUSALEA NEW CUMBERLAND PA//DALO-LER//  
 RUEADWD/DA WASHDC//CALO-ZA//  
 ZEN/COMDT USAQMS FT LEE VA//ATSM-TD TA//  
 BT

UNCLAS

SUBJ POLICY AND PROCEDURE CHANGES

1. MSG, DTG 221800Z MAY 78, FROM COMDT USAQMS FT LEE, VA IS

QUOTED AS FOLLOWS:

"1. THE QUARTERMASTER SCHOOL HAS REACHED THE POINT WHERE THE PRODUCTION OF SOLDIER'S MANUALS AND SQT'S IS IMPOSSIBLE DUE TO PENDING CHANGES TO ARMY REGULATIONS, ESPECIALLY CHANGE 5 TO AR 71J-2. REPRESENTATIVES FROM THE QUARTERMASTER SCHOOL VISITED THE LOGISTICS EVALUATION AGENCY, NEW CUMBERLAND, PA ON 9-10 MAY 78 TO REVIEW PROPOSED CHANGE 5 TO AR 71J-2. ONLY PART OF CHAPTER 2, CHANGE 5, AR 71J-2 WAS AVAILABLE FOR REVIEW. THE IMPACT OF THIS SMALL PORTION IS SIGNIFICANT HOWEVER. AN ANALYSIS OF THE IMPACT ON THE PLAN II 76Y SOLDIER'S MANUAL DELIVERED TO USATRADCC FOR PRINTING AND DISTRIBUTION ON 8 MAY 78 AND THE CURRENT SQT IS SUMMARIZED BELOW. USING THE IMPACT OF CHAPTER 2 REVISIONS, IT IS ANTICIPATED THAT OTHER CHAPTER REVISIONS WILL SIMILARLY IMPACT ON MGS'S 76D, P, AND Z.

A. SUMMARY OF 76Y SM CHANGES:

SL 10 33 PCT  
 SL 20 25 PCT  
 SL 30 16 PCT  
 SL 40

B. SUMMARY OF 76Y SQT CHANGES:

SQT 2 13.4PCT  
 SQT 3 11.4PCT  
 SQT 4 7.0PCT  
 SQT 5 1.0PCT

2. THE PLAN II 76Y SOLDIER'S MANUAL JUST DELIVERED TO USATRADOC IS NOW UNUSABLE AND MUST BE REVISED. THE CURRENT 76Y

\*\*\*\*\*  
 \* UNCLASSIFIED \*  
 \*\*\*\*\*

PAGE 01  
 062020Z JUN 78  
 RUCLAHJ/0427



\*\*\*\*\*  
\* UNCLASSIFIED \*  
\*\*\*\*\*

DEPARTMENT OF THE ARMY  
PENTAGON TELECOMMUNICATIONS CENTER

SQT IS NO LONGER VALID. FURTHER, THE SQT FOR ADMINISTRATION IN OCTOBER 1979 CANNOT BE PROVIDED AS REQUIRED BY USATRADOC AND DA. THE USAQMS HAS REACHED THE POINT WHERE SOMETHING MUST BE DONE. THE CHOICE IS BETWEEN NO SM CR SGT OR ESTABLISHING A COORDINATED PLAN THAT WILL WORK.

3. RECOMMEND THE US ARMY LOGISTICS CENTER CONVENE A WORKING CONFERENCE ATTENDED BY HIGH LEVEL REPRESENTATIVES OF DCSLOG, USALEA, USATSC, USALOGC, AND USAQMS. THE PURPOSE OF THE CONFERENCE WOULD BE TO PRESENT POLICY AND PROCEDURE CHANGE PROBLEMS FROM ALL POINTS OF VIEW AND DEVELOP A PLAN THAT WILL ACCOMMODATE THESE CHANGES AND DEVELOPMENT OF SOLDIER'S MANUALS AND SKILL QUALIFICATION TESTS. THE CONFERENCE SHOULD BE CONVENED ASAP BUT NOT LATER THAN 16 JUN 78."

2. THIS CENTER HAS CONDUCTED A MEETING WHICH INCLUDED REPRESENTATIVES OF USAQMS AND USAADMINEN LIAISON OFFICE. REGARDING PARA 1 OF QUOTED MSG, REPRESENTATIVES FROM USAQMS WHO VISITED USALEA WERE ADVISED THAT THE PROPOSED EFFECTIVE DATE FOR CHANGE 5, AR 710-2, IS 1 OCT 78. USAQMS ADVISES THAT SUCH AN EFFECTIVE DATE WILL RESULT IN THE IMPACTS AS STATED. USAQMS FURTHER ADVISES THAT A DELAY IN THE EFFECTIVE DATE TO FEB 79 WOULD REDUCE THE ADVERSE IMPACT ON THE CURRENT SQT TO AN ACCEPTABLE LEVEL.

3. IT IS THE CONSIDERED OPINION OF THIS CENTER THAT SUCH AN EXTENSION IS REQUIRED. ACCORDINGLY, THIS CENTER STRONGLY RECOMMENDS THAT USATRADOC REQUEST SUCH EXTENSION FROM DA.

4. REFERENCE PARA 3 OF QUOTED MESSAGE, THERE IS THE LARGER ISSUE OF POLICY AND PROCEDURE CHANGES OUTSIDE THE CONFINES OF SUPPLY; AS WELL AS THE REQUIREMENT TO REVISE THE PLAN II 76Y SOLDIER'S MANUAL REGARDLESS OF EFFECTIVE DATES OF CHANGES TO AR 710-2. ACCORDINGLY, THIS CENTER INTENDS TO CONVENE A MEETING WITH ADDRESSEES AND ASSOCIATED SCHOOLS AND CENTERS 13-15 JUN 78. THIS SUBJECT WILL BE ADDRESSED IN A SUBSEQUENT MESSAGE.

BT

ACTION ADDRESSEES

006 DALO

00005 TOTAL NUMBER OF COPIES REQUIRED

40427

\*\*\*\*\*  
\* UNCLASSIFIED \*  
\*\*\*\*\*

PAGE 02  
062022Z JUN 78  
RUCLAH/0427

\*\*\*\*\*  
 \* UNCLASSIFIED \*  
 \*\*\*\*\*

LTC OAKS  
 977 665

DEPARTMENT OF THE ARMY  
 PENTAGON TELECOMMUNICATIONS CENTER

EKS	TA	SM
ZX	LE	SMT
ZXT	TSM	SMS
ZXA	TST	SMM
THCL	TSE	SLW
AV	TCP	SML
		SND
		SNI
		SMB
		SMD
		SMP

CDSN = SCD471 MCN = 78159/J2738 TOR = 781601515  
 RTTUZYUW RUCLAHA0535 1582031-UUUU--RUEADWD.  
 ZNR UUUUU  
 R 071945Z JUN 78  
 FM CDRUSALOGC FT LEE VA //ATCL-SPC//  
 TO RUCLAIA/CDRTRADOC FT MONROE VA //ATTNG-A(P)/ATTNG-TD/ATCD-S//  
 RUCLEJA/CDRTNGSPTCEN FT EUSTIS VA //ATTSC-IT//  
 RUEMANA/CDRUSALEA NEW CUMBERLAND PA //DALO-LER//  
 RUCLEJA/COMDT TRANS SCH FT EUSTIS VA //  
 RUWTFHA/CDRUSACAC & FT LEAVENWORTH KS //ATCA-DM/ATSW-SE//  
 RUEADWD/OA WASHDC //DAPE-MPE//  
 RUEADWD/OA (MILPERCEN) WASHDC //DAPC-EPZ-HAA//  
 4725(\$-/COMDT ADSCH FT BLISS TX //  
 RUCIBAA/ COMDT ARMOR SCH FT KNOX KY //  
 RUEOFUA/ COMDT ENG SCH FT BELVOIR VA//  
 RUWTRQA/COMDT FASCH FT SILL CK//  
 RUCLDNA/COMDT INFSC FT BENNING GA//  
 RUCNFIN/ CDR ADMINCEN & FT BEN HARRISON IN //ATZI-TD/DCI//  
 RUWJHRA/CDRUSAICS FT HUACHUCA AZ //ATSI-TR//  
 RUCLBWA/ COMDT MPSCH FT MCCLELLAN GA //  
 RUCDGOA/CDRUSAMCS REDSTONE ARSENAL AL //ATSK//  
 RULNAPG/CDRUSAGCS AFG MD //ATSL//  
 ZEN-1/COMDT QMSCH FT LEE VA //ATSM-TD-TA//((COURIER)  
 RUCLDIA/COMDT USASIGS FT GORDON GA//  
 BT

UNCLAS  
 SUBJ: POLICY AND PROCEDURE CHANGES  
 A. COMDT USAQMS FT LEE VA ATSM-TD-TA 221800Z MAY 78 (U) NOTAL  
 B. CDRUSALOGC FT LEE VA ATCL-SPC 062020Z JUN 78 (U) NOTAL  
 1. REFERENCE A OUTLINED THE IMPACT OF PROPOSED CHANGE 5, AR 710-2 ON THE PLAN II 76Y SOLDIER'S MANUAL AND CURRENT 76Y SQT. REFERENCE A FURTHER RECOMMENDED USALOGC CONVENE A WORKING CONFERENCE, THE PURPOSE OF WHICH WOULD BE TO PRESENT POLICY AND PROCEDURE CHANGE PROBLEMS FROM ALL POINTS OF VIEW AND DEVELOP A PLAN THAT WILL ACCOMMODATE THESE CHANGES AND DEVELOPMENT OF SOLDIER'S MANUALS AND SKILL QUALIFICATION TESTS.  
 2. DISCUSSION WITHIN THIS CENTER AND WITH REPRESENTATIVES OF USAQMS AND USAADMINCEN LNC INDICATES THE SITUATION IS NOT RESTRICTED TO SUPPLY MATTERS, AND THAT OTHER SCHOOLS ARE EXPERIENCING THE SAME BASIC CONDITION.

\*\*\*\*\*  
\* UNCLASSIFIED \*  
\*\*\*\*\*

DEPARTMENT OF THE ARMY  
PENTAGON TELECOMMUNICATIONS CENTER

3. REFERENCE B TRANSMITTED REFERENCE A TO USATRADOC AND REQUESTED USATRADOC RECOMMEND EXTENSION ON THE PROPOSED EFFECTIVE DATE TO CHANGE 5, AR 710-2. REFERENCE B FURTHER ADVISED THAT THIS CENTER INTENDS TO CONVENE A MEETING ON THE LARGER CONDITION OF POLICY/PROCEDURES CHANGES AND THEIR IMPACT ON SOLDIER'S MANUALS, SQTs, AND SUPPORTING TRAINING MATERIALS.

4. ADDRESSEES ARE REQUESTED TO PROVIDE REPRESENTATION TO THE MEETING, TENTATIVELY SCHEDULED 13-15 JJ 78, IN THE COMMAND CONFERENCE ROOM, SCARVELL HALL, BLDG 10500, FORT LEE, VA. REPRESENTATIVES SHOULD BE AT THE J6 LEVEL PREFERABLY, OR WITH SUFFICIENT AUTHORITY TO SPEAK FOR THEIR ORGANIZATIONS.

5. WHILE NO SPECIFIC AND HARD AGENDA HAS BEEN DEVELOPED, IT IS ANTICIPATED AND DESIRED THAT THE FOLLOWING SUBJECTS WOULD BE COVERED BY THE ORGANIZATIONS LISTED:

A. INTRODUCTION AND PURPOSE OF THE MEETING D, SD/USALOGC

B. IMPACT OF POLICY/PROCEDURE CHANGE ON USAQMS  
SM/SQT/TRAINING MATERIALS DEVELOPMENT (SUPPLY)

C. IMPACT OF POLICY/PROCEDURE CHANGE ON USAADMINCEN  
SM/SQT/TRAINING MATERIALS DEVELOPMENT (ADMIN/  
FINANCE)

D. EXAMPLES OF IMPACTS BY OTHER ASSOCIATED  
SCHOOLS

E. DISCUSSION ON THE GENERATION AND  
REQUIREMENTS FOR CHANGE

NDA DCSLOG,  
DA DCSPER,  
USALEA  
USATRADOC,  
USATSC

F. USATRADOC PERSPECTIVE ON SQT/SM/  
TRAINING MATERIALS

6. IT IS ANTICIPATED THAT THE ABOVE LIST WOULD CONSUME THE FIRST DAY'S MEETING. THE SECOND DAY WOULD BE DEVOTED TO DISCUSSION BY ALL PARTICIPANTS. IT IS HOPED THAT SUCH PRESENTATIONS AND DISCUSSION WOULD PROVIDE A CONSENSUS AS TO RECOMMENDATIONS WHICH COULD BE PRESENTED TO USA TRADOC AS A POSITION FOR FOLLOW ON ACTIONS; AS WELL AS PROVIDE A FORUM IN WHICH ALL CONCERNED WOULD GAIN SOME FURTHER INSIGHT REGARDING IMPACTS ON THE ARMY TRAINING BASE. IT ANTICIPATED THAT THE THIRD DAY OF THE MEETING WOULD BE DEVOTED TO GENERATING THAT CONSENSUS AND THE RECOMMENDATIONS APPROPRIATE THERETO.

7 THIS CENTER WILL ENTERTAIN ANY SUGGESTIONS FROM ADDRESSEES REGARDING ANY OTHER SUBJECTS FOR DISCUSSION AT THIS MEETING. POC IS MR. RAYMOND CANTARAL, ALTVOGN 687-1352/1767.

8. IN ORDER TO INSURE WIDEST PARTICIPATION IT WOULD BE

\*\*\*\*\*  
\* UNCLASSIFIED \*  
\*\*\*\*\*

PAGE 02  
071945Z JUN 78  
RUCLAH/0535

\*\*\*\*\*  
\* UNCLASSIFIED \*  
\*\*\*\*\*

DEPARTMENT OF THE ARMY  
PENTAGON TELECOMMUNICATIONS CENTER

DESIRABLE IF USACAC & FT LEAVENWORTH AND USAADMINCEN WOULD  
PROVIDE FOR REPRESENTATION BY THEIR RESPECTIVE SCHOOLS.  
9. BILLETING ARRANGEMENTS SHOULD BE COORDINATED WITH FORT LEE  
BILLETING OFFICE, ALTGVON 687-4023/1887.

BT

\*\*\*\*\* ADDITIONAL DISTRIBUTION \*\*\*\*\*  
\* AGENCIES ADDED: DALC \*  
\* APPROVAL: MRO REVIEW, 695-1404 \*  
ACTION ADDRESSEES  
002 DAPE  
INFORMATION ADDRESSEES  
006 DALC  
EE3 DAPC  
00008 TOTAL NUMBER OF COPIES REQUIRED  
#0535

NNNN

\*\*\*\*\*  
\* UNCLASSIFIED \*  
\*\*\*\*\*

PAGE 03  
071945Z JUN 78  
RUCLAHA/0535

## CHAPTER 26

### LESSONS LEARNED

1. MACOMs should be given a date to have message implementation by - For example message goes out 1 July with an implementation date of 1 August.
2. When writing several similiar taskings on or about the same date, change subject enough to differentiate between responses received later in reference to the initial tasker.
3. Implementation of recommendations for correcting identified deficiencies such as those outlined in the DAIG Special Inspection of Management and Accountability of Army Materiel requires corrective actions that are not considered the normal procedures for correcting such problems. For example, if the recommendation is to change programs of instruction in service schools, the constraints may not allow a complete task analysis and the normal time for instructional development. Therefore the changes that are effected must be developed in an atypical manner in the time frame allotted.

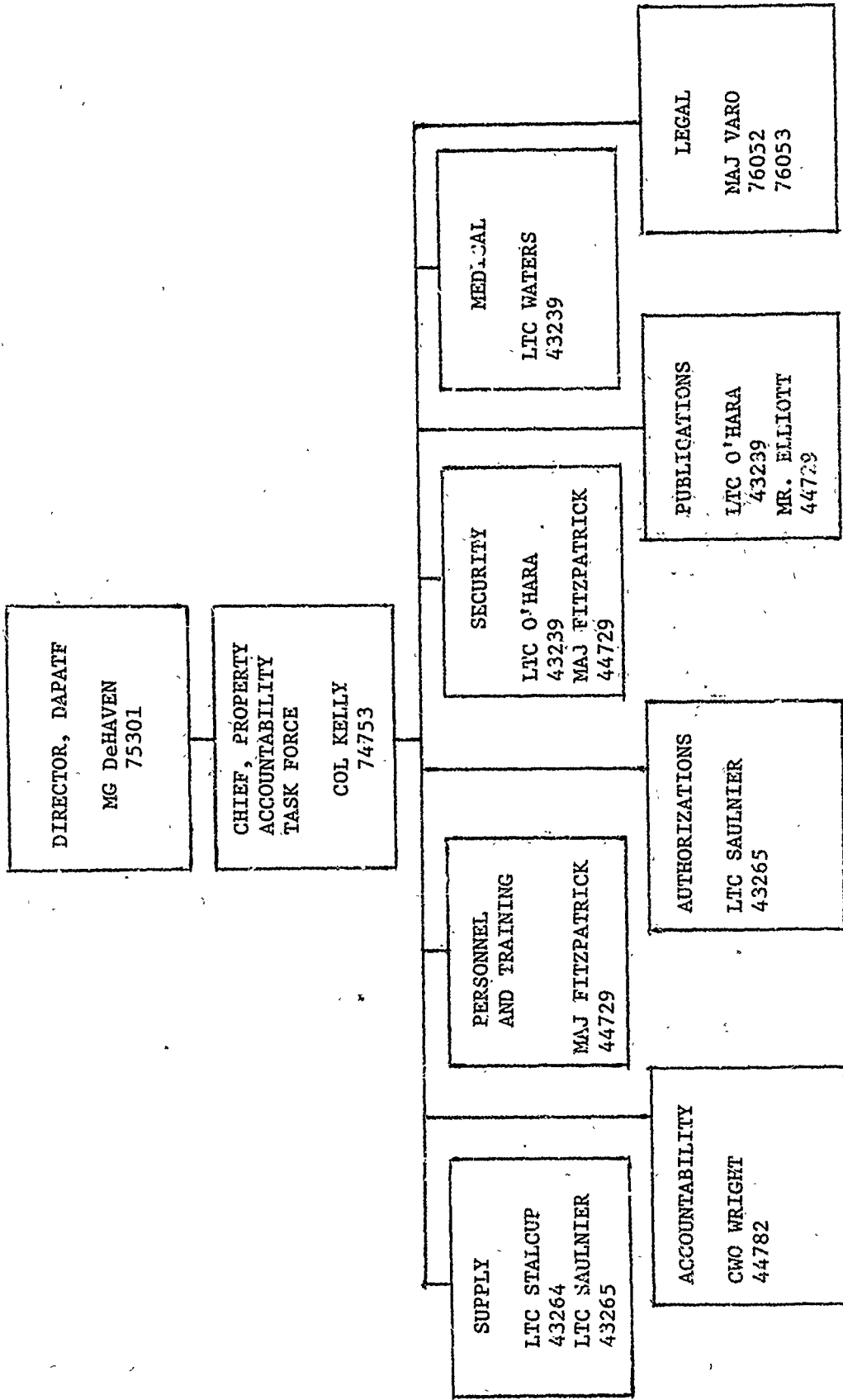

PREFIXES:  
 COMMERCIAL 202-69  
 AUTCVON 22