

AD-A053 118

NAVAL OCEAN SYSTEMS CENTER SAN DIEGO CA  
SUBMARINE TACTICAL DATA LINK HF RADIO COMPARISON TEST.(U)  
SEP 77 G P FRANCIS, W O SMITH

F/G 17/2

UNCLASSIFIED

NOSC/TR-161

NL

| OF |

AD  
A053118



END  
DATE  
FILMED  
5 -78  
DDC

NO: ADA 053118

# NOSC

12

NOSC / TR 161

Technical Report 161

## SUBMARINE TACTICAL DATA LINK HF RADIO COMPARISON TEST

GP Francis, WO Smith

21 September 1977

Test and Evaluation: June 1976 — January 1977

Prepared For  
Naval Electronic Systems Command

DDC  
RECEIVED  
APR 25 1978  
D

AD No. \_\_\_\_\_  
DDC FILE COPY

Approved for public release; distribution is unlimited

NAVAL OCEAN SYSTEMS CENTER  
SAN DIEGO, CALIFORNIA 92152



NAVAL OCEAN SYSTEMS CENTER, SAN DIEGO, CA 92152

---

AN ACTIVITY OF THE NAVAL MATERIAL COMMAND

RR GAVAZZI, CAPT, USN

Commander

HL BLOOD

Technical Director

### ADMINISTRATIVE INFORMATION

Work reported upon herein was performed by members of the Surface/Shore Systems Division, Communications Systems and Technology Department, as part of the Submarine Tactical Data Link (STD L) Program for the Naval Electronic Systems Command. Overall project direction was conducted by NAVELEX PME 11723 (Owen McPherson) and approved by CNO OPNAV 214G (CDR Harry McDonnell). Overall STD L project management was conducted by NAVSEA PMS 393 (Dick Bowers). Management at NOSC was performed by the Submarine Systems Program Office (AJ Chavez). The work was performed under Program Element 64567N, Project S0408, Task Area S0408, and Work Unit B212 between June 1976 and January 1977. This report was approved for publication 21 September 1977.

Released by  
Charles A Nelson, Head  
Surface/Shore Systems Division

Under authority of  
RO Eastman, Head  
Communications Systems and  
Technology Department

UNCLASSIFIED

SECURITY CLASSIFICATION OF THIS PAGE (When Data Entered)

14 NOSC/TR-161

REPORT DOCUMENTATION PAGE		READ INSTRUCTIONS BEFORE COMPLETING FORM
1. REPORT NUMBER NOSC Technical Report 161 (TR 161)✓	2. GOVT ACCESSION NO.	3. RECIPIENT'S CATALOG NUMBER
4. TITLE (and Subtitle) 6 Submarine Tactical Data Link HF Radio Comparison Test.	9	TYPE OF REPORT & PERIOD COVERED Technical Report - June 76 to Jan 1977,
7. AUTHOR(s) GP Francis WO Smith	10 G.F. / Francis W.O. / Smith	6. PERFORMING ORG. REPORT NUMBER
9. PERFORMING ORGANIZATION NAME AND ADDRESS Naval Ocean Systems Center ✓ San Diego, CA 92152		10. PROGRAM ELEMENT, PROJECT, TASK AREA & WORK UNIT NUMBERS 64567N;S0408;S0408 (B212)
11. CONTROLLING OFFICE NAME AND ADDRESS Naval Electronic Systems Command Washington, DC 20360		12. REPORT DATE 11 21 Sep 1977
14. MONITORING AGENCY NAME & ADDRESS (if different from Controlling Office) 16 S0408 17 S0408		13. NUMBER OF PAGES 80 12 81 p.
		15. SECURITY CLASS. (of this report) Unclassified
16. DISTRIBUTION STATEMENT (of this Report) Approved for public release; distribution is unlimited		
17. DISTRIBUTION STATEMENT (of the abstract entered in Block 20, if different from Report)		
18. SUPPLEMENTARY NOTES		
19. KEY WORDS (Continue on reverse side if necessary and identify by block number) Automatic communications Navy Tactical Data System		
20. ABSTRACT (Continue on reverse side if necessary and identify by block number) Tests were conducted to evaluate the performance of the AN/URT-23/R1051E transceiver in an A/B comparison test with standard shipboard NTDS hf radio equipment. Overall performance of the AN/URT-23/R1051E is equivalent to or slightly superior to the NTDS AN/SRC-23 radio.		

DD FORM 1473 1 JAN 73

EDITION OF 1 NOV 65 IS OBSOLETE  
S/N 0102-LF 014-6601

UNCLASSIFIED

SECURITY CLASSIFICATION OF THIS PAGE (When Data Entered)

393 159

JOB

### OBJECTIVE

Evaluate the AN/URT-23/R1051E transceiver (modified for NTDS operation) in an A/B comparison test with a "standard" shipboard NTDS hf radio (AN/SRC-23) in actual on-the-air links with ships, aircraft, and shore sites.

### RESULTS

1. On-the-air performance of the AN/URT-23/R1051E summed over all the test frequencies was found to be equivalent or slightly superior to that of the AN/SRC-23.
2. On-the-air performance of the AN/URT-23/R1051E at any single test frequency differed from that of the AN/SRC-23.
3. Signal-to-noise ratio performance of the AN/URT-23/R1051E is equivalent to that of the AN/SRC-23 at 4.5 megahertz.
4. The AGC action of the AN/URT-23/R1051E is satisfactory and is equivalent in performance to that of the AN/SRC-23.
5. The AN/URT-23/R1051E receiver is susceptible to saturation by a very near station.

### RECOMMENDATIONS

1. It is recommended that the modified AN/URT-23/R1051E transceiver be considered for NTDS Link 11 use by the Fleet.
2. The AN/USQ-59 and AN/ACQ-5 modems should be fitted with switches to disable their signal quality-detection circuits during POFA exchanges.
3. The POFA software patch for the R0280 high-speed printer should be made available to the Fleet.
4. The saturation of the AN/URT-23/R1051E receiver by extremely strong stations should be investigated and, if possible, corrected.

ADDITION for		
DTIS	White Section	<input checked="" type="checkbox"/>
DDG	Off Section	<input type="checkbox"/>
UNANNOUNCED		<input type="checkbox"/>
JUSTIFICATION.....		
BY.....		
DISTRIBUTION/AVAILABILITY CODES		
Dist.	AVAIL. CODE	or SPECIAL
A		

## CONTENTS

INTRODUCTION . . .	page 5
SYSTEM DESCRIPTION . . .	5
Modulation . . .	6
Demodulation . . .	6
Link Control . . .	8
Operational flow . . .	9
TEST PROGRAM . . .	10
Test configuration at NOSC . . .	11
Test operations . . .	11
Test data . . .	20
Radio comparison data . . .	23
Histograms . . .	29
Cumulative distributions . . .	33
Additional radio comparison data . . .	37
ANALYSIS AND CONCLUSIONS . . .	43
Difference-in-percents value . . .	43
Relative receiver performance (all frequencies) . . .	45
Relative transmitter performance (all frequencies) . . .	46
Relative radio performance (individual test frequencies) . . .	46
Comparison of BER, WER, and RMR versus Ps/Pn curves . . .	48
Receiver AGC comparison . . .	49
RECOMMENDATIONS . . .	49
BIBLIOGRAPHY . . .	50
APPENDIX A: HISTOGRAMS AT INDIVIDUAL FREQUENCIES . . .	51
APPENDIX B: SIGNAL-QUALITY DETECTION CIRCUIT INDUCED ERRORS . . .	67
APPENDIX C: SOFTWARE PATCH FOR CP-642A OR B COMPUTER POFA TO OUTPUT ON R0280 HIGH-SPEED PRINTER . . .	77

## ILLUSTRATIONS

1. Typical NTDS Link 11 system configuration . . . page 5
2. Data phase-shift encoding scheme . . . 6
3. Roll-call message formats . . . 9
4. On-the-air test configuration . . . 13
5. Audio and rf switch panel arrangements . . . 15
6. AN/SRC-23 radio and remote-control panel . . . 15
7. AN/URT-23/R1051E radio with data adapter . . . 16
8. AN/USQ-59 modem and address-control indicator . . . 16
9. AN/USQ-36 modem . . . 17
10. AN/USQ-36 remote control, address control, and address-control indicator . . . 17
11. CP-642A computer . . . 18
12. Data matrix for AN/SRC-23 . . . 21
13. Data matrix for AN/URT-23/R1051E . . . 21
14. Two-party multistation POFA with bit-error analysis . . . 22
15. Data-analysis sheet . . . 24
16. WER at NOSC versus range at a frequency of 4.5 MHz . . . 27
17. RMR at NOSC versus range at a frequency of 4.5 MHz . . . 27
18. WER at ship versus range at a frequency of 4.5 MHz . . . 28
19. RMR at ship versus range at a frequency of 4.5 MHz . . . 28
20. All-frequencies histogram of ratios of adjacent word-error rates at NOSC . . . 30
21. All-frequencies histogram of ratios of adjacent bit-error rates at NOSC . . . 30
22. All-frequencies histogram of ratios of adjacent received-message rates at NOSC . . . 31
23. All-frequencies histogram of ratios of adjacent word-error rates at the ship . . . 31
24. All-frequencies histogram of ratios of adjacent bit-error rates at the ship . . . 32
25. All-frequencies histogram of adjacent received-message rates at the ship . . . 32
26. All-frequencies cumulative distribution of ratios of adjacent word-error rates at NOSC . . . 34
27. All-frequencies cumulative distribution of ratios of adjacent bit-error rates at NOSC . . . 34
28. All-frequencies cumulative distribution of ratios of adjacent received-message rates at NOSC . . . 35
29. All-frequencies cumulative distribution of ratios of adjacent word-error rates at the ship . . . 35
30. All-frequencies cumulative distribution of ratios of adjacent bit-error rates at the ship . . . 36
31. All-frequencies cumulative distribution of ratios of adjacent received-message rates at the ship . . . 36
32. Cumulative-distribution comparison histogram . . . 37
33. BER versus  $P_s/P_n$  test set-up for the AN/SRC-23 and AN/URT-23/R1051E radios . . . 39
34. BER versus  $P_s/P_n$  for single-station POFA . . . 40
35. WER versus  $P_s/P_n$  for single-station POFA . . . 40
36. RMR versus  $P_s/P_n$  for single-station POFA . . . 40
37. Signal-strength plot for a 3-party net with NOSC using the AN/SRC-23 and AN/USQ-36 modem at the frequency of 4.5 MHz . . . 42

## TABLES

1. Tone library for NTDS Link 11 . . . page 7
2. Description of status bits . . . 7
3. Test frequencies . . . 11
4. Modem and radio test conditions . . . 19
5. NOSC link with P-3C at Moffett Field . . . 39
6. Weak station, strong station test results . . . 41
7. Relative radio performance over all frequencies . . . 43
8. Relative radio performance, individual frequencies . . . 44



## INTRODUCTION

The Navy Tactical Data System (NTDS) is an automatic communications network which provides Fleet units with the capability of performing threat detection and warning, controlling warfare functions, and managing airspace use on a near-real-time basis for the entire tactical area of the network. The Link 11 system consists of sensors and displays, an NTDS computer, cryptographic devices, an NTDS modem, two-way radio, antenna coupler, and antenna. A typical NTDS Link 11 system is shown in figure 1.

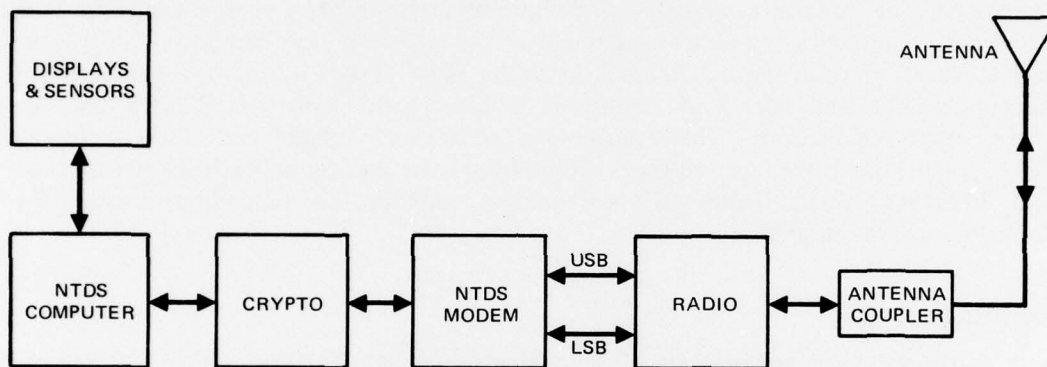

Figure 1. Typical NTDS Link 11 system configuration.

The objective of the tests reported upon in this document was to evaluate the AN/URT-23 high-frequency transmitter and its companion high-frequency receiver, R1051E, proposed for use as the two-way radio in the Link 11 configuration. The tests were of the A/B type in which the AN/URT-23/R1051E equipment was compared operationally with a standard NTDS shipboard radio.

NTDS Link 11 operates in a netted configuration. Each member of the net is a participating unit (PU), and shares tactical data by mutual exchanges with all members of the net. Exchange of data is automatic and is under the control of one PU which is designated Net Control Station (NCS). All other PUs are designated as pickets. When the net is in operation, the NTDS computer supplies digital data which are passed to the NTDS modem which converts the data to 15 audio tones used to modulate the radio carrier for transmission. During reception, the audio modulation is recovered by the radio and is delivered to the NTDS modem where it is converted back to digital form for use by the computer. Cryptographic equipment is used to encode the digital data for transmission and to decode it after reception.

## SYSTEM DESCRIPTION

In the NTDS Link 11 system, the NTDS modem provides 3 essential functions. These functions are now discussed.

## MODULATION

The first of these major functions is modulation which is performed by the modem during transmission of signals. The output from the NTDS computer is a 24-bit parallel data word for each frame time period (13.3 milliseconds in the fast data rate, and 22.0 milliseconds in the slow data rate). Each data word is delivered to the modem (via a cryptographic unit, if required) where 6 hamming bits are added for error-detection and correction purposes. The modem examines the resultant 30 bits in pairs to determine the phase angle of each of the 15 data-carrying tones in the audio tone package which is used to modulate the transmitter. In the Link 11 system the information is conveyed by phase-angle shifts of the 15 data-carrying tones. At each frame boundary, the phase of each data tone is shifted with respect to the previous frame. Figure 2 shows the phase shifts resulting from the 4 possible bit patterns of a 2-bit pair. A sixteenth tone is added to the 15 phase-modulated tones to complete the tone package. This latter tone is not phase modulated and is used to correct for doppler shifts in the received tones caused by relative motion between the transmitter and distant receiver and for the drift in frequency standards. The tone library for NTDS Link 11 is shown in table 1.

## DEMODULATION

The second major function of the modem is the demodulation of data received by the Link 11 system from another unit. The modem also demodulates its own transmitted data to check for errors. The received audio tone package is delivered to the modem where the 30 bits of data in each time frame are extracted by determining the shift in phase of each

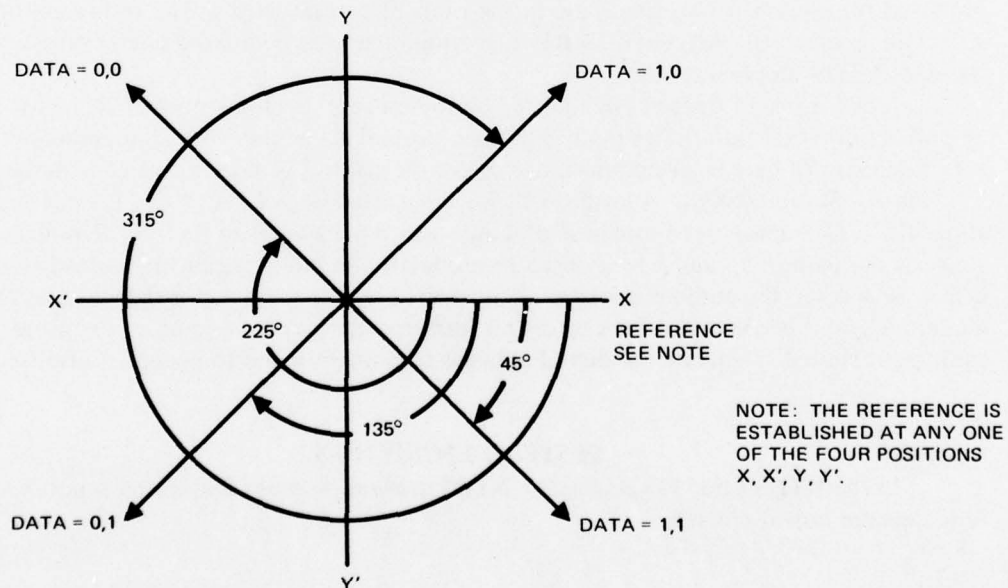

Figure 2. Data phase-shift encoding scheme.

TABLE 1. TONE LIBRARY FOR  
NTDS LINK 11.

Tone	Frequency Hz
1 (Doppler)	605
2	935
3	1045
4	1155
5	1265
6	1375
7	1485
8	1595
9	1705
10	1815
11	1925
12	2035
13	2145
14	2255
15	2365
16 (Sync)	2915

data tone with respect to the previous frame. The 30 data bits are then examined for errors. In this connection, the 6 hamming bits provide for error detection and allow for correction of a single-bit error in the received data.

The modem has sideband-selection modes which may be used for data reception. These include upper sideband alone (USB), lower sideband alone (LSB), or the diversity combination of both (SUM). A fourth mode, designated AUTO, permits automatic selection of the sideband or combination thereof which yields the least number of errors on a frame-by-frame basis.

In operation the operator has the option of having error-correction circuitry ON or OFF. When the circuitry is ON, the modem identifies the presence of what appears to be an error and, if possible, corrects the error before sending the information to the computer. Two status bits are added to the 24 data bits sent to the computer. These status bits indicate the parity of the information as sent to the computer and are shown in table 2.

TABLE 2. DESCRIPTION OF STATUS BITS.

Status	Bit 25	Bit 24	Description
0	0	0	No error detected by modem.
1	0	1	Hamming bit errors detected by modem. Uncorrectable error.
2	1	1	Even number of bit errors detected by modem. Uncorrectable error.
3	1	1	Odd number of bit errors detected by modem. Correctable single bit error.

## LINK CONTROL

The third essential function provided by the modem in the NTDS Link 11 system is that of link control. The principal modes of net operations are NET SYNC, NET TEST, and ROLL CALL. NET SYNC and NET TEST are used for net initialization while the normal mode for net operation is ROLL CALL. The AN/SSQ-29 and AN/USQ-59 modems have two additional modes, BROADCAST and SHORT BROADCAST. Brief descriptions of these modes follow.

### NET SYNC

The NET SYNC mode is used to establish a uniform time base within the net. When the NCS transmits in this mode, each PU synchronizes its individual time base with the signal being received and, from this point on, continues to monitor its synchronization with the received messages and corrects for minor differences. During NET SYNC only the doppler tone and the synchronization tone are transmitted.

### NET TEST

The NET TEST mode usually follows the use of the NET SYNC mode and immediately precedes full net operation. When in this mode, the NCS transmits a known pattern of test data (all 16 tones are transmitted). Each PU compares the pattern it receives with the same pattern generated locally. When a PU detects an error, an appropriate lamp lights on the modem.

### BROADCAST

When the BROADCAST mode is selected, one PU transmits continuously to all other units in the net. Once this mode is initiated, it is continued automatically until reset manually. Information which is transmitted consists of continuously updated data from the NTDS computer. When in this mode, all PUs can receive continuously updated information without breaking radio silence. This mode uses the Picket Reply format (see figure 3) substituting a Control Stop Code for the Picket Stop Code.

### SHORT BROADCAST

When in the SHORT BROADCAST mode, radio silence is broken only when a PU makes a single data transmission to all members of the net. This mode is initiated manually and, upon completion of the transmission, the transmitting modem is automatically reset. Use of this mode allows any net member to update the others whenever changes in the tactical situation warrant. This mode uses the Picket Reply format (see figure 3).

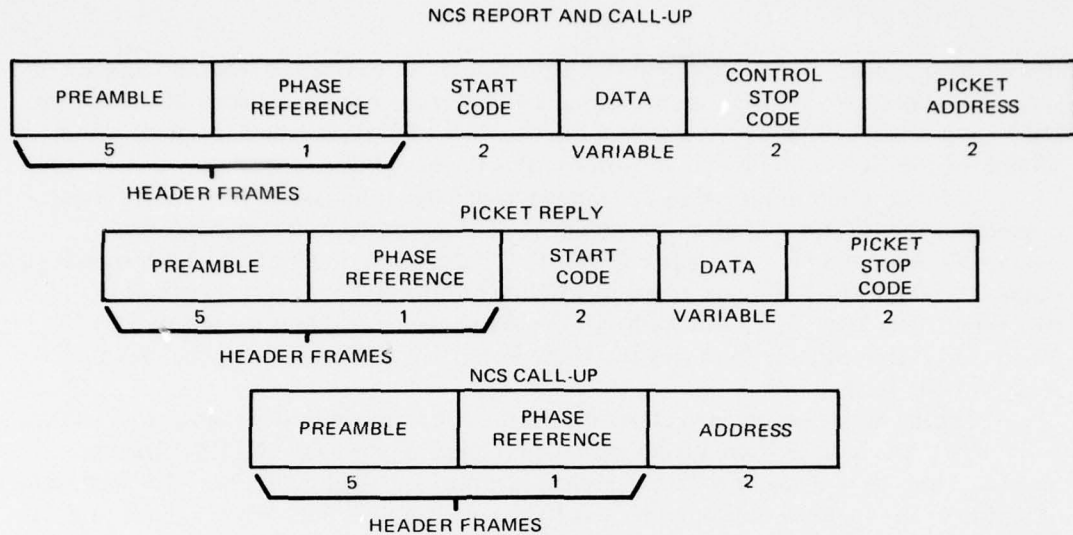

NOTE: NUMBERS INDICATE THE NUMBER OF FRAMES;  
FRAME PERIOD IS 13.3 OR 22.0 MILLISECONDS.

Figure 3. Roll-call message formats.

### ROLL CALL

The ROLL CALL mode is the normal operating mode for the net. When in this mode, NCS automatically interrogates each PU in turn. When a given PU recognizes its called address, it transmits its data to the net. After all PUs have been called, NCS then sends its own data and repeats the cycle. In this manner, real-time information for the entire tactical area covered by the net is made available to all units.

The three basic message formats used in the ROLL CALL mode are NCS Report and Call-Up, Picket Reply, and NCS Call-Up. These are illustrated in figure 3. Each message when transmitted, is preceded by five AGC frames and one phase-reference frame. These six header frames allow the receiving unit to synchronize with the frame boundaries, to determine and correct for doppler shift, and to acquire a reference phase to be used in decoding the frames which follow. If data are included in the message (as in Picket Reply or NCS Report and Call-Up) these data are bounded by a Start Code and a Stop Code. NCS transmits a special Control Stop Code.

### OPERATIONAL FLOW

In operation, the NCS initiates new cycles by transmitting the NCS Report and Call-Up message. This message includes the data from the NTDS computer at the NCS and also contains an address for a specific PU in the net. The addressed PU responds by transmitting a Picket Reply message which includes its own data. The NCS then calls the next PU by transmitting the NCS Call-Up message. This message contains no data; it contains only the address of the next PU in net. The addressed PU responds by sending its own data using the Picket Reply Message. The NCS continues calling each PU in the net, using the NCS Call-Up message, until all PUs have been interrogated. The NCS then starts a new cycle by

transmitting another NCS Report and Call-Up message. If, during the roll-call sequence, a given PU fails to respond with a reply within 16 frames after the conclusion of the call-up, the NCS automatically provides a second call-up. If the PU again fails to respond within 16 frames, the NCS continues on and interrogates the next PU.

Information transmitted by the modem originates from two sources. Data always originate at the NTDS computer while Preamble, Phase-Reference, Start, Stop, and Address Code frames may originate either at the computer or the modem. Each transmitted frame after the Phase-Reference frame has 30 bits of information, two for each of the 15 data tones. The Start, Stop, and Address Code frames generated by the modem are also 30 bits long. Immediately following the Phase-Reference frame must be either Start or Address Code frames.

During reception, the detection of a Start Code frame indicates that a block of data will follow. The data recovered from each data frame are sent to the NTDS computer. Such data may or may not include the Preamble, Start, and Address frames. The first frame of a Stop Code is sent to the computer but the second frame is not. When a block of data is transmitted it is always followed by a Stop Code. A Picket Stop Code indicates that the data were transmitted by a Picket Unit and, therefore, nothing will follow from that PU and the NCS proceeds to the next call-up. A Control Stop Code indicates that the data were originated at NCS and that two Address frames will follow. Each PU decodes the two Address frames and compares the decoded address to its own address. If a match is obtained, the PU starts a reply. If a Start Code does not follow the Phase-Reference frame, the next two frames are interpreted as being Address frames.

### TEST PROGRAM

The POFA (Performance and Operational Fault Analysis) software used for the tests of the Link 11 system was written to be used with the CP-642A or CP-642B computer.<sup>1</sup> Both computers were available at NOSC but only the CP-642A was used in the tests. To reduce the number of variables, only ships having the CP-642A or CP-642B computers were utilized. (This restriction could not be applied to the P-3C aircraft.) In order to ensure accuracy in the POFA bit-error analysis, it was necessary to operate in the uncovered mode. Approval was sought from and granted by CINCPACFLT, Makalapa, Hawaii, to operate in this manner. Documentation of the necessity for operation in the uncovered mode is contained in an NELC technical note.<sup>2</sup>

In addition, it was desired to collect data from points ranging from 20 to 300 nautical miles from NOSC at various times during the day and on various frequencies in the high-frequency band. Frequencies authorized for use in the tests are shown in table 3.

---

<sup>1</sup>NAVSHIPS 0967-011-4011, Link-11 Network Evaluation Test (POFA) for use with CP-642A or B Computer, 27 March 1973

<sup>2</sup>NELC TN 1690, Crypto-Device Error Study, by EW Cox, 20 June 1970 (NELC TNs are informal documents intended chiefly for internal use.)

TABLE 3. TEST FREQUENCIES.

Designator	Frequency (MHz)
A	3.4
B	4.5
C	5.9
D	6.8
E	7.7*
F	9.3
G	11.5
H	15.6
I	16.1
J	20.1

\*Voice-coordination frequency

#### TEST CONFIGURATION AT NOSC

The tests were conducted between NOSC and various ships in the Southern California (SOCAL) operational area. Links were also established between NOSC and P-3C aircraft and between NOSC and FCDSTCP (Pacific). Figure 4 is a block diagram of the on-the-air test configuration at NOSC. The AN/URT-23/R1051E and the AN/SRC-23 were set up side-by-side in NOSC building 4. Telephone lines to and from the Applied Systems Development and Evaluation Center (ASDEC) at NOSC and building 4 carried audio and transmitter-key signals from the modem. Figure 5 shows the audio and radio-frequency switch-panel arrangements. The switching sequence is explained in a later portion of this report.

The antennas used at NOSC were omnidirectional and broadband and did not require the use of couplers. These antennas provided a voltage-standing-wave ratio (VSWR) of 2.6 or less over the frequency range of interest. A level amplifier was used to ensure an audio level of zero dBm into the transmitter. In addition, a frequency and signal-strength monitor was provided in ASDEC for qualitative monitoring of the Link 11 signals. The intercom line was used for voice coordination between the personnel manning the radios and switches in building 4 and the modems and computer in ASDEC. On-the-air voice coordination was provided through the use of an AN/URC-32 hf radio. Figures 6 through 11 show the major items of equipment used in the radio comparison test (radios, modems, and computer).

#### TEST OPERATIONS

During the performance of the tests, the following ships and facilities provided invaluable services in coordination and linking with NOSC: USS CORAL SEA, USS CONSTELLATION, USS ENGLAND, USS BLUE RIDGE, USS JOUETT, USS HORNE, USS

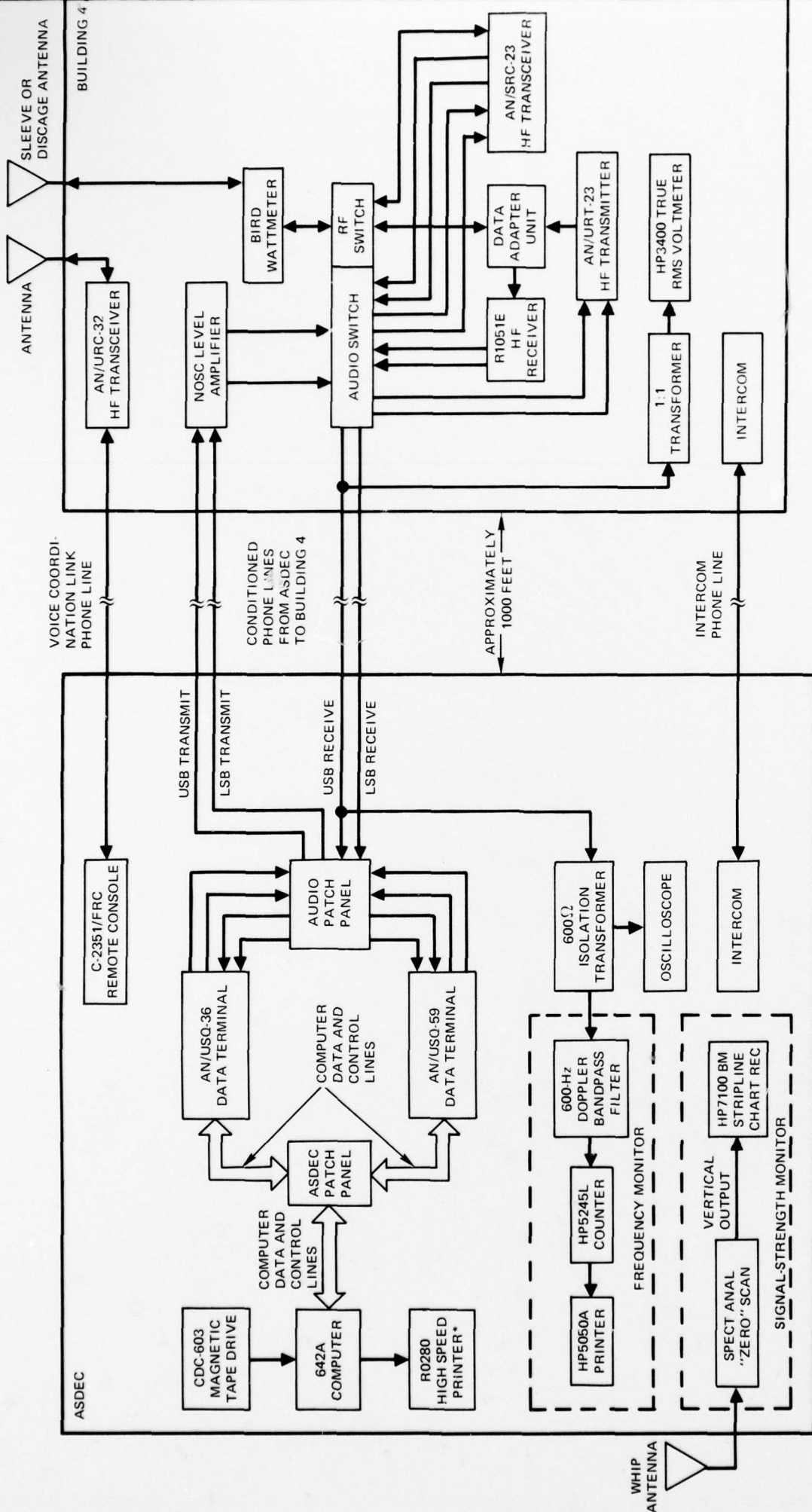

\*POFA PROGRAM MODIFIED TO OUTPUT TO HIGH SPEED PRINTER.  
(SEE APPENDIX C)

Figure 4. On-the-air test configuration.



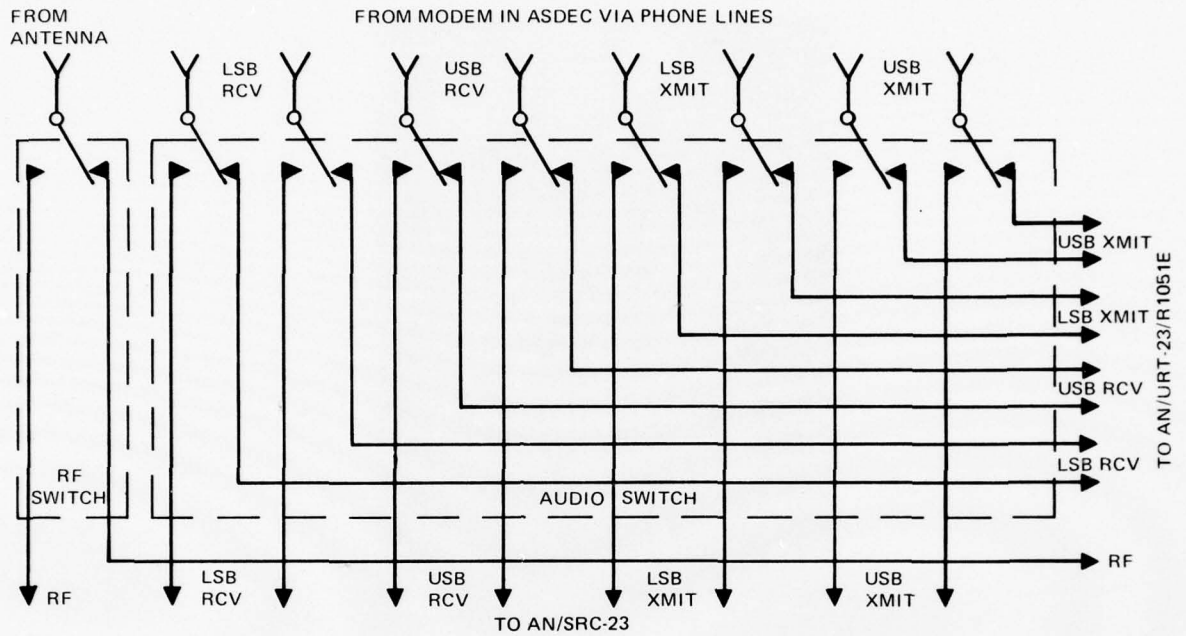
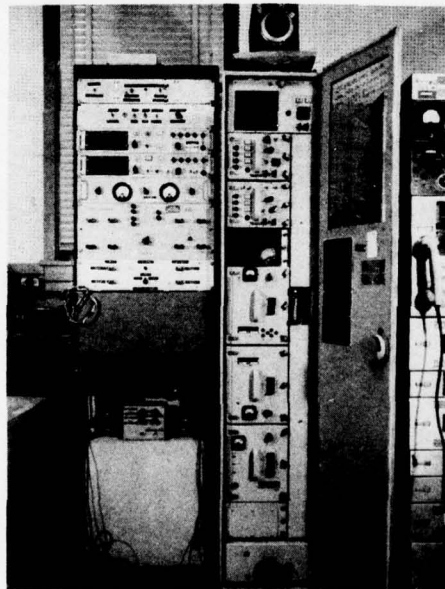
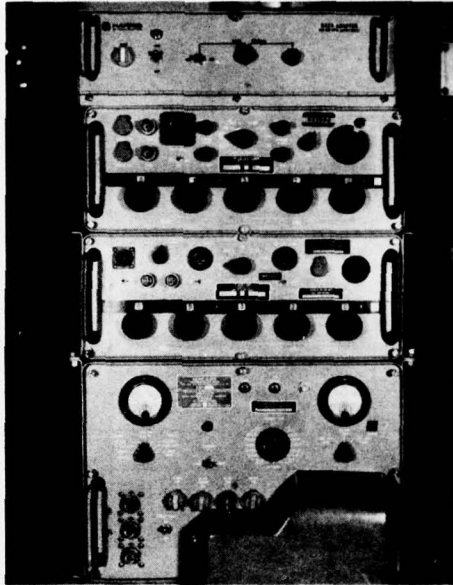

Figure 5. Audio and rf switch panel arrangements.



LSF 241-2-77

Figure 6. AN/SRC-23 radio and remote-control panel.



LSF 66-1-77

Figure 7. AN/URT-23/R1051E radio with data adapter.

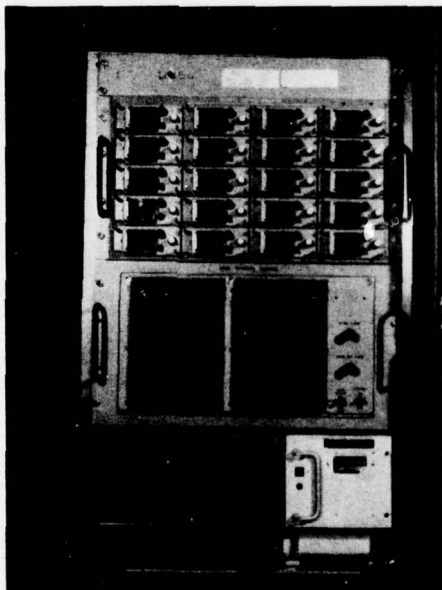

LSF 245-2-77

Figure 8. AN/USQ-59 modem and address-control indicator.

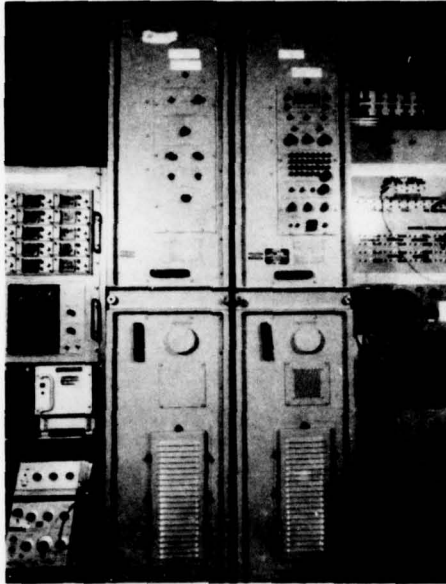

LSF 243-2-77

Figure 9. AN/USQ-36 modem.

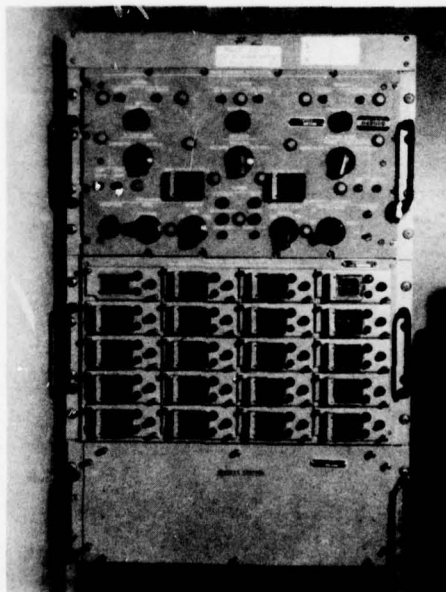

LSF 244-2-77

Figure 10. AN/USQ-36 remote control, address control, and address-control indicator.

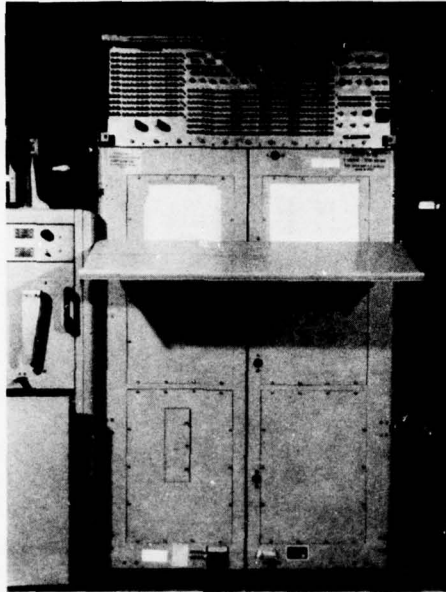

LSF 246-2-77

Figure 11. CP-642A computer.

LEAHY, USS TOWERS, COMPATWINGSPAC, VP 48, VP 19, FACSFAC, FCDSTCP, DEPCOMOPTEVFORPAC, and COMNAVAIRPAC. Without the assistance and services of these organizations, the tests would have been impossible to conduct.

#### TEST PROCEDURES

Prior to on-the-air tests on each test day, system equipment at NOSC was evaluated. Self-check and single-tone attenuation tests with the modem alone and with the modem and each radio were performed with the AN/USQ-36. Single-station POFAs were then run with the AN/USQ-36 and the AN/USQ-59 modems and with the modems and each radio. Multi-station POFA exchanges were conducted, first with the modems back-to-back and then through the radios. Audio gains were set using a Hewlett-Packard true-rms voltmeter so that the output level of both receivers and the input to both transmitters was zero dBm.

Once the NOSC equipment was found to be functioning properly, the voice-coordination net was activated. Each unit in the net transmitted NET SYNC and NET TEST while the other units observed their modems for the indications of proper reception of these signals. After it was demonstrated that all units could transmit and receive NET SYNC and NET TEST successfully, the NTDS link was activated. The modem and radio conditions applied throughout the tests are shown in table 4.

Data were obtained through POFA exchanges with NOSC as NCS on most exchanges. The first POFA exchange on a test day was performed with the AN/SRC-23 radio at NOSC. After approximately seven minutes of exchange, the NOSC modem was reset and printouts were taken at all participating units. Only a few seconds were required to output the NOSC POFA results on the R0280 high-speed printer. A special UNIVAC software patch for the

TABLE 4. MODEM AND RADIO TEST CONDITIONS.

Equipment	Conditions
AN/URT-23	ISB MAXIMUM RF GAIN FAST AGC
DATA ADAPTER	DATA ISB
R1051	ISB
AN/SRC-23 (Receiver)  (Transmitter)	DATA ISB NORMAL RECEIVER GAIN  DATA ISB MAXIMUM TRANSMITTER GAIN
AN/USQ-36	CONTROL RECOGNITION, ON DOPPLER CORRECTION, ON DATA RATE, 13/9 COMPUTER DATA, ON AUTO ERROR CORRECTION, ON ATTENUATION, OFF ROLL CALL CORRECTED TIMING ECHO TEST, OFF NET CONTROL
AN/USQ-59	DOPPLER CORRECTION, ON HALF DUPLEX INTERNAL 100 kHz AUTO TADIL A SYNC, FAST/CONTINUOUS CORRECTED TIMING NET CONTROL ERROR CORRECT ROLL CALL DATA RATE, 2250

642A and B Link 11 POFA was incorporated at NOSC to enable output of POFA results on the R0280 printer (see Appendix C for a description of this software patch).

With printouts completed and computers again zeroed at all participating units, a second POFA exchange was conducted using the AN/URT-23/R1051E radio at NOSC. Printouts were taken and computers were again zeroed at all units. This cycle of alternating NOSC radios on consecutive POFA exchanges was continued throughout each test day with as many as 40 exchanges conducted on a single test day.

A single data frequency was used on a particular test day unless it was determined that sufficient data had been obtained on that given frequency or unless propagation conditions or shipboard frequency requirements precluded further use of the frequency. The major variables in the tests (other than the NOSC radios) were propagation conditions, ranges of separation between NOSC and participating units, antenna attitudes of participating units relative to NOSC, and the NOSC modem. Figures 12 and 13 describe the number of minutes of POFA exchange obtained at each frequency and range interval (intervals of 20 nautical miles) on each NOSC radio. It should be noted that while the majority of these exchanges were with two parties, there were many 3-party exchanges (5.2 hours total on each radio, all on a frequency of 5.9 MHz). These 3-party exchanges account for approximately one third of the total data.

## TEST DATA

Figure 14 shows a typical 2-party multistation POFA printout with bit-error analysis. The major portion of this example contains information on "own-station" performance. Note that the "own station" (station 24) was on the air for 6 minutes, 59 seconds, transmitted 11 730 words, received 11 500 words (all from station 50) with 4 words in error. Note also that, of the words received at "own station", one word had 3 bits in error, 2 words had 4 bits in error, and one word had 5 bits in error. The total bits received in error were 16 (sum of the column headed "Times in Error").

The bottom portion of the report in figure 14 provides an analysis (without bit-error information) of the performance of station 50 as reported by station 50 to station 24. For station 50, 11 500 words were transmitted. 10 580 words were received (all from station 24) with 23 words in error. This particular printout originated at station 24. A similar report was generated at station 50 and was furnished NOSC for analysis.

The multistation POFA consisted of exchanging known data over the link, evaluating the received data, and transmitting the evaluation reports with the data to other stations. Evaluation reports were available for printing at each station. The full report consists of the link performance as evaluated at each "own-station" computer plus the evaluation reports received from the other stations included in the net (figure 14). A 230-word message is prepared and transmitted by each station for each transmission. This message consists of 130 words of net-status report data followed by 100 words of "canned" (fixed-pattern) data. Each message is evaluated for errors at each receiving station. The 130 net-status report words are evaluated by checking the hamming condition. The 100 canned words are evaluated by a bit-by-bit comparison. The results of the evaluations are contained in the 130 net-status report words; the bit-error analysis portion of the printout applies only to the 100 words of canned data. The word-error analysis portion of the printout applies to all 230 words.

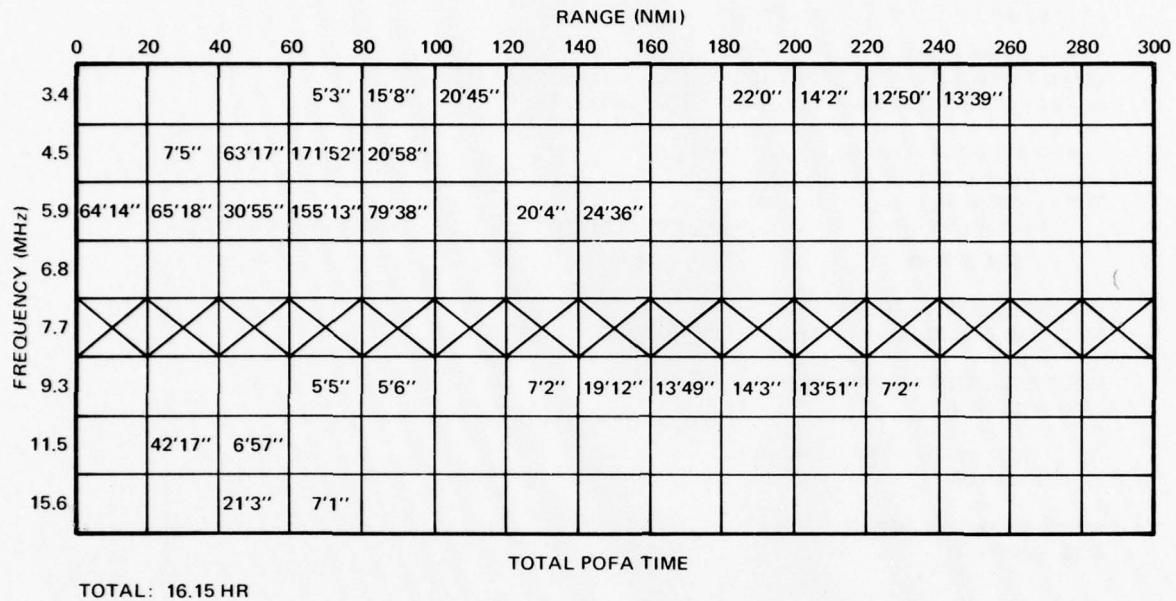

Figure 12. Data matrix for AN/SRC-23.

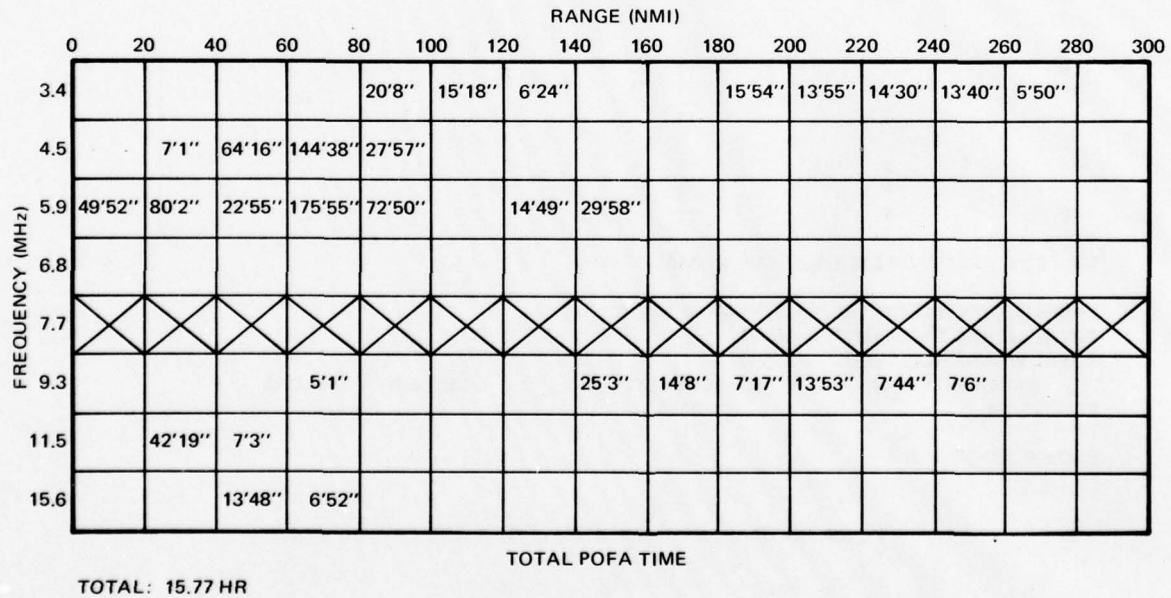

Figure 13. Data matrix for AN/URT-23/R1051E.

LINK 11 NETWORK EVALUATION TEST (PDF/A) JAN 1971-

THIS STATION IS STA. NO. 24  
 USING THE AN/USQ-36 OR CP-800 WITH AN/SSQ-29 TERMINAL TEST  
 IN THE MULTISTATION MODE WITH BIT ERROR ANALYSIS

THIS STATION WAS ON THE AIR FOR 6MIN. 59SEC.

TOTAL WORDS TRANSMITTED-11730

TOTAL WORDS RECEIVED -11500

RECEIVED FROM	WORDS RECEIVED	WORDS WITH ERRORS
STA. NO. 50	11500	4

INTERRUPT AND BUFFER STATUS

RECEIVED END RECEIVE INTERRUPT BUT NO DATA ERRORS- 1

PARITY STATUS OF ERROR WORDS

PARITY WORDS

3 4

PARITY STATUS OF CORRECT WORDS

PARITY WORDS

3 4

BITS PER WORD IN ERROR

BITS WORDS

3 1

4 2

5 1

NUMBER OF WORDS WITH BITS IN ERROR

BIT	TIMES IN ERROR	TIMES PICKED	TIMES DROPPED
2	2	0	2
3	1	0	1
6	1	1	0
7	1	1	0
8	1	1	0
9	2	1	1
10	2	1	1
12	1	1	0
13	1	1	0
14	2	1	1
17	1	1	0
18	1	1	0

OWN  
 STATION  
 REPORT

THIS STATION REPORT IS FROM STA. NO. 50

THIS STATION WAS ON THE AIR FOR 6MIN. 52SEC.

TOTAL WORDS TRANSMITTED-11500

TOTAL WORDS RECEIVED -10580

RECEIVED FROM	WORDS RECEIVED	WORDS WITH ERRORS
STA. NO. 24	10580	23

END OF REPORT

Figure 14. Two-party multistation POFA with bit-error analysis.



The software listing of the POFA is contained in reference 3, and an explanation of how the POFA program is operated and how the printout is interpreted is contained in reference 4.

### RADIO COMPARISON DATA

Figure 15 illustrates the data-analysis sheet used when 2 participating units were involved in a link. The left third of the sheet, under the heading "NOSC," contains data from the NOSC POFA printouts and calculations based on those data. The middle third of the sheet, under the heading "Ship" contains data from the ship POFA printouts and calculations based on those data. Each row represents data and calculations from one 7-minute POFA exchange.

The subheadings WER and BER refer to "Word-Error Rate" and "Bit-Error Rate" calculations, respectively. WER was calculated for a participating unit as

$$\text{WER} = \frac{\text{Error Words (received by unit)}}{\text{Received Words (total received by unit)}}$$

BER was calculated from bits analyzed at a participating unit as

$$\text{BER} = \frac{\text{Error Bits (received by unit)}}{\text{Total Bits Analyzed (by unit)}}$$

The bit-error analysis was conducted on the last 100 words of each 230-word POFA message received by the participating unit. The total number of bits analyzed was calculated as

$$\text{Total Bits Analyzed} = \frac{(\text{Received Words})(100 \text{ Words/Message})(24 \text{ Information Bits/Word})}{(230 \text{ Words/Message})}$$

WER and BER provide a measure of the quality of the received data. These error rates do not provide a total picture of link quality, however, since they are concerned only with that part of the transmitted message which was received and analyzed for error. It is quite common for one or more 230-word messages to be missed in their entirety during these POFA exchanges. For this reason, a third rate which we refer to as the "Received Message Rate" (RMR) was calculated in the analysis of these data and appears just to the right of the "Ship" heading on the analysis sheet. We define:

$$\text{RMR}_{\text{NOSC}} = \frac{\text{Total Messages Received at NOSC}}{\text{Total Messages Transmitted at the Ship}}, \text{ and}$$

$$\text{RMR}_{\text{Ship}} = \frac{\text{Total Messages Received at the Ship}}{\text{Total Messages Transmitted from NOSC}}$$

<sup>3</sup>NAVSHIPS 0967-011-4001, part 1, Program Listing for Link 11 Network Evaluation Test (POFA) for Use with CP-642A or B Computer, 27 March 1973

<sup>4</sup>NAVSHIPS 0967-011-3991, Operating Procedures for Link 11 Network Evaluation Test (POFA) for Use with CP-642A or B Computer, 27 March 1973

LINK 11 RADIO PERFORMANCE COMPARISON - SINGLE PICKET NET																											
MODEM: ANTENNA: XMIT AUDIO LEVELS TO RADIO ON NET TEST SIGNAL: SRC-23 dBm dBm AVERAGE POWER TO ANTENNA ON NET TEST SIGNAL: SRC-23 WATTS WATTS										NOSC				SHIP													
DATE	NET CONTROL STATION	PICKET																									
RUN NO.	NOSC RADIO	FREQUENCY (MHZ)	START TIME	ELAPSED TIME (SEC)	XMIT WORDS	RCVD WORDS	ERROR WORDS	ERROR BITS	WER	BER	XMIT WORDS	RCVD WORDS	ERROR WORDS	ERROR BITS	WER	BER	RMR NOSC	RMR SHIP	RANGE (NMI)	WER RATIO	BER RATIO	RMR RATIO	WER RATIO	BER RATIO	RMR RATIO		
1																											
2																											
3																											
4																											
5																											
6																											
7																											
8																											
9																											
10																											
11																											
12																											
13																											
14																											
15																											
16																											
17																											
18																											
19																											
20																											
21																											
22																											
23																											
24																											
25																											
26																											

Figure 15. Data-analysis sheet.

RMR is a measure of Start-Code recognition at the receiving modem. Should the Start Codes not be recognized, the receiving modem continues to search for Address Codes and Start Codes and will not make the data which follow the Start Codes available to the computer. To emphasize the importance of this parameter, a handful of POFA printouts reported exchanges in which one message out of 50 messages transmitted was received, and that single message was received error free. Solely on the basis of word and bit-error rates, this would be considered a high-quality link. The RMR value proves to be the only accurate indicator of link quality in these extreme cases.

Two additional rates might have been calculated but were not included as part of this data presentation. The "Transmitted Message Rate" (XMR) is defined:

$$\text{XMR} = \frac{\text{Total Messages Transmitted by the Picket}}{\text{Total Messages Transmitted by NCS}}$$

This rate is a measure of recognition of the Address Code by a picket unit. It is useful when a picket unit does not recognize the Start codes that precede an NCS message but does recognize the Address Codes at the end of that message and thus replies to the NCS interrogation. If RMR and XMR are both zero there is no communication. However, when RMR is zero and XMR is non-zero, one-way communication is still possible. POFA printouts from picket units frequently record more words transmitted than received and the XMR value is correspondingly larger than the RMR value in these cases.

A second rate of some importance is referred to as "Incomplete Message Rate" (IMR) and is defined

$$\text{IMR} = \frac{\text{Total Incomplete Messages Received}}{\text{Total Messages Received}}$$

This parameter is also a measure of link quality since incomplete POFA messages result when the "signal-quality detection circuit" of the receiving modem determines that received data fail its quality criteria and it stops the transfer of data to the computer. None of the ships used in these tests had modems with this circuit; however, the AN/USQ-59 modems at NOSC and FCDSTCP and the AN/ACQ-5 modems on the P-3C aircraft have this circuit. It is not clear that word-error and bit-error rates greater than zero are strongly correlated to nonzero incomplete message rates associated with the AN/USQ-59 modem (see Appendix B).

The right third of the data-analysis sheet (figure 15) provides space for the calculation of the ratios which make up the data points of the radio-comparison statistics. These ratios are calculated as follows:

$$\text{WER Ratio} = \frac{\text{WER (AN/URT-23/R1051E)}}{\text{WER (AN/SRC-23)}}$$

$$\text{BER Ratio} = \frac{\text{BER (AN/URT-23/R1051E)}}{\text{BER (AN/SRC-23)}}$$

$$\text{RMR Ratio} = \frac{\text{RMR (AN/URT-23/R1051E)}}{\text{RMR (AN/SRC-23)}}$$

When one of the two error rates used in a ratio is zero, the ratio is undefined and statistically unmanageable. To avoid this situation, error rate values

$$\text{WER} = 1 \times 10^{-4}$$

and

$$\text{BER} = 1 \times 10^{-4}$$

were substituted for error rates of zero. These values approximate the error rates calculated from a 7-minute POFA exchange where one word error was recorded. Exchanges where an RMR value of zero was experienced were associated with equipment failure, operator error, or unfavorable propagation conditions (for a particular combination of range and frequency) and were not used in ratio calculations.

The rates calculated from individual exchanges are not directly suitable for statistical interpretation under the test conditions that prevailed. Temporal variations in participating units, propagation conditions, range and heading of participating units, etc. made it impossible to gather a significant number of exchanges with both radios under test conditions that could be considered constant. The acquisition of data suitable for a direct comparison of rates would require the "dedicated" services of a single participating unit equipped with high-speed printout capability. Figures 16 through 19 are plots of rates as a function of range at the 4.5-MHz frequency. They are included to illustrate the temporal variation of rates calculated from test exchanges.

The most representative statistics to be extracted from this unstable (time-dependent) test environment were the ratios calculated from "time-adjacent exchanges." We define "time-adjacent exchanges" as consecutive exchanges (one with each radio) separated in time by 20 minutes or less, where frequency and Link 11 systems (other than NOSC radio) were held constant. The 20-minute upper bound is a practical consideration, dictated by duration of POFA exchange required for confidence in data and by the time required for shipboard POFA printout. Ship position was not constant over this period of time and typically resulted in a range change of 4 nautical miles. Attitude and range variations were thus unavoidable from one exchange to the next, as were spatial and temporal variations in propagation conditions. The use of "time-adjacent exchanges" in ratio calculations served to minimize the influence of these variations.

Whenever possible, the effect of time-dependent variables was further diluted by the use of each set of exchange ratios in two sets of ratio calculations, implied in figure 15 by the offset of ratio calculation rows between consecutive exchange rows. A given exchange might be used with the exchange that precedes it in one set of ratios and with the exchange which follows it in another set of ratios. The first and last exchanges of a test day, the exchange immediately preceding a change in controlled test conditions, and the exchange immediately following a change in controlled test conditions were used in only one set of ratios. Consequently, these exchanges are not afforded as much statistical weight as other exchanges. The ratio statistics are presented as (1) histograms and (2) cumulative distributions.

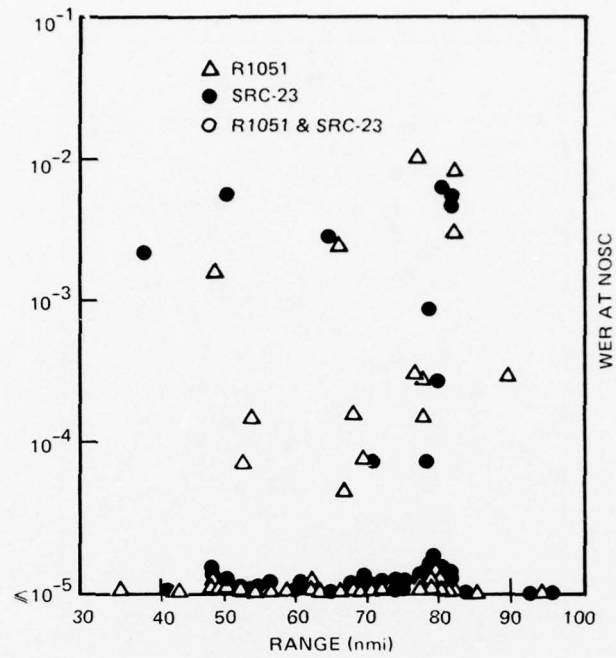

Figure 16. WER at NOSC versus range at a frequency of 4.5 MHz.

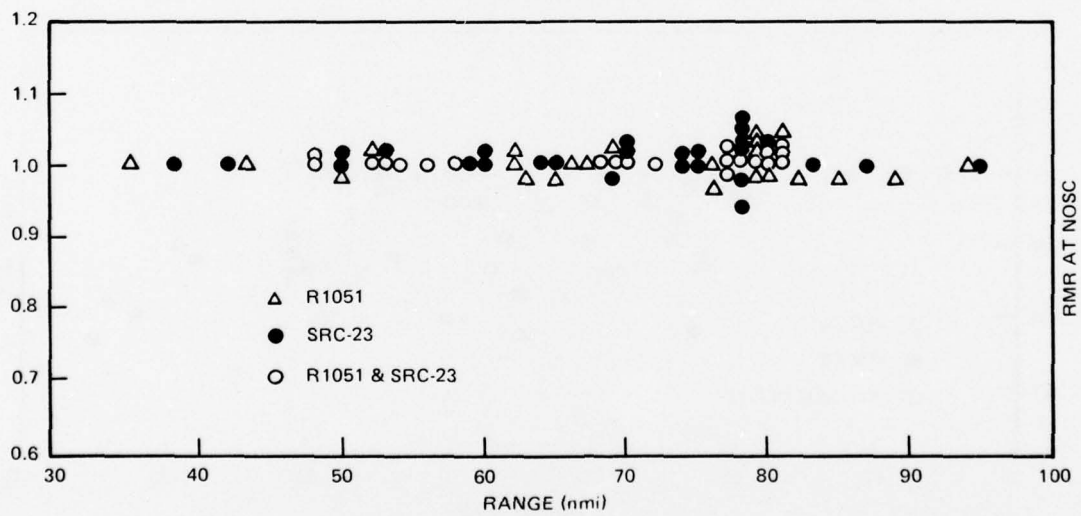

Figure 17. RMR at NOSC versus range at a frequency of 4.5 MHz.

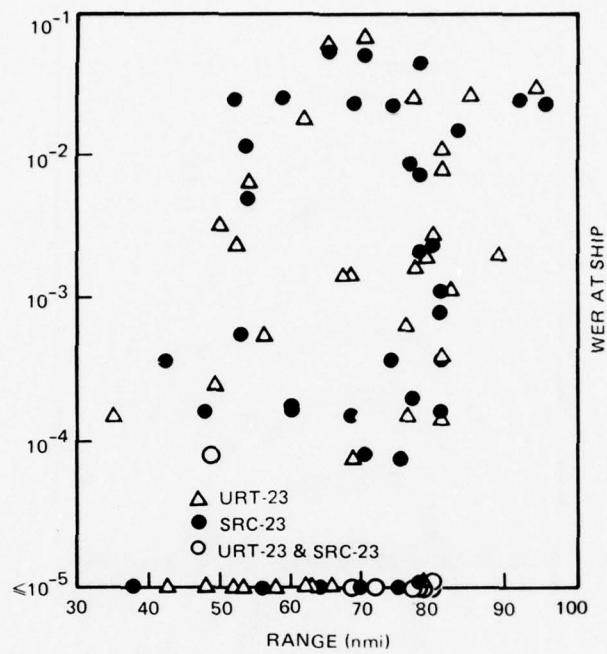

Figure 18. WER at ship versus range at a frequency of 4.5 MHz.

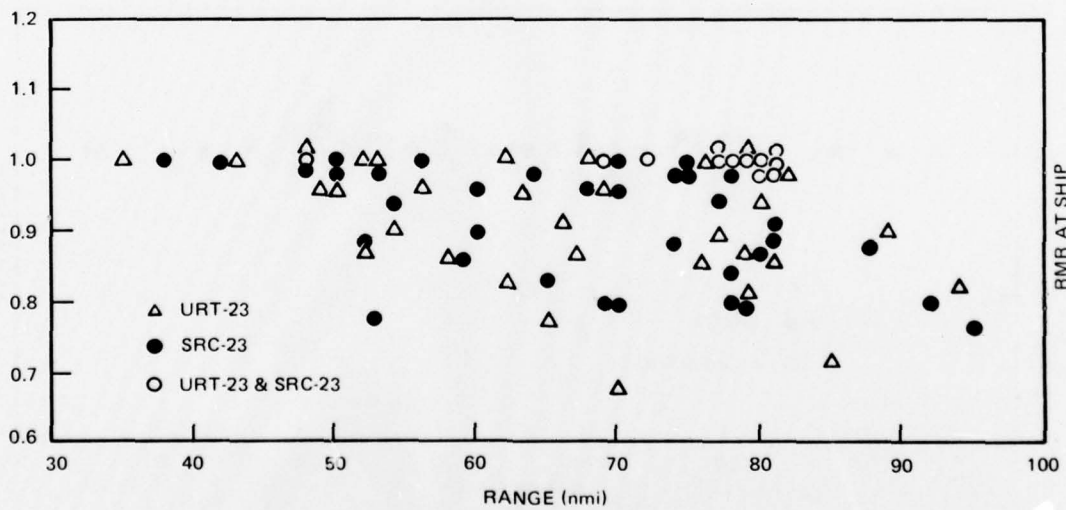

Figure 19. RMR at ship versus range at a frequency of 4.5 MHz.

## HISTOGRAMS

Figures 20, 21, and 22 are histograms of the ratios calculated from the own-station portion of the NOSC POFA printouts and figures 23, 24, and 25 are histograms of the ratios calculated from the own-station portion of the ship POFA printouts. Respectively, they tell us something about the relative performance of the NOSC receivers and about the relative performance of the NOSC transmitters. The numbers on the ordinate of each histogram represent the number of ratios summed from the ratios at all the test frequencies. There were six frequencies at which sufficient data were accumulated to warrant presentation. Appendix A contains histograms where the ordinate of each histogram represents the number of ratios at a specific frequency (or frequencies). As such, they tell us something about the relative performance of NOSC receivers (or transmitters) at a particular frequency.

The abscissas on all the histograms display ratio values from  $10^{-2}$  (left side) to  $10^{+2}$  (right side) on a logarithmic scale to the base ten. This logarithmic scale is useful because it disperses ratios from  $10^{-2}$  to unity over a linear range equivalent to that over which ratios from unity to  $10^{+2}$  are dispersed and makes comparison visually intuitive. Ratio values along the abscissa are not to be interpreted in a continuous manner but rather are quantized into 6 equal-length intervals per decade on the logarithmic scale with the central interval centered on unity. The result is a series of adjacent rectangles with the rectangle base spanning an interval of ratio values and the rectangle height representing the number of ratios whose ratio value is greater than the left-hand interval boundary (vertical line) and less than or equal to the right-hand interval boundary.

The central rectangle (interval [0.825, 1.21]) is of particular importance in that its height is generally much greater than the other rectangles and depends upon the number of ratios where the relative performances of the two radios were within 21 percent of each other. A ratio value of unity will occur when the Link 11 performance of the receivers (or transmitters) is equal in a particular performance area (WER, BER, or RMR). A distribution of rectangle heights which is symmetric about this rectangle indicates that the performance of the two receivers (or transmitters) is equivalent or nearly equivalent. If the rectangle heights on one side of the central rectangle are consistently much higher than the rectangle heights on the other side, the receiver (or transmitter) of one radio can be considered to be outperforming the receiver (or transmitter) of the other radio. Note that WER and BER ratios greater than unity indicate a better performance by the AN/SRC-23 and WER and BER ratios less than unity indicate a better performance by the R1051E (AN/URT-23). RMR ratios greater than unity indicate a better performance by the R1051E (AN/URT-23) and RMR ratios less than unity indicate a better performance by the AN/SRC-23.

Inserts appearing on the right-hand side of the histograms indicate the actual number of ratios equal to unity as well as the number of ratios less than unity and the number of ratios greater than unity. The number of ratios equal to unity is pertinent because the height of the central rectangle does not indicate the number of ratios for which the performances of the radios were equal but rather the number of ratios where the performances were within 21 percent of each other. The central rectangle height also does not indicate the number of ratios contained in that interval which are greater than unity and the number which are less than unity. It is not always obvious visually if the number of ratios on one side of the central rectangle exceeds or is equal to the number of ratios on the other side of that rectangle, nor

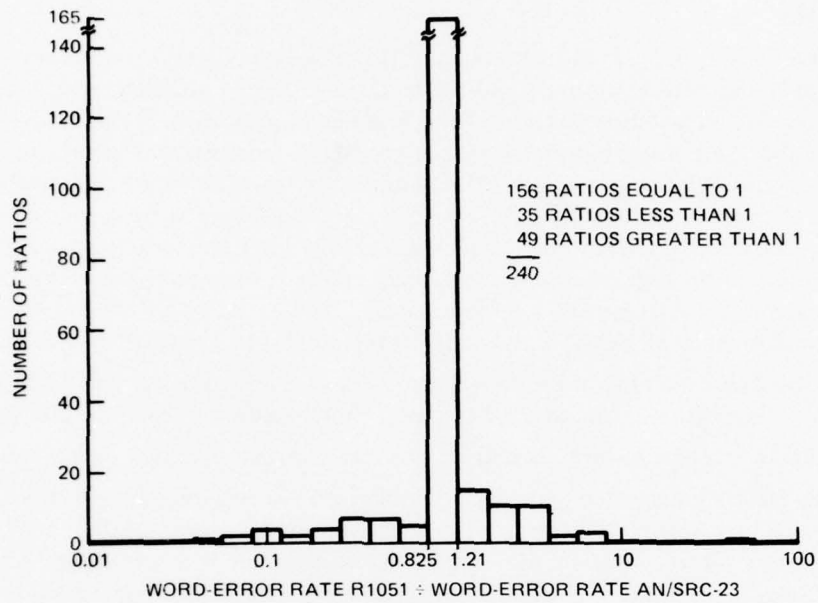

Figure 20. All-frequencies histogram of ratios of adjacent word-error rates at NOSC.

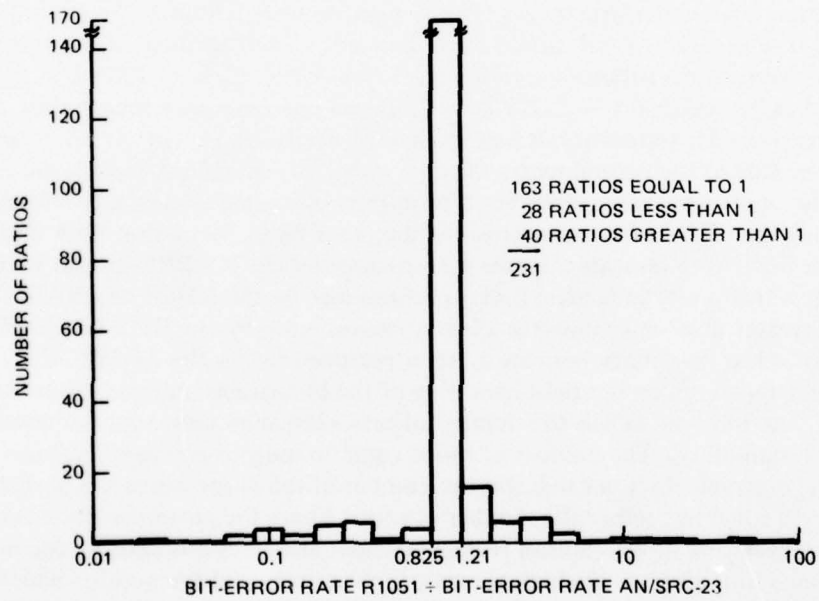

Figure 21. All-frequencies histogram of ratios of adjacent bit-error rates at NOSC.



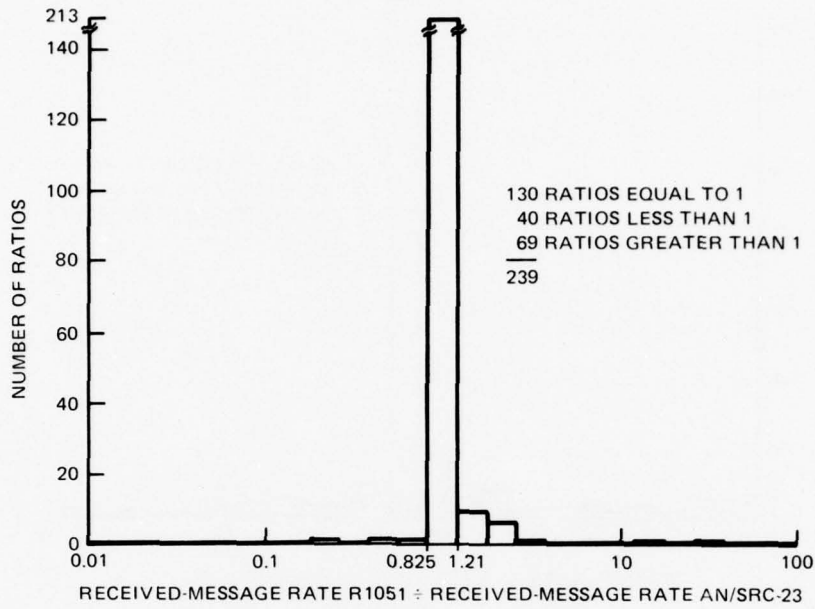

Figure 22. All-frequencies histogram of ratios of adjacent received-message rates at NOSC.

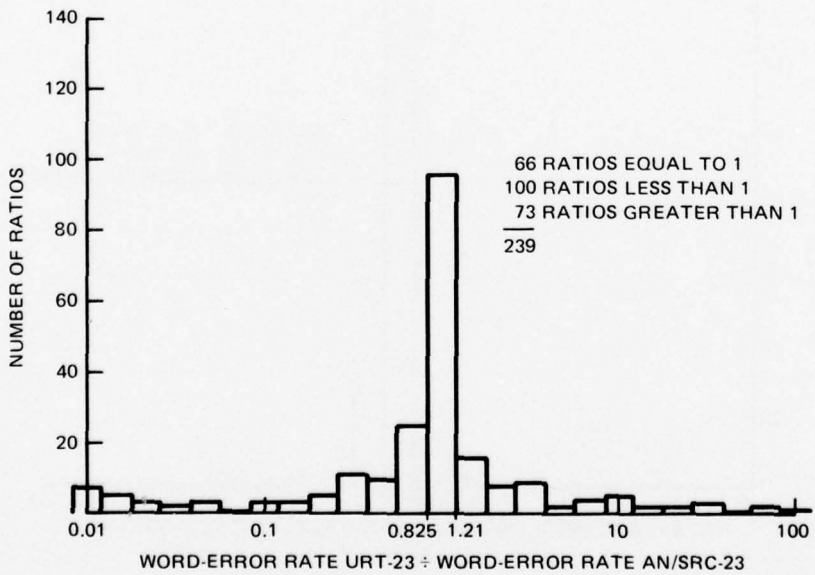

Figure 23. All-frequencies histogram of ratios of adjacent word-error rates at the ship.

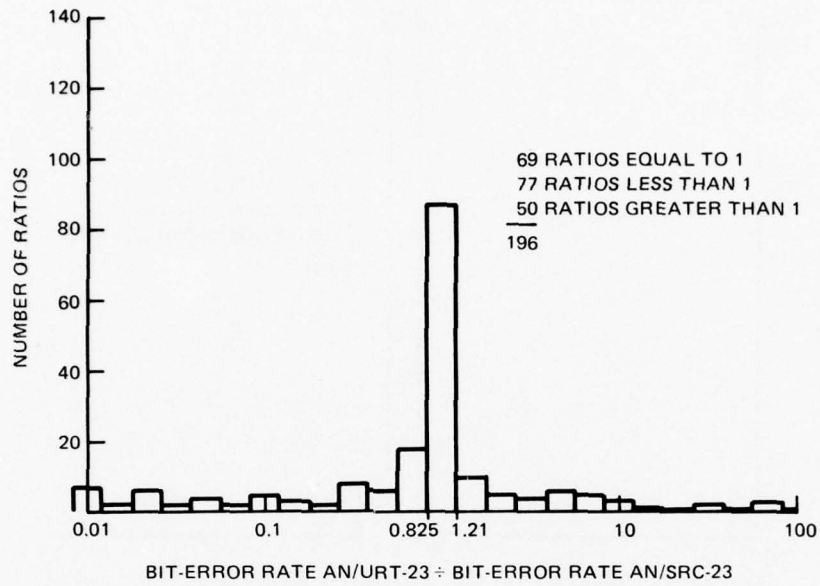

Figure 24. All-frequencies histogram of ratios of adjacent bit-error rates at the ship.

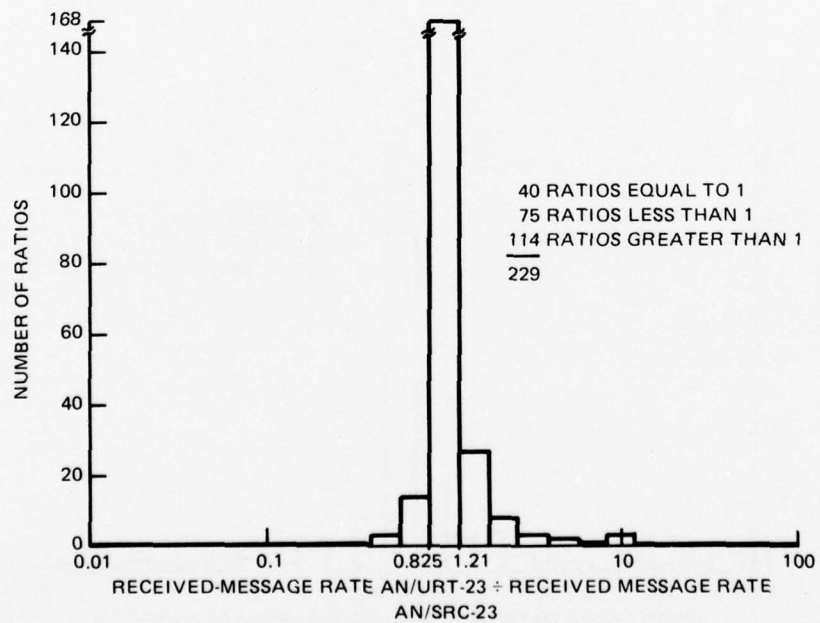

Figure 25. All-frequencies histogram of ratios of adjacent received-message rates at the ship.

is it always possible to include all the ratios on the 4-cycle logarithmic scale. For these reasons, the number of ratios greater than unity and the number of ratios less than unity contribute additional information to the histograms. In many cases, the fact that a histogram indicates a slight skewing of ratios to one side or the other of unity is not nearly as important as the fact that the majority of the ratios are unity or close enough to unity to be included in the central rectangle.

### CUMULATIVE DISTRIBUTIONS

Figures 26, 27 and 28 are cumulative distribution plots of the ratios calculated from the own-station portion of the NOSC POFA printouts and figures 29, 30, and 31 are cumulative distribution plots of the ratios calculated from the own-station portion of the Ship POFA printouts. The first three plots are based on the same ratios as those used in histogram figures 20, 21, and 22, respectively, while the latter three plots are based on the ratios used in histogram figures 23, 24 and 25. The ordinate intercepts of discrete data points on the cumulative distribution figures correspond to the percentage of ratios where the ratio value is equal to or less than the ratio value of the abscissa intercepts of these points. Like the histogram figures to which they are correlated, the abscissa ratio values of the cumulative distribution figures do not lend themselves to interpretation as a continuum of values. Again, the abscissa should be viewed as 26 discrete ratio values with a constant linear separation between adjacent discrete values.

We will continually refer to figure 32 in our discussion of the interpretation of cumulative distribution plots which follows. This figure is a superposition of histogram, figure 20, cumulative distribution, figure 26, and a cumulative distribution plot of the percentage of ratios with ratio values greater than the ratio value of the abscissa intercept (labeled R). The ordinate scale on the right side of the figure pertains to the cumulative distribution plots and the scale on the left side pertains to the histogram plot.

The two cumulative distribution plots in figure 32 are reflections of one another about the 50-percent ordinate line and contain the same information, if interpreted correctly. The plot labeled R is included only to aid in discussion of and to prevent possible misinterpretation of cumulative distribution, figures 26, 27, 28, 29, 30, and 31. Plot R appears to intersect the unity ratio value line at the 51-percent ordinate line and the plot from figure 26 seems to intersect the unity ratio value line at the 49-percent ordinate line. One might interpret the point on plot R to mean that 51 percent of the ratios were greater than unity and the point on the other plot to mean that 49 percent of the ratios were greater than unity. The fact is, points on connecting lines between actual data points (0.825 and 1.21 in this case) with the same abscissa ratio value on both plots will generally not have ordinate values that indicate an identical percentage of ratios greater than the abscissa ratio value. *Plot R (percent of ratios > ratio value) will slant interpretation of these points in favor of the AN/URT-23/R1051E, while the other plot (percent of ratios ≤ ratio value) will slant interpretation of these points in favor of the AN/SRC-23.* Referring to the right-hand insert of histogram figure 20, we see that neither one of these cumulative distribution plots gives the correct percentage of ratios greater than the ratio value unity. The correct value is 20.4 percent, considerably different than 51 percent. It is now clear that our cumulative distribution figures can be quite misleading when one attempts to evaluate points on the lines

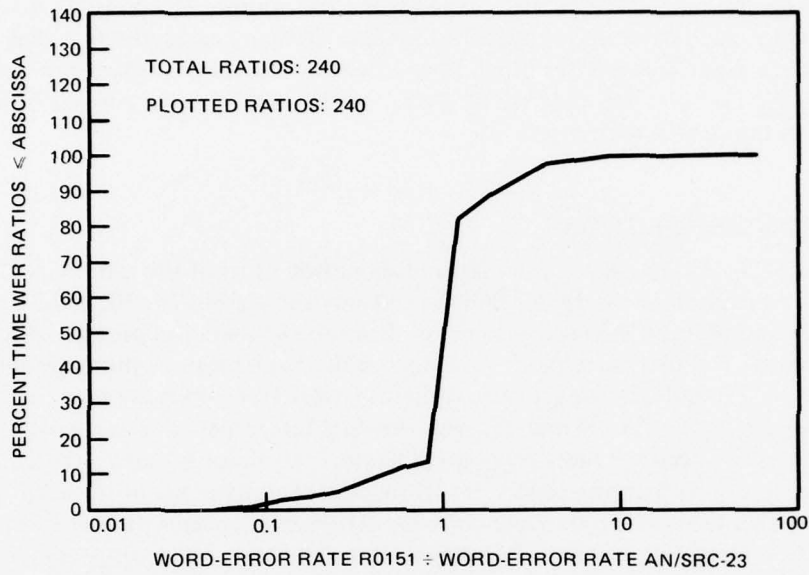

Figure 26. All-frequencies cumulative distribution of ratios of adjacent word-error rates at NOSC.

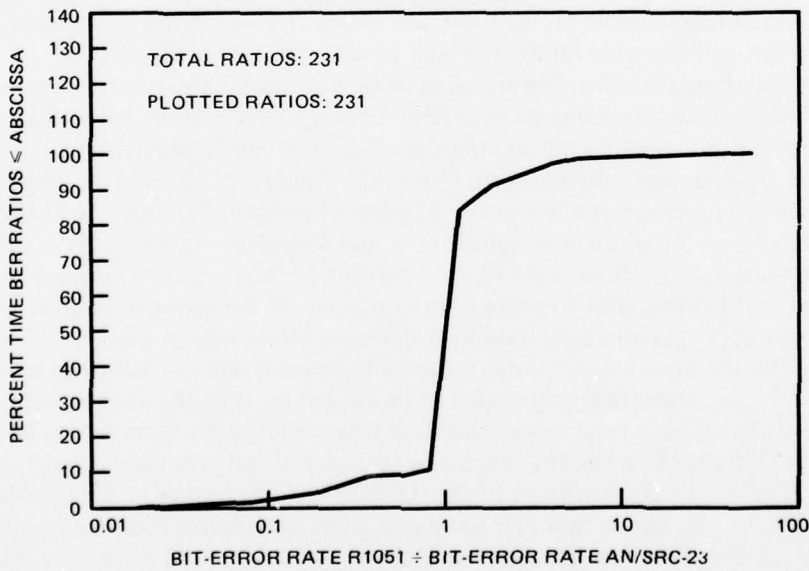

Figure 27. All-frequencies cumulative distribution of ratios of adjacent bit-error rates at NOSC.

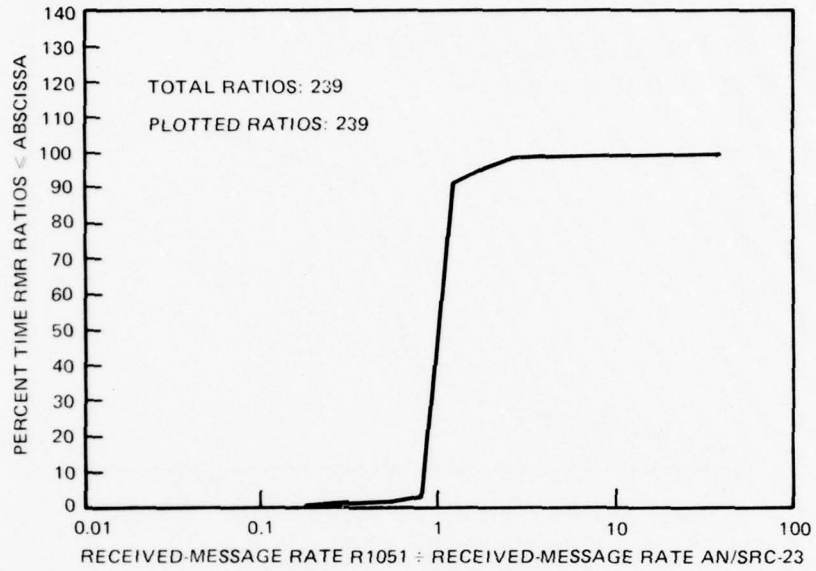

Figure 28. All-frequencies cumulative distribution of ratios of adjacent received-message rates at NOSC.

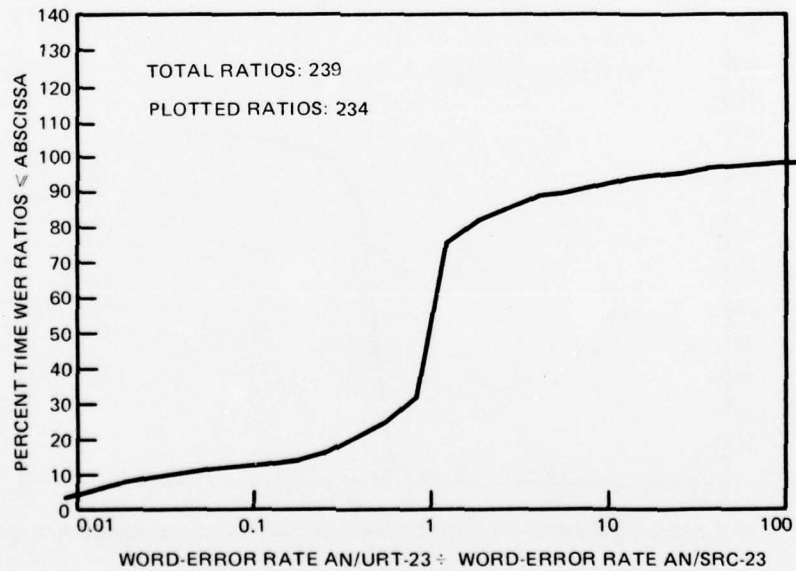

Figure 29. All-frequencies cumulative distribution of ratios of adjacent word-error rates at the ship.

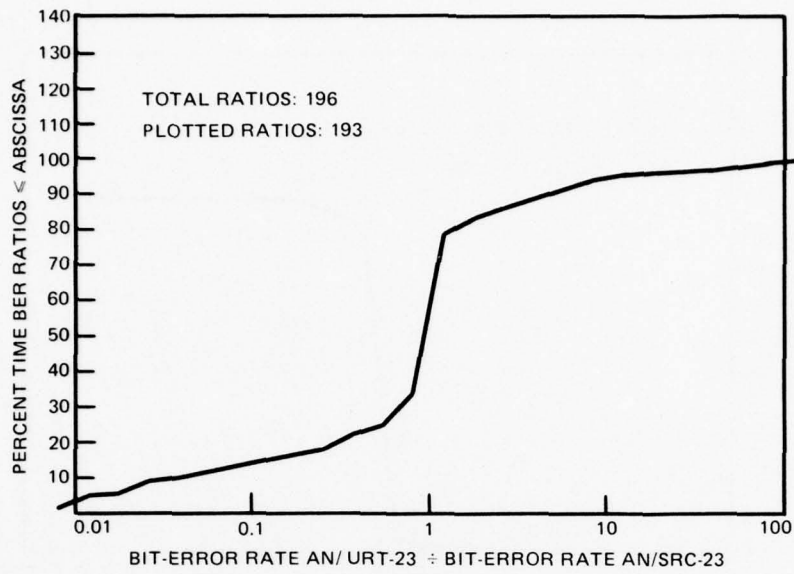

Figure 30. All-frequencies cumulative distribution of ratios of adjacent bit-error rates at the ship.

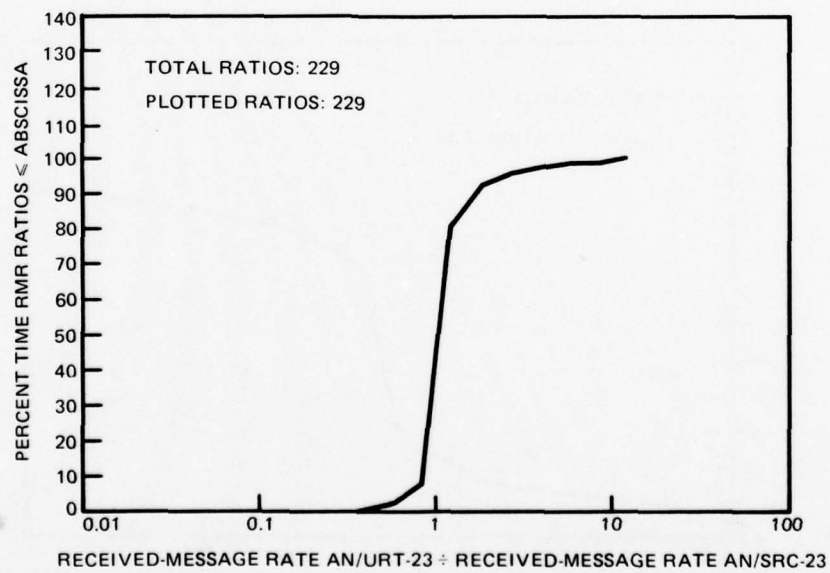

Figure 31. All-frequencies cumulative distribution of ratios of adjacent received-message rates at the ship.

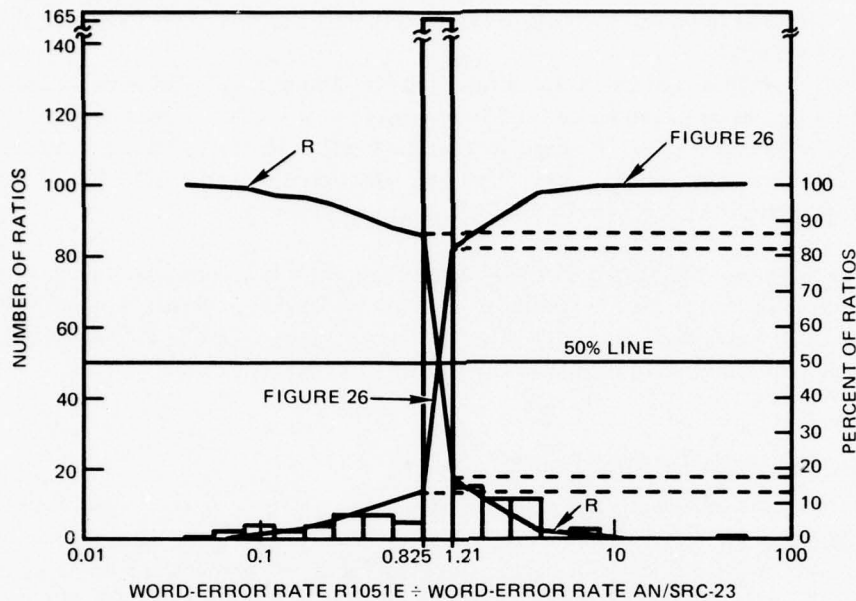

Figure 32. Cumulative-distribution comparison histogram.

connecting actual data points. This type of evaluation is particularly dangerous when the slope of a connecting line is very steep, always the case across the [0.825, 1.21] interval.

The cumulative distribution figures are useful for determining the percentage of ratios which lie between any two of the 26 discrete ratio values. For example, the difference in ordinate values of the data points at ratio values 1.21 and 0.825 in figure 26 is approximately 69 percent. This is in agreement with plot (R) in figure 32 and also with the value of 68.8 percent which can be calculated from histogram figure 20. The two cumulative distribution plots in figure 32 will always agree when compared in this manner.

#### ADDITIONAL RADIO COMPARISON DATA

Other data for radio-comparison purposes were obtained during the tests but have not been included in histograms or cumulative distributions.

#### P-3C AIRCRAFT EXCHANGES

Several exchanges were conducted at high frequencies between NOSC and P-3C aircraft during crew training flights (NIB) in November 1976. Aircraft speed and lack of NOSC control of flight plans made it invalid to apply ratio-comparison techniques to the aircraft POFA exchange data. Although the P-3C aircraft have medium-speed printer capability which reduces the separation time between POFA exchanges to seven minutes,

"time-adjacent exchanges" were unattainable once the aircraft was in the air. Range between NOSC and the aircraft changed typically by 40 nautical miles from one POFA exchange to the next.

Dedicated flights in which the aircraft can be directed to fly race-track courses at a variety of ranges are required to obtain "time-adjacent exchanges." Such exchanges were obtained prior to one flight. The P-3C was on the deck at Moffett Field, approximately 418 nautical miles from NOSC. One POFA was conducted with the AN/SRC-23 radio and one with the AN/URT-23/R1051E radio. Data from these exchanges are presented in table 5.

The Sylvania AN/ACQ-5 modem on the P-3C aircraft incorporates a signal-quality control circuit whose function is similar to that in the AN/USQ-59 (see Appendix B). Transfer of data from modem to computer is frequency interrupted during POFA messages, contributing considerable difficulty to analysis of P-3C POFA data.

#### BAND-LIMITED NOISE TESTS

Prior to the on-the-air phase of the radio comparison tests, the radios were evaluated using a single-station POFA and injecting white noise (filtered to match the audio bandwidth of the modem) at various levels of signal strength. Figure 33 shows a block diagram of this test set-up while figures 34, 35, and 36 show the results in the form of BER, WER, and RMR versus  $P_s/P_n$  (a measure of signal-to-noise ratio), respectively. Note that the base line for these curves is the operation of the modem back-to-back (the radios removed and the transmit and receive audio lines patched together in ASDEC). This test was performed only with the AN/USQ-36 modem. The AN/USQ-59 modem could not be used with its frequent interruption of data transfer from modem to computer at low  $P_s/P_n$  (below 12 dBm).

#### WEAK-STATION, STRONG-STATION TEST

Thirty-two POFAs were exchanged on two consecutive evenings on 4.5 MHz in a 3-party net consisting of NOSC (PUN), FCDSTCP (PUF), and USS ENGLAND (PUE). This exchange exercised the NOSC radios in a weak-station, strong-station situation to check for proper AGC response and for receiver front-end overload. Each station radiated approximately 100 watts of power. The position of USS ENGLAND (weak station) varied in range from 56 to 126 nautical miles with respect to NOSC. The antennas of FCDSTCP (strong station) and NOSC were separated by a distance of 550 metres. Table 6 presents the results of this test in terms of WER, BER, and RMR ratios.

Figure 37 is a signal-strength plot taken during the 3-party net (NOSC, FCDSTCP, and USS ENGLAND) tests (the PU order was N,E,F). Figure 4 shows the equipment set-up for these plots in the block labeled "Signal Strength Monitor." The monitor was calibrated before the test began by removing the antenna and replacing it with a frequency synthesizer followed by a 50-ohm variable attenuator. The spectrum-analyzer and chart-recorder settings during calibration and data acquisition were:

Input attenuation: 0 dB

Scan width: Zero



TABLE 5. NOSC LINK WITH P-3C AT MOFFETT FIELD.

NOSC Radio	Frequency (MHz)	Start Time	NOSC				P-3C				
			WER	BER	RMR	IMR	WER	BER	RMR	IMR	XMR
AN/SRC-23	4.5	1545	$1.93 \times 10^{-3}$	0	0.39	0.63	$2.1 \times 10^{-2}$	$2.5 \times 10^{-3}$	0.18	0.08	0.85
AN/URT-23/ R1051E	4.5	1555	$1.45 \times 10^{-3}$	0	0.45	0.63	$3.1 \times 10^{-2}$	$1.6 \times 10^{-3}$	0.16	0.00	0.95

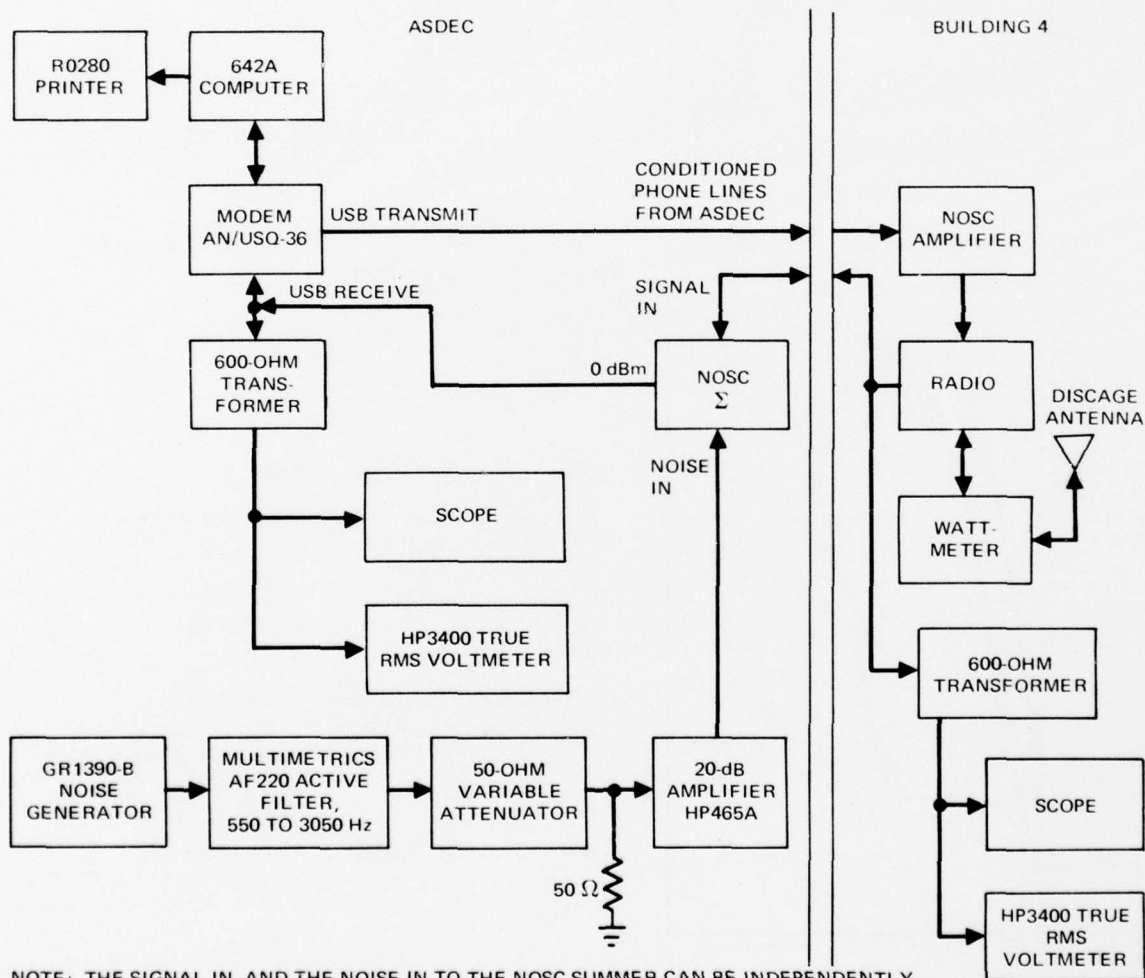

NOTE: THE SIGNAL IN, AND THE NOISE IN TO THE NOSC SUMMER CAN BE INDEPENDENTLY SWITCHED ON AND OFF TO CHECK LEVELS WITH THE VOLTMETER.

Figure 33. BER versus Ps/Pn test set-up for the AN/SRC-23 and AN/URT-23/R1051E radios.

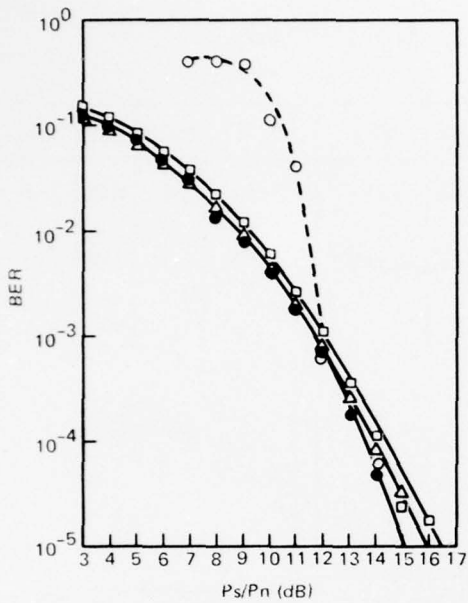

Figure 34. BER versus Ps/Pn for single-station POFA.

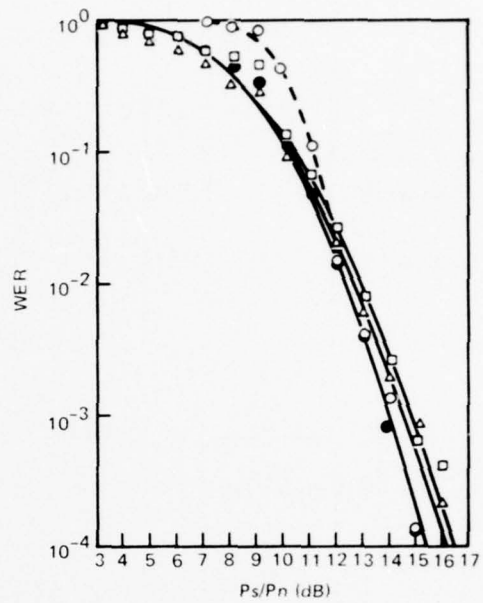

Figure 35. WER versus Ps/Pn for single-station POFA.

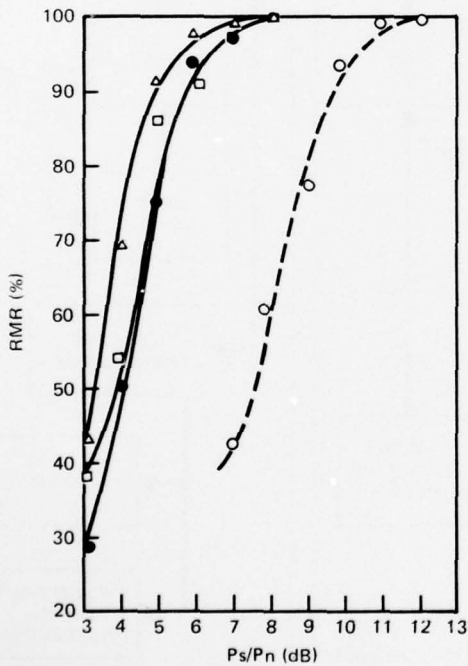

Figure 36. RMR versus Ps/Pn for single-station POFA.

LEGEND FOR FIGURES 34, 35 & 36

- USB
- DATA CORR: OFF
- DATA RATE: 13/9
- FREQUENCY: 4.5 MHz
- AN/URT-23/R1051
- USB USB
- DATA FAST AGC
- AN/SRC-23
- AN/USQ-36 MODEM: BACK-TO-BACK
- AN/USQ-59 MODEM: BACK-TO-BACK
- AN/URT-23/R1051: 0 dB INTO AN/URT-23 USING AN/USQ-36 MODEM
- AN/SRC-23: 0 dB INTO AN/SRC-23 USING AN/USQ-36 MODEM
- AN/USQ-36 MODEM: BACK-TO-BACK

TABLE 6. WEAK STATION, STRONG STATION TEST RESULTS.

NCS	Picket Sequence	WER Ratio FCDSTCP	BER Ratio FCDSTCP	RMR Ratio FCDSTCP	WER Ratio ENGLAND	BER Ratio ENGLAND	RMR Ratio ENGLAND	Range ENGLAND (nmi)
N	N,E,F	17.40	57.10	0.972	1.000	1.000	1.000	94
N	N,E,F	17.40	57.10	0.972	1.000	1.000	1.000	92
N	N,E,F	25.40	71.80	1.000	1.000	1.000	1.000	91
N	N,E,F	8.15	39.90	1.000	1.650	1.970	1.080	56
N	N,E,F	8.15	39.90	1.000	0.975	0.858	1.020	64
N	N,E,F	7.25	13.90	0.980	0.545	0.191	1.020	70
N	N,F,E	32.60	84.10	1.000	1.000	1.000	0.942	76
N	N,F,E	32.60	84.10	1.000	1.000	1.000	0.961	79
N	N,F,E	29.30	60.90	1.000	1.000	1.000	0.922	83
N	N,F,E	29.30	60.90	1.000	1.000	1.000	0.904	87
N	N,F,E	34.30	84.10	1.000	1.000	1.000	0.942	87
N	N,F,E	34.30	84.10	1.000	1.000	1.000	0.942	84
N	N,F,E	2.40	52.10	1.000	$1. \times 10^{-2}$	$2.22 \times 10^{-2}$	0.962	86
F	F,E,N	27.10	222.00	0.890	2.380	3.010	1.000	85
F	F,E,N	3.67	3.51	1.000	1.060	1.020	1.000	92
F	F,E,N	26.60	252.00	1.000	0.915	0.939	1.000	97
F	F,E,N	21.20	194.00	1.070	0.619	0.612	0.980	101
F	F,E,N	21.20	194.00	1.100	0.677	0.657	0.980	103
F	F,E,N	19.20	179.00	0.934	1.340	1.330	1.000	107
F	F,N,E	23.20	236.00	1.040	0.965	0.988	1.000	112
F	F,N,E	23.20	236.00	1.000	1.230	1.210	1.000	115
F	F,N,E	191.00	$2. \times 10^{+3}$	0.815	1.700	1.720	0.980	120
F	F,N,E	191.00	$2. \times 10^{+3}$	0.743	1.630	1.670	0.980	123
F	F,N,E	9.82	99.50	0.923	1.170	1.160	1.000	126
F	F,N,E	25.00	238.00	1.050	0.825	0.775	1.000	-

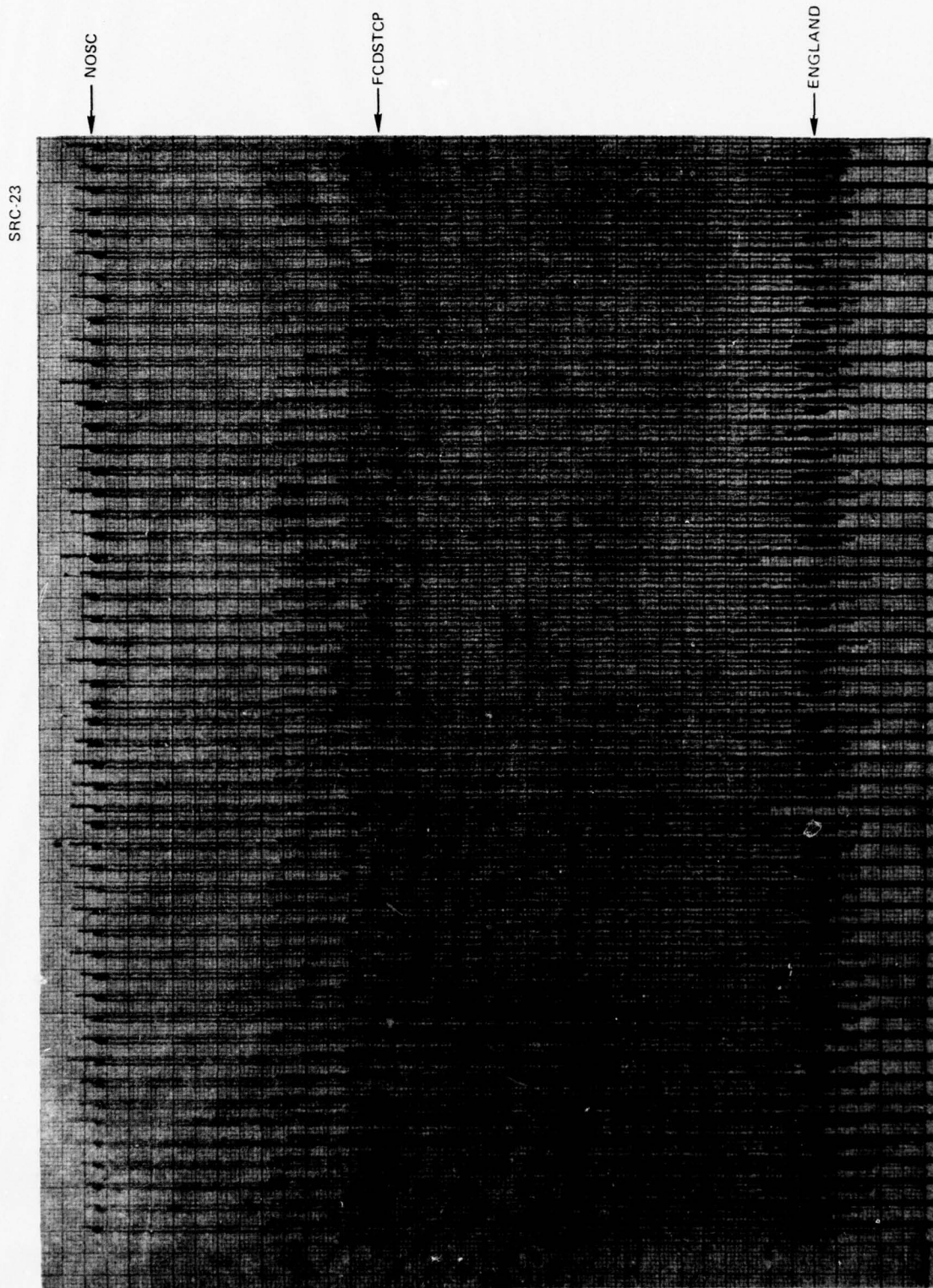

Figure 37. Signal-strength plot for a 3-party net with NOSC using the AN/SRC-23 and AN/USQ-36 modem at the frequency of 4.5 MHz.

Bandwidth: 1 kHz  
 Scan time: 5 Ms/Div.  
 Log reference level: -10 dB  
 Chart speed: 2.5 cm/minute

In this example, the USS ENGLAND was 56 nautical miles from NOSC and had a signal strength of approximately 35 dBm below the signal level from FCDSTCP (the strong station). Note that the signal from the ship was approximately 15 dBm above the noise level.

### ANALYSIS AND CONCLUSIONS

#### DIFFERENCE-IN-PERCENTS VALUE

Table 7 summarizes the receiver and transmitter radio statistics displayed in the all-frequencies WER, BER, and RMR histograms and cumulative distributions. Table 8 summarizes the receiver and transmitter radio statistics at individual test frequencies, presented in the Appendix A histograms. Both of these tables contain a calculated value, difference in percents, which is equal to:

$$(\text{Percent of Ratios} > 1) - (\text{Percent of Ratios} < 1),$$

for each receiver and transmitter category of WER, BER, and RMR and which represents a measure of relative radio performance.

TABLE 7. RELATIVE RADIO PERFORMANCE OVER ALL FREQUENCIES.

Radio Component	Ratios	Percent of Ratios >1	Percent of Ratios <1	Difference in percents	AN/SRC-23 Better	AN/URT-23 (AN/R1051E) Better	Number of Ratios
Receiver	WER	20.4	14.6	+6	x		240
	BER	17.3	12.1	+5	x		231
	RMR	28.9	16.7	+12		x	239
Transmitter	WER	30.5	41.8	-11		x	239
	BER	25.5	39.3	-14		x	196
	RMR	49.8	32.8	+17		x	229

TABLE 8. RELATIVE RADIO PERFORMANCE, INDIVIDUAL FREQUENCIES.

Frequency (MHz)	Radio Component	Ratios	Percent of Ratios > 1	Percent of Ratios < 1	Difference in Percents	AN/SRC-23 Better	AN/URT-23/R1051E Better	Number of Ratios
3.4	Receiver	WER	51.6	9.7	+42	x		31
		BER	58.1	3.2	+55	x		31
		RMR	36.7	40.0	-3	x		31
	Transmitter	WER	39.3	14.3	+25	x		28
		BER	39.3	14.3	+25	x		28
		RMR	43.5	43.5	0			23
4.5	Receiver	WER	18.4	6.9	+11	x		87
		BER	14.9	6.9	+8	x		87
		RMR	12.8	18.6	-6	x		86
	Transmitter	WER	36.3	40.0	-4		x	80
		BER	16.4	45.9	-30		x	61
		RMR	41.8	29.1	+13		x	79
5.9	Receiver	WER	3.5	23.3	-20		x	86
		BER	2.4	18.1	-16		x	83
		RMR	39.5	6.2	+33		x	81
	Transmitter	WER	21.3	41.6	-20		x	89
		BER	20.2	42.7	-22		x	89
		RMR	56.5	27.1	+29		x	85
9.3	Receiver	WER	68.8	25.0	+44	x		16
		BER	60.0	20.0	+40	x		10
		RMR	59.1	22.7	+36		x	22
	Transmitter	WER	22.7	77.3	-55		x	22
		BER						3
		RMR	68.2	31.8	+36		x	22
11.5 & 15.6	Receiver	WER	15.0	10.0	+5	x		20
		BER	5.0	25.0	-20		x	20
		RMR	10.0	10.0	0			20
	Transmitter	WER	45.0	50.0	-5		x	20
		BER	60.0	40.0	+20	x		15
		RMR	40.0	60.0	-20	x		20

The sign of the value indicates which receiver or transmitter is most likely to be associated with the larger WER, BER, or RMR rate. The magnitude of this value is related to the probability that the receiver or transmitter associated with the larger rates will experience a larger rate than the other receiver or transmitter over the spectrum of operating conditions encountered in the tests. Difference-in-percents values are more meaningful than mean-rate ratios in an unstable test environment (see section entitled RADIO COMPARISON DATA) where a small number of very large or very small ratios may unduly influence a mean-rate ratio. Also, mean WER or BER ratios are influenced by the substitution of the arbitrary value  $10^{-4}$  for WER or BER values of zero in ratio calculations involving one WER or BER value of zero.

A positive difference-in-percents value in a WER or BER category indicates that the error rate encountered in the use of the AN/R1051E or AN/URT-23 is likely to be higher than the error rate experienced under identical operating conditions with the AN/SRC-23. Conversely, a negative difference-in-percents value in a WER or BER category implies that the error rate experienced in use of the AN/R1051E or AN/URT-23 is likely to be smaller than the error rate encountered with the AN/SRC-23 under the same conditions.

A positive difference-in-percents value for receiver or transmitter RMR indicates that fewer messages are likely to be missed in use of the R1051E or AN/URT-23 than in use of the AN/SRC-23. Conversely, a negative difference-in-percents value in an RMR category implies that more messages are likely to be missed with the AN/R1051E or AN/URT-23 than with the AN/SRC-23.

#### **RELATIVE RECEIVER PERFORMANCE (ALL FREQUENCIES)**

From table 7, receiver WER difference-in-percents value is less than +6 percent and receiver BER difference-in-percents value is greater than +5 percent. These values are in close agreement, expected with 240 WER ratios and 231 BER ratios available and together imply the likelihood that data received with the AN/R1051E receiver will contain more errors than the same data received with the AN/SRC-23 receiver. This likelihood is small but does exceed the anticipated experimental error of 2 percent difference-in-percents.

Receiver RMR difference-in-percents (table 7) is greater than +12 percent, indicating that messages received with the AN/R1051E receiver are less likely to be missed by the AN/USQ-36 and AN/USQ-59 modems than messages received with the AN/SRC-23. The superior RMR performance of the R1051E is considered to, at least, balance the slightly superior data error-rate performance of the AN/SRC-23 receiver. RMR performance is a particularly important consideration in operations where one or more participating units are utilized as occasional and momentary net participants.

During on-the-air tests, 50 messages were typically transmitted by each unit in each POFA exchange. A unit experiencing one missed message in one such exchange and no missed messages in a time-adjacent exchange would calculate an RMR ratio of either 0.98 or 1.02 from the two exchanges. The difference in data loss between the two exchanges, assuming the WERs were identical on the exchanges, would then be equivalent to the difference in data loss encountered with a WER difference of  $2 \times 10^{-2}$  on two such exchanges where messages were not missed. Missed messages degrade the data rate of 2250 bps (fast data rate) to a smaller effective data rate.

Several types of NTDS messages, eg, subsurface track messages and track-amplification messages, are transmitted in every three or more transmissions. Accordingly, units employing receivers associated with smaller RMRs face a greater probability of never receiving certain types of messages than units equipped with receivers associated with larger RMRs, under degraded link conditions.

#### **RELATIVE TRANSMITTER PERFORMANCE (ALL FREQUENCIES)**

Transmitter WER difference-in-percents and transmitter BER difference-in-percents in table 7 are less than -11 percent and greater than -14 percent, respectively. The similarity of these values implies that data transmitted with the AN/SRC-23 are likely to be received with more errors than the same data transmitted with the AN/URT-23. The likelihood of such occurrences is twice the likelihood of the R1051E receiving data with more errors than the AN/SRC-23 receiving the same data. Again, anticipated experimental error is expected to account for 2 percent in difference-in-percents.

The transmitter RMR difference-in-percents value of +17 implies that messages transmitted with the AN/URT-23 are less likely to be missed by receiving AN/SSQ-29 and AN/USQ-36 modems than messages transmitted with the AN/SRC-23. Unlike the receiver ratio statistics, the transmitter WER and BER ratio statistics support the transmitter RMR statistics in defining the Link 11 performance of the AN/URT-23 transmitter to be superior to that of the AN/SRC-23 transmitter.

The all-frequencies histograms and cumulative distributions display a tendency for receiver (NOSC) WER, BER, and RMR ratios to spread out over a smaller spectrum of ratio values than transmitter (at ship) ratios. Transmitter ratios are also less likely to be unity than receiver ratios. This is reflected in larger transmitter values than receiver values under similar "percent of ratios < 1" and "percent of ratios > 1" headings within the same WER, BER, or RMR categories in table 7.

#### **RELATIVE RADIO PERFORMANCE (INDIVIDUAL TEST FREQUENCIES)**

##### **FREQUENCY OF 3.4 MHz**

Receiver WER and BER difference-in-percents values in table 8 imply that data received by the R1051E are likely to contain more errors than the same data received by the AN/SRC-23. Transmitter difference-in-percents values indicate that data transmitted with the AN/URT-23 are likely to be received with more errors than the same data transmitted by the AN/SRC-23. The difference-in-percents magnitudes in these categories exceed the rather large experimental error levels anticipated with these small-ratio sample sizes. Transmitter RMR difference-in-percents value is zero and receiver RMR difference-in-percents value is less than half the magnitude of the anticipated experimental error. The Link 11 performance of the AN/SRC-23 is found to be superior to that of the AN/URT-23/R1051E at 3.4 MHz on the basis of data error rates.



#### FREQUENCY OF 4.5 MHz

Receiver WER and BER difference-in-percents values in table 8 imply that data received with the R1051E are likely to contain more errors than the same data received with the AN/SRC-23. The receiver difference-in-percents indicates that messages received with the R1051E are more likely to be missed than the same messages received with the AN/SRC-23.

Transmitter WER and BER difference-in-percents values imply that data transmitted with the AN/URT-23 are likely to be received with less errors than the same data transmitted with the AN/SRC-23. WER and BER difference-in-percents values are generally expected to differ by less than the sum of the anticipated experimental errors calculated from the WER and BER ratio sample sizes. Several of the 4.5-MHz ratios were calculated from POFA exchanges with a ship whose printouts consistently reported sizable word-error rates and bit-error rates of zero. These BERs were rejected as inconsistent with the reported WERs, resulting in several less BER ratios available for analysis than WERs and a larger difference in WER and BER difference-in-percents magnitudes than expected from sample sizes at this frequency. The transmitter difference-in-percents values indicate that messages transmitted with the AN/URT-23 are less likely to be missed than the messages transmitted with the AN/SRC-23. Difference-in-percents values exceed or equal (transmitter WER) anticipated experimental error in all categories.

The Link 11 performance of the AN/SRC-23 receiver was superior to that of the R1051E receiver while the performance of the AN/URT-23 transmitter was superior to that of the AN/SRC-23 transmitter. Overall, the two radios are considered to perform equally at 4.5 MHz.

#### FREQUENCY OF 5.9 MHz

Difference-in-percents values in all receiver and transmitter performance categories at this frequency exceed anticipated experimental error and favor the R1051E receiver and the AN/URT-23 transmitter. Link 11 performance of the AN/URT-23/R1051E radio was found to be superior to that of the AN/SRC-23 radio at 5.9 MHz.

#### FREQUENCY OF 9.3 MHz

Receiver WER and BER difference-in-percents values in table 8 imply that data received with the R1051E are likely to contain more errors than the same data received with the AN/SRC-23. The receiver RMR difference-in-percents values indicate that messages received with R1051E are more likely to be missed than messages received with the AN/SRC-23.

Considerably more receiver WER ratios than BER ratios were available for analysis. Most of these data (figures 12 and 13) were taken at separation ranges between 120 and 220 nautical miles using the NOSC AN/USQ-59 modem. At these ranges, the modem signal-quality detection circuit occasionally interrupted the flow of data during the last 100 words of the POFA messages used for bit-error analysis. Word-error rates could be recovered with reasonable confidence from interrupted exchanges in cases where a sufficient number of words were received. Bit-error rates were not recoverable as often as word-error rates.

Transmitter WER difference-in-percents values imply that data transmitted with the AN/SRC-23 are likely to contain more errors than data transmitted with the AN/URT-23.

The transmitter RMR difference-in-percents values indicate that messages transmitted with the AN/SRC-23 are more likely to be missed than messages transmitted with the AN/URT-23. The transmitter BER ratio sample size was limited to the extent that a difference-in-percents calculation was not reasonable. Lack of BER ratios was discussed earlier (FREQUENCY OF 4.5 MHz). Difference-in-percents values exceeded expected experimental error in all categories where calculated.

The Link 11 performance of the AN/SRC-23 receiver was superior to that of the R1051E receiver and the performance of the AN/URT-23 transmitter was superior to that of the AN/SRC-23 transmitter. Overall, the two radios are considered to perform equally at 9.3 MHz.

#### FREQUENCIES OF 11.5 AND 15.6 MHz

Six ratios were calculated from the 15.6-MHz data and 14 ratios from the 11.5-MHz data in all categories save transmitter BER. These ratios were combined in the Appendix A histograms and in table 8 for display purposes. Small sample sizes combined with small data-error rates made it impossible to compare relative radio performance with any degree of confidence at these frequencies.

POFA printouts on  $10^4$  received words or less often report few or no bit errors when word-error rates are of the order  $10^{-4}$  or smaller. These incidences occur because errors are too infrequent to be distributed evenly throughout the received messages and because word errors are reported on all 230 words of a POFA message while bit errors are reported only on the last 100 words. This explains why the signs of the WER and BER difference-in-percents disagree in both receiver and transmitter categories at these frequencies. Had word-error rates of the order  $10^{-3}$  or greater been encountered or had larger ratio sample sizes been available, these WER and BER difference-in-percents values would be expected to agree in sign and to agree closely in magnitude.

In summary, relative radio performance at discrete test frequencies varies with the hf carrier frequency. The variations in relative transmitter performance are most likely to result from variations in relative transmitter average power output from one test frequency to another. Records of transmitter output power at different frequencies were not kept and a correlation between relative output power and relative transmitter performance cannot be made from these data. Variations in relative receiver performance with test frequency are more difficult to assess and are not explainable at this time.

#### COMPARISON OF BER, WER, AND RMR VERSUS $P_s/P_n$ CURVES

Filtered white noise added to the received audio signals of the AN/SRC-23 and AN/URT-23/R1051E results in some separation of the BER, WER, and RMR versus  $P_s/P_n$  curves associated with these radios. The WER curve of the AN/URT-23/R1051E moves to the left of the curve of the AN/SRC-23 above 9 dB  $P_s/P_n$ . Maximum separation in  $P_s/P_n$  approached 0.3 dB and WER ratios approach a minimum of 0.65 at 16 dB  $P_s/P_n$ . WER ratios were always less than unity above 9 dB  $P_s/P_n$ .

The BER curve of the AN/URT-23/R1051E was found to be always to the left of the BER curve for the AN/SRC-23. Maximum separation in  $P_s/P_n$  approaches 0.8 dB and BER

ratios approach a minimum of 0.53 at 16 dB Ps/Pn. BER ratios were found to be less than unity at all Ps/Pn values.

The RMR curve of the AN/URT-23/R1051E was always to the left of the AN/SRC-23 RMR curve for Ps/Pn less than 8 dB. Maximum Ps/Pn separation approaches 1 dB and RMR ratios approach a maximum of 1.4 at 4 dB Ps/Pn.

Note that in figures 34, 35, and 36, the curves for the AN/USQ-59 modem (back-to-back) follow closely the curves for the AN/USQ-36 modem (back-to-back) above a Ps/Pn of 12 dB but deviate greatly from the AN/USQ-36 curves below 12 dB. This is due, again, to the signal-quality control circuit of the AN/USQ-59.

### RECEIVER AGC COMPARISON

The AGC actions of the AN/SRC-23 and R1051E receivers were tested in the weak-station, strong-station operations. Net-control assignment and PU interrogation sequence were varied to allow receiver release and attack times to have the maximum possible influence on WER, BER, and RMR in Link 11 operations.

The word-error rate ratios calculated from POFA messages received by the R1051E receiver indicate that a baseline word-error rate of approximately  $3 \times 10^{-3}$  is experienced with data received from the strong station (550 metres from NOSC). This phenomenon is reflected in the observation that receiver WER ratios calculated on data received from FCDSTCP always exceeded unity. Similarly, a baseline bit-error rate of approximately  $8 \times 10^{-4}$  was associated with strong-station data received by the R1051E. These baseline error rates are independent of NCS assignment or PU interrogation sequence. It was also observed that the ratios calculated on data received from the weak station equalled performance by the R1051E and the AN/SRC-23.

The baseline error rates experienced with the R1051E receiver are not due to receiver AGC action. Rather, the R1051E receiver has a front-end overload problem (clipping of very strong signals) not found with the AN/SRC-23 receiver. The AGC action of the R1051E receiver was found to be equivalent in performance to that of the AN/SRC-23 and is suitable for the Link 11 application.

### RECOMMENDATIONS

Based upon the analyses of data obtained during the Link 11 performance comparison tests of the AN/SRC-23 and AN/URT-23/R1051E radios the following recommendations are made:

1. The modified AN/URT-23/R1051E should be incorporated into the NTDS Link 11 assets of the Fleet. The overall performance of this radio, its reliability and cost, make it an excellent candidate to augment and replace existing transceivers in the Fleet. Much of the Fleet already uses AN/URT-23 transmitters and R1051E receivers; by coupling them with a data adapter, the combination can be used very successfully in the Link 11 system;

2. The AN/USQ-59 and AN/ACQ-5 modems should be fitted with a front-panel switch to disable their signal-quality detection circuits. These circuits are functionally incompatible with the Link 11 POFA and should be disabled when this program is run;

3. It is recommended that the POFA patch (developed by UNIVAC for NOSC) enabling the CP-642A/B computer POFA to output directly to the R0280 high-speed printer be made available to the Fleet. This patch is particularly useful when running POFAs with aircraft. With this patch, a printout can be obtained in a matter of a few seconds (rather than several minutes); and

4. It is further recommended that the front-end overload of the R1051E receiver caused by extremely strong signals be investigated and, if possible, corrected.

#### **BIBLIOGRAPHY**

NELC TN 1690 "Crypto Device Error Study," EW Cox, 30 June 1970.

NAVSHIPS 0967-011-4001 part 1 "Program Listing for Link 11 Network Evaluation Test (POFA) For Use With CP-642A or B Computer," 27 March 1973.

NAVSHIPS 0967-011-3991 "Operating Procedures For Link 11 Network Evaluation Test (POFA) For Use With CP-642A or B Computer," 27 March 1973.

NAVSHIPS 0967-011-4011 "Link-11 Network Evaluation Test (POFA) For Use With CP-642A or B Computer," 27 March 1973.

NELC TR 1866, Compatibility of AN/URT-23/R1051 Transceiver With NTDS HF Circuit," GB Johnson, 16 March 1973.

Naval Electronic Systems Command PME-117-23 Report 1300-C796, Submarine Tactical Data Link Technical Radio Comparison Test Plan And Procedures, November 1976.

Operating Manuals for AN/URT-23, R1051, AN/USQ-36, AN/USQ-59, CP642A/B, R0280, and Harris RF Communications Data Adapter.

**APPENDIX A:  
HISTOGRAMS AT INDIVIDUAL FREQUENCIES**

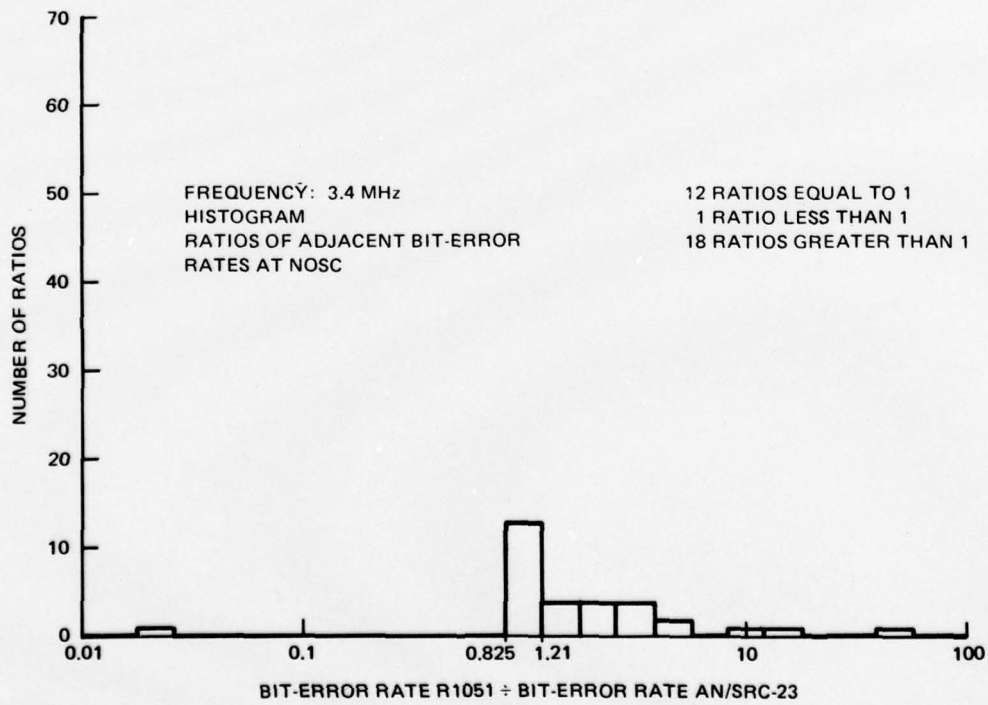
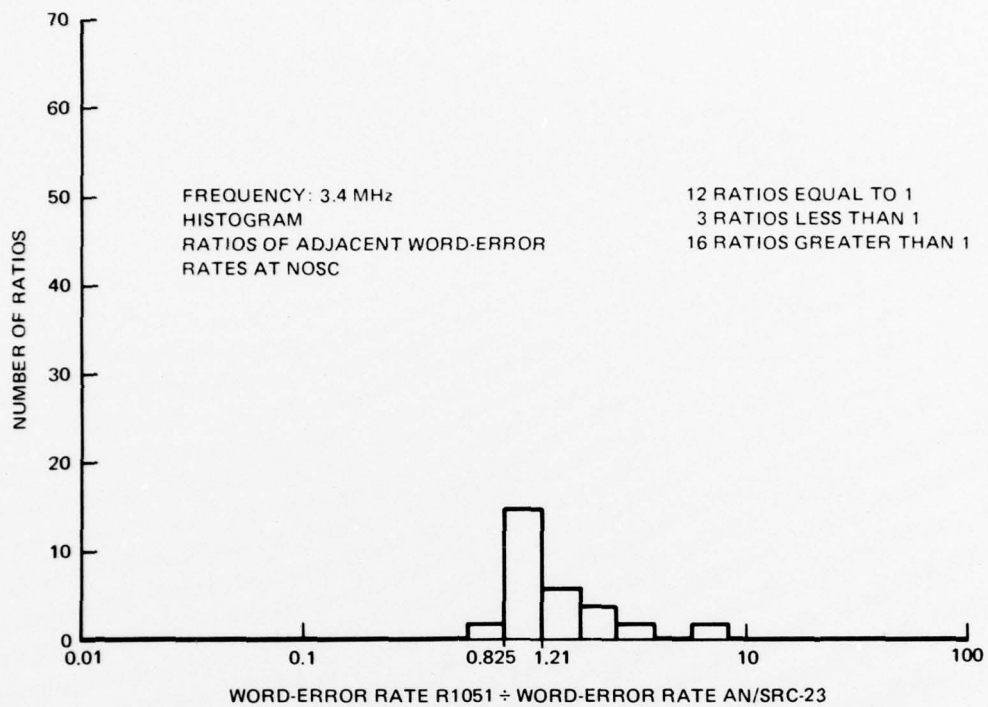

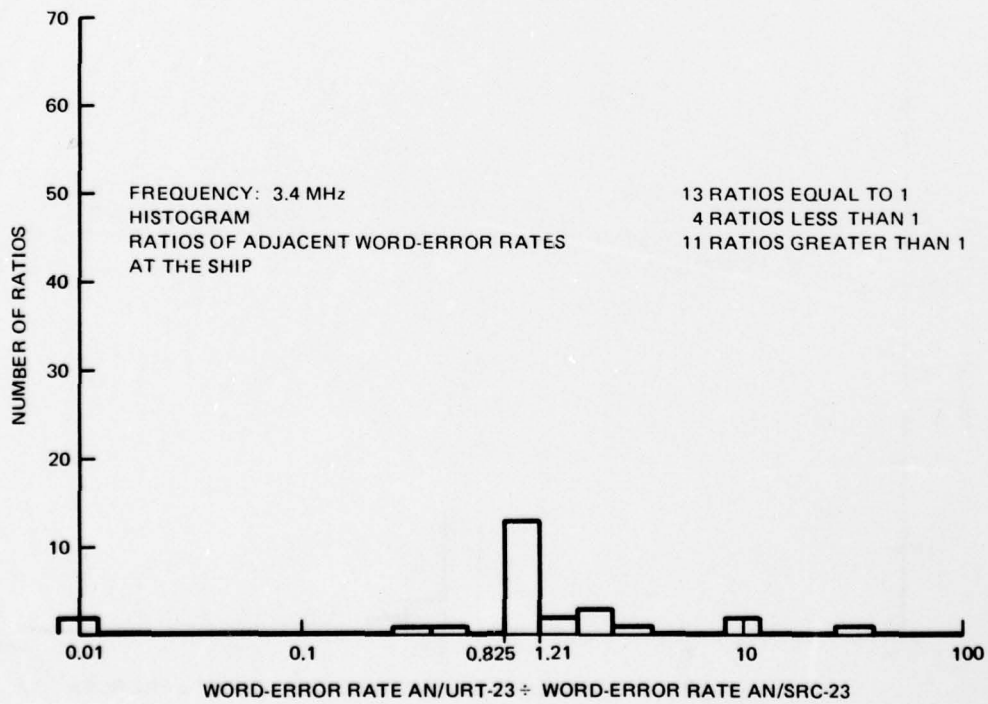
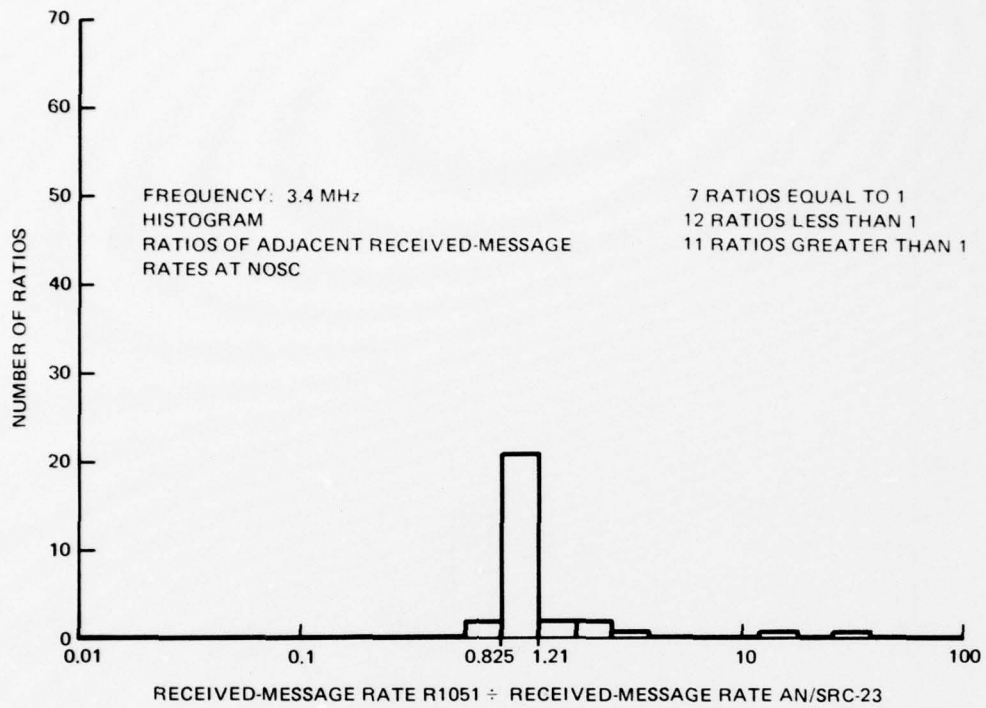

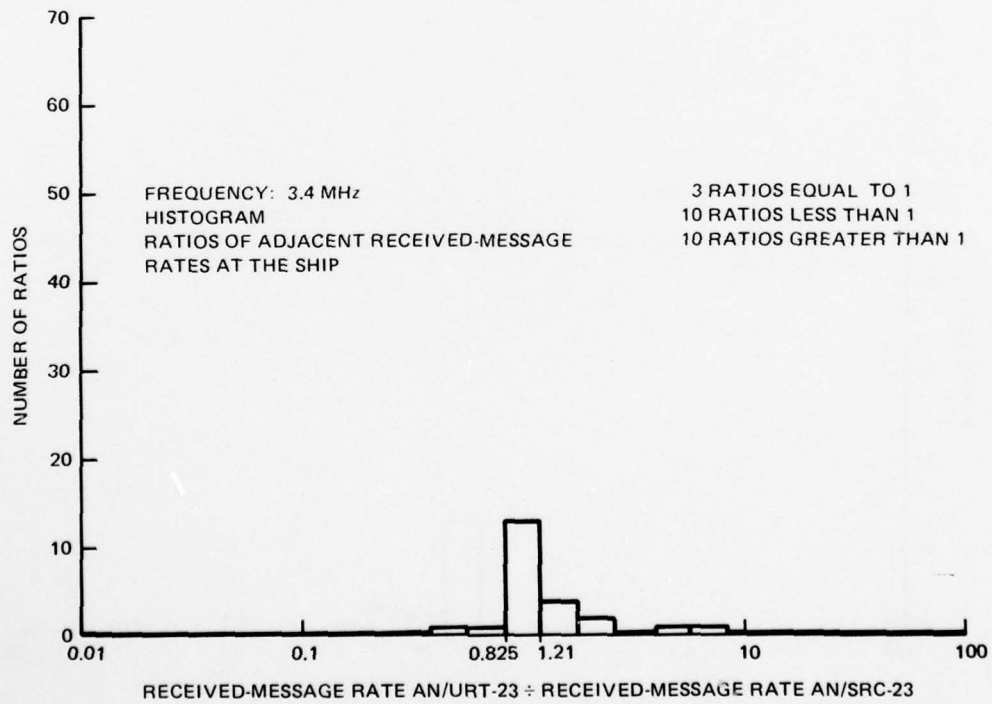
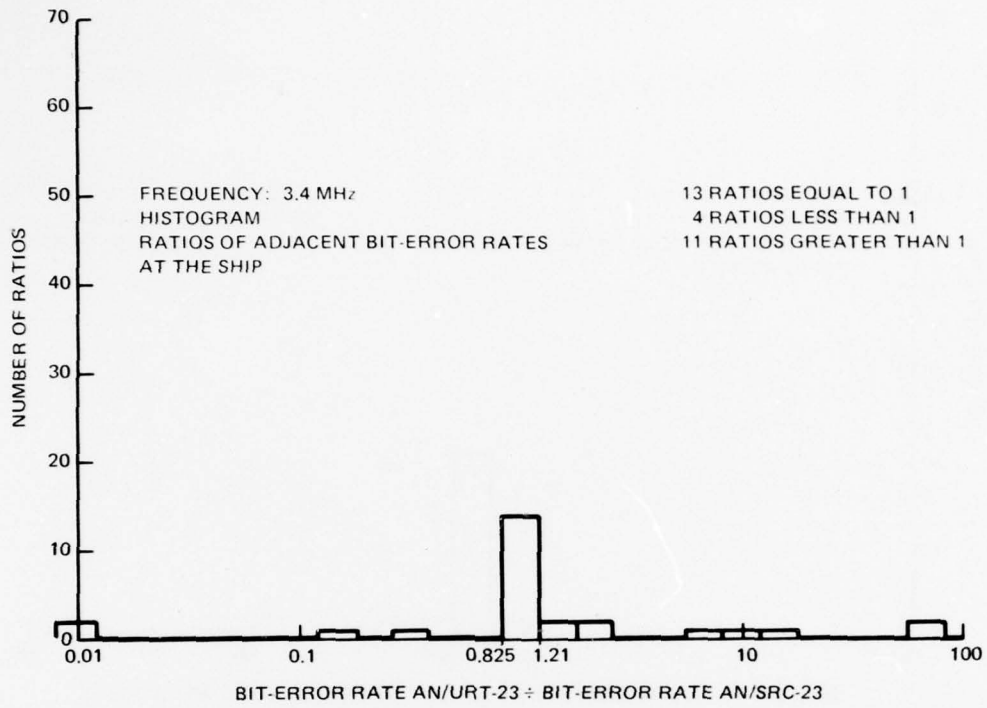



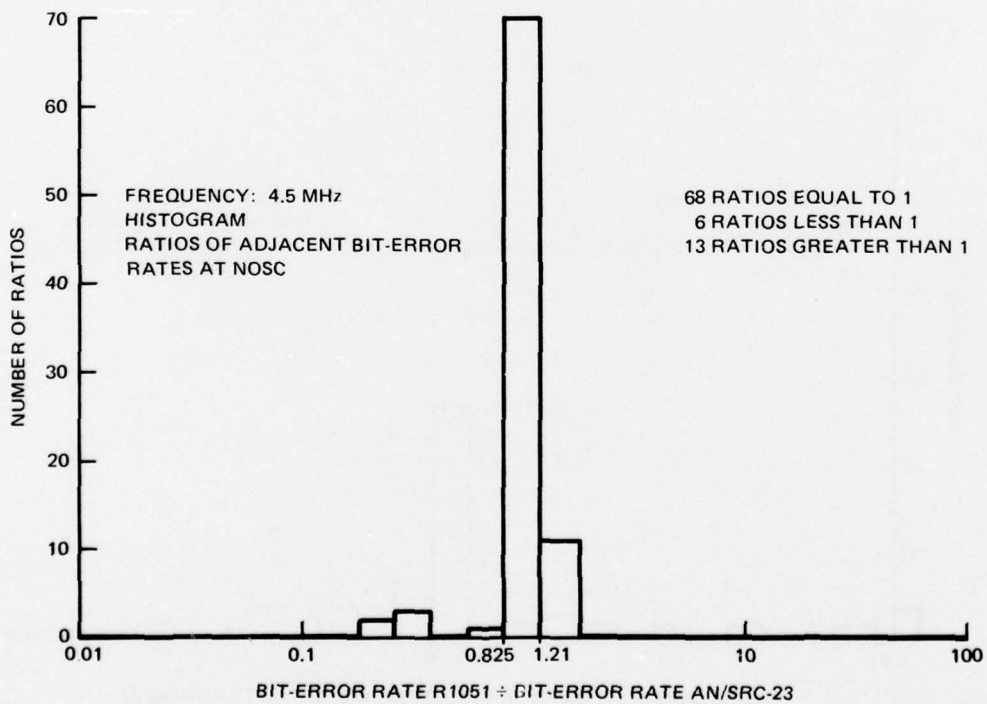
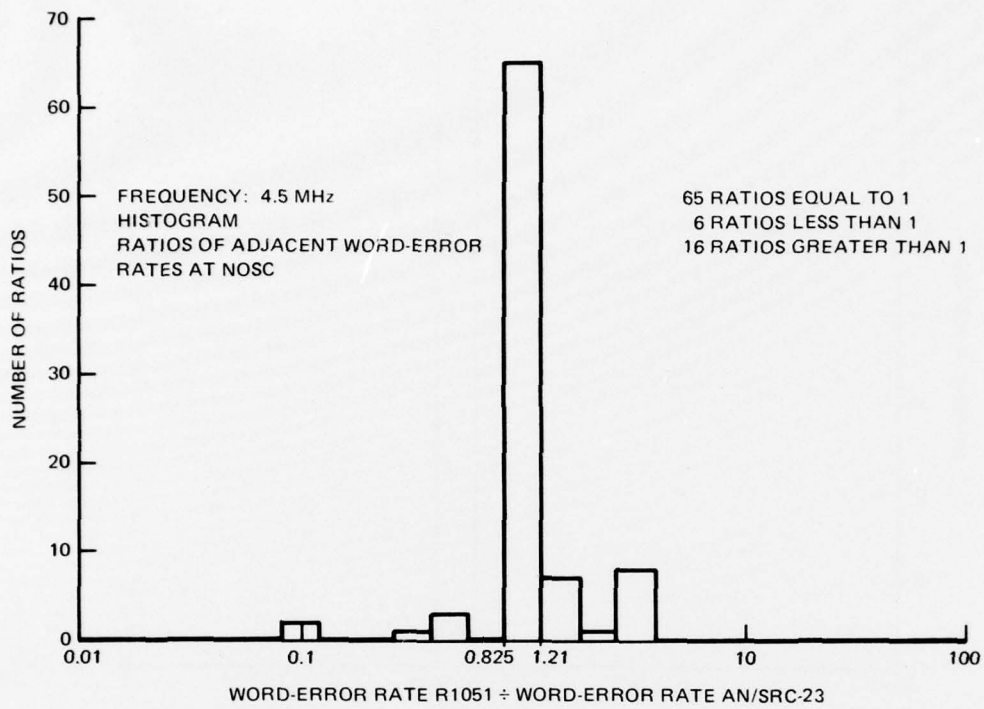

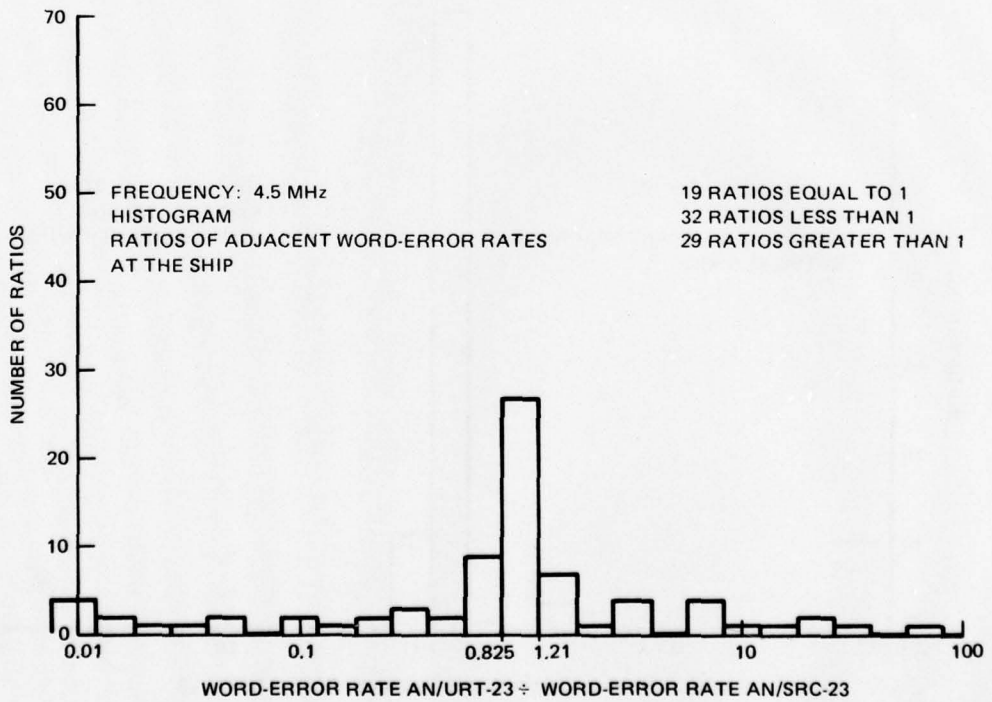
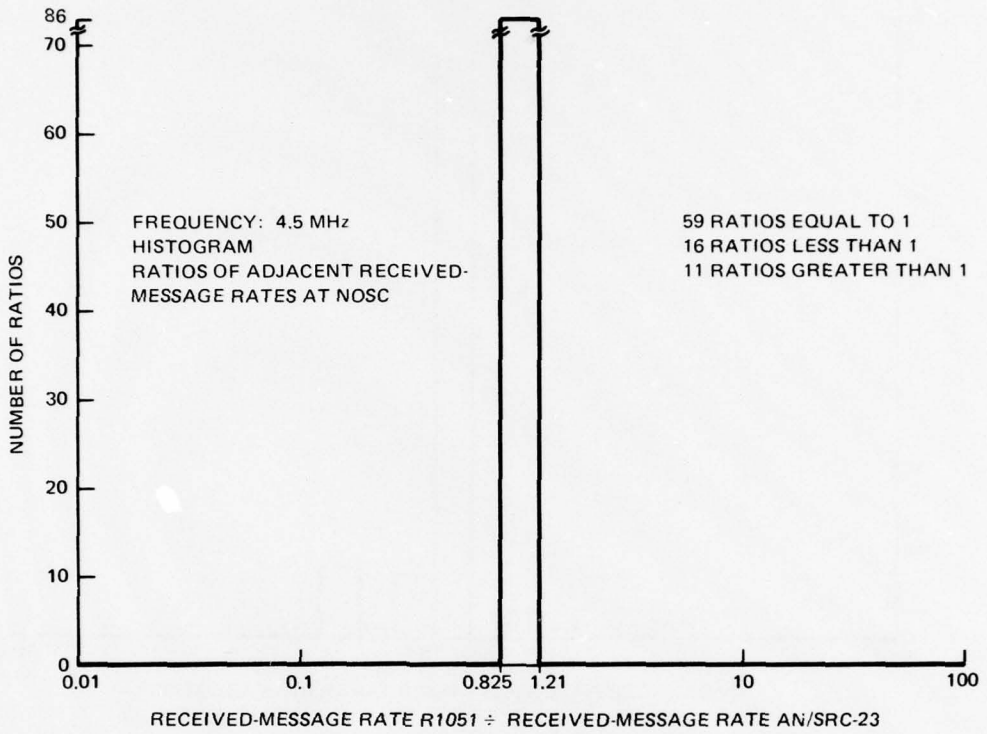

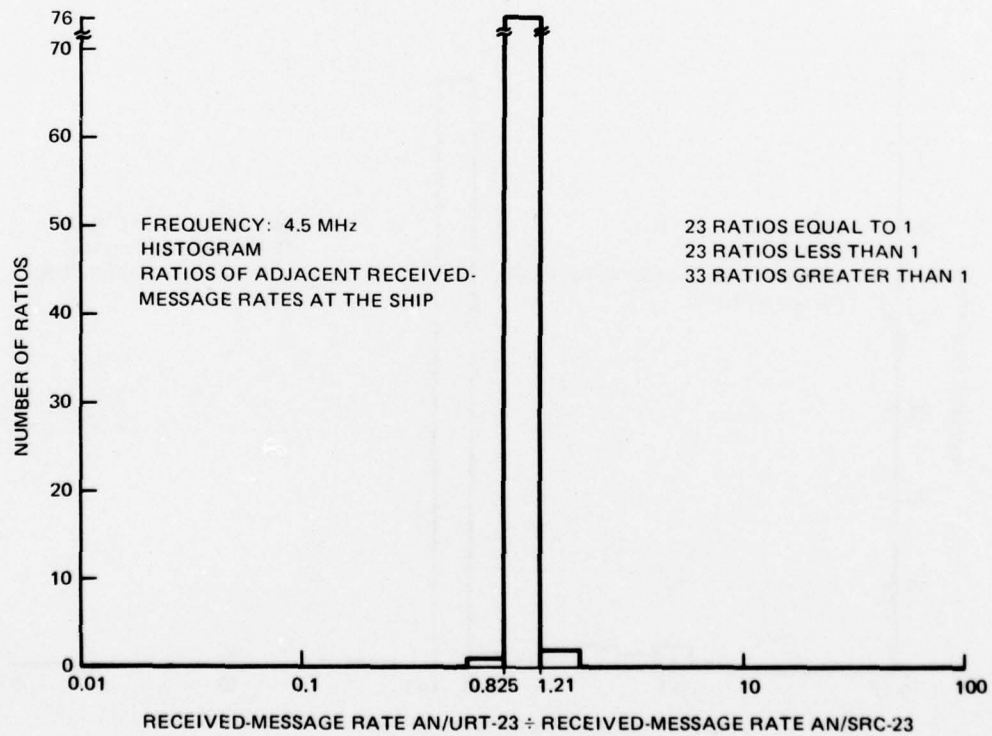
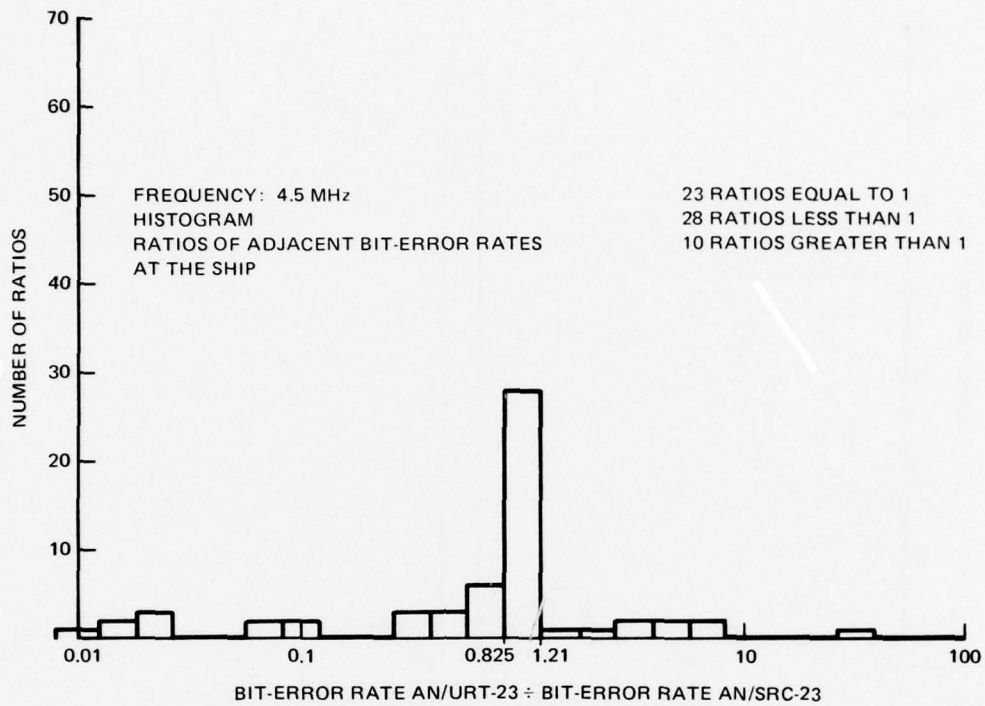

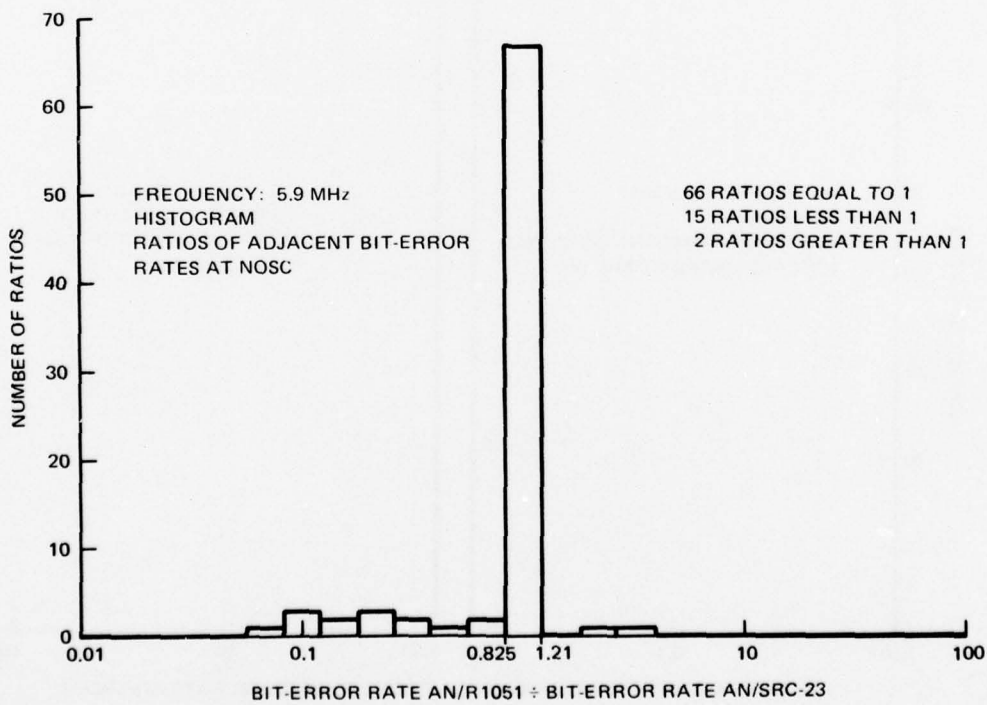
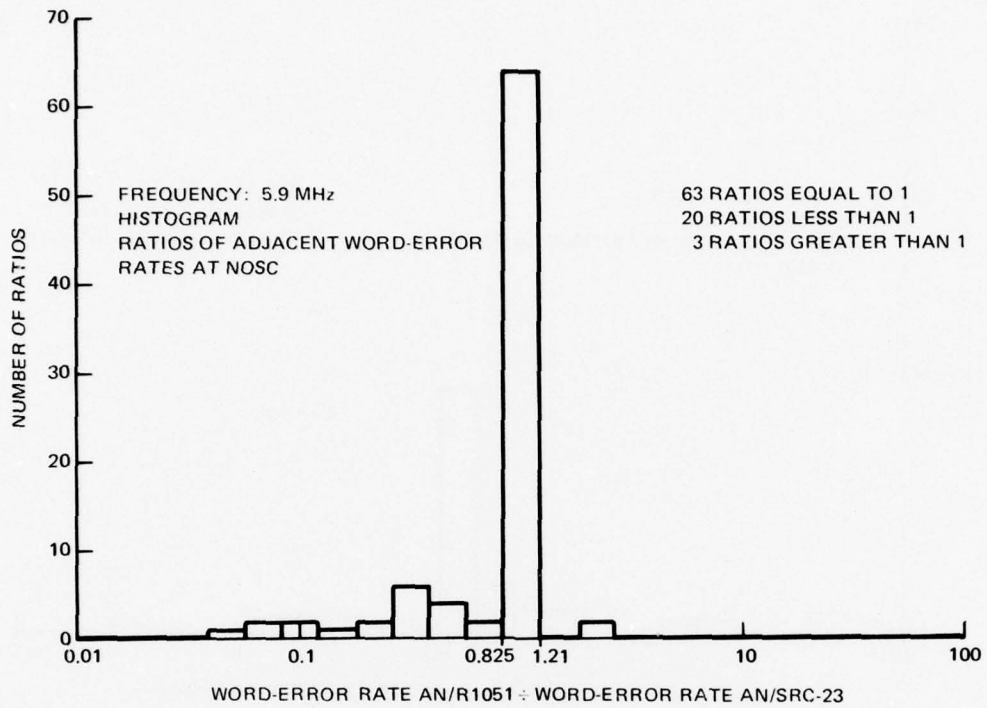

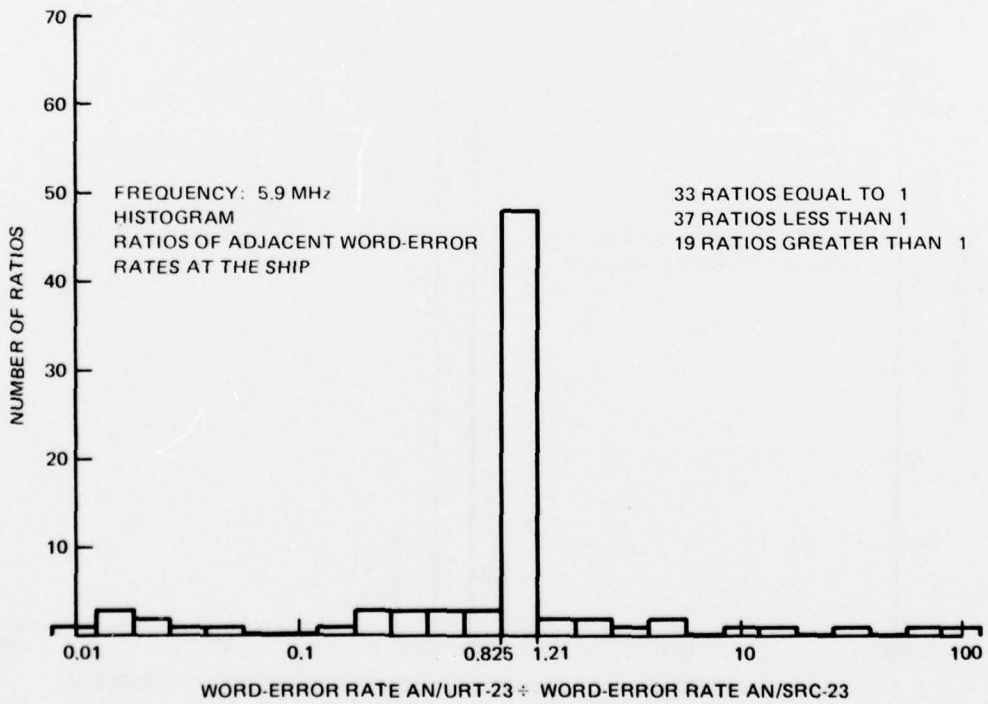
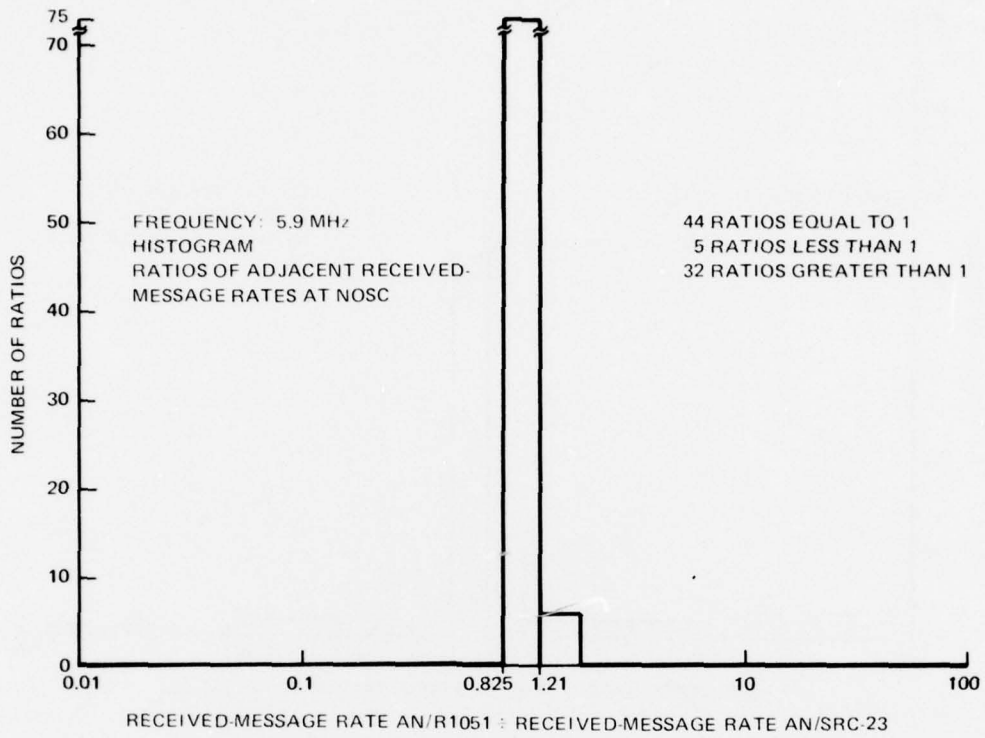

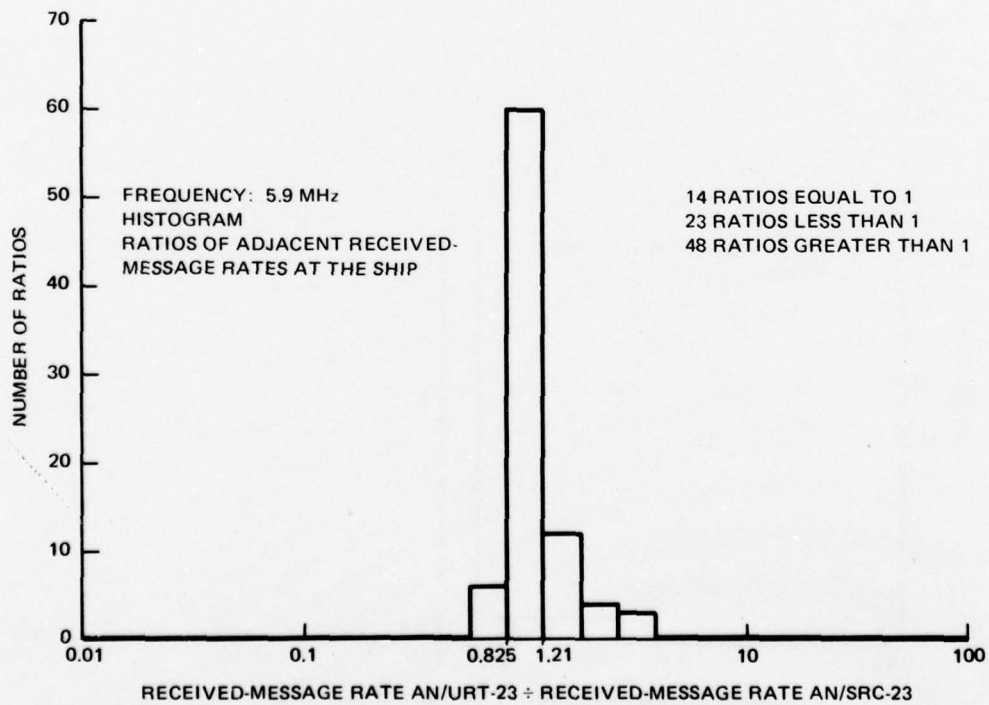
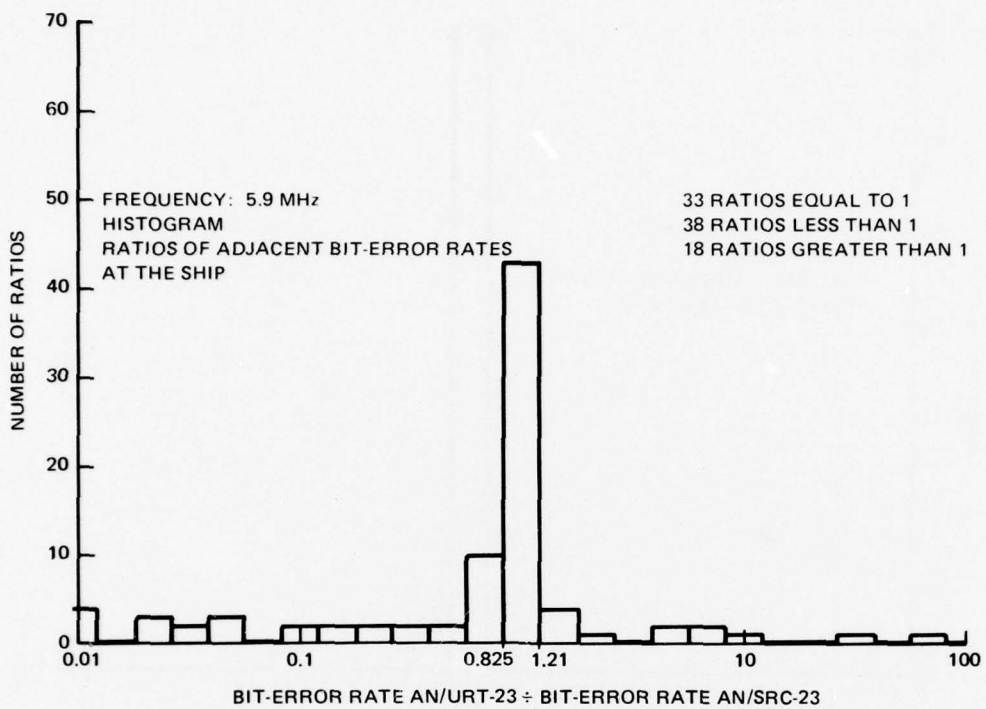

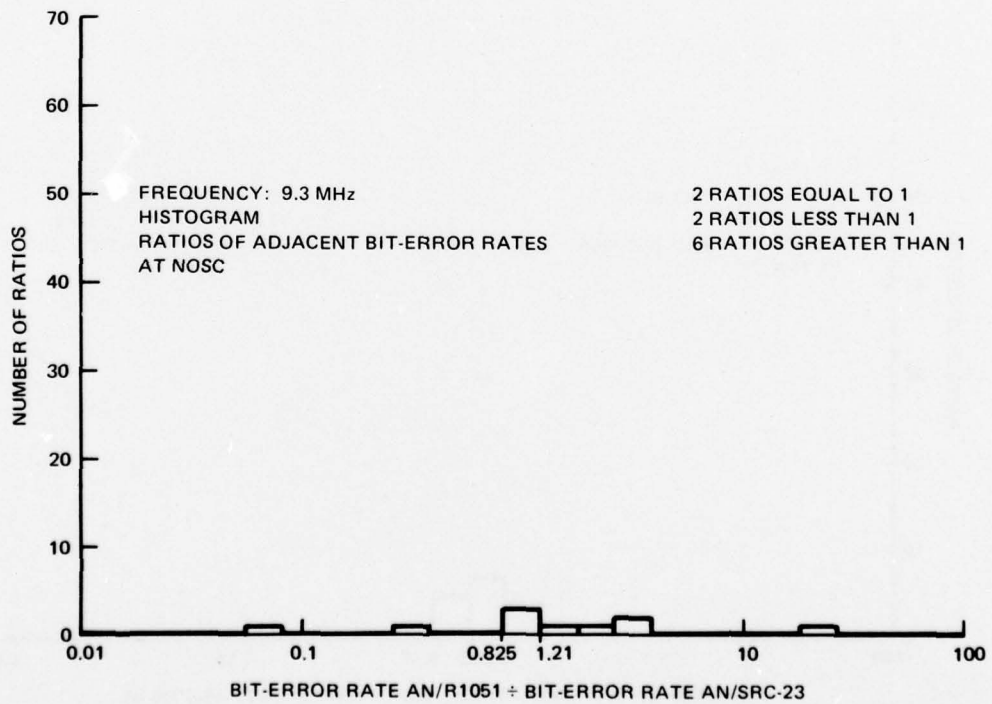
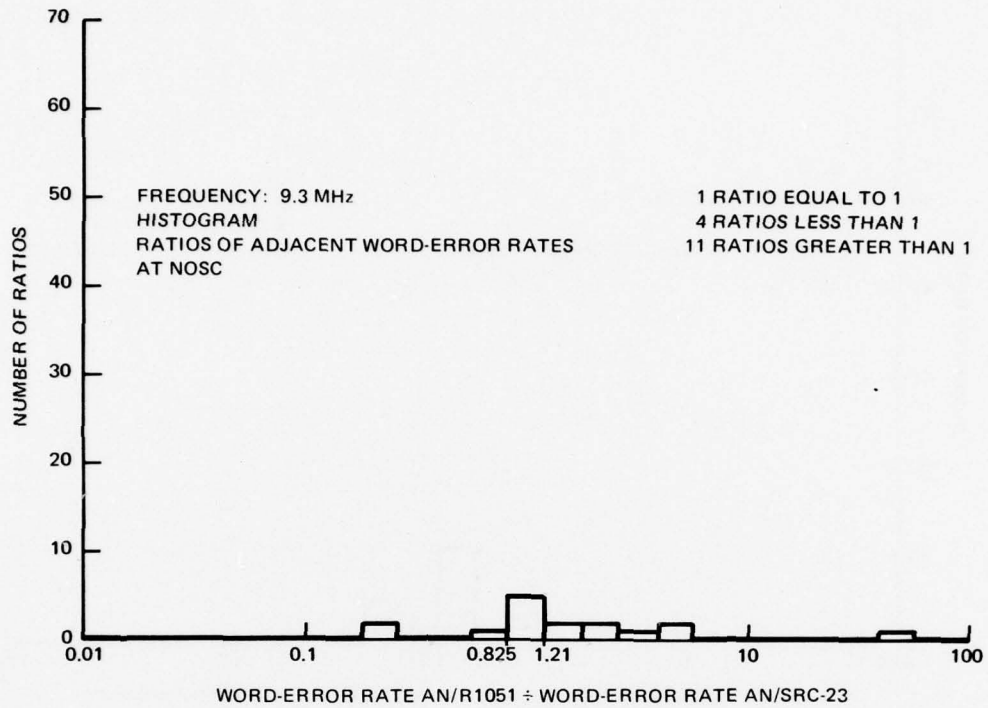

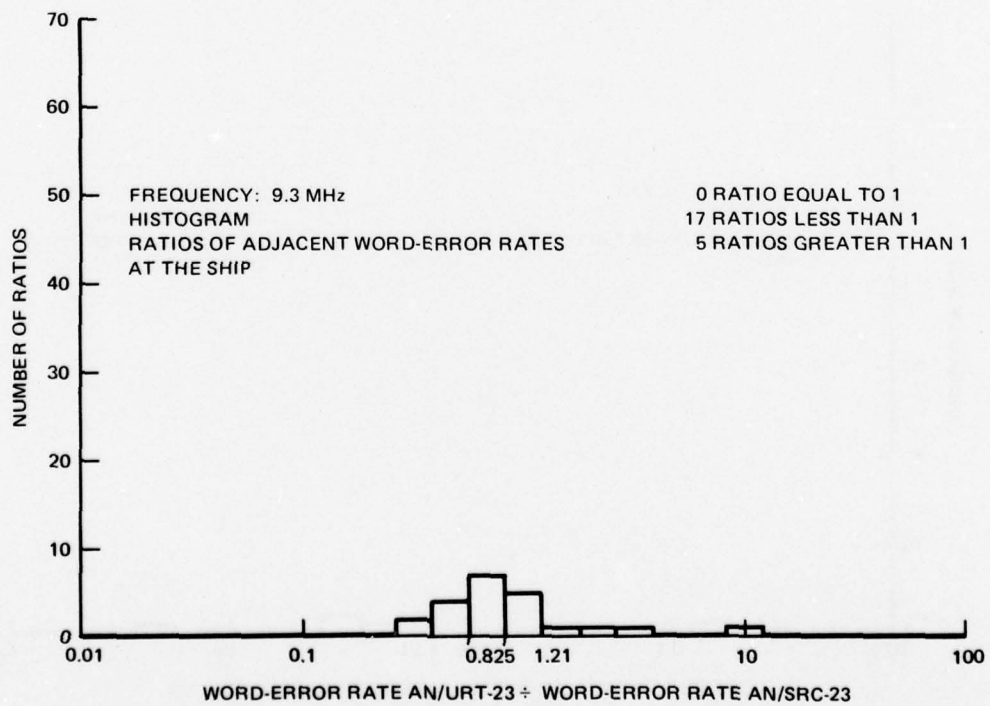
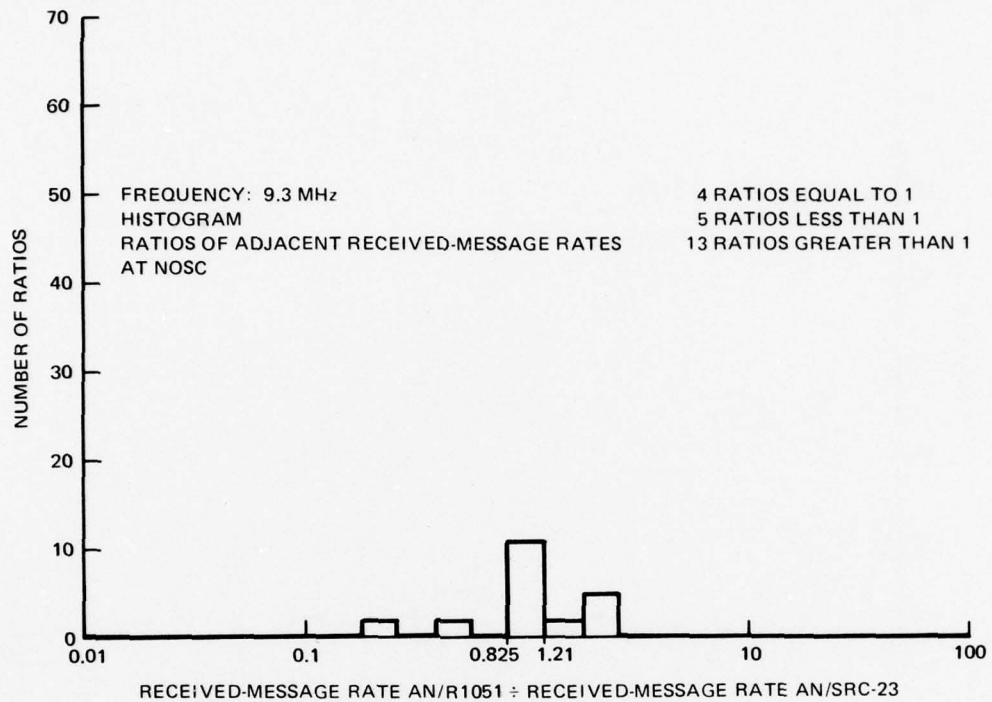



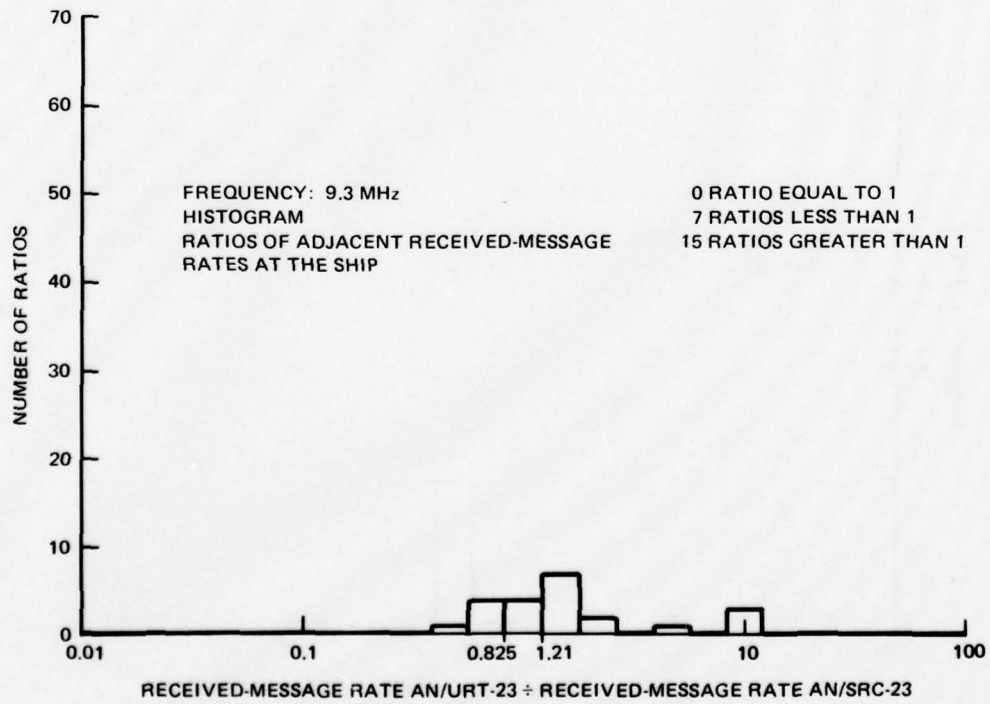
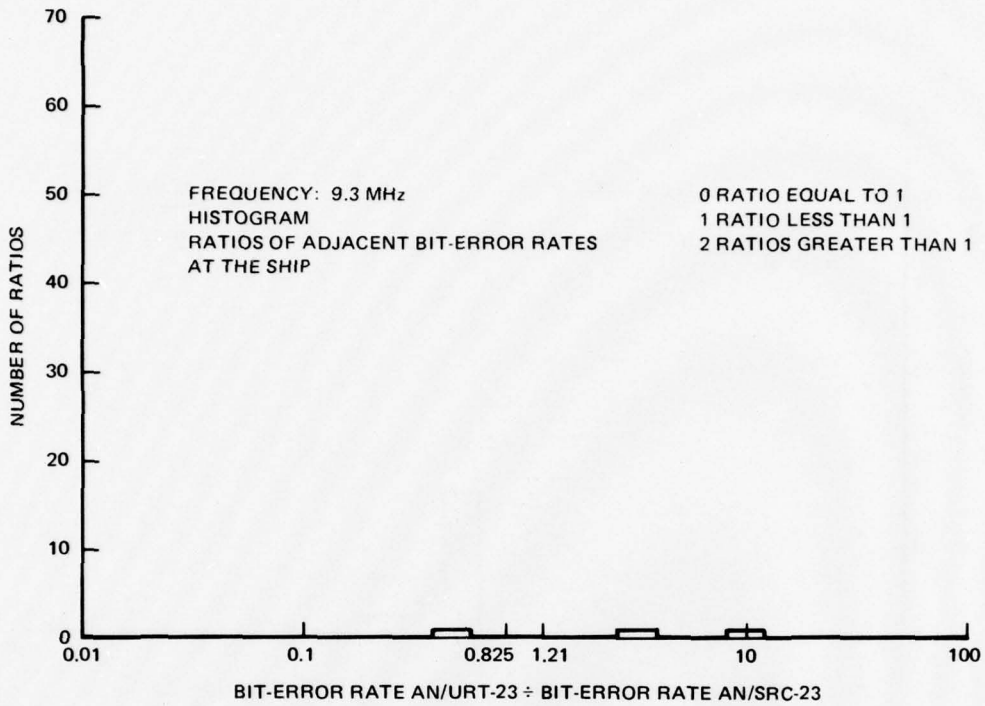

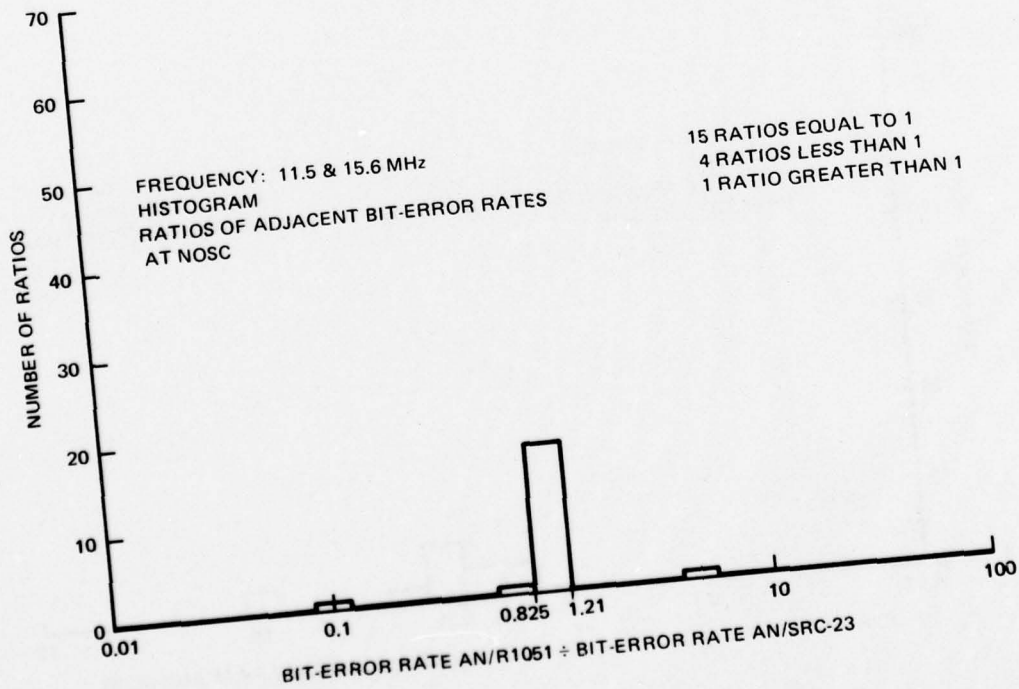
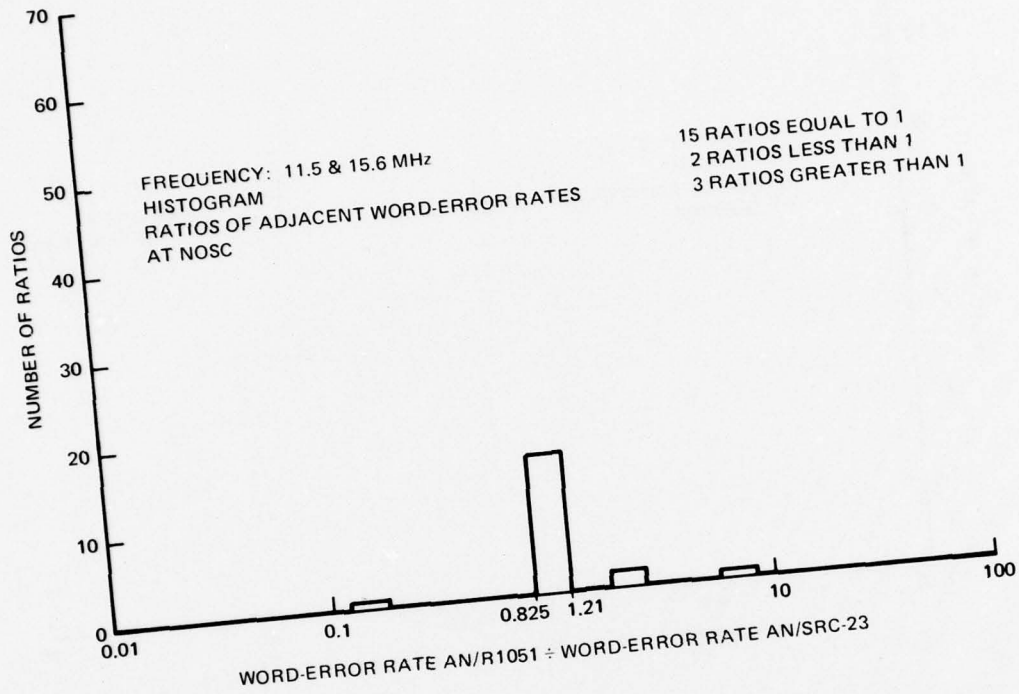

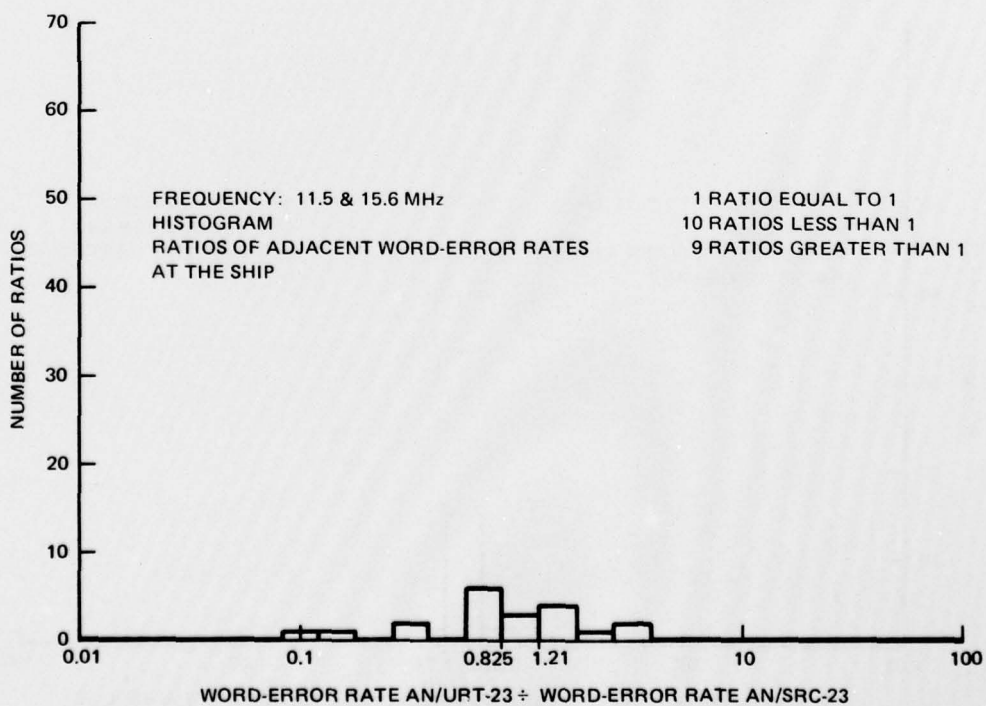
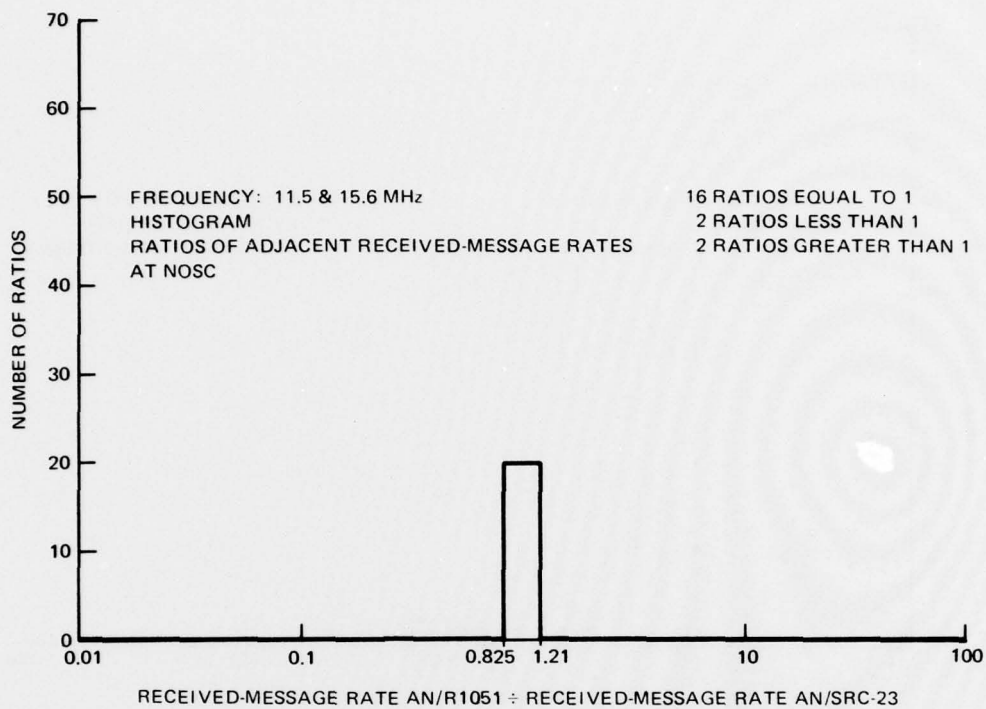

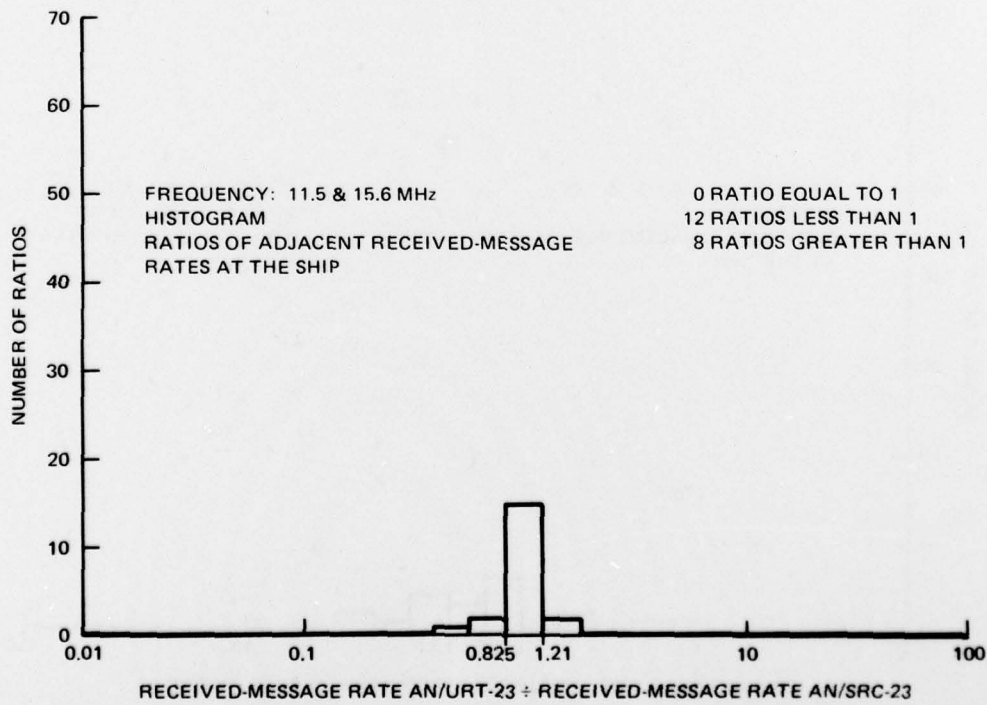
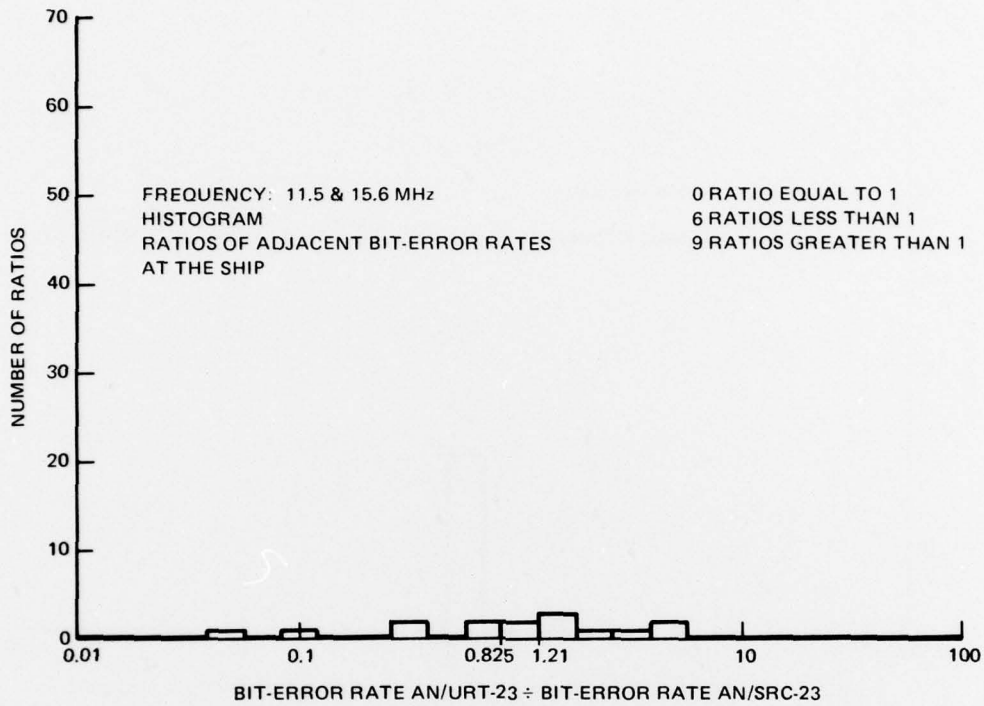

**APPENDIX B:**  
**SIGNAL-QUALITY DETECTION CIRCUIT INDUCED ERRORS**

## INTRODUCTION

The AN/USQ-59 modem has a signal-quality detection circuit that generates a "loss-of-signal-presence" signal whenever 4 consecutive frames of a message are found to contain tones whose phase angles fall  $\pm 22.5^\circ$  or more outside actual QDPSK phase values. This signal causes the modem to stop transfer of data to the computer and to revert to a search for Address Codes and Start Codes (see figure B-1). Word errors may be, but often are not, contained in the data which were transferred to the computer input buffer prior to this occurrence. The Sylvania AN/ACQ-5 modem found on the P-3C aircraft has a similar circuit, but uses a more extensive set of standards to determine if data are suitable for transfer. Data loss due to premature message termination never occurs with messages demodulated by the Collins AN/SSQ-29 and AN/USQ-36 modems since they are not provided with signal-quality detection circuits.

The creation of incomplete messages and the POFA software interaction with these messages is of fundamental concern in Link 11 POFA analysis. There is presently no standardization in this area. The P-3C aircraft POFA printout contains an analysis of that part of the message which was transferred to the computer prior to signal-quality detection circuit termination of that message. This printout reports the number (not always reconcilable to the rest of the report) of incomplete messages received by the P-3C, and from which participating unit it received these messages. In contrast, the AN/UYK-7 POFA software interacts with the AN/USQ-59 modem by aborting all incomplete messages received by the computer input buffer and reporting these messages as "Received End Receive Interrupt But No Data Errors" on the POFA printout. Data loss occurs in both these cases, however, all data contained in messages generating a "loss of signal presence" signal are lost in the AN/UYK-7/AN/USQ-59 interaction. Use of the interrupt error makes it impossible to differentiate these occurrences from actual failures of the transmitting system to include computer data in the transmitted message.

The interaction of the CP-642-A, B computer POFA (originally intended for use with the AN/SSQ-29 and AN/USQ-36 modems) with the AN/USQ-59 signal quality-control circuit is different than the cases just discussed. This interaction was observed to influence data gathered at both NOSC and FCDSTCP (San Diego) during the STDL radio-comparison tests. The frequency of incomplete message events was found to increase as the signal-to-noise ratio ( $P_s/P_n$ ) decreased, eventually making it impossible to analyze the data. This is demonstrated in the incompleted WER versus  $P_s/P_n$  and BER versus  $P_s/P_n$  curves for the AN/USQ-59 modem (figures 34 and 35). Above 12-dBm  $P_s/P_n$ , the curves for the AN/USQ-59 and AN/USQ-36 modems were quite close, but below this value the AN/USQ-59 signal-quality circuit produced so many incomplete messages that data could not be analyzed.

The data became obscured because the CP-642-A, B POFA does not recognize an incomplete message. The assumption is made that input to the computer input buffer has been completed whenever a modem generated "End Receive" interrupt is received by the computer. In reality, part or all of the last 100 words (frames) of an incomplete 230-word POFA message is missing from the input buffer and the bits in these buffer frames remain zeroes. The last 100 words of POFA are checked bit-by-bit for errors by comparison with the same 100 words stored in computer memory (see figure B-2). Each bit of each unfilled frame of the lost 100 buffer frames which is supposed to be a one is then identified as a bit error and each unfilled frame as a word error.

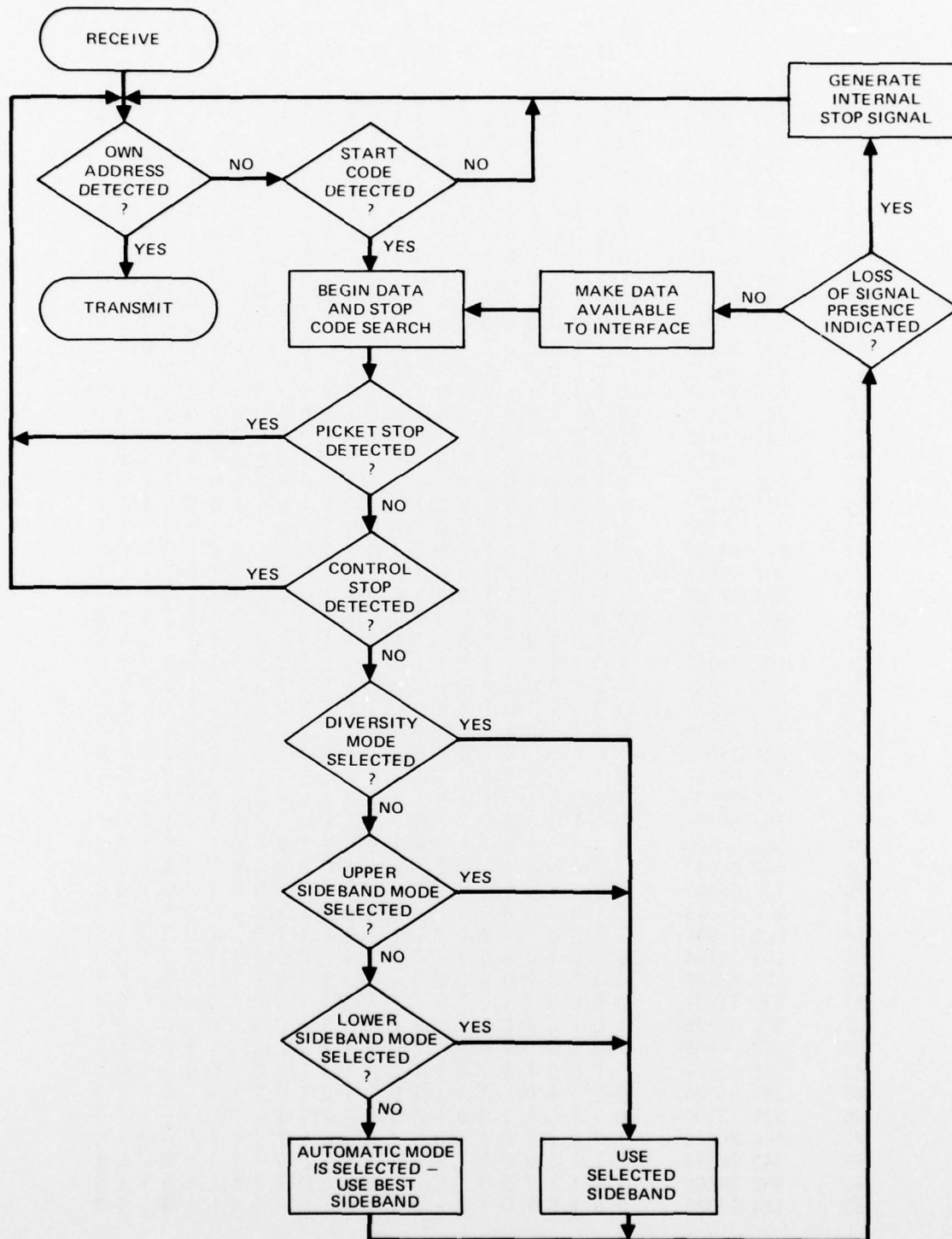

Figure B-1. AN/USQ-59 TADIL A receive operations flow chart.

Word	Octal Word	Bits																										
		23	21	19	17	15	13	11	9	7	5	3	1															
		22	20	18	16	14	12	10	8	6	4	2	0															
1	037 33030	0	0	0	0	1	1	1	1	1	0	1	1	0	1	1	0	0	0	0	0	1	1	0	0	0		
2	120 62562	0	0	1	0	1	0	0	0	0	1	1	0	0	1	0	1	0	1	1	1	0	0	1	0	1	0	
3	150 30560	0	0	1	1	0	1	0	0	0	0	1	1	0	0	0	1	0	1	1	1	0	0	0	0	0	0	
4	154 53713	0	0	1	1	0	1	1	0	0	1	0	1	0	1	1	1	1	1	0	0	1	0	1	0	1	1	
5	355 75370	0	1	1	1	0	1	1	0	1	1	1	1	1	0	1	0	1	1	1	1	1	0	0	0	0	0	
6	231 12344	0	1	0	0	1	1	0	0	1	0	0	1	0	0	1	1	1	0	0	1	1	0	0	1	0	0	
7	402 66402	1	0	0	0	0	0	0	1	0	1	1	0	1	1	0	1	0	0	0	0	0	0	0	0	1	0	
8	367 24316	0	1	1	1	1	0	1	1	1	0	1	0	1	0	0	0	1	1	0	0	1	1	1	0	1	0	
9	642 26506	1	1	0	1	0	0	0	1	0	0	1	0	1	0	1	0	1	0	0	0	0	1	1	0	1	0	
10	323 42101	0	1	1	0	1	0	0	1	1	1	0	0	0	1	0	0	0	1	0	0	0	0	0	0	0	1	
11	000 66752	0	0	0	0	0	0	0	0	0	1	1	0	1	1	0	1	1	1	1	0	1	0	1	0	1	0	
12	307 36221	0	1	1	0	0	1	1	1	0	1	1	1	1	0	0	0	1	0	0	1	0	0	1	0	0	1	
13	414 76323	1	0	0	0	1	1	0	0	1	1	1	1	0	0	1	1	0	0	1	1	0	1	0	0	0	1	1
14	360 52537	0	1	1	1	1	0	0	0	0	1	0	1	0	1	0	1	0	1	0	1	1	1	1	1	1	1	
15	353 46404	0	1	1	1	0	1	0	1	1	1	0	0	1	1	0	1	0	0	0	0	0	0	1	0	0	0	
16	437 12426	1	0	0	0	1	1	1	1	1	0	0	1	0	1	0	1	0	0	0	1	0	1	0	1	1	0	
17	306 42076	0	1	1	0	0	0	1	1	0	1	0	0	0	1	0	0	0	0	1	1	1	1	1	1	1	0	
18	245 76111	0	1	0	1	0	0	1	0	1	1	1	1	1	0	0	0	1	0	0	1	0	0	1	0	0	1	
19	044 53317	0	0	0	1	0	0	1	0	0	1	0	1	0	1	0	1	1	0	1	1	0	0	1	1	1	1	
20	272 42147	0	1	0	1	1	1	0	1	0	1	0	0	0	1	0	0	0	1	1	0	0	0	1	1	1	1	
21	666 64724	1	1	0	1	1	0	1	1	0	1	1	0	1	0	0	1	1	1	0	1	0	1	0	1	0	0	
22	304 71147	0	1	1	0	0	0	1	0	0	1	1	1	0	0	1	0	0	1	1	0	0	1	1	1	1	1	
23	454 47367	1	0	0	1	0	1	1	0	0	1	0	0	1	1	1	0	0	1	1	1	0	1	1	1	1	1	
24	076 20164	0	0	0	1	1	1	1	0	0	1	0	0	0	0	0	0	0	1	1	1	0	1	0	1	0	0	
25	201 56472	0	1	0	0	0	0	0	0	1	1	0	1	1	1	0	1	0	0	1	1	1	0	1	0	1	0	
26	137 72040	0	0	1	0	1	1	1	1	1	1	1	0	1	0	0	0	0	1	0	0	0	0	0	0	0	0	
27	315 17064	0	1	1	0	0	1	1	0	1	0	0	1	1	1	1	0	0	0	1	1	0	1	0	1	0	0	
28	064 17534	0	0	0	1	1	0	1	0	0	0	0	1	1	1	1	1	0	1	0	1	1	1	1	0	0	0	
29	155 27506	0	0	1	1	0	1	1	0	1	0	1	0	1	1	1	1	0	1	0	0	0	0	0	1	1	0	
30	424 14010	1	0	0	0	1	0	1	0	0	0	0	1	0	0	0	0	1	0	0	0	0	0	1	0	0	0	
31	300 65201	0	1	1	0	0	0	0	0	0	1	1	0	1	0	1	0	1	0	0	0	0	0	0	0	0	1	
32	426 72035	1	0	0	0	1	0	1	1	0	1	1	1	0	1	0	0	0	0	0	0	1	1	1	0	1	1	
33	141 56575	0	0	1	1	0	0	0	0	1	1	0	1	1	1	0	1	0	1	1	1	1	1	1	1	0	1	
34	064 23066	0	0	0	1	1	0	1	0	0	0	1	0	0	1	1	0	0	0	1	1	0	1	1	0	1	0	
35	454 04044	1	0	0	1	0	1	0	0	0	0	0	1	0	0	0	0	0	0	1	0	0	1	0	0	1	0	
36	440 02444	1	0	0	1	0	0	0	0	0	0	0	0	0	0	1	0	1	0	0	1	0	0	1	0	0	0	
37	202 11543	0	1	0	0	0	0	0	1	0	0	0	1	0	0	1	1	0	1	1	0	0	0	0	1	1	1	
38	620 33542	1	1	0	0	1	0	0	0	0	0	1	1	0	1	1	1	0	1	1	0	0	0	0	1	0	0	
39	253 50164	0	1	0	1	0	1	0	1	1	1	0	1	0	0	0	0	0	1	1	1	0	1	0	1	0	0	
40	122 22365	0	0	1	0	1	0	0	1	0	0	1	0	0	1	0	0	1	1	1	1	0	1	0	1	0	1	
41	033 73001	0	0	0	0	1	1	0	1	1	1	1	0	1	1	0	0	0	0	0	0	0	0	0	0	0	1	
42	526 02125	1	0	1	0	1	0	1	1	0	0	0	0	0	1	0	0	0	1	0	1	0	1	0	1	0	1	
43	503 05163	1	0	1	0	0	0	0	1	1	0	0	0	1	0	1	0	0	0	1	1	1	0	0	0	1	1	
44	735 45101	1	1	1	0	1	1	1	0	1	1	0	0	1	0	1	0	0	1	0	0	0	0	0	0	0	1	
45	357 55324	0	1	1	1	0	1	1	1	1	1	0	1	1	0	1	0	1	1	0	1	0	1	0	1	0	0	
46	321 13207	0	1	1	0	1	0	0	0	1	0	0	1	0	1	1	0	1	0	0	0	0	0	1	1	1	1	
47	466 20442	1	0	0	1	1	0	1	1	0	0	1	0	0	0	1	0	0	1	0	0	1	0	0	0	0	1	0
48	342 76343	0	1	1	1	0	0	0	1	0	1	1	1	1	0	0	0	1	1	1	0	0	0	0	0	1	1	
49	562 24666	1	0	1	1	1	0	0	1	0	0	1	0	1	0	0	1	1	0	1	1	0	1	0	1	1	0	
50	124 32324	0	0	1	0	1	0	1	0	0	0	1	1	0	1	0	0	1	1	0	1	0	1	0	1	0	0	

Figure B-2. The 100 "canned" words of POFA data.



Word	Octal Word	Bits																							
		23	21	19	17	15	13	11	9	7	5	3	1												
51	766 00067	1	1	1	1	1	0	1	1	0	0	0	0	0	0	0	0	0	0	1	1	0	1	1	1
52	263 70325	0	1	0	1	1	0	0	1	1	1	1	1	0	0	0	0	1	1	0	1	0	1	0	1
53	367 41443	0	1	1	1	1	0	1	1	1	1	1	0	0	0	0	1	1	0	0	1	0	0	0	1
54	525 06346	1	0	1	0	1	0	1	0	1	0	0	0	1	1	0	0	1	1	1	0	0	1	1	0
55	464 35326	1	0	0	1	1	0	1	0	0	0	1	1	1	0	1	0	1	1	0	1	0	0	1	0
56	421 73401	1	0	0	0	1	0	0	0	1	1	1	1	0	1	1	1	0	0	0	0	0	0	0	1
57	024 60321	0	0	0	0	1	0	1	0	0	1	1	0	0	0	0	0	1	1	0	1	0	0	0	1
58	167 54262	0	0	1	1	1	0	1	1	1	1	0	1	1	0	0	0	1	0	1	1	0	0	1	0
59	335 44064	0	1	1	0	1	1	1	0	1	1	0	0	1	0	0	0	0	0	1	1	0	1	0	0
60	124 27263	0	0	1	0	1	0	1	0	0	0	1	0	1	1	1	0	1	0	1	1	0	0	1	1
61	746 66604	1	1	1	1	0	0	1	1	0	1	1	0	1	1	0	1	1	0	0	0	0	1	0	0
62	117 40325	0	0	1	0	0	1	1	1	1	1	1	0	0	0	0	0	0	1	1	0	1	0	1	0
63	374 45465	0	1	1	1	1	1	1	0	0	1	0	0	1	0	1	1	0	0	1	1	0	1	0	1
64	102 67043	0	0	1	0	0	0	0	1	0	1	1	0	1	1	1	0	0	0	1	0	0	0	1	1
65	465 10221	1	0	0	1	1	0	1	0	1	0	0	1	0	0	0	0	1	0	0	1	0	0	0	1
66	027 73141	0	0	0	0	1	0	1	1	1	1	1	1	0	1	1	0	0	1	1	0	0	0	0	1
67	071 51321	0	0	0	1	1	1	0	0	1	1	0	1	0	0	1	0	1	0	1	1	0	1	0	0
68	571 46020	1	0	1	1	1	1	0	0	1	1	0	0	1	1	0	0	0	0	0	0	1	0	0	0
69	572 55123	1	0	1	1	1	1	0	1	0	1	0	1	1	0	1	0	0	1	0	1	0	0	1	1
70	041 42402	0	0	0	1	0	0	0	0	1	1	0	0	0	1	0	1	0	0	0	0	0	0	1	0
71	256 00363	0	1	0	1	0	1	1	1	0	0	0	0	0	0	0	0	1	1	1	1	0	0	1	1
72	027 62462	0	0	0	0	1	0	1	1	1	1	1	0	0	1	0	1	0	0	1	1	0	0	1	0
73	565 14105	1	0	1	1	1	0	1	0	1	0	0	1	1	0	0	0	1	0	0	0	1	0	0	1
74	032 46065	0	0	0	0	1	1	0	1	0	1	0	0	1	1	0	0	0	0	1	1	0	1	0	1
75	040 45401	0	0	0	1	0	0	0	0	0	1	0	0	1	0	1	1	0	0	0	0	0	0	0	1
76	420 04445	1	0	0	0	1	0	0	0	0	0	0	0	1	0	0	1	0	0	1	0	0	1	0	1
77	511 20260	1	0	1	0	0	1	0	0	1	0	1	0	0	0	0	0	1	0	1	1	0	0	0	0
78	533 02644	1	0	1	0	1	1	0	1	1	0	0	0	0	1	0	1	1	0	1	0	0	1	0	0
79	105 35242	0	0	1	0	0	0	1	0	1	0	1	1	1	0	1	0	1	0	1	0	0	0	1	0
80	322 22145	0	1	1	0	1	0	0	1	0	0	1	0	0	1	0	0	0	1	1	0	0	1	0	1
81	030 10037	0	0	0	0	1	1	0	0	0	0	0	1	0	0	0	0	0	0	0	0	1	1	1	1
82	562 52120	1	0	1	1	1	0	0	1	0	1	0	1	0	1	0	0	0	1	0	1	0	0	0	0
83	560 56150	1	0	1	1	1	0	0	0	0	1	0	1	1	1	0	0	0	1	1	0	1	0	0	0
84	713 10154	1	1	1	0	0	1	0	1	1	0	0	1	0	0	0	0	0	1	1	0	1	1	0	0
85	370 42355	0	1	1	1	1	0	0	0	1	0	0	0	1	0	0	0	1	1	1	0	1	1	0	1
86	344 70231	0	1	1	1	0	0	1	0	0	1	1	1	0	0	0	0	1	0	0	1	1	0	0	1
87	402 24402	1	0	0	0	0	0	0	1	0	0	1	0	1	0	0	1	0	0	0	0	0	0	1	0
88	316 34367	0	1	1	0	0	1	1	1	0	0	1	1	1	0	0	0	1	1	1	1	0	1	1	1
89	506 66642	1	0	1	0	0	0	1	1	0	1	1	0	1	1	0	1	1	0	1	0	0	0	1	0
90	101 42323	0	0	1	0	0	0	0	0	1	1	0	0	0	1	0	0	1	1	0	1	0	0	1	1
91	752 76000	1	1	1	1	0	1	0	1	0	1	1	1	1	1	0	0	0	0	0	0	0	0	0	0
92	221 52307	0	1	0	0	1	0	0	0	1	1	0	1	0	1	0	0	1	1	0	0	0	1	1	1
93	323 34414	0	1	1	0	1	0	0	1	1	0	1	1	1	0	0	1	0	0	0	0	1	1	0	0
94	537 64360	1	0	1	0	1	1	1	1	1	1	1	0	1	0	0	0	1	1	1	1	0	0	0	0
95	404 62353	1	0	0	0	0	0	1	0	0	1	1	0	0	1	0	0	1	1	1	0	1	0	1	1
96	426 10437	1	0	0	1	0	1	1	0	0	0	1	0	0	0	1	0	0	1	0	0	1	1	1	1
97	076 12306	0	0	0	1	1	1	1	0	0	0	1	0	1	0	0	1	1	0	0	0	1	1	0	0
98	111 26245	0	0	1	0	0	1	0	0	1	0	1	0	1	1	0	0	1	0	1	0	0	1	0	1
99	317 46044	0	1	1	0	0	1	1	1	1	1	0	0	1	1	0	0	0	1	0	0	1	0	0	0
100	147 36272	0	0	1	1	0	0	1	1	1	0	1	1	1	1	0	0	1	0	1	1	1	0	1	0

Figure B-2. (continued)

Figures B-3, B-4, and B-5 are presented as examples of one, 2, and 4 incomplete messages occurring respectively in about 50 message receptions. In each of these POFA exchanges, the modem interrupted the data transfer before the 100 words used for bit-error analysis in each incomplete message was reached. Note how a parity status of zero is assigned to all of these error words, meaning that bits 24 and 25 in the input buffer were zeroes on each error word. Fictitious error words caused by the signal-quality detection circuit of the modem do not always occur in blocks of 100 words and the exact number is usually found to be the number of error-reported words with parity status zero.

In the examples shown, the error words reported on the POFA printout are induced by the modem signal-quality circuit and do not represent real errors. This is not always the case, but is the usual situation. Perhaps, it is explained by observing that a tone phase angle can be off by  $\leq \pm 45^\circ$  without being nearer to another phase value than its true phase. The AN/USQ-59 modem will not transfer data when 4 consecutive frames have tones with phase angles  $\geq \pm 22.5^\circ$  from one of the 4 actual values. Apparently the pseudo word errors are usually introduced by the modem before real word errors are encountered. This has not been our observation with the AN/ACQ-5 modem; 4 or more word errors appear to accompany each incomplete message.

It is not our intention to give the impression that POFA data received by a modem with a signal-quality detection circuit are totally useless. Rather, these data can be easily misinterpreted and a valid analysis requires an understanding of how the POFA software interacts with this circuit. On several occasions, 10 or more consecutive POFA exchanges of 5 to 10 minutes duration were received by the AN/USQ-59 across separation ranges up to 100 nautical miles before a single incomplete message was encountered. The frequency of these interrupted messages depends upon the signal-to-noise ratio and can result in exchanges such as figure B-6 (separation range of 148 nautical miles) where every message is incomplete.

Premature message termination does represent a loss, either total or partial, of data available for link fault analysis at the very time when link quality is less than optimum and such data are most valuable. In short, the POFA is functionally incompatible with the operation of the modem signal-quality detection circuit. We recommend that modems with such a circuit be provided with a switch to disable this circuit during POFA exchanges and that Link 11 operation manuals be amended to indicate proper operation of this switch.

LINK 11 NETWORK EVALUATION TEST (POFA) JAN 1971-

THIS STATION IS STA. NO. 14  
 USING THE AN/USQ-36 OR CP-800 WITH AN/SSQ-29 TERMINAL TEST  
 IN THE MULTISTATION MODE WITH BIT ERROR ANALYSIS

THIS STATION WAS ON THE AIR FOR 6MIN. 57SEC.

TOTAL WORDS TRANSMITTED-12420

TOTAL WORDS RECEIVED -9890

RECEIVED FROM  
 DLG-27

WORDS RECEIVED  
 9890

WORDS WITH ERRORS  
 100

INTERRUPT AND BUFFER STATUS  
 RECEIVED CONSECUTIVE PREPARE TO  
 TRANSMIT INTERRUPTS ERRORS-11

PARITY STATUS OF ERROR WORDS

PARITY WORDS

0 100

PARITY STATUS OF CORRECT WORDS

PARITY WORDS

3 1

BITS PER WORD IN ERROR

BITS	WORDS
6	5
7	2
8	5
9	6
10	16
11	28
12	15
13	9
14	10
15	3
16	1

6 5

7 2

8 5

9 6

10 16

11 28

12 15

13 9

14 10

15 3

16 1

NUMBER OF WORDS WITH BITS IN ERROR

BIT	TIMES IN ERROR	TIMES PICKED	TIMES DROPPED
0	49	0	49
1	46	0	46
2	51	0	51
3	23	0	23
4	50	0	50
5	52	0	52
6	52	0	52
7	42	0	42
8	32	0	32
9	29	0	29
10	58	0	58
11	49	0	49
12	49	0	49
13	48	0	48
14	55	0	55
15	45	0	45
16	50	0	50
17	53	0	53
18	38	0	38
19	55	0	55
20	46	0	46
21	56	0	56
22	39	0	39
23	37	0	37

49

0

49

1

46

0

46

2

51

0

51

3

23

0

23

4

50

0

50

5

52

0

52

6

52

0

52

7

42

0

42

8

32

0

32

9

29

0

29

10

58

0

58

11

49

0

49

12

49

0

49

13

48

0

48

14

55

0

55

15

45

0

45

16

50

0

50

17

53

0

53

18

38

0

38

19

55

0

55

20

46

0

46

21

56

0

56

22

39

0

39

23

37

0

37

THIS STATION REPORT IS FROM DLG-27

THIS STATION WAS ON THE AIR FOR 6MIN. 50 SEC.

TOTAL WORDS TRANSMITTED-9430

TOTAL WORDS RECEIVED -7360

RECEIVED FROM  
 UNREC. STA.  
 STA. NO. 14

WORDS RECEIVED  
 1380  
 5980

WORDS WITH ERRORS  
 523  
 235

END OF REPORT

Figure B-3. Multistation POFA with one incomplete message.

LINK 11 NETWORK EVALUATION TEST (POFA) JAN 1971-

THIS STATION IS STA. NO. 14  
 USING THE AN/USQ-36 OR CP-800 WITH AN/SSQ-29 TERMINAL TEST  
 IN THE MULTISTATION MODE WITH BIT ERROR ANALYSIS

THIS STATION WAS ON THE AIR FOR 7MIN. 2SEC.

TOTAL WORDS TRANSMITTED-11960

TOTAL WORDS RECEIVED -11730

RECEIVED FROM	WORDS RECEIVED	WORDS WITH ERRORS
CVA-64	11730	200

INTERRUPT AND BUFFER STATUS

RECEIVED END RECEIVE INTERRUPT BUT NO DATA ERRORS-1

PARITY STATUS OF ERROR WORDS

PARITY WORDS

0 200

BITS PER WORD IN ERROR

BITS WORDS

6	10
7	4
8	10
9	12
10	32
11	56
12	30
13	18
14	20
15	6
16	2

NUMBER OF WORDS WITH BITS IN ERROR

BIT	TIMES IN ERROR	TIMES PICKED	TIMES DROPPED
0	98	0	98
1	92	0	92
2	102	0	102
3	46	0	46
4	100	0	100
5	104	0	104
6	104	0	104
7	84	0	84
8	64	0	64
9	58	0	58
10	116	0	116
11	98	0	98
12	98	0	98
13	96	0	96
14	110	0	110
15	90	0	90
16	100	0	100
17	106	0	106
18	76	0	76
19	110	0	110
20	92	0	92
21	112	0	112
22	78	0	78
23	74	0	74

THIS STATION REPORT IS FROM CVA-64

THIS STATION WAS ON THE AIR FOR 6MIN. 55SEC.

TOTAL WORDS TRANSMITTED-11730

TOTAL WORDS RECEIVED -16560

RECEIVED FROM	WORDS RECEIVED	WORDS WITH ERRORS
UNREC. STA.	5290	3887
STA. NO. 14	11270	0

END OF REPORT

Figure B-4. Multistation POFA with two incomplete messages.

LINK 11 NETWORK EVALUATION TEST (POFA) JAN 1971-

THIS STATION IS STA. NO. 14  
 USING THE AN/USQ-36 OR CP-800 WITH AN/SSQ-29 TERMINAL TEST  
 IN THE MULTISTATION MODE WITH BIT ERROR ANALYSIS

THIS STATION WAS ON THE AIR FOR 5MIN. 5SEC.

TOTAL WORDS TRANSMITTED-11270

TOTAL WORDS RECEIVED -11270

RECEIVED FROM  
 CG-11

WORDS RECEIVED  
 11270

WORDS WITH ERRORS  
 400

INTERRUPT AND BUFFER STATUS  
 RECEIVED CONSECUTIVE PREPARE TO  
 TRANSMIT INTERRUPTS ERRORS-1

PARITY STATUS OF ERROR WORDS

PARITY WORDS

0 400

PARITY STATUS OF CORRECT WORDS

PARITY WORDS

3 1

BITS PER WORD IN ERROR

BITS WORDS

6	20
7	8
8	20
9	24
10	64
11	112
12	60
13	36
14	40
15	12
16	4

NUMBER OF WORDS WITH BITS IN ERROR

BIT	TIMES IN ERROR	TIMES PICKED	TIMES DROPPED
0	196	0	196
1	184	0	184
2	204	0	204
3	92	0	92
4	200	0	200
5	208	0	208
6	208	0	208
7	168	0	168
8	128	0	128
9	116	0	116
10	232	0	232
11	196	0	196
12	196	0	196
13	192	0	192
14	220	0	220
15	180	0	180
16	200	0	200
17	212	0	212
18	152	0	152
19	220	0	220
20	184	0	184
21	224	0	224
22	156	0	156
23	148	0	148

THIS STATION REPORT IS FROM CG-11

THIS STATION WAS ON THE AIR FOR 5MIN. 5SEC.

TOTAL WORDS TRANSMITTED-11040

TOTAL WORDS RECEIVED -9890

RECEIVED FROM  
 STA. NO. 14

WORDS RECEIVED  
 9890

WORDS WITH ERRORS  
 115

END OF REPORT

Figure B-5. Multistation POFA with 4 incomplete messages.

LINK 11 NETWORK EVALUATION TEST (POFA) JAN 1971-

THIS STATION IS STA. NO. 14  
 USING THE AN/USQ-36 OR CP-800 WITH AN/SSQ-29 TERMINAL TEST  
 IN THE MULTISTATION MODE WITH BIT ERROR ANALYSIS

THIS STATION WAS ON THE AIR FOR 4MIN. 1SEC.

TOTAL WORDS TRANSMITTED-18850

TOTAL WORDS RECEIVED -2300

RECEIVED FROM	WORDS RECEIVED	WORDS WITH ERRORS
UNREC. STA.	460	203
CG-11	1840	800

INTERRUPT AND BUFFER STATUS

RECEIVED END RECEIVE INTERRUPT BUT NO DATA ERRORS-8

RECEIVED CONSECUTIVE PREPARE TO  
 TRANSMIT INTERRUPTS ERRORS-63

PARITY STATUS OF ERROR WORDS

PARITY WORDS

0 1000

PARITY STATUS OF CORRECT WORDS

PARITY WORDS

3 12

BITS PER WORD IN ERROR

BITS WORDS

6	50
7	20
8	50
9	60
10	160
11	280
12	150
13	90
14	100
15	30
16	10

NUMBER OF WORDS WITH BITS IN ERROR

BIT	TIMES IN ERROR	TIMES PICKED	TIMES DROPPED
0	490	0	490
1	460	0	460
2	510	0	510
3	230	0	230
4	500	0	500
5	520	0	520
6	520	0	520
7	420	0	420
8	320	0	320
9	290	0	290
10	580	0	580
11	490	0	490
12	490	0	490
13	480	0	480
14	550	0	550
15	450	0	450
16	500	0	500
17	530	0	530
18	380	0	380
19	550	0	550
20	460	0	460
21	560	0	560
22	390	0	390
23	370	0	370

THIS STATION REPORT IS FROM CG-11

THIS STATION WAS ON THE AIR FOR 3MIN. 39SEC.

TOTAL WORDS TRANSMITTED-11500

TOTAL WORDS RECEIVED -1610

RECEIVED FROM	WORDS RECEIVED	WORDS WITH ERRORS
UNREC. STA.	920	163

END OF REPORT

Figure B-6. Multistation POFA with every message received (10) incomplete.

**APPENDIX C:**  
**SOFTWARE PATCH FOR CP-642A OR B COMPUTER POFA**  
**TO OUTPUT ON R0280 HIGH-SPEED PRINTER**  
**(NAVSHIPS 0967-011-4001 DATED 23 MARCH 1973)**

## INTRODUCTION

This Appendix describes the software patch developed by UNIVAC for NOSC to allow the POFA for the CP-642A or B computer to be output on the R0280 high-speed printer. The following instructions apply:

1. Load the Link 11 POFA (NAVSHIPS 0967-011-4011 dated 27 March 1973);
2. Load the software patch;
3. Initialize the printout device and channel (the R0280 printer is field data); and
4. Run the POFA

This patch uses the channel parameter, so it is channel-changeable. A listing of the software patch appears in table C-1.



TABLE C-1. SOFTWARE PATCH FOR LINK 11 POFA (FOR CP-642A OR B)  
TO OUTPUT ON R0280 HIGH-SPEED PRINTER.

12052	02000	00027	60041	70000	77000
12254	12000	00000	60042	12200	00000
12273	12000	00000	60043	12400	00000
12330	61000	60000	60044	11130	60045
12331	12000	00000	60045	05050	50505
12332	12000	00000	60046	70100	00020
12333	12000	00000	60047	15030	60120
12560	41050	50377	60050	61000	60063
12562	05050	50505	60051	40011	12360
14041	27310	37700	60052	12314	60102
60000	11020	11707	60053	16310	60054
60001	52040	77760	60054	06000	00000
60002	10000	77037	60055	10034	60112
60003	06000	00005	60056	57032	60120
60004	57020	60031	60057	71400	00004
60005	57020	60034	60060	61000	60063
60006	57020	60036	60061	71200	00020
60007	57020	60040	60062	12000	00000
60010	11020	12304	60063	71100	00000
60011	21010	12304	60064	61000	60020
60012	15010	60063	60065	16210	60015
60013	12000	00000	60066	16410	60016
60014	12100	00000	60067	16510	60017
60015	12200	00000	60070	61000	12331
60016	12400	00000	60071	40011	12360
60017	12500	00000	60072	21400	00004
60020	10000	00077	60073	61000	60051
60021	40511	12360	60074	61000	60063
60022	61000	60063	60100	00000	60120
60023	21400	00003	60101	00000	00040
60024	61000	60071	60102	00000	00030
60025	12000	00000	60103	00000	00022
60026	16240	00000	61014	00000	00014
60027	20010	60100	60105	00000	00006
60030	15020	60100	60107	00000	00001
60031	13030	60107	60110	00000	00200
60032	70000	00700	60111	00000	00004
60033	12000	00000	60112	00777	77777
60034	74030	60100	60113	77007	77777
60035	12000	00000	60114	77770	07777
60036	63000	60036	60115	77777	70077
60037	12000	00000	60116	77777	77700
60040	13030	60101			