

**U.S. DEPARTMENT OF COMMERCE
National Technical Information Service**

AD-A051 589

ROTORCRAFT DESIGN

January 1978

**Best
Available
Copy**

ADA051589

AGARD-CP-233

AGARD-CP-233

AGARD CONFERENCE PROCEEDINGS No. 233
Rotorcraft Design

REPRODUCED BY
NATIONAL TECHNICAL
INFORMATION SERVICE
U. S. DEPARTMENT OF COMMERCE
SPRINGFIELD, VA. 22161



REPORT DOCUMENTATION PAGE

1. Recipient's Reference	2. Originator's Reference	3. Further Reference	4. Security Classification of Document
	AGARD-CP-233	ISBN 92-835-1272-3	UNCLASSIFIED
5. Originator	Advisory Group for Aerospace Research and Development North Atlantic Treaty Organization 7 rue Ancelle, 92200 Neuilly sur Seine, France		
6. Title	ROTORCRAFT DESIGN		
7. Presented at	the Flight Mechanics Panel Symposium held at the NASA Ames Research Center, Moffett Field, California, USA, 16-19 May 1977.		
8. Author(s)	Various		9. Date January 1978
10. Author's Address	Various		11. Pages 352
12. Distribution Statement	This document is distributed in accordance with AGARD policies and regulations, which are outlined on the Outside Back Covers of all AGARD publications.		
13. Keywords/Descriptors	Rotary wing aircraft Helicopters Wind tunnel tests	Military aircraft Requirements Design criteria	Civil aviation
14. Abstract	<p>These proceedings consist of the 26 papers that were presented at a Flight Mechanics Panel Symposium on Rotorcraft Design. The basic theme of this meeting was the examination of the opportunities for coordinating military and civil requirements and specifications. There were five sessions during which the following fields were covered: military requirements and new rotorcraft systems, civil operations and new designs, research vehicles, rotor wind tunnel and flight research, common ground for civil military co-operation. The meeting was concluded with a Round Table in which the possibilities for future exchanges of information, between military and civilian rotorcraft designers and operators, were examined. The many conclusions and recommendations arising from this symposium are discussed fully in a Technical Evaluation Report, AGARD Advisory Report Number 114.</p>		

THE MISSION OF AGARD

The mission of AGARD is to bring together the leading personalities of the NATO nations in the fields of science and technology relating to aerospace for the following purposes:

- Exchanging of scientific and technical information;
- Continuously stimulating advances in the aerospace sciences relevant to strengthening the common defence posture;
- Improving the co-operation among member nations in aerospace research and development;
- Providing scientific and technical advice and assistance to the North Atlantic Military Committee in the field of aerospace research and development;
- Rendering scientific and technical assistance, as requested, to other NATO bodies and to member nations in connection with research and development problems in the aerospace field;
- Providing assistance to member nations for the purpose of increasing their scientific and technical potential;
- Recommending effective ways for the member nations to use their research and development capabilities for the common benefit of the NATO community.

The highest authority within AGARD is the National Delegates Board consisting of officially appointed senior representatives from each member nation. The mission of AGARD is carried out through the Panels which are composed of experts appointed by the National Delegates, the Consultant and Exchange Program and the Aerospace Applications Studies Program. The results of AGARD work are reported to the member nations and the NATO Authorities through the AGARD series of publications of which this is one.

Participation in AGARD activities is by invitation only and is normally limited to citizens of the NATO nations.

The content of this publication has been reproduced directly from material supplied by AGARD or the author.

Published January 1978

Copyright © AGARD 1978
All Rights Reserved

ISBN 92-835-1272-3



Printed by Technical Editing and Reproduction Ltd
Harford House, 7-9 Charlotte St, London, W1P 1HD

11

AGARD-CP-233

NORTH ATLANTIC TREATY ORGANIZATION
ADVISORY GROUP FOR AEROSPACE RESEARCH AND DEVELOPMENT
(ORGANISATION DU TRAITE DE L'ATLANTIQUE NORD)

AGARD Conference Proceedings No. 233

ROTORCRAFT DESIGN

**Papers presented at the Flight Mechanics Panel Symposium held at the NASA Ames
Research Center, Moffett Field, California, USA, 16-19 May 1977.**

PREFACE

Rotorcraft and their applications have held the attention of AGARD Technical Panels for many years. They have been the subject of several Specialists Meetings and Symposia.

The AGARD Flight Mechanics Panel (FMP) organized a symposium on Advanced Rotorcraft in 1971 at NASA Langley Research Center (AGARD-CP-121).

Since that time increasing experience in the field of commercial and military helicopter operations has led to new technical and operational requirements. New government-sponsored military rotorcraft development programs incorporate advanced technology which improves not only survivability but also overall efficiency, maintainability and reliability. On the other hand, commercial rotorcraft development programs are largely funded by the manufacturers and therefore cannot include new high risk designs to meet special civil helicopter regulations or new civil operational requirements.

The AGARD Flight Mechanics Panel therefore decided to structure a new symposium on Rotorcraft Design with special emphasis to be placed on opportunities for improved coordination of military and civil requirements and specifications.

This meeting provided the military and civilian rotorcraft designers and operators with a unique opportunity for discussions and exchanges concerning common problems and grounds for civil/military cooperation.

The symposium was organized into five sessions as follows:

- Military Requirements and new rotorcraft systems
- Civil operations and new helicopter designs
- Research vehicles
- Rotor wind tunnel and flight research
- Common ground for civil/military cooperation

and a final round table discussion on

- Opportunities for coordinating military and civil requirements and specifications.

Touching on the main theme of the meeting, it is evident that many areas of incompatibility between civil and military hardware requirements are the inevitable results of the different operational environments and management constraints within which the two user groups must function. The principal opportunity for commonality will continue to be with the core dynamic components. There are, however, areas where more coordination could be beneficial. Examples are greater standardization within these user groups in establishing common procedures for accumulating experience data on new families of dynamic components, and in setting up the means by which compliance testing of dynamic components can be accepted for both civil and military verification.

The unanimous concern expressed over escalating program costs for new rotorcraft systems, especially in the larger sizes where smaller production runs make development costs a very significant part of the unit acquisition cost, supports the recommendation that the Flight Mechanics Panel undertake a more detailed study to identify the areas where common requirements exist and where uniform standards could be established. The meeting also identified areas where an investigation of opportunities for cooperative efforts between the NATO research agencies could be fruitful.

A complete summary and evaluation of the meeting is available as AGARD Advisory Report No. 114, Technical Evaluation Report on the Flight Mechanics Panel Symposium on Rotorcraft Design.

CONTENTS

	Page
PREFACE	iii
KEYNOTE ADDRESS: TRENDS IN ROTORCRAFT DESIGN AND DEVELOPMENT by M.J.Soulez-Larivière	vii
<u>SESSION I – MILITARY REQUIREMENTS AND NEW ROTORCRAFT SYSTEMS</u>	
PROJECTED NEEDS OF U.S. ARMY AVIATION by S.C.Stevens	1
GERMAN ARMY HELICOPTER DEVELOPMENT AND PROSPECTS FOR THE FUTURE by K.W.Mack and H.Jakob	2
CANADIAN NAVY EXPERIENCE WITH SMALL SHIP HELICOPTER OPERATIONS by N.H.J.Browne	3
BRITISH MILITARY HELICOPTER PROGRAMMES by J.D.W.Husband	4
THE U.S. ARMY UTTAS AND AAH PROGRAMS by R.E.Gormont and R.A.Wolfe	5
US NAVY/MARINE CORPS ROTARY WING REQUIREMENTS by J.A.Purtell	6
<u>SESSION II – CIVIL OPERATIONS AND NEW HELICOPTER DESIGNS</u>	
BRITISH AIRWAYS HELICOPTER OPERATIONS by J.A.Cameron	7
AIR-SEA RESCUE OPERATIONS. SEARCH AND RESCUE EXPERIENCE by T.Skaar	8
SOME ASPECTS OF OFFSHORE OPERATIONS IN THE NETHERLANDS by R.J.van der Harten	9
COMBINED MILITARY AND COMMERCIAL APPLICATION OF LIGHT HELICOPTERS by E.E.Cohen, K.B.Amer and R.E.Moore	10
LONG TERM EXPERIENCE WITH A HINGELESS/COMPOSITE ROTOR by G.Reichert and E.Weiland	11
THE BELL MODEL 222 by J.R.Garrison	12
THE SIKORSKY S-76 PROGRAM by R.F.Donovan	13
THE "AS 350" LIGHT HELICOPTER by R.Mouille	14
<u>SESSION III – RESEARCH VEHICLES</u>	
TETHERED RPV-ROTORCRAFT by G.Kannamüller and W.Göller	15
EVALUATION OF THE TILT ROTOR CONCEPT – THE XV-15's ROLE by J.H.Brown, Jr., H.K.Edenborough and K.G.Wernicke	16

	Reference
THE ADVANCING BLADE CONCEPT (ABC) ROTOR PROGRAM by H.R.Young and D.R.Simon	17
THE ROTOR SYSTEMS RESEARCH AIRCRAFT (RSKA) by R.J.Huston, J.L.Jenkins Jr. and J.L.Shipley	18
<u>SESSION IV – ROTOR WIND TUNNEL AND FLIGHT RESEARCH</u>	
THE NAE AIRBORNE V/STOL SIMULATOR by S.R.M.Sinclair, W.E.B.Roderick and K.Lum	19
DFVLR ROTORCRAFT RESEARCH by B.Gmelin, H.-J.Langer and P.Hamel	20
RESEARCH REQUIREMENTS FOR THE IMPROVEMENT OF HELICOPTER OPERATIONS by M.V.Lowson	21
ONERA AERODYNAMIC RESEARCH WORK ON HELICOPTERS by J.J.Philippe and C.Armand	22
WESTLAND WISP by M.J.Beward	23
TECHNICAL AND FINANCIAL FALL-OUT ON ARMED FORCES FROM COMMERCIAL AND EXPORT HELICOPTER PROGRAMMES by A.L.Renaud	24
CIVIL AND MILITARY DESIGN REQUIREMENTS AND THEIR INFLUENCE ON THE PRODUCT by D.G.Harding and J.P.Walsh	25

✓

KEYNOTE ADDRESS

TRENDS IN ROTORCRAFT DESIGN AND DEVELOPMENT

M.J.Soulez-Larivière

Preceding page blank

Mr. President, Dear Members,

I thank you for the honor given to me of delivering to you the introductory lecture of this session devoted to the rotorcraft, and I think that the subject of cooperation between civilian and military can be very interesting and profitable for both. Such an organization as AGARD, which has been trying for many years to promote cooperation between nations of similar civilization, is particularly well suited to be the point of meeting of these other aspects of cooperation between two parts of the customers of the rotorcraft industry. And, in the title of TRENDS IN ROTORCRAFT DESIGN AND DEVELOPMENT, I choose to focus on this particular point which has changed very much since our last meeting in 1971, with the growing interest of civilians in the helicopter, and their increasing part in production.

1 - FROM RETROSPECT TO PRESENT SITUATION

To begin with, let us start from the real facts derived from statistical data

1. Up to 1950, we find that small production was nearly exclusively experimental or military. The explosion of the Helicopter product follows the long years of technical maturation that have proved necessary to find solutions to the hard problems that you well know of: lift/weight ratio, stability and control, fatigue limit and mechanical strength. But such resolving of the problem has been achieved to a very high cost, both for production and maintenance, and the military user only is able to find profitable a number of specific qualities of the product which to him essentially are its ability to hover and the ubiquity thus imparted to the vehicle, i.e. surveillance, punctual liaisons, casualty evacuation, etc.. The Korean war has been the first fire baptism of the helicopter at war.
2. Between 1950 and 1960, we find on the military side a slow but smooth progress of production and, on the civil side, a beginning of operations for missions nearly similar to those of the military, namely, surveillance, liaisons to otherwise inaccessible places - particularly mountainous, land and sea rescue, and some more specific missions such as aerial work and agricultural spreading.

In this period, it can be stated that the civil helicopter has been the heir to the military. First, as regards a firm, the volume of potential customers for the civil helicopter could never account for the important and risky investments of a prototype study and a production line. Also, such a potential could never be sufficient to arrive at the necessary experience and flight hours for the development of an operational model. So much that the civil helicopter is truly, at this time, a recently demobilized helicopter, like, in fact, a pretty good number of its pilots.

This world statistical information could mask some evolutionary processes of a more local character. It thus appears that helicopter production in France began in 1955, thanks to the convergence of two independent phenomena:

- the maturity of TURBOMECA as a manufacturer of small gas turbine engines in the 500-1,000 SHP range which, owing to their simplicity, lightness, reliability, etc. were to bring to the helicopter the adequate engine which it has been lacking up to this date.
 - the Algerian war which, suddenly, revolutionized the judgment, too often a routine, of the Headquarters on this new weapon system, bringing with it both financial support and operational experience.
3. Between 1960 and 1968, events go nearly the same way as before, with the variant that the evolution found in France from 1955 onward is repeating itself in the United States with a time offset of five years: generalization of the gas turbine engine and call for production in a hurry by reason of the military requirements.

The military roles attributed to the helicopter are transport missions (tactical and logistic) but also reconnaissance and firing platform, in which the speed relatively to land vehicles and the higher relative visibility counterbalance fragility and vulnerability. We may add a number of more proximity combat missions with light armor craft.

4. However, the 20 years of technological progress have by now been sufficiently decisive for the helicopter vehicle not to be as slow as before, not so ugly, not so fragile and, starting from 1968, we can witness a steeper gradient of the civil market which, together with the decline of the military requirements, will result in sharing production between the civil and the military, which by now is a nearly fifty-fifty proportion. And it is mainly the transport and liaison function, already pioneered by the military, which is acting as a basis for such a development which is, at this time, particularly stimulated by the oil industry.

5. Then, the question that comes now to mind is this:

Will the civil/military multipurpose function of the helicopter continue, and will the civil continue to depend on, as well as benefit from, the investments of the military? At a time where the fifty-fifty proportion has been reached, with a higher gradient for the civil use, is it not, to the contrary, a reverse trend that will occur? In that case, will the military benefit from return profits arising from the civil investments? Is the helicopter to remain multipurpose in nature or, to the contrary, shall we see the appearance of different productions or even industries, one military and the other civil?

2.- SIMILITUDES

On the first side, it would be prudent to do like the meteorologist forecasting for to-morrow the same weather as to-day, because the frequency of changing occurrences is lower than that of the static mode. And we find in the past many proven reasons to justify the statement that the multipurpose function will continue. Are the air molecules not the same for the civil and the military, or are we to color them differently in the wind tunnel, depending on the Ministry that pays for them? The natural frequencies of the blades and the fatigues of the pinion gears, as well as the electrons in the equipments are exactly the same, too. And it is to remain true that the costs of developing a transmission and rotor system are so high that their manufacturer will by all means try to amortize them through a higher series production that he will sell to both types of customers. However, we find that such an argument equally applies to the molecules of the sea or those of the road concretes, and that, despite the expensiveness of a battleship or a tank, their sale to civil customers requires particularly skilled sellers or very short-sighted customers.

I therefore think it necessary to ask the question again in the place of the customer: What does he purpose to do with his helicopter? And to reply as follows:

- for the military customer, the purpose is to make war, that is to overcome the enemy, and this is expressed in terms of performance.
- for the civil customer, the purpose is to make money, and this is expressed in terms of cost/effectiveness ratio.

And I chose to emphasize the differences more than the similitudes which are well known of all of you.

3.- Differences in the Methods

3.1. The Military Method

This is not to say that the military customer is not concerned with the cost of achieving a given performance. But it is Performance, generally estimated as speed, payload, capacity of equipments, compactness, etc., that will justify the enterprise of launching a new helicopter program.

True, the Armed Forces do make cost/effectiveness analyses, thanks to some private or public operational research laboratories, but, once it has been established that a given mission can be advantageously fulfilled by a helicopter, we can be sure that it always is by means of a helicopter that does better and more than its predecessor already in service. Only the technical increment value relatively to the present state of the in-service equipments would account for the high costs of a new program. And such a phenomenon has influenced on the organization of the various departments of the Armed Forces and printed it on the methods of the industry they are sponsoring. As an example, I'll take the French organization, because I know it fairly well, and I know that, except for a few changes, it is similar to the organization in other countries.

////

Thus, once a military program has been determined which, I recall, is only justified by its technical advance as compared with the equipment already in service, a "Service Technique Gouvernemental" (Government technical Department) is appointed to lay down the precise and detailed specifications of the program, so as to deliver them to the Industry (Request for Proposal). The industrial correspondent of the "Service Technique" is a "Bureau d'Etudes" (Engineering Office) whose task shall consist in designing and developing prototypes to the specifications. And such task is difficult enough, since we are in a leading technology, for the problem not to be rendered more complex through outside considerations, above all not industrial or financial. Eventually, at the end of years of efforts, the detailed definitions of the helicopter meeting the specifications at best, as well as the test results to administer the proof of it, are delivered by the "Bureau d'Etudes" to the "Service Technique".

At this particular time, it occurs that powers are transmitted to another Government Agency in charge of procuring a definite number of products meeting the preceding definition. This organization, called "Service de Production" (Production Department) will be confronted to different speakers of the concerned Manufacturer, in order to request from them proposals for manufacturing what has been designed by their colleagues. However, the manufacture of the technical wonder which the prototype is a picture of, within the established time schedule, is another feat of strength. For it certainly cannot be spoken of altering the design to make it cheaper: the development results generally from so delicate and fragile a compromise, among all the requirements of the program, that the additional time required for developing a product suitable for manufacture would be unacceptable, making obsolete a program which too often tends to delay in time.

All these problems lead to a high, irreducible unit cost, and the aggregate sum of money allocated to a program is so immutably determined by the Government that the only free remaining variable is the number of helicopters to be manufactured.

3.2. The Civil Method

A simple comparison of the way that civil products, even of small output like, for example, luxury automobiles or small aircraft, is very telling. In fact, the parameter in which the civil customer is interested is absolutely not Performance in relation to the number of units he wants to purchase, but Performance related to the unit cost of the required product.

This means that the organization to be set up for designing and producing a civil helicopter would be very different from the other one. I am not sure that it will lead to a Cost Control Department as it works in the automotive industry, sourcing its power directly from the Chairman and having authority on both the technical and production departments. But I am sure that a minimum requirement of such an organization would be close liaisons between the engineering and production, so as to figure out, as soon as the draft stage, the price of what is drawn and to gain access to the cost/effectiveness ratio. And this requires, in turn, that the manufacturing works be, so to speak, glass-walled, so as to avail itself of a data acquisition system on costs of a high accuracy with many possible variations; while in the military organization, the risk of such an information would be that it could readily be used by the department inspectors as an information on profits, so that the tendency of the manufacturing firm is to hide this information, even for its own engineering office.

Having initiated such a physical exercise in France, we are in a position to state that this is feasible but that it is truly revolutionary for many people used to the other method.

4. DIFFERENCES IN MISSIONS

In addition to this basic divergence in the methods, I now think of the differences in the purposes followed by the military and the civil, which are to be found in the missions, particularly in the mission profiles and the equipments required, much more than in the past. Let us give a few details on such differences:

4.1. Payload

The early missions which the helicopter was capable of, were in connection with its unique capability for the hovering flight. This capability was to be paid for, not only through a high cost of operation but also through the weakness of all the remaining parameters such as payload, /X

speed, range, ceiling, etc., as compared to the performances of the fixed wing aircraft. Hence a class of early military uses, such as observation missions in the mountains, rescue of casualties, rescue at sea where performances are secondary, and the first civil missions in the aerial work, that were directly derived from the military missions.

Pressure from the customer has been very strong for an increase, first in payload to allow for tactical or logistic transport, also for armed missions for an ever-increasing weight of anti-tank or anti-submarine weapons, or even of armour. And there was an unconscious opinion that these improvements in sizes required by the military could lead to the helicopter fulfilling civil missions of passenger transport, in much the same way as had occurred for the fixed wing aircraft. However, this has not occurred, and while the military tactical transport was becoming an everyday reality and some achievements were to be seen in the logistic transport, civil transport remained confined to a very small number of areas of geographical necessity. One may wonder why and I, for my part, believe that this is to be explained by the nature of the global transport system in which the commercial helicopter is evolving. If we assume a perfect, non-saturated navigation and approach system, which is still happily true of a number of airports, the vital time advantage of the helicopter is in connection with the fact of landing nearer to the city centers. But, as we here, supposedly, speak of public transport, there remains a gap as regards surface transportation: we have still to take a taxi or the underground railway and, in the way back, we have to make calculations for a time margin of a quarter of an hour, so as not to miss take-off time. For example, supposing the diameter of a big city is 20 miles, the average distance from a heliport situated in its center is still 7 miles, but only 10 miles from a peripheral airport. The economics of the Helicopter is truly beneficial but to the Air Traffic Control and Airport Authorities, by reason of its gain in space and time, but the user could only benefit from the overall time saving, if he is landed "on site". Such is the case of the big military helicopters, but this is not true of the common carriers. However, such is also the case of the supplying helicopters to the oil-drilling platforms at sea, of the business or private liaison missions, and it is truly here that the essential development of the civil transport helicopter lies.

And this is in connection with the size ranges of the helicopter that do not overlap. The military size begins at 4/5 seats, around 1,000 lb of payload, with no superior limit within the present state of the art. This means that the capacity of carrying very heavy unit-loads on the short distances continues to be of military interest because of the non-fractional character of some loads (such as a gun or a tank), and the question arises as to whether an army can clear a given obstacle. Sizes are smaller on the civil side. At the bottom of the range, there is room for very small helicopters of 2-3 seats or 500 lb of payload, and I am sure that these will develop when suitable engines (small turbines or Wankel engines) become available. To the contrary, around the top of the range, we said just before why the size of the transport helicopter remains limited by reason of the surface split problem, which is longer and longer when the passengers increase in number, therefore increasing their area of destination. Similarly, for lifting missions, the number of non-fractional loads decreases with their tonnage, thus decreasing the economic viability of the construction and purchase of a specially-built machine.

4.2. Hovering/Cruise Trade-Off

We also have to detail a second significant difference between the two classes of missions. For the military, a high capacity for the hovering flight time is vital. It has not only to take-off and land at places hardly known or accessible only through a short hovering time, but it has frequently to remain stationary in the course of a flight, in order to camouflage, to fire missiles, to protect itself or be protected, or to listen to submarines. For the civil use, apart from the already well pioneered aerial work missions, the liaison missions will always be performed from roughly prepared or signalled landing areas, where the landing and take-off operations can be on the spot without being necessarily stationary and in the course of a flight, so that hovering is of no avail.

As far as the combination of the hovering/cruise flight is concerned, the military will continue, as before, to privilege the hovering flight, and the civil helicopter speed, or rather the lift-drag ratio. It appears to me from personal studies, that such differences in the fields of interest could lead to equally significant differences in design of helicopters, possibly with a ratio of 1.5 on a

number of parameters.

4.3 Engines, Equipments and Mission fitting Capability

A third difference is connected to a difference of interest in the field of the two-engine powerization. This is merely useful for the military who readily satisfy themselves with autorotation capabilities in the event of a failure, and for whom the dangers in fight are far superior to those of an engine failure. To the contrary, the civil customers are increasingly to require twin-engined helicopters, even for smaller helicopters, because they will find themselves forced to fly over populated areas, where landing in the autorotation configuration is not possible.

In the same way, we may believe that new military missions will not fail to be organized and tailored to the more and more sophisticated weapons and equipments offered them by technology. I believe that the military helicopter will be one piece of a more complex weapon system, and that it will have to be embodied in the other pieces of the puzzle. Firing missiles, armouring, carrying radars, sonars and torpedoes, camouflaging, protecting itself against radiations, visualizing by night in a hostile environment, these are examples at random leading to the conclusion that the helicopter has just begun its career in the military service. This career is likely to arrive at the same differentiation as that of aircraft and ships. There will be fighter helicopters, tactical and anti-tank helicopters, anti-submarine or anti-ship helicopters, all of which to become finally very different from the military transport helicopter which, itself, will differ enough from the liaison, business or touristic helicopter. To-day, nobody would dream of deriving a liaison aircraft from a fighter!

5.- CONCLUSION

I would conclude and summary, first by noting the prime interest of the military for the helicopter and their unique support of its development during twenty years.

And then, by noting the very rapid growth of civil applications since 1968, and the equal sharing of production which we can witness nowadays. The progress and development of both of them will undoubtedly continue.

However, I feel inclined to predict that the dependency of civil uses on the military will progressively diminish, and that we are likely to witness, on one hand, such technology becoming common-place and of a much easier access to new industrial firms and, on the other, the different types of helicopters becoming much more specialized as they are to-day, similar to what has occurred to aircraft and all the leading industries of the past.

Perhaps, this will be a reason more to draw the friendly bonds thus created by such community of activities and community of civilization closer, and to meet again here, for the sake of the charming Californian spring.

Addendum: After reading the proceedings of this meeting concerning the aspect shown here, I find two opposite philosophies: on one hand, Note N° 1 by Col S.C. STEVENS seems to be in agreement with mine. He emphasizes the important needs for making the helicopter a true combat vehicle with fire-proof elements, crash capabilities, etc., i.e. an expensive machine with many features of no-interest for civil use but actually able to fight in a combat area. On the other hand, paper n° 24, by André Renaud, showing the possibility to use a civil product as a cheap military machine. With this philosophy, for a given amount of money, the Army could buy more helicopters of a lower combat capability. It surely is the only way to follow, if the amount of money available does not allow for a new development; however, the global efficiency of such purchase must be compared with that of the other.

PROJECTED NEEDS OF U.S. ARMY AVIATION

BG (P) Story C. Stevens
Deputy Commanding General
U.S. Army Aviation Systems Command
St. Louis, Missouri, 63166, U.S.A.

1-1

SUMMARY

This report reviews the projected needs of U.S. Army air mobility as they are seen today within the U.S. Army Aviation Systems Command. It is an overview of the U.S. Army's envisioned future aviation requirements and how they relate to research and development needs. Special emphasis is given to those aspects of the military requirements which seem to offer the best opportunities for coordination with civil developments. The paper addresses both the short-term needs, as exemplified by the currently developing systems, and the long-term requirements, which may be represented by conceptual studies only.

In this report, the current projection of the U.S. Army's aviation needs are analyzed in order to identify technological gaps. A study of the deficiencies and shortcomings of current U.S. Army aircraft reveals many areas that are common to the inventory, such as vulnerability, high life-cycle costs, and inadequate performance. Reliability, availability, maintainability, and durability are essential to assure that equipment and facilities will be functional when required. Enhanced human effectiveness is needed to permit the best possible utilization of the Army's limited military personnel appropriation. Cost-saving and cost-avoidance programs are essential for determining what we can afford in terms of overall defense. The commonality of many of these problems for both civil and military utilization of rotorcraft is evident. Hence, the required advances in the disciplines and supporting technologies identified to meet military needs have their obvious counterparts in civil requirements.

The report examines the military needs and their relation to the advances that rotary-wing-aircraft technology is expected to experience over the next two decades. Improved rotor performance, improved structural efficiency, and reduced specific fuel consumption are certain to be realized. Continuing advances in micro-computers and other electronic devices will greatly improve navigation and control capabilities over current systems such that operations during adverse weather and reduced visibility conditions will be possible. Increased reliability and reduced maintenance requirements are sure to evolve, as will self-contained test capability. These advancements in rotorcraft technology are required to support the rapid growth in both civil and military applications projected over the next decade.

INTRODUCTION

Rotating-wing aircraft, such as helicopters, have been the subject of sporadic attention for centuries, dating back to the time of Leonardo da Vinci. U.S. Army interest in the helicopter began in 1918, when an investigation of the Peter Cooper Hewitt helicopter design was made by the Air Service Engineering Division at McCook Field, Dayton, Ohio (now the Wright-Patterson Air Force Base). The Army foresaw "great possibilities" for a machine capable of up-and-down flight and, hence, operation from restricted areas.

The U.S. Army Air Service undertook the development of rotary-wing aircraft in 1921 by contracting with Dr. George de Bothezat for the construction and flight testing of a quadrotor helicopter configuration at McCook Field. On December 18, 1922, the de Bothezat helicopter made its appearance for flight demonstration (Fig. 1). It hovered for 1 min and 42 sec at the height of a man. However, when the Army suspended support of the de Bothezat helicopter, enthusiasm in the development of such a craft waned for many years. This may have been a reflection of the following sentiments expressed in the preface to the 1922 edition of Jane's All the World's Aircraft in which helicopters appeared for the first time:

"Helicopters are included chiefly because so much public attention has been concentrated on them by the Press, thanks largely to the misguided generosity or enthusiasm of official or wealthy people who have subsidized these curious machines to an extent which would have produced notable results had similar sums been expended on practical flying machines . . . it is one's personal belief that long before anybody produces a helicopter which is of any practical use, far better results in the way of "flying straight up" will have been attained by ordinary aeroplanes with improved wings."

In 1940, the U.S. Army's helicopter program was reborn when Platt-LePage won a design competition and a contract was approved for the procurement of the Army's second helicopter - one XR-1 helicopter. By this time, there had been successful flights of the Focke-Achgelis Model F-61 in Germany and moderately successful flights of the superimposed coaxial twin-rotored helicopter designed and built by Louis Breguet in France. The Platt-LePage design, a twin, side-by-side rotor configuration, was similar to the F-61. The first free flight of the aircraft was made on June 23, 1941 (Fig. 2).

However, the U.S. Army was not satisfied with just one type of helicopter. While the Platt-LePage model was under construction, the Army was also working with another manufacturer. This resulted in the first truly successful helicopter in this country - the VS-300, laboratory model of the Vought-Sikorsky Division of the United Aircraft Corporation. The first free flight was made in May 1940 and, in January 1941, a contract was awarded to Vought-Sikorsky for the construction of the XR-4, which was a two-place, three-bladed, single-main-rotor helicopter with an auxiliary tail rotor to counteract the torque reaction. The first flight of the XR-4 was made in January 1942 (Fig. 3). On 17 May 1942 (35 years ago), the XR-4 was delivered to Wright Field, Ohio by the contractor's pilot after a cross-country flight from Stratford, Connecticut. The XR-4 was accepted May 30, 1942, and was the first helicopter delivered to the U.S. armed services.

In the three decades since the end of World War II, the U.S. Army has considerably expanded its use of the helicopter. Originally, the helicopter was thought of as being a reconnaissance, evacuation, and general-purpose aircraft that was capable of performing missions similar to those which had been performed by the light, fixed-wing aircraft. As the potential of this vehicle began to be appreciated, its use as a cargo and personnel transport was recognized and, subsequently, the roles of firepower and service support were added. The NATO exercise of last Fall, called REFORGER '76, reinforced the U.S. Army's concept of aviation's role in the combined arms team. The exercise tested the air assault concept in Europe and demonstrated the versatility of Army aviation in the conduct of extensive tactical operations. The use of air vehicles by ground forces has added another dimension to the battlefield by enhancing the ability to conduct land combat functions. Today, the mission of the aviation unit is based on the mission of the ground unit and Army aviation support is integrated with and based upon the ground tactical plan. The Army's use of air space is directly related to the performance of land battle and to the traditional functions of land combat including mobility, intelligence, firepower, combat service support, and command, control, and communication.

As a consequence of the U.S. Army's concepts of aircraft utilization, and based upon the Army's combat experiences, certain criteria have evolved that bear directly on required rotary-wing aircraft characteristics. These characteristics include the following:

1. Aircraft must have the ability to hover out of ground effect at 4,000-ft-pressure altitude, at 95° F, and at basic mission weight with approximately a 500-ft/min vertical rate of climb at 95% intermediate rated power, thus permitting aircraft to be based close to the tactical user without reliance upon prepared airfields.
2. Aircraft must have adequate speed to insure timely response, productivity (ton mi/h, missions/day, etc.) and survivability. High speeds must find justification in terms of reduced aircraft losses and increased cost effectiveness of overall mission performance.
3. Aircraft must have near all-weather, full-instrument flight capability, providing effective organic aviation support to the ground soldier under virtually any climatic condition in which he fights.
4. Aircraft must provide crashworthiness, including prevention of postcrash fires, energy absorbing structures for crash impact, and crew-restraining devices to enhance survival.
5. Aircraft must be survivable, meaning that they must have the ability to perform the mission and return safely in the face of enemy fire without paying high penalties in aircraft weight, size, or dollar costs.
6. Aircraft must be capable of terrain flight, using the terrain, vegetation, and man-made objects to enhance survivability.

Against this background of general characteristics, this report reviews the projected needs of U.S. Army air mobility as they are seen today within the U.S. Army Aviation Systems Command. This is an overview of the U.S. Army's vision of its future aviation requirements and how they relate to research and development needs.

The aircraft that the U.S. Army will procure in the short term (i.e., for the next 10-15 yr) are most probably those currently in some stage of development against an identified mission requirement and based on current technology. The aircraft that will incorporate advances in technology achieved over the next few years will be those that meet our needs of 25-30 yr hence. We are compelled to make predictions for long-range requirements that fit responsibly into known technology and known, but unsolved, problems, despite the knowledge that these requirements will depend upon unpredictable geopolitical changes and technological surprises. This puts us in the position of the prophet who deduces the future by logical extrapolation from the past, and his knowledge of the present. He is probably doomed to failure because the only certainty about the future is that it cannot be predicted with certainty.

MISSIONS

The key to U.S. Army plans must be mobility — fast, dependable, and ever-present. In a very important sense, the degree to which we increase the Army's mobility may determine the ultimate outcome of any future engagement. Mobility improves the effectiveness of the soldier and his weaponry. It helps overcome disparity in strength or numbers. In both offense and defense, tactics will be designed to achieve a wide-open, fluid battlefield. Air mobility has become an essential factor in these concepts. Employed as an integral element of the combined arms team, armed helicopter forces significantly increase the total combat power at the disposal of the ground commander and provide a critical capability to influence the battle at the right time and place. To fight the land battle, the U.S. Army makes full use of aircraft for all five functions of combat: mobility and its inseparable companion, firepower; intelligence, which encompasses reconnaissance, surveillance, and target acquisition; combat service support or logistics; and last, but not least, command, control, and communications. The following discussions of the operational, developing, and future systems to meet U.S. Army needs are reflected in the composite chart of Fig. 4.

Mobility

The demand for greater mobility has continuously increased throughout the history of warfare. The abilities to deploy light, mechanized units and mobile, air-defense artillery quickly by air; to transport assault troops, weapons, and equipment around the battlefield, over obstacles; and to bypass enemy strong points — all have been significant factors in past conflicts and will continue to be valuable in any future contingency.

For squad-sized units and small weapons, the air assault mission of the mobility function is currently performed by the UH-1 (Fig. 5). This will be replaced by the Utility Tactical Transport Aircraft System (UTTAS) (Fig. 6), for which we recently awarded a contract for low-rate initial production. The UTTAS will lift a tactical infantry squad or its transport equivalent of externally or internally loaded bulk cargo. The UTTAS will be discussed in detail in another paper at this conference (Ref. 1). For units of larger size or heavier weapons, the CH-47 (Fig. 7) provides the necessary mobility. Because of its vulnerability, the CH-47 is rarely used in the combat assault role but provides maneuverability to the fire support elements and other supporting units. For large out-sized loads that require external slinging, the CH-54 helicopter (Fig. 8) is currently used in addition to the CH-47. These concepts are summarized in Tables I-III. 1-3

Developing Mobility Systems. The follow-on system for the current CH-47 fleet for the 7-10 ton payload range will be the Modernized CH-47 Medium-Lift Helicopter (the CH-47D), essentially a major modernization effort which does not quite fall in the same category as a new development project such as the UTTAS and the Advanced Attack Helicopter (AAH).

The current CH-47 Chinook Medium-Lift Helicopter (MLH) was designed to perform the missions of artillery movement, missile transport, personnel movement, aircraft recovery, medical evacuation, transport of liquid and dry-bulk cargo, and other combat service missions. The CH-47 has the capability of carrying cargo internally and/or externally. It was developed in the late 1950's with the technology of that era.

The current fleet has four primary inadequacies: (1) system operating costs are a support burden on critical Army resources; (2) CH-47A and B series aircraft, as currently configured, are approaching planned retirement; (3) the A and B series do not meet the 15,000-lb lift requirement for air mobility of artillery and engineer equipment; and (4) the reliability, availability, maintainability, safety, and survivability features of existing CH-47s need to be upgraded to current standards.

The need for MLH capability is recognized as continuing at least through the 1980's. The program that was approved by the U.S. Army as the most cost-effective means to sustain this capability is primarily an engineering effort for the design and integration of seven improved components or systems into the modernized CH-47 aircraft (Fig. 9). The seven major modifications to the CH-47 are: (1) composite rotor blades; (2) improved Lycoming T55-L-712 engines; (3) higher capacity transmissions with integral cooling and lubrication; (4) rewired and upgraded electronics; (5) a multipoint suspension system for sling loads; (6) an advanced flight control system; and (7) an improved auxiliary power unit with electrical generator and hydraulic pump for systems checkout without starting an engine. Under the modernization plan, the improved components and systems will be incorporated into a rehabilitated airframe configuration. A key element of the program is the capability of the older CH-47 airframes to continue to operate into the 2000's.

The CH-47 modernization program is designed to improve the reliability, maintainability, and safety of the CH-47A, B, and C aircraft while upgrading the lift performance of the A and B to meet the required operational capability. The performance characteristics of the modernized aircraft are the same as the CH-47C in such areas as speed, endurance, and number of troops carried. The key performance goals are increased payload and reliability.

Future Mobility Systems. There are no current U.S. Army R&D activities that relate exclusively to a future utility or medium-lift mission system. However, a quick-reaction, high-productivity type aircraft, such as could be produced with the tilt-rotor or Advancing Blade Concept (ABC) configurations, might become a future utility system. A possible tilt-rotor configured utility aircraft is shown in Fig. 10. In addition, a Light Utility Helicopter (LUH) may be needed with performance and physical characteristics (Table IV) to replace the UH-1's in the less demanding tasks that do not require a full UTTAS capability.

For the cargo transport mission, a Heavy-Lift Helicopter (HLH) system could increase the surface mobility of ground combat forces by providing a means of crossing otherwise impassable barriers through quick emplacement of bridging, by bringing in heavy equipment to remove an obstacle, or, if required, by physically lifting the force over the barrier. An HLH is envisioned primarily as a logistic support vehicle with lift capability of 20-50 tons operating chiefly in rear areas. Its primary mission would probably include delivery and retrograde of containerized and unitized cargo, surface and aerial port clearance, unloading and loading containerships in a logistics over-the-shore operation, and recovery and evacuation of damaged vehicles and aircraft. Although the HLH program was terminated by the U.S. Army at Congressional direction on 3 October 1975, the U.S. Army's Materiel Need Document dated 10 May 1972 remains valid. Assets required to complete the program have been stored and future efforts will depend upon affordability. With the cancellation of the Boeing Vertol XCH-62A Heavy-Lift Helicopter, there are no further U.S. Army plans for heavy-lift except for the CH-47 modernization program. Proposals for hybrid lighter-than-air aircraft, composed of balloon and helicopter elements, have been considered, but no Army funds have been committed. In general, there has been a recognition of a requirement for heavy-lift but funds have not been available.

Firepower

The firepower mission includes the capability of disrupting or destroying enemy armor and mechanized forces and of providing tactical firepower mobility and fire support to air assault or airmobile operations. The U.S. Army believes that rotary-wing aircraft will play a key role by rapidly massing helicopter firepower to seek out and destroy enemy armor and armored infantry units. The antitank guided missile on the helicopter places the Army on the threshold of major advances in firepower and mobility. The use of the scout with armed helicopters as a team, maximizes the armed helicopters' capabilities and increases their survivability. To carry out these operations, aviation units must be able to operate in adverse weather and at night. Surprise is achieved by using the speed, maneuverability, and firepower of the helicopter to attack the enemy at an unexpected time and from an unexpected direction. To overcome the enemy air-defense capability, helicopters are equipped with infrared suppression, radar warning receivers, low reflective paint and low-glint, flat canopies, armor protection for critical components and crew, and space, weight, and power provisions for infrared and radar jammers and infrared detectors. They are designed for low aural, visual, and

1-4

ader signature. In addition, they (1) employ nap-of-the-earth - or terrain - flight techniques using concealment, agility, maneuverability and deception; (2) acquire maximum standoff from the target; and (3) are integrated into the scheme of maneuver of the combined arms team.

Although its importance has been downgraded in favor of emphasis on agility and maneuverability, we realize that increasing helicopter speed still has payoff on the battlefield. Higher speed means the ability to be on target in less time, or the ability to be on target in the same time from a more remote base, or to outmaneuver enemy helicopters in air-to-air combat. Furthermore, a combination of both horizontal and vertical speed reduces vulnerability by limiting exposure time and increasing tracking problems. The armed aircraft should have the maximum possible speed and maneuverability consistent with required VTOL and terrain flight capabilities. In the escort mission, the aircraft requires a higher speed capability than the escorted aircraft.

We must have the capability of operating at night and under adverse weather conditions to counter the known Warsaw Pact doctrine which emphasizes such operations. Night operations are used to extend the length of the operational day, to continue the momentum gained by a successful daylight attack, to gain surprise, to maneuver and mass attack helicopter elements, to provide continuous reconnaissance and surveillance of the enemy force, and to reduce the effectiveness of enemy fires. Elements of the attack helicopter battalion will be required to participate in offensive, defensive, and retrograde operations during periods of reduced visibility caused by various meteorological conditions, smoke, or haze.

Currently, U.S. Army aviation provides firepower via the AH-1G Cobra armed helicopter. Greater capability, particularly in the antitank role, will be provided in the near-term by the AH-1S (Fig. 11). However, the AH-1S is limited in performance and in adverse weather/night conditions. The Advanced Attack Helicopter (AAH) (Fig. 12), with laser Hellfire and a sophisticated target acquisition/designation, day/night system including night-vision aid, will provide direct aerial fires throughout the range of temperature, altitude, and visibility conditions in which U.S. forces expect to operate.

Developing Firepower Systems. The AAH can be based close to the Forward Edge of the Battle Area (FEBA), providing a shorter response time, and can operate at lower ceilings, providing a higher percentage of battlefield-day employment, than can fixed-wing fighter aircraft (Table V). The AAH will be described in more detail in a subsequent paper at this Conference (Ref. 1).

Future Firepower Systems. The employment of Army aviation units in a high-threat environment will place the greatest demands on the attack helicopter. Increased emphasis must be placed on survivability, particularly through terrain flying techniques. However, other system requirements such as agility, dash speed and endurance must not be overlooked.

R&D efforts are necessary to continue technological improvements aimed at the key performance factors of aerial attack systems. A postulated R&D planning concept for the next generation AAH (Table VI) is projected to be an aircraft with VTOL capability for operation in and out of forward bases. To attain the desired dash speeds, some type of augmentation or conversion to airplane-type operation is indicated. Possible concepts for the future firepower mission include augmented thrust helicopter, tilt rotor, tilt wing, and deflected thrust. Possible weapons include advanced fire-and-forget missiles, antimissile missiles, and air-to-air weapons.

Intelligence

Army aviation performs reconnaissance, surveillance, and target-acquisition functions in the roles of collecting and gathering intelligence for the ground commander and acquiring and designating targets for engagement by armed helicopters and other firepower means. The key performance requirements are good acquisition, aircraft agility, survivability, and the ability to operate under conditions of reduced visibility and adverse weather. For the longer-range intelligence gathering mission, the requirements are survivability, precise navigation capability, dash speed, and the ability to carry sophisticated sensors providing real-time readout of information to ground stations, in addition to considerations of loiter time, range, and endurance.

Currently, this function is being performed in the U.S. Army by the OH-58 (Fig. 13) and OH-6 (reserve components only) Light Observation Helicopters (LOH) and, for the standoff mission, by the OV-1 Short Takeoff and Landing (STOL) airplane (Fig. 14). The Advanced Scout Helicopter (ASH) is currently in the planning stage to replace the LOH for this function, and preliminary steps are being taken towards the establishment of a requirement for a replacement for the OV-1. A recent decision, following denial of ASH funds by the Congress, is to develop a limited number of interim helicopter target acquisition systems for early deployment in Europe. These will integrate a target acquisition and designation system into the UH-1 airframe for use until the ASH can be fielded.

Future Intelligence Systems. The Advanced Scout Helicopter (ASH) is expected to be a light, highly maneuverable helicopter dedicated to conducting reconnaissance, aerial observation, security, and target acquisition/designation functions, day and night, in all intensities of conflict. In performing these roles, the ASH would operate in air cavalry, attack helicopter, and field artillery units. It must be able to detect, identify and locate targets at standoff ranges, using terrain-flight tactics. The design should provide maximum agility and maneuverability during NOE flight. It must be able to remain on station for extended periods and have an accurate navigation system for precise target location. The ASH would operate as a part of a Scout/Attack Helicopter Team (Table VII), and must precisely designate targets for weapons such as Hellfire, Copperhead (a cannon-launched guided projectile), and, possibly, U.S. Air Force "smart" weapons. Remotely piloted vehicles (RPV's) are being developed to perform this function for operation in the high-threat environment (Fig. 15).

For the future, the Army sees a requirement for a system to provide the battlefield commander with intelligence information in real time. The system must include a multipurpose airborne platform which can carry the sensor system to perform the roles of surveillance, reconnaissance, target acquisition/designation, and electronic warfare. It must have a data link to the ground and be able to operate in Instrument Meteorological Conditions (IMC). To provide the standoff mission capability operating from a prepared site, a STOL aircraft configuration may be satisfactory. On the other hand, the tilt-rotor concept and the ABC are possible candidate configurations for such a manned VTOL intelligence mission platform (see Table VIII). 1-5

Combat Service Support

The combat service support mission encompasses the traditional functions of providing an airline of communication capable of delivering supplies from a rear storage area to the immediate vicinity of the user. The battlefield resupply system must be predicated on the most difficult situation the Army is likely to encounter: a fast-moving, mobile war in mid- and high-intensity. This requires the use of VTOL aircraft as the primary means for front-line resupply of the battlefield. The "retail" delivery of high-priority cargo to the company and platoon areas is accomplished by utility helicopters, while cargo helicopters perform the "wholesale" bulk delivery of high-priority cargo. Relatively short distances are involved, but within inhospitable environment and terrain.

Two factors are significantly altering the U.S. Army's concept of logistical support. The first, and probably the most important, is the growing trend toward containerization. Projections indicate that the percentage of military cargo shipped in boxes by containers will increase to 80% by 1982. Containerization offers the Army the opportunity to increase greatly the efficiency of its logistical system (that is, supply, distribution and transportation).

The second factor that is changing the complexion of the logistics system is the increasing importance of timely recovery of battle-damaged equipment. Equipment is so expensive that we can no longer afford the luxury of abandoning and replacing those items of equipment that sustain damage on the battlefield. A heavy-lift vehicle could greatly increase recovery and evacuation capability.

The current standard Army aircraft performing the utility mission of the combat service support function is the UH-1 helicopter. The CH-47C is the current Army medium-lift helicopter and the CH-54B is the current Army cargo transport helicopter.

The UTTAS can fulfill the utility mission of the combat service support function. However, the primary use of the UTTAS will be in the air assault and medical evacuation roles. The U.S. Army will retain the UH-1 in the utility role until a cost-effective replacement - such as the LUH - is developed. There are no new development efforts on cargo transport helicopter systems under consideration in the U.S. Army's R&D program at this time although a quick-reaction/high-productivity type aircraft may be needed for the combat service support utility mission by the mid-to-late 1990's.

Command, Control, and Communications

Army aviation assists the commander in exercising command and control of his forces primarily by providing him with a superior means of acquiring information and of communicating with his subordinate commanders. The function of command, control, and communication is made more challenging by the far-ranging operations envisioned for an expanded battlefield. Rapid movement and immediate response are required to supervise a widely dispersed operation. Currently performed in the U.S. Army by LOH and UH-1 aircraft, this capability for future operations might be expanded down to the company level. The UTTAS and the LUH will perform this role for the battalion and higher commanders while, for the company-level operation, we envision a simple, small, one- or two-manned aircraft system (see Table IX). No funds are presently available for development of the latter system.

TECHNOLOGICAL NEEDS

Technological advancements are critically needed over the next decade to support not only the military missions but also the expected rapid growth in civil applications of rotorcraft. Non-Communist world sales over the next 10 years are projected to be on the order of 20,000 to 25,000 units, with commercial production slightly exceeding military production (Fig. 16). This growth is attributed to the identification of new uses for helicopters and to the wide-spread introduction of new technology developed over the past decade. These new uses include key roles in energy exploration and development; in such diverse businesses as logging, shipping, and heavy construction; and an increased military role due to the development of new weapons and tactics that utilize the helicopter as an effective anti-armor weapon, in addition to its traditional supporting role.

Helicopters are now recognized by the U.S. Army as important replacements for traditional ground vehicles in the performance of certain missions which are beyond the capability of fixed-wing aircraft. However, combat experience has revealed the necessity for major improvements in rotary-wing aircraft. The state of the art of helicopter development has been described as being in the pre-DC-3 era of the fixed-wing aircraft. Major technological challenges still remain to be met. The lack of a well-developed technology base provides high payoff opportunities for research in nearly all of the related disciplines. The U.S. Army is dedicated to expanding the research and technology base and to spurring the incorporation of new technology into operational vehicles.

The Army must consider its requirements from two aspects; namely, ultimate feasibility and immediate practicability. These considerations may frequently conflict and are almost invariably in competition for

1-6
the same resources. If technological development followed only the normative approach, constrained by the objectives of future requirements, then resources would never be made available to take advantage of technological opportunities. On the other hand, if we followed only the explorative approach, projecting technology from a base of accumulated knowledge, we may never develop the things we need in a timely fashion. All one's resources can easily be absorbed trying to support a technology development program that is too strongly oriented to demonstrating feasibility; whereas, a program dictated solely by immediate practicability will deprive posterity of the needed storehouse of fundamental knowledge that is even now being used up at a dangerous rate. Technological forecasts and R&D planning, continuously updated, are essential to maintaining a balanced, practical program within available resources.

The U.S. Army Aviation Systems Command recently published the fifth edition of the Army Aviation Research, Development, Test and Engineering (RDT&E) Plan (Fig. 17) which addresses the activities required to achieve the Army's short- and long-term objectives. It presents the relationship between the current technological base and future requirements, while taking account of the potential impact of advances in the basic technologies.

On the basis of an evaluation of the performance requirements of future airmobile systems and an assessment of deficiencies in current systems, major thrusts of the U.S. Army's R&D effort have been defined. The principal factors pulling technology that represent the recognized deficiencies and projected requirements are: safety, survivability, fuel economy, self-deployability, and low life-cycle cost. Terrain-flight operations are considered one of the principal means of survival for missions proximate to enemy defenses in midintensity warfare. Such operations impact a broad base of advanced technology. Obviously, the emphasis on fuel economy will impact R&D on aerodynamic and propulsion systems. The Army needs to have a ready combat capability that can be deployed quickly. Rotorcraft, consequently, should become self-deployable. However, cost will dominate planning for the foreseeable future. In particular, the concepts of design to cost and life-cycle cost will continue to shape R&D programs (Fig. 18). The primary technological developments which are projected to constitute the key push factors are: advanced structural concepts, advanced propulsion systems, microelectronics and digital systems, and new rotary-wing configurations.

These push and pull factors are reflected in technological objectives over a spectrum of disciplines involving improvements in aerodynamic efficiency and aeromechanical stability, reductions in vibration and noise, increased agility and precision of flight control, attainment of a level of safety and pilot workload equivalent with conventional aircraft, near all-weather operating capability, improved structural efficiency, improved propulsion/transmission/drive-train systems, and improved survivability and crashworthiness through structural design. Obviously, most of these developments are equally critical to the helicopter's effectiveness in civilian applications.

Aerodynamic problems include the complex interactions of retreating blade stall effects, advancing blade shock effects, and structural dynamics. The ability to achieve improved rotor performance depends upon an adequate definition of the flow field in which the rotor blades operate and on the design of blades to be more efficient under these conditions (Figs. 19 and 20). High dynamic rotor loads limit the high-speed and maneuverability capabilities of helicopters. Dynamic loads influence the reliability and maintainability characteristics of an aircraft and, hence, its life-cycle costs (Fig. 21). We are limited by our inability to predict dynamic performance capabilities, and limited control power constrains agility. Noise detection and annoyance limit operations, even in the peacetime environment. The goals of our rotor technology program are summarized on Fig. 22, and they are equally applicable to civilian and military rotary-wing development.

At present, the articulated rotor hub is complex and composed of many parts. To reduce complexity and weight, elastomeric materials are being introduced for use as the hinge components. Another approach eliminates the hinges entirely with a rigid hub (Fig. 23). In addition to eliminating a large number of moving parts, the hingeless rotor has great potential for improvement of flying qualities. Application of new materials, particularly composites, will enable the relative stiffnesses of the rotor (chordwise, beamwise, and spanwise) to be tailored to provide optimum structural dynamic characteristics. New materials, as well as improved fabrication techniques, will also permit a much wider latitude in optimization of blade external geometry to improve performance and improvements in internal, or structural, design to reduce vulnerability to ballistic impact. However, these concepts are not without concomitant difficulties because bearingless rotors introduce structural couplings that tend to make the vibrational loads and aeroelastic stability problems more severe. We need to understand and solve these dynamic problems.

Many new and unique rotor configurations are being considered. These include the controllable twist (Fig. 24), multicyclic controllable twist, the Advancing Blade Concept (ABC) (Fig. 25), higher harmonic feathering, and variable geometry, as well as bearingless rotors. The U.S. Army recognizes the long-range implications of this work and the need for bringing successful rotor systems to the field as quickly as possible, for utilization by the civil as well as the military sector. The problem is in selecting which of these new configurations should be pursued first for extended evaluation. In order to evaluate potential payoff, objectives or goals need to be defined against which candidate rotor systems can be measured, such as weight fraction, vibration, noise level, vehicle L/D, speed, structural loading, stability, and figure of merit. Also, definitive goals for reliability, safety, survivability, and cost reduction must be considered.

A primary influence on the performance of rotorcraft is the installed power train from engine through transmission. The introduction of the turboshaft engine provided a breakthrough in powerplant size and weight; however, at some expense in engine fuel consumption compared to reciprocating engines. Improvements in engine power-to-weight ratio (Fig. 26) will depend, to a large extent, on increasing the allowable turbine-inlet temperature (Fig. 27). The limits, of course, are materials related. Therefore, we are concentrating on the two approaches that promise even further improvements; first, in the technology of new cooling schemes in combustion and turbine sections; second, in the technology associated with advanced high-temperature materials and their manufacturing processes. All engine manufacturers are conducting programs in these areas. More importantly, however, efforts are needed to improve turboshaft engine reliability (Fig. 28), time between overhauls (Fig. 29), and fuel consumption (Fig. 30). Cost of advanced engines and higher fuel prices have become major considerations in developing new helicopters that will be economical. Turboshaft engine weights are already so low that we can afford to trade off further engine weight reductions

in favor of improved time between overhauls and specific fuel consumption. Engine maintainability and reliability are major factors that must be considered in new engine technology, since this component is the single most costly item contributing to the overall aircraft system maintenance and component cost. Reductions in sizes and weights of engine accessories (fuel controls, starters, etc.) have not kept pace with engine developments, and could mean high payoff in reduced vulnerable area as well as weight. 1-7

For shaft-driven helicopters, the transmission of power from engine to rotor requires a subsystem which is a primary contributor to the weight, cost, reliability, maintainability, and survivability characteristics of the aircraft. The technological advances of the gears and bearings pace the development of drive systems (Fig. 31). As gear loading capabilities increase and transmission bearing life improves, the drive system weight can be expected to decrease (Fig. 32). However, it takes a combination of factors. An increase in load capacity will evolve from advanced gear tooth forms, new gear materials, improved tooth surface finish, improved profile tolerance, new lubricants with increased load capacity and improved methods of manufacturing. At the same time, we must arrange the components in smaller packages, while introducing transmission housings of improved stiffness to achieve the reduction in weight and vulnerability. Again, all of these concerns with the rotorcraft's installed power train are equally shared by the civilian and the military sectors.

From an overall air-vehicle performance standpoint, it is imperative that the ratio of empty weight to gross weight be kept to a minimum. The potential for improvement in this area is largely dependent upon technological advances in materials (Fig. 33) and structural design concepts (Fig. 34). With improved fiber manufacturing techniques and the use of appropriate matrix materials, the properties of composites will be tailored to meet most combinations of property requirements. This will result in improved structural efficiency and reduced weight (Fig. 35) - obviously beneficial to both civil and military rotorcraft. Concurrent with material technology development, manufacturing technology is expected to advance, permitting the efficient fabrication of these new materials with accurately repeatable characteristics. Overall, the use of composites has great potential for significantly more efficient and lighter aircraft structures with improved fatigue life, reduced vulnerability, and improved crashworthiness.

Inadequate controllability limits the pilot's ability to exploit the entire flight envelope capability of current helicopters. This is especially true at low speeds, and, therefore, impacts nap-of-the-earth and terminal area operations under Instrument Meteorological Conditions (IMC) (Fig. 36). It is important to most Army aviation missions and, in particular, to terrain-flight operations that the rotary-wing aircraft be capable of efficient and controllable hover and vertical flight. Not only should the vehicle be stable in the hover and low-speed modes, but it must also be sufficiently responsive for fine accuracy of control. These requirements sometimes run counter to one another and challenge the designers' capabilities. It is also necessary that the vehicle be able to make smooth transitions and to perform efficiently in the cruise mode. Agility and precision of flight control are fundamental to successful accomplishment of such missions as the flying crane, offshore oil transport, Advanced Scout Helicopter, and Advanced Attack Helicopter. Good handling qualities together with the appropriate avionics systems and operating procedures are needed for operations in congested terminal areas and in adverse weather conditions.

There is much room for improvement to bring helicopter flying qualities at least up to those for fixed-wing aircraft. Figure 37 compares the percentage of accidents due to disorientation error in U.S. Army rotary-wing aircraft with those in U.S. Army fixed-wing aircraft. The ability to prevent such accidents needs research but will be a tradeoff between stability and control and display characteristics and pilot training and proficiency. Figure 38 shows how 8,000 U.S. Army pilots answered the question: How many hours of instrument flight time would you need with an instructor in order for you to fly in IMC safely? Obviously, rotary-wing aircraft are more difficult to fly and a program to improve the qualities, at least to fixed-wing standards, should reduce accidents and have the additional benefit of reducing training and proficiency costs.

Current helicopter flying qualities specifications are based on an obsolete design standard. We have had to devise poorly substantiated criteria for new missions and tasks. A data base is needed to provide an understanding of why the helicopter pilot desires a particular characteristic and of the interrelations of the various factors that impact those characteristics.

The U.S. Army's R&D Program is pursuing the development of a technological data base in rotorcraft handling qualities which should enable us, for the first time, to generate knowledgeably, the criteria and the specifications on flying qualities for rotary-wing aircraft to perform military missions. Ultimately, the intent is to provide the designer with the matrix of information he needs to relate effectiveness to life-cycle costs. This data base is needed by the civilian sector as well to enable the generation of criteria and specifications peculiar to civilian applications and, therefore, this program is being conducted jointly with NASA. Also, to support the aircraft systems integration efforts, the Army, with assistance from NASA, is developing a new ground-based R&D flight simulator for rotary-wing aircraft. This facility will provide high payoff in investigations of the man-machine interactions related to conceptual designs, preliminary and detail design tradeoffs, mission capabilities, support of flight tests, and product improvement evaluations for the Army and the civilian community.

The technology is available to replace mechanical control systems in rotorcraft with "fly-by-wire" systems. Such systems should be lighter and less vulnerable than the normal mechanical system. Use of fly-by-wire control systems in helicopters promises to bring about other improvements such as simplifying rotor control mechanisms and permitting stability augmentation to be handled by electronics. However, there must be insurance that a fly-by-wire system will have "no degradable modes" in the event of malfunction, and additional research is needed before its use can become widely accepted.

The concept of minimal special support for Army aircraft generates requirements related to ground-support maintainability, simplicity, and reliability. In the forward battle area, the vehicle must perform in a reliable fashion with minimum maintenance requirements. However, the helicopter has long been plagued with short-life components requiring frequent inspection. Mean time between failures and mean time between repairs or overhauls have been extremely short. A major life-cycle-cost driver is repair and maintenance. Maintenance and parts account for over 50% of the total life-cycle costs for a typical currently fielded U.S. Army helicopter (over twice that of our fixed-wing aircraft). Therefore, if the rotary-wing aircraft

1-8
is to realize its full potential in civil, as well as military, application, it must be made more reliable and maintainable, fatigue failure modes must be identified and made failsafe, and incipient or impending failure must be detected by simplified diagnostic methods (Fig. 39). However, the effect of these improved characteristics on capability must be assessed carefully through tradeoff studies. The benefits must be provided without penalties that would reduce the effectiveness in terms of mission performance.

For military application, vulnerability to enemy action is, of course, a continual concern. The design must consider maximum capability for encountering and surviving such action. We seek the development of aircraft that can avoid or, if unavoidable, survive punishment meted out by the hostile environment.

Advances in these basic aeronautical sciences and supporting technologies make up the foundation on which are laid the interdisciplinary developments and, ultimately, the designs for new systems. These interdependent accomplishments must develop in a pyramid-like structure to support the demonstration of the technology required to attain the desired performance for each system and component. As rotorcraft technology is refined and improved, these improvements can be translated directly into greater air mobility, improved quick reaction capability, and reduced life-cycle costs (Fig. 40).

Advances in the state of the art require validation of components or systems through demonstration in actual or simulated flight conditions. Indicative of the commonality of interests in rotorcraft developments is the fact that several of these demonstrations are currently supported in the U.S. by both the military and the National Aeronautics and Space Agency (NASA). One such technology demonstrator is the Tilt Rotor Research Aircraft Program which is being conducted jointly by the U.S. Army and NASA. The key potential advantage of the tilt rotor concept (Fig. 41) is that it combines the efficient static lift (hover) capability associated with the low-disc-loading helicopter with the efficient cruise performance and low vibration of a fixed-wing turboprop aircraft with cruising speeds on the order of 300 knots. This program will be described in a subsequent presentation at this Symposium (Ref 2).

Another joint U.S. Army-NASA program is the Rotor Systems Research Aircraft (RSRA) (Fig. 42), which is a highly instrumented flying test bed, capable of accepting and testing new rotor concepts as they become available for "proof of concept" flight research. The RSRA will fly as a pure helicopter, a compound helicopter, and as a helicopter simulator where the aircraft wings, drag brakes, auxiliary propulsion engines, and elevator will be used to react the main rotor being tested. This is one cost-effective method of mapping the performance of test rotors (Ref 3).

Under an Army contract, Sikorsky Aircraft has demonstrated the feasibility and has evaluated the performance of the Advancing Blade Concept (ABC) rotor system through flight test. The ABC is a coaxial, counterrotating, "rigid" rotor with potential to overcome or reduce the limitations of conventional or "winged" helicopters. This program will also be described in a paper presented later at this Symposium (Ref. 4).

The U.S. Army and industry need a capability for accurately analyzing helicopters of various sizes and rotor types for prediction of loads, aeroelastic stability, flying qualities, and performance. This capability is necessary to reduce engineering development risk for new helicopters, prevent delays in development of new aircraft, reduce reliability and maintainability problems of operational aircraft, and prevent excessive restriction of operational capabilities of Army helicopters due to unsolved technical problems. Primarily, the system must be capable of accurate predictions; however, economy and reliability of the analysis system must be given proper emphasis to assure effective wide-scale utilization. The U.S. Army is undertaking the development and demonstration of a Comprehensive Helicopter Analysis System that will be a major step toward satisfaction of this need.

CONCLUDING REMARKS

The U.S. Army is the primary user of helicopters and motivator of rotary-wing research and development in the United States. There are some 12,000 rotary-wing aircraft in the U.S. Department of Defense (DoD) aircraft inventory of which about 10,000 are operated by the Army. Rotary-wing aircraft constitute about 35% of the total aircraft in the U.S. Department of Defense aircraft inventory. When the military inventory for the rest of the free world is considered, the number of rotorcraft in operation totals about 22,000, which represents about 30% of the military aircraft inventory. This total percentage of military rotorcraft is an indication of the relative importance of advanced technology developments required specifically for rotorcraft. However, while there has been enormous progress in rotorcraft technology over its relatively brief history, our progress in translating that technology into operational systems has been something less than spectacular.

Military research and development contributions to aviation progress have been substantial, especially since the start of World War II. Military advances in aviation will continue; however, the rate and impact of these advances are uncertain. Traditionally, procurement of military helicopters has been the mainstay of the helicopter industry. Barring a crisis, however, military requirements are generally projected to be a relatively constant, although substantial, portion of the total market in the coming 5 to 10 yr. The military helicopter market will continue to provide a foundation for both production and new technology applicable to future commercial growth. However, we see a need for an aggressive civil helicopter program to augment the military program. While the military may continue to be the primary source of support for developing the technology, the civil sector may become the primary source of operational experience to evaluate its utilization.

Design-to-cost has become increasingly important and an integral part of recent U.S. DoD acquisitions of virtually all military hardware from relatively simple components to the most sophisticated systems. The objectives of the DoD have changed from placing the overriding emphasis on improved performance to an emphasis on quality equipment that has acceptable performance for an affordable cost. In this environment, it is frequently difficult for us to demonstrate conclusively the value of a technological advance to an Army air mobility system. The commercial people have a handy criterion named profit (or loss) that helps them estimate the value of a new system, but no such single parameter is available for military systems. The reason is

fundamental); it is easy to calculate the cost of an Army air mobility system, but there is no body of experience on which to base supportable calculations of the value of that system. If a preliminary study shows that the incorporation of some technological advance will add 5%, 10% or 20% to the cost of an Army air mobility system, there is always some skeptic who demands to know exactly how you propose to get 5%, 10% or 20% more mission capability out of that system. We should be able to answer this, but it takes realistic operational experience to provide an adequate basis for justifying and configuring new systems. Such experience becomes increasingly difficult to obtain in the current environments of tight budgets, because we must be exceptionally conscientious about searching for low-cost alternatives. It is very difficult to start high-risk development programs, since the combination of the uncertainty about what a new system would do and how much it might cost to develop, too often dictates against initiation of a full-scale system development program. Therefore, with increasing utilization of helicopters for civil application, the military may very well look to that sector for additional data for its experience base. One important step, as a specific goal, would be to document the accumulation of information and experience regarding both civil and military operation and utilization of rotorcraft systems.

The helicopter today is providing an extremely important element of mobility in the U.S. Army and promises to fill an expanding need in many aspects of civil transportation. The commercial market is already accounting for half the industry sales and promises to rise. The number of civil helicopters sold in the coming decade probably will exceed the number of military helicopter procurements.

Commercial utilization of rotorcraft has nearly paralleled the military and has been based primarily on the advantages provided by vertical takeoff and landing capability and off-airport operations. Even though most civil rotorcraft in operation today are almost identical to military counterparts, with only cursory attention to specific differences from military requirements, many profitable operations are in existence. The current generation of rotorcraft is, despite its deficiencies, a profitable commercial vehicle. Nevertheless, cost is the major retardant to expansion of rotorcraft operations to fulfill civil needs.

In this respect, military and civil requirements for rotorcraft R&D are compatible and reflect common interests and priorities. All military users agree on the need for advanced research and development to increase productivity, reduce maintenance, and lower life-cycle costs. The U.S. Army's recognition that these are among the principal factors pulling technological developments has been addressed throughout this report.

In the United States, the civil needs are being addressed in part by NASA's recent emphasis on rotorcraft R&D. NASA identified the specific technical objectives that it should pursue in support of the civil helicopter market. These include reduced cost of acquisition and operation, increased capability and availability, increased maintainability and reliability, increased user acceptance, and increased community acceptance. All of these are also objectives of the U.S. Army's current R&D activities. Despite the fact that the civilian and military missions differ substantially, the fundamental aircraft characteristics that are desirable remain the same for both applications. This is evidenced by the fact that the civilian helicopters in operation today are largely either derivatives of military aircraft or based on military-developed technology. Military and civil aviation draw on a common technology base and rely on the same industrial capability.

This commonality of interests has been addressed in the U.S. through joint participation in rotorcraft R&D by the U.S. Army and NASA. The advancement of the many complex technologies of rotorcraft is currently being pursued in the U.S. primarily through the joint efforts of these two agencies. The joining of forces of the U.S. Army Aviation Systems Command and NASA through the collocation of three of the four Directorates of the U.S. Army Air Mobility R&D Laboratory (USAAMRDL) at three NASA Research Centers, has proven highly effective. It is largely through these efforts, complemented by the work of the Eustis Directorate, USAAMRDL, that the technological advancements necessary for the helicopter to realize its full potential will be made. Many technical advancements of great promise seem to be in the offing in the understanding of nonsteady rotor aerodynamics, in the use of composite materials, in avionics and flight control, in engines and drive trains, and many other disciplines. However, much remains to be done to organize and apply this technical potential effectively to the solutions of the helicopter's many problems.

Current investments and activities are grossly inadequate to reap the full potential dividends that loom for the next decade. With the constraints on the military budget and the projected growth of commercial helicopter applications, the military must begin to look to the civil sector of the helicopter industry for assistance in the utilization of advanced technology and in the establishment of a data base of operational experience.

REFERENCES

1. Wolfe, R. A., and Gormont, R. E., "The U.S. Army UTTAS and AAH Programs," Presented at the AGARD Rotorcraft Design Symposium, Ames Research Center, California, U.S.A., May 16-19, 1977.
2. Wernicke, K. G., Edenborough, H. K., and LTC J. H. Brown, "The XV-15 Tilt-Rotor Program," Presented at the AGARD Rotorcraft Design Symposium, Ames Research Center, California, U.S.A., May 16-19, 1977.
3. Huston, R. J., Jenkins, J. L., and Shipley, J. L., "The Rotor Systems Research Aircraft (RSRA)," Presented at the AGARD Rotorcraft Design Symposium, Ames Research Center, California, U.S.A., May 16-19, 1977.
4. Young, H., and Simon, D. "The ABC Rotor Program," Presented at the AGARD Rotorcraft Design Symposium, Ames Research Center, California, U.S.A., May 16-19, 1977.

TABLE I. GENERAL UTILITY HELICOPTER DESCRIPTION

1-10

GENERAL	<ul style="list-style-type: none"> The current standard utility helicopter is the Bell UH-1H which is the latest in the series of UH-1 aircraft.
PRESENT CAPABILITIES	<ul style="list-style-type: none"> The UH-1H is capable of carrying 8 to 10 combat equipped troops, or 2,400 lb of cargo more than 250 miles at a cruise speed of 100 knots. It has an external cargo hook capable of lifting 4,000 lb and is equipped for IFR flight. Large sliding doors and unobstructed cargo space allow rapid loading and unloading of internal cargo and combat troops.
DEFICIENCIES AND SHORTCOMINGS	<ul style="list-style-type: none"> The major deficiency of the UH-1 helicopter has been its inability to achieve the slated performance and payload, with reserve power for OGE vertical climb at higher density altitudes. The addition of a copilot, two door gunners, aircrew armor, and associated equipment, together with high density altitudes, has reduced the effective payload of the UH-1 to six to eight combat equipped troops, or less than 2,000 lb of cargo. Also, the UH-1 has a distinctive noise signature (blade slap) easily identifiable with this helicopter. The extensive use of honeycomb structural panels throughout the airframe has made sheet metal repair time consuming and difficult. The maintenance MNH/FH ratio is excessive and the MTBF of major components is inadequate. The installation of crashworthy fuel cells and IR-suppression devices have increased its survivability, but it is still marginal.
FOLLOW-ON SYSTEM	<ul style="list-style-type: none"> The UH-1H will be replaced by the UTTAS as the Army utility helicopter.

TABLE II. CURRENT MEDIUM-LIFT HELICOPTER DESCRIPTION

GENERAL	<ul style="list-style-type: none"> The current Army medium lift helicopter is the Boeing-Vertol CH-47C.
PRESENT CAPABILITIES	<ul style="list-style-type: none"> The CH-47C is capable of carrying 34 troops, or an internal cargo of 10 tons for a 100-nautical-mile radius mission, at 120 knots. It can also lift 23,300 lb for a 20-nautical-mile mission at 100 knots. It has a 30-ft-long cargo compartment capable of carrying two three-quarter-ton trucks or other large bulky cargo. It has an external cargo hook of 10-ton capacity that may also be used for towing operations. The aircraft has a self-contained APU and is fully IFR-equipped.
DEFICIENCIES AND SHORTCOMINGS	<ul style="list-style-type: none"> Operating costs of the current CH-47 fleet are excessive. A and B series aircraft are approaching planned retirement and their lift capability is less than optimum to provide air mobility support to the ground forces. Safety and survivability and RAM features of the existing CH-47's are inadequate and need to be upgraded.
FOLLOW-ON SYSTEM	<ul style="list-style-type: none"> The LTTAS was planned to replace the CH-47C; however, this role was abandoned when the LTTAS effort was terminated in 1970. The Army has reviewed the CH-47 operational capability and concluded that a valid requirement exists to sustain a MLH fleet well into the 1990's. As a result, the modernized CH-47(D) is now programmed to replace the CH-47 fleet. This program has DA approval and a contract is being negotiated with Boeing-Vertol for engineering development of 3 prototype aircraft.

TABLE III. CURRENT CARGO TRANSPORT HELICOPTER DESCRIPTION

GENERAL	<ul style="list-style-type: none"> The current standard Army cargo transport helicopter is the Sikorsky CH-54B. The CH-54A is also in service.
PRESENT CAPABILITIES	<ul style="list-style-type: none"> The CH-54B is equipped with a four-point load suspension system of 20,000 lb capacity and a single-point hoist with a capacity of 25,000 lb. It can carry a 25,000 lb external load for 20 nautical miles at 95 knots, or a smaller load of 15,000 lb for 120 nautical miles. Although its primary mission is external cargo, the CH-54 does have a detachable pod that can be readily attached or detached for internal cargo. The aircraft features a load-facing crewman who has limited control for hook-up and detaching of external loads. The aircraft has a self-contained APU and is fully IFR-equipped.
DEFICIENCIES AND SHORTCOMINGS	<ul style="list-style-type: none"> The CH-54B, operational readiness averages only 75%. Contributing factors are low field density and an out of production status. Additionally, its maintenance MNH/FH ratio and SFC are relatively high, its cost per ton mile is higher than surface modes and it cannot carry passengers and external loads simultaneously.
FOLLOW-ON SYSTEM	<ul style="list-style-type: none"> There is currently no system being developed to replace the CH-54B although Advanced Technology Components of a HLH system have been under development.

TABLE IV. LIGHT UTILITY HELICOPTER DESCRIPTION

MISSION	<ul style="list-style-type: none"> • Troop lift. • Aeromedical evacuation. • Command and control. • Ground scout team insertion. • Infantry TOW team insertion. • Transport of external sling loads.
KEY PERFORMANCE FACTOR	<ul style="list-style-type: none"> • Troop lift - six combat troops. • Aeromedical evacuation - two litters, one ambulatory patient and one medical attendant. • Command and control - four staff members and command and control radio equipment. • Ground scout team - four combat troops with scout team equipment. • Infantry TOW team - four combat troops and infantry TOW team equipment. • Transport sling loads - acquire, transport, and release 2500 pound external load.
PERFORMANCE CHARACTERISTICS	<ul style="list-style-type: none"> • 120-150 knot airspeed. • 2.0 hour endurance. • 450 fpm VROC. • All weather capability.
PHYSICAL CHARACTERISTICS	<ul style="list-style-type: none"> • Same as Advanced Scout Helicopter (ASH).
SYSTEM APPLICATION	<ul style="list-style-type: none"> • The LUM, in conjunction with the LAH and ASH will replace the OH-6 and OH-58 as well as assume many of the present missions of the UH 1

TABLE V. AAH ROLES AND MISSIONS

PROVIDE	<ul style="list-style-type: none"> • Antiarmor/strike-force capability. • Other hardpoint target capability. • Standoff antitank capability. • Antipersonnel capability. • Area antiarmor/antimaterial capability. • LZ preparation and support during airmobile assault. • Additional fire support to airmobile movements. • Discriminating fire support for all offensive and defensive operations in built-up areas (i.e., combat in cities). • Target identification and handoff. • Aerial escort during movement of forces to include airmobile operation, long range patrol, insertion/extraction escort, medical evaluation/resupply escort, and convey protection. • Suppressive fires during assault landings and extractions. • Augmentation and extended range of other fire support means.
CONDUCT	<ul style="list-style-type: none"> • Armed reconnaissance. • Economy of force operations. • Screening, flank, and covering force operations. • Rear area security operations.

TABLE VI. ADVANCED AERIAL WEAPONS SYSTEM DESCRIPTION

MISSION	<ul style="list-style-type: none"> ● Provide area and point target suppression/kill capability. ● Offer security and escort to troop carrying helicopters. ● Provide extended area reconnaissance.
KEY PERFORMANCE FACTOR	<ul style="list-style-type: none"> ● Ability to acquire and destroy targets. ● Survivability.
PERFORMANCE CHARACTERISTICS	<ul style="list-style-type: none"> ● 250-400 knot airspeed capability. ● All-weather operational capability. ● Self-deployable. ● 3-hour endurance at cruise speed. ● Auxiliary power unit augments lift/thrust. ● Self-contained navigation.
PHYSICAL CHARACTERISTICS	<ul style="list-style-type: none"> ● Transportable in C-5A. ● Self sealing fuel tanks.
MAINTENANCE CHARACTERISTICS	<ul style="list-style-type: none"> ● 300-hour periodic inspection. ● On-condition replacement of critical components.
SYSTEM APPLICATION	<ul style="list-style-type: none"> ● The AAWS would be a replacement for the Advanced Attack Helicopter currently being developed.

TABLE VII. ASH SYSTEM CHARACTERISTICS

ESSENTIAL CHARACTERISTICS	<ul style="list-style-type: none"> ● The ASH system shall provide reconnaissance, security, target acquisition and precision designation functions during day and night VMC and perform limited reconnaissance and security functions during IMC. ● Aircraft performance and flight handling characteristics criteria specified for the Advanced Scout Helicopter will be compatible with the requirements for the AAH and UTTAS aircraft systems. ● A flight crew of two is required, pilot and copilot/observer. The aircraft will be configured so that one pilot can perform all duties while flying the aircraft, but dual flight controls are required. ● Ballistic protection is required.
AVIONICS	<ul style="list-style-type: none"> ● As a minimum, the Advanced Scout Helicopter will have installed the basic flight instruments required for instrument flight as specified by AR 95-1 ● Provisions for an airspeed indicator capable of accurately measuring and portraying airspeeds compatible with operational requirements ● Provisions for an absolute altimeter are required ● A low level, tactical navigation system is required ● If available within the timeframe, the aircraft should have provision for communications that will enable continuous, secure non-line-of-sight communications.
VISIONICS	<ul style="list-style-type: none"> ● A target acquisition subsystem is required. ● A pilot's night vision subsystem is required to provide the pilot a capability to conduct nap-of-the-earth night operations
TARGET LOCATION/ DESIGNATION	<ul style="list-style-type: none"> ● A target designation subsystem with rangefinder and target location subsystem is required.
RELIABILITY AND MAINTAINABILITY	<ul style="list-style-type: none"> ● Built-In-Test Equipment (BITE) shall be incorporated to identify malfunction of specific modules and subsystems and to accomplish "on aircraft" maintenance
WEAPON SYSTEM	<ul style="list-style-type: none"> ● Space, weight, and power shall be provided for the installation of a three (3) round missile system.
SURVIVABILITY EQUIPMENT	<ul style="list-style-type: none"> ● State-of-the-art countermeasure protection against visual, aural, infrared and electronic systems will be incorporated in the design of the ASH.

*Unclassified Listing.

TABLE VIII. SURVEILLANCE VTOL AIRCRAFT SYSTEM DESCRIPTION

MISSION	<ul style="list-style-type: none"> • Provide immediate and continuing intelligence and target acquisition intelligence to the tactical ground commander with penetration capability.
KEY PERFORMANCE FACTORS	<ul style="list-style-type: none"> • Endurance. • VTOL capability.
PERFORMANCE CHARACTERISTICS	<ul style="list-style-type: none"> • 150-400 knot airspeed capability. • 2-3 man crew. • Agile. • Signature <ul style="list-style-type: none"> • Minimum radar cross-section image. • Minimum visual contrast profile for anticipated environment. • Self-deployable. • Mission subsystems <ul style="list-style-type: none"> • Multispectral sensors. • Stabilized electronics platform. • Data link, data processing and storage. • All weather operation. • Self-contained navigation. • Unattended remote area landing system.
PHYSICAL CHARACTERISTICS	<ul style="list-style-type: none"> • Transportable by air or ship or self ferry • Accessible configuration for ground support equipment.
MAINTENANCE CHARACTERISTICS	<ul style="list-style-type: none"> • Built-in test equipment. • Modular replacement of components. • 0.9 probability to restore to operational status within 30 minutes after failure. • On-condition replacement of critical components • 1 MMH/FH (scheduled) and 7.5 MMH/FH (unscheduled).
SYSTEM APPLICATION	<ul style="list-style-type: none"> • VTOL surveillance aircraft would replace the LOH for penetration mission requirements and supplement the OV X with VTOL capabilities.

TABLE IX. MAUNED, MINI-AIRCRAFT SYSTEM DESCRIPTION

MISSION	<ul style="list-style-type: none"> • Extend intelligence-gathering capability of the ground commander. • Deployment of small man-portable defense weapon systems.
KEY PERFORMANCE FACTOR	<ul style="list-style-type: none"> • NOE maneuverability. • Unique survivability capabilities. • Low cost. • Easy to operate.
PERFORMANCE CHARACTERISTICS	<ul style="list-style-type: none"> • Hover 4000 ft, 95° F. OGE • 40-60 knot airspeed. • 1/2-hour endurance. • 30 mile range. • 300 lb payload. • Operation in adverse weather conditions
PHYSICAL CHARACTERISTICS	<ul style="list-style-type: none"> • Highly survivable. • Minimum maintenance. • 3-5 hr solo training. • 40-60 hr flight training.
SYSTEM APPLICATION	<ul style="list-style-type: none"> • Provide mobility to the individual soldier.



Fig. 1 de Bothezat Helicopter.



Fig. 2 Platt-LePage XR-1.



Fig. 3 Vought Sikorsky XR-4.

LAND COMBAT FUNCTION	MISSION	OPERATIONAL SYSTEMS	DEVELOPING SYSTEMS		R&D PLANNING CONCEPTS									
			AAH	UTTAS	ASH	RPV	CH-47D*	HLK	OV-X	SUR/VTOL	AAWS	LAH	LUH	MMAAS
MOBILITY	UTILITY	UH-1												
	MEDIUM LIFT	CH-47												
	CARGO TRANSPORT	CH-54												
FIREPOWER	TACTICAL MOBILITY	UH-1												
	DESTROY	AH-1												
INTELLIGENCE	RSTA/D	LOH												
		OV-10												
COMBAT SERVICE SUPPORT	UTILITY	UH-1												
	MEDIUM LIFT	CH-47												
	CARGO TRANSPORT	CH-54												
COMMAND, CONTROL & COMMUNICATION	AVIATION SUPPORT	LOH												
		UH-1												

*MAJOR MODERNIZATION PROGRAM

Fig. 4 Land combat function mission systems.



Fig. 5 UH-1.



Fig. 6 Sikorsky UTTAS (YUH-60A).



Fig. 7 CH-47.



Fig. 8 CH-54.

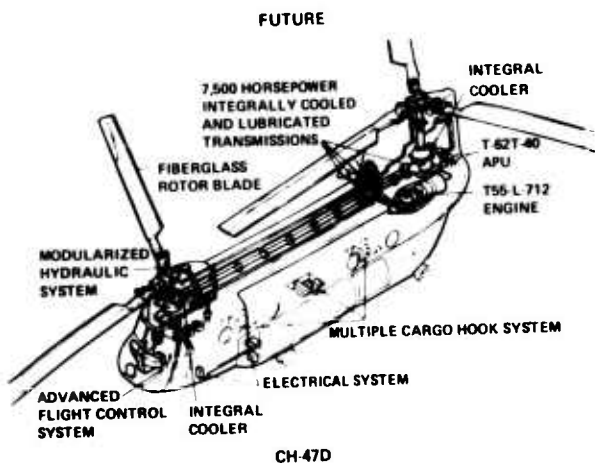

Fig. 9 CH-47 Modernization improved systems.



Fig. 10. Possible tilt-rotor version of future utility aircraft system.



Fig. 11 AH-1S.



Fig. 12 Hughes AAH.



Fig. 13 OH-58.



Fig. 14 OV-1.



Fig. 15 AQUILA RPV.

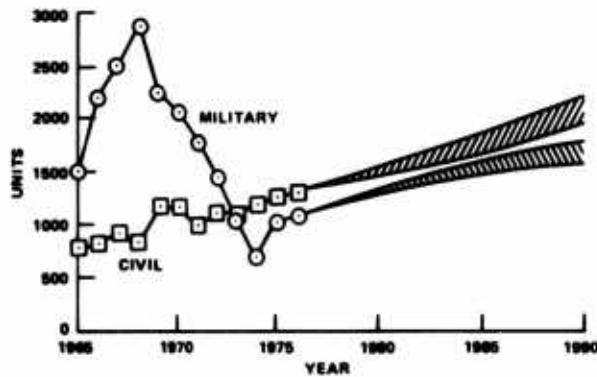

Fig. 16 Non-Communist world sales of rotorcraft, 1965-1990.



Fig. 17 RDT&E plan.

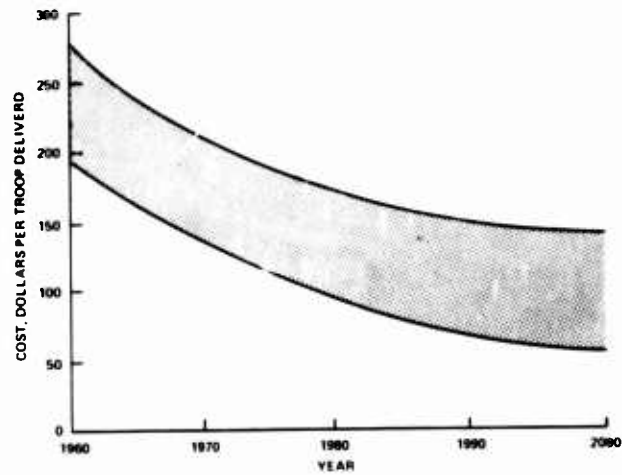

Fig. 18 Dollar cost/troop delivered.

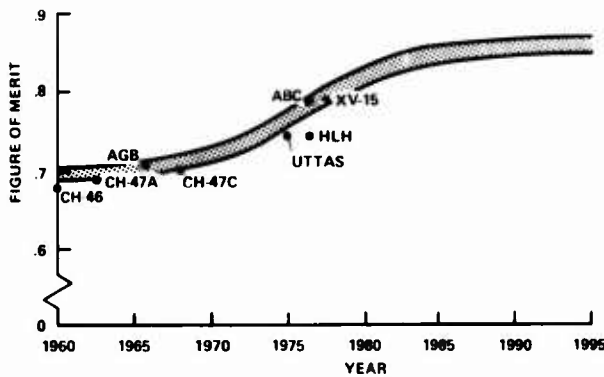

Fig. 19 Figure of merit.

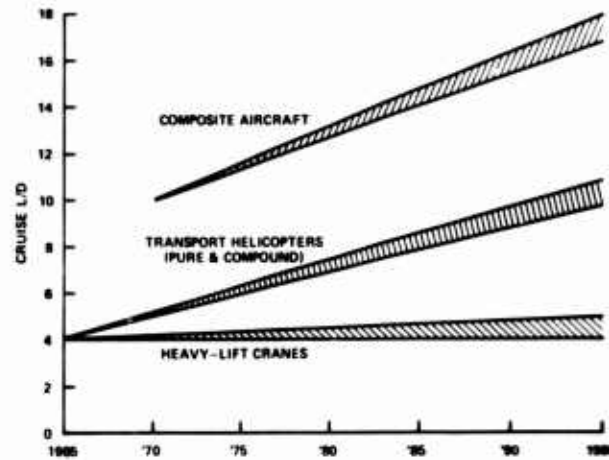

Fig. 20 Aerodynamic efficiency trend.

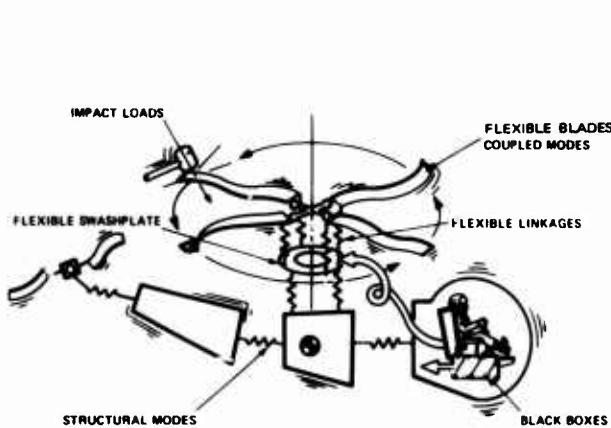

Fig. 21 Dynamics complexity.

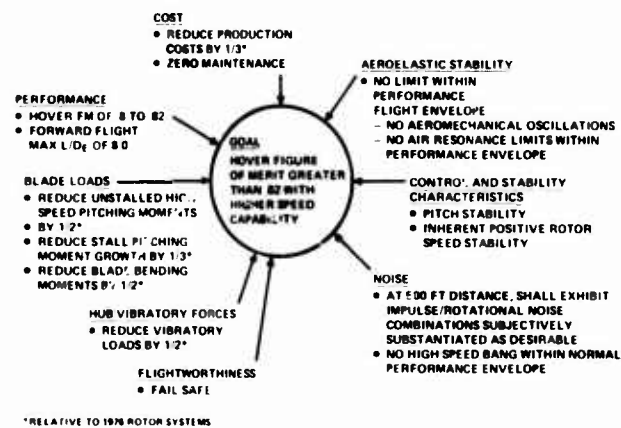

Fig. 22 Rotor technology program objectives.

1-18

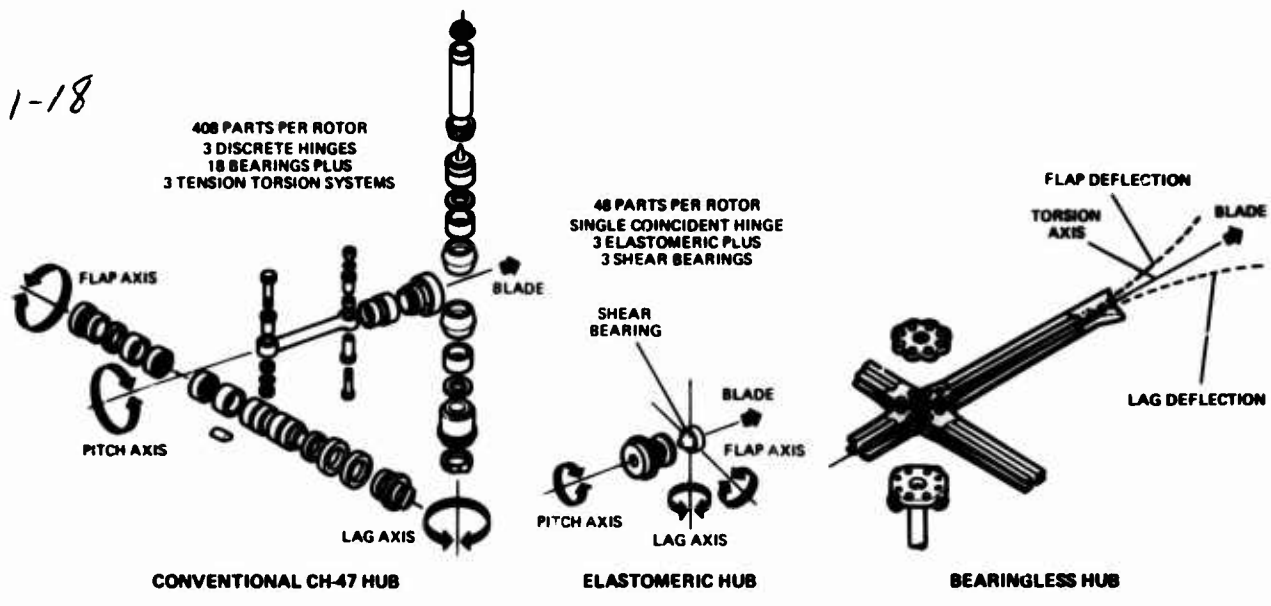

Fig. 23 Comparisons of rotor hubs.

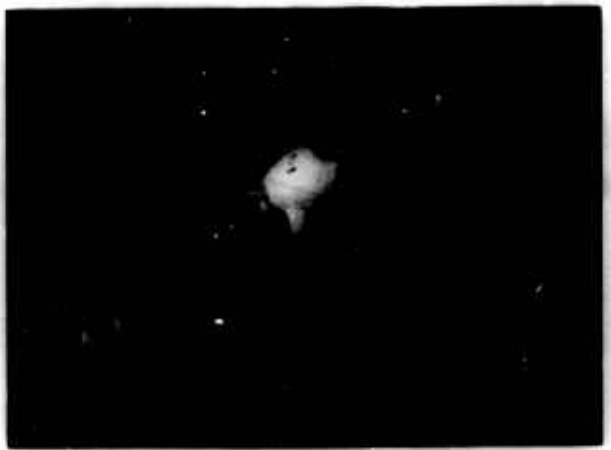

Fig. 24 The controllable twist rotor (CTR).



Fig. 25 The Advancing Blade Concept (ABC) Rotorcraft.

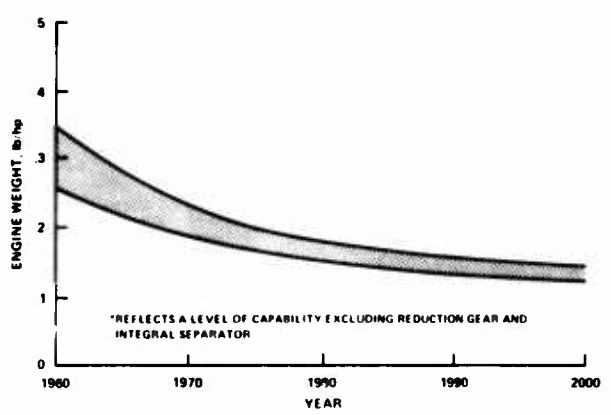

Fig. 26 Engine weight trends.

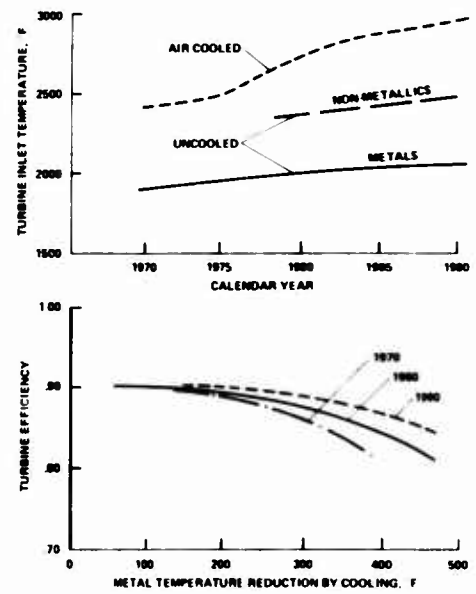

Fig. 27 Turbine inlet temperature.

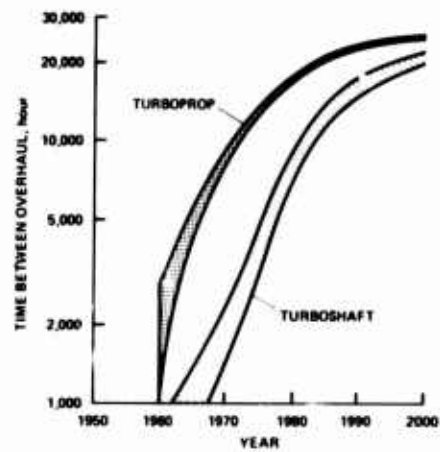
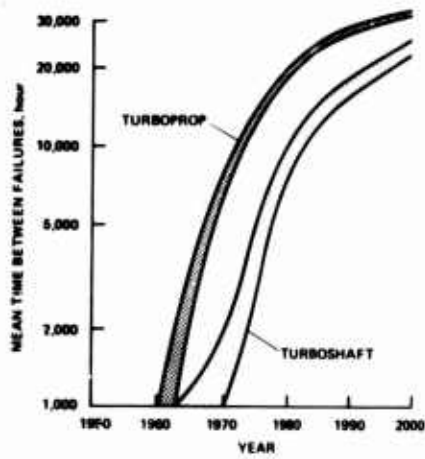

Fig. 28 Engine reliability - mean time between failure. Fig. 29 Engine maintainability - time between overhaul.

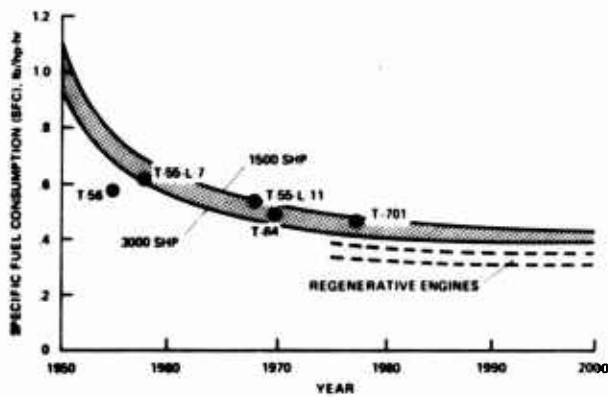

Fig. 30 Specific fuel consumption trends.

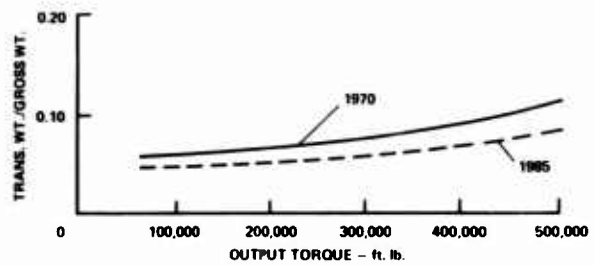
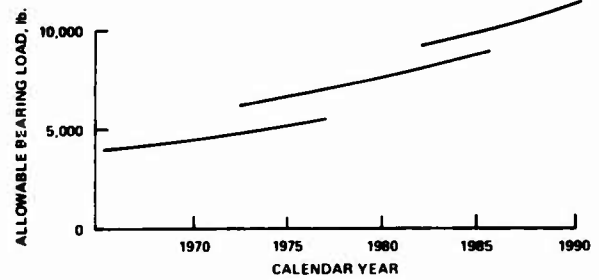
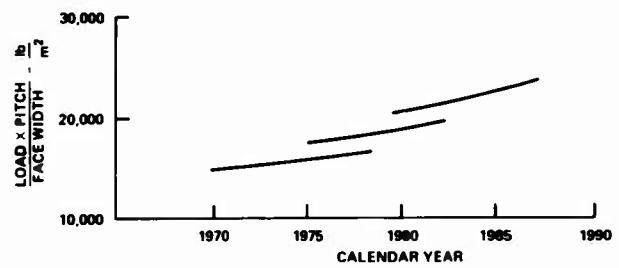

Fig. 31 Technology trends - mechanical elements.

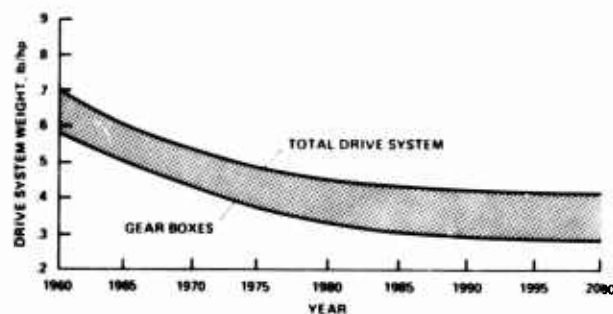

Fig. 32 Drive system weight trends.

1-20

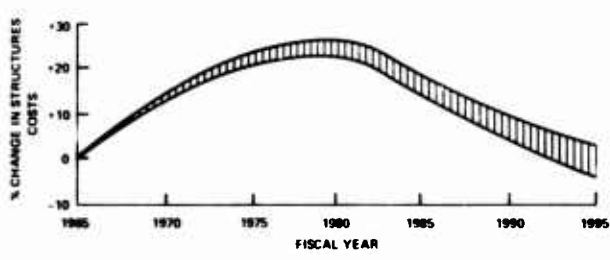
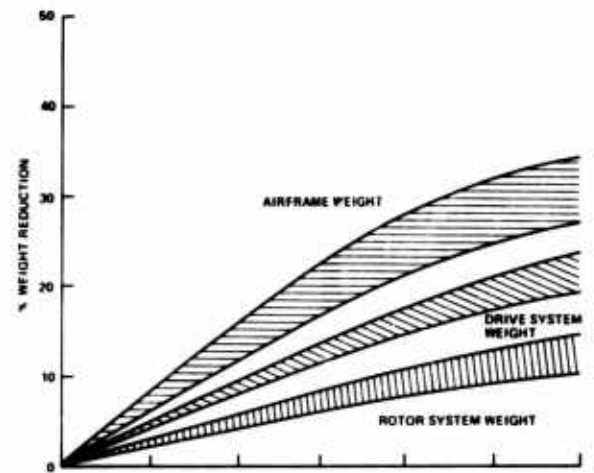
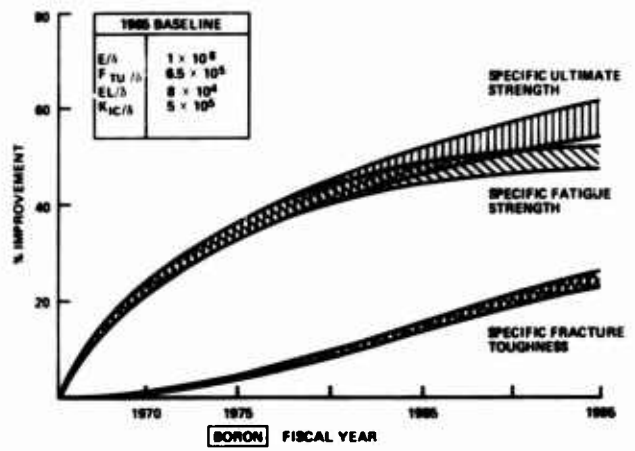
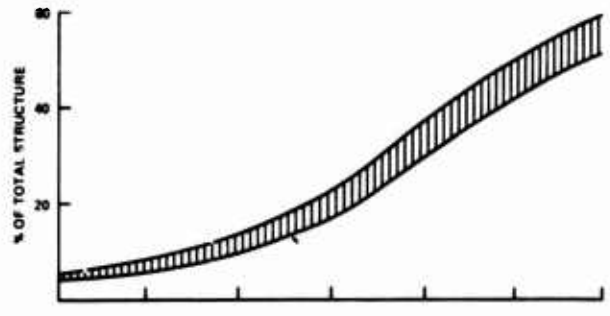
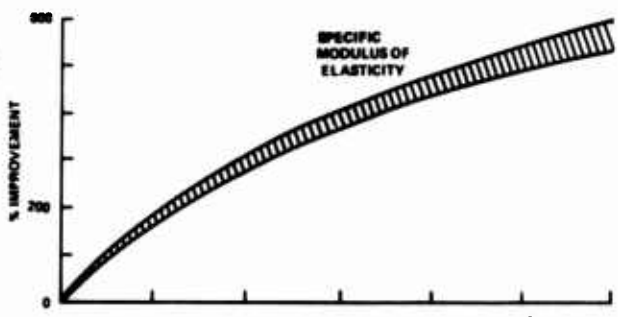

Fig. 33 Materials properties improvement and use goals.

Fig. 34 Structural concepts goals.

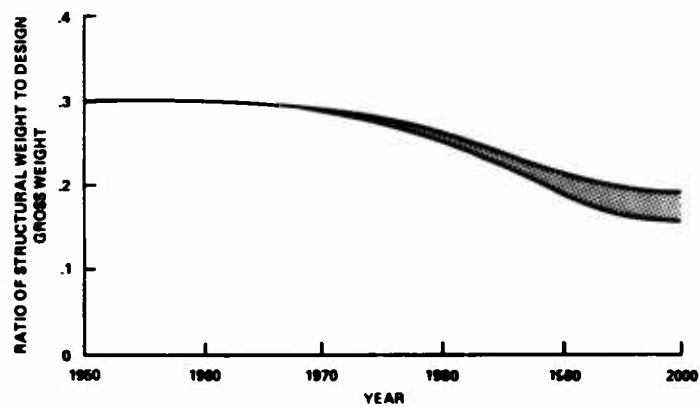

Fig. 35 Trend of ratio of structural weight to design gross weight.

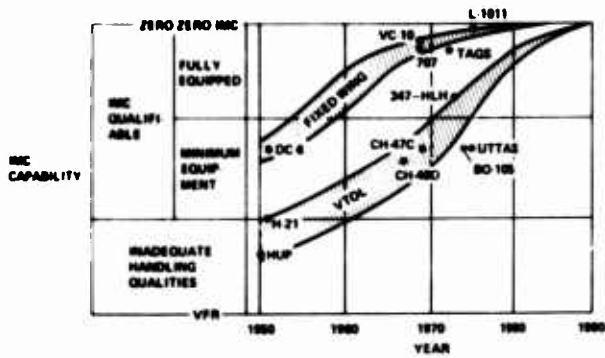

Fig. 36 IMC flying qualities.

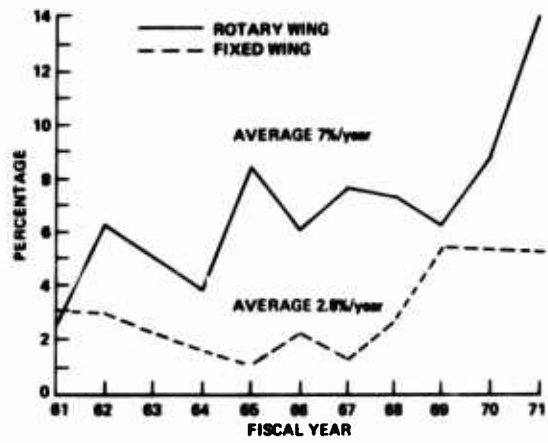

Fig. 37 Percent of accidents in which disorientation was a cause factor.

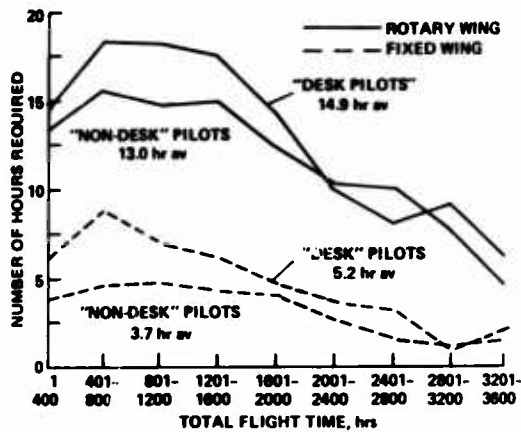

Fig. 38 Estimated time with instructor to become IMC first-pilot proficient.

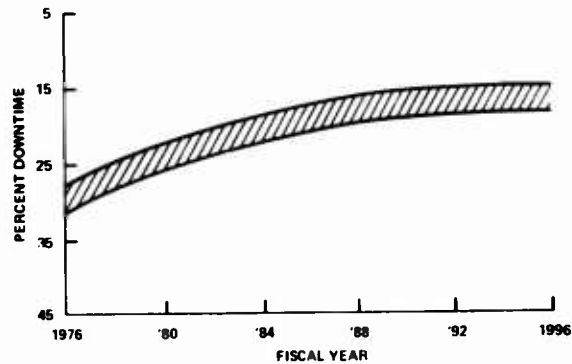

Fig. 39 Maintenance technology improvement goal.

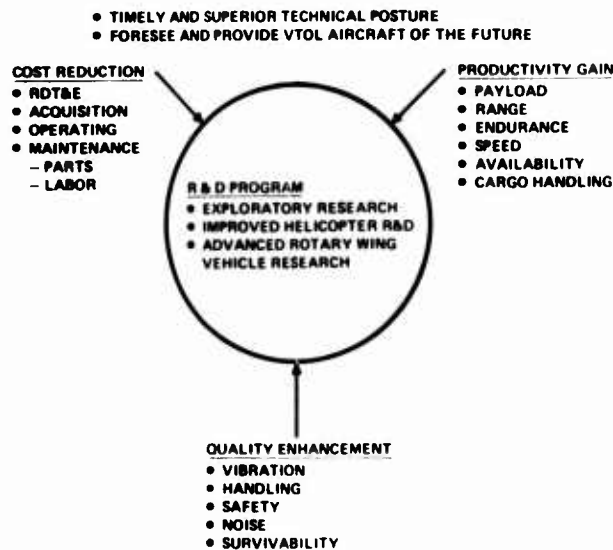

Fig. 40 R&D program objectives.



Fig. 41 XV-15 and tilt-rotor principal flight modes.

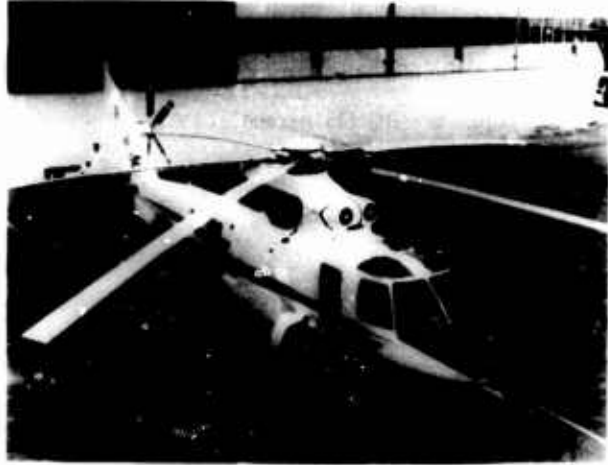

Fig. 42 RSRA-helicopter configuration.

German Army Helicopter Development and Prospects for the Future

by

K.W. Mack and H. Jakob

Bundesministerium der Verteidigung, Bonn,

Federal Republic of Germany

SUMMARY

The German military helicopter development is based on the experience of military exercises and maneuvers with special regard to the role and the tasks of the German forces in the Central European theatre of the Atlantic alliance. Studies of the war in Korea, Vietnam and Near-East have completed these experiences.

Germany has developed its own conception for use of helicopters according to the special tasks of the German forces. This conception now also will be coordinated by NATO.

The present German army helicopter development is concentrated on a light anti-tank-helicopter (ATH) and a liaison-and-observation helicopter (LOH), based on the civilian Bo105 helicopter of MBB (Messerschmitt-Bölkow-Blohm). The outstanding characteristic of these two systems is a high degree of commonality that is promising considerable advantages for cost-effectiveness, maintenance, overhaul and other logistic aspects.

Guidelines for the future German military helicopter development are among others:

- night- and bad-weather-capability;
- increased maneuverability for safe terrain-following and obstacle-avoidance;
- improved survivability and crashworthiness;
- improved maintenance, overhaul and repair by system simplification and use of equivalent or similar basic systems;
- reduction of the number of types;
- consideration of standardization and interoperability requirements.

These guidelines are used especially for the next generation ATH that is planned for introduction in the second half of the eighties.

Germany is preparing a joint development of the future ATH together with France, which will make an important contribution to the interoperability and standardization of military helicopters.

1. PRESENT DEVELOPMENT STATUS OF GERMAN ARMY HELICOPTERS

1.1 GENERAL SITUATION

Since the early seventies the evolution of German Army Aviation has been characterized by the generation change that has taken place in its fleet of helicopters.

This generation change was not confined to the replacement of outdated equipment by more modern systems; it also involved the introduction of new, that is previously unavailable, weapon systems designed to add to Army airmobility another component, that of antitank defense.

If airmobility of the Army is conceived as the ability of the Army to exploit, with organic means, the third dimension for command and control, transportation and combat purpose and if, further, the helicopter is acknowledged to be the only system possessing the decisive capabilities of

- overcoming quickly even considerable distances regardless of the configuration of the terrain and of ground obstacles, and
- if properly controlled, of adapting to the contours of the terrain, that is utilizing the cover of natural and artificial obstacles, in other words, of exhibiting tactically correct behavior,

then these propositions determine its roles as

- liaison-and-observation helicopter,
- transport helicopter, and
- combat helicopter.

As far as the transport helicopter is concerned, it is sufficient to say here that the major developments in German Army Aviation in the period from 1969 to 1974 were the additional introduction of the Bell UH-1D helicopter and the replacement of the obsolescent systems Boeing Vertol H-21 and Sikorsky H-34 by the CH-53G -- all of them systems with which you are well familiar so that I need not dwell on them any further.

1.2 LIAISON-AND-OBSERVATION HELICOPTER (LOH)

As you may know, the Alouette II light helicopter since the early sixties has fulfilled the functions of liaison-and-observation helicopter in the German Army with a high degree of reliability.

Owing to the increasingly multifarious tactical functions for which it is being used, namely

- exercising command and control from the air,
- supplementing existing and replacing disrupted telecommunications,
- serving as a command and control platform for the Forward Air Controller,
- detecting ABC warfare activities from the air,

2-2

- supervising the effectiveness of camouflage,
- directing the artillery's fire for adjustment,
- controlling surface traffic, and the evacuation of casualties

the transport capability of this system is, however, no longer sufficient. But also its basic design, the fact that it has only a single engine, as well as its lack of navigational aids do impose rather narrow limits on its tactical employment and its operation under adverse weather conditions.

For this reason the Alouette II will, beginning in 1979, be replaced by the Bo105-M/VBH liaison-and-observation helicopter which was adapted and improved for military purposes from the civilian version of the Bo105C Messerschmitt-Bölkow-Blohm helicopter. The Bo105-M/VBH has a takeoff weight of 2300 kg and carries the required payload and equipment.

Owing to its hingeless rotor the Bo105-M/VBH helicopter possesses the high degree of agility and maneuverability which the above-mentioned tasks demand. For reasons which I will discuss later the Bo105-M/VBH was equipped with the more powerful Allison 250C20B engines. In order to do this, a reinforced main gear box had to be developed to accommodate the 2 x 426 DIN horsepower. Completely new, that is tailored to the required military characteristics of the helicopter, is the radio and navigational equipment, the instrumentation, and thus also the electrical system.

In addition, the airframe was modified, among other things in order to improve its maintainability. If I may assume that you are familiar with the Bo105C as the version from which the new German liaison-and-observation helicopter was developed, I need not describe this system in further detail.

I may then go on to discuss that aspect of Army airmobility whose increasing significance is generally recognized, namely: the combat tasks.

1.3 THE GERMAN ANTITANK HELICOPTER TEST PROGRAM

In view of the growing superiority of the Warsaw Pact forces in the conventional field (fig. 1) - especially with respect to the large number of their armored forces - NATO has been compelled to investigate how the antitank capability of its land forces can be improved by the employment of antitank helicopters (ATH). An essential contribution in this field has been the so-called "Katterbach Trial", a field trial jointly undertaken by the German Army, the US Army, and the Canadian armed forces in the spring of 1972. This trial showed for the first time that the AT helicopter can be employed successfully and with good chances of survival in the Central European theater. Important results of the Katterbach trial were:

- an obtainable hit rate of approximately 63 % and
- an almost 18 to 1 superiority of the AT helicopter over the modern battle tank (fig. 2).

Subsequently a test program as well as theoretical concept analyses and operations research studies were performed. As part of this comprehensive program undertaken from September 1973 to January 1977 the following areas were studied by the German Army

- technical configuration, equipment and armament
- tactical doctrine
- communications
- logistic concept
- ability of the AT helicopter to detect armored targets
- threat to the AT helicopter on the battlefield.

In the framework of the presentation, I would like to discuss only the last two aspects.

1.3.1 ATH CAPABILITY TO DETECT ARMORED TARGETS

The effectiveness of the antitank helicopter is essentially dependent on the extent to which it is able to detect and identify armored targets at long distances.

This problem was analyzed by tests to determine the "Detection Probability, Time and Distance of Armored Vehicles by ATH". It was found that at distances between 2000 m and 4000 m the ATH detects at least one target out of a target group of 5 with a probability of 95 %. The mean-time for the first detection is 34 sec. (fig. 3)

1.3.2 THE THREAT TO THE ATH

The ATH is, according to the tactical concept of the Army, only employed over friendly territory which is not controlled by the enemy and with which the pilots are quite familiar as a result of their training and reconnaissance. The threat, to the ATH, therefore, must be viewed on the basis of the following criteria:

- risk of being detected by means of radar reconnaissance
- risk of being detected by forward artillery observer
- the air defense threat
- enemy airforce possibilities to engage the ATH.

a. Risk of Being Detected by Means of Radar Reconnaissance

Tests were conducted with the MPDR 30/1 all-round search radar of the Air Force low-level reporting system as well as the RASURA and RATAAC battlefield surveillance radar sets (fig. 4).

The test with the MPDR 30/1 was conducted to find out the rate at which ATH flights, when moving to or from the position area and during the fire flight in the position area can be detected and whether a concentration of ATH at a rendez-vous point and in a position area can be identified.

The test has proven that the MPDR 30/1 or a comparable radar system is unsuited

- to detect an ATH flight or
- to identify a concentration of ATH, and consequently to reconnoitre rendez-vous points or position areas.

2-3

The same test with the RASURA and RATIC battlefield surveillance radar sets demonstrates that the ATH will not be detected when they are moving. In a position area, however, reconnaissance is possible:

- The results of the RATIC employed by the artillery differ very much in various types of terrain. (Table 1)
- With the RASURA battlefield surveillance radar of the armored reconnaissance troops the detection rate was lower but depended less on the terrain type (Table 1).

TERRAIN TYPE	DESCRIPTION	RADAR TYPE	DETECTION RATE
1/2	UNDULATORY LOWLAND, PARTLY OPEN PLAIN, PARTLY BUILT-UP AREAS	RATIC	11,5 %
		RASURA	5,9 %
5	HILLY AREA, HIGHLAND FULL OF OBSTACLES	RATIC	0,7 %
		RASURA	5,7 %

TABLE 1: DETECTION RATE FOR DIFFERENT RADAR TYPES

Briefly stated, the means of radar reconnaissance are no actual threat to ATH. With tactically prudent behavior the ATH nearly always can evade enemy radar reconnaissance.

b. Risk of Being Detected by Forward Artillery Observer

Trials proved that unlike battlefield surveillance radar sets forward artillery observers are far more capable of reconnoitering ATH in their positions. The detection rate in both types of terrain was 27 %.

The engagement capabilities, however, are restricted by:

- the comparatively long artillery reaction time (from target acquisition by the forward observer until effect on target approximately 4 to 5 minutes), and by
- a large number of visual obstructions due to the combat environment.

c. Air Defense Threat

Tests conducted with the REDEYE 1 missile and the Bo105 helicopter resulted in the following findings (fig. 5):

- Visual contact between weapon and target is a basic requirement for acquisition of the ATH.
- The ATH can be acquired and engaged by the REDEYE 1 missile in all flight directions up to a distance of approximately 1200 m. At distances exceeding 1200 m up to approximately 1600 m the ATH is endangered only when departing (tail in direction of the REDEYE 1 missile).
- At distances exceeding 1600 m it is no longer endangered. The intensity of the Bo105 helicopter radiation source then becomes so low that infrared contact is no longer possible.

A trial to investigate ATH flight combat in a radar-guided anti-aircraft artillery threat environment demonstrated by the GEPARD anti-aircraft tank (fig. 6) was conducted in summer 1976, resulting in the following findings:

Search Radar Contacts

- when transiting over terrain type 1/2 (Table 1) the ATH will be acquired more frequently by the anti-aircraft tank than over terrain type 5,
- when on station, ATH are acquired by the search radar of the anti-aircraft tank, but they are not always identified as ATH.

Locking-on of the Tracking Radar

- the radar contacts are below the lock-on level of the tracking radar when abrupt movements or tilting of the rotor disc are avoided,
- consequently the subsequent modes of operation of the anti-aircraft tank for an engagement of ATH normally result from:
 - + Acquisition of the ATH by search radar,
 - + Identification (optical) of the ATH,
 - + Engagement (optical) of the ATH.

Engagements

- in both types of terrain approximately 35 to 40 % of the lock-ons resulted in engagements.
- Supposing that the total number of all search radar contacts is the number of all possible detections (100 %), then the ratio of lock-ons to search radar contacts can be equated with detection probability and the ratio of engagements to search radar contacts with the probability of success. The following values were determined (fig. 7):

Terrain Type 1/2: (cfr. table 1)

Detection probability	20 %
Probability of success	7 %

Terrain Type 5:

Detection probability	31 %
Probability of success	13 %

A trial with the missile-equipped ROLAND anti-aircraft tank essentially confirms the initial findings of the GEPARD trial. As an additional result, it seems to be determinable that the radar acquisition of ATH by a moving AA-missile-equipped tank is much inferior.

d. Enemy Air Force Possibilities to Engage ATH

These possibilities can be summarized as follows:

- Adverse weather and broken terrain reduce the detection possibilities of jet aircraft and favor ATH
- the main rotor circle diameter is the most important characteristic of the helicopter
- ATH on the ground and airborne are detected nearly only accidentally
- the average identification distance is 1500 m
- the main threat are surprise attacks of slow-flying tactical fighters
- in assembly areas ATH units are not more and not less threatened than any other units of the Army.

In case an airborne ATH is detected (fig. 8) it can evade enemy fire by

- taking cover as fast as possible
- a flight at maximum speed in the opposite direction or by quick flight direction changes
- flight in the opposite direction with lateral shift.

Altogether enemy air forces represent a lesser threat than other weapon systems. The ATH capabilities are not substantially restricted by an enemy air force threat.

A possible threat caused by armed enemy helicopters must be thoroughly watched; studies in this field have been started by the German Army.

1.4 WHY ATH AND NOT COMBAT HELICOPTERS?

ATH constitute an essential part of the combined arms team combat of the Army. They supplement and intensify the fire of the ground troops (fig. 9). They are less threatened by the enemy because they operate exclusively over friendly territory, and can thus fully utilize the weapons effect of the ground troops for their own fire flight. They largely fight according to the same principles as the combat troops of the Army, except that they make use of the third dimension and are, therefore, independent of the terrain, capable of rapid and wide-ranging movements. For the defensive mission of "antitank defense", ATH are optimized in design and armament.

Combat helicopters, by contrast, just like other means of aerial warfare, are designed to seek combat action independently and on their own, and to carry the fire fight into enemy territory. They fight, detached from friendly troops, mainly in enemy territory and are, therefore, subject to entirely different criteria as far as their technical design (survivability) and armament (rockets and gun) are concerned.

From this it follows that ATH

- have a considerable higher degree of survivability than combat helicopters as a result of their combat tactics;
- produce, as a result of their close contact with the combat troops, a better effect in combat than the combat helicopter as an "individual fighter";
- can, because they are specialized for their antitank defense mission, be kept very much smaller in size and weight than combat helicopters with their multi-purpose design, and
- can, therefore, be developed, manufactured, and operated at lower cost.

In summary, the results obtained through theoretical concept analyses and operations research studies, as well as the findings of these multi-year practical tests have confirmed that only a helicopter which is specially designed and equipped for antitank defense from the air can optimally match the required military characteristics.

1.5 GERMAN MILITARY REQUIREMENTS FOR ATH

The basic military requirements for an ATH are (fig. 10):

- high platform stability
- extremely good accelerating/decelerating qualities
- sufficient cruising speed (250 km/h)
- night mission capability

- small silhouette
- gyro-stabilized visionic equipment
- crashworthy airframe
- crashworthy fuel system
- endurance: 02:30 hrs + 00:20 hrs
- eight guided missiles
- passive radar warning system (ECM)
- low infrared emission
- two engines.

The order in which the items are listed above does not indicate their priority.

1.6 REALIZATION OF ATH REQUIREMENTS

Feasibility studies conducted on the basis of tactical/logistical and technical/economic criteria have shown that this optimum concept cannot be realized at the present time since

- the requirement calls for an ATH to be available not later than 1979
- the technology required for night combat and night flying will not be available in time
- the development of an ATH of a configuration commensurate with its mission constitutes a considerable technical risk, even without night combat components.

Therefore, in order to enable a feasible solution to be achieved within the given time and cost frame, the military characteristics required of the ATH with respect to

- availability by day and by night
- number of guided missiles
- mobility
- technical design

were, for the time being, reduced.

Taking into account the following significant criteria, namely

- military characteristics required as a minimum
- technical/economic aspects, such as similarity to or identity with the Bo105 M liaison-and-observation helicopter
- utilization of the HOT guided-missile weapon system which was developed in a cooperative Franco-German effort at considerable financial expense
- employment to capacity of German development and manufacturing capabilities,

the conclusion was reached that, under the given constraints, the Bo105/ATH, a helicopter which uses largely the same components as the liaison-and-observation helicopter but has been further developed for antitank defense purposes, is the best choice for an antitank helicopter of the first generation (ATH-1). This helicopter is shown in figure 11. The most essential data concerning this weapon system are contained in table 2.

CRUISING SPEED:	210 KM/H
ENDURANCE :	1:45 HOURS
COMBAT LOAD :	6 ANTITANK GUIDED MISSILES HOT
MAX. RANGE, IDENTICAL WITH MAX. COMBAT RANGE:	4000 M
SIGHT :	GLASS-OPTICAL SIGHT APX 397 (3.2 + 10.8 FOLD)
CREW :	COMMANDER (GUNNER) PILOT

TABLE 2: PERFORMANCE DATA OF THE Bo 105-ATH 1

1.7 DEGREE OF IDENTITY BETWEEN ATH-1 AND LOH

In addition, I would like to elaborate to some extent the degree to which the ATH will be identical with the Bo105M liaison-and-observation helicopter.

As I mentioned earlier, the performance of the Bo105M would be increased as compared to the Bo105C. This increased performance results from the requirement that, for economic/logistical reasons, the liaison-and-observation helicopter and the ATH should, to the largest extent possible, have the same components, based on the Bo105C.

The required identity will be achieved with respect to:

- 2-6
- the engine
 - the main rotor head
 - the main gear box
 - the tail rotor assembly
 - the fuel system
 - the flight instruments
 - the navigation system.

Due to its mission, the ATH-1 will be different from the liaison-and-observation helicopter with respect to the following items:

- reinforcement of structural parts of the airframe for the purpose of accommodating the weapon and sighting system
- weapon and sighting system
- vibration dampers at the main rotor blades for the purpose of improving stability during combat in hover flight
- yaw regulator in the tail rotor control mechanism for the purpose of improving stability about the vertical axis
- portions of the tail rotor drive system and the tail assembly
- portions of the control system.

This weapon system, the antitank helicopter of the first generation (ATH-1), will be delivered to the Army Aviation forces late in 1979, together with the liaison-and-observation helicopter.

It will close, to the extent feasible, the gap existing within the Army with respect to antitank defense until such time when an antitank helicopter of the second generation (ATH-2) which fully matches the required military characteristics will be available in the second half of the eighties.

2. PROSPECTS FOR THE FUTURE

2.1 INTRODUCTION

In the first part of this presentation you have been given an overview over the present state of military helicopter development in Germany. The next question then to be asked is: What are the prospects for the future?

What I am going to say is not to be taken as an official statement, since at present we don't have any firm military requirements for future military helicopters.

The picture I am able to paint is not a purely national German one, for it is influenced by European helicopter cooperation needs. We know very well that the requirements of the Atlantic Alliance also have to be considered, especially with reference to the very important and urgent requirements of standardization and interoperability. In the past, such requirements have been observed too little, both over here and on the other side of the Atlantic. In this area, the Western World faces very grave problems, while the Warsaw Pact, in this regard, has no trouble at all and has made great progress, since there only one country, namely the Soviet Union, decides upon development. Therefore, in the interest of standardization, our countries should be willing also to look for common solutions.

With this presentation I can give you neither a complete picture with all the details nor any spectacular fresh knowledge of future requirements. What I shall try to do, though, is to point out some important facts and aspects of future military helicopter development. I hope that this discussion may contribute to greater understanding among military planners and rotorcraft designers and constructors. I think this is also one of the purposes of this ACARD symposium.

2.2 HELICOPTER DEVELOPMENT IN THE PAST

Let us take a brief look at helicopter development in the past. Practical helicopter development began in earnest only about 40 years ago. The development of purely military helicopters began much later, I think with the Korean War. In the beginning of military helicopter development, neither doctrine nor experience was available. These had first to be evolved. This could best be done by practical exercises and, finally, by real missions in war. Thus we understand that the greatest impulses to and progress in helicopter development resulted from requirements and experiences in the Korean, Vietnam, and Middle East wars. After the Vietnam war, a large number of the possible operational requirements for military helicopters were known and could be used as a basis for development.

Today, doctrines and operational concepts in the U.S.A., and in European countries too, may differ. Such differences result from differing multi-purpose, global concepts on the one side and regional Central European operational requirements on the other. In the European countries, we have made good progress in harmonizing European concepts. In the Atlantic Alliance, there are also efforts to harmonize the U.S. and European concepts. These operational concepts must not be regarded as permanent, but as dynamic and flexible, and therefore, as time goes by and knowledge increases, they will have to be changed.

2.3 DIFFERENCES BETWEEN MILITARY AND CIVIL HELICOPTERS

We are speaking principally about military helicopters. But I think it is necessary to make some remarks about the considerable differences between military and civil helicopters. These must be taken into account. Military helicopters must meet much more stringent requirements than civil helicopters, a fact which results from the vast differences between military and civil missions. A civil helicopter will usually operate under normal flight conditions, well above ground, and clear of obstacles, without any obstacle in its flight path.

By contrast, a military helicopter in the combat zone must be capable of rapidly changing its position, satisfying extreme flight requirements near the ground, and clearing obstacles under enemy fire.

Apart from its armament, armor, and the extensive special equipment necessary for military missions, a military helicopter also needs relatively greater installed power and a stronger structure than a civil helicopter does. A comparison of different features of military and commercial helicopters is given in Table 3. The consequences with respect to the different weight proportions are shown on the figure 12.

FEATURES	MILITARY IMPORTANCE	COMMERCIAL IMPORTANCE	[%] OF GROSSWEIGHT
<u>DIFFERENT FEATURES</u>			
• ARMAMENT	++	-	5
• MISSILES (PAY LOAD)	++	-	6
• NIGHT AND BAD WEATHER FIGHT CAPABILITY			3,5
- NIGHT FIGHTING CAPABILITY OF THE MISSILES	++	-	
- FLIR FOR GUNNER	++	-	
- LASER RANGE FINDER	++	-	
• NIGHT AND BAD-WEATHER FLIGHT CAPABILITY (NOE)			1
- PILOTS NIGHT VISION	++	-	
- OBSTACLE INDICATOR	+	-	
• ARMOR	+	-	5
• SELF SEALING FUEL SYSTEM	+	-	0,7
• REDUCTION OF DETECTIBILITY			1
- NOISE	+	-	
- IR SUPPRESSION	+	-	
- OPTICAL REFLECTIONS	+	-	
• RECOGNITION AND IDENTIFICATION SYSTEMS	++	-	4
• ECH (ECCM)	+	-	2
• HEAD-UP DISPLAY	+	-	0,2
• AUGMENTED PERFORMANCE	+	-	1
<u>COMMON FEATURES</u>			
• CRASH RESISTANT STRUCTURE	++	+	0,5
• CRASH RESISTANT FUEL SYSTEM	++	+	0,7
• NIGHT FLIGHT CAPABILITY (IFR)	++	++	0,5
• ADDITIONAL COM/NAV SYSTEM	+	+	1
• DEICING-SYSTEM	+	+	1
• DUAL REDUNDANT SYSTEMS	++	+	5

(++ VERY IMPORTANT, + IMPORTANT)

TABLE 3: COMPARISON OF DIFFERENT FEATURES OF MILITARY AND COMMERCIAL HELICOPTERS

Due to these differences military helicopter development is veering more and more away from civil helicopter development. This means that the once familiar close correspondence between military and civil helicopter systems and components will continue to diminish. And it means that the specific development cost of military helicopters will continue to increase. This is one of the main reasons for the urgent necessity of cooperation and standardization in future military helicopter development.

2.4 SOME TECHNICAL ASPECTS OF MILITARY HELICOPTER DEVELOPMENT

2-8

In recent years, the helicopter has gained much ground in the spectrum of aircraft, and may will gain a still stronger position. The perspectives in future helicopter development are very promising.

The helicopter's strongest competitors in the fifties and sixties were VSTOL aircraft. But the exaggerated hopes placed in them were not to be realized, and their competition now seems to have been overcome. Today, the helicopter is indeed the only aircraft capable of hovering economically within or outside the range of ground effect for any length of time.

With regard to flight speed which for aircraft is so important, everybody understands now that the speed of a helicopter is limited by the inherent characteristics of the rotor system. In the past, great efforts have been made to increase the speed of helicopters, but the success was not very great. Efforts at making progress in helicopter design should concentrate on what rotorcraft can do within their given physical limits. Priorities in future helicopter development should therefore be set not on increasing speed, but rather on enhancing safety and reliability and on simplifying the system so as to lower the cost of maintenance and operation.

Another important fact should be mentioned, namely that the helicopter has reached a high degree of technical perfection. It therefore seems not very probable that the near future will bring sensational advances. But this does not mean that we should neglect our efforts and research work to improve our helicopters.

Whereas in the past there was a proliferation of rotorcraft types, one type has now come to be dominant, namely the classic single-rotor type. This fact also opens up new perspectives for further development: this dominant basic concept makes possible the selection of similar types, and a consequent reduction in the number of types.

But among the rotor systems and the dynamic components there are still some 5 or 6 different competitive systems. Each of these rotor systems has reached a certain degree of perfection. Each has its advantages and disadvantages, but it seems to me that the best of these systems has not been found to this day. I think there are signs that a uniform optimized solution to the rotor problem, or maybe two solutions, one for military and the other for civil helicopters, should be possible. If this goal could be set for future development, great progress could be achieved. This would also be a further important contribution to standardization.

There is still another important aspect of the rotor system, and that is the rotor blades. I don't think it should be very difficult to optimize and standardize these as well. In Germany we have been doing a lot of development work on fibre-glass blades for 20 years now on which we spent a lot of money. I believe that we have reached a high standard in this field. We have for several years considered it proven that fibre glass blades are the best possible solution for rotor blades. Due to their special characteristics and destruction mechanism, fibre-glass blades are, in respect of vulnerability and control characteristics especially suited for military helicopters. We are convinced that this modern technique will find its way into the helicopter development of tomorrow.

2.5 MANEUVERABILITY AND ITS SIGNIFICANCE FOR MILITARY HELICOPTER OPERATIONS

In my opinion, maneuverability is probably one of the most important requirements in military helicopter operations. This is also confirmed by the findings of the German helicopter flight test group presented in the first part of this paper. It is my impression that many helicopter people are not aware of the real significance of maneuverability for military helicopter operations.

Helicopter maneuverability, as demonstrated in German tactical flight tests, largely depends on the type of rotor system used. We believe such a high degree of maneuverability as was achieved can only be obtained with a rigid rotor. While the relationship between maneuverability and the functional mechanism is well understood today, quantification still poses some problems. It does not seem to be very satisfactory simply to state that negative-g maneuvers at -0.5 have been realized.

These maneuvering capabilities are most important for the antitank helicopter. Therefore, they will be incorporated in present and future German military helicopter development. We have found that apart from armor, which, as you know, carries a considerable weight penalty, tactical flying offers the best protection against enemy fire.

Figure 13 gives an idea of a typical antitank mission. Here it is broken down into four distinct phases. In this picture you may recognize the great importance of maneuverability. You will notice the frequent and abrupt changes in speed. This also places a severe stress on the engines, gears, and all dynamic parts, which is reflected in special engine requirements.

The next figures give an idea of the efficiency of the rigid rotor in comparison with a teetering rotor with regard to maneuverability.

Figure 14 attempts to represent a threedimensional compound maneuver, from the pull-up with $n = +2$ to the push-over rolling with $-1 < n < -0.5$. The practical consequences of such maneuvers are shown with the comparison of the helicopter exposure envelope for a hingeless and a teetering rotor (fig. 15). The differences of the exposure times for a hingeless rotor with 2.5 s and a teetering rotor with 9 s are very remarkable in regard to the threat by enemy fire. The reasons for the different behaviour of the teetering and the rigid rotor are found in the different control moment capabilities of the two systems (fig. 16) and the corresponding steering reactions.

These are explained with the next two figures which represent the comparison of the teetering and the hingeless rotor with regard to helicopter response with similar pilot input in the first case (fig. 17), and with regard to pilot workload with similar helicopter response in the second case (fig. 18). The first case

(fig. 17) shows what happens for identical pilot inputs. You can see the much longer reaction time of the teetering rotor with respect to the bank angle change. In the second case (fig. 18) you can see what must be done with the teetering rotor to obtain the same bank angle time history as with the hingeless rotor. With the teetering rotor you have to execute a complicated, hardly reproducible stick action. In contrast to this, the stick action for the hingeless rotor is much simpler.

These diagrams are not derived from theoretical work. The figures represent test results. Now I think you may understand better why we in Germany are preferring the rigid-rotor system for military helicopter operations.

2.6 SURVIVABILITY AND CRASHWORTHINESS

We appreciate that the U.S. Army at its laboratories has done very extensive and useful research on helicopter survivability and crashworthiness at considerable expense. The allies hope also to derive some benefit from this work.

I think the requirements of MIL STD 1290, both those concerning the crew and those concerning the helicopter, are not too severe. In my view, it is a question of fundamental importance to what extent safety arrangements for survivability and protection can be incorporated in military helicopters without prejudice to mission accomplishment. But what are the limits that must not be exceeded if we want to have still an efficient antitank helicopter instead of a flying tank? Studies of this kind seem to me necessary and essential in view of the constant rise in the cost of manpower and material.

2.7 NIGHT AND BAD-WEATHER CAPABILITY

In East and West alike, the next generation of military helicopters will be required to have a good night and bad-weather capability.

As you know, some sort of operational night and bad-weather capability is expected to be available after 1980 although the extent of that capability is still uncertain. Moreover, we are well aware of the considerable cost of meeting these requirements and the additional weight penalties involved. I am not sure whether these measures are really as useful and necessary as they are claimed to be. So it may be wise to give this problem careful consideration by further studies. It is known that the U.S. Army is well advanced in night navigation and fire technology. As an ally we may therefore expect to receive some functional support from the United States in this regard.

These noted technical requirements are determining the configuration of progressive future military helicopters.

- HIGHEST POSSIBLE MANEUVERABILITY
ALSO IN NEGATIVE "G" FLIGHT ENVELOPE
- DUAL ENGINE CONCEPT
- HIGH CRASH SURVIVABILITY
- PERFORMANCE RESERVES
AT ALL POSSIBLE CONDITIONS
- DUAL REDUNDANCY OR FAIL SAFE CONCEPT
OF ALL IMPORTANT COMPONENTS
- LOW DETECTABILITY

TABLE 4: TECHNICAL CONSEQUENCES OF ATH MISSIONS

NIGHT FLIGHT AND NIGHT FIGHTING EQUIPMENT

- MISSILES WITH NIGHT FIGHTING CAPABILITY
- INDEPENDENT FLIR SIGHTS FOR PILOT AND GUNNER
- HEAD-UP DISPLAY
- TWO INDEPENDENT NAVIGATION SYSTEMS
- ECM SYSTEM

HIGH SURVIVABILITY

- CRASH RESISTANT STRUCTURE
- REDUNDANCY IN IMPORTANT COMPONENTS
- ARMORED PILOT AND GUNNER SEATS
- ARMORED MAIN DYNAMIC COMPONENTS
- REDUNDANT SUCTION FUEL SYSTEM
WITH SELF SEALING FUEL TANKS AND LINES

TABLE 5: TECHNICAL REQUIREMENTS FOR ATH

The principal technical consequences of ATH-missions are summarized in tables 4 and 5. It must be pointed out that the requirement of night capability must be fulfilled for two somewhat different parts namely

- the night navigation equipment
- the night fighting equipment.

It must be mentioned that these components will be among the most expensive equipment of the future ATH.

According to first design studies figure 19 shows a perspective view of a possible future ATH with representation of the equipment- and especially the armament-integration. A three side view of such a ATH-design is given in figure 20. These design studies have shown that a future ATH probably must have a size with an all-up weight of about 4500 kg. The all-up weight of the ATH of the first design studies was below 3500 kg.

2.8 TENTATIVE GERMAN PROSPECTS

Germany is under no acute time pressure to establish future operational requirements, since these would essentially concern only transport helicopters, and the German transport helicopter fleet consists of light and medium transport helicopters which can stay in service well beyond 1990. Thus, there is time enough to make careful studies and to have discussions with our partners concerning a common development of succeeding types. Figure 21 now shows some future prospects.

In the light-helicopter class, we have the current development of the liaison-and-observation helicopter (LOH) and of the antitank helicopter (ATH), both on the basis of the Bo105 helicopter (fig. 21, left side below).

In the next higher weight class you see on the right side in the diagram the advanced and somewhat heavier antitank helicopter with night capability (ATH 2). This helicopter is in a preparation phase for common development with France, the goal being to put it into service in the French and the German armies in about 1986-1987. We hope that other allied countries will join this program.

As for the light transport helicopter - if such a vehicle should be wanted - we would plan it to be approximately the size of the advanced antitank helicopter, so that the light transport could be developed on an equal basis with the antitank helicopter. With such a family of related types of helicopters, we think we can achieve considerable cost and manpower savings. Furthermore, this could be a real contribution to standardization and interoperability.

Of course we are also studying the feasibility of combining the Light Transport (LTH) and the Medium Transport Helicopter (MTH) missions which we would like to concentrate in one type, namely the MTH. Such a step would enable a further reduction in types. Such a medium transport helicopter would have to transport a payload of 3.5 to 4 tons, including a land vehicle like a jeep or an armored car. Figure 22 shows an artist's impression based on a design study of such a transport helicopter. A cross-section with load of such a design is given in figure 23. But the possible requirement for a new MTH is not urgent, since the CH-53 carrying double payload will be in service well beyond 1990.

In concluding my survey of German requirement studies for future military helicopters, I must mention that the German Navy is also conducting such studies. These navy studies concern a land-based missile-equipped navy attack helicopter. It may be possible that the Navy requirements can be combined with those of the Army. If this is the case, it would serve as another example of the feasibility of the family concept, contributing to type reduction and standardization. For their frigates, which are planned to be put into service in the early eighties, the German Navy will procure ship-based helicopters of 7 to 10 t. The type that may be bought has not yet been decided upon.

From my personal point of view I estimate that the number of future antitank helicopters required may be about 200. As to the transport helicopters, one can say about 100 of each of the two classes. The number wanted by the German Navy for combat helicopter functions is much smaller.

2.9 PROBLEMS OF STANDARDIZATION OF HELICOPTERS

In this presentation it has been pointed out that standardization of military helicopters would be one of the most important needs for the efficiency of the military alliance. Therefore in Europe as well as in the US efforts are made in this direction. But all helicopter people are aware too of the great difficulties for solving the problems involved.

I only will mention one of the most important reasons for the hindrance of the development of unique military helicopters in the western world, and this is given by the existing industrial structure and the strong competition between the different helicopter producers in the US and in Europe.

Because of this no agreements about a total standardization of military helicopters can be expected within a short time, but at least it should be tried to begin with the standardization of some components and parts of the equipment and the armament. Such partial solutions could help to comply with the most urgent requirements of interoperability and also could be a useful contribution to standardization.

In this paper some areas of helicopter development have been shown that are well suited for cooperation. The rising complexity and the rising costs of the military helicopters of the next generation, which can be well estimated at present, will force all participants to be ready for collaboration.

In Europe the "Independent European Program Group" (IEPG) has been established for the treatment of all military standardization problems. In the Atlantic Alliance there are also endeavours for promoting standardization activities. We hope that the results of these actions will also lead finally to a real standardization of next generation of military helicopters.

3. CONCLUDING REMARKS

In the first part of this paper the present status of the German army helicopter development had been represented with the background of the German army doctrine for military helicopter operations. This concept is founded on the special military requirements of the Central European theatre. It has been developed by extensive theoretical and practical investigations together with flight tests.

Based upon this concept of airmobile operations by helicopters with special emphasis on the anti-tank-mission, in the second part of this paper possibilities and prospects for the future German military helicopter development have been outlined.

It has been shown that because of the enlarged requirements for the next generation of military helicopters they will become more complex and therefore more expensive than the present generation. Thus it will become difficult for one country to carry alone the resulting burdens. But it is not only for these reasons, that we have a need for cooperation in future military helicopter development. There are also urgent military interoperational requirements that are determining a demand of collaboration of the allies.

It has been pointed out that the reduction of the number of types of military helicopters and the standardization must be main goals in future development as these are basic prerequisites for improving the operational efficiency of the next generation of helicopters. A reduction of the number of all present types of military helicopters of the Western world to one quarter seems to be realistic and within reach by 1990 or slightly thereafter. But if this goal is to be reached, strong efforts must be made now in common planning of future military helicopters, both in Europe and in the Atlantic Alliance in general. Duplication of work must be avoided. I hope that this is an endeavor in which all will participate, including AGARD.

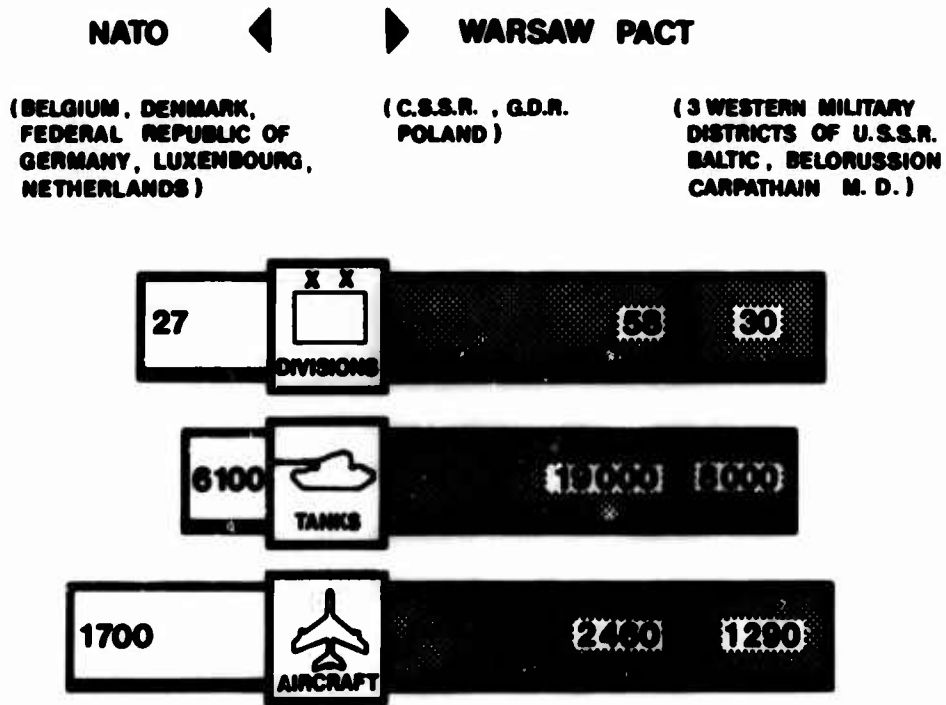

FIGURE 1: COMPARISON OF FORCES IN CENTRAL EUROPE - PRESENT FORCES

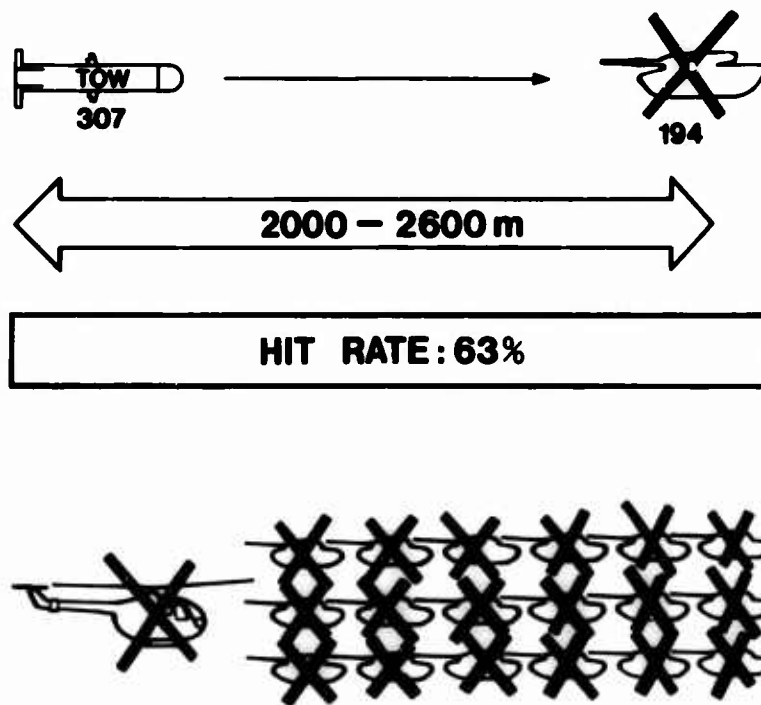

FIGURE 2: KATTERBACH TEST RESULTS

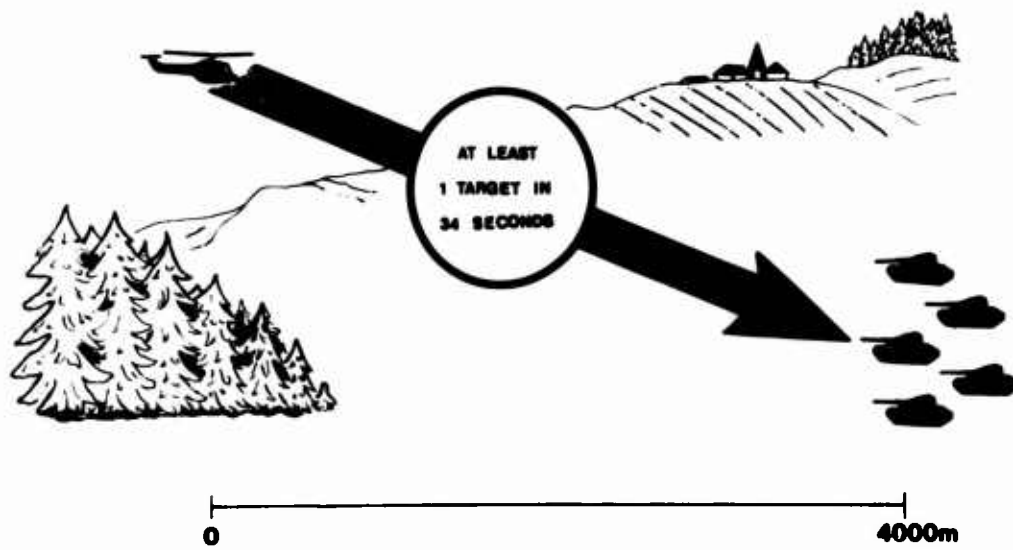

FIGURE 3: DETECTION OF ARMORED VEHICLES BY ATH

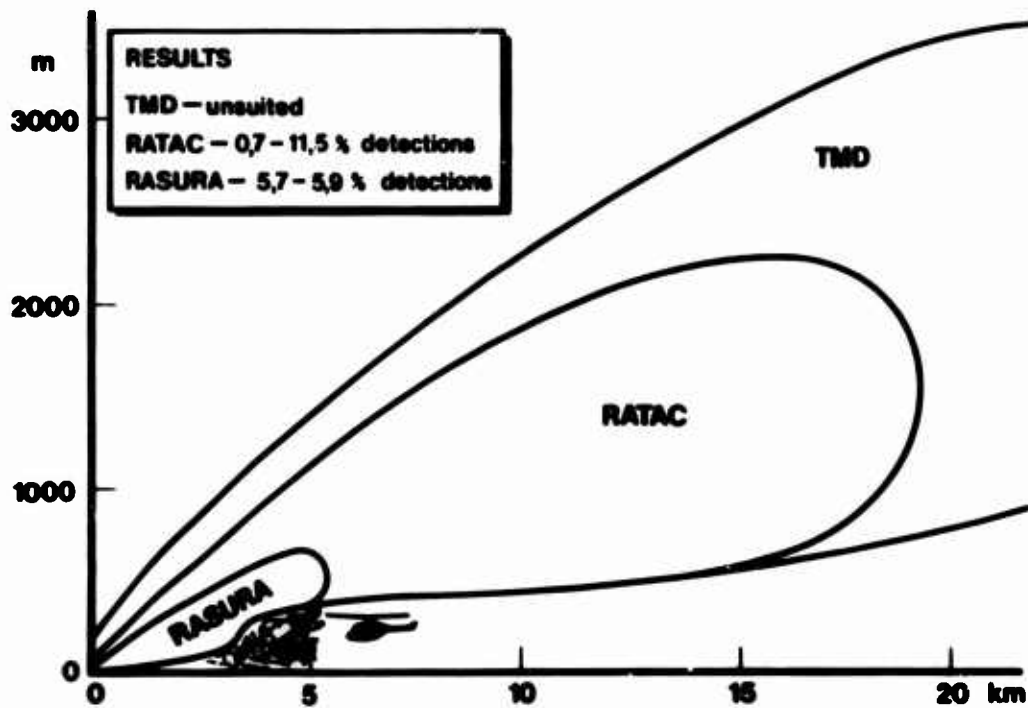

FIGURE 4: CAPABILITY OF ATH TO AVOID ENEMY RADAR DETECTION

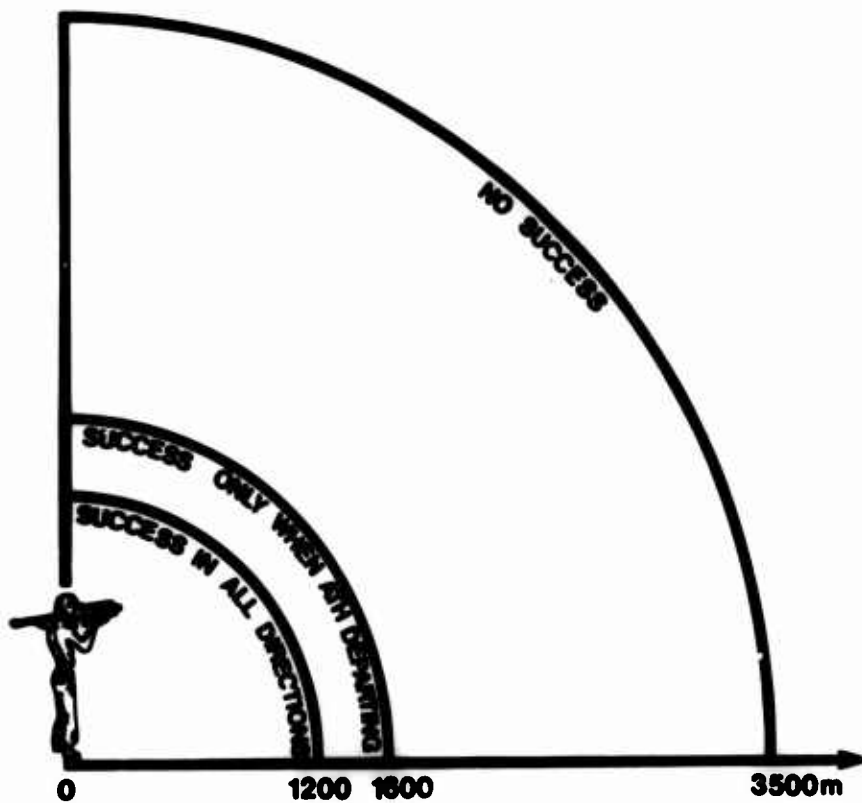

FIGURE 5: RESULTS OF REDEYE TRIAL



FIGURE 6: GEPARD ANTIAIRCRAFT TANK

FREQUENCY

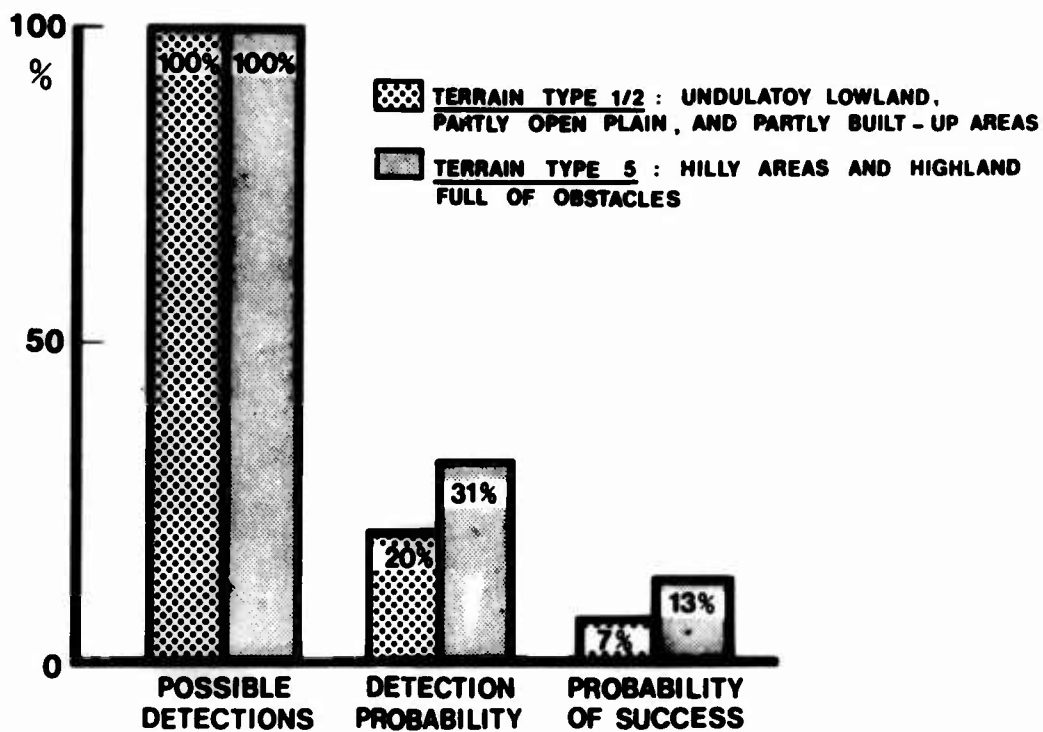

FIGURE 7: THREAT TO ATH BY ANTI-AIRCRAFT TANK



FIGURE 8: EVASIVE MANEUVERS IN CASE OF ATTACK BY ENEMY TACTICAL FIGHTER

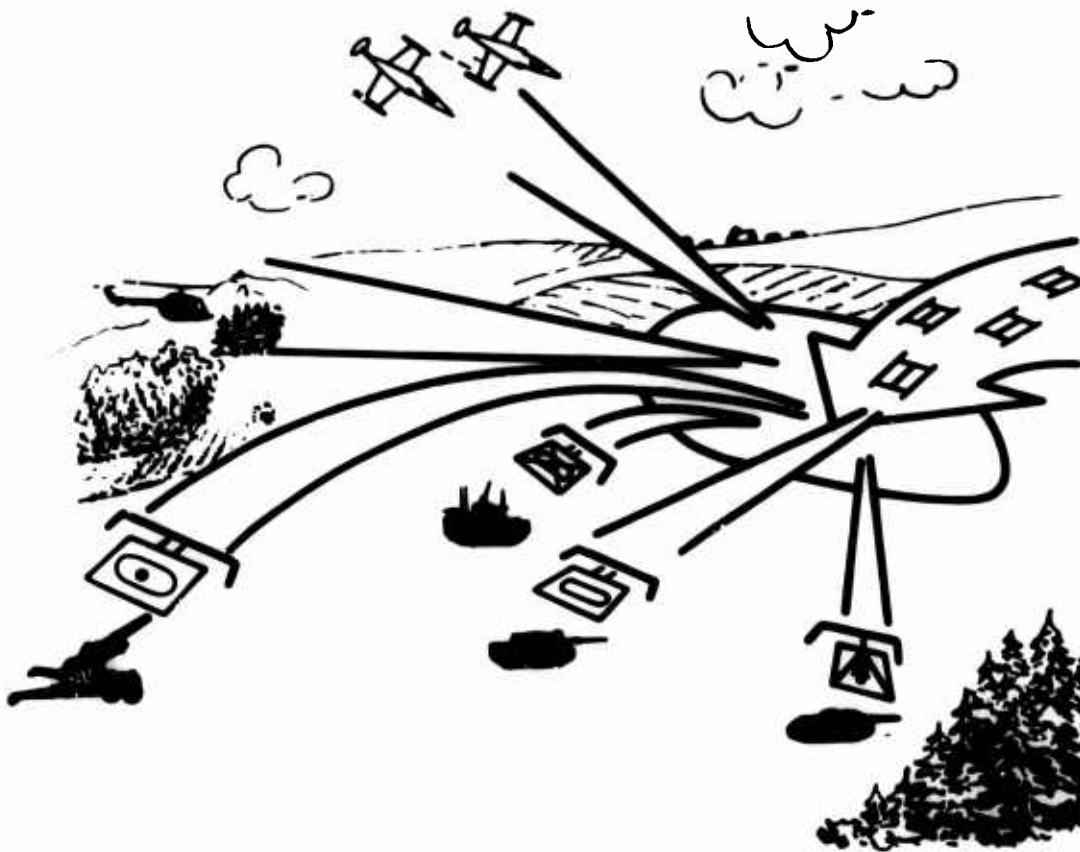

FIGURE 9: COMBINED ARMS TEAM COMBAT

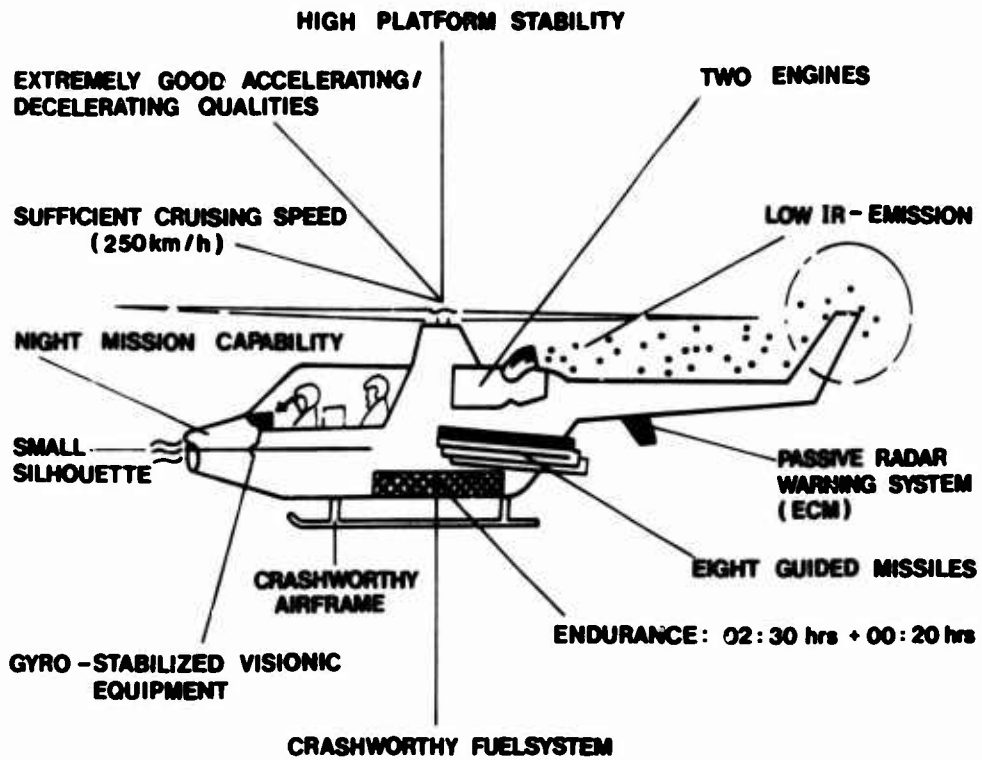

FIGURE 10: TECHNICAL CONCEPT OF AN ANTITANK HELICOPTER



FIGURE 11: Bo105-ATH 1

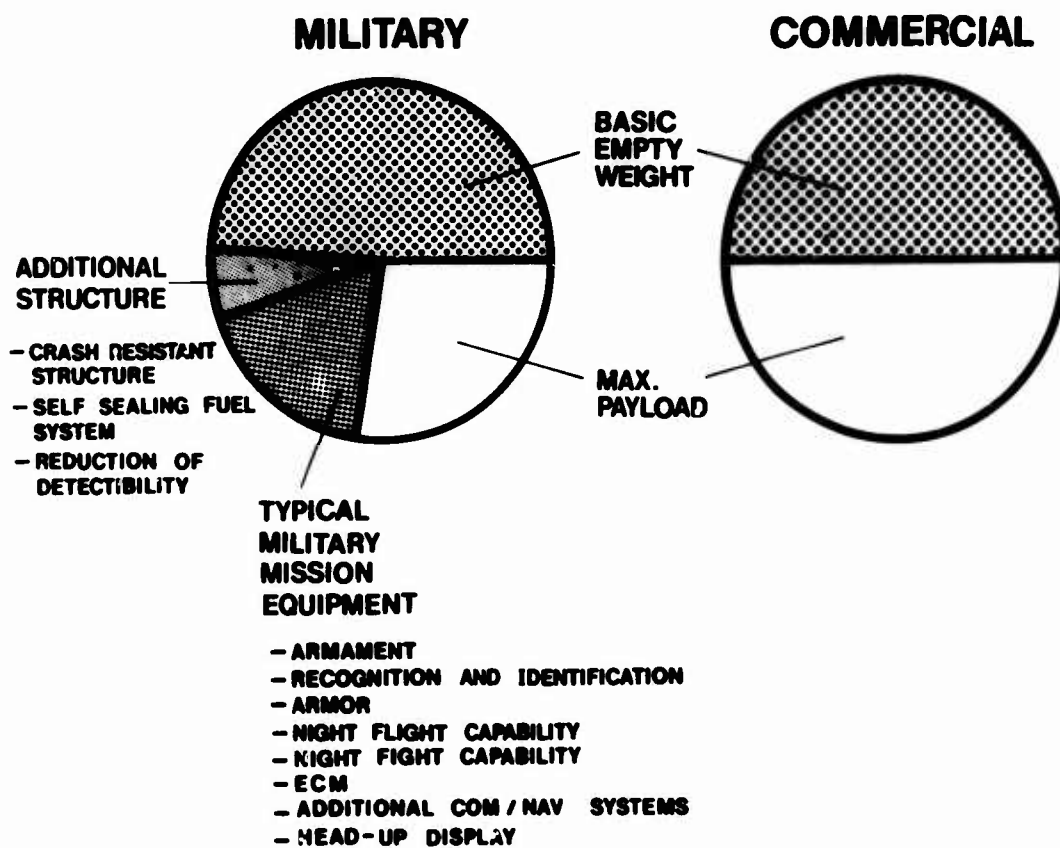
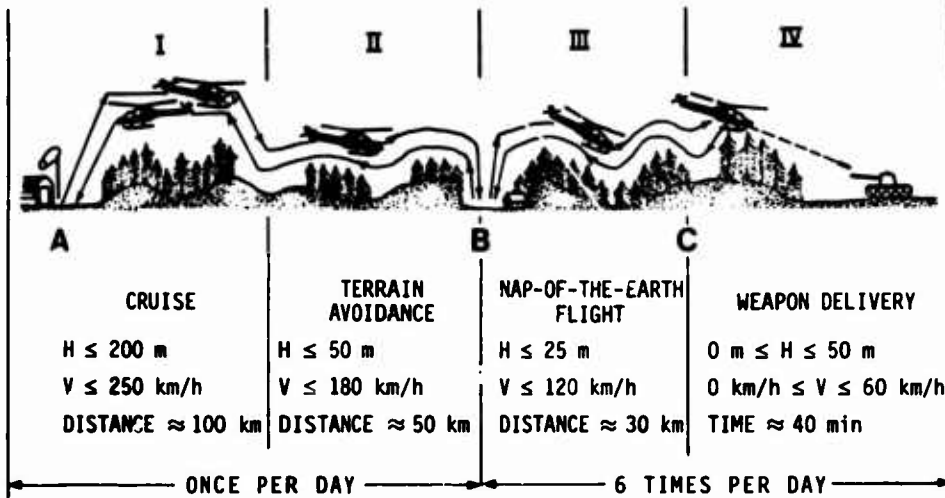

FIGURE 12: COMPARISON OF WEIGHT COMPOSITION OF MILITARY AND COMMERCIAL HELICOPTERS

5-18



- A CENTRAL BASE
- B FORWARD BASE
- C FORWARD EDGE OF THE BATTLE AREA (FEBA)

FIGURE 13: TYPICAL ANTITANK HELICOPTER MISSION

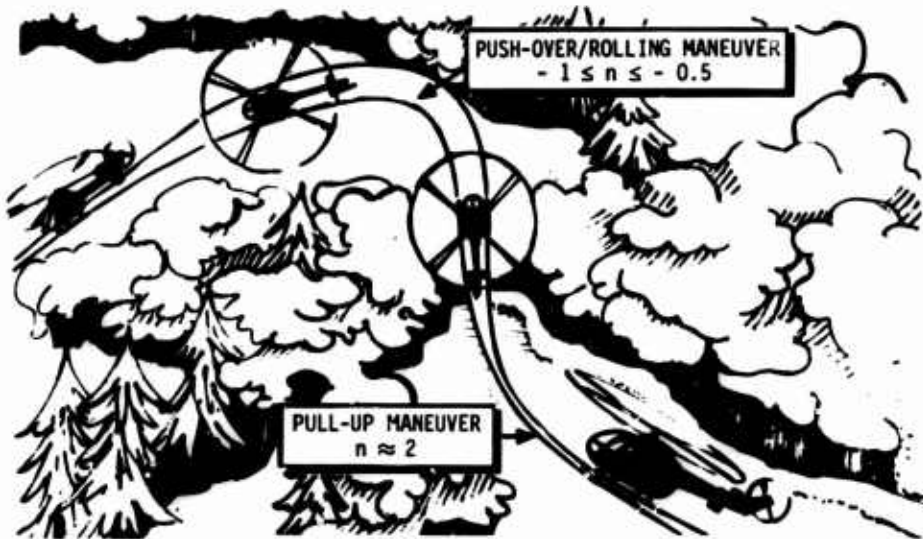
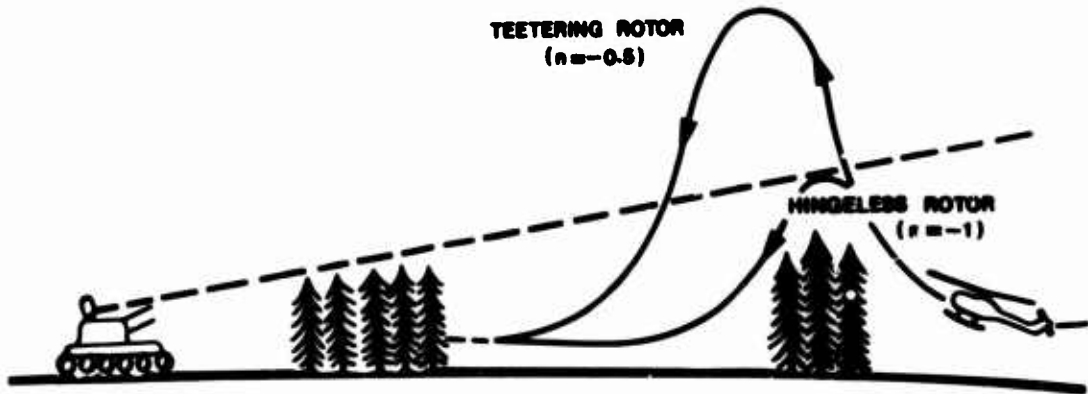

FIGURE 14: TYPICAL COMPOUND MANEUVER



ALTITUDE OVER COVER	~50m FOR TEETERING ROTOR
	~15 m FOR HINGELESS ROTOR
EXPOSURE TIME	~9 s FOR TEETERING ROTOR
	~25 s FOR HINGELESS ROTOR

FIGURE 15: HELICOPTER EXPOSURE ENVELOPE

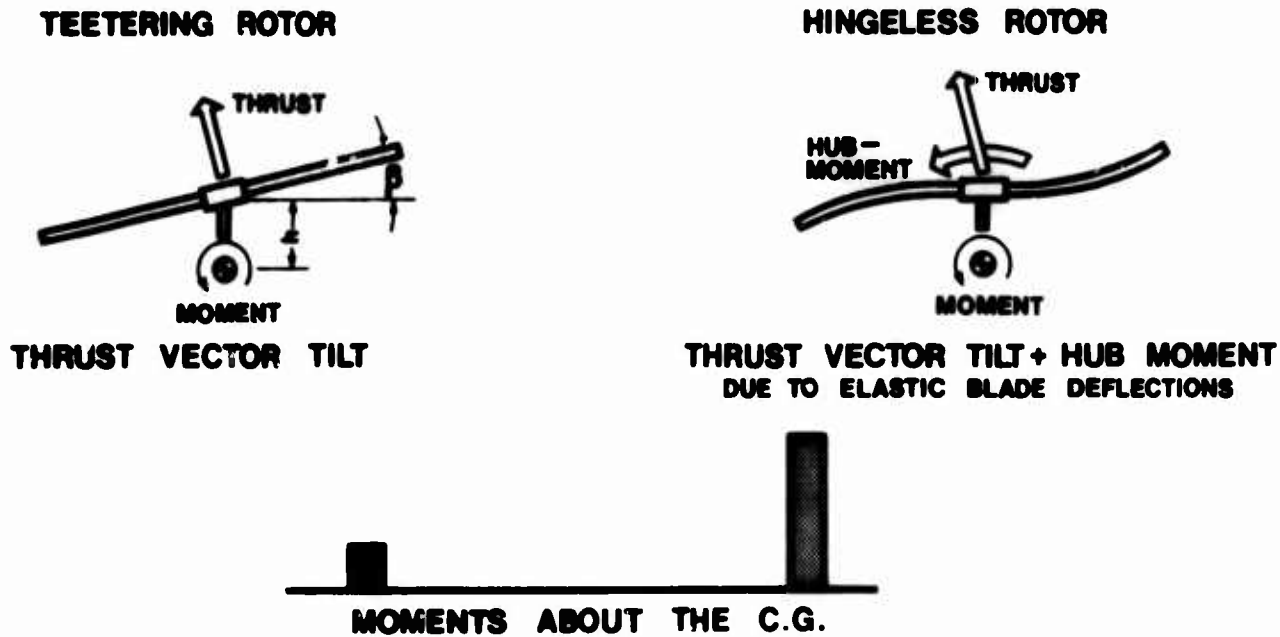

FIGURE 16: CONTROL MOMENT CAPABILITY

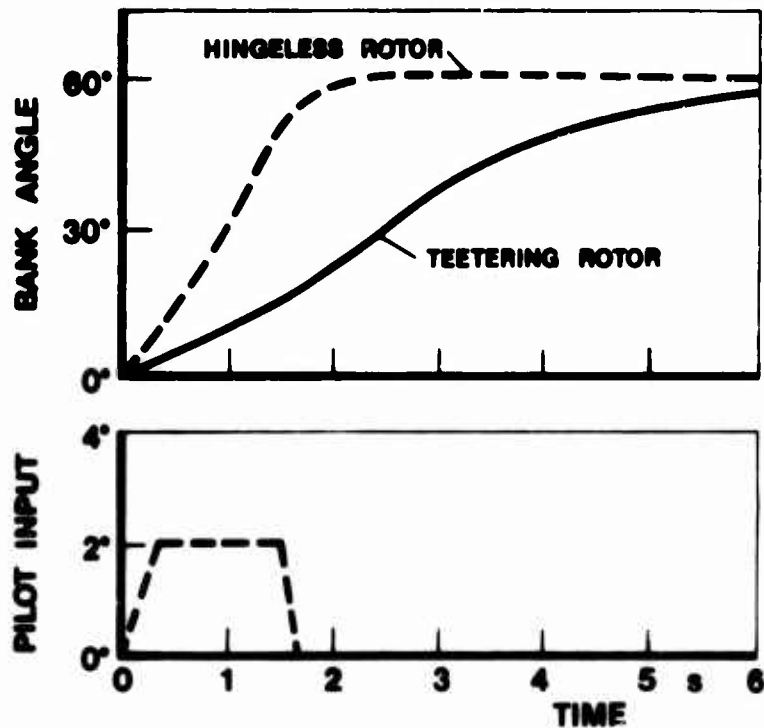

FIGURE 17: HELICOPTER RESPONSE COMPARISON FOR SIMILAR PILOT INPUT

5-20

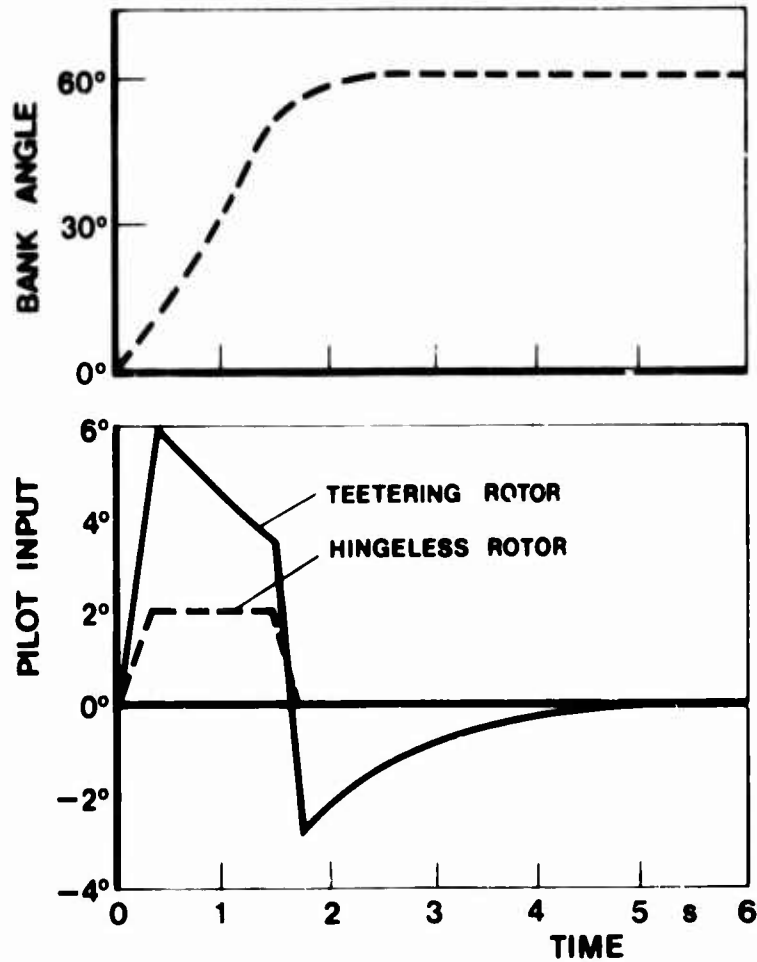

FIGURE 18: PILOT WORKLOAD COMPARISON FOR SIMILAR HELICOPTER RESPONSE

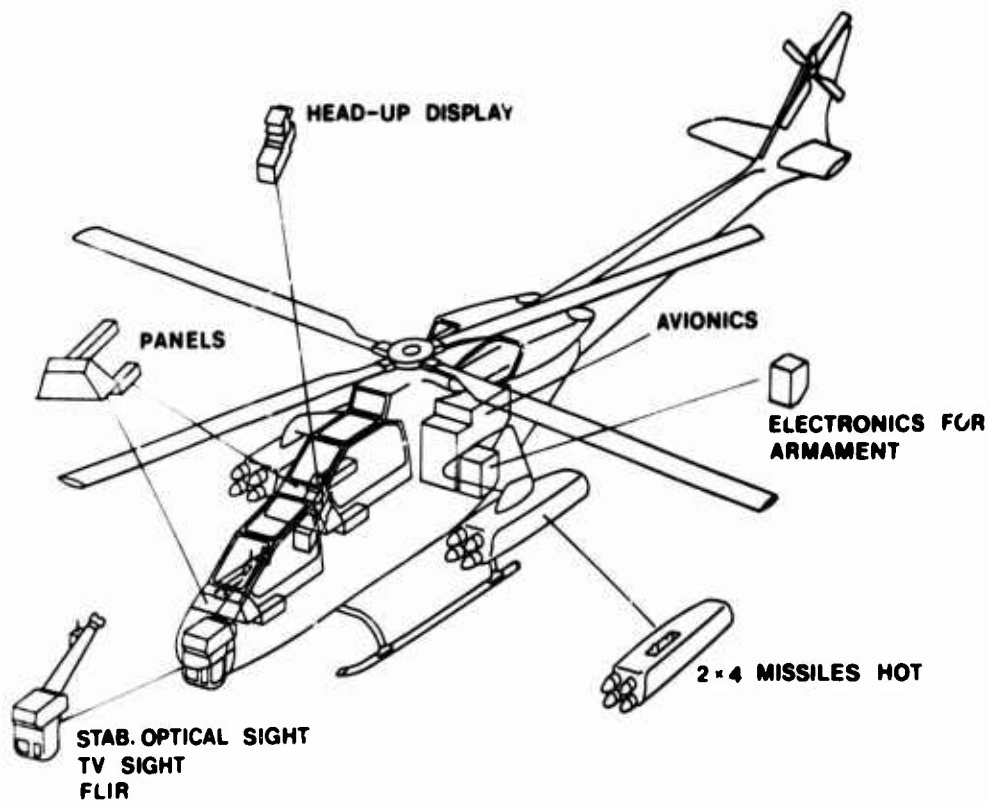

FIGURE 19: ATH-DESIGN EQUIPMENT AND ARMAMENT INTEGRATION

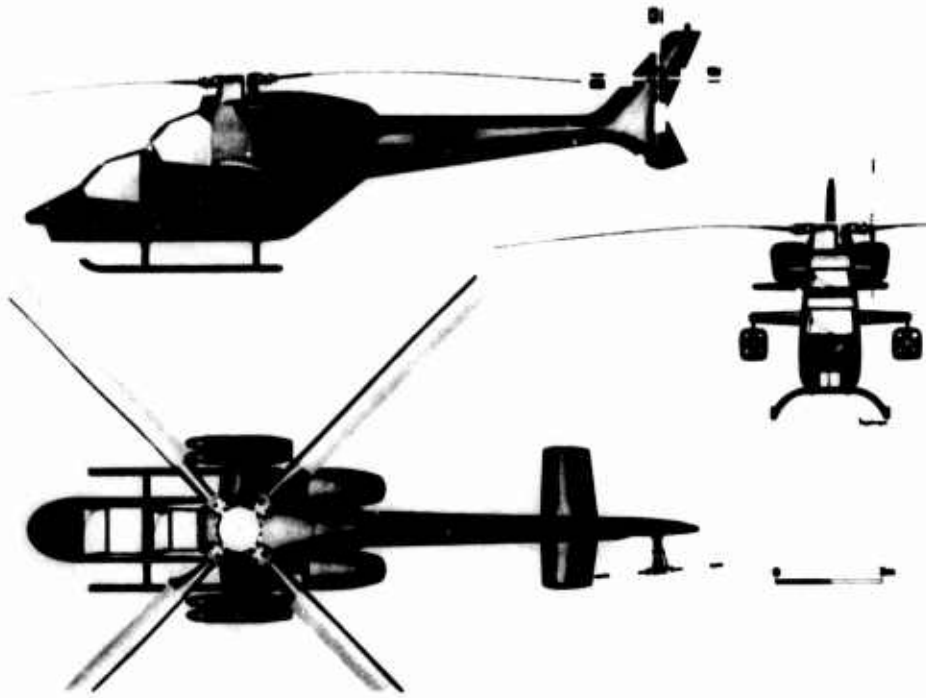

FIGURE 20: ATH2-DESIGN

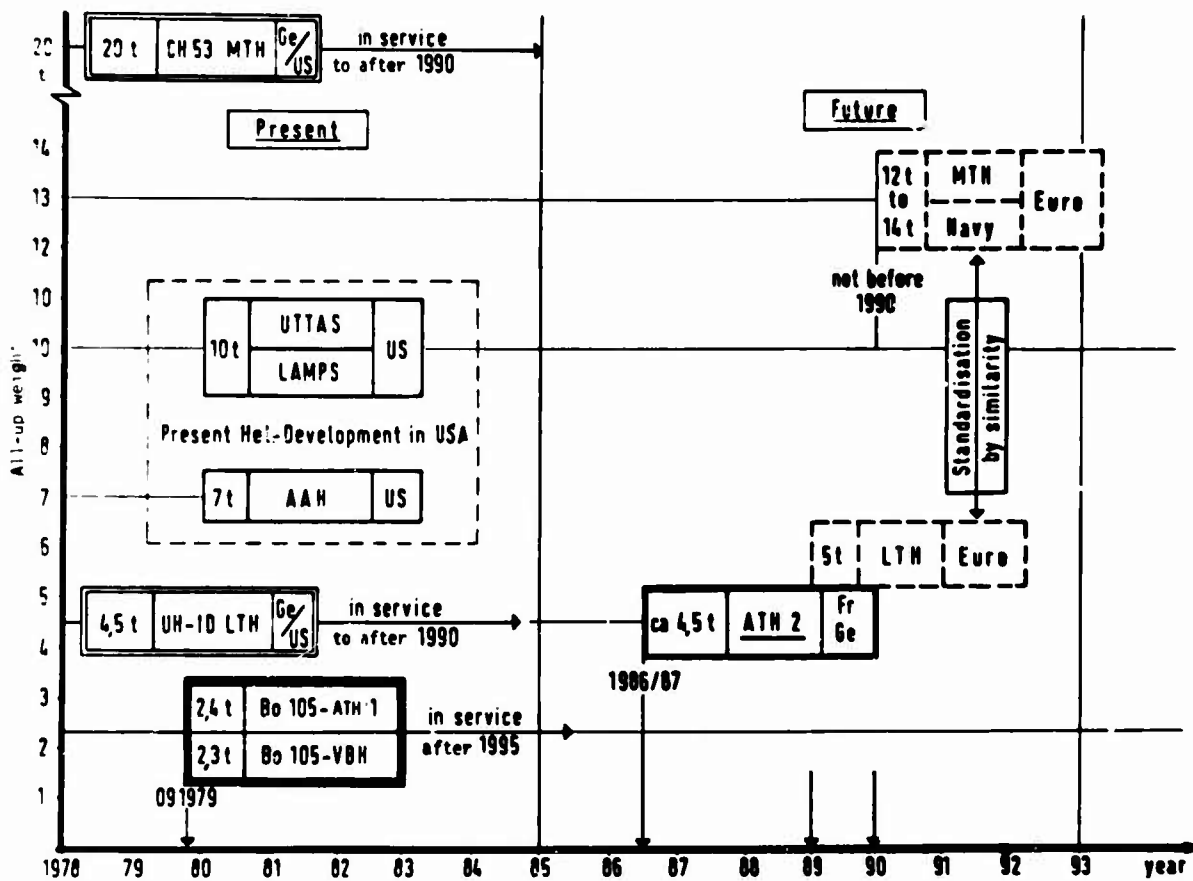

FIGURE 21: FUTURE HELICOPTER DEVELOPMENT PROSPECTS



FIGURE 22: ARTIST'S IMPRESSION OF A MEDIUM TRANSPORT HELICOPTER FOR PAYLOADS OF 3.5 - 4 TONS

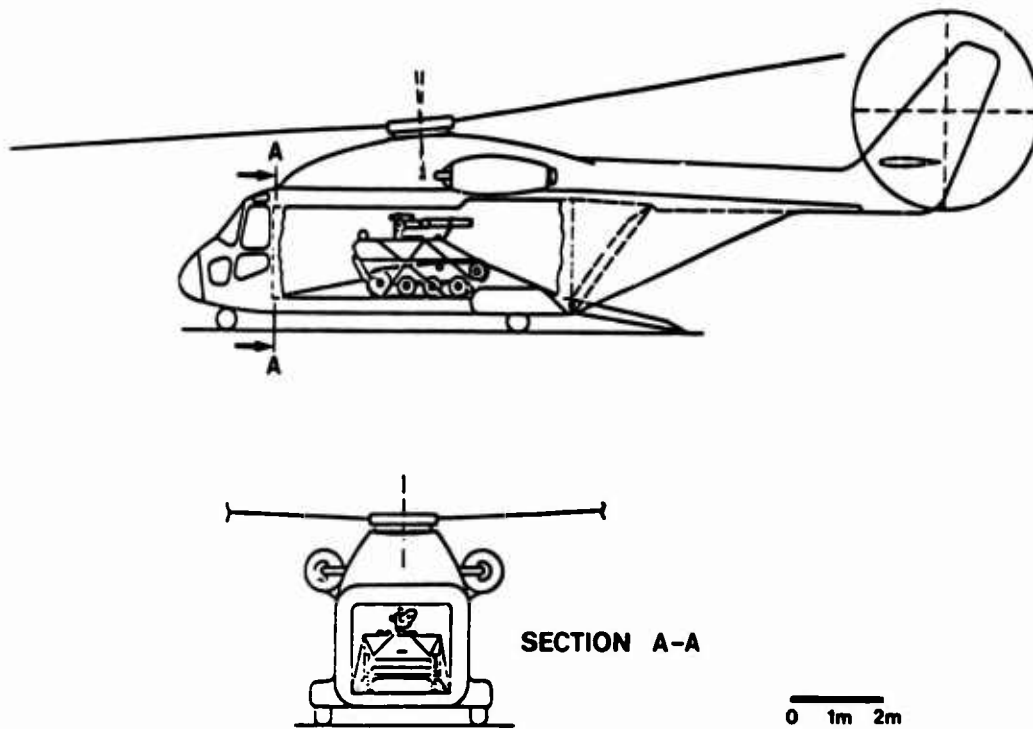

FIGURE 23: CROSS SECTIONS OF A MEDIUM TRANSPORT HELICOPTER WITH 3.5 - 4 TON COMBAT VEHICLE

CANADIAN NAVY EXPERIENCE WITH
SMALL SHIP HELICOPTER OPERATIONS

Major N.H.J. Browne
Canadian Forces Base Shearwater
Shearwater, Nova Scotia
BOJ 3A0
Canada

SUMMARY

This paper begins with a short summary of the development of the Canadian Navy's approach and solution to operating medium size helicopters from small ships in the North Atlantic. This is followed by a general description of the Helicopter Hauldown Rapid Securing Device - the main item of equipment which enabled successful open sea operations with the available equipment. The paper concludes with an overview of the operating capabilities of the Destroyer/Helicopter system, the lessons learned from its development and a subjective assessment of future helicopter requirements for the Canadian Navy.

INTRODUCTION

The aim of AGARD is in effect to provide the alliance with the fundamental scientific base upon which military equipment can be developed, produced and used. Given the ever lengthening timespan between research and development and eventual operational use, there is an inherent danger that the R&D community develops progressively remote from the operational end user. The inclusion of presentations by operational end users has the laudable objective of continuing meaningful communications between our various disciplines. It is therefore a distinct pleasure for us as operators to be given the opportunity to communicate with you in this forum. It is an even greater honour for Canadian Operational representatives because Canada's operational and R&D contribution is for many reasons but a small fraction of the total. The subject of this presentation is the Canadian Destroyer based ASW Helicopter Program. A 30 minute dissertation could not do justice to all of the many worthwhile aspects of this Program from which you might benefit. Since neither training nor opportunity has given me the chance to become well acquainted with AGARD, it was difficult to delineate the content of this talk. The objective of this presentation is to acquaint you with an unique Canadian operational contribution to the Alliance, with the lessons learned from this Program and with an operational assessment of future helicopter requirements in the Canadian Navy. To this effect you will be presented with the following:

- a. a five minute film to set the scene;
- b. a short presentation on the concept, history and development of the Canadian approach to destroyer borne helicopter operations;
- c. a presentation of the hardware which makes the large helicopter/ship marriage possible;
- d. a presentation of current capabilities, lessons learned; and
- e. an operational assessment of our future requirements.

CONCEPT, HISTORY, DEVELOPMENT

The concept of exploiting the advantages of helicopters for naval operations is practically as old as the helicopter itself. In 1952, the Canadian Navy attempted to establish the validity for helicopter conducted ASW operations by procuring sonar fitted SIKORSKY HO4S(S-55) helicopters. In 1955 the first ASW helicopter squadron was formed. It flew operationally from both our aircraft carriers. From the beginning, naval ASW tacticians enthusiastically endorsed the concept, and although initial results were mixed, a small ship trial platform test was conducted on a Prestonian Class Frigate - HMCS BUCKINGHAM. In December 1956, after 175 landings aboard this ship, the following major lessons had been learned:

- a. helicopter handling qualities did not preclude operations from small ships at sea; and
- b. a major problem affecting small ship helicopter operations was the extreme difficulty in securing and moving the helicopter subsequent to landing on deck.

To confirm these findings and gain further operating experience, the BUCKINGHAM flight deck was suitably enlarged and fitted aboard HMCS OTTAWA. This ship was a St Laurent class destroyer escort. Eventual helicopter operations were planned to be conducted from this class of ship. Trials progressed using a Sikorsky H-34 (S-58) in the fall of 1957. Again, they concluded that the helicopter borne destroyer concept was viable, provided that a suitable hauldown and rapid securing device could be developed. As a result, permanent helicopter installations were designed for the conversion of seven St Laurent class destroyers and two similar ships, yet to be constructed. This involved such things as:

3-2

- a. construction of a hangar and flight deck;
- b. provision of flight deck drainage;
- c. safety nets;
- d. hangar insulation;
- e. a hangar workshop
- f. a helicopter electronic maintenance room;
- g. an aviation store room;
- h. aviation fuel tank and associated pumping system;
- j. a flight deck control room;
- k. fire fighting facilities;
- m. an air weapon magazine;
- n. an aircrew briefing and ready room; and
- p. a hauldown, rapid securing and handling device.

Since the hauldown device was the major innovation which assured the practicability of large helicopters operating from small ships, this system will be described in greater detail. Meanwhile, between 1957 and 1962 a five year period of R&D into the best recovery assist and handling system led to hauldown trials carried out by Sikorsky employing a semi-dynamic hauldown rig. These trials proved that:

- a. precession did not affect helo controllability during hauldown; and
- b. even during the most divergent conditions, a hauldown cable always guided the helicopter to a point within two feet of the hauldown deck sheave.

Thus, a practical means of guiding the helicopter to a flight deck of limited dimensions and holding it there had been developed. Yet to be evolved was a way of coupling the hauldown feature with a means of straightening and traversing the helicopter. Funded studies with US and Canadian companies subsequently led to the present Helicopter Hauldown Rapid Securing Device (HHRSD).

In February 1965 development of ship and airborne systems had progressed to the point where ship helicopter compatibility trials could commence. Successful completion of these trials resulted in a limited clearance for service use. As experience was accumulated, equipment developed, and techniques evolved a phase by phase approach allowed clearance for operational use under progressively more difficult conditions. The system is now cleared for day, night and IFR operations down to a 200 foot ceiling and one half mile visibility.

SYSTEM DETAIL

As indicated earlier, the item of equipment which made the small ship/large helicopter marriage possible is the Helicopter Hauldown Rapid Securing Device (HHRSD). This system is presently being built by Dominion Aluminum Fabricating Ltd (DAF) in Toronto, Ontario. It was designed to satisfy the following requirements:

- a. land the helicopter on the flight deck in a position where it can be secured by the "Beartrap" securing device;
- b. secure the helicopter within four seconds of landing; and
- c. traverse the helicopter in and out of its hangar while remaining secured.

The system is capable of performing these operations in sea states causing the ship to roll 31° and pitch 8° with the flight deck heaving 20 feet per second in winds of 45 knots. After initial hook-up of the hauldown cable, the entire operation is remotely controlled from a console located near the hangar entrance. Modifications to the helicopter include a probe and probe housing near the aircraft centre of gravity, a hydraulic winch used for hoisting up the hauldown cable, and a tailprobe for restraining the tail on deck. Appropriate controls and indications are located in the pilot's cockpit.

The shipboard installation includes the securing device on the flight deck, and a two drum winch unit powered by a hydrostatic transmission below decks. One drum is wound with the hauldown cable which is reeved around a pneumatic shock absorber, or rope accumulator, and pulleys up to the beartrap. The second drum retains the traverse cable, which is attached to the forward and aft ends of the beartrap, thus forming the basis of the traverse system for transporting the helicopter to and from its hangar. The control console and associated control system components completes the shipboard installation of the hauldown system.

A detailed description of the hauldown system is probably not required. Instead, it is proposed to indicate to you a typical sequence of events when recovering the helicopter. I shall start at the point

where the helicopter has completed its approach to the ship and is hovering above the flight deck. There the pilot maintains an approximate position over the landing area well above the flight deck. He is aided in doing this by two horizon bars and a pitch bar located on top of the hangar. The main probe, normally retracted, has been selected down to position it for eventual entrapment by the beartrap. The messenger is lowered through the probe housing to the flight deck where the hauldown cable end fitting is manually hooked up to the messenger probe. The messenger and hauldown cable is then hoisted into the aircraft where the messenger automatically separates from the hauldown cable end fitting which is locked into the probe housing. The pilot then signals to the Landing Safety Officer (LSO) to select hover tension. The LSO selects the "hauldown mode" of the winch system and applies 1,500 pounds tension. The winch system will automatically maintain any selected tension within narrow limits regardless of the motion of the ship or helicopter. The tension of 1,500 pounds has by experience been found to have a significant centering effect over the beartrap without sacrificing significant reserve engine power.

3-3

Having accomplished the hook up and having the benefits of the hauldown tension centering effect, the pilot waits for an opportune moment in the motion of the ship's roll and pitch prior to positioning himself to land. The LSO, having confirmed that the ship is relatively steady, then selects hauldown tension of 3,500 - 4,500 pounds to guide the helicopter's main probe into the "Beartrap", while ordering the pilot to land.

At this point, the first requirement of the HHRSD system - to land the helicopter in a position where it can be secured by the "Beartrap" - has been met. The LSO satisfies the second requirement by firing the pneumatically actuated jaws of the "Beartrap" to secure the helicopter. The tailprobe is now lowered to engage into one of a series of retaining rails on the flight deck to secure the tail of the helicopter.

The hauldown sequence ensures that the helicopter lands in the "Beartrap". The "Beartrap" ensures that the helicopter is firmly secured to the deck. However, it is not possible to control or predict the orientation of the helicopter after landing. Since the hangar location and dimensions are such that the helicopter's longitudinal axis must be perfectly aligned with that of the hangar, it is now necessary to straighten the helicopter. The straightening operation is accomplished by tailguide winches while the "Beartrap" and helicopter are traversed.

Once aligned along the "Beartrap" guide rail or deck track, the tailprobe, which was raised during the straightening procedure, is lowered to engage the deck track. The helicopter can now be traversed into the hangar by activating the traverse drum of the system.

When two helicopters are borne on one ship, only one hauldown system including two "Beartraps", are required. This is accomplished by transferring the reeving system for the hauldown cable between the two touchdown areas for the two helicopters.

There are many safety features built into the system. From a pilot's point of view, the most important are that he can release the hauldown cable at any time either electrically or manually, that he can overpower the hauldown cable constant tension winch to the limit of the available length of the 110 foot hauldown cable, and that a shearpin is fitted in the hauldown cable end fitting which is designed to release this cable should the tension exceed $6,000 \pm 500$ pounds.

PRESENT CAPABILITIES, LESSONS LEARNED, FUTURE REQUIREMENTS

Canada has now developed and put into service a capability to safely operate a 19,000 pound helicopter from escort sized (3,000 - 5,000 ton) ships in sea states which cause the ship to roll as much as 30 degrees and under weather conditions down to a ceiling of 200 feet and a visibility of one half mile. From conceptual study in the mid fifties, it took approximately 15 years to develop a full operational capability not matched by any other navy. The Canadian experience has been an excellent operational test case which other navies have followed with interest. Before committing themselves to similar programs it would behoove navies to consider the lessons of Canada's pioneering work. What have they been? Well, there have been a few. A representative sample follows:

- a. The careful, step by step, approach taken in this development has, in retrospect, been very cost effective and, importantly, safe. The tendency to plunge ahead with certain aspects of the system in anticipation of meeting other milestones has been resisted. With limited resources, expensive equipment acquisition errors could not be afforded without gravely jeopardizing the program itself.
- b. The inability to develop this weapon system concurrently with that of the ships to be supported, and the lack of a clearly identified goal in terms of the reliability to be expected from it has caused this system to be less responsive to the requirements of the naval tacticians than they had been led to anticipate.
- c. The naval construction engineering and operational planners must be made aware of the requirements that an effective weapon system addition such as this will only result if the many aviation facilities requirements this entails are in fact designed into the ships. In addition to obvious requirements such as fuel, accommodation, shop maintenance, supply and fire fighting facilities, it is vitally necessary to include adequate meteorological, navigational, communications and aircraft approach facilities. These lessons were brought home in the original conversion of our destroyers so that our new 280 class destroyers are extremely well appointed in this respect.
- d. Present land/launch procedures require the ship to steam into the prevailing wind. This drastically curtails the manoeuvring options open to the naval tactician. Since the manoeuvring restriction is imposed by the limited flying qualities and performance

of the Sea King in cross wind conditions it is desirable that new generation helicopters not be similarly limited.

- e. More effective transition procedures are required to allow the pilot to transition safely from instrument flight to hovering with visual reference to the ship under night and instrument meteorological conditions.

As mentioned before, a decision to equip a ship with helicopters should be followed by an intensive rationalization as to the precise contribution the helicopter system will make to the ship's combat efficiency. The equipment fit of the helicopter will be an important consideration. Of equal, if not greater, importance is the reliability of the system.

THE FUTURE

I have little doubt that the Canadian Government will continue to accept the advice of the navy that the organic air support provided by helicopters borne on our small ships is a fundamental requirement in ensuring the combat capability and survivability of these units. As in the past, the Canadian Navy is likely to continue to be tasked with specialist maritime operations in support of the aims of the Alliance. It will accomplish this primarily in the area of ASW. However, anti-missile, surveillance, reconnaissance, search and rescue, resupply and communications roles will also have to be supported. R&D advances in computer and microminiaturization technology have considerably broadened the potential of the helicopter in solving the tactical problems faced by small ship formations. A delineation of the precise mix of sensors, weapons and support equipment to be fitted would presently be a matter of conjecture and properly await the result of future operations analysis studies.

When officers in the field or at sea are asked to indicate their preference for future equipment the answer is almost invariably that whatever equipment they now have should be bigger, better and faster. We are similarly inclined and tend to support the acquisition of a better helicopter borne active variable depth sonar over other ASW sensors. However, the apparent relatively weak R&D efforts on such equipment and the example of other nations in the Alliance might dissuade us in the future.

There is a general conviction that any future naval helicopter should have a good, if not excellent, ESM suit and should possibly even be equipped with an air to surface missile. For peacetime surveillance and reconnaissance roles, we shall require a stand off identification sensor. Whether this should be an infra red or low light level facility would depend on the trade-offs involved.

As to the helicopter itself, we shall undoubtedly require a helicopter with flying qualities which allow it to fulfill its role under day/night and instrument meteorological conditions. This is likely to include a requirement for the pilot to be able to accomplish at least rate two turns at low altitude under instrument conditions. A much improved out of wind hovering capability will also be necessary. Our demands for airframe and engine performance will not impinge on state of the art capabilities of manufacturers. The demands for energy conservation would undoubtedly be a factor in the selection process if there is a choice of airframes or engines.

A very major consideration will be the helicopter systems capability to meet specified maintainability and reliability criteria. The operation of complex weapon systems at sea from small ships usually entails only limited shipbased maintenance facilities and limited manning levels. However, the Officer in Tactical Command must be able to plan and rely on a specified availability of his resources.

At the eleventh annual AGARD meeting, Major General Goss, our Chief of Engineering Maintenance, unequivocally stated the heavy emphasis and importance the Canadian Forces attach to maintainability and reliability. As operators, who stress availability, we are heartened to see that these factors will be major determinants affecting future material selection processes. We would like to see significant R&D efforts expended which would result in satisfying the operators desire for tools which work. Reliability and maintainability, rather than weapon system sophistication, may be the determining factors affecting the outcome of future confrontations - we wish to avoid.

SUMMARY AND CONCLUSION

To summarize this presentation: You will have gained some insight into the history and development of the Canadian approach to making medium weight helicopter operations from small ships possible. We are now able to usefully employ our helicopters when weather condition limit the ASW effectiveness of our ships. Our experience has convinced us that the concept of employing medium helicopters with an independent weapon system capability is superior to that of operating small helicopters which are tied to a ship's weapon system. Our concept for future helicopter operations will therefore be influenced by this experience.

Since our operational commanders place such heavy emphasis on the availability and value of organic helicopter support, and since one, or at most two helicopters, are borne on each of our ships, future procurement decisions will be heavily influenced by availability criteria.

Thank you for your attention. Time has precluded a fuller treatment of this subject. I may have raised more questions than were answered. Hopefully I can make restitution during the question period to follow.

BRITISH MILITARY HELICOPTER PROGRAMMES

by
Commander J D W Husband OBE Royal Navy
Directorate of Naval Air Warfare
Ministry of Defence Main Building
Whitehall London

4-1

SUMMARY

The United Kingdom armed forces are entering a period in which they are completing the replacement programme of a range of the smaller helicopters in service use. In this area they are, therefore, in a period of relative stability in which to consider the next generation. A number of larger helicopters, notable the naval ASB helicopter to replace the Sea King, and helicopters for the support role, are now the subject of high levels of activity within the Ministry of Defence.

While the aim will always be to match, as closely as possible, the specific requirements of the tasks to be performed by future helicopters, it can be expected that the need to reduce development costs and to achieve standardisation will result in some degree of compromise between a range of requirements of the various services and countries desiring aircraft of roughly the same weight and performance.

The paper will describe the range of helicopters in current use within the UK armed services and will examine the broad requirements for the future. It is recognised that, because of the spiralling cost of development of new helicopters every effort will have to be made to reduce the through life costs by improving the life, reliability and maintainability of components. Survivability, both in crash resistance and in reduced vulnerability to hostile fire are of particular importance in the battlefield environment, while increased speed and endurance are sought in naval helicopters.

1. PROCUREMENT

As a preliminary to discussing the United Kingdom's military helicopters and the requirements for the future, the paper gives a brief outline of the structure within which British helicopters are procured. The procedure is fundamentally similar to that for all the military equipment requirements of the three Services, but the paper concentrates upon the system used for helicopter procurement.

For national projects, the procedure starts with a Staff Target prepared by the Service Operational Requirements branch. This Staff Target becomes the basis of a Feasibility Study period directed by the Procurement Executive Future Systems Branch of the Ministry of Defence with assistance from specialist equipment and armament branches and with much of the detailed work contracted to industry. If successful, the study leads to a formal Operational Requirement, again prepared by the Service staffs. This is based upon the Option recommended during Feasibility Studies. A substantial phase of project definition is then undertaken by the Procurement Executive (MOD(PE)), the object of which is to remove major uncertainties from the technical definition and programme. It is clear that one must be prepared to allow a significant amount of money and time for this stage - typically about 8-10% of the total development cost and up to 20% of the total development time. On satisfactory completion of Project Definition the project passes into the full development phase, during which a formal specification is drawn up; and the responsibility within MOD(PE) transfers from the Future Systems Directorate to a project office specially set up for the purpose in the Helicopter Projects Directorate.

During the development phase prototypes and development batch aircraft are manufactured and progressively assessed and, when a sufficient degree of confidence has been established a decision to launch production is taken. Final development continues under the direction of the project office and early production aircraft are assessed formally before a general release of the helicopter type into service is granted.

The production of the aircraft and its equipment is handled by MOD(PE) production branches who are distinct from the Project Office but who cooperate continuously with the latter on matters relating to modifications and product improvements.

The UK has, therefore, a system where the three phases - ie feasibility/project definition, full development and production are handled by three separate MOD(PE) directorates, each responsible for placing the appropriate contracts with industry, but who work together closely.

During the whole of this process the various research and development establishments of the Ministry of Defence are available to give advice and assistance. In the initial phases it is mainly the research establishments such as the Royal Aircraft Establishment at Farnborough, the Royal Signals Research Establishment at Malvern and the Admiralty Underwater Weapons Establishment at Portland who are involved. At the final stage the formal assessment of the aircraft on behalf of the Services is conducted by the Aircraft and Armament Experimental Establishment at Boscombe Down.

A firm discipline is maintained throughout the whole process by the Central Committees of the Ministry of Defence who approve the funding of the various stages. The committees ensure that the maximum coordination possible between the various service requirements is achieved and that the operational case remains valid.

For collaborative projects the procedures are much the same as for national projects. The Services are responsible for examining their requirements with other users with a view to establishing joint ventures.

MOD(PE) works with the corresponding agencies in other countries on assessment of means to satisfy the joint requirement and to establish a fair standard of work sharing between their industries. At each decision stage, authorisation to proceed must be obtained from Joint Management Boards and committees as well as from the MOD Central Committees.

2. NAVAL PROGRAMMES

Helicopters have played an increasingly important part in maritime warfare since their introduction into Royal Navy service. The earlier helicopters were used mainly for search and rescue duties, but the introduction of dipping sonar in the mid 1950s added a new dimension to the helicopter's capability. ASW helicopters deployed in the early 1960s were the Wasp and the Wessex Mk 1 with the short range 194 sonar. Since then the helicopter's capabilities have been improved with the introduction of the Wessex 3 and the Sea King, both equipped with medium range 195 sonar, radar, tactical plot and associated ASW weapons (see fig 1). The capability of the Wasp was extended in 1969 by the introduction of a visual surface attack role using the AS12 missile.

The replacement for the Wasp is the Lynx (see fig 2). This aircraft was developed as part of an Anglo French package which included the Puma and the Gazelle. The Lynx has been designed and built by Westlands, using Rolls Royce engines, but as with the other two aircraft the French helicopter company - Aerospatiale - has done a considerable element of the manufacture. In the Lynx this has been notably the rotor head. The naval variant of the Lynx is now undergoing intensive flying trials within the Royal Navy and will enter service later this year as the small ship helicopter for the next 15 to 20 years.

The Navy's requirements for this helicopter are that it should provide a weapon delivery system for the ship's own sensors but that the capability of the aircraft should be improved over that of the Wasp by the introduction of autonomous sensors and the addition of an observer or tactical controller to the crew. The relatively small size of the aircraft, with an all up weight of 9,750 lb, together with its outstanding flying and deck landing characteristics allow for one of the factors which we consider very important, namely the ability to land or take off with the relative wind in any direction. This allows maximum tactical freedom in the ship and generally removes the requirement for ships to change course in order to launch or recover their aircraft.

Flying trials carried out recently in RFA ENGADINE showed that the stated requirement for the aircraft to be able to take off or land with winds of up to 30 knots from the aircraft's stern arc was comfortably met and the pilots even indicated that, because of the reduction in wind turbulence normally evident when the wind is disturbed by the ship's superstructure they found the landings almost easier than with the wind ahead.

The sensor fit includes the Sea Spray radar, an I Band frequency agile radar with a TV raster display, a high accuracy Electronic Support Measures receiver and a computerised navigation and display system. The aircraft is also capable of being fitted with a Magnetic Anomaly detector. A wide range of weapons can be carried including the medium range semi-active Sea Skua missile which provides the aircraft with a highly accurate anti-shiping capability.

The Royal Navy have not yet, of course, started to think of the design of aircraft to replace the Lynx. They have, however, identified the desirability of a sonics fit for the aircraft and recognise the advantage to be gained by increasing the aircraft's endurance. Westlands are currently engaged in uprating the aircraft to allow additional payload and a decision on whether this uprating will be applied to the Navy's helicopters will be made sometime within the next two years. For the longer term they will have to match the desirability of speed, as might be provided by VSTOL, with the continued need for a multi-role, light-weight and flexible vehicle with capability to operate from small ships in the often hostile environment of the Eastern Atlantic.

The Sea King, which is operated from the larger ships and Royal Fleet Auxiliaries, has proved to be a most effective ASW aircraft. The airframe, based upon the Sikorsky S61 is produced under licence by Westlands, but the sensor fit and Automatic Flight Control System is entirely British. This aircraft will continue to provide the mainstay of the RNs ASW helicopter force until the mid to late 1980s, but ways in which the capabilities of the aircraft can be improved are being sought.

The main areas where the RN will seek improvements in whatever aircraft is selected to replace the Sea King are, firstly, reliability and maintainability, where considerable savings in life cycle costs can be made by the sensible use of advanced technology and materials; secondly increased speed and endurance to allow for improved speed of reaction and the capability to operate further from the force being protected for longer periods; and thirdly the introduction of improved sensors and weapons to increase the effectiveness of the system.

A two year Feasibility Study has just been completed within the UK to evaluate a number of options for the Sea King Replacement, and a decision will be made towards the end of this year to allow Project Definition to start during 1978. Again, the attractions of VSTOL are clear, but while the technology might arguably be said to exist, the development of a VSTOL aircraft with the endurance and sensor, weapon and crew carrying requirements envisaged is still some way from realisation. Besides which, the UK is limited in the flight decks available for the carriage of these aircraft, and cannot afford to embark upon a costly redesign of the new CANS or Royal Fleet Auxiliaries to carry what would almost certainly be a rather larger and heavier aircraft than the equivalent capacity helicopter. RN interest therefore lies in helicopters for the main ASW tasks for the next generation. The decision is expected to lie between either the development of a new helicopter, probably with European partners, or the major development of an existing airframe to allow for the increased speed, endurance, anti-icing and sensor fits called for in the Operational Requirement.

3. ARMY PROGRAMMES

43

The British Army differs from many other nation's armies in that it only flies its light and utility helicopters, leaving the larger support types to be flown by the RAF. Nonetheless, the Army operates the numerically largest number of helicopters of the three services. Its tasks can be summarised as:

- Observation and Reconnaissance
- Armed Action using Anti-tank Guided Weapons
- Direction of Fire as an Airborne Observation Post or forward air controller
- Command and Control

and for the limited movement of men and material - including

- Casualty Evacuation

This leaves the tasks of logistic support, aeromedical evacuation and the movement of larger numbers of troops to the RAF.

The light observation aircraft used by the Army at the moment is the Anglo French Gazelle (see fig 3) which is progressively replacing the Bell 47C Sioux. The final deliveries of the 158 Gazelles ordered by the Army are expected to be made by October this year. The Army are well pleased with the Gazelles and it has proved to be a success in its planned roles. It has additionally been regularly used in Northern Ireland for photo-reconnaissance, crowd control - for this they use an airborne loudspeaker which they test by reading recipes to the Belfast housewives, and assistance with night patrols using powerful search-lights.

The Scout AH1 which is a variant of the Westland Wasp is the current army utility aircraft. This is shortly to be replaced by the army variant of the Lynx and 100 of these will be ordered for delivery over the period 1977 to 1981. Intensive Flying Trials on this aircraft are due to start shortly and the first squadron will be equipped in mid 1978. The uprated engines and transmission mentioned earlier in connection with the Naval Lynx are of little interest to the Army at this time, since the Lynx will meet current requirements without uprating. The Lynx has, however, considerable stretch potential and a developed version with a larger fuselage and payload may meet future requirements.

The Army does not require to consider the replacement for its helicopters for some time yet. The planned life of both the Gazelle and the Lynx is 15 years, but this may well be extended to 20 years. Whereas the Navy have identified speed as one of the important factors which will be sought in their replacement helicopters, the Army do not identify an increase in speed as being a major requirement but instead, seek to improve survivability in the battlefield environment by reducing the vulnerability of the aircraft to ground fire and by reducing both aural and electro-optical signatures. In a maritime environment, this vulnerability is less important and one is torn between the desire for maximum commonality of airframe design between the services and the need to avoid carrying around armour plating and other survivability equipment which are not normally required at sea.

Like the Navy the Army will seek the maximum reduction in the through life costs of future aircraft, they will also look for improved maintainability in the battlefield area and improved performance in icing conditions.

4. AIR FORCE PROGRAMMES

In the UK the Royal Air Force is responsible for supplying support helicopters for the Army. Currently this is provided by the Wessex (see fig 4) - a twin turbine version of the S58 - and by the Puma (see fig 5). The RAF is also responsible for providing much of the Search and Rescue force around the UK and currently operate Wessex and single-engine Whirlwind helicopters to fulfil this role; they are supported in this by Royal Naval Sea Kings when long range or night SAR missions arise. In common with the Army and Navy the Gazelle is used for pilot training.

The Search and Rescue force is currently being supplemented by the purchase of 15 Sea King Mk 3 aircraft. This is a specialised version of the naval helicopter with modifications to increase its range and endurance. A very comprehensive avionic fit has been specified including a Decca Tactical Air Navigation System the computer of which accepts signals from Doppler and hyperbolic Decca and provides the crew with a wide range of navigational data to allow accurate search patterns to be performed and repeated at long range without the need for a specialised navigator. The aircraft is due to enter service in June 78 and will greatly increase the search and rescue coverage around the UK.

The requirement for a medium lift helicopter has been addressed repeatedly over the last decade but financial constraints have prevented the purchase of a suitable machine. It has always been assumed that the helicopter would be an off-the-shelf buy. With the increased pressure to provide the ground forces with flexibility the UK is once again studying the possibility of purchasing aircraft in the fairly short term. Studies are at an early stage and an acquisition is unlikely to be reached before 1978.

In the longer term the specification of the helicopter to replace the Wessex and Puma in the support role in the mid to late 1980s is being studied. The RAF sees this project as being a major opportunity for a collaborative venture.

Over the years there has been a steady improvement in the capability of the helicopter as a weapon of war to the point where it may have become a deciding factor in a major land battle. This has naturally led to the development of increasingly effective anti-helicopter weapons. The RAF is becoming increasingly concerned with the problem of protecting the support helicopter both from ground-to-air and air-to-air

attack. In the latter case the Russian Hind and Armed Attack Helicopter developments are seen to present a real threat. Major equipment fits of passive defence measures are under study and the need for active defences may soon have to be considered. It is in the general area of specialised equipment to allow the helicopter to operate in all weathers, at night and in the scenario of the European land battle that major development efforts will have to be directed. In particular, all future RAF helicopters will be equipped with an independent navigation aid to allow precision positioning in conditions of low visibility to permit the high speed nap-of-the-earth operations which we believe to be an essential part of future support helicopter tactics.

5. COLLABORATION

As the cost of the development of helicopters rises and the technical risks increases it becomes more important that every effort be made to collaborate with other nations in order to ensure a wider market for the product, both military and civil. The Anglo French collaboration agreement of 1967, which led to the development of the Puma, Lynx and Gazelle, paved the way for future ventures which are now being actively explored between the four helicopter producing nations in Europe. As a preliminary to the development of a package of helicopters it is necessary to determine that there is sufficient commonality in the requirement of the various nations, ideally not only by the individual services of the countries concerned but also between the services. Thus it is not sufficient to have agreement between say the navies of the countries, every effort should then be made to ensure that a compromise is reached with the other two services to reduce the final package to a sensible size. Only that way can the present situation, where some 27 different types of helicopters are in operation within the armed forces of Europe, be rationalised.

Nor should the search for collaboration be confined to within Europe, and NATO provides the forum in which collaboration, as a means to achieve commonality and standardisation should be continually discussed. The problem which seems to present the most difficulty, however, is that of timescale, since the replacement schedules of the various nations' helicopters rarely coincide and the compromise between differing timescales and differing operational tasks is extremely hard to achieve.

ACKNOWLEDGEMENTS

The author is grateful for the assistance of Miss M Jones, Lieutenant-Colonel J H Pike and Squadron Leader H B Lake RAF in the preparation of this paper.



Fig.1 Sea King HAS MK 1s

46



Fig.2 The Lynx HAS MK 2



Fig.3 The Gazelle

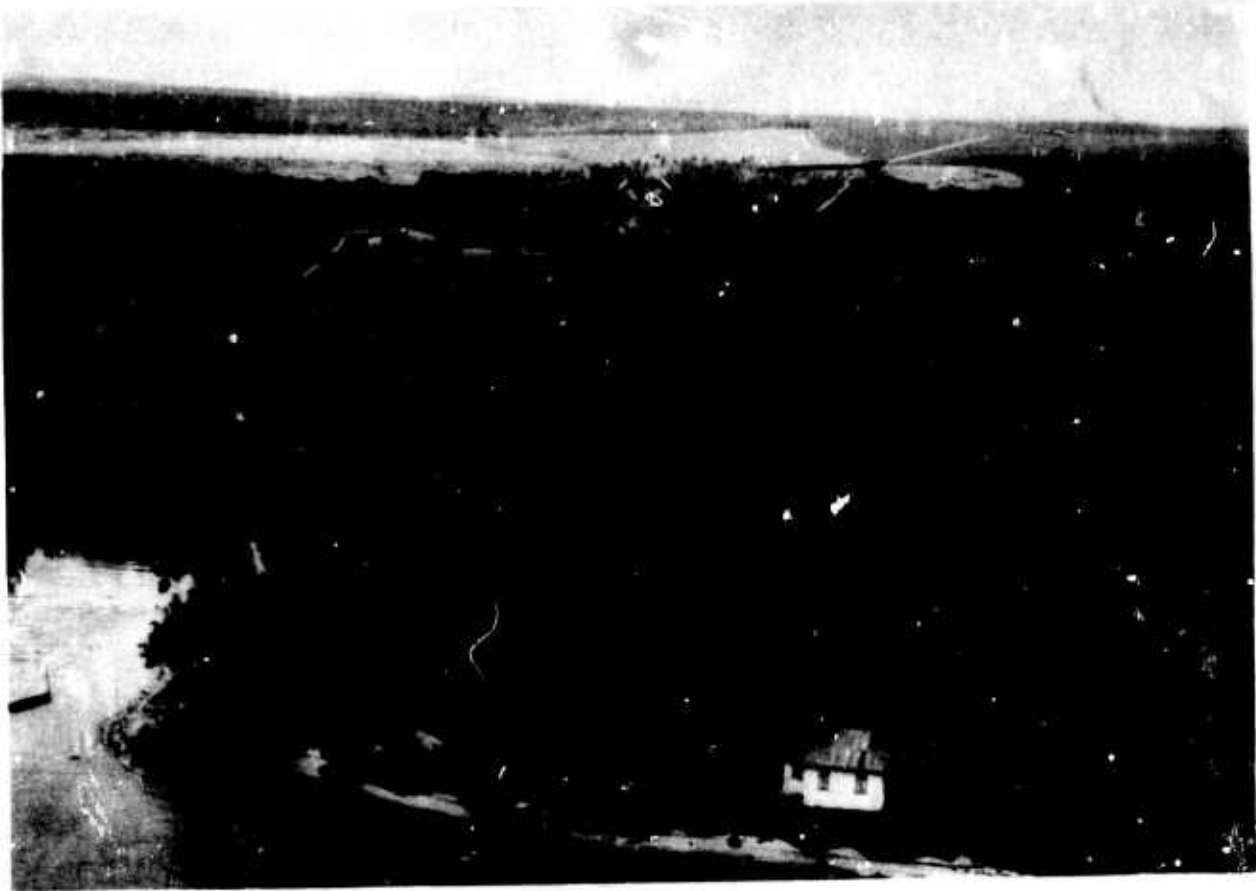

Fig.4 Wessex MK 2

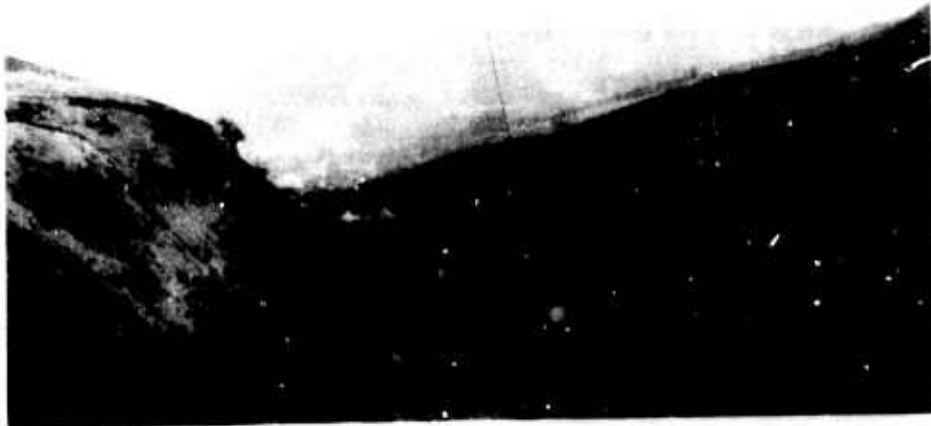

Fig.5 The Puma

THE U.S. ARMY UTTAS AND AAH PROGRAMS
by
RONALD E. GORMONT AND ROBERT A. WOLFE
AEROSPACE ENGINEERS
RESEARCH, DEVELOPMENT AND ENGINEERING DIRECTORATE
U.S. ARMY AVIATION SYSTEMS COMMAND
P.O. BOX 209
ST. LOUIS, MO 63166
USA

SUMMARY

This paper addresses the US Army's latest developed utility and attack helicopters with contracts recently awarded to Sikorsky Aircraft for the Utility Tactical Transport Aircraft System (UTTAS) and Hughes Helicopters for the Advanced Attack Helicopter (AAH). To provide details of each of these intricate helicopter designs would obviously be beyond the scope of this type of paper, however, the paper will provide a brief history into the background of the Army's requirements and need for a UTTAS and AAH, a history of the development, a general description of the aircraft with intended missions, planned activities, significant capabilities, and potential alternate uses of the resulting designs. The capabilities and potential alternate uses, which are the primary points of the paper, will consider the implication of the stringent military requirements (principally the Survivability/Vulnerability (S/V) features and derating implicit in the Army 4000 feet/95% baseline mission) in adapting the UTTAS and AAH to other non-military or non-combat missions. In addition to performance and S/V, both development programs, as highlighted in the paper, have concentrated efforts on reliability and maintainability characteristics which, when combined with performance and S/V, provide enhanced operational capability on the modern day battle field at an affordable cost. Finally it will be shown that the critical performance conditions have yielded high performance designs with attendant capabilities at off-design ambient conditions and reflect design considerations for future change requirements, thus providing a variety of alternate mission capabilities.

HISTORY OF NEED

At present the UH-1 and AH-1 series helicopters are the only utility and attack helicopters available for fulfilling the Army's air mobility and anti-armor roles. Product improvement programs will not enable these current helicopters to expand their payload sufficiently to fulfill and meet future tactical airlift, combat support, and effective direct fire mission requirements during day, night and adverse weather. A need exists in the 1980 timeframe to provide aircraft that meet the air mobility squad carrying and anti-armor roles under the more severe altitude and temperature conditions with necessary increases in reliability, maintainability, survivability, flight safety and sufficient alternate mission capability, in the case of the AAH, to accept various weapon subsystems. Sufficient increases in these areas cannot be provided on existing helicopters to assure that squad size payloads can be transported and direct aerial fire in support of ground combat forces can be provided under the environmental or threat conditions likely to be encountered. Improved helicopter systems require design concepts to increase survivability against sophisticated anti-aircraft weapons, provide sufficient anti-armor fire power in the case of the AAH, enhance operational availability and yet be capable of quick response to mission requirements throughout the range of altitude and temperature combinations where US forces can be expected to operate.

WHY UTTAS AND AAH

To fulfill these requirements the Army established a need for the Utility Tactical Transport Aircraft System (UTTAS) and the Advanced Attack Helicopter (AAH). Inherent in this need was an assurance that the final design and capability of the helicopters were kept in proper perspective relative to requirements versus tradeoffs. This was achieved by stipulating the following relative order of priorities of the requirements:

<u>UTTAS</u> (Ref 1)	<u>AAH</u> (Ref 2)
Performance	Performance
Maintainability/Reliability	Firepower
Air Transportability	Survivability
Vulnerability	Payload/Endurance
	Visionics
	RAM
	Avionics
	Reaction Time
	Deployability

The vertical flight performance of the UTTAS and AAH will permit operations with a specified payload at design gross weight over a maximum portion of the earth's land surface, thereby, augmenting the Army's strategic and tactical capability. Additionally, the capability to carry heavier payloads at reduced endurance or at heavier gross weights with reduced performance will provide maximum flexibility to meet specific missions or situation demands. To enhance survivability the UTTAS and AAH will be capable of conducting low level and nap-of-the-earth (NOE) flights. Maximum use will be made of terrain masking and active and passive protective devices to enhance survivability. The total UTTAS and AAH system will have the capability to operate in environmental conditions that include moderate turbulence and icing. The AAH system will incorporate an avionics and visionics capability which will allow it to deliver direct aerial fire day and night in helicopter visual meteorological conditions and for night NOE operations. Both aircraft will have the capability of flights to and from operational areas during instrument

meteorological conditions.

5-2 HISTORY OF DEVELOPMENT

In 1972 the Army awarded a UTTAS Basic Engineering Development (BED) contract to Boeing Vertol and Sikorsky Aircraft for prototype competitive development. The intent of the BED competition was to develop an air vehicle to proceed into a maturity phase for the purposes of final qualification leading to production of the system. In 1976 after an extensive development and competitive fly-off the Army selected the Sikorsky YUH-60A (Figure 1) to proceed to maturity testing and production. In 1973 the Army awarded a Phase 1 AAH contract to Bell Helicopter Textron and Hughes Helicopters for prototype airframe competitive development. The intent of the AAH Phase 1 competition was to develop an air vehicle to proceed into Phase 2 full scale engineering development including systems integration, eventually leading to production. In 1976 after an accelerated development and a competitive fly-off the Army selected the Hughes YAH-64 (Figure 2) to proceed into full scale engineering development.

In addition to achieving the Army's performance and mission requirements these helicopters have incorporated new technology in the areas of:

- Engine and dynamic components which have greater efficiency, reliability and ease of maintenance.
- Advanced materials (metals and composites).
- Advanced lubrication concepts.
- Advanced armor protection.
- Advanced armament systems for the AAH.

Both aircraft systems have capitalized on technological advances which are appropriate and compatible in terms of cost and risk. This exploitation results in a more effective and reliable product in accomplishing the aircraft's assigned missions.

GENERAL DESCRIPTION

Both the UTTAS and AAH are twin engine rotary wing aircraft with the UTTAS designed to carry 11 combat troops and a crew of 3 to perform primary and secondary missions by transporting internal loads under visual and instrument conditions, day and night, and external loads under visual flight. The AAH is designed to carry a crew of 2 and provide a stable manned aerial weapons system to deliver aerial point (Hellfire), area (30mm), and rocket (2.75 inch) target fires under day, night and marginal weather conditions. A general arrangement three-view of the UTTAS and AAH is shown in Figures 3 and 4 respectively with the major characteristics depicted in Tables 1 and 2. References 3 and 4 contain a complete description of the UH-60A (UTTAS) and the YAH-64 (AAH).

MISSIONS

The UTTAS primary missions include tactical transport of troops, troop units and required supplies and equipment in combat and combat support operations to include troop assault/extraction, repositioning, unit replacement, and unit resupply. The secondary missions include combat support and combat service support tasks associated with tactical operations in areas of aeromedical evacuation, administrative transport of troops and command personnel, transport of maintenance and medical personnel/supplies/equipment and aerial recovery. The AAH combat missions include anti-armor using direct aerial fire against armor/mechanized forces, air cavalry operations, and air mobile escort and fire support for air mobile operations. Both the UTTAS and AAH will be utilized in peace time for aviator and troop/unit training, mobilization and evaluating new and improved concepts. In addition the UTTAS will be used in the support of disaster relief and civic action.

PLANNED ACTIVITIES

The Sikorsky YUH-60A Ground Test Vehicle (GTV) and the three BED phase prototype helicopters are currently being modified to reflect production configuration changes and the flight vehicles have initiated Maturity Phase Testing. This program consists of contractor testing through July 1978 and will include qualification of full avionics integration and special kits. Follow-on Army testing consisting of evaluations in desert, arctic and tropic climates and final airworthiness and flight characteristics is scheduled to be completed in March 1979. The initial production contract is 15 helicopters and associated kits with the first aircraft to be delivered in August 1978. The Army will use these initial production helicopters to conduct pilot training, perform operational tests and validate reliability and maintainability capability. Total production size of the UTTAS program as presently envisioned is 1107 helicopters over a period of eight years.

The Hughes YAH-64 full scale engineering development program commences using the test vehicles developed during the competitive phase. Periods of modifications are planned to incorporate design changes or fixes that were identified as being required by the Army during the selection process. Approximately 18 months into this program, installation of various subsystems commences. The subsystems, or mission equipment package (MEP), installations are paced primarily by the Target Acquisition and Designation System (TADS) and Pilots Night Vision System (PNVS) which are being competitively developed. These two major systems will be installed and evaluated in a side-by-side fly-off. Subsequent to this fly-off a final modification is planned to remove the losing TADS/PNVS equipment, install the winning TADS/PNVS and complete MEP. Concurrently with the above actions, three new development aircraft are in the fabrication and integration stage. These aircraft join the test fleet early in 1980 and should very closely approximate an early production aircraft. Interspersed in the above described contractor program are a series of Government tests. These tests vary in length from 2 weeks to 8 months and include both

engineering and operational (user) tests. More than 1200 flight hours will be flown by Hughes and more than 800 by the Government. These hours are in addition to more than 1200 hours of GTV testing. Successful program progress will result in a commitment to production in mid-1981, approximately 7 months prior to the end of the development cycle.

53

AAH AND UTTAS CHARACTERISTICS

The following sections of the paper will summarize the significant capabilities of the UTTAS and AAH designs. Specific areas discussed are performance; avionics, visionics and firepower; survivability/vulnerability; reliability, availability and maintainability.

PERFORMANCE CHARACTERISTICS

Both the AAH and UTTAS design requirements included critical performance and agility characteristics. The intent of these requirements were to ensure designs which can both meet performance/environmental criteria, and possess enhanced agility (both low and high speed) for improved survivability. The overall design considerations had the purpose of accommodating the adversities of:

- Environment
- Mission requirements
- Growth potential
- Service operator skill levels

while at the same time avoiding unnecessary overdesign. In addition the design considerations were aimed at accounting for:

- Tactical experience
- Airframe/engine deterioration and growth trends
- Downdrafts in natural gusts and wakes of preceding aircraft
- Aircraft accidents and causes attributed to inadequate performance

In reference 5 the U.S. Army Combat Developments Command (CDC) identified criteria for use in concept formulation studies, and in material requirements identification for future Army tactical VTOL aircraft. These criteria were subsequently included in the AAH and UTTAS requirements documents. The significant criteria are:

Environment: Detailed results of extreme temperatures and elevations in areas of the world most likely to require U.S. military support, determined that a design criteria of 4000 feet/95°F was the minimum acceptable criteria. This design requirement yields a 95% probability of mission completion during daytime operation and a 97.5% probability of mission completion for 24 hour operations. It was concluded that 95% probability is the minimum acceptable for Army VTOL designs and therefore, the 4000 feet/95°F condition was required as a design criteria.

Mission Requirements: Mission requirements were developed while considering both the environmental considerations discussed above, previous tactical experience, and previous experience in airframe/engine deterioration and growth trends. The key items from a tactical standpoint are:

- Helicopters supporting ground combat operations are required to operate in confined areas.
- Vertical or near vertical takeoffs and landings are required.
- Enemy activity may require "downwind" takeoff and landing which increases demand for lift and power.
- Reserve power is required to arrest high sink speeds and zero out airspeed at the landing zone.
- Poor technique, enemy action, or clutter in the landing zone may necessitate aborted landing. Power requirements similar to vertical climb criteria are required for successful abort.
- Army helicopter missions are routinely performed in areas of known moderate turbulence, with turbulence levels defined as:

Turbulence

Light
Moderate
Severe

Vertical Component

0-4 FPS (0-240 FPM)
4-7 FPS (240-420 FPM)
7-10 FPS (420-600 FPM)

All of these considerations require a maneuver capability beyond a hover out-of-ground-effect condition. The power/maneuver margin equivalent to a vertical rate of climb (VROC) of 450 fpm was established as the minimum acceptable reserve to provide an adequate tactical capability.

In addition to the tactical considerations, the aircraft design must consider the inevitable airframe/engine deterioration and growth trends. The following items were considered to be significant factors which should be considered in the design criteria.

- Reduced rotor efficiency resulting from blade erosion due to operation in sand/dust environment. One percent performance loss may result before replacement.
- Similar erosion of engine compressor blades causes reduced power available and increased fuel consumption. Data indicates engine deterioration of 4 to 9 percent prior to replacement for erosion.
- Protective devices such as particle separators and blade erosion strips merely delay maintenance, but do not preclude performance loss.
- Airframe weight empty increases 1 to 2 percent per year. This will normally be offset by engine performance growth. (However, drive system should have reserve capability).

These items result in a requirement to meet VROC performance objectives at 95% rated power. Mission fuel loadings must be computed with a 5% mission fuel conservatism. In addition, to account for airframe weight and engine power growth, the drive train must be designed conservatively. Both the AAH and UTTAS have transmissions which are capable of absorbing 120% of the current power available at 4000 feet/950F conditions.

Growth Potential: Consideration of growth potential is required to adequately forecast anticipated design improvements over the intended service life of the helicopter. Normal growth can be expected due to service repairs, mission expansion and new technological advances. The attendant weight increases are normally offset by engine growth capability, therefore, within reasonable constraints flight performance capabilities can be maintained. However, in order to fully utilize the engine growth, the original drive system should be conservatively designed to accept the engine growth without modification. This approach incorporates the growth in the original qualification of the vehicle rather than a costly retest and modification later on. Similarly the aircraft structure must be designed to accept expanded loading requirements in service. More detailed characteristics are contained in the Growth Capability section of this paper.

Service Operator Skill Levels: Another important consideration relates to power margins and control margins available to the operational pilot. Maximum performance can only be extracted from a flight vehicle by using polished pilot techniques, intimate pilot knowledge of the aircraft, and by giving individual attention to maintaining the optimum flight profile. The typical operational pilot must contend with enemy action, navigation, formation, communications, weapon firing, and coordination with other aircraft and ground units. In this environment he is unlikely to be in a position to give undivided attention to his piloting duties. In addition, in marginal performing aircraft the pilot is more likely to attempt operations which exceed the capability of the aircraft and result in aircraft damage. Reference 5 analyzed a sampling of accident data from Army aircraft in Vietnam during January through December 1966. A significant portion of accidents were a result of marginal performance or inadequate control. The following statistics list those areas which are directly or indirectly attributed to these factors:

CAUSE	NUMBER	PERCENT	TOTAL COST
Loss of RPM, Overgross High Density Altitude	71	17.3	\$12,361,634
Aircraft Struck Obstacle	56	13.5	5,024,552
Faulty Autorotative Technique	30	7.3	2,487,212
Lost Directional Control	22	5.3	1,316,843
Hard Landing	19	4.6	1,261,069
TOTAL	198	48.0	\$22,451,310

The above statistics indicate that the cause of nearly half of all accidents can be attributed to factors related to inadequate performance or control capability. Nearly half of the remaining accidents, or 25% of the total, are related to inadequate design features which are being corrected or enhanced in the AAH and UTTAS designs, such as:

- Dual engines with single engine inflight capability to minimize accidents attributed to engine failure.
- Advanced materials technology and redundant design features to help eliminate material failures.
- Instrument flight capability to avoid weather related accidents.
- Enhanced damage tolerance features to minimize effects of foreign object damage to engines and aircraft structure.

In an attempt to overcome these problems the UTTAS and AAH designs incorporate conservative design features which will allow realization of desired flight capabilities while achieving a suitable margin for the various items discussed above. The key features incorporated in these designs (many of which will be covered in more detail later) are:

- Vertical flight and low speed agility performance
- High speed maneuver capability
- 5% power reserve
- 5% fuel conservatism

- Stringent directional control requirements
- Crashworthy airframe structure and personnel seating
- Integral engine partical separator
- Rotor blades and drive systems tolerant to object strikes

Current Performance Summary: Tables 3 and 4 summarize the salient Army performance requirements and the current estimated performance capabilities of both the AAH and UTTAS. All capabilities are at 4000 feet/ 95°F unless otherwise specified.

AVIONICS, VISIONICS AND FIREPOWER CHARACTERISTICS

The AAH and UTTAS each contain the elements of Avionics, Visionics and Firepower which are consistent with their respective intended missions. This equipment is intended to allow the AAH to deliver its firepower and the UTTAS to deliver its troops/cargo under day and night rotary wing visual meteorological conditions. In addition they will have the capability to fly to and from the operational area during rotary wing instrument meteorological conditions.

The following avionics equipment are incorporated in each design to provide required communications and navigation capabilities.

	<u>AAH</u>	<u>UTTAS</u>
Intercommunications Subsystem	X	X
UHF Communications	X	X
VHF-FM Communications and Homing	X	X
VHF-AM Communications	X	X
Communication Security	X (CP)	X (CP)
Automatic Direction Finding	X	X
Doppler Navigation	X	X
Absolute (Radar) Altimeter	X	X (CP)
Heading Attitude Reference	X	
Gyromagnetic Compass		X
Identification (IFF Security)	X	X
Crash Locator Beacon	X	X (SP)
Radar Warning	X	X (CP)
Civil Navigation Set		X
Tactical Landing System		X (SWP)
Proximity Warning Device		X (SWP)
Command Instrument System		X
Voice Warning/Recording		X (SP)

Note: CP = Complete provisions
 SP = Space and power
 SWP = Space, weight and power
 X = Installed

UTTAS requirements do not specify the need for visionics equipment. However, the AAH requires visionics equipment for target acquisition and designation, fire control and night NOE operations. The essential elements of the AH-64 visionics system are:

Copilot/Gunner's (CPG) Target Acquisition Designation Subsystem (TADS)
 Pilot's Night Vision Subsystem (PNVS)
 Integrated Helmet and Display Sight Subsystem (IHADSS)
 Video Recording and Playback (Complete Provisions)
 Symbology Generator
 Fire Control Computer

The copilot and pilot visionics systems will enable mission operation and target acquisition and designation at night or in marginal lighting conditions.

The IHADSS will provide the pilot and CPG with a heads-up display of TADS and PNVS imagery. Video recording equipment will provide a video recording and playback capability for the TADS and PNVS video. This feature provides the capability to quickly scan a suspected target area, and after reconcealment, study the area in detail via the playback feature. The symbology generator will provide displays on the pilot and CPG IHADSS, and the CPG indirect view display. The symbology generator will accept video inputs from the TADS, PNVS and video recorder. The fire control computer provides an interface between the above equipment and performs all necessary computations.

The firepower of the UH-60A consists of two M-60, 7.62mm weapons and a configuration capable of carrying a total of 1100 rounds of ammunition. The M-60 is primarily a defensive or fire suppression weapon. The AH-64 firepower consists of three armament systems; Hellfire missile point target subsystem; 30mm area weapon subsystem; and aerial rocket subsystem. The external stores subsystem, and a fire control subsystem integrate these weapon systems. The YAH-64 weapon systems and their modes of use are listed below:

a. Point target subsystem (Hellfire missile). The AAH primary mission requires eight Hellfire missiles, however, the AH-64 is capable of carrying up to 16 missiles.

(1) Prime mode. The CPG can fire all types, codes and modes of the point target subsystem using TADS as the target acquisition device. TADS laser designation will be used during autonomous launches. The pilot will fly the missile launch constraints.

(2) Backup modes. The CPG can fire laser and RF/IR missiles in all modes where the missile seeker serves as the acquisition device, and the aircraft is flown within the missile launch constraints. The pilot can fire laser seeker missiles on code selected by the CPG against cooperatively designated targets when the aircraft is flown within the launch constraints.

(3) Hellfire operational modes.

(a) Autonomous. Target designation by TADS on the launch helicopter.

(b) Cooperative. Target designation by remote (air or ground) designator.

(c) Ripple fire. Launching of two missiles within one second or less from the same helicopter against two targets being designated by two designators operating on different codes. Requires cooperative designator.

(d) Rapid fire. Launching of two missiles within 6 to 8 second intervals at two targets using one designator. Can be accomplished in either autonomous or cooperative mode.

(e) Indirect fire. Launching of a missile from a helicopter masked from the target by trees and terrain. Multi-tilt programmer in the missile is activated prior to launch. Requires cooperative designator.

(f) Pseudo-indirect. Launching of a missile prior to target designation ("lock-on" after launch). Once in flight the laser seeker locks onto target when designated. Can be accomplished in either autonomous or cooperative mode from ranges within TADS capability. Can be used in cooperative mode for ranges in excess of TADS capability by use of indirect fire mode.

b. Area weapon subsystem (30mm XM-230 Chain Gun). The AAH primary mission requires 320 rounds of ADEN/DEFA 30mm ammunition, however, the AH-64 is capable of carrying up to 1200 rounds of 30mm ammunition.

(1) Prime mode. The CPG can fire the area weapon using TADS with fire control corrections applied by the fire control computer.

(2) Backup mode. The pilot and CPG are capable of firing the area weapon in the flexible mode using IHADSS with fire control corrections applied by the fire control computer. The pilot and CPG can fire the area weapon in the stow mode utilizing the direct sight feature of IHADSS with fire control corrections applied by the fire control computer. The area weapon can be fired in the flexible and stow modes even if corrections are not available.

c. Aerial rocket subsystem (2.75 inch folding fin aerial rockets). The AAH does not require rockets for the primary mission, however, the AH-64 can carry up to 76 rockets.

(1) Precision rocket mode. The pilot can select and fire rockets using target tracking by the CPG using TADS with fire control corrections applied by the fire control computer, and aiming and steering commands provided to the pilot on IHADSS with fire control corrections applied by the fire control computer.

(2) Prime mode. The pilot can select and fire rockets using IHADSS with fire control corrections applied by the fire control computer in either a flexible pod elevation or depression mode in hover or a fixed mode at speeds over 40 knots.

(3) Backup mode. The CPG can fire rockets selected by the pilot using IHADSS with fire control corrections in either a flexible elevation mode in hover or the fixed mode over 40 knots. The rockets are capable of being fired even if corrections are not available.

d. External stores subsystem. The AH-64 external stores subsystem can accommodate four removable external store pylons, although only two pylons are required for the primary design mission. Each store station can carry up to four Hellfire missiles, or up to 19 2.75" rockets. Each station is structurally designed for a 1000 lb load at 3.5g's to accommodate future growth in requirements, and a 1250 lb load at 2g's for external ferry mission fuel cells. Currently the maximum ordnance load is the 19 rocket case which totals 646 lb for the rockets and launcher. The store stations are equipped to provide elevation travel of +4.5° to -20° relative to the helicopter longitudinal axis. In addition the stores include a jettison capability.

e. Fire control subsystem. The AH-64 fire control subsystem is a totally integrated subsystem consisting of:

- Target Acquisition Designation System (TADS)
 - Laser Rangefinder/Designator
 - Forward Looking Infrared (FLIR)
 - Day Sensors (TV and Direct View Optics)
 - Laser Tracker
 - Automatic Target Tracking Processor
- Air Data Sensors
- Attitude and Velocity Sensors

- IHADSS
- Fire Control Computer (FCC)
- Associated Controls and Displays

The fire control subsystem has the capability for simultaneous operation of any two weapon subsystems, except the Hellfire missile/rocket combination. The FCC will perform targeting navigation, weapon ballistic compensation, and supply commands required for the fire control subsystem. The computer will perform the following functions:

- Interface with avionics and weapons equipment
- Provide azimuth and elevation aiming signals
- Store ballistic parameters
- Accept air data sensor inputs
- Compute muzzle velocities
- Accept TADS target information
- Compute target kinematics and supply commands for weapon firing
- Accept helmet sight data and control helmet aiming and steering displays
- Compute aircraft attitude and maneuver information
- Compute and store target locations
- Compute and store boresight errors
- Perform fault detection and isolation
- Monitor aircraft and weapons to provide fire enable signals and perform fire interrupt

SURVIVABILITY/VULNERABILITY (S/V) CHARACTERISTICS

One of the more challenging areas of design in the UTTAS and AAH is the stringent total S/V requirements, and their relationship to achieving a good survivable design at the cost of empty weight and performance. The phrase "total S/V requirement" is used to distinguish the various design criteria necessary to achieve an increased survivable helicopter from the connotation of vulnerability to specific weapon threats. This section of the paper will discuss the key design requirements and capabilities which make up the total S/V picture and will naturally include the invulnerable capability to weapon threats.

Crashworthiness: The UTTAS and AAH have been designed to specific crashworthiness requirements relating to increased human and hardware protection and survivability. The specific areas deal with the airframe, (including engine and transmission), landing gear, fuel tanks, and living space volume reduction on impact.

Table 5 outlines the major capabilities of these areas for each helicopter. In addition to the capabilities shown in Table 5, additional design features are incorporated such as; anti-plow skid beams, energy absorbing load limiting seats, energy absorbing structure of ductile material in the fuselage, turnover protection structure, jettisonable cockpit doors, and crash inertia switches to activate fire extinguishing systems.

Redundancy: In many areas the survivability of the helicopters can be attributed to ballistic invulnerability, enhanced by redundant components and subsystems. Specific redundant designs incorporated on the UTTAS and AAH are:

- Engines widely separated with good single engine performance
- Fuel subsystem
- Flight controls
- Hydraulic system
- Electrical system
- Instruments
- Rotor - transmission - engine attachment and support structure

Transmission Dry Run Capability: The main transmission and all gearboxes of the UTTAS and AAH have the capability to operate for a minimum of 30 minutes at the power required for flight speeds for maximum range after the total loss of the lubrication system.

Detection: The UTTAS and AAH have incorporated design features to reduce detectability by radar, noise levels, and visual prominence. Specific design features are:

- Reduced radar detection by use of controlled fuselage profiles, engine inlet screening and rotor head shaping.
- Reduced external noise levels by use of advanced geometry main and tail rotor systems.
- Reduced visual prominence by use of low reflectance and camouflage paint, low helicopter profile and in the case of the AAH, near-flat glass canopy.
- Reduced engine infrared (IR) signature by provisions for an IR suppression kit on the UTTAS and an integral suppression system on the AAH.

Vulnerability: One of the most important ingredients of S/V is obviously vulnerable area to specific weapon threats. A primary design requirement of the UTTAS and AAH is the stringent allowable vulnerable area of the two designs which to date has been demonstrated by analyses and component testing. The design methods by which these capabilities are accomplished are damage tolerant or ballistic tolerant components and the use of shielding and/or armor. Further protection to the crew in the AAH is accomplished by the use of a fragmentation barrier between the pilot and co-pilot/gunner. The actual requirements differ for the two designs from a standpoint of threat and flight condition (i.e., hover and forward flight). The UTTAS requirement is zero vulnerable area to 7.62mm projectiles with a design goal to minimize vulnerable area to 12.7mm and 23mm threats. The requirement and goal is for forward

flight only. The AAH requirement is zero vulnerable area to 12.7mm projectiles and a similar design goal to minimize 23mm. Unlike UTTAS, the AAH requirements are for hover and forward flight. In addition both aircraft are designed for fuel tank self sealing capability against 12.7mm, and 14.5mm for the lower portion which contains the 30 minute reserve. The reason for the difference in requirements of the two designs is related to the design missions of the helicopters. The AAH will live in a more hostile environment, intentionally operating in and near areas of small arms fire and will spend a great deal of time in this environment while in a hovering condition. Therefore, the AAH must be capable of defeating a higher threat at more stringent flight conditions. In order to show the helicopters' capabilities relative to their design goals for the higher 23mm threat, a presentation of the percentage vulnerable area to total helicopter presented area is shown in Figure 5. For comparative purposes, the UH-1 and AH-1 percentages are also shown, keeping in mind that these helicopters were not designed for any invulnerability to specific threats. As can be seen from Figure 5, the UTTAS and AAH have achieved their goals of minimization to 23mm when compared to aircraft that had no design requirement or goal.

RELIABILITY, AVAILABILITY, AND MAINTAINABILITY (RAM) CHARACTERISTICS

The UTTAS and AAH represent a new generation of helicopter design in which significant attention to reliability and maintainability has been required by the Army to assure an improvement in availability thus enhancing the operational effectiveness and life cycle cost of the helicopter. The Army's stringent requirements in the area of RAM were successful in advancing the state-of-the-art of detail design to provide highly reliable and easily maintained aircraft. A summary of the UTTAS and AAH capabilities for significant RAM parameters is shown in Table 6. The values shown are extrapolated capabilities based on actual results measured during contractor development and Army flight testing. For purposes of definition, the mission reliability is based on a probability of completing a mission and landing at a predetermined area without occurrence of an equipment malfunction or failure that is the cause for a mission abort, given that the equipment was operationally ready at the start of the mission. For presentation purposes the probability has been converted to Mean-Time-Between-Failure (MTBF) as shown in Table 6. The dynamic component Mean-Time-Between-Removal (MTBR) capabilities represent an average for all components with no one component less than 1500 hours. It should also be noted that the difference between the two designs in the area of mission MTBF and field Maintenance Man Hour/Flight Hour (MMH/FH) is related to the contribution of the mission equipment in the AAH. Although not shown, the values for the AAH airframes alone are essentially equivalent to the UTTAS. In addition, the overall maintainability of the AAH with the mission equipment installed is enhanced by the incorporation of a Fault Detection/Location System (FD/LC) and Line Replaceable Units (LRU). The FD/LS has the capability to:

- Provide on-aircraft inflight "go/no go" status of mission essential equipment
- Detect failures of flight critical subsystems
- Fault isolate electrical/electronic failures to the replaceable unit
- Provide electrical/electronic fault isolation within replaceable units

The inherent reliability capability of the UTTAS and AAH is primarily obtained by the use of component derating, simplified design and low vibration design. Safe life requirements and capabilities are such that all fatigue critical dynamic components have a minimum life of 5000 hours on the UTTAS and 4500 hours on the AAH. The airframes are designed to preclude major overhaul in less than 4500 hours for AAH and 8000 hours for UTTAS. Each aircraft has design features which significantly lower the overall vibration levels by as much as a factor of two when compared to existing Army utility and attack helicopters.

Both helicopters have incorporated design features which enhance accessibility by the use of built-in work platforms coupled with aircraft mounted cranes which have virtually eliminated the need for workstands. Numerous external fuselage door panels provide good accessibility for inspection and maintenance activities. This attention to design has also included sound maintenance safety features. Hand holds and steps are identified and all work platforms/walkways are coated with anti-skid compound. Other general maintainability features include the use of quick disconnects throughout the electrical and hydraulic subsystems and quick acting fasteners are provided on all access panels which are frequently opened. In addition scheduled overhauls have been replaced by "on-condition" operation, and the need for lubrication has been eliminated or reduced.

These attentions to maintainability detail design coupled with the inherent reliability capabilities have allowed extended time between inspections and provides the Army with next generation helicopters with the operational availability needed coupled with reduced cost of operation.

GROWTH CAPABILITY AND POTENTIAL ALTERNATE USES

Both the AH-64 and UH-60A have inherent growth potential in their designs. As discussed previously in the Performance section, the normal in-service growth due to repairs, mission expansion, and new requirements required that the UTTAS and AAH be designed with anticipation of changing requirements in service. As mentioned previously this approach will avoid costly requalification and retrofit at a later date. The most common area of growth in past helicopter designs has been the periodic updating of the powerplant. The AAH and UTTAS have drive systems which have been (for purposes of durability) designed to use 120% of the current power available at the design condition of 4000 feet/95°F. In addition, this drive system design criteria allows more efficient use of the higher engine power available at low altitudes and/or low temperatures, where heavy weight alternate missions are required.

The AAH primary mission endurance requirement is 1.9 hours at an ambient condition of 4000 feet/95°F, requiring 1542 lb of fuel. In addition, the AAH has a 2.5 hour endurance requirement at SL/STD conditions, requiring 2374 lb of fuel. This second mission sizes the internal fuel capacity of the AAH, and provides a 54% capacity margin over the hot day mission requirement. The UTTAS endurance requirement is 2.3 hours for both the 4000 feet/95°F and SL/STD ambient conditions. The hot day mission fuel requirement is 1975 lb and the SL/STD requirement is 2350 lb, providing a 19% capacity margin over the hot day requirement. The area of mission expansion typically evolves from increased mission requirements, additional mission equipment, alternate uses of the vehicle from its primary mission, or combinations of the above. In the case of the AAH and UTTAS, critical flight performance has been specified at the primary mission gross weight and ambient conditions described above. Because of the requirement to perform alternate heavy weight missions such as external cargo missions, the structural design has included operations to significantly higher loadings. The following lift comparison illustrates the alternate mission potentials (relative to primary mission weight) while still maintaining structural integrity.

	AAH (Ref 4)			UTTAS (Ref 3)		
	Wt	Load Factor	Add'l Lift Capability	Wt	Load Factor	Add'l Lift Capability
Primary Mission Weight	13825	3.7g	-	16450	3.6g	-
Structural Design Weight	14660	3.5g	6%	16825	3.5g	2%
Maximum Weight	17650	2.9g	28%	20250	2.9g	23%

The AAH is designed for a crew of two and a primary mission ordnance load of 8 Hellfire missiles and 320 rounds of 30mm ammunition. Alternate loading capabilities are: up to 16 Hellfire missiles, up to 76 2.75" folding fin aerial rockets (FFAR), up to 1200 rounds of 30mm ammunition, or combinations of the above. The UTTAS primary mission load consists of a 3 man crew, 11 fully equipped combat troops, two M-60 weapons and 1100 rounds of 7.62mm ammunition. Alternate loading capabilities are up to 8000 lb of external or internal cargo. In addition, the UTTAS can be reconfigured to serve as an aerial command post, aeromedical evacuation vehicle, crash rescue/fire suppression vehicle, and general support vehicle.

Another frequent use of military aircraft is the civilian market. Civilian applications normally follow the development of military versions, and after the expensive development and qualification program has been funded. However, there has been a recent turn-around in this trend related to the industry's assessment of commercial helicopter needs. The industry has assessed a market need in the low to mid gross weight range and has initiated company-funded new-development efforts in lieu of modifying any existing vehicles. These new development efforts, the most notable being Sikorsky's S-76 and Bell Helicopter Textron's Model 222, are considerably different than the AH-64 or the UH-60A. Table 7 lists the salient characteristics of the AAH and UTTAS, and three medium lift commercial aircraft which are currently being developed. It can be seen from Table 7, that the two independently developed commercial aircraft (S-76 and BHT-222) are significantly smaller than the aircraft designed to military requirements. The BHT-214B, although it is more comparable in size, is again a commercial vehicle which has been modified from the 214A, developed for the Imperial Iranian Air Force.

The chief reasons for the difference in size between the military UTTAS and AAH designs on the one hand, and the commercial S-76 and BHT-222 on the other hand, are the critical military performance design requirements at 4000 feet/95°F and the crashworthy and survivability design requirements for enhanced battlefield effectiveness. The AAH and UTTAS, for example, have about 7 to 10% of their weight empty associated with crashworthiness and survivability design features. For a nominal aircraft growth factor of 1.6 lb/lb, this results in the aircraft growing 11 to 16% due to the presence of the crashworthiness and survivability requirements. This trend is compounded by the severe VROC performance criteria at 4000 feet/95°F conditions. Compare, for example, in Table 8, the UTTAS design for a crew of 3 and 11 troops (total of 14 onboard) against the S-76 with a crew of 2 and 12 passengers (total of 14 onboard). For this case of equivalent total number of people onboard, the UTTAS useful load is approximately 35% larger, and the total gross weight is approximately 80% larger. Table 8 illustrates a comparison of typical loadings for the UH-60A, S-76 and Model 222. At this condition the S-76 is unable to hover OGE on a hot day, and is limited to an HOGE condition at 75°F and sea level altitude. The UTTAS, however, can HOGE at 5000 feet/95°F with its higher useful load. The Model 222 loading condition shown is for a maximum loading of 10 people onboard and allows a hover OGE capability of 3700 feet on a 95°F day. Note that the useful load of 2780 lb is approximately half of the comparable UTTAS loading. It can be concluded from this comparison that the industry's assessment of commercial requirements is in the 8-12 passenger range, with a useful load/performance combination which is much less demanding than the current military troop transport requirements.

CONCLUSIONS

It is recognized that the Army's requirements for the UTTAS and AAH in the area of flight performance, survivability/vulnerability, reliability and maintainability and in the case of the AAH advanced firepower and avionics represent demanding design criteria, but are considered necessary to fulfill the Army's operational roles on the modern battlefield. While these requirements dictated innovative design features within design to cost goals, the UTTAS and AAH will provide the Army with truly improved next-generation helicopters capable of achieving the Army's required missions.

As a result of the Army's design requirements the resulting helicopters represent capabilities beyond those of current commercial operation requirements. However, the necessary innovative design approaches required to meet the Army's needs provide inherent advancements in rotorcraft technology which are directly applicable to commercial applications relating to reliability and maintainability, safety and reduced cost of operation.

REFERENCES

1. U.S. Army, System Specification for Utility Tactical Transport Aircraft System, Mar 1975, AMC-SS-2222-10000D.
2. U.S. Army, System Specification for Advanced Attack Helicopter, Jul 73, AMC-SS-AAH-10000A.
3. Sikorsky Aircraft, UH-60A Utility Tactical Transport Aircraft System Prime Item Development Specification, Nov 76, AMC-CP-2222-S100.
4. Hughes Helicopters, YAH-64 Phase 2 Advanced Attack Helicopter System Specification, Oct 76, AMC-SS-AAH-H10000A.
5. U.S. Army Combat Developments Command, Vertical Flight Performance Criteria, Jun 68, AD 840304.
6. Bell Helicopter Textron, Bell Model 214B Big Lifter Summary Report, Jul 75.
7. Sikorsky Aircraft, Sikorsky S-76 Technical Description, Oct 76.
8. Bell Helicopter Textron, Bell Model 222 Summary Report, Feb 77.

ACKNOWLEDGEMENT

The authors gratefully acknowledge the support of COL(P) Edward M. Browne, AAH Project Manager, and his staff, and COL Richard D. Kenyon, UTTAS Project Manager, and his staff for their support in preparation of this paper.

5-11

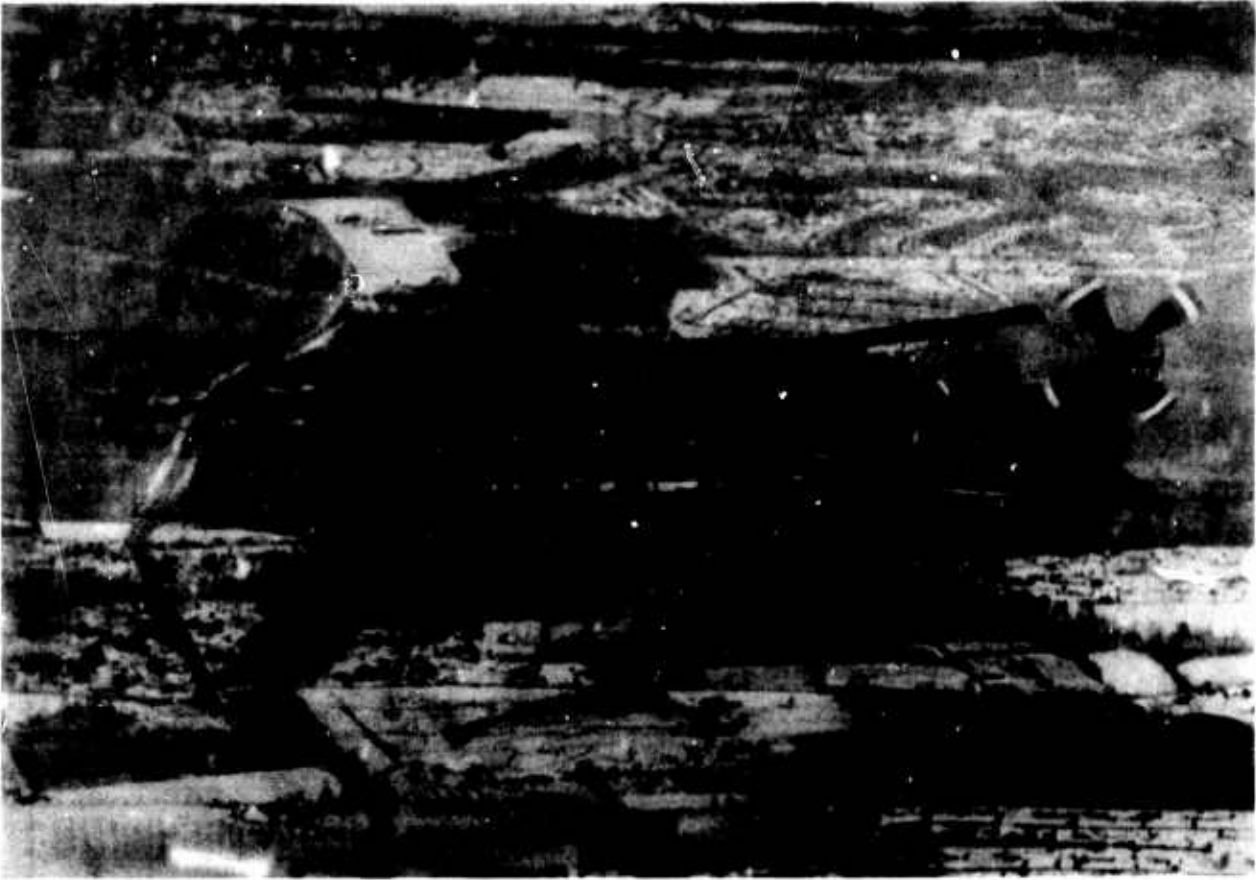

Figure 1

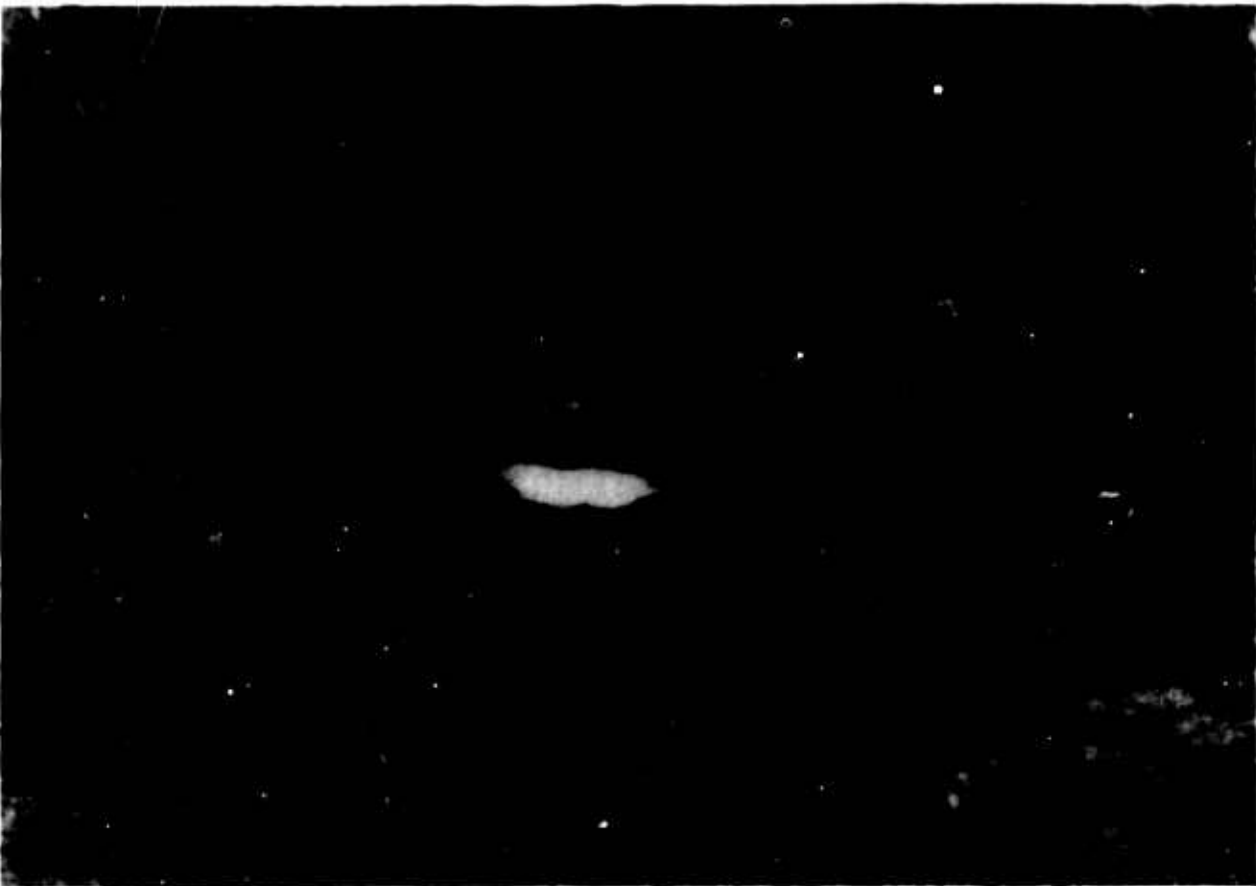

Figure 2

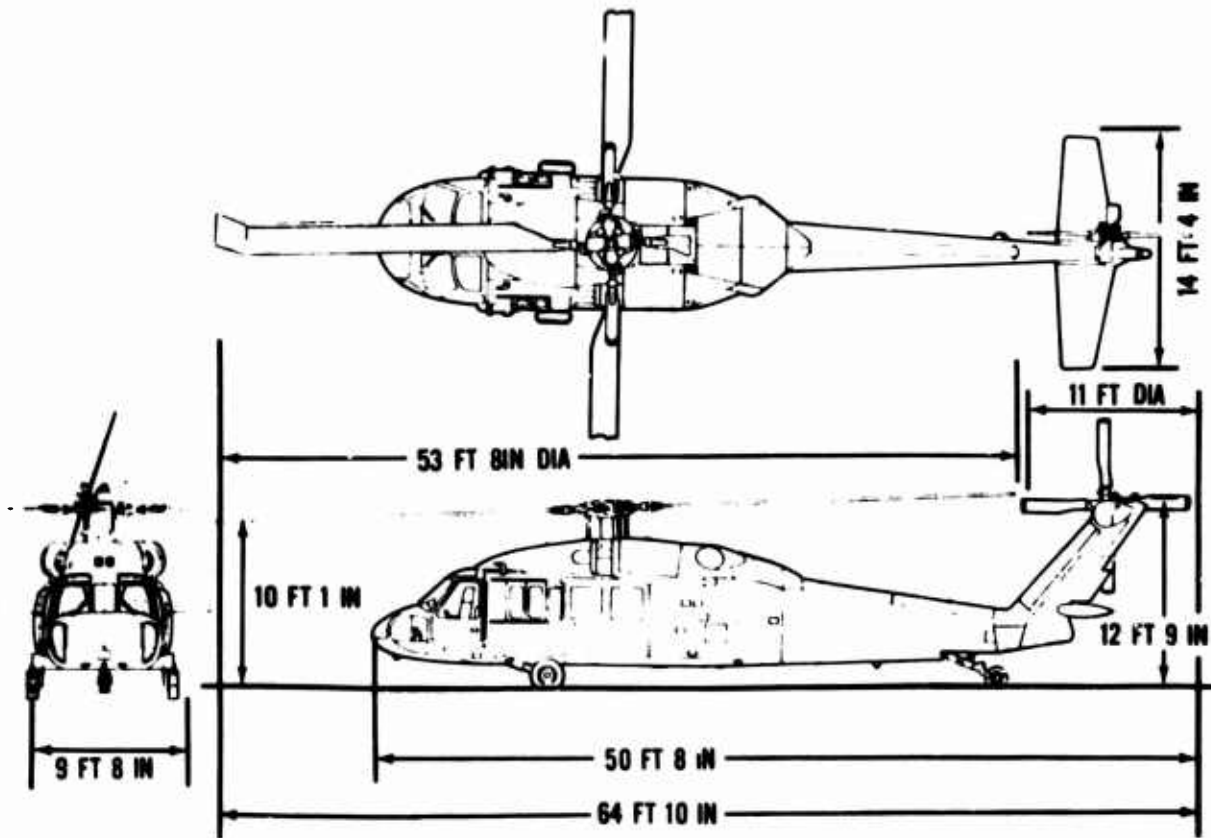

Fig.3 The Sikorsky UH-60A

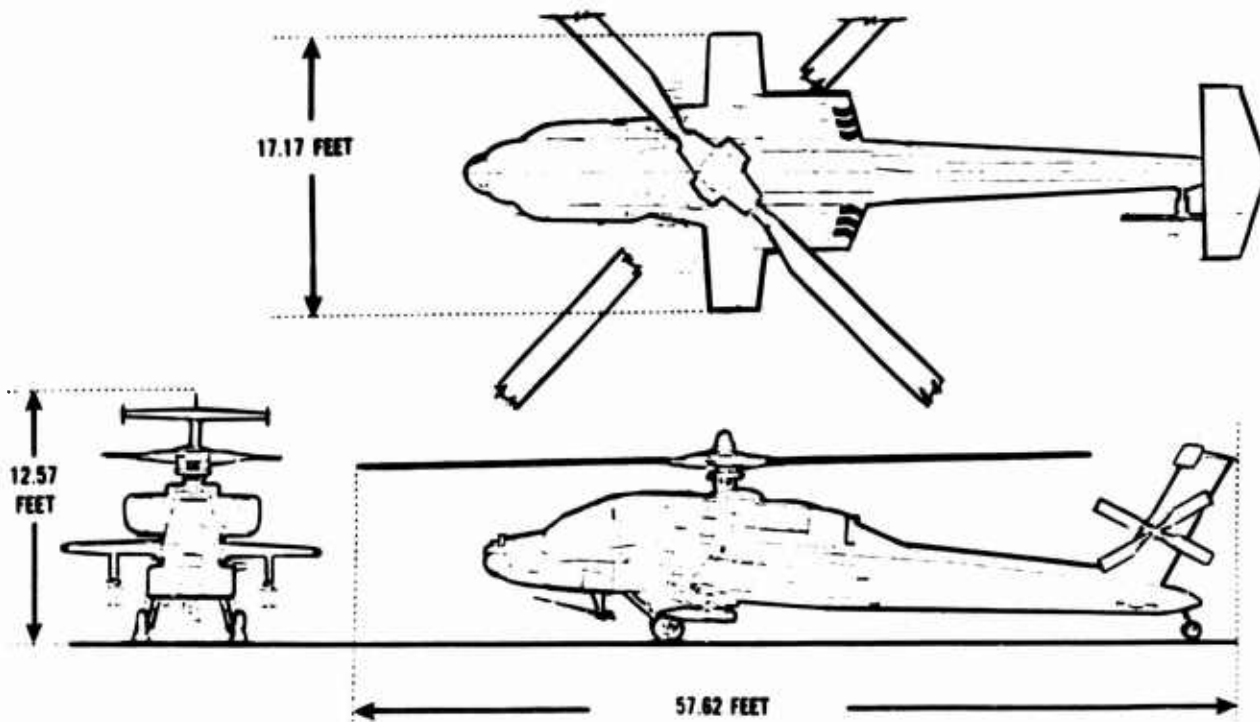

Fig.4 Hughes helicopters YAH-64

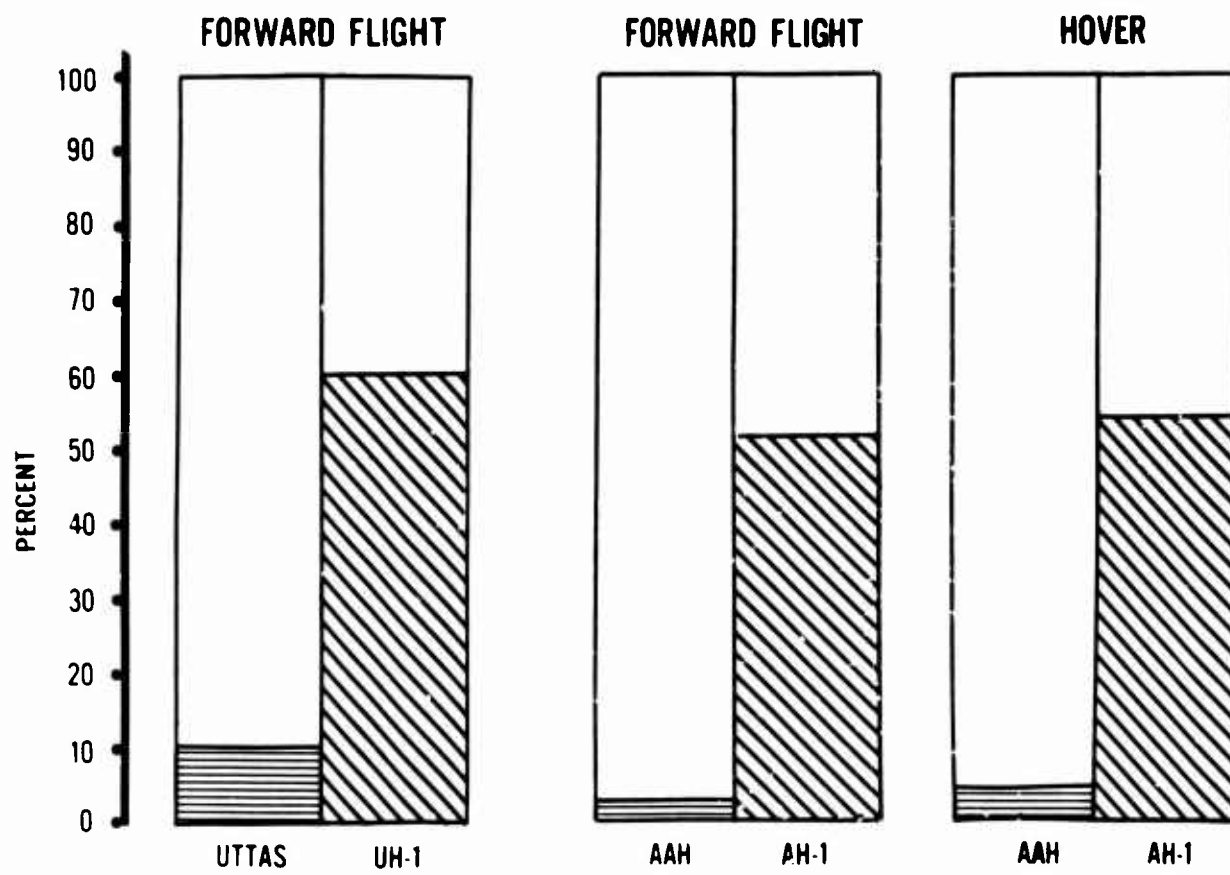

Fig.5 Vulnerable area (relative to total presented area) 23 mm HEI

TABLE 1UTTAS CHARACTERISTICS

<u>ROTORS</u>	<u>MAIN</u>	<u>TAIL</u>
Type	Articulated	Hingeless
Number of Blades	4	4
Diameter - FT	53.67	11.00
Chord - FT	1.75	0.81
Twist - DEG	18.0	18.0
Solidity	.0826	.1875
Cant Angle - DEG	N/A	20.0
Rotor Speed - RPM	258	1190
Disc Loading - PSF	7.2	---

ENGINES

Two GE T-700, 1543 SHP (ea), 20000 RPM
Solar Auxiliary Power Unit (APU), 90 SHP, 12000 RPM

HELICOPTER WEIGHT

Empty Weight - LB 10900
Useful Load - LB 5550

3 crew
11 troops
2 7.62mm M60 Guns + 1100 Rds 7.62mm
Fuel for 2.3 hours at 4000 ft/95°F

Mission Gross Weight - LB 16450
Alternate Gross Weight - LB 20250

TABLE 2AAH CHARACTERISTICS

<u>ROTORS</u>	<u>MAIN</u>	<u>TAIL</u>
Type	Articulated	Hingeless
Number of Blades	4	4
Diameter - FT	48	8.58
Chord - FT	1.75	0.833
Twist - DEG	9	9
Solidity	.092	.2409
Rotor Speed - RPM	289	1411
Disc Loading - PSF	7.6	---

ENGINES

Two GE T-700, 1543 SHP (ea), 20000 RPM
AirResearch Auxiliary Power Unit (APU), 125 SHP, 8216 RPM

HELICOPTER WEIGHT

Empty Weight - LB 10268
Useful Load - LB 3557

2 crew
1 30mm XM230 Gun + 320 Rds 30mm
2 HELLFIRE Launchers
8 HELLFIRE Missiles
Fuel for 1.83 hours at 4000 ft/95°F

Mission Gross Weight - LB 13825
Alternate Gross Weight - LB 17650

TABLE 3

CURRENT AAH PERFORMANCE SUMMARY (Ref 4)

	<u>Army Requirement</u>	<u>AH-64 Capability</u>
Weight Empty - LB	---	10268
Primary Mission Wt - LB	---	13825
VROC @ 95% IRP - FPM	450-500	880
Cruise Speed @ MCP - KTAS	145-175	146
Mission Endurance - HR		
Primary @ 4000 feet/95°F	1.83	1.83
Alternate @ SL/STD (Full Internal Fuel)	2.5-2.8	2.62
Ferry Range (STD Day) -N.M.	800-1000	820
One Engine Inop @ IRP		
Cruise Speed - KTAS	90	108
Service Ceiling @ 95°F - FT	5000	5600
Safe Land Speed - KTAS	Near Zero	Yes

TABLE 4

CURRENT UTTAS PERFORMANCE SUMMARY (Ref 3)

	<u>Army Requirement</u>	<u>UH-60A Capability</u>
Weight Empty - LB	---	10900
Primary Mission Wt - LB	---	16450
VROC @ 95% IRP - FPM	450-500	480
Cruise Speed @ MCP - KTAS	145-175	147
Mission Endurance - HR		
Primary @ 4000 feet/95°F	2.3	2.3
Alternate @ SL/STD (Full Internal Fuel)	2.3	2.3
One Engine Inop @ KTAS		
Cruise Speed - IRP	100	109
Service Ceiling @ 95°F - FT	5000	5000
Safe Landing	Req'd	Yes
Takeoff from IGE Hover	Req'd	Yes

TABLE 5
CRASHWORTHY DESIGN CAPABILITY

<u>AIRFRAME - G's</u>	<u>UTTAS</u>	<u>AAH</u>
Longitudinal	+20	+20
Vertical	+20/-10	+20/-10
Lateral	+18	+20
 <u>LANDING GEAR - FT/MIN</u>		
Reserve Energy	900	900
Crash	2520	2520
 <u>FUEL TANKS - FT/MIN</u>		
	3900	3900
 <u>MAXIMUM LIVING SPACE VOLUME REDUCTION - %</u>		
Longitudinal Impact @ 1200 Ft/Min - into rigid wall 2400 Ft/Min - into rigid wall 3600 Ft/Min - 15° nose down into level ground	Safe Evacuation	
		N/A
		5
Vertical Impact @ 2520 Ft/Min	15	15
Lateral Impact @ 1800 Ft/Min	15	15

TABLE 6
RAM CAPABILITY

<u>PARAMETER</u>	<u>UTTAS</u>	<u>AAH</u>
System MTBF - HR	4.5	3.4
Mission MTBF - HR	76	19.8
Dynamic Component MTBR - HR	3619*	4258*
Field MMH/FH	.80	5.61
Operational Availability	.86	.88

NOTE: MTBF - Mean Time Between Failure

MTBR - Mean Time Between Repair

MMH/FH - Maintenance Manhour Per Flight Hour

*Average Time for Aircraft Component Set

TABLE 7
CHARACTERISTICS OF CURRENT DEVELOPMENT HELICOPTERS

	<u>MILITARY DESIGNS</u>		<u>MODIFIED</u>	<u>CIVILIAN DESIGNS</u>	
	<u>UH-60A</u>	<u>AH-64</u>	<u>MILITARY DESIGNS</u> <u>BHT-214B</u>	<u>S-76</u>	<u>BHT-222</u>
Weight Empty - LB	10900	10268 (1) (8989)	7761	5114	4420
Maximum Gross Weight - LB	20250	17650	16000 (External) 13800 (Internal)	9700	7200
Fuel Capacity - LB	2350(JP-4)	2374(JP-4)	1372(JP-4)	1768(JP-5)	1284(JP-5)
Rotor Diameter - FT	53.7	48	50	44	39
Crew	3	2	1	2/1	2/1
Passengers	11	0	15	12/13	8/9
Engines	(2) T700-GE-700	(2) T700-GE-700	(1) LTC T5508D	(2) ALL 250-C30	(2) LTS 101-650C
Total Engine SHP (SL/STD Uninstalled)	3086	3086	2930	1300	1300
Passenger Cabin Volume - FT ³	376	--	220	204	130
Baggage Bin Volume - FT ³	--	--	--	42	42
Maximum Useful Load - LB	9350 ⁽²⁾	7382 ⁽²⁾ (8661) ⁽¹⁾	8239 ⁽²⁾	4586 ⁽²⁾	2780 ⁽²⁾
Maximum U.L./W.E. x 100%	86%	72% (96%)	106%	90%	63%
G.W. HOGE @ 4000 Ft/95°F - LB	17500	15550	13800 ⁽²⁾	7500	7100
U.L. @ 4000 Ft/95°F - LB	6600	5282 (6561) ⁽¹⁾	6039	2558	2680
U.L./W.E. x 100%	61%	51% (73%) ⁽¹⁾	78%	52%	61%

NOTE: (1) Armament Mission Equipment Removed from Weight Empty
(2) Limited by Maximum Gross Weight

TABLE 8
TYPICAL MISSION LOADINGS

	<u>UTTAS</u>	<u>S-76</u>	<u>BHT-222</u>
Crew	3 @ 725 LBS	2 @ 340 LBS	2 @ 340 LBS
Passengers	11 @ 2640	12 @ 2040	8 @ 1360
Baggage	---	180	120
Full Fuel	2350	1768	960 ⁽¹⁾
Two M-60	96	---	---
1100 Rounds 7.62mm	72	---	---
Trapped & Unusable Fluids	<u>42</u>	<u>In W.E.</u>	<u>In W.E.</u>
Useful Load	5925 LB	4328 LB	2780 LB
Empty Weight	<u>10900 LB</u>	<u>5114 LB</u>	<u>4420 LB</u>
Gross Weight	16825 LB	9442 LB	7200 LB
HOGE Altitude @ 95°F	5000 FT (30 Min Rating)	Max HOGE Temp at SL is 75°F (5 Min Rating)	3700 FT (5 Min Rating)

NOTES: (1) Capacity is 1284 LB JP-5

US NAVY/MARINE CORPS ROTARY WING REQUIREMENTS

by

Captain J.A.Purtell
US Navy

INTRODUCTION

Thank you for the opportunity to speak today about Navy and Marine Corps helicopter requirements. The Naval helicopter is unique in that it is employed throughout the world in every climate, on a mobile platform, in a salt air environment, often in very small numbers. Small maintenance detachments and junior officers operate them for months at a time in austere conditions. They must be rugged, reliable and versatile. For example, in the pace of war at sea the mode of operations changes very quickly and secondary missions often are performed on the same flight as primary missions, thus, the aircraft must always be fully equipped. Naval Rotary Wing Aircraft must be able to extend their flights, refueling on-station from the nearest ship, either in-flight or on deck. This is particularly true in anti-submarine warfare where your effectiveness is proportional to time on station.

This paper addresses three points: first, how rotorcraft fit into a Navy committed to a future VTOL force. Second, current helicopter developments in Naval aviation with emphasis upon characteristics and capabilities of CH-53E Super Stallion, LAMPS MK III, and the AH-1T improved Sea Cobra, and finally, what current trends are underway in navalized helicopters to applications.

To explain transition to a "V" Navy, I will discuss our function in the Rotary Wing Branch and how organization is changing, or, more accurately - changing very little.

The Rotary Wing Branch responsibilities today are:

- Concept formulation
- Development
- Engineering
- Test and Evaluation
- Production

as they pertain to all Navy and Marine Corps helicopters, and now to some extent to Coast Guard helicopter selection. Support, training devices and basic technology research and development are done by other offices at NAVAIR as is the overall management of projects. We do, however, provide engineering to support those functions. Here are our current helicopter programs:

- SH-3 Sea King
- SH-60B LAMPS MK III
- RH-53D Minesweeper
- AH-1T Sea Cobra
- CH-46E Sea Knight
- CH-53E Super Stallion
- SRR USCG Short Range Recovery

As VTOL projects take form and are staffed, we add project engineering for those aircraft - and perform the same functions for the "V" as well as for the helos. That is:

- AV-8A/B Harrier
- V/STOL Type A ASW/AEW/Marine Assault

The point is that V/STOL is not intended to replace rotorcraft in the Navy. Eventually, practical V/STOL are intended to fill some roles now performed by helicopters. The thrust of the study effort in VTOL is advanced development, technology development. There will be a point at which it will be decided whether HIX, HXM, combat SAR, and so on, will be conventional helos, advanced rotary wing, lift cruise fan or something else.

Here are the extended hovering roles expected to be performed by helicopters and missions, now of helicopters, which by virtue of their flight profiles, appear likely candidates for VTOL.

A. Sea based vertical flight*Helo roles*

- o Minesweeping
- o LAMPS (VTOL "C")
- o Vertrep
- o Heavy Lift/VOD
- o HS (Sea King)
- o VOD
- o SRR

Studied for VTOL "A"

- HSX
- HSM
- Attack
- Combat SAR

The concepts of ABC, tilt rotor and possibly others will be fully evaluated for their possible application to tasks appropriate to low disc loading.

The commitment of the USN to VTOL is to not be viewed as a precipitous impulse. We are embarking upon a deliberate investigative process with many decisions which remain to be taken at appropriate points. At each of these points alternate courses of action will be thoroughly explored.

NAVALIZING REQUIREMENTS

Helicopters, as discussed by the gentlemen from land based services who have preceded me, do very well in Naval roles – except – it is a vital exception – they require adaption to the shipboard environment, salt air environment, sea combat environment and over water environment.

The sea makes the difference.

The LAMPS MK III aircraft illustrates this point. These are proposed changes to be made to rotorcraft designed for Army applications which have been offered to meet the requirements of war at sea:

Shipboard Landing and Handling

- fittings added for hauldown and traversing
- landing gear stressed for rolling, pitching decks – 12 eps touchdown
- rotor brake for rapid handling and close quarters
- blade and tail boomfold for stowage
- pressure fuelling – rapid safe handling
- fuselage door changes – swinging doors and high winds don't mix
- small footprint

Salt Air

- marinize engines
- non corrosive materials/paint

Sea Combat

- increased drag – external sensors, weapons racks, etc.
- avionics – mission equipment
- weapons (torpedos)
- add sonobouys/pyrotechnics for mission support
- add third crewman – operate equipment
- remove gun mounts/armor
- added cockpit panels reflecting the increased complexity of Naval tactical aircraft

Over Water

- rescue hoist – SAR and utility missions
- flotation – all emergency landings are ditchings
- more fuel – overwater mission length
- HIFR – helo inflight refueling
- high capacity fuel dump – emergency procedure to reduce to single engine hover weight for shipboard recovery.

Pictured here is the SH-60B, LAMPS MK III. You may notice the number of externally mounted weapons, and sensors – and the number of fuselage changes for sonobouy chutes – doors, escape hatches and so on.



These material acquisition fundamentals we call the "NAVAIR New Look".

- Objectives
 - Improve Fleet Readiness
 - Enhance Material Acquisition Efficiency
- Cornerstones
 - Maximize Reliability/Maintainability
 - Optimize Quality Assurance
 - Minimize Life Cycle Cost
- R&M
 - Mission Profile Definition
 - Stress Analysis
 - Derating Criteria
 - Worst Case Analysis
 - Sneak Circuit Analysis
 - Prediction/Allocations
 - Failure Modes & Effects Analysis
 - Test, Analyze, & Fix with Closed Loop Reporting
 - Design Reviews
 - Mission Profile Qualification Test
- Q.A.
 - Process Control Attainment/Maintenance
 - Mission Profile Acceptance Test
- Cost
 - Design to Cost

These are also requirements, stressing engineering disciplines which will assure us of improved reliability and maintainability. Each of the aircraft I am discussing, has been given the "New Look" starting with design. In each case we are hearing from designers that they are happy that we insisted upon these criteria. The payoff is better aircraft for us and better product for the contractor who uses the results of R&M improvements on other products.

We are currently going into production of the improved Sea Cobra, the AH-1T. This aircraft features twin engines, improved dynamic system and 402 R&M changes from earlier Marine Cobras.

This aircraft has realized a threefold increase in ordnance capability — has added the dimension of the TOW missile to Marine close air support and is capable of operation from ship or shore. It differs significantly from its Army counterparts because it has met the hard requirements of sea basing.

MILITARY APPLICATION OF OFF-THE-SHELF CIVILIAN HELICOPTERS

The concept of using civilian helicopters for US Navy where applicable is not new. The TH-57A is used for helicopter flight training by the US Navy, and for the Marine Corps and Coast Guard has served extremely well. This is the basic Jet Ranger, B-206.

We are now cooperating in the US Coast Guard's selection of a replacement for the HH-52A. The short-range recovery aircraft is envisaged as an existing certified civilian or military equivalent helicopter. It is anticipated that the development costs for this procurement can be greatly reduced by taking advantage of civil developments with minimum modification. Several helicopter manufacturers from NATO nations have expressed a strong interest in this competition. Documentation for this procurement is now being prepared. An RFQ should be issued by the end of the year.

BRITISH AIRWAYS HELICOPTER OPERATIONS

Captain J.A.Cameron
British Airways Helicopters
Gatwick Airport
Horley
Surrey

7-1

Writing this Paper for the AGARD Symposium on Rotorcraft Design presents me with the opportunity to suggest ways in which, perhaps, the civil and military aspects of VTOL can best be progressed to the benefit of operators, manufacturers and users alike.

I am Managing Director of British Airways Helicopters and we have 30 years experience in the helicopter business and I think we can, without being accused of being immodest, rightly claim the epithet 'successful'.

For 12 years we have, as I am sure many of you know, contributed to the support of Britain's off-shore oil exploration effort in the North Sea - perhaps one of the most hostile environments in the world. The somewhat unhappy economic situation in which Great Britain has found itself has highlighted the importance of the oil in our coastal waters and as its importance has grown so the efforts of those supporting the operation has been thrown into ever sharper perspective.

But if our achievements in the North Sea give us just cause for satisfaction the fact that we operate probably the only profitable scheduled helicopter passenger service in the world is of equal importance to us - and some may say to the progress of civil rotary flight generally.

There obviously can be no direct comparison between our North Sea operations and our passenger service between Penzance on Britain's south west coast and the Isles of Scilly. But if our oil support operation is of national importance, the largely unheralded success at Penzance is of international importance because aside from the credit which accrues to British Airways Helicopters as a result of its success, the achievement at Penzance underlines the economic viability of scheduled helicopter operations. This viability, though proven, is sadly too often ignored.

Having then outlined our pedigree, I would like to expand a little on these opening remarks. Perhaps I can try and outline to you some of the factors which I feel have contributed to our success.

From the outset I was determined to keep the helicopter divorced totally from established fixed wing thinking. To this end we have our own Chairman and Board of Directors, and in effect have always 'paddled our own canoe'.

I was also determined to surround myself with staff who had a genuine enthusiasm for helicopters as well as the necessary skills. I am pleased to say that this enthusiasm for rotary wing has remained constant throughout the Company for 30 years.

It would be wrong to say that we were successful from the outset. For the first 15 years we had only a small number of single engine helicopters in our fleet and we were kept alive by a multitude of small charter operations together with a small Government contribution for development work: this contribution became more and more difficult to obtain as the years went on. However, the Government's small investment in single engine helicopters has been paid back many times over. For example, our use of helicopters for services to the Isles of Scilly enabled HM Government to close down the airport at Land's End some 12 years ago, saving them £120,000 per annum.

Thankfully our main objective whilst operating single engine helicopters was to prepare ourselves for the advent of multi-engine machines. This we did by undertaking various operations, one of which was an 80-mile night mail operation between Peterborough and Norwich, during the winter of 1949/50. This highlighted many operational problems which had to be overcome before the helicopter could take its place in the civil field. One of these was ensuring that the navigation and approach aids were suitable to our needs.

That is just one example, but the attention which was directed to the diverse problems that showed themselves in those early days resulted in British Airways Helicopters becoming the first airline in the world to carry passengers on scheduled helicopter services and later to become the first in the world to secure clearance for instrument flying and flying in icing conditions.

But to return to our Penzance operation. When the service was inaugurated in 1964, the fixed wing service was carrying fewer than 28,000 people. Last year British Airways carried 34,000. This year we anticipate carrying 90,000 passengers.

Despite the fact that we have only one helicopter on this route, the regularity and punctuality has improved from 78 per cent, which was the best a fixed wing operation could maintain, to 97.6 per cent per annum recorded over the last six years. This is a great tribute to the Sikorsky S61N helicopter and to the staff maintaining it.

We were able to improve the regularity because we brought the operation from St Just airfield on the south western tip of England, 250 feet above sea level and plagued by

7-2
sea fog, down to sea level and within walking distance of our main catchment area of Penzance.

An interesting fact has arisen from our operation and that is that ground costs are infinitesimal compared with those of fixed wing. To give an example. It costs us 40 pence to handle each passenger through our heliport. The cost of handling a passenger on any major airline through Heathrow is equivalent to £6.00.

The reasons are not hard to find, we are able to keep staff to a minimum, we do not have to use large fire tenders and trucks to race down runways when an emergency occurs, we have no runway maintenance costs and we believe in transitting our passengers through the heliport quickly. It is quite commonplace for them on the return trip to collect their baggage outside the terminal building and then depart to the car park provided, which is just a few yards away.

There is another lesson we learned from our Penzance operation which we feel has a direct bearing on its economics. It is that on short sectors, 'block time' becomes very important. For example, on the Scillies route the block speeds achieved by our S61 work out at 83 per cent of the cruising speed of the aircraft. Compare this with the block speed of a modern jet on a flight, say, from London to Paris. Here the block speed is less than 50 per cent of the aircraft's cruising speed. The reason for the vast disparity is the amount of taxiing required of the jet. This is of little significance over long routes but on those up to 200 miles it is of vital economic importance.

We operate a quick turn round on this service, the 32 passengers and baggage can be offloaded and loaded on the Isles of Scilly well within the five minutes allowed on the timetable. We find this an exceptionally difficult point to communicate to our fixed wing friends who do not understand how it can be accomplished: I can assure you it can and has been done over the last twelve years. Our Company film 'Rotor Flight' demonstrates this.

When we commenced operations the aircraft was delivered to us as a 26-seater with an all up weight of 19,000 pounds. We soon realised that the manufacturer's performance figures for this aircraft were extremely conservative so we, together with our Civil Aviation Authority, took steps to initiate trials and tests at our Royal Aircraft Establishment at Farnborough in order to get a weight increase. We were successful in doing this and we now operate this aircraft, still under Group 'A' performance, at 20,500 pounds. Also, we have now comfortably increased the seating capacity to 32.

Both these improvements have tremendously helped the economics of the operation.

Unfortunately, the Federal Aviation Authority has not to date recognised the work carried out by the Civil Aviation Authority and the Royal Aircraft Establishment: at this very moment duplicate trials and tests are being carried out in the United States by the Federal Aviation Authority in order to clear this increased all up weight. It is no wonder to me that civil helicopter scheduled services in the United States have never been successful when one views the bureaucratic nonsense manufacturers have to fight.

It is significant that our S61Ns, and indeed virtually all multi-engine helicopters in civil operations to-day, are civil derivatives of basically military helicopters. Therefore, to some extent when a civil operator takes such a helicopter it is a compromise and he has to develop certain items to meet the civil operational requirements. One area which has received considerable attention from our engineers is the development of overhaul life of major components. The civil operator is in a more favourable position to carry out such development work. While the military user may have a considerably greater number of units, his utilisation per unit is generally relatively low. Within our fleet we have six helicopters with 10,000 hours each or more to their credit and in fact each aircraft in the fleet is averaging 12/1400 hours flying each per annum.

The conventional helicopter, being a sophisticated piece of engineering equipment, results in relatively high operating costs. Therefore, all means must be given to reducing costs whilst at the same time maintaining, or if possible improving, reliability.

The overhaul life development of major mechanical units is a means of reducing costs, but this can only be done in tandem with the design and material development of mechanical components. Trial extensions of overhaul life of major units show up components which are subject to wear or mechanical deterioration and action can then be taken to rectify the problem by redesign or changes in materials. Obviously, such development can only be done where there are sufficient numbers of units available with a sufficient number of operating hours.

The first five or six years of S61N operations were carried out with a total fleet of some four or five aircraft, initially operating on average about 500/600 hours per year and this restricted early life development. Utilisation gradually increased to about 800/900 hours per year by 1970 and it then became possible to initiate trial extensions to the overhaul periods of major components.

The rapid growth in fleet size and utilisation over the last three years has resulted

in a recent step up in trial extensions and life development. This development has enabled British Airways Helicopters to keep the increase in engineering costs brought about by inflation to a reasonable limit and if reduced to 1965/6 price levels, actually shows a reduction in costs.

7-3

It is in this area of component overhaul life development that civil operators can make a significant contribution to military users, although I do not feel that they take as much advantage of this as they might. Manufacturers give little encouragement to military users to develop component overhaul life, for low overhaul life is good business to them.

I referred earlier to the attention given by British Airways Helicopters to flight icing conditions. Our North Sea operations revealed the need for the ability to operate in forecast icing conditions and our Company began a series of trials over several winters of actually flying in ice conditions and studying the effects on the performance and handling of the aircraft. This work was supported by the British Ministry of Defence and the S61 manufacturers, and over 100 hours were spent actually flying in icing conditions. The result was that British Airways Helicopters became the first civil helicopter operator in the western world to obtain clearance for flight in icing conditions. The clearance was limited to forecast light icing down to a temperature of -5 degrees Centigrade at altitudes of between 500 and 5,000 feet. This clearance, although significant, nevertheless falls short of the desired requirements. Current operations would benefit from clearance down to at least forecast moderate icing conditions of -10 degrees Centigrade with an extension of the altitude band. It is felt that such a clearance would be possible with an S61N type helicopter without any mechanical or electrical de-icing or anti-icing equipment. The necessary protection could be derived from kinetic heating and blade flexing. Any further advances in icing clearance would almost certainly call for some form of de-icing/anti-icing equipment on blades and other areas of the airframe.

It is felt that such development could be enhanced by work undertaken by the military, who would stand to gain even more from clearance into severe icing than would a civil operator. A civil operator would have to carefully consider the merits of the ability to operate on the few occasions of severe icing against the increase in equipped weight brought about by de-icing equipment.

As stated earlier our icing trials were carried out with some Ministry backing and we have kept a close liaison with the work done directly by the Aircraft and Armament Experimental Establishment at Boscombe Down, and I am sure our work on this has made a worthwhile contribution to the icing clearance now approved on several helicopters in service with the British Forces.

If I may now refer again to our Penzance passenger service, it has proved conclusively that it is possible to make profits over short stages. If it is possible with existing equipment, greater profits must be possible with newer more advanced machines.

We are fortunate that Sikorsky did certificate the S61 for public transport and with the success of our scheduled service uppermost in our minds, I have been encouraging them to similarly certificate the military CH53, in civil guise the S65. To date I have not been successful in this but I am hopeful that either this aircraft or the Boeing Vertol 'Chinook' will obtain civil certification within the next two years. This will enable operators like ourselves to use these machines on longer, more lucrative routes - for example, the short continental routes from London. These types are not only larger than our current types but they are also faster. However, this gain in speed of some 30/40 knots falls far short of what we would like.

Obviously, the pure helicopter has speed restrictions for the well known reason of compressibility of the advancing and stalling of the retreating blades. We cannot expect any great improvement in cruise speeds of pure helicopters over the 150/160 knot mark.

In our opinion design effort should be concentrated on the compound helicopter where a considerable portion of the flight loads could be offloaded to aerofoils in cruising flight. Not only would this lead to a considerable increase in cruising speed but the stress levels in the rotor system would be considerably reduced, thereby greatly prolonging rotor life. Serious project studies have been made on compound rotorcraft capable of carrying 100/120 passengers at cruising speeds of some 250/280 knots on stages of up to 500 nm. With modern technology there is no doubt that such projects are quite feasible. All that is needed is the initiative to go ahead. We have the civil requirement, is there not some similar military requirement which could help such a project to get off the ground.

The last few years have seen the introduction of new materials into helicopter construction, particularly materials associated with blade construction. We would like to see a more general use of such materials on military helicopters so that a better understanding may be obtained of their ability to stand up to every day wear and tear. Results to date of examples in service look encouraging but we would like more evidence. Blades made from glass, cotton or carbon fibres which hold out hopes of infinite life sound most attractive to the civil user.

I spoke earlier about our overhaul life development of major units. Although we have considerably extended these periods, nevertheless at the approved time the gearbox or

similar item has to be removed and sent to the workshops, stripped, inspected and re-assembled. This is still an expensive business and often unnecessary. When stripped the box is usually still in perfect condition. We would like to see gearboxes maintained on an 'on condition' basis and funding for such research projects would be money well spent. Such a situation is technically feasible utilising some form of sonic analysis and work done to date in the UK has yielded good results. I am sure that similar work is being done in the USA but we would like to see more effort being channelled in this direction.

In the environmental conscious world we civil helicopter operators are very concerned about the noise level of our aircraft. I understand that experience by the US Forces in Vietnam also highlighted the importance of reducing the noise level of military helicopters. Noise in helicopters tends to be of a different nature to that of fixed wing aircraft. With fixed wing the predominant noise is engine noise but with helicopters the problem is rotor noise.

Much work still remains to be done on rotor tip design to minimise this noise for although in general the helicopter does not result in the same painful noise from say - a jet airliner, it does have to operate close into built up areas, thus the noise level has to be kept to an absolute minimum. We feel that our operations at Penzance have been carried out without any real intrusion into the overall noise level of the town. We have become good neighbours and we hope to remain so wherever we operate.

But to conclude. I am sure there are many people who will disagree with some of my suggestions for the future development of rotor flight. Each of you has a list of priorities I am sure but there is, I am equally sure, one thing on which we all agree and that is the desperate need for greater development, whatever form it takes.

This year British Airways celebrated the 25th anniversary of the inauguration of the jet age by BOAC's Comet aircraft. Over a year ago British Airways inaugurated the supersonic era, which incidentally enables us to boast good-humouredly of being the only airline in the world to operate through a speed spectrum of zero to mach 2.2. But, to be serious, compare that with the progress made in the field of rotor flight over the last 25 years. I for one am dismayed at the general lack of progress in the world towards the next step in VTOL.

We have not properly explored, let alone reached, the capability of helicopters in civil aviation. If a percentage of the enthusiasm and technical know-how that produced Concorde could now be directed towards the research and development of VTOL we can look forward to a wide and profitable extension of helicopter services worldwide.

AIR-SEA RESCUE OPERATIONS.
SEARCH AND RESCUE EXPERIENCE.

by
Capt Tore Skaar
330 squadron/B-wing
Banak AFB
9700 Lakselv
Norway

SUMMARY

The 330th squadron operate Sea King helicopters for air-sea rescue missions all along the Norwegian coast.

The operational environment is one of the most demanding in the world.

The shortcomings of the present generations of helicopters are discussed, the most serious being the lack of in flight icing protection of the rotor systems.

1. BACKGROUND

Due to its geographic position and geological make-up, transportation has always been a problem in Norway. For centuries, the sea was the most obvious road for transportation. This led to the build-up of a fleet of considerable size and complexity. As technology progressed and took to the air, so did the Norwegians. Air transportation had its obvious advantages in a rugged country like Norway.

Helicopters and STOL aircraft became a natural element in the Norwegian air transportation system, and when oil was found in the North Sea during the sixties, the civilian helicopter market made a tremendous expansion, and it is still expanding. This expansion is expected to continue in the future as off-shore oil exploration progress northwards beyond the sixtysecond parallel. In 1976 the largest Norwegian operator of civilian helicopters (Helicopter Service A/S), flew close to thirty-thousand hours and transported more than 400 000 passengers.

During the sixties, we had a number of sea disasters in Norwegian waters. These disasters focused the public attention on the shortcomings of the air-sea rescue services. The successful use of medium sized helicopters in air-sea rescue missions demonstrated by other countries, appealed to the Norwegian public. A popular movement was formed, demanding an improvement of the air-sea rescue services along the Norwegian coast. In 1970 the Norwegian parliament decided that 10 medium sized helicopters should be included in the Norwegian rescue service. The Air Force was given the responsibility of operating the rescue helicopters. After studying various helicopter types, it was found that the Westland Sea King mark 43 would satisfy the operative needs within an acceptable economical frame. It was the opinion of the Royal Norwegian Air Force that the air-sea rescue resources would be best utilized in the form of an air-sea rescue squadron. For this purpose the 330 squadron was re-established. The 330 squadron had long lasting maritime traditions, tracing back to the second world war, and its motto "Secure the Seas" was well suited for its new mission.

The training of personell started in 1972 and was done partly in the UK and partly in Norway. In August 1973 the whole squadron was given operational status and has been on continous readiness ever since. In the period up to the 31. of December 1976, the squadron had performed 1140 rescue missions, or close to one mission each day on the average.

2. 330 SQUADRON

The primary mission of 330 squadron is air-sea rescue. In order to give the best possible coverage of the long Norwegian coastline, 330 squadron operates from four different bases. The four bases were chosen so that any position along the coast could be reached within ninety minutes of flying from one of the bases. For this purpose the squadron was divided into four "wings" (flights), named A, B, C and D-wing.

A-wing is based at Bodø. The squadron leader has command of this wing, and he has the responsibility for giving professional advice concerning the operation of the helicopters. He is also given the responsibility of co-ordinating the aircraft- and production potential in order for the squadron to maintain the optimum of operative readiness at all times.

B-wing based at Banak, C-wing based at Oerland and D-wing based at Sola are each under the command of a flight-commander. There are two Sea King helicopters at each wing. This totals eight helicopters. The two remaining Sea Kings will normally not be available due to maintenance and modifications. To operate the two Sea Kings and to maintain readiness, there are four helicopter crews on each of the wings. The normal crew consists of two pilots, one flight engineer/radar operator, one winchman/rescue-man and one observer/technician. A medical doctor normally is available and can be included in the crew when called for.

Normally, there is one helicopter with crew on one hour readiness on each of the wings. Shorter readiness can be ordered, but normally not for any extended period of time. Due to the continuous alert status with only four crews to share the burden, the crews maintain their readiness in their homes after normal working hours. Alerting is performed by use of telephone or radio. Each crew member is equipped with a small pocket radio receiver that will sound an alarm when his services are required.

The requirement for readiness is for the helicopter to get airborne in a maximum of one hour after the decision has been made at the rescue co-ordination centre. This hour is subdivided into three equal parts:

- . twenty minutes for alerting the crew and transporting them to the "wing",
- . twenty minutes for planning and making the aircraft ready, and
- . twenty minutes for start-up and take-off.

Normally there is a five minute "buffer" on each of the three phases, so that the helicopter is normally airborne within fortyfive minutes. During summer, when operations are less troublesome, reaction time is normally less than thirty minutes. The minimum reaction time for crew members being asleep in their respective beds, to airborne time, has been as low as twentyfive minutes. This being, of course, a well trimmed crew, a standard mission and splendid weather. During the winter season, we find that we use almost all of the time allotted i e very close to one hour.

The operations of "The Rescue Squadron" has brought upon itself a great deal of public interest in Norway. One can safely assume that the squadron save at least one human life every week and assist many more in various ways. This demonstration of helicopter versatility has of course been most welcomed by the public. But as a secondary effect it has brought greater demands on our operations. The pioneering days for the helicopter in Norway has ended. The present demands are to use the helicopters to their very performance and operative limits, and quite often the demands are for the helicopters to perform beyond their present limits. The demand is for the helicopter to get airborne as fast as possible, get to the disaster scene in as short a time as possible, do its job on the scene in a safe and fast manner and to recover safe and fast. The operative demands are therefore not just to have a helicopter that can fly in all sorts of weather, but a helicopter that can perform a rescue mission regardless of weather and darkness.

3. THE RESCUE HELICOPTER

The success of the helicopter and its popularity throughout the world can to a great extent be attributed to its utilization as a rescue vehicle. In spite of this, no great effort has been made to design a pure-rescue helicopter. The trend being to put a rescue winch on any usable helicopter and thereby creating a rescue helicopter. Although this might be quite satisfactory if rescue missions are of secondary importance. It is not satisfactory if rescue missions are of primary importance and 100% success is the aim.

One may question the economical wisdom of creating a specialized rescue helicopter. The majority of countries will probably not be able to afford the operation of pure rescue helicopters. Nevertheless, one feels that the experience one has gained as an air/sea rescue operator under quite adverse conditions, illuminates the demands that future generations of helicopters must fulfill. Not just for the rescue helicopter, but also to a certain extent, the demands that must be met by all future helicopters that are to operate off-shore in the Norwegian and similar areas.

4. THE ENVIRONMENT

Norway is situated in the path of the atmospheric depressions that normally forms between Iceland and Greenland. This leads to generally poor weather conditions along the Norwegian coast in the predominantly westerly winds. The damp air is lifted as the winds press towards the rugged, mountainous terrain of Norway. This often leads to poor visibility, severe turbulence and icing conditions.

The fact that Norway is a mountainous area also leads to high minimum safe enroute IFR cruising altitudes along the coast and in the inland areas. Minimum enroute altitudes of up to 8000 feet can be found on the Norwegian airways. Air traffic considerations may force the helicopter up even further to 9000 or 10000 feet in order to obtain an air traffic clearance.

As the rotorsystem of our helicopters perform very poorly at these altitudes, IFR flying along the coast and inland is not normally done. Once the helicopter gets off-shore, the safe IFR altitude reduces to 200 feet or less and the rotorsystem performs better. The weather over the open sea is generally better than along the coast. However, one will find heavy snow (mostly in the form of showers) during the winter seasons, with visibility and ceiling down to zero-zero conditions.

In the northern half of Norway the winter season is often referred to as the dark season. This is due to the fact that the sun never rises above the horizon for several months. In the far north it is gone for approximately 3 months. The 3 month arctic night is the worst period for our operations, due to the lack of daylight, poor visibility in snow and icing conditions. The weather is also normally quite unstable with high winds, often referred to as winter-storms.

The summer season is quite easy in comparison. The sun never sets (midnight sun) for 3 months, the temperature is higher and sometimes permits IFR flying up to 6000 - 8000 feet altitude. The weather is more stable and the wind forces are generally lower. If the temperature gets too high, however, fog may form over vast areas at sea. One may encounter snow showers all through the "summer" season (the light season) in the northern part of the area of operations. In the southern part of Norway the seasons are not so extreme. The weather is quite similar to what one might expect in northern Scotland.

The seagoing traffic gets heavier towards the south and therefore the activity of ships and helicopters is quite high in connection with the off-shore oil production in the North Sea. The number of missions will therefore increase towards the south due to the traffic density. In the north the density is not so high, but the ships (and people) are spread over a far larger area. The area is limited only by the extent of the arctic pack ice. This leads to a large area to be covered during the "light season" and a smaller area during the "dark season". The trend is therefore towards fewer but longer missions in the northern part of Norway, and more but shorter missions in the southern part of Norway. The total flying time used on SAR/medevac missions is generally the same for all units although the number of missions increase slightly towards the south.

5. THE MISSION

The Norwegian rescue squadron maintains one helicopter on continuous alert on each of its four bases. Disasters at sea can occur at any time, but ships often find themselves in trouble in poor weather, especially in high winds coupled with high seas. The demand is therefore for the rescue helicopter to operate safely and efficiently under such conditions. Medevacs are called for in all kinds of weather, but the rescue squadron (330 sqd) is normally called upon when no one else can do the job or when time is short. We find, therefore that the helicopter is expected to perform a variety of tasks under quite adverse conditions. The helicopters do perform these tasks and do it quite successfully in most cases. But one has to overcome a number of obstacles in order to reach the goal, the rescue. Some obstacles are quite easily overcome, and solutions can be found locally or by using certain operative techniques etc. The highest obstacles, however, can only be overcome by constructing a new rescue vehicle. In the following, we shall try to discuss the obstacles and suggest solutions where possible. The discussion will be from a pilots point of view, operating an off-shore SAR helicopter (Sea King Mk 43) in the arctic.

Scramble

The first requirement for a SAR helicopter is that it is available when you want it and at short notice. The bigger and more complex the helicopter, the harder it is for this requirement to be fulfilled. The conflict is, of course, that you will need a large and complex helicopter in order to get the range and performance required to solve the different tasks you are given.

The solution to this problem will of course be to make very reliable equipment and to reduce the factors that reduces the serviceability of the helicopter systems, such as vibrations and corrosion. Work along these lines is well on its way. Another way to cut down the reaction time is to make all equipment automatic or very simple to operate. There will be no room for any elaborate and complex setting up procedures when the pressure is high. Work is well on its way along these lines as well. The main obstacle might be the price of automatic equipment and systems.

Enroute

With the present generation of helicopters, the pilot must decide between enroute flying on instruments or enroute flying with visual contact to the ground. The modern helicopter is safe, stable and well equipped. Instrument flying is therefore no problem in itself. However, in the arctic, icing is an almost constant problem. One will find "super-cooled" droplets in almost any cloud when the temperature is below freezing. Freezing is the rule, rather than the exception in these latitudes, and the helicopter, it seems, acts as an enormous "ice-magnet", picking up ice where other aircraft get "home free".

The demand for safe obstacle clearance below the helicopter when flying on instruments, calls for high cruising altitudes. This is especially true in a mountainous country like Norway. The high cruising altitude close to the coast (in the order of 10 000 feet in some areas) calls for high pitch attitudes on the rotorblades, making them work closer to their stall-angle. The addition of ice and turbulence can further aggravate the condition and bring the helicopter out of control. The pilot, therefore, has to select a low-level route, flying below the cloudbase, often with very limited visual clues to the surface. Selecting low level routes necessitates flying along valleys and fjords, around mountains, islands and peninsulas and prohibits the direct route. This can make the route to be followed by the helicopter much longer than needed. For the rescue helicopter, time is not money, but a matter of life or death. In the cold waters of the north, unprotected survivors freeze to death in a matter of minutes, and the protected ones only last a few hours. Speed is therefore of primary importance in our operations. We often find that a cruising speed of 110 knots is too low. This speed is lowered even further in a headwind condition. Higher cruising speed is therefore wanted, so that a reasonable groundspeed can be maintained even in a strong headwind. A cruising speed of approximately 300 knots will probably be adequate. A higher speed in the missions we fly would probably not be fully utilized as the aircraft would fly "ahead" of the incoming data. The data at the start of a mission is often very

limited, and a lot of data is normally accumulated during the enroute cruise. A lot of in air planning has to be performed, and alterations of plan to be made. In a pilot's opinion, the optimum speed would be about 300 knots, but any increase of speed over the present would of course be welcomed.

The last factor in the enroute phase is range. The longer the range, the better. Specific fuel consumption of the helicopter must be reduced in order to meet this demand in a sensible fashion. For safe overwater flights, the security of the power transmission system is of importance. "Fail-safe" gearboxes are wanted to achieve this, and safe rotor-systems. To conclude the enroute phase, we want a helicopter that behaves more like a fixed wing aircraft. A helicopter that can take-off and fly on instruments up to 10 000 feet altitude in severe icing and turbulence, and that can do this on a routine basis. This is of primary importance not just to our operations in northern Norway, but to all off-shore operations in this area. The secondary requirements will be higher speed and lower specific fuel consumption. The long overwater flights also call for "fail-safe" power transmission and rotor systems.

Locating survivors

In order to rescue someone from a helicopter, one has to see him (or them). Locating survivors at sea and at night can be very difficult. The night in the north where we operate can last for 3 months (during the winter - or the dark season). One cannot wait for the daylight to come. Locating and rescuing the survivors must be performed at night. The problem of locating survivors is greatly simplified if the survivors utilize an active locating device like an emergency radio or a light signal. On the open sea we are able to locate and recover an emergency position indicating radio beacon in complete darkness down to almost zero-zero conditions with the equipment in our present Sea King helicopters. The survivors without any active signalling device are very difficult to locate. Furthermore the pilots want to see, not only the survivors, but also their environment so that they can avoid any obstacles and make a safe approach to them. A device that can utilize the low ambient light or other radiation, amplify it and present the result to the pilot in a comprehensive form is called for.

To avoid obstacles, a comprehensive presentation of radar data might be useful. A radar display that would present a picture of the area in front of the helicopter in a manner quite similar to what the pilot would see with his own eyes, is probably the best solution for low flying helicopters (and they all have to come low for the rescue or for the landing). A very narrow radarbeam, scanning both horizontally and vertically in front of the helicopter, with presentation on a television screen in front of the pilot might be a possible technical solution. Range to targets could be indicated by chromatic scale, i.e. "hot" colours close and "cool" colours far away. The range of this radar need not be more than max 5 NM. Other data necessary for the safe manoeuvring of the helicopter could be superimposed on the same screen.

The rescue

Normally, the rescue of people with helicopters are accomplished by the helicopter hovering above the survivor(s) and from this position the survivors are winched up into the helicopter. As stated before, one has to see the survivor(s) in order to rescue them. This condition is partly violated by the present generation of helicopters during the "pick-up" phase. The pilots will see the survivors before, but not during the pick-up. This is unfortunate because it is during the pick-up that the most accurate hovering is called for. This is especially true when a pick-up is performed from a ship where the margin for error is very small.

A pick-up is normally performed in the following manner: The winch operator sees the survivor and verbally tells the pilot where to fly in order to arrive in a hover directly above the survivor, from where he is winched into the helicopter. This procedure is, of course, far from optimum. The optimum procedure being, of course, that the pilot sees the survivor(s) at all times and takes direct action on what he sees. Many means have been tried in order to accomplish this, but the most reliable and efficient will probably be the use of a rear-facing pilot, because one avoids the use of elaborate electronic equipment. The use of a rear-facing pilot has so far only been utilized on "flying cranes" in order to reduce the risk and time-factor when picking up and delivering underslung loads from some specialized helicopter types (Sikorsky S-64E Skycrane, Mil Mi 10 Flying crane, Kamov Ka 25K Flying crane etc). The use of a rear-facing pilot could be particularly useful during night, and when operating over ships or similar obstructions, day or night. The use of a rear-facing pilot might also obviate the need of automatic hover, thereby simplifying that part of the flight control system. A human being is the most valuable cargo one can have as underslung load on a helicopter. The reason why provisions for a rear-facing pilot has not been included on the present search and rescue helicopters, must be, that thus, up to this time, have been so few operating solely in the rescue role, that no specialized helicopter for this role has been envisioned. To incorporate a rear-facing pilot on rescue helicopters might prove itself impossible. One might therefore accept other means for increasing the pilots view during pick-up.

The Sea King has a system whereby the winchoperator can move the helicopter around by means of a small control-stick close to the cargo door. This control gives input to the automatic flight control system and moves the helicopter about with a speed of up to 10 knots in each direction. The system is based on doppler groundspeed inputs. This system

is not considered to be as good as a system with a rear-facing pilot because of the following factors:

- . the winch operator is not a trained pilot
- . operation of both the controlstick and the winch simultaneously is very cumbersome
- . the system is not reliable enough to be trusted close to obstructions (ships etc)
- . the system is not operating very good in windspeeds above 50 knots. A very rough condition will result with engines and flight control inputs hunting rapidly around their datum.

Because of these limitations, this system has not been used very much on actual SAR missions. For picking up people from a life-raft, however, the system is quite useful. The automatic radar height hold, however, has been used extensively and has been in use in almost all missions at sea. More reliable winches are called for. The stress and strains imposed on the rescue winch during "hot" missions in rough weather, is probably much higher than the designers have envisioned.

During the rescue mission of the oil drilling rig "Deep Sea Driller" off the coast of Bergen during the spring of 1976, the winches of all three participating helicopters failed (two Sea Kings and one Bell 212). The weather was very rough, with high winds and high seas. After winching a few persons up from the sea, the winch stopped. The same thing happened with the second Sea King that was brought in and with a Bell 212. All failed internally and from different reasons, but the failures were in all probability caused by the rough conditions on that day. Fortunately the drill-rig was very close to the coast, so the rescue effort was continued with ropes hanging from under the helicopters. The survivors clinging to the ropes being lifted from the water and onto the shore as underslung load. Only 3 of the crew on the drill-rig drowned. Had the accident occurred further out at sea, however, the failure of the winches could have proved itself lethal to many more of the rescuees. More reliable winches are therefore high on the list of the improvements we want on future helicopters. A winching system that would bring the survivor or the stretcher more easily into the helicopter would also be welcomed.

The contingency power reserve of engines ought to be high enough for the helicopter to maintain hover for two minutes (in order to complete the winching) and then to transit into forward flight. Twin engine reliability is questionable when you need both engines to keep flying (as you do need in the hover). A one hundred percent increase of engine power (contingency power) might be hard to achieve, but is the only solution to the problem of twin engine reliability of a hovering helicopter, unless we use a system with 3 engines. Fifty percent increase is then sufficient. During the hover in windspeeds in excess of about 50 knots, engine performance will be of primary interest to the pilot. At high windspeeds, the air is filled with seawater spray that evaporates on its way through the engine compressors. The salt deposits on the compressor blades, disrupts the normal airflow and ultimately leads to compressor stall and engine surge with consequent power loss. The only way the pilots can keep track of the engine power condition in our present helicopter, is by comparing the indications of engine torque, engine compressor RPM and exhaust temperatures. An increase of exhaust temperature while the other indications remain constant, will indicate a build-up of salt (or ice) on the compressor blades. One will, however, find it difficult to record the settings in these high winds as power demands are rapidly fluctuating up and down. Besides, the pilots are normally very busy at this stage. The time for proper recording might not be available. There is a definite need for an engine performance indicator that automatically tells the pilot if engine performance is deteriorating. He can then take proper action by leaving the hover or (if mounted) give the engine an in-flight turbo blast in order to remove the salt. Winds induced by the rotorsystem can also produce serious saltspray. The induced winds can also be of discomfort to the survivors or even be of hazard to them, by preventing them from breathing or by blowing water into their mouths. A low rotor disc loading with low induced windflow is therefore called for. The wind-erosion of water surface made by small rotors, propellers or direct lifting jets, probably prevents their use in an efficient air-sea rescue vehicle. Endurance in the hover must be as long as possible, hence the fuel flow (power required) of the hovering helicopter must be reduced as much as possible.

Recovery

For recovery, the same factors mentioned under the heading "enroute" applies as far as anti-icing, speed, altitude, range etc is concerned. Increased range and endurance increases safety in the recovery phase.

6. SUMMARY

The most serious handicap of the present generation of helicopters operating in the arctic, is the inability to cope with serious icing conditions. For future, routine off-shore operations in northern Norway, this problem will have to be solved. The problem of high altitude flight (10 000 feet) must also be solved. The requirement is for the helicopter/aircraft to fly safely at 10 000 feet altitude during severe icing and turbulence conditions.

ACTUAL NUMBER OF MISSIONS FOR 330 SQD OVER THE LAST 3 YEARS (1974-1975-1976)

Type of mission (or equipment used)	Total number	Percent of total	Annual average
Total number of missions (3 years)	939	-	313
No of missions at night	332	35%	111
Medevacs	520	55%	173
SAR	419	45%	140
Search object:			
Total searches	343		114
Ship	180	52%	60
Raft/lifeboat	10	3%	3
Aircraft	34	10%	11
Man overboard	24	7%	8
Persons lost on land	56	16%	19
Other objects/unknown	39	11%	13
Search object localized	115	50%	58
(no reports available for 1974)			
Search object not localized	117	50%	59
No of survivors picked up	206	-	103
No of dead persons picked up	17	-	9
Assistance rendered to (2 year period)			
- ship	29	-	15
- aircraft	8	-	4
- persons	15	-	7
- forest fire	1	-	0.5
- other	1	-	0.5
Type of assistance			
- pump delivery	17	-	9
- transfer of doctor	2	-	1
- stand by over object	20	-	10
- no of persons brought to scene of disaster	195	-	98
-equipment brought to scene of disaster	9	-	4
Method of rescue			
Pick-up from land/island	10	-	5
Pick-up from the sea	1	-	0.5
Pick-up from ship	73	-	37
Pick-up from small boat	29	-	15
Pick-up from raft	47	-	24
Auto hover used	15	-	7

FIG. 1

The 4 bases of 330 th. sqd.

8-7

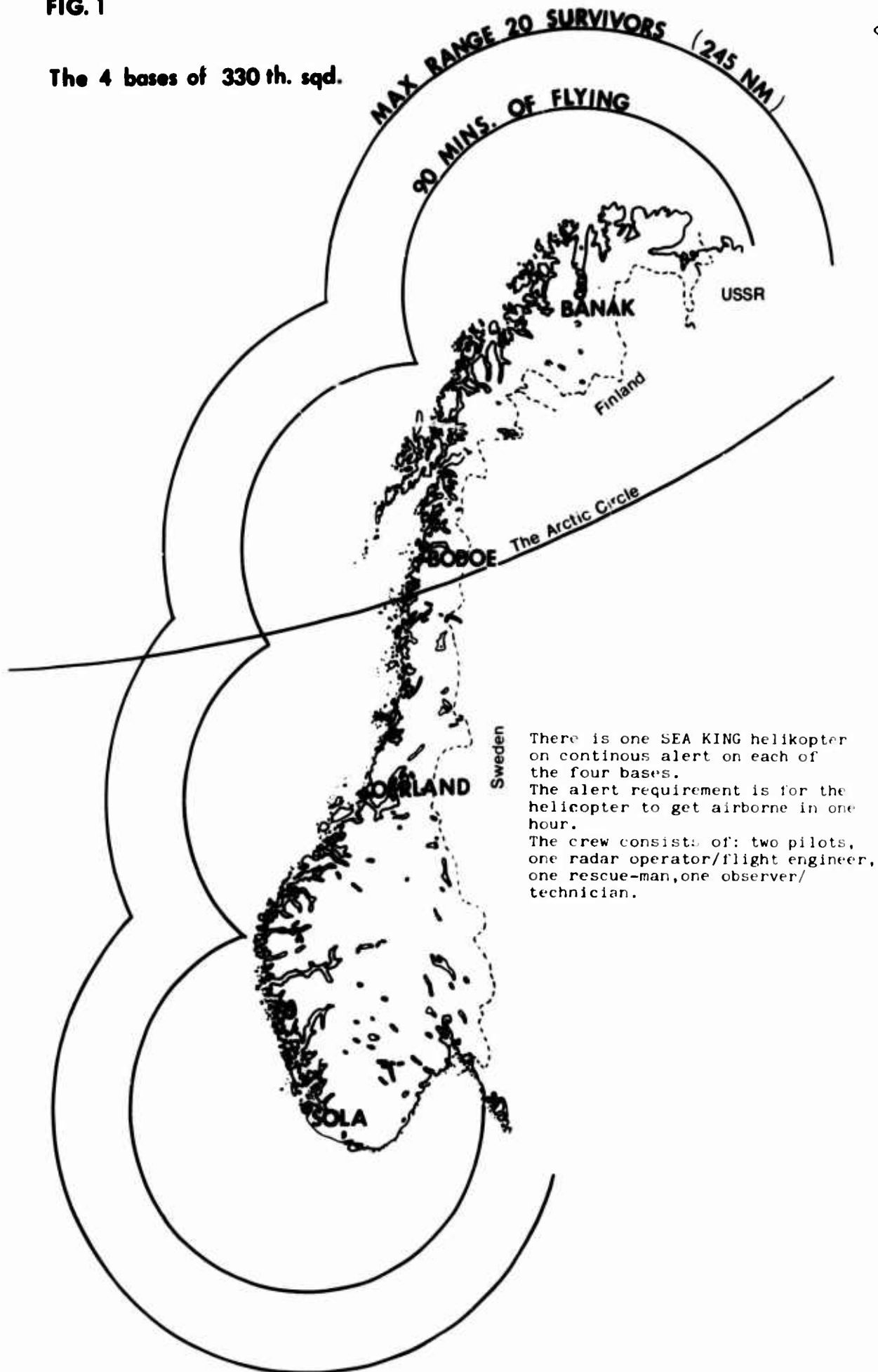

There is one SEA KING helicopter on continuous alert on each of the four bases. The alert requirement is for the helicopter to get airborne in one hour. The crew consists of: two pilots, one radar operator/flight engineer, one rescue-man, one observer/technician.

The arctic area covered by 330 squadron/B-Ving.
 The area is approximately 1500 000 square kilometers wide.

8-8

Fig. 2

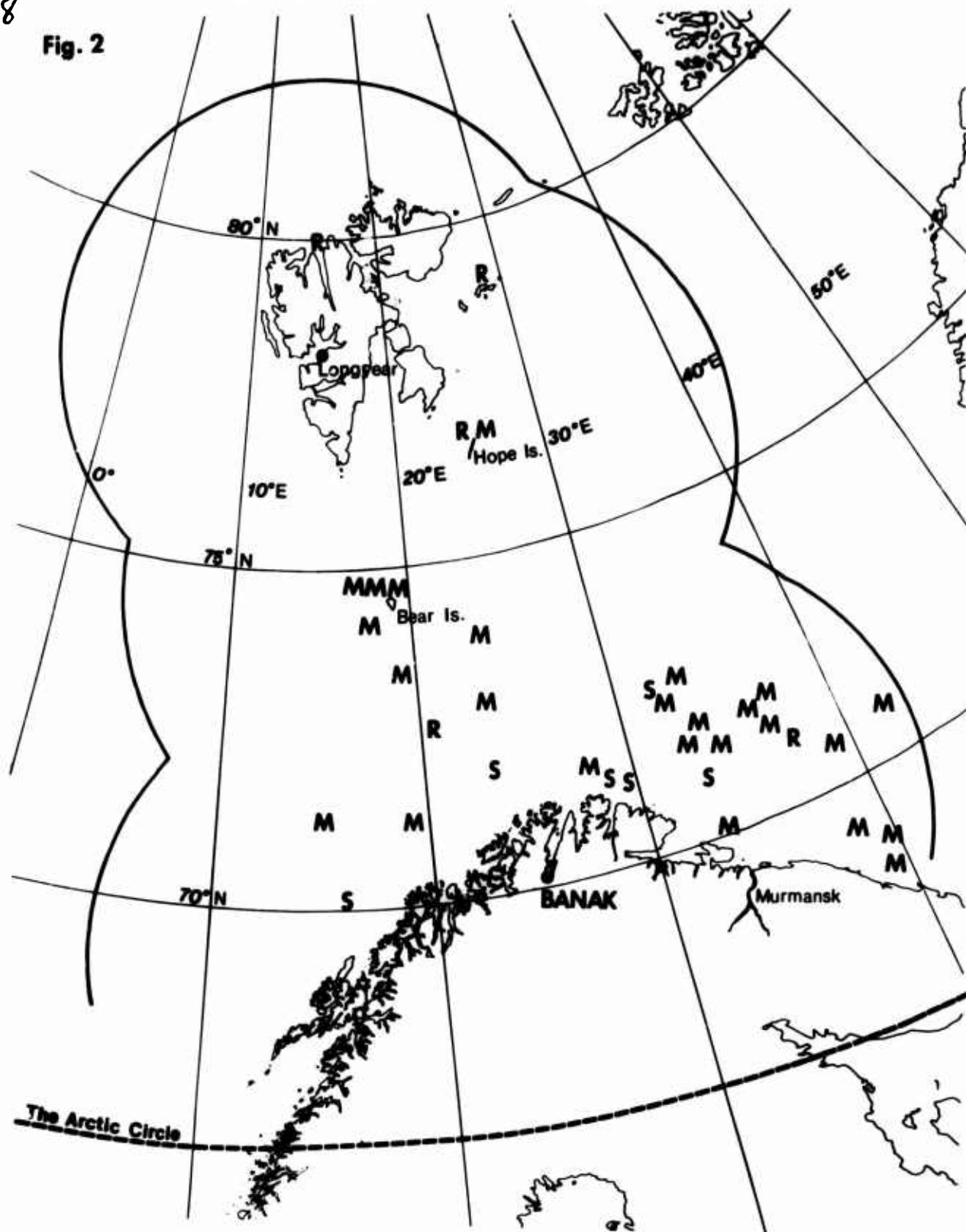

The missions performed by 330 sqd/B-ving that are more than 20 nm off shore are marked with a letter. The letter "M" means medevac, the letter "S" means search mission and the letter "R" means rescue mission. The marked missions are approximately 15% of total. Thus 85% of the missions are on the coast or inland.

SOME ASPECTS OF OFFSHORE OPERATIONS IN THE NETHERLANDS

by

R.J. van der Harten, KLM Noordzee Helikopters B.V.

SUMMARY

The oral presentation is preceded by the 19-minute sound film "Bridging the Troubled Waters" (Sikorsky Aircraft) giving a general impression of helicopter operations between mainland and naval destinations. The introduction of the paper briefly summarizes the essence of the film including data on the production of flying hours and the regularity through IFR flights of the off-shore operations.

The paper further reviews the problems, which had to be solved in order to realize the required services on a 24-hour basis. One of these problems was the certification of helicopter weather minima for IFR-flight. This involved the development and evaluation of instrument procedures and the proper choice of instruments and panel lay-out, the navigational aids and the communication system. Some special attention is paid to the radar system, which provides not only weather detection but is also used during the approach to the targets at sea, as well as to the recent evaluation of an Integrated Pilot Display System, which has a great potential for very low weather minima without the use of automatic guidance.

The various, sometimes tedious, steps taken to achieve the present state of the art are described in some detail.

Finally, the paper gives a few thoughts on possible future improvements of the helicopter transport system in a more general sense, in particular in relation to a project, presently under study at governmental level, concerning the construction of industrial islands in the North Sea. To that end a tentative proposal as to the contributions to be provided by the industry, the governmental agencies and the military and civil operators is presented.

1 INTRODUCTION

The Netherlands, sometimes also called the Low Countries, has for ages been involved with the sea, which has often proved itself as both a friend and a bitter foe.

Much of the land on which the Dutch now live has been reclaimed from this sea, and whole towns like Amsterdam had to be built on pole foundations, due to the marshy soil.

Extensive waterworks and dike systems were built to keep the sea from coming back again as the reclaimed land is below mean sea level and therefore floods, like the one in 1953, have still to be reckoned with. But the sea has also been a source of prosperity, and has made the Netherlands a nation of sea farers, shipbuilders, traders and experts in the design and building of all kinds of waterworks. In this respect it may be mentioned that in 1971, our company carried out successful trials in building a dike, using a U.S. Army CH 54 A flying crane and major assistance of Sikorsky and U.S. Army personnel.

Again the stormy North Sea showed itself a friend when, after the discovery of the big gas reserves in the Northern province of Groningen, investigations of the North Sea bottom around 1960 indicated that offshore exploration of gas and oil was feasible.

Due to the formula used to define the division of the North Sea into continental shelves as allotted to each country, with boundaries equidistant to the shorelines of these countries, the Netherlands, with its long coastline acquired a very sizeable part of the North Sea (Fig. 1).

Drilling activities started May 15, 1968. KLM Noordzee Helikopters B.V., which was founded in 1965 as a 100 % daughter company of KLM Royal Dutch Airlines, started operations for the oil companies at that date with aircraft and crews fully certified for IFR (Instrument Flight Rules). The objective was to provide 24-hour services, 7 days a week, to the oil companies, with airline regularity and dependability.

The company started with one Sikorsky S-61N and one Sikorsky S-62A. Presently we operate 5 S-61N's, 2 S-58T's (one of which belongs to the Placid Oil Company) all IFR-certificated and one Bolkow 105D, employ 120 personnel of which 29 are pilots and produce approx. 7000 flying hours per year.

Since the beginning the company has aimed for improvements of the IFR-capabilities of its helicopters and investigated new possibilities for the use of helicopters made possible by the IFR-concept (Ref. 2-6).

One of the improvements was the development and operational certification in 1969 of the airborne radar approach system (Ref. 2) to rigs which in turn led to a successful development of a 24-hr harbour pilot service at Rotterdam, the main gate of Europe, which presently accounts for 20 % of our flight hour production (Ref. 3). The radar approach concept has since been adopted by many other companies and has become a major asset in improving offshore all-weather operations. The regularity of the service is presently at, or over, 97 %.

Recently the use of a flight director system, using an Integrated Pilot Display System (IPDS), as developed by the Kaiser Aerospace and Electronics Corporation and improved according to our requirements, was very successfully evaluated during 1976 (Ref. 5,6) under operational conditions. This evaluation provided data on pilot workload reduction and indicated the feasibility for very low weather minima (below Cat II) both for radar and ILS-approaches without automatic guidance. The concept has been proven sound and, in the opinion of our pilots, is also a major flight safety break-through (Fig. 2).

Our company is a founder member of the study group which reported on the feasibility of building artificial islands in the North Sea, relieving the overpopulated mainland from the pressure of providing for industrial sites, with the necessary growth of our industrialisation process (Ref. 1).

This concept, which is presently under study by a government appointed committee, may require 8 to 10, 90-passenger helicopters per island which have to carry out regular services to transport many thousands of workers each day, to and from the mainland (Fig. 3).

9-2

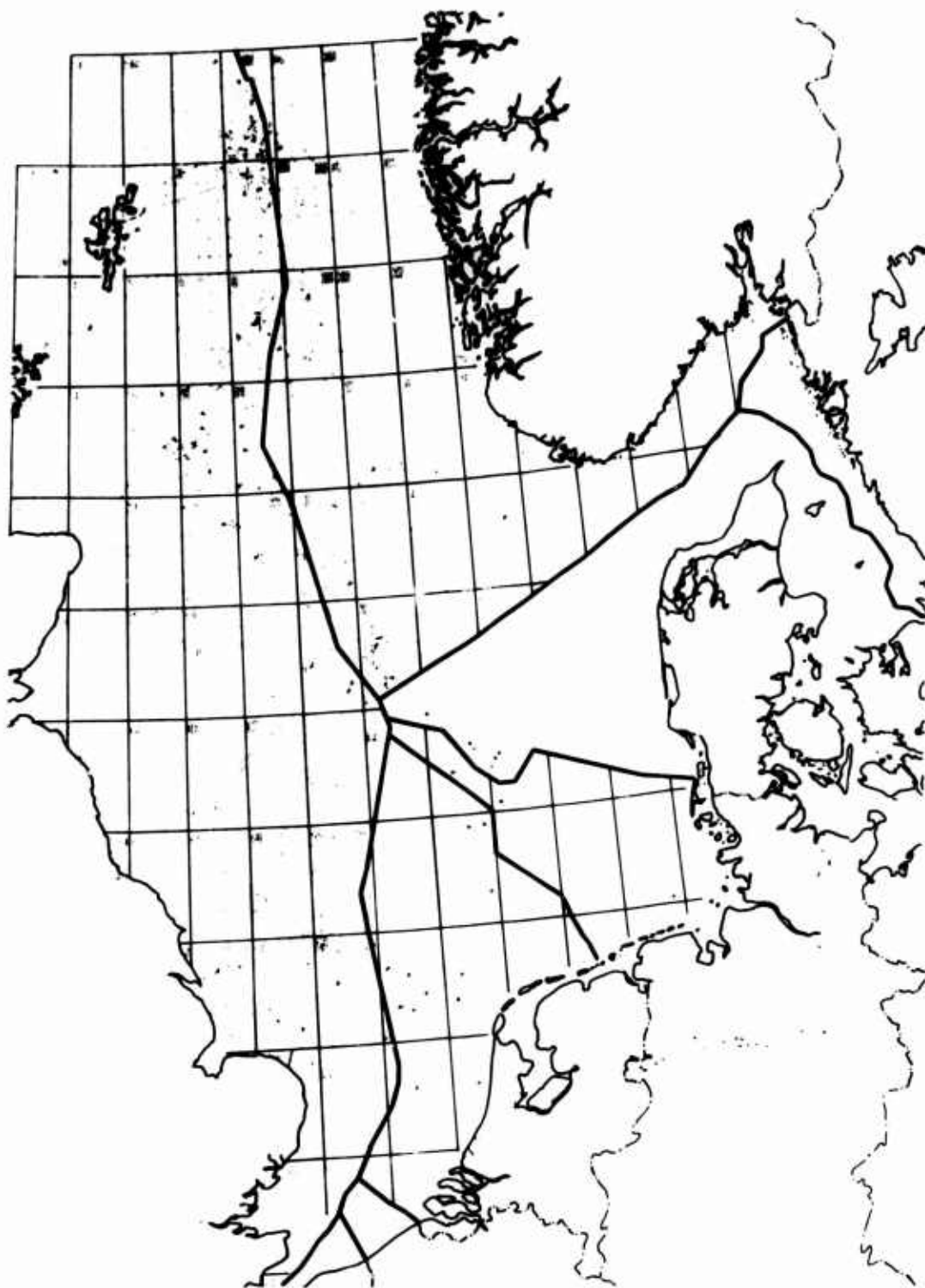

FIG. 1 CONTINENTAL SHELF BOUNDARIES IN THE NORTH SEA

The answer to the necessary all-weather capability for this venture could, in our opinion, be provided by the further development of the Integrated Pilot Display (Flight Director) System as evaluated by our company.

2 THE IFR CONCEPT

The main purpose of this paper is to review the typical difficulties which were encountered but also the possibilities which became clear when it was decided to conduct all helicopter services under full IFR certification (Ref. 2).

This IFR certification was a necessity because the Netherlands Department of Civil Aviation (RLD) had decided from the beginning that helicopter operations at night had to be carried out under Instrument Flight Rules (IFR) as defined for fixed-wing aircraft. Except for Norway, where IFR certification of

helicopters was being pioneered by Helicopter Services A.S., other countries allowed night operations under Visual Flight Rules (VFR) in Visual Meteorological Conditions (VMC). This however, in the opinion of the RLD, did not meet the safety level required for Airline Transport Category operations, under which category Dutch helicopter companies have to operate.

9-3

The RLD thus followed the example of the Norwegian CAA, which had been the first in Europe to insist on flights under IFR with helicopters at night over the North Sea for oil-rig operations. When the RLD compelled our company to instrument flight, they also took the consequences that, because of the lack of regulations and ICAO recommendations for certification of the aircraft instrumentation, approach aids and calculation methods for IFR weather minima for helicopters, they should have an open mind for new concepts differing from accepted fixed-wing regulations, provided we could prove them to be safe.

Because of the KLM background of the company the choice of the Sikorsky S-61N helicopter was obvious. This aircraft was the only civil helicopter at that time which had been certificated for instrument flight in the United States. It also was at that moment operationally the best aircraft available, was in use by several helicopter operators in the North Sea area for already a number of years, and had proved itself to be very reliable.

The RLD minimum requirements to certify helicopters for IFR flight were, at that time and still are, except for point d, the following:

- a. A reliable single automatic stabilisation system with separate channels for roll, pitch and yaw, should be installed;
- b. The aircraft must be equipped with at least two engines;
- c. The aircraft must be flown by 2 pilots and instruments must be duplicated;
- d. The aircraft must be certificated under FAR 29 and for instrument flight in its country of origin;
- e. Navigation, instrumentation and communication systems as required by law for airline transport flights must be provided for.



FIG. 2 INTEGRATED PILOT DISPLAY SYSTEM



FIG. 3 PROPOSED INDUSTRIAL ISLAND IN THE NORTH SEA

9-4

The S-61N offered no problems as to the requirements under a, b, c and d.

The requirement sub d has, from necessity, been handled with leniency in the last years because the British CAA certificated the S-58T and Bölkow 105 in a more acceptable way to airline transport requirements than the countries of origin; therefore the RLD accepted the CAA-certification of these aircraft at least partly. It may be added that the British CAA can take a more realistic standpoint than some other countries in accepting data from identical military certification trials, on civil versions of those helicopters because of their extensive experience with the type of operations the aircraft are used for. This is also the case with the French civil aviation authorities.

The requirements under e. were discussed with the RLD which accepted a different approach towards instrument flying with helicopters, from that with fixed-wing aircraft. The main consideration was that a helicopter, contrary to fixed-wing aircraft, when using the right procedures, can abort any approach at any point, and is thus never committed to land. This attitude made it possible to define a concept providing a 24-hour service, 7 days a week, to oil-rigs and ships with the high reliability and regularity comparable to regular airline services at a competitive flight hour price.

This concept was realized by:

- a. Using existing approach and navigation ground aids, utilising the specific capabilities of the helicopter, which e.g. can execute ILS-approaches to runways which, due to crosswind, are not used by the fixed-wing aircraft.
- b. Preventing undue duplication of aircraft instrument and approach systems to save weight and cost, accepting higher weather limits for approaches, when one system fails and a different system as back-up has to be used. This implies the use of multi-purpose navigation systems such as Decca, radar, ADF and VOR/ILS. The radar is used for bad weather avoidance (in particular icing conditions), for short range navigation and as an approach aid.
- c. Designing a close-scan instrument panel (Fig. 4) to obtain an intended fixation on only the necessary instruments in the critical phases of take-off, approach and landing. It must be realized that, at the

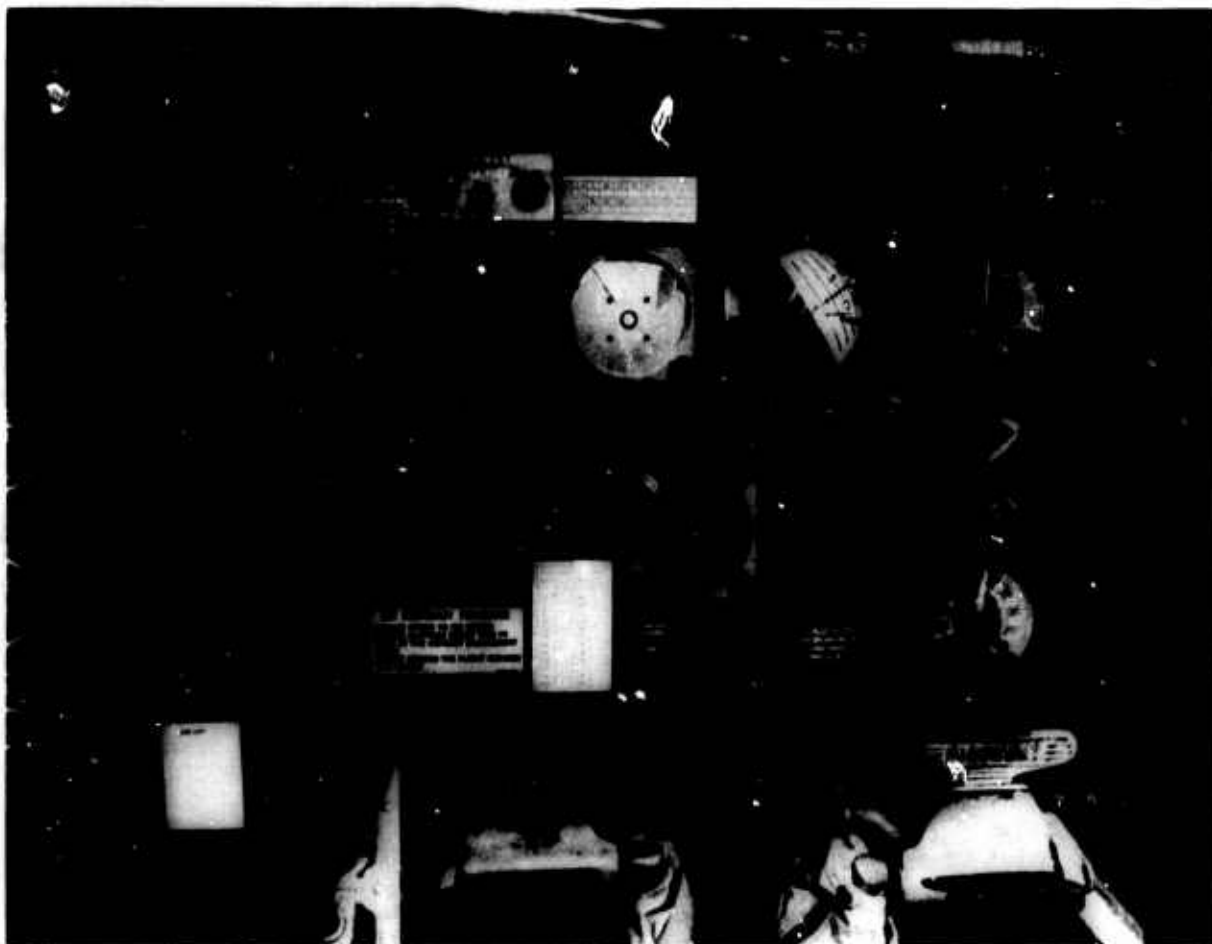

FIG. 4 PRESENT CLOSE-SCAN INSTRUMENT PANEL

low air speeds during the first phase of the take-off, in particular from rigs, as well as in the last phase of the approach, disorientation may occur if the pilot's scan would allow an inadvertant glimpse of the outside, in particular during dark nights with rain or snow. The Kaiser Integrated Pilot Display lay-out is also based on this proven concept (Fig. 5). It may be stated that, due to this disorientation risk at lower airspeeds, we do not envisage the use of a head-up type display for helicopter IFR flights.

- d. Using the full potential of the crew, which always should consist of two pilots, by sharing their tasks and thus reducing their increased workload, which is inherent in the rather simple system concept. Both pilots must be trained to captain's standard ("2-captains system"); one captain can be the designated pilot-in-command and the other the first officer. The latter e.g. is to handle that part of the take-off where visual reference and flying is required, while the pilot-in-command stays on instru-

9-6 From the foregoing it is clear that helicopter IFR operations have become routine with the North Sea operators. However, we still have to use aircraft with operational limitations and equipment which were acceptable for fixed-wing operations of the airlines somewhere in the 1950's. With the present cost of helicopters and its maintenance we still have a long way ahead of us to reach 1977 airline standards. The operators therefore have been trying for years to have a voice in helicopter R & D, with an aim to improve the economy and usage of the helicopter to near fixed-wing standards and to be able to use its full potential also in other areas, such as short-haul passenger services, where its unique IFR capability is a tremendous asset, but the cost per seat-mile is prohibitive. This was the major reason why the outcome of a joint KLM, BAH and Sikorsky study, conducted around 1971, regarding the feasibility of helicopter services between London, Paris, The Hague and Brussels, was negative.

Recently, however, improvements have been noticeable in the development of damage tolerant composite and improved rotor blades, components and structures, which might decrease the direct operating cost to a more acceptable level.

Also, as certain government funding of R & D for civil aircraft is an accepted fact in Europe (Ref. 8), it is gratifying to see that NASA has also become aware of the fact that civil helicopter R & D funding has to be increased now to maintain the U.S. lead in helicopter technology, since the risks for the private industry would be too high to fund the necessary R & D themselves.

However, where NASA can also do a tremendous job in combining military and civil R & D efforts (and where would we be without military R & D for helicopters) it is apparently still lacking the possibilities to acquire a budget for a complete prototype necessary for applied civil research, which in Europe led to the development of the Concorde, the Fokker F-27 and 28, the Airbus, the VFW 614 and others.

I personally agree that the freedom of enterprise and the competitive structure, which has made the U.S. a great nation, should not be impaired, but could there not be a way to retain this principle by adapting civil R & D funding to the accepted military R & D procedures. Presently the helicopter manufacturers are able to cope with R & D for smaller helicopters which show a direct sales potential, but, of necessity, are still using many basic military developments to decrease the R & D cost. For a large helicopter, even if the basic hardware is available, the R & D cost involved is presently too high for the risky venture of building e.g. a 90-passenger helicopter which we would require for services to an industrial island in the North Sea. Such a helicopter, however, could also open up the possibilities to compete with fixed-wing aircraft on distances up to 250 n.m. (Ref. 9). A good example is the possibility of stretching the CH-53 E (Fig. 7), and possibly the CH-47 Chinook. If this aircraft is not built because of lack of R & D funds for a complete prototype system and produced on the basis of a quantity large enough to reduce the initial procurement cost, we will remain in a vicious circle and not receive the helicopter which could start airline use. In this respect it can be mentioned that Captain Jock Cameron, Managing Director of British Airways Helicopters, has also many times expressed the need for such an aircraft (Ref. 10).

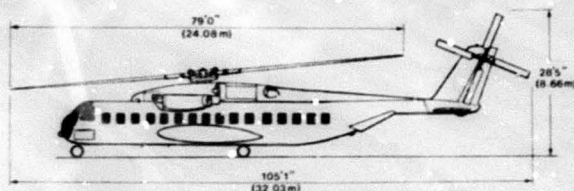

FIG. 7 POSSIBLE AIRLINE VERSION OF THE SIKORSKY CH 53 E

helicopters is required. For future long-distance flying to drilling rigs which are far out, long-range helicopters are required. As there will (initially) be only a small quantity of this type of helicopter required for these services it should possibly be built according to airline standards. It could then not only serve drilling rigs and industrial islands, but also become interesting enough as a competitive short-haul airliner. This might open the possibility for a cost-effective production line and result in a cost per pound of aircraft comparable to fixed-wing airliners.

R & D for large helicopters might be based on the following recommendations:

- The aircraft should preferably be equipped with 3 engines to allow for an acceptable n-1 engine performance for the take-off from heliports at maximum take-off weight.
- Fail-safe, redundant and multiple load path, thus damage tolerant, designs (Ref. 11) should be developed for all major components to reduce maintenance requirements and cost, by allowing safe "on condition" maintenance, as in fixed-wing aircraft. This means that FAR 29 may have to be re-defined to accept the damage-tolerant design philosophy. For the new generation of military helicopters damage-tolerant design is already common practice.
- It has to be realised that the safe fatigue life philosophy is out-dated because it depends on impeccable quality control in the manufacturing stage, and operationally on severe inspection schedules and early retirement of structures and components. From the point of view of investment and maintenance this is very costly and detrimental to the operational reliability and availability of the aircraft. Maintenance-wise these aircraft should be able to produce safely over 3000 flight hours per year to be economical.
- The first generation of large helicopters should be designed for approx. 250 n.m. range with full passenger payload under CAT A or British Group A conditions up to 25 or 30°C at sea level. Unless a solution is found to remain competitive with fixed-wing aircraft for longer ranges, which may be the case with e.g. the Sikorsky ABC and the Bell Tilt Rotor Concept, the pure helicopter still seems to offer the best chance for a cost-effective Short-Haul Transportation System (Ref. 12).
- R & D efforts should be directed at a complete prototype system to achieve fuselage-rotor-system matching for the lowest possible vibration levels (Jetsmooth) to improve reliability, unscheduled removal cost and passenger acceptance.
- Unfortunately present military R & D has to concentrate on high performance at high altitude and high outside air temperatures, combined with relatively small or fighter type fuselages which makes e.g. the

To conclude this paper I would like to dwell upon some personal ideas on future requirements for civil helicopters and to set tentative future R & D requirements.

For offshore use it looks like a substantial amount of 6- to 12-passenger and 15- to 22-passenger

CH-53E, AHH and the UTTAS uneconomical. It is recommended that future military R & D should be keyed to include versions with a fuselage of a commercially acceptable size in the design stage of new helicopters. This would allow the use of the potential payload capabilities and improved technology of new military helicopters by the civil operator, while still keeping the initial R & D-investment at an acceptable level.

- Large and small helicopters should be designed and certificated to fly IFR at CAT III limits if necessary. Systems and cockpit lay-out should be designed to enable even a single pilot to fly the aircraft IFR under normal and emergency conditions. This will require an R & D effort in defining the capabilities of advanced ground and aircraft equipment such as terminal guidance, approach and landing equipment, electronic integrated display systems and special helicopter avionics.
- Finally it should be investigated whether the FAA could consider to reduce certification cost for civil helicopters by combining military testing and FAR 29 requirements as much as possible. The cost of e.g. certifying the CH-53A and the CH-47 Chinook has been so prohibitive, despite the wealth of military testing information available for these aircraft, that FAA certification has not yet been found feasible, and efforts are now being made to certify the aircraft in Europe. This also, to my feeling, is an area in which NASA could be of assistance. We are certain that other operators with us, or societies like the Helicopter Association of America (HAA) and the International Helicopter Operators Committee (IHOC), will assist wherever required with a wealth of information at their disposal.

As far as IFR is concerned it should be mentioned that the above societies are very much involved in defining standardisation of rules and regulations, equipment, groundaids, heliports and platforms, flight safety and certification requirements which hopefully will ultimately lead to ICAO recommendations regarding operations with helicopters and future VTOL aircraft.

REFERENCES

- 1 North Sea Island Group "Industrial Island in the North Sea".
Report on the feasibility study - September 1976.
- 2 Van der Harten, R.J. "Some aspects of instrument flying with helicopters".
De Ingenieur, Jaargang 84 Nr. 23 - 9 juni 1972 - Vertiflite, Nov/Dec. 1972.
- 3 Van der Harten, R.J. "Development of the Bendix/Airequipment - RDR-1DM radar as an approach aid for helicopters".
AHS preprint No. SW-71-27, Nov. 1970.
- 4 Van der Harten, R.J. and Oprel, A. "Navigation in the use of helicopters offshore".
The Journal of the Royal Institute of Navigation, Vol. 27, Nr. 4, Oct. 1974.
- 5 Van der Harten, R.J. and Cooper, P.G. "An electronic integrated pilot display is evaluated in North Sea operations".
AHS preprint No. 1021, May 1976.
- 6 Griffith II Warren, E. and Brewer, Larry K. "Helicopter icing handling qualities".
AHS preprint Nr. 844, May 1974.
- 7 Lewis, A. "North Sea Helicopters"
Business and commercial aviation, November 1975.
- 8 Legrand, François European Prospects in the Helicopter Field.
Interavia, July 1976.
- 9 Katten, S.L. Analysis of vertical/short takeoff and landing on short-to-medium haul routes,
S.L.Katten and Associates, San Pedro, California 90732, July 1971.
- 10 Cameron, J.A. and Parker, M.A. "Civil Helicopter Operations with British Airways".
Aeronautical Journal, June 1976.
- 11 Polley, I.M. "Damage tolerant design for Helicopter Structural Integrity".
Paper No. 4 - Second European Rotorcraft and Powered Lift Aircraft forum,
September 20-22, 1976 at Bückeburg, Germany.
- 12 McHugh, F.J. and Harris, F.D. "Have we overlooked the full potential of the conventional rotor?"
Journal of the American Helicopter Society, Vol. 21, Nr. 3, July 1976.

**COMBINED MILITARY AND COMMERCIAL APPLICATION
OF LIGHT HELICOPTERS**

E.E.Cohen, K.B.Amer and R.E.Moore
Hughes Helicopters
Centinela and Teale Streets
Culver City, California 90230
Division of Summa Corporation

SUMMARY

This discussion will present an overview of light helicopters of less than 4000 pounds gross weight used by both military and commercial aviation, Hughes Helicopters background in light helicopters, the design considerations and criteria used in the development of these helicopters, and the Army's entry into light helicopter development. We will also offer some conjecture on the design considerations and criteria which might be used to develop a next generation light-weight, multi-purpose helicopter which could be used suitably by both military and commercial aviation.

ARMY LIGHT HELICOPTER

During and since World War II, as shown in Figure 1, all Army light helicopters were designed to Civil Aeronautics Agency (CAA) or Federal Aviation Administration (FAA) standards, and in most instances initial funding was by the developing company; even in those instances where the funding was by the military, the basis of the certification was Federal standards. Most of these helicopters are shown in Figure 2.

Helicopter	Time Frame	Acceptance Basis	Funding
Sikorsky R-4	World War II	CAA	Sikorsky
Bell H-13 (47)	Late 1940's	CAA	Bell
Hiller H-23 (360)	Late 1940's	CAA	Hiller
Hughes TH-55A (269)	Mid 1960's	FAA	Hughes
Hughes OH-6A (369)	Mid 1960's	FAA	Army
Bell OH-58 (206)	Mid 1960's	FAA	Army/Bell

Figure 1. Army Light Helicopters

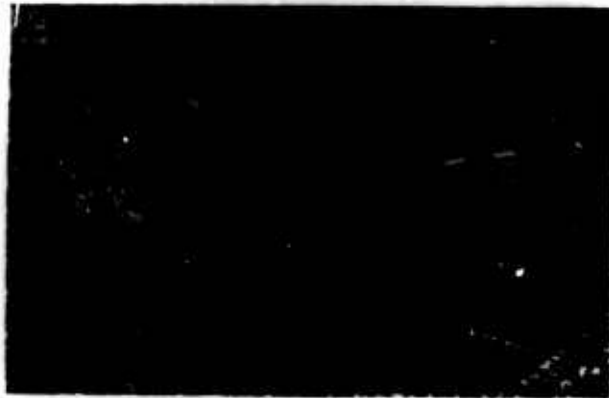

Figure 2. Army Light Helicopters

HUGHES BACKGROUND

Model 269

Since the basis for opinions is formed by experience, it is important to discuss Hughes' background in the light helicopter field. Early in 1955 we designed and built the first experimental Model 269, aimed at filling the requirements for a low-cost piston engine powered, light-weight, two-place, multi-purpose helicopter. Based on a successful experience, we designed and built seven YH02HU helicopters, five of which were delivered to the Army in 1959 for evaluation. It is noteworthy that the acceptance basis for Army evaluation was a CAA TIA (Type Inspection Authorization) which indicated that, based on company-submitted structural and flight data, the CAA agreed that the helicopter was safe for evaluation by their pilots.

Despite meeting its design goals and getting excellent performance and maintainability reports on the testing conducted by the Army at Edwards Air Force Base in California and Fort Rucker, Alabama, the helicopter was not purchased for military use since by that time the Army had come to the conclusion that its light observation helicopter would be powered by a light turbine engine. A short time later, the Army contracted with the Allison Division of General Motors to develop the Allison T63 engine, known later commercially by its 250 designation.

In 1961, without any military orders, the YH02HU was redesigned for production and was recertificated under Civil Air Regulations (CAR) 06. The first production helicopter — from a planned production of 1000 — was delivered for commercial use in April 1962. In 1964, Hughes received the first order for 20 TH-55A helicopters; eventually the Army purchased a total of 793 by 1969. These trainers were identical to the commercial 269A except for some variations in equipment. This helicopter, then and until now, has been the Army's primary trainer and has trained military pilots from many countries, including some of the countries represented at this meeting. This program has the unique distinction that normal military spares provisioning and ownership of spare parts by the Army was never initiated; instead a Hughes consignment inventory has been maintained at Fort Rucker and spares are withdrawn and paid for by the Army on an as needed basis.

There has been continuing product improvement on this helicopter by funds supplied by both the Army and Hughes. Most of the improvements have direct application to both military and commercial users. Some of the current improvement programs are being conducted on a cost-sharing basis by Hughes and the Army. Figure 3 shows the experimental helicopter and the family of versions and applications in which it is now being used.

Figure 4 shows some of the salient performance characteristics of the 269A in its original version compared to the 269C — Hughes designation 300C — now in production, which is an improved model with larger diameter main rotor blades and an improved engine. The 300CQ, a quiet version, was the first helicopter to be certificated, in 1973, by the FAA for quiet operation for a specific mission — police patrol.

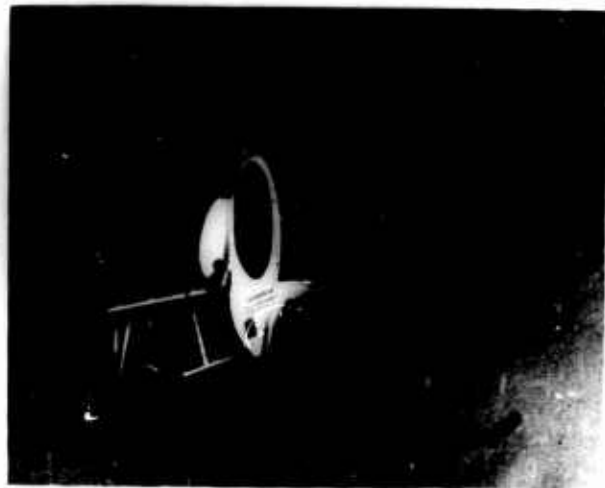
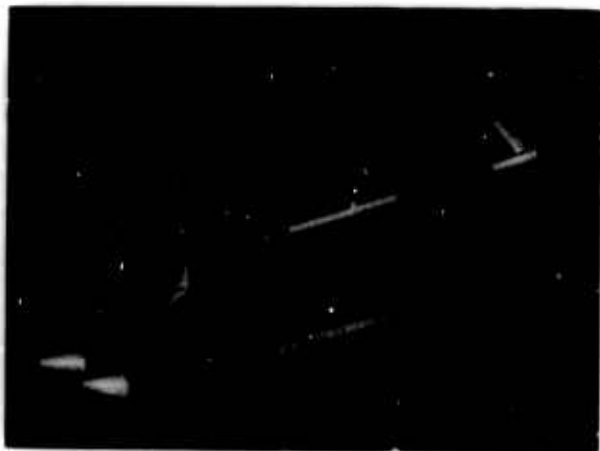
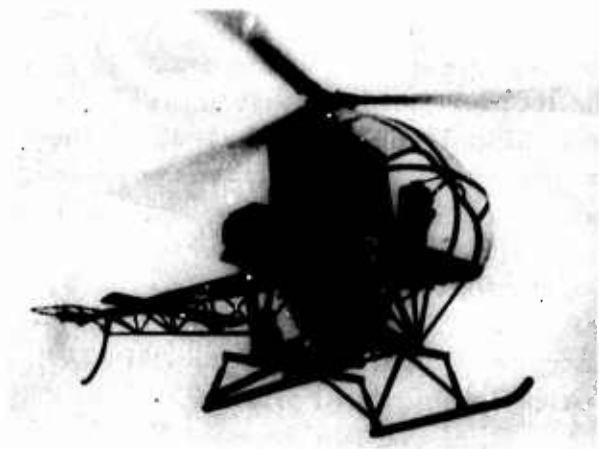

Figure 3. Hughes 269 Helicopter

	269	TH-55A	300C
Gross Weight, pounds	1550	1670	2050
Useful Load, pounds	630	662	998
Overload Gross, pounds	1850	1850	2150
V _{ne} , miles per hour	86	86	105
Hover IGE, feet			
Standard Day, 15° C	6300	4700	5900
ISA + 20° C	4500	2900	4000
Rate of Climb	1450	1240	750

Figure 4. Model 269

This successful program with 17 years of continuing flight experience, approximately 2200 helicopters sold, more than 4,000,000 flight hours, and used in more than 60 countries is a vivid demonstration of the successful partnership possible between Hughes and the Army, and is all based on the well-planned design of a commercial helicopter anticipating a military requirement.

OH-6A

Early in 1961, the Army requested, from all interested companies, a no-cost study with opinions, suggestions, and recommendations for the optimum design configuration, performance characteristics, control system, power-plant, avionics, etc., for the next generation of Army light-weight aircraft.

This study, entitled "ASR 1-60, Parametric Study of a New Light Observation Aircraft" (Figure 5) was submitted by Hughes in 1961 and was the beginning of the first operational light helicopter developed under Army guidance, and was the first in which design development funding was by the Army.

Based on its own studies and many of the opinions submitted by the numerous responders, the Army issued a request for proposal (RFP) for an Army LOH light observation helicopter. Based on the submitted proposals, the Army awarded development contracts to Hiller, Hughes and Bell (Figure 6) with the proviso that the helicopters would be developed and certificated under FAA regulations with minimal or no design supervision by the Army. The winner of that unique competition, the Hughes YOH-6A, is shown in Figure 7.

We are certain that our philosophy, small size, minimum weight, agility, and derated engine -- different from the other two competitors -- was the reason we were chosen. In 1965, the first of 1428 helicopters was delivered

New Light Observation Aircraft

Parametric Study

1965-1970
Time Period

ASR No. 1-60

***U. S. ARMY TRANSPORTATION CORPS.
Project NR9-38-10-000***



Figure 5. Parametric Study of New Light Observation Aircraft



Figure 6. Army LOH Competitors

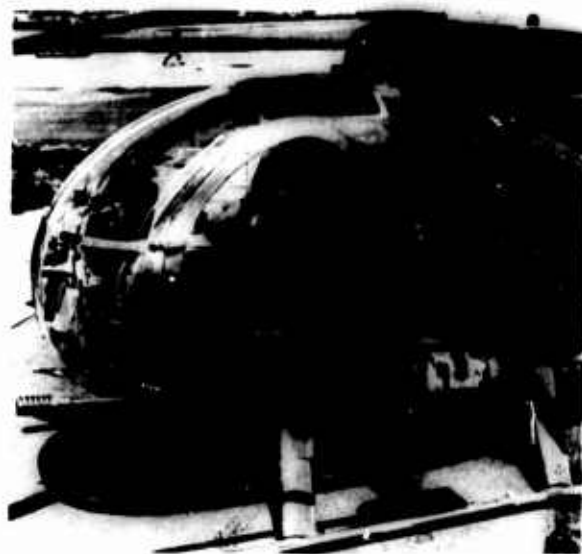

Figure 7. OH-6A Armed

Gross Weight	2100 pounds	Speed	128 K at 2100 pounds
Overload Gross Weight	2700 pounds	Hover	
Empty Weight	1050 pounds	IGE, 95° F	6240 feet
Power Plant	Allison T63, derated	Endurance*	3.9 hours
Main Rotor	Articulated, 4 blades, 26.33 ft dia	Range*	320 miles
Tail Rotor	2 blades, 4.25 ft dia	*2 minute warmup, 10 percent reserve	
Control System	Mechanical, no hydraulics, electronics		
Landing Gear	Articulated, energy absorbing		

Figure 8. OH-6A Army Light Observation Helicopter
Performance Characteristics

to the Army for operational use. Figure 8 describes the OH-6A and some of its performance characteristics.

The OH-6A in combat service in Vietnam amassed more than 2 million flight hours. Some of the helicopters, after having suffered substantial battle damage, were repaired at Hughes' Overhaul Facility in California, and were returned for service in Vietnam a second and third time.

MODEL 500 (FAA DESIGNATION 369)

From the basic OH-6 design, Hughes, in 1966, certificated the first Model 500 using the Allison 250C18 engine, and in 1972 we certificated an improved version using the increased horsepower Allison C20 engine. Performance is shown in Figure 9.

	2200 Pound	2550 Pound
Speed - Maximum Cruise, 4000 feet	155 mph	145 mph
Hover - In Ground Effect	14,400 ft @ ISA + 20°C	9,800 ft @ ISA + 20°C
Hover - Out of Ground Effect	11,500 ft @ ISA + 20°C	4,500 ft @ ISA + 20°C
Service Ceiling	18,000 feet	14,500 feet
Rate of Climb	2,100 fpm	1,700 fpm
Endurance, 4000 feet	3.9 hours	3.7 hours
Range, 4000 feet	400 miles	375 miles

Figure 9. Performance - Model 500

It should be noted that in each of these certifications, as a part of our basic philosophy, the design was predicated on using only a portion of the available engine power so that reserve power was available for emergencies. In addition, this premise provided room for logical growth of the helicopter. To date, approximately 1300 Model 500C and Model 500 helicopters have been sold and are operating in 60 countries. Figure 10 shows many of its applications.

In more than 4 million hours of total operation and with a commercial fleet now flying 850,000 hours per year, the Hughes 500 has compiled the enviable safety record shown in Figure 11.

This record is twice as good as general commercial aviation and is only the beginning. Our current program includes making the helicopter at least as safe as large fixed wing aircraft in airline operation, benefiting both commercial and military users of our 500C and 500D helicopters.



Figure 10. Model 500C Helicopter Applications

10-10

1974 and 1975 (Avg)		
Accidents per 100,000 Flying Hours, United States Operation		
	Total Accidents	Fatal Accidents
Hughes Model 500	10	0.4
All Helicopters	19	2.4
All General Aviation	14	2.1
Source: U. S. National Transportation Safety Board and Helicopter Association of America		

Figure 11. Aircraft Safety

MODEL 500D

In 1971, Hughes flew its first five-bladed Model 500 helicopter and accumulated more than 2000 hours of pilot evaluation. In December 1976, after more than 650 hours of Company and FAA flight testing, the Model 500D (described in Figures 12 and 13) was granted FAA certification; the first production helicopter was delivered and flown in commercial service several days later.

Some of the 500D's unique design features are shown in Figures 14 through 20, and pictured in Figure 30.

The 500D, a Company-sponsored and funded program, recognized the potential for military use and our FAA certification included the 500M-D, almost identical to the 500D except that the pilot's position is on the right side; it also has provisions for the inclusion of many of the military requirements. Its excellence is demonstrated by the fact that it was recently chosen as the multi-purpose military helicopter for a foreign government.

- 3000 Pounds Normal Gross Weight
- 3550 Pounds Overload Gross Weight
- Uses Allison C20B Engine, derated 375 HP
- Five Main Rotor Blades, 26.33 feet in diameter
- Two Cambered Tail Rotor Blades, 4.58 feet in diameter
- Improved Transmissions, 5000 Hour TBO Objective
- 5000 Hour Life Objective for all Dynamic Components
- Mechanical Control System - No Hydraulics or Electronics

Figure 12. The Hughes 500D Helicopter

Maximum Speed (V_{ne})	156 knots
Hover Ceiling IGE	6900 feet, 15°C 4400 feet, 35°C
Hover Ceiling OGE	3300 feet, 35°C
Rate of Climb	1875 feet per minute at sea level 1680 feet per minute at 5000 feet
Endurance	3.1 hours, 5000 feet, 2-minute warmup, no reserve
Range	330 miles, 5000 feet
Service Ceiling	14,700 feet
Payload - Normal	1065 pounds - full fuel
Payload - Overload (3550 pounds gross weight)	2000 pounds - sling load 15 minutes fuel

Figure 13. Performance of the 500D Helicopter
(3000-pound gross weight except where noted)

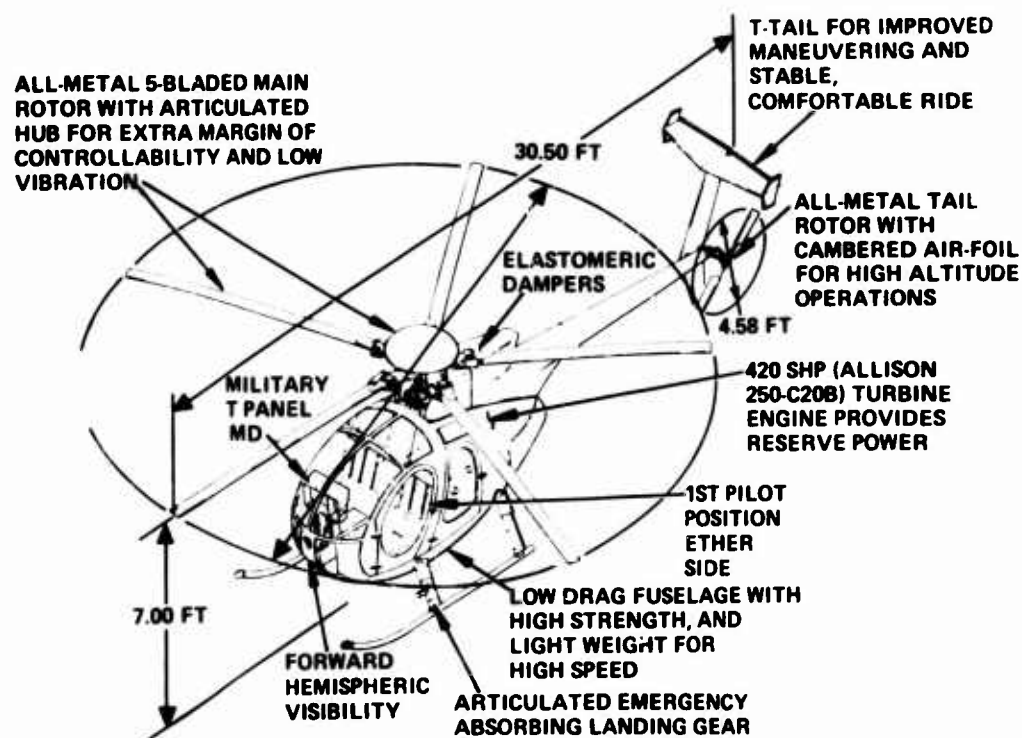

Figure 14. New 500D and 500M-D Helicopters

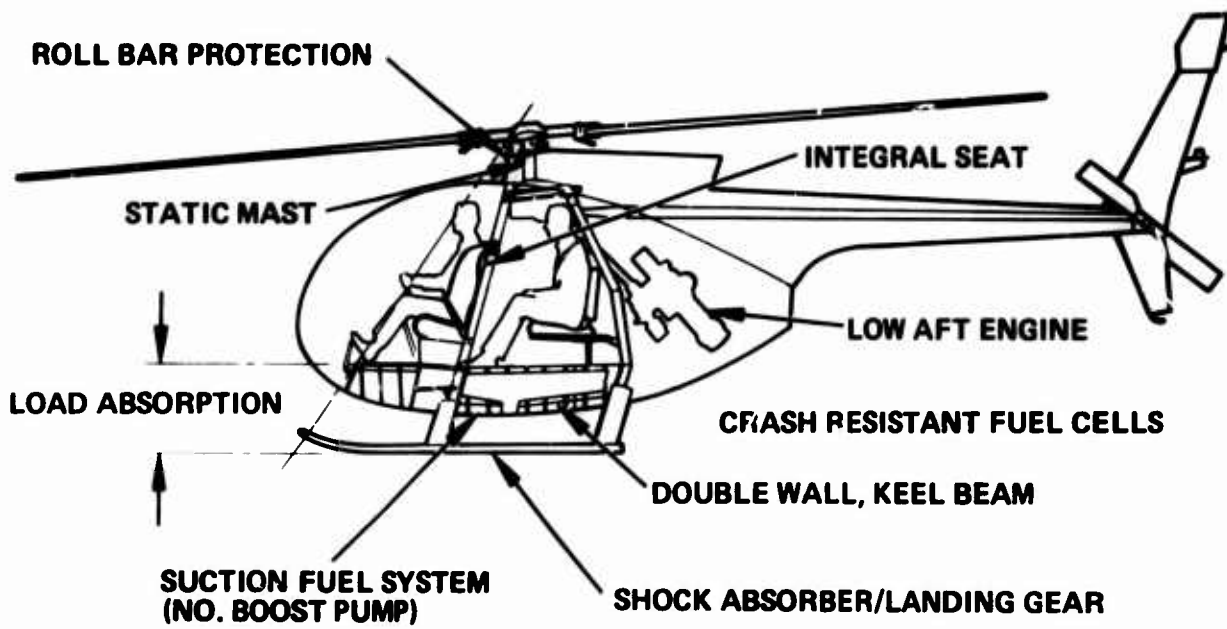

Figure 15. Crashworthy Structure

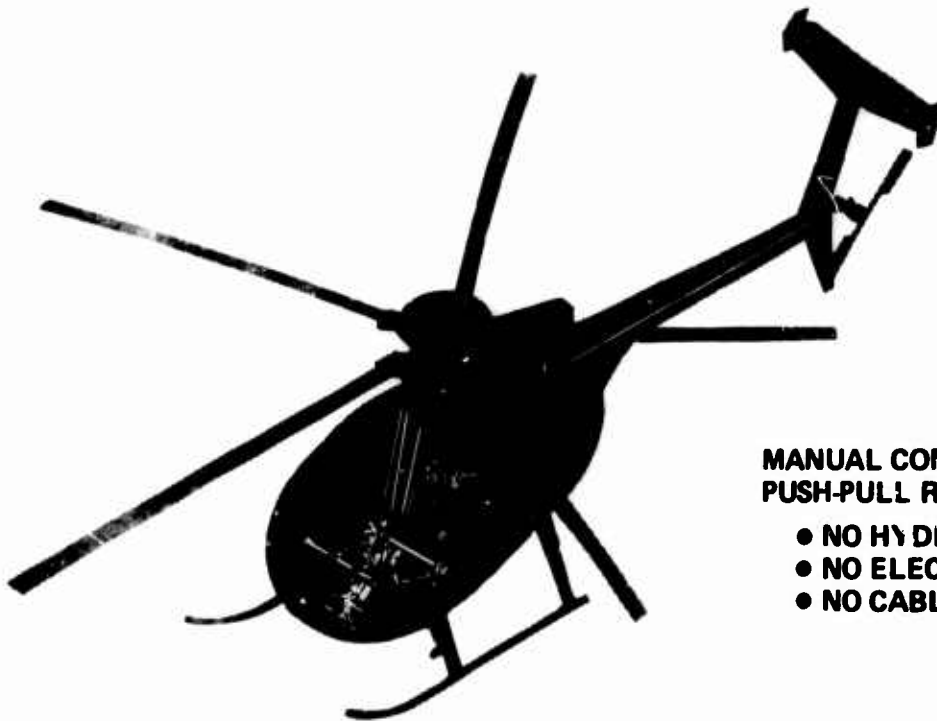

Figure 16. Simple Flight Control System

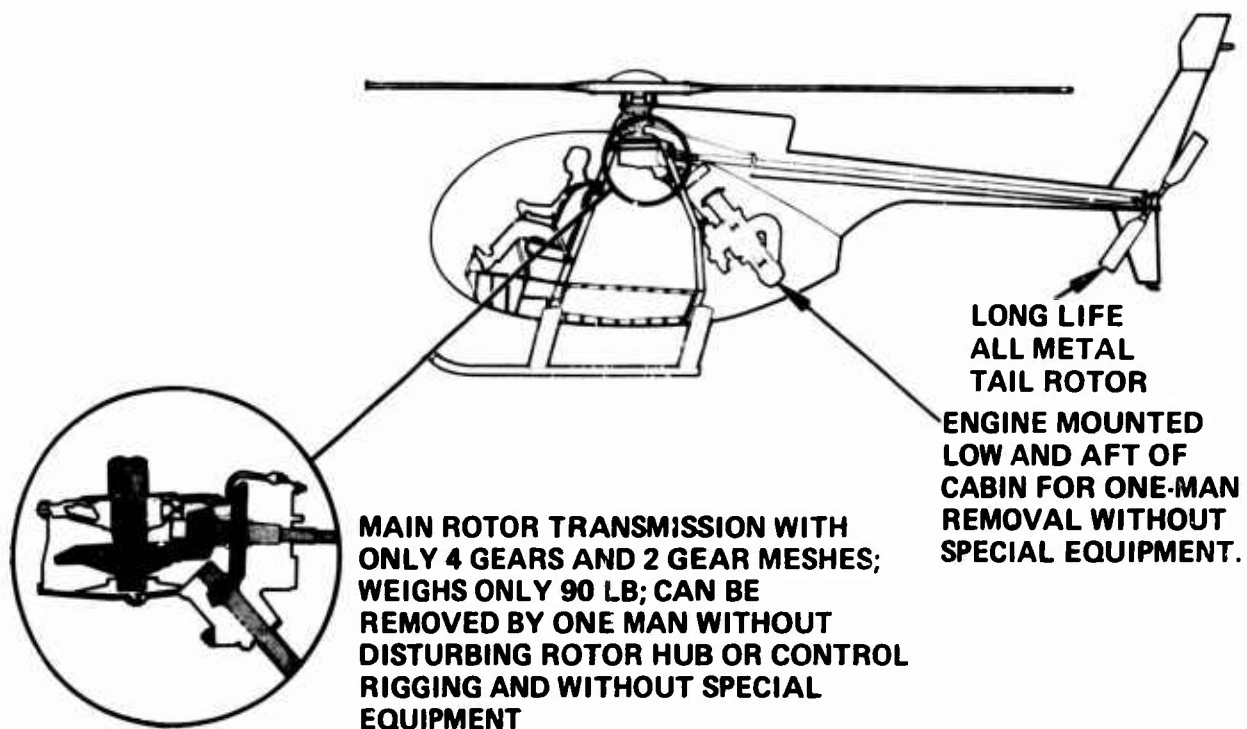

Figure 17. Mechanical Simplicity

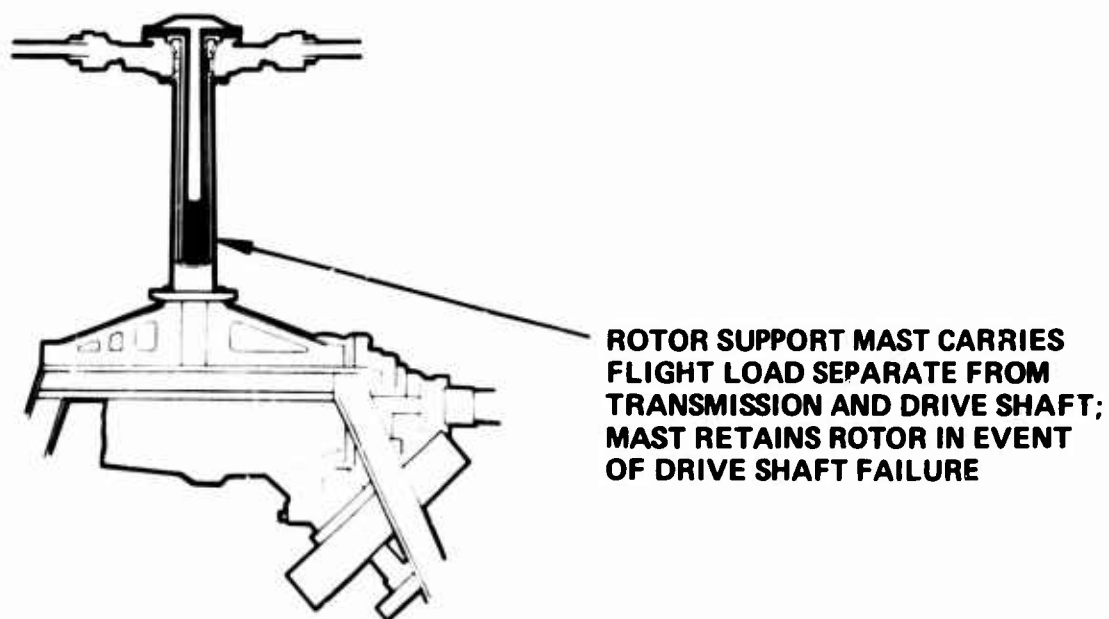

Figure 18. Fail Safe Design

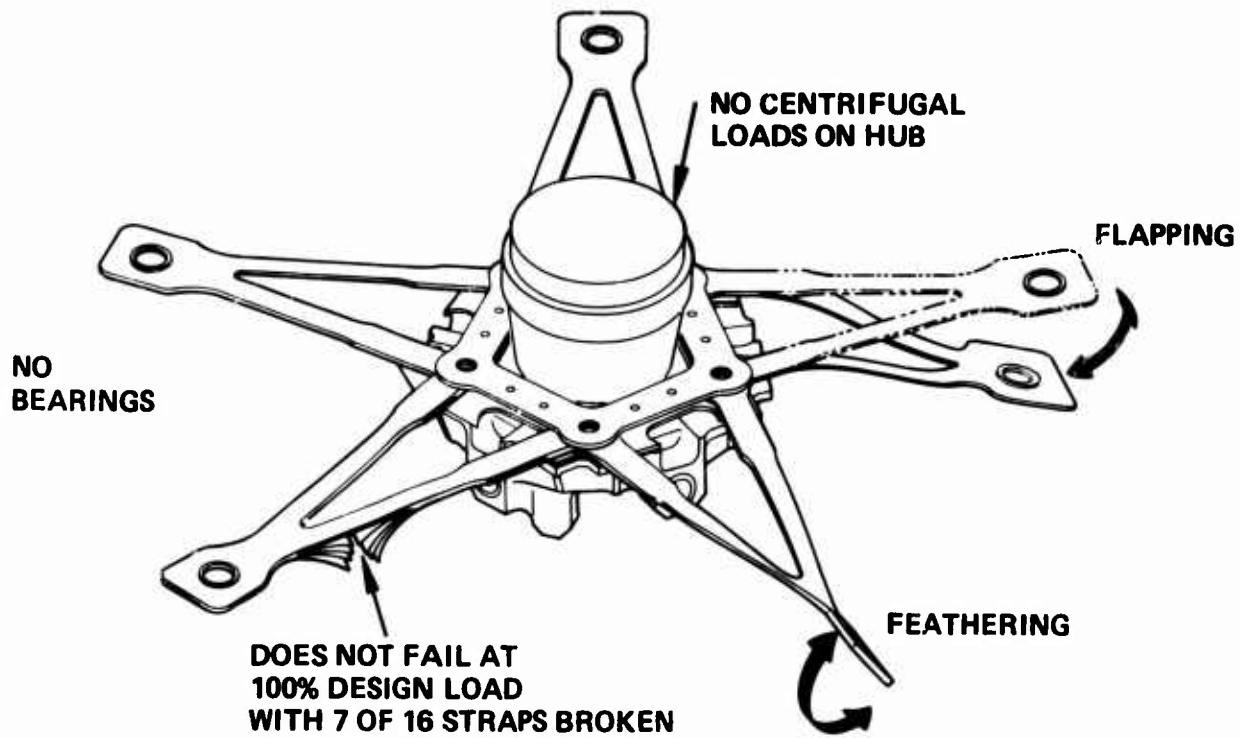

Figure 19. Strap Retention System

- 20° SLOPE LANDING CAPABILITY
- UNIQUE LANDING GEAR PREVENTS TAIL BOOM STRIKES

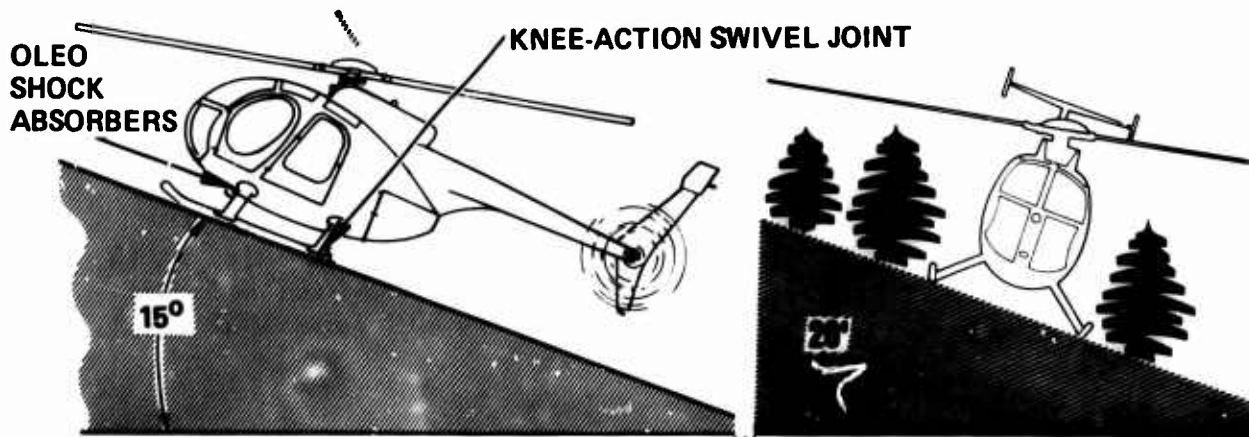

Figure 20. Landing Capability

MODEL 500M-D

The 500M-D, a third generation OH-6A, is a unique light combat helicopter capable of accepting weapons system up to and including the TOW missile. Figure 21 shows a listing of available kits. Figure 22 shows the TOW missile configuration in flight. Configured as a Scout, the 500M-D can carry a full array of night vision and target acquisition sensors.

The 500M-D/ASW configuration shown in Figure 23 is designed to provide ASW mission capability. When operated in conjunction with a naval ship, such as a destroyer, it is an extension of that destroyer and the combined capability is greater than that which each possesses separately. The 500M-D/ASW may be either destroyer-based or land-based, from where it can be deployed to fly to a datum point determined by destroyer sonar contact.

Since the Model 500M-D is a small, low cost, high performance helicopter with a high degree of combat survivability and mission flexibility, it offers significant operational and life cycle cost advantages over the conventional military helicopter. Its low detectability is helped both by its size and five-bladed main rotor helicopter. A two-blade rotor system, with the equivalent payload capability of the 500M-D, has been found to have five times its brightness. The comparative size of the 500M-D TOW and AH1 is shown in Figure 24.

The 500M-D is available with standard lightweight aircraft electronics (SLAE) (Figure 25), and passive armor for the crew and critical components of the powerplant system (Figure 26). It also incorporates an infrared suppression system (Figure 27), hardpoints for the HGS-5 Minigun subsystem and ammunition (Figure 28), and the HGS-17 rocket launcher subsystem (Figure 29).

CONCLUDING REMARKS - THE FUTURE

We have described many years of the successful applications and coordination of Hughes light helicopters, designed to commercial standards, operating in both the military arena and the commercial market. There now appears to be a need for an improved Army Scout with improved operational capabilities; such a Scout will surely have appeal to the commercial user.

To what standards and how will such a new helicopter be designed? Although there is no agreement on design standards between the Army and the FAA, we at Hughes feel that we could meet the needs of both the Army and the commercial user with a single helicopter which would be an outgrowth of the design philosophy and technology which produced our successful TH-55A/269A and OH-6A/500D helicopters.

Name	Part Number
TOW System	416-150
Utility Float	369D290086
Emergency Float	369D290121
SLAE Radio	369D294000
Gun/Rocket Armament	369D294150
Armor	369D294600
IR Suppressor System	369D294900
Dual Controls	369D297000
TACAN Subsystem	-
Radar Subsystem	-
MAD Subsystem	-
Hauldown	M30291
Smoke Marker	-
Torpedo Subsystem	-
Litter	369H90011
Hoist	369H90070
Cargo Hook	369H90072
Rotor Brake	369H90123
Searchlight	369H90142
Siren	369H90143
Range Extension	-
Night Vision	-
22 Cubic Feet Stores Kit	-
On Board Computer	-
On Board Diagnostic Kit	-

Figure 21. Model 500M-D Kits



Figure 22. 500M-D TOW Missile Aircraft in Flight



Figure 23. 500M-D ASW

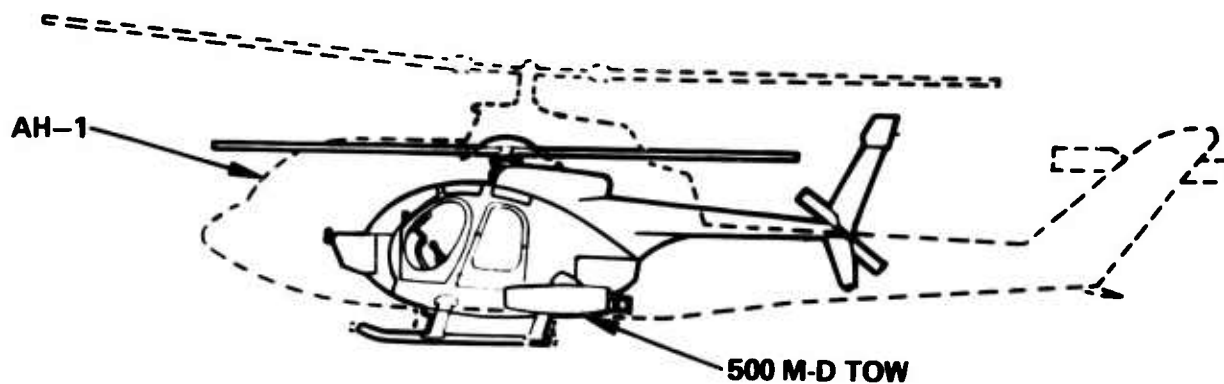

Figure 24. Relative Vulnerability

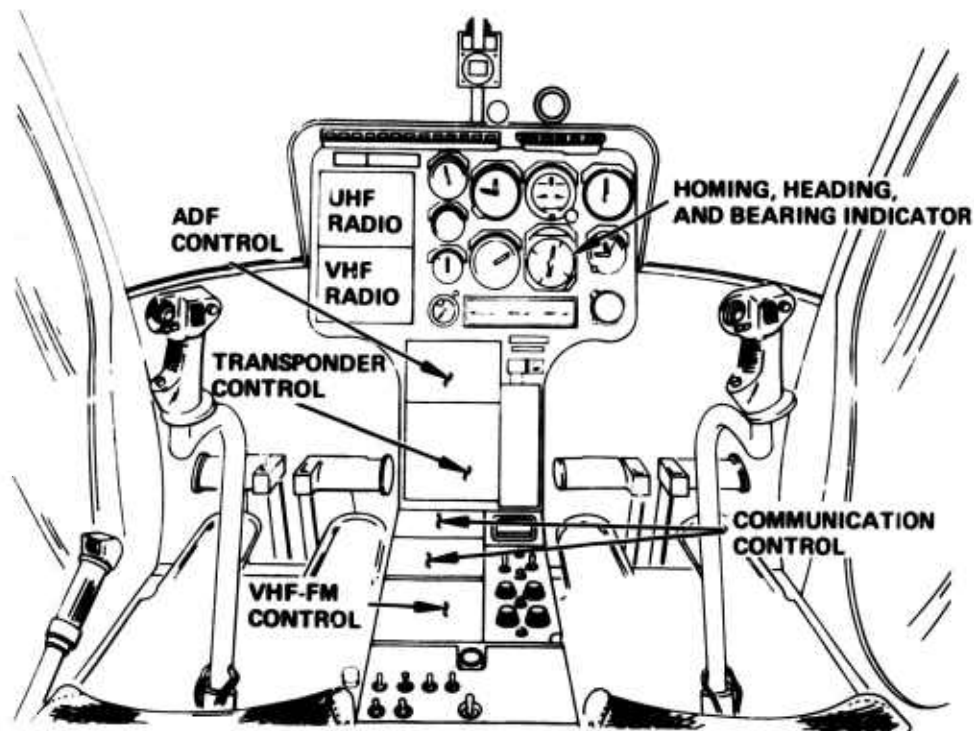

Figure 25. Standard Lightweight Aircraft Electronics (SLAE)

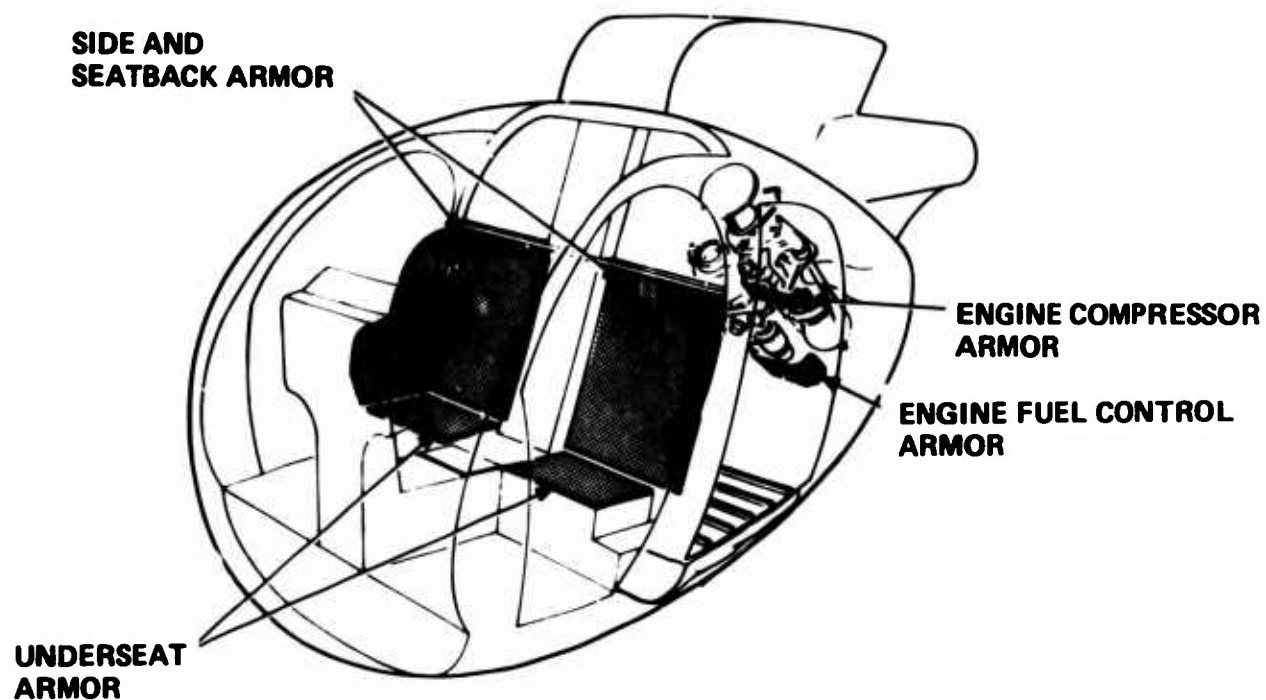

Figure 26. Armor Kit



Figure 27. 500M-D With Exhaust IR Suppression



Figure 28. HGS-5 Minigun Subsystem Configuration



Figure 29. HGS-17 Rocket Launcher Configuration



Figure 30. Model 500D Helicopter Applications

by

11-1

G. Reichert and E. Weiland
Messerschmitt-Bölkow-Blohm GmbH
Postfach 801140
8000 München 80, Germany

SUMMARY

The Messerschmitt-Bölkow-Blohm Company has gained good experience with its light helicopter MBB - BO 105, which is engaged in civilian as well as in military operations. Up to now, more than 300 BO 105 helicopters have been delivered to customers, and some 250 000 hours of flight time have been accumulated. The first helicopters have about 5 000 flight hours. This experience is especially valuable because the BO 105 is the first production helicopter with a hingeless rotor and fiberglass rotorblades which has been able to prove its ability in practical operation consistently over a long period of time. The broad spectrum of operation and experience includes the following types of missions in civilian operation: utility, executive, rescue, police, offshore, lighthouse supply, as well as LOH, scout and antitank-missions in military operation.

Besides the problems resulting from this broad field of operations, which are typical for many light helicopters, additional questions associated with the new technology were specially considered, for example the changed handling characteristics and the different loading situation of the hingeless rotor, and the behaviour of the fatigue loaded fiberglass blades.

1. INTRODUCTION AND STATUS

The Bölkow Company, now Messerschmitt-Bölkow-Blohm GmbH, started research and development activities for helicopters in the late fifties, and since that time the work has been centered around fiberglass composite rotor blades. The first experimental all-fiberglass composite rotorblade was flown in 1962. Its only basis was research work; never before had a composite blade been flown. No design rules were available at that time. There was some data on static and fatigue strength - just sufficient for an experimental program. The overall knowledge regarding this new material was very limited; knowledge of fracture mechanics, for example, was almost non-existent. Furthermore, the composites of the fiberglass as well as the manufacturing techniques were not yet optimized. During the last 15 years, however, continuous research and development activities in all the related fields, together with the operational use of the BO 105 helicopter since 1972 have almost completely changed this situation.

Arising from activities on composite rotorblades which have relatively high elasticity, the Bölkow Company came up with the idea of a hingeless rotorsystem based on flexible fiberglass rotorblades. The fiberglass material, offering high elasticity and good strength properties for fatigue loads, seemed to have potential for a rotor with flapwise and lagwise rigid attachment to the rotorblades, and the best way to understand the MBB rotorsystem is to regard it as a successful attempt to a quasi-articulated rotor whose flapping and lagging hinges are replaced by the elastic deformation of the fiberglass rotorblade. About 1960 the Bölkow Company began a research program for such a rotorsystem which included theoretical studies and windtunnel model tests. Favorable results led to the manufacture of a full scale rotor which was first flown on a helicopter in 1966, and in 1967 the helicopter BO 105 was ready for its first flight, (Ref. 1 ÷ 3).

Up to now, more than 300 BO 105 helicopters have been delivered to customers. The BO 105 helicopters are engaged in civilian as well as in military operations. The broad scope of operation and experience includes the following types of missions in civilian operation: utility, executive, rescue, police, offshore (Figure 1), lighthouse supply, as well as LOH (Figure 2), scout and antitank-mission in military operations. The operation of the helicopters in 18 countries since 1971 has resulted in the accumulation of some 250 000 hours of flight time, with 1 000 000 main rotorblade hours and 500 000 tail rotorblade hours. Sufficient data is now available for a review on a statistical basis. The first helicopters have about 5 000 hours of flight time. The environmental conditions under which BO 105 helicopters have been and continue to be flown cover a temperature range from less than -40°C up to more than +45°C with a relative humidity up to 100% even at the highest temperature. The helicopter is certified for operation from -45°C to +50°C.

The experience with the BO 105 helicopter is of great interest because the BO 105 is the first production helicopter with a hingeless rotor and with fiberglass rotorblades which has been able to prove its ability in practical operation consistently over a long period of time. The special questions associated with the new technology had to be specially considered, for example, the changed handling characteristics, the different loading situation of the hingeless rotor, and the behaviour of the fatigue loaded fiberglass rotorblades.

11-2
The MBB hingeless rotor system is of the type stiff hub and soft flapwise, soft in-plane blades (Ref. 4). The main components of the rotor are shown in Figure 3. The fiberglass blades are rigidly attached to short hub arms. The rotor hub is made of titanium (Ti Al 6 V4). The star shaped center part is forged and milled. The rotor hub is flange mounted on the rotor shaft. The feathering axes of the blades are fixed to the hub arms. The only bearings are provided for the feathering hinges, which are unloaded from the centrifugal forces by tie-bar-devices (Bendix). The rotor blade with the attachment mounting is illustrated in Figures 4 and 5. Fiberglass rovings are oriented from the blade tip to the root wound around a bolt and back to the tip.

2. LOADING AND FATIGUE SITUATION OF A HINGELESS ROTOR HELICOPTER

The history of the helicopter is marked by the struggle against dynamic forces at the rotor system and the dynamic characteristics of the whole helicopter. In the early days with the insufficient knowledge of the physical-technical correlations, the introduction of the blade attachment hinges was the only way to overcome the mechanical strength difficulties at the rotor blades and the control problems of the whole helicopter caused by the lack of symmetry in the conditions of flow. For a long period of time, all successful helicopters were equipped with articulated rotors. Nowadays, rotors with rigid or so-called hingeless blade attachment are of great interest, because they offer mechanical simplification and improved handling characteristics in comparison to articulated rotors.

For hingeless rotors without flapping hinges, it is possible, to transfer high moments from the blades to the hub and the fuselage. The changed loading situation with high moment loads at the blade root area, at the hub, and at the rotor shaft have to be considered in the design. Figure 6 illustrates the different loading situation of a hingeless rotor and of an articulated rotor with a small flapping hinge offset. If the aerodynamic lift at the blade is the same for both rotors, it produces the same force at the hinge or blade attachment respectively, as well as at the center of the hub; but for the moments there is a pronounced difference at the blade root and the hub. At an unrestrained hinge there will be no moment at all. For the hingeless rotor with blades of high elasticity, there also exists an area at the blade with relatively low moments which indicates an effective or equivalent hinge. Compared to a typical articulated rotor with a hinge offset of about $2 \pm 3\%$ of the radius, the equivalent hinge offset of a typical hingeless rotor is about 15%. Consequently, due to the different lever arm for the acting forces, the moments at the center of the hub will be quite different. The resulting moment at the hub can be reduced to a certain degree by coning the hub arms and thus producing an unloading moment from the centrifugal forces. Normally, the precone angle will be chosen for unloading with the design rotor thrust. Other thrust conditions, primarily alternating thrust of the blades will result in corresponding moments at the hub. It should be pointed out that these moments resulting from cyclic control inputs are intended; they are the basis of the improvements in handling qualities. The most stressed section of a hingeless rotor, therefore, is the blade attachment section, the rotor hub and the rotor shaft. With a proper design the blade main section is relatively low stressed.

The control of helicopters with articulated rotors is mainly done by inclination of the thrust vector, thus producing a moment around the center of gravity of the helicopter. For a helicopter with a hingeless rotor system an inclination of the thrust vector is combined with a strong hub moment, and the moment around the center of gravity is a combination of this hub moment and the moment due to the thrust inclination. The loading of the rotor shaft and the gearbox with its suspension is different in the two cases. For the articulated rotor the moment is built up linearly towards the center of gravity (cg); whereas for the hingeless rotor the hub and the shaft are subjected to a relatively high moment loading. Trim conditions, which need a rotor produced moment to overcome cg-travel or slope landing conditions, for instance, require an alternating first harmonic moment in the rotating system for the hingeless rotor, whereas in the case of an articulated rotor, because of the equivalence of cyclic control and blade flapping, only an inclination of the thrust would be necessary. For the trim requirements in forward flight there are nearly no differences between the two rotor systems, because the cyclic control is needed to overcome an aerodynamic nonuniformity, to which the dynamic systems of the rotors are of minor importance.

Higher harmonic blade loads resulting from the flow conditions in forward flight produce alternating forces at the hub for both rotor systems, and, in addition, for the hingeless rotor moments at the blade root and the hub. For a dynamically well-tuned hingeless rotor these higher harmonic moments are relatively low compared to the first harmonic moments needed for trim or flight maneuvers. Figure 7 shows a typical case with a pronounced first harmonic part. The higher harmonic loads are exciting vibrations; and a low vibration level requires good dynamic design of the rotor itself and in combination with the fuselage, for all rotor systems. However, for the component sizing for fatigue of a dynamically well-tuned hingeless rotor, only the first harmonic loads are important.

To get optimal dynamic characteristics for a hingeless rotor system, the stiffness of the rotor system should not be too high. The stiffness is defined by the flexural stiffness, which is the product of the modulus of elasticity E and the moment of inertia J , representing the cross-sectional area of the blade. The same flexural stiffness EJ can be realized for instance, with a high E of steel and a small J , i.e. a thin cross-section, or with a low E like that of fiberglass reinforced plastic material and a larger J or cross-section. In both cases the same moment loading must be tolerable for fa-

tigue. The relation of the modulus of elasticity is about 5 for the two materials, but the relation of the fatigue allowables is only about 2. Therefore, the fiberglass material is much better than steel for a hingeless attached rotor blade. The stress allowables of fiberglass material result in blades of nearly unlimited life. Steel would be a very poor solution as would aluminum because of the low stress allowables. Figure 8 illustrates these conditions. The differences in the material properties are even more pronounced if the essential notch factors are considered. It seems to be evident that the fiberglass blades are the key to success of the MBB rotorsystem. 11-3

The main section of a hingeless attached blade outside the attachment area should normally not have fatigue problems. The loads are lower, and there will be enough sectional area, because no weight-saving construction is normally necessary. For other reasons, i.e., for flight dynamical reasons of autorotational behaviour, a certain mass of the blades (or better a certain moment of inertia around the rotor axis) is desirable. This will result in favourable conditions for the stresses.

The typical fatigue problems of helicopters are high-cycle fatigue. The components of the dynamic system are loaded at frequencies which are multiples of the rotor speed with the highest loads in the first harmonic for the hingeless rotor, which means 7 cycles per second for the BO 105. This loading rate represents 25 million load cycles per thousand operating hours. The high frequency cyclic loading is normally caused by bending moments. The low-cycle loads, which are the start-stop cycles, result from centrifugal forces. Their loading rate is with about $1 \div 5\ 000$ cycles per 1 000 hours of flight, low compared to the high-cycle loads. In most cases the start-stop cycles, therefore, don't influence fatigue. But there can be some rotor components which are mainly loaded by the centrifugal forces, for instance the torsion-tension bars, which have the function of unloading the blade feathering hinges and the hub from centrifugal forces. Such components have to be sized to withstand the low-cycle fatigue loading (Ref. 5, 6).

3. DYNAMIC CHARACTERISTICS OF A HINGELESS ROTOR HELICOPTER

The feature of the hingeless rotor of transferring high moments from the rotorblades to the hub and the fuselage results in a changed situation for the control characteristics. The control of the helicopter becomes more powerful, faster and more direct, and nearly independent of rotor thrust.

The difference in the control moment of a hingeless rotor helicopter compared to an articulated rotor helicopter is illustrated in Figure 9. With an articulated rotor the control moment around the center of gravity of the helicopter is only produced by the tilt of the thrust vector (in the case of central flapping hinges with see-saw rotors). This moment is relatively small. For rotors with small flapping hinge offsets there is an additional rotor moment produced by the shear-forces at the flapping hinges. This rotor moment is much higher in the case of the hingeless rotor, which can be considered equivalent to an articulated rotor with a flapping hinge offset of about 15 percent. Its rotormoment is - for the same shearforces - about five times that of an articulated rotor with a small offset.

The effects obtainable with a certain control input and the corresponding time behaviour of the helicopter motion are the most important parameters in evaluating the control characteristics. Usually, the control efficiency will be expressed by the initial acceleration per unit stick deflection, which is equal to the ratio of the control moment obtainable with the stick deflection to the moment of inertia. The time behaviour is generally expressed by the damping moment which again is referred to the moment of inertia. For satisfactory control behaviour a definite correlation should exist between control power and damping, as illustrated in Figure 10. Along straight lines through the origin, there is the same control sensitivity, meaning the same angular velocity per stick displacement. In the diagram, values obtainable with the hingeless rotor are compared to those with the articulated rotor. As already known, a discrepancy exists between the various recommendations and specifications. Most likely, the reason lies in the fact that these were established on the basis of pilot evaluations from limited flight tests or simulation studies. Both helicopters - with articulated rotor and with hingeless rotor - have about the same control sensitivity, because of the fact that flapping offset or rigid blade attachment increases both control moment and damping moment. With a proper control ratio of stick deflection to blade deflection the helicopter with the articulated rotor is generally in the range of the old curves by Salmirs and Tapscott. The helicopter with the hingeless rotor is within quite another range than usual for conventional helicopters. The control moment for the same stick deflection is about three to five times the value of the articulated rotor; for the damping moment a similar relation exists. The damping moment is even more important than the control moment, which can be influenced to a certain amount by the control ratio. A high damping moment results in a low time constant, which is defined as the time required for reaching 63 percent of the stationary angular velocity following a control step input. When the time constant is short, the helicopter follows control inputs more directly. The time constants of the hingeless rotor helicopter are relatively short; the control is nearly a rate type control. The controllability of the hingeless rotor helicopter is much better than that of an articulated rotor helicopter. The recommendations for armed helicopters seem to apply for modern helicopters. The hingeless rotor helicopter is able to fulfil such modern requirements.

The stability behaviour of the hingeless rotor helicopter will be influenced, (as

11-4
were the control characteristics), by the high moment capacity. The rotor is more sensitive to control inputs, but external disturbances also play a role. On the other hand, the higher damping moments will be advantageous. Early studies have indicated that the phugoid mode can become highly unstable in the high speed range, and at that time it was not able to be ascertained if this was a dangerous situation or not. Quite surprising during flight tests, which showed good correlation with theoretical predictions, was the fact that the pilots did not notice this instability because of the excellent control characteristics.

Another area of uncertainty in the beginning was the phenomena of ground and air resonance. With the relatively low inplane frequency ratio of about .65 to .70 of the MBB rotor system, ground and air resonance may occur, however, theoretical studies and tests showed that this was not a critical situation. There is no necessity for a lead-lag damper at the blades, the material damping of the blades and their attachment is sufficient to avoid instability.

Now, the dynamic characteristics of the hingeless rotor helicopter, its control and stability behaviour, ground and air resonance phenomena, and aeroelastic coupling effects have been studied in numerous investigations, (for example Ref. 4, 7 + 11), and today there is a good understanding of the well-predictable phenomena.

4. OPERATIONAL AND TEST EXPERIENCE WITH A HINGELESS ROTOR HELICOPTER

Intensive flight testing with the BO 105 and broad operational experience have fully proved the excellent handling characteristics of the hingeless rotor helicopter. The BO 105 is well accepted by all pilots, they like the strong and direct control behaviour. One of the most experienced commercial operators illustrates the situation best with his comment,

"We've been quite pleased with the BO 105 which is a very well made small twin-engine helicopter with a hingeless rotor system and glass fiber blades. The hingeless rotor system is fantastic. Pilots who've flown it love it. It gives the helicopter almost fixed-wing handling characteristics".

In a brief and simplified manner, it is possible to summarize the experience as follows: The main operational advantage of the hingeless rotor is, no doubt, its powerful and direct control behaviour. Potential disadvantages, which were suspected in the beginning of the development proved to have no real adverse effects. The high control sensitivity, the changed control coupling effects, the gust sensitivity, and the phugoid instability in the high speed range are not of problematic nature to the pilot, even under IFR-operation or under extreme weather conditions, as they exist in the offshore area in the North-Sea. The powerful control enables the BO 105 to do precise maneuvers under nearly all conditions, which is very advantageous, for instance, in flying to small offshore rigs. It has the potential to do steep slope landings (Figure 11), and there is good experience with landings on small ships (Figure 12, Ref. 12). The high rotor moment capacity is also the basis for operation of a high capacity rescue hoist (Figure 13, Ref. 13), which has an eccentricity of 2 m and a certified load of 270 kg, which is relatively large for a small helicopter with a gross weight of 2 300 kg.

The advantageous handling characteristics of the hingeless rotor helicopter are even more pronounced in military operations, which require extreme N.O.E. (nap-of-earth) flight capabilities. The powerful and direct control response and the ability to perform negative g-maneuvers with full control power reduce the time and space requirements in N.O.E. maneuvers and provide increased safety margins for the pilot by reducing exposure time and vulnerability in service (Ref. 14). In addition, the hingeless rotor gives the helicopter good characteristics as a weapon platform. This could be proved in successful test programs with unguided rockets, with a 2 cm-canon of relatively high recoil (about 800 kg), and with the wire-guided antitank missile HOT (Figure 14). For some time, the German Army has been doing intensive flighttesting for antitank missions with 10 BO 105 helicopters. More than 10 000 hours of flight under simulated tactical conditions have lead to a good understanding of the related problems. The operational experience with the BO 105 is very good, and the hingeless rotor is living up to its promises. The German Army is introducing the BO 105 as liaison and observation helicopter (LOH) and will also have it equipped as antitank helicopter with the HOT missile as well.

In the beginning of the activities with the hingeless rotor, there was some fear that the high moment loading at the blades, the hub and the rotor shaft could have adverse effects on the fatigue life of these components. MBB has solved the blade problem by selecting the fiberglass material, which is best suited for such an application. It was possible from the beginning to offer a long blade lifetime, which was quite an improvement over metal blades. The design requirement for the complete rotor was to get the hub and the rotorshaft structurally well matched to the blades, and MBB has been successful. Figure 15 illustrates the fatigue strength of the titanium rotorhub. The fatigue strength was determined by S-N-testing of full-scale components. In the figure the line of 99.9 percent survival probability can be compared with flight loads. All loads of normal level flight conditions are below the fatigue endurance, only some loads of extreme maneuvers or extreme slope landing conditions will be somewhat higher. This situation is about the same for the rotorshaft and the blades. With the loads spectrum established on a conservative basis, the calculated fatigue lifetimes are 22 000 hours for the blade, 11 600 hours for the rotorhub and 5 400 hours for the rotorshaft. (Ref. 5) These values are all relatively good in comparison to those of other helicopters.

As the BO 105 was primarily designed for civilian operation and certification, it has to be checked if military operational requirements for LOH-type and antitank missions will necessitate a remarkable modification. The longterm military evaluation including extreme A.O.E. flying has proven that the highly conservative mission loads spectrum of the civilian BO 105 is also sufficient for the military version. Measurements indicate that in the tactical environment rapid and extreme maneuvers will be necessary with

11-5

maximum load factors	up to	2.5 g,
roll angles	up to	80 degrees,
rolling speeds	up to	50 degrees per second,
pitch angles	up to	40 degrees,
pitching speeds	up to	40 degrees per second.

The rapid rate of change of those parameters up to their extremes will, of course, result in high loads. But these maneuvers are all within the normal flight envelope, and the loads are within the normal loads spectrum.

5. EXPERIENCE WITH FIBERGLASS COMPOSITE ROTORBLADES

Looking to the blade section (Figure 16), the blade consists of a C-spar of unidirectional fibers in order to withstand the centrifugal forces and bending moments. The skin is made of a woven fiberglass material, and the remaining part of the blade section is filled with a low-density foam. As erosion protection for the leading edge a titanium strip is used.

Because of the fact that the utilisation of the fiberglass material for rotorblades was relatively new, extensive fatigue testing was done, including tests with specimen cut out of blades and fullscale tests. Figure 17 illustrates some results for the fatigue strength of the blade spar. A comparison of the fatigue strength with flight loads shows that the blades normally run on a low stress level and that there are large reserves between the actual working stress level and the fatigue limits, resulting in a long fatigue life.

Special tests were performed to look for the notch sensitivity. Figure 18 shows some results of tests with notched specimens out of the fiberglass material in comparison to those out of the metal. For the fiberglass material there is no loss of strength in the remaining structural section. Due to this fact, the blade is inherently insensitive to damage caused by manufacturing defects, bad maintenance, operational or ballistic defects. In addition, the failure propagation rate is extremely low. The blade is insensitive to practically any defects or damages. This is illustrated in Figure 19 with a comparison of a typical steel spar blade to a glassfiber blade designed under the same criteria. It shows that even the loss of a significant part of the fiberglass spar (more than 75 percent of the original strength) would still allow completion of any mission without restriction and without an ultimate failure which could lead to a catastrophic failure. The diagram also points out how sensitive the current metal blades are. Even if only 10 percent of the original spar strength is lost, the blade would fail ultimately after a very short flight time. These findings indicate that composite blades have a very high critical length, thus providing an inherent fail safe behaviour, because a crack can easily be detected by visual inspection or by the increased vibration level or loss of track. This behaviour is very important for ballistic damage by gunfire. Special tests with damaged blades (Figure 20) proved the high insensitivity.

The long term operation and test experience indicates that

- There is no adverse effect from aging. Tests with aged specimens and high time blades have shown that there is no reduction of blade strength due to aging.
- There has never been a blade which had to be removed from service due to a structural failure. In the beginning there had been some minor problems with the bonding of the titanium erosion protection. These problems have been solved by modification of the bonding process.
- Composite blades do not change their balance behaviour or rotor track due to water pick up, to change of stiffness or creeping effects, whether the blades experience high usage or not.
- Composite blades are not subject to corrosion.
- Composite blades have experienced a very low sensitivity to impact damage.
- Composite blades can be easily repaired even under field conditions. The repair procedure can easily be performed; only simple tools are required, and the procedure is uncritical.

The experience from and for production can be summarized as

- The matched die process using heated metal molds ensures the necessary high geometric accuracy and repeatability (Figure 21).

- 11-6
- Only simple and easy to manufacture tools are necessary for production of high quality blades.
 - The manufacturing process allows a high accuracy of blade mass characteristics (Figure 22).
 - The blade rejection rate is very low; during the production of 2 000 blades it has been lower than 1%. There is an indication that the rejection rate tends to become lower due to learning effects and experience.
 - Depending on the number of blades to be built direct impregnating and "wet" hand-lay-up method (Figure 23) or a mechanized layup procedure can be used.
 - There is only one curing process for the structural elements of the blade, i.e. spar plus skin.
 - The curing process with $105^{\circ}\text{C} \pm 3^{\circ}\text{C}$ for 8 hours $\pm 0,5$ hours is uncritical and easy to control.
 - Reliable quality control is comparatively easy and uncritical when applied during the manufacturing process (Figure 24).

6. EXPERIENCE FOR DEVELOPMENT OF HINGELESS ROTOR HELICOPTERS AND CONCLUDING REMARKS

The hingeless rotor with its fiberglass rotorblades is a new technology, today already a proven technology, offering a wide range for further improvements. An understanding of the physical correlations to the theoretical background, as well as of the materials which can withstand high loads is now available.

The more and more pronounced tendency of the modern military helicopter towards higher power and improved performance, towards higher agility and capability for extreme nap-of-the-earth flying, towards improved survivability and reliability and towards reduced costs ask for further development. The hingeless rotorsystem with fiberglass rotorblades offers a high potential. The scope of experience covers a research program in a speed range of up to more than 200 knots (Ref. 15), and by Boeing-Vertol's development of the YUH-61A gross weights up to the medium class helicopters (8 tons) (Ref. 16). Today's knowledge and existing theoretical methods allow for further improvements. By a proper optimization of the dynamic characteristics, including aeroelastic feedback control effects, it seems to be possible to tune the system to any desirable characteristics (Figure 25).

With an adequate sizing of the components the high dynamic loads are no problem. The theoretical determination of the loads is, in comparison to articulated rotors, even easier, because the critical loads are mainly firstharmonic.

For the fiberglass rotorblades there are practically no limitations resulting from manufacturing methods. It is possible to build blades strictly on the basis of aerodynamic requirements. The blades can almost as easily be built with non-rectangular planform, non-linear twist, variable camber and variable airfoil section as a standard rectangular constant cross section, linear twist, constant mass blade. This could be demonstrated with a thickness tapered blade from 12 percent to 6 percent relative thickness, and a blade combining thickness taper with a variable camber and chord plus a double sweep (Figure 26).

The blade mass and its distribution can be tailored to fit the dynamic requirements. The blade mass per length of span can be realized in a wide range, larger than is actually needed. Figure 27 shows the envelope of the possible mass distribution in which a composite blade can be realized. The proper selection of the fiber (glass, Kevlar, graphite) and the fiber orientation allows the design of the composite to match the stiffness characteristics of a rotorblade easily, in accordance with dynamic and aeroelastic considerations almost independently from other requirements (Figure 28).

The composite rotorblades ensure high reliability, long or infinite fatigue life, insensitivity to damage, and inherent fail-safe characteristics. It has been proven that they are mature for operational use, and the next decade will definitely see a change from the composite blade as an exception to the standard design rule, to the non composite blade being the exception.

Compared to the articulated rotor, the hingeless rotor is not "forgiving" which means that all the detail design parameters have to be optimized. Small deviations may result in unfavourable conditions, but small modifications may also improve the system enormously. The hingeless rotor requires a fully coupled treatment, considering aerodynamics, dynamics and aeroelasticity together. The era of the hingeless rotor has just begun and will have its future (Ref. 10, 17).

7. REFERENCES

1. Weiland, E.F.: "Development and Test of the BO 105 Rigid Rotor Helicopter", J. American Helicopter Soc. Vol. 14, No. 1, January 1969

- 2 Reichert, G.: "Review of German Activities in Helicopter Structures and Dynamics", AGARD 31st Meeting of Structures and Materials Panel, Working Group on Helicopters - VSTOL Aircraft Structures and Dynamics, November 1970
- 3 Barth, R.: "The Hingeless Rotor - A Concept to Increase Mission Effectiveness at Reduced Costs". AGARD Annual Meeting, September 1973
- 4 Hohenemser, K.H.: "Hingeless Rotorcraft Flight Dynamics", AGARDograph No. 197, September 1974
- 5 Reichert, G.: "Loads Prediction Methods for Hingeless Rotor Helicopters", in AGARD Specialists Meeting on Helicopter Rotor Loads Prediction Methods, AGARD-CP-122, 1973
- 6 Reichert, G.: "The Impact of Helicopter Mission Spectra on Fatigue" in AGARD Specialists Meeting on Helicopter Design Mission Load Spectra, AGARD-CP-206, 1976
- 7 Reichert, G.: "Flugeigenschaften bei Hubschraubern mit elastisch angeschlossenen Rotorblättern", Wissensch. Ges. Luft- und Raumfahrt, Jahrbuch 1963; or translated: "Handling Qualities of Helicopters with Elastically Attached Rotor Blades", NASA TT F-11374, 1968
- 8 Reichert, G.: "Flugmechanische Besonderheiten des gelenklosen Hubschrauberrotors", Wissensch. Ges. Luft- und Raumfahrt, Jahrbuch 1965; or translated: "Flight-Mechanical Properties of the Hingeless Helicopter Rotor", NASA TT F-11373, December 1967
- 9 Reichert, G.; Oelker, P.: "Handling Qualities with the Bölkow Rigid Rotor System", American Helicopter Soc., 24th Annual National Forum, Preprint No. 218, May 1968
- 10 Reichert, G.; Huber, H.: "Influence of Elastic Coupling Effects on the Handling Qualities of a Hingeless Rotor Helicopter", 39th AGARD Flight Mechanics Panel Meeting, Hampton, Virginia, September 1971
- 11 Reichert, G.: "Basic Dynamics of Rotors-Control and Stability of Rotary Wing Aircraft-Aerodynamics and Dynamics of Advanced Rotary-Wing Configurations" AGARD Lecture Series on Helicopter Aerodynamics and Dynamics, AGARD-LS-63, 1973
- 12 Bender, D.: "Ship Landing Trials with the BO 105", Second European Rotorcraft and Powered Lift Aircraft Forum, Paper No. 7, September 1976
- 13 Weiß, H.; Stoppel, J.: "Dynamics of a Small Helicopter with a High Capacity Rescue Hoist", Second European Rotorcraft and Powered Lift Aircraft Forum, Paper No. 12, September 1976
- 14 Attfellner, S.; Sardanowsky, W.: "Meeting the Maneuverability Requirements of Military Helicopters", Second European Rotorcraft and Powered Lift Aircraft Forum, Paper No. 27, September 1976
- 15 Huber, H.; Schick, C.; Teleki, A.: "Hochgeschwindigkeitserprobung des Hubschraubers BO 105 - HGH", Deutsche Gesellschaft für Luft- und Raumfahrt e.V., DGLR 76-222, September 1976
- 16 von Doblhoff, F.L.; Weiland, E.: "Gelenkloser Rotor für größere Hubschrauber", Deutsche Gesellschaft für Luft- und Raumfahrt e.V., DGLR 76-223, September 1976
- 17 Huber, H.: "Parametric Trends and Optimization - Preliminary Selection of Configuration - Prototype Design and Manufacture", AGARD Lecture Series on Helicopter Aerodynamics and Dynamics, AGARD-LS-63, 1973

11-8



Fig. 1 BO 105 in Offshore Operation



Fig. 2 BO 105 in Military Operation



Fig. 3 Rotorhub and Blade Attachment of the BO 105 Hingeless Rotor System



Fig. 4 BO 105 Fiberglass Rotorblade

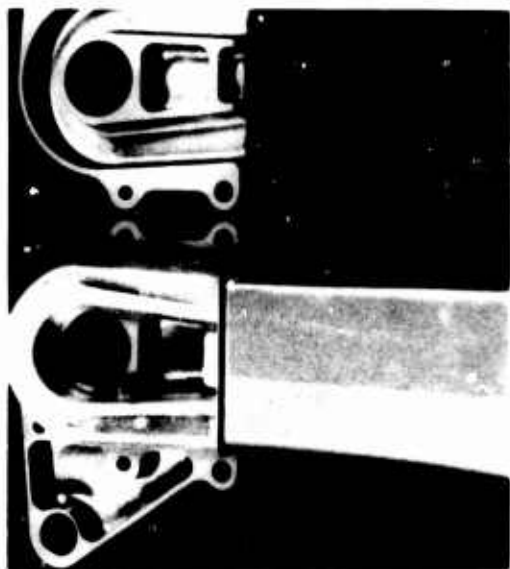

Fig. 5 BO 105 Blade Root

ARTICULATED ROTOR

HINGELESS ROTOR

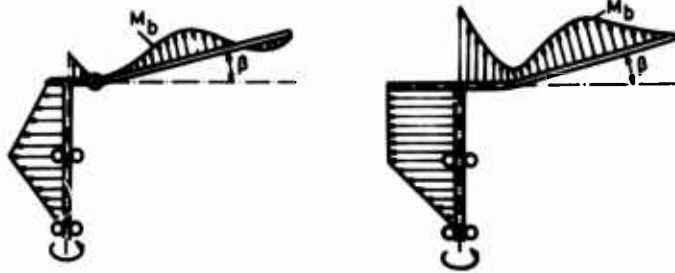

Fig. 6 Loading Situation of a Hingeless Rotor in Comparison to an Articulated Rotor

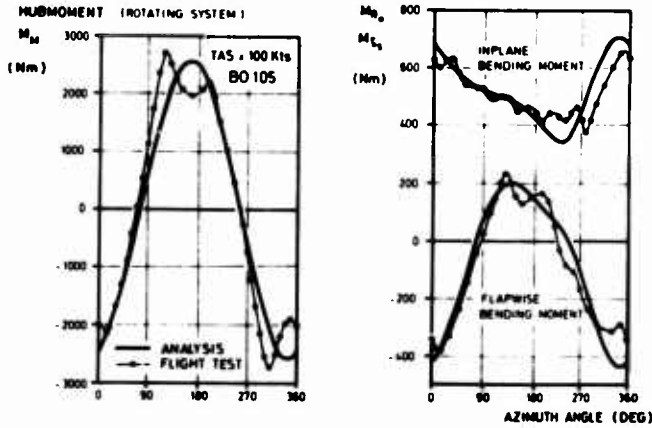

Fig. 7 Hub and Blade Root Moments in Forward Flight

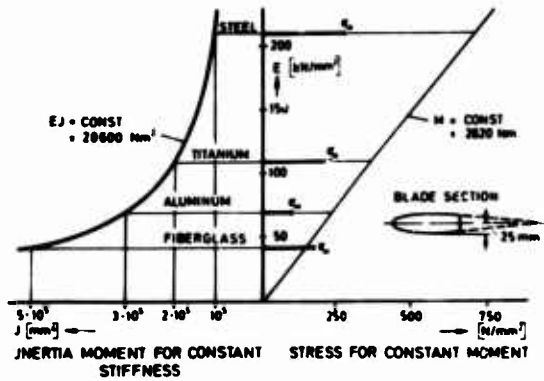

Fig. 8 Influence of Material Properties

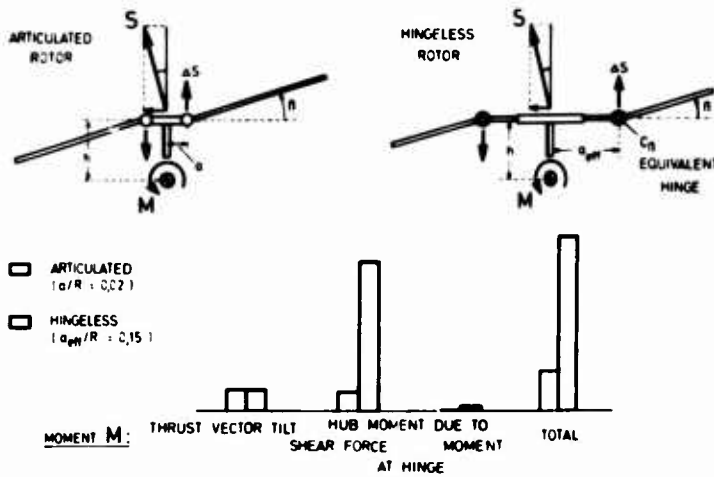
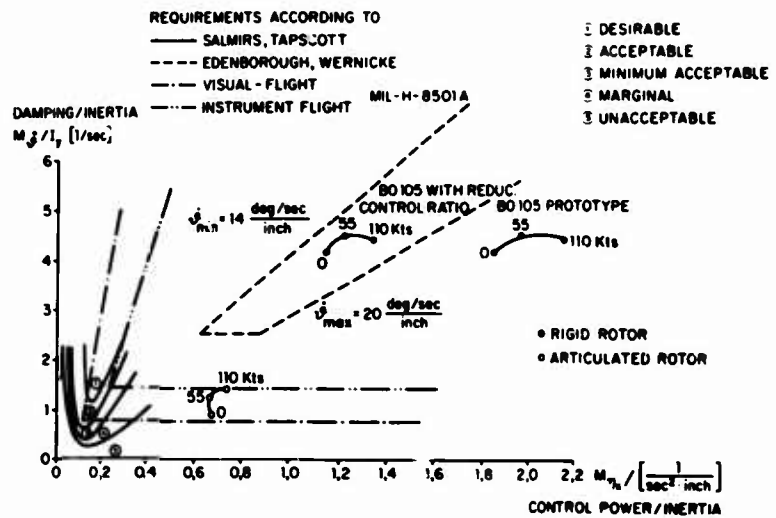

Fig. 9 Rotor Control Moment Capacity

Fig. 10 Helicopter Control Characteristics - Pitching



11-10



Fig. 11 Slope Landing



Fig. 12 Ship Landing



Fig. 13 Rescue Hoist for two persons



Fig. 14 Helicopter with Antitank Missile HOT

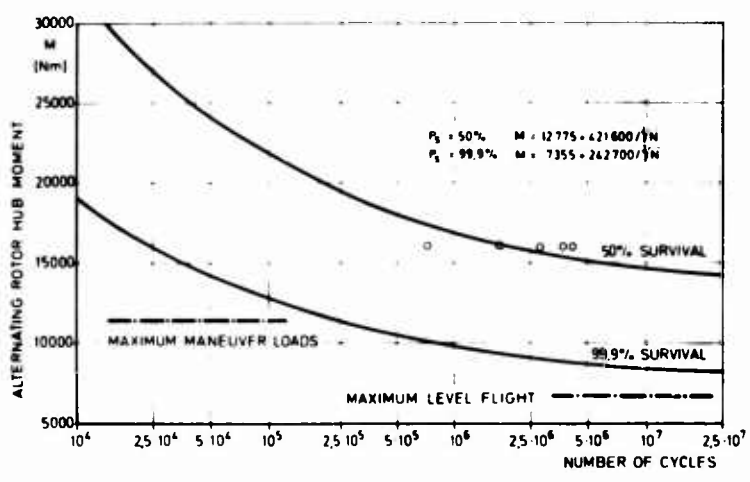

Fig. 15 Fatigue Strength of the Rotorhub

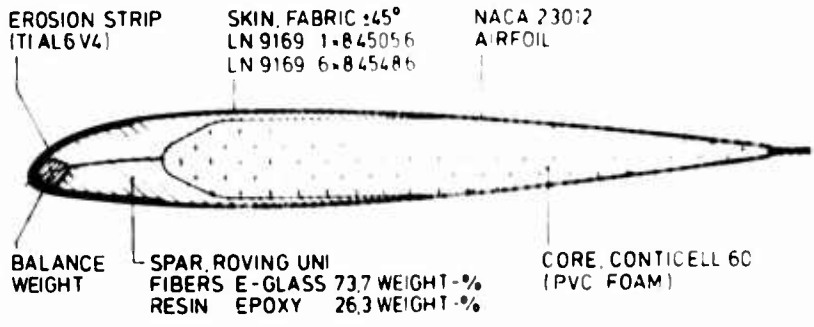

Fig. 16 BO 105 Rotorblade Section

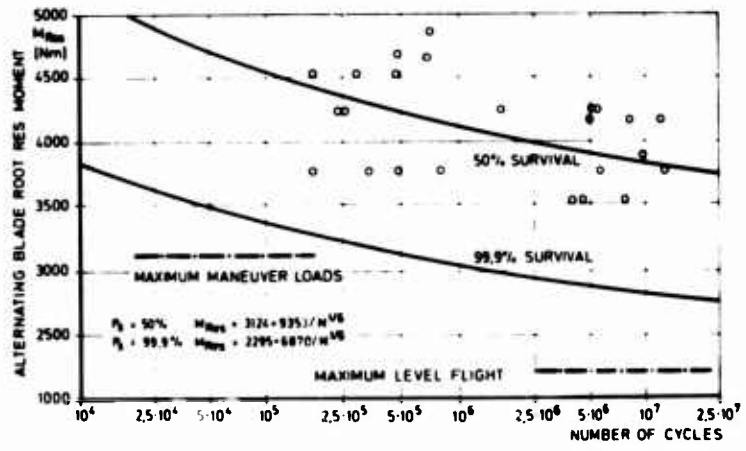

Fig. 17 Fatigue Strength of the Blade Spar

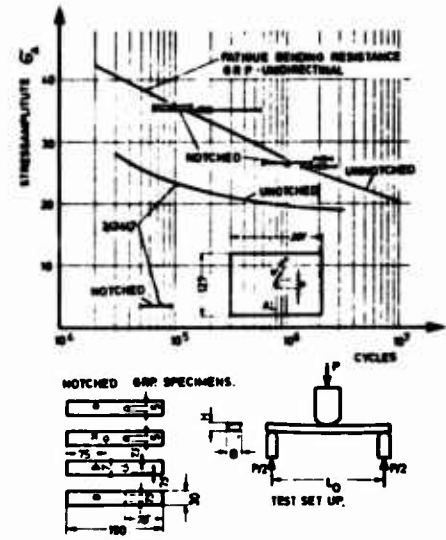

Fig. 18 Fatigue Resistance of Notched Specimen

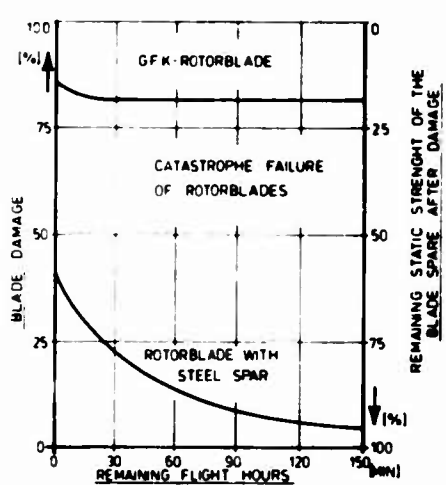

Fig. 19 Remaining Lifetime after Damage of Rotorblades



Fig. 20 Ballistic Damaged Blade Spar

11-12



Fig. 21 BO 105 Blade After Curing in the Mold

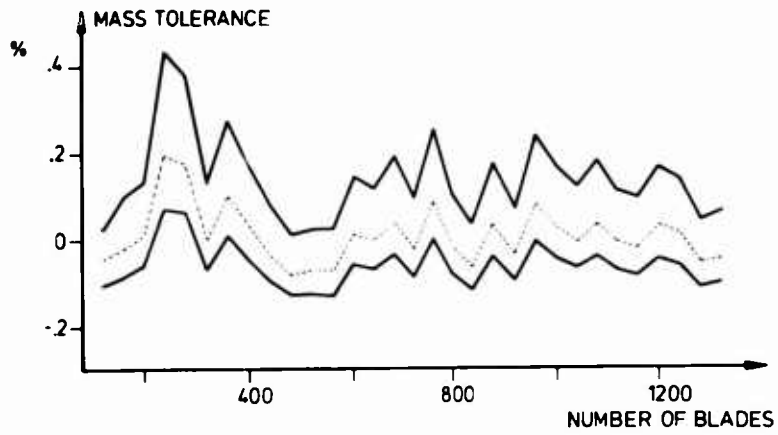

Fig. 22 Mass Tolerance After Curing of the BO 105 Blade



Fig. 23 Manufacture of the BO 105 Blade

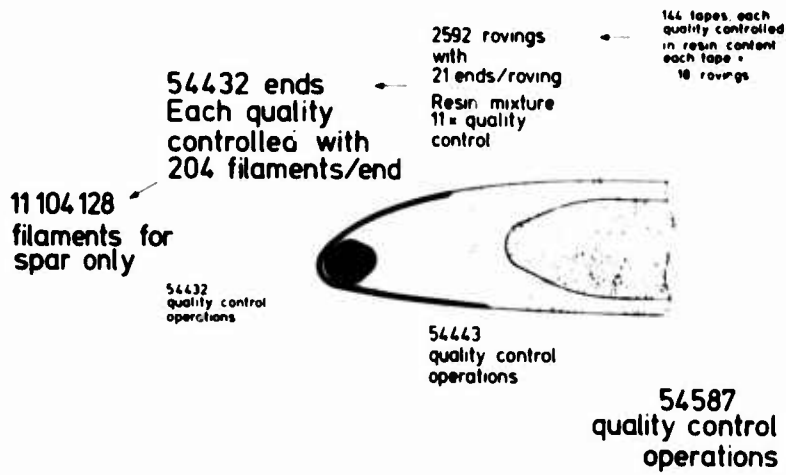

Fig. 24 Quality Control of BO 105 Blade Spar

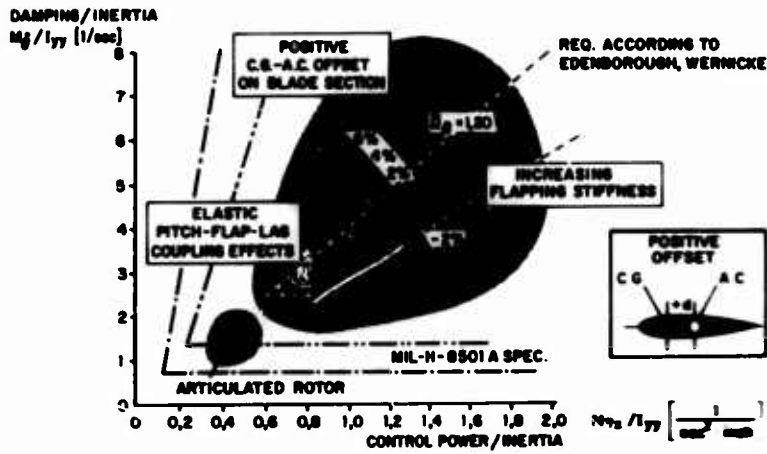

Fig. 25 Range of Potential Control Characteristics of a Hingeless Rotor Helicopter



Fig. 26 Composite Rotorblades with Rectangular Planform and with Swept Tip

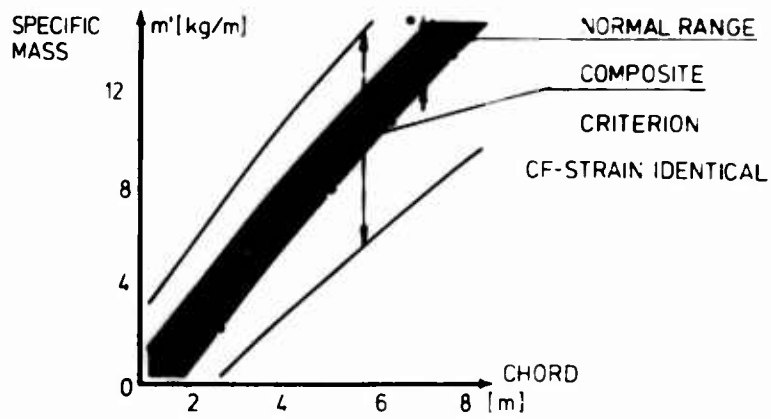

Fig. 27 Specific Mass Variation Capability of a Composite Airfoil Section

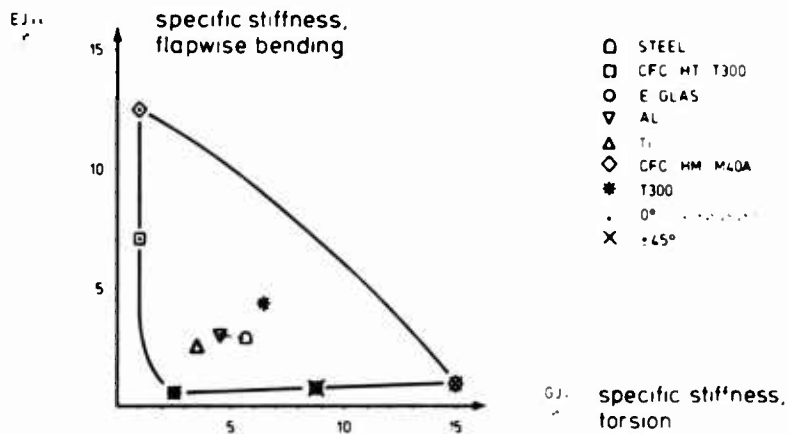

Fig. 28 Stiffness Variation Capability of a Composite Airfoil Section

THE BELL MODEL 222

12-1

James R. Garrison
Chief, Model 222 Project
Bell Helicopter Textron
P. O. Box 482
Fort Worth, Texas 76101
USA

ABSTRACT

This paper describes the design objectives, features and performance of the recently developed Bell Model 222. The Model 222 was designed to meet the needs of the worldwide commercial market. Primary design objectives were safety, efficiency, reduced cost of ownership, and superior handling qualities. From the test results, the Model 222 is a fuel conservative, productive aircraft with excellent flying qualities.

The first flight was in August 1976 and development is essentially complete. The aircraft will be delivered in early 1979 after the most comprehensive test program ever conducted on a commercial helicopter.

Federal Aviation Administration Airworthiness Standards, Transport Category Rotorcraft (FAR Part 29 - Category A) provides the basis for civil certification; however, the 222 far exceeds the FAA requirements for fail-safe design and crashworthiness. Redundancy, 8g seats, crash resistant fuel tanks, and real twin-engine safety are examples. The latter refers to the fact that for any altitude at which the helicopter can hover OGE, it can continue to cruise if one engine fails.

Recent military design requirements differ from the commercial requirements which guided the design of the 222. This paper shows some of these differences and how the 222 might be adapted to satisfy the military requirements of the NATO countries.

INTRODUCTION

The Bell Model 222 is an 8-place helicopter powered by two Lycoming LTS101 engines. It is the result of extensive engineering design studies and marketing surveys conducted by Bell Helicopter to determine the size, power, and performance needed for the light twin of the future.

Figure 1 shows a full scale mock-up of the 222 built in early 1974. It was used extensively by Bell Engineering and Marketing to establish the final configuration.

The mock-up was shown at several conventions and suggestions were solicited from commercial and military customers.



Figure 1. Model 222 Mock-up.

Many customer suggestions were incorporated in the design, including increases in visibility and cabin volume, cowl styling, performance targets, and kits.

12-2

The design was established principally as an executive transport helicopter. This is a new market segment first penetrated by the Bell JetRanger. Bell studies indicate that the potential is outstanding for sales of a light twin-engine helicopter of the 222's size in the executive market segment. Studies have also shown the 222 to be the right size for the offshore oil rig support market. The promise of these two markets was sufficient for Bell to proceed with the development of the 222 with company funds.

Bell's extensive commercial experience has shaped the 222 design. There has been major emphasis on safety, mission efficiency, and low life-cycle costs. Additionally the 222 has been made to be a pilot's best friend.

Safety is the overriding factor in the design. Examples here include redundant attachments in the pylon and blade areas, crash resistant fuel tanks, and high-g seats. Most of the aircraft's safety features will be discussed in the subsequent sections of this paper; however, the unique single-engine performance safety feature of the 222 may not be so obvious and should be highlighted.

The 222 has an optimum match of useful twin-engine power and weight such that the helicopter's single-engine service ceiling is above any altitude and gross weight combination at which the 222 will hover OGE. This means that at any altitude at which the helicopter can hover OGE, one engine can fail, and the helicopter can continue to cruise on one engine. This is real twin-engine safety. Although a demanding criterion, it will be required in the marketplace of the future.

Mission efficiency is achieved through advanced technology. High-efficiency Bell-developed airfoils, low fuel consumption light-weight power plants, advanced low-cost structural design, compact external size with large cabin volume, and stylized low-drag fuselage are examples. The combined features of the 222 and advanced technology make it a most fuel conservative helicopter.

Careful attention has been paid to reduce life-cycle costs through lower initial costs, increased reliability, and reduced maintenance. Initial cost is reduced by the design, the use of low-cost materials, and tooling such as universal mechanical machining and automatic riveting. Fuel costs can be expected to be 25% less than competitive models. Reliability and maintainability, strong features of the design, will be verified by a Bell conducted accelerated service test. Diagnostics are provided to aid in this. Because of these factors major cost reductions can be expected.

Finally, that it is a pilot's aircraft is an established fact. The excellent handling qualities of the basic aircraft, low vibration levels due to the proven nodal beam system, the comfortable high-g seats, good visibility, low noise levels, exceptional instrument panel, the new pilot collective control arrangement, all combine to make the aircraft most comfortable and pleasant to fly.

Figure 2 is a three-view of the 222 showing the overall dimensions.

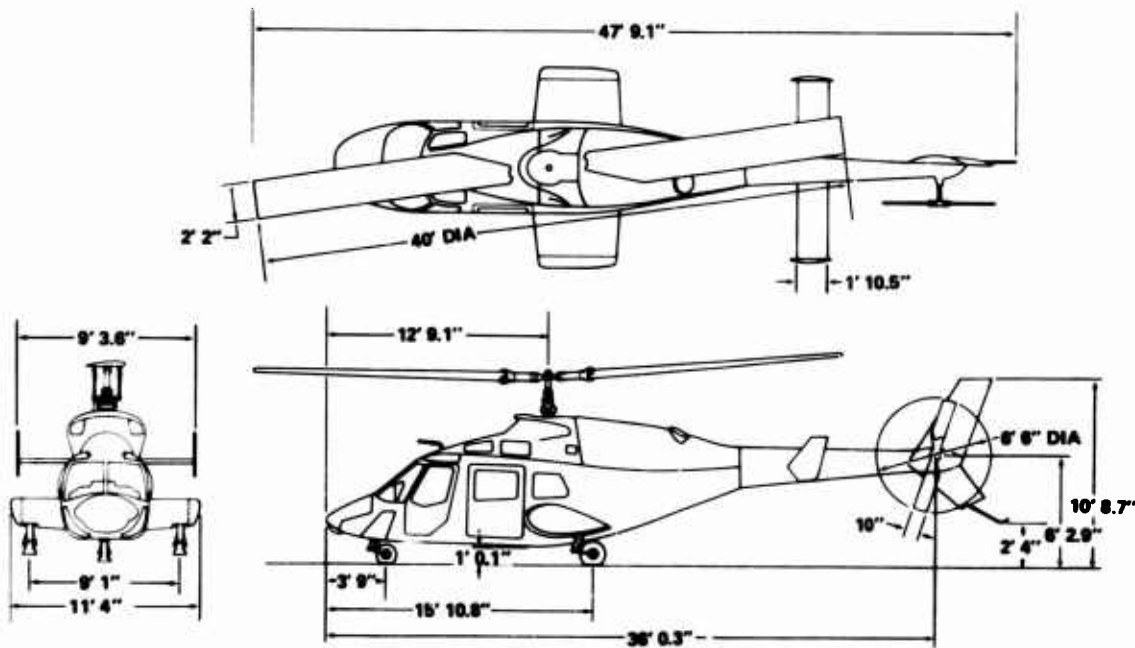

Figure 2. Model 222 Overall Dimensions.

Other highlights of the design include:

12-3

- Speed of 150 knots at maximum continuous power.
- Range of 370 nmi with 20 min reserve fuel, cruising at 8000 ft.
- Useful load of 2950 lb.
- Single engine service ceiling of 9000 ft at 7200 lb gross weight on a standard day.
- Retractable tricycle wheel landing gear as standard, with skid gear and flotation options.
- Flexible seating arrangements with large baggage space (43 cu ft).

Figures 3, 4 and 5 summarize the outstanding safety, maintenance and comfort features of the 222.

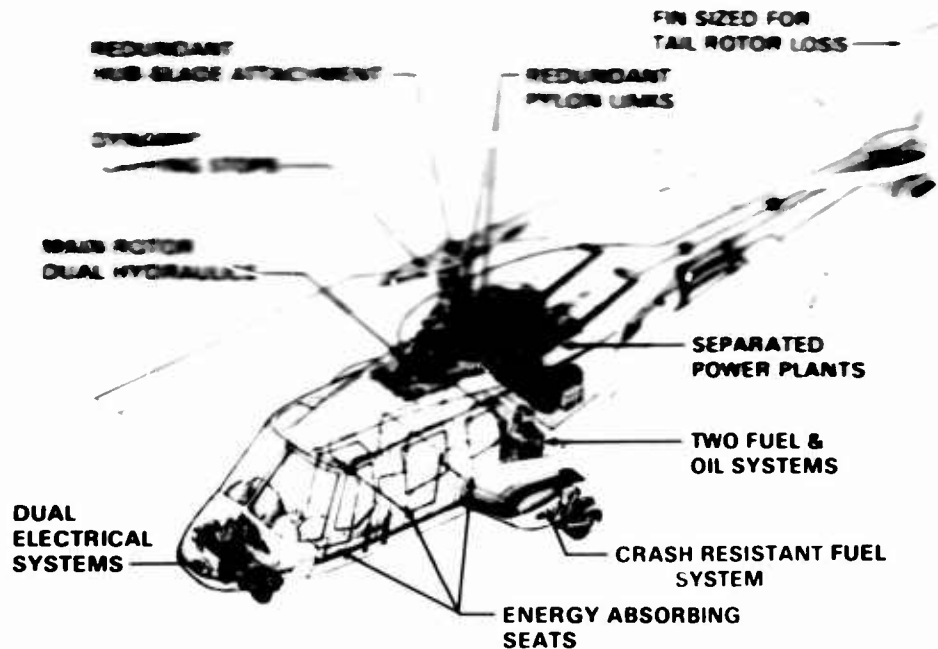

Figure 3. Safety Features.

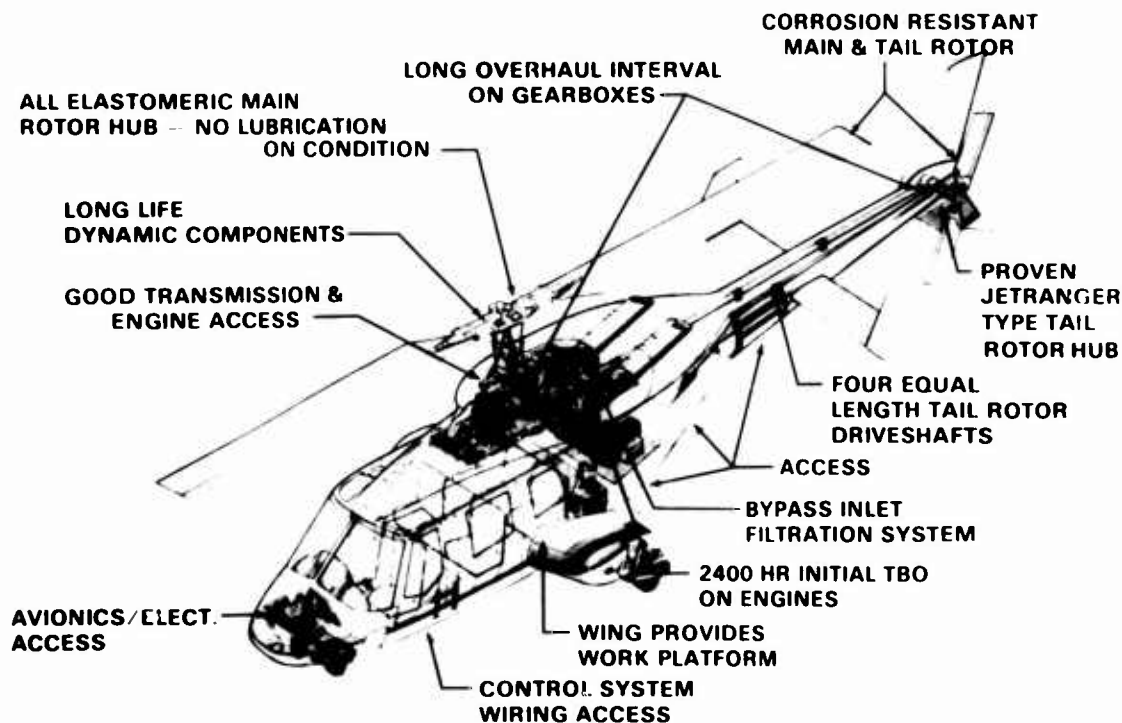

Figure 4. Maintenance Features.

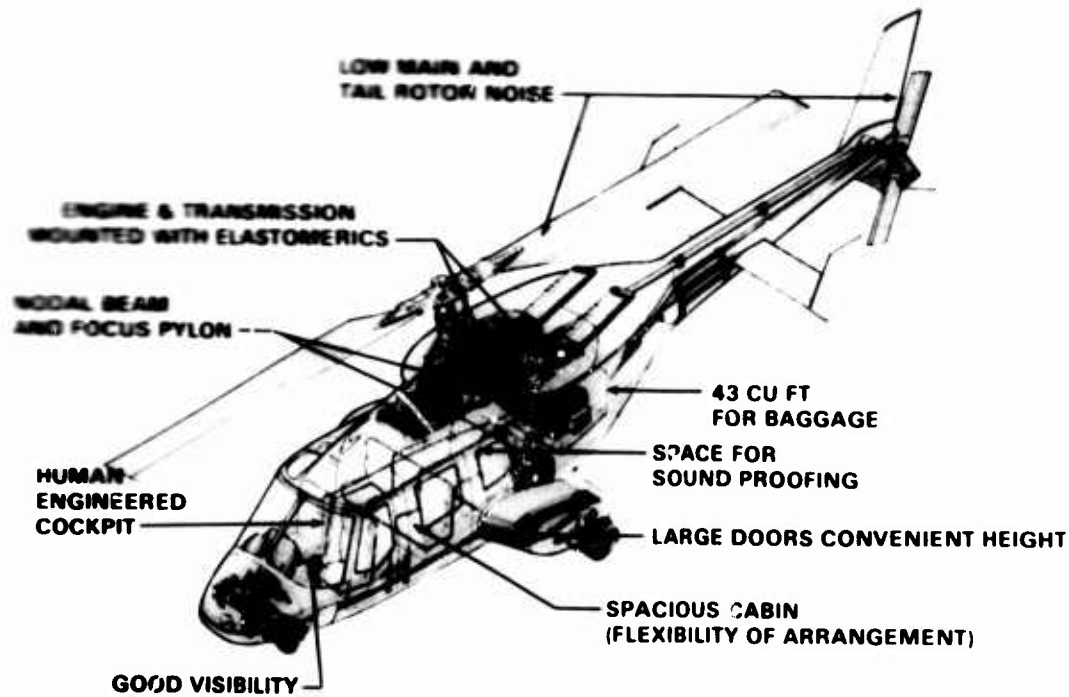

Figure 5. Comfort Features.

DESIGN HIGHLIGHTS

Main Rotor Hub

Reduced maintenance, safety, and long component lives have been designed into the semirigid two-bladed main rotor hub shown in Figure 6.

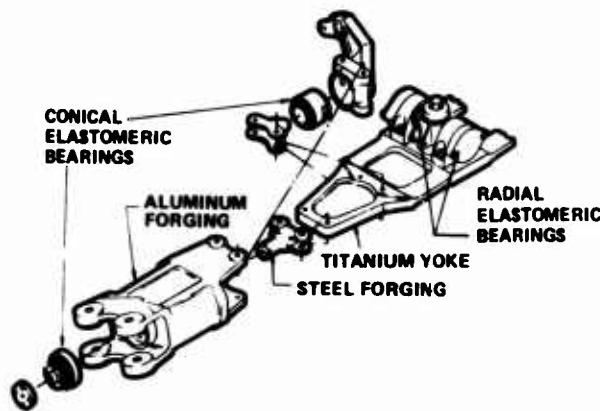

Figure 6. Main Rotor Hub.

This hub uses elastomeric bearings for pitch change and for flapping, eliminating the need for lubrication. Pitch change is accomplished by twisting of the conical elastomeric bearings. For full cyclic and collective pitch these bearings twist through approximately 40°. These conical elastomeric bearings are redundant. Either of the bearings can fail and the remaining bearing is sufficient to carry the centrifugal force of the main rotor blade.

The aluminum grip attachment to the main rotor blade is also redundant. Any one of the lugs which attach the grip to the blade can fail and the remaining three will carry the normal flight loads.

The yoke is a machined titanium plate and is designed with a flexure to accommodate coning and to reduce the oscillatory forces transmitted to the pylon. Flapping occurs about the mast by means of radial elastomeric bearings. The elastomeric bearings are supplemented by elastomeric springs, providing hub restraint. The hub restraint improves handling qualities, increases control power, provides more c.g. travel, and allows high-wind startup and shutdown.

The blade weights and frequencies have been placed, and all structural elements have been sized, to give long component lives. Based on the current test data, the objective of having a 5000-hour life on all of the dynamic components in the main rotor hub and control system will be achieved. 17-5

As can be seen from Figure 7, the elastomeric bearings in the hub are easy to inspect. The failure mode of these bearings is a gradual visible deterioration; therefore, no life limit will be assigned these bearings. They will be replaced on condition.

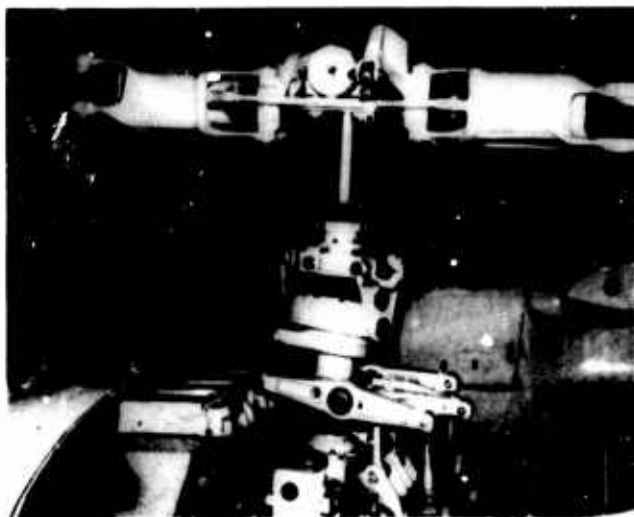

Figure 7. Main Rotor Hub.

Main Rotor Blade

Design Parameters

Diameter	40.0 ft
Chord	26.0 in
Number of Blades	2
Thrust Coefficient	.14
Design Tip Speed	708 ft/sec
Airfoil Section	8% Thick FX71-H-080

Redundancy and long component life is built into the 222 blades. The main rotor blade has an 8% thick Wortmann 080 airfoil and 40 ft diameter. It is constructed of stainless steel and fiberglass. The stainless steel built-up structure (first 25% of blade chord) provides the primary load carrying structure for the blade. The after body is constructed of fiberglass skins with a Nomex honeycomb core. For redundancy, fiberglass safety straps, as shown in Figure 8, are placed inside the steel spar on the upper and lower surfaces. These fiberglass safety straps extend from the root of the blade, where they wrap around the blade retention bolt bushings, to the tip of the blade. These straps are designed to carry the full centrifugal force of the blade in the event of a failure of the primary steel structure.

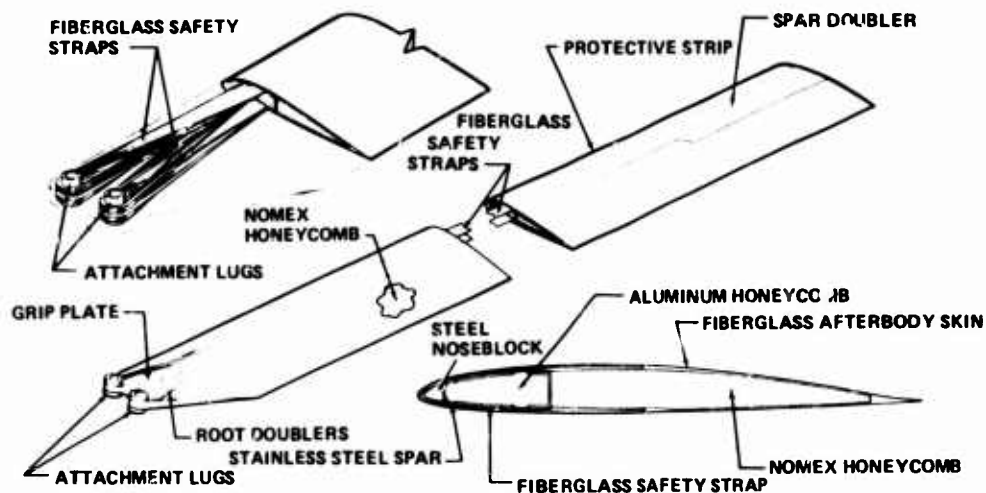

Figure 8. Main Rotor Blade.

12-6

The straps perform two distinct functions. First, if a crack develops in the blade, the fiberglass strap will slow the rate of crack propagation. Second, after the crack has progressed to its maximum extent, the fiberglass safety straps retain the blade structure and prevent a catastrophic separation. Tests show that the fiberglass straps will carry the load indefinitely after primary spar failure, thus assuring that routine inspections will reveal any problems.

Figure 9 shows a finished blade with the fiberglass straps laying on the top side of the blade to illustrate how the strap wraps around the retention bolt bushings.

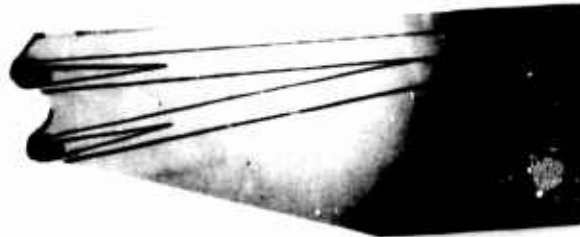

Figure 9. Main Rotor Blade Showing Fiberglass Straps.

With the long predicted life of these blades and the incorporation of the safety straps, the 222 blade is expected to achieve on-condition replacement soon after its introduction into service.

Tail Rotor

Design Parameters

Diameter	6.5 ft
Chord	10.0 in
Number of Blades	2
Design Tip Speed	621 ft/sec
Airfoil Section	BHT 10.9% Forward Camber

The tail rotor is a semirigid type. The hub is comprised of a titanium yoke and a 4130 steel trunnion. Needle-type bearings are used in the flapping axis and dual low-friction spherical bearings provide feathering motions. Pitch links are fixed length with teflon-lined spherical bearings for low maintenance.

The blades have a Bell-developed 10.9% forward cambered airfoil that has a very high stall angle. Sideward flights in quartering winds have been performed at high altitude in Alamosa, Colorado, and adequate directional control margins have been demonstrated.

Rotor Drive System

The rotor drive system shown in Figure 10 consists of two LTS101-650C-2 engines, engine-to-transmission drive shafts, two overrunning clutches, a tail rotor drive of four equal-length shafts, and a tail rotor gearbox.

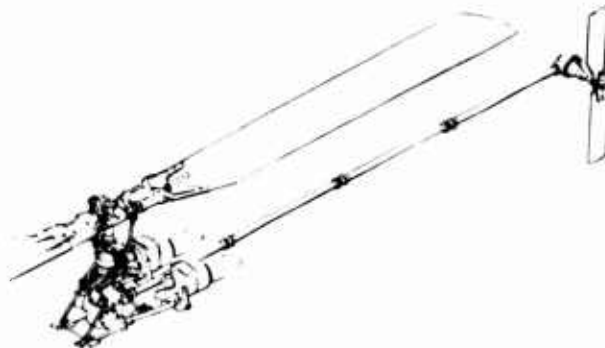

Figure 10. Drive System.

The prebalanced input drive shafts have grease-packed crown tooth couplings at each end that attach to mating adapters on the engine and transmission input quills. The couplings are designed to operate with angular misalignment and chucking to allow for pylon motions. Particular attention has been paid to seal designs. Seal contact velocities are kept as low as possible throughout the drive system to minimize grease leakage problems.

The overrunning clutches are sprag-type freewheeling units mounted in each transmission input quill. These freewheeling units will provide for long periods of single-engine operation as well as conventional autorotational features.

The four identical interchangeable tail rotor shafts are each prebalanced and equipped with adapter flanges on each end. The main transmission has a grease-packed crown tooth coupling attaching it to the tail rotor driveshaft to accommodate transmission motions. The remaining shafts are connected by flexible Thomas couplings to accommodate angular misalignment. They are supported by three bearing hangers. Each hanger consists of coupling flanges mounted by a fixed spline to a grease-packed bearing. A redundant strap retainer supports the shaft in the event of a hanger bearing failure. Each bearing hanger has a pad for mounting an accelerometer for shaft balancing.

Main Transmission

The main transmission combines power from the two engines to drive the main rotor, tail rotor, and hydraulic pumps. The input speed is 9265 rpm and the transmission drives the main rotor mast at 338 rpm, the tail rotor drive shaft at 3298 rpm and the hydraulic pumps at 5000 rpm. The reduction is accomplished in three stages: first stage is through a spiral bevel gear set in the right and left outboard input gearboxes; second stage is through a spiral bevel collector gear set; and third stage is through a planetary gear set. The tail rotor drive shaft is driven by the collector bevel gear. Both hydraulic pumps are driven by the collector bevel gear through an independent spiral bevel gear.

Gear noise is minimized by advanced gear technology with increased tooth contact ratios in the planetary stage. Higher tooth contact ratios in the spur gears provide smoother transfer of forces at lower pressures, thus reducing bearing and gear noise.

The transmission is designed to accept full engine power from either engine with one engine inoperative (OEI). The installation is derated at the main rotor mast for normal twin engine operations. This derating results in a light-weight, efficiently-designed transmission since the power plant installation has approximately 33% excess power to accommodate high altitude and high ambient temperature operations. The mast contains an integral torquemeter to allow use of the full horsepower capability of the mast regardless of other power requirements - increasing hover performance and payload.

The transmission is attached to the nodal beams by a four-bar linkage. Elastomeric bearings in the links isolate the fuselage from noises and high-frequency vibrations. Fore and aft and lateral stops on the beam limit motion and provide a redundant means of reacting loads in the event of a support link failure. Elastomeric mounts provide fore and aft and lateral pylon restraint and tune the pylon to isolate two-per-rev inplane hub shears.

The transmission lubrication system has its own reservoir and oil cooler. The oil cooler receives forced air from both engines so that cooling air is supplied with one engine inoperative.

Nodal Beam

Crew and passenger isolation from the rotor-induced vertical two-per-rev vibration is provided by the nodal beam structure shown in Figure 11.

The four links which attach to the transmission are focused at predetermined points for isolation of fore and aft and lateral forces and are attached to the nodal beam for vertical isolation. The nodal beam has fiberglass flexures which are dynamically tuned by adding or subtracting tuning weights to tailor the force inputs to the fuselage to a low value. The effects of tuning are shown in Figure 12. As can be seen, dramatic improvements in vibration levels were made with the 11 lb weight.

12-8

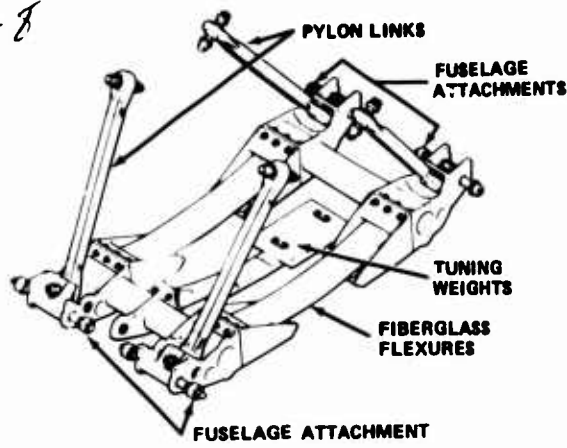

Figure 11. Nodal Beam Arrangement.

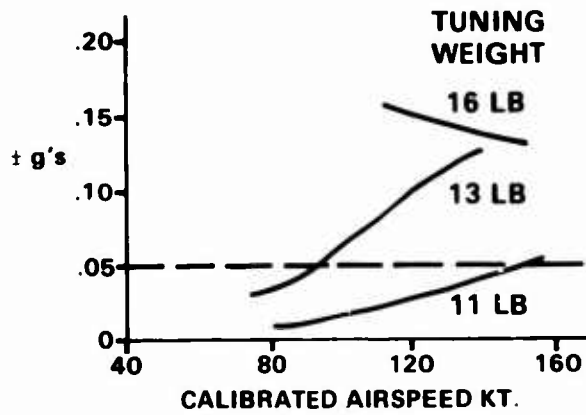

Figure 12. 2-Per-Rev Vertical Vibration at Crew Station.

Power Plant

Two LTS101-650C-2 engines shown in Figure 13 provide the 222 with the power reserve required for outstanding single engine performance. Each is rated at 615 shaft horsepower for takeoff and 590 shp for continuous operations. There is also a special rating of 675 shp for 2-1/2 minutes with one engine inoperative. The LTS101 is a simple design with one axial and one centrifugal stage compressor and only three main shaft bearings. The gas generator turbine and power turbine are both single stages.

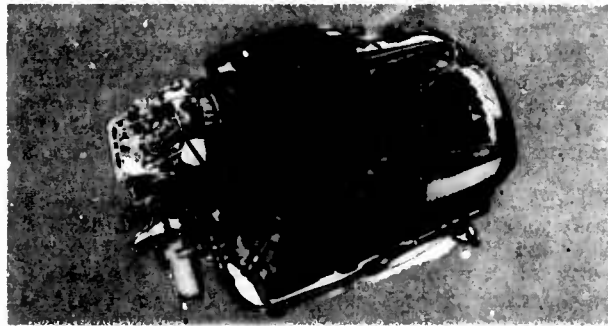

Figure 13. LTS101-650C-2 Engine.

Goals for reduced operating costs are achieved in the LTS101 by its simple modular design which allows easy replacement of units and quick "hot-end" inspections with standard hand tools. The engine contains only three major modules plus the quick-disconnect inlet scroll. The major modules are shown in Figure 14. In 1975 the LTS101 was certified with a 1200-hour TBO. In early 1977, based on extensive testing, the TBO was extended to 2400 hours. The potential is high for further increased TBO.

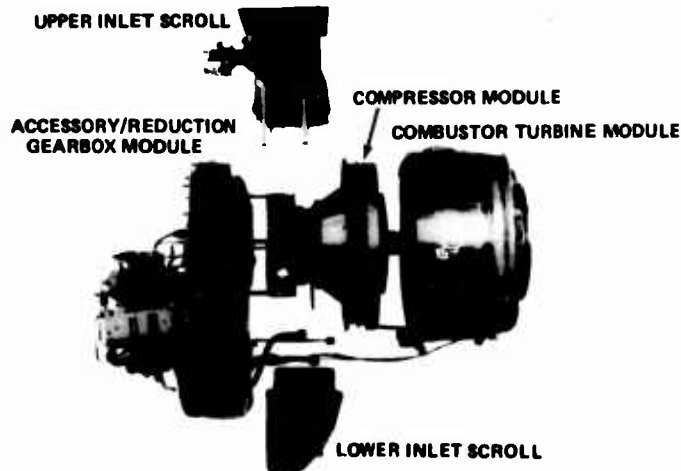

Figure 14. Major Modules of the LTS101 Engine.

Other features of the LTS101 engine include a minimum number of moving parts, low oil heat rejection, easy starting, fuel consumption optimized for partial powers, and a high speed accessory drive for the oil cooling fan. 12-9

The 222 has a bypass air filtration system for the engine installation. This bypass air filtration system is shown schematically in Figure 15. Air enters the cowling inlet through the forward firewall. The air must turn approximately 90° to enter the engine. In so doing, particles in the air are centrifuged to the bypass duct and are taken overboard with a tail pipe ejector. This system is common to the Bell models 212 and 214 engine installations and, in service throughout the world, has demonstrated outstanding filtration efficiency for sand, snow, and ice.

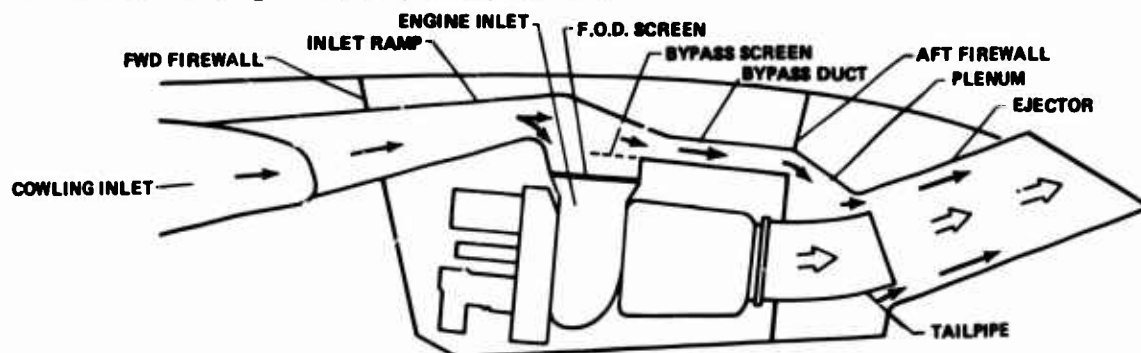

Figure 15. Engine Air Filtration System.

Fuel System

Four rugged impact-resistant cells provide the 222 fuel system with safety features far in excess of FAA requirements, see Figure 16. Two cells are in the wing structure, and two are in the fuselage just aft of the passenger compartment.

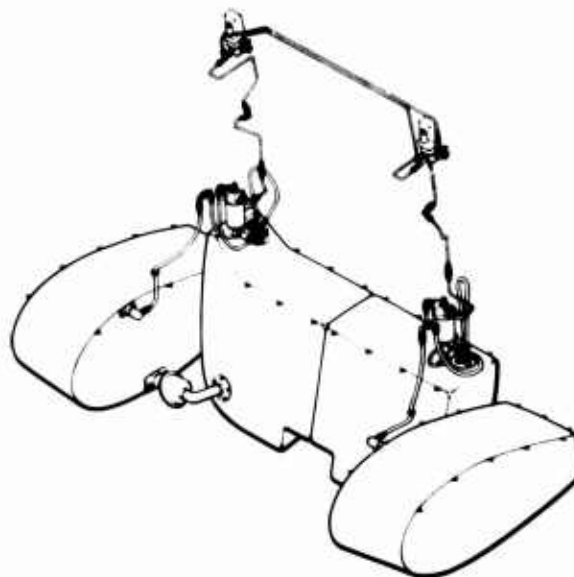

Figure 16. Fuel System.

The wing attaching fuel lines and vent lines have breakaway fittings to minimize the possibility of a post-crash fire from fuel spillage. These fittings have been shown to be a major deterrent to fire injury.

All cells are made of a material developed by Uniroyal to be rupture resistant. In testing at Uniroyal, each cell has been subjected to free-falls with ground contact velocities of 56 ft per sec without rupture.

This fuel system is a derivative of the systems developed for the Army in the Huey series helicopters. A dramatic reduction in post-crash fires and injuries has been evidenced since incorporating that system.

Fuselage

The fuselage of the 222, as shown in Figure 17, is of conventional semi-monocoque construction. To minimize costs, flat-wrapped all-aluminum skins have been used where possible. No magnesium has been used to avoid corrosion and cracking problems.

12-10

Fiberglass honeycomb panels have been restricted in use to the fuel cell areas. Titanium has been used sparingly because of its cost.

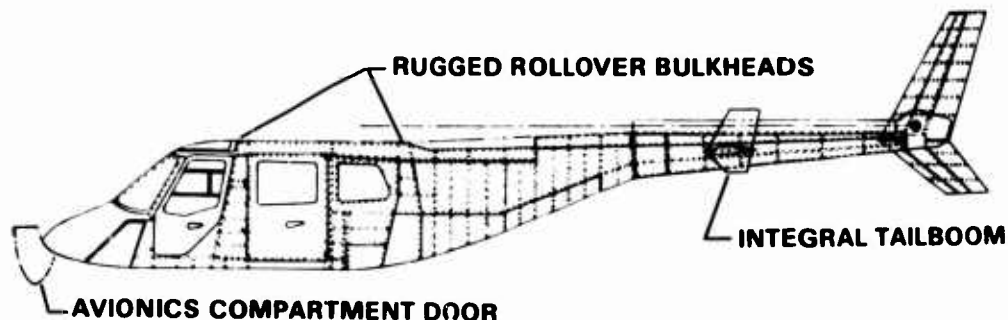

Figure 17. Model 222 Semi-Monocoque Construction Fuselage.

Large rugged leak-proof doors provide easy entrance and egress. The cabin volume is large (130 cu ft) even though the overall size of the helicopter is small. Maximum utilization is made of the space. The easy-access baggage compartment may be reached from either the cabin or outside.

The wings which contain two of the fuel cells also house the retractable landing gear. This wide-spread gear arrangement provides good ground stability.

Cockpit

Figure 18 is a photograph of the cockpit area of the 222. A large instrument panel has been provided that can be equipped with an IFR array of instrumentation and radios, and yet retain good visibility for the VFR operator.

The collective control on the pilot's side shown in this figure is unique. The collective lever is located in the lower console and has the throttles extending laterally from the collective head. This collective arrangement offers three advantages. First, it puts the left and right throttles in the proper relative position with respect to the instruments and engines. Second, this unique collective arrangement provides a flat, rather than an up-down travel. Up collective is still the same basic motion, the elbow bends in the same manner as in the older collective stick arrangements. With this control system pilot-induced oscillations are eliminated thus reducing the requirement for collective friction to a minimum. Finally, this collective system allows an open space between the pilot and co-pilot seats for cabin access and the storage of maps, manuals, etc. Pilot acceptance of this collective configuration has been outstanding.

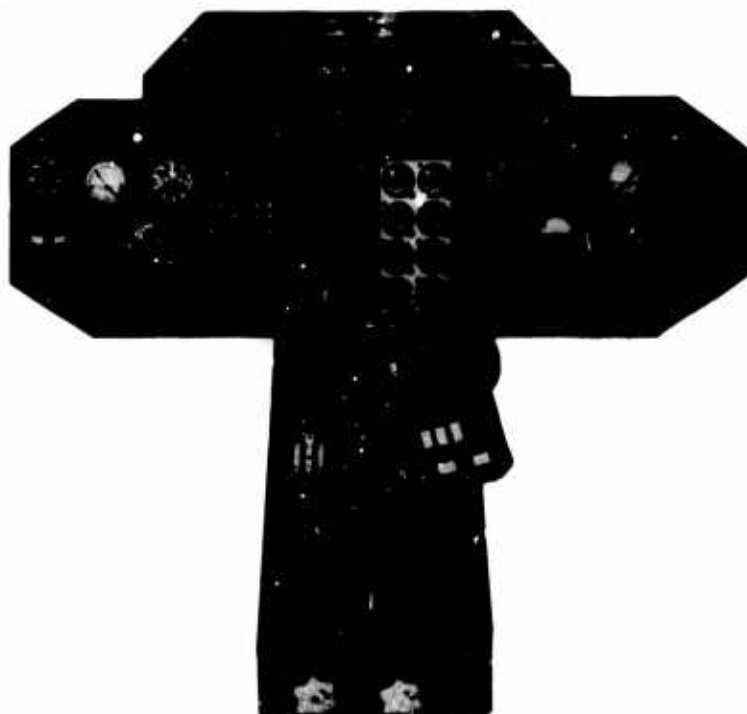

Figure 18. IFR Instrument Panel.

Interiors

The 222 cabin and crew compartment areas offer a great deal of flexibility. A seven-place configuration, Figure 19, with two aft facing seats provides a convenient executive arrangement and still allows an aisleway into the cockpit. Figure 20 shows the standard passenger compartment with six seats. The outboard two seats in the forward three-man seat fold for access to the back seat. A two-man seat can be added in the passenger compartment, see Figure 21, by moving the forward three-man seat slightly aft. This provides the cabin with eight seats for a total of ten places. 12-11

All the seats can be removed and the baggage compartment door left open aft of the passenger compartment, as shown in Figure 22, providing an unobstructed distance of 12.5 feet from the back of the crew compartment to the back of the baggage compartment. The baggage compartment, aft of the cabin, has 43 cubic feet for storage and the passenger compartment has 130 cubic feet.

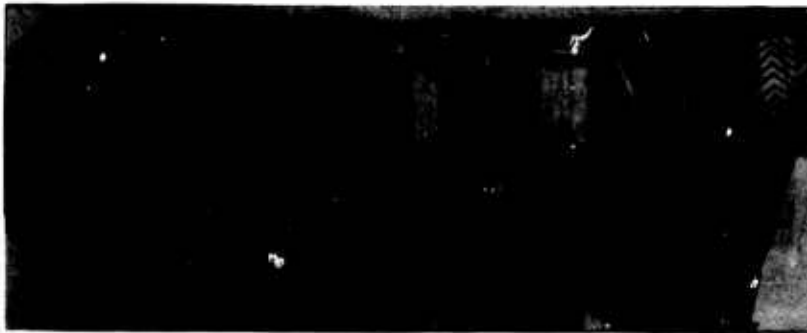

Figure 19. Customized Executive Configuration.



Figure 20. Standard 8-Place Configuration.



Figure 21. High Density 10-Place Configuration.



Figure 22. Utility Configuration.

Seats

The crew seat incorporates energy absorbing material in the back supporting strut, and allows for seat adjustment vertically and fore and aft. Figure 23 shows the seat during drop tests conducted by the FAA in Oklahoma City.



Figure 23. Crew Seat in FAA Test.

These test results have not been published; however, the data show that a 170 lb occupant would receive no major injuries from vertical accelerations when the seat contact velocity is 30 ft per sec. These seats far exceed FAA design requirements. Seat crash load factors for the 222 throughout the aircraft are 8 g's forward, 8 g's down and 4 g's lateral. These are double the FAA requirements, further evidence of the 222's safety.

Flight Test

Figure 24 shows Ship 1 in flight test. The first flight of Ship 1 was in August of 1976. Since August, four additional prototype aircraft have flown and 350 flight test hours have been accumulated. Cross-country flights and offsite high altitude tests have been conducted for the evaluation of both the main rotor and the tail rotor.



Figure 24. Ship 1 in Flight Test.

Early testing showed the requirement to relocate the horizontal tail. On the first aircraft the horizontal tail was located on top of the fin as seen above. The tail now has been moved to the boom, as shown in Figure 25, to prevent an abrupt cyclic stick input requirement as the aircraft accelerated into forward flight. This is illustrated on Figure 26.



Figure 25. Ship 4 With Relocated Horizontal Tail.

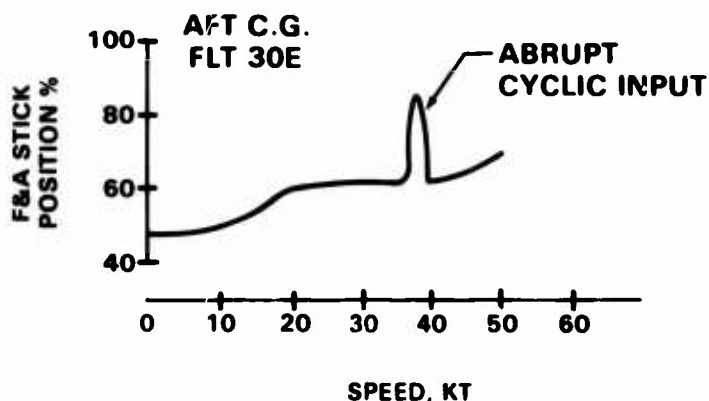

Figure 26. Cyclic Stick Position Vs Speed for the "T" Tail Configuration.

The stick motion shown is due to the main rotor wake impinging on the horizontal tail. Tests of a similar tail configuration on the Bell Model 206 had indicated the surface could be spoiled to prevent this abrupt pitch-up, but this was not the case for the 222.

The "T" tail also caused an abrupt pitch with yaw at high speed. This, too, was solved by relocating the horizontal tail to the boom.

Not shown on Figure 25 are small end plates located on the tips of the boom-mounted horizontal tail. These will be a part of the production configuration.

With the fixed boom-mounted horizontal tail, excellent handling qualities have been achieved with stable stick plots throughout the flight envelope, good dihedral and excellent dynamic stability, and rearward flight characteristics. These help to make the 222 a pilot's helicopter.

Tests have been conducted at Bell's flight test facility in Arlington, Texas, and at Alamosa, Colorado. The data show that the aircraft performs as expected, that the tail rotor is adequate for good high-altitude control, and that long component lives can be expected.

FAA certification testing of the 222 begins this summer and Bell will obtain an FAA Part 29, Category A certificate for the Model 222 during 1978. Production deliveries will be made in early 1979.

Before the aircraft is delivered, a stringent five-ship accelerated service test will be conducted in a number of differing environments. Also, the aircraft will be tested in the cold-weather hangar at Eglin AFB in Florida. These are not requirements for certification but are additional steps being taken by Bell to assure low cost of ownership. It is believed that the 222 will be the most thoroughly tested commercial helicopter ever to be put in service.

Noise

Noise measurements on the 222 have given the results shown by Figures 27 and 28. Figure 27 shows that the external noise in a hover is essentially the same as that of a Bell Model 206L, which has been well accepted in the commercial environment. This low noise level was achieved because of the low tip speed of the main and tail rotors.

As can be seen by Figure 28, internally the 222 is quieter than the 206L for both the bare ship and the finished interior configurations. This has been achieved through the use of elastomeric bearings mounting the engine and transmission to eliminate structure-borne noise and careful attention to space allowance for soundproofing materials.

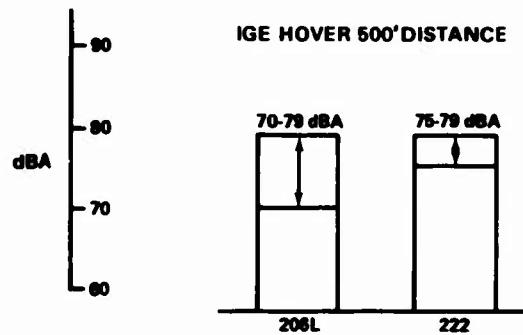

Figure 27. External Noise Comparison.

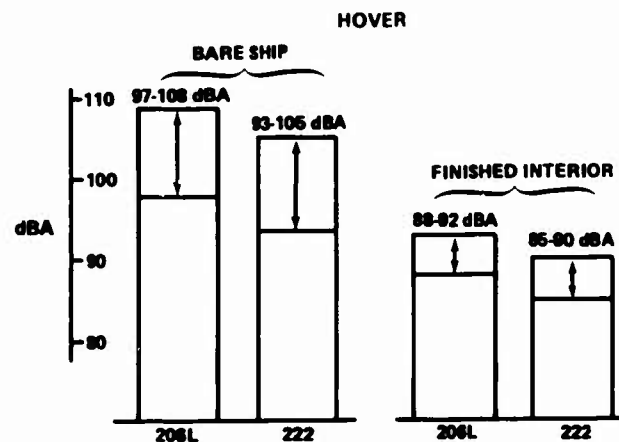

Figure 28. Passenger Cabin Noise Levels.

Performance

The following table summarizes the key performance parameters of the Model 222. These data are based on early flight test results.

Performance Data at 7200 Pounds Gross Weight

Maximum Cruise Speed	150 Knots
Range at 8000 ft, with 20 minute reserve fuel	370 nmi
Hover Ceilings, OGE	
Standard Day	8200 ft
Standard Day +20°C	4000 ft
Hover Ceilings, IGE	
Standard Day	13000 ft
Standard Day +20°C	10000 ft
Single Engine Service Ceiling, 30 minute power	
Standard Day	9000 ft
Standard Day +20°C	5100 ft
Useful Load	2950 lb

Comparison of FAA and Military Requirements

The following table compares the requirements of the Military and FAR Part 29 for seven items. This comparison is the author's evaluation, could occupy many pages of discussion, and is an obvious over-simplification. It does, however, highlight the different requirements. Any helicopter designed with the efficiency required to be competitive in the commercial marketplace will not meet the full Military requirements for hot-day hover, landing gear energy absorption, survivability, and crashworthiness.

Comparison of Requirements
Military Vs FAA Part 29/222

ITEM	MILITARY	FAA PART 29/222
FLYING QUALITIES		
VFR	EQUAL	EQUAL
IFR	-	MORE SEVERE
PERFORMANCE	ARMY MUCH MORE SEVERE	-
STRUCTURAL (EXCLUDING LANDING GEAR)	EQUAL	EQUAL
LANDING GEAR ENERGY ABSORPTION	MORE SEVERE	-
SURVIVABILITY AND CRASHWORTHINESS	MORE SEVERE	-
POWER PLANT FIREWALL SEPARATION	-	MORE SEVERE
SYSTEM REDUNDANCY	-	MORE SEVERE

The 222 meets all of Part 29 requirements plus has some crashworthiness features never before introduced into the commercial market. The 222 offers the Military the option of buying an off-the-shelf helicopter that has many desirable features not in other civil aircraft.

The Coast Guard has a stated requirement for an off-the-shelf certified helicopter. With the two-bladed rotor requiring no folding, the 222 will fit the Coast Guard's ship-board hangar, thus the small mission-efficient commercial machine is sized right for the Coast Guard (Figure 29).



Figure 29. Model 222 in Coast Guard Colors.

The dynamics of the 222 can be adapted to a new airframe which meets the Military requirements for a small gunship configuration, Figure 30. Other Military requirements obviously can be met with a 222 derivative if some compromises can be made in the areas of survivability and crashworthiness, Figure 31. These compromises would be small because of the fail-safe design concept used in the commercial machine, yet major cost savings could result.

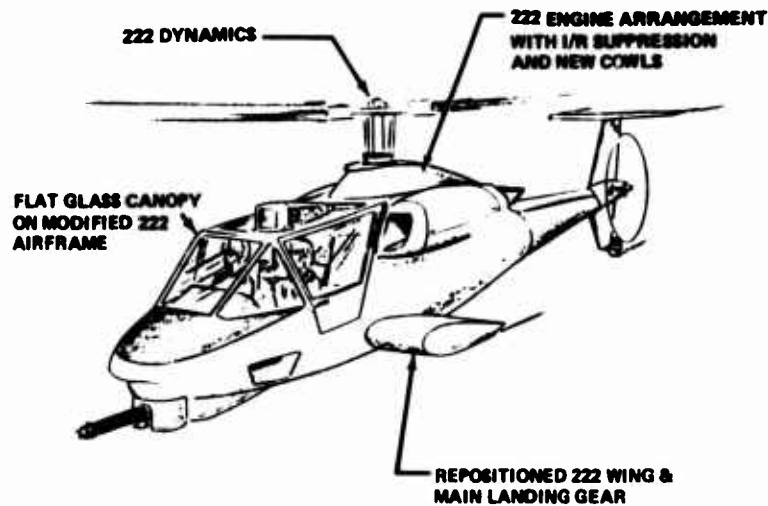

Figure 30. Model 222 Dynamics Adapted for Gunship.



Figure 31. Model 222 Dynamics and Modified Airframe for Missiles.

CONCLUSION

The 222 has many advanced features. Bell's extensive commercial experience has led to heavy emphasis on safety, flying qualities, efficiency and fuel economy, mission effectiveness, and reduced life cycle costs. These characteristics make it ideal for the civil executive market, and offer major advantages for the offshore support and utility user. Its size, performance, and outstanding dynamic components make it readily adaptable for several Military uses.

Bell Helicopter Textron is proud to add the 222 to its successful fleet of production helicopters, Models 47, HTL, HUL, 204, 205, 206, 206L, 209, 212 and 214.

THE SIKORSKY S-76 PROGRAM

R.F. Donovan
Sikorsky Aircraft
Division of United Technologies

Let us introduce the Sikorsky S-76. The S-76 is a completely new helicopter designed for the commercial market in general, and in particular, is designed to serve the off-shore oil market and meet its requirements; that is to carry 12 passengers and a crew of two on a 400 nautical mile radius mission with flotation equipment and operate IFR Category A. A definite requirement exists for a long range, over water helicopter to transport crews to and from the oil rigs. The S-76 is designed to that mission. All this is to be achieved in a helicopter weighing less than 10,000 lbs. This helicopter is going to be very necessary to the continued exploration for oil. As you know, we have searched for and found oil on land and off the shore line. As time passes, we are forced to move further off shore. A long range overwater helicopter is a necessity.

Figure 1 is the aircraft development schedule. The program was begun in 1975, first flight was scheduled for May 1977 and occurred two months ahead of schedule. The FAA/CAA multi-engine IFR certification will occur in 1978 and the first production delivery will be in July 1978.

In Figure 2 we show the attributes of the S-76. Maximum weight is 9,700 lbs., and useful load is 4,758 lbs. It has a maximum speed of 156 knots at sea level standard, cruise speed of 145 knots under the same conditions, and a best range of 125 knots. Range is 400 nautical miles at 3,000 ft. ISA.

The S-76 has four-bladed main and tail rotors as shown on the three-view Figure 3. The main rotor is 44 ft. in diameter; the tail rotor is 8 ft. in diameter. It is powered by two Allison DDA 250-C30 free turbine engines mounted on the top deck behind the rotor. The landing gear is a tricycle configuration, fully retractable with doors over all wheel wells. The placement of the horizontal stabilator and the tail rotor are designed to preclude the possibility of passengers walking into the tail rotor.

The interior passenger configuration has the passengers arranged in three rows of four seats abreast. There are four cabin doors, two on each side. The two forward doors are used by the flight crew and the front row of passengers, the two aft doors are used by the two aft rows of passenger seats. Behind the cabin with doors on both sides of the aircraft is the baggage bin with a capacity of 42 cubic feet.

In order to achieve the design goals, the S-76 employs Sikorsky's latest technology, most of which was developed with the U. S. Army UTTAS helicopter. This is shown on Figure 4. Among the features are the improved titanium and composite main rotor blade, a bearingless composite tail rotor, the elastomeric main rotor head, bifilar vibration absorber and the simplified main rotor transmission. Figure 5 shows some of the details of the main rotor blade construction. This is truly a blade with a composite of materials, including a titanium spar which does not corrode and provides strength for infinite life - a fiberglass cover - a redundant graphite root end - a Kevlar tip cap and Nomex honeycomb in the trailing edge. The aerodynamic shape reflects the latest Sikorsky technology developed from extensive two dimensional airfoil testing.

The construction details of the composite bearingless tail rotor are shown in Figure 6. The principal structural element is the cross beam spar. The cross beam tail rotor is designed to take advantage of the special capabilities of unidirectional composites. To this end the tail rotor consists of two assemblies each of which provide two blades of a four bladed tail rotor. The spar which connects opposite blades is made of unidirectional graphite and is laid up in a rectangular cross sectional shape. The resultant beam is flexible in the torsional and flapwise direction, but is very stiff in the edgewise direction. An airfoil shape is bolted to each end of the cross beam to form one half of a tail rotor. Two of these assemblies are clamped at right angles to one another to form the tail rotor. The resultant tail rotor is free of instabilities and requires no lubrication or maintenance.

The main transmission has as its final reduction a bull gear with two spur gear inputs. This is considerably simpler than a typical planetary system shown in Figure 7. This approach is possible for a helicopter with a relatively small main rotor, since for a constant tip speed, the rotor RPM on a small rotor is considerably higher than it is on a large rotor such as our CH-53. As a consequence, the reduction required between engines and rotor is considerably less. Each engine has a separate power train all the way up to the bull gear through a single spur mesh and a bevel mesh. The tail take off is from the left engine power train. In case of left engine failure the tail take off still drives through from the right-hand engine to the bull gear back through the bevel set and to the tail take off. The free wheeling units are inside the first spur gear forward of each engine. The approach using the simplified bull gearing system reduces the number of bearings and gears by a significant amount over the conventional planetary gearing approach.

Power for the S-76 is provided by two Allison Model 250-C30 turbo shaft engines. The engine cut-away is shown in Figure 8. The engine is the easily recognized basic Model 250 design. The C-30 engine has a maximum rating of 700 h.p. for 2-1/2 minutes with one engine inoperative. The 700 h.p. is available up to 90°F, sea level. The take off rating is 650 h.p. and the 30 minute one engine inoperative rating is 650 h.p. at sea level standard, dropping to 630 h.p. at 1,000 ft. altitude. The maximum cruise h.p. at sea level standard is 557 h.p.

Since the S-76 is designed to operate over water, the flotation system has been built into the aircraft and is completely flush to minimize drag. The flotation system is shown in Figure 9. The system is stowed in two compartments on either side of the nose gear and on the inside of the main landing gear doors. The flotation bags of which there are four are each divided into two separate compartments. Each bottle is connected to one cell on each side of the aircraft. In this way should one bottle fail to operate, a lateral unbalance would not be created or if a cell of one of the bags is punctured, the cell on the opposite side will deflate also. Reserve buoyancy has been provided so that the aircraft can float satisfactorily with one cell on each side uninflated.

Figure 10 is a photograph of the No. 1 aircraft at roll out. As you can see, the outer contours are extremely smooth. With the exception of the tail cone which is a wrapped surface, all exterior surfaces of the S-76 are formed against hard dies so that the outer surfaces are carefully controlled. The entire aircraft is flush riveted. This not only gives a pleasing effect but also gives an extremely low drag airframe. Most of the outer surface is formed honeycomb panels which consists of aluminum inner and outer skins bonded to aluminum honeycomb. Extensive use is made also of fiberglass and Kevlar.

Good concepts are essential to a high performance helicopter but without a thorough test program the potential will never be realized. Sikorsky's commitment to the S-76 program resulted in an extensive test program.

Figure 11 shows the original 1/10 scale model of the S-76 in the United Technologies wind tunnel in Hartford, Connecticut. This was the first preliminary test to get a look at airframe drag and stability.

The 1/5 scale model of the S-76 is shown in Figure 12. This model has a powered rotor dynamically scaled and is equipped with three internal balances to measure forces and moments. It is also aspirated to simulate the engine air intake and engine exhaust, and the exhaust from the engine oil coolers and the main transmission oil cooler.

The same 1/5 scale model is shown in Figure 13 in the model hover facility at Stratford, Connecticut. The height of the model above the ground can be varied to get test results in and out of ground effect. This is a new facility and the S-76 is the first aircraft to take advantage of it before first flight.

Figure 14 shows the 8,000 h.p. whirl stand at Stratford with the S-76 rotor installed. This provides full scale performance and structural data.

In Figure 15 the S-76 rotor is shown in the 40 x 80 ft. tunnel here at the Ames Research Center. We furnished a S-76 rotor with various tip configurations as part of an R&D program to investigate the effect of tip shape on rotor performance. This is part of a NASA research goal concerning tip configuration for two and four bladed rotors. The two bladed research had been completed previously. The tip investigation showed a spread between the best and worst tip configuration of 5% on max. cruise speed, 6% on one engine inoperative allowable gross weight and 2% on range. During the investigation the rotor envelope was expanded 1.75 g's and forward speeds of 170 knots.

Figure 16 is an overall view of the fatigue lab at Stratford for testing various elements of the dynamic system. This and the newly constructed test cell for the S-76 main gear box are common test facilities in the industry. Figure 17 shows the gearbox mounted in the test cell.

Figure 18 shows the inlet to the engine air plenum chamber mounted in the NASA Lewis icing tunnel in Cleveland, Ohio. The test verified the engine ice protection arrangement and the plenum chamber pressure recovery.

Figure 19 is a picture of the variable stability flying simulator operated by the Canadian government. Here again we entered into a cooperative agreement to simulate the yaw characteristics of the S-76 for comparison with the flight article. This correlation is continuing and is the subject of another paper at this forum.

The tie down facility in Stratford dedicated to the S-76 project is shown in Figure 20. This facility is used for endurance testing of the complete system, and to accumulate system operational hours well in advance of the flight vehicle.

Figure 21 is an overall view of the newly constructed Sikorsky flight test facility at West Palm Beach which at the present time is dedicated to the flight test program of the S-76.

As a result of the extensive pre-flight test program, the S-76 flight test program has been able to proceed at an accelerated pace. During the first twenty days after first flight the number one flight test aircraft had flown to 35 knots in left and right sideward flight and also rearward flight. It had flown to its maximum gross weight of 9700 pounds and to a forward speed of 172 knots. We feel the test program has paid for itself.

The question has been posed, "What are the essential differences in a helicopter that is designed for a commercial application as compared to a helicopter designed for a military application?" I think the differences can be shown by comparing payload range curves that result from the two design approaches.

In Figure 22 the top line illustrates the case where the machine is designed for commercial service. The power train and the cabin volume are matched to the maximum engine capability and therefore the maximum take off gross weight. If the operator has occasion to operate under conditions of high altitude and temperature, he will off load at the longer ranges. The extreme altitude temperature conditions happen rather infrequently, however, and under less severe conditions he will have the cabin volume to take advantage of the available lift. This commercial aircraft in a military adaptation will show payload capabilities at long range under high altitude, hot day conditions as shown in the payload range curve on the right. In the case where the helicopter is conceived to meet a military requirement with a high altitude high temperature requirement from the outset, the range payload curve will be as shown on the lower left. The power train and the cabin volume will be matched to the hot day, high altitude gross weight. In most cases the military range requirement is less than the commercial and the fuel volume is sized to this shorter range. For the commercial adaptation of the military design under more benign conditions the range payload curve is precisely the same as it is for the military since the aircraft is limited in fuel volume and cabin volume. The operator cannot take advantage of the increased lift capability at lower temperatures and altitudes since the cabin and fuel volume have been sized for the high altitude hot day conditions.

In airframe systems the military design will tend to have a smaller cabin for the same gross weight since the payload in the military machine is flat rated just like the dynamic components. This probably is the most serious shortcoming when the military helicopter is turned to commercial use and the operator is unable to utilize the lift capability in the machine because the cabin is sized for the high altitude hot day conditions. The other notable airframe differences between the military and the commercial helicopter are principally in the areas of ballistic vulnerability. Many of these military features, which are receiving increased emphasis, will make future conversion of the military designs less palatable in the commercial market. I am referring to those features installed to enable the components to survive ballistic hits. These features are a liability in the commercial area because they increase weight and reduce single engine stayupability. The military helicopter is a highly specialized machine and as we learn more and more about designing to live and operate in the military environment, the gap between military and commercial helicopter designs will widen.

The Sikorsky S-76 and the Sikorsky UTTAS for the U. S. Army offer an interesting comparison. Both aircraft use essentially the same technological base. Both carry twelve passengers and a crew of two. The UTTAS has a range of 330 nautical miles, the S-76 has a range of 400 nautical miles. The UTTAS has a gross weight of 16,450 pounds. The S-76 has a gross weight of 9700 pounds.

So in conclusion, let me say that we recognize this widening gap between the commercial and the military. For this reason, we have chosen to design the S-76 specifically for the commercial market.

S-76 MAJOR MILESTONES

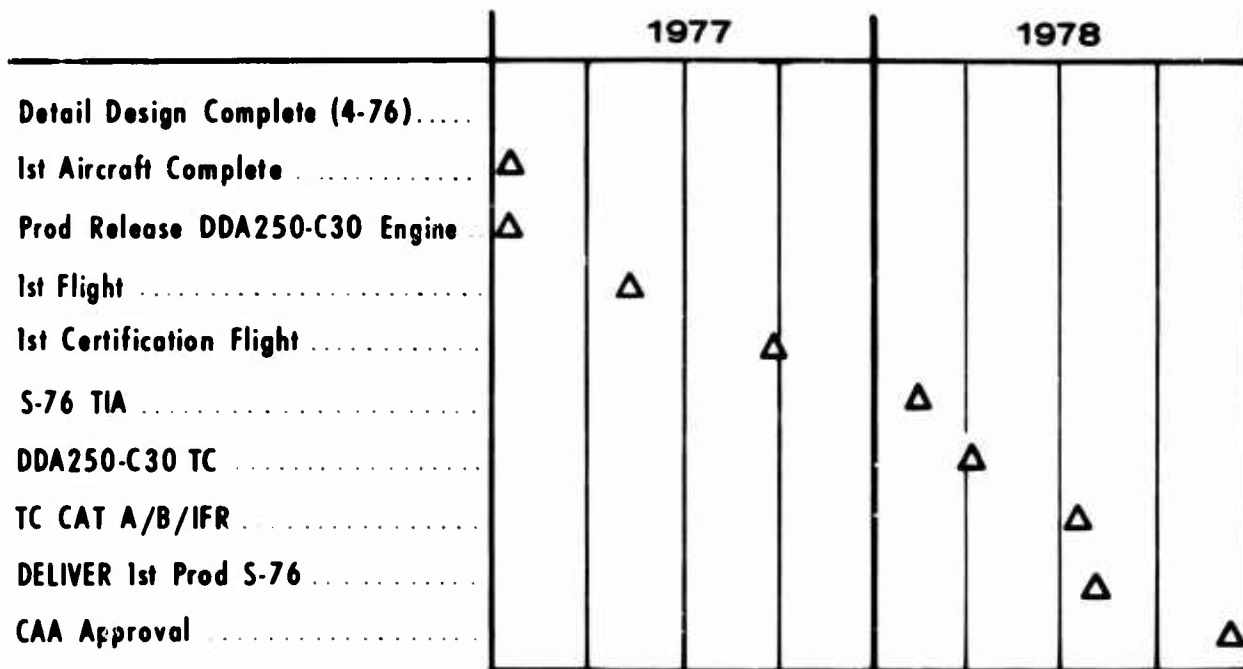

Figure 1

S-76 ATTRIBUTES

Maximum Weight 9700 Lbs.
 Empty Weight 4942 Lbs.
 Useful Load 4758 Lbs.
 Fuel Capacity 272 Gals.

AT 9700 LBS.

Maximum Speed 156 Knots SL STD
 Cruise Speed 145 Knots SL STD
 Best Range Speed 125 Knots
 Range 400 N Mi 3000' ISA

Figure 2

13-5



Figure 3

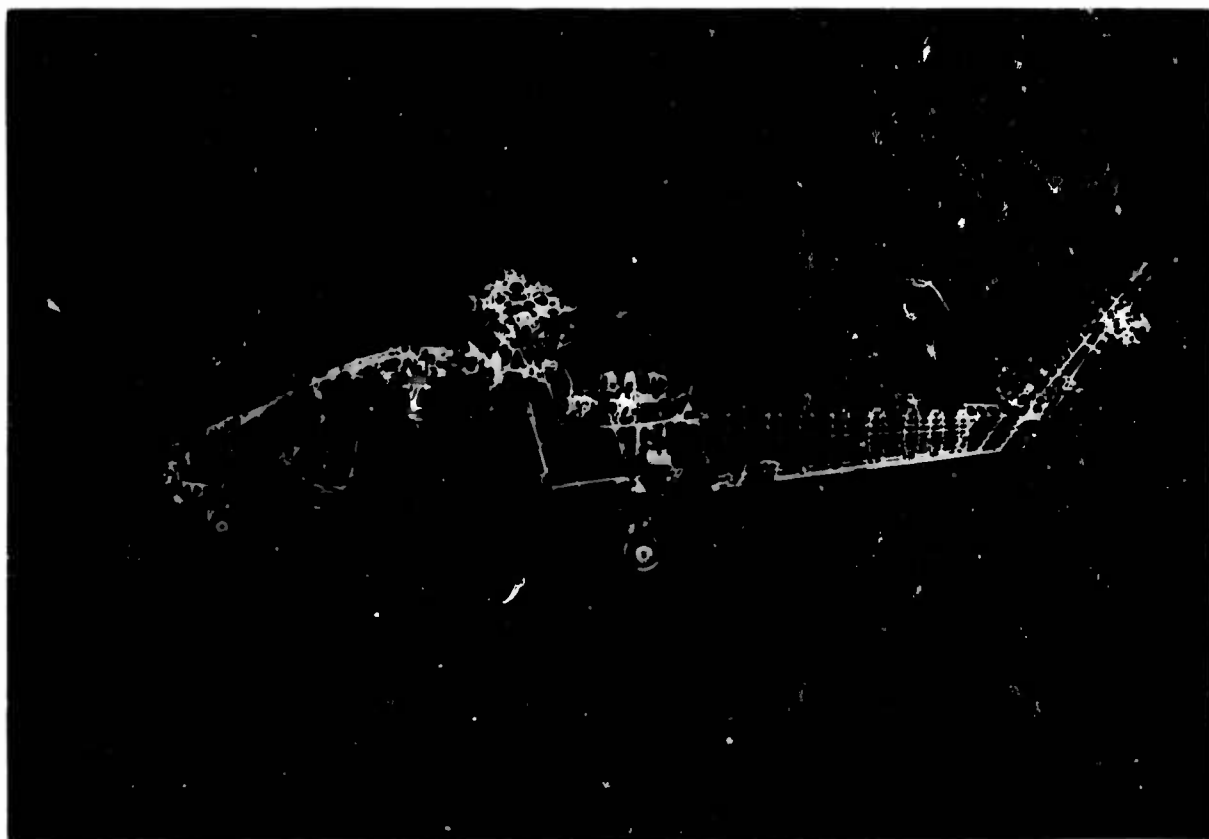

Figure 4

13-6

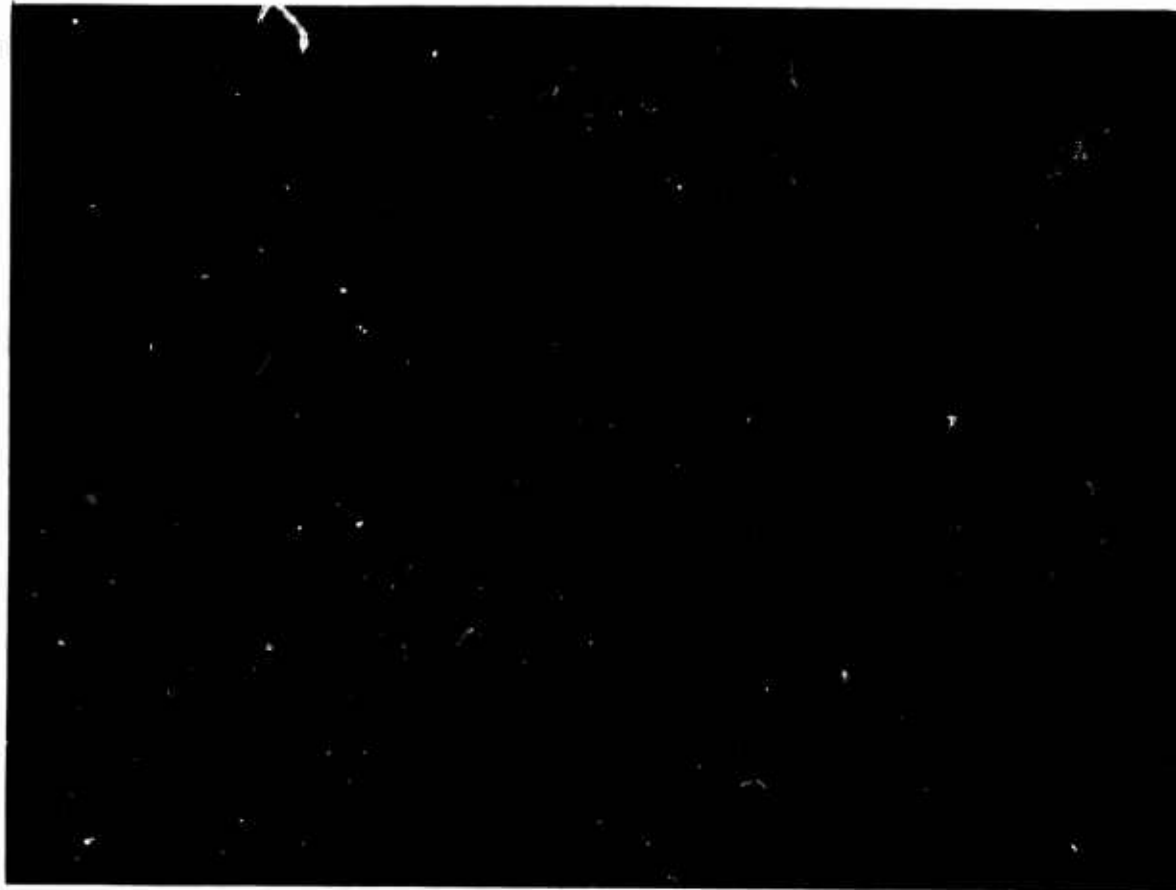
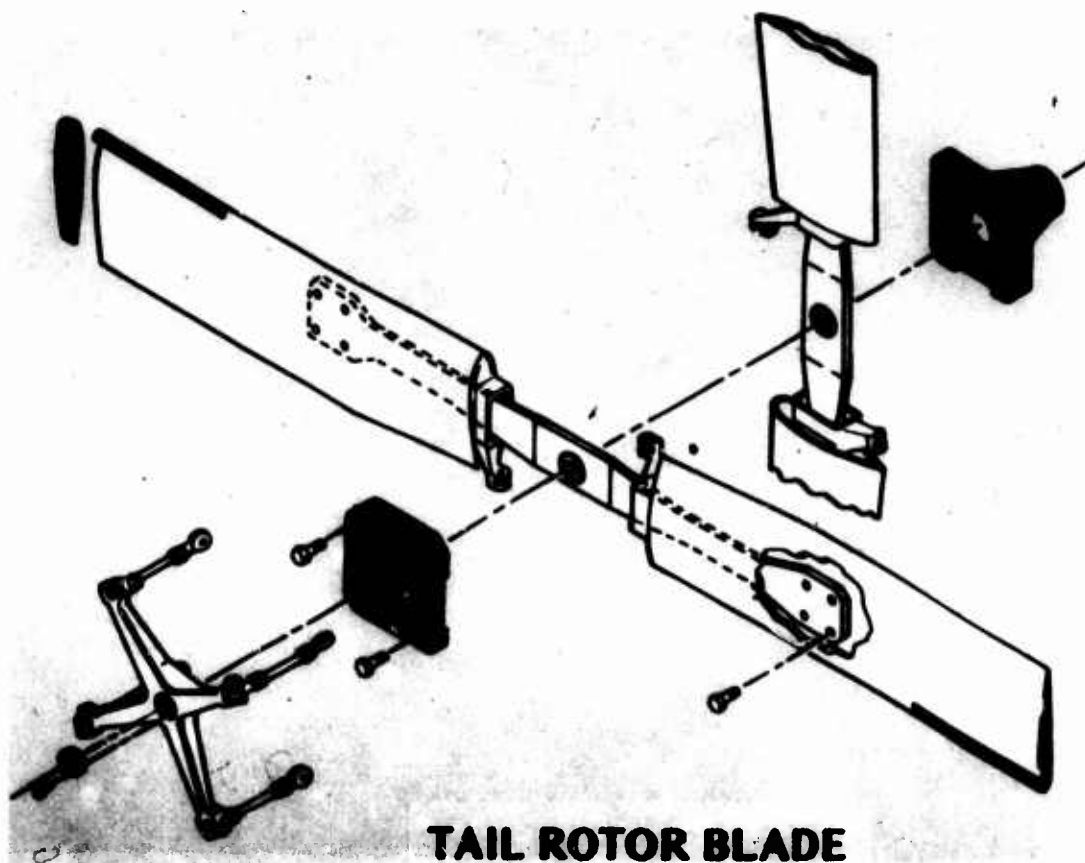

Figure 5



TAIL ROTOR BLADE

Figure 6

SIMPLIFIED TRANSMISSION

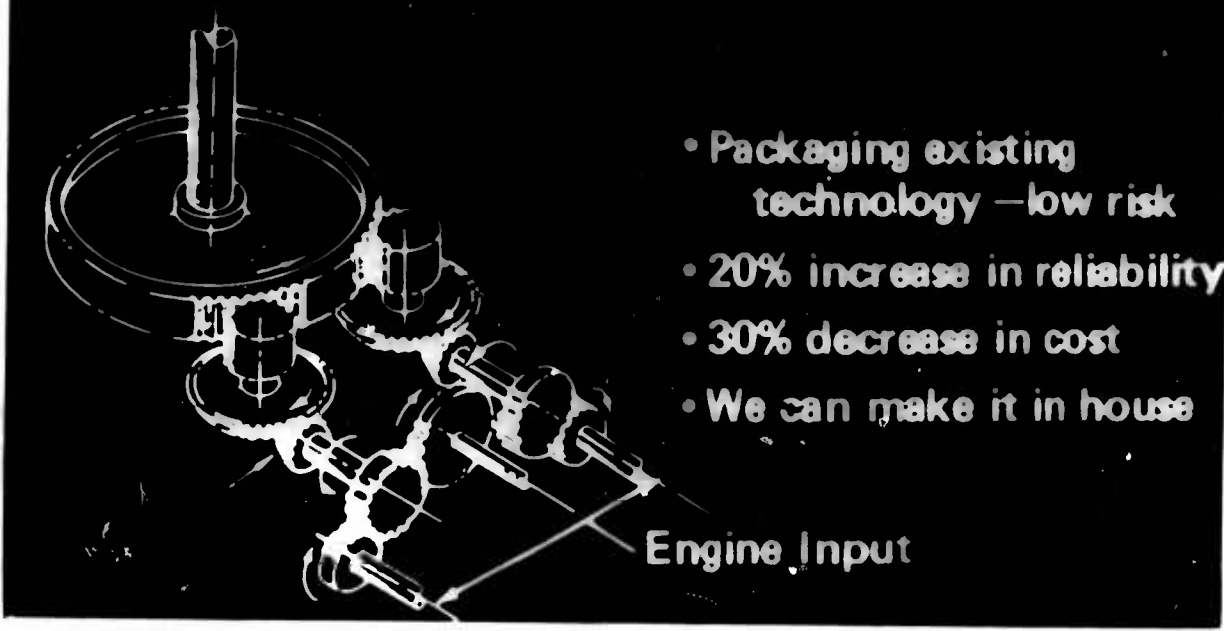

Figure 7

ALLISON MODEL 250 TURBOSHAFT ENGINE

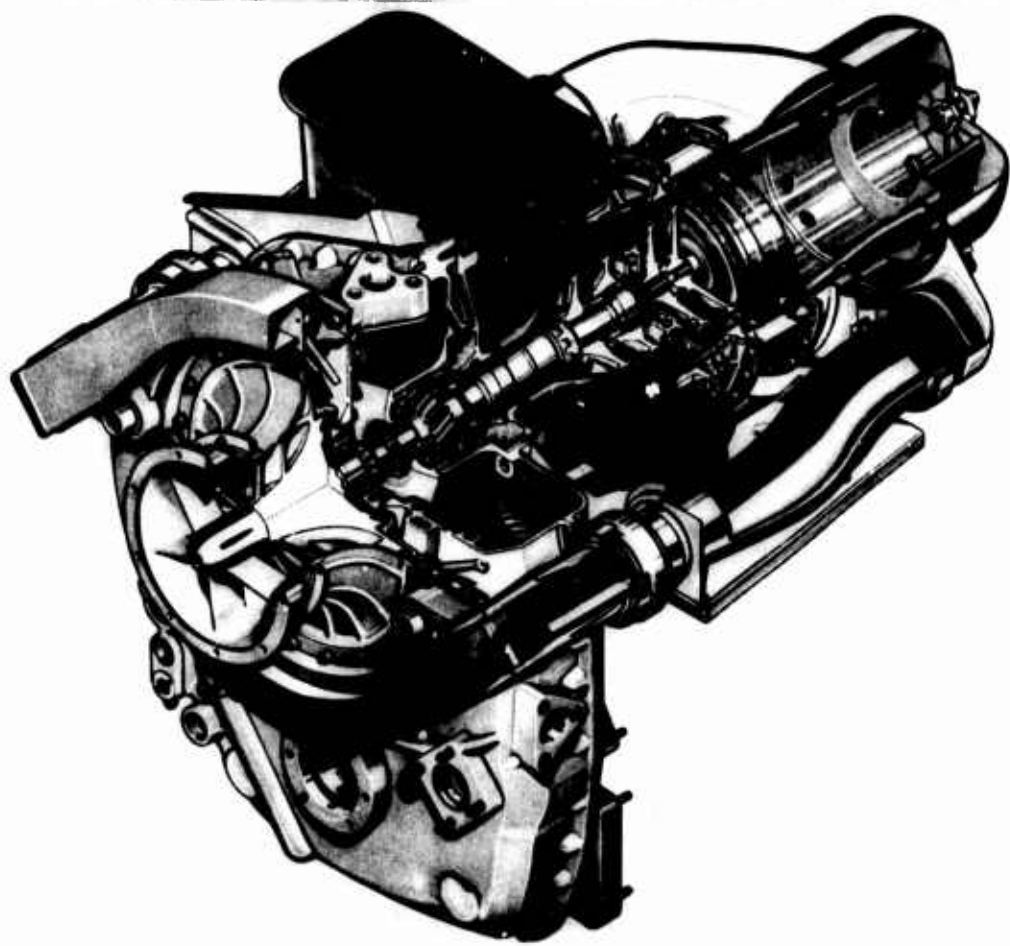

Figure 8

13-8

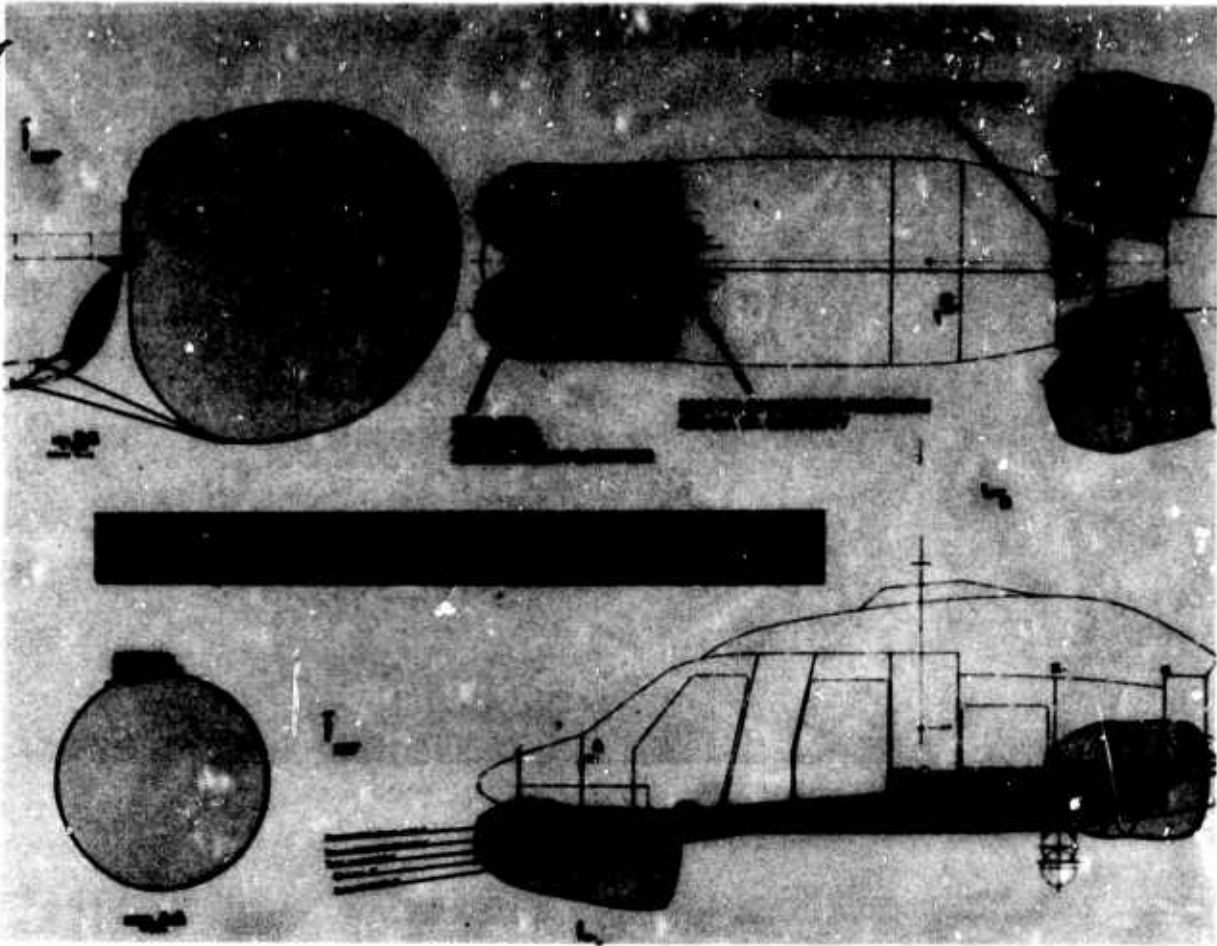

Figure 9



Figure 10

13-9



Figure 11



Figure 12

13-10

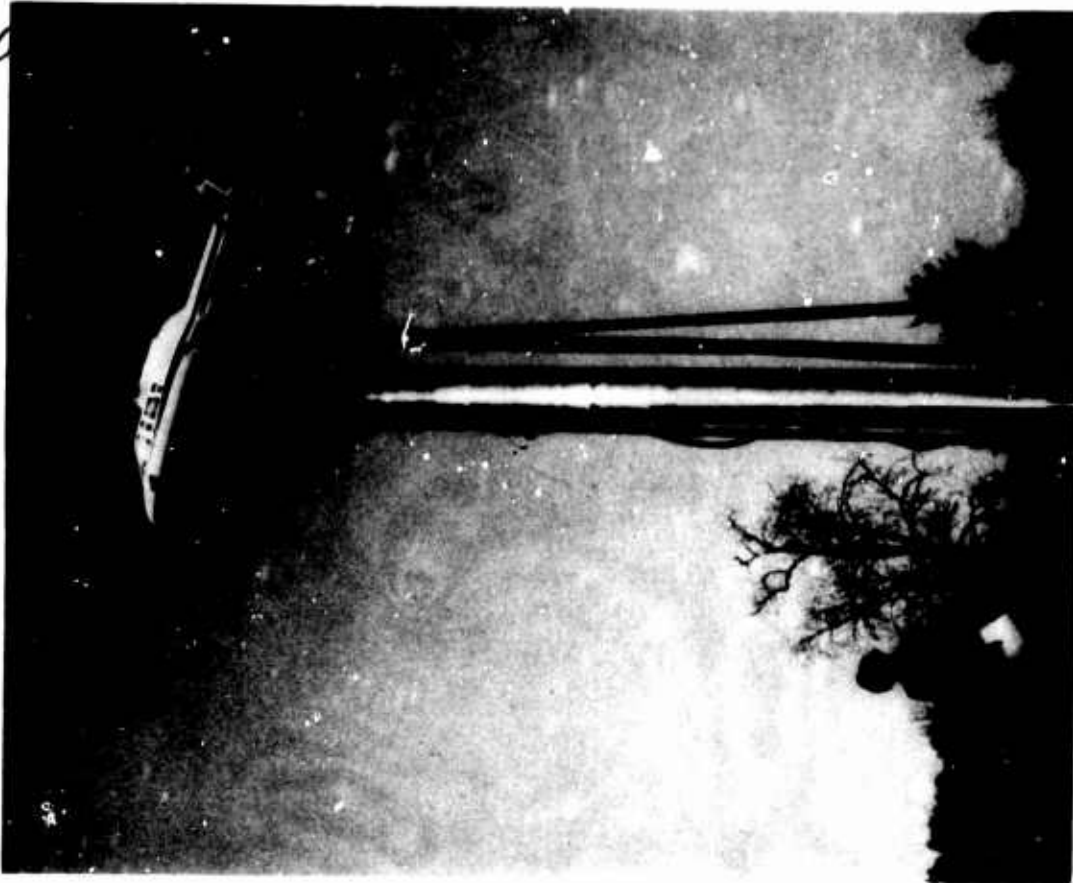

Figure 13

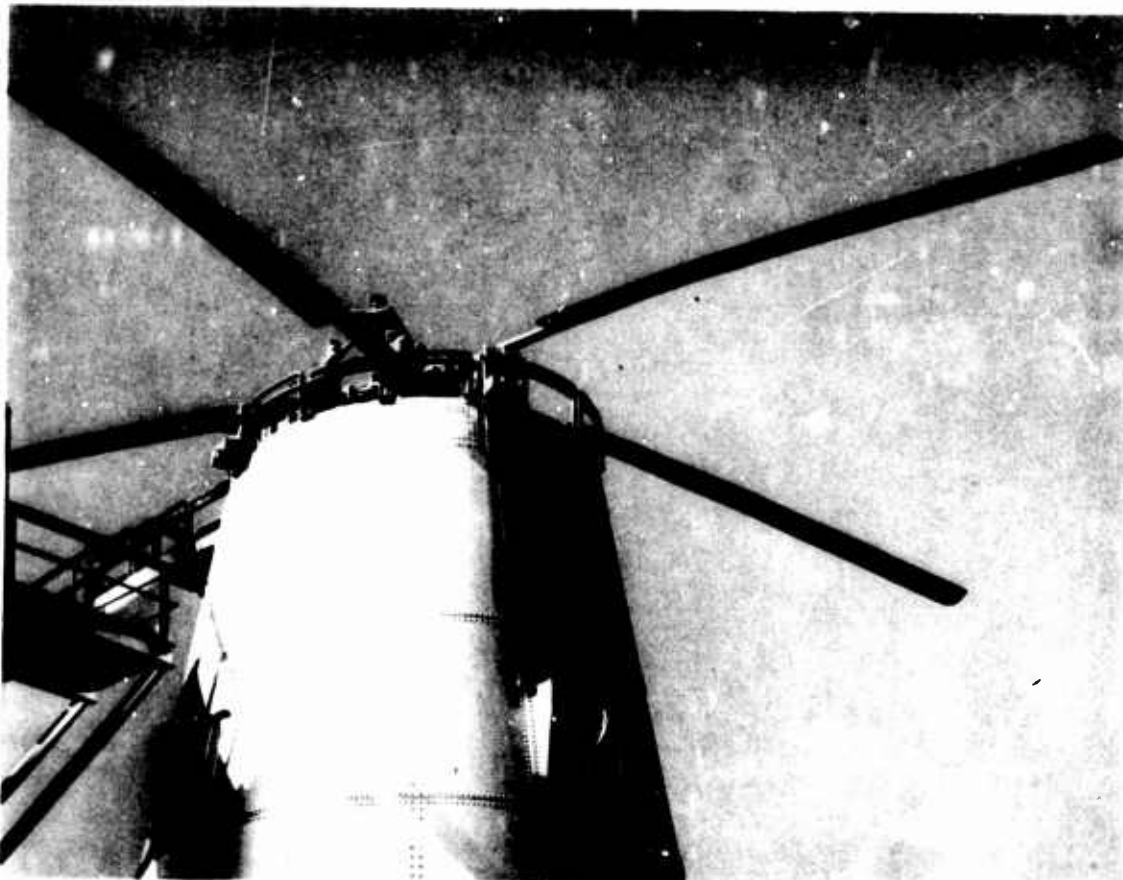

Figure 14

13-11

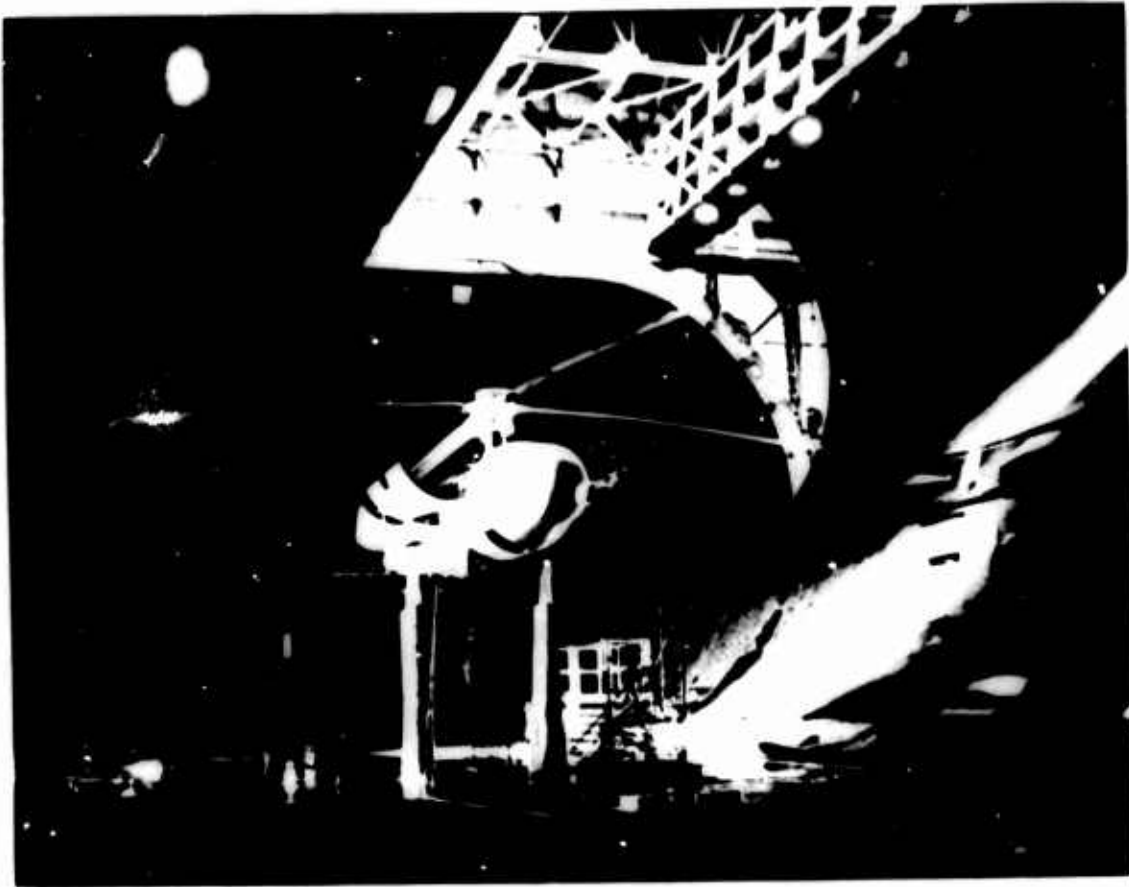

Figure 15



Figure 16

13-12

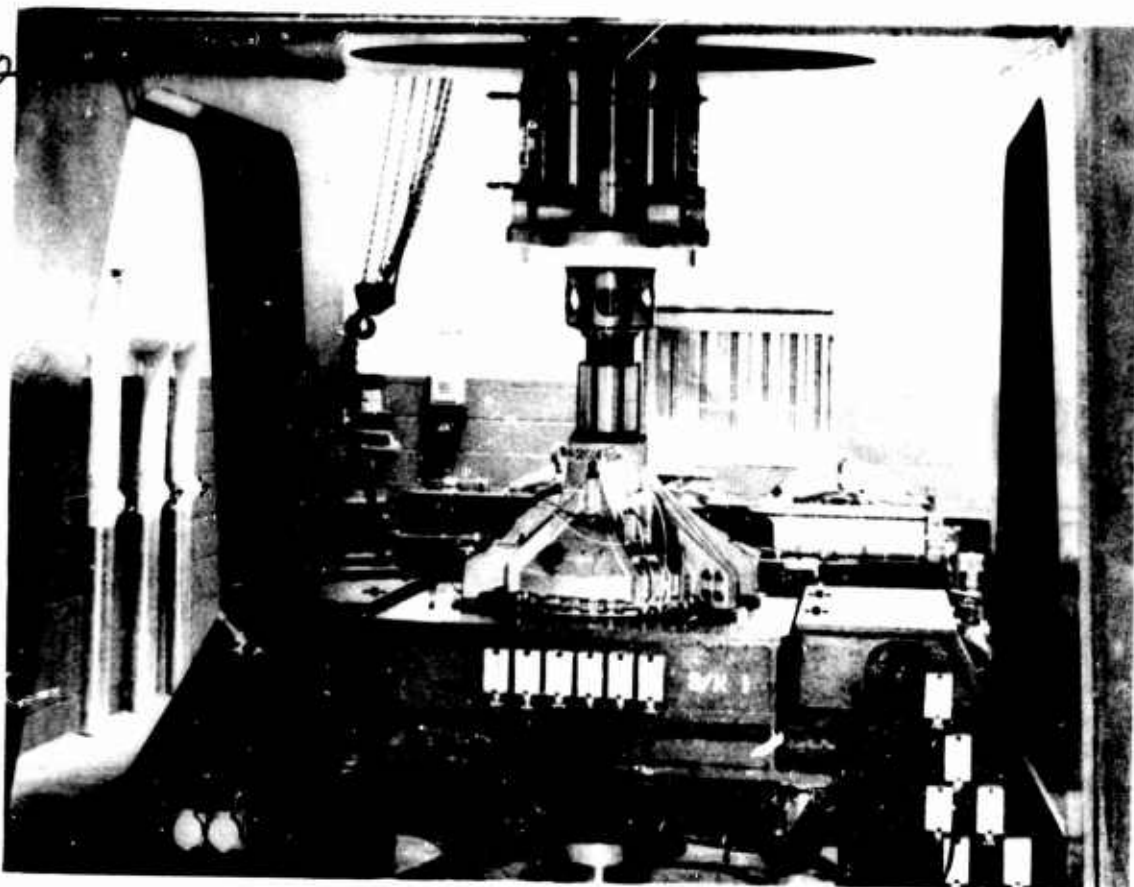

Figure 17

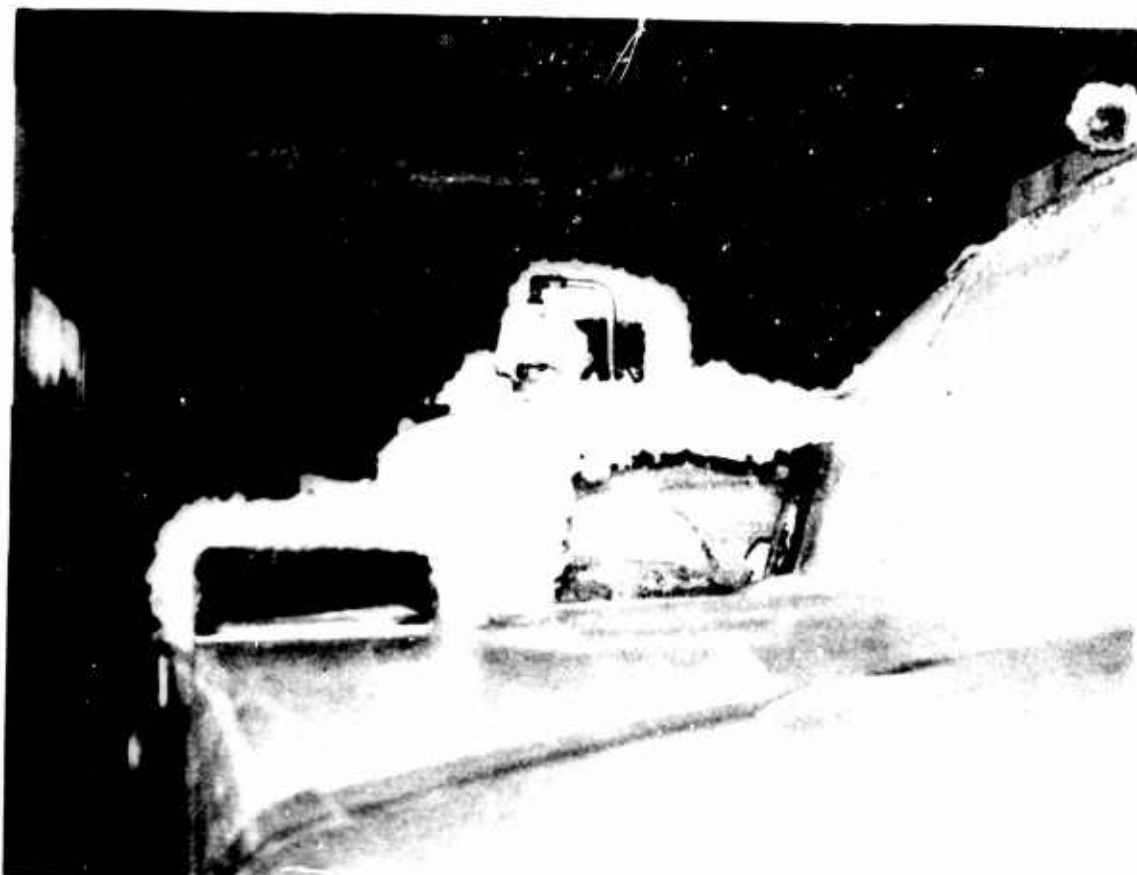

Figure 18



Figure 19



Figure 20

13-14



Figure 21

COMMERCIAL VS MILITARY DESIGN

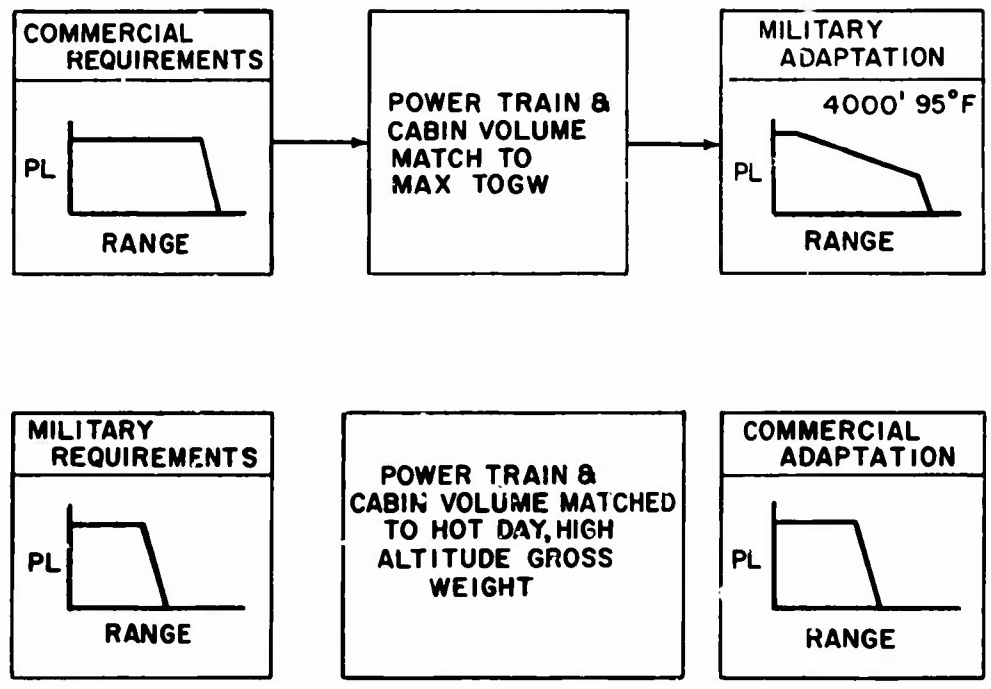

Figure 22

THE "AS 350" LIGHT HELICOPTER

by René MOUILLE

Deputy Director, Helicopter Design

SOCIETE NATIONALE INDUSTRIELLE AEROSPATIALE

Division Hélicoptères - Direction des Etudes

The AHS meeting held in Washington last week, gave me the opportunity to speak about the AS 350 helicopter, as a "design to cost exercise".

To day, I would like to introduce the AS 350, as a modern light helicopter, an efficient and low-cost machine having characteristics which could be interesting also for military people.

WHAT DID WE INTEND TO DO, WHEN DESIGNING THE AS 350 ?

We wanted to design a new machine of the Alouette II or Alouette III size, specially for civil operators. The Gazelle has been designed for military purpose and we thought we could produce a cheaper machine more adapted to the civil market with a special effort on the cost aspect, procurement cost and operating cost.

We shall see later that it has been necessary to develop new technologies which could be also interesting for military users.

WHAT ARE THE CHARACTERISTICS OF THE AS 350 AND THE NEW TECHNOLOGIES APPLIED ?

The AS 350 is a single engined helicopter (fig. 1) which has an all-up weight of 4200 lbs and can carry two people at the front and three or four at the rear.

The main rotor, 35 ft in diameter, comprises a Starflex semi-rigid head and 3 glass-resin composite blades (fig. 2).

The one piece two-bladed tail rotor is also made of glass-resin composite.

The AS 350 may equally be equipped with either the Lycoming LTS 101 engine (600 HP) or the Turbomeca Arriel engine (650 HP). Both are of the free turbine type.

Full access to the cabin is provided on each side by a large door and a small one (fig. 3).

A rear and two lateral compartments provide a total volume of 35 cu ft for the baggage (fig. 4).

The sling has a load capacity of 2000 lbs.

Owing to the payload and the cabin space, the AS 350 may be considered really as the successor to both the Alouette II and the Alouette III as shown by the following table (fig. 5). The payload is close to that of the Alouette III over a distance of 200 km (108 n.m.) in spite of the fact that the power installed is the same as on the Alouette II and the gross weight is between that of the Alouette II and the Alouette III.

The overall architecture has been thought to reduce the number of components and the engine design is very important in that way. On the AS 350, the free turbine turboshaft engine make it possible to delate the clutch unit. Moreover, as the engine power take off is off-set, it is possible to eliminate a couple of bevel gears in the main gearbox as well as an intermediate gearbox and one section or the tail rotor drive shaft as you can see on the figure 6.

THE STRUCTURE (fig. 7) consists of a stressed framework including pressed sheet metal parts.

Most of the components are independent of the external shape and can have simple and straight profiles.

The external shape is achieved by molded cowlings made of fiberglass resin laminates and the canopy made of thermoformed polycarbonate panels (fig. 8).

The tail boom and baggage compartment have a shape which may be flat-patterned and are both made of a rolled sheet without stringer.

Altogether, the structure includes 300 parts only compared to 1000 on the Alouette II.

THE MAIN ROTOR of the AS 350 appears as the most significant novelty with the Starflex rotor head (fig. 9) which you probably know already.

Compared to the Alouette rotor head (fig. 10) the Starflex rotor head shows a reduction in weight of 45% with 70 components only, instead of 377 components for the Alouette.

Central star and sleeves made of fiberglass resin composite have fail-safe characteristics. Elastomeric spherical thrust bearings, visco elastic dampers and any one of its components can be replaced in the field in less than 10 minutes.

THE MAIN ROTOR BLADES are entirely made of fiberglass and epoxy resin composite (fig. 11). They have the reliability, fail-safe and ruggedness features of the Gazelle blades but owing to a mechanized processing they are produced 3 times cheaper.

BOTH BLADES OF THE TWO-BLADED TAIL ROTOR (fig. 12 and fig. 13) made of glass-resin composite material are moulded directly on the same glass-roving beam.

The assembly is articulated in "see-saw" manner on self lubricated bearings.

A substantial reduction in weight and price has been achieved through this new rear rotor concept, requiring no maintenance and having a very high MTBF.

THE MAIN GEARBOX is a very simple design with one stage of epicyclic gears and a couple of bevel gears.

All components are largely dimensioned so the main gearbox can be kept in service almost indefinitely with no scheduled removal.

Fig. 14 compares the Alouette II and AS 350 main gearbox. The number of parts and production cost have been reduced roughly by 2 while the operating cost could be divided by 3.

THE TAIL ROTOR GEARBOX has also been dimensioned for the whole life of the aircraft without removal.

THE ENGINE-MAIN GEARBOX COUPLING SHAFT (fig. 15) is fitted with flexible couplings. It is housed in a large diameter tube which connects the engine to the main gearbox and transfers the engine counter-torque to the latter.

Thus, the engine-structure attachment is very simple and the engine contributes to the vibration filtering efficiency.

THE ANTI-VIBRATION SYSTEM (fig. 16 and fig. 17) is the same in its principle as that of the Puma or Gazelle or Dauphin (Barbecue system). However, the design of the gearbox flexible attachment to the structure is different and based on the use of laminated elastomeric pads which transfers the torque almost without any deflection while allowing horizontal displacement of the main gearbox bottom.

This system is very simple, light, cheap and very efficient and there is no fatigue stressed parts and no scheduled removal.

EQUIPMENT has been selected with special care. In many cases, we have found equipment in the general or automotive industry as light, sometimes lighter, more reliable and very much cheaper than the corresponding aeronautical equipment.

Such was the case for :

- . a car plastic fan (fig. 18)
- . light alloy cooler (fig. 19)
- . various pressure and temperature sensors (fig. 20)
- . electrical relays, warning lights, and even the hydraulic pump (fig. 21) has been found in the general mechanical industry.

Some techniques of the general or automotive industry have been used for production of some equipment very specific to the AS 350 such as roto-molding for fuel, oil and hydraulic tanks (fig. 22 and fig. 23).

Qualification tests required for the use of these items on aircraft have been carried out.

WHAT ADVANTAGES ARE DERIVED FROM THIS NEW DESIGN AND COULD THEY INTEREST MILITARY PEOPLE

The cost is not the first priority for military machines, either purchase or operating cost.

Nevertheless, it is interesting to point out that it is possible to reduce the life of modern helicopters by adopting new technologies improving retirement life, TBO and reducing the cost of all parts, the cost of maintenance and the cost of fuel, all this being achieved on the AS 350 as compared with the Alouette.

Figure 24 gives the comparison in terms of DOC between Alouette II and AS 350 and fig. 25 the comparison in terms of Total Operating Cost.

It appears that the price per kg carried out over a distance of 200 km (108 n.m.) is about 3 times lower than with the Alouette II.

But may be availability is more attractive for military users. New concepts developed for the AS 350 contribute to improve the machine in this respect through the simplicity of the aircraft, the maintenance very light, the ruggedness of the machine with largely dimensioned components, deletion of scheduled removals for life limited parts and TBO.

SAFETY AND LOW VULNERABILITY due to new fail-safe concepts for composite blades and rotor heads is also a very attractive feature for military users. In addition to the others fail-safe concepts pertaining to the structure it gives to the AS 350 a high degree of safety.

Moreover special tests have demonstrated the tolerance to damage of blades and hubs (fig. 26, 27, 28, 29, 30) and the possibility for blades to cut branches and even trees up to about 10 inches in diameter (fig. 31).

OPERATIONAL CAPABILITIES have been improved also due to these new concepts by reducing the empty weight and the fuel consumption while the gross weight could be increased for roughly the same amount of power.

It is the reason why the AS 350 can carry almost the same payload as the Alouette III over a distance of 200 km (108 n.m.) in spite of the fact that is a smaller machine.

The improvement of loading capability of the machine in addition to the capacity of the cabin, increases the aircraft versatility thus allowing for various types of installations.

TO CONCLUDE, we can say that the AS 350, well adapted to the civil market, thanks to its low purchase and operating cost, offers new concepts which should be of great interest to military users :

- . low empty weight
- . High safety and low vulnerability
- . High reliability
- . Improved performance
- . Very light maintenance

That is to say a high degree of cost effectiveness.

The AS 350 demonstrates that trying to make a low-cost helicopter lead to a very 'cost effective' machine incorporating new concepts which are of a great interest not only to the civil operators but also to the military users.

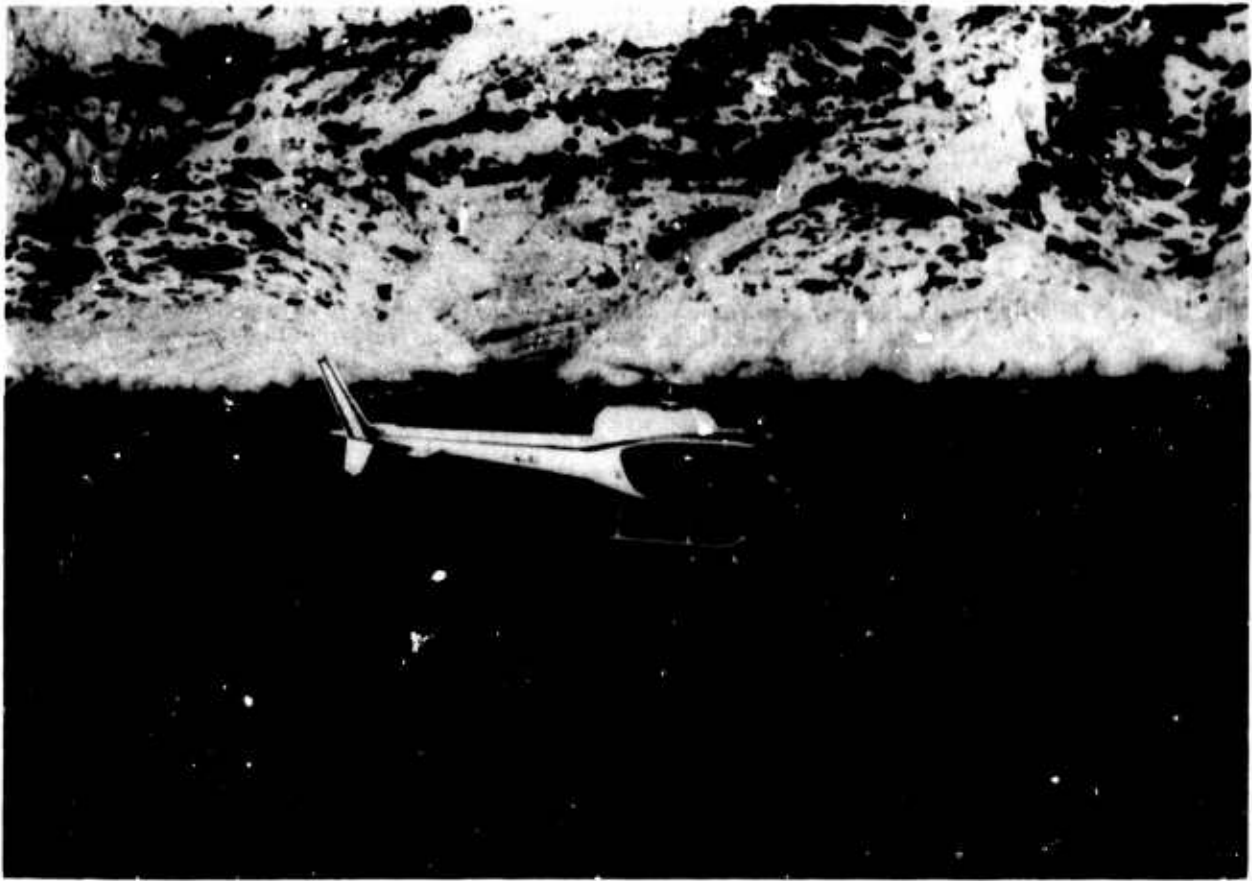

Figure 1

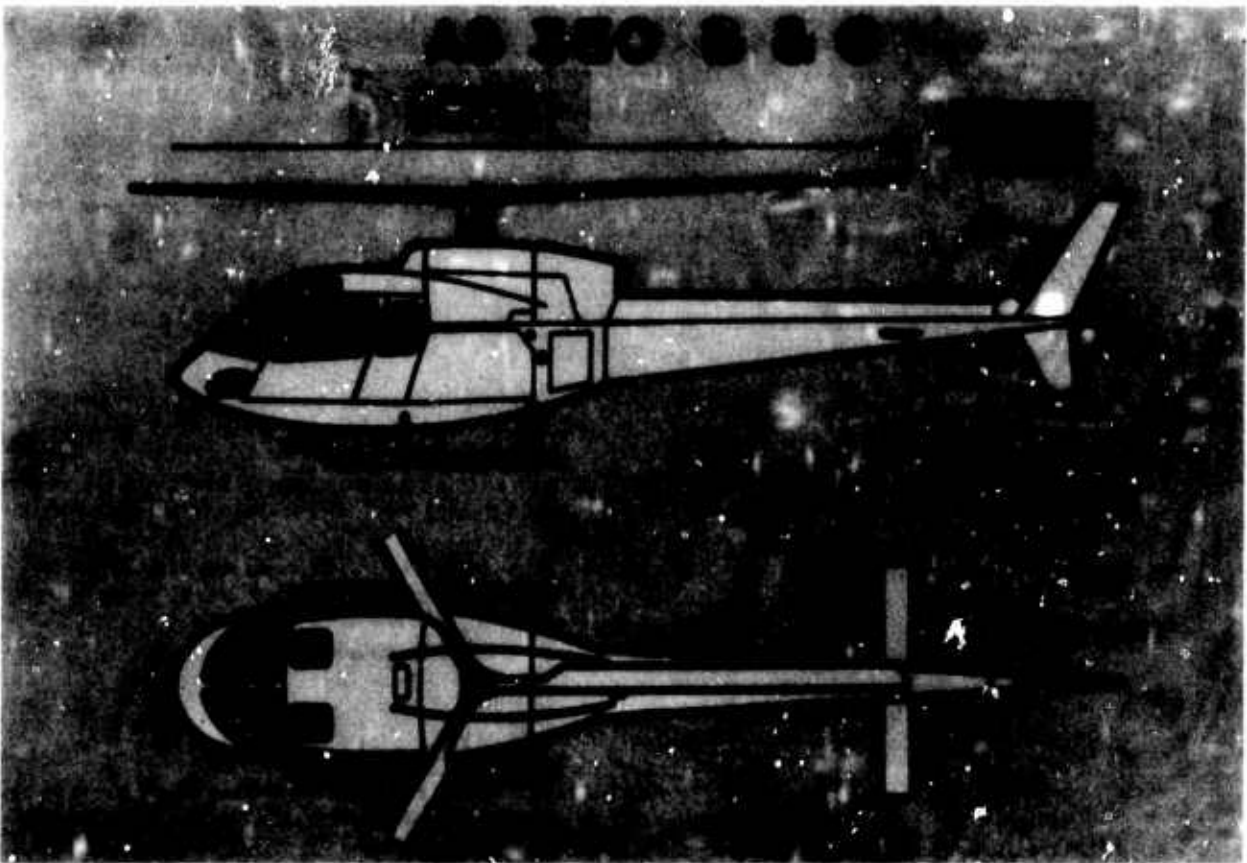

Figure 2

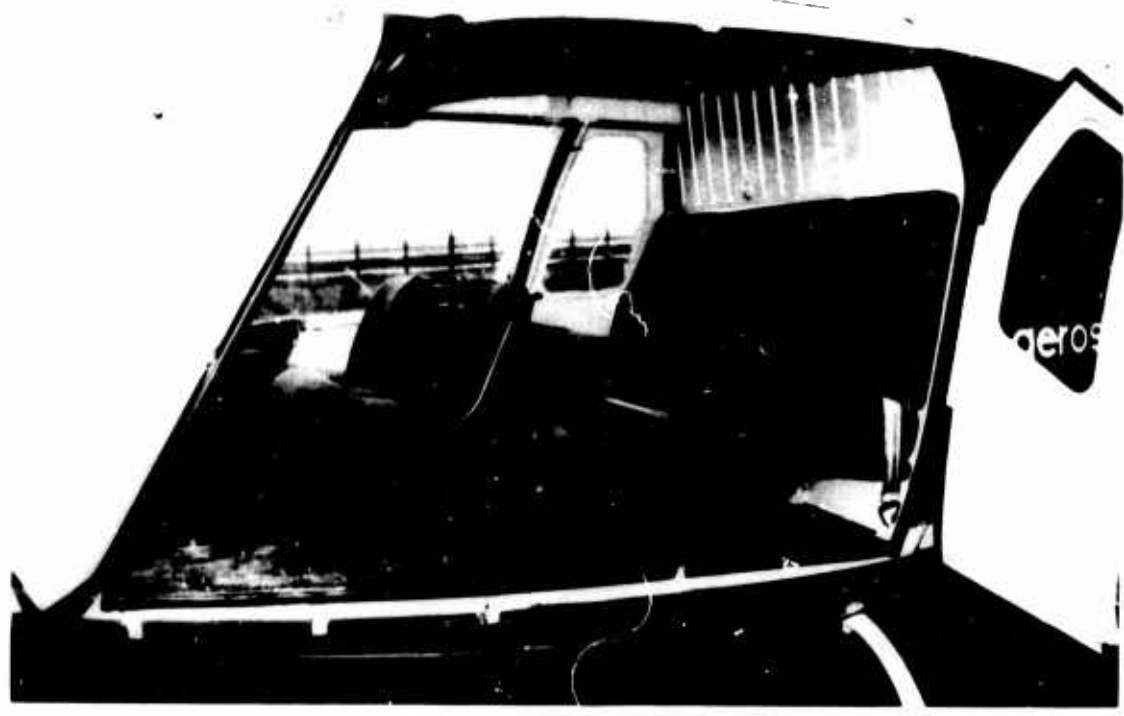

Figure 3

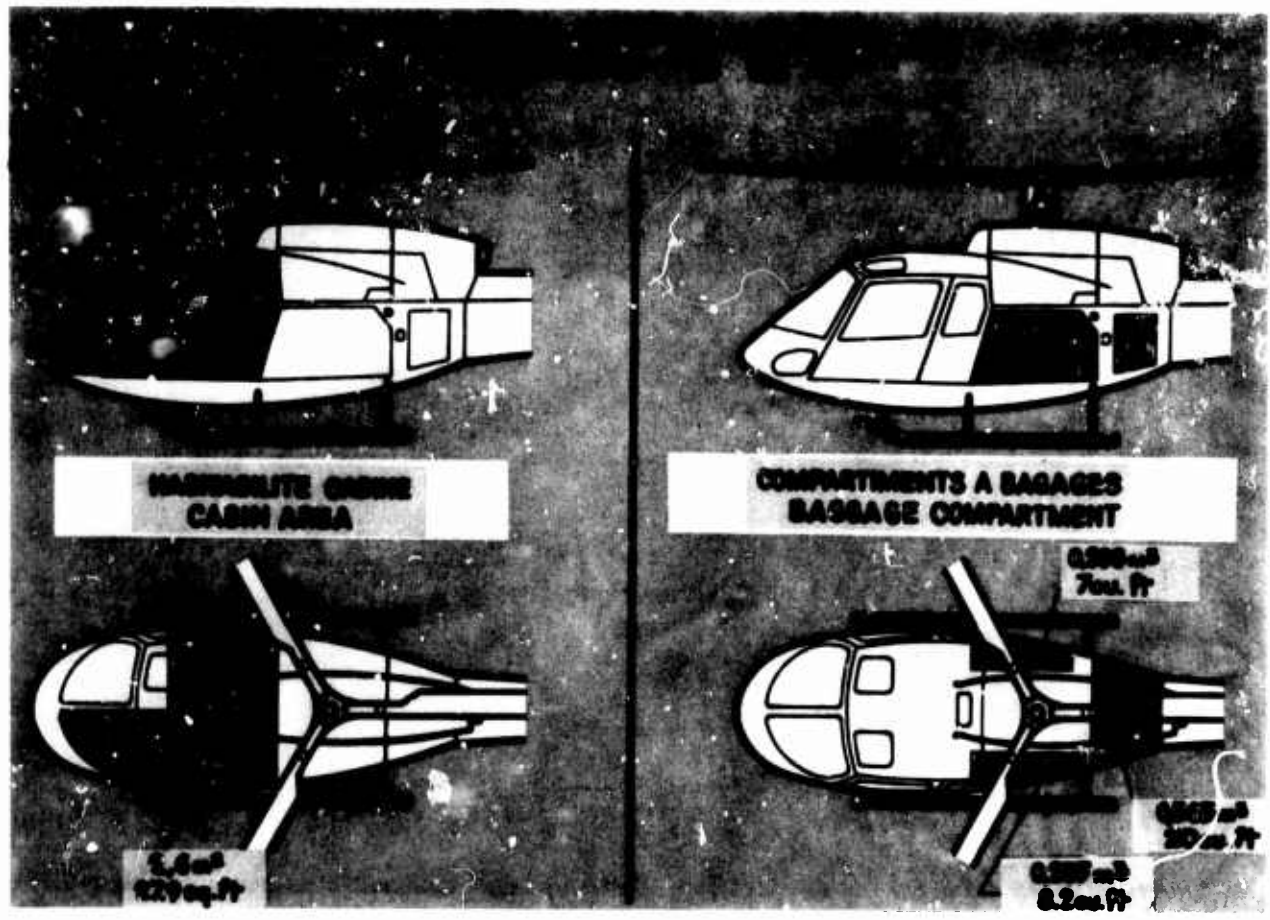

Figure 4

14-6

	ALOUETTE II	ALOUETTE III
MASSE TOTALE ALL-UP WEIGHT	1650 kg 3638 lb	2250 kg 4960 lb
NOMBRE DE PLACES NUMBER OF SEATS	5	7
MOTEUR ENGINE	ASTAZOU II 580ch. 572HP	ASTAZOU III 672ch. 650HP
VITESSE CROISIERE RAPIDE FAST CRUISING SPEED	190 km/h 102 kt	205 km/h 110 kt
DISTANCE FRANCHISSABLE RANGE	740 km 340 nm	644 km 348 nm
CHARGE PAYANTE SUR 500 km PAYLOAD, OVER 270 nm	280 kg 617 lb	665 kg 1465 lb

Figure 5

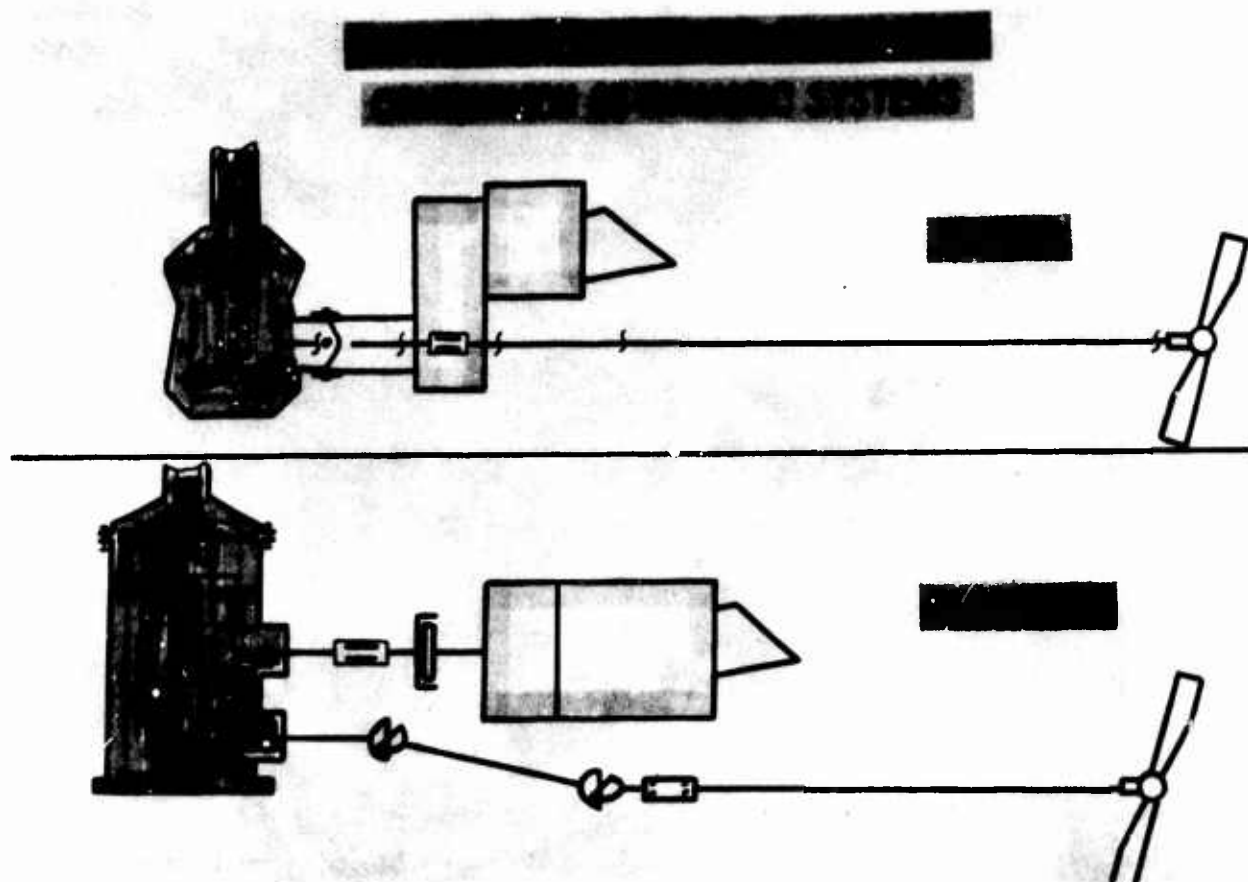

Figure 6

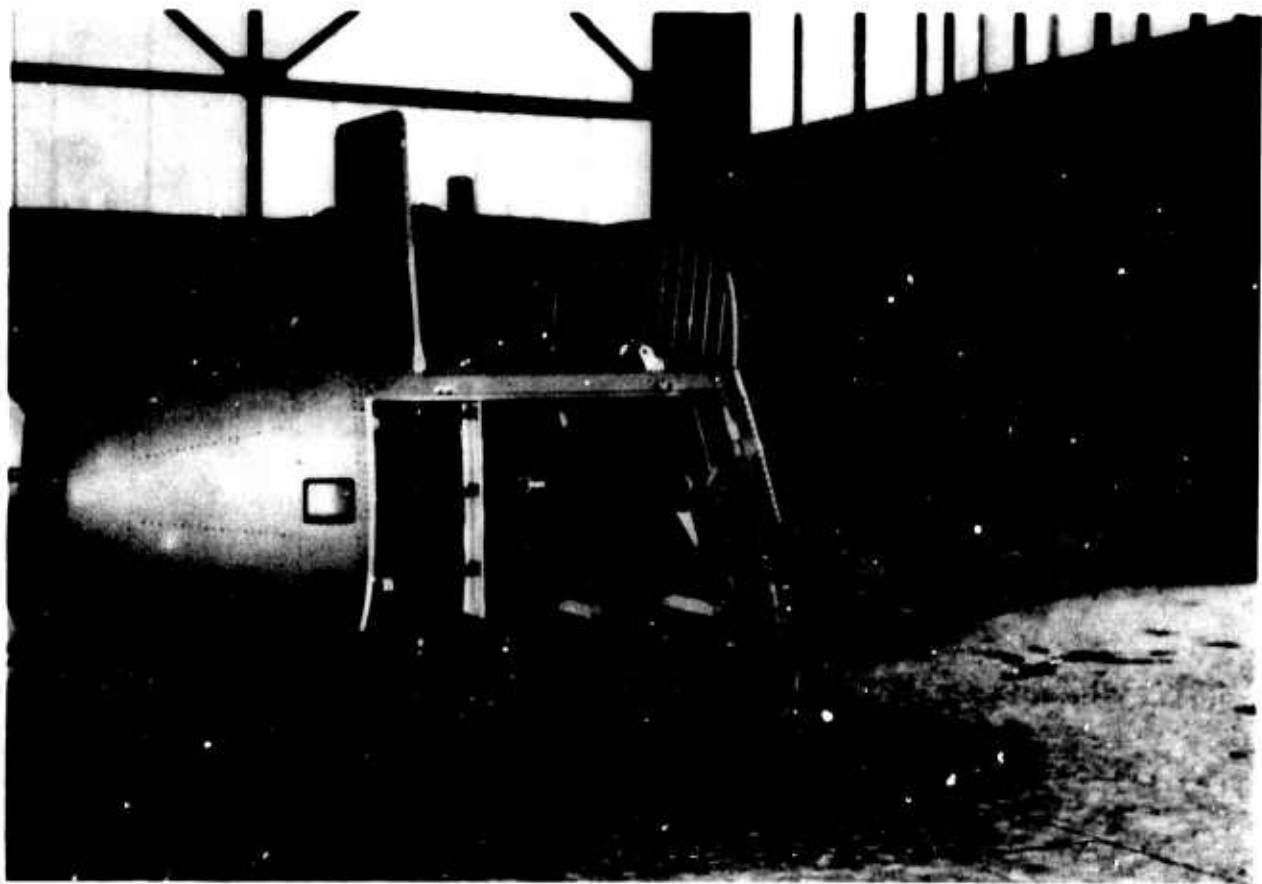

Figure 7

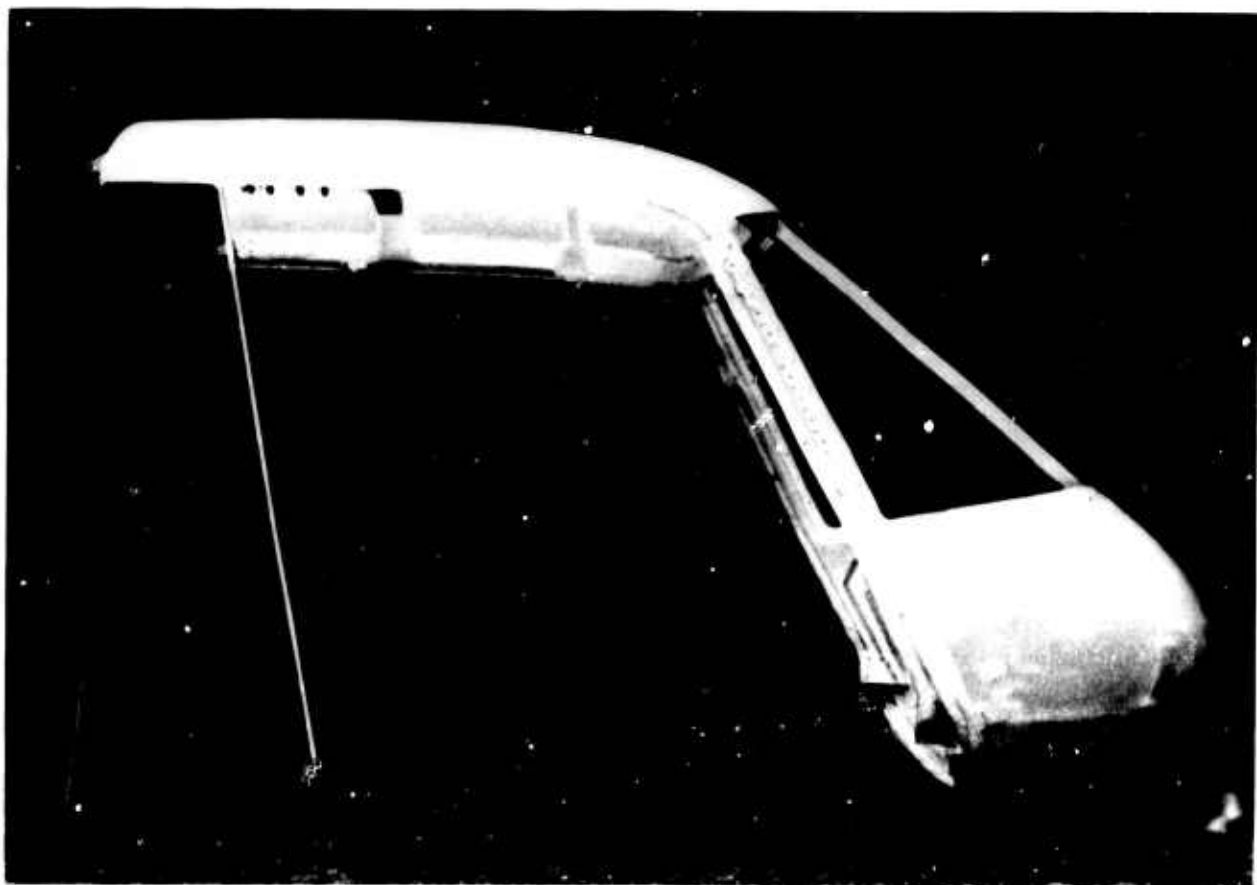

Figure 8

14-8

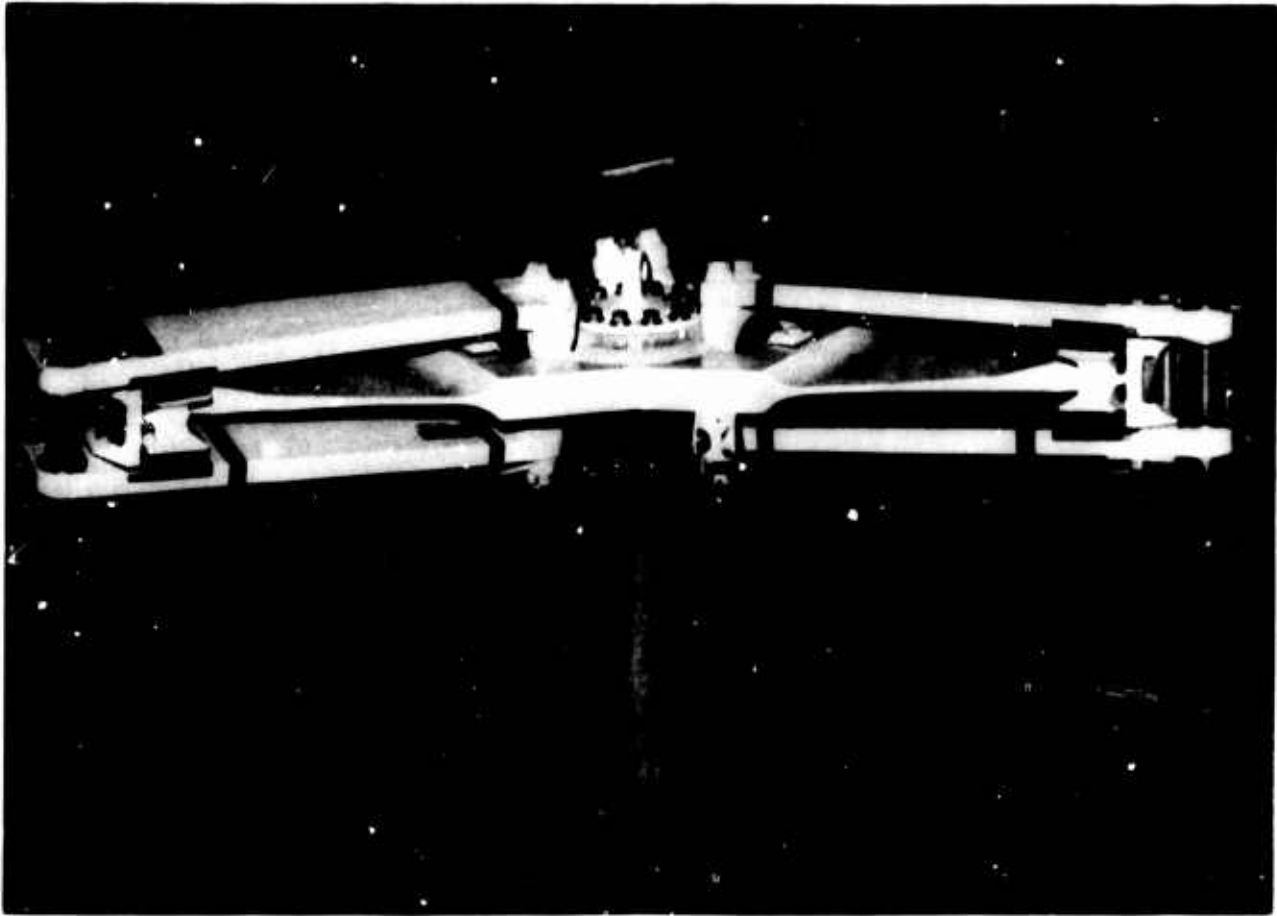
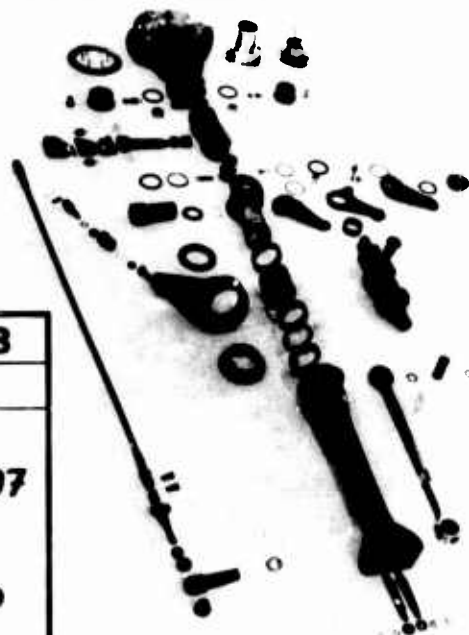

Figure 9

AS.350 COMPARAISON MOYEURS ROTORS PRINCIPAUX

STARFLEX AS 350

SA 318 ARTICULE



NOMBRE DE PIECES		AS 350	SA 318
TOTAL		70	377
DONT	ROULEMENTS	0	30
	JOINTS	0 } 0	45 } 97
	GRAISSEURS	0	22
	PALIER AUTOLUBRIFIANTS	3 } 6	0 } 0
	PALIER LAMIFIES	3	0

Figure 10

AS 350 LAMINATED BLADE TECHNOLOGY

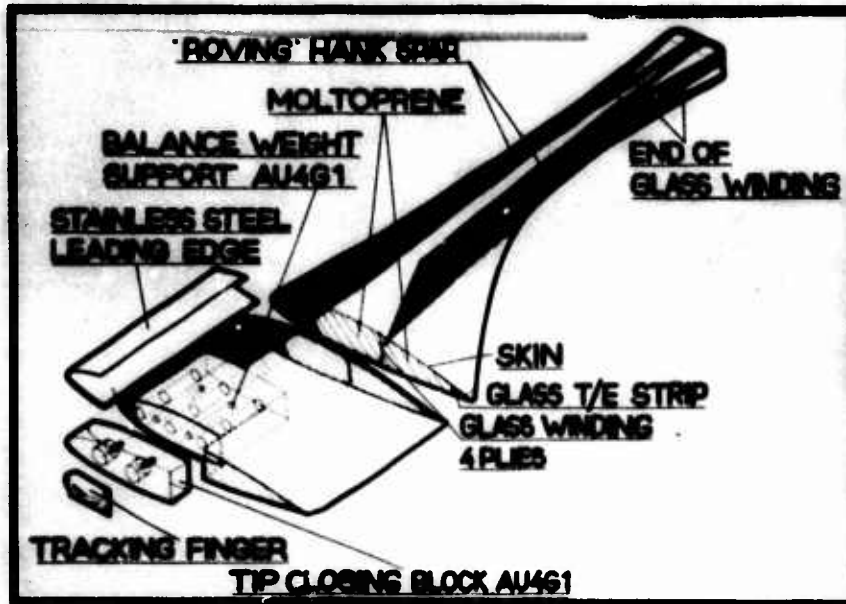

Figure 11

MOYEUX ROTOR ARRIBRE COMPARE COMPARISON OF TAIL ROTOR HEADS

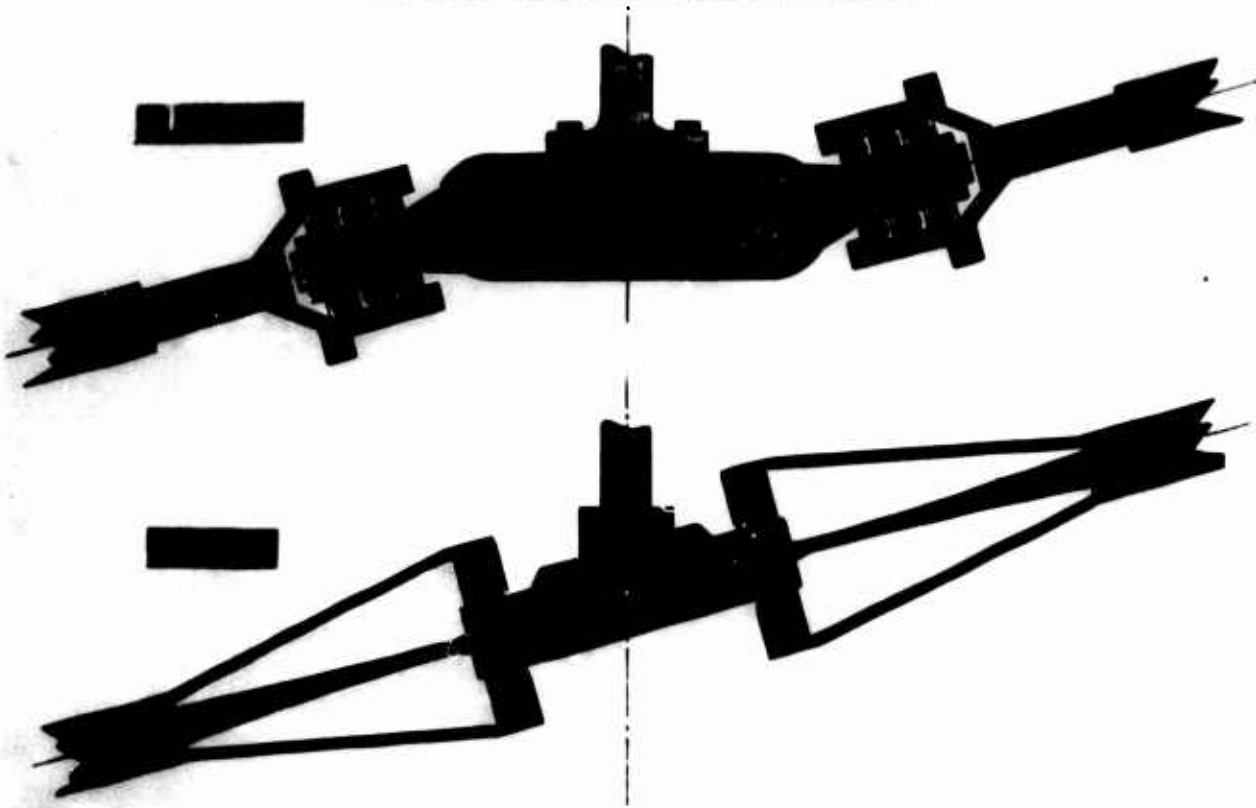

Figure 12

14-10

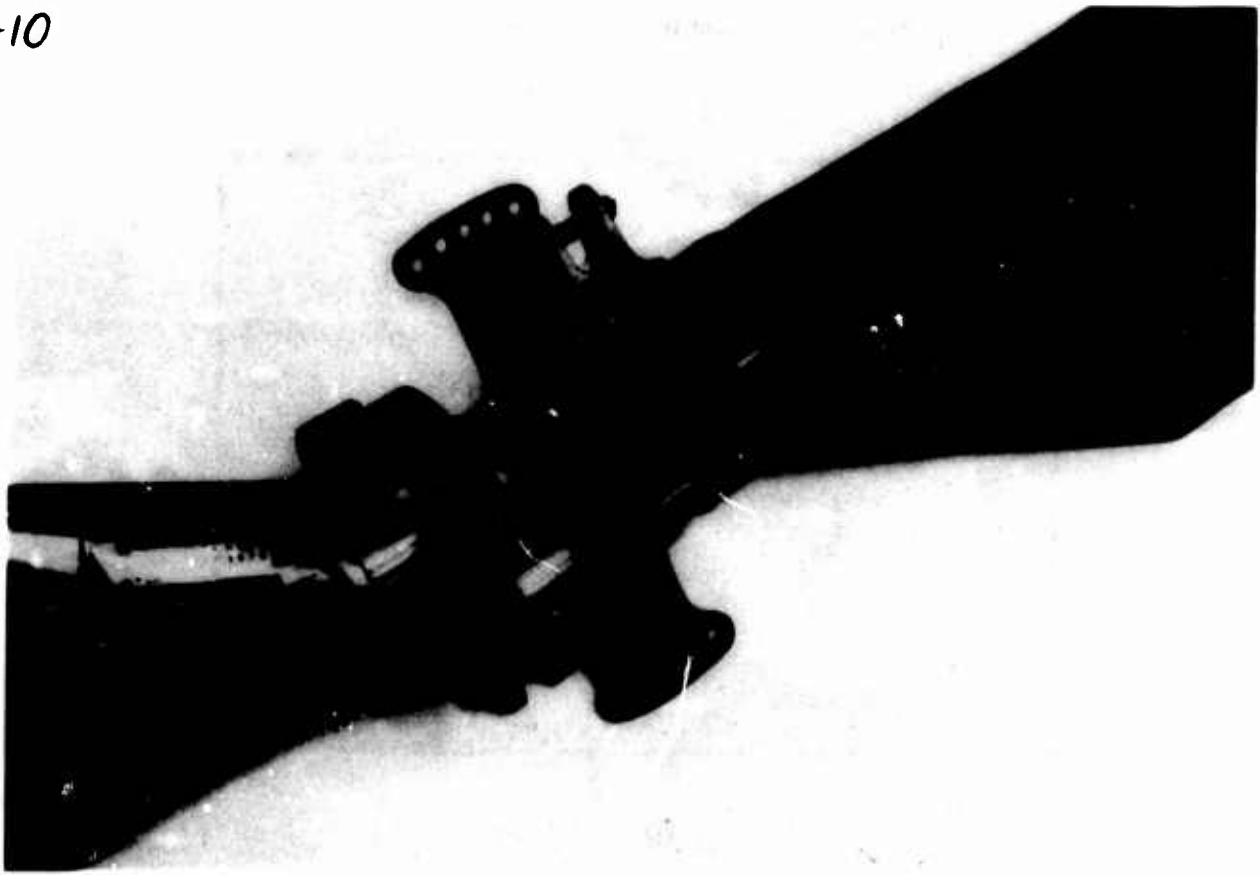

Figure 13

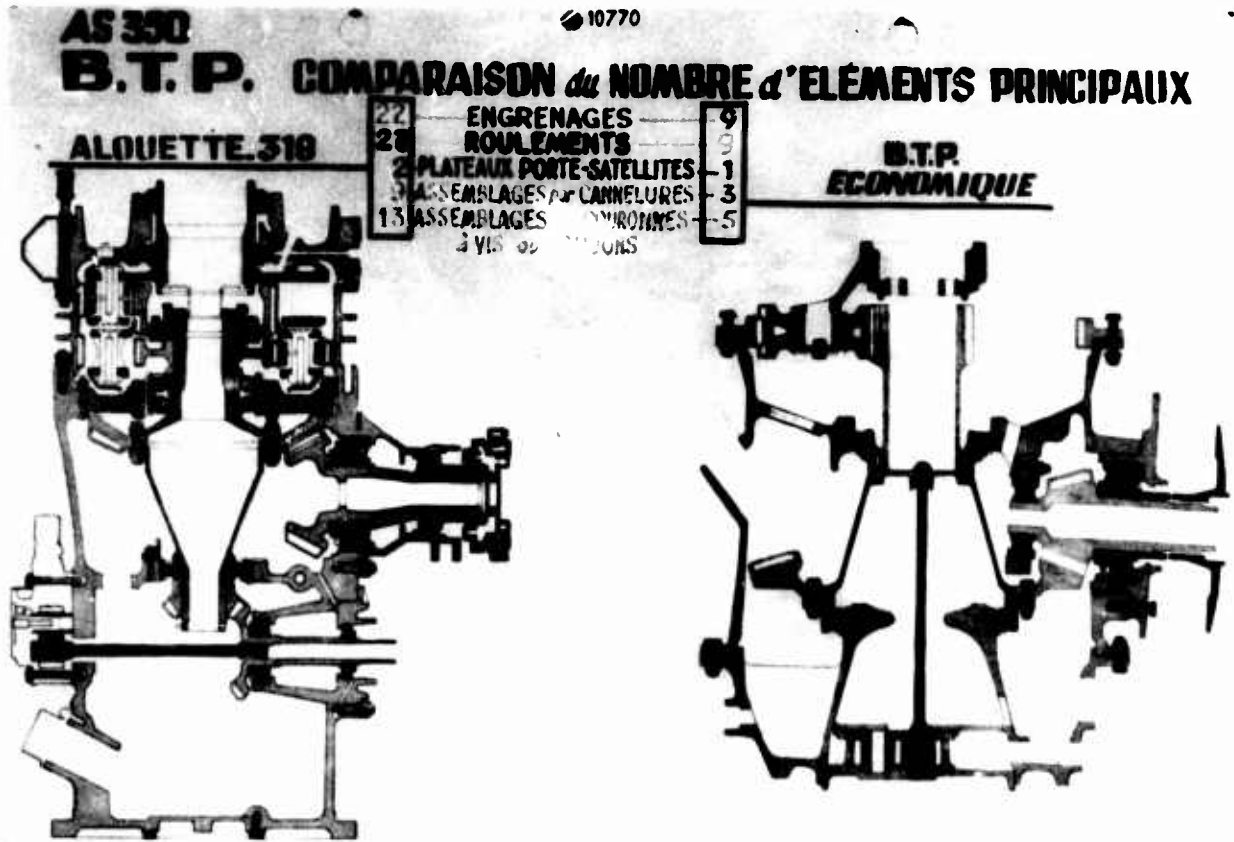

Figure 14

14-11

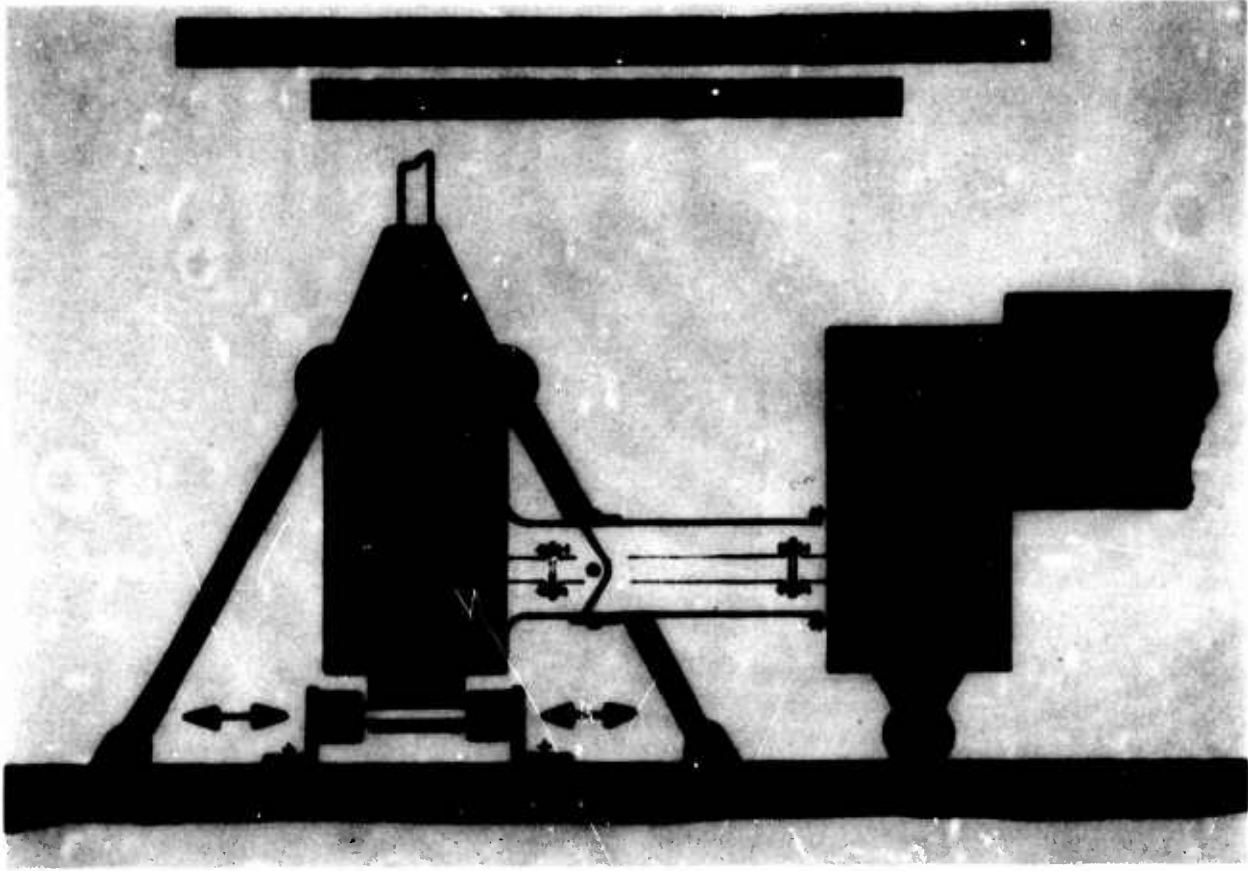

Figure 15

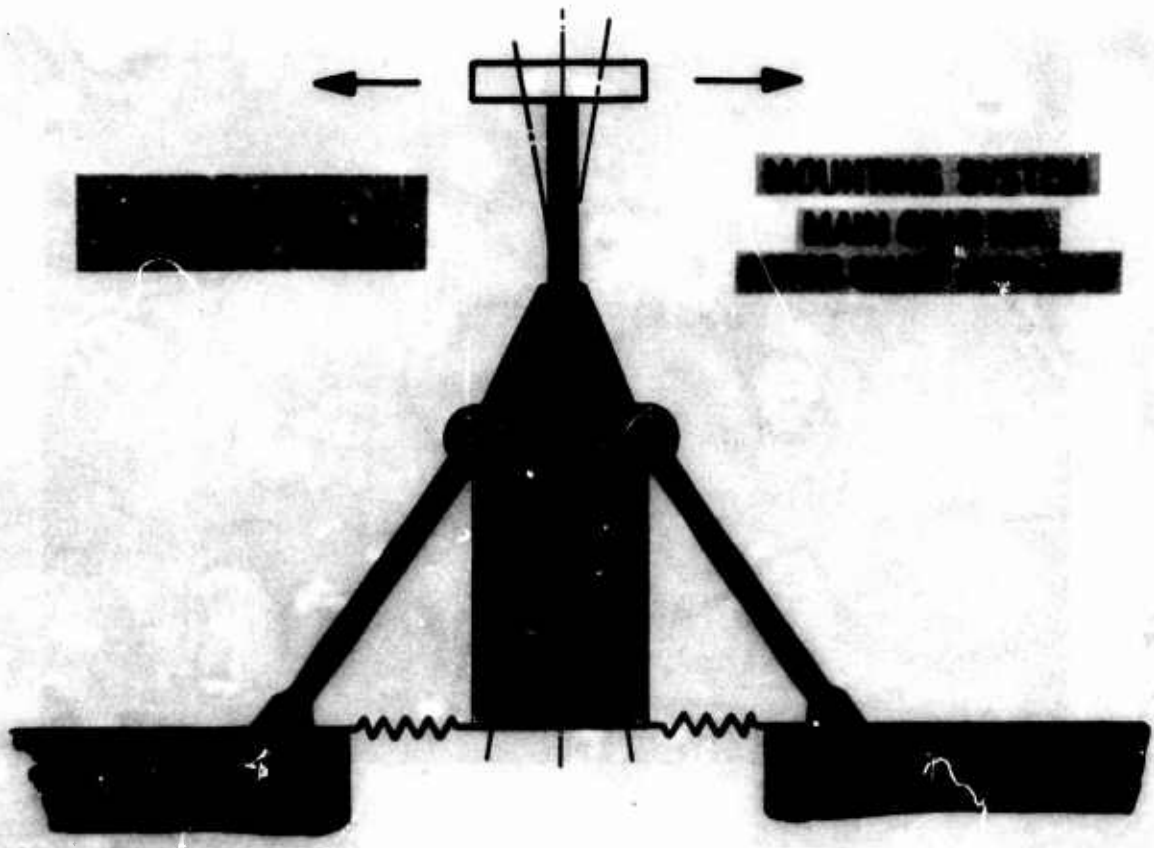

Figure 16

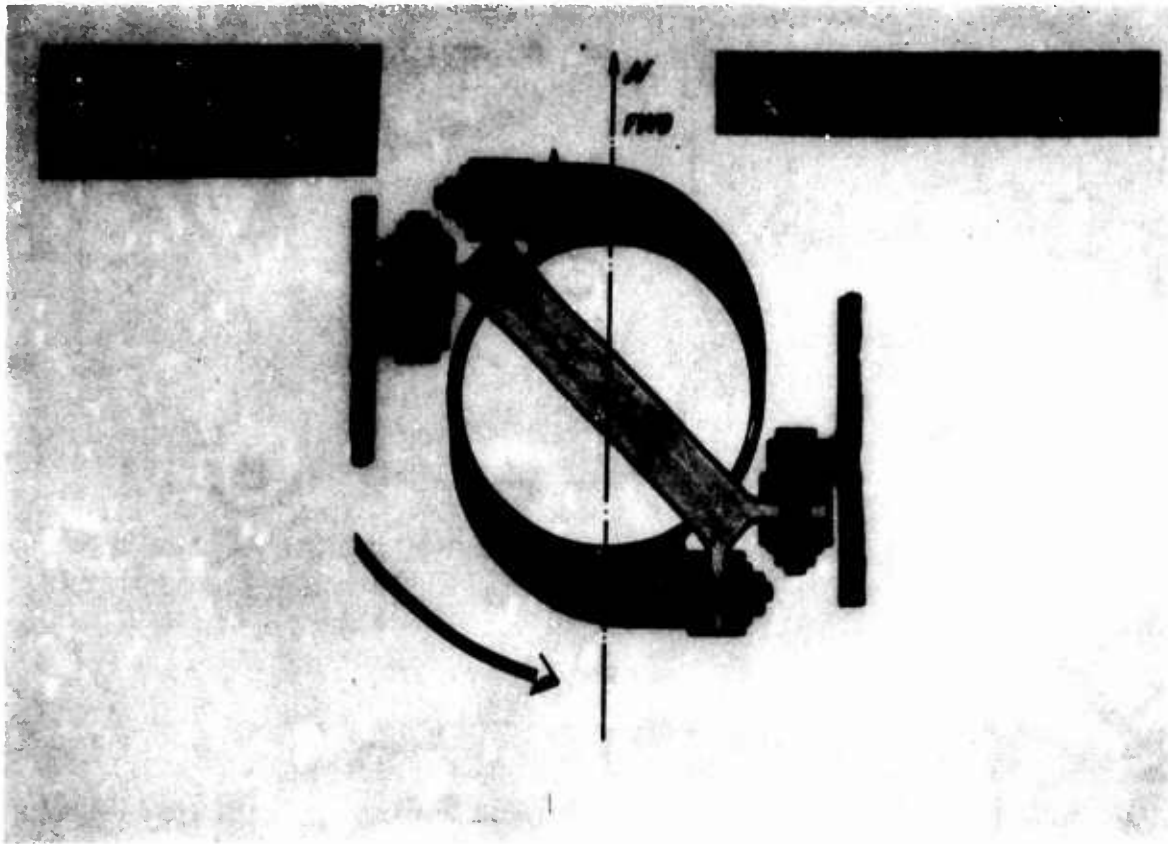

Figure 17

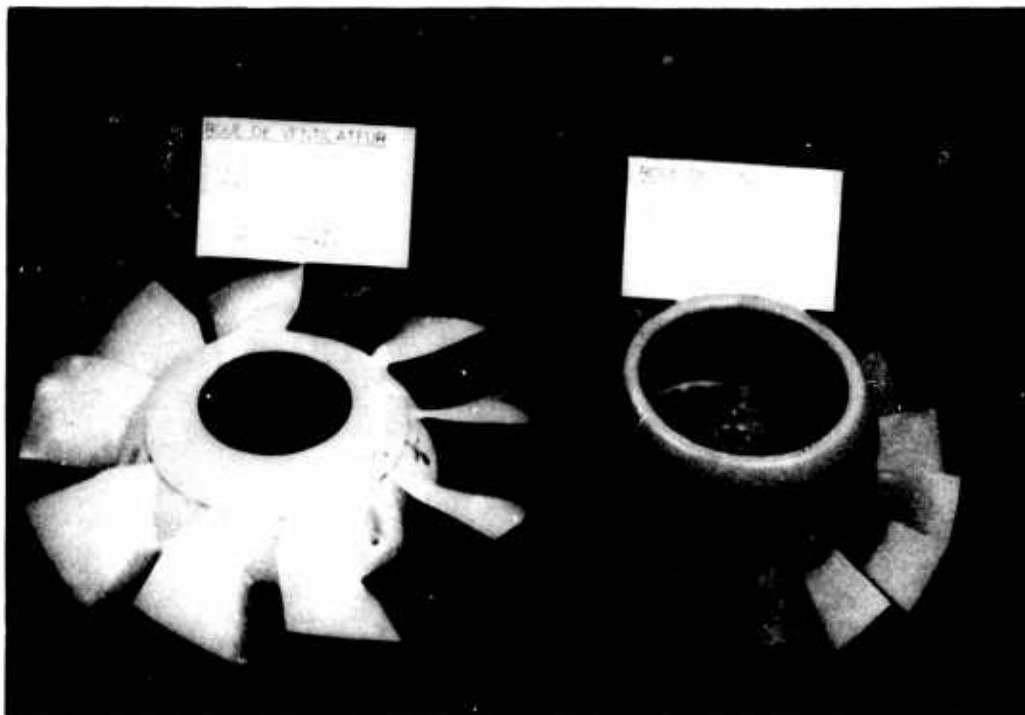

Figure 18



14-13

Figure 19



Figure 20

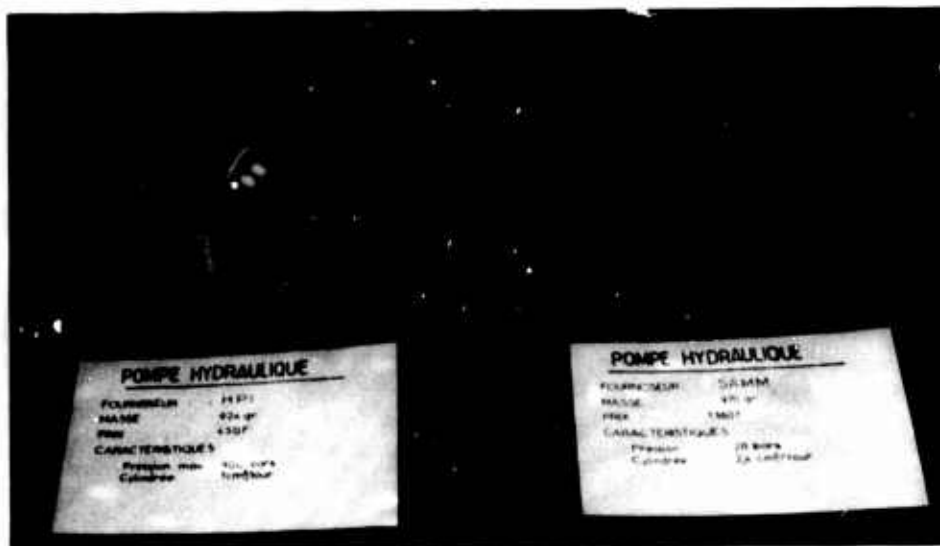

Figure 21

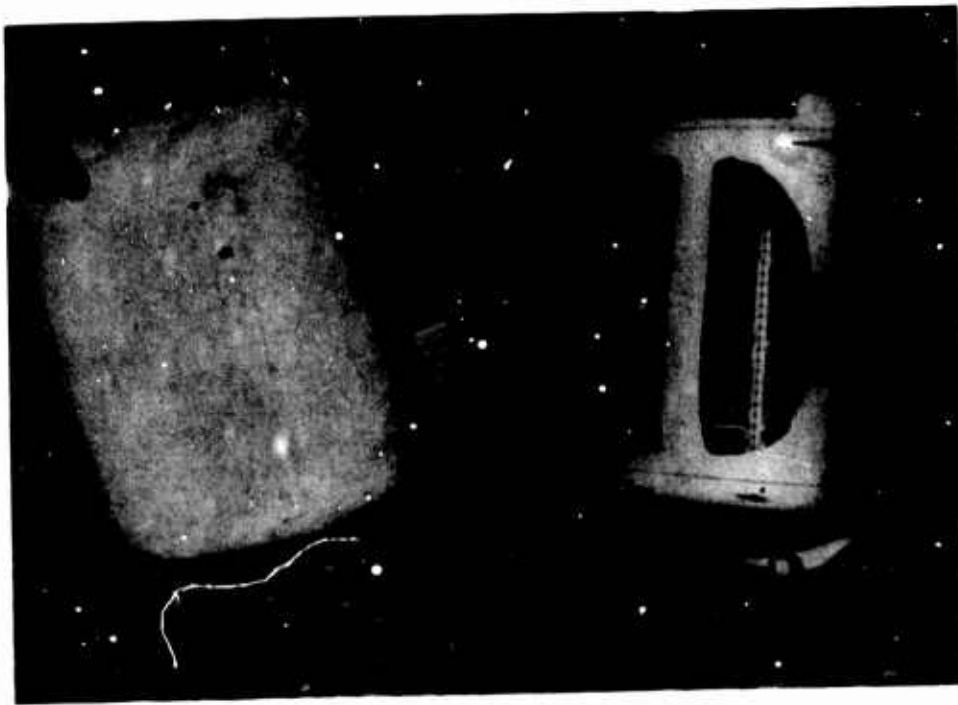

Figure 22

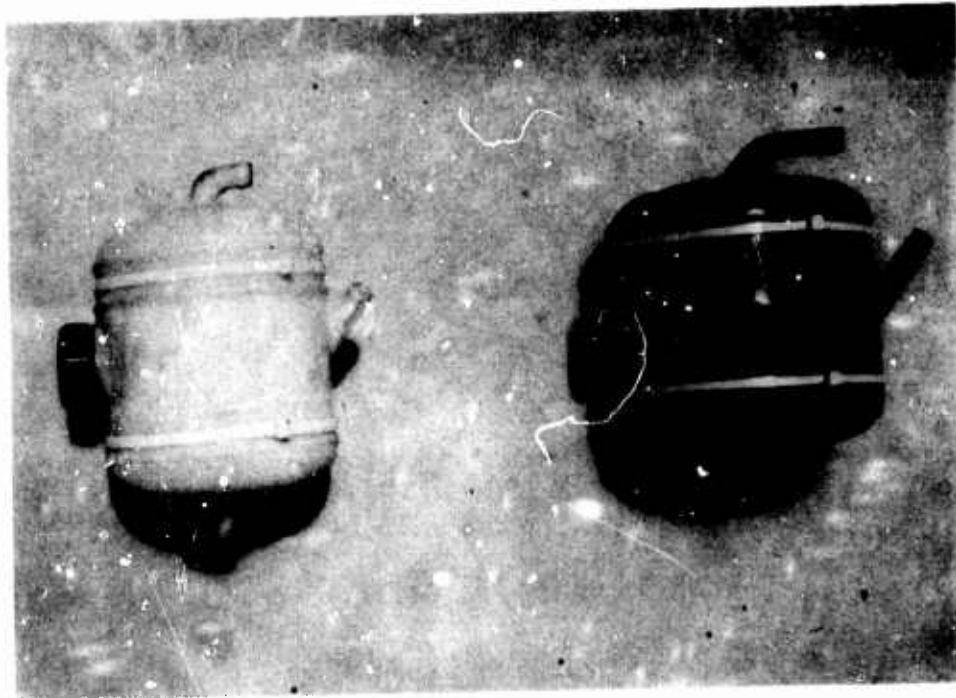

Figure 23

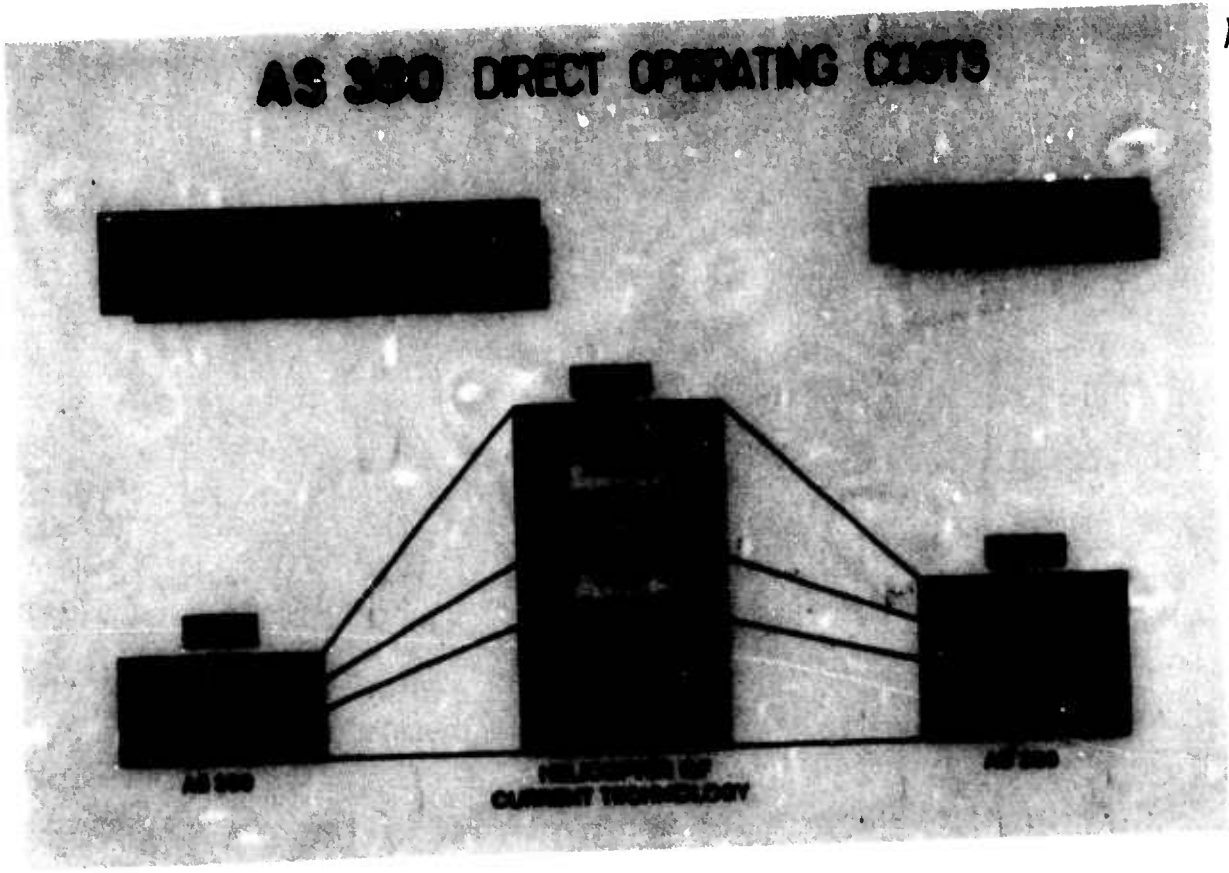

Figure 24

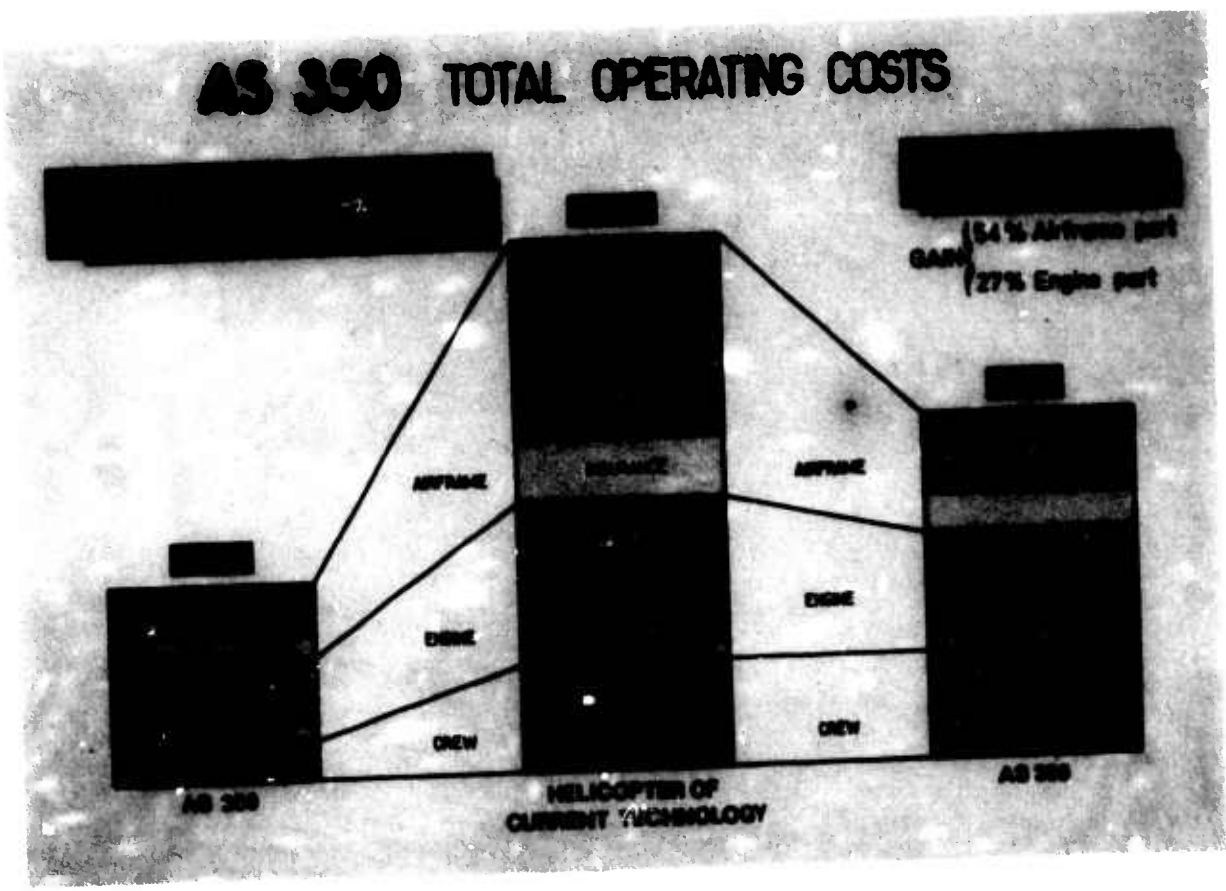

Figure 25

1416

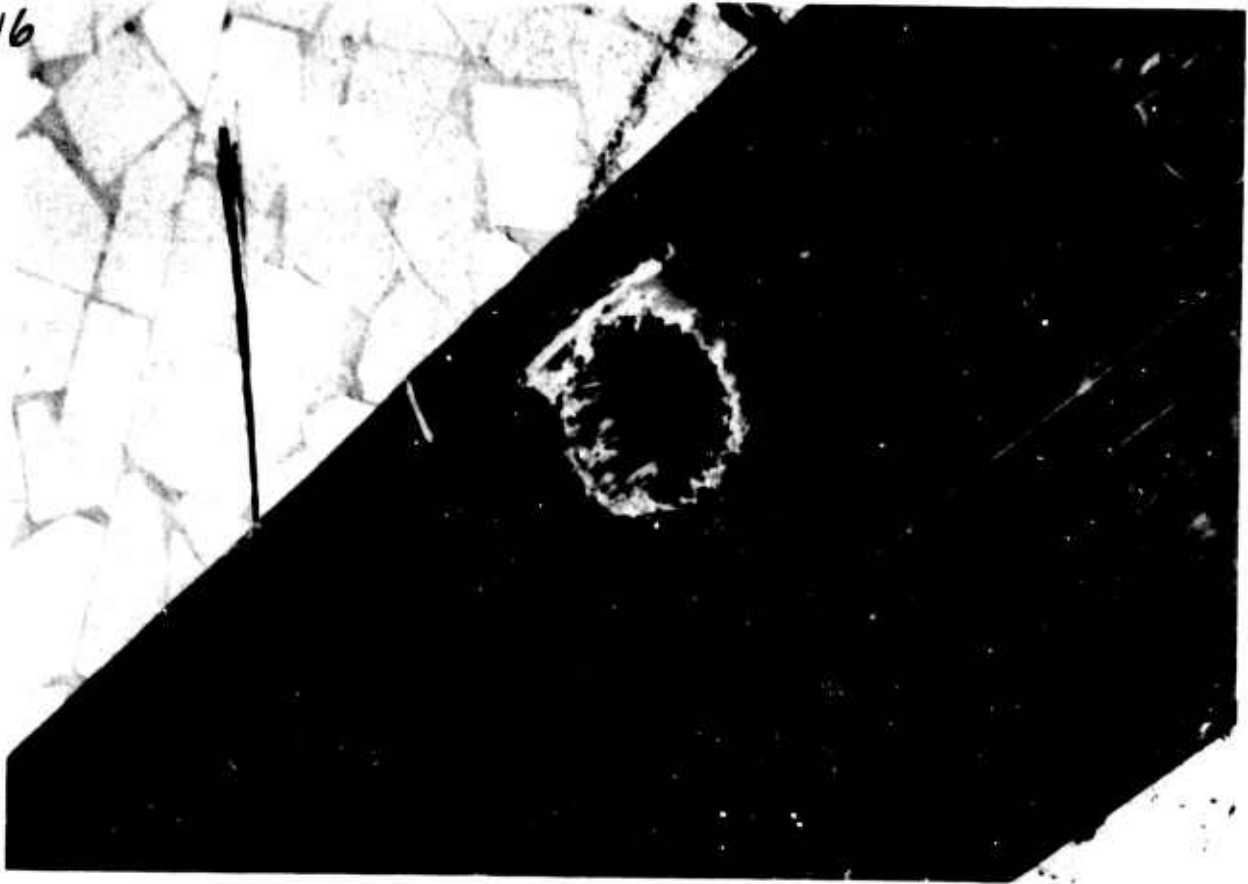

Figure 26

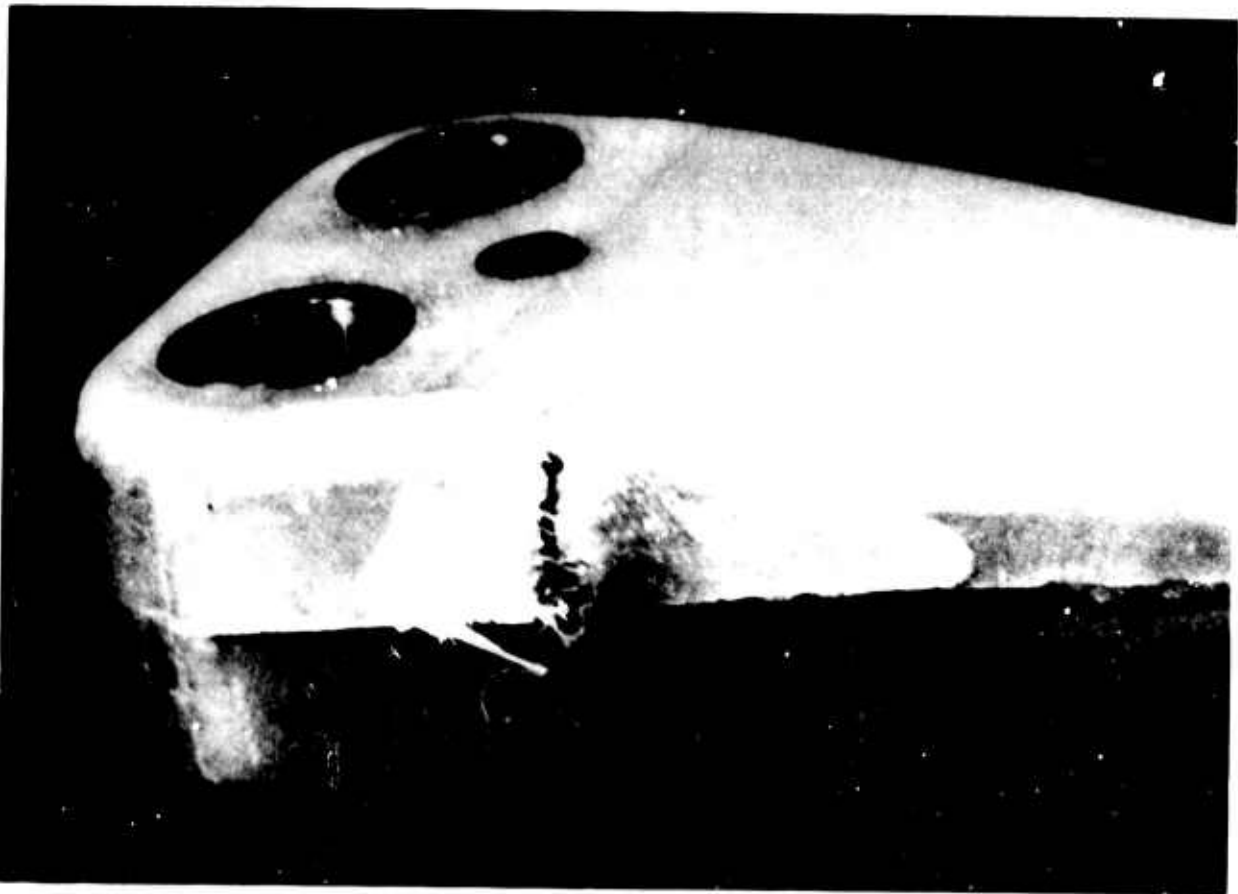

Figure 27

TETHERED RPV - ROTORCRAFT

by

G. Kannamüller, W. Göller

DORNIER GMBH, 7990 Friedrichshafen, Germany

15-1

1. INTRODUCTION

After a short definition of the tethered rotor platform the following paper will continue with a description of the objectives pursued with such an equipment. Then, a report will be given on the current development of the tethered rotor platform KIEBITZ, a project being carried out by DORNIER under contract from the "Bundesministerium für Verteidigung" (Federal Ministry of Defence).

Finally, promising possibilities for the use of the KIEBITZ, above all the French-German cooperative development of a battlefield surveillance system ARGUS will be discussed.

2. DEFINITION

A tethered rotor platform is designed for the stabilization of transmitters and receivers of electromagnetic waves at an adequate altitude over a ground control station for military and civil purposes. The complete system consists of rotor platform, tethering cable, and ground control station. The rotor platform is unmanned and stabilized by means of an autopilot. A tethering cable constitutes the link between the rotor platform and the ground control station. The platform is controlled by an operator in the ground control station. Apart from the transmission of command and information data the tethering cable is also used for the power supply.

3. OBJECTIVE

Tethered rotor platforms can be used primarily in the military field for the following missions:

- Surveillance of battlefield, sea surface and air space
- Electronic warfare
- Fire control
- Communication

These operational tasks are based on several requirements:

- Adequate altitude, payload and stability for the operation of the individual transmitters or sensors
- Long endurance without any restrictions due to adverse weather conditions and nighttime
- ECM-resistance
- Low detectability
- Cross country mobility
- Cost-effectiveness in comparison with alternative systems

It is the primary task of a tethered rotor platform to elevate modern transmitters and sensors for electromagnetic waves, that are characterized by straight-line propagation, and to position them at an altitude above the ground at which the maximum range of these systems can be fully used, without restriction by terrain roughness and vegetation.

Figure 1 shows the cumulative intervisibility by an elevated sensor versus range.

However for certain military applications near the forward edge of the battlefield area (FEBA) high altitude generates increased threat by ground based air defence systems of the enemy.

Figure 2 demonstrates this by the example of a helicopter and a tethered rotor platform for battlefield surveillance. In order to avoid the effective range of an enemy SA-6 for example, higher altitude has to be combined with greater distance to the FEBA.

The application of transmitters and sensors the performance of which is rather independent of weather conditions calls for a flight vehicle with bad weather capability qualified for long endurance.

For tethered rotor platforms, only very high wind speeds and lightning are problematical. Here, certain restrictions have to be accepted.

ECM resistance has to be required for the flight control of the rotor platform as well as the data transmission from air to ground.

Limited detectability has to be required for observation with eye, infrared sensors, and radar.

The required mobility calls for a quick positioning of the rotor platform at the mission height as well as reeling-in and change of the position of the ground control station in short time.

The cost-effectiveness has to be evaluated by means of comparison with alternative ground-based systems, helicopters, and captive balloons.

4. TETHERED ROTOR PLATFORM KIEBITZ

DORNIER is developing the tethered rotor platform Do 34 KIEBITZ under a contract from the "Bundesministerium für Verteidigung" (Federal Ministry of Defence). This programme was initiated after the successful flight evaluation of a small demonstrator platform, that was also called Kiebitz. The military requirement of the German Army calls for a rotor platform for the stabilization of a payload of 140 kg for a period of up to 24 hours at an altitude of 300 m above the ground.

Dynamic system

DORNIER had gained good experience with the pneumatic rotor drive for various other flight vehicles. For KIEBITZ this propulsion system was chosen as well since it is qualified for continuous operation due to its relative simplicity. The gas turbine Allison 250-C 20 B that is mounted in the KIEBITZ drives a radial compressor (Figure 3). The compressed air is conducted through the hollow rotor hub and the hollow rotor blade spars to the blade tip nozzles. It is deflected in the direction of the blade rotation and expands whereby the rotor is driven by reactive forces.

The turbine exhaust gas is conducted to two yaw control nozzles. The control about the yaw axis of the rotor platform can be effected by deflection of the exhaust gas jet.

The two rotor blades are connected with the rotor head by a central flapping hinge. The cyclic or collective blade pitch control is effected by a spider.

Stabilization system

Rotor blade pitch and yaw nozzle control as well as engine control are carried out by the stabilization system. The following control loops are used for the stabilization of the rotor platform:

- Attitude control in pitch and roll combined with translation damping in the longitudinal and cross direction
- Angular velocity control in yaw
- Cable tension control through the rotor thrust

Using preset values for the attitude control loop in pitch and roll the operator in the ground control station can control the lateral offset of the rotor platform. He can also control the flight vehicle about the vertical axis by commanding a yaw velocity.

Using the signals of an azimuth reference in the yaw control loop the flight vehicle can be stabilized in a chosen azimuth direction.

Apart from the attitude control a translation damping is also necessary for the stabilization of the flight vehicle.

The translation accelerations are measured in two axes and utilized by the autopilot. The necessary degree of amplification of these acceleration signals is determined by the length of the tethering cable.

As shown in Figure 4 the amplification is effected in three steps.

The length and the tension of the tethering cable have a decisive influence on the flight mechanical behaviour of the rotor platform. There is an upper and a lower limit for the permissible cable tension depending on the length of the tethering cable.

High cable tension leads to high frequencies of the pitch and roll oscillation of the rotor platform. It is limited by the pitch and roll frequency to be handled by the autopilot. Low cable tension leads to insufficient translatory restoring forces in the case of a lateral offset of the platform. The lower limit value of the cable tension is determined by the requirement concerning adequate damping of the translatory movements of the rotor platform. (See Figure 5.)

The operator in the ground control station can choose between three types of control, the attitude control, position control, or offset control. (See Figure 6.)

14-18

Figure 30



Figure 31



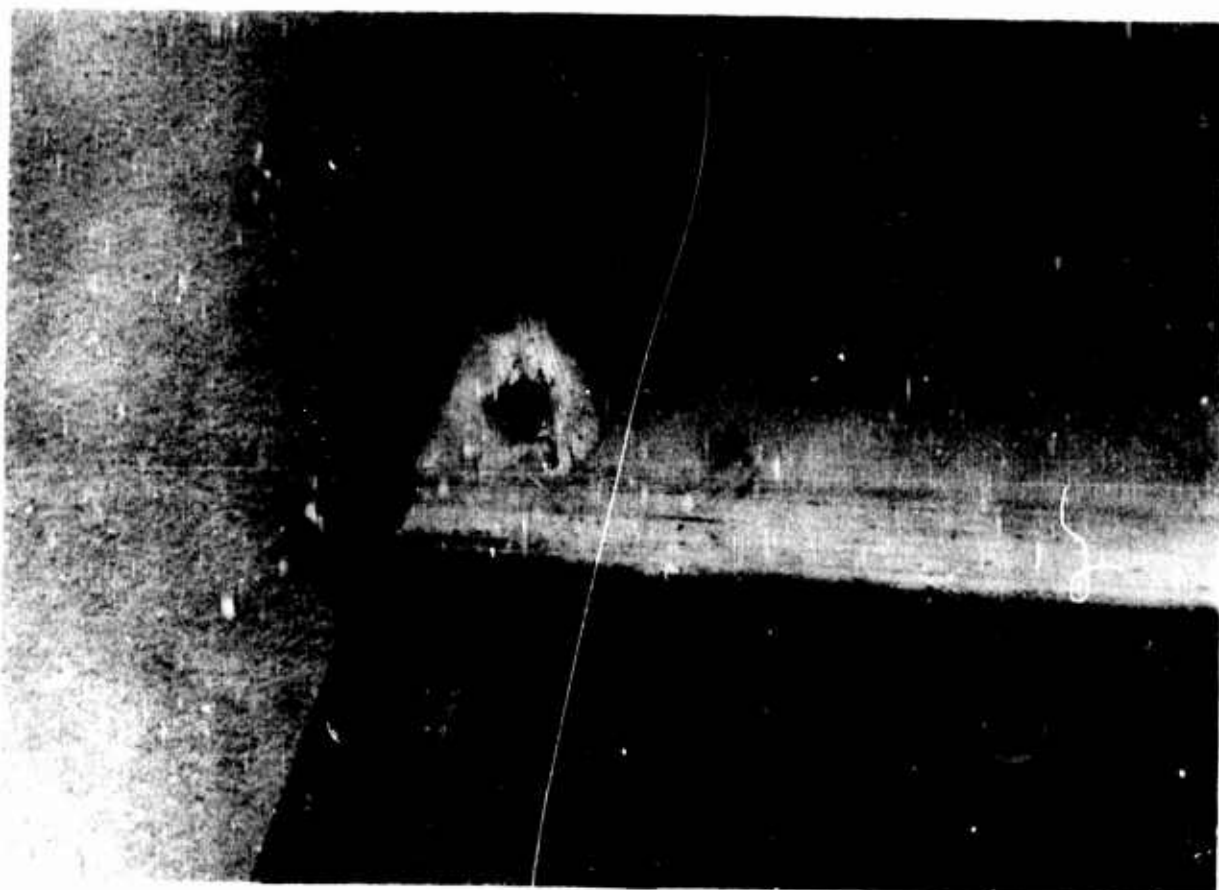

Figure 28



Figure 29

In the case of attitude control the vertical attitude of the KIEBITZ is stabilized and wind forces cause a drift. In the case of position control the position above the ground control station is stabilized and wind forces lead to an inclination of the flight vehicle. In the case of offset control the operator in the ground control station can preset an offset value of up to 100 m horizontal distance from the ground control station that is kept constant by the autopilot. The inclination of the flight vehicle is then determined by the wind velocity.

The lateral offset of the KIEBITZ is measured by means of a radio beacon. Aboard the KIEBITZ a transmitter is installed. Four antennas on the ground station measure the phase shift of the electromagnetic waves. On the basis of the phase shift the lateral offset angle with respect to the vertical is determined.

Airframe

The upper part of the airframe of the KIEBITZ contains all those systems that are necessary for the operation. (See Figure 7.) The lower part of the airframe has a conical shape and ends in an landing ring. The hollow conical part of the airframe permits adequate clearance for the tethering cable in the case of lateral offsets of the flight vehicle. At the outer frame of the conical structure different sensor payloads can be mounted. Figure 7 shows the KIEBITZ with a radome of a battlefield surveillance radar.

When the design of the KIEBITZ was developed special attention was paid to the possibility of using other sensor payloads without having to change the carrier system.

Tethering cable

The connection between ground station and flight vehicle is provided by means of a tethering cable (Figure 8). Its components are as follows:

- A fuel hose for the continuous fuel supply for the flight vehicle.
- Two coaxial lines or one coaxial line and a pair of shielded lines for the transmission of the sensor payload data in the video frequency range.
- 72 single wires for the transmission of control and monitoring signals for flight vehicle and payload and for the transmission of the tethering force.
- A sheath.

Ground control station

The mobile ground control station permits the transportation and the autonomous operation of the KIEBITZ (Figure 7). It is accommodated in a container that can be transported by a truck, by train or by airplane. For transportation purposes the rotor blades are folded and the platform is tilted forward and thus positioned in the container.

The major components of the ground control station are as follows:

- Take-off and landing pad
- Cable winch
- Operation cabine for the flight vehicle
- Power supply system for the electric and hydraulic power consumption of the ground control station
- Fuel supply system for the rotor platform
- Operation control system

For the operation of the sensor payload and the processing of the sensor data another vehicle will be provided.

Flight performance

The flight envelope of the rotor platform KIEBITZ is determined by the available rotor thrust, the available length of the tethering cable, and the load capacity of the airframe with respect to the maximum payload.

Figure 9 shows the altitude/payload range for the design requirements concerning the altitude of the ground control station location and the atmospheric conditions.

The KIEBITZ was designed for:

- | | |
|---|----------------|
| - Payload | 140 kg |
| - Operational height | 300 m |
| - Altitude of the ground control station location | 1000 m |
| - Environmental temperature of | ISA + 10° C |
| - Max. wind velocity on the ground | 14 m/s ± 8 m/s |

The operational height is the flight altitude above the ground control station.

Reliability

In the case of the unmanned KIEBITZ a non-redundant design was chosen. The achievable reliability is considered adequate and it meets the requirement concerning the provision of a relatively simple overall system.

Cost-effectiveness

Compared with the manned helicopter meeting the same requirements the tethered rotor platform causes only half as much cost for procurement and operation. Furthermore, this system promises much greater availability than alternative systems because of its capability to operate under adverse weather conditions as well as during nighttime.

Development status of the project

At present the tethered rotor platform is in the flight testing phase. At the same time the testing of a battlefield surveillance system based on the tethered rotor platform KIEBITZ has been started.

5. MISSION POTENTIAL OF THE KIEBITZ

The KIEBITZ was designed as a multi-purpose carrier system for different sensors and transmitters. The most important applications of the KIEBITZ are as follows:

- Battlefield surveillance
- Electronic warfare
- Communication
- Detection of low-flying aircraft
- Sea surface surveillance

Battlefield surveillance

The German as well as the French Army intend to use the KIEBITZ for battlefield surveillance by means of radar. In German-French cooperation the system ARGUS is being developed which consists of the carrier system KIEBITZ of DORNIER and the MTI-radar ORPHEE and the analyzing equipment PREDICADOR of the French firm LCT.

The system ARGUS is planned to be used for:

- continuous surveillance of the battlefield and
- target acquisition for areal weapons.

It will be possible to detect moving targets in a distance of up to 60 km. Due to the wide range of the radar the ARGUS can be located in adequate distance from the FEBA in order to be protected against any attacks by air defence guns and small ground/air missiles. The rotor platform with the radar equipment remains outside the effective range of long-range, ground/air missile systems as well as artillery fire of the enemy. Sectors that are interesting from the tactical point of view can be continuously surveyed for more than 24 hours. A French/German military evaluation campaign of ARGUS is being prepared for 78.

Electronic warfare

Another important field for the use of the KIEBITZ considered by the German Army is the SIGINT. Here, the reconnaissance range can also be considerably extended by elevating the sensors. The higher the transmission frequencies, the higher will be the range increase percentage. Depending on the frequency it may amount to an increase of 100 to 200 %. (Figure 10.)

By means of a COMINT-sensor the direction of VHF- and UHF-transmitters in greater distance can be found and the transmitters can be intercepted.

With an ELINT-sensor continuous direction finding and identification of enemy radar equipment is possible. The identification is carried out by means of comparison of the received radar signals with the stored characteristic data of different radar systems.

The combination of the radar-direction finding/analyzing system with a jammer can be used for deceptive jamming of the enemy radar.

Communication

Apart from the building-up of a directive radio link at short notice for the bridging of broken-down radio relays, especially the setting-up of an elevated relay station for RPV and UGS (unattended ground sensors) is of great importance. Between the RPV and its ground control station a radio contact has to be maintained. Depending on the mission, video signals of the airborne sensors have to be transmitted to the ground station and command data for the control of the flight vehicle have to be transmitted to the flight vehicle. Since the frequency used by the transmission channels requires a more or less straight-line transmission a relay station that is located at an adequate altitude has to be interposed in order to provide sufficient penetration depth.

The transmission of signals from the UGS via a relay station in a rotor platform looks promising. Due to the long surveillance time before the perception of possible signals resulting from enemy movements continuous operation of the relay station is required. A tethered rotor platform with a relay station could provide a reasonable coverage of the terrain for long periods of time. The elevated position of the relay station leads to an extension of the range that is twice to four-times as great as in the case of ground-based equipment.

Detection of low-flying aircraft

For the detection and tracking of air targets radar and target have to be in a straight line. Enemy aircraft can take advantage of the earth curvature and of terrain features in order to avoid or at least to delay a possible detection and attack by air defence weapons.

The probability of placing the radar and the air target in a straight line depends on the altitude at which the radar equipment is located above the ground. A radar equipment that is operated at an altitude of several hundred meters above the ground is much more effective against low-flying aircraft because of better coverage of the terrain.

A radar equipment for the detection of low-flying aircraft that is mounted on the KIEBITZ permits the detection and identification of low-flying aircraft about 1,5 minutes or 25 km earlier than ground-based radar equipment. That is equivalent to a two-fold increase in the early warning time whereby the combatting of low-flying aircraft by means of guns and missiles could be considerably improved.

Sea surface surveillance (Figure 11)

A tethered rotor platform with active and passive sensors can be operated from ships or from the coast. It has the effect of an antenna mast that has been extended to a length of 300 m and enables the ship to detect targets within a range that otherwise could only be covered by special direction finding devices outside the ship.

The range of many SS-missiles exceeds considerably the range of direction finding equipment aboard the ship. The radar horizon of the ship can be extended to 60 km by mounting the KIEBITZ together with a radar equipment on the ship.

According to the results of investigations carried out so far the flight mechanical problems of a ship-based tethered rotor platform can be solved.

6. SUMMARY

The combination of tethered rotor platforms with efficient transmitters and sensors constitutes a cost-effective solution for a number of tasks.

This system is especially qualified for battlefield surveillance by radar as well as signal intelligence in order to guarantee the continuous surveillance within a range of 10 to 50 km behind the forward edge of the battle area in stand-off operation.

The following characteristic properties qualify the system for these tasks:

- Continuous operation capability without any restrictions due to bad weather conditions and nighttime
- ECM-resistance of the data transmission
- Cost-effectiveness because of low cost of ownership and operation
- Immediate availability and independent operation of the system by ground troops

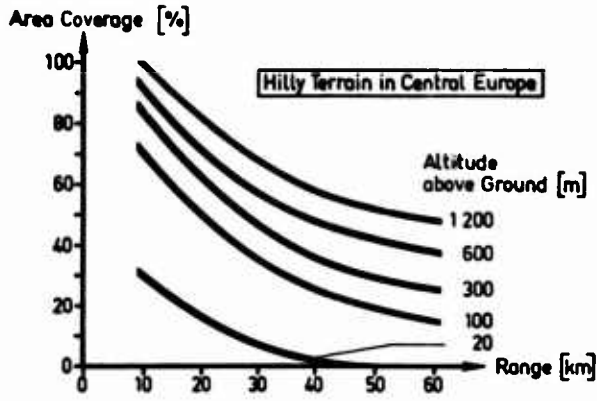

CUMULATIVE VISIBILITY VERSUS RANGE **DORNIER**

①

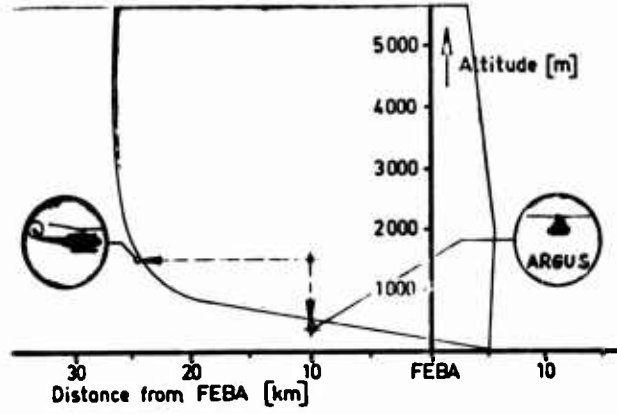

DORNIER Stand-off Position, Altitude and Threat by SA6

②

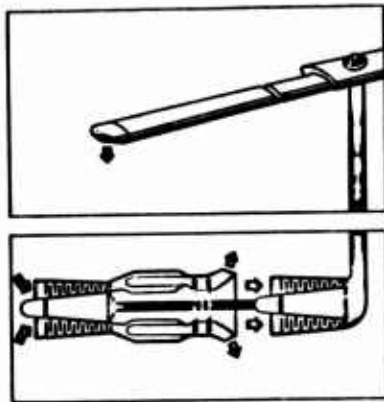

DORNIER Cold Cycle Rotor Drive System

③

Relative Amplification of Translatory Acceleration Signal

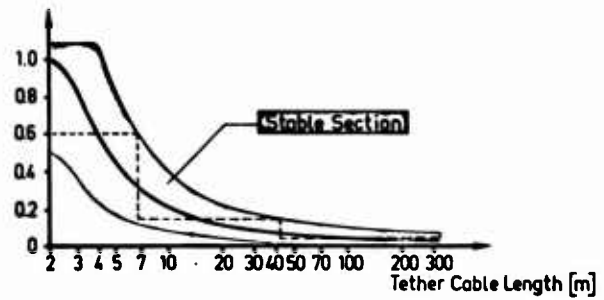

DORNIER Height Adaptation of the Stabilization System

④

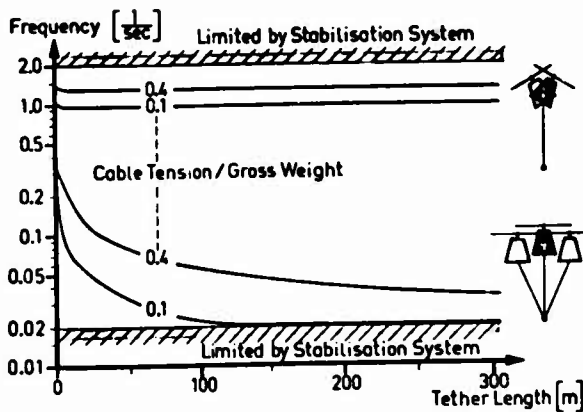

DORNIER INFLUENCE OF CABLE TENSION ON STABILISATION

⑤

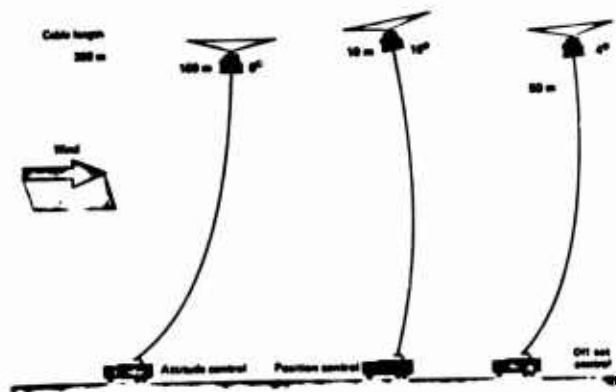

DORNIER Control possibilities

⑥

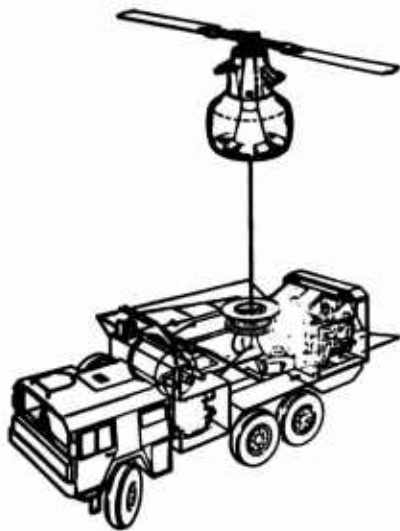

DORNIER Schwebgerät Kistler

7

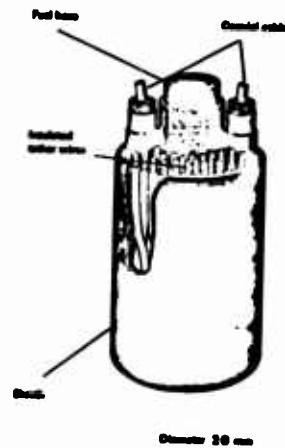

DORNIER Tether cable

8

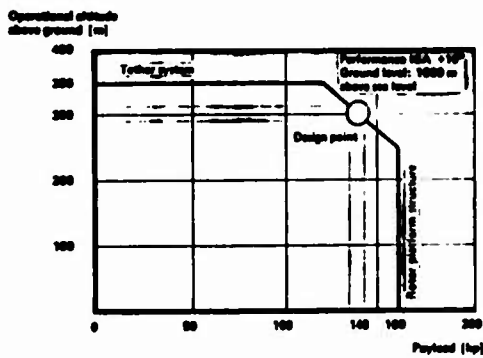

DORNIER Mission limitations

9

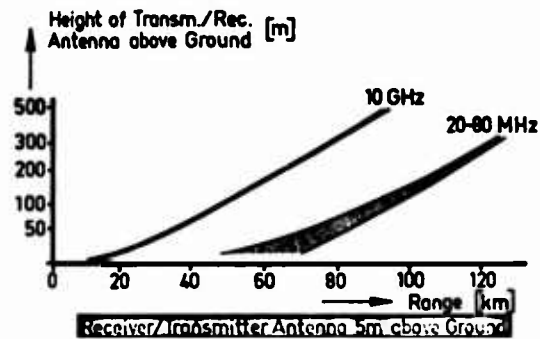

DORNIER Influence of Antenna Elevation on Range

10

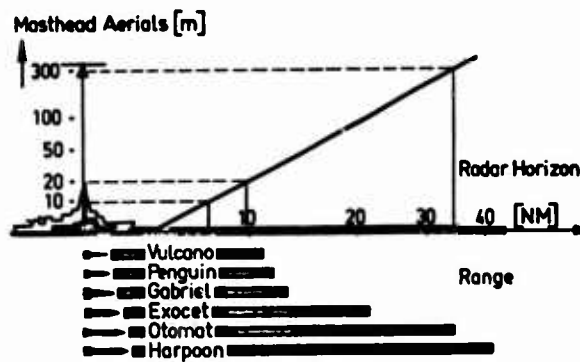

DORNIER Range of SS-Missiles and Target Acquisition Radar

11

EVALUATION OF THE TILT ROTOR CONCEPT
THE XV-15'S ROLE

by
LTC James H. Brown, Jr.
Deputy Manager (Test and Simulation)
and

H. Kipling Edenborough
Chief Engineer
Tilt Rotor Research Projects Office
NASA-Ames Research Center and
Ames-Directorate U. S. Army
Airmobility R&D Laboratory
Moffett Field, California
and
Kenneth G. Wernicke
XV-15 Chief Engineer
Bell Helicopter Textron
Fort Worth, Texas

ABSTRACT

In a continuing effort to expand the versatility of their aircraft, VTOL designers have for many years tried to combine the desirable features of various concepts into a single aircraft. This is a formidable task and most efforts have met with limited success. This paper explores the need for an aircraft combining the efficient VTOL capability of a helicopter with the efficient high speed characteristics of a fixed wing turboprop. The ability of the tilt rotor concept to fill this requirement and examples as to its potential usefulness in both military and civil missions is discussed. The status of the current Army/NASA/Bell XV-15 program and its role in proving the viability of the concept is reviewed.

DESIRABLE HIGH SPEED VTOL VEHICLE CHARACTERISTICS

In considering any advanced VTOL concept, it must be recognized that the VTOL capability does not come without penalty. This penalty is generally realized in terms of increased complexity, and increased empty weight factor. Both of these factors increase costs as compared with CTOL and STOL vehicles of an equal size and otherwise equal capabilities. The first decision that must be made is whether or not the potential user not only needs VTOL, but is willing to pay its price. Having determined that the versatility of VTOL is necessary in his application, he must investigate further to determine whether it is an integral part of the anticipated mission. If that is the case, considerable operation at hover and below the threshold of fixed wing flight may be required. An evaluation of these parameters will direct the potential user toward the appropriate type of propulsive lift needed.

At the other end of the spectrum is the search for the proper cruise mode configuration to operate efficiently at the ranges and airspeeds necessary to complete the desired mission. The range requirement will greatly influence the choice of propulsion system. The helicopter is obviously best suited for very short range VTOL missions. As range and airspeed requirements increase, the importance of the drag reduction increases significantly. The interference drag caused by the lift producing devices is an important consideration in this evaluation. The final decision on the configuration needed is based on a series of tradeoffs between VTOL and cruise performance parameters to obtain the desired compromises that fit the situation. The AV-8 Harrier represents a successful solution to this equation where high speed is needed but extended hover flight is not required.

CHARACTERISTICS OF THE TILT ROTOR

The tilt rotor concept is characterized by an aircraft having three principal flight modes: helicopter, conversion, and airplane (Figure 1).

In evaluating the characteristics of the tilt rotor, the concept has been compared with the conventional helicopter. The primary advantage of the tilt rotor is that it combines the efficient static lift (hover) capability normally associated with the low disc loading helicopter with the efficient cruise performance and low vibration of a fixed wing turboprop aircraft with cruising speeds of over 300 knots. Eliminating the requirement to operate the rotor in the edgewise flight mode for high speed cruise permits the blades to be tailored with a high spanwise twist and camber distribution that significantly reduces induced and profile losses, therefore improving hover efficiency. Figure 2 illustrates the effects of the major rotor characteristics on hover and cruise mode performance. The impact of the improved hover efficiency (Figure of Merit) is illustrated in Figure 3, where, for equivalent disc loadings (and also downwash velocities), the tilt rotor could operate at reduced power levels and rotor diameters as compared to the helicopter to produce the same thrust.

As in all multiple point design situations, the tilt rotor blade geometry represents a tradeoff between the hover and cruise requirements. However, by reducing the rotor tip speed (RPM) to about 80 percent of the hover value after conversion to the airplane mode, the extent of the compromise is minimized due to the increase in blade loading. Therefore,

cruise propulsive efficiency is increased while engine performance and engine transmission/drive system torques are maintained at desirable levels.

A significant product of the combination of high efficiency of the tilt rotor in both the hover and cruise flight modes is fuel conservation. For example, the higher rotor performance results in a requirement for smaller engines to perform a typical hover/cruise/hover transport mission. As an additional bonus for mid-to-long-range applications, the increased cruise mode speeds (at lower power levels) will also result in an increase in productivity (ton-miles/dollar). High endurance capability at moderate airspeeds due to a reduction in power required (see Figure 4) is another benefit of the fuel conservative tilt rotor.

The relatively short duration of forward flight in the helicopter mode for most tilt rotor applications results in a favorable fatigue environment for both the vehicle and the crew, as compared to the helicopter (see Figure 5). The use of the wing to sustain lift in cruise flight and the associated reduction in the dynamic loadings on the rotors will also contribute to a reduction of crew fatigue by improving flying qualities and lowering cabin vibration levels. A further result, and perhaps the most significant, is the expected increase in reliability and reduced maintenance required.

Additional benefits of the use of low disc loadings include low downwash velocities which allow efficient ground operations below a hovering tilt rotor aircraft with improved personnel safety and autorotation capability to achieve a safe descent and landing in the event of a total power loss.

The tilt rotor concept is also unique in that the conversion corridor (i.e., the band between the minimum and maximum flight speeds throughout the rotor-mast tilting process) is broad, typically greater than 60 knots, and noncritical. Furthermore, the conversion may be stopped and reversed, or the aircraft may be flown in steady-state at any point in the conversion corridor. This feature is expected to provide great flexibility in field operations, enhance survivability because of low-speed agility, and permit the performance of STOL operations at greater than VTOL gross weights.

The two tiltable low-disc-loading rotors, located at the wing tips, are driven by two or more gas turbine engines. The engines may be located in the tilting nacelles mounted at the wing tips, or may be fixed with respect to the wing. A cross-shaft system mechanically links the rotors so that power sharing for maneuvers or control is possible and asymmetric thrust in the event of single engine malfunction is avoided. Independent control of each engine/rotor can be maintained should simple cross-shaft failure occur (due to combat damage, for example). The rotor/nacelle tilt mechanism is provided with redundant fail-safe design features, thus preventing asymmetric tilt conditions and binding of the mechanism in any fixed position.

The stiffness and mass distributions of the rotor/nacelle/wing/dynamic system are tuned to remain clear of resonances in the range of operating rotor rotational speeds. Special emphasis is placed on meeting both the structural and dynamic stability requirements. Therefore, the aircraft was designed to be free of rotor stall flutter and wing/pylon/rotor dynamic coupling problems throughout the entire tilt rotor operational flight envelope.

The control system in hover is similar to that of a "side-by-side" twin rotor helicopter. Fore and aft cyclic pitch provides longitudinal control and (differentially applied) yaw control, eliminating the need for a tail rotor. Differential collective pitch provides roll control. In the cruise flight mode, control is achieved with conventional airplane control surfaces. The presence of the rotor cyclic and collective controls would permit, with further development, the use of the rotor in cruise for control augmentation, aircraft stabilization, and gust alleviation. A mechanism for phasing of control functions from helicopter to aircraft type controls as a function of mast angle is applied during conversion.

PROOF-OF-CONCEPT OBJECTIVES

The current NASA/Army program with Bell Helicopter Textron to design, fabricate, and test two tilt rotor research aircraft will determine whether or not the tilt rotor concept is viable and ready for full-scale development to meet military or civil aircraft requirements. The proof-of-concept research aircraft, designated the XV-15, is shown in Figure 6.

Proof-of-concept objectives which have been selected to determine concept viability are:

Verification of rotor/pylon/wing dynamic stability and performance over the entire operational envelope.

Initial assessment of handling qualities and establishment of a safe operating envelope.

Investigation of gust sensitivity.

Investigation of the effects of disc loading and tip speed on downwash, noise, and hover mode operations.

At the end of the proof-of-concept flight tests, and after the data have been reviewed, additional flight tests will be conducted to assess the mission suitability of the XV-15. During this phase of the program, selected mission profiles will be flown within the established flight envelope to determine the potential of the tilt rotor concept to satisfy potential mission requirements.

14-3

POTENTIAL MISSIONS

There are certain military and civil missions which appear particularly well suited to the characteristic capabilities of the tilt rotor. These missions are listed in Figure 7. The efficient cruise performance of the tilt rotor also results in increased point-to-point mission productivity within a 50- to 500-nautical mile radius.

Military

All potential military mission applications would benefit from the rapid response characteristics resulting from VTOL and cruise airspeeds in the 300-plus knot speed range. The tilt rotor cruise performance would also result in longer ranges and increased endurance for a given fuel load.

One obvious mission application is the search and rescue vehicle. This mission requires the rapid response and extended range capability earlier discussed and in addition must have a loiter capability in the search area. With variable pylon angles, the tilt rotor can search at the airspeeds required by the conditions. For example, for an ocean search, where the area is large and open, the airspeed would be higher than for a search over a forested area. During the rescue, extended hover out of ground effect may be necessary. The tilt rotor, with its low disc loading, would be well suited for this operation. The relatively efficient hover also results in lower downwash velocities.

Reconnaissance and surveillance missions require many of the same capabilities as the search and rescue mission, with some additional requirements. The on-station loiter for a surveillance mission takes advantage of the same capability used during the search. In addition, this vehicle would have the low speed agility and ability to operate in the nap-of-the-earth near enemy front lines where operations as a conventional fixed wing aircraft could be hazardous. The absence of a tail rotor will be beneficial in reducing the noise and radar signature of the tilt rotor. Preliminary noise measurements indicate the noise signature of the tilt rotor will be less than a comparable turboprop operating under the same conditions. Because most of the engine power is transferred to the rotor, the IR signature of the vehicle will be minimal and easily suppressible.

The limited number of vehicles required for either search and rescue or reconnaissance and surveillance by any one service places a barrier in the way of full-scale development. The Department of Defense would be required to coordinate such an effort in order to make it affordable.

The good productivity (ton-miles/dollar) potential of the tilt rotor makes it a likely candidate for logistics and airborne assault missions of all three branches of the U. S. military. The ability to disperse aircraft landing areas and the elimination of the need for runways would give an added degree of flexibility. It is envisioned that a light transport in the 30- to 50,000-pound class would be developed first before proceeding with larger and heavier sizes.

Another potential application is to the utility mission. As the name implies, this mission is made up of a number of diverse requirements. The Navy Type A V/STOL is an example of this type of mission. Basically, this mission requires VTOL and adequate range/payload/air-speed capability to be productive. For Navy application, the ability of the vehicle to operate aboard ships is an important factor. All of the services have potential utility mission requirements, and the possibility of commonality is distinct. Although the tilt rotor is only one of a number of candidate concepts to satisfy the Navy Type A mission, it appears to possess a number of desirable unique characteristics.

Application of the tilt rotor concept to a variety of military missions is illustrated in Figures 8 through 15.

Civil

Some of the same characteristics that make the tilt rotor attractive for military missions also make it attractive for civil missions. The tilt rotor must also satisfy other requirements necessary for civil operation. Characteristics of the tilt rotor that make it suitable for civil applications are listed and discussed below.

Characteristics that make the tilt rotor attractive for civil missions:

- Low Noise
- Improved Maintenance and Component Life
- Safety
- Fuel Economy
- Productivity

Sideline noise in takeoff and landing of the tilt rotor aircraft will be less than for an equal gross weight helicopter and considerably less than other VTOL types as shown

16-4
in Figure 16. As in other types of aircraft, designing for low noise imposes some design compromise. Figure 17 shows the impact of designing for noise on the Direct Operating Cost (DOC) of 21-, 45-, and 100-passenger airliners.¹ During cruise flight, the speed of the rotors is slowed down to increase propulsion efficiency. This decreases the external and internal noise to an exceptionally low level and the tilt rotor airliner will be notable for its quietness.

Ride characteristics of the tilt rotor will be comparable to the jet airliner. During takeoff and landings, there will be some rotor-induced vibration, but it will be at a low level, equal to or better than that of the smoothest riding helicopter. After tilting over to the airplane cruise mode, rotor induced vibration will be very low. Gust response of the wing will also be at a low level because high wing loadings (with their insensitivity to gusts) can be used since the wing is not sized by takeoff and landing requirements. Gust response of the rotor has been of some concern, but this area is expected to be researched during the XV-15 program.

The tilt rotor aircraft operates in the helicopter regime of flight a very small portion of its total operating time. The XV-15 research aircraft can accelerate from a hover to airplane cruise flight in 30 seconds. Conversion time is 12 seconds. In a civil operation approach and departure, times would be lengthened to several minutes as dictated by airport and traffic control procedures, but still, helicopter time would be only a small portion of total flight time. This means that the rotor and other components subject to vibratory and fatigue loading would have greatly extended TBO's and service lives in comparison to their counterparts on helicopters which are subject to these vibratory loads for their total flight time. The use of advanced composite structures and non-lubricated bearings that the helicopter industry is now turning to will make replacement of components on the tilt rotor a "conditional" requirement, rather than at a finite service life as has been the past practice and one of the biggest operating expenses of helicopters.

Safety for the commercial and executive passenger will have to be maintained at the same high level that has been provided by the jet airliner. The smaller tilt rotor aircraft that will be used by the commercial operators and corporate owners will have twin engines and be able to operate in helicopter, airplane, and conversion modes on a single engine in the event of a loss of one engine. The system redundancies and safety features built into the XV-15 would also be provided in civil tilt rotor aircraft (see Reference 2 for safety features of the XV-15). The airliner, for added safety, would be provided four engines so that it could hover and continue takeoff with one engine failed. As shown in Figure 18, the airliner would typically have two engines mounted on each wing tip pivoting with the rotors. In addition to the single-engine-out flight capability, all civil tilt rotor aircraft will have the capability to autorotate as a helicopter. Figure 19 shows the autorotative performance of the XV-15; it is comparable to that available in the current new generation of twin engine helicopters. Autorotation can be initiated from airplane flight by windmilling the rotors and making a power-off reconversion to helicopter autorotation.

The tilt rotor promises to be a "two-edged sword" on the fuel and energy crises. It will offer extended speed, payload, and range over that of the helicopter for the support of off-shore oil operations. This will be a boom to the exploration and production of oil at greater distances from shore than is now practical. Additionally, the tilt rotor in military as well as in civil operations will be an economizer of fuel. Its transport of payload for a nautical mile per pound of fuel surpasses the helicopter and approaches closely the fixed wing turboprop airplane. Figure 20 illustrates the fuel and time economy of the tilt rotor in performing the off-shore oil support mission in comparison with the helicopter and boat. Figure 21 compares the tilt rotor with the bus, train, airplane and helicopter.

The real determining factor as to whether or not the tilt rotor will be a viable aircraft type will be dollars, be it for the commercial operator, corporate owner, or for the airlines. More specifically, will the total cost in terms of ton-miles per dollar or passenger-mile per dollar be competitive? In assessing this question, all cost elements such as initial cost of aircraft, facilities, direct operating costs, etc., should be included. However, this assessment can be reduced to an assessment of technical parameters if vehicle cost and cost of ownership are assumed to be a linear function of aircraft weight and operating costs are proportional to fuel and operating time. This was done by Kingston and DeTore (Reference 3) in comparison of productivity of a variety of VTOL types. Figure 22 shows the result of this analysis and the tilt rotor is seen to have the greatest productivity (indicates the highest ton-mile/dollar) of other VTOL types for all but the shortest ranges where the helicopter is superior.

MILITARY/CIVIL COMPATIBILITY

It is believed that the NASA/Army proof-of-concept program will establish that the technology is available for any of the military and civil applications discussed. It is also believed that successful aircraft development could commence at the completion of this program.

As mentioned earlier, a coordinated effort by the Department of Defense may be required to initiate development of a reconnaissance and/or search and rescue aircraft because of the limited numbers of aircraft of this type required by any one service. Other mission applications can justify larger numbers of aircraft and single-service

development may be possible. However, because of present inventories, the reconnaissance/surveillance search and rescue aircraft appears to be the most likely first development.

Because of the development expense, the first civil tilt rotor aircraft will have to await the development by the military. Technology, performance, safety, reliability and maintenance requirements are quite similar. Basic differences in a military and civil aircraft would be in the furnishings and equipment. For instance, the first military aircraft envisioned could readily be converted to civil applications with only changes in the fuselage to provide for doors, windows, passenger seats and baggage compartments. However, the reliability and maintainability and survivability requirements would be different for the civil aircraft.

The reconnaissance/surveillance search and rescue aircraft would be appropriately sized and powered for civil applications as an air taxi, executive transport, and for off-shore oil support. The light transport for the military missions would be an ideal size for the first introduction and trial service for the tilt rotor in a city-center-to-city-center airline operation. Larger military transports as well as other tilt rotor aircraft could be modified to civil application by placing the wing with the entire propulsion packages onto a fuselage designed for a specific civil mission. This type of development approach is also envisioned for a variety of military missions. A ground support aircraft and a utility aircraft could be developed using the same wing propulsion system and would only differ in their fuselages as shown in Figure 23.

CURRENT XV-15 PROGRAM STATUS

The fabrication and assembly of Aircraft No. 1 has been completed and the aircraft is now undergoing its ground and hover testing. The final assembly of Aircraft No. 2 is approximately 90 percent complete. After the completion of its ground tests, Aircraft No. 1, rigged for remote control operations, will be shipped to Ames for evaluation in the 40-foot-by-80-foot wind tunnel. Aircraft No. 2 will soon begin ground testing to include a 60-hour ground qualification test of the integrated propulsion system prior to contractor flight tests scheduled to begin next year.

The program has included extensive use of the Ames Flight Simulator for Advanced Aircraft for both the competitive evaluation and during the final design of the XV-15. The extensive analytical and model testing data base should be of great value in resolving difficulties, should they arise, during the testing program.

Aircraft No. 1 has undergone approximately forty hours of ground tiedown testing, Figure 24, and two hours of hover and air taxi tests at speeds to 40 knots, Figure 25. Detailed status of the test program is reviewed in Reference 4. These tests have been highly successful and their results give rise to optimism with regard to the future of the concept.

REFERENCES

1. DeTore, J. A., and Sambell, K. W., "Conceptual Design Study of 1985 Commercial Tilt Rotor Transports," Volume 1, VTOL Design Summary, Bell Helicopter Company Report Number D312-099-002, November 15, 1974.
2. Wernicke, K. G., "Performance and Safety Aspects of the XV-15 Tilt Rotor Research Aircraft," Preprint Number 77.33-14, Presented at the 33rd Annual Forum of the American Helicopter Society, Washington, D.C., May 1977.
3. Kingston, I., and DeTore, J., "Tilt Rotor V/STOL Aircraft Technology," Paper Number 36, Presented at the Second European Rotorcraft and Powered Lift Aircraft Forum, Buckeburg, Federal Republic of Germany, September 1976.
4. Brown, LTC James H., Jr. and Edenborough, H. K., "Status Report on XV-15 Tilt Rotor Test Program," Preprint Number 77.33-64, Presented at the 33rd Annual Forum of the American Helicopter Society, Washington, D.C., May 1977.

16-6



Figure 1. Tilt rotor principal flight modes.

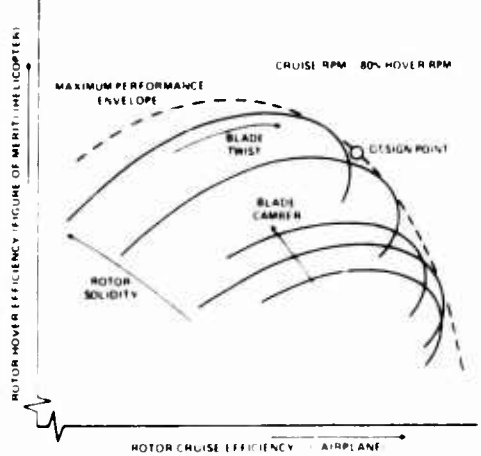

Figure 2. Effect of rotor parameters on hover/cruise performance tradeoff.

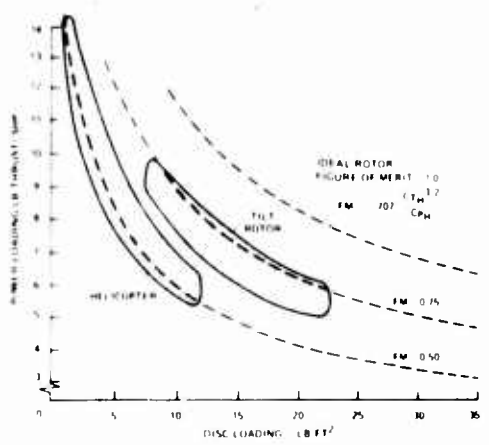

Figure 3. Disc loading effect on rotor hover efficiency.

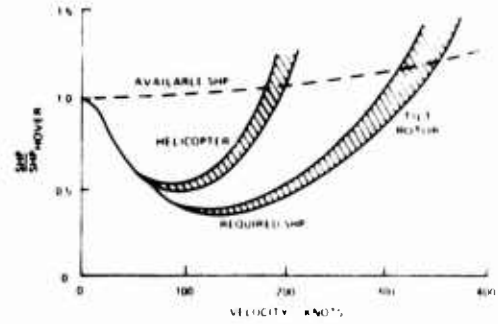

Figure 4. Power required comparison.

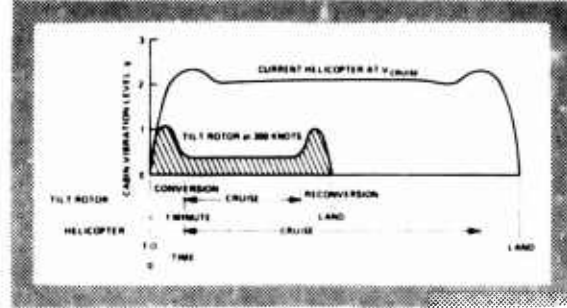

Figure 5. Vibration environment.



Figure 6. XV-15 tilt rotor research aircraft.

TILT ROTOR APPLICATIONS

- CIVIL
 - EXECUTIVE TRANSPORT
 - OFF SHORE OIL SUPPORT
 - INTER CITY COMMERCIAL CARRIER
- MILITARY
 - ARMY INTELLIGENCE MEDIUM LIFT
 - NAVY ASW SAR
 - MARINE ASSAULT TRANSPORT RECONNAISSANCE
 - AIR FORCE COMBAT RESCUE FAC

Figure 7. Potential missions for tilt rotor aircraft.



Figure 8. Reconnaissance/surveillance tilt rotor aircraft.



Figure 11. Ground support tilt rotor aircraft.



Figure 9. Utility tilt rotor aircraft.



Figure 12. Light transport tilt rotor aircraft.



Figure 10. Airborne assault tilt rotor aircraft.



Figure 13. Typical rescue mission profile for tilt rotor aircraft.

16-8



Figure 14. Typical surveillance mission for tilt rotor aircraft.

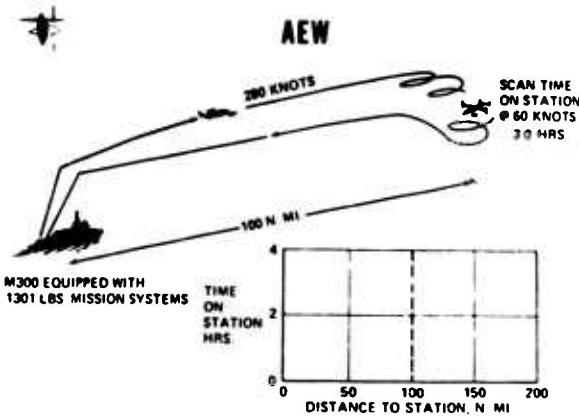

Figure 15. Typical advanced early warning profile tilt rotor aircraft.

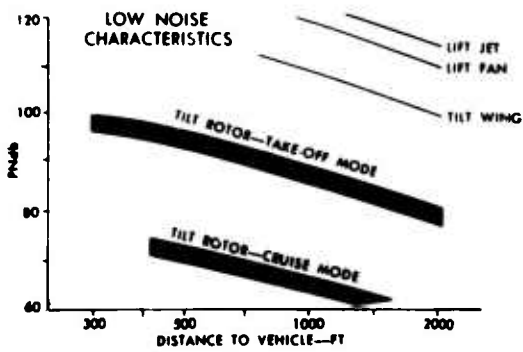

Figure 16. Comparison of estimated noise levels of various VTOL types.

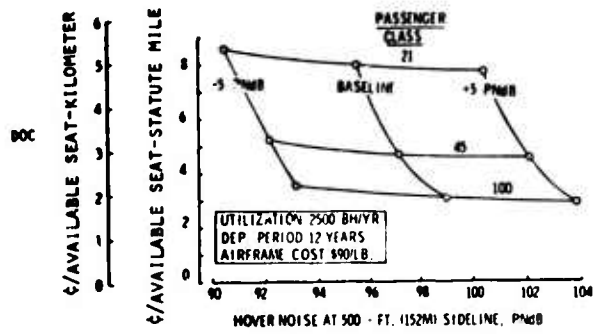
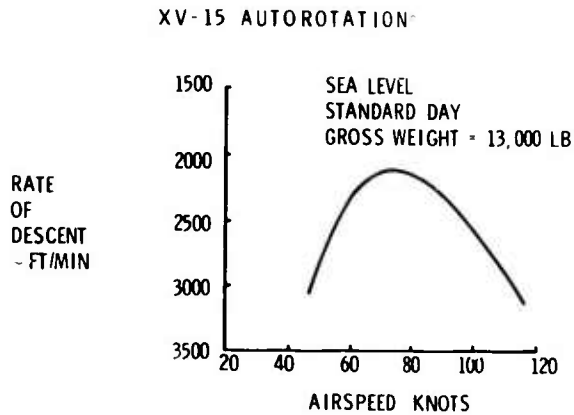

Figure 17. Direct operating cost versus size and noise.



Figure 18. Four-engine tilt rotor airliner.



*DATA DERIVED FROM TUNNEL TESTS

Figure 19. Autorotation of XV-15.

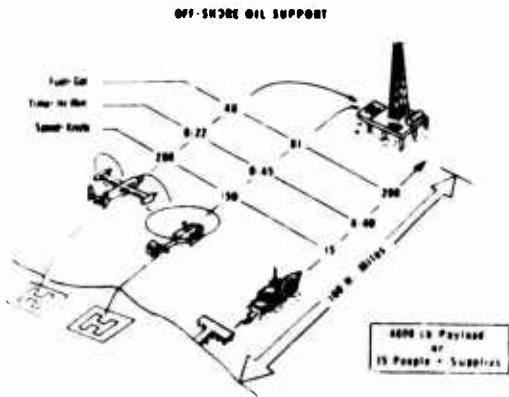

Figure 20. Comparison of tilt rotor with other modes for off-shore oil support.



Figure 23. Same wing/propulsion system used with different fuselage for a variety of tilt rotor missions.

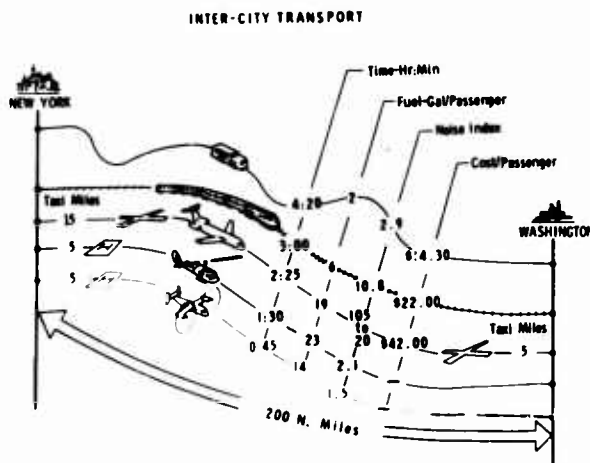

Figure 21. Comparison of tilt rotor with other modes of inter-city transportation.



Figure 24. XV-15 on ground tiedown test facility.

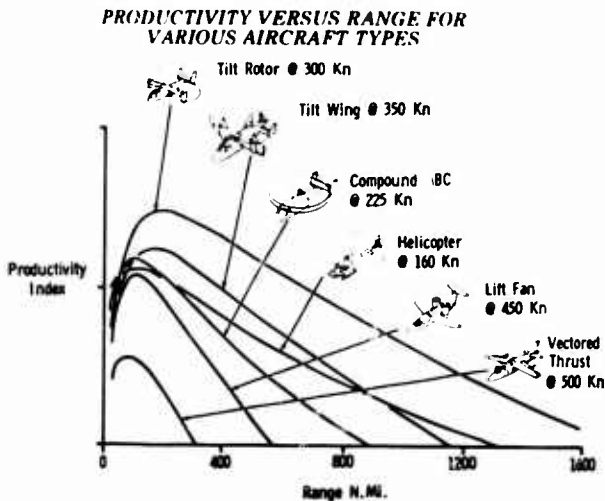

Figure 22. Comparison of productivity (ton-miles/dollar) of tilt rotor with other VTOL types.



Figure 25. First hover flight of XV-15.

THE ADVANCING BLADE CONCEPT (ABC) ROTOR PROGRAM

Harvey R. Young
Aerospace Engineer

and

Duane R. Simon
Research Test Pilot

17-1

US Army Air Mobility Research and Development Laboratory (AVSCOM)
Eustis Directorate
Fort Eustis, VA 23604

SUMMARY

The Advancing Blade Concept (ABC) is a relatively new type of helicopter rotor system that has been flight tested 67 hours. Flight results in a basic helicopter configuration have confirmed several important advantages of the concept and have identified some shortcomings. The background and current status of the program are presented in this paper. Rotor and test aircraft features are briefly described. Flight-test data are compared with similar data from other helicopter flight tests. A qualitative assessment based upon 2 hours of US Government flying is presented. It is noted that this concept is feasible and Army contract objectives have been satisfied. It is concluded that rotor and control system weight fractions must be reduced to achieve the full potential of this concept. This would involve design and development of a lighter weight rotor system utilizing high-modulus material and redesign of the control system.

SYMBOLS AND ABBREVIATIONS

v	Inflow velocity, ft/sec
C_W	Gross weight coefficient = $W/\rho A (\Omega R)^2$
C_P	Power coefficient = $550 \text{ HP}/\rho A (\Omega R)^3$
C_T	Thrust coefficient = $T/\rho A (\Omega R)^2$
N_R	Rotor speed, RPM
θ	Ambient temperature ratio = $\text{Ambient OAT}^\circ\text{K}/283.15^\circ\text{K}$
δ	Ambient pressure ratio = $p/29.92 \text{ in. Hg}$
W	Gross weight, lb
ρ	Atmospheric density, slugs/ft ³
A	Rotor disc area = πR^2 , ft ²
R	Rotor radius, ft
ΩR	Rotor tip speed, ft/sec
HP_T	Engine output horsepower
HP_R	Engine horsepower to rotors
IGE	In ground effect
OGE	Out of ground effect
T	Rotor thrust, lb
M_A	Aircraft figure of merit = $\frac{W}{550(\text{HP}_T)} \sqrt{\frac{W}{A(2\rho)}}$
PL	Power loading, lb/HP = W/HP_T
DL	Disc loading, lb/ft ² = W/A
M_R	Rotor figure of merit = $\frac{T}{550(\text{HP}_R)} \sqrt{\frac{T}{A(2\rho)}}$
σ	Rotor solidity ratio = $bc/\pi R$
b	Number of main rotor blades
c	Rotor blade chord, ft
Γ	Cyclic phase angle, azimuth angle where blade feathering is applied, referenced from $\psi = 0^\circ$ position
p	Atmospheric pressure, in. Hg
V_v	Vertical rate of descent, ft/min

μ	Rotor advance ratio, $1.69 \text{ KIAS}/\Omega R$
KIAS	Knots, Indicated Airspeed
KCAS	Knots, Calibrated Airspeed
KTAS	Knots, True Airspeed
ψ	Azimuth angle, $= 0^\circ$ when blade is over tail of aircraft
N_s	Directional control power, $\text{rad}/\text{sec}^2/\text{in.}$
L/D	Lift/drag ratio

INTRODUCTION

The ABC is a coaxial, counterrotating, hingeless helicopter rotor system. It differs from other coaxial helicopter rotors in both physical construction and operational capability. The ABC rotor blades are extremely stiff and are rigidly attached to the rotor hub. The static deflection of the tip of the 18-foot-long blade, due to the blade's own weight, is only $3/8$ inch, compared to about 6 inches of deflection for a conventional rotor blade of similar length. The combination of extremely stiff blades and rigid retention of blades to the hub results in an equivalent flapping hinge offset of approximately 50 percent of rotor radius. More conventional rotors have offsets which range from 0 percent of rotor radius to 25 percent of rotor radius, depending upon whether the rotor is a teetering, articulated, or hingeless type. The stiff blades of the ABC preclude excessive deflections under high loads, and their rigid retention to the rotor hub prevents flapping excursions associated with conventional rotors. Rotor blade pitch is controlled by swashplates in the same manner as conventional rotors. Unique to this concept, however, is the ability to intentionally vary the loading on the advancing side of the rotor as compared to the retreating side. This feature, made possible by the stiff and counterrotating, rigidly attached blades, largely eliminates classical retreating blade stall and permits operation at higher thrust coefficients and advance ratios. Further, the stiff blades should be able to operate more easily without aeroelastic instabilities as rotor speed is reduced. Such operation is required for high-speed flight where the advancing blade tip Mach number should not exceed a value of approximately 0.85.

Advantages of this rotor may be summarized as follows:

1. Rapid control response characteristics of rigid rotors.
2. Superior maneuverability, particularly at high speeds and high altitudes.
3. Deletion of the requirement for a tail rotor with attendant benefits in safety, simplicity, vulnerability, compactness, noise signature, and performance.
4. High-speed capability without wings when provided with a source of horizontal thrust.

The main purpose of this paper is to report the flight-test results and how these results compare with similar data from other helicopter flight tests.

An attempt is made to sort out results which are believed to be germane to the concept from those results incidental to the test program. Rotor and test aircraft features are briefly described.

BACKGROUND

Several approaches to increasing helicopter speed capability have been tried in the past, and new concepts are currently under development. The idea of compounding an existing helicopter by using wings to unload the rotor and adding auxiliary propulsion for forward thrust has been investigated on several different helicopters and is reported in Reference 1. Although this approach was demonstrated to be feasible, the disadvantages due to wing drag, weight, complexity, and interference effects were evident. The ABC rotor system is designed to penetrate beyond the classical speed boundaries governed by blade stall on the retreating side of the rotor and by compressibility on the advancing side of the rotor by making better use of lift potential on the advancing side and by operating the rotor at reduced speed, thereby eliminating the need for a wing at high speeds. Figure 1 compares the lift distribution of a conventional single rotor and the ABC. Note that in order to keep roll moments balanced on a conventional single rotor, the amount of lift that can be developed on the advancing side of the rotor disc is limited by that which can be developed on the retreating side. This is not a limitation on the ABC, however, since roll moments are automatically balanced by the coaxial, counterrotating rotors. As with conventional helicopters that are compounded, some means of providing horizontal thrust must be supplied for high-speed applications.

Sikorsky Aircraft Division, United Technologies Corporation, began to explore the possibilities of this rotor concept in 1964. Theoretical work and actual tests with experimental hardware were initiated. Major efforts were directed toward investigating materials and manufacturing technology, design concepts, and conducting wind tunnel tests of ABC rotors. This work is presented in considerable detail in Reference 2. One of the most significant findings from the materials investigation was that titanium, with the proper metallurgical characteristics, could be produced in usable form with fatigue allowables 40 percent higher than those previously considered for that metal. This meant that the weight penalty previously associated with a hingeless, highly-loaded titanium rotor would be acceptable, at least for demonstrating the concept. Another one of the more significant events was wind tunnel testing of a full-scale, 40-foot-diameter ABC rotor in the NASA-Ames 40- by 80-foot wind tunnel. During this program, the rotor was tested at 25 combinations of flight conditions, up to a maximum advance ratio of 0.91 and up to an advancing blade tip Mach number of 0.83. Although the wind tunnel tests were limited in scope, the results verified the aeromechanical stability, high lift capability, and structural integrity of the rotor at the conditions tested.

In December 1971, the Eustis Directorate of the US Army Air Mobility Research and Development Laboratory, Fort Eustis, Virginia, awarded a contract to Sikorsky Aircraft to design, fabricate, and flight test two ABC-configured research aircraft. Aircraft target design speed was 140 to 170 knots in the basic helicopter configuration and up to 300 knots in the auxiliary propelled mode using two J-60 turbojets to provide the horizontal thrust. The target hover design point was hover out of ground effect (OGE) at sea level, 95°F, at design gross weight, in the auxiliary-propelled helicopter configuration. The maneuver and structural objectives were rather severe for the basic helicopter, and included the ability to achieve sustained load factors of 2.5 g in the speed range of 70 knots to 170 knots with satisfactory maneuvering stability and stress levels in all critical components limited to not more than 150 percent of their fatigue endurance limits.

The first flight of the ABC aircraft (designated the XH-59A) occurred on 26 July 1973. On 24 August 1973, the first aircraft, while flying at 25 to 30 knots at an altitude of about 50 feet, pitched nose-up, lost altitude, and was extensively damaged in a hard, tail-first landing. A detailed accident investigation, involving wind tunnel tests of a 1/5 Froude scale model XH-59A aircraft, was conducted. Results of the wind tunnel tests, projected to the full-scale XH-59A aircraft, disclosed a significant difference between analytically assumed fore-and-aft variation of inflow through the rotors and the actual inflow. Figure 2 shows the longitudinal inflow velocity through the rotors at 25 knots as assumed prior to flight test and as revised after the accident investigation. Figure 3 is a plan view of the inflow velocity distribution for the same conditions. Note the significantly higher induced velocities at $\psi = 0^\circ$ (tail of aircraft position) than were originally predicted. The high-induced velocity had the effect of reducing blade angle of attack more than expected. Consequently, more forward longitudinal cyclic pitch was required for a given (low-speed) trim condition than had been predicted. Unfortunately, the forward longitudinal cyclic stick travel was deliberately rigged to provide a maximum of six degrees of cyclic pitch. This was done to prevent pilot over-control of the aircraft. During the accident sequence, the pilot had commanded full forward travel of the cyclic stick, but the resulting cyclic pitch on the blades was inadequate to prevent pitch-up and subsequent settling of the aircraft. The flight control system was then modified in the other test aircraft to essentially double the longitudinal and lateral cyclic control ranges. Other modifications included the addition of a 10-percent authority, rate feedback, stability augmentation system (SAS) for the pitch and roll axes; viscous stick dampers; and an in-flight adjustable cyclic phase angle changer. This latter device is the mechanism for varying the relative loading of the advancing and retreating sides of the rotor discs. It allows the pilot to select, within a range of 70 degrees, the azimuth angle where blade feathering is applied. The first flight with the modified flight control system occurred in July 1975. After 12 hours of flight testing, it was concluded that the modified control system resolved the problem that caused the crash of the first aircraft, and sufficient control margin was available to expand the flight envelope to contract objectives.

AIRCRAFT DESCRIPTION

Figure 4 shows the XH-59A aircraft flying in its test configuration. The cylindrical "can" between rotors contains slip rings essential for transmitting rotor blade strain gage information. Aircraft and rotor specifications are given below:

Aircraft Length (overall)	41 ft, 5 in.
Aircraft Height (overall)	12 ft, 11 in.
Main landing gear tread	8 ft
Design gross weight	9000 lb
Rotor diameter	36 ft
Disc loading at design gross weight	9 lb/ft ²
Blades per rotor	3
Rotor separation	30 in.
Blade taper ratio	2:1
Blade twist	-10 degrees (nonlinear)
Rotor solidity	0.127
Design rotor tip speed	650 ft/sec - helicopter 450 ft/sec - aux propulsion
Drive system design HP	1500
Tail surface - horizontal	60 ft ²
- vertical	30 ft ²
Design load factor	
Helicopter (9000 lb)	2.5 - 0.5
Auxiliary propulsion (11,100 lb)	2.0 - 0.5
Maximum speed, level flight - helicopter	160 knots
Maximum dive speed - helicopter	196 knots
Maximum speed, level flight - aux propulsion	280 knots
Maximum dive speed - aux propulsion	345 knots
Aircraft fuel capacity	242 gallons
Helicopter engine (United Aircraft Canada, Ltd)	PT6-3/T-400 (twin engines)
Auxiliary propulsion (2 Pratt & Whitney)	J60-R2 (2900 lb thrust each)

More detailed information on the rotor and control system may be found in Reference 3.

CURRENT PROGRAM STATUS

As of this writing, the XH-59A aircraft has been flown 67 hours in the basic helicopter configuration. After incorporation of the modified control system, the aircraft has been free of major technical problems that normally plague new helicopter developments. Army contract objectives relative to demonstrating the rotor concept up to conventional helicopter speeds have been satisfied. Plans for investigating the performance of this rotor at higher speeds are being reformulated at the present time.

FLIGHT TEST RESULTS AND ANALYSES

Some flight test results have been reported in References 3 and 4. A few of these results are included in this paper for continuity of subject material. Results from flight tests of other types of helicopters are also shown for comparison purposes.

HOVER PERFORMANCE

Nondimensional OGE hover performance of the XH-59A aircraft is shown in Figure 5 and is reported in Reference 5. The OGE data were taken when the lower rotor was 45 and 85 feet above ground level (a wheel height of 35 and 75 feet). Figure 6 shows this same data compared with hover performance of other Army helicopters. The expression $C_W = 1.93 C_P^{0.774}$ was given in Reference 6 as representative of Army helicopter OGE hover capability. This expression, which was derived from hovering tests of the OH-58A, UH-1H, TH-55A, OH-6A, UH-1C, AG-1C, and CH-47C helicopters, has been extrapolated beyond values given in Reference 6 to permit comparison with the XH-59A data. Hover data for the CH-54B helicopter at a high disc loading are also shown in Figure 6. These data are from tethered hover tests at 145-foot wheel heights as reported in Reference 7. Since the C_W vs C_P plot is based on actual test data, the total effects of disc loading, vertical drag, rotor efficiency, and tail rotor power (or the lack of it) are all accounted for. Note that the XH-59A aircraft exhibits better than trend hover performance in spite of relatively high vertical drag (calculated at 6 percent of gross weight) and relatively high disc loading (approximately 10.4 lb/ft² at conditions tested). The benefits of not having to power a tail rotor and the improved efficiency of a coaxial rotor are apparently worth more than the penalty of high vertical drag and high disc loading.

Figure 7 shows the XH-59A aircraft figure of merit (M_A) compared to other Army helicopter figures of merit which were reported in Reference 6. Note that on this plot, the XH-59A aircraft is shown to be considerably more efficient in hovering than other Army helicopters. Since $M_A = \frac{\text{Power Loading}}{550} \sqrt{\frac{\text{Disc Loading}}{2X \text{ Density}}}$, this method of showing hover performance does not penalize high disc loading rotors. In addition, since some air is believed to be pulled in between the XH-59A's upper and lower rotor, the effective disc loading, for purposes of determining induced losses in hovering, would be somewhat lower than the disc loading, $W/\pi R^2$, used in the above expression. However, the most obvious reasons for the high M_A of the XH-59A aircraft is simply that there is no tail rotor to power, which normally accounts for 8 to 10 percent of total power. The average value of M_A for the XH-59A aircraft was 0.67 for the data in the range tested.

One method of presenting isolated rotor hover performance is to show rotor figure of merit (M_R) plotted against blade loading (C_P/σ). This requires that a value be assigned for vertical drag (thrust developed by the rotor which is not used to help lift the helicopter). Power losses through the transmission must also be accounted for if test data are based on engine torque or power. Figure 8 shows ABC rotor figure of merit compared with the preliminary design estimate. The ABC M_R assumes a vertical drag of 6 percent of gross weight, and a power loss (power developed by engines but not used in turning the rotors) of 75 horsepower. The 6 percent vertical drag was calculated using the polar moment of inertia method of Reference 8. This method is based on a single velocity distribution beneath a hovering rotor over areas of a characteristic shape. The calculation yielded a 7.6 percent drag assuming an "average helicopter" fuselage, or 5.0 percent assuming a cylindrical shape. Since the XH-59A aircraft fuselage is shaped more cylindrically than an average helicopter, the use of 6 percent seems to be a reasonable compromise. Note that in the expression of M_R , the rotor thrust is raised to the 1.5 power, so that any error in the assumed vertical drag is magnified. The actual vertical drag of any helicopter with an ABC rotor is likely to be higher than an average helicopter designed for a typical Army mission. This is because the ABC rotor tends to be a relatively high disc-loading concept, which implies a higher ratio of the plan view area of the fuselage to the rotor disc area. Although the disc loading of an ABC aircraft could be reduced to more conventional values of 5 to 7 lb/ft², this would either reduce speed and maneuver capability or would require stiffer rotor blades or an increase in rotor separation to avoid blade intersection. The drag and weight penalty associated with increased rotor separation or longer blades may not be acceptable for missions requiring high speeds. The assumed 75 horsepower loss, which is approximately 5 percent of total power, was based on no-load transmission lube test results and assumed power needed to drive accessories through the accessory drive train.

LEVEL FLIGHT PERFORMANCE

Level flight performance data are shown in Figures 9 and 10. Solid lines are fairings based on the actual test data points with the helicopter in its "dirty" test configuration. The dashed line in Figure 9 from 120 knots to maximum speed is intended to show power requirements at 11,000 lb, adjusted for deletion of test instrumentation such as the 3.3 ft² (projected area) interrotor slip ring installation (a flat plate drag area of 2 ft² has been assumed for this test instrumentation). Speed for best range at 11,000 lb and sea level standard (SLS), based on the intersection of a straight line drawn tangent to the power required airspeed curve, is 120 KCAS. Speed for best endurance is 85 to 90 KCAS. Total helicopter L/D at SLS in its test configuration at 120 KCAS is approximately 4. Figure 9A shows how this value compares with other Army helicopters. Total helicopter lift/drag ratios shown in this figure were calculated at speed for best range and represent various configurations, gross weights, and altitudes.

Figure 10 shows nondimensional level flight performance data for two different gross weight coefficients and two different referred rotor speeds. As shown in this figure, the advance ratio for minimum power required is approximately 0.22. Although this differs from the representative value of 0.14 given in Reference 6, Figure 11 shows this result might be expected when gross weight coefficients and advance ratios are extrapolated to values flown by the XH-59A helicopter. In a production version of an ABC helicopter, the rotor hub and shank portions of the rotor blades would be faired to reduce drag. It is also likely that in a production version of an ABC helicopter designed for conventional speeds only, the rotor and transmission would be pretitled forward a few degrees to reduce the fuselage nose-down attitude with its attendant drag rise at high speed (the XH-59A has zero degrees tilt, considered to be the best compromise between conventional helicopter speed requirements and high-speed requirements with auxiliary propulsion).

AUTOROTATION

The XH-59A autorotational characteristics were determined during the flight program. This was an area of concern since it is known that coaxial helicopters, which use differential collective pitch for yaw control, can experience control reversal at low collective pitch settings. The high disc loading of 10.5 lb/ft² compounded this problem. Figure 12 is a plot of the autorotational characteristics and shows lines of constant directional control power as a function of vertical rate of descent and airspeed. These lines were developed from data showing XH-59A response to pedal steps and they represent the yawing moment contribution due to differential rotor torque and due to the twin rudders (9 ft² total area) that are linked to the pedals. Notice the control power weakens gradually as the region of reversed directional control is approached. This means more pedal travel is progressively required to develop a given yawing moment and at the threshold of reversed directional control, a pedal step will not produce any directional control response. Pilot corrective action at this point consists of either increasing collective pitch or using the cyclic stick to effect a turn. 17-5

During the flight program, steady-state autorotations were flown at 60, 80, 100, and 120 knots forward airspeed as shown by the band in Figure 12. Under these conditions, the aircraft responded positively to cyclic stick turns. Entry RPMs ranging from 95 percent, N_R , to 105 percent, N_R , were investigated. Flare attitudes up to 25 degrees were attained during recovery, and forward airspeed was reduced to a minimum of 35 to 40 knots.

Controllability during autorotational flares was investigated with differential collective pitch in both the "fixed mode" and "automatic mode." In both modes, the rudders remain linked to the pedals and move 10 degrees per inch of pedal travel. In the fixed mode, directional control is augmented by differential collective pitch, which changes a constant 2 degrees per inch of pedal travel throughout the speed range. However, in the automatic mode, differential collective pitch is washed out linearly between airspeeds of 40 knots and 80 knots, so that all directional control comes from the rudders at speeds above 80 knots. An operational corridor in terms of rotor RPM, flare attitude, and collective pitch was demonstrated. Autorotative touchdown landings were not attempted.

Reference 6 reported that the minimum autorotational rate of descent divided by main rotor tip speed was essentially constant for the five single-rotor helicopters that were tested. The expression $\frac{V_v}{60DR} = 0.04$

was established to approximate this relationship, and it was also noted that the tandem rotor CH-47C exhibited a trend 25 percent higher than the referred rate of descent. Figure 13 shows referred rate of descent plotted against disc loading for several helicopters, including the XH-59A. Note that the XH-59A exhibits a slightly higher referred rate of descent than might be expected based on single-rotor helicopter data only. Additional data points for helicopters at disc loadings between 6 to 9 lb/ft² are obviously needed to reach a general conclusion regarding the relationship of disc loading to referred rate of descent. For the XH-59A helicopter, the minimum rate of descent at 100 percent rotor speed was about 2280 ft/min at 60 to 70 knots. This sink rate could be reduced to 2000 ft/min by reducing rotor speed 5 percent. If the expression $\frac{V_v}{60DR} = 0.04$ was used to compute the XH-59A helicopter minimum rate of descent, the result would

be 1560 ft/min at 100 percent rotor speed, and 1482 ft/min at 95 percent rotor speed. This comparison shows that single-rotor helicopter test data, within the tip speed and disc loading ranges reported in Reference 6, are not valid for projecting ABC autorotational trends.

BLADE STALL ALLEVIATION

Flight results demonstrated that classical retreating blade stall could be substantially delayed. The first indication of blade stall occurred in a 1.75 g maneuver at 10,000 feet. Figure 14 compares blade loading capability of the XH-59A helicopter with other Sikorsky helicopters. Note that the ABC rotor sustains lift as advance ratio is increased, whereas conventional rotors lose lift at higher advance ratios as stall is encountered. This result was expected from previous full-scale wind tunnel tests of an ABC rotor.

STRUCTURES

The sustained load factor envelope demonstrated during the flight program is shown in Figure 15. Load factors shown in this figure have been increased beyond measured values by the ratio $\frac{\text{Actual gross weight}}{\text{Design gross weight}}$ to account for flying at higher than design gross weight. All load factors shown in this figure were attained without reaching the endurance limit of any critical component. This was considered a major achievement and indicates potential for considerable weight reduction in a production ABC helicopter.

Flying an ABC helicopter is sometimes likened to flying a stacked set of propellers sideways. Aerodynamic lift applied to the extremely stiff, rigidly mounted rotor blades creates high bending moments which must be carried across the feathering bearings and into the rotor shaft without flapping relief. During the flight program, the feathering bearing retainers did, on two occasions, begin to extrude between races, but this type of failure was not classified as catastrophic in nature. Bearing condition was monitored by conducting periodic spectographic analyses of grease purged from the rotor blade sleeve bearing assemblies. Bearing deterioration was detectable as a high one per revolution (1P) vibration in the controls and, since all push rods were instrumented, it was obvious which blade sleeve bearing assembly was failing. In a production version of the ABC rotor, this area would need redesign to provide a longer life expectancy for the feathering bearings and associated parts.

Rotor blade stresses, which can be varied by changing the cyclic pitch phase angle, Γ , or by introducing differential cyclic pitch, were never a limiting factor during the flight program. Typical, flatwise vibratory stresses at 120 knots were 8,000 lb/in² compared to an endurance limit of 20,000 lb/in². Evidently, the stiffness required for adequate tip clearance guarantees ample stress margins in the blades. Figure 16 shows the upper rotor shaft prior to its installation in the transmission. The shaft is 7-1/2 feet long and 8 inches in diameter. Shaft stresses were highest at high rates of descent when the 60 ft horizontal tail produced aircraft nose-down pitching moments which had to be balanced by a nose-up pitching moment

17-6

developed by the rotors. This was the only primary structural parameter that exceeded endurance limits during the flight program. This parameter was of less concern after installation of an elevator-to-collective coupling modification that had the dual purpose of reducing shaft stress in descents and reducing total longitudinal stick travel required throughout autorotational entry and flare. Analytically predicted and measured pushrod loads for the upper rotor are shown in Figure 17. Lower rotor pushrod loads are somewhat less. Measured loads turned out to be about 33 percent of predicted loads and less than 20 percent of endurance limits at 155 KIAS. Although it is apparent that the controls are overdesigned on the XH-59A aircraft, it is not obvious how much weight savings could be achieved on a production ABC aircraft. This is because the control system design is stiffness-critical rather than strength-critical.

WEIGHTS

The primary objective of the Army contract was to demonstrate the feasibility of the ABC rotor through flight testing. This objective had to be satisfied within budget and time constraints that precluded separate or special component developmental efforts. Consequently, the XH-59A was designed with conventional materials and was fabricated using state-of-the-art manufacturing methods. Some components were intentionally overdesigned to assure a high probability of being able to demonstrate the XH-59A to flight envelope extremes (up to 345 knots) without encountering structural limitations. Costly machine operations, which could have been used to hog out nonstructural material in the rotor and transmission systems, were omitted. Final aircraft weight also included redundancy in the control system to accommodate different control schemes, different control couplings, and gain changing features. As an example, the transmission housing was designed to accommodate a mechanism that would allow the rotors to turn at different speeds. This provision was not used, but the weight penalty was paid.

The ABC rotor diameter was established as 36 feet before the aircraft detail design was completed. During detail design, weight growth occurred which increased the disc loading about 10 percent beyond the preliminary design value. The effect of increased disc loading manifested itself most noticeably during autorotation as an increase in sink rate.

The weight breakdown for major subsystems in the XH-59A demonstrator aircraft and the final weight of the aircraft is as follows:

Rotor group	1896 lb
Flight controls	1260 lb
Drive system	1119 lb
Body group	1184 lb
Empty weight	8060 lb
Flight gross weight	10,500 to 10,800 lb

A production version of an ABC helicopter would undoubtedly incorporate a lighter weight rotor made of high modulus material and a redesigned control system. The benefit of using high modulus material, such as graphite composite, in an ABC rotor is much more pronounced than the benefit of using this same material in a conventional rotor system because of the stiffness requirement for the ABC blades.

ROTOR DYNAMICS

Prior hingeless rotor testing suggested that rotor dynamics be monitored at least until damping and response trends could be established. The main concern was associated with edgewise response of the blades in the absence of lag dampers. Figure 18 shows the percentage of critical damping for the edgewise mode throughout the flight-test speed range. As shown, the edgewise mode was stable throughout the speed range and concerns of rotor instability were dismissed.

A tip path monitoring (TPM) system was installed to measure rotor-to-rotor blade tip separation as a function of flight condition. The operation of this system is described in Reference 3. Figure 19 shows rotor blade tip clearance as a function of load factor for speeds up to 150 knots and cyclic phase angles of 40 and 60 degrees. Note that in level flight at a 1 g load factor, the tip clearance is considerably reduced from the 30-inch static tip separation distance. Since each rotor has the same precone angle (3 degrees), this demonstrates that the advancing blades are lifting more than the retreating blades. Other factors that influence tip clearance are pitch and roll rate, rotor speed, and gusts.

A minimum clearance of 10.5 inches was recorded during the flight program. Sufficient information was obtained to verify that the blade stiffness and rotor spacing were quite adequate when the XH-59A is flown as a conventional helicopter.

VIBRATION

During the flight program, it was found that pilots could satisfactorily fly the XH-59A to envelope extremes without the need for vibration isolators. Vibration was shown to be a strong function of differential rotor loading which could be varied through the application of differential longitudinal cyclic control. Vibratory levels were also sensitive to cyclic phase angle settings and rotor speed. The primary source of vibration was three per revolution (3P) lateral forces and rolling moments.

Figure 20 shows the 3P lateral vibration band versus airspeed measured by an accelerometer located near the pilot's feet. Data within this band represent vibratory levels after installation of a single 100-lb spring-mass absorber in a nonoptimum location. Prior to installation of the vibration absorber, vibratory levels at speeds above 100 knots were higher and reached 0.9 g at 155 knots as shown by the line in Figure 20. Vibration, with the absorber installed, was lowest at 95 percent N_R up to 120 KIAS, was reduced somewhat by operating at 100 percent N_R beyond 120 KIAS, and reached 0.4 g at 155 KIAS. Vibration in the 40 to 60 KIAS range depends, to a large extent, on cyclic phase angle, and the phase angle for lowest vibration varies with airspeed. However, since very little flight time was devoted to vibration investigations per se, data shown in Figure 20 should not be construed as vibration characteristics inherent with an ABC rotor. Rotor configuration changes, such as re-indexing the upper rotor with respect to the lower rotor, or aircraft

configuration changes, such as reducing the size of the large horizontal tail, were not investigated, but would be expected to influence vibration in a significant way. Based on the data available, a production version of an ABC helicopter would probably incorporate some vibration abatement or isolation device more sophisticated than spring-mass absorbers. 17-7

CONTROL AND RESPONSE CHARACTERISTICS

As was expected with the rigid rotor, the XH-59A aircraft demonstrated crisp response about the pitch and roll axes. Response about the yaw axis, which depends upon differential torque between upper and lower rotor, was quicker than predicted. A 360-degree hover turn could be made in 6 seconds with virtually no overshoot. Figure 21 shows representative pitch, roll, and yaw control power as a function of airspeed. These control powers were derived from the helicopter rate response to pilot-applied step control inputs. Additional comments on handling qualities are contained under the heading "Government Flight Evaluation."

ACOUSTICS

The acquisition of acoustical data was not a prime objective of the program. Consequently, there was no emphasis on recording sound pressure levels for a wide variety of test conditions. Sound pressure levels that were recorded in hover are compared with other helicopters in Figure 22. Results show the XH-59A helicopter, in spite of its high disc loading, is much quieter than all other helicopters except the OH-6. Credit for the low noise signature is attributed to lack of a tail rotor and to running the rotor at a relatively low tip speed of 650 ft/sec. The quietness of the XH-59A helicopter in forward flight is dramatic when compared with two-bladed helicopters.

GOVERNMENT FLIGHT EVALUATION

GENERAL

The Army performed a brief flight evaluation of the XH-59A in July of 1976 after the contractor had acquired 41.3 hours of envelope expansion and exploratory testing. The evaluation consisted of 3 flights totalling 2 hours. While the evaluation was essentially qualitative in nature, quantitative data was acquired at 56 test conditions to complement the pilot comments.

The surface wind was generally 10 to 15 knots with an occasional gust to 30 knots and the turbulence at the test altitudes was light to moderate. The takeoff gross weight of 10,700 pounds equated to a disc loading of 10.5 pounds per square foot and the center of gravity was approximately 3 inches forward of the mast centerline. The aircraft configuration was pure helicopter only (without thrust engines) with the doors on and off.

In general, the XH-59A exhibited some excellent handling qualities attributable to the rigid coaxial rotor system and it exhibited some undesirable characteristics that may or may not be related to the rotor system.

TAXI AND GROUND HANDLING

The tricycle-type wheel handling gear provided for very good ground handling; however, two characteristics relating to the concept were somewhat degrading or at least not very compatible with a wheel-type landing gear. Directional control during taxi was dependent upon the proper amount of collective pitch, in that a directional control crossover or reversal occurred as collective was lowered below approximately 12 to 15 percent (100 percent being full up collective). Although slightly sluggish, adequate directional control was available during taxi operations with the collective positioned at approximately 30 percent. Engine/rotor system runup and shutdown was conducted with the collective set at about 15 to 18 percent with the cyclic stick slightly offset to the left to reduce airframe vibration. The recommended technique for taxiing was to select approximately 30 percent collective pitch and to control forward speed with cyclic pitch and brakes. Application of more than about 35 percent collective in combination with forward cyclic pitch tended to cause the rear wheels to lift off the ground, while the use of less than about 10 percent collective involved reversed directional control. The capability to initiate forward rolling motion and accelerate seemed limited even on a smooth ramp, although prudence was exercised in the use of forward cyclic. It is very likely that taxi tests on unimproved ramps would show this to be a significant limitation. While nose wheel power steering might provide a reasonable improvement in directional control, both of these deficiencies, directional control power and the weak forward propulsive force, can obviously be avoided by air taxiing.

HOVER

Although longitudinal and lateral control power and damping were outstanding, stabilized hover in ground effect (IGE) was difficult to perform in the gusty wind conditions prevalent during the initial portion of the flight evaluation. The difficulty stemmed from frequent, abrupt, but random, lateral accelerations of the entire aircraft along with bothersome yawing and heading deviations. The magnitude of the upsets varied with the magnitude of wind, gust level, wind azimuth, hovering height, and whether the doors were on or off. Removing the doors improved the pilot rating by two points. Under less severe wind conditions and with the doors removed, the lateral upsets were not much of a problem and stabilized hover was relatively easy to perform with SAS either on or off. The unstableness also varied dramatically with hover height. The aircraft was much more stable hovering out of ground effect (OGE) than IGE, although near the ramp at a wheel height up to about 1 foot, it exhibited improved handling. The shape of the fuselage is believed to be the primary contributing factor in that the contractor reported a marked decrease in the instability by temporarily attaching longitudinal strakes to the sides of the fuselage.

Directional control power and response were characterized by a yaw acceleration of 40 degrees/sec/sec and a peak yaw rate of 70 degrees/sec produced by a 1.3 inch (22 percent) pedal input. However, the time required to achieve a steady-state yaw rate was approximately 3 seconds, indicating a level of directional damping

17-8 similar to that of the Gazelle and Blackhawk fan-in-fin aircraft.

LOW-SPEED MANEUVERS

The aircraft exhibited very good handling qualities in low-speed maneuvering up to about 50 knots. The ease and preciseness with which accelerations, flares, quick stops, multi-axis turning maneuvers, and hover translations were performed related to the absence of control cross-coupling and large trim changes, particularly in yaw, plus the presence of high damping, rapid response characteristics and a general feeling of solid stability. Occasionally, however, there were uncommanded trim changes about the pitch axis in flaring maneuvers that hinted of downwash effect on the horizontal tail surface. Many helicopters have a similar characteristic, but not necessarily in the flare.

FORWARD FLIGHT

The aircraft exhibited a bothersome pitch stability problem in climbs between approximately 50 to 70 KIAS. Frequent but random longitudinal trim upsets occurred which tended to produce nose-up and nose-down attitude excursions of as much as 10 degrees, which, if uncorrected, caused large errors in trim airspeed. Excessive pilot effort was required to maintain a trimmed condition. The problem, believed to be caused by air flow over the horizontal tail, diminished at airspeeds beyond about 80 KIAS; however, the apparent speed stability throughout the forward flight envelope was disappointing in that considerable attention to pitch attitude was required to maintain a given airspeed. This fairly high gust sensitivity adversely contributed to pilot workload. The effect of SAS is discussed later.

Precise aircraft control, very good turn coordination, and the absence of control cross-coupling were characteristics that were impressive in forward flight maneuvers including pushovers, pullups, and symmetrical turns as the load factor was varied from 0.2 to 1.8 g at speeds up to 140 KIAS. The ease of performing maneuvers was also impressive. This related not only to control responsiveness, but also to the lack of increased vibration and noise as increased load factor and roll rate were applied. As with the BO-105, the XH-59A was extremely maneuverable, almost enticing one to perform aerobatics.

AUTOROTATION

Autorotation entries followed by steady-state autorotative descents and power recoveries were performed at 60 and 80 KIAS. The autorotation entries were very straightforward except for the compensation required for the strong collective to pitch coupling caused by the large horizontal tail. The rate of descent at 60 KIAS was 2280 fpm at a gross weight of 10,100 lb., a rotor speed of 348 rpm, and a cyclic phase angle of 43 degrees. While no abrupt autorotative maneuvers were performed, it was apparent that rotor speed control was very sensitive to collective pitch variations.

The XH-59A exhibited the same directional control reversal in autorotative descents as it did in taxi, with the collective pitch positioned at that setting required to maintain proper autorotative rotor speed. The rudders provided enough positive directional control in autorotation at 80 KIAS to overcome the negative directional contribution of differential collective pitch, but as airspeed was decreased to 60 knots, the differential collective pitch contribution became more predominant and an effective mild control reversal was observed. To perform an autorotative landing, one would conceivably initiate an aircraft flare at approximately 80 KIAS which would allow (or require) enough increase in collective pitch to retain positive directional control during the time required to arrest the sink, decelerate, and complete the landing. This has not yet been demonstrated.

SAS EVALUATION

The pitch and roll SAS (rate damping only) was briefly evaluated at various flight conditions and was found to be "bracketed." The SAS was dualized, with each system providing 50 percent of the input, so that either system could be selected on or off. In general, the ride qualities deteriorated with both systems on as if the gains were too high, yet more damping was desired with both systems off; therefore, the evaluation was flown for the most part with half SAS. However, it is important to note that at all the flight conditions explored, the aircraft was completely manageable without SAS, although half SAS was clearly beneficial.

VIBRATION

The predominant XH-59A vibration was felt in the cockpit as a 3P lateral, varying in intensity throughout the envelope from almost nonexistent to approximately 0.6 g. Aside from the shaking of the airframe and instrument panel, it was not bothersome, probably because the crew seats were located near a node. At times, the instrument panel shake resembled that of some of our older piston-powered cargo helicopters when passing through translational lift into hover, but the XH-59A vibration was noticeably different due to the absence of typical tail rotor induced vibrations. Regions of pronounced vibration were in climbs, in descending flight around 50 knots and at high forward airspeeds. Regions of low vibration included hovering flight and forward flight maneuvers involving increased load factor. When compared to some other rigid-rotor aircraft and even some articulated or soft-mounted teetering systems, the XH-59A vibration did not seem too bad, particularly in view of the fact that the XH-59A was a feasibility demonstrator with its gearbox solidly bolted to the airframe. Nevertheless, it was excessive and some sort of vibration attenuation is required.

SIMULATED ENGINE FAILURE

Single engine chops were performed during level flight at 120 KIAS to observe aircraft trim changes. The only effect was a very slight nose-down trim change during the time it took for the operating engine to respond and produce the required power.

SUMMARY OF FLIGHT-TEST RESULTS

The following summary is based upon results of flight testing the XH-59A helicopter for 67 hours as a pure helicopter.

1. The lift distribution on the rotors in forward flight can be easily controlled to alleviate retreating blade stall. Conversely, lift distribution on the rotors in forward flight must be controlled to prevent overloading the advancing sides of rotor discs. Controls required to properly distribute rotor lift are straightforward and conceptually simple.
2. Hover performance based on rotor figure of merit calculations was excellent. A maximum rotor figure of merit of 0.80 was computed. Hover performance, nondimensionalized in terms of C_w and C_p , was better than trend data from tests of other Army helicopters.
3. Level flight performance expressed in terms of total helicopter L/D was within the same range as most other helicopters. An L/D of 4 for the XH-59A helicopter in its test configuration was computed at speed for best range. Performance would improve if the test hardware and associated drag were deleted.
4. The rotors remained aeromechanically stable throughout the test program and no adverse elastic couplings were recorded. Rotor blade tip clearance exceeded 10 inches for all flight conditions.
5. Control loads were approximately one-third of predictions, and blade stresses remained well below endurance limits for most flight regimes. Shaft stresses reached endurance limits at high descent rates prior to the elevator/collective coupling modification. Stresses were below endurance limits after the coupling modification was installed, except for low collective, high-speed descents.
6. Hover control power and damping in pitch and roll were outstanding. Directional control power and response were characterized by a yaw acceleration of 40 degrees/sec² and a peak yaw rate of 70 degrees/sec achieved 3 seconds after control input.
7. Handling qualities in low-speed maneuvers up to 50 KIAS were very good. A bothersome pitch stability problem existed in climbs between 50 and 70 KIAS. Considerable pilot attention to pitch attitudes was required to maintain a given airspeed at speeds above 80 KIAS and fairly high gust sensitivity contributed to pilot workload. The absence of control cross-coupling, precise aircraft control, and very good turn coordination were impressive characteristics during forward flight maneuvers including pushovers, pullups, and symmetrical turns.
8. Autorotational entries were stable and relatively straightforward. Minimum rate of descent was 2280 ft/min at 100 percent rotor speed and 2000 ft/min at 95 percent rotor speed. Directional control reversals at low collective pitch settings were experienced. Flare attitudes up to 25 degrees were attained on autorotational recoveries, but no autorotational touchdowns were attempted.
9. Vibratory levels in the cockpit were highest at 50 knots and at maximum speed. The primary sources of vibration were three-per-revolution lateral forces and rolling moments. Lateral cockpit vibration levels up to 0.9 g were recorded at 155 knots with the transmission hard-mounted and no absorbers installed. This value was reduced to 0.4 g with installation of one 100-lb spring-mass absorber.

CONCLUSION

The feasibility of the ABC rotor has been demonstrated by flight testing the XH-59A helicopter up to speeds of 160 KIAS during a 67-hour flight-test program.

The main advantages of this rotor are: alleviation of retreating blade stall, which provides improved maneuverability at high advance ratios and altitudes; and deletion of the tail rotor with attendant benefits in safety, compactness, vulnerability, noise, handling qualities, and hover performance.

Primary disadvantages include high hub drag, less favorable autorotational landing characteristics, and higher rotor and controls weight fractions.

To achieve the full potential of the concept, the rotor and control system weight fractions must be reduced. This would involve design and development of a lighter weight rotor system utilizing high modulus material, and redesign of the control system.

REFERENCES

1. Ludi, L. H., "Development of High-Performance Rotary-Wing VTOL Aircraft," Paper No. 660314, presented at the National Aeronautic Meeting, Society of Automotive Engineers, Inc., New York, New York, April 1966.
2. Burgess, R. K., "Development of the ABC Rotor," Paper No. 504, presented at the 27th American Helicopter Society National Forum, Washington, DC, May 1971.
3. Ruddell, A. J., "Advancing Blade Concept (ABCTM) Development," Paper No. 1012, presented at the 32d American Helicopter Society National Forum, Washington, DC, May 1976.
4. Klinghoff, R. F., "Stability and Control Characteristics of the XH-59A (ABC) Demonstrator Helicopter," Paper No. 1045, presented at the 32d American Helicopter Society National Forum, Washington, DC, May 1976.
5. Arents, D. N., "An Assessment of the XH-59A Advancing Blade Concept (ABC) Hover Performance," Technical Note 25, Eustis Directorate, US Army Air Mobility Research and Development Laboratory, Fort Eustis, Virginia, May 1977.
6. Lewis, R. B., II, "Army Helicopter Performance Trends," presented at the 27th American Helicopter Society National Forum, Washington, DC, May 1971.
7. Johnson, J. N., et al, "Limited Performance Tests, CH-54B (Tarhe) Helicopter," USAASTA Final Report 72-40, February 1973.
8. Engineering Design Handbook, Helicopter Engineering, Part One, Preliminary Design AMCP 706-201, August 1974.

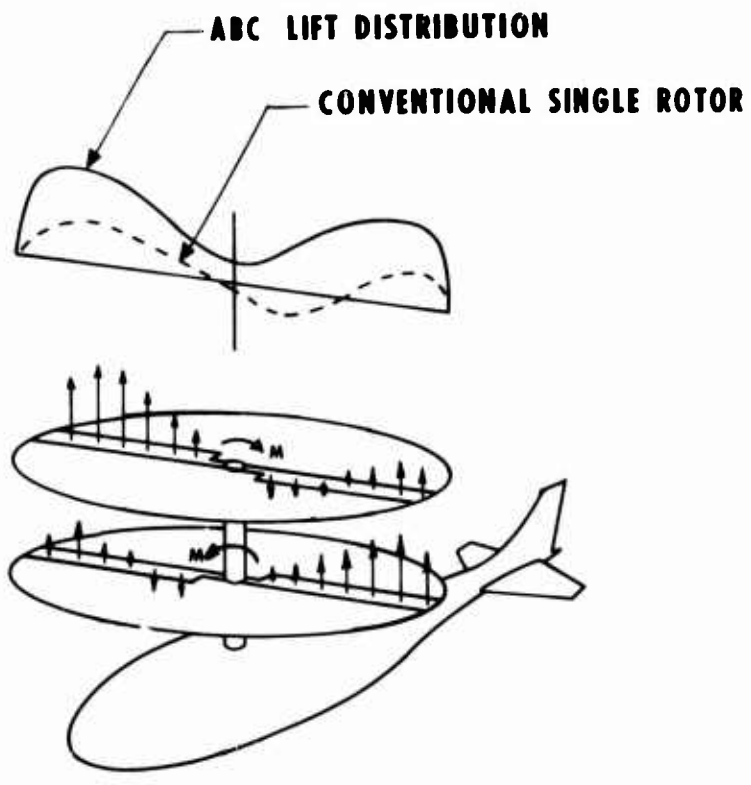

Fig.1 ABC rotor lift distribution

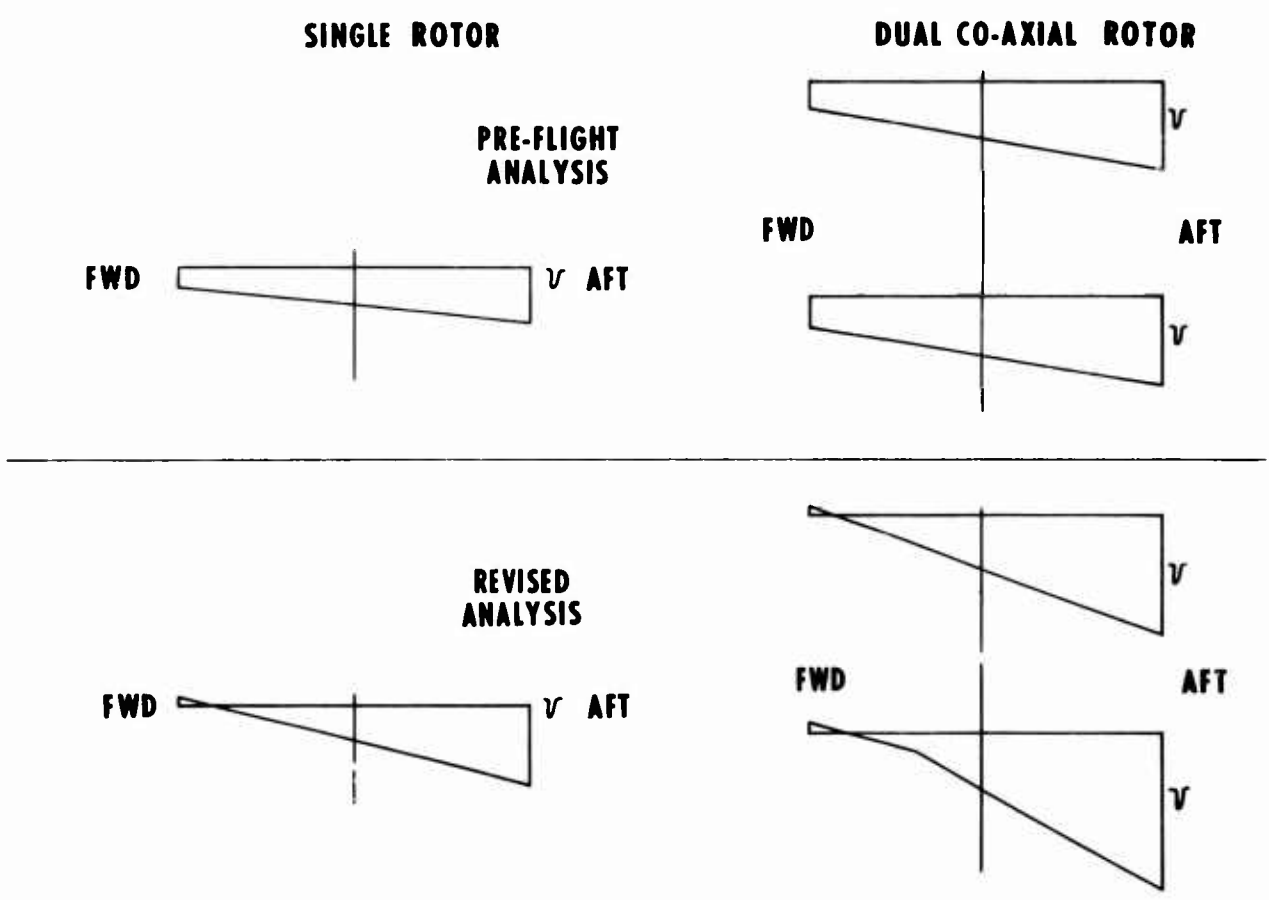

Fig.2 Longitudinal inflow pre-flight analysis and revised 25 kn airspeed

17-12

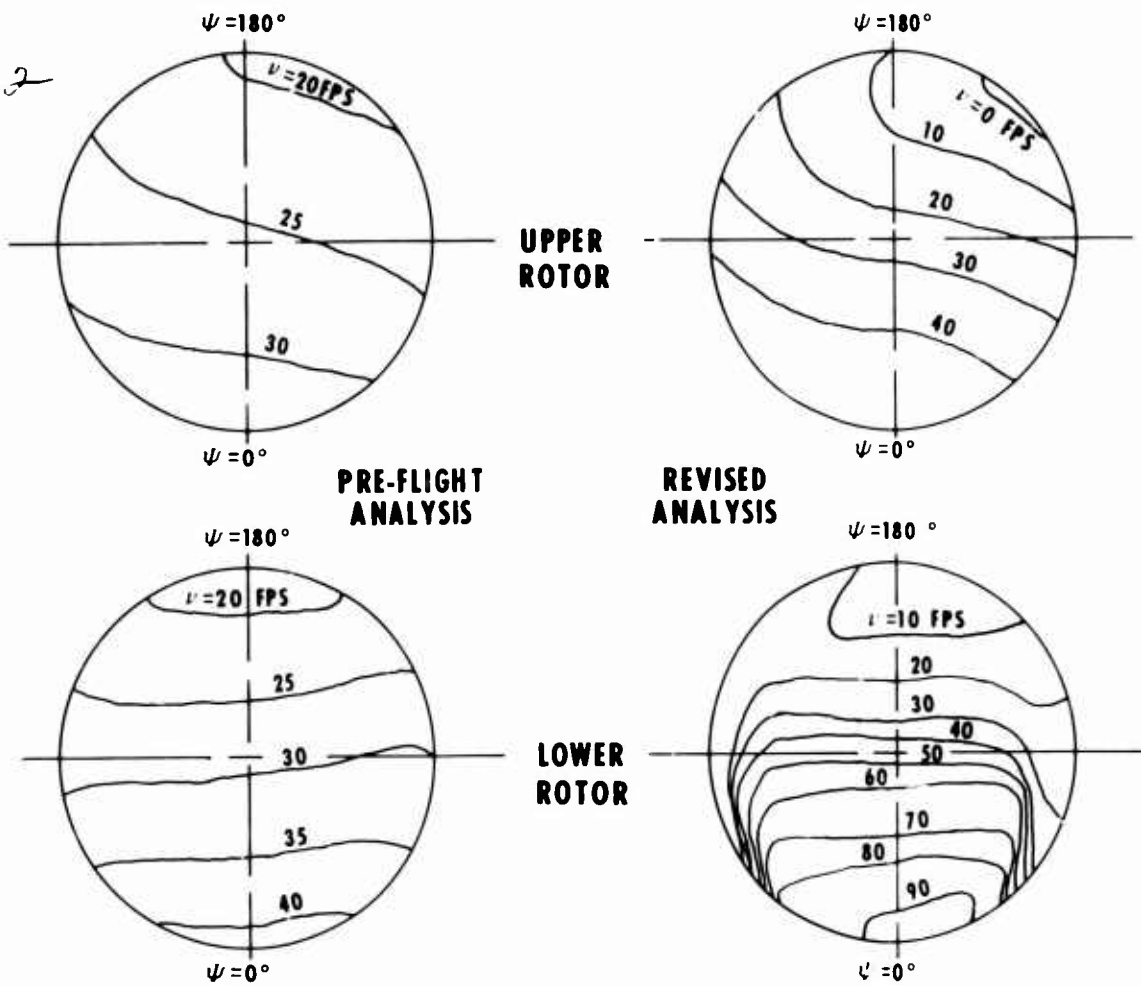

Fig.3 Induced inflows at 25 kn airspeed trim



Fig.4 XH-59A ABC demonstrator

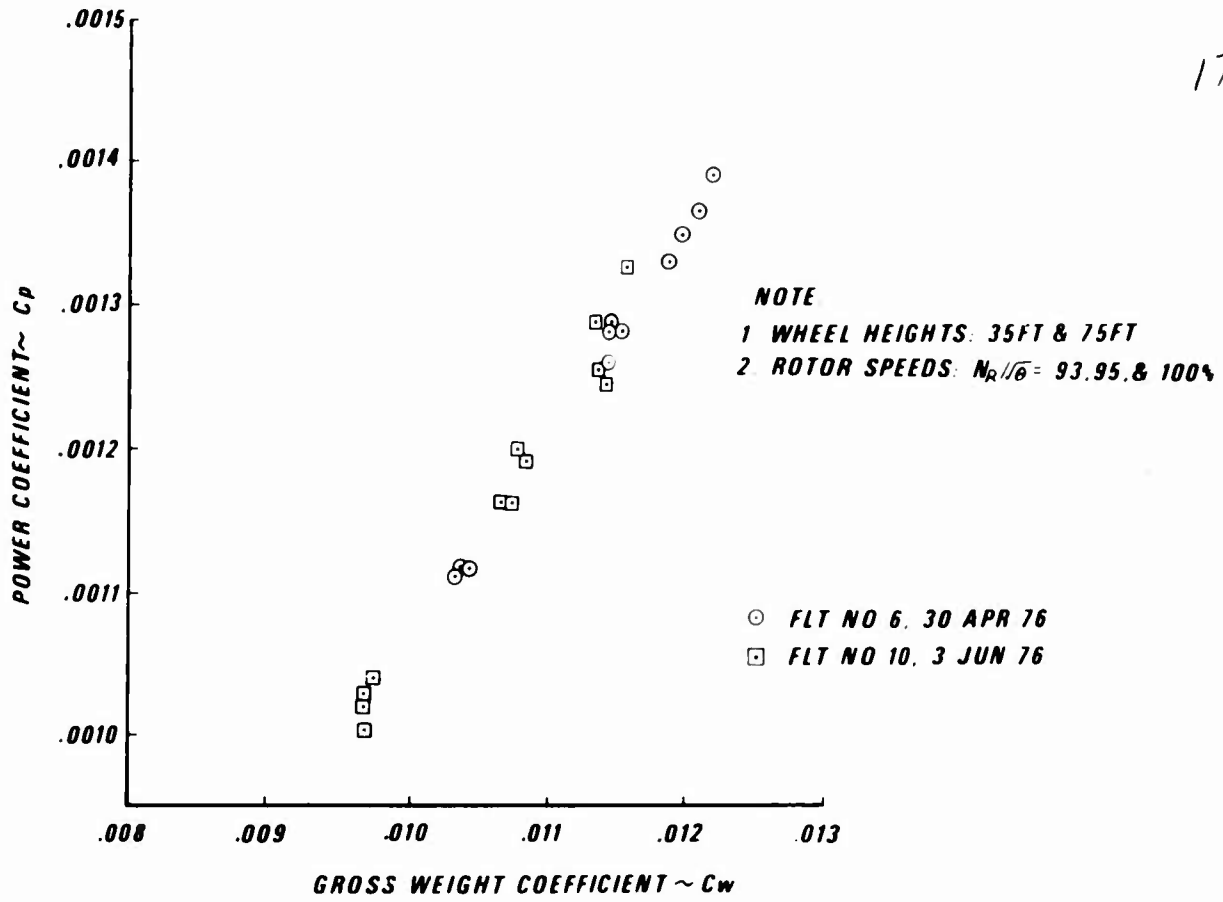

Fig.5 XH-59A hover performance out of ground effect

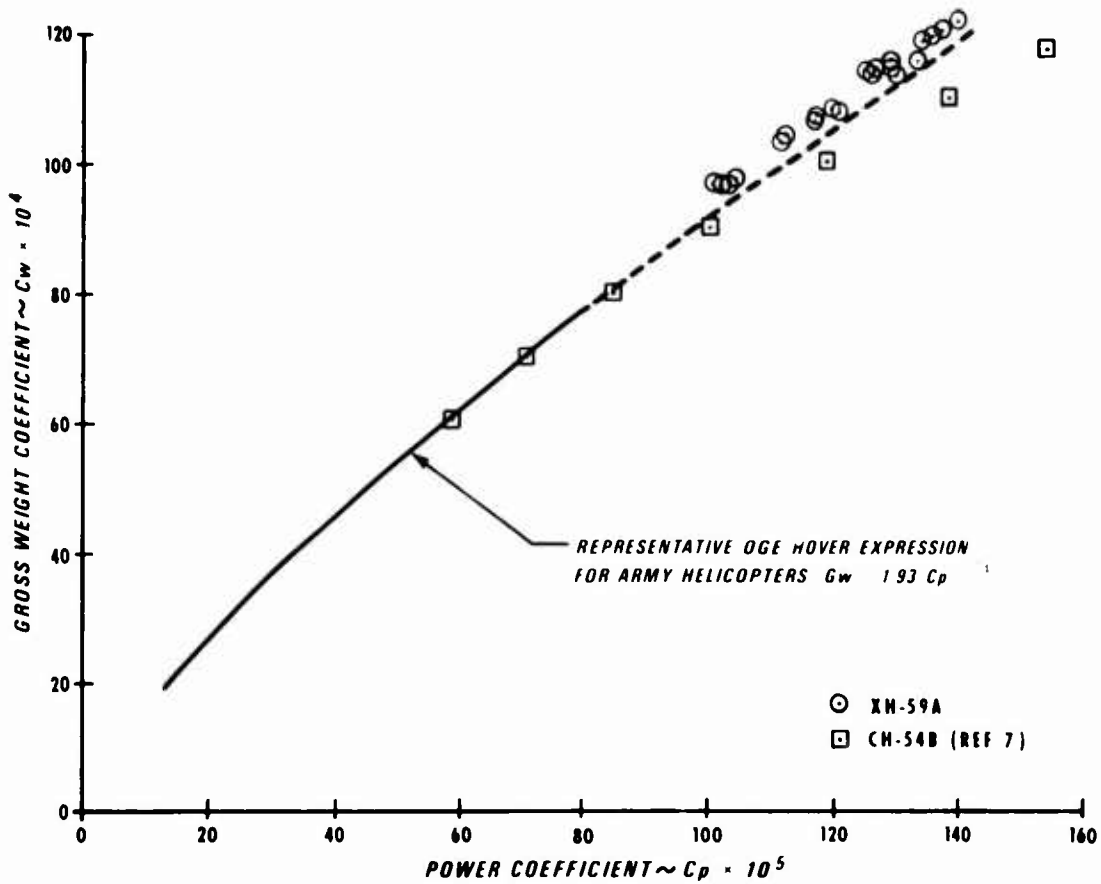

Fig.6 XH-59A and current army helicopters

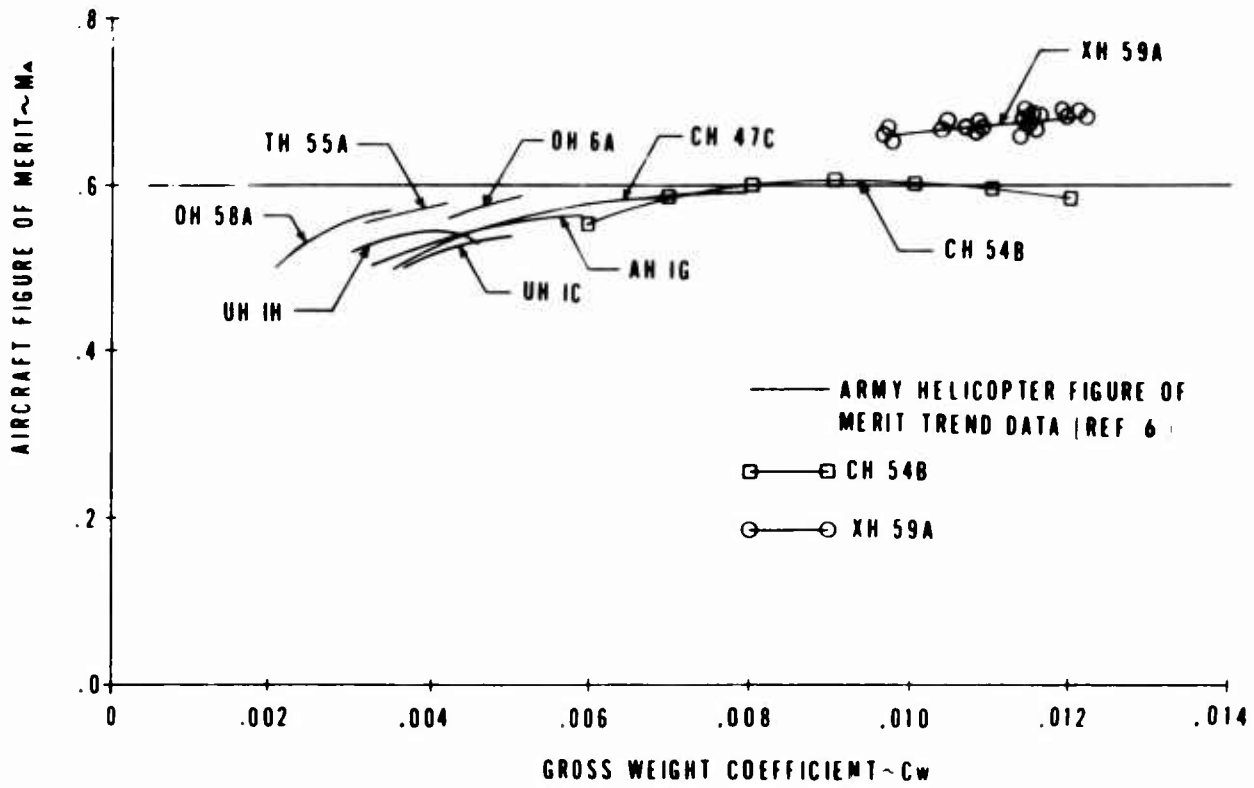

Fig.7 Helicopter figure of merit trends

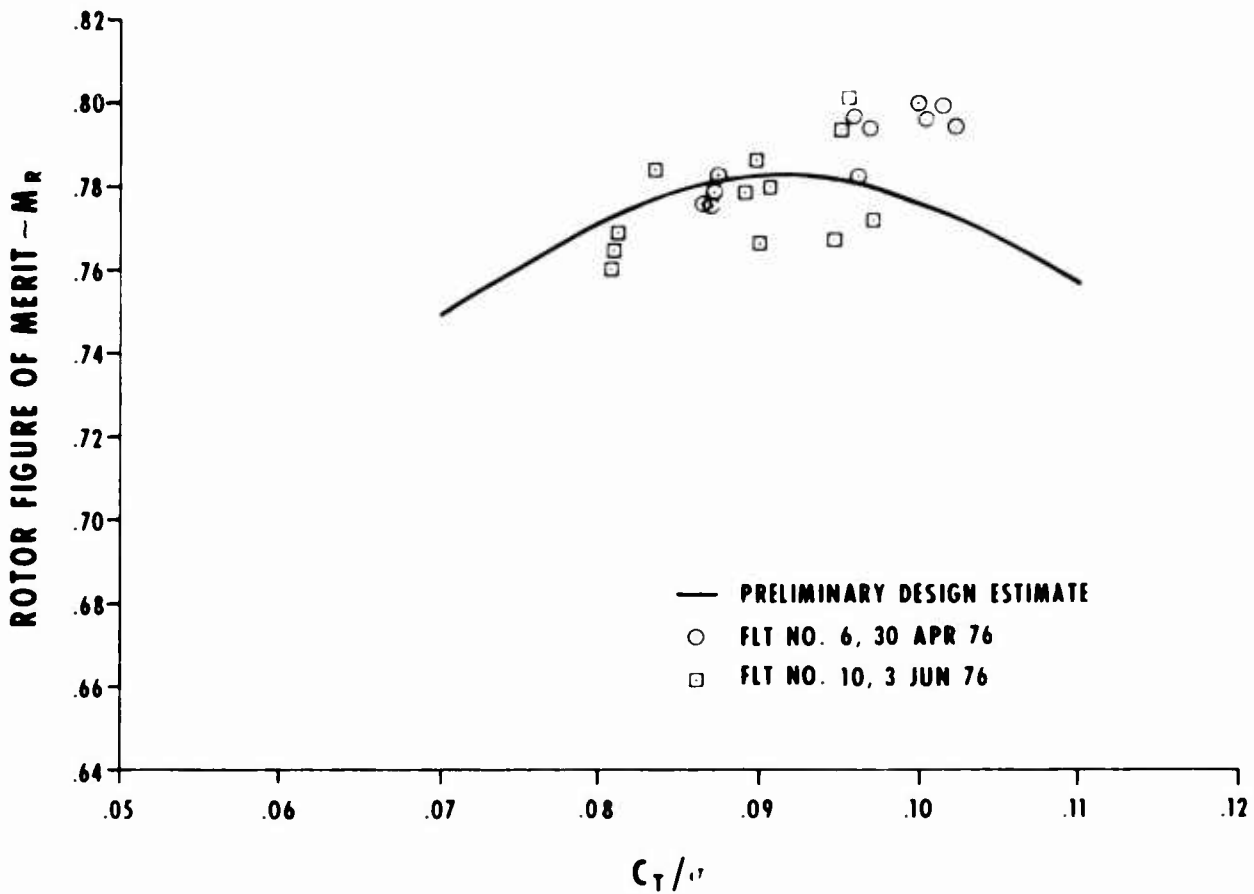

Fig.8 XH-59A rotor figure of merit

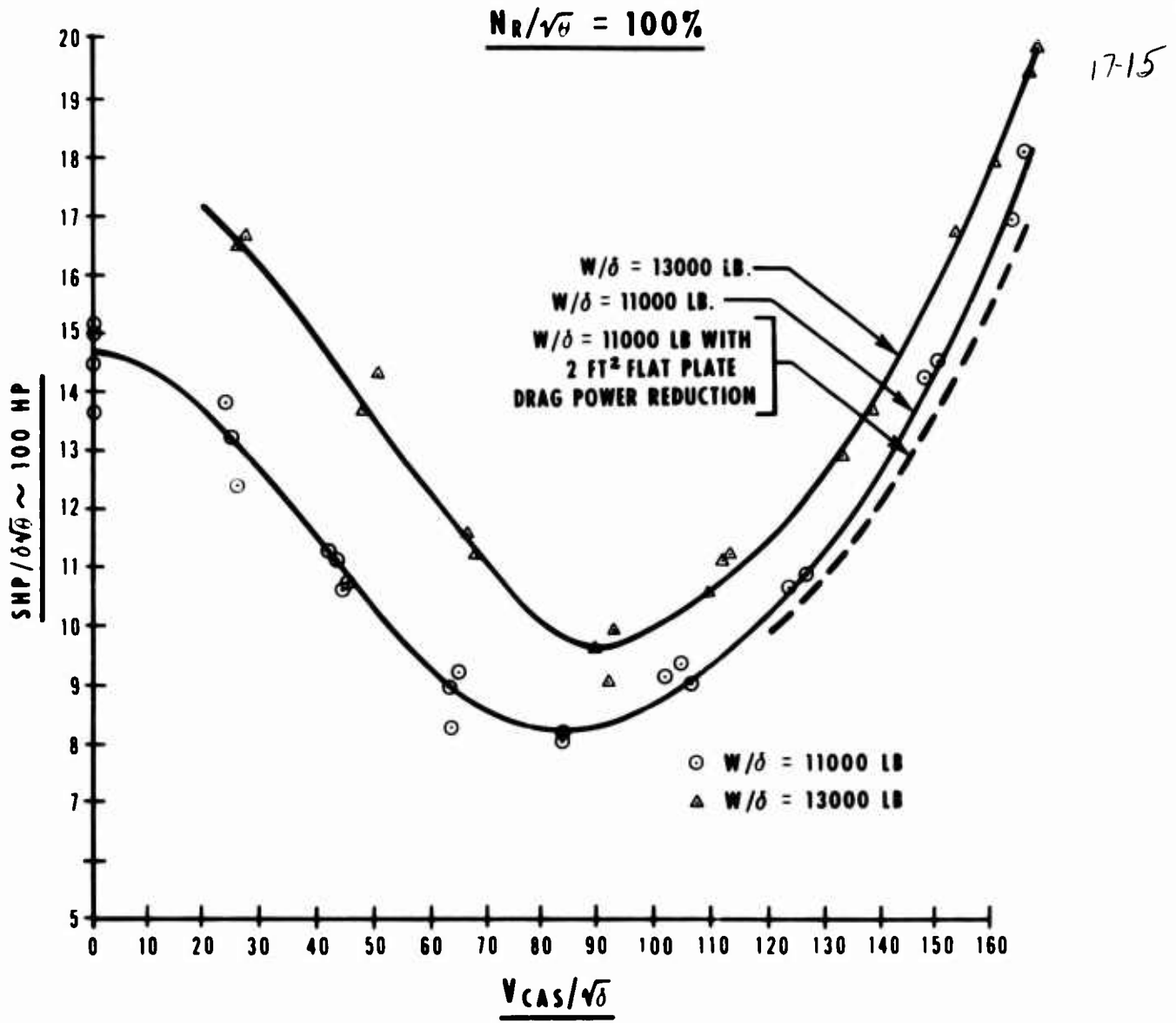

Fig.9 Level flight performance data

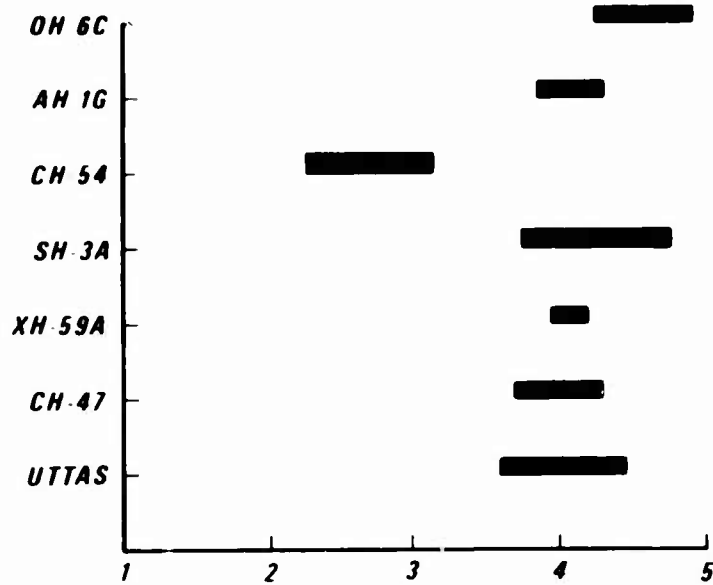

Fig.9A Total aircraft lift/drag

17-16

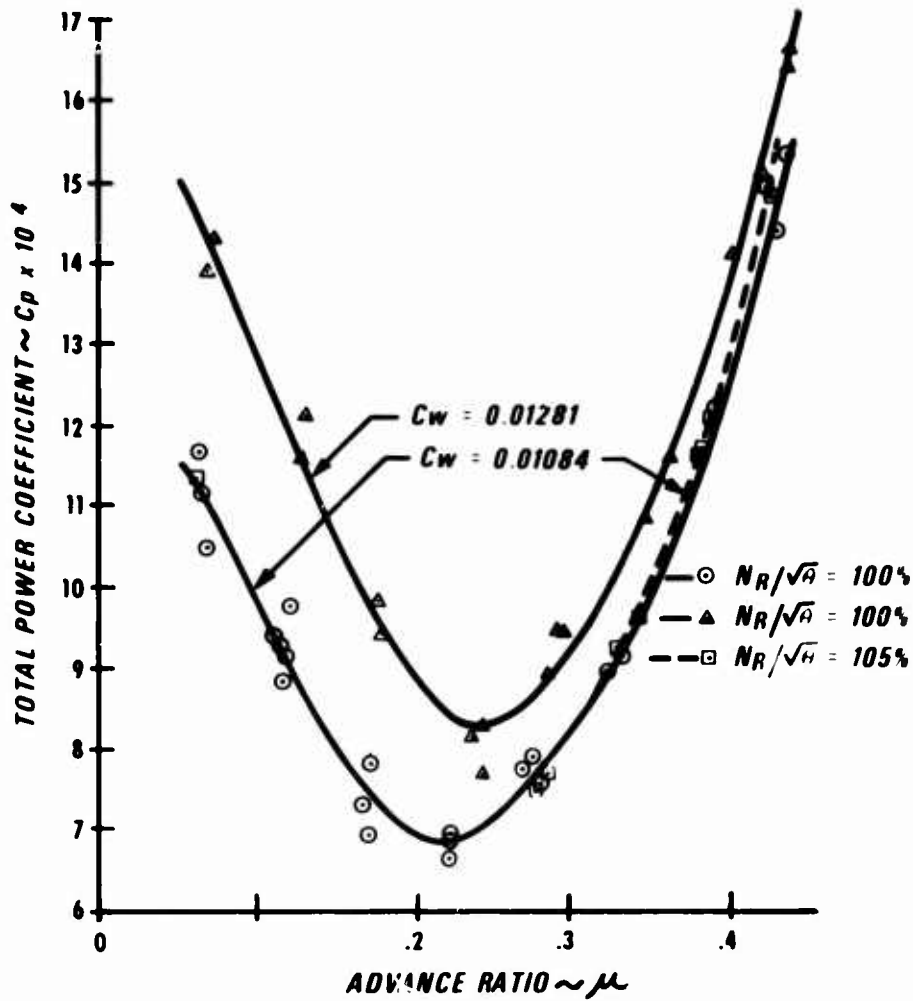

Fig.10 Non-dimensional level flight performance data

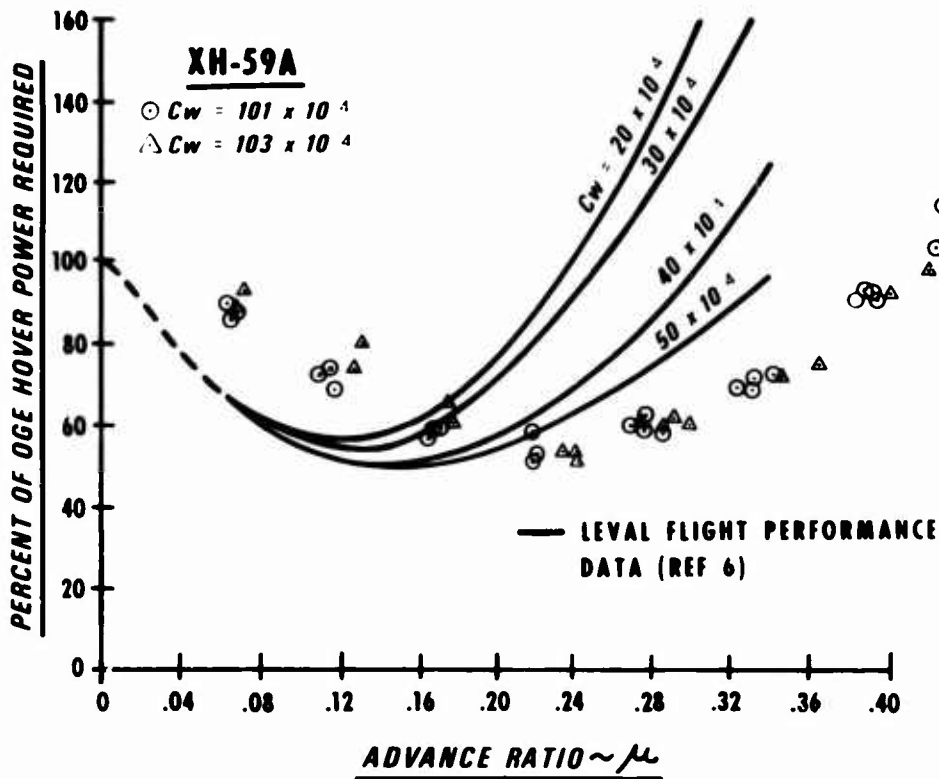

Fig.11 Generalized level flight performance

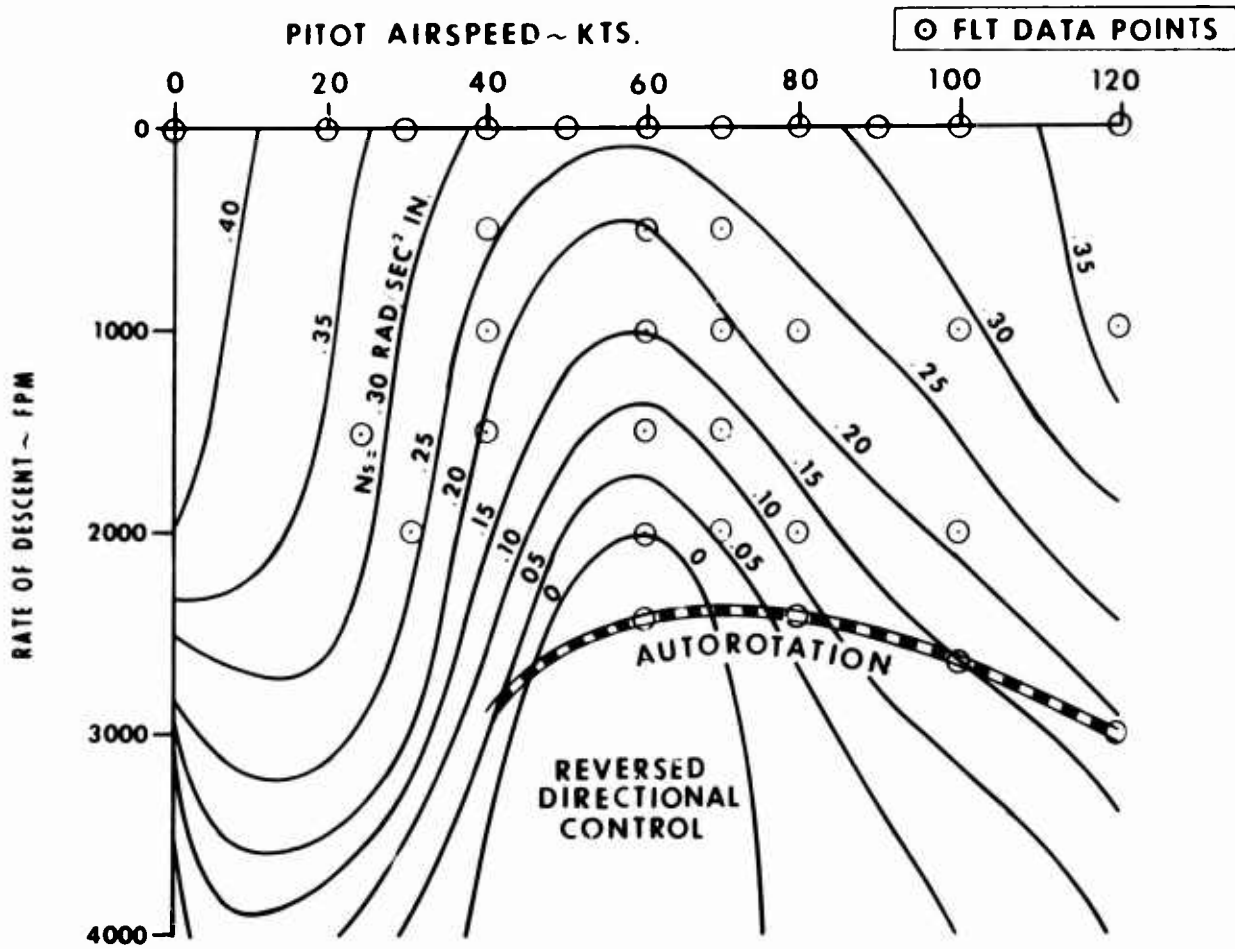

Fig.12 Directional control for steady flight

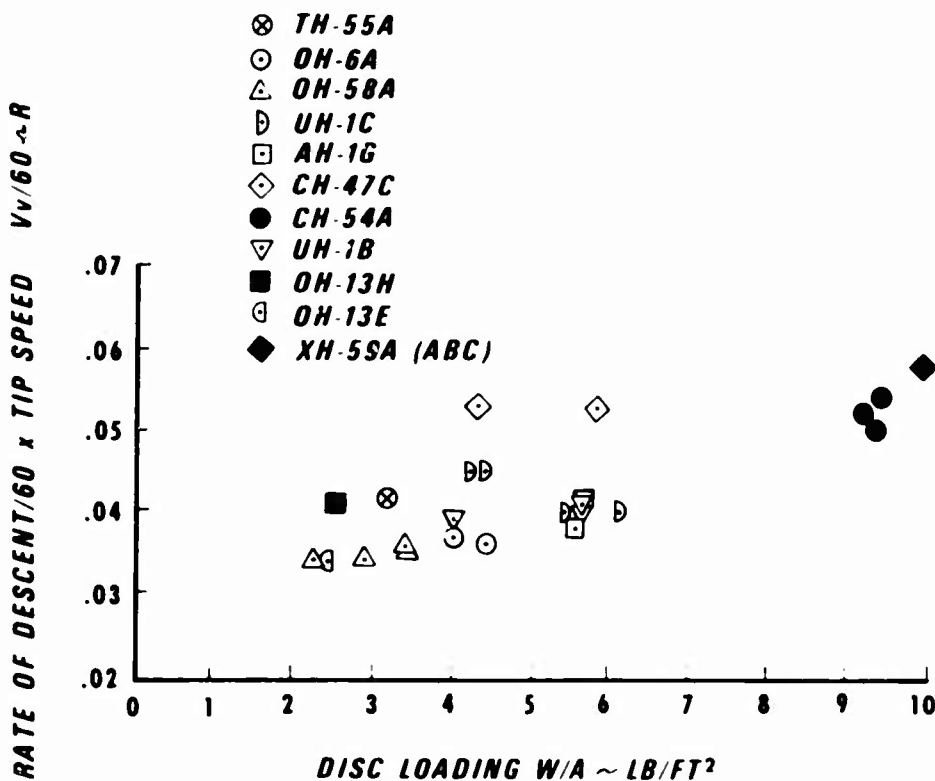

Fig.13 Autorotational performance summary

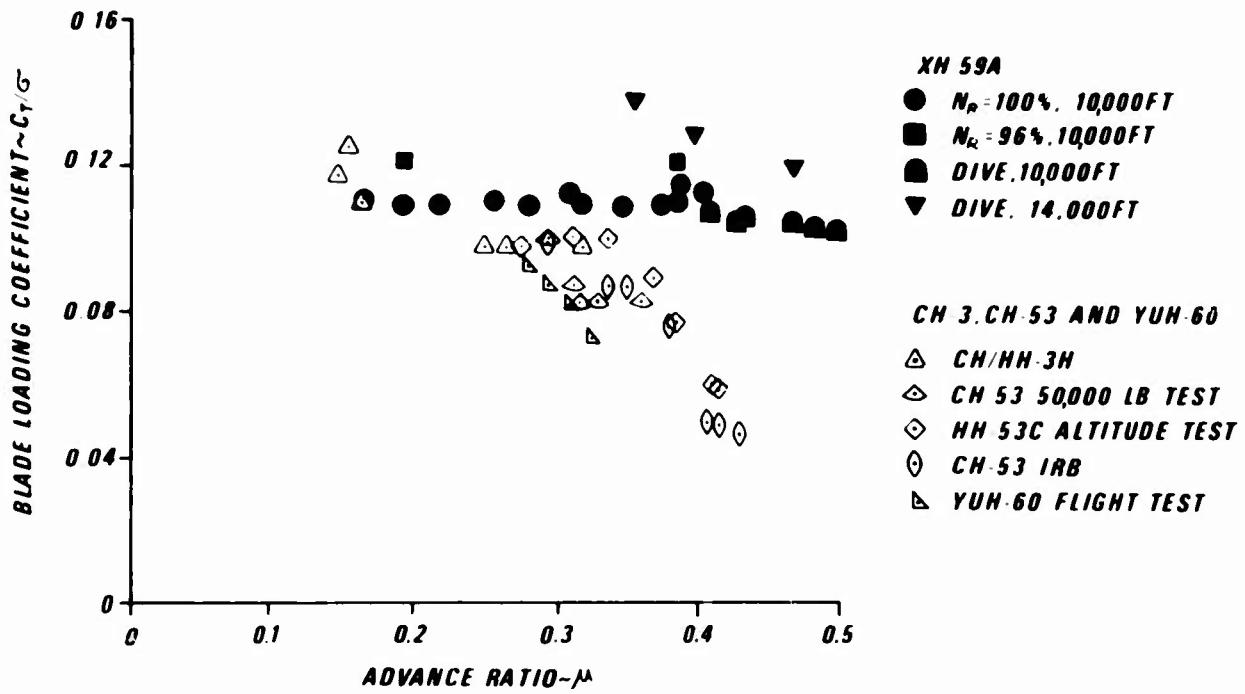

Fig.14 Maximum steady state blade loading coefficient

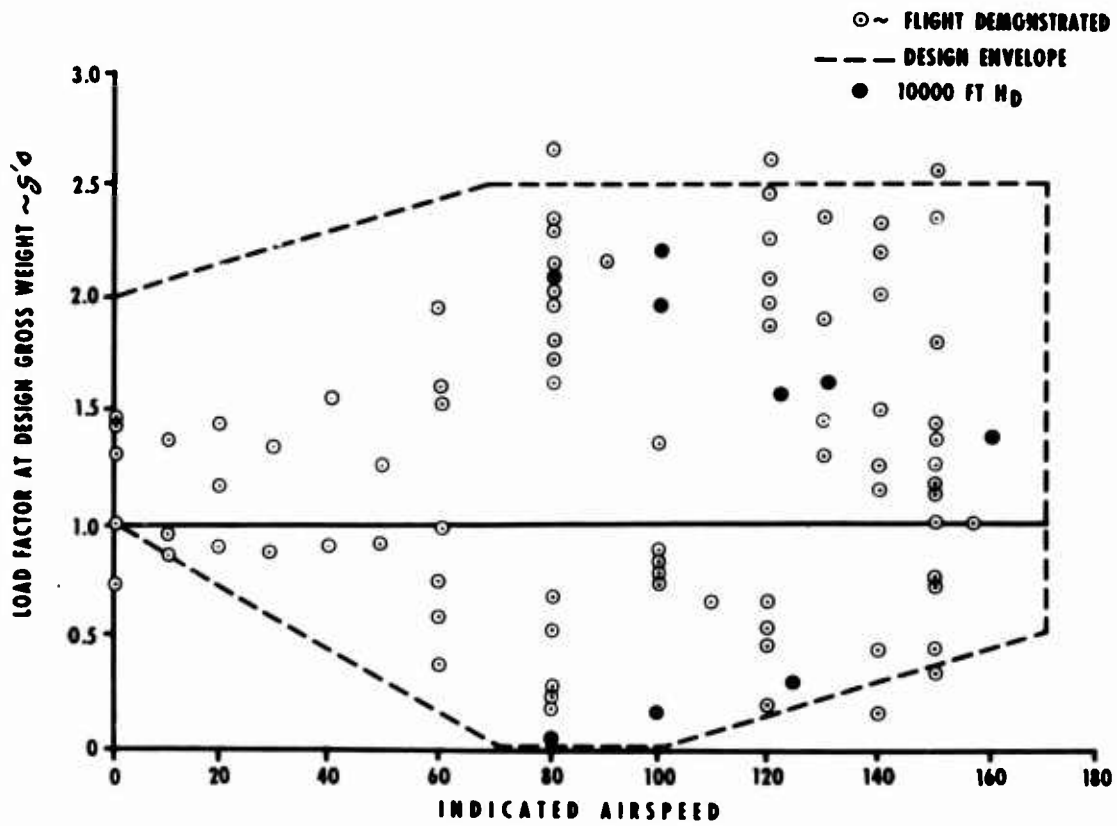
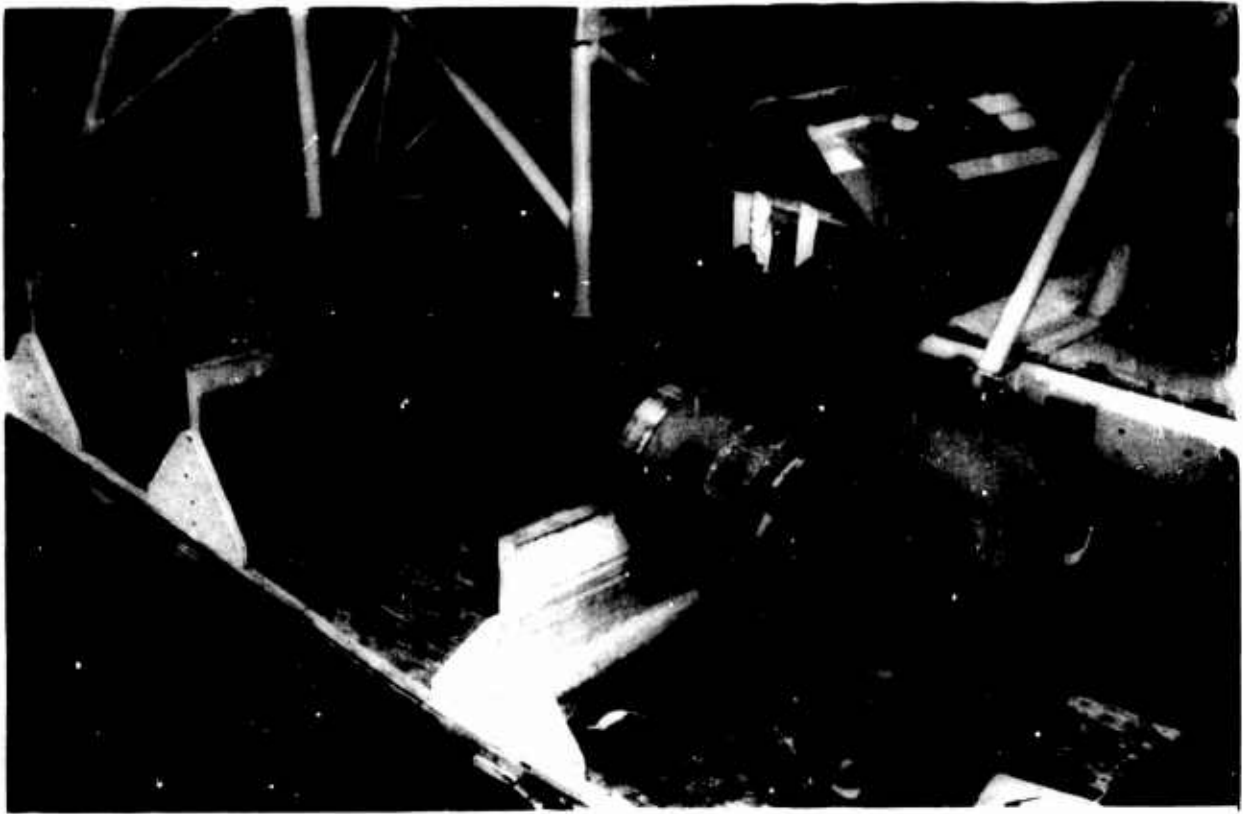

Fig.15 Maneuver envelope



17-19

Fig.16 ABC upper rotor shaft

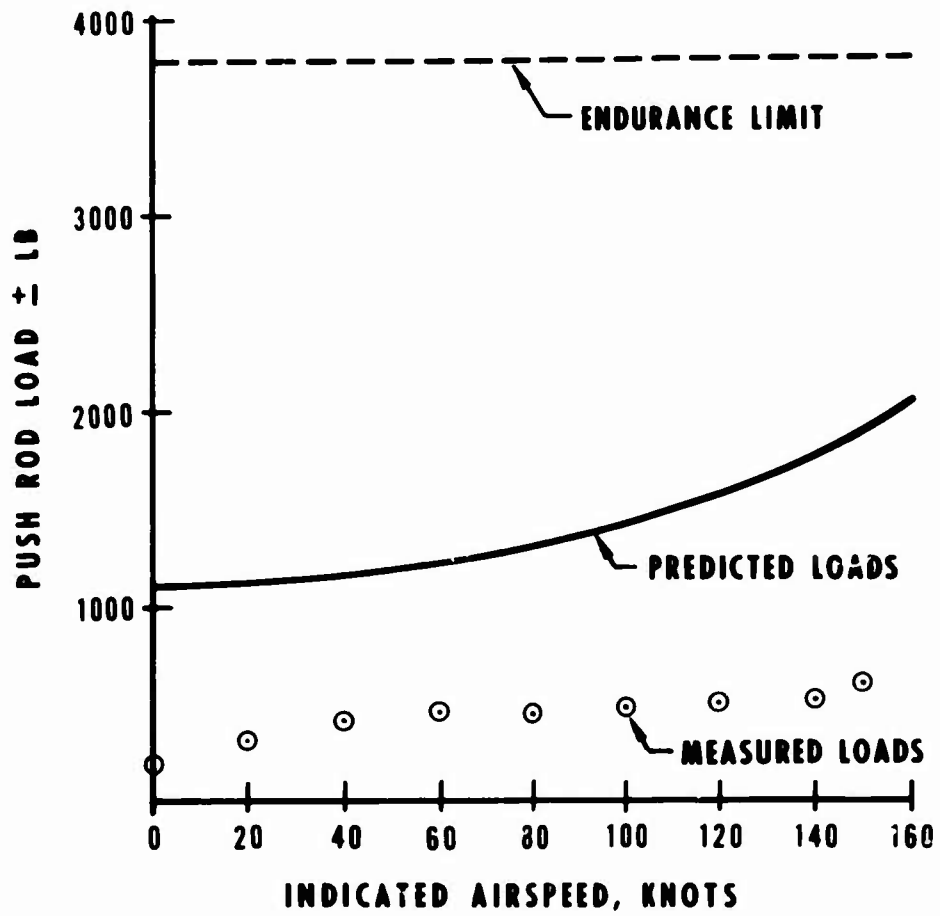

Fig.17 Upper rotor push rod load

17-20

BLADE
EDGEWISE
DAMPING

% CRITICAL

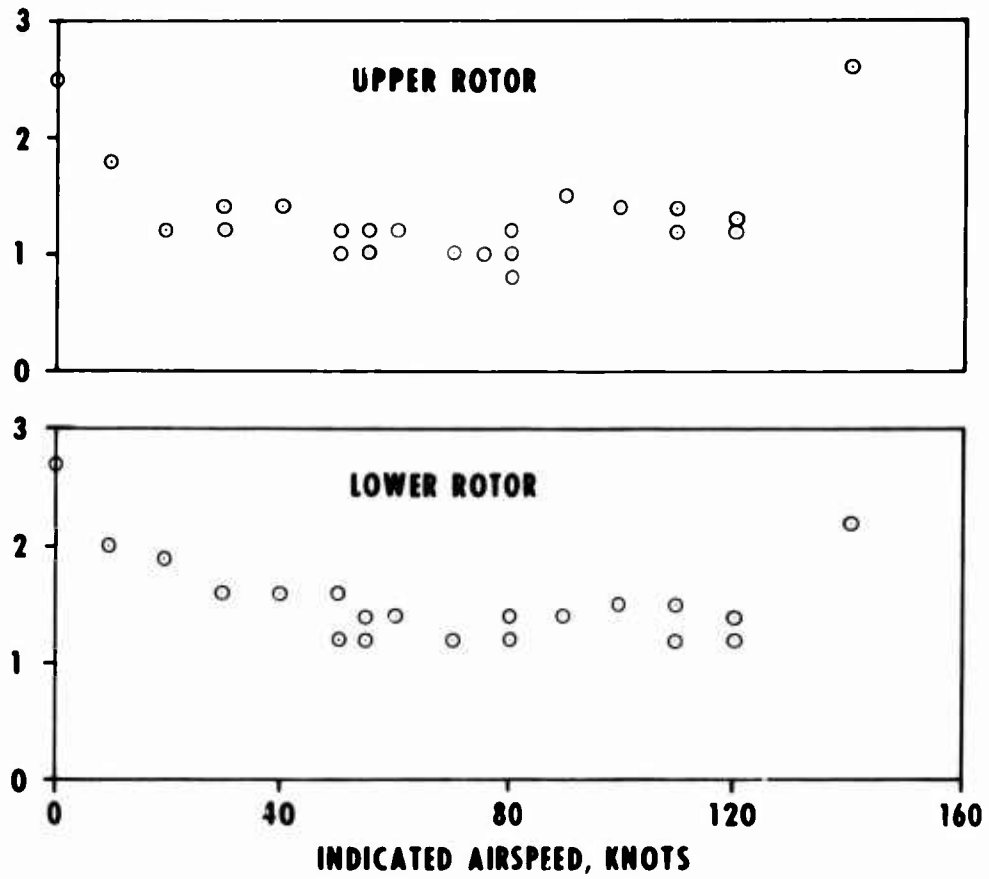

Fig.18 Blade edgewise damping

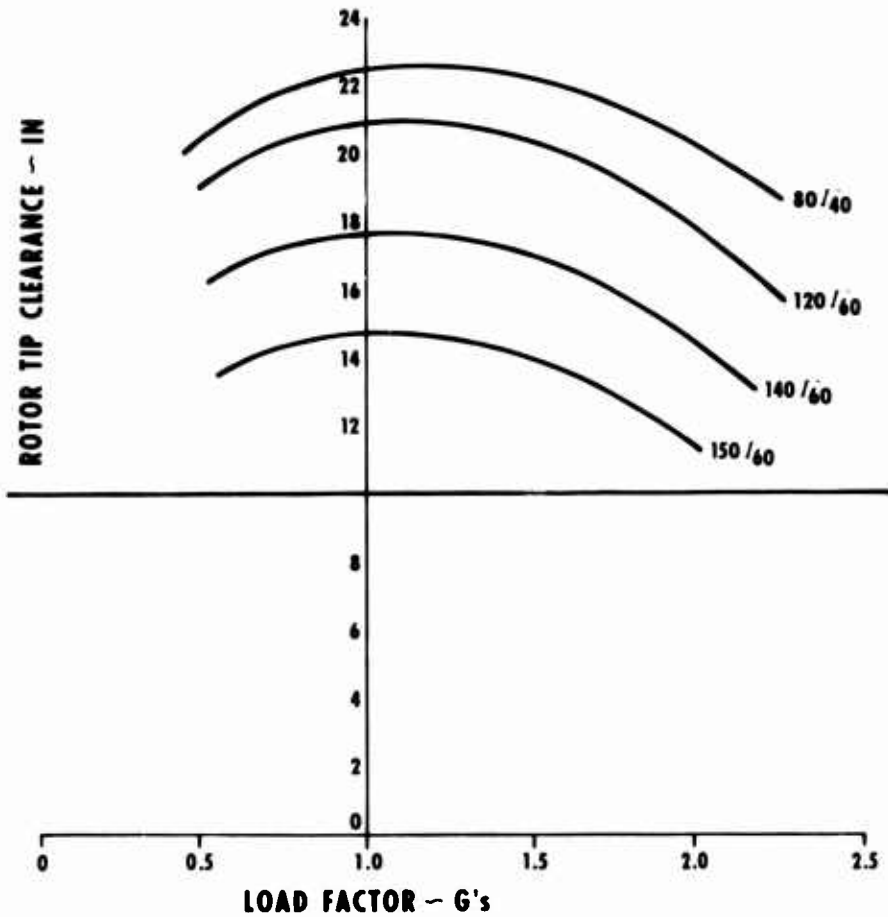

Fig.19 ABC rotor tip clearance

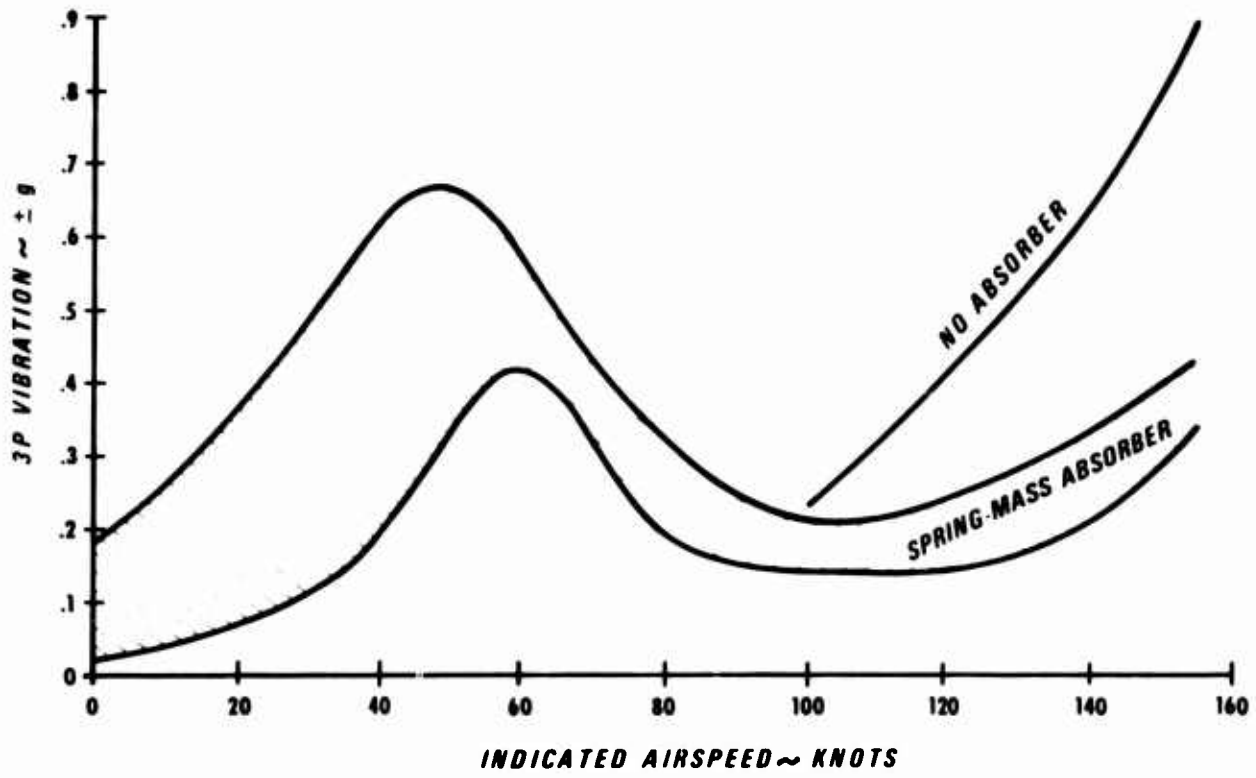

Fig.20 Cockpit vibration. 3P lateral - no isolation

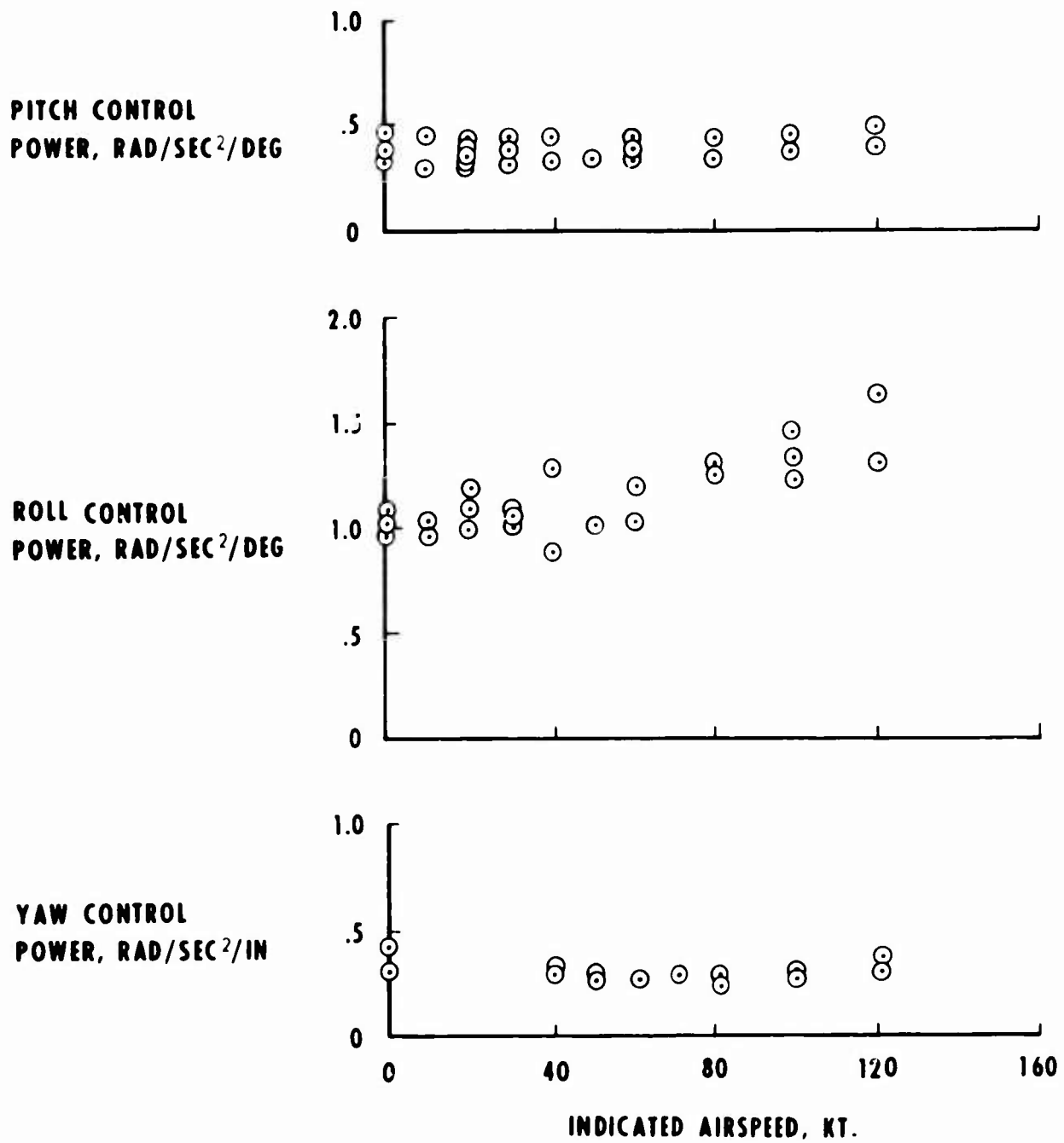

Fig.21 Pitch, roll and yaw control powers

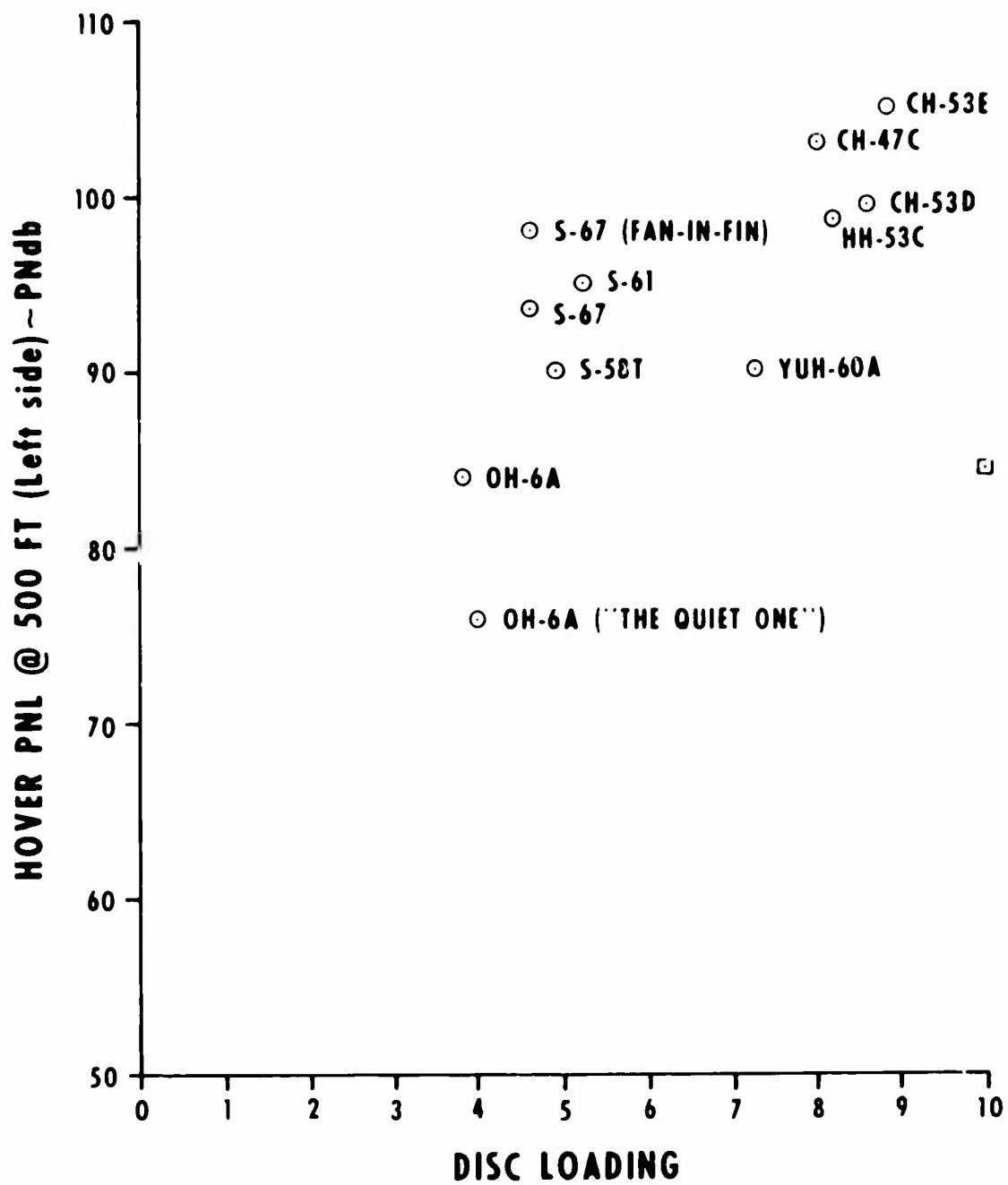

Fig.22 External noise hover

THE ROTOR SYSTEMS RESEARCH AIRCRAFT - A NEW STEP IN THE TECHNOLOGY AND ROTOR SYSTEM VERIFICATION CYCLE

Robert J. Huston, Julian L. Jenkins, Jr.
NASA Langley Research Center
Hampton, Virginia 23665

and John L. Shipley
Langley Directorate
U.S. Army Air Mobility Research and Development Laboratory (AVSCOM)
NASA Langley Research Center
Hampton, Virginia 23665

18-1

SUMMARY

The National Aeronautics and Space Administration and the United States Army have jointly contracted for the development of two Rotor Systems Research Aircraft (RSRA). These flight research vehicles are being developed specifically to provide a National Facility with the capabilities necessary for the effective and efficient in-flight test and verification of promising new rotor concepts and supporting technology developments. This paper addresses the capabilities of the RSRA aircraft for potential research programs. Research activities to be conducted on the RSRA are discussed with a review of technological advances anticipated from several advanced rotor concepts.

INTRODUCTION

The development of the RSRA vehicles is a unique effort in that the vehicles are not intended to have a specific operations application for either the military or civil use, but are to be solely dedicated as research tools for the advancement of rotary-wing science. This paper covers the developments leading to the RSRA, details of the RSRA concept, technological advances anticipated from several advanced rotor designs under study, and planned research activity aimed at "technology verification."

RSRA BACKGROUND

The concept of the RSRA dates back to late 1968. At that time the development of the AH-56, Cheyenne, was plagued by problems that indicated the available analysis techniques were inadequate for predicting the dynamics, stability, control, and performance of a new vehicle type that was pushing back the frontiers of operational capability. Prior to the development of the Cheyenne, a number of Army-sponsored experiments with high-speed helicopters had explored new operational requirements, out to speeds in excess of 300 miles per hour. However, the main missing element in these research programs was a rational and consistent verification that the various analytical techniques applicable to dynamics, stability and control, performance, aeroelasticity, and loads could be correlated with flight-test measurements. Neither could there be a pragmatic attempt at correlating the various parameter variations available as a function of the operational envelope. The key missing factor was that good measurements of the rotor operational state were not consistently obtained from these experimental studies. This is not to make light of the very significant accomplishments of programs done at Bell, Lockheed, Sikorsky, and Kaman, because each of these programs was a significant accomplishment in its own right. However, all of the vehicle experiments performed in the 1960's had been based on taking an existing airframe, modifying the aircraft to add wings and auxiliary propulsion, providing basic safety of flight and aircraft state measurements, and then investigating the vehicle operational and performance limits of each individual approach to extending the operating capability of rotary-wing vehicles.

During this time period, the Langley Research Center and the U.S. Army AVLABS had jointly participated in all of these experimental programs and had firsthand knowledge of the test results, limitations, and the degree of or lack of correlation between experiment and theoretical predictions. Based on this knowledge, Langley proposed a program to develop a rotor test vehicle which would attempt to eliminate the fundamental restraints on the previous programs. The concept of the rotor test vehicle was one which would provide sufficient performance measurements of rotor and aircraft state such that all types of analytical computation could be properly referenced to the vehicle operating conditions. In recognition of this approach, the vehicle would be designed from the outset primarily as a measurement device. The concept of the rotor test vehicle was laid down initially by a small group of people in the Flight Research Branch at Langley Research Center. Concurrent with the Langley identification of requirements for a rotor test vehicle to perform essential rotorcraft research, the staff of the AVLABS was also studying ways to remove the restraints on the previous Army-sponsored industry flight studies. Informal contact between the two laboratories served as a stimulation to the individual efforts.

On December 3, 1970, by joint agreement of the LRC Director for Aeronautics, the Commanding Officer of the U.S. Army Aviation Materiel Laboratories, Ft. Eustis, and the Director of the newly established U.S. Army Aeronautical Research Laboratory, Langley, a joint NASA/Army working group was established. This working group was responsible for identifying the essential features of a rotor systems test vehicle, the detailed technical requirements, and developing an overall technical and financial plan for the development of a vehicle which would assure that the commonality of NASA and Army objectives was met. This plan resulted in a November 1, 1971, agreement between the Army and NASA for the joint development of the rotor systems test vehicle at the Langley Research Center. Subsequent to this agreement, the program was formally designated the NASA/Army Rotor Systems Research Aircraft (RSRA) program.

As the first step in this formal cooperative agreement, two predesign study contracts were awarded to Bell Helicopter Textron and Sikorsky Aircraft Division, United Aircraft Corporation. These predesign studies specified the flight research requirements established by the joint NASA/Army working group. The specifications centered around the requirement to accurately measure the rotor operating state and the

18-2
vehicle state for compound operating conditions up to 300 knots, for helicopter operating conditions from 0 to 200 knots, and for "helicopter simulation" (in the compound helicopter configuration) from 120 knots to 200 knots. The two contractors addressed these requirements by two different approaches.

A key conclusion of these studies (Refs. 1 through 6) was that the feasibility of the RSRA concept was established and sound, and that the vehicles would be an important tool for both Government and industry in the future research to be performed. These results and results of in-house Government research were combined into a detailed set of specifications for the RSRA. Based on the apparent wide interest shown by industry in the RSRA concept, NASA issued a request for proposals to the helicopter industry on March 1, 1973. Sikorsky Aircraft was selected to design and build two RSRA vehicles and commenced design work on the RSRA on November 6, 1973.

In concluding this background to the development of the concept of the RSRA vehicles, several key points should be noted. The key objective of the joint NASA/Army program was to develop two versatile flight vehicles capable of real-world verification of rotorcraft-supporting technology and for performing research on promising new rotor concepts. The RSRA vehicles were also to provide a focus for research efforts in a broad range of disciplines ranging from fundamental aerodynamics, performance, loads, dynamics, and acoustics through flight dynamics, stability and control, and operational techniques. The RSRA, as a U.S. National Facility, is a new step in the technology and rotor systems verification cycle. It will not replace initial small-scale and/or large-scale experimental explorations into entirely new regions of the rotorcraft flight environment, but it will provide new confidence in the future development of theoretical techniques and/or the obtainment of pragmatic variations of parameters throughout the operational envelope. In addition, with the capabilities inherent in the RSRA concept, and built into the design of the vehicle, inspired technology breakthroughs can be expected. This result requires only that rotorcraft researchers be allowed to experiment, to quantify and evaluate their results, and to experiment again. This is the promise of the RSRA!

RSRA CONCEPT

General Description.- Two RSRA vehicles are being developed (Fig. 1). One aircraft is configured as a compound helicopter with a removable wing, lower horizontal stabilizer, and a pair of auxiliary propulsion engines. The second aircraft is configured as a helicopter on which the wing, stabilizer, and auxiliary engines can be mounted. Other than these obvious external differences, the two aircraft are essentially identical internally and can interchangeably perform the same mission. In the basic helicopter configuration, the RSRA utilizes the dynamic components of the Sikorsky H-3 series helicopter with the rotor powered by two General Electric T-58-GE-5 engines. For the compound configuration, besides the addition of the variable incidence wing and stabilizer, two General Electric TF34-GE-400A turbofan engines provide auxiliary propulsion. Details of the geometry of the two configurations are presented in Figure 2, Tables I and II.

Design Priorities.- The design philosophy of the RSRA vehicles can best be understood by relating the design features to the basic objectives of the RSRA program. These objectives, plus the management philosophy adopted, resulted in a set of vehicle design priorities upon which programmatic decisions could be weighed during the design and development of the RSRA vehicles. The concept upon which the management of the RSRA program proceeded was that every effort would be made to prevent rigid adherence to requirements and specifications from causing cost growth. This management philosophy required that a set of design and development priorities be established and that the impact of day-to-day decisions, as well as the cataclysmic events that every project encounters, be assessed in terms of their impact on priorities (hence the basic objectives of the program) as well as the dollar cost to the program.

In keeping with the objectives of the program to obtain, at the lowest possible cost, a capability to perform real-world verification of rotorcraft supporting technology and to perform research on promising new rotor concepts, a set of design and development priorities were established at the beginning. The technical priorities are, in order of importance:

1. Measurement accuracy
2. Accurate control of test conditions
3. A broad test envelope
4. Adaptability to new rotor systems
5. A sufficient (or adequate) performance envelope.

One item not included in this list of technical priorities is and continues to be an overriding priority. That priority is safety.

Safety.- The design of the RSRA has always considered safety both from the standpoint of aircraft airworthiness and from the standpoint of extraordinary features to prevent loss of lives. In this regard, the RSRA is equipped with an emergency escape system. The RSRA is the first rotary-wing vehicle to be designed from the ground up with an emergency escape system. Details of the emergency escape system will be covered later in this paper.

Measurement Systems.- The requirement for a high degree of measurement accuracy was fundamental to the basic design of the RSRA vehicles in that the aircraft was designed around the required measurement systems. This concept is shown in figures 3 and 4, which illustrate the primary force and moment measurement systems of the RSRA vehicle.

The force and moment measurement system provides the capability to measure loads for particular aircraft subsystems (rotor, wing, tail rotor and auxiliary engines), providing a breakdown of the contribution of each of these subsystems to the total flight loads experienced by the aircraft. In general, these aircraft subsystems are mounted to the airframe on load cells in configurations that minimize force interactions and provide an accurate determination of the particular flight loads for that subsystem. Specifically, the main rotor transmission is mounted to the airframe (as shown in Fig. 5) by seven uniaxial load cells, the outputs of which will be utilized to calculate the main rotor longitudinal force, side force, vertical force, pitching moment, rolling moment and yawing moment. The expected accuracies of these measurements are listed in Table III. The wing is mounted to the airframe as shown in figure 6 with a

biaxial load cell at each of the two pivot points and with a uniaxial load cell incorporated in each of the two wing-tilt actuators. The load cell outputs are used in calculating wing lift, drag, pitching moment, and rolling moment. Each auxiliary thrust TF34 engine is mounted to the airframe as shown in figure 7, with the uniaxial load cell output used in calculating the auxiliary engine thrust. The tail rotor is mounted to the airframe as shown in figure 7, with the uniaxial load cell output used in calculating the tail rotor thrust. 18-3

A necessary part of any measurement system is a comprehensive calibration. During the vehicle development stage, the purpose of calibration is a one-time determination of random and systematic errors, so that the sources of systematic errors (friction, alternate load paths, etc.) can be identified and either minimized or included in the detailed data analysis algorithms. Once the RSRA is operational, the calibration will be performed to assure that all measurements are traceable to the Bureau of Standards, to determine "cross talk" influence coefficients, and to provide periodic verification of the balance systems measurement integrity. A calibration fixture designed to meet these requirements is illustrated in figure 8. The data reduction algorithm has been derived and is published in reference 7.

An essential part of the RSRA instrumentation is the vehicle state measurement system. The vehicle state measurement system provides conventional test instrumentation for measuring aircraft attitudes, rates, and accelerations as well as stress measurements on the rotor blades, controls, rotor shaft, and airframe. In addition, over 30 control surface and actuator positions are measured. There are 57 aircraft measurements identified for the baseline or delivered aircraft. These, along with the 15 for the force and moment measurement system are listed in Table IV. In addition to these 72 measurements, there will be 216 spare channels available for measurements required by any particular investigation or future research program. Also, a 192 channel slip-ring assembly mounted on the main rotor shaft provides the capability for recording rotor information required for future research programs.

The flight research measurements listed in Table IV are provided by standard sensors. To provide sufficiently accurate data for a particular research program, it may be necessary to change sensors. For example, in gathering data for stability derivative extraction it may be necessary to replace the rate gyros with sensors of greater sensitivity over a smaller range to increase the accuracy of the measurements.

All of the data generated by the RSRA can be processed, recorded, and telemetered to the ground by the Piloted Aircraft Data System (PADS). The Piloted Aircraft Data System is a versatile data collection system designed at the Langley Research Center (LRC) specifically for aeronautical flight research programs. Each RSRA will have a data recording system comprised of two PADS. Each PADS provides up to 104 Pulse Code Modulated (PCM) channels for use in recording up to 10 Hz data, and up to 40 constant bandwidth (CBW) frequency modulated (FM) channels for use in recording up to 400 Hz data. The PCM uses a nine bit analog to digital converter to provide accuracy of ± 0.2 percent of full scale for ± 5 volt inputs and ± 0.5 percent full scale for ± 10 milli-volt inputs. The constant bandwidth-frequency modulated subsystem is comprised of voltage-controlled oscillators and mixer-amplifiers, the root sum squared error being less than or equal to 2-percent full scale. In addition, one channel is provided for recording voice and events and one channel for recording PCM time code for use in correlating the measurements recorded onboard and the measurements telemetered to the ground station. The telemetry capability provides for up to 104 channels of PCM data and 10 channels of FM data. A ground station provides (a) real-time display and hard-copy recording of a limited number of selected channels of data; (b) recording on tape all of the telemetered data channels; and (c) off-line data editing, reformatting, and the generation of a digital tape for use in automatic data processing.

Control System.- The RSRA vehicle requires a unique control system. First, the control system must provide accurate and repeated setting of test conditions in the multi-dimensional parameters of rotorcraft operation, for correlation with flight and wind-tunnel test results. The RSRA also performs transients and maneuvers in a repeatable precise manner. This portion of the RSRA control system, a fly-by-wire flight control system, is based on the model-following concept discussed in references 8, 9, and 10.

The model-following control concept has been used for many years as a research tool for in-flight simulation, and its principles, if not already, will probably be applied eventually to stabilization system and autopilot design. Briefly, the model-following concept is based on the principle of forming error signals between the response commanded by a desired set of model dynamics and the response measured by a set of motion sensors. These error signals, in turn, are used to drive the aircraft control surfaces in order to null the error and, thus, achieve response compliance. More details of this approach are given in reference 10.

Second, in order to provide the broad envelope of rotor and flight test conditions, the airplane control surfaces are used to create the reactive forces and moments necessary to exercise the candidate research rotors throughout their operating envelopes. As shown in figure 9, a variable incidence wing provides a force to react the rotor trim lift, while high-speed flaps generate transient reactive lift on the rotor about the trim rotor lift. In the longitudinal axis, auxiliary thrust engines provide a force to react the rotor trim drag, while high-speed drag brakes generate a transient longitudinal force to react the rotor propulsive force. In addition to generating forces to react the rotor forces, the aircraft generates trim and transient moments to react the rotor moments. The elevator, ailerons, and rudder provide this capability.

Third, in keeping with the philosophy of paramount safety, the fly-by-wire flight control system must be backed up by a mechanical system capable of flight in all regions of operation

Fourth, because of other requirements, the aircraft is designed to fly in three configurations as shown in figure 10. As a compound helicopter, the auxiliary propulsion engines and a variable incidence wing are installed, while in the helicopter configuration these items are removed. The final configuration is as a fixed-wing airplane that provides a fly-back capability should it become necessary to jettison the rotor during compound operation due to a potentially catastrophic operating condition.

18-4
The control concept that meets these four requirements is a computer-controlled fly-by-wire system, operating through a mechanical system, described in detail in reference 11. Figure 11 shows the functional layout of the primary flight control system for each axial of control. The control system in the pitch, roll, and yaw axes provides the safety pilot with integrated control of the rotorcraft and airplane control surfaces. Figure 12 shows the functional layout of the fly-by-wire flight control system for each axis of control. The system exercises control of the main rotor, tail rotor, elevator, ailerons, rudder, flaps, and drag brakes. The configuration of the fly-by-wire flight control system is shown in figure 13. The heart of this system is the Teledyne Systems Company TDY-43, general-purpose, flight-qualified, digital computer, the characteristics of which are listed in Table V.

The research versatility of the RSRA is provided by use of the research control modes. Three basic modes are provided: manual, automatic, and auto/manual. These form the basic format within which the control laws to be used for a research mission will be implemented. In the manual mode, all of the RSRA control surfaces are under the manual control of the evaluation pilot. For example, this mode will be utilized in the helicopter configuration to accomplish handling qualities research using the RSRA as a five degrees-of-freedom variable-stability in-flight simulator. In the manual/auto mode, several of the RSRA control surfaces, or degrees-of-freedom, are under the manual control of the evaluation pilot, the remaining control surfaces or degrees of freedom are under the automatic control of the fly-by-wire system. For example, the evaluation pilot could exercise manual control of the rotor under test while the fly-by-wire system uses five degrees-of-freedom fixed-wing controls to automatically simulate a fuselage of different aerodynamic and mass/inertia properties, thus simulating a range of fuselage characteristics for a given rotor system under test. This control task is the case that was used to size the flight computer computational capability. In the automatic mode, all of the RSRA control surfaces are under the control of the fly-by-wire flight control system. This mode will be used in the compound helicopter configuration for the automatic control and indexing of rotor test conditions. For example, the fly-by-wire system would step main rotor collective pitch over a range of values as stored in an array in memory while holding cyclic pitch constant and maintaining the vehicle flight path and airspeed constant by use of the fixed-wing control surface. This flight control capability, coupled with the platform force and moment general capability, permits precise and repeatable mapping of rotor performance over a broad range of each variable, independently of the other variables.

Comprehensive rotor and vehicle information must be available in the flight computer to permit the use of the fly-by-wire flight control system to provide accurate and repeatable conditions for the varied research tasks envisioned for the RSRA. This information is derived from signals supplied by aircraft-mounted sensors that include some from the onboard research instrumentation system. Specifically, the information for the direct setting and control of rotor test conditions is taken from the rotor force and moment measurement system. The output signals are sent to the flight computer where the forces and moments are calculated and used in control by the fly-by-wire system.

The concept of using rotor force and moment feedback in the control feedback loop was experimentally examined and reported in reference 12. Sikorsky Aircraft performed a contracted study consisting of analytical and simulation studies followed by in-flight demonstrations of techniques for employing blade motion electronic feedback signals as primary control input shaping functions. This investigation provided engineering data concerning signal conditioning techniques, allowable gains, and stability characteristics of various feedback signals in the control network. In addition, the results have general application in the areas of rotor gust response suppression, high-speed helicopter control sensitivity, and compound helicopter rotor-wing lift control.

Test Envelope.- The requirement for utility of operation of the RSRA, that is, the capability to obtain technology verification data in a broad envelope of operating conditions, is fundamental to any research facility. In design of the RSRA this factor is accounted for in a number of ways.

First, the concept of the "super rotor" was used for defining the various control surface requirements and for sizing the aircraft structure, fixed wing, and aerodynamic surfaces. The "super rotor" is a fictitious rotor that combines the most severe characteristics of a number of different types of rotors. The characteristics of this "super rotor" are contained in Table VI.

Second, the design limit load factor of the basic airframe was established at +4 and -1.5. Design maneuver loads were determined for symmetrical and rolling pullout maneuvers with limiting pitching and rolling acceleration of 2.0 rad/s^2 and yaw angular acceleration of 1.0 rad/s^2 . Combining these two factors with the maximum speed capability of the RSRA results in the available operating test envelope illustrated in figure 14. That portion of the envelope available for testing a rotor in straight and level flight is shown cross-hatched, with the specific limitation for maneuvers noted.

These boundaries are established as the basic test envelope capability of the RSRA. A specific rotor system may have a more restrictive envelope because of inherent limitations that prevent that rotor system from being investigated to the limits of the capability of the RSRA vehicle. For example, the initial delivered rotor (the Sikorsky H-3 rotor system) is anticipated to be limited to approximately 200 knots in forward speed due to unsatisfactory loads and dynamic characteristics.

Adaptability.- The RSRA vehicles are designed to requirements that anticipate the aircraft will be adapted to a variety of new rotor types, including adapting to rotor types with numbers of rotor blades from two to six.

The approach to designing the RSRA to accommodate other rotor systems has been to: (a) provide the basic aircraft strength and control adequate for rotors anticipated in the future (as per the test envelope requirements); provide a configuration that is flexible enough to allow future modification; and (c) provide mechanisms that facilitate modification and/or adaptation of the specific requirements of new rotor systems. The first of these three elements is satisfied by the design requirements for a broad test envelope. The second element is satisfied by the vehicle airframe concept. The airframe concept, a clean structural deck with adequate hardpoints upon which is mounted the rotor, main transmission, and shaft engines, provides a configuration flexible enough to allow replacement of the dynamic system, if necessary.

A key mechanism that provides adaptability to new rotor systems with differing numbers of blades is the Active Rotor Balance/Isolation System (ARBIS). A report on the ARBIS and the design of the RSRA, from a vibration viewpoint, is presented in reference 13. 17-5

The ARBIS is a mechanism to allow the RSRA vibration characteristics to be readily adjustable for vibration compatibility with foreseeable rotors. In particular, the requirement to mount different rotors leads to vibration loadings at the rotor hub where the frequency varies drastically and where there is shifting of significance among the six components of load. This is in contrast to the normal problem of the helicopter designer, where the primary load is of a single frequency and its harmonics and only a relative few of the components need be addressed. The function of the ARBIS includes both the measurement of rotor forces and the control of vibration, and the approach has been to introduce special units for that purpose into the main rotor transmission support system as shown in figure 15. The ARBIS units, illustrated in figure 16 and shown schematically in figure 17, are installed as replacement components for the load cells units in the rotor force measurement system (previously illustrated in figure 3).

The design of the Active Rotor Balance/Isolation System has evolved from past NASA/Army supported research and development programs. In one of these programs, actuators were fabricated and shake-tested in an installation involving a CH-53 fuselage and gearbox. This program proved the feasibility of the approach for vibration control. A separate program investigated the use of these hydropneumatic actuators as load measuring devices. The component loads in each unit are determined by pressure transducers in the hydraulic chamber on each side of the piston. Measurement accuracies were shown close to those provided by load cell systems over a broad range of frequencies from steady state and transient conditions to frequencies in the vibratory loads range (see Ref. 14). In the vibratory load range, special emphasis will be placed on the accuracy of the accelerometer used to measure the inertia response of the transmission/rotor head.

Aircraft Performance.- The final priority requirement in the development of the RSRA vehicle was to have a sufficient (or adequate) performance envelope. The performance elements under consideration are aircraft velocity, payload, and endurance. The critical mission that sized the RSRA vehicles in the preliminary design stage was the high-speed flight requirement at sea level and 9,500 feet density altitude. (See Fig. 18.) That requirement was specified as:

"The aircraft shall be designed to perform in one flight at sea level standard conditions, straight-line, level, one-g flight at 300 KTAS for 15 minutes, while carrying a minimum total payload of 2,000 pounds and a representative main rotor and hub defined to operate with an equivalent flat plate drag of 10.96 square feet, at zero lift, and with a weight equal to that of the rotor system to be delivered with the aircraft."

This requirement was established as the extreme operating requirement of the aircraft, based on the predesign studies of references 1 through 6, and once the aircraft design was established, subsequent changes in the aircraft to meet this requirement were not accepted. In addition to the high-speed requirement, the RSRA vehicles, in the helicopter configuration (with the wing and auxiliary propulsion system removed) at sea level standard and sea level, 95°F day are required to (see Fig. 19):

"be capable of hovering (OGE) for thirty (30) minutes at sea level standard atmosphere, proceeding for ten (10) nautical miles, performing two (2) minutes of hover (OGE), and landing with required fuel reserves."

Emergency Escape System.- The RSRA system that was specified as having the highest priority in the design and development phase of the program also holds the distinction as being the only system for which tests in flight are not planned. It has, however, proceeded through a rigorous development and test cycle prior to installation on the RSRA vehicles.

The requirement for an emergency escape system was identified early in the RSRA concept development. The probability of an accident with a research aircraft operating to the extremes of operating boundaries over a ten-year research life with various new rotor systems appeared too high for the Government to place in jeopardy any individual or group of individuals. In addition, during the predesign studies, it was shown that the technology elements of a helicopter emergency escape system had been demonstrated. This led to the logical conclusion that, for crew safety, an emergency escape system was required and technically feasible. Also, during the predesign studies, an optional mode of emergency escape operation while in the compound helicopter configuration was shown to be feasible. The pilot(s) are offered an escape mode whereby only the rotor blades are severed and the aircraft can be safely returned and landed in a fixed-wing mode of operation. This would result in the recovery of the RSRA vehicle should a potential catastrophic blade failure occur in flight that would otherwise prevent safe continued flight and return to a normal landing. This option then requires that the RSRA fly in the three modes of operation illustrated in figure 10.

The emergency escape system operates as illustrated in figure 20. The major functions of the emergency escape system include rotor blade explosive severance, overhead canopies explosive severance/fracture, cyclic stick pyrotechnic hinge/release, rocket motor pyrotechnic ballistic launches, rocket extraction of each crew member and pyrotechnic release of the seat frame. Further, the alternate emergency mode provides blade severance, followed by automatic engine restart for hydraulic pressure to allow the aircraft to return to base as a fixed-wing aircraft.

The system is constructed of pyrotechnic and mechanical components only. No electrical signals are used to time or fire the system. The aircrew escape sequence is initiated by activation of either of the cockpit extraction control handles (see Fig. 21). The handle pull initiates pyrotechnic detonation in transfer lines, which propagate the signal to all the escape system elements. The detonation transfers through redundant lines to a rotary transfer unit located on the underside of the main transmission housing. The rotary transfer unit mechanically transfers the signal from the stationary structure to the rotating shaft and establishes the shaft rotational orientation at which each blade separates. The detonation signals are then transferred up the main shaft to the rotor blade severing charges that simultaneously sever only

18-6

three blades to prevent striking the empennage (see Fig. 22). Rotor blade severance is accomplished by linear shaped charges located on each blade spar immediately outboard of the blade cuff as shown in figure 23. Concurrently with the transfer of the detonation signal to the rotating shaft for blade severance, the signal passes through a pyrotechnic time delay that allows time for blade severance before canopy jettison and crew extraction. Canopy jettison is by pyrotechnic severing and fracturing of the acrylic glass into small pieces. The development of the technique of reliability and reproducibly severing and fracturing the 0.635 cm cast acrylic canopy into acceptably small fragments is discussed in reference 15.

Crew extraction is accomplished with rocket extraction seats, manufactured by Stanley Aviation Corporation. The aft crewman's seat faces aft in order to maximize clearance during extraction. Crew members are extracted in a two-step sequence, first the aft crewman and the right-hand pilot are simultaneously extracted. After a 1.3 second delay, the left-hand pilot is extracted. The rocket launcher is a pyrotechnic gas-operated device that propels the rocket through the canopy opening. When the rocket reaches the end of its tether, the rocket ignites and pulls the tethered crewman safely away from the aircraft. Extraction of the crew is begun within one-half second after activation of the extraction control handle, and all crew members are clear of the aircraft within 2 1/2 seconds. Approximately one second after rocket launch the rocket separates and the crewman's parachute deploys.

The emergency escape system has completed an extensive sequence of qualifications tests, from component tests under a variety of environmental conditions, through partial (seat extraction) and full system qualification (blade severance and seat extraction) on a sled test vehicle on the Holloman Air Force Base test track. The Holloman Air Force Base system tests (at V = 0, 134, 166, 209, and 210 knots) were performed using the center and forward fuselage of the Sikorsky NH-3 compound helicopter pushed down the track by rocket motors. The tests were completed with no system failures. The sequence shown in figure 24 is from high-speed camera coverage of the safety pilot and flight engineer extractions. The sequence is: T = 0 seconds, system initiation; T = 0.06 seconds, three blades severed; T = 0.14 seconds, two blades severed; T = 0.43 seconds, extraction rockets ignite (blades impacting the ground forward and to the left of sled vehicle); T = 1.00 seconds, crew dummies clear; T = 1.50 seconds, extraction rocket burnout; T = 1.65 seconds, parachute deployment; T = 2.20 seconds, parachute inflation; T = 2.85 seconds, parachute inflated.

While the system is not yet qualified to the full 300 knot capability of the RSRA vehicles, further development of the seat system is anticipated to provide that capability in the future.

ROTOR SYSTEMS RESEARCH

Improvements in rotorcraft performance and operational attributes are the goal of a wide variety of theoretical, experimental, and applied research programs. Some of these programs have and will continue to generate new and novel rotor concepts. To review the gains attributed to all of these current or proposed advanced rotor systems is beyond the scope of this paper, but the gains obtainable with a few of the concepts will be outlined.

The multitude of rotor concepts in various stages of development represent a difficult challenge to those in Government and industry who must identify and support the development of those systems which embody the potential for significant technological advancement. Compounding the difficulty is the fact that the major technical thrust of the various rotors often differ. For example, some concepts are directed toward improved weight fractions and better reliability, whereas others stress increased performance and efficiency. Figure 25 typifies the situation where several rotor concepts are reflected on trending curves of different performance indices. Consider, for illustration, the Composite Structures Rotor (CSR) which projects up to a 25-percent reduction in rotor hub weight. Achieving this in the current time frame would represent a significant impulse to the technology trend.

This represents only one of many examples which could be cited, and, thus, the challenge is to use the available research tools to identify and assess the more productive concepts. The development of the RSRA provides the Government and industry with a tool capable of fully documenting the potential of a rotor concept while also providing unique data for disciplinary research. To capitalize on this capability, a task team at Langley identified several rotors for which design studies have been carried out to assess problems in fabricating and testing of experimental systems on the RSRA. These candidate systems identified for potential early evaluation on the RSRA and discussed herein are:

- (1) The Variable Geometry Rotor (VGR)
- (2) The Composite Structures Rotor (CSR)
- (3) The Flexhinge Rotor (FHR)
- (4) The Aero/Acoustic Rotor (A/AR)

There are many other rotors, such as the Controllable Twist Rotor (CTR), which also represent candidate systems. These will not, however, be discussed.

Variable Geometry Rotor (VGR)

The interaction between rotor blades and their trailed vortices has been shown to have significant effects on rotor performance, acoustic signature, vibration, and blade loads. The Variable Geometry Rotor (VGR) evolved from a systematic investigation of the blade/vortex interaction problems and is directed toward developing a better understanding of these problems and toward providing a means to alleviate the adverse effects generated by blade/vortex interactions. The following discussion describes some of the pertinent research activities carried out on the VGR concept. These studies are summarized more completely in reference 16.

Initial Analytical Studies.- Early investigation of the numerous configurations of the VGR were carried out using the digital computer code described in reference 17. The computer code incorporates both a freely-deformed wake and an elastic rotor blade and can analyze the numerous permutations associated with the VGR. These initial studies indicated that the harmonic loads could be altered significantly by changes in the geometric configurations.

VGR Model Tests.- In order to experimentally examine the analytical results of reference 17, a model VGR was fabricated and tested in both hover and forward flight. The results are presented in reference 18. 18-7 Various combinations of blade length, axial spacing between the corotating rotors, azimuthal spacing between alternate blades, and differential collective pitch were investigated. A significant result of these tests was that axial separation of the rotor provided a measurable improvement in hover performance at high thrust levels. The major percentage of the performance gain was achieved with one chord length of axial separation. Forward-flight test results were mixed. Integrated model performance was basically unchanged for the configurations tested; however, blade spacing variable did result in variations in blade response. It should be noted that the model blades were not dynamically scaled, and further investigations are planned.

Full-Scale Hover Performance Tests.- To confirm the model rotor hover performance improvements, whirl tests of a full-scale VGR were conducted and are reported in reference 19. These tests confirmed the findings at model scale. Specifically, improvements in rotor thrust at constant power as high as 6 percent were demonstrated (equivalent to greater than 9 percent increase in Figure of Merit), as shown in figure 26. Also, improvements in the acoustic signature were seen to accompany the gains in hover performance.

Maneuver Analysis.- Since a major impetus for the VGR concept was derived from the problem of blade/vortex interactions in maneuvering flight, and analytical study (Ref. 20) has been carried out to examine the effect of these interactions on rotor performance, blade loads, integrated vibratory loads and acoustics. The level flight portion of the analysis indicated a potential 5-percent reduction in torque required for the same lift at a tip speed ratio of 0.2. This gain decreased to about 3.5 percent at a tip speed ratio of 0.3. In both cases, the gain was attributable to an axial separation of one chord length between the two sets of three blades. Simulated pullup maneuvers produced a rather complex picture of transmitted loads for each VGR configuration. Significant changes in the character and magnitude of the vibratory loads transmitted to the fuselage could be affected by changes in the azimuthal spacing between the blade sets.

In order to examine the blade loads and vibration characteristics further, a dynamically-scaled model of the VGR has been fabricated, and tests are planned for the Transonic Dynamics Tunnel at Langley (Fig. 27).

Full-Scale Flight Hardware.- Based on the encouraging results achieved in the analytical and experimental studies carried out to date, the VGR concept is considered a candidate system for further experimental investigations to be carried out on the RSRA. As such, an advanced systems design study of a VGR configuration for the RSRA was conducted and is reported in reference 21. The configuration consists of two corotating, three-bladed, fully-articulated rotors. The two rotors have an axial separation of one chord length and are designed to allow the upper rotor to lead the lower rotor by as little as 15 degrees and as much as 75 degrees. The study also examined the performance, structural and weight considerations, dynamics, and handling qualities. No significant problems were uncovered in any of these areas.

Composite Structures Rotor (CSR)

The composite bearingless main rotor concept evolved as a logical extension of the research done to develop bearingless tail rotors. The Composite Structures Rotor (CSR) offers the potential of improved reliability and maintainability through elimination of bearings, reduction of hub drag, and also a potential 25-percent hub weight reduction. An overview of CSR research activities carried out to date is presented in reference 22. Several of these activities are outlined herein.

Concept Feasibility.- Under a jointly-sponsored NASA/Army contract, a comprehensive feasibility demonstration program has been carried out. As originally conceived, the tasks included dynamically-scaled wind-tunnel model tests, flexure material fatigue tests, and supporting aeroelastic analyses of the program.

The program evolved through a number of configuration changes directed toward resolution of stability problems associated with control system coupling through the torque sleeve. The coupling is caused by the structural constraints on the torque sleeve. At the outboard end, the displacements and rotations must be compatible with the flexure. At the inboard end, the pitch link constrains out-of-plane displacements. Due to the offset of the pitch link from the pitching axis, resolution of such motion produces twisting of the flexure. The magnitude of the coupling is a function of the load condition and relative stiffness of the structural components. Two equivalent modifications to the rotor were derived which would alleviate the problem encountered. One of these, the pinned-pinned torque tube configuration was successfully tested. The results of these feasibility studies are presented in reference 23.

Aeroelastic Analysis.- Attempts to analyze the aeroelastic characteristics during the feasibility studies pointed out deficiencies of existing rotor analytical computer code that precluded meaningful correlation. For any bearingless rotor configuration, the torsional deflection of the flexure introduces time-variable structural twist into the rotor dynamics that had not been previously considered. In order to provide a reasonable analytical simulation, a hingeless rotor computer code (G-400) was modified extensively. The code employs the normal modes approach and includes an eigenvalue extraction routine for blade stability analyses, a time history calculation from the complete nonlinear equations, and a transient spectral stability analysis of the calculated time history. Structural loads are calculated by the force integration technique rather than modal displacements. This approach is particularly well suited to bearingless rotor configurations with concentrated shear loading at torque tube attachments or at the auxiliary damper connection. The results of the aeroelastic analysis, which were performed after the G-400 modifications, are presented in reference 23, and the computer program is described in reference 24.

Development of the CSR.- The CSR concept has also been under consideration as one of the candidate systems for flight tests on the RSRA. Consequently, advanced design studies have been carried out on the concept by two contractors. The results of these two studies are presented in references 25 and 26. These two studies produced very different configurations for the flexbeam portion of the hub as well as differences

18-8

in the control rod/torque tube mechanism. In neither case were restrictions encountered which would prohibit flying the CSR on the RSRA.

Flexhinge Rotor

The Flexhinge Rotor evolved from a series of efforts to develop a hingeless rotor system. Fundamental experimental work in arriving at the configuration was carried out in a cooperative test program between Bell Helicopter Company, NASA-Langley, and the U.S. Army Air Mobility R&D Laboratory, Langley Directorate.

The Flexhinge hub is composed of two orthogonally-stacked flexures. Outboard of the virtual flapping hinge formed by the fiberglass flexure loops is a fitting which houses the elastomeric pitch change and centrifugal force bearing. The hub also incorporates an elastomeric lag damper.

The Flexhinge Rotor was also identified as a candidate for tests on the RSRA. The predesign study of reference 27 produced a rotor suitable for the Utility Mission.

The rotor is a four-bladed, hingeless, soft-inplane system having a 62-foot diameter and a 29-inch chord

Aero/Acoustic Rotor (A/AR)

The renewed efforts directed toward developing improved airfoil sections and tip planform modifications for rotary-winged aircraft have created a need for more efficient and effective methods of evaluating these modifications in the complex aerodynamic environment of flight. Two-dimensional, steady and unsteady flow, wind-tunnel testing techniques are invaluable in defining improved airfoil sections; however, the combined unsteady effects to which a rotor blade is subjected in flight create uncertainties as to the actual performance of the airfoil in this more demanding environment. The development of the RSRA represents a significant step toward providing a test vehicle capable of operating a rotor through a wide range of controlled test conditions and of measuring and recording the significant parameters necessary to assess the performance gains attributable to the new rotor blade configuration. In order to guide the development of sound, cost-effective techniques for modifying rotor blade geometry for research testing, predesign studies of an Aero/Acoustic Research Rotor System were carried out by two independent contractors to define methods to obtain these low-cost, flightworthy rotor blades. Results of the two studies are reported in references 28 and 29.

These studies establish the technical feasibility of two distinctly different approaches to fabrication of experimental hardware. One method provided a reusable blade structure which consisted of a basic inner structural member covered with a balsa wood shell which is formed to the desired airfoil shape. The structural member remains constant for all airfoils and the balsa wood is reshaped or replaced to achieve the desired geometry variations. The second method provided individually-fabricated blade sets for each airfoil and then modified the blade bonding fixture in order to form a new blade set.

These studies showed that in order for an A/AR system to be cost effective on the RSRA, it should be based on an integration of technology elements. For example, this integrated design could incorporate advances such as the advanced airfoils and tip shapes developed and currently being flight-tested on the AH-1G and UH-1H helicopters. These flight-test programs, being conducted at Langley Research Center, are summarized to show the type of research and technology advanced elements to be incorporated in a research program using the Aero/Acoustic Rotor.

Advanced Airfoil Testing. - The advent of the supercritical airfoil technology renewed the interest in airfoil design technology throughout the aviation community. The application of this new technology to helicopters offers promising gains in rotor aerodynamic performance; however, the design constraints for a helicopter are more stringent than for fixed-wing application. In order to evaluate the total design-to-flight evaluation loop, a comprehensive program was initiated at Langley to examine all aspects of the rotor-airfoil design process. The program includes the design of three distinctly different airfoil sections, two-dimensional test and analysis of the section characteristics, two-dimensional unsteady testing, and finally, flight and whirl-tower tests of three sets of rotor blades fabricated with the new airfoils. The flight program is currently in progress, and it is anticipated that the completed data package will significantly improve the capability to confidently apply even newer technology to the blade design process. The flights are being carried out on an AH-1G aircraft. The AH-1G is instrumented so as to provide data on the flight state, performance, rotor loads, and chordwise pressure distribution on the airfoil section at 90 percent radius. Flight test and initial data reduction have been completed for "shockless" airfoil design (NLR-1). Flight work is in progress on a modified O010-64C airfoil with testing of a supercritical section to follow. Data for correlation with the NLR-1 flight results include math-model predictions of both airfoil and rotor aerodynamics and wind-tunnel data for steady and oscillating airfoil tests.

Ogee Tip Rotor. - Flight testing of the Ogee tip is the culmination of several years of research directed toward modifying the tip planform of a rotor so as to reduce the intensity of the tip vortex. Small model rotating and nonrotating testing of the Ogee concept, as illustrated in figure 28, from reference 30, have shown that the planform has a dramatic effect on the vortex intensity as characterized by the tangential velocities. The success of the ground-based tests provided the impetus to proceed to full-scale whirl-tower and flight testing. These two investigations are well along and are continuing to produce encouraging results in the areas of performance, acoustics, and blade loads.

Results of the whirl-tower investigation (Fig. 29) are typified in figure 30. The thrust-power polars for both a standard square-tipped rotor and the Ogee-tip configuration indicate a substantial improvement in the hovering performance of the Ogee configuration. These results have also been borne out by the results obtained on the flight vehicle illustrated in figure 31. Figure 32 presents a comparison of the level-flight power-required curve for the standard and Ogee-tipped rotor. Over the speed range investigated, the Ogee configuration requires considerably less horsepower than does the standard blade. Testing is continuing at higher gross weights and in maneuvering flight to ascertain the limitation one might expect from the lower solidity of the Ogee planform.

The data presented in figure 33 indicate that the Ogee rotor has a dramatic effect on the acoustic signature. The data are for the flight condition wherein the standard blades produced their most intense blade/vortex interaction. These pressure histories were recorded by instrumentation mounted on a boom installed on the side of the aircraft. These data indicate both a significant reduction in the intensity of the sound and a dramatic change in the character of the pressure history. 18-9

The data presented in figure 34 compare the pitch link loads of both the standard and Ogee configured rotors. Here again, the Ogee demonstrates a significant improvement.

These promising results are being analyzed in detail and more investigation of the critical flight regimes are being carried out at the present time.

An Aero/Acoustic Rotor System for the RSRA would be based on an integration of airfoil, planform, and tip research and designed for a specific application. Such rotor systems may incorporate a thick airfoil designed for high maximum lift coefficients at the inboard portions of the rotor, a thin airfoil designed to delay drag divergence at the tip, a more optimum blade planform and twist distribution to match the nominal operating condition, and a tip vortex diffusion type of tip such as the Ogee.

Technology Advances Indicated

The examples cited in the previous sections indicate that the performance improvements indicated in figure 25 will be realized. In the past, these improvements were paced by the need to demonstrate, in flight, both the performance gain as well as confidence that other factors were not compromised by the real-world environment of flight. The RSRA concept is a new tool to accelerate that pace by comprehensive flight investigation to extremes of the operating envelope usually omitted in research rotor developments.

DISCIPLINARY RESEARCH ACTIVITIES

Coincident with research on new rotor systems will occur disciplinary or generic research to advance the basic technology of rotorcraft engineering development. The key to advances in many disciplinary areas is good measurements in the real-world flight environment that can be related to the operating condition of the vehicle. The RSRA is intended to provide the means to obtain these measurements.

Rotorcraft technology verification requirements abound in aerodynamics, dynamics, handling qualities and control, acoustics, and structures. The following sections identify a few of the opportunities for which current plans exist to take advantage of the data generated during the RSRA development and in the initial Government flight-test investigations with the delivered Sikorsky H-3 rotor system. Many of these opportunities will continue into investigations with new rotor systems installed on the RSRA and will serve to broaden the data base upon which verification and/or correction of theoretical approaches are made. The opportunities for technology verification discussed in this section are not considered to be all inclusive, nor are they generally the most important to any specific future development. Their inclusion in current planning is based solely upon the circumstance that a general need exists to improve that technology or that the technology has been found lacking at critical decision points in recent rotorcraft developments.

Correlation of Flight-Test Data with Scale-Model Wind-Tunnel Data.- Recent experiences in designing helicopter systems have shown that model-scale studies during the design phase have a high payoff. To increase the areas of application of small-scale results, it is necessary to perform more extensive correlation with flight results. For example, a Generalized Rotor Model System (GRMS) has been developed for use in the Langley V/STOL tunnel, and has the capability of measuring the identical force and moments of the aircraft subsystems (rotor, wing, tail rotor, auxiliary engine) of the RSRA, as well as the overall forces and moments. Wind-tunnel investigations with that model, in the configuration of the RSRA (Refs. 31, 32, 33, and 34), were used to refine the definition of the aerodynamic characteristics of the RSRA (for stability, control, and performance), to define the influence of the rotor wake, and to optimize the contribution of the empennage to stability and control.

Flight-test data from the RSRA in helicopter, compound-helicopter, and fixed-wing configurations will be correlated with wind-tunnel data from the GRMS model to improve the utilization of aerodynamic and dynamically-scaled models for refining the design of future helicopters.

Verification of Hover, Climbing, and Forward-Flight Performance Prediction Methods.- A comparison of 10 different but conventional methods of predicting rotor forces, power, control positions, and blade flapping generally show only small to moderate differences (Ref. 35). However, while the various methods show little difference, significant differences exist between predicted performance results and actual performance results, even in the current generation of newly-developed helicopters. Usually, these performance differences are explained away as the result of various factors for which no direct measurement existed, such as aerodynamic download on the fuselage or horizontal surfaces, nonrepresentative rotor wake, and dynamic blade twist. In addition, few if any systematic comparisons between different rotor types exist because helicopter manufacturers tend to specialize their rotor designs around a given set of parameters (hub geometry, blade tip speed, torsional characteristics, etc.) which have proven successful before, and for which they have established experimental judgment factors. This leads to the danger that extrapolations in configurations become extrapolations of theory.

Flight-test data from the RSRA will be used to correlate aerodynamic performance over a broad range of level flight and climbing conditions (Fig. 36) with the delivered Sikorsky H-3 rotor system and subsequent rotors tested on the RSRA.

Development and Verification of Forward-Flight Maneuvering Analysis.- The inadequacies of theoretical treatments of rotorcraft performance are subject to larger errors in accounting for flight maneuvers. Modern rotorcraft mission requirements specify that more agility and maneuverability capability than has existed in the past be designed into the aircraft. Theory is inadequate to successfully predict the limiting factors. The capability of the RSRA to precisely execute and repeat maneuvers will allow the detailed expansion of the level flight performance data acquisition to the limits of the maneuver envelope.

18-10 The RSRA will explore the limits of maneuvering rotors and provide experimental data for improved maneuvering theories or for the determination of experimental limits on a pragmatic basis.

Verification of Predicted Stability, Control, and Simulation Results.- The aerodynamic data obtained from the GRMS model (Fig. 35) was used in a Flight Dynamics Analytical Model used to assess the RSRA stability, control and handling qualities. The math model is a total force, nonlinear, large angle representation in six rigid body degrees-of-freedom (see Ref. 36). In addition to the body degrees-of-freedom, blade flapping, blade lagging, and hub rotational degrees-of-freedom are also included. The modularized format of the RSRA math model is shown in figure 37. This format provides the flexibility to model all three of the RSRA configurations. The modular format consists of six major components of the aircraft. The complete model provides real-time operation and batch processing capability and is being used to support the RSRA development and downstream research operations.

This model will be updated as flight-test data become available. It is important to note that the RSRA measurement systems provide measurements of the rotor forces and moments which can be directly correlated with the rotor forces and moments calculated in the rotor module of this model. The model will, therefore, be used for a theory/experimental correlation of stability and control parameters.

Development and Validation of Stability Derivative Extraction Techniques.- Investigations are proceeding toward the process of determining helicopter stability and control derivatives from statistical analysis of flight measured vehicle state time histories (Fig. 38). The process known as "parameter identification" has been used for many years for identification of fixed-wing vehicle characteristics. Recent applications have essentially utilized fixed-wing methods considering a "lumped" fuselage-rotor identification model. The domination of the rotor in the helicopter response, the high degree of cross-axis coupling, the range of flight regimes and the severe helicopter testing environment result in serious limitations in applying fixed-wing parameter identification methods. In a joint effort of NASA-Langley NASA-Ames, USAAMRDL-Langley Directorate, and USAAMRDL-Ames Directorate, a contract for the development of a parameter identification method specifically designed for helicopter applications has been initiated. The method, if successful, will provide for rotor degrees-of-freedom, nonlinear aerodynamics, cross-coupling effects, rotor-to-fuselage aerodynamic effects, and account for the limitations of helicopter testing. The four important areas of parameter identification will be investigated, namely: flight data preprocessing (state estimation), mathematical modeling, control input design and identification algorithm. A mathematical model for the RSRA will be developed to include rotor degrees-of-freedom, rotor to rotor, and rotor to fuselage/tail aerodynamic interference and to account for the unique independent rotor and fuselage force and moment measurement system of the RSRA. A corresponding state estimation technique for the RSRA measurement system for estimation of vehicle/rotor state variables, biases, scale factor errors, wind gusts and dynamic effects of air data measurements will be developed. Simulated flight data to include reasonable measurement noise and moderate wind gust will be used with the state estimation and parameter identification algorithms developed for the RSRA configuration.

The RSRA is an excellent tool for establishing the validity of the helicopter parameter identification method. A key feature, from the viewpoint of parameter identification, is the capability of using optimally designed control inputs of various shapes. The RSRA is designed and equipped with all the necessary controls and instrumentation to provide the necessary flight measurements for parameter identification (Ref. 7).

Correlation of Aeroelastic Stability Predictions.- The operating envelope of current rotorcraft designs are usually limited by some phenomena generally classed as aeroelastic in nature. The current techniques of analysis of flight-test data (Refs. 37, 38, 39, and 40) include a newly-developed technique that allows subcritical testing to determine the level of damping of appropriate modes of the rotor (Ref. 37). The capability of establishing a complete aeroelastic stability map in flight (while operating safely by continuously ascertaining the level of stability) will allow a correlation of the applicable analytical methods with experiment. A key factor in the success of these prediction methods will be a general improvement in the prediction of rotor loads, perhaps by the steps outlined in reference 35. These steps included standard comparisons between theoretical results, isolation of theoretical anomalies between results, fundamental experimental research on helicopter aerodynamic peculiarities, and key experimental correlation with large-scale wind-tunnel tests. To that list must be added key experimental flight tests where real-world environment of maneuvers, gusts, and transient control phenomena can be assessed.

Flight test data from the RSRA will be correlated with theoretical predictions of rotor aeroelastic and loads characteristics.

Correlation of Airframe Dynamics and Flight-Test Results with Predictions of In-Flight Vibrations and Rotor Vibration Loads on an Airframe.- The capability to a priori predict the in-flight vibration of a new rotorcraft design is nearly nonexistent. Finite element dynamic modeling of the helicopter airframe, such as NASTRAN, appears only spasmodically successful in predicting frequencies for design analysis. This appears to be a user-related problem requiring additional flexibility in input/output and pre/post processors. Moreover, the NASTRAN approach is not responsive to use as a design tool. In addition, the necessary basic correlation of NASTRAN with experiment is still lacking for helicopter configurations in order to give confidence to the designer.

The prediction of vibration loads from the main and tail rotors is inadequate. A comparison of rotor blade root vibratory shears (Ref. 35), as predicted by a large number of different theoretical methods, has shown large to very large differences. In fact, flight-test data (Ref. 35) has been shown to exceed worst-case analytical results for inplane shears that are a major contributor to vibration.

The helicopter designer has had to resort to working with the best available tools, making no changes until test data are in hand, knowing full well that he must use the analysis tools as guides to fix a problem using the auxiliary vibration control techniques of fuselage detuning, rotor isolation, and applying conventional absorbers.

The RSRA vehicles, by the time they are operational, will have had detailed shake tests to identify structural dynamic parameters, including natural frequencies, modal damping, mode "shapes," generalized masses, and rigid body parameters. A flight-test survey will identify accelerations and vibratory loads experienced in critical structural members, components, and subsystems. The rotor-load measurement system will allow vibratory loads (frequency and amplitude) to be measured near the rotor source. Through correlation techniques, the airframe dynamics model, in-flight vibrations, and rotor loads predictions can be verified. From efforts along this line, increased confidence in vibration prediction techniques will evolve. 18-11

Flight-test data from the RSRA will be correlated with predicted airframe dynamics, rotor loads, and vibrations.

CURRENT STATUS

The first flight of the number one RSRA in the helicopter configuration was made on October 12, 1976 (Fig. 39). The first flight included four landings and takeoffs, SAS on and off, and flight controlled through both the fly-by-wire and mechanical flight control systems. Twenty-one flights were completed through February 7, 1977, (14 flight hours) before the aircraft was downed for installation of the compound wing and auxiliary engines (Fig. 40). Flight test of the number one aircraft is expected to resume in July 1977 with compound testing to commence in August 1977 at the Wallops Flight Center. During the development flight test of the RSRA helicopter configuration the flight envelope was expanded from +0.5g to +1.75g, with airspeeds up to 150 knots. Loads and vibration were generally as expected with only minor development type changes required. The flying characteristics of the RSRA helicopter configuration are acceptable throughout the speed range investigated (Ref. 36).

The number two RSRA aircraft is being configured to fly the Active Rotor Balance Isolator System (ARBIS). First flight of that aircraft is expected to occur in August 1977, with the aircraft moved to Wallops Flight Center in December 1977.

Development flight tests are expected to be completed by late summer of 1978, after which the two RSRA vehicles will be moved to the Ames Research Center.

CONCLUDING REMARKS

The RSRA vehicles are designed to meet a recognized need in supplying accurate, real-world flight data for verification and guidance in the further development of rotorcraft technology. The development and/or verification of a wide range of rotorcraft prediction methods will be significantly improved with the insight gained through the use of high quality data. In addition, where theoretical methods are uncertain, data from the RSRA will allow pragmatic progress to occur with more certain confidence.

The adaptability of the RSRA to new rotor types and concepts will provide a lower cost approach to the high risk development that can cause impulses in the technology trends of rotorcraft. In addition, because of the quality of data obtained, and the capability for direct comparisons, greater confidence will result in the necessary comparison of rotor types.

The RSRA is anticipated to act as a catalyst to inspire technology breakthroughs by supplying a new step in the technology and rotor system verification cycle.

REFERENCES

1. Bell Helicopter Company: Predesign Report for the Rotor Systems Research Aircraft. (A Textron Company; NASA Contract No. NAS1-11251) NASA CR-112156, 1972.
2. Bell Helicopter Company: A Conceptual Study of the Rotor Systems Research Aircraft. (A Textron Company; NASA Contract No. NAS1-11251) NASA CR-112157, 1972.
3. Linden, Arthur W., et al: Rotor Systems Research Aircraft Predesign Study; Final Report, Vol. I; Summary and Conclusions. (Sikorsky Report No. SER 50775; NASA Contract No. NAS1-11228) NASA CR-112152, 1972.
4. Schmidt, Steven A.; Linden, Arthur W.; et al: Rotor Systems Research Aircraft Predesign Study; Final Report, Vol. II; Conceptual Study Report. (Sikorsky Report No. SER 50775; NASA Contract No. NAS1-11228) NASA CR-112153, 1972.
5. Schmidt, Steven A.; Linden, Arthur W.; et al: Rotor Systems Research Aircraft Predesign Study; Final Report, Vol. III; Predesign Report. (Sikorsky Report No. SER 50775; NASA Contract No. NAS1-11228) NASA CR-112154, 1972.
6. Miller, Alfred N.; Linden, Arthur W.; et al: Rotor Systems Research Aircraft Predesign Study; Final Report, Vol. IV; Preliminary Draft Detail Specification. (Sikorsky Report No. SER 50775, NASA Contract No. NAS1-11228) NASA CR-112155, 1972.
7. Condon, Gregory W.: Rotor Systems Research Aircraft (RSRA) Requirements for, and Contributions to, Rotorcraft State Estimation and Parameter Identification. Presented at the AGARD Flight Mechanics Panel Specialists Meeting on "Methods for Aircraft State and Parameter Identification," Hampton, Virginia, November 5-8, 1974.
8. Garren, John F., Jr.; and Kelly, James R.: Description of an Analog Computer Approach to V/STOL Simulation Employing a Variable-Stability Helicopter. NASA TN D-1970, 1964.

18-12

9. Garren, John F., Jr.; Niessen, Frank R.; Abbott, Terence S.; and Yenni, Kenneth R.: Application of a Modified Complementary Filtering Technique for Increased Aircraft Control System Frequency Bandwidth. In High Vibration Environment. NASA TM X-74004, 1977.
10. Niessen, Frank R.; Kelly, James R.; Garren, John F., Jr.; Yenni, Kenneth R.; and Person, Lee H.: The Effect of Variations in Controls and Displays on Helicopter Instrument Approach Capability. NASA TN D-8385, 1977.
11. Letchworth, Robert (Lt. Col.); and Condon, Gregory W.: Rotor Systems Research Aircraft (RSRA). Presented at the AGARD Flight Mechanics Panel Symposium, Valloire, France, June 9-12, 1975.
12. Briczinski, Stanley J.; and Cooper, Dean E.: Flight Investigation of Rotor/Vehicle State Feedback. (Sikorsky Report No. SER 50905; NASA Contract No. NAS1-11563) NASA CR-132546, 1975.
13. Walton, W. C., Jr.; Hedgepeth, R. K.; and Bartlett, F. D., Jr.: Report on Rotor Systems Research Aircraft Design for Vibrations. Presented at the Society of Automotive Engineers, Inc., 1976 Aerospace Engineering and Manufacturing Meeting, (Paper No. 760895) San Diego, California, Nov. 30-Dec. 2, 1976.
14. Kenigsberg, Irwin J.; and DeFelice, John J.: Active Transmission Isolation/Rotor Loads Measurement System. (Sikorsky Report No. SER 50821, NASA Contract No. NAS1-11549) NASA CR-112245, 1973.
15. Bement, Laurence J.: Rotor Systems Research Aircraft (RSRA) Canopy Explosive Severance/Fracture. Presented at the Ninth Symposium on Explosives and Pyrotechnics, Philadelphia, Pennsylvania, Sept. 15-16, 1976.
16. Mantay, Wayne R.; and Rorke, James B.: The Evolution of the Variable Geometry Rotor. Proceedings of the Symposium on Rotor Technology of the American Helicopter Society, Mideast Region, August 1976.
17. Sadler, S. Gene: Development and Application of a Method for Predicting Rotor Free Wake Positions and Resulting Rotor Blade Air Loads. NASA CR-1911, 1971.
18. Landgrebe, A. J.; and Bellinger, E. D.: Experimental Investigation of Model Variable-Geometry and Ogee Tip Rotors. NASA CR-2275, 1974.
19. Rorke, J. B.: Hover Performance Tests of Full-Scale Variable Geometry Rotors. NASA CR-2713, 1976.
20. Gangwani, Santu T.: The Effect of Helicopter Main Rotor Blade Phasing and Spacing on Performance, Blade Loads, and Acoustics. NASA CR-2737, 1976.
21. Longobardi, John A.; Cassarino, Sebastian J.; and Gold, William A.: Advanced Systems Design Study of a Variable Geometry Rotor for the RSRA; Vol. I - Design, Analysis, and Development Plan. (Sikorsky Report No. SER 72033; NASA Contract No. NAS1-14111) NASA CR-14508C, 1976.
22. Swindlehurst, Carl E., Jr.: Development of the Composite Bearingless Main Rotor System. Proceedings of the Symposium on Rotor Technology of the American Helicopter Society, Mideast Region, 1976.
23. Bielawa, Richard L.; Cheney, Marvin C., Jr.; and Novak, Richard C.: Investigation of a Bearingless Helicopter Rotor Concept Having a Composite Primary Structure. NASA CR-2637, 1976.
24. Bielawa, Richard L.: Aeroelastic Analysis for Helicopter Rotor Blades with Time-Variable, Nonlinear Structural Twist and Multiple Structural Redundancy - Mathematical Derivation and Program User's Manual. NASA CR-2638, 1976.
25. Kraus, Timothy A.: Advanced Systems Design Study of a Composite Structures Rotor for the RSRA; Vol. I - Design, Analysis and Development Plan. (Sikorsky Report No. SER 72034, NASA Contract No. NAS1-14114) NASA CR-145082, 1976.
26. Boeing-Vertol Company: Advanced System Design Study of a Composite Structures Rotor. Vol. I (Boeing-Vertol Report No. D210-11092-1) NASA CR-145092, 1976.
27. White, B. P.: Predesign Study of the Flexhinge Rotor for the Rotor Systems Research Aircraft, Vol. I - Design Analysis. NASA CR-145162, 1977.
28. White, B. P.: A Development Plan for an Aeroacoustic Research Rotor System. Vol. I. (Bell Helicopter Textron Tech Report 299-099-834; NASA Contract No. NAS1-13979) NASA CR-145015, 1976.
29. Boeing-Vertol Company: Predesign Study for an Aero/Acoustic Research Rotor System. Vol. I. (Boeing-Vertol Report No. D210-11042-1; NASA Contract No. NAS1-13980) NASA CR-145017, 1976.
30. Rorke, James B.; and Moffitt, Robert C.: Wind Tunnel Simulation of Full Scale Vortices. NASA CR-2180, 1973.
31. Wilson, John C.: A General Rotor Model System for Wind-Tunnel Investigations. AIAA Journal of Aircraft, July 1977. (Also presented at AIAA Testing Conference, June 1976.)
32. Mineck, Raymond E.; Freeman, Carl E.; and Hassell, James L., Jr.: Aerodynamic Characteristics of a 1/6-Scale Model of the Rotor Systems Research Aircraft with the Rotor Removed. NASA TN D-8198, 1976.
33. Mineck, Raymond E.; and Freeman, Carl E.: Aerodynamic Characteristics of a 1/6-Scale Powered Model of the Rotor Systems Research Aircraft. NASA TM X-3489, 1977.

34. Mineck, Raymond E.: Tail Contribution to the Directional Aerodynamic Characteristics of a 1/6-Scale Model of the Rotor Systems Research Aircraft. NASA TM X-3501, 1977.
35. Ormiston, Robert A.: Comparison of Several Methods for Predicting Loads on a Hypothetical Helicopter Rotor. Presented at the AHS/NASA-Ames Specialist's Meeting on Rotorcraft Dynamics, Moffett Field, California, February 13-15, 1974.
36. Moore, Frederick L.; and Occhiato, John J.: The Basic Flying Characteristics of the Rotor Systems Research Aircraft. Presented at the 33rd Annual National Forum of the American Helicopter Society, Washington, D.C., May 1977.
37. Hammond, Charles E.; and Doggett, Robert V., Jr.: Determination of Subcritical Damping by Moving-Block/Randomdec Applications. NASA SP-415, 1975, pp. 59-76.
38. Kuczynski, William A.: Inflight Rotor Stability Monitor. NASA SP-415, 1975, pp. 457-472.
39. Miao, Wen-Liu; Edwards, W. Thomas; and Brandt, David E.: Investigation of Aeroelastic Stability Phenomena of a Helicopter by In-Flight Shake Test. NASA SP-415, 1975, pp. 473-499.
40. Yen, Jing G.; Viswanathan, Sathy; and Matthys, Carl G.: Flight Flutter Testing of Rotary Wing Aircraft Using a Control System Oscillation Technique. NASA SP-415, 1975, pp. 501-512.

TABLE I.- AERODYNAMIC SURFACE AREAS

Wing area, total	369.9 square feet (34.36 meter ²)
Wing flap area, total	57.8 square feet (5.37 meter ²)
Aileron area, total	35.7 square feet (3.32 meter ²)
Horizontal tail area:	
Lower (compound)	88.3 square feet (8.20 meter ²)
Upper (compound)	17.2 square feet (1.60 meter ²)
Upper (helicopter)	35.4 square feet (3.29 meter ²)
Lower stabilizer (to elevator hinge)	61.8 square feet (5.74 meter ²)
Elevator	26.48 square feet (2.46 meter ²)
Vertical tail area, total	100.8 square feet (9.36 meter ²)
Fin (to rudder hinge)	81.3 square feet (7.55 meter ²)
Rudder	19.5 square feet (1.81 meter ²)
Main rotor blade area	40.5 square feet (3.75 meter ²)
(one (1) blade)	
Main rotor geometric disk area	3019 square feet (280.47 meter ²)
(total)	
Main rotor blade geometric solidity ratio	0.0775
Tail rotor blade area	3.24 square feet (0.30 meter ²)
Tail rotor geometric disk area	88.3 square feet (8.20 meter ²)
(total)	
Tail rotor geometric solidity ratio	0.184

TABLE II.- DIMENSIONS AND GENERAL DATA (REF. SES-720001, REV. NO. R-1, PAGE 45)

Wings	
Span, maximum	45.1 feet (13.75 meters)
Chord:	
At root	115.2 inches (2.93 meters)
At construction tip	76.8 inches (1.95 meters)
Mean aerodynamic	100.8 inches (2.56 meters)
Airfoil at root	63 ₂ 415
Airfoil at construction tip	63 ₂ 415
Thickness	15 percent
Incidence:	
At root	Variable, +15 to -9 degrees (0.262 to -0.157 radians)
At construction tip	Variable, +15 to -9 degrees (0.262 to -0.157 radians)
Sweepback at 25 percent chord	3.0 degrees (0.052 radians)
Dihedral	7.0 degrees (0.122 radians)
Aspect ratio	5.52
Ailerons:	
Span	46 inches (1.17 meters)
Chord (average percent wing chord)	30 percent
High lift and drag increasing device:	
Type	Single slotted flap
Span, exclusive of cutouts	64.7 percent
Chord (average percent wing chord)	30 percent
Tail	
Lower horizontal (compound only):	
Span	22.5 feet (6.86 meters)
Chord (MAC)	3.9 feet (1.19 meters)
Airfoil	NACA 0015
Incidence	Variable, +8, -8 degrees (± 0.140 radians)
Sweep of leading edge	0
Dihedral	0
Aspect ratio	5.73
Elevator:	
Span (percent of tail span)	100 percent
Chord (percent of tail chord)	30 percent
Upper horizontal (compound only):	
Span	8.58 feet (2.62 meters)
Chord (MAC)	2.05 feet (0.62 meters)
Airfoil	NACA 0015
Incidence	Ground adjustable, ± 5 degrees (± 0.087 radians)
Sweep of leading edge	12.5 degrees (0.218 radians)
Dihedral	0
Aspect ratio	4.29
Upper horizontal (helicopter only):	
Span	13.25 feet (4.04 meters)
Chord (MAC)	2.78 feet (0.85 meters)
Airfoil	NACA 0015
Incidence	Ground adjustable, ± 5 degrees (± 0.087 radians)
Sweep of leading edge	12 degrees (0.209 radians)
Dihedral	0
Aspect ratio	4.97

TABLE II (CONT.)

Tail (continued):	
Vertical:	
Airfoil	NACA 0015
Sweep at 25 percent chord	48 degrees (0.838 radians)
Aspect ratio	3.62
Rudder tab cord	8 inches (0.20 meters)
Height over highest fixed part of aircraft:	
Reference line level	20.1 feet (6.13 meters)
Three-point	17.9 feet (5.46 meters)
Height over highest part of tail	20.1 feet (6.13 meters)
Height in hoisting attitude	18.0 feet (5.49 meters)
Length, Maximum:	
Reference line level	70.6 feet (21.52 meters)
Three-point	70.6 feet (21.52 meters)
Length from hoisting sling to farthest aft part of tail, reference line level, rudder neutral, elevator down	
	48.6 feet (14.81 meters)
Distance from wing MAC quarter chord point to lower horizontal tail MAC quarter chord point	
	28.57 feet (8.71 meters)
Distance from centerline of main rotor to lower horizontal tail MAC quarter chord point	
	29.57 feet (9.01 meters)
Ground angle	2.45 degrees (0.043 radians)
Wheel size:	
Main wheels	24 by 8.00-13
Auxiliary wheel (tail)	18 by 5.5
Tire size:	
Main wheels	24 by 8.00-13
Auxiliary wheel (tail)	18 by 5.5, Type VII
Tread of main wheels	10.8 feet (3.29 meters)
Wheel base	40.9 feet (12.47 meters)
Vertical travel, extended/compressed	
Main wheels	10.5 inches, right gear (0.26 meters) 12.0 inches, left gear (0.30 meters)
Tail wheel	12.0 inches (0.30 meters)
Angle between lines joining center of gravity with point of ground contact of main wheel tires, static deflection of 1W (front elevation)	
	64.16 degrees (1.120 radians)
Angle of line through center of gravity and ground contact of main wheel tire to vertical line, reference line level, static deflection of 1W (side elevation)	
	28.79 degrees (0.502 radians)
Maximum slope helicopter can be parked upon without overturning (nose downhill)	
	28.79 degrees (0.502 radians)
Critical turnover angle	25.98 degrees (0.453 radians)
D = diameter of main rotor	62.0 feet (18.90 meters)
Number of blades main rotor	5
W_g = geometric disk loading (W/A_g)	6.095
Airfoil section designation and thickness	NACA 0012 (modified)
Width - main rotor blades (turning)	62.0 feet (18.90 meters)
Length:	
Maximum - main rotor blades (at rest, one (1) trailing)	73.6 feet (22.43 meters)
Maximum - main rotor blades turning	79.6 feet (24.26 meters)
Height:	
Over main rotor blades at rest	14.5 feet (4.42 meters)
Main rotor clearance (ground to tip, rotor static)	11.0 feet (3.35 meters)
Main rotor clearance (ground to tip, rotor turning)	14.5 feet (4.42 meters)
Main rotor clearance (structure to tip, rotor static)	5.0 feet (1.52 meters)

TABLE II (CONCLUDED)

17-16
Height (continued):

Main rotor clearance (structure to tip, rotor turning)	7.5 feet (2.29 meters)
Diameter tail rotor	10.6 feet (3.23 meters)
Tail rotor clearance (ground to tip, rotor turning)	5.0 feet (1.52 meters)

TABLE III.- ROTOR FLIGHT LOADS MEASUREMENT SYSTEM ACCURACY

Force/moment component	Range	Accuracy (1 σ)
Vertical force (lb)	-3K/ +48.8K	$\pm 313/ \pm 152$
Longitudinal force (lb)	$\pm 10K$	± 71
Lateral force (lb)	$\pm 10K$	± 110
Pitching moment (ft-lb)	$\pm 24K$	$\pm 796/ \pm 421$
Rolling moment (ft-lb)	$\pm 12K$	$\pm 669/ \pm 507$
Yawing moment (ft-lb)	-3K/ +65K	$\pm 424/ \pm 220$

TABLE IV.- RESEARCH INSTRUMENTATION MEASUREMENTS

Measurement	Sensor Type	Measurement	Sensor Type
Rotor lift cell "A"	Load cell	Drag brake position	Pot.
Rotor lift cell "B"	Load cell	Wing pitch actuator cell "H"	Load cell
Rotor lift cell "C"	Load cell	Wing pitch actuator cell "I"	Load cell
Rotor lift cell "D"	Load cell	Wing pivot point cell "J"	Load cell
Main rotor torque drive shaft	S.G.	Wing pivot point cell "K"	Load cell
Transmission torque cell "E"	Load cell	Wing pivot point cell "L"	Load cell
Transmission torque cell "F"	Load cell	Wing pivot point cell "M"	Load cell
Long. force cell "G"	Load cell	Wing incidence angle	Pot.
MR rpm	Photo cell	Right aileron position	Pot.
MR azimuth 1/72 per rev	Photo cell	Right flap position	Pot.
MR blade flap β	Linear Gener.	Antitorque cell "N"	Load cell
MR blade hunt γ		Tail drive shaft torque	S.G.
MR blade pitch θ		Elevator pos.	Pot.
Right lateral servo position	Pot.	Rudder position	Pot.
Left lateral servo position	Pot.	Left engine auxiliary thrust	Load cell
Longitudinal servo position	Pot.	Right engine auxiliary thrust	Load cell
Airspeed (swiveling probe)	TBD	Pilot's lateral control position	Pot.
Pitch attitude	Gyro	Copilot's lateral control position	Pot.
Roll attitude	Gyro	Pilot's longitudinal control pos.	Pot.
Yaw attitude	Gyro	Copilot's longitudinal control pos.	Pot.
Pitch rate	Gyro	Pilot's collective control pos.	Pot.
Roll rate	Gyro	Copilot's collective control pos.	Pot.
Yaw rate	Gyro	Antitorque control position	Pot.
Pitch acceleration	Gyro	Lateral control stick force	S.G.
Roll acceleration	Gyro	Longitudinal control stick force	S.G.
Yaw acceleration	Gyro	Antitorque control force	S.G.
Vertical linear acceleration	Accel.	Pitch phasing unit position	Pot.
Lateral linear acceleration	Accel.	Roll phasing unit position	Pot.
Longitudinal linear accel.	Accel.	Yaw phasing unit position	Pot.
Angle of attack	Pot.	Ho. long. servo series trim	Pot.
Sideslip	Pot.	Elev. series trim control pos.	Pot.

TABLE IV (CONCLUDED)

Measurement	Sensor	Measurement	Sensor
	Type		Type
Helo. at. servo ser. trim pos.	Pot.	Altitude	Press.
Roll series trim cont. pos.	Pot.	OAT	Res.
No. 1 eng. T-58 torque	Press.	Rate of climb	Press.
No. 2 eng. T-58 torque	Press.	Collective control stick force	S.G.
Main rotor push rod load	S.G.		

TABLE V.- TDY-43 FLIGHT COMPUTER CHARACTERISTICS

Memory	Core, 16K x 16, 1.3 μ s cycle
Computation process	Parallel
Formats:	
Data	Fixed point, fractional binary, 2's complement
Word length	16 bits
Instruction	Single address, single instruction
Addressing	Immediate direct, relative, indexed, and indirect
Addressing range	To 65K words
Instructions	70
Clock frequency	3 MHz
Registers	Dual 8-register file
Execution speeds (direct, relative, indexed)	
Add/subtract	2.67 μ s
Multiply	6.00 μ s
DP add/subtract	5.33 μ s
Divide	8.67 μ s
Input/output	4 synchro inputs 13 ac inputs (2nd order filters) 34 dc inputs (2nd order filters) 39 dc inputs (single pole filters) 35 dc inputs (unfiltered) 62 dc outputs (single pole filters) 64 28 Vdc discrete inputs 31 28 Vdc discrete outputs
Interrupts	8 (3 dedicated internally)
Real-time clock	16 bits; program accessible 0.1 msec resolution 6.5536 seconds range
BITE	Memory check Instruction check Wrap-around I/O check Reset timer

TABLE VI.- "SUPER ROTOR" CHARACTERISTICS

Thrust	66,000 lb
Propulsive force	15,000 lb
Side force	9,300 lb
Pitching moment	72,000 ft-lb
Rolling moment	48,000 ft-lb
Power	5,000 hp
Rotor speed	203 rpm

18-18

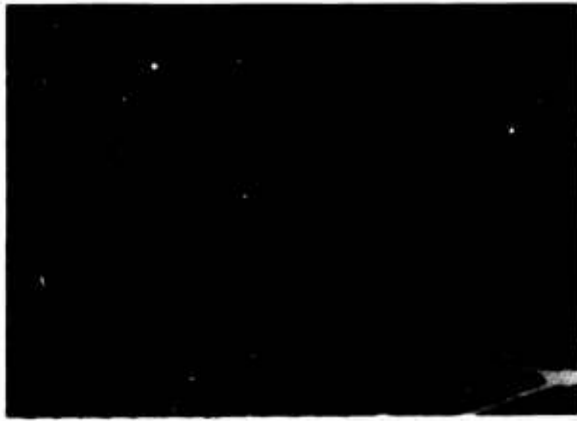

Figure 1.- Rotor Systems Research Aircraft.

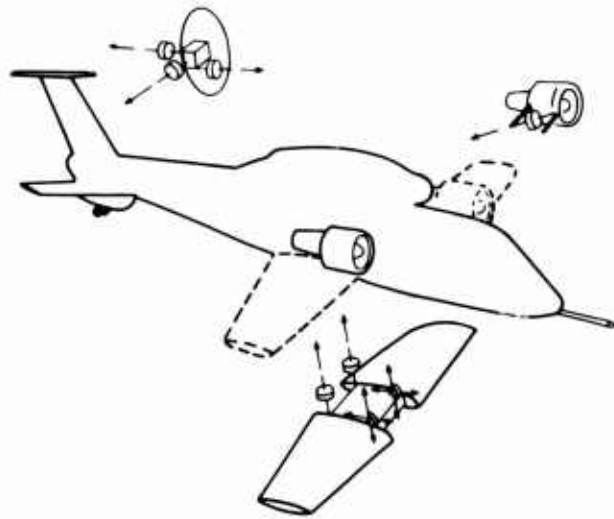

Figure 4.- RSRA Auxillary Measurements System.

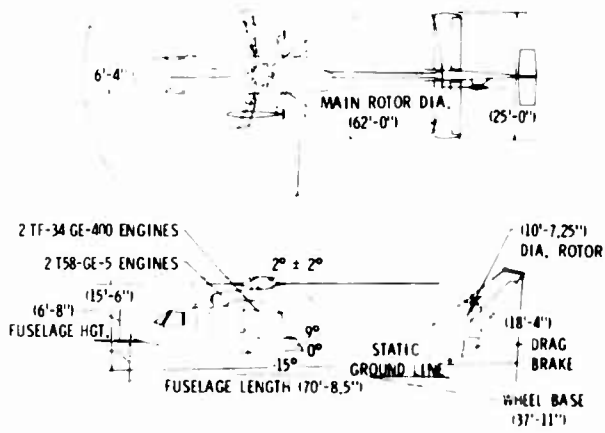

Figure 2.- RSRA Physical Characteristics.

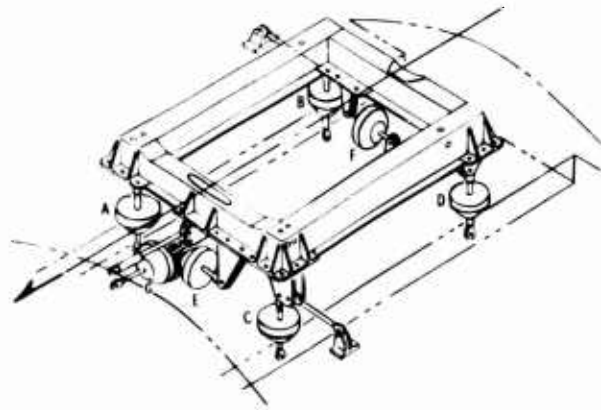

Figure 5.- Main Rotor Load Measurement System.

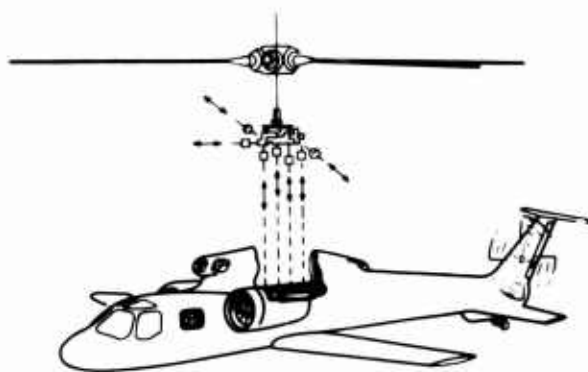

Figure 3.- RSRA Rotor Force Measurement System.

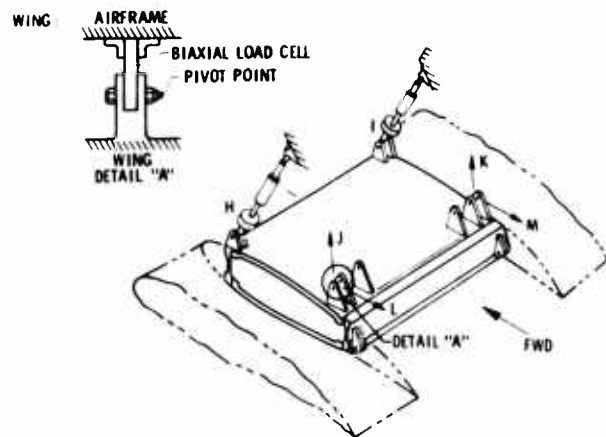

Figure 6.- Wing Flight Loads Measurement Systems Configuration.

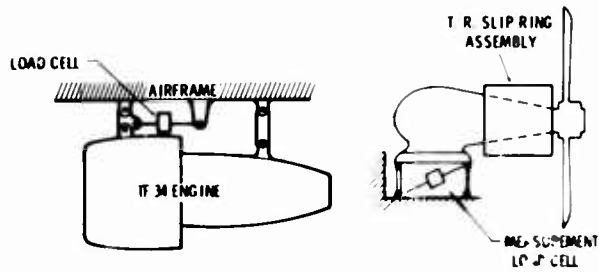

Figure 7.- Auxiliary Propulsion and Tail Rotor Flight Loads Measurement Systems Configuration.

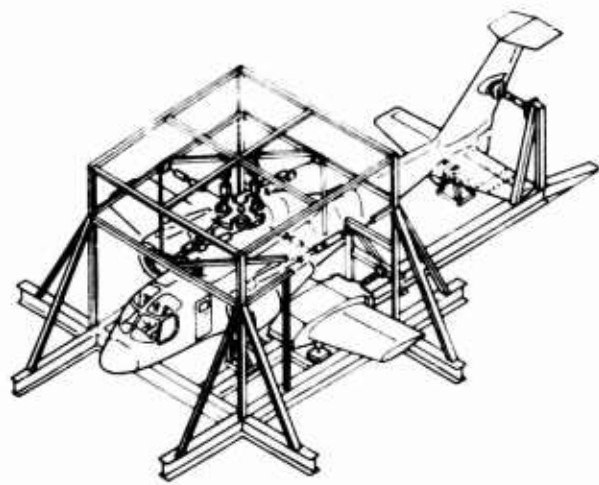

Figure 8.- Flight Loads Measurement Systems Calibration Fixture.

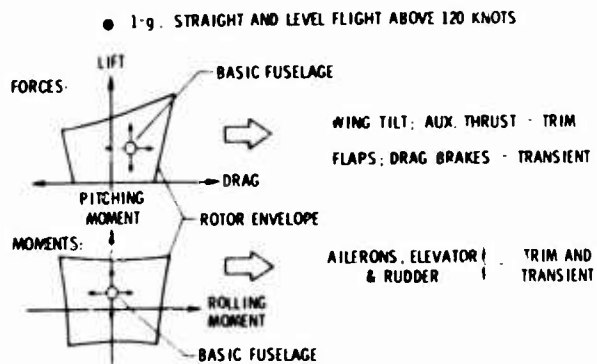

Figure 9.- Control Surface Requirements Based Upon Rotor Test Envelope Requirement.

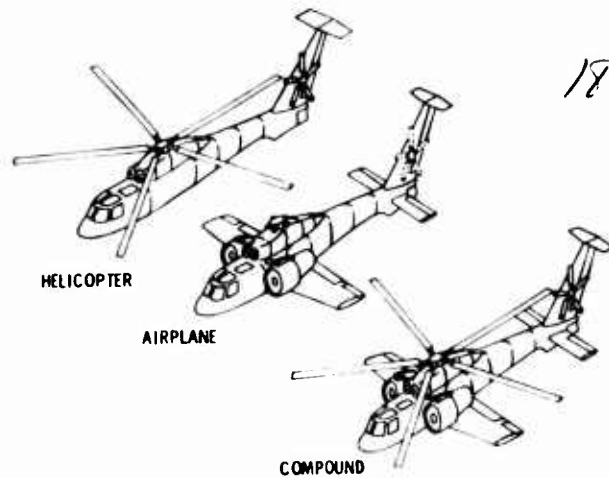

Figure 10.- RSRA Flight Configurations.

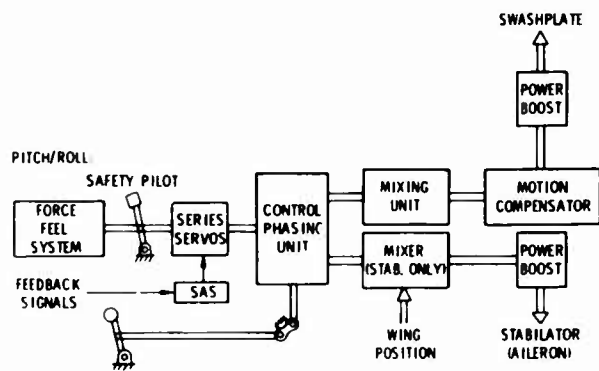

Figure 11(a).- Primary Flight Control System.

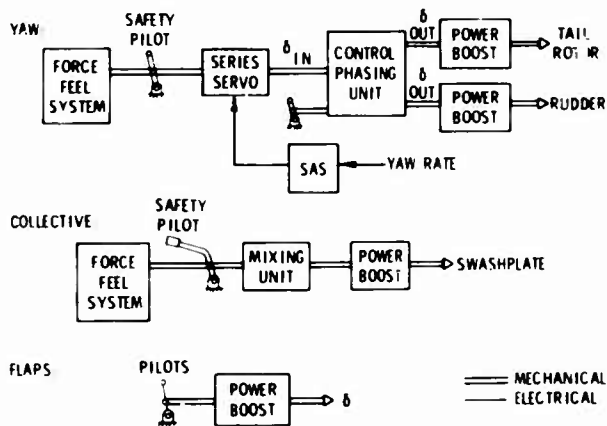

Figure 11(b).- Primary Flight Control System (Continued).

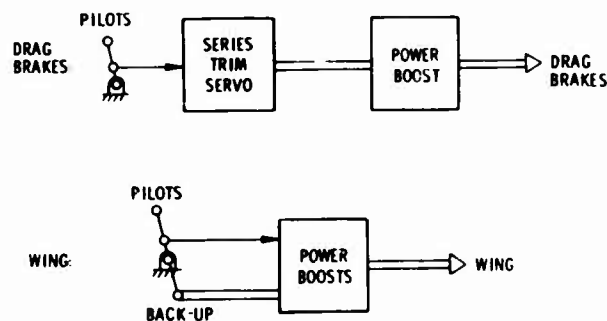

Figure 11(c).- Primary Flight Control System (Concluded).

18-20

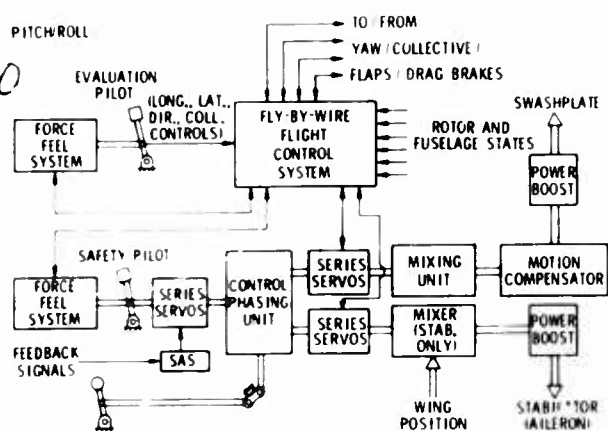

Figure 12(a).- Fly-By-Wire Flight Control System.

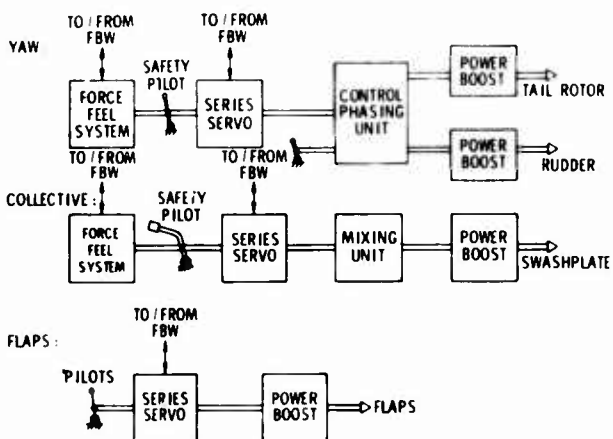
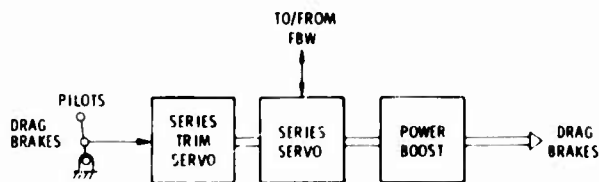

Figure 12(b).- Fly-By-Wire Flight Control System (Continued).



MECHANICAL
ELECTRICAL

Figure 12(c).- Fly-By-Wire Flight Control System (Concluded).

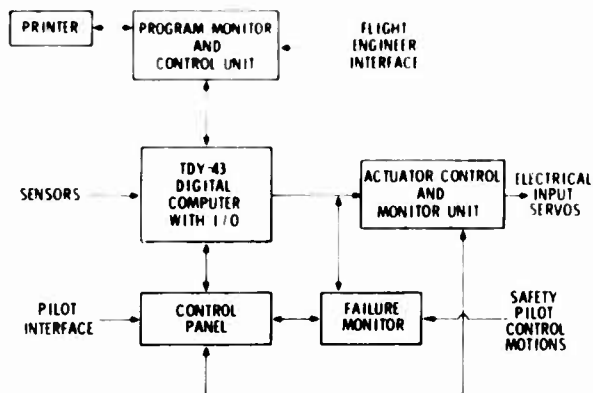

Figure 13.- Fly-By-Wire Flight Control System Configuration.

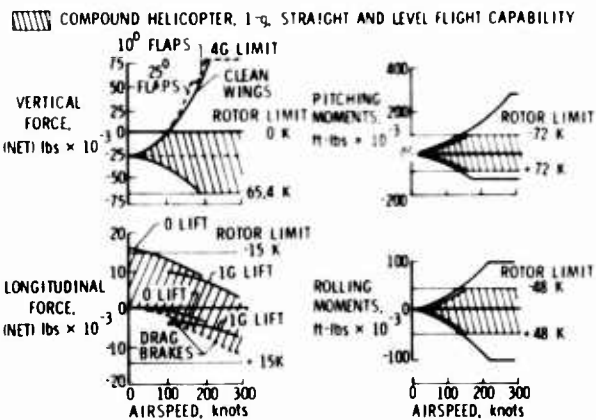

Figure 14.- RSRA Fixed-Wing Airplane Force and Moment Generation Capability.

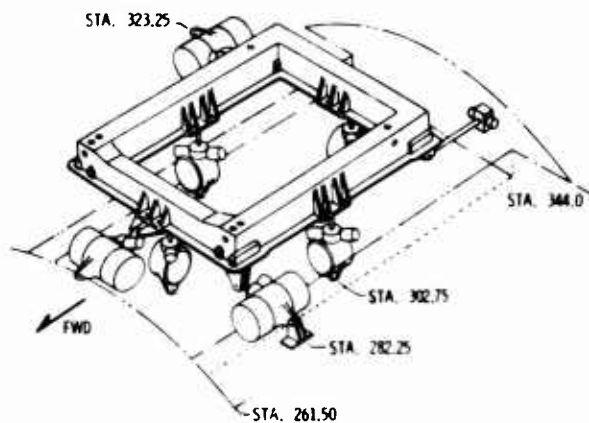

Figure 15.- Typical Active Rotor Balance/Isolation System Configuration.

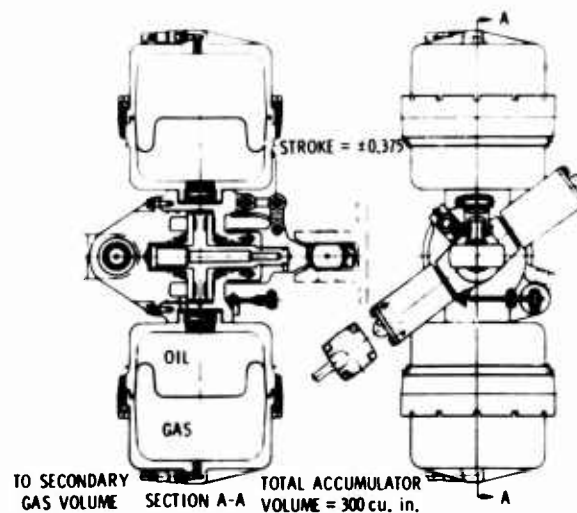
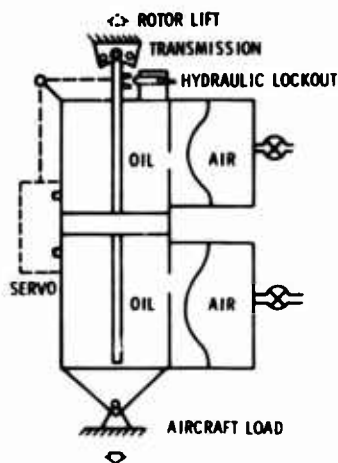

Figure 16.- Active Isolator Drawing.



ACTIVE ISOLATOR CAPABILITIES

- ADJUSTABLE STIFFNESS
- HYDRAULIC CENTERING
- ADJUSTABLE FOCUS
- PRESSURE SENSING
- FAIL SAFE LOCKOUT ALLOW
- ANTIRESONANT TUNING
- BROAD BAND ATTENUATION
- LOAD MEASUREMENT WITH
- CONTROL OF STATIC DISPLACEMENTS
- SAFETY-OF-FLIGHT

Figure 17.- Active Isolator Schematic.

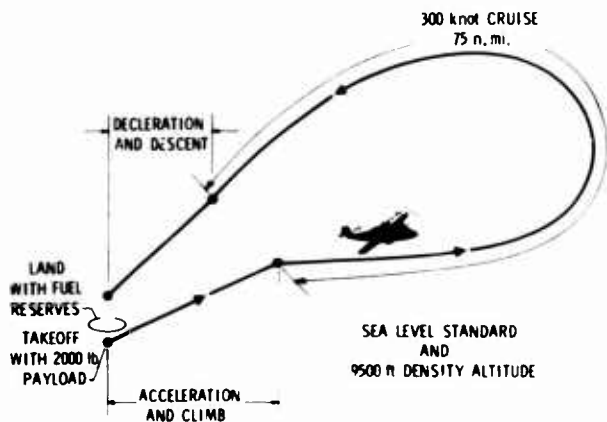

Figure 18.- RSRA High-Speed Requirement.

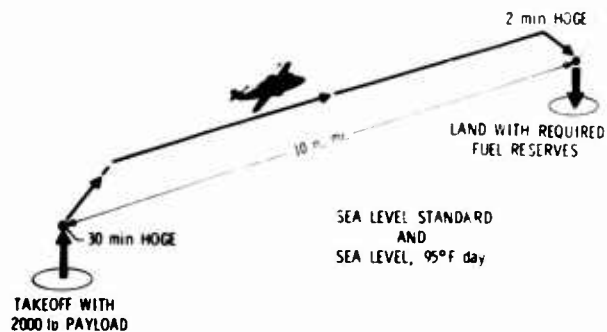

Figure 19.- RSRA Hover Requirement.

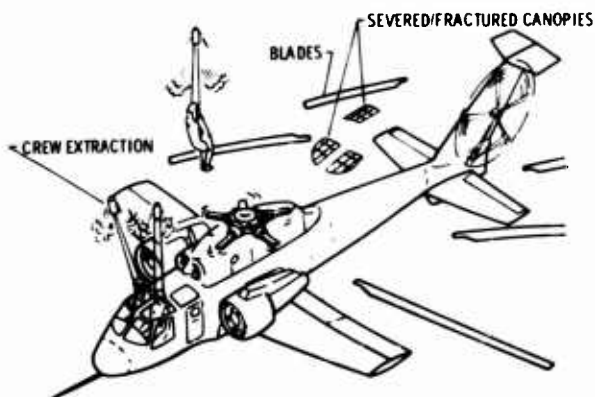

Figure 20.- RSRA Crew Escape System.

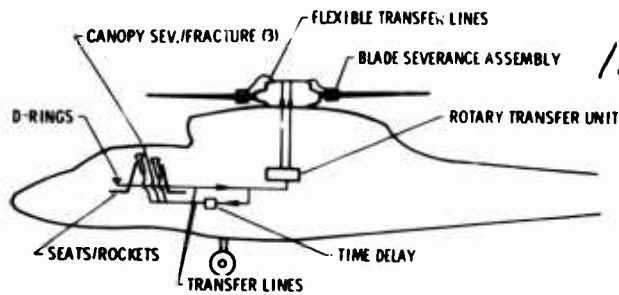

Figure 21.- RSRA Emergency Escape System.

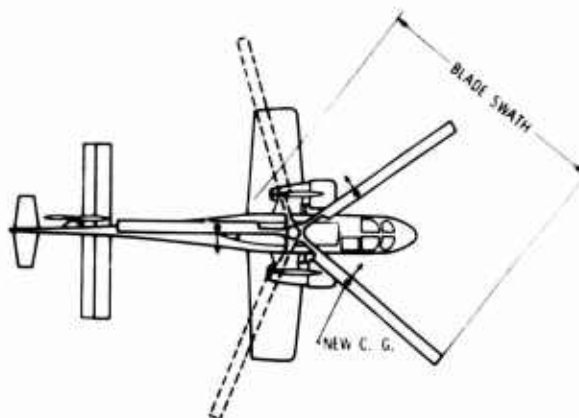

Figure 22.- Emergency Escape System Blade Trajectories.

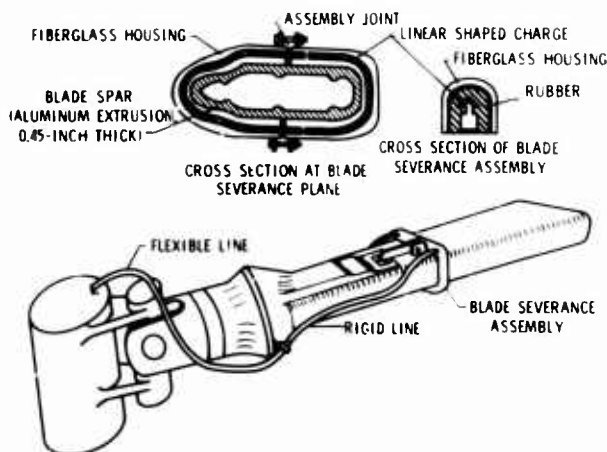

Figure 23.- RSRA Blade Severance Concept.

18:22

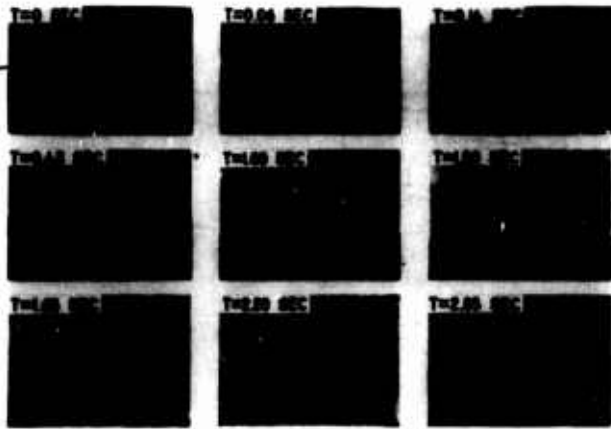

Figure 24.- Sequential Views of 134 KEAS Sled Test of RSRA Emergency Escape System. Coverage of Safety Pilot and Flight Engineer's Extractions.

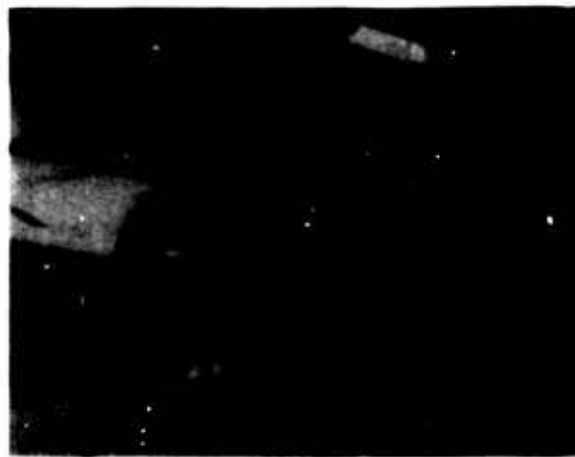

Figure 27.- Variable Geometry Rotor Model.

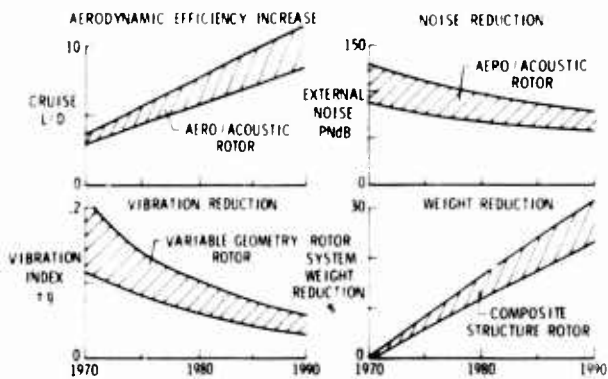

Figure 25.- Helicopter Trend Index and Potential of Advanced Rotor Concepts.

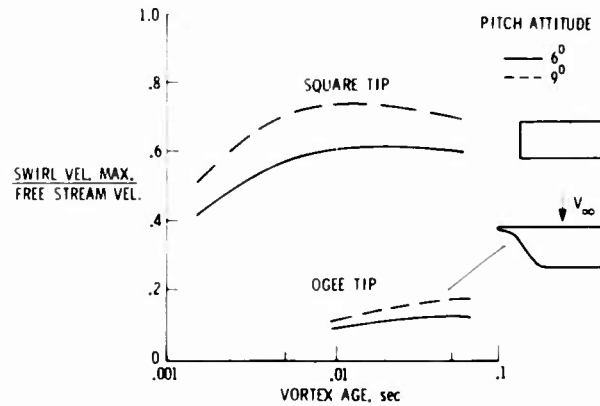

Figure 28.- Effect of Tip Shape on Maximum Swirl Velocity.

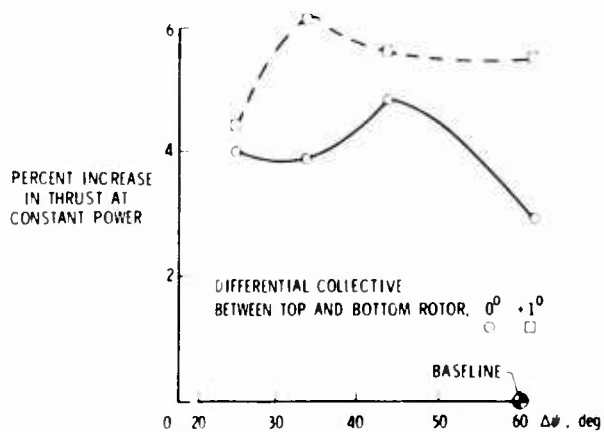

Figure 26.- Full-Scale Hover Performance, Variable Geometry Rotor, Tip Mach Number = 0.523.



Figure 29.- OGEE Rotor on Langley Whirl Tower.

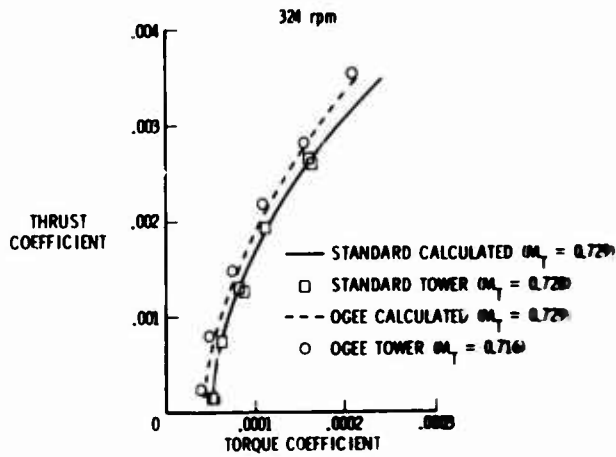

Figure 30.- Rotor Hover Performance Comparison, 324 RPM.

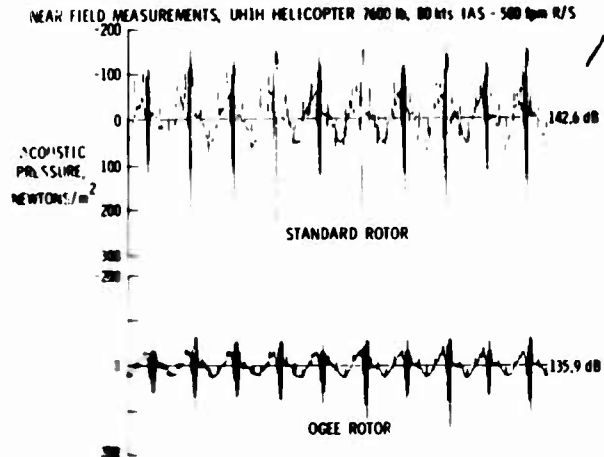

Figure 33.- Comparison of Near Field Acoustic Signature for OGEE and Standard Rotor.



Figure 31.- OGEE Rotor on Langley UH-1H Helicopter.

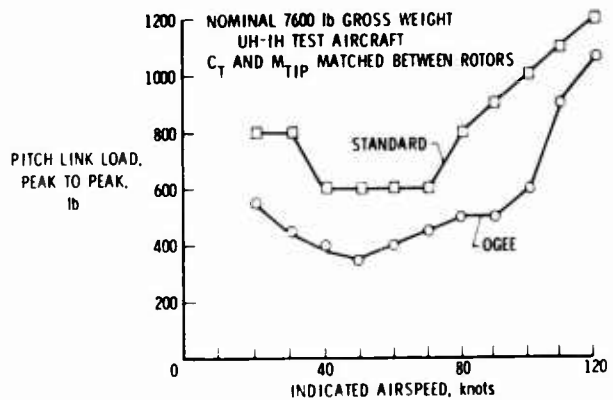

Figure 34.- Comparison of Pitch Link Loads for OGEE and Standard Rotor.

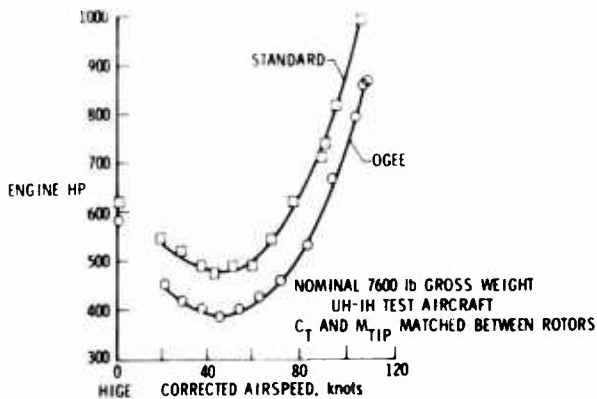

Figure 32.- Comparison of Power Required for OGEE and Standard Rotor.



Figure 35.- Generalized Rotorcraft Model System in V/STOL Tunnel.

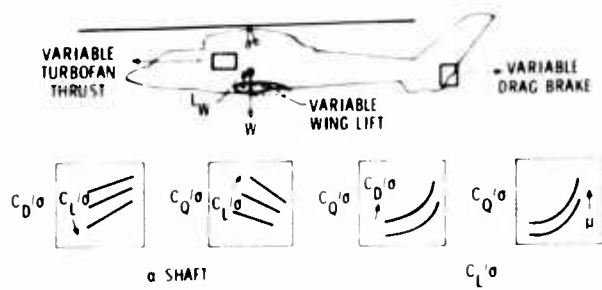

Figure 36.- Rotor Performance Mapping.

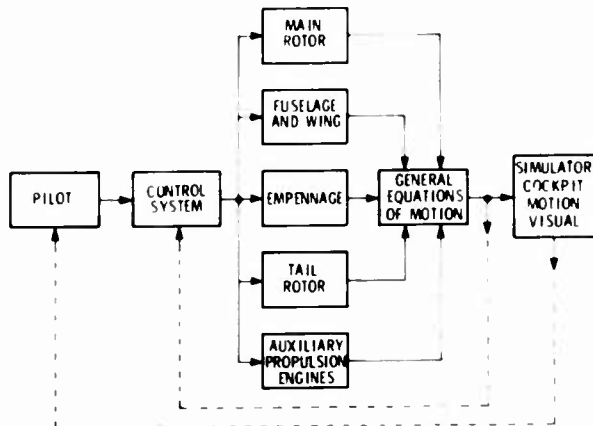

Figure 37.- RSRA Math Model.



	p	q	r
L	X	X	X
M	X	X	X
N	X	X	X
Z	X	X	X

Figure 38.- Dynamic Derivative Mapping.

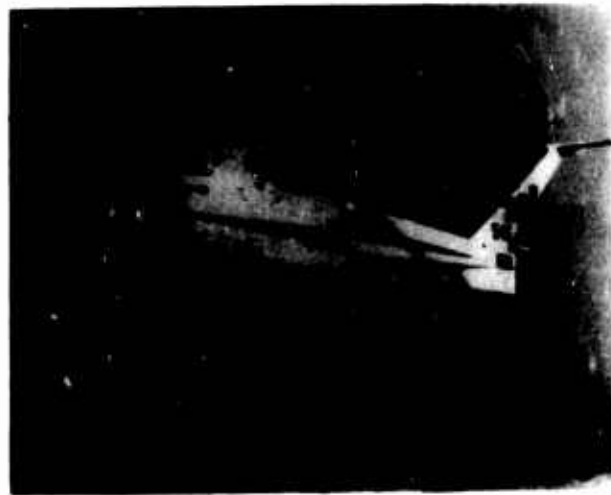

Figure 39.- RSRA Helicopter Configuration.



Figure 40.- RSRA Compound Configuration.

THE NAE AIRBORNE V/STOL SIMULATOR

S.R.M. Sinclair, W.E.B. Roderick, K. Lum
 National Aeronautical Establishment
 Ottawa, Canada
 KIA OR6

1. INTRODUCTION

The Canadian government and the Canadian aerospace industries have maintained a substantial commitment to the development of STOL and VTOL technology over the past fifteen years. In Canada, as elsewhere, the level of interest of potential users of this technology in the development and operational application of V/STOL systems has varied greatly during this period; nevertheless, since 1960 many of the concepts which have been proposed for achieving short-field or vertical-flight performance have been explored and some have been carried through to full-scale flight systems. Among these are several Canadian developments including the Canadair CX-84 tilt-wing aircraft, the De Havilland Dash-7 STOL transport, and the US-Canada Augmentor Wing Research Aircraft.

To support V/STOL development programs and the basic research efforts which have proceeded in parallel with them, the National Aeronautical Establishment of Canada (NAE) has developed specialized facilities for investigating the problems associated with high-lift, low-speed flight. One of these facilities, the NAE Airborne V/STOL Simulator (AVS), is the subject of this paper.

2. DESCRIPTION OF THE SIMULATOR

The aircraft shown in Figure 1 represents the third generation in a family of light, single-rotor helicopters which have been adapted to the airborne simulation role by the Flight Research Laboratory of NAE. This latest version is based on the Bell 205-A1 helicopter and incorporates significant improvements in control system and computational capabilities over its predecessors which were derived from Bell 47 models.

The modification of a production model 205-A1 to the airborne simulator configuration has involved four major areas of systems development, namely: installation of an electrohydraulic actuator system to interface with the basic helicopter controls, development and integration of a hybrid computing system, implementation of a model-following autopilot, and development of a broadband motion sensing system. A short description of each of these systems is given in the following sections. Aside from the installation of the electrohydraulic actuator system, the basic helicopter has undergone little modification. All of the project equipment, that is the computation and sensing systems, is installed as cargo and interfaces with the aircraft only through the actuators. Other modifications include removal of the stabilizer bar, replacement of the elevator-to-longitudinal-cyclic mechanical connection with an electrohydraulic actuator and transfer of the command pilot's controls from the right to the left hand side of the cockpit.

2.1 Fly-By-Wire System

The Airborne V/STOL Simulator accommodates a two-man crew. The safety pilot, who occupies the left hand seat, is provided with a direct link to the primary helicopter controls through the standard mechanical control runs. The evaluation pilot, seated on the right hand side of the cockpit (Fig. 2), has conventional rudder pedals, a control stick and power lever, however the link between these and the helicopter controls is a purely electrical one.

A simplified schematic diagram of one of four channels of the AVS control system is shown in Figure 3. The central element of the system is the Hydraulic Research Hydomat, an electrohydraulic actuator which replaces the hydromechanical power-following actuator of the production helicopter. The Hydomat has two operating states, a mechanical input or disengaged mode and a servo actuator or engaged mode. In the disengaged mode, the safety pilot has exclusive control and the system operates in response to his mechanical inputs in a manner similar to a conventional power-boost actuator.

When the system is engaged, the actuator operates in an electrohydraulic mode with mechanical position feedback to the servo valve torque motor. Although the safety pilot's controller tracks the motions of the actuator in this mode, a lockout spring arrangement isolates the servo spool from inputs along this mechanical path. These springs have been designed to allow the safety pilot to override each servo system channel by applying a force of approximately 12 kilograms to the appropriate controller.

In the servo mode the system has 100% position and rate authority.

Another important element of the simulation system which is depicted in Figure 3 is the programmable force feel system. The evaluation pilot's rudder pedals and control column are electrohydraulically servo driven. Forces applied at the surfaces of the pedals and at the hand grip of the control column are sensed by internally mounted strain gauge bridges and voltages proportional to these applied forces are supplied to a small dedicated analog computer on which the force-displacement characteristics of the simulated controller are programmed. The resulting computed displacements become command signals for electrohydraulic servo actuators which position the evaluation pilot controller appropriately. These same signals are fed to the main simulation computing system where they represent controller inputs to the simulated aircraft model.

Standard force-displacement characteristics such as gradient, break-out, friction, control throw, backlash and inertia are controlled by manual-set potentiometers which are situated in the centre console between the two pilots. The analog model will also accommodate externally-derived signals which may, for example, represent forces resulting from dynamic or aerodynamic feedback.

2.2 Simulator Computing Systems

Two fundamentally different approaches to aircraft modelling are used on the AVS, the choice between these depending upon the detailed objectives of the simulation program. The more powerful and precise of these approaches, the model-following technique depicted in Figure 4, is conceptually identical to a modern ground-based simulation scheme. In both cases, electrical signals from the evaluation pilot's controllers are fed to a computer model of the simulated aircraft and the model's computed responses are supplied to the "motion system". In the airborne simulator this "motion system" is a high bandwidth model-following autopilot which drives the helicopter, as a servo mechanism, to minimize the errors between helicopter and computed model motions.

In the alternate approach, illustrated in Figure 5, the natural responses of the helicopter to the evaluation pilot's control inputs are modified by control augmentation and response-feedback stability augmentation. Although this method is inherently less precise than model-following, it has the benefit of simplicity when the experiment depends only upon prescribed general response characteristics of the model and not upon precise duplication of detailed characteristics. In either case, the commands to the control actuators are computer-generated in response to both the evaluation pilot's control movements and motion signals fed back from the helicopter motion sensing system.

The computing requirements to support the complete simulation task depend upon the complexity of the model and upon the choice of simulation technique. In general, however, the major computing tasks include the following: the solution of the mathematical model of the simulated aircraft, autopilot implementation, signal processing (as part of the motion sensing system). These requirements are met in the AVS by the hybrid system shown schematically in Figure 6. This computing system is presently being up-graded with the addition of a PDP 11/03 digital microprocessor shown in the lower block of the diagram. Simulations performed to date have used only those system elements shown in the upper block; a 24K-byte Interdata Model 5 minicomputer and the main project analog computer which has 180 operational amplifier/integrator modules and 150 manual and servo-set potentiometers.

The new computer represents the first step in the direction of a multiprocessor, distributed processing system. The microprocessor, by assuming some of the fixed tasks which have previously been performed by the minicomputer, will enhance the overall computational capacity of the system. As the master processor, the minicomputer will continue to perform all input/output operations and will also control exchanges of data and status information with the microprocessor via the data transceivers. The two computers will be synchronized by the common system clock.

The keyboard/CRT display units shown in Figure 2 are part of the airborne hardware and are situated in a centre console between the two pilots along with an analog computer mode selector and a servo potentiometer control panel. In combination these systems provide extensive in-flight interactive capability with each of the processors and in conjunction with a high speed cartridge recorder facilitate program modifications or replacement in the course of a flight.

2.3 The Model-Following Autopilot

The Airborne V/STOL Simulator has the normal four independent control motions of a single main rotor helicopter - lateral and longitudinal cyclic pitch of the main rotor and collective blade pitch of the main and anti-torque rotors. With these, four of the six degrees of freedom of the simulator's motion can be independently controlled and hence the simulator autopilot can be designed to model-follow in these same four degrees of freedom.

The development and implementation of this four channel autopilot on the AVS has been a relatively recent exercise and at the time of writing only two channels, roll and yaw, have been implemented and used successfully in a simulation program.

The roll and yaw channels are functionally equivalent in their loop closure design and general implementation (Fig. 7). In each case a direct decoupling signal is injected into the appropriate control actuators (lateral cyclic actuators for roll and tail rotor collective actuator for yaw) to eliminate or at least diminish the contaminating effects of cross-coupling derivatives. This step is equivalent to a control and response feedback de-augmentation of the basic helicopter cross-coupling stability derivatives. Two loops are then closed on the decoupled system, an inner rate loop using rate gyro feedback and an outer attitude loop using attitude and directional gyro feedbacks for the roll and yaw channels respectively.

One additional path is shown in the diagram, an open-loop "lead" term which, through an approximation to the inverse transfer function of the decoupled helicopter, commands a simulator response to match the model values.

Figure 8 illustrates the performance of the two model-following channels.

2.4 Motion Sensing System

The simulator's motion sensing system was originally designed to provide feedback signals for the autopilot and simulation model calculations. High quality attitude, angular rate and linear acceleration signals are available as well as air and earth-referenced linear-velocities in the helicopter axis system.

Figure 9 shows schematically the elements of these air and earth-referenced velocity measuring systems. The vanes, pitot-static and static pressure systems, and ambient temperature sensor provide the raw inputs for a true air velocity calculation which is performed, on-line, in the digital computer. The doppler radar, accelerometers, rate gyros, and vertical gyro constitute a wide-band strapped-down inertial velocity system. As in the case of the airspeed system, the necessary filtering, sensor position compensation and kinematic calculations are performed in the digital computer.

In addition to supplying motion feedback for simulation tasks, this system provides a measure of the ambient atmospheric motions. The velocity vectors of the centre-of-mass of the helicopter relative to the local air mass and relative to the ground, are subtracted in the body-axis reference frame in which they are calculated and the resulting wind components are transformed to an earth-fixed reference system. The complete calculation is performed on-line, as part of the normal simulation computation cycle.

19-3

This airborne sensing capability has been used to measure and record the winds and turbulence encountered during handling qualities simulation studies. One of these experiments is described below in section 3. The simulator has also been employed in a strictly airborne sensing role as part of the meteorological data gathering exercises associated with the Ottawa-Montreal STOL Demonstration Program. Wind, turbulence, and temperature profiles were measured in the vicinity of the approach paths to the Ottawa STOLport under a variety of upper level wind and surface layer stability conditions and these data were correlated with measurements from an extensive array of ground-based sensors.

3. RECENT PROGRAMS

The following paragraphs contain brief descriptions of some recent project applications of the AVS. The results of these experiments are not dealt with in any detail in this paper since, in each case, they have either been reported elsewhere or are in the process of analysis. The purpose here is to illustrate the application of the airborne simulator to a range of flight mechanics problems.

Within the past year, two short programs have been performed on the simulator for the Sikorsky Helicopter Company, each evaluating handling qualities in a very limited region of the flight envelope of a specific helicopter. The first of these investigated hovering characteristics of the U.S. Army/NASA Rotor Systems Research Aircraft (RSRA). In this instance, the response feedback approach was used to simulate the control sensitivity and angular rate damping derivatives of the RSRA in hovering flight. Control force characteristics were also simulated.

The evaluation concentrated on a lack of harmony between the high roll sensitivity and the relatively low pitch and yaw sensitivities of the RSRA in its helicopter configuration. The primary objectives were to provide the project pilots with experience in hovering a helicopter with these characteristics before first flight of the RSRA, and to investigate the improvements in handling qualities resulting from various levels of augmentation to the RSRA rate damping derivatives. The validity of this simulation of general hover handling characteristics of the RSRA has been supported by the initial flight evaluations of that aircraft.

The second of these helicopter programs dealt with the high speed lateral-directional characteristics of a light single-rotor helicopter. In this brief program, the lateral-directional modes of the modelled helicopter were simulated for the normal cruise and maximum speed flight conditions. The simulation was performed in this case by model-following in roll and yaw, using the simulated aircraft y-force characteristics in the lateral-directional mathematical model and augmenting the longitudinal characteristics to approximate the modelled aircraft pitch and heave sensitivities and pitch damping. Various model configurations, including the SAS-OFF and SAS-ON conditions and configurations which simulated design alternatives for the empennage geometry, were evaluated in a series of VFR and simulated-IFR flight tasks.

Several of the recent AVS programs have been directed toward better understanding the influences of wind shears and turbulence on the approach and landing flight phases for STOL aircraft. The major areas of concern for conventional aircraft operating in the presence of strong atmospheric disturbances - increased flight crew workload, encroachment on safe-flight boundaries and excessive demands on automatic flight control systems - are all relevant to STOL operations; however, the STOL environment adds to these the aggravating influences of low approach speeds, steep approach paths, and in many cases, unconventional aircraft response to airspeed changes. This is a challenging area of investigation for flight simulation since it adds to the normal simulation modelling requirements the necessity to provide the evaluation pilot with a realistic representation of the atmospheric disturbances.

An experiment which has involved both the AVS and the NASA Flight Simulator for Advanced Aircraft (FSAA) has attempted to isolate some of the many interacting aspects of this problem.* A model of a STOL transport, having back-sided power versus speed characteristics during the approach, (Fig. 10) was implemented on the airborne simulator and flown in a simulated-IFR approach task within the operational environment of the Ottawa STOLport. To the degree that synoptic meteorological information permitted, flights were planned when the atmospheric conditions were conducive to the generation of moderate-to-strong turbulence or significant wind shear in the vicinity of the MS approaches to the STOLport. The winds and turbulence encountered during each approach were recorded and the evaluation pilot provided an assessment of the task and of the significant influences of atmospheric disturbances on the task in response to a questionnaire which was completed following each approach. Approximately 80 evaluations were flown in a range of turbulence and shear conditions by four pilots.

The experiment has since been repeated on the FSAA, duplicating as closely as possible on the ground-based facility the characteristics of the STOL model flown in the airborne phase. The three components of the ambient atmospheric velocity which were measured and recorded during the flight-phase approaches were injected into the FSAA simulation model as winds and turbulence. Additional comparison runs were flown in the ground-based phase using modelled turbulence.

The primary objective of the experiment was to investigate, by two very different simulation techniques, the influence of real turbulence and wind shears on the approach tracking characteristics of a STOL transport model. The airborne phase of the experiment has also provided data on the behaviour of the earth's boundary layer in its lower levels, in this case in the vicinity of a downtown STOLport.

* This was a cooperative program involving the U.S. Federal Aviation Administration and the National Aeronautical Establishment of Canada.

Figure 11 shows wind and temperature profiles for one of a number of stable frontal shear layers which were encountered during the experiment. This system persisted over the field for several hours during which time the inversion layer descended as the surface front approached the airport. The two sets of profiles, which were recorded during separate evaluation flights on the same day, show this motion of the frontal surface in the intervening hours. During each flight, however, the characteristics of the shear layer changed very little and each evaluation pilot flew repeated approaches under similar atmospheric conditions. An interesting result, though not an unexpected one, is illustrated by the variation in pilot ratings for the IFR tracking task on the repeated approaches (Fig. 12). It should be noted that a significant degrading factor in this overall approach task was the necessity to complete the approach in the presence of a tailwind. The active runway was 27. Nevertheless the task could be completed with an acceptable level of pilot effort and without exceeding the capabilities of the modelled aircraft once the pilot had experienced the unusual conditions and could anticipate the necessary compensating rate of descent and heading adjustments.

Analyses of the data from the two phases of the experiment are in progress.

4. FUTURE DEVELOPMENTS

At a time of rapidly advancing state-of-the-art in the design of digital microprocessors and electronic display systems it is necessary to strike a balance between continuous development of the simulator and its dedication to flight dynamics experiments. The first steps along the path to a more flexible, user-oriented digital computing system have already been taken and it is anticipated that this system will continue to evolve without interrupting simulator applications. A similar approach will be followed in the development of an advanced cockpit display system for project use.

From the beginning of the Airborne V/STOL Simulator program it has been part of the development plan to expand the simulation capability of the helicopter to five or a full six degrees of freedom. To do this, additional force generators must be incorporated as independent helicopter controls and these controls must be integrated into the fly-by-wire system. Several candidate approaches to providing these independent controls have been investigated in detail and are being evaluated comparatively for eventual implementation. Although the absence of additional force generators places some limitations on the simulator's capabilities, the variety of STOL and VTOL control, guidance and handling qualities problems hitherto requiring investigation has been more than adequate to ensure its full utilization.

5. CLOSURE

Airborne flight simulators developed from production single-rotor helicopters have been the main experimental tools used by the Flight Research Laboratory of NAE in a wide-ranging STOL and VTOL aircraft research program (Refs. 1-12). The new simulator, described above, is expanding the scope of this program by providing significant improvements in modelling capability and an expanded simulation flight envelope.

6. REFERENCES

1. Gould, D.G. The Model-Controlled Method for Development of Variable Stability Aircraft. NRC, NAE Aero. Report LR-345, National Research Council of Canada, June 1962.
2. McGregor, D.M. An Investigation of the Effects of Lateral-Directional Control Cross-Coupling on Flying Qualities Using a V/STOL Airborne Simulator. NRC, NAE Aero. Report LR-390, National Research Council of Canada, December 1963.
3. McGregor, D.M. Simulation of the Canadair CL-84 Tilt Wing Aircraft Using an Airborne V/STOL Simulator. NRC, NAE Aero. Report LR-435, National Research Council of Canada, July 1965.
4. Smith, R.E. A Comparison of V/STOL Aircraft Directional Handling Qualities Criteria for Visual and Instrument Flight Using an Airborne Simulator. NRC, NAE Aero. Report LR-465, National Research Council of Canada, August 1966.
5. McGregor, D.M. A Flight Investigation of Various Stability Augmentation Systems for a Jet-Lift V/STOL Aircraft (Hawker-Siddeley P1127) Using an Airborne Simulator. NRC, NAE Aero. Report LR-500, National Research Council of Canada, February 1968.
6. Hindson, W.S. Simulation of the CX-84 for Canadian Armed Forces Pilot Training Using the NAE Airborne Simulator. NRC, NAE Lab. Tech. Report LTR-FR-18, National Research Council of Canada, December 1969.
7. Hindson, W.S. Utilization of the NAE V/STOL Simulator to Assess the Handling Qualities of a Medium STOL Aircraft Equipped with Non-linear Lateral Controls, with Application to the Proposed DHC-7 STOL Airliner. NRC, NAE Lab. Tech. Report LTR-FR-21, National Research Council of Canada, February 1970.
8. Madill, D.R. Colavincenzo, O.M.S. Roderick, W.E.B. The Effect of Lateral Control Non-Linearities on the Handling Qualities of Light STOL Aircraft. A Flight Simulator Study. ICAS Paper No. 70-55, September 1970.

9. Doetsch, K-H., Jr. Parameters Affecting Lateral Directional Handling Qualities at Low Speeds. Paper presented to the AGARD Flight Mechanics Panel Specialists Meeting on Handling Qualities Criteria, Ottawa, September 28, 1971.
10. Doetsch, K-H., Jr. Gould, D.G. McGregor, D.M. A Flight Investigation of Lateral-Directional Handling Qualities for V/STOL Aircraft in Low Speed Manoeuvring Flight. NRC, NAE Aero. Report LR-549, National Research Council of Canada, October 1971.
11. Doetsch, K-H., Jr. Laurie-Lean, D.W. The Flight Investigation and Analysis of Longitudinal Handling Qualities of STOL Aircraft on Landing Approach. Air Force Flight Dynamics Laboratory, Wright-Patterson Air Force Base, AFFDL-TR-74-18, March 1974.
12. Doetsch, K-H., Jr. Influence of STOL Longitudinal Handling Qualities on Pilots' Opinions. Paper presented at AGARD Flight Mechanics Panel Meeting on Take-Off and Landing, Edinburgh, April 1974.



FIG. 1 NAE AIRBORNE V/STOL SIMULATOR

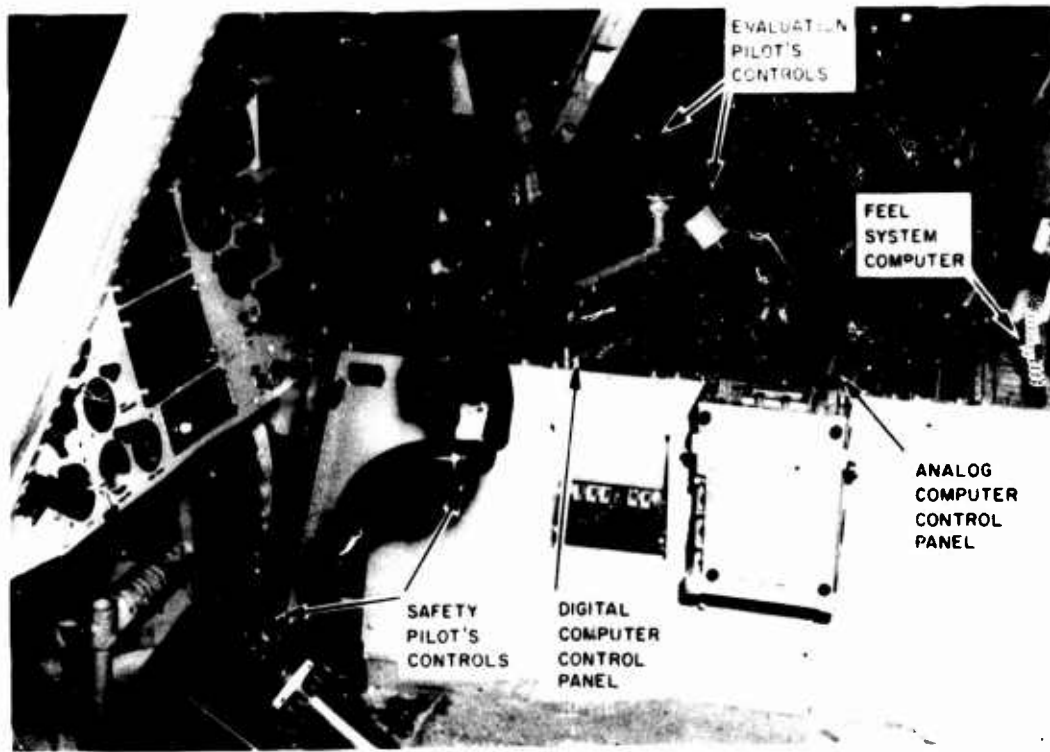

FIG. 2 SIMULATOR COCKPIT

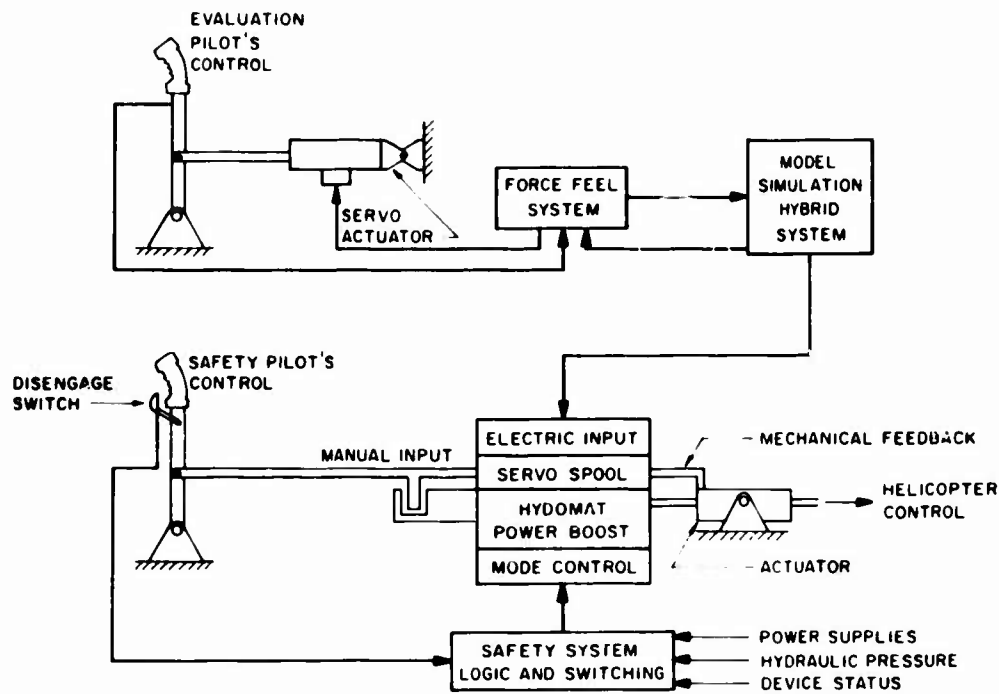

FIG. 3 SCHEMATIC DIAGRAM OF TYPICAL CONTROL CHANNEL

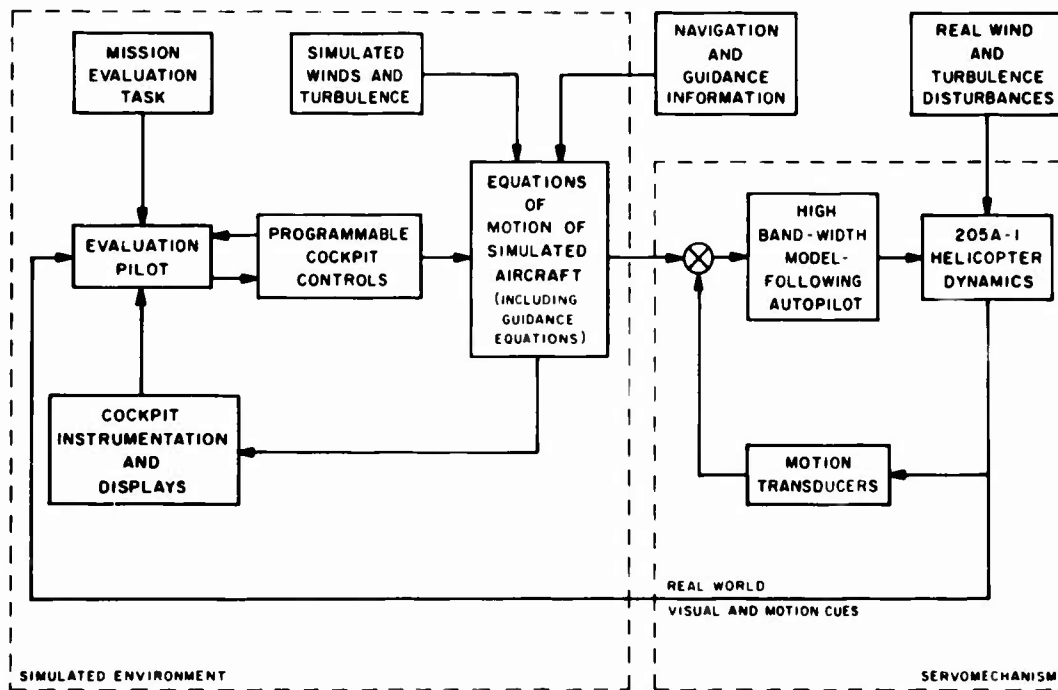

FIG. 4 SIMULATOR — MODEL-FOLLOWING MODE

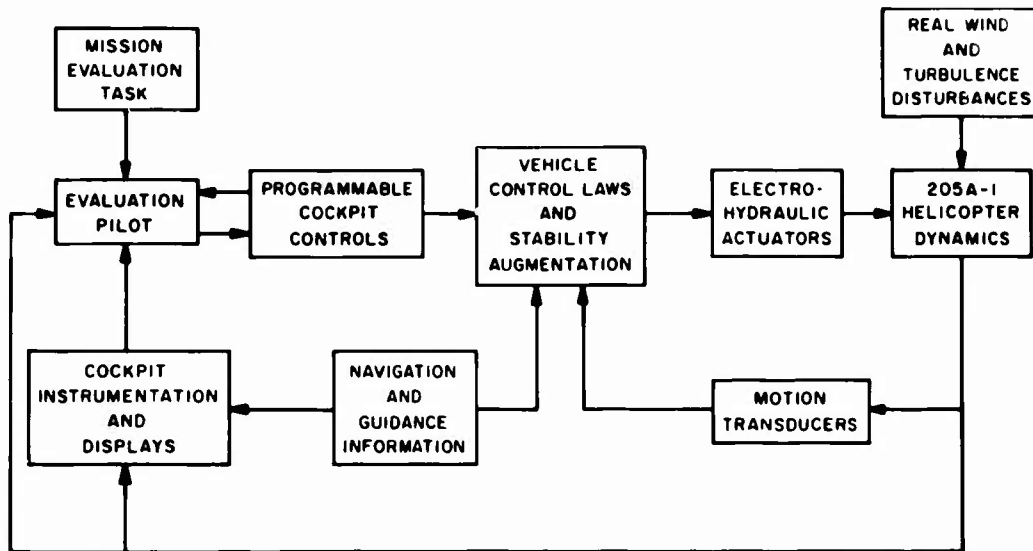

FIG. 5 SIMULATOR - STABILITY AND CONTROL AUGMENTATION MODE

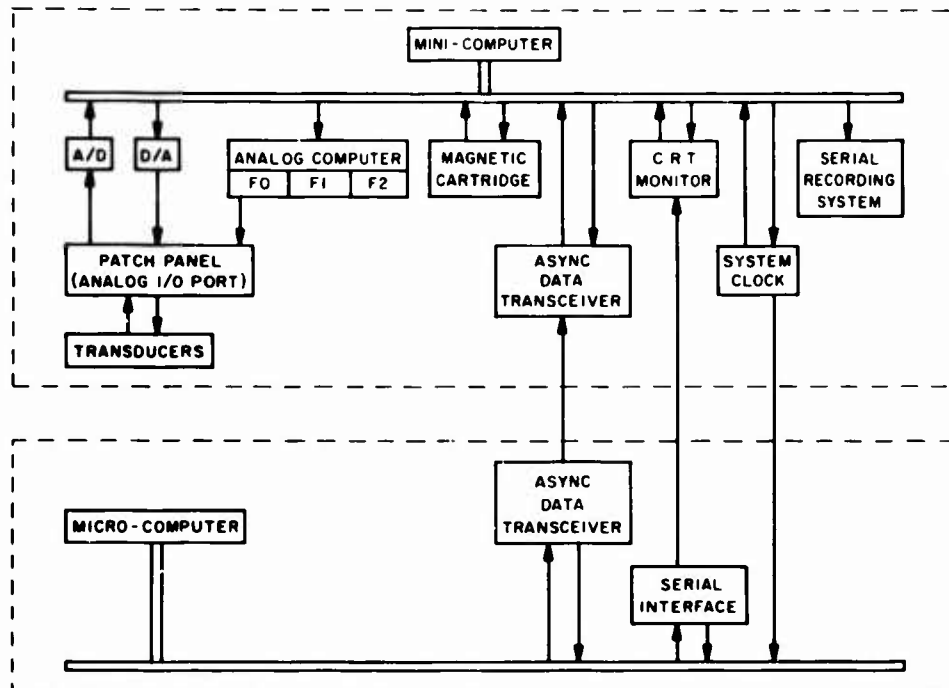

FIG. 6 COMPUTING SYSTEM

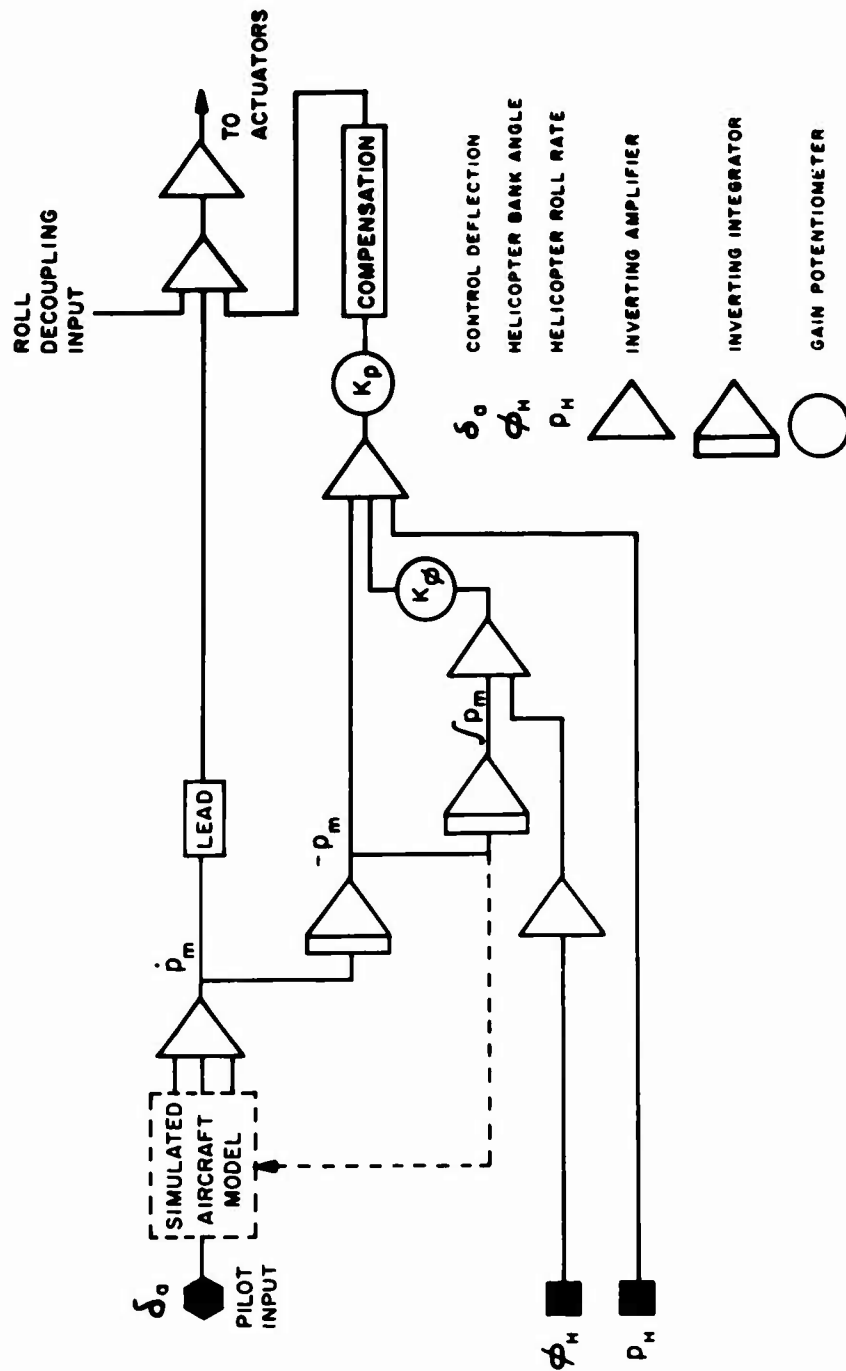

FIG. 7 AUTOPILOT SCHEMATIC - ROLL CHANNEL

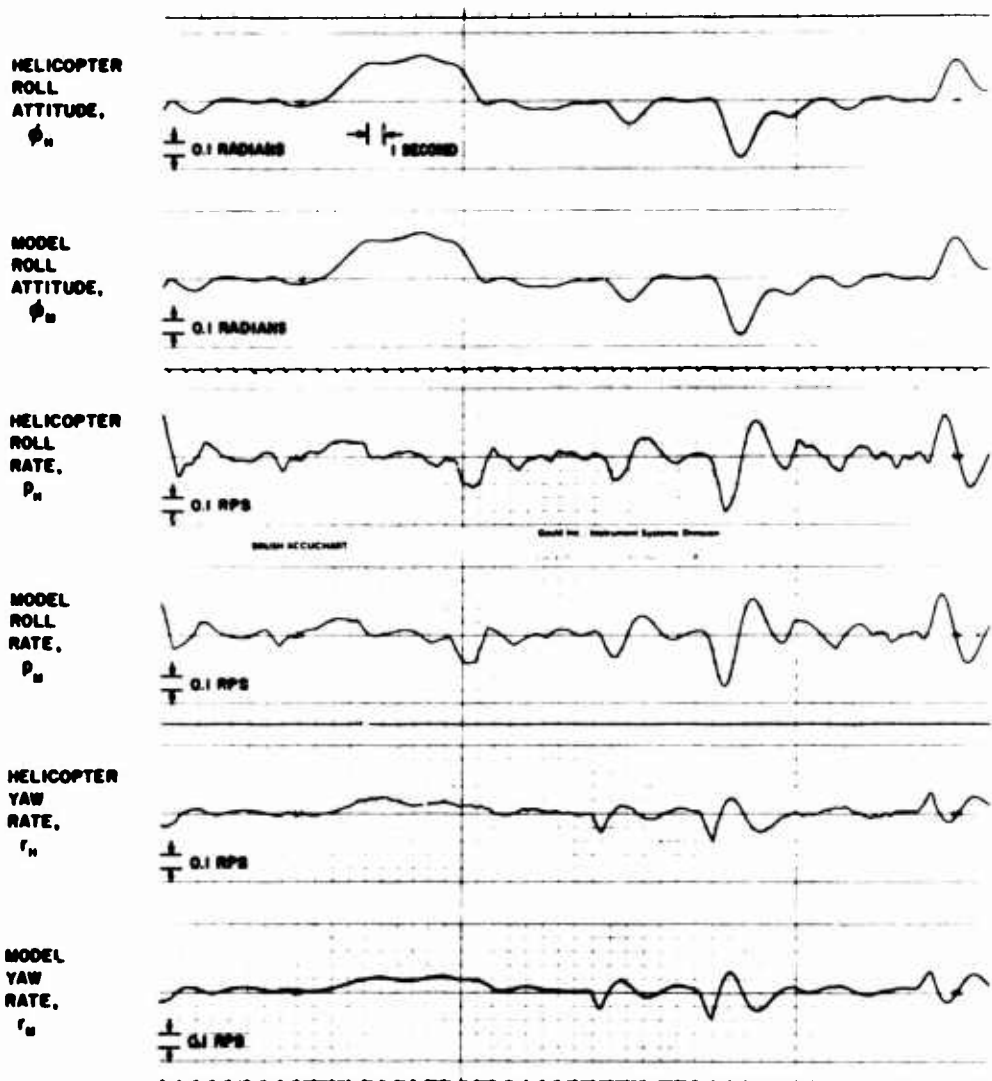

FIG. 8 SIMULATOR MODEL FOLLOWING IN ROLL AND YAW

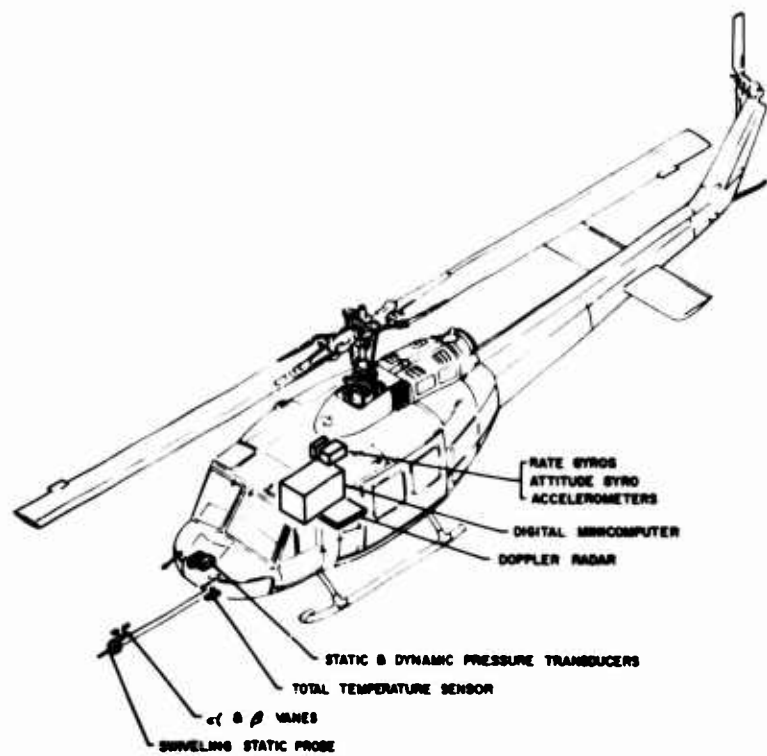

FIG. 9 MOTION SENSING SYSTEMS

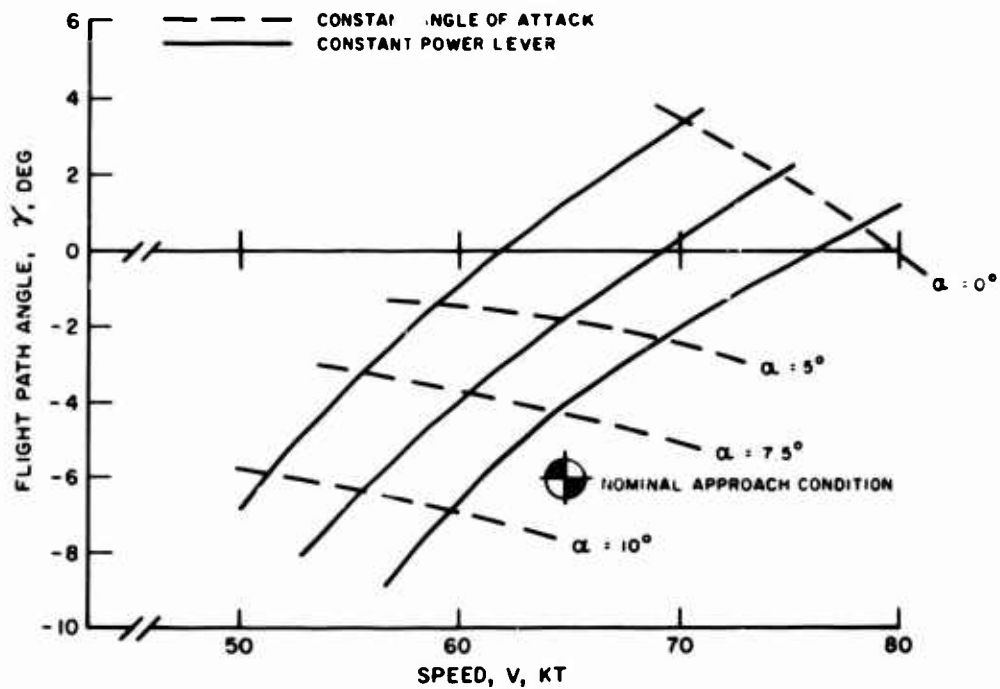

FIG. 10 STOL MODEL - γ vs V PLOT

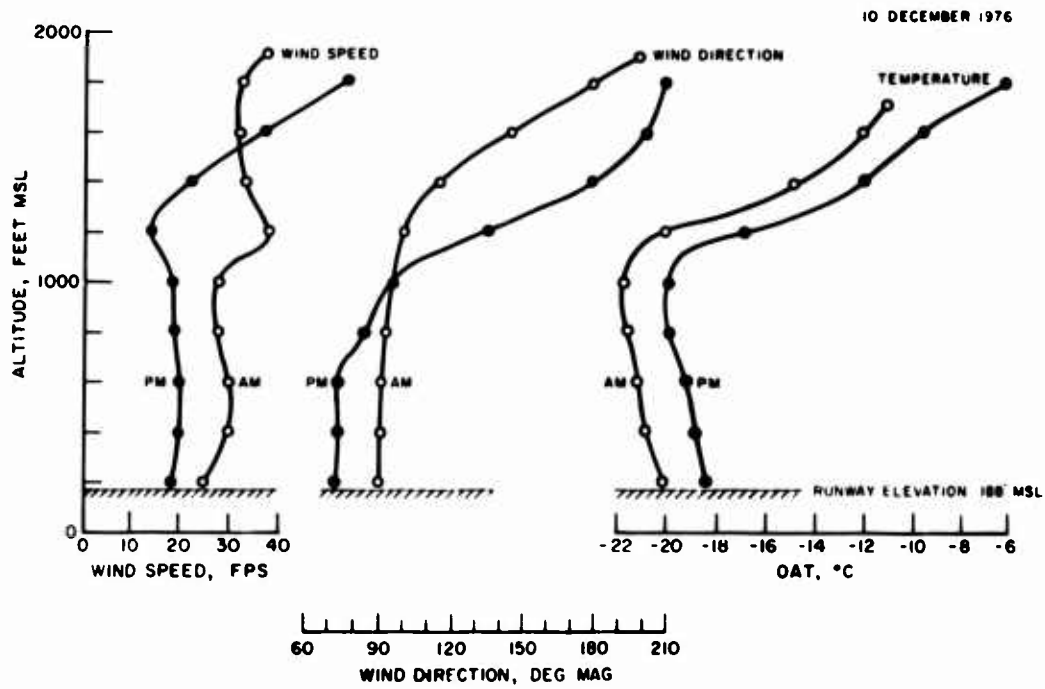

FIG. 11 WINDSHEAR PROFILES

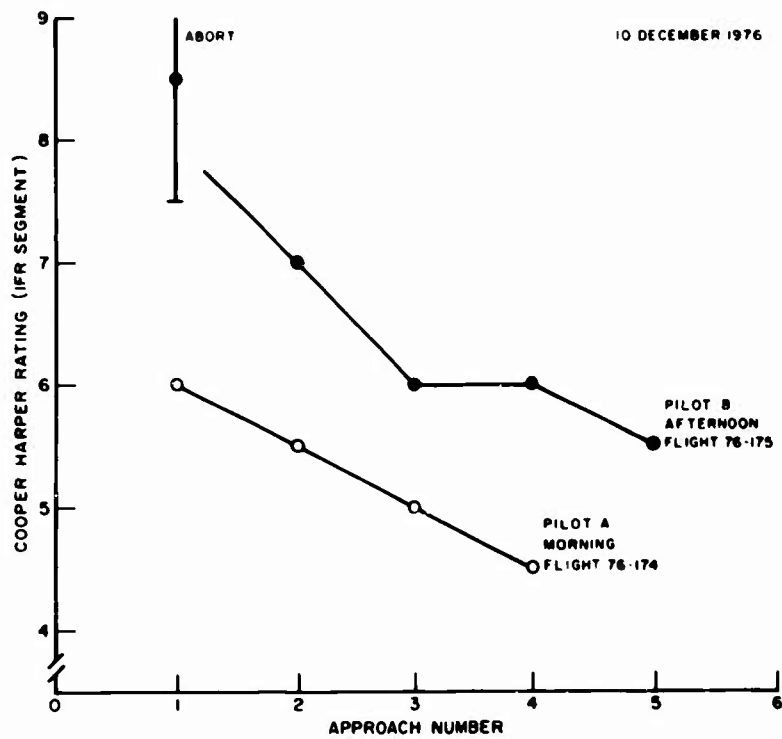

FIG. 12 PILOT RATINGS FOR APPROACH TASK IN STRONG WINDSHEAR

DFVLR ROTORCRAFT RESEARCH

by

B. Gmein, H.-J. Langer, and P. Hamel

Institut für Flugmechanik

Deutsche Forschungs- und Versuchsanstalt
für Luft- und Raumfahrt e.V. (DFVLR)
Postfach 3267
Braunschweig-Flughafen

SUMMARY

Helicopter research and development is being done at a number of Institutes within the German Aerospace Research Establishment (DFVLR). Both experimental and theoretical investigations are in progress. Particular emphasis is planned on verification and understanding of analytical work using experimental tools.

This paper reviews selected DFVLR activities in the field of rotorcraft research.

- Helicopter Windtunnel Test Stand
In a joint program with German aircraft companies, a helicopter test stand for large windtunnels has been assembled at DFVLR. The design of the test equipment and first results from windtunnel tests are discussed.
- Helicopter System Identification
In a joint program with MBB, DFVLR has extracted derivatives from helicopter flight test data. The project is reviewed and initial system identification results are presented.
- Active Vibration Control
MBB and DFVLR are jointly conducting studies to develop an Active Vibration Isolation System. After reviewing passive means of vibration control, special optimum controller logics for adequate active vibration suppression are discussed.
- Helicopter Crew Escape Systems
The DFVLR activities in the field of crew rescue from rotorcraft are reviewed, including rotorblade severance studies with an RPV helicopter model. Additionally performance characteristics of ejection and extraction systems are compared.

The investigations are sponsored by the German Ministry of Defense (BMVg) and the Ministry of Research and Technology (BMFT).

1. INTRODUCTION

Today's helicopters are used for an ever increasing number of tasks by both civilian and military users. Particularly for military helicopters, there is a continuously increasing need for increased aircraft performance, optimized stability and control behaviour, and better noise reduction. To satisfy these requirements, additional knowledge in the fields of helicopter aerodynamics, flight mechanics, aeroelastics, dynamics, and acoustics is essential.

In the Federal Republic of Germany the groundwork for several helicopter projects, both military and civilian, will be completed in the next few years. Research for these projects is being done by both industry and DFVLR. The DFVLR is working mainly in the following areas:

- Helicopter windtunnel testing (Ref. 1),
- Aeroelastics of rotary-wing aircraft (Ref. 2),
- Helicopter flight test techniques and simulation (Ref. 3),
- Digital flight control systems for helicopters (Ref. 4),
- Helicopter escape system and survivability studies (Ref. 5),
- Rotor noise (Ref. 6), and
- Helicopter display system for limited visibility operation (Ref. 7).

Selected topics of DFVLR activities will be reviewed in this paper:

- Helicopter windtunnel test stand,
- Helicopter system identification,
- Active vibration control, and
- Helicopter crew escape systems.

These investigations are undertaken in close cooperation with the potential users, industry, and Federal Ministries.

2. HELICOPTER WINDTUNNEL TEST STAND

20-2 In recent years theoretical work in helicopter aerodynamics, aeroelastics, dynamics, acoustics, and flight mechanics has been intensified. It is necessary now more than ever before, to verify and expand theoretical results with proper and sufficient testing. This will help to establish a reliable data base for further development of rotary-wing aircraft. Moreover, extensive configurational studies and tests are required to obtain aerodynamic and flight mechanic improvements for the design of novel helicopter systems.

A helicopter test stand for large windtunnels has been assembled in Germany to do this experimental work (Figure 1). Under contract to the German Ministry of Defense, the test equipment was produced in a joint program by DFVLR, Dornier, MBB, and VFW-Fokker.

2.1 Design Requirements and Hardware Realization

From the beginning the versatility of the test equipment had to be considered. The test stand must be adaptable to many investigations in different fields. This dictated the following requirements:

- Test stand should be suitable for many different investigations in the fields of aerodynamics and dynamics, and
- Transferability of test results to full-scale helicopters must be valid for these investigations.

In general it is impossible to accomplish these requirements with one model. Considerations of the similarity principles show conflicting requirements dictated by different model scaling laws.

Because of the many investigations to be conducted in the field of aerodynamics it is necessary to have a "Mach scaled" model. The requirement for Mach scaling plus the requirement for sufficient transferability dictate that the model be as large as possible. The scaling laws concerning this model are discussed in detail in Ref. 1.

In addition, the test stand should be suitable for different models such as shaft driven and reaction driven rotor systems. And, the test stand should be adaptable to different fuselage, tail, and tail rotor configurations.

Finally, the test stand should fit in the large windtunnels available. At this time in Germany there are two windtunnels suitable for experiments with large rotor models. One is at the Volkswagen research facility at Wolfsburg. It has a test section 7.5 meters wide and 5.0 meters high and a 50 m/sec maximum test section wind speed. The other is at the Daimler-Benz facility in Stuttgart. It has a test section 7.4 meters wide and 4.9 meters high and a 80 m/sec maximum test section wind speed. Additionally, in 1979 the German-Dutch Windtunnel (DNW), which is now being constructed, will be available. This large subsonic tunnel will be particularly suitable for model rotor investigations.

Drive System

There are many difficulties in the selection of the power plant for a Mach scaled rotor model. The available electric, hydraulic and air turbine motors are still too heavy to allow proper dynamic scaling (Ref. 8). The best way to achieve dynamic scaling weight objectives is to mount the drive system external to the rotor model.

A high power (90 kW at 1050 RPM) compact hydraulic motor was installed in the test stand. The bulky primary power unit, that is the electric motor and hydraulic pump, can be easily positioned as required for set up in various windtunnels. The pump and the motor are connected with high pressure hoses. Special flex couplings have been designed and fabricated to have the required torque capability. To allow accurate measurements at the rotor-balance, the couplings are "soft" enough so that axial force, lateral force, and moment losses to the test stand are very small compared to the loads measured.

Rotor Model

Presently in Germany, work is being concentrated on helicopters of up to eight tons gross weight. The corresponding rotor diameter is approximately sixteen meters. To maximize data transferability, the model rotor diameter was made as large as possible while still allowing use in the available windtunnels. The maximum rotor diameter is four meters.

The first rotor fitted to the model is a hingeless four blade, Mach scaled unit (Figure 2). The rotor was designed to model the dynamic and geometric characteristics of the MBB BO-105 main rotor. The rotor blades are soft flapwise and soft inplane. The hub is stiff flapwise and stiff inplane. In the design of the scaled rotor care was taken to model the stiffness and mass distribution of the BO-105 rotor accurately (Ref. 9). With only a few exceptions, the dimensions and wall thickness were scaled linearly. The blades are fiberglass and the hub is steel. This design resulted in a rotor system which is sufficiently strong to allow operation over the entire flight regime of the full-scale rotor system. The following table gives the important characteristics of the rotor:

Diameter	D	=	4	m
Number of blades	z	=	4	
Solidity	$\sigma_{0.7}$	=	7.73	%
Blade planform			rectangular	

Blade profile	NACA	23012
Twist	$\Delta\theta$	= $-6^{\circ}14'$
Flapping frequency ratio	ω_{β}/Ω	= 1.12
Lagging frequency ratio	ω_{ζ}/Ω	= 0.71
Rotor speed	n	= 1050 RPM
Tip speed	U	= 220 m/sec
Torque	M_T	= 815 Nm
Design thrust	T	= 3630 N
Disc area loading	T/A	= 290 N/m ²
Maximum thrust in hover	T_{max}	= 4400 N

Fuselage Model

The fuselage consists of a supporting structure and outer shell (Ref. 10). The fiberglass outer shell can be changed for various experiments. A representative fuselage for a medium weight transport helicopter is presently on the test stand.

The fuselage is mounted on the test stand using a six-component balance. By mounting the fuselage shell in various positions it is possible to change the position of the fuselage relative to the rotor hub and/or the fuselage's longitudinal flight angle. Auxiliary wings can be mounted on the fuselage. Provisions have also been included for a tail rotor drive system.

Data Acquisition and Presentation

The most important factors in the design of the measurement equipment were

- On-line presentation of all critical data to ensure safety and flight monitoring,
- High reliability and accuracy of the data, and
- Flexibility and adaptability of the equipment to different measurement tasks.

For measuring the forces and moments at the rotor hub and at the fuselage, two six-component strain gage balances have been installed. These strain gage balances measure the steady-state loads with good accuracy (error < 2 % of maximum load). They also provide dynamic load data up to 4 per revolution.

Because the forces and moments of the rotor are measured independently of the fuselage loads, interference effects between rotor and fuselage can be identified. RPM, torque, and rotor power are obtained from a measurement package fitted in the drive shaft.

For many investigations it is necessary to obtain data from the rotor concerning blade motion, blade loads and other variables. Data from the rotor is transmitted to the stationary test stand by PCM telemetry. The telemetry transmitter and antenna are located on top of the rotor hub and rotate with the rotor. Thirty-two data channels are provided, each with a frequency response of 100 Hz. By reducing the number of data channels, the available frequency response can be increased. Since the data is transmitted in digital form there is no possibility of bias errors common to analog systems.

The DFVLR data acquisition and presentation system consists of two elements

- Quick-Look Data System, and
- Dynamic Data System.

The Quick-Look Data System allows monitoring of analog data from the six-component balances, the measurement shaft, and the strain gage bridges fixed on the rotor. This allows timely decisions to be made while experiments are being run.

In the Dynamic Data System (Figure 3) analog data from the balances and the measurement shaft are digitalized. This data together with the digital data from the rotor is recorded on magnetic tape. Detailed analysis of the experiments are accomplished off-line.

Control System

In the design of the swashplate, provisions were made to allow the use of either shaft driven or reaction driven rotors as well as different blade numbers. The rotor shaft angle is controlled by tilting the upper part of the test stand. The ability to remotely control both collective and cyclic blade angles and rotor shaft angle allows rapid changes in test conditions without shutting down the model or the windtunnel.

2.2 Preliminary Investigations

The test stand was run for the first time in 1976. A number of tests were necessary to assure flight safety and to check the basic properties of the model. The following investigations have been accomplished:

20-4

- Static and dynamic tests and calculations prior to first run
 - Calibration of measuring system,
 - Measurement of control elasticity and clearance, and
 - Investigation of ground resonance conditions.
- Hover tests
 - Balancing and tracking of rotor system,
 - Checking of the rotating measurement system, and
 - Confirmation of the resonance diagram of the rotor system.

Calibration

The main task was the calibration of the two six-component balances. Static calibration of the balances was accomplished using standard weights. A linear relationship between load and measured value as well as negligible balance movement were assumed. The equation

$$\underline{K} = \underline{A} \cdot \underline{P}$$

describes the calibration method, where

$$\underline{K} = (K_1 \dots K_7)$$

are the measured values, and

$$\underline{P} = (P_1 \dots P_6)$$

are the calibrated weights. The calibration matrix \underline{A} with its elements

$$A_{ij} = \partial K_i / \partial P_j$$

is obtained from the loading tests. The inverted matrix

$$\underline{P} = \underline{A}^{-1} \cdot \underline{K}$$

defines the relationship between the measured and actual data. A resonance investigation between 10 and 100 Hz showed that the six-component rotor balance had a number of natural frequencies in the neighbourhood of the fundamental (1/REV) and harmonic frequencies (4/REV) of the rotor itself (Figure 4). After theoretical investigations the balance was modified by mechanical frequency adjustment (Ref. 11). Figure 4 shows the dynamic response of both the original and modified balance.

Ground Vibration Tests

For safe operation it is important to know the ground resonance characteristics. From ground vibration tests with various configurations and axis orientations, sufficient information was obtained about the matrices of generalized mass, damping and stiffness. Finally, rotor vibration characteristics were calculated from rotor mass and stiffness distribution data. From the computed natural frequencies of the coupled and damped rotor/rotor support system, it was concluded that there are no ground resonance problems in the rotor operating speed regime (Ref. 12).

Hover Tests

Because of high rotor speeds (1050 RPM), balancing problems could be expected. Therefore careful dynamic balancing of the hub assembly and static balancing of the rotor blades was necessary to realize successful overall system balancing and tracking. Using strain gages, blade dynamic response-lagging and flapping- was measured for small pitch step inputs. Test results were in good agreement with calculated data (Ref. 13) (Figure 5).

2.3 Windtunnel Tests

The first windtunnel tests took place in the VW windtunnel at Wolfsburg. This wind-tunnel has climatic control which allows tests to be conducted at temperatures as low as -20°C. To use the climatic control the test section must be enclosed using a moveable cover. In order to maintain a constant temperature - and therefore a constant rotor RPM for a particular blade Mach number - the first tests were conducted with the test section moveable cover in place. The measured data showed stochastic large amplitude fluctuations for the rotor forces and moments (Figure 6). This effect resulted from interference caused by the walls of the closed test section and was not present with the cover removed.

During these first tests, the following was accomplished (Ref. 14):

- Measurement of rotor characteristics,
- Definition of regions of flight safety,
- Investigation of aerodynamic interference effects between rotor and fuselage, and
- Measurement of rotor downwash at selected field points.

Figure 7 shows typical results from the rotor/fuselage interference investigation. For constant thrust, expected differences in required rotor collective pitch angle for configurations with and without fuselage could be quantified.

2.4 Conclusions and Future Activities

First windtunnel tests have demonstrated the feasibility of the basic concept of the DFVLR Rotor test stand and its measuring system. Future plans include tests by various

German research institutes and aircraft industries in the following research areas:

20-5

- Rotor downwash identification,
- Rotor stall limits,
- Aerodynamic interference effects,
- Pressure distribution on rotor blades,
- Dynamic response of rotor systems,
- Offset-lift rotor systems,
- Aeroacoustical effects,
- Novel rotor control systems, and
- Fuselage, tail unit and tail rotor aerodynamics.

This work will be done in the various windtunnels available with the existing model and with new models. In the future, gathering of basic data and configurational investigations will contribute to new designs of novel rotary-wing aircraft.

3. HELICOPTER SYSTEM IDENTIFICATION

The goal of a joint research project between the DFVLR Institut für Flugmechanik and MBB is the extraction of stability and control derivatives from helicopter flight test data. The program, which is sponsored by the German Ministry of Defense, has four phases.

In the first phase, system identification methods for helicopters were investigated and improved. Different model structures for the description of helicopter flight dynamics were evaluated. In the second phase, simulated data was used to investigate the unique problems associated with helicopter system identification. Based on these investigations, preparations were made for the third, flight test, phase. The flight test vehicle was a MBB BO-105 helicopter. In the fourth and final phase, the flight data was processed and the identification executed.

MBB's experience in the field of helicopter modeling combined with DFVLR's experience with parameter identification methods led to a successful joint program (Ref. 3). The program is described and some of the results presented.

3.1 General

There is a great need to accurately know stability and control derivatives for the following applications:

- Verification of flying qualities,
- Establishment of a data base to be used for improving handling qualities,
- Optimal design of automatic control and stability augmentation systems,
- Design of flight simulators, both ground and inflight, and
- Comparison with analytical aircraft modeling techniques and windtunnel results.

During the past years, parameter identification methods have been successfully applied to fixed wing aircraft (Ref. 15). The application of equivalent methods to rotorcraft (Ref. 16 and 17) is a more complicated task because of

- Additional degrees of freedom,
- Coupling of lateral and longitudinal motions,
- High vibration levels which contaminate measured data, and
- Short test periods due to inherent helicopter instability.

Figure 8 presents a general procedure for parameter identification.

3.2 Mathematical Model

The rotorcraft modeling problem is a difficult task because of the large number of degrees of freedom and the complexity of aerodynamic effects. For simulation studies, linear and nonlinear models were used. A rigid-body 6 DOF linear model was developed from a computer program which included nonlinear effects. This model adequately describes the low frequency, rigid-body flight dynamics. The high frequency contributions of the rotor dynamics are included in the rigid-body derivatives. The nonlinear model included flapping, lagging and torsion modes and control flexibility for each blade in addition to the rigid-body modes.

For the identification from flight data a linear 6 DOF model including specific longitudinal-lateral aerodynamic coupling derivatives was applied. Starting from a basic forty-two parameter model a final twenty parameter model was found to adequately describe the BO-105.

3.3 Input Design

During the simulation phase it was shown that the accuracy of the identification results is highly dependent on the input signal used. Because step and doublet inputs, which are frequently used in flight testing, give unsatisfactory identification results, more efficient input signals were developed by the DFVLR Institut für Flugmechanik (Ref. 18). These optimum signals take into account the following conflicting requirements:

20-6

- Wide frequency band,
- Short time duration, and
- Easily flyable by the pilot.

Figure 9 indicates one of these input signals and its power spectral density. The two level, seven seconds duration signal is described by a sequence of step functions filtered by a second-order digital filter. This signal shape, optimized by simulation, contains the necessary frequency band (from 0.15 to 2.8 rad/sec) for evaluating the desired flight mechanic parameters of the BO-105. The corresponding blade pitch amplitudes were limited to 0.5 degrees such that the dynamic response amplitudes could be kept small. Therefore, nonlinear aerodynamic effects could be neglected in the mathematical model.

3.4 Instrumentation and Data Processing

Flight tests were conducted using a BO-105 helicopter equipped with a fly-by-wire flight control system. Accelerations, attitudes, rates, speed components, and control inputs were measured and recorded on an analog magnetic tape on board the helicopter. A low airspeed sensing and indicating system (LASSIE) was used to measure airspeed. Flight test were conducted at a speed of 70 knots. Each run was about 30 seconds long. The chosen input signals were generated electronically and fed to the fly-by-wire flight control system. This assured high repeatability between the runs.

Much effort was spent in the data processing as shown in the flow chart of Fig. 10. All signals were filtered identically using 16 Hz analog low-pass filters and finally digitized. Some signals, especially accelerations and rates had to be filtered further because of high vibration levels. Therefore zero phase-shift digital low-pass filters, developed by the Institut für Flugmechanik, were used. After the evaluation of the calibration tape the data was converted to physical units and corrected for CG location. Non-measured data, such as rotational accelerations, were obtained by taking derivatives of the measured rates.

3.5 Analysis of Simulation and Flight Test Data

For the identification of the BO-105, three different techniques were used: Least Squares and Instrumental Variable, both of which are equation error methods, and a Maximum Likelihood output error method. Advantages of the Least Squares method are short computation time and the fact that no *a priori* values are needed. In general, output error methods give better results from noise contaminated flight test data. The Maximum Likelihood method requires longer computation time and also needs *a priori* values to converge.

Figures 11 and 12 present time history comparisons of typical identification results. Figure 11 shows in detail flight test data and simulated data using the identified models from the Least Squares and Instrument Variable methods. Figure 12 shows similar identification results using the Maximum Likelihood technique. In addition, good correlation between identified and theoretically estimated derivatives has been shown in Ref. 3.

From these identification results the following main conclusions can be drawn:

- Linear mathematical models can be chosen for sufficiently accurate helicopter parameter extraction from flight data,
- Preliminary simulation studies are effective tools for preparing for and evaluating helicopter system identification flight tests.

4. ACTIVE VIBRATION CONTROL

Important factors limiting helicopter operation are rotor oscillatory aerodynamic and inertia loads. These loads cause fuselage vibrations which must be eliminated or reduced for the following important reasons:

- Improvement of ride comfort for crew and passengers,
- Improvement of operational handling qualities during mission oriented flight tasks (target acquisition and tracking, hover with sling loads),
- Reduction of pilot workload during IFR and night flights,
- Minimization of structural fatigue, and
- Improvement of subsystem life, particularly avionics.

In the past a number of mechanical devices have been developed which can alleviate excessive fuselage vibrations. Passive means of fuselage or cabin isolation can be realized using soft springs which include damping devices (elastomers). Such a simple spring/damper isolation (Figure 13, upper part) has undesirable characteristics. For example, low frequency motions are aggravated by the soft springs as can be seen from the transmissibility diagram. In addition, large static deflections between the rotor-system and the fuselage during transient maneuvering may occur. This would be incompatible with helicopter control requirements.

A modification to the simple spring isolator described above led to the Kaman DAVI principle (Dynamic Anti-Resonant Vibration Isolator) in which pivoted spring-mass-systems enable sufficient isolation in selected degrees of freedom (Figure 13, center part). The system is claimed to eliminate the disadvantages of the conventional soft mounting approach. Boeing/Vertol applied the DAVI principle in the development of a multi-axis-nodal isolation system for hingeless rotor helicopters. This Improved Rotor Isolation System (IRIS) provides

isolation between the rotor transmission and the fuselage in the vertical and lateral translational, pitch, and roll degrees of freedom. It was successfully flight tested on the BO-105 and the UTTAS (YUH-61A) prototype. Suspending the airframe from the node-points of a beam system is another derivative of the DAVI system which provides passive isolation (Bell Noda-Magic). A good survey of the most important contributions in the field of passive vibration control can be found in Ref. 19. 20-7

Further technical improvements in helicopter vibration control can be achieved by introducing active control technology. Problems generated with passive isolation systems such as spring travel and bottoming, mechanical control coupling, and difficult isolator adaptability to system changes, may be more easily overcome using electro-hydraulic actuators with feedback rather than passive springs. Such flexible system should improve the vibration isolation at all important frequencies and flight speeds.

In a government sponsored research program, MBB and DFVLR are jointly conducting studies to develop a Vibration Isolation System using Active Control Technology (Figure 13, bottom). The basic principle is to control the rotor-induced oscillatory loads such that - independent of deflections between rotor and fuselage - a constant value is reached on the airframe. In this case, vibrations will not be induced on the airframe, whereas there will be vibrations on the rotor system. On the other hand, any deflections between rotor and airframe caused by transient maneuvers have to be compensated. The transmissibility in Figure 13, bottom, shows typical notch-filter characteristics.

DFVLR has contributed to the solution of this problem by developing special controller logics based on optimal control theory (Ref. 20). Because the rotor induced loads P_R are essentially unmeasurable disturbances, and because only limited information about the model state is available, the control task can be defined as the output control of a linear time-invariant multivariable system with unmeasurable arbitrary disturbances.

DFVLR has developed and applied two different controller logics for a simplified discrete model of the BO-105 (Ref. 21):

- Dynamic compensation with notch-filter (case 1), and
- State and disturbance observation with Riccati-Feedback (case 2).

Some representative simulation results of the dynamic compensator (case 1) are shown in Figure 14. The dynamic response of the incremental control actuator signal u and the fuselage heave deflection z for BO-105, 4/REV oscillatory rotors loads P_R are indicated in the first column of Figure 14. The rotor induced fuselage response z is attenuated within one rotor revolution (1 REV). For a 2.5 g transient maneuver (second column of Figure 14), initiated by a P_R -ramp input, the relative deflection between the rotor and the fuselage Δz is minimized within less than five rotor revolutions (5 REV). Similar good results are achieved with the state and observer feedback system (case 2) as can be seen in Figure 15.

At the moment, DFVLR is applying modern control theory to higher-order system dynamics. Together with MBB, extensive computer simulations are in progress to develop an active control isolation system for a hingeless rotor helicopter. This model takes into account multifrequency, 5 DOF rotor oscillatory forces and moments. On the other hand, the dynamic response of the helicopter fuselage will include 6 DOF rigid-body modes and selected flexible modes.

In general, it can be stated that low multi-frequency vibration levels may be achieved in the future with active control technology. The development risk to design such systems for practical application is centered on the requirements for compact electro-hydraulic actuators. In particular, there are stringent requirements for system sensitivity, dynamics, low friction, and hysteresis as well as system reliability, maintainability, and cost-effectiveness.

5. HELICOPTER CREW ESCAPE SYSTEMS

In the final report of the AGARD Working Group *Escape Measures for Combat Helicopter Crews* (Ref. 22) it is emphasized, after reviewing the helicopter accident statistics of various NATO countries and available literature, that the development of a rescue system for helicopter crews is necessary.

Expansion of the normal operating regions of modern military helicopters dictates that crew escape systems be included. That is why specifications of new tactical helicopters require crew escape systems. DFVLR participated in preliminary investigations published in the report of the AGARD Working Group. Currently at DFVLR comparison studies of various escape concepts are in progress under German Ministry of Defense sponsorship (Ref. 5).

One concept that DFVLR is investigating is upward extraction with separation of the rotor blades. The development of this type of rescue systems can be achieved only in close cooperation with the helicopter manufacturer since the design of such a system has to be considered as an integral part of the total helicopter development. Thus, DFVLR considers its task to be conduct of the basic research necessary for the development of such rescue systems. In order to obtain generally valid criteria for the feasibility of specific rescue concepts, these investigations are not restricted to any specific type of helicopter.

5.1 Model Tests

One of the key problems to be resolved for a rescue system with upward extraction of the crew is the elimination of the blades. The starting point for studying this problem is to investigate the dynamic behaviour of a helicopter after severance of the blades, and to investigate the separation flight path of the blades.

20-8

Initial calculations have shown that theoretical prediction of the dynamics of the helicopter and blades after severance is difficult. The difficulties exist because of factors which cannot be predicted accurately enough, for instance the blade loads immediately before severance and the drag coefficients of various elements.

Therefore windtunnel and free flight model tests are used to improve the theory. Basic research using models has several advantages:

- Free-Flight and windtunnel model are identical,
- Simulations of any flight condition,
- Reproducibility of any extreme initial conditions,
- Single modification possibilities,
- No safety problems, and
- Cost and time effective.

At present RPV helicopter models are used for free-flight tests. In order to be able to conduct the planned investigations, the rotor hub assembly had to be modified for blade separation by pyrotechnic means. Two possible solutions were tested:

- Blade severance with radial acceleration of the blade, and
- Blade severance with no acceleration.

During these tests, a pilot dummy was ejected using a pyrotechnic ignition assembly. In order to assure transferability of model test data to full-scale helicopters, the scaling laws must be used. However, for a small model it is impossible to achieve a complete simulation. Therefore, it is necessary for future tests to use larger models and examine the influence of model scaling laws.

5.2 Rescue System Performance Investigations

The first and foremost design consideration for crew escape systems is the proper consideration of human tolerances. This requires attention to acceleration, windblast, flailing of head, arms, and legs, and atmospheric environment. To evaluate the performance of rescue systems with regard to these criteria, a dummy was instrumentated with sensors and telemetry (Figure 16). In the present configuration the following values are measured:

- Linear accelerations in the three body axis directions,
- Angular rates about three axis, and
- Force/time histories during parachute deployment and filling phase.

The performance investigations of a pilot extraction system was started with a test under zero/zero conditions. Figure 17 shows the DFVLR test set-up. It was concluded from the measured data, that essential improvements are necessary before applying the system to helicopters. In particular, the parachute filling characteristics and trajectory control need to be improved. Figure 18 gives some results from DFVLR tests. The curves indicate the minimum distance from the parachute/rocket/man-system to the ground. Comparison of the flight data results for a rocket assisted fighter ejection system and the rocket powered extraction system shows possible advantages that can be achieved using DFVLR proposed pyrotechnic system improvements.

Presently, a modified extraction system is being prepared for tests which will use a tethered Alouette II helicopter. Additionally, several different methods of pyrotechnically severing the rotating blades will be investigated.

5.3 Future Research Activities

There are some discussions about the necessity for crew escape systems for special helicopters, about the expense and about the effectiveness for typical helicopter missions. So that decisions can be made, DFVLR is continuing its investigations in the following areas:

- Investigations of helicopter accidents with particular attention paid to their origins,
- Improved model tests in combination with theoretical investigations, and
- Evaluation, comparison and improvement of escape systems.

The investigations will help overcome the lack of data existing at present in the area of crew rescue from helicopters.

6. CONCLUSION

In summary, based on the technical contents of the paper, the following general points are appropriate:

- Main subjects of the DFVLR in the field of rotorcraft research and development have been presented,
- In particular, those contributions which have a strong relevance to flight mechanic problem areas were discussed,
- Because of the high complexity of rotorcraft design, experimental investigations will play an increasingly important role in the future,

- Test facilities and procedures which will be routinely applied by DFVLR in future helicopter development programs were discussed, and
- DFVLR's participation in government supported helicopter research and development programs with industry is increasing.

7. ACKNOWLEDGEMENTS

In the development of this report we wish to acknowledge the technical assistance contributed by Mr. Jürgen Kaletka, Mr. Ohad Rix and Mr. Ulf Schmidt, members of the DFVLR Institut für Flugmechanik.

The support in translating this report of Capt. Hank Garretson, our guest scientist, from US Air Force Systems Command is particularly appreciated.

8. REFERENCES

1. Gmelin, B.: A Model for Windtunnel Rotorcraft Research - Model Design and Test Objectives. Second European Rotorcraft and Powered Lift Aircraft Forum, Paper No. 32, Bückeburg, 20-22 Sept. 1976.
2. Triebstein, H.: Instationäre Druckverteilungsmessungen an angestellten Rotorblattspitzen in inkompressibler Strömung. DLR-Forschungsbericht FB-76-42, 1976.
3. Rix, O.; Huber, H.; Kaletka, J.: Parameter Identification of a Hingeless Helicopter. Preprint No. 77. 33-42. 33rd Annual National Forum of the American Helicopter Society, Washington, D.C., May 1977.
4. Leyendecker, H.; Bangen, H.-J.; Hoffmann, W.; Seelmann, H.: Investigation of a Helicopter Manoeuver Demand System. Second European Rotorcraft and Powered Lift Aircraft Forum, Paper No. 28, Bückeburg, 20-22 Sept. 1976.
5. Schmidt, U.: Recent Research in Combat Aircraft and Helicopter Rescue Systems. Presented at the Flight Mechanics Panel Symposium of AGARD on "Aircraft Operational Experience and Its Impact on Safety and Survivability". Sandefjord/Norway, 31 May - 3 June 1976.
6. Hummes, D.: Programm zur Berechnung des Rotorlärms. DFVLR IB 154-76/6, 1976.
7. Beyer, R.: An Experimental Study on a Combined Outside World/Instrument Display for Helicopter Operation at Night and in Bad Weather. Second European Rotorcraft and Powered Lift Aircraft Forum, Paper No. 29, Bückeburg, 20-22 Sept. 1976.
8. Albrecht, C.O.: Factors in the Design and Fabrication of Powered Dynamically Similar V/STOL Wind Tunnel Models. American Helicopter Society, Mid-East Region Symposium, 1972.
9. Derschmidt, H.; Weiss, H.: Auslegung eines Modellrotorblattes für ein gelenkloses Rotormodell von 4 m Ø. MBB TN-D125-1/75, 1975.
10. Rehm, D.: Auslegung, Konstruktion und Fertigung eines Baukasten-Rumpfmodells. VFW-Fokker No. T/RF41/RF410/41083, 1976.
11. Lehmann, G.: Untersuchung des dynamischen Verhaltens einer 6-Komponenten-Waage. DFVLR IB-154-77/7, 1977.
12. Langer, H.-J.; Kiessling, F.; Schröder, R.: A Model for Wind Tunnel Rotorcraft Research - Ground Resonance Investigations -. Second European Rotorcraft and Powered Lift Aircraft Forum, Paper No. 33, Bückeburg, 20-22 Sept. 1976.
13. Kreder, H.: Schwingungsmessung am DFVLR-Forschungsrotor zur Erstellung eines Frequenz-Resonanzdiagramms. Dornier VS 730-B1, 1976.
14. Langer, H.-J.; Hummes, D.; Junker, B.: Windkanalversuche mit dem DFVLR-Rotorversuchsstand. DFVLR IB 154-76/46, 1977.
15. Hamel, P.G.: Status of Methods for Aircraft State and Parameter Identification. Session II: Flight Test Technique for Correlation. AGARD Conference Proceedings No. 187, June 1975.
16. Molusis, J.A.: Rotorcraft Derivative Identification from Analytical Models and Flight Test Data. Session V: Rotorcraft Parameter Identification. AGARD Conference Proceedings No. 172, November 1974.
17. Gould, D.G.; Hindson, W.S.: Estimates of the Stability Derivatives of a Helicopter and a V/STOL Aircraft from Flight Data. Session V: Rotorcraft Parameter Identification. AGARD Conference Proceedings No. 172, November 1974.
18. Marchand, M.; Koehler, R.: Determination of Aircraft Derivatives by Automatic Parameter Adjustment and Frequency Response Methods. Session IV: Analysis of Flight Test Data. AGARD Conference Proceedings No. 172, November 1974.
19. Balmford, D.E.H.: The Control of Vibration in Helicopters. Aeronautical Journal, Febr. 1977 p.p. 63-67, Vol. 81.
20. Schulz, G.: Konzepte zur Auslegung eines vollaktiven Hubschrauber-Schwingungs-Isolations-Systems mittels Ausgangsvektorrückführung. DFVLR IB 552-76/12, 1976.
21. Strehlow, H.; Hagemann, W.: Theoretisches Konzept eines vollaktiven Hubschrauber-Schwingungs-Isolations-Systems. MBB-TN-D 123-18/75, 1976.
22. Escape Measures for Combat Helicopter Crews. AGARD-AR 6, 1973.



Fig. 1: DFVLR Test Stand in the VW-Large Scale Windtunnel

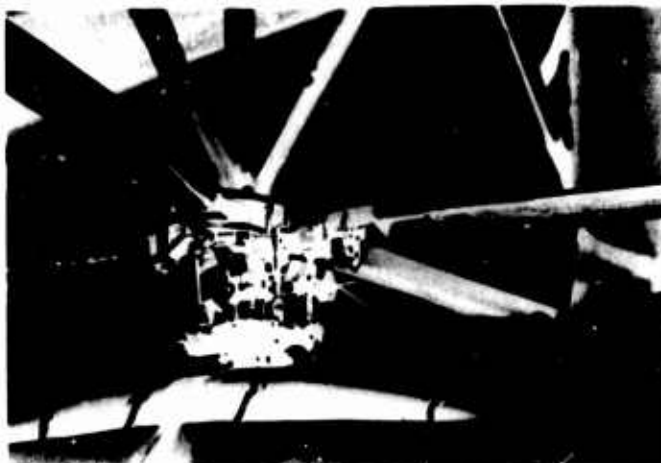

Fig. 2: Hub Assembly of the Hingeless Rotor Model

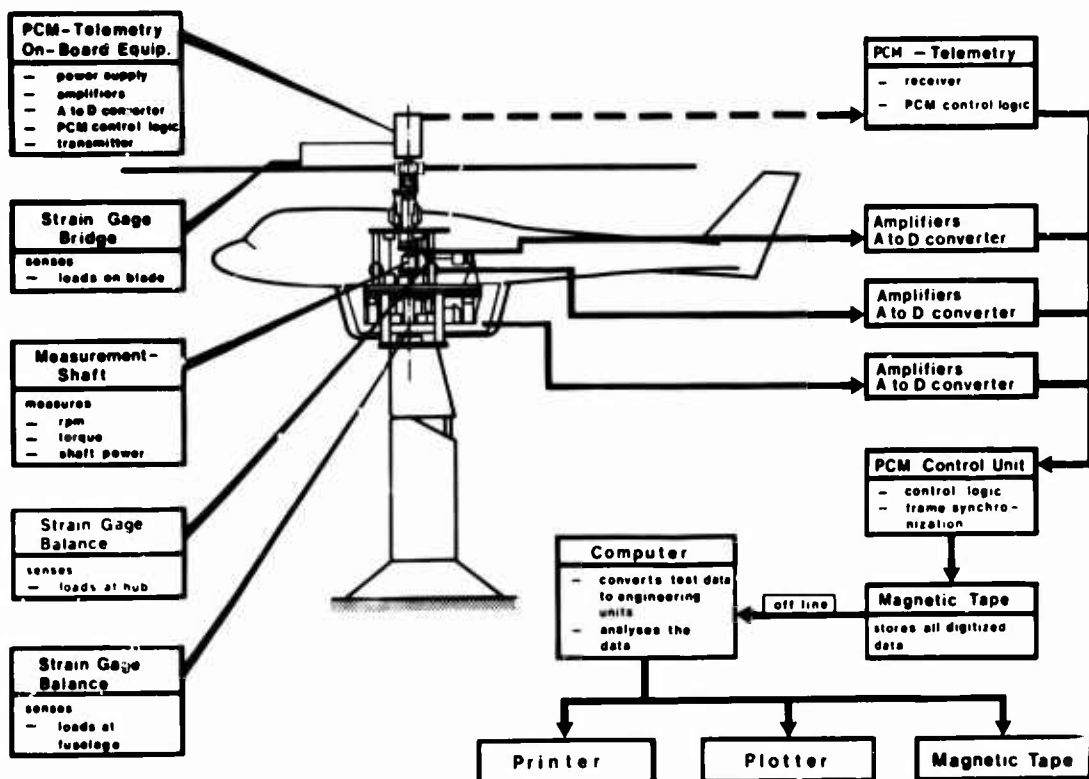

Fig. 3: Dynamic Data System for Helicopter Test Stand

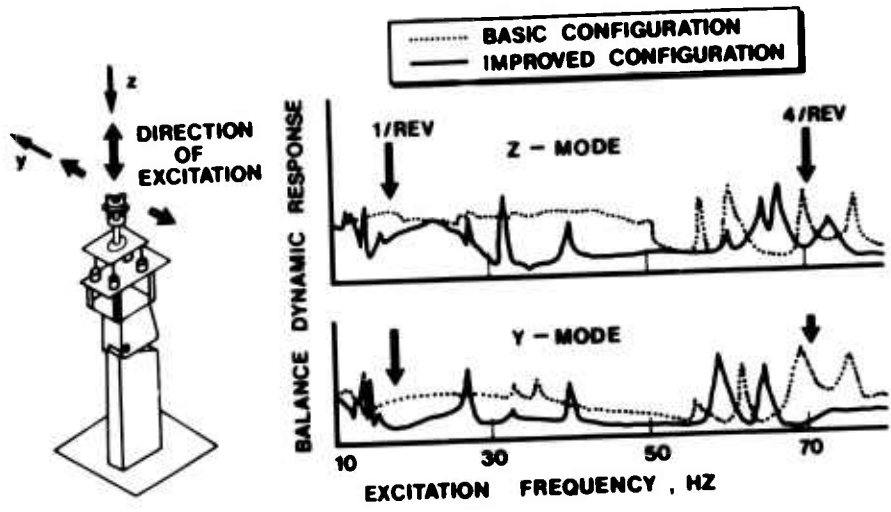

Fig. 4: Rotor Balance Sweep Tests

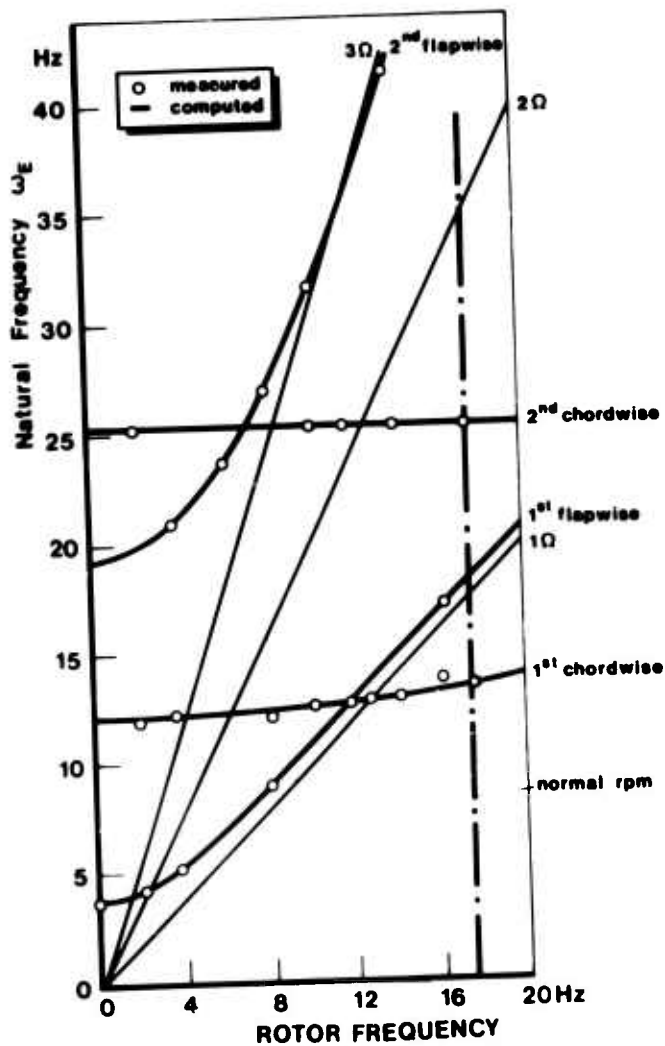

Fig. 5: Rotor Blade Resonance Diagram

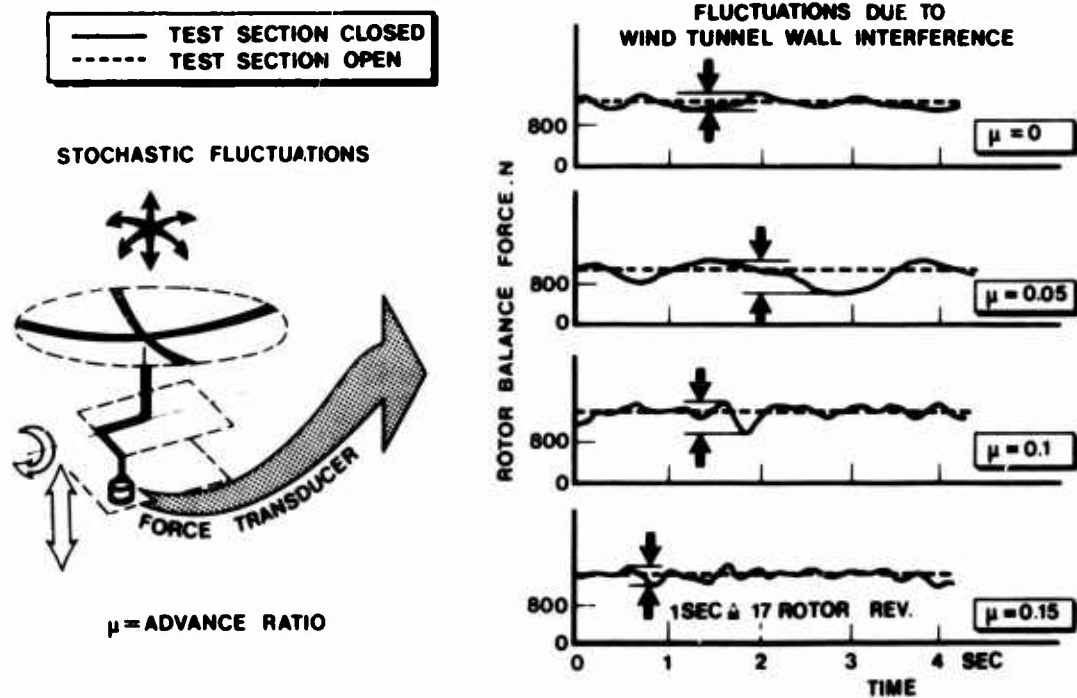

Fig. 6: Influence of Windtunnel Wall Interference on Rotor Aerodynamic Forces

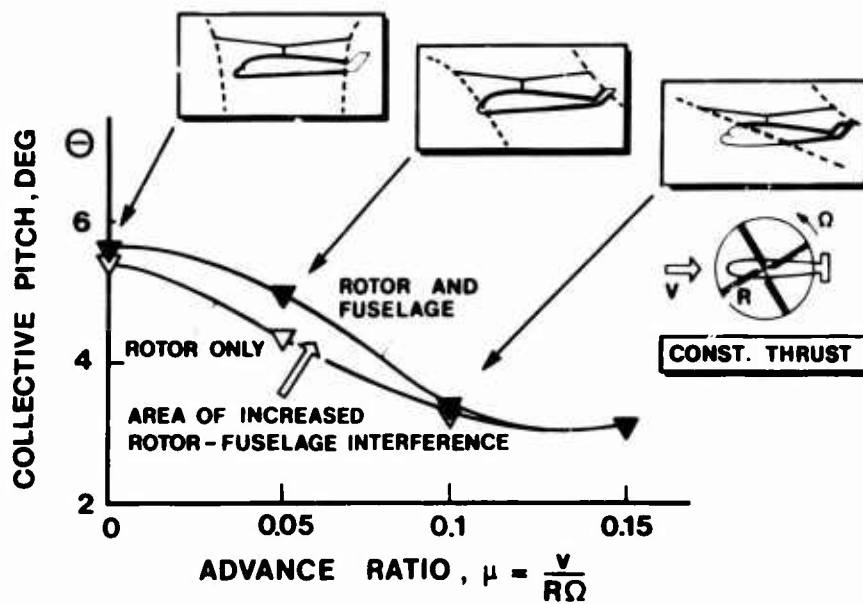

Fig. 7: Effect of Rotor-Fuselage Interference on Collective Pitch Required

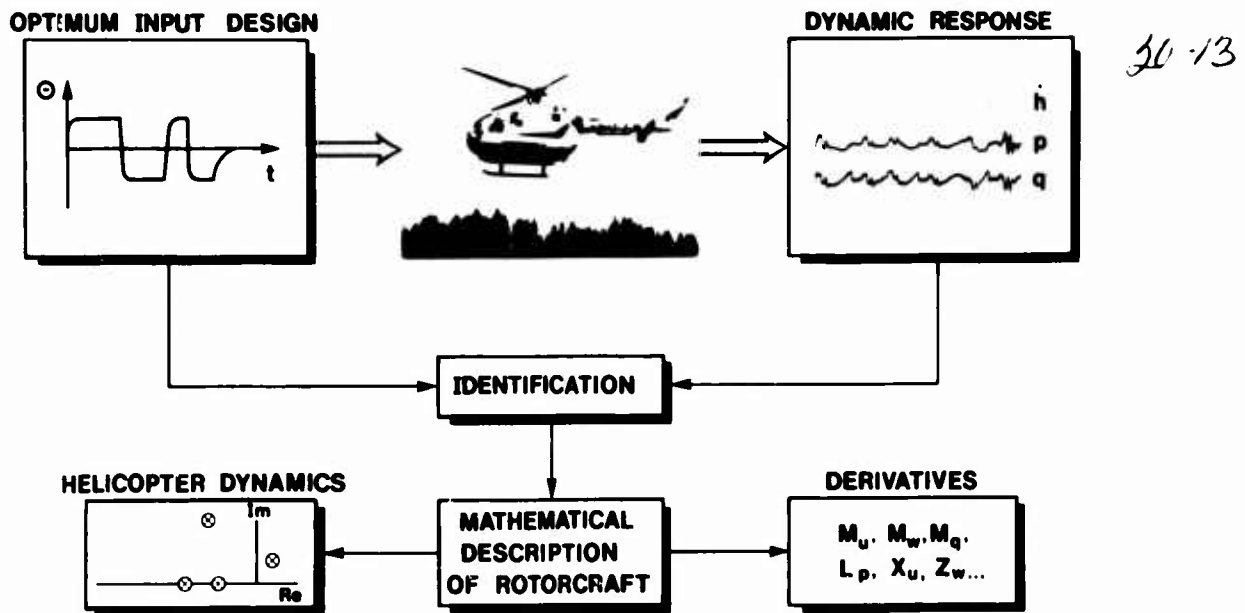

Fig. 8: Helicopter Identification Procedure

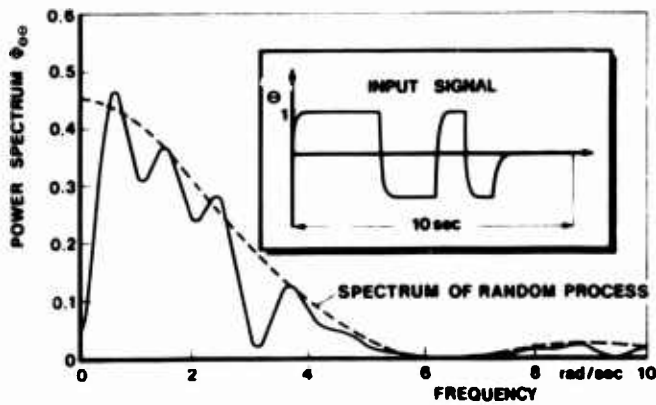

Fig. 9: Optimum Input Signal and Power-Spectrum

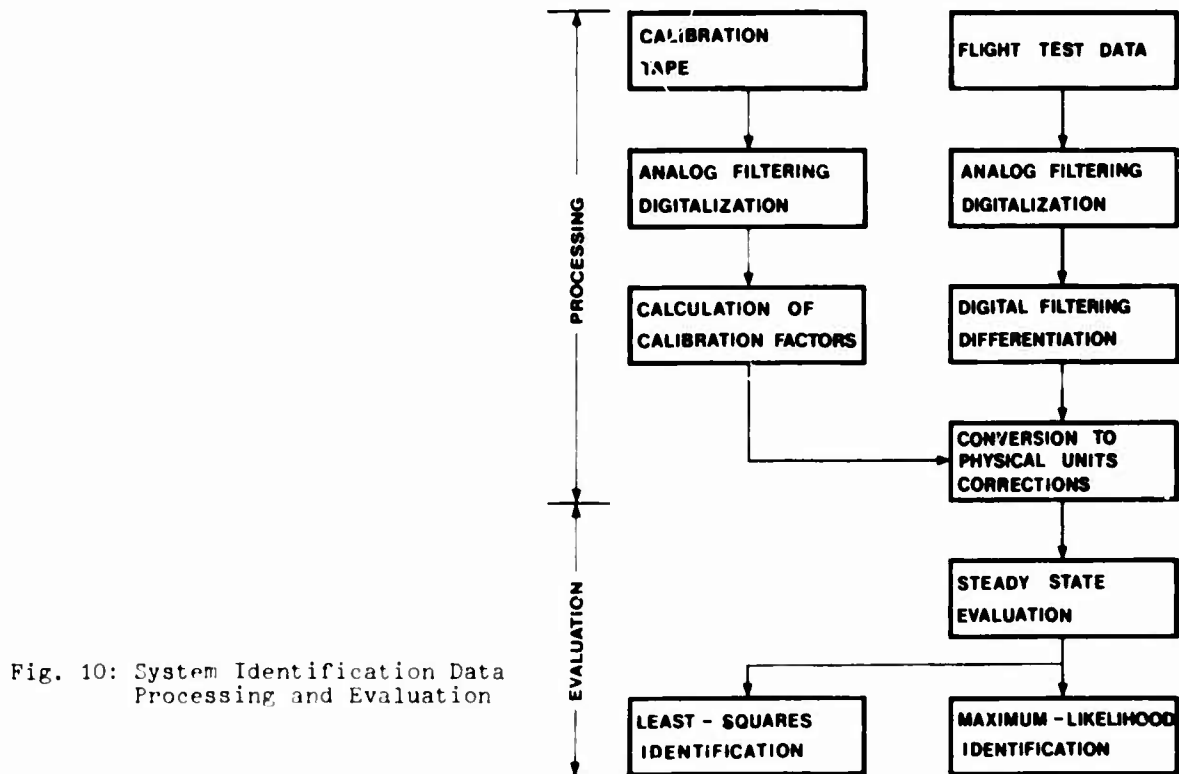

Fig. 10: System Identification Data Processing and Evaluation

20-14

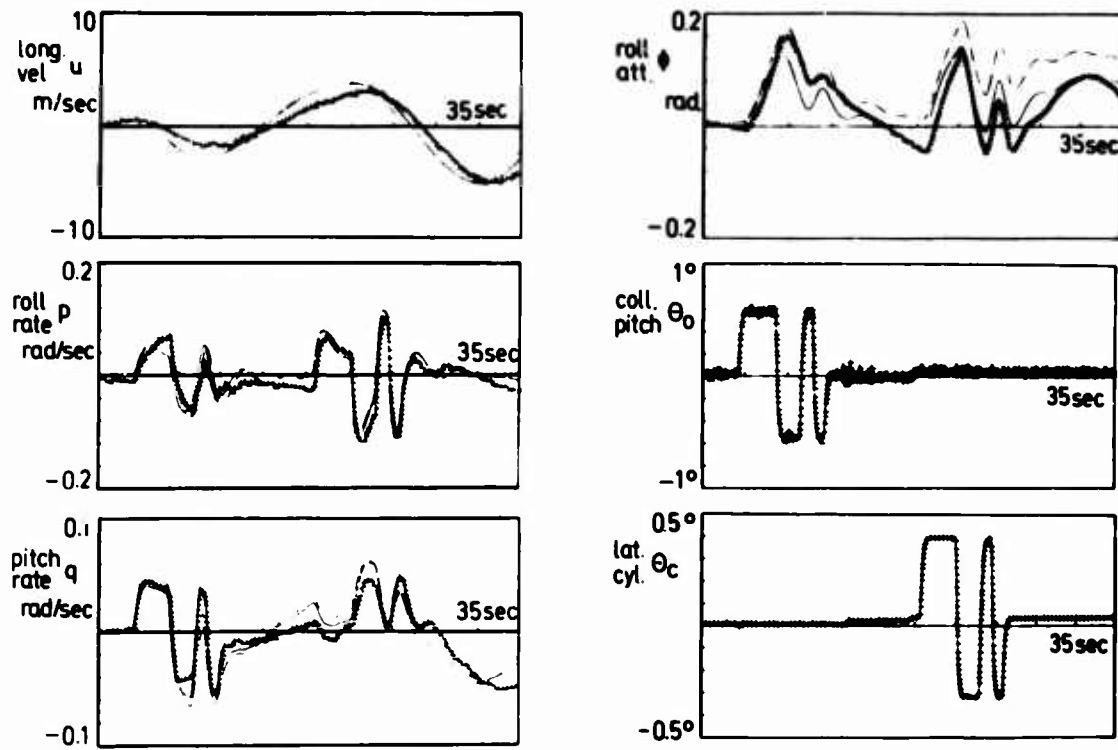

Fig. 11: Comparison of BO-105 Flight Data(+++) with Estimated Data Obtained Using Least Squares (---) and Instrument Variable Models (-)

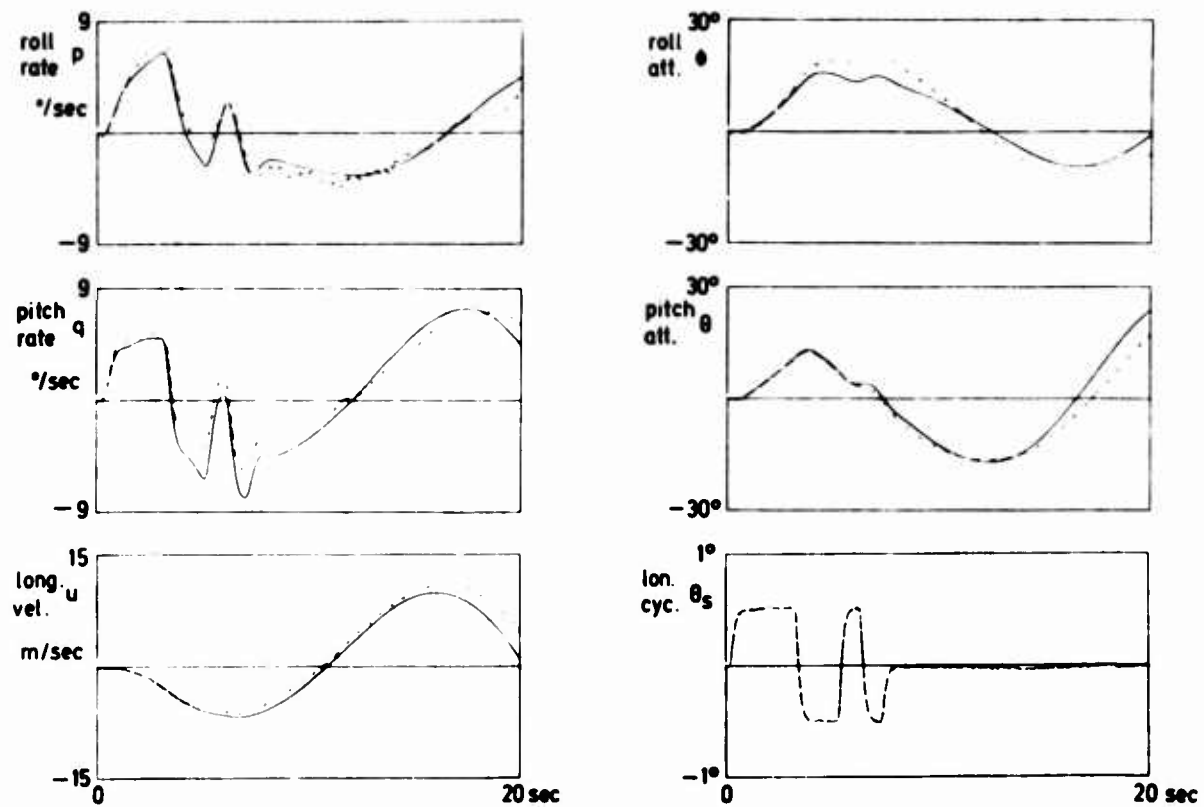

Fig. 12: Comparison of BO-105 Flight Data (---) with Estimated Data Obtained Using Maximum-Likelihood Model (—)

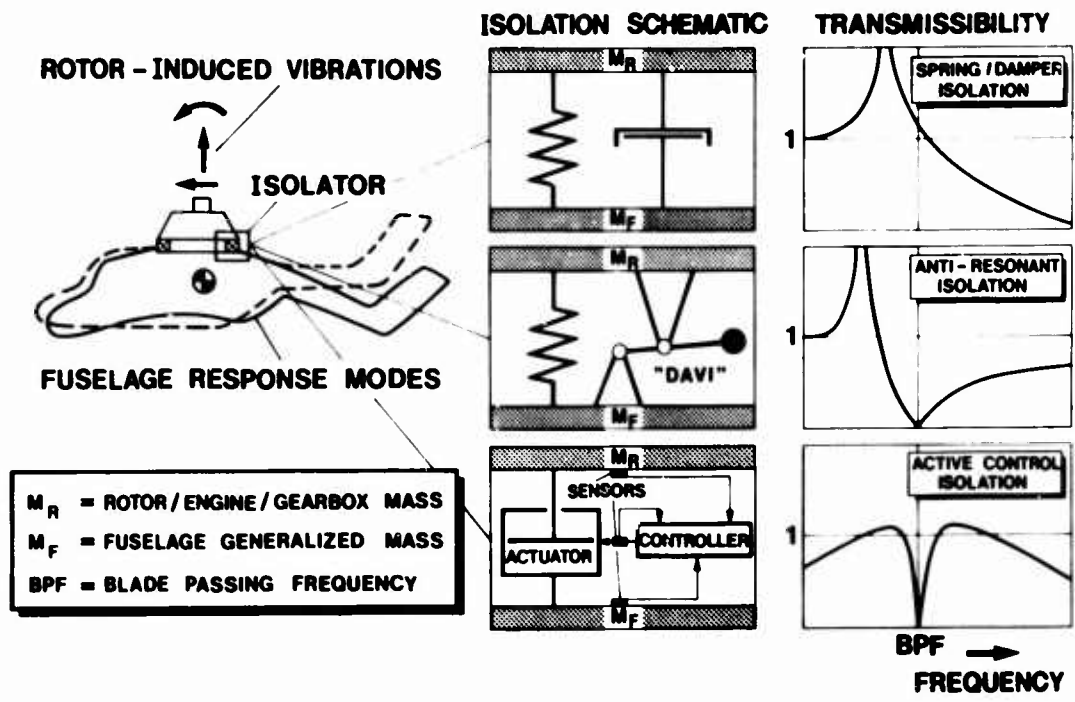

Fig. 13: Principles of Helicopter Vibration Reduction

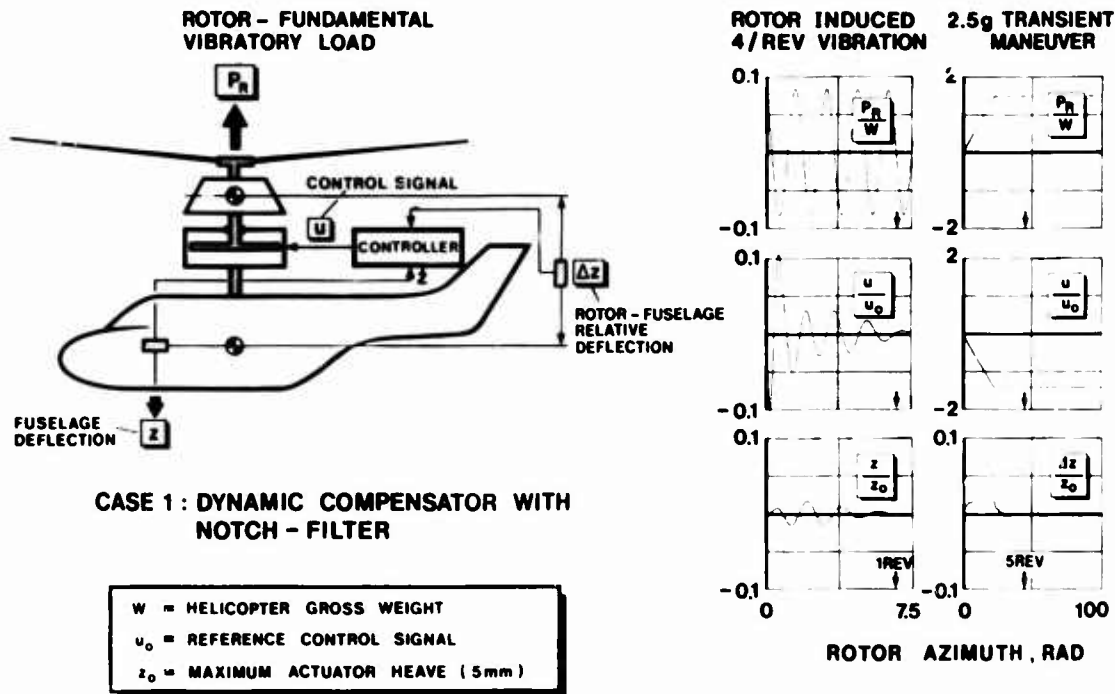
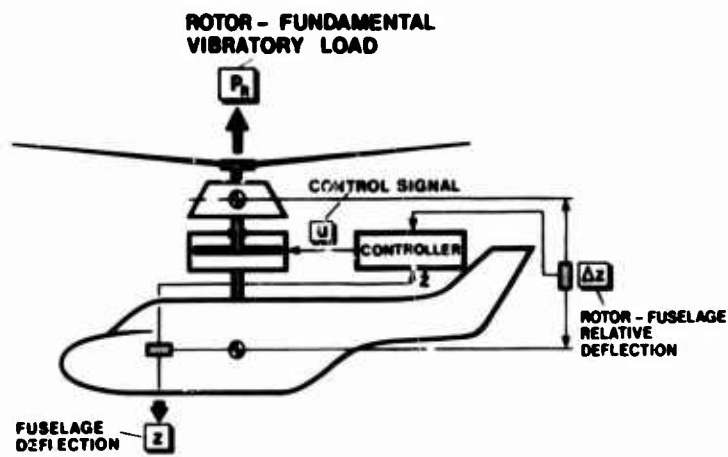

Fig. 14: Vibration Isolation by Active Control-Case 1: Dynamic Compensator with Notch-Filter



CASE 2 : STATE - AND DISTURBANCE OBSERVER WITH RICCATI - FEEDBACK

w = HELICOPTER GROSS WEIGHT
 u_0 = REFERENCE CONTROL SIGNAL
 z_0 = MAXIMUM ACTUATOR HEAVE (5mm)

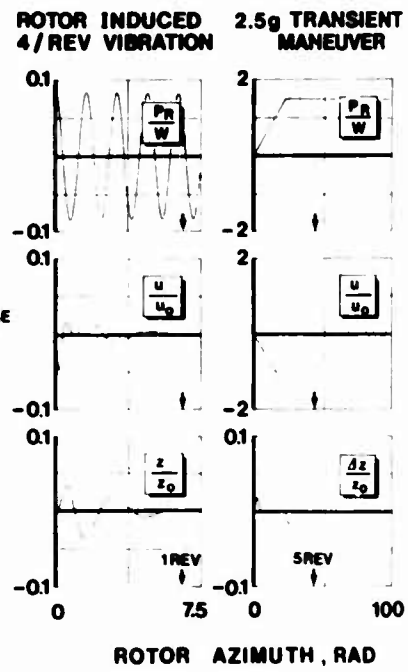

Fig. 15: Vibration Isolation by Active Control-Case 2:
State and Disturbance Observer with Riccati-Feedback



Fig. 16: Instrumented Dummy for
Escape System Testing



Fig. 17: Test Set-up Zero/Zero
Pilot Extraction

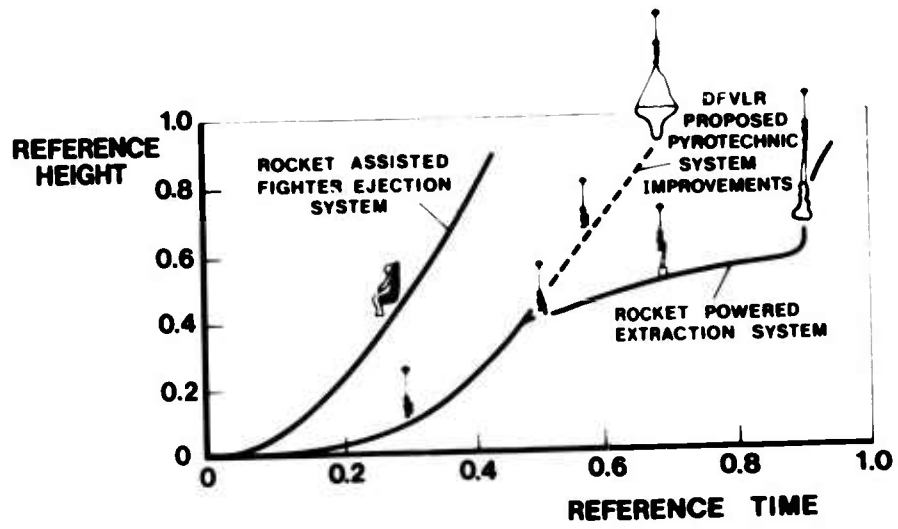

Fig. 18: Escape System Comparison (DFVLR Flight Test)

RESEARCH REQUIREMENTS FOR THE IMPROVEMENT OF HELICOPTER OPERATIONS

by

Martin V. Lowson
Chief Scientist
Westland Helicopters Limited
Yeovil, Somerset, England.

21-1

SUMMARY

Future requirements for helicopters will place still greater emphasis on those features of the helicopter which make for simple, low cost, and effective operation. Some research necessary to meet these needs is described in the current paper. The requirements for low cost operation are reviewed. This implies a considerable improvement in fatigue life, time between overhauls, and in general maintainability of the aircraft. This can be achieved by the intelligent use of new materials and a move towards on-condition maintenance of major components.

Many of the operational targets for future helicopters can be met by engineering application of principles which are substantially understood at the present time. Two important exceptions to this are noise and icing. Basic features of external and internal noise are reviewed and recommendations for future work put forward. Icing research is reviewed in the light of recent British activity.

1. INTRODUCTION

Many, probably the majority of the features which make a helicopter attractive to the operator result from good design and from good product support rather than being the outcome of research studies. Furthermore, improvements in helicopter operation are at least as dependent on features such as navigation and communication aids as on mechanical aspects of the vehicle. Nevertheless research studies can contribute to the improvement of helicopter operations. In this paper some areas of work which seem to be of special relevance are discussed.

Many transport operations require a vehicle with a capability for taking off and landing from small or inaccessible areas. During the past decade a wide variety of vehicles to meet this need has been proposed, and in many cases, demonstrated. However it has now become clear that by far the most satisfactory method of meeting the requirement at the present time is a helicopter of more or less conventional form.

The helicopter has undergone considerable improvement in its basic performance over the past ten years. Recognition of this fact has led to a massive growth in helicopter operations both civil and military. However it seems unlikely that the growth in performance of the conventional helicopter can be maintained. Application of our basic knowledge of the fundamental aerodynamic and structural parameters to helicopters now in the design stage should show substantial benefits over previous helicopters, but it seems unlikely that there will be much more to come for future generations. The classical areas of research for helicopters are therefore into an area of diminishing returns.

The fundamental efficiency of fixed wing aircraft and helicopters is not dissimilar, for example, induced drag at cruise is almost the same (Ref.1). Opportunities for improving the efficiency of the helicopter are therefore limited. The major difference between the fixed and rotary wing types lies in the mechanical and dynamic complexity of the latter. Massive rotating parts have to be used, incorporating flap, lag and feathering flexures or hinges. These are driven at low rotational speed, and therefore high torque, through a minimum weight transmission system. The helicopter itself is a highly sophisticated system needing substantial effort in its engineering and development, while the market for the helicopter is specialised and therefore small. Thus compared to a fixed wing machine, the cost of a helicopter is high, and a primary objective must be to reduce costs of all types to a minimum. It is cost-effectiveness and not performance which must set future research priorities.

The basic cost impact of a modern helicopter is shown in Figure 1. This is shown in terms of life cycle costs, but naturally a similar balance occurs for direct operating costs. Figure 1 shows that only one quarter of the cost is attributable to the initial purchase price of the aircraft. Something over a third of the costs are covered by the "reliability" areas, life items, overhaul, and maintenance, leaving a quarter of the costs due to the engine and equipment overhauls, and the remaining fraction for fuel and crew costs. Although the operator has many desires in obtaining an efficient service from his helicopter, in the end these must be quantified in terms of cost. Figure 1 is thus a reasonable starting point for a discussion of research requirements to improve future operational capability.

The requirements for both civil and military helicopters are not dissimilar. A proposed 10 point plan for helicopter research is shown in Table 1. Also shown are a series of specifically civil requirements in rough order of priority developed from opinions offered to us by operator over the past few years. A comparison of the features does suggest some general agreement between military and civil requirements for helicopter research. Military priorities on cost are of the same order as those of the civil operator, both for initial costs and overall cost ownership. Equally civil emphasis on all weather capabilities including cost effective equipment for IFR and anti-icing requirements has now approached that of a military operation.

21-2

The major difference between military and civil operation is utilisation. Few military helicopters are in the air for more than 500 hours a year, whereas many civil helicopters operate for more than 1000 hours a year. Thus although recent military specifications have strongly emphasised reliability/maintainability, the priority must necessarily be even higher in civil operations. Other differences between civil and military use are in speed, system requirements, and noise. High speed seems to be of a limited military value except in special circumstances, such as naval operations, while it is of obvious importance to the civil operator for productivity. Noise has been receiving an increasing military priority in recent years but can be of considerable importance to civil operations. High internal noise levels could preclude helicopter operation in an executive/VIP role while the prospect of international legislation on community noise clearly raises important issues in external noise radiation.

Thus future requirements for helicopters will place still greater emphasis on those features of the helicopter that make for simple, low cost, and effective operation. Some research necessary to meet these needs is described in the current paper. Requirements for low cost operation are reviewed in the next section while subsequent sections of the paper describe research possibilities in noise, both external and internal, and finally the perennial helicopter all weather operational problem of icing.

2. DESIGN FOR LOW COST

Figure 1 demonstrates that to provide a more cost effective vehicle the helicopter manufacturer must place considerable emphasis on reliability issues.

The lifed items on a helicopter must be replaced due to possible fatigue damage after expiry of a fixed flying time, typically a few thousand hours. There are in principle three possible approaches to fatigue life extension:

- a) stress levels in components can be reduced
- b) improved materials can be used which have better fatigue characteristics
- c) we can move away from a fixed replacement time to replacement on condition as defined by some monitoring device

In order to provide a safe life it is usual to come back from the average failure point on S-N curve by a substantial margin, around 3σ (where σ is the standard deviation). A further reduction of 10-20% in stress is enough to provide a virtually infinite life according to the standard S-N curve predictions. In many cases a 10% reduction in stress could be achieved by 10% additional material in the part under consideration. Unfortunately evaluation suggests that this increase in weight and life would not generally be cost effective. Furthermore, in many circumstances the addition of weight is not an adequate way of improving life. A notable example on the helicopter is the semi-rigid rotor hub where it can be shown (Ref. 2) that the addition of material actually causes an increase in stress level.

Change of material is a valuable way of improving the reliability. Figure 2 shows specific fatigue characteristics for a number of materials. This parameter applies particularly to material selection for helicopter rotor blades but has some general value in evaluating the benefit of new materials. It will be seen that the aluminium alloy conventionally used for helicopter construction does not come out very well in this presentation. The benefits of modern materials for improving helicopter reliability justify detailed study. However the fundamental objective is reduction of costs. Aluminium alloy is a material which is well understood from the point of view of airworthiness, design, and manufacture. A strong case must be made before any substantial change can be contemplated.

The third possible approach is the further development of techniques for damage tolerant design, which could lead to on-condition replacement. Strong operational arguments in favour of such a change have been given by Polley, Ref. 3. Current safe life philosophy means that of all replacements on "life" less than one in a million makes an immediate contribution to airworthiness. Development of damage tolerant design together with a reliable condition monitoring device for helicopter parts could in principle result in large savings, since mean life is considerably in excess of safe life. However the reliability of the monitoring device must itself be of a high order to allow acceptance for airworthiness clearance.

Some items on the helicopter are already maintained "on condition". An example is the Sikorsky Blade Inspection Method (BIM) which checks the integrity of the spar by pressure monitoring. In practice this is effectively used as the on-condition retirement indicator for rotor blades. Thus it is an extension of the on-condition philosophy which is sought rather than its introduction.

There are also several possible techniques for monitoring which show promise, for example, emission of sound or heat from the damaged area. One area which has been studied at Westlands is monitoring of gear vibration to detect gear tooth cracking. Typical results from research tests on this are shown in Figure 3. It can be seen that before the appearance of a crack in a tooth there are clear increases in the side bands around the tooth passing frequencies. There is some way to go before this technique can be incorporated routinely into service, but the benefits are obvious.

The second most significant factor in the helicopter cost from Figure 1 is the initial cost. This has been a popular area of research for some years for obvious reasons. One of the most important cost drivers for aircraft structure has been found to be parts count (see Ref. 1). The

parts count arguments put forward relate only to the labour content involved in the build of the aircraft assembly. However reduction of parts count could have additional far reaching effects. A typical helicopter consists of 15000 items, the typical weight of which is around 50 grammes. Each of these must be individually drawn, planned, and administered through the factory design, development and production processes. This is a major burden on overheads. A reduction of parts count could do much to reduce administrative and overhead cost associated with helicopter manufacture. Equally reduction of number of parts will also increase reliability on the common-sense grounds that there would be less parts which could go wrong. This argument may be proved more formally by statistics if desired.

213

There are other areas where unexpected impact of technology may occur in the production process. The benefits of automatic manufacturing methods, such as automatic rivetting, have been highlighted in previous papers, e.g. Ref. 4. However there is a considerable fringe manufacturing cost associated with processes, such as heat treatment, anodising, painting, etc. The root requirement for these processes lies on the nature of material traditionally used in the aircraft construction, and is associated in many cases with their tendency to corrode. Selection of modern materials with very much reduced requirements for either heat treatment prior to manufacture, or for corrosion protection during manufacture, could eliminate over half of the operations required in some areas of helicopter manufacture. This would provide a major saving both in cost of production and in the time taken.

Very strong emphasis was placed on reliability, robustness, and ease of maintenance in the original Lynx specification, as outlined in a paper by Berrington (Ref. 5). The targets for the Lynx are listed in Table 2 and compared with figures achieved by other types. These predicted figures were based on an active design management effort. For example the 2.7 maintenance man hours based on the achievement of the following targets in the three major segments.

Flight Servicing 0.6 mh/fh

After flight inspection	53	Man minutes
Before flight inspection	25	" "
Turn round inspection	15.6	" "

Scheduled Servicing 1.2 mh/fh

25 hr inspection	2.5	man hours
100 hr inspection	42	" "
300 hr inspection	50	" "
4 wk inspection	6.5	" "
1 yr PMB inspection	34	" "

Unscheduled Servicing 0.9 mh/fh

Initial design targets are being exceeded on the production Lynx aircraft.

As is well known the Lynx features a semi-rigid rotor head. Figure 4 compares the head with the head of a Wessex. The simplicity of the Lynx head has obvious attractions from the maintainability point of view. Indeed the number of servicing points has been reduced as follows:-

	Lynx	Wessex
Oil Servicing Points	4	8
Grease Points	0	52

Furthermore the complete prerigged rotor head assembly can be held in the stores. This can be changed in average operational conditions by 2 men in under 3 hours.

A similar policy of design simplicity has been followed on the Lynx transmission system (see Figure 5). This has been brought about, in part, by taking advantage of the superior load carrying characteristics of conformed gears. In particular this allowed the use of a high reduction ratio in the final stage, allowing a major reduction of transmission components, especially in the high torque paths. A comparison with the Sea King gearbox is shown below.

	Lynx	Sea King
Number of gears	7	16
Number of bearings	19	28

Thus the component numbers are reduced from 44 in the Sea King to 26 on the Lynx with anticipated proportional benefits in reliability and rapid growth of TBO and fatigue life.

3. NOISE

Helicopters designed in the 1980's will be required to meet certification standards for external noise. Details of these are now being finalised. It is anticipated that future helicopters will meet specified levels for take-off, landing, and flyover. Both manufacturer and operator must now put increased emphasis on the achievement of acceptable community noise levels.

21-4
Helicopter noise is a subject which is only partly understood. Although there are some reasonable suggestions for basic mechanisms, many of the processes underlying noise generation by the helicopter are not understood well enough to permit proper engineering attack. In this section of the paper some mechanisms underlying helicopter noise will be described and indications given of the prospects for noise control.

External noise radiation from a helicopter is dominated by the aerodynamically generated noise from the rotors, both main and tail. Subjectively the tail rotor is often the most annoying source and this therefore justifies special attention. However mechanisms of noise generation from main and tail rotor are not dissimilar and these will be discussed together.

Figure 6 shows a general radiation spectrum, characteristic of both rotors. The lower frequencies are dominated by the blade passing frequency and its harmonics, which gradually merge into a general broadband noise radiation. Typically this broadband content peaks a little below a Strouhal Number based on chord (fc/V_T) of unity. Recent studies have shown that a high frequency broadband hump also exists. Here it is possible to be more precise about the peak frequency (Ref.6). It is at $f = 1.1 V_T/t$ where V_T is the tip speed and t the blade thickness. This result agrees also well with fixed wing airframe noise data. (Ref.7).

The relative importance of the various radiating components depends on the parameters of the rotor concerned. For the main rotor the discrete frequencies start from around 10 or 20 Hz, below the normal range of hearing. Thus it is only the higher harmonics (perhaps the 40th or 50th) which can be important. For the tail rotor however these lower harmonics dominate the observed signature. The broadband noise radiation especially from the main rotor is also significant. In some cases it can effectively control overflight noise levels. The high frequency hump for the main rotor, may occur around 3000 Hz, and is subjectively important close to the helicopter. The possibilities for control of these sources will be discussed below.

A theory describing the discrete frequency noise radiation from the rotor in terms of the harmonic forces on the blade exists. (Ref. 8). However this requires specification of the fluctuating force field on the blade at very high frequencies, a task which is well beyond the capabilities of the present rotor aerodynamic theories. In principle, however, it can be seen that there are two major sources of harmonic disturbances. One is the interaction of the rotor with its own vortex wake. If the wake passes particularly close to the next blade, for example, during landing, a distinctive impulsive "blade slap" results.

Theoretical models for this noise radiation process exist; however engineering solution to these may well be found in a better modelling of the vortex interactions at the design stage of a new helicopter. This blade slap noise may also be avoided by piloting technique, e.g. (Ref. 9).

An equivalent source of noise is probably significant in the hover. This is the ingestion of eddies from the surrounding atmosphere. Because of the strong contraction of the stream as it enters the rotor these eddies are very much elongated and form vortices. Recent studies, Ref.10, have suggested that the vortex formed by eddy stretching into a free rotor may well persist for as many as 16 revolutions. This provides a strong potential source of noise. The prospects for controlling this source are less favourable. Theoretical models indicate that higher blade twists could offer an improvement in noise together with an increase in hover figure of merit.

Impulsive noise radiated by the blades becomes particularly significant at high rotor speeds. Noise from this source may be heard as much as 10 miles in front of the helicopter, and is therefore of special significance in detectability and in community annoyance. Recent theoretical studies suggest that this noise is due to direct radiation due to displacement of air by the blade tip. Good agreement of prediction with experiments has been achieved. An example of this is shown in Figure 7 where calculations based on the theory of Ref.11 are compared with experimental data reported by Schmitz and Boxwell, Ref. 12. In view of the fact that there are no empirical parameters contained within the theoretical prediction, the agreement between theory and experiment, both from the point of view of trend and level, is very encouraging. This theory can be used as an engineering tool to minimise the high speed noise radiation of a helicopter, both by shaping the blade and suggesting appropriate tip speeds. For typical helicopter rotors the theory suggests a dependence on tip speed above $V_T^{1.5}$ for this source.

To what extent can helicopter noise be controlled? Early theoretical and experimental work suggested that noise was proportional to $V_T^2 T^2$ where V_T is the tip speed and T the thrust. This seems to hold little promise for a quiet helicopter since for a fixed rotor thrust a reduction of noise by 6dB would require a halving of rotor speed. Recent work gives grounds for greater optimism.

A large amount of data on rotor noise has been taken by Westland Helicopters during the past few years. In Ref. 6 it was shown that the T^2 law was obeyed at higher thrusts but not at lower. Figure 8 reproduces these results. Also shown on the graph is the point at which tip incidence is predicted to reach 0° . At lower thrusts some internal recirculation on the rotor is likely. At these low thrusts it is found that the velocity dependence of the noise exceeds V_T^2 . This could apply to a tail rotor in forward flight.

More characteristically, rotors operate at positive tip incidence. The data available can be analysed to indicate some of the major trends. Figure 9 shows some results, where cases with tip incidence below 0° have been rejected. The upper curve gives the broadband noise peak level corrected for thrust by the T^2 law. It will be seen that the data collapses to within about 2dB. A $V_T^{1.5}$ curve has been drawn through the data.

The middle set of results in Figure 9 gives the peak level for the higher frequency hump. In this case the data shows no dependence on thrust and no thrust correction has been made. It seems likely that this noise is associated with the noise radiated by eddies leaving the trailing

edge of the rotor. Theory for this case suggests a V^5 law (Ref. 13), and the data can be seen to support this trend. Further supporting evidence comes from the dependence of frequency on thickness referred to earlier. 215

The last set of data shown in Figure 9 gives the level of the 40th harmonic, again corrected by a T^2 law. The data show a strong increase of level with speed, and at the rotational speeds characteristic of present helicopters follow a V^6 law.

The overriding conclusion from these analyses is that helicopter rotor noise is far more sensitive to rotor speed than normally suggested. Reducing rotor speed also provides additional subjective benefits (Ref. 14) due to the lower frequency of the noise. Since tail rotor noise is particularly important subjectively, choosing a lower tip speed for the tail rotor would be useful. Several helicopters have now adopted this approach. But there are prospects for further control of helicopters main rotor noise by a systematic attack on all the components discussed above.

Fixed wing noise control experience suggests that in the end engineering methods are more effective than extended academic study and this conclusion may well prove to apply equally to helicopter noise. However it is important to realize that the range of opportunities open to the engineer for helicopter noise control are more limited. Furthermore, noise control engineering has not been particularly successful when applied to helicopters up to the present. A substantial body of work was accomplished under ARPA/NASA sponsorship at the beginning of the decade and substantial claims have been made from this. Close analysis of the results suggests only modest noise reductions occurred. For example, in Ref. 15 reductions of up to 14dB were claimed. Evaluation of the data presented suggests a more characteristic reduction would be 9 - 10 dB. This was achieved by a 33% reduction in rotor RPM which must necessarily give rise to a reduction in thrust. In this case because of the increase from 4 to 5 blades on the modified aircraft actual thrust loss would be around 46%. This obviously has severe repercussions on the operational characteristics of the helicopter, and indeed no claim that this quieter helicopter was suitable for operational use was ever advanced. Closer studies of an operationally viable helicopter based on this data suggests that only around 2-3dB can be claimed as a result of the modifications suggested throughout this programme. In view of the benefits claimed above for rotor speed reduction it may be thought surprising that a better result was not obtained. However it will be very difficult to design an operationally viable helicopter which simultaneously optimizes all the noise parameters mentioned above.

A further exercise was carried out on a S61 helicopter (Ref. 16) and although benefits of up to 3dB were claimed in this case, analysis of the data suggests that in some cases the modified helicopter was actually noisier than the original helicopter. Data has also been presented on a HH 43B helicopter Ref. 17, suggesting improvements of around 8dB. Again no claim was made that this modified helicopter was viable for operational use. There is some additional interest in this case because of the counter-rotating intermeshing rotors employed in the HH 43B. It appears that counter-rotating rotors do have a naturally lower noise level than the single rotor type, typically, around 6dB. If very severe noise restraints are placed upon future helicopter design it may be that configurational changes could provide part of a solution. However with conventional helicopters there is inevitably a price to pay for noise reduction and current estimates suggest that this will be at least 10% of the payload for each 3dB.

4. INTERNAL NOISE

At the present time the internal noise levels of helicopters are perhaps of even higher significance commercially than the external noise levels. The designers attempts to pass more and more power through a lighter and lighter weight structure has led to a substantial increase in helicopter noise. Noise levels inside untreated helicopters have risen by about 10dB in 10 years. The problem of internal noise clearly justifies priority study.

The basic mechanisms of noise radiation inside the helicopter are quite different from those outside. Internal noise is essentially due to mechanical sources, particularly from the transmission. It is found that the internal noise spectrum is dominated by the tooth meshing frequencies from the principal gear pairs. The basic source of the noise is the non-uniform meshing of the gear teeth. These create both torsional and flexural vibrations within the gear train which are likely to be amplified by local resonances within the gear system. These high frequency vibrations then pass into the helicopter structure from which they are finally radiated as acoustic energy into the cabin.

This cause and effect chain is complex and little fundamental understanding of helicopter internal noise exists at the present time. Most existing aerospace work on internal noise has been oriented to broadband excitation rather than the discrete high frequencies characteristic of the helicopter. However the complexity also provides many opportunities for noise control: within the gearbox, its mounting system, the structure and finally, by acoustic treatment within the cabin. Attack on all these fronts is required. The pay-offs from such approach could be great, perhaps a 20-30dB improvement over current levels.

The achievement of a good mesh between gear components is a primary objective of the transmission designer. It is therefore unlikely that any substantial noise gains can be achieved by closer study of the gear teeth. However the transmission of this vibrational energy in the gear-in system is a topic which does justify closer study. It has been shown (Ref. 18) how response calculations for transmission systems are feasible and can be used to control noise. The engineering benefits to date have been small. The noise reductions from this approach have been no larger than those from an equal mass acoustic treatment. Nevertheless the application of such models in conjunction with finite element models for predicting distortion of the gear casing appears to offer promise for control of gear noise in future helicopter transmissions. Reduction

of vibration within the gearbox could also be expected to improve reliability.

31-6
The mounting of gearbox to fuselage structure also offers an opportunity for noise control. In principle it is certainly possible to make suspensions which impede high frequency noise transmission, but which also meet normal vibration engineering criteria in the low frequency range. A modest R & D programme should allow such mountings to be developed. The transmission of vibrations within the fuselage structure also offers an opportunity for control. This has been the subject of study for many years now in the case of ships and many of the features established for ship noise control could transfer to the helicopter.

Finally the possibilities of conventional acoustic treatments must not be overlooked. A well designed acoustic attenuation treatment can be extremely effective in reducing internal noise for helicopters. A recent exercise at Westlands (Ref. 19) was aimed at quietening a VIP Commando Helicopter (Fig. 10). The basic concept in the acoustic design was an inner cabin isolated from the main fuselage, and has proved very successful. Internal noise treatments depend critically upon attention to detail on all parts of the design. For example, it was found that noise leaked in around the windows in an early trial scheme. Noise levels for the basic helicopter, for the standard treatment and for the final scheme are shown in Fig. 11. The sound levels were reduced to those characteristic of civil fixed wing passenger transport. It can be seen that the overall attenuation achieved compared to the bare helicopter is around 5-10dB at low frequencies rising to 25-30dB at the high frequencies. It is the high frequencies which are the most important in defining the speech interference level within the cabin. Subjective impression of the noise environment has been very favourable and it can be seen from Fig. 11 that the speech interference level has in fact been reduced by 23dB compared with the bare helicopter and by 9dB compared with conventional soundproofing. The weight penalty for this treatment was 500lbs. However in the VIP role proposed this was quite acceptable.

5. ICING

Proper operational utilisation of a helicopter demands a full all weather flight capability. With the increasing requirements for operation in areas of potential icing, such as the North Atlantic, both for military and civil purposes, the problem of icing has assumed increasing importance in present helicopter design. On fixed wing aircraft practical icing clearances have existed for many years so that sustained flight in icing conditions is almost a matter of routine. However the situation in the helicopter is very much more difficult.

There are many fundamental parameters which affect the icing of a helicopter, a better understanding of the fundamental meteorological conditions which affect icing is required. There is no present capability of making accurate meteorological assessments of icing probabilities, which involve the effects of water content, droplet size distribution, ice particles, rain, snow, etc. The helicopter combines a large cluttered low speed fuselage with a rotor on which speed varies with radius. The helicopter therefore encounters virtually all possible combinations of geometric and aerodynamic icing parameters simultaneously. It is not surprising that helicopter icing has been described as "being steeped in mythology".

Fortunately, as a result of extensive trials and studies, understanding of icing is starting to grow (Ref. 20). The helicopter icing problem may be divided into two parts; the rotor, and the fuselage/engine. It is generally found that successful solutions to fuselage icing problems can be achieved by the application of common sense engineering principles. Local de-icing may be applied to areas which are of particular concern, for example, pitot heads, transparencies, and the engine intakes. The fuselage lines must be laid out in conjunction with the engine installation so that any shedding from the fuselage will not cause damage to the engine.

A high standard of engine protection must be achieved on the helicopter. In order to achieve satisfactory icing flight clearance for the engine it is necessary to test the engine installation at full scale with a representative intake and adjacent airframe structure. Recent studies have been undertaken at Westlands on a side intake design for the Sea King. This is shown in Fig. 12. This was developed first in wind tunnel tests and was tested recently in the NGTE Cell 3 West icing facility where it showed considerable promise in a wide range of operating conditions without appreciable performance loss. (Figure 13) Thus it would appear that extensions of existing engineering practice are adequate to provide a reasonable standard of icing clearance for the helicopter fuselage and engine systems.

The rotor has been a much more difficult problem. It has the benefit of some kinetic heating towards the tip. On a high speed rotor this may well be enough to prevent ice formation on the outer parts of the blades, but flight in icing conditions will still result in the accumulation of some ice on the inboard portion of the rotor. The basic mechanism of ice formation on the rotor is reasonably straightforward to understand. The rotor is cooled due to radiation and evaporation and is heated by the kinetic energy of the air and impinging water droplets. For much of the rotor the equilibrium temperature in icing conditions is 0°C. In these circumstances the heat balance is maintained by the release of latent heat of freezing of the ice. In other words, ice is formed on the blade and starts to build up. On the inboard part of the rotor temperatures may drop below 0°, in which case all impinging water freezes and the heat balance is maintained by change of rotor temperature.

The model described above can be formulated mathematically, for example in the paper by Messinger (Ref. 21). This has been the basis of theoretical work at Westland Helicopters. A comparison of some predictions from this theory with tests reported by Stallabrass (Ref. 22) is shown in Figure 14. The good agreement both in trends and absolute level of ice accretion rate may be observed. The theory is apparently insensitive to the type of ice built up. It is of

interest to note that the mushroom and spearhead ice appears at 0° on the rotor leading edge, whereas the knife-edge ice formation corresponds to temperatures below 0°C .

21-7

It has been suggested that more complicated theories involving variation of the input parameters over the chord and account of thermal conduction within the skin would be necessary to achieve acceptable prediction of ice accretion rates. Figure 14 suggests that the simpler theories are adequate. It is therefore reasonable to assume that most of the unknowns in the rotor icing process are associated with the icing parameters of the practical environment. The results shown in Figure 14 were taken on the NRC Spray rig. Over the years it has become established that results from the Spray rig are not consistent with those in natural icing conditions. This must be largely due to the variability which occurs in real clouds together with effects of forward flight. Thus flight experience in natural icing conditions is essential, both to develop a better understanding of icing problems and to establish reasonable statistics for icing clearance.

An extensive series of Lynx trials has been performed recently in Scandinavia. The flight programme is shown in Table 3. The following findings are noteworthy:

1. Over a wide range of conditions the aircraft was found to operate perfectly satisfactorily.
2. In conditions that gave rise to a performance penalty this took a progressive form providing ample time for evasion action if desired.
3. On no occasion was the autorotation capability of the helicopter unacceptably impaired.
4. On leaving the icing environment the helicopter performance rapidly returned to the datum.

These trial results have formed the basis of a request from Westlands for an extensive initial CA release for good weather and icing operations. The proposed release is for flight up to 8000' and down to -10°C , subject to a 20 knot reduction in the flight envelope. (See Figure 15)

With the application of this experience in future helicopters there is some prospect that reasonable icing release conditions will be achieved. However if a deeper penetration into icing is required then artificial de-icing must be applied to the rotor as is already done on the fuselage. The fundamental power requirements to prevent any ice build up are large. The accretion rate of Figure 14 can be translated directly as a power requirement over large portions of the blade. $0.01\text{m}/\text{sec}$ is equivalent to $3.3\text{kW}/\text{m}^2$. For a typical helicopter around 60kW of power would be required in the rotor for complete anti-icing protection.

Such power levels are unattractive, and a better solution is local cyclic heating to cause ice break-up and shedding. Any such system has to overcome two inherent problems. Firstly, to achieve clean shedding a certain thickness of ice must be allowed to build up. On sensitive areas of the blade profile even these small thicknesses may cause unacceptable loss of performance. Secondly, variations of icing conditions are so great that a system which shed ice cleanly in all conditions would seem to require a controller of great complexity.

A Wessex with Lucas electro-thermal cyclic blade de-icing has now been test flown for several winters. These continuing development trials have resulted in suggestions for improved cyclic patterns which should overcome the problems outlined above, and operate at relatively small power levels (Ref. 23). These will be flight tested in natural icing conditions during Winter 1977/78.

6. CONCLUSIONS

The integration of current knowledge in the classical areas of conventional helicopter performance will provide helicopters with a major increment in operational capability. It seems unlikely that further research into these classical areas can prove equally cost-effective. However comparatively little fundamental work has been carried out into aspects which directly affect operating costs. There are several areas of research which could give results of direct value to the operator.

1. The application of new materials throughout the helicopter offers the promise of a cheaper, more robust, and probably lighter, helicopter.
2. The further development of damage tolerant design methods together with on-conditioning monitoring techniques offers promise for a substantial extension in both life and TBO
3. Cost research can provide the basis for more effective value engineering during the initial design.

There are also several areas where important operational benefits occur which cannot be readily quantified in terms of cost. The two areas studied in this paper, noise, both external and internal, and icing, suggest the following conclusions.

4. Basic knowledge of external noise radiation exists but this requires more detailed study and interpretation before it can provide clear guidelines for design trade-offs.
5. Reduction of rotor speed appears to be rather more effective as a noise control method than suggested by simple theories.
6. Further research in internal noise has the potential of providing substantial benefits. Meanwhile conventional acoustic engineering provides a useful palliative.
7. The principal difficulties in helicopter icing arise from uncertainties in meteorology rather than in areas under the designers control. Further work is probably more usefully oriented to practical flight evaluation in natural icing conditions.

8. Present generation aircraft can offer valuable increases in standards of icing release. If required, further improvements in rotor icing can be achieved by intermittent electro-thermal de-icing.

REFERENCES

1. Jones, J.P. "The rotor and its future". Aeronautical Journal Vol.77 pp 327-337 July 1973
2. Cook, C.V. "Requirements and uses of new materials in helicopters". Paper to the Royal Aeronautical Society Feb. 1976.
3. Polley, I.M. "Damage tolerant design for helicopter structural integrity". Paper No.4 2nd European Rotorcraft & Powered Lift Aircraft Forum Sept. 1976.
4. Marchinski, L.J. "Aircraft structures designed to cost". AIAA Paper 74-962 Aug.1976
5. Barrington, D.K. "Design and development of the Westland Sea Lynx". Paper No.711 AHS Forum May 1973.
6. Leverton, J.W. "The noise characteristics of a large clean rotor". Journal of Sound & Vibration Vol. 27 pp 357-376 1973
7. Fink, M.R. "Approximate prediction of airframe noise". Journal of Aircraft Vol. 13 pp 833-834 Nov. 1976.
8. Lowson, M.V. and Ollerhead, J.B. "A theoretical study of helicopter rotor noise". Journal of Sound and vibration" Vol. 9 pp 197-222 1969.
9. "Flying Neighbourly" Bell Helicopter Publication.
10. Whitfield, C.E. Ph.D. Thesis, Loughborough University 1977.
11. Hawkins, D.L and Lowson, M.V. "Tone Noise of high speed rotors". Progress in Astronautics and Aeronautics Vol. 44 pp 539-558 1976.
12. Schmitz, F.H. and Boxwell, D.A. "In-flight far-field measurement of helicopter impulsive noise". 32nd Meeting of AHS 1976.
13. Ffowcs Williams, J.E. and Hall, L.H. "Aerodynamic sound generation by turbulent flow in the vicinity of a scattering half plane" Journal of Fluid Mechanics Vol.40 pp 657-670 Mar. 1970
14. Lowson, M.V. "Rotorcraft and Propeller noise". AGARD LS 1975
15. Henderson, H.R., Pegg, R.I. and Hilton, A. "Results of the noise measurement programme on a standard and modified OH 6 A Helicopter". NASA TND - 7216 Sept. 1973.
16. Schlegel, R.G. "Hush Final Report - Quiet Helicopter Programme". Serial 611478 Sikorsky Report
17. Bows, M.A. "Test and evaluation of a quiet helicopter configuration H4-43B" Journal of Acoustic Society of America Vol.54 pp 1214-1218 1974.
18. Badgley, R.H. and Hartman, R.N. "Gearbox noise reduction". Journal of Engineering Industry Vol. 96 pp 567-577 1974.
19. Pollard, J.S. and Leverton, J.W. "Cabin noise reduction - use of isolated inner cabins". Paper No.19 2nd European Rotorcraft and Powered Lift Aircraft Forum. Sept. 1976
20. McKenzie, K. and Shepherd, D.R. "Design for maximum survival in icing" Symposium at Royal Aeronautical Society Nov. 1975.
21. Messinger, B.L. "Equilibrium temperature of an unheated icing surface as a function of airspeed" Journal of Aeronautical Society Vol. 20 No.1 1963
22. Stallabrass, J.R. "Canadian research in the field of helicopter icing". Helicopter Association of Great Britain Aug. 1961
23. Shepherd, D.R. "Rotor ice protection systems". Paper No.6 2nd European Rotorcraft and Powered Lift Aircraft Forum Sept. 1976

TABLE 1

Helicopter Features of Operational Interest

<u>Ten Point Plan</u>	<u>Civil Operator</u>	<u>Corporate/VIP User</u>
Low cost of ownership	Payload/Range	Cabin comfort
Cost effective performance	Operating costs	Low noise levels
Reliability & maintenance	Initial price	Initial price
More effective systems	Reliability/Maintenance	Operating costs
Agility	Single engine performance	Reliability
Low vibration	Cabin space	High speed
All weather/night operation	Optional role equipment	All weather capability
Improvement environment & workload	All weather capability	Single pilot IFR
Safety/survivability	High speed	Range
Low noise	Low noise levels	IFR
	Single pilot IFR	

TABLE 2

Naval Maintenance Targets

	<u>MTEF</u>	<u>Mission Reliability</u>	<u>Maintenance Mh/Fh</u>
Wasp	47	98.25%	4.05
Sea King	16	88.0%	4.91
Lynx	33	95.5%	2.7

TABLE 3

Lynx Icing Trials 1975/6

<u>Weather Condition</u>	<u>No. of Sorties</u>	<u>Flying Time (hrs)</u>
Icing cloud	59	31
Freezing fog	6	3
Recirculating snow	20	10
Precipitating snow	4	2
	<u>89</u>	<u>46</u>

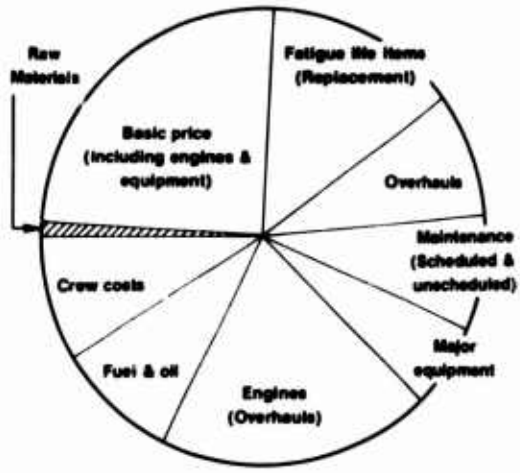

Fig.1 Life Cycle Cost Breakdown
- Typical Modern Military Helicopter

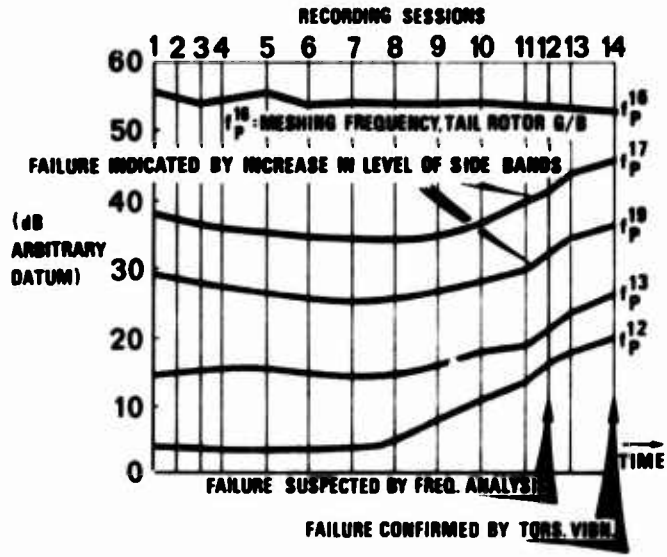

Fig. 3 Effects of Gear Faults on Vibration Spectrum Levels

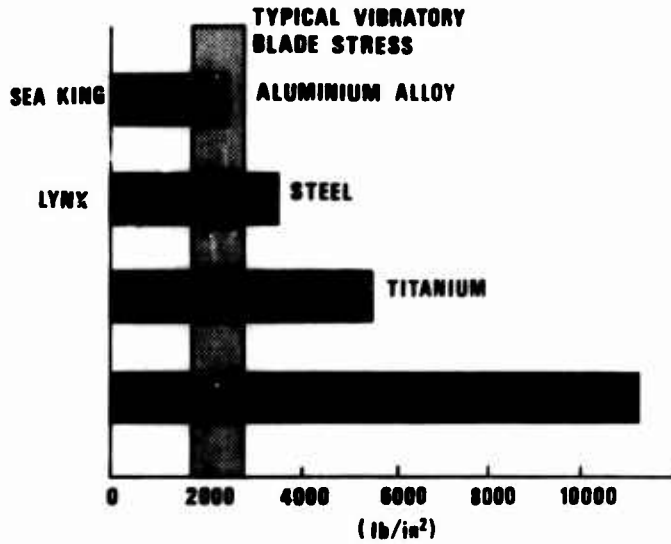

Fig.2 Specific Fatigue Strength

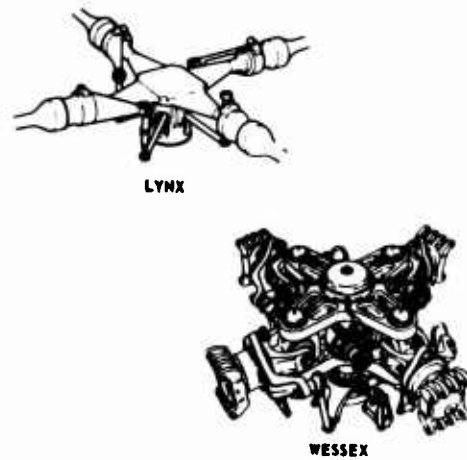

Fig.4 Comparison of Lynx and Wessex Rotor Heads

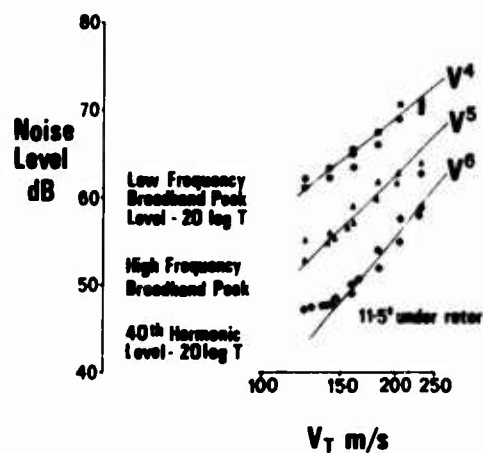

Fig.9 Rotor Noise Component Levels vs Tip Speed

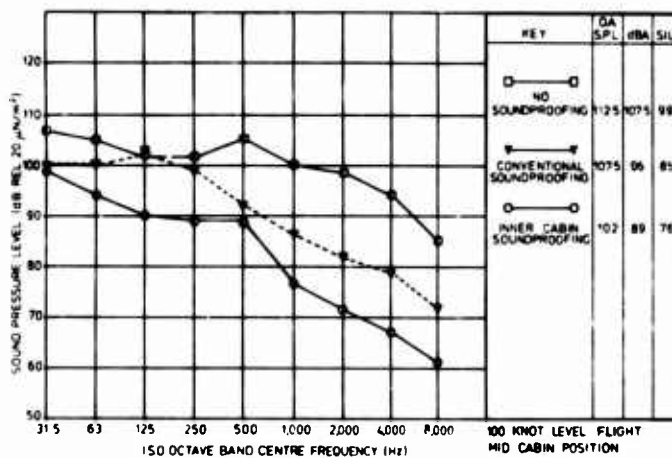

Fig.11 Commando Aircraft - Internal Noise Levels (from Pollard Ref.19)



Fig.10 VIP Commando Aircraft - Interior



Fig.12 Icing Trials Sea King Side Facing Intake



Fig.13 Icing Trials Sea King Sand Filter

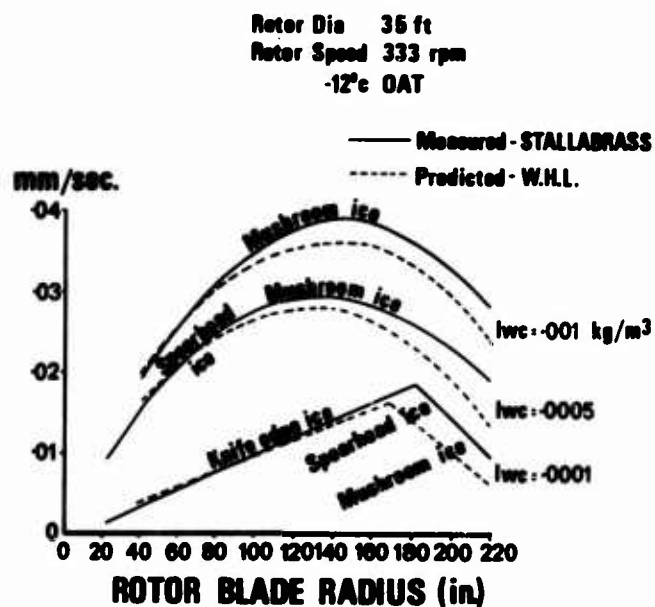

Fig.14 Comparison of Theory and Experiment for Ice Accretion

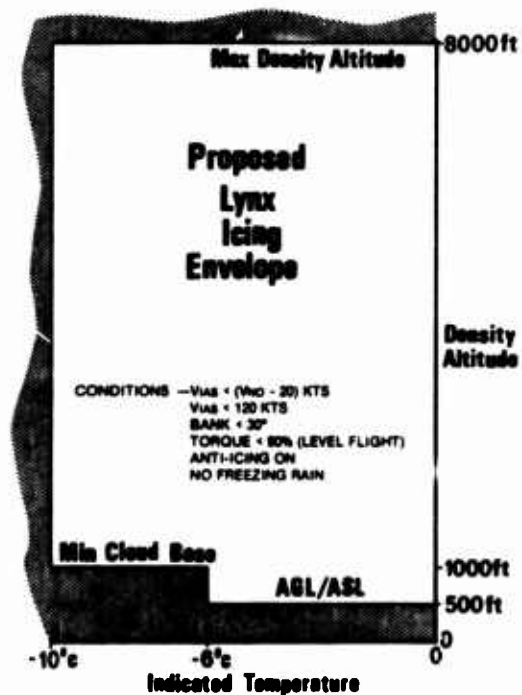

Fig.15 Lynx - Proposed Icing Release

ONERA AERODYNAMIC RESEARCH WORK ON HELICOPTERS

32-1

by Jean-Jacques PHILIPPE and Claude ARMAND

Office National d'Etudes et de Recherches Aérospatiales (ONERA)
92320 Châtillon (France)

Summary

ONERA aerodynamic research on helicopters includes basic research in two or three-dimensional flows and studies on rotors.

Basic research is carried out for improving the understanding of complicated phenomena which are difficult to study in detail on rotor blades. It concerns in particular the study of steady and unsteady characteristics of airfoils and of problems pertaining to blade tips and to vortex interactions. For the rotors, ONERA developed a computing program for the forces on the blades, based on the acceleration potential method. The problems of unsteady transonic aerodynamics related to high speed flight are the object of in-depth studies in cooperation with the US Army AMRDL (Ames Directorate).

In order to perform wind tunnel tests for helicopter companies and for research purposes, ONERA developed two rotor test rigs ; one is located at the Modane Center in the 8 m dia. S1 wind tunnel ; the other is at Chalais-Meudon in the 3 m dia. S2 wind tunnel. Measuring techniques which are used and the more characteristic results for total forces on helicopter or convertible, for absolute pressures on the blades, for identification of the boundary layers, for smoke visualizations, and for rotating blade deformations are described.

Main notations

C_L	Lift coefficient = $L/(1/2 \rho V_0^2 cb)$
C_D	Drag coefficient = $D/(1/2 \rho V_0^2 cb)$
C_m	Pitching moment coefficient = $M/(1/2 \rho V_0^2 cb)$
b	Span (m)
c	Chord (m)
x/c	Dimensionless chordwise location
y/b	Dimensionless spanwise location
α	Incidence ($^\circ$)
V_0	Wind tunnel speed (m/sec)
M_0	Wind tunnel Mach number
Re	Reynolds number based on V_0 and c
p	Pressure (Pa)
p_i	Total pressure (Pa)
p_0	Static pressure (Pa)
k	Reduced frequency ($\omega c/2 V_0$)
ω	Frequency of oscillation or rotation (rad/sec)
\bar{L}	Rotor lift coefficient = $100 L/(1/2 \rho (\omega R)^2 S\sigma)$
\bar{D}	Rotor drag coefficient = $100 D/(1/2 \rho (\omega R)^2 S\sigma)$
\bar{Q}	Rotor torque coefficient = $100 Q/(1/2 \rho (\omega R)^2 RS\sigma)$
\bar{P}	Rotor required power coefficient = $100 P/(1/2 \rho (\omega R)^2 S\sigma)$
R	Rotor radius (m)
S	Rotor disc surface (m^2) = πR^2
n	Blade number
σ	Solidity ratio = $nc/\pi R$
ωR	Rotor tip speed (m/sec)
$M(1,90^\circ)$	Advancing blade tip Mach number
μ	Rotor advance ratio = $V_0/\omega R$
α_q	Rotor shaft angle ($^\circ$)
ψ	Azimuth ($^\circ$)
r/R	Dimensionless blade spanwise location
θ	Collective pitch angle ($^\circ$)
C_p	Pressure coefficient = $(p - p_0)/1/2 \gamma p_0 M^2$
M	Instantaneous incident Mach number = $(\omega r + V_0 \sin \psi)/a_0$

a_0	Sound speed (m/sec)
M_x	Local Mach number on the profile.

1. INTRODUCTION

Problems raised by the three-dimensional unsteady aerodynamics of helicopter rotors are as numerous as they are complex. ONERA endeavors to approach them both by calculation and by actual experimentation on rotors, but also in a more analytical way through basic research aiming at an improved understanding of phenomena that are difficult to study in detail directly on rotors.

The basic research work concerns mainly, in two-dimensional flow, the study of steady and unsteady characteristics of airfoils, and in three-dimensional flow that of problems pertaining to blade tips and to vortex interactions. For the rotors, ONERA developed a computing program for the forces on blades, based on the acceleration potential method, which can be applied to both flexible and rigid blades for moderate advance ratios. The problems of unsteady transonic aerodynamics related to high speed flight are also the object of in-depth studies, with experimental verification on rotors in the wind tunnel.

For its experiments, ONERA has at its disposal rotor test rigs at the S2 Chalais-Meudon and the S1 Modane wind tunnels ; their possibilities and the measuring techniques used are also presented below.

The ONERA work is carried out by its Aerodynamics, Structures and Modane Wind Tunnel Departments, in close contact with the Aérospatiale Company. Some studies of a more fundamental character, are also carried out very efficiently in cooperation with the Ames Laboratory of the U.S. Army, within the framework of an MOU (Memorandum Of Understanding) on Helicopter Aeroelasticity.

2. BASIC RESEARCH

2.1. Airfoil study in steady flow

The helicopter blade airfoils have to operate within a very broad range of Mach number and incidence, as the advancing blade is a near-zero incidence at Mach numbers higher than 0.8, while the retreating blade works at near-stall incidences at Mach numbers of 0.3 or 0.4. For hovering flight, an optimal operation is sought for, at Mach numbers near 0.6, in order to minimize the power on the rotor.

Table I sums up the main requirements for operating conditions, which the blade profiles should meet, governed by respective levels of maximum lift, L/D ratio or drag divergence Mach number. It is practically impossible to find any profile fulfilling all these conditions together, so it is necessary to design blades with evolutive profiles. This is an approach similar to that chosen, for instance, by Boeing-Vertol for the determination of the VR profiles [1].

Table I
Requirements for a helicopter blade

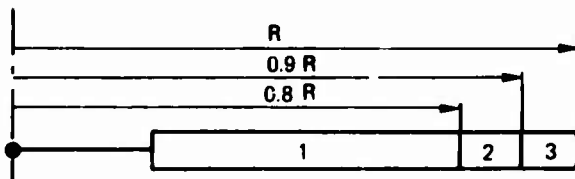

Flight conditions	Preponderant aerodynamic coefficient	Sections		
		1	2	3
Advancing flight	Drag divergence Mach number at $C_L \sim 0$	≥ 0.8	0.85	0.9
	$ C_{m0} $	< 0.01	0.01	0.01
Hovering	L/D ratio at $M_0 \sim 0.5-0.6$	> 75	72	85
Maneuver	$M_0 = 0.3$	> 1.5	1.4	1.1
	$M_0 = 0.5$	> 1.3		

We shall also note the objective of having a C_{m0} as low as possible within the whole Mach number range, as an excessive value of this coefficient would involve too big a power for pitch control and non-negligible vibrations and deformations due to a coupling between blade flapping and torsion. This has been shown during tests on a rotor [2] equipped with a NACA 0012 profile with cambered extension (defined at ONERA), which on the other hand extended the rotor stall limits (fig. 1) thanks to maximum lift coefficient at low Mach numbers higher than those of NACA 0012 without penalty on performance at transonic Mach numbers (fig. 2).

Fig. 2 - Steady characteristics of NACA 0012 profiles with and without cambered extension.

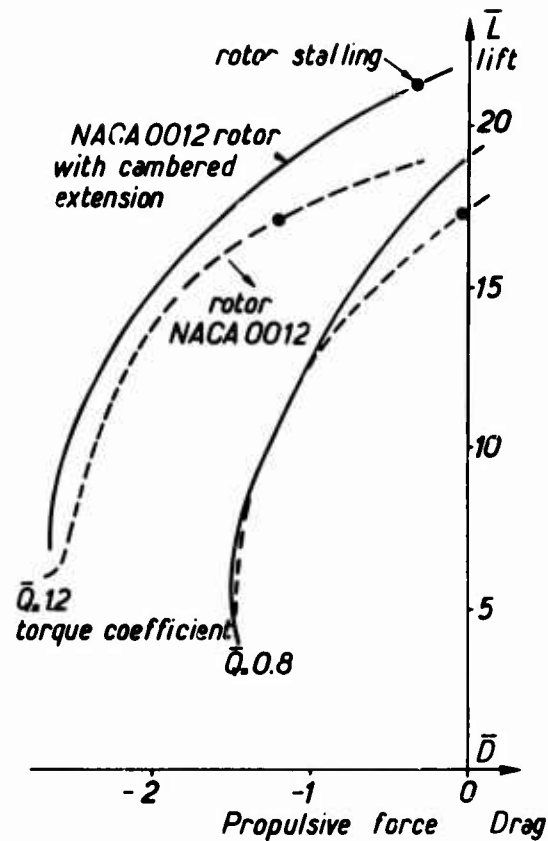
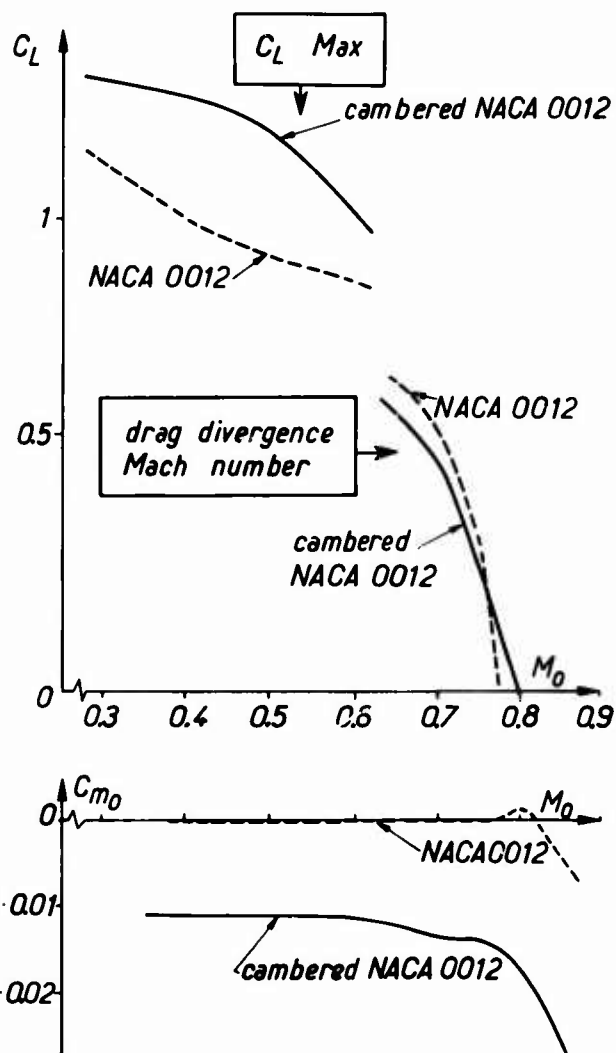

Fig. 1 - Compared performance of two rotors for an advance ratio $\mu = 0.3$ ($\omega R = 200$ m/sec ; $V_0 = 60$ m/sec).



References [2, 3] emphasize the interest of choosing a family of profiles with decreasing relative thickness (SA 13112, 13109, 13108 adapted by Aérospatiale) : for a given lift coefficient, the torque to be provided to the rotor is lower and the rotor propulsive force higher than for the rotor equipped with constant NACA 0012 profile blades (fig. 3).

The determination of a family of profiles for helicopter blades fulfilling the conditions of Table I is undertaken by a close association of the efforts of ONERA research scientists and Aérospatiale Marignane design engineers.

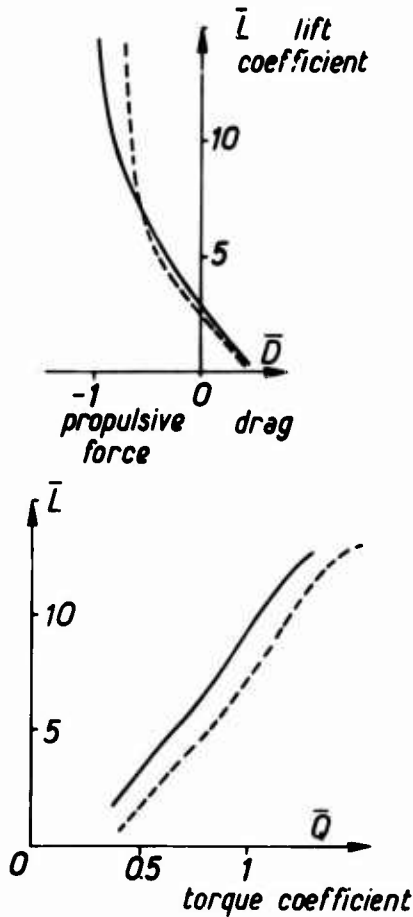

Fig. 3 - Compared performance of two rotors for an advance ratio $\mu = 0.5$ ($\omega R = 208$ m/sec ; $V_0 = 104$ m/sec). $\alpha_a = -16^\circ$.
 — blade with Aérospatiale evolutive profiles - $M(1,90^\circ) = 0.91$
 --- blade with NACA 0012 profile - $M(1,90^\circ) = 0.93$

2.2. Unsteady performance of airfoils

The operating conditions of helicopter blade profiles are essentially unsteady, as both incident Mach numbers and incidences are function of the blade azimuth. If Mach number variations are sinusoidal, it is not so for the aerodynamic incidences which vary much more rapidly for the retreating blade than for the advancing one. The aerodynamic characteristics of the profiles are thus different from the stationary ones, particularly when flow separations occur on the profiles ; then there appears phenomena related to dynamic stall, which may lead to stall flutter.

A test rig allowing pitch oscillations of a two-dimensional model has been built for the S10 wind tunnel of CEAT (Toulouse Test Center of the Ministry of Defense), where airfoils up to 0.40 m chord can be tested up to Mach 0.4. Figure 4 shows an example of comparison of performance of NACA 0012 profiles

with and without cambered extension at the leading edge, as a function of the maximum angle of attack during the oscillation.

22.3

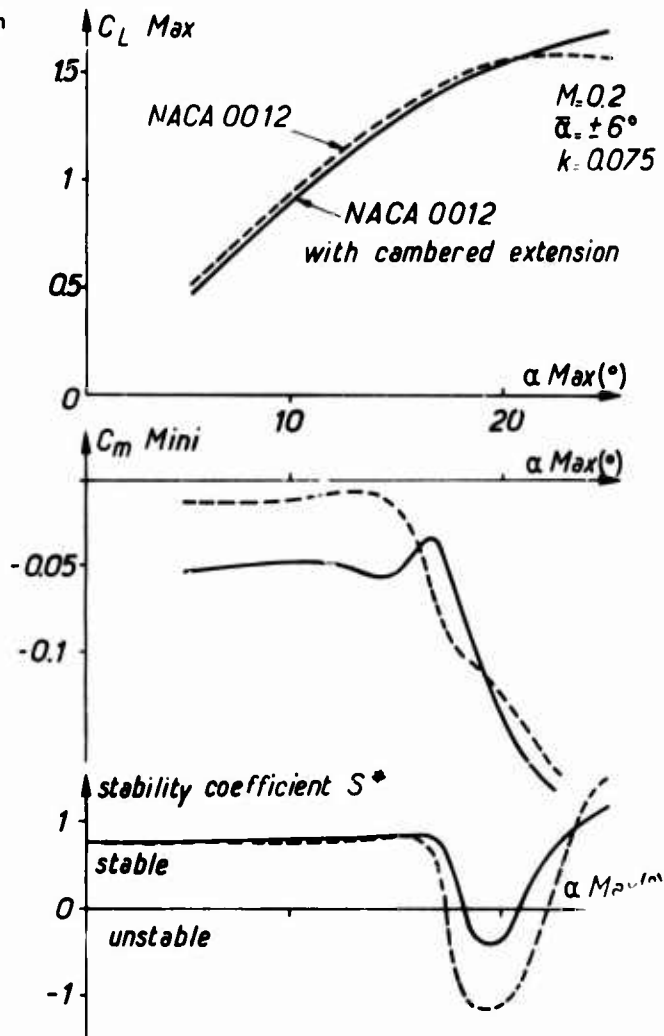

Fig. 4 - Unsteady characteristics of profiles.

The detailed study of the process of dynamic stall has been the object of many studies worldwide, at ONERA in particular [4]. The studies carried out in cooperation with the U.S. Army Ames Laboratory on the theoretical [5] and experimental [6] point of view brought to light the various phases of dynamic stall. Figure 5 shows the evolution of separations on oscillating profiles, deduced from results of tests on NACA 0012 with and without leading edge extension in the 7 x 10 ft U.S. Army Ames wind tunnel. This phase of up-travel of flow separation starting at the trailing edge takes place before the phase of generalized separation with a vortex character ; this has as a consequence the appearance of maximum lifts much higher than those obtained in steady flow, and also the creation of very important pitch-down moments that can render the work of aerodynamic forces positive, which may make the incidence movement unstable. Stall flutter may also interest the upstream blade position, as shown by tests made at the S3 Modane wind tunnel by the ONERA Structures Department. Figure 6 reveals the existence of an "instability pocket" when the Mach number increases on a NACA 63A015 profile of 0.25 m chord oscillating around a 10° angle of attack at a frequency of 34 Hz.

20-4

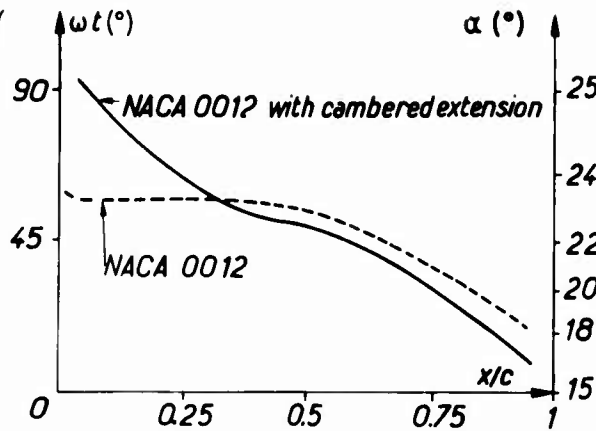

Fig. 5 - Evolution of the turbulent separation point on oscillating airfoil. $\alpha = 15^\circ + 10^\circ \sin \omega t$; $k = 0.10$; $R_e = 2.5 \times 10^6$.

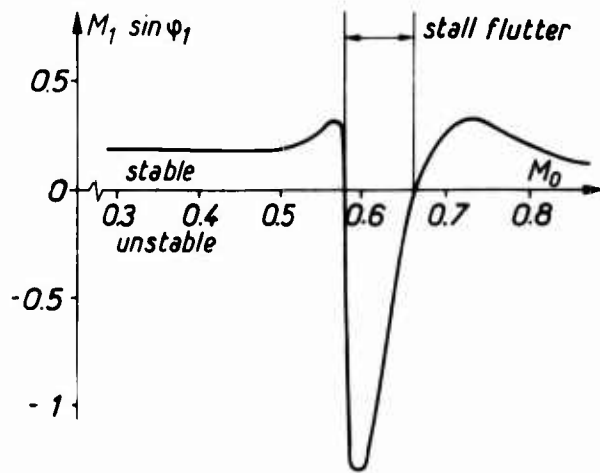

Fig. 6 - Stall flutter experimental study. Pitching oscillations. Axis located at $x/c = 0.375$. Aerodynamic moment coefficient: $C_m = M_0 + M_1 \cos(\omega t + \varphi_1) + M_2 \cos(2\omega t + \varphi_2) + \dots$

2.3. Blade tip study in steady flow

The research is devoted to the knowledge and prediction of the flow on blade tips, which may contribute very noticeably to the power balance of the rotor. As early as 1970, many blade planforms have been tested in subsonic and transonic wind tunnel [7], but the performance gain was not significant enough to justify experiments on rotors.

In 1976 tests have been started anew on a half wing with a 30-degree sweep tip, mounted at the wall of the S3 wind tunnel of Chalais-Meudon with the purpose of setting a reference for comparisons with theoretical results (three-dimensional transonic calculations) and with pressure distributions measured on a swept tip, 2-blade rotor at the S2 wind tunnel of Chalais-Meudon (see section 4.3). Figure 7 shows the favorable effect in steady flow of the blade tip sweep. The gain in drag at given lift is all the bigger as the Mach number is higher.

Flows on swept blade tips are complex, especially at transonic speeds as shown, figure 8, by the pressure distributions calculated with a computer program written by F.X. Caradonna, of U.S. Army Ames Laboratory [8]. This program integrates numerically the three-dimensional equation of small transonic perturbations of the velocity potential for a non lifting rotor in hovering flight. Adapted for the calculation of pressure distributions on a half wing at the wall, the program provides a good description of the flow on the blade tips, as shown by the comparison of isobaric lines, calculated and measured at zero angle of attack and Mach 0.85 (fig. 9).

2.4. Vortex interaction wind tunnel simulation

The vortex emitted by the blade tip interacts with the following blade. The flow over the interacted blade is modified, and can have an effect upon the rotor performance, especially in hovering flight.

A wind tunnel simulation may be obtained by placing a so-called receiving half wing (R) close to the tip vortex emitted by another half wing, called emitting (E), placed upstream and perpendicular to the former (fig. 10). A detailed study was performed a few years ago in low speed flow [9]. Tests have been renewed at the S3 Chalais-Meudon wind tunnel for Mach numbers between 0.5 and 0.85.

Figure 11 shows that the vortex interaction entails :
 - a loss of lift when the receiving blade is at a given angle of attack,
 - an important drag increase for a given lift.

Fig. 7 - Influence of the tip sweep of a half wing.

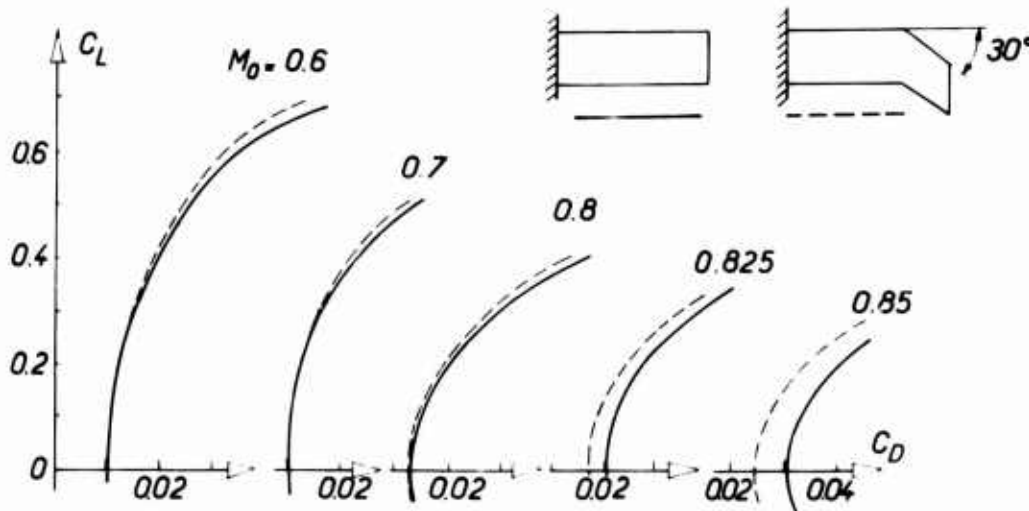

22-5

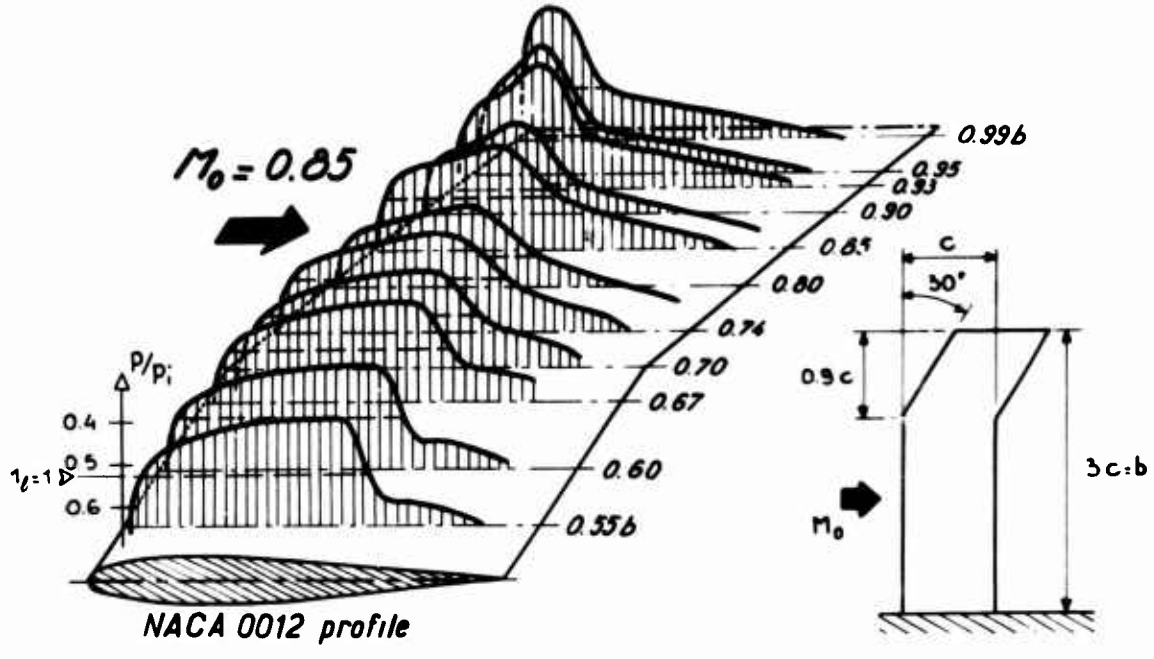

Fig. 8 - Pressure distributions on a swept tip half wing ($\alpha = 0^\circ$).

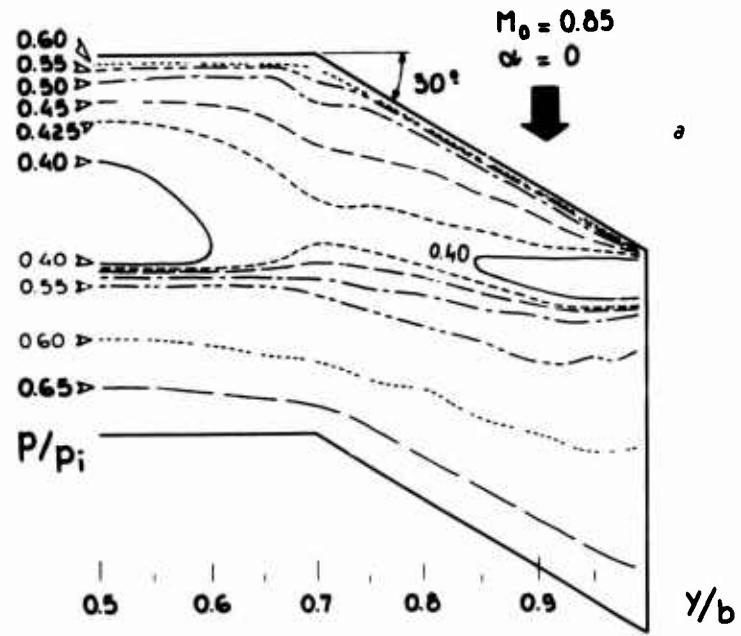
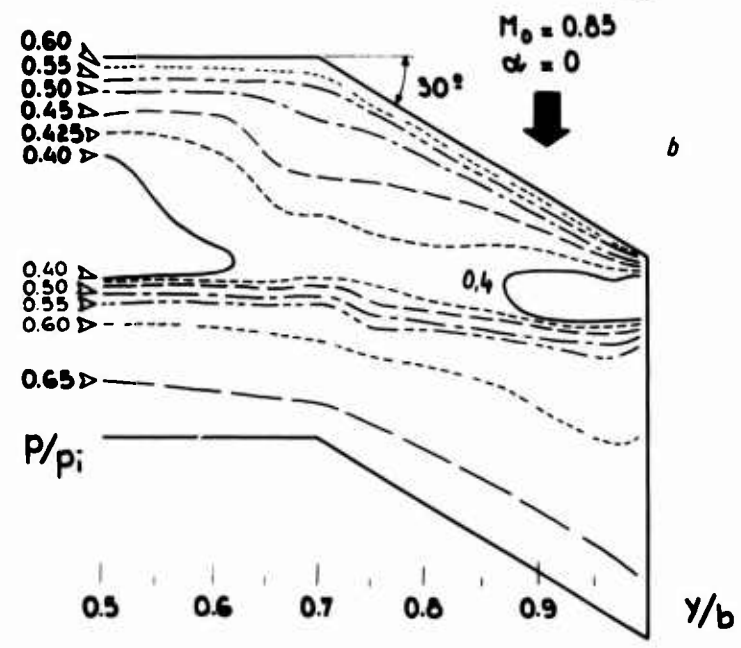

Fig. 9 - Non lifting swept tip half wing. Isobaric lines p/p_i

a - Three dimensional calculation



b - Tests at the S3-Ch wind tunnel.

22-6

Fig. 10 - Vortex interaction wind tunnel simulation.

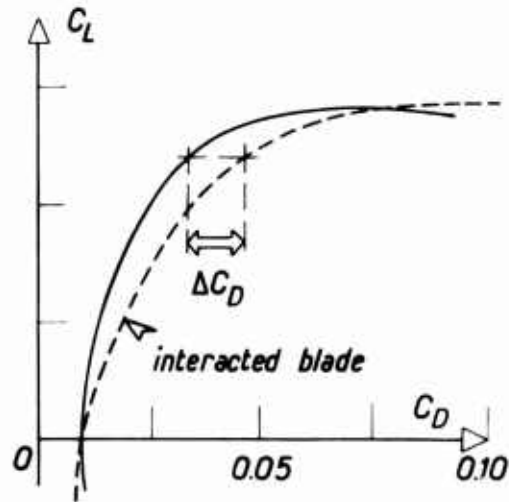
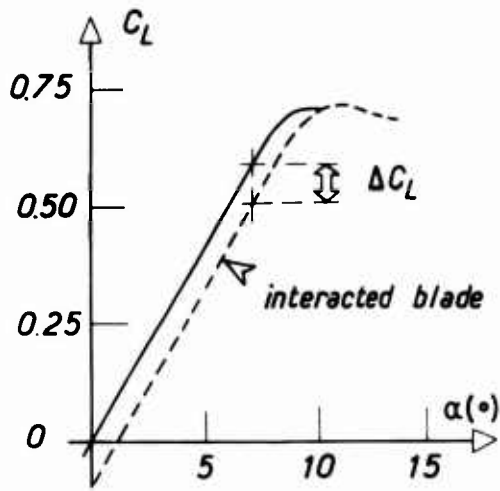
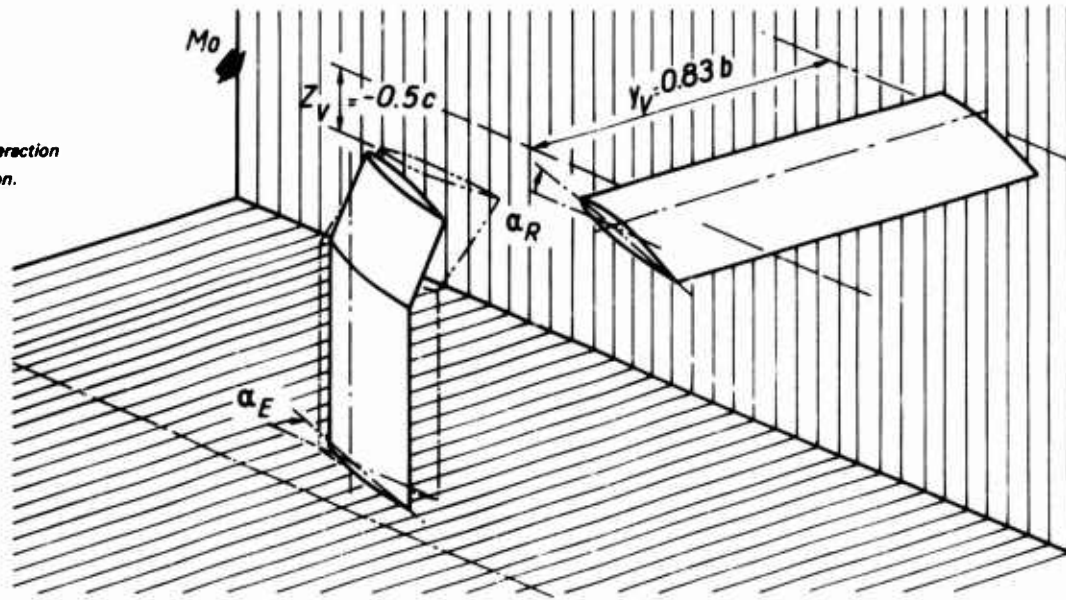

Fig. 11 - C_L , C_D curves of a NACA 0012 half wing with or without vortex interaction at $M_o = 0.6$.

Figure 12 shows the evolution of the drag as a function of the emitting blade angle of attack, for various levels of lift of the receiving blade. In the simulation of a rotor hovering flight, the lift of the emitting blade is equal to that of the receiving blade; we see (circled points on figure 12) that in this case, for Mach 0.6, the drag increases may reach nearly 40%. This proves the importance of the vortex interaction phenomenon.

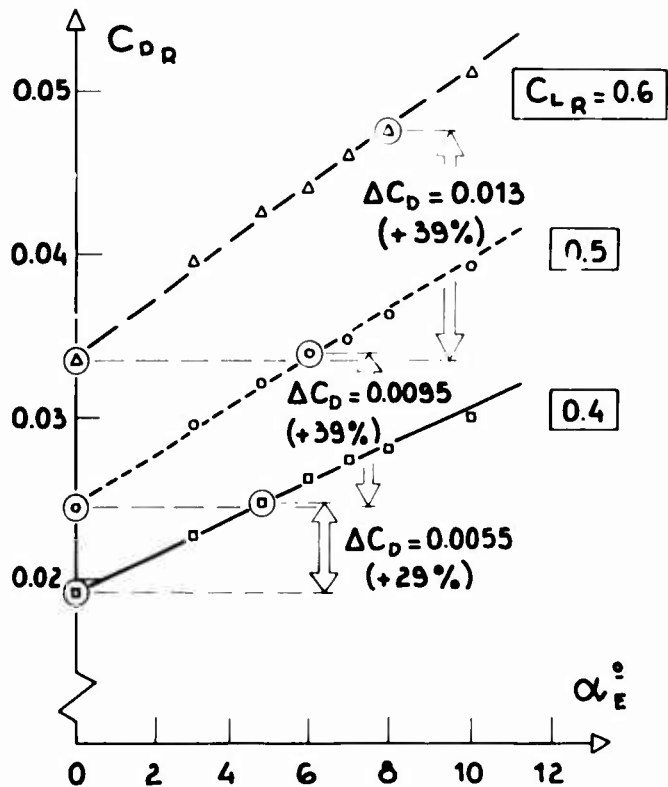

Fig. 12 - Drag increase due to the vortex interaction at $M_o = 0.6$.

3 - CALCULATION OF THE FORCES ACTING ON THE ROTOR

3.1. Principle of the method used

The linear lifting surface theory is successfully used in aircraft flutter calculations. The ONERA Structures Department developed a formulation that applies to a blade whose movement is arbitrary, and that takes into account three-dimensional effects and the effects of perturbation propagation by acoustic waves [10].

The lifting surface is schematized by a pressure discontinuity surface that moves and may be distorted, in the case of flexible blades, by the action of the aerodynamic forces. The pressure discontinuity is directly proportional to the accelerative potential, temporal derivative of the velocity potential :

$$\Delta p(M, t) = -2 \rho_{\infty} \dot{\psi}(M, t).$$

For application to helicopters [11], and to simplify the numerical computation, we use only one line of acceleration doublets, located at the quarter-chord (lifting point), oriented perpendicularly to the blade and of intensity q equal to :

$$q(M, t) = \frac{\Delta p(M, t)}{\rho_{\infty}}.$$

By writing the tangency condition at the three-quarter chord (collocation point), we obtain a set of linear algebraic equations, whose solving gives the unknown intensities q .

The method provides directly the sum of local velocities due to the free vortices and to the vortices attached to the blade.

Thus, the method permits the direct calculation of local loads, without having to take explicitly into account the vortex wakes and the local aerodynamic incidences.

3.2. Application to the case of rigid blade rotor

In the case of moderate helicopter advance ratio and of local incidences lower than that of profile stall, the results obtained by this linear, but compressible, three-dimensional and unsteady, aerodynamic calculation, are satisfactory not only for the total forces acting on the rotor, but also for local loads, as shown on figure 13 presenting the local loads as calculated and as measured in the S1 Modane wind tunnel on a 3-blade Aérospatiale rotor. The rotor lift coefficient \bar{L} is here 16.1 (the rotor is moderately loaded). In the case of high lift configuration there appear incidences for which the profiles separate. An original calculation method has been developed by J.J. Costes [12], who introduces into the lifting laws the characteristics experimentally obtained on profiles either fixed or oscillating in pitch. The linear method of acceleration potential is still used, but the calculation of an effective aerodynamic incidence is introduced, which is in a way the equivalent incidence of the linear theory for a separated profile (fig. 14). For the configurations of unsteady stall, the effective incidence is a function of the actual incidence α and of its derivative $\dot{\alpha}$, in a way similar to that of the method proposed by Gross and Harris [13].

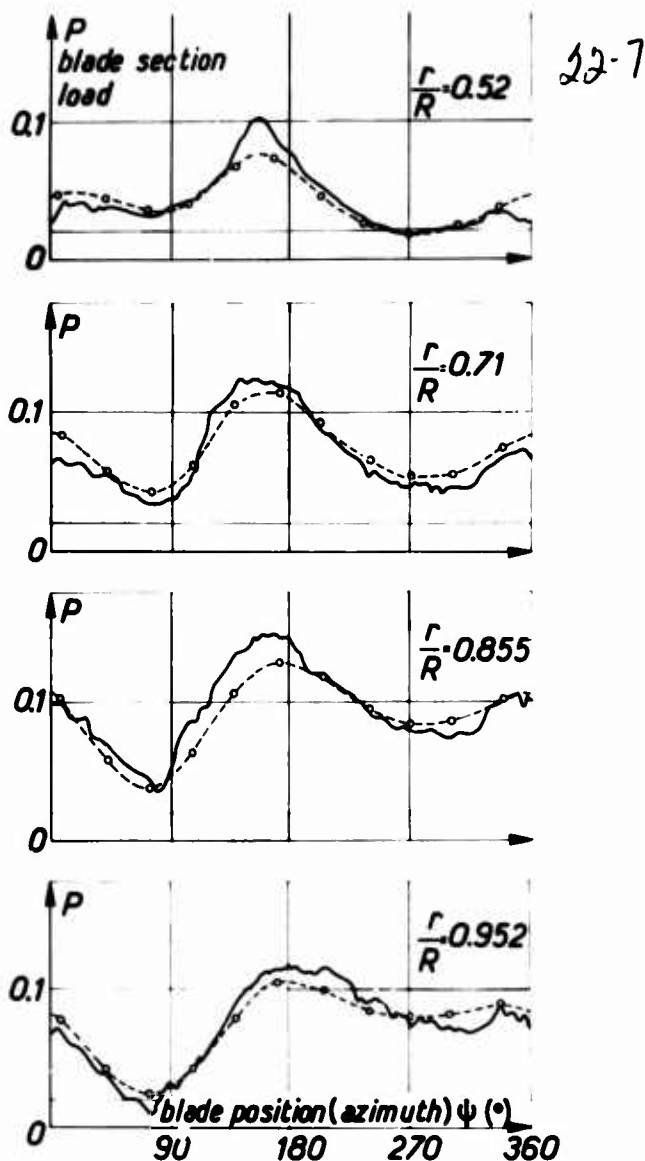

Fig. 13 - Evolution of local loads in the case of a moderately loaded 3-blade rotor ($\bar{L} = 16.1$; $\bar{D} = -2.3$) at $\mu = 0.3$ ($\alpha_0 = -16^\circ$; $\theta = 11.7^\circ$). Tests in S1-MA wind tunnel.

$$\text{Local load } P = \int_{-1}^{+1} \frac{\Delta p}{2 \rho_0} d\xi$$

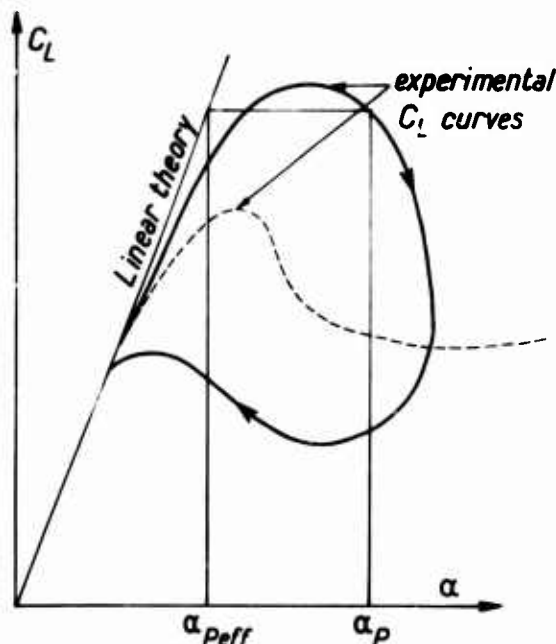

Fig. 14 - Definition of the effective aerodynamic incidence in the case of an oscillating airfoil.

22-8

Figure 15 shows the azimuthal evolution of the local loads in the case of a heavily loaded rotor ($\bar{L} = 18.7$) for which the retreating blade is certainly separated over a broad azimuthal sector.

The calculation that account for unsteady separations provide a noticeable improvement for the prediction of local loads. A difference appears only in the last measuring section, located at 0.952 R, where non-linear, three-dimensional phenomena of the blade tips are not taken into account in the calculation.

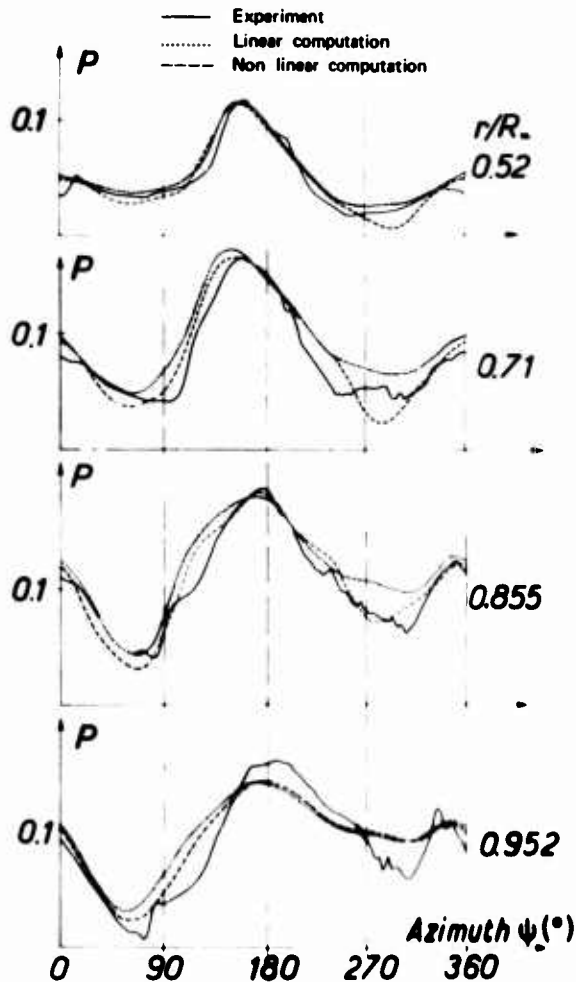

Fig. 15 - Evolution of local loads in the case of a heavy loaded 3 blade rotor ($\bar{L} = 18.7$; $\bar{D} = -2.4$) at $\mu = 0.3$, $\alpha_q = -16^\circ$, $\theta = 13.5^\circ$

3.3. Application to the case of flexible blade rotor

The calculation model has been adapted to the case of flexible blades (not subjected to flow separations) by coupling the aerodynamic calculations program to that of blade dynamics, in which are introduced the blade structural characteristics and shape modes [14]. The first results obtained are encouraging, as they agree rather well with flight test results on a research helicopter of the Aérospatiale Company (SA 349 Z Gazelle). Figure 16 shows a comparison between the moduli of the harmonics of the flapping bending moments of the blade measured in flight and those calculated either considering a fixed rotor hub or taking account of the measured hub motions [15].

The study is also pursued with a view to know the vibrations transmitted to the fuselage by introducing the dynamic transfer function of the rotor head.

It is also planned to improve the calculation of the aerodynamic forces on the rotor by using a true formulation of lifting surface instead of that of lifting line hitherto adopted in the numerical calculations.

4. UNSTEADY TRANSONIC FLOW STUDY ON HELICOPTER ADVANCING BLADE TIP

4.1. The S2-Ch helicopter rotor test rig

The S2-Ch wind tunnel has a 3-m-dia. test section, in which the maximum velocity is 110 m/sec (400 km/h). This tunnel allows tests on 1.5-m-dia. models of rotors, at advancing velocities much higher than the maximum speeds of standard helicopters. Figure 17 shows a layout of this research rig: the rotor is driven by a hydraulic motor; a 6-component balance and a rotating torque-meter measure the total forces acting on the rotor and the torque applied. Two slipring assemblies, of 48 and 55 channels respectively, give access to a large number of local data picked up on the blades (stresses, pressures, boundary layer detectors).

The total forces and the torque are processed on line by a T2000 computer attached to the S2-Ch wind tunnel; the corresponding aerodynamic coefficients are visualized continually on a television screen near the control and test monitoring desk.

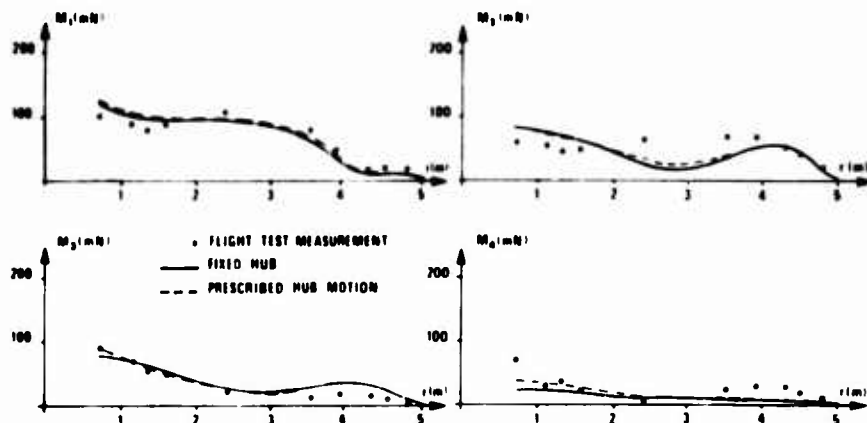

Fig. 16 - SA 349 flapwise bending moment amplitudes (harmonic analysis)
 $\mu = 0.33$; $\bar{L} = 13.4$.

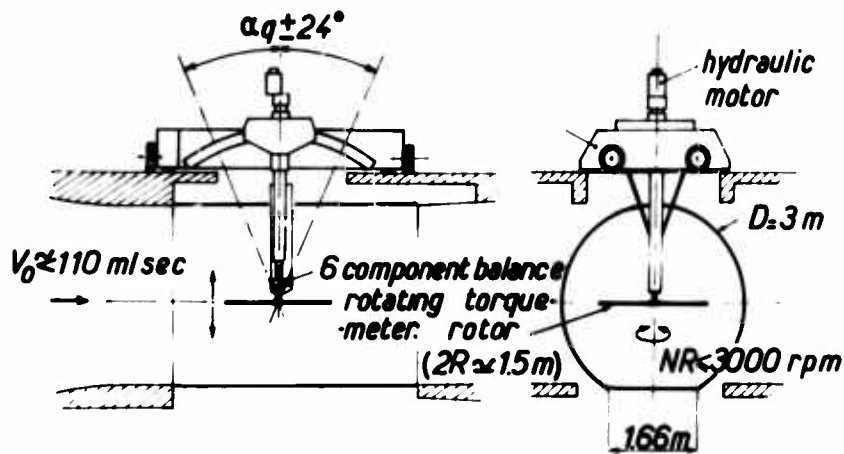

Fig. 17 - ONERA S2 Chalais wind tunnel rotor test rig.

For the measurement of unsteady local pressures, there is also a hybrid (analog-digital) unit which provides averages, over n consecutive turns and for 256 geometrically known azimuthal positions, of the instantaneous values provided by the pressure transducers. Within a maximum delay of one hour after the test we can have the tabulations and graphs of the azimuthal evolution of the actual absolute pressures or of the pressure coefficients, thanks to a processing on a CII 10020 computer.

Operational since 1974, the S2-Ch rotor research rig is used by :

- the ONERA Aerodynamics Department for the development of absolute pressure measurement techniques and for studies of unsteady transonic flows on helicopter rotor blade tips (see Section 4.2) : figure 18 shows the rotor used for these studies, and figure 19 gives a layout of a blade tip equipped with absolute pressure transducers Kulite LDQL (the lead tube is connected either to an upper surface or a lower surface by a T-shaped tube whose one of the branches is obturated) ;

- the Aérospatiale Company for measurements on 4-blade rotors in order to study the influence of parameters such as twist or blade tip planform on the rotor performances ;

- the Giravions Dorand Company for the study of multi-cyclic rotors or of active control of rotary wings [16, 17].



Fig. 18 - The 1.5-m-dia. research rotor in the S2-Ch wind tunnel.

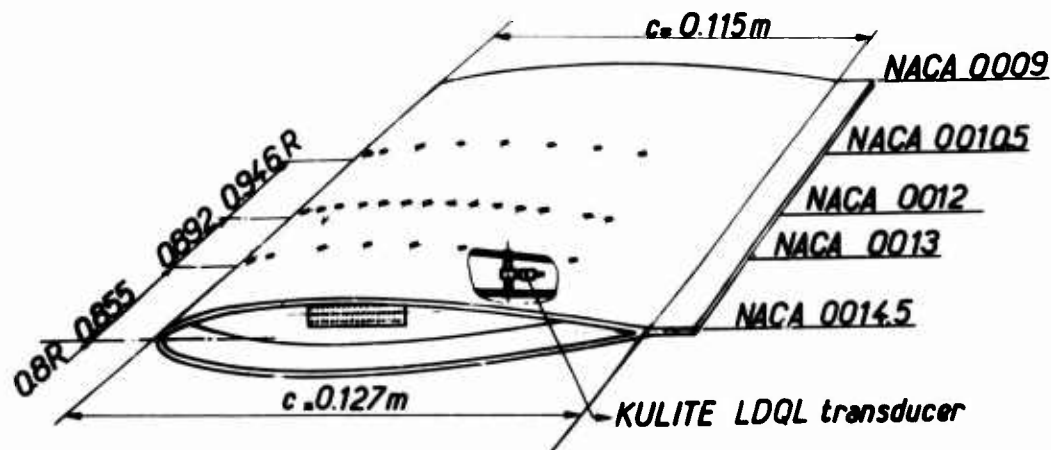

Fig. 19 - Instrumented rotor blade tip layout.

4.2. Study on non lifting rotor with straight blade

22-10

In 1975, F.X. Caradonna and M.P. Isom [18] showed by calculation the importance of unsteady effects on transonic flows that may exist on the advancing blade in the case of a non lifting rotor.

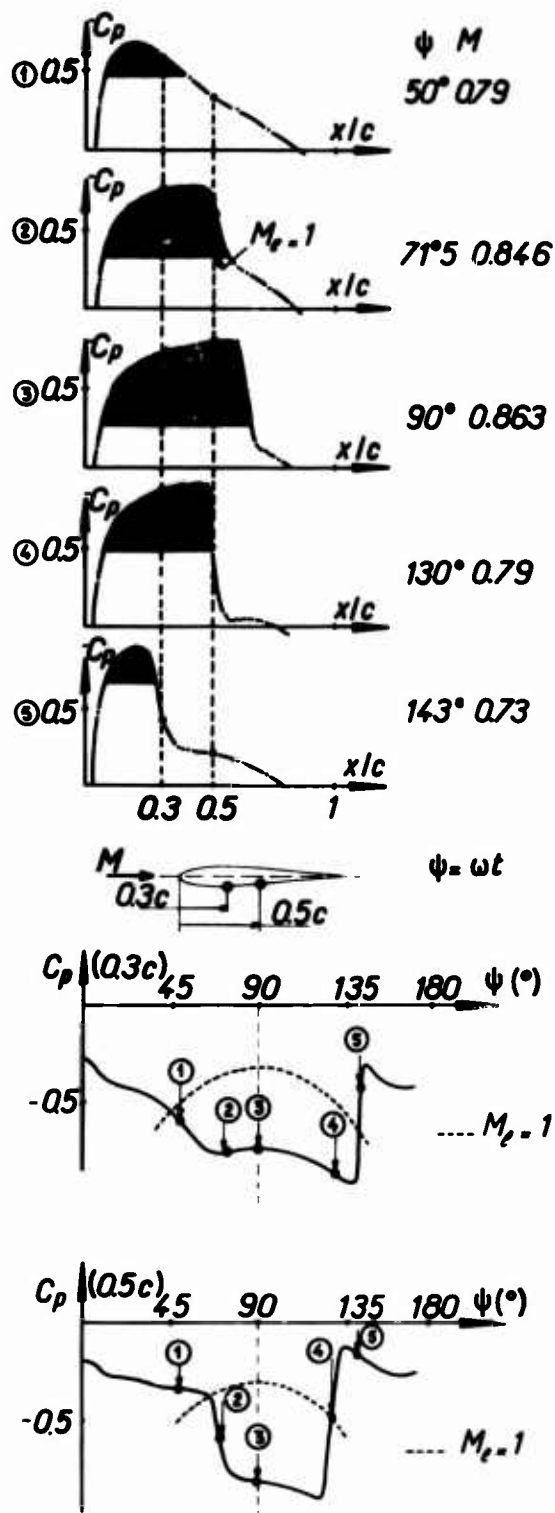

Fig. 20 - Theoretical pressure evolution - Non lifting case.
 $M = 0.536 + 0.327 \sin \psi$.

The method consists in solving the equation of small perturbation of the velocity potential for unsteady transonic flows. Within the approximation of a two-dimensional flow for a given blade section, figure 20 shows the calculation results for a NACA 0012 profile at zero angle of attack in a sinusoidally varying free stream. The dissymmetry of local pressures and pressure

distributions relative to azimuth 90° show clearly the favorable effects of an increasing incident Mach number (delay of the appearance of shock waves as compared to the equivalent steady conditions), and the unfavorable effects of a decreasing Mach number giving rise to wider supersonic expansion region and stronger shocks than when the Mach number increases. In this respect, pressure distributions at azimuths 50° and 130° ($n^\circ 1$ and 4) are significant).

Within the framework of the Memorandum of Understanding between the USA and France on Helicopter Aeroelasticity, a version of the computing program written by F.X. Caradonna has been transmitted to ONERA in order to carry out comparisons between the calculations and the results of its rotor tests.

A rotor with untwisted blades and symmetrical profiles NACA 00XX has been tested on the helicopter rotor test rig of the S2 wind tunnel of Chalais-Meudon (see section 4.1), and the absolute pressures have been measured on three sections near the blade tip. Figure 21 shows the quite satisfactory agreement between the two-dimensional flow calculations and the measurements for sections $r/R = 0.855$ and 0.892 . But a noticeable disagreement appears in the 0.846 section, for which the three-dimensional effects on the blade tip cannot be neglected any more. Details on the calculation and test results are given in reference [19].

It is indeed surprising that small perturbation calculations for so high Mach numbers on a 12% thick profile give such good results, but it should be pointed out that they concern a case with no lift.

The ONERA effort is presently centered on the following points:

- The resolution of the complete Euler equations for two-dimensional, unsteady flows [20].

Calculations performed for an in-plane motion of the profile and corresponding to conditions of attack of the profile of the blade section at $r/R = 0.892$ are promising, considering the small number of meshes, as shown figure 22. The calculation method will be adapted for simulating as well as possible the flow around a section of helicopter blade (in a two-dimensional approximation first, and then in the three-dimensional case).

- The coupling between boundary layer and potential flow for two-dimensional, transonic unsteady flows.

The non-viscous fluid calculation is still done by solving the small perturbation equation of velocity potential proposed by F.X. Caradonna but, this time, on profiles which, at each step of time (or azimuth) are redefined by taking into account, until it converges, the displacement thicknesses calculated by the resolution of the integral equations of unsteady boundary layers. This work, undertaken by J.J. Thibert, of the ONERA Aerodynamics Department, is in the course of development. Figure 23, however, confirms the interest of such calculations as they predict, for instance, in the case of a rotor tested at S2-Ch wind tunnel, for a rotor tip speed of 200 m/sec and a wind velocity of 100 m/sec, a backward travel of the shock not exceeding the mid-chord, while a calculation of the potential flow alone predict that this shock moves back behind this mid-chord point.

The U.S. Army at Ames is developing a program for calculating the three-dimensional, transonic unsteady flow in the case of a non lifting rotor, which should provide a better prediction of the pressure distributions in sections very close to the blade tips.

Fig. 21 - Evolution of absolute pressures on a non lifting rotor blade tip at $V_o = 110$ m/sec and $\omega R = 200$ m/sec.

27-11

— Tests at S2-Ch - - - Calculations.

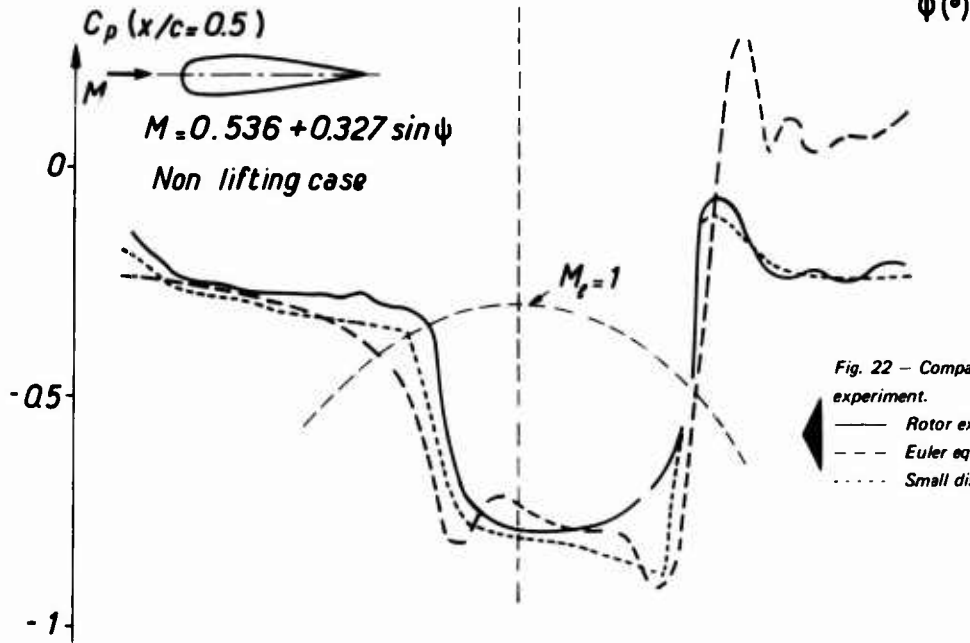
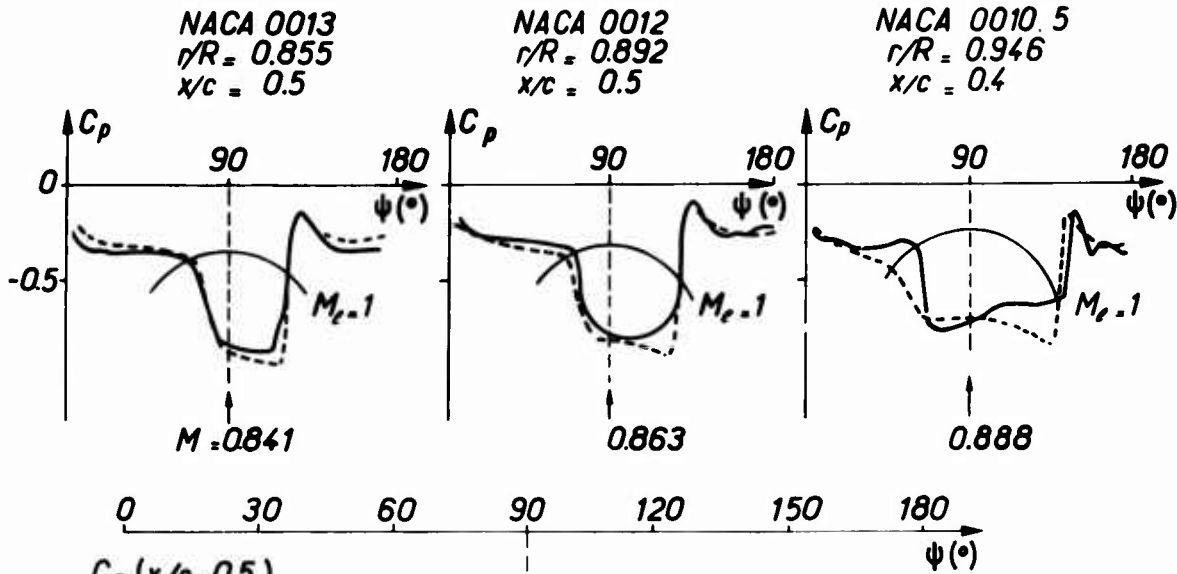

Fig. 22 - Comparison between calculations and experiment.

— Rotor experiment in S2-Ch wind tunnel
 - - - Euler equations (in-plane motion)
 ····· Small disturbance potential equation.

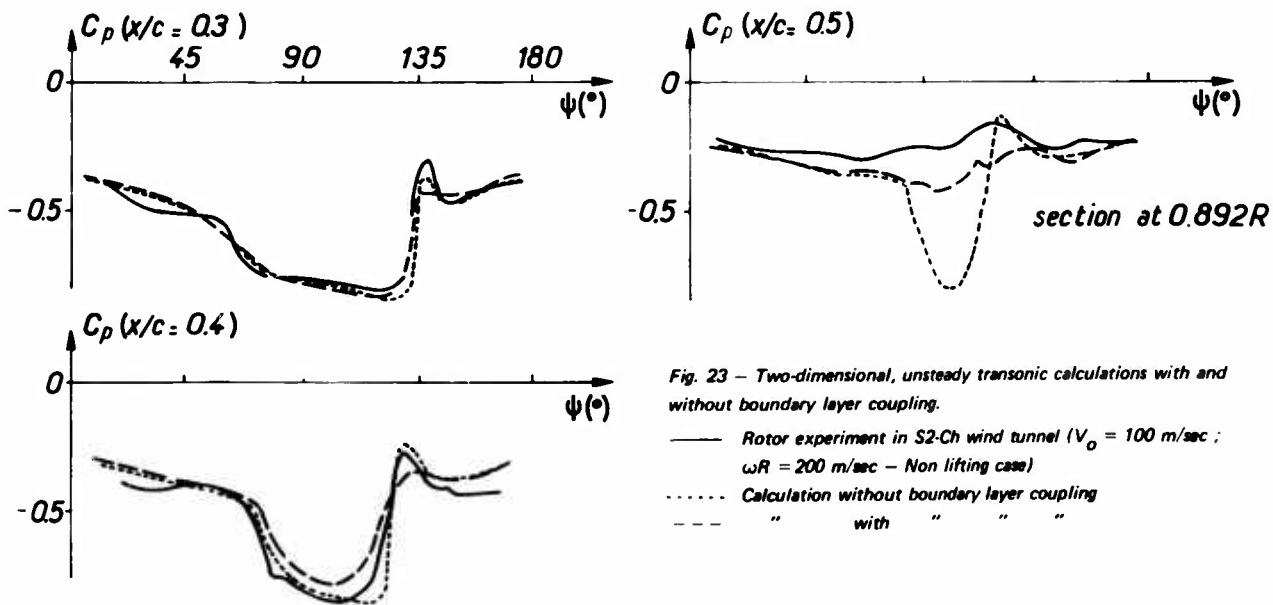

Fig. 23 - Two-dimensional, unsteady transonic calculations with and without boundary layer coupling.

— Rotor experiment in S2-Ch wind tunnel ($V_o = 100$ m/sec ; $\omega R = 200$ m/sec - Non lifting case)
 ····· Calculation without boundary layer coupling
 - - - " " " " " " " "

22-12

4.3. Study on non lifting rotor with swept blade tips

A 2-blade rotor with a 30° sweep of blade tips has been tested at S2-Chalais wind tunnel. The blades have decreasing thickness laws identical to those of the previous rotor with straight tips. In that manner, we can study both totally and locally the influence of the blade tip sweep. Figure 24 shows that the drag of the rotor with swept blade tip and the power it requires are lower than those of the straight blade tip rotor only when the Mach number at the tip of the advancing blade, $M(1,90^\circ)$, is higher than 0.87, which corresponds here to a helicopter flight speed of about 310 km/h. This is well understood if we examine the pressure distributions on the two rotors for the advancing blade (fig. 25), where the advantage of the swept tips is most noticeable for azimuths around 90°, where the local dynamic pressures are maxima. We should however notice that from slightly below 120° azimuth the local Mach numbers on the profile become more important on the swept tip than on the straight tip, while the actual aerodynamic sweep angle (algebraic sum of geometric and aerodynamic sweep angle) remain, in absolute value, favorable to the swept tip up to azimuth 133° for the blade section and the test conditions presented here. Thus, it will be necessary to predict very well these three-dimensional and unsteady effects if we intend to optimize the blade tip platform.

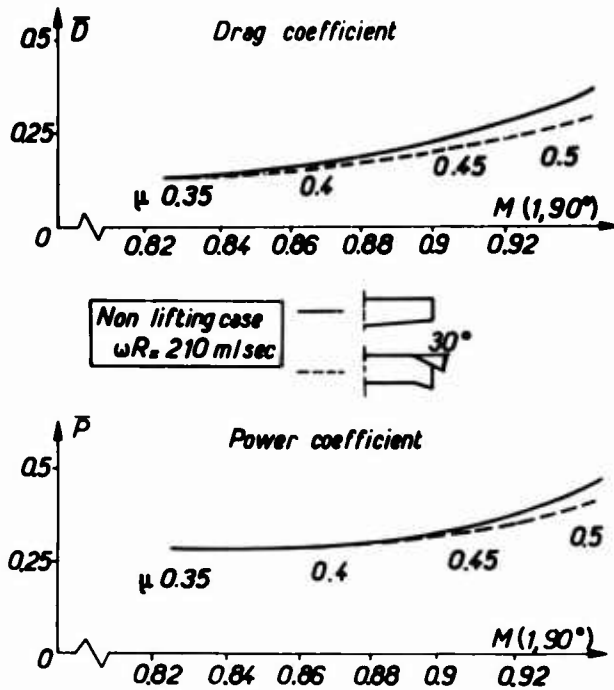

Fig. 24 - Influence of blade tip sweep on rotor drag and required power.

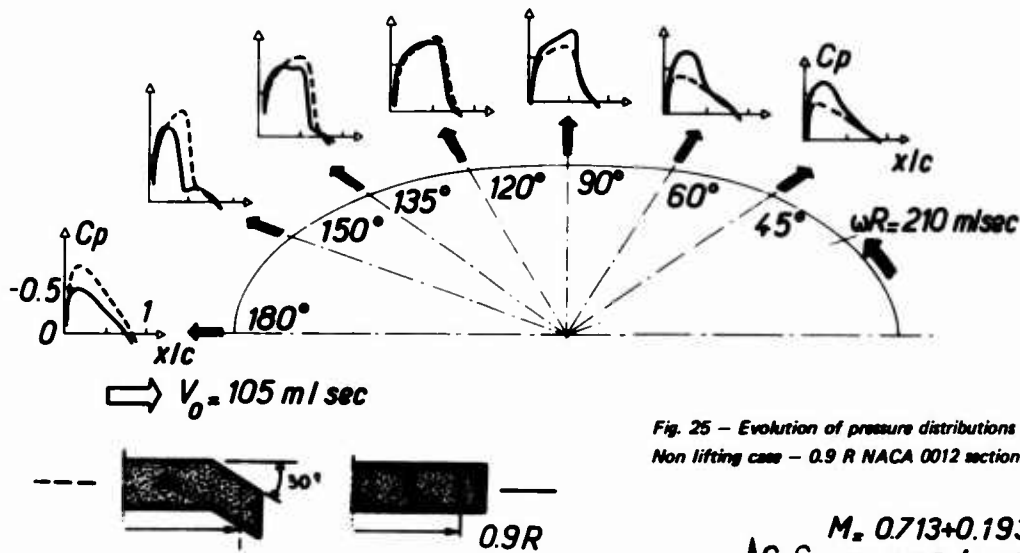

Fig. 25 - Evolution of pressure distributions on rotor blade tips. Non lifting case - 0.9 R NACA 0012 section.

4.4. Case of lifting rotor

The preceding studies concern the "irrealistic" case of a non lifting rotor, whose interest is to prove the validity of calculation methods, at least, for simple cases. The case of lifting rotor is still much more complex, as it raises the problem of the precise knowledge of actual local incidences. The calculations performed by F.X. Caradonna [19] of lift and moment responses of a blade section subjected to simultaneous sinusoidal variations of incidence and Mach number show (fig. 26) :

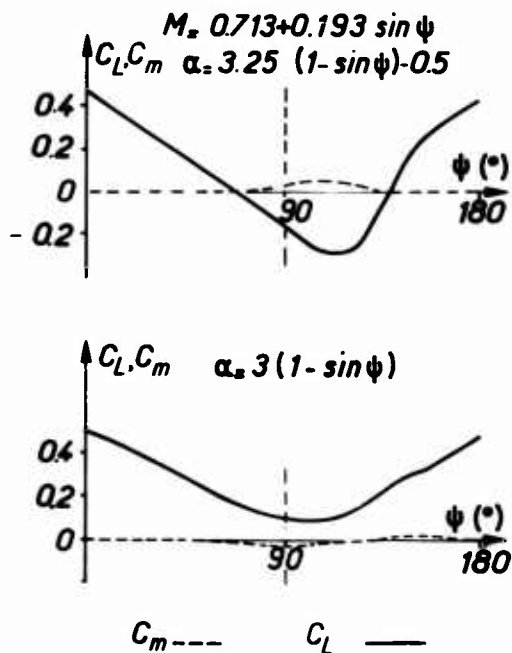

Fig. 26 - Calculated evolution of C_L and C_m at the 0.925 R NACA 0012 section of a lifting rotor. ($\mu = 0.25$; $M(1,90^\circ) = 0.906$, blade aspect ratio : 13.7).

– the influence of unsteady incident conditions of that profile, revealed by a dissymmetry of lift and moment curves relative to azimuth 90° , while the incidence and Mach number conditions are symmetric ;

– the problems raised by the possibility to have weakly negative incidences on the advancing blade tip, as then strong negative lift and pitch up moments appear. We may see there an explanation of the difficulties encountered in flight on the Sikorski NH-3 [21] or on Bolkow BO-105 [22] helicopter during tests at high speed flight.

These complex phenomena will be studied in more detail in the ONERA S2-Ch wind tunnel from late 1977 on a 3-blade rotor with twisted blades whose tips will be equipped with absolute pressure transducers.

5 – THE ROTARY WING TEST RIG OF THE S1 WIND TUNNEL OF MODANE

The S1-MA wind tunnel has an 8-m-dia., 14-m long test section ; the flow velocity may reach the sound speed ; figure 27 shows the rotary wing test rig [23, 24] and Table II gives its main characteristics. A frame, carrying a 6-component balance, a 110-channel slip ring assembly and a torquemeter, is mounted on a support that may tilt during the test. This frame can be replaced by the front part of the propeller test rig, which can be used up to Mach 0.8 (fig. 28). The rotary wing test rig can not be used at Mach numbers exceeding 0.5 (170 m/sec). The rotor speed and the wind tunnel velocity can be adjusted so as to obtain at the same time actual values of advance ratio and advancing blade tip Mach number for rotors with diameters up to 5 m. The test rig can be complemented with elements reproducing the rotary wing environment ; an example is presented on figure 29, where we can see a propeller studied in the presence of a wing.

The test rig is equipped with an analog and digital measuring system, which provides the signals to survey and ensure the safety of the test and allow the local calculation of the main aerodynamic data. A central computer calculates the final results and displays them on a screen within a few seconds after measurement acquisition.



Fig. 27 – The rotary wing test rig at the S1 wind tunnel of Modane-Avrieux.

Table II

Main characteristics of the rotary wing test rig

<i>Test section diameter</i>	8 m
<i>Test section length</i>	14 m
<i>Rotor diameter</i>	up to 5 m
<i>Rotor rotation direction</i>	both are possible
<i>Rotor speed</i>	600 to 1400 r.p.m.
<i>Tip speed</i>	only limited by rotor diameter and speed
<i>Advancing blade tip Mach number</i>	investigated to nearly 1.0
<i>Advance ratio</i>	investigated up to 0.85
<i>Shaft angle</i>	from + 25°(up) to -95° (down)
<i>Balances</i>	with interchangeable dynamometers. Axial thrust up to 45,000 N
<i>Torquemeter</i>	of strain gage type, self contained amplifier and slip ring. Several capacities
<i>Collective and cyclic pitch</i>	according to hub. At present, electrically controlled hydraulic actuator (Aérospatiale rotor)
<i>Drive</i>	two connected turboprops
<i>Power</i>	up to 1000 kW
<i>Wind tunnel velocity</i>	up to Mach 0.5 (170 m/sec) on the rotor test rig, up to Mach 0.8 on the minimum body propeller rig.



Fig. 28 – The minimum body propeller test rig.

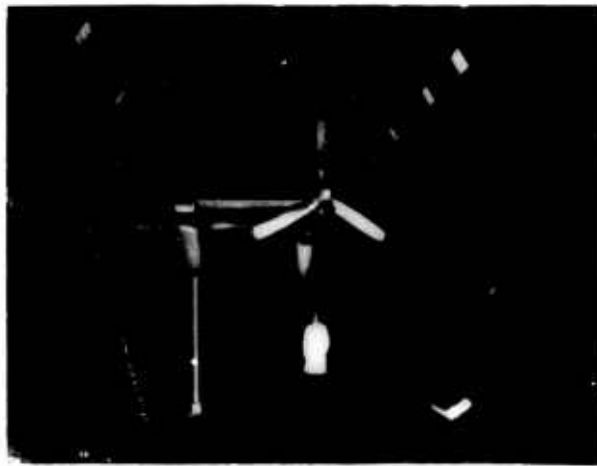

Fig. 29 – Test of a tilt propeller with its tilting wing.

27-14

5.1. Measurement of total forces

The total forces are measured by 6-component balances, designed and built at the Modane Centre. Figure 30 shows one of the balances used ; similar balances equip the S2 wind tunnel of Chalais-Meudon and the Aérospatiale low speed wind tunnel of Marignane.

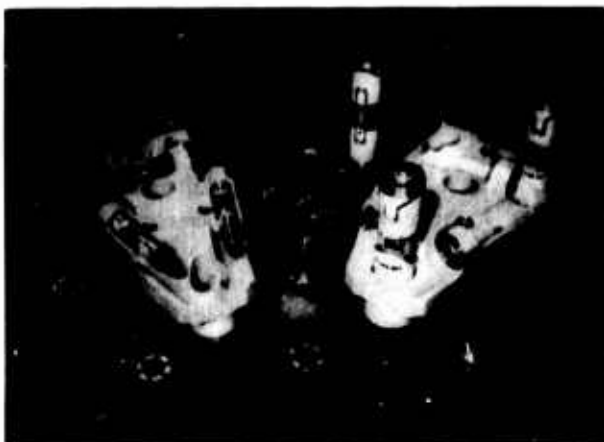

Fig. 30 - 6 component-balance of the rotary wing test rig.

A few examples are presented to illustrate the various possibilities of study in the S1-MA wind tunnel. Figure 31 presents the compressibility effects on the performances of an Aérospatiale helicopter rotor. Rotor speed and advance ratio are adjusted so as to obtain an increase of advancing blade tip Mach number from 0.79 to 0.94 while maintaining a constant advance ratio of 0.5. We shall remark that :

- for a -8° rotor shaft angle and for moderate lifts, the rotor polar curve (lift as a function of torque) is unchanged in spite of a Mach number increase from 0.79 to 0.91 ; only the polar curve obtained at Mach 0.94 displays a slight performance decrease ;

- the curves of lift coefficient as a function of drag coefficient, for a same rotor shaft angle, are practically independent of the advancing blade tip Mach number. The compressibility effects on this type of rotor are thus relatively weak ; such a result can only be obtained on a rotor whose blade tips have been especially studied to this end. It may also be remarked that an operation at this advance ratio could be that of a fast compound helicopter using a lifting rotary wing and separate propulsion means.

NASA and ONERA cooperated for the study of a tilt-rotor from hover to advancing flight up to Mach 0.77 [25]. Figure 32 shows that in forward flight the thrust and efficiency evolution is a function of advance ratio but is noticeably affected by the blade elasticity.

Figure 33 is taken from the study of a tilt-wing. The rotor performance is qualified by an efficiency. The presence of a wing placed in the rotor wake and tilting together with it induces a noticeable decrease in rotor performance.

A 5-m-dia. rotor of an Aérospatiale convertible (at full scale) has been studied in cruise flight, in helicopter flight and during conversion. Conversions were realized between 35 to 55 m/sec of the tunnel wind velocity in 14 seconds, as planned in the final project [26, 27]. Figure 34 shows the differences between performances measured during conversion and that measured in similar conditions, but stabilized step by step.

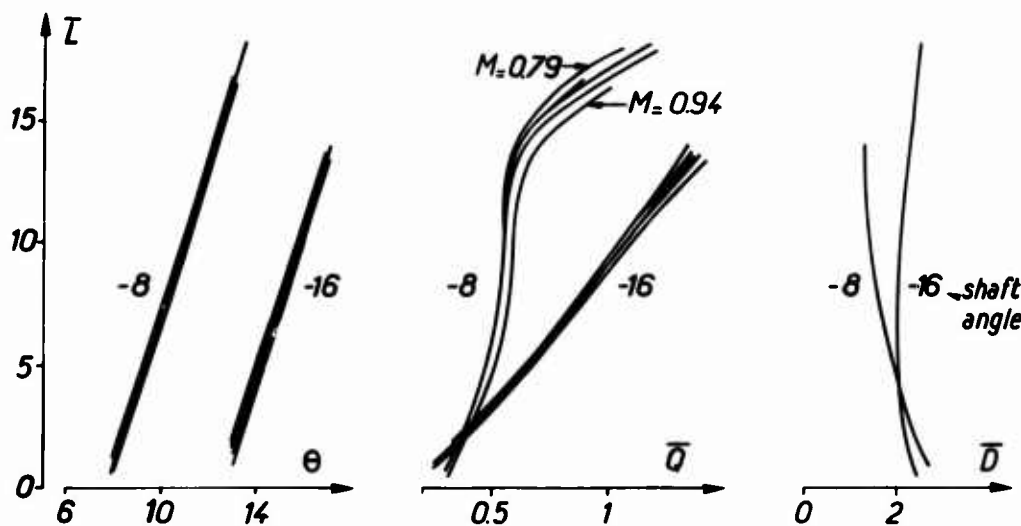

Fig. 31 - Compressibility effects on rotor performances at $\mu = 0.5$.

V_0 (m/sec)	91	96	100	104	107
ωR (m/sec)	182	192	200	208	214
$M (1.90^\circ)$	0.79	0.83	0.87	0.91	0.94

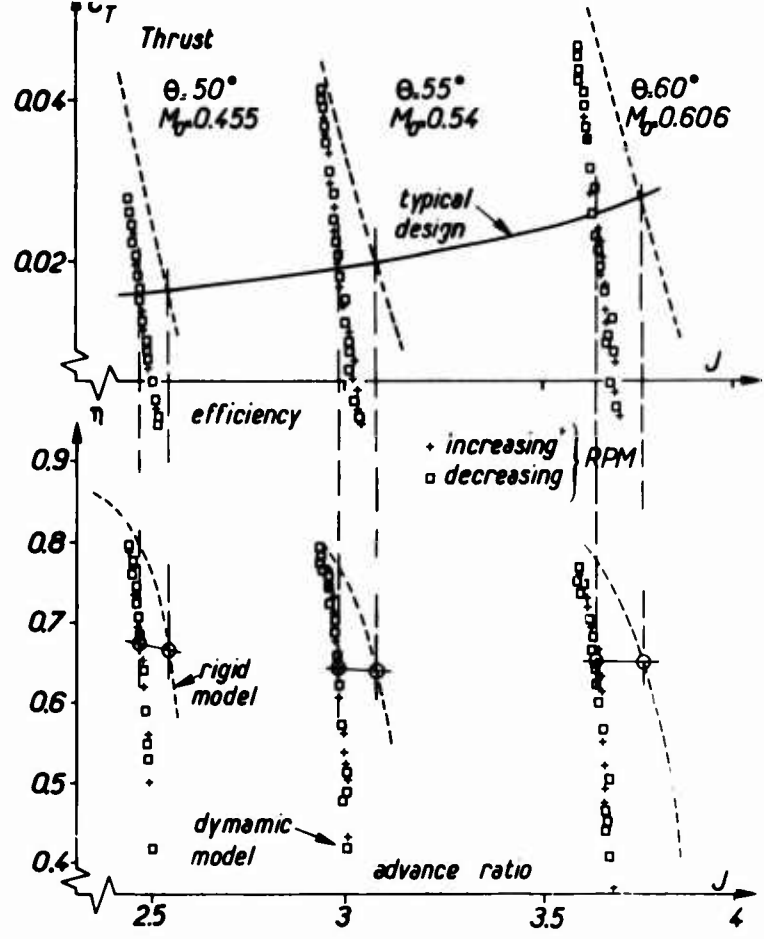

Fig. 32 - Influence of blade elasticity on tilt rotor performances (36° twist).

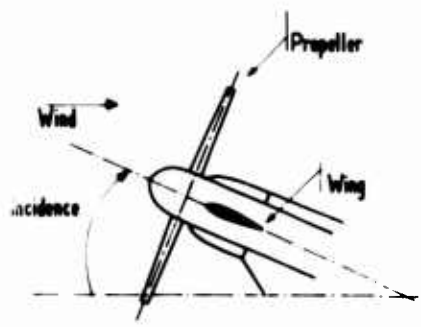
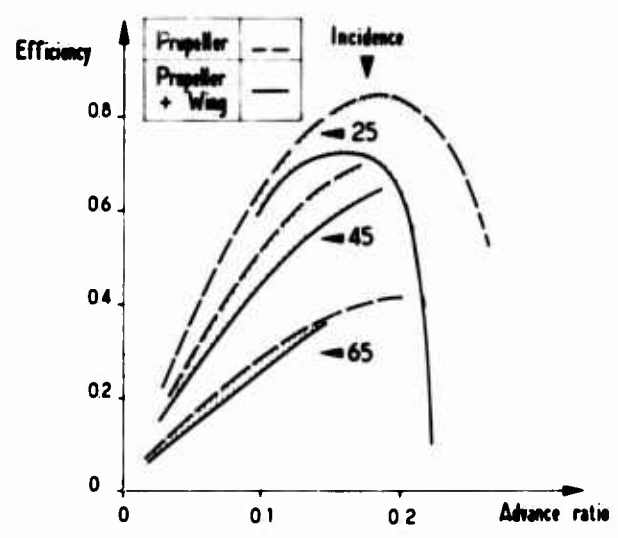

Fig. 33 - Influence of the presence of the wing tilting with the propeller.

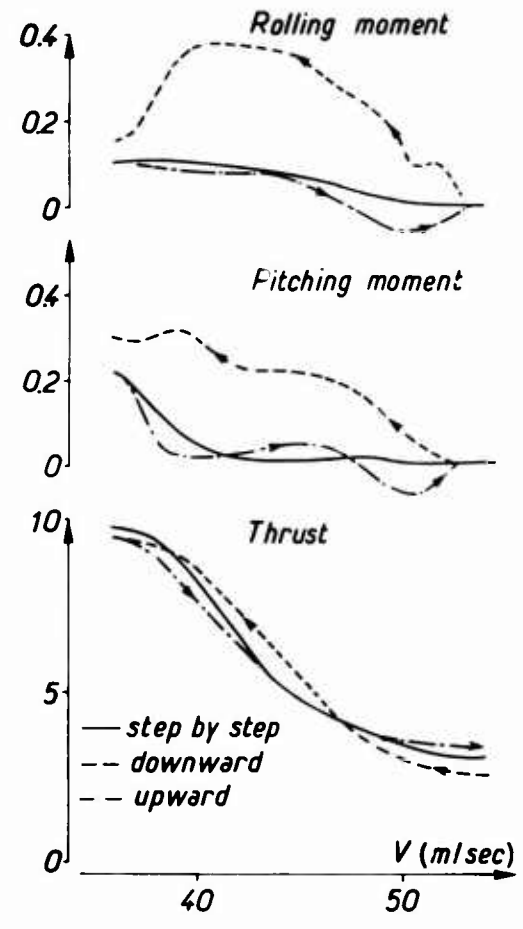

Fig. 34 - Performance evolution during the conversion phase of a convertible rotor.

carried out in the wind tunnel in icing condition respecting conditions similar to those in flight [28]. Figure 35 shows that the deposit on the blades entails a decrease of the rotor propulsive force and an increase of the absorbed torque, the rotor lift remaining practically constant.

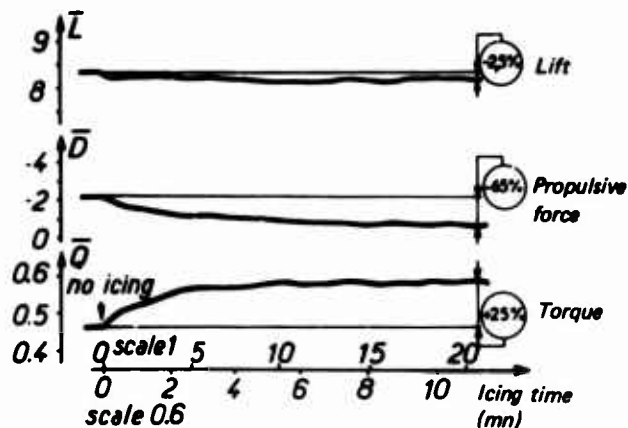

Fig. 35 - Icing effect on rotor characteristics in forward flight. ($V_0 = 42$ m/sec ; $\omega R = 200$ m/sec).

5.2. Local measurements

— Pressure measurements on the blades have been made with ONERA differential pressure transducers, type 20H62, inserted within the blades [24, 29, 30]. Figure 36 presents an example of the normal force evolution, measured at a section $r/R = 0.71$ for an advance ratio of 0.3. The curves of maximum normal force and drag divergence Mach number are those obtained in two-dimensional tests in the S3-MA wind tunnel [31] for the same profile, at the same Mach and Reynolds numbers. The influence of unsteady phenomena on maximum lift on the retreating blade appears clearly here.

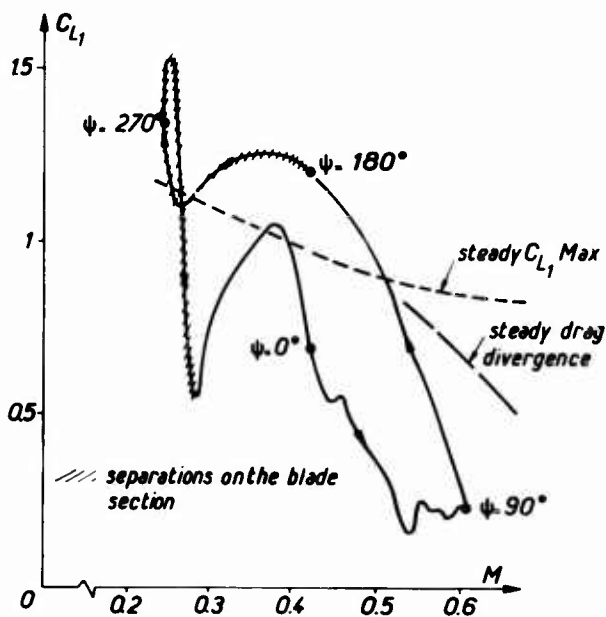

Fig. 36 - Blade section normal force evolution as function of incident Mach number.

$$(r/R = 0.71 ; \mu = 0.3 ; \bar{L} = 20.5 ; \bar{D} = -0.23).$$

have been used for detecting the laminar, turbulent or separated state of the blade boundary layers. Figure 37 shows the evolution of the signals from three hot films located at the upper surface of a blade section. The evolution of the separation zone as a function of the blade azimuth and collective pitch is emphasized. Figure 38 shows the extent of the separation zones on the rotor disc, when the advance ratio varies from 0.3 to 0.5, for a constant rotor lift coefficient.

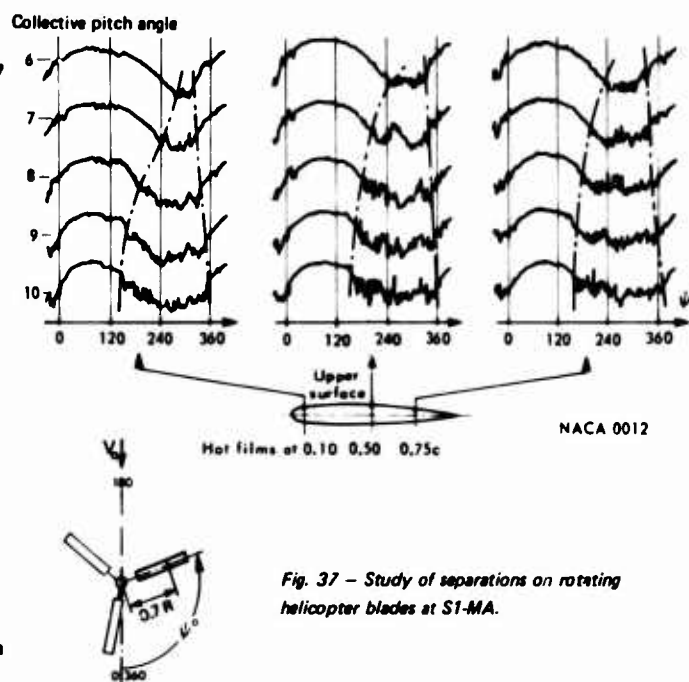

Fig. 37 - Study of separations on rotating helicopter blades at S1-MA.

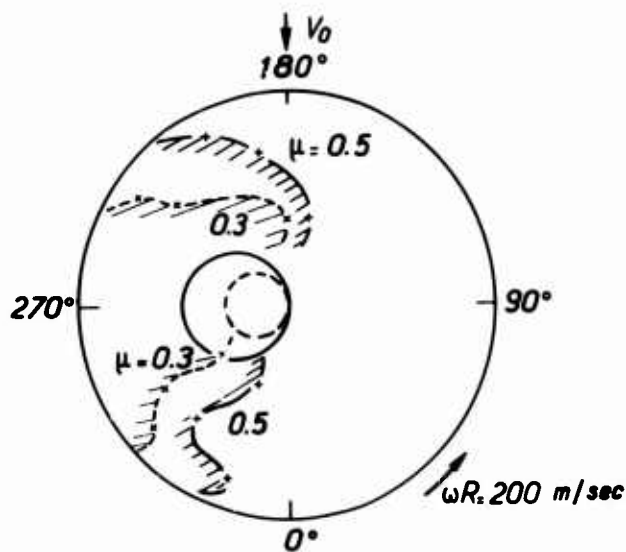

Fig. 38 - Separation zones on the rotor disc as a function of the advance ratio (lift coefficient $\bar{L} = 17$; $\alpha_q = -8^\circ$).

The observation of wool threads under stroboscopic lighting also appeared as an adequate method for describing separation phenomena [33]. The photographs of figure 39 were obtained with six successive sparks at the same azimuth. The very marked separations are revealed by instabilities of the thread for one turn to the other. Two examples of separation charts obtained with this method are also presented on figure 39.

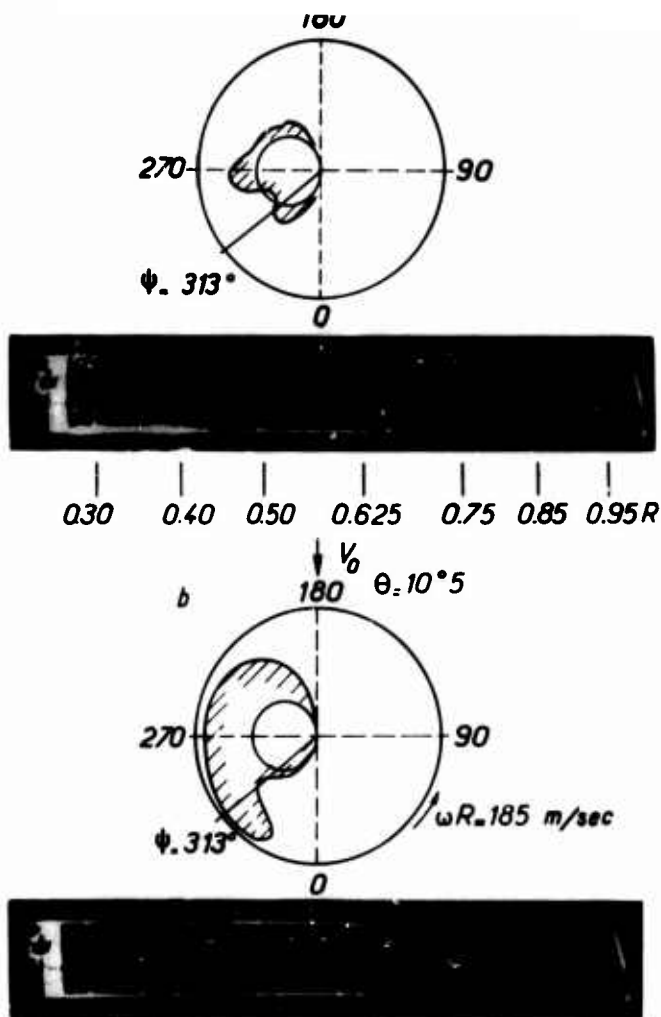

Fig. 39 - Separation charts obtained with wool threads visualizations under stroboscopic lighting.

- The determination of the deformation of a convertible rotor blade has been obtained by stereoscopic restitution from two photographs taken with a stroboscopic spark. Figure 40 presents the blade twist modification between the rest and hover or cruise flight at 145 m/sec. This technique will be applied to the deformation of helicopter blades.

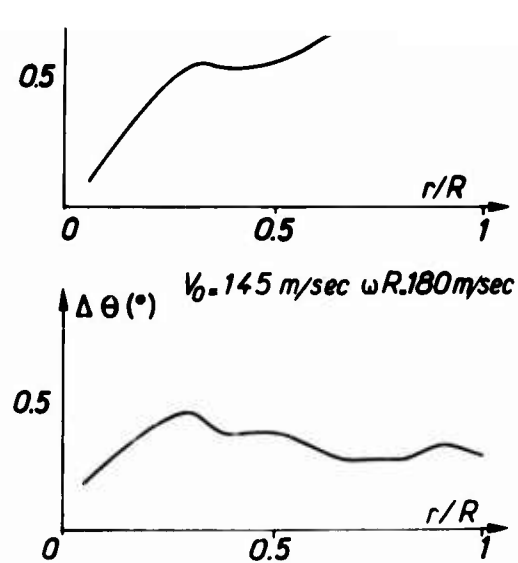

Fig. 40 - Twist variation on a -35° twisted tilt rotor between the rest and the rotation with or without wind in the wind tunnel.
 $\Delta\theta$ = twist at rest — twist in rotation.

5.3. Measurements in the rotor environment

- The aerodynamic field around rotors has been described by smoke visualizations, sometimes complemented by observations with stroboscopic lighting. These visualizations are used for the study of the deflection of wakes and trajectories of vortices emitted by the blade tips (fig. 41). They complement those that can be obtained at very small scale in the water tunnel of the ONERA Aerodynamics Department [34].



Fig. 41 - Blade tip vortex smoke visualization in the S1-MA wind-tunnel.

- The studies on rotor environment also concern its noise. In the wind tunnel, the noise emitted by the rotor is partly masked by the wind tunnel background noise. For the rotor in forward flight, the emitted noise is characterized by a strong periodic part, which can be represented by a Fourier series whose fundamental frequency is the rotation frequency. A system of harmonic analysis, whose samples are taken in synchronization 128 times per rotor revolution, retains only as an average, the part of the periodic noise in phase with the rotation, thus eliminating all other noises. This method, called total sampling synchronization [35], has been applied to the noise of a rotor tested

22-12

at 0.5 advance ratio. Figure 42 compares the spectrum obtained with this method with that resulting from a standard analysis of power spectra. This type of measurement should allow interesting comparative analyses between local blade aerodynamics and the noise emitted by the rotor.

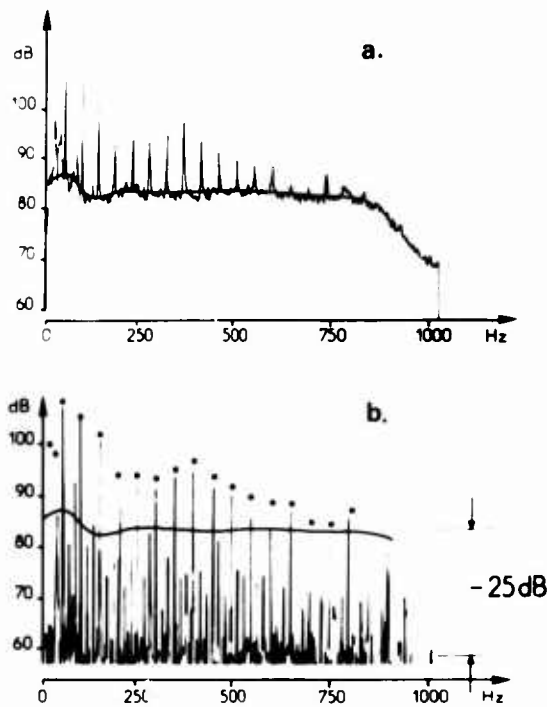

Fig. 42 - Analysis of rotational noise of a rotary wing in a wind tunnel ($V_0 = 100$ m/sec ; $\omega R = 200$ m/sec).

a) Classical spectral analysis ($\Delta f = 2$ Hz)

b) Total sampling synchronization method (128 per rev.).

6 - CONCLUSIONS

The main directions of research at ONERA on helicopter aerodynamics are as follows :

- study of profiles in steady and unsteady flows, with or without separation,
- study of blade tips in steady flow and wind tunnel simulation of vortex interaction problems,
- study of unsteady transonic flows on rotor blade tips,
- calculation of the forces acting on the rotor, using the acceleration potential method.

For rotor studies, ONERA has equipped two test facilities :

- the 8-m-dia. S1 wind tunnel of Modane, that allows rotor tests in helicopter configuration up to 170 m/sec and propeller tests up to 270 m/sec,
- the 3-m-dia. S2 wind tunnel of Chalais-Meudon, that allows rotor tests up to 110 m/sec.

These facilities offer the possibility of precise measurements of total aerodynamic forces, but also of detailed local measurements in order to know pressures, boundary layer states or deformations of rotating blades.

References

- 1 L. DADONE, T. FUKUSHIMA. A review of Design Objectives for Advanced Helicopter Rotor Airfoils. National Symposium on Helicopter Aerodynamic Efficiency AHS, Hartford, March 1975.
- 2 P. FABRE. Drag Problems on Rotary Wing Aircraft, in AGARD Lecture Series No 63 on Helicopter Aerodynamics and Dynamics, April 1973.
- 3 J. RENAUD, F. NIBELLE. Effects of the Airfoil Choice on Rotor Aerodynamic Behaviour in Forward Flight. Second European Rotorcraft and Powered Lift Aircraft Forum. Bückeburg, 20-22 September 1976.
- 4 J.J. PHILIPPE, M. SAGNER. Calcul et mesure des forces aérodynamiques sur un profil oscillant avec et sans décrochage, in "Aerodynamics of Rotary Wings" AGARD CP No 111, 1973.
- 5 W.J. Mc CROSKY, J.J. PHILIPPE. Unsteady Viscous Flow on Oscillating Airfoils. AIAA Journal, vol. 13 No 1, January 1975.
- 6 W.J. Mc CROSKY, L.W. CARR, K.W. Mc ALISTER. Dynamic Stall Experiments on Oscillating Airfoils, AIAA paper 75 125, 1975.
- 7 Ph. POISSON-QUINTON. Recent French Research on the Aerodynamics of Rotors, paper given at the Royal Aeronautical Society. Rotorcraft Section, 3th March 1971.
- 8 W.F. BALLHAUS, F.X. CARADONNA. The Effect of Planform Shape on the Transonic Flow past Rotor Tips, in AGARD CP No 111, 1973.
- 9 B. MONNERIE, A. TOGNET. Influence du tourbillon marginal issu d'une pale d'hélicoptère sur l'écoulement autour de la pale suivante. L'Aéronautique et l'Astronautique No 29 (1971-5).
- 10 R. DAT. Aeroelasticity of Rotary Wing Aircraft, in AGARD Lecture Series No 63 on Helicopter Aerodynamics and Dynamics, 1973.
- 11 J.J. COSTES. Calcul des forces aérodynamiques instantanées sur les pales d'un rotor d'hélicoptère. AGARD Report No 595 and Recherche Aérospatiale No 1972-2 (trad. NASA TT-F-15039, 1973).
- 12 J.J. COSTES. Rotor Response Predictions with non-linear Aerodynamic Loads on the Retreating Blade. Second European Rotorcraft and Powered Lift Aircraft Forum. Bückeburg, 20-22 September 1976, also : Recherche Aérospatiale No 1975-3.
- 13 D.W. GROSS, F.D. HARRIS. Prediction of Inflight Stall Airloads from Oscillating Airfoil Data. Annual National Forum, AHS, May 1969.

- 14 C.T. TRAN, W. TWOMEY, B. DAT. Calcul des caractéristiques dynamiques d'une structure d'hélicoptère. Recherche Aérospatiale No 1973-6.
- 15 C.T. TRAN, J. RENAUD. Theoretical Predictions of Aerodynamic and Dynamic Phenomena on Helicopter Rotors in Forward Flight. First European Rotorcraft and Powered Lift Aircraft Forum. Southampton, 22-24 September 1975. Provisional edition : ONERA TP 1976-16.
- 16 M. KRETZ. Research on Multicyclic and Active Control of Rotary Wings. First European Rotorcraft and Powered Lift Aircraft Forum. Southampton, 22-24 September 1975.
- 17 M. KRETZ. Relaxation of Rotor Limitations by Feedback Control. Annual National Forum, AHS, May 1977.
- 18 F.X. CARADONNA, M.P. ISOM. Numerical Calculation of Unsteady Transonic Potential Flow over Helicopter Rotor Blades. AIAA Journal, vol. 14 No 4, April 1976.
- 19 F.X. CARADONNA, J.J. PHILIPPE. The Flow over a Helicopter Blade Tip in the Transonic Regime. Second European Rotorcraft and Powered Lift Aircraft Forum. Bückeburg, 20-22 September 1976. Provisional edition : ONERA TP 1976-115.
- 20 A. LERAT, J. SIDES. Numerical Calculation of Unsteady Transonic Flows. AGARD Meeting on Unsteady Airloads in Separated and Transonic Flow. Lisbon, April 1977.
- 21 W.F. PAUL. A Self-Excited Rotor Blade Oscillation at High Subsonic Mach Number. Annual National Forum, AHS. Paper No 228, May 1968.
- 22 H. HUBER, H. STREHLOW. Hingeless Rotor Dynamics in High Speed Flight. First European Rotorcraft and Powered Lift Aircraft Forum. Southampton, 22-24 September 1975.
- 23 A. SCHWEISCH. Installation d'essais de rotors d'hélicoptère dans la grande soufflerie de Modane-Avrieux, in Fluid Dynamics of Rotor and Fan Supported Aircraft at Subsonic Speeds, AGARD CP No 22 (1968).
- 24 M. LECARME, C. ARMAND. Essais de rotor d'hélicoptère dans la grande soufflerie de Modane. L'Aéronautique et l'Astronautique No 24 (1970-8).
- 25 Ph. POISSON-QUINTON, W.L. COOK. A summary of Wind Tunnel Research on Tilt Rotors from Hover to Cruise Flight, in Aerodynamics of Rotary Wings, AGARD CP No 111, 1973.
- 26 M. LECARME. Test of a Convertible Aircraft Rotor in the Modane Large Wind Tunnel. Second European Rotorcraft and Powered Lift Aircraft Forum. Bückeburg, 20-22 September 1976.
- 27 G. BEZIAC. Formules nouvelles d'appareils à décollages et atterrissages verticaux. L'Aéronautique et l'Astronautique No 62 (1977-1).
- 28 C. ARMAND, F. CHARPIN. Givrage en similitude d'un rotor d'hélicoptère dans la soufflerie S1-MA. L'Aéronautique et l'Astronautique No 55 (1975-6).
- 29 J. GALLOT. Calcul des charges sur rotor d'hélicoptère, in Helicopter Rotor Loads Prediction Methods, AGARD CP No 122, 1973.
- 30 M. LECARME. Comportement d'un rotor au-delà du domaine usuel à la grande soufflerie de Modane, in Aerodynamics of Rotary Wings, AGARD CP No 111, 1973.
- 31 M. BAZIN. Dispositif d'essais de profils en courant plan dans la soufflerie S3 de Modane-Avrieux. Note Technique ONERA No 203 (1972) (trad. NASA TT-F-17253).
- 32 W.J. Mc CROSKEY, E.J. DURBIN. Flow Angle and Shear Stress Measurements Using Heated Films and Wires. ASME J. Basic Eng. vol. 94 No 1, March 1972.
- 33 M. LECARME. Airflow over Helicopter Blades. First European Rotorcraft and Powered Lift Aircraft Forum. Southampton, 22-24 September 1975.
- 34 H. WERLÉ, C. ARMAND. Mesures et visualisations instantanées sur les rotors. 6^e Colloque d'Aérodynamique Appliquée AAAF, Toulouse, Novembre 1969. Provisional edition : ONERA TP 777.
- 35 C. ARMAND. Rotational Noise Measurement in a Wind Tunnel by Total Sampling Synchronization. Provisional edition : ONERA TP 1976-111. Published in Vertica, vol. 1, 1976.

M. J. BREWARD
Head of RPH Design
Westland Helicopters Ltd., Yeovil, Somerset, UK.

Westland Helicopters Ltd. have been active in the field of Remotely Piloted Vehicles since 1968. Feasibility studies for a surveillance and target acquisition system led to a proposal for a remotely piloted helicopter (RPH) with co-axial twin rotors having symmetry about the rotor axis. This paper describes the RPH, Westland Wisp, one of a number of projects that have proceeded into hardware status and which has commenced flight trials. Wisp carries a trainable television camera and gyro based automatic stabilisation equipment, it is operable by 2 persons, one of whom performs all piloting functions.

INTRODUCTION

Westland Helicopters Ltd. (WHL) have been active in the field of Remotely Piloted Vehicles (RPV's) since 1968. Our feasibility studies for a surveillance and target acquisition system led to a proposal for a remotely piloted helicopter (RPH) with co-axial twin rotors having symmetry about the rotor axis (i.e. plan-symmetric). The reasons for the adoption of such a solution have been reported elsewhere (Ref. 1). The purpose of this paper is to describe the RPH, Westland Wisp, one of a number of projects that have proceeded into hardware status.

DESIGN HISTORY

It is clear that the level of sophistication in the design and operation of RPH's must depend upon the roles envisaged. The WHL approach has been to develop from the less sophisticated.

The hardware starting point was a company funded experimental programme to confirm the controllability, particularly in yaw, of small plan-symmetric co-axial rotor helicopters. An RPH, known as MOTE (Fig. 1) was built using transmission and rotor components from commercially available model helicopter kits and flown under remote radio control. It had a gross weight of 18 lb., 5 ft. diameter, 2-bladed teetering rotors and was powered by two 1.5 bhp engines. Pitch stabilisation was by means of teetering 'paddle bars' on each rotor.

The aircraft was found to be fully controllable in yaw, the control of heading being significantly easier than single rotor model helicopters of similar size. Pitch and roll control, i.e. horizontal positioning in the presence of wind turbulence was not easy requiring continual pilot intervention and therefore a high degree of skill. In spite of this a successful series of flights were undertaken during which the design was developed to improve its integrity and reliability involving substitution of WHL designed components for most of the original model kit parts.

The Westland WISP, initially known as SUPER MOTE, was an attempt to develop a more powerful aircraft incorporating a gyro-based electronic auto-stab system and capable of carrying a television camera. The design had to be acceptable for trials in, initially, limited surveillance roles and it had to be developed in short timescale at minimum cost.

Whilst the mechanical and structural design of WISP was proceeding, the electronic AFCS was developed and flight tested on MOTE (Fig. 2) during which control system gains and damping coefficients were determined in conjunction with flight simulation on our in-house computer facilities. Considerable progress was made in achieving stabilised flight. During this programme the all up weight of MOTE was increased from 18 to 32 lb.

To complete the picture mention may be made of a parallel programme to produce a more sophisticated system having longer range and larger payload capability. This aircraft, known as WIDEYE, is in construction and owes much to the MOTE and WISP designs.

WISP DESIGN TASK

The design task was to produce, in a very short timescale, an aircraft capable of carrying a trainable stabilised TV camera and gyro based automatic stabilisation equipment. It was to be based upon the rotor/transmission/control principles used in MOTE. Unlike MOTE it was to have a structural integrity predicted by calculation but with limited test substantiation.

SPECIFICATION REQUIREMENTS

The aircraft specification was intentionally limited to a low level of performance so that, in particular, the design cases could be limited to low speed manoeuvres, landing and ground handling. It was felt, however, that an enhanced performance would be in our longer term interests and efforts were made to exceed the design requirements on important items.

DESIGN PHILOSOPHY

The basic design philosophy was to uprate the MOTE design to increase the allowable AUW and to house the extra components within an aerodynamically clean body shell. The increase in rotor capability was achieved by increasing rotor rotational speed and changing from a symmetrical to a cambered blade section. The increased power requirements led to the use of two 5 HP Kolbo engines. Trim considerations based upon wind tunnel test results led to the adoption of a cambered oblate spheroid for the body shell with a major diameter of 24 ins, this dimension being found critical. Overall dimensions had to be compatible with stowage in a land hover. The basic mechanical configuration was unchanged from MOTE but each component was assessed

232

and redesigned to be compatible with design cases and strength factors formulated by WHL for this class of aircraft. At an early stage in the development of WISP it was decided to convert the Kolbo engines from glow plug to spark ignition to improve fuel consumption at part throttle and to overcome rotation direction inconsistency at start up. Whilst the foregoing represented the prime design requirements, importance was placed on a variety of attributes, the most significant of which were:-

Ease of Manufacture

Much thought was expended in assessing the method of manufacture and assembly of each design and solutions were adopted which were believed to be most suitable to the small quantities involved and the facilities available. Special tools were avoided where possible. Standard catalogue items were specified where practicable. Full discussions were had down to workshop operator level before and during detail design. Use was made of sub-contractors expertise, particularly in the design of control actuators.

Maintainability

A modular construction was adopted for ease of maintenance, component testing and handling. Discussions have been had with the user on this aspect and they have expressed satisfaction with the solutions adopted.

Low Maintenance

A low level of maintenance is highly desirable and features of the design reflect this, for example, the use of 'sealed for life' grease-packed bearings, the adoption of a non-lubricated gearbox and the extensive use of glass fibre construction.

Reliability

The possibility of component failure was minimised by designing to beyond material fatigue limits with a minimum design life of 200 hrs. Where life/load data was limited substantial testing was carried out, for instance, on rotor control rod ends and on the power train gears. The number of individual components was kept to a minimum to further reduce the likelihood of failure. All fastenings feature locking devices. The adoption of a twin engine configuration provides engine out capability, there being sufficient power available from one engine for sustained hovering.

Safety

Mandatory requirements of safe operation within military range were met by inclusion of an engine cut off facility activated by breaking the radio command link. In order to protect the aircraft from this or from an inadvertent command link malfunction a time delay is incorporated and the loss of signal results in the control system demanding a slow rate of descent with zero cyclic input. The operators are protected from rotor rotation during start up by a blade 'gag' the blades being stressed to take the full range of engine torque.

Ruggedness

Attention was paid to ruggedising of the aircraft to protect against mishandling. This is reflected in particular in the adoption of a GRP body shell, the design of the undercarriage feet, the encasement of the rotor controls by a rotor hub fairing and the stout nature of control rods and linkages.

WISP LEADING PARTICULARS

WISP is shown in Fig. 3.

Payload

Philips LDH 830 3/4 ins vidicon monochrome television camera trainable in elevation from 15° above to 105° below horizontal. Azimuth orientation by aircraft rotation in yaw. 28° fixed field of view.

Stabilised in pitch and roll.

Omnidirectional video signal transmission.

Range : 1000 m
Weight : 2.5 kg

Airframe

Rotors: Twin co-axially mounted contra rotating
Teetering flap hinge
Diameter 1525 mm
Chord 55 mm
Tip Speed 116 m/s

Overall Height : 860 mm
Body Diameter : 610 mm
Mission All up Weight : 30 kg
Mission Fuel Weight : 2.3 kg

Power Plant

2 x 5 HP Kolbo D238 2-stroke engines with spark ignition.

Aircraft Role Performance (ISA SL)

Endurance : 45 mins total
20 mins sustained hover
Maximum Cruise Speed : 55 kts
Rotor Power Requirements : 4.0 HP (Hover)

The aircraft configuration comprises 3 distinct modules, structural, mechanical and avionics.

23-3

Structural Module

The structural module which includes the undercarriage is shown in Fig. 4. It is of GRP construction and is built around four pillars connected by shear panels forming a box shaped structure. The pillars provide attachment points for the undercarriage and for the mechanical module which is isolated from the structure by multi-directional AV mounts. The lower half of the body shell is integral with this structure and is stiffened with radial shear panels which form four segmental bays accommodating the engines and fuel tanks, the camera and the sensor elements of the flight control system. The undercarriage provides protection from landing loads arising from descent velocities of up to 3 m/sec. The electronic elements of the flight control system are carried on shelves above the camera and gyro bays within the upper half of the body shell. The upper shell is split diagonally to form removable cowls.

The body shells contain inlet and exhaust ducts for engine cooling air. The bottom shell incorporates a perspex window through which the camera is aimed.

Mechanical Module

Fig. 5 shows the major components of the mechanical module in exploded form. Each engine ostensibly drives one rotor via a toothed belt, a centrifugal clutch and a spur gear reduction train. The train for the upper rotor includes an idler gear to provide contra rotation. The two rotors are synchronised by a toothed belt connecting the input from each clutch. This enables both rotors to be driven by the surviving engine in the event of an engine failure. A drive is taken off from each input shaft for electrical power generation.

The rotor blades are of laminated construction with beech leading edges and balsa trailing edges completely covered with glass fibre cloth. Copper dowelling is housed in the leading edges to provide chordwise balance.

The rotor masts are supported by a conical pylon containing the main lift bearings. The pylon has four radial legs which extend out to form the attachment points of the mechanical module to the structural module. The gearbox casing, upon which the engines are directly mounted, is attached and located on the arms of the pylon.

Aerodynamic control of the rotor is invested in five channels, two axes of cyclic pitch to give roll and pitch control, collective pitch for vertical control, differential collective pitch for yaw control and engine throttle adjustment coupled with rotor speed governing. An engine overspeed limiter is incorporated. The cyclic actuators are mounted from the top of the gearbox and operate the blade pitch rods via an arrangement of swashplates. The collective and differential collective actuators are mounted below the gearbox and operate the blade pitch rods via push rods passing up through the centre of the rotor shafts. All actuators are of WHL design, this being necessitated by the lack of suitable commercially available alternatives. For the sake of clarity the components of the mechanical control system are not shown in the photograph.

The engines directly drive fans providing cooling air which is directed over the engine cylinders and ejected with the exhaust gases through ports in the lower body shell. Each engine has an independent fuel supply, the fuel being drawn from fuel tanks located in the engine bays. Spark ignition equipment has been developed in conjunction with Kolbo. The engines are started by use of a hand held power drill adapted to incorporate a fly wheel and free wheel mechanism.

The Mechanical Module may be removed from the structural module as a complete unit for bench running, servicing or replacement (Fig. 6).

Power Plant

WISP employs two 63 cc Kolbo D238 2 cylinder 2-stroke engines developed for fixed wing R/V applications. In their initial glow plug form they are rated at 5-6 HP at 8000 RPM. WISP requires around 4 HP total engine power which allows ample reserve for engine out performance. The glow plug engine suffers from poor fuel consumption, particularly at part throttle settings and inconsistency in rotation direction at start up. This has confirmed the adoption of a spark ignition system developed by WHL in conjunction with Kolbo. Whilst this has resulted in a reduction of the maximum power to 4.2 HP, the fuel consumption has improved to give SFCs of around 1.1 lb/HP/hr at full throttle and 1.4 at part throttle. Power and SFC curves are shown on Fig. 7.

Avionic Module

Fig. 8 shows the component parts of the avionic module including AFCS and sensor package. The Automatic Flight Control System (AFCS) developed by WHL employs an attitude demand system in four channels, roll, pitch, yaw and height. Gyroscopic sensors determine the attitude of the aircraft and assessment is made of the error from that demanded. Aircraft control is applied proportional to the error. A closed loop control is employed with provision for rate damping in each channel. The pendulum vertical gyro (roll and pitch) magnetically steered directional gyro (yaw) and rate gyro (yaw) are supplied by Humphrey Inc., San Diego. A laser system is being developed to sense altitude. The AFCS components and representative electronic circuitry have been flight tested on MOTE during which control system gains and damping co-efficients have been established in conjunction with simulation studies using in-house computer facilities.

Seven control commands are transmitted to the aircraft from the ground station. These are:-

- Lateral velocity (roll attitude)
- Longitudinal velocity (pitch attitude)
- Azimuth position - 2 channels, sin and cos
- Height
- Throttle
- Camera position (tilt)

The aircraft configuration comprises 3 distinct modules, structural, mechanical and avionics.

23-3

Structural Module

The structural module which includes the undercarriage is shown in Fig. 4. It is of GRP construction and is built around four pillars connected by shear panels forming a box shaped structure. The pillars provide attachment points for the undercarriage and for the mechanical module which is isolated from the structure by multi-directional AV mounts. The lower half of the body shell is integral with this structure and is stiffened with radial shear panels which form four segmental bays accommodating the engines and fuel tanks, the camera and the sensor elements of the flight control system. The undercarriage provides protection from landing loads arising from descent velocities of up to 3 m/sec. The electronic elements of the flight control system are carried on shelves above the camera and gyro bays within the upper half of the body shell. The upper shell is split diagonally to form removable cowls.

The body shells contain inlet and exhaust ducts for engine cooling air. The bottom shell incorporates a perspex window through which the camera is aimed.

Mechanical Module

Fig. 5 shows the major components of the mechanical module in exploded form. Each engine ostensibly drives one rotor via a toothed belt, a centrifugal clutch and a spur gear reduction train. The train for the upper rotor includes an idler gear to provide contra rotation. The two rotors are synchronised by a toothed belt connecting the input from each clutch. This enables both rotors to be driven by the surviving engine in the event of an engine failure. A drive is taken off from each input shaft for electrical power generation.

The rotor blades are of laminated construction with beech leading edges and balsa trailing edges completely covered with glass fibre cloth. Copper dowelling is housed in the leading edges to provide chordwise balance.

The rotor masts are supported by a conical pylon containing the main lift bearings. The pylon has four radial legs which extend out to form the attachment points of the mechanical module to the structural module. The gearbox casing, upon which the engines are directly mounted, is attached and located on the arms of the pylon.

Aerodynamic control of the rotor is invested in five channels, two axes of cyclic pitch to give roll and pitch control, collective pitch for vertical control, differential collective pitch for yaw control and engine throttle adjustment coupled with rotor speed governing. An engine overspeed limiter is incorporated. The cyclic actuators are mounted from the top of the gearbox and operate the blade pitch rods via an arrangement of swashplates. The collective and differential collective actuators are mounted below the gearbox and operate the blade pitch rods via push rods passing up through the centre of the rotor shafts. All actuators are of WHL design, this being necessitated by the lack of suitable commercially available alternatives. For the sake of clarity the components of the mechanical control system are not shown in the photograph.

The engines directly drive fans providing cooling air which is directed over the engine cylinders and ejected with the exhaust gases through ports in the lower body shell. Each engine has an independent fuel supply, the fuel being drawn from fuel tanks located in the engine bays. Spark ignition equipment has been developed in conjunction with Kolbo. The engines are started by use of a hand held power drill adapted to incorporate a fly wheel and free wheel mechanism.

The Mechanical Module may be removed from the structural module as a complete unit for bench running, servicing or replacement (Fig. 6).

Power Plant

WISP employs two 63 cc Kolbo D238 2 cylinder 2-stroke engines developed for fixed wing RPV applications. In their initial glow plug form they are rated at 5-6 HP at 8000 RPM. WISP requires around 4 HP total engine power which allows ample reserve for engine out performance. The glow plug engine suffers from poor fuel consumption, particularly at part throttle settings and inconsistency in rotation direction at start up. This has confirmed the adoption of a spark ignition system developed by WHL in conjunction with Kolbo. Whilst this has resulted in a reduction of the maximum power to 4.2 HP, the fuel consumption has improved to give SFCs of around 1.1 lb/HP/hr at full throttle and 1.4 at part throttle. Power and SFC curves are shown on Fig. 7.

Avionic Module

Fig. 8 shows the component parts of the avionic module including AFCS and sensor package. The Automatic Flight Control System (AFCS) developed by WHL employs an attitude demand system in four channels, roll, pitch, yaw and height. Gyroscopic sensors determine the attitude of the aircraft and assessment is made of the error from that demanded. Aircraft control is applied proportional to the error. A closed loop control is employed with provision for rate damping in each channel. The pendulum vertical gyro (roll and pitch) magnetically steered directional gyro (yaw) and rate gyro (yaw) are supplied by Humphrey Inc., San Diego. A laser system is being developed to sense altitude. The AFCS components and representative electronic circuitry have been flight tested on MOTE during which control system gains and damping co-efficients have been established in conjunction with simulation studies using in-house computer facilities.

Seven control commands are transmitted to the aircraft from the ground station. These are:-

- Lateral velocity (roll attitude)
- Longitudinal velocity (pitch attitude)
- Azimuth position - 2 channels, sin and cos
- Height
- Throttle
- Camera position (tilt)

The command receiver is of the model aircraft type operating in the HF band of 6 volts supply, 50mA consumption. The aerial is mounted integral with the body structure.

The surveillance system consists of the TV camera trainable in elevation. The current development programme aims at stabilisation in pitch and roll. Azimuth orientation is by rotation of the aircraft in yaw. The picture is relayed to the ground station by a UHF video signal radio transmitter via an omni-directional aerial located on the exterior of the body shell. Slant range of the video link is of the order of 1000 m.

Electrical power source is a pair of rate earth DC generator giving 8 Amps at 12 volts. These are operated at 16000 rpm via toothed belts driven from each of the gearbox input shafts. A standby 12v rechargeable nickel cadmium battery is provided to smooth the power supply. The installation of the avionic module components into the structural module is shown in Fig. 9. Fig. 10 shows a view of the aircraft complete with the mechanical module prior to the final addition of the upper cowlings.

Ground Equipment

Ground Equipment comprises a control console (Fig. 11) containing the video aerial and receiver, a 12 inch television monitor and pilots controls and the free standing command transmitter and aerial. Support equipment includes the hand held power drill for engine starting, re-fuelling gear, basic tools and check out equipment, ground power supplies and instruction manual. Electrical power will be taken from the vehicle for engine starting but, for security of supply, separate batteries will be used for the command and data links. This equipment and the aircraft is stowable in a 109" wheelbase Land Rover (Fig. 12).

The system is operable by 2 persons of which one performs all piloting functions. It will be possible to bring the aircraft into action from a stowed position within 30 minutes and within 5 minutes from a ready for action state.

OPERATIONAL EXPERIENCE

Over twenty flights (Figs. 13 and 14) have been carried out with WISP and trials have been carried out with the TV camera operable on the second aircraft. Specification performance requirements have been exceeded and 'hands off' flying has been demonstrated.

Initially a manual throttle control was used and the pilots had difficulty in correlating throttle movement with collective inputs to counteract rotor speed droop. A rotor speed governing system has since been incorporated and this has eliminated the problem. Considerable care in the operation of collective is, however, needed during transitions from lateral translations through hover. As with all helicopters, the aircraft has a tendency to climb when coming to the halt from a lateral translation requiring a reduction of collective demand to maintain altitude. Any subsequent lateral velocity demand to, say, counteract an overshoot or to change direction requires an increase in collective demand and the aircraft may not respond quick enough if the collective and power settings have already been much reduced due to the previous manoeuvre and the aircraft will lose altitude. The one 'heavy landing' experienced so far was attributed to these effects.

The incorporation of a laser based height hold system currently being developed in conjunction with EMI should ease the problem. In the meantime a routine is being followed to bring the aircraft to the hover prior to any new lateral demand to allow it to 'settle'.

Much the most difficult aspect of the development work has concerned electro-magnetic compatibility (EMC). The close proximity of the electrical components and the presence of engine spark ignition equipment gave rise to considerable interference effects which manifested themselves in spurious malfunctions of the avionic control systems. Considerable attention had to be paid to earthing and screening and any change of component disposition within the airframe tended to produce a new set of problems. In order to keep the aircraft weight down, screening was initially kept to a minimum, but it was found that the incorporation of aircraft standard screened plugs were essential and aircraft type bonding had to be resorted to.

CONCLUSION

The successful outcome of the WISP project has laid the foundation for subsequent generations of RPH's. The WHL policy of development from the less sophisticated to the ultimate has been vindicated. WHL are now in a position to offer meaningful solutions to RPV requirements with genuine confidence.

References

1. "Control Aspects of the Plan-Symmetric Remotely Piloted Helicopter" by A. J. Faulkner. Paper No. 25 presented to AGARD Symposium, Avionics Guidance and Control for Remotely Piloted Vehicles. Florence, Italy, October, 1976. WHL Brochure B1026.

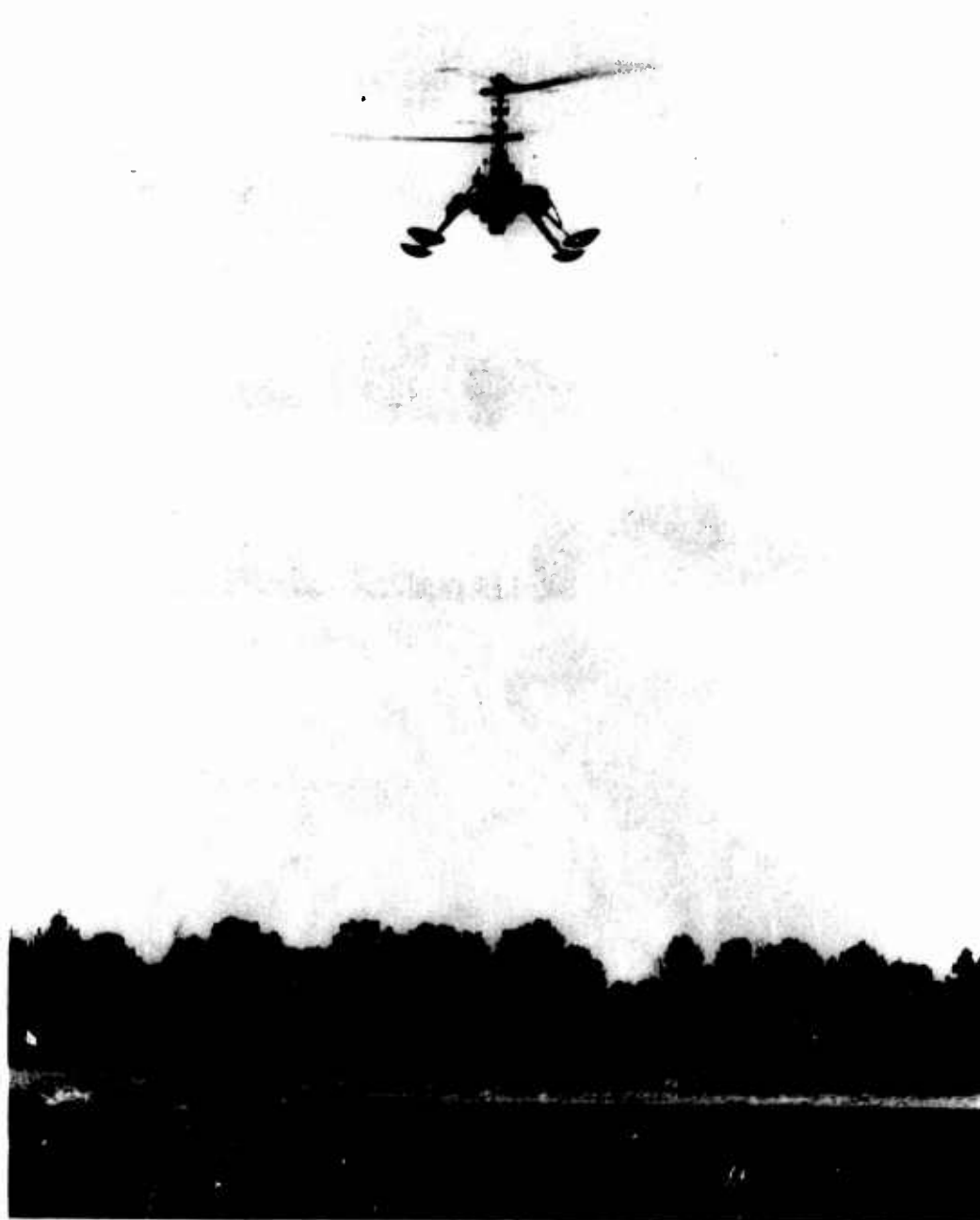

FIG.1 MOTE WITHOUT A.F.C.S.

23-6

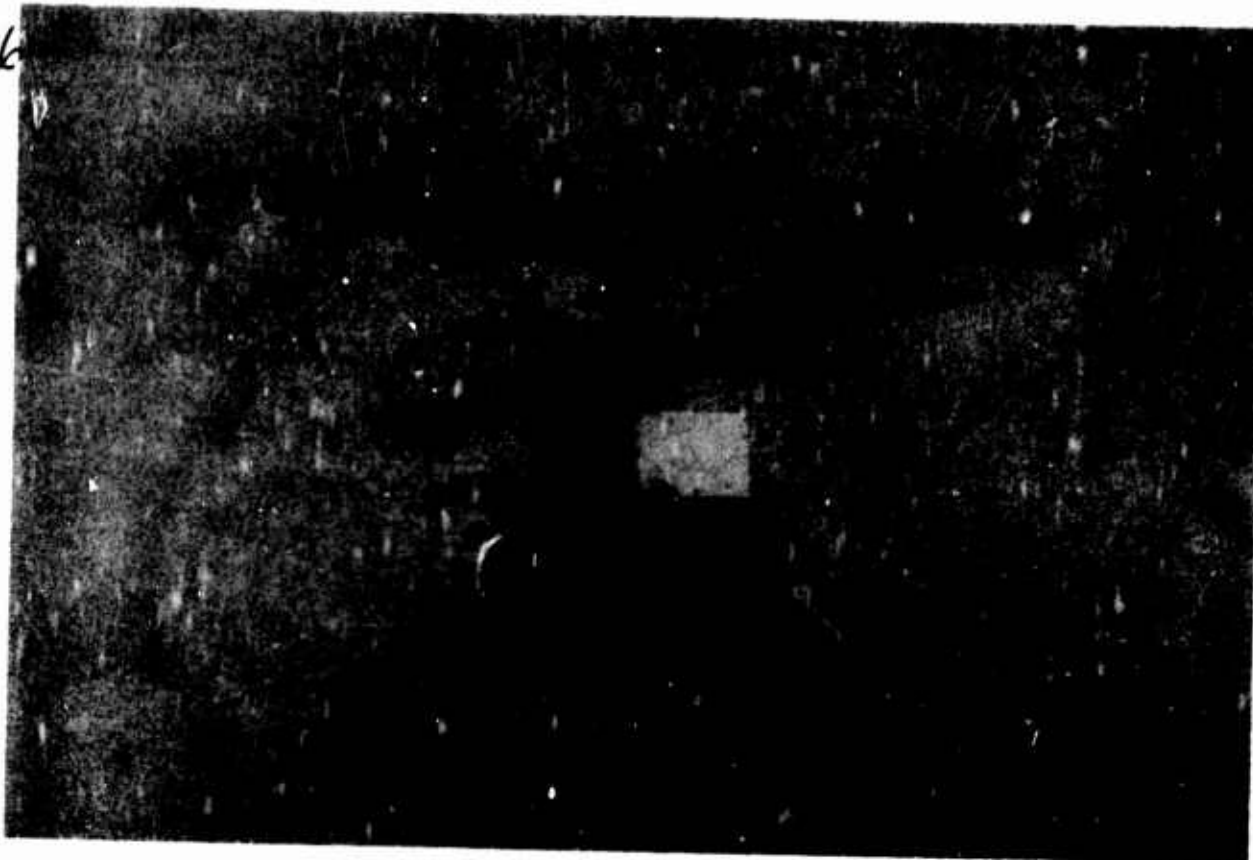

FIG. 2 MOTE WITH A.F.C.S.

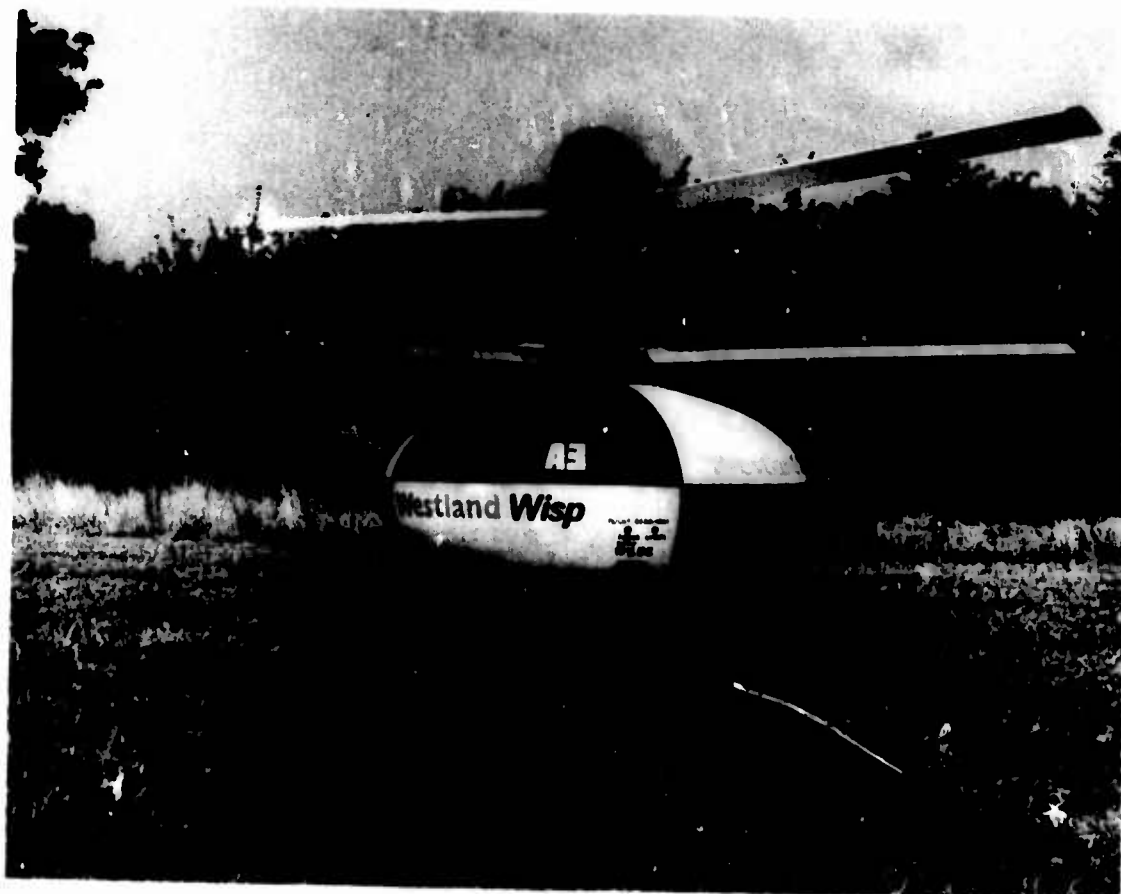

FIG. 3 WISP

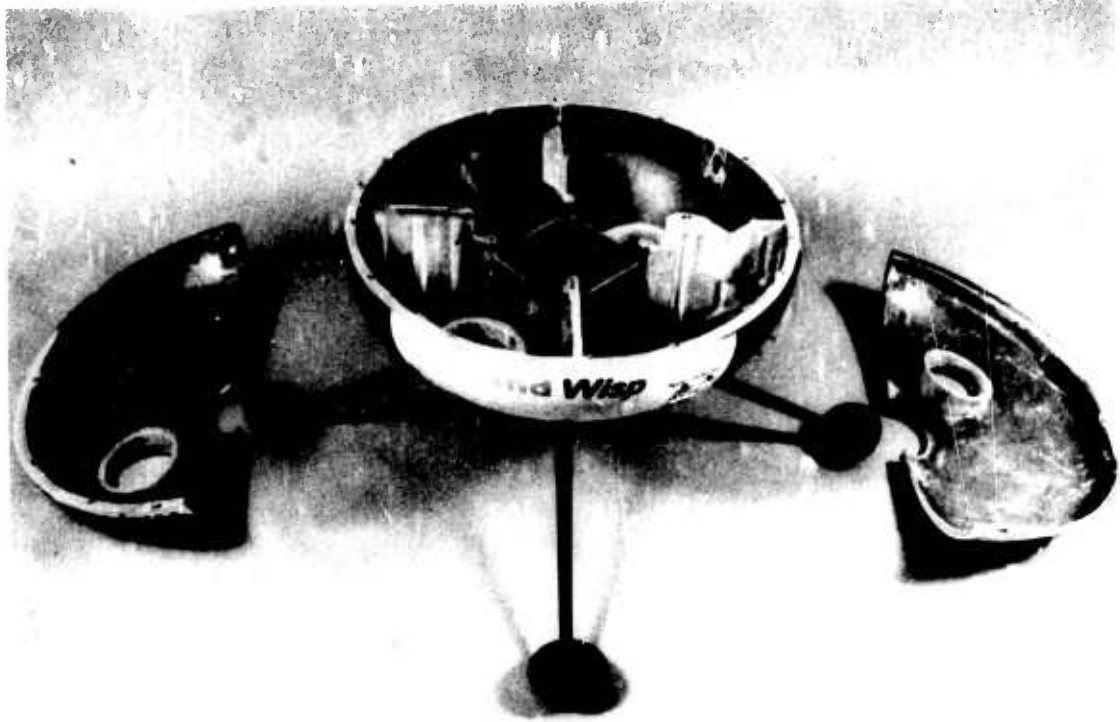

FIG.4 WISP STRUCTURAL MODULE

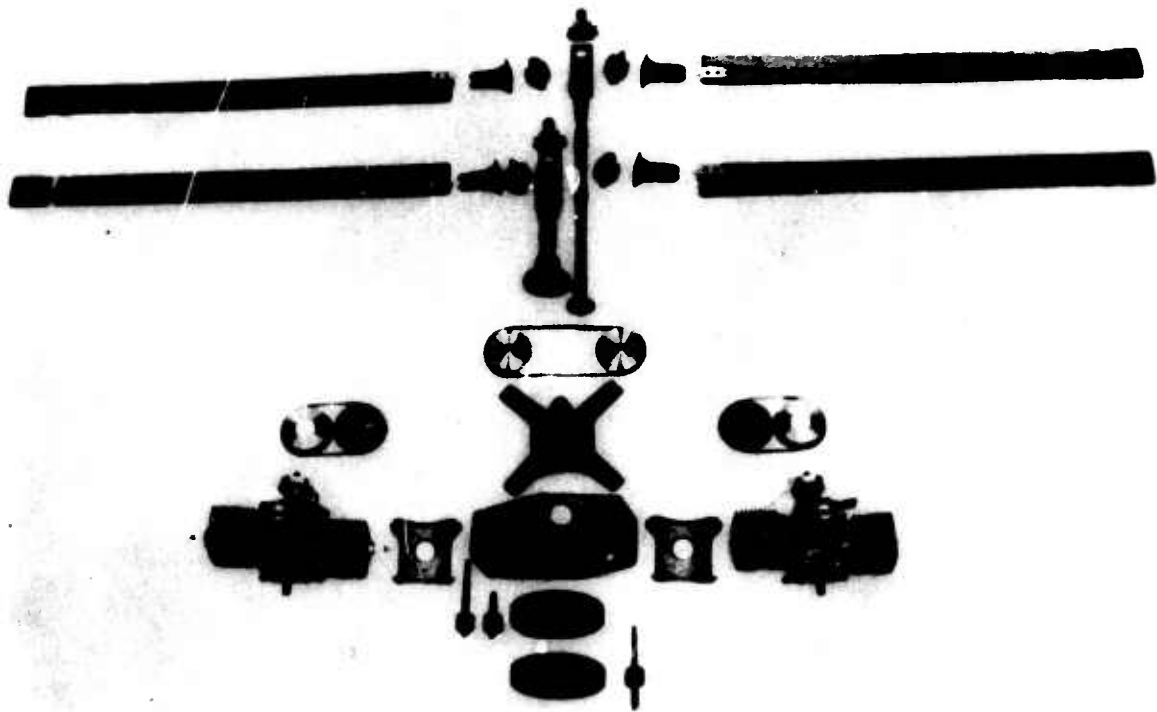

FIG.5 WISP MECHANICAL MODULE COMPONENTS



FIG.6 WISP MECHANICAL MODULE

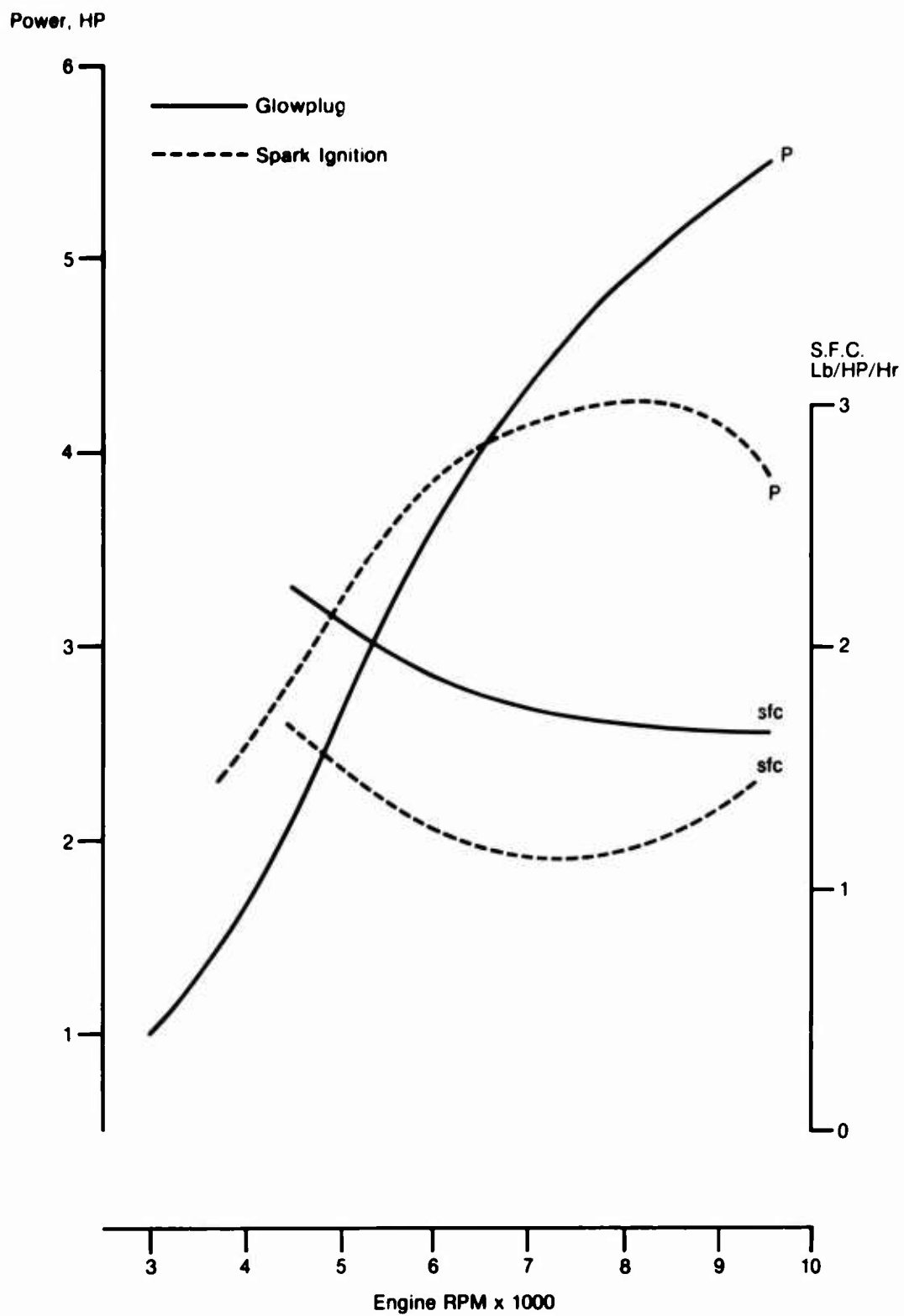

FIG. 7 KOLBO D238 CHARACTERISTICS

13-10



FIG.8 WISP AVIONIC MODULE COMPONENTS

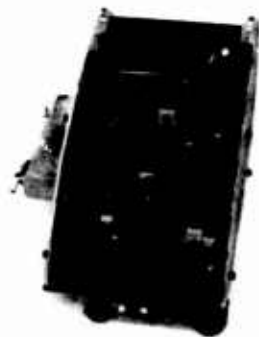
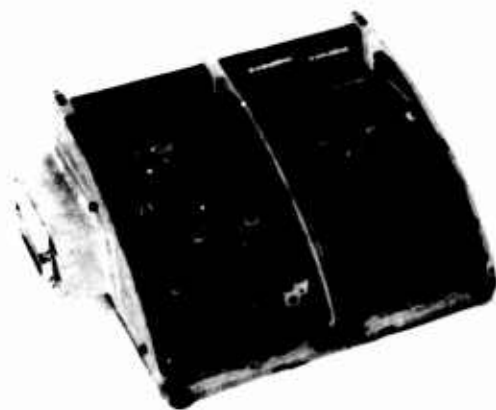



FIG.9 WISP INSTALLATION OF AVIONIC MODULE



FIG.10 WISP INSTALLATION
OF MECHANICAL MODULE



FIG.11 WISP GROUND STATION



FIG.12 WISP IN LAND ROVER



FIG.13 WISP

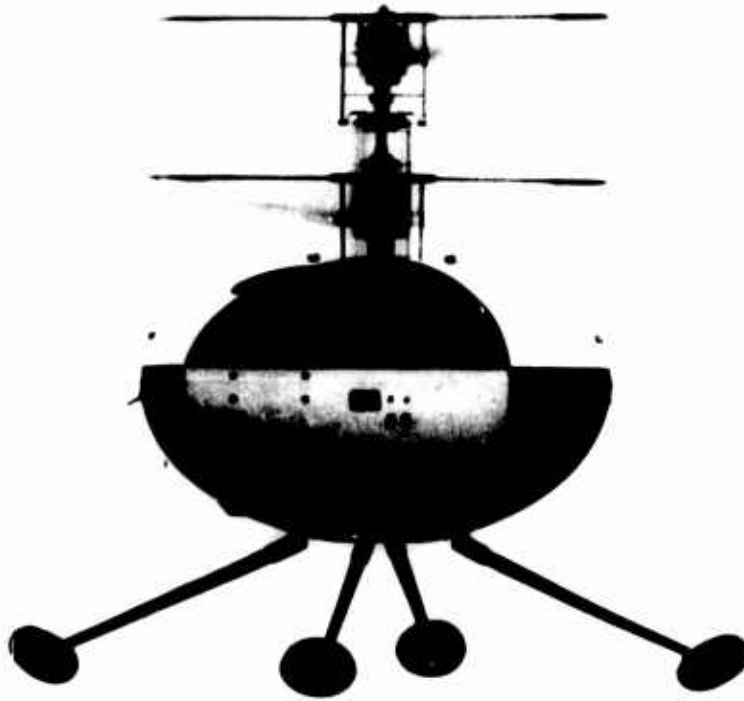

FIG. 14 WISP

TECHNICAL AND FINANCIAL FALL-OUT
ON ARMED FORCES
FROM COMMERCIAL AND EXPORT HELICOPTER PROGRAMMES

Lecture by André L RENAUD
Helicopter Programme Policy Manager
AEROSPATIALE
2 à 20, avenue Marcel Cachin
LA COURNEUVE
93126
France

SUMMARY

Launched as private ventures, there are currently several helicopter programmes. This paper, after analyzing the reasons behind this situation, tries to highlight its drawbacks for the industry and the advantages for the armed forces.

The drawbacks for the industry lie in the heavy investments which are drawn from the manufacturers' cash flow, the lack of operational and technical specifications and of official crews' judgement on the aircraft.

The advantages for the military operators are the deferred and lower non-recurring costs for them to pay if they select a helicopter developed as part of a private venture, and the need for the industry to strive after reducing its production costs, another aspect beneficial to the armed forces.

INTRODUCTION

When reviewing the various helicopter programmes currently underway, it is striking to note that a good number of these were launched as private ventures, that is to say without the industry being supported by a government order. Several examples are the Bell 222 and the Sikorsky S.76 here in the States, the Bolkow 105 in West Germany, the Agusta 109 in Italy and the Dauphin and AS 350 in France.

There is probably more than just a coincidence in this state of affairs and it is of interest to study the underlying reasons before trying to set off the advantages and drawbacks for the armed forces and the manufacturers, which should lead to a few conclusions of a practical nature.

WHY ARE SO MANY PROGRAMMES LAUNCHED INDEPENDENTLY OF GOVERNMENT ORDERS ?

Let us begin to enlighten the following account by asking ourselves the question "why are there so many programmes launched at the manufacturers' own initiative without governmental orders ?".

As a preliminary remark it should first be noted that these private ventures concern relatively light aircraft with a maximum take-off weight lying between 1.9 tonnes for the AS 350 and 4.5 tonnes for the S.76. The reason for this gross weight limit is that in this size of aircraft the development costs are still within the financial possibilities of the manufacturers. Indeed there is a limit to the money the industry can earmark for the development and marketing of a new product. This amount is limited not only in absolute value but also because of the financial risk involved in putting on the market a helicopter which the manufacturer's country has not decided to order for the requirements of its own forces or departments.

Well, it might be said, why embark upon such an undertaking ?

The first reason results certainly from the suitability of this type of light aircraft for a sizeable civil market which the helicopter manufacturers cannot disdain. But there are also military export markets for these types of aircraft and, since over the past years, armies' preoccupations have been focused on the replacement of transport or attack aircraft with any new military programme in the 2 to 4 tonne category becoming a second priority, as evidenced by the SCOUT story in the United States, the helicopter manufacturers had, therefore, to manage without national military support to launch these types of aircraft, if they wanted to respond to the military customer interested by the utility or light transport helicopter.

AEROSPATIALE was already confronted with a situation of this kind at the outset of the Alouette III programme, and now that the production of this aircraft is going to be halted, it is of some interest to discuss the lessons learnt.

These will obviously bring to light some advantages as well as some drawbacks. We will start off by looking at the latter.

DRAWBACKS

The drawbacks are mainly of three sorts : financial, operational and technical.

Financial aspect

The drawbacks for a manufacturer having to develop and produce a helicopter outside a government programme are, primarily, financial. He is obliged, on the one hand, to put up the necessary funds in full knowledge of the fact that they will be irrecoverable if the programme is a failure. On the other hand, he has to include in his sales prices a sufficient allowance to amortise his development and production charges. The latter aspect is not the less important in relation to marketing. In particular, for their part, if the rival aircraft benefit from government backing the competitiveness of an unsupported aircraft may be seriously affected.

Operational aspect

From the point of view of the suitability of the aircraft to the mission, the absence of orders from the national armed forces deprives the manufacturer of any precise operational specifications. Far from placing him in a favourable situation, this absence of clear-cut requirements, especially in the definitions of the missions to be performed and the performance level to be achieved, is a definite handicap. Indeed, though the manufacturer can always either use his own imagination to impose specifications upon himself or show conservatism in extrapolating those which were applicable years before to a similar type of equipment, he very often lacks an accurate expression of specific military requisites.

These vary, of course, according to the missions assigned to the armed forces by the governments, which missions are dependent on the circumstances and which in turn are dependent on the most likely threat. In addition, this threat is reflected not only by the mission to be accomplished but also by the enemy armaments to be avoided or withstood and the staff are the organisations who know these elements and can translate them into operational specifications.

Technical aspect

The lack of technical specifications, drawn up by the government agencies, results for the manufacturer in the difficulty of "arbitrating" between the various possible technical solutions, once the guide lines of the aircraft he intended developing are laid down.

In other words, it is possible, by definition, to optimize the top priority features only in the light of well defined missions, thus forcing the designer to elect solutions which may entail sacrificing the secondary uses of the aircraft.

However, it may be argued that the general standards issued by the government agencies will supply a framework which, in the absence of technical specifications, should make it possible to develop equipment likely to satisfy the armed forces. This is true, but only to a certain extent. Indeed, the standards can take particular operating cases into account only with a certain delay, since they are not only the results of theoretical thinking, but also the outcome of concrete operational experience. Now, it takes some time to draw the lesson from this experience. Therefore, if the manufacturer must rely only upon general standards like the MIL-SPEC, he will be forced to adopt some form of conservatism.

Moreover, certain standards call upon subjective notions. This is the case, for instance, when it comes to the flying qualities of a helicopter. If the aircraft - through lack of governmental programme - cannot be subjected to the criticism of a sampling of pilots, such as those in the official test centers, it may be difficult for the manufacturers' crews to express their opinions on certain points.

Another example of the problems which may be badly solved by the industry alone will easily spring to the mind of those who have suffered the pains of delivering the arrangement of crew stations. So many conflicting elements are to be taken into consideration that it is indeed agreeable to have a government agency to take the final decision ! !

SOLUTIONS FOR THE INDUSTRY

In the face of these drawbacks, the manufacturer needs being seriously motivated for taking the risk of developing an aircraft in the absence of an order from the armed forces of his country. The incentive may stem from the requirements of foreign armies, as was the case for the Bell 214, but then : the mission is defined, the technical specification is discussed with persons well aware of the use they want to make of the aircraft and, most probably, flying crews from the purchasing country will be led to express their criticism. Therefore, this case is not very different from the situation existing with a national order.

On the contrary, a development conducted outside of any order from a domestic or a foreign army involves more difficulties. First of all there will be strong reluctance on the part of any potential customer to commit himself in taking part in the detailed specification of the aircraft, especially in the problems connected with the layout of the crew stations, since he is anxious not to set himself any obligation, be it merely moral, to purchase the aircraft.

A second problem is that, in the case of a private venture, the helicopter contemplated should as far as possible meet the requirements of a large range of potential customers, not only military but also commercial. As the sales to the latter are subject to the certification of the aircraft, the manufacturer may adopt for developing the aircraft, the spirit of the conditions demanded by the civil aviation authorities concerned. He has thus a ready-made guide with its inherent drawbacks and limits. It provides a technically-based definition, but gives no indications for adapting the aircraft to the customers' needs, which can only result from a study of the latter's requirements.

Lastly, there will lack, at the moment of going into service, the organization which will use the aircraft in actual operating conditions and would perform the necessary flights to define the inevitable modifications to be introduced in the aircraft, for it to be more suitable for the missions envisaged or for improving its maintainability.

ADVANTAGES FOR MILITARY OPERATORS

Contrary to the industrial side, the military operators can certainly find a number of advantages in helicopters being developed by the industry, without having to commit themselves with an initial order. These advantages may be not only financial but also technical in certain aspects.

Financial advantages

If the armies do not advance the money to cover the development costs, they already may find an advantage there. Of course, if they buy the helicopter later on, a share of the development and production costs will be included in the purchase price. But this share will be proportional to the number of helicopters that they order and may eventually be less than the total amount of the fixed costs incurred. Besides, payment of this share will be deferred until such time the aircraft are procured and not made several years before as in the case of a government-financed development.

Moreover, the manufacturer will try to keep the production costs of his helicopter as low as possible, since the absence of a significant initial government order means that the development costs must be amortised in the selling price and that the latter will be based on a smaller number of aircraft than in the case of a government ordered aircraft. These problems prompted the efforts of Aérospatiale to lower its manufacturing prices. Having started with Dauphin project, these efforts have been intensified for the AS 350 programme (Ecureuil or Astar) and their results are expounded elsewhere.

But one could say why would the armies not profit from this trend ? Obviously, it is to their advantage if they purchase aircraft manufactured in this spirit. But this imaginative and creative effort would probably have been more difficult to achieve, had it not been imposed by the necessity due to the lack of an initial order from the armies, as was the case for both the Dauphin and Ecureuil programmes mentioned above. Isn't there a French proverb which says, "nécessité fait loi", which roughly translated is "where needs must" ?

A thought immediately comes to mind here : won't this saving in the manufacturing be to the detriment of the technical advance of the helicopters thus constructed ?

Technical advantages

Contrary to this objection, the recent experience of Aérospatiale shows that some technical progress can be made on helicopters which are not initially ordered by the government and that some interesting developments may even be made during these programmes, precisely for the reasons of trying to lower the costs, whether it be the initial outlay or the operating expenses.

A notable example of the type of technical progress made during the search for economy in the areas of the production and operating costs is shown by the rotor head referred to as STARFLEX, as used on Dauphin and AS350. The advantages of this rotor head, as described in the presentation of the AS350 programme, are of course now available for the armies.

This rotor head will probably mark the introduction of the fail-safe concept in helicopter design. Indeed, it is hoped that the civil aviation authorities will certify this component as a fail-safe part. This will constitute a new step forward to the benefit of the armies who now justly attach great importance to the improvement of helicopter survivability.

Besides, this is one of the fields in which it would be necessary to make civil and military regulations converge towards common requirements. This theme will be expounded in another presentation, but it already seems useful to raise the question of how the armies can take full advantage of the developments achieved on the occasion of private ventures.

HOW CAN THE ARMIES PROFIT FROM THE INDUSTRY-INITIATED DEVELOPMENTS

It may seem useless to say that, for the armies to take full advantage of the development of helicopters launched without their initiative, the aircraft they seek should not diverge too much from those proposed by the industry. There should be no confusion about the meaning of this tautology: if certain helicopters intended for precise combat firms such as the AAH, UTTAS or LAMPS, must be designed to specifications derived from mission requirements, it is conceivable that liaison, utility or even training aircraft are not that much different from their civil counterparts. For that matter, have we not heard of late various armies stating that they were seeking off-the-shelf helicopters, that is machines already wholly developed, for such and such missions, as illustrated by the US ARMY SCOUT programme?

This example is instructive enough for it to be worth thinking about for a few seconds. In actual fact, at the same time as they were asking for an off-the-shelf aircraft, the US Army, in its specifications - although they were preliminary - were detailing a certain number of purely military standards and, often, even purely US Army standards.

Through this case - which is nothing unusual - it is possible to put a finger on the difficulty the armies find, in taking advantage of the developments resulting from the manufacturers' own initiative. However, ideas along these lines are progressing, and, in France, the armed forces are seriously thinking about forsaking, for their utility or training aircraft, the reference to stringent standards, which however will remain necessary for combat helicopters.

The problem now is undoubtedly to proceed even further while striving to come as close as possible to the civil and military standards. Indeed the safety requirements are not so conflicting in the two sorts of standards that they would justify different interpretations.

But this topic will be tackled later in another lecture. Therefore this is not the time to push this discussion any further.

CONCLUSION

Without prejudicing the outcome of probing into this important problem of greater similarity between civil and military standards, it is conceivable that the armies can benefit largely from the development of helicopters conducted by manufacturers as a private venture.

Reduced and deferred investments for the government with, however, large freedom of innovation both in the technical and production fields, definitely constitute invaluable advantages.

Conversely, the absence of any definition as to the missions to be fulfilled and of early testing of the equipment in its development phase are a handicap to be overcome by the manufacturer.

CIVIL AND MILITARY DESIGN REQUIREMENTS AND
THEIR INFLUENCE ON THE PRODUCT

25-1

David G. Harding and John P. Walsh
Manager Project Engineer
Product Development Product Development

Boeing Vertol Company
Box 16857
Philadelphia, Pennsylvania 19142

SUMMARY

This paper addresses those civil and military design and qualification requirements which are either common in intent or significantly affect the application in the other field.

Airworthiness requirements are common in intent but different in detail among agencies. This results in substantial costs, particularly for civil application of military helicopters.

Airworthiness requirements have been common among agencies in the past and could be again. It is suggested that this is unlikely to occur.

Military use of civil helicopters will be tempered by the difficulty of achieving their crashworthiness and vulnerability standards.

Civil use of new military helicopters is less than optimally efficient because the cabin size that matches the military hot and high ambient performance is too small under civil conditions.

Aircraft design requirements fall into two basic categories:

- Airworthiness
- Utility

Clearly the intent of airworthiness requirements is the same among all procuring agencies: design and substantiation of a safe, operationally acceptable aircraft.

Indeed, these requirements are similar among the agencies, not only because the intent is the same, but at one time or another they have been common. However, the basic fact is that, although similar, the requirements are not identical, and the small technical differences are of no small program consequence.

It is not our intent to present a comprehensive comparison of the various airworthiness specifications; this has been done several times before. Rather it is to show the effect of the differences by examining the civil certification programs of various Boeing Vertol military helicopters.

The CH-47 Chinook was procured for the U.S. Army by the U.S. Air Force to Air Force requirements in effect in the late 1950's. It was planned immediately following the Vertol 107, which was designed to civil specifications. The Chinook has been an excellent helicopter in all respects; over 700 have been built, and in the 15 years during which it has accumulated over 1.5 million flight hours it is by official government records one of the safest helicopters in history (Figure 1). Notwithstanding this record, it has not been available to the civil sector. The costs of obtaining the ticket have been until now simply too high for the civil operator to bear.

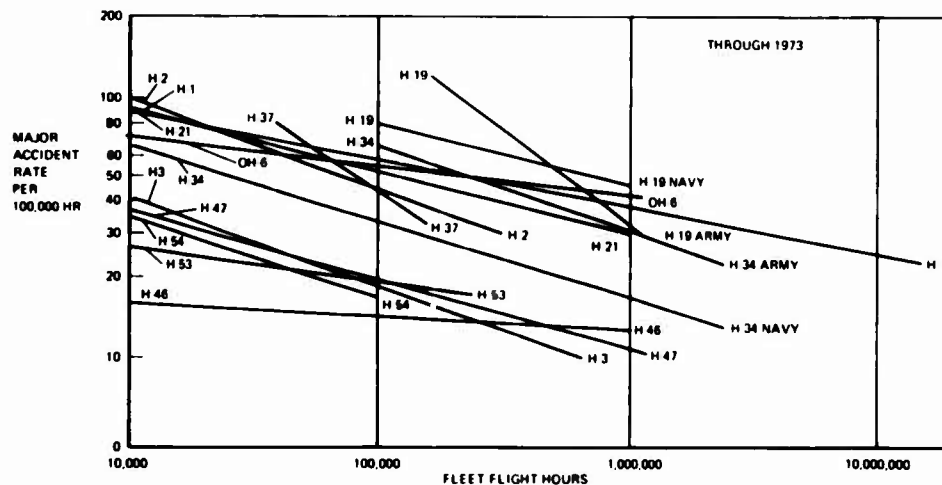

Figure 1. U.S. Military Helicopter Accident Experience

15-2

In the case of the CH-47C, the cost is on the order of \$10 million, half for changes mandated by Federal Aviation Regulation specifications and half for substantiating tests. Figure 2 lists the hardware changes necessary to accommodate the civil requirements. We will not debate them individually; we will not question that, although none of them would have prevented an accident, the aircraft would be better with them included. Suffice it to say that they were not required by the Air Force specification.

- Add one additional anticollision light
- Add third Pitot-static system
- Add APU fire protection
- Add triple-tachometer system
- Add fireproofing to engine mounts
- Add fireproofing to skin panels
- Add flammable-fluid-line isolation
- Add heater-compartment fire protection
- Add CABIN DOOR LOCKED lights
- Add gang bar to electrical-system cutoff switches
- Add power OFF flag feature to flight instruments
- Add generator protection
- Add transformer/rectifier on/off switches
- Add battery-temperature cutoff system
- Reroute main wire runs to separate main feeders
- Reroute transformer/rectifier vent system
- Install AFCS system
- Install jamproof actuators

Figure 2. CH-47C Modifications to Comply With FAR Part 29 Requirements

Much of this additional cost can be avoided if the commitment to both civil and military certification is made from the outset. We have two different examples of this, the CH-47D Modernization Program and the Model 179/YUH-61A UTTAS/LAMPS.

Although the U.S. Army CH-47D is a rebuilt and modernized CH-47A, B, or C, the changes involve almost all of the subsystems involved in airworthiness: drive, flight controls, hydraulics, and electrical. Boeing Vertol therefore decided to explore the application of FAA requirements to the CH-47D in anticipation of civil production versions in the future.

It was found that, in most cases, design options allowed incorporation of the FAR requirement or straightforward provisions for later addition of FAR features such as those shown in Figure 3. Furthermore, this preplanned approach also applies to the qualification and demonstration testing which, although in excess of the military requirement, can be done at the same time and at minimum cost, if properly planned (Figure 4).

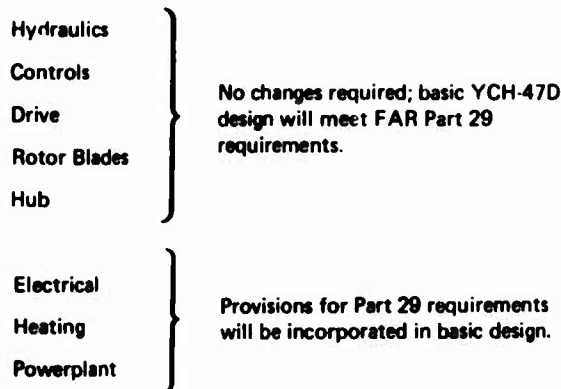

Figure 3. YCH-47D System Review for FAA Certification

Bench — No delta test required to meet FAR requirements

Flight — Accomplished with Army testing

- Flying Qualities
YCH-47D program will be adequate to cover FAR requirements.
- Stress and Motion
FAR requires that data be obtained in the following regimes not covered by the YCH-47D test program:
 1. Pushover
 2. Control reversals during autorotation
 3. Quick stop
 4. Level-flight turns — 30, 60, 90% V_{NE}
 5. Autorotation turns — 30, 60, 90% V_{NE}
 6. RPM effect (assume 42,000 lbs, aft cg, and 8,000-ft altitude)

Flight — FAA peculiar

- Category A performance

Figure 4. YCH-47D FAA Certification Test Program Additions

The Model 179/YUH-61A program is somewhat different from that of the CH-47D. It was a new undeveloped airplane, and it was a fierce competition. It was intended from the start to conduct both military and civil certification, and this was generally accomplished, although not without cost and much anguish; the decision to proceed from the military 150-hour ground-test-vehicle qualification to the civil 200-hour run was exceptionally tough. In a reliability competition, zero failures in 150 hours is a much better score than one in 200 hours. The addition of weight or cost to the basic military airplane in the cause of possible future civil business (only after winning the military competition) was very, very difficult. 253

Just imagine the difference in program and attitude if the qualifications were identical! Both UTTAS competitors would be well on the way to a civil program now.

Until now, we have examined those airworthiness requirements which are similar but not identical among agencies, but there is one facet of airworthiness where the requirements are markedly different: crashworthiness.

The Army's crashworthiness requirements are much more severe than those of the FAA. Furthermore, most of them are not readily accommodated unless included at the time of basic configuration layout.

The requirements contained in MIL-STD-1290 (Figure 5) are well-founded in extensive accident-data studies² (Figure 6), crash-environment-definition tests (Figure 7), and crashworthy-subsystem-development tests (Figure 8). Indeed, where they have been applied, they have proven exceptionally successful: for example, the crashworthy-fuel-system retrofit to Army helicopters (Figure 9) where there hasn't been a single thermal injury since introduction of the system. Our own experience with the YUH-61A accident is compared with an almost identical UH-1 fatal accident in Figure 10.

Impact Condition	Requirements	
	Structural	Other
Longitudinal	20 fps into rigid wall; safe evacuation of crew 40 fps into rigid wall; troop-compartment reduction no more than 15% 60 fps at 10° nose down; reduction of cockpit or troop-compartment living space no more than 5%	95th-percentile seats; cockpit: 50 fps, MIL-S-58095 passenger: 50 fps
Vertical	42 fps; living space reduction no more than 15%	95th-percentile seats; cockpit and passenger: 42 fps
Lateral	30 fps; reduction in compartment living space no more than 15%	95th-percentile seats; 30 fps
Turnover Structure	Aircraft resting on ground; 4W perpendicular to WL; 4W longitudinally parallel to WL; 2W laterally Ground impact at 100 fps at 5° angle; passenger-occupied volume reduction no more than 15%	
Nose Flowing	Forward 25% fuselage uniformly loaded 10g up and 4g aft (10g based on effective mass); preclude scooping	
Tail Bumper	MIL-A-003862A; 10-fps sink speed and pitch attitude corresponding to IGE hover in 60-knot tailwind	
Blade Strike	Rotor mast shall not fail; transmission shall not be displaced into occupiable section when main-rotor blades impact into a rigid 8-inch-diameter object in the outer 10% blade radius at operational rotor speed	
Mass-Item Retention	±20g longitudinal; 20/-10g vertical; ±10g lateral	
Postcrash Fire	--	Fluid containment; ignition sources; separation of fluids from occupants; shielding
Evacuation	--	30-second evacuation time (crew and passengers)

Figure 5. MIL-STD-1290 Crashworthiness Requirements

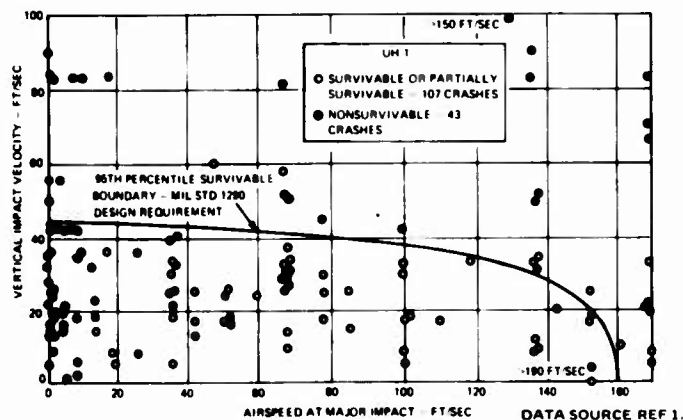
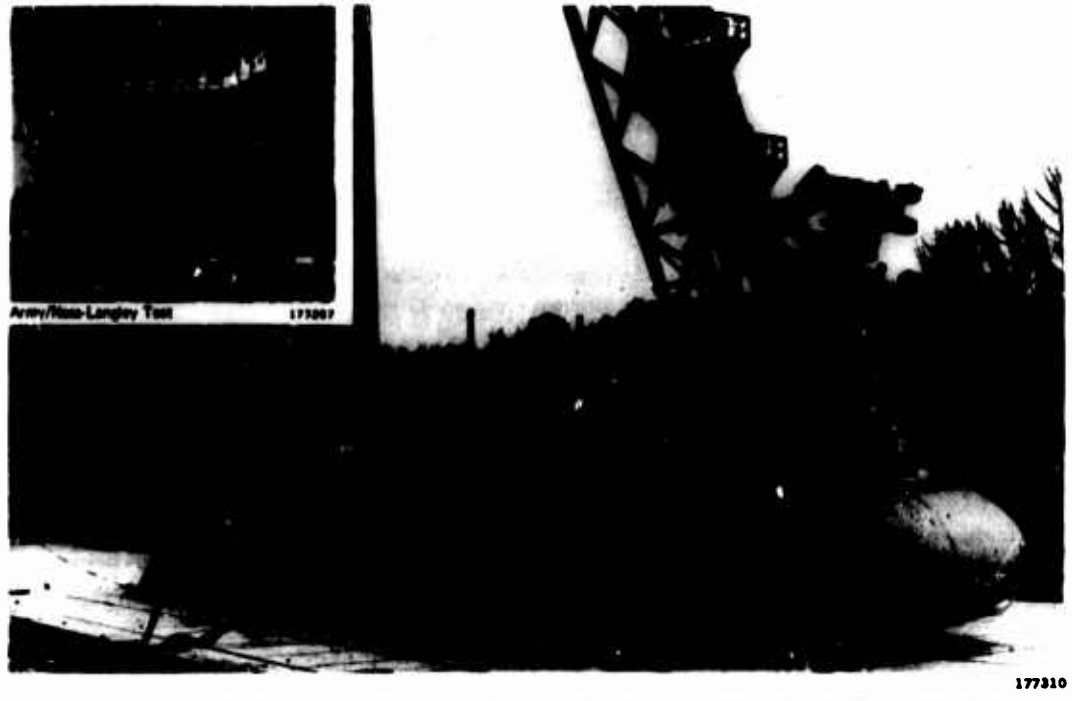

Figure 6. MIL-STD-1290 Crashworthiness Requirements Are Substantiated by Accident Statistics

25-4



177810

Figure 7. CH-47 Crash Test Defines the Survivable Crash Environment



Figure 8. Dynamic Tests of Occupant Seats to MIL-STD-1290 Requirements

	FATALITIES		INJURIES	
	THERMAL	NON-THERMAL	THERMAL	NON-THERMAL
WITHOUT CWFS				
AH-1G	3	38	2	68
OH-58A	5	38	3	62
UH-1D	8	7	1	23
UH-1H	86	128	80	225
TOTAL	101	210	86	378
WITH CWFS				
AH-1G	0	8	0	11
OH-58A	0	5	0	11
UH-1D	0	3	0	18
UH-1H	0	54	0	266
TOTAL	0	70	0	286

Figure 9. No Thermal Injuries With Crashworthy Fuel Systems

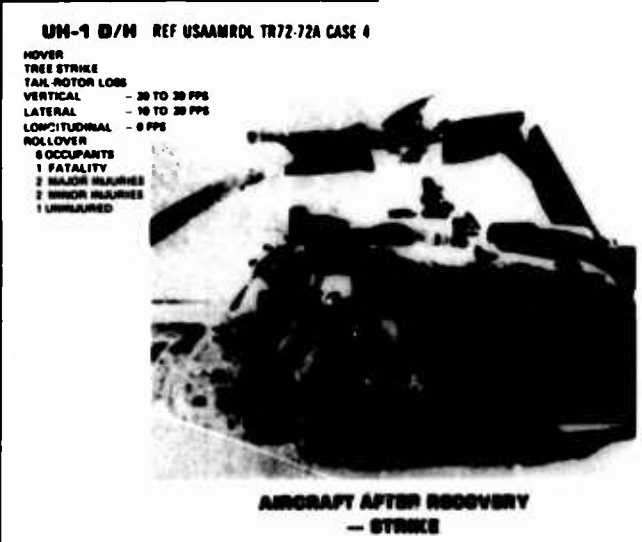
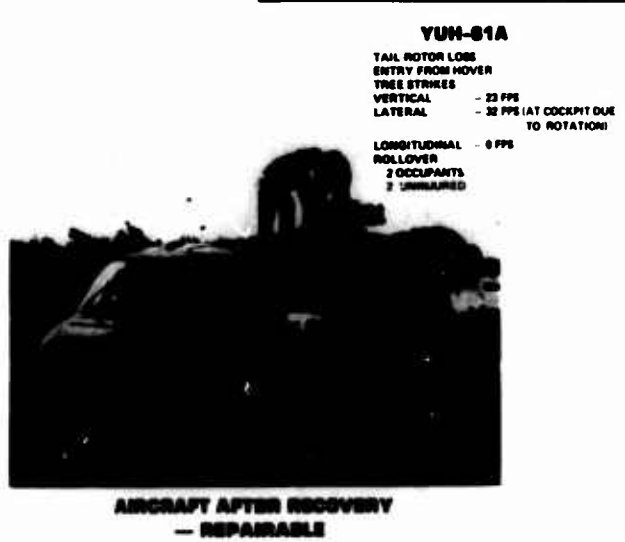

Figure 10. Comparison of Similar Accidents Involving Tail-Rotor Loss and Tree Strike; MIL-STD-1290 Crashworthiness Works

The key features of the basic configuration necessary to accomplish such crash protection are shown in Figure 11. When accorded from the beginning, the costs of this protection are minimal and, according to the U.S. Army, very cost-effective (Figure 12).

45-5

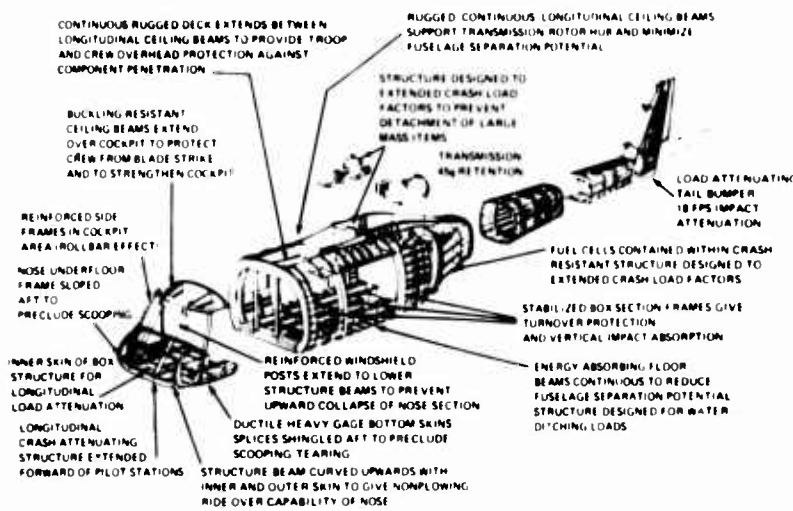

Figure 11. Principal Crashworthiness Features of the UH-61A Structure

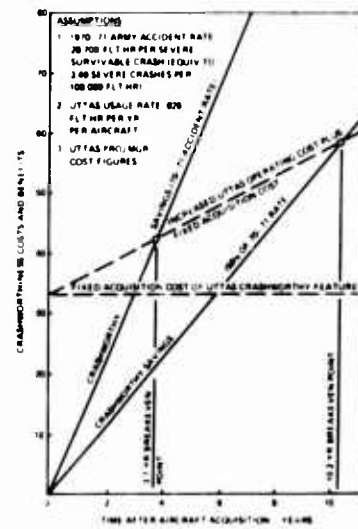

Figure 12. UTTAS Crashworthiness Investment Saves the Army Money as Well as Lives

So, unless designed to these requirements from the beginning, it is difficult to imagine a civil helicopter being acceptable to the U.S. Army without major change.

We will now examine civil and military utility design requirements which appear to significantly affect application in the other sphere.

Most U.S. military design requirements specify mission performance under 95th-percentile-probability ambient conditions anywhere in the world, whereas most civil operations will accept a performance degradation under extreme conditions (Figure 13). The result of this is that the military cabin size does not match the performance at normal civil ambients, and vice versa (Figure 14).

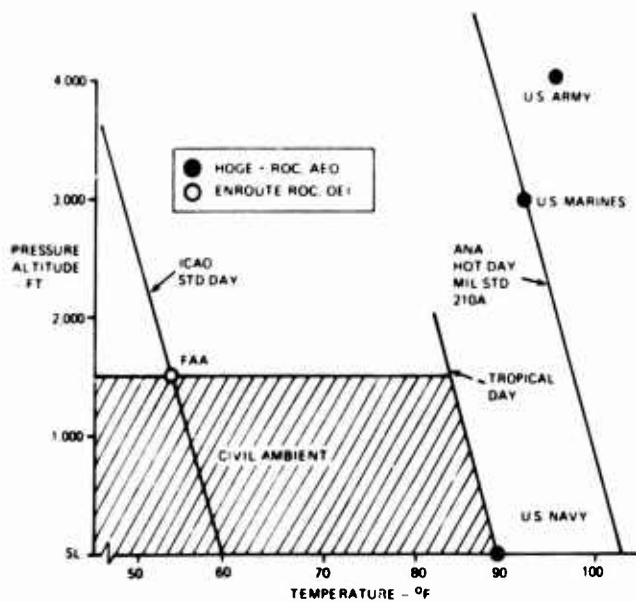

Figure 13. Military Performance Requirements Are at Extreme Ambient Conditions

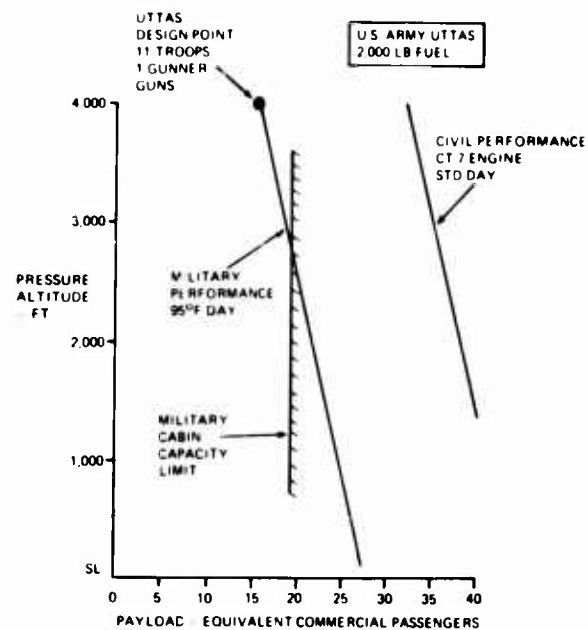

Figure 14. The Military Helicopter Cabin Size Does Not Match the Civil Performance Capability

Noise has always been a concern in all fields of helicopter operation and understanding of the phenomenon has allowed us to eliminate rotor bang in new helicopters. Further reduction in noise, however, is very costly, and certainly this is an area where future requirements could drive either the civil or military sector out of the realm of the other.

Requirements for military high-speed maneuvers and nap-of-the-earth flight have a marked influence on both rotor solidity and hub configuration; neither is required for civil applications, so the strictly civil product may not satisfy the military.

Most military helicopters are viable only if they have sufficient survivability to operate in the front lines in the presence of a severe enemy threat. All UTTAS and AAH competitors proved that this is feasible, particularly against the anti-aircraft gun threats,

256

but again only if designed so from the beginning. Rotor-blade material and chord (Figure 15), fuel-tank installation, and tailboom configuration and structure (Figure 16) are areas where major differences in vulnerability or major redesign costs are involved in adapting a civil design to a military application.



Typical Steel Blade Damage



Typical Titanium Blade Damage

C26154

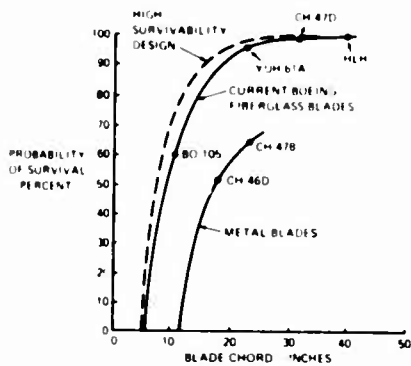

Fiberglass Blade Survive

161047

Outboard Spar Section

- FATIGUE TESTED
- 100% level flight loads for 6 hours
 - 1.65g maneuver loads for 8 minutes
- Result
- No damage propagation

Figure 15. Blade Survival Probability Given a 23-mm HEI Hit

HYDRAULIC RAM
ATTENUATING
STRUCTURE
3 IN ZEE STIFFENERS

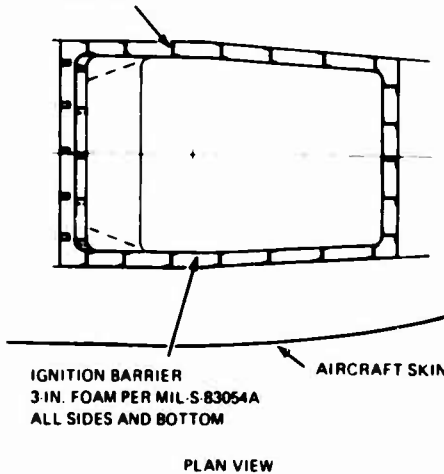

IGNITION BARRIER
3-IN. FOAM PER MIL-S-83054A
ALL SIDES AND BOTTOM

PLAN VIEW

FIRE ELIMINATION AFTER 23-MM HEI T IMPACT

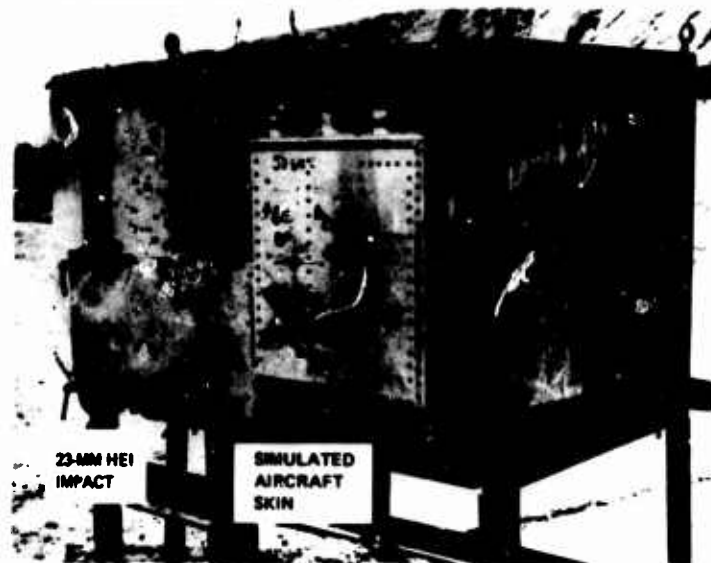

23-MM HEI
IMPACT

SIMULATED
AIRCRAFT
SKIN

BOEING-UNIQUE DESIGN PROVIDES EFFECTIVE PROTECTION AGAINST HYDRAULIC RAM, ARMOR-PIERCING INCENDIARY, AND 23-MM HIGH-EXPLOSIVE-INCENDIARY TRACER

Figure 16. Fuel Cell Protection Must Be Designed In (1 of 2)

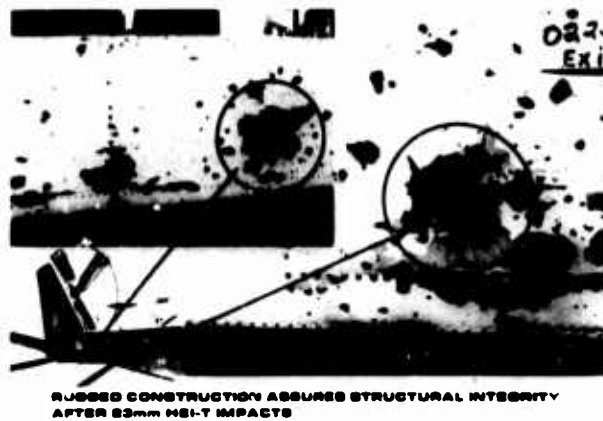

Figure 16. Tailboom Survives Multiple Hits (2 of 2)

Clearly these utility differences reflect in the overall cost-effectiveness of applying or modifying a helicopter from one sphere to another and influence the new-versus-derivative decision of the procuring agency, be it civil or military.

So let us now return to the basic airworthiness requirements which *could* be the same among agencies.

Why aren't they the same? Because each agency is responsible for certifying the airworthiness of the procured product. Charged with this responsibility, each agency will develop what it considers to be the most appropriate requirements. Since the agencies are separately responsible, the requirements they develop are bound to be different.

But why should they be the same? Because there can be savings! But who saves?

If it is in the best interests of the military to purchase a civil-qualified aircraft, they may and have chosen to waive further military certification. This is because the user, purchaser, and technical cognizance are all part of the same agency. They can resolve the differences among certification and the associated costs within the agency (Figure 17).

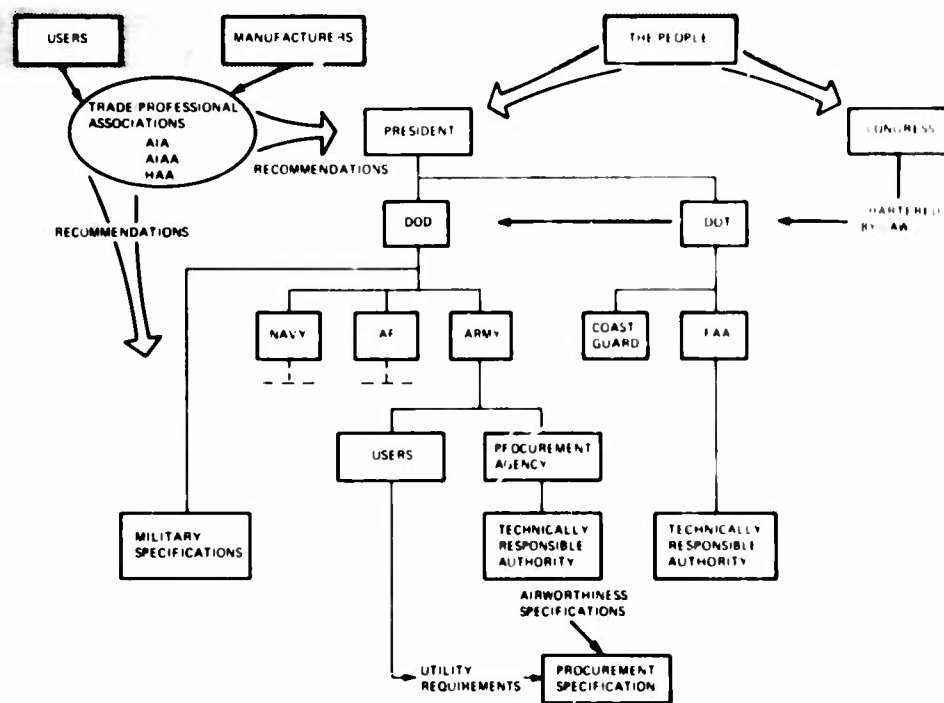

Figure 17. Airworthiness Responsibilities

On the other hand, if a civilian operator wishes to purchase a military helicopter, he does not have the mechanism to waive civil certification. In this regard, the FAA's prime responsibility is ensuring that the product is safe and only secondarily encouragement of commercially viable aviation endeavors. The FAA does not save; only the operator has a financial stake.

The third possibility for saving is if the military encourages civil certification in parallel with military. In this case he increases the production quantity, lowers his unit price, and enjoys a quicker maturing process and a more stable production base throughout the program. But these savings are all in the out years when viewed from the development/certification end. And it is the front-end funds which are the most difficult to obtain. So increases in development costs to accomplish civil certification and the resulting downstream savings are usually rejected. A noteworthy exception was the U.S. Army LOH Program. When the Army bought the

LOH, its first helicopter procured directly rather than through the Air Force or Navy, it specified FAR Part 27 as the airworthiness requirement. The three competitors subsequently each had successful civil programs, and in fact saved the Army considerable money because they were all still in production for the competitive follow-on buy. However, the Army requirements have since diverged and are no longer common with the FAA.

So there are savings associated with common airworthiness requirements, but they are not large enough or soon enough at the agency level to cause change from within. This is probably why the most recent AIA effort to encourage common specifications failed (Reference 3).

Change, if it is to come, must come from those who ultimately benefit, the people. It must come through the political process and so influence the President and the Congress to mandate change on the agencies. This, too, has been tried, with mixed results.

The munitions board of the 1930's did bring about joint Army, Navy, and Commerce standards; the ANC series which remained with us in part through the late 1950's, indeed at the detail hardware level is still with us.

In the 1950's and 60's, however, each agency considerably expanded its own specifications so that the basic ANC specifications were no longer adequate and the services were again different.

A noteworthy meeting, similar to this one, was sponsored in 1953 by IATA on Helicopter Operation and Design Requirements (Reference 4). The problems were the same as today despite the infancy of the helicopter at the time. No significant changes came from the initiative despite the widespread interest and optimism on the part of the major airlines.

Presidential order of the late 1950's resulted in much work aimed at bringing the services back together and concurrent military and civil certification of the C-141. Neither was accomplished. A similar effort in 1965⁵ also failed to mature.

So as a conclusion to this paper and opening gambit of the following round-table discussion, I suggest: Everyone would benefit from common airworthiness qualification specifications, but not enough to move the necessary political and bureaucratic machinery.

REFERENCES

1. Haley, J.L., and Hicks, J.E., CRASHWORTHINESS VERSUS COST: A STUDY OF ARMY ROTARY WING AIRCRAFT ACCIDENTS IN PERIOD JANUARY 1970 THROUGH DECEMBER 1971, USAAAVS, Presented at the Aircraft Crashworthiness Symposium, University of Cincinnati, Ohio, October 1975.
2. CRASH SURVIVAL DESIGN GUIDE, USAAMRDL TR71-22, Eustis Directorate, U.S. Army Air Mobility Research and Development Laboratory, Fort Eustis, Virginia, 1971.
3. Harr, Karl G., Jr., COMMON CIVIL/MILITARY AIRWORTHINESS STANDARDS FOR HELICOPTERS, Letter to Director of Defense Research and Engineering, Aerospace Industries Association of America, Inc., Washington, DC, March 1972.
4. HELICOPTER OPERATION AND DESIGN REQUIREMENTS, International Air Transport Association, Presented at Symposium on the Operation and Design Requirements of Helicopters, 6th Annual Technical Conference of IATA, Puerto Rico, April 1953.
5. CONFERENCE ON DESIGN REQUIREMENTS, Federal Aviation Administration and Department of Defense, Washington, DC, November-December 1965.