

UNCLASSIFIED

AD

AD-E404 030

Technical Report ARMET-TR-17044

**ANTI-ARMOR, CONFINED SPACE, REDUCED SENSITIVITY (AT4CS-RS)  
INSENSITIVE MUNITIONS (IM) EFFORT:  
SUMMARY AND CONCLUSIONS**

Leon Moy  
Edward Yang  
Daniel Ruland  
Stacey Yauch  
Renee Bober

May 2018



U.S. ARMY ARMAMENT RESEARCH, DEVELOPMENT AND  
ENGINEERING CENTER

Munitions Engineering Technology Center

Picatinny Arsenal, New Jersey

Approved for public release; distribution is unlimited.

UNCLASSIFIED

**UNCLASSIFIED**

The views, opinions, and/or findings contained in this report are those of the author(s) and should not be construed as an official Department of the Army position, policy, or decision, unless so designated by other documentation.

The citation in this report of the names of commercial firms or commercially available products or services does not constitute official endorsement by or approval of the U.S. Government.

Destroy by any means possible to prevent disclosure of contents or reconstruction of the document. Do not return to the originator.

**UNCLASSIFIED**

**UNCLASSIFIED**

REPORT DOCUMENTATION PAGE			Form Approved OMB No. 0704-01-0188		
<p>The public reporting burden for this collection of information is estimated to average 1 hour per response, including the time for reviewing instructions, searching existing data sources, gathering and maintaining the data needed, and completing and reviewing the collection of information. Send comments regarding this burden estimate or any other aspect of this collection of information, including suggestions for reducing the burden to Department of Defense, Washington Headquarters Services Directorate for Information Operations and Reports (0704-0188), 1215 Jefferson Davis Highway, Suite 1204, Arlington, VA 22202-4302. Respondents should be aware that notwithstanding any other provision of law, no person shall be subject to any penalty for failing to comply with a collection of information if it does not display a currently valid OMB control number.</p> <p><b>PLEASE DO NOT RETURN YOUR FORM TO THE ABOVE ADDRESS.</b></p>					
1. REPORT DATE (DD-MM-YYYY) May 2018		2. REPORT TYPE Final		3. DATES COVERED (From - To) 2008 through 2012	
4. TITLE AND SUBTITLE  ANTI-ARMOR, CONFINED SPACE, REDUCED SENSITIVITY (AT4CS-RS) INSENSITIVE MUNITIONS (IM) EFFORT: SUMMARY AND CONCLUSIONS			5a. CONTRACT NUMBER		
			5b. GRANT NUMBER		
			5c. PROGRAM ELEMENT NUMBER		
6. AUTHORS  Leon Moy, Edward Yang, Daniel Ruland, Stacey Yauch, and Renee Bober			5d. PROJECT NUMBER		
			5e. TASK NUMBER		
			5f. WORK UNIT NUMBER		
7. PERFORMING ORGANIZATION NAME(S) AND ADDRESS(ES) U.S. Army ARDEC, METC Energetics & Warheads Directorate (RDAR-MEE-M) Picatinny Arsenal, NJ 07806-5000			8. PERFORMING ORGANIZATION REPORT NUMBER		
9. SPONSORING/MONITORING AGENCY NAME(S) AND ADDRESS(ES) U.S. Army ARDEC, ESIC Knowledge & Process Management (RDAR-EIK) Picatinny Arsenal, NJ 07806-5000			10. SPONSOR/MONITOR'S ACRONYM(S)		
			11. SPONSOR/MONITOR'S REPORT NUMBER(S) Technical Report ARMET-TR-17044		
12. DISTRIBUTION/AVAILABILITY STATEMENT Approved for public release; distribution is unlimited.					
13. SUPPLEMENTARY NOTES					
14. ABSTRACT  An effort was initiated to develop an insensitive munitions packaging solution for the AT4CS-RS. The effort investigated several promising designs. Initial engineering testing showed that the most promising design is the deflection plate concept, which will achieve a type IV reaction for Slow Cook Off, Fast Cook Off, and Bullet Impact testing with a minimal impact to the cost and the weight to the packaged AT4.					
15. SUBJECT TERMS Anti-armor Warhead Recoiless Countermass Insensitive munition (IM) Heat mitigation Deflection plate Barrier AT4 AT4CS-RS AT4CS-TW CA30 M136A1 M136					
16. SECURITY CLASSIFICATION OF:			17. LIMITATION OF ABSTRACT	18. NUMBER OF PAGES	19a. NAME OF RESPONSIBLE PERSON
a. REPORT	b. ABSTRACT	c. THIS PAGE			Leon Moy
U	U	U	SAR	75	19b. TELEPHONE NUMBER (Include area code) (973) 724-1570

Standard Form 298 (Rev. 8/98)  
Prescribed by ANSI Std. Z39.18

**UNCLASSIFIED**



UNCLASSIFIED

CONTENTS

	Page
Introduction	1
Program Summary	1
Item Description	1
Insensitive Munitions Baseline	4
Initial Concepts	5
Insensitive Munitions Venting Concepts (December 2008 to June 2009)	5
Insensitive Munitions In-bore Concepts (November 2009)	6
Insensitive Munitions Packaging Concepts	9
Ruggedized Container	10
Deflection Plate	11
Ballistic Sleeve	15
Heat Mitigation	16
Preliminary Testing	20
Ballistic Sleeve	20
Heat Mitigation	22
Ruggedized Container and Deflection Plate – Initial Testing	23
Ruggedized Container	25
Deflection Plate	30
Concept Evaluation and Down Selection	32
Deflection Plate, Further Development	33
Plate Optimization – Test Plan	34
Plate Optimization – Test Results	35
Conclusions and Path Forward	39
Concepts for Further Development	39
Estimated Funding Required to Complete Effort	40
Intellectual Property	40
Appendices	
A Ballistic Sleeve Concept – Test Plan	41
B Fast Cook-off Test Report (Test Number One)	45
C Fast Cook-off Test Report (Test Number Two)	49
D Redstone Test Center –Test Site Satellite Imagery	53
E Trip Report	57
F Test Plan to Determine Capability of Prototype Restraining Packaging for AT4	63
Distribution List	69

FIGURES

	Page
1 AT4CS-RS system overview	2
2 AT4CS-RS launcher	2
3 Top view AT4CS-RS packaging	3
4 Side view of hinged box end of AT4CR-RS packaging	3
5 Sock concept	7
6 Cutting wedge concept	8
7 Locking wedge concept	8
8 Deflector concept	9
9 Guillotine concept	9
10 Early concept drawing (ruggedized container)	10
11 M&S (ruggedized container)	10
12 Internal design (ruggedized container)	11
13 Steel cabled braid around launcher (ruggedized container)	11
14 Deflection plate concept	12
15 Location of damage to fuze	12
16 M&S on projectile	13
17 Deflection plate packaging concept	13
18 Deflection plate packaging prototype	14
19 Deflection plate size comparison	14
20 Ballistic sleeve concept	15
21 Ballistic sleeve design	15
22 Heat mitigation concept	16
23 Simulation of predicted FCO results	17
24 Heat mitigation concept design	18
25 Water filled blister liner	18

UNCLASSIFIED

FIGURES  
(continued)

	Page
26 Heat mitigation packaging	19
27 Blister liner enclosed with sealed foil/plastic barrier material	19
28 Snail shell	20
29 Ballistic sleeve test setup	21
30 Four thermal couples	23
31 Test setup at RTC	24
32 Test setup for deflection plate tests	25
33 Screenshot from video of test no. 3 (ruggedized container), detonation results	27
34 Screenshot from video of test no. 3 (ruggedized container), fuze detonation	27
35 Test no. 3 side view (ruggedized container)	28
36 Recovered impact plates with warhead impression	28
37 Recovered fin and fuze assemblies	28
38 Container propelled into steel wall	29
39 Recovered warhead fragments	29
40 Screenshot from video of test no. 4 (1-in. thick plate)	31
41 Screenshot from video of test no. 5 (1/2-in. thick plate)	31
42 Recovered unarmed fuze and fin assembly (x-rayed)	31
43 Recovered copper liner	32
44 Recovered warhead fragments	32
45 Down selection summary	33
46 Boxes procured for optimal plate thickness testing	34
47 Tree diagram for plate thickness test sequence	35
48 Actual plate thickness test sequence	36
49 Impacted deflection plates (post-test)	39





# UNCLASSIFIED

## INTRODUCTION

### Program Summary

The M136 AT4 (primary light anti-tank weapon) has been in production since 1986, and has undergone several product improvements that both enhance the munition's lethality and the Soldier's survivability. The latest version fielded for the U.S. Army, the M136A1, 84-mm, anti-armor, confined space, reduced sensitivity (AT4CS-RS) provides Soldiers with fire-from-enclosure capability, thus providing a significant improvement to Soldier survivability.

The AT4CS-RS uses an insensitive munitions (IM) enhanced warhead explosive (PBXN-110), as opposed to the Octol explosive in the original M136 AT4. However, since the AT4CS-RS is essentially a "ready-to-fire" rocket launcher, loaded with a high-explosive projectile, it still fails IM testing when the rocket motor launches the projectile during IM tests.

An effort was initiated to develop an IM solution for the AT4CS-RS. Because of difficulties arising from the system being contractor owned, the program was split into a contractor effort to investigate changes to the item and a government effort to develop packaging to improve IM performance for the AT4 family of shoulder-launched munitions.

The contractor effort is detailed in another report (contract no. W15QKN-08-D-0436/Saab Dynamics AB, Kariskoga, Sweden). The solutions provided by the contractor included technical challenges which need to be overcome and that may not be complete solutions. Funding was not available to continue that effort.

The packaging effort investigated several promising designs. Initial engineering testing showed that the most promising design is the deflection plate concept, which will achieve a type IV reaction with a minimal impact to the cost and the weight to the packaged AT4. The addition of a plain 4-lb mild steel plate in front of the barrel during launch renders the warhead inoperable.

Funding to the program was cut before IM testing could be completed; however, initial testing indicates that the design is rugged, and there is a low risk of failure.

### Item Description

#### **The Anti-armor, Confined Space, Reduced Sensitivity M136A1-CA30**

The latest variant of the M136 AT4 fielded for the U.S. Army is the M136 E1, AT4CS-RS. The AT4CS-RS, shown in figure 1, is a light, recoilless, anti-armor weapon intended for military operations in urban terrain environments. It is a preloaded weapon intended for firing one round that is fired from the shoulder, after which the expended launcher assembly is discarded. The launcher houses a cartridge case assembly, counter-mass container, and a fin stabilized high explosive anti-tank (HEAT) projectile (fig. 2).

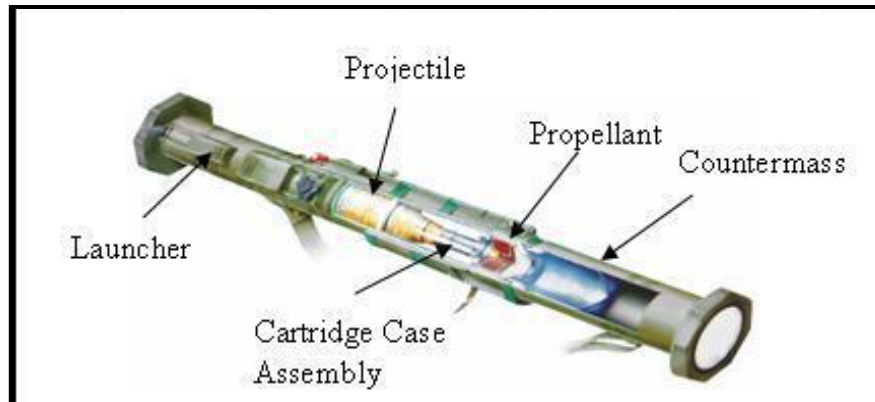

Figure 1  
AT4CS-RS system overview

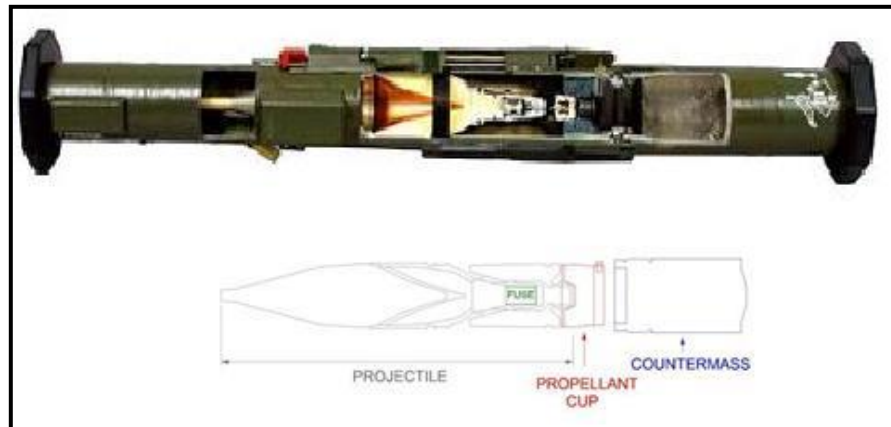

Figure 2  
AT4CS-RS launcher

The main parts of the AT4CS-RS are the barrel with firing mechanism, HEAT round, sights, shoulder stop, face and shoulder pad, carrying sling, front grip, and front and rear rubber bumpers. These rubber bumpers serve to protect the barrel from mechanical damage and do not have to be removed before firing. The barrel is made of fiberglass reinforced plastic with the firing mechanism on the right side of the barrel.

The HEAT round consists of a projectile and a cartridge case assembly. The main parts of the cartridge are the warhead and the fuze system/fin assembly. The fuze is located in the fin assembly of the warhead. The warhead is stabilized in flight by the folding fins. The warhead consists of a standoff cap and a shell body with a shaped-charge liner and explosive. The propellant, igniter composition, and percussion cap are mounted in the rear part of the cartridge case. The counter-mass container is screwed from the rear into the barrel. The most significant parts of the fuze system are: (1) a piezoelectric crystal, (2) a safety and arming (S&A) device, (3) an electric unit, and (4) an electric detonator. Setback and pressure are the two physical arming conditions.

There are two sights: rear and front. They are protected by sliding housings. When the sliding housings are opened, the sights pop up automatically. The firing range can be set at 50-m intervals between 100 and 400 m by an elevation knob attached to the rear sight.

UNCLASSIFIED

The shoulder stop is attached to the bottom of the barrel and is unfolded when preparing for firing. It is combined with a face and shoulder pad that is cemented to the barrel. The plastic front grip is also attached to the front of the barrel and is unfolded when preparing for firing.

The system is currently packaged in a wooden box containing two rounds, each separated by a wooden divider. Each round is individually sealed, in a heat-sealed bag, which provides protection from moisture and other environmental factors until it is opened for use. The wooden box is reinforced by metal angle brackets along each of its edges and has two handles on each side to facilitate carrying by the Soldier. The rounds are loaded into the box from the top during load assembly and packaging. However, it is then sealed and is accessible to the Soldier by a hinged side panel, on the short side, that swings open. This panel has two hinged locks that allow the end to open and close. These features can be seen in figures 3 and 4.



Figure 3  
Top view AT4CS-RS packaging



Figure 4  
Side view of hinged box end of AT4CR-RS packaging

**The AT4-M136-C995**

The original AT4 is similar to the AT4CS-RS except for the following:

- Does not have a counter mass.
- Contains more propellant.
- Propellant is more energetic.
- More sensitive energetic in the warhead.
- Higher velocity (290 m/s versus 220 m/s) projectile.

The projectile is similar, however, in regard to the form and function of that of the AT4CS-RS. The AT4 was used in place of the AT4CS-RS when the item was remotely triggered to test the ability of packaging to contain or disable the warhead.

**The AT4CS-TW (Tandem Warhead) Trainer**

The TW variant is a confined space, tandem warhead system used to defeat bunkers and light armor. It uses the same propellant and counter mass system as the AT4CS-RS, making it ideal for bullet impact (BI) and cook-off testing. Additionally, the trainer version of the TW uses an inert aluminum warhead, allowing testing to be performed onsite at the U.S. Army Armament Research, Development and Engineering Center (ARDEC), Picatinny Arsenal NJ.

**INSENSITIVE MUNITIONS BASELINE**

Baseline IM testing on the AT4 (C995) and AT4CS-RS (CA30) was performed in 2008 at Redstone Test Center (RTC), Redstone Arsenal, AL. The results showed that the predominant failure mode was the ignition of the propulsion system that launched the projectile. The warhead detonated upon impact, with the ground/barriers in most cases, and was likely armed in the other tests where the warhead was launched due to propellant ignition.

The IM test results relevant to this report are shown in table 1.

Table 1  
Select IM test results for AT4CS-RS

CS-RS	FCO	SCO	BI
Logistical	IV*		
Test 1		I*	
Test 2		I*	
Propellant			I*

AT4	FCO	SCO	BI
Logistical	III*		
Test 1		I*	
Test 2		I*	
Propellant			IV

FCO: fast cook-off
SCO: slow cook-off
Type VI: no reaction
Type V: burn
Type IV: deflagration
Type III: explosion
Type II: partial detonation
Type I: detonation

**Note:** The warhead launched and was likely to be armed.

## INITIAL CONCEPTS

Initial efforts focused on neutralizing the propulsion system through a variety of methods to venting the system. The focus of the program was shifted after the initial program planning because the test articles would not be available from the contractor to meet the program schedule.

The program was restructured to investigate packaging solutions that could be tested using systems on hand. Since the main failure mode of the system was launch of the warhead due to propellant ignition, the focus of the packaging solutions were to prevent/delay the warhead from leaving the packaging. Several packaging solutions were developed, including in-bore solutions, which required the removal of the front dust cover to position in-bore devices to prevent a launch.

The program was further refocused to develop packing-only solutions for the entire AT4 family of shoulder-launched munitions. This was driven by the lack of CA30s available for testing, and the desire to avoid any rework on munitions.

### **Insensitive Munitions Venting Concepts (December 2008 to June 2009)**

#### **Primer vent**

A region around the percussion cap would be machined away. Inserts in the barrel and/or propellant cup would retain the integrity of the system. The inserts would be made of steel components soldered together with low melting temperature eutectic alloys. During a thermal event, the inserts would lose integrity, allowing the propulsion system to vent out the enlarged primer hole.

#### **Melting threads**

Testing performed by the United Kingdom showed that the absence of a counter mass prevents the launch of the projectile. The counter mass is held in place with threads. Using low temperature eutectic alloys, a thread insert may be used to melt the threads to fail at elevated temperatures, allowing the counter mass to fall out of position, and permit the propellant gasses to vent during a reaction. The gap between the barrel wall and counter mass is minimal, requiring the counter mass to be moved to the end of the barrel and allow sufficient venting.

#### **Counter mass drain**

Plugs may be installed on the rear of the counter mass such that in a thermal event, the plugs will melt, allowing the saline solution in the counter mass to drain out. The counter mass functions as a heat sink that may isolate the plugs from thermal events.

#### **Counter mass thermite**

Thermite with a heat-sensitive igniter would be positioned on the counter mass in a manner to burn through it, allowing the saline solution to drain out.

#### **Counter mass rupture**

An out-gassing material inside the cartridge case would be used to build sufficient pressure to rupture the counter mass container in a manner similar to a ball or grenade style fire extinguisher.

### **Counter mass flood**

The saline solution in the counter mass would be used to flood the propellant. The propellant cup would be made of a low melting temperature ionomer resin to allow the intrusion of the saline solution. The counter mass functions as a heat sink, which would isolate any plugs from thermal events.

### **Barrel crush**

A device in the packaging would be used to crush the barrel to provide venting to the propulsion system. The power source, electric, chemical, mechanical, and thermal for the device would need to last twenty years in storage.

### **Barrel burn**

Thermite with a heat sensitive igniter would be positioned on the barrel in order to vent the barrel. This would accelerate the reaction to thermal stimuli, but would also reduce the severity.

### **Drill**

A device in the packaging may be used to pierce (bullet) or drill through the barrel to allow venting. The device would require a chemical (propellant) or thermal (boiling liquid) power source.

### **External**

A device in the packaging connected to the counter mass and/or propellant cup with tubing may use compressed gas to force liquid out of the counter mass and/or force liquid into the propellant cup. A pin held in place with low melting point material and pushed by the spring, when exposed to a thermal event, would be released and allowed to puncture the seal of a compressed gas cartridge, allowing the device to function.

### **Nose down**

The pallet may incorporate a sturdy steel plate on which boxes of AT4s are stacked with the nose facing down. Should the AT4s be triggered by an unplanned stimulus, the AT4 would be launched into the pallet, damaging the fuze before it is able to arm. The pallet of boxes would need a standoff and be reinforced such that the initiation of one AT4 does not compromise the IM features of the pallet. These pallets may not have anything stacked on top of them because the back blast would throw off the top pallet.

### **Melting fuze component**

The fuze of the projectile may incorporate an electrical wire or solder connection that has been replaced with a low melting point alloy. When the AT4 is exposed to high temperatures, the low melting point alloy may melt, breaking the electrical circuit, preventing the warhead from arming.

## **Insensitive Munitions In-bore Concepts (November 2009)**

### Sock

The sock concept consists of a sock or stocking made of Kevlar gathered around a fixture positioned at the end of the barrel. During initiation of the propellant, the projectile would enter the sock and carry the sock with it. The sock would prevent the fins from opening, and provide drag, to reduce the distance the projectile would travel. The sock could also be used to direct the projectile into the ground before arming.

The pressure piston of the S&A was misinterpreted as a button that the fin opening piston would depress, with the intention that preventing the fins from opening would prevent the warhead from arming. As a result, the concept was fundamentally flawed based on this misinterpretation, although it could have still potentially restricted the range of the projectile (fig. 5).

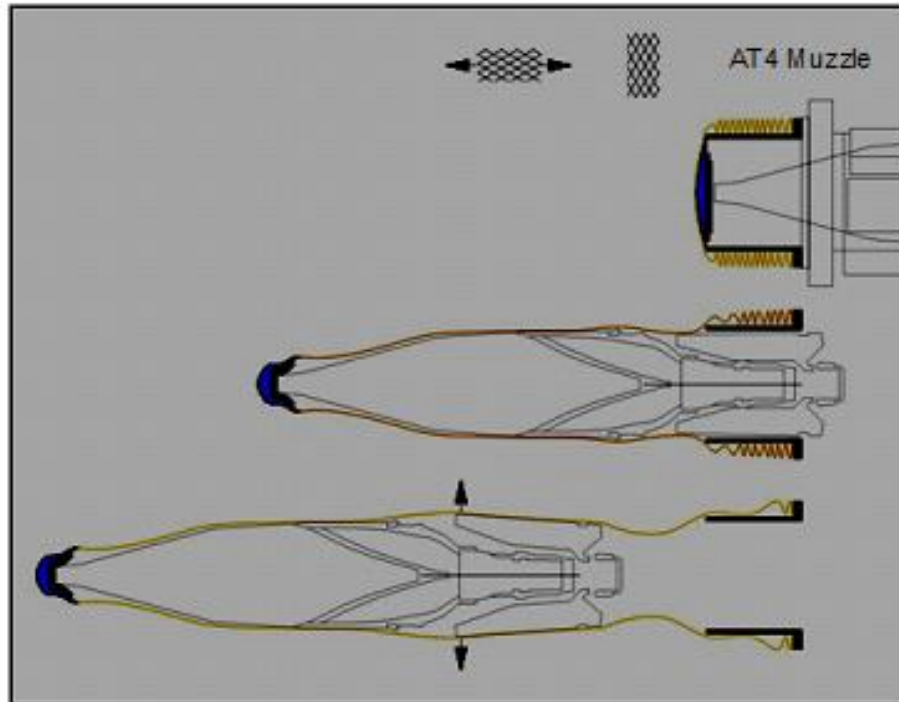

Figure 5  
Sock concept

### Cutting wedge

A long narrow wedge with sharp faces, positioned between the nose of the projectile and the barrel, could use the forward movement of the projectile to cut through the wall of the barrel, providing venting (fig. 6).

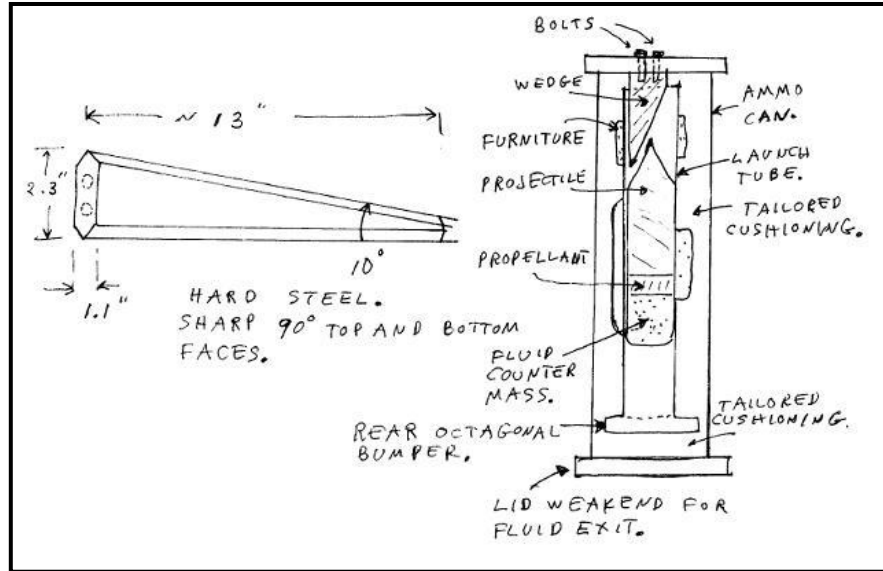

Figure 6  
Cutting wedge concept

**Locking wedge.** A steel tube could be modified such that the wall thickness at one end tapers gradually to a fine edge, and axial cuts divide the end into a series of wedges that fit inside the circumference of the barrel. This array of wedges may be positioned in the barrel, nearly touching the projectile. Any forward movement of the projectile would expand these wedges outward against the barrel, locking the projectile in place or rupturing the barrel. This locking wedge would deprive the fuze of the inertial stimuli required to arm the fuze. It would also either stop the projectile from leaving the barrel, or greatly reduce its velocity (fig. 7).

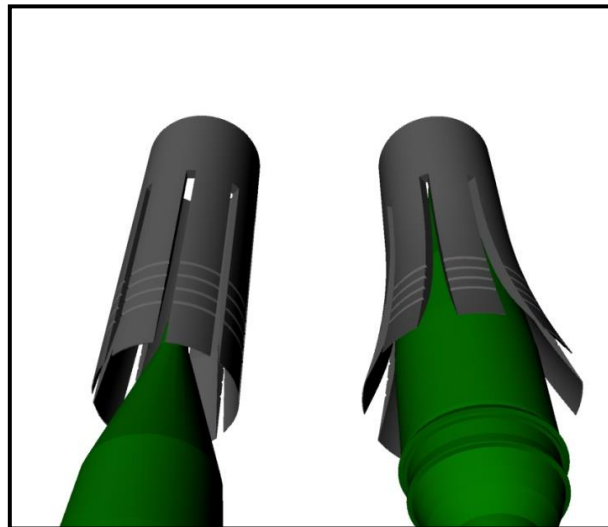

Figure 7  
Locking wedge concept

**Deflector.** A heavy steel fixture located at the end of the barrel, with a strike face at 45 deg, would provide a surface for the warhead to impact and damage the piezoelectric crystal used by the fuze, to sense impact (fig. 8).



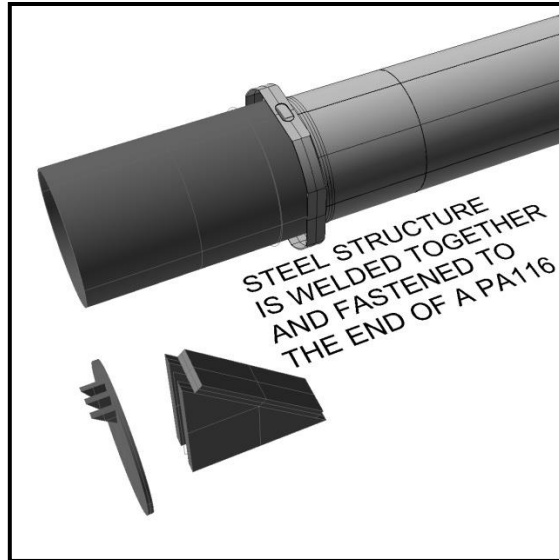

Figure 8  
Deflector concept

**Guillotine.** A steel fixture located in front of the barrel would use momentum from the impact of the projectile to cause it to spin and impact the projectile in the fuze region to damage the fuze, such that the detonator will no longer be able to rotate into an in-line position and initiate the warhead (fig. 9).

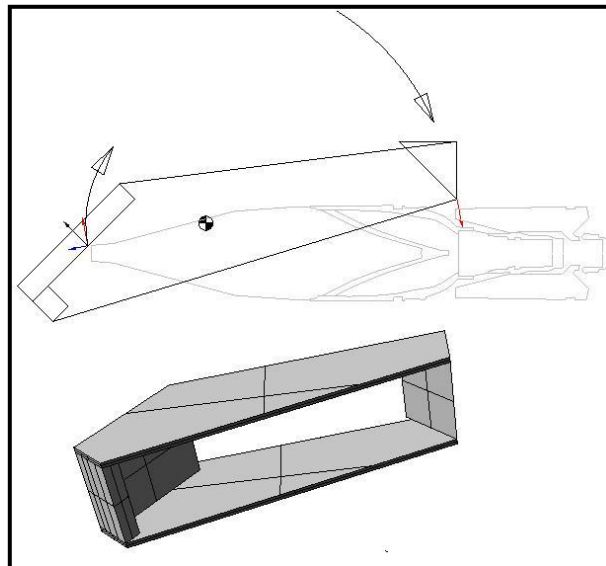

Figure 9  
Guillotine concept

### INSENSITIVE MUNITIONS PACKAGING CONCEPTS

Down selection yielded four packaging concepts, including one complete solution targeting a Type V reaction and three concepts targeting a partial solution with a lower cost.

### Ruggedized Container

The current wooden box for the AT4CS-RS is 40-in. long, as provided by Saab Dynamics. Standard pallet sizes for the U.S. Army are up to 54-in. long. Enlarging the packaging would allow up to 14 in. of space to design new packaging that will contain the projectile within it should it launch. This would provide a Type V reaction to SCO, FCO, and BI. The kinetic energy of the projectile could be transferred to the launch tube, the packaging, and the pallet (fig. 10).

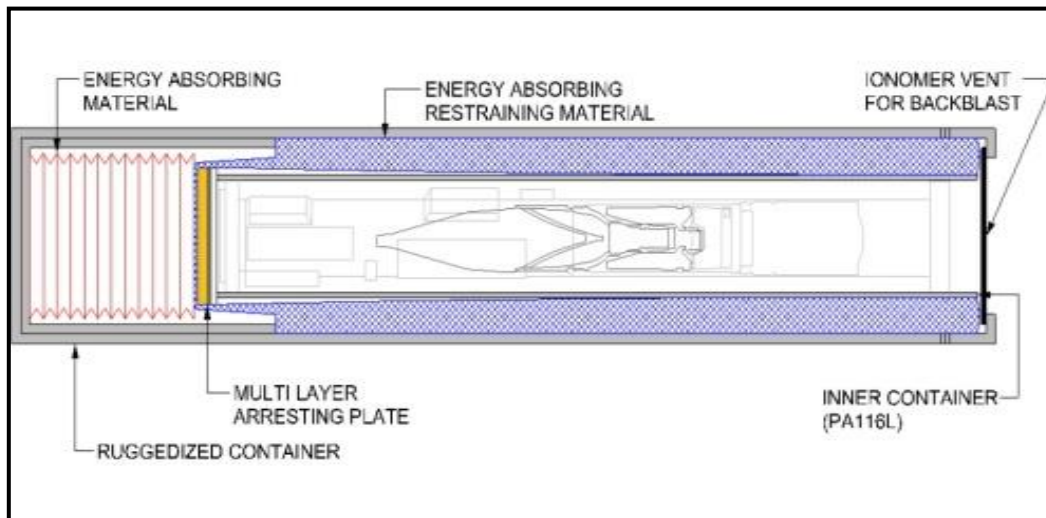

Figure 10  
Early concept drawing (ruggedized container)

The modeling and simulation (M&S) showed that a 1/2-in. mild steel plate inserted in front of the launch tube would be sufficient to stop the projectile if properly restrained (fig. 11).

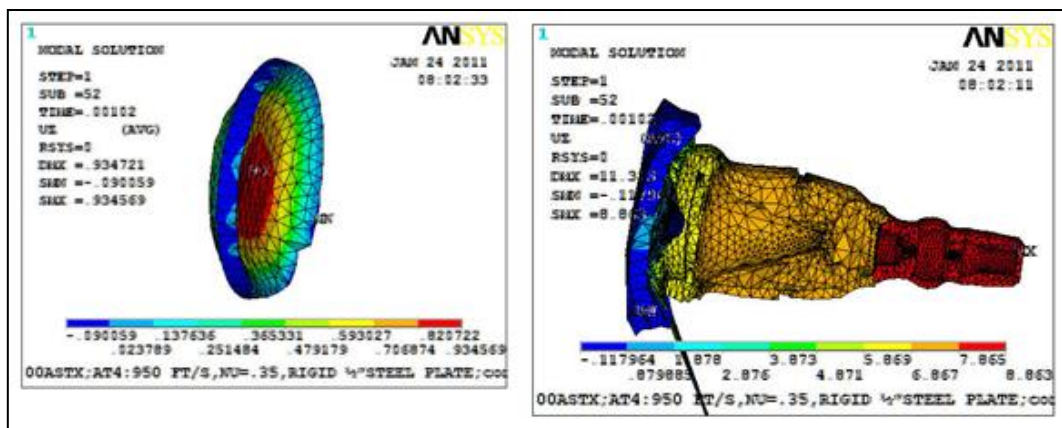

Figure 11  
M&S (ruggedized container)

Steel cable braided into the strike face, around the weapon, and fastened to the container could transfer the kinetic energy from the projectile into the strike face, through the cable, causing the braid to constrict around the warhead, transferring the kinetic energy to both the weapon and the container. The container could be interlocked and strapped to other containers to minimize movement (figs. 12 and 13).

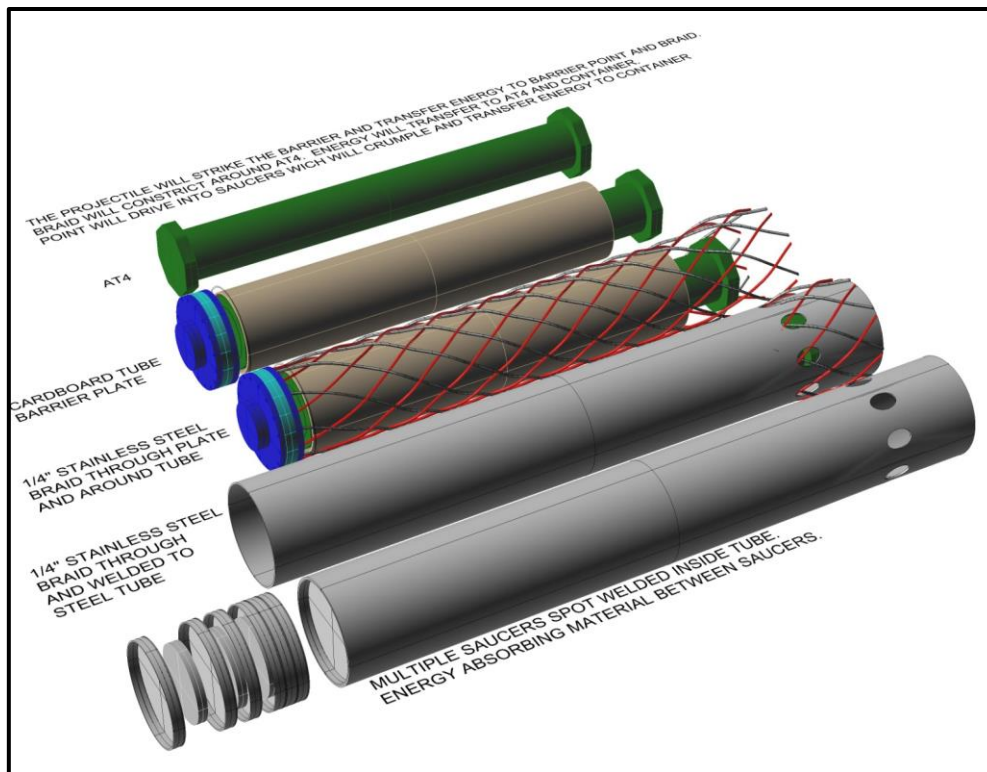

Figure 12  
Internal design (ruggedized container)

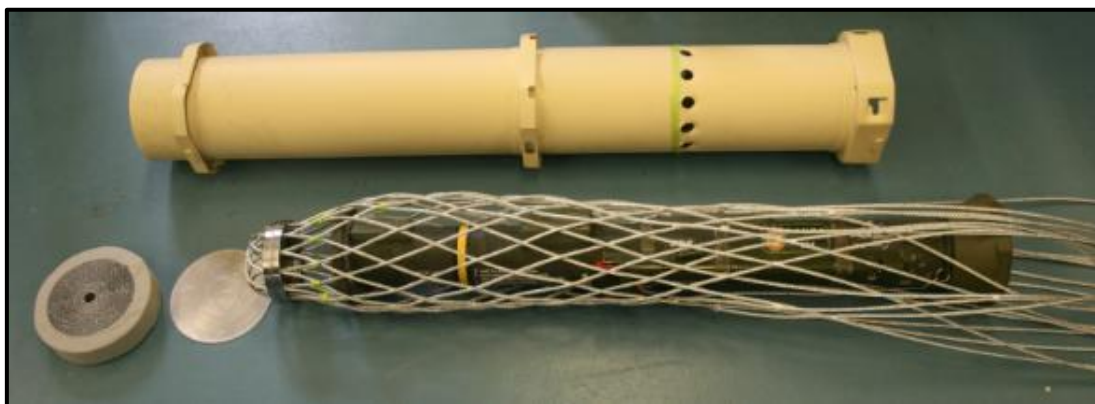

Figure 13  
Steel cabled braid around launcher (ruggedized container)

### Deflection Plate

The fuze of the projectile uses pressure and inertia to trigger the rotation of the detonator into an in-line position. A piezoelectric crystal is used to provide the electric impulse to trigger the detonator on impact.

Positioning a strike face at 45 deg in front of the barrel, such that during a launch the projectile, while impacting the strike face, may cause sufficient damage to the piezoelectric crystal or the fuze to prevent proper operation of the fuze. This will not provide a complete IM solution, but would provide a Type IV reaction to SCO, FCO, and BI (figs. 14 and 15).

Approved for public release; distribution is unlimited.

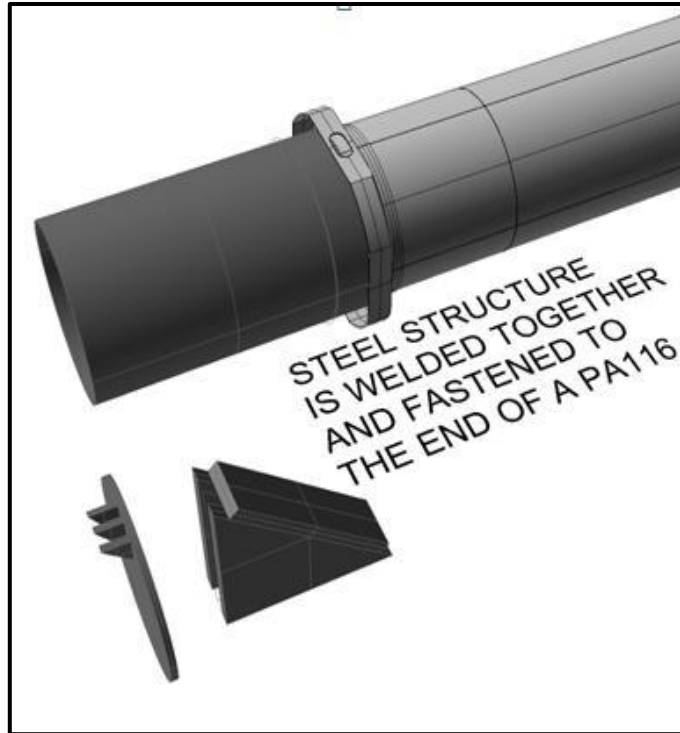

Figure 14  
Deflection plate concept

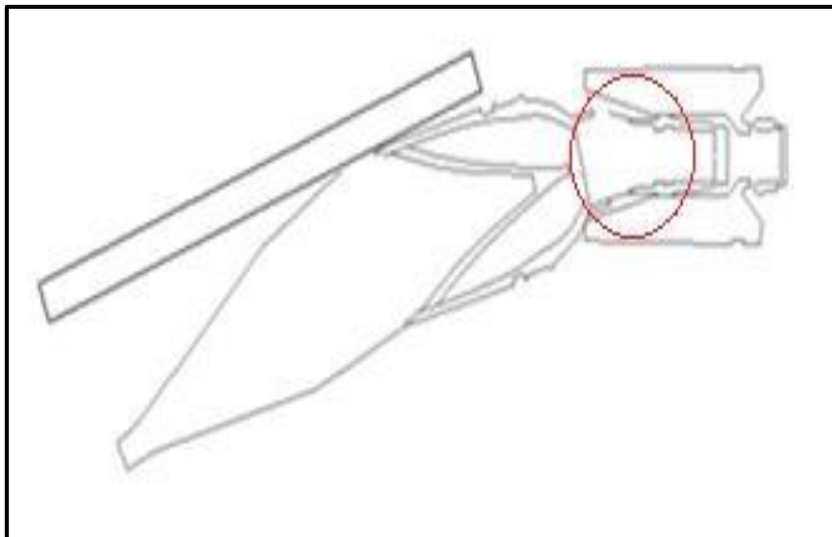

Figure 15  
Location of damage to fuze

The M&S performed on the projectile, striking a 1/2-in. steel plate, shows that the yield strength of the metal parts around the fuze and booster charge are exceeded during the impact (fig. 16).

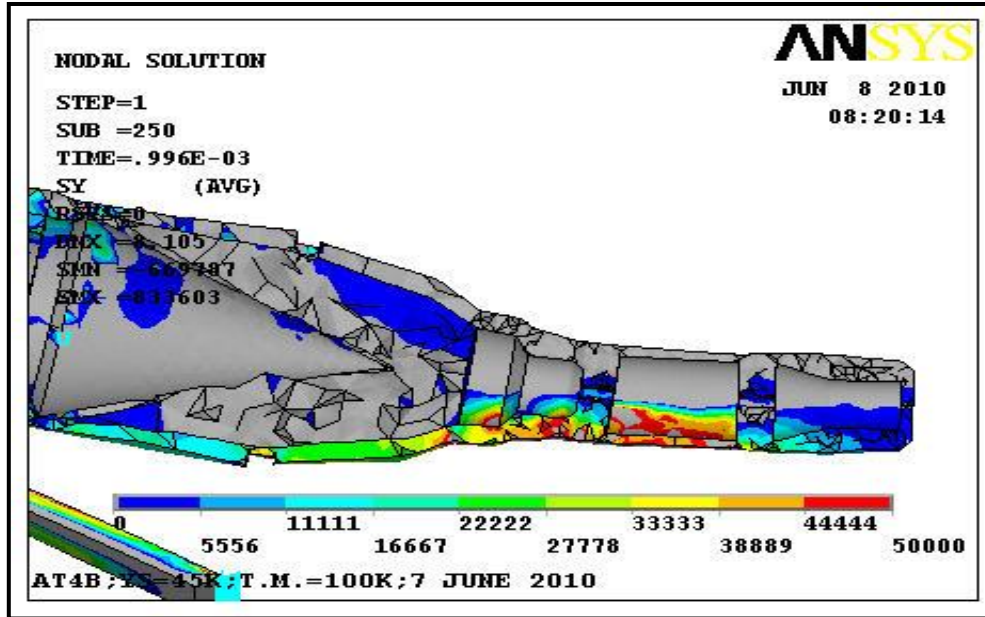

Figure 16  
 M&S on projectile

The packaging may be changed such that a single round is stored in each box, with a steel plate at a 45-deg angle to the projectile, at the front of the launcher. In the case of a FCO, framing may be needed to retain structural integrity. Alternatively, the AT4 may be stored in a metal container with the steel plate inside or welded outside. While this would only provide a Type IV reaction, the design could be a very economical solution (figs. 17 through 19).

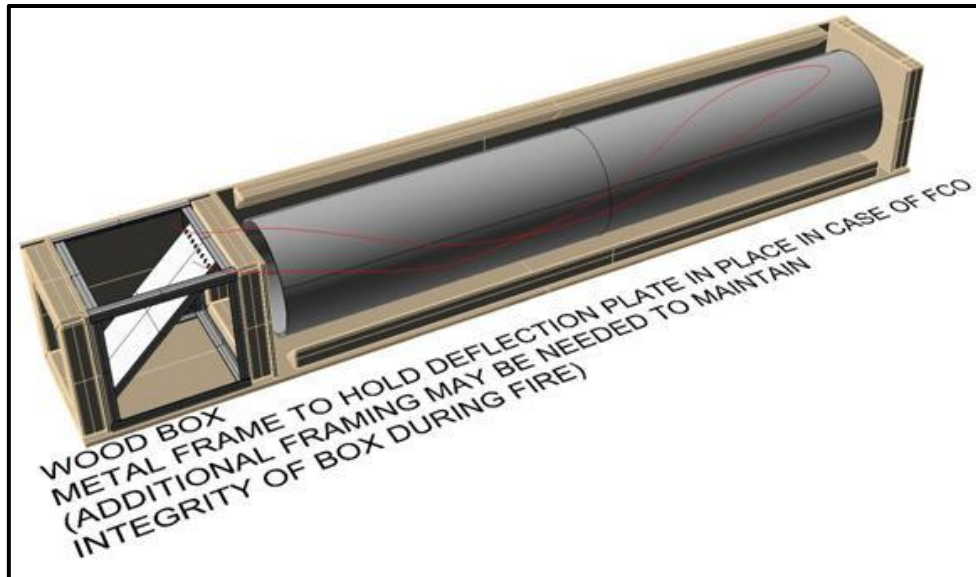

Figure 17  
 Deflection plate packaging concept



Figure 18  
Deflection plate packaging prototype



Figure 19  
Deflection plate size comparison

The rolled homogeneous armor (RHA) steel plates were fabricated in three thicknesses to determine feasibility. A 1-in. steel plate was fabricated for the first test, and 1.5 and 0.5-in. plates were fabricated for the second test. Testing would bracket the required thickness to achieve a Type IV reaction.

### Ballistic Sleeve

As a mitigation concept, if the ruggedized container and the deflection plate concepts fail, the ballistic sleeve addresses the BI. Slowing down the bullet with a steel and plastic sleeve may reduce the energy of the projectile sufficiently to prevent ignition of the propellant.

It was determined that a 6-in. long liner would provide adequate coverage to the propellant cup. A 1/2-in. thick outer steel liner, with a high-density polyethylene (HDPE) inner liner, would add 20 lb to the weight of the packaged round and was determined to be the heaviest acceptable solution (figs. 20 and 21).

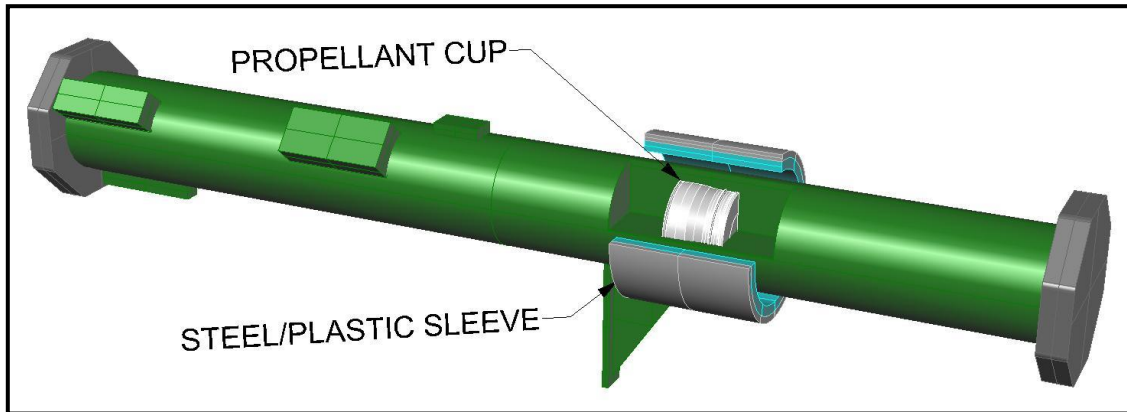

Figure 20  
Ballistic sleeve concept

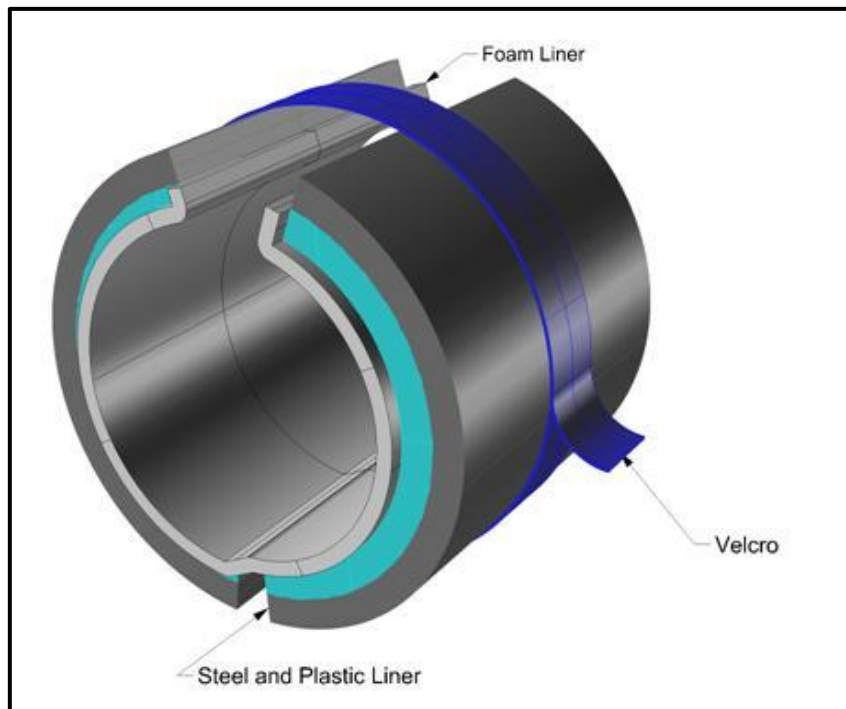

Figure 21  
Ballistic sleeve design

## Heat Mitigation

As an additional mitigation concept, should the primary concepts fail, the heat mitigation concept attempts to delay the reaction during FCO to provide additional time for the fire to burn out or for personnel to evacuate.

The heat of vaporization of water is 540 times greater than its specific heat. Additionally, water will maintain a temperature of 100°C until it has vaporized, providing cooling until it has completely boiled away. Using water in the form of a hydrogel, a liner of water may be wrapped around the weapon to provide cooling during a FCO (fig. 22).

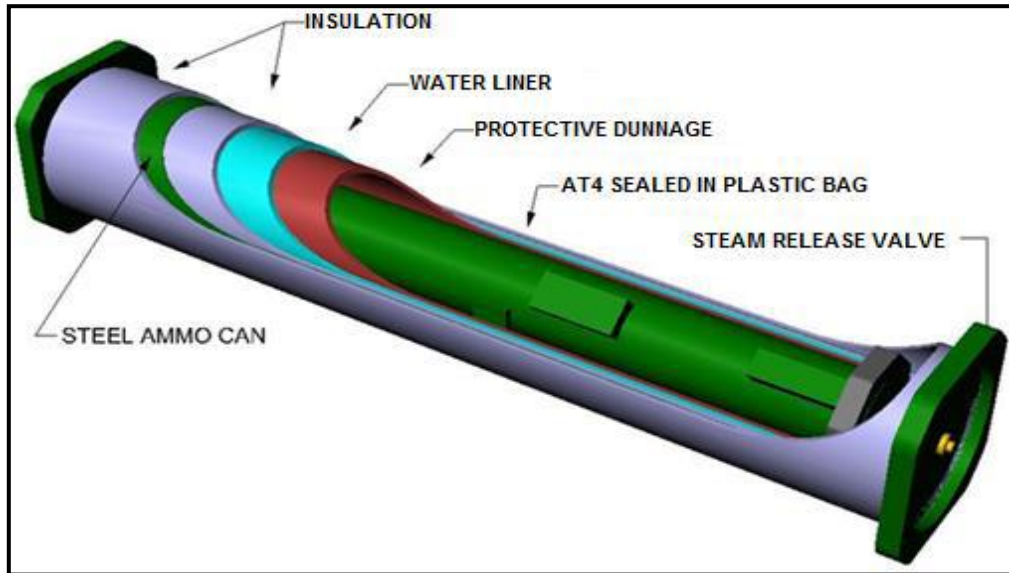

Figure 22  
Heat mitigation concept

The M&S shows the temperature of the propellant inside of an AT4, packaged inside a metal can, and heated during a FCO scenario. It shows that a 1/4-in. common commercial insulation alone delays the time it takes the propellant to reach its ignition point of 130°C, from 7 to 16 min. The water is expected to further delay this time significantly. However, due to the complexity of modeling evaporating vapor, M&S was not performed with a hydrogel wrapped AT4 (fig. 23).



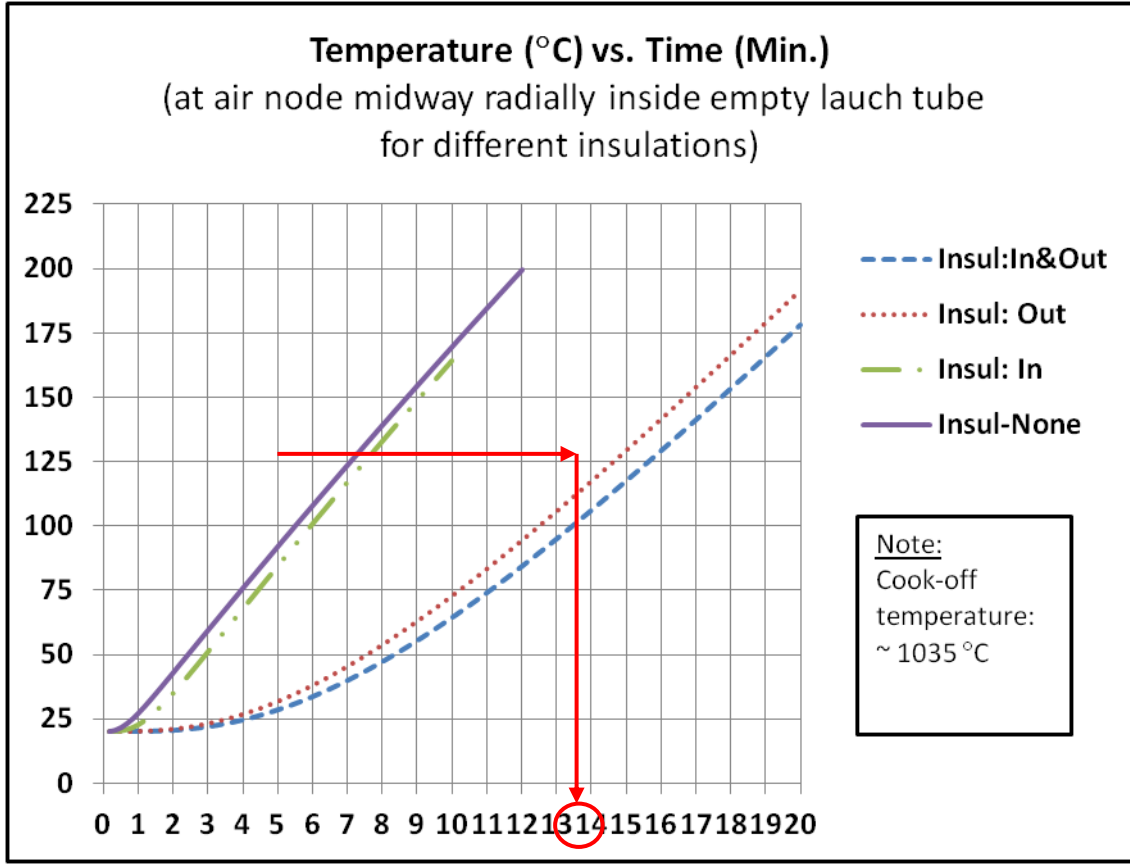

Figure 23  
Simulation of predicted FCO results

In place of a metal ammunition can, a 16-gauge steel conduit was obtained. Insulation was bonded to both the inside and outside. While the inside layer provides little insulation, it is used to allow capillary action to carry water up the walls of the can to provide additional cooling. A layer of foil tape was placed over both layers to provide protection during handling. A 1/2-in. diameter hole in the cap was covered with eutectic to provide venting for the steam (figs. 24 through 26).

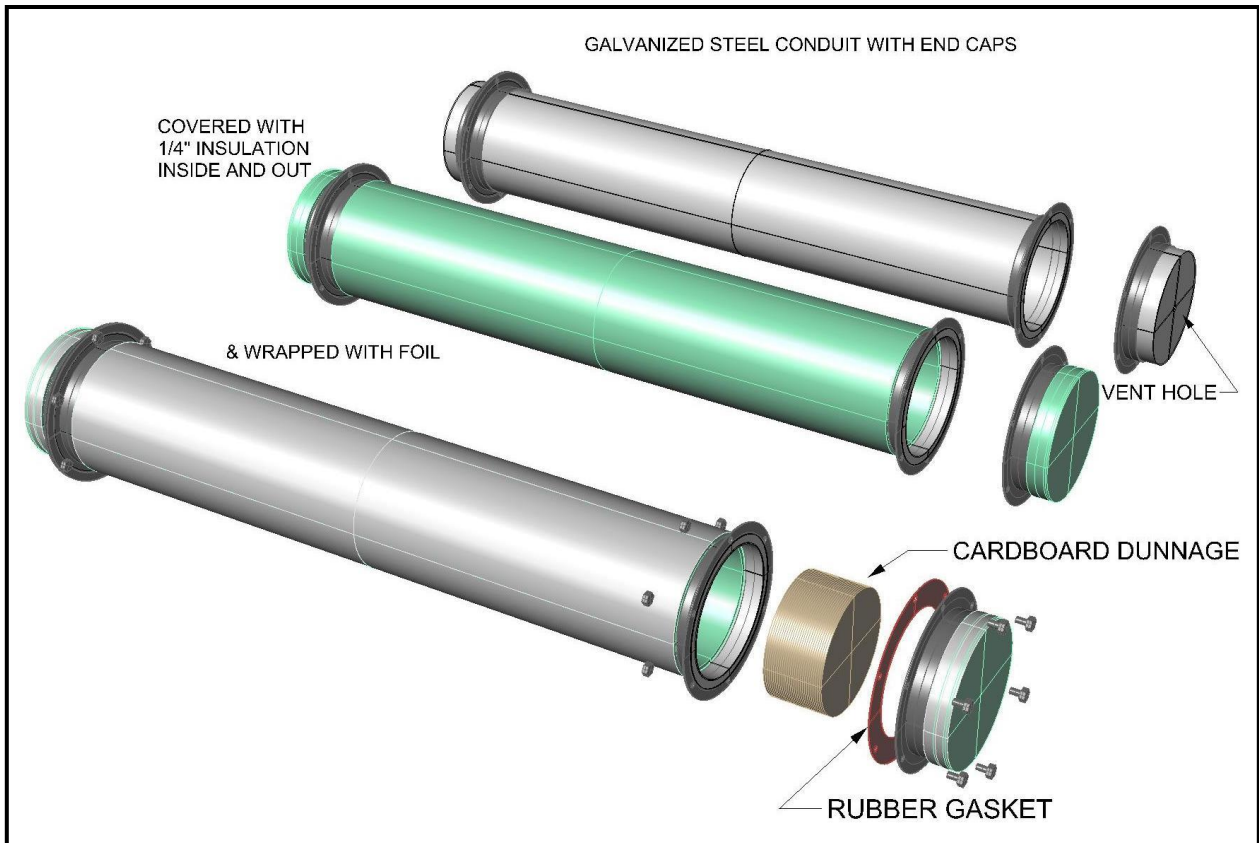

Figure 24  
Heat mitigation concept design

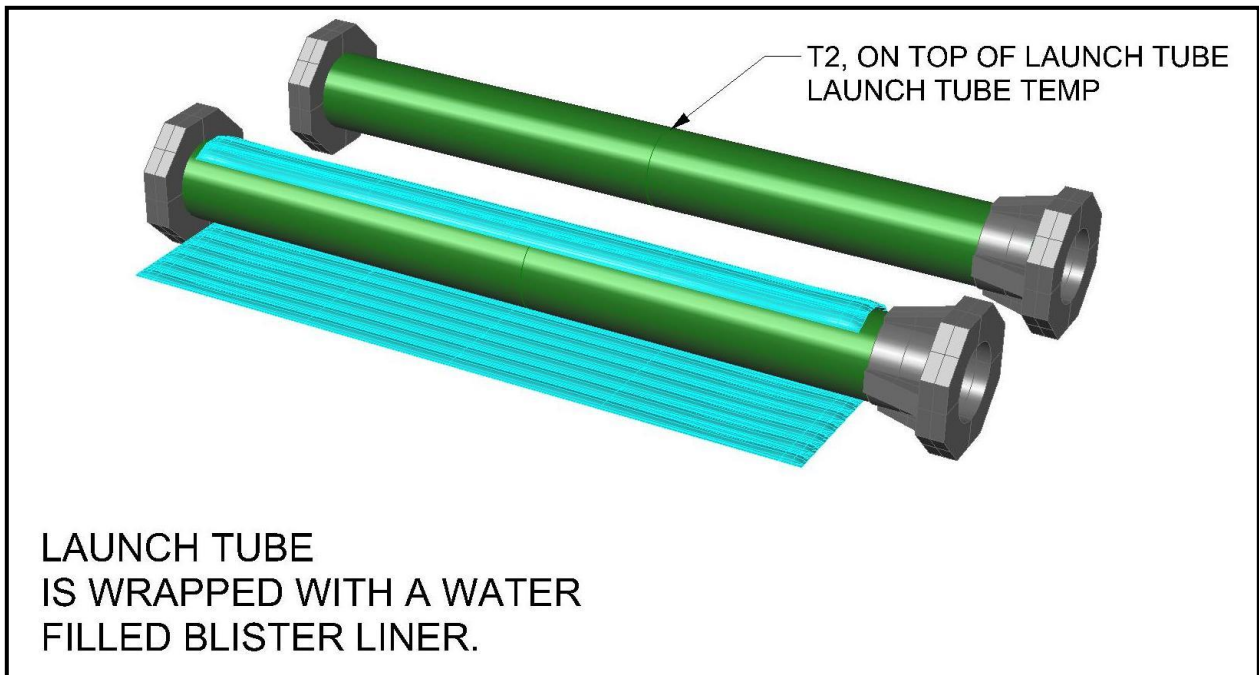

Figure 25  
Water filled blister liner

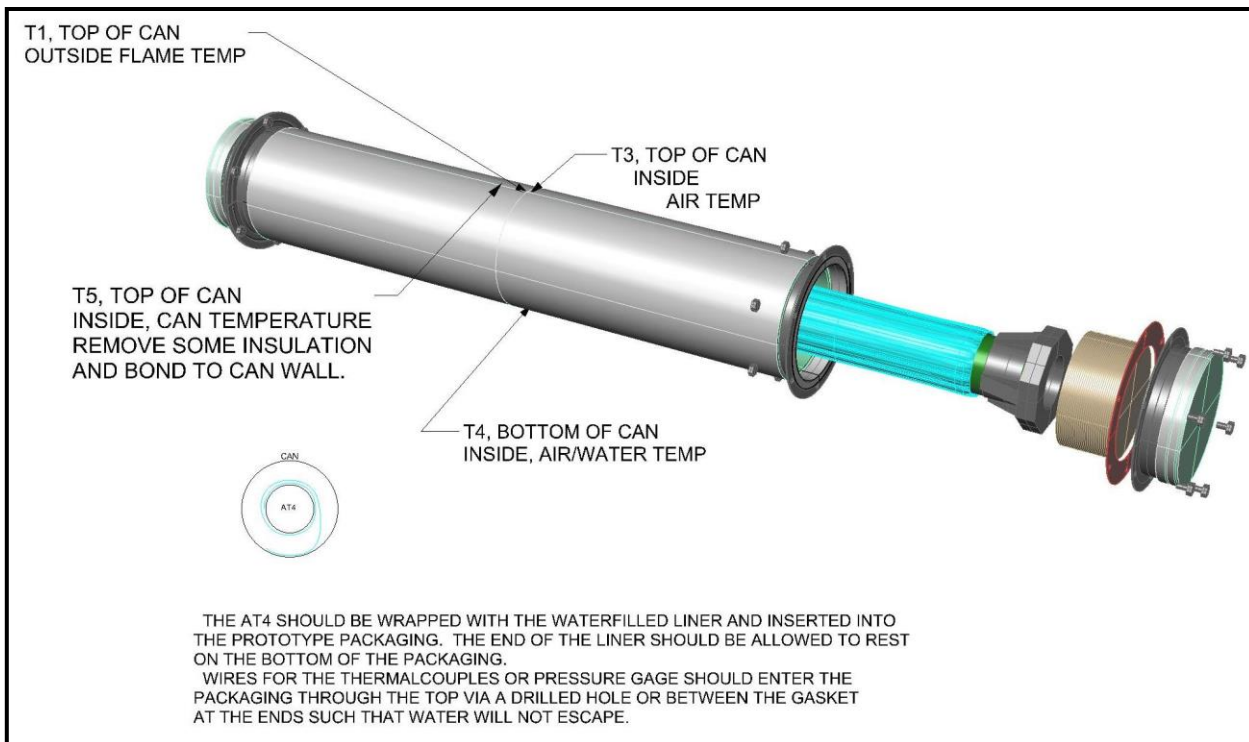

Figure 26  
Heat mitigation packaging

The prototype liner for the first FCO used a barrier bag made of a foil/plastic barrier material. It was found that the material was not sufficiently rugged and started to leak during handling. However, the foil did not burn.

For the second test, the prototype liner was revised. A more durable plastic-only material was used in order to avoid leaking. A single layer of the foil/plastic barrier material was placed under the liner and wrapped around the AT4 with the liner. Duct tape was then used to gather each end of the liner close to the barrel of the AT4 (fig. 27).



Figure 27  
Blister liner enclosed with sealed foil/plastic barrier material

This allows the foil to retain the water as it escapes the plastic liner. Additionally, the foil forms a "snail shell," where water vapor travels from the cool inner layers to the hotter outer layers. This allows the water to carry heat away from the inside of the snail shell in the most efficient way possible (fig. 28).

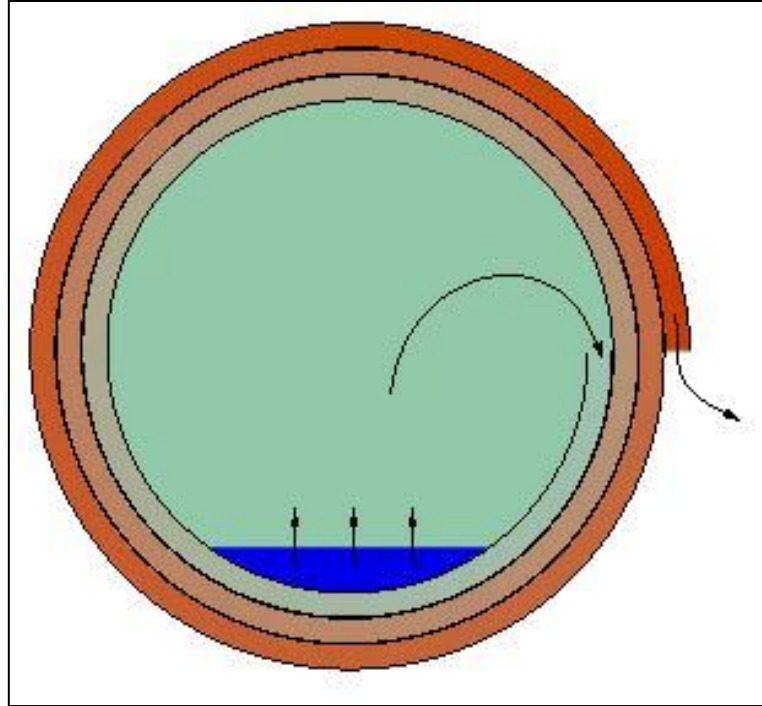

Figure 28  
Snail shell

## PRELIMINARY TESTING

### Ballistic Sleeve

The ballistic sleeve was tested at ARDEC on August 8, 2011. Engineering testing was performed in accordance with MIL-STD-2105, Revision B (single bullet) due to the capability of the test facility. An AT4CS-TW trainer was used because an inert warhead is required for testing at ARDEC.

The total thickness of the liner is 1 in., with a strike face of 1/4, 3/8, or 1/2-in. RHA steel and the remainder made of HDPE plastic. The 3/8-in. steel sleeve was tested first, with the 1/4 and 1/2-in. sleeves available to be tested based on the results of the first test. The test stand was set up inside a steel "cave" with sandbags to catch the projectile if it launched (fig. 29). The test plan is shown in appendix A.

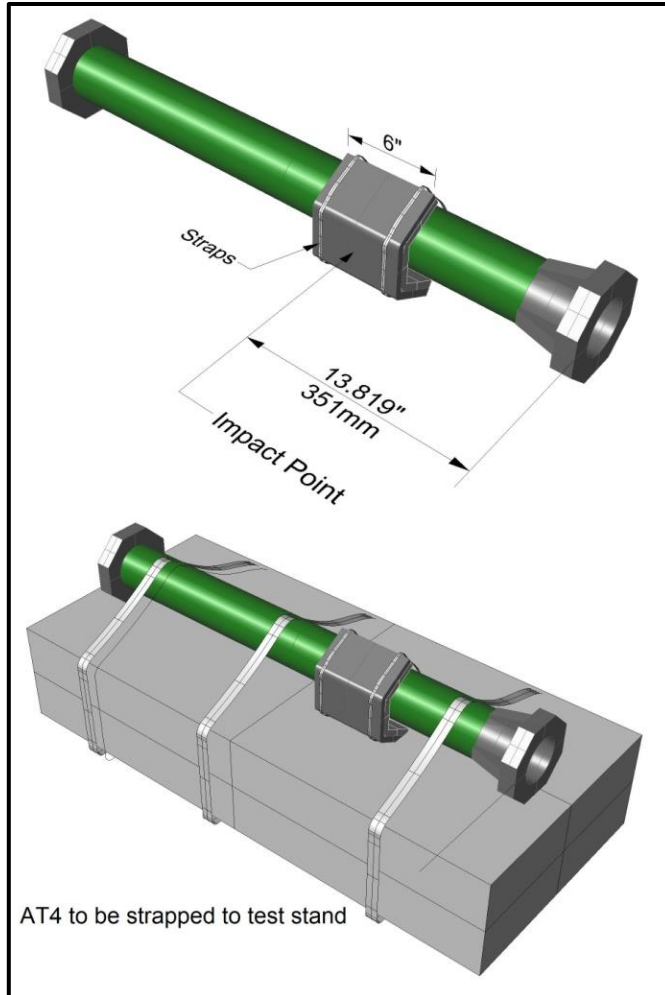

Figure 29  
Ballistic sleeve test setup

### Test Number One – Three-eighths Inch Steel and High-density Polyethylene

The propellant ignited and the weapon functioned. The slow motion camera failed to function. Propellant gasses from the ruptured barrel propelled the liner into the velocity screen stands, damaging them. The liner was considered to have failed, so the thicker 1/2-in. steel liner was selected to be tested next.

### Test Number Two – Half-inch Steel and High-density Polyethylene

The propellant ignited 200 ms after the impact of the bullet, and the projectile launched at 60% of normal velocity. The liner was propelled and struck the camera enclosure.

The concept was determined to be a failure.

## Heat Mitigation

The FCO test was performed at ARDEC on November 10 and 28, 2011. Based on historic data, the burn pans were filled with sufficient fuel to meet the required burn times. However, the burn times required were much longer than previous tests performed at ARDEC, and it was falsely assumed that the burn time was directly related to fuel depth. Burn times were shorter than desired, but sufficient data was obtained to determine that the concept is feasible. However, success with other concepts alleviated the need to pursue this concept. Burn times of 17 and 22 min were achieved with no reaction. Test reports may be found in appendices B and C.

### Test Number One: Observations

- The liner was made of a foil/plastic barrier material.
- Upon opening the containers, the bumpers had mostly melted away and everything was wet.
- Removing the liner and the round from the container showed that the outside layers of the liner were melted and burned; however, the inner layers of the liner were not melted and pools of water were trapped between the layers.
- The AT4, other than the ends, showed no sign of excessive heat. Parts were not melted and stickers were intact.
- The results were inconclusive on whether the propellant vented or failed to react.

### Test Number Two: Observations

- Test results were similar to test no. 1.
- The results were also inconclusive on whether the propellant vented or failed to react.
- The round was cut open to look inside and determine whether or not a reaction had occurred. The propellant cup and the foam inserts were still intact. The foam was tested, and it was found that the melting point was below 230°F.

Figure 30 shows four thermal couples: (1) the temperature of the FCO flames, (2) the temperature of the inside of the can above the liner, (3) the inside of the can below the liner which would become wet when the liner bursts, and (4) the top surface of the AT4 inside the liner, that should be the hottest location on the AT4 since water will not remain in this location.

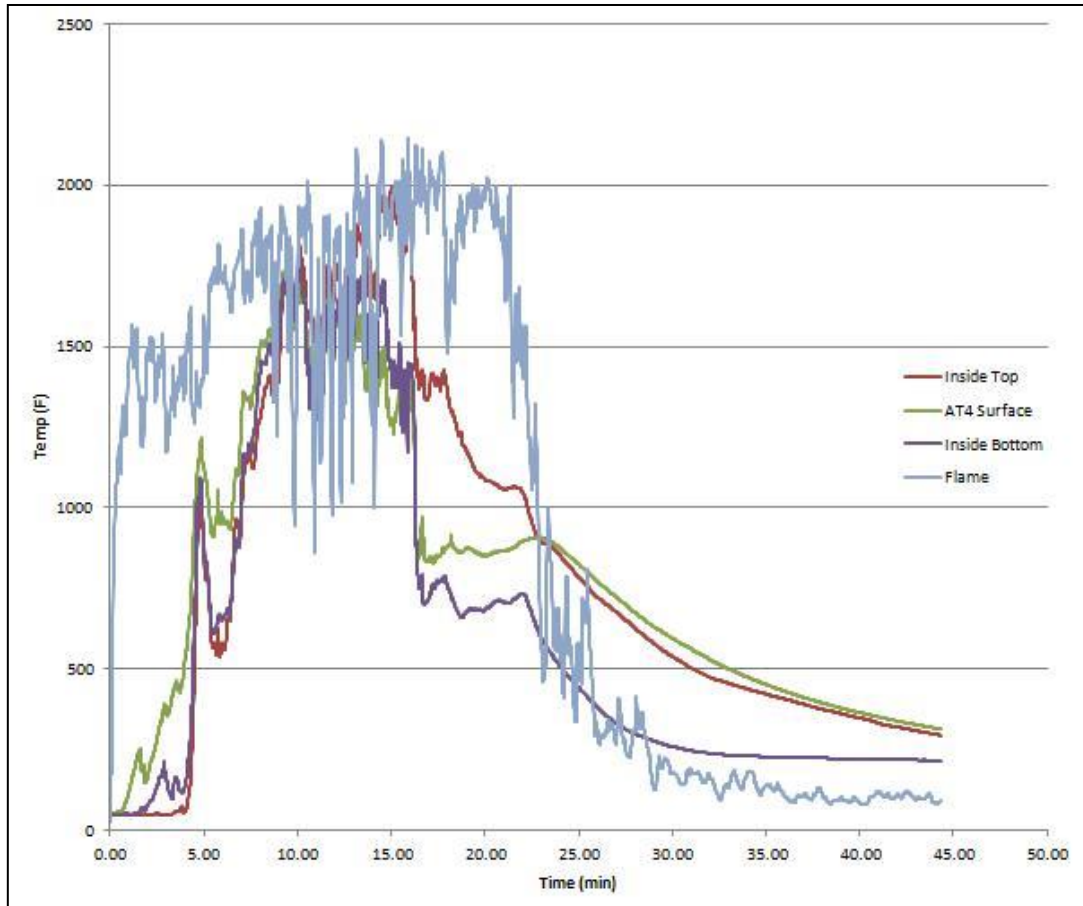

Figure 30  
Four thermal couples

The drop in internal temperature at 5 min was most likely caused by the water liner blisters in contact with the bottom of the can boiling and bursting. Looking at the inside bottom temperature, more drops can be seen at 12 and 15 min as more blisters reached a boil and burst. At 17 min, there is a sudden drop in temperature similar to the drop at 6 min, and the temperatures are maintained for the duration of the test. The drop in temperature was assumed to be caused by many blisters bursting. As the flame cools, the inside bottom of the can immediately cools to 212°F, the boiling point of water.

Observations have shown most of the water liner blisters did not burst until after 15 min, and water remained in the container even after the container remained in the hot burn pit overnight. Additionally, the integrity of the foam showed the propellant remained at a temperature somewhere below 230°F. These factors indicate the design could have achieved a much longer burn time than the 22 min the test site was able to provide.

### Ruggedized Container and Deflection Plate – Initial Testing

Testing was performed at RTC on August 16 and 17, 2011 (see app. E for trip report). Both the ruggedized container and deflection plate were tested simultaneously using the same setup because the concepts essentially worked in a similar fashion to one another, to attempt to defeat the warhead after a launch caused by stimuli initiating the propellant.

Packaging prototypes were loaded with M136 AT4s and the rounds were remotely triggered to observe how well the packaging mitigated the IM threat.

To remotely trigger the AT4s, the firing mechanism was modified. The angled surface on the back of the firing pin was filed flat. The plastic housing around the firing pin had a hole drilled through to allow access to the back of the firing pin. A short rod was inserted through the hole to make contact with the back of the firing pin. Taped to the back of the rod was a detonator that would propel the rod into the firing pin and the firing pin into the percussion cap.

The steel box was open, facing the test stand, and designed as a target area to contain the effects of the warhead. This was centered in front of a concrete wall, which was approximately 10-ft high and 40-ft wide. An even larger steel cage was behind this wall, but performed no noticeable function in the testing besides a point of reference and possible barrier to contain fragments (fig. 31).

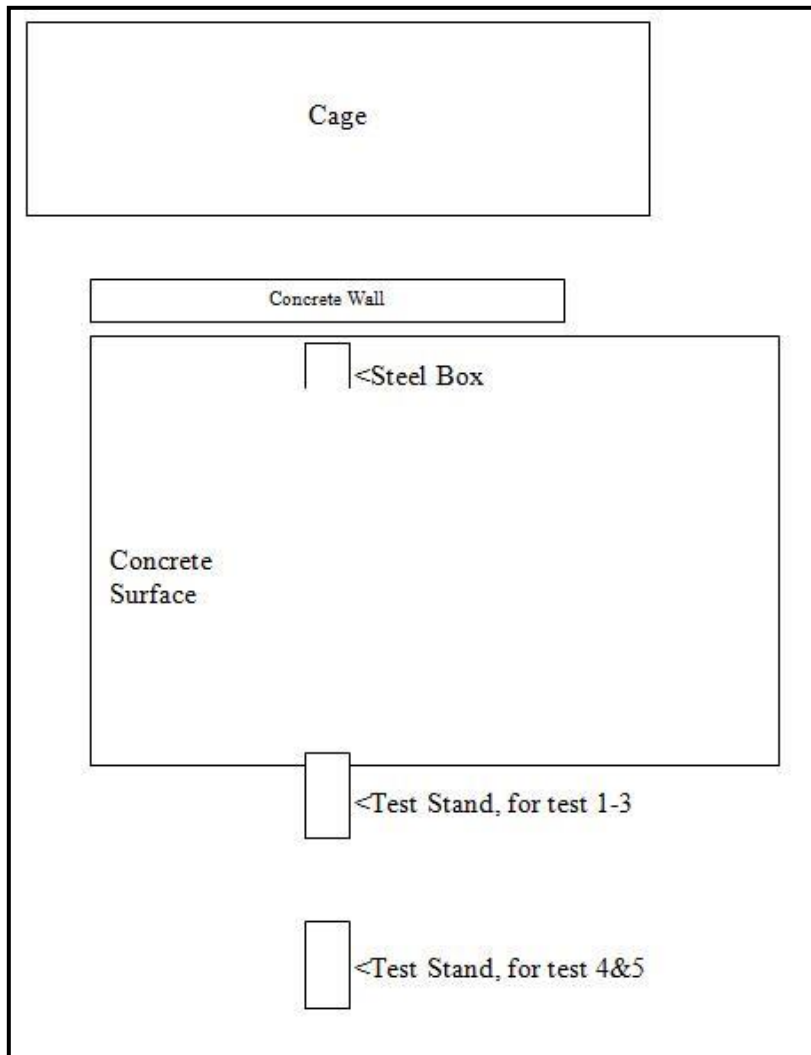

Figure 31  
Test setup at RTC

Figure 32 shows the range setup from the point of view of standing behind the test stand used for the deflection plate concept (test nos. 4 and 5).





Figure 32  
Test setup for deflection plate tests

Test nos. 1 through 3 were for the different variations of the ruggedized container and test nos. 4 and 5 were for the deflection plate. Due to availability, the original M136 AT4 was used in place of the M136A1 AT4CS-RS for the concept testing. The AT4CS-RS assets available for testing were designated to be used during official IM tests. For reference, the AT4 has a velocity of 290 m/s and AT4CS RS has a velocity of 220 m/s. The test report may be found in appendix D.

### Ruggedized Container

The following are observations of each of the three tests performed on the ruggedized container.

**Test no. 1** – ruggedized container, PA116, 1/2-in. strike face, six pairs of cables.

## UNCLASSIFIED

- Dents were found at 12 locations around the circumference of the container, indicating the nose cone "splashed" on impact with the plate and the debris impacted with the can in the 12 gaps between the cables. The debris most likely damaged the cables. Only small fragments less than 1/4-in. wide were recovered from the nose cone.
- The container bottom was ripped free at the weld line and was not found.
- The container lid was thrown by the back blast and was not found.
- The steel plate was thrown from the container.
- The steel plate showed a large dent from the tip of the nose cone, as well as aluminum residue.
- The projectile was launched out from the container.
- The container followed the projectile at a high velocity.
- The launch tube was ejected out of the container, but remained mostly intact.
- The warhead was broken apart. The copper liner and chunks of explosive were ejected forward and impacted the concrete wall.
- The warhead base/fin assembly and chunks of explosives impacted the steel box.
- On impact, explosive dust was propelled out of the warhead base to the left. A small amount of this dust ignited and burned.
- The fuze was in the 0-deg position (unarmed). The small booster charge did not burn and was found in the fin assembly.
- No detonation, explosion or deflagration occurred, just burning.
- Projectile velocity: 156 m/s (290 baseline).

**Test no. 2** – ruggedized container, PA116, 1/2-in. strike face, 12 pairs of cables, no lid.

- Results were very similar to test no. 1.
- The copper liner impacted steel box.
- The launch tube moved less than 10 ft, while the container almost hit the metal box.
- The fuze was in the 10-deg position (unarmed). The small booster charge did not burn and was found in the fin assembly.
- No detonation, explosion or deflagration occurred, just burning.
- Measured projectile velocity: 121 m/s (290 baseline).

**Test no. 3** – ruggedized container, PA116L, 1/2-in. strike face, 1/2-in. ring, 12 pairs of cables, 2-in. honeycomb.

- Again, similar results to test no. 2.
- The warhead was shredded as it left the container. A cloud of explosive powder was seen.
- Explosive chunks and dust trails were left on the ground.
- As the fin assembly impacted the steel box, there was a detonation of the detonator and/or small booster charge.
- A line of dents in the steel box showed where shrapnel from fuze burst in a radial plane. The most likely cause was detonation/explosion of the detonator and/or small booster pellet (1.5 g).

Figures 33 through 35 are screenshots extracted from high-speed video that was taken during testing:

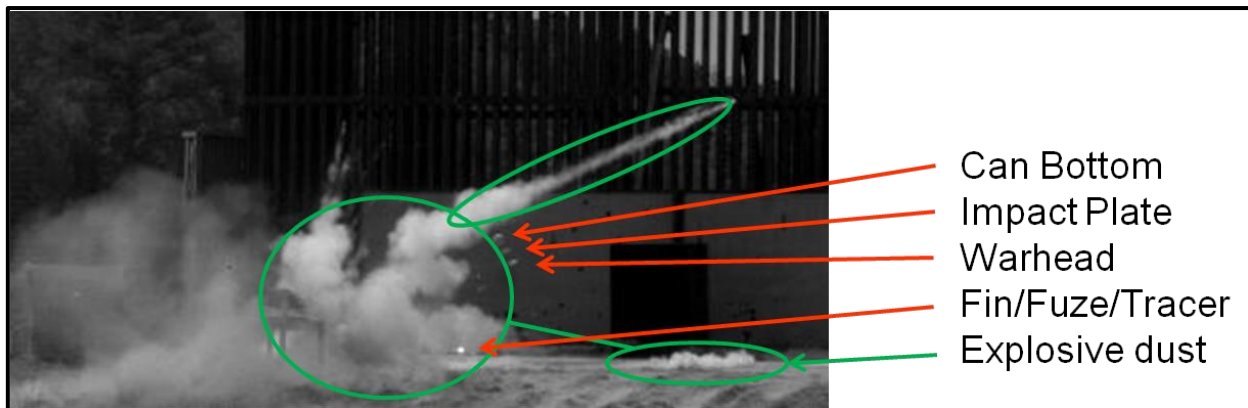

Figure 33  
Screenshot from video of test no. 3 (ruggedized container), reaction results

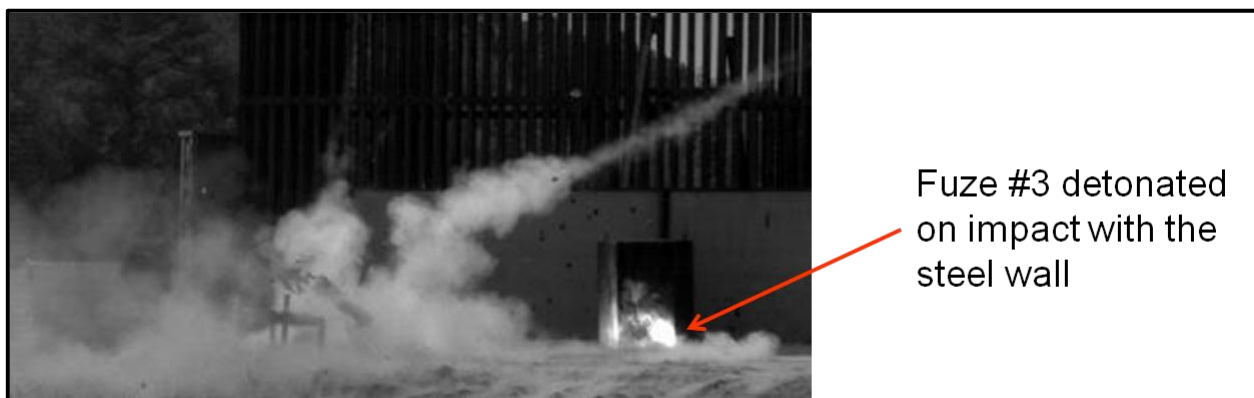

Figure 34  
Screenshot from video of test no. 3 (ruggedized container), fuze detonation



Figure 35  
Test no. 3 side view (ruggedized container)

This side view of test no. 3 depicts a white cloud of pulverized warhead explosives to the right of the AT4, showing the extent of the damage sustained by the projectile.

Figures 36 through 39 were taken during the course of test nos. 1 through 3. They are photographs of the remains recovered following a thorough inspection of the test area after the conclusion of each individual test. These portray the information presented in the detailed description of each test. The nosecone and portions of the warhead body were pulverized into pieces too small to collect.

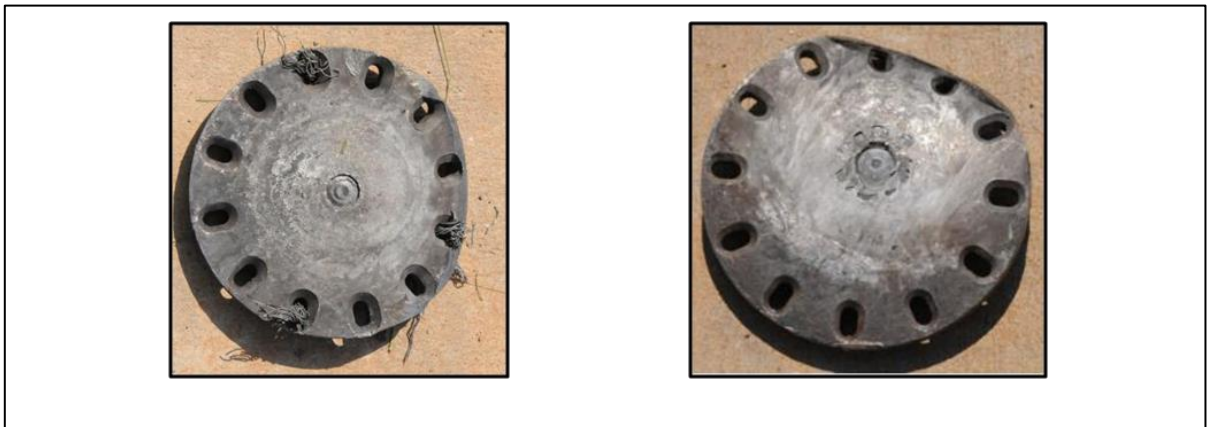

Figure 36  
Recovered impact plates with warhead impression

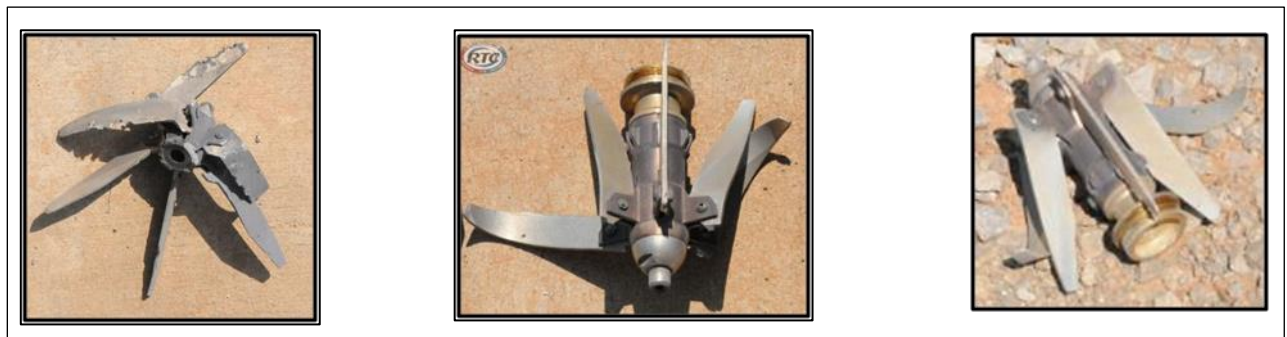

Figure 37  
Recovered fin and fuze assemblies

Approved for public release; distribution is unlimited.



Figure 38  
Container propelled into steel wall

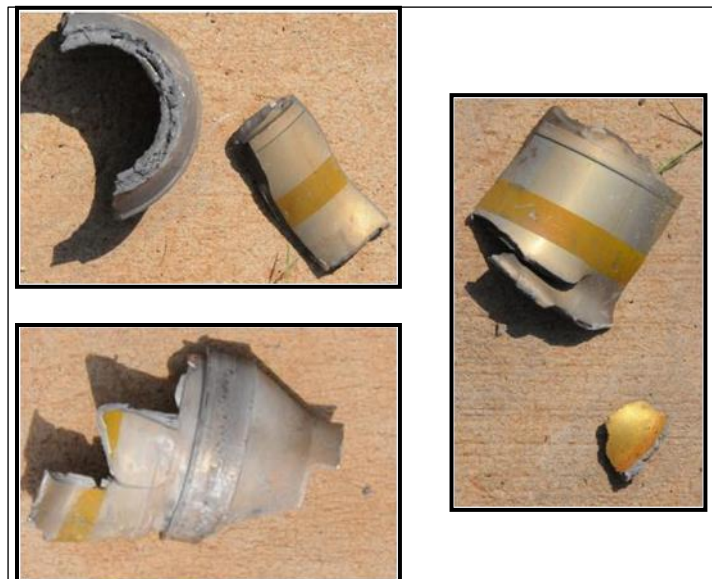

Figure 39  
Recovered warhead fragments

Testing showed the prototypes failed to achieve the desired Type V reaction. While the prototypes could be modified to achieve a Type V reaction, the results from the test show the warhead experienced extensively more damage from the impact than expected. The test results provided significant confidence that the deflection plate concept will be a success.

## Deflection Plate

For the tests performed on the deflection plate concept, the test stand was moved back approximately 30 ft from the concrete surface (shown in the test setup fig. 31) such that the projectile would strike soil after impact and minimize damage to the remains of the warhead. After each test, the S&A fuzes were x-rayed to determine whether or not the fuzes had moved into the armed position.

**Test no. 4** – deflection plate, wood box, 1-in. RHA steel plate.

- The warhead shattered against the deflection plate and was projected at a 45-deg angle downward into the ground.
- No energetic reaction occurred.
- The fin was found to the left of the concrete area.
- The fuze was determined to be in the 0-deg position (unarmed). Small booster charge remained in the fin assembly.
- The steel plate was not found after the test and was assumed to be lost in a wooded area greater than 1,000-ft away or in the woods to the right of the test setup.

**Test no. 5** – deflection plate, wood box, 1/2-in. RHA steel plate.

- Warhead shattered against the deflection plate and was projected at a 30-deg angle downward into the ground.
- A cloud of explosive dust burned in the air in front of the test stand and was likely caused as a result of the aluminum warhead striking the steel plate.
- The fin was found between the concrete wall and cage with almost no damage. The fin appeared to have broken off from the warhead, was thrown upwards, and avoided impact with the plate.
- The fuze was determined to be in the 0-deg position (unarmed). The small booster charge remained in the fin assembly.
- The deflection plate was not found after the test and was assumed to be lost in a wooded area greater than 1,000-ft away or in the woods to the right of the test setup.

Figures 40 and 41 are screenshots extracted from high-speed video taken during testing:

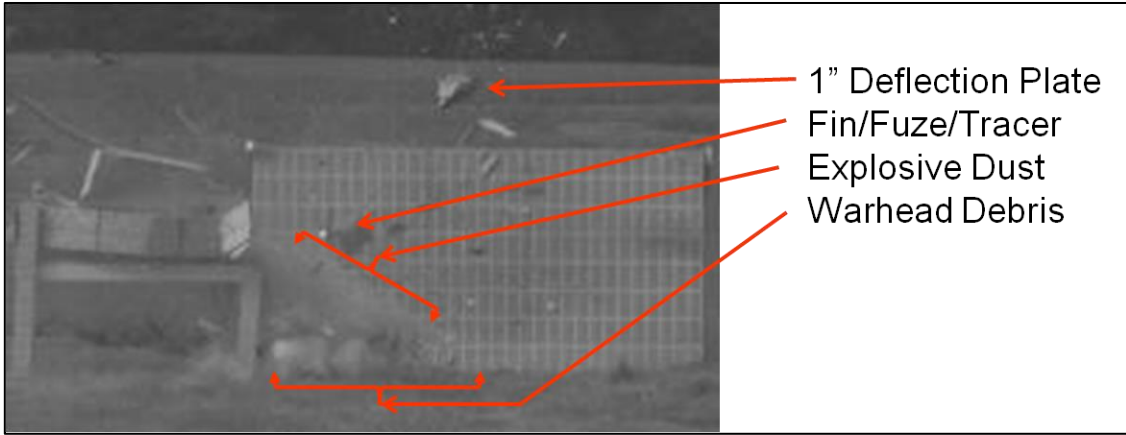

Figure 40  
Screenshot from video of test no. 4 (1-in. thick plate)

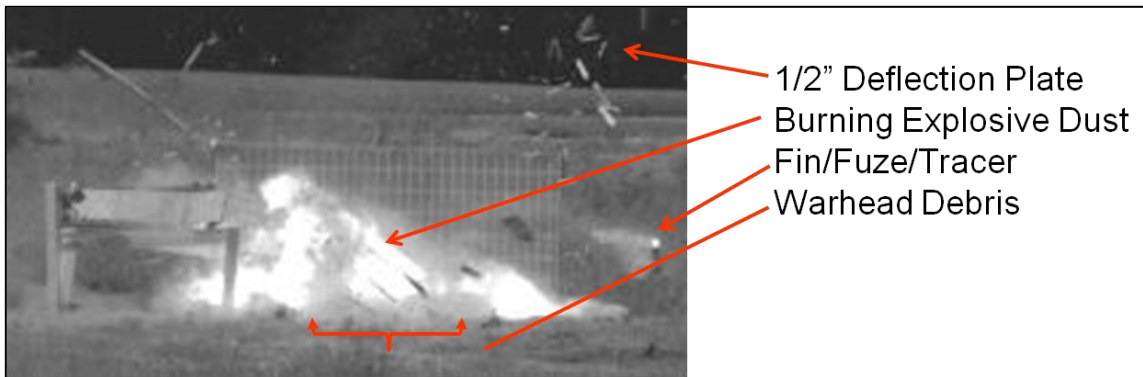

Figure 41  
Screenshot from video of test no. 5 (1/2-in. thick plate)

Figures 42 and 43 were taken during the course of test nos. 4 and 5. The images are photographs of the remains recovered following a thorough inspection of the test area after the conclusion of each individual test. The images portray the information presented in the detailed description of each test.



Figure 42  
Recovered unarmed fuze and fin assembly (x-rayed)



Figure 43  
Recovered copper liner

The results of the test were completely successful with regard to the intended performance of the deflection plate. The results were unofficially evaluated as a Type IV reaction due to the plate being launched, as well as fragments from the warhead and packaging (fig. 44).



Figure 44  
Recovered warhead fragments

### Concept Evaluation and Down Selection

After the initial testing of all four concepts, a down selection process occurred to determine which concept showed the most potential so resources could be focused into developing a single solution. The success of the ruggedized container and deflection plate to achieve a Type IV alleviates the need to consider the mitigation concepts no. 3 (ballistic sleeve) and no. 4 (heat mitigation).

The ruggedized container achieved a Type IV reaction and with moderate risk to achieve a Type V reaction with further investment in design and testing. However, the solution would come at a significant increase in cost and weight to the system.

The deflection plate achieved much more than disabling the fuze, such as breaking the fuze free from the warhead and shattering the warhead, ensuring no detonation. The 1/2-in. steel plate could be integrated into the packaging with minimal impact to cost and weight. Further testing could optimize the design, providing a solution with near certain success in the final IM testing.



It was determined that attempting to achieve a Type V reaction with the ruggedized container posed too many risks. There still existed technical challenges to achieve the Type V reaction that needed to be overcome. There was a very high risk of providing a solution, which would be too costly and heavy.

The deflection plate was selected as the optimal concept, providing a solution that was certain to achieve a Type IV reaction with low cost and weight impact on the final configuration.

**Summary of Results**

Figure 45 displays the concept down selection process from ruggedized container to heat mitigation.

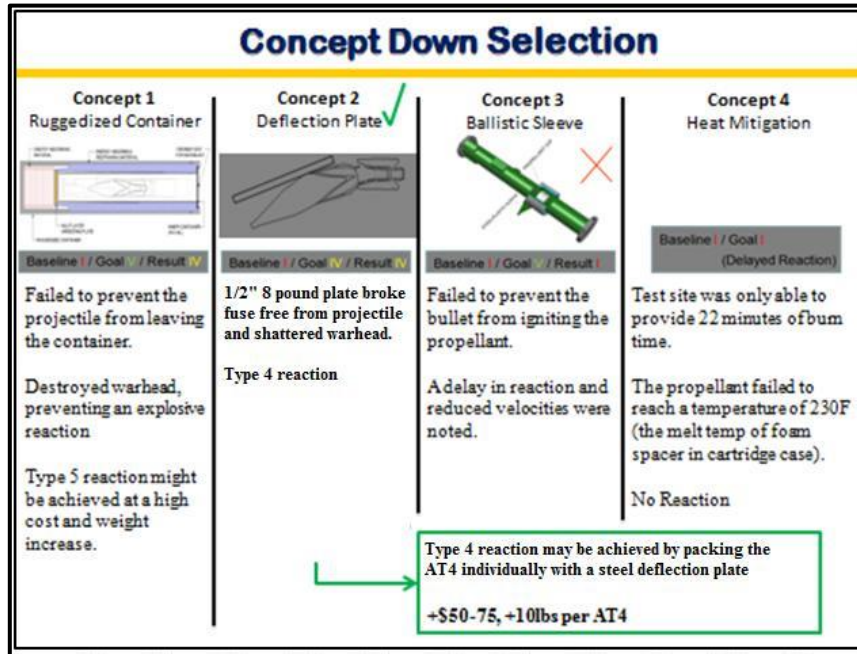

Figure 45  
Down selection summary

**DEFLECTION PLATE, FURTHER DEVELOPMENT**

Based on the down selection, the deflection plate concept was refined further to minimize the weight while still attaining the same level of performance as previously demonstrated. Boxes procured were similar to the U.S. Army standard MIL-DTL-2427 (the standard specification for nailed wooden boxes, which would be used for the final design) and were designed and fabricated to hold a single AT4 and a deflection plate. The box had hinges and latches at the end to allow users to remove the AT4 from the end of the box in the same manner as removal from the current box (fig. 46).



Figure 46  
Boxes procured for optimal plate thickness testing

### Plate Optimization – Test Plan (app. F)

Deflection plates were fabricated out of mild steel. Thicknesses of 1/8 to 3/4 in., in 1/8-in. increments, were fabricated. Each plate weighed approximately 2 lb per 1/8-in. of thickness.

A test plan was developed to perform up to five tests with the following passing criteria:

- Warhead separates from fuze.
- No reaction more severe than a burning reaction.
- Burning dust is acceptable.
- Detonating fuze is acceptable.
- Lethal projectiles are acceptable.

Figure 47 shows the sequence of tests that will be performed. If the same thickness plate passes twice, the plate will be considered the plate that has passed this round of testing. A plate 1/8-in. thicker would be used for further IM testing to provide a margin of safety. A margin of safety is required because the AT4CS-RS has a lower velocity, and the BI test may cause the projectile to launch at a reduced velocity.

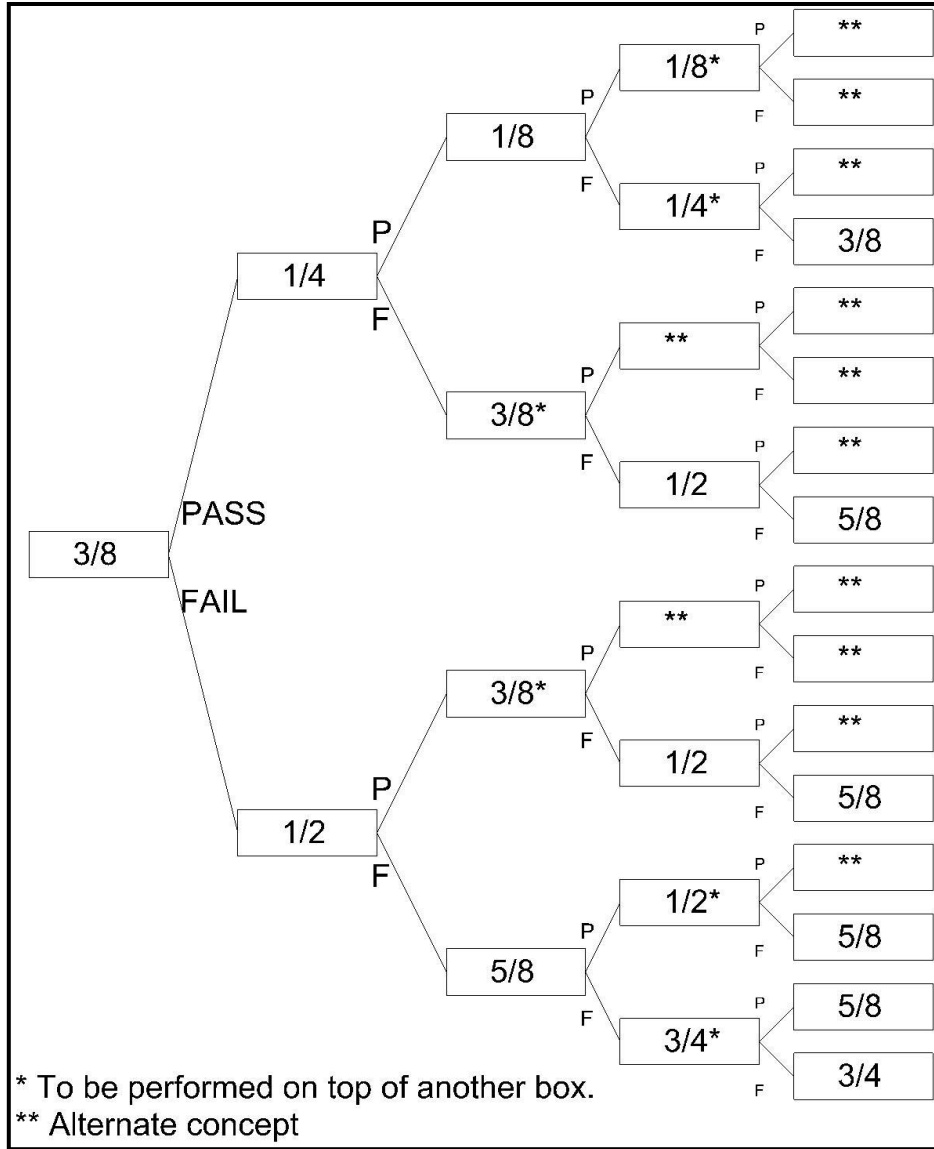

Figure 47  
 Tree diagram for plate thickness test sequence

There was concern that the reaction of an AT4 firing would damage an adjacent box, disabling the IM feature. To determine the extent of the damage, one of the tests will be performed on top of another box with a deflection plate inside.

**Plate Optimization – Test Results**

Testing was performed at RTC on December 12 and 13, 2011. The test configuration was the same as the prior tests at RTC. Figure 48 shows the test sequence performed.

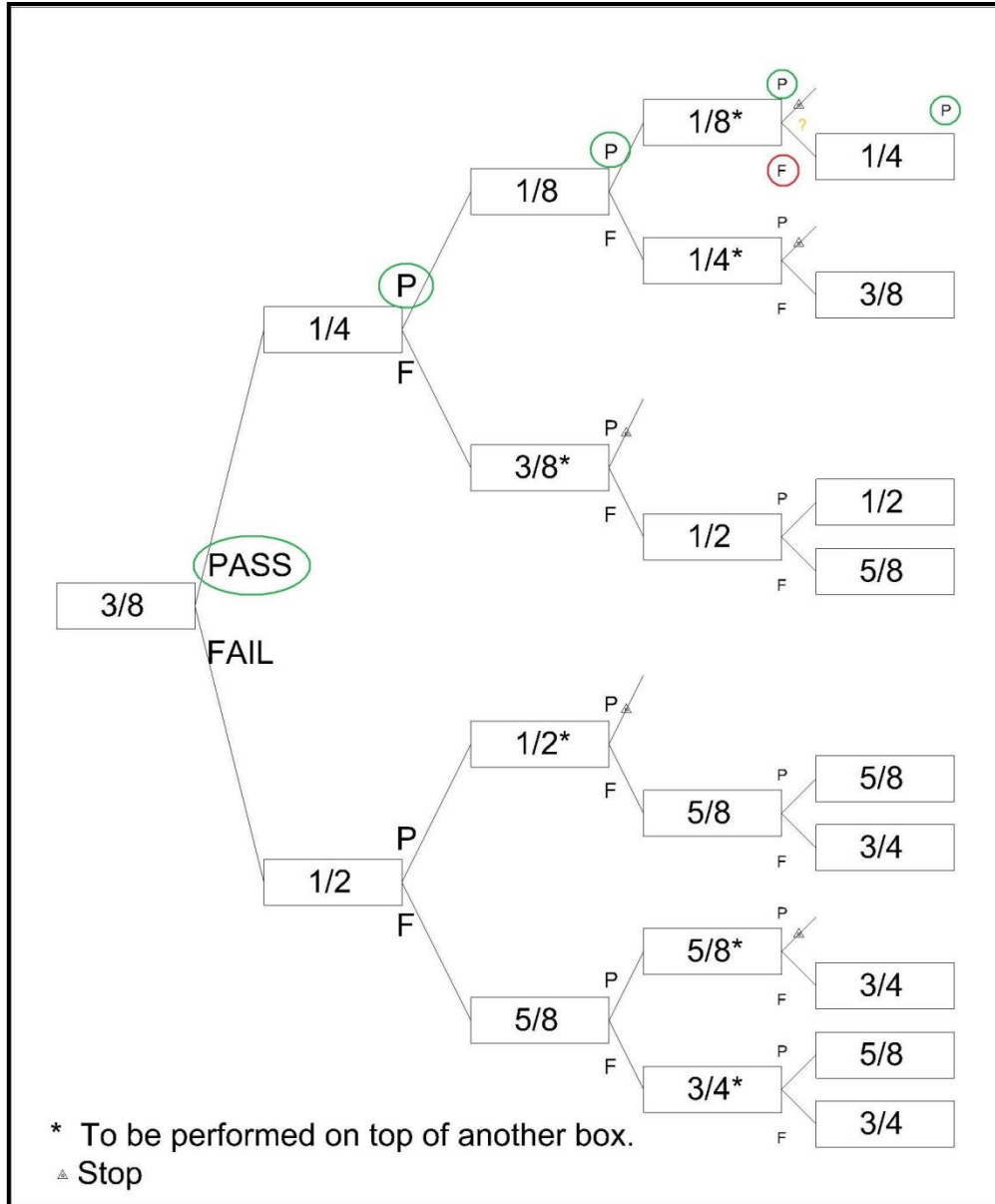

Figure 48  
 Actual plate thickness test sequence

Typical Reaction (based on all deflection plate tests performed):

- Nosecone disintegrates against deflection plate.
- Warhead strikes deflection plate.
- Fuze separates from warhead. Threads break before or after booster.
- Liner is damaged (flattened to 50% crushed).
- Explosives are pulverized into dust and granules.

## UNCLASSIFIED

- Dust ignites.
- Most of the explosives fall out of warhead as it tumbles down range.
- Warhead strikes steel wall.
- Additional explosive dust is generated.
- Dust ignites.

### Test 1:

Plate: 3/8 in., 770 ft, bent ~60 deg  
Fuze: separated from warhead, 50 ft  
Warhead: empty, 50 ft, booster intact  
Liner: flat, 3 ft  
Burning: at launch  
Detonation: no  
Reaction: IV

### Test 2:

Plate: 1/4 in., 700 ft, bent ~ 100 deg  
Fuze: separated from warhead, 50 ft  
Warhead: empty, 450 ft, boosters intact  
Liner: rim damaged, 50 ft  
Burning: at launch  
Detonation: no  
Reaction: IV

### Test 3:

Plate: 1/8 in., 3/4-in. hole, bent >135 deg  
Fuze: separated from warhead, 50 ft  
Warhead: split (two pieces), empty, 50 ft  
Liner: rim damaged, 50 ft  
Burning: at launch, warhead and fuze on impact on wall  
Detonation: no  
Reaction: IV

### Test 4:

Plate: 1/8 in. Broke apart. 50 ft for 1/6, 265 ft for 5/6, bent ~135 deg.  
Fuze: separated from warhead, 50 ft  
Warhead: gone  
Liner: gone  
Burning: No  
Detonation: yes, 6-in. hole in 1/2-in. steel plate  
Shockwave traveling 2,500 to 3,200 ft/s  
Reaction: I

**Test 5:**

Plate: 1/4 in., 710 ft, bent ~100 deg  
Fuze: separated from warhead, booster empty, 50 ft  
Warhead: cracked, empty, 50 ft  
Liner: rim damaged, 50 ft  
Burning: at launch  
Detonation: no  
Reaction: IV

Lighter plates progressively resulted in larger nosecone fragments, less deflection of the flight path, and less damage to the warhead. Five tests were performed. All tests successfully broke the warhead free from the fuze. This was the primary passing criteria.

In test no. 4, the deflection plate broke into two pieces. The fuze broke free from the warhead, but the booster remained with the warhead. The liner did not break free from the warhead on impact with the deflection plate. As the warhead tumbled, some powder could be seen coming out from the booster. The warhead struck the steel wall with the booster impacting first. The warhead detonated, creating a 6-in. hole in the 1/2-in. steel wall. The shockwave knocked the 2,000-lb wall/box over. The shockwave appears to be moving 2,500 to 3,200 ft/sec.

It was observed in prior tests, when the aluminum projectile strikes the steel deflection plate or steel wall, the explosive dust ignited and burned. The powdered remnants of the first booster charge in the warhead ignited when the booster end of the warhead struck the steel wall. The burning powder, confined between the booster charge cavity and the steel wall, ignited the second booster charge, which ignited the shaped warhead.

For the C995, the test was considered a failure. For the CA30, due to the lower sensitive energetic material, the munition would have higher potential for passing. Further testing would need to be conducted to verify the passing of this assumption. As a precaution, the test was treated as a fail and the 1/4-in. plate was tested again.

The test with 1/8-in. plate on top of the empty box resulted in the bottom box being damaged but surviving the reaction.

Based on the test results, the passing plate thickness was 1/4 in. As a margin of safety, a 3/8 in. will be used for further IM testing. Figure 49 shows the post-test impacted deflection plates.

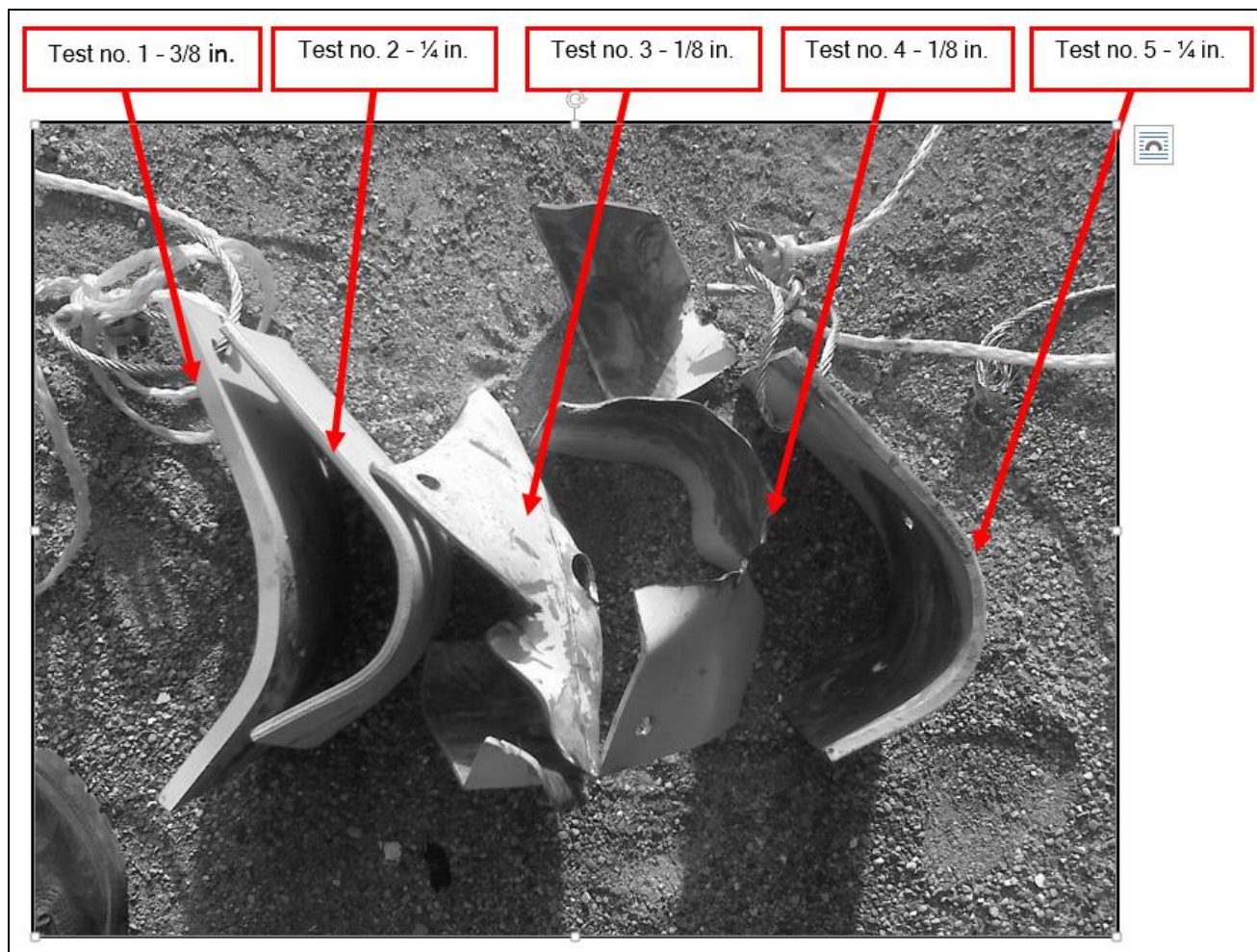

Figure 49  
Impacted deflection plates (post-test)

## CONCLUSIONS AND PATH FORWARD

The anti-armor, confined space, reduced sensitivity (AT4CS-RS) insensitive munition (IM) effort set out with the goal of developing an IM solution for the AT4CS-RS. Although the program has been cancelled, initial testing has provided confidence that the deflection plate packaging concept will improve fast cook-off (FCO), slow cook-off (SCO), and bullet impact (BI) for both the AT4 and AT4CS-RS to a Type IV reaction with low impact to cost or weight.

The deflection plate concept and the numerous concepts investigated by the AT4CS-RS IM team may be leveraged to provide IM solutions for future shoulder-launched munitions developed for the U.S. Army such as the individual assault munition.

### Concepts for Further Development

The following are improvements to the tested design that were considered, but further development was not pursued due to schedule and funding:

## UNCLASSIFIED

- Preliminary sheet metal framing designs were developed to maintain the position of the deflection plate in front of the AT4 during a FCO.
- The use of tubular ammunition containers with deflection plates packaged inside or deflection plates welded outside were investigated. Foam could be molded around deflection plates to provide a single packaging item that would provide padding and an IM solution.

Potential design variations are:

- The deflection plate was designed to damage the fuze, not to destroy the warhead. Various concepts were created to maximize damage to the warhead instead. These concepts consisted of blocks, blades, wedges, and spikes that would penetrate or crush through the warhead to split open the shaped charge. These concepts may be encapsulated in foam to be stored in the packaging, or may incorporate a steel tube that can be fastened to the end of a standard ammunition container.
- The guillotine concept was created, which used the initial impact of the projectile against a strike face, to cause the IM feature to rotate in a manner to damage the secondary warhead or its fuze.

### Estimated Funding Required to Complete Effort

Initial testing has shown the deflection plate concept will most likely pass IM testing with minimal changes and low risk. In order to complete the testing, the table shows what would be required:

Costs required for deflection plate concept

Prototype fabrication:	\$15,000
IM testing: two FCO, two BI, and two SCO	\$250,000
Packaging testing:	\$90,000
<b>Total:</b>	<b>\$365,000</b>

\***Note:** Values given are in fiscal year 2012 dollars.

Test assets will need to include at least six live AT4CS-RS systems for IM testing, and at least 12 inert systems for packaging testing.

This funding estimate is only for the continuation of this effort specific to AT4CS-RS. Additional testing and development would be required to adapt the design developed to a different system. While the work done to this point would serve as a strong basis to implement the deflection plate concept to a new weapon system, there would be inherent differences in a future system presenting additional challenges. At minimum, a good starting point would be to re-evaluate the mass of the deflection plate by performing a similar test done during the plate optimization testing.

### Intellectual Property

- Patents have been awarded for the deflection plate concept, water liner concepts, and counter mass flood/rupture/external concepts.
- A report will be published to prevent other concepts from being patented.

Approved for public release; distribution is unlimited.

UNCLASSIFIED



UNCLASSIFIED

APPENDIX A  
BALLISTIC SLEEVE CONCEPT – TEST PLAN

Approved for public release; distribution is unlimited.

UNCLASSIFIED



## 1.0 Objective

The M136A1 AT4CS-RS fails IM testing (BI) because when exposed to stimuli, the propellant is ignited and the projectile is launched downrange. IM may be achieved by protecting the propellant cup with a ballistic sleeve located in the packaging. An effort has been initiated to develop packaging which may be utilized by the AT4 family.

The objective of this test is to test the ballistic sleeves to determine if they will protect the AT4 sufficiently to prevent a launch of the projectile. Gathered data will provide insight into the system to refine and develop designs for further IM testing.

An AT4CS-TW TP will be utilized for this test. Compared to the AT4CS-RS, it has the same propellant and uses a similar counter mass. However, it has a larger warhead which is inert.

- 3 prototype sleeves will be fabricated for BI: 1/4", 3/8" and 1/2".
- 2 tests will be performed.

## 2.0 Procedure

### 2.1.1 Test Setup

1. The AT4CS-TW TP with a ballistic liner strapped (or equivalent) to one side, will be strapped to a test stand and tested for the Bullet Impact in accordance with MIL-STD-2105, Revision B, paragraph 5.2.3. The AT4 will be orientated with the primer faced down. The impact point for the test is the propellant cup, located along the centerline of the round. The impact point should be 351.3mm from the rear of the AT4.
2. A slow motion video camera shall be used to record the test. It shall be positioned to observe the projectile should it launch from the weapon so that velocity may be estimated (+/- 200ft/sec).
3. Photographs of the test site shall be taken to establish what type of reaction occurred to the propellant.
4. Ballistic sleeves will be recovered for inspection.
5. ARDEC shall be informed one week before the test date.
6. All video footage and data will be provided to the AT4CS-RS IM Packaging IPT after testing is completed.

### 2.1.2 Test Sequence

1. The 3/8" ballistic liner will be tested first.
2. Depending on the success or failure of the 3/8" ballistic liner to prevent a launch, the 1/4" or 1/2" line will be tested second.



UNCLASSIFIED

**APPENDIX B**  
**FAST COOK-OFF TEST REPORT (TEST NUMBER ONE)**

Approved for public release; distribution is unlimited.

**UNCLASSIFIED**



## UNCLASSIFIED

- 1) Witnesses: David Yung, Leon Moy, Stacey Yauch
- 2) Date: 10 Nov 2011
- 3) Destination: Picatinny Arsenal, Area 650
- 4) Purpose: AT4-CS-RS IM Packaging - Test the thermal mitigation concept against a Fast Cook-Off

5) Test Description:

An AT4TW-TP was packaged in prototype packaging:

- The AT4TW-TP had the firing pin removed due to security requirements.
- 7 pounds water contained in a plastic/foil blister liner wrapped around the AT4TW-TP.
- 16ga galvanized steel can with 1/4" common fiberglass insulation and foil tape inside and out. A 1/2" melt out vent hole was located at the end of the can.
- The AT4TW-TP was loaded into the can with the percussion cap faced down.

The FCO pan was filled with 400 gallons of gasoline and aerated to accelerate heating and burn temp. Estimated burn time was 20-30 minutes.

Past IM test show that the baseline box reacted at 7 minutes.

Molding and Simulation (M&S) shows that without the water and degradation of the insulation, the item will react at 16 minutes.

6) Test Results:

- Burn time was only ~17 minutes
- White smoke was seen coming from the vent side of the can (also the direction the wind and sun were coming from) starting ~14 minutes
- Temperature inside the container reached ~600°F
- There was no noticeable energetic reaction

7) Discussion:

- It is being discussed whether the propellant failed to ignite or vented.
- EOD needs to determine if the package needs to be detonated or if it can be opened prior to disposal.
- Thermal couple data is being waited for to determine if the internal temperature of the can would have raised the temperature of the propellant cup to the ignition temperature.





UNCLASSIFIED

APPENDIX C  
FAST COOK-OFF TEST REPORT (TEST NUMBER TWO)

Approved for public release; distribution is unlimited.

UNCLASSIFIED



## UNCLASSIFIED

- 1) Witnesses: David Yung, Leon Moy, Stacey Yauch, Dan Ruland
- 2) Date: 29 Nov 2011
- 3) Destination: Picatinny Arsenal, Area 650
- 4) Purpose: AT4-CS-RS IM Packaging - Test the thermal mitigation concept against a Fast Cook Off
- 5) Test Description:  
Same as previous except:
  - A smaller burn pan was used and filled with 500 gallons of gasoline. Estimated burn time was 45 minutes, based on the depth of fuel being 120% deeper.
  - Past IM test show that the baseline box reacted at 7 minutes.
  - M&S shows that without the water and degradation of the insulation, the item will react at 16 minutes.
- 6) Test Results:
  - Burn time was only ~22 minutes
  - There was no noticeable energetic reaction
  - Water remained in the foil wrap and the region around the middle of the item showed no sign of excessive heating. The paint, tape, stickers, and plastic liner all remained intact with no sign of melting or burning.
  - The item was cut open and the foam next to the propellant cup was retrieved intact. The foam starts melting below 230°F, indicating the interior never reached that temperature, despite the interior of the can maintaining an elevated temperature even after the fire burned out.
- 7) Discussion:
  - Unfortunately, the assumption by the test group that the burn time is proportional to the depth of fuel was incorrect. Increasing the depth by 120% only increased the burn time by 29%, for a total burn time of 22 minutes.
  - We were able to achieve a burn time of 22 minutes which allowed us to meet our threshold. The condition of the packaging and the item provides evidence that we may achieved or come close to our goal of 45 minutes.



UNCLASSIFIED

APPENDIX D  
REDSTONE TEST CENTER –TEST SITE SATELLITE IMAGERY

Approved for public release; distribution is unlimited.

UNCLASSIFIED









UNCLASSIFIED

APPENDIX E  
TRIP REPORT



Trip Report

Traveler: David Yung, Leon Moy, Dan Ruland

Date: 16-17 Aug 2011

Destination: RTC, Redstone Arsenal, Alabama

Purpose: To attend the IM testing for AT4 Packaging Concepts

Test Description:

An AT4 C995 will be remotely triggered inside of the prototype packaging to determine if the packaging can improve the IM performance of the round. Fuzes were recovered and x-rayed to determine if they were armed.

Prototype packaging has been fabricated to determine the feasibility of packaging concepts to improve the IM performance of the AT4 family. The AT4 C995 was used due to resource availability. The AT4 has velocity of 290m/s and AT4CS RS has velocity of 220m/s.

Tests were conducted on two types of packaging: 1) Ruggedized containers with steel cables and 2) wooden containers with metal deflection plate.

Concepts Description:

Ruggedized containers (3 tests): Three ruggedized containers of increasing ruggedness were fabricated to prevent the projectile from leaving the package. They consisted of a PA116 or PA116L container, a 1/2" steel strike face and steel cables restraining the strike face. The steel cables were braided in a manner to constrict around the launch tube and container when the projectile impact the strike face, in order to transfer the energy from the projectile to the container and launch tube.

Deflection plate container (2 tests): this is a wood box with a steel plate inclined at 45 degrees. When the warhead strikes the plate, the warhead should be deflected down, damaging the fuze or booster charges. Two boxes were fabricated. A 1" plate was to be tested first followed by a 1/2" or 1-1/2" plate depending on the results.

Test Setup:

- Concrete Wall:10' high, 40' wide.
- Steel Box. Located 5 feet in front of the concrete wall. Wall facing the launcher is open. 4ft wide x 6ft high.
- Test stand :Located 50 ft away from face of steel box.

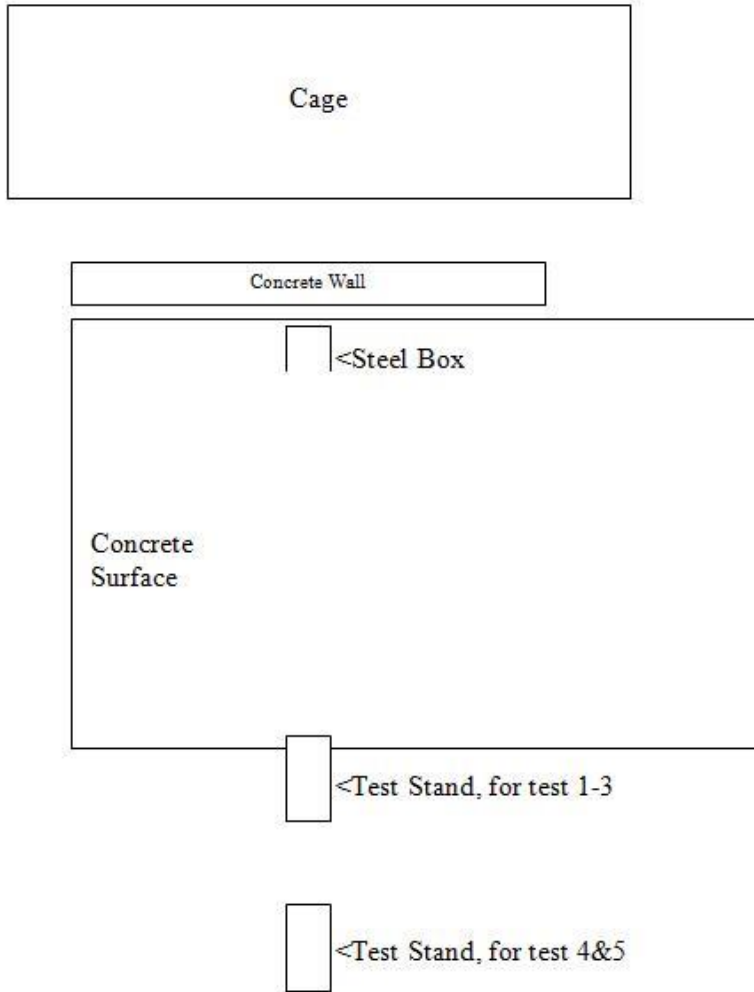

- Test #1 Ruggedized Container. PA116. 1/2" strike face. 6 pairs of cables.
- Test #2 Ruggedized Container. PA116. 1/2" strike face. 12 pairs of cables. No lid.
- Test #3 Ruggedized Container. PA116L. 1/2" strike face. 1/2" ring. 12 pairs of cables. 2" Honeycomb.
- Test #4 Deflection Plate. Wood box. 1" steel plate.
- Test #5 Deflection Plate. Wood box. 1/2" steel plate.

Test Results:

Test #1 (Ruggedized Container. PA116. 1/2" strike face. 6 pairs of cables.)

- Dents were found at 12 locations around the circumference of the container, indicating that the nose cone "splashed" on impact with the plate, and that the debris impacted with can in the 12 gaps between the cables. This debris likely damaged the cables. Only pebbles are recovered from the nose cone.
- Container bottom rips free at weld line. Not found.
- Container lid thrown by back blast. Not found.
- Steel plate and projectile launched out from container.
- Steel plate showed dent from the tip of the nose cone, and aluminum residue.
- Container was moved by projectile launching and it was moved behind projectile.
- Launch tube was moved out the container.
- Warhead was broken apart. Copper liner and chunks of explosives impacted the ground.
- Warhead base/fin assembly and chunks of explosives occurred inside of the steel box.
- On impact, explosive dust is propelled out of the warhead base to the left. A small amount of this dust ignites and burns.
- Fuze was in the 0 deg position (unarmed). Small booster charge did not burn and was found in the fin assembly.
- No detonation, explosion or deflagration occurred. It was just burning.
- Projectile Velocity: 156 m/s (290 baseline)

Test #2(Ruggedized Container. PA116, 1/2" strike face,12 pairs of cables. No lid. )

- Similar results to Test#1
- Copper liner impacted steel box.
- Launch tube moves <10 feet. Container almost hits box.
- Fuze was in the 10 deg position (unarmed). Small booster charge did not burn and was found in the fin assembly.
- No detonation, explosion and deflagration occurred. It was just burning.
- Projectile Velocity: 121 m/s (290 baseline)

Test #3 (Ruggedized Container. PA116L,1/2" strike face,1/2" ring and 12 pairs of cables +2" Honeycomb. )

- Similar results to Test#2
- Warhead was shredded as it leaves the container. A cloud of explosives was seen.
- Explosive chunks and dust trails were left on the ground.
- As the fin assembly impacted the steel box, there was a detonation of the detonator and/or small booster charge.
- A line of dents (removed rust) in the steel box showed where shrapnel from fuze burst in a radial plane. Possible cause was detonation/explosion of detonator and/or small booster pellet (1.5g).

## UNCLASSIFIED

[Deflection Plate Concepts: Test stand was moved back 30' so that the projectile will strike soil instead of concrete]

Test#4 (Deflection Plate, wood box, 1" steel plate)

- Warhead "splashed" against the deflection plate and was projected at a 45-degree angle downward into the ground.
- No energetic reaction.
- Fin was found to the left of the concrete area.
- Fuze was in the 0deg position (unarmed). Small booster charge remained in the fin assembly.
- Steel plate was not found. Possibly lost into the woods far away.

Test #5 (Deflection Plate, wood box, and 1/2" steel plate)

- Warhead "splashed" against the deflection plate and was projected at a 30-degree angle downward into the ground.
- Cloud of explosive dust burn in the air in front of the test stand.
- Fin was found between the concrete wall and cage with almost no damage. It appeared that the fin broke off from the warhead, was thrown upwards, and avoided impact with the plate.
- Fuze was in the 0 deg position (unarmed). Small booster charge remain in the fin assembly.
- Steel plate was not found. Possibly lost in the woods far away.

Conclusion

- Ruggedized containers failed to contain the projectile, but successfully destroyed the warhead and prevented 2/3 fuzes from arming.
- Deflection plate was 100% successful with the 1" and 1/2" plates.
- All reactions were type IV due to the flying projectile or packaging.
- A formal test report from RTC is expected in ~2 weeks.

David Yung //s//

Leon Moy//s//

Dan Ruland//s//

UNCLASSIFIED

APPENDIX F  
TEST PLAN TO DETERMINE CAPABILITY OF PROTOTYPE RESTRAINING PACKAGING FOR  
AT4





10/17/2011, Draft

## 1.0 Objective

The M136A1 AT4CS-RS fails IM testing (SCO, FCO, BI) because when exposed to stimuli, the propellant is ignited and the projectile is launched downrange. IM may be improved by destroying the warhead as the projectile is launched. An effort has been initiated to develop packaging which may be utilized by the AT4 family

The objective of this test is to test prototypes to determine if they will destroy the warhead when the AT4 is remotely triggered and to gather data for future design efforts. Gathered data will provide insight into the system to refine and develop designs for further IM testing.

The M136 AT4 (C995) will be utilized for testing. 6 will be made available.  
5 tests will be performed.

## 2.0 Procedure

### 2.1 Test Setup

- 1) An AT4 will be outfitted with a remote trigger by the testing facility and placed in the prototype packaging. The packaging will be placed on a test stand at least 3' above soil and will not be secured in place.
- 2) A slow motion video camera will be positioned to the side, with the field of view centered on the muzzle end of the packaging. The field of view should encompass at least 1ft beyond the rear of the packaging and at least 45 feet beyond the front of the packaging. This will record the initiation of the back blast and the first 45 feet of movement of the projectile or the packaging as it is propelled forward.
- 3) A marker shall be used to provide a reference of scale to determine projectile velocity using the slow motion video camera.
- 4) A conventional video camera will be positioned to the side. The field of view should encompass at least 1ft beyond the rear of the packaging and at least 45 feet beyond the front of the packaging.
- 5) Velocity of the projectile and packaging will be recorded. [camera]
- 6) Test setup shown in fig 1.
- 7) The location and condition of the dunnage shall be recorded and photographed. Should the projectile leave the packaging intact, the location of the projectile and/or parts shall be recorded and photographed. Should the projectile detonate, the location of the detonation shall be recorded and photographed.

All debris and parts from the testing shall be recorded including distance and photos.  
Primary objects of interest include:

- Nose cone
- Warhead liner
- Warhead body
- Warhead energetics
- Booster charges
- Fuze assembly
- Deflection plate

- 8) ARDEC shall be informed two weeks before the test date.
- 9) All video footage, as well as documentation of projectiles and packaging will be provided to the AT4CS-RS IM Packaging IPT after testing is completed.

10) The Picatinny engineer on site will select one of the tests and a DVD will be provided with the video on photos of this test before leaving.

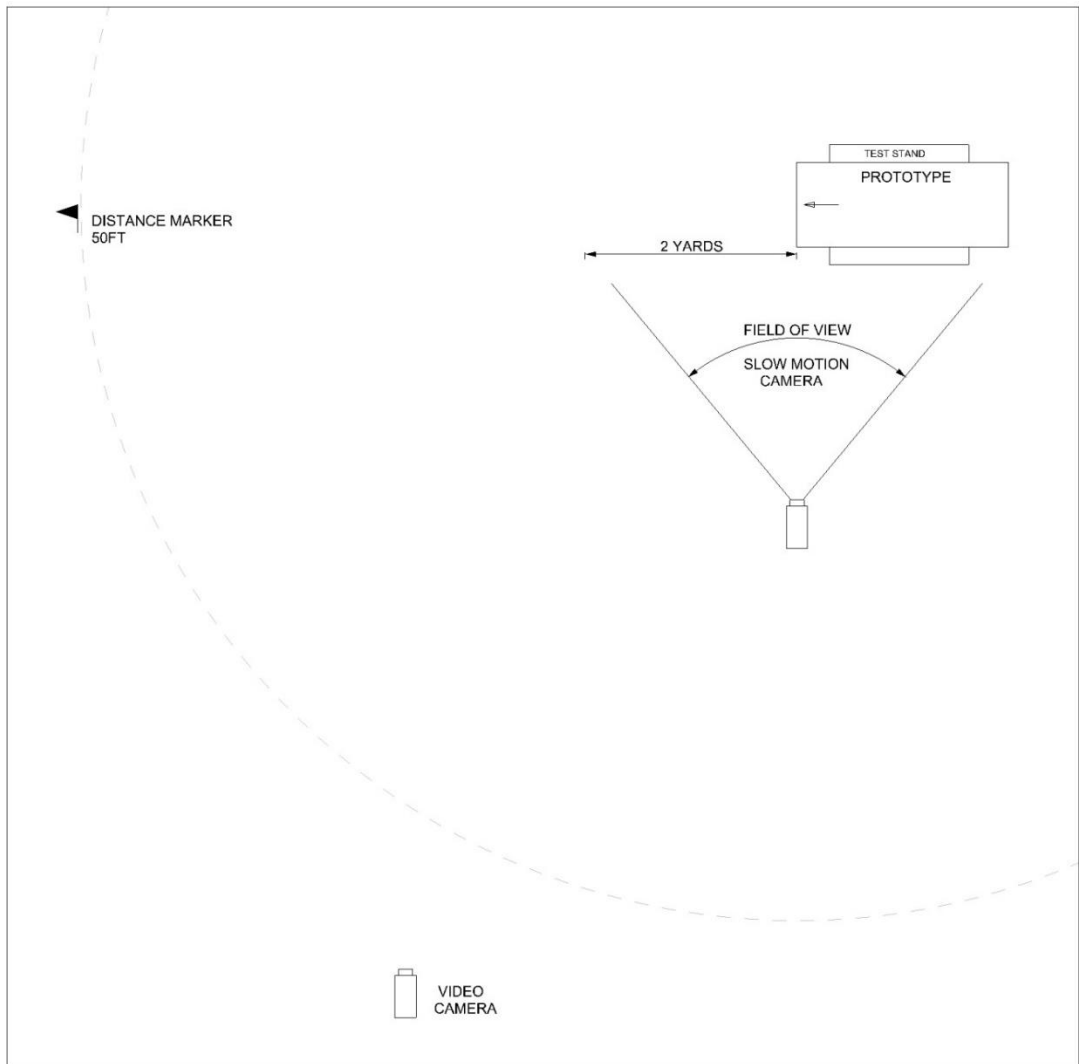

[Needs to be updated to reflect what we did last time. Camera views should extend to the wall. We would like the projectile to strike the soil after being deflected downwards.]

2.2 Passing Criteria

- 1) Warhead does not detonate
- 2) No reaction more severe than a burning reaction
- 3) Warhead separates from fuze
- 4) Most of the booster charge is no longer in line with the fuze
- 5) Burning dust is acceptable
- 6) Detonating fuze is acceptable
- 7) Lethal projectiles are acceptable

2.3 Test Sequence

- 1) The following is the sequence the deflection plate thicknesses that will be tested. An engineer on site will determine if the test is a pass or a fail.

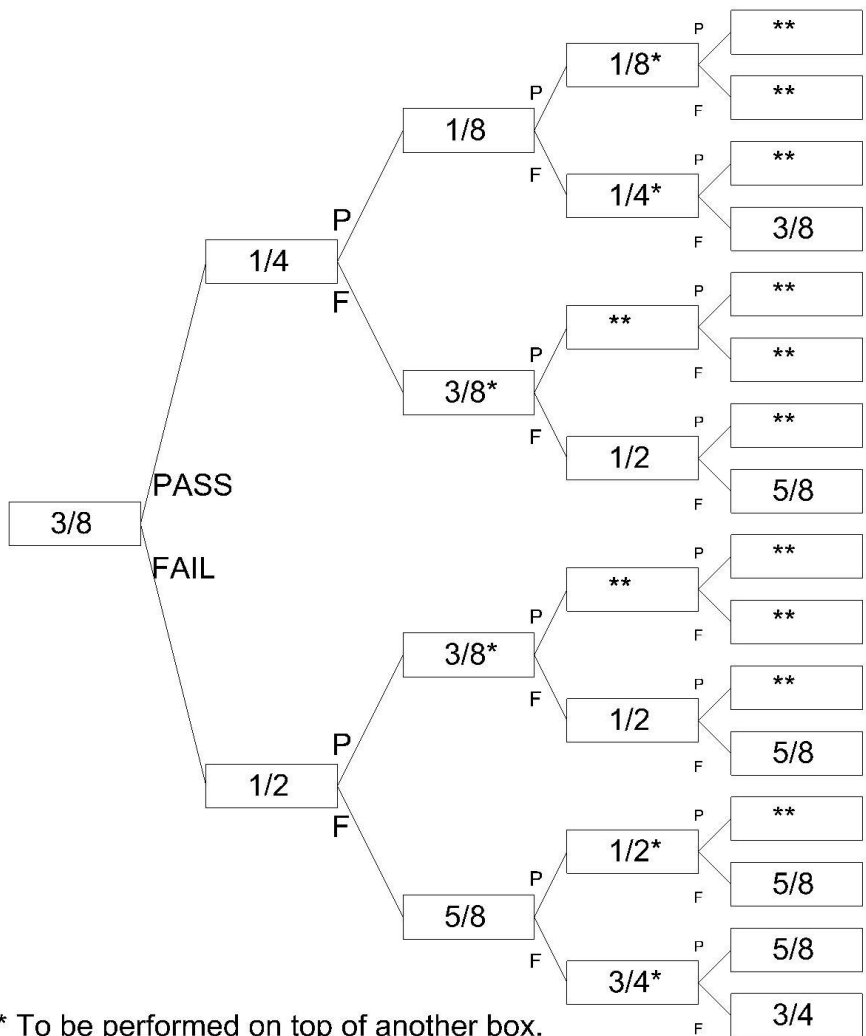

\* To be performed on top of another box.

\*\* Alternate concept

[We may use a smaller deflection plate, in which case all the thicknesses will increase by 1/8". We will bring an updated chart if this happens]

## 2.4 Packaging Setup

- 1) Selected deflection plate shall be placed in the front of the packaging such that during initiation, the projectile will be deflected downwards and the deflection plate will be thrown upwards.
- 2) [Box will be closed on top. Design in progress]
- 3) The AT4 will be loaded from the opening at the rear of the box.
- 4) The detonator will be installed through a hole pre-cut in the top of the box.

## 3.0 Prototypes

### 3.1 Deflection Plate

The deflection plates are mild steel plates held at a 45 degree angle by the packaging. The packaging may include a metal frame or device to maintain the position of the deflection plate in front of the barrel should the packaging experience a fast cook off scenario. The packaging may be made of WBP (water and boil proof) plywood or a substitute board and metal hardware.

[at this time, we don't expect our final design to be ready, we it will probably be a plain wood box.]

### 3.2 Alternate Design

An alternate design may be an alternate mild steel structure meant to break apart the warhead as it is launched.

UNCLASSIFIED

DISTRIBUTION LIST

U.S. Army ARDEC

ATTN: RDAR-EIK

RDAR-MEE-M, L. Moy

E. Yang

S. Yauch

R. Bober

F. Cruz

Picatinny Arsenal, NJ 07806-5000

Defense Technical Information Center (DTIC)

ATTN: Accessions Division

8725 John J. Kingman Road, Ste. 0944

Fort Belvoir, VA 22060-6218

GIDEP Operations Center

P.O. Box 8000

Corona, CA 91718-8000

[gidep@gidep.org](mailto:gidep@gidep.org)

REVIEW AND APPROVAL OF ARDEC REPORTS

THIS IS A:

- TECHNICAL REPORT                       SPECIAL REPORT  
 MEMORANDUM REPORT                       ARMAMENT GRADUATE SCHOOL REPORT

FUNDING SOURCE \_\_\_\_\_

[e.g., TEX3; 6.1 (ILIR, FTAS); 6.2; 6.3; PM funded EMD; PM funded Production/ESIP; Other (please identify)]

AT4CS-RS IM Effort: Summary and Conclusions  
Title

AT4CS-RS  
Project

Leon Moy  
Author/Project Engineer

\_\_\_\_\_  
Report number/Date received (to be completed by LCSD)

4-1570  
Extension

307  
Building

RDAR-MEA-P  
Author's Office Symbol

PART 1. Must be signed before the report can be edited.

a. The draft copy of this report has been reviewed for technical accuracy and is approved for editing.

b. Use Distribution Statement A X, B\_\_\_\_, C\_\_\_\_, D\_\_\_\_, E\_\_\_\_, or F\_\_\_\_ for the reason checked on the continuation of this form. Reason: \_\_\_\_\_

1. If Statement A is selected, the report will be released to the National Technical Information Service (NTIS) for sale to the general public. Only unclassified reports whose distribution is not limited or controlled in any way are released to NTIS.

2. If Statement B, C, D, E, or F is selected, the report will be released to the Defense Technical Information Center (DTIC) which will limit distribution according to the conditions indicated in the statement.

c. The distribution list for this report has been reviewed for accuracy and completeness.

Mark Carlini                      2/23/17  
Division Chief                      (Date)

PART 2. To be signed either when draft report is submitted or after review of reproduction copy.

This report is approved for publication.

Mark Carlini                      2/23/17  
Division Chief                      (Date)

Andrew Pskowski                      2/27/17  
RDAR-CIS                      (Date)