

# REPORT DOCUMENTATION PAGE

*Form Approved*  
*OMB No. 0704-0188*

The public reporting burden for this collection of information is estimated to average 1 hour per response, including the time for reviewing instructions, searching existing data sources, gathering and maintaining the data needed, and completing and reviewing the collection of information. Send comments regarding this burden estimate or any other aspect of this collection of information, including suggestions for reducing this burden, to Department of Defense, Washington Headquarters Services, Directorate for Information on Operations and Reports (0704-0188), 1215 Jefferson Davis Highway, Suite 1204, Arlington, VA 22202-4302. Respondents should be aware that notwithstanding any other provision of law, no person shall be subject to any penalty for failing to comply with a collection of information if it does not display a currently valid OMB control number.  
**PLEASE DO NOT RETURN YOUR FORM TO THE ABOVE ADDRESS.**

<b>1. REPORT DATE (DD-MM-YYYY)</b> 12-12-2017			<b>2. REPORT TYPE</b> Final			<b>3. DATES COVERED (From - To)</b>		
<b>4. TITLE AND SUBTITLE</b> Test Operations Procedure (TOP) 01-1-011B Vehicle Test Facilities at Aberdeen Test Center and Yuma Test Center					<b>5a. CONTRACT NUMBER</b>			
					<b>5b. GRANT NUMBER</b>			
					<b>5c. PROGRAM ELEMENT NUMBER</b>			
<b>6. AUTHORS</b>					<b>5d. PROJECT NUMBER</b>			
					<b>5e. TASK NUMBER</b>			
					<b>5f. WORK UNIT NUMBER</b>			
<b>7. PERFORMING ORGANIZATION NAME(S) AND ADDRESS(ES)</b> Automotive Directorate (TEDT-AT-AD) U.S. Army Aberdeen Test Center 400 Collieran Road Aberdeen Proving Ground, MD 21005-5059  U.S. Army Yuma Proving Ground Yuma Test Center 301 C. Street Yuma, AZ 85365-9498						<b>8. PERFORMING ORGANIZATION REPORT NUMBER</b> TOP 01-1-011B		
<b>9. SPONSORING/MONITORING AGENCY NAME(S) AND ADDRESS(ES)</b> Policy and Standardization Division (CSTE-TM) U.S. Army Test and Evaluation Command 2202 Aberdeen Boulevard Aberdeen Proving Ground, MD 21005-5001						<b>10. SPONSOR/MONITOR'S ACRONYM(S)</b>		
						<b>11. SPONSOR/MONITOR'S REPORT NUMBER(S)</b> Same as item 8		
<b>12. DISTRIBUTION/AVAILABILITY STATEMENT</b> Distribution Statement A. Approved for public release; distribution is unlimited.								
<b>13. SUPPLEMENTARY NOTES</b> Defense Technical Information Center (DTIC), AD No.:  This TOP supersedes TOP 01-1-011A Vehicle Test Facilities at Aberdeen Test Center and Yuma Test Center, dated 27 February 2012.  Marginal notations are not used in this revision to identify changes, with respect to the previous issue, due to the extent of the changes.								
<b>14. ABSTRACT</b> This Test Operations Procedure (TOP) describes the vehicle test facilities of Aberdeen Test Center (ATC) at Aberdeen Proving Ground (APG), Maryland and the automotive test courses located at Yuma Test Center (YTC), Arizona.								
<b>15. SUBJECT TERMS</b> ATC    YTC    automotive test courses    paved    gravel    cross-country								
<b>16. SECURITY CLASSIFICATION OF:</b>			<b>17. LIMITATION OF ABSTRACT</b>	<b>18. NUMBER OF PAGES</b>	<b>19a. NAME OF RESPONSIBLE PERSON</b>			
<b>a. REPORT</b> Unclassified	<b>b. ABSTRACT</b> Unclassified	<b>c. THIS PAGE</b> Unclassified			SAR	153	<b>19b. TELEPHONE NUMBER (include area code)</b>	

(This page is intentionally blank.)

U.S. ARMY TEST AND EVALUATION COMMAND  
TEST OPERATIONS PROCEDURE

\*Test Operations Procedure 01-1-011B  
DTIC AD No.

12 December 2017

VEHICLE TEST FACILITIES AT ABERDEEN TEST CENTER AND YUMA TEST CENTER

		<u>Page</u>
Paragraph	1. SCOPE.....	2
	2. ABERDEEN TEST CENTER COURSES AND FACILITIES.....	11
	2.1 Churchville Test Area (CTA).....	11
	2.2 Environmental Testing Facilities.....	15
	2.3 Dynamometer Course.....	19
	2.4 Mile Loop.....	19
	2.5 Mountain Highway.....	22
	2.6 Munson Test Area (MTA).....	24
	2.7 Land Vehicle Maintenance Facility .....	54
	2.8 Automotive Technology Evaluation Facility (ATEF).....	54
	2.9 Perryman Test Area (PTA).....	56
	2.10 Phillips Army Airfield (PAAF).....	63
	2.11 Lift and Tie-Down Facility.....	64
	2.12 Automotive Laboratory Facilities .....	64
	2.13 Fire Control Test Facilities.....	72
	2.14 Scalable Net Centric Test Area (SNCTA) .....	80
	2.15 Rail Transport Facility.....	81
	3. YUMA TEST CENTER COURSES AND FACILITIES.....	82
	3.1 Endurance Courses .....	83
	3.2 Performance Courses.....	95
	3.3 Off-Site Courses .....	121
	3.4 Direct Fire Ranges.....	124
	3.5 Test Facilities .....	127
	3.6 Maintenance Facilities.....	143
APPENDIX	A. ABBREVIATIONS.....	A-1
	B. REFERENCES.....	B-1
	C. APPROVAL AUTHORITY.....	C-1

\*This TOP supersedes TOP 01-1-011A Vehicle Test Facilities at Aberdeen Test Center and Yuma Test Center, dated 27 February 2012.

---

Approved for public release; distribution unlimited.

1. SCOPE.

a. This Test Operations Procedure (TOP) describes the vehicle test facilities of the U.S. Army Aberdeen Test Center (ATC) at Aberdeen Proving Ground (APG), Maryland, and the Yuma Test Center (YTC) at Yuma Proving Ground (YPG), Arizona (as outlined in Tables 1 and 2). It is designed for use in planning tests of wheeled and tracked vehicles, including vehicular weapon systems. Specific procedures for wheeled and tracked vehicle endurance testing are found in TOP 02-2-506A<sup>1\*\*</sup>. This TOP does not include descriptions of the equipment and instrumentation used to obtain test data. The test facilities at ATC and YTC meet the needs of the vibration environment categories of Military Standard (MIL-STD)-810G CN1<sup>2</sup>, Procedure 514 Vibration.

TABLE 1. ATC COURSE COMPOSITION/LENGTHS AND FACILITIES

TOP SECTION NO.	TEST AREA	PAGE NO.	TEST AREA TYPE	FACILITY DIMENSION		
				METRIC	ENGLISH	
2.1 Churchville Test Area (CTA)	Hilly Cross-Country (Course A)	12	Severe, wooded and rocky terrain	Not Applicable (NA)	NA	
	Hilly Cross-Country (Course B)	12	Native soil and stone, grades to 29%	5.8 km	3.6 mi	
	Hilly Secondary Road (Course C)	13	Grades to 10%	2.4 km	1.5 mi	
	Prepared Soil Slopes	14	Grades of 10, 15, 20, 25, and 60%, Side slopes of 30 and 40%	37 to 183 m	120 to 600 ft	
	Harford Loop	14	Paved, rolling hills	29.8 km	18.5 mi	
	Conowingo Loop	14	Paved	74.8 km	46.5 mi	
2.2 Environmental Test Facilities	Multi-Purpose Environmental Chamber	15	Temperature range from -54 to 74 °C (-65 to 165 °F)	12.2 x 22.9 x 7.3 m	40 x 75 x 24 ft	
	Mobility Test Chamber	15	Temperature range from -54 to 74 °C (-65 to 165 °F)	9.1 x 18.3 m	30 x 60 ft	
	Firing Test Chamber	16	Temperature range from -54 to 74 °C (-65 to 165 °F)	12.2 x 12.2 m	40 x 40 ft	
	Vibration Facility	17	Electrodynamics Vibration System	177,929 N	40,000 lb	
	Climatic Simulation Facilities	Wind machine	17		161 km/hr	100 mph
		Stationary temperature – humidity chamber			2.9 x 2.4 x 2.0 m	9.5 x 7.9 x 6.4 ft
		Portable chambers			1.8 x 1.4 x 1.5 m	6.0 x 4.7 x 5.0 ft
		Solar radiation chamber			3.0 x 3.7 x 0.9 m	10 x 12 x 3 ft
		Altitude Chamber			2.4 x 3.5 x 3.0 m	8 x 11.5 x 10 ft
	Electromagnetic Interference Test Facility (EMITF)	18	Multiple chambers		28.7 x 18.3 x 8.5 m	94 x 60 x 28 ft

\*\* Superscript numbers correspond to Appendix B, References.



TABLE 1. CONT'D

TOP SECTION NO.	TEST AREA	PAGE NO.	TEST AREA TYPE	FACILITY DIMENSION	
				METRIC	ENGLISH
2.3 Dynamometer Course	Dynamometer Course	19	Bituminous concrete	1.6 km	1 mi
2.4 Mile Loop	Mile Loop	19	Paved and gravel	1.6 km	1 mi
	Winch Test Facility	20	Concrete base	NA	NA
	Pothole-Crosstie Course	20	Concrete potholes	61 m	200 ft
		21	Wooden crossties in concrete	40 m	132 ft
	1-Inch Bump Course	21	Iron rod in concrete	67 m	220 ft
Rain Towers	22	Two towers	9.1 m	30 ft	
2.5 Mountain Highway	Mountain Highway	22	Paved	64.4 km	40 mi
2.6 Munson Test Area (MTA)	Paved Road	25	Bituminous concrete	681 m	2235 ft
	Improved Gravel Road	26	Compacted gravel	3.2 km	2 mi
	Rolling Hill Course	26	Compacted stone/dust	620 m	2034 ft
	Sand Course	27	Washed beach sand	153 m	503 ft
	Rubble Pile	28	Large boulders, concrete, steel	30.5 m	100 ft
	Corrosion Facility	28	Various corrosive environments	NA	NA
	Abrasive Mud Course	29	Sand loam	73 x 290 m	240 x 950 ft
	Shallow Water Fording Basin	31	Concrete	82 m	270 ft
	Deep Water Fording Facility	32	Concrete	96 m	315 ft
	Amphibian Ramp	32	Bituminous concrete	6 x 15 m	21 x 50 ft
	Shallow Water Swimming Area	33	Channel, 3 m deep x 15 m wide (10 x 50 ft)	305 m	1000 ft
	Belgian Block Course	34	Granite blocks in concrete	1.2 km	0.75 mi
	Imbedded Rock Course	35	Granite stones in concrete	244 m	800 ft
	Side Slopes	36	Concrete: 20%	83 m	271 ft
			Concrete: 30%	220 m	723 ft
			Concrete: 40%	91 m	300 ft
	Longitudinal Grades	37	Asphalt: 5%	147 m	483 ft
			Asphalt: 10%	91 m	300 ft
			Asphalt: 15%	78 m	256 ft
			Asphalt: 20%	61 m	199 ft
			Concrete: 30%	45 m	149 ft
			Concrete: 40%	34 m	112 ft
			Concrete: 45%	18 m	59 ft
Simulated Loading Ramps	38	Concrete: 20 °	12 m	38 ft	
		Concrete: 15 °	6 m	20 ft	
2-Inch Washboard	40	Concrete	251 m	822 ft	
2- to 4-Inch Radial Washboard	41	Concrete	74 m	243 ft	
3-Inch Spaced Bump	42	Concrete	233 m	764 ft	
6-Inch Washboard	42	Concrete	243 m	798 ft	
Wave Course	43	Concrete	135 m	443 ft	

TABLE 1. CONT'D

TOP SECTION NO.	TEST AREA	PAGE NO.	TEST AREA TYPE	FACILITY DIMENSION	
				METRIC	ENGLISH
2.6 Munson Test Area (MTA)	Vertical Walls	44	Concrete and Wood	NA	NA
	Bridging Device	45	Steel	NA	NA
	Standard Ditch Profile	46	Concrete	7.8 m	25.5 ft
	Turning Circle	47	Concrete	76 m	250 ft
	Profile IV Course	48	Concrete	142 m	465 ft
	Marsh	49	Low soil strength, heavy vegetation	NA	NA
	Load Vibration Course	49	Concrete, gravel, and paved	2.9 km	1.8 mi
	Fuel Consumption Course	50	Gravel, paved	2.4 km	1.5 mi
	Urban Terrain Course	52	Concrete, gravel, and paved	5.6 km	3.5 mi
	Half Rounds for Ride Quality	54	Reinforced steel pipe	NA	NA
2.7 Land Vehicle Maintenance Facility	B338	54	Shop area of 45,000 square ft	4180 square m	45,000 square ft
2.8 Automotive Technology Evaluation Facility (ATEF)	High Speed Paved	55	Paved tri-oval with two lanes and a wide section.	7.2 km	4.5 mi
	High Speed Gravel	55	Bank run gravel tri-oval.	7.2 km	4.5 mi
	Vehicle Maneuvering Test Area (VMT)	55	Vehicle performance testing pad.	122 x 244 m	400 x 800 ft
2.9 Perryman Test Area (PTA)	Perryman No. 1	58	Moderate; native loam with quarry spall/gravel	8.4 km	5.2 mi
	Perryman No. 2	58	Moderately rough; native loam with quarry spall	2.9 km	1.8 mi
	Perryman No. 3	59	Rough; native loam	5.3 km	3.3 mi
	Perryman No. 4	60	Severe; native loam with natural marsh	4 km	2.5 mi
	Perryman No. 5	61	Extremely severe; Gabion (No. 6 stone)	305 m	1000 ft
	3-Mile Straight-Away	61	Bituminous concrete (including turnarounds)	6.1 km	3.8 mi
	Mud Bypass Course	61	Native loam prepared by tilling	610 m	2000 ft
	Secondary Road A	62	Unimproved country road, sweeping turns	3.9 km	2.4 mi
	PTA Ride Quality	62	Unimproved road, level straight-away	5.1 km	3.2 mi
	Figure 8	62	Native loam with gravel figure 8 course	772 m	2534 ft
	Dig Site 1	63	USCS Classification of SC-SM	482 m x 73 - 24 m	1580 ft x 240 - 80 ft
	Dig Site 2	63	USCS Classification of SM	27 - 37 m x 640 m	90 - 120 ft x 2100 ft
	Dig Site 3	63	USCS Classification of CL	165 m x 84 m	540 ft x 275 ft
Dig Site 4	63	USCS Classification of CL-ML	366 m x 30 m	1200 ft x 100 ft	

TABLE 1. CONT'D

TOP SECTION NO.	TEST AREA	PAGE NO.	TEST AREA TYPE	FACILITY DIMENSION	
				METRIC	ENGLISH
2.10 Phillips Army Airfield (PAAF)	PAAF	63	One runway	2438 x 61 m	8000 x 200 ft
2.11 Lift and Tie-Down Facility	Lift and Tie-Down	64	54 tons (metric) (60 tons) hydraulic load system	NA	NA
2.12 Automotive Laboratory Facilities	Automotive Engineering Test Facility (B436)	64	Shop area	2,790 square m	30,000 square ft
	Tilt Table	65	Steel platform	30.5 x 4.3 m	100 x 14 ft
	Roadway Simulator Complex	67	Roadway Simulator	36,300 kg	80,000 lb
		67	Vehicle Durability Simulator	11,800 kg	26,000 lb
		68	Tire Test Rig	NA	NA
		69	Shock Absorber Dynamometer	NA	NA
		70	Moment of Inertia Test Facility	63 tons (metric)	70 tons
	Powertrain Dynamometer Facility	71	Engine dynamometers rated at 350 hp and 600 hp	NA	NA
	Wheeled Vehicle Roller Brake Dynamometer	71	Brake forces up to 45 kN (10,000 lb) at axle weights up to 2000 kg (44,000 lb)	NA	NA
	Platform Scales	71	Vehicle weight up to 90,700 kg (200,000 lb)	NA	NA
Wheel Scales	72	Capacity of 9,072 kg (20,000 lb)	NA	NA	
2.13 Fire Control Test Facilities	Fire Control Test Ranges	72	Ranges for direct fire; moving target; cross-country courses	1.6 km	1 mi
	Tank Armament Test Range (Henry Field)	73	Direct fire range	3 km	1.9 mi
	Evasive Target Firing Range (TW I)	77	Evasive laser beam target	2.4 km	1.5 mi
	Moving Target Simulator	78	Air supported hemisphere	30.5 m radius	100 ft radius
	Multiple Target Firing Range (TW II)	79	Stationary vehicle/stationary target	4 km	2.5 mi
	Ride Quality Courses (Henry Field)	80	Gravel roads	100 to 162 m	330 to 530 ft
2.14 Scalable Net Centric Test Area (SNCTA)	Small Unmanned Ground Vehicle (SUGV) Test Course	80	Various surfaces and obstacles	37 x 67 m	120 x 220 ft
	Large Unmanned Ground Vehicle (LUGV) Test Course (Proposed)	81	Designed for safety and performance testing of LUGVs up to 9,100 kg (20,000 lb) gross vehicle weight	NA	NA
2.15 Rail Transport Facility	Rail Transport Facility	81	Facility/equipment to ensure compliance with Military Surface Deployment and Distribution Command transportation certification requirements	NA	NA

Notes:

km = kilometer	mi = mile	m = meter	ft = foot
°C = °Celsius	°F = °Fahrenheit	N = Newton	lb = pound
mph = miles per hour	hr = hour	in. = inch	SM = silty sand
hp = horsepower	kN = kilonewton	TW = Trench Warfare	ML = silt
USCS = unified soil classification system		SC = clayey sand	
CL = clay of low plasticity			

TABLE 2. YTC COURSE COMPOSITION/LENGTHS AND FACILITIES

TOP SECTION NO.	TEST AREA	PAGE NO.	TEST AREA TYPE	FACILITY DIMENSION	
				METRIC	ENGLISH
3.1 Endurance Test Courses	Patton Level Gravel	83	Compacted gravel	5.6 km	3.5 mi
	Patton Hilly Trails	83	Sand, gravel, rock, grades to 40%	4.2 km	2.6 mi
	Patton Level Trails	84	Level Sand, undulating terrain	10.5 km	6.5 mi
	Patton Hilly Gravel	84	Sand, gravel, rock, grades to 30%	8.0 km	5.0 mi
	Kofa High Speed Gravel	85	Compacted gravel	6.7 km	4.2 mi
	Kofa Level Gravel	85	Compacted gravel	4.8 km	3.0 mi
	Laguna Level Trails, East	86	Sand, gravel	4.5 km	2.8 mi
	Laguna Level Trails, West	87	Sand, gravel	9.0 km	5.6 mi
	Laguna Hilly Trails	87	Sand, gravel, rock, grades	3.3 km	2.1 mi
	Middle East	88	Loamy sand, gravel	33.3 km	20.7 mi
	Rock Ledge	89	Sand, cobbled rock	6.3 km	3.9 mi
	Desert March	90	Sand, gravel	40.8 km	25.4 mi
	Vapor Lock Wash	91	Gravel	4.0 km	2.5 mi
	Highway 95	91	Asphalt	80 km	50 mi
	3.2 Performance Test Courses	Longitudinal Grades	95	Concrete: 5%	37.8 m
Concrete: 10%				45.1 m	148 ft
Concrete: 20%				91.4 m	300 ft
Concrete: 30%				72.5 m	238 ft
Concrete: 40%				47.2 m	155 ft
Concrete: 60%				32.3 m	106 ft
Roll On/Roll Off Ship Ramps		96	Metal: 12°	18.3 m	60 ft
			Metal: 15°	14.6 m	48 ft
Side Slopes		97	Concrete: 10%	150.9 m	495 ft
			Concrete: 15%	151.2 m	496 ft
	Concrete: 20%		150.9 m	495 ft	
	Concrete: 30%		121.3 m	398 ft	

TABLE 2. CONT'D

TOP SECTION NO.	TEST AREA	PAGE NO.	TEST AREA TYPE	FACILITY DIMENSIONS	
				METRIC	ENGLISH
3.2 Performance Test Courses	Sand Grades	97	Sand: 5%	61 m	200 ft
			Sand: 10%	30 m	100 ft
			Sand: 15%	55 m	180 ft
			Sand: 20%	37 m	120 ft
	Fording Basin	98	Concrete (L x W)	67 x 25 m	220 x 82 ft
	Kofa Dust Course	99	Sand, Dust	3.2 km	2.0 mi
	Cibola Dust Course	100	Sand, Dust	6.3 km	3.9 mi
	Cibola Mud Course	100	Sand, Clay	152 m	500 ft
	Dyno Mud Course	101	Sand, Clay, Silt	0.6 km	0.4 mi
	Laguna Mud Course	101	Clay	0.6 km	0.4 mi
	Sand Dynamometer	102	Sand	NA	NA
	Ride Dynamics	103	Compacted Gravel	251 to 305 m	825 to 1000 ft
	Fuel Transfer and Test Site Area	103	Concrete Pad	12 m x 37 m	40 ft x 120 ft
	Airfield Delivery Loading Ramp	104	Concrete Pad	96 by 148 m	315 by 485 ft
	Half Rounds and Curb Impact Course	105	Asphalt with interchangeable half round drums	10, 15, 20, 25, 30 cm	4, 6, 8, 10, 12 in.
	C-130 Air Transportability Test Bed	106	C-130 Hulk	NA	NA
	Urban Rubble	107	Concrete boulders	91.4 m	300 ft
	Hot Weather Test Complex	108	Asphalt	7.2 km	4.5 mi
	Laguna High Speed Paved Oval	108	Asphalt	7.2 km	4.5 mi
	Laguna Paved	109	Asphalt	3.2 km	2.0 mi
	General Motors (GM) High Speed Circle Track	110	Asphalt	5.6 km	3.5 mi
	GM Vehicle Dynamics Pad	110	Asphalt	305 x 305 m	1,000 x 1,000 ft
	GM Performance Straight Track	110	Asphalt	4.8 km	3.0 mi
	GM Engineered Ride Road	110	Asphalt and concrete	5.0 km	3.1 mi
GM Belgian Block and Granite Block	111	Granite	76 m	250 ft	
Potholes Course	111	Steel potholes embedded in gravel	49.1 m	161 ft	
Vertical Steps	111	Concrete steps with replaceable timber edges	30, 46, 61, 76, and 91 cm	12, 18, 24, 30, and 36 in.	
"V" Ditch	112	Concrete: Direct Approach	7.6 m	25 ft	
		Concrete: Angled Approach	7.0 m	23 ft	

TABLE 2. CONT'D

TOP SECTION NO.	TEST AREA	PAGE NO.	TEST AREA TYPE	FACILITY DIMENSION	
				METRIC	ENGLISH
3.2 Performance Test Courses	MOUT Obstacle Course	113	Concrete Curb	4.3 m	14 ft
			Log obstacle	9.1 m	30 ft
			Washboard Terrain	6.1 m	20 ft
			9 in Half Rounds (length)	16.8 m	55 ft
			Steel Staircase (length)	6.1 m	20 ft
	Winch Test Facility	115	Concrete Deadman (max load) 578,000 N (130,000 lb)	NA	NA
	Lift/Tiedown Test Facility	115	Max Longitudinal Force 1,000,000 N (240,000 lb); Max Lateral Force 400,000 N (90,000 lb); Max Vertical Force 267,000 N (60,000 lb)	NA	NA
	Bridging Test Area	118	Sand and Gravel	NA	NA
3.3 Off-Site Courses	Tilt Table	120	Lifting Capacity 136,000 kg (300,000 lb)	3.7 m x 27 m	12 ft x 90 ft
	Boresight Slopes	120	Sand and Gravel	NA	NA
	Imperial Sand Dunes, CA	121	Loose Sand	48.3 x 64.4 km	30 x 40 mi
	Rail Impact	122	Rail	480 m	1,575 ft
	Safari (Interstate 8)	123	Paved Highway, Asphalt	560 km	348 mi
	Safari (Death Valley National Monument)	124	Paved Roads, Asphalt	295 km	183 mi
3.4 Direct Fire Ranges	Safari (Camp Navajo)	124	High Altitude (2,900 m (9,400 ft)), Steep Grades	NA	NA
	Safari (White Mountain Research Center)	124	High Altitude (4,300 m (14,200 ft)), Steep Mountain Grades	NA	NA
3.5 Test Facilities	Combat Systems Direct Fire Range	124	Sand and Gravel	2 x 7 km	1.2 x 4.5 mi
	Moving Target Range	126	Caswell Target Max Speed 32 kph (20 mph). Oehler Target Max Speed 18 kph (11 mph)	2500 m	1.6 mi
3.5 Test Facilities	Rain Facility (Rain and Blowing Rain)	127	Chamber (W x L x H)	6.1 x 12.2 x 4.1 m	20 x 40 x 13.5 ft
			Door (W x H)	9.6 x 5.5 m	31.5 x 18 ft
	Blown Air Dust and Sand System (BADSS)	128	Max Speed	96 km/hr	60 mph
			Diameter	1.8 m	6 ft
			Material Feed Rate	9 to 18 kg/min	20 to 40 lb/min
	Load Handling System (LHS) Simulators	129	Fabricated steel structure with LHS and hydraulic system	NA	NA
	Environmental Chamber with Weapons Firing Capabilities	130	Dimensions (L x W x H)	13.7 x 8.8 x 4.4 m	45 x 29 x 14.5 ft
			Door (W x H)	5.2 x 4.0 m	17 x 13.2 ft
			Firing Port (W x H) Caliber: Up to 8-inch artillery	1.2 x 5.2 m	4 x 17 ft
			Temperature Range -54 to +71 °C (-65 to +160 °F) Humidity: 5 to 95 percent RH	NA	NA

TABLE 2. CONT'D

TOP SECTION NO.	TEST AREA	PAGE NO.	TEST AREA TYPE	FACILITY DIMENSION	
				METRIC	ENGLISH
3.5 Test Facilities	Large Multipurpose Environmental Chamber (LMPEC)	131	Main Chamber (L x W x H)	13.1 x 6.1 x 3 m	43 x 20 x 10 ft
			Antechamber (L x W x H)	1.8 x 1.8 x 2.0 m	6 x 6 x 6.6 ft
			Door (W x H)	5.2 x 4.0 m	17 x 13 ft
			Firing Port (W x H) Caliber: Up to 40 mm	1.2 x 2.4 m	4 x 8 ft
			Temperature Range -54 to +71 °C (-65 to +160 °F) Humidity: 5 to 95 percent RH	NA	NA
	Climatic Simulation Facility (Vehicle Component Level Tests)	132	Hot/Cold with Humidity Chamber max temperature range: -57 to +82 °C (-70 to +180 °F)	NA	NA
			Hot with Humidity Chamber max temperature range: +4 to 82 °C (+40 to +180 °F)	NA	NA
			Cold without Humidity Chamber max temperature range: -57 °C (-70 °F)	NA	NA
			Hot/Cold without Humidity max temperature range: -54 to +63 °C (-65 to +145 °F)	NA	NA
			Altitude Chamber max altitude: 30,480 m (100,000 ft) max temperature range: -57 to +74 °C (-70 to +165 °F)	NA	NA
			Salt Fog Chamber max temperature range: +35 °C (+95 °F)	NA	NA
			Immersion Tank max temperature range: 113 L (4 cu ft)	NA	NA
			Solar Chamber max temperature range: +4 to +82 °C (+40 to +180 °F)	NA	NA
	Material Analysis Laboratory	135	Building Size	650 m <sup>2</sup>	7,000 ft <sup>2</sup>
	Starter Test Stand	138	ST-24 Computerized Starter Tester	NA	NA
Tire Maintenance Facility	139	Maintenance Facility	NA	NA	

TABLE 2. CONT'D

TOP SECTION NO.	TEST AREA	PAGE NO.	TEST AREA TYPE	FACILITY DIMENSION	
				METRIC	ENGLISH
3.5 Test Facilities	Tire X-ray Facility	139	LumenX 1027B Inspection System	NA	NA
	Hybrid Electric Facility	140	Facility and Load Banks	250 kW max	NA
	Vibration Facility	141	Six electromagnetic vibration systems	NA	NA
	Physical Test Facility	141	Physical measurements, non-destructive measurements, material properties testing, and mass properties testing	NA	NA
	Site 3 Drop Test Facility	141	Item Capacity and Height	454 kg at 9 m	1,000 lb at 30 ft
	12 Meter Drop Test Facility	142	Item Capacity and Height	1,800 kg at 18 m	4,000 lb at 60 ft
3.6 Maintenance Facilities	Operations and Maintenance Division Complex	143	Maintenance Facility with Secure Storage yard	892 m <sup>2</sup>	9,600 ft <sup>2</sup>
	Main Test Maintenance Facility	143	Maintenance Facility with Lighted Storage yard	8,300 m <sup>2</sup>	90,000 ft <sup>2</sup>
	Ancillary Test Maintenance Facility	144	Maintenance Facility with Lighted Storage yard	2,482 m <sup>2</sup>	26,712 ft <sup>2</sup>
	MT Test Maintenance Facility	144	Maintenance Facility	1486 m <sup>2</sup>	16,000 ft <sup>2</sup>
	Welding and Metal Shop Facility	144	Maintenance Facility	5,417 m <sup>2</sup>	58,310 ft <sup>2</sup>

b. The test facilities at ATC contain approximately 64 km (40 mi) of automotive test courses on more than 1320 hectares (3300 acres) of land. In addition, there are water areas and firing ranges for vehicle testing. Each automotive test course and facility is designed to meet a particular military vehicle specification and many exceed commercial standards. Information regarding test course severity is located in TOP 01-1-010A<sup>3</sup>.

c. The test facilities at YTC contain more than 100 miles of test courses. Although YTC spans over 1,300 square miles, the automotive endurance and performance courses and test facilities are situated within close proximity of each other within the southern portion of YTC, which allow for tailoring vehicle tests to any specified mission profile. Each automotive test course and facility is designed to meet a particular military vehicle specification and many exceed commercial standards. Information regarding test course severity is located in TOP 01-1-010A.



2. ABERDEEN TEST CENTER COURSES AND FACILITIES.

2.1 Churchville Test Area (CTA).

a. Purchased in 1942, this area is north of the town of Churchville, and borders the east side of Maryland Highway 136 and the south side of Deer Creek (Figures 1 and 2). It consists of 98.7 hectares (244 acres), located approximately 19 km (12 mi) from APG, and is used for endurance testing of all types of automotive vehicles. It is well suited for determining the durability and reliability of engines and power train systems.



Figure 1. Aerial view of Churchville Test Area.

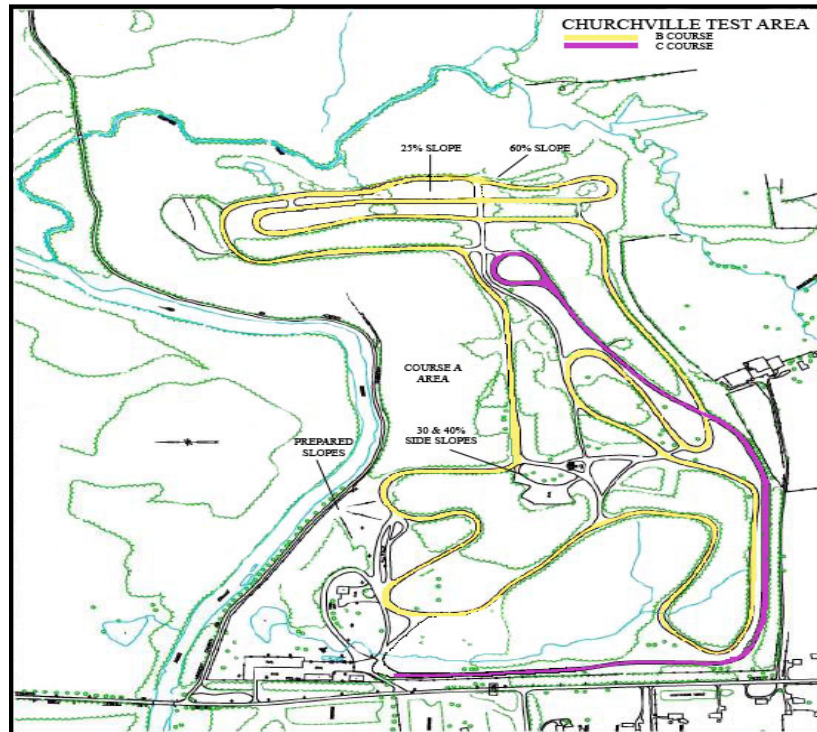

Figure 2. Topographic map of Churchville Test Area.

b. Hilly Cross-Country Courses.

(1) The entire Churchville area is characterized by a series of steep hills with grades as great as 30 percent, and is heavily wooded in some parts. Test courses are in closed loops over and around the hills.

(2) Course A, more accurately identified as an area, is the most severe of the hilly cross-country courses. It is heavily wooded and includes rocky terrain, ravines, grades as steep as 30 percent, and side slopes.

(3) Course B (Figure 3 and 4), consists of grades as steep as 29 percent. The terrain is native soil topped with bank run gravel ranging from muddy to dusty, depending on the weather.



Figure 3. Hilly Cross-Country Course B.



Figure 4. Hilly Cross-Country Course B.

(4) Course C is a 2.4-km (1.5-mi) secondary road with maximum grades of 10 percent and a turnaround at each end, as shown in Figure 2. The course is well suited for tests of trailers and semi-trailers. Soil side slopes of 30 and 40 percent are available for mobility and stability challenges.



c. Prepared Soil Slopes. These slopes are used for controlled tests to evaluate the tractive ability of vehicles. Five longitudinal grades: (1) 10 percent, 67 meters (220 ft), (2) 15 percent, 76 meters (250 ft), (3) 20 percent, 67 meters (220 ft), (4) 25 percent, 183 meters (600 ft), and (5) 60 percent, 37 meters (120 ft) are particularly useful for measuring mobility performance and for comparison tests of experimental and standard vehicles. Soil side slopes of 30 and 40 percent are available for mobility and stability challenges. The soil slope gradients can be reconfigured to suit specific test requirements with advanced planning. The soil type associated with the soil slopes conforms to the Unified Soil Classification System, type SC.

d. Harford Loop. This area is a paved, closed loop course comprised of local highways located north of the CTA. It is 29.8 km (18.5 mi) in length and is generally described as gentle rolling hills with grades ranging from 2 to 10 percent, and includes three stop signs and one traffic light. It is driven at posted speed limits ranging between 48 and 80 km/hr (30 and 50 mph) to determine vehicle fuel consumption characteristics. A mapping of the course, outlined in blue, is presented in Figure 5.

e. Conowingo Loop. This area is a paved, closed loop course, 74.8 km (46.5 mi) in length, comprised of segments of local and federal public highways located north of the CTA of ATC. The course is designed to satisfy requirements of Society of Automotive Engineers (SAE) procedures J1264<sup>4</sup>, J1321<sup>5</sup>, and J1526<sup>6</sup>, which are used to assess medium to heavy duty in-service vehicles. A mapping of the course, outlined in red, is presented in Figure 5.

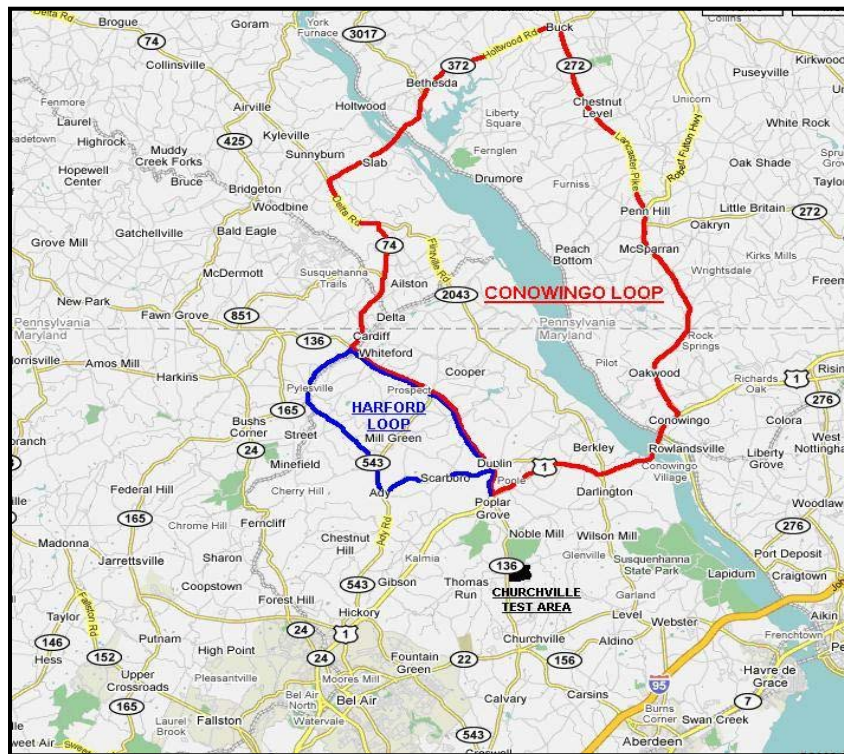

Figure 5. Harford Loop and Conowingo Loop map locations.

## 2.2 Environmental Testing Facilities.

The facilities described below are used for simulated environmental testing of a variety of equipment at ATC. Some of these chambers are of the proper size and capacity to accommodate automotive vehicles and allow the firing of a variety of weapons.

a. **Multi-Purpose Environmental Test Chamber.** This spacious multipurpose facility provides temperature, humidity, and icing testing capabilities meeting the requirements of MIL-STD-810G CN1. The chamber is 12.2 meters wide by 22.9 meters long by 7.3 meters high (40 ft wide by 75 ft long by 24 ft high) and is divided into two 12.2 by 11.3 meter (40 by 37 ft) chambers having independent climatic controls. Each chamber has a 4.9 by 4.9-meter (16 by 16 ft) door (Figure 6). The temperature range is -54 to 74 °C (-65 to 165 °F). An adjacent area is available for data acquisition and control instrumentation.



Figure 6. Multi-purpose Environmental Test Chamber.

b. **Mobility Test Chamber.** This chamber (Figure 7) is utilized for non-firing tests at extreme environmental conditions. The facility has two test cells each, approximately 9.1 m wide by 18.3 m long (30 ft wide by 60 ft long). Temperature conditions are variable from -54 °C (-65 °F) to 74 °C (165 °F) with 141.6 cubic meters per minute (cmm) (5,000 cubic feet per minute (cfm)) conditioned makeup air and exhaust systems. The facility also has a solar array used to simulate extreme solar environments.



Figure 7. Mobility Test Chamber.

c. Firing Test Chamber. This chamber (Figure 8) has large and small caliber firing capability at extreme environmental conditions. Extreme conditions are variable from  $-54\text{ }^{\circ}\text{C}$  ( $-65\text{ }^{\circ}\text{F}$ ) to  $74\text{ }^{\circ}\text{C}$  ( $165\text{ }^{\circ}\text{F}$ ) with 5,000 cfm conditioned makeup air and exhaust systems.

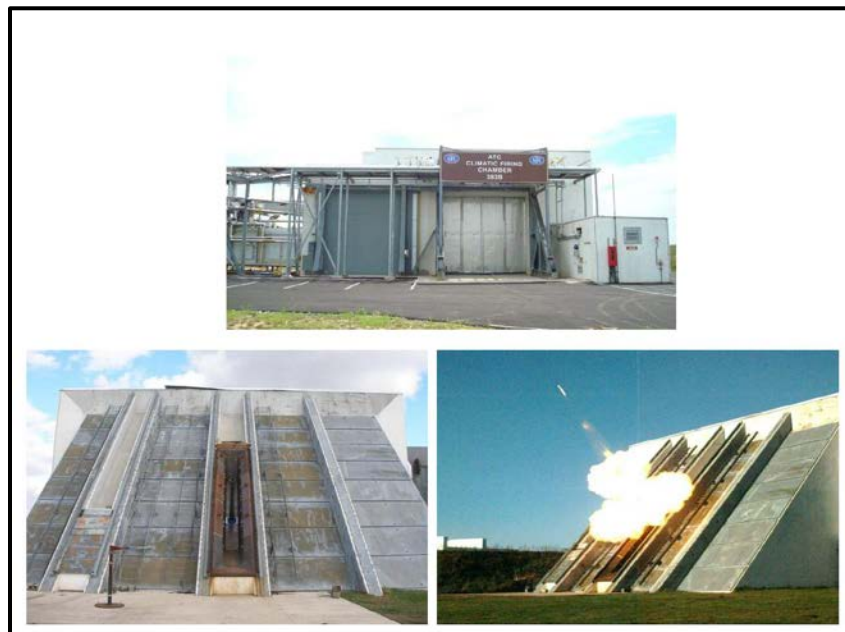

Figure 8. Firing Test Chamber.

d. **Vibration Facility.** Three remotely controlled electrodynamic vibration systems capable of testing to MIL-STD-810G CN1 are available. These systems are used for shock and vibration testing of vehicle components, equipment, weapons, and ammunition (Figures 9a and 9b). Laboratory vibration schedules are developed from field data. Vibration exciter force capabilities are available up to 178 kN (40,000 pound force) in single axis, three planes. The available temperature range available is from -54 to 74 °C (-65 to 165 °F).



Figure 9a. Vibration facility vertical exciter. Figure 9b. Vibration facility horizontal exciter.

e. **Climatic Simulation Facilities.** These facilities (some of which are shown in Figures 10a and 10b) provide climate test support in accordance with the test methods in MIL-STD-810G CN 1. Three portable wind machines generate up to 161 km/hr (100 mph) winds. In addition, a portable wind-driven rain machine produces 10 cm/hr (4 in./hr) of rain with up to 80 km/hr (50 mph) wind. Two stationary temperature-humidity chambers 2.9 by 2.4 by 2.0 m (9.5 by 7.9 by 6.4 ft) and nine portable units 1.8 by 1.4 by 1.5 m (6.0 by 4.7 by 5.0 ft) having temperature ranges -62 to 93 °C (-80 to 200 °F) with humidity up to 100 percent are available. A solar radiation chamber 3.0 by 3.7 by 0.9 m (10 by 12 by 3 ft) is also available. Pressurized water up to 345 kilopascals (kPa) (50 pounds per square inch (psi)) can be provided over a 3.7 by 7.3 m (12.0 by 24.0 ft) area. Steam pressure up to 103 kPa (15 psi) and 118 °C (245 °F) is available in a 2.1 m diameter by 3.7 m long (7 by 12 ft) vessel. Altitude Chamber 2.4 x 3.5 x 3 m (8 x 11.5 x 10 ft) capable of simulating 1524 m (5000 ft) at ambient temperature.



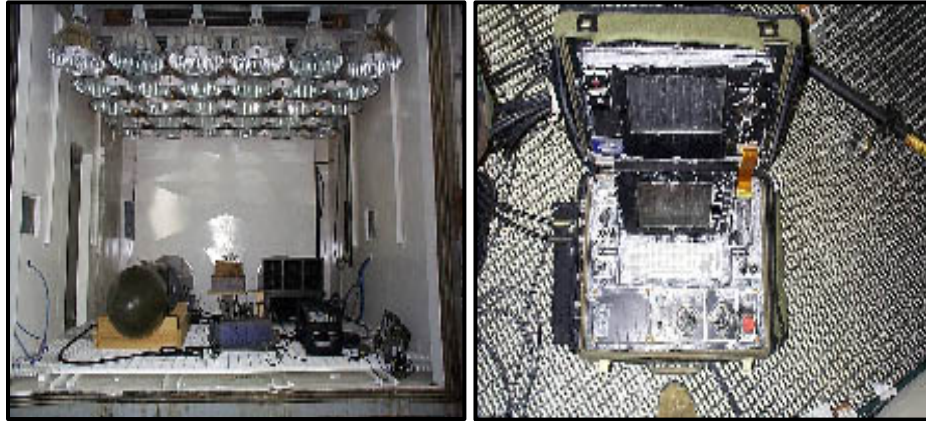

Figure 10a. Solar radiation chamber.      Figure 10b. Salt test.

f. Electromagnetic Interference Test Facility (EMITF). The facility consists of three test chambers, the largest of which measures 28.7 m long by 18.3 m wide by 8.5 m high (94 by 60 by 28 ft), making it large enough for combat vehicles, tactical trucks, large caliber weapons systems, and helicopters (Figure 11). Testing is available through the frequency range of 16 Hertz (Hz) to 40 Gigahertz (GHz), with susceptibility levels up to 200 volts per meter (V/m). Testing can be accomplished in accordance with Military, SAE, Comite International Special de Perturbations Radioelectriques (CISPR), and Federal Communications Commission (FCC) standards. The shielded enclosure has magnetic field attenuation of 40 decibels (dB), 14 Kilohertz (kHz) to 1 Megahertz (MHz), electric field attenuation of 90 dB, 14 kHz to 30 MHz, and plane wave attenuation of 90 dB, 30 MHz to 1000 MHz.

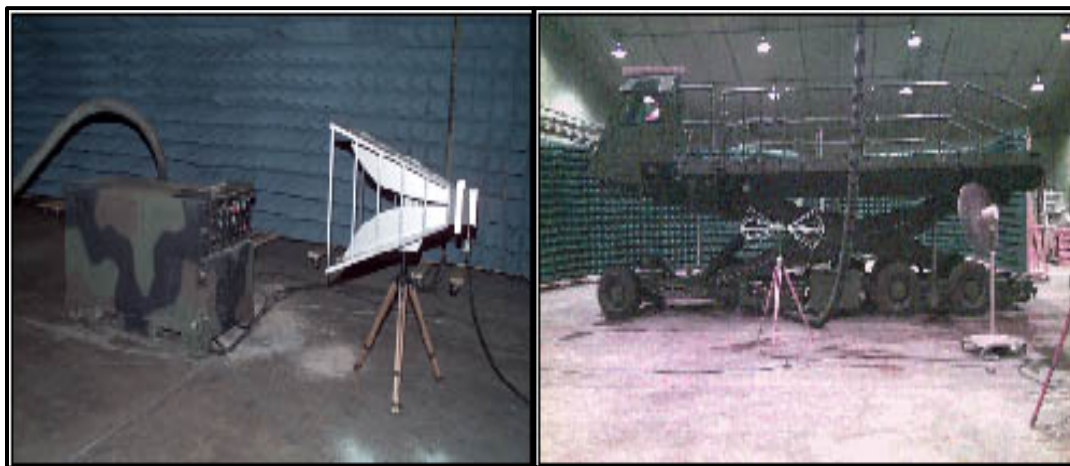

Figure 11. Electromagnetic Interference Test Facility.



### 2.3 Dynamometer Course.

a. This course, in the Michaelsville area of ATC, is constructed of reinforced concrete, with a hot mixed bituminous surface making it suitable for operations of the heaviest tracked vehicles. The course has a total gradient of less than 0.1 percent in its 1.6 km (1 mi) length, and turnarounds are provided at each end. It is used for closely controlled engineering tests such as drawbar pull (Figure 12), tractive resistance measurements, coast-down, braking, and fuel consumption. These tests are conducted at low to moderate speeds.



Figure 12. Drawbar pull test conducted on Dynamometer Course.

b. A gravel connector between the straight portions of the Perryman No. 1 course and Secondary Road A (Section 2.8) is referred to as the Dirt Dynamometer Course. It provides an approximately 2.4 km (1.5 mi) straight, level, dirt surface to allow dynamometer testing of steel-tracked vehicles which could damage paved surfaces.

### 2.4 Mile Loop.

a. This oval-shaped facility was originally constructed in 1933 as a level concrete course for continuous high-speed operating tests of vehicles (Figure 13). The Mile Loop consists of two straight sections, each 0.4 km (0.25 mi) long, joined at each end by 0.4-km sections of regular curvature to form an oval totaling 1.6 km (1 mi) in circumference. The curves are slightly banked at a gradient of 4 percent.



Figure 13. Aerial view of the Mile Loop.

b. The course has been modified by covering and maintaining the surface with hot mixed bituminous concrete and by adding a gravel surface parallel to and outside the oval. Located within the Mile Loop are additional facilities, as described below.

(1) Winch Test Facility. This device has a restraining capability of 445 kN (100,000 lb), and is used mainly as an anchor during winch performance and endurance testing.

(2) Pothole-Crosstie Course. This oval facility is situated on a concrete pad within the mile loop, and consists of a series of concrete potholes on one straight side of the oval, a series of wooden crossties on the opposite straight side, and two 10.7 meter (35 ft) radius gravel ends connecting the two straight sections.

(a) The pothole section consists of eight concrete potholes 5 m (17 ft) apart (8 m (25 ft) center to center) (Figure 14). Each pothole is 1.8 m (6.0 ft) wide, 2.4 m (8.0 ft) long, and 30.5 cm (12.0 in.) deep, sunk below the concrete surface. The sides of each pothole are sloped 45 percent (24.2 degrees) and the ends are sloped 100 percent (45 degrees). The total length of this segment of the course is 61 m (200 ft).

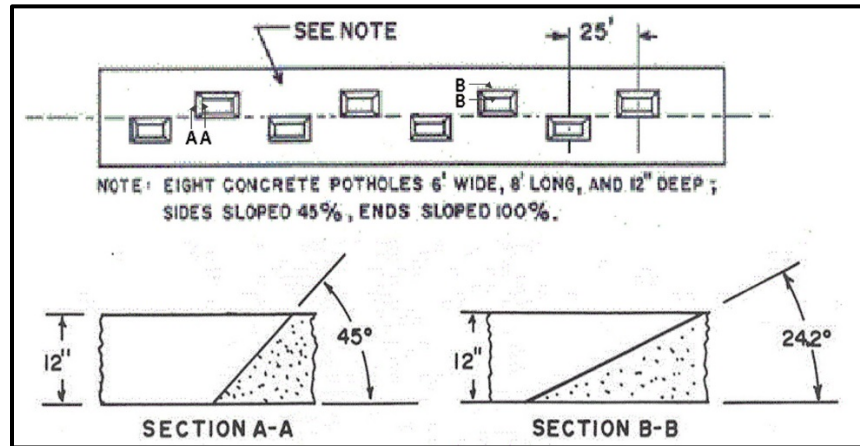

Figure 14. Pothole section of Pothole-Crossstie Course.

(b) The crossstie section of the course consists of 11 crosssties, 1.8 m (5.9 ft) long, 15.2 cm (6.0 in.) high, and 15.2 cm (6.0 in.) wide, mounted to the concrete surface by means of 7.6 cm (3.0 in.) angle iron. The ties are spaced at 3.7 m (12.0 ft) intervals (center to center) at alternate right and left sides of the course. The total length of this segment is 40.2 m (132 ft). Figure 15 shows a vehicle negotiating the Pothole-Crossstie Course.



Figure 15. Vehicle negotiating Pothole Test Course.

(3) 1-Inch Bump Course. The 2.5 cm (1 in.) bumps are iron rods, 4.3 m (14 ft) long, 5 cm (2 in.) wide and 2.5 cm high, mounted on the flat concrete surface in the center of the pothole-crossstie course. A total of 39 1-inch bumps are spaced at random 1.5 and 1.8 meter (5 and 6 ft) intervals perpendicular to the direction of travel. The course length is 67 m (220 ft).

(4) Rain Towers. The rain towers at ATC offer a dynamic rain course where personnel perform simulated combat activities. The course consists of two 9.1 m (30 ft) high towers that accommodate items up to 9.1 by 15.2 m (30 x 50 ft) in area and up to 7.6 m (25 ft) tall. The rain towers produce simulated free-falling rain of intensities up to 10.2 cm (4 in.) per hour. The rain course accommodates the evaluation of associated shelter support/restraint systems (stakes, guy lines, etc.), generators, environmental control units, and all other wheeled and tracked vehicles. Figure 16 shows the Rain Towers at ATC.



Figure 16. Rain Towers at Mile Loop.

## 2.5 Mountain Highway.

This is a 64 km (40 mi) mountainous section of U.S. Route 30 in the vicinity of Jennerstown, Pennsylvania. Considered one of the most severe areas in the region for brake fade testing, it is used by ATC and the brake-manufacturing industry for brake fade testing. With grades as steep as 11 percent and at various elevations (Figure 17), this section of public highway is admirably suited for testing military wheeled vehicle brakes (test procedures are described in TOP 02-2-608<sup>7</sup>). Standard test conditions are obtained by controlling speed, brake line pressure, and deceleration. Brake temperatures and pressures, and vehicle road speed and stopping distances are measured throughout the test. Figure 18 shows a test vehicle descending a mountain during the mountain brake endurance test.



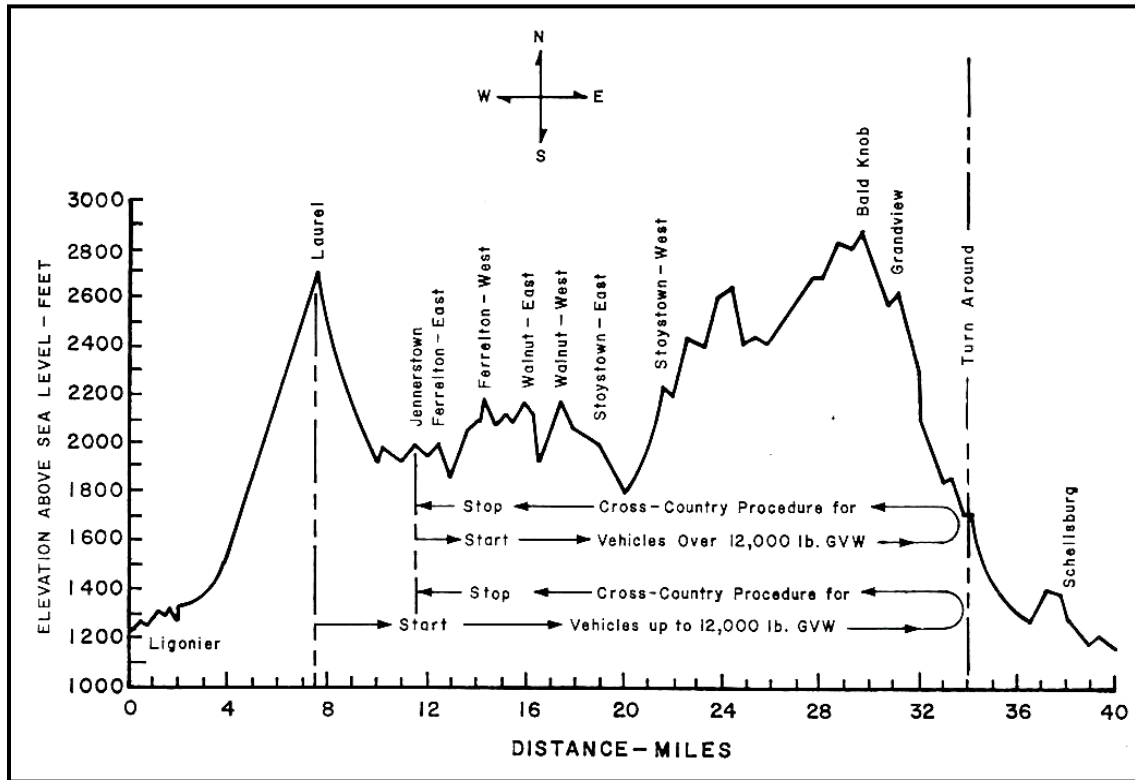

Figure 17. Profile of Mountain Test Course.



Figure 18. Test vehicle and data van / safety escort vehicle descending mountain.

2.6 Munson Test Area (MTA).

a. Located near the eastern boundary of APG and bordering the shores of the Spesutie Island Narrows portion of the Chesapeake Bay, the MTA encompasses about 60 hectares (150 acres) of land. The facility is named in honor of Lieutenant Max Munson who lost his life in 1941 while testing an experimental vehicle.

b. The test courses are designed for making specific measurements and determinations of vehicle performance in the field. All special obstacles and test roads were permanently constructed, and are maintained, according to specifications. The courses and network of connecting roads total 14.5 km (9 mi). Figure 19 shows relative locations of the courses, and Figure 20 is an aerial view.

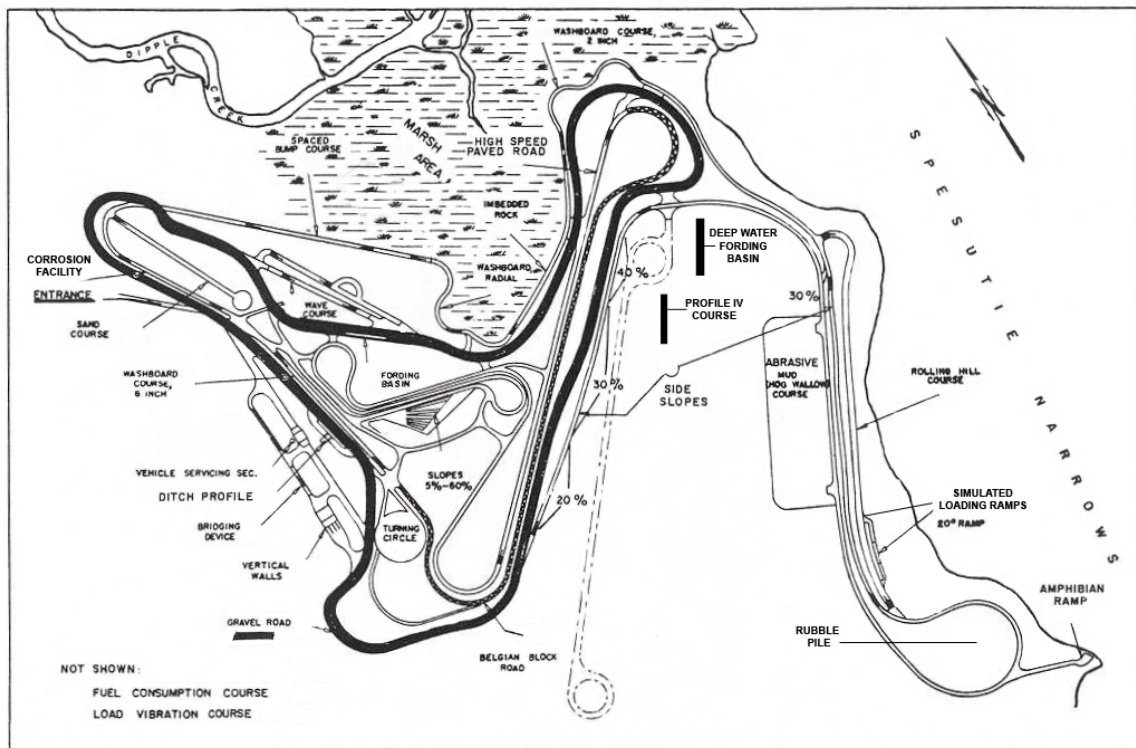

Figure 19. Munson Test Area.



Figure 20. Aerial view of Munson Test Area.

### 2.6.1 Paved Road.

This is a level road (Figure 21) that permits the operation of most military vehicles at high speed. It provides a sharp contrast in operating conditions when used as part of a loop including the Belgian Block Course.

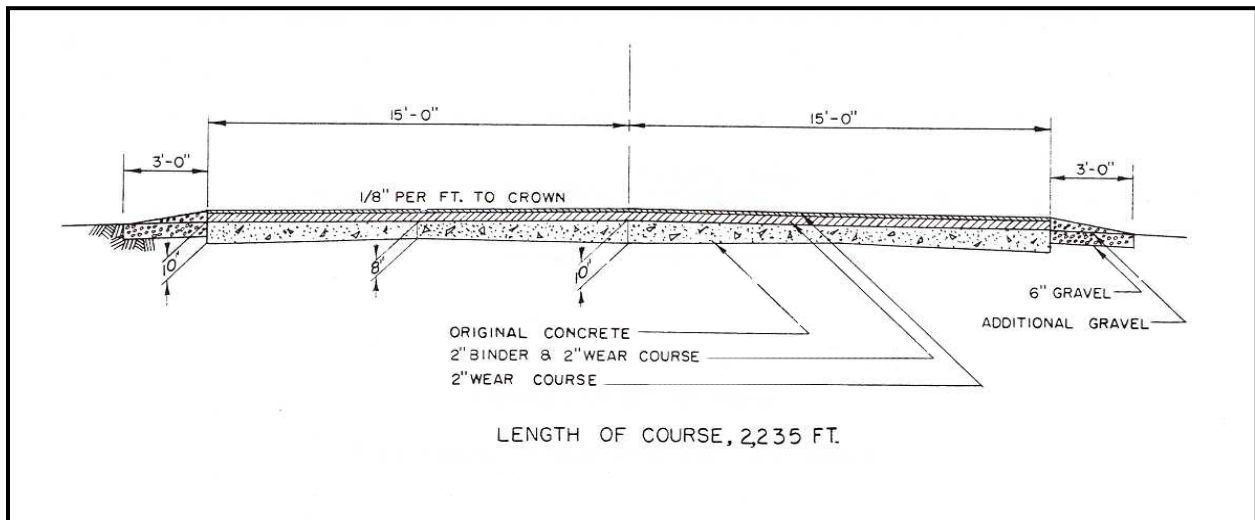

Figure 21. Cross section of Paved Road.

### 2.6.2 Improved Gravel Road.

This is a loop of about 3.2 km (2 mi) with left and right curves; the surface is compacted gravel maintained by grading (Figure 22). This gravel road (along with other test courses) is used for endurance testing.

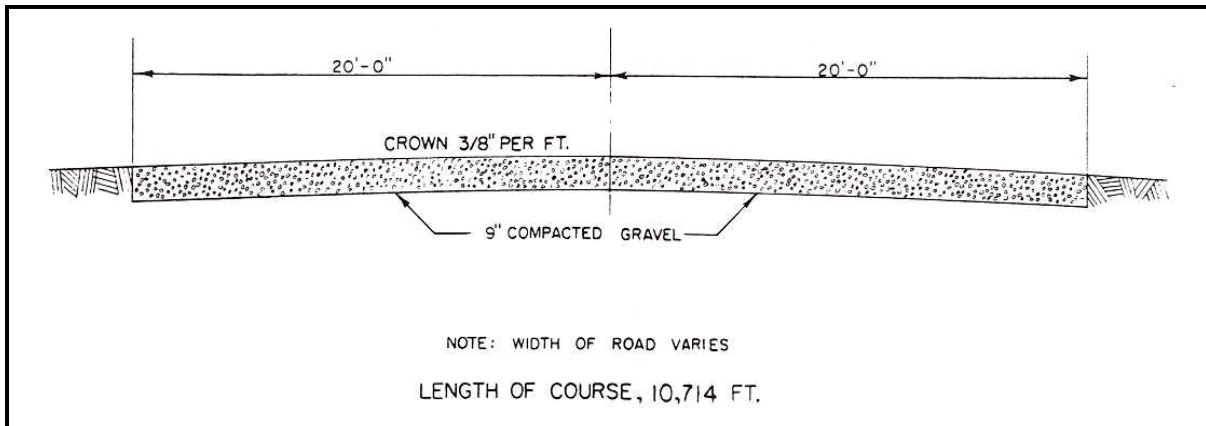

Figure 22. Cross-section of Improved Gravel Road.

### 2.6.3 Rolling Hill Course.

This was designed to provide short, closely spaced grades. As a vehicle alternates between up- and down-grades on this course (Figure 23), the engine and power train are subjected to rapid variations in loading. The surface consists of crushed stone compacted with stone dust binder.

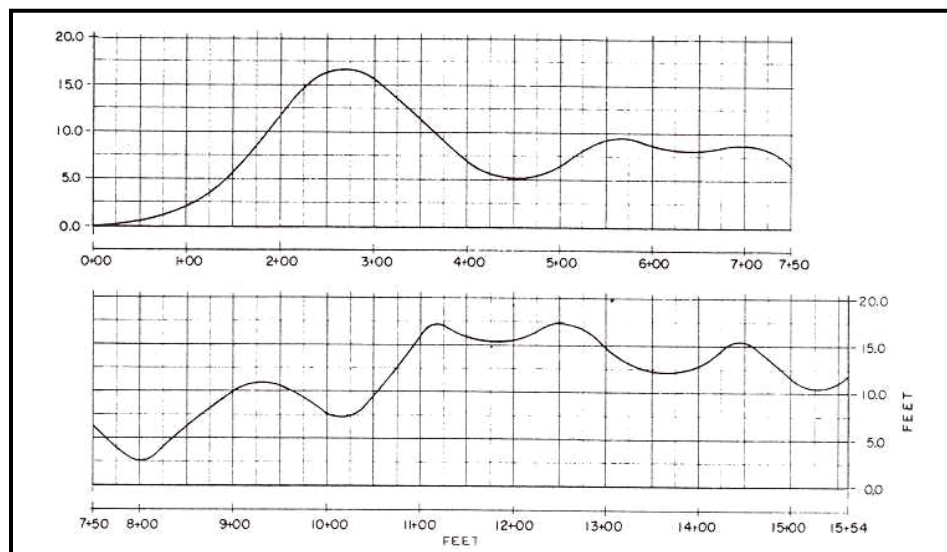

Figure 23. Profile of Rolling Hill Course.



#### 2.6.4 Sand Course.

This course provides a standard for evaluating drawbar pull of wheeled and track-laying vehicles under controlled conditions. The coarse grained sand, conforming to the Unified Soil Classification soil type SP (poorly graded sand), is contained in a concrete bin that facilitates tilling and drainage, and prevents contamination from the surrounding soil (Figure 24). The straight portion of the course has sufficient length to produce stabilized data for a given load and/or speed condition. The circular bed at the end of the course is useful for evaluating the ability of vehicles to steer in sand, and for determining track-throwing tendencies and the effect of sand accumulation in suspension systems. Figure 25 shows drawbar pull testing conducted on the Sand Course.

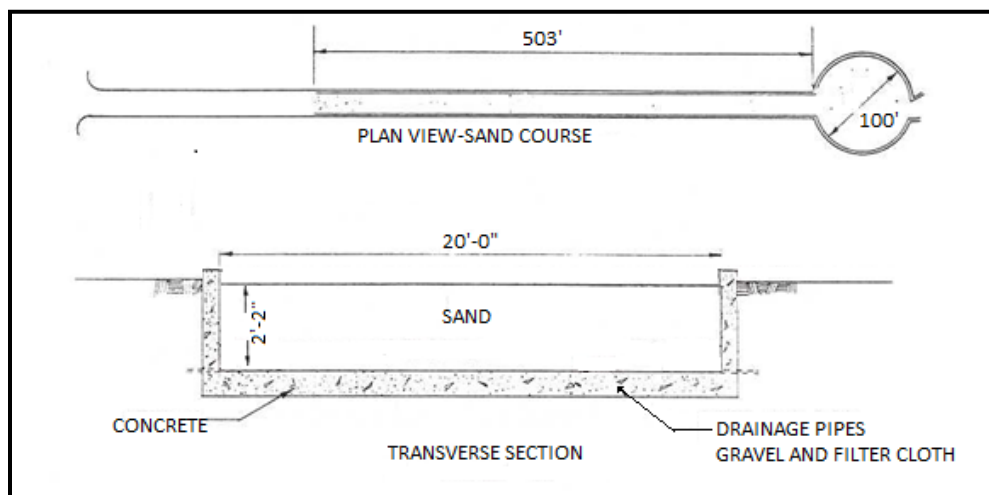

Figure 24. Plan view and transverse section of Sand Course.



Figure 25. Drawbar pull testing in Sand Course.

### 2.6.5 Rubble Pile.

The Rubble Pile course is approximately 30.5 m (100 ft) in length, consisting of large boulders and pieces of concrete and steel (Figure 26). A test on this course is conducted to determine a vehicle's ability to negotiate this type of obstacle.



Figure 26. Rubble Pile at MTA.

### 2.6.6 Corrosion Facility.

a. This facility provides aggressive controlled exposure of corrosive conditions to land systems to hasten their weathering process and determine susceptibility to the environments. Fifteen test cycles replicate one year of field corrosion; a 22-year corrosion assessment can be implemented in 200+ days.

b. Each test cycle includes a series of individual corrosive environments (Figure 27): Splash Trough – 22.9 m long x 6.1 m wide (75 ft long x 20 ft wide), solution depth up to 5 cm (2 in.) subjected to undercarriage; Mist Booth – 18.3 m long x 4.6 m wide x 4.6 m high (60 ft long x 15 ft wide x 15 ft high) up to 3-minute mist applied to top and vertical surfaces; Grit Trough – 22.9 m long x 4.3 m wide (75 ft long x 14 ft wide), slurry depth up to 0.2 m (8 in.) subjected to undercarriage; High Heat / High Humidity Chamber – 12.2 m long x 6.1 m wide x 6.1 m high (40 ft long x 20 ft wide x 20 ft high), up to 74 °C (165 °F), 1 to 2 milliliter per hour (mL/hr) condensate; Deep Water Fording Basin – 57.9 m long x 6.7 m wide (190 ft long x 22 ft wide) with adjustable water depth up to 2.1 m (84 in.), and a 3-percent sodium chloride (NaCl) solution which replicates ocean environment. Facilities instrumentation and equipment are used to provide identification, analysis, and documentation of corrosion to the test item.



Figure 27. Accelerated Corrosion Complex.

### 2.6.7 Abrasive Mud Course.

Also known as the hog wallow, this facility (Figure 28) has an independent piped water supply that provides the means for maintaining muddy conditions, regardless of the season. The soil is sandy, with some clay and silt, making it particularly useful for evaluating the effects of abrasion on seals, brakes, and other components, as well as the effectiveness of seals. The ability to control the moisture content in dry periods makes it possible to adjust the course conditions and soil strength profile (within limits) to suit test requirements of any particular vehicle. The soil conforms to the Unified Soil Classification System soil type SM. The course can be tilled to various depths to a maximum of 0.8 m (2.8 ft). The course is 73 by 290 m (240 by 950 ft). Figure 29 shows a vehicle undergoing crossing velocity testing on the Abrasive Mud Course. Figure 30 shows the Abrasive Mud Course under wet conditions.

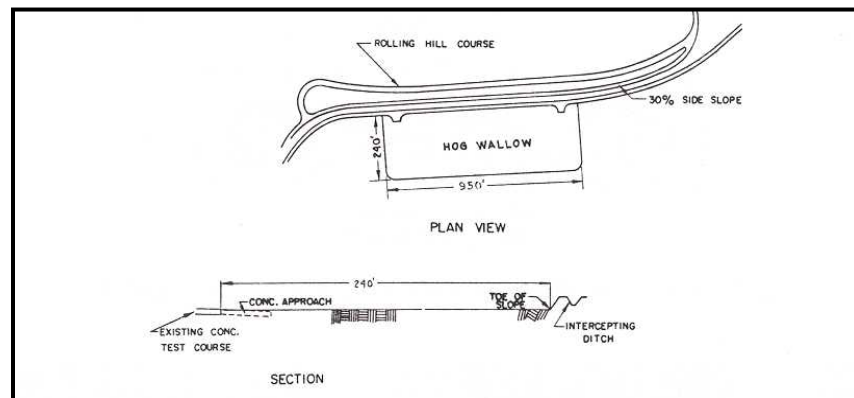

Figure 28. Plan view and section, Abrasive Mud Course.





Figure 29. Crossing velocity test in the hog wallow.



Figure 30. Abrasive Mud Course under wet conditions.

### 2.6.8 Shallow Water Fording Basin.

Also known as the bathtub, this concrete facility was designed to provide still water at controlled depths to 1.5 m (5.0 ft) (Figures 31 and 32). Ramps at both ends permit gradual immersion if desired. Length and width of the basin are sufficient for running preliminary flotation tests on some amphibious vehicles. The main uses of the basin are for determining fording characteristics of non-floating vehicles and for studying the effects of water on running gear components such as brakes, seals, and universal joints. The length of this course is 82 m (270 ft).

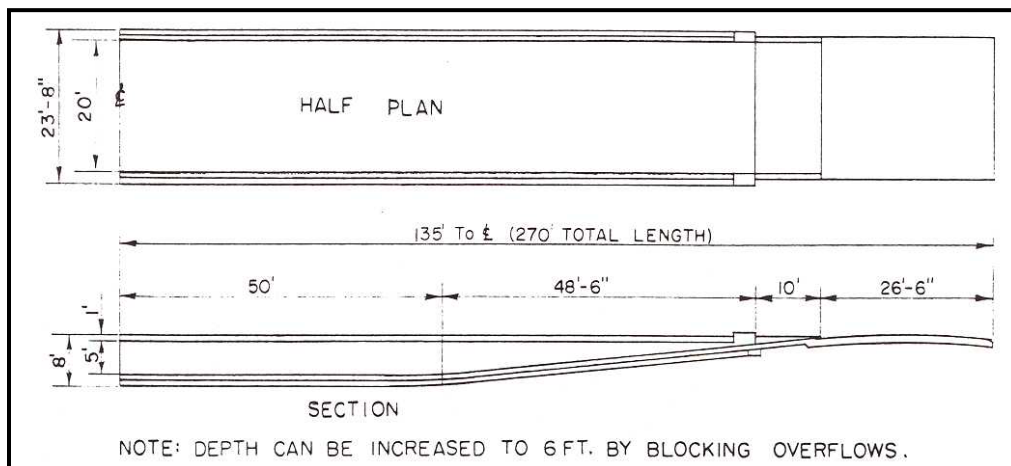

Figure 31. Half plan and section views, Fording Basin.



Figure 32. Fording Basin.

### 2.6.9 Deep Water Fording Facility.

Some vehicles can neutralize water obstacles by submerging. Vehicle effectiveness while submerged is tested in this concrete facility (Figure 33), in which water depths can be adjusted to 6.1 m (20 ft). Performance and safety of operations are evaluated under water and on the 40- and 50-percent entrance and exit slopes. The length of this facility is 96 m (315 ft).

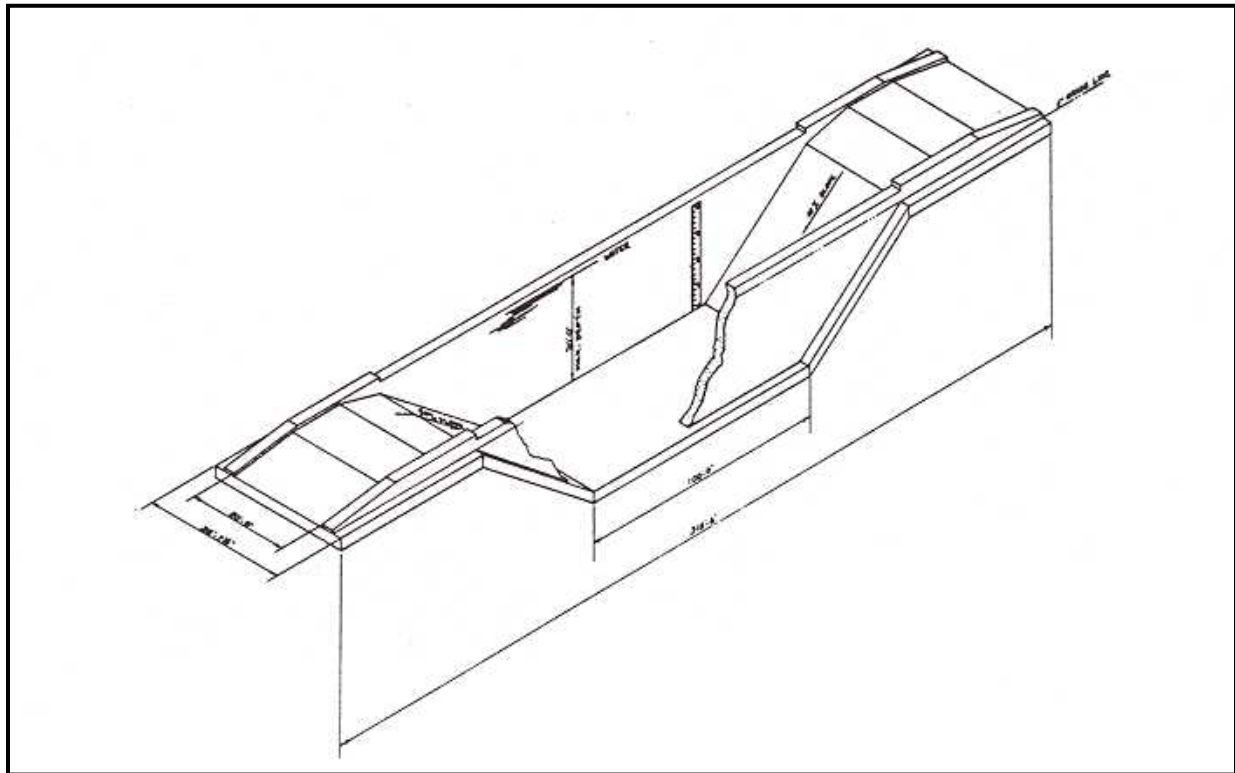

Figure 33. Underwater Fording Facility.

### 2.6.10 Amphibian Ramp.

This is used for evaluating the ability of vehicles to enter and leave a natural body of water by means of an articulated concrete mat which is composed of concrete blocks and cables. It is anchored in place, and the blocks are filled with aggregate (Figure 34). The moderately sloped ramp extends into the water sufficiently to permit the safe launching of test vehicles whose flotation characteristics are known. The ramp is an ideal location for conducting bollard pull for marine vehicles and amphibians (Figure 35). For water entrance and exit interface tests, earthen slopes are constructed by grading. The ramp is 15 m (50 ft) wide and 6 m (21 ft) long.



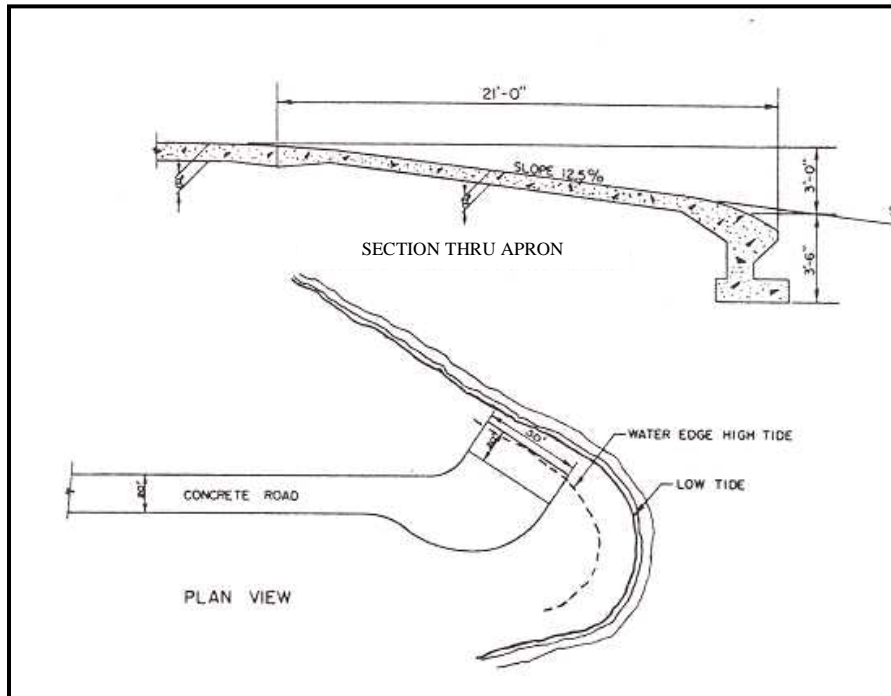

Figure 34. Plan view and section, Amphibian Ramp.



Figure 35. Bollard pull using mobile field dynamometer.

#### 2.6.11 Shallow Water Swimming Area.

The Spesutie Island Narrows has a 305 m (1000 ft) channel typically 3 m (10 ft) deep and 15 m (50 ft) wide suitable for evaluating the swimming and floating capabilities of amphibious

vehicles in still water (Figure 36). Fuel consumption and speed tests, as well as tests to evaluate floating bridges and rafts, are conducted here. Entrance to the Spesutie Narrows is by way of the amphibian ramp. The Spesutie Narrows leads to deeper waters of the Chesapeake Bay where additional testing may be conducted if necessary. Rather large vessels, such as landing craft, can gain access to the MTA through the Chesapeake Bay and the Spesutie channel.



Figure 36. Shallow water swimming.

#### 2.6.12 Belgian Block Course.

This facility is paved with unevenly laid granite blocks forming an undulating surface (Figures 37 and 38). It duplicates the rough cobblestone road found in many parts of the world. About 1.2 km (0.75 mi) long, the course is useful as a standard rough road for accelerated tests of wheeled vehicles, and is generally included in cycles of courses used for vibration studies. The motion imparted to a vehicle is a random combination of roll and pitch and high-frequency vibrations imparted by the granite paving blocks. Belgian Block course is not a closed loop and must be paired with either MTA Paved or MTA Improved Gravel Road.

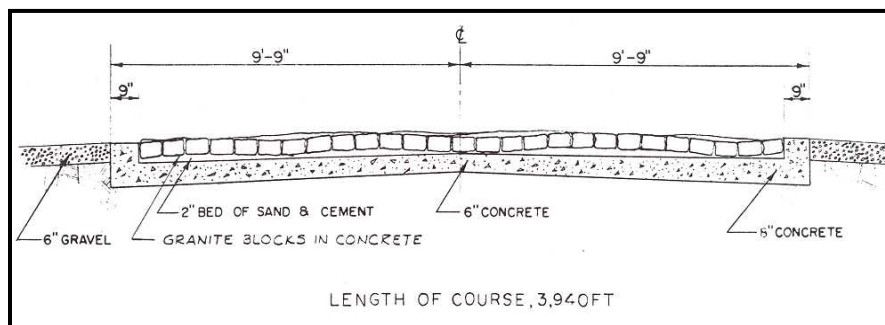

Figure 37. Transverse section, Belgian Block Course.







Figure 40. Endurance testing using Imbedded Rock Course.

#### 2.6.14 Side Slopes.

Side slopes of 20, 30, and 40 percent are used as standards for testing the stability and controllability of tactical vehicles (Figures 41 and 42). In addition to being used in engineering tests to measure steering efforts and lateral loading effects, the courses are sufficiently long to be incorporated in endurance tests involving other types of operation. A 1.8 m (5.9 ft) level gravel shoulder adjoining the slopes permits operation at gradients less than those of the actual slopes. When required for specific tests, side slopes with other gradients are constructed with a grader. The course lengths are shown in Table 1.

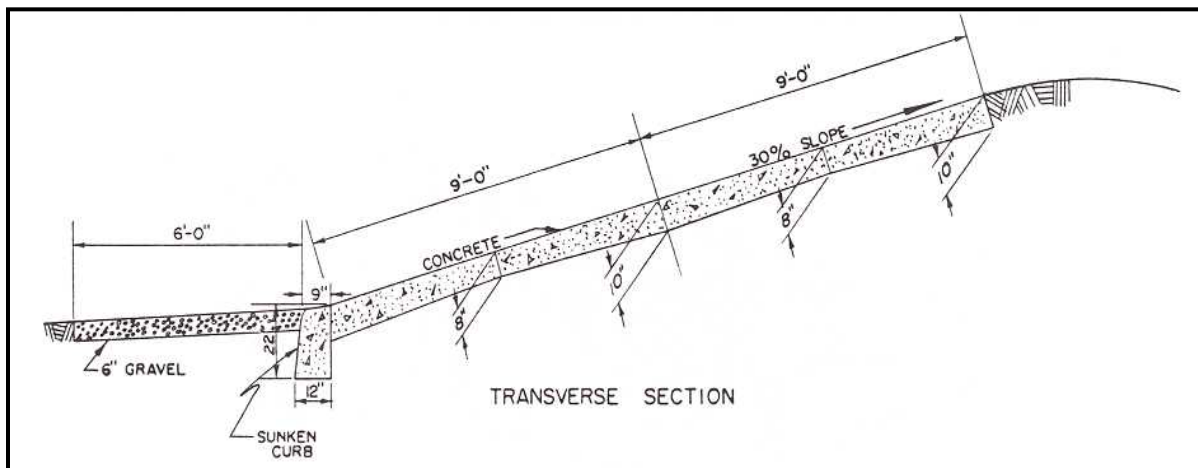

Figure 41. Transverse section of 30-percent side slope.



Figure 42. Vehicle negotiating the 20-percent side slope.

#### 2.6.15 Longitudinal Grades.

Gradeability of vehicles is a basic characteristic usually given in design specifications of military vehicles. The MTA longitudinal grades (Figures 43 and 44) cover a range of 5 to 60 percent. They are used to determine optimum drive ratios and maximum attainable speeds on each grade, as well as brake-holding ability and adequacy of angles of approach and departure. With the test vehicle in ascending and descending attitudes, functions such as lubrication, fuel flow, and fuel system performance are investigated. The effect of imbalance on turret-traversing efforts and functioning of turret drive systems may also be studied on the grades. The 5-, 10-, 15-, and 20-percent grades, about 4.3 m (14 ft) wide, are paved with asphalt; the 30-, 40-, 45-, 50-, and 60-percent slopes with concrete. A 7-percent vertical grade is asphalt. The grade lengths are shown in Table 1.

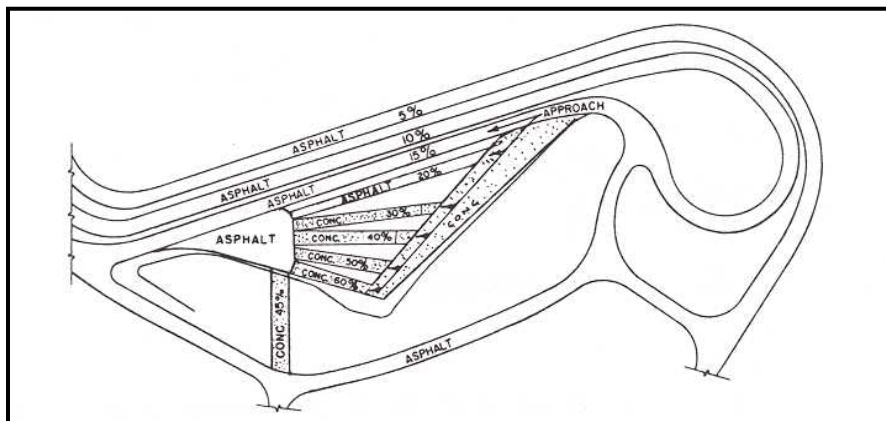

Figure 43. Plan view of Longitudinal Grades.



Figure 44. Vehicle ascending 60-percent longitudinal grade.

2.6.16 Simulated Loading Ramps.

Tactical vehicles designed for transportation by either aircraft or ramp-equipped landing craft must be capable of entering and leaving the transporting vehicle by means of an inclined surface or ramp. Two concrete simulated loading ramps, one with a 20-degree incline, 12 m (38 ft) long (Figure 45) and the second, with a 15-degree incline, 6 m (20 ft) long (Figure 46), enable vehicles to be tested not only for adequacy of approach and departure angles, but also for adequate ground clearance and freedom from interference at the point of articulation between towing and towed vehicles (Figure 47).

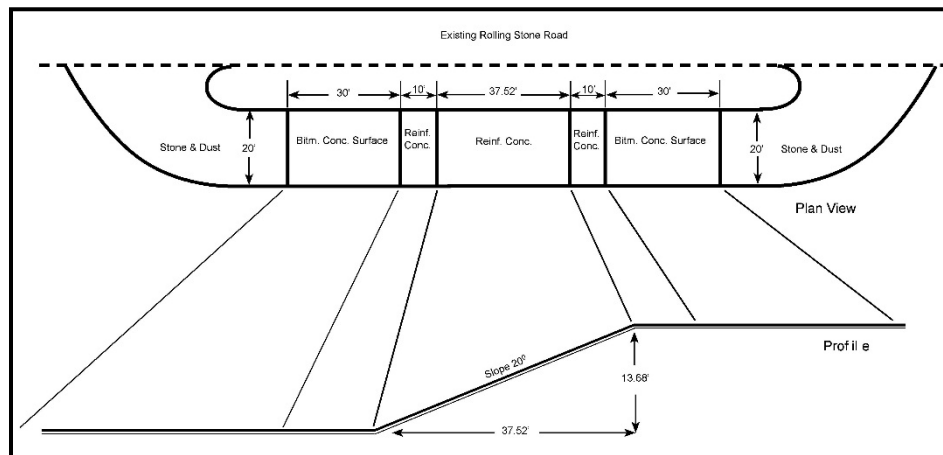

Figure 45. Plan view and section of 20-degree simulated loading ramp.





Figure 46. Vehicle on 15-degree simulated loading ramp.



Figure 47. Vehicle on 20-degree simulated loading ramp.

2.6.17 2-Inch Washboard.

The test course (Figure 48) is comprised of regular undulations with a wavelength of 0.6 m (2.0 ft) and provides a regular series of periodic humps with a crest to trough height of 5.1 cm (2 in.) for testing wheeled vehicle suspensions (Figure 49). It can be used for one phase of endurance tests involving other courses in the area. Shocks imposed on the vehicle are influenced by design factors such as axle spacing and wheel size.

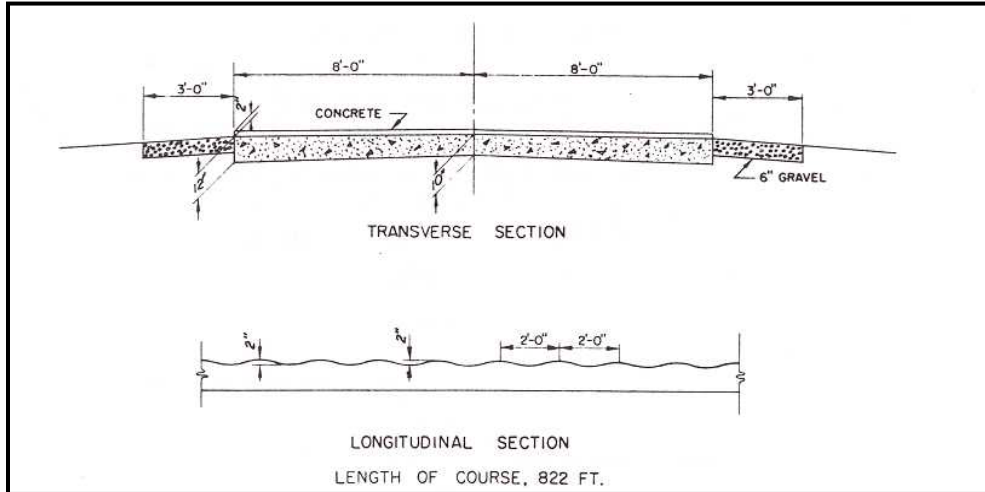

Figure 48. Sections of 2-Inch Washboard.



Figure 49. Testing wheeled vehicle suspension on 2-Inch Washboard Course.



2.6.18 2- to 4-Inch Radial Washboard.

This course is constructed using reverse curves in such a manner that the wheels of a test vehicle are subjected to impacts at varied frequencies for any given speed (Figure 50). The course is useful for evaluating wheel fight and tendencies toward front-wheel shimmy (Figure 51).

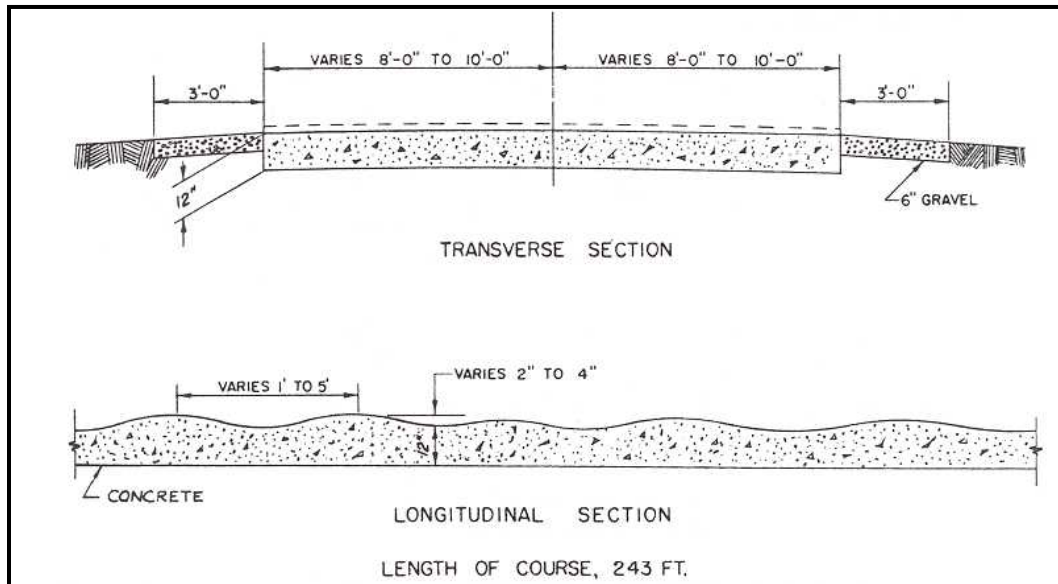

Figure 50. Sections of Radial Washboard.



Figure 51. Vehicle testing on the 2- to 4-Inch Radial Washboard Course.

2.6.19 3-Inch Spaced Bump.

This course gives a vehicle an irregular jolt by means of 7.6 cm (3 in.) rounded sections that cross the road surface at various angles (Figure 52). The spacing allows the suspension to settle down between jolts. This course is used mainly to impose shock and vibration stress on wheeled vehicle suspensions.

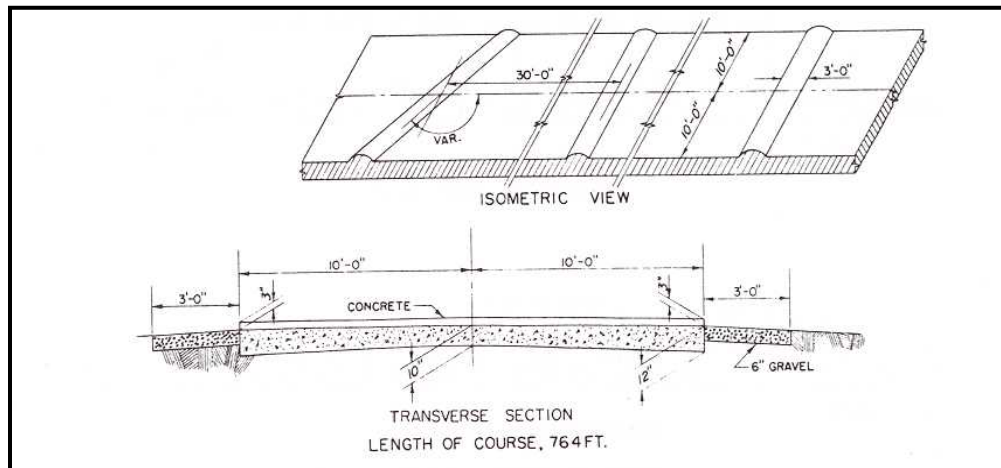

Figure 52. Isometric view and section of 3-Inch Spaced Bump.

2.6.20 6-Inch Washboard.

This course is the most severe of the regular washboard courses, and is designed to evaluate vehicle pitching characteristics (Figure 53). The pitching is induced at various speeds. The relatively large radius of the wave configuration and the 1.8 m (6 ft) intervals ensure that the larger wheels and track pitches ordinarily do not bridge the depressions.

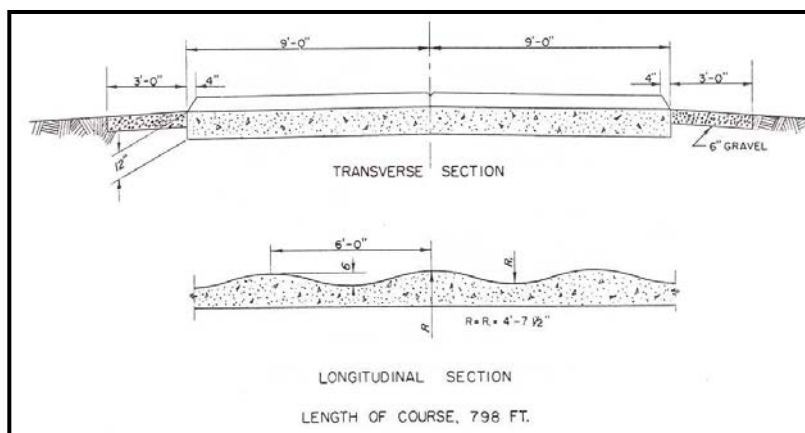

Figure 53. Sections of 6-Inch Washboard.



### 2.6.21 Wave Course.

Also known as the frame twister, this concrete course (Figures 54 and 55) is designed to deflect the opposite wheels of a vehicle in alternately contrary directions. Articulation of the suspension increases with tread width. The course provides a severe test of differentials and universal joints, as well as suspensions. Distortion of vehicle bodies is checked by operating doors, dump bodies, engine hoods, etc., after stopping the vehicle with the suspension at extremes of vertical travel.

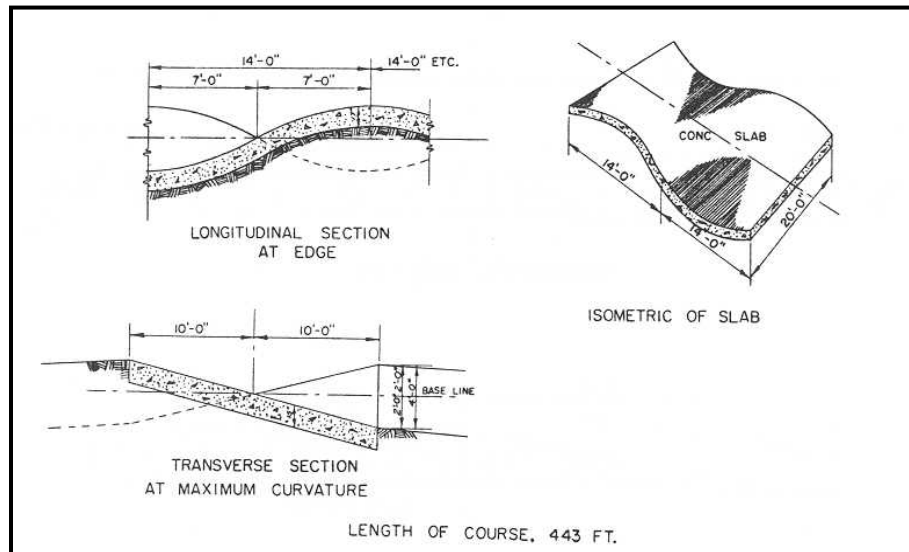

Figure 54. Sections of Wave Course.



Figure 55. Vehicle negotiating the Wave Course.

2.6.22 Vertical Walls.

Wall-climbing ability is a characteristic that is measured for all tactical vehicles. Maximum capability may be limited by projections from the vehicle that extend beyond the wheels or tracks. The vertical wall (Figures 56 and 57) is equipped with replaceable timbers at the top so that the wall may be maintained in a standard condition following damage from tests.

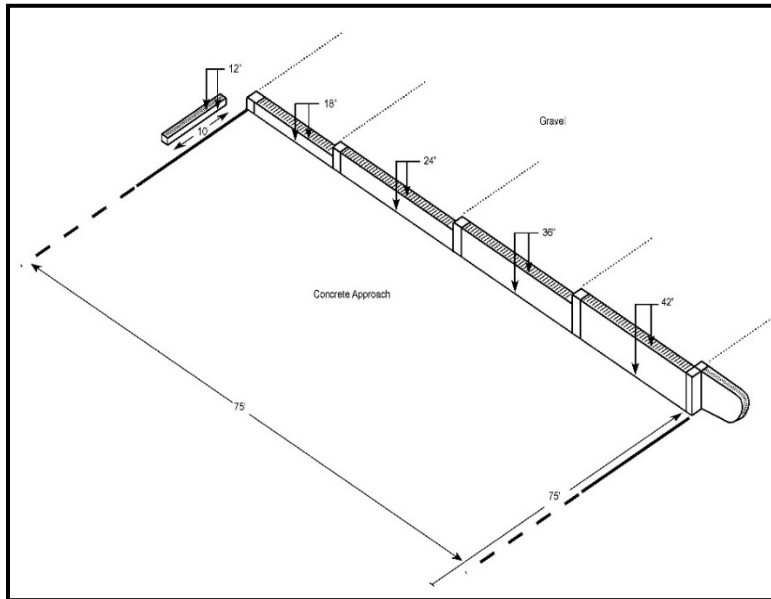

Figure 56. Isometric view of Vertical Walls.



Figure 57. Vehicle ascending the 18-inch Vertical Wall.

### 2.6.23 Bridging Device.

The bridging requirement for various types of tracked vehicles is usually specified in the technical characteristics or design specifications. The steel bridging device provides an adjustable gap for measuring the maximum opening that the vehicle can cross unsupported (Figures 58 and 59). The maximum gap is 5.5 m (18 ft).

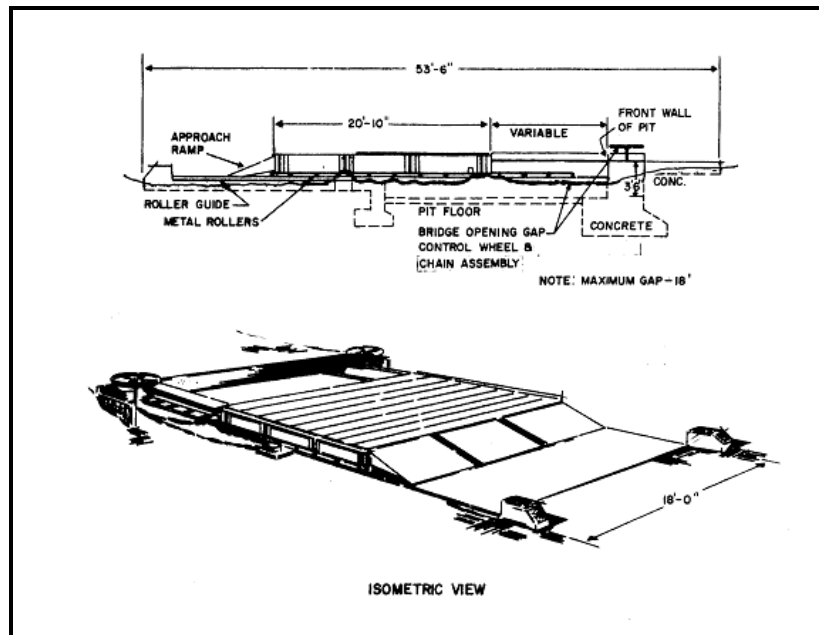

Figure 58. Plan and isometric view of the Bridging Device.



Figure 59. Vehicle negotiating the Bridging Device.

2.6.24 Standard Ditch Profile.

The standard concrete ditch is used to check the adequacy of the angles of approach and departure of tactical vehicles (Figures 60 and 61). Tracklayers usually require rubber tracks for sufficient traction for pulling out of the ditch. The ditch has a 36.5-percent gradient for both ingress and egress.

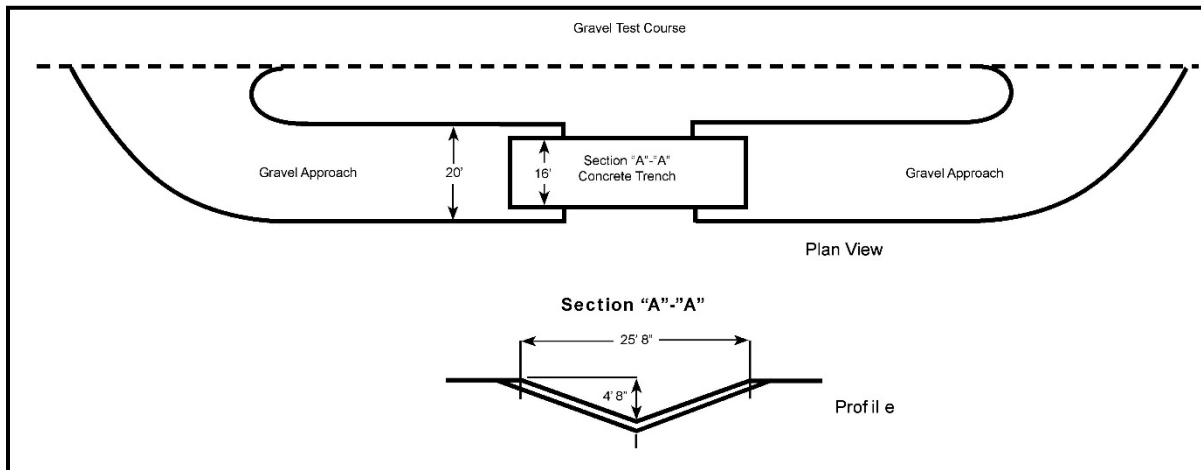

Figure 60. Plan and section view of standard ditch.



Figure 61. Vehicle negotiating the standard ditch.



### 2.6.25 Turning Circle.

This course is used for measuring vehicle turning diameters on a hard surface (Figure 62). It is large enough, at a diameter of 76 m (250 ft), to permit figure-8 turns by the largest vehicles and for plotting limits of vision (Figure 63). It is also used for other activities requiring a large and essentially flat concrete surface.



Figure 62. Measurement of vehicle turning diameter on the Munson Turning Circle.

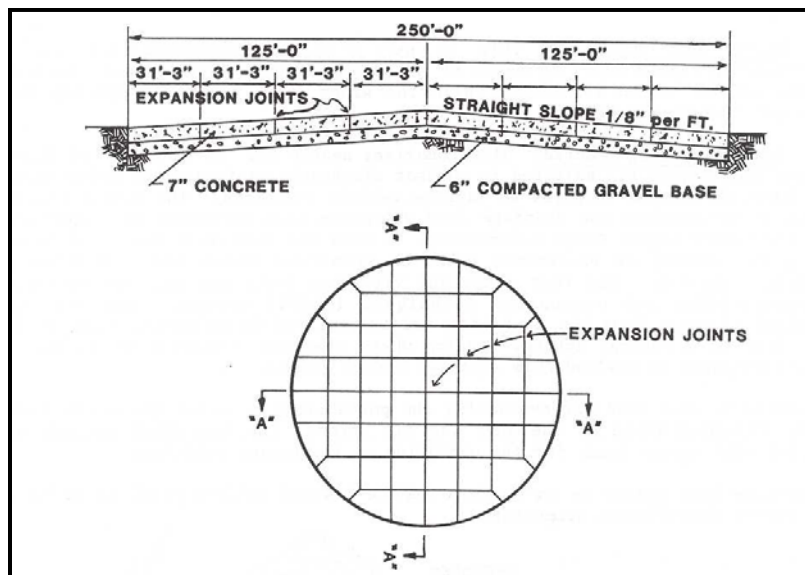

Figure 63. Section and plan view of Turning Circle.



2.6.26 Profile IV Course.

The Profile IV Course consists of a series of eleven different types of bumps (some of which are repeated) distributed over a 142 m (465 ft) long concrete course. The height (displacement) of each of the bumps was computed for each inch of longitudinal travel. The course layout is shown in Figure 64. An M1 tank traversing the MTA Profile IV Course is shown in Figure 65.

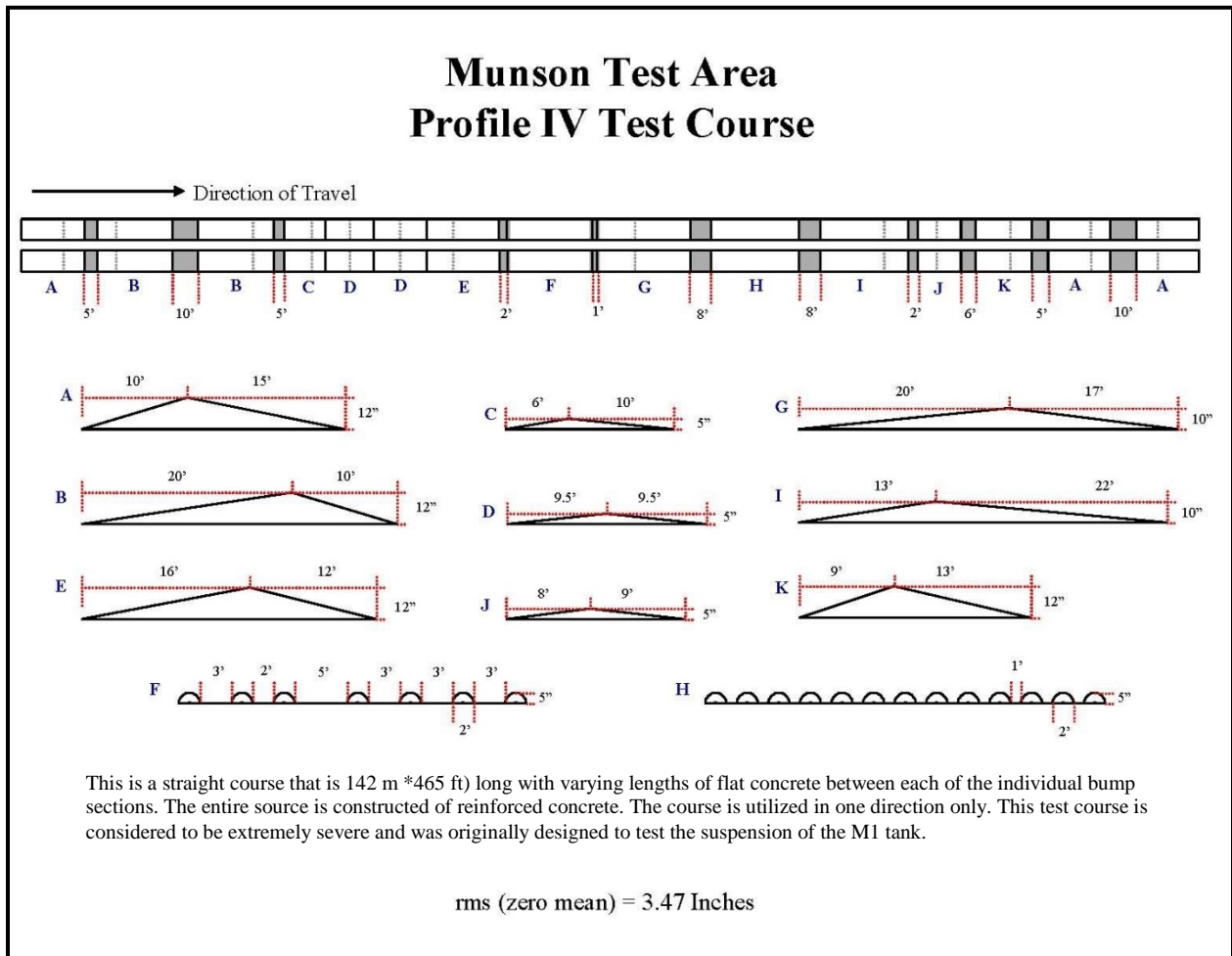

Figure 64. MTA Profile IV Test Course layout.



Figure 65. Abrams tank traversing the MTA Profile IV Test Course.

#### 2.6.27 Marsh.

a. Between the Munson area and Dipple Creek is a marsh with marginal soil strength that represents adverse conditions for mobility testing. The marsh has a heavy growth of vegetation, much of which is periodically flooded by tidal action. The area is ideally suited for single pass vehicle cone index tests and is a significant mobility challenge for conventional and marginal terrain vehicles. The soil type is classified as conforming to the USCS soil type MH (silt of high plasticity).

b. Around the edge of the marsh, a water filled simulated jungle trail has been cut in a woody area by vehicular traffic. It passes through heavy vegetation consisting of vines, swamp grass, and matted roots.

#### 2.6.28 Load Vibration Course.

a. This comprises nearly 2.9 km (1.8 mi) of MTA courses (Figure 17) selected to subject electronic equipment and other sensitive loads in wheeled vehicles to various vehicle reactions. The course is arranged to accommodate the standard load vibration test developed in cooperation with the former Signal Corps Laboratories at Fort Monmouth, New Jersey as a means for determining the ability of electronic units to withstand shock and vibration in specified vehicles. The course layout of the Standard Load Vibration test is outlined in Figure 66.

b. The course is also used for evaluating the portability of other special military loads, including those of the Navy and Air Force.

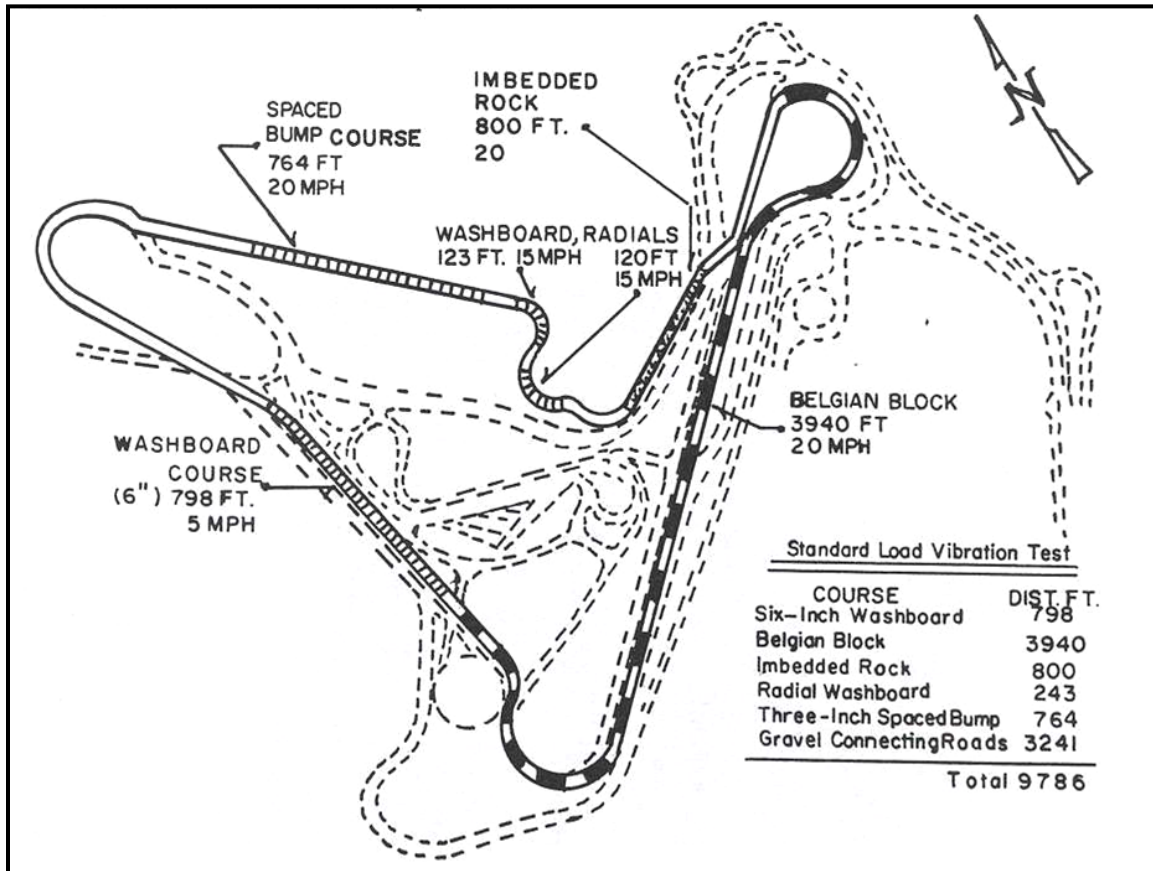

Figure 66. Load Vibration Course.

2.6.29 Fuel Consumption Course.

This course is a loop of gravel and paved road surfaces with longitudinal grades totaling 2.4 km (1.5 mi). The course is used for a specific standard test (TOP 02-2-603A<sup>8</sup>), in which the vehicle is operated around the loop a specific number of times in both clockwise and counterclockwise directions (Figure 67). Fuel consumption data are recorded and used for evaluating vehicle design, vehicle comparison, and determining the fuel consumption rate that might be expected under field conditions. The course layout of the Fuel Consumption Course is described in Table 3.

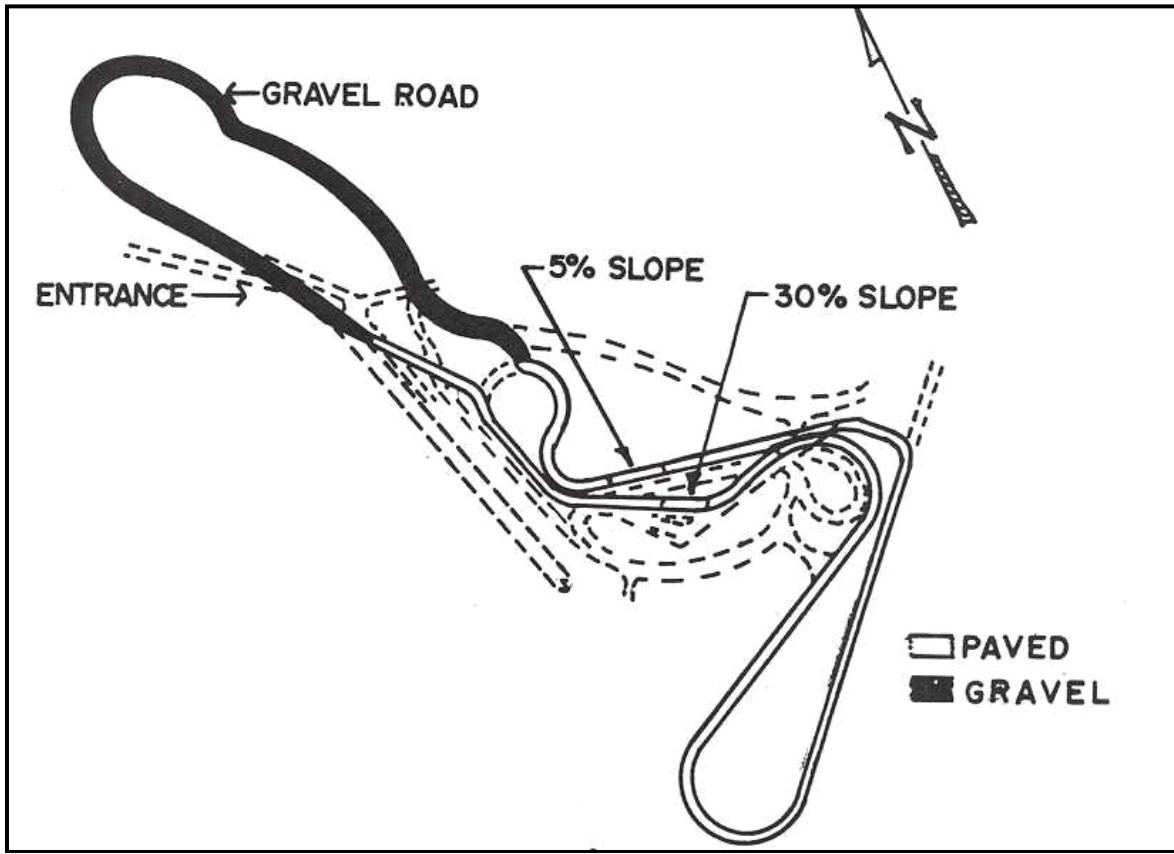

Figure 67. Fuel Consumption Course.

TABLE 3. FUEL CONSUMPTION COURSE

SURFACE	GRADE, %	OPERATING DISTANCE <sup>a</sup>			
		CLOCKWISE		COUNTERCLOCKWISE	
		meters	feet	meters	feet
Gravel	Less than 1	828	2718	828	2718
Bituminous concrete	Less than 1	1198	3930	1198	3930
	1 to 5	142 up	467 up	142 down	467 down
	5	147 down	483 down	147 up	483 up
	15	78 down	256 down	78 up	256 up
Concrete	30	45 up	149 up	45 down	149 down
Total		2439	8003	2439	8003

Note a: Included are short lengths of approach roads in addition to the centerline dimensions of individual test course.



2.6.30 Urban Terrain Course.

This course is a loop of graded gravel- and concrete-paved roads totaling 5.6 km (3.5 mi) (Figure 68). The concrete-paved road is 3.5 km (2.2 mi) or 65 percent of the total profile. The test vehicle is operated in clockwise and counterclockwise directions, with stop and go, maneuverability, and obstacle negotiation challenges. The layout of the Urban Terrain Course is described in Table 4.

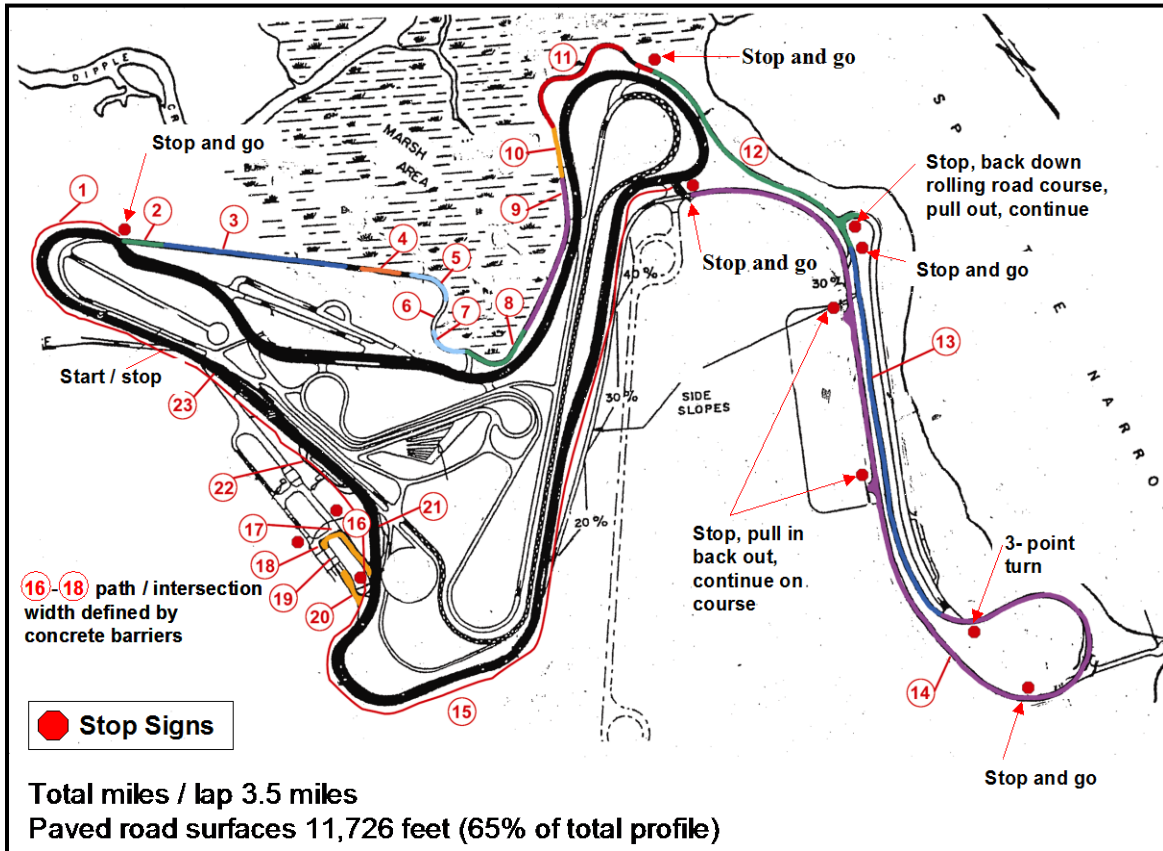

Figure 68. Urban Terrain Course

TABLE 4. URBAN TERRAIN COURSE

COURSE SEGMENT	CONSTRUCTION	ATTRIBUTE/VEHICLE CHALLENGE	LENGTH meters <sup>a</sup>	LENGTH feet <sup>a</sup>	TOTAL meters	TOTAL feet
1	Compacted gravel	Acceleration, steering, braking	322	1056	322	1056
2	Bituminous concrete	Corduroy road surface (approach to spaced bumps)	<b>110</b>	<b>360</b>	432	1416
3	Concrete 3-inch spaced bump	Vibration, suspension exercise	<b>229</b>	<b>750</b>	660	2166
4	Rough concrete	Mild vibration	<b>73</b>	<b>240</b>	733	2406
5	Concrete radial washboard	Vibration, steering and suspension exercise	<b>37</b>	<b>120</b>	770	2526
6	Smooth concrete	Allows suspension to settle	<b>35</b>	<b>115</b>	805	2641
7	Concrete radial washboard	Vibration, steering and suspension exercise	<b>37</b>	<b>120</b>	842	2761
8	Concrete serpentine path	Steering	<b>148</b>	<b>485</b>	989	3246
9	Imbedded rock	Tire performance, steering, vibration	<b>244</b>	<b>800</b>	1233	4046
10	Brushed smooth concrete	Allows suspension to settle	<b>30</b>	<b>100</b>	1264	4146
11	Concrete 2-inch washboard	Suspension, steering, vibration	<b>251</b>	<b>822</b>	1514	4968
12	Bituminous concrete	Moderate speed, sweeping turns, slight grade	<b>402</b>	<b>1320</b>	1917	6288
13	Rough concrete sideslope 30%	Stability, steering performance, lateral loading of suspension, tires, etc	<b>515</b>	<b>1690</b>	2431	7978
14	Bituminous concrete loop (poorly maintained primary road)	Moderate speed, steering, acceleration, braking	<b>1400</b>	<b>4594</b>	3832	12,572
15	Compacted gravel	Moderate speed, steering, acceleration, braking	1013	3325	4845	15,897
16	Loose gravel	Maneuverability (low speed w/90° steer required)	79	260	4925	16,157
17	Deteriorated concrete/gravel	Maneuverability (low speed w/90° steer required)	<b>24</b>	<b>80</b>	4949	16,237
18	Rough concrete	Maneuverability (low speed w/90° steer required)	<b>40</b>	<b>130</b>	4989	16,367
19	18-inch vertical step	Obstacle negotiation/maneuverability, tire performance	N/A	N/A	N/A	N/A
20	Loose gravel (return to Munson gravel)	Hard steer (>135°) to return to Munson gravel	102	335	5090	16,702
21	Compacted gravel	Acceleration, steering	108	355	5199	17,057
22	Gravel and concrete (V-ditch)	Obstacle negotiation/maneuverability, tire performance, power	83	270	5281	17,327
23	Compacted gravel to starting point	Acceleration, braking	198	650	5479	17,977

Note a: Bold italic font denotes concrete road surfaces totaling 3,574 m (11,726 ft) (65% of total profile).

### 2.6.31 Half Rounds (MTA).

These obstacles are reinforced steel pipes cut in half longitudinally of 10, 15, 20, 25, and 30 cm (4, 6, 8, 10, and 12 in.) radii affixed to a level, gravel course. They are used to address the shock portion of ride quality testing.

### 2.7 Land Vehicle Maintenance Facility.

a. This facility (Figure 69) is comprised of 4,180 square meters (45,000 square feet) of interior bay space that includes 13 maintenance bays, an electric/battery shop, an engine test cell, and a closed-loop steam cleaning facility.

b. The shop facility provides maintenance/diagnostic analysis to direct support/general support level for prototype, standard/production, and foreign systems and rebuild capability for electrical components/systems, hull/chassis assemblies, and power train components.



Figure 69. Land Vehicle Maintenance Facility.

### 2.8 Automotive Technology Evaluation Facility (ATEF).

The ATEF (Figure 70) is a phased project, specifically engineered as a concentric multi-surface, paved and gravel high-speed test track. The flat, 7.2 km (4.5 mi) long and 61 m (200 ft) wide tri-oval includes generous safety run-off areas and wireless monitoring of every test vehicle for real-time data capture. The military specific road bed will support vehicle weights in excess of 109 tons metric (120 tons). ATEF enables the Department of Defense (DOD) to effectively, efficiently, and safely conduct high-performance, endurance, and reliability testing on all wheeled and tracked vehicles, of both manned and un-manned ground platforms.



Figure 70. Automotive Technology Evaluation Facility.

### 2.8.1 High Speed Paved.

This is a 7.2 km (4.5 mi) long and 8 m (27 ft) wide high speed loop. There are two lanes to allow multiple vehicles to operate at different speeds. There is a 427 m (1400 ft) long by 37 m (120 ft) wide section of High Speed Paved which is utilized for vehicle performance testing (e.g., brake testing, lane change, etc).

### 2.8.2 High Speed Gravel.

This is a 7.2 km (4.5 mi) long 9 m (30 ft) wide high speed loop composed of bank run gravel. There is a 427 m (1400 ft) long by 12 m (40 ft) wide area parallel to the High Speed Paved brake test evaluation area.

### 2.8.3 Vehicle Maneuvering Test Area (VMT).

This is a 122 m (400 ft) by 244 m (800 ft) pad with acceleration ramps off of ATEF High Speed Paved designed for vehicle performance testing (e.g., skid pad, J-turn, etc).



2.9 Perryman Test Area (PTA).

a. The PTA adjoins the northwestern boundary of APG, and includes about 800 hectares (2000 acres) (Figure 71). Originally devoted to farming, the area is now used mainly for cross-country testing of vehicles for endurance, durability and reliability. Facilities for other tests are also in the area. A detailed mapping of the various courses located at the PTA is shown in Figure 72.



Figure 71. Aerial view of Perryman Test Area.



Figure 72. Detailed map of test courses located at PTA.

b. Although surface variations due to weather are a desirable feature of most PTA courses, course geometry is assessed periodically by a test course profilometer that provides appropriate data to maintain the courses to the same severity. Details of the procedure are provided in TOP 01-1-010A. Test course area supervisors also make daily inspections and maintain an on-site log of climatic and course conditions.

### 2.9.1 Perryman Off-Road Courses.

Five off-road courses graduated in severity are within the PTA.

a. Perryman No. 1 is moderate with a substantial roadbed composed primarily of quarry spall and bank gravel (Figure 73). The loop includes sharp and sweeping curves, and the surface ranges from smooth to rough (roughness being due to potholes, washboard, and rutting). Potholes and other sharp depressions are usually limited to a depth of 15 cm (6 in.) by filling with crushed stone. During wet weather, the whole course is characterized by light mud which affects wheeled vehicles mainly by splash. The course is 8.4 km (5.2 mi) long. The average root mean square (rms) roughness is 0.89 cm (0.35 in.).



Figure 73. Perryman No. 1 roadbed characteristics.

b. Perryman No. 2 is laid out in a loop of moderately irregular terrain. The native soil includes Sassafras loam, a silty loam with 17.3-percent clay content, and Sassafras silt loam, a silty loam with less than 15-percent clay. Surfaces range from smooth to rough, and there are sweeping turns. Under wet conditions, the course is extremely muddy (Figure 74); when dry, it is dusty (Figure 75). One area of the course used for testing earthmoving equipment includes earthen side slopes, a cut-and-fill area, and a figure-8 course. The course is 2.9 km (1.8 mi) long. The average rms roughness is 2.3 cm (0.9 in.).





Figure 74. Perryman No. 2 under muddy conditions.



Figure 75. Perryman No. 2 under dusty conditions.

c. Perryman No. 3 is rougher still, and is composed of native soil similar to that of Perryman No. 2. Mud ranges from light (with free water) to cohesive. Although dust is severe when the course is dry, there is always mud in some areas (Figure 76). Much of the course is rough due to many years of testing tank-type vehicles. The course is 5.3 km (3.3 mi) long. The average rms roughness is 7.4 cm (2.9 in.).





Figure 76. Vehicle negotiating Perryman No. 3.

d. Perryman No. 4 is a tract of extremely rough terrain including marshy areas with swamp-type vegetation (Figure 77). The drier areas are characterized by a succession of depressions that develop after intensive operation of heavy tracked vehicles. The difference in the slopes is attributed to the fact that vehicles have generally been run in one direction. The soil of the course is native soil as described under Perryman No. 2. The course is 4 km (2.5 mi) long.



Figure 77. Vehicle negotiating Perryman No. 4.

e. Perryman No. 5 is constructed of Gabion (No. 6 stone) and is approximately 305 m (1000 ft) long (Figure 78). This course is designed to be extremely severe; the average rms roughness is 9.7 cm (3.8 in.).



Figure 78. View of Perryman No. 5 Course.

### 2.9.2 3-Mile Straight-Away.

This is a 6.1-km (3.8-mi) level straight-away with banked turnaround loops at each end for tests requiring uninterrupted operation such as cooling tests. This course is made of bituminous concrete (including turnarounds). A 305 m long by 15 m wide (1000 ft x 50 ft) section of bituminous concrete is located midway between the turnarounds and is suited for conducting brake testing, and evasive handling maneuvers. A portion of the travel lane is treated with a sealer that when wetted down provides a low coefficient of friction road surface used for testing traction control and anti-lock brake features.

### 2.9.3 Mud Bypass Course.

This is a 610 m (2000 ft) bypass off of Perryman No. 1. It is most useful in periods of dry weather for exposing vehicles to muddy conditions to evaluate seals, brakes, or other mud-sensitive components during endurance operations. The course is prepared by tilling and pumping water onto it from a local renewable water source using irrigation piping and sprinklers (Figure 79).





Figure 79. Mud Bypass Course with sprinklers operating.

#### 2.9.4 Secondary Road A.

Secondary Road A is a closed loop course 3.9 km (2.4 mi) in length with long, sharp, sweeping turns typical of unimproved country roads. The course surface is about 10.7 m (35 ft) wide, maintained by grading and filling with native soil. The average rms roughness is 0.84 cm (0.33 in.).

#### 2.9.5 PTA Ride Quality.

PTA ride quality course is a 5.1 km (3.2 mi) long, level straight course. The four ride quality sections were constructed on the former PTA Secondary Road B. The four sections are straight and do not abut each other. Space between courses is provided for vehicles to achieve desired test speeds. The four ride quality sections vary in different levels of roughness. All four sections are composed of compacted gravel with the wear surface held together by a binding agent. The four sections from least rough to most rough are labeled as B, C, A, and D. Section B is 610 m (2000 ft) long. Section C is 366 m (1200 ft) long. Section A is 351 m (1150 ft) long. Section D is 290 m (950 ft) long.

#### 2.9.6 Figure 8 Test Course.

PTA Figure 8 test course is a 772 m (2534 ft) figure “8” course composed of native soil and gravel. The course is primarily used for unmanned ground vehicles.

### 2.9.7 PTA Dig Sites.

PTA has four dig site areas. The dig sites have permanent sediment and erosion controls. Dig sites are used for simulated vehicle recovery, excavation testing activities, etc. If unused, the areas tend to grass over and are periodically reopened using an offset disc. After each test program the disturbed area is leveled until the next use. Dig site 1 has large trapezoidal shape and is 482 m (1580 ft) in length while the width changes from 73 m (240 ft) to 24 m (80 ft) at its narrowest point. The soil is classified as SC-SM by the USCS. Dig site 2 is a long relatively narrow area having a width of 27 to 37 m (90 to 120 ft) and a length of 640 m (2100 ft). The soil is classified as SM by USCS. Dig site 3 is an area that is 165 m (540 ft) long and 84 m (275 ft) wide. The soil is classified as CL by USCS. Dig site 4 has a length of 366 m (1200 ft) and a width of 30 m (100 ft) and is classified as CL-ML by USCS.

### 2.10 Phillips Army Airfield (PAAF).

a. The airfield (Figure 80) utilizes a hard surface runway that measures 2,438 by 61 m (8,000 by 200 ft). Automotive testing accomplished on this runway includes: steering and handling tests such as lane changes and J turns, brake testing in all weight classes and at high speeds, and mobile field dynamometer testing.



Figure 80. Phillips Army Airfield.



### 2.11 Lift and Tie-Down Facility.

This facility is used to test the lifting and tie-down capability of military vehicles in accordance with MIL-STD-913A<sup>9</sup> and MIL-STD-209K<sup>10</sup>. The facility has a 50-ton metric (55-ton) overhead chain hoist with a remotely controlled 54-ton metric (60-ton) hydraulic load application system (Figure 82). In addition, it has two hydraulically operated bridge cranes of 45- and 136-ton metric (50- and 150-ton) capacities.



Figure 82. Lift and Tie-Down Facility.

### 2.12 Automotive Laboratory Facilities.

#### 2.12.1 Automotive Engineering Test Facility (B436).

a. This facility (Figure 83) supports engineering tests addressing performance and reliability, availability and maintainability (RAM) analysis for the areas of Automotive, Fire Control and Live-Fire/Vulnerability, Road Shock and Vibration, Transportability, and Environmental Conditions.

b. Provided are the resources to design, plan, and conduct testing, and for the acquisition, processing, analysis, and reporting of test data. It includes nearly \$50 million of state-of-the-art instrumentation, over 2,800 square meters (30,000 square feet) of laboratory and shop space, on-site instrumentation and hardware fabrication facilities.



Figure 83. Automotive Engineering Test Facility

c. Also provided are specialized off-site data transfer capabilities that include fiber optic and bi-directional microwave telemetry links that provide high speed data transfer and real-time test control, and secure, single source data access from any location in the world via the internet.

#### 2.12.2 Tilt Table Facility.

The tilt table facility is located adjacent to the Automotive Engineering Test Facility. This steel table is used to determine the static roll over threshold, and in turn, the propensity of a test vehicle to roll over when operating on a side slope or during steady-state cornering. Six hydraulic cylinders are employed to raise and lower the table. The table platform is accessible from each end and at its center (Figure 84). The tilt table is 4.3 m (14 ft) wide at each end with a center width area of 7.6 m (25 ft) for additional maneuverability for rough terrain forklift testing. The overall table length is 30.5 m (100 ft), with a lift capacity of 127 tons metric per 6.1 m (140 tons per 20 ft) of length, for a total theoretical capacity of 635 tons metric (700 tons). The table's maximum tilt angle is 40 degrees (83.9 percent). Tilt table testing is performed in accordance with SAE J2180<sup>11</sup>. The test vehicle is typically tilted about its roll axis until the uphill tires lift off the platform, at which point safety cables restrain the vehicle from an actual rollover (Figure 85).



Figure 84. Tilt Table Facility.



Figure 85. Tilt table testing to determine roll over threshold.



### 2.12.3 Roadway Simulator Complex.

a. Roadway Simulator. This facility provides a dynamic hardware-in-the-loop simulation for conducting engineering level automotive performance tests under strictly defined and controlled conditions. It supports vehicles ranging from 2,270 kg (5,000 lb) 2-axle light trucks to 36,300 kg (80,000 lb) tractor trailers (Figure 86). It was designed to perform vehicle dynamics, power train performance, and shock and vibration testing in a laboratory environment. The test vehicle is adaptively constrained in the longitudinal, lateral, and yaw directions through its center of gravity, and is free to move in the vertical, roll and pitch directions. A robotic autopilot drives the truck on a series of treadmills, while vehicle body forces are measured in the constrained degrees of freedom. The motion of the treadmills is coordinated to provide a coherent roadway over various terrain profiles.



Figure 86. Roadway Simulator.

#### b. Vehicle Durability Simulator (VDS).

(1) The VDS consists of a 6-degrees-of-freedom spindle-coupled MTS 329LT test rig\*\*\* (Figure 87). The facility provides laboratory-based simulation of off- and on-road shock and vibration testing. Structural components and subsystems on 2-axle trucks up to 11,800 kg (26,000 lb) can be tested 24-hours per day with precise control of the test scenario. Drive files are produced using the remote parameter control (RPC) process, using force and/or acceleration feedback. The simulator can also be used as a kinematics and compliance measurement system to support vehicle modeling initiatives.

\*\*\* The use of brand names does not constitute endorsement by the Army or any other agency of the Federal Government, nor does it imply that it is best suited for its intended application.





Figure 87. Vehicle Durability Simulator.

(2) The strengths of the VDS are:

(a) Accelerated durability testing of automotive systems, subsystems, and components (suspensions, computers, wiring, plumbing, and chassis).

(b) Troubleshooting and diagnosing component fatigue failures.

(c) Vehicle model development.

c. Tire Test Rig. This facility (Figure 88) is used for measuring tire performance parameters at various axle loads, slip conditions, tire pressures, and speeds. The rig consists of a MTS Systems Flat-Trac rolling ground plane positioned beneath a structural beam and spindle. The tire is mounted to the spindle with an MTS Systems SWIFT wheel force transducer that measures the three forces and three moments applied to the tire. The tire can be cambered up to 8 degrees, and vertical loads can exceed 6,800 kg (15,000 lb), depending on the camber condition. Ground speeds can reach 260 km/hr (160 mph), and slip angle can exceed 15 degrees. Typical tests include lateral force measurement (versus vertical load and slip), vertical stiffness (static and dynamic), and tire durability assessments. Advantages of the ATC tire test rig include the ability to test at high axle weights and large tire diameters frequently encountered with military vehicles. High slip rates are also achievable.



Figure 88. Tire Test Rig.

d. Shock Absorber Dynamometer. The Shock Absorber Dynamometer (Figure 89) is used to characterize damper and spring performance that simulates off-road conditions of performance and durability testing at loads up to 890 kN (200,000 lb) and rates up to 3.8 m/s (150 inch/second). The shocks are driven using a hydraulic actuator, with a bell crank for speeds exceeding 2.0 m/s (80 inch/second). Drive cycles can be simulated for durability and cooling tests, within a 50-Hz frequency range.



Figure 89. Shock Absorber Dynamometer.

e. Moment of Inertia (MOI) Test Facility. The Moment of Inertia Facility provides the means to measure inertia tensor and center of mass properties on the full spectrum of tactical and combat vehicles and vehicle components, up to 63500+ kg (70+ ton) vehicles (Figure 90). The facility uses modular platforms appropriately sized for different classes of vehicles. The MOI fixtures measure the inertia and mass properties by swinging the vehicle in the yaw, roll, and pitch directions and recording the period of oscillation of the pendulum. The fixtures are located indoors to eliminate measurement error associated with the presence of wind. The facility is adjacent to the Roadway Simulator (RWS) and Vehicle Durability Simulator (VDS) Facilities, providing continuity with the modeling and simulation resources at those facilities.





Figure 90. Vehicles subjected to inertia tensor and center of mass testing.

#### 2.12.4 Powertrain Dynamometer Facility.

The Powertrain Dynamometer Facility provides flexible dynamometer style suites that enable full or partial drivelines to be tuned, optimized, characterized and tested. The site consists of two engine dynamometers and a separate test cell with electrical power processing capability. The engine dynamometers, rated at 350 hp and 600 hp, have the capability to absorb and/or deliver power making them invaluable for drive cycle development and for prove-out of driveline concepts. The power processing components are computer controlled bi-directional alternating current and direct current load banks. These units are transformer coupled to the utility grid and are able to supply power to electric drive components as well as absorb power to allow testing of hybrid drivelines or components of hybrid drivelines. The test cells have upgraded fire suppression systems, overhead cranes and bed plates.

#### 2.12.5 Wheeled Vehicle Roller Brake Dynamometer.

The roller brake dynamometer is capable of dynamically testing brakes and anti-lock brake systems (ABS). It can also test automatic traction control and electronic stability control (ESC) components and functions that are controlled by the ABS electronic control unit (ECU). Testing of the brakes, ABS, automatic traction control, and ESC are performed in an automated, closed loop manner. The ABS test checks the function of individual wheel speed sensors, ABS valves, automatic traction control valves, ABS and automatic traction control warning lights and wiring harnesses. Tests also confirm proper communication between the ABS ECU and the engine ECU. The brake dynamometer is capable of measuring and recording brake forces of up to 45 kN (10,000 lb.) per wheel and weights at each axle of up to 20,000 kg (44,000 lb.) with an accuracy of within 2.5 % on both measurements.

#### 2.12.6 Platform Scale.

The 90,700 kg (200,000 lb.) capacity platform scale measures 9.1 m in length and 4.6 m wide (30 x 15 ft). There are 30.5 m (100 ft) level concrete approach and departure lanes provided so



that accurate weight distributions can be conducted. Figure 91 shows vehicles undergoing weight, and center of gravity measurements on the platform scale.



Figure 91. Vehicles on platform scales.

#### 2.12.7 Wheel Scales.

Wheel scales with a capacity of 9072 kg (20,000 lb.) and a resolution of 1 kg (2 lb.) are located at the same site as the platform scale.

#### 2.13 Fire Control Test Facilities.

The testing and evaluation of tank armament is conducted on unique firing ranges at the Gunpowder Neck (Figure 92) and Trench Warfare (TW) areas. Tracking data are collected by two gated TV systems with input from a video camera boresighted with the tank gun (to collect lead angle and tracking data), and another video camera in the sight (to collect gunner tracking data). These systems are video digitizers that output constantly updated signals equal to the target's azimuth and elevation deflections in the field-of-view of the video cameras. The signal output may be merged with other data recorded directly to the ballistics computer memory. Video recorders capture the tracking data and monitors allow the test director real time monitoring of the video data.



Figure 92. Aerial view of Henry Field at Gunpowder Neck.

### 2.13.1 Tank Armament Test Range (Henry Field).

a. This is a direct fire; multi-range, test area used for evaluating tank armament systems under moving and stationary tank and target scenarios and is located at the Henry Field area of Gunpowder Neck (Figure 93). The direct-fire ranges are arranged with wide-angle safety fans with line-of-sight targets as far away as 3 km (1.9 mi). For specialized long-range firing, a range of 5 km (3.1 mi) (partly over water) is available. Special firing slopes (15-percent up, 30-percent down, and various combination slopes up to 20 percent) permit firing at maximum gun elevation and depression, as well as over a variety of vehicle attitudes. Supporting facilities include a four-bay maintenance shop with adjoining offices and briefing room, range control/instrumentation shelters, ammunition magazines, meteorological instrumentation, and communications and other equipment. The H-Field Firing Range was renamed in honor of Mark Henry who lost his life on 21 May 2009 while conducting firing trials.

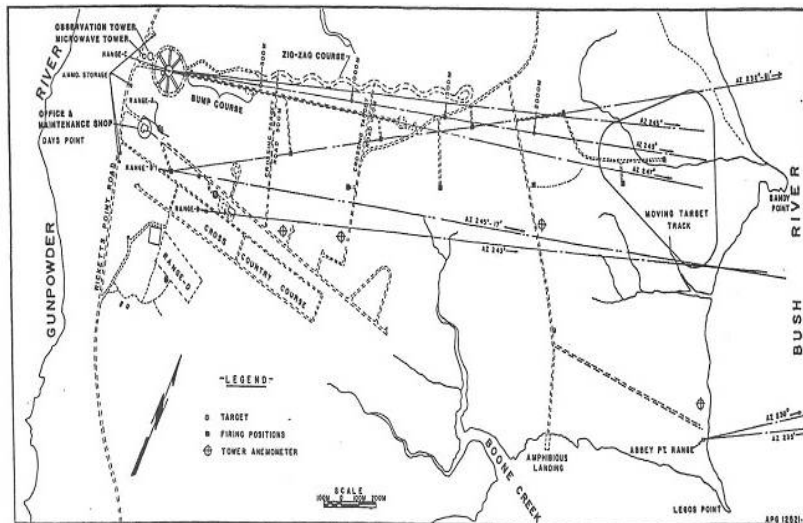

Figure 93. Henry Field, Gunpowder Neck.

b. Various terrain courses that include gravel, bump, zig-zag, and natural earth are available for comparative performance testing of tank turret-stabilized fire control systems. A cross-country course of about 1.6 km (1.0 mi) long is in the area for providing insight into effects of mobility operations on gunnery systems. Two standardized configurations of the Bump Course are: (1) Elevation Stabilization Bump Course (Figure 94), and (2) RRC-9 Bump Course (Figure 95). These courses use two types of bumps: (1) Type A Bump (Figure 96), and (2) Type B Bump (Figure 97).

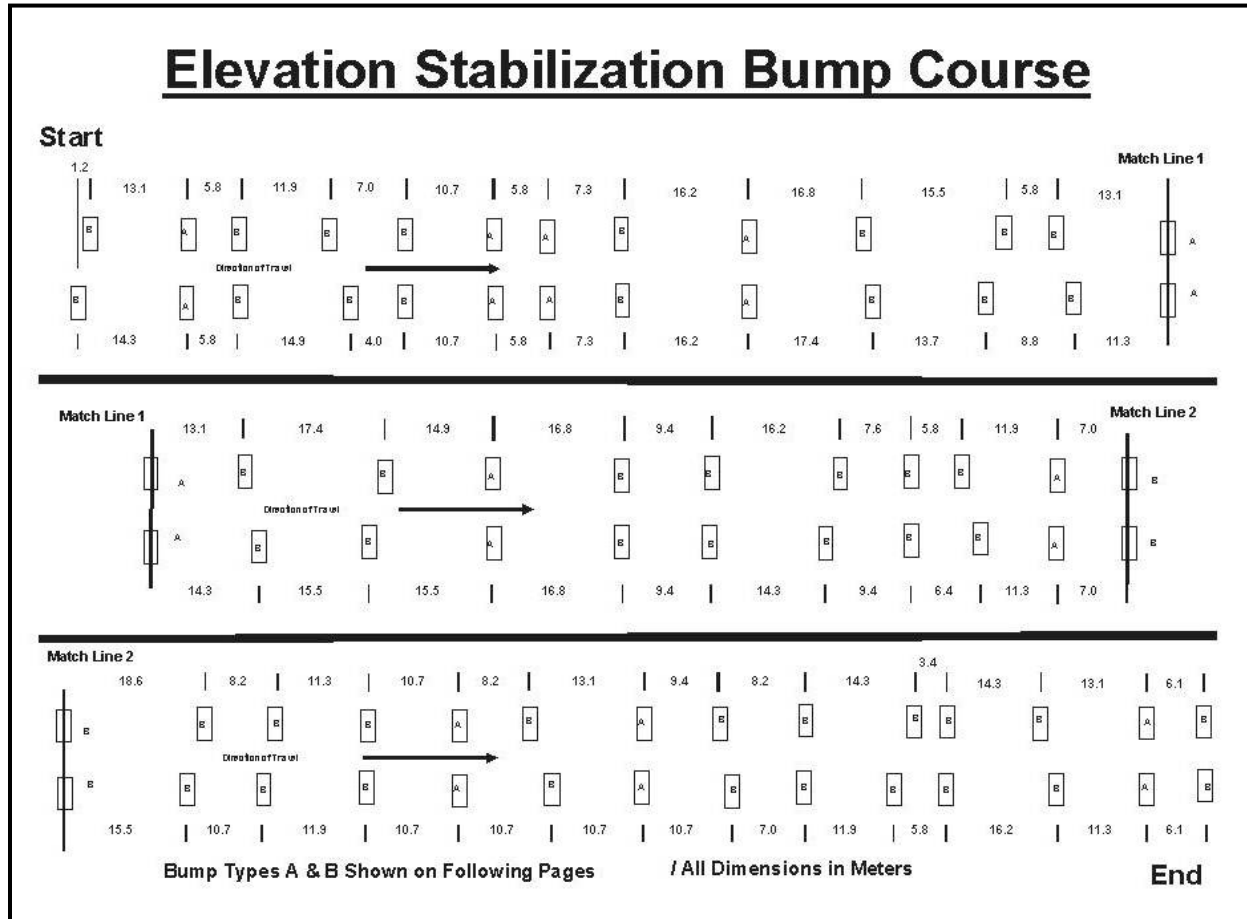

Figure 94. Elevation Stabilization Bump Course.

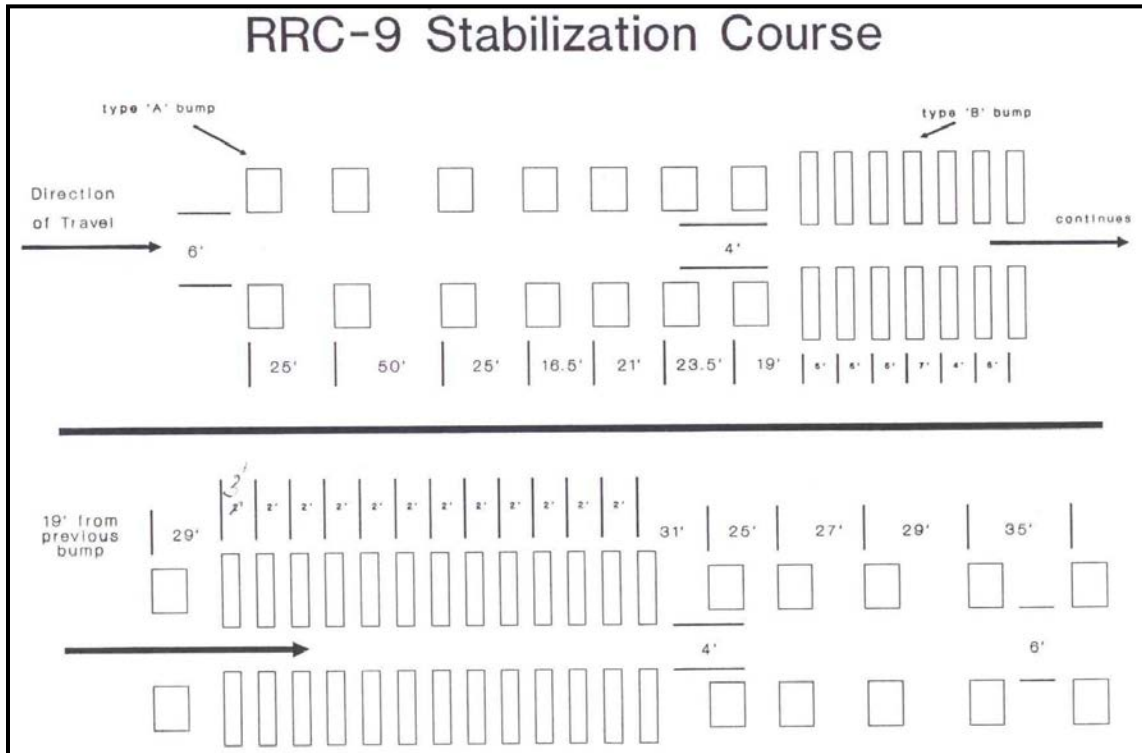

Figure 95. RRC-9 Stabilization Course.

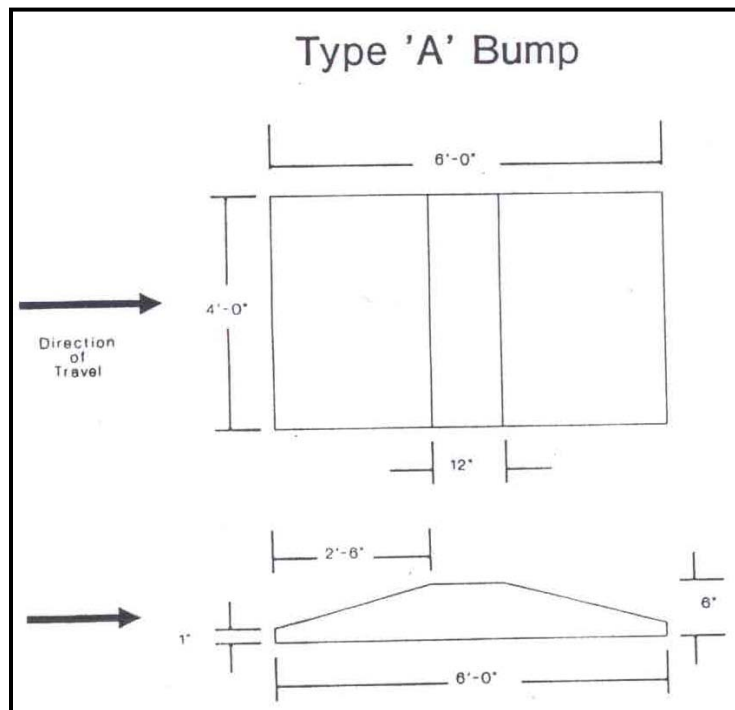

Figure 96. Type A Bump.



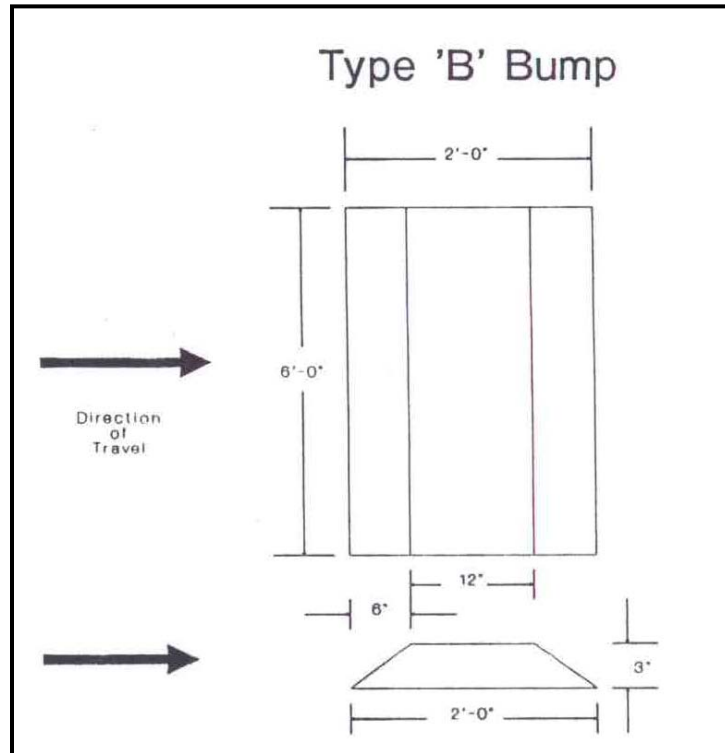

Figure 97. Type B Bump.

c. A 6 by 6 m (20 by 20 ft) moving target facility allows for speeds as great as 56 km/hr (35 mph). With a vehicle at either a stationary position, or traversing the gravel bump or the zig-zag course, the moving target is remotely controlled around an adjacent 2 km (1.25 mi) triangular railroad layout. The speed and orientation of the moving target changes in relation to the line of fire. The moving target is used to measure accuracy of fire for tank turrets, including those equipped with hyper-velocity guns or guided missiles.

d. In addition, the Henry Field ranges are equipped with video scoring instrumentation to remotely record target impacts. Down-range meteorological data are obtained by means of a fully automated meteorological station. Other telemetry and data-processing instrumentation are available to record and reduce data obtained from monitoring on-board vehicular equipment such as gun sight optics, ballistics computer output, rangefinder readings, and main gun aimpoint.

e. Testing capabilities at the principal ranges of Henry Field are summarized in Table 5.

TABLE 5. HENRY FIELD TANK GUNNERY RANGE TEST CAPABILITY

MAXIMUM DISTANCE FOR DIRECT FIRE (METERS 0 TO)	FACILITIES	TYPE OF TEST
3000	Targets and bombproofs; slopes for firing in 15% reverse, 30% forward position, or other vehicle attitudes to 20%.	Miscellaneous.
2000	Moving (vehicle-mounted) target area.	Tracking of vehicle mounted targets.
5000	Targets partly across water.	High velocity, long range.
3000	Remotely controlled moving target 0 to 56 km/hr (0 to 35 mph) controllable to $\pm 3.2$ km/hr ( $\pm 2$ mph).	Accuracy firing on moving targets, including light armor plate structures.
3000	Stabilizer course (zig-zag, gravel, straight, black-top, chronograph, jump targets, cant slopes, bump; automated meteorological station including down-range wind profile).	Effectiveness of stabilizers, functioning of traversing mechanisms.
500 and 1100	Crossing target roads.	Tracking and laying tests.
3000	Targets and bombproofs.	Width-angle accuracy firing.
457	Sand buttes.	Machin-gun and mine tests, vulnerability of vehicles.

2.13.2 Evasive Target Firing Range (TW I).

a. The Trench Warfare I (TW I) range (Figure 98) is a direct fire range for assessing tank fire control systems under stationary and moving test item/target scenarios. Maximum distance for stationary targets is 3 km (1.9 mi). A laser beam-simulated moving target is located at 2.4 km (1.5 mi) range. This computer-controlled evasive laser beam target is projected on a replaceable, reflective surface. Gravel, bump, zig-zag, and natural earth courses are available for fire-on-the-move exercises. A thermal target capability is also available. Automated data acquisition capabilities for target scoring, projectile velocity, meteorological, thru-site and weapon pointing video, data bus activity and system performance are provided. A physical moving target 2.4 km (1.5 mi) from the firing pad is also installed. This rail-mounted target, moving laterally at variable speeds, provides the capability of moving-vehicle, moving-target engagements.



Figure 98. Evasive Target Firing Range (TW I).

b. The TW I range is also used for longer distance non-firing target surveillance and observation exercises to evaluate combat vehicle night sights. Its large open area with undulating terrain can accommodate targets as far as 4.0 km (2.5 mi) from the viewing vehicle.

### 2.13.3 Moving Target Simulator (MTS).

The Moving Target Simulator (MTS) facility provides a laboratory environment for assessing weapon control systems such as laying, tracking, and fire control system accuracy/performance tests to determine hit probability (Figure 99). It uses a 30.5 m (100 ft) radius air-supported hemisphere. Inside the hemisphere a computer-controlled laser beam generates repeatable stationary vehicle versus moving target test scenarios. The laser projected moving target is projected on the interior of the hemisphere. The computer-generated stationary, moving and evasive ground and aerial targets are produced by the laser beam steering system. Instrumentation acquires data such as video scoring, weapon and thru-sight video, data bus activity, weapon system/component performance, and target position.

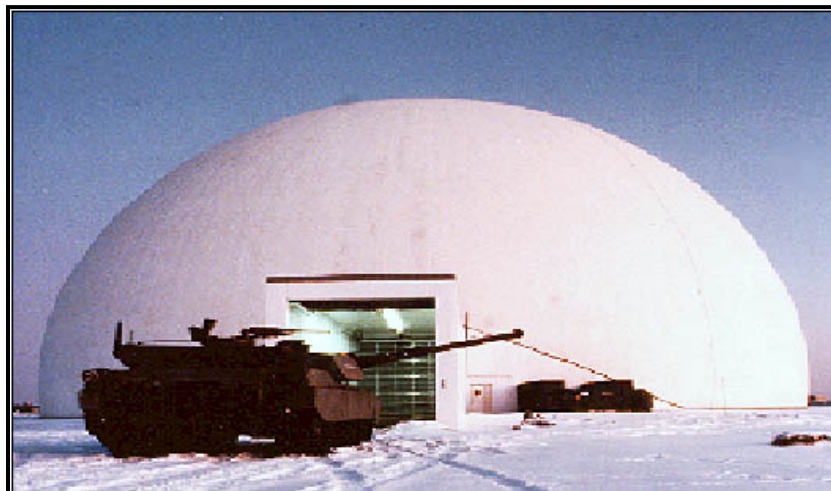

Figure 99. Moving Target Simulator.

### 2.13.4 Multiple Target Firing Range (TW II).

This highly instrumented, stationary vehicle/stationary target direct-firing range is designed to determine interactions of the fire control system, weapon, ammunition, and weapon mount (Figure 100). Two lines of fire are available to accommodate depleted uranium and live high-explosive projectiles. Multiple targets are available to 4 km (2.5 mi). A continuous velocity profile is provided by Doppler radar. Real-time measurement of jump, projectile miss distance, boresight retention, trajectory mismatch, aim error, weapon system implementation error, and hit probability can be determined. Instrumentation includes weapon and thru-sight video, target scoring, projectile velocity, data bus acquisition, weapon system/component measurements, and meteorological data.

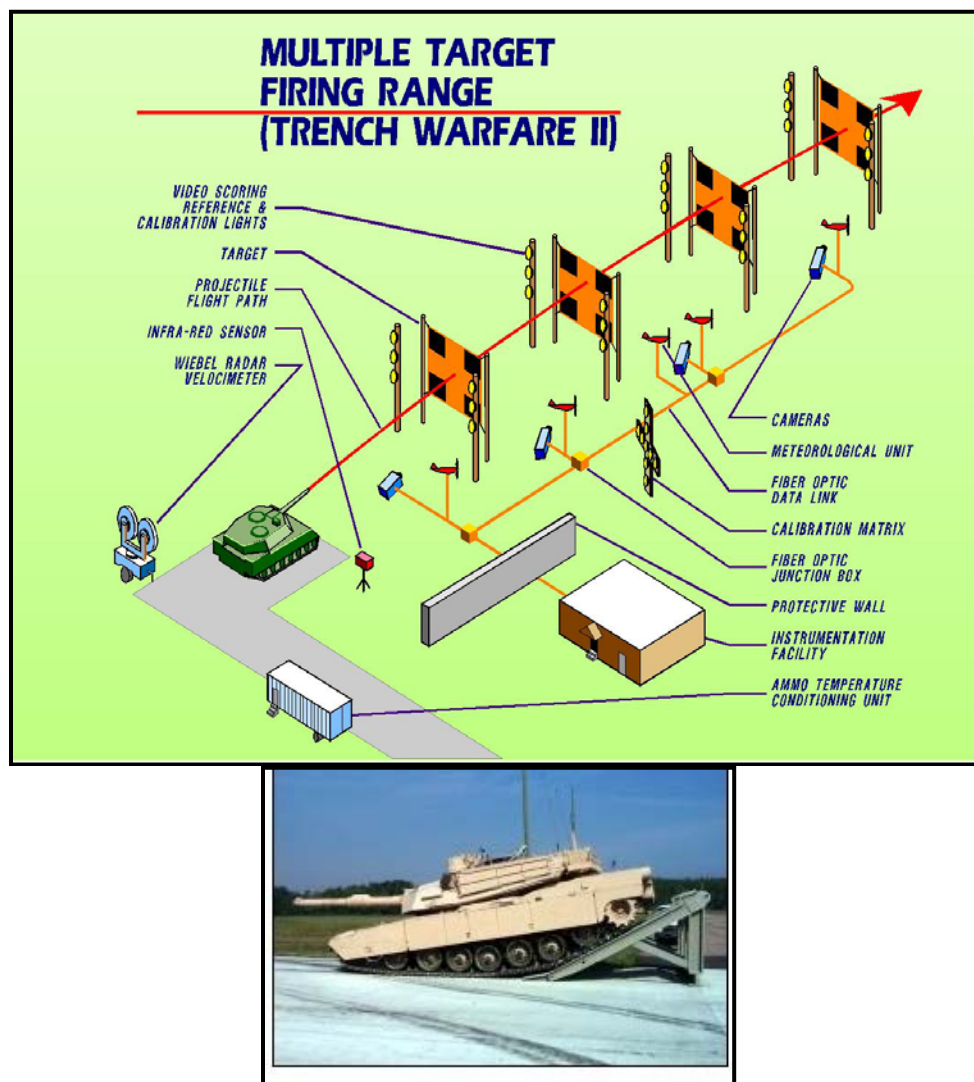

Figure 100. Multiple Target Firing Range (TW II).



2.13.5 Ride Quality Courses No. 1 through 4, Henry Field Area.

These four straight courses are composed of gravel, and range in length from 100 to 162 m (330 to 530 ft). The WES developed these courses solely for the purpose of ride quality testing. The surface roughness varies from approximately 3.0 to 7.6 cm rms (1.2 to 3 in. rms), depending on the test course selected.

2.14 Scalable Net Centric Test Area (SNCTA).

The SNCTA consists of two test courses, the Small Unmanned Ground Vehicle (SUGV) test course and the Large Unmanned Ground Vehicle (LUGV) test course. All elements of the SNCTA are being designed to provide real-world challenges to the sensor and safety systems being engineered into unmanned ground vehicles (UGVs).

2.14.1 Small Unmanned Ground Vehicle (SUGV) Test Course.

The SUGV Test Course has several test stations that allow an operator to evaluate a broad range of vehicle capabilities. A top view sketch of the course is shown in Figure 101a, and photographs of the course are shown in Figure 101b. The test course is nominally 37 m x 67 m (120 ft x 220 ft). Two test loops, each measuring 1.5 m (5 ft) wide, enclose a 24 m x 46 m (80 ft x 150 ft) open land grass area, which is the location of the course operator. Adjacent to the course is a wooded area marked off to provide a small course used to test vehicle mobility through grass, leaves, and low undergrowth.

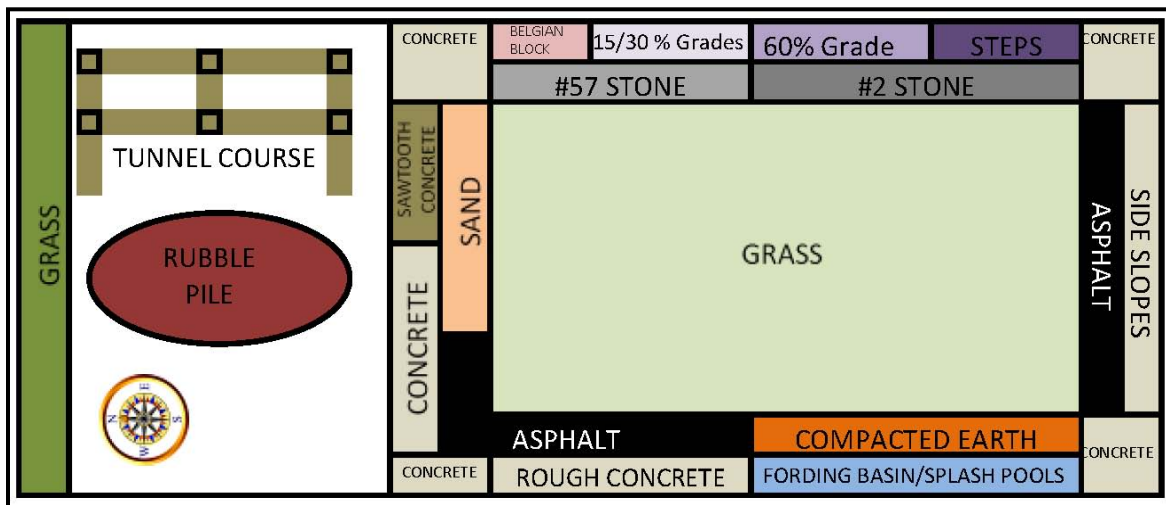

Figure 101a. Plan View of the Interim SUGV Test Course.



Figure 101b. The SUGV Test Course.

#### 2.14.2 Large Unmanned Ground Vehicle (LUGV) Test Course (Proposed).

This course is geared for safety and performance testing of LUGVs up to 9,100 kg (20,000 lb) gross vehicle weight. The eventual goal is to operate UGVs on standardized automotive test courses in order to adequately evaluate system performance and reliability. However, because this will require the UGVs to operate in the vicinity of manned vehicles and personnel, it's critical that extensive safety and performance testing be conducted prior to these operations. This course will be used to evaluate these safety and performance characteristics; specifically vehicles equipped with autonomous navigation systems. The course will replicate operational conditions that will be encountered by these systems and assess their ability to negotiate obstacles and terrain expected to be encountered during UGV operations.

#### 2.15 Rail Transport Facility.

The facility is designed to ensure compliance of materiel transported by rail with Military Surface Deployment and Distribution Command transportation certification requirements in accordance with MIL-STD-810G CN1. The facility is fully instrumented to record velocity and shock levels, and includes still photography, video, and high-speed video. The site features a covered railcar loading/unloading and tie-down facility with stocked supplies of rigging materials, tools, and wood-working machinery for producing required chocks and cribbage. On-site locomotive and standard railcar equipment is available, and the determination of tunnel clearance of loaded railcars is also available.

### 3. YUMA TEST CENTER COURSES AND FACILITIES

Figure 102 shows the layout of the over 100 miles of vehicle test courses and test facilities available at YTC, situated within the desert terrain of Southwest Arizona. Although YTC spans over 1,300 square miles, the automotive endurance and performance courses and test facilities are situated within close proximity of each other within the southern portion of YTC, which allow for tailoring vehicle tests to any specified mission profile.

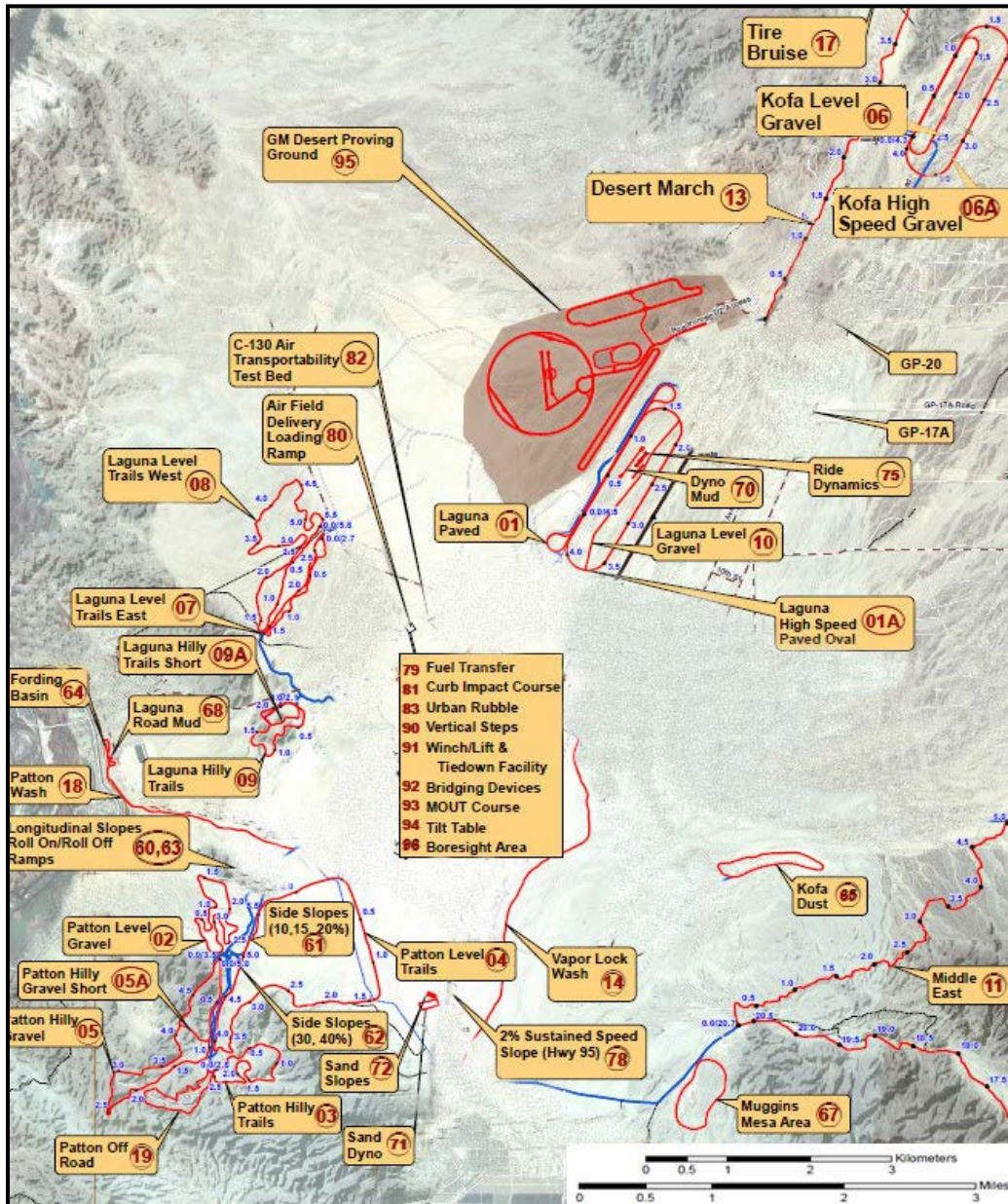

Figure 102. YTC Courses.



### 3.1 Endurance Courses.

a. Patton Level Gravel. The site is a 5.6 km (3.5 mi) secondary course where the terrain is basically Limey Upland, Deep and is composed of the River-bend Family- Carrizo Family Complex which are comprised of extremely gravely-coarse soils. Figure 103 shows the typical terrain of the course and a course map. The course is designed in a loop configuration consisting of short straight sections, and curves of various radii. The course provides an excellent surface for evaluating steering performance, track durability, and vehicle operations at medium speeds. The average rms is 1.19 cm (0.47 in.).

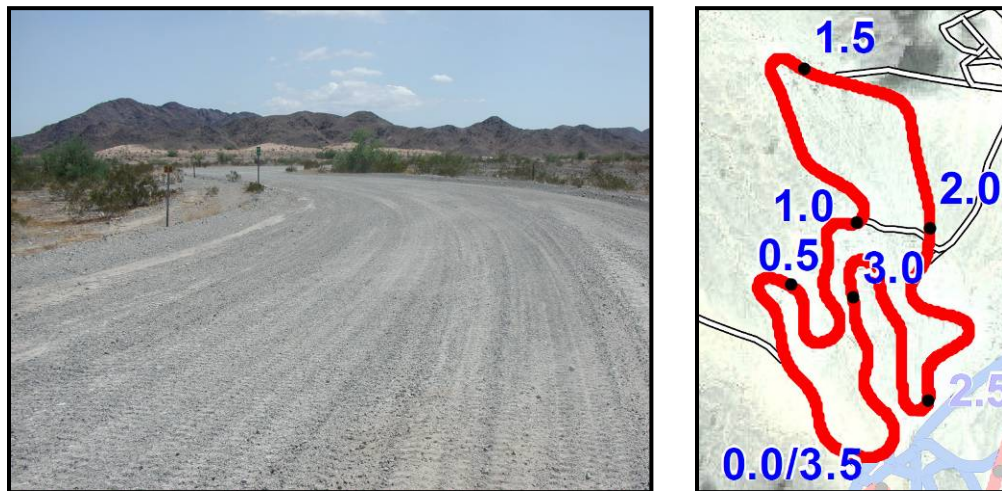

Figure 103. Typical terrain of Patton Level Gravel Course (left) and course map (right).

b. Patton Hilly Trails. This site is a 4.2 km (2.6 mi) loop course situated on a basalt hill range site which is located on a series of relic beach terraces. The course begins on the edge of a heavily dissected beach terrace complex and climbs up the side slope of the terrace and then proceeds down the opposite side of the terrace down into the wash bottom, repeating this pattern numerous times. Several of the grades on the course are as steep as 32 percent, with the average grade being 11%. The design of the course allows testing the full function of the transmission, braking, steering, suspension, and track systems. The average rms is 4.32 cm (1.70 in.). Figure 104 shows the typical terrain of the course and a course map.





the climbing scenarios with higher gear ratios, less engine speed, but with increased braking demands being placed on the service brake system. The average rms value is 1.30 cm (0.51 in). Patton Hilly gravel also has a shorter loop that is available for track vehicle use. Figure 106 is a characteristic photograph of the terrain and a course map.

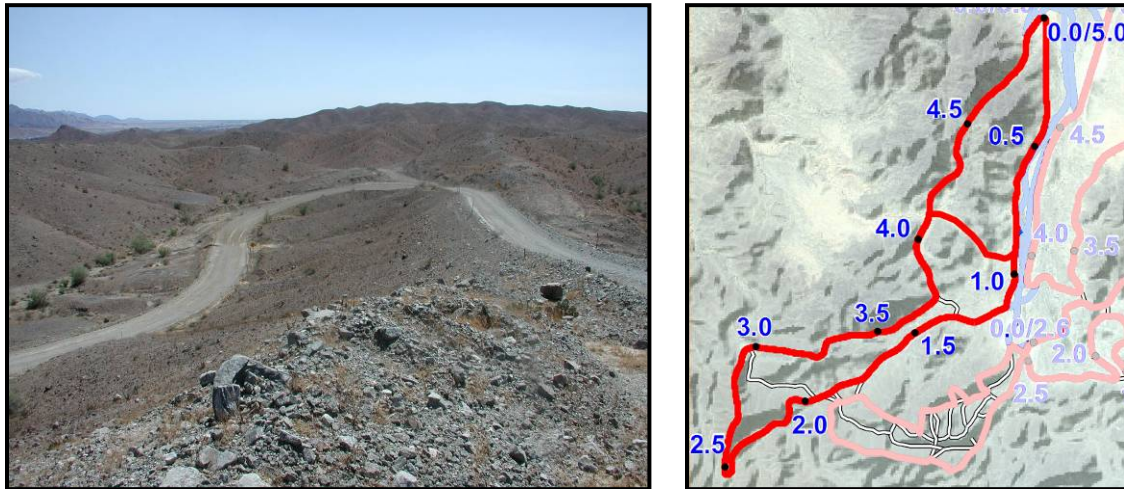

Figure 106. Typical terrain of Patton Hilly Gravel (left) and course map (right).

e. Kofa High Speed Gravel. This course is a 6.7 km (4.2 mi) oval loop that circles around the Kofa Level Gravel loop, as shown in Figure 107. The course is composed of quarried road construction grade gravel that has been compacted and graded. Compared to Kofa Level Gravel, the course is maintained to be smoother, with fewer washboards. The larger size and the larger turns allow vehicles to maintain higher sustained course speeds. The average rms is 0.28 cm (0.11 in), and the gradient averages 1.0%.

f. Kofa Level Gravel Course. This improved secondary gravel road is a nearly level oval loop 4.8 km (3.0 mi) long and 12 meters (40 ft) wide. The course is composed of quarried road construction grade gravel that has been compacted and is regularly graded. Mild to heavy washboarding is allowed to naturally accumulate on the course between grading cycles. The average rms for the course is 0.43 cm (0.17 in.), and the gradient averages 1.0%. Figure 108 shows a vehicle on the course and a course map.





Figure 107. Aerial view of Kofa Level Gravel and Kofa High Speed Gravel.



Figure 108. Vehicle on Kofa Level Gravel (left) and a course map (right).

g. Laguna Level Trails East. This course is a 4.5 km (2.8 mi) loop constructed on a relic lake floor, and is mostly level with the exception of gentle grades (max grades less than 10%) associated with desert wash bottoms and is suitable for testing commercial trucks. The course terrain features are best described as Limey Upland Deep and provides an excellent example of

the unimproved roadways of the Middle East. The course is composed of the Gilman Family, Harqua Family, Glenbar Family Complex soils. These soils compact easily and provide a hard surface which is susceptible to erosion by the winds. The eroding of the surfaces produce mild wash boards which add to overall effects of the course. The average rms for the course is 1.04 cm (0.41 in). Figure 109 shows the typical terrain of the course and a course map.

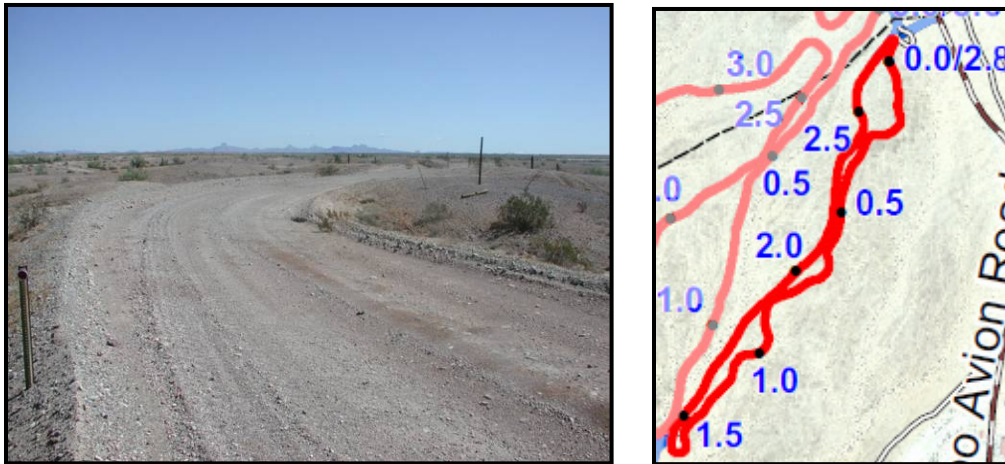

Figure 109. Typical terrain of Laguna Level Trails East (left) and course map (right).

h. Laguna Level Trails West. This trail is 9.0 km (5.6 mi) in length loop course. The loop crosses surfaces composed mostly of sand and gravel. The Laguna Level Trails West has more gravel and sand washes than the East Loop. The course is nearly level except for gentle embankments where alluvial washes are crossed (max grades less than 10%). The four landforms that the Laguna Level Trails West course crosses are dissected fan, alluvial fan and terrace, and wash. The surface cover of the upper 5 cm (2 in.) of these landforms are mostly sub-rounded to angular gravel that range from poorly-graded gravel with either silt, sand or clay to well-graded gravel with sand. The average rms is 1.8 cm (0.70 in.). Figure 110 shows the typical terrain of the course and a course map.

i. Laguna Hilly Trails. This trail is a 3.3 km (2.1 mi) loop course that traverses hilly terrain composed of loose rock, gravel, and sand with grades up to 30% with lengths up to 30 meters (100 ft). The four landforms that the Laguna Hilly Trails course crosses are bedrock, dissected fan, alluvial terrace, and alluvial wash. The surface cover of the upper 5 cm (2 in.) of these landforms are mostly sub-rounded to angular gravel that range from poorly-graded gravel with either silt, sand or clay to well-graded gravel with sand. The average rms is 1.32 cm (0.52 in.). Figure 111 shows the typical terrain and a course map.



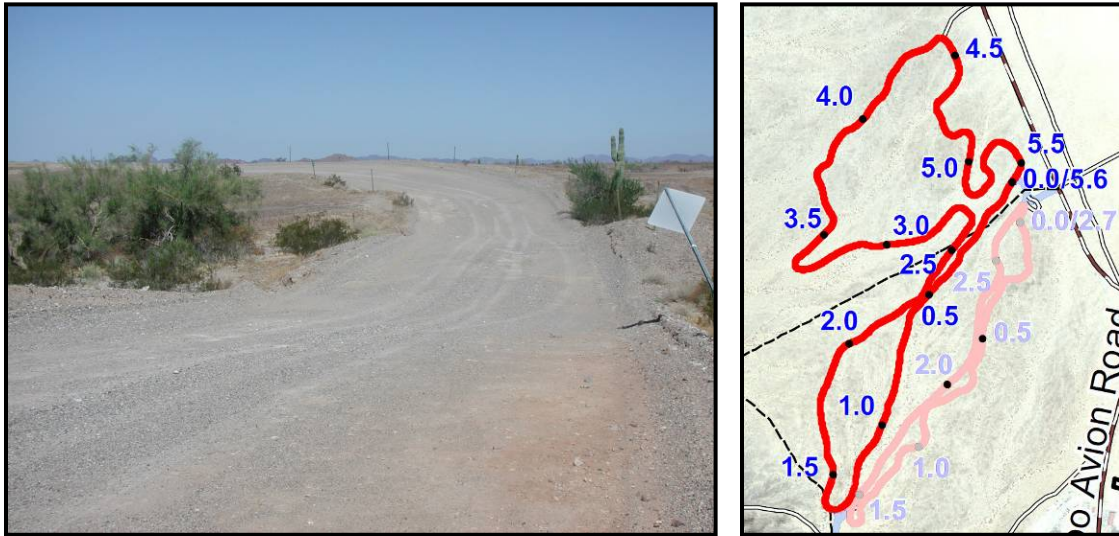

Figure 110. Typical terrain of Laguna Level Trails West (left) and a course map (right).

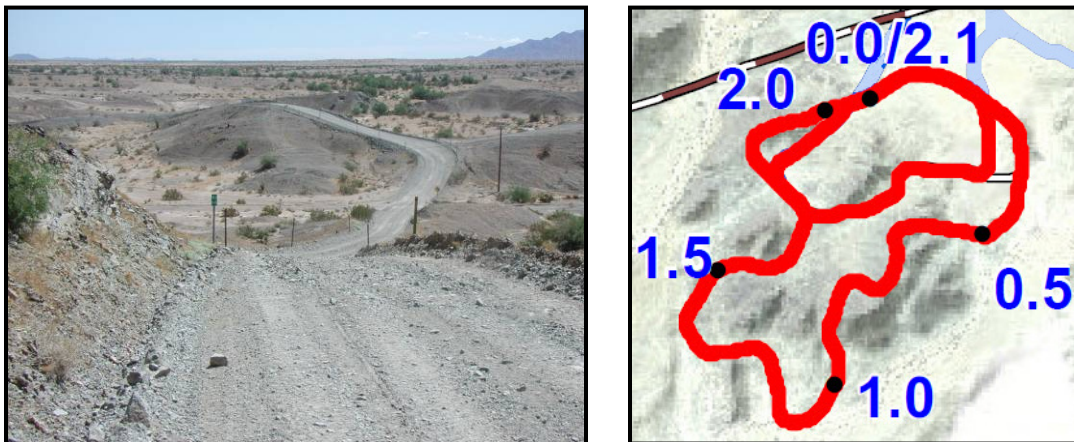

Figure 111. Typical terrain of Laguna Hilly Trails (left) and a course map (right).

j. Middle East Course. The site is a 33.3 km (20.7 mi) composite course operating on the lower reaches of the Muggins Mountains, with terrain representative of comparable operations in the deserts of the Middle East. The course takes advantage of wash bottoms for concealment, terrace side slopes for speed, terrace tops for orientation, and basin floors for speed and concealment. Some of all the 9 soil complexes found at YTC are encountered around the course. The varied landforms and terrain features found on this course provide an excellent composite of desert conditions to test the vehicle endurance and performance parameters. The average rms for this course is 5.11 cm (2.01 in.). The maximum grade encountered on the course is 31%, and the average grade is around 5%. Figure 112 shows examples of the typical terrain on the course and Figure 113 is a course map.



Figure 112. Rough, rocky wash (left) and vehicle on course (right).

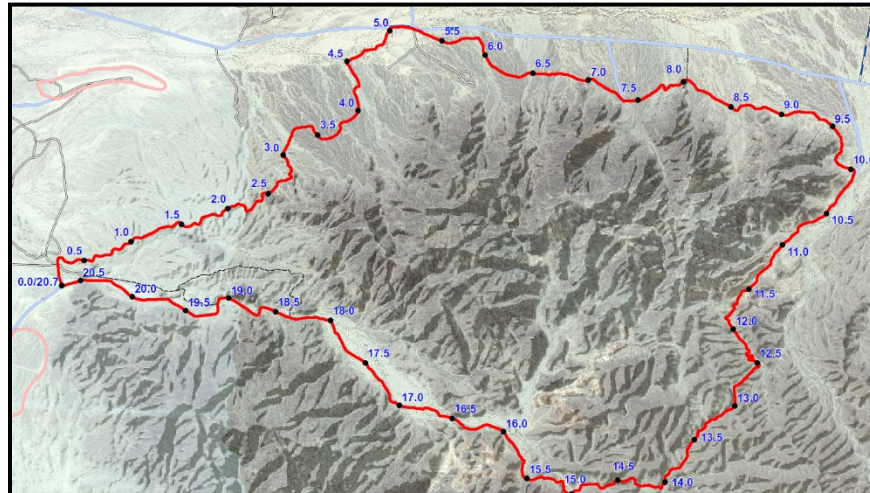

Figure 113. Middle East Course map.

k. Rock Ledge Course. This course is 6.3 km (3.9 mi) long, is located between two vertical rock outcroppings, and is traversed with several exposed rock ledges. The course follows a natural water course through the mini canyon. The terrain is classified as basalt hills, and volcanic hills. The surface of the trail is primarily composed of Riverbend Family-Carrizo Family Complex soils which are very coarse sands which are very heavily cobbled. The second soil class is the Lithic and Typic Torriorthents complex. These soils are composed of fragmented bedrock, vertical rock outcrops and very thin soil layers. They are usually strewn with large stones up to 76 cm (30 in.) in diameter that have spalled off the vertical ledges. In many sections there are no soils, just rocks of various sizes. The average rms is 3.96 cm (1.56 in). Grades are relatively mild, and the maximum grade is 15%. A characteristic photograph of the terrain and an overall course map is presented in Figure 114.



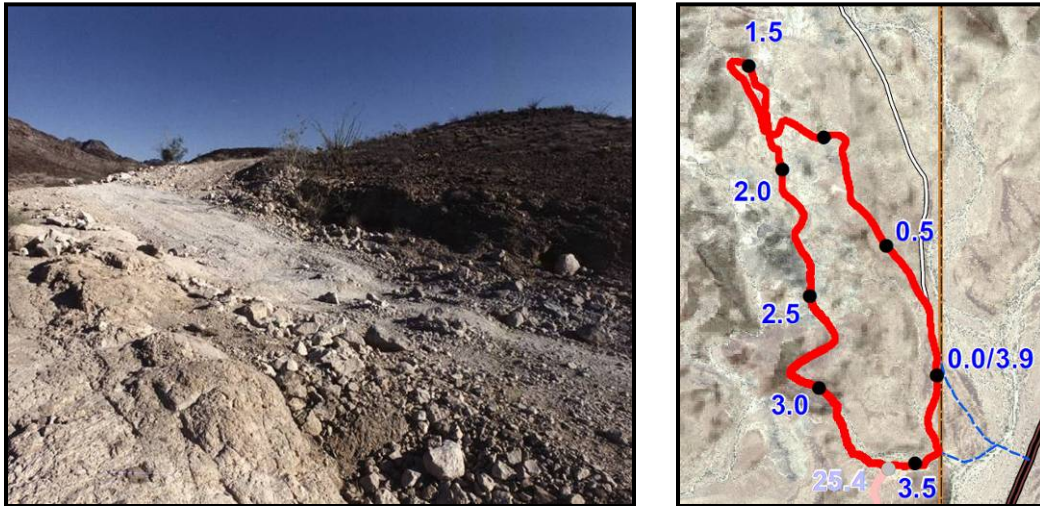

Figure 114. Typical terrain of Rock Ledge (left) and course map (right).

1. Desert March Course. The site is a 40.8 km (25.4 mi) course through a variety of desert terrain features including limey fans, limey fan sandy, sandy uplands, sandy bottoms, and gravelly and rocky hills. The route exposes a test vehicle to a rigorous test condition which exercises the suspension system, braking systems and the transmission with repeated shifting due to the torque requirements needed to traverse the varied terrain. The average rms is 2.87 cm (1.13 in.). Grades are generally mild (average grade 3%), but several hills push the steepest grade to 24%. Figure 115 shows the typical terrain and a course map.



Figure 115. Typical terrain of Desert March (left) and course map (right).

m. Vapor Lock Wash. The site is a course located along the bottom of a watercourse at the foot of an ancient beach terrace, and is classified as sandy bottom, deep. The course follows the natural wash bottom for some 4.0 km (2.5 mi). The course provides deep sand and consists of twists and turns along its course. The course was previously used to test for vapor locking of fuel feed systems. Presently it is used for vehicle maneuverability and handling in deep sand conditions, as well as to present a large stress on vehicle cooling systems. The grades are essentially flat, and roughness descriptions are not provided due to the sandy nature of the terrain. Figure 116 shows the typical terrain and a course map.



Figure 116. Typical terrain of Vapor Lock Wash (left) and course map (right).

n. Highway 95. YTC has use of an 80 km (50 mi) stretch of U.S. Highway 95 spanning from the intersection with Imperial Dam Road (mile marker 44) north almost to Quartzite AZ at mile marker 105. The asphalt highway is used to conduct endurance operations over primary terrain at speeds up to the 105 kph (65 mph) speed limit for vehicles that can attain a permit to operate on U.S. highways. A stretch of U.S. Highway Route 95 running through YTC is shown in Figure 117.

o. Bereznuik Track Evaluation. This site is an approximately 2.4 km (1.5 mi) course over relatively undisturbed rocky terrain. Tracked vehicles are tested on this course to evaluate the durability characteristics of track systems over rocky terrain. Figure 118 shows the course map.





Figure 117. Aerial view of Highway 95.

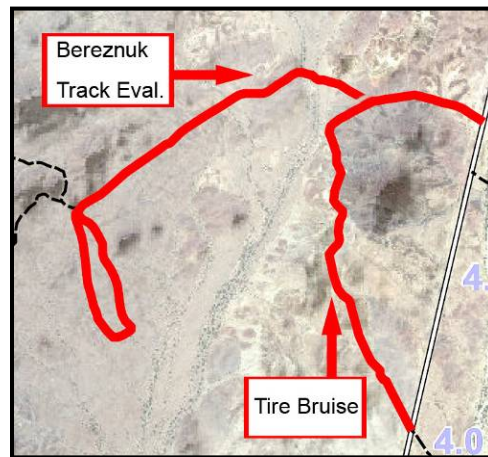

Figure 118. Course map for the Bereznuik Track Evaluation and Tire Bruise.

p. Tire Bruise. This course is approximately 2.1 km (1.3 mi) in length and is used primarily for evaluating tire durability and exercising suspension components. The surface of the course contains many 10 to 20 cm (4 to 8 in.) diameter rocks. Figure 118 shows the course map.

q. Patton Wash. This test course is located within a gravel and sand wash that runs approximately parallel to the Imperial Dam road. One end of the course is located at the YTC fording basin, which has been used as a water source to allow pipeline or flexible conduit water pumping operations along the length of the 3.7 km (2.3 mi) course; this capability allows for testing deployment and distribution petroleum and water systems. The Patton Wash is an active wash, meaning that heavy rainfall periodically restores the terrain. The layout of the course is shown in Figure 119 and the typical terrain is shown in Figure 120.

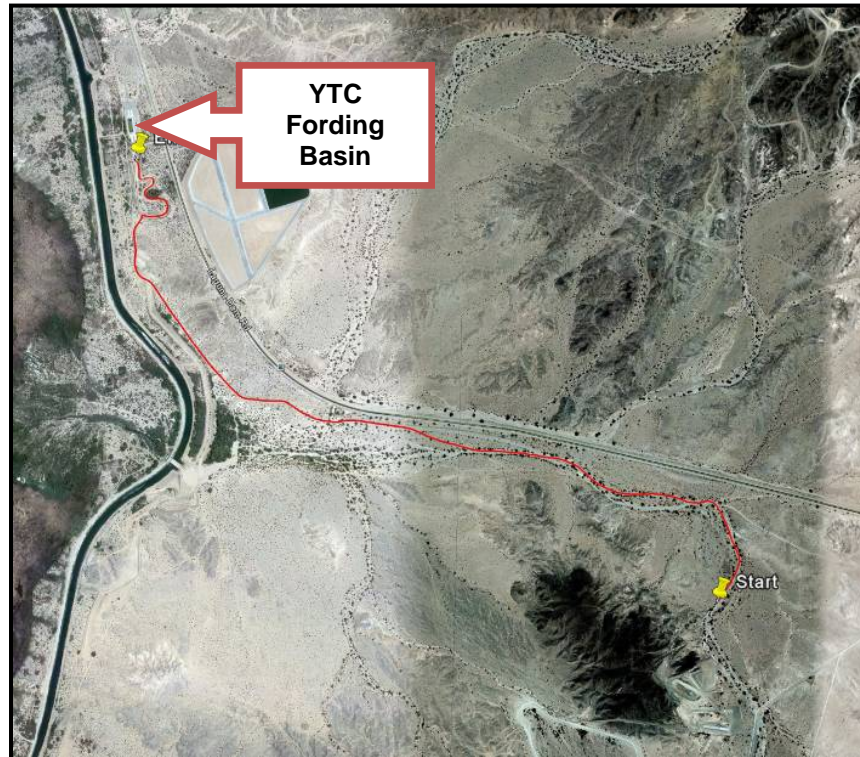

Figure 119. Overview of Patton Wash Course.



Figure 120. Typical terrain of Patton Wash.

r. Patton Off-Road. This course is a severe cross country course with the steepest grades, approaching 50-percent, of any course at YTC. In addition to the steep grades, severe terrain obstacles are present due to rocky terrain and washout of the material. The course is situated on a basalt hill range site which is located on a series of relic beach terraces. Due to the severity of the terrain, the course is generally used for mobility evaluations of lighter wheel vehicle platforms with significant off road capability. The 5.0 km (3.1 mi) course layout allows for different routes to be followed through the course to tailor the profile for the system. The grade profile of the course is shown in Figure 121 and the course terrain and map are shown in Figure 122.

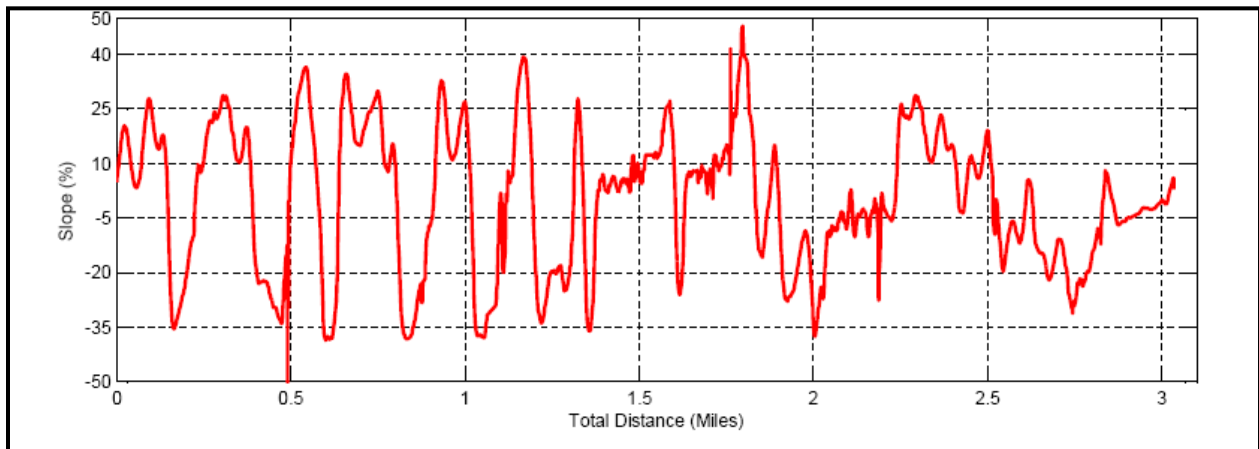

Figure 121. Patton Off Road Course grade profile.





Figure 122. Patton Off Road Course terrain (left) and course map (right).

### 3.2 Performance Courses.

a. **Longitudinal Grades.** At this facility, test vehicles can ascend or descend concrete grades ranging from 5 to 60 percent, as well as demonstrate both service and parking brake hold testing; maintainability of satisfactory lubricant and fluid levels; engine restart capabilities; and proper and satisfactory operation of vehicle component systems. Table 6 shows the dimensions of the longitudinal grades. Figure 123 shows the 20 through 60% concrete surfaced longitudinal grades.

TABLE 6. YTC LONGITUDINAL GRADE DIMENSIONS

SLOPE (percent)	WIDTH m (ft)	LENGTH m (ft)
5	9.1 (30)	37.8 (124)
10	9.1 (30)	45.1 (148)
15	4.3 (14)	91.4 (300)
20	6.1 (20)	72.5 (238)
30	4.6 (15)	78.3 (257)
40	4.6 (15)	47.2 (155)
60	6.1 (20)	32.3 (106)



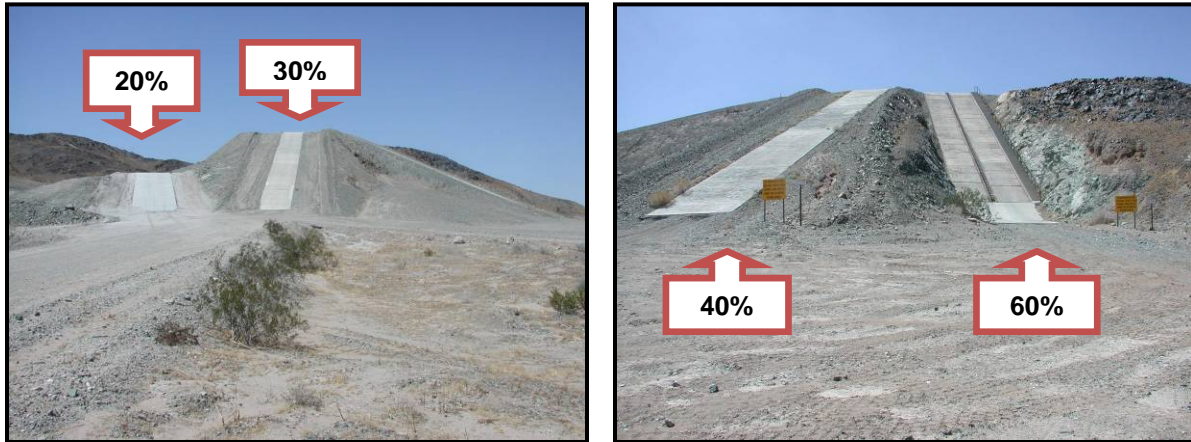

Figure 123. Longitudinal grades.

b. Roll On/Roll Off Ship Ramps. This facility consists of two metal ramps, one at an approach angle of 12 degrees and the other at an approach angle of 15 degrees, as shown in Figure 124. Ship loading operations do not occur when the ramp angle is in excess of 15 degrees, whereas the interior deck ramps of the ship are at approximately 12 degrees, which is the basis of the ramp angles. The ramps are used to evaluate adequate power and traction as well as ramp approach and exit clearance and interference. This simulated test can also provide procedural checks for proper negotiation. Both ramps are 3 m (10 ft) wide; the 12 degree ramp is 18 m (60 ft) long, and the 15 degree ramp is 15 m (48 ft) long.



Figure 124. Roll on/roll off ramps.

c. Side Slopes. At the concrete side slope facilities, test vehicles can demonstrate satisfactory traverse and stability on side slopes from 10 to 40 percent, as well as the maintainability of satisfactory fluid levels and integrity of seals. Table 7 shows the side slope dimensions. Figure 125 shows the 30 and 40 percent concrete surfaced side slopes.

TABLE 7. SIDE SLOPE DIMENSIONS

SLOPE (percent)	WIDTH m (ft)	LENGTH m (ft)
10	9.1 (30)	150.9 (495)
15	10.4 (34)	151.2 (496)
20	9.1 (30)	150.9 (495)
30	9.4 (31)	121.3 (398)
40	9.8 (32)	72.8 (239)



Figure 125. 30-percent side slope (left) and 40-percent side slope (right).

d. Sand Grades. The longitudinal sand grades have nominal grades of 5, 10, 15, and 20 percent. Figure 126 shows the four grades of the course area, and Figure 127 shows the 20% sand slope. The course material is soft, loose, dry, wind sorted beach sand that was imported from southern California. The sand slopes are prepared prior to test for a uniform condition by disc harrowing. The testable portions of each grade is a different length: 5% grade is 61 m (200 ft), 10% grade is 30 m (100 ft), 15% grade is 55 m (180 ft), and the 20% grade is 37 m (120 ft) in length.

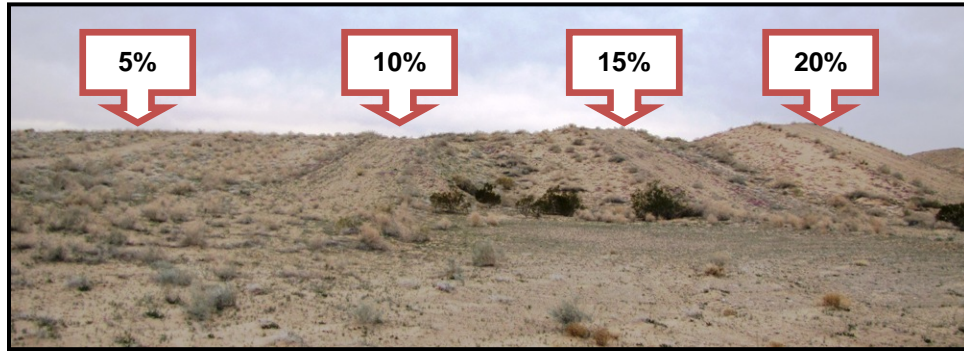

Figure 126. Sand Grades.



Figure 127. 20-percent Sand Grade.

e. Fording Basin. Vehicles and equipment are evaluated for the ability to ford deep and shallow water in the fording basin. This facility (see Figure 128) is approximately 67 m (220 ft) long, 25 m (82 ft) wide, adjustable to a maximum 2.3 m (7.7 ft) deep and is fully lined with concrete. The basin is filled with water from a nearby canal to the depth required. There are two sides to the fording basin with two different approach and departure slopes described in Figure 129.



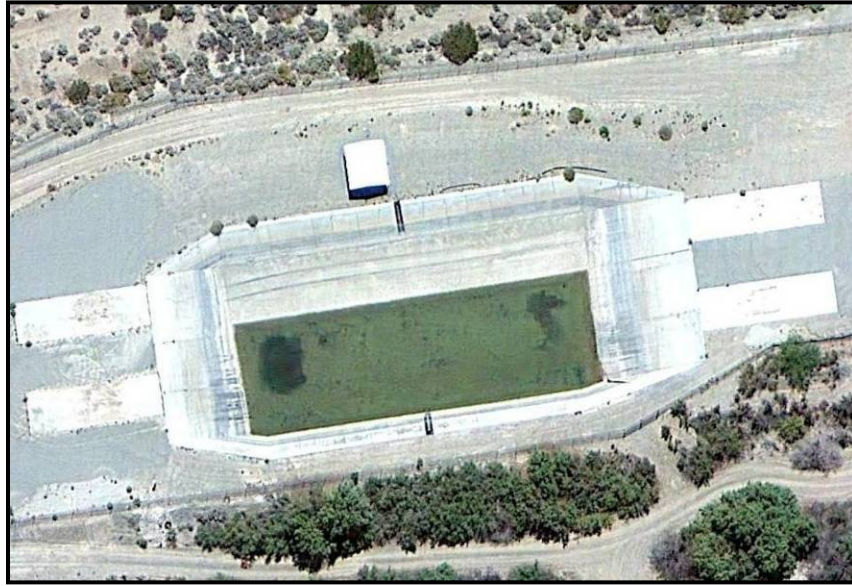

Figure 128. View of Fording Basin.

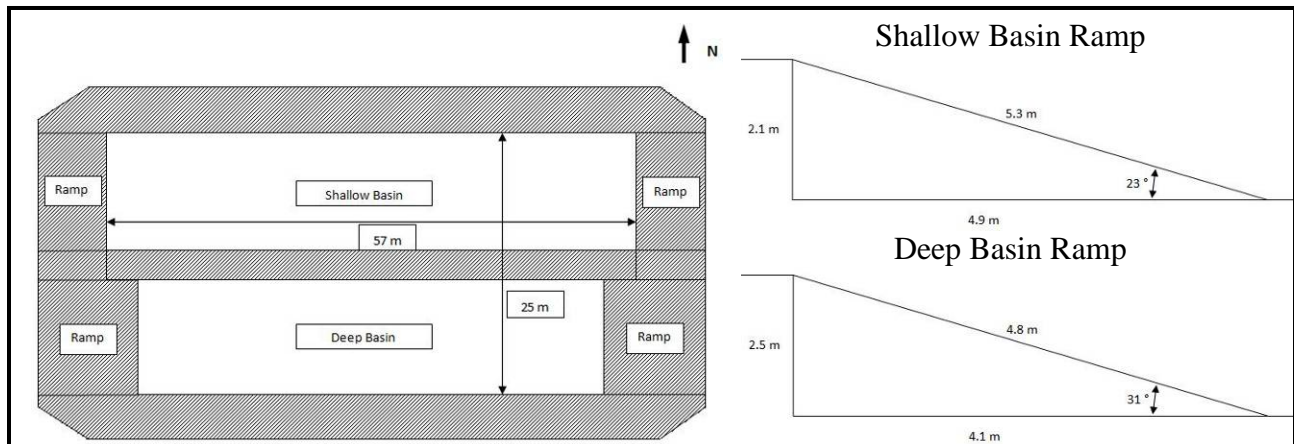

Figure 129. Fording basin layout.

f. Kofa Dust Course. This course is a 3.2 km (2.0 mi) long circular track through a classical basin floor composed of Gilman Family-Harqua Family, Glenbar Family Complex soils. The terrain is classified as limey fan and is characterized as very fine silty-loams, which are easily elevated into the air producing very dense dust clouds which remain suspended for significant periods of time. The particles in these soils are extremely small, in some cases less than 5 microns, and are slightly abrasive. This course is used to test the ability of engine filtration systems to filter out the dust particles. Additionally, the course is used to evaluate the filtration systems and sealing capabilities of the vehicle and crew compartments. Figure 130 shows a vehicle on the Kofa Dust Course and a map of the course.





Figure 130. Vehicle performing non-convoy dust testing on Kofa Dust Course (left) and map of Kofa Dust Course (right).

g. Cibola Dust Course. The dust course is approximately 6.3 km (3.9 mi) long, and crosses surfaces composed mostly of silt and sand with gravel. The percent mean dust content of the alluvial fan generally ranges from 40 to 50 percent. The particles in these soils are extremely small, in some cases less than 5 microns, and are slightly abrasive. This course is used to test the ability of engine filtration systems to filter out the dust particles. Additionally, the course is used to evaluate the filtration systems and sealing capabilities of the vehicle and crew compartments. Figure 131 shows the typical terrain of the Cibola Dust course and a course map.



Figure 131. Vehicle performing convoy testing on Cibola Dust Course (left) and map of Cibola Dust Course (right).

h. Cibola Mud Course. This course is a prepared pad 91.4 m (300 ft) wide by 152.4 m (500 ft) long with a mud surface consisting of fine grained clay soils in combination with water to produce muddy surface approximately 1.2 cm (3 in.) deep to perform tire traction testing.

i. Dyno Mud Course. This course is 0.6 km (0.4 mi) long and is maintained at an approximate depth of 46 cm (18 in), over a firm base. The mud is a mixture of sand, clay, and silt. Water is added to the course with a sprinkler array and the quantity of water added to the course will change the consistency of the mud. The course provides a severe test of seals on road wheels, road arms, constant velocity joints, suspensions, brakes and steering components. Figure 132 shows a vehicle operating on the YTC Dyno Mud Course.



Figure 132. Vehicle operating on Dyno Mud.

j. Laguna Mud Course. This course is approximately 0.6 km (0.4 mi) long with a very uniform soil distribution over its entire length. The soil is classified as inorganic clays with high compressibility. The clay/sand surface can be wet to produce a representative muddy surfaced clay road used for maneuverability testing of vehicles. The mud is created by flooding the course from a nearby canal. Figure 133 shows a vehicle operating on Laguna Mud Course.



Figure 133. Vehicle operating on Laguna Mud.

k. Sand Dynamometer. This course is composed of primarily Gilman Family, Harqua Family, and Glenbar Family soils which are very sandy silty loams with very fine particles. These soils are easily moved by wind action and tend to build extensive low dunes. The sand dynamometer terrain is described as sandy upland. The course is built upon one of the larger dunes and has adequate space for multiple passes over untracked terrain between surface preparations. The consistence and uniformity of the course surface is maintained by disc harrowing. The course is used primarily to determine vehicle speeds and mobility in deep sand. Figure 134 shows the Sand Dynamometer Course.



Figure 134. YTC Sand Dynamometer Course.



1. Ride Dynamics Course. YTC has five ride dynamics courses developed by the U.S. Army Corps of Engineers WES. These courses are used to determine vehicle and human response to a specific, frequency-based road input. YTC's ride quality courses vary in length from 251 to 305 m (825 to 1000 ft) and in surface roughness from 1.0 to 8.6 cm (0.4 to 3.4 in.) rms (Figure 135).



Figure 135. RMS 5 Ride Dynamics course.

m. Fuel Transfer and Test Site Area. This area is designed for fuel truck, tanker-to-fuel truck, and tanker transfer endurance tests inside a 34 m by 61 m (110 ft x 200 ft) fenced area. The area has a 12 m by 37 m (40 ft by 120 ft) concrete parking and fuel spill containment pad. The facility is equipped with a 19,000 L (5000 gal) fuel spill collection tank. Figure 136 shows fuel tanks undergoing storage testing and a fuel tanker at the Fuel Transfer and Test Site Area. An additional large-scale fueling site is located in the center of the Dyno complex for fueling systems that do not fit within the confines of the Fuel Transfer Site.





Figure 136. Fuel tanks undergoing storage test (left) and fuel tanker at the Fuel Transfer and Test Site Area (right).

n. Airfield Delivery Loading Ramp. This site at Laguna Army Airfield (LAAF) is used as a skid pad for steady-state cornering testing. The concrete pad measures 96 by 148 m (315 by 485 ft). Figure 137 shows a vehicle undergoing testing on the test site.



Figure 137. Vehicle undergoing testing on the Airfield Delivery Loading Ramp.

o. Half Rounds and Curb Impact Course. These courses are used to analyze the vehicles ability to absorb impacts at various speeds and assesses the input into the vehicle operator. The half round course consists of interchangeable 10, 15, 20, 25, 30 cm (4, 6, 8, 10, 12 in.) steel half rounds. Figure 138 shows the ten inch half rounds. The curb impact course consists of one concrete curb as shown in Figure 139. The height of the curb can be adjusted up to 2 feet in height by grading the gravel surface below the curb.



Figure 138. Ten Inch Half Rounds.



Figure 139. Curb Impact Course.

p. C-130 Air Transportability Test Bed (ATTB). This facility, located at the Air Delivery complex, is a C-130A fuselage designed to provide a cost effective alternative for test loading combat vehicles and logistics systems under development, as shown in Figure 140. The ATTB allows programs the opportunity to determine if their test items will fit onboard a standard military cargo craft. The cargo compartment dimensions, concentrated cargo/pneumatic tire load limits and aircraft tiedown points onboard the ATTB (shown in Figure 141) are fully representative of all C-130 E/H and J model aircraft currently in service. The ATTB is equipped with fully functional electrical and hydraulic systems, cargo ramp and door, ground loading ramps, paratroop doors, cargo winch, aerial delivery system components (excluding static line retrieval winches), A/A32H-4A cargo handling system, pendulum release, static-line cable system, and an internal climate control system. Additional uses of the ATTB include fit/function aircraft interface developmental testing of aerial delivery systems and components, and use as an airborne test mission rehearsal simulator.



Figure 140. Aircraft Transportability Test Bed.



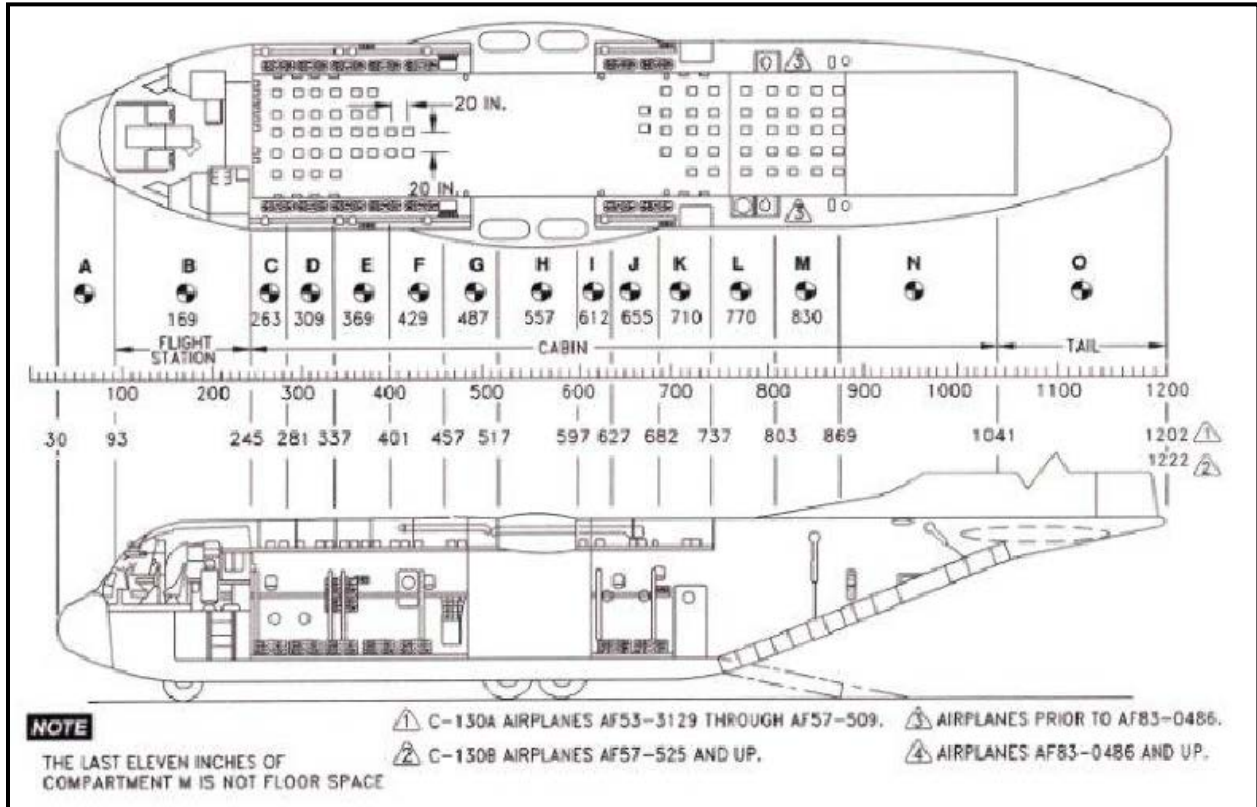

Figure 141. C-130 ATTB dimensions.

q. Urban Rubble. This course is approximately 30 m (100 ft) in length and 9 m (30 ft) wide. The course consists of large boulders, pieces of concrete and construction debris spread throughout the length of the course as shown in Figure 142.



Figure 142. Urban Rubble Course.



r. Hot Weather Test Complex (HWTC). This complex is a joint use facility located at YTC comprised of two test complexes; one a series of test courses constructed for the Army, and the other the General Motors (GM) Desert Proving Grounds - Yuma. The HWTC contains the Laguna High Speed Paved Oval, Laguna Paved, Kofa Level Gravel, Kofa High Speed Gravel, and GM Performance Test Courses. The Army HWTC facilities were constructed to give YTC the ability to test the heaviest combat and combat support vehicles at high sustained speeds coupled with the high temperatures experienced in the Middle East. Figure 143 shows a map of the HWTC. Testing at the complex allows for the full range of testing to include, but not limited to: maximum and minimum speeds, acceleration, braking (including split friction, low friction and J-turn), steering and handling, drawbar pull, fuel consumption, cooling, rolling resistance, tractive effort, endurance testing of wheeled and tracked vehicles, and evaluation of overweight and over length vehicles.

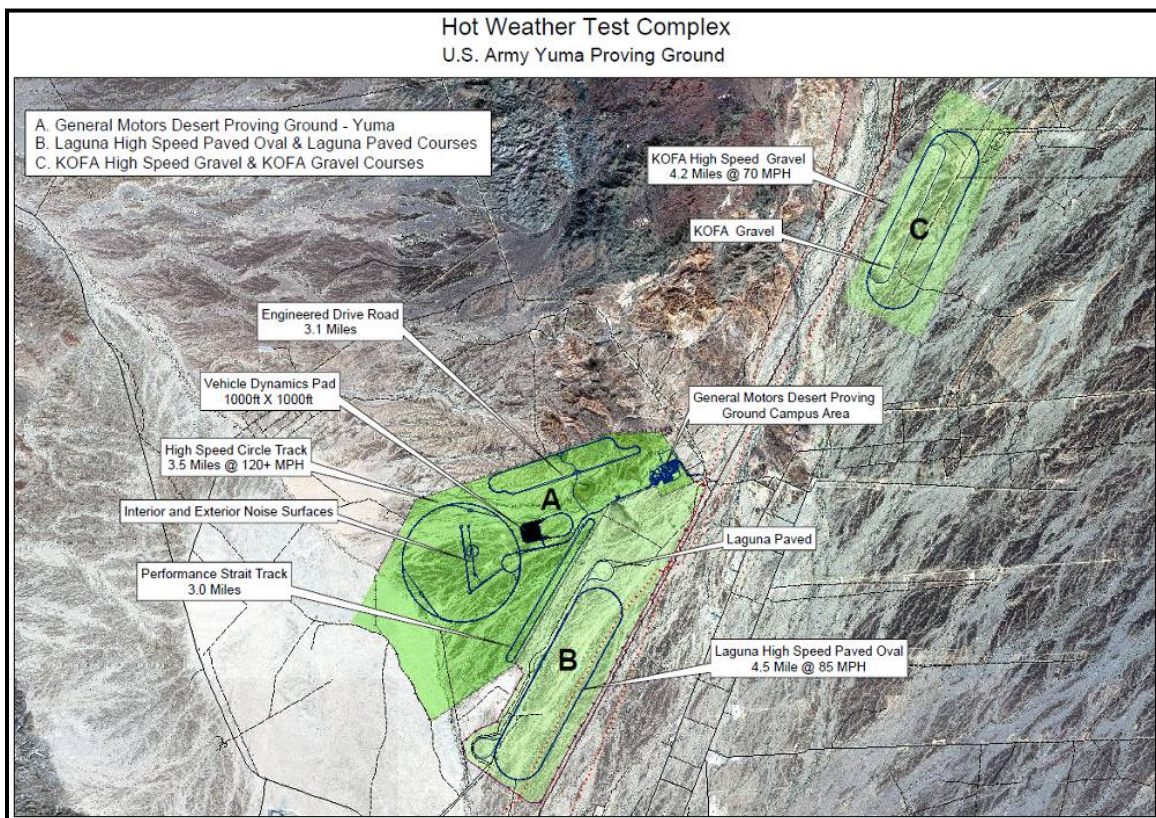

Figure 143. HWTC map.

s. Laguna High Speed Paved Oval. This course is a 7.2 km (4.5 mi) long, two-lane oval test track with straightaways 2370 m (7,780 ft) in length and cornering radii are 370 m (1,200 ft) as shown in Figure 144. The course is level with a minimal 0.8 percent grade, is approximately 143 m (470 ft) above sea level, and consists of firm reinforced bed covered with a high-strength asphalt coating. The Laguna High Speed Paved Oval course allows for wheeled vehicles with weights up to 113,398 kg (250,000 lb).

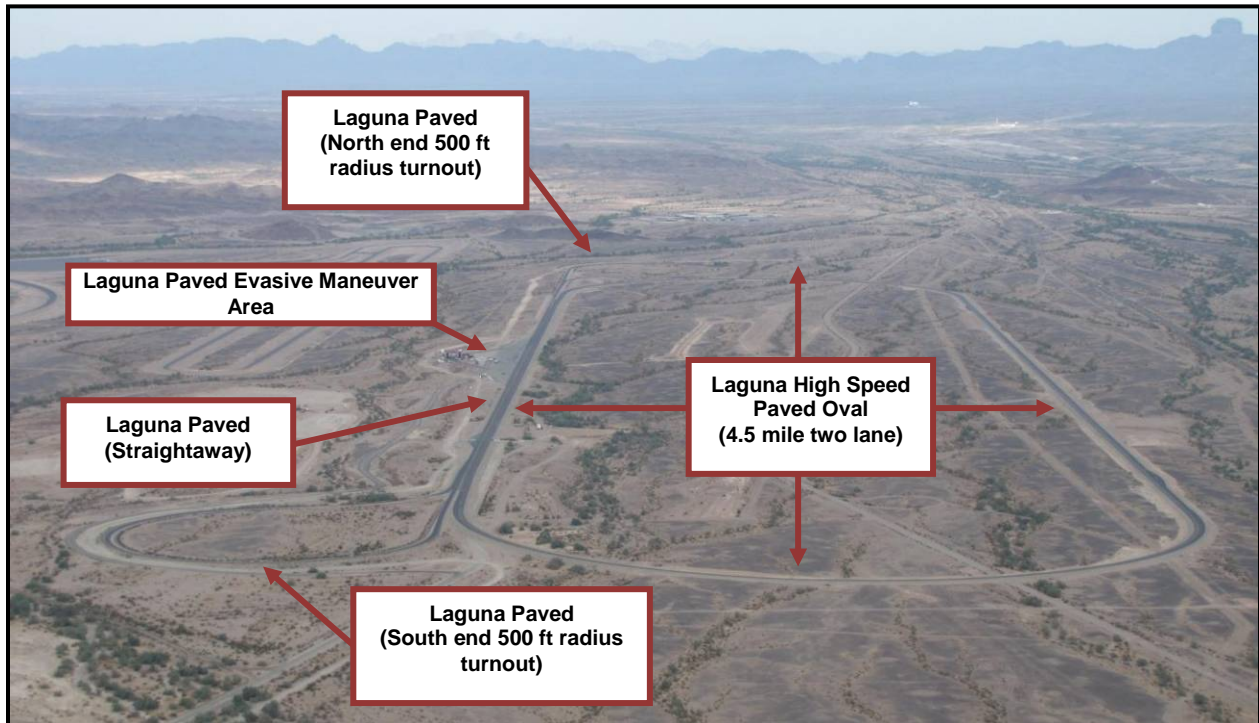

Figure 144. Aerial view of the Laguna Paved and Laguna High Speed Paved Oval.

t. Laguna Paved. This course is 3.2 km (2.0 mi) in length, comprising of a single lane straightaway and two 152 m (500 ft) radius turnouts at each end as shown in Figure 144. The Laguna Paved course accommodates both track and wheeled vehicles with weights up to 113,398 kg (250,000 lb) for both endurance and performance testing. This course, along with the capability of the YTC Mobile Dynamometers, provides the capability of conducting Full Load Cooling, Tractive Effort, and other performance tests plus paved highway endurance testing. The Laguna Paved course is level with a minimal 0.8 percent grade, and is approximately 143 m (470 ft) above sea level. The course consists of firm reinforced bed covered with a high-strength asphalt coating. The peak coefficient of adhesion varies slightly between 0.89 and 0.93 depending on the section of the course used. There is a 305 m (1000 ft) long by 30.5 m (100 ft) wide automotive handling and evasive maneuver testing area co-located with the Laguna Paved course also shown in Figure 144. The evasive maneuver testing area contains two low friction jennite surface sections for low friction or split friction testing. The first is a straight 122 m x 4 m (400 ft x 12 ft) lane. The second section is a 107 m x 7 m (350 ft x 24 ft) curved section with a 152 m (500 ft) radius of curvature. Figure 145 shows the layout of the low friction test areas.



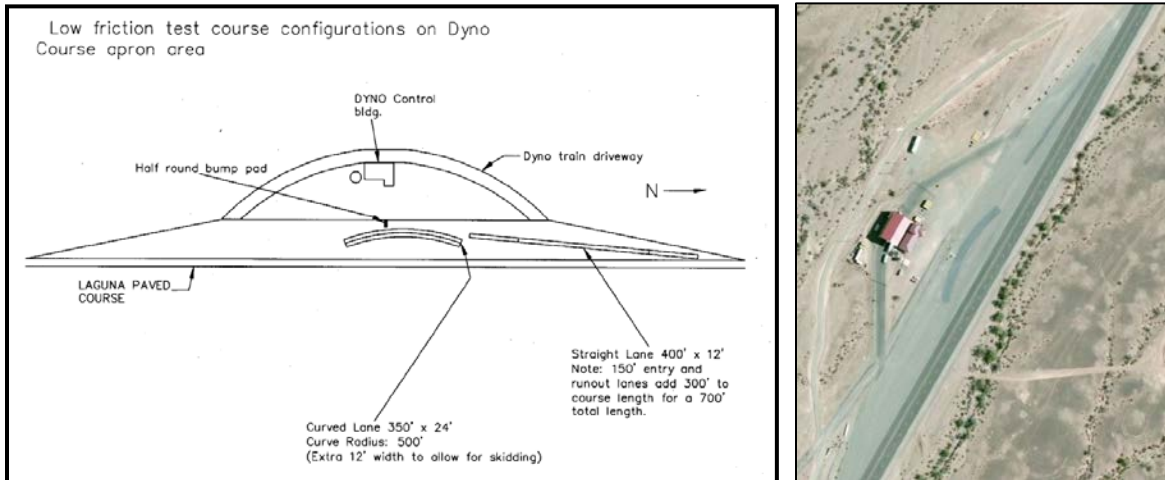

Figure 145. Low friction areas of the Laguna Paved Test Course.

u. GM Desert Proving Grounds Yuma Courses. As part of the Enhanced Use Lease agreement which developed the Hot Weather Test Complex, YTC has access to the GM performance courses for use in vehicle tests within the weight limits of the facilities.

(1) GM High Speed Circle Track. The track is a three lane 5.6 km (3.5 mi) asphalt circle with the lanes banked parabolically enabling speeds in excess of 190 kph (120 mph) without excessive lateral friction or banking load. Wheeled vehicles with a gross vehicle weight (GVW) of 36,300 kg (80,000 lb) and axle weights of 9,000 kg (20,000 lb) are able to be tested on this test course, primarily for endurance operations or tire testing.

(2) GM Vehicle Dynamics Pad. The pad is a 305 m by 305 m (1,000 ft x 1,000 ft) square of asphalt with two ingress/egress lanes. Wheeled vehicles with a GVW of 36,300 kg (80,000 lb) and axle weights of 9,000 kg (20,000 lb) are able to be tested on this test course. This test course is used primarily for vehicle dynamics testing such as North Atlantic Treaty Organization (NATO) lane change, lateral stability, and National Highway traffic Safety Administration (NHTSA) J-turn maneuver, steady increasing steer or sine with dwell maneuvers.

(3) GM Performance Straight Track. The track is 4.8 km (3.0 mi) in length and consists of two parallel 2.3 km (1.4 mi) asphalt straightaways connected with 180-degree curves at either end. Wheeled vehicles with a GVW of 36,300 kg (80,000 lb) and axle weights of 9,000 kg (20,000 lb) are able to be tested on this test course. This test course is used primarily for automotive performance such as acceleration and braking.

(4) GM Engineered Ride Road. The road is 5.0 km (3.1 mi) in length with two or three lanes (depending on the section of the course) of specially constructed asphalt and concrete road sections. Each road section has been specially designed to replicate real world road surfaces that have been found to excite a vehicles suspension and affect ride dynamics in a unique way. Due to the sensitive nature of the specially constructed road surfaces, testing on this course is determined on a case by case basis depending on program requirements.

(5) GM Belgian Block and Granite Block. A 76 m (250 ft) section of Belgian block and a 152 m (500 ft) section of granite block is used for ride dynamics and shock and vibration testing. Wheeled vehicles with a GVW of 36,300 kg (80,000 lb) and axle weights of 9,000 kg (20,000 lb) are able to be tested on these road surfaces.

v. Pothole Course. This course consists of six steel fabricated potholes. The potholes range in size from 10 to 30 cm (4 to 12 in.) in depth, 1.2 to 2.4 m (4 to 8 ft) in length, and 1.2 to 1.8 m (4 to 6 ft) in width respectively, sunk flush with the gravel surface. Figure 146 shows a close-up of a pothole on the course and describes in detail the dimensions and spacing of each pothole. The sides and ends of the two 30 cm (12 in.) deep potholes are sloped 45 degrees, whereas the smaller potholes are sloped 45 degrees on the sides, with one end open and the other end sloped at 90 degrees. The course is laid out to allow vehicles ample room to reach desired speeds and approach each pothole with either the right or left side tires. The potholes are designed to be approached individually, from the right or left sides, with the vehicle entering the course perpendicular to the line of potholes. The potholes are not staggered such that they can be run successively in a straight line.



Figure 146. YTC Potholes Course (left) and dimensions of the YTC Potholes Course (right).

w. Vertical Steps. This site consists of permanent concrete walls of 15, 30, 46, 61, 76, and 91 cm (6, 12, 18, 24, 30, and 36 in.) in height with replaceable timbers placed at the vehicle approaching end. The replaceable timbers minimize damage to test vehicles components upon contact with the steps. This course is use to determine the test vehicles' capability to climb vertical objects. Figure 147 shows the characteristics of the vertical steps.





Figure 147. Vertical Steps.

x. V-ditch. The V-ditch obstacles consist of a direct approach concrete V-ditch, and an angled approach concrete V-ditch. The direct approach V-ditch is 4.6 m (15 ft) wide, and 7.6 m (25 ft) from crest to crest. The angled approach V-ditch is 12 m (40 ft) wide, and 7.0 m (23 ft) from crest to crest. The angled approach V-ditch can be traversed so that either the right or left side tires drop into the V-ditch first. Both V-ditches feature a 20-degree angle relative to level. Figures 148 and 149 show the V-ditches.



Figure 148. Direct approach V-ditch.

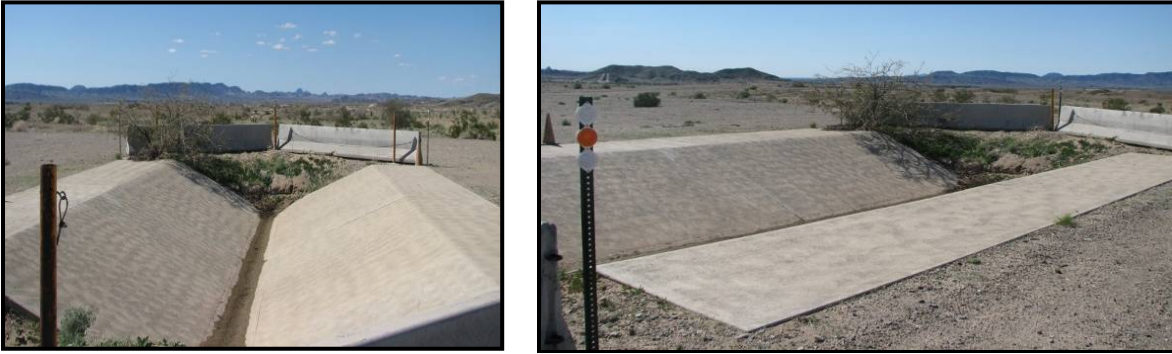

Figure 149. Angled approach V-ditch side view (left) and 45 degree front view (right).

y. Military Operations on Urban Terrain (MOUT) Obstacle Course. The MOUT course consists of a curbs obstacle, logs obstacle, washboard terrain, 23 cm (9 in.) half rounds, 35-percent longitudinal grade, and staircase obstacle. The obstacles are designed to be run individually or in series as an obstacle course. The curbs obstacle (Figure 150) is 4.3 m (14 ft) in length and 6.1 m (20 ft) wide, and consists of five concrete barriers laying on their sides and sunk into the gravel. The curbs are angled at 45 degrees in one direction and 90 degrees in the opposite direction, and range in height from 15 to 21.6 cm (6 to 8.5 in.). The logs obstacle (Figure 151) is 9.1 m (30 ft) in length and 6.1 m (20 ft) wide, and consists of logs laid side-by-side varying in diameter from 18 to 35 cm (7 to 14 in.). The washboard terrain (Figure 152) is 6.1 m (20 ft) in length and 4.6 m (15 ft) wide. The half round obstacles (Figure 153) consists of 7 half rounds, each 23 cm (9 in.) high, and offset so that a vehicle's right and left side tires alternate traversing the obstacle every 3.4 m (11 ft) (center to center). The half rounds cover a span of 16.8 m (55 ft) in length and a maximum track width of 2.7 m (9 ft). The staircase obstacle (Figure 154) is a series of 17 steel steps with antiskid coating. The stairs treads are 38 cm (15 in.) deep, and have a rise of 15 cm (6 in.) each (approximately 23 degree longitudinal grade). The staircase is 6.1 m (20 ft) long (hypotenuse) and 4.3 m (14 ft) wide.



Figure 150. Curbs obstacle.



Figure 151. Logs obstacle.



Figure 152. Washboard terrain obstacle.



Figure 153. 9-inch Half Rounds obstacle.





Figure 154. Staircase obstacle.

z. Winch Test Facility. This facility provides the capability to test the operational characteristics of winches. The winch facility is equipped with a concrete deadman that can be used to secure the winch cable the vehicle itself, as shown in Figure 155. The concrete deadman can resist a maximum load of 578,000 N (130,000 lb). Winch testing can also be performed at the Lift and Tiedown Test Facility (LTTF) facility, discussed in Paragraph aa.



Figure 155. Vehicle undergoing winch testing.

aa. Lift/Tiedown Test Facility. The LTTF provides the capability to test the strength of lifting and tiedown provisions on military equipment with the purpose of validating compliance



with the requirements of MIL-STD-209K and MIL-STD-913A. The LTTF is equipped with hydraulic rams, platform, and deadmen to setup and restrain the test item and apply the required loads to the lift and tiedown provisions. The layout of the facility is shown in Figure 156. The primary components of the LTTF facility are a longitudinal-force cylinder with a 1,000,000 N (240,000 lb) maximum longitudinal force capacity, a downward-force cylinder with a 400,000 N (90,000 lb) maximum lateral force capacity, and a downward-force cylinder with a 267,000 N (60,000 lb) maximum vertical force capacity. The longitudinal-, lateral-, and vertical-force hydraulic rams are shown in Figures 157 to 159. The LTTF facility is also equipped with additional items that facilitate the setup and restraining of test equipment. The facility is equipped with a large deadman that can resist a longitudinal force of up to 1,000,000 N (240,000 lb) and a lightweight deadman that can resist a longitudinal force of up to 712,000 N (160,000 lb) as shown in Figure 160. The deck of the lift and tiedown table has six rows of anchor points for use with chain or clevis attachments to restrain test items, and each anchor can resist a maximum pull of 178,000 N (40,000 lb) in any direction.

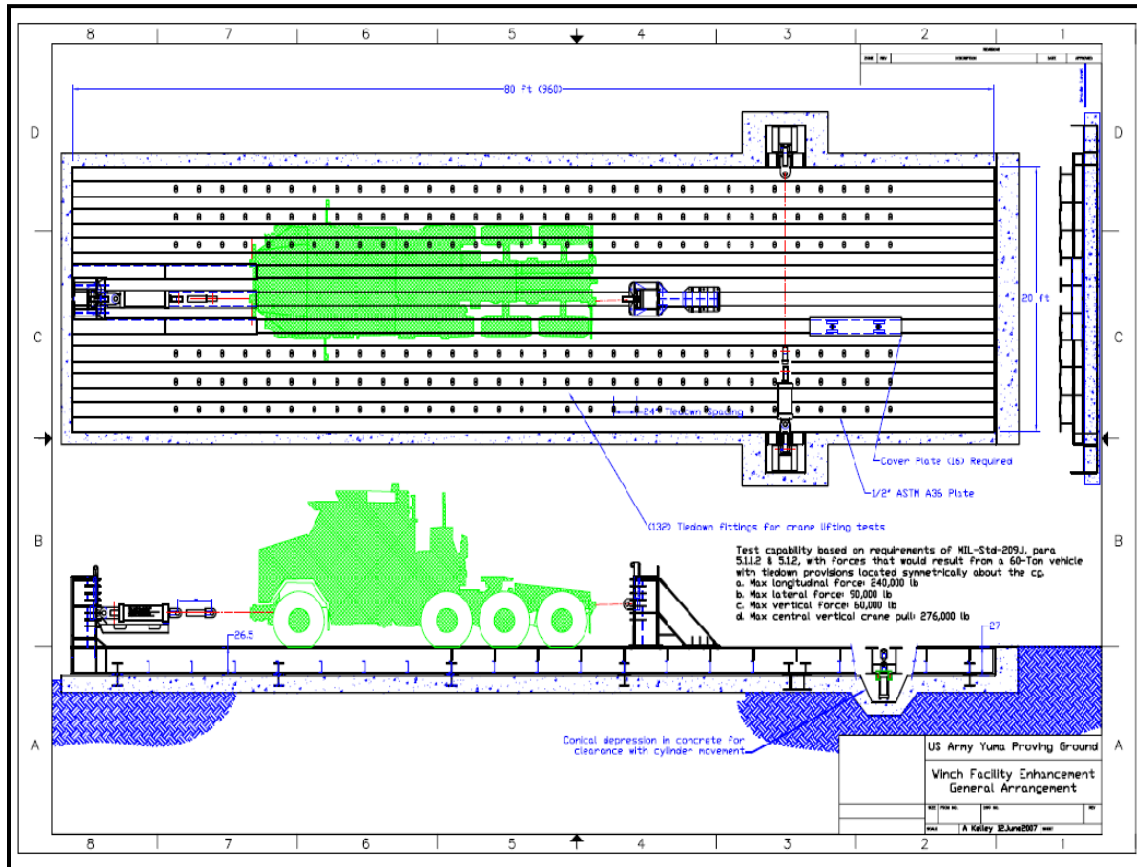

Figure 156. Lift and Tiedown Facility (LTTF).

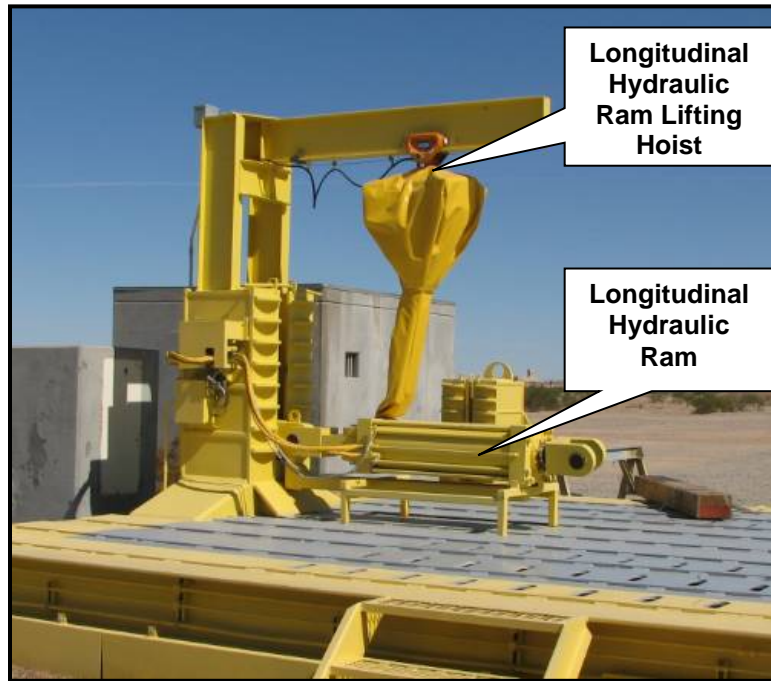

Figure 157. LTTF longitudinal hydraulic ram.

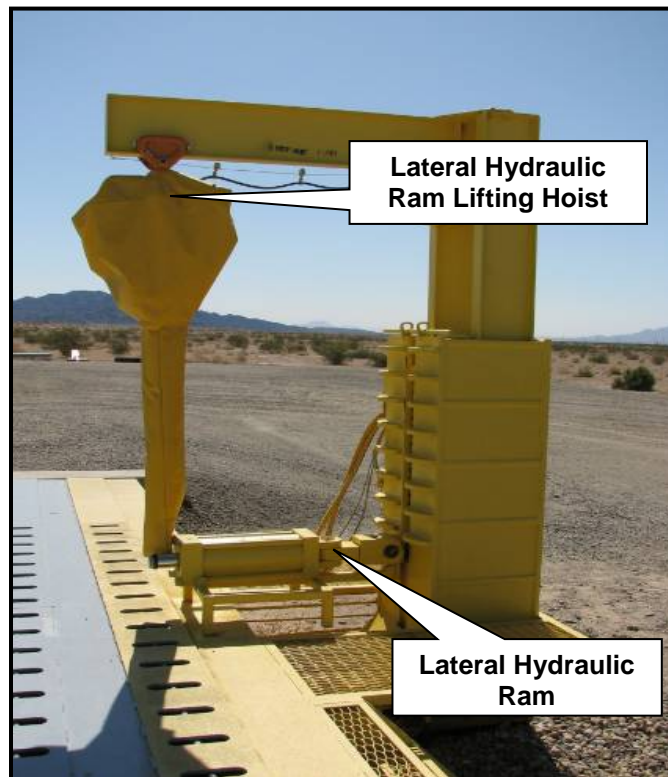

Figure 158. LTTF lateral hydraulic ram.

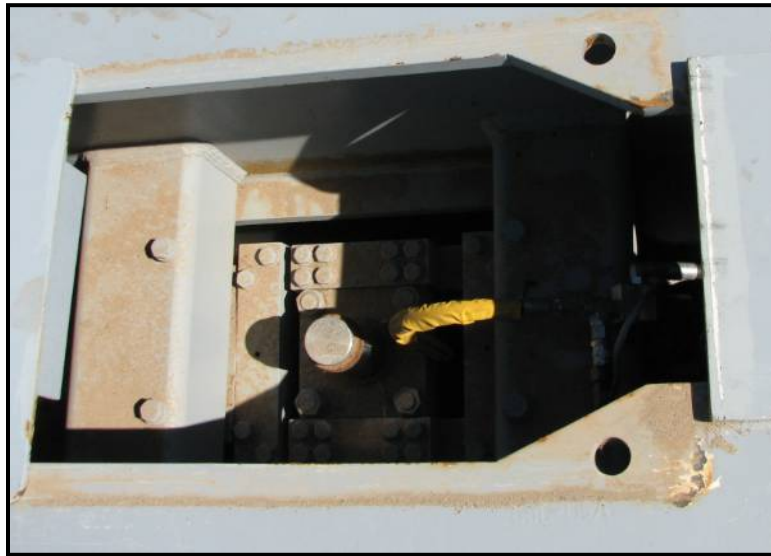

Figure 159. LTTF vertical hydraulic ram (located under the surface of the LTTF bed).

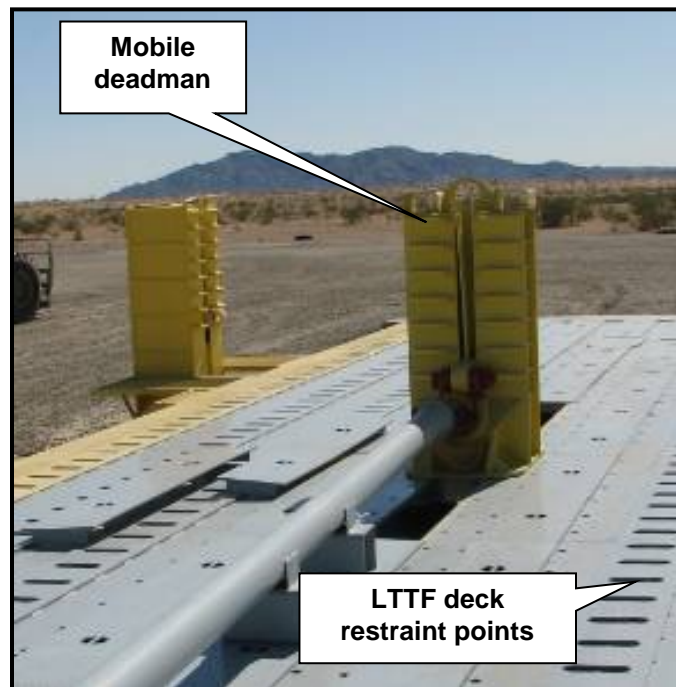

Figure 160. LTTF deadman and deck restraints.

bb. Bridging Area. Areas are available for testing bridging devices and systems. The area to the north of the concrete 10% side slope has been disturbed by earth moving equipment leaving an assortment of trenches and steps that can be used as obstacles for deploying and

retrieving bridging equipment. Figure 161 illustrates a typical ‘trench’ or ditch feature with a bridging device being deployed. The surface of this area can be altered to suit test scenario needs on a case by case basis. For floating type bridging devices (pontoon bridge assemblies) the fording basin and Senator Wash are available for deploying and retrieving trials. YTC can use Senator Wash Reservoir for amphibious testing of vehicles and bridging systems by coordinating with the U.S. Bureau of Reclamation. The reservoir is primarily an irrigation storage facility, and is used to modulate water flow in the Colorado River downstream of the reservoir. At normal levels, the reservoir provides water depths of 15 m (50 ft) and over, near the main dam structure. Access to the lake is made via a concrete boat launching ramp, as shown in Figure 162.



Figure 161. Bridging device test ditch.



Figure 162. Senator's Wash Reservoir Swim Test Facility.



cc. Tilt Table. The facility was designed to determine the static rollover threshold of vehicles following SAE tilt table procedures. The steel table structure has a platform size of 3.7 m (12 ft) wide by 27 m (90 ft) long, accommodating up to the largest Army vehicles, including a full loaded Heavy Equipment Transporter System. The table provides a maximum tilt angle of 47 degrees, a 0.3 degree per second angle speed, and a lift capacity of 136,000 kg (300,000 lb). The facility includes tiedown provisions on the table and necessary restraints to prevent vehicle rollover from the table. The tilt table facility is shown in Figure 163.



Figure 163. YTC Tilt Table Facility.

dd. Boresight Slopes. This location is where most combat vehicles under test start and end daily operations, and is shown in Figure 164. The boresight pad offers geodetically surveyed points designed to help test accuracy of Position/Navigation Systems as well as self-location accuracy. The boresight slopes area also provides for several targets designed to test target location accuracy and multiple return capability from laser range finders with permanent targets at ranges from 200 meters out to more than 3,000 meters and the capability to emplace targets at any desired range within line of sight. This location also contains two separate slopes on either side of the concrete pad, which are designed to allow for measurement/characterization of sight/weapon synchronization at various elevations. The boresight slopes area is also available for over the air checkouts of electronic warfare radio frequency jammer type devices for programs that require checkouts as part of their RAM testing. Typical targets are shown in Figure 165.



Figure 164. Boresight slopes.



Figure 165. Typical boresight targets.

### 3.3. Off-Site Courses.

a. Imperial Sand Dunes. Also referred to as the Algodones Dunes, the dunes occupy an area approximately 8.0 km (5.0 mi) wide by 72.4 km (45.0 mi) long located in Southern California approximately about 20 miles west of the city of Yuma. Within the southern portion

of this area is an 11.3 km (7 mi) marked course utilized by YTC for mobility testing. This area features large areas of sand hills, sand plains, and a variety of dune formations with sand grades up to 60 percent and is classified as sandy upland and sandy bottom, deep. This area also contains areas with slip faces up to 91-122 m (300-400 ft) high, which overlook large flat-floored basins sand free depressions, which are interpreted as exposed parts of the desert floor with a succession of advancing barchans. Use of this course must be coordinated with the Bureau of Land Management (BLM). Figure 166 shows a vehicle undergoing test at the Imperial Dunes.



Figure 166. Vehicle undergoing testing in Imperial Sand Dunes.

b. Rail Impact Site. The rail impact site (located at Blaisdell) is a facility where equipment is tested to evaluate the structural integrity to withstand the impacts that can occur during rail transport, shown in Figure 167. The rail impact site and equipment outsourced to support rail impact testing varies to meet specifications set forth in MIL-STD-209K and MIL-STD-810G CN1 test requirements. The rail site is composed of a straight, dry, level ramp section of railroad track 480 m (1575 ft) long. The rail impact instrumentation package utilized during testing includes (but not limited to) the emergency brake system (Figure 168), optical fifth wheel (monitor speed), and accelerometers at prescribed locations to record shock.





Figure 167. YTC Rail Impact Site.

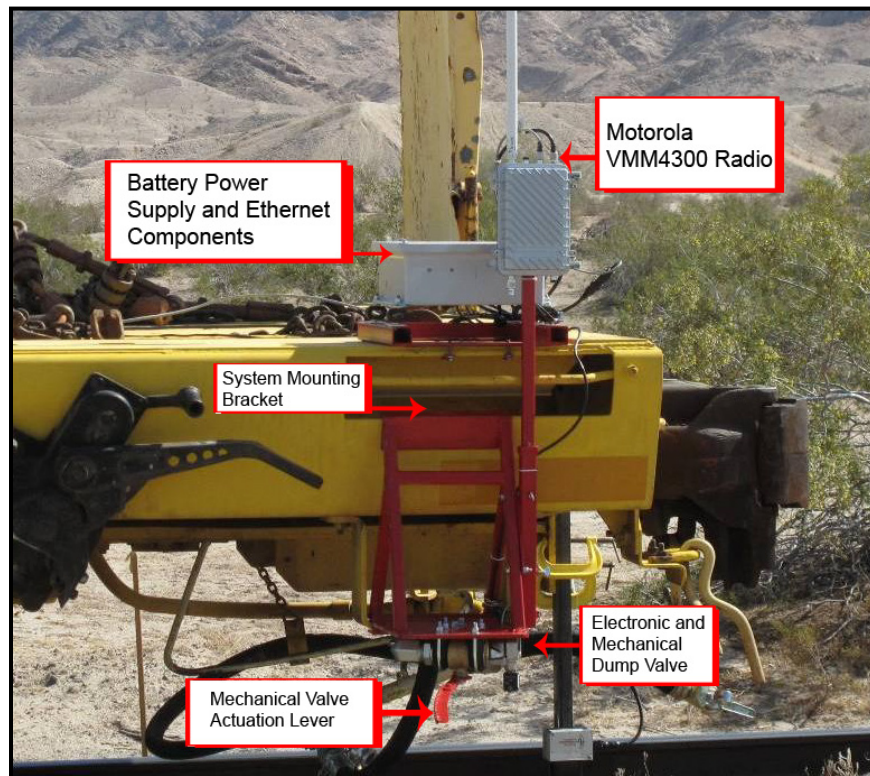

Figure 168. YTC Rail Impact emergency brake system components

c. Interstate 8. Part of the U.S. Interstate Highway System, I-8 runs from Casa Grande, AZ at its eastern terminus, passes through Yuma, AZ at about its midpoint, and proceeds to San



Diego, CA at its western terminus, for a total length of 560 km (348 mi). This multi lane highway offers a variety of terrain from below sea level to mountain passes over 1,219 m (4000 ft) in elevation. In California, west bound from mile marker 89 to the top of the Mountain Springs/In Ko Pah grade, the route is divided through two separate canyons, as the freeway ascends/descends 1,219 m (4000 ft) vertically in 17.7 km (11 mi). Also long relatively flat sections Interstate-8 within CA and AZ provide opportunities for un-interrupted high speed operations. I-8 can be accessed in Yuma, which is about a 20-minute drive from YTC.

(1) Sustained Speed Operations. Beginning at Arizona mile marker 21 and continuing east bound, sustained speed operations of 105 - 120 kph (65 - 75 mph) can be accomplished for up to 246.2 km (153 mi). The terrain is generally flat with a slight rise over Mohawk pass (1.2% up grade, 2.3 % slope down grade in the east bound direction). As it continues east from Mohawk pass, the road averages less than 1% to Gila Bend (exit 119) and then through the Sonoran Desert National Monument it begins a steady climb of 1-1.4% grade until mile marker 161. It maintains a slight down grade/level profile to its eastern terminus at I-10. Diesel fuel can be obtained at Dateland (mile marker 67) and Gila Bend (mile markers 116 and 119).

(2) 5% grade near El Cajon CA. Located in San Diego County, between mile marker 27 and 30, is a section of road way with a sustained 5% grade for 1.1 miles in the east bound direction. The test vehicle can exit at mile marker 27 (Dunbar Lane- Harbison Canyon), pass under the freeway, and gather speed on the slight down grade/on ramp east bound. Once at required speed the vehicle then proceeds up the 5% grade to mile marker 30 (Tavern Road). Diesel fuel is available on Tavern Road.

d. Death Valley National Monument. The road network in the Death Valley National Monument is utilized on a special permit basis coordinated by YTC. A 295 km (183 mi) paved test route between Beatty, Nevada, and Panamint Springs, California, with grades up to 14 percent is used for tests of wheeled vehicles, engines, and transmission and automotive lubricants. Summertime temperatures on the valley floor frequently reach 51.7 °C (125 °F) and elevations that can be reached by roads and trails ranging from 85 m (280 ft) below to 2,400 m (8,000 ft) above mean sea level. Beatty, Nevada, is located 666 km (414 mi) from YTC.

e. Camp Navajo. This area is located near Flagstaff, AZ, and is used as a base of operations for high altitude testing, with nearby roads featuring steep grades and reaching 2,900 m (9,400 ft) above mean sea level.

f. White Mountain Research Center, Barcroft Station. Located in California's White Mountain Range, this area serves as a base of operations for high altitude testing, presenting altitudes of up to 4,300 m (14,200 ft) above mean sea level and steep mountain grades.

### 3.4 Direct Fire Ranges.

a. Combat Systems Direct Fire Range. The range is an area 2 km by 7 km (3,460 acres) located on the Kofa range approximately 16 km (10 mi) down Pole Line Road. The firing range can be configured with a Stabilization Bump Course in accordance with International Test Operations Procedure (ITOP) 03-2-836 (1.3.2.2)<sup>12</sup>. The Stabilization Bump Course consists of

trapezoidal metal blocks that can be moved to specified positions on a straight, level compacted gravel road in a direct line with a stationary target. The layout of the elevation bump courses can be configured according to the performance of the stabilization system. The course is also configurable for Table V Gunnery in accordance with Field Manual (FM) 3-20.21<sup>13</sup> with 14 radio controlled stationary infantry targets (SIT) shown in Figure 169, 2 moving infantry targets (MIT), 15 stationary armored targets (SAT) shown in Figure 170, and 2 moving armored targets (MAT). SAT and MAT targets are hit sensor capable for .50-cal up to 120-mm ammunition, and the SIT and MIT targets are hit sensor capable for small arms ammunition up to 25-mm. Target dimensions are in accordance with FM 17-12-7<sup>14</sup> and can be configured with an infrared (IR) signature and are multiple integrated laser engagement system (MILES) XXI adaptable. The characteristics of target pop-up and fall are programmable for firing scenarios. The range is not authorized for high explosive (HE) or depleted uranium (DU) munitions. A map of Combat Systems Direct Fire Range is shown in Figure 171.



Figure 169. Stationary Infantry Target (SIT) System.



Figure 170. Stationary Armor Target (SAT) System.

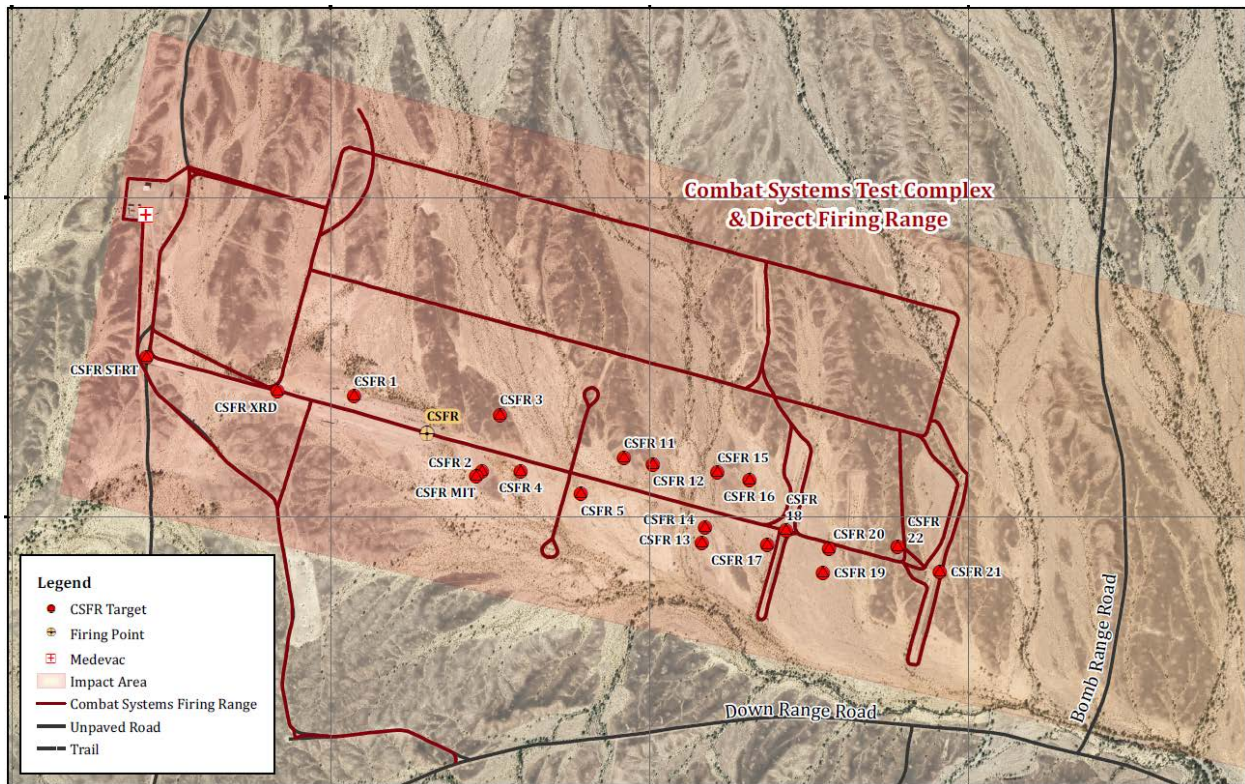

Figure 171. Combat Systems Direct Fire Range map.

b. Moving Target Range. The range consists of two remote controlled rail-mounted moving target carriers. The target carriers can be equipped with a pop-up target (cloth or plywood) up to 3 m by 6 m (10 ft by 20 ft) or a 6 m x 6 m (20 ft x 20 ft) target with the Oehler acoustic scoring system. The rail mounted target carriers are capable of speeds of 32 kph (20 mph). Both configurations are used to test ground vehicle mounted direct fire weapons at ranges of 1500 or 2500 m (to 0.9 or 1.6 mi), depending on which target line is utilized. A characteristic photograph of the two targets is shown in Figure 172.

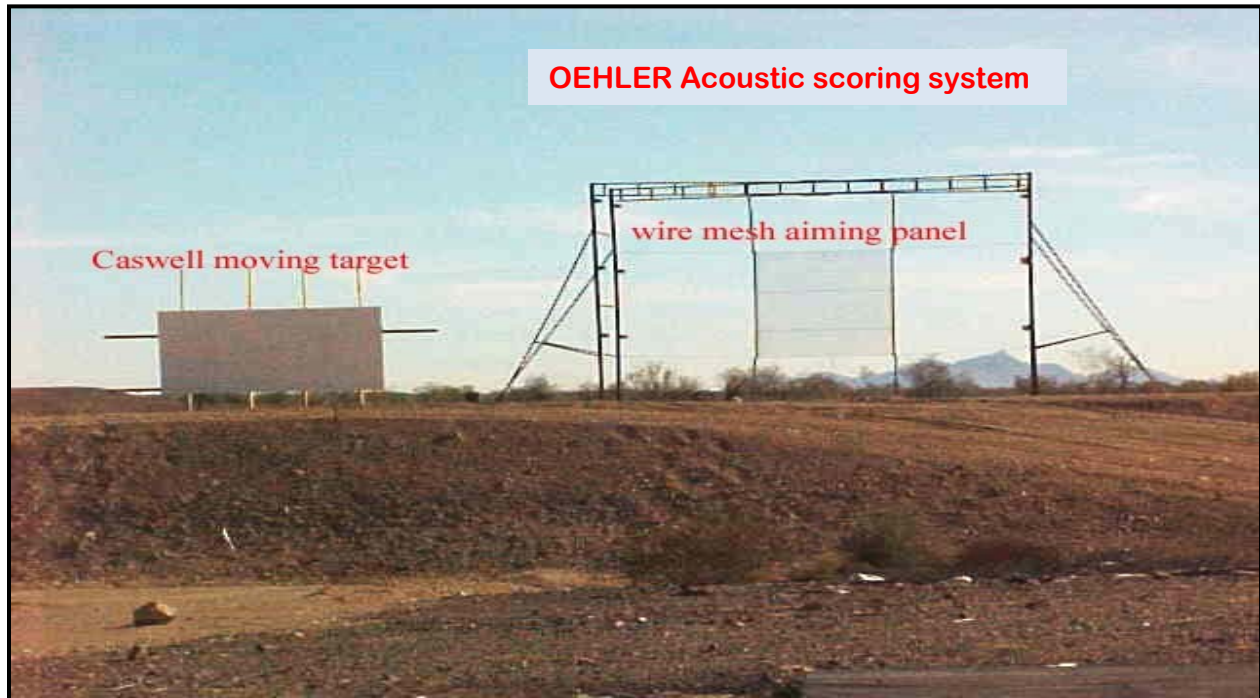

Figure 172. Remote controlled rail-mounted carriers equipped with pop-up targets and an Oehler acoustic scoring system target.

### 3.5 Test Facilities.

a. Rain and Blowing Rain Facility. This facility provides rain and blowing rain testing capabilities that comply with specifications set forth in MIL-STD-810G CN1 (Method 506.6). The facility simulates static and wind-driven rain for testing the adequacy of military equipment against the effects of wet weather and near-hurricane conditions. The facility consists of 580 adjustable nozzles (with a pressure up to 275 kPa (40 psi)) that are capable of simulating rain on the top and sides of the item(s) under test. Wind-driven rain can be simulated via a portable fan that produces wind speeds up to 80 km/hr (50 mph). The rainfall rate can be adjusted to the specific needs of the test. The facility is 6.1 meters wide by 12.2 meters long by 4.1 meters high (20 ft by 40 ft by 13.5 ft). The chamber door is 9.6 meters wide by 5.5 meters high (31.5 ft by 18 ft). The facility does not provide for temperature conditioning so testing is performed under ambient conditions. Figure 173 shows a vehicle under test in the Rain Facility.





Figure 173. Vehicle inside Rain and Blowing Rain Facility.

b. Blown Air Dust and Sand System (BADSS). The BADSS is an environmental simulation apparatus available as alternative to dust chamber testing as described in MIL-STD-810G CN1, Method 510.5, and compliant with the specifications provided in TOP 01-2-621<sup>15</sup>. Testing is generally performed in order to assess the effectiveness of protective covers, cases, and seals; the effectiveness of intake filters; the effects of sand or dust accumulation on the test item and any physical deterioration that may result; and the capability of the test item to satisfy its performance requirements after exposure to the sand and dust environments. It should be noted that the BADSS system is for the static assessment of dust exposure, and should not be confused with dynamic sand and dust testing (e.g., vehicle in motion), described in TOP 02-2-819<sup>16</sup>. The BADSS is comprised of a 1.8 m (6 ft) diameter fan with flow guide, and particulate feed mechanism, mounted on a two-axle trailer. Figure 174 shows the BADSS system in use. The BADSS is capable of producing wind speeds in excess of 60 mph, with sufficient particulate capacity to perform 90-minutes of uninterrupted testing with an adjustable particulate feed rate. The BADSS is capable of blown dust densities in excess of the 2.2 grams per square meter ( $\text{g}/\text{m}^2$ ) required by MIL-STD-810G CN1.



Figure 174. BADSS System (right) and system under test (left).

c. Load Handling System (LHS) Simulators. The LHS Simulators are located in Building 2090 and have the capability to perform load/unload cycles with a fully loaded (16,400 kg or 36,250 lb) flatrack. The simulators have two 1.5 m (5 ft) hydraulic cylinders that power the LHS hook arm, and two 2.1 m (7 ft) hydraulic cylinders that power the main arm. The hydraulic system is run from electric motors connected to the building electrical system. The simulator can be operated from the control panel or by using the remote control box. One of the two LHS Simulators is shown in Figure 175.



Figure 175. LHS Simulator.

d. Environmental Chamber with Weapons Firing Capabilities. The weapons firing chamber is able to subject weapons (up to 8-inch) to high or low temperatures and humidity (in any combination required) while providing the capability of the weapon firing (up to an elevation of 60 degrees) under those conditions. The facility can also be closed and utilized as just a hot or cold environmental chamber. The facility's Virtual Private Network (VPN) allows remote access to the control computers, providing 24/7 monitoring even when personnel are not on-site. Extensive instrumentation records the test item's performance throughout the full range of operation, including the ability to measure downrange performance of projectiles with ballistic cameras and radar. The chamber can host a wide variety of test vehicles and items including remote piloted vehicles, artillery, direct fire systems, tactical wheeled and tracked vehicles, and helicopters. The chamber can attain temperature and humidity combinations from -54 to +71 °C (-65 to +160 °F) and 5 to 95 percent relative humidity (RH) to simulate worldwide conditions. The hot and dry settings can reach up to +71 C (+160 °F) with less than 5 percent RH and hot and humid up to 71 °C (+160 °F), with up to 95 percent RH. Extreme Cold can reach down to -54 °C (-65 °F). The chamber dimensions are 13.7 m long by 8.8 m wide by 4.4 m high (45 ft x 29 ft x 14.5 ft), with the height measured at the center of the chamber (the general shape of the chamber is a hemispherical conduit). The access door to the chamber of 5.2 m wide by 4.0 m high (17 ft x 13.2 ft), and the firing port is 1.2 m wide (4 ft). Figure 176 shows the exterior and a vehicle inside the Weapons Firing Chamber.





Figure 176. Exterior view (left) and vehicle inside the Weapons Firing Chamber (right).

e. Large Multipurpose Environmental Chamber (LMPEC). The LMPEC Chamber shown in Figure 177 is equipped with a chassis dynamometer which provides a unique capability of conducting simulated vehicle, weapon, and soldier system operation tests under extreme climatic conditions. The chamber also provides controlled climatic conditions for firing and functional testing of weapon systems up to 40-mm. Stationary testing of vehicles and equipment may also be conducted at required extreme temperatures/humidity parameters and tests include performance and reliability.



Figure 177. Outside view of LMPEC (left) and view into LMPEC from access door opening (right).

(1) The LMPEC can achieve temperature-humidity combinations from  $-54$  to  $+71$  °C ( $-65$  to  $+160$  °F) and 5 to 95 percent humidity to simulate worldwide environmental conditions from the one extreme to the other. Figure 178 shows the chamber during extreme cold testing. The chamber can achieve hot/dry up to  $71$  °C ( $+160$  °F) with less than 5 percent relative humidity, and hot/humid up to  $+71$  °C ( $+160$  °F) with up to 95 percent relative humidity. The chamber can achieve extreme cold down to  $-54$  °C ( $-65$  °F), and can operate with humidity at  $+48$  °C ( $+120$  °F) up to 100 percent. The facility provides a transition environment which



separates ambient air from chamber temperatures, and provides one additional chamber unit for conditioning other material to be included in test.



Figure 178. Test vehicle operating on the chassis dynamometer at -32 °C (-26 °F).

(2) The LMPEC is equipped with a chassis dynamometer, as shown in Figure 178, with a unique ten roller system that can handle a maximum vehicle weight of 11,300 kg (25,000 lb) per axle, and can accommodate wheelbases up to 8.4 m (27.4 ft). The rollers allow for repositioning from 135 to 157 cm (53 to 62 in.) from the center of the adjacent double roll set. Vehicles may be tested at speeds up to 105 kph (65 mph) under controlled environmental conditions with a power absorption capability up to 373 kW (500 hp).

(3) In addition, the LMPEC has an adjustable firing port to accommodate the required elevation of the test item, and is capable of firing weapons up to 40-mm caliber out of the firing port. The chamber is 13.1 m long by 6.1 m wide by 3 m high (43 ft x 20 ft x 10 ft), with an access door opening of 5.2 m long by 4.0 m high (17 ft x 13 ft), and a firing port of 1.2 m wide by 2.4 m high (4 ft x 8 ft). The additional conditioning chamber is 1.8 m long by 1.8 m wide by 2 m high (6 ft x 6 ft x 6.6 ft).

f. Climatic Simulation Facility. This facility enables YTC to perform a variety of environmental tests to individual vehicle components or equipment to national and international Military Standards. These tests simulate the effects of a variety of environmental extremes and climatic conditions, and the facility is customizable to meet any specific requirements. Table 8 lists the different chambers at this facility and their specifications. Figure 179 shows the Climatic Simulation Facility. Figure 180 shows a test item after climatic icing test and Figure 181 shows a test item after salt fog testing.

TABLE 8. CLIMATIC SIMULATION FACILITY SPECIFICATIONS.

CHAMBER TYPE	NO. OF CHAMBERS	TEMPERATURE AND HUMIDITY RANGE	DIMENSIONS
Hot/cold with humidity	4	-57 to +82 °C (-70 to +180 °F) Up to 100 percent humidity	3 m (L) x 2.1 m (W) x 2 m (H) (10 ft (L) x 7 ft (W) x 6.5 ft (H)) (3 chambers) 1.2 m (L) x 1.2 m (W) x 2 m (H) (4 ft (L) x 4 ft (W) x 6.5 ft (H)) (1 chamber)
Hot with humidity	6	+4 to +82 °C (+40 to +180 °F) Up to 100 percent humidity	3 m (L) x 2.1 m (W) x 2 m (H) (10 ft (L) x 7 ft (W) x 6.5 ft (H)) (5 chambers) 1.2 m (L) x 1.2 m (W) x 2 m (H) (4 ft (L) x 4 ft (W) x 6.5 ft (H)) (1 chamber)
Cold chamber without humidity	1	-57 degrees °C (-70 degrees °F)	Not Available
Hot/cold without humidity chamber	2	-54 to +63 °C (-65 to +145 °F)	3 m (L) x 2.1 m (W) x 2 m (H) (10 ft (L) x 7 ft (W) x 6.5 ft (H)) (1 chamber) 1.2 m (L) x 1.2 m (W) x 2 m (H) (4 ft L x 4 ft (W) x 6.5 ft (H)) (1 chamber)
Altitude chamber	1	Simulates up to 30,480 m (100,000 ft) Can be used as a cold box with a temperature range of -57 to +74 C (-70 to +165 F)	1.8 m (L) x 1.5 m (W) x 1.5 m (H) (5.7 ft (L) x 5 ft (W) x 5 ft (H))
Salt fog chamber	1	+35 °C only (+95 °F)	1.5 m (L) x 1.5 m (W) x 1.5 m (H) (5 ft (L) x 5 ft (W) x 4.8 ft (H))
Immersion (leak) tank	1	NA	Capacity of 113 L (4 cu ft)
Solar chamber	1	Combined solar, temperature and humidity Full solar spectrum (280 to 3000 nm wavelength) +4 to +82 °C (+40 to 180 °F), with 5 to 95 percent relative humidity	2.4 m (L) x 2.4 m (W) x 3.4 m (H) (8 ft (L) x 8 ft (W) x 11 ft (H)) room with approximately 0.46 sq meters (5 square feet) of test space



Figure 179. Component level climatic chambers.



Figure 180. Test item after climatic icing test.



Figure 181. Test item after climatic salt fog testing.

g. Material Analysis Laboratory. This laboratory has over 650 square meters (7,000 square feet) of internal air-conditioned laboratory and office space with both refrigerated and non-refrigerated external chemical storage space. A mobile van may be utilized for toxic fume gas analysis on site. Equipment is available for determining the physical and chemical properties of a wide variety of materials. The laboratory has an internal local area network (LAN) linking major equipment to the Laboratory Information Management System (LIMS) where laboratory data are stored.

(1) Foremost among the laboratory test capabilities are the analysis of petroleum, oil, and lubricants (POL) and coolants, including such analytical techniques as wear metal, kinematic viscosity, carbon residue, sulfated ash, diesel fuel dilution, oil in fuel, closed cup flash point, American Petroleum Institute (API) gravity, water by distillation, water by Karl Fisher titration, total base number, free water, water reaction with fuel, sediment content, fuel distillation, coolant freezing point, low temperature characteristic, cloud point, arid pour point, low temperature pumping viscosity, sulfur content, insolubles, and particle counting in fluids analyses.

(2) Additional capabilities included analytical techniques such as Fourier Transform Infrared (FT-IR) spectroscopy, Energy Dispersive X-ray Fluorescence (ED-XRF) spectroscopy, granite furnace/flame Atomic Absorption (AA) spectroscopy, Inductively Coupled Plasma Mass Spectroscopy (ICP-MS), Ultraviolet/Visible (UV/NIS) spectroscopy, Gas Chromatography (GC), High-Performance Liquid Chromatography (HPLC), pH and conductivity measurements of aqueous solutions, and melting point determination. The chemical laboratory is shown in Figure 182, while Figures 183 through 186 show laboratory equipment contained within the facility.





Figure 182. Material Analysis Laboratory.

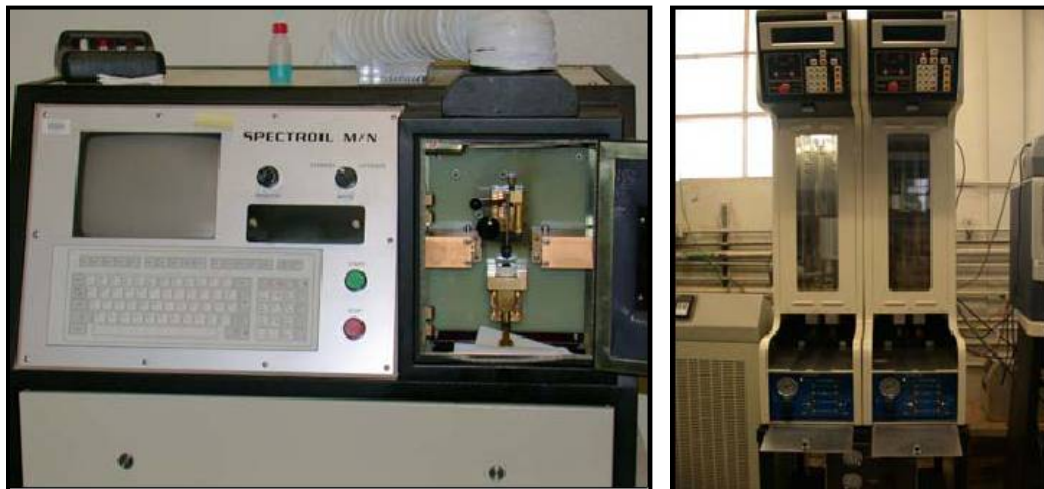

Figure 183. Spectroil rotating disk optical emission spectrometer used for wear metal analysis (left) and CAV2000 automatic viscometer used for measuring kinematic viscosity (right).

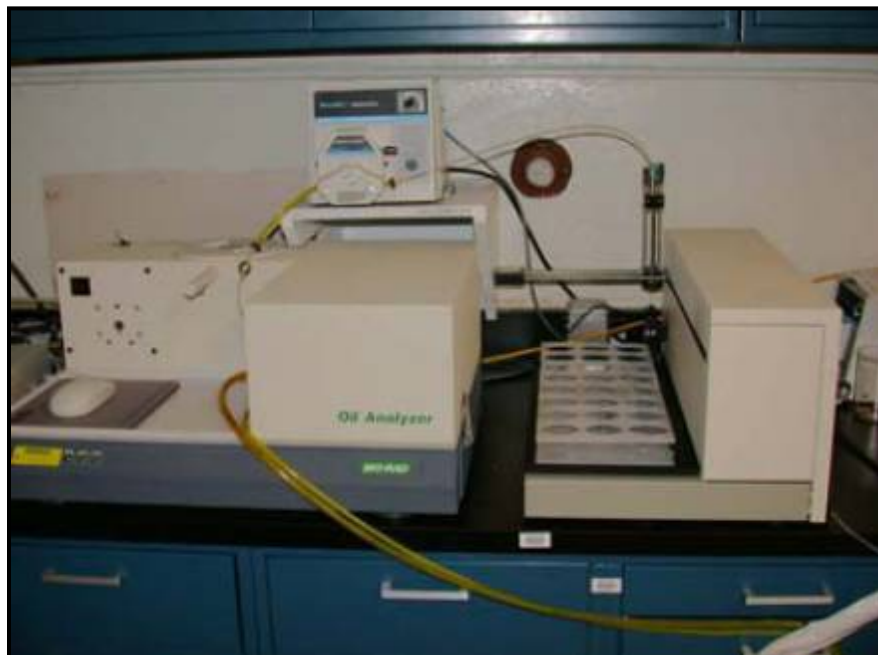

Figure 184. Advanced oil analyzer platform Fourier Transform Infrared Spectrometer used for molecular analysis of lubricants and hydraulic fluids.



Figure 185. Gas chromatograph with turbomatrix heads pace sampler used to measure diesel fuel dilution.



Figure 186. Automatic distillation unit used to measure fuel distillation (left) and automatic cloud and pour point used to measure low temperature characteristics (right).

h. Starter Test Stand. The ST-24 computerized starter tester checks automotive starters simulating real working conditions of the vehicle, analyzing the device timing to detect solenoid, drive and spring problems. The test stand is shown in Figure 187. During the test, the ST-24 automatically recognizes the starter rotation direction and applies a programmable load. The ST-24 returns the mechanical energy produced from the starter back to the power supply to reduce power consumption. The built in separate power supply for the starter and solenoid allows the solenoid function to be tested at a programmable reduced voltage during the test. The ST-24 is able to scan in a set of programmable points for the performance curve in less than 10 seconds, increasing the accuracy and decreasing result variation caused by temperature. The ST-24 provides a precise waveform analysis for accurate armature and commutator diagnostics and has the capability to check the results against preset limits and generate an output report.

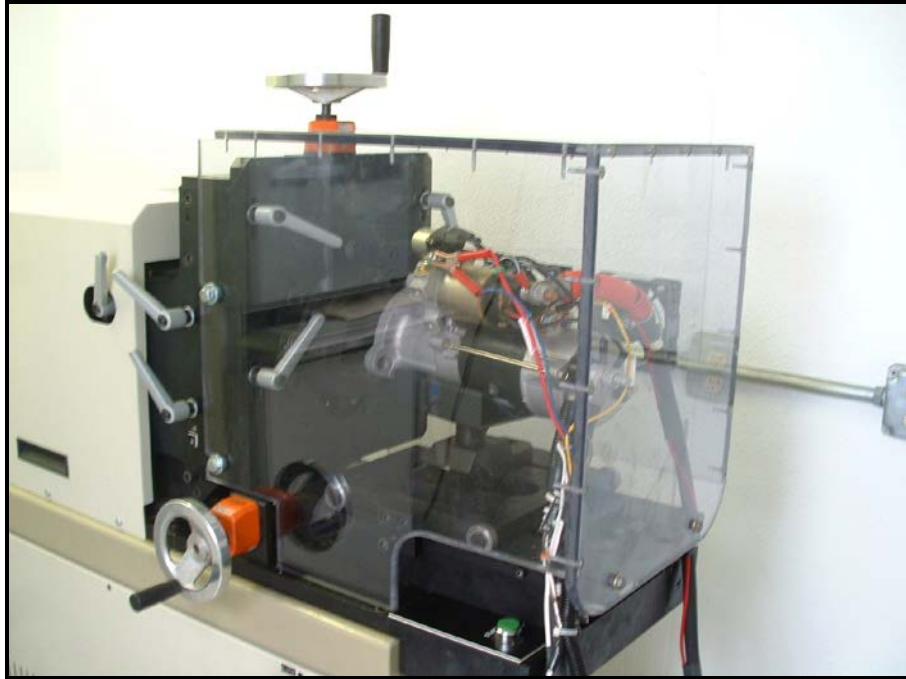

Figure 187. ST-24 starter test stand.

i. Tire Maintenance Facility. The facility provides equipment for the servicing of tires, including vehicle wheel alignment and tire balancing. The tire testing facility has two run flat machines capable of installing and removing run flat inserts from tires, a tire spreader for exposing tire defects, a tire inflation cage for safely inflating tires, two tire changing machines, and a computerized wheel balancer. Tire ground-pressure footprint data are also gathered.

j. Tire X-ray Facility. This facility has the capability to perform real time x-ray inspections on tires using the LumenX 1027B Inspection System as shown in Figure 188. The LumenX 1027B Inspection System is an automated, PLC based, on-line production machine designed to inspect passenger, truck, bus, and heavy equipment tires, bead to bead. The system allows the inspection of all tire construction parameters such as body ply cord spacing and turn ups, chamfer height, belt step-off and splice, and concentricity of bead bundles.





Figure 188. Tire Test Facility, overall (left) and Closeup Inspection Chamber (right).

k. Hybrid Electric Facility. This facility allows for testing of hybrid electric vehicles and onboard power generation systems. The facility is equipped with an AV 900 load bank tied into the electrical grid as well as a smaller ABC 150 load bank. Numerous portable direct current (DC) and alternating current (AC) load banks are available for onboard vehicle installation as well. The load banks allow for power absorption up to 250 kW, and accommodate up to 900 Volts DC and current ranges up to 1000 amps. Extensive instrumentation to load and record the DC power and AC power circuits are available. The facility and AV 900 load bank system are shown in Figure 189.



Figure 189. Hybrid Electric Facility (left) and AV900 Load Bank (right).

1. **Vibration Facility.** The vibration test facilities are used to improve the reliability of military hardware, avionics instrumentation, and automotive components on a subsystem level. The vibration facility has six electrodynamic vibration systems available for testing, with two shown in Figure 190. All vibration systems are controlled from remote data acquisition and processing centers capable of immediate data analysis for test control. The capabilities include various tests that specify sine random, shock, sine-on-random, random-on-random, and other complex waveforms as well as replicating data that are collected from real world situations. Testing is conducted in accordance with national and international Military Standards. Custom vibration testing may also be supported.



Figure 190. T4000 Vibration Chamber (left) and T5000 Vibration Chamber (right).

m. **Physical Test Facility.** The facilities are comprised of four major areas: physical measurements, non-destructive inspections, material properties testing, and mass properties measurements. They include a 30-inch optical comparator, a Faro laser tracker, a multi-sensor coordinate measuring machine, a high precision coordinate measuring machine for cannon gun tube measurement and inspection (173 cm (68 in.) long by 302 cm (119 in.) wide by 279 cm (110 in.) high). The Physical Test facilities are equipped with load cells capable of measuring from 9 to 445,000 N (2 to 100,000 lbf), a large capacity 711 kN (160 klbf) Universal Testing Machine, and a small capacity 56 kN (12.5 klbf) Universal Testing Machine. The test area includes a level concrete pad, a 136,000 kg (300,000 lb) capacity platform scale, and mobile cranes up to a 63,500 kg (140,000 lb) capacity.

n. **Site 3 Drop Test Facility.** The site hosts a drop test tower (Figure 191) that is capable of dropping up to 454 kg (1000 lb) from varying distances up to a maximum height of 9 m (30 ft); the tower can be used for vehicle component-level or vehicle transported equipment tests. Four different drop surfaces are available: 7.6 cm (3 in.) of steel above 61 cm (24 in.) of concrete; 7.6 cm (3 in.) of steel above 46 cm (18 in.) crushed rock; anvil top; and reinforced concrete. Three digital video recorders are available to capture the test from separate angles and a video of the test can be provided. Two environmental chambers are available for conditioning items. They have interior dimensions of 2 m (7 ft) wide, 2 m (7 ft) high, and 4.1 m (13.5 ft)

deep. One of these chambers is used for cooling and is capable of cooling to  $-62\text{ }^{\circ}\text{C}$  ( $-80\text{ }^{\circ}\text{F}$ ). The second chamber is used for heating and is capable of reaching temperatures in excess of  $74\text{ }^{\circ}\text{C}$  ( $165\text{ }^{\circ}\text{F}$ ).



Figure 191. Site 3 Drop Tower and inspection conex (left) with aerial view of Site 3 (right).

o. 12 Meter Drop Test Facility. The site hosts a tower (Figure 192) that is capable of dropping up to 1,800 kg (4,000 lb) up to 18 m (60 ft). The drop surface consists of one pad with 7.6 cm (3 in.) thick steel (with a Brinell hardness of 269 - 311) above 61 cm (24 in.) of concrete above 46 cm (18 in.) of crushed stone. Two digital video recorders are available to capture the test from separate angles and a video of the test can be provided. Two environmental chambers are also available at this site for conditioning items, with interior dimensions of 2 m (7 ft) wide, 2 m (7 ft) high, and 2 m (7 ft) deep with capabilities that allow conditioning to  $-62\text{ }^{\circ}\text{C}$  ( $-80\text{ }^{\circ}\text{F}$ ) or  $74\text{ }^{\circ}\text{C}$  ( $165\text{ }^{\circ}\text{F}$ ).



Figure 192. 12 Meter Drop Test facilities.

### 3.6. Maintenance Facilities.

a. Operations and Maintenance Division Complex. This complex is centrally located to the primary automotive test areas. The facilities sit on a fenced 52,600 square meter (13 acre) compound with lighting for parking of test and fleet support vehicles, and to setup and conduct of tests of individual and troop support equipment such as shelters. The facility contains 892 square meters (9,600 square feet) of lighted work area with adjacent offices, support shops, and tire repair area. There is a complete tool room and supply function on-site. A fleet of test support vehicles are available, including several types of tactical trucks, M88A1 Recovery Vehicles, M113 Personnel Carriers, tractor-trailer combinations for transport and recovery of test vehicles, generators, and other support equipment. The storage yard holds a 4,500 L (1,200 gal) fuel station for storing and dispensing test fuels, and 30 connex storage units measuring 2.4 m by 2.4 m by 6 m (8 ft by 8 ft by 20 ft), for storing dedicated test items, system support packages, and residue. Test and support facilities located adjacent to the complex include a 136,000 kg (150 ton) platform scale, tilt table, and vehicle wash rack.

b. Main Test Maintenance Facility. The largest building on YTC, which is located on Kofa Firing Range, covers approximately 8,300 square meters (90,000 square feet). Maintenance is performed on tactical vehicles (wheeled and tracked) and weapons systems in the southern three-quarters of the building. There are three large bays, two of which are served with overhead traveling cranes. There is a 36,000 kg (40 ton) and three 9,000 kg (10 ton) cranes. The repair of approximately 30 vehicles can be accommodated simultaneously. Compressed air is available to operate multiple air tools and a chassis lift. A unit supply section maintains bench stock, shop stock, and test system support packages; along with a tool room, it supports both the vehicle and artillery maintenance functions within the shop. Common shop tools, such as cutting torch, grinder, hydraulic press, drill press, and injector testers are available for issue to all personnel using the shop. The shop also has access to 208 VAC 3-phase and 440 VAC 3-phase power. An air-conditioned office space and break room are incorporated; however, the main work area is cooled with evaporative coolers, because some of the seven large electrically



operated doors are frequently opened. An approximately 12 m (40 ft) wide concrete apron encircles the building. A wash rack with a steam cleaner, an outside shade area for work on approximately four test vehicles, a large 11,300 square meter (2.8 acre) asphalt-covered storage yard with lockable connex containers, a loading dock, an oil and fuel drum holding area, and over 20,000 square meters (5 acres) of gravel parking lot comprise the rest of the facility.

c. Ancillary Test Maintenance Facility. The facility is located adjacent to the main test maintenance facility on Kofa Firing Range. The facility provides organizational and direct support level maintenance and inspections for tactical vehicles, commercial light, medium, and heavy duty vehicles as well as emergency response and construction grade vehicles and cranes. The facility has access to parts management and storage areas as well as a secure storage area. The shop floor is cooled with an evaporative cooling system in the ventilated indoor work bays. The shop contains nine work bays in a 22 m by 113 m (72 ft x 371 ft) area of the facility. There is access to an 18,100 kg (20 ton) and 36,300 kg (40 ton) overhead crane. The shop features access to 208 VAC 3-phase power and has six portable axle/wheel lifts with a combined 40,800 kg (90,000 lb) lift capacity. A separate section of the facility offers offices, conference rooms, and staff office for maintenance and parts management personnel.

d. MT Test Maintenance Facility. The shop has full maintenance capabilities and equipment. There are six shop bays available that can support up to six test vehicles and two load handling systems. The shop features one 22,700 kg (25 ton) overhead crane, one 4,500 kg (5 ton) overhead crane, and eight portable axle/wheel lifts with a combined 54,400 kg (120,000 lb) lift capacity.

e. Welding and Metal Shop Facility. The facility is located in the west side of the ancillary maintenance facility, and features full machine, fabrication, and welding support in a 5,417 square meters (58,310 square foot) facility. The welding and metals shop facility provides custom metal payloads for both wheeled and track vehicles to meet their test mission weight requirements as well as support vehicle modifications and repairs.

APPENDIX A. ABBREVIATIONS.

AA	Atomic Absorption
ABS	anti-lock brake system
AC	alternating current
API	American Petroleum Institute
APG	Aberdeen Proving Ground
ATC	U.S. Army Aberdeen Test Center
ATEF	Automotive Technology Evaluation Facility
ATTB	Aircraft Transportability Test Bed
BADSS	Blown Air Dust and Sand System
BLM	Bureau of Land Management
°C	°Celsius
cfm	cubic feet per minute
CISPR	Comite International Special de Perturbations Radioelectriques
CL	clay of low plasticity
cm	centimeter
cmm	cubic meters per minute
CTA	Churchville Test Area
dB	decibel
DC	direct current
DOD	Department of Defense
DU	depleted uranium
ECU	electronic control unit
ED-XRF	Energy Dispersive X-ray Fluorescence
EMITF	Electromagnetic Interference Test Facility
ESC	electronic stability control
°F	°Fahrenheit
FCC	Federal Communications Commission
FM	Field Manual
ft	feet
FT-IR	Fourier Transform Infrared
g/m <sup>2</sup>	grams per square meter
GC	Gas Chromatography
GHz	Gigahertz
GM	General Motors
GVW	gross vehicle weight

APPENDIX A. ABBREVIATIONS.

HBCT	Heavy Brigade Combat Team
HE	high explosive
hp	horsepower
HPLC	High-Performance Liquid Chromatography
hr	hour
HWTC	Hot Weather Test Complex
Hz	Hertz
ICP-MS	Inductively Coupled Plasma Mass Spectroscopy
in.	inch
IR	infrared
ITOP	International Test Operations Procedure
kHz	Kilohertz
km	kilometer
km/hr	kilometer per hour
kN	kilonewton
kPa	kilopascal
kW	kilowatt
LAAF	Laguna Army Airfield
LAN	local area network
lb	pound
LHS	Load Handling System
LIMS	Laboratory Information Management System
LMPEC	Large Multipurpose Environmental Chamber
LTTF	Lift and Tiedown Facility
LUGV	large unmanned ground vehicle
m	meter
MAT	moving armored target
MH	silt of high plasticity
MHz	Megahertz
mi	mile
MIL-STD	Military Standard
MILES	multiple integrated laser engagement system
MIT	moving infantry target
ML	silt
ml/hr	milliliter per hour
MOI	moment of inertia
MOUT	Military Operations on Urban Terrain
mph	miles per hour
MTA	Munson Test Area
MTS	moving target simulator

APPENDIX A. ABBREVIATIONS.

N	Newton
NA	not applicable
NaCl	sodium chloride
NATO	North Atlantic Treaty Organization
NHTSA	National Highway Traffic Safety Administration
PAAF	Phillips Army Airfield
POL	petroleum, oil, and lubricants
psi	pounds per square inch
PTA	Perryman Test Area
RAM	reliability, availability and maintainability
RH	relative humidity
rms	root mean square
RPC	remote parameter control
RWS	Roadway Simulator
SAE	Society of Automotive Engineers
SAT	stationary armored target
SC	clayey sand
SIT	stationary infantry target
SM	silty sand
SNCTA	Scalable Net Centric Test Area
SP	poorly graded sand
SUGV	small unmanned ground vehicle
TOP	Test Operations Procedure
TW	Trench Warfare
UGV	unmanned ground vehicle
USCS	unified soil classification system
UV/NIS	Ultraviolet/Visible
V/m	volts per meter
VDS	Vehicle Durability Simulator
VMT	Vehicle Maneuvering Test Area
VPN	Virtual Private Network
WES	U.S. Army Waterways Experiment Station
YPG	U.S. Army Yuma Proving Ground
YTC	Yuma Test Center



(This page is intentionally blank.)

APPENDIX B. REFERENCES.

1. TOP 02-2-506A, Wheeled and Tracked Vehicle Endurance Testing, 2 October 2014.
2. MIL-STD-810G Change Notice 1, Department of Defense Test Method Standard: Environmental Engineering Considerations and Laboratory Tests, 15 April 2014.
3. TOP 01-1-010A, Vehicle Test Course Severity (Surface Roughness), 12 December 2017.
4. SAE J1264, Joint RCCC/SAE Fuel Consumption Test Procedure (Short Term In-Service Vehicle) Type I, 10 May 2011.
5. SAE J1321, Joint TMC/SAE Fuel Consumption Test Procedure - Type II, 6 February 2012.
6. SAE J1526, Joint TMC/SAE Fuel Consumption In-Service Test Procedure Type III, Recommended Practice, 17 September 2015.
7. TOP 02-2-608, Braking, Wheeled Vehicles, 20 May 2008.
8. TOP 02-2-603A, Vehicle Fuel Consumption, 10 May 2012.
9. MIL-STD-913A Notice 1 Department of Defense Design Criteria Standard: Requirements for the Certification of Sling Loaded Military Equipment for External Transportation by Department to of Defense Helicopters, 11 June 2002.
10. MIL-STD-209K, Department of Defense Interface Standard for: Lifting and Tie-down Procedures, 22 February 2005.
11. SAE J2180, Tilt Table Procedure for Measuring the Static Rollover Threshold for Heavy Trucks, 17 May 2011.
12. ITOP 03-2-836 (1.3.2.2), Combat Vehicle Fire Control Systems Gun/Turret Drive Systems-Stabilization, 16 October 2000.
13. FM 3-20.21, Heavy Brigade Combat Team (HBCT) Gunnery, 3 September 2009.
14. FM 17-12-7, Tank Gunnery Training Devices and Usage Strategies, 1 May 2000.
15. TOP 01-2-621, Outdoor Sand and Dust Test, 6 February 2009.
16. TOP 02-2-819, Sand and Dust Testing of Wheeled and Tracked Vehicles and Stationary Equipment, 18 November 2009.

(This page is intentionally blank.)

APPENDIX C. APPROVAL AUTHORITY.

CSTE-TM

12 December 2017

MEMORANDUM FOR

Commanders, All Test Centers  
Technical Directors, All Test Centers  
Directors, U.S. Army Evaluation Center  
Commander, U.S. Army Operational Test Command

SUBJECT: Test Operations Procedure (TOP) 01-1-011B Vehicle Test Facilities at Aberdeen Test Center and Yuma Test Center, Approved for Publication

1. TOP 01-1-011B Vehicle Test Facilities at Aberdeen Test Center and Yuma Test Center, has been reviewed by the U.S. Army Test and Evaluation Command (ATEC) Test Centers, the U.S. Army Operational Test Command, and the U.S. Army Evaluation Center. All comments received during the formal coordination period have been adjudicated by the preparing agency. The scope of the document is as follows:

This TOP describes the vehicle test facilities at Aberdeen Test Center and Yuma Test Center. It is designed for use in planning tests of wheeled and tracked vehicles, including vehicular weapon systems. This TOP does not include descriptions of the equipment and instrumentation used to obtain test data.

2. This document is approved for publication and will be posted to the Reference Library of the ATEC Vision Digital Library System (VDLS). The VDLS website can be accessed at <https://vdls.atc.army.mil/>.

3. Comments, suggestions, or questions on this document should be addressed to U.S. Army Test and Evaluation Command (CSTE-TM), 2202 Aberdeen Boulevard-Third Floor, Aberdeen Proving Ground, MD 21005-5001; or e-mailed to [usarmy.apg.atc.mbx.atc-standards@mail.mil](mailto:usarmy.apg.atc.mbx.atc-standards@mail.mil).

BRACAMONTE.LA  
ZARO.F.123173344  
9



LAZARO F. BRACAMONTE  
Associate Director, Test Management Directorate (G9)

FOR

RAYMOND G. FONTAINE  
Director, Test Management Directorate (G9)



(This page is intentionally blank.)

Forward comments, recommended changes, or any pertinent data which may be of use in improving this publication to the following address: Policy and Standardization Division (CSTE-TM), U.S. Army Test and Evaluation Command, 2202 Aberdeen Boulevard, Aberdeen Proving Ground, Maryland 21005-5001. Technical information may be obtained from the preparing activity: Automotive Directorate (TEDT-AT-AD), U.S. Army Aberdeen Test Center, 400 Colleran Road, Aberdeen proving Ground, MD 21005-5059; and U.S. Army Yuma Proving Ground, Yuma Test Center, 301C Street, Yuma, Arizona 85365-9498. Additional copies can be requested through the following website: <http://www.atec.army.mil/publications/topsindex.aspx>, or through the Defense Technical Information Center, 8725 John J. Kingman Rd., STE 0944, Fort Belvoir, VA 22060-6218. This document is identified by the accession number (AD No.) printed on the first page.