

TECHNICAL REPORT
NATICK/TR-16/019



AD _____

DEVELOPMENT OF A MIDSCALE TEST FOR FLAME RESISTANT PROTECTION

by
Margaret A. Auerbach
Thomas A. Godfrey
Michael J. Grady
Gary N. Proulx
and
Margaret E. Roylance

August 2016

Final Report
October 2010 – March 2016

Approved for public release; distribution is unlimited

**U.S. Army Natick Soldier Research, Development and Engineering Center
Natick, Massachusetts 01760-5000**

DISCLAIMERS

The findings contained in this report are not to be construed as an official Department of the Army position unless so designated by other authorized documents.

Citation of trade names in this report does not constitute an official endorsement or approval of the use of such items.

DESTRUCTION NOTICE

For Classified Documents:

Follow the procedures in DoD 5200.22-M, Industrial Security Manual, Section II-19 or DoD 5200.1-R, Information Security Program Regulation, Chapter IX.

For Unclassified/Limited Distribution Documents:

Destroy by any method that prevents disclosure of contents or reconstruction of the document.

REPORT DOCUMENTATION PAGE

Form Approved
OMB No. 0704-0188

Public reporting burden for this collection of information is estimated to average 1 hour per response, including the time for reviewing instructions, searching existing data sources, gathering and maintaining the data needed, and completing and reviewing this collection of information. Send comments regarding this burden estimate or any other aspect of this collection of information, including suggestions for reducing this burden to Department of Defense, Washington Headquarters Services, Directorate for Information Operations and Reports (0704-0188), 1215 Jefferson Davis Highway, Suite 1204, Arlington, VA 22202-4302. Respondents should be aware that notwithstanding any other provision of law, no person shall be subject to any penalty for failing to comply with a collection of information if it does not display a currently valid OMB control number.

PLEASE DO NOT RETURN YOUR FORM TO THE ABOVE ADDRESS.

1. REPORT DATE (DD-MM-YYYY) 08-08-2016		2. REPORT TYPE Final		3. DATES COVERED (From - To) October 2010 – March 2016	
4. TITLE AND SUBTITLE DEVELOPMENT OF A MIDSCALE TEST FOR FLAME RESISTANT PROTECTION				5a. CONTRACT NUMBER	
				5b. GRANT NUMBER	
				5c. PROGRAM ELEMENT NUMBER 622786	
6. AUTHOR(S) Margaret A. Auerbach, Thomas A. Godfrey, Michael J. Grady, Gary N. Proulx, and, Margaret E. Roylance				5d. PROJECT NUMBER	
				5e. TASK NUMBER	
				5f. WORK UNIT NUMBER	
7. PERFORMING ORGANIZATION NAME(S) AND ADDRESS(ES) U.S. Army Natick Soldier Research, Development and Engineering Center ATTN: RDNS- SEW-TMM 10 General Greene Avenue, Natick, MA 01760-5000				8. PERFORMING ORGANIZATION REPORT NUMBER NATICK/TR-16/019	
				10. SPONSOR/MONITOR'S ACRONYM(S)	
9. SPONSORING / MONITORING AGENCY NAME(S) AND ADDRESS(ES)				11. SPONSOR/MONITOR'S REPORT NUMBER(S)	
12. DISTRIBUTION / AVAILABILITY STATEMENT Approved for public release; distribution is unlimited.					
13. SUPPLEMENTARY NOTES					
14. ABSTRACT This report details the development of a novel test for assessment of the flame resistant performance of textiles and garment design details during flame engulfment. It provides step by step information on how to prepare the test apparatus and carry out the test. It also includes a systematic enumeration of the key decisions made during test development. The test employs a propane cell similar to that used for the ASTM F1930, Standard Test Method for Evaluation of Flame Resistant Clothing for Protection against Fire Simulations Using an Instrumented Manikin, which provides both radiant and convective heat flux to produce a realistic flame engulfment fire scenario. The test apparatus can accommodate a range of test forms including an instrumented flat plate, cylinder, head form, and others. The results of the test include transmitted heat flux, fluence, depth of burn, predicted burn injury, and Energy Transmission Factor measured at each heat flux sensor to characterize the protection provided. A standard ASTM test method for the Midscale Test for FR Protection is under development.					
15. SUBJECT TERMS					
FIRES	HEAT FLUX	COMBUSTION	TEST AND EVALUATION	RADIANT HEAT FLUX	
FLAMES	MANIKINS	BURNS(INJURIES)	THERMAL PROPERTIES	DEMONSTRATIONS	
FABRICS	SCENARIOS	FLAMMABILITY	LABORATORY EQUIPMENT	FLAME RETARDANT	
PROPANE	PROTECTION	TEST FACILITIES	FIRE PROTECTIVE CLOTHING		
TEXTILES	DEFICIENCIES	TEST METHODS	FIRE RESISTANT MATERIALS		
TORCHES	SIMULATION	TEST EQUIPMENT	FLAME RESISTANT CLOTHING		
PERFORMANCE(ENGINEERING)			CONVECTION(HEAT TRANSFER)		
16. SECURITY CLASSIFICATION OF:			17. LIMITATION OF ABSTRACT	18. NUMBER OF PAGES	19a. NAME OF RESPONSIBLE PERSON
a. REPORT	b. ABSTRACT	c. THIS PAGE			Margaret E. Roylance
U	U	U	SAR	52	19b. TELEPHONE NUMBER (include area code) 508-233-5085

This page intentionally left blank

Table of Contents

List of Figures.....	iv
1. Introduction.....	1
1.1 Limitations of the F1930 Test	1
1.2 Midscale FR Performance Test Proposed to Augment the Capabilities of the F1930.....	3
2. Critical Decisions Made During Development of Midscale Test Method	5
2.1 Use of Existing ASTM F1930 Propane Cell	5
2.2 Decisions Made During Test Form Development.....	5
2.3 Use of Copper Slug Sensors from Precision Products/Engineering Technology Incorporated.....	7
2.4 Use of Binder Clips to Mount Test Specimens to Test Forms	7
2.5 Assessment of FR Performance Using Measures Other than Predicted Second or Third Degree Burns	8
3. Midscale Test Apparatus.....	9
3.1 Test Cell/Test Chamber	9
3.2 Gas System	10
3.3 Burners.....	10
3.4 Thermal Energy Sensors.....	12
3.5 Data Acquisition System	12
4. Midscale Test Procedure.....	13
4.1 Preparation of Test Specimens	13
4.2 Preparation for Testing	13
4.3 Performing the Test	14
5. Conclusions and Recommendations	17
6. References.....	19
Appendix A. NSRDEC/NCSU Comparison Testing Summary	21
Appendix B. TTA.....	23
Appendix C. Draft Test Method Balloted April 2014	27
Appendix D. Detailed Drawings	43

List of Figures

Figure 1. Cylindrical test form.....	5
Figure 2. Flat plate test forms	6
Figure 3. Pyrohead™.....	7
Figure 4. Articulating Arm	7
Figure 5. Representative incident heat flux variability measured on the Midscale test forms. a) Flat plate test form; b) Cylindrical test form.....	9
Figure 6. Cylindrical test form with eight burners/four stands.....	11
Figure 7. Flat plate test form with two burners/one stand	11
Figure 8. Clamping of fabric specimen: Cylindrical and flat plate test forms.....	14

DEVELOPMENT OF A MIDSCALE TEST FOR FLAME RESISTANT PROTECTION

1. Introduction

This report covers work by the Natick Soldier Research, Development and Engineering Center (NSRDEC) from October 2010 to March 2016 with the aim to develop a flame resistant (FR) test method that predicts performance of textiles and garment design details during flame engulfment. In the past, the Army has provided FR garments to mounted Soldiers and others who might expect to encounter a flame or thermal threat in the course of their customary duties. In the current asymmetric battlefield, however, flame and thermal protection has become increasingly important to all Warfighters due to the prevalence of Improvised Explosive Devices (IEDs) and other incendiary weapons. Given the importance of FR protection, it is essential that test methods used to predict performance of these FR garments and their materials reproduce as closely as possible the actual battlefield threat against which they are meant to protect

One important element of textile flame and thermal protection is the extent to which the fabric prevents transmitted heat flux from reaching the skin. Even if the textile is self-extinguishing, burn injury can occur due to heat transmitted to the skin through the fabric during a fire, and even after the fire has been extinguished. The best known full scale transmitted heat flux test is the "ASTM F1930 Standard Test Method for Evaluation of Flame Resistant Clothing for Protection Against Fire Simulations Using an Instrumented Manikin" [1] or Standing Manikin Test in which a manikin 1.85 m in height is instrumented with a minimum of 100 heat sensors and exposed to a simulated fire condition using propane torches. The F1930 test is the only system level test available for assessing FR protection of garments and is the only current standard test method for FR protection that employs both radiant and convective heat flux to produce a realistic flame engulfment fire scenario.

1.1 Limitations of the F1930 Test

As the only available system test, the F1930 is widely used to predict performance of FR ensembles. The test method itself, Test Method ASTM F1930 [1], however, states that it is not intended to be a quality assurance test:

5.2 This test method provides a measurement of garment and clothing ensemble performance on a stationary upright manikin of specified dimensions. This test method is used to provide predicted skin burn injury for a specific garment or protective clothing ensemble when exposed to a laboratory simulation of a fire. It does not establish a pass/fail for material performance.

5.2.1 This test method is not intended to be a quality assurance test. The results do not constitute a material's performance specification.

This limitation on the use of F1930 burn injury predictions is based on several factors. While results for each laboratory may exhibit reasonable reproducibility, previous inter-laboratory

testing has shown that the lab-to-lab variability in the F1930 test and in the parallel international standard ISO 13506 is very high. As stated in the F1930 Precision and Bias statement, the reproducibility limit from lab to lab is higher than 50% for some garments, casting doubts on the validity of the F1930 as a standard test method.

An ISO project group, PG13506, is currently working to identify and minimize the sources of variability in the ISO standard, and the results of the round robin testing should inform future versions of both ISO 13506 and ASTM F1930. Although the NSRDEC is actively involved in PG13506 and awaits the results with great interest, a previous round of comparison testing between North Carolina State University (NCSU) and NSRDEC was carried out in 2012. The results of this comparison testing strongly suggest that it is possible to decrease this lab-to-lab variability to minimal levels if details of test methodology are shared between labs. More information about this comparison study is included in Appendix A, but key sources of variability appear to include lack of precision in controlling heat flux exposure times and different methods of calculating burn injury predictions. Variations in sensor type and calibration methods are also important, but they are secondary sources of variability. If the F1930 test were modified to specify the manner in which the incident heat flux data from the sensors were to be reduced, for instance to account for baseline drift, use of different sensors by different laboratories might cease to be a potential source of concern.

As more laboratories worldwide have begun to perform the F1930 or the ISO13506, several other limitations of the F1930 have become apparent. For prediction of burn injury, the F1930 uses measured transmitted heat flux as a function of time, then employs a mathematical model of the three layers of the human skin (epidermis, dermis, and subcutaneous) to calculate predicted depth of burn as a result of the incident heat flux. This depth of burn is then binned as negligible, second (within the dermis), or third degree burn (full skin thickness). Since the dermis accounts for about 90% of the skin thickness, reporting only second or third degree burns puts superficial second degree blisters in the same category as near full thickness burns.

A significant amount of detailed information about the nature and local surface distribution of the potential burn injury using the F1930 test is also lost by distributing sensors so they are able to sample only a small portion of the manikin surface. For example, 123 manikin heat flux sensors may be distributed, roughly equally over the body surface, excluding the hands and feet. The responsive element in each copper slug sensor is 1.27 cm in diameter, and as such, the device measures heat flux over a very small element of the manikin surface (i.e., the area of the copper disk, $1.267 \times 10^{-4} \text{ m}^2$). In fact, though a large number of sensors is employed, a comparison between the total sensor area and typical numbers for body surface area (1.62 m^2 excluding hands and feet) reveals that the sensors are sampling a little less than 1% of the manikin surface.

In garment tests, however, garment design features vary with position, and the response of the garment is not uniform over the large surface areas between sensor locations. The predicted body burn from the F1930 is calculated from data on widely separated sensors using a burn injury model that is validated against a very limited number of superficial second degree human burn injuries on the forearm. There are therefore critical localized effects which are not detected in

the response of the sparse sensor array and the burn injury model does not take into account the variation in the skin physiology across the surface of the body.

Limitations of the F1930 test may be summarized as follows:

- High cost of performing
- Additional cost required to prepare a garment if information on FR performance of novel fabrics or changes in design details in a realistic flame engulfment fire scenario is all that is required
- High lab-to-lab variability which suggests to the testing community that some aspects of the test are not well understood or controlled as evidenced by the formation of the ISO project group
- High variability from the nominal 84kW/m^2 incident heat flux across the surface of the manikin
- Low density of heat flux sensors across the surface of the manikin (less than 1% of the manikin surface area)

1.2 Midscale FR Performance Test Proposed to Augment the Capabilities of the F1930

In an effort to address some of the limitations of the F1930, NSRDEC proposed a project to develop a midscale test method that would use the same heat flux as the F1930 with a simple flat plate or cylindrical test fixture at much lower cost than the full scale test. New candidate FR materials could be evaluated under realistic flame engulfment fire conditions without the expense of fabrication of an entire ensemble for each test. The smaller area of the midscale test specimen compared to the manikin would allow greater control of the standard target value of 84 kW/m^2 heat flux and much higher density of sensors per unit surface area to provide much richer information on the FR performance of design details.

Although second and third degree burn injuries can still be predicted at each midscale sensor using a burn injury model identical to the F1930, other new ways of reporting results can be used to provide better understanding of the severity of the predicted burn. Depth of burn can be used to differentiate between superficial and severe second degree burns. Measurement of transmitted fluence or Energy Transmission Factor or ETF (discussed in Section 2.5) can be used to eliminate dependence on questionable burn injury predictions based on a physiologically inaccurate burn injury model.

As part of the NSRDEC Collaborative Science and Technology (S&T) Planning (CSTP) process, this proposal was presented to Program Executive Office Soldier (PEO-Soldier) and the Training and Doctrine Command at a PEO-Soldier Prioritization Review in spring 2010, and it was selected by PEO-Soldier for support from NSRDEC core S&T funds. The NSRDEC FY11 budget was realigned to support the effort. A Technology Transition Agreement (TTA), which can be found in Appendix B, was signed by NSRDEC and Project Manager Soldier Protection and Individual Equipment (PM-SCIE) in September 2010 to document the agreement. The TTA called for the midscale testing capability to be available to PM-SCIE at NSRDEC by the end of FY13. The Midscale test apparatus and a draft ASTM standard test method for use of the apparatus were delivered on schedule according to the TTA.

NSRDEC Thermal Test Facility (TTF) personnel requested and received permission to form an ASTM task group to consider the new test method in January 2014. The draft test method entitled “Evaluation of Materials and Design Attributes for Protection Against Fire Simulations Using an Instrumented Test Apparatus”, (known as the Midscale Test for FR Protection) was presented to the Task Group on 30 January 2014 in Houston, TX. The draft was balloted in April 2014 before the next Task Group meeting, and the comments were discussed at the meeting in West Conshohocken, PA on 11 June 2014. The draft is available in Appendix C.

Validation and Verification (V&V) testing was performed at the request of the PM-SCIE to elucidate the relationship between results obtained from the Midscale test and the F1930 [2]. The results of this testing will be used to inform a revised Precision and Bias Statement for the Midscale test. The initial set of materials chosen for the V&V testing exhibited limited variation in FR performance, which in turn limited the potential utility of the resulting data for precision and bias determination. NSRDEC therefore plans to continue the testing after the completion of the formal V&V to augment the data with FR materials exhibiting a greater range of performance. The results of this testing will be reported to the next ASTM Task Group meeting in June 2016 in Chicago and incorporated into a revised Precision and Bias Statement for the next draft of the Midscale test. A revised draft Midscale test method reflecting both the results of this testing and the findings of the ISO Project Group will be submitted for ballot before the January 2017 Task Group meeting.

2. Critical Decisions Made During Development of Midscale Test Method

2.1 Use of Existing ASTM F1930 Propane Cell

Although the existing propane cell was used, some modifications were made to the burner system that was used for the F1930. These changes were made to increase the capabilities of the existing system and to allow the Midscale and F1930 systems to operate independently. These changes included:

- The team utilized the separate propane vaporizer that is used for the Navy Traversing Manikin System, which operates at an initial pressure of 100 psi compared to the F1930 vaporizer, which has an initial pressure of 50 psi. 50 psi is adequate for the F1930 testing, but 100 psi pressure allows longer time exposures if desired.
- The team used the so-called “Big Bertha” burners, which are widely employed for the F1930 test, rather than the burners used in the NSRDEC F1930 set, and they were mounted on different burner stands

Use of the existing F1930 propane cell should make it easier for any laboratory currently performing the F1930 to perform the Midscale test.

2.2 Decisions Made During Test Form Development

Cylindrical Form: The initial CSTP proposal for development of a Midscale test included only a cylindrical geometry for the test form. The cylinder was chosen because it was similar to the human torso. The cylindrical test form was constructed with a 42 in circumference – the same as the chest of the manikin. The cylinder contains 24 sensors arranged in alternating columns of 5 sensors and 4 sensors each. This sensor pattern reproduced the sensor spacing on the manikin, although closer sensor spacing could be employed if desired. These similarities to the F1930 manikin should facilitate comparison between Midscale and F1930 test results. A picture and drawing of the cylindrical test form with sensor locations are shown in Figure 1.

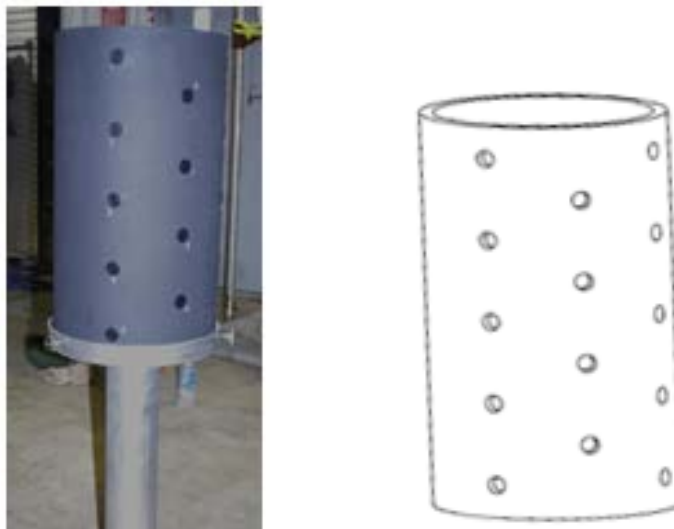

Figure 1. Cylindrical test form

Flat Plate Forms: In the course of the first year of development, the decision was made to add

two different flat plate test forms in addition to the cylinder. One key reason for this decision was the need to provide closer sensor spacing for the assessment of design details. The first flat plate form was 13 x 13 in, containing a total of 13 sensors – 12 heat flux sensors evenly placed around the center of the plate with a Medtherm Schmidt-Boelter Thermopile Sensor (non water cooled) in the center. The Schmidt-Boelter Sensor acts as a reference to ensure that all sensors are calibrated to 84 kW/m². A 7 x 7 in plate was also constructed with 13 sensors uniformly distributed across the surface of the test area. The 7 x 7 in plate form was added to accommodate testing when a limited amount of material was available. It also provided a higher sensor density. Pictures of the 13 x 13 and 7 x 7 in flat plate test forms are shown in Figure 2.

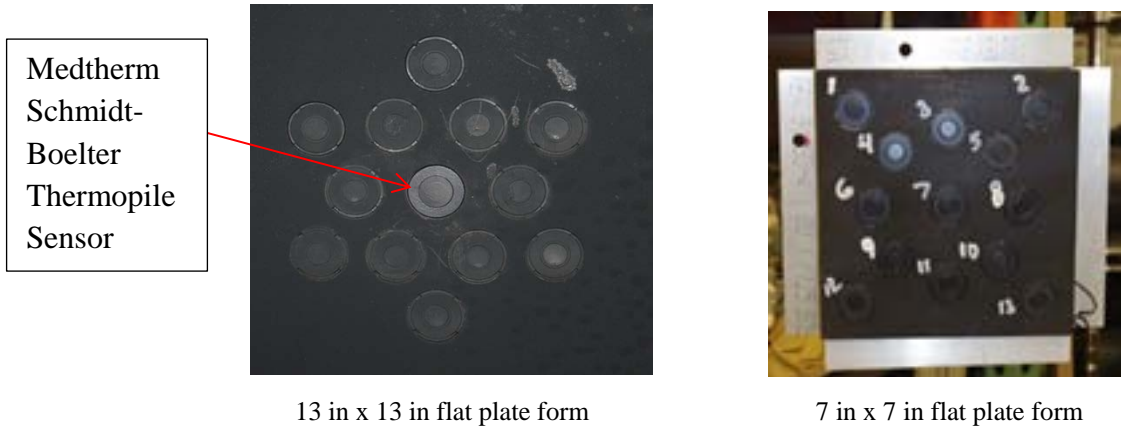

Figure 2. Flat plate test forms

See Appendix D for details of sensor placement and mounting of the test forms.

A thermoset matrix composite material known as Micarta was employed for all the flat plate and cylindrical Midscale test forms. Micarta phenolic sheet is a hard, dense material made by applying heat and pressure to layers of paper or glass cloth impregnated with a phenolic resin. These laminated layers can be reinforced with cellulose paper, cotton fabrics, synthetic yarn fabrics, glass fabrics, or unwoven fabrics. The material used in the test forms was reinforced with medium/heavy weave (canvas) cotton fabric. When heat and pressure are applied to the layers, a chemical crosslinking reaction transforms the layers into a high-pressure thermoset industrial laminated plastic.

Micarta was chosen because it was available in a pre-formed tube of the desired diameter, has good high temperature dimensional stability, excellent durability, low cost, and is easily machinable to provide sensor placement locations. Although the name Micarta is used generically, it is a registered trademark of Industrial Laminates/Norplex, Inc.

Other Test Forms: In addition to the cylindrical and flat plate test forms, the Midscale test method can also be used with other test forms, including head, hands, and an articulating arm. The arm, which is Navy-owned, was used to observe the performance of wrist seals for water immersion suits for the Navy. The head form provided by PM-SCIE was used to evaluate the performance of the neck seals on the immersion suits and the FR performance of a new webbing system for the HG56D helmet for the Air Warrior. Figures 3 and 4 are photographs of head and articulating arm test forms which have been used with the Midscale test apparatus. Neither the

head form nor the articulating arm were instrumented, so incident heat flux data were not obtained during testing, but they served as test stands to demonstrate stability of the seal and webbing materials during a realistic flame engulfment fire scenario. Close visual observation of a garment or item of equipment often provides additional qualitative but valuable information on FR performance of design details beyond what can be obtained from the transmitted heat flux data.



Figure 3. Pyrohead™



Figure 4. Articulating Arm

2.3 Use of Copper Slug Sensors from Precision Products/Engineering Technology Incorporated

Copper slug sensors from Precision Products/Engineering Technology Incorporated were selected for use on the Midscale test system because they are identical to the sensors used in the NSRDEC manikin. Use of the same sensors should facilitate good agreement between the transmitted heat flux measured in the Midscale and in the manikin. These sensors are similar to those used by NCSU but are available commercially. Although these sensors have strengths and weaknesses, it was considered beneficial to use the NCSU style of sensor to enable them to do the Midscale FR Performance test with their in-house sensors. As noted in Section 2.2, a Schmidt-Boelter Thermopile Sensor was added to the center of the flat plate sensor array to ensure that all sensors are calibrated to 84 kW/m^2 .

2.4 Use of Binder Clips to Mount Test Specimens to Test Forms

At the suggestion of ASTM personnel, it was decided to use binder clips to mount the specimens to allow for fabric dimensional changes during testing. The binder clips have low thermal mass so their effect on the incident heat flux to the test form surface is minimal. The binder clips are constructed from spring steel and are therefore very rugged and durable. While the air gap left between the surface of the test form and the fabric was not initially specified, extensive testing of transmitted heat flux through a wide range of fabrics using the CO_2 laser (3) have indicated that the thickness of the air gap has a very strong effect on the results. A new specimen mounting device has therefore been designed for the flat plate test form, which may be used in future testing to control the air gap.

2.5 Assessment of FR Performance Using Measures Other than Predicted Second or Third Degree Burns

In addition to the predicted burn injury calculated using the F1930 burn injury model, other measures of FR performance are reported in the Midscale test results. These include depth of burn (which is calculated and used to predict burn injury in F1930 but is itself not reported), total fluence (i.e., the time integral of transmitted heat flux), bare fluence measured during the nude calibration burn, and ETF (the ratio of the total fluence divided by the bare fluence). Specifically, ETF is the ratio of the transmitted fluence to the fluence on the sensor during “nude” calibration burn, as nude value varies with position. The ratio varies from 0 to 1 corresponding to the amount of incident heat energy transmitted to the sensor. A value of 1 means the fabric provides no protection, and a value to 0 corresponds to 100% protection. A direct measurement of comparative fabric performance, independent of any skin burn injury models.

Reporting these additional data avoids the loss of detailed information about the nature of the potential burn injury that occurs in the F1930 test. In that test, a depth of burn is calculated at each sensor location, second or third degree burn injury is predicted at each location based on that depth of burn, and then only three levels of burn injury are reported. Since the dermis accounts for about 90% of the skin thickness, reporting only second (within the dermis) or third degree (through the dermis) burns puts superficial second degree blisters (depth just over 75 μm) in the same category as near full thickness burns (depth of 1200 μm).

3. Midscale Test Apparatus

3.1 Test Cell/Test Chamber

The propane test cell in the TTF is used for the Midscale test. It contains a propane delivery system, as well as alarms and an exhaust system. All building systems are controlled from within the control room and include a wet scrubber system, fire alarm/wet deluge system, propane delivery system, underground storage tank, data acquisition system, and system software to safely run the test. There is no specified test chamber size for the Midscale. The only requirement is that the chamber allow an average heat flux of 84 +/- 5% to be delivered to the test specimen.

The F1930 standard requires that the calculated heat flux standard deviation is not greater than 21 kW/m². Since this high standard deviation in incident heat flux to individual sensors in the F1930 is due to the geometry of the manikin test form, it is possible to achieve a much lower variation in incident heat flux to the sensors in the Midscale test forms. Representative plots of incident heat flux measured during a Midscale test calibration on the flat plate and cylindrical test forms are shown in Figure 5.

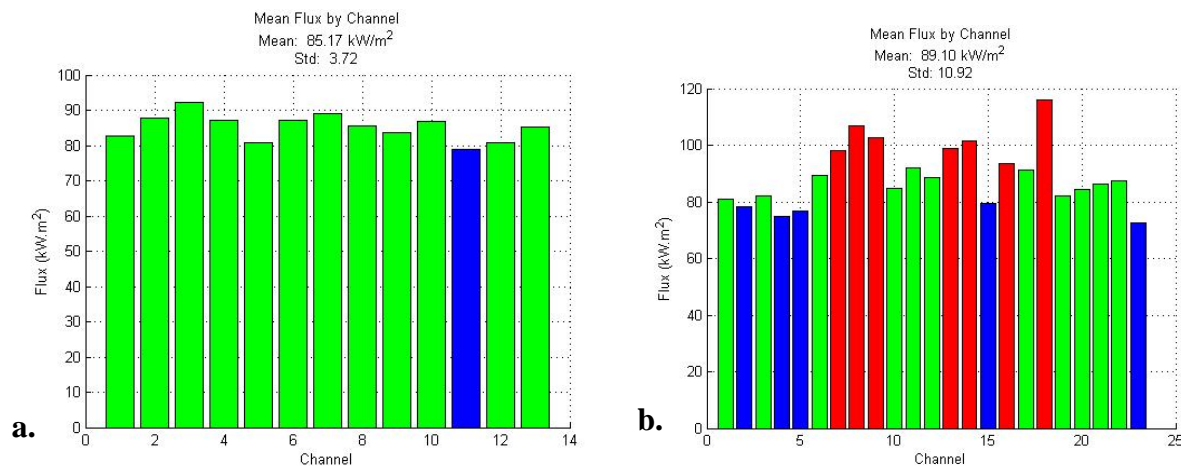

Figure 5. Representative incident heat flux variability measured on the Midscale test forms. a) Flat plate test form; b) Cylindrical test form

Channels shown in red are >5% higher than the mean, and channels shown in blue are >5% lower than the mean. Based on these results, a maximum of +/- 8 kW/m² standard deviation in incident heat flux might be specified in the final test standard for the flat plate test form and +/- 15 kW/m² for the cylindrical test form. The higher variability in the cylindrical test is due to the greater complexity of the test form shape. A final, realistic value for the standard deviation that can be achieved in incident heat flux for both flat plate and cylindrical test forms will be determined based on a larger data set. This larger data set will include the V&V testing results, coupled with additional measurements planned on materials with a broader range of FR performance.

There is no air movement within the test chamber other than the natural air flow required for the combustion process, so that the pilot flames and the exposure flames are not affected by air flow before or during the test exposure.

3.2 Gas System

A vaporizer outside the building is used to supply the proper gas flow rate to the burners for testing. The vaporizer currently used for the Midscale test operates at 100 psi outside the building and comes into the building at 50 psi. A system of piping, pressure regulators, and valves consistent with local codes is used to safely deliver gaseous propane to the ignition system and exposure torches. The delivery system is sufficient to provide an average heat flux of 84 kW/m^2 for an exposure time of at least 20 s. Fuel delivery is controlled to provide known exposure duration within ± 0.1 s of the set exposure time. For a detailed schematic of gas piping, regulators, valves, etc. see Appendix D.

3.3 Burners

Large, induced combustion air, industrial style 400K BTU propane burners (so-called Big Bertha burners) are positioned directly in front of the test apparatus to produce a uniform laboratory simulation of a fire (a large fuel rich reddish-yellow flame). Each exposure burner is equipped with an ignition system positioned near the exit of the burner, but not in the direct path of the flames. This prevents interference with the exposure flame pattern. The ignition system is interlocked to the burner gas supply valves to prevent premature or erroneous opening of these valves. Any electrical-magnetic-field generated by the ignition system is small enough so as not to interfere with the quality of the data acquisition and recording process. Standing pilot flames are used in the Midscale. The arrangements of the burners as described for each set-up below are designed to optimize incident heat flux for that test form. Each user of the test would need to determine the best burner arrangement for each test form in their own laboratory setting.

Burner Setup for the Cylindrical Test Form: Eight of these large, induced combustion air, industrial style propane burners are used to provide the required average exposure level of 84 kW/m^2 , producing a large, fuel-rich reddish-yellow flame. The eight burners are positioned in an arc of 180° around the cylindrical form on four stands containing two burners per stand. On each stand, one burner is situated approximately 24-28 in above the ground and the other approximately 38-40 in above the ground. Each stand is approximately 25-30 in from the test form. In another facility, the burners and test forms could be set in another arrangement as long as the burner can deliver 84 kW/m^2 heat flux to the test form. Since this process for the cylindrical test form is the same as that used to set up burners for the F1930, any lab with experience in F1930 testing can achieve this required incident heat flux. Figure 6 shows a photograph and drawing of the burners set up around the cylindrical test form.



Figure 6. Cylindrical test form with eight burners/four stands

Burner Setup for the Flat Test Forms: Two large, induced combustion air, industrial style propane burners are positioned directly in front of the flat plate test apparatus to produce a uniform laboratory simulation of a fire. These burners produce a large, fuel-rich reddish-yellow flame. Two burners are used when testing with the flat plate. The two burners are on one stand, approximately 12 in from each other horizontally, and 32 to 33 in from the plate. One burner is 24.5 in from the floor and the other is 26.5 in from the floor, approximately 25-30 in from the test form. Burners can be adjusted easily to achieve the desired heat flux during the initial calibration of the system prior to testing. Another lab may choose to set burners up in an alternate configuration to achieve the required incident heat flux of 84 kW/m^2 . Figure 7 shows a photograph and drawing of the burners set up with the 13 x13 in flat plate test form.

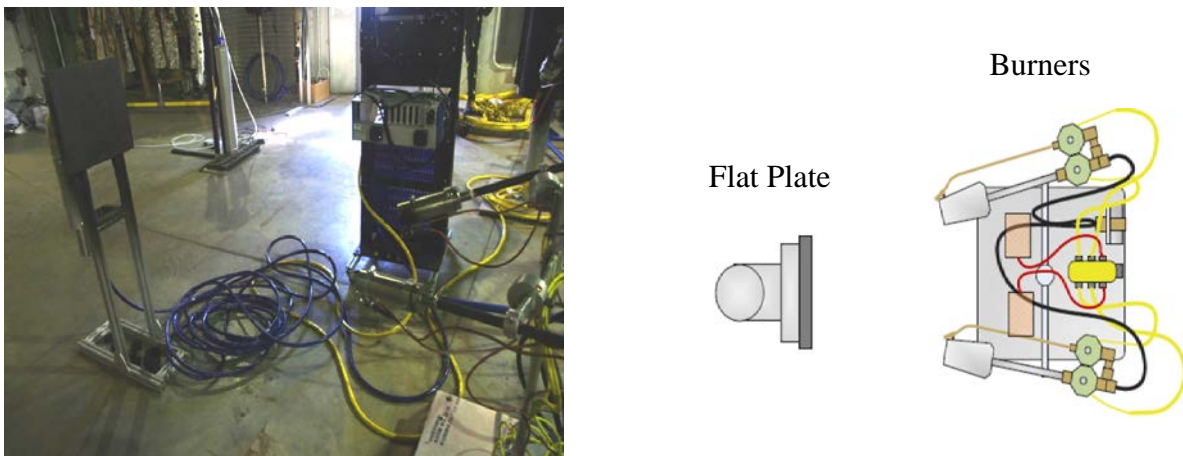

Figure 7. Flat plate test form with two burners/one stand

3.4 Thermal Energy Sensors

Each sensor has the capacity to measure the incident heat flux over a range from 0.0 to 165 kW/m². This range allows the sensors to be used in calibrating the test exposure level by directly exposing the instrumented test apparatus to the controlled fire scenario without any test specimen (nude test form calibration) and then to be used in testing to measure the heat transfer to the sensor when covered with a test specimen. The sensors should be constructed of a material with known thermal and physical characteristics. They are used to indicate the time varying heat flux received at the sensor surface. As with the F1930, the minimum response time for the sensors should be ≤0.1 s. The sensor surface should have an emissivity of a least 0.9. Coating the sensor with a thin layer of flat black high temperature paint with an emissivity of at least 0.9 has been found to be effective in F1930 testing.

All sensors must be calibrated using a traceable heat flux measuring device prior to placement in the test form. The Thermal Barrier Test Apparatus (TBTA) developed under a Small Business Innovation Research (SBIR) contract with NSRDEC and now commercially available from SDL Atlas under the name ThermaRate is used for calibration at NSRDEC. The TBTA is a pure radiant energy source. Other laboratories may use alternate sensor calibration devices that they currently employ for calibration of the F1930 sensors. The calibration determined for each thermal energy (heat flux) sensor is recorded and the calibration results are entered into the data acquisition system for use in data analysis. The system is then calibrated to the exposure and heat transfer conditions experienced during test setup and garment testing, typically over a range of 8.4 kW/m² to 84 kW/m². The TBTA uses a NIST traceable reference sensor.

3.5 Data Acquisition System

The data acquisition system must have the capability of acquiring and storing the results of the measurement from each sensor at least five times per second for the data acquisition period. The computer controlled data acquisition system should record the output from each sensor at least five times per second during the calibration. The accuracy of the measurement system should be less than 2% of the reading or ±1.0 °C (±1.8 °F) when a temperature sensor is used. The system employed at the NSRDEC TTF is manufactured by National Instruments, but other systems capable of acquiring data during F1930 testing can be used.

4. Midscale Test Procedure

In this Chapter, the Midscale test procedure is described step-by-step. Many details of specimen conditioning and testing are based on those specified in the F1930 test, since these methods have been shown to decrease variability in measured materials performance in a fire engulfment scenario. The actual draft test method balloted by the ASTM Midscale Task Group in June 2014 can be found in Appendix C.

4.1 Preparation of Test Specimens

A minimum of three specimens should be tested. A greater number of specimens can be used to improve precision of test results. Samples may be tested unlaundered, laundered, or dry cleaned. For materials designated to be washed, each test specimen should be laundered with one wash and one dry cycle prior to conditioning using the AATCC Test Method 135, (1, V, A, iii). For dry cleaning, Sections 9.2 and 9.3 of AATCC Test Method 158 should be used.

Each test specimen is conditioned for at least 24 h in a controlled environment to 21 ± 1 °C (70 ± 2 °F) and $65 \pm 2\%$ relative humidity prior to testing and must be tested within 30 min of removal from the conditioning area. The chamber temperature prior to a test must be between 15 °C (58 °F) and 30 °C (85 °F) but there is no requirement for ambient humidity. If the specimen cannot be tested within 30 min, it should be sealed in a manner that restricts moisture loss or gain until immediately prior to testing. Testing of such garments should be within 20 min after removal from the bag. No specimens should remain in the bag for longer than 4 h before removal for testing.

4.2 Preparation for Testing

Before placing the specimen on the selected test form, the system must be readied for testing by performing the following.

Charge the gas lines: The Vaporizer is turned on. The valves should be open to the fuel supply to charge the system with propane gas pressure up to, but not into, the chamber. If pilot flames are used as the ignition source, they should be charged and lit. The flash fire for both Midscale test apparatuses is controlled by simultaneously opening a solenoid valve for each burner. The duration of the opening is set with an electronic timer. The data acquisition system records data from each of the heat flux sensors at a sampling rate of 5 Hz.

The heat flux is calibrated on the bare Midscale test apparatus. The incident heat flux on the bare test form is calibrated to within $\pm 5\%$ of the target 84 kW/m^2 by adjusting the standoff and positioning of the burner flame. Propane is supplied to the burners at 50 psi, and for these tests, a 3/32 in burner orifice was used. Nude calibration is performed by running 4 s exposure on the bare plate or cylinder.

The chamber temperature prior to a test must be between 15 °C (58 °F) and 30 °C (85 °F), but there is no requirement for ambient humidity.

Calibration of the fire exposure on the nude test apparatus is performed as the first and last test each test day. In addition, if a break in testing is taken, another nude calibration burn is

performed before work begins after the break. Results of this exposure are reported as the average absorbed heat flux in kW/m², fluence in kJ/m² and exposure duration in seconds.

Any defective sensor should be replaced prior to testing when possible. The software should have the ability to scan for open thermocouples and identify the channel for defective sensors.

4.3 Performing the Test

1. Mount the Conditioned Test Specimen on the Test Form.

Cylindrical Test Form: The cylindrical form requires approximately 2/3 yd of fabric (24 in by 50 in) for testing. The material is wrapped around the 13.5-in diameter test cylinder and clamped on the back side of the cylinder with binder clips as shown in Figure 8. Excess material should be trimmed. The circumference of the test cylinder is 42 in, which is equal to the chest circumference of the thermal test manikin.

Flat Test Form: When fabrics are being tested on the 13 x 13 in flat plate, a 20 x 20 in sample is required. The fabric is clamped around the 13 in square test panel as shown in Figure 8. Clamping is accomplished in the same manner for the 7 x 7 in flat plate test form. A 14 x 14 in fabric swatch is required for use on the 7 x 7 in test form.

Whether using a fabric or testing a design feature such as a pocket, the test sample should be placed on the test apparatus in the same way it would be expected to be used by the end-user/wearer or as specified by the test requestor. It should be noted in the test report how the test specimen was tested. The same test procedure should be used for each of the three replicates in the sample set to be tested to minimize variability in the test results.



Figure 8. Clamping of fabric specimen: cylindrical and flat plate test forms

2. Record the Test Attributes—The information that relates to the test is recorded, including: purpose of test, test series, test specimen identification, layering, material style number or pattern

description, test conditions, test remarks, exposure duration, data acquisition time, persons observing the test, and any other information relevant to the test series.

3. Set Test Parameters—The specified exposure time and data acquisition time are entered into the burner management control system. The data acquisition time shall be long enough to ensure that all of the thermal energy stored in the test specimen is no longer contributing to burn injury. It should be confirmed that the acquisition time is sufficient by having the heat flux versus time information inspected to determine that all of the sensors have leveled off and are not continuing to rise at the end of the data acquisition time. If the heat flux is not constant for the last 10 s of acquisition time, the acquisition time should be increased to achieve this requirement.

4. Light the Pilots (if required)—If pilot lights are used, the pilot flames should be lit and it should be confirmed that all of the pilot flames on the burners that will be used in the test exposure are actually lit. (Warning—the presence of each pilot flame should be visually confirmed. The test exposure shall be initiated only when all of the safety requirements are met, the pilot flames are ignited and visually confirmed, and the final valve in the gas supply line is opened).

5. Start Image Recording System—The recording system is started and used to visually document each test in real time.

6. Expose the Test Specimen—The data acquisition is started, the burner gas supply solenoid valves are opened for the time of the exposure, and the data acquisition is stopped at the end of the specified time.

7. Acquire the Transmitted Heat Flux Data—The data are collected from all installed thermal energy sensors. Note that data collection during and after the fire exposure shall be done in a still air environment. Generally, data are collected for 90-120 s.

8. Stop Image Recording System After Data Collection Period.

9. Record Observations of Test Specimen to the Exposure—These remarks include but are not limited to the following: occurrence of after-flame (time, intensity, and location), ignition, melting, smoke generation, unexpected material or specimen failures (for example, formation of holes), material shrinkage, and charring or observed degradation.

10. Process Data—Heat flux data are processed, and determination is made of total fluence, depth of burn (or predicted burn injury of each thermal energy sensor), the total predicted burn injury, the percentage of predicted second-degree, and predicted third-degree injury.

11. Remove the Combustion Products Resulting from the Fire Exposure—The system should be run long enough to ensure a safe working environment in the exposure chamber prior to entering.

12. Visually Examine Test Specimen —The test specimen is examined visually.

13. Prepare for the Next Test Exposure—The exposed specimen is removed from the test apparatus. The test form and sensor surfaces are wiped with a damp cloth to remove any residue,

if necessary. The test form and sensors are inspected to ensure that they are free of any decomposition materials, and if a deposit is present, the test form and sensors are carefully cleaned with soap and water or a petroleum solvent. The gentlest method that is effective in cleaning the sensor should be used. If required, the surface of the sensor is repainted and the paint is dried. It should be ensured that the test apparatus and sensors are dry, and if necessary, they should be dried, for example with ventilating fan(s), before the next test is conducted. The sensors should be inspected for damage, for example cracks or discontinuities in the sensor surface. Damaged or inoperative sensors should be repaired or replaced. Repaired or replaced sensors should be calibrated before being used. Before starting the next exposure, it should be ensured that the average temperature of all the sensors located under the test specimen is 32 ± 2 °C (90 ± 4 °F) and no single sensor exceeds 38 °C (100 °F).

14. Test Remaining Specimens—The remaining specimens are tested at the same exposure conditions.

Note: The NSRDEC system requires a 20 min period between tests in order for the vaporized gas to replenish the reservoir and achieve adequate fluence to perform another test.

5. Conclusions and Recommendations

5.1 Conclusions

The limitations of the F1930 testing were summarized in the introduction of this report, and the Midscale FR Performance test was proposed as a way of addressing some of these limitations and augmenting the capabilities provided by the F1930. The first challenge with using F1930 is the high cost of performing the test. The cost of the F1930 reflects the expense of maintaining all the equipment for safely providing the required heat flux within the specified range, fabricating a garment, and dressing and undressing the manikin. **The Midscale test is a less expensive alternative to F1930 in some cases** because it allows a new garment fabric, a shirt, a pant, a pocket, or other design details to be evaluated in a realistic flame engulfment fire scenario without the cost of garment fabrication or assembly of an entire ensemble.

With a range of test forms available, the transmitted heat flux, fluence, depth of burn, predicted burn injury, and ETF can be determined using a cylinder with a diameter of the chest or the arm, or on a flat plate with closely spaced sensors and very low variation in incident heat flux, or additional forms which can be developed in the future. The choice of which test form to use in a given situation would depend upon the amount of material available, the detail in transmitted heat flux required, and the objective of the test.

Another concern with the F1930 is the high lab-to-lab variability which has been observed for the test. There is an active investigation within the ASTM F1930/ISO 13596 community into the sources of this high lab-to-lab variability and ways to decrease it to provide a more truly standard test. While making changes to a well-entrenched test method such as the F1930 may move slowly, changes such as introduction of new, more precisely specified methods of controlling exposure time should be possible in a new method such as the Midscale test. Such changes will be included in the next draft to be submitted for ballot to the ASTM Task Force.

Since the Midscale test can be performed in any facility which is equipped to perform the ASTM F1930, barriers to performing the test have been minimized and upon successful adoption as a standard test method, labs across the US and the world can begin to use it to assess performance of FR fabrics. **Results obtained with the more controlled Midscale test method should significantly decrease the lab-to-lab variability which is currently observed with the F1930.** This decrease in lab-to-lab variability could be demonstrated through multi-lab round robin testing and lead the way to making similar changes to the F1930 in the longer term.

The F1930 is primarily an ensemble test rather than a materials test. The high variability from the nominal 84kW/m^2 incident heat flux across the surface of the manikin limits the utility of the F1930 for systematically evaluating and understanding the effects of new fabrics on the level of FR protection they can provide. This high variability is due in part to the complex geometry and static pose of the manikin, and in part to the chaotic nature of combustion during flame engulfment. In a realistic flame engulfment fire scenario, some variability in incident heat flux across the manikin surface and as a function of time during exposure is unavoidable, but the data summarized in Figure 5 demonstrate that **using the Midscale test can decrease this variability**

by more than 50% in the cylindrical test form and by almost an order of magnitude in the flat plate test form.

The low density of heat flux sensors across the surface of the manikin in the F1930 (less than 1% of the manikin surface area) means it is unlikely that burn injury associated with local design details will be observed during F1930 testing. The flat plate test form in the Midscale test provides a much higher density of sensors and, as discussed above, almost an order of magnitude decrease in variability in the incident heat flux at these sensor locations. **The Midscale flat plate test form therefore provides a much clearer understanding of the effect of design details and the comparative performance of FR fabrics than does the F1930.**

As discussed above, another limitation in the F1930 test is the loss of detailed information about the nature of the potential burn injury that occurs when the depth of burn is calculated and second or third degree burn injury is predicted at each sensor location based on that depth of burn, but depth of burn is not reported. Reporting only second or third degree burns puts superficial second degree blisters in the same category as near full thickness burns. In the Midscale, reporting at each sensor location includes depth of burn, total fluence (i.e., the time integral of transmitted heat flux), bare fluence measured during the nude calibration burn and Energy Transmission Ratio (ETR) which is the ratio of the total fluence divided by the bare fluence. Reporting these results in **the Midscale test provides much more detailed information on burn injury and FR protection than does the F1930.** In the longer term, the F1930 test method should be modified to report these results as well.

5.2 Recommendations

The primary recommendation concerning the development of a Midscale Test for FR Protection is to prepare a revised draft of the Midscale test method and submit it for ASTM ballot before the January 2017 Task Group meeting. Several changes should be made in the next draft based on the results of ongoing Midscale testing and lessons learned from participation in the ASTM F1930 Task Group and the ISO 13506 Project Group.

Recommended changes to the test method include:

1. Incorporation of a Precision and Bias Statement based on the V&V and other testing
2. Inclusion of transmitted heat flux, fluence, depth of burn, predicted burn injury and ETF in the reporting requirements
3. Specification of a method for precise control of exposure time
4. Implementation of a mounting system for the flat plate test form that allows control of the air gap between fabric and sensor face.

Since previous work [3] has indicated that the depth of an air gap between the fabric and the sensor can have a strong effect on transmitted heat flux, consideration should be given to devising a similar mounting system for the cylindrical test form as well.

In addition to making the recommended changes then reballotting the Midscale test method, it is recommended that NSRDEC continue to work with ISO and ASTM to ensure that these new methods of reporting results and controlling exposure time be incorporated in the F1930 tests as well as into the Midscale method.

This document reports research undertaken at the U.S. Army Natick Soldier Research, Development and Engineering Center, Natick, MA, and has been assigned No. NATICK/TR-16/019 in a series of reports approved for publication.

6. References

1. ASTM test method F1930, “Evaluation of Flame Resistant Clothing for Protection against Fire Simulations Using an Instrumented Manikin”
2. “Validation and Verification Testing on Midscale FR Test Method”, NSRDEC Technical Report in preparation
3. J. Fitek, M. Auerbach, T. Godfrey and M. Grady, “High Intensity Thermal Testing of Protective Fabrics with CO₂ Laser”, STP1593 on the Tenth Symposium on Performance of Protective Clothing and Equipment: Risk Reduction through Research and Testing, San Antonio, TX, January 2016

This page intentionally left blank

Appendix A. NSRDEC/NCSU Comparison Testing Summary

(Reproduction of an NSRDEC draft report)

The PM-SCIE have had all their F1930 Quality Assurance (QA) testing for the FRACU done at NCSU. Even though the F1930 is not intended to be a quality assurance test, there was no other method available to meet the need for QA testing when the FRACU was under development. The PM is now concerned that doing this testing at any other laboratory could produce results that vary from those obtained at NCSU.

While these concerns are understandable, it would be impossible for the results of two different labs to match exactly even though they were both performing the test according to the specification. To provide a basis for comparison between the F1930 results from NSRDEC and NCSU and to identify how the results might be brought into line with each other if that became necessary, a round of F1930 comparison testing between the two labs was performed.

PM-SCIE provided some limited funding to NSRDEC along with a series of four garments for F1930 testing: A2CU, FR ACU, iCVC and ASTM standard coverall with 60% Kevlar and 40% polybenzimidazole (PBI). NCSU tested the same garments under the same nominal conditions. NSRDEC prepared a report on our testing and provided it to the PM-SCIE in September 2012. When NSRDEC received the report prepared by NCSU a comparison of the results from the two facilities showed that the NCSU results for a reported 4 second exposure of the four systems were very close to the NSRDEC results for the same four systems at a reported 5 second exposure (see Figure 1).

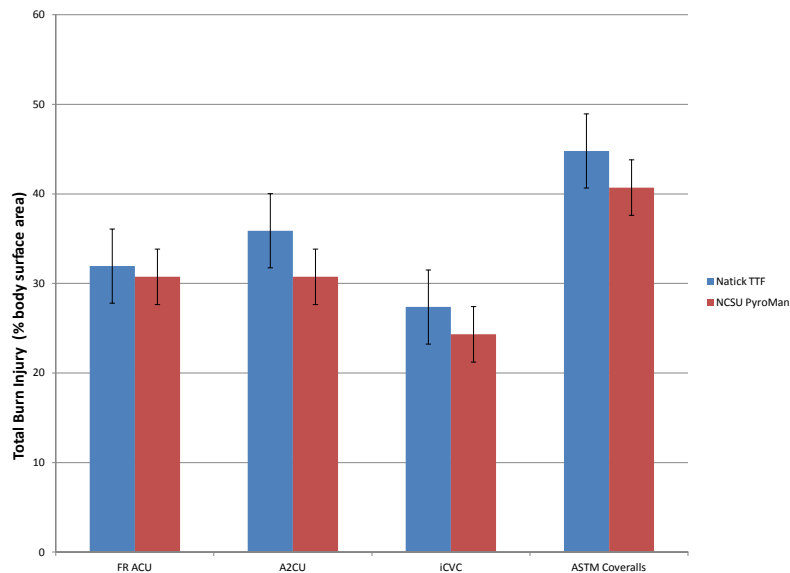

NSRDEC and NCSU predicted burn injury for four garments at 5 and 4 seconds respectively

Discussions of the ASTM F1930 Task Group revealed that different facilities doing the F1930 measure the duration of exposure in different ways. Unfortunately, details of how that duration was measured were not provided as part of the reports from NCSU and NSRDEC. This duration measurement is very important because the propane remaining in the line continues to burn after the valve is closed. As a result, opening a burner valve for 5 seconds actually produces a flame duration of more than 5 seconds. Even a fraction of a second difference in the burn duration can change the relative performance of materials containing FR additives to render them self-extinguishing, which is the case with the FR rayon in the FRACU.

NSRDEC set the exposure duration based on a series of observations that showed that a 5 second flame duration in our F1930 test apparatus was produced by opening the burner valves for about 4.75 seconds. This condition also produced a cumulative incident thermal energy which was the equivalent of a 5 second square pulse of 84 kW/m². When asked about their method for setting exposure time, NCSU indicated that their method was to open their valves for 4 seconds. This would provide a burn duration of longer than 4 seconds.

These results strongly suggested that a very close correlation could be obtained between NSRDEC and NCSU results if the two facilities calculated the exposure duration in exactly the same way. At this time, the NSRDEC predicted burn injury from F1930 tests is slightly lower than that from NCSU, but the NCSU results could be duplicated if the exposure time were increased by a fraction of a second specifically for that purpose.

Appendix B. TTA



RDNS-ADT

DEPARTMENT OF THE ARMY
US ARMY RESEARCH, DEVELOPMENT AND ENGINEERING COMMAND
NATICK SOLDIER RD&E CENTER
KANSAS STREET
NATICK MA 01760-

Collaborative Science & Technology Planning (CSTP)
Technology Transition Agreement (TTA)

Between

Project Manager Soldier Clothing & Individual Equipment (PM-SCIE)

And

**Warfighter Science, Technology and Applied Research Directorate (WarSTAR), Natick Soldier
Research, Development & Engineering Center (NSRDEC)**

Subject: Transition of Mid-Scale Flame Resistant (FR) Test System

1. Overview. PEO Soldier and NSRDEC hereby mutually agree to enter into this TTA for the purpose of defining technology deliverables from the Mid-Scale Flame Resistant (FR) Test System project. The purpose of this TTA is to document a clear understanding between both parties of the conditions required to ensure a successful transition of testing capabilities that will be available at the NSRDEC Ouellette Thermal Test Facility (TTF) for PM-SCIE to utilize to evaluate materials, garments and individual Soldier equipment. This capability could support multiple PM-SCIE clothing and individual equipment (CIE) programs and projects.

2. NSRDEC responsibilities.

- a. Technology products to be delivered: WarSTAR will develop a mid-scale FR test apparatus and test method capable of assessing multiple aspects of performance relative to clothing items and equipment that require flame resistance. Project will result in a new mid-scale test apparatus and method for assessing durability and flame resistance on mock-up garment constructions/systems that can be tested on a smaller scale prior to full-scale ASTM F1930 testing, to provide an indication of results that will be seen during full mannequin testing. Orientation and configuration of materials in prototype system will be similar to actual wear conditions and data is expected to correlate to full-scale testing.
- b. Project metrics are shown in the table below.

Measure	Current Status	Effort Objective	Army Objective	TRL
Cost	Approximately \$2000/set-up \$450/test plus garment cost	50% decrease in cost	More cost effective FR testing	Start – TRL 3 End – TRL 5
Schedule/Time	3 tests per hour	25% decrease in time	More rapid testing	Start – TRL 2 End – TRL 5
Ability to use a single test to evaluate multiple aspects of field performance	Not possible	Possible	To simulate more realistic field conditions during test and evaluation of new approaches to protection	Start – TRL 3 End – TRL 5

c. Delivery schedule. Testing capability will be available to PM-SCIE at NSRDEC by the end of FY13.

3. PEO Soldier responsibilities.

a. Integration strategy.

(1) Upon successful demonstration of key performance requirements (ability to demonstrate the correlation of the developed mid-scale test with ASTM F1930 instrumented manikin test), PM-SCIE intends to leverage the mid-scale flame resistant (FR) test system and utilize the NSRDEC Ouellette Thermal Test Facility for multiple on-going and next generation clothing and individual equipment (CIE) projects and programs under PE 643827.S53 and PR 654601.S60.

b. Risk analysis.

(1) A mid-scale FR test that will have the ability to support and predict the technical testin requirement results associated with each FR clothing item as specified in the individual Purchase Description (PD) and will significantly reduce RDT&E timelines. Additionally these evaluations should support the Key Performance Parameters (KPPs) and Key System Attribute (KSAs) that support the thresholds and objectives outline in the applicable Capability Development Documents (CDD) (e.g., Core Soldier CDD) and the Capability Production Documents (CPDs) (e.g., Army Combat Shirt and FR Fuel Handler's Coverall CPDs).

(2) PM-SCIE intends to encourage a collaborative environment with its other FR testing partners (North Carolina State University) during this project.

(3) PM-SCIE will also consider providing additional funding (PE 643827.S53 and PR 654601.S60, as appropriate) to further support this project.

4. Periodic review.

- a. Current programmatic activities and overall status provided to PM-SCIE at least on a quarterly basis, prior to the Product Manager's scheduled quarterly review.
- b. This TTA will be reviewed annually by PM-SCIE and NSRDEC for potential renegotiation resulting from issues such as changes in funding, deliverables, technology development issues, or Mid-Scale Flame Resistant (FR) Test System program changes.

5. Points of contact.

- a. NSRDEC S&T Project Officer: Ms. Peggy Auerbach, Textile Technologist, Margaret.auerbach@us.army.mil, 508-233-4074.
- b. PEO-Soldier Project Engineer: Ms. Celia Powell, Project Engineer, celia.powell@us.army.mil, 508-233-5802.

Concurrence:

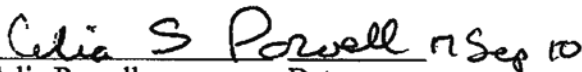

Celia Powell Date 17 Sep 10
Project Engineer, PM-SCIE



Jeffrey Myhre Date 17 Sep 10
Assistant Product Manager
PM-SCIE, PEO-Soldier

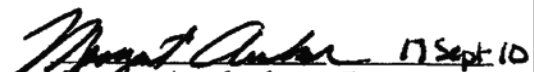

Michael E. Sloane, LTC Date 20 SEP 10
PM-SCIE

Approval:

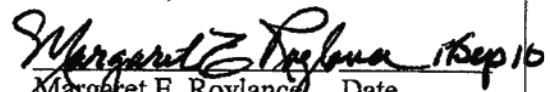
William E. Cole, COL Date 22 SEP 10
PM-SPIE
PEO-Soldier

Margaret Auerbach Date 17 Sept 10
Textile Technologist
WarSTAR, NSRDEC

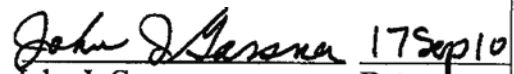
Margaret E. Roynance Date 17 Sep 10
Chief, Materials &
Defense Science Division
WarSTAR, NSRDEC

John J. Gassner Date 17 Sep 10
Director, WarSTAR
NSRDEC

CF:
PEO-Soldier G7 (T.J. Junor)
NSRDEC/PEO-Soldier Liaison (K. Gerstein)
NSRDEC (T. Mattus)
NSRDEC (H. Girolamo)

This page intentionally left blank

Appendix C. Draft Test Method Balloted April 2014

Standard Test Method for Evaluation of Materials and Design Attributes for Protection Against Fire Simulations Using an Instrumented Test Apparatus

This standard is issued under the fixed designation Fxxxx; the number immediately following the designation indicates the year of original adoption or, in the case of revision, the year of last revision. A number in parentheses indicates the year of last reapproval. A superscript epsilon (ϵ) indicates an editorial change since the last revision or reapproval.

1. Scope

1.1 This test method can be used to provide predicted human skin burn injury for single or multiple layers of materials, mounted on a stationary upright instrumented test apparatus which is exposed in a laboratory to a simulated fire environment having a controlled heat flux, flame distribution, and duration. This test can also be used to evaluate different component designs (pockets, zippers etc.), constructions and fabrics to assist in final prototype designs and fabric down selections and/or layering schemes prior to ASTM F1930 testing. The average incident heat flux is 84 kW/m² (2 cal/s•cm²), with durations up to 20 seconds.

1.2 The visual and physical changes to the materials are recorded to aid in understanding the overall performance and how the predicted human skin burn injury results can be interpreted.

1.3 The skin burn injury prediction is based on a limited number of experiments where the forearms of human subjects were exposed to elevated thermal conditions. This forearm information for skin burn injury is applied uniformly to the entire surface to be tested.

1.4 The measurements obtained and observations noted can only apply to the material(s) or design(s) tested using the specified heat flux, flame distribution, and duration.

1.5 This standard is used to measure and describe the response of materials, products, or designs to heat and flame under controlled conditions, but does not by itself incorporate all factors required for fire-hazard or fire risk assessment of the materials, products, or designs under actual fire conditions.

1.6 This method is not a fire-test-response test method.

1.7 The values stated in SI units are to be regarded as standard. The values given in parentheses are mathematical conversions to inch-pound units or other units commonly used for thermal testing. If appropriate, round the non-SI units for convenience.

1.8 *This standard does not purport to address all of the safety concerns, if any, associated with its use. It is the responsibility of the user of this standard to establish appropriate safety and health practices and determine the applicability of regulatory limitations prior to use.*

1.9 Fire testing is inherently hazardous. Adequate safeguards for personnel and property shall be employed in conducting these tests.

2. Referenced Documents

2.1 ASTM Standard ²

D123 Terminology Relating to Textiles

D1835 Specification for Liquefied Petroleum (LP) Gases

E177 Practice for Use of the Terms Precision and Bias in ASTM Test Methods

E511 Test Method for Measuring Heat Flux Using a Copper-Constantan Circular Foil, Heat-Flux Transducer

E691 Practice for Conducting an Interlaboratory Study to Determine the Precision of a Test Method

F1494 Terminology Relating to Protective Clothing

2.2 AATCC Standards: ³

Test Method 135 Dimensional Changes of Fabrics after Home Laundering

Test Method 158 Dimensional Changes on Dry-Cleaning in Perchloroethylene: Machine Method

2.3 Canadian Standards: ⁴

CAN/CGSB-4.2 No. 58-M90 Textile Test Methods Colorfastness and Dimensional Change in Domestic Laundering of Textiles

CAN/CGSB-3.14 M88 Liquefied Petroleum Gas (Propane)

2.4 NFPA Standards: ⁵

NFPA 54 National Fuel Gas Code, 2009 Edition

NFPA 58 Liquefied Petroleum Gas Code 2008 Edition
NFPA 85 Boiler and Combustion Systems Hazards Code, 2007 Edition
NFPA 86 Standard for Ovens and Furnaces, 2007 Edition

3. Terminology

3.1 For definitions of terms used in this test method use the following documents. For terms related to textiles refer to Terminology D123, .

3.2 Definitions:

3.2.1 *burn injury, n*—thermal damage which occurs to human skin at various depths and is a function of local temperature and time.

3.2.1.1 *Discussion*—Burn injury in human tissue occurs when the tissue is heated above a critical temperature (44°C (317.15 K) or 111°F). Thermal burn damage to human tissue depends on the magnitude of the temperature rise above the critical value and the duration that the temperature is above the critical value. Thus damage can occur during both the heating and cooling phases of an exposure. The degree of burn injury (second or third degree) depends on the maximum depth within the skin layers to which tissue damage occurs. The first-degree burn injury is considered minor relative to second-degree and third-degree burn injuries.

3.2.2 *fire exposure, n*—the fire exposure is a propane-air diffusion flame with a controlled heat flux and spatial distribution, engulfing the test apparatus for a controlled duration.

3.2.2.1 *Discussion*—The flames are generated by propane jet diffusion burners. Each burner produces a reddish-orange flame with accompanying black smoke (soot).

3.2.3 *flame distribution, n*—, a spatial distribution of incident flames from burners to provide a controlled heat flux over the surface area of the test apparatus (see 10.4)

3.2.4 *heat flux, n* - the thermal intensity indicated by the amount of energy transmitted divided by time and area; kW/m²(cal/s•cm²)

3.2.4.1 *Discussion*- Two different heat fluxes are referred to in this test method. The incident heat flux refers to the energy striking the nude test apparatus, or the exterior of the test specimen when mounted during flame engulfment. The absorbed heat flux refers to only the portion of the incident heat flux which is absorbed by each thermal energy sensor based on its absorption characteristics. The incident heat flux is used in setting the required exposure conditions while the absorbed heat flux is used in calculating the predicted skin burn injury.

3.2.5 *test apparatus, n*—a structure designed and constructed to represent a flat panel of a given dimension or a tube having the chest dimension of an adult-size human both of which is fitted with thermal energy (heat flux) sensors on its surface.

3.2. 5.1 *Discussion*—The test apparatus is fabricated to specified dimensions from a high temperature resistant material with thermal energy (heat flux) sensors, distributed over the test surface.

3.2. 6 *predicted second-degree burn injury, n*—a calculated second-degree burn injury to skin based on measurements made with a thermal energy sensor.

3.2. 6.1 *Discussion*—For the purposes of this standard, predicted second-degree burn injury is defined by the burn injury model parameters in which the area of coverage by each sensor is equally weighed

3.2. 7 *predicted third-degree burn injury, n*—a calculated third-degree burn injury to skin based on measurements made with a thermal energy sensor.

3.2. 7.1 *Discussion*—For the purposes of this standard, predicted third-degree burn injury is defined by the burn injury model parameters in which the area of coverage by each sensor is equally weighed.

3.2. 8 *predicted total burn injury, n*—the test surface area represented by all thermal energy sensors registering a predicted second-degree or predicted third-degree burn injury, expressed as a percentage, in which the area of coverage by each sensor is equally weighed.

3.2. 9 *second-degree burn injury, n*—complete necrosis (living cell death) of the epidermis skin layer.

3.2. 10 *thermal energy sensor, n*— a device which produces an output suitable for calculating incident and absorbed heat fluxes.

3.2. 10.1 *Discussion*—Types of sensors which have been used successfully include slug calorimeters, surface and buried temperature measurements and circular foil heat flux gauges. Some types of sensors approximate the thermal inertia of human skin and some do not. The known sensors in current use have relatively small detection areas. For the purposes of this test laboratories assign the same coverage area to each sensor over which the same burn injury prediction is assumed to apply.

3.2.11 *thermal protection, n*—the property that characterizes the overall performance of a material(s), design or construction relative to how it retards the transfer of heat that is sufficient to cause a predicted second-degree or predicted third-degree burn injury.

3.2. 11.1 *Discussion*—Thermal protection of a material(s), design, construction and the consequential predicted burn injury(second-degree and third-degree), is quantified from the response of the thermal energy sensors and use of the skin burn injury prediction model. In addition to the calculated results, the physical response and degradation of the material(s), design or construction is an observable phenomenon useful in understanding garment or protective clothing ensemble thermal protection.

3.2. 12 *third-degree burn injury, n*—complete necrosis (living cell death) of the epidermis and dermis skin layers.

4. Summary of Test Method

4.1 This test method covers quantitative measurements and subjective observations that characterize the performance of single or multiple layers of materials, garment constructions, different component designs (pockets, zippers etc.), constructions and fabrics to assist in final prototype designs and fabric down selections and/or layering schemes prior to fullscale ASTM F1930 testing, mounted on an upright instrumented test apparatus . The conditioned test specimen is placed on the instrumented test apparatus at ambient atmospheric conditions and exposed to a propane-air diffusion flame with a controlled heat flux, flame distribution and duration. The average incident heat flux is 84 kW/m² (2 cal/s•cm²) with durations up to 20 seconds.

4.2 The test procedure, data acquisition, calculation of results and preparation of parts of the test report are performed with computer hardware and software programs. The complexity of the test method requires a high degree of technical expertise in the test setup and operation of the instrumented test apparatus and the associated data collection and analysis software.

4.3 Thermal energy transferred through and from the test specimen during and after the exposure is measured by thermal energy sensors located at the surface of the test apparatus. A computer based data acquisition system is used to store the time varying output from the sensors over a preset time interval.

4.4 Computer software uses the stored data to calculate the incident heat flux and the absorbed heat flux and its variation with time for each sensor. The calculated absorbed heat flux and its variation with time is used to calculate the temperature within skin and subcutaneous layers (adipose) is used to predict the onset and severity of human skin burn injury. The computer software calculates the predicted second-degree and predicted third-degree burn injury and the total predicted burn injury resulting from the exposure.

4.5 The overall percentage of predicted second-degree, predicted third-degree and predicted total burn injury is calculated by dividing the total number of sensors indicating each of these conditions by the total number of sensors on the test apparatus.

4.6 The visual and physical changes to the test specimen are recorded to aid in understanding overall performance and how the resulting burn injury results can be interpreted.

4.7 Identification of the test specimen, test conditions, comments and remarks about the test purpose, and response of the test specimen to the exposure are recorded and are included as part of the report.

4.8 The performance of the test specimen is indicated by the calculated burn injury area and subjective observations of material response to the test exposure.

5. Significance and Use

5.1 Use this test method to measure the thermal protection provided by different materials, layering schemes, design and construction features when exposed to a specified fire exposure and/or to determine the maximum protection time afforded by the test specimen. (see 3.2.2, 4.1, and 10.4).

5.1.1 This test method does not simulate high radiant exposures, for example, those found in electric arc flash exposures, some types of fire exposures where liquid or solid fuels are involved, nor exposure to nuclear explosions.

5.2 This test method provides a measurement of material, design and construction responses on an upright test apparatus of specified dimensions. This test method is used to provide predicted skin burn injury for a tested specimen when exposed to a laboratory simulation of a fire. It does not establish a pass/fail for material performance.

5.2.1 This test method is not intended to be a quality assurance test. The results do not constitute a material's performance specification.

5.2.2 The effects of fit, air spacing, and movement are not currently addressed in this test method.

5.3 The measurement of the thermal protection provided by materials is complex and dependent on the apparatus and techniques used. It is not practical in a test method of this scope to establish details sufficient to cover all contingencies. Departures from the instructions in this test method have the potential to lead to significantly different test results. Technical knowledge concerning the theory of heat transfer and testing practices is needed to evaluate if, and which departures from the instructions given in this test method are significant. Standardization of the test

method reduces, but does not eliminate, the need for such technical knowledge. Report any departures along with the results.

6. Apparatus

6.1 *Instrumented test apparatus* —An upright test apparatus such as those specified shall be used (see Fig. 1 and 2).

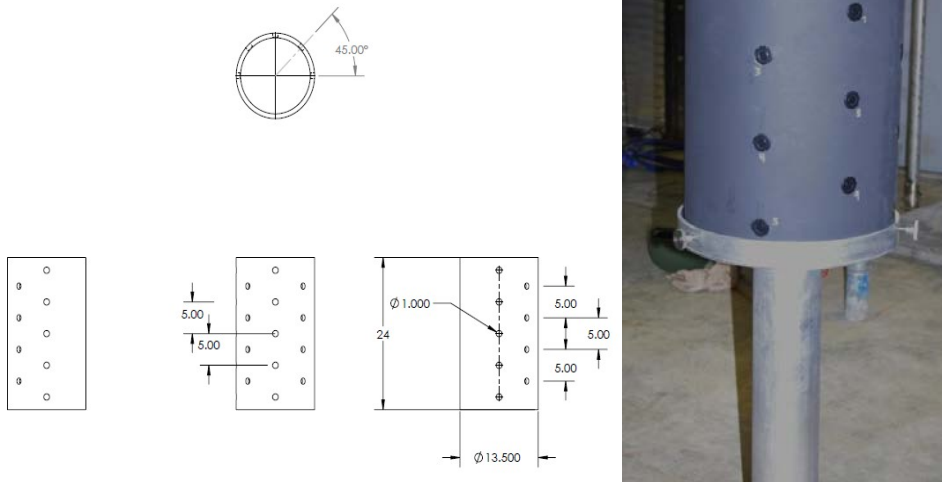

FIG. 1 Cylindrical form – 106.68 cm (42 inch) circumference = 106.68 cm (42 inch) chest on ASTM F1930 manikin –71.12 cm (28 inches) off the floor and 63.5 cm (25 inches) high

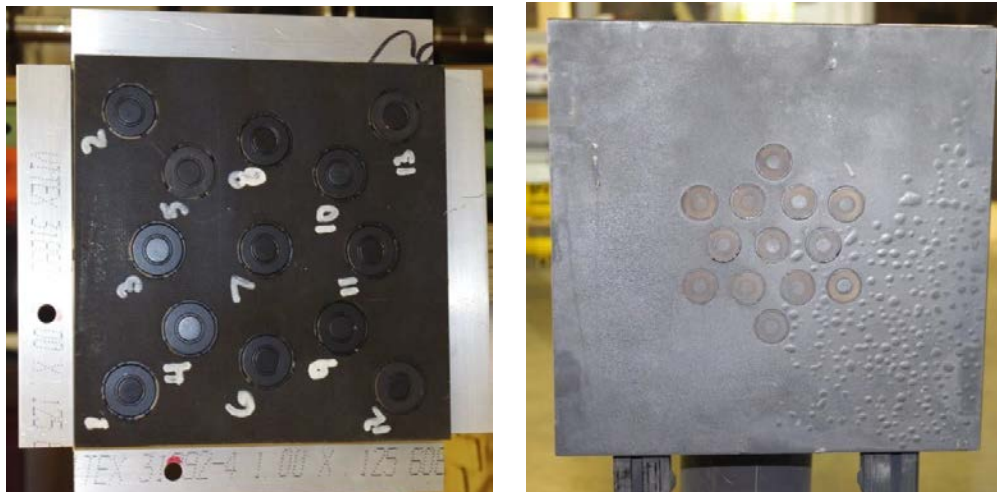

FIG. 2 Flat Plate – 17.78 cm (7 inches) x 17.78 cm (7 inches) and 33.02 cm (13 inches) x 33.02 cm (13 inches) shown –88.9 cm – 101.60 cm (35- 40 inches) off the floor

6.2.2 *Thermal Energy Sensors*—Each sensor shall have the capacity to measure the incident heat flux over a range from 0.0 to 165 kW/m² (0.0 to 4.0 cal/s•cm²). This range allows the sensors to be used in calibrating the test exposure level by directly exposing the instrumented test apparatus to the controlled fire without any test specimen and also have the capacity to measure the heat transfer to the sensor when covered with a test specimen.

6.2.2.1 The sensors shall be constructed of a material with known thermal and physical characteristics that shall be used to indicate the time varying heat flux received by the sensors. The minimum response time for the sensors shall be ≤0.1 s.

(1) *Discussion* - Refer to E 457, E511 and E2683 for technical information on the different types of sensors

6.2.2.2 The sensor surface shall have an absorptivity of a least 0.9. Coating the sensor with a thin layer of flat black high temperature paint with an absorptivity of at least 0.96 has been found effective.

6.3 *Apparatus for Calibration of the Thermal Energy Sensors*

6.3.1 *Energy Sources* – Pure radiant, pure convective or a combination of these two energy sources have been found effective for these calibrations.

6.3.1.1 *Discussion* - Understanding the energy source – thermal energy sensor interaction is critical to obtaining accurate calibrations as temperature changes during calibration will affect the heat transfer to the sensor and its calibration.

6.3.2 *Calibration Heat Flux Sensor* - A traceable heat flux measuring device⁷ used to confirm the output of calibrate the energy source used to calibrate the thermal energy sensors over a range of heat fluxes.

6.3.2.1 *Discussion* - Understanding the energy source – calibration heat flux sensor interaction is critical to obtaining accurate calibrations as different heat flux sensor designs respond differently to different modes of heat transfer that may be produced by different energy sources.

6.3.3 The calibration determined in 10.2 for each thermal energy sensor shall be recorded and the most recent calibration results used to carry out the burn injury analysis.

6.3.3.1 *Discussion*—Refer to E511 for guidance if copper constantan circular foil heat flux transducers are used.

6.4 *Data Acquisition Hardware*—A system shall be provided with the capability of acquiring and storing the results of the measurement from each sensor at least two times per second for the data acquisition period.

6.4.1 *Discussion*—The data acquisition rate of two readings per second from each sensor is the minimum necessary to obtain adequate data. Higher sampling rates are desirable during the flame exposure period. Laboratories sample up to ten samples per second per sensor during this period. The minimum rate of two samples per second per sensor is adequate after the flame exposure. The accuracy of the measurement system shall be less than 2 % of the reading or ±1.0°C (±1.8°F) for temperature measurements.

6.5 *Software programs*

6.5.1 *Logging of Recorded Data* - The software shall log the output from the thermal energy sensors in identifiable files for the preset time at or above the minimum specified data acquisition rate.

6.5.2 *Heat flux calculations* – The software shall convert the recorded thermal sensor outputs into a measured heat flux using a method appropriate for the thermal energy sensor design.

6.5.2.1 *Incident Heat Flux* – The incident heat flux at each sample point for each thermal energy sensor shall be calculated using the calibration characteristics determined in 10.2. These values shall be stored for use in calculating the average incident heat flux and its standard deviation for nude exposures as required in 10.4.

6.5.2.2 *Absorbed Heat Flux* – Using the absorption characteristics of the thermal energy sensors calculate and store the absorbed heat flux for each sensor for each sample point.

6.5.3 *Burn Injury Calculations* - The computer software program used shall have the capability of using the calculated time dependent incident and absorbed heat flux files to calculate the temperatures within the skin and subcutaneous layers (adipose) as a function of depth and time, and calculating the time when a predicted second-degree or third-degree burn injury will occur for each sensor utilizing a skin burn injury model. The total predicted burn injury and the percentage predicted burn injury shall be calculated using only the sensors having a calculated second-degree and third-degree burn injury. The calculation requirements of this program are identified in Section 12.

6.5.3.1 *Discussion*—The computer software program, shall, as a minimum, calculate the predicted skin burn injury at the epidermis/dermis interface and the dermis/subcutaneous (adipose) interface.

6.5.4 *Burn Injury Assessment* – The predicted second-degree burn injury is defined by the burn injury model parameters in which the area of coverage by each sensor is equally weighed.

Sensors which receive sufficient energy to result in a predicted second-degree burn shall be the predicted second-degree burn assessment. Sensors which receive sufficient energy to result in a predicted third-degree burn shall be the predicted third degree burn assessment. Sensors registering a second-degree or third-degree burn injury shall be the total predicted burn injury resulting from the exposure to the fire condition.

6.5.4.1 *Discussion*—The calculated results report the burn injury assessment as a percentage (%) based on the total number of sensors on the entire test apparatus

6.5.5 *Additional Computer Software Requirements*—In addition to monitoring and controlling the operation of the fire, data acquisition systems, and carrying out the incident heat flux, absorbed heat flux and skin burn injury calculations, the computer software shall be used to prepare some of the materials for the report, sensors calibrations etc

6.6 *Exposure Chamber*—A ventilated, fire-resistant enclosure with viewing windows and access door(s) shall be provided to contain the test apparatus.

6.6.1 *Exposure Chamber Size*—The chamber size shall be sufficient to provide a uniform flame engulfment of the test apparatus and shall have sufficient space to allow safe movement around the test apparatus for testing preparation without jarring and displacing the burners. The minimum interior dimensions of the chamber shall be 2.1 by 2.1 by 2.4 m (7.0 by 7.0 by 8.0 ft). There is no maximum chamber size, but all chambers and burner systems shall meet the requirements in 4.1, 10.4, and in repeated exposures.

6.6.1.1 *Discussion*—There is no limitation on maximum size provided the operators are safely isolated from the chamber during and after the exposure when combustion products and toxic gases are likely to be present.

6.6.2 *Burner and Test Apparatus Alignment*—Procedures for checking the alignment of the burners and test apparatus position prior to each test shall be available.

6.6.3 *Chamber Air Flow*—The chamber shall be isolated from air movement other than the natural air flow required for the combustion process so that the pilot flames, if fitted, and the exposure flames are not affected before or during the test exposure. The isolation from air movement shall continue during the data acquisition period after the exposure flames are extinguished. An exhaust system for removal of combustion products after the data acquisition period shall be provided.

6.6.4.1 *Discussion*—The unaided air flow within the chamber shall be sufficient to permit the combustion process needed for the required heat flux during the exposure period and shall be controlled to provide a quiet atmosphere for the data acquisition period. Openings to the exterior of the test chamber shall be provided for the passive supply of adequate amounts of air for safe combustion of the fuel during the exposure. The forced air exhaust system for rapid removal of combustion products after the data acquisition period shall conform to NFPA 86 (1999), Section 5-4.1.2. Due to their nature the products of combustion from diffusion flames contain toxic materials such as unburned fuel, carbon monoxide and soot.

6.6.5 *Chamber Safety Devices*—The exposure chamber shall be equipped with sufficient safety devices, detectors and suppression systems to provide safe operation of the test apparatus. Examples of these safety devices, detectors and suppression systems include propane gas detectors, motion detectors, door closure detectors, hand held fire extinguishers and any other devices necessary to meet the requirements of local codes. A water deluge system and an interlocked—LEL/Exhaust system have been found effective. LEL is the Lower Explosion Limit. For pure propane gas in air the value is 2.1 % by volume (1). s.

6.6.5.1 Additional information on safety devices is available from NFPA 54 and NFPA 85 or equivalent local standards.

6.7 *Fuel and Delivery System*—The chamber shall be equipped with fuel supply, delivery, and burner systems to provide reproducible fire exposures.

6.7.1 *Fuel*—The propane fuel used in the system shall be from a Liquefied Petroleum (LP) Gas supply with sufficient purity and constancy to provide a uniform exposure.

6.7.1.1 *Discussion*—Fuels meeting the HD-5 specifications (See Specification D1835, CAN/CGSB 3.14 M88, or equivalent) have been found satisfactory. Liquefied Petroleum (LP) Gas is commonly referred to as propane fuel or propane gas. Propane gas are the words used in this standard to identify the LP Gas.

6.7.2 *Delivery System*—A system of piping, pressure regulators, valves, and pressure sensors including a double block and bleed burner management scheme (see NFPA 58) or similar system consistent with local codes shall be provided to safely deliver gaseous propane to the ignition system and exposure torches. This delivery system shall be sufficient to provide an average heat flux of at least 84 kW/m² (2.0 cal/s•cm²) for an exposure time of at least 5 s. Fuel delivery shall be controlled to provide known exposure duration within ±0.1 s of the set exposure time.

6.7.3 *Burner System*—The burner system shall consist of one ignition system for each exposure burner, and sufficient burners to provide the required range of heat fluxes with a flame distribution uniformity to meet the requirements in 10.4, 10.4.1, and 10.4.3.

6.7.3.1 *Exposure Burners*—

Cylindrical Form - Large, induced combustion air, industrial style propane burners are positioned 180° around the cylindrical test form to produce a uniform laboratory simulation of a fire. These burners produce a large fuel rich reddish yellow flame. If necessary, enlarge the burner gas jet, or remove it, to yield a fuel to air mixture for a long

luminous reddish-yellow flame that engulfs the test apparatus. . A minimum of eight burners, to yield the exposure level and uniformity as described in 10.4, 10.4.1, and 10.4.3 shall be used when using the instrumented cylindrical form to simulate the exposure of the ASTM F1930 test. A satisfactory exposure has been achieved with eight burners, positioned 180 ° degrees -four stands, two burners per stand - one burner approximately 60.96 – 71.12 cm (24-28 inches) above the ground, and one positioned approximately 96.52 – 101.60 cm (38 -40 inches) above the ground approximately 63.5 - 76.2 cm (25 – 30 inches) from the test form.

Flat Plate - Large, induced combustion air, industrial style propane burners are positioned directly in front of the flat plate test apparatus (0°) to produce a uniform laboratory simulation of a fire. These burners produce a large fuel rich reddish-yellow flame. If necessary, enlarge the burner gas jet, or remove it, to yield a fuel to air mixture for a long luminous reddish-yellow flame that engulfs the test apparatus. When a flat plate is used, four burners shall be used. One stand with two burners approximately, 25.40cm (10 inches)from each other, 182.88 cm (72 inches) from the plate, 71.12 cm (28 inches) from the floor, have been found to be satisfactory.

Variations in exposure chamber size and air flow detail might require use of additional burners to achieve the desired flame distribution

6.7.3.2 *Ignition System*—Each exposure burner shall be equipped with an ignition system positioned near the exit of the burner, but not in the direct path of the flames so as to interfere with the exposure flame pattern. The ignition system shall be interlocked to the burner gas supply valves to prevent premature or erroneous opening of these valves. Any electrical magnetic-field generated by the ignition system shall be small enough so as not to interfere with the quality of the data acquisition and recording process. Standing pilot flames have been found to perform satisfactorily.

6.8 *Image Recording System*—A video system for recording a visual image of the test before, during, and after the flame exposure shall be provided.

6.9 *Safety Check List*—A standard operating procedure shall be established to ensure that all safety features have been satisfied before the flame exposure can occur. The procedural safety checks shall be documented.

6.10 *Test Specimen Conditioning Area*—The area shall be maintained at $21 \pm 2^{\circ}\text{C}$ ($70 \pm 5^{\circ}\text{F}$) and $65 \pm 5\%$ relative humidity. It shall be large enough to have good air circulation around the test specimens during conditioning.

6.10.1 *Discussion*—The permitted variation in the conditioning temperature and relative humidity is larger than other ASTM textile testing standards. This larger range was set to reflect present practice used in the ASTM F1930 test. Some laboratories who conduct this testing do not have conditioning rooms which can meet the more stringent requirements.

7. Hazards

7.1 Procedural operating instructions shall be provided by the testing laboratory and strictly followed to ensure safe testing. These instructions shall include, but are not limited to; exhaust of the chamber prior to any test series, isolation of the chamber during the test to contain the combustion process and the resulting combustion products, and ventilation of the chamber after the test exposure.

7.2 The exposure chamber shall be equipped with an approved fire suppression system.

7.3 Care shall be taken to prevent personnel contact with combustion products, smoke, and fumes resulting from the flame exposure. Exposure to gaseous products shall be prevented by adequate ventilation of the chamber.

Appropriate personnel protective equipment shall be worn when working in the exposure chamber, handling the exposed garments and cleaning the manikin after the test exposure.

8 Types of Tests, Test Specimens and Sampling

8.1 Types of Tests

8.1.1 *Cylindrical Form and Flat Plate* - This test method is useful for three types of evaluations /comparisons of 1) single or multiple layering schemes of materials, 2) designs such as pocket and zipper designs, and 3) construction techniques. In addition to these uses it can be used to determine the maximum time (in seconds) the test specimen provides protection or the point at which the test specimen protection is compromised. However, it is not limited to these evaluations.

8.2 *Test Specimen*—A specimen is any given material or material combination, with the same or different design features and/or construction techniques.

8.2.1 Test a minimum of three specimens. A greater number of specimens can be used to improve precision of test results.

8.2.1.1 *Discussion* - When different design, construction and/or construction techniques are being compared a minimum of three identical replicates of each should be tested.

8.2.2 The mass per unit area (weight) of the test specimen shall be determined in accordance with D3776. The swatch shall be cut from the same lot of material as the test specimen (when possible).

8.2.3 The test specimen size will depend of the test apparatus used.

9. Preparation of Test Specimen and Cutting Samples for Area Density Measurements

9.1 Laundering- Samples may be tested unlaundered, laundered or dry cleaned.

9.1.1 For materials designated to be washed, launder each test specimen one wash and dry cycle prior to conditioning using the AATCC or CAN/CGSB procedure identified in 9.1.4.

9.1.2 For materials designated to be dry-cleaned, launder each test specimen one dry clean cycle prior to conditioning using the AATCC procedure identified in 9.1.5.

9.1.3 For materials designated as either washed or dry-cleaned, test specimens shall be tested after one cycle of washing and drying as specified in 9.1.4, or after one cycle of dry-cleaning as specified in 9.1.5.

9.1.4 Use laundry conditions of AATCC Test Method 135, (I, V, A, iii) or CAN/CGSB-4.2 No. 58-M90.

9.1.5 Use dry cleaning procedures of Sections 9.2 and 9.3 of AATCC Test Method 158.

9.2 Conditioning—Condition each test specimen for at least 24 h in an environment controlled to $21 \pm 1^\circ\text{C}$ ($70 \pm 5^\circ\text{F}$) and $65 \pm 5\%$ relative humidity. Each test specimen shall be tested within 30 min of removal from the conditioning area. If the specimen cannot be tested within 30 min, seal it in a manner that restricts moisture loss or gain until immediately prior to testing. Test specimens within 20 min after removal from the bag. Specimens shall not remain isolated for longer than 4 h prior to testing.

9.3 Additional material shall be supplied when possible to determine the area density of the tested specimen (see 8.3.2). When extra material is not available swatches shall be taken from an untested area of each test specimen.

10. Calibration and Preparation of Apparatus

10.1 *Calibration Principles* - The thermal energy sensors and the burn injury calculation routine are calibrated using energy sources of known characteristics. Pure radiant and combined convection and radiation sources have been found effective. A traceable calibration heat flux sensor shall be used when setting the energy levels for these calibrations. Sensor calibrations shall be completed before the required flame exposure conditions for specimen testing are set.

10.1.1 Thermal energy sensors are used to measure the fire exposure intensity and the thermal energy transferred to, and absorbed by, the test apparatus during a nude exposure and during specimen testing. Calibrate each sensor against a suitable NIST (or other recognized standards body) traceable reference (6.3.2). Calibrate to the exposure and heat transfer conditions experienced during nude test setup and during specimen testing, typically over a range of 5 kW/m² to 100 kW/m² (0.125 cal/s•cm² to 2.5 cal/s•cm²).

10.2 *Calibration of Thermal Energy Sensor* - Using the calibration energy source generate a calibration curve for each thermal energy sensor by exposing the sensor to at least four different heat fluxes over the range of 5 kW/m² to 100 kW/m² (0.125 cal/s•cm² to 2.5 cal/s•cm²). Measure the heat fluxes produced by the calibration energy source with the calibration heat flux sensor (6.3.2).

10.2.1 Check the response of the thermal energy sensor to the different exposure energies. The ideal response is linear. If the response is linear but not within 5% of the known calibration exposure heat flux, include a correction factor in the heat flux calculations. If the response is not linear and not within 5% of the known calibration exposure heat flux, determine a correction factor curve for each sensor for use in the heat flux calculations.

10.2.2 Calibrate each sensor prior to start up of a new manikin, whenever a sensor is repaired or replaced, and whenever the results appear to have shifted or to differ from the expected values.

10.3 *Confirmation of Burn Injury Prediction*- In addition to individual sensor calibration, check the thermal energy sensor - data acquisition - burn injury prediction model as a unit. Expose a randomly selected sensor to a known constant heat flux with a duration which will result in a second – degree burn injury being calculated by the burn injury computer program. Table 4 lists a range of absorbed heat fluxes and durations to be used and the required agreement. Use any exposure conditions that will result in absorbed energies within the range listed, accounting for sensor surface heat absorption characteristics (e.g. absorptivity). Precise matching to a heat flux is not required. If interpolation is required, account for the highly non linear behavior of the relationship, or calculate the exposure duration using the burn injury prediction computer code. If the calibration falls outside the recommended values in Table 1, identify the reason and correct.

10.3.1 *Discussion* -The parameters in Table 1 cover the range of absorbed heat fluxes used by Stoll and Greene (2) in their experiments. The values listed do not match the average values arrived at by Stoll and Greene (see Table 7 for Stoll and Greene values). Stoll and Greene used constant intensity fixed duration exposures that resulted in the injury occurring some time after the exposure is terminated as the skin layers cool. It is the total time that the

growing cells are above 44 °C that is important in producing cell damage and blistering of the skin (second degree burn injury). Here the heating is continuous to the end point. With continuous heating the onset of a second degree burn injury will occur at a time later than the exposure time used by Stoll and Greene because no cool down period is included and the final omega value will be greater than 1.0.

Table 1 Sensor – Burn Injury Prediction – In situ Calibration Parameters

Absorbed Heat Flux - W/m ²	Absorbed Heat Flux - cal/s•cm ²	Recommended Minimum Continuous Heating Time – Sec.	Range of Values of Required Times for Omega Equal to 1.0
4 000	0.096	40	33.0 – 34.1
6 000	1.433	25	19.4 – 20.0
8 000	1.912	20	13.2 – 13.7
10 000	2.389	15	9.7 – 10.0
12 000	2.867	10	7.5 – 7.8
14 000	3.344	10	6.0 – 6.2
16 000	3.822	10	4.9 – 5.1

10.4 *Setting the Incident Heat Flux* — Using the procedure described in Section 11, expose the nude test apparatus to the test fire for four seconds or for the test duration if less than four seconds. Confirm that the average calculated incident heat flux is 84 kW/m² ± 5% and its standard deviation is not greater than 21 kW/m² (0.5 cal/s•cm²) using the procedure in 10.4.2. If the calculated average heat flux or standard deviation is not within these specifications, determine the cause and correct before proceeding with specimen testing. The calculated average is the average exposure heat flux level for the test conditions, and the standard deviation is a measure of the exposure uniformity.

10.4.1 *Discussion*-Exposing a nude test apparatus for more than four seconds will result in surface temperatures high enough to cause deterioration of the shell of the test apparatus and some sensor designs.

10.4.2 The average value of all sensors shall be determined taking into account the sensor calibrations and characteristics. The average heat flux value reported is the average of the averages for each of the sensors for the steady region of the exposure duration (see Figure 3). The incident heat flux values calculated for each sensor at each time step shall be placed in a file for future use in estimating the temperature history within the skin and subcutaneous layers (adipose) for the burn injury calculation.

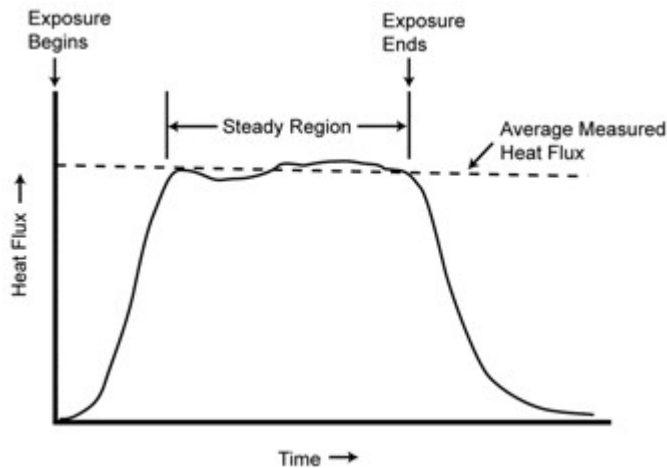

FIG. 3 Average Heat Flux Determination for a Nude Exposure

(Exposure begins – Burner gas valve opens)

(Exposure ends – Burner gas valve closes)

10.4.3 *Confirmation of Heat Flux Distribution*—The burners shall be positioned so that the average incident heat flux calculated for the all sensors is within ± 15% of the average incident heat flux required in 4.1 or 10.4.

10.4.4 Expose the nude test apparatus to the flames before testing a set of specimens and repeat the nude exposure at the conclusion of the testing of the set. If the average exposure heat flux for the test conditions differs by more than 5

% between the before and after measurements, report this and give consideration to repeating the sequence of specimen tests. As a minimum, check the nude test apparatus exposure level at the beginning and at the end of the work day as required in 13.4.1. A control charting method shall be used.

10.4.5 *Confirmation of Steady Fuel Flow* – Providing a steady fuel delivery rate during the testing is essential for maintaining the required heat flux, The fuel flow rate can be monitored directly by using an appropriate flow meter such as a turbine meter or indirectly by monitoring fuel pressure. With any fire exposure longer than four seconds ensure that the fuel flow rate does not fall by more than 10 % during the exposure.

10.4.6 *Measurement of the Exposure Duration* - The duration of the fire exposure shall be controlled by the internal clock of the computer control system. The measured duration of the exposure (Figure 3) shall be the specified value ± 0.1 seconds or ± 5 %, whichever is smaller.

10.4.7 The average heat flux calculated in 10.4.2 shall be the specified test condition ± 5 %. If not, adjust the fuel flow rate by modifying the gas pressure or flow at the burner heads. Repeat the calibration run(s) until the specified value is obtained. Repeat nude calibrations shall only be conducted when the average temperature of all sensors is less than 34°C (93°F) and no single sensor temperature exceeds 38°C (100°F) in order to eliminate the effect of any elevated internal temperature or temperature gradients on the calculation of the heat flux.

10.4.7.1 *Discussion*—Depending on the sensor design it is possible that internal temperature gradients are present when this criterion is met. Individual laboratories shall have a thorough understanding of their sensors characteristics and how elevated internal temperatures affect results.

10.5 *Defective Sensor Replacement*—Damaged or inoperative sensors shall be repaired or replaced when they no longer function properly and the non-functional thermal energy sensors are located under the test specimen. Repaired or replaced sensors shall be calibrated.

10.6 *Laboratory Precision Analysis*—It is recommended that each laboratory determine the precision and bias of its equipment and test procedure. One laboratory found testing 30 identical garments under the same test exposure conditions to be effective. Report the laboratory precision with test results.

11. Procedure

11.1 *Test set up* —Place the test specimen on the test form. Arrange the test specimen on the test apparatus in the same way it would be expected to be used by the end-user/wearer or as specified by the test author. Note in the test report how the test specimen was tested. Use the same test procedure for each test to minimize variability in the test results.

11.2 *Preparation of Apparatus*—Exposing the instrumented test apparatus to the short duration fire in a safe manner and evaluating the test specimen requires a startup and exposure sequence that is specific to the test apparatus. Some of the steps listed require manual execution; others are initiated by the computer program, depending upon the individual apparatus. Perform the steps as specified in the apparatus operating procedure. Some of the steps that shall be included are:

11.2.1 *Burn Chamber Purging*—Ventilate the chamber for a period of time sufficient to remove a volume of air at least ten times the volume of the chamber. The degree of ventilating the chamber shall at a minimum comply with NFPA 86. This purge is intended to remove any fuel that would form an explosive atmosphere if any had leaked from the supply lines.

11.2.2 *Gas Line Charging*—The following procedure or a comparable procedure shall be used for gas line charging. Close the supply line vent valves and open the valves to the fuel supply to charge the system with propane gas pressure up to, but not into, the chamber. If pilot flames are used as the ignition source, charge and initiate them first before charging the header in the exposure chamber for the main burners. High and low pressure sensors shall be used on the main at the operating burner header as safety interlock devices to address equipment failures during the charging process. Set the high and low pressure detectors as close to the operating pressure as feasible to provide system shut down with a gas supply failure. In a double block and bleed burner management system (chamber piping arrangement), a mass flow sensor shall be used to detect failure of the main burner bleed valve(s) prior to main burner ignition.

11.3 *Record the Test Attributes*—Record the information that relates to the test, including: purpose of test, test series, test specimen identification, layering, material style number or pattern description, test conditions, test remarks, exposure duration, data acquisition time, persons observing the test, and any other information relevant to the test series. As a minimum, provide the information listed in Section 13.

11.4 *Burner Alignment*—Verify that burner alignment is correct as established in 10.2.2.2.

11.5 *Test Apparatus Alignment*—Verify that the manikin is spatially positioned and aligned in the exposure chamber via a centering or alignment device as established in 6.6.2.

11.6 *Set Test Parameters*—Enter into the burner management control system the specified exposure time and data

acquisition time.

11.6.1 The data acquisition time shall be long enough to ensure that the thermal energy stored in the test specimen is no longer contributing to burn injury. Confirm that the acquisition time is sufficient by inspecting the calculated burn injury versus time information to determine that the total burn injury of all of the sensors has leveled off and is not continuing to rise at the end of the data acquisition time. The data acquisition time shall be long enough to ensure that all of the thermal energy stored in the test specimen is no longer contributing to burn injury. Confirm that the acquisition time is sufficient by inspecting the calculated burn injury versus time information to determine that the total burn injury of all of the sensors has leveled off and is not continuing to rise at the end of the data acquisition time. If the amount of burn injury is not constant for the last ten seconds of acquisition time, increase the acquisition time to achieve this requirement.

11.6.1.1 *For the cylindrical form*, the minimum data acquisition time shall be 60 seconds for all exposures with test specimens. Shorter data acquisition times with nude burn calibrations are possible subject to the characteristics of a particular laboratory/test apparatus - sensor combination. The data acquisition time shall be long enough to ensure that the thermal energy stored in the test specimen is no longer contributing to burn injury. Confirm that the acquisition time is sufficient by inspecting the calculated burn injury versus time information to determine that the total burn injury of all of the sensors has leveled off and is not continuing to rise at the end of the data acquisition time. If the amount of burn injury is not constant for the last ten seconds of acquisition time, increase the acquisition time to achieve this requirement.

11.6.1.2 *For the flat plate*, data acquisition times of less than 60 seconds may be desired in order to evaluate specific material properties.

11.7 *Confirm Safe Operation Conditions*—Follow the standard operation procedures established by the individual test facility to ensure all safety requirements have been met and that it is safe to proceed with the test.

11.8 *Ignition System Check*—When all of the safety requirements are met, check the operation of the ignition system.

11.8.1 If pilot lights are used, light the pilot flames and confirm that all of the pilot flames on the burners that will be used in the test exposure are actually lit. (**Warning**—Visually confirm the presence of each pilot flame. The test exposure shall be initiated only when all of the safety requirements are met, the pilot flames are ignited and visually confirmed, and the final valve in the gas supply line is opened.)

11.8.2 If a spark ignition is used, activate the system and visually confirm that a spark is present at each igniter.

11.9 *Chamber Temperature*—Record the chamber temperature.

11.10 *Start Image Recording System*—Start the video recording system used to visually document each test in real time.

11.11 *Expose the Test Specimen*—Initiate the test exposure by pressing the appropriate computer key. The computer program will start the data acquisition, open the burner gas supply solenoid valves for the time of the exposure, and stop the data acquisition at the end of the specified time.

11.12 *Acquire the Heat Transfer Data*—Collect the data from all installed thermal energy sensors. Note that data collection during and after the fire exposure shall be done in a still air environment.

11.13 *Record Test Specimen Response Remarks*—Record observations of test specimen to the exposure. These remarks include but are not limited to the following: occurrence of after-flame (time, intensity and location), ignition, melting, smoke generation, unexpected material or specimen failures (for example, formation of holes), material shrinkage, and charring or observed degradation. These remarks become a permanent part of the test record.

11.14 *Initiate Test Report Preparation*—Initiate the computer program to perform the calculations to determine the predicted burn injury of each thermal energy sensor, the total predicted burn injury, the percentage that is predicted second-degree and predicted third-degree injury, and to prepare the test report. Perform these operations immediately or, if warranted, delay them for later processing.

11.15 *Initiate Forced Air Exhaust System*—Start the forced air exhaust system to remove the combustion products resulting from the fire exposure. Run the system long enough to ensure a safe working environment in the exposure chamber prior to entering.

11.15.1 *Discussion*—The operating time for the exhaust system to produce a safe working environment is laboratory and test specimen specific. Refer to NFPA 85 and NFPA 86 for guidance.

11.16 *Prepare for the Next Test Exposure*—Carefully remove the exposed specimen from the test apparatus. Wipe the test form and sensor surfaces with a damp cloth to remove residue from the test specimen exposure, if necessary. The test form and sensors shall be inspected to ensure that they are free of any decomposition materials, and if a deposit is present, carefully clean the test form and sensors with soap and water or a petroleum solvent. Use the gentlest method that is effective in cleaning the sensor. If required, repaint the surface of the sensor and dry the paint. Ensure that the test apparatus and sensors are dry, and if necessary, dry them, for example with ventilating

fan(s), before conducting the next test. Visually inspect the sensors for damage, for example, cracks or discontinuities in the sensor surface.

11.17 *Sensor Replacement*—Repair or replace damaged or inoperative sensors. Calibrate repaired or replaced sensors before using (see 10.2, 10.2.1, and 10.2.2).

11.18 *Sensor Temperatures*—Before starting the next exposure ensure that the average temperature of all the sensors located under the test specimen is $32 \pm 2^\circ\text{C}$ ($90 \pm 4^\circ\text{F}$) and no single sensor exceeds 38°C (100°F). (see 10.4.7, 10.4.7.1)

11.19 *Test Remaining Specimens*—Test the remaining specimens at the same exposure conditions.

12. Skin Burn Injury Prediction

12.1 Determination of test apparatus sensor heat flux values.

12.1.1 Convert the recorded thermal energy sensor responses at each time step into their respective time-dependent absorbed heat flux values in kW/m^2 ($\text{cal/s}\cdot\text{cm}^2$) using the method appropriate for the sensor.

12.1.1.1 Discussion—Different laboratories use different sensor technologies. Each requires a different method to convert the measured responses into respective absorbed heat flux values.

12.2 Determination of the predicted skin and subcutaneous fat (adipose) internal temperature field.

12.2.1 Assume the thermal exposure is represented as a transient one dimensional heat diffusion problem in which the temperature within the skin and subcutaneous layers (adipose) varies with both position (depth) and time, and is described by the linear parabolic differential equation (Fourier's Field Equation):

$$\rho Cp(x) \partial [T(x,t)] / \partial t = \partial [k(x) \partial [T(x,t)] / \partial x] / \partial x \quad (1)$$

where:

$\rho Cp(x)$ = Volumetric heat capacity, $\text{J/m}^3\cdot\text{K}$ ($\text{cal/cm}^3\cdot\text{K}$)

T = Time, s

X = Depth from skin surface, m [cm]

$T(x,t)$ = Temperature at depth x , time t , K

$k(x)$ = Thermal Conductivity, $\text{W/m}\cdot\text{K}$ ($\text{cal/s}\cdot\text{cm}\cdot\text{K}$)

12.2.1.1 Discussion—Use of absolute temperatures is recommended when solving Eq 1 because Eq 2, which is used for the calculation of Ω , the burn injury parameter, requires absolute temperatures.

12.2.2 Solve Eq 1 numerically using a three-layer skin model that takes into account the depth dependency of the thermal conductivity and volumetric heat capacity values as identified in Table 2. Each of the three layers shall be constant thickness, lying parallel to the surface.

TABLE 2 Physical Properties for Skin Burn Injury Model

Parameter	Epidermis	Dermis	Subcutaneous Tissue
Thickness of layer (m) (μm)	75×10^{-6} (75)	1125×10^{-6} (1125)	3885×10^{-6} (3885)
Thermal conductivity k ($\text{W}/\text{m}\cdot\text{K}$) ($\text{cal}/\text{s}\cdot\text{cm}\cdot\text{K}$)	0.6280 (0.0015)	0.5902 (0.00141)	0.2930 (0.0007)
Volumetric heat capacity ρCP ($\text{J}/\text{m}^3\cdot\text{K}$) ($\text{cal}/\text{cm}^3\cdot\text{K}$)	4.40×10^6 (1.05)	4.186×10^6 (1.00)	2.60×10^6 (0.62)

12.2.2.1 Discussion—The property values stated in Table 2 are representative of *in vivo* (living) values for the forearms of the test subjects who participated in the experiments by Stoll and Greene (2). They are average values. The thermal conductivity of each of the layers is known to vary with temperature due to the generalized thermo-physical characteristics of the layer components (simplified composition: water, protein and fat). Laboratories accounting for this report an improved correlation to the reference dataset presented in 12.4. This is done by modeling the temperature dependence of the thermal conductivity of each layer after that of water. See X1.13.

12.2.2.2 The discretization methods to solve Eq 1 that have been found effective are: the finite differences method (following the —combined method| central differences representation where truncation errors are expected to be second order in both Δt and Δx), finite elements method (for example the Galerkin method), and the finite volume method (sometimes called the control volume method).

(1) Discussion—Equally spaced depth intervals (Δx), denoted as —nodes| or —meshes|, are recommended for highest accuracy in all numerical models. A value for Δx of 15×10^{-6} m has been found effective. Sparse or unstructured meshes are not recommended for use in the finite difference method.

12.2.3 Use the following initial and boundary conditions:

12.2.3.1 The initial temperature within the three layers shall have a linear increase with depth from 305.65 K (32.5°C) at the

surface to 306.65 K (33.5°C) at the back of the subcutaneous layer (adipose). The deep temperature shall be constant for all time at 306.65 K (33.5°C).

(1) Discussion—Pennes (3) measured the temperature distributions in the forearms of volunteers. For the overall thickness of the skin and subcutaneous layers (adipose) listed in Table 2, the measured rise was 1 K (1°C). The skin surface temperature of the volunteers in the experiments by Stoll and Greene (2) was kept very near to 305.65 K (32.5°C).

12.2.3.2 The absorbed heat flux is applied only at the skin surface and it is assumed that heat conduction is the only mode of heat transfer in the skin and subcutaneous layers (adipose). This calculation excludes any thermal radiation components that could penetrate the skin.

(1) Discussion—Assuming heat conduction only within the skin and deeper layers ignores enhanced heat transfer due to changing blood flow in the dermis and subcutaneous layers (adipose). The *in vivo* (living) values listed in Table 2 are back calculated from the experimental results of Stoll and Greene (2) and numerical extensions by Weaver and Stoll (4). The values account to a large degree for the blood flow in the test subjects.

12.2.3.3 The absorbed heat flux at the skin surface at time $t = 0$ (start of the exposure) is zero (0).

12.2.3.4 The absorbed heat flux values at the skin surface at all times $t > 0$ are the time dependent absorbed heat flux values determined in 12.1.1. No corrections are made for radiant heat losses or emissivity/absorptivity differences between the sensors and the skin surface used in the model.

12.2.4 Calculate an associated internal temperature field for the skin model at each sensor sampling time interval for the entire sampling time by applying each of the sensor's time-dependent heat flux values to individual skin modeled surfaces (a skin model is evaluated for each measurement sensor). These internal temperature fields shall include, as a minimum, the calculation of temperature values at the surface (depth = 0.0 m), at a depth of 75×10^{-6} m (the skin model epidermis/dermis interface used to predict second-degree burn injury), and at a depth of 1200×10^{-6} m (the skin model dermis/subcutaneous interface used to predict a third-degree burn injury).

12.2.4.1 Discussion—Equally spaced depth intervals (Δx), denoted as —nodes| or —meshes|, are recommended for highest accuracy in all numerical models. A value for Δx of 15×10^{-6} m has been found effective. Sparse or unstructured meshes are not recommended for use in the finite difference method.

12.3 Determination of the Predicted Skin Burn Injury:

12.3.1 The Damage Integral Model of Henriques (5), Eq 2, is used to predict skin burn injury parameter based on skin temperature values at each measurement time interval at skin model depths of 75×10^{-6} m (second-degree burn injury prediction) and 1200×10^{-6} m (third-degree burn injury prediction).

$$\Omega = \int P e^{-(\Delta E/RT)} dt \quad (2)$$

where:

Ω = Burn Injury Parameter; Value, ≥ 1 indicates predicted burn injury

T = time of exposure and data collection period, s

P = Pre-exponential term, dependent on depth and temperature, 1/s

ΔE = Activation energy, dependent on depth and temperature, J/kmol

R = Universal gas constant, 8314.5 J/mol • K

T = Temperature at specified depth (in kelvin) K

12.3.2 Determine the second-degree and third-degree burn injury parameter values, Ω 's, by numerically integrating Eq 2 using the closed composite, extended trapezoidal rule or Simpson's rule, for the total time that data was gathered.

12.3.3 The integration is performed at each measured time interval for each of the sensors at the second-degree and third-degree skin depths (75×10^{-6} m and 1200×10^{-6} m respectively) when the temperature, T , is ≥ 317.15 K (44°C).

12.3.4 A second-degree burn injury occurs when the value of $\Omega \geq 1.0$ for depths $\geq 75 \times 10^{-6}$ m and $< 1200 \times 10^{-6}$ m.

12.3.5 A third-degree burn injury occurs when the value of $\Omega \geq 1.0$ for depths $\geq 1200 \times 10^{-6}$ m

12.3.6 For the second-degree and third-degree burn injury predictions, the temperature dependent values for P and $\Delta E/R$ are listed in Table 3.

TABLE 3 Constants for Calculation of Omega Using Eq 2

Skin Injury	Temperature Range	P	$\Delta E/R$
Second-degree (4)	317.15 K $\leq T \leq$ 323.15 K (44°C $\leq T$	$2.185 \times 10^{124} \text{ s}^{-1}$	93 534.9 K
Third-degree (9)	$\leq 50^\circ\text{C}$) $T > 323.15$ K ($T > 50^\circ\text{C}$)	$1.823 \times 10^{51} \text{ s}^{-1}$	39 109.8 K
	317.15 K $\leq T \leq$ 323.15 K (44°C $\leq T \leq 50^\circ\text{C}$)	$4.322 \times 10^{64} \text{ s}^{-1}$	50 000 K
	$T > 323.15$ K ($T > 50^\circ\text{C}$)	$9.389 \times 10^{104} \text{ s}^{-1}$	80 000 K

12.4 Skin burn injury test cases

12.4.1 The calculation method used in 12.2 and 12.3 shall meet the validation requirements identified in Table 4

TABLE 4 Skin Model Validation Data Set^A

Absorbed Exposure Heat Flux (constant for the exposure)		Exposure Duration	Required Size of Time Step
W/m ²	(cal/s•cm ²)	S	S
3935	(0.094)	35.9	0.01
5903	(0.141)	21.09	0.01
11 805	(0.282)	8.30	0.01
15 740	(0.376)	5.55	0.01
23 609	(0.564)	3.00	0.01
31 479	(0.752)	1.95	0.01
39 348	(0.940)	1.41	0.01
47 218	(1.128)	1.08	0.01
55 088	(1.316)	0.862	0.001
62 957	(1.504)	0.713	0.001
70 827	(1.692)	0.603	0.001
78 697	(1.880)	0.522	0.001

12.4.2 When validating the skin burn injury model, use the layer thickness, thermal conductivity and volumetric heat

capacity values specified in Table 2 and the boundary and initial conditions of 12.2.3 with the exception that the exposure heat fluxes in 12.2.3.4 become the constant valued ones listed in Table 4. The total calculation time shall be chosen so that the temperatures at the epidermis/dermis and dermis/subcutaneous interfaces both fall below 317.15 K (44°C) during the cooling phase. For these test cases the skin surface shall be assumed to be adiabatic during the cooling phase, that is, no heat losses from the surface during cooling. Minor changes in the values of thermal conductivity and volumetric heat capacity listed in Table 2 are permitted providing the validation requirements specified in Table 4 are met with one set of values for all twelve test cases.

12.4.2.1 *Discussion*—The adiabatic boundary condition during cooling is selected because of the lack of detail in the published documents on the orientation of the forearms and the proximity of surrounding equipment used to conduct the experiments. Furthermore, the data gathered from the thermal energy sensors when conducting this test method takes into account convection and radiation heat losses inherently through the calculation of the net energy absorbed by the thermal energy sensors. Therefore this adiabatic assumption only applies to the model validation data set and not the entire test method.

13. Report

13.1 State that the specimens were tested as directed in Test Method--- noting any deviations. Describe the material sampled, the method of sampling used, and any deviations from the method.

13.1.1 *Describe the test specimen.* In the material description include fabric weight, fiber type, color, and non-standard or special garment features and design characteristics. (see Section 8.3, 8.3.1, 8.3.1.1, 8.3.2)

13.2 *Report the information in 13.3–13.6.*

13.3 *Type of Test* (see Section 8)

13.3.1 *Cylindrical Form* - Single or multiple layering schemes of materials, component designs such as pocket and zipper designs, and/or construction techniques.

13.3.2 *Flat Plate* – In addition to the uses listed in 13.3.1, the flat plate test can be used to determine the maximum time (in seconds) the test specimen provides protection or the point at which the test specimen protection is compromised.

13.4 *Exposure Conditions*—The information that describes the exposure conditions, including:

13.4.1 The average of the exposure heat flux and the standard deviation of the average heat flux from all sensors determined from the nude exposures taken before and after each test series.

13.4.2 The nominal heat flux, the duration of the exposure, and the duration of the data acquisition time for each test.

13.4.4 The temperature and relative humidity in the room where the test specimens were held prior to testing.

13.4.5 Any other information relating to the exposure conditions shall be included to assist in interpretation of the test specimen results.

13.5 *Calculated Results*—

13.5.1 Report predicted burn injury, expressed as a percentage,

13.5.1.1 Predicted second-degree burn injury (%).

13.5.1.2 Predicted third-degree burn injury (%).

13.5.1.3 Total predicted burn injury (sum of second- and third-degree burn injury) (%), and associated variation statistic.

13.5.1.4. Diagram of the test apparatus showing location and burn injury levels as second- and third-degree areas.

NOTE 1—Multiple colors increase the clarity of the resulting exposure results. Different colors have been used to denote sensors registering a predicted second-degree burn injury, sensors registering a predicted third-degree burn injury and sensors that failed during testing.

13.6 *Subjective and Recorded Observations*—Document the results of the exposure on the test specimen in narrative form.

Support the observations with the real time, video image recorded in 11.10 and, if necessary, a still photographic record.

These observations shall include, but are not limited to:

13.6.1 Intensity and duration of after flame or ignition.

13.6.2 Amount of smoke generated.

13.6.3 Physical stability of the test specimen: shrinkage, char formation, melting, generation of holes, etc.

13.7 *Additional Results from flat plate testing:* record the maximum protection provided by the test specimen or the point at which the protection of the test specimen is compromised.

13.7.1 Discussion this is determined by plotting the absorbed heat flux vs. time

14. Precision and Bias Not yet established.

ANNEX and APPENDICES are identical to ASTM F1930 and not included

Appendix D. Detailed Drawings

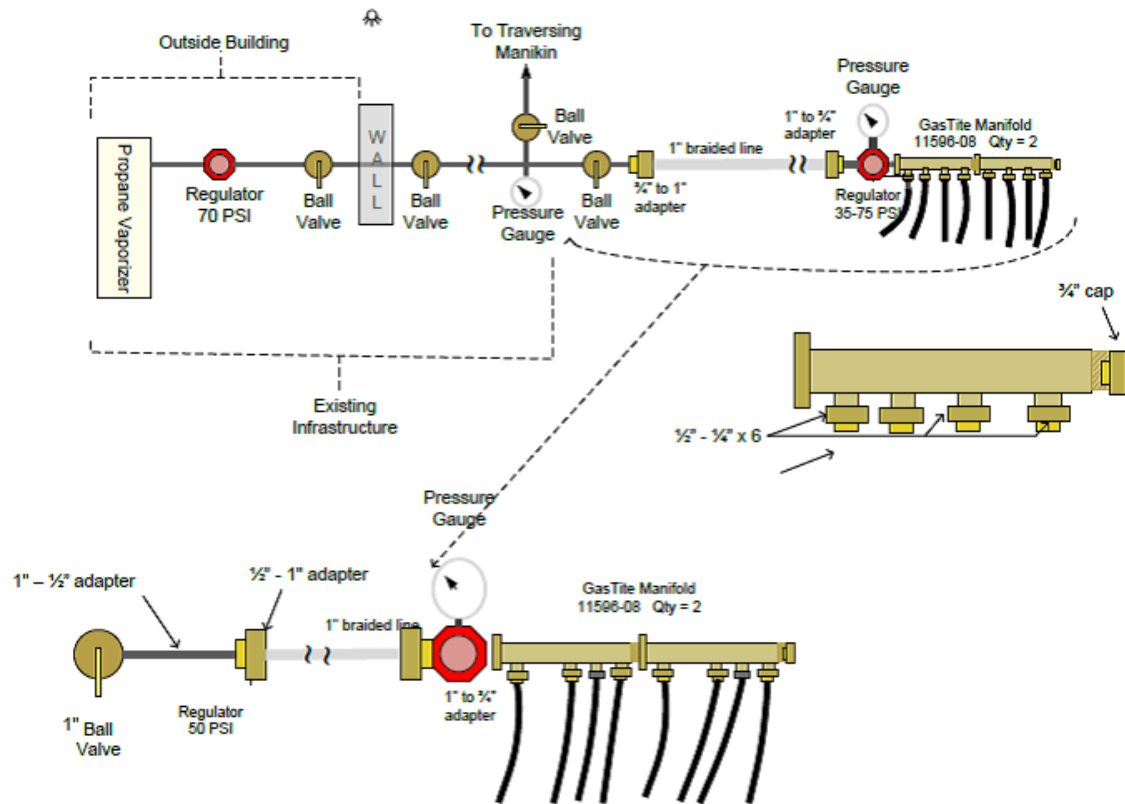

Figure D1. Details of Gas valving and delivery system

Height adjustable stand to support micarta tube.
Will be exposed to direct high heat flame. Top ring should be able to
secure the tube to this test stand. Tubing should be 3" minimum to
accommodate the thermocouple wire test cable

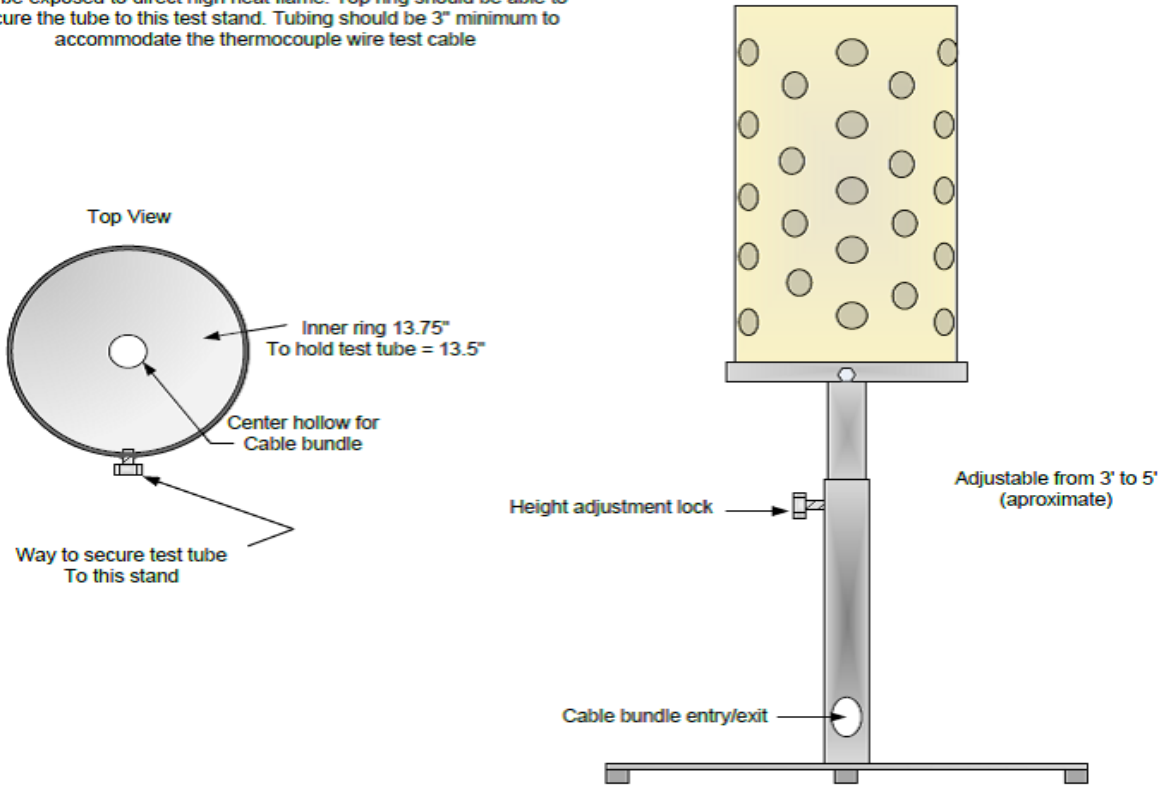
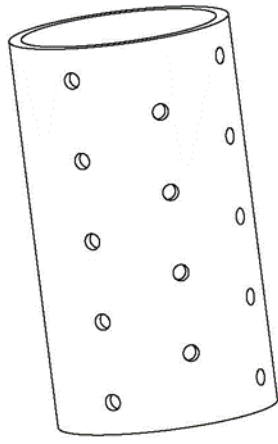
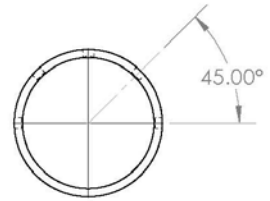

Figure D2. Design Details of Cylindrical Form



Sensor Layout - 24 sensors over 180 degrees of the column
 19.6 sq.-in area per sensor
 three columns of 5 sensors
 two columns of 4 sensors



45 degrees between columns

approximately 5" vertical spacing

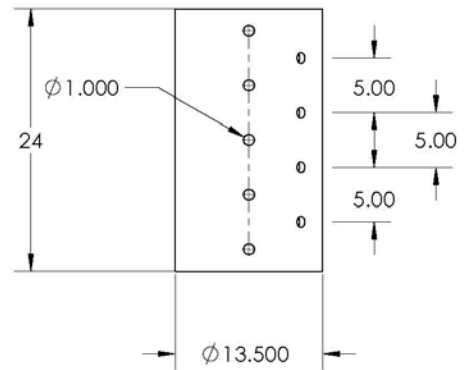
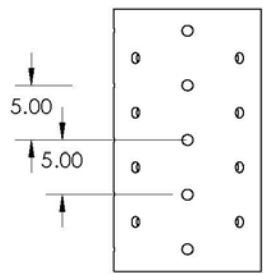
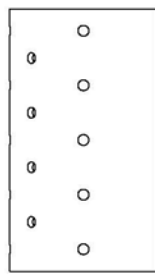

Figure D3. Detailed Sensor Layout for Cylindrical Form

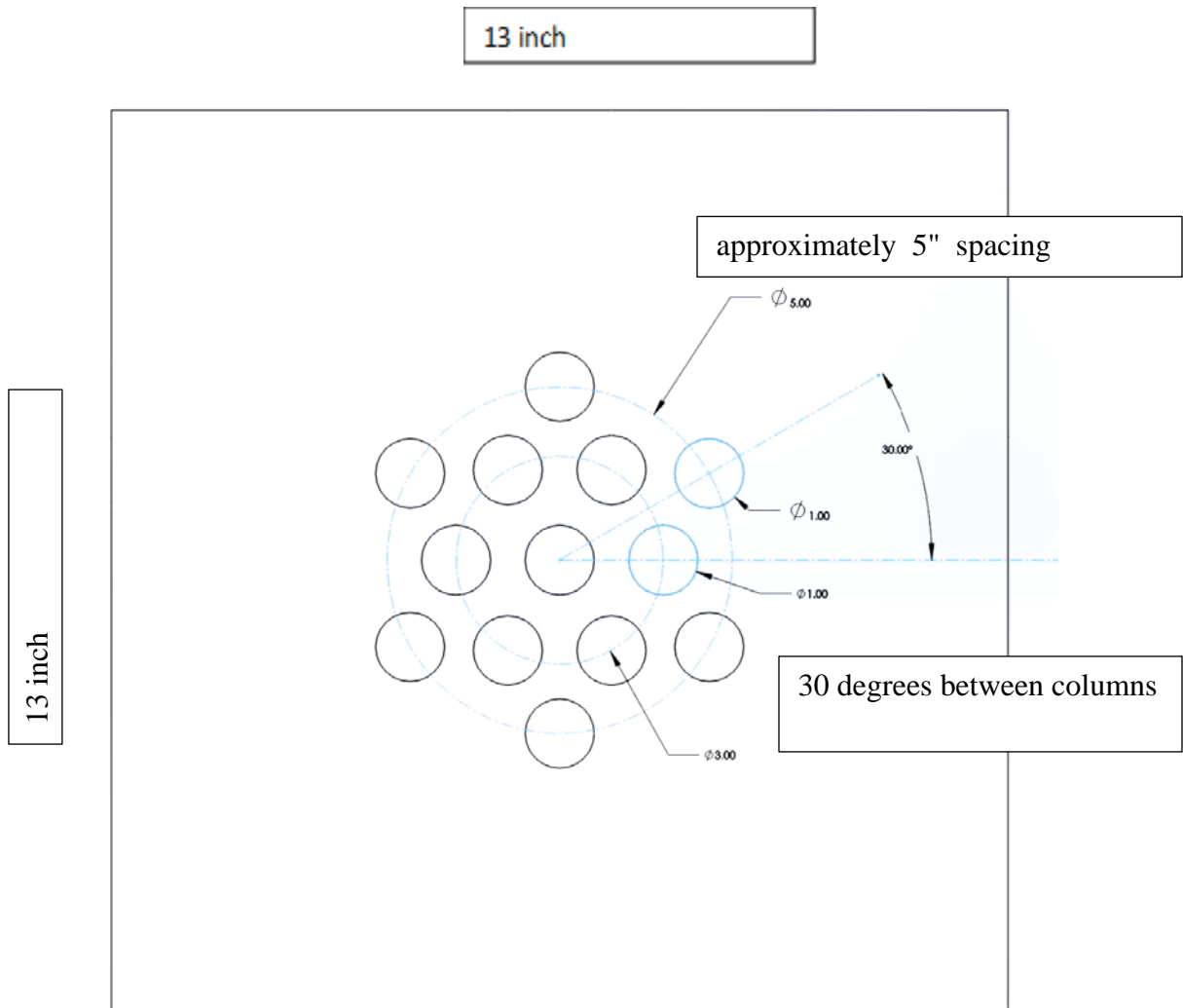

Figure D4. Detailed Sensor Layout 13 in x 13 in Flat Plate

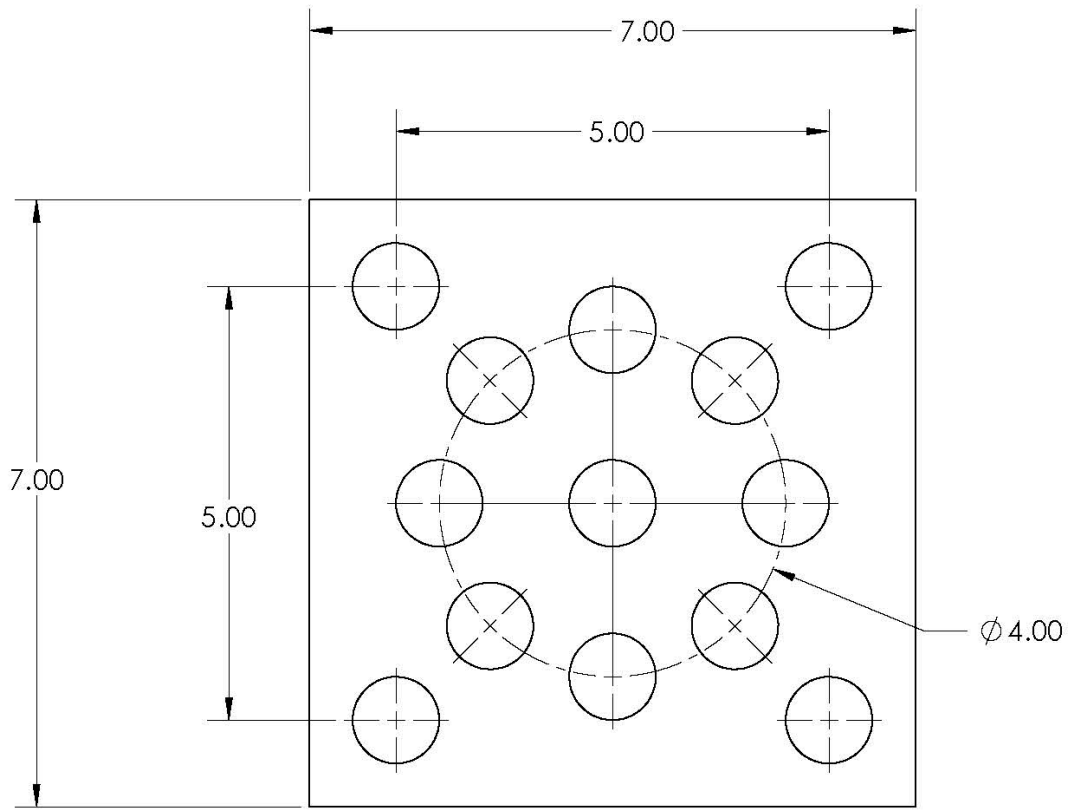

Figure D5. Detail Sensor Layout 7 in x 7 in Flat Plate