

**Best Available  
Copy  
for all Pictures**

AD-787 483

EXPEDIENT SHELTER HANDBOOK

G. A. Cristy, et al

Oak Ridge National Laboratory

Prepared for:

Defense Civil Preparedness Agency  
Atomic Energy Commission

August 1974

DISTRIBUTED BY:

**NTIS**

**National Technical Information Service  
U. S. DEPARTMENT OF COMMERCE  
5285 Port Royal Road, Springfield Va. 22151**

ACCESSION NO.	
NTIS	NTIS FILE
DTIC	DTIC FILE
UNCLASSIFIED	
CONFIDENTIAL	
BY	
DTIC NUMBER/AVAILABILITY OFFICE	
DATE	
A	

Printed in the United States of America. Available from  
 National Technical Information Service  
 U.S. Department of Commerce  
 5285 Port Royal Road, Springfield, Virginia 22151

This report was prepared as an account of work sponsored by the United States Government. Neither the United States nor the United States Atomic Energy Commission, nor any of their employees, nor any of their contractors, subcontractors, or their employees, makes any warranty, express or implied, or assumes any legal liability or responsibility for the accuracy, completeness or usefulness of any information, apparatus, product or process disclosed, or represents that its use would not infringe privately owned rights.

ACCESSION NO.	
NTIS	NTIS FILE
DTIC	DTIC FILE
UNCLASSIFIED	
CONFIDENTIAL	
BY	
DTIC NUMBER/AVAILABILITY OFFICE	
DATE	
A	

ib

UNCLASSIFIED

AD 787483

SECURITY CLASSIFICATION OF THIS PAGE (When Data Entered)

REPORT DOCUMENTATION PAGE		READ INSTRUCTIONS BEFORE COMPLETING FORM
1. REPORT NUMBER ORNL-4941	2. GOVT ACCESSION NO.	3. RECIPIENT'S CATALOG NUMBER
4. TITLE (and Subtitle) Expedient Shelter Handbook		5. TYPE OF REPORT & PERIOD COVERED Final Report
		6. PERFORMING ORG. REPORT NUMBER
7. AUTHOR(s) G. A. Cristy and C. H. Kearny		8. CONTRACT OR GRANT NUMBER(s) Interagency Agreement OCD-PS-64-284, AEC-40-31-64
9. PERFORMING ORGANIZATION NAME AND ADDRESS Oak Ridge National Laboratory P.O. Box X Oak Ridge, Tennessee 37830		10. PROGRAM ELEMENT PROJECT TASK AREA & WORK UNIT NUMBERS Task Order 1615B (Amendment No. 1)
11. CONTROLLING OFFICE NAME AND ADDRESS Defense Civil Preparedness Agency Washington, D.C. 20301		12. REPORT DATE August 1974
		13. NUMBER OF PAGES 152
14. MONITORING AGENCY NAME & ADDRESS (if different from Controlling Office)		15. SECURITY CLASS. (of this report) Unclassified
		15a. DECLASSIFICATION DOWNGRADING SCHEDULE
16. DISTRIBUTION STATEMENT (of this Report) Approved for public release; distribution unlimited		
17. DISTRIBUTION STATEMENT (of the abstract entered in Block 20, if different from Report)		
18. SUPPLEMENTARY NOTES Reproduced by NATIONAL TECHNICAL INFORMATION SERVICE U S Department of Commerce Springfield VA 22151		
19. KEY WORDS (Continue on reverse side if necessary and identify by block number) Expedient Shelters      Car-Over-Trench Shelter      Semi-Buried Blast Resistant      Covered Trench Shelter      Shelter Small Pole Shelter      Catenary Wire Shelter Door-Over-Trench Shelter      Underground Shelter		
20. ABSTRACT (Continue on reverse side if necessary and identify by block number) This manual is designed to assist local civil defense organiza- tions prepare plans consistent with the changing strategic conditions of the seventies. The Defense Civil Preparedness Agency is moving into a new program of "all-hazards, all-contingencies" planning which will involve developing a crisis-oriented evacuation capability. This capability will increase the survivability of the population in		

UNCLASSIFIED

SECURITY CLASSIFICATION OF THIS PAGE(When Data Entered)

the event of a nuclear attack and will be a counter against certain "nuclear blackmail" threats. Planning for the development of shelter capabilities for either an "in-place" or evacuated posture will require an ability to rapidly build large numbers of new expedient shelters in addition to upgrading existing fallout shelters. (Expedient shelters are shelters which can be built under crisis conditions, within 48 hours using only locally available materials, equipment, and labor.)

Detailed step-by-step instructions and pictorial design drawings of fifteen expedient shelters are included in the Appendices. The instructions and drawings for any of these shelters can be pre-printed by local C.D. organizations for rapid dissemination in a crisis. The shelter designs are simple enough that they can be built by ordinary Americans, even ones who have had no previous building experience and who have no guidance other than these drawings and instructions. Many of the designs have been proof-tested (i.e., built under simulated crisis conditions by unskilled urban or rural people with no prior preparation other than reading these instructions for building one of these shelters). Designs and instructions for building Kearny Air Pumps (KAP's) and an expedient, quick-closing blast door are also included in the Appendices.

It is recommended that all of these shelters, especially the designs that have not yet been built by average citizens, be proof-tested under simulated crisis conditions by ordinary civilians and that the experiences so gained be used to refine and improve the designs and instructions.

ia

UNCLASSIFIED

SECURITY CLASSIFICATION OF THIS PAGE(When Data Entered)

ORNL-4941  
UC-2 - General, Miscellaneous  
and Progress Reports

HEALTH PHYSICS DIVISION  
Civil Defense Research Section

FINAL REPORT  
EXPEDIENT SHELTER HANDBOOK

by

G. A. Cristy and C. H. Kearny

for

Defense Civil Preparedness Agency  
Washington, D.C. 20301

Interagency Agreements AEC-40-31-64  
and OCD-PS-64-284, Task Order No. 1615B (Amendment No. 1)

DCPA Review Notice

This report has been reviewed in the Defense Civil Preparedness Agency and approved for publication. Approval does not signify that the contents necessarily reflect the views and policies of the Defense Civil Preparedness Agency.

AUGUST 1974

APPROVED FOR PUBLIC RELEASE; DISTRIBUTION UNLIMITED

OAK RIDGE NATIONAL LABORATORY  
Oak Ridge, Tennessee 37830  
operated by  
UNION CARBIDE CORPORATION  
for the  
U.S. ATOMIC ENERGY COMMISSION

ii

## ABSTRACT

This manual is designed to assist local civil defense organizations prepare plans consistent with the changing strategic conditions of the seventies. The Defense Civil Preparedness Agency is moving into a new program of "all-hazards, all-contingencies" planning which will involve developing a crisis-oriented evacuation capability. This capability will increase the survivability of the population in the event of a nuclear attack and will be a counter against certain "nuclear blackmail" threats. Planning for the development of shelter capabilities for either an "in-place" or evacuated posture will require an ability to rapidly build large numbers of new expedient shelters in addition to upgrading existing fallout shelters. (Expedient shelters are shelters which can be built under crisis conditions within 48 hours using only locally available materials, equipment, and labor.)

Detailed step-by-step instructions and pictorial design drawings of fifteen expedient shelters are included in the Appendices. The instructions and drawings for any of these shelters can be preprinted by local C.D. organizations for rapid dissemination in a crisis. The shelter designs are simple enough that they can be built by ordinary Americans, even ones who have had no previous building experience and who have no guidance other than these drawings and instructions. Many of the designs have been proof-tested (i.e., built under simulated crisis conditions by unskilled urban or rural people with no prior preparation other than reading these instructions for building one of these shelters). Designs and instructions for building Kearny Air Pumps (KAP's) and an expedient, quick-closing blast door are also included in the Appendices.

It is recommended that all of these shelters, especially the designs that have not yet been built by average citizens, be proof-tested under simulated crisis conditions by ordinary civilians and that the experiences so gained be used to refine and improve the designs and instructions.

CONTENTS

	<u>Page</u>
I. INTRODUCTION . . . . .	1
A. World Strategic Situation . . . . .	1
B. Recent Changes in U.S. Preparedness Planning . . . . .	3
C. Assumptions . . . . .	4
D. Preparation of Evacuation Plans . . . . .	4
E. Protection Factors . . . . .	4
II. GUIDE FOR COMMUNITY PLANNERS . . . . .	8
A. Determine Probable Risks . . . . .	8
B. Determine What Plans and Capabilities are Needed . . . . .	9
1. For "In-Place" Protection . . . . .	9
2. For Crisis Relocation (Emergency Evacuation) . . . . .	9
C. Establish an Organizational Framework . . . . .	9
D. Make an Inventory of Existing Shelters . . . . .	9
E. Estimate the Population Load . . . . .	10
F. Estimate the Requirements for Additional (Expedient) Shelters . . . . .	10
G. Make an Inventory of the Resources . . . . .	10
1. Lumber . . . . .	10
2. Miscellaneous Materials of Construction . . . . .	10
3. Tools . . . . .	11
4. Construction Equipment . . . . .	11
5. Timber . . . . .	11
6. Construction Crews . . . . .	11
H. Locate and Select Construction Sites . . . . .	11
1. Existing Structures to be Modified . . . . .	11
2. Other Potential Shelters . . . . .	12
3. New Expedient Shelter Sites . . . . .	12
4. Pre-Emergency Site Preparation . . . . .	14
I. Determine Construction Needed . . . . .	15
1. Determine What Modifications are Needed on Existing Structures . . . . .	15
a. Ventilation Upgrading . . . . .	15
b. Shielding Upgrading . . . . .	17



CONTENTS (Cont'd)

	<u>Page</u>
c. Basement Modifications . . . . .	17
d. First and Intermediate Floor Modifications . . .	18
e. Single Story or Top Floor Modifications . . . .	18
f. Structural Reinforcements . . . . .	19
g. Materials . . . . .	19
2. Utilize Available Mines, Caves, Tunnels . . . . .	20
a. Entrances and Exits . . . . .	20
b. Structure . . . . .	21
c. Drainage . . . . .	21
d. Ventilation . . . . .	21
e. Water Supply . . . . .	21
f. Accessibility . . . . .	21
3. Select Designs for Building New Expedient Shelter .	21
J. Anticipate Ventilation and Heat Problems . . . . .	28
1. Minimum Ventilation Rates . . . . .	28
2. Cold Weather Ventilation . . . . .	29
3. Warm and Hot Weather Ventilation Rates . . . . .	29
K. Plan to Improve the Habitability of Shelter . . . . .	30
1. Improve Water Supply . . . . .	30
2. Construct Seats and Bunks . . . . .	30
3. Cover Walls and Floor . . . . .	30
4. Provide Safe Light and Heat . . . . .	31
5. Provide for Austere Cooking . . . . .	31
6. Improve Sanitary Arrangments . . . . .	31
7. Prepare Food for Storage . . . . .	32
L. Prepare Detailed Plans . . . . .	32
M. Consider Stockpiling and Establishing Pre-Crisis Agreements . . . . .	33
N. Plan for Selection and Training of Cadres . . . . .	33
III. RECOMMENDATIONS FOR FURTHER RESEARCH AND DEVELOPMENT . . . .	33
IV. ACKNOWLEDGMENTS . . . . .	34
V. REFERENCES . . . . .	35

CONTENTS (Cont'd)

	<u>Page</u>
VI. APPENDIXES	
APPENDIX A - SHELTER DESIGNS . . . . .	A-1
A-1 - Small Pole Shelter . . . . .	A-1.1
A-2 - Family-Size, Log-Covered Trench . . . . .	A-2.1
A-3 - Catenary Wire Roofed Shelter . . . . .	A-3.1
A-4 - Two-Family A-Frame Pole Shelter . . . . .	A-4.1
A-5 - Shored Trench Stoop-In Shelter . . . . .	A-5.1
A-6 - Two-Family A-Frame Lumber Shelter . . . . .	A-6.1
A-7 - Rigid Frame Underground . . . . .	A-7.1
A-8 - Trench Wall - Underground . . . . .	A-8.1
A-9 - Rigid Frame - Continuous Vent . . . . .	A-9.1
A-10 - A-Frame, Semiburied . . . . .	A-10.1
A-11 - Wood Grate Roof Underground Shelter . . . . .	A-11.1
A-12 - Trailer Van Shelter . . . . .	A-12.1
A-13 - Car-Over-Trench . . . . .	A-13.1
A-14 - Door-Over Trench Shelter . . . . .	A-14.1
A-15 - Lumber Version of the Small-Pole Shelter . . . . .	A-15.1
References - Appendix A . . . . .	A-15.12
APPENDIX B - HOW TO MAKE AND USE A HOMEMADE, LARGE VOLUME, EFFICIENT SHELTER-VENTILATING PUMP: THE KEARNY AIR PUMP (KAP) . . . . .	B-1
APPENDIX C - EMERGENCY WATER SUPPLIES, EXPEDIENT LIGHTS, AND SANITATION . . . . .	C-1
APPENDIX D - EXPEDIENT, QUICKLY CLOSABLE BLAST DOOR . . . . .	D-1
APPENDIX E - HOW TO CUT AND HAUL LOGS MORE EASILY . . . . .	E-1

## LIST OF ILLUSTRATIONS

<u>Fig. No.</u>	<u>Caption</u>	<u>Page</u>
1	Fallout Pattern from UNCLEX Attack . . . . .	6
A-1.1	Small Pole Shelter - Pictorial View . . . . .	A-1.10
A-1.2	Small Pole Shelter - Plan and Elevation . . . . .	A-1.11
A-2.1	Log-Covered Trench Shelter - Pictorial View . . . . .	A-2.6
A-2.2	Log-Covered Trench Shelter - Details . . . . .	A-2.7
A-3.1	Catenary Wire-Roofed Shelter - Basic Design . . . . .	A-3.11
A-3.2	Catenary Wire-Roofed Shelter - Alternate Design . . . . .	A-3.12
A-4.1	Two-Family A-Frame Pole Shelter - Semiburied . . . . .	A-4.8
A-4.2	Two-Family A-Frame Pole Shelter - Frozen Ground Version . . . . .	A-4.9
A-5.1	Shored Trench Stoop-In Shelter - Plan and Elevation . . . . .	A-5.11
A-5.2	Shored Trench Stoop-In Shelter - Escape Hatch Details . . . . .	A-5.12
A-6.1	Two-Family A-Frame Lumber Shelter - Pictorial View . . . . .	A-6.10
A-7.1	Rigid-Frame Underground Shelter - Pictorial View . . . . .	A-7.14
A-7.2	Rigid-Frame Underground Shelter - Plan and Elevation . . . . .	A-7.15
A-8.1	Trench Wall Underground Shelter - Plan and Elevations . . . . .	A-8.17
A-8.2	Trench Walls Underground Shelter - Construction Methods . . . . .	A-8.18
A-9.1	Rigid-Frame Continuous Vent Shelter - Plan and Elevations . . . . .	A-9.18
A-9.2	Rigid-Frame Continuous Vent Shelter - Construction Methods . . . . .	A-9.19
A-10.1	A-Frame Expedient Shelter - Plans and Elevations . . . . .	A-10.11
A-10.2	A-Frame Expedient Shelter - Alternate Air Vent Design . . . . .	A-10.12

LIST OF ILLUSTRATIONS (Cont'd)

<u>Fig. No.</u>	<u>Caption</u>	<u>Page</u>
A-11.1	Wood Grate Roof Underground Shelter - Plans and Sections . . . . .	A-11.13
A-11.2	Wood Grate Roof Underground Shelter - End Wall and Entrance . . . . .	A-11.14
A-12.1	Trailer Van Shelter - Pictorial View and Sections . . . . .	A-12.6
A-12.2	Trailer Van Shelter - Ventilation Details . . . . .	A-12.7
A-13.1	Car-Over-Trench Shelter - Pictorial View . . . . .	A-13.6
A-13.2	Car-Over-Trench Shelter - Plan and Elevation . . . . .	A-13.7
A-13.3	Car-Over-Trench Shelter - Front View and Cross Section . . . . .	A-13.8
A-14.1	Door-Over-Trench Shelter - Pictorial View . . . . .	A-14.8
A-14.2	Door-Over-Trench Shelter - Making a "Roll" . . . . .	A-14.9
A-15.1	Pictorial View of Lumber Version of Small-Pole Shelter . . . . .	A-15.10
A-15.2	Details of Lumber Version of Small-Pole Shelter . . . . .	A-15.11
B-1	Section through doorway showing operation of Kearny Air Pump . . . . .	B-2
B-2	KAP in doorway (with flaps open during its return stroke) . . . . .	B-2
B-3	KAP frame (looking at the <u>back side</u> of the frame) . . . . .	B-6
B-4	Completing the frame . . . . .	B-7
B-5	Flap pattern . . . . .	B-8
B-6	Size of notches in flaps . . . . .	B-9
B-7	Finished flap . . . . .	B-10
B-8	End view of flap . . . . .	B-11
B-9	Marking for pivot wires . . . . .	B-12
B-10	Marking for flap stops . . . . .	B-12
B-11	Attaching flap stops . . . . .	B-13
B-12	Side view of assembly . . . . .	B-15
B-13	Mesh wire stops . . . . .	B-16

LIST OF ILLUSTRATIONS (Cont'd)

<u>Fig. No.</u>	<u>Caption</u>	<u>Page</u>
B-14	Installation of Kearny Air Pump . . . . .	B-18
B-15	Use of air divider . . . . .	B-19
B-16	Air distribution in large shelter . . . . .	B-20
B-17	Improvised pulley from a wide-angled forked limb . . . . .	B-22
B-18	Improvised pulley with saddle notch . . . . .	B-22
B-19	Quick removal bracket . . . . .	B-24
B-20	Connection of pull-cord to center brace . . . . .	B-26
B-21	Y-bridle for pull-cord on Kearny Air Pump . . . . .	B-26
B-22	Operation of large Kearny Air Pump . . . . .	B-27
B-23	Side baffles . . . . .	B-28
B-24	Push-pole flexible connection . . . . .	B-29
B-25	Use of "divider" to ventilate a shelter with only one opening . . . . .	B-30
B-26	Installing a KAP in steel-framed doorway . . . . .	B-34
B-27	Quick-removal bracket for steel-framed doorway . . . . .	B-35
C-1	Wire-Stiffened-Wick Lamp . . . . .	C-3
C-2	Floating Wick Lamp . . . . .	C-4

## EXPEDIENT SHELTER HANDBOOK

### I. INTRODUCTION

This manual has been prepared as an aid to local Civil Defense Directors in their attempts to update, modify, and improve their plans in response to the strategic threats of the seventies.

#### A. World Strategic Situation

The decade of the seventies has already introduced many tremendous changes in the strategic situation. The present clear and admitted superiority of the Soviet Union both in weapons and in weight of their missile force is a sharp contrast to the massive superiority of the U.S. in nuclear weapons in the fifties and early sixties.<sup>1</sup>

Another cause of concern to Civil Defense planners is the rapid development of Chinese nuclear capabilities and the dangers from a confrontation (and/or a nuclear exchange) between the Soviet Union and the People's Republic of China. Although the detente between the USA and the USSR and between the USA and Red China has as one of its goals the reduction of that threat, it would not be prudent to ignore it in planning.

However, the Soviet Union has done more than achieve a state of superiority in nuclear weapons (a condition which has been accepted by the U.S. in the Interim Agreement on Offensive Weapons in conjunction with the Strategic Arms Limitation Treaty (SALT); the Soviet Union has also developed a strategic evacuation plan which can have a vital impact upon the strategic balance, especially when this balance depended for so long upon an assured destruction policy. The Soviet evacuation plan is a well organized and sophisticated plan based upon a clear statement of Soviet nuclear policy. The Soviet Union does not subscribe to the doctrine that nuclear war means the end of mankind. On the contrary, it instructs and prepares its citizens on how to survive such a war. Marshal V. I. Chuykov puts it this way:

"Without slighting the serious consequences of a possible war, we should in all responsibility state that there is no

poison for which there cannot be an antidote nor can there be a weapon against which there is no defense. Although the weapons we have examined are called mass weapons, with the knowledge and skillful use of modern defense measures they will not affect masses, but only those who neglect mastery, and use of these measures."<sup>2</sup>

The Soviet evacuation plans are well documented<sup>3,4,5</sup> and are available for study by any Civil Defense planner. Consequently, only a general outline of the Soviet strategy and plan will be included here.

The Soviet Civil Defense program is under the jurisdiction of the Council of Ministers of the USSR and is organized and staffed as an integral part of the Soviet armed forces. It is "organized throughout the Soviet Union on a territorial-industrial basis. It involves all branches of government, as well as all plants, institutions, schools, kolkhozs, and sovkhoszs and includes the entire population."<sup>2</sup>

"Protection of the population is implemented by dispersing and evacuating the people to outlying areas and providing them protective shelters and personal means of protection."<sup>2</sup> The workers in essential industries and their families will be "dispersed" (i.e., relocated) into nearby, low-risk areas so that the workers can commute to work on 12-hour shifts. The workers in non-essential industries, school children, elderly persons, etc. will be "evacuated" to areas more remote from the city. Every industrial plant, institution, school, and collective farm, as well as every branch of the government, must prepare, try out, and refine a detailed plan for the evacuation-dispersal program. Furthermore, each Soviet citizen is required to undergo civil defense training and practice. A Soviet school child receives a total of 115 hours of civil defense instruction by the time he completes the tenth grade.

Soviet defense analysts claim<sup>3</sup> and some U.S. analysts agree<sup>6,7,8</sup> that an early dispersal and evacuation can reduce the casualties produced by a nuclear attack to as low as 5%. This is less than the level of losses suffered by the USSR during World War II -- a level which did not noticeably damage the viability of either the USSR government or its society.

The Chinese have taken the threat of nuclear war very seriously. The recently unveiled tunnels in Peking<sup>8</sup> have alerted the rest of the world to the fact that in only 5 years the Chinese have succeeded in building well equipped tunnel shelters for the people in their large cities. Thus in China, a country afflicted with severe economic woes, where (at least according to Western folk lore) life has little or no value, far more has been done to protect the lives of the citizens than in the U.S.

In sharp contrast to China and the Soviet Union, which have continued to increase their already substantial civil defense programs, the U.S. has de-emphasized civil defense. Our shelter program is still based on fallout-only shelters located in existing buildings. The NFSS (National Fallout Shelter Survey) has located and initially stocked a great many fallout shelter spaces. Unfortunately, the vast majority of these shelter spaces are in the very places which, under a Soviet-type defense system, would be evacuated. The Defense Civil Preparedness Agency (DCPA), its predecessor agencies, and their contractors have supplemented the NFSS shelters by surveys of home basements and other potential shelters. However, there remains a tremendous shelter deficit, particularly in the rural and suburban areas. With the exception of certain regional and state civil defense Emergency Operating Centers facilities, no provision has been made for blast shelters. Such lack of preparedness is not due to a lack of belief in the value of blast shelters by civil defense authorities but rather to stringent budget limitations, a political philosophy of "non-provocation" and expediency forced upon the civil defense community.

#### B. Recent Changes in U.S. Preparedness Planning

Recognizing that the "assured destruction" doctrine is in jeopardy as a result of the sophisticated Soviet evacuation system, the U.S. civil defense community is now giving serious consideration to counter-evacuation planning. There are many problems in such planning, most of which are beyond the scope of this handbook. However, any counter-evacuation plan must solve the problems of protection of evacuees and



host population from the effects of fallout. In some areas provision must also be made to protect the population from the effects of the thermal pulse and low levels (5 to 30 psi) of blast overpressure. It is to these needs that this handbook is addressed.

#### C. Assumptions

In preparing this handbook, it was assumed that an evacuation policy for the U.S. would be evolved, one which would require some modification of the present budgetary and political constraints on the national level and greatly increased participation at local levels. The anticipated evacuation policy would have to be based upon using existing transportation, road nets, and civil organizations. It was anticipated that no stockpiling of supplies or tools would be practical but that plans — including widely distributed shelter-building instructions — could and would be generated in advance of any crisis.

#### D. Preparation of Evacuation Plans

Evacuation plans must be simple and easily publishable for rapid dissemination in a crisis. Local C.D. organizations should pretest the elements of the plans for accuracy, completeness, and workability.

Local civil defense planners will find many difficult problems to solve in preparing such plans. One of the most severe is the problem of providing adequate protection against nuclear effects in the host areas. The host areas would be located in rural or suburban areas where very few fallout and no blast shelters exist. In areas where many of the homes have basements, the inhabitants can improve the sheltering capacity and the protection factor using methods available in C.D. literature.<sup>10</sup>

#### E. Protection Factors

The need for improved protection factors is not always appreciated. This wide range and the complexity of the variables involved in evaluating the level of radiation which can be expected in any locality has discouraged many persons from making the attempt. However, there are a

number of facts that have emerged from all the discussions and calculations that have been made on the subject. The following facts, while greatly over simplified, may at least suggest that each locality should obtain the highest degree of radiation protection possible, consistent with the available time, energy, and supplies.

FACT NO. 1

Radiation will cause sickness and death.

The amount of radiation that a person can receive without ill effects varies with the person's health and general condition. Generally, we can be fairly sure that whole body radiation doses over 600 roentgens, if received within a few days, will always result in death, whereas whole body radiation doses between 200 and 600 roentgens will cause severe illness in most cases, and death in many. Whole body doses between 100 and 200 roentgens may result in sickness but would not likely be fatal under normal circumstances.

To determine the "allowable" radiation dosage for survival it becomes necessary to define the term "survival." If it means that no sickness is tolerable and that people continue normal activities, the maximum allowable dose would be about 100 roentgens in four days.<sup>11</sup>

FACT NO. 2

The Soviet Union has the capability of causing very high levels of radioactive fallout all across the country as well as of producing large areas of blast and fire damage.

D CPA (and/or predecessor agencies) has already made many studies of the possible and probable hazard levels from potential enemy nuclear attacks. From these previous studies should emerge, within the very near future, a series of program guidance documents which will define the probable levels of risk for each state and local area.

Meanwhile, it has been shown<sup>12</sup> that attacks well within the capabilities of the USSR force levels approved by SALT (for example, the UNCLEX attack) would result in levels of fallout which would produce 4-day maximum dose levels as shown in Fig. 1.

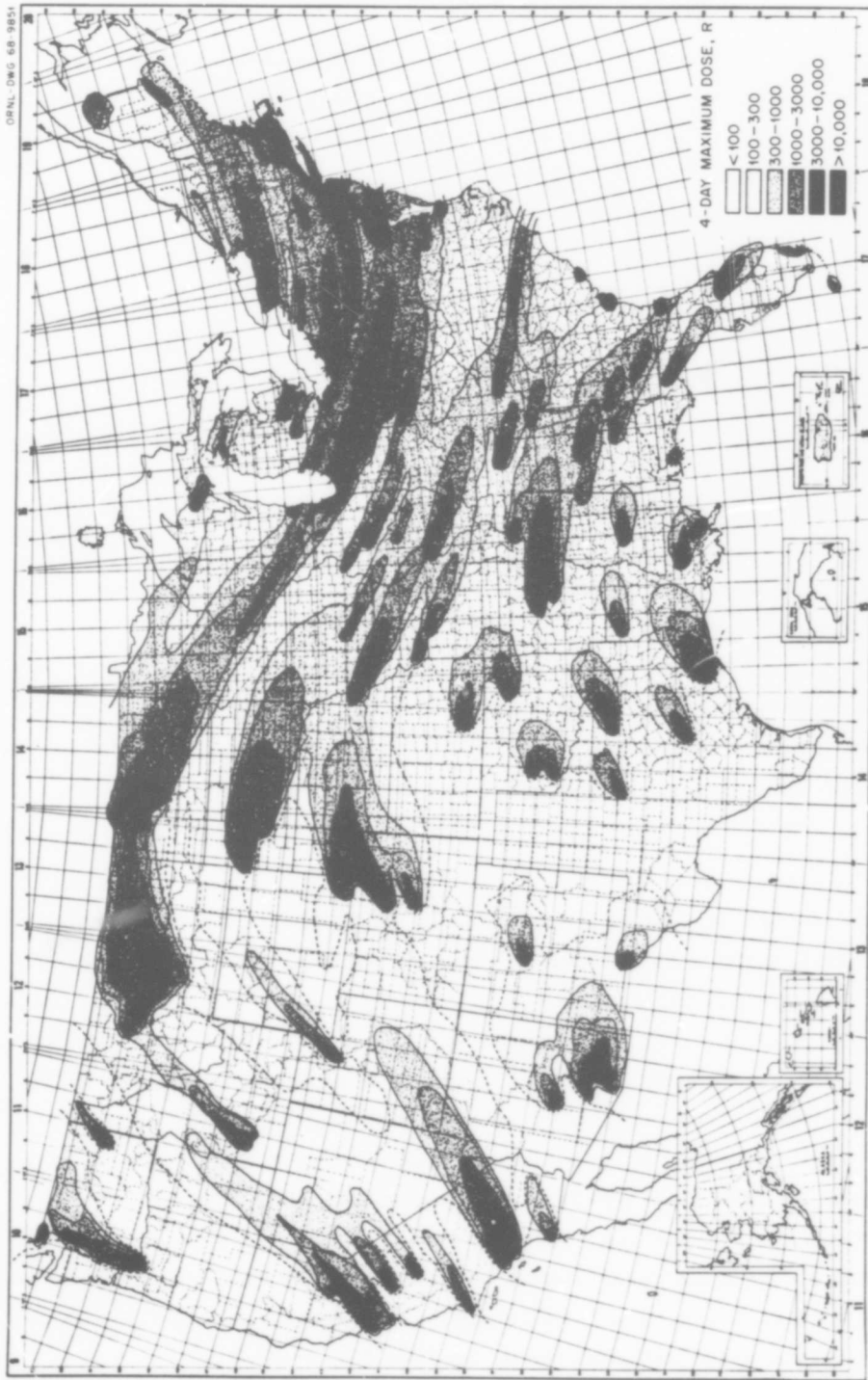

Fig. 1. Fallout Pattern from UNCLEX Attack.

FACT NO. 3

Fallout shelters can tremendously increase the probability of survival.

The UNCLEX attack study provides evidence of the effect of fallout shelters.

Under the assumption that the population of the major cities had been evacuated before the attack and the population of each OBE\* had been equally distributed throughout the OBE, the casualties were as shown in Table 1.

Table 1. Rural Area Fallout Casualties<sup>a</sup> Produced by 1000 Weapons<sup>12</sup>

Protection Factor (Fallout Only)	Prompt Effects <sup>b</sup>		Fallout		Total Fatalities
	Fatalities	Injuries	Fatalities	Injuries	
2	0.4	0.9	23.3	32.4	23.7
5	0.4	0.9	15.0	22.1	15.4
10	0.4	0.9	6.5	16.7	6.9
20	0.4	0.9	2.1	6.7	2.5
40	0.4	0.9	0	2.5	0.4
100	0.4	0.9	0	0.0	0.4

<sup>a</sup>Casualties are expressed in percent of total U.S. 1975 population of 226 millions. All weapons - 1-megaton surface-burst; reliability, 75%. Population was assumed evacuated in such a manner that each OBE contained all its original population but dispersed so that it was equally distributed within the OBE area.

<sup>b</sup>Prompt effects include blast, fire, initial nuclear radiation.

Another graphic illustration of the advantages of good fallout shelter, prepared by Samuel,<sup>13</sup> is shown in Table 2.

\* Economic areas as defined by the Office of Business Economics.

Table 2. Downwind Fallout Radiation Dose  
(5-Megaton Yield - Surface Burst - 15 mph Effective Wind)

Distance from Ground Zero (miles)	4-Day Dose - Roentgens					
	CONDITION FATAL			CONDITION DANGEROUS		CONDITION SAFE
	NO Shelter	PF 10	PF 20	PF 40	PF 100	PF 150
18	10600	1060	530	265	106	70-3/4
30	11000	1100	550	275	110	73-1/4
45	12000	1200	600	300	120	80
60	8000	800	400	200	80	53-1/4
75	5500	550	275	137-1/2	55	36-3/4
90	3500	350	175	87-1/2	35	23-1/4
105	2400	240	120	60	24	16
130	1200	120	60	30	12	8
145	750	75	37-1/2	18-3/4	7-1/2	5
175	350	35	17-1/2	8-3/4	3-1/2	2-1/4

## II. GUIDE FOR COMMUNITY PLANNERS

This section is essentially an expanded check list for community planners to use in developing or modifying local plans to embody the "all-hazards, all-contingency" approach to civil preparedness.

### A. Determine Probable Risks

In determining probable needs the first step is to appraise the probable hazards to the local community realistically. The hazards assessment requires a cooperative effort between local civil preparedness directors, and State or Federal agencies. These efforts may be initiated either by local directors or by the Federal or State agencies.

**B. Determine What Plans and Capabilities are Needed**

Contingency planning requires a dual set of plans, those for protection in-place and those for crisis relocation (emergency evacuation). The nature of the two sets of plans will depend in large measure upon the probable risk to the community.

**1. For "In-Place" Protection**

All localities need to reevaluate the existing shelter situation to ensure basing plans upon maximum use of the "best available" shelter. "Best available" shelter may need to be redefined on the basis of expected risk. For example, in areas of high risk from nuclear attack, the blast-resistant potential of all shelters must be evaluated.

**2. For Crisis Relocation (Emergency Evacuation)**

When the danger of flood or hurricane threatens the community, or a nearby community, and when an international crisis poses the threat of nuclear war, both the communities of high risk and the adjacent communities of low risk must be prepared to execute with efficiency and speed emergency evacuation plans.

**C. Establish an Organizational Framework**

The organizational framework should include a control center sufficiently large for the project.

**D. Make an Inventory of Existing Shelters**

To form the basis for realistic planning each community should update the inventory of existing shelters. The inventory should indicate the capacity, location, protection factor, and probable resistance to blast overpressure. Included in the inventory should be:

- (a) All NFSS-located shelters,
- (b) Home basements,
- (c) Structures modifiable,
- (d) Mines, caves, or tunnels,

(e) All non-NSF shelters,

(f) Boats and ships.

The inventory should indicate what actions are required to improve home basement shelters to increase capacity and/or the protection factor (PF), and to improve the other structures to provide the level of blast protection, ventilation, or PF needed.

#### E. Estimate the Population Load

The need for shelter in each community will vary greatly between the in-place plans and the crisis relocation plans. Each community should evaluate the problem on the basis of both conditions and coordinate with such other communities as may be required.

#### F. Estimate the Requirements for Additional (Expedient) Shelters

Once the existing shelters have been compared with the estimated population load under each condition, the shelter deficit (if any) can be established and preparations made to alleviate the deficit.

#### G. Make an Inventory of the Resources

##### 1. Lumber

Determine lumber resources in lumber yards, sawmill yards, and industrial stockpiles. Include all sources within easy transporting distance (some may be available in the area being evacuated). This effort must be coordinated with the efforts of adjacent counties (communities) to avoid duplications or omissions.

##### 2. Miscellaneous Materials of Construction

Determine availability of miscellaneous materials of construction needed for expedient shelter. Examples are sheet polyethylene, other sheet plastic, nails, wire, concrete block, interior doors, shower curtains, sheet metal roofing.

3. Tools

Determine availability of tools, including hammers, pliers, hand saws, power saws (both chain saws and circular saws), shovels, spades, crowbars, picks, and axes.

4. Construction Equipment

Inventory construction equipment that can be useful such as bulldozers, farm tractors, front-end loaders, backhoes.

5. Timber

Locate timber stands that can be cut in case of an emergency to build pole-type shelters and/or which can be cut by local sawmills to provide rough lumber for expedient shelters.

6. Construction Crews

Determine number of experienced construction crews available. Recruit a cadre of experienced, skilled persons to be used as foremen for emergency construction crews. (It will be necessary to assure such men that the first shelters built will include space for their own families.)

H. Locate and Select Construction Sites

With the space deficit known, the first task is the location of potential sites within the shelter-deficient areas. The second task is to compare such potential sites with each other and select the most favorable sites for development in each area.

1. Existing Structures to be Modified

First priority should be given to the investigation and selection of all existing structures in a shelter-deficient area which can be modified to provide a PF of 40 or more. This priority, however, is applicable only after it has been determined that spaces created by building modification will:



- (a) require less resources and time than the construction of new expedient\* shelters,
- (b) require no major structural alteration to the building, and
- (c) involve no more than a minor disruption of the present usage of the facility.

Each structure to be modified may require an individual analysis by an architect or engineer, and a qualified fallout shelter analyst, to determine the extent and character of modification required to create PF 40 spaces. The two general categories of structural modification, which when applied create fallout shelter space, are (a) increased shielding and (b) improved ventilation.

## 2. Other Potential Shelters

Expedient shelter planners should investigate and appraise special facilities such as mines, caves, or tunnels, which are located within a reasonable distance of shelter-deficient areas and which by modification or improvement can be utilized as shelters.

## 3. New Expedient Shelter Sites

The location for new expedient shelter sites should be investigated in population areas where shelter space deficiencies would still exist after modification of existing structures. In the selection of new sites, consideration should be given to:

- (a) the availability of public-owned lands;
- (b) the existence of hazardous or essential utilities, power, or communication facilities;
- (c) availability of water supplies;
- (d) terrain and accessibility factors.

---

\* Expedient construction is defined as construction that can be accomplished under crisis conditions within a period of 48 hours using only locally available equipment, materials, and manpower.

The type of shelter which can be constructed in an area is determined by the soil, geologic and drainage characteristics of the area and by the construction resources available. For this reason, it is important to make a complete and thorough appraisal of all available sites and to select those which will yield the most shelter in the shortest period of time.

In the selection of sites for construction of new expedient shelters, primary consideration should be given to the availability and location of public lands satisfying the requirements. This is significant because of the more ready availability of the land for public use in an emergency and also because of the less likelihood that the land will be developed for other purposes. Schools and parks, for example, because of their pattern of location in residential areas, make excellent expedient shelter sites. Other public lands, such as the peripheral portions of some airports, fairgrounds, golf courses, and land purchased but not built upon or developed, may be considered. Airports with runways 8000 ft or longer should be avoided as possible enemy targets. If sufficient public lands are not available within any given area, it may be necessary to utilize private property for expedient shelter construction sites. Open lands on military installations may or may not be available or usable, depending upon the mission of the installation.

If private property is to be utilized, the site selected should be one which would require the least construction and restoration effort. An open field where no immediate plans for development are anticipated would be the most desirable. Areas near farmhouses are desirable in many cases to encourage cooperation between farmers and evacuees.

The owner should be consulted by a local government representative, and the potential utilization of his property discussed. This contact would also be helpful in ascertaining the existence of underground utilities, sub-surface conditions, the seasonal depth of the water table, and other factors which influence the selection of the shelter type and its location on the property. When utilizing private property for shelter sites, an alternate site should be appraised and investigated in the event the prime site becomes unavailable.

In the selection of sites for new construction, the topography, the depth and type of soil to be encountered, and the seasonal depth of the water table are important considerations. These parameters dictate the type of equipment to be used as well as the type of shelter which can be built at a specific site. Loose sandy and silty soils will generally require support because of their unstable nature, while clayey and loamy soils, depending on their cohesiveness, may be stable, requiring little or no support, and suitable for building unshored trench shelters. Construction is more easily performed on a level or gently sloping site. Areas which are susceptible to flooding, or where high ground water prevails during any portion of the year, should be avoided. If possible, sites should be selected which will permit construction thereon during any period of the year. The depth of cut for buried or semiburied shelters, if possible, should be at least two feet above the maximum ground water elevation that can be expected at that site.

Another consideration in the selection of shelter sites is the availability of power. Commercial power or portable generators are desirable both to light the sites and to operate power equipment during the construction phase. The local utility company should be consulted and the availability of power confirmed at each individual site.

The existence of utilities traversing the site is another major consideration in selection. Underground gas, water, and sewer pipes and overhead electrical wires should be avoided.

Other considerations which enter into the appraisal and comparison of sites, as well as the selection of shelter types, are the accessibility for construction equipment, material delivery, and the accessibility for stocking the completed shelters with food and water. The shape of the site from the standpoint of efficient shelter layout is important in that there also must be space for equipment and material storage and for cutting and assembly.

#### 4. Pre-Emergency Site Preparation

After the selection of a site to be either modified or built upon for future shelter use, the local government may be able to budget money

to cover certain preparatory work to be completed before an emergency arises. Such work might consist of cleanup and incidental leveling or drainage improvements to drain the site. It should be understood, however, that this is an action strictly on the part of local government, but one which also is incidental to the expedient shelter effort.

### I. Determine Construction Needed

#### 1. Determine What Modifications\* are Needed on Existing Structures

Modifications will involve ventilation improvements to existing shelter areas, providing storage space and equipment for food and water, and/or adding dense materials to walls, floors, and roofs to increase shielding. Each individual structure will require an independent investigation and analysis to determine what modification is indicated and where it should be made. Because of the time element and the need for specialized design and equipment, ventilation improvements considered herein do not include installation of any ductwork or filters.

Typical methods of upgrading the protection factor of a structure by modification are illustrated in the Federal Civil Defense Guide.\*\*

##### a. Ventilation Upgrading

Ventilation modifications can be applied both to existing structures with PF 40 or better and to those upgraded to PF 40. Although a potential shelter area may provide, or have been upgraded to provide, adequate shielding, its usable capacity and value as a shelter is limited if it is improperly ventilated. There are several basic alternative methods of ventilation improvements that should be considered. These are as follows:

---

\* These modifications apply to buildings which need to be upgraded to provide fallout shelter only. When blast protection is needed more rigorous construction techniques are required.

\*\* The Federal Civil Defense Guide is now out of print but will be replaced by a new series in the near future according to DCPA sources.

- (1) Diversion of Forced Ventilation System: Existing ventilation systems may be used by cutting off the flow to non-shelter areas and diverting the air flow into the shelter.
- (2) Natural Ventilation ("Stack Effect"): Upper parts of windows above required protection height may be opened and/or new shielded openings in walls, partitions, ceilings, shafts, and stairwells may be provided. Also, existing entrances may be opened and used with the addition of baffled shielding.
- (3) Forced Ventilation: Fan units available in the locality or in the building may be relocated to draw air from within the upper part of the building. The fans may exhaust through exterior shielded openings, and/or vents, shafts, windows, doors, or new apertures. Alternatively, plans may be made to provide shielded exterior openings for intake fans to draw into existing interior shafts or stairwells. For interior core rooms, openings in partitions can be provided for circulation by the wall fans.
- (4) Kearny Air Pumps (KAP): KAP's may be constructed by the shelterees during early stages of occupancy if they obtain or are provided with the materials and the instructions given in Appendix B.
- (5) Packaged Ventilation Kits (PVK's): When available and stocked in the area, PVK's could be utilized in conjunction with or as an alternative to other methods of ventilation.
- (6) Combinations of Foregoing: Improvements in ventilation may require use of more than one of the foregoing methods in combination, such as the addition of fans with the Diversion method to increase the flow through the system, particularly where the distances are extremely long, or assisting natural ventilation flow with fans.

CAUTION: If the hazard evaluation indicates the likelihood of prolonged electric power interruption, due either to the widespread effects of a hurricane or to enemy actions in a nuclear confrontation, reliance for forced ventilation should be upon KAP's or PVK's rather than upon electrically powered forced ventilation, unless emergency generating capacity is provided within the shelter.

b. Shielding Upgrading

Modifying a building by shielding is the addition of mass between the shelter occupant and the contaminated environment outside the shelter. This is accomplished by increasing the weight of, or the weight resting against, the walls and the overhead parts of the structure. Existing buildings generally are not designed to structurally support large increases of weight on either their roofs, floors, or walls.

The addition of weight or mass to a building to upgrade its wall shielding characteristics should be limited to blocking existing openings or adding mass veneers resting on grade outside of, but adjacent to, the exterior walls. For this reason basements particularly lend themselves to upgrading. In cases where additional weight (mass) is to be placed on the building frame or its sub-components, structural modifications may be necessary to insure the safety and integrity of the structure. Structural problems may be involved not only in connection with shielding but also with ventilation upgrading where it is necessary to create large openings for the passage of air. Structural analysis and modifications may be time consuming and costly and should not be utilized if other solutions to the shelter space deficiency are available.

c. Basement Modifications

Basements may be modified by any of the following means or combinations thereof:

- (1) Brick up or otherwise close windows, window wells, and areaways and/or cover such openings with earth fill.

- (2) Place earth fill against exposed walls.
- (3) Veneer walls and/or windows with sandbags or earth-filled hollow masonry blocks, resting on the ground or on an earth mound.
- (4) Add baffle walls to protect exterior entrances, using sandbags or earth-filled hollow masonry units. Expedient methods similar to those shown in Appendix A may be used (see Figure A-14.2).
- (5) Increase overhead weight by spreading sand or earth over paper or tarpaulin placed on the floor. When structurally required to carry added weight, install shoring for increased support.

d. First and Intermediate Floor Modifications

These modifications may include veneering walls and/or windows with sandbags or earth-filled hollow masonry units, resting on ground or on an earth mound. These methods are adapted to increasing the weight of a wall if the floor line is not too high above the ground.

- (1) Where the floor line is high above outside grade and the walls have sufficient weight but contain a significant percentage of windows, the apertures can be blocked by stacking sandbags or earth-filled hollow concrete blocks in the windows or upon shelves built at sill height. Shoring under the floor may be required.
- (2) Where exterior walls do not have the required weight and cannot be shielded inside or outside, use may be made of the interior core rooms and corridors by blocking the doors and openings between the interior rooms (or corridors) and the exterior rooms. The latter would not be occupied.

e. Single Story or Top Floor Modifications

Same treatment as for First and Intermediate Floor Modifications with the following additional considerations:

- (1) Where the roof does not provide the required weight for shielding, sand or earth over paper or plastic may be added to the roof or to a floor above the shelter area. A structural analysis, however, should be made of the building to determine where and how it should be shored to support the additional load.
- (2) In large buildings with extremely high ceilings, consideration should be given to the construction of a shelter within the building by the addition of false walls and ceiling. The thickness of the false walls and ceiling is determined in combination with building walls and roof.
- (3) In buildings with large areas of glass, and where the roof and floor are structurally adequate to support the added weight, consideration should be given to the addition of roof mass and the installation of shielding partitions to the height required for protection, but set back from the exterior walls. Partitions could be made of sandbags or earth-filled hollow concrete blocks, and should have baffled entrances. The space between these partitions and the exterior building walls should not be occupied.

f. Structural Reinforcements

In the investigation and analysis of each building, a thorough check is required to ascertain if the additional loads to be imposed can be supported by the structural elements of the existing building. If not, and if it is still desired to modify the building, reinforcement will be required to support the added loads. Adequacy of new construction and/or modifications must be provided to maintain safety, protection, and possible continuation of normal use of the building.

g. Materials

Shielding materials may include earth or sand; sandbags; filled wooden boxes; filled concrete blocks; bricks; available store or warehouse stock -- packaged, bagged, or boxed. Waterproofing materials may be polyethylene film, roofing felt, or shower curtains.



## 2. Utilize Available Mines, Caves, Tunnels

Potentially usable "special facilities" (which may or may not have been included in either phase of the National Fallout Shelter Surveys or subsequent updating surveys), such as mines, caves, or tunnels, if within the allowable travel time, should be investigated as possible expedient shelter sites. Large numbers of people may be sheltered in such facilities with relatively simple modifications required. All such potential shelter sites should be explored and appraised as to their usage prior to the planning of construction of new expedient shelters. Prior to the addition of any facility to the modification list, an economic appraisal should be made to ascertain if a like number of spaces could be provided by new shelter construction in a shorter period of time or at a substantially lower use of critical materials for sheltering a like number of people. Many mines, caves, and tunnels may require too much time to convert to make them candidates for an expedient shelter program.

The same criteria pertaining to protection factor and ventilation requirements of new shelters shall apply to these facilities, except that for mines, caves, or tunnels, 500 cubic feet of air per person should be provided if the facility is not equipped with mechanical ventilation. Modifications or improvements of these facilities may involve any one of, or a combination of, the following considerations.

### a. Entrances and Exits

Improvement or enlargement of the entrances may be required to permit the rapid entry of large numbers of people into the facility. Shoring and bracing of the cavity entrance should be investigated, particularly if it has been enlarged.

Two means of exit are required. This requirement can be met by providing two separate entrances or by providing an escape shaft or drift exit located some distance away from the single entrance.

b. Structure

The entire facility should be carefully examined and areas requiring shoring or bracing and lining should be improved. Areas which are dangerous and hazardous should be blocked off and not utilized.

c. Drainage

Flowing water either from streams or seepage should be diverted from the occupancy area. This may be accomplished by ditching or piping and by using waterproof lining material. Moisture and drainage conditions vary seasonally in these types of facilities and therefore should be checked periodically.

d. Ventilation

The potential for providing mechanical ventilation to the facility should be explored. This could require the installation of emergency generators, or the use of large expedient KAP's (see Appendix B). Also, a shaft for supply of exhaust air may be required.

e. Water Supply

Provision should be made for collecting and storing drinking water. Natural water found in the facility should be checked for usability.

f. Accessibility

Improvements to the access road or vehicular parking and turnaround areas at the entrances could be required.

3. Select Designs for Building New Expedient Shelter

Appendix A contains plans and detailed step-by-step instructions for constructing 15 different shelter designs. After an extensive review of all expedient shelter design, these 15 were selected as being the best available. The selection includes types of shelters for a wide variety of conditions. Table 3 summarizes the characteristics and major materials requirements of the shelters.

Table 3. Shelter Characteristics

Shelter Number	Shelter Name	Basic Type <sup>a</sup>	Capacity		Earth Conditions Required	Major Materials Required					Protection Factor (Minimum)	Blast Protection (Estimated)			
			As Shown	Max. Recom. (Expanded Length)		Lumber (bd ft/person)		Plywood (ft <sup>2</sup> /person)	Logs or Poles (ft <sup>3</sup> /person)			W/O Blast Door	With Blast Door	W/O Blast Door	With Blast Door
						W/O Blast Door	With Blast Door	W/O Blast Door	With Blast Door						
A-1	Small Pole	U,S,A	12	24	Any	<1	8	None	21	24	1000	15 psi	30 psi		
A-2	Log-Covered Trench	U	4	20	Firm Earth Low Water Table	<1	N.A.	None	15	N.A.	1000	5 psi	N.A.		
A-3	Catenary Roof	U	5	20	Firm Earth Low Water Table	None	<sup>b</sup>	None	5	<sup>b</sup>	1000	15 psi	30 psi		
A-4	Two-Family, A-Frame Pole	S,A	10	20	Any	2	N.A.	None	18	N.A.	1000	10 psi	N.A.		
A-5	Shored-Trench Scoop-In	U	4	20	Any with Low Water Table	227 <sup>c</sup>	300	None	None	None	500	15 psi	15 psi		
A-6	Two-Family A-Frame Lumber	S,A	10	20	Any	85	N.A.	54	None	N.A.	500	2 psi	N.A.		
A-7	Rigid Frame	U	60	60	Any with Low Water Table	51	56	30	None	None	500	2 psi	2 psi		
A-8	Trench Wall	U	60	60	Firm Earth Low Water Table	39	44	21	None	None	500	2 psi	2 psi		
A-9	Rigid Frame Continuous Vent	S	60	60	Any	63	68	30	None	None	500	None	None		
A-10	A-Frame	S,A	60	60	Any	30	35	12	None	None	500	2 psi	2 psi		
A-11	Wood-Grate Roof	U	60	60	Low Water Table	50	N.A.	15	None	N.A.	500	2 psi	N.A.		
A-12	Trailer Van	S	100	100	Any	50	N.A.	40	None	N.A.	500	2 psi	N.A.		
A-13	Car-Over-Trench	S	6	Not Expandable	Firm Earth Low Water Table	None	None	None	None	None	100	None	None		
A-14	Door-Over-Trench	U	3	15	Firm Earth Low Water Table	None	N.A.	None	None	N.A.	200	5 psi	N.A.		
A-15	Lumber Version Small Pole	U,S,A	12	24	Any	46	54	43	None	None	1000	5 psi	5 psi		

<sup>a</sup>U = Underground, S = Semiburied, A = Aboveground

<sup>b</sup>Based on expanded length with capacity of 15 persons. The blast resistant entryways and the blast door require so much material that it is recommended only for the expanded size.

<sup>c</sup>By using the 14-person, double-ended model the lumber drops to 124 bd ft/person without blast door or to 153 bd ft/person with blast door.

NOTE: N.A. means that a blast door is not applicable to this shelter.

Each locality should select the shelter designs which best meet its particular needs. Each local CD director should choose one "shelter-of-choice" for his jurisdiction with others as alternate choices for special and unusual conditions. The selection of types of shelters generally should include some using lumber and some using poles to assure utilization of all timber and lumber resources. After selecting the designs most likely to meet the needs of the locality, local civil defense organizations should field test the models under simulated crisis conditions. Such field tests may disclose unanticipated problems which would require modifications of the plans or of the instructions. All such field tests should be reported through channels to Federal DCPA headquarters so that the information obtained could be made available to other jurisdictions which may have similar problems.

The shelters presented in Appendix A should be broad enough in scope to meet the requirements of any locality for new expedient shelter construction. The Small-Pole Shelter, A-1, is the best design and should be used whenever possible. In areas with very firm ground the Log-Over-Trench, A-2, could be used in its place. When adequate supplies of lumber, machinery, and semiskilled manpower are available, the larger shelters provide the local directors with a wide choice of design. When timber and lumber are scarce the Door-Over-Trench, A-14, offers an acceptable alternate. The Wire-Catenary-Roof Shelter, A-3, is an attractive choice in areas where fence posts and hogwire are readily available. As a last resort, the Car-Over-Trench, A-13, may be used. However, it should be noted that the Car-Over-Trench provides the most meager accommodations and immobilizes the family's transportation.

The small shelters allow much more flexibility in planning and execution than do the larger shelters. Also, they allow greater exploitation of individual initiative and unskilled manpower.

The design and construction history of each of the fifteen shelters is given in Appendix A. The advantages and disadvantages of each of the fifteen shelter designs are discussed below.

A-1 - Small Pole Shelter - The Small-Pole Shelter is the most versatile and the most thoroughly tested of all the designs. It also provides protection from blast and thermal pulse effects over the 30 psi overpressure range. It is recommended as the "shelter of choice" for all localities where conditions for its selection can be met. A preliminary survey<sup>14</sup> has shown that a large percentage of the OBE's in the (48) coterminous United States have sufficient commercial forest resources to provide timber for enough small-pole shelters to accommodate all its population.

When the water table is low enough (i.e., at least 8 ft below the surface) and where rocks near the surface either do not exist or can be avoided, the small-pole shelter can be built as an underground shelter. Where the ground water level is too high or the earth cover over the rocks is too shallow for a fully buried shelter, it can be built either as a semiburied or as an aboveground shelter. A serious disadvantage of using it as a semiburied or aboveground shelter lies in the difficulty of moving the quantity of earth needed to provide a mound over the shelter to the required three feet. Such a mound should have a slope on the outside of no steeper than 2:1 (i.e., no more than 1 foot of vertical drop to 2 feet horizontally). Further, such an aboveground shelter would not have as much blast resistance as a fully buried one.

The trench for the small-pole shelter can be dug quite rapidly by a backhoe or a small front-end loader if such equipment is available. However, lack of such equipment is no serious handicap. It is estimated that even inexperienced, suburban residents can build the shelter, including hand digging of the trench in a period of less than 48 hours.

The small-pole shelter can easily be modified in length to accommodate any size group up to 24 persons. Extending the shelter beyond that capacity complicates the construction project and ventilation, increases the difficulty of locating a suitable site, runs an unnecessary risk of friction between family groups, makes shelter management and control more difficult, and increases the risk from contagious diseases.

The small-pole shelter can even be used in wintertime on frozen ground as an aboveground shelter with snow cover. In such cases the pole-type entry can be eliminated and a tunnel entry dug through packed snow.

However, there will be some areas where there will not be sufficient timber available to make the number of expedient shelters needed.

A-2 - Log-Covered Trench - The log-covered trench is easier to build than the small-pole shelter and uses only about 2/3 the timber. On the other hand, it is not nearly so versatile. It can be built only in areas where the earth is firm enough to stand up in unsupported trenches 4-1/2 feet deep, and where the normal ground water level is greater than 6 feet deep. In some areas it may have an additional advantage over the small-pole shelter - it can be built with larger diameter logs.

A-3 - Catenary-Roof - The catenary-roof shelter (without blast entry) is the ideal shelter for areas seriously deficient in timber resources but which have reasonably large supplies of fence posts and wire fencing materials (hog wire, cyclone fence, or other strong wire netting. Caution - do not use barbed wire!) It can also be used to advantage as a blast shelter where sufficient logs are available to make the blast entryway. In such cases, the pole requirement is only one-third that of the small-pole shelter. It is a little more complicated to build than the small-pole shelter. Because it depends upon a firm earth for its walls, it can be built only as a fully buried shelter; consequently the normal water table should preferably be at least 10 feet below the original surface of the site.

A-4 - Two-Family, A-Frame Pole - The two-family, A-frame pole shelter is designed to be built either as a semiburied or aboveground model. It is particularly useful in wintertime, when the ground is frozen too deeply for digging and where deep snow is available for shielding cover. It requires about the same amount of timber per occupant as the small-pole when the pole-type entrance is used, but somewhat less when using a snow tunnel entry.

Disadvantages include:

- (1) It does not lend itself well to blast protected entryways,
- (2) It requires some skill in cutting the logs (poles) for the roof.

A-5 - Shored-Trench Stoop-In - The shored-trench stoop-in shelter is particularly useful as a blast shelter for areas in which the earth is not self-supporting (e.g., sand or other unconsolidated materials). It requires a large investment of lumber per person so this shelter must be used sparingly. It can be built by inexperienced persons in a very short period of time. Since it is primarily intended for use as a fully buried shelter, the normal water table must be at least 6 feet below original ground level at the construction site.

A-6 - Two-Family, A-Frame Lumber - When lumber is available, this shelter is an easy one for small groups (one or two families) to build. It can be built either as a semiburied or aboveground shelter. It can even be used on frozen ground with snow cover and a snow-tunnel entrance.

A-7 - Rigid Frame - The rigid frame shelter is an economical shelter to build. It can be used in soft ground as a fully buried or semiburied shelter. The aboveground model is not recommended although it is a possible variation. The size of the shelter makes it highly desirable to have mechanical excavation equipment such as a bulldozer, a backhoe, or a front-end loader. An aboveground model would be virtually impossible to cover with shielding material within 48 hours without dump trucks or other mechanical means of hauling and dumping earth. The design is simple enough for unskilled persons to build but would require extensive cooperation between well organized groups. Prior field testing is especially important in this model. The workers who conduct the field test could then be used as cadres for building the shelters during a crisis.

A-8 - Trench Wall - When mechanical excavation equipment is available and the shelter site has firm ground and a low water table, shelters of the trench wall design can give extremely rapid shelter for large numbers of persons with a minimum of lumber. Prior field tests are highly recommended. Field test crews are logical persons to use as cadres for crisis construction.

A-9 - Rigid Frame, Continuous Vent - The continuous vent model can be quite useful, particularly in summertime when ventilation becomes a serious problem. It requires mechanical construction equipment, especially for loading the roof with shielding materials. Men with wheelbarrows could accomplish the task but it would be a hazardous, time-consuming job. This model should not be used where there is danger of blast because it would be vulnerable to the high winds accompanying even low (e.g., 2 psi) overpressures.

A-10 - A-Frame (60 Person) - The A-frame (60 person) model provides somewhat less head room for its occupants than the other 60-person designs. However, it is quite easily built and can be used as either semiburied or aboveground. Although having mechanical construction equipment available would greatly speed the work, it is not absolutely necessary. Prior field testing is highly recommended. Field testing crews could then serve as cadres for the crisis construction period.

A-11 - Wood-Grate Roof - The wood-grate roof would be a good shelter to use where only plywood and 2" x 4" lumber were available (or a serious shortage of dimensioned lumber other than 2" x 4" existed). It is easy to build but does require cooperation between large numbers of people. Mechanical excavation equipment is highly desirable, particularly for the deep center trench. Prior field testing is recommended in order to have trained cadres for the crisis construction periods.

A-12 - Trailer Vans - Shelters of the trailer-van design can provide tremendous quantities of shelter quickly. The most serious disadvantages of this type of shelter are:

- (1) It requires semi-trailers which may be urgently needed for other chores at the very time they should be being buried;
- (2) It requires mechanical excavation equipment, and
- (3) It requires skilled carpenters or construction workers.
- (4) The strength of the resulting shelter is highly variable.

However, the vans need not be in good mechanical condition, so long as they can be moved into the trench and the body is reasonably intact.



A-13 - Car-Over-Trench - The car-over-trench is the least protective of the 14 shelters selected. It is extremely narrow and therefore uncomfortable. However, it does have these advantages:

- (1) Even in dry, hard earth, an unskilled urban family with pick and shovel (and a family car) can build this shelter in one day.
- (2) The occupants can carry all the equipment necessary to build it in the ordinary family car.
- (3) It can serve as a "stop-gap" measure while more elaborate shelter is being built.
- (4) It can be used in areas where other building materials cannot be found.

It is not recommended for long occupancy.

A-14 - Door-Over-Trench - The door-over-trench shelter uses a construction material likely to be available in homes almost anywhere - interior doors. Interior doors are light, compact, and easily transportable. A family with a car with a roof rack, a station wagon, or a pickup truck can take doors from their own home as they evacuate the high-risk areas. The shelter space provided is seriously limited and this shelter should be used only when other building materials cannot be found. It requires ground firm enough for earth walls at least 40 inches high to stand unsupported.

A-15 - Lumber Version of the Small-Pole Shelter - This shelter has many of the advantages of the Small-Pole Shelter. It can be built fully buried, semi-buried, or aboveground. However, it does require a large amount of lumber per person and, if it is not fully buried, may require mechanical excavation of the large amount of earth required to provide the cover.

## J. Anticipate Ventilation and Heat Problems

### 1. Minimum Ventilation Rates

The minimum standards for ventilation established by the Office of Civil Defense at 3 cubic feet per minute per occupant (cfm/occ) is based upon the necessity for keeping the carbon dioxide concentration at

a healthfully low level. Any level of ventilation below that minimum cannot be considered in expedient shelters. Ventilation rates much higher than this minimum may be required in hot weather.

## 2. Cold Weather Ventilation

It has been found<sup>15</sup> that 3 cfm/occ will probably maintain the interior of a fully occupied, uninsulated shelter which has 10 sq ft or less of floor space per occupant at or above 50°F without the use of auxiliary heaters (other than the occupants) throughout the 48 United States (Alaska and Hawaii were not considered) at ambient temperatures as low as 0°F. Therefore, an occupied, underground expedient shelter should need no auxiliary heat, provided that the ventilation is controlled to provide the standard 3 cfm/occ, and provided the occupants have warm winter clothing. (It should be noted that the car-over-trench shelter is an exception to this conclusion.)

## 3. Warm and Hot Weather Ventilation Rates

As the outside air temperature rises above the very low winter temperatures, more than the 3 cfm/occ of air will be required to remove the heat generated by the occupants. During mild weather, adequate ventilation can be obtained in most of the expedient shelters in this handbook by natural convection methods, with some adjustment of the openings required, depending on the direction and velocity of the wind.

During warm or hot weather (i.e., ambient air temperatures of 75°F or above), augmentation of natural ventilation will be desirable and may be essential. In all of these expedient shelters the required augmentation of natural ventilation can be provided by building and using Kearny Air Pumps (KAP's). KAP's can be built using only materials found in most American homes. Appendix C gives detailed instructions for building and using KAP's. In the small shelters one KAP will generally suffice. For the larger shelters it may be advisable to use at least two, one for inlet, one for exhaust. In extremely hot weather (ambient temperatures 85°F and above) the larger shelters should have small KAP's to distribute the air within the shelter and fan the occupants as well as having large inlet and outlet KAP's to supply adequate outside air.

## K. Plan to Improve the Habitability of Shelter

All of the expedient shelters considered here are extremely austere. However, after the shelters have been built and occupied, the occupants should use the time available to improve the habitability of the shelters. With the use of a little ingenuity and effort, the shelters can be made quite comfortable even though they will not be spacious or luxurious. A few methods of improving habitability are listed below; occupants should be encouraged to devise additional ones:

### 1. Improve Water Supply

Water is the most critical of all supply items for shelter living. Occupants must have enough water to maintain bodily functions and to provide sufficient sweat to cool their bodies in hot weather. Methods of improving water supply are suggested in Appendix C.

### 2. Construct Seats and Bunks

Rough seats are easily added to any of the expedient shelters except the very narrow car-over-trench shelter. Overhead bunks can be built in shelters with ceilings higher than 5-1/2 feet, as shown on the drawing of several of the expedient shelters. The best type of bunks are those shown in the small-pole shelter. The seats and bunks can be made more comfortable by covering them with sheets, quilts, or blankets brought to the shelter by the occupants.

### 3. Cover Walls and Floor

Rough boards or even logs on the floor often make a shelter more comfortable. Sheets or curtains draped on the earth walls keep sweaty, bare skin from getting muddy in warm weather, make the shelter warmer in cold weather, and keep dirt crumbling off the walls from getting into the eyes.

#### 4. Provide Safe Light and Heat

The simplest way to provide light and heat for shelters is to use candles. Many households keep an assortment of used candles to light if the power goes off. Advise all occupants of expedient shelters to bring all readily available candles to the shelter.

Another method of providing light and heat is to improvise simple lamps that burn cooking fats such as lard, bacon grease, vegetable shortening, or vegetable oil. Instructions for using materials found in almost all homes to make expedient lamps quickly are given in Appendix C.

It should be noted that although normal, healthy persons in a shelter with about 10 sq ft of floor space per occupant will probably not require augmented heat (other than their own body heat), it is advisable to have some auxiliary heat for old, sick, or very young occupants. Also, although people can survive for long periods without light, morale in shelters will be much higher if some light is regularly provided.

#### 5. Provide for Austere Cooking

Although it is advisable that most of the food brought to shelters not require cooking, morale can be greatly improved by some warm or hot meals. Provision for some cooking will require pre-planning of food and utensils. Dried foods like wheat and beans can be prepared without difficulty. Several good books are available to assist in planning for use of these dry materials.<sup>16,17,18</sup>

#### 6. Improve Sanitary Arrangements

Sanitation is one of the most critical problems of shelter living. All kinds of waste generated by the occupants must be carefully controlled and periodically removed from the shelter. Any food dropped on the floor or furnishings must be immediately picked up or scrubbed off and put into disposal bags or buckets. Human wastes are best collected in containers (preferably containers with air-tight lids) and periodically removed. During the period when the outside is too radioactive for

occupants to venture out, excrement can be put into plastic sacks or pieces of plastic which can be tied up to contain it. Excrement can then be tossed outside the shelter but flies cannot get to it or breed in it. Urine should be collected in a bucket; it can be safely emptied outside. As soon as it is safe to spend a few minutes outside, the waste should all be buried.

## 7. Prepare Food for Storage

Food brought to the shelter must be carefully stored to prevent spoilage or waste, and to avoid attracting insects. Metal, glass, and plastic air-tight containers are best. The shelter atmosphere will generally be too humid for cardboard containers. The best storage space for food is under the benches or bunks where there is little danger of its being stepped on or stumbled over. Food can also be stored near the entries where the shielding is least (this will free space with the best shielding for the occupants).

### L. Prepare Detailed Plans

It is hard to overstress the need to develop formal plans for providing expedient shelter for a community. The advent of the "All-Hazards, All-Contingency" planning at the national level provides sufficient impetus for local Civil Preparedness agencies to initiate plans immediately. The concept that a nuclear emergency is more likely to build up through an extended period of increasing tension, rather than come like a "bolt from the blue," coupled with the knowledge that the Soviet Union has a very sophisticated dispersal evacuation plan based on that concept, should alert all American civil preparedness officials to the need to develop adequate plans for a counterevacuation, including rapid improvement of existing shelters and building of new shelters. Consideration of the problems of such a counterevacuation indicates that careful prior planning is imperative to assure the effectiveness of the operation. Instructions for preparing and testing local evacuation and shelter plans is beyond the scope of this handbook. Guidance will be issued from national, regional, or state levels. However, this handbook does provide considerable assistance in implementing such guidance.

#### M. Consider Stockpiling and Establishing Precrisis Agreements

During the development of detailed local plans, it will probably become apparent that some items are, or likely will be, in short supply in time of emergency. Items most likely to be in short supply are: hand tools, lumber, polyethylene plastic, nails. Each jurisdiction should give careful consideration to the feasibility of establishing and maintaining stockpiles of a few critical items. In most areas, it is advisable to keep a current list of the owners and operators of mechanical excavation equipment and construction equipment -- particularly bulldozers, backhoes, front-end loaders, scrapers, dump trucks, and tractors. It is advisable to get pre-crisis agreements with owners and operators of such equipment to assure its availability during a crisis, and to develop plans that will assure that the persons who will operate these machines will be guaranteed shelter spaces for themselves and their families.

#### N. Plan for Selection and Training of Cadres

The selection of the shelters in this handbook was made on the assumption that no pretraining of the working crew would be feasible. However, in any jurisdiction where pretraining of cadres is feasible it is highly recommended. The construction of any shelter will be much easier if some of the workers have had previous experience building that shelter.

### III. RECOMMENDATIONS FOR FURTHER RESEARCH AND DEVELOPMENT

Experience gained in building some of the shelters shown in this handbook has demonstrated that simple step-by-step instructions are very effective in helping inexperienced persons build shelters for themselves and their families.<sup>19</sup> This experience has also demonstrated that the instructions need to be proof-tested several times and by several different types of persons to detect and correct errors and oversights. Therefore, it is highly recommended that all the designs in this handbook be subjected to rigorous proof-testing in several areas throughout the U.S. and that the results of these tests be used to refine and update the handbook.

#### IV. ACKNOWLEDGMENTS

The authors are deeply indebted to many persons for help, advice, and guidance. The financial support and guidance from the Defense Civil Preparedness Agency and the Atomic Energy Commission were indispensable for the preparation and publication of this handbook.

The leadership, encouragement, and advice of C. V. Chester are sincerely appreciated. Without the diligence and patience of Ruby Thurmer in typing and proofreading the manuscript and her expertise in detecting and correcting the authors' errors this book could never have been published.

A sincere heartfelt thanks to all who have contributed to this effort!

G. A. Cristy

C. H. Kearny

V. REFERENCES

1. "The Strategic Balance - 1971-1972," Institute for Strategic Studies, London.
2. Marshal V. I. Chuykov, "Civil Defense as Common Concern," *Nauka i Zhizn*, (Science and Life), No. 1, 1969.
3. N. I. Akimov (editor) *Civil Defense*, Kolos, Moscow, 1969, translated, edited, and published as ORNL-tr-2306, Oak Ridge National Laboratory, April 1971.
4. P. T. Egorov, I. A. Shlyakov, and N. I. Alabin, *Civil Defense*, Publishing House for Higher Education, Moscow 1970, translated, edited, and published as ORNL-tr-2656, Oak Ridge National Laboratory.
5. Yu. Yu Kammerer and A. Ye Kharkevich, *The Operation of Civil Defense Shelters*, 2nd ed. revised and supplemented, Construction Literature Press, Moscow 1970, translated, edited, and published as ORNL-tr-2745, Oak Ridge National Laboratory, October 1973.
6. E. P. Wigner, "The Myth of Assured Destruction," *Survive*, July-August 1970.
7. Mark E. Schneidar, "Six and Sixty," *Survive*, May-June 1972.
8. C. V. Chester, G. A. Cristy, C. M. Haaland, *Strategic Considerations in Planning a Counter Evacuation*, ORNL-4888.
9. "Interview with Dr. Ishwer Ojha," *Bostonia*, (Boston University Alumni Magazine), April 1972.
10. Defense Civil Preparedness Agency, *Publications Catalog*, MP20, Feb. 1972.
11. National Committee on Radiation Protection and Measurement, "Exposure to Radiation in an Emergency," Report No. 29, Jan. 1962, p. 89.
12. C. M. Haaland, "ANCET Developments for the OEP-CD Study," January 1970, unclassified data assembled for inclusion in a classified OEP-CD Study.



13. John A. Samuel, "Fallout: How Far? How Fast? How Much?" *Survive*, Vol. 5, No. 1, January-February 1972, p. 8.
14. G. A. Cristy, *Expedient Shelters Survey, Final Report, July 1973*, ORNL-4860, July 1973.
15. C. E. Rathman, *Analytic Studies of Shelter Environment*, GARD-1475-2, General American Research Division, December 1970.
16. Esther Dickey, *Passport to Survival*, Bookcraft, Inc., Salt Lake City, Utah (1969).
17. D. G. Jones, *The Soybean Cookbook*, Arc Books, Inc., New York (1968).
18. M. & A. Keys, *The Benevolent Bean*, Doubleday & Co., Inc., Garden City, NY (1967).
19. C. H. Kearny, "Hasty Shelter Construction Studies," *Annual Progress Report Civil Defense Research Project, March 1970-March 1971*, ORNL-4679, March 1972, pp. 112-122.

**VI. APPENDIXES**

APPENDIX A  
SHELTER DESIGNS

The expedient shelters included in this appendix represent the best designs presently available in the United States. Some of these designs have been tested by being constructed by small groups of rural or urban Americans with little or no previous building experience; some have been built by U.S. Army troops who, though disciplined soldiers, were not experienced builders; one was built by two carpenters; some were built by Engineer troops led by experienced Engineer leaders; and some have not been built at all.

Other designs have been reviewed and evaluated by the authors.<sup>1\*</sup> Any design not included has been rejected for one or more of the following reasons:

1. Too difficult for inexperienced groups to build under emergency conditions;
2. Too expensive in materials;
3. Requires tools, equipment, or materials that will not be readily or widely available in a crisis situation; or
4. Takes too long to build.

Some of the ones included could have been ruled out for one of these reasons but were retained in the interest of presenting a fairly broad spectrum of type of shelter from which the local civil defense director can choose.

The detailed instructions and the pictorial drawings for construction of the shelters are printed separately for each of the fourteen shelters. The instructions and drawings need to be supplemented in nearly every case by additional instructional material which has been printed here as separate appendices (B, C, D, and E). A separable introductory page is included at the beginning of each shelter package giving the design and construction history of that particular shelter. These introductory pages should prove useful to local civil defense directors in evaluating the practicality of each shelter for use in his locality and circumstances.

---

\* Numbers indicate references located at the end of Appendix A.

#### A-1. Small Pole Shelter

This shelter is a modification of a Russian design. The first modifications were made by C. H. Kearny who pioneered in the development of detailed, written, well illustrated instructions which can be used by inexperienced Americans as the only guidance to build expedient shelters under crisis conditions within a 48-hour period. (This 48-hour period includes the time required to cut and haul poles to the building site.) The first shelter (called Hasty Pole Shelter at that time) was built in eastern Tennessee by three small families headed by men typical of non-farming rural or suburban Americans.<sup>2</sup> Two other shelters were built by two groups of men using mechanized equipment, and a fourth shelter was built using creosoted poles by city employees of Athens, Tennessee.<sup>2</sup> Lessons learned from these tests were incorporated into other instructions which were used by members of one platoon of the 82nd Airborne Division to build two double-size (24-person capacity) shelters as a part of Exercise Laboratory Shelter.<sup>3</sup> Two half-scale prototypes of this shelter were built and successfully tested at 29 psi overpressure as part of the 1,000,000 lb TNT blast in Operation Mixed Company.<sup>4</sup> These instructions are paraphrased from the instructions used by the 82nd Airborne Division soldiers at Ft. Bragg, N.C., and incorporate all the information available from the extensive testing program on this remarkably strong, extremely versatile shelter.

Locally published instructions for this shelter should include Appendixes B, C, D, and E.

A-1-i

A-1

SMALL-POLE SHELTER  
(Capacity 12 Persons)

1. This expedient shelter has a protection factor (PF) greater than 1000 if covered with 3 ft of earth - that is, an occupant of this shelter would receive less than 1/1000th of the radiation from fallout that he would receive outside in the open. Furthermore, this shelter would give good protection against thermal radiation and the fires that large nuclear explosions, even 30 to 40 miles away, could ignite. Calculations and a blast test have shown that in most soils this shelter can survive and save its occupants from blast overpressures over 30 pounds per square inch. Such a pressure would destroy most buildings.

2. For 12 persons to successfully live for days in this shelter, the benches and bunks must be built with the dimensions and spacings given in the pictorial view. Then 3 persons out of the 12 can sleep in shifts on the overhead bunks, while the remaining persons can sit with plenty of head room. On each side of the shelter there should be 9 feet of benches and 9 feet of overhead bunks.

3. Study both of the two drawings and read all of these instructions before beginning work. THEN CHECK OFF EACH STEP WHEN COMPLETED.

4. Materials required for building a 12-person small-pole shelter:

- a. Green Poles - with no pole having a smaller diameter top (= small end) than the minimum diameter specified for its use by the drawings. Table 1 lists the required number and sizes.
- b. Rainproofing Materials
  - (1) Preferably one 100-ft roll, 12-ft-wide, 6-mil polyethylene, or at least 200 sq ft of 6-mil polyethylene, or at least 100 sq ft of other waterproof plastic, plastic table cloths, shower curtains, and/or linoleum rugs.
  - (2) Three hundred feet of sticks, 1/2-in. to 1-1/2 in. in diameter, of any lengths (for drains).

Table 1

Length	Minimum Diameter (= Diameter of Top)	Number of Poles Required	Width <sup>c</sup>
6 ft, 2 in.	5 in.	2	---
3 ft, 1 in.	5 in.	6	---
10 ft, 8 in.	4-1/2 in.	-	9 ft
10 ft, 6 in. <sup>b</sup>	4-1/2 in.	2	---
7 ft, 2 in.	4-1/2 in.	-	43 ft
5 ft, 6 in. <sup>a,b</sup>	4-1/2 in.	8	---
2 ft, 3 in.	4-1/2 in.	8	---
7 ft, 2 in.	4 in.	-	12 ft
6 ft, 3 in.	3-1/2 in.	4	---
5 ft, 6 in. <sup>a,b</sup>	3-1/2 in.	10	---
3 ft, 10 in.	3-1/2 in.	-	15 ft
10 ft, 6 in. <sup>b</sup>	3-1/2 in.	2	---
2 ft, 2 in.	3-1/2 in.	6	---

<sup>a</sup>To be cut to fit for crossbraces.

<sup>b</sup>These poles for the horizontal bracing should have tops with diameters no more than about 15% larger than the minimum diameters specified.

<sup>c</sup>Distance measured across a single layer of poles when a sufficient number of poles are laid on the ground side by side and touching, so as to cover a rectangular area.

NOTE: The above list does not include flooring materials, to be placed between the bottom crossbraces. Scrap boards, poles, sticks, etc., will serve.

## c. Nails, Wire, and/or Cord

Ten pounds of 40-penny nails plus 4 lbs of 16-penny nails are ideal. However, 7 lbs of 16-penny nails can serve. Nails are useful but not essential - for you can use wire, cord, or rope instead of nails to hold crossbraces, etc., in place until earth pressure tightens all parts of this shelter and holds it together.

## d. Boards for Benches and Overhead Bunks

(Boards are desirable, but not essential.)

- (1) 2" x 4" boards - 70 feet for frames (or use 3-in.-diameter poles).
- (2) 1" x 8" boards - 100 feet (or use 1-in. to 2-in.-diameter poles).

5. To cut and haul poles more easily and safely, study the instruction sheet, Appendix E, HOW TO CUT AND HAUL LOGS AND POLES MORE EASILY.

6. Desirable tools for building a 12-person, small-pole shelter:

<u>Tools</u>	<u>Quantity</u>	<u>Tools</u>	<u>Quantity</u>
Axe, long handle	2	Hammer, claw	2
Saw, bow, 28-inch	2	File, 10-inch	1
Saw, cross-cut, 2-man	1	Tape, steel, 10-ft	1
Pick	2		
Shovel, long handle	3		

(Also useful: a 50-ft steel tape and 2 hatchets)

7. To save time and work, sharpen all tools, and keep them sharp.

8. Wear gloves from the start - even tough hands can blister after hours of digging and chopping. Blisters are painful, seriously slow the work, and could result in dangerous infections.

9. Before staking out the outlines of the excavation, check for rock depth - by driving down a 6-ft, sharpened small pipe or rod. To avoid groundwater problems, avoid low ground.

10. To help drain the floor, locate the shelter so that the original ground level at the entrance is about 12 inches lower than the original ground level at the far end of the shelter.

11. Stake out the trench for the entire shelter. Even in very firm ground, at the surface make the excavation 9 ft, 8 in. wide and 18 ft long (3 ft longer than the entire length of the wooden shelter). The sloping sides of the excavation are necessary, even in firm earth, to provide adequate space for backfilling and tamping.

12. Check the squareness of the staked trench outline by making its diagonals equal.

13. Clear all brush, tall grass, etc., off the ground to a distance of 10 ft, all around the staked location — so that later you can easily shovel loose earth back onto the roof.

14. If excavating in unstable ground, excavate with appropriately less steep sides.

15. When digging the trench for the shelter, use a stick 7 ft, 8 in. long (the minimum bottom width) to repeatedly check excavation width.

16. When digging with a shovel, pile the earth dug from near ground level about 10 ft from the edges of the excavation. Then earth dug from 5 or 6 feet below ground level can easily be piled on the surface only 1 to 5 ft from the edge of the excavation.

17. Finish the bottom of the excavation so that it slopes 1/2-inch vertically per foot of length toward the entrance, and also slopes toward the central drain ditch — in which will be placed sticks covered with porous fabric, to serve like a crushed-rock drain leading to a sump.

18. While some persons are excavating, others should be cutting green poles and hauling them to the site. Cut poles having tops with diameters (not including bark) no smaller than the diameters specified for each type of pole.

19. For ease in handling the wall and roof poles, select poles with top diameters no more than 50% larger than the specified minimum diameters.

20. Sort the poles by size and lay all poles of each size together, near the excavation.

21. Before a shelter is completed, some workers should provide for essential forced ventilation in warm or hot weather by building an expedient Kearny Air Pump (KAP). Carefully follow the instructions given in Appendix B. (For additional information on expedient water storage, lights, and sanitation measures, see Appendix C.)



22. Before the excavation is completed start building the ladder-like, horizontal parts of the shelter frame. Construct these parts on smooth ground near the excavation. Place two straight poles, each 10 ft-6 in. long (with small-end diameters of 3-1/2 to 4 in.), on smooth ground, parallel and 6 ft, 2 in. apart. Securely hold these poles so that their outer sides are exactly 6 ft, 2 in. apart, by driving into the ground two pairs of stakes so that they just touch the outsides of the two longitudinal poles. Each of the four stakes should be located about one foot from the end of a pole. To keep the 10 ft, 6 in. poles from being rotated, during the next step, nail two boards or small poles across them perpendicularly, as temporary braces about 4 feet apart.

Then with an axe or hatchet, slightly flatten the inner sides of the two poles at the spots where the ends of the 6 cross braces will be nailed. Next saw each cross brace pole to the length required to fit snugly into its place, and toenail each cross brace in place, preferably with two 40-penny nails in each of its ends.

23. Place the lower, ladder-like part of the shelter frame of the main room on the floor of the excavation.

24. Build the frame of the main room. Secure the vertical poles in their vertical positions by nailing, wiring, or tying temporary diagonal brace-boards (or small-diameter, temporary brace-poles) to their inner sides and to the inner sides of the longitudinal frame poles on the bottom of the excavation. To keep the vertical frame poles exactly 6 ft, 2 in. apart until the ladder-like upper horizontal part of the frame is secured in position, nail a temporary horizontal brace across the vertical frame poles, about a foot below their tops.

25. To support the ladder-like upper horizontal part of the frame, nail blocks to the inner sides of the vertical frame poles (as shown in the upper right-hand corner of the pictorial view). If you have big nails, use a block about 3 inches thick and 6 inches long, best cut from a green, 4-in.-diameter pole.

26. In the finished shelter, do not leave vertical poles under the upper longitudinal poles; to do so would seriously reduce the usable space for benches, bunks, and occupants.

27. While some workers are building the frame of the main room, other workers should be making the rectangular entrance frames and then the complete entrance. To keep the rectangular entrance frames square during construction and backfilling, nail a temporary diagonal brace across each one.

28. Once all frame poles of the main room are in place, put the vertical wall poles between the frame poles, touching each other, until all walls are completed. When placing the wall poles, keep them vertical by alternately putting a butt and a top end uppermost. Wall poles can be held in position by backfilling and tamping about a foot of earth against their lower ends, or they can be wired in position until backfilled.

29. Be sure to use the two 5-in.-diameter poles, each 6 ft, 2 in. long, by placing one next to the top and the other next to the bottom of the doorway to the main room. Use braces, each 2 ft, 3 in. long, to hold the top and bottom of this doorway apart.

30. To prevent dirt from coming through the larger cracks between wall poles, cover the cracks with plastic, rugs, roofing, scrap lumber, sticks, or even cardboard.

31. After all horizontal bracing and vertical wall poles are in place, begin backfilling, putting earth between the walls and trench sides. Pay particular attention to the order of filling. The earth fill behind all the walls must be brought up quite evenly, so that the earth fill behind one side is no more than 12 inches higher at any one time than the earth on the opposite side. Tamp earth fill in 6-inch layers. Do not use a mechanical tamper. A log makes a good tamper.

32. Next, lay the roof poles side by side, touching each other. Cover at least the larger cracks with plastic, roofing, boards, or sticks to keep dirt from falling through. If the earth is sandy, cover the whole roof with some material (such as bed sheets or even several thicknesses of newspaper) to keep sand from running through cracks.

33. CAUTION: Do not try to rainproof this flat roof, and then simply cover it with earth — because, if you do, water will seep straight through the loose earth cover, puddle on the flat roofing material, and leak through the joints between pieces of roofing material or through small holes in the roofing material.

34. Mound earth over the shelter, piling it about 15 inches deep along the center line of the roof and sloping it toward the sides of the roof, so that the earth is only about 2 inches deep over the ends of the roof poles. (Preparatory to mounding earth onto the roof, place grade-stakes in position, so you will be able to know the locations and depths of roof poles as you cover them.) Continue these slopes to two side drainage ditches (that are to be buried later, as shown in the drawing). Smooth this mounded earth with a rake, and remove any sticks or rocks likely to puncture the rainproofing roofing material to be laid on it later.

35. Place rainproofing material (preferably plastic film, such as 6-mil polyethylene — or roofing, plastic shower curtains and table cloths, or canvas) on top of the smooth, mounded earth, as shown in sections of the drawings.

36. Place the rest of the earth cover over the shelter, being sure that the corners of the shelter have at least 2-1/2 feet of earth over them. Mound the dirt, smoothing its surface so that water will tend to run off to the surface drainage ditches which you should dig on the two sides.

NOTE: If enough rainproofing material is available, the buried drain ditches can be omitted by continuing the buried-roof rainproofing material, sloping it all the way out to the surface drain ditches around the outermost edges of the mounded earth cover.

37. To install a 36-in.-long x 24-in.-wide KAP (Kearny Air Pump) — to keep a crowded shelter from dangerous overheating in warm weather — narrow the ends of the overhead bunks so that the aisle between them is about 28 inches wide for a distance of 38 inches from the doorway.

38. Build the benches and overhead bunks. If available, use boards. If not, use small, straight poles. On each side, build a row of benches and bunks 9 ft long, centered in the shelter. In order to use the shelter space to the greatest advantage, make the heights and widths of the benches and bunks the same as the thoroughly tested heights (14 in., and 4 ft-5 in.) and widths (16 in., and 24 in.) given by the drawings. Also be sure

to space their vertical supports 3 ft apart — so two men can sit between each pair of vertical supports.

39. Place a fly or canopy — open on all sides — over the entrance, to minimize the entry of sand-like descending fallout particles. The plan and elevation drawing shows a "plastic fly cover," its ridgepole, and one of its two vertical pole supports. Such a fly also can be made of canvas or shower curtains with wires or cords connected to the fly corners and to 4 stakes.

40. To improve the floor, lay small poles (or sticks covered with scrap boards) between the lower brace poles, so that the floor is approximately level.

41. If the water table is very near the surface and gravity drainage by ditching is not practical, this shelter should be built in a shallower excavation, or even on the surface. However, the mounded earth should slope not more steeply than 2:1, and mechanized earth-moving equipment probably would be necessary to cover it adequately within 48 hours of a typical civilian group's beginning construction.

42. Expedient Ventilation — Cooling. (If pushed for time, those workers who are only going to work on the shelter itself need not read this section before beginning their work.)

Install a 24" x 36" KAP near the top of the doorway. (See Appendix B for instructions.) To enable the KAP to efficiently pump fresh air from the outdoors all the way through the shelter, block the lower half of the KAP doorway with a quickly removable covering, such as a plastic-covered frame made of sticks. Be sure to connect the KAP's pull-cord only 11 inches below its hinge line. This prevents excessive arm motions which would cause unnecessary fatigue.

In windy or cold weather, control the natural flow of air through the shelter by hanging adjustable curtains in the doorways at both ends, and/or by making and using trapdoors on the tops of the vertical entryway. For an adjustable curtain, use a piece of plastic with a supporting stick connected to its upper edge — so that you can provide different sized openings in the doorway above the top of the adjustable curtain.

Even in the coldest weather, in order to occupy this crowded underground shelter for hours without getting headaches, or worse, from breathing too much exhaled carbon dioxide, it is necessary that about 3 cubic feet per minute of air from the outdoors should flow through the shelter for each shelter occupant. An airflow of 36 cfm (3 x 12) is enough for 12 persons. This very slow-moving but essential airflow can be checked by repeatedly dropping a dry piece of toilet paper measuring only 1/4 in. and 1/2 in. Drop this small piece of paper in the center of the shelter, from a height of 7 ft, being careful that no one breathes toward it. If on the average this paper lands on the floor about 1-1/2 inches off the vertical and consistently in one direction, then about 36 cfm is flowing through the shelter.

Smoking produces carbon monoxide, which causes severe headaches under ventilation conditions which, though austere, are adequate when no one smokes.

43. When building a shelter for more than 12 persons, increase the illustrated 10 ft-6 in. length of the main room by one ft for every person beyond 12. Furthermore, to assure adequate cooling-ventilation (especially in warm or hot weather) for Small-Pole Shelters sized for 12 to 24 persons, the ventilation duct should be replaced by a second full-sized entryway.

44. If more than 24 persons are to be sheltered, build two or more separate shelters.

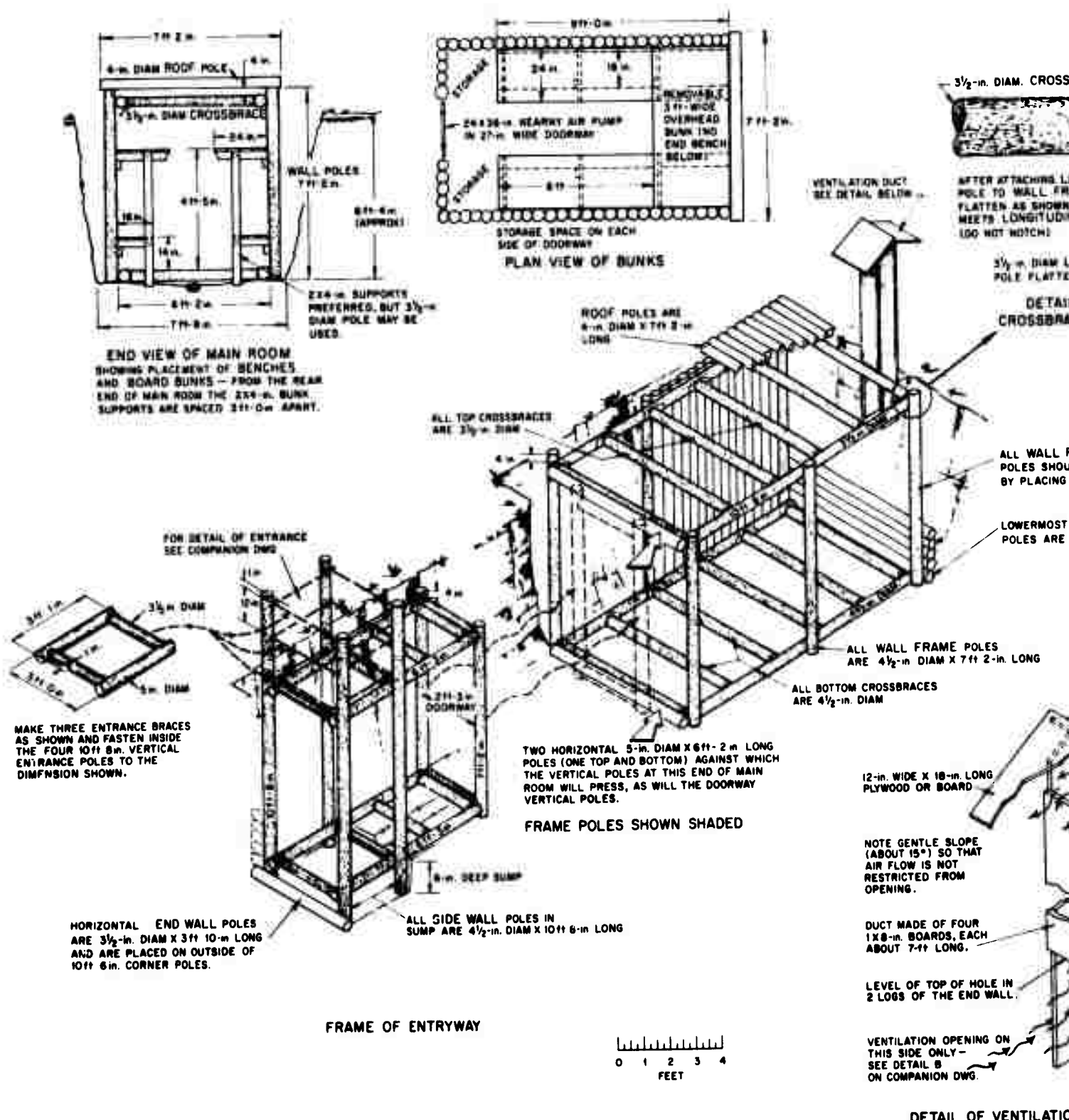

Fig. A-1.1. Small-Pole Shelter, Pictorial View.

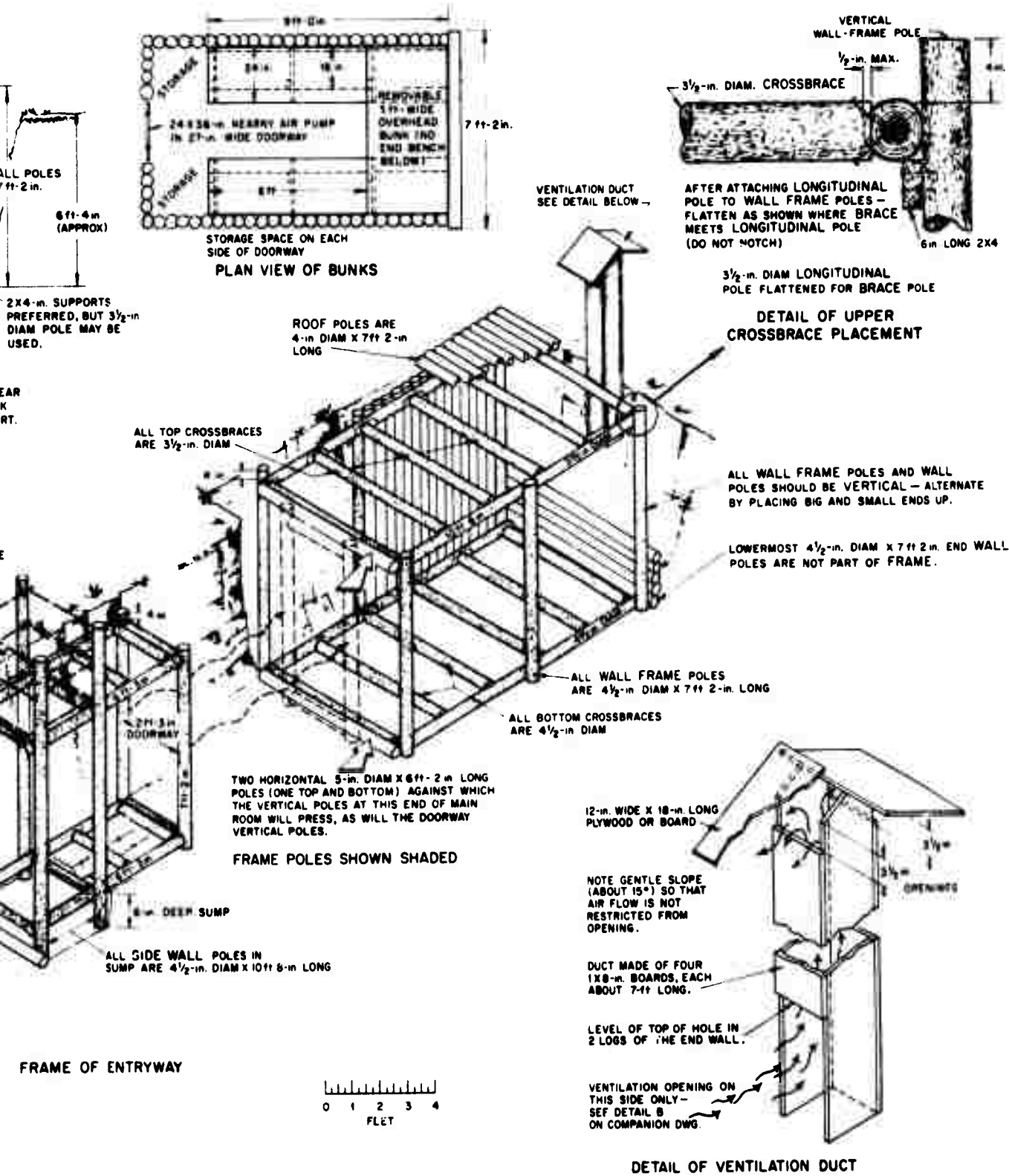

Fig. A-1.1. Small-Pole Shelter, Pictorial View.

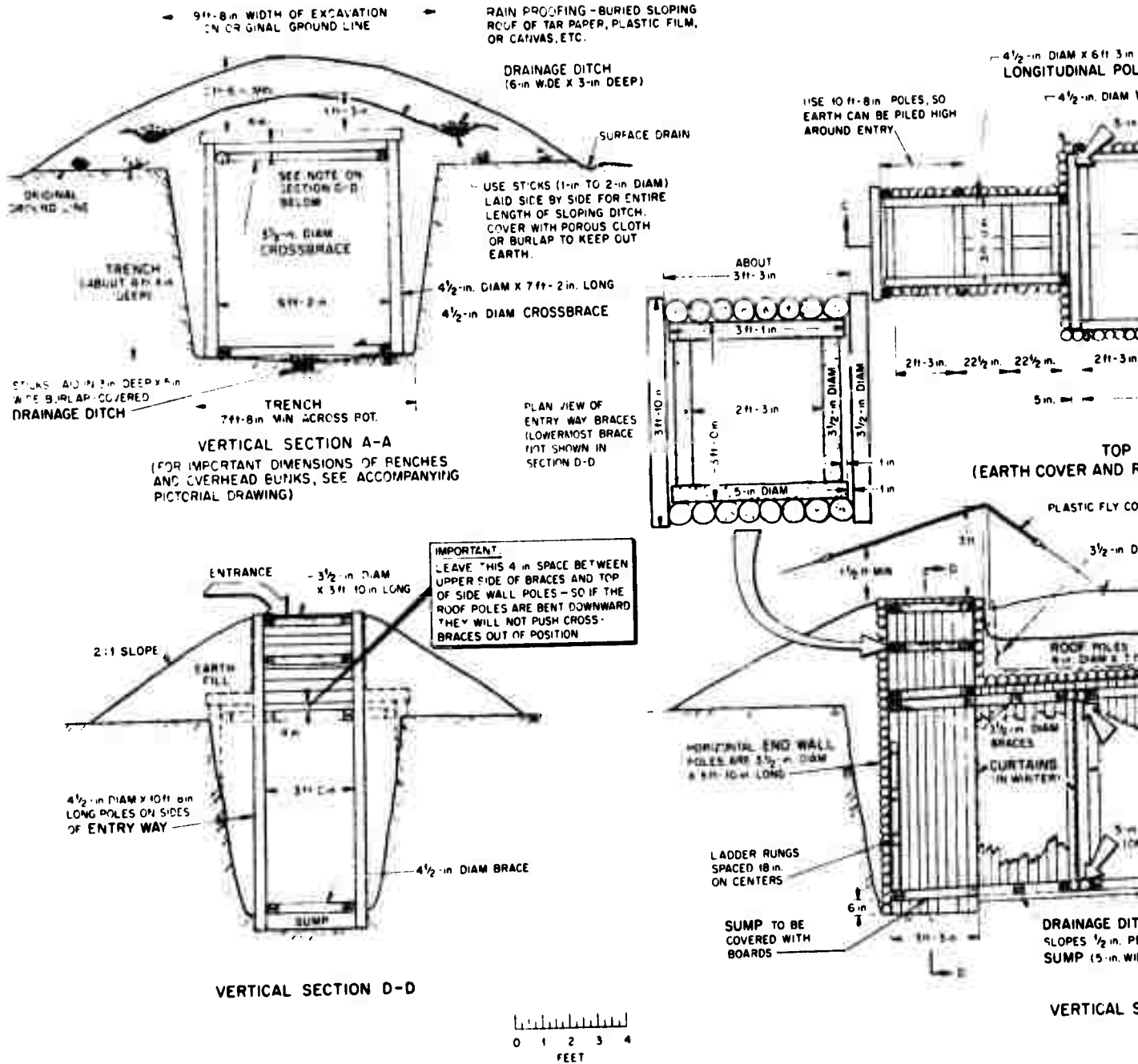
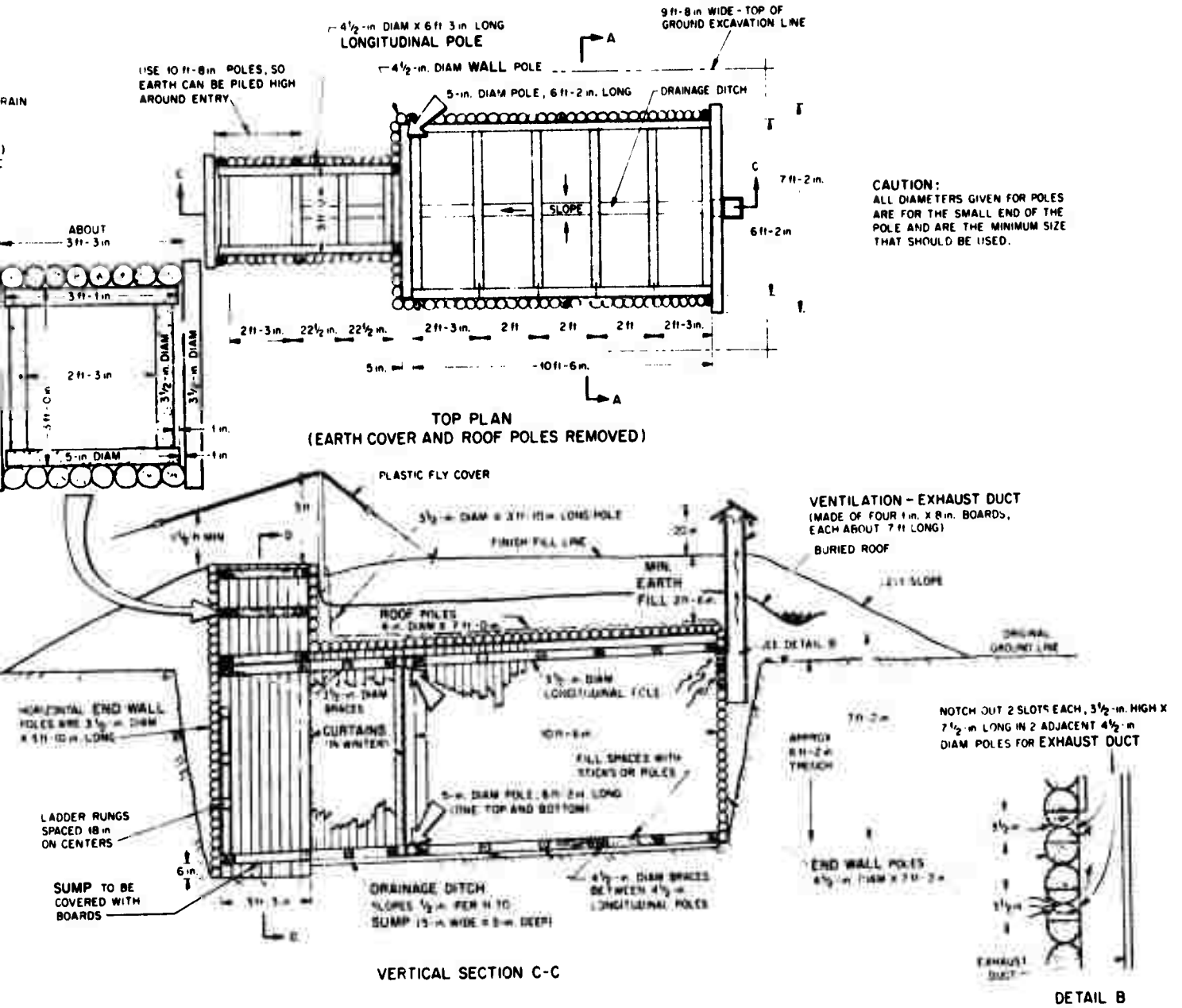

Fig. A-1.2. Small-Pole Shelter, Plan and



TOPPING  
FILM,

RAIN



A-1.2. Small-Pole Shelter, Plan and Elevation.

## A-2. Family-Size, Log-Covered Trench

Various models of this simple shelter have been built as parts of C. H. Kearny's shelter-building experiments. The first model<sup>5</sup> was built by laborers at ORNL. It was 30 ft long, 6.5 ft deep, and 6 ft wide at ground level (3.5 ft wide at floor level), and had 12-ft-long roof logs. This model pioneered the "buried roof" polyethylene waterproofing and the Russian-style stick-filled drains which have been included in some of the shelters in this handbook. A second model, a smaller version<sup>5</sup> also built by ORNL laborers, was 8 ft long, 4 ft wide, and 4.5 ft high, roofed by 8-ft-long logs with 3 ft of earth cover. Two additional log-covered trenches were built<sup>2</sup> by two East Tennessee families with no previous experience and using only hand-powered tools, guided only by the Kearny-developed, step-by-step instructions. One shelter, for 8 persons, was 16 ft long and was built in 28.7 hours using 92.2 person-hours or 12 person-hours per shelter space. The other for 4 persons was 8 ft long and was built in 27.7 hours using 69.2 person-hours or 17 person-hours per shelter space. (Note: These times include the time spent cutting trees and hauling logs to the site.) A one-meter-wide, log-covered trench shelter was built<sup>6</sup> in soil frozen one ft deep in Colorado by experienced lumbermen using a bulldozer with a ripper blade to break the frozen ground. Due to rock being encountered at only 4-1/2 ft, the trench was excavated only 4-1/2 ft deep; therefore, it could be used only as a 5-person, austere stoop-in shelter. It required 15 minutes of bulldozer-ripper time plus 28 man-hours, or 5.6 man-hours per space.

The instructions for constructing the log-covered trench are based upon C. H. Kearny's experiences in having untrained Americans build this type shelter.

Locally published instructions should include Appendixes C and E.

A-2-i.

ONE-FAMILY LOG-COVERED TRENCH SHELTER  
(Capacity 4 Persons)

Practical construction tests have shown that an average rural family in a wooded area can build this shelter for themselves in 48 hours or less including felling the trees.

CAUTION: This shelter should be dug only in very firm earth that will stand in vertical banks about 5 feet high, provided the bank soil is kept dry. Make sure that the earth is firm and stable enough so that the walls of the trench will not cave in. As a test, dig a small hole about 18 inches deep. Remove all loose earth from the bottom of the hole and then try to push a bare thumb into the undisturbed (natural state) earth in the bottom of the hole. If the thumb can be pushed into the earth no further than one inch, the earth should be suitable for this type of shelter. If the earth does not pass this test, move to another location and try the test again. Continue to relocate and repeat until suitable earth is found. (If the earth is not stable, build a Small-Pole Shelter or an A-Frame Pole Shelter.)

The special shape and thick earth covering of this shelter are designed to give maximum protection, while requiring a minimum of hours of work to secure this good protection. (Using only hand-powered tools and starting with standing trees, only 12 to 18 person-hours of work per person sheltered are required in average-to-hard soils.) The 3 ft of earth on its log roof, combined with the special crawlway entrance, permit less than one one-thousandth (1/1000) of the outside fallout radiation to reach a person inside this shelter. (Three feet of earth cover overhead gives about 100 times as much protection against fallout radiation as does one foot of earth overhead.)

Once this simple covered-trench shelter has been built — as time permits — shore up (strengthen) the entrance and walls, make homemade lights and furnishings, and, in hot weather, a KAP ventilating pump.

RECOMMENDED CHECK LIST FOR BUILDING THIS SHELTER

1. Before doing any work, read and study all of the following instructions.
2. Sharpen all tools before starting to work and keep them sharp. A dull saw, pick, shovel, or axe will increase the difficulty of the work.
3. Wear gloves from the start — even tough hands can blister after hours of digging and chopping. Blisters are painful, seriously slow the work, and could result in dangerous infections.
4. If possible, select a location for the shelter that is in the open and at least 50 feet from a building or woods. Remember that on a clear day the thermal pulse (flash of heat rays) from a large nuclear explosion may cause fires tens of miles away.
5. If on steeply sloping ground, locate the shelter with its length crosswise to the direction of the slope.
6. Whenever practical, face the shelter entrance away from the nearest probable enemy target, such as the center of a nearby city. The blast from a 25-megaton air burst can wreck a frame house 15 miles away.
7. Stake out the outlines of the trench, driving stakes as shown in the two accompanying drawings.
8. Clear the ground of saplings and tall grass within 10 feet of the staked outlines — so that later the excavated earth can be easily shoveled back onto the completed shelter roof.
9. Start digging, throwing the first earth about 10 feet beyond the staked outlines of the trench. Less able members of the family should do the easier digging, near the surface, while the best axe and saw men cut and haul logs.
10. Pile all excavated dirt at least 3 feet beyond the edges of the trench, so roofing logs can be laid directly on the ground.

11. Get only fresh-cut or sound dry logs. For a 4-person shelter (with a 10-ft-long room) the following number of logs will be needed.

No. of Logs (if minimum diameter)	Minimum Length	Minimum Diameter (small end)	Use
27 <sup>a</sup>	7 ft	4-1/2 in.	Trench roof
18	5 ft	4-1/2 in.	Trench roof
2	6 ft	6 in.	2 sides of the ventilation hole
2	7 ft	6 in.	2 sides of the entrance hole
4	2 ft	6 in.	Other 2 sides of ventilation and entrance holes

<sup>a</sup>Add 2 feet of main trench length (requiring five or six more 7-ft logs) for each additional person to be sheltered.

12. Follow the advice of the attached suggestion sheet (Appendix E), "How to Cut and Haul Logs and Poles More Easily."

13. While some members of the family are digging the shelter, others should get the following rainproofing materials for the roof of a shelter with a 10-ft-long main room: about 25 square yards of tar paper or plastic film, or shower curtains, or canvas, or other water-shedding material.

14. To provide adequate ventilation and cooling, at the far end of the shelter dig the illustrated ventilation-emergency exit trench 15 in. deep x 18 in. wide. (Even a big man can get out of this opening quite easily, by wriggling out on his back with his arms extended forward.) In cool weather or when fallout is descending, canvas or plastic curtains should be hung in the openings to control air flow.

15. Lay the logs side by side over the shelter, starting with the 7-ft log next to the shelter entrance — as shown in the plan. Be sure to keep the small ends of the logs together as shown until the logs lie straight across the main room; then, alternate large and small ends to keep them straight across the room.

16. Cover or fill the cracks between the logs with sticks, cloth, leaves, metal pieces (flattened tin cans), or any other material that will keep dirt from running down between the cracks. If weak material such as sheets or thin plastic is used, fill the bigger cracks first with sticks, to keep the earth which will later be piled on the log roof from breaking the weak covering material.

CAUTION: DO NOT try to rainproof this flat roof, and then simply cover it with earth — because then, water will seep straight through the loose earth cover, puddle on the flat roofing material, and leak through the joints between pieces of roofing material or through small holes in the roofing material.

17. Place 6-ft-long logs, one on top of the other, next to the entrance to keep earth to be placed on top of the logs covering the crawlway entrance from falling into the open entrance. Secure these logs — best by wire. (See VERTICAL LONGITUDINAL SECTION, Figure A-2.2.)

18. Mound earth about 18 in. deep in the center over the shelter roof (as shown in "VERTICAL CROSS SECTION"), to form the surface of the future "buried roof." Smooth this mounded earth surface, removing sharp objects that might puncture thin rainproofing materials to be placed upon it. At the edges of the area to be covered with rainproofing materials, dig small, sloping drainage ditches, as shown. Make buried drains (best made by lining the bottom of ditches with waterproof materials, then placing sticks 3/4-in. to 1-1/2-in. in diameter as shown, and putting sacking or other porous material on top of the sticks to keep earth from stopping up the spaces between the sticks).

19. Spread the waterproofing material in shingle-like fashion, starting at the lower sides of the mounded earth.

20. Cover with another 18 inches of mounded earth in the center, and smooth this final earth surface.

21. Finish the entrance by putting some shorter boards or logs between the two large logs shown in Plan view, and bank earth at least 7 in. deep around the sides of the entrance, so that rain water on the ground cannot run into the shelter entrance.

A-2.5

22. Dig surface drainage ditches around the outside of the mounded earth over the logs, and around the entrance.

23. Place a piece of water-shedding material over the entrance, like an open-ended canopy or tent fly, so that most rain will not fall into the shelter, and most of any fallout would settle on this suspended canopy, rather than fall, like sand, into the shelter opening.

24. As time and materials permit, continue improving the livability of the shelter by doing such things as:

- (a) Build the bench shown in Detail A.
- (b) Cover the side walls and floors with plywood, small boards, cloth, etc. Covering is best done before placing the roof logs over the trench.
- (c) Make expedient lights (see Appendix C).

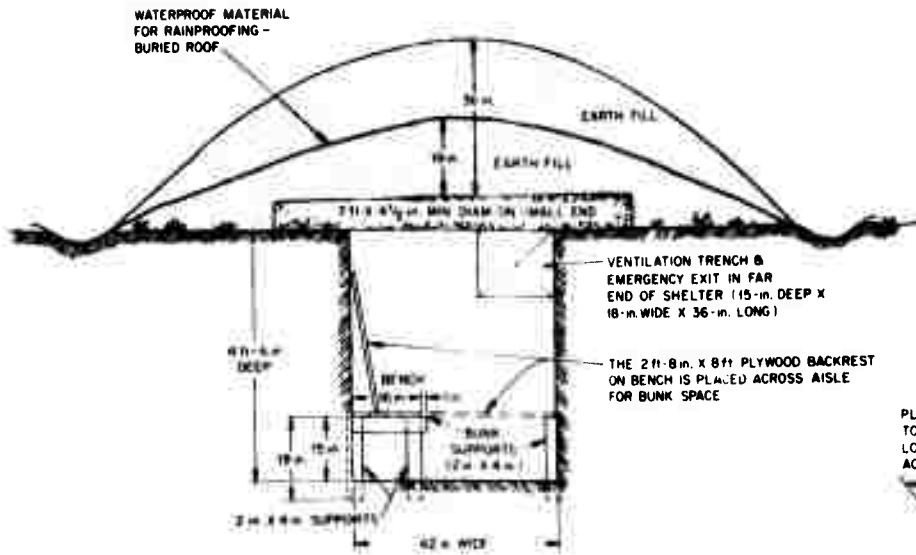

DETAIL A - A CROSS SECTION OF MAIN ROOM WITH BENCH AND BUNK SUPPORTS IN PLACE.

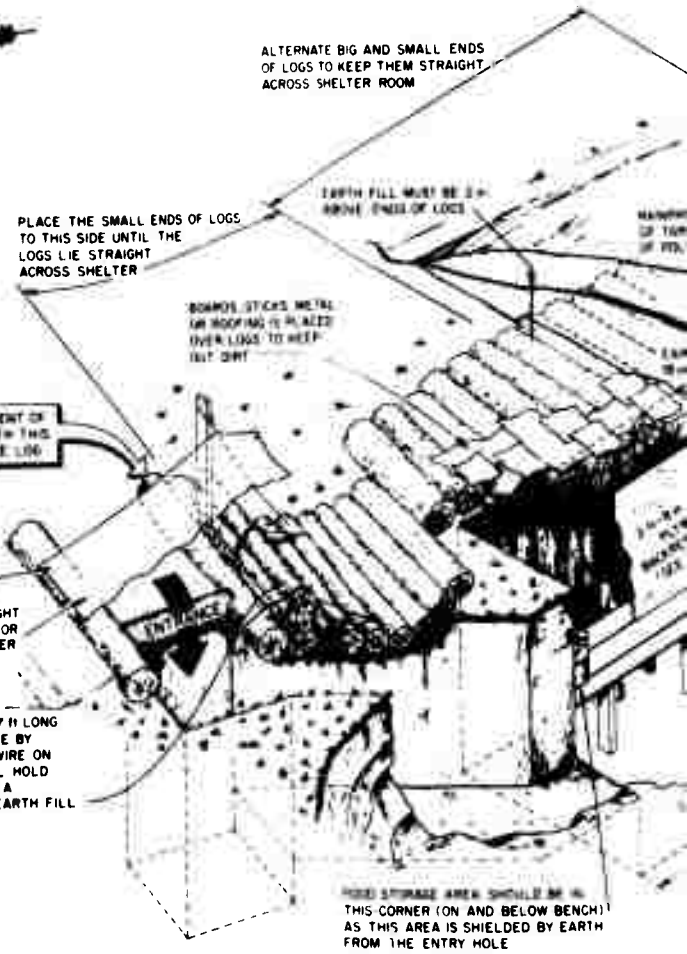
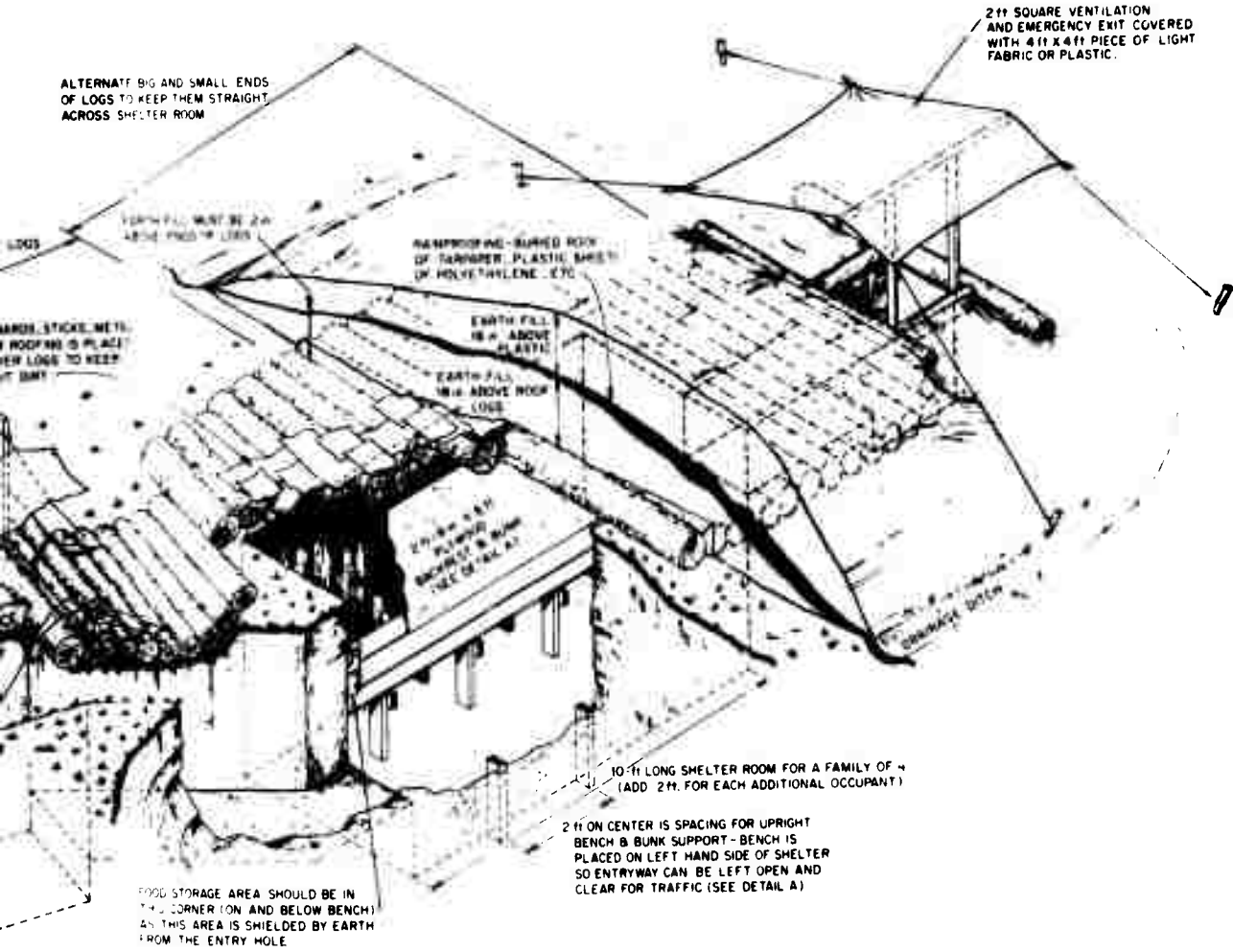

Fig. A-2.1. Log-Covered Trench Shelter, Pictorial View



ORNL - DWG 71-1663R2



Trench Shelter, Pictorial View.

A-2.7

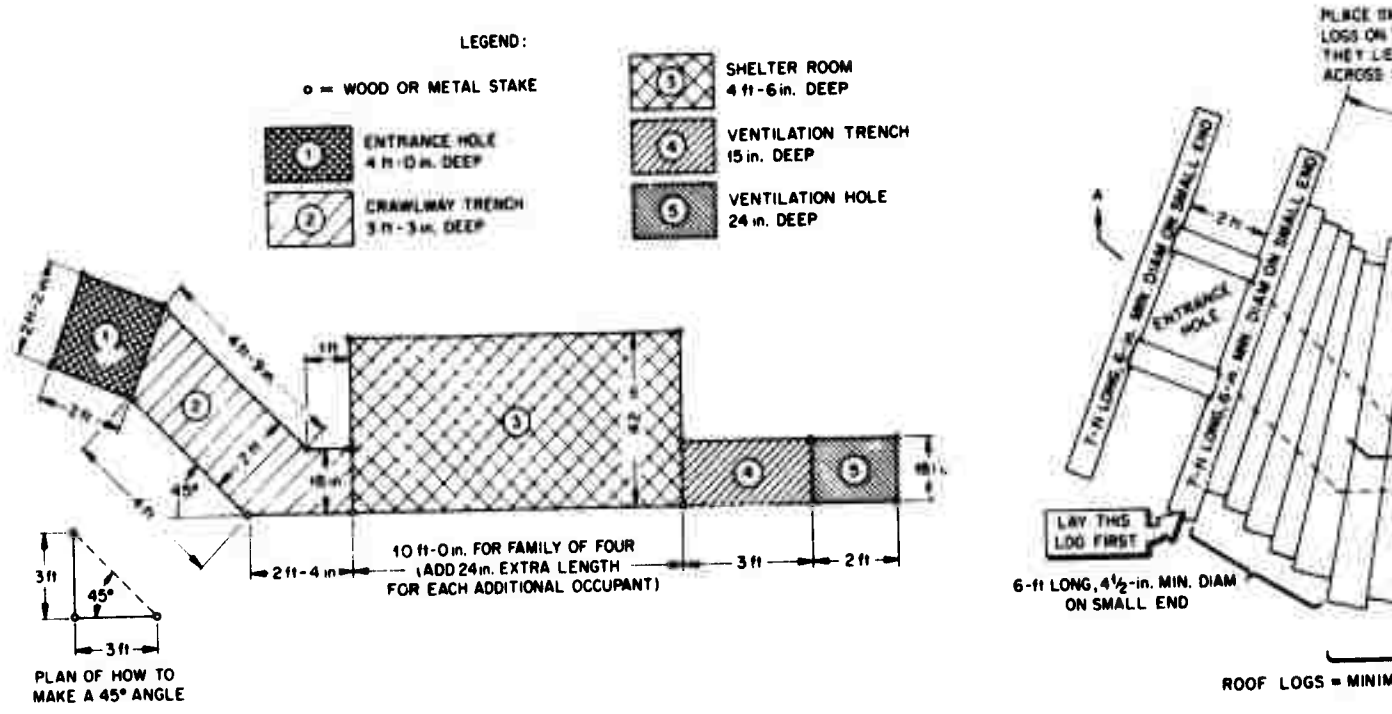

PLAN FOR STAKING OUT TRENCH ON TOP OF GROUND (SEE LEGEND FOR 5 DIFFERENT DEPTHS OF TRENCH)

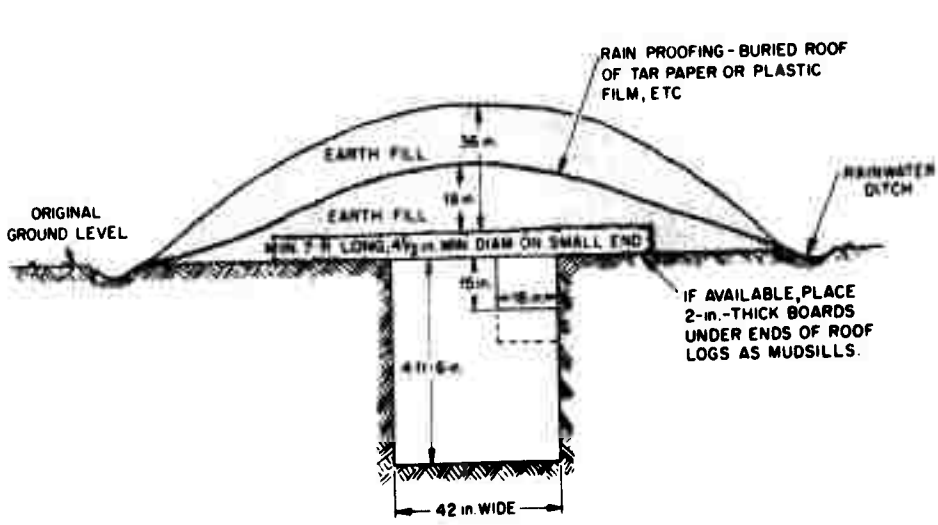

VIEW B-B', CROSS SECTION THROUGH WIDTH OF TRENCH SHELTER

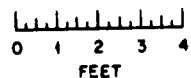
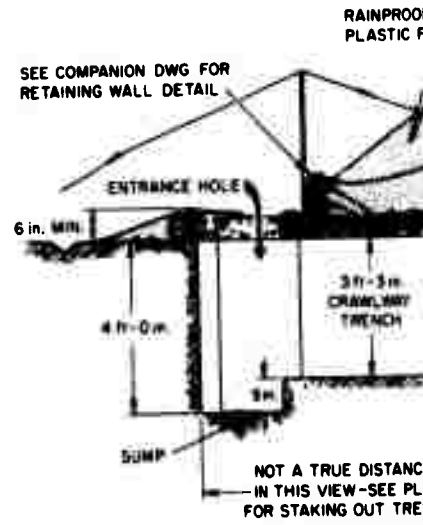
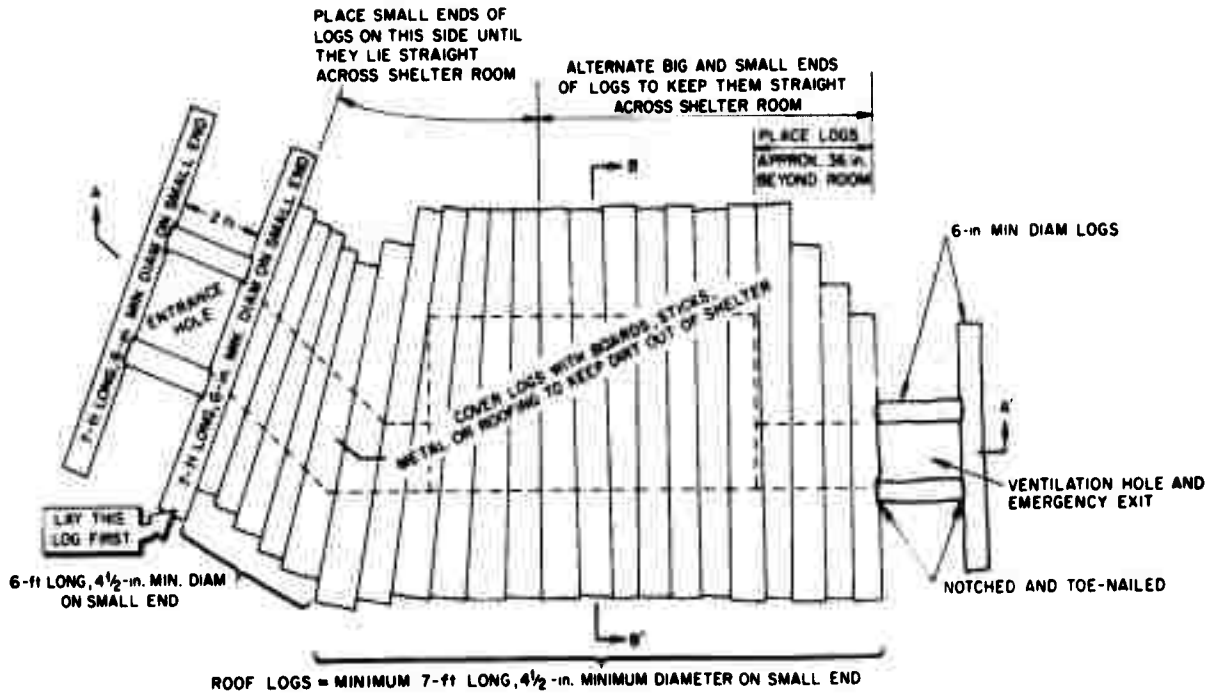
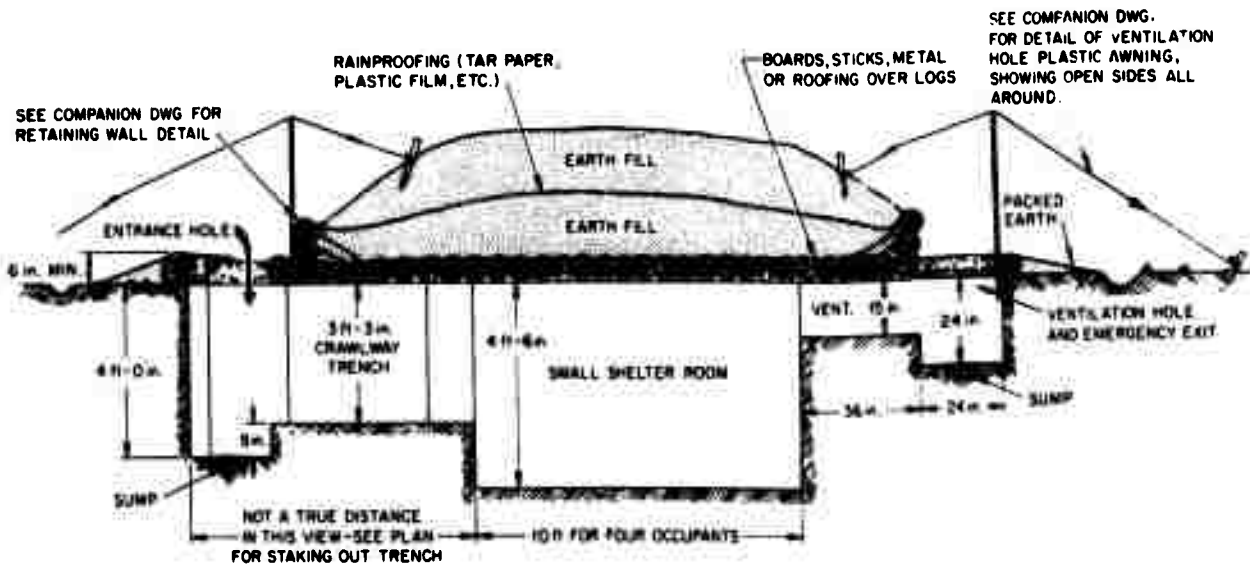

Fig. A-2.2. Log-Covered Trench Shelter, 1



PLAN VIEW OF TOP OF SHELTER—SHOWING PLACEMENT OF LOGS FOR ROOF—EARTH FILL NOT SHOWN



VIEW A-A', CROSS SECTION THROUGH LENGTH OF TRENCH SHELTER

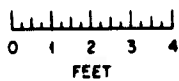

A-2.2. Log-Covered Trench Shelter, Details.

### A-3. Catenary Wire Roofed Shelter

This shelter is a modified version of the one developed by C. H. Kearny. In 1963 the U.S. Army Engineers built a catenary-wire roofed shelter. In their design, the logs which held the wire catenary were anchored horizontally by two rows of "deadmen" buried in narrow trenches parallel to the main trench. These proved to be inadequate in wet weather so the design was abandoned. In 1969 C. H. Kearny introduced a new idea which made the design practical. He used posts (or logs) in compression to resist the horizontal component of stress. The first model was built by ORNL laborers<sup>5</sup> and was prooftested for stability by driving a 36,000-lb bulldozer over the top of the completed shelter. Two full-scale (66 inches deep and 42 inches wide) models and one half-scale closed model were successfully tested at 12 and 29 psi in the Mixed Company High Explosive tests<sup>4</sup> in 1972. These tests also proved conclusively that earth arching does improve the stability of these shelters (and other shelters) far beyond what had previously been estimated.

Two versions are included here. The basic type should be used where fence posts are the only source of wood available. The alternate design has a more blast-resistant entry, including a blast door.

The step-by-step instructions have not yet been prooftested.

Locally published instructions should include Appendixes B and C. When conditions permit using the blast-resistant entry, Appendixes D and E should also be included.

## CATENARY WIRE ROOFED SHELTER

1. A family of four or five can build this shelter for themselves in less than 48 hours. It uses a minimum of building materials and is particularly suited to rural areas where lumber and trees are scarce. It requires only fence posts, or fence-post-sized trees, or lumber to make 4" x 4" posts, plus hog wire (or sheep wire). It requires firm earth that will stand in almost vertical banks about 6 ft high. To test the proposed site for earth stability, dig a small hole 18 inches deep. Remove all loose earth from the bottom of the hole and then try to push a bare thumb into the undisturbed earth in the bottom of the hole. If the earth does not pass this test, move to another location and repeat the test. Continue to relocate and repeat until suitable earth is found. If the earth is not stable, select another design (if materials can be found).

This shelter provides a protection factor of at least 1000, when the specified depth of earth cover is in place. It will also protect occupants from the blast and thermal effects at least up to 10 psi blast overpressure. The basic design has a capacity of five persons and requires two "bays".\* The shelter can be increased in capacity by adding additional bays. Each additional bay increases the capacity by 2-1/2 persons. The preferred entryway design should be chosen when no trees are available and fence posts are the only source of wood available. The alternate design is recommended when trees are available and more blast resistance is desired (or required). The alternate design uses so much timber for the entryways that it is recommended only in the maximum expanded (6 bay) mode.

---

\* A "bay" is a unit consisting of two wire catenary loops, two support poles each 7 ft long, and three strut posts.

A-3.2

2. Before doing any work, read and study all of the following instructions. Then check off each item when it is completed.

3. Sharpen all tools before starting to work and keep them sharp. A dull pick, shovel, saw, or axe will slow the work and increase the effort required.

4. Materials

The materials listed are based on using 39-inch-high hog wire. Other heights of hog wire (or sheep wire) may be used but the materials will need some adjustment. The length of the catenary support poles will be two times the height of the hog wire, plus 6 inches.

a. Preferred Entrance Design (materials for a 5-person shelter)

(1) Fence posts, or logs from trees, or 4" x 4" lumber, or

Use	Minimum Diameter	Length	No. of Poles	Width*
Catenary Support	4 in.	7 ft	6	
Strut Posts	4 in.	7 ft	9	
End Wall	4 in.	5 ft	-	3 ft

\* Width is the distance measured across a single layer of poles when a sufficient number are laid on the ground side by side and touching so as to cover a rectangular area.

(2) Nails

20-penny (4-in-long) - 2 lbs

(if no 20-penny nails are available, use smaller nails)

(3) Hog Wire (or sheep wire)

39" high                      90 ft long

(four lengths each 22'-5")

(4) Polyethylene sheet (6-mil preferred)

12 ft wide by 30 ft long

(5) Materials to cover the wire to keep earth from falling

through (about 60 sq ft of scrap lumber, old roofing, rugs, canvas, and/or even cardboard)

(6) Materials to make "sand bags" for the entrances (12

sacks, or 12 pillowcases, or 4 bed sheets with which to make earth-filled "rolls")

A-3.3

(7) Non-essential but useful materials

(a) Wire, No. 9 or heavier - 200 ft

(b) Boards for benches

(c) Scrap boards or roofing to cover floor

b. Alternate Entryway Design (6-bays - providing shelter for 15 persons)

(1) Fence posts, or posts from trees, or lumber to make 4" x 4" posts:

Use	Minimum Diameter	Length	No. of Poles	Width*
Catenary Support	4 in.	7 ft	12	
Strut Posts	4 in.	7 ft	18	
End Wall	4 in.	5 ft	--	3 ft
Entryway (2)	4 in.	8 ft	16	
Entryway	3-1/2 in.	18 in.	16	
Entryway	3-1/2 in.	26 in.	16	
Entryway	3-1/2 in.	3 ft	--	22 ft

\*Width is the distance measured across a single layer of poles when a sufficient number are laid on the ground side by side and touching so as to cover a rectangular area.

(2) Nails

20-penny (4 in. long) - 10 lbs

(3) Hog Wire (or sheep wire)

39" high 270 ft long

(12 lengths each 22'-5")

(4) Polyethylene sheet, 6-mil preferred

12 ft wide by 50 ft long

(5) Materials to cover the wire to keep earth from falling through (about 180 sq. ft of scrap lumber, old roofing, rugs, canvas, and/or even cardboard).

A-3.4

- (6) Materials to make "sand bags" for the entrances  
(18 sacks or 18 pillowcases, or 6 bed sheets  
with which to make earth-filled "rolls").
- (7) Non-essential but useful materials
  - (a) Wire  
No. 9 (or heavier)                      200 ft.
  - (b) Boards for benches
  - (c) Scrap boards or roofing to cover the floor.
- (8) Materials for blast trapdoors over the entryways.  
See appendix D for materials list and detailed  
instructions for construction.

5. Recommended Tools

Axes	2	File, 10-inch	1
Saws, bow	2	Tape, steel 10-ft	1
Picks, long handle	1	Pliers	3
Shovels, long handle	3	Wire Cutter	1
Saws, carpenters	1		
<u>Hammer, claw</u>	1		

Also useful: a 50-ft steel tape and hatchet.

6. Wear gloves from the start. Even tough hands can blister after hours of digging and chopping. Blisters are painful, seriously slow the work, and are likely to cause infection if suffered by persons who will live in the shelter.

7. Before staking out the outlines of the trench, check to make sure that rock is not near the surface in the proposed site by driving down a 6-ft, sharpened small pipe or rod. To avoid groundwater problems, avoid low or swampy ground.

8. To help drain the floor, locate the shelter so that the original ground level at one end is about 12 inches lower than the original ground at the other end.

9. Stake out the trench for the entire shelter, making the width of the staked-out outline only 42 inches wide, the width of the bottom of the trench.



10. Clear all brush, tall grass, stones, etc. off the ground for a distance of at least 10 ft all around the staked location to provide clear working space, to keep trash out of the excavated earth, and to make it easier to handle the excavated earth.

11. Make a measuring stick 42 in. long and check the width of the trench frequently as it is being dug with its sides vertical clear to ground level. Pile the excavated earth well away from the edge of the trench; two feet of clear space is needed on each side of the trench. The earth excavated near the surface should be placed about 10 ft from the edge of the trench so that the earth excavated from several feet down can be thrown out of the trench without having to relocate the pile. After the ditch has been dug to depth, carefully cut the 45° angle bevels from the two long edges of the trench, after marking two parallel lines on the ground surface, 60 inches apart and each 38 inches from the centerline of the trench.

12. Finish the bottom of the excavation so that it slopes at least 1/2 inch vertically per foot of length from one entry to the other. Be sure that it also slopes from the bench side to the opposite side. If you believe that water may seep into the shelter, dig a 6-in.-wide, 4-in.-deep drain ditch along the wall. Place short lengths of sticks (or small stones) in the ditch and cover with a porous material to improve drainage capability. Dig a sump in the lower entryway. (If using the alternate crawl-in entryway, the sump will need to be inside the shelter.)

13. While some persons are digging the trench, others should be preparing the poles. If the poles around which the wire is to be looped are commercial fence posts, cut them off square to the required lengths and stack them in a location convenient to the trench. If the poles are to be cut from local trees, use the method shown in Appendix E: "How to Cut and Haul Logs and Poles More Easily." For safety, be sure that each pole has a top diameter, not including bark, at least as large as the diameter specified for the use for which it was selected. For convenience, the top should not be greater than 50% more than the specified diameter. To assure good fit, cut the strut-posts a few inches longer than the specified final length. They will be cut to exact length later.

14. Sort the poles by size and lay all poles of each size together, near the excavation.

15. Measure and cut the hog wire to the specified length. Allowing 9 inches on each end to make the splice, splice each end of the horizontal wires together as shown on the sketch to form a loop of wire. Lay each loop on the ground with two poles inside it, and mash it nearly flat, with the spliced ends near the center and on the top of the flattened loop.

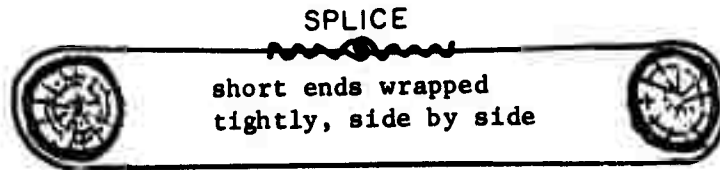

Sketch A-3.1. Assembly of Wire Loops.

16. To make sure that the strut-posts will fit properly, "prefabricate" the units (each unit consists of the two catenary support poles and the three strut-posts that hold them apart) as follows:

- a. On a clear area near the shelter lay out two catenary support poles so that their inner sides will be exactly 7 ft apart.
- b. Drive several stakes in the ground on each side of both poles to hold them exactly 7 ft apart. The stakes should be located so they will not interfere with the future location of the strut-posts.
- c. Measure each catenary support pole to find the exact locations for its strut-posts. Flatten the support poles with an axe (or hatchet) at the points of future contact with the squared-off ends of the strut-posts.
- d. Lay a strut-post in its approximate position between the two support poles, mark its exact required length, and then cut it off square.

17. As soon as the five wood parts of one unit have been "prefabricated," some of the workers should start assembling the five pieces and their two wire loops to complete a catenary unit, while other workers continue to "prefabricate" more wood parts.

18. Assemble a catenary unit as follows:

- a. Lay two flattened wire loops side by side on the ground.
- b. Put two catenary support poles inside the two wire loops.
- c. Carry the assembled poles and wire loops to their proper positions near the sides of the trench and across the trench.
- d. Push the wire loop down into the trench to form the catenary.
- e. Place the strut-posts in position, being sure their squared-off ends rest against the flattened places on the catenary support poles. (To permit the upper cross-trench wires near an end of a strut-post to curve downward smoothly, two or three of the upper short wires near an end of a strut-post must be cut.)
- f. Toenail the strut-posts to the support poles, using three 20-penny nails in each end of each strut post.

19. Cover the wire catenary with materials to keep the earth from passing through the wire. This may be sheets of plastic, sheet metal scraps, canvas, cloth, scrap lumber, roofing felt, or even flattened tin cans. Carefully cover the wire with earth in layers 6 to 9 inches deep and tamp to compact the earth below the strut-posts and to stretch the wire into the catenary shape. Cover the catenary and the supporting logs, mounding the earth at the center until the strut logs are covered with 12 inches of earth above the centerline of the shelter. Rake the mound smooth.

20. Cover the mound with the waterproof material for a buried roof. Cover the waterproof material with earth, being careful not to dislocate or puncture the roof. Continue adding earth until the cover is two feet deep over the strut logs at the middle of the shelter. Dig a ditch all around the mounded earth to carry away surface water.

21. While the catenary units are being assembled and loaded with earth, other persons in the work crew should be installing the end walls. These are five-foot-long poles which go into a slot at each end of the shelter to keep the earth from falling off the end of a catenary unit. The poles are merely laid into the 6-in.-wide, 18-in.-deep slot dug into the end of the assembled catenaries.

22. While the catenary units are being loaded with earth, the construction of the entryways should be started. If the alternate entryway is being built, proceed as follows:

- a. Construct the four internal braces as shown in the drawing. To hold the braces square until they are installed and loaded by the backfill, nail on two temporary crossbraces of scrap lumber.
  - b. Place the four corner posts in place and hold them in position by wiring the internal braces in place.
  - c. Add the remainder of the vertical poles along each side and wire them to the braces.
  - d. Add the 3-ft logs to the outer side from bottom to top and on the inner side above the ground level. Hold these logs in place temporarily by nailing or wiring them to the corner poles, or place them later one by one, as the backfill level is raised.
  - e. Backfill all around the entryway structures in 6- to 9-inch layers with hand tamping. Remove the temporary crossbraces on the internal braces.
  - f. After all backfilling has been completed, including that on the main shelter, install the blast door. (See Appendix D for bill of materials and instructions.)
23. If the preferred entryway is being used, proceed as follows:
- a. If sandbags are available, fill them with sand or earth and stack them around the openings as shown on the drawings. (Note: Improvised sand bags can be made from pillow cases, flour sacks, lawn care bags, or garbage bags.
  - b. If no sandbags or improvised bags are available, substitute for the 18" layer of sandbags two 9"-high "rolls," one on top of the other.

To make a 9-inch-high "Roll" (R):

- (1) Select a piece of cloth or plastic at least as strong as a new bed sheet, 2 ft wider than the side of the opening to be protected, and 5 ft long.
- (2) Place 2 ft of the length of the cloth on the ground, as illustrated.
- (3) While using both hands to hold up 3 feet of the length of the cloth and pressing against the cloth with your body, have another person shovel earth onto and against the cloth.
- (4) While still pulling on the cloth, pull the upper part down over the earth on the lower part of the cloth.
- (5) Cover the upper edge of the cloth, forming an earth-filled "hook" in this edge, as illustrated.

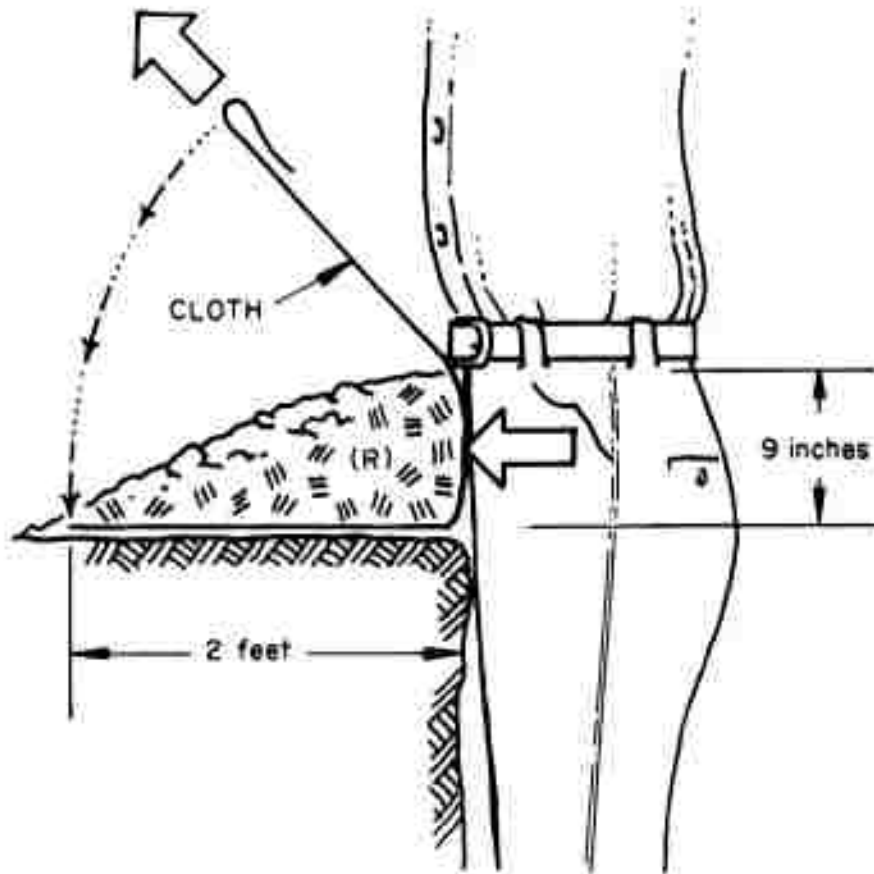

A-3.10

- c. Mound the earth up on the shelter side of the openings so that it will be at least 18 inches above the original ground level.
24. Occupy the shelter. As time and materials permit, improve the habitability of the shelter. Suggested additions:
- a. Build the bench along one wall of the shelter. Materials for the bench are included in the materials list.
  - b. Make expedient lights and provide additional water storage facilities. See Appendix C for instructions.
  - c. If the shelter is to be used in hot weather (i.e., above 80°F), construct and install a Kearny Air Pump. See Appendix B for instructions.

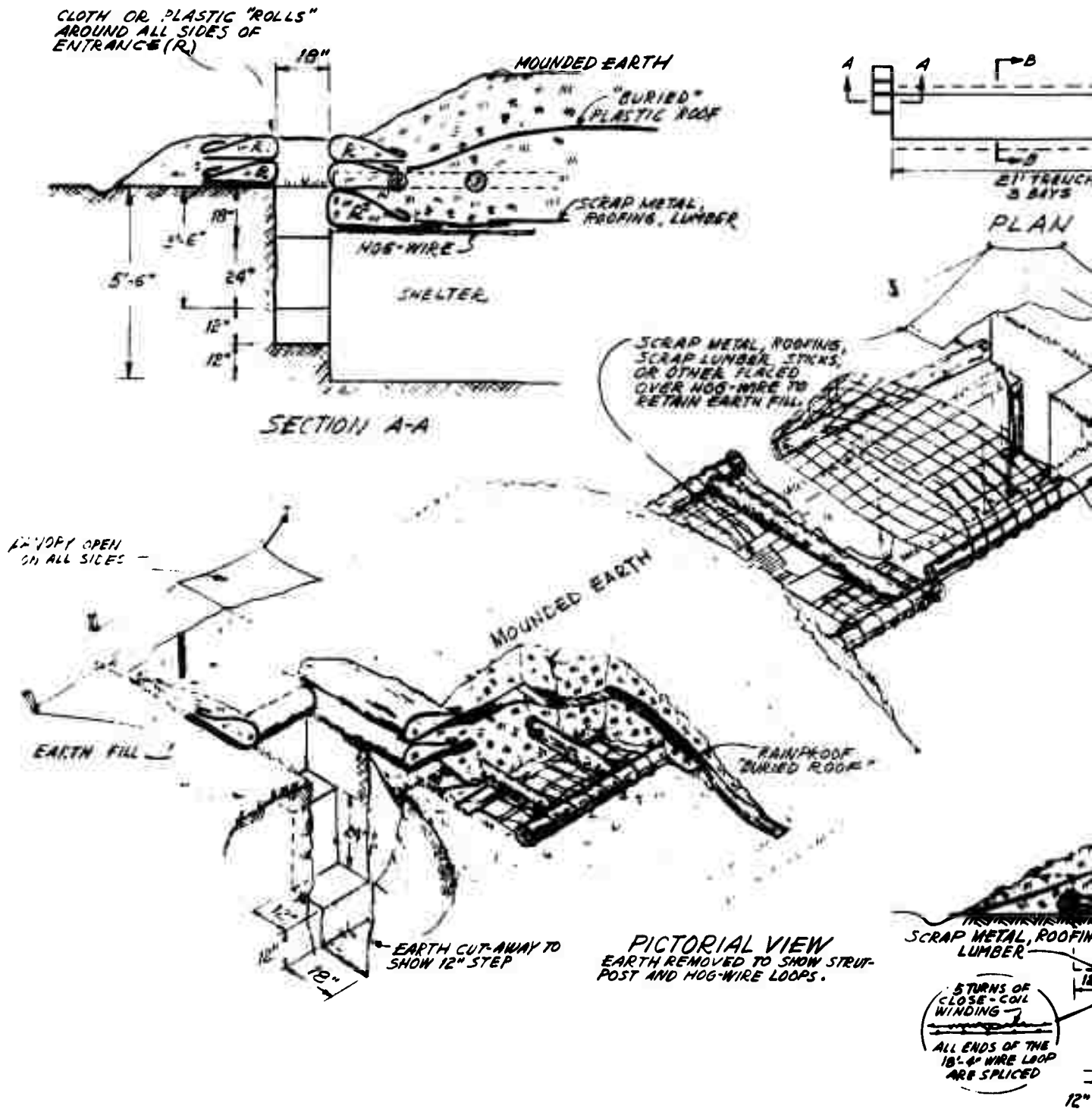

Fig. A-3.1. Catenary wire roofed shelter - basic de

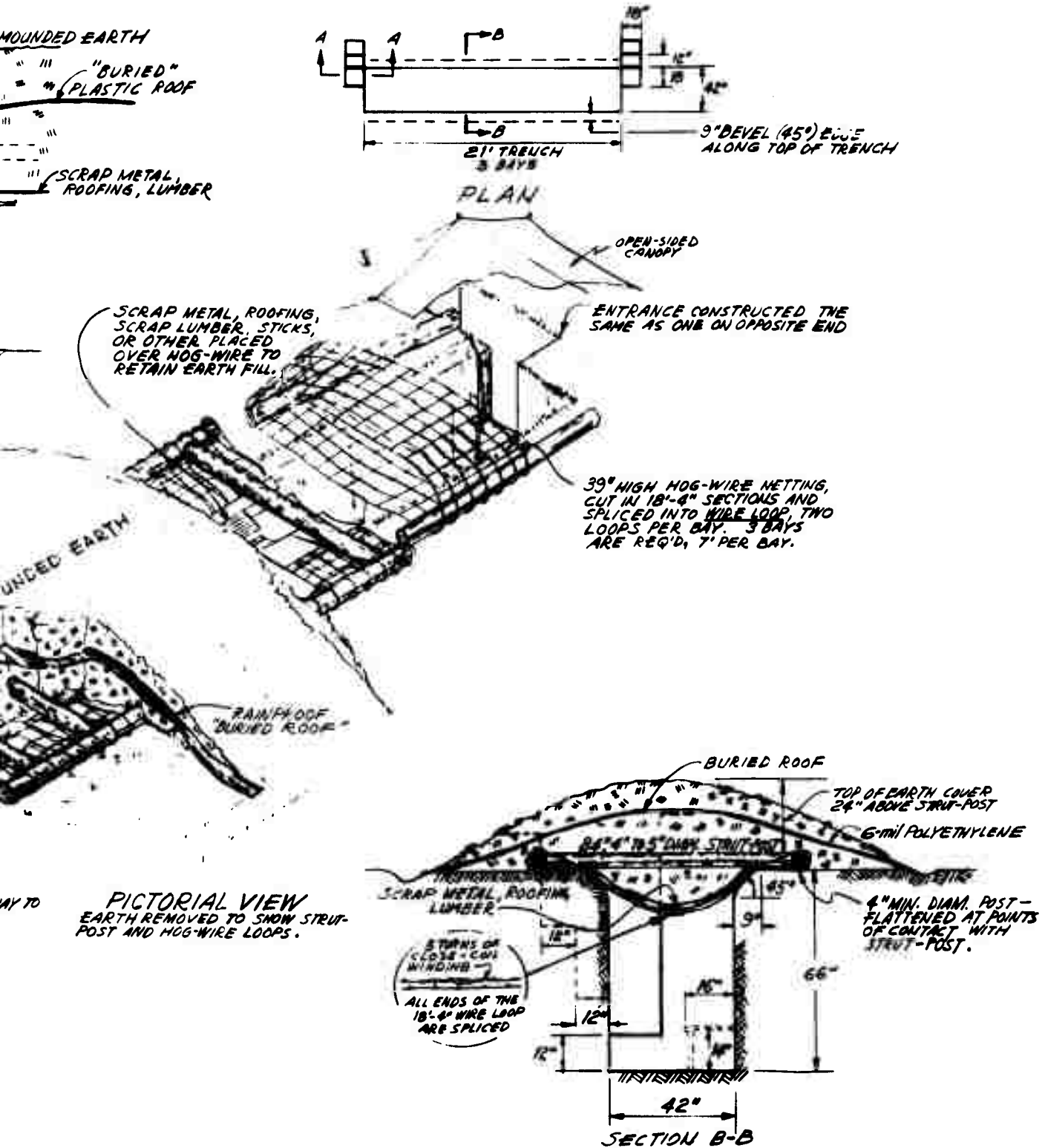

Fig. A-3.1. Catenary wire roofed shelter - basic design.



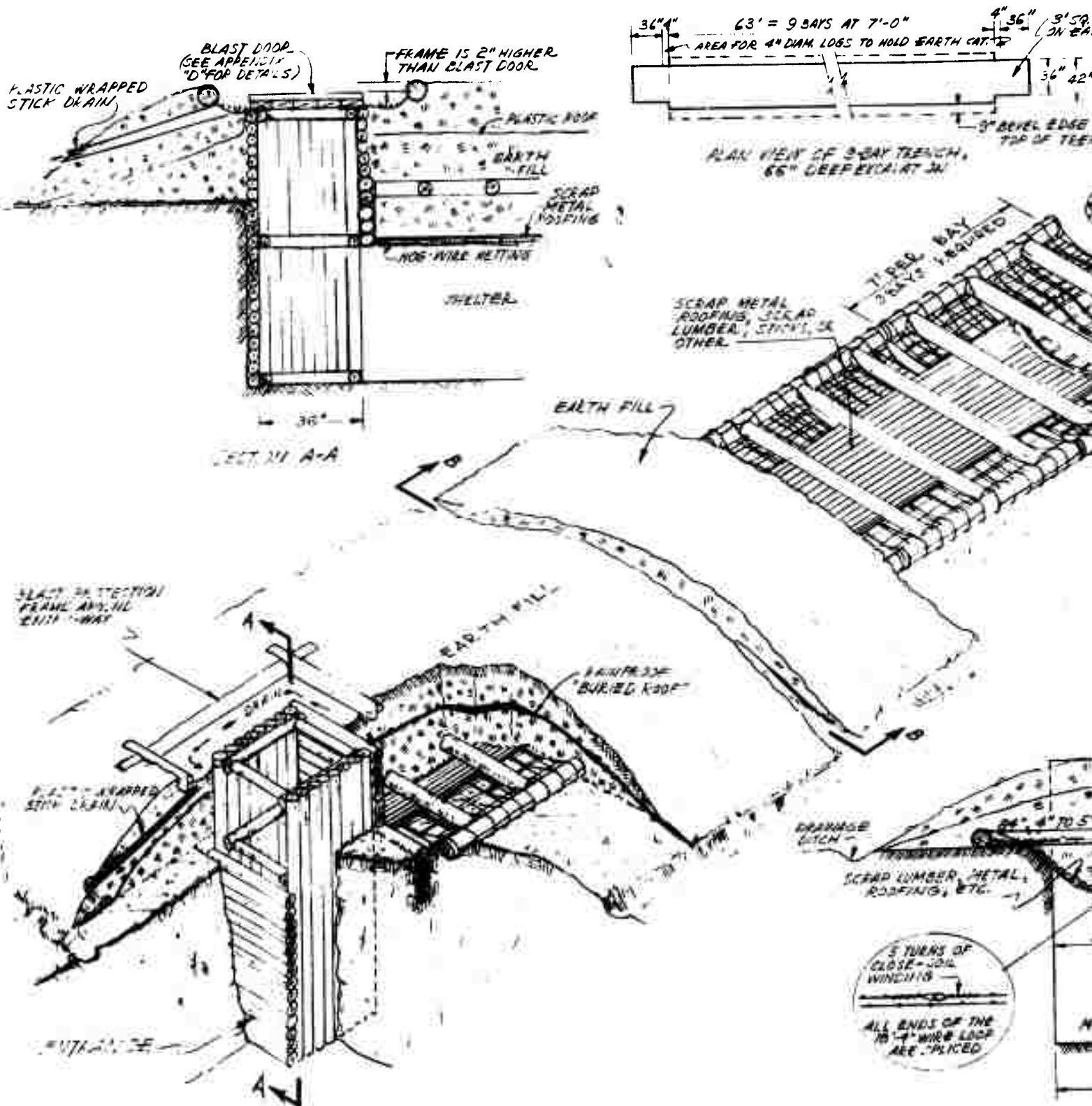
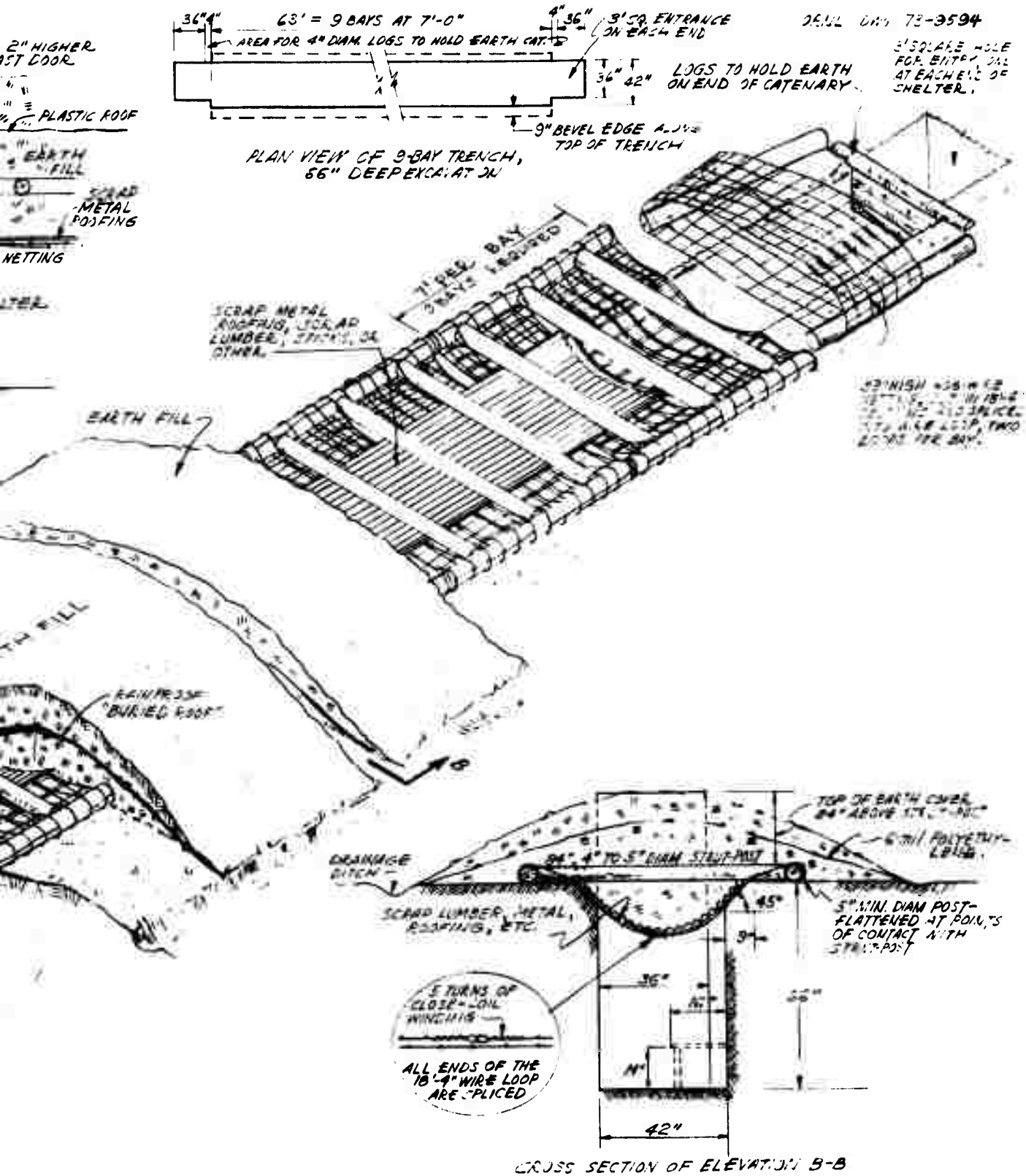

Fig. A-3.2. Catenary wire roofed shelter - alternate design.

CROSS SECTION



A-3.2. Catenary wire roofed shelter - alternate design.

#### A-4 Two-Family A-Frame Pole Shelter

A shelter similar to this design was suggested by PSDC<sup>7</sup> (Protective Structures Development Center) in 1965, but evidently no A-Frame Pole Shelter was built. An early version of this shelter using a ridge log supported by two green stumps was built<sup>5</sup> as an aboveground shelter by ORNL laborers. A second aboveground version using 7-ft fence posts and a single 2" x 6" ridge board 12 ft long was built<sup>2</sup> by three men with only 19 man-hours of labor (exclusive of covering with earth). Two additional A-Frame Pole Aboveground shelters were built<sup>6</sup> in Colorado in wintertime by experienced lumbermen and covered with snow using a bulldozer. As the result of these tests, it was concluded that the A-Frame Pole Shelter using two green stumps introduced more trouble and complexity than the advantages warranted.

A half-scale aboveground model was built and successfully blast tested<sup>4</sup> at 17 psi in the Mixed Company Event. Test results indicate that this shelter could take much higher pressure than the 17 psi to which it was subjected, particularly when covered by as much as 2 ft of earth. The version included in this appendix uses the 2" x 8" lumber ridge board. The step-by-step instructions incorporate the experience gained by building these five shelters but have not yet been proof-tested.

Locally published instructions should include Appendices B, C, and E. If blast doors are required, include Appendix D.

A-4-i.

**TWO-FAMILY A-FRAME POLE SHELTER  
(10-Person Capacity)**

1. This shelter can be built by two or three families working together. It can be built by three or four persons with no previous building experience. The shelter may be built semiburied or aboveground. It may even be built on frozen ground and covered with snow to provide shielding. It provides excellent protection against fallout radiation and the thermal pulse from megaton weapons. It has some inherent protection against blast effects, especially in the semiburied mode, although it was not designed for blast protection. If at all possible, the trench should be dug and the earth cover placed by mechanical means.

2. Study both drawings and read all the instructions before starting the work.

3. Materials Required

a. Green poles (or logs)

No pole should be smaller at its top (i.e., its minimum diameter) than the minimum diameter specified on the drawings. On the other hand, to keep the poles light enough to handle easily, poles should be selected with diameters no greater than 50% larger than the specified diameters.

Use	Length	Minimum Diameter	No. of Poles	Width to be Covered*
Base logs	12 ft	4-1/2 in.	2	--
Base logs	10 ft	4-1/2 in.	2	--
Entryway Sides	11 ft	4-1/2 in.	(approx) 12	6 ft
Roof	7 ft	4 inch	(approx) 50	20 ft
Entryway Ends	3 ft, 10 in.	3-1/2 in.	(approx) 30	14 ft
" Frames	3 ft, 1 in.	3-1/2 in.	8	--
" "	3 ft, 0 in.	3-1/2 in.	10	--
End Walls	varies from 2 ft to 7 ft	3-1/2 in.	--	24 ft
End Brace	9 ft	3-1/2 in.	1	--

\* Width to be covered is the distance measured across a single layer of poles laid on the ground side by side (alternating butt and top ends) and touching.

## b. Lumber

Ridge board      2" x 8" x 14'      one required  
 (or hew with an axe a 14-ft pole approximately  
 8-in. in diameter by flattening two opposite  
 sides to produce flats at least 6 inches wide)  
 Vent              1" x 8" x 7'      four required  
 Vent Cover      1" x 8" x 1'      two required

## c. Rainproofing Materials

Preferably, 6-mil polyethylene 20 ft wide and 30 ft long.  
 As an alternate, at least 200 sq ft of other waterproof  
 plastic (plastic table cloths, shower curtains), linoleum  
 rugs, tarps, or roofing felt.

## d. Other Materials

Nails      40-penny (5 in. long)      10 lbs  
             8-penny (2-1/4 in. long)      1 lb

If 40-penny nails are not available use same weight of  
 either 20-penny (4 in. long) or 16-penny (3-1/2 in. long)  
 nails. If no large nails are available, use wire, rope, or  
 cord.

## 4. Desirable Tools

Axe	3	Hammer, claw	3
Saw, Bow	3	Square, carpenters	1
Saw, Cross Cut, 2-man	1	File, 10-inch	1
Pick, long handle	3	Tape, steel 10-ft	1
Shovel, long handle	4	Buckets, large	4
		(or large can with bail handle)	

---

(Also useful if available: a bulldozer, backhoe, or front-end  
 loader, chain saw, 50-ft tape, 2 hatchets)

5. To cut and haul poles easily and safely, study and use the  
 methods shown on the attached instruction sheet: (Appendix E) "How to  
 Cut and Haul Logs and Poles More Easily."

6. To save time and effort, sharpen all tools and keep them sharp.

7. Wear gloves from the start. Even tough hands can blister after hours of digging and chopping. Blisters are painful, seriously slow the work, and could lead to dangerous infections.

8. Before staking out the outlines of the excavation, check the rock depth by driving down a sharpened, small rod or pipe. If rock is less than 4 ft below the surface, try another location. Use the best location available. To prevent groundwater problems, avoid low ground. If the water level is too high, or the rocks are too near the surface, or the ground is frozen, build the aboveground model.

9. To help drain the floor, if practical locate the shelter so that the original ground level at the entrance is about 6 inches lower than the other end.

10. Stake out the trench. Even in firm ground make the excavation at the surface 18 ft long and a maximum of 16 ft wide. This provides for sloping sides to prevent caving of the edges during construction.

11. Ensure the squareness of the staked trench outline by making the diagonals equal.

12. Clear all brush, tall grass, etc. off the ground to a distance of 10 ft all around the staked location to provide storage for the earth to be excavated and to make it easier to shovel the earth back onto the top of the shelter. If the shelter is being built on frozen ground and is to be covered with snow, clear only about two feet outside the shelter outline.

13. Dig the trench 4 ft deep or as deep as is practical. Be sure that the trench is a full 14 ft wide at the bottom. The trench may be dug by a bulldozer, backhoe, front-end loader, or with hand tools.

14. When digging with shovels and carrying earth in large buckets or cans, pile the first earth dug from the excavation about 10 ft from the edges of the trench to allow sufficient room to pile all the earth removed without having to move it twice.

15. Finish the bottom of the excavation so that it slopes 1/2-inch vertically per foot of length towards the entrance, and also so that it slopes toward the central drain ditch. Dig the central drainage ditch 6 in. wide and 4 in. deep. Place short lengths of sticks in the drainage

ditch and cover with porous fabric. Dig the sump in the bottom of the entrance area.

16. While the trench is being dug, some of the workers should be cutting green poles and hauling them to the site. FOR SAFETY: Cut poles having tops with diameter, not including bark, no smaller than the diameter specified for each size. FOR CONVENIENCE IN HANDLING: Select trees with top diameters no more than 50% larger than the diameter specified. For example, the top diameter, not including bark, of the poles for the roof must not be less than 4-1/2 inches but should not be more than 7 inches.

17. Sort the poles and stack them by sizes, near the excavation.

18. If building an aboveground model (either on frozen or unfrozen ground), notch the two end logs as shown in Fig. A-4.1, then lay out on the ground the two end logs and the two base logs. Drive small stakes on the outside of the two end logs to keep them from rolling. If the ground is frozen the end logs can be held in position by toenailing the two base logs to the two end logs (at the notches).

If building a semiburied model, the base logs do not need to be notched. Just lay them out in position at the bottom of the trench and hold them in place temporarily by small stakes or by tamping earth against the outside of each log.

19. The poles for the roof need to have one end cut at a 45-degree angle to fit against the ridge board. To cut off the ends more accurately and faster, make a guide (a template) by cutting off one end of a wide board at a 45° angle. Then lay the pole to be cut off at 45° on top of this guide board, so the end of the pole can be cut off at 45°. Cut four roof poles to the specified 7-ft length.

20. Erect the ridge board. Two persons should hold the ridge board in place while two other persons install the two poles on each end of both sides. Place the butt ends of each of the four corner poles inside the base framework. These first four poles should have their smaller ends up, and the upper ends should be nailed\* to the ridge board. Use two nails

---

\* If 40-penny nails are not available use 20-penny.

to each pole. Be sure that at least 8 inches of the ridge board protrudes at the rear of the shelter to provide a place to nail the vent later. Hold the ridge board and the corner pole structure in position by temporarily bracing it at each end with poles.

21. Cut the rest of the roof poles to the different lengths necessary to make them extend from a base log to the ridge board. (Logs and trenches are not straight and uniform like commercial lumber.) Before cutting, each pole should be lifted so that its squared-off butt rests against the base log and its upper end is near its final position. Then the correct position for the 45° cut on the pole can be marked. Or these different required pole lengths can be measured with a tape and then marked on each pole to be cut.

22. Add the rest of the roof poles, alternating top and butt ends to keep the poles relatively straight and even. Keep the poles as close together as practical to reduce the spaces between poles.

23. While the roof poles are being installed, other persons should be making the rectangular entrance frames, and then the complete entrance. To keep the rectangular entrance frames square during construction and backfilling, nail a temporary diagonal brace across each one, using scrap lumber or small poles. The frames may be wired together if nails are in short supply. The vertical entrance poles should be held in place by nailing or wiring them to the extended ridge board and to the entry frames.

24. Assemble the vent stack and nail it to the ridge board.

25. When all the roof poles are in place, cover the cracks in the roof with small sticks, scrap lumber, rugs, roofing, plastic, cardboard, or even leaves.

26. Put the end walls in place. Hold them in place with wire, twine, or nails. These short poles should be long enough to lean against the corner roof poles without falling into the shelter. Some overlap is desirable.

27. Start backfilling. Even with the semiburied shelter, backfill material will have to be obtained in addition to the earth excavated. Place the backfill carefully all around and bring the level of backfill



up evenly all around. Continue the backfilling until the earth fill reaches the original level of the ground and is mounded over the top of the ridge board. For a snow-covered shelter it is advisable to put a plastic or fabric covering over the shelter before starting to add the snow.

28. Rake the mounded earth smooth and remove any sharp objects such as sticks or stones which might puncture the waterproof layer. Cover the mound with polyethylene sheet or other waterproofing material. If the waterproofing material is not large enough to cover the entire shelter in one piece, be sure to lap the joints like shingles (i.e., the upper pieces lap the lower pieces).

29. Continue backfilling until the earth is 3 ft deep over the ridge board. If the excavation and backfilling is being done by hand, there may not be enough time to cover the shelter to the full 3 feet before occupying it. However, if time is available after occupying the shelter, add the remainder of the earth backfill.

30. Dig a 6"-deep ditch all around the outside of the mounded earth and carry the ditch at least ten feet beyond the backfilled area on the downhill side. Be sure the top of the entryway is at least 6 inches above the backfilled mound.

31. Erect a fly over the opening to keep out rain and fallout. Install the fly with at least 12" of air space all around for ventilation purposes.

32. Occupy the shelter.

33. As time and materials permit, continue improving the habitability of the shelter by such things as:

- a. Building a Kearny Air Pump (KAP) and installing it in the doorway to the shelter if the shelter will be used in warm or hot weather. See Appendix B for instructions to build a KAP.
- b. If the shelter is to be occupied in cold weather, make an expedient cover for the entryway which can be used to reduce the opening.

CAUTION: The entry of an occupied shelter should never be completely covered more than a few minutes at a time because of carbon dioxide buildup.

- c. Make expedient lights (see Appendix C).
- d. Add flooring or waterproof ground cover inside the shelter.

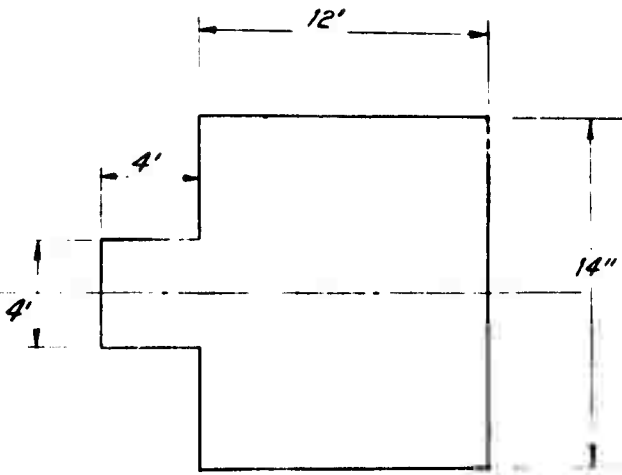

PLAN VIEW OF TRENCH - 4' DEEP

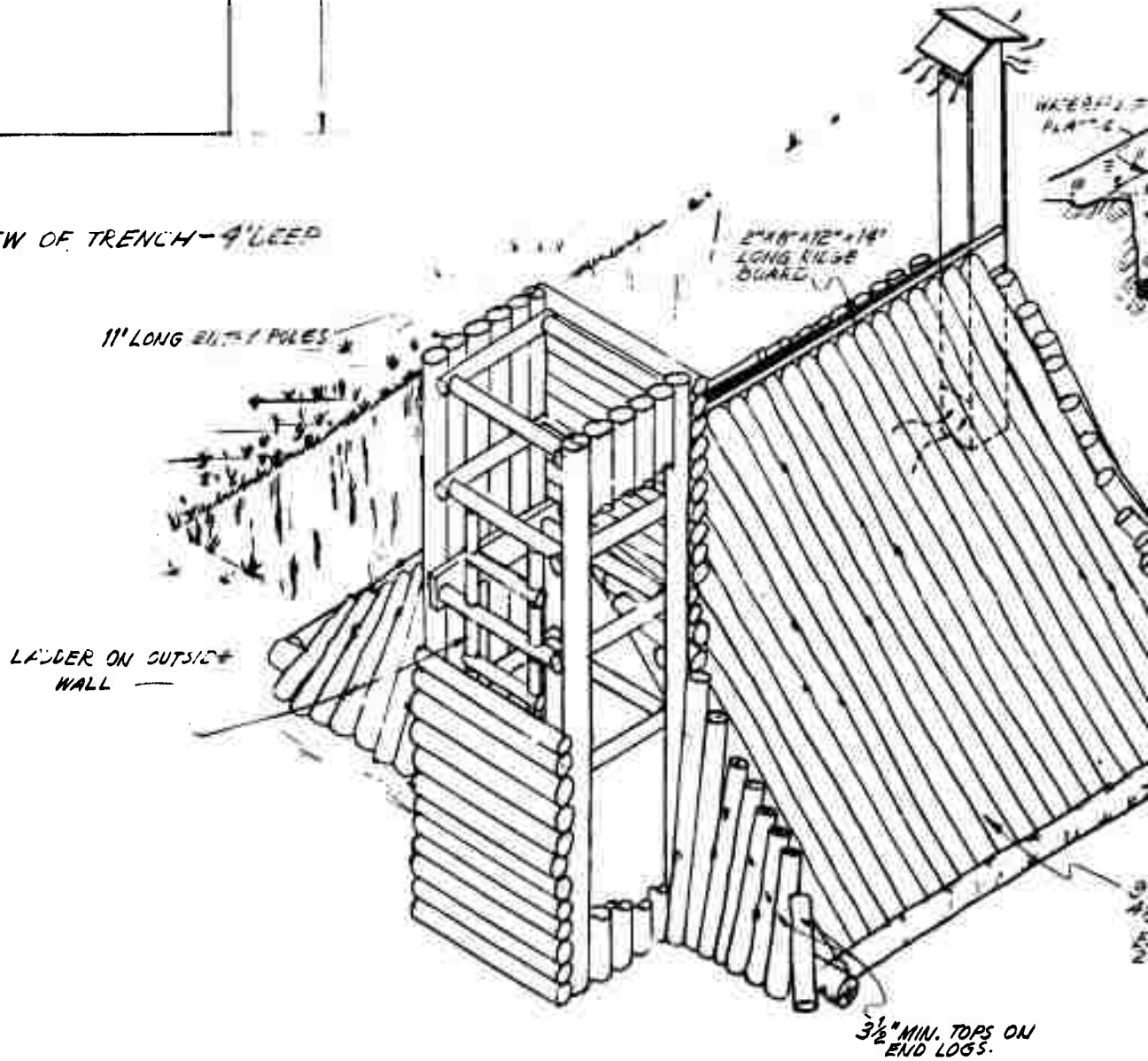

Fig. A-4.1. Two-Family A-Frame Pole Shelter, Semiburied.

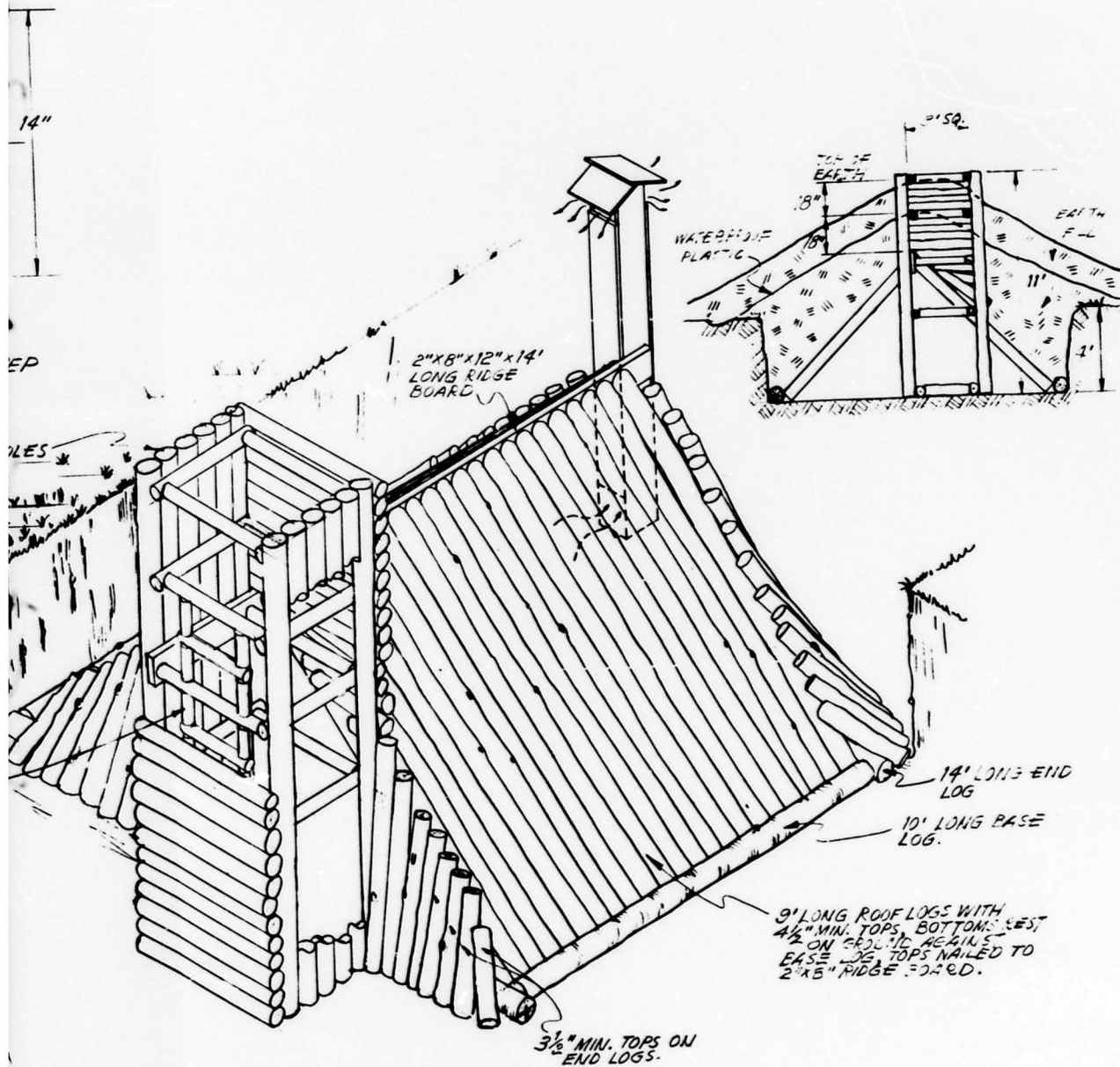

Fig. A-4.1. Two-Family A-Frame Pole Shelter, Semiburied.

**CAUTION:** The entry of an occupied shelter should never be completely covered more than a few minutes at a time because of carbon dioxide buildup.

- c. Make expedient lights (see Appendix C).
- d. Add flooring or waterproof ground cover inside the shelter.

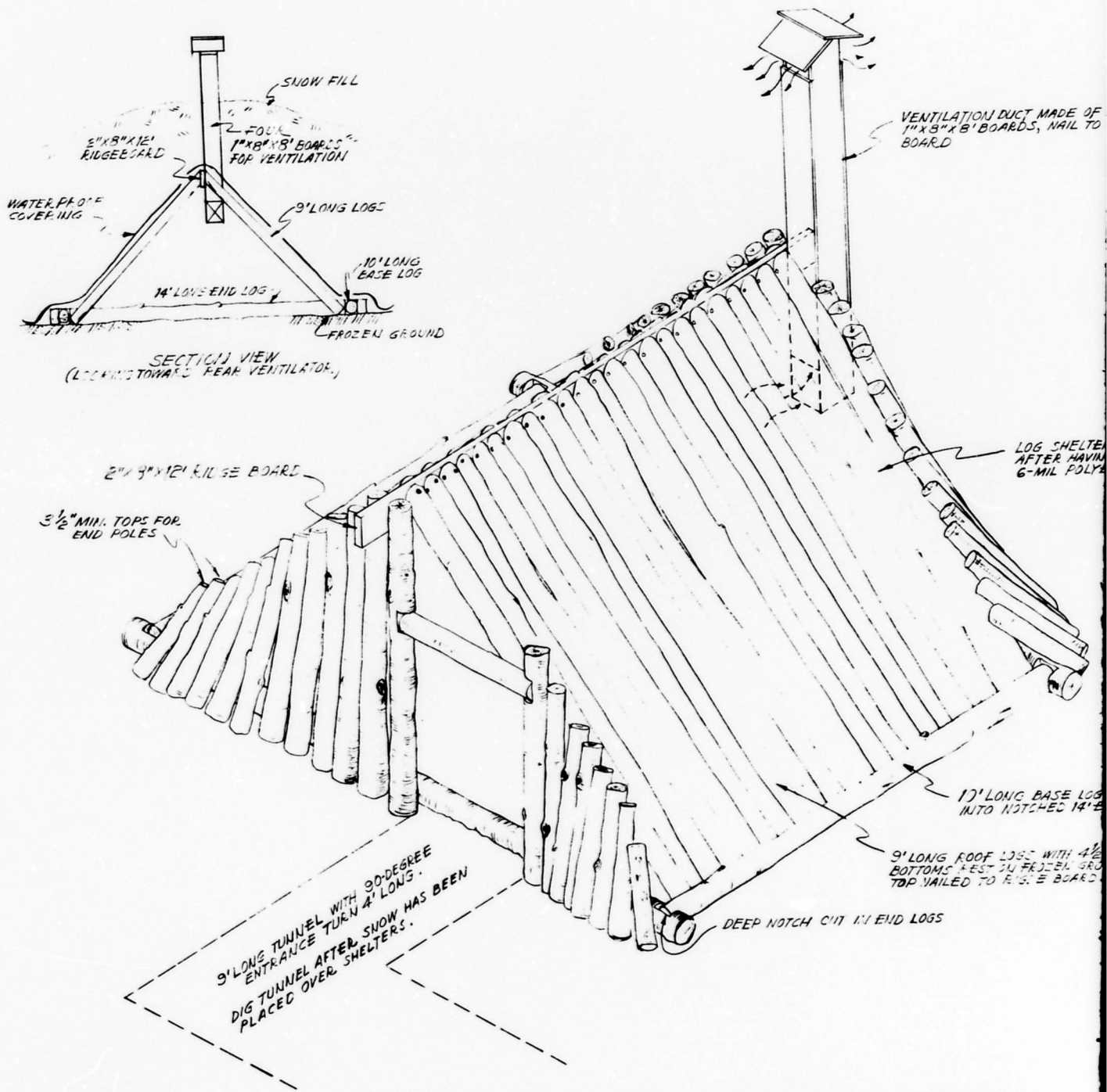

Fig. A-4.2. Two-Family A-Frame Pole Shelter, Frozen Ground Version.

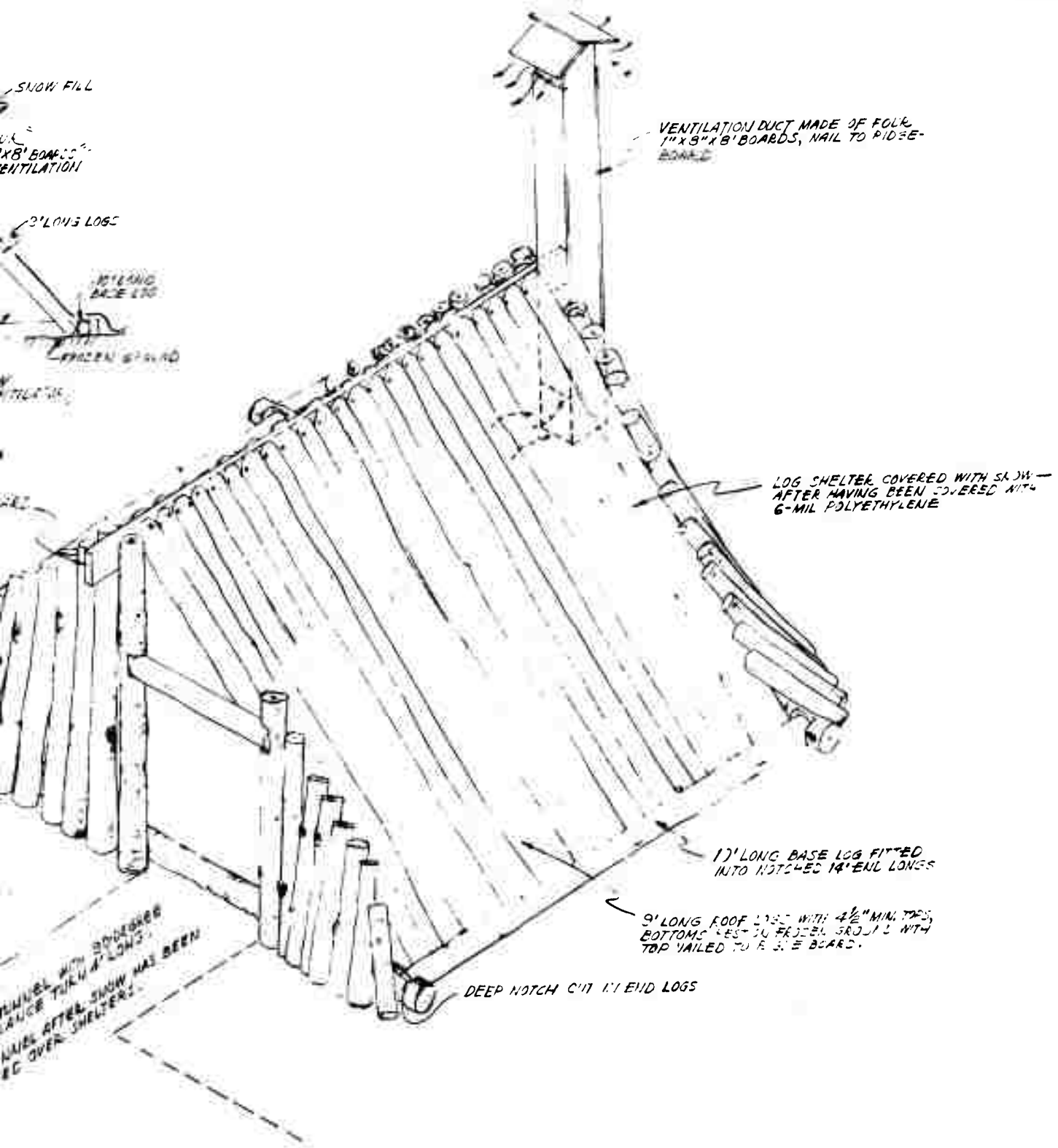

Fig. A-4.2. Two-Family A-Frame Pole Shelter, Frozen Ground Version.

#### A-5. Shored-Trench Stoop-In Shelter

This shelter is an improved version of the shored-trench shelters used by the British during the Blitz and is similar to those which the Israelis plan for sheltering civilians who lack permanent shelters. A 5-man prototype was subjected to 12 psi blast overpressure in the Mixed Company Event without damage.<sup>4</sup> The step-by-step instructions have not been prooftested.

Locally published instructions should include Appendixes B, C, and D.

A-5-i



SHORED-TRENCH STOOP-IN SHELTER\*  
(Capacity 4 to 14 Persons)

1. This family-size expedient shelter has a radiation protection factor of about 500, and will protect its occupants from blast overpressures of at least 15 pounds per square inch (psi) — a blast that demolishes most buildings. With an expedient blast closure, it should protect occupants up to 30 psi. (See Appendix D for details of the blast closure device.) This shelter can be built even in very soft earth or sand. If the necessary lumber is available on the site, this shelter can be built within 48 hours of beginning work. It can be built by persons with very little prior experience in construction, provided only that at least one member of the family can use a hammer and a saw.

2. The shelter as shown in the two drawings is sized for a family of four persons. If two or more families (with a total of no more than 14 persons to be sheltered) work together, they can build a better shelter by building two of the illustrated shelters back-to-back, leaving off the back walls and the ventilation-escape hatch from each.

The shelter can be lengthened to accommodate more people by adding one 28-in.-long bay\*\* for each additional person. It is recommended that the one-family shelter (with one entryway) not be lengthened more than three bays (maximum 7 persons) and that the two-family shelter (two 4-person shelters joined together with an entryway at each end) not be lengthened more than 6 bays (maximum of 14 persons).

3. Materials and tools needed for the illustrated 4-person model.

a. Lumber

Table 1 provides a convenient shopping list for ordering the lumber. Table 2 lists the sizes of lumber after cutting it to the required lengths. Table 3 shows one way to cut the lumber to get the necessary pieces with a minimum of scrap.

---

\* This shelter was called the ISRAELI Shelter in Reference 1.

\*\* A bay is the space between two consecutive braces. Increasing the shelter by one bay involves adding an additional brace structure and lengthening the side wall boards by 28 inches.

Table 1. Lumber List

4" x 4" x 12'	11 pcs <sup>*</sup>	176 bd ft
2" x 8" x 8'	1 pc	11 bd ft
2" x 6" x 12'	30 pcs	360 bd ft
2" x 6" x 6'	1 pc	6 bd ft
2" x 4" x 12'	2 pcs	16 bd ft
2" x 4" x 10'	1 pc	7 bd ft
1" x 6" x 12'	52 pcs	312 bd ft
1" x 4" x 12'	4 pcs	16 bd ft
1" x 4" x 8'	1 pc	3 bd ft
	(227 bd ft/person)	907 bd ft

\* If 4" x 4" lumber is not available, substitute 22 pieces of 2" x 4" x 12' lumber.

Table 2. Actual Sizes Required

Use	Sizes	Pieces Required to Build		
		As Shown	Double Model 8 Persons	Double Model 8 Persons
Posts for entry	4" x 4" x 7'	4 pcs	8 pcs	8 pcs
Posts for main shelter	4" x 4" x 5'	18 pcs	36 pcs	48 pcs
Horizontal braces	2" x 6" x 3'6"	26 pcs	52 pcs	64 pcs
Horizontal braces	2" x 6" x 1'8"	6 pcs	12 pcs	12 pcs
Shelter roof	2" x 6" x 6'	26 pcs	52 pcs	80 pcs
Entry roof	2" x 6" x 5'	14 pcs	28 pcs	28 pcs
Escape hatch frame*	2" x 4" x 21"	12 pcs		
	1" x 4" x 22"	12 pcs		
	1" x 4" x 19-1/4"	12 pcs		
Escape hatch siding*	1" x 6" x 7'	12 pcs		
	1" x 6" x 2'	4 pcs		
	1" x 6" x 5'	4 pcs		
	2" x 6" x 2'	12 pcs		
	2" x 6" x 2'4"	8 pcs		
Shelter siding	1" x 6" x 12'0"***	22 pcs	44 pcs	38 pcs
	1" x 6" x 2'10"	11 pcs	22 pcs	22 pcs
	1" x 6" x 3'10"	11 pcs	22 pcs	22 pcs
	1" x 6" x 5'4"	11 pcs	22 pcs	22 pcs
	1" x 6" x 3'2"	11 pcs	22 pcs	22 pcs
	1" x 6" x 2'4"	20 pcs	40 pcs	40 pcs
Shelter End*	1" x 6" x 3'9"	5 pcs		
	2" x 8" x 3'9"	2 pcs		
	1" x 4" x 2'9"	14 pcs		
Bench	2" x 4" x 16"	5 pcs	10 pcs	15 pcs
	2" x 4" x 14"	5 pcs	10 pcs	15 pcs
	1" x 4" x 22"	4 pcs	8 pcs	12 pcs
	1" x 6" x 10'	2 pcs	4 pcs	6 pcs

\* For two-family (i.e., double size) shelter omit all escape hatch and end wall lumber but use double quantities for the remainder.

\*\* If the lumber must be carried to the building site in a private car or station wagon, each of these 12-ft boards can be cut into one 4' 9-3/4" and one 7' 2-1/4" board.

Table 3. Cutting Schedule

		From Each Piece
4" x 4" x 12'	4 pcs*	Cut 1 piece 4" x 3" x 7' Get 1 piece 4" x 4" x 5'
4" x 4" x 12'	7 pcs*	Cut 2 pieces 2" x 8" x 5'
2" x 8" x 8'	1 pc	Cut 2 pieces 2" x 8" x 3'9"
2" x 6" x 12'	13 pcs	Cut 2 pieces 2" x 6" x 3'6" Get 1 piece 2" x 6" x 5'
2" x 6" x 12'	13 pcs	Cut 2 pieces 2" x 6" x 6'
2" x 6" x 12'	2 pcs	Cut 3 pieces 2" x 6" x 2'4" Cut 3 pieces 2" x 6" x 1'8"
2" x 6" x 12'	2 pcs	Cut 2 pieces 2" x 6" x 2'
2" x 6" x 6'	1 pc	Cut 2 pieces 2" x 6" x 2'4"
2" x 4" x 12'	2 pcs	Cut 6 pieces 2" x 4" x 21" Cut 1 piece 2" x 4" x 16"
2" x 4" x 10'	1 pc	Cut 3 pieces 2" x 4" x 16" Cut 5 pieces 2" x 4" x 14"
1" x 6" x 12'	22 pcs**	Cut 1 piece 1" x 6" x 7'2-1/4" Get 1 piece 1" x 6" x 4'9-3/4"
1" x 6" x 12'	4 pcs	Cut 1 piece 1" x 6" x 7' Get 1 piece 1" x 6" x 5'
1" x 6" x 12'	8 pcs	Cut 1 piece 1" x 6" x 7' Cut 2 pieces 1" x 6" x 2'4"
1" x 6" x 12'	11 pcs	Cut 1 piece 2'10" Cut 1 piece 3'10" Get 1 piece 5'4"
1" x 6" x 12'	3 pcs	Cut 3 pieces 3'2" Cut 1 piece 2'4"
1" x 6" x 12'	1 pc	Cut 3 pieces 3'9"
1" x 6" x 12'	1 pc	Cut 2 pieces 3'9" Cut 1 piece 3'2"
1" x 6" x 12'	1 pc	Cut 1 piece 3'2" Cut 1 piece 2'4" Cut 3 pieces 2'
1" x 6" x 12'	2 pcs	Cut 1 piece 10' Get 1 piece 2'
1" x 4" x 12'	4 pcs	Cut 3 pieces 22" Cut 3 pieces 19-1/4"
1" x 4" x 8'	1 pc	Cut 4 pieces 22"

\* If 2" x 4" lumber has been substituted for the 4" x 4", this will be twice the number shown.

\*\* If the lumber is delivered to the site in 12-ft lengths do not cut these 12-ft boards.

The lumber lists call for 2" x 6" boards for the roof and 1" x 6" boards for the sides. However, a smaller number of wider boards may be used if desired and available.

b. Other Materials

Polyethylene film, 6-mil (20' x 10')	200 sq ft
Nails, 16-d (3-1/2 in. long)	15 lbs
Nails, 8-d (2-1/4 in. long)	5 lbs

c. Tools for four workers

Square, carpenters	1
Axe or hatchet	1
Saw, bow or carpenters	1
Pick, long handle	2
Shovel, long handle	3
Hammer, claw	2
File, 10-inch	1
Knife	1
Tape, steel (6, 8, 10, or 12 ft)	1
Level, carpenters (optional)	1
String	1 ball
Pencil, carpenters	1
Rope (1/2" manila or equal)	50 ft

---

NOTE: A 50-ft tape would be useful, though not absolutely necessary. Also helpful would be a set of colored crayons or felt-tipped pens (4 or 5 colors at least).

4. Before starting work, each person who will work on the shelter should read all these instructions carefully.

5. To save time and work, sharpen all tools and keep them sharp.

6. All persons working on the shelter should wear gloves from the start. Even tough hands will blister from long hours of hard work! Blisters are painful, slow the work, and could cause dangerous infections.

7. Before staking out the outlines of the trench, check to make sure there is no rock near the surface by driving a 6-ft-long, sharpened small pipe or stiff rod into the earth in several places. To avoid groundwater problems, avoid low ground.

8. To help drain the floor, if sloping ground is readily accessible locate the shelter so that the original ground level at the entrance is about 6 inches lower than the far end.

9. Stake out the trench for the entire shelter. At the surface, make the main shelter trench 10 ft wide and the entry trench 8 ft wide. Make the trench at the surface 3 ft longer at each end than the shelter. The sloping sides are necessary to provide working room outside the boards of the shelter and to reduce the danger of the bank caving in during the construction of the shelter.

10. Check the squareness of the staked trenches by making sure the diagonals are equal.

11. Clear all brush, tall grass, rocks, trees, etc. off the ground to a distance of at least 10 ft all around the staked location, to provide working room and to avoid mixing sticks and stones with the backfill earth.

12. When digging the main trench, use a 4-ft-long stick (the minimum bottom width of the trench is 4 feet) to repeatedly check excavation width. When digging the entryway trenches, use a 3-ft-long stick.

13. When digging with a shovel, pile the earth dug from near ground level about 10 ft from the edge of the staked outline. Then the earth dug from four or five feet down can easily be piled on the surface only one to five feet from the edge of the excavation.

14. Finish the bottom of the excavation so that it slopes toward the entrance 1/2 inch vertically for each foot of length.

15. While the trenches are being dug, one person can be cutting and marking the lumber — if it was not cut prior to delivery. As each piece is cut it should be marked to indicate where it will be used. A color code method of marking, using crayons or felt-tipped pens, would be very helpful. To simplify construction later, the lumber list in these instructions should be marked by the same color used on the pieces (for example, the pieces for the main shelter could be one color; the pieces for the ventilation escape hatch, another; and the entry tunnel, a third). Stack the cut pieces in a location convenient to the shelter but where it will not be in the way of the excavation workers.

16. If 4" x 4" lumber was not available and 2" x 4" lumber was substituted, make up each 4" x 4" post by nailing two 2" x 4" boards together, using 16-penny nails. Use at least 10 nails per post and drive half of them in from one side, and half from the other. Clinch (brad over) the protruding points of all these nails.

17. In cutting the 2" x 6" cross braces, be careful to cut the notches square and do not make the cuts deeper than necessary to form the notch. This requires that the saw be worked vertically (not at an angle) as the inner corner of the notch is approached. All measurements should be made accurately and all cuts made as square as possible.

18. If making the two-family version with a full-scale entrance at each end, this step (18) will be omitted. As soon as the lumber has been cut, assemble the two boxes which form the ventilation shaft. The simplest way to make the boxes is to make each side of each box as a panel by laying out the 1" x 6" sides on a flat surface and nailing the cross braces to them. This will ensure that the heads of the nails will be on the inside and no nails will protrude into the box. This is a safety precaution to prevent injuries if the ventilation duct does have to be used as an escape hatch. To keep the boxes square until they are put together in the ground, nail a 1" x 4" temporary diagonal brace across each open end.

19. Assemble each pair of vertical posts with its two cross braces, being careful to make each assembly square. Nail a temporary diagonal brace on each assembly to hold it square until incorporated into the structure. A 5'6" length of 1" x 4" can be used for this.

20. Assemble the four entryway corner posts into two subassemblies of two posts each with their respective cross braces. Add a temporary diagonal brace to each subassembly to hold it square until erected. Add the ladder rungs and ladder rung scabs to the outside assembly.

21. Assemble the shelter structure in the trenches, starting with the main entry. Place the first (outer) subassembly in place in the trench. Hold the subassembly in place, by using either four boards braced against the ground outside the trench or by using four lengths of rope or wire attached to four stakes located outside the trench. Place

the second entry subassembly into position and nail the rest of the cross braces to the two entry subassemblies.

22. Place the vertical post assemblies in position in the trenches, holding each in a vertical position by nailing two temporary supports (1" x 4" will do) from the top brace of each assembly to the top brace of the preceding assembly.

23. Check the vertical alignment of all posts before adding siding.

24. Start building the sides of the shelter. As each board is added, nail it to the 4" x 4" posts. Be sure to bring the siding boards up on all sides at the same rate. If the 12-ft-long siding boards had to be cut for transportation to the site, or if the shelter has been lengthened by adding bays, be sure to stagger the joints of the siding. After the second board has been added all around, start adding backfill and tamping. Backfill should be added in small increments (6 inches maximum) and tamped thoroughly. Tamping can be done by using the end of one of the roof boards or a post or pole. Do not use a mechanical tamper.

25. As soon as the siding and backfill reach the level of the base of the ventilation-escape hatch, place the preassembled escape hatch in position against the two horizontal 2" x 8" cross braces at the end of the shelter room. Remove the temporary diagonal brace from the open end of the shelter room. Remove the temporary diagonal brace from the open end of the escape hatch and nail the 2" x 8" cross brace to the bottom frame of the escape hatch. Nail the two 1" x 4" x 18" scabs to the outside of the vertical corner posts. Nail the upper 2" x 8" cross braces to the corner posts and to the upper cross brace of the escape hatch. Nail the vertical 1" x 4" x 22" siding pieces to the outside of the two 2" x 8" cross braces. Continue installing the siding and backfill until all the siding of the main shelter and entry tunnel has been added. Remove all temporary cross bracing and other temporary pieces or guy wires.

26. Continue to backfill, tamping the backfill in 6-in.-deep layers all around the shelter, until the backfilled earth around the shelter is 1-1/2 to 2 inches higher than the tops of the side shoring boards. Carefully tamp, and then level, this final layer of backfilling. Then place



the 6-ft-long roof boards so that they rest only on this level backfilled earth, and NOT on the side shoring boards. Study the drawing.

27. The 45° turn in the horizontal part of the entry requires some boards to be lapped. Do not cut the roof boards to make them fit this 45° turn.

28. Complete the siding around the upper part of the vertical section of the entry.

29. Mound earth over the shelter, piling it 18 inches deep along the centerline and sloping it toward the sides and at the end so that the earth is only 4 inches deep over the outer edges of the roof boards. Rake the mound smooth and remove any sharp objects, such as sticks, stones, or large clods that might puncture the rainproof "buried roof" material.

30. Place the polyethylene film or other rainproofing material over the mounded earth. The waterproofing should be wide enough to extend beyond the ends of the roof boards, and preferably wide enough to extend out to the drainage ditch around the mound. See the drawing. The "buried roof" should extend at least 1 foot beyond the ends of the shelter. If polyethylene plastic is not available, use shower curtains, plastic table cloths, mattress covers, tar paper, tarpaulins, or other waterproofing materials. If the waterproofing material used is not large enough to cover in one piece, lap the pieces shingle-fashion - that is, the pieces on the uphill side should lap over the pieces on the downhill side of a slope.

31. Cover the waterproof covering (the "buried roof") with earth, being careful not to disarrange or puncture it. The depth of the earth over the main shelter room should be a total of 36 inches. The outer slope should be no steeper than 2:1.

32. Install a canopy, open on all sides, over each opening, to minimize the entry of the sand-like fallout particles and rain. A canopy can be made of canvas or polyethylene film, or a plastic table cloth. To tie cords to a plastic film without tearing it, first tie a 3/4-in.-diameter pebble or clod in each corner.

33. If time and materials are available and there is a danger that the shelter will be subjected to blast overpressure from megaton weapons,

construct and install an expedient blast door over the main entrance and the escape hatch (see Appendix C for instructions). NOTE: Construction of blast doors does not eliminate the need for the canopy mentioned in Step 32. The blast doors must be closed and latched within four seconds after seeing the bright flash from a large detonation. If blast dangers are anticipated, prepare extra canopies and stakes to be installed between the time that thermal pulse and blast strike and the time (at least 15 minutes later) when the first fallout arrives.

34. If the shelter must be occupied in hot weather (above 80°F), construct and install a Kearny Air Pump (KAP) in the entry trench. Fasten it to the cross brace at the opening into the main shelter room. Due to the small opening the KAP should be only 19 inches wide and 3 ft long. The area below the KAP should be temporarily blocked by plywood or polyethylene film when the pump is being operated.

35. As time and materials permit, improve the interior of the shelter, by such things as:

- a. Install the 10-ft-long bench.
- b. Dig a stand-up hole in the bottom of the main shelter room, to permit occupants of the shelter to stand erect occasionally.
- c. Provide for additional water storage, improvise lights, hang privacy screen adjacent to the entryway being used as an air exhaust opening.  
(See Appendix C for discussion and instructions.)

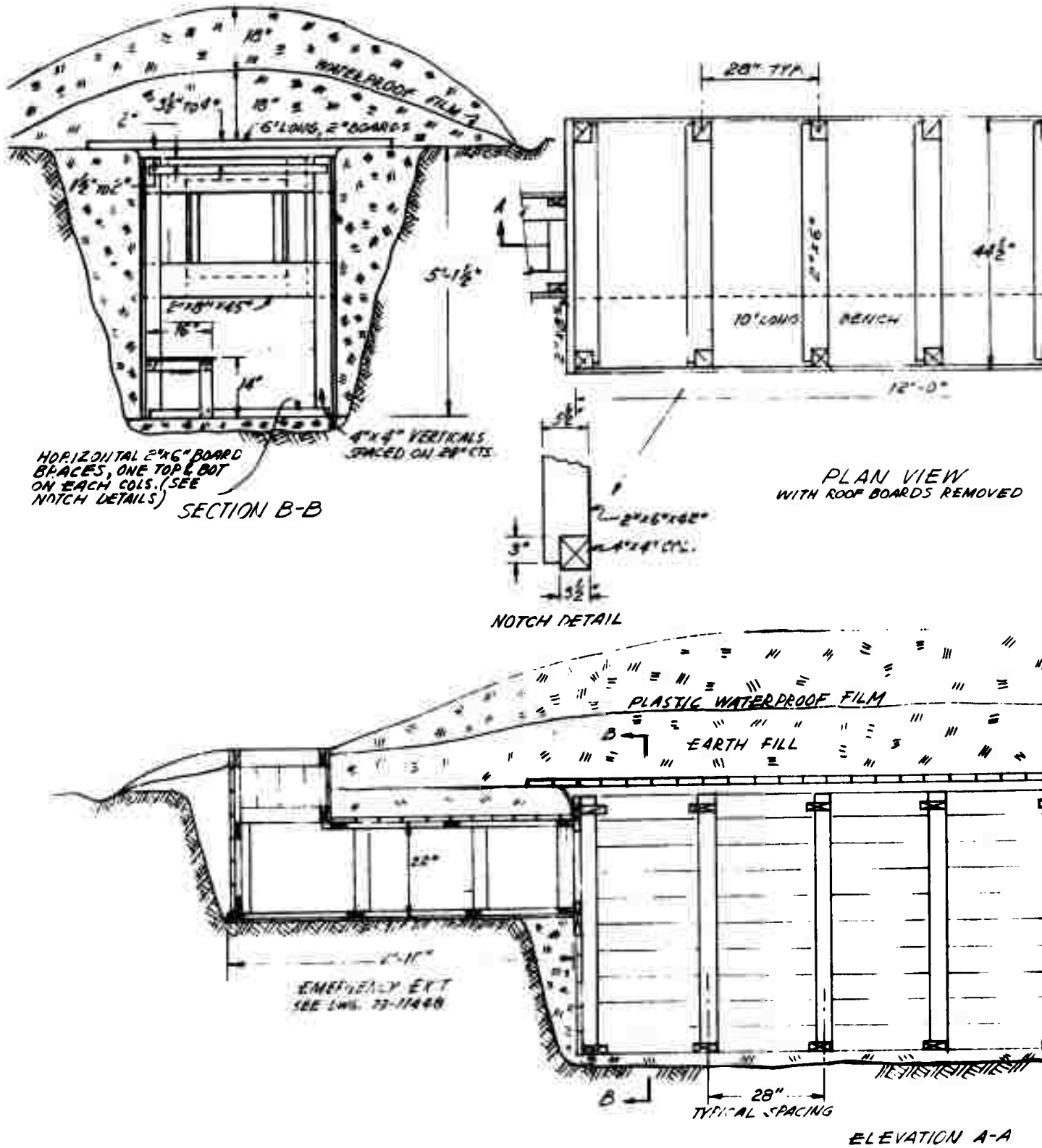
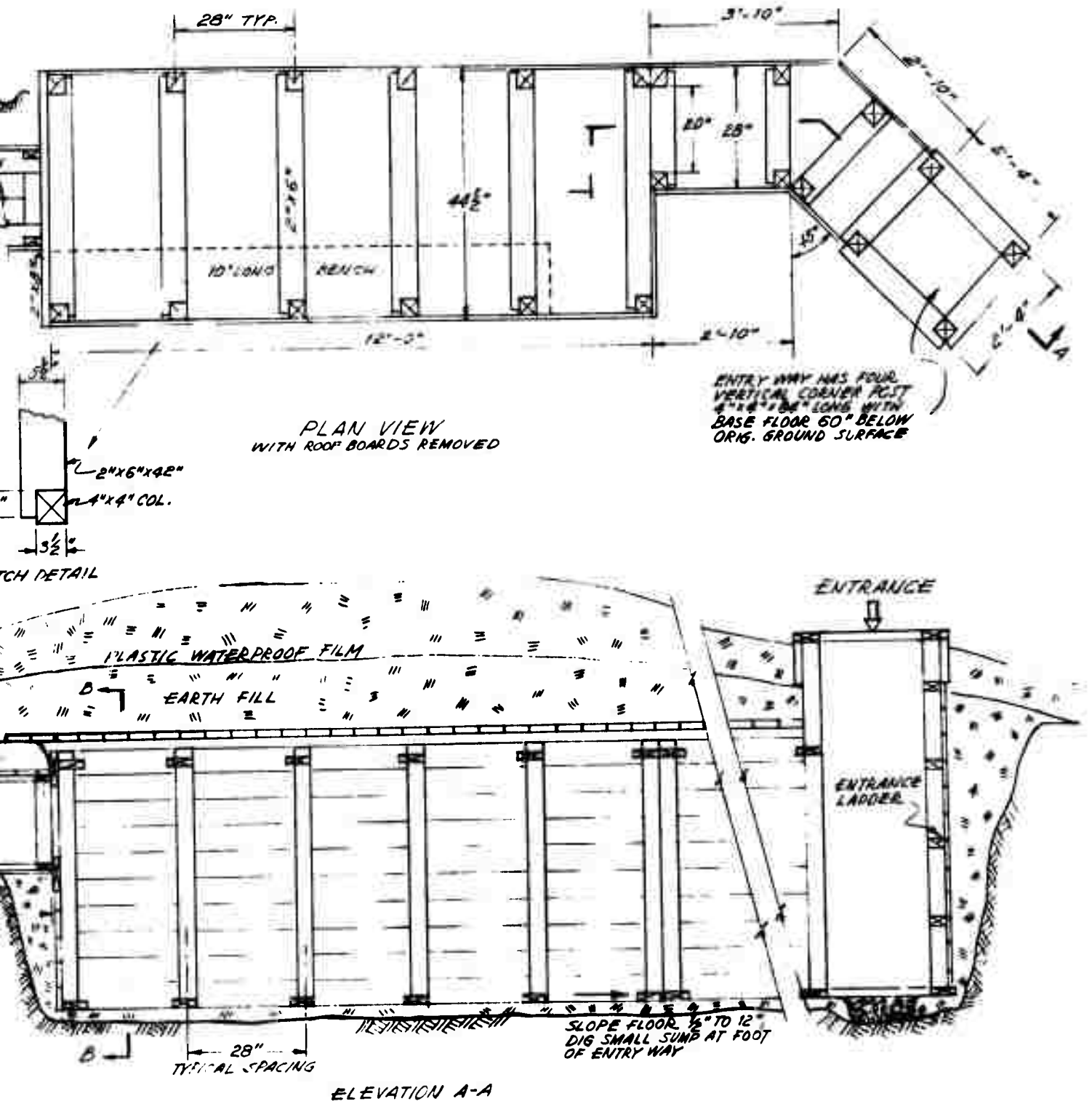
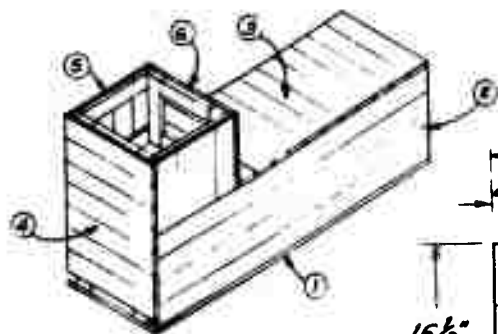

Fig. A-5.1. Shored Trench Stoop-In Shelter, Plan and



A-5.1. Shored Trench Stoop-In Shelter, Plan and Elevation.



KEY VIEW—SHOWING ASSEMBLY OF SECTIONS MARKED 1-6

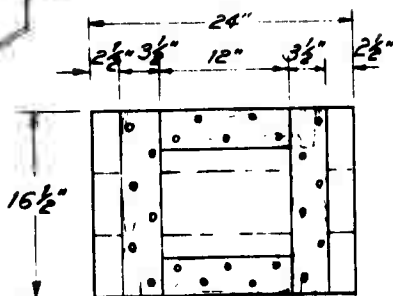

INNER FACE OF INNER SECTION OF VERT. EXIT, MARK ⑥

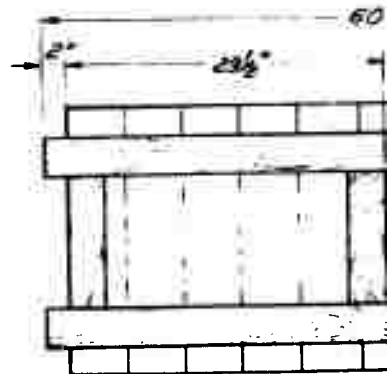

INSIDE FACE OF THE TOP SECTION, MARK ⑤

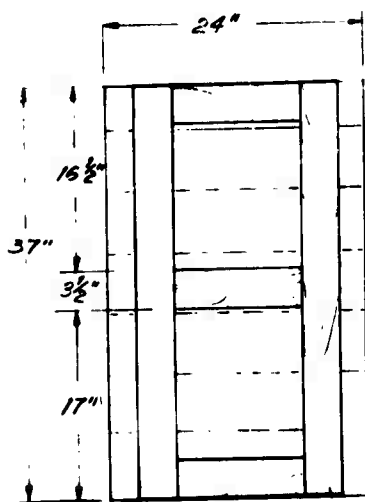

INSIDE FACE OF OUTER VERT. SECTION OF EXIT TUNNEL, MARK ④

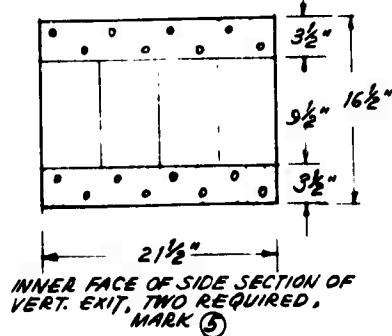

INNER FACE OF SIDE SECTION OF VERT. EXIT, TWO REQUIRED, MARK ③

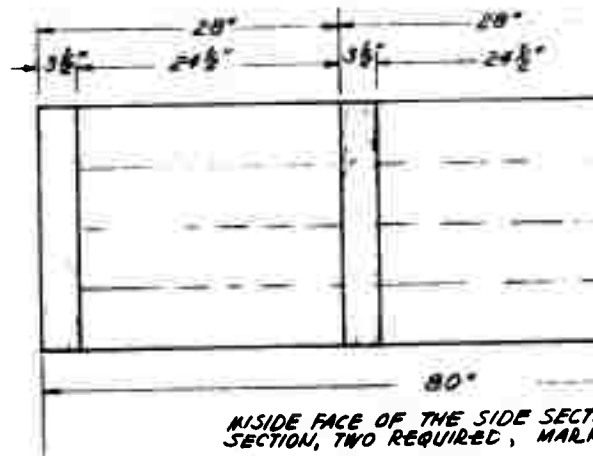

INSIDE FACE OF THE SIDE SECTION, TWO REQUIRED, MARK ③

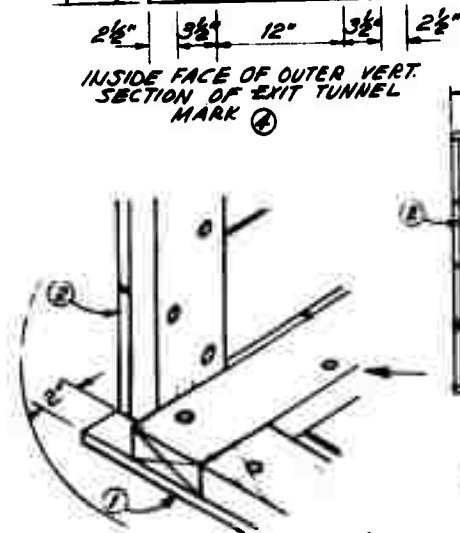

DETAIL A SHOWING 2" EXTENSION OF BOTTOM SECTION TO RECEIVE END VERT. SECTION MARKED ④

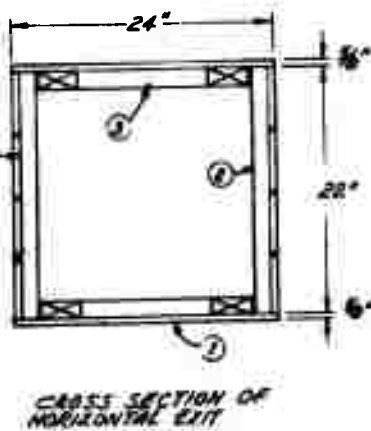

CROSS SECTION OF HORIZONTAL EXIT

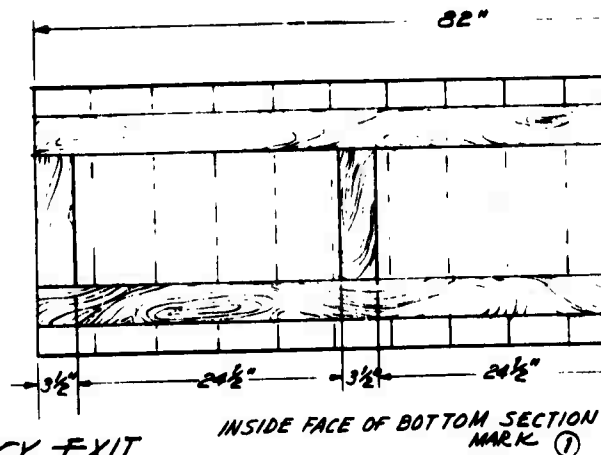

INSIDE FACE OF BOTTOM SECTION, MARK ①

EMERGENCY EXIT

Fig. A-5.2. Shored Trench Stoop-In Shelter, Escape Hatch Details.

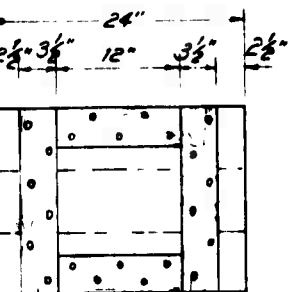

INNER FACE OF INNER SECTION  
VERT. EXIT, MARK ⑥

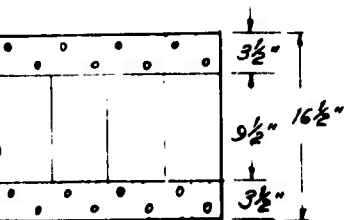

INNER FACE OF SIDE SECTION OF  
VERT. EXIT, TWO REQUIRED,  
MARK ⑤

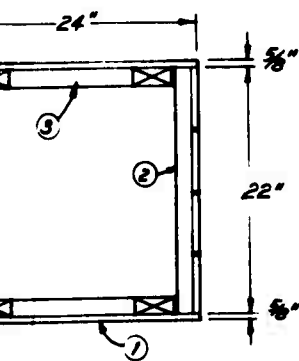

CROSS SECTION OF  
HORIZONTAL EXIT

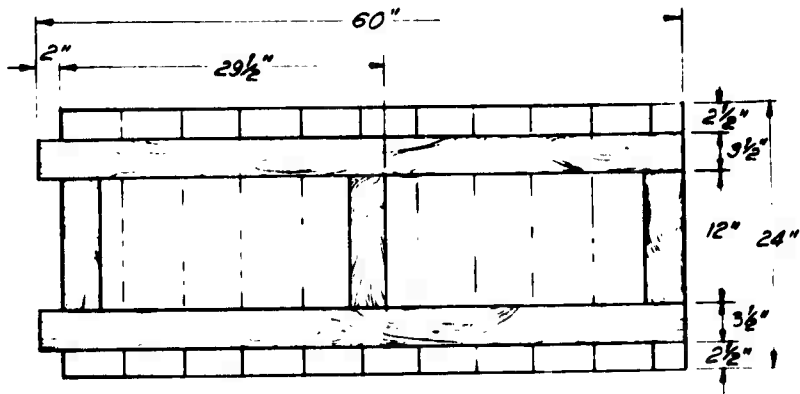

INSIDE FACE OF THE TOP HORIZONTAL SECTION  
MARK ③

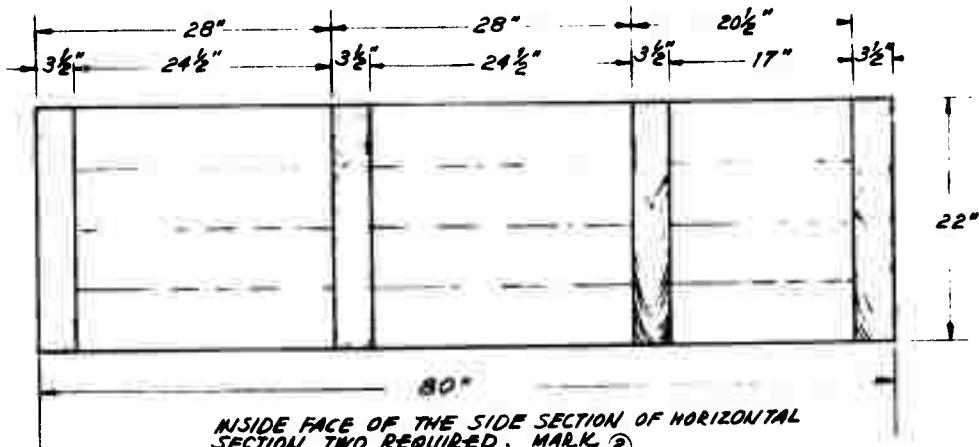

INSIDE FACE OF THE SIDE SECTION OF HORIZONTAL  
SECTION, TWO REQUIRED, MARK ②

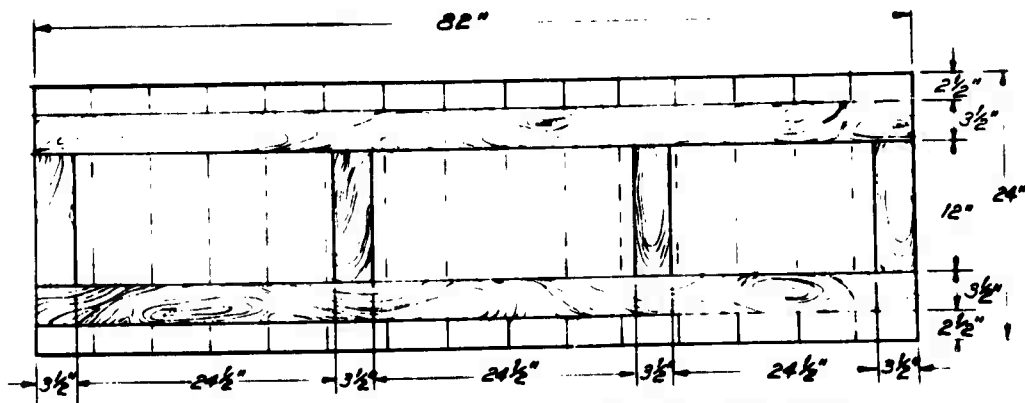

INSIDE FACE OF BOTTOM SECTION OF HORIZONTAL SECTION  
MARK ①

**EMERGENCY EXIT**

A-5.2. Shored Trench Stoop-In Shelter, Escape Hatch Details.

A-6. Two-Family A-Frame Lumber Shelter

This is a slight modification of the A-Frame Aboveground Shelter built at Protective Structures Development Center by two carpenters working 6 days of 8 hours each. The step-by-step instructions have not been proof-tested.

Locally published instructions should include Appendixes B and C.

**A-FRAME TWO-FAMILY SHELTER**  
**(Above Ground or Semi-Buried)**  
**(10-Person Capacity)**

1. This shelter can be built by two or three families working together. It will provide excellent protection against fallout radiation and the thermal pulse from megaton weapons. It has some inherent protection against blast effects, although it was not designed for blast protection. The semiburied model can be built by four or more persons with only moderate carpentry skills within a period of not more than 48 hours. An aboveground model requires so much earth shielding that dump trucks or other construction equipment may be needed to complete the shelter within 48 hours.

2. **Materials and Tools Required**

a. **Lumber**

This shelter requires some long lengths of lumber which would require truck delivery to the building site. If that is impractical, choose another shelter design. Table 1 gives the exact lengths and numbers of pieces required. Table 2 gives a lumber list as it should come from the supply source (lumber yard or sawmill). Table 3 provides one method of getting all the needed pieces from the sizes given in Table 2.

b. **Other Materials**

(1) **Polyethylene film**

2 pieces      20 ft x 30 ft      (1200 sq ft)  
 or equivalent waterproofing materials such as  
 roofing felt, shower curtains, etc.

(2) **Exterior Plywood**

1/2" x 4' x 8'      17 sheets      (544 sq ft)

Figure 1 shows layouts for cutting the plywood to give maximum strength with a minimum of cutting.



## (3) Nails

16-d	20 lbs
6-d	15 lbs
8-d	5 lbs

## c. Recommended Tool List

Pick, long handle	1	Knife, pocket	1
Shovels, long handle	4	File, 10-inch	1
Axe or hatchet	1	Rule, carpenters folding	1
Hand saw, carpenters	3	or steel tape, 6 ft,	
Level, carpenters	1	8 ft, 10 ft, or 12 ft	1
Plumb line	1	Steel tape, 50 ft	1
Square, carpenters	2	String	
Claw hammers	4	Work Gloves	4 pr
Rakes	2	Wheelbarrows	2
Pencil, carpenters	1		

3. Each person working on the shelter should read all of the instructions and study the accompanying drawings before starting the work.

4. Sharpen all tools and keep them sharp. Dull tools waste much time and energy!

5. Wear gloves from the start. Even tough hands can blister after hours of digging and chopping. Blisters are painful, will seriously delay the work, and could cause dangerous infection.

6. Women and children can be of tremendous help. Do not waste valuable resources.

7. If the shelter is to be semiburied, check to make sure the site selected does not have a rock problem; hammer down a sharpened rod or small, sharp-ended pipe 4 ft into the ground in several places. To avoid groundwater problems, avoid low ground.

8. To help drain the floor, if sloping ground is readily accessible locate the shelter so that the original ground level at one end is about two feet lower than the other.

9. Stake out the outline of the shelter. Stakes can be cut from brush or small trees or from scrap lumber. Check the squareness of the staked outline by making the diagonals equal. For an aboveground shelter,

Table 1.

## Bill of Materials (Lumber Only)

Ridge Board	2" x 8" x 16'	1 pc
Sills (Shelter Side)	2" x 6" x 16'	4 pcs
Rafters	2" x 6" x 10'	48 pcs
Entry Studs	2" x 6" x 10'	4 pcs
Entry Stud	2" x 6" x 4'2"	1 pc
Entry (Door Lintel)	2" x 6" x 2'6"	1 pc
Sills (Shelter End)	2" x 4" x 14'8"	4 pcs
Floor Ties*	2" x 4" x 14'8"	5 pcs
Ladder Sides & Stud Spans	2" x 4" x 10'	4 pcs
Studs	2" x 4" x 7'2"	1 pc
Studs	2" x 4" x 5'10"	4 pcs
Studs	2" x 4" x 4'6"	4 pcs
Studs	2" x 4" x 3'2"	4 pcs
Studs	2" x 4" x 1'10"	4 pcs
Ladder Rungs	2" x 4" x 1'6"	8 pcs
Entry Frame (Top & Bottom)	2" x 4" x 3'	4 pcs
Entry Frame " "	2" x 4" x 2'8"	8 pcs
Entry Frame " "	2" x 4" x 2'4"	4 pcs
Nailers for Entry Sides	2" x 4" x 5'10"	2 pcs
Vent (Sides)	1" x 8" x 6'	2 pcs
Vent (Sides)	1" x 8" x 5'8"	2 pcs
Vent (Bottom)	1" x 8" x 8"	1 pc
Vent (Roof)	1" x 8" x 12"	2 pcs
Nailer for Vent	1" x 4" x 4'	1 pc
Ladder Scabs**	2" x 2" x 8"	16 pcs

\* Floor ties are required for aboveground shelter but may be safely omitted for the semiburied shelter.

\*\* Make from 2" x 4" x 8" by splitting with an axe or hatchet.

Table 2.  
Lumber List

2" x 8" x 16'	1 pc	22 board feet
2" x 6" x 16'	4 pcs	64 board feet
2" x 6" x 10'	52 pcs	520 board feet
2" x 6" x 8'	1 pc	8 board feet
2" x 4" x 16'	4 pcs	44 board feet
2" x 4" x 16'	5 pcs*	54 board feet
2" x 4" x 12'	11 pcs	88 board feet
2" x 4" x 10'	4 pcs	28 board feet
2" x 4" x 6'	1 pc	4 board feet
1" x 8" x 12'	2 pcs	16 board feet
1" x 8" x 2'	1 pc	2 board feet
1" x 4" x 4'	1 pc	
Total for Aboveground		<u>850</u> board feet
Total for Semiburied		796 board feet
or 85 bd ft/person for aboveground shelter		
80 bd ft/person for semiburied shelter		

\*For semiburied shelter omit this line.

Table 3.  
Cutting Schedule

		<u>Cut from Each</u>
2" x 8" x 16'	1 pc	no cutting required
2" x 6" x 16'	4 pcs	no cutting required
2" x 6" x 10'	52 pcs	no cutting required
2" x 6" x 8'	1 pc	cut 1 pc 2" x 6" x 4'2" cut 1 pc 2" x 6" x 2'6"
2" x 4" x 16'	5 pcs	cut 1 pc 2" x 4" x 14'8" cut 2 pcs 2" x 4" x 8" (split these with axe to make 2" x 2")
2" x 4" x 16'	12 pcs *	cut 1 pc 2" x 4" x 14'8" get scrap 2" x 4" x 1'4"
2" x 4" x 10'	4 pcs	no cutting required
2" x 4" x 12'	1 pc	cut 1 pc 2" x 4" x 7'2" cut 2 pcs 2" x 4" x 2'4"
2" x 4" x 12'	3 pcs	cut 2 pcs 2" x 4" x 5'10"
2" x 4" x 12'	2 pcs	cut 2 pcs 2" x 4" x 4'6" cut 2 pcs 2" x 4" x 1'6"
2" x 4" x 12'	1 pc	cut 4 pcs 2" x 4" x 3'
2" x 4" x 12'	2 pcs	cut 2 pcs 2" x 4" x 3'2" 2 pcs 2" x 4" x 2'8"
2" x 4" x 12'	2 pcs	cut 2 pcs 2" x 4" x 2'8" cut 1 pc 2" x 4" x 2'4" cut 2 pcs 2" x 4" x 1'10"
2" x 4" x 6'	1 pc	cut 4 pcs 2" x 4" x 1'6"
1" x 8" x 12'	1 pc	cut 2 pcs 1" x 8" x 6'
1" x 8" x 12'	1 pc	cut 2 pcs 1" x 8" x 5'8" get 1 pc 1" x 8" x 8"
1" x 8" x 2'	1 pc	cut 2 pcs 1" x 8" x 1'
1" x 4" x 4'	1 pc	no cutting required

\*For semiburied shelter omit this line.

A-6.6

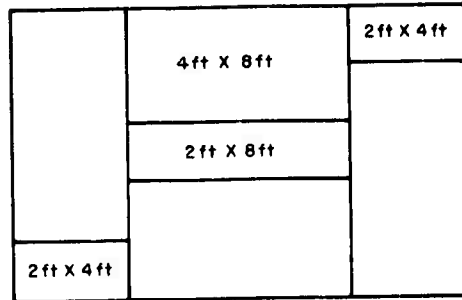

1.a TYPICAL LAYOUT FOR ROOF. 4 UNCUT SHEETS, ONE SHEET CUT TO PRODUCE ONE 2 ft X 8 ft AND TWO 2 ft X 4 ft PIECES. (TOTAL REQUIRED = 10 SHEETS)

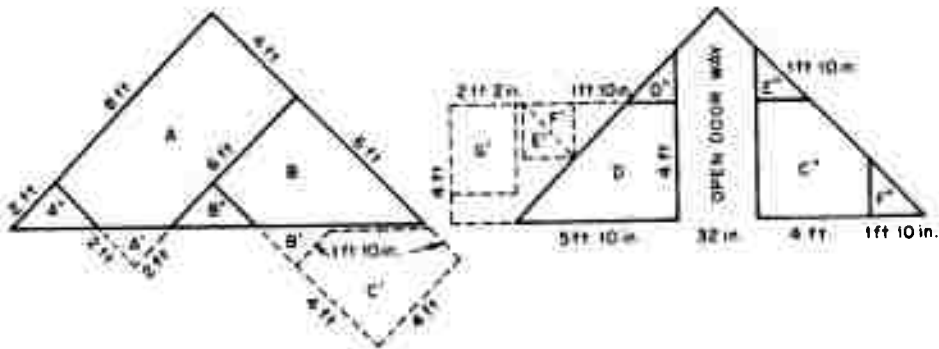

1.b LAYOUT FOR ENDS. USE PIECE A' IN POSITION A", USE PIECE B' IN POSITION B", PIECE G' MAY BE CUT TO 3 ft X 2 ft FOR ONE PIECE OF THE ENTRYWAY SIDING. (TOTAL REQUIRED = 3 SHEETS)

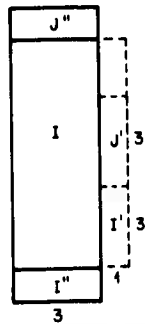

1.c TYPICAL LAYOUT FOR THREE SIDES OF ENTRY HATCH. TOTAL REQUIRED = 3 SHEETS  
USE PIECES I' AND J' IN POSITION I'' AND J'', FOURTH SIDE REQUIRES A PIECE 3 ft X 4 ft 2 in. WHICH MUST BE CUT FROM THE 17th PIECE OF PLYWOOD. SAVE THE SCRAP TO USE IN CONJUNCTION WITH THE K.A.P.

Fig. 1. Plywood Cutting Pattern.

batter boards should be erected at each corner using a line level and a carpenter's level to establish the proper height.

10. Clear all brush, tall grass, small trees, etc., off the ground to a distance of 10 ft all around the staked location to provide storage space for the excavated earth and working space for the construction.

11. When digging the trench for the shelter, make the trench at least two feet wider and longer at the top than at the bottom. As the trench is being dug, check the width frequently using one of the 2" x 2" x 14'8"-long sills to check the width of the trench. Pile the earth dug from near ground level about 8 ft from the edge of the trench. Then the earth dug from 3 to 4 feet down can easily be piled on the surface only 1 to 5 ft from the edge.

12. While the trench is being dug for the shelter, one or two persons can be cutting the lumber into the required lengths. As each piece is cut it should be marked to indicate its location in the shelter structure. One method would be to mark numbers on each piece with a pencil or felt-tipped colored marker. If colored markers are available one color could indicate entryway pieces, another color the main shelter, etc. Stack the pieces by size in a location convenient to the construction area but where it will not be in the way of the excavation workers.

13. The entryway structure can be preassembled outside the shelter area, either while the trench is being dug or while the main shelter is being built. The bottom and top frameworks should be assembled first and nailed firmly, being careful to keep the openings square. Next add the 2" x 6" studs. Square the assembly and add the 1/2" plywood siding to at least two sides to help hold it square until installed.

14. Precut the ends of the 2" x 6" rafters at a 45° angle. This will be easier and the job more uniform if the miter box is used. An expedient miter box can be made from two 1" x 6" boards and a 1" x 8" board, each about three feet long. Nail the 1" x 6" board to the edge of the 1" x 8" to form a right angle thus:

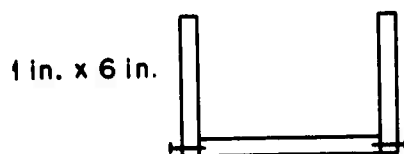

The miter box will be more stable if a short length of 1" x 6" is nailed across one end as shown in Figure 2. Carefully mark and cut a slot in the upright board at a 45° angle to the long axis of the miter box. Mark the 45° line on the horizontal board to serve as a guide to the person doing the sawing.

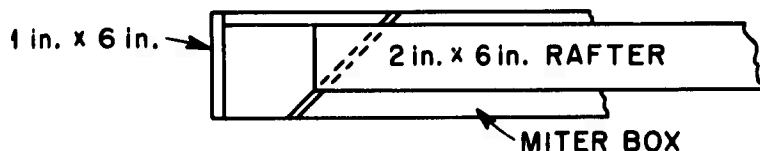

Fig. 2. Use of Expedient Miter Box to Cut Rafters at 45°.

15. If an aboveground shelter is being made, dig a small trench along each side using strings from the batter boards as guides for alignment. The edge of the bottom of the trenches should be cut as approximately 45° to provide a bearing surface for the 2" x 6" sills. Also dig a trench at each end for the 2" x 4" sills laid flat.

16. When the trench is finished, trim the bottom carefully to assure that the floor will drain to the center drain and that the center drain will drain to the sump in the bottom of the entryway.

17. Nail the two 2" x 4" x 14'8" boards together to form the double 2" x 4" sills for the two ends. Nail the two 2" x 6" x 16' boards together to form the sills for the sides of the structure. Place the double 2" x 6" sills in the trench along each side of the trench. Place the double 2" x 4" sills in the trench at each end of the structure.

18. Start erecting the roof framing. First, place two rafters at each end to support the ridge board. Add additional rafters at intermediate points (about every 4 ft). Hold the roof framing in place by temporary braces at each end. Complete the rafter assembly. Add the 2" x 4" studs at each end. Fit the 2" x 4" spacers between the studs and the next rafter to provide lateral stability.

19. In the aboveground shelter, dig narrow trenches across the floor of the shelter for the 2" x 4" ties. Place the ties in the trench and nail them to the rafters and sills.

20. Nail the plywood sheathing to the rafters.

21. Place the preassembled entry structure at the end of the shelter and nail it to the rafters. Attach the two 2" x 4" nailers to the entry structure. Add the remaining plywood sheath to the structure.

22. Construct the 8"-square ventilation duct. Cut an opening in the plywood sheath at the rear of the shelter to allow air to pass from the shelter into the vent. Install the vent on the rear of the shelter.

23. Cover the roof with polyethylene. (NOTE: If polyethylene plastic is in short supply, this covering can be omitted.)

24. Cover the shelter with earth until the depth over the ridge line is 18 inches. (For the aboveground shelter, all the covering earth will have to be dug up from surrounding area and hauled in.) Mound the earth at the center (along the ridge board) so that the mound does not extend beyond the edge of the trench for the semiburied shelter or so that the depth over the outer edge of the aboveground shelter is only 18 inches. Rake the mound smooth. Remove any stones or sharp objects that might puncture the waterproof film.

25. Cover the mound with water proof membrane (or polyethylene film, roofing felt, shower curtains, etc.). If the waterproof material is not large enough to cover the mound all in one piece, overlap the pieces like shingles (that is, the pieces on the upper side lap over the ones on lower side).

26. Complete the shielding by covering the waterproof membrane with earth until the depth of earth over the ridge board is three feet. The excavation will not provide this much earth so other earth must be dug up and hauled in to cover the shelter.

27. If the shelter is to be occupied during warm weather (i.e., above 70°F), a Kearny Air Pump should be constructed and installed (See Appendix B for directions).

28. If time permits, improve the habitability of the shelter by such things as:

- a. providing additional water storage facilities,
- b. adding flooring boards,
- c. constructing expedient lights, and
- d. erecting curtains for privacy (see Appendix C for instructions).



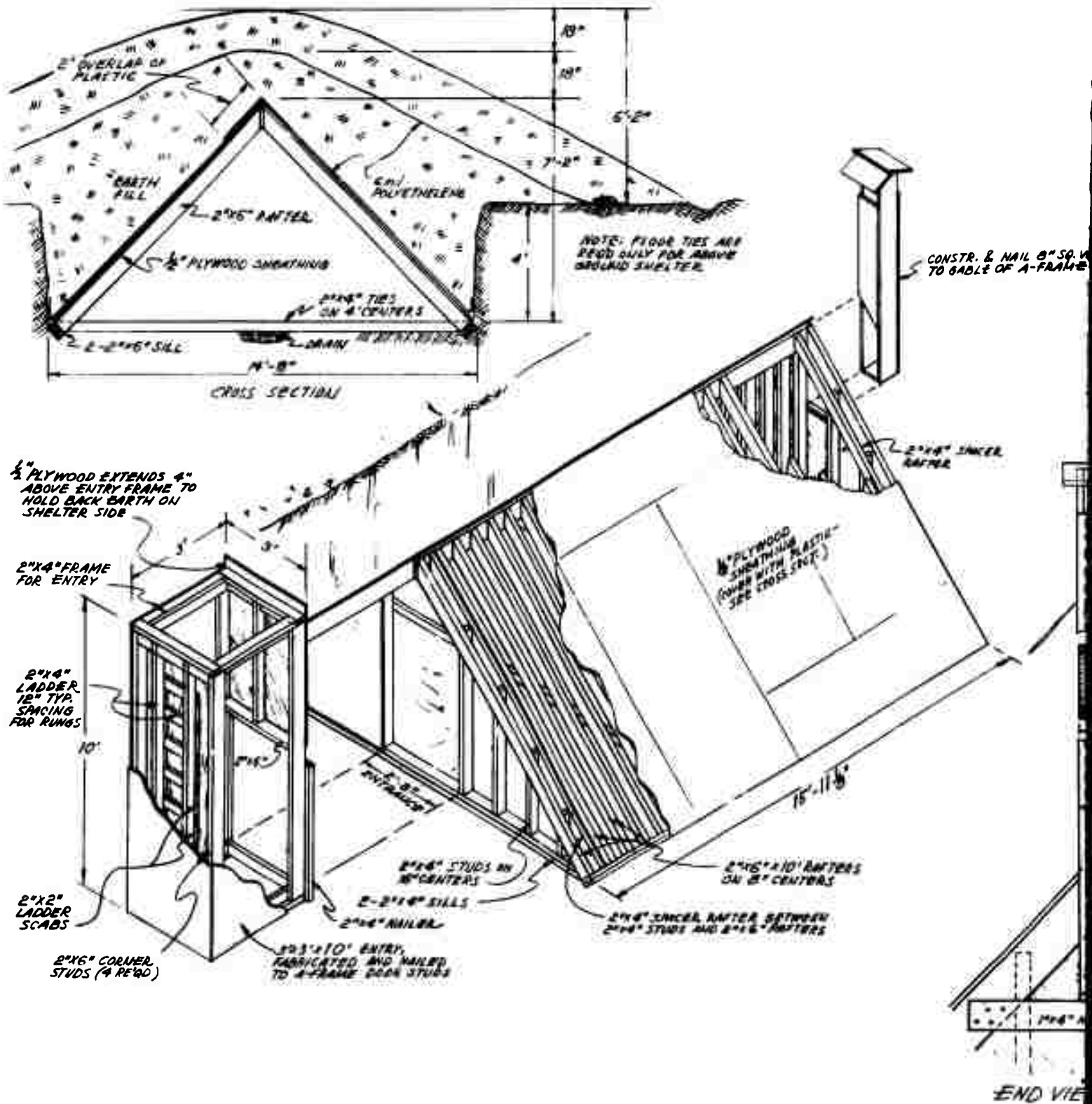

Fig. A-6.1. Two-Family, A-Frame Lumber Shelter

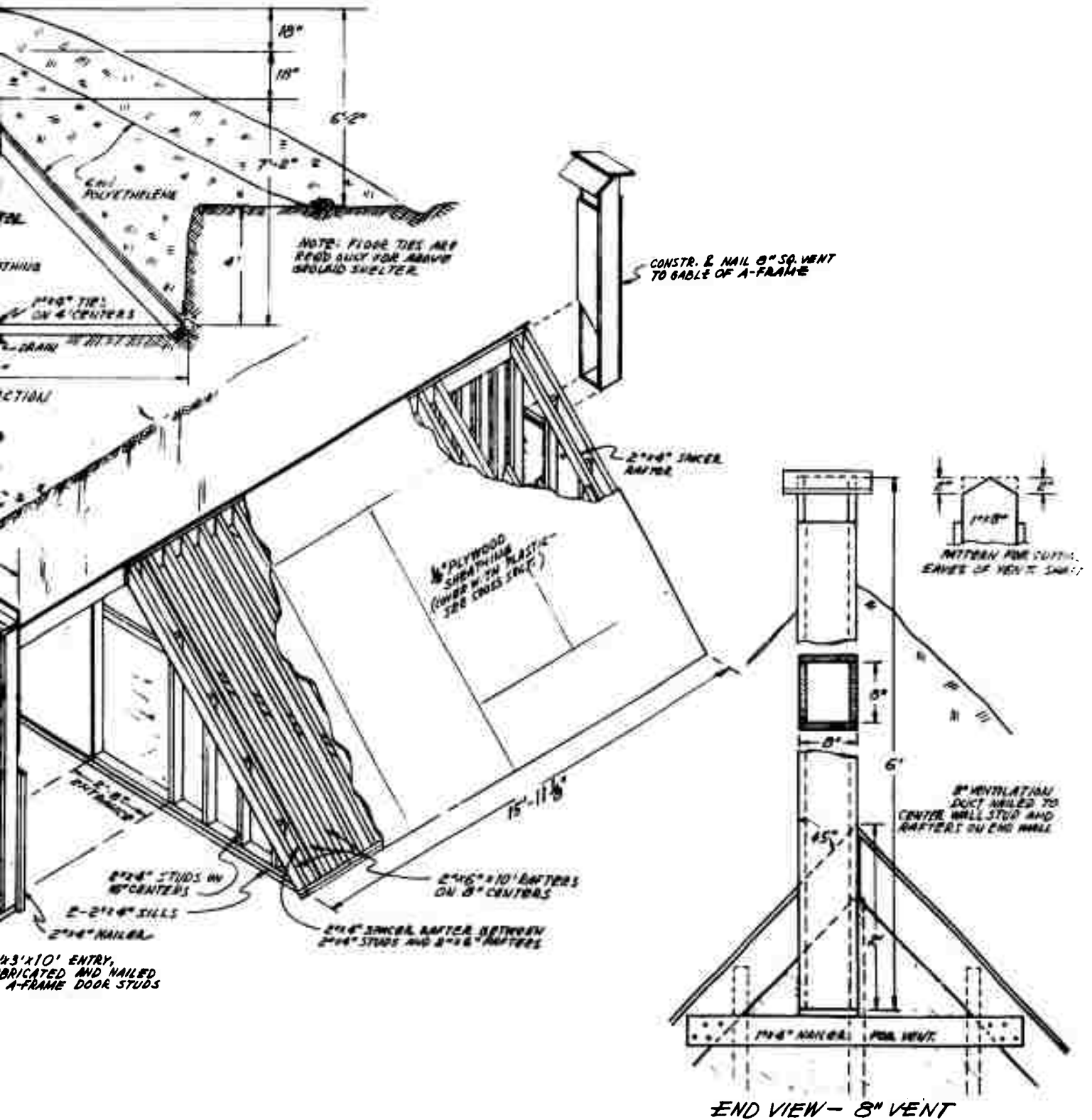

Fig. A-6.1. Two-Family, A-Frame Lumber Shelter

#### A-7. Rigid Frame Underground

This shelter design was originally published in the Department of the Army Pamphlet 500-1-1 "Army Survival Measures Planning Guide" which reported that it was developed by the Office of Civil Defense and the Department of the Army for use by reserve units when other shelter was not available. The only known model of this shelter that has been built is the one constructed<sup>3</sup> by a platoon of the 82nd Airborne Infantry troops as part of Exercise Laboratory Shelter. The version included in this appendix incorporates the lessons learned as reported by the after-action report, and has been strengthened by adding center supports under each joist. It is designed for construction by inexperienced persons using only the step-by-step instructions provided. The step-by-step instructions are based on proven principles as reported by Kearny but have not been prooftested.

Locally published instructions should include Appendixes B and C.

APPENDIX A-7  
RIGID FRAME UNDERGROUND SHELTER  
(60-Person Capacity)

1. This shelter can be built by a crew of from 15 to 30 inexperienced persons who are willing to work together to provide for themselves and their families protection from the dangers of radioactive fallout.

2. The length of time required to build this shelter depends upon many things. If a tractor with a dozer blade is available, the trench for the shelter can be excavated in two and three hours. Other evacuation equipment such as backhoes or front-end loaders can be used. If no mechanical equipment is available, the trench can be dug by hand but this will require much longer.

3. Each person who will be working on the construction of the shelter should study the two drawings and read all of these instructions before starting the work.

4. Materials and tools required:

a. Lumber

In many areas lumber will be available in lengths up to 16 ft. In such places the first list below should be used since it saves lumber by making maximum use of the longer lengths. However if only 14-ft and shorter lengths are available use list No. 2. When only 12-ft and shorter sizes are available use list No. 3. In case shorter sizes are available some of the shorter pieces can be substituted for some of the lengths listed. After delivery of the lumber to the building site it should be cut into the lengths as shown on list No. 4. (CAUTION: Lumber will be in very short supply so the cutting must be done carefully to avoid waste. The shorter pieces must be cut from scrap produced by cutting the longer pieces.)

A-7.2

(1) Lumber required if 16-ft lengths are available:

2" x 12" x 16'	9 pcs	228 bd ft		
2" x 10" x 16'	6 pcs	160 bd ft		
2" x 10" x 12'	37 pcs	740 bd ft		
2" x 8" x 16'	6 pcs	128 bd ft		
2" x 8" x 12'	2 pcs	32 bd ft		
2" x 6" x 16'	63 pcs	1008 bd ft		
2" x 4" x 16'	3 pcs	32 bd ft		
2" x 4" x 14'	37 pcs	346 bd ft		
2" x 2" x 12'	40 pcs	320 bd ft		
			<u>2994 bd ft</u>	(50 bd ft per person)

(2) Lumber required if only 14-ft and 12-ft lengths are available:

2" x 12" x 14'	9 pcs	252 bd ft	2" x 8" x 14'	6 pcs	112 bd ft
2" x 12" x 8'	2 pcs	32 bd ft	2" x 8" x 12'	3 pcs	48 bd ft
2" x 10" x 14'	6 pcs	140 bd ft	2" x 6" x 14'	72 pcs	1008 bd ft
2" x 10" x 12'	37 pcs	740 bd ft	2" x 4" x 14'	37 pcs	346 bd ft
2" x 10" x 8'	2 pcs	27 bd ft	2" x 4" x 12'	44 pcs	352 bd ft
					<u>3057 bd ft</u>

(3) Lumber required if only 12-ft lengths are available:

2" x 12" x 12'	12 pcs	288 bd ft	
2" x 10" x 12'	45 pcs	900 bd ft	
2" x 8" x 12'	10 pcs	160 bd ft	
2" x 6" x 12'	90 pcs	1080 bd ft	
2" x 4" x 12'	97 pcs	756 bd ft	
			<u>3184 bd ft</u> (53 bd ft per person)

(4) Actual sizes needed:

(4)	Actual Sizes Needed	Substitutes to Use Shorter Lengths				
		Max 14'	Max 12'	Max 12'		
1. Ledgers	2" x 12" x 16'	9 pcs	2" x 12" x 14' 2" x 12" x 8'	9 pcs 2 pcs	2" x 12" x 12'	12 pcs
2. Headers & Joists	2" x 10" x 16' 2" x 10" x 12'	6 pcs 37 pcs	2" x 10" x 14' 2" x 10" x 12' 2" x 10" x 8'	6 pcs 37 pcs 2 pcs	2" x 10" x 12'	45 pcs
3. Stud Footings	2" x 8" x 16' 2" x 8" x 12'	6 pcs 2 pcs	2" x 8" x 14' 2" x 8" x 12'	6 pcs 3 pcs	2" x 8" x 12'	10 pcs
4. Entryway Frames	2" x 6" x 11'	16 pcs				
5. Studs	2" x 6" x 6'6"	74 pcs				
6. Stud Scabs	2" x 6" x 2'	148 pcs				
7. Column Footings	2" x 4" x 16'	3 pcs	2" x 4" x 12'	4 pcs	2" x 4" x 12'	4 pcs
8. Spreaders	2" x 4" x 10'9"	19 pcs				
9. Center Columns*	2" x 4" x 7'4" 2" x 4" x 7'2" 2" x 4" x 6'6" 2" x 4" x 6'4"	18 pcs 19 pcs 18 pcs 19 pcs				
10. Entryway Frames & Knee Braces	2" x 4" x 4'	53 pcs				
11. Ladder Rungs	2" x 4" x 1'6"	20 pcs				

\* If 16-ft lengths are available, each 15-ft board will make two column pieces (for example, one 7'4" and one 6'4") with very little scrap. However, if only 12-ft lumber is available each 12-ft board will make only one; and the left-over lengths must be used to make the entry frames, knee braces and ladder rungs.

A-7.4

b. Other building materials needed:

Plywood 1/2" x 4' x 8'	56 pcs
Polyethylene - 6-mil (one 100-ft roll of 20-ft-wide polyethylene)	2000 sq ft
Nails - 20 penny (4 in. long)	14 lbs
16 penny (3-1/2 in. long)	17 lbs
6 penny (2 in. long)	8 lbs
Sticks (may be cut from brush)	1/4 to 1-inch-diameter (of any length to use for drains)

NOTE: If 20-penny nails are not available, substitute an additional 18 lbs of 16-penny. 8-penny nails (2-1/2 in. long) can be substituted for 6-penny nails.

- c. Materials to build a Kearny Air Pump (see Appendix B).
- d. Tools required for a 24-person crew to work efficiently (adjust tool list to the number of workers available - note that not all the tools can be used at any one time):

<u>Tool</u>	<u>Quantity</u>	<u>Notes</u>
Hand Saw, carpenters	8	(If electricity is available, one or two circle saws can do most of the cutting)
Levels	2	
Rakes	3	
Plumb lines	2	
Axes or hatchets	4	
Claw hammers	12	
Pick, long handle	2	} (If hand excavation is necessary, multiply these numbers by 5)
Shovels, long handle	4	
Pencils, carpenters	2	
Felt Marking Pens (optional)	3 or 4 colors	
Square, carpenters	2	
Work gloves	25 pr	
File - 10-inch	3	
Steel tape - 50-ft	1	
Steel tape - 10-ft	3	
String	1 ball	
Wheelbarrows	2	

#### A-7.5

5. To save time and work, sharpen all tools and keep them sharp, even if it takes one man full time to do it!

6. Wear gloves from the start — even tough hands can blister after hours of hard work. Blisters are painful, seriously delay the work, and could cause dangerous infections.

7. To avoid confusion, wasted time, and effort, organize the work group into teams. Many variations are possible. A suggested division of tasks, based on a 24-person working force divided into 4 crews of 6 persons each is given at the end of these instructions.

8. Before staking out the outlines of the excavation, check to make sure that rock will not be too near the surface by driving down a 6-ft-long sharpened rod or small pipe in several places over the proposed site. To avoid groundwater problems, avoid low ground.

9. Cut the lumber to the required lengths. Mark each piece (with a name or number) to indicate where it goes in the structure to assure that the required long pieces are not subsequently cut up for the shorter pieces. Colored marking pens can be used to color-code the pieces to speed identification during construction.

10. To help drain the floor, locate the shelter so that the original ground level at one end is about three feet lower than the other end.

11. Stake out the trench for the shelter. Even in very firm earth, make the excavation at the surface 16 ft, 6 in. wide (2 ft-6 in. wider than the 14-ft-wide bottom of the trench). If the excavation is dug by hand, make the length 50 ft long at the bottom, 52 ft-6 in. long at the top plus two 6-ft-square holes for the entry ways. The sloping sides of the excavation and the 14-ft-wide bottom are necessary even in firm earth for safety and adequate working room. In soft, crumbly earth the width at the top must be even greater to ensure that no lumps will cave off the sides during construction.

12. Check the squareness of the staked outline by making the diagonals equal. Extend the stakes out both ends far enough to guide the dozer operator during the digging operation.

13. Clear all brush, tall grass, trees, etc. off the ground to a distance of 15 ft on each side and to a distance of 25 ft at each end of the staked location. This is necessary to provide room to store the



earth before putting it back on the roof. The backfill material should not contain any brush, sticks, or large stones.

14. Use a 14-ft-long 2" x 4" board or the tape to check the excavation width frequently as the trench is being dug.

15. If the trench is dug by shovels, pile the earth dug near ground level at least 10 ft from the sides of the trench. Then as the trench deepens, the earth dug from 5 or 6 ft down can be piled on the surface only 1 to 5 ft from the edge.

16. When the bulldozer has finished, trim the bottom of the trench with shovels. Slope the floor to drain toward the two center drains. Be sure the bottom of the trench slopes at least 1/2 inch vertically for each foot of horizontal length — either slope all in one direction or slope both ways from the middle. Dig a 2-ft-square x 1-ft-deep sump at each end. Water collected in the sump will be bailed out by hand as necessary. Dig two drain ditches down the middle, one on each side of the center column base plate (each 6 inches wide and 4 inches deep). Lay small sticks in the drain and cover with porous fabric to serve as a crushed rock drain leading to the sumps.

17. While the trench is being excavated, start construction of the two entry subassemblies on a clear area near one end of the excavation. Meanwhile, another crew can assemble the joist-stud subassemblies and the center post assemblies.

18. Lay out and carefully align the stud base plates and the center post base plate on the floor of the trench. Drive several small stakes on each side of the stud base plates to maintain the alignment. The exact location of these stakes is not critical since they will be removed later.

19. Measure along each stud base plate and mark on the base plate the location for each stud.

20. Measure along the center post base plate and mark the location for each post.

21. Install the 19 spreaders and the thrust plates. Nail the thrust plates to the spreaders. Use short 2" x 4" blocks (from the scrap pile) to hold the two ends of each spreader off the floor until the nails are driven, then remove the blocks for use on the next spreader.

22. Carry one of the entryway assemblies into the trench and set it in place at the end of the stud plate (already installed). The assembly will stand unsupported but it will be safer to install four temporary braces (2" x 4" x 10' or 12') as shown in the sketch, until the joist-stud assemblies have been installed and fixed to the entryway.

23. Install the joist-stud assemblies, starting at the end where the entryway has been erected. Hold the joist-stud assemblies in place by nailing on the headers and the ledgers. Remove the stakes which were put in earlier to hold the stud plate in place.

24. As soon as the joist-stud assembly installation has progressed far enough to provide a stable structure (about four or five joists), one part of the work force can start installing the studs at the end of the shelter.

25. Install the center posts and the centerpost ledger.

26. Install the other entryway assembly and the studs at this end of the structure.

27. Cover the roof and the sides with plywood.

28. Install the plywood sheathing to the first entryway and the end of the shelter.

29. Make several tempers. Start backfilling around the entryway and the finished end. Spread the loose earth evenly to a depth of about 4 inches (never more than 6 inches at a time) and tamp by hand only. Continue adding earth and tamping until the fill reaches the roof line. If the bulldozer is still available, it can be used to move the dirt into the ramp area, but the earth fill within two feet of the structure should be hand placed and tamped. If the bulldozer is not available, wheelbarrows should be used to haul the earth from the storage pile into the ramp area.

30. As soon as the plywood has been installed on the sides of the shelter, backfill (with tamping) to the roof level. The earth can be shoveled into the excavation, but care must be taken to avoid dropping dirt on the tampers, and to be sure that the earth is spread evenly no more than 6 inches deep before tamping. The earth fill must be brought up evenly on both sides so that the earth fill on one side is never more than 12 inches higher than on the other.

A-7.8

31. Form a drainage ditch on both sides of the shelter. The outer edge of the backfill area is a convenient location. Extend the ditch at least ten feet beyond the end of the shelter. Slope the bottom of the ditch at least 1/2 inch per foot of length.

32. Cover the roof with waterproofing material (polyethylene, roll roofing, etc.). CAUTION: This is not the weatherproofing for the shelter! It is only to keep dirt and moisture from the earth from seeping through. The rainproofing comes later.

33. Place grade stakes along the edge of the trench for use later in checking the depth of the earth cover.

34. Mound earth over the shelter, piling it about 15 inches deep along the center line of the roof and sloping it toward the sides of the roof so that the earth is only about 2 inches deep over the edges of the roof. Continue to slope out to the side drainage ditches, which will be buried later (see drawing). Smooth the mounded earth with rakes and remove any sticks or stones so they will not puncture the rainproofing material which is put on it later.

35. Place rainproofing material (6-mil polyethylene, roofing felt, plastic shower curtains and table cloths, or canvas) on top of the smooth mounded earth. Be sure the rainproofing extends beyond the drainage ditches. Lay short sticks on top of the water proofing in the drainage ditch and roll the edge of the water-proofing around them as shown in the drawing.

36. Place the rest of the earth cover over the shelter, being careful not to puncture the waterproof cover. Be sure that the edges and the corners have at least 2-1/2 feet of earth cover. Mound the earth, smoothing the surface with rakes so that the water will tend to run off the sides.

37. Dig a 6"-deep, surface drainage ditch all around the completed earth mound.

38. Install the KAP in the doorway of the entry which is located in the direction from which the wind is blowing. It can be moved to the other doorway when the wind changes.

39. Cover each entrance with a fly or canopy (open on all sides) to minimize entry of fallout particles.

40. Occupy the shelter.

41. As time, energy, and materials permit, improve the interior of the shelter by one or more of the following activities:

- a. Fill in the floor between spreaders with earth and cover with plywood or 1-inch boards.
- b. Build benches and overhead bunks. Be sure to space the vertical supports 3 feet apart so two men can sit between each pair of supports.
- c. For windy and/or cold weather, make temporary covers for one or both of the entryways from plywood (1 sheet of 1/4" x 4' x 8' plywood will make 2 covers). The amount of air can be adjusted as necessary by sliding the plywood covers back or forth to obtain the required size opening.

42. The following is a suggested division of tasks based on 4 crews of 6 persons each:

a. With bulldozer

Crew A - (1) Stake out the outlines of the trench.

(2) Clear brush, grass, etc. from the site.

(3) (a) Check width of trench frequently.

(b) Assist dozer operator as necessary.

(c) Part of the crew assist other crews while waiting for dozer to finish.

(4) Trim bottom of trench with shovels; dig center drains and fill with sticks provided by Crew D. Dig sumps.

(5) Install the stud baseplates and the centerpost base plate.

(6) Mark the base plates to locate the positions for the studs and the center posts.

(7) Install the spreaders and the thrust plates.

(8) Assist Crew B install the joist-stud subassemblies.

(9) Cover sidewalls with plywood.

(10) Spread and tamp backfill along both side walls.

(11) Assist Crews D and B finish the backfilling and tamping of the end structures.

(12) Assist Crew C cover the roof with earth.

A-7.10

- Crew B --
- (1) Check tools to be sure all the necessary tools are available.
  - (2) Check sharpness of tools and sharpen any dull ones.
  - (3) Assemble the two entry structures.
  - (4) Assisted by Crew C erect the first entryway assembly.
  - (5) Install the joist-stud assemblies and their headers and ledgers, assisted by Crew A.
  - (6) Assisted by Crew C install the second entryway.
  - (7) Spread and tamp backfill around first end wall and entryway.
  - (8) Assist Crew C cover the roof with earth.
  - (9) Install the fly covers over the entryways.
- Crew C --
- (1) Inventory the lumber and other materials to be sure the required materials are on hand. Correct any shortage discovered.
  - (2) Cut the lumber into the desired lengths, mark the pieces, and stack in piles at a location convenient to the trench but not in the way of the bulldozer.
  - (3) Assemble the 37 joist-stud subassemblies.
  - (4) Assist Crew B in erecting the first entryway assembly.
  - (5) Assemble the center posts.
  - (6) Install the center posts.
  - (7) Assist Crew B install the second entryway.
  - (8) Cover the roof with plywood.
  - (9) Install first waterproof materials (directly to the plywood).
  - (10) Assisted by all crews, place mound of earth on roof of shelter and rake smooth.
  - (11) Place second waterproof membrane on shelter.
  - (12) Finish covering the roof with earth.

- Crew D —
- (1) Assist Crew A in clearing the site.
  - (2) Cut short lengths of sticks for use in the shelter drains.
  - (3) Build the Kearny Air Pump (during breaks between other tasks).
  - (4) Install the first end wall studs.
  - (5) Cover the first end wall and entryway with plywood.
  - (6) Install the second end wall studs.
  - (7) Cover the second end wall and entryway with plywood.
  - (8) Spread and tamp backfill around second end wall and entryway.
  - (9) Assist Crew C cover the roof with earth.

b. Without Mechanical Excavation Equipment

- Crew A —
- (1) Stake out the outlines of the trench.
  - (2) Clear brush, grass, etc. from the site.
  - (3) Assisted by Crews B, C, and D excavate the trench.
  - (4) Trim bottom of trench with shovels; dig center drains and fill with sticks provided by Crew D. Dig sumps.
  - (5) Install the stud baseplates and the centerpost base plate.
  - (6) Mark the base plates to locate the positions for the studs and the center posts.
  - (7) Install the spreaders and the thrust plates.
  - (8) Assist Crew B install the joist-stud subassemblies.
  - (9) Cover sidewalls with plywood.
  - (10) Spread and tamp backfill along both side walls.
  - (11) Assist Crews D and B finish the backfilling and tamping of the end structures.
  - (12) Assist Crew C cover the roof with earth.

A-7.12

- Crew B -
- (1) Check tools to be sure all the necessary tools are available.
  - (2) Check sharpness of tools and sharpen any dull ones.
  - (3) Assist Crew A dig the trench.
  - (4) Assemble the two entry structures.
  - (5) Assisted by Crew C erect the first entryway assembly.
  - (6) Install the joist-stud assemblies and their headers and ledgers, assisted by Crew A.
  - (7) Assisted by Crew C install the second entryway.
  - (8) Spread and tamp backfill around first end wall and entryway.
  - (9) Assist Crew C cover the roof with earth.
  - (10) Install the fly covers over the entryways.
- Crew C -
- (1) Inventory the lumber and other materials to be sure the required materials are on hand. Correct any shortage discovered.
  - (2) Cut the lumber into the desired lengths, mark the pieces, and stack in piles at a location convenient to the trench.
  - (3) Assist Crew A dig the trench.
  - (4) Assemble the 37 joist-stud subassemblies.
  - (5) Assist Crew B in erecting the first entryway assembly.
  - (6) Assemble the center posts.
  - (7) Install the center posts.
  - (8) Assist Crew B install the second entryway.
  - (9) Cover the roof with plywood.
  - (10) Install first waterproof materials (directly to the plywood).
  - (11) Assisted by all crews, place mound of earth on roof of shelter and rake smooth.
  - (12) Place second waterproof membrane on shelter.
  - (13) Finish covering the roof with earth.

- Crew D -
- (1) Assist Crew A in clearing the site and digging the trench.
  - (2) Cut short lengths of sticks for use in the shelter drains.
  - (3) Build the Kearny Air Pump (during breaks between other tasks).
  - (4) Install the first end wall studs.
  - (5) Cover the first end wall and entryway with plywood.
  - (6) Install the second end wall studs.
  - (7) Cover the second end wall and entryway with plywood.
  - (8) Spread and tamp backfill around second end wall and entryway.
  - (9) Assist Crew C cover the roof with earth.



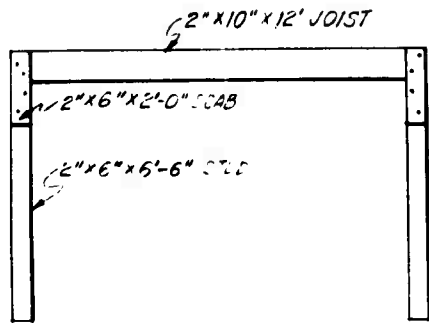

ELEV. VIEW - SUBASSEMBLY

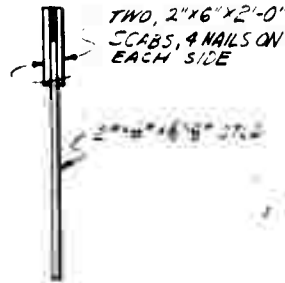

END VIEW

6'X8' PLASTIC OR CANVAS  
COVER OVER ENTRYWAY  
(2"X4" FRAME)

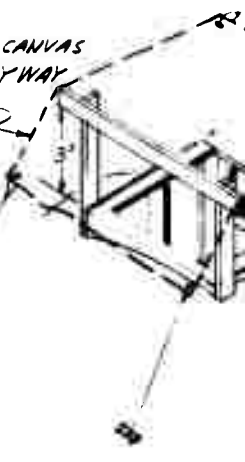

MOUND EARTH 3'-4"  
TOP OF SHELTER

2"X4'X4'-LONG KNEE BRACE  
BY ALTERNATE STUD

2"X6"X2'-0" SCABS

2"X10"X12'-LONG  
ROOF JOIST

2"X12" CONTINUOUS  
LEDGER



ENTRYWAY  
LADDER  
HANG KEARNY AIR PUMP (KAP)  
FROM ROOF JOIST IN ENTRY-  
WAY TO ENTRANCE, COVER  
AREA BELOW KAP WITH  
PLYWOOD

2"X6"X11'-LONG STUDS  
(8 REQ'D FOR ENTRY)

2"X4"X10'-9 1/2"  
CH. LEADER (13 REQ'D)

2"X4" CONTINUOUS THRUST  
PLATE

2"X8" CONTINUOUS STD. FACE PLATE

1/2" PLYWOOD  
ROOF

2"X10" CONT.  
TRUSS

1/2" PLYWOOD  
SHEATHING

2"X4"X4'-LONG  
KNEE BRACE  
BY ALTERNATE STUD

2"X6"X6'-  
6 REQ'D ON  
1/2" PLYWOOD  
BACKFILL  
AREA  
(BOT. OF  
2"X6"  
ROOF)

Fig. A-7.1. Rigid Frame Underground, Pictorial View.

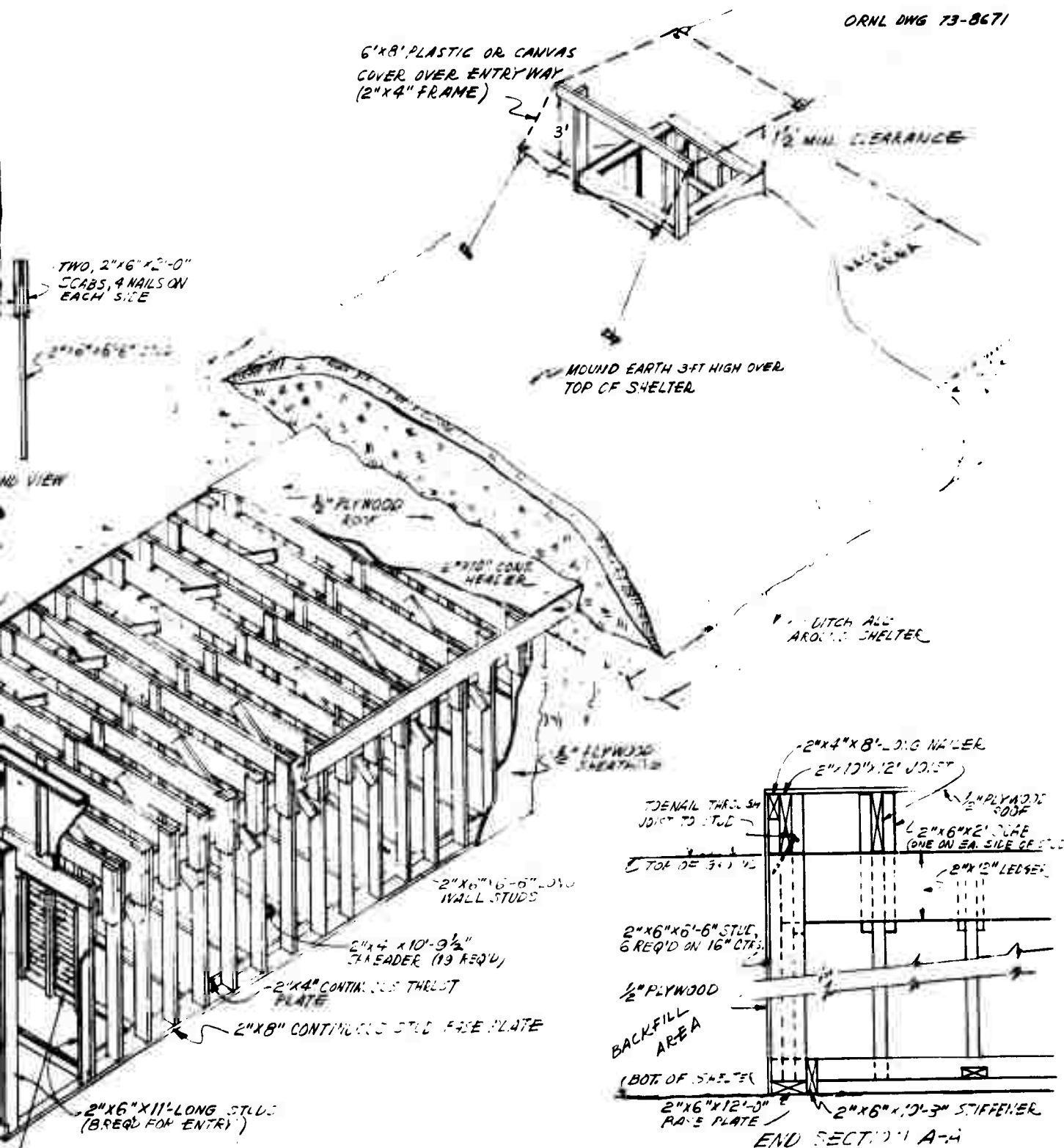
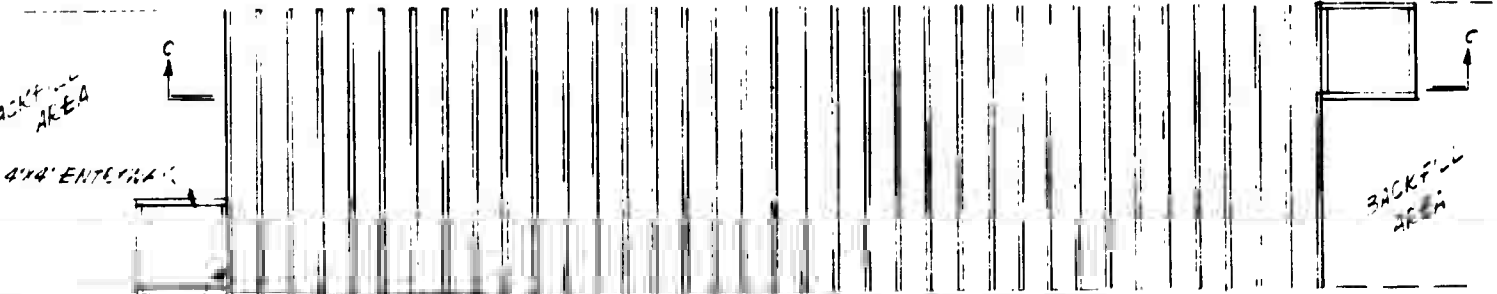

fig. A-7.1. Rigid Frame Underground, Pictorial View.

A-7.13

- Crew D —
- (1) Assist Crew A in clearing the site and digging the trench.
  - (2) Cut short lengths of sticks for use in the shelter drains.
  - (3) Build the Kearny Air Pump (during breaks between other tasks).
  - (4) Install the first end wall studs.
  - (5) Cover the first end wall and entryway with plywood.
  - (6) Install the second end wall studs.
  - (7) Cover the second end wall and entryway with plywood.
  - (8) Spread and tamp backfill around second end wall and entryway.
  - (9) Assist Crew C cover the roof with earth.





BY AIR PUMP (KAP) AT  
 CE. MAKE HP 48"  
 E. HANG 20"  
 ENTRYWAY - COVER  
 W/TH PLYWOOD  
 COMPANION DUG.

37 SUBASSEMBLED JO. 2" x 4" = 18'-0"  
 PLAN VIEW - SHOWS STUD LOCATIONS

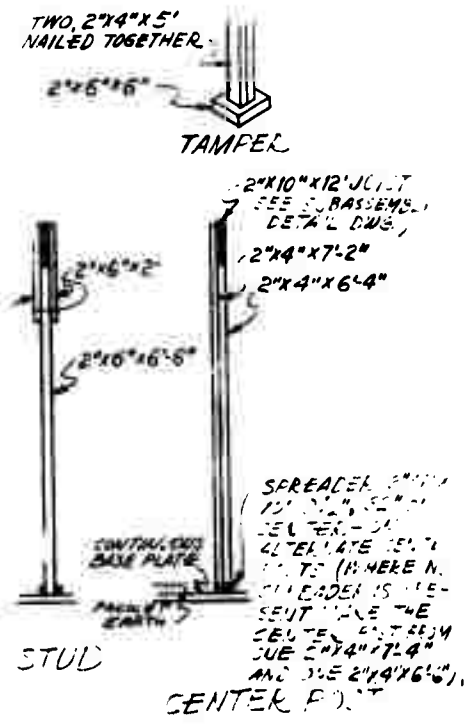
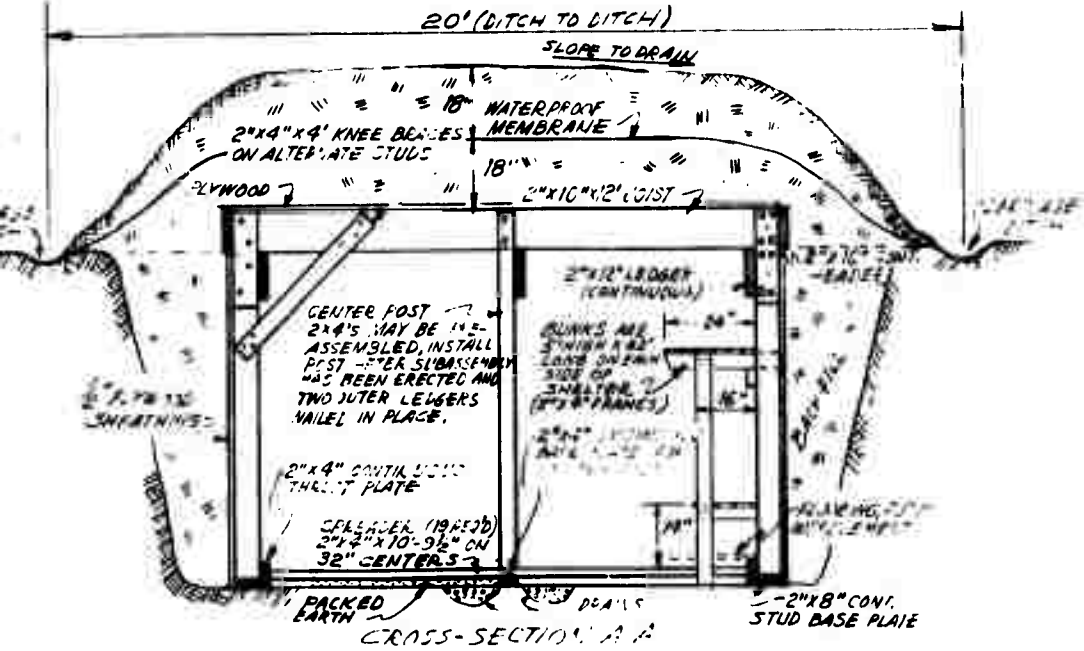
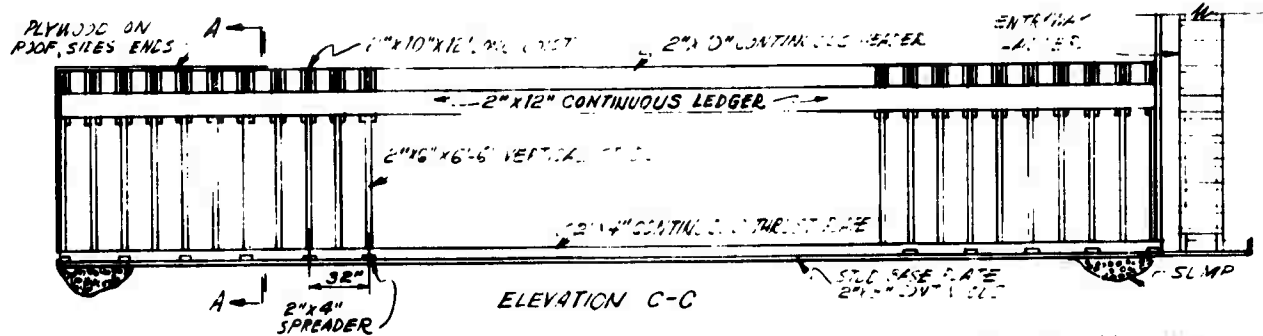

Fig. A-7.2. Rigid Frame Underground, Plan and Elevation.

A-8. Trench Wall - Underground

This is a modification of shelter shown in Army Pamphlet 500-1-1 "Army Survival Measures Planning Guide." The modifications are intended to make it feasible to build the shelter with an inexperienced crew using only the step-by-step instructions provided. As far as can be ascertained this shelter has never been built and (naturally) the step-by-step instructions have not been proof-tested.

Locally published instructions should include Appendixes B and C.

TRENCH WALL-UNDERGROUND SHELTER  
(Capacity 60 Persons)

1. This shelter can be built by a crew of from 15 to 30 inexperienced persons who are willing to work together to provide for themselves and their families protection from the dangers of radioactive fallout. This shelter requires good firm earth of either clay or clay-silty loam. Avoid sand or gravel areas and areas which have a high water table (i.e., minimum depth to water must be 10 ft).

2. The length of time required to build this shelter depends upon many things. If a bulldozer is available, the trench for the shelter can be excavated in two or three hours. Other excavation equipment such as backhoes or front-end loaders can be used. If no mechanical equipment is available, the trench can be dug by hand but this will require much longer.

3. Each person who will be working on the construction of the shelter should study the two drawings and read all of these instructions before starting the work.

4. Materials and tools required:

- a. In many areas lumber will be available in lengths up to 16 ft. In such places any one of the first 3 lists below may be used. However, if only 14-ft and shorter lengths are available, use list No. 2 or list No. 3. When only 12-ft and shorter sizes are available, use list No. 3. In case shorter sizes are available, some of the shorter pieces can be substituted for some of the lengths listed. After delivery of the lumber to the building site, it should be cut into the lengths on list No. 4.

A-8.2

(1) Lumber required if 16-ft lengths are available:

2" x 12" x 16'	12 pcs	384 bd ft
2" x 8" x 16'	6 pcs	128 bd ft
2" x 8" x 10'	68 pcs	907 bd ft
2" x 6" x 16'	20 pcs	320 bd ft
2" x 6" x 14'	14 pcs	196 bd ft
2" x 6" x 12'	11 pcs	132 bd ft
2" x 4" x 16'	17 pcs	182 bd ft
1" x 8" x 16'	6 pcs	<u>65</u> bd ft

2314 bd ft (39 bd ft per person)

(2) Lumber required if only 14-ft and 12-ft lengths are available:

2" x 12" x 14'	14 pcs	392 bd ft
2" x 8" x 14'	8 pcs	150 bd ft
2" x 8" x 10'	65 pcs	866 bd ft
2" x 6" x 14'	30 pcs	420 bd ft
2" x 6" x 12'	23 pcs	276 bd ft
2" x 4" x 12'	17 pcs	136 bd ft
1" x 8" x 14'	7 pcs	<u>65</u> bd ft

2305 bd ft

(3) Lumber required if only 12-ft and shorter lengths are available:

2" x 12" x 12'	16 pcs	384 bd ft
2" x 8" x 12'	18 pcs	288 bd ft
2" x 8" x 10'	56 pcs	747 bd ft
2" x 6" x 12'	57 pcs	684 bd ft
2" x 4" x 12'	17 pcs	136 bd ft
1" x 8" x 12'	8 pcs	<u>65</u> bd ft

2304 bd ft



## (4) Actual sizes needed:

## Trench Wall #6 R - Bill of Materials

	Actual Sizes Needed	Substitutes to Use Shorter Lengths			
		Max 14'		Max 12'	
1. Girder & Bearing Plates	2"x12"x16' 12 pcs	2"x12"x14' 14 pcs	2"x12"x12' 16 pcs		
2. Joists	2"x8"x10' 74 pcs				
3. Blocking	2"x8"x1' 36 pcs				
4. Stud Footings	2"x6"x12' 4 pcs				
5. Entryway Frame	2"x6"x11' 16 pcs				
6. Studs	2"x6"x6'10" 28 pcs				
7. Center Posts	2"x6"x5'10" 18 pcs				
8. Stud Footings	2"x6"x4' 4 pcs				
9. Stud Scabs	2"x6"x2' 44 pcs				
10. Footings	2"x6"x1' 9 pcs				
11. Entry Frame & Knee Braces	2"x4"x4' 20 pcs				
12. Stakes	2"x4"x2' 26 pcs				
13. Ladder Rungs	2"x4"x1'6" 20 pcs				
14. Header	1"x8"x16' 6 pcs	1"x8"x14' 7 pcs	1"x8"x12' 8 pcs		

## b. Other building materials needed:

Plywood 1/2" x 4' x 8' 50 pcs

Polyethylene, 6-mil 4000 sq ft  
(two 100-ft rolls of  
20-ft-wide polyethylene)

Nails - 20 penny (4 in. long) 12 lbs

16 penny (3-1/2 in. long) 14 lbs

6 penny (2 in. long) 8 lbs

Sticks 1/4 to 1-inch-diameter  
(may be cut from brush) (of any length to use for drains)

NOTE: If 20-penny nails are not available, substitute an additional 14 lbs of 16-penny. 8-penny nails (2-1/2 in. long) may be substituted, if necessary, for 6-penny.

- c. Materials to build a 3' x 4' Kearny Air Pump (see Appendix B).
- d. Tools required for a 24-person crew to work efficiently (adjust tool list to the number of workers available – note that not all the tools can be used at any one time):

<u>Tool</u>	<u>Quantity</u>	<u>Notes</u>
Hand saw, carpenters	8	(If electricity is available, one or two circular saws can do most of the cutting)
Levels	2	
Rakes	3	
Plumb lines	2	
Axes & hatchets	4	
Claw Hammers	12	
Pick, long handle	2	(If hand excavation is necessary, multiply these numbers by 5)
Shovels, long handle	4	
Pencils, carpenters	2	
Squares, carpenters	2	
Work gloves	25 pr	
File – 10-inch	3	
Steel tape – 50-ft	1	
Steel tape – 10-ft	3	
Rope 3/8" manila	200 ft	
String	1 ball	
Wheelbarrows	2	

5. To save time and work, sharpen all tools and keep them sharp, even if it takes one person full time to do it!

6. Wear gloves from the start – even tough hands can blister after hours of hard work. Blisters are painful, seriously delay the work, and could cause dangerous infections.

7. To avoid confusion, wasted time and effort, the working force should be organized into teams. Many variations are possible. A suggested division of tasks, based on a 24-person working force divided into 4 crews of 6 persons each, is given at the end of these instructions.

8. Before staking out the outlines of the excavation, check to make sure that rock is not near the surface by driving down a 6-ft-long, sharpened rod or small pipe. To prevent groundwater problems, avoid low ground.

9. Cut the lumber to the required lengths. Mark each piece to indicate where it goes in the structure to assure that the required long pieces are not subsequently cut up for shorter pieces. If colored marking pens are available, establish a color-code scheme and write the number (from the list of materials) on each piece. The color can indicate the location within the shelter (i.e., roof, side wall, entry, etc.).

10. To help drain the floor, locate the shelter so that the original ground level at one end is about three feet lower than the other end.

11. Stake out the trench for the shelter. Even in very firm earth, make the excavation at the surface 14 ft, 6 in. wide (2 ft-6 in. wider than the 12-ft-wide bottom of the trench). If the excavation is dug by hand, make the length 50 ft long at the bottom, 52 ft-6 in. long at the top plus two 6-ft square holes for the entryways. The sloping sides of the excavation are necessary even in firm earth for safety and adequate working room.

12. Check the squareness of the staked outline by making the diagonals equal. Extend the stakes out past both ends far enough to guide the dozer operator during the digging operation.

13. Clear all brush, tall grass, trees, etc. off the ground to a distance of 15 ft on each side and to a distance of 25 ft at each end of the staked location. This is necessary to provide room to store the earth before putting it back on the roof. The backfill material should not contain any brush, sticks, or large stones.

14. Use a 12-ft-long 2" x 4" and check the excavation width frequently as the trench is being dug.

15. If the trench is dug by shovels, pile the earth dug near ground level at least 10 ft from the sides of the trench. Then as the trench deepens, the earth dug from 5 to 6 ft down can be piled on the surface only 1 to 5 ft from the edge.

16. When the bulldozer has finished, trim the bottom of the trench with shovels. Dig a drain down the middle of each side. (Each ditch should be 6 in. wide and 4 in. deep.) Slope the floor to drain from the sides toward the two middle drain ditches. Be sure the bottom of the ditches slopes at least 1/2 inch vertically for each foot of horizontal length — either slope the bottom of the ditches all in one direction or slope downward both ways from the center. Dig a 2-ft-square x 1-ft-deep sump at the lower end (or ends if sloping from the center of the shelter). Water collected in the sump will be bailed out by hand as necessary during occupancy. Lay small sticks in the drains and cover with porous fabric to serve like crushed rock drains leading to the sumps.

17. While the trench is being excavated, start construction of the two entry subassemblies on a clear area near one end of the excavation. The plywood should be added to at least two adjacent sides to make the assembly rigid enough to handle easily. Meanwhile, another crew can assemble the double 2" x 12" center beam. Be sure to stagger the joints by at least 2 ft

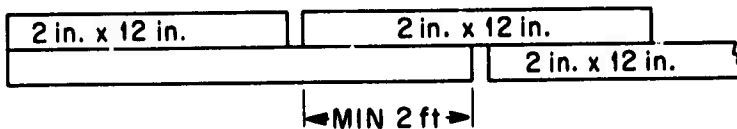

18. Lay out and carefully align the center post base plate on the floor of the trench. Drive a stake on each side of each center post base plate to maintain the alignment. The exact location of these stakes is not critical since they will be removed later. Meanwhile, another crew should assemble the 9 center columns by nailing together the two 5'-10" long 2" x 6"'s. Another crew can be laying out the 2" x 12" bearing plates along the side of the trench.

19. Carry the assembled center beam into the trench and lay it on the center post base plates. CAUTION: The assembled beam weight is 500 lbs, so be sure to use a large enough crew (at least 10 persons) so that no one strains himself. Lay the center posts alongside the beam.

20. Raise the center beam into position and install the center posts to support it. Step-by-step procedure for this task is as follows:

- a. Obtain two short logs (size and length are not critical). Lay the logs along each side of one end of the trench so that the center of the logs are opposite one end of the center beam.
- b. If there is a tree fairly close (10 to 30 ft) to the end of the trench it may be used to anchor the rope. If not, take a 4-ft-long 2" x 4", sharpen one end with a hatchet and drive it at least 2 ft into the ground just outside of the logs.
- c. Tie one end of the 3/8" (or larger) rope around the anchor (tree or stake), place the rope across the log, down into the trench, under the end of the center beam (at least 3 ft from the end), back up the other side of the trench, over the other log, then to the truck or bulldozer. If the truck or bulldozer has a winch line, the winch line can be used instead of the rope. (see Figure A-8.2.)
- d. Take up the slack in the rope (or winch line). Place a short length of 2" x 12" board under the rope, at each edge of the ditch, to prevent the rope digging into the earth.
- e. Take a 20-ft length of 3/8" rope and tie a clove hitch around the center beam in the middle of the rope (see Figure A-8.2). Nail a short length of 1" board to the side of the beam near the end.
- f. Have two men use the two ends of the rope to steady the end of the beam and hold it in place (horizontally) while the truck or bulldozer lifts the end of the beam. When the beam is high enough, have two men lift the end center post into position and nail it to the underside of the beam. Use the short 1" board as a handle to turn the beam to the proper position for nailing.

- g. Drive two stakes in the floor of the shelter near the walls at the end of the shelter. Tie the two ropes securely to the stakes to serve as temporary guys while the other end of the center beam is being raised.
  - h. Raise and guy the other end of the center beam the same way as was done on the first end.
  - i. Install all center posts. Nail the center beam to the center posts using 20-penny nails.
  - j. Nail on the plywood gussets with 6-penny nails.
  - k. Remove the 1" scabs used as handles.
  - l. Leave the rope guys in place until the joists have been added.
21. An alternate method of installing the center beam and center posts is as follows:
- a. Lay the center beam flat along one edge of the trench. Nail the center posts to the center beam using 20-penny nails. Nail the gussets to the top side of the assembly using 6- or 8-penny nails.
  - b. Using two 40-ft lengths of 3/8" rope, tie a clove hitch around the center beam near each end so that the hitch is in the middle of each piece of rope (see sketch).
  - c. Have one person take the end of each rope (4 persons required) to the ground outside of the trench, two persons on each side. With at least 4 persons in the trench lifting on the assembly, tilt the assembly into an upright position. The 4 persons on the ropes can hold it steady while the rest of the crew "walks" the assembly into the center of the trench by lifting and pushing on one end center post at a time. Alternately part of the "walking" can be accomplished by tapping the base of each center post in succession with a sledge until the bases of the posts are alongside the base plates. The last few inches of movement must be made by lifting each leg in turn onto its base plate.

A-8.9

- d. Guy the center beam assembly by tying each of the 4 rope ends to a stake driven in the ground outside the trench. Leave the guys in place until the joists have been installed.
- e. The remaining plywood gussets can be nailed on after the joists have been installed.

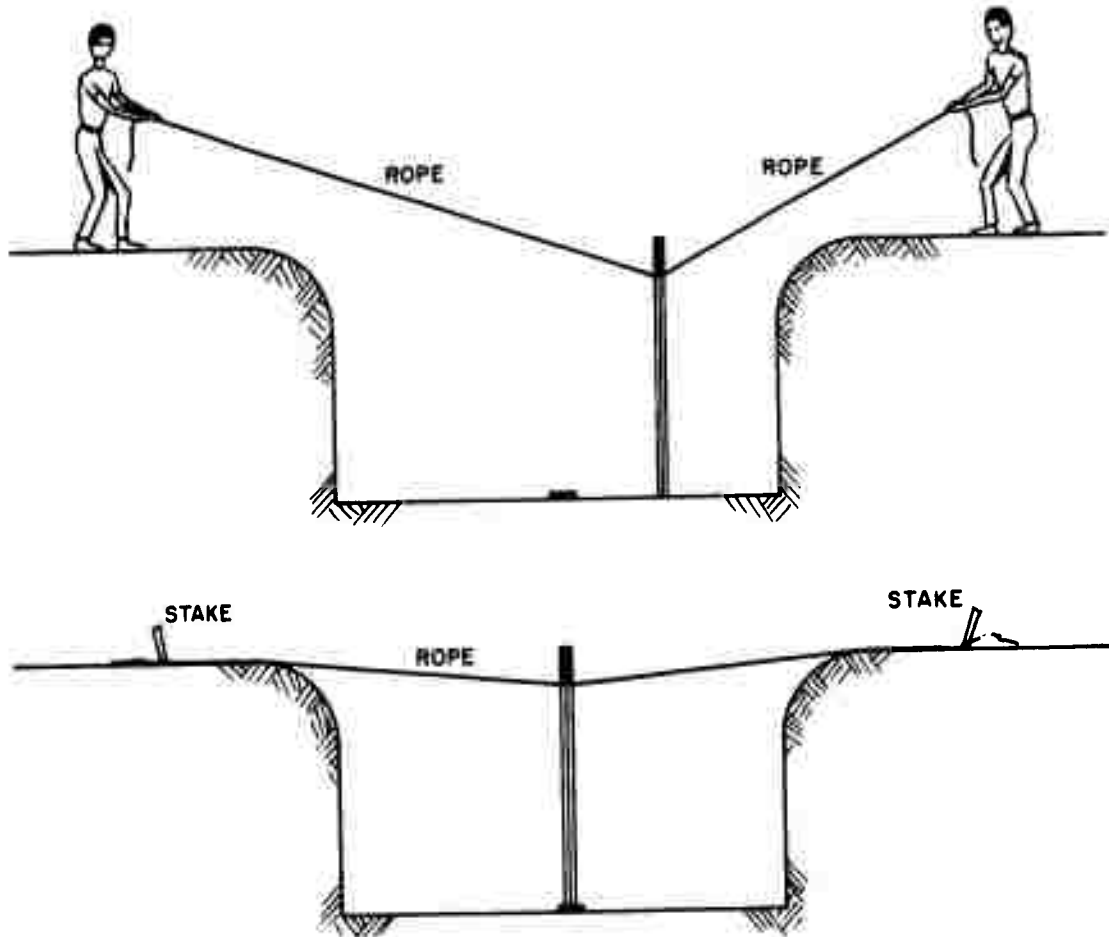

22. Carry the two entryway assemblies into the trench and set them in place. Each assembly will stand unsupported, but it will be safer to install four temporary braces (2" x 4" x 10' or 12') until the end joist has been installed and fixed to the entryway.

23. Install the joists, starting at each end and where the entryways have been erected. Hold the joists in place by nailing to the center beam and the bearing plates. Remove the temporary braces which were put in earlier to hold the entryways in place. If the spacing between the last two joists does not quite match (a very likely thing to happen) the spacer can be shortened or lengthened a little to make a good tight fit. Install the 1" x 8" header along the outer ends of the joists.

24. As soon as the first four joists at each end of the shelter have been installed, one crew can start installing the stud plates and studs at each end of the shelter. Note that the studs extend 4 ft down each side from each end of the shelter.

25. Nail on the plywood sheathing on each end wall, and complete the sheathing of the two entryways.

26. Install the plywood sheathing to the roof. Allow the plywood to overhang the header as necessary to preclude the necessity for cutting (approximately 3" on each side is required).

27. Make several tampers. Start backfilling around the entryways and the ends. Spread the loose earth evenly to a depth of about 4 inches (never more than 6 inches at a time) and tamp. Continue adding earth and tamping until the fill reaches the roof line. If the bulldozer is still available, it can be used to move the dirt into the ramp area, but all earth fill within two feet of the structure should be hand placed and tamped. If the bulldozer is not available, wheelbarrows should be used to haul the earth from the storage pile into the ramp area.

28. Cover the roof with waterproofing material (polyethylene, roll roofing, etc.). CAUTION: This is not the weatherproofing for the shelter! It is only to keep dirt and moisture from the earth from seeping through. The rainproofing comes later.



29. Place grade stakes along the edge of the trench for use later in checking the depth of the earth cover.

30. Mound earth over the shelter, piling it about 15 inches deep along the center line of the roof and sloping it toward the sides of the roof. Continue to slope out to the inner drainage ditches, which should be at least 2 ft outside the edge of the roof. Smooth the mounded earth with rakes and remove any sticks or stones so they will not puncture the rainproofing material, which is put on it later.

31. Place rainproofing material (preferably two layers of 6-mil polyethylene or roofing, plastic shower curtains and table cloths, or canvas) on top of the smooth mounded earth. Be sure the rainproofing extends beyond the inner drainage ditches. Lay short sticks on top of the waterproofing in the drainage ditch, and roll the edge of the waterproofing material around them as shown in the drawing.

32. Place the rest of the earth cover over the shelter, being careful not to puncture the waterproof cover. Be sure that the edges and the corners have at least 2-1/2 feet of earth cover and that the center has 3 ft of cover. Mound the earth, smoothing the surface with rakes so that the water will tend to run off the sides.

33. Dig a 6"-deep, surface drainage ditch all around the completed earth mound.

34. Install the KAP in the doorway of the entry which is located in the direction from which the wind is blowing.

35. Cover each entrance with a fly or canopy (open on all sides) to minimize entry of fallout particles.

36. Occupy the shelter.

37. As time, energy, and materials permit, improve the interior of the shelter by one or more of the following methods:

- a. Cover the floor with plywood or 1-inch boards.
- b. Build benches and overhead bunks. Be sure to space the vertical supports 3 feet apart so two men can sit between each pair of supports.
- c. For windy and/or cold weather, make temporary covers for one or both of the entryways from plywood (1 sheet of 1/3" x

4' x 8' plywood will do nicely). The amount of air can be adjusted as necessary by sliding the plywood covers back or forth to obtain the required size opening.

- d. Shore the remaining walls with plywood, held in place by additional studs and stud plates. Hold the stud plates in place with stakes.

38. The following is a suggested division of tasks based on 4 crews of 6 persons each:

a. With bulldozer

- Crew A —
  - (1) Stake out the outlines of the trench.
  - (2) Clear brush, grass, etc, from the site.
  - (3)
    - (a) Check width of trench frequently.
    - (b) Assist dozer operator as necessary.
    - (c) Part of the crew assist other crews while waiting for dozer to finish.
  - (4) Trim bottom of trench with shovels; dig center drains and fill with sticks provided by Crew D. Dig sumps.
  - (5) Install the center post base plates.
  - (6) Help Crew C carry the center beam into the trench.
  - (7) Assisted by Crew C install the center beam and center posts, using either one of the methods given in paragraphs 20 and 21.
  - (8) Assisted by Crew D install the joists.
  - (9) Nail on the 1" x 8" headers.
  - (10) Cover the roof with plywood, assisted by Crew B.
  - (11) Assist Crews D and B finish the backfilling and tamping of the end structures.
  - (12) Assist Crew C cover the roof with earth.
- Crew B —
  - (1) Check tools to be sure all the necessary tools are available.
  - (2) Check sharpness of tools and sharpen any dull ones.

A-8.13

- (3) Assemble the two entry structures.
  - (4) Assisted by Crew C, erect the entryway assemblies.
  - (5) Install the stud plates and studs at one end of the shelter.
  - (6) Assist Crew A cover the roof with plywood.
  - (7) Spread and tamp backfill around first end wall and entryway.
  - (8) Assist Crew C cover the roof with earth.
  - (9) Install the fly covers over the entryways.
- Crew C -
- (1) Inventory the lumber and other materials to be sure the required materials are on hand. Correct any shortage discovered.
  - (2) Cut the lumber into the desired lengths, mark the pieces, and stack in piles at a location convenient to the trench but not in the way of the bulldozer.
  - (3) Install the 2" x 12" bearing plates along the sides of the trench.
  - (4) Assemble the center beam and the nine center posts. Carry the assembled pieces into the trench, assisted by Crew A.
  - (5) Assist Crew A in erecting the center beam assembly.
  - (6) Assist Crew B install the two entryway assemblies.
  - (7) Install the stud plates and studs at the other end of the shelter.
  - (8) Cover one end wall and entry assembly with plywood.
  - (9) Install first waterproof materials (directly to the plywood roof).
  - (10) Assisted by all crews, place mound of earth on roof of shelter and rake smooth.

- (11) Place second waterproof membrane on shelter.
- (12) Finish covering the roof with earth.

- Crew D —
- (1) Assist Crew A in clearing the site.
  - (2) Cut short lengths of sticks for use in the shelter drains.
  - (3) Build the Kearny Air Pump.
  - (4) Assist Crew A install the joists.
  - (5) Cover the other end wall and entryway with Plywood.
  - (6) Spread and tamp backfill around second end wall and entryway.
  - (7) Dig inner and outer drainage ditches around the shelter.
  - (8) Assist Crew C cover the roof with earth.

b. Without Mechanical Excavation Equipment

- Crew A —
- (1) Stake out the outlines of the trench.
  - (2) Clear brush, grass, etc. from the site.
  - (3) Assisted by Crews B, C, and D, excavate the trench.
  - (4) Trim bottom of trench with shovels; dig center drains and fill with sticks provided by Crew D. Dig sumps.
  - (5) Install the center post base plates.
  - (6) Help Crew C carry the center beam into the trench.
  - (7) Assisted by Crew C, install the center beam and center posts using either one of the methods given in paragraphs 20 and 21.
  - (8) Assisted by Crew D, install the joists.
  - (9) Nail on the 1" x 8" headers.
  - (10) Cover the roof with plywood, assisted by Crew B.
  - (11) Assist Crews D and B finish the backfilling and tamping of the end structures.
  - (12) Assist Crew C cover the roof with earth.

A-8.15

- Crew B -
- (1) Check tools to be sure all the necessary tools are available.
  - (2) Check sharpness of tools and sharpen any dull ones.
  - (3) Assist Crew C dig the trench.
  - (4) Assemble the two entry structures.
  - (5) Assisted by Crew C, erect the entryway assemblies.
  - (6) Install the stud plates and studs at one end of the shelter.
  - (7) Assist Crew A cover the roof with plywood.
  - (8) Spread and tamp backfill around first end wall and entryway.
  - (9) Assist Crew C cover the roof with earth.
  - (10) Install the fly covers over the entryways.

- Crew C -
- (1) Inventory the lumber and other materials to be sure the required materials are on hand. Correct any shortage discovered.
  - (2) Cut the lumber into the desired lengths, mark and stack in piles at a location convenient to the trench.
  - (3) Assist Crew A dig the trench.
  - (4) Install the 2" x 12" bearing plates along the sides of the trench.
  - (5) Assemble the center beam and the nine center posts. Carry the assembled pieces into the trench, assisted by Crew A.
  - (6) Assist Crew A in erecting the center beam assembly.
  - (7) Assist Crew B install the two entryway assemblies.
  - (8) Install the stud plates and studs at the other end of the shelter.

A-8.16

- (9) Cover one end wall and entry assembly with plywood.
- (10) Install first waterproof materials (directly to the plywood).
- (11) Assisted by all crews, place mound of earth on roof of shelter and rake smooth.
- (12) Place second waterproof membrane on shelter.
- (13) Finish covering the roof with earth.

- Crew D --
- (1) Assist Crew A in clearing the site and digging the trench.
  - (2) Cut short lengths of sticks for use in the shelter drains.
  - (3) Build the Kearny Air Pump.
  - (4) Assist Crew A install the joists.
  - (5) Cover the second end wall and entryway with plywood.
  - (6) Spread and tamp backfill around second end wall and entryway.
  - (7) Dig inner and outer drainage ditches around the shelter.
  - (8) Assist Crew C cover the roof with earth.

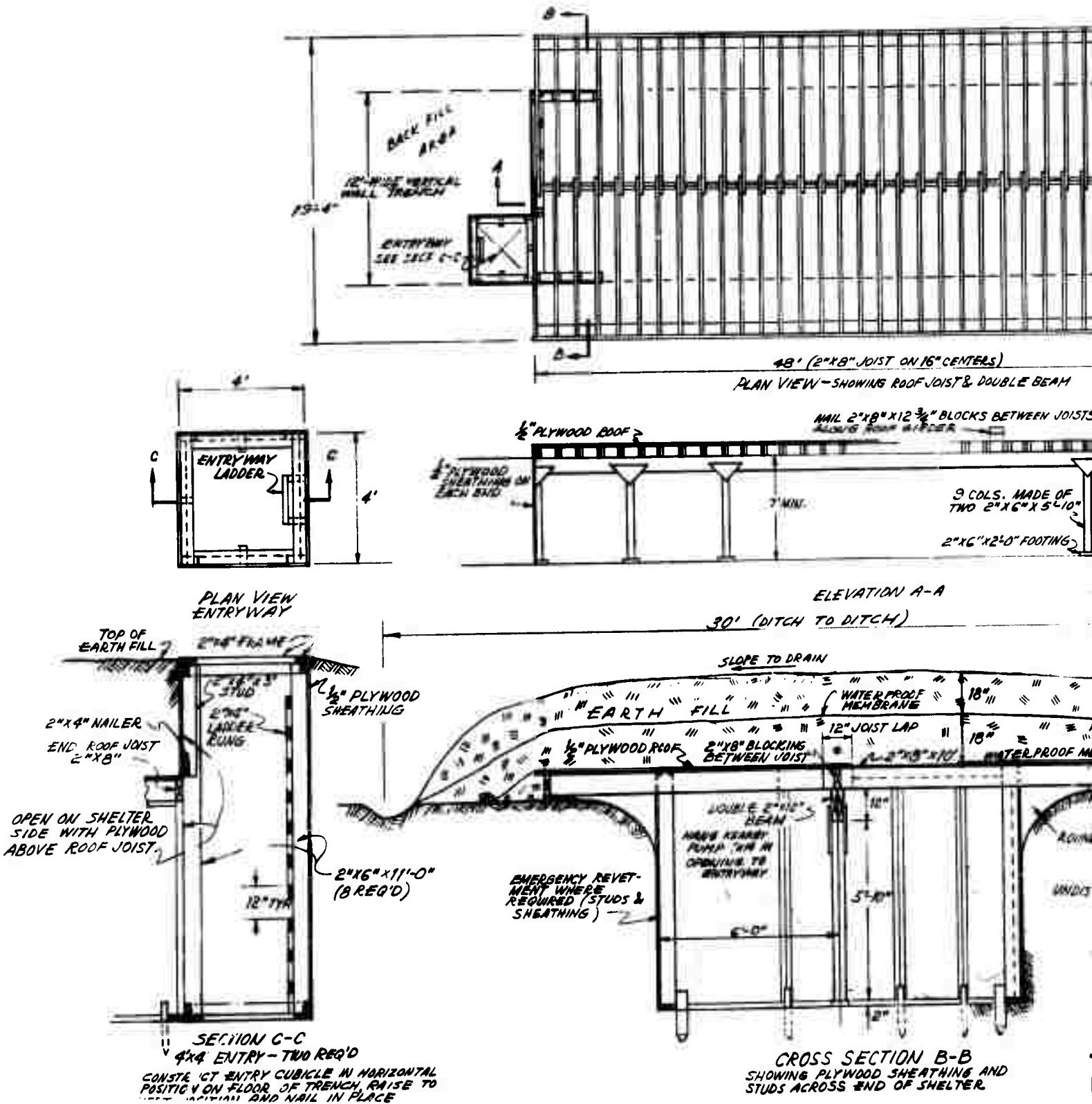

Fig. A-8.1. Trench Walls, Underground Shelter.

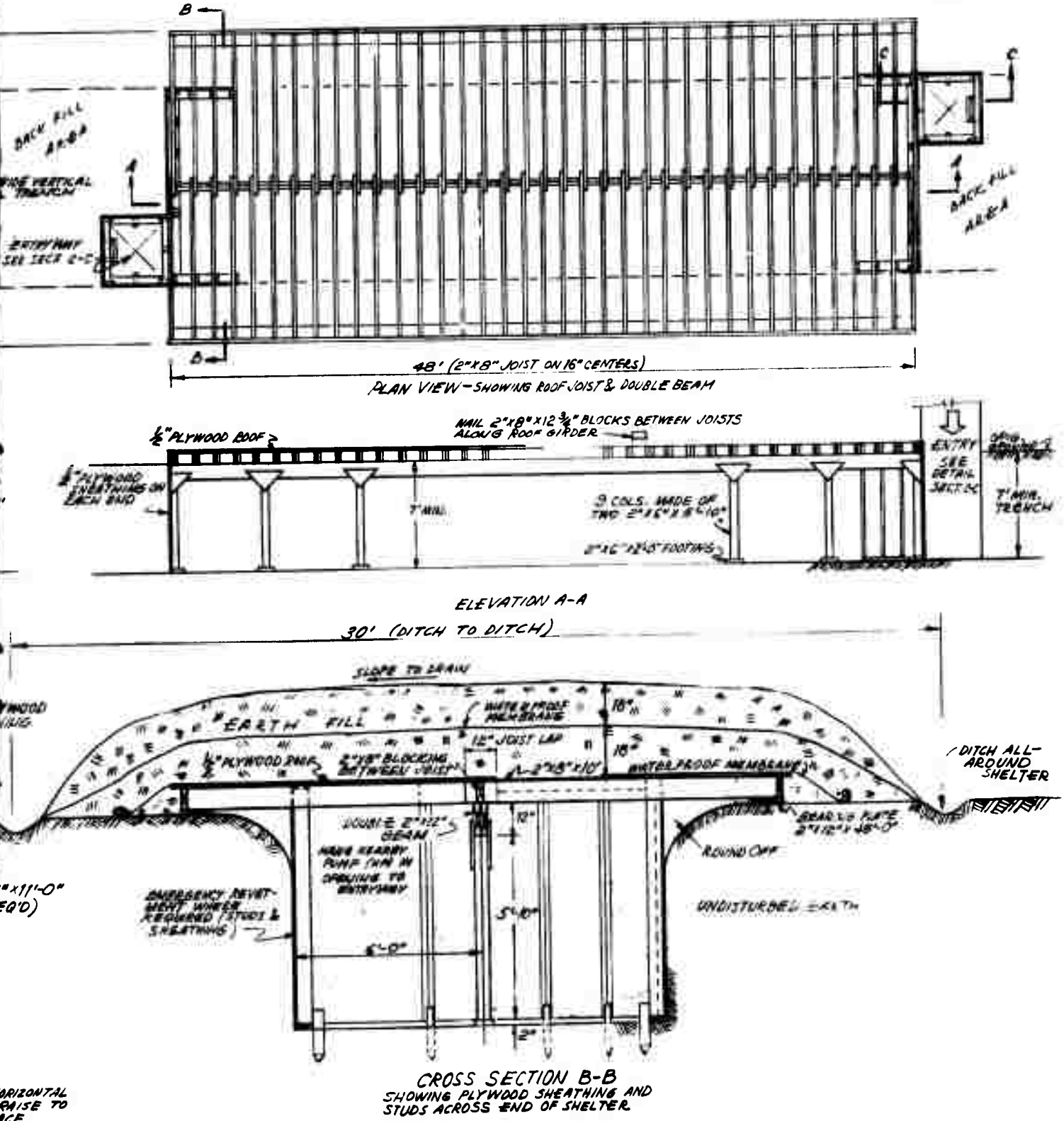

Fig. A-8.1. Trench Walls, Underground Shelter.



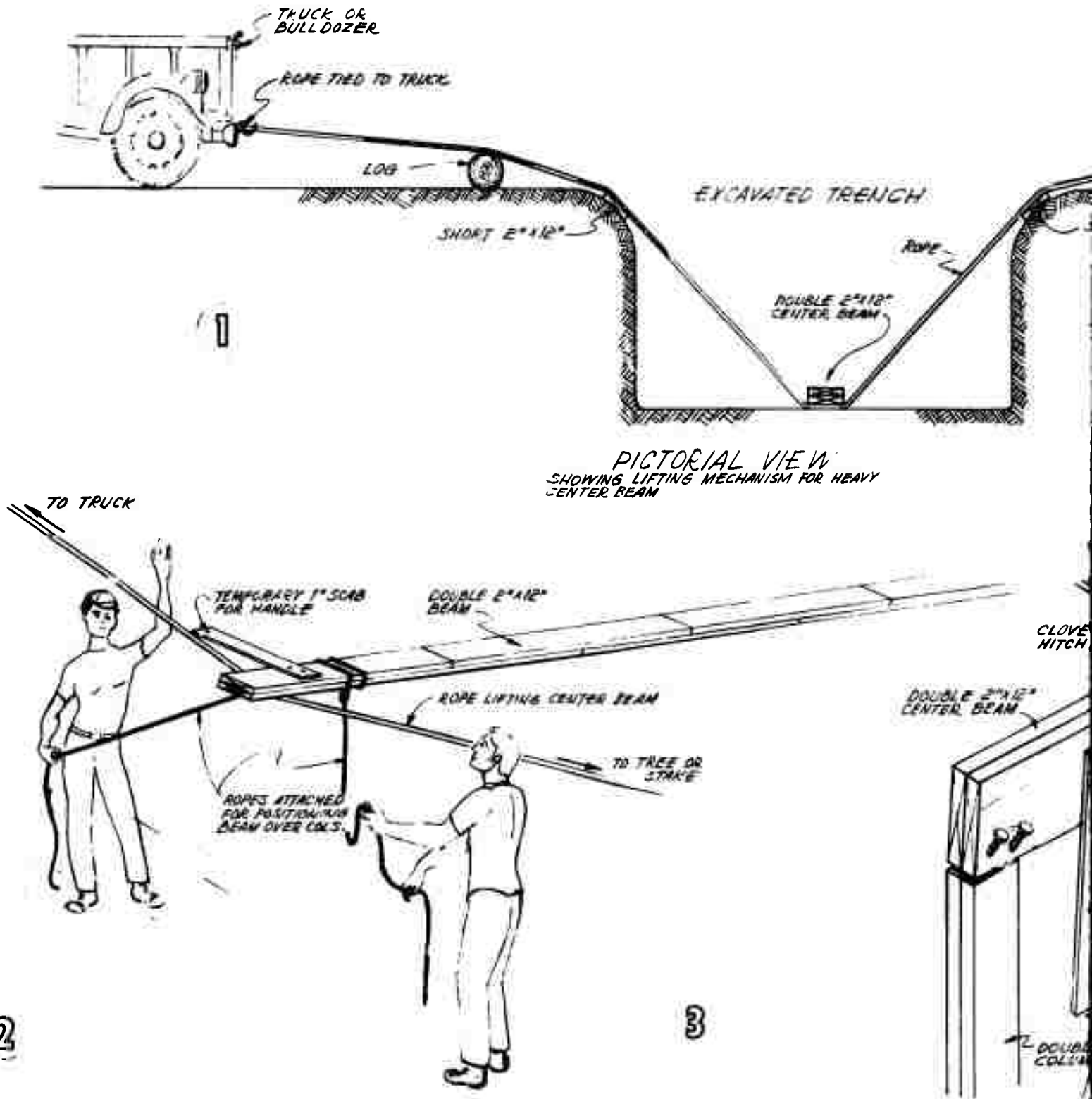
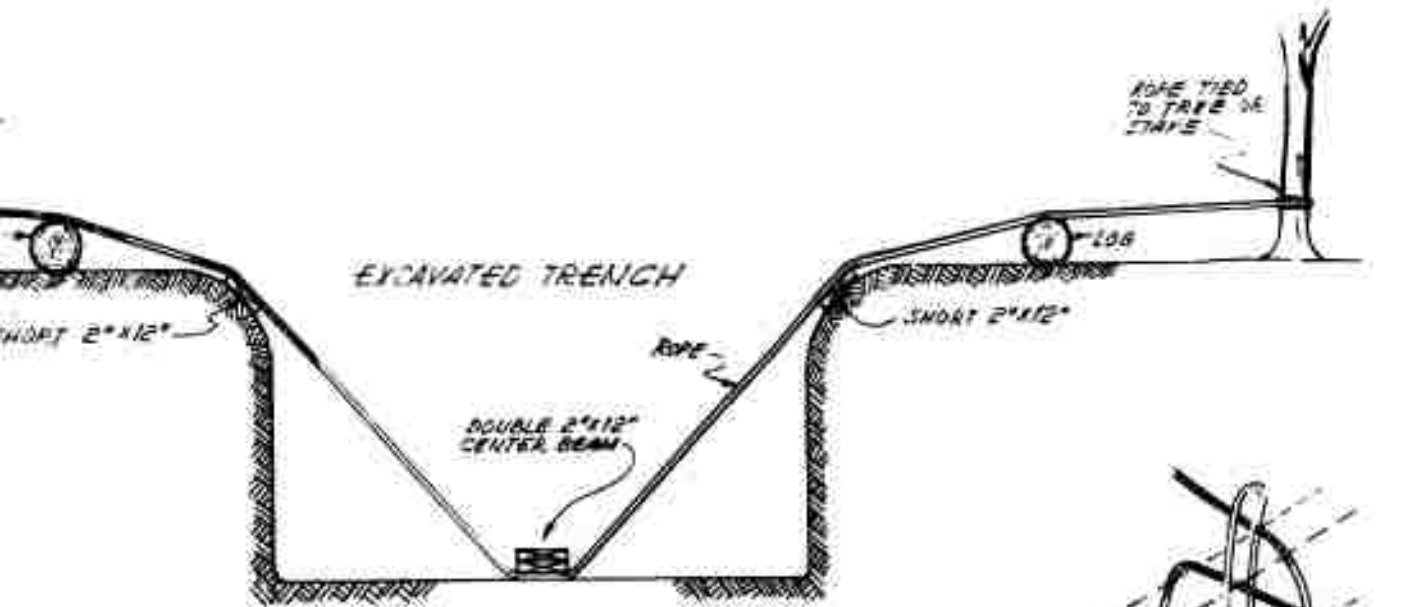
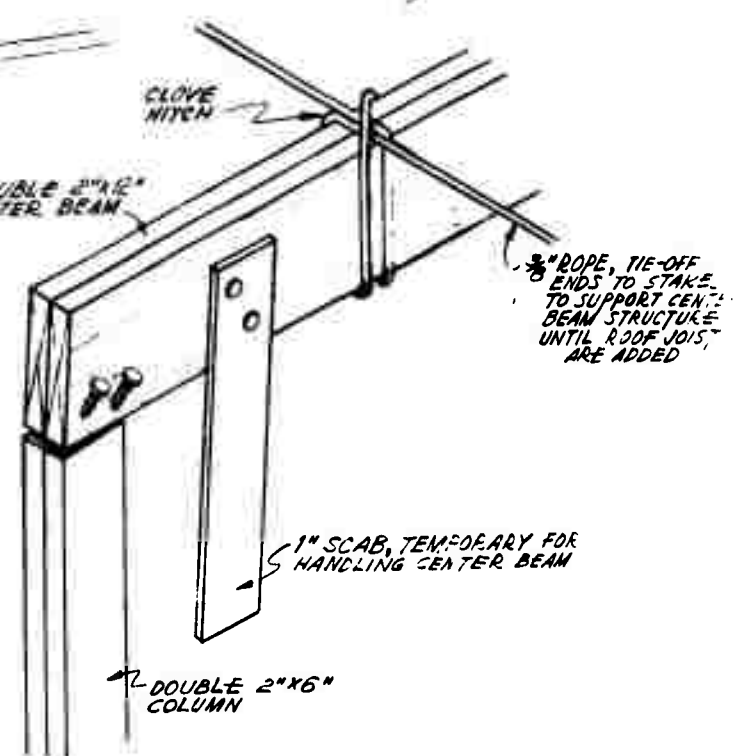
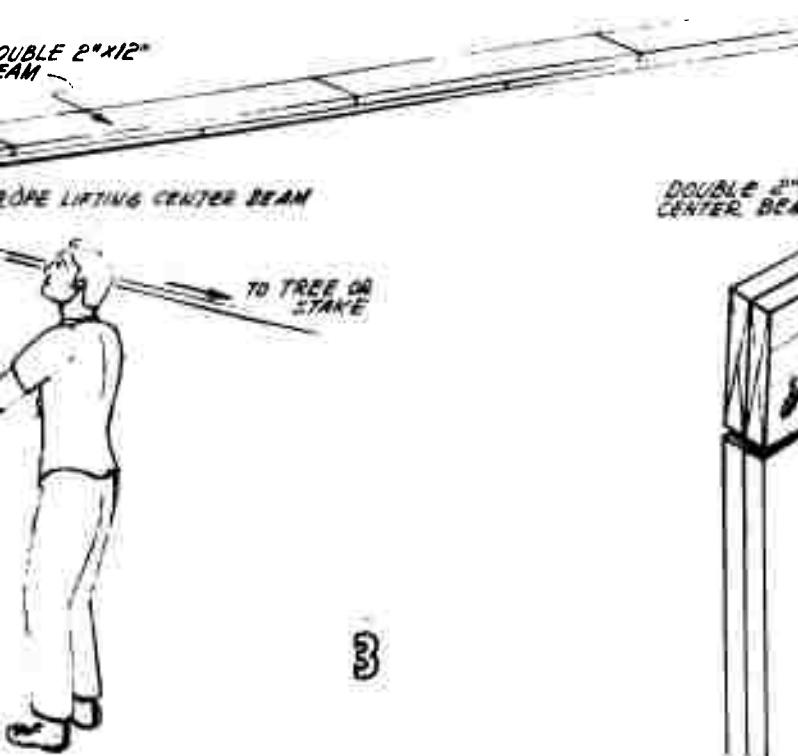
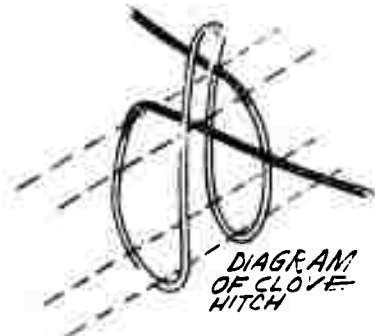

Fig. A-8.2. Trench Walls Underground Shelter, Construction Methods.



PICTORIAL VIEW  
SHOWING LIFTING MECHANISM FOR HEAVY  
CENTER BEAM



2. Trench Walls Underground Shelter, Construction Methods.

A-9. Rigid Frame - Continuous Vent

This is a modification of a shelter shown in Army Pamphlet 500-1-1 "Army Survival Measures Planning Guide." The modifications are intended to make it feasible to build the shelter with an inexperienced crew using only the step-by-step instructions provided. As far as can be ascertained this shelter has never been built and (naturally) the step-by-step instructions have not been prooftested.

Locally published instructions should include Appendixes B and C.

A-9-i,

RIGID FRAME SEMIBURIED SHELTER -- CONTINUOUS VENT  
(Capacity 60 Persons)

1. This shelter can be built by a crew of from 15 to 30 inexperienced persons who are willing to work together to provide for themselves and their families protection from the dangers of radioactive fallout. The trench should be as deep as ground conditions permit. It can be as little as 2 ft or as much as 6 ft deep.

2. The length of time required to build this shelter depends upon many things. If a tractor with a dozer blade is available the trench for the shelter can be excavated in two or three hours. Other excavation equipment such as backhoes or front-end loaders can be used. If no mechanical equipment is available, the trench can be dug by hand, but this will require much longer.

3. Each person who will be working on the construction of the shelter should study the two drawings and read all of these instructions before starting the work.

4. Materials and tools required:

a. Lumber

The quantity of lumber needed is listed in Table 1 in lengths normally available at the lumber yard. After delivery of the lumber to the building site, it should be cut into the lengths as shown in Table 2.

(CAUTION: Lumber will be in very short supply so the cutting must be done carefully to avoid waste. The shorter pieces must be cut from scrap produced by cutting the longer pieces.)

b. Other building materials needed:

Plywood 3/8" x 4' x 8'	56 pcs (Note: 1/2" may be substituted for 3/8" whenever necessary)
------------------------	--------------------------------------------------------------------

Polyethylene, 6-mil (one 100-ft roll of 20-ft-wide polyethylene)	2000 sq ft
------------------------------------------------------------------------	------------

Table 1  
Lumber Needed (in Lumber Yard Lengths)

2" x 12" x 12'	16 pcs	384 bd ft
2" x 8" x 12'	16 pcs	256 bd ft
2" x 8" x 10'	73 pcs	974 bd ft
2" x 6" x 14'	37 pcs*	518 bd ft
2" x 6" x 12'	58 pcs*	696 bd ft
2" x 4" x 12'	63 pcs	<u>504</u> bd ft
		3332 bd ft

(or 56 bd ft per person)

\* If 14-ft lengths of 2" x 6" are not available, it will require a total of 107 pieces 2" x 6" x 12'. This increases the scrap by 70 bd ft.

CAUTION: This list is based on cutting the short pieces most efficiently from the scrap of the longer pieces. No allowance was added for error in cutting.

Table 2  
Lumber Needed (in Lengths as Used)

1. Headers and Center Beams	2" x 12" x 12'	16 pcs
2. Headers and Ledgers	2" x 8" x 12'	16 pcs
3. Joists	2" x 8" x 10'	72 pcs
4. Column Footings	2" x 8" x 1'	7 pcs
5. Stud Base Plates	2" x 6" x 12'	10 pcs
6. Entryway Studs	2" x 6" x 11'	16 pcs
7. Studs	2" x 6" x 7'	74 pcs
8. Center Columns	2" x 6" x 6'	14 pcs
9. Stud Scabs	2" x 6" x 2'	148 pcs
10. Thrust Plates	2" x 4" x 12'	8 pcs
11. Spreaders	2" x 4" x 10'9"	19 pcs
12. Entryway frames, nailer, and knee braces	2" x 4" x 4'	89 pcs
13. Roof Cleats	2" x 4" x 1'8"	26 pcs
14. Ladder Rungs	2" x 4" x 1'6"	20 pcs

A-9.3

Nails - 20 penny (4 in. long)	14 lbs
16 penny (3-1/2 in. long)	17 lbs
6 penny (2 in. long)	8 lbs
Sticks (may be cut from brush)	1/4 to 1-inch-diameter (of any length to use for drains)

**NOTE:** If 20-penny nails are not available, substitute an additional 18 lbs of 16-penny. 8-penny nails can be substituted, if necessary, for 6-penny.

- c. Materials to build a 3' x 4' Kearny Air Pump (KAP) are listed in Appendix B. This small sized KAP is recommended for use in distributing the air within the shelter in very warm weather.
- d. Tools required for a 24-person crew to work efficiently (adjust tool list to the number of workers available - note that not all tools can be used at any one time):

<u>Tool</u>	<u>Quantity</u>	<u>Notes</u>
Hand saw, carpenters	8	(If electricity is available one or two circular saws can do most of the cutting.)
Levels	2	
Rakes	3	
Plumb lines	2	
Axes or hatchets	4	
Claw Hammers	12	
Pick, long handle	2	} (If hand excavation is necessary, multiply these numbers by 5)
Shovels, long handle	4	
Pencils, carpenters	2	
Brace and bit	1	
Squares, carpenters	2	
Work gloves	25 pr	
File, 10-inch	3	
Steel tape, 50-ft	1	
Steel tape, 10-ft (or carpenters ruler, 6-ft)	3	
String	1 ball	

Rope (3/8" or larger)	100 ft
Wheelbarrows	2
Felt tipped marking pens (in 3 or 4 colors)	(optional)

5. To save time and work, sharpen all tools and keep them sharp, even if it takes one person full time to do it!

6. Wear gloves from the start - even tough hands can blister after hours of hard work. Blisters are painful, seriously delay the work, and could cause dangerous infections.

7. To avoid confusion, wasted time, and effort organize the available workers into teams. Many variations are possible. A suggested division of tasks, based on a 24-person working force divided into 4 crews of 6 persons each is given at the end of these instructions. Women and children can be of tremendous help. Don't waste any resources!

8. Before staking out the outlines of the trench, check possible sites by driving down a 6-ft-long, sharpened rod or small pipe in several places to find out which has the least rock problems. If possible, avoid low ground to avoid groundwater problems.

9. Cut the lumber to the required lengths. Mark numbers on each piece to indicate where it goes in the structure to assure that the required long pieces are not subsequently cut up for the shorter pieces. If colored marking pens are available, color-code the numbers to indicate locations, such as entryway, end wall, sidewall, or roof.

10. To help drain the floor, locate the shelter so that the original ground level at one end is about three feet lower than the other end.

11. Stake out the trench for the shelter. Even in very firm earth, make the excavation at the surface 16 ft wide (2 ft wider than the 14-ft-wide bottom of the trench). If the excavation is dug by hand, make the length 50 ft long at the bottom, 52 ft long at the top, plus two 6-ft-square holes for the entryways. The sloping sides of the excavation and the 14-ft-wide bottom are necessary for safety and adequate working room. In soft, crumbly earth the width at the top must be even greater to ensure that no lumps will cave off the sides during construction.

12. Check the squareness of the staked outline by making the diagonals equal. Extend the stakes out past both ends far enough to guide the dozer operator during the digging operation.

13. Clear all brush, tall grass, etc, off the ground to a distance of 15 ft on each side and to a distance of 25 ft at each end of the staked location. This is necessary to provide room to store the earth before putting it back on the roof. The backfill material should not contain any brush, sticks, or large stones.

14. Use a tape and check the excavation width frequently as the trench is being dug.

15. If the trench is dug by shovels, pile the earth dug near ground level at least 10 ft from the sides of the trench. Then as the trench deepens, the earth can be piled on the surface only 1 to 5 ft from the edge.

16. When the bulldozer has finished, trim the bottom of the trench with shovels. Dig a drain down the middle of each side. (Each ditch should be 6 in. wide and 4 in. deep.) Slope the floor to drain from the sides toward the two middle drain ditches. Be sure the bottom of the ditches slopes at least 1/2 inch vertically for each foot of horizontal length -- either slope the bottom of the ditches all in one direction or slope downward both ways from the center. Dig a 2-ft-square x 1-ft-deep sump at the lower end (or ends if sloping from the center of the shelter). Water collected in the sump will be bailed out by hand as necessary during occupancy. Lay small sticks in the drains and cover with porous fabric to serve as crushed rock drains leading to the sumps.

17. While the trench is being excavated, start construction of the two entry subassemblies on a clear area near one end of the excavation. Meanwhile, another crew can assemble the center beam and the center post assemblies.

18. Lay out and carefully align the stud base plates on the floor of the trench. Drive several small stakes on each side of the stud base plates to maintain the alignment. The exact location of these stakes is not critical since they will be removed later.



19. Measure along each stud base plate and mark on the base plate the location for each stud.

20. Place the center post base plate in position. Drive temporary stakes along each side of each base plate to hold it in place during erection of the center beam and center posts.

21. Carry the entryway assemblies into the trench and set them in place at the ends of the stud base plates (already installed). The assemblies will stand unsupported, but it will be safer to hold them in place by installing four temporary braces (some of the 2" x 4" spreaders can be temporarily used for this purpose).

22. Carry the assembled center beam and the center columns into the shelter.

CAUTION: The assembled beam weighs about 500 lbs so be sure to use a large enough crew (10 persons) so that no one strains himself.

23. The next step, erecting the center beam assembly, is the most difficult one of the entire construction. If construction personnel and equipment are available, they could be called in to do this job. However, unskilled people can do the job safely. There are several ways it can be done. Two alternate ways are suggested here:

a. Assembly-in-Place Method

- (1) Build a mound of earth (from the excavation) at least 4 ft high on each side of each end of the trench.
- (2) Obtain eight short logs, each at least 4 inches in diameter and at least 2 feet long.
- (3) Tamp the earth at the top of each mound enough to make a level spot on which to place the logs. Place two logs on each mound with the length of the logs parallel to the trench and located so that the center of the logs are opposite one end of the center beam. Drive stakes on the outside of the logs to keep them from rolling.
- (4) If there is a tree fairly close (10 to 30 ft) to one side of the end of the trench, it may be used to

#### A-9.7

anchor the rope. If not, take a 4-ft-long 2" x 4", sharpen one end with a hatchet, and drive it at least 2 ft into the ground well outside one of the mounds of earth.

- (5) Tie one end of the 3/8" (or larger) rope around the anchor (tree or stake), place the rope across the logs, down into the trench, under the end of the center beam (at least 3 ft from the end), back up the other side of the trench, over the other log, then to the truck or bulldozer. If the truck or bulldozer has a winch line, the winch line can be used instead of the rope. (See Figure A-9.2.)
- (6) Take up the slack in the rope (or winch line). Place a short length of 2" x 12" board under the rope, at each edge of the ditch to prevent the rope digging into the earth.
- (7) Take a 20-ft length of 3/8" rope, and tie a clove hitch (see sketch) around the center beam in the middle of the rope. Nail a short length of 1" board to the side of the beam near the end.
- (8) Have two men use the two ends of the rope to steady the end of the beam and hold it in place (horizontally) while the truck or bulldozer lifts the end of the beam. When the beam is high enough, have two men lift the end center post into position and nail it to the underside of the beam. Use the short 1" board as a handle to turn the beam into the proper position for nailing.
- (9) Drive two stakes in the floor of the shelter near the walls at the end of the shelter. Tie the two ropes securely to the stakes to serve as temporary guys while the other end of the center beam is being raised.

A-9.8

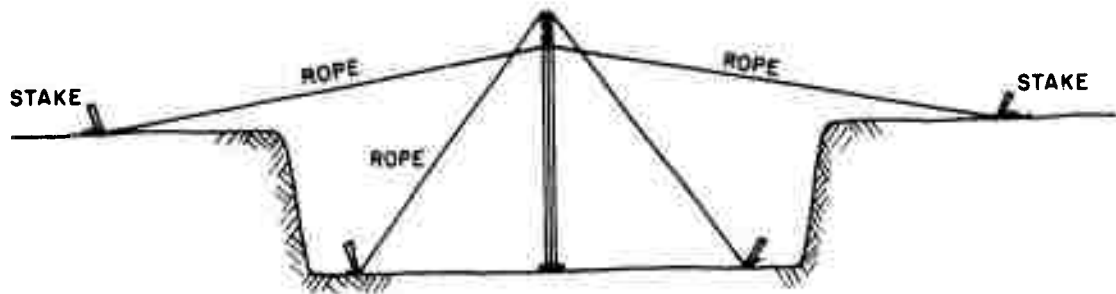
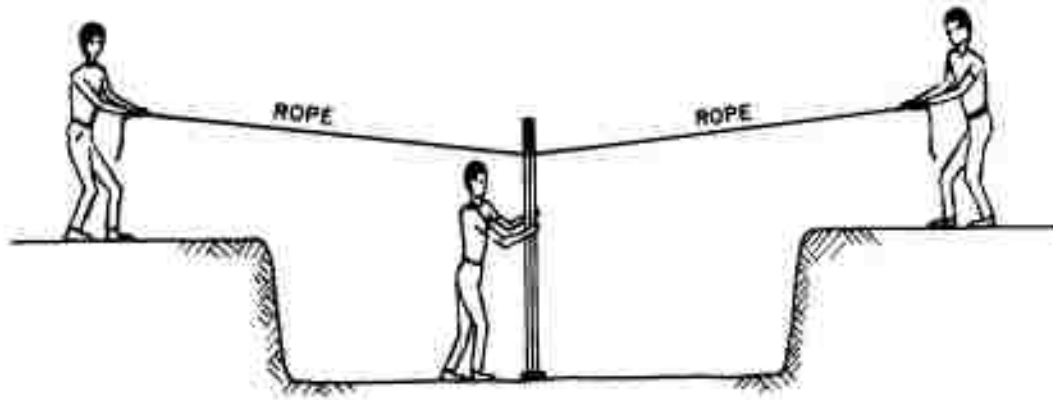

- (10) Raise and guy the other end of the center beam the same way as was done on the first end.
- (11) Install all center posts. Nail the center beam to the center posts, using 20-penny nails.
- (12) Nail on the plywood gussets with 6-penny nails.
- (13) Remove the 1" scabs used as handles.
- (14) Leave the rope guys in place until the joists have been added.

b. Preassembly Method

- (1) Lay the center beam flat along one edge of the trench. Nail the center posts to the center beam, using 20-penny nails. Nail the gussets to the top side of the assembly, using 6- or 8-penny nails. Move the assembly over to the side of the trench so that the center beam is against the wall of the trench. Adjust the position as necessary to be sure that the bottom of each center post is on its respective base plate.
- (2) Using two 40-ft lengths of 3/8" rope, tie a clove hitch around the center beam near each end so that the hitch is in the middle of each piece of rope.
- (3) Have one person take the end of each rope (4 persons required) to the ground outside of the trench, two persons on each side. With at least 7 persons (at least one at each center post) in the trench lifting on the assembly, tilt the assembly into an upright position. The 4 persons on the ropes can hold it steady while the rest of the crew "walks" the assembly into position by lifting and pushing on one center post at a time. Alternately, part of the "walking" can be accomplished by tapping the base of each center post in succession with a sledge until the bases of the posts are centered on the base plates.

- (4) Guy the center beam assembly by tying each of the 4 rope ends to a stake driven in the ground outside the trench. Additional guys can be added by tying ropes around the center beam and staking them to the outer sides of the trench floor. Leave the guys in place until the joists have been installed.
- (5) The remaining plywood gussets can be nailed on after the joists have been installed.

24. Installation of the joists and studs can be made easier by prefabricating units consisting of one joist and one stud with its scabs and knee braces. Be careful to assure that the studs are accurately located and that all assemblies are square. The prefabrication can be done either inside or outside the trench as convenient.

25. Install the joists and the studs, starting at each end where the entryways have been erected. Nailing the first joist to the entryway will give the structure stability during assembly. As soon as two studs have been erected at each end, start adding the continuous 2" x 8" ledger on each side to improve longitudinal stability.

26. As soon as the first four joists at each end have been installed, other crews can install the stud plates and studs at each end of the shelter.

27. The 2" x 8" continuous header can be nailed to the ends of the joists as the installation of the joists proceeds.

28. Install the thrust plates and the spreaders.

29. As soon as the joists and studs are in place, add the plywood sheathing to the sides and ends. Complete the installation of plywood on the entryways.

30. Whenever time from other jobs allows, one crew should build the Kearny Air Pump (KAP).

31. Start backfilling around both sides and both ends. Shovel in earth in a 6-inch layer all around. Tamp thoroughly, using short lengths of 2" boards or logs. Continue adding 6-inch layers and hand-tamping until the backfill is 6" to 12" above the original ground level. Add earth to the outside of the backfill, with tamping, to make a slope which

extends out about 8 ft on both sides of the shelter. Be sure to bring the sides and ends up evenly all around the shelter. Dig a 6-in.-deep trench along the sides of the shelter to serve as a drain.

32. Install a polyethylene sheet (or other waterproofing materials) to both sides of the shelter extending from the 2" x 8" ledgers out to the ditch. Add earth on top of the waterproofing to bring the level up to the top of the ledgers. Be sure that the mounded earth slopes down in the outward direction.

33. While the backfilling is being done, another crew can install the plywood roof and drill the "weep holes."\* The "weep holes" should be 1/4-in.-diameter and located on each side about 6 inches from the outside of the roof. The holes should be about 1 foot apart.

34. Lay the 2" x 12" boards for the upper header out on the ground, and nail the 2" x 4" cleats to them (on 4-ft centers). Put the headers in place, and nail the cleats to the 2" x 8" headers.

35. Fill the roof box with earth until it is at least 18" deep along the center line of the shelter. Rake the mounded earth smooth and remove any sticks, stones, or other sharp objects which might puncture the waterproof membrane. Be sure that the mound slopes down at a fairly uniform slope.

36. Cover the mounded earth over the shelter with a sheet of polyethylene film (or other waterproofing). Be sure that the waterproofing slopes downward at both sides and at each end. Extend the sides of the waterproofing over the top of the 2" x 12" headers and down the outside several inches. Extend the waterproofing at each end beyond the two entryways.

37. Add earth to the top of the waterproof covering until the earth at the center line is 3 ft deep. Slope the surface slightly until the edge of the shelter is reached, then sharply at the outer edges.

38. Install the KAP in the doorway of the entry which is located in the direction from which the wind is blowing.

---

\*NOTE: The "weep holes" need to be put in to allow any water condensed on the underside of the upper waterproof layer to drip outside the shelter.

39. Cover each entrance with a fly or canopy (open on all sides) to minimize entry of fallout particles.

40. Occupy the shelter.

41. As time, energy, and materials permit, improve the interior of the shelter by one or more of the following methods:

- a. Fill in the floor between spreaders with earth, and cover with plywood or 1-inch boards.
- b. Build benches and overhead bunks. Be sure to space the vertical supports 3 feet apart so two men can sit between each pair of supports.
- c. For windy and/or cold weather, make temporary covers for one or both of the entryways from plywood (1 sheet of 1/4" x 4' x 8' plywood will do nicely). The amount of air can be adjusted as necessary by sliding the plywood covers back or forth to obtain the required size opening.
- d. Improve the water supply by building improvised water storage pits.
- e. Build expedient lights. See Appendix C for instructions.

42. The following is a suggested division of tasks based on 4 crews of 6 persons each:

a. With Bulldozer:

- Crew A -
- (1) Stake out the outlines of the trench.
  - (2) Clear brush, grass, etc. from the site.
  - (3) (a) Check width of trench frequently.  
(b) Assist dozer operator as necessary.  
(c) Part of the crew assist other crews while waiting for dozer to finish.
  - (4) Trim bottom of trench with shovels; dig center drains and fill with sticks provided by Crew D. Dig sumps.
  - (5) Install the stud base plates and the center post base plates.
  - (6) Mark the base plates to locate the positions for the studs.

A-9.13

- (7) Assemble 37 joist-stud subassemblies (half of the total required).
- (8) Assist Crew D erect the center beam and center columns.
- (9) Assist Crew B install the joist-stud subassemblies.
- (10) Install the spreaders and thrust plates.
- (11) Cover sidewalls with plywood.
- (12) Spread and tamp backfill along both side walls.
- (13) Assist Crews D and B finish the backfilling and tamping of the side walls and end structures.
- (14) Assist Crew C cover the roof with earth.

- Crew B -
- (1) Check tools to be sure all the necessary tools are available.
  - (2) Check sharpness of tools and sharpen any dull ones.
  - (3) Assemble the two entry structures.
  - (4) Assisted by Crew C, erect the two entryway assemblies.
  - (5) Assist Crew D erect the center beam and center columns.
  - (6) Install the joist-stud assemblies and their headers and ledgers, assisted by Crew A.
  - (7) Spread and tamp backfill around first end wall and entryway.
  - (8) Spread and tamp backfill along one side wall.
  - (9) Assist Crew C cover the roof with earth.
  - (10) Install the fly covers over the entryways.

- Crew C -
- (1) Inventory the lumber and other materials to be sure the required materials are on hand. Correct any shortage discovered.



- (2) Cut the lumber into the desired lengths, mark it, and stack in piles at a location convenient to the trench but not in the way of the bulldozer.
  - (3) Assemble 37 joist-stud subassemblies (half of the total needed).
  - (4) Assist Crew B in erecting the two entryway assemblies.
  - (5) Assist Crew D in erecting the center beam and center columns.
  - (6) Install the first end wall studs and cover with plywood.
  - (7) Cover the roof with plywood.
  - (8) Install first waterproof materials (directly to the plywood).
  - (9) Assisted by all crews, place mound of earth on roof of shelter and rake smooth.
  - (10) Place second waterproof membrane on shelter.
  - (11) Finish covering the roof with earth.
- Crew D —
- (1) Assist Crew A in clearing the site.
  - (2) Cut short lengths of sticks for use in the shelter drains.
  - (3) Prefabricate the center beam and the center columns.
  - (4) Build the Kearny Air Pump (during breaks between other tasks).
  - (5) Assisted by all crews, erect the center beam and columns.
  - (6) Install the second end wall studs.
  - (7) Cover the second end wall and entryway with plywood.
  - (8) Spread and tamp backfill around second end wall and entryway.
  - (9) Backfill and tamp along one side wall.
  - (10) Assist Crew C cover the roof with earth.

b. Without Mechanical Excavation Equipment

- Crew A -
- (1) Stake out the outlines of the trench.
  - (2) Clear brush, grass, etc. from the site.
  - (3) Assisted by Crews B, C, and D, excavate the trench.
  - (4) Trim bottom of trench with shovels; dig center drains and fill with sticks provided by Crew D. Dig sumps.
  - (5) Install the stud base plates and the center post base plates.
  - (6) Mark the base plates to locate the positions for the studs.
  - (7) Assemble 37 joist-stud subassemblies (half the total required).
  - (8) Assist Crew D erect the center beam and center column.
  - (9) Assist Crew B install the joist-stud subassemblies.
  - (10) Install the spreaders and thrust plates.
  - (11) Cover sidewalls with plywood.
  - (12) Spread and tamp backfill along both side walls.
  - (13) Assist Crews D and B finish the backfilling and tamping of the side walls and end structures.
  - (14) Assist Crew C cover the roof with earth.
- Crew B -
- (1) Check tools to be sure all the necessary tools are available.
  - (2) Check sharpness of tools and sharpen any dull ones.
  - (3) Assist Crew A dig the trench.
  - (4) Assemble the two entry structures.
  - (5) Assisted by Crew C, erect the two entryway assemblies.

- (6) Assist Crew D erect the center beam and center columns.
  - (7) Install the joist-stud assemblies and their headers and ledgers, assisted by Crew A.
  - (8) Spread and tamp backfill around first end wall and entryway.
  - (9) Assist Crew C cover the roof with earth.
  - (10) Install the fly covers over the entryways.
- Crew C -
- (1) Inventory the lumber and other materials to be sure the required materials are on hand. Correct any shortage discovered.
  - (2) Cut the lumber into the desired lengths, mark it, and stack it in piles at a location convenient to the trench.
  - (3) Assist Crew A dig the trench.
  - (4) Assemble 37 joist-stud subassemblies (half of the total needed).
  - (5) Assist Crew B in erecting the two entryway assemblies.
  - (6) Assist Crew D in erecting the center beam and the center columns.
  - (7) Install the first end wall studs and cover with plywood.
  - (8) Cover the roof with plywood.
  - (9) Install the first waterproof materials (directly to the plywood).
  - (10) Assisted by all crews, place mound of earth on roof of shelter and rake smooth.
  - (11) Place second waterproof membrane on shelter.
  - (12) Finish covering the roof with earth.
- Crew D -
- (1) Assist Crew A in clearing the site and digging the trench.
  - (2) Cut short lengths of sticks for use in the shelter drains.

A-9.17

- (3) Prefabricate the center beam and the center columns.
- (4) Build the Kearny Air Pump (during breaks between other tasks).
- (5) Assisted by all crews, erect the center beam and the center columns.
- (6) Install the second end wall studs.
- (7) Cover the second end wall and entryway with plywood.
- (8) Spread and tamp backfill around second end wall and entryway.
- (9) Backfill and tamp along one side wall.
- (10) Assist Crew C cover the roof with earth.

ORNL

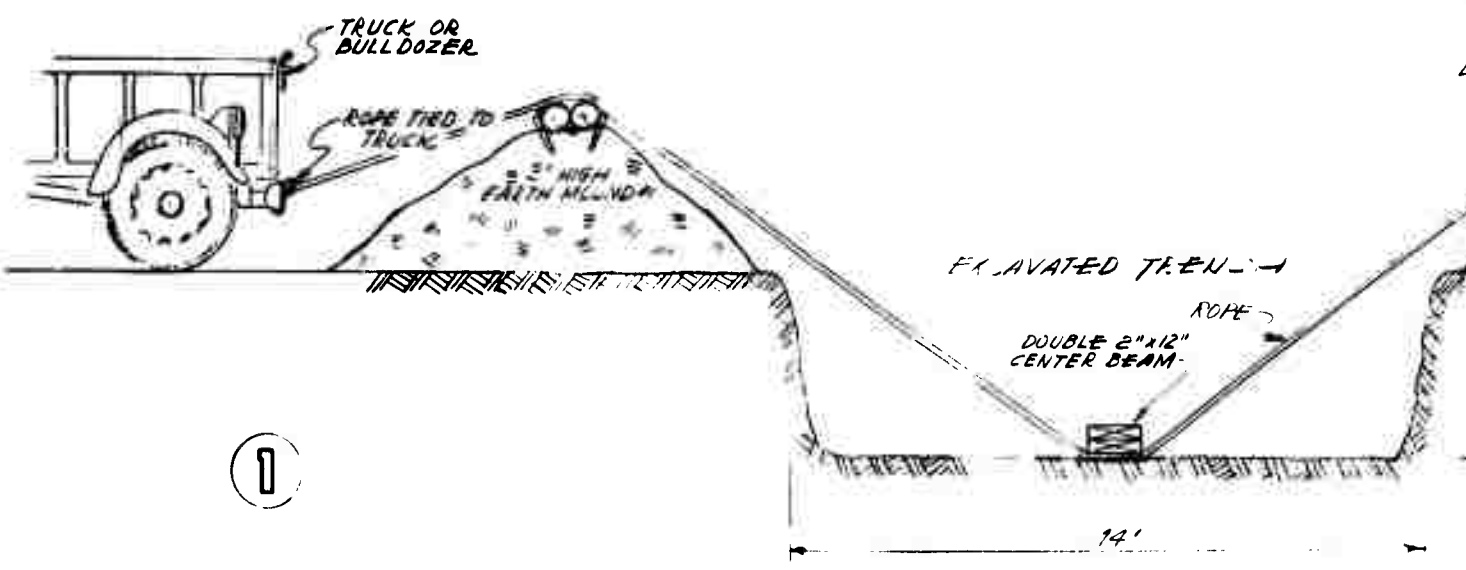

PICTORIAL VIEW SHOWING LIFTING MECHANISM FOR HEAVY CENTER BEAM

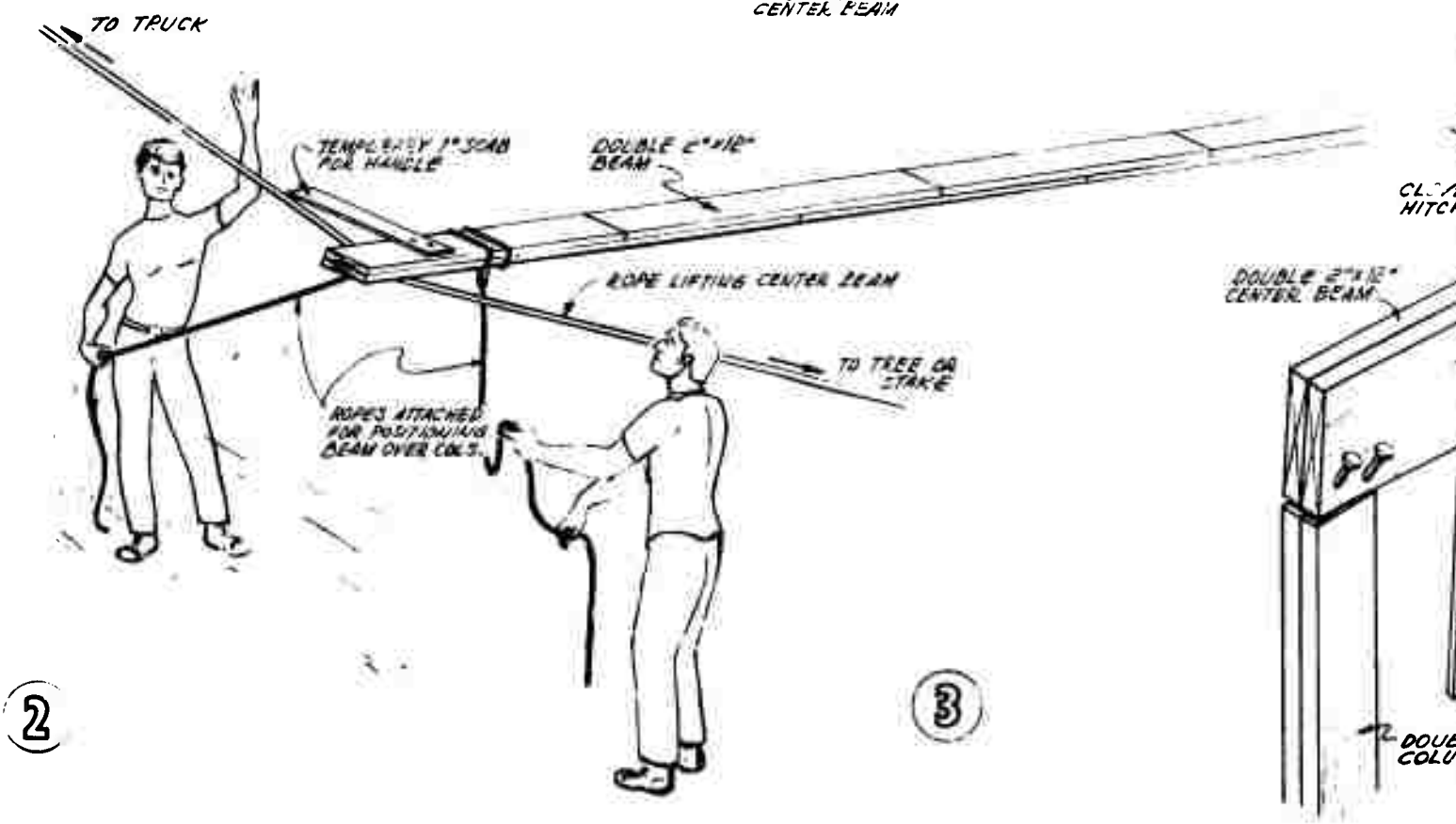
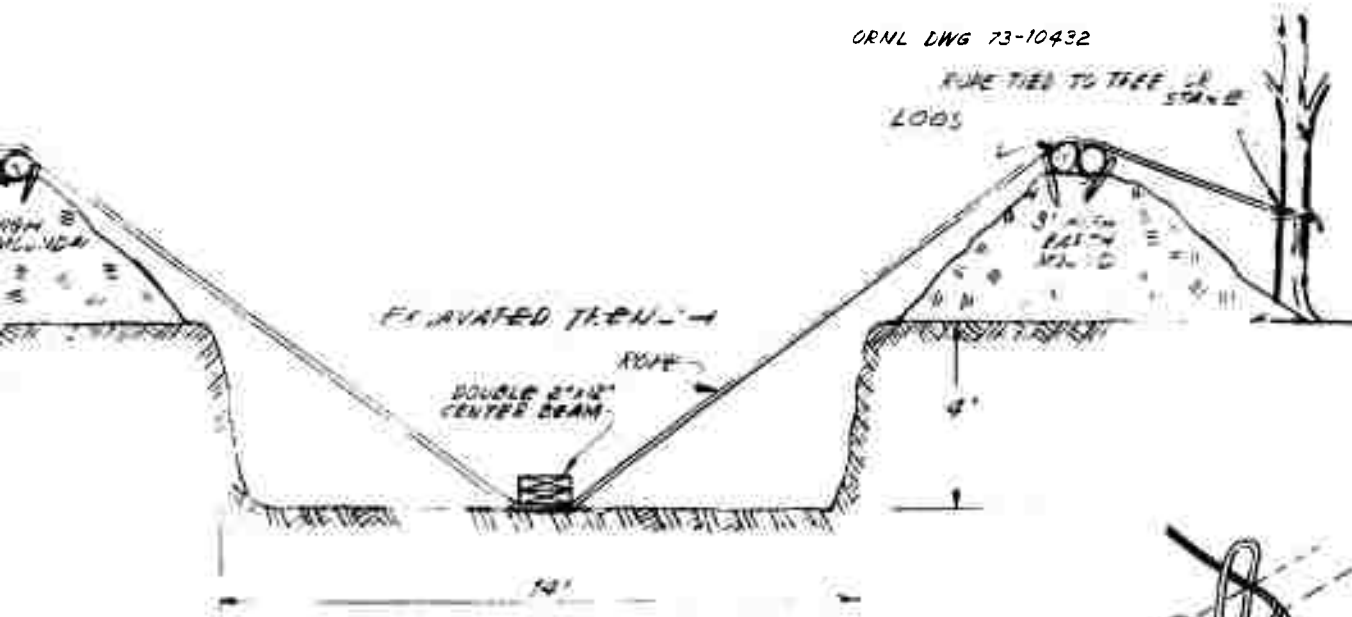
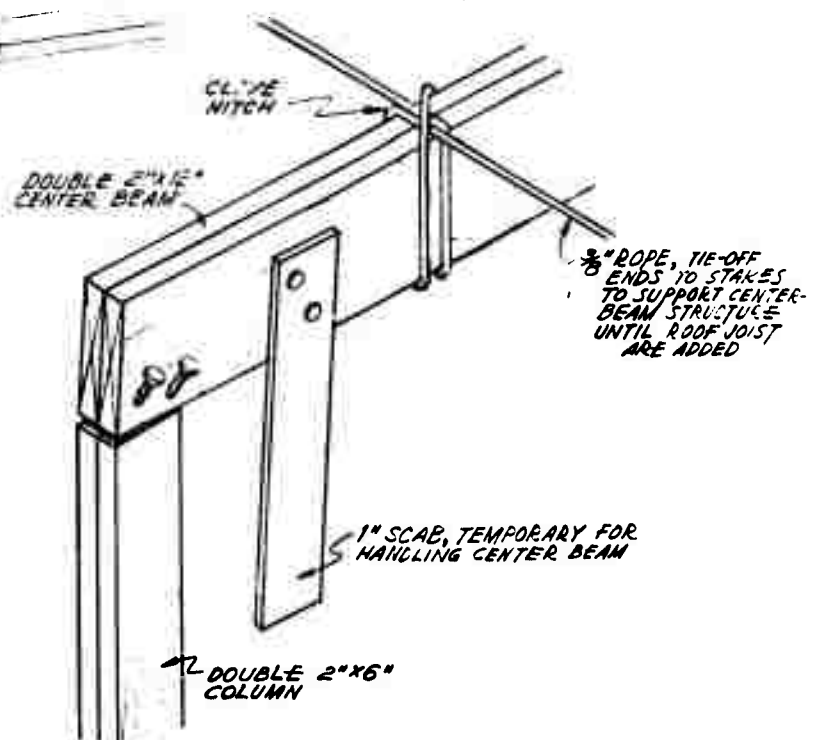
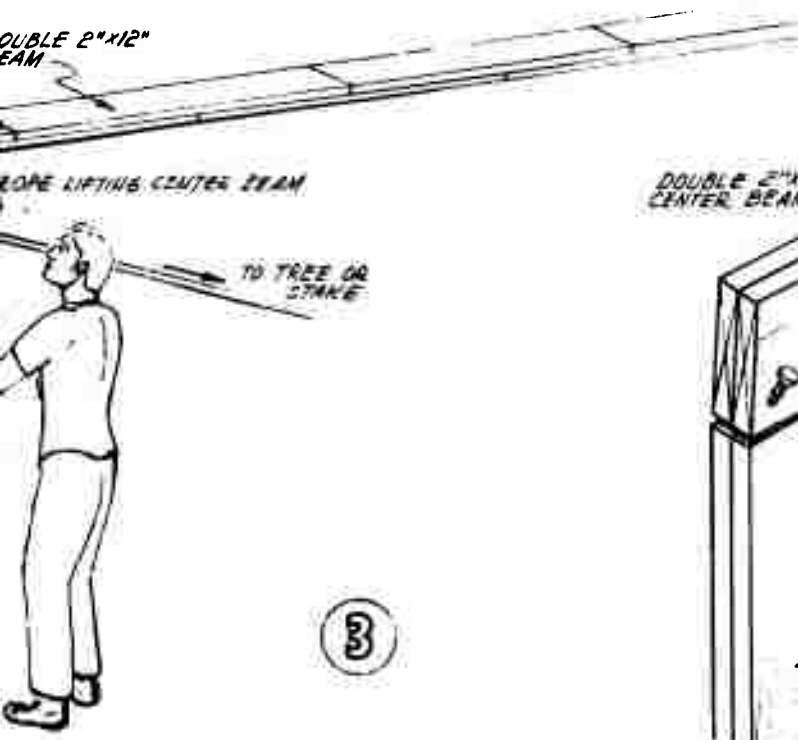
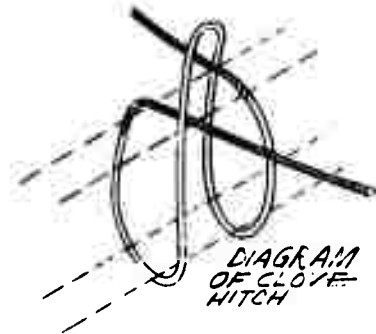

Fig. A-9.1. Rigid-Frame, Continuous Vent, Semiburied Shelter, Plan and Elevation.

ORNL DWG 73-10432



PICTORIAL VIEW  
SHOWING LIFTING MECHANISM FOR HEAVY  
CENTER BEAM



A-9.1. Rigid-Frame, Continuous Vent, Semiburied Shelter, Plan

ion.

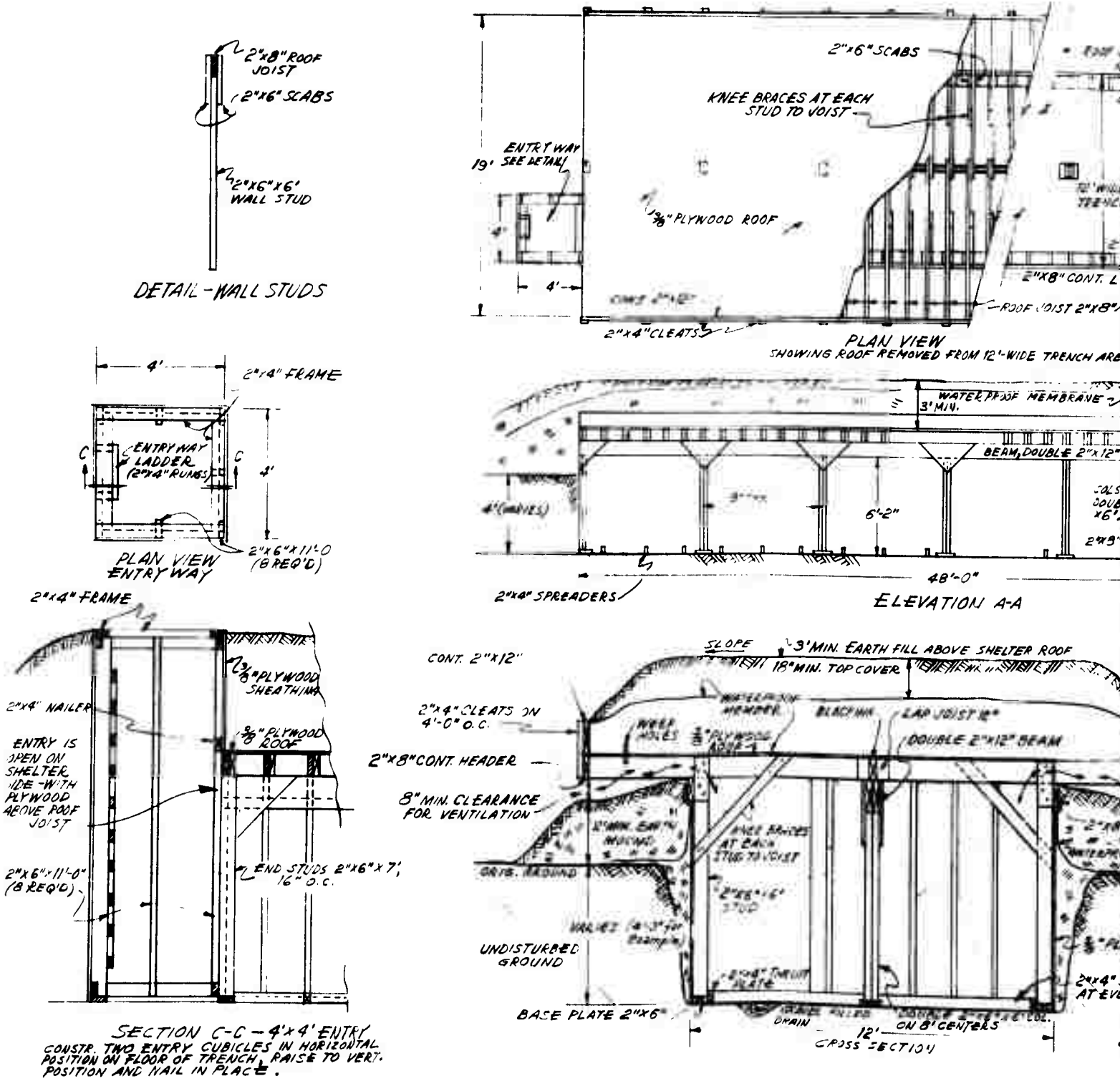

Fig. A-9.2. Rigid-Frame, Continuous Vent, Construction Methods

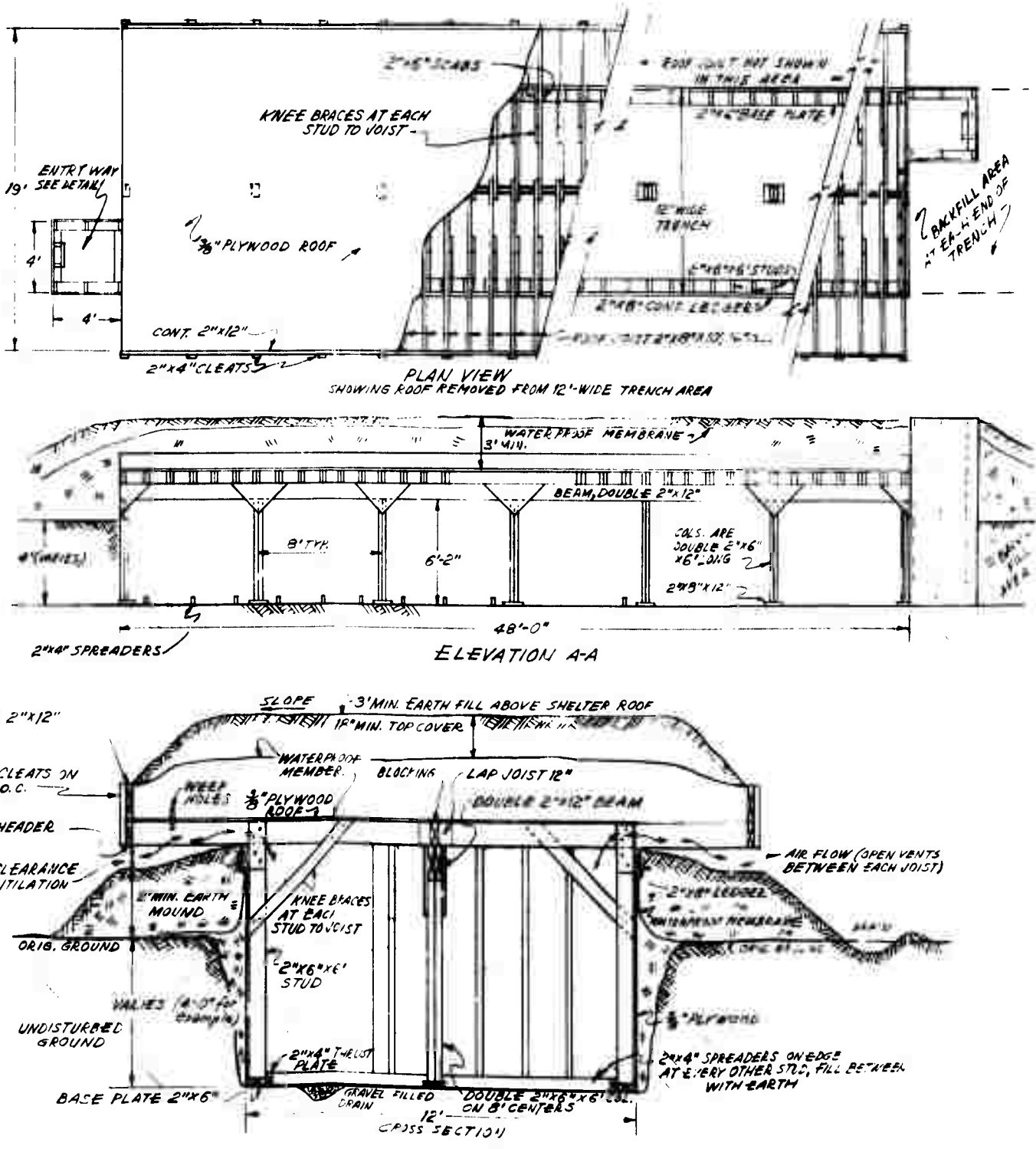

Fig. A-9.2. Rigid-Frame, Continuous Vent, Construction Methods



A-10 A-Frame, Semiburied

This shelter is a slightly modified (smaller) version of a shelter designed and built by the Protective Structures Development Center.<sup>7</sup> The PSDC 100-man version was built in a 24-hour period by a crew of 33 unskilled but disciplined men (Engineering Corp Troops) using hand tools for rough carpentry and a bulldozer and road grader for excavation and placing of earth cover. The step-by-step instructions given in this Appendix have not been prooftested.

Locally published instructions should include Appendixes B and C.

"A" FRAME, SEMIBURIED SHELTER  
(Capacity 60 Persons)

1. This expedient shelter can be built by a group of 15 to 30 persons inexperienced in construction work who are normally healthy adults (or youths) able and willing to work together to prepare effective fallout shelters for themselves and their families. These instructions have been designed for use by just such inexperienced persons and are therefore much more detailed than would be required by experienced carpenters.

2. The plans as drawn can be modified slightly to provide a number of different options. For example, it can be shortened if a smaller capacity is desired (a 32-foot-long shelter would house 40 persons). The two entries need not be different; the shelter can be built with two entrances of either type. Furthermore, it is strongly recommended that a Kearny Air Pump (KAP) be installed in one of the entryways; but local conditions or preferences may lead to construction of the optional roof ventilation box instead (a much more difficult task than building the KAP).

3. The length of time required to build this shelter depends upon many factors. If a tractor with a dozer blade is available, the trench for the shelter can be excavated in two or three hours under normal conditions. Other excavation equipment, such as backhoes or front-end loaders, can be used. If no mechanical equipment is available, the trench can be dug by hand, but this will require much longer.

4. Each person who will be working on the construction of the shelter should study the two drawings and read all of these instructions before starting the work.

5. Materials and tools required:

A-10.2

- a. The lumber needed, in lengths normally available in lumber yards:

2" x 12" x 12'	26 pcs
2" x 12" x 10'	74 pcs
2" x 10" x 12'	8 pcs
2" x 6" x 12'	14 pcs
2" x 6" x 8'	12 pcs
2" x 4" x 14'	10 pcs
2" x 4" x 12'	32 pcs
1" x 6" x 14'	5 pcs

- b. The lumber as used should be cut into the lengths shown in this table:

Mud Sill and Ridge Beam	2" x 12" x 12'	12 pcs	288 bd ft
Rafters	2" x 12" x 10'	74 pcs	1480 bd ft
Braces, Lintel, & Risers	2" x 12" x 4'	40 pcs	320 bd ft
Rafter Sill	2" x 10" x 12'	8 pcs	160 bd ft
Rafter Sills and Hatch Frame	2" x 6" x 12'	12 pcs	144 bd ft
Hatch Frame	2" x 6" x 5'	2 pcs	10 bd ft
Exit Frames	2" x 6" x 8'	13 pcs	104 bd ft
	2" x 6" x 4'	1 pc	4 bd ft
Temp. Braces	2" x 4" x 14'	10 pcs	93 bd ft
Hatch Frame	2" x 4" x 12'	8 pcs	64 bd ft
Studs and Exit Frames	2" x 4" x 6'	22 pcs	88 bd ft
Studs	2" x 4" x 4'	4 pcs	11 bd ft
Ladder Rungs	2" x 4" x 3'	12 pcs	24 bd ft
Stakes	2" x 4" x 2'	48 pcs	64 bd ft
Temp. Brace	1" x 6" x 7'	10 pcs	35 bd ft

Total 2899 bd ft

- c. The above lists do not include lumber for the optional ventilation box. If that is to be built, provide the following additional pieces:

A-10.3

Frame	2" x 6" x 12'	4 pcs	48 bd ft
Frame	2" x 6" x 4'	6 pcs	24 bd ft
Frame	2" x 6" x 2'	4 pcs	8 bd ft
Frame	2" x 4" x 12'	4 pcs	32 bd ft
Frame	2" x 4" x 4'	4 pcs	11 bd ft
Frame	2" x 4" x 2'	4 pcs	6 bd ft
		Total	129 bd ft

d. Other materials required:

Plywood	1/2" x 4' x 8'	33 pcs	1056 sq ft
Polyethylene	6-mil	2000 sq ft	
Nails	20 d (4 in. long)	12 lbs	
	16 d (3-1/2 in. long)	15 lbs	
	6 d (2 in. long)	5 lbs	

-----Additional Materials for Optional Air Vent-----

Plywood	1/2" x 4' x 8'	5 pcs	160 sq ft
Nails	16 d	2 lbs	
	6 d	1 lb	

If the optional air vent is not built, obtain materials to build a Kearny Air Pump (KAP). (See Appendix B for instructions.)

e. Tools required for a 24-person crew to work efficiently (adjust tool list to the number of workers available - note that not all the tools can be used at any one time):

<u>Tool</u>	<u>Quantity</u>	<u>Notes</u>
Hand saw, carpenters	8	(If electricity is available, one or two circle saws can do Most of the cutting)
Levels	2	
Rakes	3	
Plumb lines	2	
Axes or hatchets	4	
Step ladders	2	
Claw hammers	12	
Pick, long handle	2	} (If hand excavation is necessary, multiply these numbers by 4)
Shovels, long handle	4	
Pencils, carpenters	2	
Squares, carpenters	2	
Work gloves	25 pr	
File - 10-inch	3	
Steel tape - 50-ft	1	
Steel tape - 10-ft	3	
String	1 ball	
Wheelbarrows	2	

6. To save time and work, sharpen all tools and keep them sharp, even if it takes one person full time to do it!

7. Wear gloves from the start - even tough hands can blister after hours of hard work. Blisters are painful, seriously slow the work, and could result in dangerous infections.

8. To avoid confusion, wasted time, and effort organize the work force into teams. Many variations are possible. A suggested division of tasks, based on a 24-person working force divided into 4 crews of 6 persons each, is given at the end of these instructions.

9. Before staking out the outlines of the excavation, check to make sure that rock will not be encountered by driving down a 6-ft-long, sharpened rod or small pipe. To avoid groundwater problems, avoid low ground.

10. Cut the lumber to the required lengths. Mark each piece to indicate where it goes in the structure to assure that the required long pieces are not subsequently cut up for the shorter pieces.

11. To help drain the floor, locate the shelter so that the original ground level at one end is about three feet lower than the other end.

12. Stake out the upper trench. Even in very firm earth make the excavation 18 feet wide at the surface (2 ft wider than at the bottom of the upper trench). The sloping sides of the excavation is needed for safety and for working room. In soft, crumbly earth, the width of the top must be even greater to ensure that no lumps cave off the sides during construction.

13. Check the squareness of the staked outline by making the diagonals equal. Extend the stakes out both ends far enough to guide the dozer operator during the digging operation.

14. Clear all brush, tall grass, trees, etc. off the ground to a distance of 15 ft on each side and to a distance of 25 ft at each end of the staked location. This is necessary to provide room to store the earth before putting it back on the roof. The backfill material should not contain any brush, sticks, or large stones.

15. Use a 16-ft-long 2" x 4" board or a pole to check the excavation width frequently as the trench is being dug.

16. If the trench is dug by shovels, pile the earth dug near ground level at least 10 ft from the sides of the trench. Then as the trench deepens, the earth dug from 5 to 6 ft down can be piled on the surface only 1 to 5 ft from the edge.

17. When the bulldozer has finished the first (upper) trench, stake out the lower trench, 12 feet wide.

18. When the bulldozer has finished, trim the bottom of the trench and the bench with shovels. Be sure the floor slopes toward the center drain and that the floor drain slopes at least 1/2-inch vertically for each foot of horizontal length. The slope may be all in one direction or both ways from the middle. Dig a 2-ft-square x 1-ft-deep sump at each end. Water collected in the sumps will be bailed out by hand as necessary.

A-10.6

Dig the center floor drain, 6-inches-wide x 4-inches deep. Lay small sticks in the drain and cover with porous fabric to serve as a crushed rock drain leading to one or both sumps.

19. While the trench is being excavated, start assembling the A-frame subassemblies on a clear area near one end of the excavation. In assembling the rafter subassemblies use a short length of 2" x 12" as a temporary spacer to be sure that the 2" x 12" ridge board will slip easily into place later. Use of a template to guide the cutting of the upper end of the rafters will speed the work and avoid wasted lumber.

To make a template for marking the 2" x 12" rafters for cutting, cut a full length rafter with the correct angle on its upper end by:

- (1) Marking a point A exactly 10 ft from a square end of a 2" x 12" board;

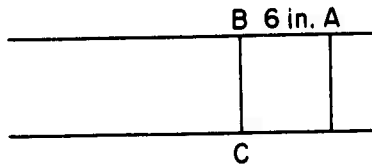

- (2) Marking a point B, on the same edge and 6 inches from A, toward the square end of the board;
- (3) Drawing a line square across the board from point B to point C on the opposite edge;
- (4) Measuring 8 inches from point B to point D, along line BC

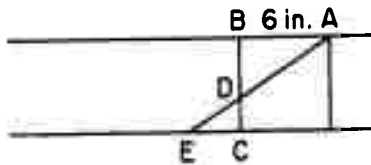

- (5) Drawing a straight line through point A and point D, to point E;
- (6) Checking the accuracy of your measurements by measuring the distance from A to D, which should be exactly 10 inches;
- (7) Cutting off the end of the template-rafter along the line AE.

To use this template-rafter as a template so as to make all the other rafters identical, lay it on top of a 2" x 12" board, with its square end exactly over a square end of the board to be cut. Then mark the board to be cut along the line AE. Repeat, marking in turn all the remaining rafter boards to be cut, always using the same rafter-template.

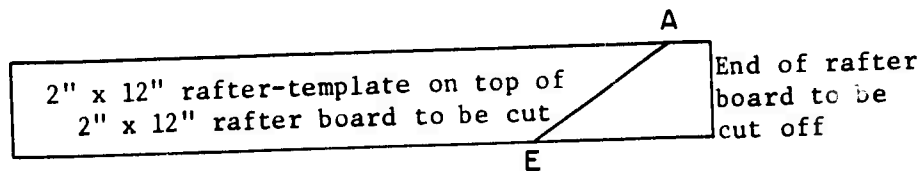

When assembling the first A-frame, carefully check to be sure that the width at the bottom is exactly 16 feet. Use the first A-frame unit as a template for the other units: (1) lay the completed A-frame unit on the ground, or on a pair of saw horses, with the temporary braces down; (2) lay the rafters for the next assembly on top of the rafters of the completed unit; (3) holding the new rafters carefully in place, nail on the brace and the temporary braces. Meanwhile, another crew can assemble the escape-hatch entryway. Another crew can begin construction of either the vent box or the Kearny Air Pump.

20. Install the 2" x 12" mud sills on each bench. Drive the stakes to hold them in place.

21. Carry the escape-hatch entryway structure into the trench and set it up. Hold the structure in place by temporary braces (use 2" x 4"'s) or by temporary guy-wires (wire or rope may be used).

22. Assemble the two "L" shaped rafter sills by nailing the 2" x 6" to the 2" x 10" thus:



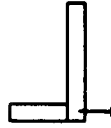

Lay the rafter sills on the mud sills.

23. Carry the rafter A-frame assemblies into the trench, using three persons per assembly (they weigh a little over 100 lbs each). Erect the A frame rafters, starting at the end next to the escape-hatch entryway. The first A-frame may be nailed to the escape-hatch to give the structure stability. Be sure each rafter is properly spaced and is sitting in the "L"-shaped rafter sill as shown in the drawing before nailing it in place. Nail short lengths of 1" lumber to successive rafters to temporarily hold the rafter assemblies in the vertical position until the tenth assembly has been erected. Now place the first ridge beam into place, being sure that it is exactly 12 feet long and that the end of the 2" x 12" is centered in the slot of the tenth assembly (leaving room for the next ridge beam to be put into the same slot with room to nail both beams to the rafters).

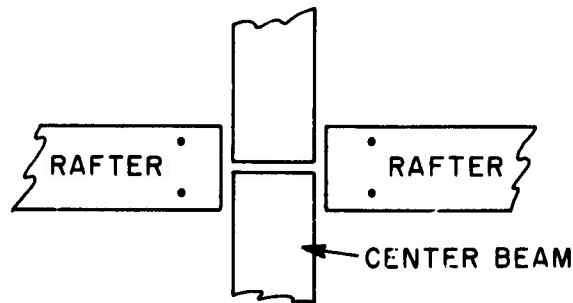

Continue erecting rafter assemblies until the 19th rafter assembly has been erected. Install the ridge beam as before. Erect the remaining rafters and the last ridge beam. Remove all temporary bracing as soon as the rafters and ridge beams have been firmly nailed together.

24. If the optional vent box design is being used, construct the box and install it as shown on the drawing.

25. Nail the plywood sheathing to the rafters and to the outside of the escape hatch.

26. While the rafters are being installed, another crew should hand-excavate two-ft.-deep trenches at each end of the two, 2-ft.-high benches. Lay the 16-ft.-long, 2" x 8" stud plates across each end of the shelter. Install the studs at each end of the shelter. Nail studs to rafters and stud plates. Put plywood sheath on the outside of the studs.

27. Construct the covered entrance. Some hand excavation will be required to provide the steps.

28. While the entryway is being constructed, cover the roof of the shelter with plastic or roofing material. (CAUTION: This is not the waterproof cover - that comes later. This covering is to keep out loose dirt and moisture trapped under the waterproof covering.)

29. While steps 26 and 27 are being done, another crew can start backfilling at the escape hatch end of the shelter. As soon as the entryway has been constructed, start backfilling at that end also. The backfill material should be placed by hand and tamped by hand. Place backfill no more than 6" deep between each tamping.

30. Preparatory to backfilling, place grade stakes in position, so you will know how much earth you have over the roof.

31. As soon as the backfill at the end has reached the level of the lower edge of the roof, start mounding earth over the shelter. All backfill on the roof should be placed by hand. If a bulldozer is available, it can move the earth so it will be within easy shoveling distance of the backfill crew.

32. As the backfilling progresses, keep the level of the backfill about the same at both ends and on the top. Mound the earth about 15 inches deep, over the entire shelter. Be sure the mound is higher in the center than at the ends to assist drainage. Smooth the mound with a rake.

33. Place the rainproofing material (preferable 6-mil polyethylene sheets) over the mounded earth, extending it well beyond the edge of the upper trench, and well beyond the ends of the two entryways. Roll up small sticks in the edge of the waterproof material to serve as a drain conduit.

34. Place the rest of the earth cover over the shelter, being careful that the waterproofing is not punctured. Check the level carefully to be sure to have a full three feet of earth cover. Smooth the surface to improve natural drainage. Dig a shallow (1-ft) ditch all around the shelter to keep surface water from running into the shelter.

35. If the Kearny Air Pump method of ventilation is being used, one crew should build and install the KAP while the rest of the group is back-filling.

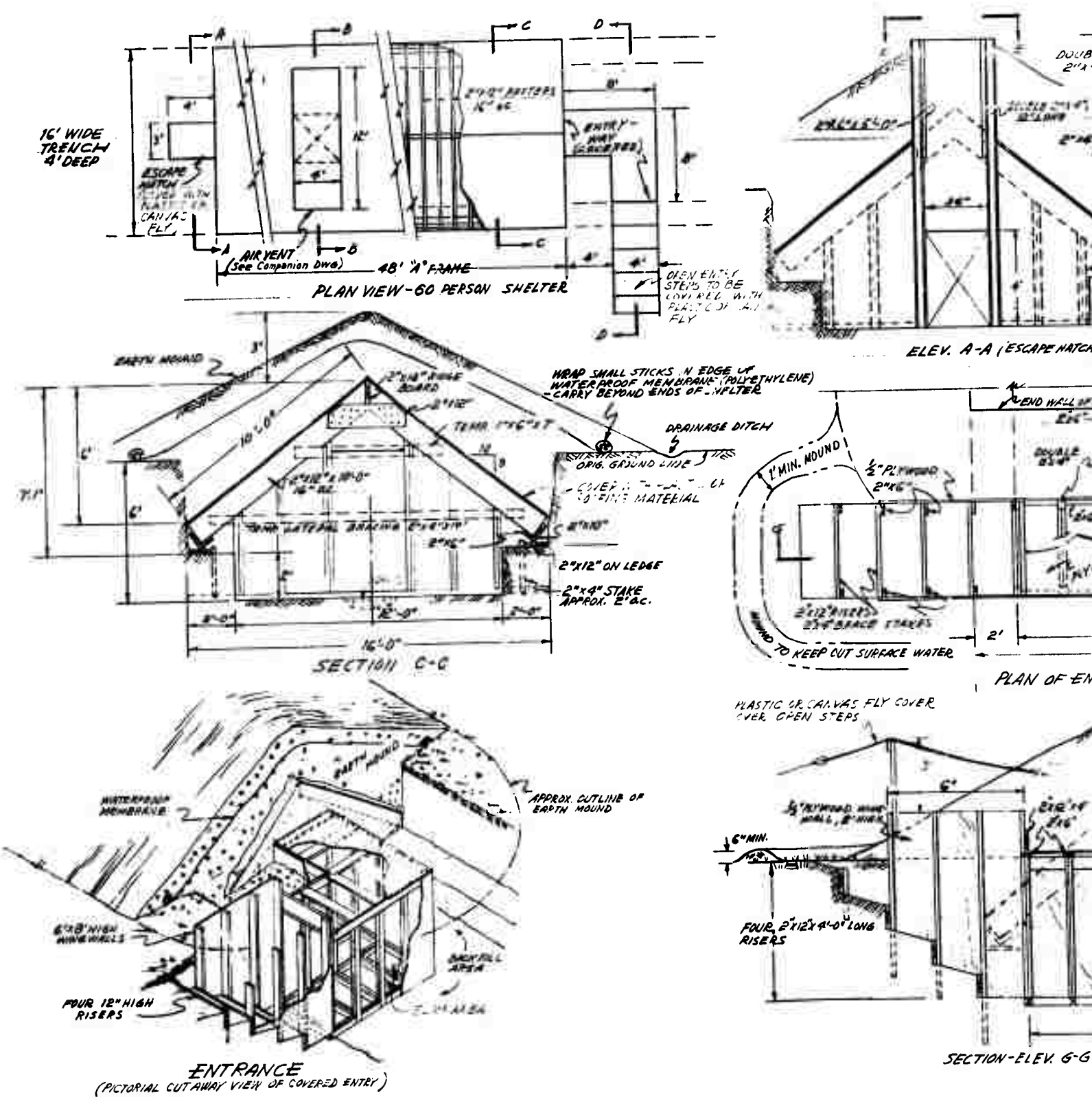
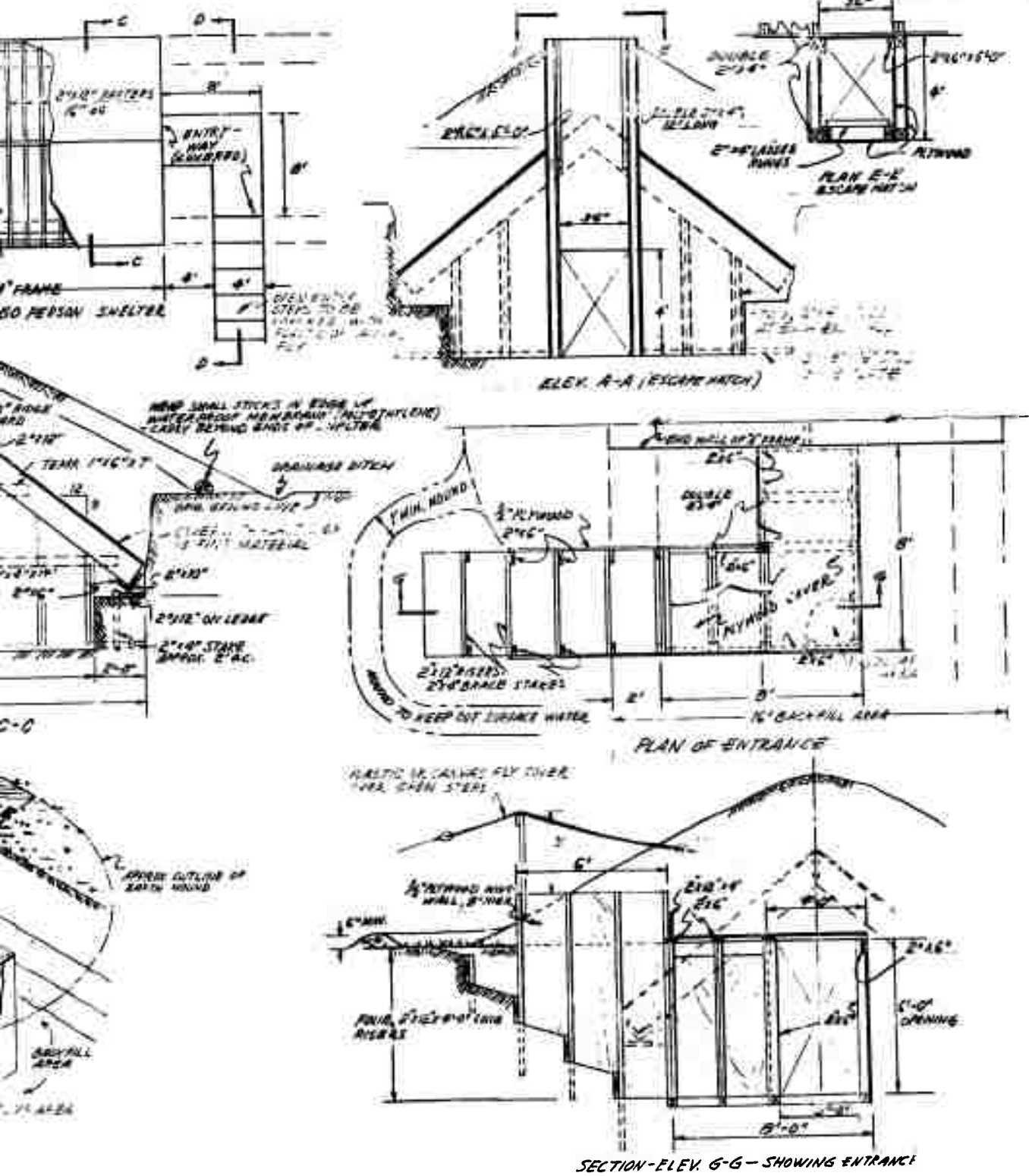

Fig. A-10.1. "A"-Frame Expedient Shelter, Plans and Elevation.



A-10.1. "A"-Frame Expedient Shelter, Plans and Elevation.

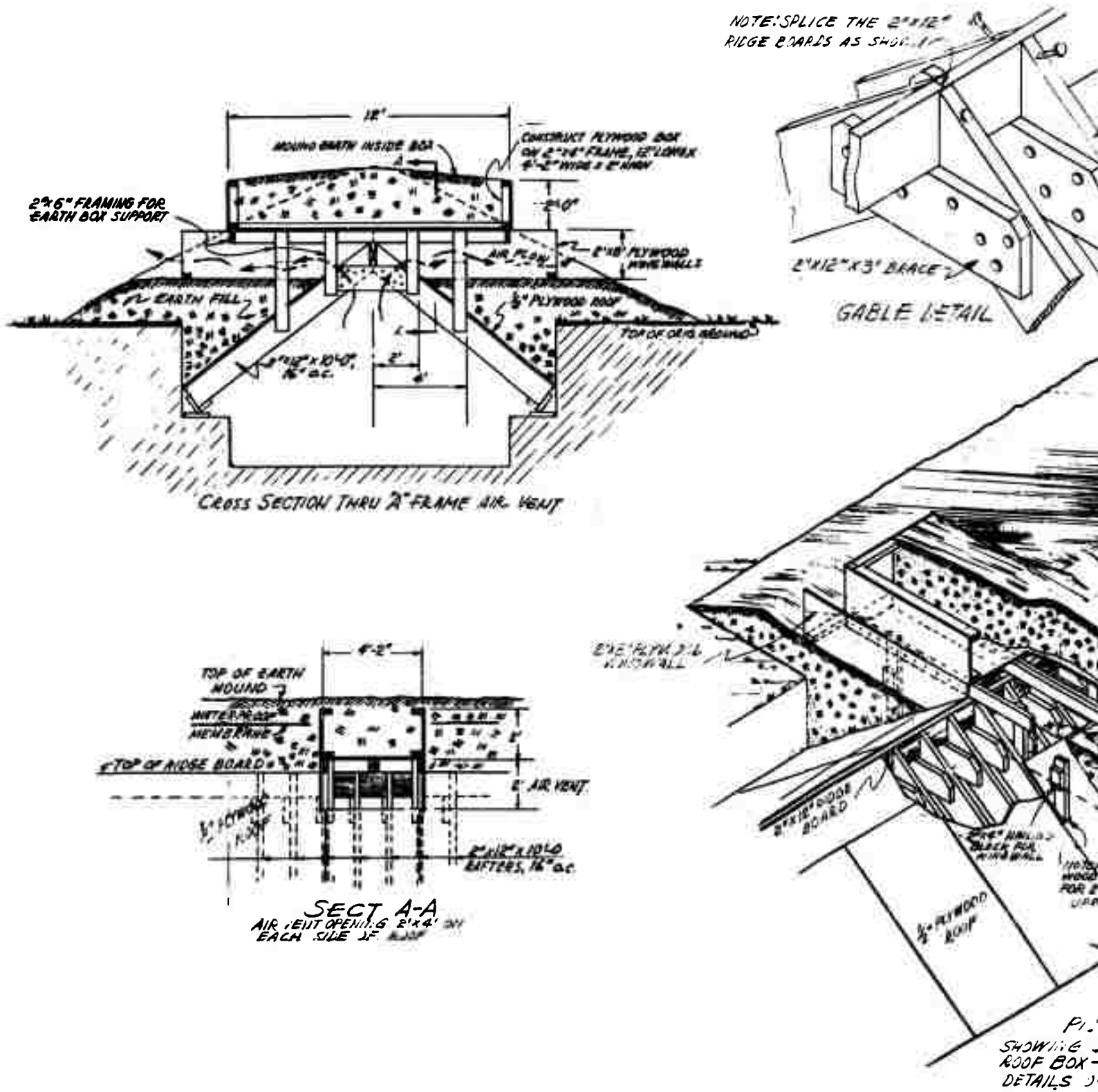

Fig. A-10.2. A-Frame Expedient Shelter, Alternate Air Vent Design.



A-11. Wood Grate Roof Underground Shelter

This shelter was designed and built<sup>8</sup> by Protective Structures Development Center using an unskilled but disciplined work force of 25 men, including 3 skilled supervisors, in a 20-hr period. The shelter built by PSDC actually used two designs. One half was an unshored model, the other provided shoring for the outer walls. The design included in this appendix used only the shored version. In addition, the entryways have been somewhat simplified to reduce the work required. The step-by-step instructions have not been prooftested.

Locally published instructions should include Appendixes B and C.



**WOOD-GRATE-ROOF UNDERGROUND SHELTER  
(Capacity 60 Persons)**

1. This shelter can be built by a crew of from 15 to 30 inexperienced persons who are willing to work together to provide protection for themselves and their families from the dangers of radioactive fallout. It should be built only in fairly firm earth with a low water table.

2. The length of time required to build this shelter depends upon many things. If a bulldozer is available, the trench for the shelter can be excavated in three or four hours. Other excavation equipment such as backhoes, front-end loaders, or tractors with a dozer blade can be used. If no mechanical equipment is available, the trench can be dug by hand, but this will require much longer.

3. Each person who will be working on the construction of the shelter should study the two drawings and read all of these instructions before starting to work.

4. Materials and tools required: Table No. 1 is a list of the building materials required, itemized by the required use of the item and showing the actual lengths and sizes needed. Table No. 2 lists the lumber needed in the lengths to be supplied by the lumber yard.

Table 1. Bill of Material for Wood Grate Roof 60-Person Shelter (8 R)  
(see Table 2 for Consolidated Lumber List)

Center Beam*	2" x 12" x 16'	2 pcs	64 bd ft
Mud Sills*	2" x 12" x 14'	4 pcs	112 bd ft
Center Beam*	2" x 12" x 12'	2 pcs	48 bd ft
Risers for Steps	2" x 12" x 3'	8 pcs	48 bd ft
Column Footings and Girder Scabs	2" x 12" x 2'	25 pcs	100 bd ft
Stop for Retaining Wall	2" x 4" x 14'	4 pcs	38 bd ft
Rafters	2" x 4" x 12'	210 pcs	1680 bd ft
Stud Plates	{ 2" x 4" x 9'	4 pcs	24 bd ft
	{ 2" x 4" x 8'	16 pcs	36 bd ft
	{ 2" x 4" x 7'	4 pcs	18 bd ft

Table 1 (continued)

Columns, End Wall Studs, Wales and Corner Posts	2" x 4" x 6'	94 pcs	376 bd ft
Studs	2" x 4" x 6'	16 pcs	43 bd ft
Stud Plates, Braces, and Entryway Joists	2" x 4" x 3'	26 pcs	52 bd ft
Stud Plates	2" x 4" x 32"	4 pcs	14 bd ft
Entryway Spreaders	2" x 4" x 28-3/4"	10 pcs	16 bd ft
Stakes	2" x 4" x 2'	64 pcs	86 bd ft
Spacers	2" x 4" x 6"	316 pcs	105 bd ft
Roof Stiffeners and Bench Trim	1" x 8" x 14'	16 pcs	150 bd ft
			<u>3060 bd ft</u> (50 bd ft/ person)
Plywood	1/2" x 8' x 4'	6 pcs	
(992 square feet)	1/2" x 4' x 4'	6 pcs	
	1/2" x 6' x 4'	12 pcs	
	1/2" x 7' x 3'	2 pcs	
	1/2" x 6' x 2'	4 pcs	
	1/2" x 6' x 1'	2 pcs	
	1/2" x 6' x 3'	4 pcs**	
	1/2" x 6' x 32"	2 pcs	
Nails	20 d (4 in. long)		14 lbs
	16 d (3-1/2 in. long)		25 lbs
	6 or 8 d (2 - 2-1/2 in. long)		10 lbs
Roll Roofing	60 lb/square		1700 sq ft
Polyethylene	6 mil		2000 sq ft
Wire	No. 9		500 ft

Materials to build a 6-ft Kearny Air Pump (see Appendix B)

\*The distribution of sizes of 2" x 12" listed allows use without cutting these boards. Any combination of 16, 14, and 12-ft lengths can be used that gives a total of 112 linear feet.

\*\*These four pieces can be replaced by the 12 pieces 1/2" x 3' x 2" cut from the scrap left in cutting the 12 pieces 1/2" x 6' x 4". This will save four 8' x 4' sheets of plywood.

Table 2. Wood Grate Roof (8 R) 60-Person Shelter - Lumber List

2" x 12" x 16'*	2 pcs
2" x 12" x 14'*	5 pcs
2" x 12" x 12'*	7 pcs
2" x 4" x 14'	4 pcs
2" x 4" x 12'	306 pcs
1" x 8" x 14'	16 pcs
1/2" x 8' x 4'	31 pcs

\* This selection of lengths assumes that the 16' lengths will be used in the center beams without cutting, four of the 14' lengths will be used as mudsills without cutting, 2 of the 12' lengths will be used in the center beam without cutting. The remainder will be cut into 3' and 2' lengths for the steps, footings, and scabs.

Tools required for a 24-person crew to work efficiently (adjust tool list to the number of workers available - note that not all the tools can be used at any one time):

<u>Tools</u>	<u>Quantity</u>	<u>Notes</u>
Hand saw, carpenters	8	(If electricity is available, one or two circular saws can do most of the cutting)
Levels, carpenters	2	
Rakes	3	
Brace and Bit	1	
Plumb lines	2	
Axes and Hatchets	4	
Sledge Hammer 6#	1	
Claw hammers	12	
Pick, long handle	2	(If hand excavation is necessary, multiply these numbers by 4)
Shovels, long handle	5	
Knife, pocket	2	
Pencils, carpenters	2	
Squares, carpenters	2	
Work gloves	25 pr	
File - 10-inch	3	
Steel tape - 50-ft	1	
Steel tape - 10-ft		
or Folding rule - 6-ft	4	
String	1 ball	
Wheelbarrows	2	

5. To save time and work, sharpen all tools and keep them sharp, even if it takes one person full time to do it!

6. Wear gloves from the start — even tough hands can blister after hours of hard work. Blisters on hands are painful, seriously delay the work, and could cause dangerous infections.

7. To avoid confusion, wasted time and effort, organize the work force into teams. Many variations are possible. A suggested division of tasks, based on a 24-person working force divided into 4 crews of 6 persons each, is given at the end of these instructions.

8. Before staking out the outlines of the excavation, check the rock depth by driving down a 6-ft-long sharpened rod or small pipe. To avoid groundwater problems, avoid low ground.

9. Cut the lumber to the required lengths. Mark each piece to indicate where it goes in the structure to assure that the required long pieces are not subsequently cut up for the shorter pieces.

10. To help drain the floor, locate the shelter so that the original ground level at one end is about three feet lower than the other end.

11. Stake out the trench for the shelter. Even in very firm earth, make the excavation at the surface 22 ft wide (2 ft wider than the 20-ft-wide bench). If the excavation is dug by hand, make the length 28 ft long at the bottom, 32 ft long at the top, exclusive of the entryway. The sloping sides of the excavation are necessary even in firm earth for safety.

12. Check the squareness of the staked outline by making the diagonals equal. Extend the stakes out both ends far enough to guide the dozer operator during the digging operation.

13. Clear all brush, tall grass, trees, etc., off the ground to a distance of 15 ft on each side and to a distance of 25 ft at each end of the staked location. This is necessary to provide room to store the earth before putting it back on the roof. The backfill material should not contain any brush, sticks, or large stones.

14. Use a tape to check the excavation width frequently as the trench is being dug. When the upper (20-ft-wide) trench has been completed, stake out the lower (12-ft-wide) trench. Check squareness by making the diagonals equal.

15. If the trench is dug by shovels, pile the earth dug near ground level at least 10 ft from the sides of the trench. Then as the trench deepens, the earth dug from 4 to 6 ft down can be piled on the surface only 1 to 5 ft from the edge to reduce the amount of handling of the excavated earth.

16. While the trench is being excavated, start prefabrication of the retaining wall subassemblies on a clear area near one end of the excavation. Meanwhile, another crew can assemble the center beam and the center posts; then assemble the column and the posts, including the diagonal braces and the 2" x 12" scabs. CAUTION: Be sure the splices in the center beam do not coincide with the location of the center posts.

17. When the bulldozer has finished, trim the bottom of the trench with shovels. Slope the floor to drain toward the two center drains. Be sure the bottom of the trench slopes at least 1/2 inch vertically for each foot of horizontal length — either slopes all in one direction or slopes both ways from the middle. Dig a 2-ft-square x 1-ft-deep sump at each end. Water collected in the sump will be bailed out by hand as necessary. Dig two drain ditches down the middle, one on each side of the center column base plates (each 6 inches wide and 4 inches deep). Lay small sticks in the drain and cover with porous fabric to serve as a crushed rock drain leading to the sumps.

18. Assemble the double corner posts and door lintels. The number and sizes of these are:

Shelf corner posts	4 ft long	4 required
Door corner posts	6 ft long	4 required
Entry corner posts	6 ft long	8 required
Door lintels	3 ft long	2 required

19. Lay out and carefully align the center post base plates on the floor of the trench. Dig 2-ft-square by 4-in.-deep holes and level the bottom of the holes. Install the base plates and check the level of the

plates using a 2" x 4" rafter as a straight edge. The plates must be level to give uniform bearing to the center posts.

20. Lay out the mud sills on each side of the trench. Drive stakes (made from 2" x 4" lumber scraps) in the ground along the outside edge of each sill and nail them to each sill to prevent lateral movement of the sills.

21. Using a crew of at least 10 persons, carry the assembled center beam structure into the trench. Place the assembly in an upright position, align the assembly, use the plumbob to be sure it is vertical. Hold the assembly in place using at least four temporary side braces to hold it in position (one simple way to do this is to use 4 rafters on each side, temporarily nailed to the top of the center beam and to the 2" x 12" mud sill on the edge of the trench). Nail the center posts to the base plates using 20-penny nails.

22. Carry in the prefabricated retaining wall sections, and secure them in place along the face of the earth ledge by means of stakes driven into the ground. Check and adjust the alignment with a 2" x 4" rafter used as a straight edge or by a cord pulled tight along the length of the trench. Check and adjust the height of the wall sections by placing a level on rafter laid across the center beam and the wall section. Each side wall requires three full-size and one half-size wall assembly. As soon as the alignment and level are correct, nail the panels securely together using 16- or 20-penny nails driven through adjoining studs.

23. Install the 2" x 4" rafters. Start at the center and work both ways, being careful to keep the ends tightly against the adjacent one over the center beam, and use the 2" x 4" spacers between each rafter at the outer ends to keep the rafters straight and true. Nail the rafters to the center beam, the mud sills and to the top studs of the wall panels. When all rafters have been installed, nail the 2" x 4" retaining wall stop to the under side of the rafters.

24. While the rafters are being installed, other crews can install the end wall panels and the entryway panels. Drive stakes along the inside and outside of the base of each panel to hold it in place. Nail the panels together and to the corner posts to give them stability. Nail

the double 2" x 4" door lintels to the top of the door posts using 20-penny nails. Add the 2" x 4" entryway spreaders; toenail them to the studs. Install the 2" x 4" joists over the two entry passageways, and nail them to the top stud plates using 16-penny nails. Add the plywood roof pieces (one 1/2" x 3' x 7' and one 1/2" x 3' x 6' panel for each entryway), and nail securely with 6-penny nails. Install the wales on the endwalls and the entry walls. Drill holes in the plywood for the wire ties. Nail a temporary spacer (one 2" x 4" x 4' is adequate) to the top of the entry wall and the adjacent end wall to prevent the wire ties pulling the entry wall out of position. Thread the 9-gauge wire through the holes around the stud and the wales. Twist the ends together to form a loop. Tighten the wires, using a short stick to twist the two wires together (see sketch on the drawing). Install the step risers.

25. Nail the 1" x 8" stiffeners to the roof as soon as all the rafters have been installed. Cover the roof with roofing felt, overlapping one-half the roll width. Place the laps parallel to the rafters. The primary function of the roll roofing is to prevent the earth from falling between rafters, but it should be laid very carefully so that it can also serve as a water stop for any moisture trapped below the waterproofing layer which will be installed later above part of the earth fill. Install grade stakes along the outer edges of the roof to serve later as guides in checking the depth of the earth cover.

26. As soon as the entryway structures have been erected, start backfilling between the entryways and the shelter. Add backfill earth in small layers (not more than 6" deep at one time), and carefully tamp the fill using a short pole as a tamper made of two 3" x 4"'s nailed together. Backfill (with tamping) on the outside of the entryways. Continue the backfill and tamping until the roof level is reached.

27. When the roof of the main shelter has been completed and the backfilling around the two entryways reaches roof level, start covering the roof, both main shelter and entryway, with backfill, being careful that no sticks or stones are in the fill which is placed directly on the roofing felt. Mound the earth over the shelter. Add fill until the center is covered to a depth of 18 inches and the outer edges of the shelter and the ends of the entryway roofs are covered to a depth of 2

to 4 inches. Rake the mounded backfill to provide a smooth surface, being sure it contains no sticks, stones, or other sharp objects which might tear or cut the waterproofing cover. Lay out the polyethylene sheet over the mound, being careful to overlap the edges at least 12 inches. Dig a shallow (4" deep) ditch under the outer edges of the waterproof cover, lay short lengths of sticks in the outer edge of the sheet, and roll up the edge over the sticks. This will serve as a drain for water which percolated through the top layer of backfill to the waterproof sheet. Be sure the drain thus formed will drain out past both ends of the shelter. Continue the backfilling until the depth of earth cover is two feet over the center and at least 18 inches at the edge of the roof. Mound the earth so that rain will tend to run off toward the sides and the ends. Dig a 1-ft-deep trench all around the mound to carry off the runoff and to keep surface water away from the shelter. Carry the trench well beyond the end of the shelter.

28. Occupy the shelter.

29. Improve the shelter as much as time and available materials allow. The first improvement should be the construction and installation of a Kearny Air Pump (KAP). In very warm weather, the KAP should be constructed while the shelter is being built. Other improvements include:

- (a) Install flooring in the 6-ft-deep portion of the shelter, using plywood or planking as available.
- (b) In windy or cold weather, control the flow of air through the shelter by hanging adjustable curtains in the entryways.
- (c) Make expedient lights. (See Appendix C.)

30. The following is a suggested division of tasks based on 4 crews of 6 persons each:

a. With bulldozer

- Crew A — (1) Stake out the outlines of the upper trench.
- (2) Clear brush, grass, etc., from the site.
- (3) (a) Check width of trench frequently.
- (b) Assist dozer operator as necessary.
- (c) Part of the crew assist other crews while waiting for dozer to finish.



A-11.9

- (4) When upper trench is completed, stake out lower trench.
- (5) Trim bottom of trench with shovels; dig center drains and fill with sticks provided by Crew D. Dig sumps.
- (6) Install the centerpost base plates.
- (7) Install the mud sills and stake them down.
- (8) Install the braces to hold the centerpost assembly in place.
- (9) Install the rafters and the roof stiffeners.
- (10) Cover the roof with roofing felt.
- (11) Assist Crews C and D finish the backfilling and tamping of the end structures.
- (12) Assisted by the other crews, cover the roof with the first layer of earth.
- (13) Rake the mound and install the waterproof cover.
- (14) Finish the backfill over the roof.

- Crew B -
- (1) Check tools to be sure all the necessary tools are available.
  - (2) Check sharpness of tools and sharpen any dull ones.
  - (3) Prefabricate the center beam assembly.
  - (4) Assisted by Crews C and D, carry the center beam assembly into the shelter and erect it.
  - (5) Install the sidewall panels.
  - (6) Assist Crews C and D install the entryway panels and roofs.
  - (7) Assist Crew A cover the roof with first layer of earth.
  - (8) Dig the drainage ditches.

- Crew C -
- (1) Inventory the lumber and other materials to be sure the required materials are on hand. Correct any shortage discovered.

- (2) Cut the lumber into the desired lengths and stack in piles at a location convenient to the trench but not in the way of the bulldozer.
- (3) Prefabricate the sidewall panels, the end wall panels and the entryway panels.
- (4) Assist Crew B in erecting the center beam assembly.
- (5) Install the end wall panels at one end.
- (6) Install the entryway panels (same end).
- (7) Install the entryway spreaders and roof.
- (8) Backfill and tamp around the end wall and entry.
- (9) Help Crew A cover the roof with earth.

- Crew D -
- (1) Assist Crew A in clearing the site.
  - (2) Cut short lengths of sticks for use in the shelter drains.
  - (3) Build the Kearny Air Pump (during breaks between other tasks).
  - (4) Assist Crew B in erecting the centerbeam assembly.
  - (5) Install the second end wall panels.
  - (6) Install the second entryway panels.
  - (7) Install the entryway spreaders and roof.
  - (8) Spread and tamp backfill around second end wall and entryway.
  - (9) Assist Crew A cover the roof with earth.

b. Without Mechanical Excavation Equipment

- Crew A -
- (1) Stake out the outlines of the upper trench.
  - (2) Clear brush, grass, etc., from the site.
  - (3) Assisted by Crews B, C, and D, excavate the upper trench.
  - (4) Stake out the outline of the lower trench.
  - (5) Assisted by Crew D, excavate the lower trench.
  - (6) Trim bottom of trench with shovels; dig center drains and fill with sticks provided by Crew D. Dig sumps.
  - (7) Install the center post base plates.
  - (8) Install the mud sills and stake them down.

- (9) Install the braces to hold the center beam assembly in place.
  - (10) Install the rafters and the stiffeners.
  - (11) Cover the roof with roofing felt.
  - (12) Assist Crews C and D finish the backfilling and tamping of the entryway structures.
  - (13) Assist Crew C cover the roof with earth.
- Crew B -
- (1) Check tools to be sure all the necessary tools are available.
  - (2) Check sharpness of tools and sharpen any dull ones.
  - (3) Assist Crew A dig the upper trench.
  - (4) Prefabricate the center beam assembly and the retaining wall panels.
  - (5) Assisted by Crews C and D, carry the center beam assembly into the trench and erect it.
  - (6) Install the retaining wall panels.
  - (7) Assist Crews C and D install the entryways.
  - (8) Assist Crews C and D backfill and tamp the end walls and entryway.
  - (9) Assist Crew A cover the roof with earth.
- Crew C -
- (1) Inventory the lumber and other materials to be sure the required materials are on hand. Correct any shortage discovered.
  - (2) Cut lumber into the desired lengths and stack in piles at a location convenient to the trench.
  - (3) Assist Crew A dig the upper trench.
  - (4) Prefabricate the endwall panels and the entryway panels.
  - (5) Assist Crew B carry the center beam assembly into the trench and erect it.
  - (6) Install the end wall panels, the entryway panels, spreaders, and roof of the first entryway.
  - (7) Backfill and tamp around the end wall and entryway.
  - (8) Assist Crew A cover the roof.

- Crew D —
- (1) Assist Crew A in clearing the site and digging the trench.
  - (2) Cut short lengths of sticks for use in the shelter drains.
  - (3) Build the Kearny Air Pump (during breaks between other tasks).
  - (4) Install the end wall panels, the entryway panels, spreaders, and roof of the second entryway.
  - (5) Backfill and tamp around the end wall and entryway.
  - (6) Assist Crew C cover the roof with earth.
  - (7) Dig the ditches around the shelter.

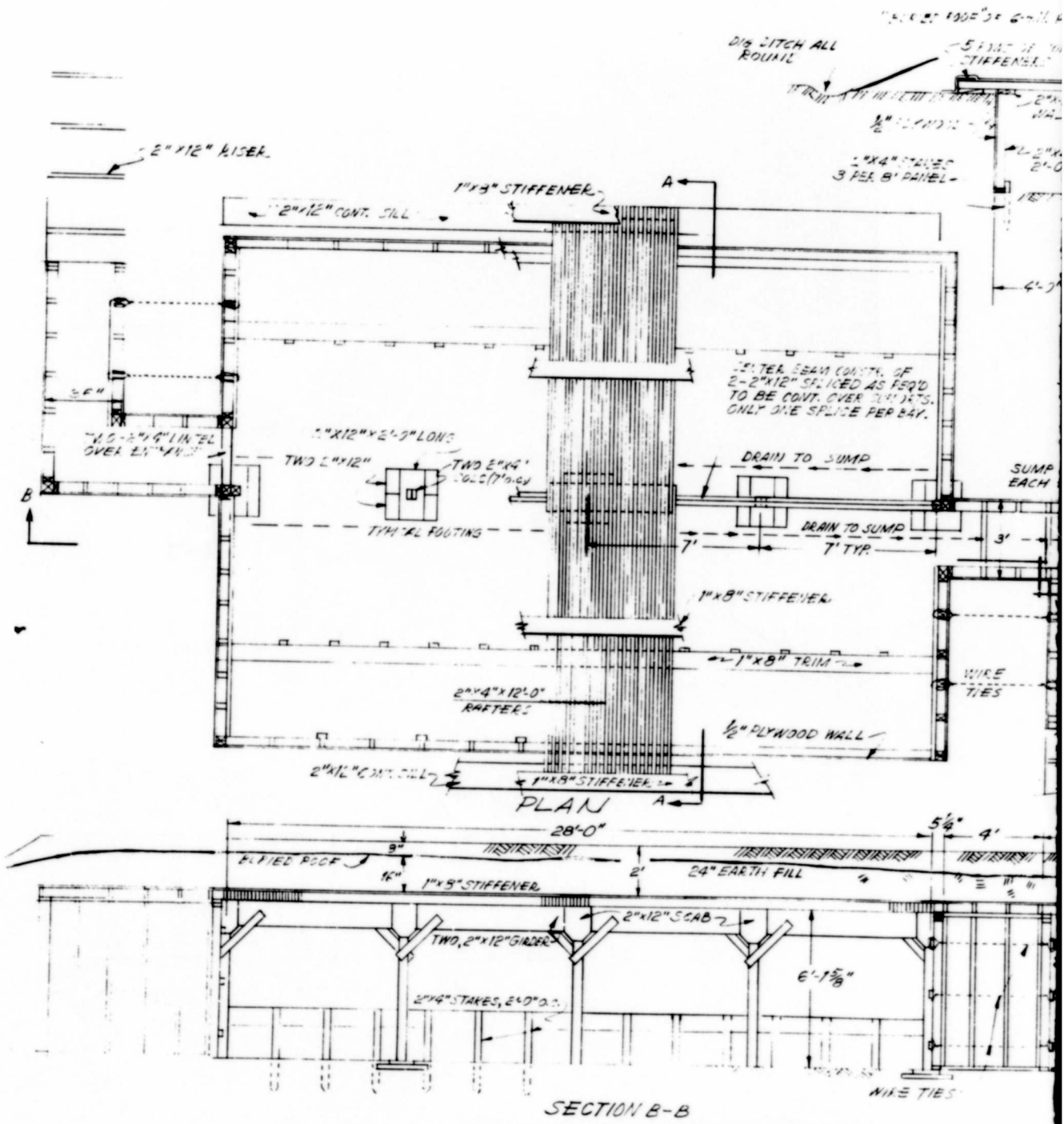
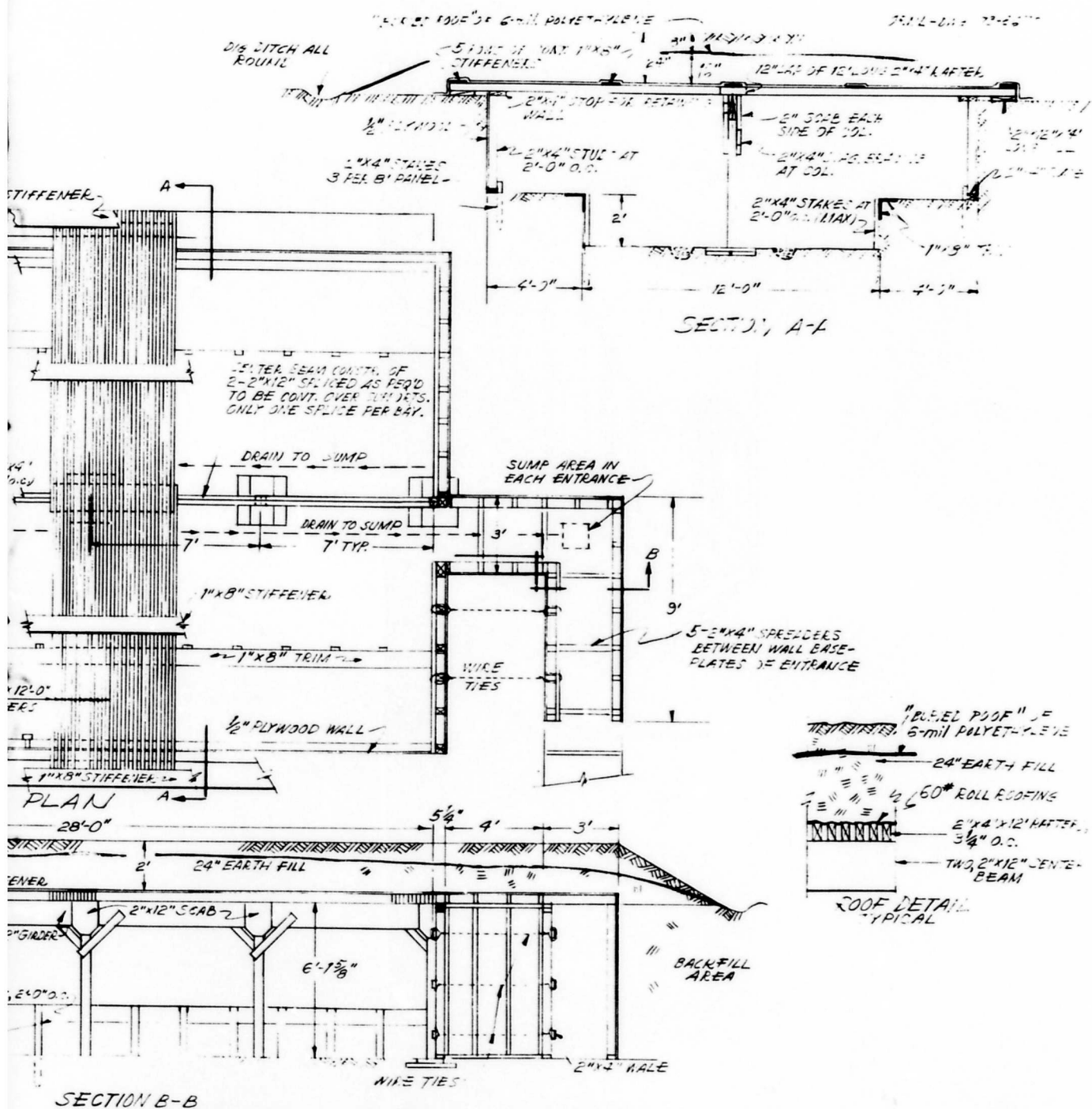

Fig. A-11.1. Wood Grate Roof Underground, Plans and



SECTION B-B

Fig. A-11.1. Wood Grate Roof Underground, Plans and Section.

END WALL & ENTRANCE

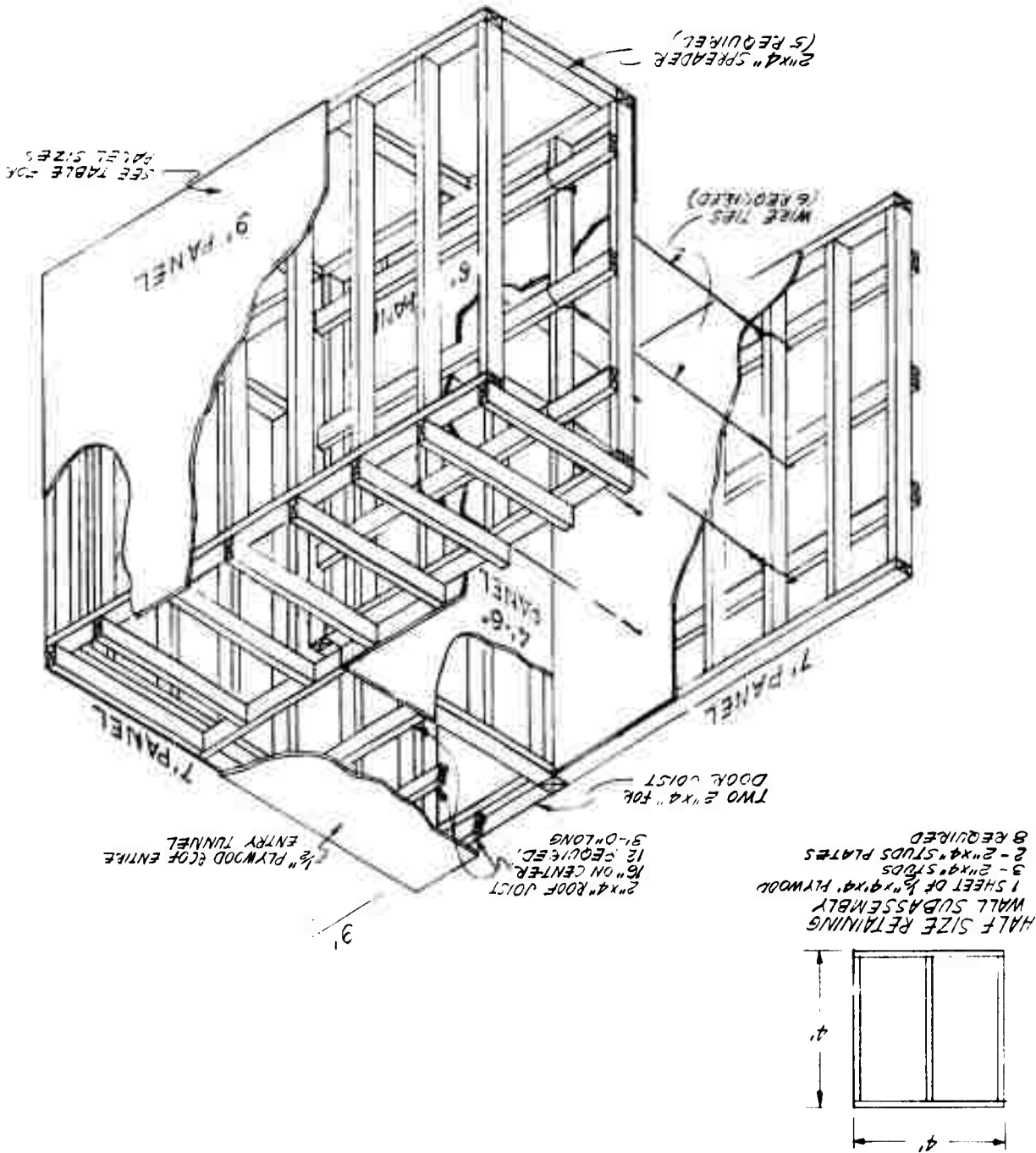

73-1542

Fig. A-11.2. Wood Grate Roof Underground Shelter.

END WALL & ENTRY

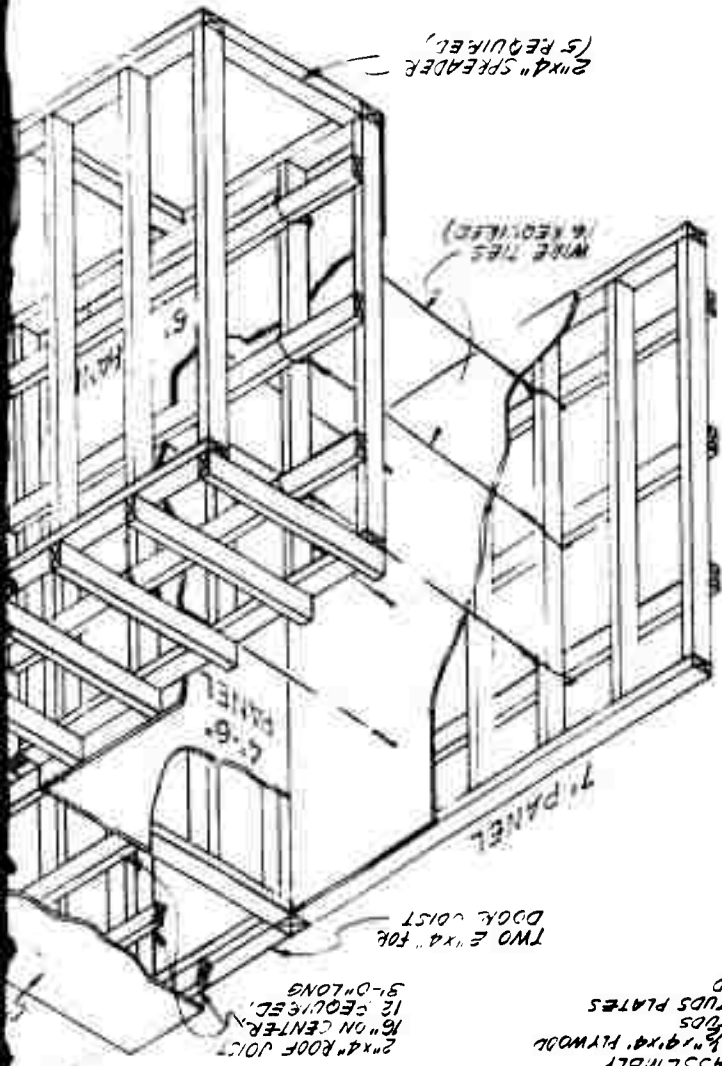

NO	7"	2
FEED	9'-0"	2
	7'-0"	4
	6'-0"	2
	4'-6"	2
	3'-0"	2

END WALL AND ENTRYWAY PANELS  
 ALL STUDS 2"x4" X 6' HIGH  
 ALL STUD PLATES 2"x4"  
 12 PANELS REQUIRED

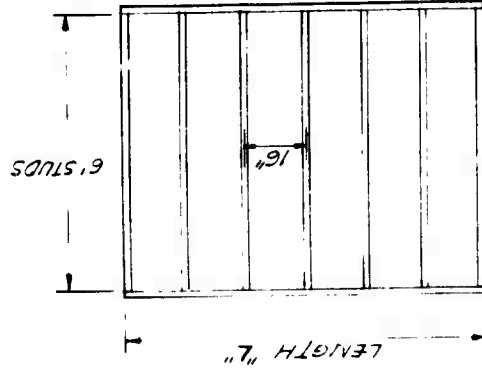

RETAINING WALL SUBASSEMBLY  
 1 SHEET OF 1/2" PLYWOOD  
 5-2"x4" STUDS  
 2-2"x4" STUD PLATES  
 6 REQUIRED

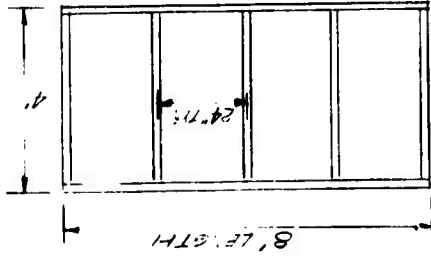

HALF SIZE RETAINING WALL SUBASSEMBLY  
 1 SHEET OF 1/2" PLYWOOD  
 3-2"x4" STUDS  
 2-2"x4" STUD PLATES  
 8 REQUIRED

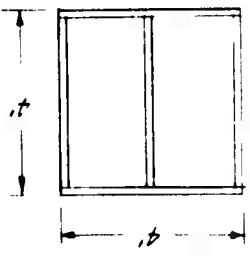

Fig. A-11.2. Wood Grate Roof Underground Shelter.



A-12 Trailer Van Shelter

The design presented is a modified version of a design proposed by Penn State<sup>9</sup> but a model has never been built.\* The design is considered too complicated for unskilled workmen to complete without some assistance or direction by skilled construction workers or carpenters. Consequently, the step-by-step instructions are not as detailed for this shelter as for the others.

Appendixes B and C should be made available for the builders of this shelter.

---

\* The Protective Structures Development Center built a trailer-van shelter of another type -- using Army radar vans.<sup>13</sup>

**TRAILER VAN SHELTER**  
(Capacity - Approximately 100 Persons)

1. This shelter is recommended for use only where experienced construction workers or carpenters are available. Any two trailer vans that can be made available can be used. Neither the width nor the length is critical. However, the internal framework must be sized to fit snugly.

2. **Materials and Tools Required**

a. **Two Trailer Vans**

They need be in only fair condition, but should be able to be moved into position by a semi-trailer tractor.

b. **Lumber**

The following lumber list is based on two vans, each 8 ft wide, 10 ft high, and 35 ft long, that will provide shelter for 56 persons, allowing 10 sq ft for each person. The list will need to be modified to conform with the sizes of the vans used.

Bill of Materials

	Lumber		
Beams	2" x 12" x 12'	12 pcs	288 bd ft
Rafters	2" x 10" x 12'	72 pcs	1440 bd ft
Joists	2" x 8" x 9'	13 pcs	156 bd ft
Joists	2" x 6" x 9'	82 pcs	738 bd ft
Columns	2" x 6" x 12'	12 pcs	144 bd ft
Internal Frame	4" x 4" x 9'6"	36 pcs	456 bd ft
Internal Joists	2" x 6" x 12'	36 pcs	402 bd ft
Internal Braces	2" x 4" x 7'	36 pcs	168 bd ft
Internal Knee Braces	2" x 4" x 4'	72 pcs	192 bd ft
Underpinning	2" x 4" x 3'6"	36 pcs	168 bd ft
Underpinning Base Plates	2" x 8" x 1'	36 pcs	48 bd ft
End Wall Abutments	2" x 4" x 14'	12 pcs	112 bd ft
End Wall Abutments	2" x 4" x 7'	12 pcs	56 bd ft
End Wall Abutments	2" x 4" x 11'	8 pcs	59 bd ft

A-12.2

Bill of Materials (Cont'd)

Entry Boxes	2" x 4" x 12'	8 pcs	64 bd ft
Entry Boxes	2" x 4" x 3'	112 pcs	224 bd ft
Vent Framework	2" x 4" x 9'	8 pcs	48 bd ft
Vent Framework	2" x 4" x 7'	16 pcs	76 bd ft
Vent Framework	2" x 4" x 6'	12 pcs	48 bd ft
Vent Framework	2" x 4" x 8'	8 pcs	43 bd ft
Vent Framework	2" x 4" x 11'	8 pcs	59 bd ft
End Wall Studs	2" x 4" x 7'	4 pcs	18 bd ft
	2" x 4" x 5'	4 pcs	7 bd ft
	2" x 4" x 3'6"	4 pcs	10 bd ft
	2" x 4" x 1'6"	4 pcs	<u>4 bd ft</u>
			5028 bd ft

(or 50 bd ft/person)

External Plywood	1/2" x 4' x 8'	125 sheets	4000 sq ft
------------------	----------------	------------	------------

- - - -Miscellaneous- - - -

Salvage Oil Drums	12
Wire - No. 9	120 ft
Polyethylene Film 6-mil	6000 sq ft
Nails - 20-d	25 lbs
- 16-d	20 lbs
- 6-d	15 lbs

- - - -Equipment and Tools- - - -

Bulldozer or Backhoe or Front End Loader	(to dig trench and place backfill)
Semi-Trailer Tractor	(only long enough to move trailer vans into position)
Shovels	4
Saws	6 (a power saw would be very convenient if electricity is available)
Hammers	12
Pliers	2 pr

### A-12.3

Miter Box	1
Levels, Carpenters	2
Wheelbarrows	4
Rakes	6

3. Have the bulldozer (or backhoe or front end loader) dig a trench 11 ft wide, 6 ft deep, and 80 ft long. Pile the excavated earth on both sides of the trench, leaving 4 ft clear space on each side of the trench.

4. Dig a shallow trench on each side of the excavated trench, 4 ft from the top of the trench. This can be dug by hand while the trench is being excavated.

5. While the trench is being dug, cut and fit the internal framework into the two vans. After the framework has been assembled in the vans, wedge the framework snugly in place, using small wood wedges under the interior columns.

6. Back the two trailer vans into the trench, one from each end, leaving exactly 12 ft between the back ends of the two vans.

7. Install the 2" x 4" underpinnings and their footings under the vans directly below each interior frame column. Wedge the underpinnings in place with small wood wedges.

8. If the work crew is large enough, the following items can be done concurrently.

- a. Prefabricate the two abutments for the fronts of the two vans.
- b. Dig two trenches one near the front of each van for the entry boxes.
- c. Prefabricate the two entry boxes and place them in the trenches.
- d. Cut the heads out of the 12 oil drums and weld strap between each pair to hold them in position end-to-end.
- e. Cut holes in the top of the vans for the roof ventilation (see drawings).
- f. Assemble the 2" x 6" joists and 2" x 10" rafters on the tops of the two vans.

A-12.4

- g. Prefabricate the four internal 6" x 6" columns by nailing together three 2" x 6" x 12' boards for each column.
- h. Prefabricate the four 6" x 12" beams by nailing together three 2" x 12" x 12' boards.

9. Erect the internal structure between the ends of the two vans. The four 6" x 6" columns rest on and are nailed to each end of the two 6" x 12" footing beams. The two 6" x 12" beams rest on (and are nailed to) the four 6" x 6" columns. Gussets are nailed to the columns and footing beams to hold them square and prevent thrust loading the ends of the vans. Add the 2" x 8" joists on 12-inch centers to span the space between the top 6" x 12" beams.

10. Cover all the joists and rafters with plywood (NOTE: the five rafters on each side that span the space between vans must be cut at the top end so they fit against the 6" x 12" beams and installed so they will be parallel to the rafters along the sides of the two vans.)

11. Erect the vent box structure.

12. Place the abutments in place at the ends of the vans and fill them with earth. This filling operation should be done by hand to avoid putting a load on the vans.

13. Cover the sides, then the top with earth. Care must be exercised to place the cover symmetrically to prevent racking. A bulldozer may be used to push the loose earth to a convenient location but the earth should be placed by hand, especially on the upper sides and top. When a depth of about 12 inches of earth has been reached over the centerline of the structure, rake the mound smooth, removing any sharp objects which might puncture the waterproofing.

14. Cover the mound with a waterproof covering, preferably 6-mil polyethylene. If polyethylene is not available, other waterproofing materials such as roofing felt may be used, provided the laps in the material are made like shingles.

15. Continue covering of the shelter with earth until a depth of 24 inches has been reached.

16. Occupy the shelter.

17. As time and materials permit, improve the habitability of the shelter by:

- a. improvising additional water storage containers (see Appendix C),
- b. building the internal floor structures shown on the drawing (materials are not included in the bill of materials),
- c. building a Kearny Air Pump (KAP), using instructions given in Appendix B,
- d. making expedient lights (see Appendix C for details).

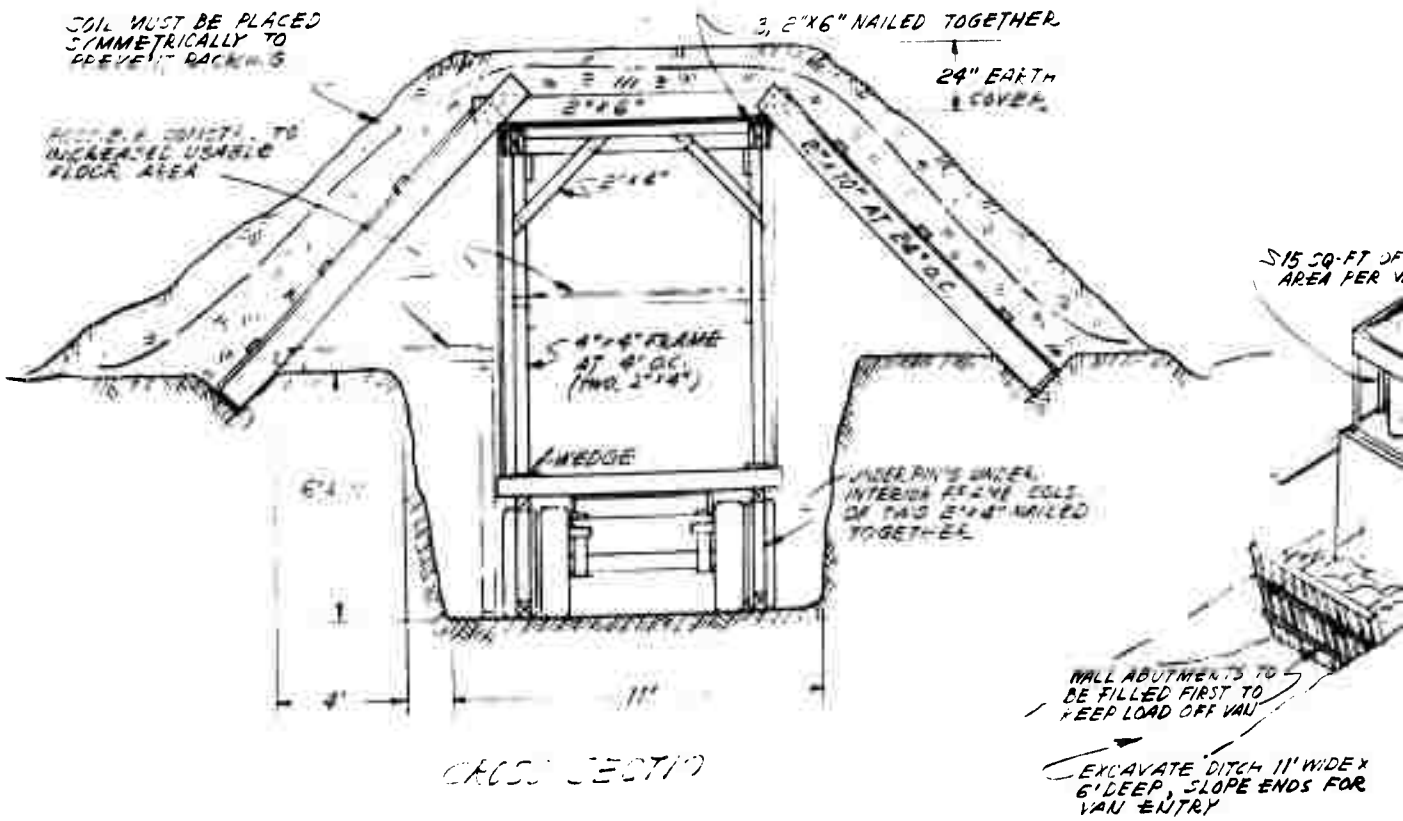
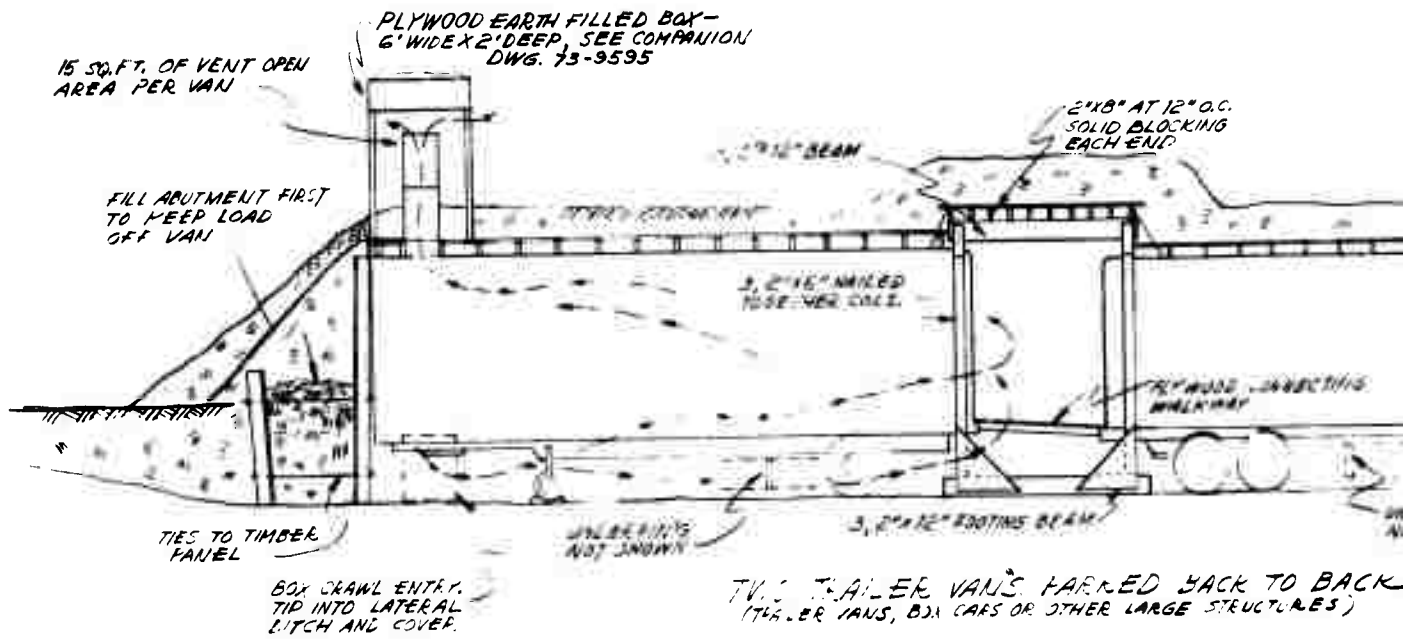

TRAILER VAN SHELTER

Fig. A-12.1. Trailer Van Shelter, Pictorial View and Sections

BOX-COMPAKION  
5

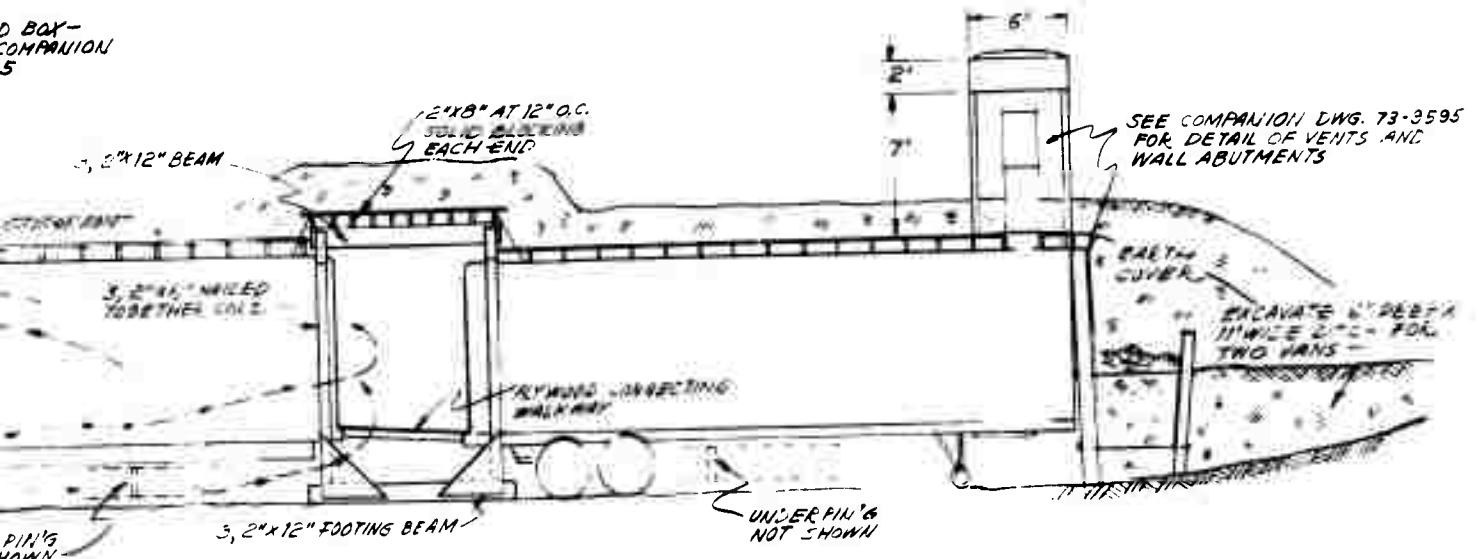

THIS TRAILER VANS PARKED BACK TO BACK (TRAILER VANS, BOX CARS OR OTHER LARGE STRUCTURES)

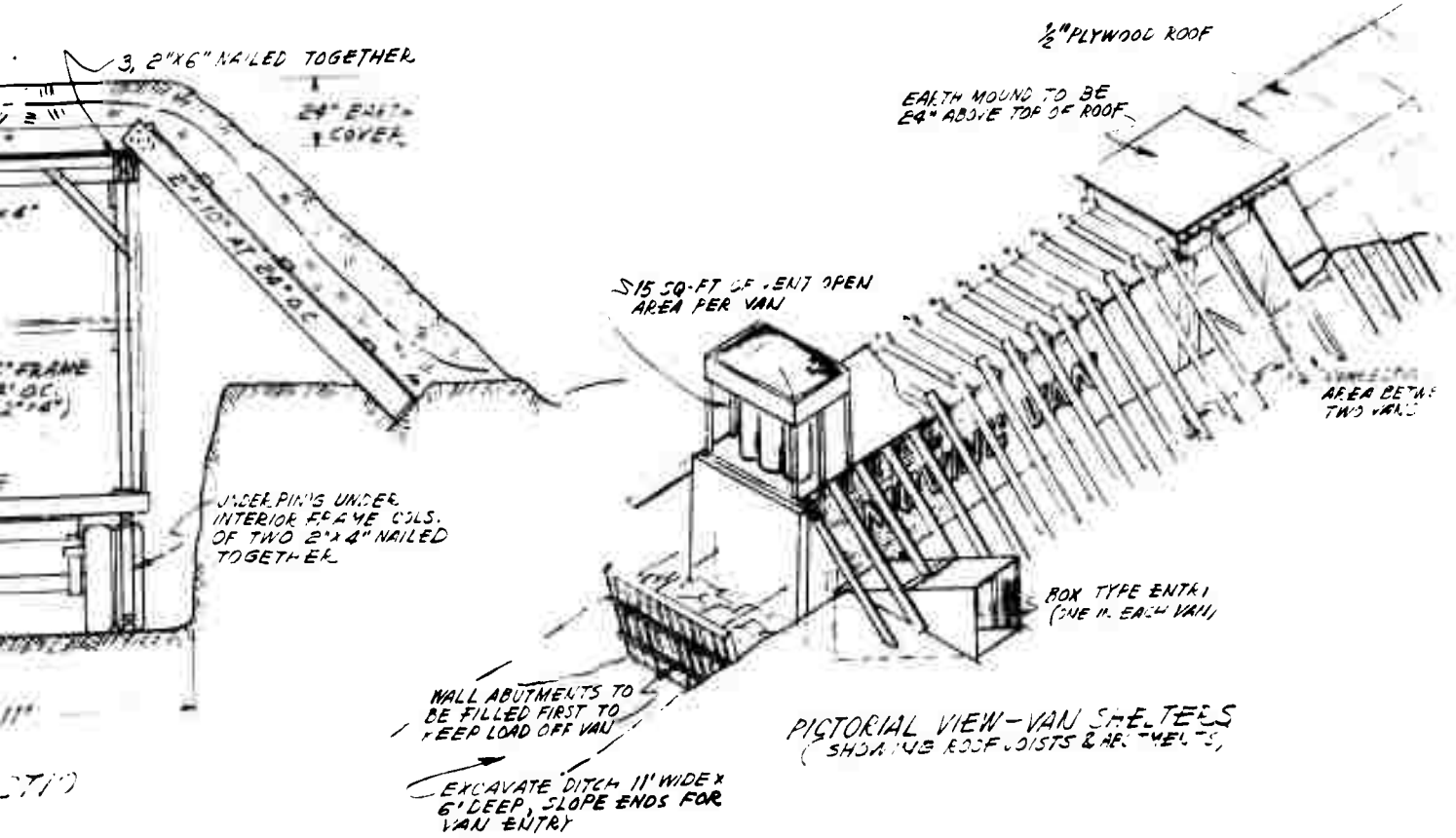

### TRAILER VAN SHELTER

1. Trailer Van Shelter, Pictorial View and Sections.



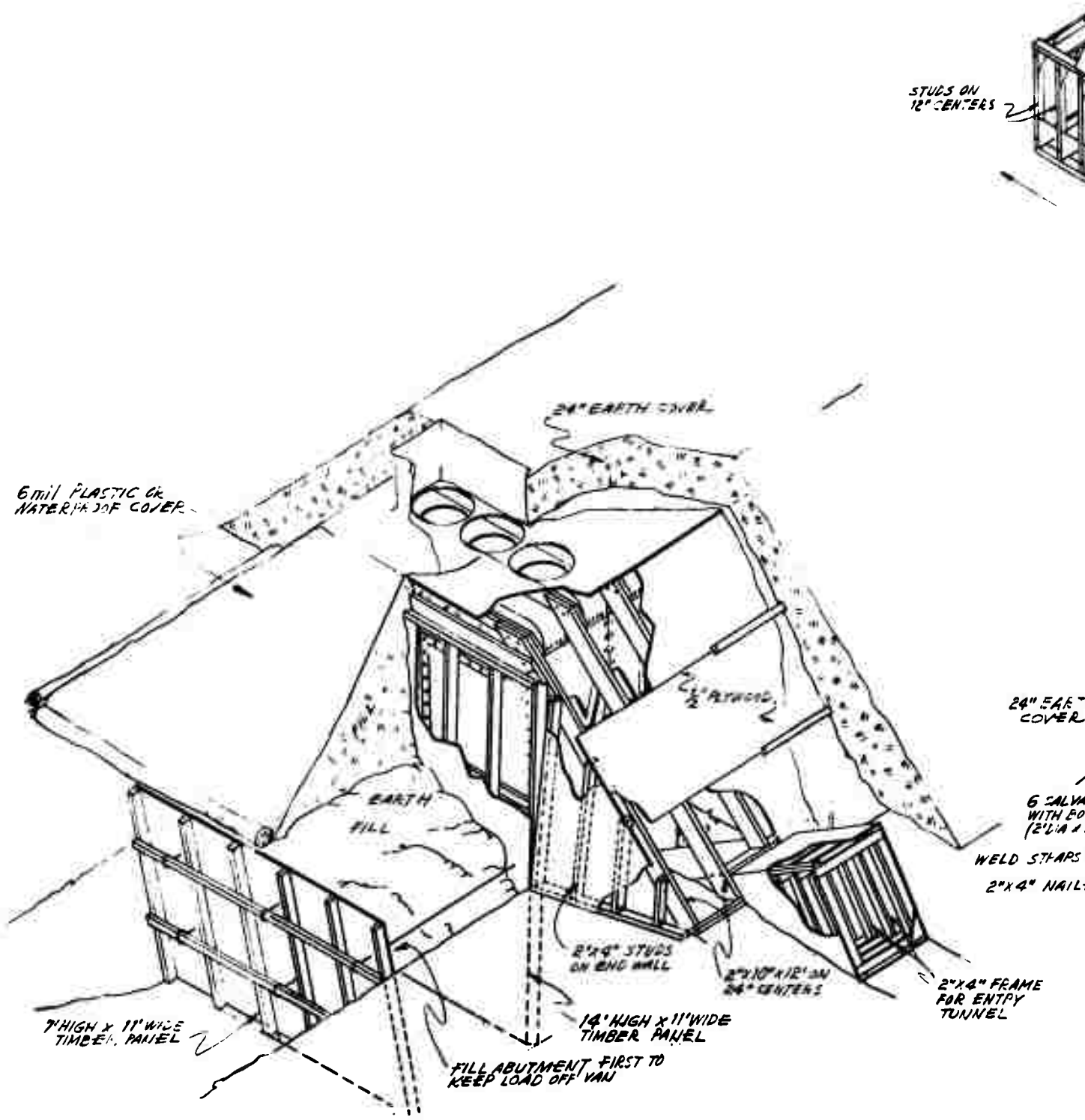

PICTORIAL VIEW OF FRAMING AT END OF VAN SHELTER

Fig. A-12.2. Trailer Van Shelter, Ventilation Det.

79-3535

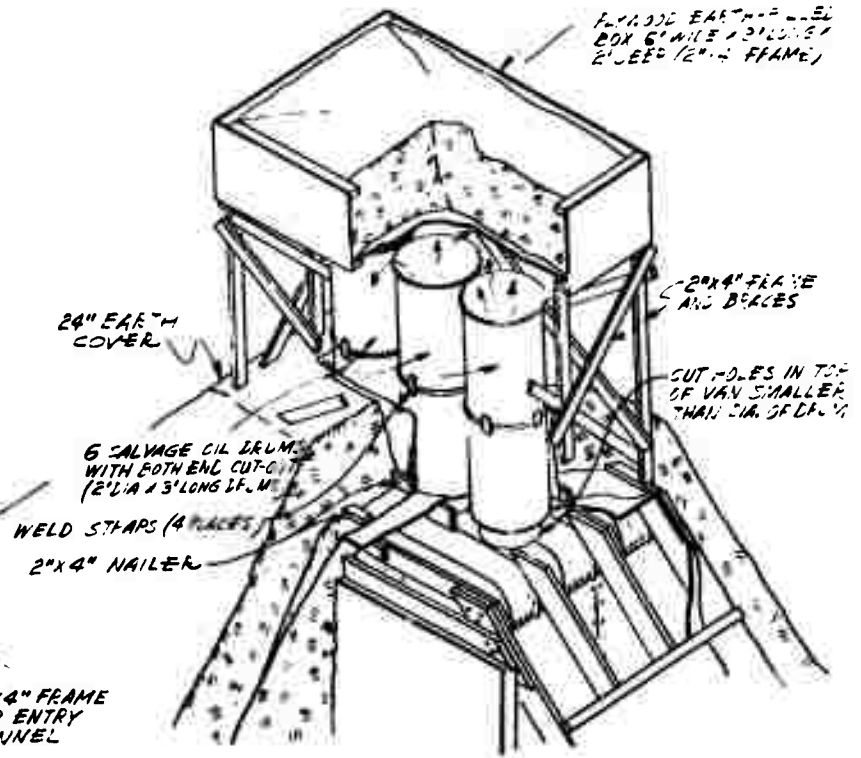
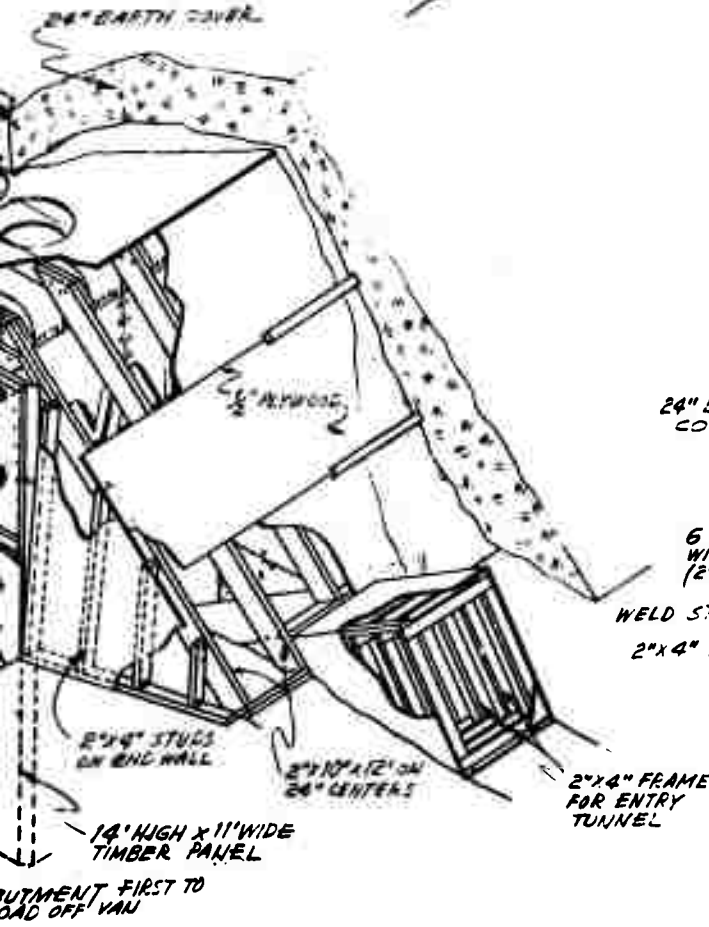
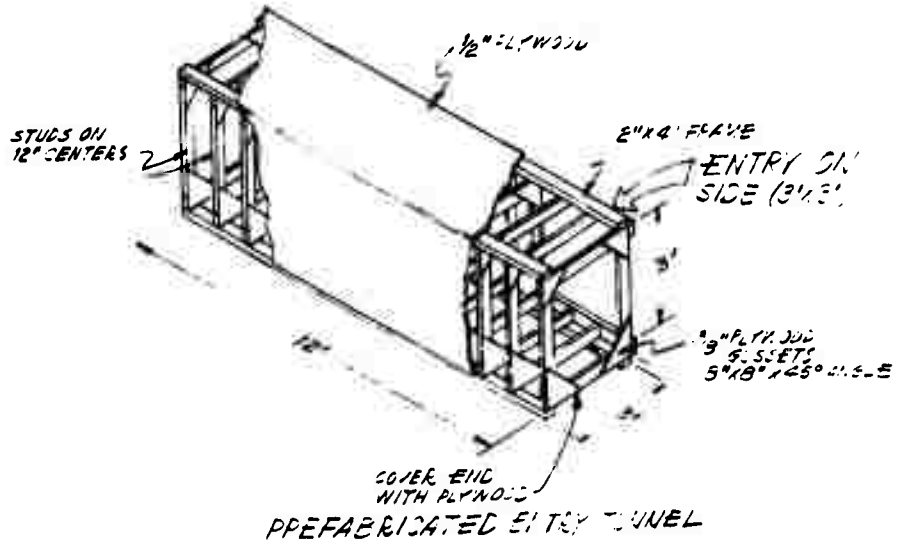

OIL DRUM VENT STACKS

FAMING AT  
TER

Fig. A-12.2. Trailer Van Shelter, Ventilation Details.

A-13 Car-Over-Trench

The Car-Over-Trench idea was proposed by SRI and evidently built at least once.<sup>10</sup> C. H. Kearny built one in Colorado,<sup>11</sup> had one built by an untrained rural family in East Tennessee,<sup>11</sup> and had another one built by an untrained urban family in Colorado.<sup>12</sup> Each family used only the step-by-step instructions included in this appendix. Both shelters were dug in dry, hard clayey earth. The Tennessee family completed the shelter in one day; the Colorado family required two days since only the one adult male was able to work effectively.

**CAR-OVER-TRENCH SHELTER**  
(Capacity            Persons)

(Better read all these instructions before you begin work and then use them as a checklist as you work.)

**1. Purpose and Suitable Locations**

This type of shelter is being considered for those parts of the country where there is a shortage of building materials to construct better expedient shelters and where the earth is sufficiently firm that the walls of the shelter will not cave in. A Car-Over-Trench Shelter will provide fallout protection for 4 to 6 people, depending on whether the car is a compact or a big station wagon.

Here are some preliminary guidelines to determine whether the earth possesses the necessary firmness: If the earth is primarily a sand or if it is very sandy, it will seldom be firm and stable enough to keep the trench sidewalls from caving in. Thus, the trench should not be dug in this kind of earth unless the sand grains are cemented together to form a stable earth. A quick test to determine whether or not earth is firm enough is given below (Item 5). Also, this shelter should not be dug where the ground water table or depth to solid rock is too near the surface.

**2. Materials Required**

**a. Essential Materials**

- (1) A car that can be parked over a trench.
- (2) Digging tools - pick and shovel preferred.

**b. Useful Materials**

- (1) Plastic sheeting (such as polyethylene film at least 4 mils thick, shower curtains, or plastic table cloths) and/or (as a second choice) cloth (bed sheets, bed spreads, etc.) to keep earth mounded around the car from falling into the trench and to provide a storage shelf on the surface of the ground around the trench.

Ten to twelve bed sheets, or an equivalent area of other materials, will be needed.

- (2) Eight pillowcases or sacks — for "sandbags" of earth.
- (3) String, cord, and rope.
- (4) A measuring tape, yardstick, or ruler.

3. Wear gloves during the construction of this shelter (including digging test holes) to avoid injury to hands and possible infections.

4. Select reasonably level ground that is accessible by car.

5. Make sure that the earth is firm and stable enough so that the walls of the trench will not cave in. As a test, dig a small hole about 18 in. deep. Remove all loose earth from the bottom of the hole and then try to push a bare thumb into the undisturbed (natural state) earth in the bottom of the hole. If it is possible to push the thumb into the earth no further than one inch, the earth should be suitable for this type of shelter. If the earth does not pass this test, move to another location and try the test again. Continue to relocate and repeat until suitable earth is found.

6. Dig a trench 28 inches wide and 40 inches deep. To determine the length of the trench, measure the overall length of the car (front to rear bumper). Subtract 48 inches from this measurement and use this dimension as the length of the trench. See illustrations attached.

7. Clear any brush, grass, or weeds that are more than a few inches high from the area where the trench is to be dug, and from the ground around all sides, out to a distance of about 8 feet from the sides and ends of the trench.

8. Stake out a rectangular trench 28 inches wide and of a length as determined above. Also stake out the entrance.

9. Use a pick and shovel, or other available tools to excavate the trench and entrance. Place the excavated soil along both sides (length) of the trench so that no earth is piled nearer than 3 feet from its sides. This will allow adequate clearance for the car to be driven over the trench and will provide adequate space for the cloth or plastic (used to keep mounded earth around the car from falling into the trench) to be placed properly on the original ground surface around the car.

10. Excavate the main trench and the 24-inch-long part of the entryway trench, both to a depth of 40 inches. To save work, cut a stick 28 inches long and use it repeatedly to help keep the main trench its full 28 inches wide as it is dug down. To keep out radiation, do not make the entrance larger than illustrated, unless a very fat person must enter.

11. If the soil changes as the trench is being excavated, again make the same soil test that was used in the test hole. If the soil does not pass the test, do not dig the trench any deeper.

12. If the supply of sheets, bedspreads, plastic, and/or other materials is plentiful, line the trench walls before driving the car over the trench. The wall lining should reach the floor of the trench. A trench with lined walls is more livable, especially since the lining keeps dirt from falling into eyes. Remove loose earth and rocks from the edges and walls before placing the lining. Hold the lining in place with a little earth placed near the edges of the lining that lies on the ground outside the trench.

13. After the trench has been dug and cleaned out to a depth of 40 inches or the excavation stopped because the soil has changed, drive the car carefully over the trench. Have someone guide the driver as he does this.

14. To shield against radiation coming from above the trench shelter, put excavated earth into the car (on the front and rear floor, and where the seats were, and inside the trunk) - all to an average depth of at least one foot.

15. To keep earth that is to be banked around the car from falling into the trench, use plastic sheets at least 4 mils thick, shower curtains, bed sheets, or other material - as illustrated in the attached drawings. To do so, first fold a sheet about 15 inches from one of its long edges. Then secure the folded edge of the sheet in bottom of the door frame by closing the door on it. Place the longer part of the sheet on the ground in such a position that the line along which the cloth contacts the ground surface, when the cloth is pushed inward toward the trench, is an inch or two inside the line joining the inner sides of the

front and rear wheels. Next put some earth on the larger part of the sheet to hold it in place on the ground.

16. Shovel more earth on and against this held-in-position, larger part of the sheet, up to the height of the bottom of the car door. Meanwhile, keep the 15-inch-wide outer flap of the sheet above the banked earth, until this flap can be placed (as shown in the attached illustration) on the outward-sloping side of the banked earth. So placed, this flap will help carry away from the shelter any rain or fallout that may run off the car. For added shielding, bank earth 20 inches high around the car.

17. Secure the folded material in the front door so that enough of it extends in front of the front door to enable you to prop up this part of the fold under the front fender — so that water that may run off the car roof from its drain channel will not run under the car.

Similarly secure plastic or cloth sheets under the closed hood and car trunk, so as to keep earth piled around the front and rear of the car from falling under the car.

18. To lead rainwater away, dig shallow ditches just outside the earth banks piled around the car.

19. Place "sandbags" on the ground around three sides of the entrance. A pillowcase about 2/3 full of earth, tied closed at its mouth, makes a satisfactory "sandbag." Mound earth around these "sandbags" on the outside and almost as high as the "sandbags," to keep possible rainwater on the ground from running into the shelter trench. Study the illustrations attached.

20. To provide the essential ventilation — especially for enough cooling outdoor air in warm weather — build a ventilation opening at the rear of the car. See attached drawing. Make this opening 10 inches wide and at least 6 inches high.

21. To minimize rain and fallout that otherwise might enter the front and rear openings, cover each of them with an open-sided awning. Secure these two small awnings under the closed car hood and trunk lid, respectively, and by strings tied to stakes as shown in the attached drawings.

22. After otherwise completing the shelter, put 6 to 8 inches of earth on top of the car hood, to increase the shielding provided by the engine and to prevent the sun from overheating the hood and thus the air inside the shelter.

23. To increase the radiation shielding of the entrance at times when temperatures inside the shelter permit most of the entrance to be closed, fill a car seat with earth. Then a shelter occupant can pull the upside-down, earth-filled car seat over the entrance hole, as required. If the car lacks a hollow seat, use an earth-covered spare tire, or boards.



AWNING OVER VENTILATION  
SEE DETAILS ON COMPASS

AT LEAST 12" OF EARTH  
IN TRUNK, AFTER  
REMOVING SPARE TIRE

AT LEAST 12" OF  
EARTH ON FLOOR  
AND SEATS

AVERAGE STANDARD  
2-DR. SEDAN

6 TO 8 IN. OF  
EARTH ON HOOD

OPEN-SIDED PLASTIC  
OR CLOTH AWNING  
OVER ENTRANCE

"SANDBAG"

PLASTIC OR CLOTH  
TO SHOW SHEET-FOLD

SLOPE EARTH  
FILL AROUND  
"SANDBAGS" FOR  
DRAINAGE

SECURE PLASTIC OR CLOTH SHEETS UNDER  
FRONT AND TRUNK TO KEEP EARTH FILL PILE  
AND REAR OF CAR FROM FALLING UNDER

ENTRANCE EXTENDS 12" IN  
FRONT OF BUMPER, AND IS  
18" WIDE X 3' LONG

TRENCH UNDER CAR IS 28" WIDE X 40" DEEP, LENGTH  
IS 4 FT. LESS THAN LENGTH OF CAR

SANDBAGS, EARTH AND AWNING  
REMOVED FROM LEFT FRONT OF CAR  
TO SHOW ENTRY WAY.

Fig. A-13.1. Car-Over-Trench Shelter, Pictorial View.

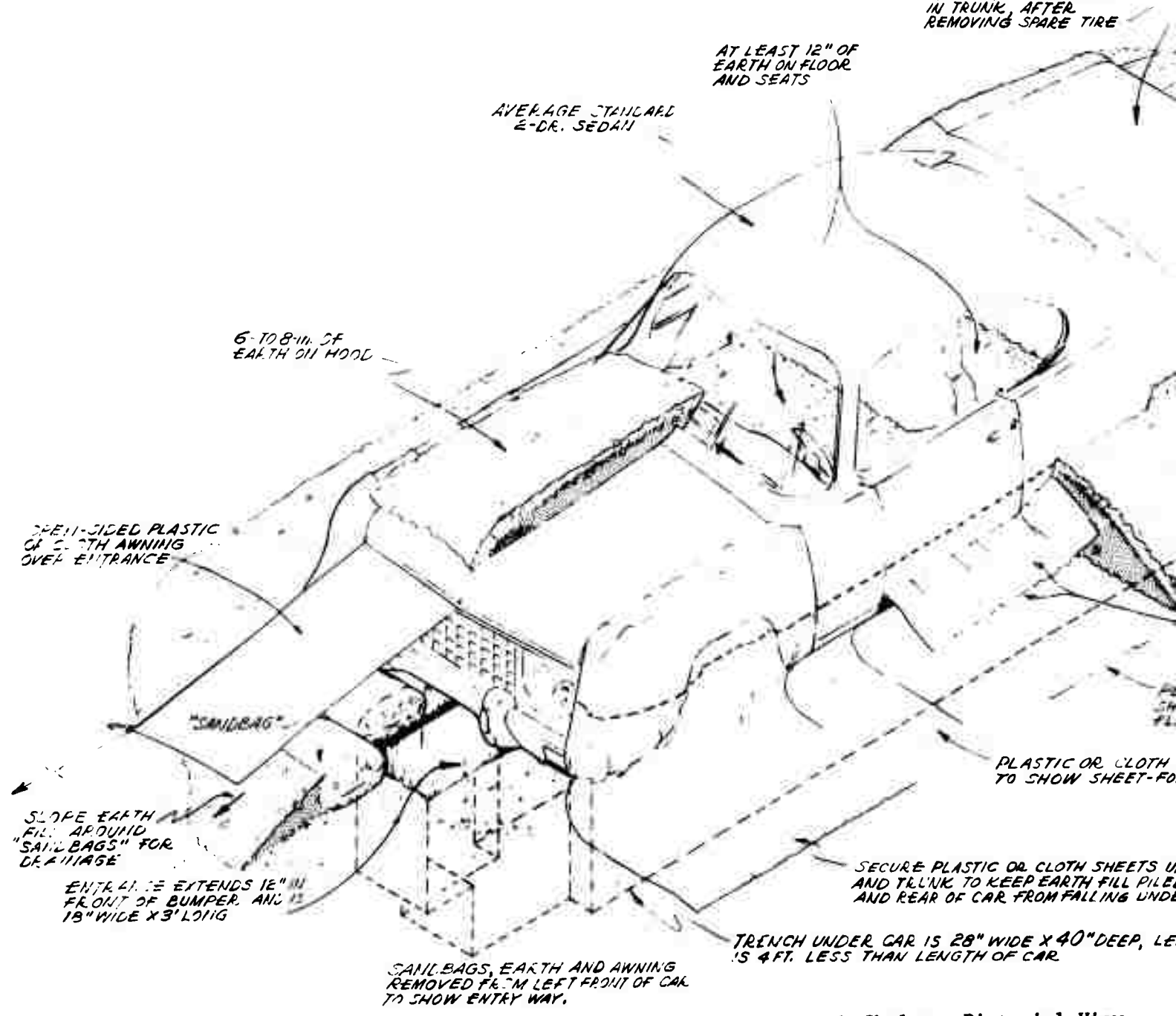

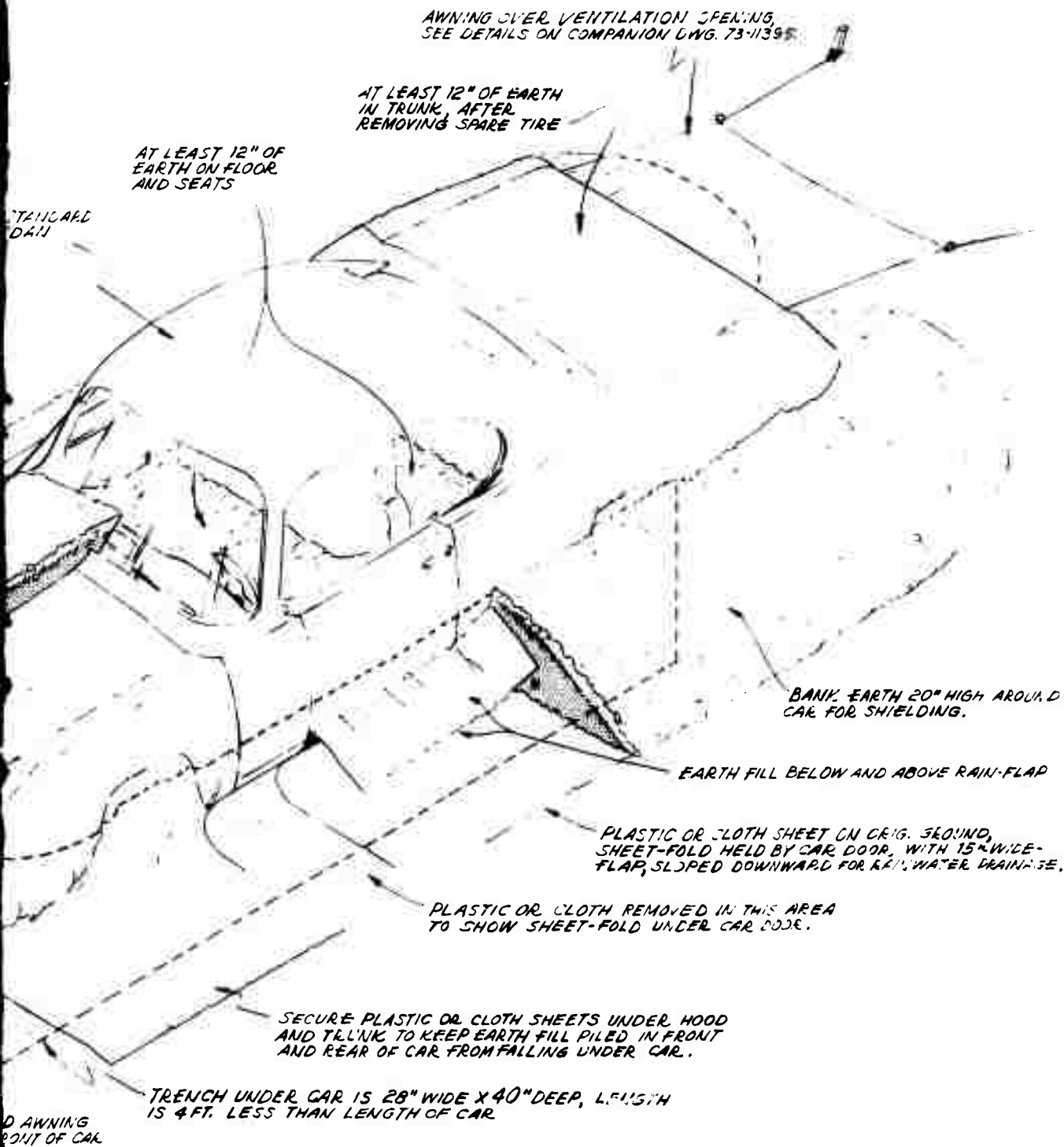

13.1. Car-Over-Trench Shelter, Pictorial View.

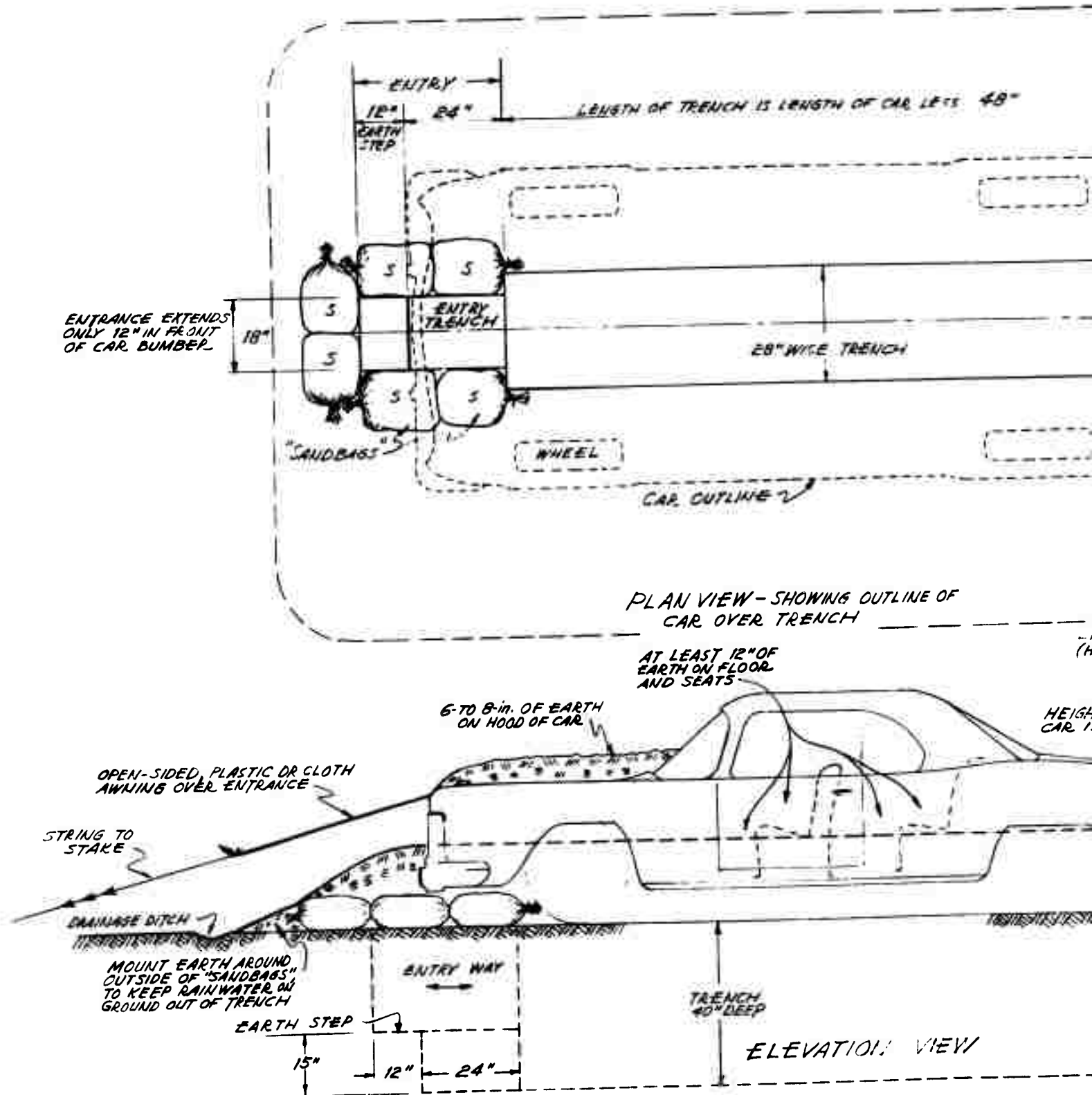

Fig. A-13.2. Car-Over-Trench Shelter, Plan and Elevation.

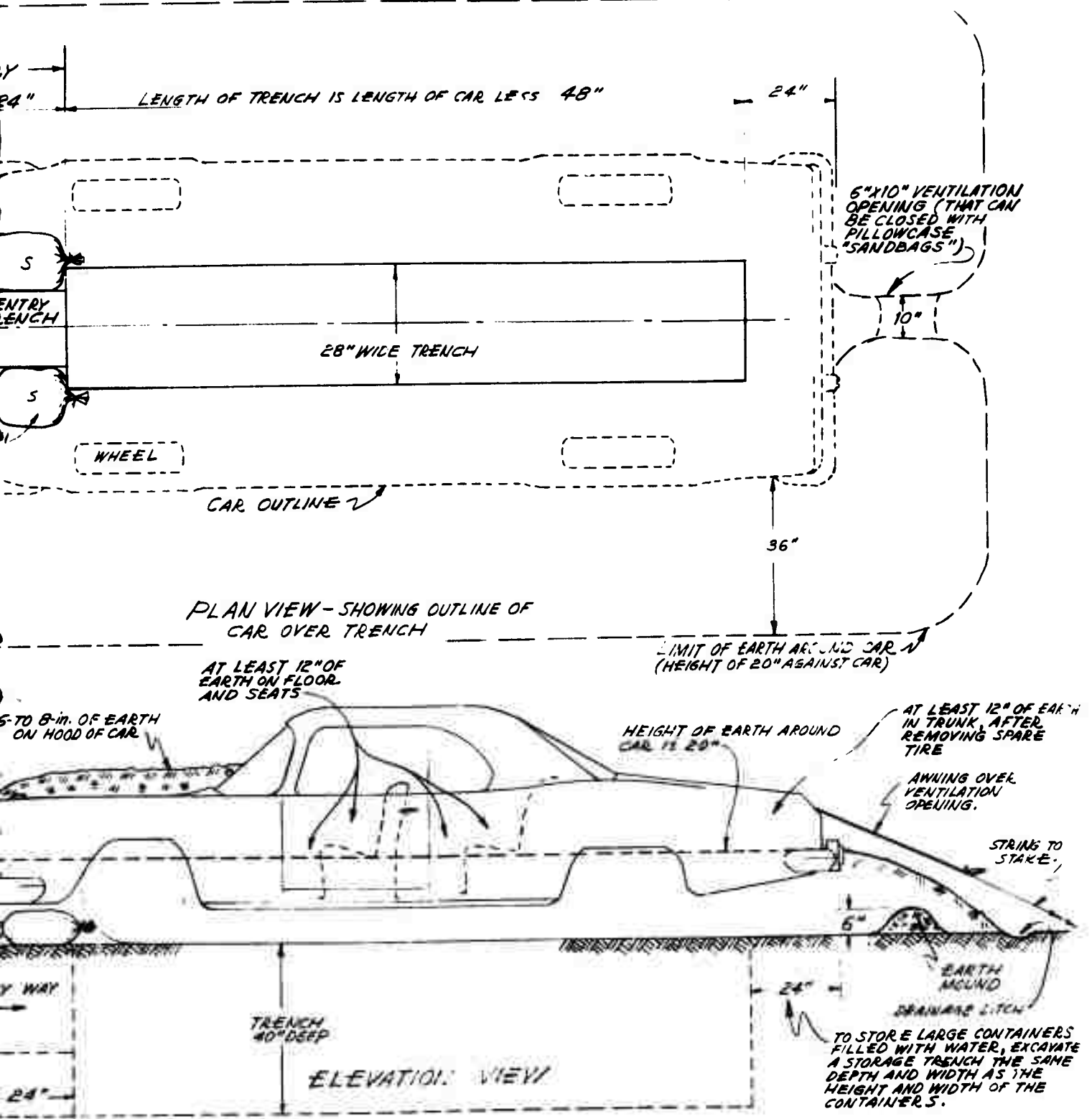
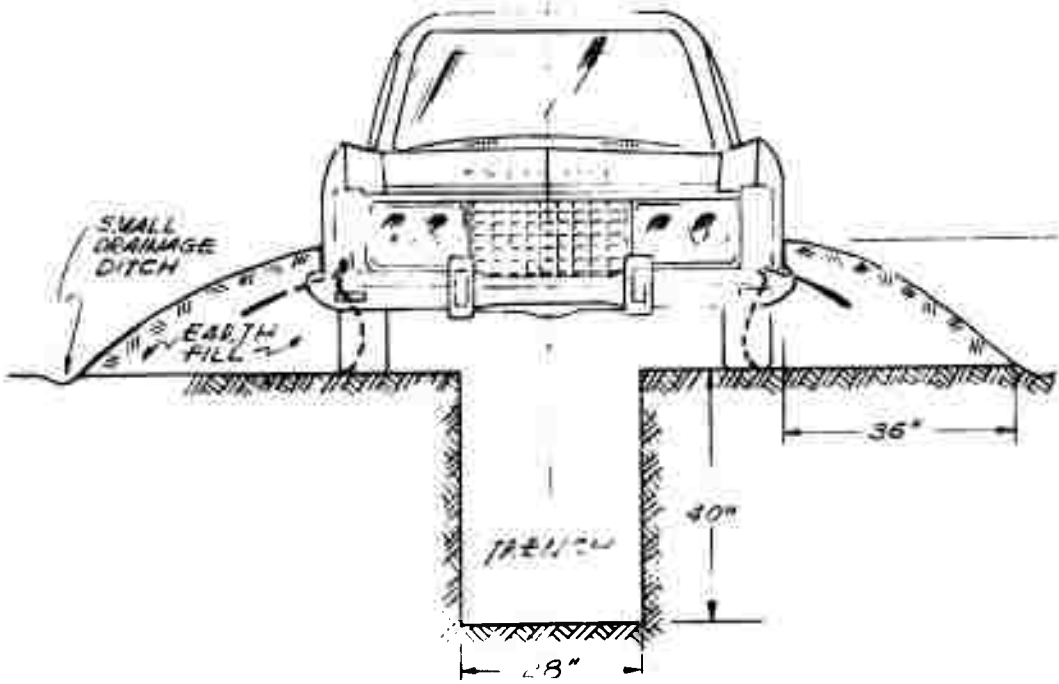

Fig. A-13.2. Car-Over-Trench Shelter, Plan and Elevation.



CAR OVER-TRENCH SHELTER

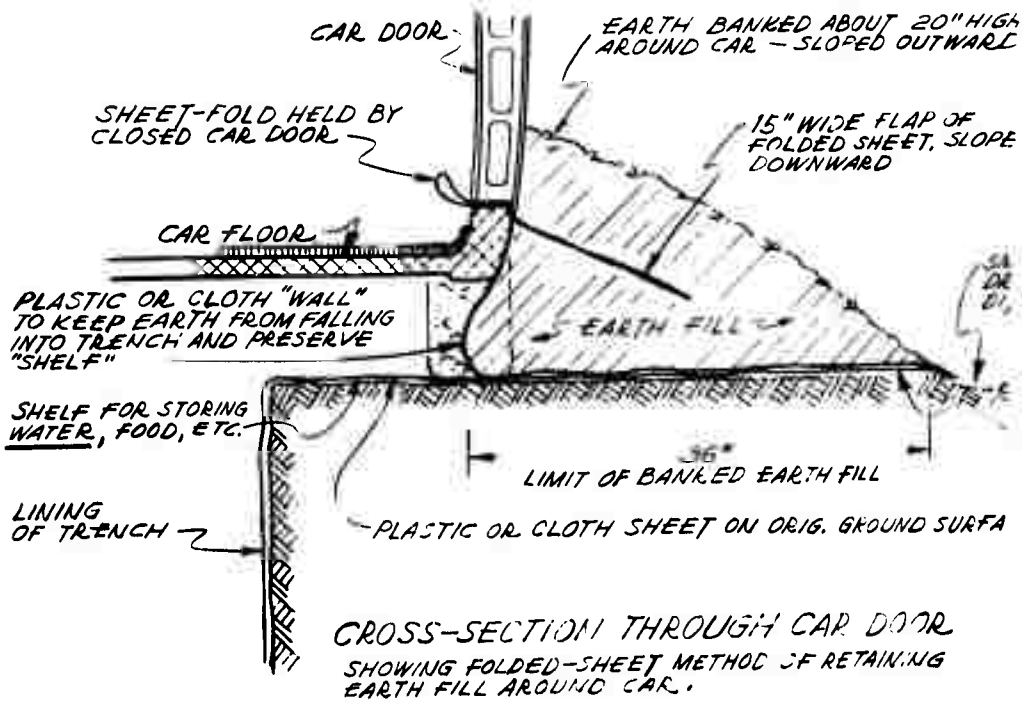

Fig. A-13.3. Car-Over-Trench Shelter, Front View and Cross Section.

#### A-14 Door-Covered Trench Shelter

A door-covered trench shelter was suggested by SRI<sup>10</sup> and a crude one was built by a workman. Two shelters of a much more habitable model were built by Kearny and were blast tested as open shelters at 5 psi and 3 psi overpressure during the Mixed Company Event.<sup>4</sup> The design and the step-by-step instructions included in this appendix were used by two inexperienced urban families in Colorado to construct prototypes in 1973 (Ref. 12) in less than 36 hours.

A-14-i

## DOOR-COVERED TRENCH SHELTER

(Study all these instructions and illustrations carefully before starting work, and then use them as a checklist.)

### 1. Purpose and Suitable Locations

This type of shelter is being considered for those parts of the country where there is a shortage of building materials to construct expedient shelters and where the earth is sufficiently firm that the walls of the shelter will not cave in. A Door-Covered Trench Shelter will provide fallout protection for one adult or large child for each door used, and provides better fallout, blast, and fire protection than does a Car-Over-Trench Shelter. A family evacuating a probable target area during a crisis can carry with them — provided they have a car with a roof rack, a station wagon, or a pickup truck — enough doors with the knobs removed to build this shelter.

First determine whether the ground is firm enough to be safe. If the earth is primarily sand or if it is very sandy, it will seldom be firm and stable enough to keep the trench sidewalls from caving in. Thus, the trench should not be dug in this earth. A quick test to determine whether or not earth is firm enough is given in step 3 below. Also, before beginning to make this shelter, the builders should dig a test hole to make sure that the ground water table or depth to solid rock is more than 40 inches below the surface.

### 2. Materials

#### a. Essential Materials

- (1) Doors — even hollow-core interior doors will serve. Use one door for each adult, or for each large child, or for two small children to be sheltered.
- (2) Digging Tools — pick and shovel preferred. One digging tool for each worker is desirable, but not essential, since most people cannot dig continuously for hours.

b. Usually Essential Rainproofing Materials

- (1) To make the "buried roof" — especially needed to keep possible rain or melted snow from wetting and dangerously weakening the earth-covered doors. At least 25 square feet per person of such waterproof materials as plastic sheeting (3 mils or more thick), canvas, shower curtains, plastic tablecloths, waterproof mattress protectors, etc.
- (2) To make the two canopies over the two shelter openings — to keep fallout and/or rain from falling into the shelter openings — a piece of rainproof material about 6' x 6' and another piece about 4' x 4'. (Ordinary cloth prevents fallout particles, but not water, from passing through it.)

c. Very Useful Materials

- (1) An additional 50 square feet (about the area of one bed sheet) per person of plastic or cloth to line the trench and to make "rolls"\* to raise and strengthen the entryway and ventilation hole openings. Plastic, bed-sheets, bedspreads, stout curtains, canvas, etc. will serve.
- (2) Two pillowcases per person to fill 2/3 full of earth and to use as sandbags.
- (3) String and/or cord, a knife, and a file for sharpening tools.
- (4) Four sticks or boards (each about 4 feet long) and eight stakes — to support the awnings over the shelter openings.
- (5) A measuring tape, yardstick, or ruler.

3. If at all possible, wear gloves while building this shelter (including digging test holes) to avoid blisters.

---

\*The method of making "rolls" is illustrated in Drawing A-14.1.



4. Sharpen all tools before beginning work, and keep them sharp.
5. Select reasonably level ground, preferably accessible by car.
6. Make sure that the earth is firm and stable enough so that the walls of the trench will not cave in. As a test, dig a small hole about 18 inches deep. Remove all loose earth from the bottom of the hole. Then make a "thumb test" by pushing a bare thumb into the undisturbed (natural state) earth in the bottom of the hole. If thumb can be pushed into the earth no further than one inch, the earth should be suitable for this type of shelter. If the earth does not pass a "thumb test," move to another location and try the test again. Continue to relocate and repeat until suitable earth is found.

To make doubly sure the earth is sufficiently stable and safe, make "heel tests" as the trench is deepened. To make a "heel test," first make an undisturbed, smooth earth step at least 4 inches wide, at least 16 inches long, at least 18 inches below the surface, and at least 8 inches above whatever depth you have dug the trench. If the earth step does not break off when a 150-lb man stands on the outermost 4 inches of this step with all of his weight on one heel while raising his toe slightly, then the earth is stable enough for safely digging a vertical-walled trench at least as deep as 8 inches below this earth step.

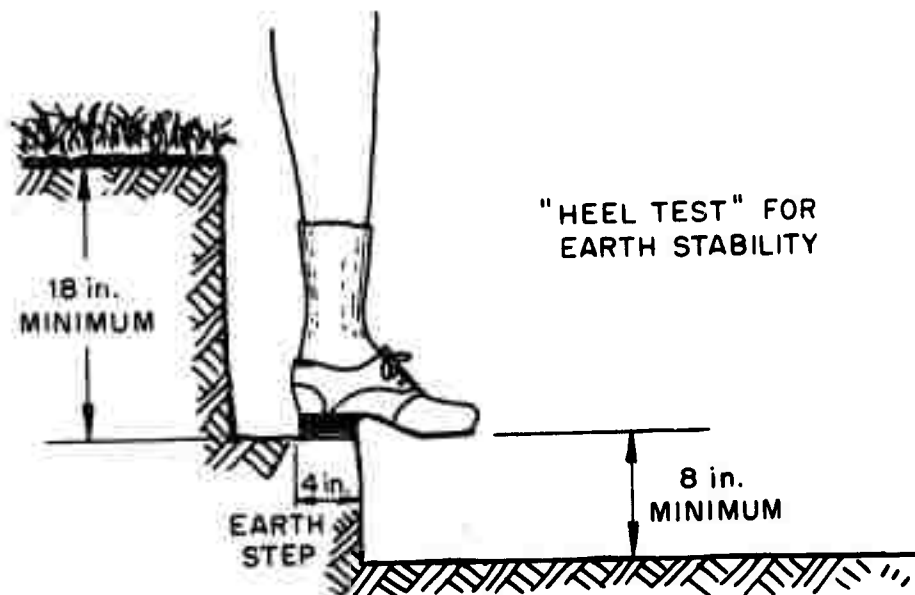

7. Prepare to dig a vertical-walled trench 4-1/2 feet deep and 3 feet wide. To determine the length of the trench, add together the widths of all the doors to be used for roofing it, and then subtract 8 inches from this sum. (To avoid arithmetical errors, it is best to lay all the doors side by side on the ground.)

8. Clear any brush, grass, or weeds that are more than a few inches high from the area where the trench will be dug, and from the ground around all sides of the trench, out to a distance of about 8 feet from the sides and ends of the trench.

9. Stake out a rectangular trench 36 inches wide and of a length as determined above. Also stake out the illustrated entrance at one end and the ventilation hole at the other.

10. Dig the main trench, the entryway trench, and the ventilation-hole trench. Place the excavated earth along both lengthwise sides of the trench so that no earth is piled nearer than 3 feet from the sides.

11. To reduce the labor of removing hard earth with a pick, pick-mattock, or grubbing hoe:

- (1) Keep tools sharp,
- (2) After shoveling out and leveling the temporary bottom of the trench, start picking in the center of the trench, digging and then shoveling out a shallow hole clear across the width of the trench.
- (3) Then with the pick or mattock break off row after row of small chunks of earth, breaking off each row clear across the width of the trench. A little experimentation may be necessary to determine the optimum size chunk which will break off with each pick stroke. Move forward as the work progresses.



(4) Shovel out the loose earth until the trench floor is again about level.

(5) Repeat.

12. To keep each trench its full width as it is dug, cut sticks 36, 18, and 12 inches long, and use them repeatedly from the start as width measures. Keeping the trench full width will save much work and time later.

13. If the soil changes as the trench is being excavated, again make the same two soil tests — the "thumb test" and the "heel test" — that were used in the test hole. If the soil does not pass the tests, do not dig the trench any deeper.

14. Carefully level and smooth the ground to a distance of 2-1/2 feet from the sides of the trench, so that the doors will lie flat on the ground.

15. If plenty of sheets, bedspreads, plastic, and/or other materials are available, line the trench walls with them. The wall lining should reach to within about one inch of the floor of the trench. A trench with lined walls is more livable, especially since the lining keeps dirt from falling into occupants' eyes. Remove the loose earth and rocks from the edges and walls before placing the lining.

16. To rainproof the shelter and to prevent the roofing doors from being dampened and weakened, use available waterproof materials as follows:

- a. If the earth is dry, the easiest and best way to make a rainproof roof is to place the doors directly on the ground, with each of the end doors overlapping an end of the main trench by 4 inches. Be sure to first level the ground surface so that doors touch the ground close to all edges of the trench. Next mound dry earth over the doors until the mound is about 12 inches deep above the centerline of the trench and slopes to both sides so as to just cover the ends of the doors. Next, smooth off the earth mound, being careful to remove sharp stones and sticks that might puncture rainproof material. Then place waterproof material over

the smooth mound, making the illustrated "buried roof." Finally, carefully mound an additional 6 to 12 inches of earth on top of the "buried roof."

- b. If the earth is wet, place the waterproof material directly on top of the doors, to keep them dry and strong. To make water run off this waterproof covering and keep water from collecting on a horizontal surface and probably leaking through, slope the doors toward one side of the trench by raising the other side of the trench by about 3 inches. One way to raise a side (while not increasing the distance the doors must span and thus decreasing the depth of earth that they will support) is to place an earth-filled "roll" of bed sheets or other material along one long edge of the trench. To keep the waterproof material used to cover the doors from sliding down the slope of the doors when earth is shoveled on, tuck the upper edge of the material under the higher ends of the doors. Finally, mound earth over the doors, so that the mound is 18 inches deep above the centerline of the roof and is 3 or 4 inches deep over both ends of the doors.
- c. If more waterproof material is available than is required to make a "buried roof" (or to cover the doors) and is needed to make the two illustrated canopies over the two shelter openings, use this excess material to cover the ground on which the doors are placed.

17. In order to be able to place an adequately thick depth of shielding earth right up to and around the entryway and ventilation hole, before placing the earth cover on the roof, stack improvised "sandbags" around these two openings, or use cloth or plastic material to make "rolls" of earth, as illustrated by the drawing. (See Fig. A-14.1)

18. Shovel earth around the "rolls," "sandbags," or other means used to raise the level of the earth around the two shelter openings. Slope this earth outward, and pack it, so that rain water on the ground cannot run into the shelter.

19. Dig small drainage ditches around the completed shelter, to lead runoff water away.

20. To keep rain and/or sand-like fallout particles from falling into the shelter openings, build an open-sided canopy over each opening, as illustrated in Fig. A-14.2. Support each canopy on two sticks placed firmly in the ground, and pull the corners of each canopy with cords tied to the bases of four stakes.

21. To sit on inside the shelter, make a "bench" of water and food containers, bedding, etc., placed along the side of the trench that is farthest from the off-center shelter openings. If the trench floor is damp, it is best to cover it with a waterproof material.

22. In cold weather, restrict air flow through the shelter by hanging curtains or otherwise partially obstructing the two shelter openings. But always leave at least a few square inches open in each opening, to assure enough ventilation to prevent a dangerous concentration of exhaled carbon dioxide. To keep exhaled water vapor from wetting clothing and bedding and reducing its insulating value, except when fallout is descending, keep the ventilation openings as wide open as is practical while maintaining not intolerably cold shelter temperatures.

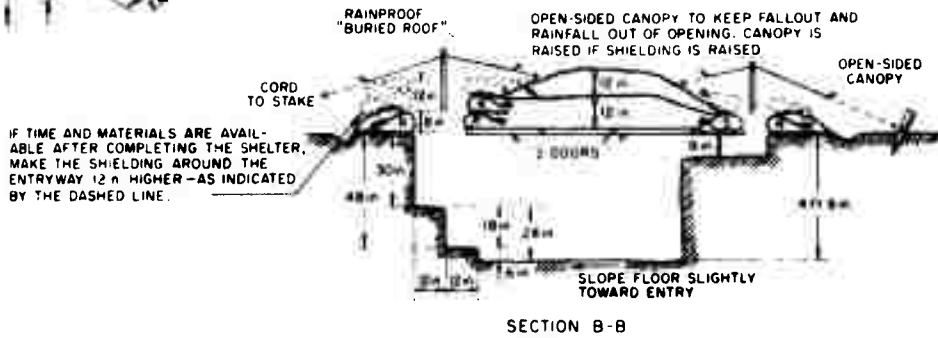
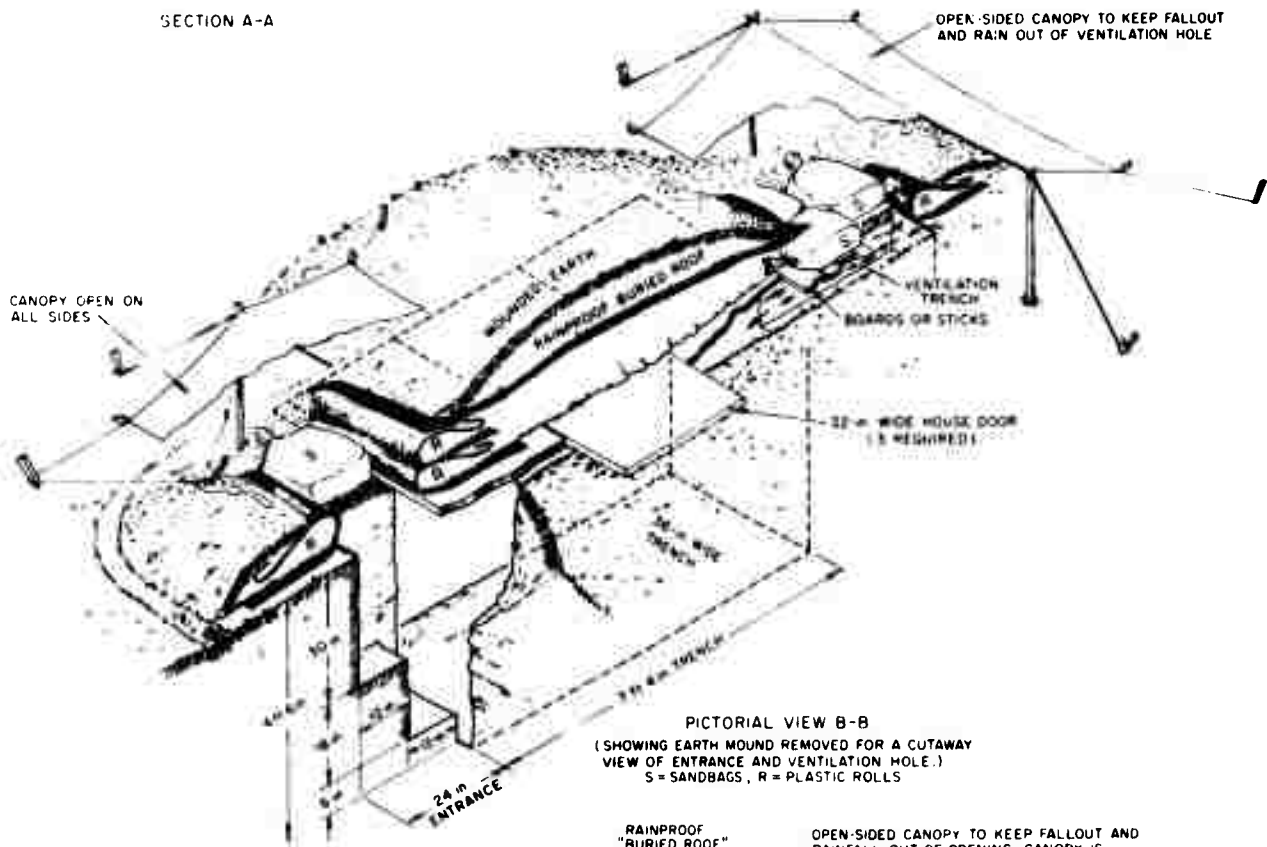
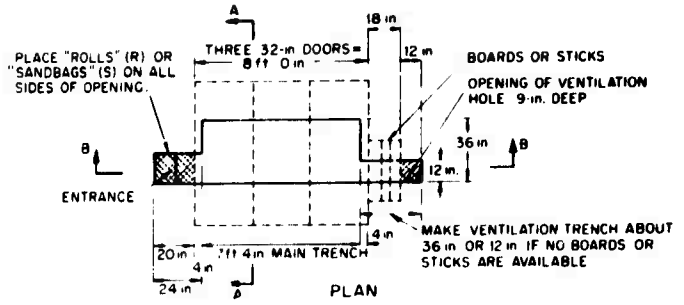
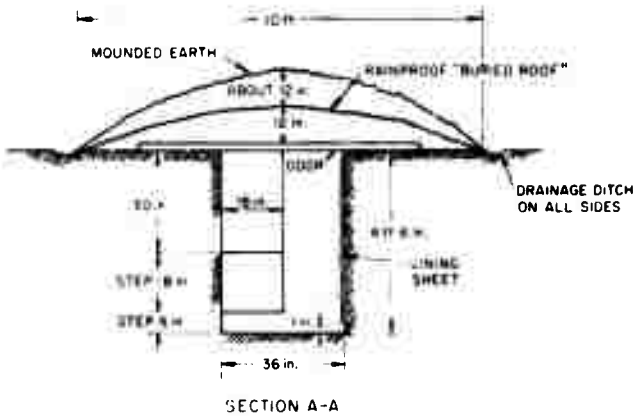

Fig. A-14.1. Door-Over-Trench Shelter, Pictorial View.

TO MAKE AN 8" HIGH "ROLL" (R) :

1. SELECT A PIECE OF CLOTH OR PLASTIC AT LEAST AS STRONG AS A NEW BED SHEET, 2 FT. WIDER THAN THE SIDE OF THE OPENING TO BE PROTECTED, AND 5-FT LONG.
2. PLACE 2 FT. OF THE LENGTH OF THE CLOTH ON THE GROUND, AS ILLUSTRATED.
3. WHILE USING BOTH HANDS TO HOLD UP 3 FT. OF THE LENGTH OF THE CLOTH AND PRESSING AGAINST THE CLOTH WITH YOUR BODY, HAVE ANOTHER PERSON SHOVEL EARTH ONTO AND AGAINST THE CLOTH.
4. WHILE STILL PULLING ON THE CLOTH, PULL THE UPPER PART DOWN OVER THE EARTH ON THE LOWER PART OF THE CLOTH.
5. COVER THE UPPER EDGE OF THE CLOTH, FORMING AN EARTH-FILLED "HOOK" IN THIS EDGE, AS ILLUSTRATED.

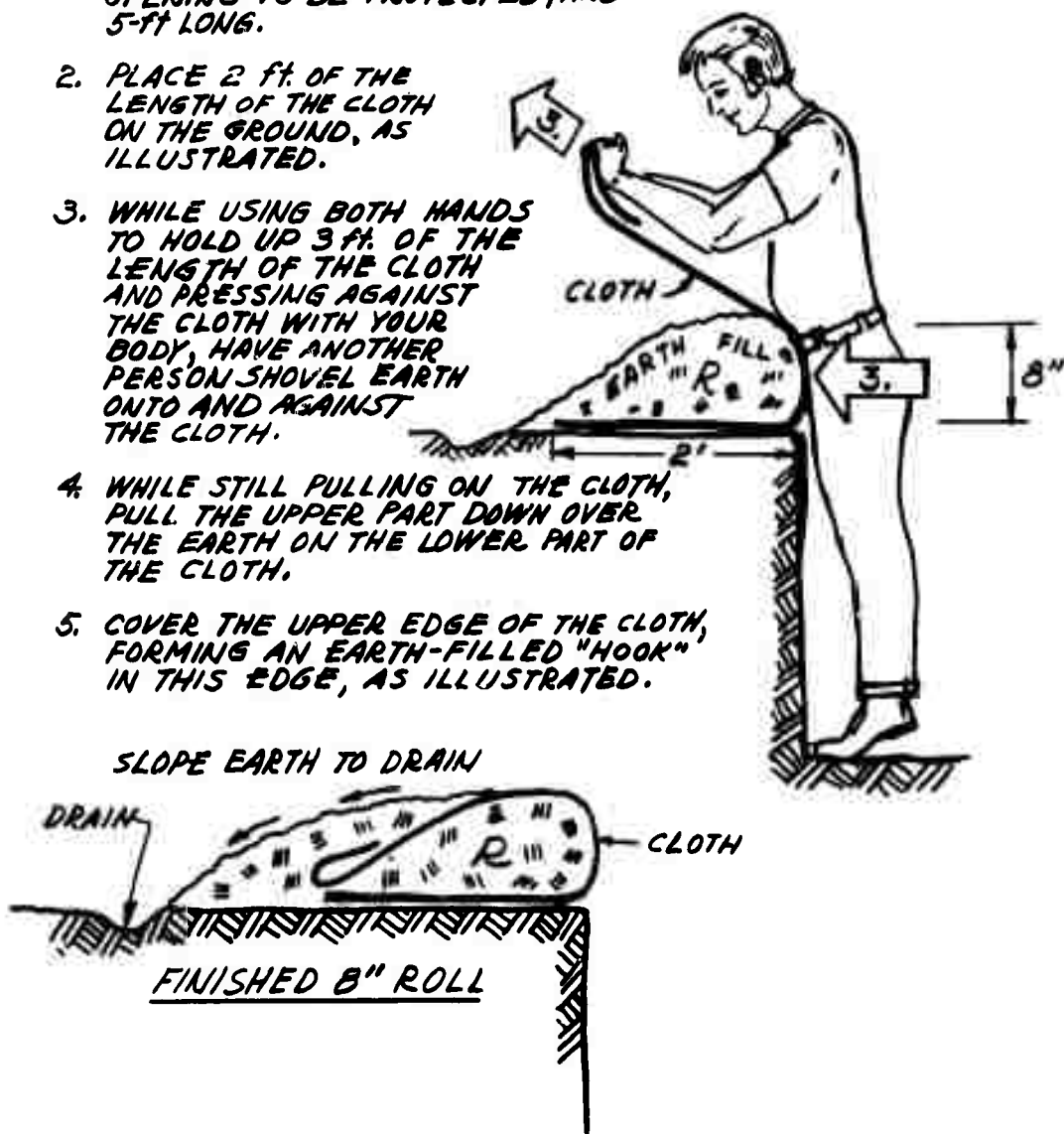

Fig. A-14.2. Door-Over-Trench Shelter, Making a "Roll."

A-15 Lumber Version of the Small-Pole Shelter

This shelter design is a very recent adaptation of the Small-Pole Shelter. It was designed by DCPA and modified by the authors. One shelter was built by two families in Colorado in 1974, using only copies of drawings and instructions similar to the ones in this Appendix. The instructions and drawings have been improved to include the results of the "proof-test." In the field experiment, the trench was dug by machinery and the uncut lumber was piled onsite before the families started their work. Under these conditions, the 11 persons completed the shelter including the earth cover in 13 hours and 12 minutes.

We believe that under crisis conditions ordinary evacuees could build this type shelter for themselves, including hand digging of the trench, in less than 48 hours.

This shelter has many of the advantages of the Small-Pole Shelter. It can be built fully buried, semi-buried, or aboveground. However, it does require a large amount of lumber per person and, if it is not fully buried, may require mechanical excavation of the large amount of earth required to provide the cover.



LUMBER VERSION OF THE SMALL-POLE SHELTER  
(the illustrated shelter is for 12 persons)

I. PURPOSES AND SUITABLE LOCATIONS

1. This expedient shelter has a protection factor (PF) greater than 500 if covered with 3 ft of earth — that is, an occupant of this shelter would receive less than 1/500th of the radiation from fallout that he would receive outside in the open. Furthermore, this shelter would give good protection against thermal radiation and the fires that large nuclear explosions, even 30 to 40 miles away, could ignite. In areas where the earth is not stable enough to make vertical-walled trenches without shoring their walls, this box-like shelter is suitable, if lumber and nails are available.

2. For people to live successfully for days in this shelter when it is fully occupied, the benches and bunks must be built with the dimensions and spacings given in the pictorial view. Then about one-third of the occupants can sleep in shifts on the overhead bunks, while the remaining two-thirds can sit with plenty of head room. For the illustrated 12-person shelter, there should be 9 feet of benches and 9 feet of overhead bunks on each side, plus a 3-ft-wide overhead bunk across the rear end.

3. If more than 12 persons are to live in this shelter, make the main room (and the excavation) two feet (2 ft) longer for each additional 2 persons above 12.

4. If more than 15 persons (but no more than 24) are to be sheltered, or if the weather is hot, make an identical entryway at each end. That is, make two of the illustrated 12-person shelters back-to-back, with no end-wall or ventilation duct.

5. If more than 24 persons are to be sheltered, build two or more separate shelters.

6. Two families, with 11 of their 14 members old enough to do some consequential work, completed this shelter in a model sized for 13 persons

just 13 hours and 12 minutes after reaching the rural site. About 95% of the excavation had already been dug, and the uncut lumber had been piled near the site.

## II. CHECK LIST FOR BUILDERS

1. Study both of the two drawings and read all of these instructions before beginning work. THEN CHECK OFF EACH STEP WHEN COMPLETED.

2. TOOLS AND MATERIALS NEEDED FOR A 12-PERSON SIZE SHELTER

a. Lumber

Table 1 (on the following page) lists the required sizes and quantities.

b. Rainproofing Materials

(1) Preferably a piece of 6-mil polyethylene 12 ft wide and 26 ft long, or at least 200 sq ft of 5-mil or 4-mil polyethylene, or at least 200 sq ft of other waterproof plastic, plastic table cloths, shower curtains, and/or linoleum rugs.

(2) Three hundred feet of sticks, 1/2-in. to 1-1/2 in. in diameter, of any lengths (if necessary for drains - see Section 34).

c. Nails

20 pounds of 10-penny (3") cement-coated nails, or common nails.

3. Desirable tools for building a 12-person, cut-lumber version of a Small-Pole Shelter:

<u>Tools</u>	<u>Quantity</u>	<u>Tools</u>	<u>Quantity</u>
Saw	2	Rake	1
Square	2	Carpenter's Apron (or purse with shoulder strap)	4
Axe or Hatchet	1	Buckets, large pots, and/or 5-gal cans with bail-handles (to carry earth, and later to store water, and for waste disposal)	6
Pick	2		
Shovel, long handle	4		
Hammer, claw	4		
File, 10-inch	1		
Tape, steel, 10-ft	1		

(Also useful: a 50-ft steel tape.)

TABLE 1

LUMBER FOR A 12-PERSON SHELTER

Use	Size	Number	Exact Length	Order for Minimum Waste Number	Length (feet)
<b>A. For a <u>12-Person</u>* Main Room with Benches, Bunks and Ventilation Duct (but <u>not</u> including lumber for entryway):</b>					
Joists and Studs*	2" x 4"	62	7'0"	35	14'
Cross-braces*	2" x 4"	12	6'2"		
Lengthwise Plates and Braces*	2" x 4"	8	10'6"	8	12'
Sheathing (exterior grade plywood, sheets)*	1/2"	11	4' x 8'	11	4' x 8'
Benches*	1" x 8"	4	9'0"	4	10'
Side Bunks*	1" x 6"	8	9'0"	8	10'
End Bunk*	1" x 6"	6	6'5"	3	14'
Bench and Bunk Frames*	2" x 4"			7	10'
Duct	1" x 8"	3	7'0"	2	14'
		1	6'0"		
<b>B. For <u>One</u> Entryway:</b>					
4 corners of vertical entry	2" x 4"	4	10'6"	4	12'
Studs	2" x 4"	4	7'0"	2	14'
Plates	2" x 4"	4	3'9"	3	8'
Braces	2" x 4"	4	2'0"		
Entryway Joists	2" x 4"	5	3'0"	2	10'
Top and Bottom Plates and Braces	2" x 4"	4	6'0"	2	12'
Entry Top-braces, and Ladder	2" x 4"	8	2'2'	2	10'
Horizontal Entry-braces	2" x 4"				
Siding and Roofing (exterior-grade plywood sheets)	1/2"	5	4' x 8'	5	4' x 8'

\*For every 2 additional persons beyond 12, the room should be made 2 ft longer, requiring:

- (a) 8 additional studs and cross braces each 7'10" long;
- (b) 2 additional cross-braces each 6'2" long;
- (c) all the lengthwise plates of the room to be lengthened 2 feet;
- (d) proportionally more 2 x 4-in. and other boards to make 2 additional feet of benches and bunks on each side;
- (e) 1-1/2 additional sheets of plywood; and
- (f) 3 lbs more of 10-penny nails.

#### A-15.4

4. To save time and work, sharpen all tools, and keep them sharp.
5. Wear gloves from the start — even tough hands can blister after hours of digging and chopping. Blisters are painful, seriously slow the work, and could result in dangerous infections.
6. Before staking out the outlines of the excavation, check for rock depth — by driving down a 6-ft, sharpened small pipe or rod. To avoid groundwater problems, avoid low ground.
7. To help drain the floor, if practical locate the shelter so that the original ground level at the entrance is about 6 inches lower than the original ground level at the far end of the shelter.
8. Stake out the trench for the entire shelter. Even in firm, stable ground, at the surface make the excavation 12 ft wide and 23 ft long (5 ft longer than the entire length of the wooden 12-person shelter). (The sloping sides of the excavation are necessary, even in firm earth, to provide adequate space for backfilling and tamping. The space around the shelter is also needed for nailing on plywood sheathing — for essential added strength.
9. Check the squareness of the staked trench outline of the shelter room by making its diagonals equal.
10. While some workers are making the excavation, other workers should be cutting lumber to the required lengths — as specified in Table 1, but using increased lengths for the boards that run lengthwise in the main room, if the shelter is being built for more than 12 persons. Cutting all the lumber into the required lengths at this time will save extra labor later. Be sure to cut the longer available boards into the longest lengths specified in Table 1.
11. Before the excavation is completed, workers on the surface should complete the ladder-like brace-frames, side-frames, end-frames, entryway frames, and the ventilation duct. They should also assemble the complete entryway (or the two entryways, if two are to be installed), ready to lift into the excavation. (Study Section 18, below).
12. Clear all brush, tall grass, etc., off the ground to a distance of 12 ft, all around the staked location — so that later you can easily shovel loose excavated earth back around and over the shelter. Grass and brush mixed with loose earth makes shoveling very difficult.

13. If excavating in unstable ground, excavate with appropriately less steep sides. (That is, make the top dimensions of the excavation larger in both directions.)

14. When digging the trench for the shelter, use a stick 9 ft long (the minimum bottom width) to repeatedly check the width of excavation.

15. When digging with a shovel, pile the earth dug from near ground level about 10 ft from the edges of the excavation. Then earth dug from 5 or 6 ft below ground level can easily be piled on the surface, 1 to 5 ft from the edge of the excavation. This way, no earth need be shoveled twice.

16. Finish the bottom of the excavation so that it slopes  $1/4$  inch vertically per foot of length toward the entrance, and also slopes toward the central drain ditch — in which will be placed sticks covered with porous fabric, to serve like a crushed-rock drain leading to a sump. Be sure to make the bottom of the excavation smooth for a length equal to the illustrated 20-ft length (plus 2 ft of additional length for every additional person above 12 to be sheltered).

17. Before a shelter is completed, some workers should provide for essential forced ventilation in warm or hot weather by building an expedient Kearny Air Pump (KAP). Carefully follow the instructions given in Appendix B. (For additional information on expedient water storage, lights, and sanitation measures, see Appendix C.)

18. Construct all of the ladder-like frames on smooth ground near the excavation. To build a frame, place its two longest boards on the ground and parallel to each other. Put all of the equal-length cross-pieces in their specified positions, and nail each of their ends by driving two 10-penny nails through one of the longest boards and into the end of a cross-piece.

19. So that the frames can be moved slightly in order to make them fit together properly, do not nail any temporary diagonal bracing onto any of the frames to hold it square.

20. Place the lower brace-frame of the main room on the floor of the excavation.

21. Place the two completed side-frames of the main room in the excavation, with the lower plate of each pressed against and nailed to the ladder-like lower brace-frame on the floor.

22. Place the rear end-frame in its proper position, and nail it to the adjacent side-frames and to the lower brace-frame.

23. Lift the upper brace-frame into its position, with its upper side 3 inches below the upper sides of the two side-frames, and nail it in this position. (To hold the upper brace-frame in its proper position until it can be nailed, it is helpful to have nailed four small 2 x 4-in. "scabs" one to each of four studs. Two of these four studs should be on each side-frame, and near its ends. The top of each scab should be 6-1/2 inches below the upper side of its side-frame.)

24. Put the front end-frame in position, and secure it by nailing.

25. Once all the frames of the main room are nailed together, start covering the outer sides with plywood. The plywood sheets should be placed with their long dimensions vertical, and nailed to each of the studs, and to the plates of all the frames they lie against. For adequate shelter strength, space these nails no farther apart than 10 inches.

26. Cut an air-exhaust hole (7-1/2 inches wide and 12 inches high) in the plywood that is to be attached where the air duct is to be nailed later.

27. Lift the completed entryway frame as a unit into the excavation, and attach it to the doorway opening of the main room. Then cover it with plywood sheathing, also nailed with minimum 10-inch spacings between nails.

28. Attach the completed ventilation duct.

29. Start backfilling all around the plywood-covered walls. Pay particular attention to the order of filling. The earth fill behind all the walls must be brought up quite evenly, so that the earth fill behind one side is no more than 12 inches higher at any one time than the earth on the opposite side. Tamp earth fill in 6-inch layers. Do not use a mechanical tamper. A 10-ft pole, or a 2 x 4 in. board about 10 ft long, makes a good tamper.

30. While some workers are backfilling, others should nail the 7-ft-long roof joists, spaced 6 inches center-to-center, to the upper plates of the side frames. Each end of each joist should both be toenailed to a plate, and attached with a nail driven through the adjacent plywood into its end. (Also nail the joists to the entryway frame.)

31. Before covering the roof joists and shutting out the light, the 2 x 4-inch vertical supports for the benches and overhead bunks should be cut to lengths that result in the bunks being 4 ft-5in. above the upper sides of the lower cross-braces (see Pictorial View). Be sure to place the vertical supports 3 ft apart, so two persons can sit between each pair. Then all benches and bunks should be completed.

32. Next, cover the roof with plywood sheathing, with the sheets cut off to 7-ft lengths and the lengths placed parallel to the joists. Nail the plywood to each joist, with a 10-inch minimum spacing. Especially if the earth is sandy or dry, cover cracks in the sheathing with bed sheets, cardboard, or newspapers.

CAUTION: Do not try to rainproof this flat roof, and then simply cover it with earth — because, if you do, water will seep straight through the loose earth cover, puddle on the flat roofing material, and leak through the joints between pieces of roofing material or through small holes in the roofing material.

33. Mound earth over the shelter, piling it about 15 inches deep along the center line of the roof and sloping it toward the sides of the roof, so that the earth is only about 2 inches deep over the ends of the roof joists (or the upper edges of the vertical sheathing). (Preparatory to mounding earth onto the roof, place grade-stakes in position, so you will be able to know the locations of the ends of the roof joists as you cover them.)

34. If not enough rainproof materials are available to make a "buried roof" that slopes outward all the way to the edges of the mounded earth at ground level, make the illustrated "buried drain ditches" near the edges of the available waterproof materials. Rake and remove sharp pointed objects from the mounded earth surface, before placing rainproofing materials on the mounded surface.

35. If enough rainproofing materials are available, the buried drain ditches can be omitted, and the rainproofing material can be extended all the way out to the surface drain ditches around the outermost edges of the mounded earth cover.

36. Place the rest of the earth cover over the shelter, being sure that the corners of the shelter have at least 2-1/2 feet of earth over them. Mound the earth, smoothing its surface so that water will tend to run off to the surface drainage ditches, which should be dug on all sides.

37. Install a 36-inch-long x 26-inch-wide homemade KAP (Kearny Air Pump) to swing in the 29-inch-wide entryway, hinging it to the top of the doorway opening of the main room. Especially if this underground shelter has only one entryway, in warm or hot weather forced ventilation must be provided in order to prevent dangerously humid-hot shelter conditions.

To enable the KAP to efficiently pump fresh air from the outdoors all the way through the shelter, block the lower half of the KAP doorway with a quickly removable covering, such as a plastic-covered frame made of sticks. Be sure to connect the KAP's pull-cord only 11 inches below its hinge line. This prevents excessive arm motions which would cause unnecessary fatigue.

38. Place a fly or canopy - open on all sides to a height of at least 12 inches above the ground - over the entrance, to prevent almost all of the sand-like descending fallout particles from entering the entryway. The "Vertical Section A-A" in the plans shows a "plastic canopy cover," its ridgepole, and one of its two vertical pole-supports. Such a canopy also can be made of canvas or shower curtains, with wires or cords tying the corners of the canopy to four stakes.

39. To improve the floor, lay small poles (or sticks covered with scrap boards) between the lower cross-braces, so that the floor is approximately level.

40. In windy or cold weather, control the natural flow of air through the shelter by hanging adjustable curtains in the doorways at both ends, and/or by making and using trapdoors on the tops of vertical



entryways. For an adjustable curtain, use a piece of plastic with a supporting stick connected to its upper edge — so that you can provide different sized openings in the doorway above the top of the adjustable curtain.

41. Even in the coldest weather, in order to occupy this crowded underground shelter for hours without getting headaches, or worse, from breathing too much exhaled carbon dioxide, it is necessary that about 3 cubic feet per minute of air from the outdoors should flow through the shelter for each shelter occupant. An airflow of 36 cfm (3 x 12) is enough for 12 persons. This very slow-moving but essential airflow can be checked by repeatedly dropping a dry piece of toilet paper measuring 1/4 in. by 1/2. Drop this small piece of paper in the center of the shelter, from a height of 7 ft, being careful that no one breathes toward it. If on the average this paper lands on the floor about 1-1/2 inches off the vertical and consistently in one direction, then about 36 cfm is flowing through the shelter.

42. Smoking produces carbon monoxide, which causes severe headaches under minimum-ventilation conditions which, though austere, are adequate when no one smokes.

43. After the whole shelter is completed (including the canopy and a homemade ventilating pump, a KAP) take a rest. Later, if practical, increase the radiation protection factor of the shelter by making the earth cover over the room a full 3 ft thick.

44. If the water table is very near the surface and gravity drainage by ditching is not practical, or if rock is near the surface, this shelter should be built in a shallower excavation, or even on the surface. However, the mounded earth should slope not more steeply than 2:1, and mechanized earth-moving equipment would be necessary to cover it adequately within 48 hours of a typical civilian group's beginning construction.

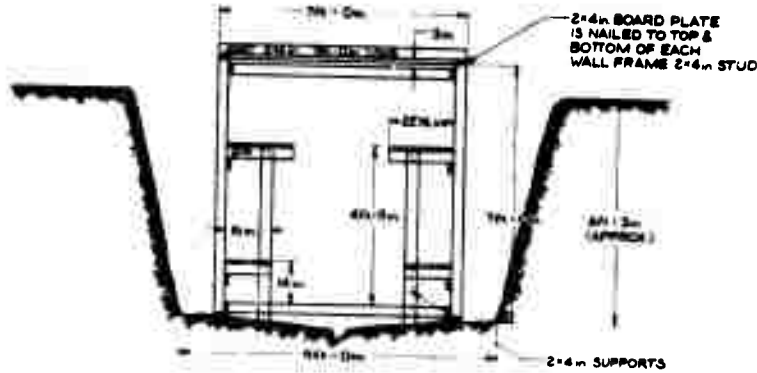

**END VIEW OF MAIN ROOM**  
 SHOWING PLACEMENT OF BENCHES  
 AND BOARD BUNKS - FROM REAR  
 END OF MAIN ROOM THE 2x4 BUNK  
 SUPPORTS ARE SPACED 3ft-0in APART.

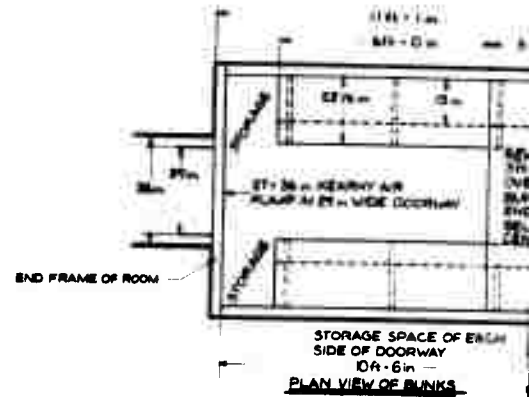

**PLAN VIEW OF BUNKS**  
 STORAGE SPACE OF EACH  
 SIDE OF DOORWAY  
 10ft-6in

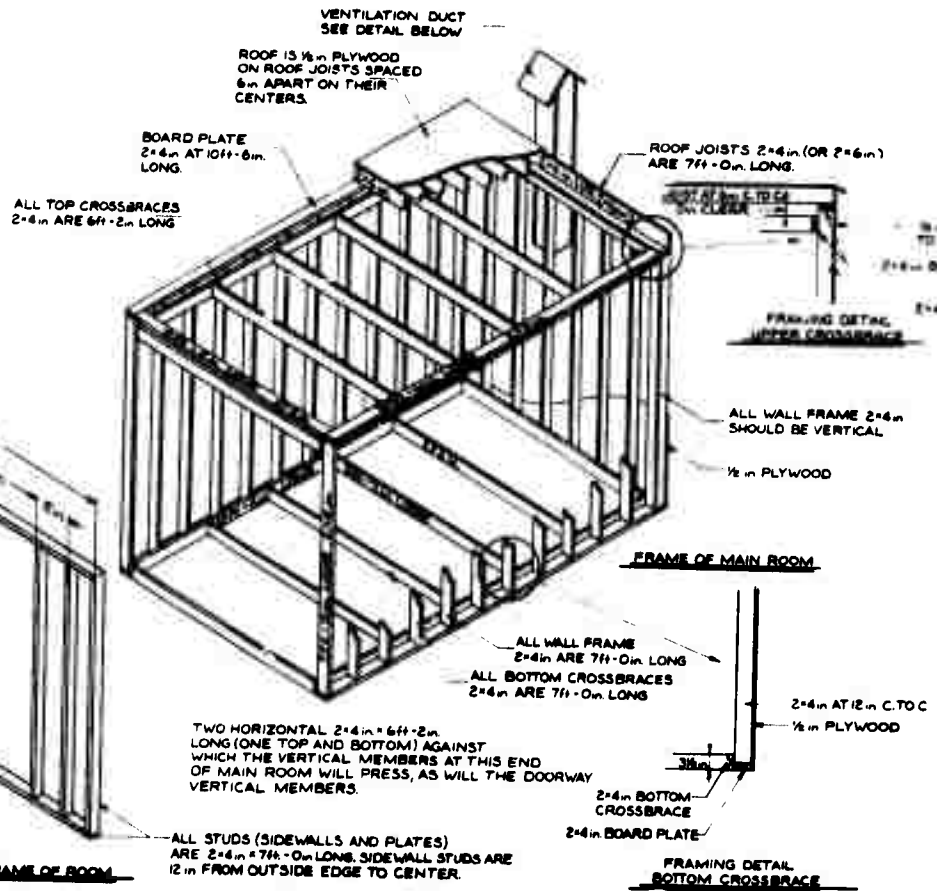

2x4in AT 12in C.T.O.C.  
 FOR DETAIL OF ENTRANCE  
 SEE COMPANION DRAWING

ALL VERTICAL END WALL  
 MEMBERS ARE PLACED ON  
 OUTSIDE OF 2ft-2in HORIZONTAL  
 MEMBERS (ONE TOP AND BOT.) WHICH  
 IN TURN PRESS AGAINST ENDS OF 6ft-0in  
 LONGITUDINAL MEMBERS.

**FRAME OF ENTRYWAY**

ALL SIDE WALLS NOT IN SUMP  
 ARE 2x4in x 7ft-0in LONG

ALL SIDE WALL STUDS IN  
 SUMP ARE 2x4in x 10ft-6in LONG

TWO HORIZONTAL 2x4in x 6ft-2in  
 LONG (ONE TOP AND BOTTOM) AGAINST  
 WHICH THE VERTICAL MEMBERS AT THIS END  
 OF MAIN ROOM WILL PRESS, AS WILL THE DOORWAY  
 VERTICAL MEMBERS.

ALL STUDS (SIDEWALLS AND PLATES)  
 ARE 2x4in x 7ft-0in LONG. SIDEWALL STUDS ARE  
 12in FROM OUTSIDE EDGE TO CENTER.

ALL WALL FRAME  
 2x4in ARE 7ft-0in LONG  
 ALL BOTTOM CROSSBRACES  
 2x4in ARE 7ft-0in LONG

2x4in AT 12in C.T.O.C.  
 1/2 in PLYWOOD

2x4in BOTTOM  
 CROSSBRACE

**FRAMING DETAIL  
 BOTTOM CROSSBRACE**



Figure A-15.1 Pictorial View of Lumber Version of Small-Pole Shelter

2x4 in BOARD PLATE IS NAILED TO TOP & BOTTOM OF EACH WALL FRAME 2x4 in STUD

6ft - 3in (APPROX)  
2x4 in SUPPORTS

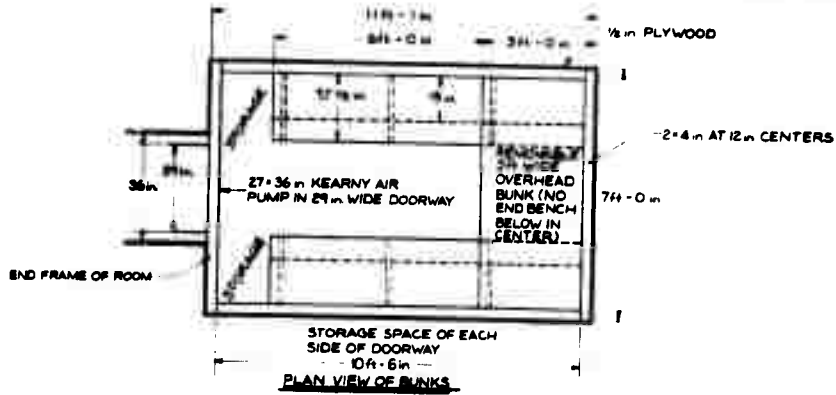

VENTILATION DUCT  
SEE DETAIL BELOW

ROOF IS 1/2 in PLYWOOD ON ROOF JOISTS SPACED 6 in APART ON THEIR CENTERS.

BOARD PLATE 2x4 in AT 10ft - 6 in LONG.

CROSSBRACES 1ft - 2 in LONG

ROOF JOISTS 2x4 in (OR 2x6 in) ARE 7ft - 0 in LONG.

1/2 in PLYWOOD NAILED TO 2x4 in  
2x4 in BOARD PLATE

2x4 in AT 12 in C TO C  
**FRAMING DETAIL UPPER CROSSBRACE**

12 in WIDE x 18 in LONG PLYWOOD OR BOARD

ALL WALL FRAME 2x4 in SHOULD BE VERTICAL

1/2 in PLYWOOD

**FRAME OF MAIN ROOM**

DUCT MADE OF FOUR 1x6 in BOARDS, EACH ABOUT 7ft LONG  
LEVEL OF TOP OF HOLE IN THE END WALL  
VENTILATION OPENING THIS SIDE ONLY

**DETAIL OF DUCT VENTILATION**

ALL WALL FRAME 2x4 in ARE 7ft - 0 in LONG  
ALL BOTTOM CROSSBRACES 2x4 in ARE 7ft - 0 in LONG

2x4 in AT 12 in C TO C  
1/2 in PLYWOOD

TWO HORIZONTAL 2x4 in x 6ft - 2 in LONG (ONE TOP AND BOTTOM) AGAINST WHICH THE VERTICAL MEMBERS AT THIS END OF MAIN ROOM WILL PRESS, AS WILL THE DOORWAY VERTICAL MEMBERS.

2x4 in BOTTOM CROSSBRACE  
2x4 in BOARD PLATE

**FRAMING DETAIL BOTTOM CROSSBRACE**

ALL STUDS (SIDEWALLS AND PLATES) ARE 2x4 in x 7ft - 0 in LONG. SIDEWALL STUDS ARE 12 in FROM OUTSIDE EDGE TO CENTER.

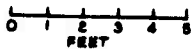

1 Pictorial View of Lumber Version of Small-Pole Shelter.

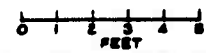
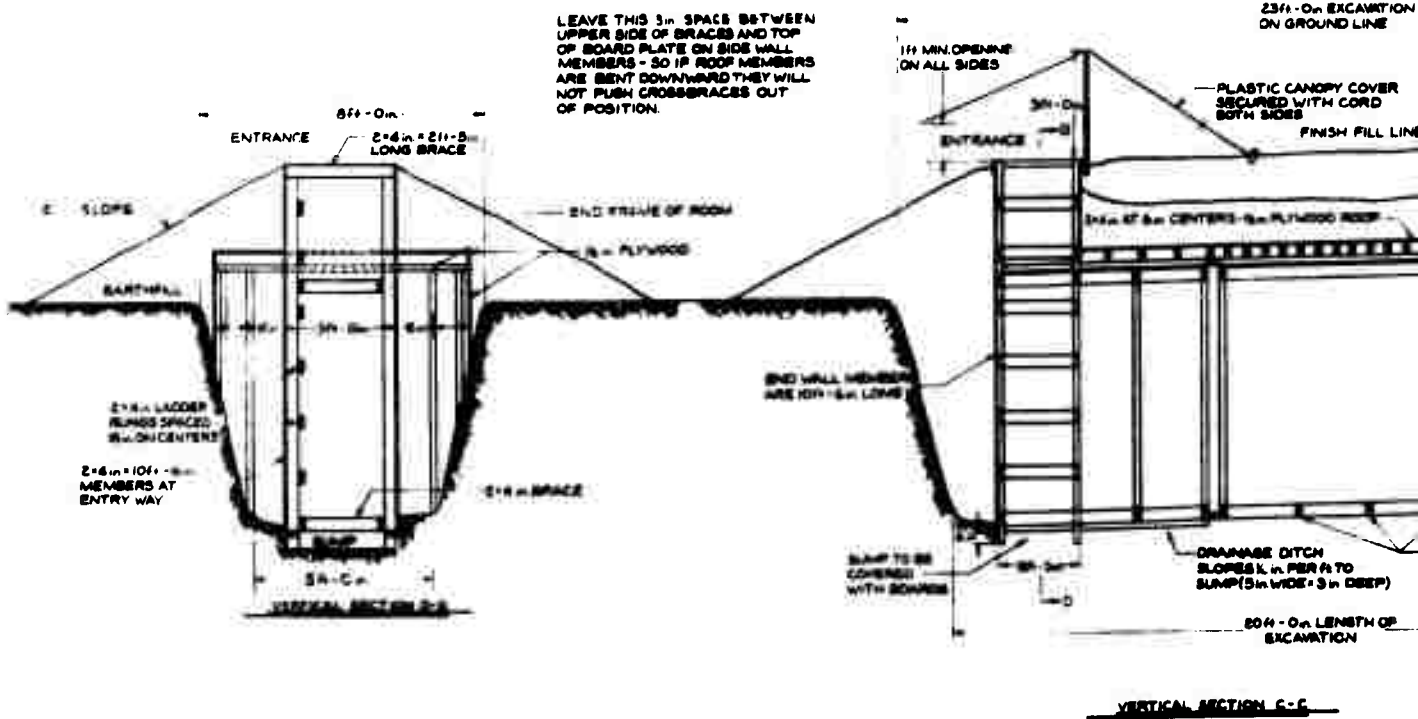
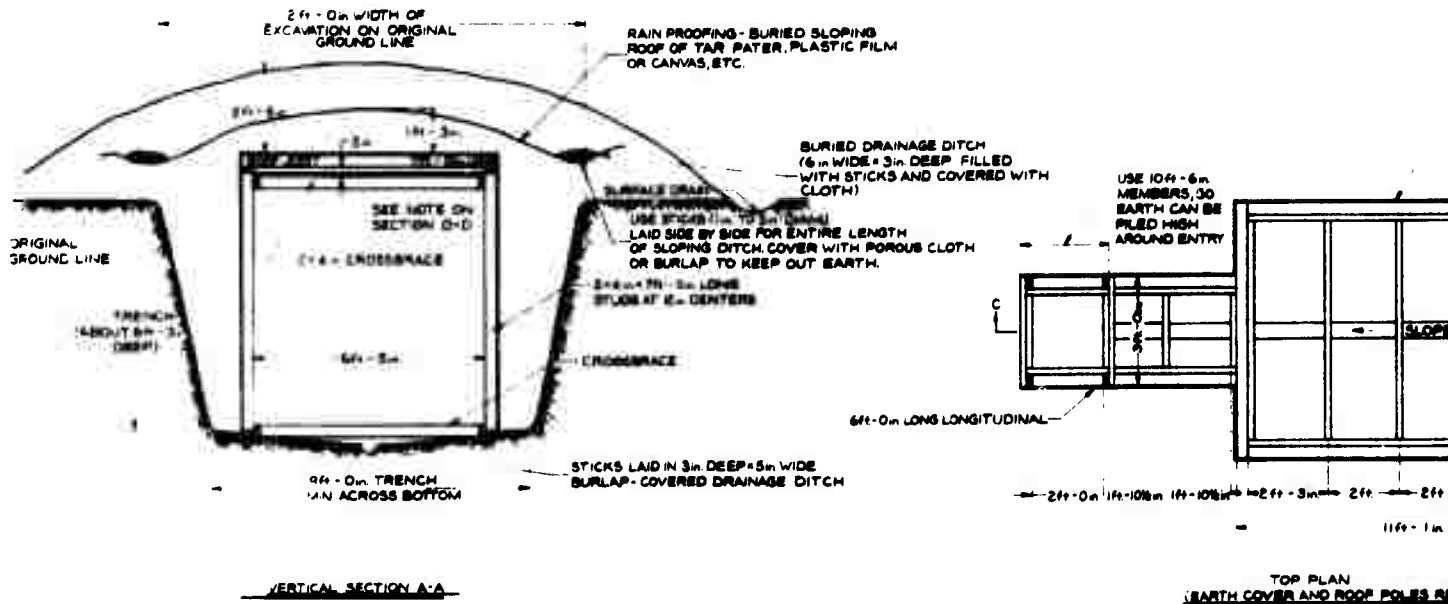

Figure A-15.2 Details of Lumber Version of Small-Pole Shell



## REFERENCES - (Appendix A)

1. G. A. Cristy, *Expedient Shelters Survey, Final Report, July 1973*, ORNL-4860, July 1973.
2. C. H. Kearny, "Hasty Shelter Construction Studies," in *Civil Defense Research Project Annual Progress Report March 1970-March 1971*, ORNL-4679, March 1972, pp. 112-122.
3. After-Action Operation Laboratory Shelter, Hq. U.S. Army XXIV Airborne Corps, Ft. Bragg, N.C.
4. C. H. Kearny and C. V. Chester, *Blast Tests of Expedient Shelters*, ORNL-4905, January 1974.
5. C. H. Kearny, "Hasty Rural Shelters," in *Annual Progress Report, Civil Defense Research Project, March 1969-March 1970*, ORNL-4566 Part 1, April 1971, pp. 65-76.
6. C. H. Kearny, "Construction of Hasty Winter Shelters," in *Civil Defense Research Project Annual Progress Report March 1971-March 1972*, ORNL-4784, 1973, pp. 78-89.
7. Protective Structures Development Center, *Expedient Community Shelter - Semi-Buried "A"-Frame*, PSDC-TR-2, May 13, 1965.
8. Protective Structures Development Center, *Expedient Community Shelter - Wood Grate Roof, Below Ground*, PSDC-TR-3, May 14, 1964.
9. Pennsylvania State University, *The Planning and Development of Expedient Shelter Facilities*, March 1965, p. 60.
10. Stanford Research Institute, *Low-Cost Family Shelters*, Oct. 1961.
11. C. H. Kearny, Letter to D. A. Bettge, "Car-Over-Trench Construction" Oct. 1973.
12. C. H. Kearny, Personal Communication, Dec. 1973.

## REFERENCES -- (Appendix A)

1. G. A. Cristy, *Expedient Shelters Survey, Final Report, July 1973*, ORNL-4860, July 1973.
2. C. H. Kearny, "Hasty Shelter Construction Studies," in *Civil Defense Research Project Annual Progress Report March 1970-March 1971*, ORNL-4679, March 1972, pp. 112-122.
3. After-Action Operation Laboratory Shelter, Hq. U.S. Army XXIV Airborne Corps, Ft. Bragg, N.C.
4. C. H. Kearny and C. V. Chester, *Blast Tests of Expedient Shelters*, ORNL-4905, January 1974.
5. C. H. Kearny, "Hasty Rural Shelters," in *Annual Progress Report, Civil Defense Research Project, March 1969-March 1970*, ORNL-4566 Part 1, April 1971, pp. 65-76.
6. C. H. Kearny, "Construction of Hasty Winter Shelters," in *Civil Defense Research Project Annual Progress Report March 1971-March 1972*, ORNL-4784, 1973, pp. 78-89.
7. Protective Structures Development Center, *Expedient Community Shelter -- Semi-Buried "A"-Frame*, PSDC-TR-2, May 13, 1965.
8. Protective Structures Development Center, *Expedient Community Shelter -- Wood Grate Roof, Below Ground*, PSDC-TR-3, May 14, 1964.
9. Pennsylvania State University, *The Planning and Development of Expedient Shelter Facilities*, March 1965, p. 60.
10. Stanford Research Institute, *Low-Cost Family Shelters*, Oct. 1961.
11. C. H. Kearny, Letter to D. A. Bettge, "Car-Over-Trench Construction" Oct. 1973.
12. C. H. Kearny, Personal Communication, Dec. 1973.

## APPENDIX B

### HOW TO MAKE AND USE A HOMEMADE, LARGE-VOLUME, EFFICIENT SHELTER-VENTILATING PUMP: THE KEARNY AIR PUMP\*

**CAUTION:** Before starting to build this unusual type of air pump, ALL WORKERS SHOULD READ THESE INSTRUCTIONS AT LEAST UP TO SECTION IV, INSTALLATION, before anyone starts work.

When getting ready to build this pump, all workers should spend the first half-hour studying these instructions and getting organized. Then, after materials are assembled, two average Americans working together should be able to complete the 3-ft model described in the following pages within 4 hours. To speed up completion, divide up the work. For example, one person can start the flaps while another begins work on the pump frame.

#### I. HOW A KEARNY AIR PUMP WORKS

As can be seen in Figs. 1 and 2, a Kearny Air Pump (KAP) operates by being swung like a pendulum. It is hinged at the top of its swinging frame. When a KAP is pulled by a cord, as illustrated (or pushed by a pole, see Fig. 24) its flaps are closed, and it pushes and "sucks" air through the opening in which it swings. This is called its power stroke. During its power stroke, a KAP's flaps are closed against its flap-stop wires or strings, which are fixed in the plane of its frame.

When a KAP swings freely back as a pendulum on its return stroke, all its flaps are opened by air pressure, and the pumped air stream, due to its inertia, continues to flow in the pumped direction, while the pump swings in the opposite direction.

---

\* Excerpts from ORNL-TM-3916, "How to Make and Use a Home-Made, Large-Volume, Efficient Shelter-Ventilating Pump: The Kearny Air Pump," by C. H. Kearny, August 1972.



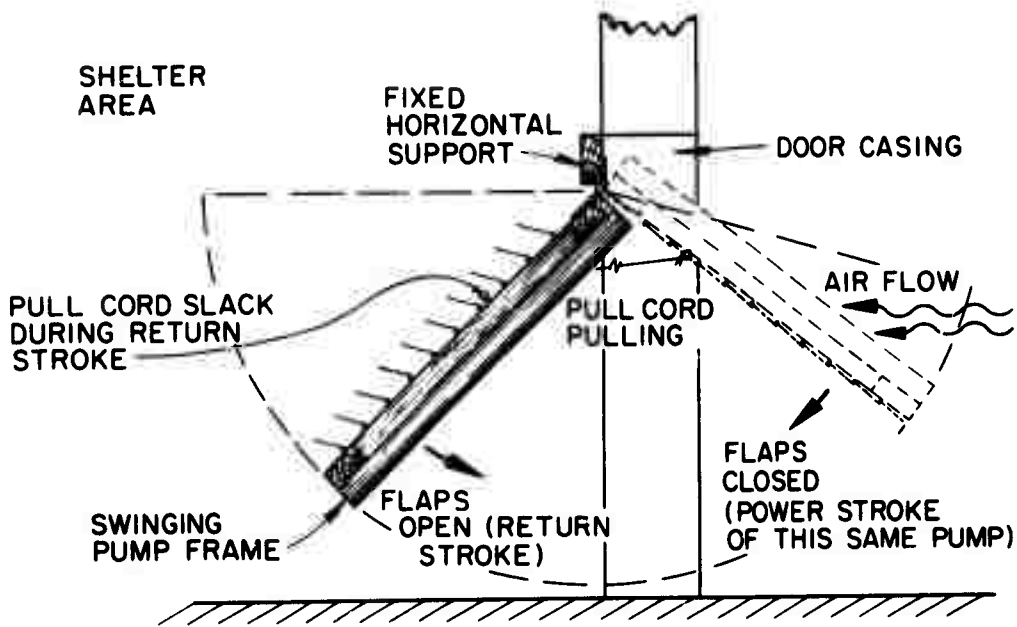

Fig. B-1. Section through doorway showing operation of Kearny Air Pump.

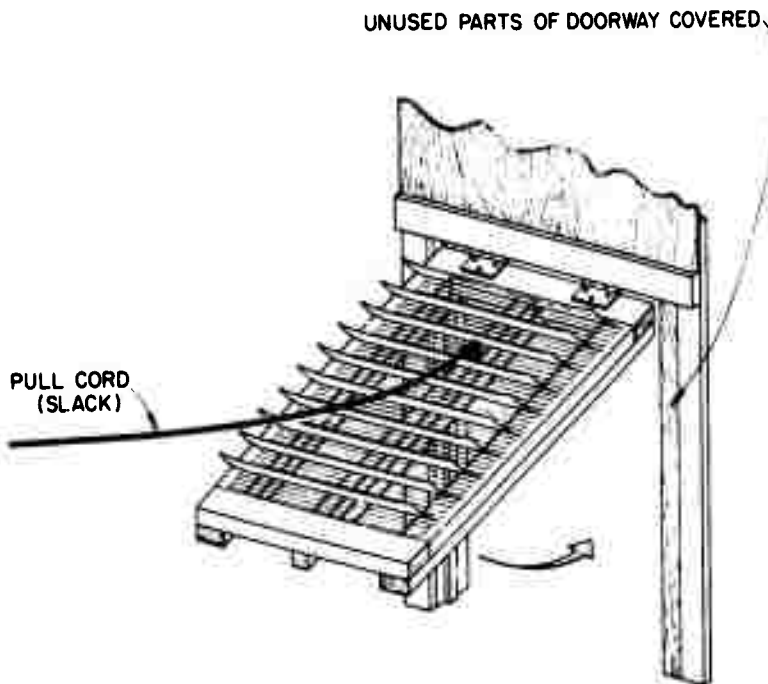

Fig. B-2. KAP in doorway (with flaps open during its return stroke).

To force outdoor air through a shelter, an air-supply KAP can be used either as an air-intake pump (see Fig. 1) by pulling it with a cord, or as an air-exhaust pump by pushing it with a pole (see Fig. 24).

For distributing air within a shelter and/or fanning the occupants, an air-distribution KAP may be hung overhead and operated as described later.

## II. INSTRUCTIONS FOR BUILDING A KEARNY AIR PUMP

### A. Materials Needed to Build a KAP 36-in. High by 29-in. Wide (the best width KAP to install in an opening 30 inches wide)

The preferred material is listed first, and second and third choices of materials for each use are listed in order. It is best to spread out and check all materials before starting construction.

#### 1. For the Wooden Pump Frame (Fig. 3) and Its Fixed Support

- a. A total of 22 ft of 1-in. x 2-in. boards. (A 1-in. x 2-in. board actually measures 3/4-in. x 1-3/4-in., but the usual, nominal dimensions will be listed.) Also, 6 feet of 1-in. x 1-in. boards, all preferably soft wood. (If boards with approximately 1-in. x 2-in. dimensions are available, use them.) No single piece need be longer than 3 ft. (Even straight sticks, metal rods, etc. can be used to make a flat-faced frame.)
- b. For the fixed horizontal support, a length of 1-in. x 4-in. (or 1-in. x 3-in., or 1-in. x 2-in.) lumber that is at least 1 ft wider than the opening in which the pump will be installed.
- c. A pair of ordinary door or cabinet butt hinges (or metal strap hinges, or improvised hinges made out of leather, woven straps, or cords, or four eyescrews which can be joined to make two hinges).
- d. Small nails (at least 18; No. 6 box nails are best — about 1/2-inch longer than the thickness of the two boards, so the nails can be bent over and clinched), plus screws or nails for the hinges.

2. For the Flaps (See Figs. 1, 2, 6, 7, and 8)
  - a. 30 ft of smooth, straight wire, at least as heavy and springy as coat-hanger wire, to make the flap pivot-wires (or 10 wire coat hangers, or 35 ft of thinner smooth wire, or about 35 ft of string, preferably nylon string about the diameter of coat-hanger wire).
  - b. 30 small staples (or 30 very small nails, or 60 tacks), to attach the flap pivot-wires to the frame.
  - c. 12 square feet of polyethylene film, 3 to 4 mils thick (3 or 4 one-thousandths of an inch thick) in pieces at least 30-in. wide (or plastic drop cloth; or raincoat-type coated fabric; or even tough paper as a last choice, in pieces capable of being cut into ten rectangular strips, each 30-in. x 5-1/2-in.).
  - d. Pressure-sensitive waterproof tape, 30 ft of 3/4" or 1"-wide tape, any cloth duct tape or glass tape that does not stretch and then shrink afterwards and wrinkle the flaps (or adhesive, Scotch, or masking tape) to secure the hem tunnels of the flaps. Or use needle and thread to sew the hem tunnels to the flaps.
3. For the Flap-Stops
  - a. 150 ft of light string (or 150 ft of light smooth wire, or very strong thread).
  - b. 90 tacks or 90 very small nails. (Tacks or nails are desirable but not essential, since the flap-stops can be tied to the frame.)
4. For the Pull-Cord  
10 ft of cord (or strong string or wire).

B. Desirable Tools

Hammer	Scissors
Saw	Knife
Wirecutter pliers	Yardstick
Screwdriver	Pencil

C. Steps to Build a 36-in.-High x 29-in.-Wide Kearny Air Pump\*

A 36-in. x 29-in. KAP with good hinges is most effective if operated in an air-intake or exhaust opening about 40-in. high and 30-in. wide. (If the shelter could have more than 25 occupants in hot weather, read all these instructions in order to understand how to build a larger pump, as briefly described in Section VI.)

NOTE THAT THE WIDTHS AND THICKNESSES OF ALL FRAME PIECES ARE EXAGGERATED IN ALL ILLUSTRATIONS.

1. The Frame

- a. Cut two pieces of 1-in. x 2-in. boards, each 36-in. long, and two pieces of 1-in. x 2-in. boards, each 29-in. long; then nail them together (see Fig. 3). Use nails that do not split the wood, preferably long enough to go through the boards and stick out about 1/2 in. on the other side. (To nail thus, first block up the frame so that the nail point will not strike the floor.) Then bend over nail points which go through.

Next, cut and nail onto the frame a piece of approximately 1-in. x 1-in. lumber 36-in. long, for a center vertical brace. (If you lack time to make or find a 1-in. x 1-in. board, use a 1-in. x 2-in. board.) Figure 3 shows the back side of the frame; the flap valves will be attached on the front (the opposite) side.

---

\* A 4-ft x 29-in. KAP should be made essentially the same way as a 3-ft x 29-in. KAP. Merely make the frame 48 inches instead of 36 inches and make 13 flaps instead of 10.

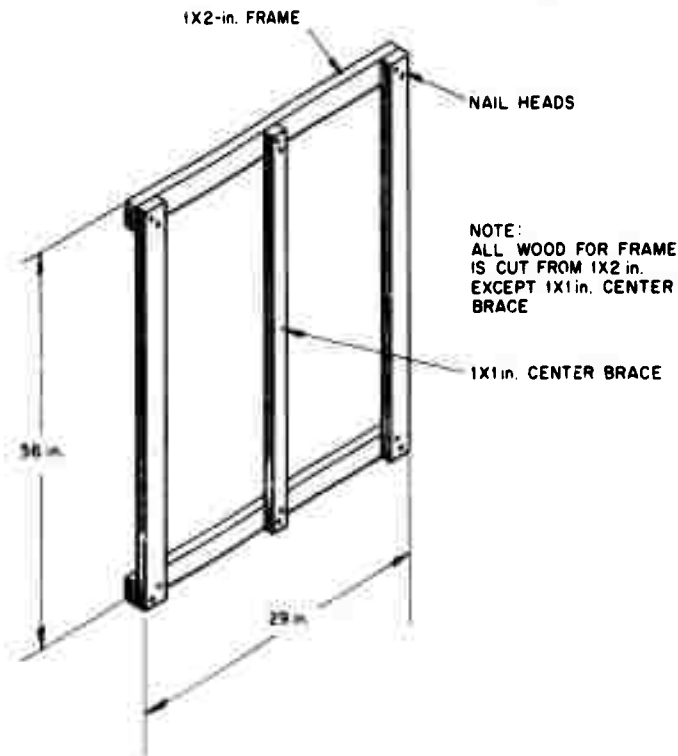

Fig. B-3. KAP frame (looking at the back side of the frame).

- b. To make the front side smooth and flat so that the flaps will close tightly, fill in the spaces as follows: cut two pieces of 1-in. x 2-in. boards long enough to fill in the spaces on top of the 36-in. sides of the frame between the top and bottom horizontal boards; nail them in place. Do the same thing with a 1-in. x 1-in. board (or whatever size board you used for the center brace) as a filler board for the center brace (see Fig. 4).

If the frame is made of only one thickness of board  $\frac{3}{4}$  to 1-in. thick, it will not be heavy enough to swing back far enough on its free-swinging return stroke.

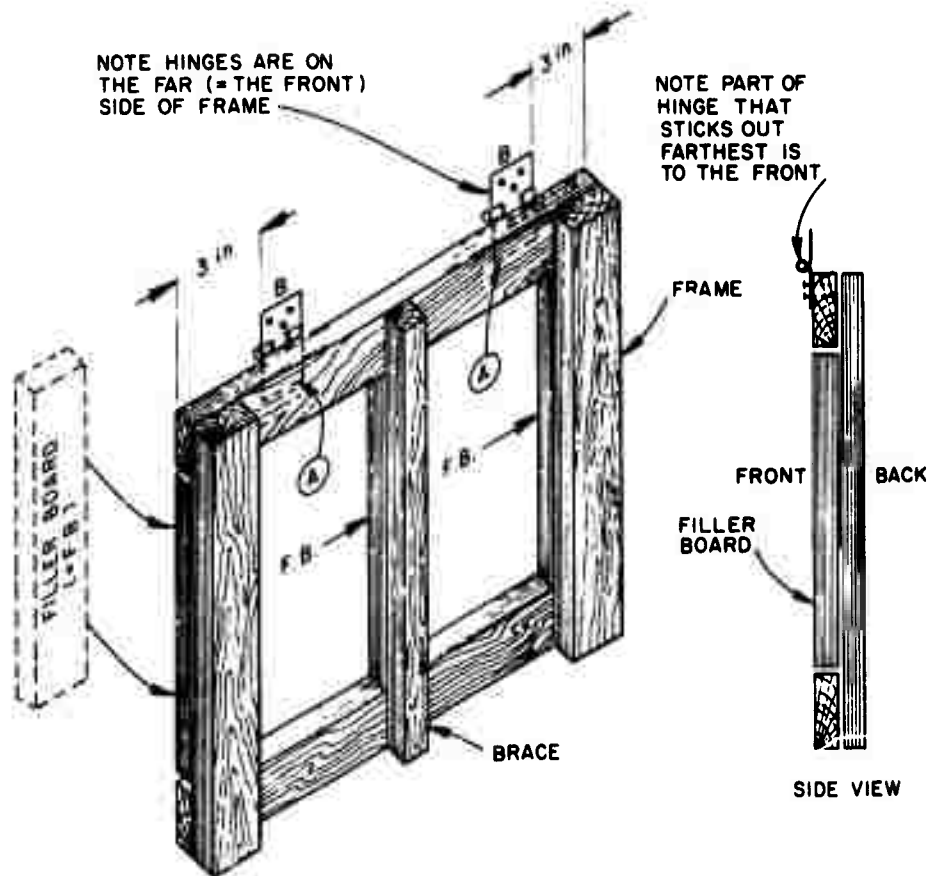

Fig. B-4. Completing the frame.

## 2. The Hinges

Ordinary door butt hinges are best, but, in order that the pump can swing even past the horizontal position, the hinges should be screwed onto the top of the frame (pick one of the 29-in. boards and call it the top) in the positions shown in Fig. 4. (If no drill is available to drill a screw hole, make a hole by driving a nail and then pulling it out. Screw the screw into the nail hole.)

## 3. The Flaps

- a. Make 10 flap pivot wires.

If smooth straight wire as springy and thick as the wire of coat hangers is available, make ten 28-1/2-in.-long,

straight lengths of wire. If not, use wire from coat hangers, or strings. First, cut off all of the twisted and hooked vertical handle part of each coat hanger. If using only ordinary pliers, use its cutter to "bite" the wire all around; then it will break at this point if bent there. Next, straighten each wire carefully. Straighten all the minor bends so that each wire is straight within 1/4-in. Proper straightening takes 1 to 5 minutes per wire. To straighten, repeatedly grasp the bent part of the wire with pliers in slightly different spots, each time bending the wire a little with the other hand. Finally, cut each wire to 28-1/2-in. lengths.

b. Make 10 polyethylene flaps.

First cut ten strips, making each strip 30-in. long by 5-1/2-in. wide (see Fig. 5). To cut plastic flaps quickly and accurately, cut a long strip of plastic 30-in. wide.

ORNL DWG 71-7004A

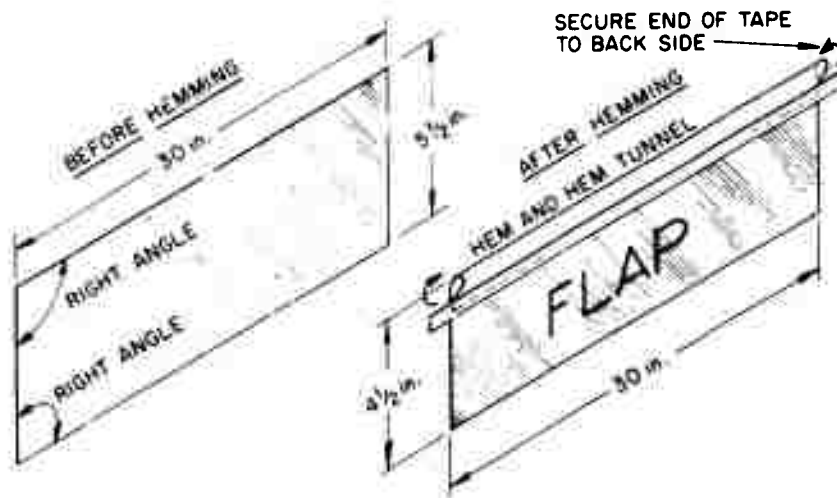

Fig. B-5. Flap pattern.

Then cut off a flap by: (1) drawing a cutting guideline on a wide board 5-1/2-in. from an edge; (2) placing the 30-in.-wide plastic strip clear across this board, with

its end edge just reaching the edge of the board; (3) placing a second board over the plastic on the first board, with a straight edge of this second upper board over the guideline on the lower board, and finally, (4) cutting off a flap by running a sharp knife along the straight edge of the upper board.

To form a hem along one of the 30-in. sides of a 5-1/2-in. x 30-in. rectangular strip, fold in a 1-in. hem. To hold the folded hem while taping it, paper clips or another pair of hands are helpful. Make each hem with two pieces of pressure-sensitive tape, each about 1-in. wide and 16-in. long. Or make the hem by sewing it shut very close to the cut edge, to form a hem-tunnel (see Fig. 5).

After the hem has been made, take a pair of scissors and cut a notch (see Figs. 6 and 7) in each hemed corner of the flap. Avoid cutting the tape holding the hem. This notch should extend downward about 1/2-in. and should extend horizontally from the outer edge of the flap to 1/4-in. inside the inner side of the frame, when the flap is positioned on the frame as shown in Fig. 6.

ORNL-DWG 66-12324

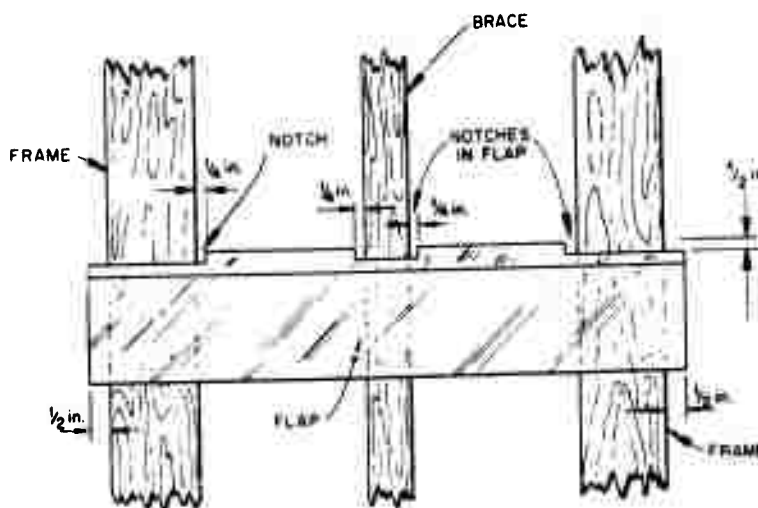

Fig. B-6. Size of notches in flaps



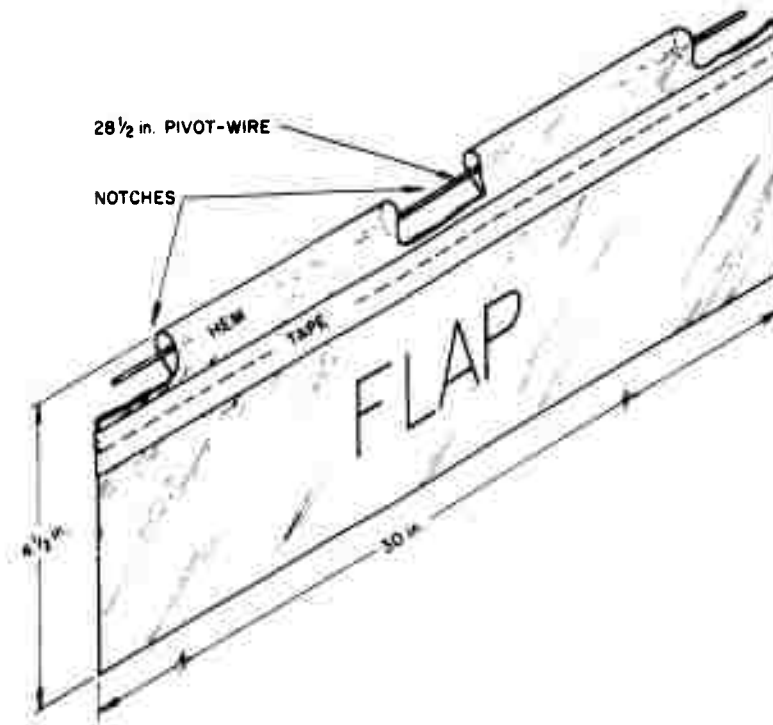

Fig. B-7. Finished flap.

- Also, cut a notch in the center of the flap (along the hem line) so that this notch extends 1/2-in. downward and extends horizontally 1/4-in. beyond each of the two sides of the vertical brace (see Fig. 6). But if building a pump using wire netting for the flap-stops as in Section III, then do not cut out a notch in the center of a flap.
- c. Take the 10 pieces of straightened wire and insert one of them into and through the hem-tunnel of each flap, like a curtain rod running through the hem of a curtain. Check to see that each flap swings freely on its pivot-wire, as illustrated by Figs. 7 and 8.

ORNL-DWG 66-12325

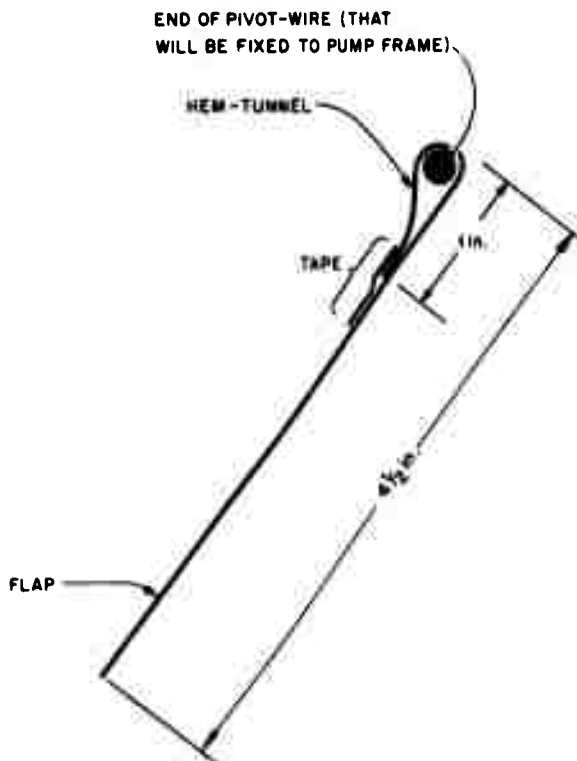

Fig. B-8. End view of flap.

- d. Put the flaps and their pivot-wires to one side for use after the flap-stops and the hinges have been attached to the frame, as described below.
- e. Using the ruler printed on the edge of this page, mark the positions of each pivot-wire (the arrowheads numbered 0, 3-1/4, 6-1/2, 9-3/4 in.) and the position of each flap-stop (the four unnumbered marks between each pair of numbered arrowheads on this ruler). All of these positions should be marked both on the vertical sides of the 36-in.-long boards of the frame and on the vertical brace. Mark the position of the uppermost pivot-wire (the "0" arrowhead on the ruler) 1/4-in. below the top board to which the hinges have been attached (see Figs. 9 and 10).



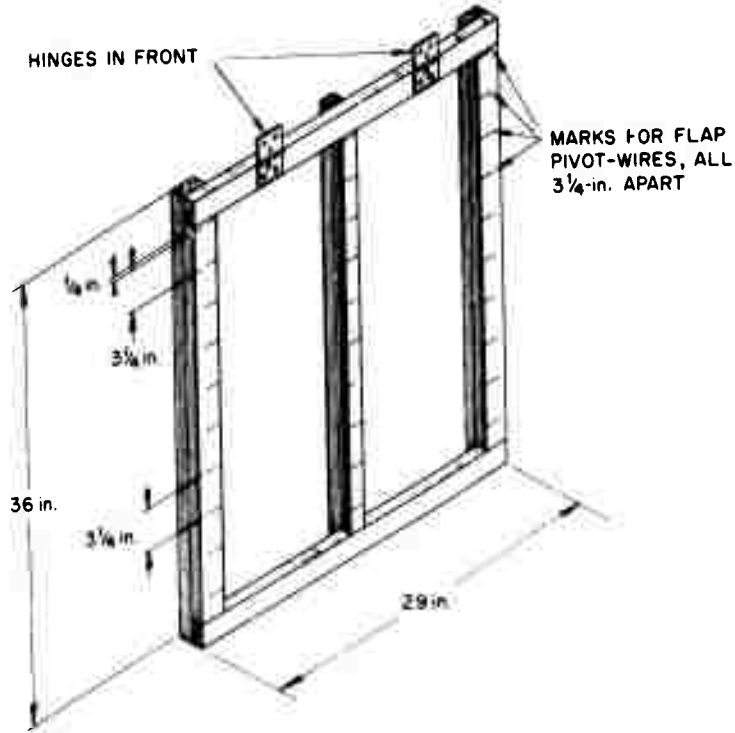

Fig. B-9. Marking for pivot wires.

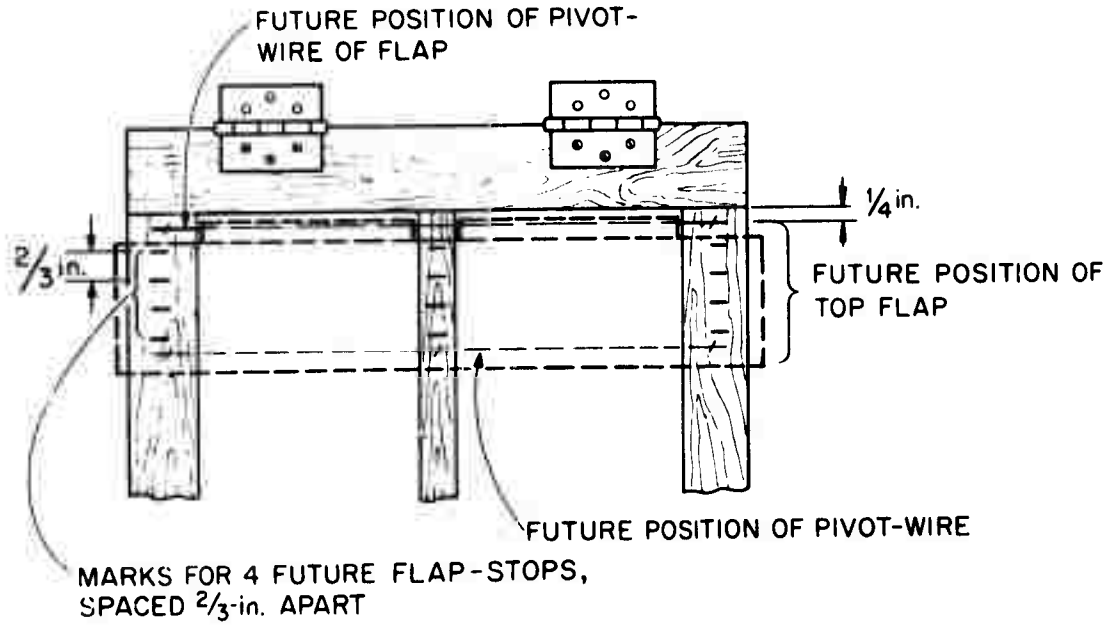

Fig. B-10. Marking for flap stops.

#### 4. The Flap-Stops

In order that the flaps may turn (open) on only one side (the front, or face) of the frame, attach horizontal flap-stops (strings or wires) across the face of the frame (see Figs. 10 and 11). Nail or tie four of these flap-stops between each pair of the marked future positions of the horizontal pivot-wires of the flaps, being careful not to connect any flap-stops so that they cross the horizontal open spaces in which the flap pivot-wires will be attached later.

ORNL DWG 71-7007

NOTE:  
SKETCH NOT DRAWN  
TO SCALE

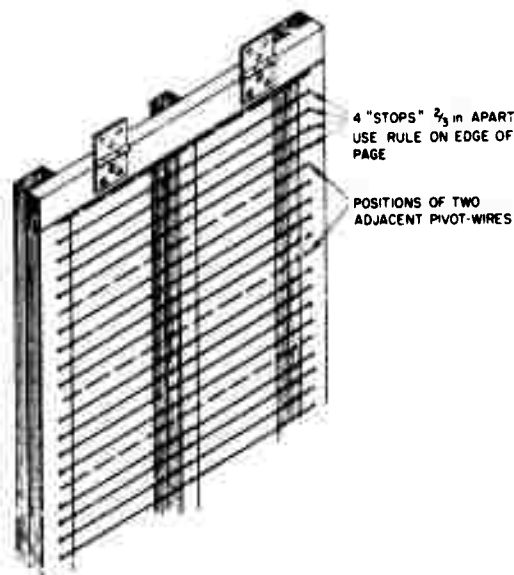

Fig. B-11. Attaching flap stops.

If tacks or very small nails are available, drive three in a horizontal line to attach each flap-stop — two in the vertical 36-in. sides of the frame and one in the vertical center brace (see Fig. 11). First, drive all of these horizontal lines of tacks about three-quarters of the way into the boards. Then, secure the flap-stop string or thin wire tight to grip the string (see Fig. 11). (If no tacks or nails are available, merely cut notches where the flap-stops are to be attached;

cut these notches in the edges of the vertical sides of the frame and in an edge of the center brace.) Next, secure the flap-stops (strings or wires) in their proper positions by tying each stop in its notched position. This tying should include wrapping each horizontal flap-stop once around the vertical center brace. The stops should be in line with (in the same plane as) the front of the frame. Do not stretch stops too tight, or it may bend the frame.

#### 5. Final Assembly

- a. Staple, nail, tack, or tie the ten flap pivot-wires, or pivot-strings (each with its flap on it) in their marked positions, at the marked 3-1/4-in. spacings. Start with the lowest flap and work upward (see Fig. 11). Connect each pivot-wire at both of its ends to the 36-in. vertical sides of the frame, and also connect it to the vertical center brace. BE CAREFUL TO NAIL THE PIVOT-WIRES ONLY TO THE FRAME AND THE BRACE AND DO NOT NAIL ANY PLASTIC DIRECTLY TO THE WOOD.
- b. Screw or nail the upper halves of the hinges onto the horizontal fixed support board on which the KAP will swing. (A 1-in. x 3-in. board, at least 12-in. wider than the doorway or other opening for this KAP, is best.)

Be careful to attach the hinges in the UNusual, OUT-OF-LINE POSITION shown in Fig. 12.

CAUTIONS: Do NOT attach a KAP's hinges directly to the door frame; its hinges will be torn loose on its return stroke, or on its power stroke.

If making a KAP to fit into an opening, make the KAP 4-in. SHORTER than the height of its opening.

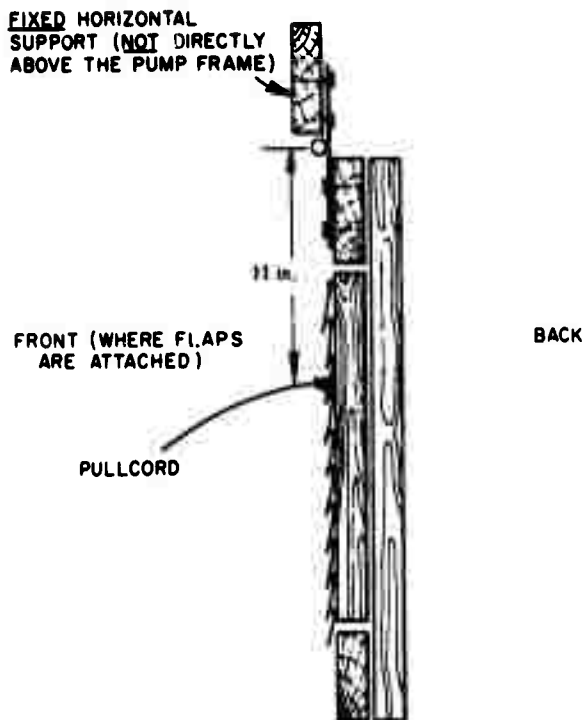

Fig. B-12. Side view of assembly.

- c. For this 3-ft model, tie the pull-cord to the center brace 11-in. below the hinge line. (If it is tied lower, the required arm movements will waste energy.) Use small nails or wire to keep the tie from slipping up or down on the center brace. For a more durable connection, see instructions in Section.

### III. A QUICKER CONSTRUCTION

Skip this section if chicken wire and 1/4-in.-thick boards are not readily available.

If chicken wire and boards about 1/4-in. thick are available to use as the flap-stops, the time required to build a given KAP can be reduced by about 40%. One-inch woven mesh is best. (Hardware cloth is unsatisfactory because it has sharp points, and window screen is unsatisfactory because it resists air flow too much.)

Figure 13 illustrates how the mesh wire should be stapled to the KAP frame. Next, unless the KAP is wider than 3 ft, the front of the whole frame, except for the center brace, should be covered with thin boards approximately 1/4-in. thick, such as laths. Then the pivot-wires, with their flaps on them, should be stapled onto the 1/4-in.-thick boards. This construction permits the flaps to turn freely in front of the chicken-wire flap-stops.

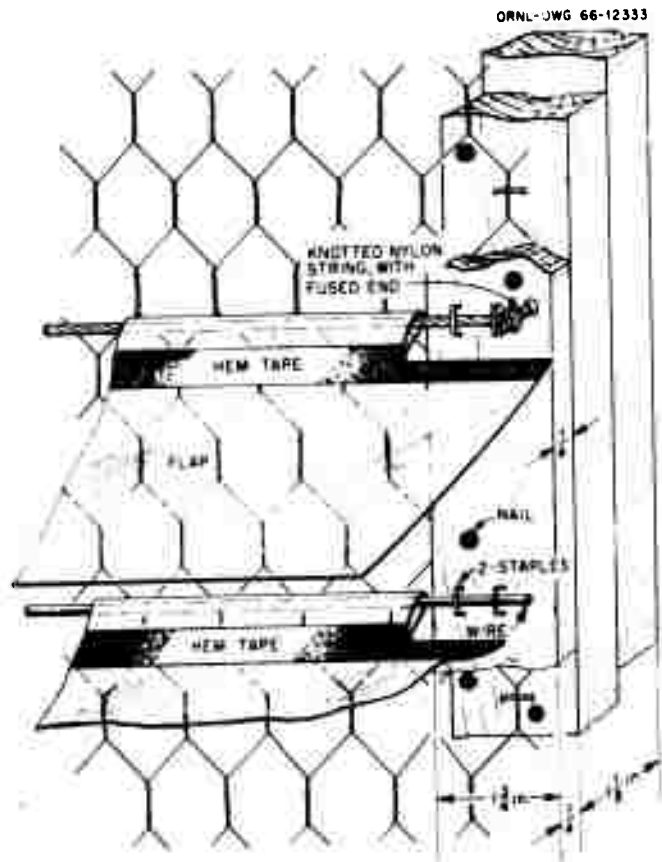

Fig. B-13. Mesh wire stops

With this design, the center of each pivot-wire should NOT be connected to the center brace, nor should the center of the flap be notched. However, the pivot-wires attached this way must be made and held straighter than the pivot-wires used with flap-stops made of straight strings or wires. Or strong pivot-strings should be used.

Note in Fig. 13 that each pivot-wire is held firm and straight by two staples securing each of its ends. The wire used should be at least as springy as coat hanger wire. For pivot-strings, nylon about the diameter of coat hanger wire is best.

If the KAP is wider than 3 ft, then the center vertical brace should also be covered with a 1/4-in.-thick board, the center of each flap should be notched, and the center of each pivot-wire (or pivot-string) should be attached to the center brace.

#### IV. INSTALLATION

##### A. Minimum Open Spaces Around a KAP

To pump its maximum volume, an air-supply KAP with good hinges should be installed so that it swings with a clearance of only about 1/2-in. above the bottom of its opening and only 1/2 to 1-in. from the sides of its opening.

##### B. Large Enough Air Passageways

When using a KAP as an air-supply pump to force air through a shelter, it is essential to provide a low-resistance air passageway all the way through the shelter structure from an outdoor air-intake opening to a separate, outdoor air-exhaust opening (see Fig. 14).

If smaller air passageways or air-exhaust openings are provided, the volume of air pumped will be greatly reduced. For example, if the air-exhaust opening is only 1-3/4 square feet (that is, only 1/4 of the size of this KAP), then this KAP will pump only about 500 cfm. And if the air-exhaust opening is only a 6-in. x 6-in. exhaust duct (1/4-sq ft), then this same 36-in. x 29-in. KAP will pump only about 50 cubic feet per minute — not enough outdoor air for more than one shelter occupant in a well-insulated shelter under heat-wave conditions in one of the hotter parts of the United States. In contrast, when the weather is cold, and while the shelter itself is cold enough to absorb the heat produced by the shelter occupants, this same 6-in. x 6-in. exhaust duct and the air-intake doorway will cause about 50 cfm of outdoor air to



flow by itself through the shelter without using any pump. This is because in cold weather body heat warms the shelter air, and warm air rises. Under these cold conditions — provided the air is distributed evenly throughout the shelter by KAP or otherwise — 50 cfm is enough outdoor air for about 17 people.

66-12331AR

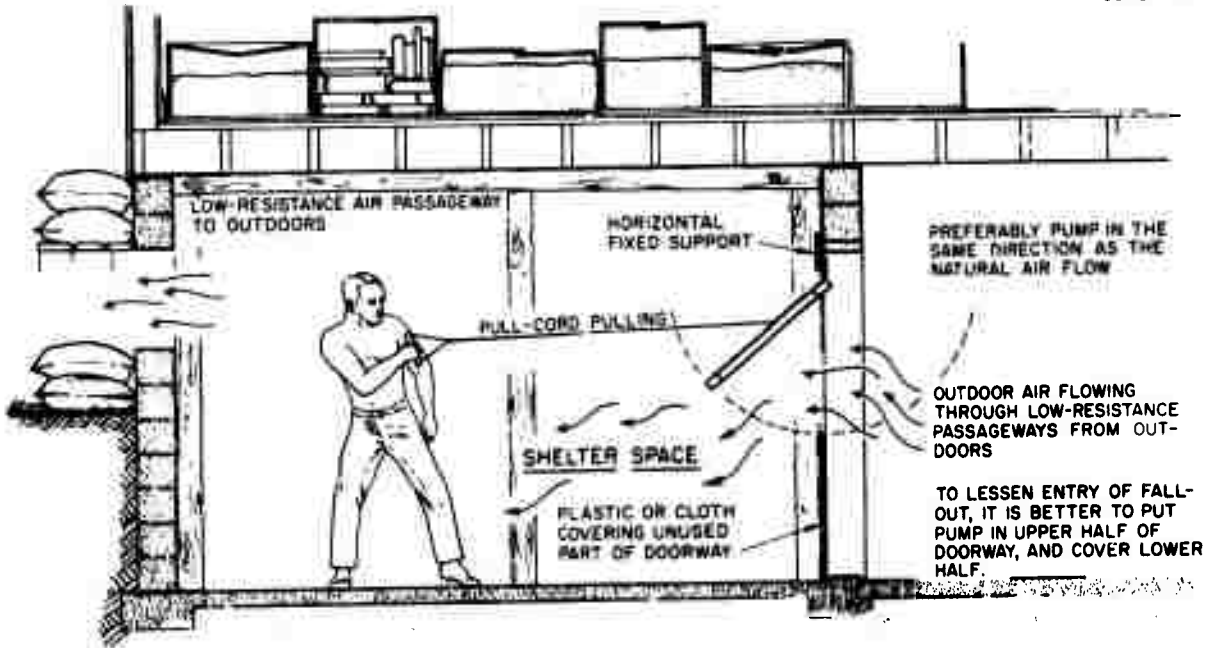

Fig. B-14. Installation of Kearny Air Pump.

To provide adequately large air passageways for air-supply KAP's to ventilate shelters in buildings, in addition to opening and closing doors and windows, you may have to build large ducts (as described below), or even break holes in windows, ceilings, or walls to make large efficient air passageways.

Figure 15 illustrates how a 3-ft KAP can be used as a combined air-supply and air-distribution KAP to adequately ventilate a small underground shelter with an exhaust opening too small to provide adequate ventilation in warm weather. (A similar installation can be used to ventilate a basement room having only one opening, its doorway.) Note how, by installing a "divider" in the doorway and entryway, the single

entryway is converted into a large air-intake duct and a separate, large air-exhaust duct. To attain the maximum increase in volume of fresh outdoor air that can be pumped through the shelter — a total of about 1000 cfm for a 36-in. x 29-in. KAP — the "divider" should extend about 4 ft horizontally into the shelter room, as shown in Fig. 15. The end 6 ft of the "divider" (the approximately horizontal part under the KAP) advantageously can be made of plywood, provided it is so installed that it can be jerked out of the way in a few seconds.

ORNL DWG 72-6630

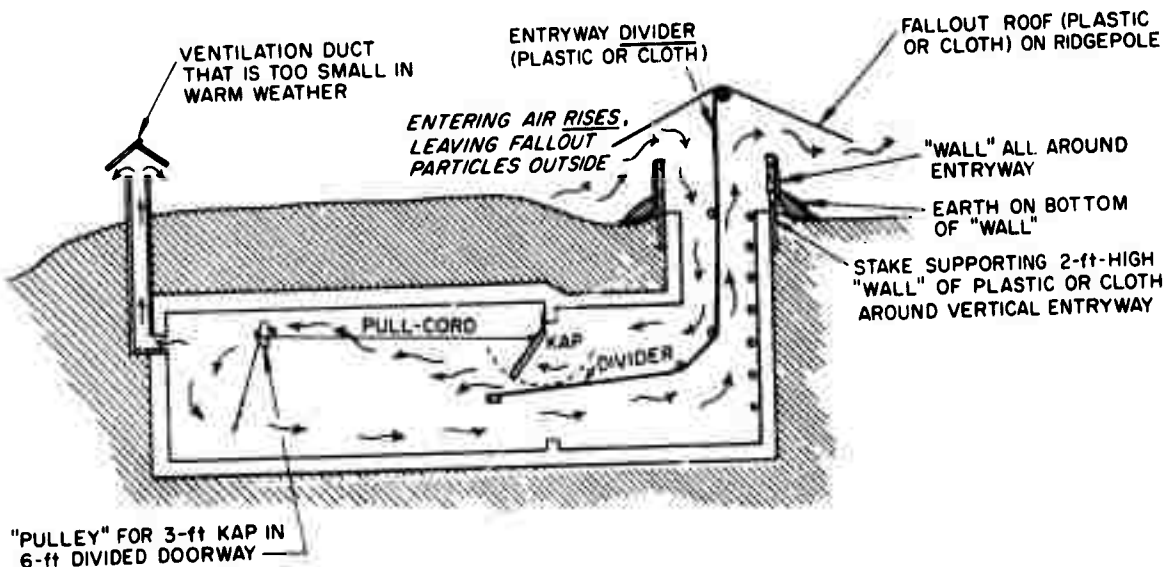

Fig. B-15. Use of air divider.

Note also how the entry of fallout into a shelter can be minimized by covering the entryway with a "roof" and by forcing the slow-moving entering air to rise over an obstruction (the "wall") before it flows into the shelter.

### C. Adequate Distribution of Air Within the Shelter

To make sure that each shelter occupant gets his fair share of the outdoor air pumped through the shelter, air-distribution KAP's should be used inside most large shelters, separate from and in addition to air-supply KAP's (see Fig. 16). Air-distribution KAP's can serve in place of both air-distribution ducts and cooling fans. For these purposes, one or more 3-ft KAP's hung overhead from the shelter ceiling are usually most practical. If KAP's cannot be readily hung from the ceiling, they can be supported on light frames made of boards or metal, somewhat like those used for a small child's swing.

ORNL DWG 72-7547

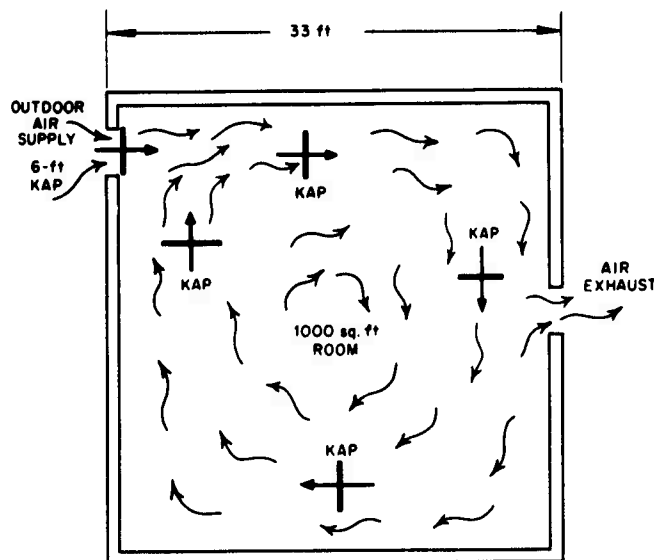

Fig. B-16. Air distribution in large shelter.

Make and use enough KAP's to cause air movement that can be felt in all parts of the shelter. Remember that if KAP's are installed near the floor and the shelter is fully occupied, then the occupants' bodies will partially block the pumped airflows more than if the same KAP's were suspended overhead.

As a general rule, for shelters having more than about 20 occupants, provide one 3-ft air-distribution KAP for every 25 occupants. In relatively wide shelters, these interior air-distribution KAP's should be

positioned so that they produce an airflow that circulates around the shelter and prevents the air that is being pumped into the shelter from flowing directly to the exhaust opening. Figure 16 illustrates how four KAP's can be used in this manner to distribute the air within the shelter and to fan the 100 occupants of a 1000-square-foot shelter room. Avoid positioning an air-distribution KAP so that it pumps air in a direction at more than a right angle to what will be the final direction of airflow in its location.

#### D. Operation with a Pulley

A small KAP, if installed at head height or higher, can be pulled most easily by running its pull-cord over a pulley, or over a greased homemade "pulley," such as one of those described in Figs. 17 and 18. The pulley should be hung at approximately the same height as the hinges of the KAP, as illustrated in Fig. 15. To make a comfortable hand hold on which to pull downward on the end of the pull-cord, tie two or three overhand knots in a strip of cloth.

Such a "pulley" can also be used to operate a bail bucket remotely to remove water or wastes from the shelter.

### V. OPERATION AND MAINTENANCE

#### A. Pumping

Operate the 3-ft KAP by pulling it with an easy, swinging motion of the arm. To pump the maximum volume of air, it should be pulled toward the operator until its frame swings out almost horizontal. Then quickly move the hand so that the pull-cord is kept slack during the entire, free-swinging return stroke. This necessary motion is described in the following section, VI-B.

Be sure to provide a comfortable handhold on the pull-cord. Blisters can be serious under unsanitary conditions.

ORNL DWG 71-7242

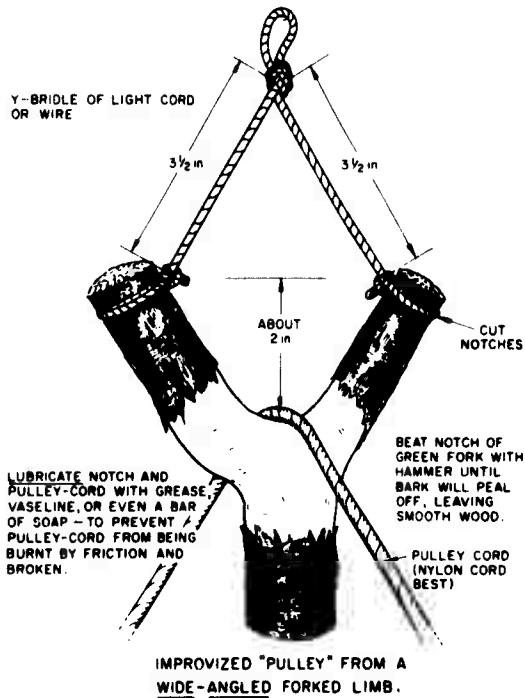

Fig. B-17. Improvised pulley from a wide-angled forked limb.

ORNL DWG 71-7243

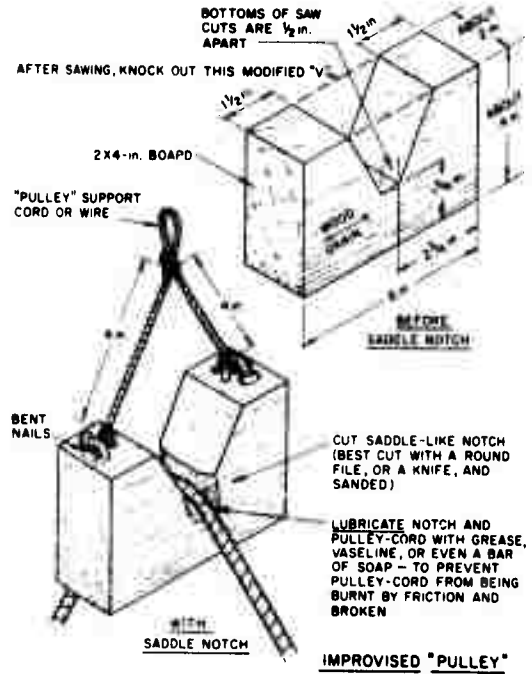

Fig. B-18. Improvised pulley with saddle notch.

To pull a KAP via an overhead pulley with minimum effort, sit down and pull as if tolling a bell -- except raise your hand and keep it raised -- so that the pull-cord remains slack, during the entire return stroke. Or move back away from the pulley and operate the KAP by swinging an extended arm back and forth from the shoulder.

**B. Taking Advantage of the Natural Direction of Air Flow**

A KAP can pump more air through a shelter if it is installed so that it pumps air through the shelter in the direction in which the air naturally flows. Since this direction can be reversed by a wind change outdoors, it is desirable to provide means for quickly removing the pump and repositioning it so that it pumps air in the opposite direction. This can be done by making one set of quick-removal brackets in one air opening and a second set in the other.

### C. Using Quick-Removal Brackets to Reduce Blast Hazards

Beyond the area in which shelters are actually wrecked by a nuclear explosion is a much larger area in which injuries can be caused by this same explosion. As an extreme example, a 25-megaton weapon, if surface bursted at a distance of 9.2 miles away, can produce blast overpressures of 4 pounds per square inch (psi), with accompanying blast winds blowing 130 miles per hour. Nineteen miles away, the blast overpressure is reduced to about 1.4 psi, and the velocity of the blast wind is only some 50 mph.

However, over these extensive areas in which most fallout shelters would survive, hurricane-like blast winds would rush into the surviving fallout shelters. The relatively low-level shock waves and blast winds experienced in these areas could pick up a KAP or other object that remained in a doorway and could hurl it into the shelter room. Shelter occupants could be injured if they were hit by such flying objects, whereas they probably would not be hurt by the hurricane-velocity winds themselves if they had taken protective action.

Shelter occupants expecting an attack should be ready, if they see a very bright flash, to get out of the path of the blast winds that might soon enter, and to lie down on the floor.

Between the moment a typical foreign nuclear weapon would explode and give off a very bright light, and the moment the shock wave and blast winds would reach a fallout shelter located far enough away so as not to be destroyed, enough time would elapse to permit prepared occupants to get KAP's and themselves out of entryways and other pathways of entering shock waves and blast winds. For example, at a point 3 miles away from a one-megaton surface burst, the maximum unreflected overpressure is 4.2 psi, and the accompanying blast wind blows about 130 mph and takes 9 seconds to arrive. At the same overpressure and wind velocity from a 10-megaton surface burst, the distance is 6.5 miles, and the time interval is about 20 seconds.

If a 6-ft KAP is supported in a quick-removal bracket (see Fig. 19), then a man standing beside it can — within 3 or 4 seconds of seeing a bright flash — grasp the pump frame with both hands, lift it upward a few inches, and carry the KAP out of the way.

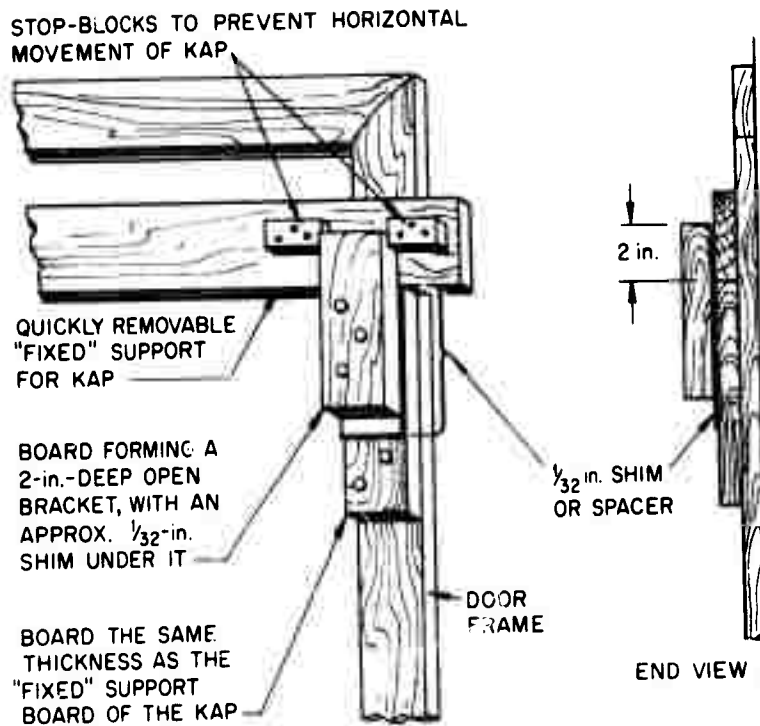

Fig. B-19. Quick-removal bracket.

#### D. Maintenance

To operate a KAP efficiently, keep its flaps in good repair and make sure that there is the minimum practical area of open spaces (both in and around the KAP) through which air can flow back, in the opposite-to-the-pumped direction. Therefore, keep in the shelter at least some extra flap material, some extra tape, and the few tools needed to make repairs.

### VI. LARGER KEARNY AIR PUMPS

#### A. Construction

A 6-ft-high x 29-in.-wide model can be constructed in the same way as a 3-ft model — except that it should have a horizontal center brace (a board about  $\frac{3}{4}$ -in. thick and  $1\frac{3}{4}$ -in. wide is best), as well as a vertical center brace of this size board. To increase the strength of a 6-ft KAP, all parts of its double-thickness frame and its vertical

center brace should be made of two thicknesses of approximately 3/4-in. x 1-3/4-in. soft wood boards, securely held together with clinched nails. Also, to increase the distance that the pump will swing back by itself during its return stroke, it is worthwhile to attach a 6-ft piece of 3/4-in. x 1-3/4-in. board (not illustrated) to the back of each side of the frame. Do not attach weights to the bottom of the frame; this would slow down the pumping rate.

The flaps on the lower part of a large KAP must withstand hard use. But if 1/2-in.-wide strips of tape are attached along the bottom and side edges of these lower flaps, then even flaps made of ordinary 4-mil polyethylene will remain serviceable for over 1000 hours of pumping. However, the lower flaps of large KAP's can advantageously be made of 6-mil polyethylene.

The pull-cord should be attached to the vertical center brace of a 6-ft KAP about 14-1/2-in. below the hinge line. A 3/16-in. nylon cord is ideal.

To adequately ventilate and cool very large and crowded shelters in buildings, mines, or caves, KAP's larger than 72-in. x 29-in. should be used. Better advantage can be made of large doorways, elevator shaft openings, etc., by "tailor-making" each air-supply KAP to the size of its opening — that is, by making it as large as is practical. The frame and brace members should be appropriately strengthened, and one or more "Y" bridles should be provided, as described in the section below. A 7-ft x 5-1/2-ft KAP, with a 1/4-in. pull-cord attached 18 in. below its hinge line, and with two "Y" bridles, pumped over 11,000 cubic feet per minute through a large basement shelter.

To make a durable connection of the pull-cord to the center vertical brace: (1) Attach a wire loop (see Fig. 20) 14-1/2-in. below the hinge line; this loop should be made of coat-hanger wire, or a softer single-strand wire, and should be kept from slipping on the center brace by bending four 6-penny nails over it in front, and two smaller nails in back. (2) Make a free-turning, triple-wire loop connected to the fixed loop. (3) Tape one end of the free-turning loop, and tie the pull-cord to this loop, tightly over the tape.



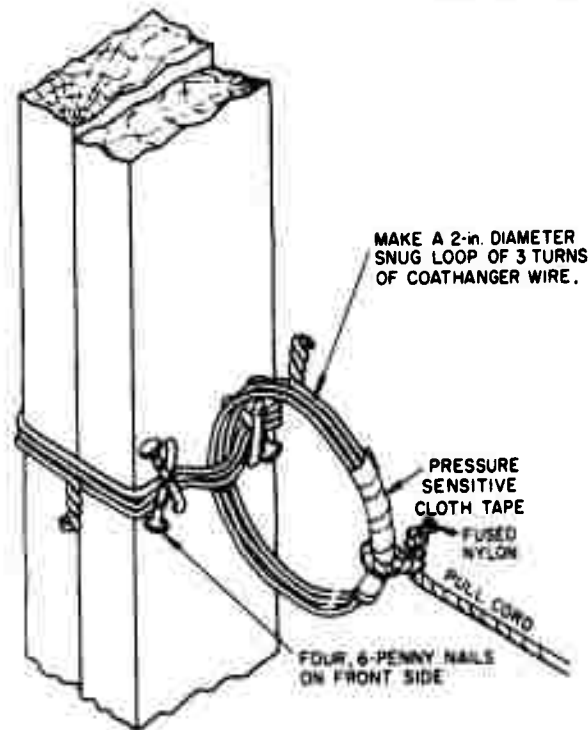

Fig. B-20. Connection of pull-cord to center brace.

B. Operation of Larger KAP's

A larger KAP can be pulled most easily by providing it with a "Y" bridle (see Fig. 21) attached to the end of its pull cord.

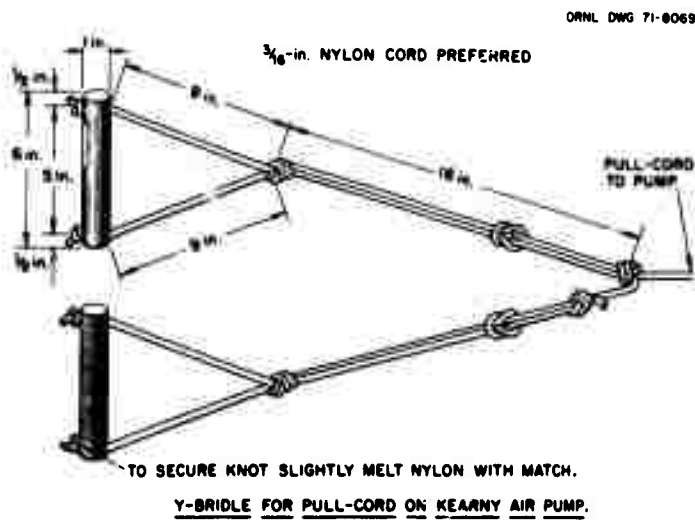

Fig. B-21. Y-bridle for pull-cord on Kearny Air Pump.

An average man can operate a 6-ft x 29-in. KAP by himself, pumping over 4000 cubic feet per minute through a typical large shelter, without working hard; tests have shown that he must deliver only about 1/20th of a horsepower. However, most people prefer to work in pairs when pulling a 6-ft KAP equipped with a "Y" bridle.

To pump the maximum volume of air with minimum effort, study Fig. 22 and follow the instructions given below for operating a big KAP.

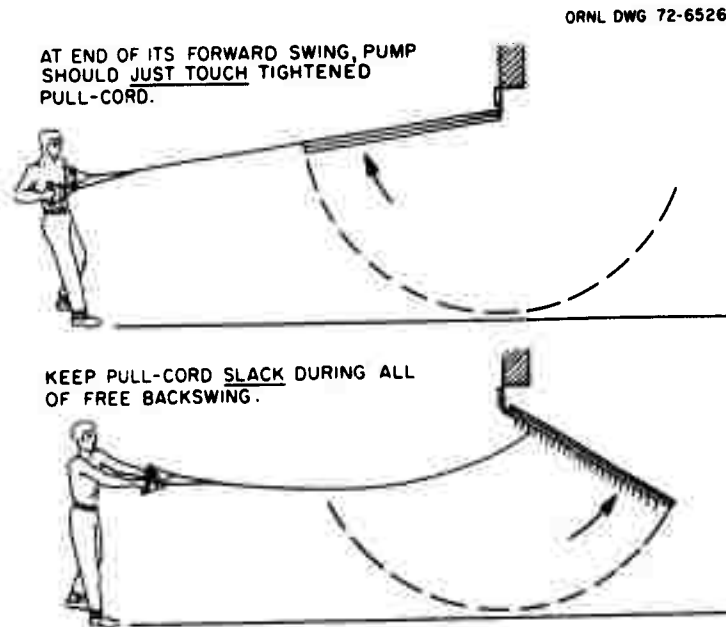

Fig. B-22. Operation of large Kearny Air Pump.

1. Gradually start the pump swinging back and forth, moving arms and body as illustrated, and pulling mostly with legs and body.
2. Stand at such a distance from the pump that you can pull the pump toward you until the forward-swinging pump just touches the tightly stretched pull-cord – and at such a distance that you can keep the pull-cord slack during the whole of the pump's free backswing.
3. To be sure you do not reduce the amount of air you pump, rapidly move your arms forward as soon as the forward-swinging pump touches the tightened pull-cord – and hold your arms forward until the pump again starts to swing toward you.

## VII. SOLUTIONS TO SPECIAL PROBLEMS

## A. Increasing the Effectiveness of a KAP

To increase the volume of air that a KAP can force through a shelter, install side baffles (see Fig. 23). Side baffles should be rigidly fixed to form two stationary "walls," one on each side of the swinging pump frame. They can be made of plywood boards, doors, table tops, or even well-braced plastic. A space, or clearance, of 1/2-in. to 1-in. should be maintained between the inner side of each baffle and the outer side of the swinging frame.

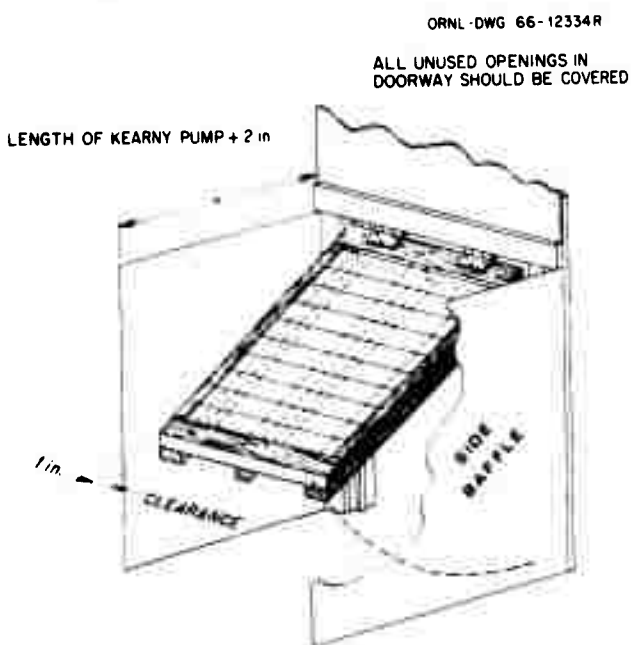

Fig. B-23. Side baffles.

Provided the KAP is in good repair and the openings around it are small, installing side baffles may increase the volume of air it will pump by up to 20%.

## B. Operating a KAP as an Exhaust Pump

In some shelters, a KAP can be operated most effectively by using it as an exhaust pump - by pushing it with a push-pole attached to its center vertical brace. Push-pole operation is sometimes the best way to

"suck" outdoor air into a shelter by pumping air out of the shelter in the natural direction of air flow, for example, up an elevator shaft or up a stairwell. This method is especially useful in those shelters in basements in which the air-intake openings — such as exposed small windows, or holes broken in the shelter ceiling — are impractical for installing KAP's.

Figure 24 shows an improvised flexible connection of a push-pole to the vertical center brace of a 6-ft KAP. This connection is best made 28-in. from the top of the frame.

ORNL-DWG 66-1232P

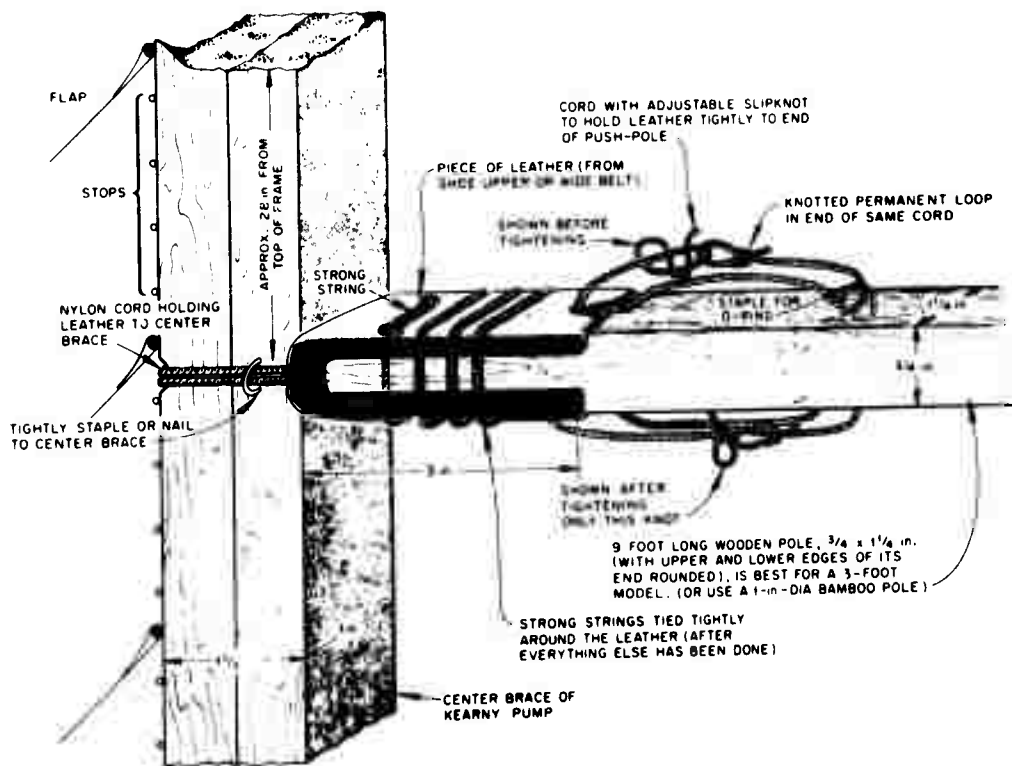

Fig. B-24. Push-pole flexible connection.

To pump a large KAP most effectively with a push-pole, stand with your back to the KAP, grasp the push-pole with both hands, and — using mostly your leg muscles — push the KAP by pulling the free end of its push-pole toward you.

### C. Ventilating a Shelter with Only one Opening

Some basement rooms that may be used as shelters have only one opening, the doorway. A KAP can be used to ventilate such a shelter room — provided enough well-mixed and distributed air is moving, or can be pumped in from outdoors by another KAP, so as to flow past this doorway, just outside it. Figure 25 indicates how to ventilate such a one-opening room by operating a 3-ft KAP as an air-intake pump in the upper part of the doorway.

ORNL DWG 72-8203

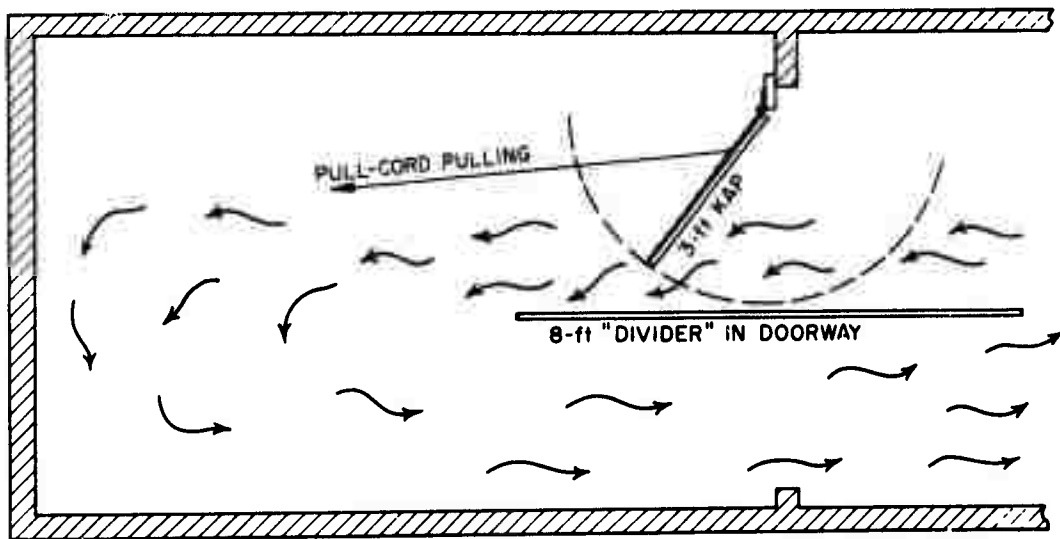

Fig. B-25. Use of "divider" to ventilate a shelter with only one opening.

Below such a doorway KAP, a "divider" 6 to 8 ft long can be installed. The "divider" permits the exhaust air to flow out of the room, without much of it being "sucked" back into the room by the KAP swinging above it. Plywood, reinforced heavy cardboard, or even well braced plastic can be used to make a "divider." But in any case, a "divider" should be installed so that, in a possible emergency, it can be jerked out of the way in a few seconds.

When used thus with a "divider," a 36-in. x 29-in. KAP can pump almost 1000 cubic feet of air per minute into and out of a shelter room. Whereas 1000 cubic feet of well distributed air is sufficient for

several times 25 shelter occupants under most temperate-climate conditions, it is enough for only about 25 people in the one-entry room under exceptionally severe heat-wave conditions. Further, to make it habitable for even 25 people under such conditions, the air in this room must be kept from rising more than 2°F above the temperature outdoors. This can be done by pumping through enough outdoor air with a second air-supply KAP, plus in some cases also using air-distribution KAP's in spaces outside the one-entry room. The KAP in the doorway of the one-entry room should supply 40 cfm per occupant of this room.

In order to prevent any of the used, warmed exhaust air from the room from being "sucked" by the doorway KAP back into the room, a stiffened rectangular duct can be built so as to extend the lower part of the doorway-opening several feet outside the one-entry room. Such a duct can be built of plastic supported by a frame of small boards. It can be used to discharge the exhaust air far enough away from the KAP and "downstream" in the airflow outside the one-entryway room, so that no exhausted air can be "sucked" directly back into the room.

#### D. Building More Durable KAP's

If KAP's are built in normal times, they can be made of materials that will make the pumps last longer even though these materials are more difficult to obtain and are somewhat more expensive.

Durability tests have shown that the parts used with a KAP that wear out first are the flaps and the pulleys. In 6-ft KAP's, the lower flaps are subject to hard use; lower flaps made of 6-ounce (per square yard), clear, nylon-reinforced, plied vinyl have lasted undamaged for over 1000 hours of full-stroke pumping, without having their edges reinforced. Lower flaps made of 6-mil nylon-reinforced polyethylene, without edge reinforcements, have lasted for 1000 hours with only minor damage.

The best pulley tested was a marine pulley (such as is used on small sailboats), with a Delrin (DuPont) 2-in.-diameter wheel and 3/16-in. stainless steel shaft. This pulley was undamaged after 324 hours of use operating a 6-ft KAP and appeared good for hundreds of hours more.

The best pulley cords tested were of braided dacron or nylon.

### E. Using Air Filters

Supplying shelter occupants with filtered air usually would be of much less importance to their survival and health than providing them with adequate volumes of outdoor air to maintain tolerable temperatures. However, filtering the entering air could prove worthwhile, provided:

1. Work on the filters starts only after more essential work has been completed.
2. Low-resistance filters (such as fiberglass dust filters used in furnaces and air conditioners) and other materials are available with which to build the necessary large, supported filter in front of the KAP.
3. The KAP can pump an adequate volume of air through the filter and the shelter.
4. The filter is installed so that it can be easily removed if shelter temperatures rise too high.

To prevent a filter used with a KAP from causing too great a reduction in the volume of air that the KAP can pump through the shelter, use large areas of low-resistance filter material. For example, in one ventilation test of a large basement shelter (which had two ordinary doorways at its opposite ends serving as its air-intake and its air-exhaust openings), a 72-in. x 29-in. KAP, operated in one doorway, pumped almost 5000 cubic feet per minute through the shelter. But when a filter frame holding 26 square feet of 1-in.-thick fiberglass dust filter was placed across the air-intake stairwell, then the KAP could pump only about 3400 cfm through this filter and the shelter.

### F. Pre-Cooling Shelters

If the shelter itself is cool, then more of the body heat of occupants can flow into its cool walls, ceiling, and floor. Therefore, especially during hot weather, it would often be advantageous to pre-cool a shelter that might soon be occupied. KAP's (or other air pumps or fans) can be used to pre-cool a shelter by forcing the maximum volume of outdoor air through the shelter and by distributing it within the shelter. A shelter should be pre-cooled at all times when the air

temperature outdoors is lower than the air temperature in the shelter when the shelter is not being ventilated. Then, if the pre-cooled shelter is used, the occupants would be kept cooler at a given rate of ventilation (because the air will not have to carry all of their body heat out of the shelter), than if the shelter had not been pre-cooled.

G. Increasing the Usefulness of Shelters by  
Supplying 40 cfm per Planned Occupant

If a shelter is fully occupied for days during hot weather and is cooled by pumping through it and distributing at least 40 cubic feet per minute of outdoor air for each planned occupant -- more than is required to maintain tolerable temperatures at night -- then:

1. The shelter occupants will be exposed to effective temperatures less than 2°F higher than the current ET's outdoors, and at night will get relief from extreme heat.

2. The floors, walls, etc., of a shelter so ventilated will be cooled at night well below daytime temperatures. Therefore, during the day a consequential fraction of the occupants' body heat will flow into the shelter itself, and thus during the hottest hours of the day less body heat will have to be carried out by the exhaust air. Therefore, daytime temperatures will be reduced.

3. Since the shelter occupants will be cooler and will sweat less, especially at night, they will require less water than they would have required if the shelter had been ventilated at a rate of less than 40 cfm per occupant.

4. If the shelter were to be endangered by the entry of outside smoke, carbon monoxide, or other poisonous gases, the ventilation of the shelter could be temporarily restricted or stopped for a longer period than would be practical if the shelter itself were warmer at the beginning of such a crisis period.

5. The shelter could be occupied beyond its rated capacity without overcrowding causing as serious problems as would be the case if smaller capacity air pumps had been installed.



### H. Installing a KAP in a Steel-Framed Doorway

If it becomes necessary (or desirable) to install a KAP in a steel-framed doorway and it is not feasible to screw or otherwise permanently connect it to the doorway, attach the KAP by using a few boards and some cord, as illustrated in Figs. 26 and 27. The two horizontal boards shown extending across the doorway are squeezed tightly against the two sides of the wall in which the doorway is located by tightening two loops of cord, one near each side of the doorway. One loop is illustrated. A cord is first tightened around the two horizontal boards so that the upper and lower sides of the cord are horizontal. Then the cord is further tightened by binding and squeezing it in its center.

ORNL DWG 72-6364

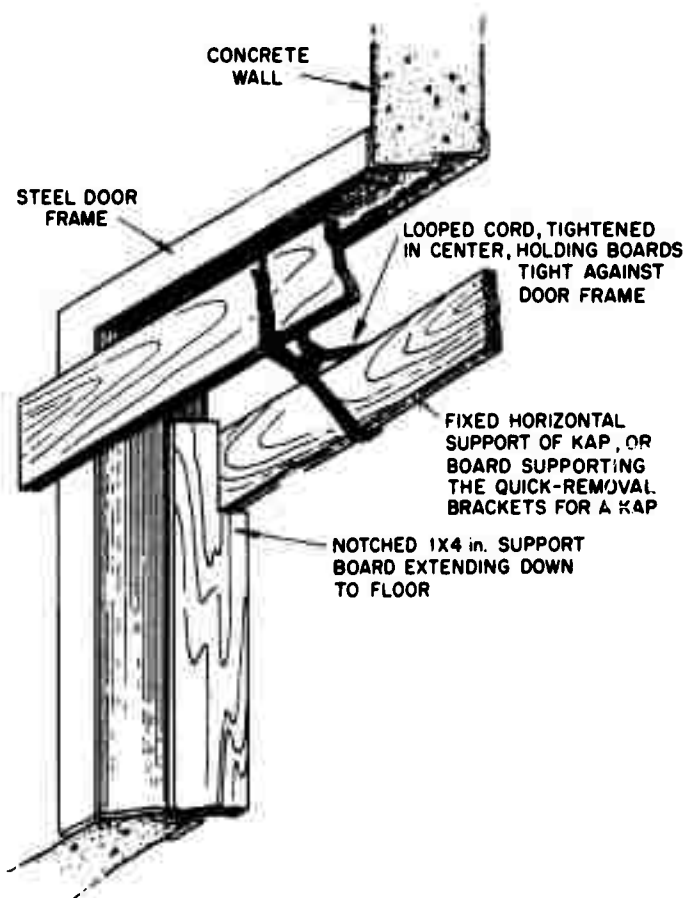

Fig. B-26. Installing a KAP in steel-framed doorway.

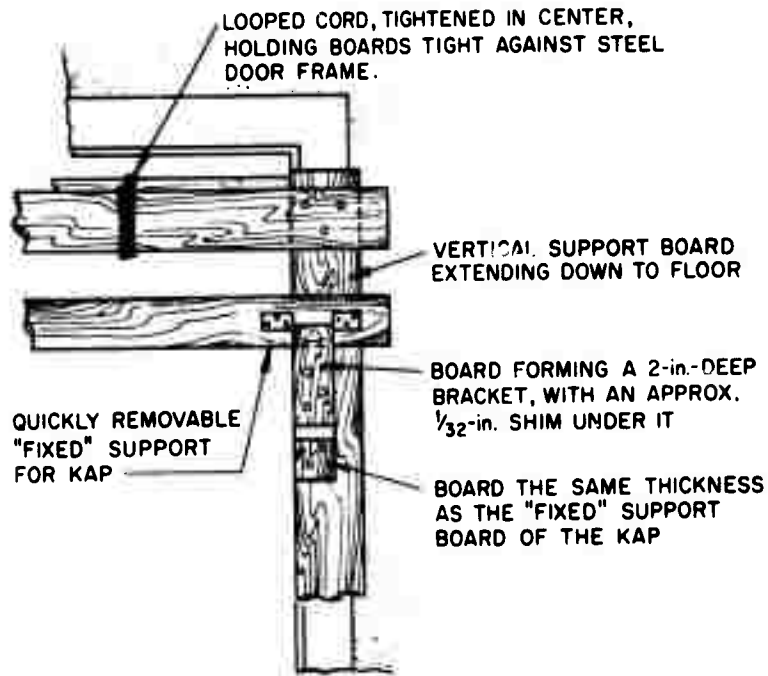

Fig. B-27. Quick-removal bracket for steel-framed doorway.

Two large "C" clamps serve even better than two looped cords. However, secure support for a swinging KAP still requires the use of a vertical support board on each side of the doorway, as illustrated.

Figure 27 shows a quick-removal bracket supported by two horizontal boards tightened across the upper part of a doorway by looped cords, as described above. Also, study Fig. 19.

## APPENDIX C

### EMERGENCY WATER SUPPLIES, EXPEDIENT LIGHTS, AND SANITATION

#### I. EXPEDIENT WATER STORAGE

If a man is eating ordinary food, even in cool weather he needs about 14 quarts of water to live 14 days. In very hot weather a man must drink about 14 gallons of water to survive for 14 days, even if a crowded, underground shelter is well ventilated. Few units have enough customary water containers to store up to 14 gallons of water for each shelter occupant, inside and/or near expedient shelters. Therefore, lined garbage cans should be used for water storage by first cleaning and disinfecting them. Strong polyethylene film or bags can be used to line water containers, including boxes, both to make them water-tight and to improve the taste of water stored in them. To improve the healthfulness of stored water, to each 5 gallons add one teaspoonful of 5-1/4% chlorine solution, such as "Clorox."

To keep the plastic that lines a water pit or box from being punctured, first line such a large improvised container with a blanket or other fabric. Then fold enough plastic (preferably 2 sheets thick) into the pit or box so that the water pressure will press plastic against all parts of the container that are below water level, without stretching any part of the plastic. If a water-storage pit is made outside a shelter, after filling it you should cover it with plastic, then with poles, and finally with about 6 inches of earth. A storage pit outside a shelter should be designed so that a man can quickly bail out bucketfuls of water when the decay of fallout radiation permits short excursions outside the shelter.

## II. DEPENDABLE LIGHTS FOR SHELTERS\*

If a nuclear attack occurs, normal electric power is likely to fail, even in communities completely outside the areas of blast damage. Furthermore, people building hasty or expedient shelters where they cannot get public power should save their portable electric lights for post-attack use. Therefore, to be sure expedient shelters will have dependable, safe lights.

1. Instruct all persons coming to the shelter to bring with them all available flashlights, electric lanterns, extra batteries and bulbs, and candles.

2. In most communities, not enough such emergency lights are available to provide shelters with even very low-level, continuous illumination for several weeks. Therefore, prepare to make homemade lamps by taking to the shelter edible fats and oils and the other common household materials needed to make and operate several self-adjusting homemade lamps, as shown in Figs. C-1 and C-2. An even better preparation is to make, test, and store in the shelter these homemade lamps before they are needed. (With the smallest practical wick, a lamp burns only about 3 ounces of edible fat, or grease in 24 hr.)

3. Because the air of an occupied shelter frequently becomes so damp that it makes exposed matches difficult or impossible to strike, always provide moisture-proof match containers.

4. To minimize the danger of an open flame setting fire to the shelter or contaminating the air, all open flames and tobacco smokers should be restricted to locations near the air-exhaust opening of the shelter.

5. Never allow any gasoline to be taken into a shelter, and do not light a kerosene lamp unless it is certain that no blast wind will enter the shelter and knock it over.

---

\* Excerpts from ORNL-TM-3916, "How to Make and Use a Homemade, Large Volume, Efficient Shelter-Ventilating Pump: The Kearny Air Pump," by C. H. Kearny, August 1972.

**WARNING**  
 DO NOT USE KEROSENE,  
 DIESEL FUEL, OR GAS-  
 OLINE — USE ONLY FATS  
 OR OILS OF THE KINDS  
 FOUND IN THE KITCHEN.

LOOP TO HANG LAMP  
 (LARGE ENOUGH FOR FINGER)

TO LIGHT LAMP, FIRST  
 MAKE MATCH LONGER  
 BY TAPING OR TYING  
 IT TO A STICK.  
 TO EXTINGUISH, DRIP  
 OIL ON WICK.

ATTACH ALUMINUM FOIL  
 $\frac{2}{3}$  AROUND JAR AND UNDER  
 ITS BOTTOM AND TO WIRES  
 TO ACT AS A REFLECTOR.  
 (NOT ILLUSTRATED)

LIGHT WIRE

CLEAN GLASS JAR  
 FREE OF LABELS

FILL JAR NO MORE  
 THAN HALF-FULL  
 WITH COOKING OIL  
 OR FAT

FLAME FROM END  
 OF WICK IS JUST  
 ABOVE OIL SURFACE

BENT NAIL, TIED  
 OVER TOP OF ANOTHER  
 BENT NAIL, SO THE  
 BASE WILL NOT ROCK.

A FINE WIRE TIED IN  
 ITS CENTER AROUND  
 THE NAILS, WITH THE  
 ENDS OF THE WIRE  
 WOUND IN OPPOSITE  
 DIRECTIONS AROUND  
 THE COTTON-STRING-  
 WICK. USE COTTON  
 THAT IS SLIGHTLY  
 LESS THAN  $\frac{1}{8}$ -in.  
 IN DIAMETER. USE  
 WINDOW SCREEN  
 WIRE OR OTHER  
 EQUALLY FINE WIRE.

USE NAILS ABOUT  $\frac{1}{2}$ -in.-  
 SHORTER THAN THE  
 DIAMETER OF JAR

KEEP EXTRA WIRE AND  
 WICK-STRING IN SHELTER

Fig. C-1. Wire-Stiffened-Wick Lamp

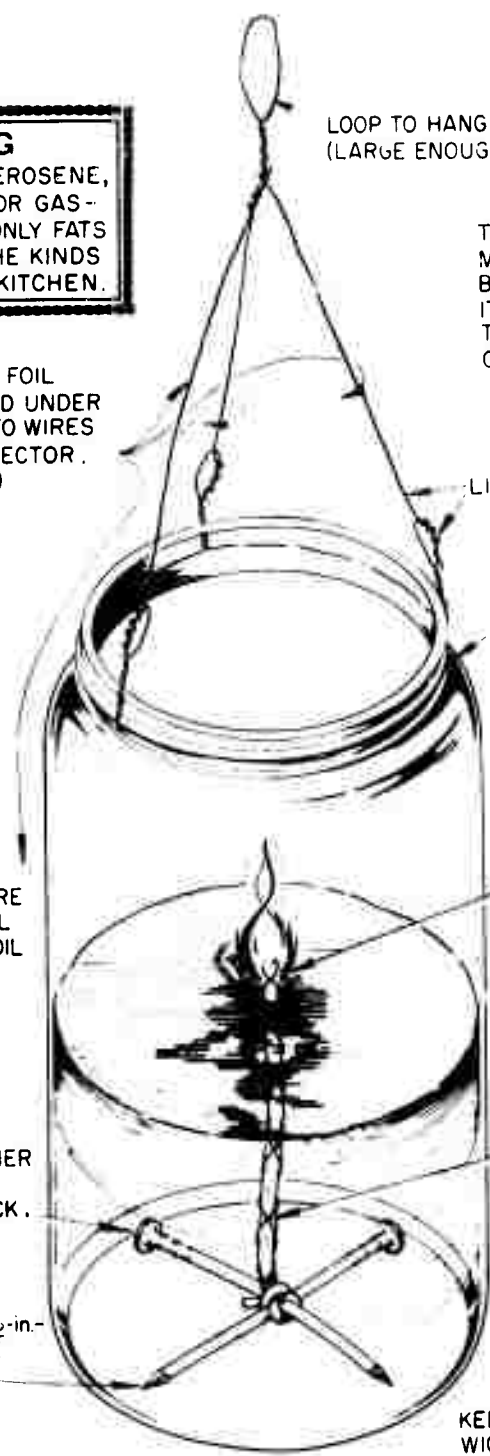

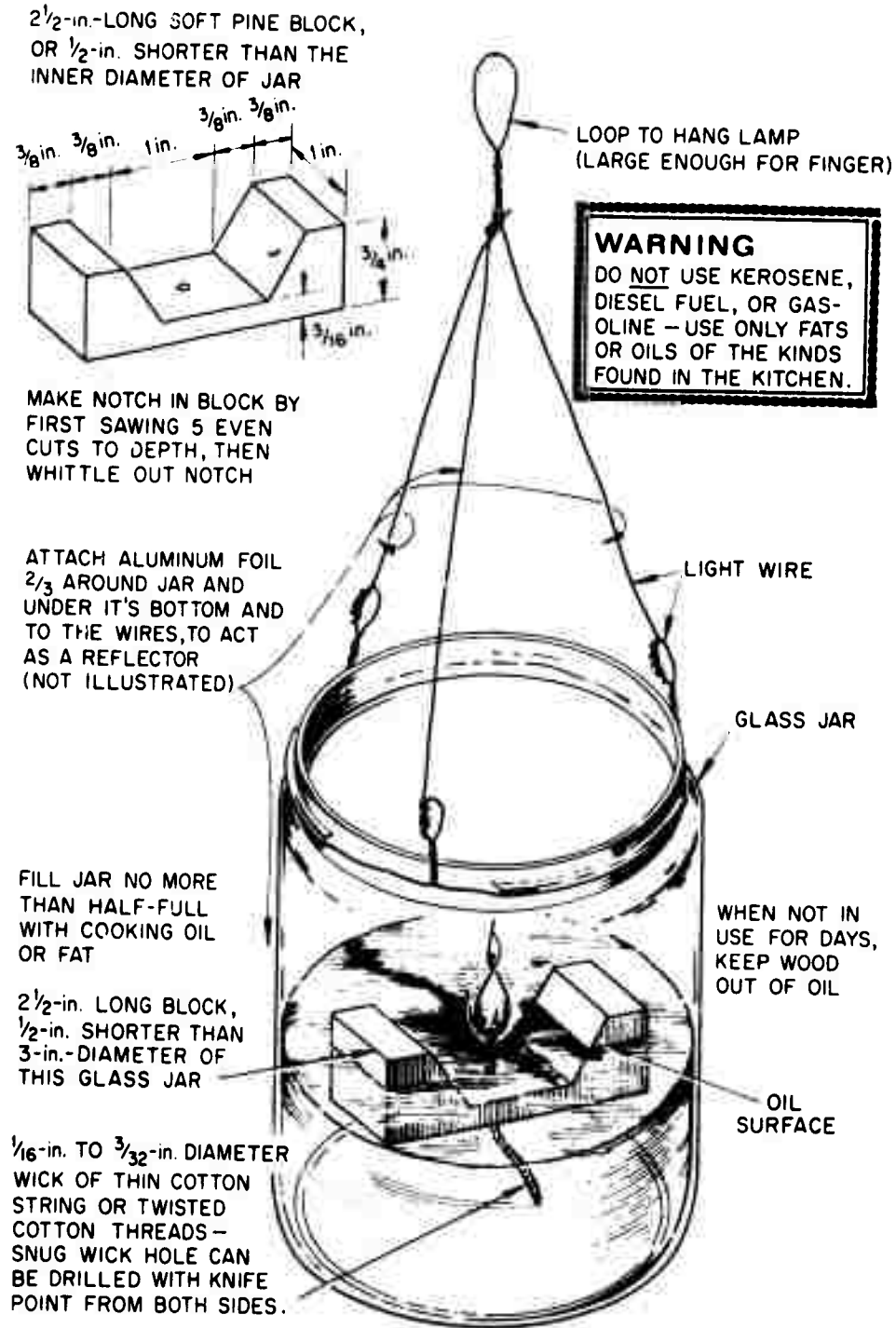

Fig. C-2. Floating Wick Lamp

### III. MANAGING THE CONSUMPTION OF WATER AND SALT

If shelter occupants are to sweat enough to enable their skin to act as fully effective evaporative coolers when exposed to large volumes of moving air in the manner described in these instructions, they must drink enough water. A good rule of thumb for a person to apply when trying to conserve water over a period of days and keep healthy is to drink enough so as to urinate only about one pint every 24 hours.

When an adult is living at normal temperatures and is not sweating much, he requires a daily total salt intake of about 1/6th of an ounce of salt; a person eating normally requires no additional salt — even if he is living in a quite warm shelter. But if an adult is living in a well ventilated shelter during very hot weather and must sweat some four quarts a day to survive, he should consume a total of about 1/3 ounce of salt a day. Hence, if he is living for days under these very hot conditions and is eating very little, he will benefit by taking 1/3 of an ounce of salt daily, and will find that water with some salt dissolved in it tastes better.

### IV. EXPEDIENT SHELTER SANITATION

1. To minimize odors inside the shelter, the entryway should be used for the toilet space. Urine merely needs to be collected separately in a bucket and periodically thrown out. An excrement disposal procedure that requires a minimum of preparation is to have several persons defecate onto a piece of plastic or into an open plastic bag, and occasionally to tie the plastic around the excrement and throw it out of the shelter. If excrement, after being thrown outside, remains covered with unbroken plastic that is tied (not sealed) shut, gas can slowly leak out and thus not break the plastic. Then flies usually cannot breed in the excrement, nor can flies get their feet in it and thus spread disease.

2. Bring disinfectants, medical supplies, and toilet paper to the shelter.

3. Especially in warm weather, heat rash and skin diseases are likely to become serious problems in crowded, long-occupied shelters. If every day, a person uses only a glass or two of water to rub off with his fingers the salt and filth that accumulate on his skin, serious skin troubles can often be prevented.

4. Each person should wear minimum clothing to reduce sweating and water consumption and to help keep his skin dry and healthy.

5. To keep ants from becoming a problem, keep all shelter foods in containers or in tied-shut plastic coverings, and do not drop crumbs or scraps. If mosquitoes or other flying insects become troublesome, mosquito netting or insect screening can be placed diagonally across the vertical entryway, and - except in very hot weather - the KAP can still pump enough air through the shelter to maintain tolerable temperatures.



## APPENDIX D

### EXPEDIENT, QUICKLY CLOSABLE BLAST DOOR

1. This expedient blast door was designed to protect the occupants of a blast-resistant shelter from nuclear-weapon-generated blast wind and shock and the accompanying contamination. It was designed in such a way that the entryway to be protected by the blast door could be used as a large, low-resistance air duct until visual warning of a large detonation. Occupants of a shelter equipped with this blast door can close and secure this door within 4 seconds after seeing the bright light from a large detonation. Securing the door prevents loss of the door either due to spring action from positive phase loading or due to the negative phase pressure reversal. A full-scale model of this door proved completely successful in blast testing at 16 psi overpressure.

2. Figure D-1 shows the construction details for the door. The illustrated size can be fitted over the combined vent-escape hatches of any of the following shelters:

- A-1 Small Pole Shelter
- A-3 Catenary Wire Roof — Preferred Entry
- A-5 Shored Trench Stoop-In
- A-7 Rigid Frame Underground
- A-8 Trench Wall Underground
- A-9 A-Frame Semiburied (only if the two entryways are both the escape-hatch type and the optional air vent is omitted — using KAP's for ventilation).

For use on the Two-Family A-Frame — Lumber the door size can be reduced to 3 ft x 3 ft and the bill of materials adjusted accordingly.

### 3. Materials Required

Since every shelter must have two openings to provide ventilation, two blast doors will be required to protect a shelter from blast. Table D-1 shows the materials required for two 4' x 4' doors or two 3' x 3' doors.

ORNL DWG 73 1083

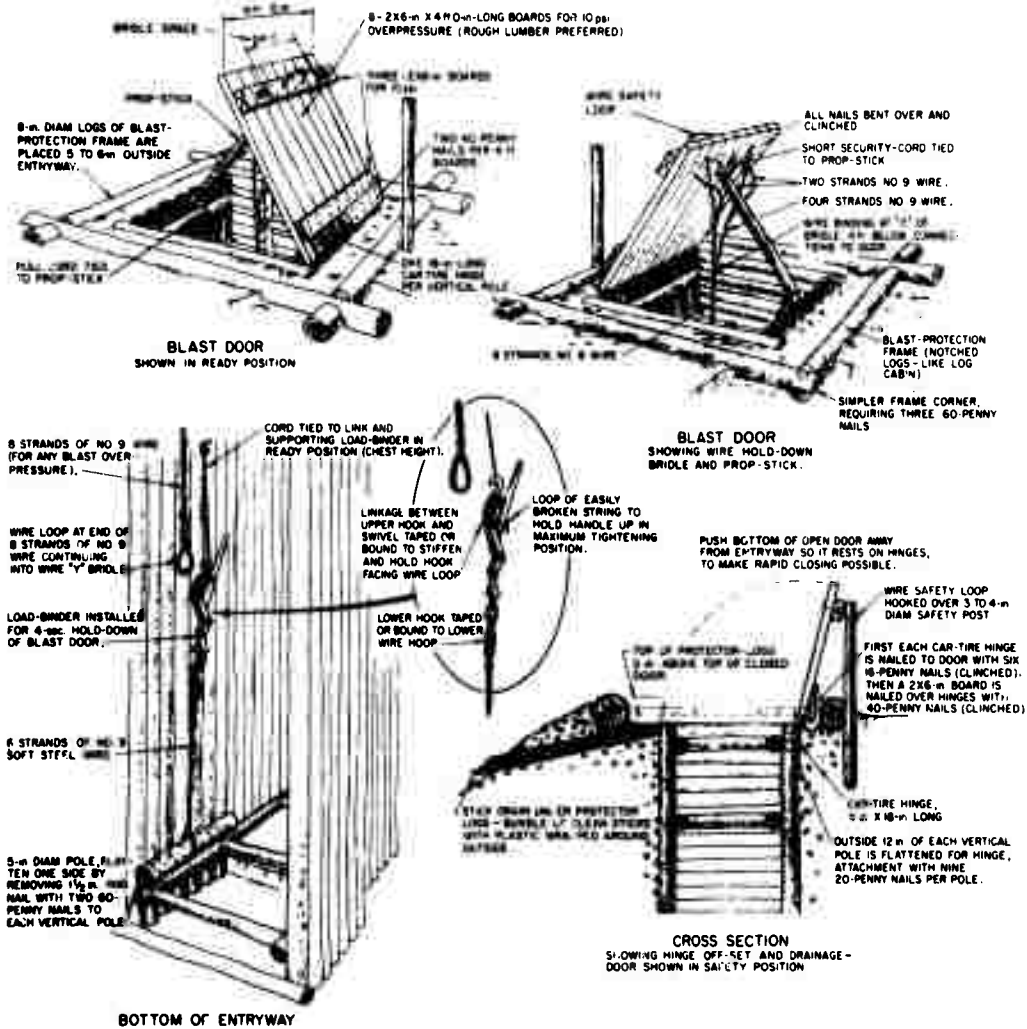

Fig. D-1. Expedient Blast Door for Small-Pole Shelter.

Table D-1

Use	Material	Size	4' x 4' Door		3' x 3' Door	
			Length	Quantity	Length	Quantity
Protector	Logsa	8-inch diameter	8-1/2'	8	7-1/2'	8
Lid & Cleats	Lumber	2" x 6"	4'	22 <sup>b</sup>	3'	17 <sup>b</sup>
Safety Post	Logsa	4" diameter	5'	2	4'	2
Tie Down Bar	Log <sup>a</sup>	5" diameter 4" x 4"	3' } 4' }	2	3'	2
	Lumber <sup>a</sup>					
Prop Stick	Stick	2" diameter	40"	2	30'	2
Hinge Support (for lumber entryways only)	Lumber	2" x 10"	4'	2	3'	2
Hinges	Worn car tires	4" wide	18"	14	18"	10
	Nails	60-penny		6 lbs		6 lbs
	Nails	40-penny		14 lbs		14 lbs
	Nails	16-penny		3 lbs		3 lbs
	Wire, Mild Steel	No. 9		130 ft		180 ft
	Cord or Rope	1/4"		32 ft		32 ft
	Load Binder <sup>c</sup>	2-1/2" to 3-1/2" stroke		2		2
	Tape, Pressure sensitive			1 Roll		1 Roll

<sup>a</sup>If logs are not available and lumber is, each log can be replaced by properly sized lumber (the 8-in.-long log by a 6" x 6" - three 2" x 6"'s nailed together; the 5" log by a 4" x 4" - two 2" x 4"'s nailed together).

<sup>b</sup>The illustrated 4' x 4' door will provide 15 psi protection and uses 22 pieces of 2" x 6". To provide 25 to 30 psi protection use 32 pieces of 2" x 6". For a 3' x 3' door to provide 25 to 30 psi protection use 28 pieces of 2" x 6".

<sup>c</sup>If no load binders are available, make a hook out of a steel bar at least 1/2 inch in diameter.

#### 4. Instructions for Constructing Doors

- a. Before beginning work, study the drawings (Fig. D-1) and all these instructions.
- b. So that the expedient blast door can rest evenly on top of the entryway, the top of the entryway must be built even and level. When using poles for the entryway it is best to erect the poles, then draw a line all around the entryway at the height desired for the level tops of the poles. Next, cut off the tops of the vertical poles along this horizontal line. Cut the two uppermost horizontal poles of the entryway so that their tops are level and at the same height as the cut-off tops of the vertical poles.
- c. One side of the entryway must be prepared to hold the car-tire strap hinges. It is recommended that the side selected for the hinges be the side located closest to the direction of the anticipated nuclear target. For entryways made of lumber, nail a hinge support 2" x 10" x 4' long (or one 2" x 6" x 4' and one 2" x 4" x 4') board to the outside of the hatch, with its upper edge level and parallel with the top of the hatch. For entryways made of poles proceed as follows:
  - (1) Flatten the outer sides of all the vertical poles on the side chosen for attaching the hinges. The narrowest flattened area on any pole must be 3 inches wide.
  - (2) To be sure that all the flattened areas are in the same plane, first draw a straight guideline across the tops of the vertical poles. Cut each of these vertical flattened areas so that it extends about 12 inches down the outside of a vertical pole.
- d. If no drill is available to make the 1/2-inch-diameter holes for the bridle wires, notch the edges of the boards with a saw or hatchet before nailing them together so that the holes will be available when the door is assembled.

- e. For 15 psi protection assemble the door lid as illustrated, using two of the boards as cleats to hold the other 8 boards together. (NOTE: the third cleat will be added later, after the hinges have been installed.) For 30 psi protection make the cleats continuous. That is, the door will be two complete layers of 2" x 6" boards with the boards of one layer at right angles to the boards in the outer layer. Leave one cleat off until after the hinges have been attached. Bend over and clinch all nails so that the points are away from the hinge side. This minimizes the danger of snagging persons who have to push the door open from the inside.
- f. Make the rubber-tire strap hinges each 18 inches long by cutting from smooth worn passenger car tires. Wide tread tires are best. Use a sharp knife, repeatedly dipped in oil and frequently sharpened, to cut a flat strip, preferably the full width of the worn part of the tire. For pole-type entries make one strap per pole. For lumber-type entries make enough straps so that the hinges will be continuous across the face.
- g. Place the unfinished door (i.e., the door will be short one cleat) in its closed position on top of the entryway and mark the centerline positions of its hinges on both the door and on the side of the entryway (NOTE: for pole-type entryways the centerline of each hinge should coincide with the centerline of its corresponding vertical pole.) Remove the door.
- h. Nail a strap hinge to the door in each marked position with the end of each hinge pressed against the side of the adjacent cleat, 6 inches from the hinge edge of the door. Use six 16-penny nails to connect each hinge. Turn the door over and clinch all nails.

- i. Install the tie-down bar.
  - (1) For lumber-type entryways use two 2" x 4" x 4' boards nailed together with 16-penny nails. Nail the tie-down bar to the 2" x 6" studs at the bottom of the entryway, opposite the hinge side.
  - (2) For pole-type entryways, flatten one side of a 5-inch-diameter, 3-ft pole by removing about 1-1/2 inches from one side. Remove the bark from the vertical poles at the area where the tie-down bar must fit near the bottom of the entryway. Nail the tie-down bar to the vertical entryway poles opposite the hinge side.
- j. Make a triple loop of one piece of No. 9 mild steel wire around the center of the tie-down bar just installed. Make the loop just large enough so that when it is twisted into a six-strand wire and the lower hook of the load-binder is hooked into a loop at its upper end, the upper hook of the load-binder will be at chest height to a man standing on the floor in the entryway. Twist the loop to form the 6-strand wire and attach the load-binder as shown in the drawings.
- k. Place the door in its closed position with its hinged side exactly above the marked centerlines on the entryway side. Starting with one outside hinge, one person should strongly bend the loose end of the hinge down and press it against the hinge support (on pole-type entryways the flattened side of the vertical pole). Another person should nail the hinge to the hinge support using nine 40-penny nails. Nail the other outside hinge in a similar manner, then nail on all the remaining hinges.
- l. Make a wire bridle to hold the closed blast door down against the negative pressure phase. Cut two lengths of No. 9 wire each 32 ft long and make a 2-strand, slightly twisted wire, 16 ft long from each length. Bend each

16-ft-long, 2-strand wire in the middle and twist together both doubled wires to produce an 8-strand wire with a small loop in one end as shown on the drawing. The small loop must be large enough to slip easily over the gripper hook of the load-binder: the other end must be formed into a double "Y" bridle consisting of four 2-strand wires as shown in the drawing. Thread the four 2-strand ends of the "Y" bridle upward through the 1/2-in. holes in the blast door. Then, with the door closed, pull the 2-strand wires upward until the loop on the lower end of the 8-strand lower part is at the same height as the tip of the upper hook of the load-binder in its extended position. Twist together (splice) the upper ends of the 2-strand wires so that each pair encircles the 2" x 6" cleat which is located 6 inches from the free edge of the door. To strengthen the wire loops, nail down the splices with 16-penny nails.

- m. To adjust the hold-down wires so that the door can be held down securely, stretch all the wires by tightening them with the load-binder. Release the load-binder, disconnect the upper hook, and shorten the 8-strand lower part of the wire by twisting it. Repeat these operations until a 40 to 50 pound downward pull on the handle of the load-binder is required to pull the door closed and secure.
- n. By installing the prop-stick as illustrated, a shelter occupant will be able to make the blast door slam shut within 2 seconds after seeing the bright light from a nuclear explosion. In warm weather use a 40-inch-long prop stick. Cut grooves about 2 inches from each end. Tie a 16-ft-long pull cord securely around the prop stick in one of the grooves. Connect the other end of the prop stick to a nail in the door, using a short security cord (to keep from getting hit on the head when the prop stick is yanked out from below). By a little experimentation,

the prop-stick can be supported at different locations to provide the occupants a choice of different sized openings, depending on weather conditions.

- o. Practice rapid door-closings by having one shelter occupant stand near the entryway watching it (but not where he can see the sky). Have another occupant outside with a light which he can shine, without warning, on the door. The sentry posted inside should yank out the prop stick, hook the load-binder onto the end loop of the 8-strand wire, and tighten the load-binder securely closed. Repeat this exercise until each occupant can perform the operation in less than 4 seconds.
- p. To prevent the blast door injuring someone by being accidentally blown shut by the wind, provide the door with a wire safety loop and a safety post to loop it over.
- q. To protect the blast door and entryway from airblast effects and to prevent them being hit directly by objects hurled toward them by the blast, build a blast-protection frame around them. Blast testing has shown that good protection is afforded by 4 logs or timbers installed as illustrated. After installing the blast protective frame, mound earth up to the top of the frame on the outside of the frame.
- r. To minimize the risk of the exposed wood of the shelter and the door being set on fire by the thermal pulse, or fires resulting from the explosion, the exposed wood may be coated with a thick paste made of cement and water or a lime whitewash. Standard concrete or sheet-metal could be used if preferred.
- s. Building stronger blast doors may be justified if:
  - (1) the shelter is a shored trench stoop-in (A-5) built according to specifications or,
  - (2) a catenary wire roof - with preferred entryway (A-3), or



- (3) a small-pole shelter (A-1) built with green poles at least as large as those specified with an escape hatch-entry at each end; and
- (4) the shelter is located in an area expected to be close to a probable target.

If building the blast door to the 30 psi specification, it is advisable to increase the earth cover to 4 ft with sides of the mound no steeper than 2:1. In a small-pole shelter made from the minimum specified diameter poles, additional rectangular entryway braces should be installed to strengthen the upper part of the entryway which cannot be protected by the earth arching.

- t. Stronger blast doors can be made by using three thicknesses of 3/4-inch exterior plywood nailed together with 50 clinched, 16-penny nails.

## HOW TO CUT AND HAUL LOGS AND POLES MORE EASILY

1. SHARPEN YOUR TOOLS BEFORE GETTING TO WORK -- NO MATTER HOW MUCH THE RUSH.
2. WHEN SAWING GREEN TREES, OIL YOUR SAW WITH KEROSENE OR DIESEL FUEL. IF YOU LACK THESE, USE MOTOR OIL, GREASE, OR EVEN SOAP.
3. WHEN FELLING A SMALL TREE, TO CUT IT OFF SQUARE, TO KEEP YOUR SAW FROM BEING PINCHED, AND TO HELP MAKE THE TREE FALL IN THE DESIRED DIRECTION: (A) FIRST SAW THE TREE ABOUT ONE-THIRD THROUGH ON THE SIDE TOWARD WHICH YOU WANT IT TO FALL. (B) THEN WHILE SAWING THE OPPOSITE SIDE, HAVE ANOTHER PERSON PUSH ON THE TREE WITH A 10-FT. PUSH-POLE, BY PRESSING THE END OF THE PUSH-POLE AGAINST THE TREE ABOUT 10 FEET ABOVE THE GROUND. A PUSH-POLE WITH A FORKED END OR A BIG NAIL ON ITS END IS BEST.
4. AFTER A TREE IS FELLED, TRIM OFF ALL LIMBS AND KNOTS SO THAT THE LOG OR POLE IS SMOOTH, AND WILL REQUIRE NO ADDITIONAL SMOOTHING WHEN YOU ARE PREPARING TO DRAG IT, OR USE IT TO BUILD YOUR SHELTER.
5. TO SPEED UP THE MEASURING OF POLES AND LOGS AND TO CUT THEM THE RIGHT LENGTH, MAKE AND USE A MEASURING STICK.

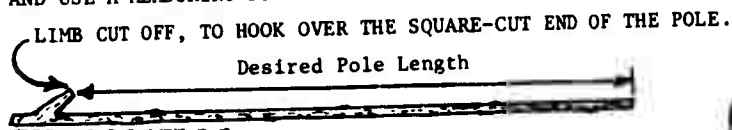

6. WHEN DRAGGING POLES, IT IS USUALLY BEST FIRST TO CUT THEM EXACTLY TWO OR THREE TIMES THE LENGTH OF THE FINAL POLES TO BE USED IN THE SHELTER. TO DRAG SEVERAL POLES (OR A LOG) BY HAND, CUT A 3-1/2 FT. LONG STICK (2 TO 2-1/2 INCHES IN DIAMETER), TIE A SHORT PIECE OF ONE-QUARTER-INCH (OR STRONGER) ROPE TO ITS CENTER; MAKE A LASSO-LIKE LOOP AT THE FREE END OF THE ROPE, SO THAT WHEN IT IS LOOPED AROUND THE LOG AND TWO MEN ARE PULLING THE LOG (SEE ILLUSTRATION) THE END OF THE LOG IS RAISED ABOUT 6 INCHES ABOVE THE GROUND. THE LOOP SHOULD BE TIGHTENED AROUND THE LOG ABOUT 2 FT. FROM ITS END, SO THAT THE END OF THE LOG CANNOT STRIKE THE BACKS OF THE LEGS OF THE TWO MEN PULLING IT.

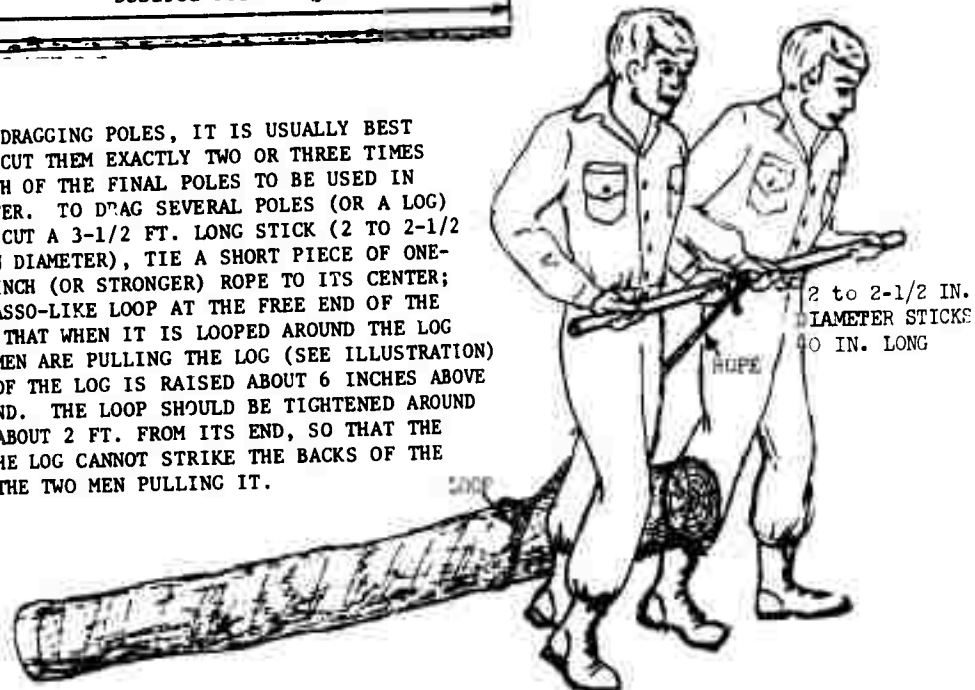

**CAUTION:** IF YOU DRAG A LOG DOWN A STEEP HILL, ONE MAN SHOULD TIE A ROPE TO THE REAR END OF THE LOG, AND THEN FOLLOW THE DRAGGER, ALWAYS KEEPING READY TO ACT AS THE BRAKE.

7. AVOID CARRYING LOGS ON YOUR SHOULDERS: YOU CAN INJURE YOURSELF SEVERELY IF YOU TRIP, AND YOU WILL CERTAINLY TIRE YOURSELF MORE THAN IF YOU DRAG THEM.
8. WHEN YOU GET YOUR POLES OR LOGS TO THE LOCATION WHERE YOU ARE BUILDING THE SHELTER, CUT THEM TO THE DESIRED MINIMUM DIAMETERS AND SPECIFIED LENGTHS, AND PLACE TOGETHER ALL OF ONE SPECIFIED TYPE. BE SURE THAT THE DIAMETER OF THE SMALL END OF EACH POLE OF ONE TYPE IS AT LEAST AS LARGE AS THE MINIMUM DIAMETER SPECIFIED FOR ITS TYPE.