

AD-777 092

TORPEDO PROPULSORS. A REVIEW OF
DESIGN PROCEDURES, MANUFACTURE,
INSPECTION, AND TESTING

Naval Ordnance Systems Command Hydroballistics
Advisory Committee
Washington, D.C.

February 1974

DISTRIBUTED BY:

NTIS

**National Technical Information Service
U. S. DEPARTMENT OF COMMERCE
5285 Port Royal Road, Springfield Va. 22151**

Additional Copies of this Report
may be Requested from
Naval Ordnance Systems Command
Code 035
Washington D.C. 20360

Compiled at
Naval Undersea Center
San Diego, California 92132

* SECTION BY	
KTIS	White Section <input checked="" type="checkbox"/>
W/C	Def: Section <input type="checkbox"/>
W/S	SECED <input type="checkbox"/>
JUSTIFICATION	
BY	
DISTRIBUTION/AVAILABILITY CODES	
Dist.	AVAIL. AND/OR SPECIAL
A	

AD-777092

ORDHAC

TECHNICAL REPORT

NAVAL ORDNANCE SYSTEMS COMMAND HYDROBALLISTICS
ADVISORY COMMITTEE

TORPEDO PROPULSORS

A Review of Design Procedures, Manufacture, Inspection, and Testing

ORDHAC TR 74-1
February 1974

Distribution Unlimited

Reproduced by
NATIONAL TECHNICAL
INFORMATION SERVICE
U S Department of Commerce
Springfield VA 22151

DISTRIBUTION STATEMENT A
Approved for public release
Distribution Unlimited

Details of illustrations in
this document may be better
studied on microfiche.

///

CONTENTS

Section

1.	Introduction	1
	History	1
	Purpose of Report	2
2.	Glossary for Torpedo Propulsors	5
3.	Propulsor Design	17
	Major Steps from Design to Production of Propulsors	17
	Propulsor Design - General	18
	Propulsor Design - Preliminary Information Needed	20
	Type of Propulsor	21
	Pumpjet Design	22
	Initial Design Considerations (Pumpjets)	23
	Cavitation Performance (Pumpjets)	24
	Blade Geometry and Loading Distribution (Pumpjets)	25
	Blade Design (Pumpjets)	25
	Propeller Design	26
	Single Versus Counterrotating Propellers	27
	Number of Propeller Blades	28
	Choice of Material	29
	Propeller Diameter	30
	Lift Distribution (Propellers)	30
	Blade Section Shape (Propellers)	31
	Planform of Propeller Blade	33
	Skew (Propellers)	34
	Fillets	34
	Status of Propulsor Design Theories	35
4.	Tolerances	37
	Tolerance Setting	37
	Some Examples of Tolerance Errors	38
	Principles of Tolerance Settings	39

CONTENTS (Cont'd)

Section

	Factors Influencing Performance	41
	Angle-of-Attack (or Pitch) Error	41
	Camber Error	42
	Area or Chord-Length Error	42
	Blade-Thickness Error	43
	Stackup Error	43
	Spacing Angle and Tracking Error	43
	Errors Requiring Careful Control	44
	Factors Influencing Cavitation	44
	Suggested Tolerances	48
	Displacement of Blade Cross Section	48
	Blade-Thickness Tolerance	49
	Camber Line and Angle-of-Attack Tolerance	50
	Pumpjet Blade-Section Tolerance	50
	Surface Finish Tolerance	51
	Waviness Tolerance	52
	Chord-Length Tolerance	53
	Hub Tolerance	53
	Leading Edge Tolerance	53
	Dynamic Balancing	54
5.	Documentation	55
	Drawings as Official Documentation	55
	Other Documentation and Government Furnished Material	56
	Drawing Standards	56
	Considerations in Documenting Pumpjet Blades	60
6.	Production Methods	62
	Pantographing from Templates	62
	Pantographing from Masters	63
	Line-Follower Milling Machine	63
	Casting	63
	Forging	64
	Coining	64
	Numerical Control Milling	64

CONTENTS (Cont'd)

Section

7.	Inspection Procedures	66
	Quality Assurance	66
	Design-Manufacturer-Inspector Relationships	67
	Inspection for Design Verification	69
	Gaging	71
	Optical Comparator	71
	Comparison Gage	72
	Pin Gage	72
	Blade-Edge Microscope	73
8.	Propulsor Testing	74
	Wind Tunnel	74
	Water Tunnel	74
	Towing Basin	75
	Rotating Arms	75
	Cable-Guide Ranges	76
	Instrumented Free Ranges	76
9.	References	77

SECTION 1 INTRODUCTION

HISTORY

In December of 1960, a report entitled "Torpedo Propulsors — Documentation for Design Verification, Production and Quality Assurance" was issued as NAVWEPS OD 18374 (Ref. 1) by the Navy Central Torpedo Office (CTO) at Newport, Rhode Island. The compiling and editing was done by a task team chaired by Mr. N. J. McKenna of CTC. Other members of the team were:

L. J. Langfield	Central Torpedo Office (CTO)
T. W. McGraw	Central Torpedo Office (CTO)
R. J. Whitaker	Central Torpedo Office (CTO)
G. Calara	Central Torpedo Office (CTO)
A. Lehman	Ordnance Research Laboratory (ORL)
N. Goodman	Naval Ordnance Plant (NOP)
A. Ross	Naval Ordnance Plant (NOP)
H. Eggers	Bureau of Naval Weapons (BuWeps RUAW)
Lt. R. Asleson	Bureau of Naval Weapons (BuWeps FQQA)

OD 18374 has been particularly useful to designers, documentors, and inspectors of present-day torpedoes. However, even at the time the report was issued, it was apparent that, as the state-of-the-art progressed, certain parts of the report would have to be revised to be in line with new techniques. Use of the report showed that there were ambiguities or misinterpretations that could arise in the area of documentation. Accordingly, a subcommittee on Propulsor Research of the Naval Ordnance Systems Command Hydroballistics Advisory Committee (ORDHAC) recommended, in November 1968, that OD 18374 be

revised and updated. As a result, the Naval Ordnance Systems Command (Code 035B, Dr. T. E. Pierce) has sponsored the preparation and publication of this revised report. The principal contributors are:

R. Davis	Applied Research Lab. (ARL), Pennsylvania State University, University Park, Pennsylvania 16801
Wm. Morgan	Naval Ship Research and Development Center, Washington, D. C. 20007
R. Hecker	Naval Ship Research and Development Center, Washington, D. C. 20007
A. Lehman	Oceanics Inc., Plainview, Long Island, New York, 11803
M. Larsen	Naval Undersea Center (NUC), San Diego, California 92132
G. Mosteller (Editor and Compiler)	Naval Undersea Center (NUC), San Diego, California 92132
D. Nelson	Naval Undersea Center (NUC), San Diego, California 92132
L. Petersen	Naval Undersea Center (NUC), San Diego, California 92132
J. Green	Naval Undersea Center (NUC), San Diego, California 92132

PURPOSE OF REPORT

The purpose (here paraphrased) of OD 18374 was:

1. To provide a guide for torpedo propulsor development, including production and inspection.
2. To assure that production documentation precisely reflects proven prototype propulsors by specifying and illustrating proper production and quality assurance methods.

3. To assist production and inspection personnel to understand, appreciate, and use propulsor documentation by explaining approaches employed in its preparation.
4. To specify and illustrate documentation and quality assurance methods.
5. To standardize torpedo propulsion terminology used by Bureau of Naval Weapons (now Naval Ordnance Systems Command) documentation.

The above purposes are still pertinent and apply to this revision. In addition, the aim of this report is to fill in some blanks and shift the emphasis as follows:

1. To better define and document propulsor shape, such as the leading edge, and between the presently-described sections along the blade span.
2. To describe a method of blade-coordinating specification different from that specified in OD 18374. This change has resulted from experience gained by NUC and ARL in recent propulsor developments.
3. To reorient the philosophy and practice of tolerance settings, basing it on known hydrodynamic principles, and alerting the designer (who sets the tolerances) to costs and the needs and preferences of planners, manufacturers, and inspectors.
4. To review and discuss methods of documentation of the approved design. To recommend two methods of documentation of propulsors, one for propellers and one for pump-jets. To promote better communication between various activities concerned with the same propulsors.
5. To acquaint the nondesigner with propulsor design procedures in the form of an outline and annotated references.
6. To discuss effects of abnormalities on the performance of a propulsor, based on experiment and theory, so that the designer, the manufacturer, and particularly the inspector may have an appreciation of the need for adhering to reasonable tolerances.
7. To discuss propeller testing and available facilities.
8. To emphasize the importance of good inspection and quality assurance.

9. To discuss new design and fabrication methods and their probable impact on future propulsors.
10. To point out the need, and set up guidelines, for better relationships between designer, vendor, inspector, and procurement people.

SECTION 2
GLOSSARY FOR TORPEDO PROPULSORS

The following definitions and symbols are in respect to torpedo propulsors only. Whenever possible American-British-Canadian-Navy Standards have been used.

Advance Ratio	J	Ratio of forward speed to rotational speed $J = V/nD$ (where V and D should be designated by subscripts)
	λ	$J/\pi = V/\pi nD$
Angle of Attack	α	Angle between the direction of the relative velocity and some reference surface or line. If referred to the zero-lift line ($\beta_0 - \beta_1$) it is called hydrodynamic angle-of-attack. (Fig. 1)
Angle of Zero Lift	α_0	That angle measured from the chord line to the two-dimensional flow zero lift line ($\beta_0 - \phi$). It is zero for symmetrical sections. (Fig. 1)
Angle, Section	ϕ	Angle measured from plane of rotation to chord line of blade section. (Fig. 1)
Angle, Blade Section	β_0	Angle measured from plane of rotation to line of zero lift. (Fig. 1)
Angle, Hydrodynamic Pitch	β_1	Angle measured from plane of rotation to relative velocity vector at lifting line.

$$\beta_1 = \tan^{-1} \frac{v + U_A}{\omega r - U_T} \quad (\text{Fig. 1})$$

Area	A	Reference area.
	A_p	Propeller disk area, πR_p^2 ; where R_p is radius of propeller tip.
	A_T	Torpedo cross section area, πR_T^2 ; where R_T is radius of torpedo body.
Base-Vented Propellers		A propeller that has truncated trailing edges with a trailing cavity, into which a gas is forced, to increase the cavity pressure and reduce the base drag. (Fig. 2)
Bernoulli's Law		$p + (\rho/2)u^2 = \text{constant along a streamline}$ (incompressible fluids)
Blade		The blade is that solid figure made up of stacked and faired finite-thickness wing sections. It is integral with the hub or attached thereto. Blades constitute the lifting portions of a propulsor.
Blade Section		That area developed by intersecting a blade with a plane, cylinder, or cone. (Fig. 3)
Boundary Layer		The region of moving fluid close to a solid body within which transverse velocity gradients are large as compared with longitudinal gradients, and shear stress is significant. Boundary layers may be laminar, turbulent, or transitional. (Fig. 4)
Boundary-Layer Thickness	δ	The normal distance from a wall or solid boundary in which fluid velocity is affected by the shear stresses due to the boundary. The boundary layer thickness is commonly defined as the normal distance from a boundary at which the velocity becomes 99 percent of that in the local free stream. It is also defined as normal distance to that point at which the pressure head plus the dynamic head equals that in the local free stream (when gravity head is removed from both). (Fig. 4)

Bound Vorticity		The vorticity affixed to a lifting surface that determines the circulation about it.
Camber Line		The camber line is the locus of points midway between corresponding points on the suction and pressure faces of a blade section. Corresponding points on the faces are on lines perpendicular to the camber line. Normally, camber line is determined in the process of propeller design, and blade surface is measured from the camber line. Camber is used to give lift. (Fig. 1)
Camber Offset	f_m	Offsets from reference straight line to camber line.
Cavitation		Cavitation in water is the formation of bubbles consisting of water vapor and residual gas which may come out of solution. Cavitation results from a lowering of pressure to or below the vapor pressure of water.
Cavitation Number	σ	$\frac{p - p_v}{(\rho/2)V^2}$
Chord, Blade Section	c	Distance from leading to trailing edge of section.
Chord Line		The chord line is that straight line which passes through the intersections of the camber line with the leading and trailing edges. (Fig. 1)
Circulation	Γ	The mathematical representation of the flow induced in the surrounding fluid by a lifting surface. It is the line integral of the velocity vector around a curve enclosing the lifting surface $\Gamma = \oint V \cdot dl$.
Circulation, Dimensionless	G	$G = \Gamma/\pi D_p V$ (per blade)

Control Surfaces		Lifting surfaces that provide steering for torpedo bodies. (Fig. 4)
Counterrotating Propellers		(See Propeller)
Cruciform		In the form of a cross or crossed at right angles.
Curve Fitting		Process of forming a curve through a set of points.
Datum Point		The datum point of a blade section is a point designated by the design agency as an initial reference.
Datum Section, Blade		That section to which all other blade sections are referenced.
Density	ρ	Mass density of fluid.
Diameter	D	Reference Diameter.
	D_p	Propeller Diameter.
	D_T	Torpedo Diameter.
Drag	D or R_T	Fluid force acting to retard forward motion.
Drag Coefficient	C_D	Drag expressed as a dimensionless number. It is defined as drag divided by the product of dynamic pressure and a reference area, $D/(\rho/2)V^2A$.
Ducted or Shrouded Propeller		A rotating blade system that operates in a close-fitting casing or shroud. The inflow may be accelerated or decelerated by the shroud. The system in which the flow is accelerated at the rotating blades is normally called a Kort nozzle. The system where the duct decelerates the flow at the blades is normally called a pumpjet. (Figs. 5 and 6)

A water jet consists of a propeller enclosed in a long duct so that little or no circulation is generated around the duct.

Efficiency η_0 **Figure of merit for propeller performance**

$$\eta_0 = \frac{TV}{Q\omega} = \frac{C_{Th}}{C_p} = \frac{K_T}{K_Q}$$

Expanded Area A_E **Expanded area is area of the expanded blade.**

$$A_E = Z \int_{R_h}^{R_p} c dr$$

Expanded Blade That blade outline obtained by fairing a line through the leading and trailing edges of expanded blade sections; that is, cylindrical or piercing cylinder sections rolled out into tangent planes.

Fairing A structure whose primary purpose is to produce a smooth outline, in order to reduce drag or stresses at junctures. Blades are generally faired into hubs by means of a concave cylindrical fillet.

Fillet Any filling of a juncture such as where a blade and hub join. (See Fairing)

Flow, Laminar Laminar flow is a flow of a viscous liquid in layers or laminae. Momentum transfer and shear between layers are those due to molecular interaction only.

Flow, Potential Potential flow is flow in which the fluid velocity is equal to the gradient of a scalar velocity potential, ϕ . This implies that the viscous stresses are zero.

Flow, Turbulent		Turbulent flow is flow in which there are rapid random fluctuations of velocity both in magnitude and direction.
Goldstein Function	κ	Relates the tangential component of induced velocity to the circulation for a lightly loaded optimum propeller with finite number of blades.
Hub-Vortex Cavitation		Cavitation in the vortex downstream of the hub of a propeller produced by excessive loading near the hub of the propeller blades. (Fig. 7)
Hydrodynamic Pitch Angle	β_1	(See Angle, Hydrodynamic Pitch)
Ideal Flow		The flow of a fluid having no viscosity. The flow that corresponds to potential flow.
Inflow Velocity		The velocity flowing into a propulsor. On a torpedo it is the velocity in the boundary layer at the propeller plane. (Fig. 4)
Kinematic Viscosity	ν	Viscosity/Density = $\frac{\mu}{\rho}$
Kort Nozzle		(See Ducted Propeller)
Laminar Flow		(See Flow, Laminar)
Leading Edge		The locus of points where blade section camber lines intersect the blade surface at the forward edge of the blade (may not be most forward point). (Fig. 1)
Lift Force	L	Hydrodynamic force perpendicular to relative flow. (Fig. 1)
Lifting Line		That line upon which the bound vorticity is located in lifting-line solutions of flow problems.

Lifting Surface		A hydrofoil or a propulsor blade which develops lift. Mathematically a lifting surface may be represented by a system of vortex elements distributed over the surface rather than by a single vortex line, as in lifting-line theory.
Lift Coefficient	C_L	The nondimensionalized lift, or the lift divided by the product of dynamic pressure and a reference area. $C_L = L/(\rho/2)V^2A$
Longitudinal Axis		The longitudinal axis is the line which in most cases is the propulsor axis of rotation. It is also the center of radial coordinates that define the body shape for axisymmetric bodies. (Fig. 4)
Longitudinal Planes		Longitudinal planes pass through the longitudinal axis and through a specified datum point on each blade which is generally the stacking point.
Number of Blades	Z	Blades on propeller.
Piercing Cylinder (or cone) Sections		Imaginary surfaces formed by intersection of the blade by cylinders (or cones) that pass through specified radial datum points on the blade. The axis of the cylinder (or cone) is coincident with the longitudinal axis. (Fig. 3)
Piercing-Plane Sections		Imaginary surface formed by intersection of a blade with planes that pass through the blade normal to a radial line, usually the stacking line. These sections are used in rectangular-coordinate dimensioning. (Fig. 3)
Pitch Angle, Hydrodynamic		(See Angle, Hydrodynamic Pitch)
Planform		Literally, the form of a blade in plan view. Practically, because of twist in a blade, each section must be rotated in attack angle so that its chord line lies in a common plane with the others. The view is then taken along a normal to this plane.

Power	P	Reference Power
	P_0	Power delivered to propellers, $Q\omega$
	P_T	Thrust power, TV
Power Coefficient	C_p	$C_p = P/(\rho/2)V^3A$
Pressure	p	Force per unit area.
Pressure Face		Pressure face is the afterface of a propulsor blade designed to have maximum pressure. (Fig. 1)
Pressure, Vapor	p_v	(See Vapor Pressure)
Propeller		A propulsion device consisting of a system of rotating blades or lifting surfaces. Counter-rotating propellers are two propellers on the same axis rotating in opposite directions. (Fig. 8)
Radius	r	Radial coordinate
	R	Reference radius
	R_h	Of hub (normally at stacking point)
	R_p	Of tip
Rake		Rake is a term used to describe the displacement in a longitudinal plane of the blade stacking points, from their normal location in a transverse plane. (Fig. 9)
Reynolds Number	R_n	Velocity times a length divided by kinematic viscosity $R_n = uL/\nu$
RPM, Propeller		The revolutions per minute of the propeller. For counterrotating propellers it should be labeled fore or aft. The absolute sum of the fore and aft RPM's is sometimes designated "relative RPM".

RPS	n	Revolutions per second. (See RPM.)
Section Angle	ϕ	(See Angle, Section)
Skew		A displacement of the stacking line along the pitch helix. (Fig. 9)
Solidity		Expanded area of blades divided by area of propeller disk minus area of hub $= A_e / \pi (R_p^2 - R_h^2).$
Span	b	Radial distance from blade hub to blade tip. $(R_p - R_h)$
Stacking Point or Stack-Up Point		Stacking point is a point on or near each blade section which is a reference point for positioning the blade sections along the stacking line. Some designers assume a radial stacking line and shift the stacking point to achieve skew. Others keep the same stacking point position for all sections and bend or curve the stacking line to achieve skew. (Fig. 9)
Stacking Line		Reference line for positioning blade sections to define a complete blade. (Fig. 9)
Stagnation Point or Line		That point or line that divides the flow going past a blade into that flowing over the forward, or suction surface, from that going over the after or pressure surface. (Fig. 10)
Streamline		That line in a flowing fluid across which there is no component of flow velocity (neglecting turbulence). (Fig. 4)
Stress	σ	Forces per unit area within a material such as in a propulsor blade.
Suction Face		Suction Face is the forward face of a propulsor blade designed to have minimum pressure. (Fig. 1)

Supercavitating Propellers		Propellers which are designed to operate with the suction face entirely cavitating. (Fig. 11)
Thickness	t	Maximum thickness of blade section.
Thrust	T	Component of propelling force parallel to axis of the torpedo and positive in a direction from tail to nose of the torpedo. (Fig. 1) $T = D/(1 - \tau)$
Thrust Loading Coefficient		Nondimensional thrust. Thrust divided by the product of dynamic pressure and some reference area. $C_{T_h} = \frac{T}{(\rho/2)V^2A}$ Sometimes a different definition is used, i. e., $K_T = \frac{T}{\rho n^2 D_p^4}$
Thrust Deduction Fraction	τ	That fraction of the total thrust that must be added to the tow drag to equal the thrust required to propel a torpedo body at a certain velocity. Thrust deduction is caused by a reduction in pressure over the afterbody due to velocity induced by the propulsor. $\tau = 1 - \frac{D}{T}$
Tip Vortex Cavitation		Cavitation occurring in the low-pressure core of the tip vortex. Tip vortex cavitation is reduced by decreasing the loading near the tips of propulsor blades. (Fig. 7)
Tolerance Zone		A tolerance zone is an area over which a tolerance or tolerances apply. (Fig. 12)
Torque	Q	Moment; tending to produce rotation.

Torque Coefficient C_q Nondimensionalized torque. Torque divided by the product of dynamic pressure, reference area, and a lever arm.

$$C_q = \frac{Q}{(\rho/2)V^2 A D}$$

Sometimes a different definition is used, e. g. ,

$$K_q = \frac{Q}{\rho n^2 D_p^5}$$

Tow Drag R_T or D (See Drag)

Tracking Error Tracking error is the blade-to-blade variation in the distance from a transverse plane to a reference point on the blade.

Transverse Plane Transverse plane is a plane perpendicular to the longitudinal axis and through a datum point which is normally the stacking point.

Turbulent Flow (See Flow, Turbulent)

Vapor Pressure p_v Equilibrium pressure between a liquid and its vapor; a function of temperature.

Velocity v Local in-flow velocity; velocity in boundary layer. (Fig. 4)

V Axial (advance) velocity of torpedo.

u Velocity in a fluid, general.

U_A Axial velocity induced by propeller at lifting line. (Fig. 1)

U_T Tangential velocity induced by propeller at lifting line. (Fig. 1)

V_A Mean velocity through propeller neglecting propeller-induced velocity.

V_r Resultant velocity of fluid and propeller at lifting line. (Fig. 1)

	ω	Angular velocity - $2\pi n$ (Fig. 1)
Vented Propellers		Propellers having gas introduced into a separated region or cavity on the blades. (Fig. 2)
Viscosity	μ	Ratio of stress to velocity gradient in a shearing flow.
Wake Function	w	Velocity decrement in the inflow to a propulsor expressed as a fraction of free-stream velocity.
Warp or Warpage		Warp is a term used to describe the displacement in a transverse plane of the blade stacking points from their normal location in a longitudinal plane. (Fig. 9)
Water Jet		(See Ducted Propeller)
Waviness		Waviness may be described as undulations in the surface which deviate from design. They are of long wavelength or spacing as compared with roughness. Roughness may be superimposed on waviness.
Zero Lift Line		The line defining the direction of the inflow velocity for which a blade section would have zero lift in two-dimensional flow. (Fig. 1)

SECTION 3 PROPULSOR DESIGN

MAJOR STEPS FROM DESIGN TO PRODUCTION OF PROPULSORS

The development of a new torpedo propulsor can be considered to progress through four phases:

1. The "design" phase consists of all analytical work in hydrodynamics and structural considerations. This phase results in:
 - a. Preliminary drawings (nonauthenticated)
 - b. Printout from computer
 - c. Magnetic tape with digital data
2. The "prototype" propulsor phase consists of producing, inspecting, and testing a unit that is as close as possible to the design dimensions. Hand work may be required in the absence of production tooling to come later. Testing (towing basin and water tunnel) is to verify that design requirements are met. This prototype phase might also be considered a model phase.
3. The "first-production" phase initially involves drawing authentication based upon results of the above prototype phase. Decisions are made at this time regarding tooling and gaging. The first units so produced will be carefully inspected to verify dimensional conformance, and tested on a torpedo to verify in-water performance. (Drawings should still be under local configuration-control management.)
4. The "quantity-production" phase follows the clear indication of acceptable units from the above first-production phase. Firm and official production drawings are made, which are no longer under control of the local design agency. Formal procedures are well established for tooling and inspection.

PROPULSOR DESIGN - GENERAL

The following is a discussion of various factors influencing propulsion design. This section may be skipped if the reader is interested in other aspects (manufacturing, inspection, etc.).

The details of propulsor design are many and may be found in current reports, some of which are referenced in this work (Refs. 2-23, 37-39). Propulsor design is a highly specialized field, requiring high-speed electronic computers for the more sophisticated methods. Design methods are changing so rapidly that any detailed report that might be included here on current methods could be obsolete soon after it was issued. Thus, it seems wise to include only a skeleton of current design methods, with references, and to point out the trends in design methods, so that the lay reader may appreciate the importance of careful design and may understand the many considerations involved in generating the numbers that the designer furnishes for coordinates and tolerances. The methods given here are in general not detailed enough to permit the use of this text to arrive at an acceptable design. However, the bibliography is included for those readers who may wish to delve further into the field.

Torpedo propulsors, unlike the propulsors of surface ships and pleasure boats, generally operate in a fairly well-defined velocity field and at nearly constant body drag coefficient. Thus, the loads at a given speed are reasonably well specified. For this reason, the propulsor may be designed for high efficiency and low cavitation tendency with little need for compromises because of a wide range of operating conditions. One of the design parameters for propulsors, J , the advance ratio, is proportional to the ratio of forward speed of the torpedo to tangential velocity of the propulsor tips. When properly designed, the propulsor will have its highest efficiency and least tendency to cavitate at or near its design J (Figs. 13 and 14). Because of the nature of the torpedo application, the propulsor can generally operate at or near design J .

In a torpedo propulsor, high efficiency is important because it means conservation of fuel, or some combination of higher speed and/or longer duration of run. Cavitation of a torpedo propulsor should be avoided because it can result in loss of efficiency and in cavitation noise. There are two reasons why noise may be objectionable. One is that most torpedoes must not give their position away to the target by producing detectable (radiated) noise. The other is that propulsors must not generate so much noise as to interfere with the acoustic signal on which the torpedo is attempting to home (i.e., self noise). Experience has shown that cavitation noise, even though generated relatively far from the acoustic homing transducer, is more apt to interfere with homing than is machinery noise from gears, commutators, pumps, etc. Even slight cavitation is generally not acceptable since it immediately produces troublesome self noise. Machinery noise, on the other hand, is most apt to reveal the presence and location of a torpedo, as shown by experience. The nature of the frequency spectrum of machinery noise is quite different from that of cavitation noise. Machinery noise is generally characterized by fundamental tones, and numerous harmonics such as those generated by meshing gears. These have high-energy content in the lower-frequency, low-absorption region which transmits over long ranges. The spectrum is characterized by sharp peaks. Cavitation noise, by contrast, is at a high frequency and is a so-called "white noise" whose spectrum is relatively flat. Quantitative data on torpedo noises are generally confidential. One useful source of information is Ref. 24, which gives frequency spectra of operating torpedoes, mines, etc.

In summary — a good modern torpedo propulsor will provide the following:

1. Required thrust at or near design RPM
2. High efficiency
3. No cavitation at or below design depth.

PROPULSOR DESIGN — PRELIMINARY INFORMATION NEEDED

Some preliminary information is necessary before a designer of any type of propulsor starts the design. Such performance specifications should set the forward speed, depths of operation, allowable self-noise, etc. The rotational speed of the propulsor (RPM) is generally dictated, within limits, by the nature of the prime mover (engine, motor, gearbox, etc.). In general, propulsor RPM's should be low for good efficiency, whereas prime movers have higher specific power at relatively high RPM's. On the other hand, reduction gears are often noisy. Thus, the designer has some basic decisions to make before commencing on the propulsor configuration. Therefore, each new torpedo should represent a study in optimization for efficiency and quietness.

One of the first things that must be known about a torpedo body is the velocity distribution in the boundary layer at the plane* of the propulsor (Fig. 4). This information, along with the RPM, determines the relative inflow velocity. The boundary layer velocity profile may be calculated but it should also be measured. This can be done at the same time the body drag is being obtained.

The drag of a torpedo body must be known in order to determine the thrust, and thus the horsepower, necessary to drive the torpedo at the required speed. In determining the required thrust a factor known as thrust deduction, τ (Refs. 25-27), must be taken into account. This factor may be calculated or estimated from previously obtained test data. The operation of the propulsor increases the drag of the body so that the required thrust is equal to the measured drag (i.e., towed) divided by $(1 - \tau)$. The power needed to generate this thrust and hence the efficiency, η , of the propulsor comes out of the propulsor design solution as other criteria are satisfied.

* In the case of pumpjets, the velocity distribution at the plane of the propulsor may be calculated from a known distribution upstream.

The drag of a torpedo may be calculated with the help of Refs. 28 and 29 with fair accuracy, but it should always be measured, as appendages and changes in shape would prevent precise calculation. Probably the best place to measure the tow-drag of a torpedo is in a towing basin, such as that at the Naval Ship Research and Development Center (NSRDC) (formerly David Taylor Model Basin). Another method is to measure body drag in a wind tunnel of sufficient test-section size so as to minimize wall-interference effects. Measurements can also be made in a water tunnel such as the 48-inch water tunnel at the Applied Research Laboratory (ARL), Pennsylvania State University, or the 36-inch diameter water tunnel at NSRDC, Washington, D. C. ; however, wall interference effects make accurate determination of drag difficult (Ref. 30).

Type of Propulsor

The variety of conceivable types of torpedo propulsors include pumpjets, water jets (Ref. 31), hydropulses, screw propellers, and cycloidal propellers. The requirements for torque balance and stealth and the need for high efficiency favor pumpjets (Refs. 32 and 33) and counterrotating subcavitating (i. e., fully-wetted) propellers.

The pumpjet has the following advantages over propellers:

1. It may offer a significant reduction in cavitation inception number because the pressure may be build up around the impeller by decelerating the flow with proper shaping of the shroud.
2. The shroud masks some of the radiated noise that might be generated inside the pumpjet.
3. The rotor requires only one drive shaft in contrast to the two required for counterrotating propellers. The whirl is taken out with stationary vanes.

The counterrotating propellers have the following advantages over pumpjets:

1. No expensive close fitting shroud is necessary
2. Propellers have less drag than a pumpjet with its shroud.

Therefore, counterrotating propellers are apt to be more efficient than pumpjets. However, the shroud increases the stability of the torpedo so that any comparison must include the effect of all stabilizing surfaces on drag and be made for equally stable configurations.

There may be other minor advantages that could be cited for or against either the pumpjet or counterrotating propellers, but the experimental demonstration of these advantages is lagging or inconclusive.

Other types of propulsors that have been tested include supercavitating (Refs. 34 and 35) and base-vented propellers (Ref. 36); (see Figs. 2 and 11). Neither of these is as efficient as fully-wetted propellers. At very high torpedo speeds and shallow operating depths, it may be necessary to go to one of these cavitating types of propellers or to a pumpjet or waterjet propulsor.

PUMPJET DESIGN

The term pumpjet defines a hydrodynamic propulsor that consists of a rotating vane system operating in an axisymmetric diverging shroud or duct to diffuse, or reduce, the inflow velocity. In addition to the rotating vane system, a stationary vane system is used at the exit to take out the whirl (Figs. 5 and 6).

The interest in pumpjets has resulted primarily from efforts to develop propulsor systems for both high-speed surface and submerged vehicles. The attractiveness of pumpjets for high-speed applications originates from the ability

to design the propulsor to operate with inflow velocity at the vanes lower than the forward velocity of the propeller body, so that the blading is less apt to cavitate than unshrouded blading. Reduction in the velocities relative to the rotating blade system can normally be accomplished only if the shaft speed and the circumferential flow velocity are also reduced. In most cases, this leads to high-torque propulsors of low shaft speeds.

The original efforts in the design and development of pumpjets are summarized in Ref. 37. Much of this design philosophy is still used. However, Ref. 38 presents an approach that incorporates the results of recent cascade work, and includes some of the techniques presently used in axial flow compressor design. This method permits the sizing and design of a pumpjet to satisfy specified performance criteria relating to:

1. Vehicle forward velocity (Ref. 37)
2. Available power for propulsion (Ref. 38)
3. Propulsor shaft speed (Ref. 38)
4. Vehicle size and shape (Ref. 39)
5. Required submergence depth below which no cavitation is tolerable (Ref. 40).

Initial Design Considerations (Pumpjets)

The propulsor configuration and its performance are highly dependent on the hydrodynamic characteristics of the body or vehicle to which it is to be applied. Some estimate of the drag of the body, as well as that increment of drag caused by the addition of the propulsor unit, must be obtained (Refs. 28 and 38). The energy characteristics of the velocity profile of the fluid stream near the aft end of the body must also be obtained (Ref. 39). Having these, the optimum mass flow ingested by the pumpjet can be derived (as described in Refs. 38-41) with a

view toward minimizing both the losses in the shroud inlet and the kinetic energy lost in the discharge jet. Once the optimum mass flow has been derived, the disk area, blade solidity, and shaft speed must be determined that will permit the design of a vane system satisfying specified limits of resistance to flow separation and cavitation.

Cavitation Performance (Pumpjets)

The problem of propulsor cavitation is largely dependent on the degree to which cavitation must be avoided (for a discussion on the causes and control of cavitation, see "Factors Influencing Cavitation;" Section 4). It has been well established that limited cavitation occurring within the blade passages of pumps, propellers, and pumpjets does not affect the propulsor performance or efficiency, but strongly developed cavitation can lead to complete performance breakdown and falloff in shaft torque, as well as blade erosion. However, the problem is considerably complicated when it is necessary to avoid local incipient cavitation as a possible source of noise at specified vehicle speeds and depths.

The mass flow through the propulsor is selected to minimize energy losses. This value of mass flow and the respective rotor disk area is used in selecting the advance ratio to satisfy specified cavitation performance. In general, for a given disk area and mass flow, as advance ratio is increased (shaft speed decreased) the cavitation performance improves. Also, for a given advance ratio and mass flow, as the disk area is increased, the cavitation index improves.

It must be emphasized that the preceding design considerations have been directed toward controlling the onset of blade surface cavitation. A second form of cavitation occurs in shrouded propulsors due to the presence of secondary flows such as tip-clearance leakage flow. This flow, resulting in a tip vortex, generates cavitation in the clearance gap itself. The leakage flow also impinges on the top of the stator system, causing periodic cavitation. In pumpjets it is usual to find

that the cavitation resulting from secondary flows occurs before blade surface cavitation. However, research described in Refs. 40, 42, and 43 provides design criteria that, if properly applied, will give overall propulsor cavitation performance equal to limits predicted for blade surface cavitation.

Blade Geometry and Loading Distribution (Pumpjets)

Satisfying the cavitation requirements of the blading does not imply that flow separation will not occur from excessive blade loading, especially near the root section where relative flow velocities are low. Flow separation leads to high energy losses and creates large wakes that promote both cavitation and vibration. Therefore, it is necessary to determine established limits of blade loading, considering the fluid energy needed to propel the vehicle. The selection of the radial distribution of rotor head must also be based on consideration of the resulting velocity profile of the discharge jet, since a jet with high shear (a large velocity gradient) inherently has large energy losses associated with it. In addition, secondary flows can form which give rise to the hub vortex, energy losses, and added vehicle drag. To obtain a high-performance pumpjet it is evident that a balance has to be achieved among factors such as: energy losses due to the presence of a discharge jet of varying energy in the radial direction, blade loading, secondary flows, and cavitation. A detailed discussion describing the selection of rotor head to satisfy the above requirements is given in Ref. 33.

Blade Design (Pumpjets)

The next phase of pumpjet design uses the energy distribution of the ingested mass flow in conjunction with the selected radial distribution of rotor head to obtain an axisymmetric solution of the flow at various stations through the pumpjet, such as given in Ref. 44. The results of this solution provide the energy and velocity distributions required for the design of the cylindrical blade sections

(Fig. 3). Numerous blade design techniques can be used at this stage, including the use of two dimensional cascade data and the selection of blade profiles as outlined in Ref. 45. However, to obtain superior cavitation resistance, it has been necessary to design blade sections with loading and thickness distributions significantly different from those for which cascade data exists. A method that has been used with success in a number of propulsor designs is the "Mean Streamline Method" of Ref. 46.

PROPELLER DESIGN

The above sections apply to pumpjet design. When unshrouded propellers are to be designed the following steps are suggested:

1. Collect the necessary input data for design: body shape, body tow drag, boundary layer velocity and pressure profiles at propeller plane, and depth below which no cavitation should occur.
2. Calculate the thrust deduction factor or estimate it from previously obtained experimental data.
3. Carry out an approximate optimization study for the efficiency while meeting the cavitation requirements. In this study the advance ratio, propeller diameter, blade planform, thickness distribution, and number of blades are varied.
4. Determine the radial pitch variation, shaft power, and efficiency from modified lifting-line theory which includes a correction for viscous drag of blades.
5. Check smoothness of radial pitch variation and alter radial circulation distribution to improve blade surface smoothness as needed.
6. Determine ideal angles-of-attack and camberlines from lifting-surface theory.
7. Carry out detailed cavitation calculations to see if propeller meets design requirements.

8. Make strength analysis.
9. Determine blade section coordinates by superimposing thickness distribution on camberlines oriented to yield the proper radial pitch distribution and ideal angles of attack.

In applying these steps a considerable amount of iteration may be required. For example, the propeller diameter and/or advance ratio used in step 2 may be altered by step 3; the circulation distribution used in steps 2,3, and 4 may be altered by step 5; and the blade geometry used in steps 3,4, and 6 may be altered by steps 7 or 8. However, as the designer gains experience his initial choices often are sufficiently close that extensive iteration is bypassed.

Single Versus Counterrotating Propellers

The designer first determines whether a single propeller or counterrotating propellers are to be used. Counterrotating propellers (Fig. 8) are usually chosen because they can be designed for torque balance, with good cavitation resistance, and have proven to be more efficient since the energy in the whirl behind the forward propeller can be recovered to a great extent by the after propeller.

With single propellers, one or more of the following devices may be used to take out body torque and prevent roll.

1. "Pull around" weight or metacentric-height stability
2. Splayed controls
3. Stationary straightening blades.

Each has its disadvantages. For instance, it is difficult, if not impossible, to get enough moment with "pull around" weight to avoid body roll. Splayed controls produce drag that goes up with the torque. Stationary straighteners are almost as expensive as an after propeller, and do not develop much thrust. The trend, then, is toward the use of counterrotating propellers. These propellers are

sometimes driven by a counterrotating engine or motor in which both shafts (such as rotor and stator) are freely rotating so that torque balance is automatic. If the propellers must be driven at fixed RPM (fore and aft), such as by a fixed-ratio gear box, any residual torque imbalance in the propellers is transmitted to the body. Additional burden is thus placed on the designer to achieve near-perfect torque balance at given RPM's. This is a difficult task, and an error in torque of a few percent could be troublesome, whereas such a percentage error in thrust would be of little consequence. This torque-balance requirement dictates tighter tolerances than would otherwise be required.

Number of Propeller Blades

The number of blades of a propeller should be chosen on the basis of achieving minimum noise generation (from unsteady forces, cavitation and vibration), and of minimizing the cost. The following generalities may help in this choice:

1. The lowest cost generally results from the least number of blades for machined propellers. If manufacturing processes such as molding, coining, or forging can be used, this is not necessarily the case.
2. Most torpedoes use a cruciform arrangement of control fins or shroud supports upstream of the propellers. An even number of blades on a single or forward propeller would cause more than one blade at a time to come into the wake of these obstructions resulting in a greater fluctuation in thrust and torque with the attendant increase in radiated noise and structural vibration. Since the after propeller passes through the wakes of both the forward propeller and the fins, the same reasoning indicates that it should not have the same number of blades as the forward propeller and also, should have an odd number of blades. However, ease-of-manufacture considerations may override and an even number of blades could be used on the after propeller. This may be justified on the basis that the after propeller is farther away from the fins than the forward propeller, and the forward propeller tends to smooth out the fin wakes. Thus the effect of the fin wakes on the after propeller may be considerably less severe than on the forward propeller.

3. The use of numerous blades of large chord length may result in an overlapping of blades circumferentially (high solidity). This can complicate manufacturing processes such as numerical control milling, coining, forging, and even molding.
4. For most torpedo-propeller blades, stresses are not great enough to be important. However, for a given type of blade cross section geometry and for constant total lifting area, the least stress comes with the least number of blades. While each blade must produce more thrust, the blades in general will be sufficiently thicker to reduce the stress.

Choice of Material

The choice of the material from which a propulsor is to be made is very important. The following principles are considered in the selection of materials for a particular propulsor:

1. Strength

The yield strength of the material must be greater than the maximum anticipated stress with some safety factor for uncertainty in design calculation. For air-dropped torpedoes, allowances should be made for stresses due to slap into the water-entry cavity sidewall.

2. Corrosion Resistance

Even though a torpedo is a one-shot weapon, every torpedo is so constructed that it can be run in salt water, retrieved, worked over, and rerun numerous times. This is particularly important during proofing and training. Moreover, for ready storage on shipdeck the need for corrosion resistance is also important. Protective coatings such as hard anodizing are recommended on aluminum alloys. Plastic or paint coatings can be used on aluminum and other materials subject to corrosion but the danger of scratches and peeling adversely affecting the surface contour or smoothness makes such protection less desirable. If stainless steel can be used, no surface protection is required.

3. Ease of Machining

Aluminum alloys are particularly easy to machine, whereas most stainless steels are tough and difficult to machine. If the manufacturing process calls for milling or hand working, the selection of a material will strongly favor aluminum alloys.

4. Special Properties

For forging, casting, and other production methods, special properties are required (i. e., plasticity, uniform shrinkage, etc.).

5. Density (weight)

The density of the material is considered if it adversely affects the overall weight or trim of the torpedo.

Propeller Diameter

The propeller diameter is normally chosen to optimize the efficiency while meeting the other constraints put on the design. The resultant diameter will usually coincide approximately with the outer edge of the boundary layer on the body at the propeller plane (Fig. 4). This outcome is a consequence of the fact that the efficiency is greatest if the energy decrement in the boundary layer fluid can be exactly replaced by the propeller action.

A diameter larger than that given by efficiency considerations is sometimes required to keep the propeller "moderately loaded." Existing propeller design theory is based on the concept of moderate loading which means the velocities induced by the propeller must be small compared to the undisturbed inflow velocities to the propeller. Increasing the propeller diameter (holding other things constant) decreases the propeller-induced velocities. Other factors may also necessitate the choice of a diameter that is not determined from efficiency considerations, i. e., the desirability of avoiding a strongly varying wake generated by control surface or tabs forward of the propeller.

Lift Distribution (Propellers)

The radial distribution of lift generated by the propeller blades is determined by the radial distribution of bound circulation. This bound circulation distribution is not chosen to optimize efficiency as optimum efficiency distributions for wake

adapted propellers are unsuitable from a practical standpoint. Two other requirements govern the shape of the radial distribution of bound circulation: (1) the circulation must decrease gradually near the tip so that a strong tip vortex susceptible to cavitation is not formed, and, (2) the circulation distribution must give rise to a smoothly varying radial pitch distribution. Physical reasoning leads to the conclusion that radial pitch distributions with abrupt changes in slope (discontinuities in blade surface) probably will not develop the prescribed circulation. A further restriction for single propellers is that the circulation must go to zero near the hub so that there is no whirl component there to give rise to a strong hub vortex which is susceptible to cavitation. This restriction is unnecessary for counterrotating propellers as the whirl generated by the forward propeller is normally removed by the after propeller.

Lift is generally developed by cambering the blade rather than giving it an angle-of-attack. Such a choice results in a more uniform loading along the chord and, therefore, smaller negative pressure peaks and accompanying increased cavitation resistance. A widely used chordwise lift distribution is the $a = 0.8$ loading (Ref. 47) which is uniform from the leading edge to 0.8 of the chord and drops off linearly from there to the trailing edge. A possibly better loading distribution is a trapezoidal one that unloads the leading edge (Ref. 48). With such a distribution the loading due to camber and off-design angle-of-attack do not add in the critical region near the leading edge.

Blade Section Shape (Propellers)

The blade section shape describes the distribution of blade thickness along the chord. NACA airfoil shapes, as given in Ref. 47, are often used because they have been carefully tested and a large amount of data is available. These

data include the local velocities over the surface resulting from thickness and angle-of-attack. The cavitation calculations for the propeller utilize these velocities in determining the minimum pressure on the blades.

In some cases the designer may choose to alter the shapes given in Ref. 47 or calculate a unique shape for some special purpose (Ref. 49). Reference 50 gives a method of determining pressure distribution on arbitrary profiles. Reference 51 gives minimum-pressure envelopes for three airfoil shapes and a design chart for selecting an optimum shape.

In choosing a blade section shape there is normally nothing to be gained by a selection which attempts to preserve laminar flow since the in-flow is generally already turbulent. Care should be taken, however, to choose a shape with a fairly large leading edge radius. The leading edge radius controls, to a great extent, the minimum pressure in the vicinity of the leading edge at angle-of-attack. A very small leading edge radius makes the propeller excessively sensitive, cavitation wise, to off-design operation (a portion of the lift being developed by angle-of-attack rather than camber).

The percent thickness of an airfoil is the ratio of the maximum thickness of the foil to the chord, expressed as a percent. Keeping similar shapes, the velocities due to thickness on an airfoil decrease as the percent thickness decreases. For this reason the percent thickness is often decreased from hub to tip to offset the increase in thickness-induced velocity on the foil that results from the higher relative velocity of the fluid and the blade near the tip.

A choice of percent thickness based strictly on strength consideration will often be a poor one as it commonly leads to overly thin blades. The choice of percent thickness should be made to provide blades with a moderate amount of thickness that does not excessively decrease the cavitation resistance of the propeller. The practical considerations that dictate such a choice are:

1. Thicker blades generally mean larger leading-edge radii and consequently improved off-design operations as discussed above.
2. Thicker blades are generally safer for handling than thin, sharp blades.
3. Thicker blades are more rugged and have greater resistance to accidental deformation damage.
4. Thicker blades sections make possible modern, more economical fabrication methods such as hot forging.

Even if the percent thickness is not restricted by cavitation considerations it must not become too large or the blade drag will become excessive with a consequent loss of efficiency. Furthermore, with overly thick blades empirical corrections to blade angle and camber become necessary (Ref. 56). This decreases the certainty of the design calculations.

Several different trailing-edge configurations have been suggested in an attempt to suppress self-induced vibrations called singing (Refs. 50-53).

Planform of Propeller Blade

The blade planform is a "side" view of the blade as seen after rotating the blade sections so that all chord lines lie in a common plane. Almost any reasonable planform may be chosen, but the following factors guide a choice of shapes:

1. The root chord must be large enough to develop the required section modulus to keep the bending stress below a maximum allowable value.
2. The tip chord may be zero since it is not loaded, but some designers believe that a finite chord length at the tip is desirable to decrease the strength of the tip vortex by providing boundary layer material for the vortex core (Ref. 9).
3. Since the relative flow velocity between blade and fluid is greatest at the tip, the drag per unit chord length is high there and is proportional to the chord length. Blades that have long chords near the tip waste energy in unnecessary drag.
4. In general, the outline of a planform should have no abrupt discontinuities from hub to blade tip which might induce unpredictable crossflow effects.

By utilizing two-dimensional data on thickness effects and the prescribed radial and chordwise loading a rough planform shape can be calculated for a given constant cavitation number (Ref. 53). Although such a shape cannot be used exactly as calculated, it serves as a very useful guide in choosing a final shape.

Skew (Propellers)

The radial pitch distribution of the propeller defines a helical sheet extending from hub to tip. In skewing the blades each cross-section may be displaced along this sheet (at a constant radius) an amount depending on its radial location. The amount of displacement varies smoothly from hub to tip and is normally zero at the hub and a maximum at the tip. Warp and rake are related to skew (see Fig. 9). The principal reason for skewing blades is to reduce the fluctuations in thrust and torque which occur when the blades cut through wakes from fins, control surface, shroud supports, or any other upstream obstruction. The skewed blades enter the wakes more gradually, lessening the fluctuations and the consequent radiated noise and vibration associated with them. Obviously skew can be considered as a distortion of the stacking line or as a series of displacements from a radial stacking line.

Fillets

There are two reasons for using a fairing, or fillet, at the base of a propeller blade. One is a hydrodynamic reason, in that the interference drag between the hub and the blade is reduced by a fillet. The other reason is a structural consideration. The full bending strength of a cantilevered attachment is not developed unless a fillet is used to spread the load. According to Ref. 58, for a uniform cross-sectional shape, the stress concentration factor is a function of a fillet radius and the radius of the fillet should be about equal to the thickness of the blade to keep the stress-concentration factor as low as 1.1. Practically, to

allow for ease of fabrication, the radius should be constant so that a spherical cutter could form the whole fillet in one traverse.

Some work has been done on parabolic fillets that shows an increase in strength for the same amount of material left in the fillet. This seems like a costly refinement for torpedo propellers, except where the fillet is formed by other than cutting (i. e., by casting, forging, etc.).

STATUS OF PROPULSOR DESIGN THEORIES

Several design agencies, associated with the U. S. Navy, have devoted much time and effort in developing advanced methods of propulsor design. These agencies are: The Applied Research Laboratory, Penn State University; the Naval Ship Research and Development Center, Washington, D. C.; and the Naval Undersea Center, San Diego, California. Over the years, design procedures have evolved from relatively simple methods suitable for hand calculations, to sophisticated methods requiring the use of high-speed digital computers.

It is possible, using only a desk calculator, to design a propeller using techniques described in Ref. 7, which uses the circulation or lifting-line theory, and uses a correction based on lifting surface to arrive at a design said to "meet the design conditions within the accuracy of the test" (then used: ed.). Reference 7 covers single propellers only, not counterrotating propellers. A reference that does cover counterrotating propeller design and may still be used with a desk calculator is Ref. 8. This report, published one year later (1956) than Ref. 7, also uses lifting-line theory with suitable corrections for the presence of a finite hub, finite thickness, and wide-blade effects. The report describes experimental measurements on propellers designed using the Ref. 8 method and concludes: "The agreement between experimental and theoretical results is satisfactory."

The following is a quotation from the conclusions in Ref. 7: "Although this method represents a practical solution to the propeller design problem, there remains some aspects of the theory that require more research. One involves a rigorous determination of the change of curvature of flow over each blade section that would necessitate the development of a rigorous lifting-surface theory." This is now being done by modern designers. In his state-of-the-art report (Ref. 22) G. G. Cox says ". . . lifting surface theory development, particularly with regard to numerical evaluation techniques for use with propeller design methods, has continued from the late 1950's. Undoubtedly the increasing availability of high-speed digital computers has provided the necessary stimulus for this effort." And he continues: "Theoretical development has proceeded along one of two paths, Strecheletzky (Ref. 10)*, Kerwin (Ref. 11)*, and English (Ref. 12)* use a vortex-lattice representation for the lifting-surface model; i. e., discrete separated vortexes, while Sparenberg (Ref. 13)*, Pien (Ref. 14)*, Nishiyama and Makajima (Ref. 15)*, Yamazaki (Ref. 16)*, and Nelson (Ref. 17)* use a continuous vortex sheet representation."

Several reports are available (Refs. 20 and 21) on the performance of propellers designed by new methods. One series of propellers (Ref. 20) was designed by the combined methods of Kerwin (Ref. 11), Pien (Ref. 14), Cheng (Ref. 19), and Cox (Ref. 18). Reference 20 states that the propellers so designed operated near their design performance except for propellers of very large blade area for which the pitch corrections tend to be high, and for very thick blade sections for which the pitch corrections were too small. Analytical approaches for prediction of the flow in pumpjets are being developed by several agencies (Refs. 59 and 60). The complete design of a pumpjet based on calculation of the flow around torpedo body, shroud, and blades is foreseeable in the near future.

* Reference numbers are for this report.

SECTION 4 TOLERANCES

TOLERANCE SETTING

Tolerance setting is clearly the job of the design agency. It is one of the most difficult areas in torpedo propulsor design because of its complexity and its possible effect on costs. The design activity should work closely with production and/or quality assurance representatives in establishing realistic tolerances. The designer must be assured that the propeller he has carefully designed does not have its performance degraded by loose tolerances but, at the same time, the cost of the propeller must not become prohibitive because of excessively tight tolerances. This brings in the need, on the part of the designer, for a knowledge of machining and hand-finishing costs as a function of tolerances. The exact increase in cost due to reducing the tolerance is difficult to determine. It certainly would be a function of the type of work necessary to achieve the tighter tolerance, but in the case of hand-finishing it may even depend on the proficiency of the workman doing the job. A hypothetical case of a propeller was discussed with several NUC manufacturing specialists. Their estimate was that it would cost from five to ten times more to produce a propeller to ± 0.002 than to ± 0.005 inch. A tolerance of ± 0.002 inch might be necessary within about 10 percent of the chord from the leading edge, but it need not be specified in other areas on most propulsor blades.

Normally, a propeller is designed by starting with a desired thrust, a propeller RPM, etc., and then determining blade section shape to satisfy the design requirements. The "reverse" problem, of starting with a blade-section shape and calculating its performance, has not yet been solved so that a rigorous

approach to determining the effects of tolerances is not yet available. Nevertheless, the state of propulsor design is fast approaching that point where the performance closely agrees with the design requirements. There may still be some need for final handwork on propulsor blades as they are being tested, say, in a water tunnel. Both the old and the new shape should be carefully documented if anything is to be learned about tolerance from such a modification.

Often, counterrotating propellers are driven through a gear box so that the ratio of the rotational speed of the forward propeller to that of the after propeller is fixed. In such cases the achievement of a reasonably good torque balance is essential. Errors in blade shape can upset the torque balance so that control of the blade shape through proper tolerancing may be even more important for counterrotating propellers than for single-rotating propellers. Fortunately, there is some experimental evidence (Ref. 61), which agrees with a logical analysis of the flow system, that torque error in the forward propeller may be partly balanced out by the after propeller due to the changed flow angles. However, this fact does not relieve the added burden on the designer to use tolerances that will adequately control torque balance.

In setting dimensional tolerances on a propulsor the new designer should start with a set of tested tolerances on a similar propulsor that has resulted in satisfactory performance. Since the system of setting tolerances to be suggested in this report is partly new, no such experience exists in some areas.

SOME EXAMPLES OF TOLERANCE ERRORS

Some tests have been run in the 48-inch water tunnel at ARL on Torpedo Mk 46 counterrotating propellers comparing shapes having rather startling differences. One test (Ref. 62) describes the effect of thickening Mk 46 blades 10 percent on each surface (20 percent total). Results showed there was little difference in the cavitation index, and no noticeable difference in thrust and

torque coefficient, except for a slight decrease in torque coefficient (about two percent) on the after propeller. Another test (unpublished) was with propellers selected from lots of three different manufacturers. The first set was within 0.002 inch of nominal at all points measured. The second set had leading edges out of round and with an effective leading edge radius of 0.0075 inch instead of the design 0.003 inch. Other radii were proportionately larger. The third set had a 20-minute twist in the angle-of-attack at one point on the forward propeller leading edge, and a 17-minute twist in the leading edge of the after propeller. The after propeller leading edge was out of thickness tolerance by as much as 0.003 inch, mostly in the direction of reducing the leading edge radius. Abrupt discontinuities in shape were prevalent in the leading edge of the last two sets described. In spite of these large differences in contour, the thrust of all of these propellers was quite similar. However, there was a six percent difference in net torque at design J between the extremes. This difference might be unacceptable in terms of maintaining an adequate torque balance. The cavitation number for the leading edge suction face of one after propeller was 0.85, while for another it was only 0.52. The factor most responsible for this difference was shown to be abrupt discontinuities in the leading edge contour. The higher cavitation number would not be acceptable for certain high speed, shallow running conditions.

Three sets of a different propeller design were similarly measured for conformity to the design and tested in the ARL tunnel. The results, which are similar to the above, are given in Ref. 63.

PRINCIPLES OF TOLERANCE SETTINGS

In the past, the philosophy of tolerance setting on propulsor blades has not always been based on a thorough understanding of propulsor performance. A typical rationale for a tolerance in blade angle, for instance, was that "metals

do warp when stress relieved so we must include an angular tolerance to take care of warpage." It is not clear how the thickness tolerance for a current torpedo propeller was set at only ± 0.003 on its pressure side, but was ± 0.010 on the suction side where deviations from nominal can probably do the most harm. The philosophy of tolerance setting to be presented here will suggest a loosening of those tolerances that need not be tight, but a tightening of others as intelligently and sparingly as required by two hydrodynamic principles of propulsor performance.

The first of these principles is that the mean camber line distribution and the angle-of-attack distribution of the propeller blades largely determine the generated thrust and torque. In other words, two different blades (neither of which is cavitating) having different thickness distributions, but identical mean camber line and angle-of-attack, will have almost exactly the same lift and drag. The thrust and torque vectors of the two blades will, therefore, be almost identical. Thus, tolerance limits that ensure that the mean camber line and the angle-of-attack do not change appreciably in spite of a difference in thickness will result in performance quite like that of the nominal propeller.

The second of these principles is that the resistance of a propeller blade to cavitation is determined to a great extent by the shape of the leading edge region. Hence, special handling of the tolerances in that region is required. The tolerance call-outs must assure not only that the contour agrees reasonably well with the desired shape but also that the contour is smooth and free of abrupt changes in slope.

The old documentation method of using zone tolerances only on the pressure and suction faces (Fig. 12) fails chiefly in that it unnecessarily restricts thickness tolerances to tie down the shape of the camber line, and it does not guarantee an acceptable leading edge contour.

FACTORS INFLUENCING PERFORMANCE

Defects often occur on blades of a propeller, and result from some error in manufacturing. These defects may have an appreciable effect on thrust, torque, and cavitation. How these defects influence lift, and consequently thrust, and torque is discussed first. Their influence on cavitation is discussed later.

No lifting-surface solution to the "reverse" design problem of determining the loading of a propeller, given its geometry, has been obtained to date. Hence, no rigorous method exists to predict the effect on performance of loose tolerances which result in angle-of-attack errors, camber errors, etc. Moreover, for low aspect ratio lifting-surfaces, such as marine propeller blades, the loading at one station on the blade will be markedly affected by the geometry of the remainder of the blade. Thus any simplified method which attempts to relate loading of local geometry is of little value. However, some idea of the relative importance of various types of errors can be gained from a simplified analysis based strictly on two-dimensional flow.

Angle-of-Attack (or Pitch) Error

The change in section lift coefficient due to a given change in angle-of-attack can be evaluated approximately by using the theoretical slope of the two-dimensional lift curve, i.e., 2π per radian or 0.11 per degree. The change in lift coefficient for a 0.1 degree error in angle would be 0.011. If the section lift coefficient, C_l , is for example 0.1, the error in lift due to this angle-of-attack error is 11 percent. The width of the tolerance band that would allow a maximum error 0.1 degrees in angle is 0.1745 percent of chord.

Camber Error

Suppose, to consider a condition comparable to that of the angle-of-attack error discussed above, we allow the camber line to vary within the same tolerance band which would limit the corresponding angle-of-attack error to 0.1 degrees. In doing this it will be assumed that the altered camber line retains the same relative distribution of camber offsets, but that the ends and middle of the camber line are at opposite limits of the tolerance band. Using an NACA $a = 0.8$ camber line, a typical one for propeller blades, the maximum camber for a C_l of 0.1 is 0.67 percent of chord. For the altered camber line, the maximum camber offset will be changed by 0.1745 percent of chord, resulting in a change in C_l of 0.0257 (lift developed by camber is proportional to the magnitude of the camber offsets). Hence, the error in lift is 26 percent in contrast to 11 percent for the angle-of-attack error within the same tolerance band.

Area or Chord-Length Error

One of the effects of a chord length error is to alter the area of the blade surface. If all other factors remain constant, the percent change in lift will be proportional to the percent change in area. If a tolerance band of the same width as that used in the previous two examples is assumed around the leading and trailing edge region, the maximum probable error in area, and consequently in lift, is 0.349 percent. This value is almost negligible compared to the values computed for angle-of attack and camber error cases.

If the chord length error results from either the loss or excess of material at the leading and/or trailing edge of a cambered section, the orientation of the chord line and the magnitude of the camber offsets will be changed accordingly, causing lift errors due to the altered angle-of-attack and camberline. Fortunately the slope of the camberline in the leading and trailing edge regions for realistic

values of lift is sufficiently small so that these effects are of secondary importance and a further examination of them may be neglected.

Blade-Thickness Error

For thin airfoil sections developing lift by camber, the changes in section lift and drag for moderate changes in thickness are essentially negligible. Hence, smoothly changing errors in thickness that do not alter the shape of the camber line need not be tightly controlled by the tolerance specification.

Stackup Error

To form a complete propeller blade the blade cross-sections are stacked on a line that is normally radial, called the stacking line. The point on a cross-section that should coincide with the stacking line is the stacking point. Errors in locating the stacking point on the stacking line will cause deviation from the desired rake, warp, or skew of the blade. Since propeller performance is affected little by small changes in these parameters, tight tolerances on locating the stacking point are unnecessary as long as the error varies smoothly so that discontinuities in the blade surface do not occur.

Spacing Angle and Tracking Errors

Errors in the spacing angle of the blades around the hub and tracking errors (the blade-to-blade variation in the distance of the stacking line from a reference transverse plane) have relatively little effect on performance. Although the velocities induced by each blade have an effect on the other blades, the blades are so far apart that a small error in placement does not make a significant difference in performance.

Errors Requiring Careful Control

The preceding discussions and simplified analysis indicate that to maintain proper performance the most stringent control must be placed on the camber line shape. Tight control must also be maintained on the angle-of-attack but the tolerance can probably be somewhat relaxed over that for the camber line. All other errors are of secondary importance in maintaining performance but they must be sufficiently well controlled to assure a smoothly varying blade contour with no large deviations from the intended shape. In particular, tight control of blade thickness, per se, is of little value in maintaining performance, although it is frequently controlled very accurately to indirectly control the camber line.

FACTORS INFLUENCING CAVITATION

Cavitation is the formation of bubbles in fluid because of low pressure. It results from the vaporization (evaporation) of the fluid at ambient temperature when the localized pressure is reduced below the vapor pressure. Related effects caused by reduced local pressure also include the expansion of suspended or entrapped air bubbles, and the release of dissolved gas coming out of solution.

High velocities occur when water is forced to flow around curved surfaces having small radii of curvature, particularly around sharp corners. These high velocities result in reduced localized pressures (Bernoulli effect) which may fall below the fluid vapor pressure and thus cause sudden and localized cavitation. Cavitation can also occur on a smooth surface, such as the suction face of a blade, if the pressure is low enough. Vapor cavitation bubbles violently collapse as they are swept into a region of higher pressure. The violent collapse of these vapor bubbles results in intense cavitation noise. In addition all surface cavitation is evidence of lost energy or reduced efficiency. A general discussion of cavitation may be found in Ref. 64.

Cavitation has been classified according to type as:

1. Sheet Cavitation — spread out in a single attached flat region
2. Streak — occurring in a line along a vortex core or in a narrow sheet
3. Bubble — isolated bubbles over a large volume
4. Cloud or Mist — cloud of very fine bubble.

Cavitation has also been classified according to its location with respect to a propulsor blade as:

1. Pressure Face, P. F.
2. Suction Face, S. F.
3. Hub Vortex, H. V.
4. Tip Vortex, T. V.
5. Leading Edge, L. E.
6. Trailing Edge, T. E.
7. Forward Propeller, Fwd
8. After Propeller, Aft.

For instance, "LEPF aft" would mean leading-edge, pressure face on the after propeller (Fig. 14). It might further be described as streak or bubble cavitation at that location.

If perturbations in the otherwise smooth blade surface occur, they can cause local increases in velocity over the basic velocity and thus become regions of incipient cavitation. Some experimental and analytical work has been done on the effects on cavitation inception of certain types of perturbations on a flat surface (Refs. 65 through 71), and on propellers (Ref. 72). These perturbations range

from smooth undulations (waviness) in a surface to jagged tool marks of the saw-tooth type. Cavitation is most apt to occur when rough tool marks are across the streamlines at right angles.

The effect of roughness on the tendency to cavitate is a function of how the rough peaks protrude into the boundary layer. The lamina of water right at the blade surface is moving with the surface so is not affected by small roughness irregularities. As the surface roughness increases in size, the peaks of roughness protrude into faster and faster water and the local velocities around the peaks eventually become high enough for cavitation inception. The boundary layer near the leading edge of a blade is very thin. Therefore roughnesses at or near the leading edge have a much greater effect on cavitation than those toward the rear where the boundary layer is thicker.

If accidental roughnesses (gouges, nicks, scratches) occur on a propeller in use they may be repaired by grinding and polishing until a well-rounded, smooth depression remains in place of the rough spot. The depression will cause the local incipient cavitation number to be greater than normal, but less than for the roughness. Nicks or gouges that occur on the leading edge should be removed by completely reworking the leading edge, top and bottom, to preserve the original position of the mean chord and restore the design smoothness of contour.

A qualitative example of the effect of surface roughness on a specific propeller is given in Ref. 72. Another report, (Ref. 66), is a thorough study of the effects of various types of three-dimensional roughness embedded on a flat plate. Cavitation inception number, based on water velocity, is plotted as a function of ratio of roughness height to boundary layer thickness.

"The Effects of Surface Roughness on Cavitation-Inception Speeds of a Hydrofoil" (Ref. 69), shows how to use data from previous studies on roughness

elements for a particular hydrofoil. The report emphasizes the need for smoothness, particularly near the leading edge. The report cites two-dimensional roughness elements (i. e., tool marks) perpendicular to flow lines as most critical, and two-dimensional circular arcs or three-dimensional hemispheres as less critical.

Manufacturing errors can result in one or more blades being twisted in the direction of increased or decreased angle-of-attack. Also, deficiencies in design methods can result in the blades developing lift by angle-of-attack where lift developed by camber was desired. Moreover, torpedo propellers normally operate in the wake of fins or struts so that a fluctuating angle-of-attack occurs. The change in angle-of-attack caused by these factors can shift the stagnation pressure point from its normal location near the leading edge to a point on the upper or lower surface of the blade (Fig. 10). High local velocities can then result as the flow goes around the leading edge with attendant low pressure and danger of cavitation. The magnitude of the maximum velocity at or near the leading edge in such circumstances is critically dependent on the details (size of leading edge radius, presence of flat spots or humps, etc.) of the leading edge shape. Hence, care must be taken to assure that the leading edge region not only conforms reasonably well to the desired leading edge contour but also is smooth and free of abrupt changes in slope.

Well designed propellers will not have strong hub or tip vortices with the attendant low resistance to cavitation. However, errors in blade shape may cause either additional loading near the hub giving rise to a cavitating hub vortex or an excessively rapid unloading of the blade near the tip giving rise to a cavitating tip vortex (Fig. 7). Since this type of cavitation results indirectly from changes in the blade loading, control of the factors influencing performance discussed in the preceding section should control such cavitation.

SUGGESTED TOLERANCES

The following illustrates the types of tolerances that should be a part of propulsor documentation. In lieu of better tolerance figures, it is suggested that the tolerances specified here be considered for a 12-inch diameter propeller or scaled to other diameters. They are based primarily on experience from past propulsor developments and test results, and represent an application of the philosophy of tolerance setting outlined earlier. It is hoped that as test data are accumulated, or more theoretical work is done, some of these tolerances could be loosened.

Displacement of Blade Cross Section

The best fit concept as applied to propulsors considers two blade contour conditions:

1. When all of the section coordinate points are within the tolerance band for shape, best fit means that the section is positioned so that the actual coordinate points are as nearly equal distance as possible from the basic contour shape.
2. When all the section coordinate points are not within the tolerance band for shape, best fit means that the section is positioned so that the maximum possible number of coordinate points lie within the tolerance band, and that those points outside of the tolerance band have been positioned as close as possible to the limits of the tolerance band.

The datum section of a propulsor blade is that section to which the rest of the blade is referenced. Any section may be the datum section. However, the same section becomes the datum section for all the blades on the propulsor. A propulsor blade cross section may be within the tolerance zone for shape, but, within limitations, may be displaced from its normal location relative to the datum section. Angle-of-attack displacement should not be permitted except as allowed by the camber line tolerances. Basic coordinate points are all defined relative to some designated (datum) point on the blade. Any major displacement of that

point from its proper location must be accompanied by a similar displacement of all the other coordinate points of the section so that the "best fit" still places the contour within the tolerances zones. It is suggested that the datum point may be allowed to shift in any direction in the section plane by as much as ± 1 percent of the maximum chord length. For a typical blade of 3-inch maximum chord the shift could be ± 0.030 inch. The datum point tolerance zone is then 0.060 inch in diameter. The shift should occur gradually to eliminate the possibility of a jagged leading or trailing edge, so a limit is placed on relative shift between adjacent sections. A suggested limit is:

$$\Delta S = \frac{2L}{n}$$

where

ΔS = section-to-section shift between adjacent datum points

L = width of tolerance zone for datum point

n = number of evenly spaced sections tabulated on drawings

For the above propulsor blade with 20 sections tabulated:

$$\Delta S = \frac{2 \times 0.060}{20} = 0.006 \text{ inch}$$

Blade-Thickness Tolerance

Thickness tolerance of a blade section is based on the section chord length and may vary along the span as the chord varies (Figs. 16 and 17). The suggested tolerance on total thickness is 0.78 percent of the chord length and is apportioned +0.60 percent and -0.18 percent. For instance, for a chord length of 3 inches the plus tolerance band for a surface is 0.009 inch (0.018-inch on total thickness), and the minus tolerance is 0.0027.

Camber Line and Angle-of-Attack Tolerance

As has been stressed before, the camber line is vital in determining the section lift. The actual camber line of a section cannot be measured directly on inspection since it is only an imaginary line inside the blade. It is defined as the locus of points midway between corresponding points on the suction and pressure faces of a blade section. To complicate the inspection, the corresponding points must lie on a line perpendicular to the camber line being determined. The exact location of these camber line points can only be arrived at by some iterative construction method. The desired camber line coordinates should be given on the propulsor drawings (Figs. 16 and 17). The suggested total width of the camber line tolerance band is 0.2 percent of chord. For a typical section of 3-inch chord, the tolerance zone would then be $0.002 \times 3 = 0.006$ -inch wide (i. e. , ± 0.003 inch).

Special tolerance call-outs to control angle-of-attack are unnecessary as the camber line tolerance band inherently controls the angle-of-attack.

Pumpjet Blade-Section Tolerance

The concept of propeller blade-section tolerancing based on the deviation from the true camber line, as described above, is of limited use in pumpjet blading. This is due to the greatly increased amount of camber of a pumpjet blade versus that of a typical propeller. It is therefore desirable to document tolerances on pumpjet blading as shown in Fig. 12. This figure shows three different tolerance bands whereas for a recent pumpjet design only the first 10 percent of the leading edge is held to a tighter tolerance band than the rest of the blade section. Extreme care must be taken to ensure that the transition from the relatively tight tolerance band on the leading edge to the relaxed tolerance band on the remainder of the blade is accomplished with no sharp deviation in surface contour.

Surface Finish Tolerance

The surface finish is discussed in Ref. 73 (ASA B46.1-1962, "American Standards Surface Texture; Surface Roughness, Waviness, and Lay"). Waviness is described in the next section. Lay is the direction of the predominant surface pattern of tool marks and minute scratches, ordinarily determined by the production method used. The lay of the surface texture of all propulsor blades must be parallel to the blade section in either piercing planes or cylindrical coordinates. It is unacceptable for the direction of lay to run between the tip and root of the blade (i. e., spanwise, or against the flowlines). Of course, the lay of roughness is important as long as the roughness makes it so; there obviously being a degree of smoothness for which lay is no longer important. Since that point cannot be clearly established, it is considered good engineering practice to retain the preferred direction of lay no matter how smooth the finished product may be. The direction of lay is optional for the hub and the fillet radius between the hub and the blade surface.

The recommended roughness height in the first 10 percent of chord at the leading edge is /16 microinches. For the remainder of the blade, /32 microinches is acceptable. The hub surface and fillets should be /125 microinches or better. There is some, as yet undocumented, evidence that the above surface finishes are unnecessarily smooth; castings having a finish of about /64 microinches seem to have performed satisfactorily.

It is recommended that flat specimens having a surface area about 1-1/2 inches square be prepared by the manufacturer and examined and certified by the Quality Assurance Agency as acceptable for surface finish. Thereafter, the manufacturer could use these specimens for surface finish comparison.

Waviness Tolerance

Reference 64 defines waviness as follows: "Waviness is the usually widely-spaced component of surface texture and is generally of wider spacing than the roughness-width cutoff." Waviness may result from such factors as machine or work deflections, vibration, chatter, heat treatment, or warping stains. Roughness may be considered as superimposed on a wavy surface. A reasonable rule to follow is that the waviness must be such that it cannot be detected by hand when a very light pressure is applied to the fingers as they pass over the surface of the blade. However, in order to control waviness in the relaxed-tolerance zone behind the leading-edge zone, the difference in deviation from desired thickness between adjacent tabulated coordinate points along the chord should be less than:

$$\Delta t = T/n$$

where

Δt = difference in deviation from desired thickness between tabulated coordinate points

T = total thickness tolerance

n = number of evenly spaced tabulated points along chord in the relaxed-tolerance zone

For example, with 23 points tabulated in the relaxed-tolerance zone for our 3-inch-chord case:

$$\Delta t = \frac{0.0234}{23} = 0.001\text{-inch}$$

If the coordinate points are not evenly spaced, the maximum allowable difference in deviation from desired thickness should be:

$$\Delta t = \frac{S \times T}{c}$$

where

S - distance between adjacent coordinate points

c - chord length

T - total-thickness tolerance

Chord-Length Tolerance

The chord-length tolerance is dictated by the blade-thickness tolerance at the trailing edge. Hence, the error should not exceed 0.6 percent of nominal chord. Both the suction and pressure faces must be continuous and smooth right up to the details of a rounded, flat or chiseled edge, or any other trailing-edge feature.

Hub Tolerance

All features of hub shape that can affect the hydrodynamic performance of a propulsor should be under the cognizance of the propulsor designer. This would include the hub diameter and any allowable step between hub and torpedo body or between fore and aft hubs, or any gap between aforementioned parts. It also includes surface texture of hubs and afterbody. It is suggested that a step of 0.020-inch and a gap of 0.125-inch should not be exceeded. Furthermore, the step should be "down" with the direction of flow. Protuberances should be avoided.

Leading Edge Tolerance

Leading-edge tolerance should be specified by the design of an inspection reticle, as shown in Fig. 16. The basic reticle coordinate points are those of the design leading-edge shape. The tolerance zones consist of one zone inside, and several larger zones outside, the basic leading-edge contour. After the reticle is positioned so that the leading edges coincide, if the data point nearest

to the leading edge lies within a certain tolerance zone, all other data points must also lie within that particular zone.

Dynamic Balancing

In order to reduce noise due to vibration and to reduce bearing forces, propellers should be dynamically balanced. This balancing consists of adding or removing weight in two different transverse planes until the true principal central axis of the propeller coincides with the axis of rotation. The maximum allowable imbalance for the Torpedo Mk 46 propellers is 0.05 ounce-inch². This is not difficult to achieve on a modern precision balancing machine, which has proven to be acceptable for those particular propellers. For other propellers, the designer may decide upon either tighter or looser specifications, depending upon rotating mass, RPM, bearing location, etc.

SECTION 5 DOCUMENTATION

DRAWINGS AS OFFICIAL DOCUMENTATION

It should be possible to express on a drawing, or drawings, all necessary coordinate points, datum planes, notes, etc., that would make it possible to produce propulsors near enough alike, and like the prototype propulsor, that the differences in performance would be negligible between propulsors made to the drawings by different proficient machine shops. This report recommends the use of a drawing, or drawings, as the documentation for all propulsors. Drawings are relatively inexpensive to produce, can be revised readily, and are easily read, reproduced, and stored. No other device for documentation has all of these virtues. A drawing is important even if digital data, for instance, is available for a numerical mill. The manufacturer needs at least a side view and projected view of a propulsor so that he can cut out a metal blank to machine. They are also useful in detecting gross errors in fabrication.

It is recognized that there may be errors in callouts of coordinates, etc., and these have been detected even in official production documentation. Such errors may not result in a propulsor which is seriously degraded, but they must be investigated and perhaps corrected. There are devices such as the Engineering Change Order (ECO), by which changes can be made temporarily to cover parts in the process of being fabricated, and until the drawing can be changed to correct the error for future production.

OTHER DOCUMENTATION AND GOVERNMENT FURNISHED MATERIAL

The demands for accuracy and the complexity of design of the modern-day propulsor make it difficult to find shops that can or will fabricate them. As a result, some agencies have found it necessary to assist prospective manufacturers in any way required to assure an acceptable product. This has taken the form of supplying prototype propellers, supplying models such as single blades or half-blade contours on back-up blocks, or of making cross-section charts or line drawings on dimensionally stable plastics. These aids serve a valuable purpose but the manufacturer must guard against over-relying on them. Their use could result in rejected parts, with the resulting question of who is responsible. Prototypes may be damaged, and models can wear out and change shape. Draftsmen can make mistakes on charts, or charts can get switched. Whatever happens to these aids in the manufacturing process, there should be a firm understanding that the official documentation, the drawings, must be adhered to, and an agreement made about who is responsible for maintaining the intermediate aids in their compliance with the official document. The official position (see MIL-I-45208A) is that the drawing is the documentation and that any material furnished by the Government may be used by the manufacturer at the risk of it being in error. The manufacturer then must assume the maintenance of models, charts, etc., and should check these, or have them checked periodically against the official drawing.

DRAWING STANDARDS

A reason for much of the past uncertainty in interpreting drawings has been the lack of contour data points in the region between the blade sections called out. Theoretically, there is only one proper contour for a blade surface. This is the one that would result if an infinite number of blade sections were properly calculated by the designer, each with an infinite number of contour points. In practice,

there is an infinity of different surfaces that could be fitted through the limited number of blade sections generally supplied in the past. One of the worst of these surfaces would be that formed by a straight-line fit between corresponding data points for adjacent piercing-plane blade sections. This would result in a discontinuous blade surface along the real flow lines. A more proper fit would result from a smooth curve obtained by a lofting fit through corresponding blade section coordinates using splines or a mathematical fit such as a "spline fitting" technique (Ref. 74). The principle advocated herein is to increase the number of piercing-plane sections documented on the drawings to the point that a "smooth" curve, fitted spanwise through corresponding coordinate points on the sections by whatever method, would lie everywhere so close to the proper surface that any adverse effect due to the difference would be negligible. It is difficult to determine how many blade sections would thus be required. There are now only seven and eight sections given on Torpedo Mk 46 propeller drawings for the forward and after blades, respectively. Since acceptable propellers have been made from these drawings, the inference might be that seven or eight sections are sufficient. However, this number of sections represents only one data point in about 1/2-inch along the span and it is unlikely that all curve fits would satisfy the above criterion in this case. Rather, it is believed that a minimum of 15 data sections are required to document a typical torpedo propeller. The paucity of data on past drawings is a carryover from the days of desk calculators. With high-speed electronic computers, the number of computed coordinates that can economically be obtained from the design calculations has greatly increased, and any number of data sections can be generated for documentation by using spline-surface fits to these coordinates.

A traditional format for propulsor drawings has evolved at each of the several design agencies. As a result, it has proven difficult for one agency to interpret the drawings of another, and some ambiguities have arisen. To avoid these,

several drawings of each agency have been studied in an attempt to incorporate the essential and good points of each into a type, or types, of drawing acceptable to, and understandable by, all agencies concerned. The suggested format is given below. Only a general format is suggested, and it would remain for the individual draftsman to arrange details as desired.

Propeller drawings should conform to the general practice of MIL-STD-100A. The drawings will consist of at least three D-size sheets (approximately 22 inches x 34 inches) for each propeller of a set (see Figs. 15, 16, and 17) as follows:

- Sheet 1) Side and rear view of propeller with notes, and expanded views of details as required. The Z coordinate is defined, as is the stacking line (Fig. 15).
- Sheet 2) Blade section outline view (suggested 2x), plus view showing camber line detail (suggested 5x). These views define x and y coordinate system for the camber line, and for the pressure and suction faces. Also shown are details of the trailing edge and of a reticle for leading-edge inspection (Fig. 16).
- Sheet 3) Tabulation of coordinates. Included are a number of blocks, each for a different Z, of X-Y coordinates for the suction and pressure faces, and for the camber line. Separate blocks include coordinates for the reticle for leading edge inspection (Fig. 17).

Sheet 1 (Fig. 15) will be views of the entire propeller so that the user can better visualize the end product. Metal blanks can be cut to size using this drawing. Details of the hub machining are shown. Notes are used to supplement graphic details. Notes might include information on the following:

- Material to be used and preliminary treatment required
- Preliminary inspection of material
- Surface smoothness

- Fairing technique between tabulated coordinates and the lay of waviness
- Stacking line definition
- Orientation of blade sections
- Dynamic balance requirement and allowable area for lightening holes
- Surface treatment
- Applicable drawing and inspection standards

The above list is not exhaustive. The designer may choose to add notes on blade tip design, fillets, etc.

Sheet 2 (Fig. 16) shows the blade section coordinate system orientation. Any section can be shown and it need not be to scale. The two section views are separate for clarity, but could be combined into one view. The reticle detail is shown to aid in the preparation of reticles for leading-edge inspection. A "chiseled" trailing edge is drawn in Fig. 16 to show one of the early "cures" for "singing". However, the designer may select a different trailing edge configuration.

Sheet 3 (Fig. 17), and perhaps continuation sheets, tabulate coordinate points for the blade suction face, pressure face, and camber line if available. When camber line coordinates are available, the suction and pressure face coordinates should be located by a perpendicular through the camber line, so as to correspond to the camber line coordinates. Such an arrangement allows an almost direct check of the camber line position by inspecting the corresponding suction and pressure face coordinates. The example shows 21 sets of coordinates. This number should be sufficient to fully define the section shape, but more may be supplied at the designer's discretion. A separate tabulation block is included for each Z section (i.e., different radii). A second block (for each Z section)

contains coordinates of the reticle, as drawn on sheet 2, to be used for inspection of the leading edge.

The size and general arrangement of these drawings has been chosen to avoid crowding and for simplicity. If the tables are typed or printed by a computer, the size of the tables may be reduced considerably without loss of readability.

CONSIDERATIONS IN DOCUMENTING PUMPJET BLADES

The modern pumpjet propulsor (Fig. 6) with its rotor and stator system enclosed in a flow-controlling shroud is a much more complicated propulsor than the single propeller or counterrotating set (Fig. 8). For example, a recent pumpjet design contained a total of 32 blades (17 rotor and 15 stator), versus a total of 11 blades for a recent set of counterrotating propellers, or the commonly used 7 blades for a single propeller. This large number of blades, fitting on a hub of relatively small diameter, essentially dictates that the blades be produced individually and then mounted on a hub. An attempt (Ref. 75) has been made to reproduce a set of pumpjet blades integral with a hub, but this has not been completely successful.

An additional complication of pumpjet blading over conventional types of propellers is the complex shape of the blades. This is caused by a combination of the range of fluid velocities encountered in the duct formed by the pumpjet shroud and the body, and the variation in blade loading or work performed by each section of the blade from root to tip. The relatively low rotor shaft RPM dictates blade sections of high camber, and a large amount of twist from root to tip section. This in turn greatly complicates the methods that can be used for production of pumpjet blading.

There are two basic methods of specifying pumpjet blade shapes (see Fig. 3). The propulsor designer must design blade sections on cylindrical (or conical) surfaces concentric with the axis of rotation of the propulsor. These sections — denoted as "cylindrical design sections" — are used to completely define the blade shape. However, the blade manufacturer usually requires blade sections defined on flat planes, perpendicular to an imaginary line running from the root to tip of the blade. These rectangular plane sections can be derived from the original cylindrical design sections by some type of lofting process (such as outlined in Ref. 76), or they can be computed by a coordinate translation program. Any lofting process has the objective of initially defining a contoured surface by a limited number of points, passing a smooth and continuous curve through these points, and generating (interpolating) enough additional points to completely define the surface. In the case of a propulsor blade, this is accomplished by defining a point on each cylindrical design section at some equal percentage chord station, and joining these points by a smooth continuous curve spanwise along the blade. This curve then represents a line on the surface of the blade and one may then interpolate any required number of additional points on the blade surface. The number of points that can be generated on any one blade section shape are thus infinite. In practice, even under a modern computerized process, the number of sections specified per blade is limited and usually depends on the manufacturing process under consideration. Thus many digital points would be specified for a numerically controlled machining process, and as few as six to eight sections would be specified for an airfoil milling machine with a built-in interpolation process. No standardized drawings have been included herein for pumpjets. Presumably they would be similar to Figs. 15, 16, and 17 but with the addition of a sheet showing details of a shroud and one or more sheets giving details for straightening vanes.

SECTION 6 PRODUCTION METHODS

The following is a survey of existing and prospective methods for manufacturing propulsors. Admittedly, the review is superficial, and is designed to merely acquaint the reader with a range of possible production techniques.

PANTOGRAPHING FROM TEMPLATES

A pantograph is a system of linkage so arranged that one point (the cutter) is made to move in a figure similar to, but perhaps relatively smaller or larger, than that in which another point (the tracer) moves. The second point may be a rider or follower on a template, and the linkage can be hydraulic, electric, pneumatic, or mechanical. For the sake of accuracy in preparing the template, it may be five or ten times the size of the section to be milled.

In the Airfoil Milling Machine, the technique consists of using rectangular-coordinate blade sections, specified at discrete stations along the blade span. These sections, represented as machined brass plates which are staked on a single shaft in the correct spacial relationship, are used as a guide for a follower mechanism which in turn controls the cutter path. Intermediate points are interpolated by a metal spline running between the sections. The twist of the blade is accomplished by a separate mechanism on the machine. This type of milling machine is used extensively in the turbine blade industry to produce the first master blade, which in turn may be copied by some other production technique to produce the desired quantity.

PANTOGRAPHING FROM MASTERS

This differs from the above in that the master is a continuous surface rather than discrete two-dimensional sections, and therefore any number of cuts may be made as the tool is progressed along the span of a propulsor blade. If the master is to be made to the same scale as the propulsor, it may be necessary to make the master as two separate surfaces, each on a backup block to prevent distortion under pressure of the rider.

LINE-FOLLOWER MILLING MACHINE

Although none of these have been reported as having been used to produce a torpedo propulsor, there exists a milling machine in which the guiding device follows a line on a drawing. It would be possible to use cross-section outlines of a blade, drawn on dimensionally-stable materials, to mill a blade at one section, then to change the drawing and cut a section at the next radial distance, etc. Modern plotting machines that accurately plot digital data from tapes make this method seem feasible in the production of a prototype propulsor.

CASTING

Propulsors have been successfully cast for such torpedoes as the Mk 44. The chief deficiency has been lack of strength. However, modern aluminum casting alloys can provide yield stresses close to 60,000 psi. The surface is smooth, and the dimensions may be kept accurate by properly allowing for shrinkage. The parting line for the mold may produce a fine ridge which must be removed by handwork. A few pinpoint air holes may appear in the surface of the aluminum, but these can be flush filled with plastic.

FORGING

Aluminum forgings can be made that have excellent strength, but exact control of size and shape for propellers is difficult when extruding hot metal into a die for thin blades. Oversize propeller blanks have been forged for the Mk 46, however, and these have been used as the starting blanks for subsequent machining on pantographic millers. The flowing of the hot metal from a central heated billet out into the die for the blades makes a favorable grain orientation that strengthens the blades.

COINING

Cold stamping, called coining, could be used to give propellers that are preformed by some other process, such as forging, a more perfect shape. Presumably, coining could take out any warpage and leave only a feathery flash around the edges that could be easily removed. For propellers whose blades overlap, the two coining dies conceivably could be rotated as they were pressed together.

NUMERICAL CONTROL MILLING

The numerical control (NC) miller, as its name implies, is a milling machine that is guided by coordinate numbers that have been converted to punched holes in a tape so that, as the machine is running, the tape instructs the tool, or the part, to move incrementally in one of its several modes of motion (Fig. 18). NC milling machines have from two to five axes of motion, including rotation of the part or tool axis. It would be impossible to exchange tapes between all different types of NC milling machines. However, at one point in the process of converting high-speed computer output data to the punched tape that controls the milling machine, the data are basically the same. This particular stage, known as postprocessor to the APT (Automatically Programmed Tools) program, should be carefully standardized among all of the torpedo propulsor agencies.

The NC milling machine concept now seems to be the most promising for producing prototype propulsors to design. These propulsors could then be the models for other mass production methods such as casting or forging. Or, NC milling machines can be used to cut identical parts so that one proven tape could turn out as many propulsors as desired, and the same tape can be reproduced for use with other machines operating at the same time.

**SECTION 7
INSPECTION PROCEDURES**

QUALITY ASSURANCE

Quality assurance procedures are required to verify the conformance of propulsor to the drawings and specifications. The following procedure would be recommended for the development of an acceptable quality level by a propulsor manufacturer.

1. Convene a meeting to be attended by the propulsor design activity, the designated quality assurance activity, the procurement activity, the propulsor manufacturer, and the resident or local government representative. The purpose of the meeting is to answer questions and resolve any problems that the manufacturer or government activities may have concerning the propulsor. It would also serve to acquaint the manufacturer with any services available from the design and quality assurance activities which would assist in developing the manufacturer's capability to produce a high-quality propulsor. Gage design concepts would be discussed and agreed on. The quality assurance activity might agree to inspect and/or calibrate contractor-owned gages. (It would be the responsibility of the contractor to maintain the accuracy, and to request recalibration, of all gages used.)
2. The first propulsor produced by the contractor that is considered to fulfill the drawing requirements would be submitted to the quality assurance activity, which would then completely inspect the propulsor and inform the supplier of the degree of conformance to the drawing requirements. A copy of the inspection report would be furnished the supplier upon request. This detailed inspection, of course, would be in addition to the continuing routine inspection required of the manufacturer. The government need not accept or be obligated to pay for any production propulsors until a first-article item had been accepted.
3. Sample propulsors from the first lot produced should be selected by the local government representative and submitted to the quality

assurance activity for detailed inspection. The sample lot size, sampling plan, and inspection procedures should be clearly established by official documentation. This procedure should be repeated until samples from four consecutive lots have been inspected and accepted. It should be the option of the government to require the supplier to provide a sample of production at any time during the life of the contract. The sample would be inspected and returned without cost to the contractor. The contractor would be paid the price of the propulsor if it is damaged while in the custody of the government.

DESIGNER-MANUFACTURER-INSPECTOR RELATIONSHIPS

The relationships between designer, manufacturer, and inspector vary with the stage in the design-to-production sequence of a propulsor. The manufacturing of a prototype for initial performance tests may well be on a "model shop" basis wherein designer and manufacturer work closely in a day-to-day relationship. Manufacturing costs are often of secondary importance during production of the prototype. The in-house precision inspection must be adequate to insure that the prototype so manufactured is truly the propulsor documented. Any changes made during testing — and they should be a few — should be carefully documented also. Next, when the authenticated drawings are produced and are issued for first production, the designer should still maintain control over changes. Changes may be suggested by the manufacturer, perhaps because he proposes a fabrication method not compatible with some feature of the drawing. There is a normal mechanism for implementing changes called "Local Configuration Control Management," which should be invoked. The documents for accomplishing changes are the Engineering Change Order or ECO. These can be proposed by either the design agency or the manufacturer. They should be carefully entered as a notation on the official documentation and distributed to manufacturers and inspectors.

Waivers may be approved by the design agency for accepting a propulsor that does not pass inspection, but which may be needed by the agency for immediate tests. It should be understood by the manufacturer, however, that waivers are for the convenience of the Navy and not the manufacturer. Some propeller contracts may contain clauses that insure the manufacturer against losses due to his own manufacturing errors or deficiencies, so that the design agency is forced to pay for any and all experimenting on processes that the manufacturer wishes to try. Such research is commendable when properly controlled and should be encouraged, but at the discretion of the design agency.

When the propulsors go out for final production, the production drawings are no longer under local control except by more difficult processes. These controls can be Engineering Change Proposals (ECP's) or Notices of Revision (NOR), which must be approved by a Naval Systems Command agency or delegated authority. When approved, they become revision directives. Presumably, these are to be used only in extreme cases, where lack of a change would seriously impair performance, work some great hardship, or incur considerable loss of funds. Another procedure for change is through the Value Engineering Change Proposal and the Value Engineering Change Order. These are generally originated by the manufacturer who may participate in any monetary savings that result. The designer should always be consulted on any such change that might affect the hydrodynamic functioning of the propulsor.

In spite of good documentation for a propulsor, an inspector can change the emphasis on a requirement, or interpret some figure in such a way as to make an inspection meaningless or more expensive than necessary. The design engineer should strive to know how the propulsors are being inspected at the source, and why they are being accepted or rejected. Conversely, the inspector should submit his plans to the designer for study, and should call his attention to errors or omissions, particularly on the authenticated drawings.

INSPECTION FOR DESIGN VERIFICATION

Each new design must be precision-inspected after fabrication. The results of this inspection of the first propeller produced from the design data verify whether it is, in fact, the propeller that was designed. If it is, then performance tests will be valid and the propeller may be designated the official prototype if the tests show satisfactory performance. Design data or measurements of the prototype may then be used interchangeably in preparation of the authenticated drawings.

If inspection of the first prototype shows deviation from the design data, there are several alternatives. If the prototype meets the design criteria in tests, one might suggest that it be measured carefully and documented as the official propulsor instead of using the design data. However, this would not show whether the first prototype, that deviated from design, gave better or poorer performance than if the unit had been fabricated to design data. This could only be determined by fabricating and testing another, on-design, prototype. As propeller design techniques improve, and they have in recent years, the designed propeller is more apt to satisfy the requirements than any model that deviates from the design.

Inspection of the first model should be done on equipment capable of high precision. With the use of numerical-controlled (NC) milling machines, the possible accuracy of fabrication becomes so great that only precision inspection will detect deviations from the nominal shape. Also, the model may become the documented propulsor and the inspection points that result may become documented points of the drawing.

Each design agency must set up minimum inspection criteria for its prototype. The following is used at NUC: One blade of the propeller is completely inspected at every point documented on the original drawing. All the other blades are checked sufficiently to satisfy the inspector about the uniformity of fabrication.

In addition, the surface of the blade is surveyed by determining coordinate points in a grid pattern of 0.050 inch or less. For at least five percent of each section near the leading and trailing edges, the grid is reduced to 0.001 inch to clearly describe the exact shape in those regions. These data are stored for future reference.

The inspection device at NUC for accomplishing the above design-verification inspection is shown in Fig. 19. It consists of a precision dividing head on which the propeller is mounted, and a three-coordinate (mutually perpendicular) measuring machine (TCMM) on which a probe is mounted. The probe point is rotated so that it is nearly perpendicular to the blade surface. The TCMM is traversed until the probe contacts the blade surface, as indicated by electrical continuity on an ohmmeter. Coordinates are then read from the three lead-screw dials on the TCMM.

At NSRDC a method is being perfected for using the numerical control milling machine for inspection. On the first tests of this principle, dial indicators were mounted in the tool holder as the machine was run. The indicators were monitored for errors. In a more sophisticated development, differential transformers or other distance-sensing electronic devices will be used and errors will be printed out.

After the designer has selected the coordinate points that are to be documented on the final drawing, it may be important to measure the shape of the blade-section surface for a distance of 0.003 inch forward and aft of each documented position. This gives the slope of the surface at these points, which become useful in the graphical determination of chamber and thickness tolerance zones. It is possible that the slope of the section contour can be obtained more easily from the original computer output, and can be used in place of inspection data.

GAGING

The precision inspection described above for design verification is tedious and requires an extremely high degree of accuracy. For inspection on a production basis, other gaging devices would be preferred.

Optical Comparator

The optical comparator (Fig. 20) with 10 to 1 magnification has proved adequate to control the quality of propulsor blades from different production sources. This method uses a tracer that is moved over the surface of the blade section. A spotter is attached to the tracer in such a way that its motion corresponds to the motion of the tracer. The spotter is part of an optical system by which its image is projected on a ground-glass screen. A transparent chart of the blade section being investigated, showing the blade outline and the thickness tolerance zone, is overlaid on the ground-glass screen.

This report is recommending that the camber line and the camber tolerance also be shown on the overlay. Some method should be devised which shows the locus of points midway between the separate spotter images for the pressure and suction sides. This could consist of two tracers free to spread apart as they are moved over opposite surfaces on the blade section. The two tracers could be joined by a linkage arrangement whereby the spotter defines the midpoint. The spotter would thus trace out the camber line on the screen, which in turn must stay within the desired camber line tolerance band. Such a device would improve over the obviously tedious graphical method (impractical for production inspection) of separately marking the suction and the pressure traces, and constructing the midpoint between them. However, it must be stressed that the device described above does not currently exist, and its development could entail a costly program. It is not practical using existing optical comparator equipment to check the camber line on a production basis.

Comparison Gage

Figure 21 shows a source-inspection comparator used to check a production propeller against a master. The dial indicator shown reads out discrepancies directly. Care must be exercised to insure that any discrepancies are correctly converted to the proper coordinate system and related tolerance limits. Since this device compares blade surface coordinates only, it cannot be used to check camber line.

Pin Gage

A special-purpose pin-gage (Fig. 22) has been successfully employed by a manufacturer for source-inspection of blade surface. Propellers produced by this manufacturer were among the best obtained from at least five different sources.

As seen in Fig. 22, hardened pins are positioned into a plate; separate plates are used for the pressure and suction surfaces. The pins are located in positions corresponding to coordinate points on the official drawings. A propeller is mounted on a hub fixture at such an angle that the pins are almost perpendicular to the datum offset lines that can be determined from the drawings. The pins are pressed lightly against the blade surface and the height of each pin, with respect to the plate surface, is measured with a dial indicator. A master blade was used to set the pin lengths so that any dial reading other than zero would indicate a plus or minus error. One drawback of such an inspection device is that it provides only a partial check on the blade surface as no information is gained on regions between the discrete points measured by the pins.

A special pin-gage could be developed which would measure the corresponding points on opposite faces of the blade. From the readings for opposite points, the midpoints could be calculated, yielding points on the camber line. The cost

of developing such a gage should be moderate, and the additional time required of the inspector to calculate the midpoints would be minimal. Thus, such a pin-gage very likely offers a ready method of directly measuring camber line position on a production basis.

Blade-Edge Microscope

The light-section blade-edge microscope (Fig. 23), or projector, is considered best for precision inspection of leading or trailing edge. A thin band of light illuminates a narrow zone of the blade edge and, through a clever optical system, the blade edge profile is projected on a reticle. This device is not easy to use, the chief obstacle being in staging the propeller section. Here, some vise or a universal movement is needed to help in positioning and holding the propeller. As of now, no better way is known to quickly and accurately check the most critical part of the propeller. The optical comparator, described above, is often used to inspect the leading edge but equivalent precision is not achieved and the procedure is more tedious.

SECTION 8 PROPULSOR TESTING

Torpedo body testing is often conducted prior to propulsor design to establish velocity and pressure distributions, and various hydrodynamic coefficients. Finished propulsors are tested to establish performance coefficients. The following is a brief survey of the type of testing facilities available.

WIND TUNNEL

Because wind tunnels are generally available across the country, they become attractive for torpedo testing and are used to measure drag, pressure distribution, boundary layer velocity profiles, and static hydrodynamic coefficients of the bare body. High air speeds are required to match the Reynolds' Number of the torpedo in water because of the differences in kinematic viscosities between air and water. High air speeds are also desirable to produce great enough forces to measure coefficients with accuracy. However, it is impractical to run the propellers at high enough RPM to maintain the proper advance ratio, J . Wind tunnel tests, then, are generally confined to the acquisition of data for an unpowered condition. However, the data from such tests provide essential inputs for carrying out propulsor design.

WATER TUNNEL

A water tunnel is one of the best facilities in which to obtain the cavitation characteristics of a propulsor, and data on thrust and torque coefficients as a function of advance ratio. The torpedo is supported on the tunnel centerline and water is moved past it. The largest U. S. water tunnel is at Pennsylvania State

University, with a working section that is 48-inches in diameter. To reduce wall interference effects, the test section must be fitted with a liner around at least the after portion of the torpedo body (Ref. 30). The contour of the liner conforms approximately to the shape of a streamline for flow past the body in an infinite fluid. The liner will be correct for only one position and attitude of the body, and for only one setting of the control surfaces. For the small control surface excursions generally encountered in service however, water tunnel data may be acceptable. For cavitation tests, the tunnel must be capable of static pressure variations to regulate cavitation numbers.

TOWING BASIN

Torpedo performance with powered propulsor can best be obtained in a towing basin. The torpedo is suspended from a rolling carriage into a long water-filled channel, or basin. The longest U. S. towing basin is at NSRDC (3,000 feet long), which is capable of towing at speeds up to 60 knots. Torpedo propulsor tests are conducted at much lower speeds due to limitations on the propulsor drive power which can be installed in the model. Here, however, cavitation performance would be difficult to observe and a desirable range of cavitation numbers hard to obtain because of limited depth and/or speed. The towing channel can be used to obtain dynamic hydrodynamic coefficients of the torpedo related to stability and control, which may not be obtained as easily, if at all, in a water tunnel.

ROTATING ARMS

Here, the torpedo is suspended from one end of a rotating beam, or arm, and moved through the water in a circular pond or a ring channel. Though not widely used for the purpose, rotating arms can be adapted for tests of torpedo performance with powered propulsor. As with the towing basin, it is not practical

to obtain cavitation information in this facility. The torpedo, by necessity, operates in a turn, which to some extent reduces the value of the data.

CABLE-GUIDE RANGES

In this facility, a torpedo is guided by shoes running on an underwater cableway. Since its path is predetermined, narrow-beam hydrophones can pick up a pattern of noise from a powered torpedo and localize the noise source. Power and RPM are recorded inside the torpedo. The drag of shoes and supports is a problem.

INSTRUMENTED FREE RANGES

The final test of a torpedo is its performance on a free-running test range. These ranges are acoustically instrumented to give position versus time so that speed may be known. The internal instrumentation in a test torpedo can record the shaft power, the RPM of the propulsor, and the depth at which the torpedo is operating. If sonar gear is used, the noise generated by the torpedo may be measured.

SECTION 9
REFERENCES

1. Navy Central Torpedo Office. Torpedo Propulsors, Documentation for Design Verification, Production, and Quality Assurance, 15 Dec. 1969, (NAVWEPS OD 18374).
2. Goldstein, S. , "On the Vortex Theory of Screw Propellers." Proceedings of the Royal Society of London, 1929 Ser. A. Vol. 63.
3. Lerbs, H.W. , "Moderately Loaded Propellers with a Finite Number of Blades and an Arbitrary Distribution of Circulation," SNAME, Trans. 1952, Vol. 60.
4. Hill, J. G. , "The Design of Propellers," SNAME, Trans. 1949, Vol. 5, p. 143-170.
5. Aerodynamische Versuchsanstalt, On the Theory of Screws with Wide Blades, by H. Ludwig and I. Ginzler, Goettingen, Germany 1944 (Report 44/A/08).
6. David Taylor Model Basin, Propeller Pitch Correction Arising from Lifting Surface Effect, by H.W. Lerbs, Washington, DTMB 1955 (Report No. 942).
7. Eckhardt, M. K. , and Morgan, Wm. B. , "A Propeller Design Method," SNAME Trans. , 1955, Vol. 63, p. 325-374.
8. Ordnance Research Laboratory, Penn. State Univ. A Study of Torpedo Propellers, Part I, by B.W. McCormick, J.J. Eisenhuth, and J.E. Lynn, University Park, Penn. , ORD, 30 Mar. 1956 (Serial No. NOrd 16597-5).
9. Ordnance Research Laboratory, Penn. State Univ. A Study of Torpedo Propellers, Part II, by B.W. McCormick, and J.J. Eisenhuth, University Park, Penn. , Mar. 1956 (Serial No. NOrd 16597-13).
10. Streckeleitzky, M. Hydrodynamische Grundlagen zur Berechnung der Schiffsschrauber. , Verlag G. Braun, Karlsruhe, 1956.

11. Mass. Inst. of Technology, Dept. of Naval Arch. and Marine Engineering. **The Solution of Propeller Lifting Surface Problems, by Vortex Lattice Methods, by J. E. Kerwin, Cambridge, Mass., MIT, June 1961.**
12. National Physics Laboratory Great Britain. **The Application of a Simplified Lifting Surface Technique to the Design of Marine Propellers, by J. W. English, 1962 NPL Report S. H. R. 30/62.**
13. Sparenberg, J. A., "Application of Lifting Surface Theory to Ship Screws," **Proc. of Konenki. Nederlands Akademie van Wetenschappen, Amsterdam, 1959, Ser. B, 62, No. 5.**
14. Pien, Pao C., "The Calculation of Marine Propellers Based on Lifting Surface Theory," **J. Ship RES, Vol. 5, No. 2 (Sept. 1961.)**
15. Nishiyama, T., and Makajima, Y., "Lifting Surface Theory of Widely Bladed Propellers," **Society of Naval Architects of Japan, Vol. 109, (1961).**
16. Yamazaki, R., "On the Theory of Screw Propellers," **Fourth ONR Symposium on Naval Hydrodynamics, Wash. D.C., 1962.**
17. U. S. Naval Ordnance Test Station, Pasadena. **A Lifting-Surface Propeller Design Method for High-Speed Computers, by D. M. Nelson, China Lake, Calif. NOTS, Jan. 1964 (NAVWEPS Rept.8442, NOTS TP-3399).**
18. **Correction to the Camber of Constant Pitch Propellers, by Cox, G. G., Quarterly Trans. Royal Inst. of Naval Arch. (1961).**
19. David Taylor Model Basin, **Hydrodynamic Aspects of Propeller Design, Based on Lifting-Surface Theory, by H. M. Cheng, Wash. D. C., Part I—Uniform Chordwise Load Distribution, Sept. 1964 (DDC-AD-607-702) Part II—Arbitrary Chordwise Load Distribution, June 1965 (DDC-AD-438-855).**
20. Naval Ship Research and Development Center, **Cavitation and Open-Water Performance Tests of a Series of Propellers Designed by Lifting-Surface Methods, by S. B. Denny, Wash., D. C., Sept. 1968 (Report 2878).**
21. Morgan, W. B., Silovic, V., Denny, S. B., "Propeller Lifting-Surface Corrections," **SNAME Trans., 1968, Vol. 76, p. 309.**
22. Cox, G. G., **State-of-the-Art for Sub-cavitating Propeller Design Methods, International Towing Tank Conference, Propeller Committee, Rome, Sept. 1969.**

23. Cox, G. G. and Morgan, Wm. B., "Application of Theory to Propeller Design," International Symposium on Fluid Mechanics and Design of Turbomachinery, ORL, Penn. State, Aug., 1970.
24. U.S. Naval Torpedo Station, Typical Torpedo Noise Signatures, by D.O. Jones, Keyport, Wash., Oct. 1961, (NTS Report 587). (C)
25. Stevens Institute of Technology, Experimental Towing Tank, Stern Propeller Interaction with a Streamline Body of Revolution, by B. V. Korvin-Kroukovsky, Hoboken, N. J. SIT, Sept. 1954 (Report No. 544).
26. David Taylor Model Basin. Analytical Prediction of Thrust Deduction for Submarines and Surface Ships, by J. L. Beveridge, Wash., D. C. Apr. 1968 (DDC-AD-835-511).
27. J. L. Beveridge, "Analytical Prediction of Thrust Deduction for Submersibles and Surface Ships," J. Ship Res. Vol. 13, No. 4, Dec. 1969.
28. J. D. Brooks, T. G. Lang, "Simplified Methods for Estimating Torpedo Drag, Underwater Missile Propulsion," Edited by L. Greiner, Compass Publications, 1967.
29. U.S. Naval Ordnance Test Station, Pasadena, Hydrodynamic Drag of Torpedoes by T. G. Lang and J. D. Brooks, China Lake, Calif., NOTS, Feb. 1958, (NAVORD 5842).
30. Ordnance Research Laboratory, Penn. State Univ., Elimination of Water Tunnel Interaction with a Coaxial Test Body by a Flow Correcting Liner and an Application to the Test of an ALBACORE Model, by A. F. Lehman, J. H. Light, and T. E. Pierce, State College, Pa., July 1958. (Penn. State Serial No. NOrd 16597-39).
31. Johnson, V. E. Jr., "Water Jet Propulsion," Appendix VI, Report of Propeller Comm., 12th International Towing Tank Conference, Prepared by Hydronautics, Inc., Planeview, N. J.
32. Ordnance Research Lab., Penn. State Univ., Results of Water Tunnel Tests on the Axial Flow, Low Internal Velocity Pumpjet (AFLIFUS) by W.S. Gearhart, University Park, Penn., June 1969, TM 514.2491-12.
33. Ordnance Research Laboratory, Penn. State Univ. A Method for the Design of Pumpjets, by R. E. Henderson, J. F. McMahan, and G. F. Wislicenus, University Park, Penn. ORD, 15 May 1964 (Serial No. NOW-63-0209-C-7).

34. David Taylor Model Basin. DTMB 3-Bladed Supercavitating Propeller Series, by E. B. Caster, Wash., D.C., Aug. 1959 (DTMB Report 1245).
35. International Towing Tank Conference, Propeller Committee, State-of-the-Art for Supercavitating Propeller Design Methods, by G. G. Cox, Rome, Sept. 1969.
36. U. S. Naval Ordnance Test Station, Pasadena. Base Vented Propeller, G. Mosteller China Lake, Calif., NOTS, May 1963 (NAVWEPS Report 8058, NOTS TP 3061).
37. The Johns Hopkins University. Hydraulic Jet Propulsion and Incipient Cavitation, by G. F. Wislicenus and L. R. Smith, Silver Springs, Md., Mar. 1952, (Internal Flow Research Report 1-6, Part A).
38. Bruce, E. P., Gearhart, W. S., Ross, J. R., and Treaster, A. L., "The Design of Pumpjets for Hydrodynamic Propulsion." The International Symposium on Fluid Mechanics and Design of Turbo-machinery. Penn. State Univ., University Park, Penn. Sept. 1970.
39. U. S. Naval Ordnance Test Station, Pasadena. On a Rapid Estimate of Inlet Velocity Distribution for a Pumpjet Operating in a Prediffused Turbulent Boundary Layer of an Axially Symmetric Body, by A. Mager and F. J. Hill, China Lake, Calif., NOTS, Sept. 1952, (NOTS Report TM 671).
40. Admiralty Research Laboratory. An Experimental Investigation of Cavitation Inception in the Rotor Blade Tip Region of an Axial Flow Pump, by A. B. Mitchell, Aug. 1958, Report ARL/R1/G/HY/11/2.
41. Wislicenus, G. F., "Hydrodynamics and Propulsion of Submerged Bodies," J. American Rocket Society 1960, Vol. 30, pp 1140-1148.
42. California Institute of Technology. Tip Clearance Flows in Axial Flow Compressors and Pumps, by D. A. Rains, Pasadena, June 1954, Hydrodynamics Lab. (Its Report 5).
43. Gearhart, W. S., "Tip Clearance Cavitation in Shrouded Underwater Propulsors," J. Aircraft, Mar-Apr., 1966 Vol. 3, No. 2.
44. Ordnance Research Laboratory, Computerized Application of the Streamline Curvature Method to the Indirect Axisymmetric Turbomachine Problem, by A. L. Treaster, Univ. Park, Penn. Oct. 1969, (TM 514.2491-16).

45. National Aeronautics and Space Administration. "Aerodynamic Design of Axial-Flow Compressors," Edited by I. A. Johnsen, and R. O. Bullock. SP-36, Wash. D. C. , 1965.
46. Wislicenus, G. F. , "Fluid Mechanics of Turbomachinery," Volumes 1 and 2, Dover Publications, Inc. , New York, N. Y. , 1965.
47. Abbot, I. H. , VonDoenhoff, A. E. "Theory of Wing Sections" New York, Dover Publications, 1958.
48. U. S. Naval Ordnance Test Station, Pasadena. Slender-Airfoil Camberlines with Trapezoidal Lift Distributions, by M. L. Sturgeon, China Lake, Calif. NOTS, June 1963 (NAVWEPS Report 8092, NOTS TP 3145).
49. David Taylor Model Basin. A TMB Mean Line Series to Delay Cavitation, by R. J. Wirth, Wash. , D. C. , May 1960 DTMB, (Report 1429.)
50. David Taylor Model Basin. Steady Two-Dimensional Pressure Distributions on Arbitrary Profiles, by Terry Bocket, Wash. D. C. , Oct. 1965, DTMB Rept. 1821.
51. U. S. Naval Ordnance Test Station. Review of Marine Propeller Noise Vibration Studies by C. E. Work. Inyokern, NOTS, Sept. 1950. (Propulsion Memo 74).
52. David Taylor Model Basin, Preliminary Study of Vortex-Induced Propeller-Blade Vibrations and Singing by R. A. Cumming, Wash. , D. C. Sept. 1965 (DDC-AD-470-558).
53. Gongwer, C. A. , "A Study of Vanes Singing in Water," Aerojet Engineering Corporation, Azusa, Calif. RTM-76, May 3, 1951.
54. McGinley, J. H. , "Singing of Propellers and Appendages," J. of Underwater Acoustics, April 1956 (C).
55. David Taylor Model Basin. Minimum Pressure Envelopes for Modified NACA-66 Sections with NACA $a = 0.8$ Camber and BUSHIPS Type I and Type II Sections, by Terry Bocket, Washington, D. C. , Feb. 1966, DTMB, (R&D Report 1780).

56. David Taylor Model Basin. **Effect of Increasing Blade Thickness on the Open-Water Characteristics and Cavitation Inception of a Destroyer Propeller** by G. L. Ober and J. G. Peck, Wash., D.C., DTMB, March 1963, (Report C-1434) (C).
57. National Research Council of Canada. **Optimum Length and Thickness of Propeller Blade Sections from Cavitation and Strength Considerations**, by S. T. Mathews and J. S. C. Straszak, Ottawa, Canada, April 1961, (Mechanical Engineering Report MB-231).
58. Roark, Raymond J., **Formulas for Stress and Strain**, 4th Edition, New York, 1965 McGraw-Hill.
59. Stevens Inst. of Technology. **A Theory for the Propeller-Duct Interaction** by S. Tsakonas, W. R. Jacobs and M. R. Ali, Davidson Laboratory, Castle Point, Haboken, N. J., April 1970 (R-1309).
60. Morgan, W. B. and Caster, E. B., "Comparison of Theory and Experiment of Duct Propellers," Prepared for Seventh ONR Symposium on Naval Hydrodynamics, Rome, Italy, Naval Ship Research and Development Center, Wash. D. C., Aug. 1968.
61. David Taylor Model Basin. **Effect of Propeller Pitch Changes on Torque Unbalance of Counterrotating Propellers** by Wm. B. Morgan, Wash., D. C., Mar. 1957 (Report 1124).
62. U.S. Naval Ordnance Test Station. **Water Tunnel Tests of a Thickened Mk 46-0 Propeller** by G. Mosteller, China Lake, June 1966 (IDP NO. 2583).
63. Ordnance Research Laboratory, Penn. State Univ., **Blade Profile Measurements and Comparison of Three Sets of G. E. Ex 2 Torpedo Propellers** by A. Lehman, State College, Penn. ORL, Feb. 1957 (TN 6.3003-11).
64. Morgan, Wm. B. and Lichtman, J. Z., "Cavitation Effects on Marine Devices," Reprint from *Cavitation State of Knowledge*, ASME, 1969.
65. Holl, J. W., "The Inception of Cavitation on Isolated Surface Irregularities," *J. of Basic Engineering*, Trans. of ASME, Ser. D. Mar. 1960, p. 169-183.
66. David Taylor Model Basin, Hydromechanics Lab R&D Report. **Cavitation Inception of Three-Dimensional Roughness Elements** by Bruce W. Benson, Wash. D. C., Report 2104, May 1966.

67. David Taylor Model Basin. Cavitation of Surface Roughnesses by K.K. Shalnev, (Translated by R.D. Cooper) Wash., D.C., Dec. 1955, (Translation 259).
68. David Taylor Model Basin. The Effects of Distortion of Sub-Cavitating Foil Contours on Cavitation Inception Velocity, by G.P. Moeckel, Wash., D.C., Oct. 1965.
69. Naval Ship Research and Development Center. The Effect of Surface Roughness on Cavitation Inception Speeds of a Hydrofoil by Wm. G. Sounders, Wash., D.C., NSRDC, June 1968 (Report 2330).
70. Numachi, R., Oba, R., and Chida, I., "The Effects of Surface Roughness on Cavitation Performance of Hydrofoils," J. of Basic Engineering ASME, Report 1, Ser. D., June 1965, p. 495-503.
71. Arndt, R.E., and Ippen, A.T. "Rough Surface Effects on Cavitation Inception," J. of Basic Engineering, ASME, Vol. 90, Ser. D, No. 2, June 1968, p. 249-261.
72. Naval Ship Research and Development Center. Effect of Hand Polishing on the Performance of Rough Machine Mk 30 Counterrotating Propellers by A.A. Campo, Wash., D.C., (337-H-01) June 1969.
73. Surface Texture (Surface Roughness, Waviness and Lay), ASME, ASA B 46.1-1962 (Sponsored by SAE and ASME).
74. Ordnance Research Laboratory, Penn. State Univ. Spline Curve Fit Functions, Their Derivation and Use by R.R. Davis, University Park, Penn., ORL Technical Memo File No. TM512.3531-02, 23 July 1968.
75. Ordnance Research Laboratory, Penn. State Univ. Cast Propulsor Tests by R.F. Davis, ORL TM File No. 512 and 706, April 20, 1970, Serial No. AA448. (C).
76. Ordnance Research Laboratory, Penn. State Univ., Marine Propeller Blade Section Definition by R.F. Davis, ORL TM512.3531-04, Feb. 14, 1969.

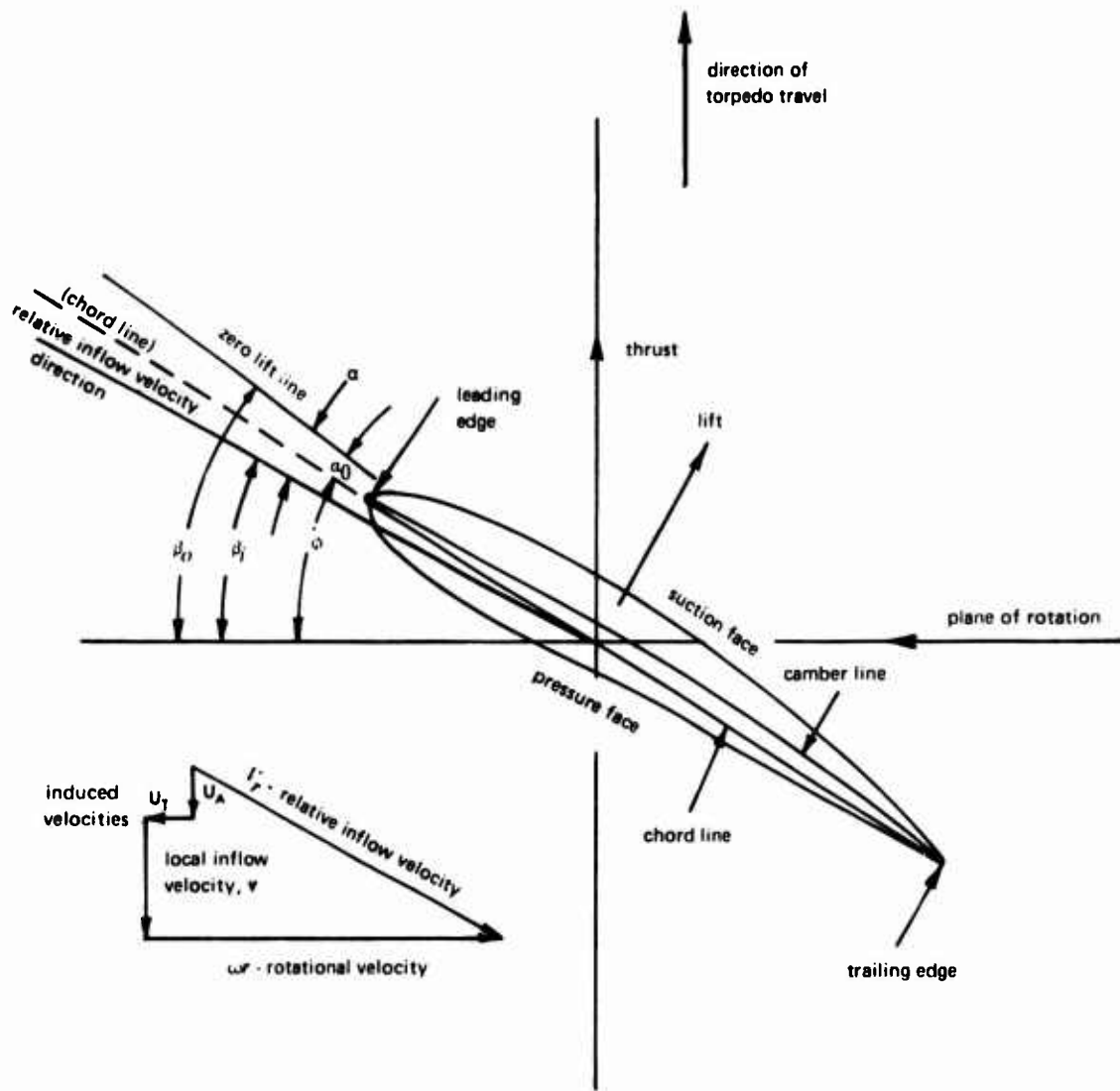

FIG. 1. Blade Section Orientation.

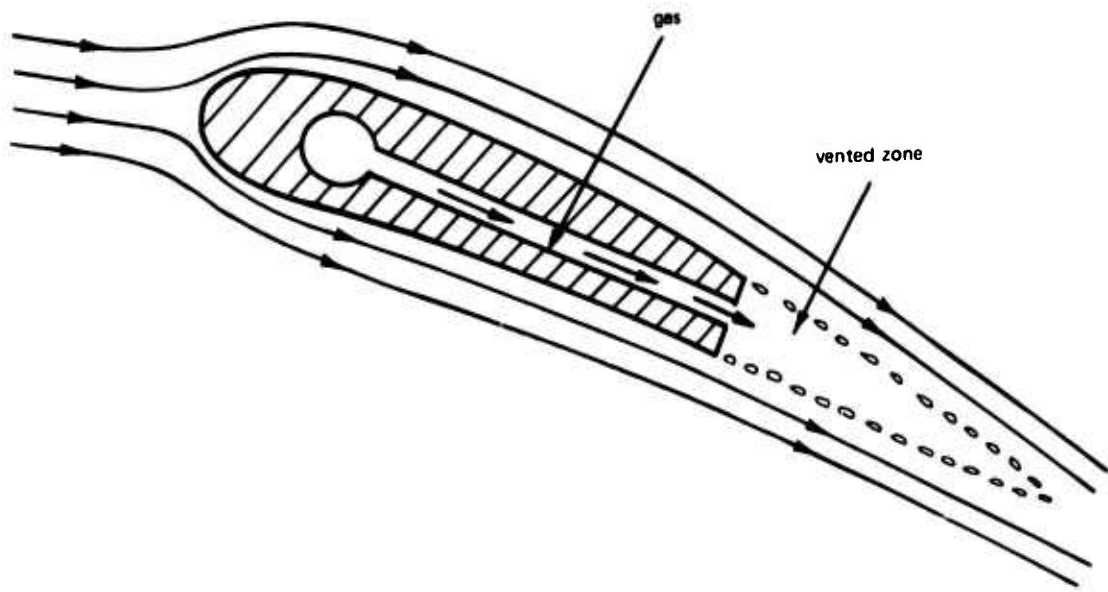

FIG. 2. Base Vented Blade Section.

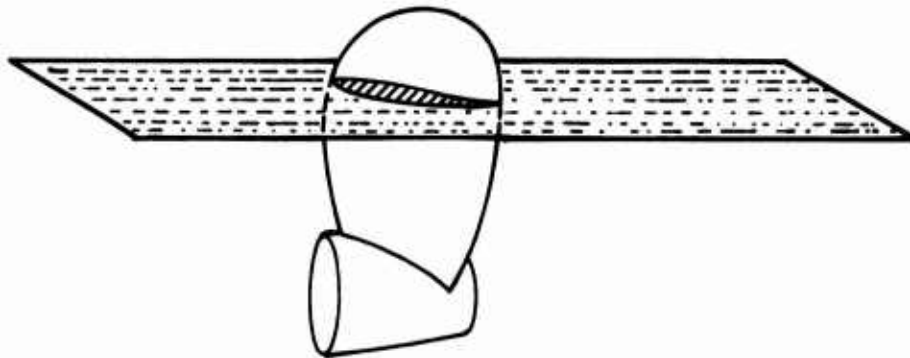
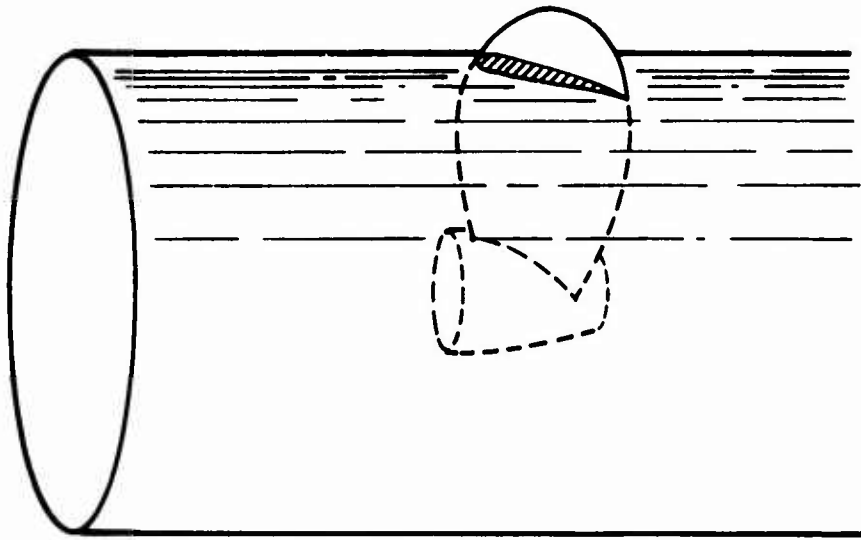

FIG. 3. Sections Generated by Piercing Cylinders and Planes.

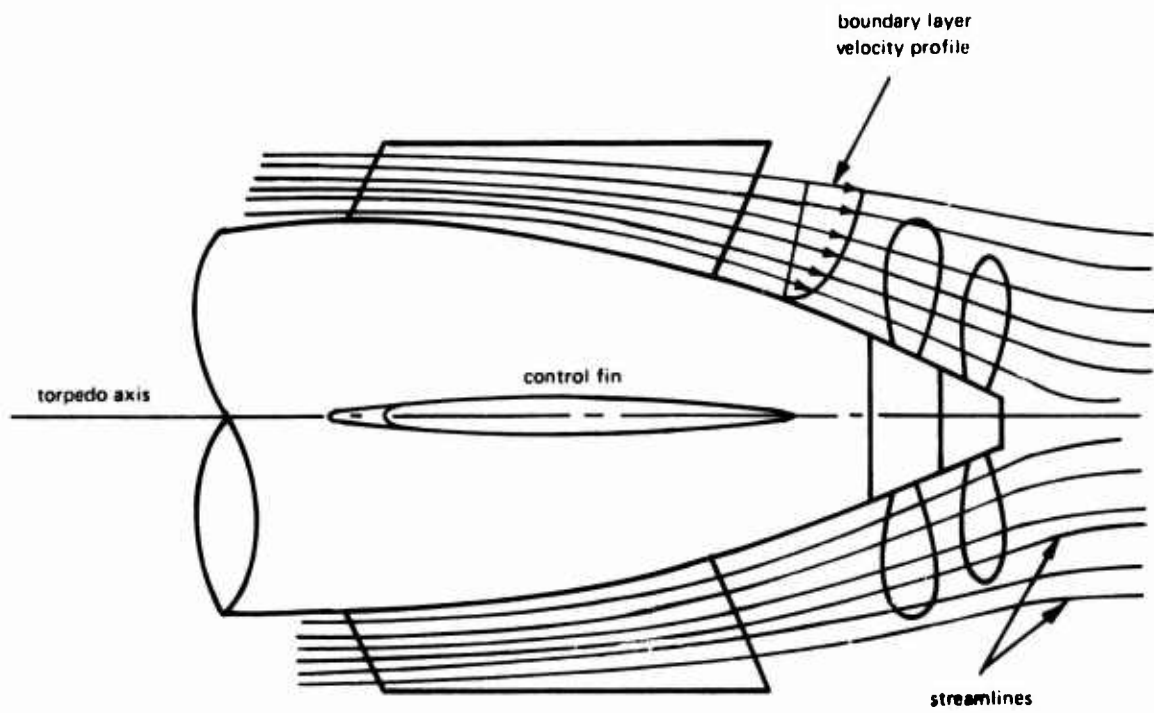

FIG. 4. Schematic of Boundary Layer.

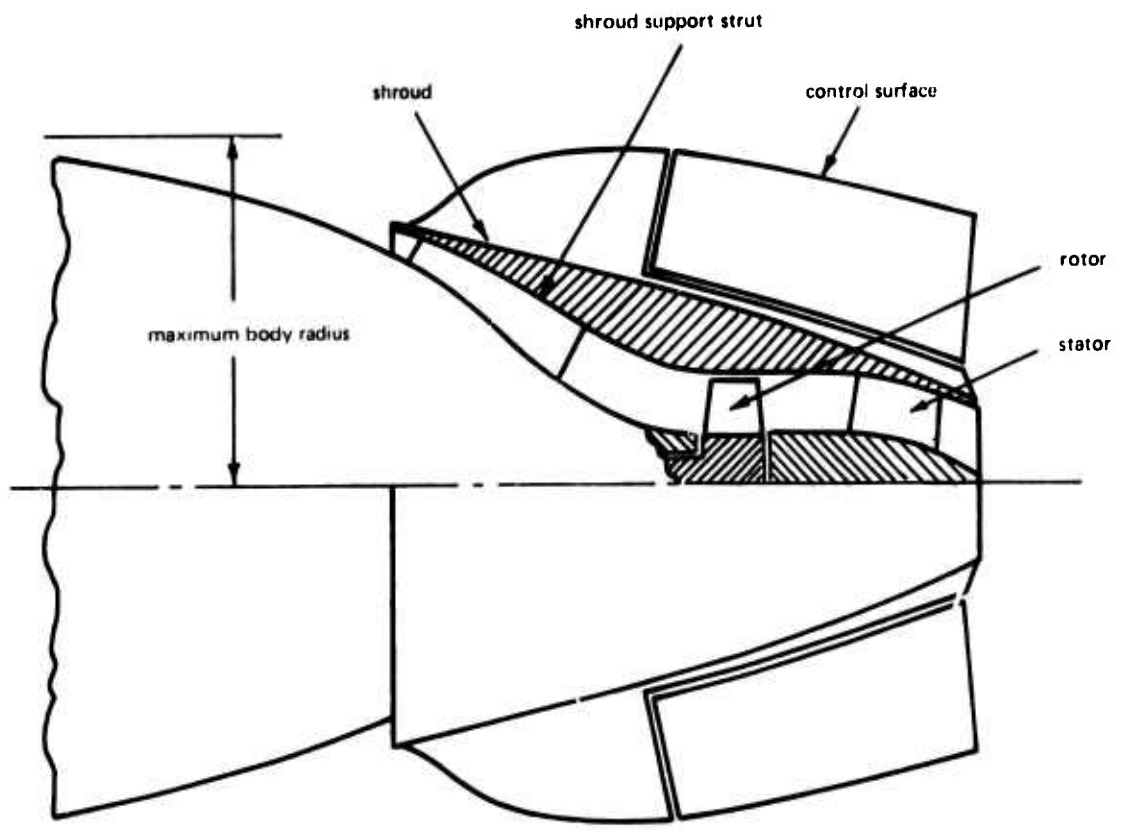

FIG. 5. Typical Pumpjet Propulsor Unit.

PUMPJET PICTURE

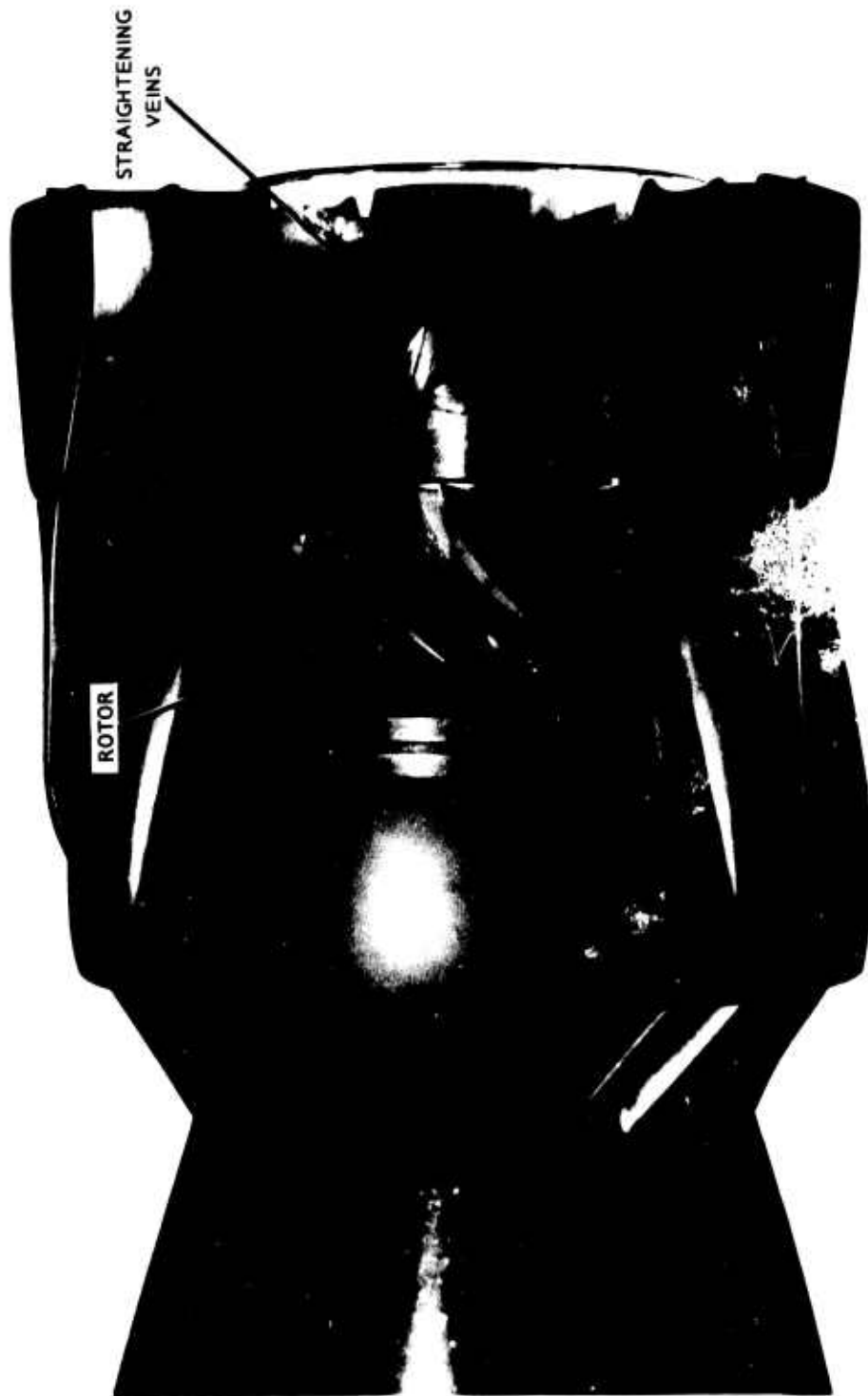
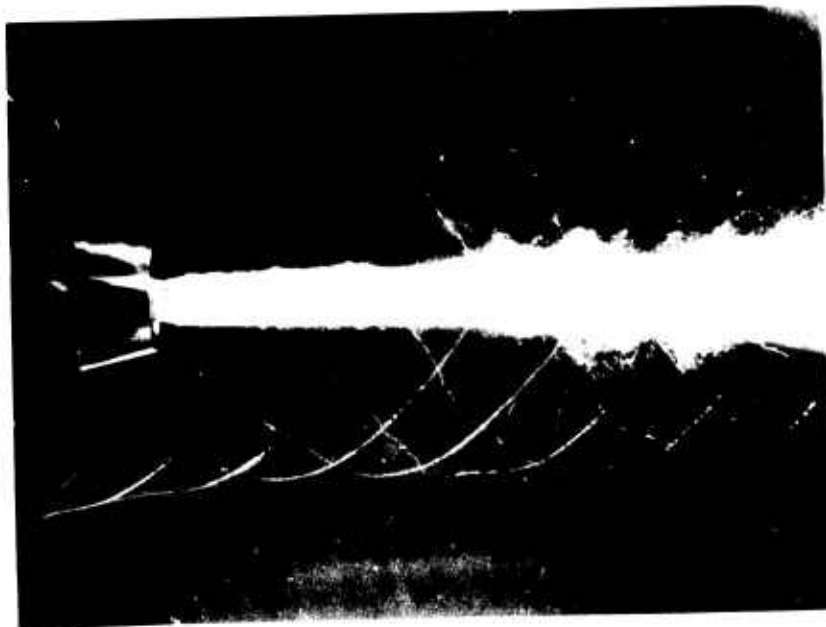

FIG. 6. Transparent-Shroud Pumpjet Model.



a. Well Developed Tip Vortex.



b. Hub Vortex (with some tip-vortex).

FIG. 7. Propeller Vortex Cavities.



FIG. 8. Counterrotating Propellers.

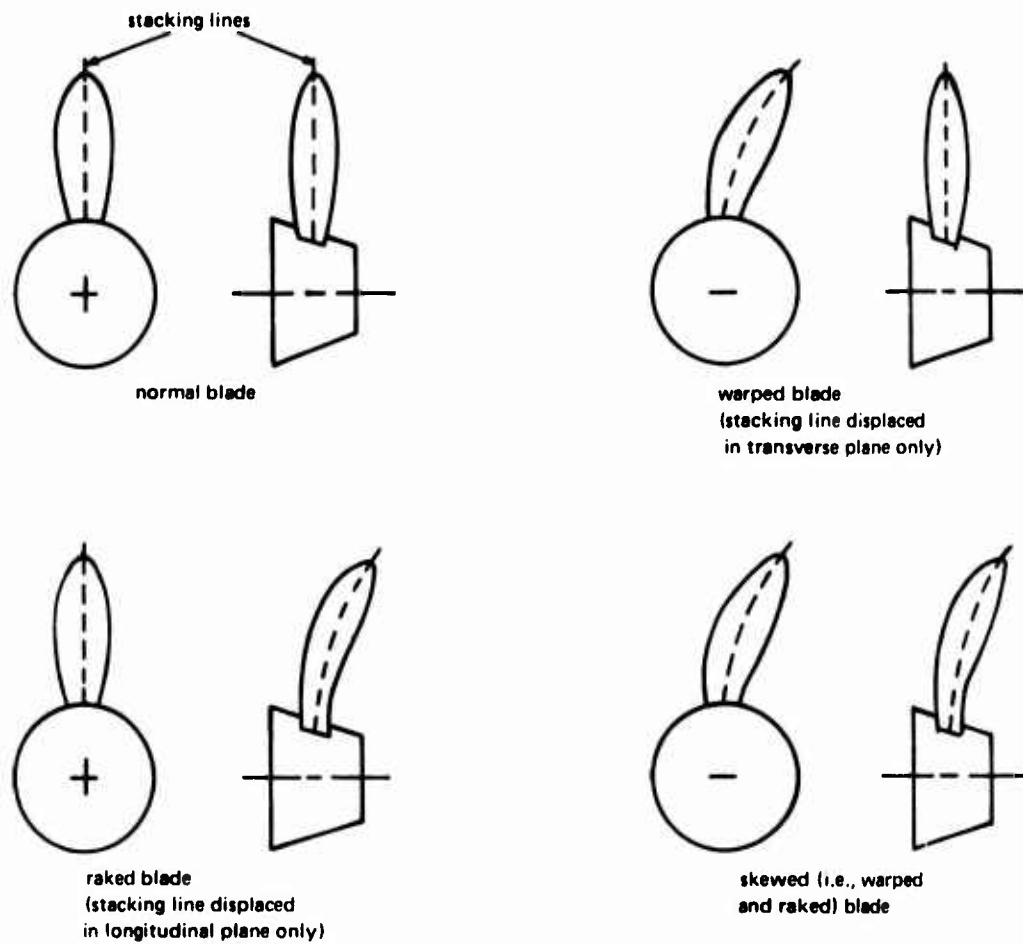

FIG. 9. Skew, Warp, and Rake.

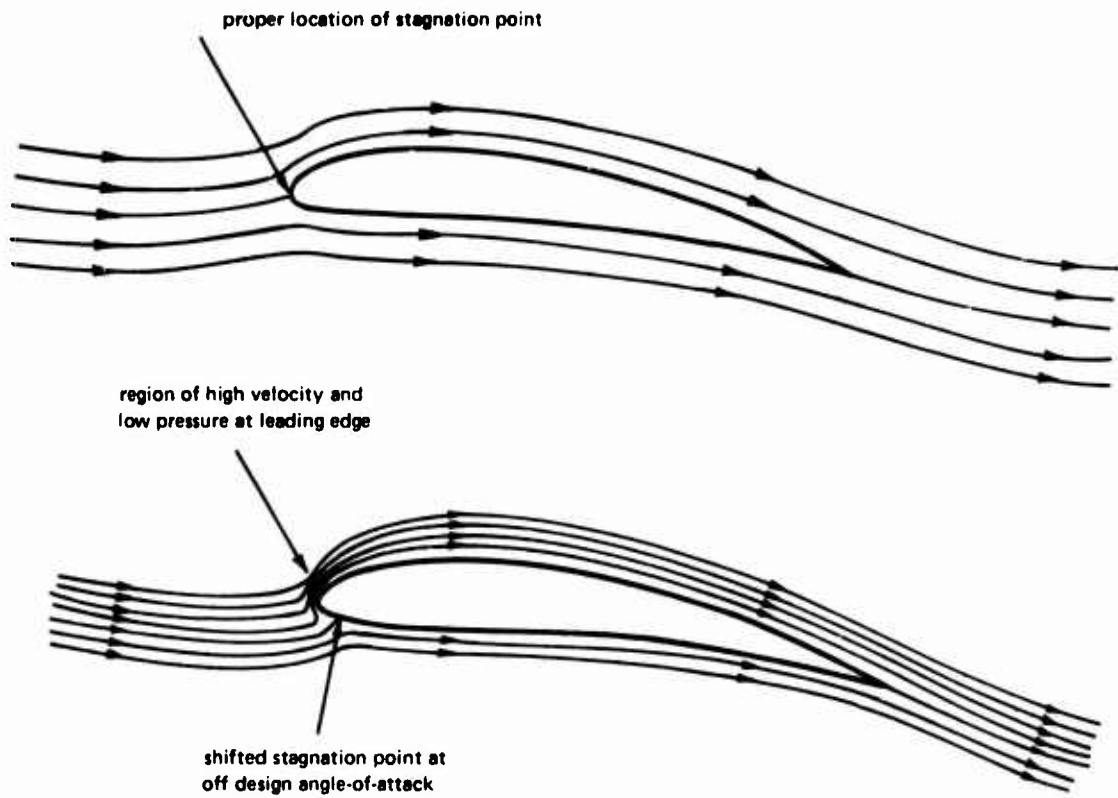

FIG. 10. Effect of Stagnation Point Shift.

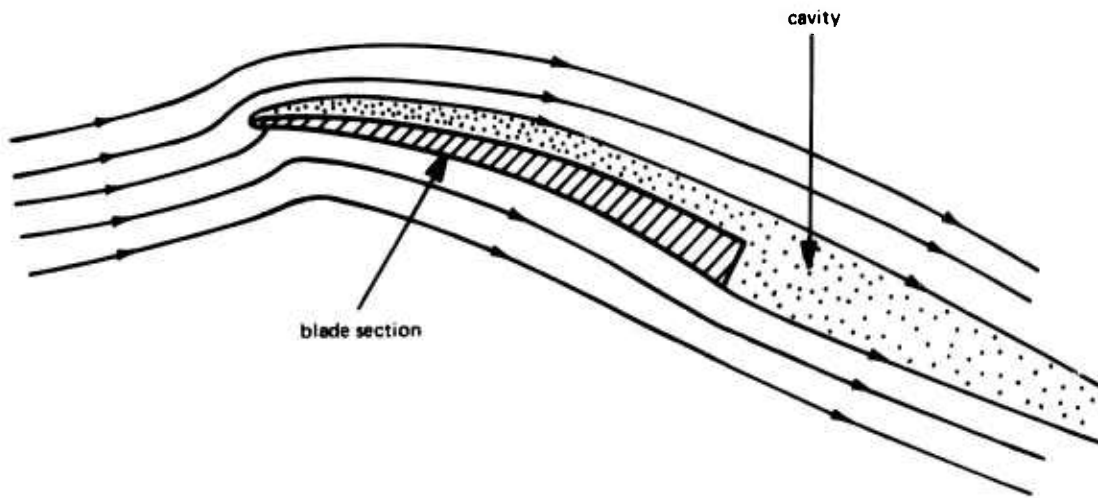

FIG. 11. Supercavitating Blade Section.

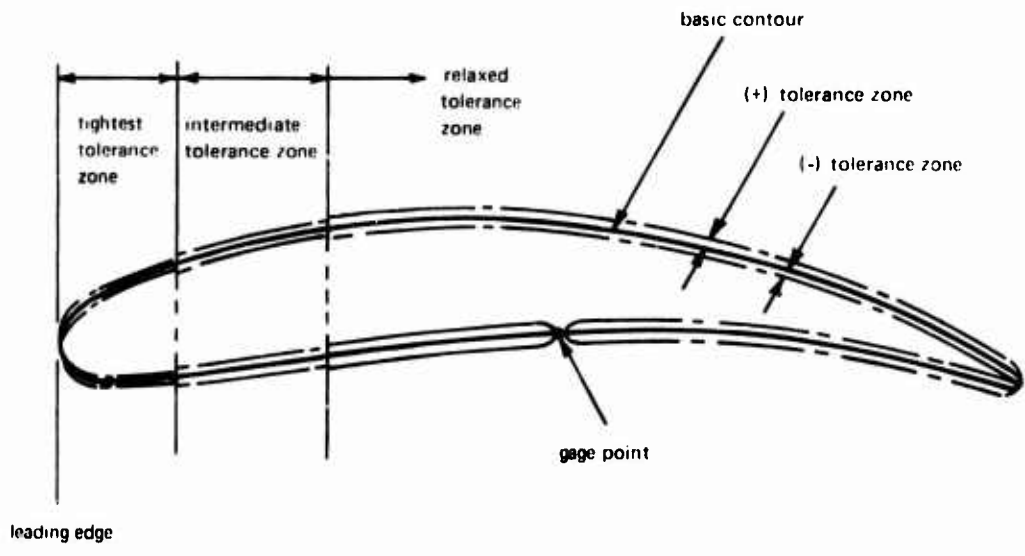

FIG. 12. Schematic of Thickness Tolerance Zones for Pumpjet Blades.

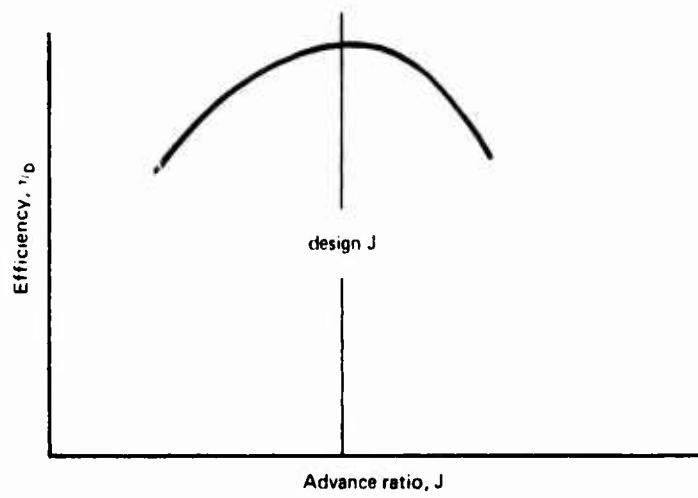

FIG. 13. Efficiency Versus Advance Ratio; Typical.

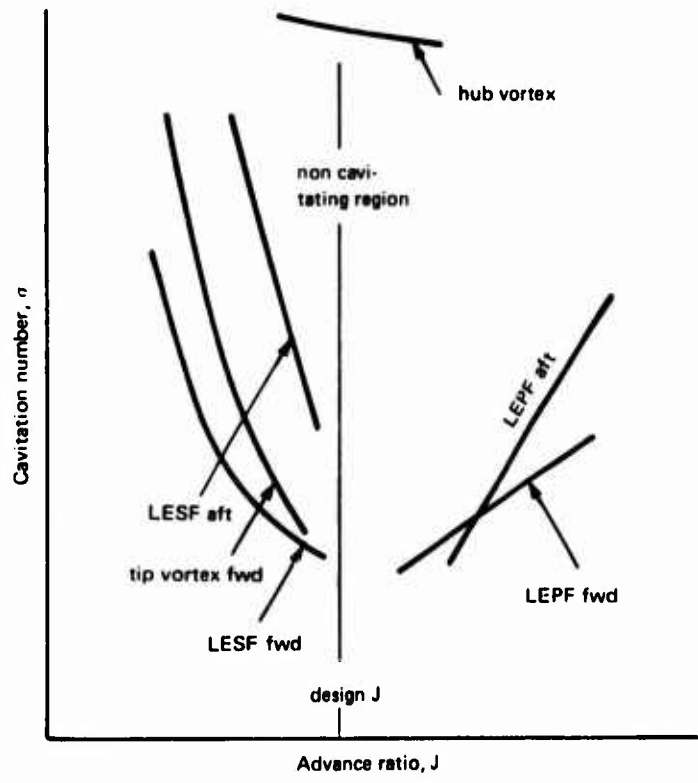

FIG. 14. Cavitation Number Versus Advance Ratio; Typical.

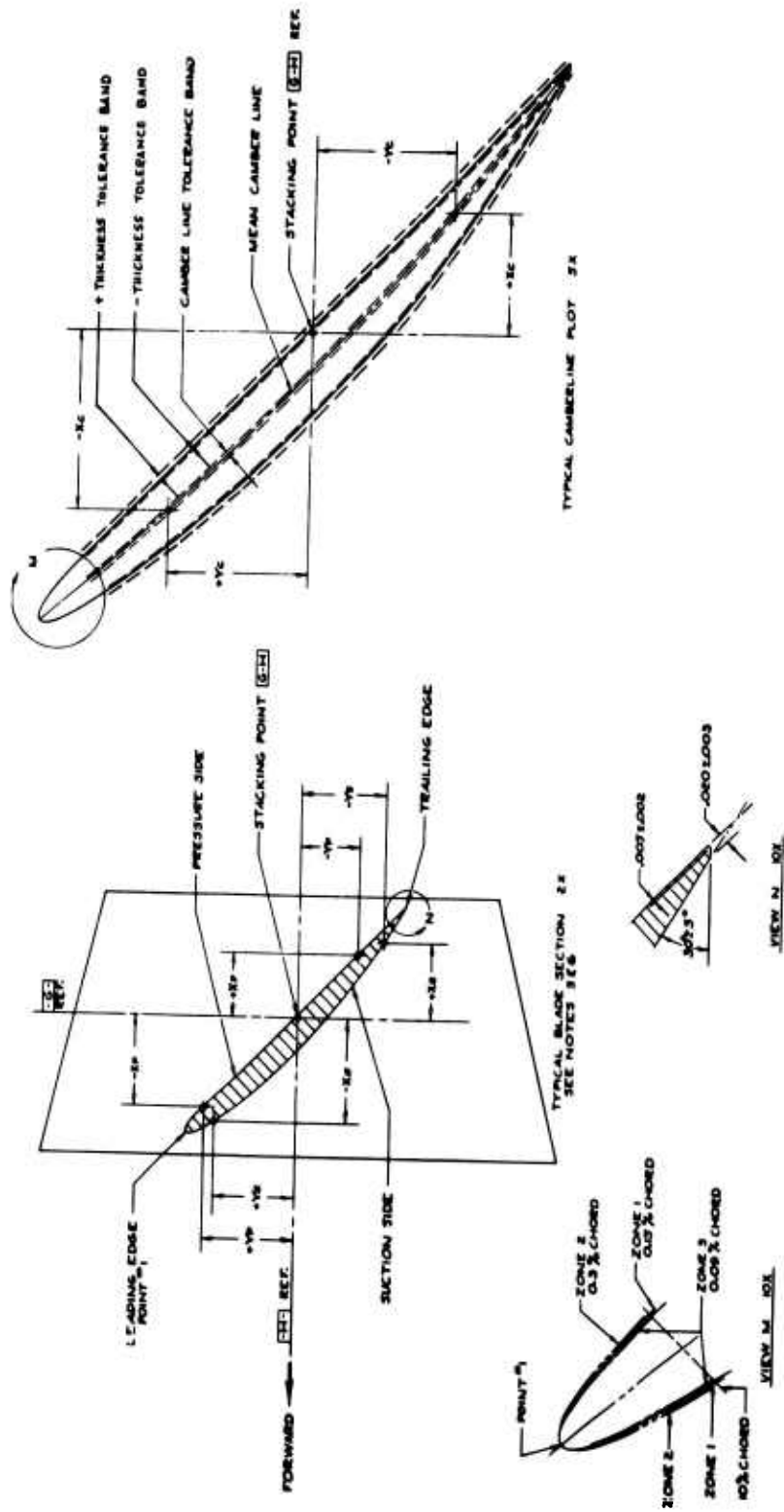

FIG. 16. Propeller Drawing -- Sheet 2.

SECTION TO DATUM SECTION		BLADE THICKNESS ± 0.0009 - 0.0027										CAMBERLINE TOLERANCE WIDTH - 0.006									
		2	3	4	5	6	7	8	9	10	11	12	13	14	15	16	17	18	19	20	21
X ₁																					
Y ₁																					
X ₂																					
Y ₂																					
X ₃																					
Y ₃																					

SECTION TO DATUM SECTION		LEAD. EDGE TOL. RETICLE Z =												
		ZONE 1			ZONE 2			ZONE 3						
X ₁														
Y ₁														
X ₂														
Y ₂														
X ₃														
Y ₃														
X ₄														
Y ₄														
X ₅														
Y ₅														

FIG. 17. Propeller Drawing -Sheet 3.

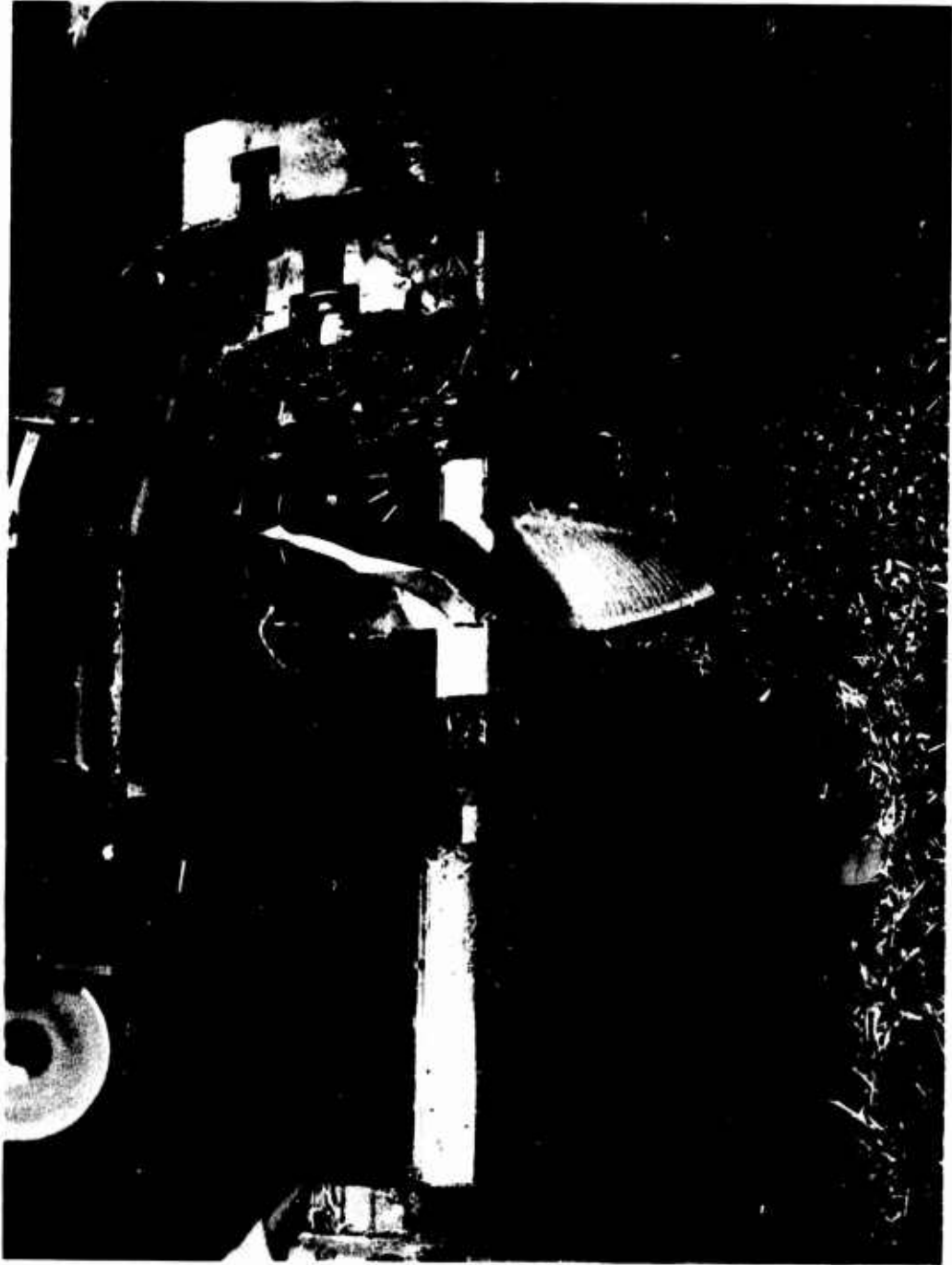

FIG. 18. Numerical Control Milling Machine.

101

Reproduced from
best available copy.



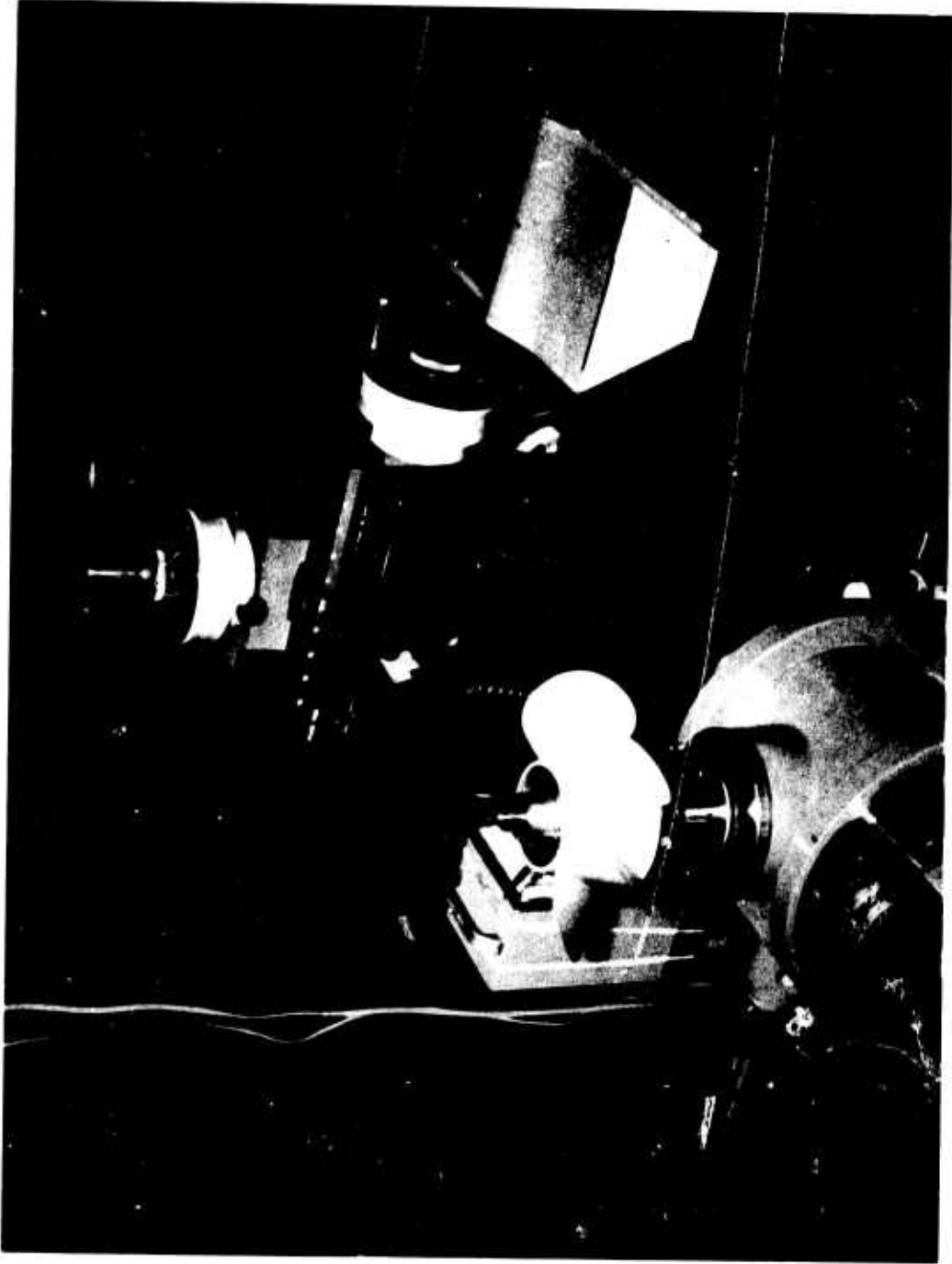

FIG. 19. Three-Coordinate Measuring Machine.

102

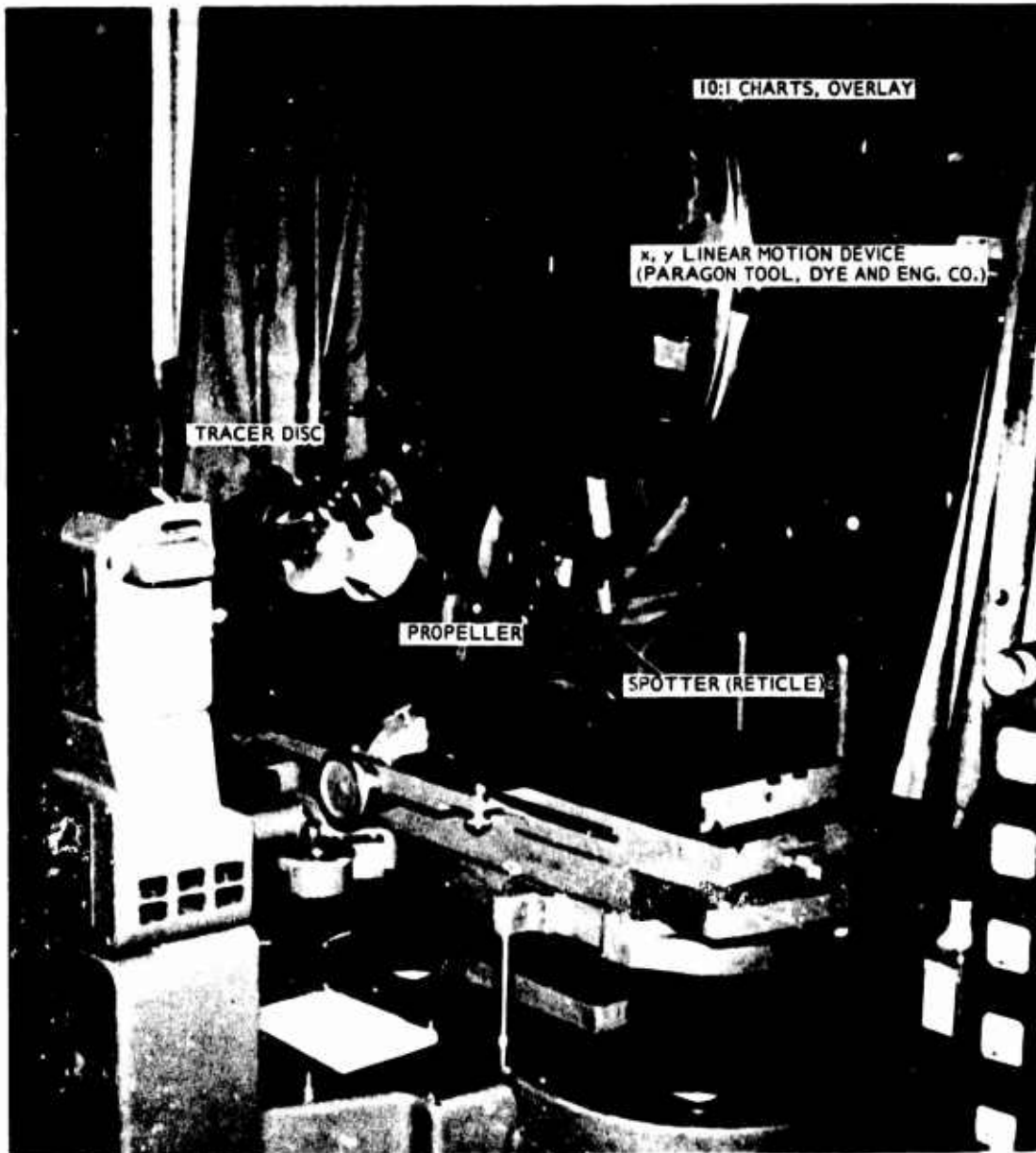

FIG. 20. Optical Comparator.

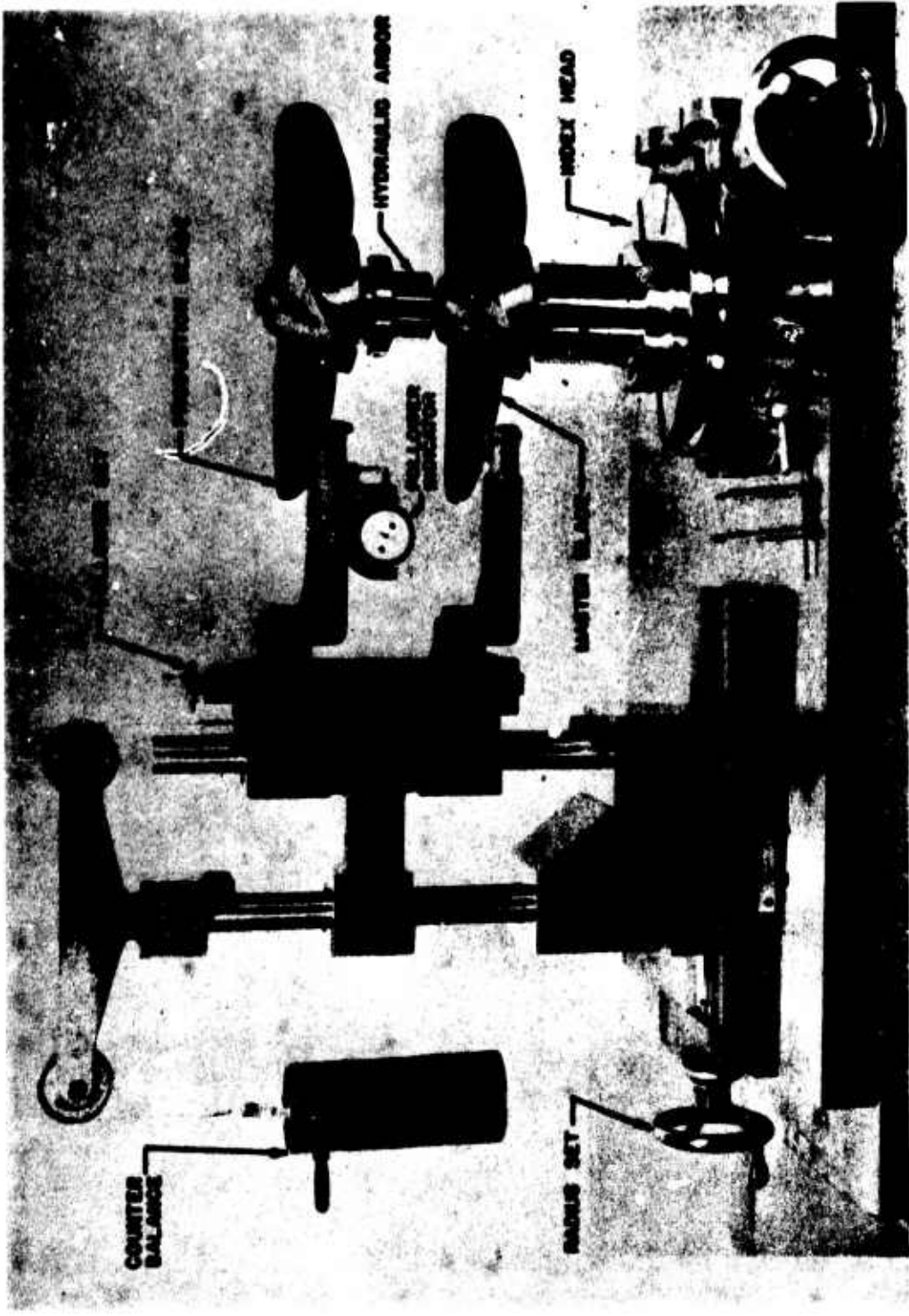



FIG. 21. Comparison Cage.

104



FIG. 22. Pin Gage.

105

Reproduced from
best available copy. 

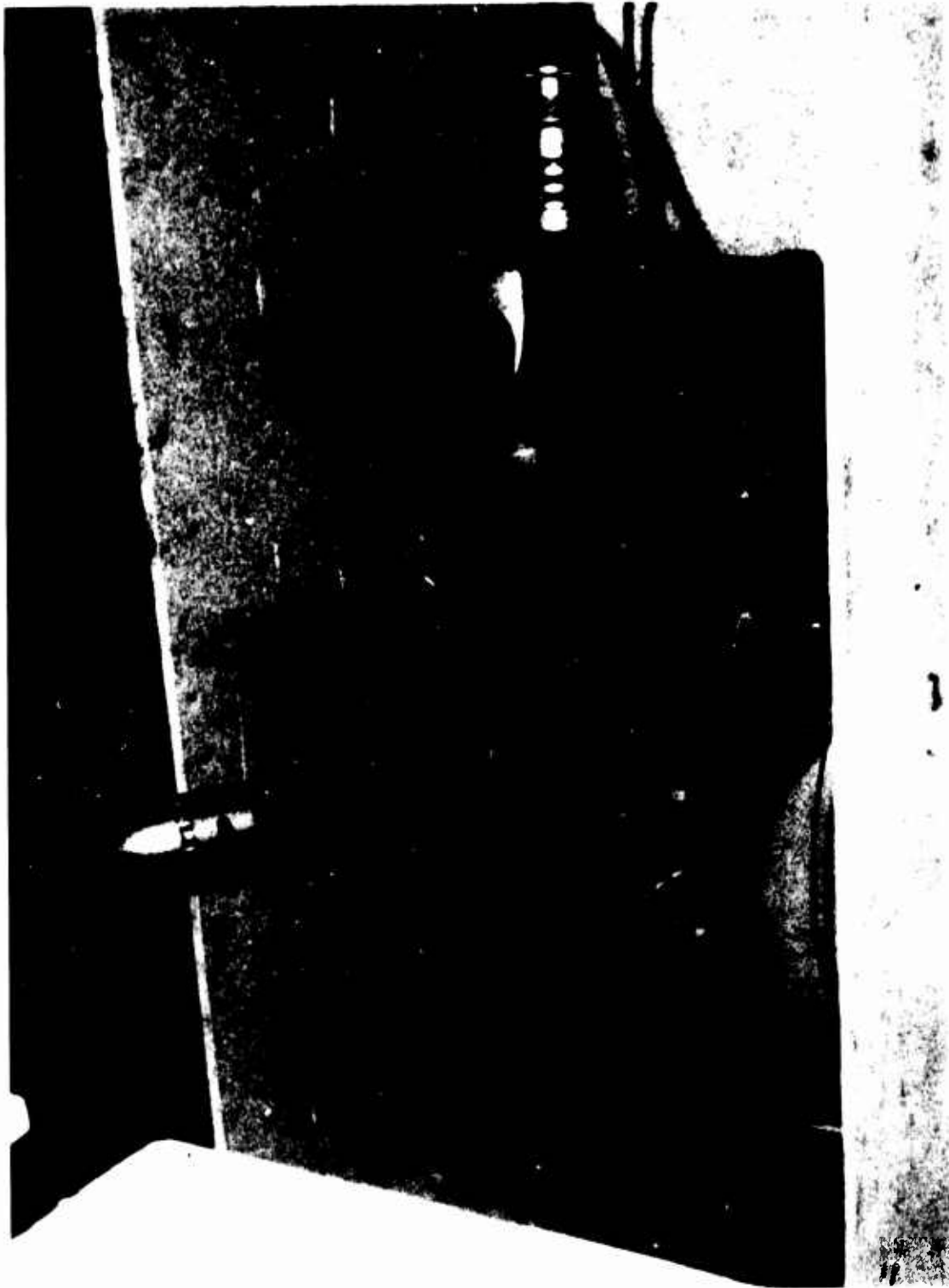

FIG. 23. Blade-Edge Microscope.

106