

AFFDL-TR-71-170

AD 740911

# VARIABLE DIAMETER ROTOR STUDY

Arthur W. Linden, et al  
SIKORSKY AIRCRAFT

Technical Report AFFDL-TR-71-170

January 1972

Approved for Public Release; Distribution Unlimited

Reproduced by  
NATIONAL TECHNICAL  
INFORMATION SERVICE  
Springfield, Va. 22151

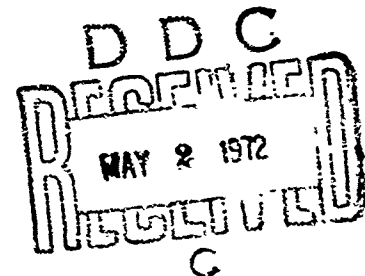

AIR FORCE FLIGHT DYNAMICS LABORATORY  
AIR FORCE SYSTEMS COMMAND  
WRIGHT-PATTERSON AIR FORCE BASE, OHIO

201

**Best  
Available  
Copy**

NOTICE

When Government drawings, specifications, or other data are used for any purpose other than in connection with a definitely related Government procurement operation, the United States Government thereby incurs no responsibility nor any obligation whatsoever; and the fact that the government may have formulated, furnished, or in any way supplied the said drawings, specifications, or other data, is not to be regarded by implication or otherwise as in any manner licensing the holder or any other person or corporation, or conveying any rights or permission to manufacture, use, or sell any patented invention that may in any way be related thereto.

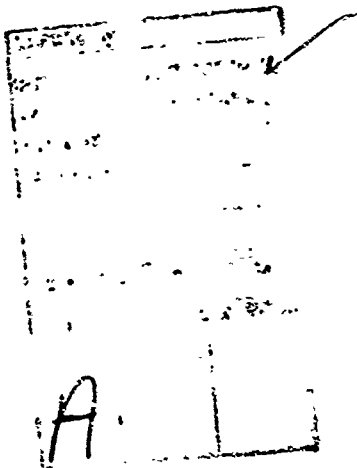

Copies of this report should not be returned unless return is required by security considerations, contractual obligations, or notice on a specific document.

VARIABLE DIAMETER  
ROTOR STUDY

Arthur W. Linden, et al

Approved For Public Release; Distribution Unlimited



## FOREWORD

This document was prepared by Sikorsky Aircraft, a Division of United Aircraft Corporation, Stratford, Connecticut, under contract F33615-71-C-1186. The contract was initiated under Project 1366, "Aeromechanics Technology for Military Aerospace Vehicles," Task 136617, "Aeromechanic Analysis of Advanced Military V/STOL Aircraft", and administered by the Air Force Flight Dynamics Laboratory, Wright-Patterson Air Force Base, Ohio, Capt. Forrest S. Stoddard (AFFDL/PTB), Project Engineer. The report covers work conducted during the period January 1971 - July 1971, and was released by the author in January 1972.

Major technical contributions were made by the following Sikorsky employees:

Mr. William E. Bauach - Acoustics  
Mr. David Beck - Reliability/Maintainability  
Mr. Mario D'Onofrio - Systems Analysis  
Mr. Robert Fleming - Performance  
Mr. Edward S. Hibyan - Mechanical Design  
Dr. Robert A. Johnston - Dynamics  
Mr. Arthur J. Linden - Task Manager  
Mr. Robert J. Murrill - Test Requirements  
Mr. David K. Unsworth - Mass Properties

The contractor's report number is SER-50718.

This technical report has been reviewed and is approved.

*(Ernest J. Cross, Jr.)* *(Ernest J. Cross, Jr.)*  
Ernest J. Cross, Jr.  
Lt. Colonel, USAF  
Chief, Prototype Division

Unclassified

Security Classification

DOCUMENT CONTROL DATA - R & D

Security Classification of this report and underlying information shall be entered when the overall report is classified

1. CONTRACTING ORIGINATOR'S NAME (Company or address) <b>Sikorsky Aircraft          United Aircraft Corporation          Stratford, Conn. 06497</b>		2A. REPORT SECURITY CLASSIFICATION <b>UNCLASSIFIED</b>	
		2B. GROUP <b>R/A</b>	
3. REPORT TITLE <b>VARIABLE DIAMETER ROTOR STUDY</b>			
4. DESCRIPTIVE NOTES (Type of report and inclusive dates) <b>Final Report (Jan 71 - July 71)</b>			
5. AUTHOR(S) (Last name, middle initial, first name) <b>Linden, Arthur W., et al.</b>			
6. REPORT DATE <b>January 1972</b>		7B. TOTAL NO OF PAGES <b>196</b>	7C. NO OF FIGS <b>12</b>
8A. CONTRACT OR GRANT NO <b>F33615-71-C-1186</b>		9B. ORIGINATOR'S REPORT NUMBER(S) <b>SEP-50718</b>	
B. PROJECT NO <b>1366</b>		9C. OTHER REPORT NO(S) (Any other numbers that may be assigned to a report) <b>AFDL-TR-71-170</b>	
C. Task Area Number: <b>17</b>			
D. Work Unit Number: <b>018</b>			
10. DISTRIBUTION STATEMENT <b>Approved for public release; distribution unlimited.</b>			
11. SUPPLEMENTARY NOTES		12. SPONSORING MILITARY ACTIVITY <b>Air Force Flight Dynamic Laboratory          Wright-Patterson Air Force Base          Ohio 45433</b>	
13. ABSTRACT <p>This report documents the findings of a Variable Diameter Rotor Systems Concept Study which Sikorsky Aircraft performed under U. S. Air Force contract, F33615-71-C-1186. The objective of the study was to investigate the various schemes that have been proposed for variable diameter rotors for compound helicopters, determine the merits of each, and conclude which is most promising. Three basic types of variable diameter rotors were investigated. These were classified by the type of rotor blade construction, and include telescoping rigid blades, folding rigid blades, and flexible blades. Examples of each of these were adapted to a large compound helicopter design. All aircraft were sized to perform the same mission and a quantitative analysis was performed which rated each design on overall system cost effectiveness. In addition to this quantitative analysis, qualitative judgements were made to further rate the potential of each design. These were combined with the cost effectiveness scores to get an overall merit rating score for each concept. From this analysis, the most promising rotor type was found to be a flexible bladed rotor which uses thin blades that can be retracted by rolling them on drums within the rotor head. This design concept permits a very low hovering disc loading to be obtained and, in addition, can be retracted to 10% of its hovering diameter. The concept could be further extended to a stowed rotor configuration by stowing the rotor within the contour of the fuselage. This would provide efficient high speed cruise as well as low disc loading hover capability. The final task of the study included the identification of a development program for this rotor system.</p>			

Unclassified

Security Classification

14 KEY WORDS	LINK A		LINK B		LINK C	
	ROLE	WT	ROLE	WT	ROLE	WT
Variable Diameter Rotors Rotor Dynamics Rotor Aerodynamics Control System Design Flexible Structures						

Unclassified

Security Classification

## ABSTRACT

This report documents the findings of a Variable Diameter Rotor Systems Concept Study which Sikorsky Aircraft performed under U. S. Air Force contract, F33615-71-C-1186. The objective of the study was to investigate the various schemes that have been proposed for variable diameter rotors for compound helicopters, determine the merits of each, and conclude which is most promising. Three basic types of variable diameter rotors were investigated. These were classified by the type of rotor blade construction, and include telescoping rigid blades, folding rigid blades, and flexible blades. Examples of each of these were adapted to a large compound helicopter design. All aircraft were sized to perform the same mission, and a quantitative analysis was performed which rated each design on overall system cost effectiveness. In addition to this quantitative analysis, qualitative judgments were made to further rate the potential of each design. These were combined with the cost effectiveness scores to get an overall merit rating score for each concept. From this analysis, the most promising rotor type was found to be a flexible bladed rotor which uses thin blades that can be retracted by rolling them on drums within the rotor head. This design concept permits a very low hovering disc loading to be obtained and, in addition, can be retracted to 10% of its hovering diameter. The concept could be further extended to a stowed rotor configuration by stowing the rotor within the contour of the fuselage. This would provide efficient high speed cruise as well as low disc loading hover capability. The final task of the study included the identification of a development program for this rotor system.

TABLE OF CONTENTS

I. INTRODUCTION AND SUMMARY. . . . .	1
II. SURVEY OF VARIABLE DIAMETER ROTOR CONCEPTS. . . . .	3
1. Telescoping Blades. . . . .	4
2. Folding Blades. . . . .	7
3. Flexible Blades. . . . .	9
III. EVALUATION OF CONCEPTS. . . . .	15
1. Technical Approach. . . . .	15
a. General Approach. . . . .	15
b. The Baseline Aircraft, and its Modification to accept Variable Diameter Rotors . . . . .	19
c. The Detailed Evaluation . . . . .	22
(1) Areas of Investigation . . . . .	23
(a) Dynamic Analysis . . . . .	23
(b) Performance Analysis. . . . .	23
(c) Mechanical Design . . . . .	24
(d) Weight . . . . .	24
(e) Reliability/Maintainability/Availability Analysis. . . . .	24
(f) Accoustic Analysis . . . . .	25
(2) Quantitative Analysis . . . . .	25
(3) Qualitative Analysis . . . . .	26
(a) Technical Risk . . . . .	26
(b) Off-design Performance . . . . .	27
(c) Adaptability to Stowed Rotor Design. . . . .	27
(d) Growth Potential. . . . .	27
(e) Handling Qualities. . . . .	27
(f) Safety. . . . .	27
(g) Maneuverability . . . . .	27
(h) Vibration . . . . .	28
(i) Hovering Downwash . . . . .	28
(j) Stowability/Transportability. . . . .	28
2. General Aerodynamic Analysis Applicable to all Concepts. . . . .	34
a. Hover Performance. . . . .	35
(1) Figure of Merit. . . . .	35
(2) Vertical Drag in Hover . . . . .	36
b. Parasite Drag. . . . .	36
c. Level Flight Performance . . . . .	37
(1) General. . . . .	37
(2) Wing Performance . . . . .	37
(3) Propeller Performance. . . . .	40
3. The Rotor Designs at 62,800 lbs Gross Weight. . . . .	47
a. Eight Segment Telescoping Rotor. . . . .	47
(1) Mechanical Design. . . . .	48
(2) Dynamic Considerations. . . . .	51
(3) Aerodynamic Considerations. . . . .	53
(4) Rotor System Weight. . . . .	54
(5) Summary. . . . .	55

b.	Roll-up Rotor, Thin Flexible Blades. . . . .	.62
	(1) Dynamic Considerations. . . . .	.62
	(a) Ground Resonance . . . . .	.63
	(b) Pitch Control and Torsional Stability. . . . .	.65
	(2) Mechanical Design. . . . .	.69
	(a) The Four Bladed Rotor. . . . .	.69
	(b) The Two Bladed Rotor . . . . .	.72
	(3) Aerodynamic Considerations. . . . .	.73
	(4) Rotor System Weight. . . . .	.76
	(5) Summary. . . . .	.77
c.	Roll-up Rotor, Pneumatic Blades. . . . .	.91
	(1) Mechanical Design. . . . .	.91
	(2) Dynamic Considerations . . . . .	.92
	(3) Aerodynamic Considerations. . . . .	.93
	(4) Rotor System Weight. . . . .	.94
	(5) Summary. . . . .	.95
d.	Alternate Approaches for Roll-up Rotors. . . . .	100
	(1) The Catenary Rotor . . . . .	.100
	(2) The Control Line Rotor . . . . .	.100
e.	Implane Fold Rotor. . . . .	102
	(1) Mechanical Design. . . . .	.102
	(2) Dynamic Considerations. . . . .	.103
	(3) Aerodynamic Considerations. . . . .	.104
	(4) Rotor System Weight . . . . .	.105
	(5) Summary. . . . .	.106
f.	Two Segment Telescoping Rotor. . . . .	.110
	(1) Mechanical Design. . . . .	.110
	(2) Dynamic Considerations. . . . .	.111
	(3) Aerodynamic Considerations. . . . .	.112
	(4) Rotor System Weight. . . . .	.113
	(5) Summary. . . . .	.113
4.	Comparative Results at Initially Assumed Gross Weight. . . . .	120
a.	Aerodynamics. . . . .	.120
	(1) Hover. . . . .	.121
	(2) Transition . . . . .	.122
	(3) Cruise . . . . .	.122
b.	Weights. . . . .	.125
c.	Reliability and Maintainability. . . . .	.125
	(1) The Base Line Aircraft . . . . .	.126
	(2) The Eight Segment Telescoping Rotor . . . . .	.126
	(3) The Roll-up Rotor with Thin Blades. . . . .	.126
	(4) The Roll-up Rotor with Pneumatic Blades . . . . .	.127
	(5) The Implane Fold Rotor. . . . .	.127
	(6) The Two Segment Telescoping Rotor . . . . .	.128
	(7) Fan-in-Fin Tail Rotor . . . . .	.128
	(8) Predictions . . . . .	.128
d.	Acoustics. . . . .	.129
e.	Rotor System Dollar Costs. . . . .	.132
	(1) Recurring Costs . . . . .	.132
	(2) Non-recurring Costs . . . . .	.137

5.	Systems Integration. . . . .	138
a.	Quantitative Results. . . . .	138
	(1) Design Gross Weight. . . . .	138
	(2) Aircraft Cruising Speed. . . . .	141
	(3) Wing Size Trade Off. . . . .	141
	(4) Mission Related Parameters . . . . .	146
	(5) Aircraft Costs. . . . .	146
	(6) Summary. . . . .	153
b.	Qualitative Results. . . . .	155
	(1) Technical Risk. . . . .	155
	(2) Off Design Performance. . . . .	156
	(3) Adaptability to Stowed Rotor Designs. . . . .	156
	(4) Growth Potential. . . . .	157
	(5) Handling Qualities. . . . .	158
	(6) Safety. . . . .	158
	(7) Maneuverability. . . . .	158
	(8) Vibration. . . . .	159
	(9) Hovering Downwash. . . . .	159
	(10) Stowability/Transportability. . . . .	159
c.	Completed Evaluation Matrix. . . . .	160
6.	Conclusions from Detailed Evaluation. . . . .	161
IV.	APPLICATION TO AIRCRAFT . . . . .	162
V.	DEVELOPMENT PROGRAM FOR ROLL-UP ROTORS. . . . .	167
1.	Phase I - Initial Effort. . . . .	169
a.	Non-Rotating Aeroelastic and Aerodynamic Testing. . . . .	169
	(1) Two Dimensional Airfoil Tests. . . . .	169
	(2) Model Tip Weight Tests. . . . .	169
b.	Rotating System Dynamically Scaled Testing . . . . .	171
c.	Analytic Procedure. . . . .	171
	(1) Developing Analytic Tools. . . . .	171
	(2) Analytic Studies . . . . .	171
	(3) Correlation. . . . .	171
d.	Hardware Design and Development . . . . .	171
	(1) Blade Structural Design. . . . .	171
	(2) Tip Control Actuator Mechanism . . . . .	172
2.	Phase II DETAILED EFFORT . . . . .	172
a.	Non-Rotating Aeroelastic and Aerodynamic Testing . . . . .	172
	(1) Model Tip Weight . . . . .	172
	(2) Installed Rotor Head Drag. . . . .	172
	(3) Two Dimensional Airfoil Tests. . . . .	172
b.	Rotating System Dynamically Scaled Testing. . . . .	172
	(1) Ground Resonance Tests. . . . .	172
	(2) Variable Diameter Rotating System Tests . . . . .	174
	(3) Remotely Retracting Rotating System Test. . . . .	174
c.	Analytic Procedures. . . . .	174
	(1) Design Optimization . . . . .	174
	(2) Analytic Development. . . . .	174
	(3) Correlation and Analysis. . . . .	174

d.	Hardware Design and Development. . . . .	174
(1)	Blade Fabrication and Materials. . . . .	174
(2)	Rotor Head Mechanism. . . . .	175
(3)	Tip Control Tab Actuator. . . . .	175
3.	Phase III - LARGE SCALE MODEL TESTS. . . . .	175
a.	Non-Rotating Aeroelastic and Aerodynamic Testing. . . . .	175
b.	Rotating System Testing - Ames Wind Tunnel . . . . .	175
c.	Analytic Procedures. . . . .	175
(1)	Design Optimization. . . . .	175
(2)	Correlation of Wind Tunnel Tests. . . . .	175
d.	Hardware Design and Development. . . . .	177
4.	Phase IV FLIGHT TESTS . . . . .	177
VI.	STUDY CONCLUSIONS. . . . .	178
Appendix I	U.S. Patents Applicable to Variable Diameter Rotors. . . . .	181
Appendix II	Effect of Varying Design Disc Loading. . . . .	189
References.	. . . . .	194
Bibliography.	. . . . .	195



LIST OF FIGURES

<u>FIGURE</u>		<u>PAGE</u>
1	Internal Retracting Rigiflex Variable Diameter Rotor. . . . .	13
2	Helicopter Trend Model Flow Diagram. . . . .	29
3	General Arrangement S65-300 V/STOL U.S. Air Force Compound. . . . .	31
4	General Aircraft Designs with Variable Diameter Rotors. . . . .	33
5	Wing Drag vs Wing Attitude and Flap Deflection. . . . .	41
6	Characteristics of Baseline 475 Square Foot Wing. . . . .	42
7	Wing Size Trends at 52,800 lbs Wing Lift. . . . .	43
8	Wing Size Trends with Gross Weight Changes. . . . .	44
9	Propeller Performance at 100% RPM. . . . .	45
10	Propeller Performance at 80% RPM. . . . .	46
11	Eight Segment Telescoping Rotor Design. . . . .	57
12	Eight Segment Telescoping Rotor - Performance Characteristics. . . . .	59
13	Eight Segment Telescoping Rotor - Steady and Vibratory Blade Flatwise and Edgewise Moments. . . . .	60
14	Eight Segment Telescoping Rotor - Blade Tip Displacement During Steady Trimmed Flight. . . . .	61
15	Roll-up Rotor - Effect of Drag Vane Area and Rotor Speed on Stability. . . . .	79
16	Roll-up Rotor - Flatwise and Torsional Response at 100 Knots, 36000 lbs Lift, Elastic Axis, Mass Axis, and Aerodynamic Axis at 25% Chord, Inboard Pitch Control. . . . .	80
17	Roll-up Rotor - Flatwise and Torsional Response at 100 Knots, 36000 lbs Lift, Elastic Axis, Mass Axis and Aerodynamic Axis at 25% Chord, Blade Tip Pitch Control. . . . .	81
18	Roll-up Rotor - Flatwise and Torsional Response at 100 Knots, 36500 lbs Lift, Elastic Axis and Mass Axis at 23% Chord; Aero- dynamic Axis at 25% Chord, Blade Tip Pitch Control. . . . .	82
19	Four Bladed Roll-up Rotor Design, 2% Thick Reflex Airfoil. . . . .	83
20	Four Bladed Roll-up Rotor - Tip Weight Required. . . . .	85
21	Two Bladed Roll-up Rotor Design. . . . .	87
22	Roll-up Rotor - Airfoil Characteristics, 2% Thick Reflexed Camber Airfoil, $C_L$ and $C_D$ versus angle of attack. . . . .	89
23	Roll-up Rotor, Thin Airfoil - Performance Characteristics. . . . .	90
24	Pneumatic Blade, Four Bladed Roll-up Rotor. . . . .	97
25	Roll-up Rotor, Pneumatic Airfoil - Performance Characteristics. . . . .	99
26	Inplane Fold Rotor Design. . . . .	107
27	Inplane Fold Rotor - Performance Characteristics. . . . .	109
28	Telescoping Two Segment Variable Diameter Rotor. . . . .	115
29	TRAC Blade Schematic Drawing. . . . .	117
30	TRAC Rotor Head and Transmission Schematic Drawing. . . . .	118
31	Two Segment Telescoping Rotor-Performance Characteristics. . . . .	119
32	Octave Band Spectra @ 500 Feet. . . . .	130
33	Wing Size Trade-off - Eight Segment Telescoping Rotor. . . . .	143
34	Wing Size Trade-off - Roll-up Rotor, Two Thin Blades. . . . .	143
35	Wing Size Trade-off - Roll-up Rotor, Four Thin Blades. . . . .	144

FIGURE

PAGE

36	Wing Size Trade-off - Roll-up Rotor, Four Pneumatic Blades. . .	144
37	Wing Size Trade-off - Inplane Fold Rotor. . . . .	145
38	Wing Size Trade-off - Two Segment Telescoping Rotor. . . . .	145
39	General Arrangement - Aircraft Design Using Flexible Roll-up Rotor. . . . .	165
40	Development Program, Roll-up Rotor System. . . . .	168
41	Phase I - Development Program. . . . .	170
42	Phase II - Development Program. . . . .	173
43	Phase III - Development Program. . . . .	176
44	Disc Loading Trade-off, Eight Segment Telescoping Rotor. . . .	191
45	Disc Loading Trade-off, Roll-up Rotor, Two Thin Blades. . . .	191
46	Disc Loading Trade-off, Roll-up Rotor, Four Thin Blades. . . .	192
47	Disc Loading Trade-off, Roll-up Rotor, Four Pneumatic Blades. .	192
48	Disc Loading Trade-off, Inplane Fold Rotor. . . . .	193
49	Disc Loading Trade-off, Two Segment Telescoping Rotor. . . . .	193

LIST OF TABLES

<u>TABLE</u>		<u>PAGE</u>
I	Variable Diameter Rotor Concepts. . . . .	11
II	System Attribute Structure. . . . .	16
III	Evaluation Matrix. . . . .	18
IV	Basic Aircraft Parameters. . . . .	21
V	Hover Performance, Figure of Merit and Vertical Drag, 62800 lbs Gross Weight. . . . .	121
VI	Wing Size, 62,800 lbs Gross Weight. . . . .	122
VII	Parasite Drag Summary, 62,800 lbs Gross Weight. . . . .	123
VIII	Cruise Speed Performance, 12000 Ft. Standard Conditions, 62,800 lbs Gross Weight. . . . .	124
IX	Summary Weight Statements at 62,800 Pounds Design Gross Weight. . . . .	125
X	Reliability and Maintainability Predictions. . . . .	129
XI	Perceived Noise Level and Detection Range Ratio. . . . .	132
XII	Complexity Factors Used in Recurring Cost Estimates. . . . .	133
XIII	Recurring Cost Estimates for Variable Diameter Rotors Based on Assumed Design Gross Weight of 62,800 Pounds. . . . .	136
XIV	Complexity Factors Used in Non-Recurring Cost Estimates. . . . .	137
XV	Summary Weight Statements at 10,700 Pounds Design Payload. . . . .	140
XVI	Aircraft Cruise Speed Capabilities. . . . .	141
XVII	Wing Size Trade-off Results. . . . .	146
XVIII	Aircraft Mission Parameters. . . . .	147
XIX	Unit Development Costs With and Without Rotor System RDT&E Cost. . . . .	148
XX	Cost Summary - S-65-300. . . . .	149
XXI	Cost Summary - Eight Segment Telescoping Rotor. . . . .	149
XXII	Cost Summary - Roll-up Rotor - Two Thin Blades. . . . .	150
XXIII	Cost Summary - Roll-up Rotor - Four Thin Blades. . . . .	150
XXIV	Cost Summary - Roll-up Rotor - Four Pneumatic Blades. . . . .	151
XXV	Cost Summary - Inplane Fold Rotor. . . . .	151
XXVI	Cost Summary - Two Segment Telescoping Rotor. . . . .	152
XXVII	Summary of Quantitative Analysis. . . . .	153
XXVIII	Quantitative Evaluation Rating. . . . .	154
XXIX	Completed Evaluation Matrix. . . . .	160
XXX	Aircraft Weight Statements. . . . .	164

## SECTION I

### INTRODUCTION AND SUMMARY

This study was limited to variable diameter rotors as applied to compound helicopters. In this application they provide the capability for low hovering disc loadings plus higher speed, more efficient cruise performance. If they can be retracted to very small diameters, they can be stopped to prevent the least drag and to completely eliminate the rotor aeroelastic boundaries which presently limit the forward speed of conventional compound helicopters. With these capabilities in mind, a baseline fixed diameter compound aircraft, the Sikorsky S-65-300, was chosen, and the variable diameter rotor concepts applied to it. A hovering disc loading of five psf was selected, along with a desired ratio of extended to retracted rotor diameter of 10 to 1.

The study was subdivided into three phases. The first consisted of surveying the technical literature to determine the various schemes that have been proposed, developing a merit rating system to judge them, and preparing preliminary layout drawings for the detailed evaluation. Phase two was the evaluation phase, at the end of which the merit rating system was used to choose the most promising concept. During phase three an experimental test program was identified for the selected scheme and an aircraft employing the chosen rotor was compared to the conventional fixed diameter compound aircraft.

The search of the technical literature and patents revealed three basic types of variable diameter rotors. These include those with telescoping blades, those with folding blades, and those with flexible blades. There are many variations of each, varying mainly in the type of mechanism used to control the blade retraction and blade pitch. Retraction ratios (the ratio of extended to retracted diameter) vary from 1.2 to 1 to over 10 to 1.

From these many varying concepts five examples were chosen for detailed evaluation. These include two telescoping rotors, one folding rotor, and two flexible rotors. The first telescoping rotor uses one telescoping blade segment and one rigid segment, and has a retraction ratio of 1.7 to 1. The second uses eight telescoping segments and achieves a retraction ratio of 5 to 1. The folding rotor folds the blades in the plane of the rotor disc, around a hinge located at one-third blade radius. As such, it achieves a retraction ratio of 3 to 1. The flexible rotors use blades that can be retracted by winding them on drums within the rotor head, and they are easily capable of the desired 10 to 1 retraction ratio. The first of these flexible rotors uses very thin blades made of low modulus material, and the second uses a pneumatic blade that can be inflated to present a more conventional airfoil.

The merit rating system that was used to evaluate these concepts included the capability to combine both quantitative and qualitative inputs. All the attributes that could be quantified were incorporated into overall cost effectiveness values. Qualitative judgements on attributes such as technical risk and growth potential were then added to cost effectiveness to complete the total evaluation of each concept.

Using this evaluation method, the flexible roll-up rotor using four thin blades was found to be most attractive. It does achieve the desired hovering disc loading and retraction ratio, and it is lighter than any of the other concepts investigated. It causes the fewest penalties in the overall aircraft design.

This conclusion is made in spite of the high technical risk which has been assessed against this concept. It has many unique problems in the areas of blade pitch control, ground resonance, and aeroelastic instabilities. Solutions are proposed in the study for each of these problems, but this rotor is still an unproven concept. Its high technical risk has resulted in the flexible rotor having a high rotor system RDT&E cost. In spite of this, it has a higher cost effectiveness than any of the concepts which approach the desired retraction ratios.

When the rotor was applied to the baseline fixed diameter compound aircraft, it was found that the gross weight had to grow by ten percent to perform the same mission. Because of improved efficiency, the aircraft could cruise at 280 knots, rather than 250 knots, using the same power levels. Even more important is the fact that the rotor has been retracted and stopped, and the rotor no longer limits forward speed. With more power, and perhaps with the rotor stowed within the fuselage contour, substantially higher speeds would be achievable.

The development program identified for this concept extends over a period of five years and includes four separate phases of development. This is done to determine solutions to the more basic problems early, and at minimum cost. This program culminates in a flight test in the fifth year.

## SECTION II

### SURVEY OF VARIABLE DIAMETER ROTOR CONCEPTS

The initial segment of this study included a survey of technical literature in order to identify what concepts have been proposed for varying the diameter of helicopter rotor systems. Information has been collected from patents, magazine articles, news releases, and technical reports. This research has disclosed many diverse concepts, although many of these have not been developed beyond the initial conceptual phase.

Three basic types of variable diameter rotors have been found. These differ in the type of blade construction, and include those with telescoping blades, those with folding blades, and those with flexible blades. They cover a wide range of rotor retraction ratio,  $D_e/D_r$ , defined as the ratio of extended to retracted rotor diameter. There are many variations on these three basic concepts, particularly in the method of retraction and of blade pitch control.

Telescoping rotors are those with two or more rigid segments that can be telescoped with respect to each other to vary rotor diameter. Retraction ratios vary depending upon the number of telescoping segments. A variety of mechanisms have been proposed to retract these blades, including cables and straps, screw drives, compressible and incompressible hydraulic systems, rack and pinion gearing, plus various forms of rigid mechanical rods.

Two basic forms of folding blades have been found; those that fold in the plane of the rotor and those that fold out of rotor plane. The most common form of inplane fold is a two bladed rotor with a vertical hinge located at one third of the blade radius. The blade can be folded approximately 160 degrees about this hinge to give a retraction ratio of 3 to 1. Out of plane folding schemes use two or more segments with horizontal hinges between them. These fold in a vertical plane.

Flexible blade types include accordion blades, roll up rotors using either pneumatic blades or thin solid blades that can be rolled on a drum, and an internal retracting blade. Various examples of the roll up and accordion blades have been found in the literature. These all achieve the desired retraction ratio of 10 to 1. The internal retracting rotor is a new concept; it can achieve retraction ratios on the order of 2 to 1.

Some concepts have been found which combine these retraction methods. One concept uses a multisegment telescoping blade which is then folded about a vertical hinge to further increase its retraction ratio. In another concept, the Kaman Rotocopter, out of plane fold is combined with a telescoping blade to achieve high retraction ratios.

Many of the ideas found were never intended for helicopter rotors, being applied instead to propellers or to rotor parachutes. The propeller concepts have very low retraction ratios and the rotor parachutes usually include extending the rotors in flight but not retracting them. It is not inconceivable that these concepts could be applied to helicopter rotors and they were included in the initial phase of the program. At this point in the study, no judgement was made on the feasibility of the concepts. It was intended only to record what concepts have been proposed for variable diameter rotor systems. Their respective merits were not judged until the evaluation phase of the study.

Table I lists the various concepts by type and by retraction ratio and identifies the examples of each that were found during the literature search. The numbers on this table refer to U.S. Patent numbers. Appendix I gives a brief description of these patents including inventor, date of issuance, and unique features of each.

#### 1. TELESCOPING BLADES

Telescoping rotors use rigid blade segments that telescope radially for retraction. Large variations in retraction ratio can be achieved by varying the number of blade segments. Many of the examples found use only one fixed and one telescoping segment. This simplifies their mechanical complexity, but results in a retraction ratio of less than 2 to 1. The two variable diameter rotors which are presently undergoing serious development, Bell's VDR (Variable Diameter Rotor) and Sikorsky's TRAC (TeleScoping Rotor AirCraft), are examples of this concept.

A variety of methods for retracting the blades has been found, as shown on Table I. The first of these uses a JACKSCREW and nut system with the nut attached to the telescoping segment. The screw extends through the fixed inboard blade segment, where it is driven by a mechanism within the rotor head. This mechanism also includes a synchronizing feature so that all blades are retracted in unison.

The first column on Table I shows five screw driven concepts with a retraction ratio of approximately 1.2 to 1. These are specifically applied to propellers, which explains the low retraction ratios. The first of these, number 1,461,733, is dated July 17, 1923.

The next five concepts have retraction ratios on the order of 1.7/1.8 to 1. They are specifically applied to helicopter rotors and use one telescoping and one rigid segment. Patent 1,922,866 first introduces the helicopter rotor with telescoping blades. Patent 2,145,413 adds safety devices to disconnect power to the screw mechanism when the limits of extension and retraction have been reached. Patent 2,163,482 introduces a method to drive the retraction screw in an articulated rotor by using a universal joint in the screw drive mechanism at the point where it passes through the articulation hinges. Patent 3,297,094, which is assigned to Boeing, shows a method to vary blade twist with diameter.

Sikorsky's TRAC is presently undergoing development and testing. In this design, which is applied to a fully articulated rotor, the jackscrew is used as the primary tension member of the blade. The outboard blade segment is the main lifting member and telescopes over the inboard segment. The inboard segment is a torque tube which encloses the jackscrew, transmits blade pitch control motion to the outboard blade, and carries bending moments across the sliding joint.

The final example of screw driven telescoping blades uses more than one telescoping segment to achieve higher retraction ratios. The screw drive mechanism is complex, with a separate screw and nut within each segment with an interconnection scheme between all of them.

The most popular method proposed for retracting telescoping blades is by using CABLES or STRAPS. A total of 24 concepts using this type of retraction have been found in the literature. The first of these, patent no. 1,922,866, is dated August 15, 1933 and shows a three segment blade. One cable is used per blade, attached to the outer blade segment. This cable is wound on a drum within the rotor head for retraction. Resulting retraction ratio is 3 to 1.

Patent 2,510,216 shows a variable diameter propeller using cables for retraction. Here the blade is attached through a helical ball spline so that the blade pitch varies during diameter changes. As with other propeller designs, this scheme achieves only a small retraction ratio.

The next column list six concepts using one telescoping segment and one fixed segment and having a retraction ratio of 1.7/1.8 to 1. All of these show the outer segment having a smaller chord than the inboard, with the outer telescoped within the inner for retraction. Patent 2,684,212 is concerned with a stowed rotor type of aircraft and replaces the inner segments with a large disc wing into which the blades are retracted. This disc has a diameter equal to one half of the extended rotor diameter and serves as the only fixed wing surface during high speed flight. This 1954 patent was assigned to Piasecki Helicopter Corporation.

Patent 3,128,829 is the patent upon which the Bell VDR is based. The inventor is Arthur M. Young. The patent shows the cable drums and the rotor hub both driven by the aircraft propulsion unit through planetary gearing to give the rotor an automatic retraction feature. When the drum torque exceeds the blade centrifugal force, the blade is automatically retracted. When it does not, the blade is automatically extended. The drum can also be controlled manually by the pilot, if desired.

The Bell VDR modifies this concept somewhat in that the rotor hub is supported on bearings on the rotor shaft and is not powered. This also provides the automatic blade retraction feature when rotor driving torque exceeds blade centrifugal force. Bell has designed, constructed, and tested a 25 foot diameter three bladed VDR rotor system, which reduces to 15 foot diameter when retracted.



Two different methods have been found to further increase the retraction ratio for cable controlled telescoping blades. The first of these is the obvious solution of dividing the blade into more segments. The second method has only one telescoping segment, but it telescopes beyond the centerline of the rotor to achieve a 3 to 1 retraction ratio. This is shown in patents no. 1,922,866 and 2,464,285, which use two bladed rotors. When retracted, one blade is nested above or beside the other.

Patent 2,749,059 is assigned to Vertol and uses two telescoping segments retracted within a third rigid segment. It also discusses a method to use the kinetic energy of the rotor to provide the power for blade retraction.

The remaining two design, patents 2,852,207 and 2,989,268, extend the above concepts. Both use two segment blades and retract the blade segments beyond the rotor centerline to give the 3 to 1 retraction ratio. The first patent retracts the blades into a center disc wing, the second patent discussed how this type of rotor could be tip driven.

Retraction ratios higher than 3 to 1 are also proposed for cable controlled telescoping rotors. These use many blade segments and as such tend to be complex. Numbers 2,108,245; 2,120,168, and 2,173,291 are all by the same inventor. The first shows the retracting cable wound around a spring loaded drum to automatically retract the blades as the rotor is slowed down. Each of the blade segments is rigid, with a flexible joint between them to give the blade flexibility. Each blade is controlled by one cable mounted to the outboard section. During retraction each segment is fully retracted within the next most inboard segment before this next segment retracts. The second patent introduces separate cables to each individual blade segment that are wrapped around different diameter drums in the rotor head so that all segment telescope together, i.e. when the blade is retracted half way, each segment is retracted half way into the next segment. This patent also introduces a cyclic telescoping feature where the blades would retract and extend once per rotor revolution. This is proposed as an alternate to the blade cyclic pitch variation normally used to balance the rotor lift during forward flight. The third patent is an extension of the previous two to cover counterbalanced single bladed rotors.

Patents 2,457,376; 2,458,855; 2,523,216; 2,637,406; 2,640,549; 2,713,393, and 2,717,043 are all by the same inventor. They are all involved with the same basic idea of using a multisegment, cable controlled, telescoping blade which after retraction can rotate about a vertical hinge to further reduce its retracted diameter. The individual patents are concerned with the details of blade construction.

The last two ideas in this section, 2,776,017 and the Kaman Rotochute, are specifically applied to rotor parachutes which extend while airborne but do not retract. The Kaman Rotochute combines telescoping blades with an out of plane fold feature. The blades are trailed in a folded position until the rotor is spun up. Then they fold out 90° to form the rotor disc and the individual blades telescope out to increase the rotor diameter.

Two patents have been found which show a HYDRAULIC RETRACTION method. Both of these are applied to propellers and therefore have a small retraction ratio. The first of these, patent no. 2,002,712, proposes the use of both compressible and incompressible fluids. The blade diameter is extended under centrifugal force and as it extends the outward radial movement of the blades expels an incompressible fluid. This fluid is used to compress a second fluid which is stored and then used to retract the blade inwardly when the propeller is slowed down and centrifugal force is decreased.

Patent no. 2,372,350 uses an incompressible fluid and introduces a feature to vary blade pitch automatically with rotor diameter.

RAK AND PINION GEARING has also been proposed for telescoping propeller and rotor blades. Because the length of the rack must equal the total blade retraction distance, it is difficult to apply this method to rotors having large retraction ratios. Of the four concepts found, three were for propellers and had retraction ratios of less than 1.5 to 1, and only one was applied specifically to a helicopter rotor. This latter patent, no. 1,969,077, is similar to the screw retraction discussed earlier. It shows a retraction drive shaft extending up through the rotor shaft to the head and out the blade. Included is a universal joint where the shaft passes across the articulation hinges. Rather than using a ball and screw assembly in the blade, this scheme shows a bevel gear which drives the pinion of a rack and pinion assembly.

The final type of mechanism for actuation telescoping rotors uses RIGID MECHANICAL RODS. The three concepts found all are applied to propellers and, like the two previous methods, have small retraction ratios. All have the blades splined on the hub with the blade radial position controlled by the mechanical rods and links. Two of these, nos. 2,380,540 and 2,404,290, have automatic features to vary diameter with driving torque and RPM. The third, patent, no. 2,442,291, uses a helical spline to vary blade pitch with diameter.

## 2. FOLDING BLADES

Folding blades also use rigid blade segments. Retraction ratios vary from 2 to 1 to 10 to 1. Maximum retraction ratios are achievable by folding the blades out of the plane of the rotor disc. These out of plane folding rotors would be difficult to apply to a practical compound helicopter; many of the examples found are applied to rotor parachutes where the rotor is extended in flight by not retracted.

With an inplane folded rotor it would be difficult if not impossible to develop rotor lift at reduced rotor diameters. The lift on a partially retracted blade would be felt as a moment about the inboard section of the blade. If conventional pitch change bearings are used inboard, this moment would have to be reacted by the blade control system.

The first example of INPLANE FOLD uses a two bladed rotor with a vertical hinge at one third of the blade radius. For retraction the blade is folded about this hinge approximately  $160^\circ$  to give a 3 to 1 retraction ratio. Both patent number 2,464,285 and the Hiller Retractable Rotor are examples of this.

The Ryan Disc Rotor is similar in concept. It uses three fully articulated blades and a large disc-shaped centerbody into which the blades are retracted during the high speed mode of flight. This centerbody shields the blades from the ambient airstream so that no aerodynamic forces are generated during rotor stopping operations. To retract the blades the rotor hub is rotated approximately  $90^\circ$  within the centerbody. The blade folds about a vertical hinge and is pulled in through a slot in the centerbody. The Ryan patent also mentions a feature whereby the blades " . . . are counterbalanced about their swing axes to minimize retraction loads while the rotor is rotating".

The four inplane folded rotors shown with higher retraction ratios are all by the same inventor and use inplane fold in conjunction with telescoping rotor blades. The inplane fold feature gives a retraction ratio of 2.5 or 3 to 1 with the remainder of the retraction achieved through telescoping the blades.

The rotors using OUT OF PLANE FOLD are not proposed for applications where the rotor extends and retracts in flight. Patent 2,021,470 and 2,869,649 use out of plane fold to reduce rotor diameter on the ground for aircraft stowage. The first uses two blade segments, the second at least four which are folded out of plane so that they are stored horizontally on top of each other. As the rotor is spun up, centrifugal force extends the rotor to its full diameter. There is no operation proposed at any intermediate rotor diameters.

The next three concepts are for rotochutes which extend but do not retract in flight. The Kaman Rotochute and the General Electric Rotochute both use the same concept, combining out of plane fold with telescoping blades to achieve maximum retraction ratios. In the stored position the blades are retracted and folded aft in a trailing position. To extend the rotor, the blades are folded  $90^\circ$  to form the rotor disc, and as it is spun up, centrifugal force telescopes the blade out to a maximum diameter.

The Ryan Flyball Rotor consists of two blade segments hinged horizontally together. The inboard segment is also hinged horizontally to the rotor hub. The blade segments can then be folded vertically to a minimum diameter. A tip weight is included on the outer segment. The inner section is hollow and contains a spring which hold the rotor in the folded position. As the rotor gains speed, centrifugal force overcomes the spring tension and holds the blade in the extended position.

The last three patents, numbers 2,172,333; 2,172,334, and 2,330,803, are by the same inventors. Here a many segmented blade is shown with horizontal hinges between each blade segment. For retraction these segments are wound on a hexagonal drum within the rotor head.

### 3. FLEXIBLE BLADES

The final type of variable diameter rotor uses flexible blades. The majority of these retract the blades by winding them on drums within the rotor head. This leads to minimum retracted rotor diameters and maximum retraction ratios. Due to their extreme flexibility and lack of torsional stiffness, all of these concepts have difficult control and dynamic problems. They promise to be mechanically simpler than other types of variable diameter rotors, if solutions can be found to these problems.

The first of these concepts uses THIN FLEXIBLE BLADES with low modulus materials so that they can be wound on the drums. Blade thicknesses are on the order to two to four percent of the blade chord. Dr. David S. Jenney has investigated this type of rotor system at both Sikorsky Aircraft and the United Aircraft Research Labs, and his work has included the design and testing of various rotors and an initial attempt to develop a practical control system. Similar concepts are shown in ten other patents. Patent 2,614,636 includes a method to stiffen the blade chordwise by using longitudinal wires or straps. Patent 3,065,799 covers these type of rotors with propulsion units on the blade tips. It also proposes various blade control schemes using control surfaces mounted on these propulsion units, control tabs on the blades themselves, or by varying the angle of incidence of the tip of the blades with respect to the propulsion units.

Patent 3,188,020 introduces a method to put chordwise tension in the blade. This is done by supporting a tip weight with catenary cables in the leading and trailing edges of the blade. The leading and trailing edges of the blade are concave in the plan view so that tension in the catenary cables places the blade membrane in chordwise tension.

Patent 3,120,275 shows a flexible rotor using the Magnus effect. The blade is made up of cylindrical sections which are rotated about their longitudinal axes to develop lift. For retraction the blade is wound on a drum within the rotor head.

A reference has also been found to a "VIDYA FLEXROTOR" which uses the same concept. This was a news release dated May, 1961, and no further information has been found on it.

A variation of the roll up rotor uses PNEUMATIC BLADES that increase their thickness when extended. This gives them better aerodynamic characteristics and increases their rigidity while still allowing them to be wound on small diameter drums. Patents 3,184,187 and 3,298,142, both by the same inventor, show a blade made up of two resilient sheets joined at their edges, with collapsible spars between them. With the spars deflated the blades are very flat and can be rolled on the drum within the rotor head. As the blades are extended, the spars are pressurized to give them thickness and improve their aerodynamic and dynamic characteristics.

A Goodyear patent, number 2,967,573, constructs the entire airfoil of airtight fabric. As in the previous idea, when the blade is deflated it can be wound on a realistically sized drum and when inflated it has stiffness and a reasonable shape. The shape of the pressurized blade is held by "... a plurality of flexible, substantially non-extensible threads in a number between about 25 and about 100 per square inch positioned in substantially parallel relationship inside the envelope and extending substantially vertically between and connecting the top and bottom surfaces of the envelope."

Patent 3,362,665 shows a similar concept applied to a rotochute.

The next type of flexible variable diameter rotor folds the blades ACCORDION fashion. Patent 2,616,509 uses this feature with rigid struts and pneumatic pressure to hold the desired shape. Patents 2,996,121 and 2,969,211 are somewhat similar to the roll up rotors. They have a blade tip weight supported by two cables with a flexible aerodynamic surface supported at various points along the length of the cables. To retract the blade, the cables are wound on a drum while the flexible outside shape folds accordion fashion into a cuff assembly at the root end of the blade.

A further patent, no. 3,321,020, has been found which considers accordion type fold. It shows a blade where only the outside airfoil shape is retracted; the rigid spar cannot retract. The idea is to reduce the blades response to aerodynamic forces without the complication of a completely retracted blade.

The final concept shown on Table 1 is the INTERNAL RETRACTING FLEXIBLE ROTOR. This is a new concept that was conceived of during this phase of the study, and is shown in Figure 1. This unique variable diameter rotor concept has a rigid inboard segment into which the outboard flexible segment is retracted. A retraction cable is attached to the tip of the flexible segment so that when the cable is reeled in, the tip is pulled inside the inboard segment. When fully contracted, the tip would be near the rotor centerline and the retracted rotor would have a diameter of one half the original diameter.

A three bladed rigid type rotor system is shown in Figure 1 with the blades having both tapered planform and thickness to facilitate retraction. The outboard segment obtains its stiffness from the centrifugal force generated by the tip weight and in part from the inflated wall construction as shown in section AA.

The major problem area appears to be holding the required airfoil shape on the outboard flexible segment. Because of the retraction scheme, drop threads cannot be used between the upper and lower surfaces. Figure

1 shows the airfoil shape being held by the pneumatic blade skin. Other problem areas are similar to those connected with the other flexible blade systems, such as stability and control. The short span length of the flexible section should help to moderate these effects. Stability during retractions, when the cable has relieved the centrifugal input of the tip weight, is also a concern. The inboard half of the blade could conceivably be made of conventional rigid construction.

	1.5	2
<b>I. Telescoping Blades</b>		
Method of Retraction:	1,461,733 <sup>(1)</sup>	1,922,866
A. Screw	1,957,887	2,145,413
	2,403,899	2,163,482
	2,403,946	Sikorsky TRAC
	2,457,576	3,297,094 (Vertol)
B. Cable or Strap	2,510,216	2,021,470
		2,110,553
		2,465,703
		2,684,212 (Piasecki Disc Rotor)
		Bell VDR (2)
		3,128,829(2)
C. Hydraulic		
1. Compressible	2,002,712	
2. Non Compressible	2,002,712	
	2,372,350	
D. Rack & Pinion	1,077,187	1,969,077
	1,922,866	
	2,979,238	
E. Rigid Mechanical Rods	2,380,540 <sup>(2)</sup>	
	2,404,290 <sup>(2)</sup>	
	2,442,291	
<b>II. Folding Blades</b>		
A. Inplane Fold		
B. Out of Plane Fold		2,021,470
<b>III. Flexible Blades</b>		
A. Roll Up Rotor		
1. Thin Flexible Blade		
2. Pneumatic Blade		
B. Accordion Rotor		
C. Internal Retracting Rotor		(New Concept)

(1) Numbers refer to U. S. Patent Numbers

(2) Automatically operated with Rotor Torque or RPM

# TABLE I

## Variable Diameter Rotor Concepts

Retraction Ratio  $\frac{D_e}{D_r} = \frac{\text{Extended Diameter}}{\text{Retracted Diameter}}$

3

7

8

9

3,249,160

1,922,866  
2,464,285  
2,749,059 (Vertol)  
2,852,207  
2,989,268

2,108,245(2)  
2,120,168(2)  
2,173,291  
2,457,376  
2,458,855  
2,523,216

2,637,406  
2,640,549  
2,713,393  
2,717,043  
2,776,017

2,464,285  
Hiller Retractable Rotor System  
3,273,655 (Ryan Disc Rotor)

2,457,376  
2,523,216  
2,637,406  
2,717,043

2,869,649

3,616,509

meter  
meter

8

9

10

2,108,245(2)  
2,120,168(2)  
2,173,291  
2,457,376  
2,458,855  
2,523,216

2,631,406  
2,640,549  
2,713,393  
2,717,043  
2,776,017

Kaman Rotochute

2,457,276  
2,523,216  
2,637,405  
2,717,043

2,869,649

Kaman Rotochute 2,172,333  
GE Rotochute 2,172,334  
Ryan Flyball Rotor 2,330,803

Sikorsky "Roll Up" Rotor  
2,172,332 2,996,121  
2,172,334 3,065,799  
2,226,978 3,117,630  
2,452,353 3,120,275  
2,614,636 3,188,020

VIDYA FLEXROTOR

2,967,575 (GoodYear)  
3,164,187  
3,298,142 3,362,665

2,996,121(?)  
3,321,020  
2,969,211



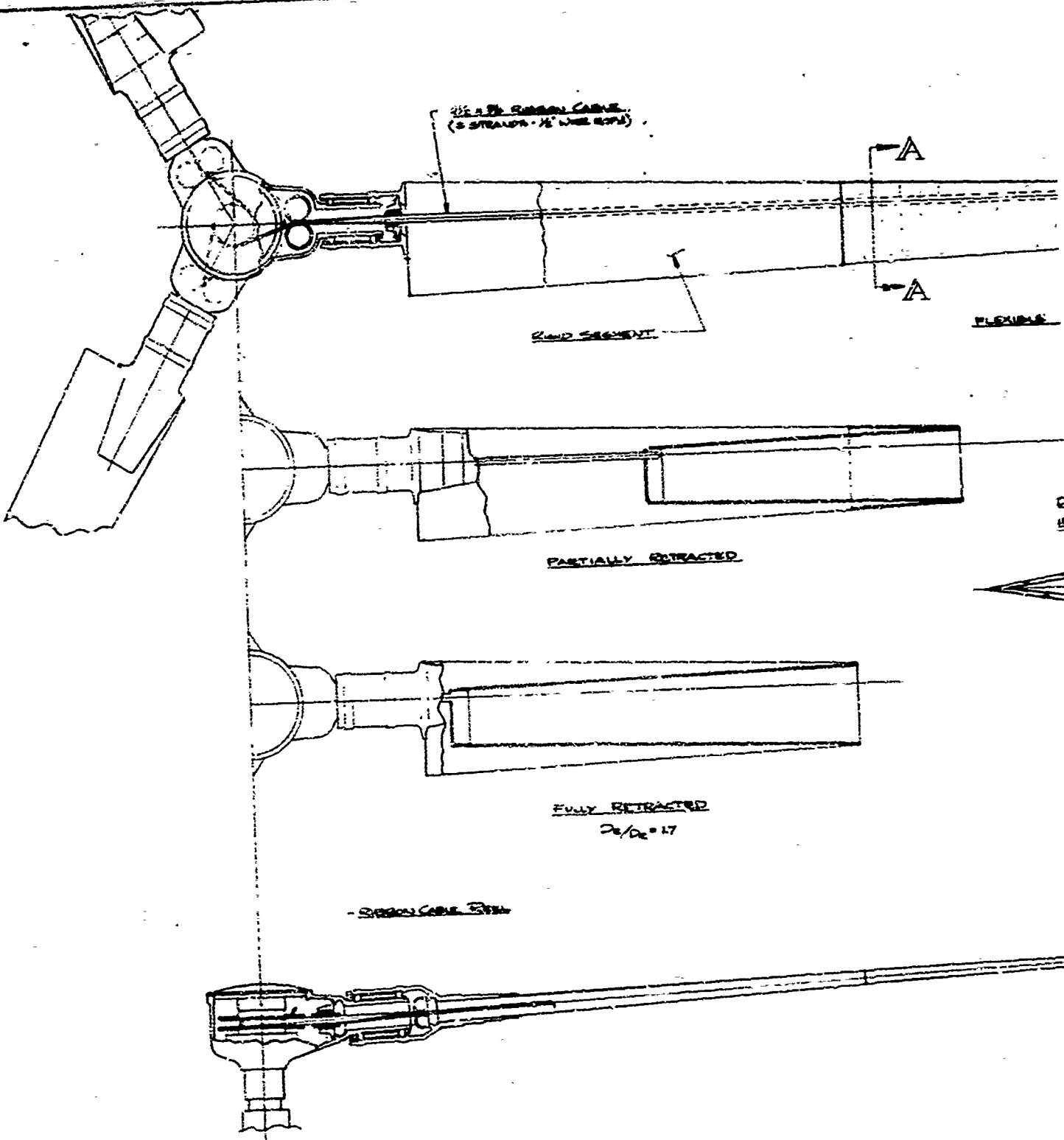

Preceding page blank

15 10

B

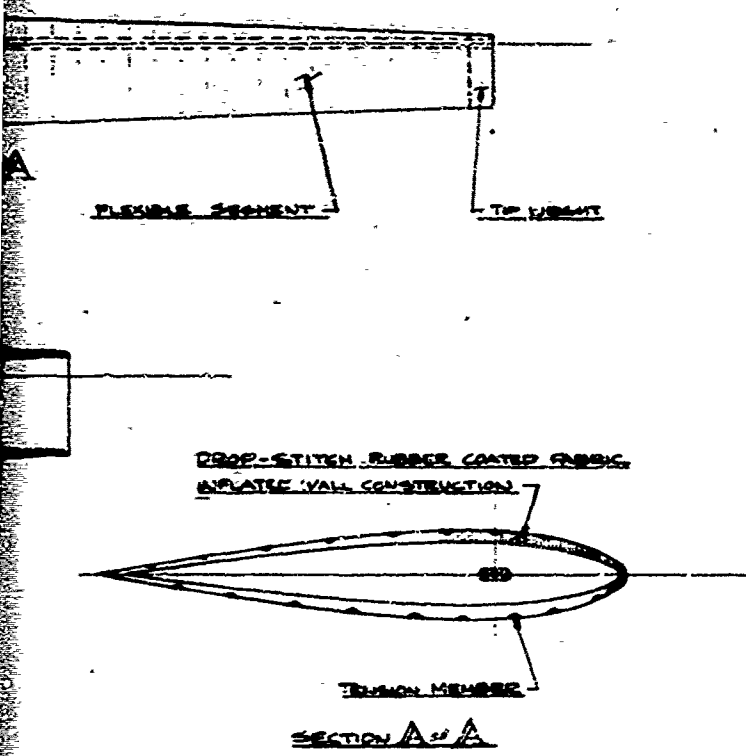

ROTOR DATA

ROTOR DIAMETER	85.4 FT
GROSS WEIGHT	12 000 LBS
DISC LOADING	1.2 PSF
TIP SPEED	780 FPS
C/C	0.90
TOTAL BLADE AREA	522 FT <sup>2</sup>
NUMBER OF BLADES	3
BLADE CHORD	3.54 FT
BLADE ASPECT RATIO	11.5
ROTOR SOLIDITY	0.083

FIGURE 1

DESIGNED BY	DATE	APPROVED BY	DATE
DRAWN BY	DATE	CHECKED BY	DATE
SCALE	1:1	PROJECT NO.	OS-507-7-5
REPORT NO.	PAGE NO.	TOTAL PAGES	13
<b>INTERNAL RETEASTING RIBBED VARIABLE DIAMETER ROTOR ROTOR SYSTEM CONCEPT STUDY</b>			
DESIGNED BY	DATE	APPROVED BY	DATE
---	---	---	---

### SECTION III

#### EVALUATION OF CONCEPTS

##### 1. TECHNICAL APPROACH

From the many variable diameter rotor concepts identified in the survey of technical literature, five representative rotor systems were chosen for detailed evaluation. These cover all three types of variable diameter rotors (those with telescoping blades, those with folding blades, and those with flexible blades) and retraction ratios from under 2 to 1 to over 10 to 1. Included are:

- Telescoping rotor, two segments,  $D_e/D_r$  of 1.7
- Telescoping rotor, eight segments,  $D_e/D_r$  of 5.0
- Folding rotor, inplane fold,  $D_e/D_r$  of 3.0
- Roll up rotor, thin flexible blades,  $D_e/D_r = 10+$
- Roll up rotor, pneumatic blades,  $D_e/D_r = 10+$

Each of these concepts has unique design characteristics with respect to performance, weight, complexity, cost, reliability, and maintainability. Since these characteristics are not themselves functionally oriented to a specific mission utilization, it is difficult to assess their relative importance. By integrating these characteristics into a total aircraft system which was sized to meet a specific mission requirement, the relative merit of each concept was evaluated by rating the total aircraft system attributes. During the evaluation phase of this study, each concept was designed for a large compound aircraft sized to perform a specific mission. A 1978-1980 timeframe was assumed. The resulting aircraft design was then analyzed with the merit rating system described below.

##### a. General Approach

Table II lists the system attributes which are important for this type of aircraft. A majority of these attributes are integrated into system cost effectiveness, defined to be the mission effectiveness divided by the total life cycle cost. Mission effectiveness is the product of mission capability, availability, and dependability, where:

- 1) Mission capability is assumed to be productivity, i.e., the product of payload multiplied by range and divided by mission block time.
- 2) Mission availability is defined as the probability that the aircraft will be available for a mission on demand. This depends largely on maintenance requirements.
- 3) Mission dependability is the probability that an available aircraft, once underway, will be able to complete its mission. This includes such factors as vulnerability and detectability.

**Preceding page blank**

Table II

SYSTEM ATTRIBUTE STRUCTURE

- I. Cost effectiveness
  - A. Mission effectiveness
    - 1. Mission capability
      - Mission payload
      - Mission range
      - Mission block time
    - 2. Mission dependability
      - Mission reliability
      - Mission survivability
      - Mission vulnerability
      - Mission detectability
    - 3. Mission availability
      - Maintainability
      - Design complexity
      - Mission reliability
  - B. Unit life cycle cost
    - 1. Unit development cost
      - Non-recurring cost
      - Fleet size
      - Required fleet effectiveness
      - Mission effectiveness
    - 2. Acquisition cost
      - Vehicle
      - Initial spares
      - Ground support equipment
      - Initial training & travel
    - 3. Operating cost
      - Crew
      - Replenishment spares
      - Fuel, oil, & lubricants
      - Maintainability
      - Design complexity
      - Mission reliability
- II. Technical risk
- III. Off-design performance
- IV. Adaptability to stowed rotor designs
- V. Growth potential
- VI. Safety
- VII. Handling qualities
- VIII. Maneuverability
- IX. Vibration
- X. Hovering downwash
- XI. Stovability/transportability

The resulting cost effectiveness, measured in ton-knots per megadollar, is a powerful measure of merit since it integrates most of the significant system attributes and can be expressed as a numerical value. Hence, it inherently weighs the relative importance of each attribute and establishes an aggregate merit score for all the attributes it encompasses.

Ideally, all system attributes should be related to cost effectiveness. Actually, some attributes do not lend themselves to quantitative analysis or would demand a depth of analysis greatly exceeding the scope of this study. These attributes were treated qualitatively and combined with the cost effectiveness number to complete the total merit rating structure shown in Table II. These qualitative attributes include:

- Technical Risk
- Off-design Performance
- Adaptability to Stowed Rotor Designs
- Growth Potential
- Handling Qualities
- Safety
- Maneuverability
- Vibration
- Hovering Downwash
- Stowability/Transportability

The total merit rating of a concept is the sum of weighted scores for all of the above attributes. These weighted scores are the product of a raw score and a weighting factor. The raw score is a relative value ranging from 0 to 1. A value of 1 is assumed to be the most favorable attainable score for a particular attribute. It was assigned to that design concept having the highest value of the subject attribute. Thus, six concepts having cost effectiveness values of 180, 175, 182, 200, 190, and 173 ton-knots per megadollar would be converted to respective raw scores of .9, .875, .91, 1.00, .95, and .865. If judgement is the basis of scoring, then this judgement was expressed directly as the raw score.

Weighting factors quantify the relative importance of the individual system attributes. It was assumed that a total of 100 points was distributed among the system attributes in accordance with their relative importance. These weighting points represent a perfect score, that is a design concept having perfect raw scores of 1 for all attributes would total a weighted score of 100. The distribution of the perfect score among the system attributes is a matter of judgement. Table III shows the evaluation matrix which is the end product of this type of analysis, and also shows how the score was distributed for this study. Cost effectiveness was given greatest importance since it encompasses so many of the most significant attributes. It encompasses half the total score, with the other half distributed among the remaining attributes.

Table III

EVALUATION MATRIX

Attributes	Perfect Score	Design Concept					
		A	B	C	D	E	F
Cost effectiveness	50						
Technical risk	10						
Off-design performance	6						
Adaptability to stowed rotor designs	6						
Growth potential	6						
Handling qualities	6						
Safety	6						
Maneuverability	3						
Vibration	3						
Hovering downwash	2						
Stowability/transportability	2						
Total score	100						
Ranking	-						

To develop the information required to complete this evaluation table, the concepts were first sized for a fixed aircraft design gross weight. A baseline fixed diameter compound, the Sikorsky S-65-300, was chosen for comparative purposes, and the rotors were sized for its 62,800 pound gross weight. Because of the differences which result from the various rotor concepts, these initially designed aircraft will not all perform the S-65-300 mission at the 62,800 pound gross weight. The next step was to use Sikorsky's Helicopter Trend Model and Helicopter Computer Design Model to resize each solution until it did perform the required mission.

These helicopter models produce parametric design trends of vehicle and mission attributes as functions of installed power characteristics and design criteria. The most significant variables are described in the HTM flow diagram shown in Figure 2. A design analysis establishes rotor and wing geometry for a given design gross weight within the constraints of power available, allowable disk loading, and allowable blade loading. Mission fuel was computed for the specified mission profile. Weight and cost equations with adjustable coefficients and exponents were used to obtain weight empty and costs. Analysis was adjusted for state-of-the-art technology.

A specified payload option permitted computation and trending at a fixed payload level.

**b. The Baseline Aircraft, and its Modification to Accept Variable Diameter Rotors**

The Sikorsky S-65-300 transport aircraft was chosen as a baseline since it is a modern example of a compound helicopter and its size is representative of future Air Force requirements. It is designed to perform a mission similar to the Air Force 8.5 ton V/STOL transport mission. It has a cruise speed of 250 knots and uses a 79 foot diameter, seven bladed, fully articulated main rotor. Its hover disc loading is 12.8 pounds per square foot. A general arrangement drawing of this aircraft is shown in Figure 3.

A primary objective of this study was to develop rotor systems which will permit lower disc loading, with a disc loading of five pounds per square foot a goal. At 62,800 pounds this results in a rotor with a diameter of 126.4 feet. For rotors with high retraction ratios this may be feasible. However, for rotors with low retraction ratios, such as the two segment telescoping rotor, this disc loading goal did not seem realistic. The rotors after retraction would still have a diameter of seventy feet. Therefore, two different approaches were followed. For the rotors with high retraction ratios ( $D/D_r$  of 3 or higher) an initial hover disc loading of 5 psf was assumed. For the lower retraction ratio of the two segment telescoping rotor, an initial disc loading of 10 psf was used. It was felt that this approach would lead to an objective analysis of the advantages and disadvantages of all the different concepts.

Figure 4 shows sketches of how the S-65-300 design could be modified to accept these disc loadings. Both of these aircraft are assumed to have the same gross weight as the S-65-300. Version A is the disc loading of ten solution. This is quite similar to the S-65-300; it has the rotor diameter increased from 79 to 89.4 feet. The tail rotor is slightly smaller and is moved aft for rotor clearance. The aircraft nose is extended slightly for balance.

Version B has the 26.4 foot rotor required to give a disc loading of five pounds per square foot. Because of this large rotor, it is impractical from an aircraft balance point of view to use a conventional tail rotor located aft of the main rotor disc. Mounting the tail rotor under the main rotor is difficult due to ground clearance and personnel safety. Because of this, a high disc loading variable pitch fan was used under the main rotor. These anti-torque fans are presently receiving considerable attention in the helicopter industry, and may replace tail rotors on some future helicopter designs.

It would be possible to ease the tail rotor sizing problem by using some type of torqueless rotor drive systems. However, this study was concerned strictly with shaft driven rotors.

Table IV lists the important parameters of the S-65-300 plus the initial values that were assumed for the two variations that were used for this study. It is emphasized that these are initial values only. These were allowed to change during the detailed evaluation if this was advantageous, and they also were varied from one concept to another.

The S-65-300 has a design cruise speed of 250 knots. With the variable diameter rotors, the aircraft parasite drag is the same or higher than the S-65-300, which would be expected since their rotor heads are larger and more complex. With the rotors retracted, the overall lift to drag ratio of the aircraft is improved since the rotor is providing little rotational drag and its power is substantially reduced. If the rotor is stopped, the lift to drag ratio is further improved since no power goes to the rotor and all the lift is generated by the wing. As a result, the aircraft with variable diameter rotors are able to cruise at higher speeds than the S-65-300 with no more installed power. To measure this increased speed potential, the speed capability of each variable diameter rotor concept was determined using the same installed power as the S-65-300.

The potential for the high retraction ratio variable diameter rotors is not only in providing higher lift to drag ratios in the 250 knot speed range. With the rotors retracted and stopped, rotor rotational drag and dynamic instabilities are eliminated. Efficient higher speed flight is achievable with the addition of more installed power. To assess this potential, the maximum speed of each concept was determined with the arbitrary addition of 20 percent more installed power.



Table IV

## Basic Aircraft Parameters

	Fixed Diameter S-65-300	Variable Diameter $D_e/D_r < 3$	Variable Diameter $D_e/D_r > 3$
Gross Weight	62,800 lbs	62,800 lbs	62,800 lbs
Cruise Speed	250 knots	(to be determined)	(to be determined)
Hover Disc Loading	12.3 PSF	10 PSF	5 PSF
Rotor Diameter	79 ft	89.4 ft	126.4 ft
Tip Speed, Hover	700 FPS	750 FPS	750 FPS
$C_T/\sigma$ , S.L. Std	0.090	0.090	0.090
Blade Area, Total	599 ft <sup>2</sup>	522 ft <sup>2</sup>	522 ft <sup>2</sup>
Number of Blades	7	4	2 or 4
Chord	2.167 ft	2.92 ft	4.13 ft or 2.06 ft
Aspect Ratio	18.2	15.3	15.3 or 30.6
Solidity	.1222	.0830	.0825
Anti-Torque System:			
Anti-Torque Device	Tail Rotor	Tail Rotor	High Disc Loading Variable Pitch Fan
Rotor Power, Hover	9030 HP	8080 HP	5780 HP
Rotor Torque, Hover	280,400 ft lbs	263,900 ft lbs	267,800 ft lbs
Anti-Torque Device Moment Arm	48.7 ft	53.2 ft	52.5 ft
Anti-Torque Device Thrust	5760 lbs	4960 lbs	5100 lbs
Anti-Torque Device Diameter	21.5 ft	19.9 ft	9.3 ft
Anti-Torque Device Disc Loading	15.9 PSF	15.9 PSF	75 PSF

Although not a part of this study, it would be advantageous to apply some of these rotors to stowed rotor type aircraft. It might be quite conceivable to stow the rotor system within the fuselage contour and thereby eliminate the high parasite drag of the retracted rotor system. Perhaps some combination of stowing and fairing the rotor would lead to the best solution. This would greatly increase the speed potential of these concepts for efficient high speed flight, while still providing the desired low disc loading during hover.

The S-65-300 uses a rotor hover tip speed of 700 feet per second. During cruise the rotor is slowed to a tip speed of 540 feet per second to avoid sonic speeds on the advancing side of the rotor disc. This is a speed change of 23 percent, and is achieved by varying the engine power turbine speed.

With a variable diameter rotor the tip speed will be slowed down by decreasing the rotor diameter without varying the speed of the drive system. These speed variations will be at least forty percent. It is possible, therefore, to further increase the hover tip speed without running into advancing tip Mach number effects. Since higher tip speed generally results in a lighter rotor weight, a tip speed of 750 FPS was assumed for the variable diameter rotors.

The blade  $C_T / \sigma$  value at the design hover conditions was held constant for all the rotors. For a gross weight of 62,800 lbs and 750 fps tip speed, this results in 522 square feet of blade area being required for the variable diameter rotor systems. This is achieved on the disc loading of ten rotor with four blades of 2.92 foot chord. The disc loading of five rotor was initially assumed to have two blades with a 4.13 foot chord, although four blades were also used here, if this was found to be advantageous. This use of a minimum number of rotor blades simplifies the rotor heads and tends to result in the lowest weight rotor systems.

Also shown on table IV are pertinent anti-torque system design parameters. As the disc loading is reduced, the rotor power required drops since induced power is falling. For constant tip speed, the rotor RPM is also decreasing. As a result, the rotor torque does not vary with disc loading. As the tail rotor is moved aft to clear the larger rotor, its moment arm increases and this will decrease its required anti-torque thrust. The disc loading of ten solution, with its 89.4 foot main rotor, requires slightly less anti-torque thrust than the baseline; 4960 pounds compared to 5760 pounds. Using the same tail rotor disc loading as the baseline, a 19.9 foot diameter tail rotor is required compared to the baseline's 21.5 feet.

The disc loading of five solution uses the highly loaded fan to react torque. It has an anti-torque disc loading of 75 PSF, which results in a diameter of 9.3 feet.

#### c. The Detailed Evaluation

During the evaluation phase of the study, the following specific technical areas were investigated:

- . Dynamics
- . Performance
- . Mechanical Design, Including Method of Propulsion and Control
- . Weight
- . Reliability and Maintainability
- . Acoustics

(1) Areas of Investigation

(a) Dynamic Analysis

Each rotor design concept was investigated for problems with flutter, resonance, flapping and torsional divergence, control loads, and vibration. It was intended to delete any concept which could not meet an acceptable level for all of these characteristics, although this was not found to be necessary. The concepts did exhibit a significant variability in these characteristics and this was reflected in the various attributes of the merit rating system.

(b) Performance Analysis

Hover and forward flight performance analysis was used in the helicopter models to size aircraft rotors, wing, and propellers for the given set of design requirements. Critical hover performance parameters, which vary depending on the type of rotor system, include figure of merit, vertical drag, and overall hover power efficiency. Of these, the figure of merit was the most important in this study. Many rotor parameters vary, including airfoil shape, root cutout, planform, twist, tip shape, blade loading, and disc loading, and all affect the attainable rotor figure of merit.

Aircraft forward flight performance depends on parasite drag, wing requirements, and powerplant losses similar to those in hover. These were assessed for both full and retracted normal RPM operations, plus slowed and stopped operation, where applicable.

After these parameters were determined for each rotor, they were used as inputs to the helicopter computer models to parametrically determine the solution aircraft designs. For model use they were converted into the following efficiencies:

1. Rotor figure of merit ratio correction factor - The ratio of the figure of merit of the study rotor to the figure of merit of conventional rotor. This conventional rotor is assumed to have the same disc and blade areas, and a blade with constant chord and airfoil distributions. For reference, the baseline S-65-300 has a figure of merit of .653 at its design hovering condition. Because it uses a conventional blade construction, it has a figure of merit ratio correction of 1.00.

2. Vertical drag ratio - The ratio of vertical drag to hover gross weight.
3. Hover power efficiency - The ratio of main rotor hover power to the corresponding engine power.
4. Parasite drag cleanliness coefficient - The ratio of 2/3 equivalent parasite drag area to (design gross weight)
5. Forward flight power efficiency - The ratio of main rotor forward flight power to the corresponding engine power.

(c) Mechanical Design

The mechanical design segment of the study continued the effort which was done to develop the preliminary layout drawings. Components were sized so that their weights could be determined. Any required dynamic performance constraints were incorporated. The retraction mechanism was sized. Rotor control systems were also developed, again using the requirements developed during the dynamic and aerodynamic analysis.

(d) Weight

With the sizes of components determined, the rotor weight could be developed. This was done at the initially assumed size corresponding to the 62,800 pound aircraft gross weight. The computer models were then used to parametrically vary the rotor weight and other component weights over a range of aircraft gross weights so that the solution aircraft size could be determined. These models use parametric equations to estimate subsystem weights. Design parameters used in these equations include such things as total blade area for rotors, main gear box torque for drive systems, installed power for engine installations, and gross weight for airframe and subsystems, such as flight controls, hydraulics, etc. These weight equations were modified for each rotor concept to reflect the difference in baseline concept weight and/or a difference in design parameters.

(e) Reliability/Maintainability/Availability Analysis

The design complexity of variable diameter rotors, including the inherent requirement for actuating systems, has a direct impact on reliability and maintainability. The system reliability of each rotor concept was estimated and translated into an aircraft mission reliability. Maintainability in terms of maintenance - manhours

flight hour was estimated consistent with design complexity and system reliability. This maintenance burden, translated into down-hours per flight hour, was then used to assess the relative mission availability of each aircraft.

(f) Acoustics Analysis

Factors such as number of blades, rotor tip speeds, and power requirements contribute to the noise levels of each concept. These relative noise levels were assessed for each concept.

After all of the above analysis had been performed and the helicopter computer models had resized all of the aircraft to perform the mission, the evaluation of the concepts was made and the matrix table shown in table III completed.

(2) Quantitative Analysis

Mission Effectiveness was defined as the product of mission capability, mission availability, and mission dependability. Mission capability was obtained from the helicopter computer models and mission availability from the availability analysis.

Mission dependability was defined to be the product of mission reliability and mission survivability. Mission reliability was obtained from the reliability analysis but mission survivability was basically a judgement evaluation. Consideration was given to the relative impact of size and rotor configuration on vulnerability and the relative change in detectability, due to the aircraft's acoustic signature. A quantification of survivability, including the size and type of hostile threat, suppressive fire, and the interaction of visual and acoustic detectability, would require a combat theater simulation beyond the scope of this study, and all of these factors were considered qualitatively to arrive at a value for mission survivability.

Unit Life Cycle Cost is the sum of unit development cost, acquisition cost, and operating cost. These costs were estimated by a life cycle cost model which utilizes cost factors to measure variations due to size and configuration.

Unit development cost was computed as the total non-recurring cost of the system depreciated over the total number of aircraft procured:

$$\text{Unit development cost} = \frac{\text{Total development cost}}{\text{Fleet size}}$$

The total development cost of each aircraft was based on a dollars per pound factor for each rotor system and retraction mechanism, plus a weight empty function for the remainder of the aircraft. Fleet size was obtained by:

$$\text{Fleet size} = \frac{\text{Required fleet effectiveness}}{\text{Unit mission effectiveness}}$$

Fleet effectiveness was assumed as the total mission effectiveness of 100 aircraft performing the specified mission with 100% availability and dependability. Thus, each concept requires a different fleet size, depending on its availability and dependability.

Total acquisition cost is the sum of vehicle, initial spares, ground support equipment, and initial training and travel costs. Vehicle cost was estimated on a subsystem level. Dollars per pound factors were applied to all subsystems except engines, which were costed on the basis of installed power. Initial spares and ground support equipment costs were assumed as percentages of vehicle cost. Initial training and travel costs for flight crew officers, crew chief, and maintenance personnel were the product of cost factors and number of people in each category. This personnel count allowed for officer availability and maintenance personnel turnover.

Operating cost is the sum of crew, replenishment spares, maintenance, and fuel, oil and lubricants costs. Replenishment spares cost per year were assumed to be a percentage of vehicle acquisition cost. Crew cost per life cycle flight hour was assumed to be proportional to number of officers and number of enlisted men in the crew. Similarly, fuel, oil, and lubricants cost per life cycle flight hour were assumed to be proportional to average mission fuel flow. Maintenance cost per life cycle flight hour was found from the product of a cost factor and the maintenance manhours per flight hour value obtained from the maintainability analysis. The cost factors, in dollars per maintenance-man-hour, were increased over a base rate to allow for overhead support and personnel efficiency.

Once the above analysis had been completed, cost effectiveness was computed for each design concept. The concept having the highest value of cost effectiveness was assigned a raw score of 1. A proportional translation of cost effectiveness values to raw scores was then applied for the remaining concepts.

### (3) Qualitative Analysis

Scores for the remaining attributes on the evaluation matrix table were judgements based on the information developed during the technical analysis of the concepts, the type of concept, and on size effects determined from the parametric computer models. It was felt that these qualitative judgements were necessary in addition to the cost effectiveness analysis to accurately evaluate the concepts. Being qualitative, they are open to discussion. Within the limited scope of the study, no attempt was made to prove these values quantitatively.

#### (a) Technical Risk

This factor assesses the relative probability that a workable production design of the rotor concept can be developed within the time frame assumed.

(1978-1980) A concept requiring use of advanced composite materials, for example, would have greater technical risk than one using more conventional aluminum.

(b) Off-design Performance

This is a measure of the versatility of the concept in performing other than the specific design mission. For example, superior hover fuel consumption enhances capability for missions requiring extended hover periods, and superior cruise lift-drag ratio maximizes ferry range. The ability to fly with any intermediate rotor diameter between the fully extended and fully retracted extremes is an asset.

(c) Adaptability to Stowed Rotor Design

This factor measures each concept's potential for increased speed through elimination of rotor-imposed constraints. With appropriate installed power, some of the rotor concepts can significantly exceed 300 knots.

(d) Growth Potential

This attribute measures the ability of a concept to accept design modifications, such as extended blade radius, chord increase, or improved airfoil, to enhance performance, and the degree to which engine uprating can be absorbed by the rotor system to increase gross weight capability.

(e) Handling Qualities

This attribute measures the ease with which the pilot controls the aircraft. This includes such factors as the damping of the system to flight disturbances, its forgiveness of inadvertent or excessive control inputs, and the degradation of tail effectiveness due to turbulent wake from the rotor hub. The pilot attention required for rotor retraction and extension is also a handling qualities factor. Internal noise and other distracting dynamic effects, such as flutter resonance and control loads were also given consideration.

(f) Safety

The vulnerability of the rotor is accounted for in the mission dependability component of cost effectiveness in terms of the ability to sustain damage and continue the mission. Safety refers to the crew survivability and crashworthiness of an aircraft following a mission abort. For example, a damage blade tip on a flexible roll up rotor is more likely to be catastrophic than similar damage on a more rigid blade.

(g) Maneuverability

Rotor blade area was sized to provide the same hovering blade loading for all concepts. However, the various retracted rotor configurations contribute

to cruise maneuver capability to varying degrees. The speed with which rotor diameter can be changed also affects acceleration/deceleration capability.

(h) Vibration

This factor measures the relative cockpit and cabin vibration levels. Number of rotor blades and susceptibility to aeroelastic flutter were significant conceptual considerations.

(i) Hovering Downwash

This attribute relates primarily to the relative disc loadings of the various concepts. Since downwash severity is related both to velocity and mass flow, gross weight was also a factor.

(j) Stowability/Transportability

This is a measure of both the size to which the configuration can be packaged, and the conversion time required.



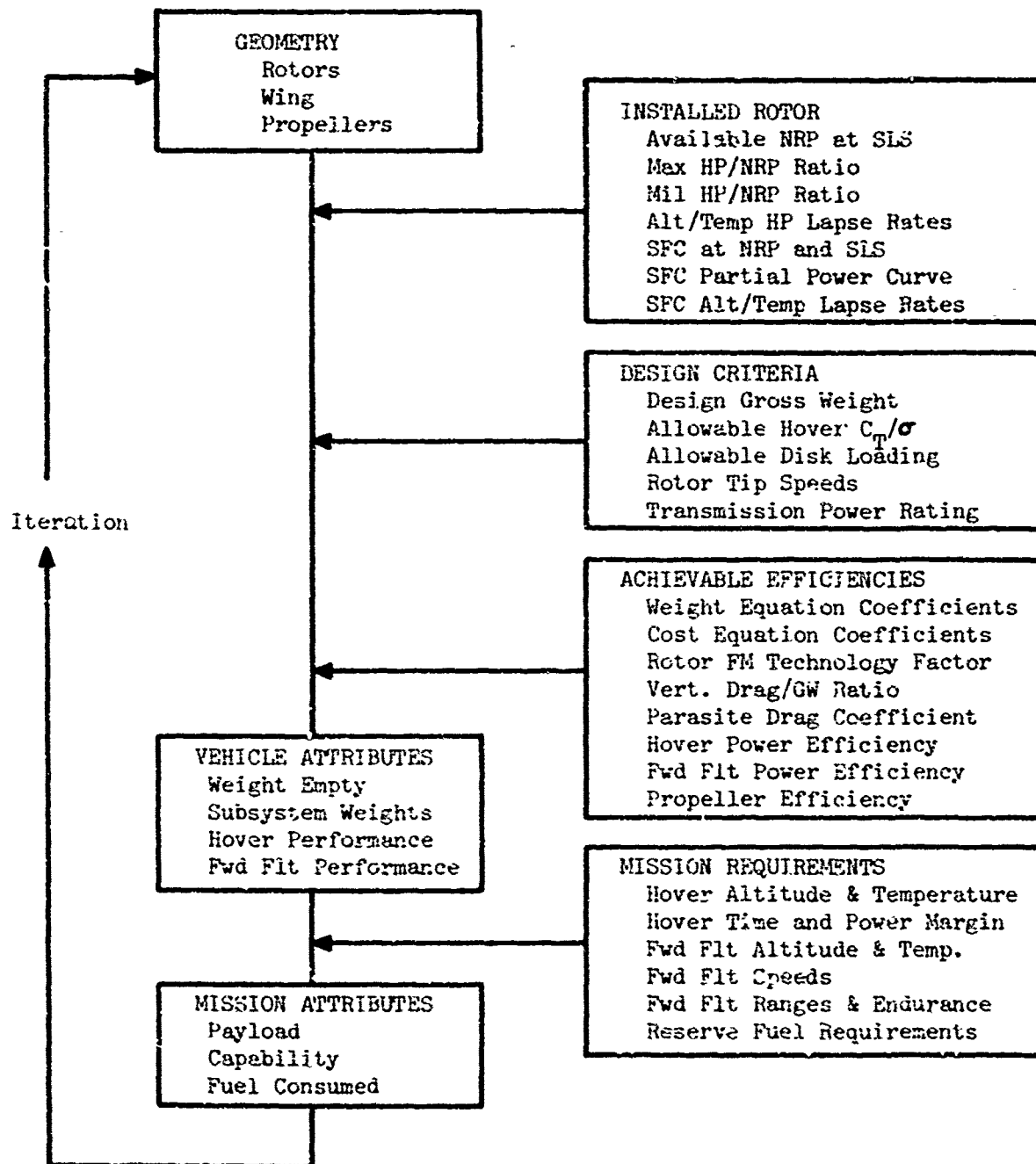
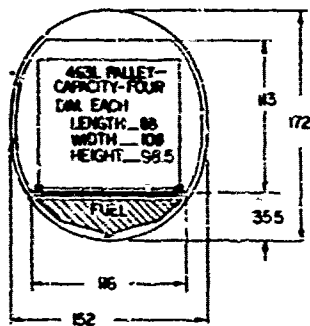
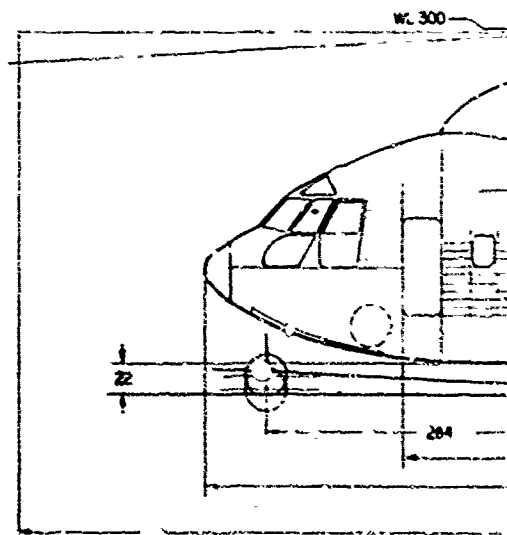
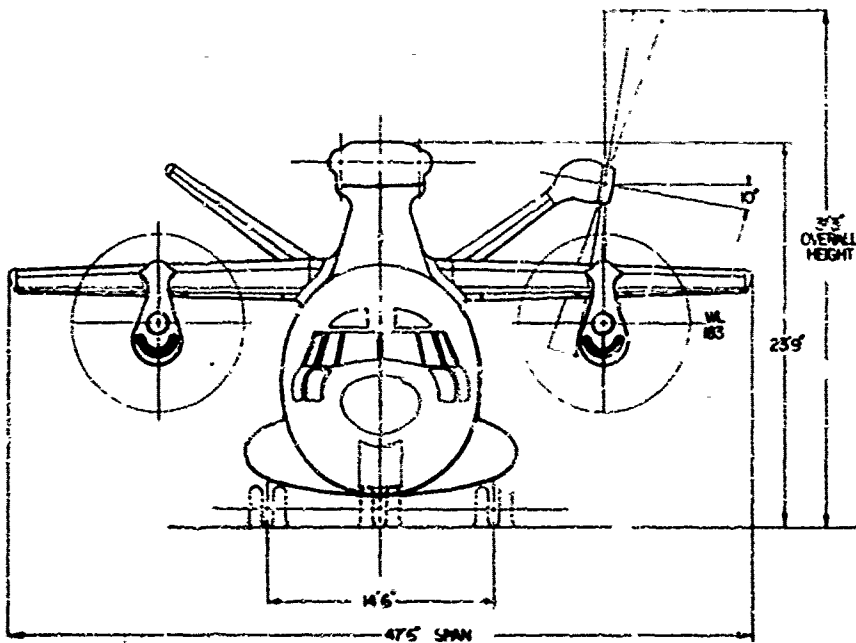
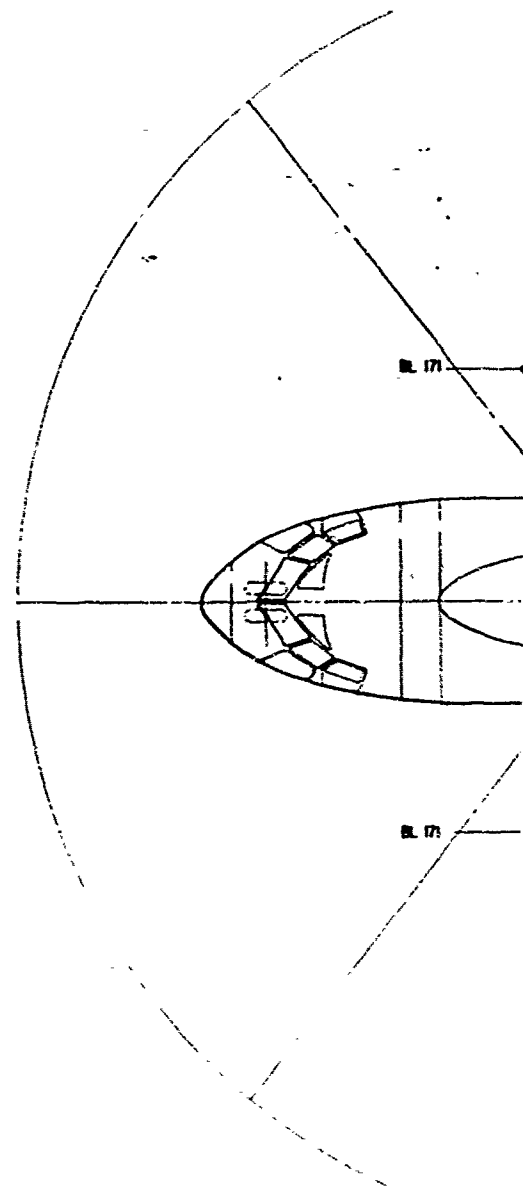

Figure 2

Helicopter Trend Model Flow Diagram



CADN. SECTION



Preceding page blank

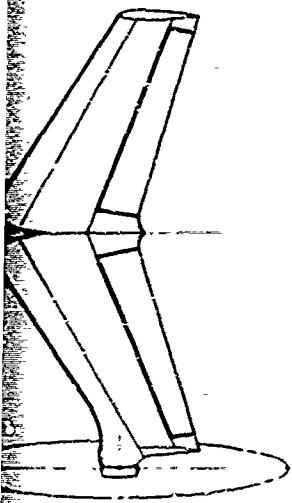

**MAIN ROTOR**  
 DIA 79'0"  
 BLADES 7  
 CHORD 26"  
 SOLIDITY 32

**TAIL ROTOR**  
 DIA 24'6"  
 BLADES 4  
 CHORD 25.25"  
 SOLIDITY 23

**PROPELLER**  
 DIA 15'0"  
 BLADES 4

**ENGINES**  
 (2) LYCOMING LTC4V-1

**WING**  
 SPAN 47'6"  
 AREA 475 FT<sup>2</sup>  
 ASPECT RATIO 4.75  
 TIP/ROOT CHORD 4/63  
 AIRFOIL NACA 63/45  
 INCIDENCE 8.5°

**EMPELLAGE (V-TAIL)**  
 AREA 250 FT<sup>2</sup>  
 ASPECT RATIO 4.45  
 TIP/ROOT CHORD 5/50  
 AIRFOIL - ROOT NACA 008  
 - TIP NACA 005

**FUEL SYSTEM**  
 INTERNAL CAPACITY 867 GAL

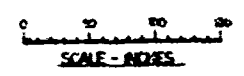
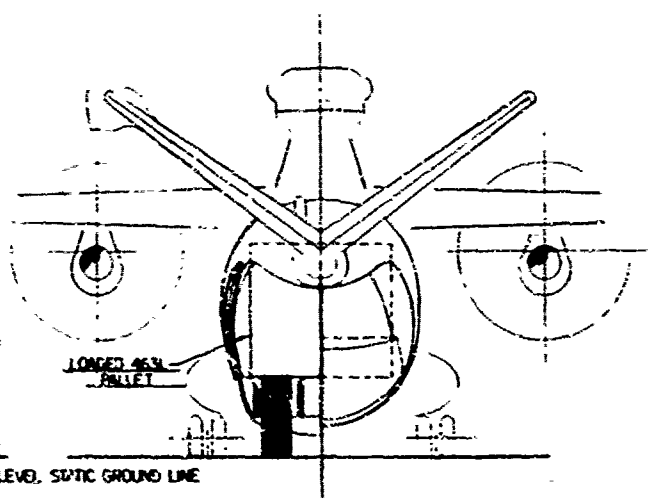
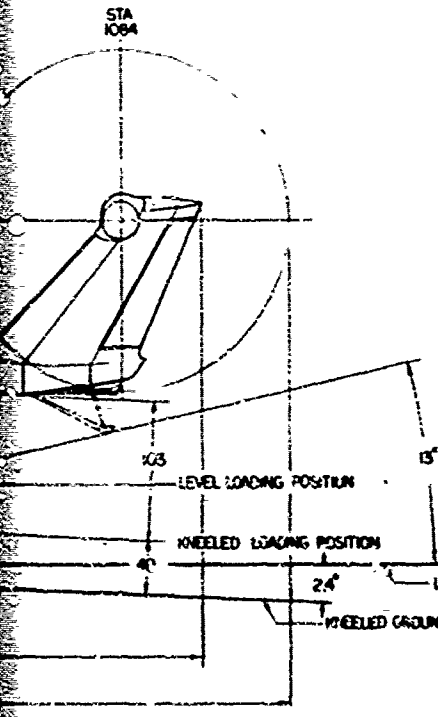

**FIGURE 3**

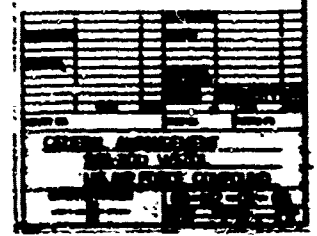

Preceding page blank

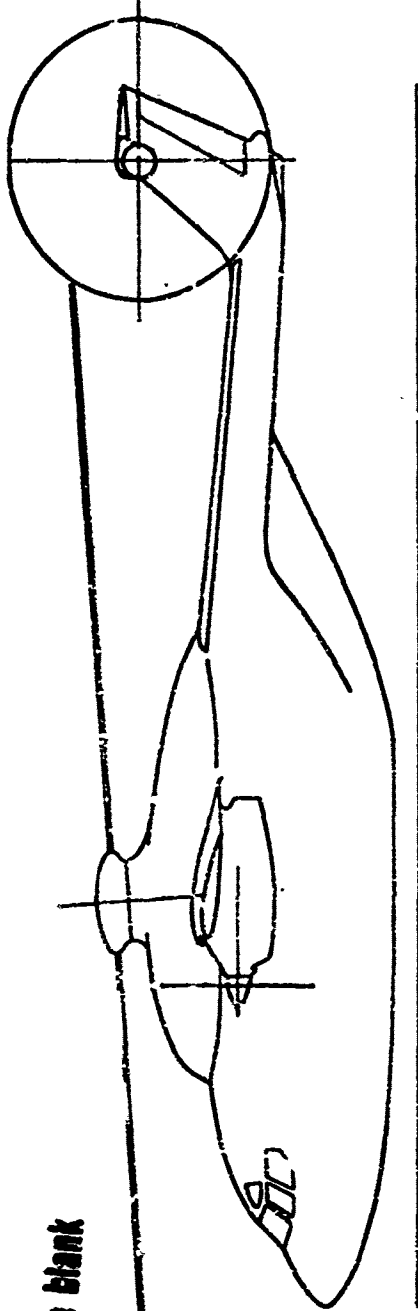

GW = 62,800 lbs  
Rotor Dia. = 89.4 ft

A. 10 PSF HOVER DISC LOADING

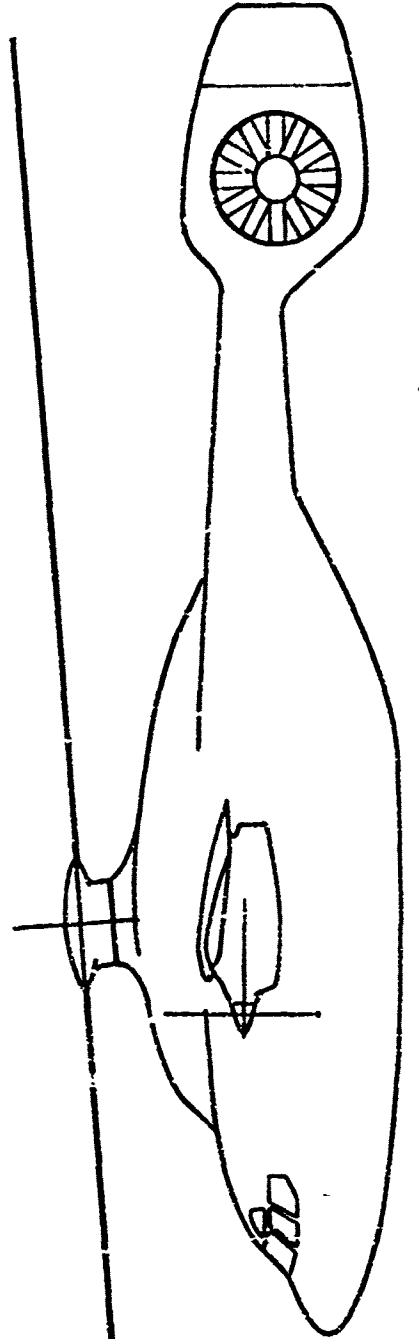

GW = 62,800 lbs  
Rotor Dia. = 126.4 ft

B. 5 PSF HOVER DISC LOADING

Figure 4

GENERAL AIRCRAFT DESIGNS WITH VARIABLE DIAMETER ROTORS

## 2. GENERAL AERODYNAMIC ANALYSIS APPLICABLE TO ALL CONCEPTS

The conventional helicopter is limited to approximately 200 knots forward flight speed by a rapid increase in rotor power and control restraints. Power is required to overcome rotor blade profile drag and rotor horizontal force (H force), while providing lift and propulsion. The compound adds small wings and auxiliary propulsion to reduce these rotor forces and increase flight speeds above 200 knots. This solution requires added rotor power or propulsive force as speed increases. In addition, rotor rotational speed must be reduced at these speeds to avoid sonic Mach numbers on the advancing rotor blades, and this RPM reduction can lead to aeroelastic problems. The promise of the variable diameter rotor is that it can produce efficient higher speed flight for the compound without these aeroelastic problems, and still provide the efficient, low disc loading hover capability of the conventional helicopter.

To understand the aerodynamics of the variable diameter rotor system, it is instructive to first investigate the power requirements of a conventional, fixed diameter compound. The baseline S-65-300 can cruise at 250 knots at 12,000 feet on a standard day. Its required power at this speed is 11,400 horsepower, which can be broken into the following components:

Rotor Horsepower	900
Propeller Horsepower	9,700
Tail Rotor Horsepower	115
Main and Tail Rotor Gear Box Losses	540
Propeller Gear Boxes Losses	45
Accessories	<u>100</u>
Total	11,400

By far, the largest component is propeller power, which is used to provide the propulsive force. Components of this propulsive force are:

Parasite Drag, Including Rotor Hub	50%
Wing Drag (Induced & Profile)	29%
Rotor Drag - H Force	<u>21%</u>
Total	100%

The desirability of a helicopter system with a stopped or retracted rotor is clear upon examination of the above numbers. Rotor retraction reduces the H force by the fourth power of the radius ratio and the horsepower by the fifth power of the radius ratio. While the extended radius of the variable diameter rotors in this study are much larger than that for the fixed diameter system to achieve the desired 5 psf disc loading, the gains achievable with retraction are still large. For a retraction ratio of 5:1, there is a reduction in power required of approximately 2500 horsepower. This can be used to save fuel or increase maximum cruise speed. Stopping the rotating system will save an additional 800 horsepower.

These reductions in power requirements will most likely be accompanied by increases in parasite drag, due to the larger size of the rotor heads. Blade stresses may also limit the speeds at which the variable diameter rotors may be operated. The retraction and stopping of the rotors removes any of these blade stress restriction on high speed performance, and permits even higher forward flight speeds.

.. Hover Performance

1) Figure of Merit

Sikorsky's Figure of Merit Ratio Method has been used to establish the basic hover performance for the variable diameter rotor systems. This method consists of establishing, based on available test data, the degree to which the theoretical maximum figure of merit is achieved for specified  $C_T/\sigma$ , solidity, and tip Mach number. The maximum figure of merit was calculated, assuming a representative blade profile drag and tip loss,

$$M = \frac{.707 C_T^{3/2}}{\frac{C_T^{3/2}}{B\sqrt{2}} + \frac{\sigma \bar{C}_d}{8}}$$

where  $B = .97$

$$\bar{C}_d = .0087 - .0216 \alpha + .4 \alpha^2$$

$$\alpha = 6C_T/aB\sigma$$

$$a = 5.73/\text{radian}$$

The ratio of actual maximum figure of merit (FMR) was established empirically by normalizing all test data to  $-4^\circ$  linear blade twist and 20% root cutout. Figure of merit ratio correction factors have been calculated to account for blade taper, non-linear blade twist, blade root cutout, and other characteristics of the variable diameter rotor concepts.

To determine the actual figure of merit for each rotor, the following procedure was used. First, a baseline figure of merit was calculated. This assumed that a conventional blade construction was being used. The disc area, blade area, number of blades, and twist were all assumed to be the same as the study rotor. In addition, chord and airfoil section were assumed constant along the blade. Linear twist was assumed, as was a conventional root cutout percentage. Next, a figure of merit ratio correction factor was determined to account for the unusual features of the variable diameter concepts, such as varying airfoils, non-linear twists, and large root cutouts. The actual figure of merit was then found by multiplying the theoretical figure of merit by this correction factor.

For reference, the baseline S-65-30 aircraft has a figure of merit of .653. Its figure of merit ratio correction factor is 1.00 and its linear

twist of  $-4^{\circ}$  and cutout of 20% were taken as the baseline for VDR hover evaluation.

## (2) Vertical Drag in Hover

The vertical drag of the S-65-300 has been calculated using the polar area moment of inertia method. This method uses the drag of characteristic shapes tested under rotors and the polar area moment of fuselage elements to obtain vertical drag. The vertical drag of the S-65-300 using this method is 6.43% of gross weight.

Because the variables associated with the variable diameter rotor concepts are not fully accounted for in the polar area moment of inertia method, a strip analysis method was selected for this study. This involves the determination of impingement velocities and drag coefficients of small fuselage and wing elemental areas. This method correlates well with the polar area moment of inertia method for the S-65-300.

### b. Parasite Drag

The variable diameter rotor concepts were evaluated for their drag contribution, based on S-65-300 parasite drag. Reference 1 and other available wind tunnel data were used, although considerable judgement was required to obtain the drag of the large hubs required to house retraction mechanisms, and large blade surfaces.

The S-65-300 has a parasite drag of 38.0 square feet of equivalent flat plate area. Of this 2.7 square feet is wing profile drag at zero incidence and 10.0 square feet is rotor head drag. In this study, wing profile drag has been considered separately in the wing section and only changes in rotor head and fuselage size are considered here. Basic drags were determined at the initially assumed gross weight of 62,800 pounds. These were then parametrically trended for other gross weights.

To illustrate the effect of parasite drag and overall lift-to-drag ratios, all of the variable diameter rotor concepts have been designed for a maximum airspeed at 12,000 feet, standard conditions, with an installed power equal to that of the S-65-300. With this power, the S-65-300 achieves 250 knots.

To bracket the variable diameter rotors, it is interesting to see how fast a conventional fixed wing aircraft could go with the same gross weight and power. Since a large part of the total aircraft drag on the compound is rotor head and pylon drag which the comparable fixed wing aircraft eliminates, it will show even more improved performance. A drag reduction of 14 square feet of equivalent flat plate area is possible, while still maintaining the same basic fuselage size. If the same wing size (475 square feet) is also maintained, the maximum speed of the fixed wing aircraft is found to be 320 knots. A wing size increase to 625 square feet, which is a minimum optimum aerodynamic size ( $C_L = .4$ ), increases the

maximum speed to 345 knots. Although these solutions look favorable, not only has vertical lift been eliminated, but take-off speeds for each of the above solutions is greater than 160 knots. If wing size were further increased to 1100 square feet, the aircraft would also have a maximum cruise speed of 345 knots, but would still require a take-off speed greater than 120 knots.

Although this study was only concerned with variable diameter rotors as applied to compounds, some of the concepts could conceivably be applicable to stowed rotor vehicles. By fairing the rotor head, or by stowing it within the fuselage contour, significant reductions would be made in overall parasite drag. This could approach the low drag of the fixed wing aircraft and still provide the VTOL flight mode.

c. Level Flight Performance

(1) General

A primary configuration constraint for most of the variable diameter rotor aircraft is the ability to transition from a compound aircraft, at the rotor's maximum or optimum speed, to a stopped rotor configuration.

Using the parasite drag values that have been determined for both rotors stopped and rotors turning, plus the rotor, wing and propeller performance characteristics, performance at the transition and high speed flight regimes was calculated. Rotor performance was generated from the Generalized Rotor Performance Method (GRP) (References 2 and 3). This computer program supplied power, drag, lift and shaft angle for input rotor collective pitch and inflow ratio. This provided all the information necessary to find the optimum total power, fuselage attitude, and wing flap deflection. This optimization gives an optimum wing/rotor lift sharing and rotor collective pitch. The propellers have been used to overcome all aircraft drag, including wing induced drag and all unbalanced rotor forces.

Transition to stopped rotor configuration has been accomplished by reducing rotor lift to zero, reducing drive system speed to 80% and retracting and stopping the rotors. The S-65-300 and the two segment telescoping rotor do not have such a transition sequence, since they do not operate in a stopped rotor configuration. Each does change tip speed with increasing airspeed to maintain an advancing blade tip Mach number of .9; the conventional aircraft by reducing tip speed, and the telescoping system by decreasing rotor radius.

(2) Wing Performance

A comprehensive analysis of the wing sizing for the variable diameter rotor concepts was necessary to properly account for each system's individual characteristics. Lift sharing between the rotor and the wing is an important consideration with these unusual types of rotor systems. They all have different forward flight dynamic and aerodynamic characteristics, and a wing design must be developed for each rotor concept to complement the rotor system. Ideally, the wing would be sized by cruise conditions only. However, if



various concepts could not maintain sufficient rotor lift in the 100 to 200 knot transition speed range, or if dynamic instabilities were uncovered, the wing capabilities had to be increased to offload the rotor lift at lower speeds. This was accomplished by using more wing area or by adding flaps.

The S-65-300 wing airfoil (63.415) and aspect ratio (4.75) were retained for this study. The results of small scale tests (Reference 1) for a scaled wing area of 475 square feet were corrected for Reynolds number and used as a base for wing performance. Flap data was synthesized using the trends of the NACA 23012 airfoil (Reference 4). Figure 5 shows the variation of  $C_{D0}$  with wing attitude for a range of flap deflections.

Figure 6 shows further characteristics of the baseline wing. Figure 6a shows the variation of lift coefficient with fuselage attitude, for a range of flap deflections. The wing incidence is 8.5 degrees with respect to the fuselage. The maximum L/D line on the curve is used to determine the most efficient flap deflection for any desired lift coefficient. It is seen the the maximum nose-up fuselage pitch attitude required to achieve maximum L/D is less than five degrees.

Figure 6b shows the incremental equivalent drag change due to fuselage pitch attitude and flap deflection. This is for the baseline 475 square foot wing. This drag change includes the effects of wing profile drag, wing induced drag, flap drag, and the incremented fuselage parasite drag due to changes in fuselage pitch attitude. These drag increments are in addition to the basic aircraft drag of 35.3 square feet. The overall equivalent drag of the aircraft may be found by adding the 35.3 square feet of basic parasite drag, the incremental drag from Figure 6b, and the equivalent drag of any rotor shaft horsepower.

To determine drag increments for wing sizes other than the baseline 475 square foot wing, the drag has been calculated by multiplying by the wing area ratio.

In sizing the wings for each variable diameter rotor concept, two specific flight conditions were analyzed. The first of these was the mission cruise segment, where the most cost effective wing size was determined. This analysis is discussed on page 141 "Wing Size Tradeoff". The second condition analyzed was the transition phase where the aircraft gross weight was transferred from the rotor to the wing. Figure 7 shows the wing trend plot that was used to analyze this transition phase. This is for the baseline gross weight of 62,800 pounds and for the 12,000 foot, 16<sup>0</sup> conditions. It plots equivalent wing drag as a function of forward velocity, for a number of wing sizes. For information, the line of zero flap deflection is shown.

The advantage of a higher transition speed is evident, since wing drag drops dramatically as forward speed increases. It is emphasized that the use of this type of analysis leads to the most efficient transition for each concept. The minimum power is determined, constrained only by the physical constraints

of the aircraft.

As an example of how this curve is used, consider a rotor system which must make a transition at 200 knots. It is seen that both the 1100 and the 900 square foot wings could support the aircraft during transition with no flap deflection. The 750 square foot wing would require only minor flap deflections, and both the 600 square foot and 475 square foot wing would require substantial flap deflections, or perhaps the use of more sophisticated high lift devices.

As the wing size is reduced, and more flap deflection is used, the wing drag increases substantially. This wing drag must be overcome by the propellers. Unless the installed power of the aircraft is increased for the transition phase, there is a finite limit to the propulsive force that the propellers can provide. This maximum thrust available to the wing prior to transition is shown as the dashed line in Figure 7. For the example of 200 knots, it is seen that any wing smaller than approximately 700 square feet would require additional installed power for the transition phase. No degree of sophistication in high lift devices would change this fact because they would increase wing drag as well as lift. Because of this match between thrust required and thrust available must be maintained, no flap deflection is required for transitions above approximately 210 knots. Below this, a combination of wing flaps and added area must be used to provide lift at transition speed.

This wing sizing is further discussed in the wing size tradeoff study on page 141. Any wing sized for the transition is not substantially greater than the most cost effective wing size for cruise. In no case is it greater than twenty percent larger than the most cost effective cruise wing.

The effect on wing size for gross weights other than the baseline 62,800 pounds is shown in Figure 8. The minimum size wing for transition speeds of 140 knots and 220 knots is shown as a function of the incremental gross weight above the 62,800 pound baseline. Wing size is again determined from available thrust considerations. A constant wing loading cannot be maintained as the gross weight increases. Instead, the minimum wing areas must be approximately:

$$\text{Wing Area} = \text{Wing Area @ 62,800 lb} \left( 1 + \frac{2 (\text{GW}' - 62,800)}{62,800} \right)$$

where the primed quantities are the final iterated solution gross weights.

The wing loading of the variable diameter concepts was also compared to wing loadings of comparable fixed wing aircraft. The wing for the eight segment telescoping rotor, for example, has a wing loading of 84 psf, similar to the DC9-10 and significantly higher than STOL or conventional propeller aircraft, that average less than 60 psf. The rotored aircraft can operate efficiently with this high loading, which reduces cruise power and wing weight, since the wing is not required to support the aircraft during takeoff and landing maneuvers.

### (3) Propeller Performance

This study used the propeller design of the S-65-300, maintaining the diameter of 11 feet. This design had four blades and a design  $C_L$  of .5. Performance was calculated from Reference 5 and is shown in Figures 7 and 10 for the operating speeds of 100% and 80% at 12,000 feet on a standard day. The propellers provide all of the aircraft propulsive force for the variable diameter concepts and, by limiting the maximum thrust for a given power available, fix minimum-transition wing size and define the maximum cruise speed for each configuration.

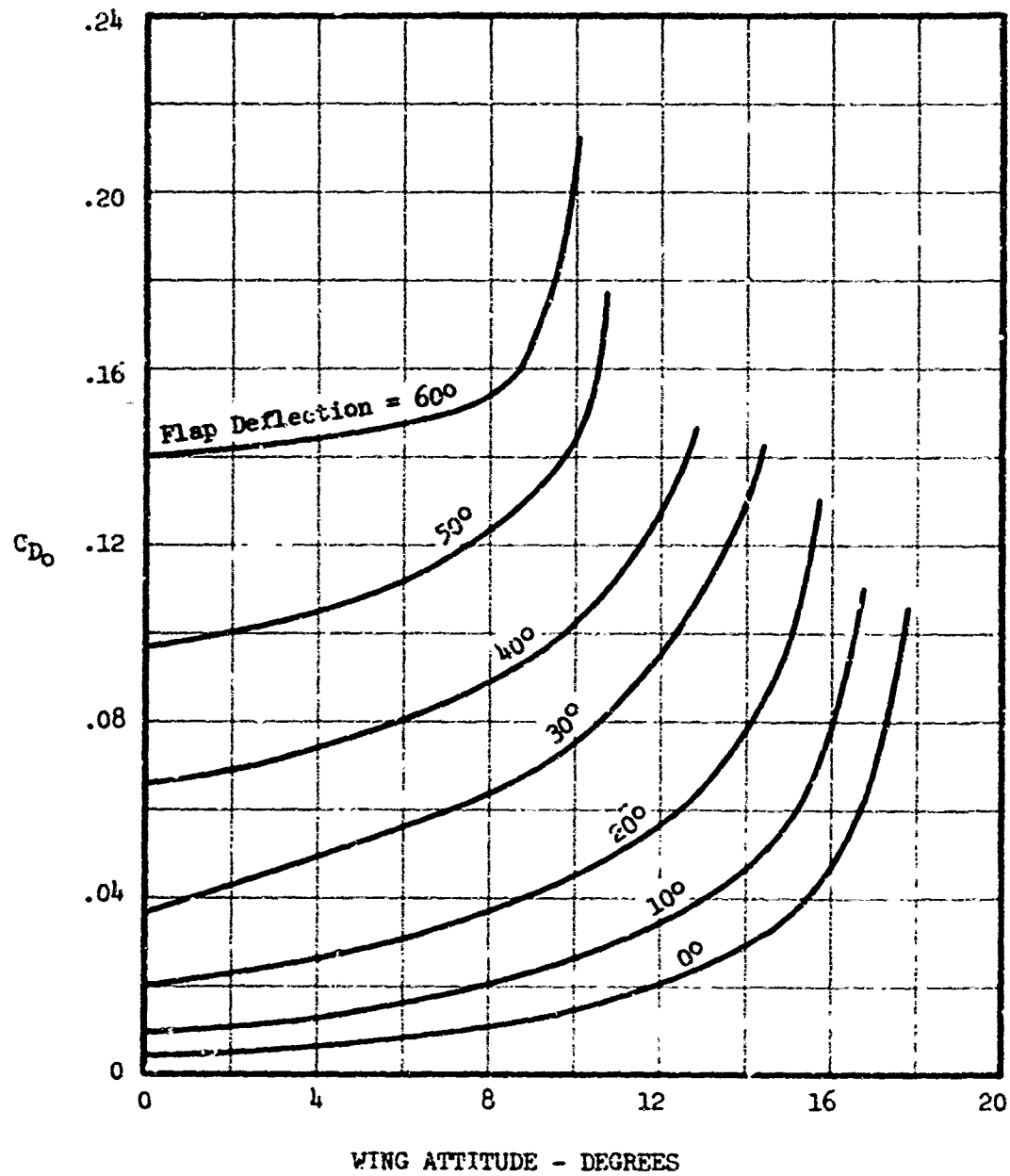

FIGURE 5  
WING DRAG VS WING ATTITUDE AND FLAP DEFLECTION

Figure 6a

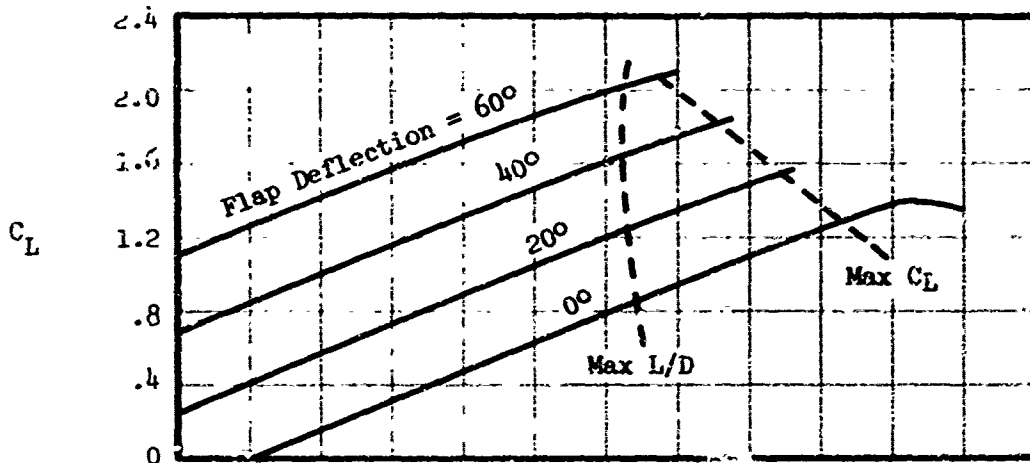
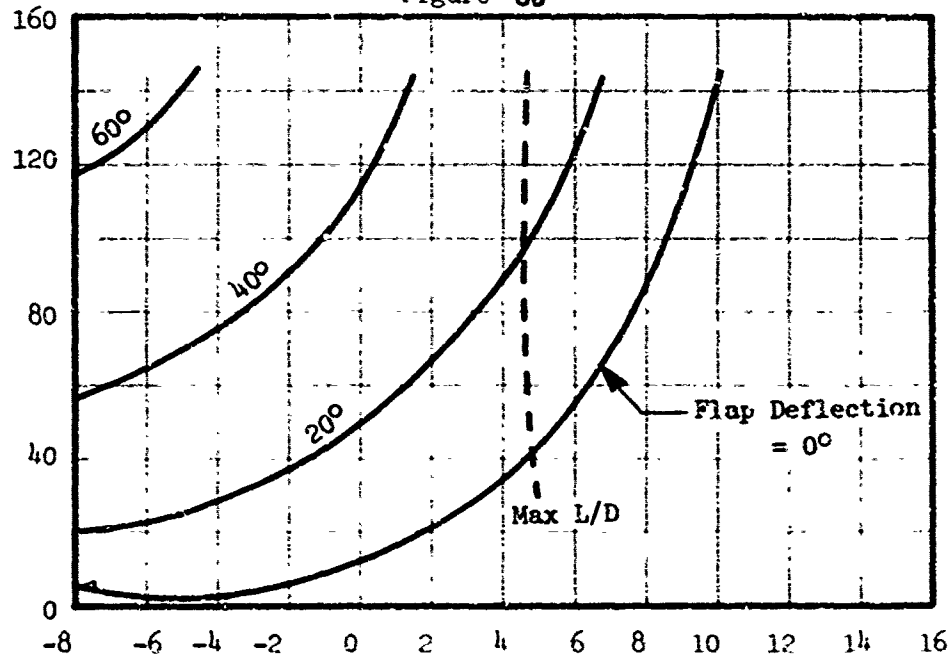

Figure 6b

$\Delta$  DRAG,  $FT^2$   
 (INCORPORATES THE EFFECT OF WING  
 PROFILE, INDUCED, AND FLAP DRAG  
 PLUS THE ADDED FUSELAGE DRAG DUE  
 TO CHANGES IN ATTITUDE)



FUSELAGE ATTITUDE - DEGREES

FIGURE 6  
 CHARACTERISTIC OF BASELINE 475  $FT^2$  WING  
 4.75 ASPECT RATIO,  $e = 0.8$   
 FLAP CHORD = 30% OVER 67% OF WING  
 WING ANGLE OF INCIDENCE =  $8.5^\circ$  WITH RESPECT TO FUSELAGE

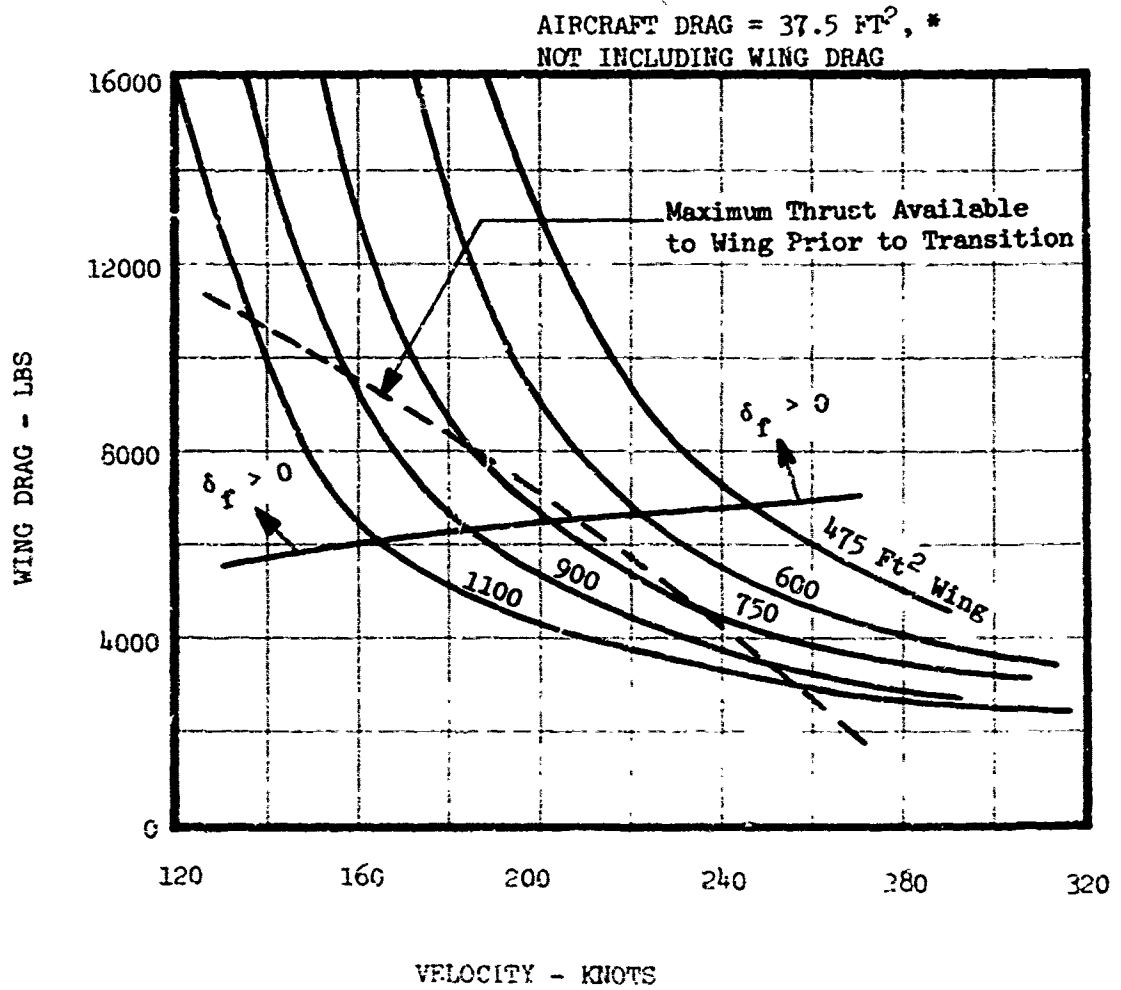

\* This is a representative drag value for these aircraft. Drag actually varies for each specific variable diameter rotor type.

FIGURE 7  
WING SIZE TRENDS  
AT 2800 LBS WING LIFT  
12000' 16°F

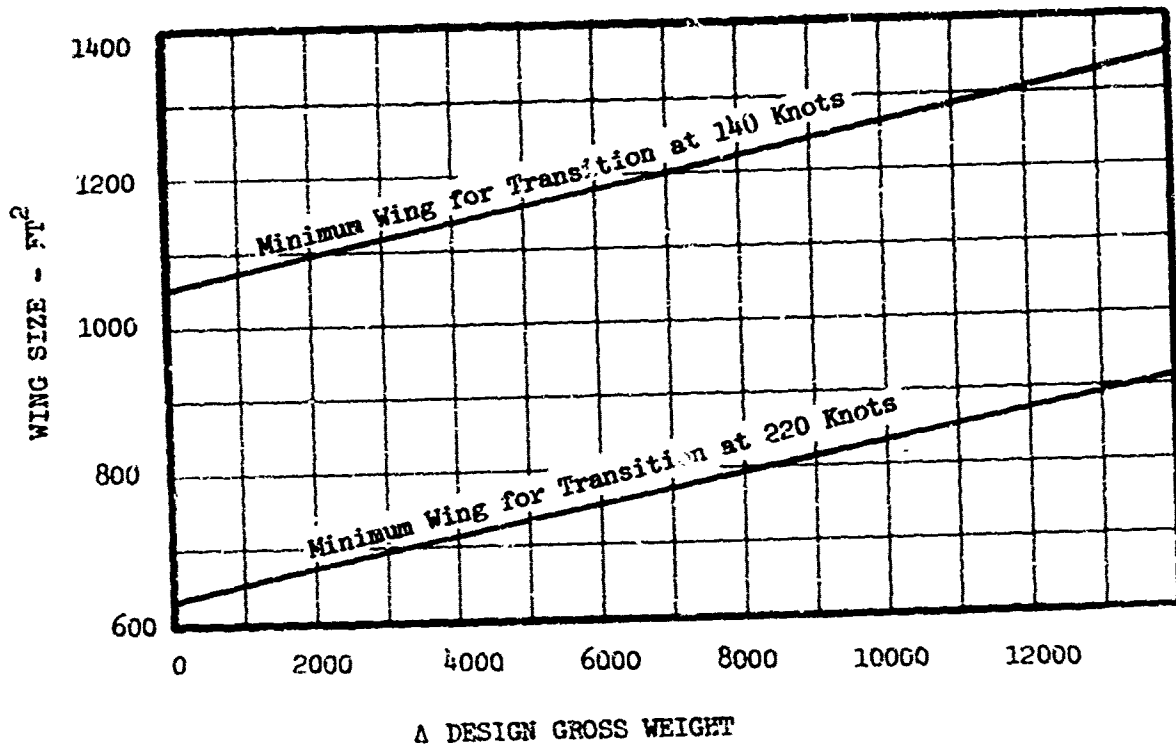

FIGURE 8  
WING SIZE TRENDS WITH GROSS WEIGHT CHANGES

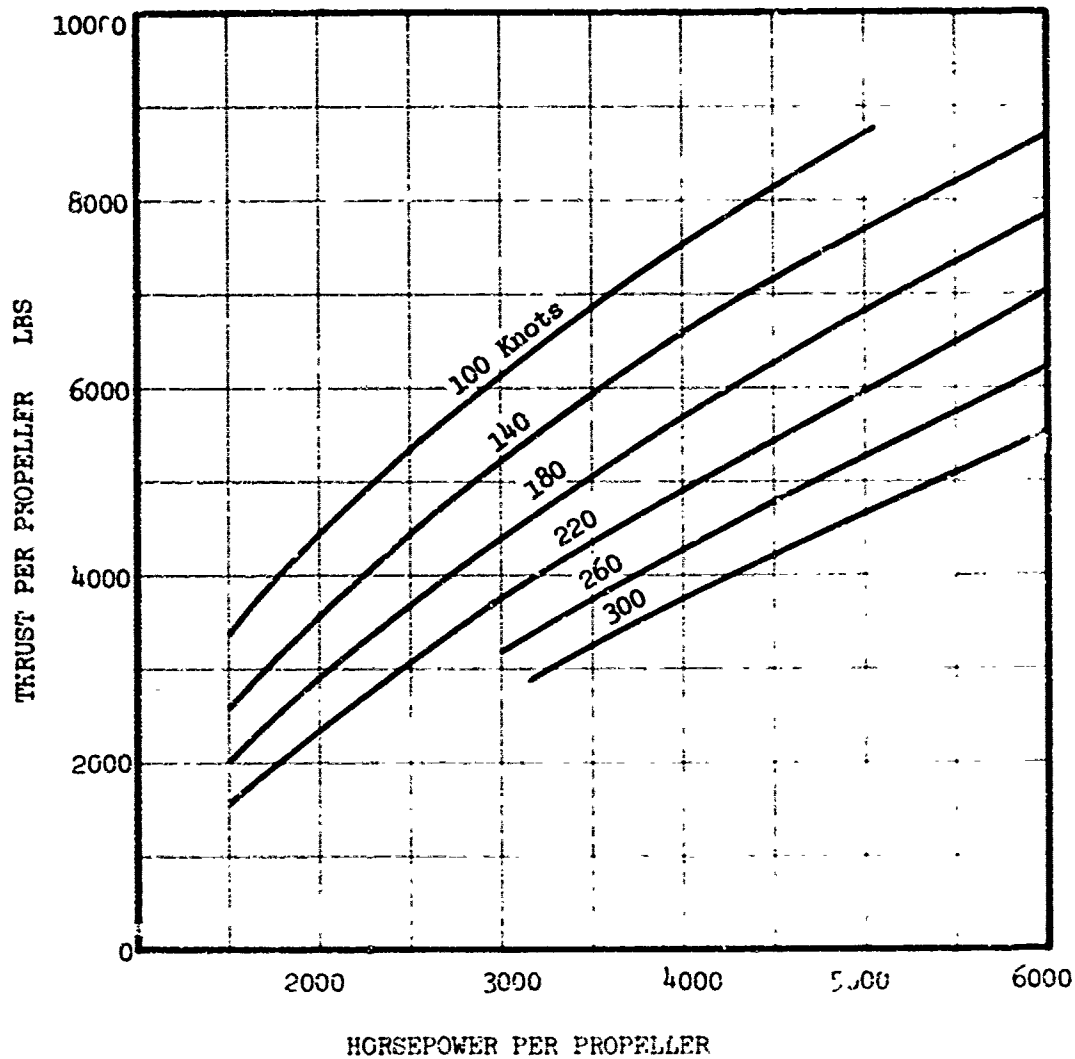

FIGURE 9  
 PROPELLER PERFORMANCE AT 100% RPM  
 12000' 16°

ND = 19630  
 DIA = 11 FT  
 b = 4

AF = 180  
 $C_{L_i} = 0.5$



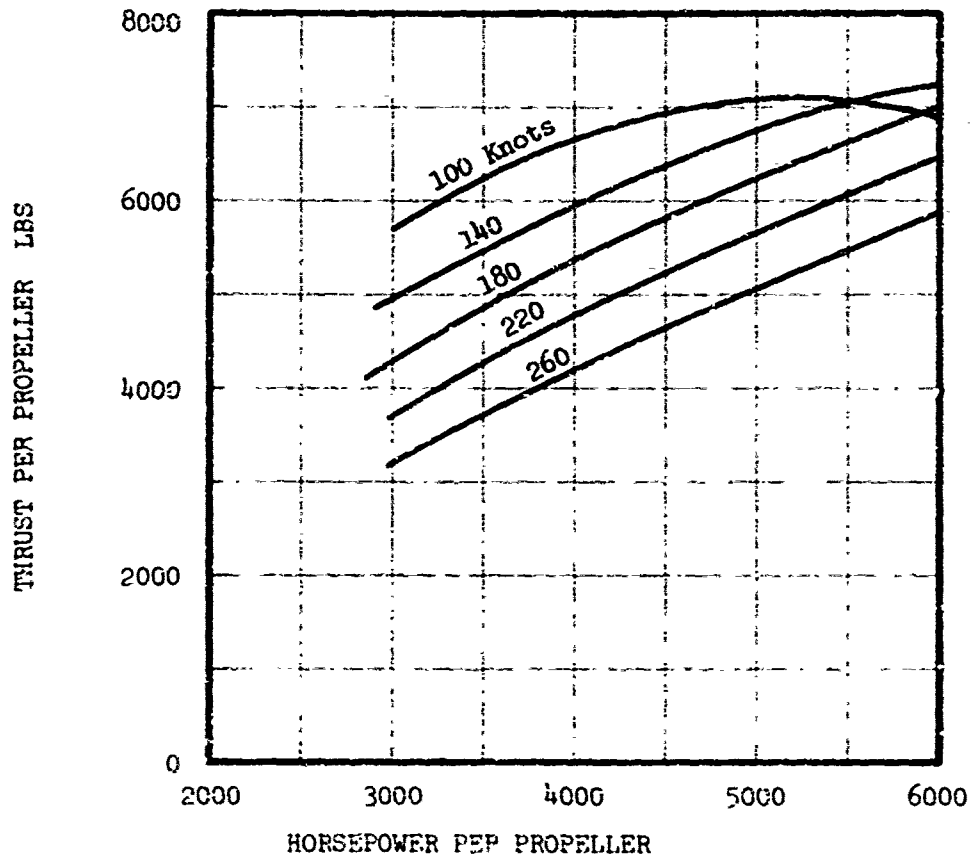

FIGURE 10  
 PROPELLER PERFORMANCE AT 80% RPM  
 12000' 16°F

ND = 15700                      AF = 180  
 DIA = 11 FT                     $C_{L_i} = 0.5$   
 $b = 4$

### 3. THE ROTOR DESIGNS AT 62,800 lbs GROSS WEIGHT

The following sections describe each rotor design in detail. Each concept was sized for the initially assumed gross weight of 62,800 pounds. By assuming this weight, actual designs could be developed and sized since dimensions and basic load requirements were known. After each design was completed, its weight and performance capabilities were determined. These were then described parametrically for alternate aircraft gross weights. The following sections discuss each concept at the initially assumed gross weight only. Section 5 discusses the resizing of the designs required to give each variable diameter rotor aircraft the same range and payload as the baseline S-65-300.

#### a. Eight Segment Telescoping Rotor

Two variable diameter rotors are presently undergoing serious development effort in the United States. These are Bell's VDR and Sikorsky's TRAC, which both use the telescoping blade approach. Both of these also use only one moveable segment that telescopes inboard, over or within a second segment. As such, they do not approach the high retraction ratios which are desired in this study. By extending these concepts to include more than one telescoping segment, the high retraction ratio can be achieved. The first concept investigated in this study is an eight segment telescoping rotor. It has a retraction ratio of 5 to 1.

Unlike some of the other rotors described in later sections, the major problems for this concept are in the design area rather than the dynamic or aerodynamic area. Most of these design problems are concerned with the blade itself. This blade must provide an airfoil section with the required structural properties and at the same time meet the constraints imposed by telescoping one section within another. This constraint prevents the use of a conventional blade design approach consisting of a load carrying spar with a non-structural trailing edge or pockets; now all the structure must be in the outer blade shell. Also, adequate support must be provided in the segment overlaps to transfer the inflight blade loads and yet permit the sections to slide during the extension and retraction cycles. These conditions must all be met within a reasonable blade weight.

(1) Mechanical Design

The eight segment telescoping rotor design is shown in Figure 11. The ROTOR HEAD chosen for this concept is a teetering type, using two rotor blades. With the large 126.4 foot diameter which is required to give the 5 psf disc loading, few blades are required to give the total necessary blade area. By using two blades, the blade aspect ratio is 15.3. Increasing the number of blades would increase this aspect ratio, and the static droop of the blade would probably be so excessive that stopping the rotor in the extended position would be impossible. In addition to the blade considerations, the use of only two blades greatly simplifies the design of the rotor head. Only one teetering bearing is required in addition to the blade pitch change bearings, rather than the flapping and lead-lag hinges that are required for each blade in an articulated rotor.

A teetering rotor has a distinct disadvantage in a conventional helicopter application, due to the high vibratory nature of the lift which is produced in forward flight. In an application to the variable diameter compound, this is not so great a disadvantage since the wing offloads the rotor as speed increases and eventually the rotor is stopped.

The blades are retracted with cables which are wound around a drum within the rotor head. A further advantage of the two bladed configuration is that it permits all the retraction mechanism to be designed into only one drum assembly within the head.

The majority of the rotor head components are constructed of titanium for high strength and low weight. All bearings are of the elastomeric type to avoid lubrication problems. In order to reduce blade coriolis moments, the blades have been underslung 45 inches below the teetering axis.

A blade control linkage has been developed to permit accurate blade pitch control independent of the rotor teetering motion. This is done by passing the linkage through a joint which is on the blade teetering axis, so that teetering motions do not introduce unwanted inputs to the control system.

The BLADES are also constructed of titanium. A tapered planform has been chosen to permit one section to telescope within another, sliding on teflon bearing surfaces. A dynamic analysis was used to determine stresses along the blade span, and the wall thickness distribution was varied to bring all stresses within the allowable values for titanium (10,000 psi steady plus or minus 18,000 psi vibratory).

The dimensions of the individual blade segments are as follows:

Segment	Length Inches	Chord Inches	Thickness Percent
1 (INBOARD)	101	75	18.0
2	87	68	16.5
3	87	62	15.0
4	87	56	13.5
5	87	49	12.0
6	87	44	10.5
7	87	38	9.0
8 (OUTBOARD)	39	32	7.5

The blades are attached to the head by individual lugs which are used to minimize assembly problems.

An important blade design consideration is the question of what type of overlap is required to carry the loads and provide adequate bending stiffness between the blade segments. The basic question is whether the blades must be mechanically locked together when they are at the extended diameter, or whether the centrifugal force is high enough to hold them rigid. It has been determined that the centrifugal force will rigidly lock the sections together so that no positive mechanical locking mechanism is required. The centrifugal force distribution, which is always in tension, is substantially larger than the force distribution due to the bending moments, which is in both compression and tension. Therefore, the resultant forces across the joint are always in tension and no positive locking is required to carry compressive loads. This holds true for all the segments since the ratio of centrifugal force to bending moment is approximately constant along the span of this teetering rotor blade.

During blade retraction, the particular segment being retracted is not held rigid with the next most inboard segment unless a further moment carrying device is included. The blade moment which the joint must react is substantially reduced, since the span of blade outboard of the joint is never longer than the span of one segment. To carry this small moment during retraction, the segments are overlapped by eight inches and provided with bearing blocks.

The RETRACTION MECHANISM consists of a hydraulically driven winch assembly within the rotor head to pull in a band type of cable which is attached to the tip of the most outboard blade segment. This cable band consists of six  $\frac{1}{2}$ " diameter cables bonded together as a flat strap. This is done to give the cable sufficient tensile strength and yet hold the cable thickness to a minimum so that it can be wound on a reasonably sized drum.

The power required to retract the blades directly influences the size of the required mechanism. This power is a function of the blade centrifugal force and the speed at which the retraction takes place. Centrifugal force varies as the square of the rotor speed and can be substantially reduced if the rotor RPM is slowed down before blade retraction is attempted. It has been assumed that rotor speed is reduced by 20 percent before retraction; this reduces the centrifugal force which the mechanism must overcome by 36 percent. This drop in rotor RPM can be accomplished with a conventional free turbine engine by varying the speed of the power turbine.

The retraction rate that was assumed is 50 feet per minute. This results in full rotor retraction taking place in approximately 60 seconds. With this centrifugal force and retraction rate, the power required for retraction is 110 horsepower per blade.

Two types of drive mechanisms were investigated for the retraction winch; a strictly mechanical drive system driven off the rotor shaft, and a hydraulic drive system driven by a pump on the accessory section of the main gearbox. The mechanical drive is difficult to configure since the winch is in the head and therefore teeters with it. This requires universal joints and/or gears in the drive system to pass the power through the teetering joint. The hydraulic retraction easily solves this problem, but it suffers from lower mechanical efficiencies. With respect to weight, the two systems are very similar; the mechanical system weighs 57 $\frac{1}{2}$  pounds and the hydraulic system weighs 549 pounds.

In addition to the slight weight advantage, the hydraulic system would be smoother operating, especially when accelerating, and it has been chosen over the mechanical system.

A separate hydraulic motor is used for each blade. They drive the retraction drums through high reduction ratio gearing, which is used to reduce the torque requirements, and therefore the size, of the hydraulic motors. Each motor is 6.7 inches in diameter by 12 inches in length. The gearing used is a Curtis Wright "Powerhinge", with each Powerhinge designed for 150 horsepower. The two hydraulic motors and the two Powerhinges are all mounted on the same axis. In this configuration the high reaction torques developed in the gearing are reacted from one Powerhinge to the other. The overall width of the mechanism is 44 inches.

The two drums are mounted concentrically to this mechanism and have diameters of 18 inches.

## (2) Dynamic Considerations

In the fully extended configuration this system can be expected to have fairly conventional aeroelastic properties. Although the retraction mechanisms complicate the blade design, the structural properties of the blade can be accommodated within the framework of existing technology.

The object of this dynamic evaluation was to establish blade structural properties which would ensure acceptable blade stress and response characteristics at the low speed-high thrust and high speed-low thrust ends of the flight envelope.

The conditions analyzed were (a) 45,000 lb G.W.; 120 knots and (b) 19,000 lb G.W.; 200 knots. A Sikorsky Aeroelastic Rotor Analysis, which employs the Myklestad approach, was used for this purpose. This analysis determines the aeroelastic and dynamic response of an N bladed rotor system subjected to given steady state flight conditions. Airloads are determined initially using classical aerodynamic theory in conjunction with two-dimensional airfoil data. An iterative procedure is then used to determine the proper control settings needed to trim the rotor. The airloads are applied to the dynamic response blade equations which include fully coupled blade flatwise, edgewise, and torsional motions. The blade response characteristics which satisfy the root boundary conditions are then determined for each radial station in terms of azimuthal harmonics. Knowing these blade motions it is next possible to calculate a refined set of airloads which include blade flexibility effects. A dynamic response analysis is then performed with these airloads and final blade motions and forces are found.

For this type of analysis the rotor blades are represented by a number of discreet masses situated at discreet radii. The blades then have as many flatwise, edgewise, and torsional degrees of freedom as there are discreet masses.

In this study 18 masses were used. Since the blade airloads are known at each azimuthal station the deflected form of the blades is readily obtained by balancing the aerodynamic shear forces and moments with the blade internal shear forces and moments such that the known blade root and tip boundary conditions are satisfied.

To conduct this study a preliminary blade design was laid out and from this an initial assessment of the blade mass and stiffness distributions were made. With these blade structural properties, the two flight conditions mentioned above were simulated. The flight conditions were effected by varying the collective and cyclic pitch control inputs until the rotor lift, propulsive force, pitching moment, and rolling moment were within prescribed limits. Comparison of the resulting blade airloads and stresses showed the 45,000 lb 120 knot flight condition to be most critical. This condition was therefore used in subsequent analysis.

The blade airloads, moments and stresses obtained from the critical flight condition were used to establish new blade structural properties. The flight condition was again simulated and new moments and stresses obtained which were again used to establish new blade structural properties. This process was repeated to minimize blade weight and stresses.

To reduce the effect of inplane Coriolis moments the rotor system studied was underslung and the blades precone 7 deg. such that the blade center of gravity was in line with the effective teetering axis. The analysis used in the study did not have the capability to include underslinging. An assessment of the effect could nevertheless be made by using the blade responses obtained for the precone, non-underslung system to calculate the magnitude of the Coriolis moments. Subtracting these moments from the total moments on the non-underslung system gives a measure of the moments which would be experienced by an underslung system. Although not mathematically exact, this procedure gives values which are certainly adequate for preliminary design studies. This effect is reflected in Figure 13a and 13b which show the envelopes of maximum steady and vibratory flatwise and edgewise moments on the system at 45,000 lb, 120 knots.

These figures show the moments that were used for the final blade design. The blade structure was designed to carry these moments within the allowable titanium stress limits of 10,000 psi steady stress plus or minus 18,000 psi vibratory stress. The edgewise moments, although reduced by the underslinging are nevertheless substantial. Due to the absence of inplane articulation the blade feathering bearings must carry these moments. This leads to more stringent bearing design requirements than in the case of an articulated system.

Figure 14 shows the blade tip displacement over one cycle of trimmed flight at 45,000 lb, 120 knots. The blade tip motion is seen to be less than 80 inches. This is a deflection of the tip path plane of  $\pm 3$  degrees. Since the clearance between the rotor and the fuselage would be approximately 12 degrees there is no danger of the blade tip contacting the fuselage.

An examination of the blade torsional response for each of the flight conditions analyzed revealed no stall flutter tendencies. To identify stall onset, a parameter which identified rapid increases in blade profile torque was used. This parameter,  $bC_{QD}/\sigma$  (where  $b$  is number of blades,  $C_{QD}$  is blade drag coefficient, and  $\sigma$  is rotor solidity) has been used in numerous Sikorsky Aircraft studies. It has been found that when the parameter has a value less than 0.004 the rotor is unstalled. For each of the conditions analyzed this parameter had a value less than 0.003. Since the blade is mass balanced at the quarter chord, classical blade flutter will not occur.

This dynamic examination did not directly examine the effects resulting from retraction and extension of the blades. Sikorsky Aircraft has conducted a substantial amount of research in this area on the two segment TRAC rotor. This research has shown that blade extensions and retractions can be performed without encountering any instabilities or undesirable response characteristics. This is discussed in detail in section III-3.f. It is expected that the eight segment telescoping rotor would display similar characteristics.

### (3) Aerodynamic Considerations

The eight segment telescoping rotor has very good low speed and transition characteristics. It has the best hover and low speed performance of all the concepts studied including the S-65-300. The transition to a stopped/retracted rotor can occur at speeds as high as 250 knots permitting transition to occur at the minimum transition power speed of 220 knots.

As the aircraft forward speed increases the main rotor RPM remains constant until an advancing tip mach number of 0.9 is achieved. This occurs at approximately 125 - 150 knots, depending upon ambient temperature conditions. Above this speed rotor RPM is reduced to keep the advancing tip mach number at 0.9. This requires a 20% RPM reduction at 220 knots forward speed. The advance ratio at this point is approximately 0.6.

The high speed at which the transition from rotor supported to wing supported flight occurs allows the wing size to be determined by cost effectiveness rather than the maximum transition power available.

The figure of merit of this rotor is .628. This results from a figure of merit ratio correction factor of 1.02 applied to a baseline figure of merit of .616. This correction factor is based on a combination of the following individual corrections.



. Taper	1.02
. Blade Discontinuities	.98
. Root Cutout	1.01
. Airfoil (18% to 7.5%)	1.01

The vertical drag of the aircraft is 1.65 percent of gross weight for the baseline 475 square foot wing. This increases as wing size increases to a maximum of 2.05 percent of gross weight for a 900 square foot wing.

High speed performance of this concept is restricted by the relatively high parasite drag of the large teetering rotor head. At 62,800 pounds gross weight this aircraft can cruise at 275 knots using the same power that the S-55-300 requires at 250 knots. The components of the power required by the eight segment telescoping rotor at 250 knots are as follows:

Propeller Power		9160 HP
- To Overcome Fuselage and Rotor Hub Parasite Drag	5950 HP	
- To Overcome Wing Drag (Induced & Profile)	3210	
- To Overcome Rotor Rotation Drag	0	
Gearbox Losses		50
Accessories		100
	TOTAL	<u>9310 HP</u>

Figure 12 shows the power requirements of this system as a function of forward flight speed, along with the lift sharing, fuselage pitch attitude, and wing flap deflections necessary to sustain level flight. Lift is transferred from the rotor to the wing as the aircraft accelerates from 60 knots to 220 knots. In the range of 220 knots the rotor is retracted and stopped and the aircraft continues to higher speeds, flying as a fixed wing aircraft.

#### (4) Rotor System Weight

The total weight for this rotor system is 9118 pounds, or 14.5 percent of the 62,800 pound gross weight. This is broken down as follows:

<u>Telescoping Blades (2 Required)</u>	2100 LBS/BLADE	<u>4200 LBS</u>
Spar & Balance Weights	1885	
Extension & Retraction Stops	140	
Tip Cap	25	
Cable Guide	50	
<u>Rotor Head</u>		
Teetering 'U' Beam	917	<u>2988 LBS</u>
Housing, Rotor Head	830	
Spindle	524	
Sleeve	546	
Spline	80	
Misc.	91	

<u>Mechanism</u>		<u>1930 LBS</u>
Drum	332	
Cable	520	
Drum Supports	323	
Drum Drive Mechanism	720	
Misc.	126	
	TOTAL	<u>9118 LBS</u>

(5) Summary

The eight segment telescoping rotor is a heavy variable diameter rotor system, but one which has few dynamic and aerodynamic problems.

Advantages

- . High Retraction Ratios Possible
- . Fairly Conventional Aeroelastic Characteristics
- . Conventional Blade Pitch Control System
- . Few Compromises in Blade Airfoil Shape
- . Good High Speed Performance - Rotor can operate at speeds over 200 knots.
- . Only simple sliding motions in blade
- . Minimum size retraction winch assembly
- . Fail safe blade retention system
- . Rotor Head Simplicity
- . Rotor may be stopped in extended position should any malfunction occur in the retraction mechanism.

Disadvantages

- . Blade Complexity
- . High total rotor weight
- . Large rotor head parasite drag due to underslung teetering rotor head design.
- . Possibility of blade binding during retraction
- . Inflight blade damage may prevent blade retraction
- . Retraction components are not readily accessible within rotor head
- . Blade inspection requires manual extension
- . Blade weight necessitates care in handling, special equipment, and poses a safety problem
- . Blade construction necessitates segment scrapping if major damage is sustained, and means depot level repair
- . No provisions for detecting blade or structural failure
- . High vibration in high speed, rotor-borne flight

If this rotor design were pursued, the following areas would have to be investigated further:

- . Effects of retraction on blade dynamic response
- . Effect of blade bending on segment interfaces
- General aeroelastic behavior during start-stop operations with the blades extended and following rapid control inputs
- . Small aerodynamic vortices at each blade discontinuity
- . Methods to reduce rotor head drag
- . Methods to improve assembly and inspection
- . Possibility of fatigue problems in segment stop areas, due to concentrated loads.

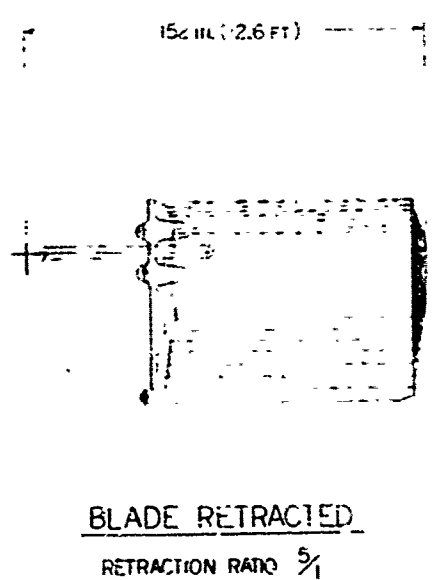
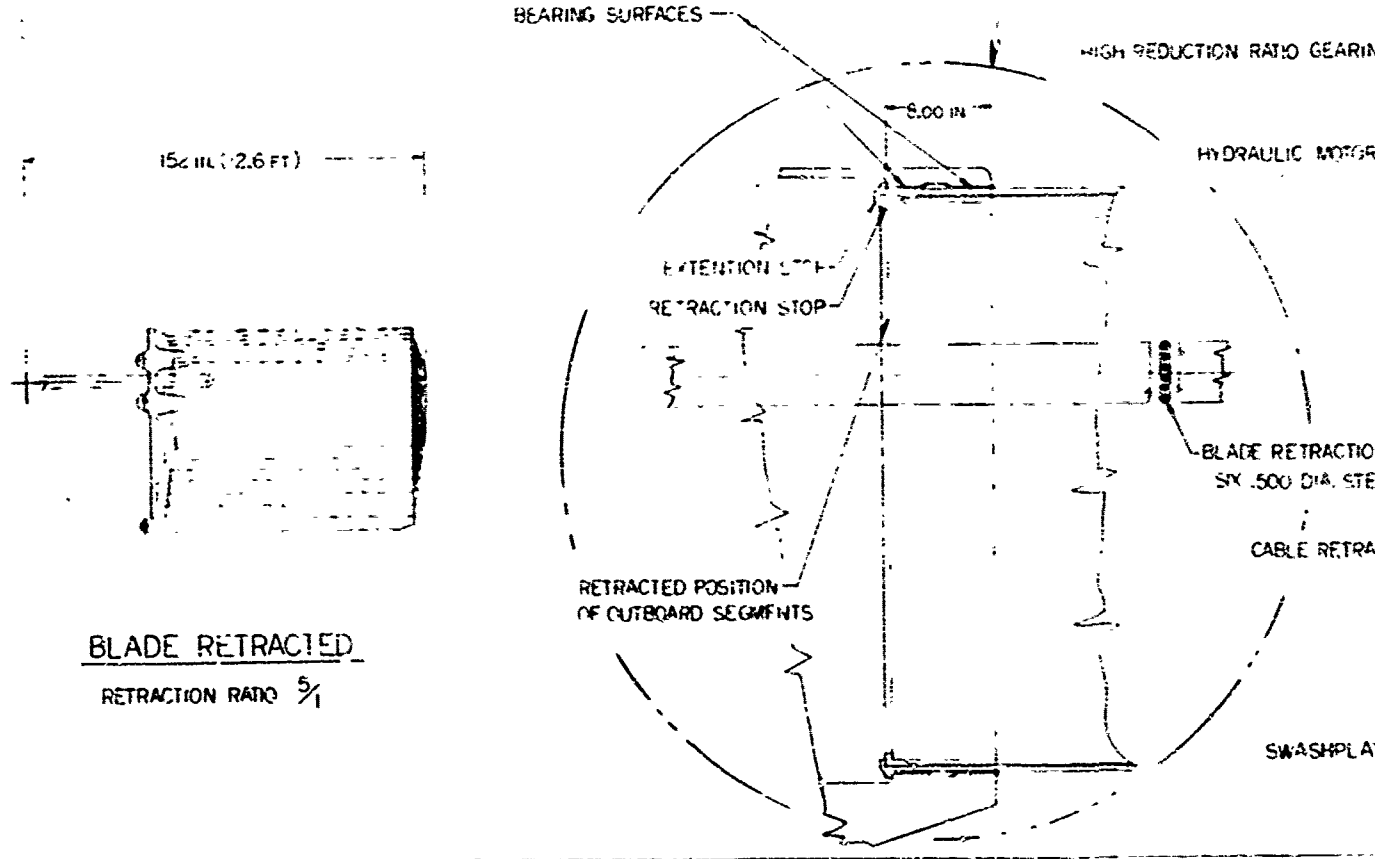
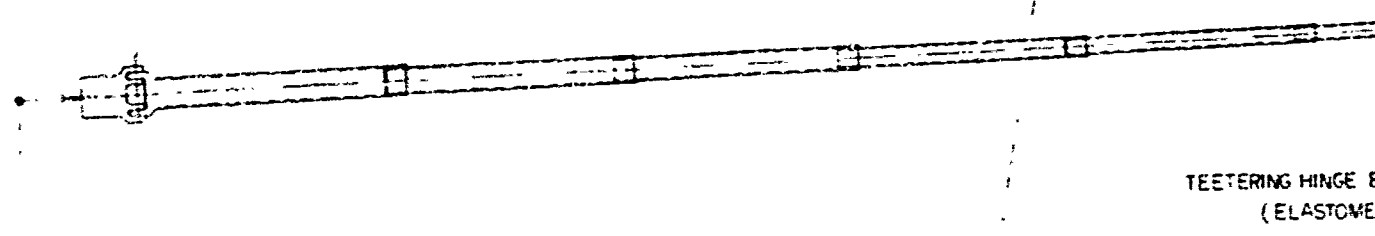
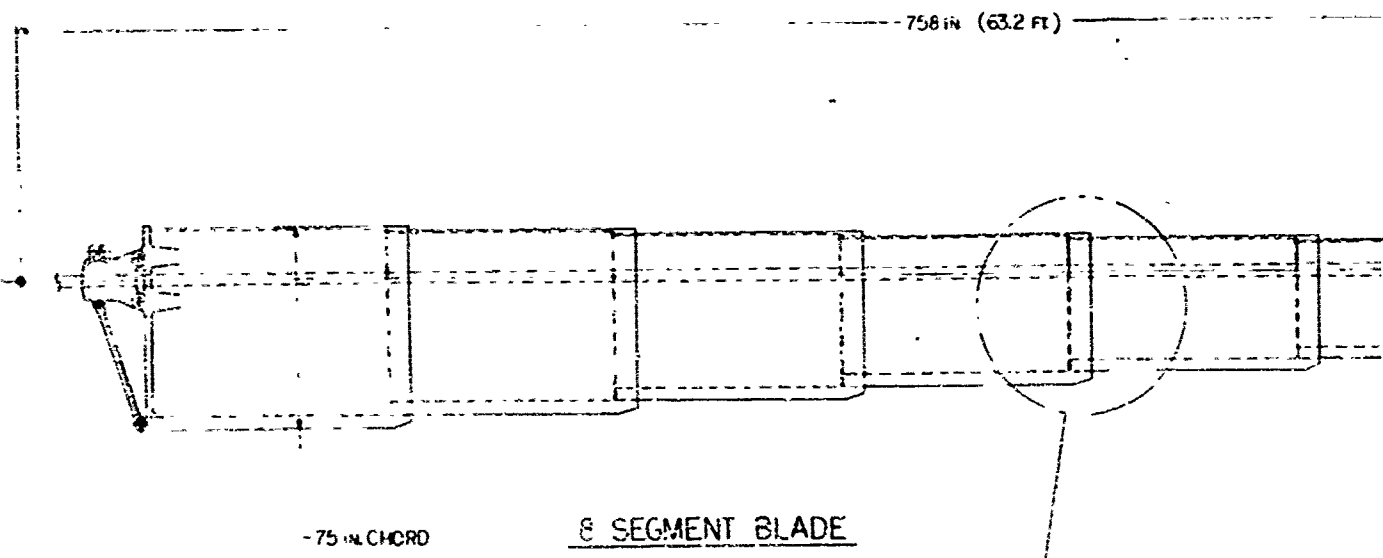

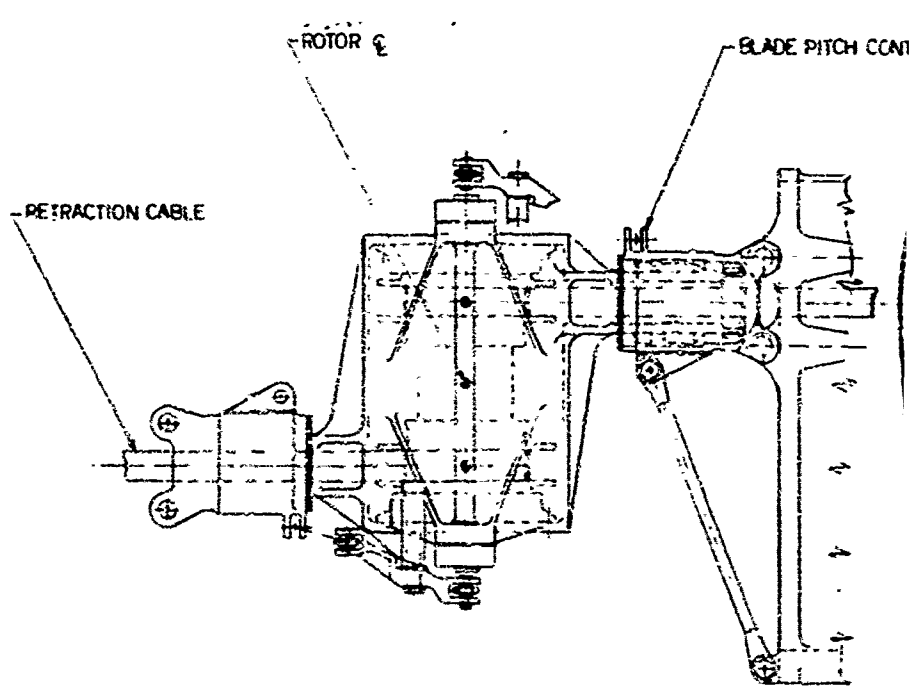
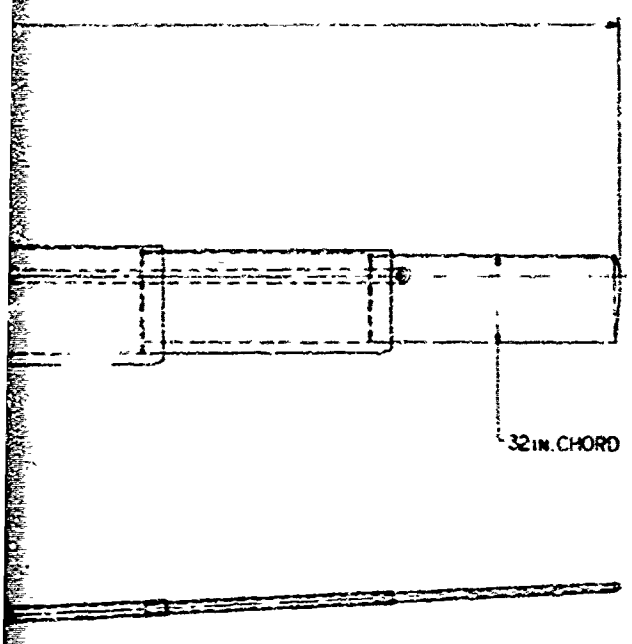

TWO BLADED TEETERING  
ROTOR HEAD

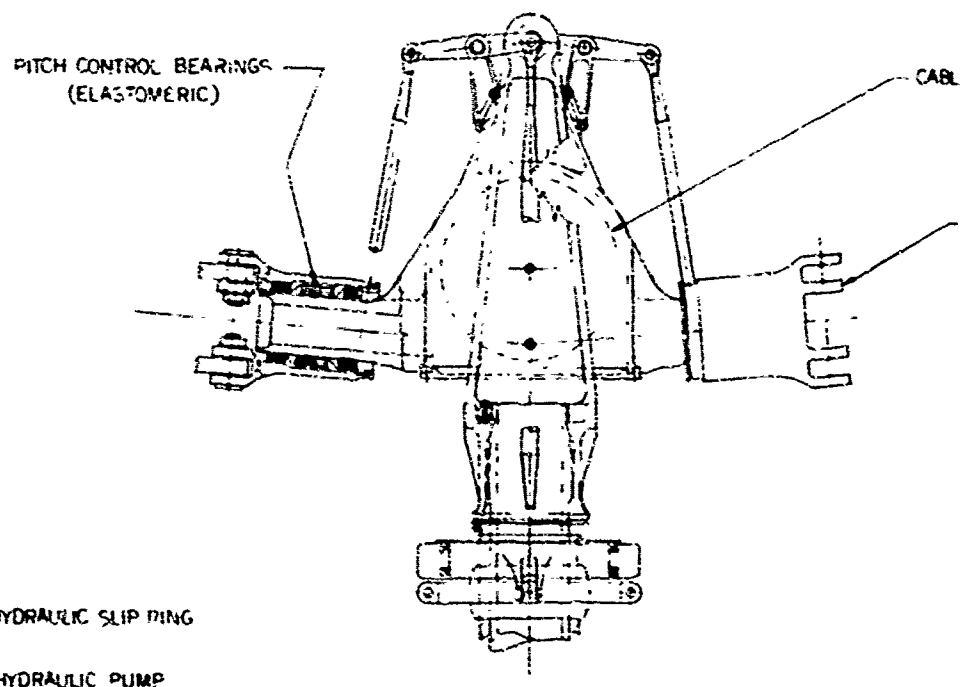
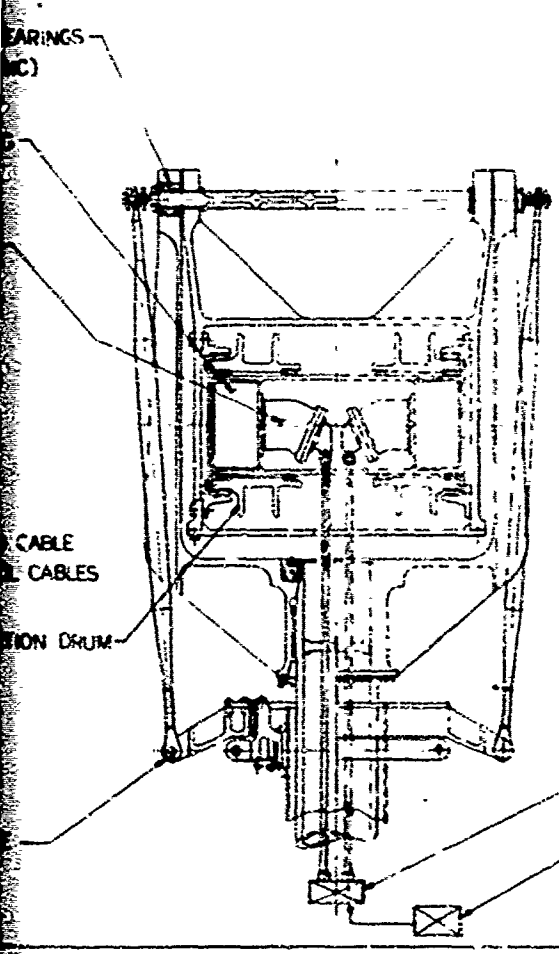

HYDRAULIC SLIP RING

HYDRAULIC PUMP

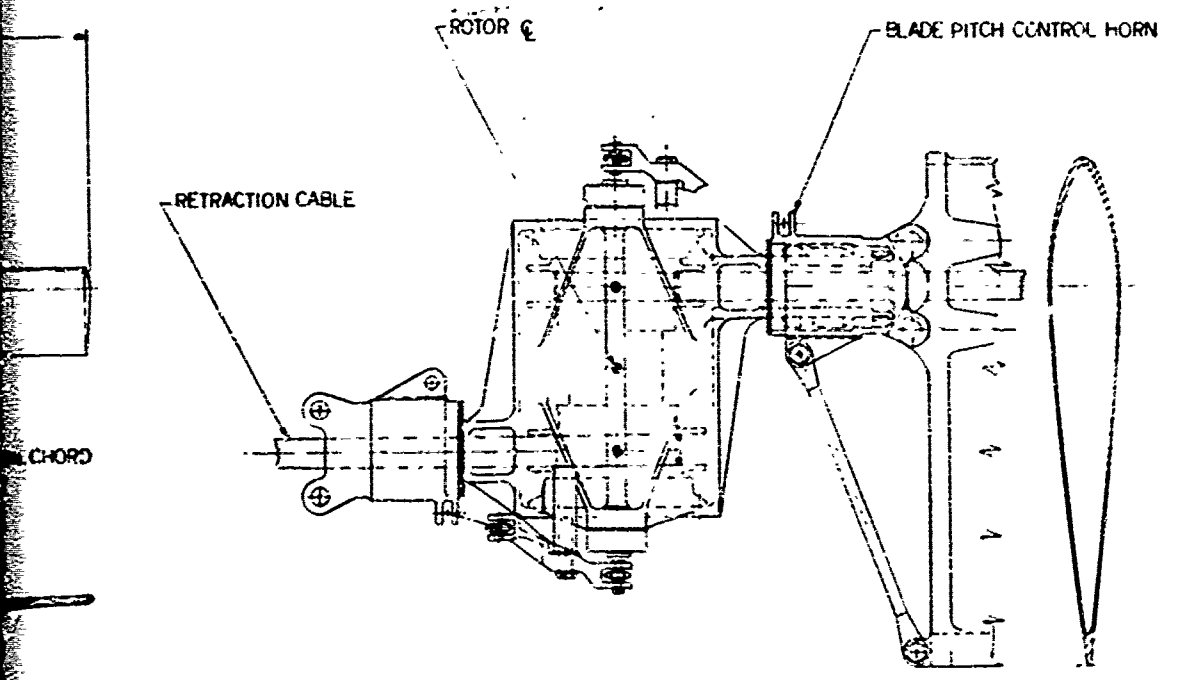

TWO BLADED TEETERING ROTOR HEAD

BLADE SECTION

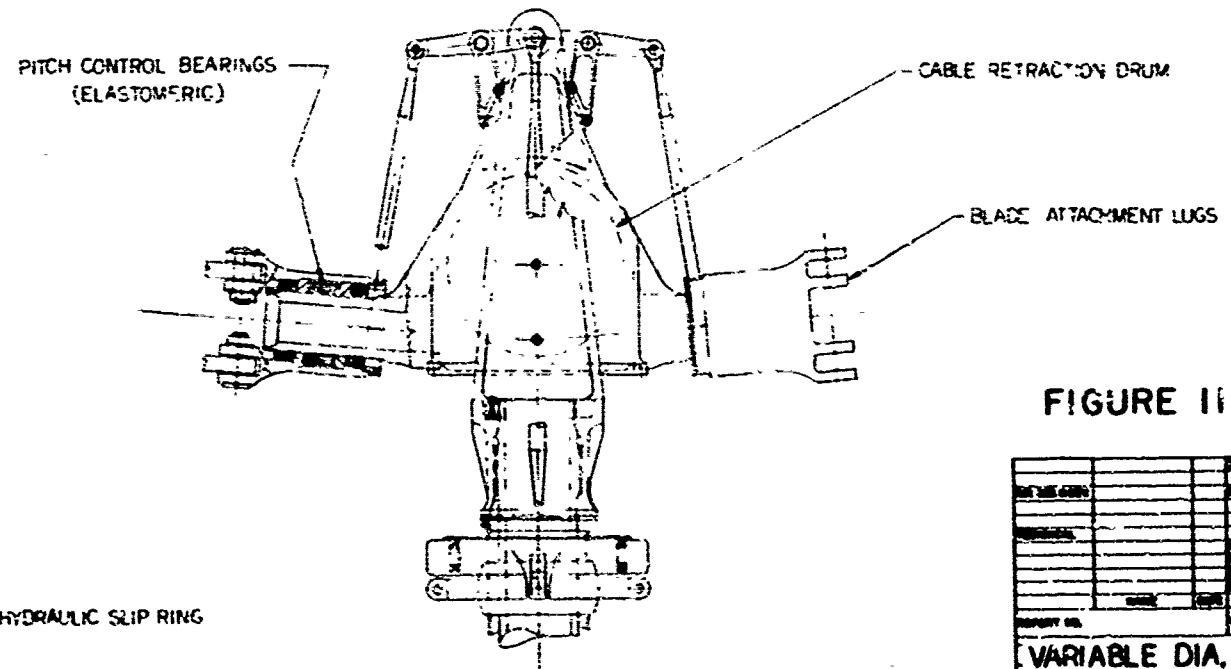

HYDRAULIC SLIP RING  
HYDRAULIC PUMP

FIGURE II

REPORT NO.	DATE	BY	CHK'D BY
VARIABLE DIA. ROTOR STUDY			
EIGHT SEGMENT TELESCOPING ROTOR			
DESIGNED BY			
DRAWN BY			

57

DS-307-7-8

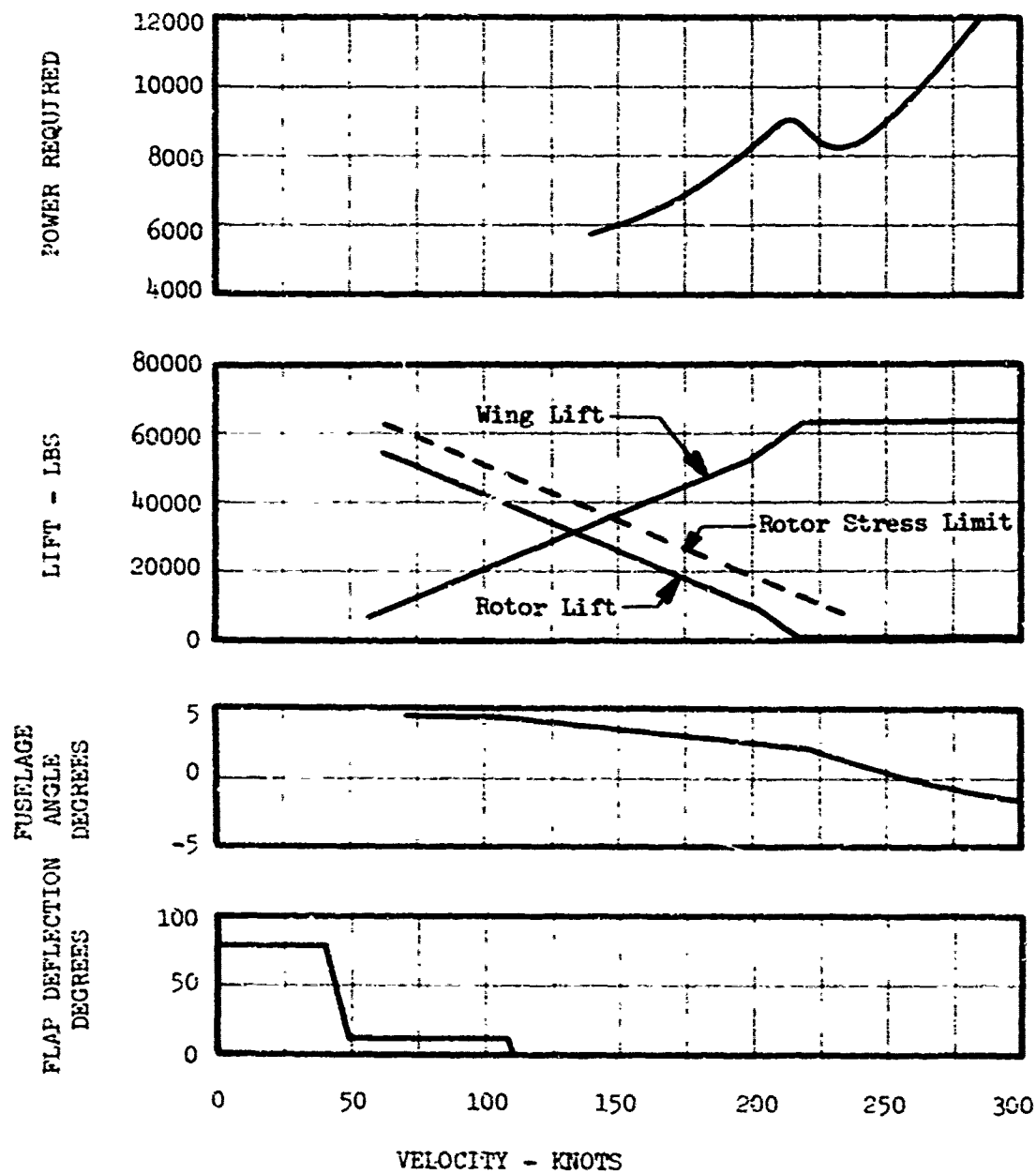

FIGURE 12  
 EIGHT SEGMENT TELESCOPING ROTOR PERFORMANCE CHARACTERISTICS  
 12000 FT, 16° F  
 62900 LBS GROSS WEIGHT  
 750 SQ FT WING AREA

Preceding page blank

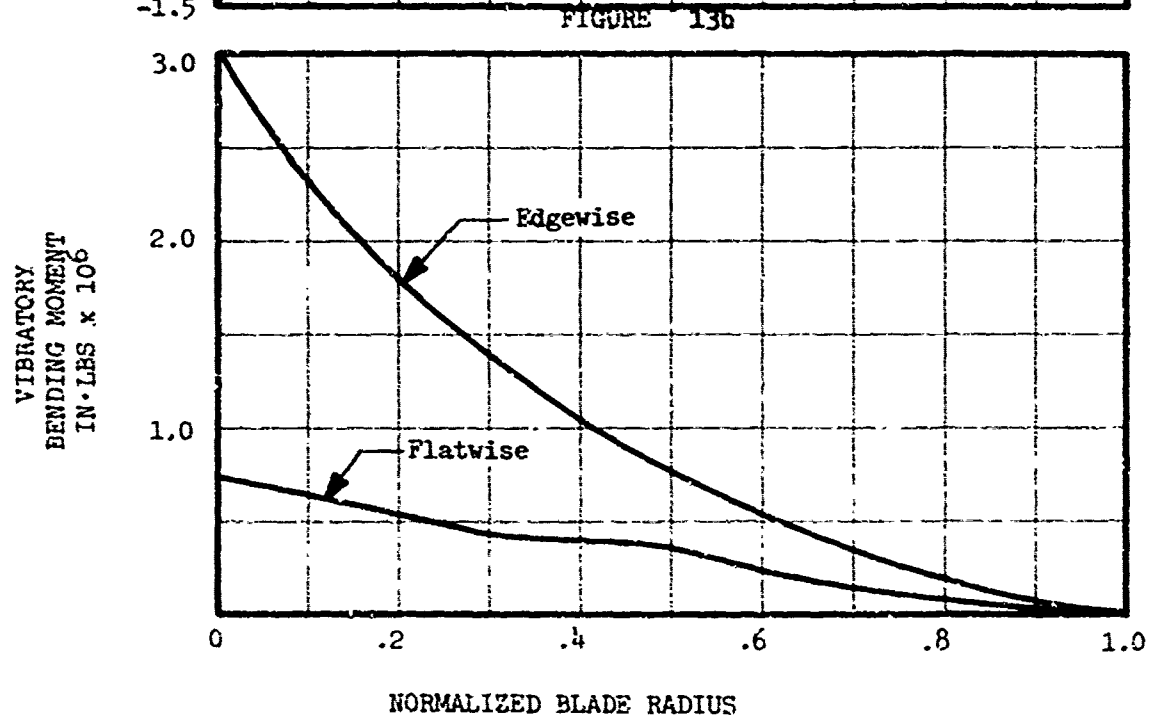
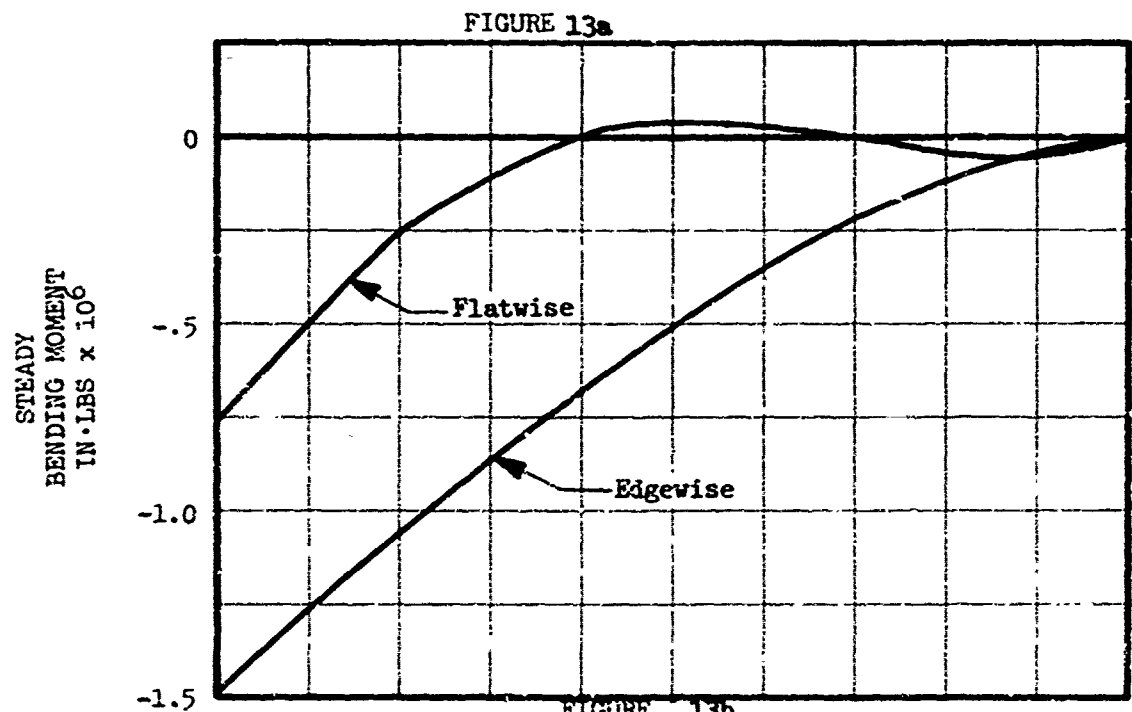

FIGURE 13  
 EIGHT SEGMENT TELESCOPING ROTOR  
 STEADY AND VIBRATORY BLADE FLATWISE AND EDGEWISE MOMENTS  
 120 KNOTS, 45000 LBS LIFT



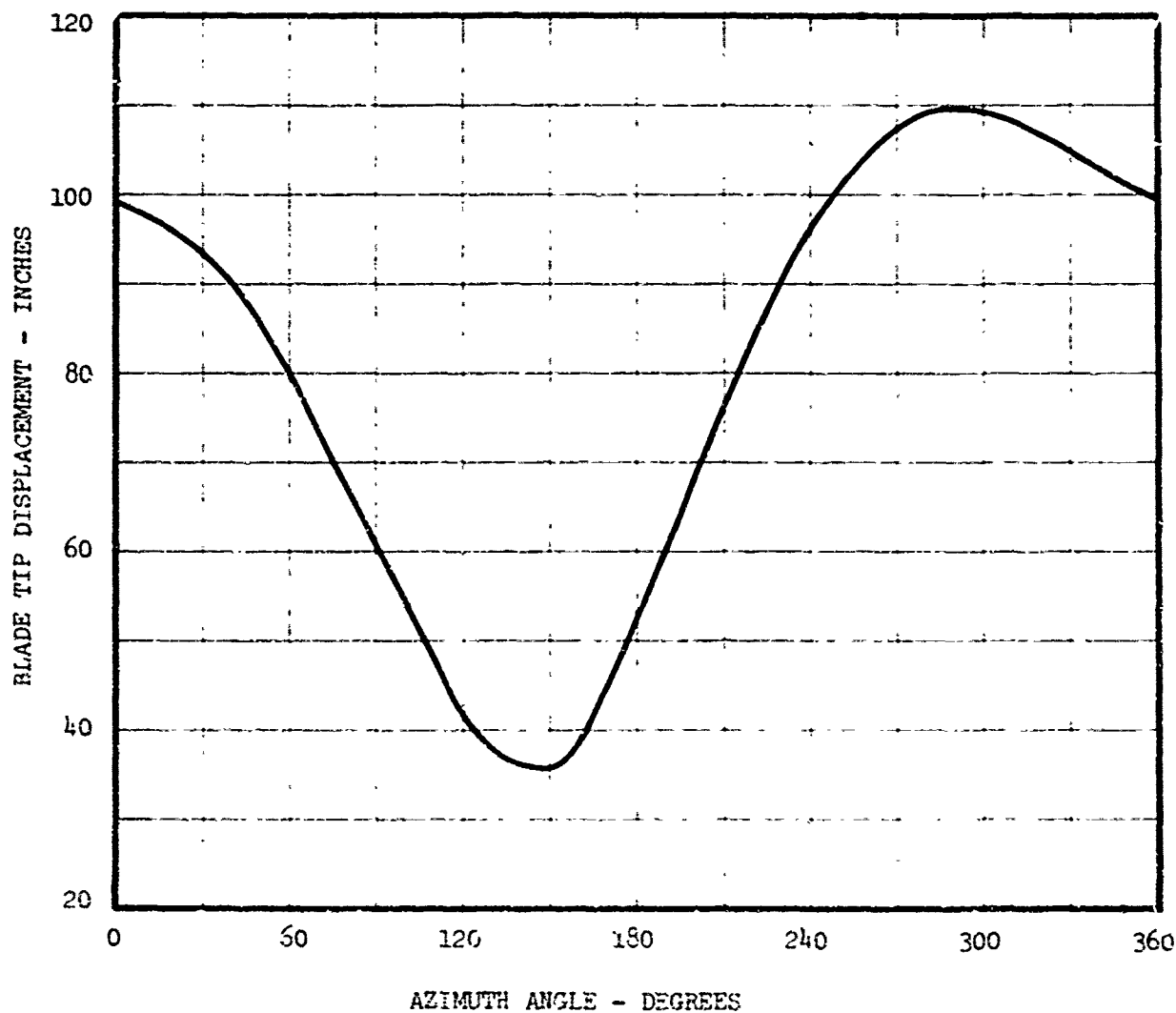

FIGURE 14  
 EIGHT SEGMENT TELESCOPING ROTOR  
 BLADE TIP DISPLACEMENT DURING STEADY TRIMMED FLIGHT  
 120 KNOTS, 45000 LBS LIFT

b. Roll-up Rotor, Thin Flexible Blade

Another interesting variable diameter concept uses very flexible blades that can be retracted by winding them on drums within the rotor head. Two variations of this concept have been investigated. The first uses blades with only two percent thickness, and the second uses pneumatic blades that can be blown up to provide a twelve percent thick airfoil when extended and then be deflated for retraction. The thin blades are discussed in this section. The pneumatic blade is discussed in the next section.

These rotors are also designed for a hovering disc loading of 5 psf and have an extended diameter of 126.4 feet at the 62,800 pounds gross weight. Both two bladed and four bladed rotors were investigated. The two bladed rotor has a chord of 50 inches and an aspect ratio of 15.3. The four bladed rotor has the same total blade area. It has blades with a 25 inch chord and an aspect ratio of 30.6.

By far the most critical item in the rating of these flexible rotors is in the area of blade dynamics. The rotors are simple mechanically and promise to be reasonably light if their unique dynamic problems can be solved.

(1) Dynamic Considerations

This system is unique inasmuch as the blade stiffnesses are much lower than those normally associated with conventional helicopter rotor blades. This fact gives rise to the possibility of instabilities associated in particular with blade torsional motions and blade inplane motions. These effects are discussed in the following paragraphs.

Although this rotor is not articulated, the extreme flatwise flexibility of the blades makes the system behave essentially as a system with flapping articulation. The fact that the blade edgewise stiffness is low leads to the frequency of the first elastic inplane mode of the blades being less than one per rev. and introduces the possibility of ground resonance. The problem is compounded by the fact that mechanical blade dampers of the type employed in conventional inplane articulated rotor systems to alleviate ground resonance cannot be employed in this non-articulated system. If, for example, this system were articulated inplane, it is difficult to conceive a mechanical damper having the desired effect since even if the damping coefficient of the damper were infinite, the part of the blade outboard of the point of application of the damper would still respond elastically at a frequency less than one per rev. and this motion would still be essentially undamped.

Other means must be sought to surmount this problem.

Air resonance is also a problem which requires consideration. This is not as critical as ground resonance since the blade motions are aerodynamically damped and there is less likelihood of blade and airframe modes coalescing such as to produce instability.

The reduced torsional stiffness of the blades increases the possibility of blade torsional instability. Martin, Reference 6, investigated the stability of their cable blade configuration and showed that for a blade having zero stiffness (flatwise, edgewise, and torsional) stability could be achieved by placing the elastic axis ahead of the aerodynamic center axis but behind the center of gravity axis. Subsequently, some work was carried out at the United Aircraft Research Laboratories, Reference 7, in which it was shown that stable operation of a system with a small but finite blade edgewise stiffness could be achieved for (a) elastic, center of gravity, and aerodynamic axes coincident, and (b) coincident elastic and center of gravity axes ahead of the aerodynamic center axis. Unstable operation was obtained for the coincident elastic axis and center of gravity position aft of the aerodynamic center axis. This latter result is not unexpected since aft center of gravity positions even in conventional blades can lead to flutter problems. Stability of forward, non-coincident elastic and center of gravity axes for systems with small but finite blade edgewise stiffness has yet to be verified.

Another area of primary concern in the dynamic analysis of the roll-up rotor is pitch control. Consider a system employing blades with a symmetrical airfoil and the elastic, center of gravity, and aerodynamic axes all coincident. If the blades employ relatively large tip masses for centrifugal stiffening then the propeller moment from this tip mass will always attempt to keep the tip of the blade in flat pitch. It is not difficult to see that if the blades are very soft torsionally any pitch impressed inboard will tend to wash out at the tip due to the fact that the blade is incapable of transmitting significant elastic moments to the tip without undergoing large torsional displacements. In such a system inboard pitch control would be impractical.

The blades may be cambered such as to produce positive, nose up, pitching moments of sufficient magnitude to overcome the tip mass propeller moment and give outboard angles of attack. In this system, movements of the aerodynamic center due to possible stall, compressibility effects, and reversed flow could lead to torsional divergence. This can be counteracted by positioning the blade elastic axis ahead of the aerodynamic axis to produce a stabilizing nose down moment. Pitch changes could then be effected by employing an aerodynamic tab on the tip mass or possibly a combination of tip tab and conventional inboard control. These various methods of control and their effect on the blade dynamics were investigated in the study.

In the following paragraphs the investigations carried out relating to the above subjects is discussed.

#### (a) Ground Resonance

Ground resonance is a phenomenon which can occur when blade inplane motions couple with airframe motions when a helicopter is on the ground or is partially airborne. It can only occur if the frequency of the blade inplane motions is less than the rotor speed. Blade inplane motions are transmitted into the fixed airframe axis system at frequencies equal to the rotor speed plus or minus

the frequency of the blade inplane motions. If any airframe mode has a frequency equal to the lower of these, instability can occur. This is caused by the airframe mode and the blade mode coalescing such that the two modes have the same frequency. This results in one mode being positively damped (stable) while the other is negatively damped (unstable). The problem is generally surmounted by using mechanical dampers to damp both the airframe motion and the blade motion.

Ground resonance is important in the roll-up rotor since conventional blade root inplane dampers cannot be effectively employed. Since the internal damping of almost any practical blade material is invariably much too small to ensure freedom from this problem, other means of introducing blade damping must be sought. To this end, aerodynamic means seem to be a logical choice. By employing drag vanes on the tip mass it is possible to introduce significant inplane aerodynamic damping. Use of such vanes will require power, but for articulated-type rotors the ground resonance phenomenon only occurs when the aircraft is partially airborne or wholly on the ground, and the drag vanes may be retracted as soon as the aircraft is clear of the ground.

The analysis used to establish the area of the drag vanes required to eliminate this problem was developed by Sikorsky Aircraft. It is a fully automated analysis which includes airframe roll, pitch, and lateral modes of oscillation and symmetric and unsymmetric blade rigid body and elastic inplane and out of plane modes of oscillation. All motions are fully coupled. The analysis also has the capability to incorporate aerodynamic effects.

To introduce a degree of conservatism in this study it was assumed that at normal operating rotor speed the frequency of the airframe roll mode,  $\omega_R$ , was equal to the rotor speed,  $\Omega$ , minus the blade inplane natural frequency,  $\omega_Y$ , i.e.  $\omega_R = \Omega - \omega_Y$ . This is generally the most critical condition since ground resonance can occur when these modes coalesce. The frequency of the airframe pitch mode was assumed equal to  $0.3 \omega_R$ . These values are typical of conventional aircraft. Since ground resonance can only be eliminated by damping both the airframe and the blade motions, airframe damping levels characteristic of conventional aircraft were employed. The airframe roll mode was assumed 25% critically damped, the pitch mode 10%, and the lateral mode 5%.

Using the above values, the area of the tip mass drag vanes was varied until stable operation was obtained through and beyond normal operating rotor speed.

Figure 15 gives the results of this analysis. This shows the effect of rotor speed on the critical system root locus for various drag vane areas. It can be seen that with zero drag vane area the system is unstable from rotor speeds of about 55 RPM to well in excess of 220 RPM. Since the normal rotor speed is 113 RPM this system is clearly unacceptable. Two square feet of drag vane area per blade gives a system which is stable at all rotor speeds except from approximately 140 to 150 RPM. Six square feet per blade ensures absolute stability at all rotor speeds. From this analysis it may be concluded that approximately 2 to 3 square feet of drag vane area per blade will ensure freedom from ground resonance.

It should be noted that these studies were conducted with the blades fully extended. This is the area of concern, since ground resonance problems occur during take off and landing when the rotor is at full diameter. It is also interesting to look at resonance at reduced diameters. As the blades are retracted the effective damping moment is reduced due to the reduced blade tip velocity. Since the blades are not articulated their inplane natural frequency will also increase as the blades are retracted. The net effect will be to reduce the percent critical damping of the blade inplane motion. This would have serious implications if the blade inplane natural frequency remained below one per rev. Fortunately, this is not the case. When the blade radius is about 0.7 times the fully extended value the blade inplane frequency will have increased to above one per rev., thus eliminating any possibility of ground resonance at radii below this value. This is true no matter what the level of inplane damping. The drag vanes are designed to produce sufficient inplane damping to preclude ground resonance at radii above 0.7 times the fully extended value.

Another method of attacking the ground resonance problem would be to employ a damped dynamic absorber at the blade tip. This concept was not examined in detail during this study but it does merit consideration. One possible drawback in the concept relates to the tuning of the absorber. For a given set of system parameters, an absorber could possibly be designed which would preclude ground resonance. The effectiveness of the absorber is linked to its tuning in relation to the blade inplane natural frequency. Since as the blades are retracted their inplane natural frequency increases, the absorber will become detuned and may lose its effectiveness. This can only be overcome by designing an absorber which is effective over a fairly wide frequency range. This may be difficult to achieve unless the absorber has variable tuning.

#### (b) Pitch Control and Torsional Stability

Pitch control in the roll-up rotor system is an area of primary importance. The use of conventional inboard control may be impractical due to the relatively low torsional stiffness of the blades and their resultant incapacity to transmit moments to the outboard blade elements without undergoing large elastic torsional deformation.

This study was aimed at investigating various means of pitch control to ascertain to what extent pitch control is possible and to suggest the best means for effecting this control.

The analysis used for this purpose was the Sikorsky Normal Modes Blade Aeroelastic Analysis. This is a single blade analysis which represents blade motions as the sum of the number of the normal modes of oscillation of the blades. Up to ten blade elastic modes may be used in addition to rigid body flapping and lagging. The analysis solves the fully coupled system equations of motion by computing the blade response characteristics at each instant of time as the blade travels azimuthally. In doing so it makes available a complete description of all blade motions and deflections, the blade stresses and moments consistent with these deflections, and the root shears and moments. Since the analysis gives this time history of the blade motions, it gives information as to the stability of a given configuration in a given flight condition.

This analysis was developed primarily to study systems employing conventional inboard collective and cyclic pitch control. With a relatively minor modification it was possible to simulate outboard pitch control by inserting the desired pitching moment coefficients on the blade tip element. With this modification the effect of tip control alone could be studied, but this eliminated the capability to employ conventional inboard control at the same time. Thus, conventional control alone could be examined with the unmodified analysis and tip control alone could be examined with the modified analysis.

The study was conducted along the following lines. A system with the elastic, center of gravity, and aerodynamic axes coincident was subject first to tip control then to conventional control. Hovering capability was first established and then the control parameters were varied to see if an approximate 100 knot, 35,000 lb trimmed flight condition could be achieved without encountering stall or excessive flapping or torsional responses. In conducting these studies no attempt was made to minimize hub moments. It being the intent to examine the feasibility of the control schemes, a trimmed condition was defined as one in which all blade responses repeated within specified tolerances each revolution, which gave the desired lift at the specified flight speed, and which produced propulsive forces, rolling moments, and pitching moments deemed controllable. Figures 16 and 17 show the blade tip flatwise and torsional responses as functions of azimuth position obtained using each of these control concepts. The important aspect of these figures is that they show that trimmed flight is possible and that the flatwise and torsional blade responses are acceptable. The flatwise response corresponds to approximately  $\pm 3$  degrees of tip path plans motion. The clearance allowed between the rotor and the fuselage is about four times this. The torsional response of approximately  $\pm 4$  degrees is no greater than would normally be applied in conventional rotors through the use of cyclic pitch inputs. In the case of the tip tab control the maximum pitching moment required to be developed by the tabs was -6000 in.lb. which can be achieved with reasonable sized tip tabs.

Although control by each of these means was possible, it was found that in the case of the tip control only, very large tip moments were required to reduce the lifting capability of the rotor which involves a nose up pitching moment of sufficient magnitude to produce large blade tip angles. This is the result of the pitching moment characteristic of the airfoil employed. This airfoil produces these substantial nose up pitching moments at almost all negative angles of attack and positive angles of attack up to 15 deg. To reduce the rotor lift it was therefore necessary to apply tip pitching moments which would balance the pitching moments from the remainder of the blade. This is an undesirable characteristic. In the case of conventional control only a similar problem existed. That is, although reducing collective pitch and varying cyclic control could be used to reduce the rotor lift, it was impossible to exercise sufficient control of the outboard segments of the blade to avoid stall. It was concluded, at this point, that use of conventional inboard pitch control alone was impractical.

To overcome the need for large pitching moments in the tip controlled system, the blade elastic axis was next positioned slightly ahead of the aerodynamic axis (quarter chord), the center of gravity remaining coincident with the elastic axis. The tip mass center of gravity was assumed to remain coincident with the aerodynamic axis. This results in the blade lift vector producing a nose down blade moment which acts against the nose up blade pitching moment for positive lifts. These moments can be made to balance at the design lift condition. Figure 18 shows the flatwise and torsional responses obtained from this system in trimmed flight at 107 knots, 36,500 lb. These can be seen to be acceptable. It should be noted that although only the tip response is shown the torsional deflection distribution along the blade displayed a gradual decrease from the tip value to zero at the root. Thus, there was no tendency for the blade angles at mid-radius to be excessive. With this system it was found that increases or decreases in rotor lift could be accomplished with much smaller tip flap moments than in the case where all axes were coincident. It was also found that the system tended to operate further away from the stall boundaries. It was concluded from this study that the elastic axis should be ahead of the aerodynamic axis in the roll-up blades.

Although it does appear feasible to use only outboard control, it is felt that a combination of conventional inboard control and outboard tip flap control would give the best overall results. It is considered that perhaps the use of conventional inboard control for collective inputs and tip flap control for cyclic inputs would lead to a system in which the blade angle of attack distribution could be "smoothed" in such a manner as to delay stall onset and also to minimize or eliminate stall associated blade response phenomena. This smoothing is in effect the capability of the tip blades to vary the blade twist as it travels azimuthally. Use of both systems naturally complicates the rotor system design but the pay-offs in aircraft control may justify such an approach.

In regard to torsional stability the systems treated above had either

- (a) elastic, center of gravity, and aerodynamic axes coincident at 25% chord location,
- or (b) elastic and center of gravity axes coincident at 23% chord, aerodynamic axis at 25% chord.

Each of these systems was found to be stable.

The effect on stability of center of gravity axis position relative to the elastic and aerodynamic axes positions was examined by respectively moving the center of gravity axis ahead and aft of the elastic axis by 2% chord. The aft position corresponded to coincident aerodynamic and center of gravity axes. The results of this study were somewhat inconclusive but in neither of the cases did any of the blade responses tend to diverge. Whereas in the case where the center of gravity was moved ahead of the elastic axis a previously trimmed flight condition remained trimmed, in the aft center of gravity case a converged flight condition was obtained. This seems to suggest that the aft center of gravity produces a less stable system than the forward center of gravity. This is in line with the findings of References 6 and 7.

It is felt that further studies of this type require a better definition of the actual effect the tip control would have on the torsional response of a practical system. It was stated earlier that the program used in these studies was modified by inserting pitching moment coefficients on the tip segment of the blade to simulate the tip flap effect. This ties the actual applied moment to the actual blade tip angle of attack at any azimuth position. In practice this need not be the case since the tip flaps would be moved to produce any desired pitching moment. Employing such a capability would clearly alter the blade response. This would be important in stability studies. In any follow on studies the analysis should be modified to include this capability in addition to that of conventional inboard collective control. A comprehensive torsional stability study would then be performed. Immediate indications are that flutter and torsional divergence can be avoided.

The major conclusions to be drawn from this dynamic analysis are

- (a) ground resonance in the roll-up system can be avoided,
- (b) by proper placement of the elastic, center of gravity, and aerodynamic axes, flutter and torsional divergence can be eliminated
- (c) pitch control is possible, as is unstalled steady flight.



## (2) Mechanical Design

Designs for both the two bladed and the four bladed configuration were developed. Each has its advantages. The two bladed rotor has less drag in the stopped position and has a simpler rotor head design. It has a wider blade chord and there is a greater possibility of achieving thin flat plate deflections which distort the airfoil and change its aerodynamic and dynamic characteristics. Because the optimum number of blades is not obvious, both types of rotors were carried through the detailed evaluation phase.

### (a) The Four Bladed Rotor

The four bladed rotor is shown in Figure 19. A basic decision for this rotor is the magnitude of the normal operating coning angle which should be permitted. Low coning angles require large tip weights to increase centrifugal force in the blade. This large force makes the design of the blade section that much more difficult. Figure 20 shows the tip weight required as a function of the operating coning angle and also the magnitude of the resulting centrifugal force. It is clear from this analysis that the coning angle should be made as large as is practical possible because rotor system weight will decrease rapidly as the coning angle increases. Because of these considerations, 15 degrees has been chosen as an operating coning angle. This results in a tip weight requirement of 150 pounds.

The design requirements for the this flexible ROTOR BLADE include the requirement for high tensile strength to support this tip weight, plus minimum blade thickness and a low modulus material, so that flexural stresses can be minimized when the blade is wound on the retraction drum. With these constraints, a two percent thick blade has been designed. It is made up of a thin flat structural spar, which has a second low modulus material bonded to it to complete the airfoil shape.

The total blade chord for the four bladed rotor is 25 inches. With a two percent thick airfoil shape, this results in a maximum blade thickness of one half inch. Even with these very thin blades, it would be difficult to find a material which would allow a homogeneous blade construction and still permit the blade to be retracted on a reasonable sized drum. Because of this, the heterogeneous construction has been chosen with the blade made up of two materials with different characteristics. The spar is fiberglass, chosen for its high strength and low modulus, and is ten inches in width. Two flat straps are used, each with a thickness of .050 inches. The spar is located in the forward part of the blade for blade balance considerations. Fiberglass is the obvious choice for a spar material, with its high strength and low modulus. With the dimensions of the chosen spar, it could be wrapped around a drum as small as six inches in diameter without exceeding design flexural stresses. Equivalent diameters of a steel spar are about six times as much. Graphite and boron composites have higher tensile strengths than fiberglass but also have substantially higher modulus.

There was a question as to whether to use E-type or S-type fiberglass. S-glass has both a higher strength and a higher modulus than E-type, and

it was found that there was no difference in the minimum diameter which they could be wound around. S-type glass was chosen, since its higher strength permitted the use of less material to carry the tensile load and this led to the minimum weight solution.

The blade spar is surrounded by a polyester material to complete the airfoil shape. The polyester would have chordwise grooves cut into it every few inches to relieve the flexural stresses that result from rolling it on the small diameter drums. As discussed earlier, blade mass balance is important for the dynamic stability of these flexible blades. The blade center of mass must be at, or slightly in front of, the quarter chord. Because of this requirement, the blade construction aft of the spar is composed of lightweight honeycomb construction. Nomex is used for both lightweight and flexibility. The upper and lower surfaces of the blade are composed of polyester sheet. The construction still did not yield a blade which was balanced properly and lead tape was added near the nose of the blade. This brought the center of mass slightly ahead of the quarter chord, as desired.

The attachment of the blade to both the inboard retraction drum and the outboard tip weight is achieved by wrapping the fiberglass spar material around lugs at both ends of the blade. When the blade is fully extended, there are still three wraps on the drum. This relieves stress in the attachment joint and makes a smaller joint possible.

The ROTOR HEAD DESIGN required for this type of system is quite simple. Because of the high flexibility of the blades themselves, no hinges are required within the rotor head; it is mounted rigidly to the rotor shaft. In these designs one drum is used to retract two blades.

A conventional articulated rotor system will operate with the blades in a lagged position when driving torque is applied. This generates an inplane moment about the rotor shaft because the blade tensile forces no longer intersect the rotor shaft axis. The particular lag position will be that angle at which the torque due to these tensile forces is equal to the rotor driving torque.

To avoid the natural tendency of the blades to lag, these designs have the rotor pre-lagged; i.e. their axes do not intersect the rotor shaft axis, but instead pass in front of it. This eliminates the tendency of the blade to lag under rotor driving torque. On these roll-up rotors, it has a further advantage in that it eases the problem of nesting two blades onto one retraction drum. As shown on Figure 19 the section of blades aft of the quarter chords are nested together on the drum. However, because of the prelag of the blades, the sections ahead of the quarter chords do not intermesh. This results in minimizing the overall diameter of the drum when the blades are wound around it. The better aerodynamic design also leads to the simplest mechanical design.

Outboard of the retraction drums are blade guiding rollers. These are

used so that all blades are in the same plane. They also give the rotor a flapping offset in the conventional sense. The blade flapping motion takes place at the rollers and as the blade flaps, a component of its tensile force is felt as a vertical force on the rollers. The product of this vertical force and the offset of the rollers from the rotor shaft axis produces a moment on the rotor head. This becomes part of the total control moment which the rotor system imparts to the aircraft.

Because of this offset, reduced tip path plane deflections (i.e. reduced blade flapping) is required to produce a given control moment on the fuselage.

The RETRACTION MECHANISM is quite similar to that used for the eight segment telescoping rotor, only the drums are much wider to accept the entire blade rather than just a retraction cable. Hydraulic motors are again used to drive the drums through high reduction ratio gearing. The rotor is slowed to 80 percent RPM before retraction to reduce the centrifugal force which the mechanism must overcome.

The blade TIP WEIGHT includes the mechanism for both outboard pitch control and aerodynamic damping. For pitch control, three types of systems were investigated. The first used a controllable flying servo tab to control blade pitch at the tip. This would be actuated by an electrically driven servo. The second scheme varied the angle of incidence of the blade tip with respect to the tip weight, which is used to define a reference plane. This also would be controlled by an electric servo. The third scheme is a combination of the first two, using the tip weight to generate inputs to the aerodynamic servo tab mounted on the blade.

The concept of varying the incidence of the blade tip with respect to the tip weight, although theoretically interesting, was difficult to design since the tip weight has to be supported through a bearing on the end of the blade which allows each component to pitch independently. This bearing must hold the 150 pound tip weight under an acceleration of approximately 275 g's.

The aerodynamic trim tab requires no such bearing. In addition to this, the aerodynamic control was found to be stronger and to require less power to operate. For these reasons an aerodynamic type of control at the blade tip was chosen.

The blade dynamic analysis, previously discussed, investigated the tip tab control concept by imparting various twisting moments at the blade t.p. This moment was then converted to tab size and distance from the elastic axis. A .71 square foot tab is used on each blade, with its aerodynamic center located ten inches aft of the blade quarter chord. The analysis indicates that this will provide sufficient tip pitching moment on the blade for adequate control. One of the primary tasks of any follow-on effort on this concept should be concerned with a further determination of tab size. This could be done by placing various size tabs on a model rotor system.

The aerodynamic damper is located in the trailing edge of the tip weight.

where its operation will minimize interference with the blade lift and control functions. A separate electrically controlled actuator is used to deploy two surfaces, one above and one below the tip weight. When deployed these surfaces remain in a fixed rigid position. Damping is achieved because of the varying aerodynamic pressure on the fixed surfaces as the blade "hunt", or lead and lag during inplane motions. Although this method appears feasible, it requires substantial power when it is deployed. A better solution might be to have the area of the damper vary as well as the dynamic pressure. The amount of exposed area could be controlled by inertial effects or an accelerometer. This could achieve the same damping effect without the high power penalties of the fixed position system. Either of these schemes would have to be developed and proven by dynamic tests; their basic concepts appear completely reasonable.

The center of mass of the blade tip weight is located on the quarter chord of the blade, for stability reasons.

Blade ROOT PITCH CONTROL is achieved by passing the blade through two rollers mounted outboard of the head itself by approximately two feet. The pitch of these rollers is varied by a conventional swashplate and pitch rod mechanism. The blade is warped between the rollers and the head for pitch control. This appears to be the simplest and lightest inboard pitch control mechanism since it permits the retraction drums to be rigidly mounted within the head, and still permits two blades to be wound on one drum.

A further feature of this pitch control mechanism is that it is hinged about an axis passing through the head mounted blade guide rollers. This permits the entire mechanism to flap with the blade without introducing unwanted pitch variations and without carrying a portion of the rotor lift through the control mechanism. As with a conventional control system, this mechanism could be modified to permit mixing of blade pitch and blade flapping motions if this is desired.

#### (b) The Two Bladed Rotor

The design for the two bladed configuration is shown in Figure 21. All basic mechanisms and construction techniques are similar to the four bladed rotor. The blade chord has been doubled, so that the total blade area is the same for both rotors. The tip weight required to give the same 15 degree coning angle is now 300 pounds per blade. To carry the resulting higher tensile stresses the blade spar chord has been doubled, from 10 inches to 20 inches. Two .050 inch thick straps are still used.

The use of only two blades results in a smaller, more simple rotor head, with only one retraction drum. This drum would have to be twice as wide as the drums on the four bladed rotor to accept the wider chord blades.

Figure 21 also illustrates the simplification that would result if inboard pitch control was not required. This is for illustrative purposes only, since it is presently felt that both blade tip control and blade root control are probably required for these rotors. In the comparative analysis

both were assumed to be present. If this design were practical with only two blades, and with no inboard pitch control system, this rotor would obviously have the simplest and lowest drag rotor head of any of the concepts studied.

### (3) Aerodynamic Considerations

These rotors use a two percent thick reflexed camber airfoil. Performance was calculated using airfoil data that had been previously developed by the United Aircraft Research Laboratories during an earlier study of this type of rotor system. This effort is reported in Reference 7.

Figure 22 shows lift and drag coefficients of this airfoil at various Mach numbers plotted as functions of angle of attack. At low Mach numbers this is based on experimental results. Airfoil data for the higher Mach numbers was generated based on the test data and a computed critical Mach number - angle of attack relationship.

The hovering figure of merit ratio correction factor for these configurations is .96, if the reflex camber airfoil shape can be maintained. This was derived from a combination of the following corrections.

Tip Weight	.97
Reduced Tip Vortex Strength	1.03
Cutout (.05)	1.02
Twist Washout	.96
Blade Thickness	.98

The baseline figure of merit for the two bladed rotor is .617. Multiplying this by the .96 correction factor results in an actual figure of merit of .592. The four bladed rotor has a figure of merit of .593, based on a baseline value of .623 multiplied by the .96 correction factor.

The question of maintaining the airfoil shape is important with these flexible rotor blades. The dynamic analysis has shown that the blade is dynamically stable at all radial locations. This increases confidence in the assumptions that the blades hold their shape, and no further penalty has been included in the calculation of hover performance. This rotor system is penalized in the technical risk section of the merit rating system to account for a lack of 100% confidence in this area. The two bladed rotor gets penalized more than the four bladed because its large chord would tend to further aggravate any tendency to distort the airfoil shape.

An item that would substantially reduce the figure of merit is the use of the aerodynamic dampers for avoidance of ground resonance. Although they need not be deployed during steady state hover conditions, they do have to be used during takeoff and landing. The dynamic analysis discussed earlier showed that two or three square feet of drag is required on each blade of the four bladed rotor to completely avoid ground resonance. The drag of two square feet on each blade requires an additional 6,200 horsepower to drive at the normal rotor tip speed of 750 feet per second. This compares to the 6070 total rotor power required when the aerodynamic dampers are not deployed. Because of this, the figure of merit correction factor of .96 would drop to .48 when these dampers were being used. The figure of merit for each rotor would be cut in half.

Although this is a very poor figure of merit, there is still enough power available to drive the rotor system. This is because of the disc loading which has reduced the hover power requirements substantially below the power required to cruise the aircraft. In addition, the dampers are only used during takeoff and landing when the rotor is in ground effect, a fact which somewhat negates the low figure of merit.

From the above analysis it can be seen that the use of these aerodynamic dampers substantially compromises this rotor design. An alternate damper design would therefore be advantageous as discussed earlier. Ground resonance is a very real problem with these rotors, and some device such as this must be used to alleviate it.

The vertical drag for the two bladed rotor is 1.65 percent of gross weight for the baseline wing area of 475 square feet. This increases to a value of 2.65 percent of gross weight for a wing area of 1200 square feet. Similar values for the four bladed rotor are 1.95 percent and 3.25 percent.

In high speed forward flight, the two bladed configuration has been found to have superior performance to the four bladed configuration. This is because its parasite drag is about four square feet less than the four bladed rotor head. Because these flexible rotors do not require the hinges of the other designs, they eliminate the need for the large teetering rotor head required on the other more rigid valuable diameter concepts. This results in the two bladed head having less drag than those other concepts. The elimination of the hinges on the four bladed version does not produce a significant drag improvement due to the additional frontal area of the second roller drum.

The total rotor head parasite drag is:

	<u>Rotor Turning</u>	<u>Rotor Stopped</u>
2 Blades	8.3 Sq Ft	8.8 Sq Ft
4 Blades	12.6 Sq Ft	12.7 Sq Ft

In addition to the rotor head contribution to total aircraft drag, the basic fuselage drag is increased 1.5 square feet in both cases. The pylon and lower rotor head fairing contributes 1.3 and 2.2 square feet for the two and four blade configurations respectively. The total aircraft drag including an allowance for leakages and protruberances is:

	<u>Rotor Turning</u>	<u>Rotor Stopped</u>
2 Blades	36.4 Sq Ft	36.9 Sq Ft
4 Blades	42.1 Sq Ft	42.2 Sq Ft

As a result, the power required to cruise the 62,800 pound aircraft at 250 knots is:

	<u>TWO BLADES</u>	<u>FOUR BLADES</u>
Propeller Power	7620 HP	8305 HP
To Overcome Fuselage and Rotor Hub Parasite Drag	4950 HP	5650 HP
To Overcome Wing Drag (Induced and Profile)	2670	2670
To Overcome Rotor Rotational Drag	0	0
Gearbox Losses	40	45
Accessories	100	100
	<hr/> 7760 HP	<hr/> 8450 HP

The two bladed version of the roll-up rotor has been found to have the highest cruise speed of any of the concepts studied. Using the same 11,400 horsepower that the S-65-300 requires at 250 knots, this aircraft can cruise at 295 knots. Because of the larger drag of the four bladed rotor its equivalent cruise speed is 282 knots.

Although these concepts do have excellent high speed performance with the rotors stopped, the transition to the stopped rotor configuration is not as easily achieved as in the telescoping rotors. From the analysis of forward flight dynamics, flight above about 140 knots is not practical with the rotors turning. Therefore, the rotor has been assumed to be fully retracted and stopped by 140 knots. The advance ratio at the initiation of retraction is approximately 0.3.

The wing size required for this low speed transition must be determined as well as the wing size required for cruise. The analysis of both of these mission points showed that a 1080 square foot wing size would fulfill all the mission requirements.

The transition analysis was discussed in Section III-2 and illustrated in Figure 7. At the 140 knot transition speed the power available to the propellers to overcome aircraft drag is limited by the power installed in the aircraft. Wing drag must be equal to or lower than the thrust available to overcome that drag. As shown on Figure 7 this is only possible with a wing of 1050 square feet or larger.

This transition power required analysis may be considered conservative since it assumes all lift is transferred onto the wing before any rotor retraction takes place. In a fully developed system rotor retraction would probably occur slowly as the aircraft forward speed increased, and the rotor would maintain some lift as it retracted. Because the system has received little detailed analytic and test effort at the present time, the more conservative approach was followed.

If the wing were sized for cruise considerations only, its size would be somewhat different. A trade-off study was performed to determine the most cost effective wing size. The details of this tradeoff are discussed in Section III-5 of this study. At the 62,800 pound gross weight, the most cost effective wing size was found to be 1080 square feet, or 30 square feet larger than that

required for transition. This led to the selection of the 1080 square foot wing.

(4) Rotor System Weight

The total weight for the four bladed rotor system is 5439 pounds, or 8.7 percent of the 62,800 pounds gross weight. This is broken down as follows:

Blade (4 required)	442 LBS/blade	1768 LBS
Spar	60 LBS	
Trailing Edge	35	
Leading Edg (Mylar)	103	
Lead Tape	94	
Tip Weight, Including Controls	150	
 Rotor Head		1877 LBS
Basic Head	1626	
Spline	80	
Misc.	171	
 Retraction Mechanism		1794 LBS
Drums	442	
Rollers	156	
Drum Supports	268	
Drum Drive Mechanism	862	
Misc.	66	
	TOTAL	5439 LBS

The two bladed rotor head is 726 pounds heavier with a weight of 6165 lbs. Its weight is broken down as follows:

Blades (2 required)	1195 LBS/blade	2390 LBS
Spar	120	
Trailing Edge	88	
Leading Edge (Mylar)	476	
Lead Tape	211	
Tip Cap, Including Controls	300	
 Rotor Head		1386 LBS
Basic Head	1630	
Spline	80	
Misc.	176	
 Retraction Mechanism		1889 LBS
Drum	508	
Rollers	266	
Drum Supports	308	
Drum Drive Mechanism	720	
Misc.	87	
	TOTAL	6165 LBS



(5) Summary

In summary, the flexible roll-up rotors do have unique aeroelastic problems. If these can be solved, these rotors appear very attractive. They offer the highest retraction ratio, possibly the least drag in the retracted position, and one of the lightest solutions.

Advantages

- . High retraction ratio. Blade can be fully stowed for high speed flight.
- . Low parasite drag
- . Light weight
- . Simple rotor head, with no flapping, lead lag, or teetering hinges required
- . Simple, fail safe blade spar
- . Blade construction offers "throw-away" benefits with no depot level maintenance and blade handling requirements

Disadvantages

- . Unconventional Aeroelastic Characteristics
- . Need for complex tip weight for pitch control and ground resonance alleviation
- . Possible Material Technology problems
- . Low transition speed requires large wing area
- . Rotor cannot be stopped in the extended position
- . Aerodynamic damper at blade tip, with its large drag, may offset much of the power benefit of the low disc loading during takeoff and landing
- . Four bladed head offers poor component accessibility
- . Blade inspection requires manual extension and special handling equipment
- . Blade electrical flight control inputs must be transmitted through two rotary connections
- . Failure of the blade extension/retraction mechanism leads to safety problems during rotor shut-down
- . Two percent thick airfoil requires small aerodynamic compromises
- . Cyclic motions required from electric actuator at blade tip

If this rotor design were pursued, the following areas would have to be investigated further:

- . Whether both blade tip and blade root pitch control schemes are indeed needed
- . Type, feasibility, and size of aerodynamic damper to solve ground resonance problems

- . Size requirement of the tip tab aerodynamic control
- . Forward flight torsion associated instabilities
- . Dynamic instabilities during rotor retraction, during critical maneuvers, and in presence of a turbulent environment
- . Blade construction techniques
- . Aerodynamic characteristics of this airfoil sections
- . How to assure blade tracking and dynamic balance
- . Blade erosion prevention

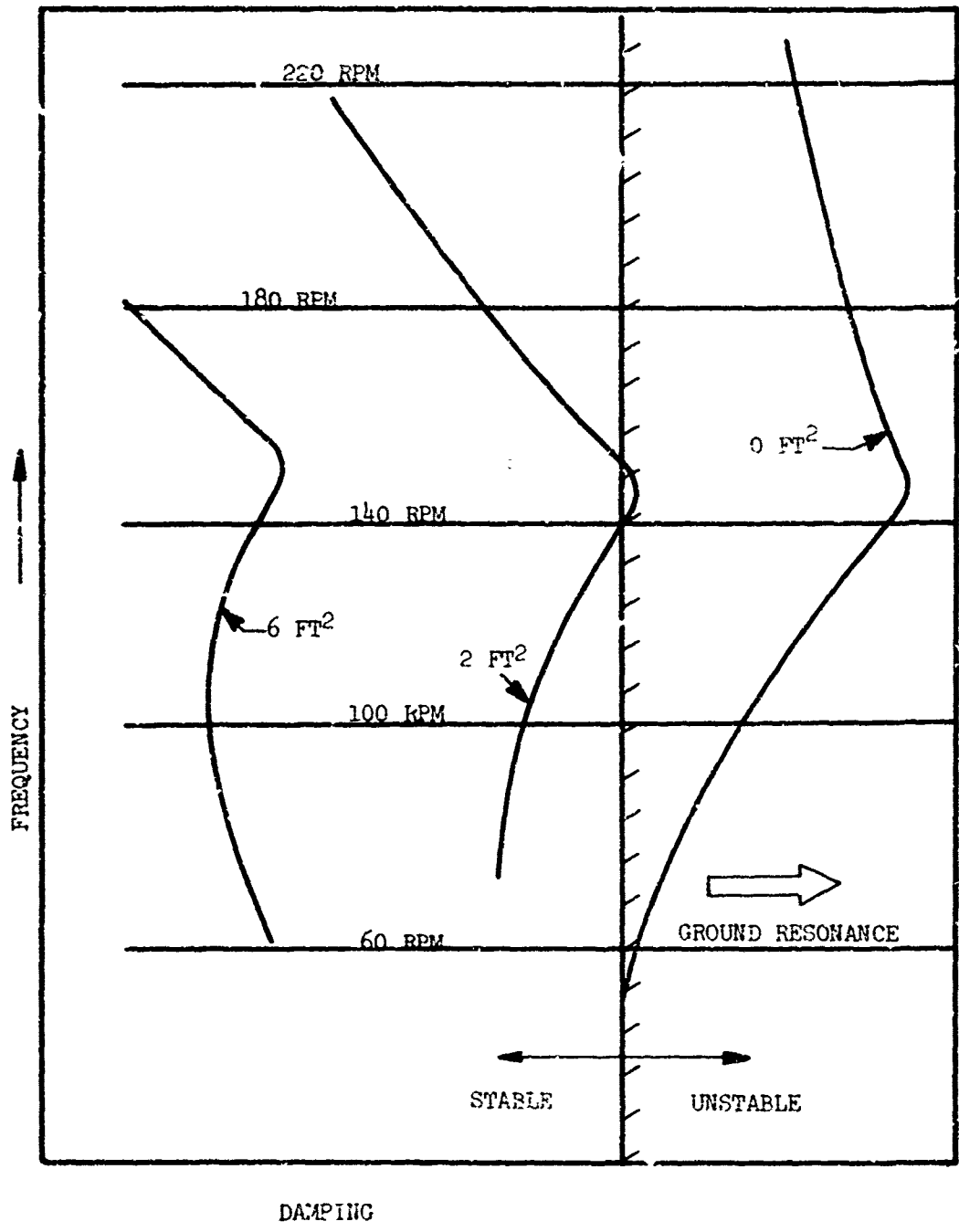

FIGURE 15  
 ROLL-UP ROTOR  
 EFFECT OF DRAG AREA AND ROTOR SPEED ON STABILITY

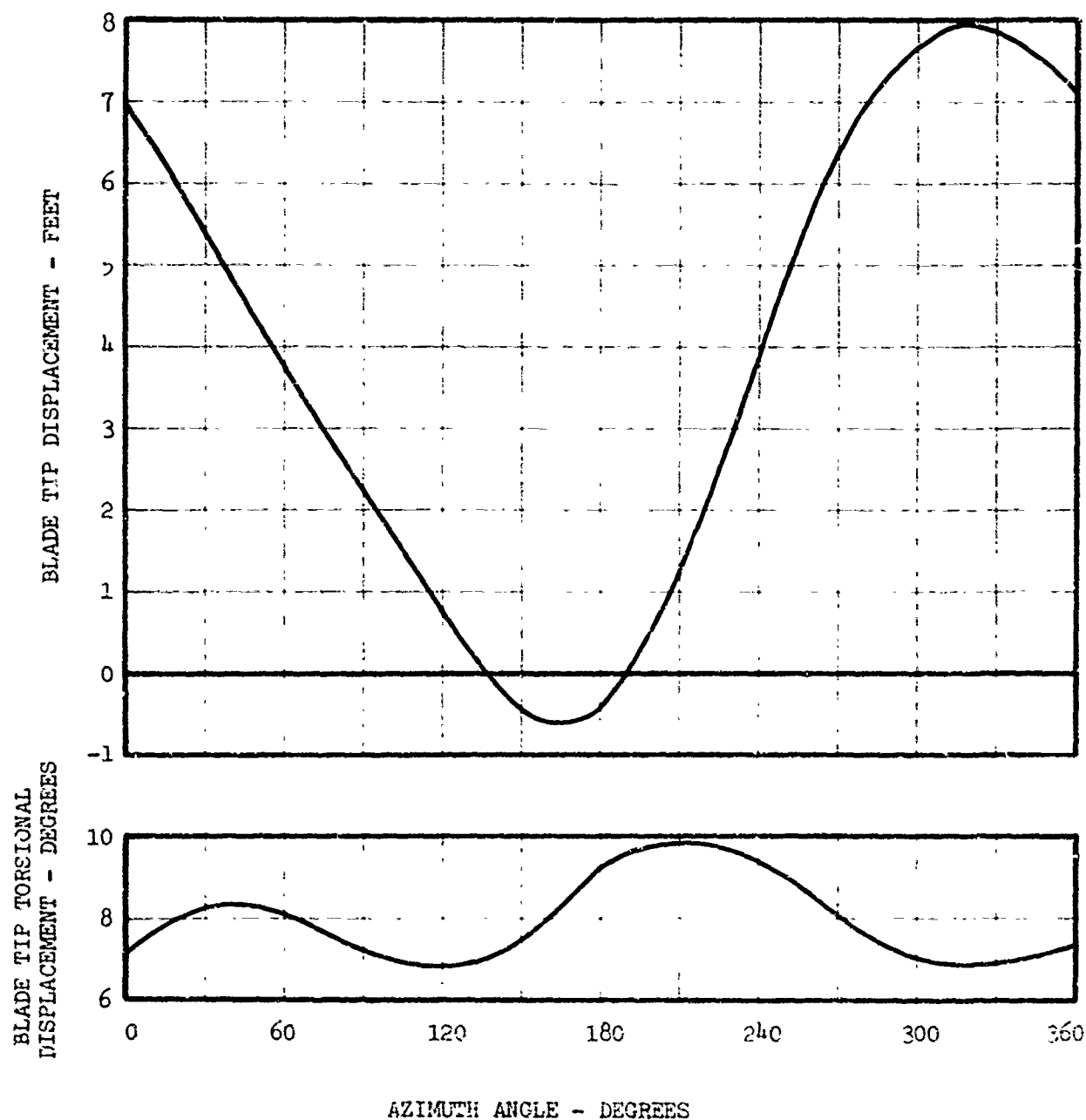

FIGURE 16  
 ROLL-UP ROTOR  
 FLATWISE AND TORSIONAL RESPONSE AT 100 KNOTS, 36000 LBS LIFT  
 ELASTIC AXIS, MASS AXIS, AND AERODYNAMIC AXIS COINCIDENT AT 25% CHORD  
 INBOARD PITCH CONTROL.

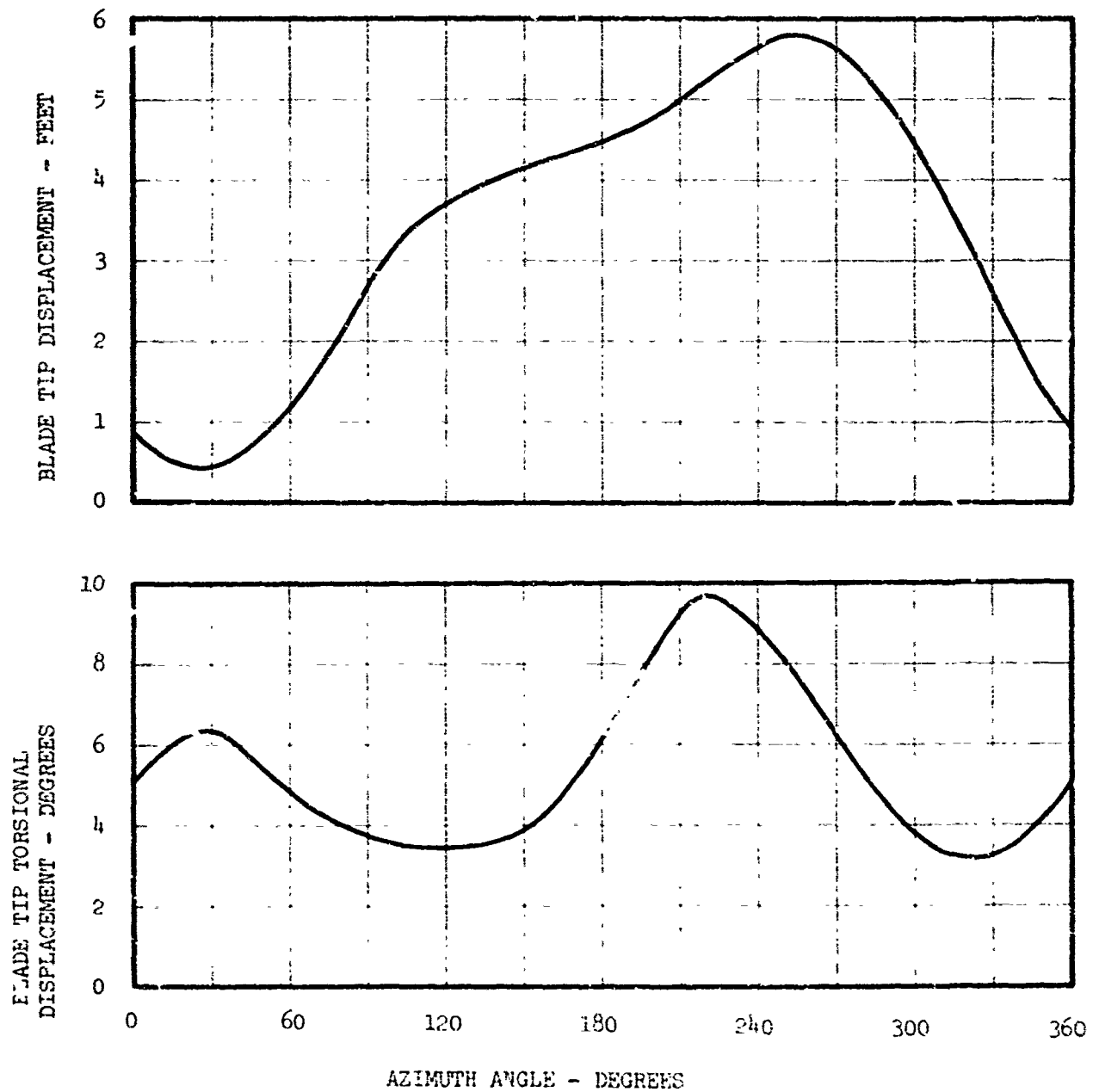

FIGURE 17  
 ROLL-UP ROTOR  
 FLATWISE AND TORSIONAL RESPONSE AT 100 KNOTS, 36000 LBS LIFT  
 ELASTIC AXIS, MASS AXIS, AND AERODYNAMIC AXIS COINCIDENT AT 25% CHORD  
 BLADE TIP PITCH CONTROL.

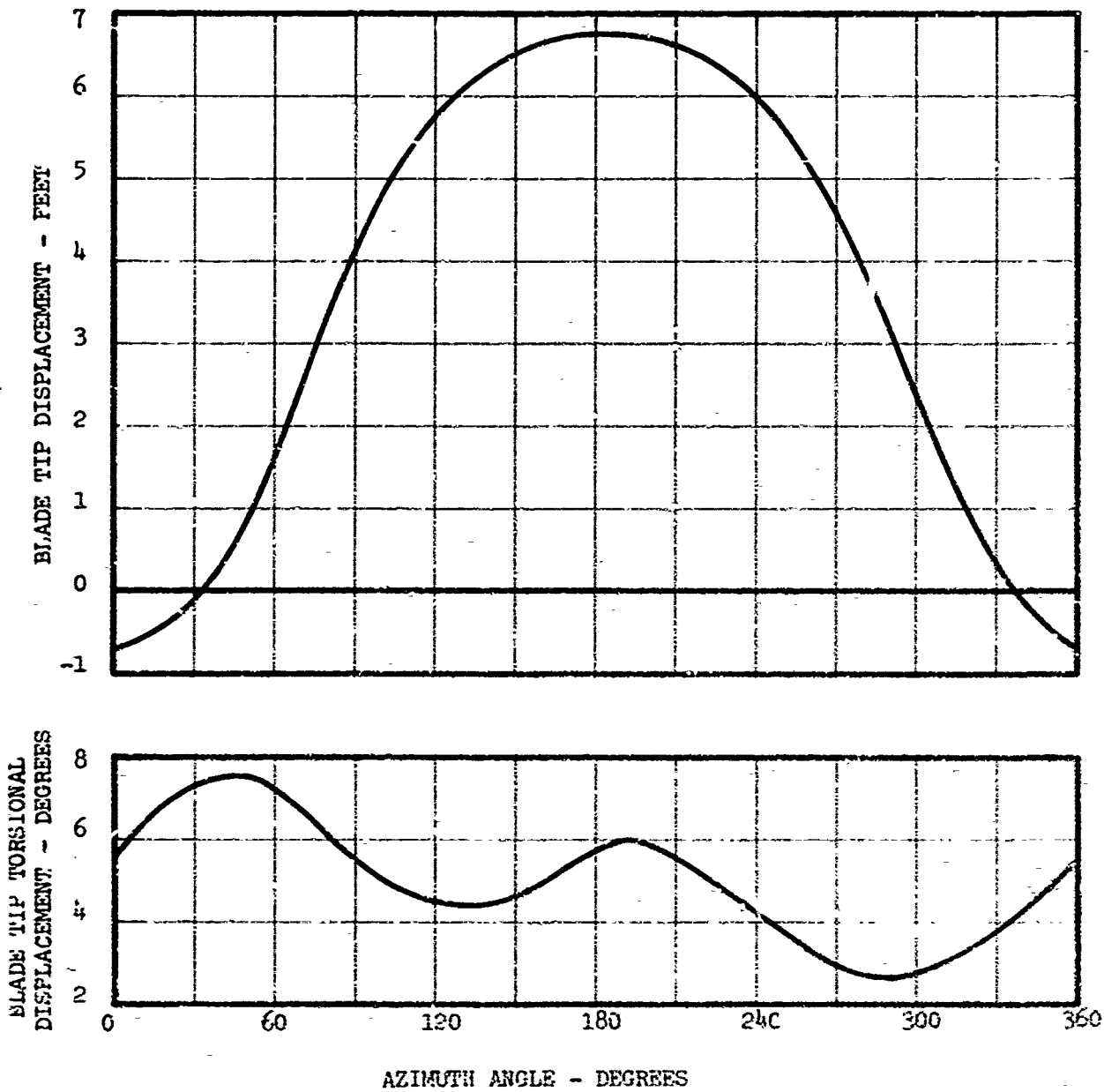
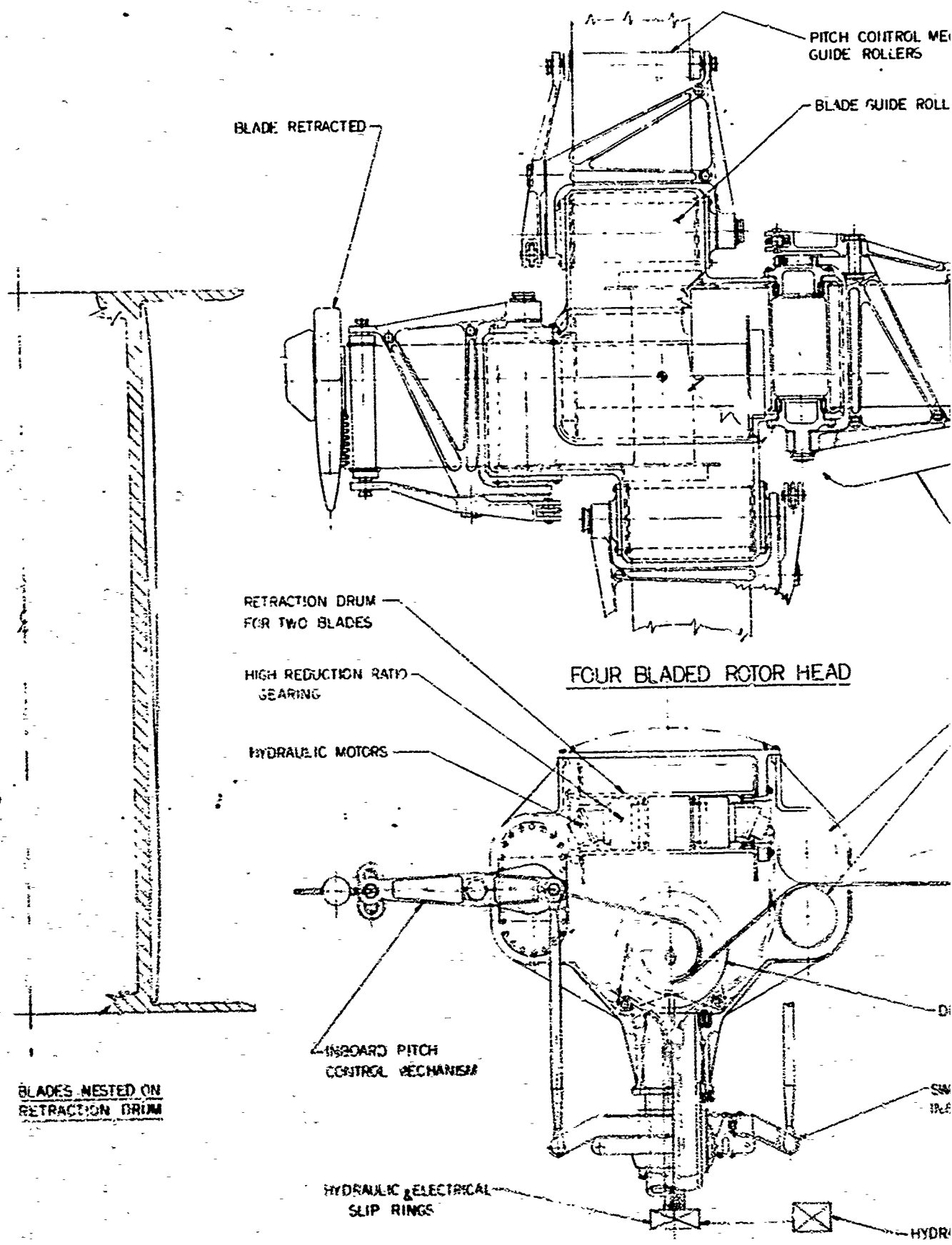

FIGURE 18  
 ROLL-UP ROTOR  
 FLATWISE AND TORSIONAL RESPONSE AT 100 KNOTS, 36500 LBS LIFT  
 ELASTIC AXIS & MASS AXIS AT 23% CHORD; AERODYNAMIC AXIS AT 25% CHORD  
 BLADE TIP PITCH CONTROL







CONTROL MECHANISM

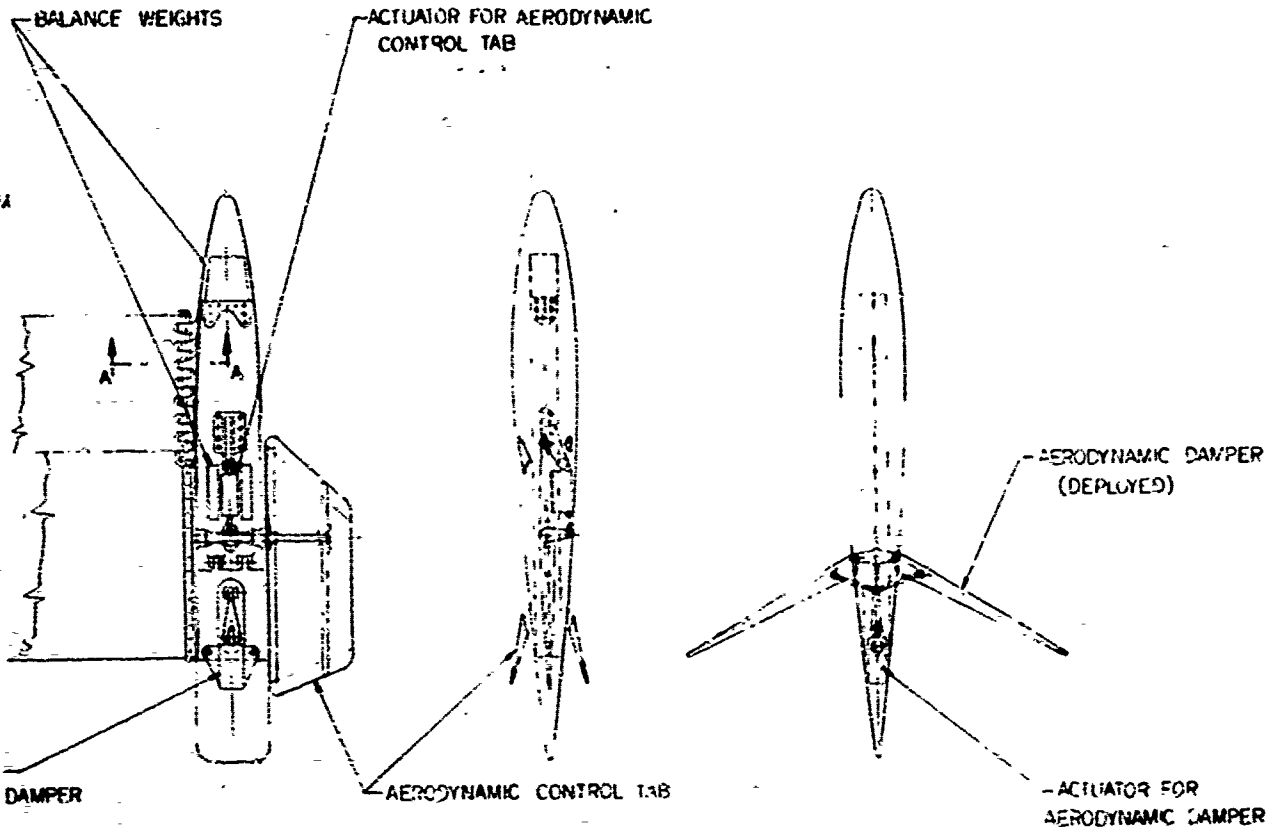

BOARD

TIP WEIGHT MECHANISM

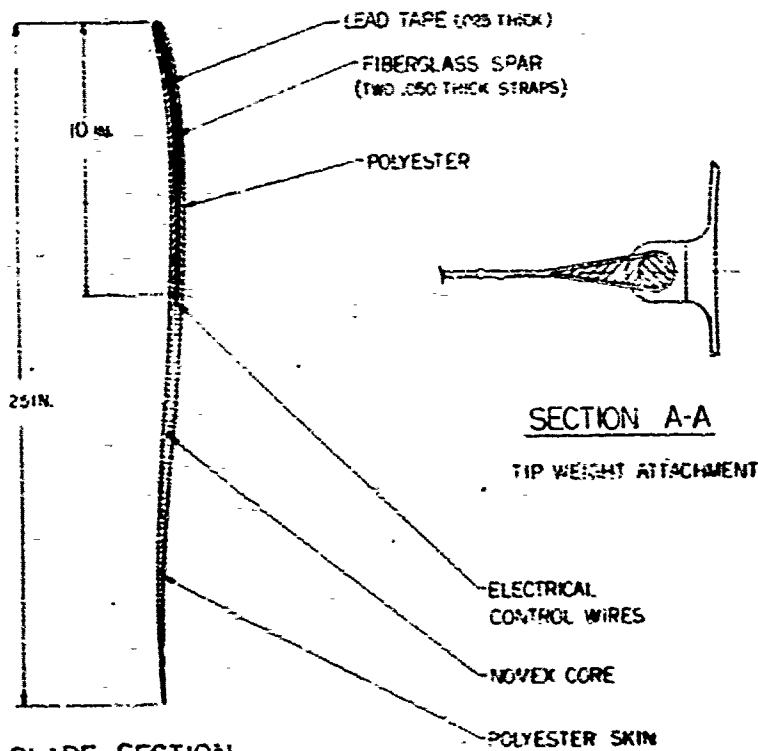

BLADE SECTION

2 3/8 THICK REFLEX CAMBERED AIRFOIL

**FIGURE 19**

REV	DATE	BY	CHKD
<b>VARIABLE DIA. ROTOR STUDY</b> <b>FOUR BLADED ROLL-UP ROTOR</b> <b>2 3/8 THICK REFLEX AIRFOIL</b>			

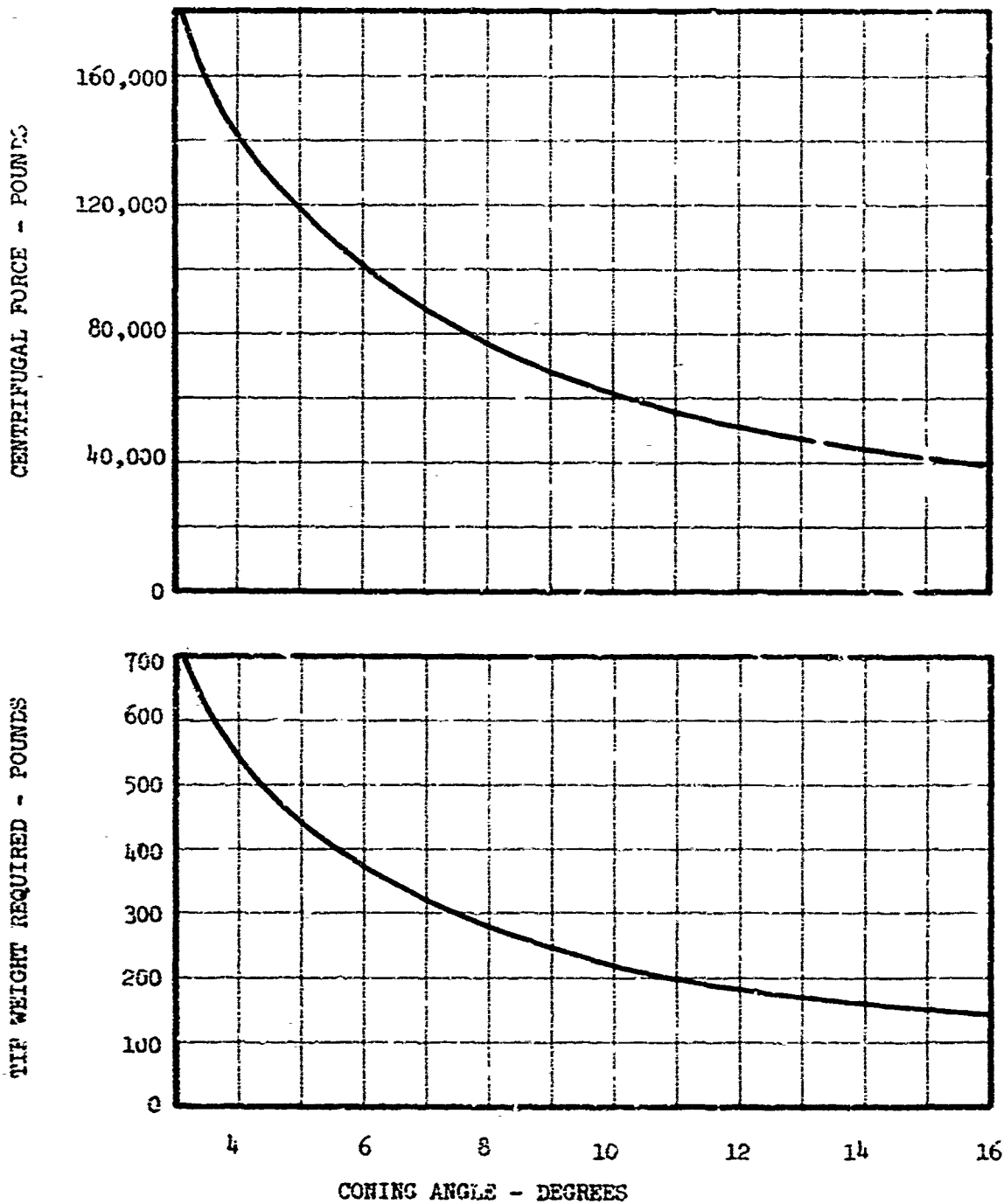
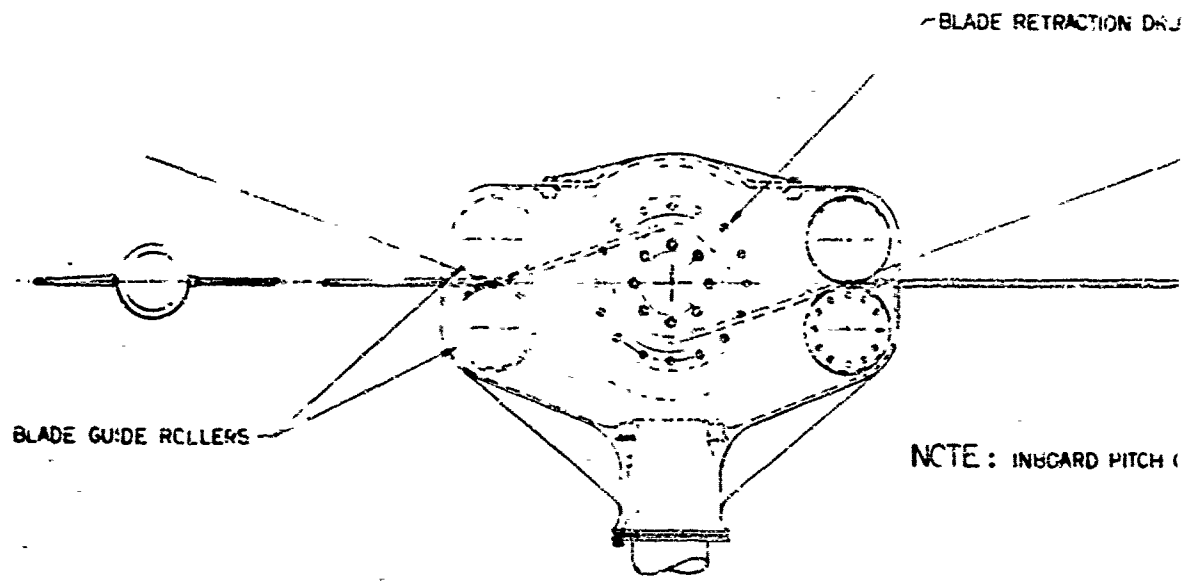
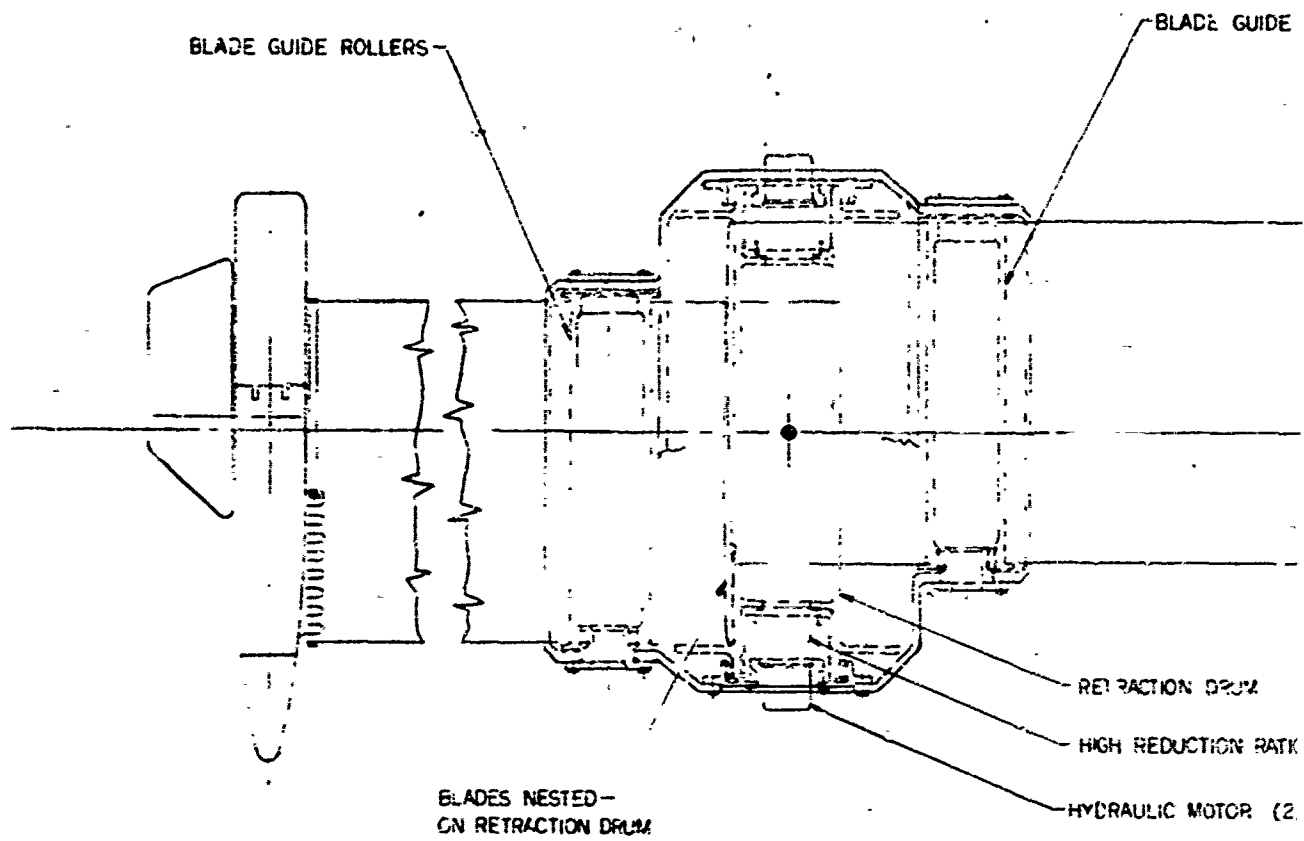

FIGURE 20  
 FOUR BLADED ROLL-UP ROTOR  
 TIP WEIGHT REQUIRED

*Preceding page blank*



Preceding page blank



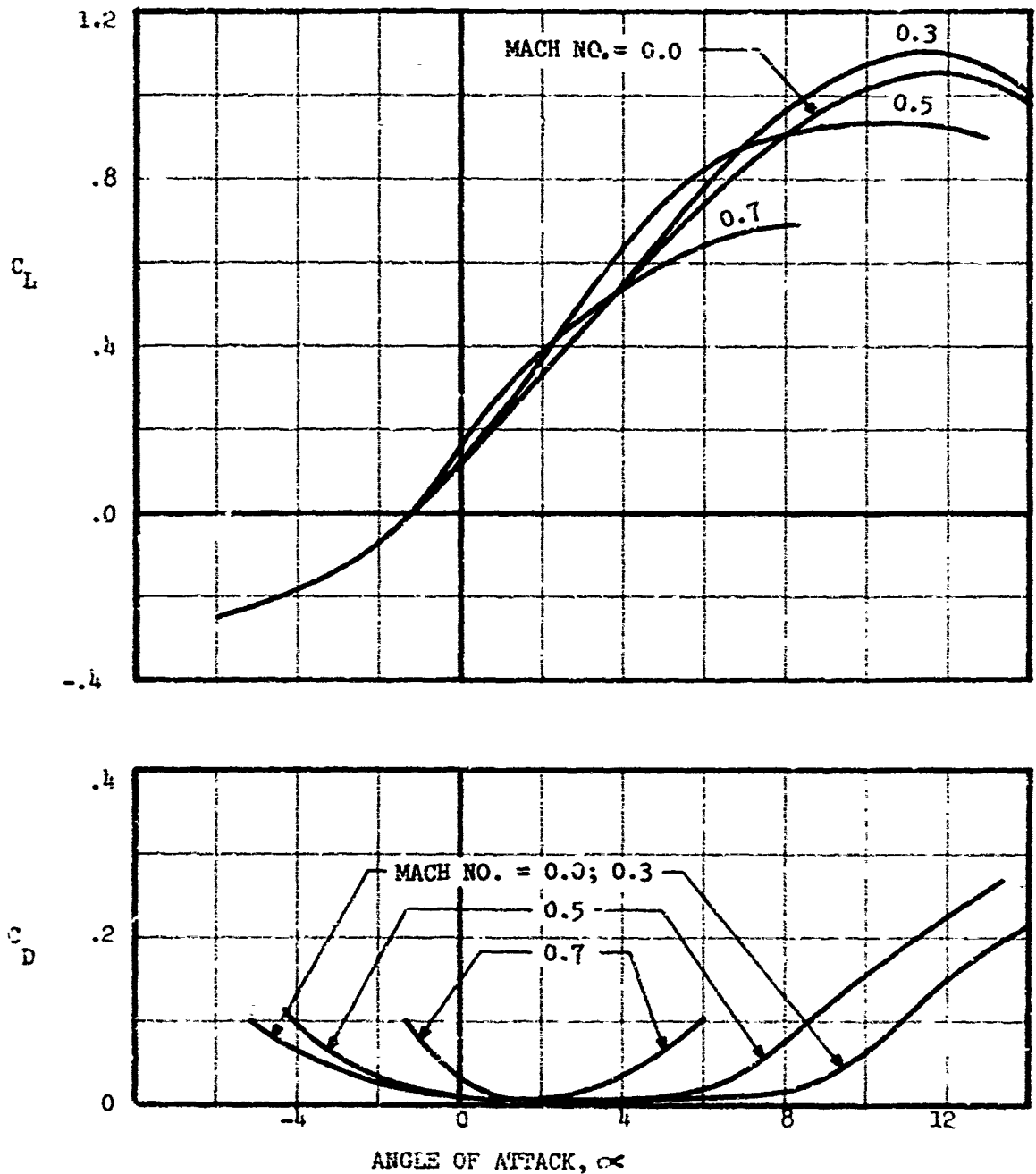

FIGURE 22  
 ROLL-UP ROTOR  
 AIRFOIL CHARACTERISTICS - 2% THICK REFLEXED CAMBER AIRFOIL  
 $C_L$  AND  $C_D$  VERSUS ANGLE OF ATTACK

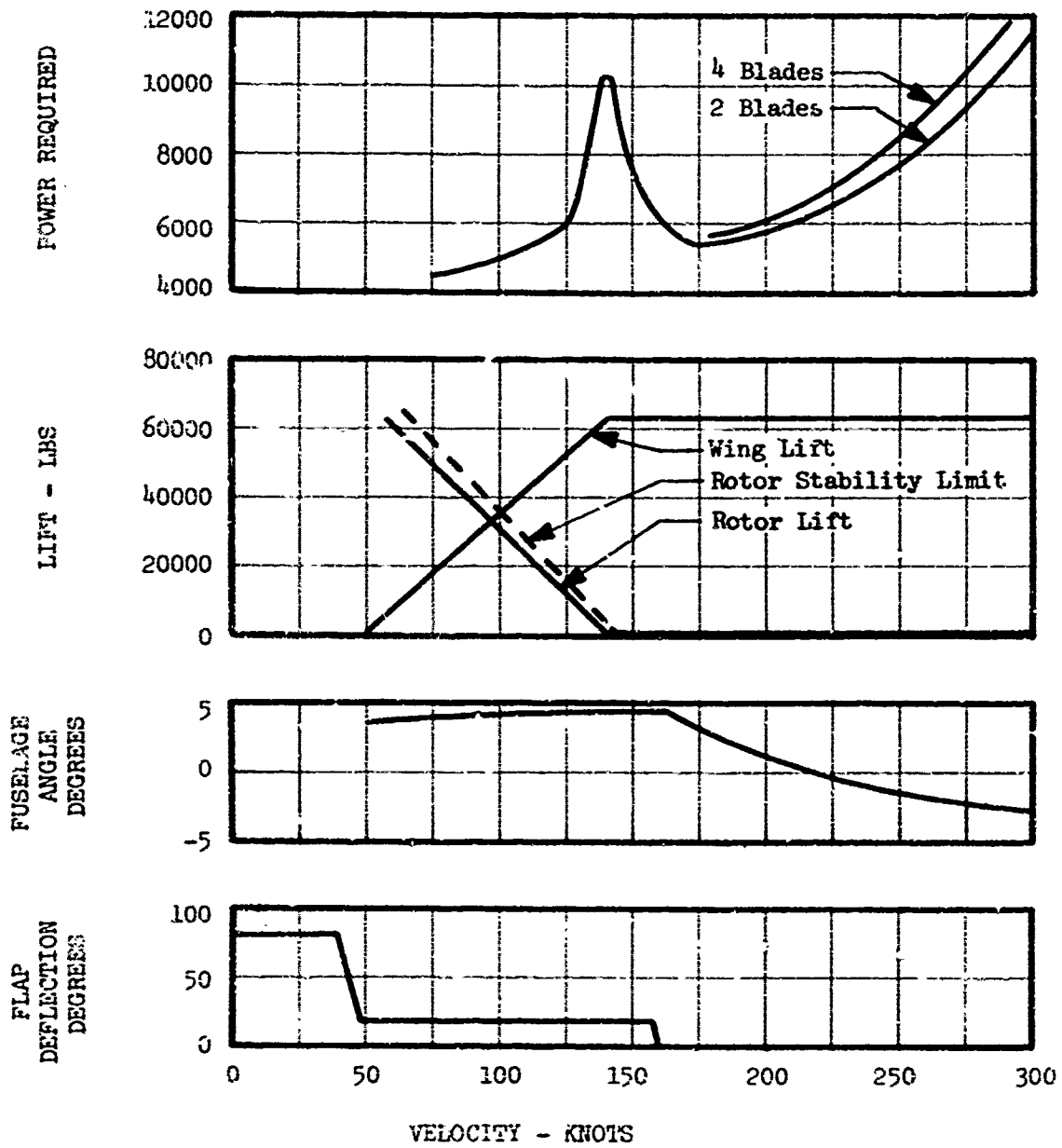

FIGURE 23  
 ROLL-UP ROTOR, THIN AIRFOIL - PERFORMANCE CHARACTERISTICS  
 12000 FT, 16°F  
 62800 LBS GROSS WEIGHT  
 1080 SQ FT WING AREA

### c. Roll-up Rotor, Pneumatic Blades

An alternative to the thin solid blades for the roll-up rotors would be a pneumatic blade. This would be inflated when the rotor is deployed to give a more conventional thicker airfoil shape. With appropriate construction techniques, it could provide substantially higher torsional stiffness than the thin flexible blade. Although the present analysis does not indicate that higher torsional stiffness is a requirement for these blades, more detailed analysis and model tests may conclude that this is desirable.

The following pages discuss the differences between the pneumatic and the thin bladed roll-up rotor.

#### (1) Mechanical Design

The major differences in the design of this rotor and the design of roll-up rotor discussed in the preceding section are confined to the blade construction itself. The rotor head, tip weight, and control mechanisms are basically the same as those previously described.

A cross section of the pneumatic blade is shown in Figure 24. It has been designed using the Goodyear "airmat" type of construction, as described in patent #2,967,573. The blade is made of rubberized fabric with nylon "drop threads" connecting the upper and lower blade surfaces. Under pressure the predetermined airfoil shape is achieved. Without pressure the blade section can be compressed and wound on retraction drums. The blade is divided lengthwise into two separate chambers so that the trailing edge chamber can be held at a lower pressure than the leading edge chamber. This permits a lighter weight construction for the aft portion of the blade and aids in blade balance. Lead tape is still required in the leading edge to completely balance the blade about its quarter chord.

Blade tip weights for the pneumatic blade are the same as for the thin solid blades. Blade tensile loads due to centrifugal force are also similar. To achieve adequate tensile strength fiberglass spanwise filaments are incorporated in the blade upper and lower surfaces. This provides the required tensile strength while remaining thin enough to be wound on the retraction drums without exceeding allowable flexural strains.

The blades are pressurized by engine bleed air. This will not penalize engine performance since once the blades are blown up, very little further bleed air is required. The inflation cycle will occur either on the ground before lift off or, when landing, during a later segment as the rotor system is deployed. Air is ducted from the engines through plumbing which includes two rotary slip rings, one in the rotor shaft and the second in the retraction drums. A chordwise membrane is used just outboard of the blade pitch change mechanism to close off the pneumatic chambers. To simplify the inflation mechanism, inflation is not initiated until the blade is in its fully extended position.

Operating blade pressure requirements are not easily determined in a study of this depth. It has been determined that the maximum aerodynamic induced pressure load on the blade is on the order of 4.8 pounds per square inch. So the blade will not be deformed under its operating airloads, a pressure of 12 psi in the leading edge chamber and 6 psi in the aft chamber has been assumed. The question of how much pressure to use is not critical in this design since the construction lends itself to higher pressures should it turn out that these are required.

For deflation, a pneumatic relief valve is employed at the blade tip which will allow the air to escape as the blade is retracted.

Patents 3,184,187 and 3,298,142 show an alternate construction for a pneumatic blade. Here the blade is made up of two resilient sheets joined at their edges, with collapsible spars between them. With the spars deflated, the blade is flat enough to be rolled on the retraction drums. After the blades are extended, the spars are pressurized to obtain the desired thickness. This construction would appear to offer few advantages over the airmat. Inflation and deflation methods would be similar, but the blade construction techniques would be more difficult. The blade skins would have to be of some type of stiffer material such as thin metallic sheets, since they are only supported locally. The airmat construction is supported by internal pressure over its entire area. The stiffer material would make retraction more difficult and perhaps require larger diameter retraction drums.

A distinct advantage of this stiffer skin construction would be its torsional characteristics. If the edges of the two surfaces could be held rigidly together, the blade would have some torque carrying capability. This would perhaps permit a design with inboard pitch control only. This advantage by itself does not seem to warrant the more complex blade construction required.

Torque carrying capability could be added to the airmat blade by wrapping the blade with graphite or carbon fibers at 45 degrees to the blade axis. These could be made to provide the desired torsional stiffness while still being thin enough to permit winding on the retraction drums.

## (2) Dynamic Considerations

A limited study conducted by the United Aircraft Research Laboratories, Reference (2), showed that a 2% thick airfoil has a lower maximum lift coefficient than a conventional 0012 airfoil. This caused the thin blades to encounter retreating blade stall at lower advance ratios that would be the case with thicker airfoils. From this viewpoint, the pneumatic roll-up rotor has an advantage over the thin airfoil system. The pneumatic system does have the distinct disadvantage in that it requires a blade inflation system which adds to the design, complexity, weight, and maintenance requirements.

The pneumatic roll-up system can be given similar elastic properties to the thin airfoil system previously discussed. It would then possess the



same ground resonance and torsional stability characteristics. There does not in general appear to be any areas where major differences in aeroelastic response characteristics are expected, except possibly effects resulting from distortions of the pneumatic blade airfoil section. Consideration in the pneumatic system must be given to ballistic or foreign object blade damage. A blade which would deflate as a result of small arms damage would be unacceptable. Means would therefore have to be sought to provide some type of self-sealing capability.

### (3) Aerodynamic Considerations

The performance of this rotor is similar to that for thin roll-up rotor as described in the preceding section. In the four bladed configuration, its hover figure of merit is .60%, based on a figure of merit ratio correction of .97 applied to a baseline value of .616. This correction factor is 1% higher than the thin roll-up rotor, and is based on the following individual corrections.

Tip Weight	.97
Reduced Tip	
Vortex Strength	1.03
Cutout (.05)	1.02
Twist Washout	.96
Blade Imperfections	.99

The two bladed rotor has a figure of merit of .598, and has the same correction factor.

The baseline vertical drag and parasite drag are the same as for the thin roll-up rotors. The vertical drag for the two bladed rotor is 1.65 percent of gross weight for the baseline wing area of 475 square feet. This increases to a value of 2.65 percent of gross weight for a wing area of 1200 square feet. Similar values for the four bladed rotor are 1.95 and 3.25 percent.

The total aircraft drag including an allowance for leakages and protuberances is:

	<u>Rotor Turning</u>	<u>Rotor Stopped</u>
2 Blades	36.4 Square Feet	36.9 Square Feet
4 Blades	42.1 Square Feet	42.2 Square Feet

The power requirements at the 250 knot speed used for these comparisons are also similar to the thin solid roll-up rotors:

Propeller Power	8355
To Overcome Fuselage and Rotor Hub Parasite Drag	5600

(Cont'd on next page)

To Overcome Wing Drag (Induced and Profile)	2755	
To Overcome Rotor Rotational Drag	0	
Gear Box Losses		45
Accessories		<u>100</u>
		8500 HP

Transition to the stopped rotor configuration is also similar to the thin roll-up rotors. The rotor has the same dynamic characteristics as the other roll-up rotors at moderate forward speeds and the rotor is assumed to be retracted and stopped at 140 knots airspeed. Figure 25 shows the power requirement during this transition, plus other pertinent parameters plotted against forward speed. The aircraft has the same maximum speed capability as those with the thin roll-up rotors; 295 knots in the two-bladed configuration and 282 knots in the four-bladed configuration.

#### (4) Rotor System Weight

The total weight for this rotor system in a four-bladed configuration is 4980 pounds or 7.9 percent of the 62,800 pound gross weight. This is 460 pounds lighter than the thin flexible roll-up rotor. The weight is broken down as follows:

<u>Inflatable Blades</u> (4 required)	322 Lb/Blade	1288 Lb
Spar	59 Lb	
Trailing Edge	11	
Rubberized Fabric	54	
Lead Tape	33	
Miscellaneous	15	
Tip Weight Including Controls	150	
<u>Rotor Head</u>		1877 Lb
Basic Head	1626	
Spline	80	
Miscellaneous	171	
<u>Retraction Mechanism</u>		1815 Lb
Drum	442	
Rollers	156	
Drum Supports	268	
Drum Drive Mechanism	862	
Miscellaneous	87	
Total		4980 Lb

(5) Summary

The pneumatic bladed roll-up rotor has much in common with the thin flexible rotors described in the preceding section. In addition, it has further advantages and disadvantages as itemized below:

Advantages

- . More optimum airfoil shape
- . Blade could be constructed with higher torsional stiffness should this become necessary

Disadvantages

- . Added complexity of pneumatic mechanism
- . Higher development risk than thin roll-up rotor
- . Possible need for sealed blade compartments to prevent complete blade collapse from ballistics damage

If this rotor design were pursued, the following areas would have to be investigated. These are in addition to the items listed in the preceding section for thin flexible roll-up rotors.

- . Problems associated with blade inflation
- . Maintenance of blade pressure after ballistic damage, and during autorotation with all engines inoperative
- . Pressures required to maintain blade shape under all flight conditions
- . Any unique fabrication problems

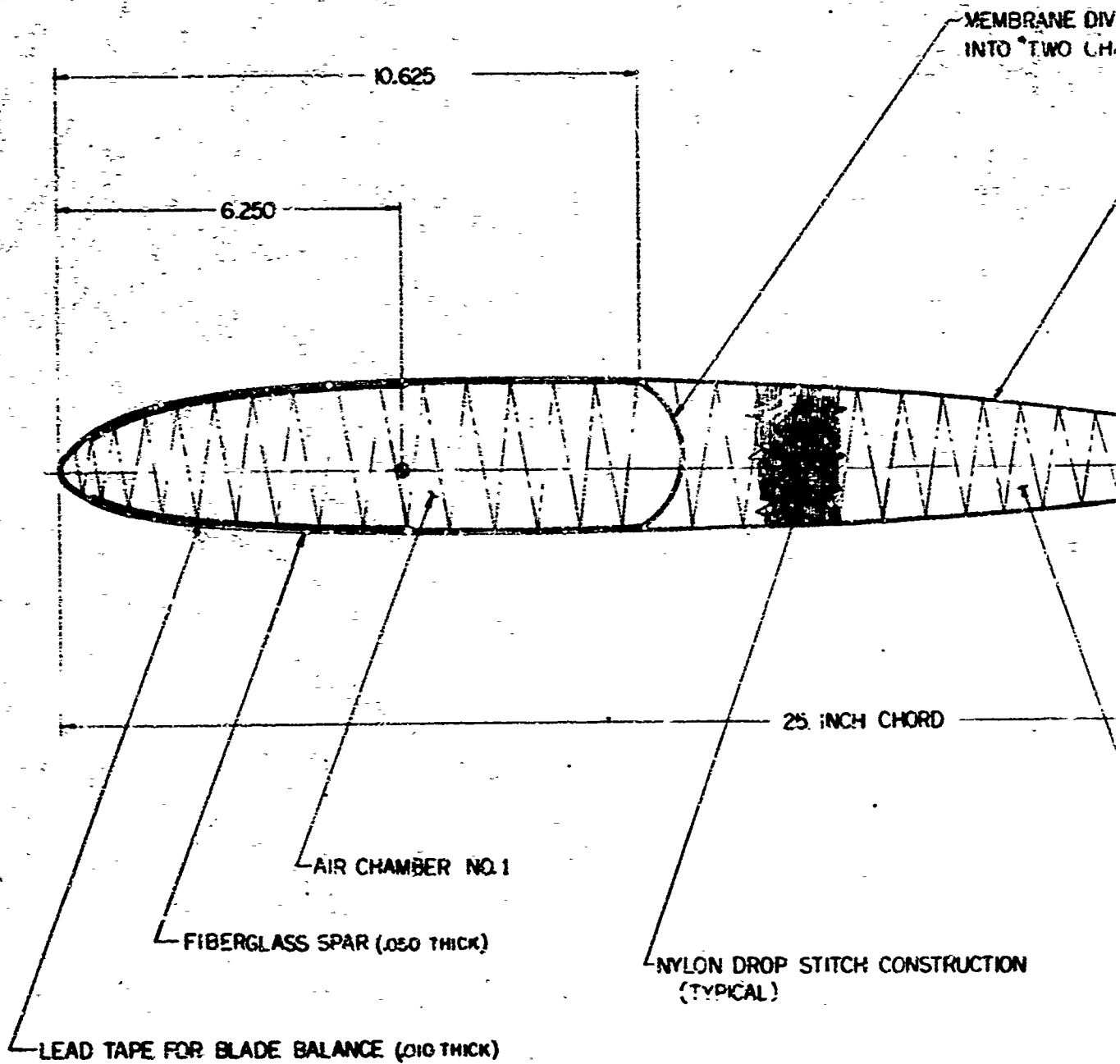

8

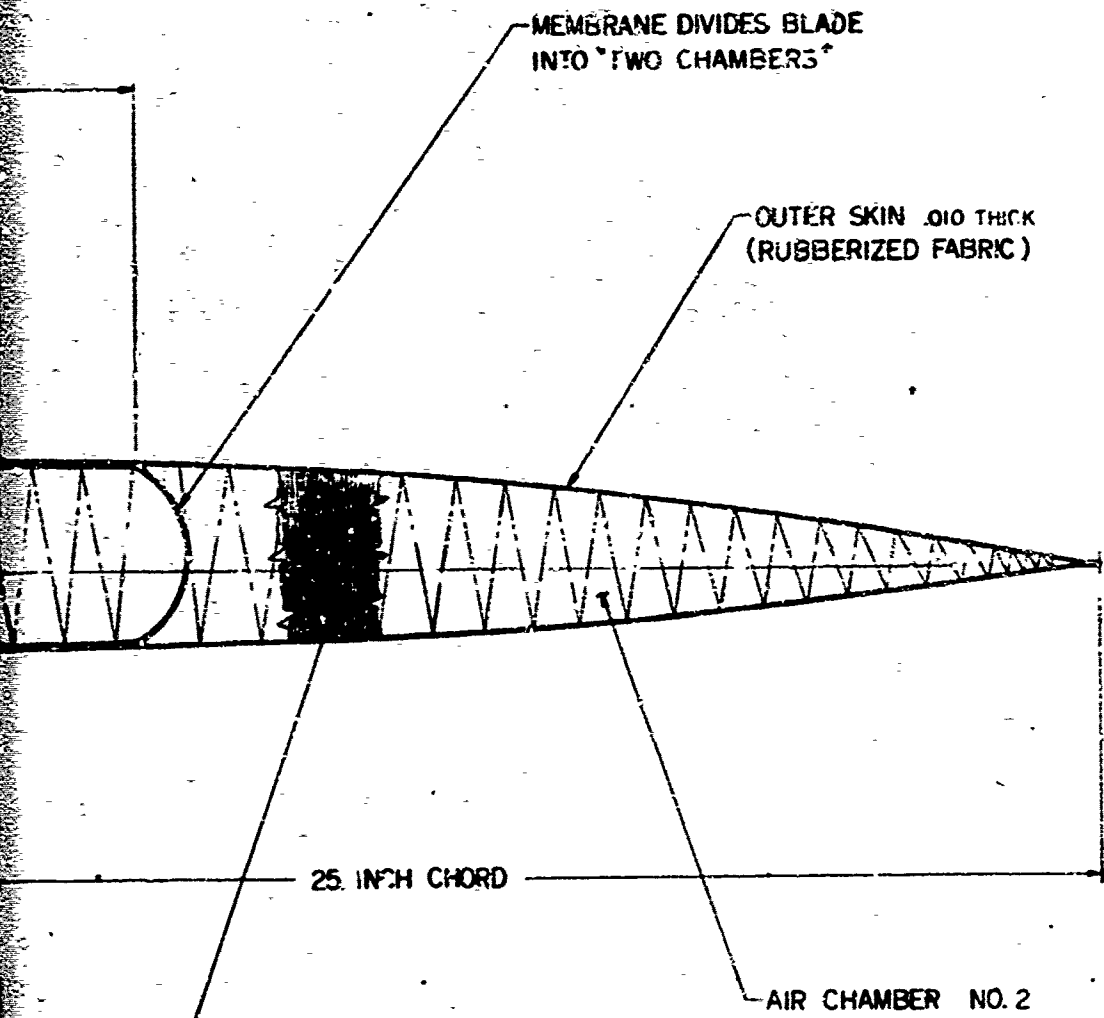

FIGURE 24

DESIGNED BY	DATE	SCALE	FIGURE NO.
DRAWN BY			
CHECKED BY			
APPROVED BY			
REPORT NO.	PAGE NO.	FIGURE NO.	
<b>VARIABLE DIA. ROTOR STUDY</b>			
<b>PNEUMATIC BLADE</b>			
<b>FOUR BLADED ROLL UP ROTOR</b>			
Sheets	DS-507-8-2		

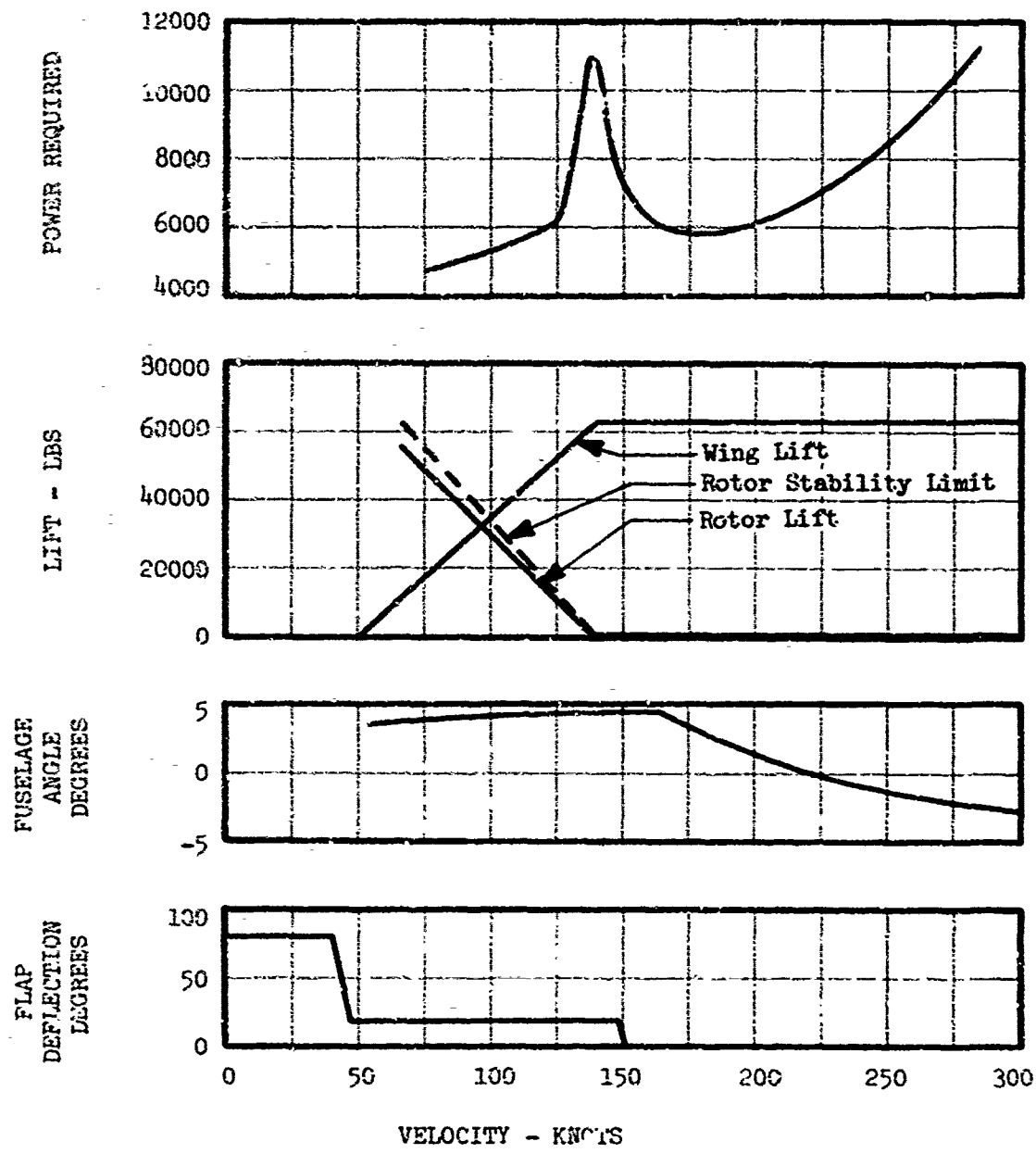

FIGURE 25  
 ROLL-UP ROTOR, PNEUMATIC AIRFOIL - PERFORMANCE CHARACTERISTICS  
 FOUR BLADES, 12000', 16°F  
 62800 LBS GROSS WEIGHT  
 1080 SQ. FT. WING AREA

Preceding page blank

#### d. Alternate Approaches for Roll-up Rotors

Both the roll-up rotor using thin flexible blades and the roll-up rotor using pneumatic blades were investigated in this study. Certain other roll-up rotor concepts and modifications of the study concepts were revealed during the literature and patent search. These were not studied during this program, but certain comments are included in the following discussion on two of the more interesting designs - the catenary rotor and the control line rotor.

##### (1) The Catenary Rotor

Patent number 3,188,020 proposes the use of a varying blade chord with the tip weight supported by catenary cables in the leading and trailing edge of the blade. This system could be used to place the flexible blade in chordwise tension when centrifugal force puts the catenary cables in tension. Although this would tend to solve any chordwise deflection, this concept is not without compromises in other areas. The variable chord is not close to any optimum aerodynamic ideal and would require larger retraction drums within the rotor head. This would further increase rotor head size, weight, and parasite drag.

A preliminary dynamic examination indicates that this system is subject to problems similar to the other roll-up rotors. Specifically, ground resonance, pitch control, and torsional effects. Although the concept appears to be as feasible dynamically as the roll-up rotor in hover and steady forward flight, it may not have any improvement in gust response characteristics.

For system gross weights of the order of those considered in this report, the catenary cable rotor does not appear to have any advantages over the fixed chord roll-up rotor in regard to aeroelastic characteristics.

In summary, the inclusion of the catenary cable feature in the roll-up rotors does not seem warranted at the present time. If further development shows that chordwise deflection is more of a problem than presently anticipated, this might be a feasible solution to the problem.

##### (2) The Control Line Rotor

The control line rotor concept uses an outboard rigid blade segment, which is connected to the hub by means of two cables. The length of the rigid segment may be on the order of twenty percent of the blade radius. With this type of construction, the control line rotor is a compromise between the roll up rotors and the more rigid types. It allows reasonable retraction ratios, since the cables can be reeled in to reduce rotor diameter, and yet the rigid outboard segment is not subject to the many deflection problems of the roll-up rotors. Blade pitch control would be achieved by using a blade tip aerodynamic control surface, as with the roll-up rotors.

The most obvious drawback to this concept is the fact that it cannot achieve the high retraction ratios of the pure roll-up concepts. If the rigid segment has a length of twenty percent of the blade radius, for example, the rotor retraction ratio would be on the order of 4 to  $4\frac{1}{2}$  to 1.

Pitch control and torsional stability would seem to be able to be handled as in the roll-up rotor, except that use of any conventional inboard control is not feasible, since the blades have essentially zero stiffness. The first torsional natural frequency of these blades will be very close to one per rev; this might lead to problems associated with flap/torsion coupling, since the first flatwise frequency of the blades will also be close to one per rev. The roll-up rotor had a first torsional frequency of about 1.6 per rev, which reduced this coupling.

Ground resonance in this system could present a bigger problem than in the roll-up rotor. The only inplane stiffness this system has is produced by centrifugal force. It will behave as an inplane articulated system. The inplane natural frequency in terms of cycles per rev. will remain essentially constant no matter what the rotor radius. As pointed out in the discussions on the roll-up rotor, this could have serious consequences. If drag vanes are employed to give aerodynamic damping, the effective damping produced by a constant drag vane drag area is reduced as the radius is reduced and this aspect would certainly require some further study.

Work is also required to examine controllability and torsional stability.

From the above it is felt that the control line rotor does have some serious drawbacks of its own, particularly in the total retraction ratio achievable. On the other hand, the unusual dynamic and control problems of the roll-up rotors, which the control line rotor might help to solve, were not found to be insurmountable. As such, it would appear that the control line rotor is not as promising as the roll-up rotor types described in the preceding sections.



The inplane fold rotor has two blades with vertical fold hinges at one-third blade radius to permit the blades to be folded alongside the rotor head. As such, it has a retraction ratio of 3 to 1. Unlike the other rotor types, the blade diameter cannot be retracted gradually, due to the unsymmetric distribution of airloads on the blade during folding. This would appear to be the major disadvantage with this concept.

### (3) Mechanical Design

This rotor design is shown in Figure 26. A two-bladed tee ring rotor head is used with 50 inch chord blades. These blades have an aspect ratio of 15.3. This gives them reasonable static strength, and they can be stopped in the fully extended position. Titanium is used throughout the rotor head; the bearings are of the elastomeric type. The control linkage is similar to that used on the eight segment telescoping rotor, with a conventional swashplate controlling the blade through a linkage which passes through the teetering hinge.

Because of the nature of the folding, the dynamic and aerodynamic loads on the blade during folding result in moments about the feathering bearings. These have to be reacted by the control system, unless a further feature is added to carry this moment. In this design, a pitch lock device is included in the rotor head to lock the pitch mechanism during folding, and prevent these loads from being felt by the control system.

Between the rotor head and the hinge mechanism is an elliptic tube. Besides carrying blade loads in conventional flight, it must also carry these high torques during blade folding.

Outboard of the tube is the RETRACTION MECHANISM. This employs a hydraulic power cylinder and blade coupling linkage, using the trailing edge blade cuff pin as a pivot to rotate the outer blade segment to a stowed position. Locking pin cylinders insert and retract the leading edge lock pins at the command of operational sequence valves and relays. These protect against inadvertent operation.

The hinge must carry the high centrifugal force from the outboard blade section and it is also subject to significant oscillatory flexural loads. The combination of both of these causes the hinge fatigue characteristics to be a critical design consideration.

A capturing mechanism has been included to hold the blades in the folded position. This is also shown in Figure 26. An arm extends off the trailing edge of the blade. During folding, this arm is "captured" by a mechanism bolted to the elliptic head extension tubes. A locking pin holds it rigid in the folded position.

The blade outboard of the folding hinge is of conventional construction. One of the advantages of this concept is that virtually no compromise is required, either aerodynamically or structurally, in this blade. The spar is tapered titanium with a titanium sheet outer skin. Honeycomb is used in the trailing edge and mass balance weights are located ahead of the spar.

During folding, the airload assymetrics which result from gusts and other disturbances effect the aircraft stability. This may be critical since conventional controls cannot be used to alleviate the problem. This study did not carry the analysis of this problem into any depth. It is thought that perhaps a spoiler will be necessary on the blade to destroy its response to gusts during blade folding. This would further complicate the blade design.

## (2) Dynamic Considerations

In the area of general aeroelastic characteristics in the normal helicopter mode, the only part of the design that could produce significant differences between this and a conventional blade is the hinge. It produces both mass and stiffness discontinuities which are not common to conventional blades. An effect of these will be to alter certain blade mode shapes and hence the blade response in these modes. This is not expected to produce any real problems. To avoid adverse effects on the blade flutter characteristics, the hinge should be quarter chord balanced. Clearly, slop in the hinges cannot be tolerated. The fact that the hinge is situated at an outboard blade station, makes it subject both to substantial centrifugal loads to oscillating bending loads.

Most of the problems associated with this system exist during and after blade fold. For example, if the system encounters a 50 ft/sec vertical gust when the blade fold angle is  $90^\circ$ , the outboard blade segment can impart a torque of 20,000 ft.lb. on the inboard section. Since the blade root torsional motion will be locked out during folding, this torque will not be felt by the control system. It is, nevertheless, a large torque which the inboard blade section must react. In addition, if the torques vary between the two blades, a resulting upsetting moment will be felt by the airframe.

Two methods of folding were investigated. The first incorporates a powered fold mechanism (which complicates the blade design) for controlled folding. In the second scheme, the hub is decelerated to allow the outboard blade segment to fold under its own momentum. A short analysis was conducted which assumed this latter type of folding. The analysis ignored aerodynamic effects. The first case assumed the hub to be decelerated from normal rotor speed to a stop in 10 seconds. This is equivalent to a constant deceleration of  $1.21 \text{ rad/sec}^2$ . It was found that the outboard section took 10.6 seconds to travel through an angle of  $180 \text{ deg}$ . and that the kinetic energy of the blade at this time was approximately 24,000 ft lb. For a 30 second deceleration time, the blade kinetic

energy at 180 deg. was about 3000 ft.lb. A blade snubbing mechanism would be required to absorb this energy without allowing rebound or causing undue blade stresses or damage. This idea seems to be completely impractical. If during the folding there is any unusual occurrence which causes the outboard blade segment to lose momentum, it may never reach the snubbing mechanism in which case it would be out of control. This could have disastrous consequences. Because of this, it is felt that a controlled fold is mandatory.

Folding this system at other than zero rotor speed will require a substantial amount of power. Consequently, the fold mechanism will be required to transmit this power and react the outboard blade segment loads. These requirements lead to a heavy fold mechanism. If the rotor is stopped prior to folding, stopped rotor phenomena becomes important. Sikorsky Aircraft has done a substantial amount of work in this area; this is described in detail in Reference 9. A significant finding of this work was that for successful conversion in rough air, very stiff blades are required. Clearly all articulation must be locked out. This requirement will again lead to weight penalties.

The aerodynamic environment of the stopped/folded configuration is also an area of concern. Interference effects between all of the blade segments will cause complex loadings of the folded blades and may subject the aircraft to buffeting which could result in undue airframe response. This would certainly have an adverse effect on the aircraft structural integrity. The drag on the folded blades must also limit speed potential.

In summary, this system appears to have problems associated with it which will require "heavy" solutions. It also appears to be a high risk system.

### (3) Aerodynamic Considerations

The inplane fold rotor is the only variable diameter concept that permits the optimum aerodynamic design of the blades. Use of this freedom has offset the figure of merit loss of the rotor caused by the large root cutout. The figure of merit for this rotor is .616. This is based on a figure of merit ratio correction factor of 1.09, which is the sum total of the following corrections:

Root Cutout (.35)	.96
Locking Mechanism Drag : Interference	.98
Blade Fold Hinge	.99
Advanced Blade Tip	1.03
Advanced Blade Twist	1.05
Inboard Blade Taper	.99

The large root cutout reduces vertical drag to 1.45 percent of gross weight for the basic wing. This increases to 3.65 percent of gross weight for a 1350 square foot wing.

Low speed performance of this rotor is good but transition and blade folding must be accomplished at a speed of 140 knots to reduce blade instabilities during folding to a tolerable level. The advance ratio at the start of retraction is approximately 0.3.

Unlike the other variable diameter rotor types, the blades on the folding rotor cannot be retracted gradually. This is one of the major disadvantages of this concept. This low forward speed at which rotor folding must be performed results in a requirement for a large wing size and also means that power requirements are high during transition. High speed performance also tends to be limited by the large exposed blade surfaces. At 62,800 pounds, this aircraft can cruise at 283 knots using the same power that the S-65-300 requires at 250 knots.

The components of the power required by the inplane fold rotor at 250 knots are as follows:

Propeller Power		8900 HP
To Overcome Fuselage and Rotor Hub Parasite Drag	5700	
To Overcome Wing Drag (Induced & Profile)	3200	
To Overcome Rotor Rotational Drag	0	
Gearbox Losses		45
Accessories		100
Total		<u>9045 HP</u>

Figure 27 shows the power requirements of this system as a function of forward flight speed, along with the lift sharing, fuselage pitch attitude, and wing flap deflections necessary to sustain level flight.

#### (4) Rotor System Weight

The total weight for this rotor system is 8,741 lbs or 1.9 percent of the 62,800 lbs gross weight. This is broken down as follows:

<u>Inplane Fold Blades (2 required)</u>	2062 lbs/blade	
Basic Blade	1253 lbs	4124 lbs
Torque Tube	809	
<u>Rotor Head</u>		3331 lbs
Teetering 'U' Beam	1187	
Rotor Head Housing	870	
Spindle	524	
Sleeve	546	
Spline	80	
Miscellaneous	124	
<u>Blade Fold Mechanism</u>		1286 lbs
Fold Hinge	319	
Pitch Lock	112	
Blade Lock	170	
Cylinders	275	
Fold Pins	106	
Hydraulic System	264	
Miscellaneous	40	
Total		8741 lbs

(5) Summary

The inplane fold rotor is heavy and also requires a large, heavy wing for its low speed transition requirements. It is also not capable of sustained flight at any intermediate rotor diameters between the fully extended and fully retracted positions.

Advantages

- . Fairly conventional aerelastic characteristics
- . Blade can be designed for optimum aerodynamic shape without compromising blade dynamics or design.
- . Rotor head simplicity with few major components.
- . Blade construction leads to field level repairability
- . Rotor may be stopped in extended position

Disadvantages

- . High rotor weight
- . Required low speed transition leads to large wing size requirements
- . Flight at intermediate diameter positions impossible
- . Retraction ratio of only 3 to 1
- . Difficult to control outboard half of blade during folding
- . High drag of stopped blades
- . Head and blade torque tube are one unit and require disassembly for ease of handling
- . Dependency on hydraulic and electrical system coordination for safety during blade extension and retraction.

If this rotor design were pursued, the following areas would have to be investigated further:

- . Response to gusts during blade folding/possible necessity of blade spoiler to reduce response
- . Aerodynamic effects on folded system
- . Further analysis of powered fold vs "momentum" fold, method of stopping the blade after a "momentum" fold, and the associated blade and rotor head loads.

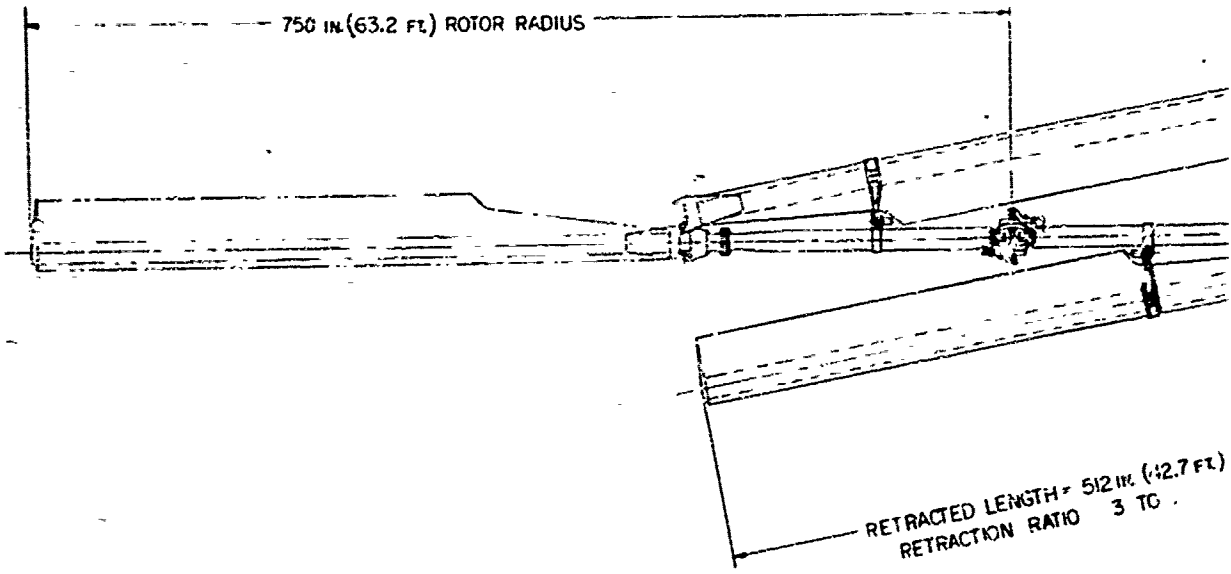

BLADE LOCK ACTUATOR

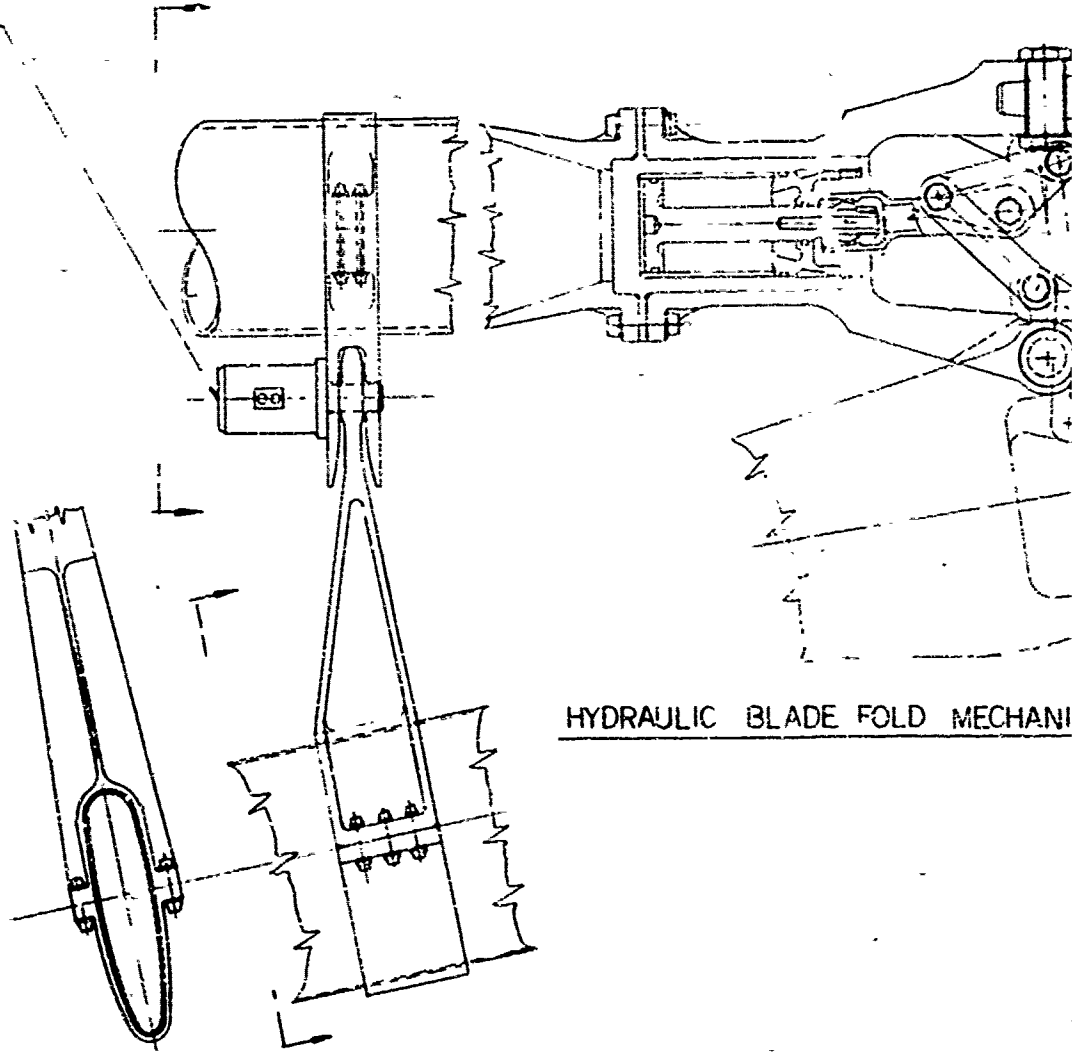
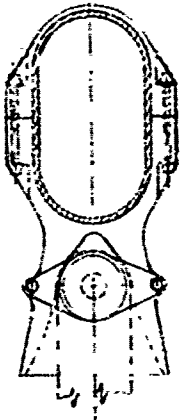

**B**

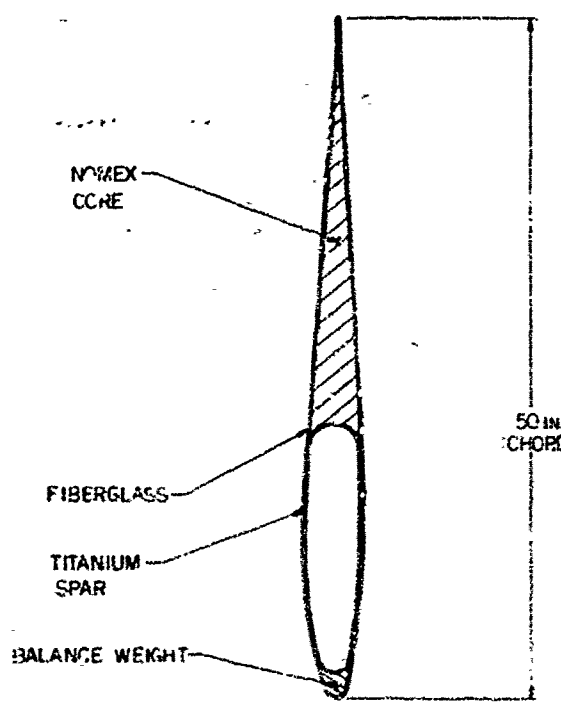
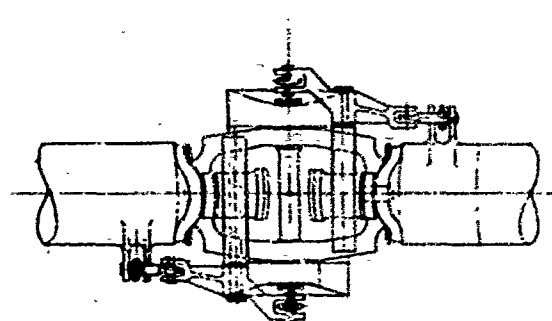
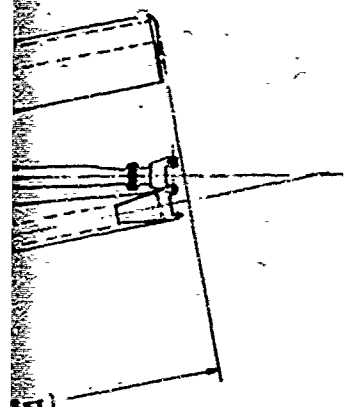

TEETERING TWO BLADED ROTOR HEAD

BLADE CONSTRUCTION

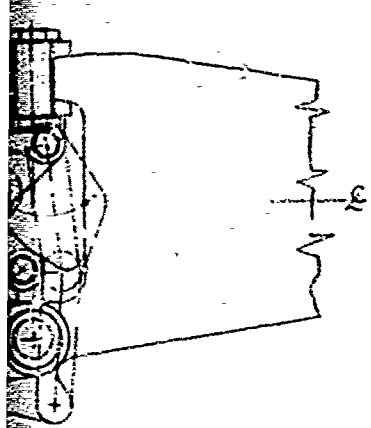

**MNISM**

PITCH CHANGE BEARINGS  
(ELASTOMERIC)

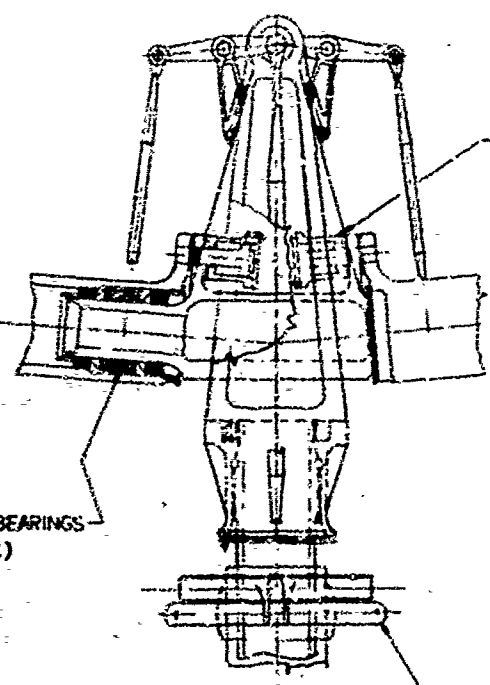

BLADE PITCH LOCK

SWASHPLATE

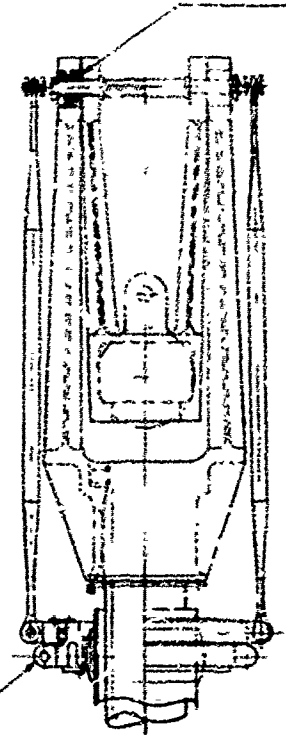

9

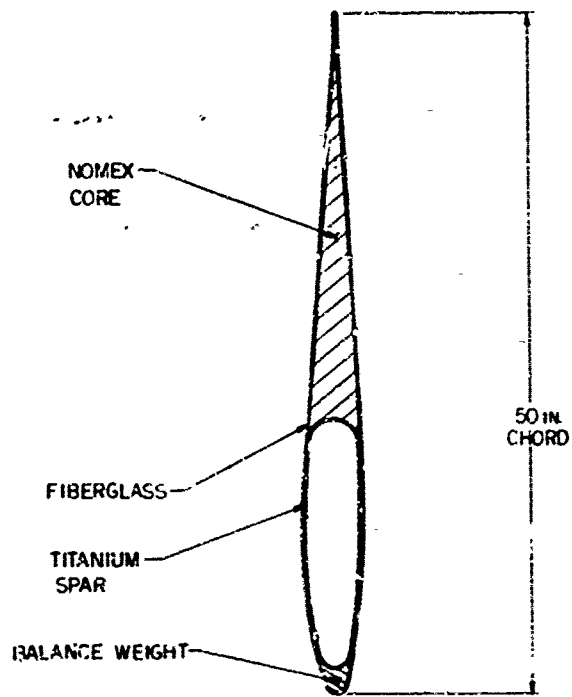
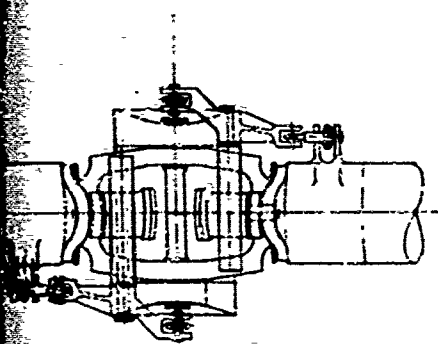

6 TWO BLADED ROTOR HEAD

BLADE CONSTRUCTION

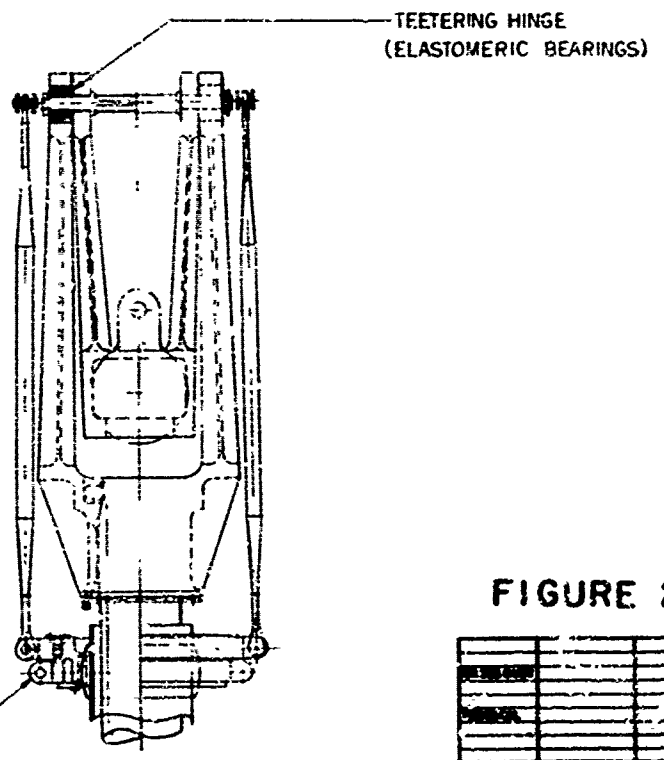
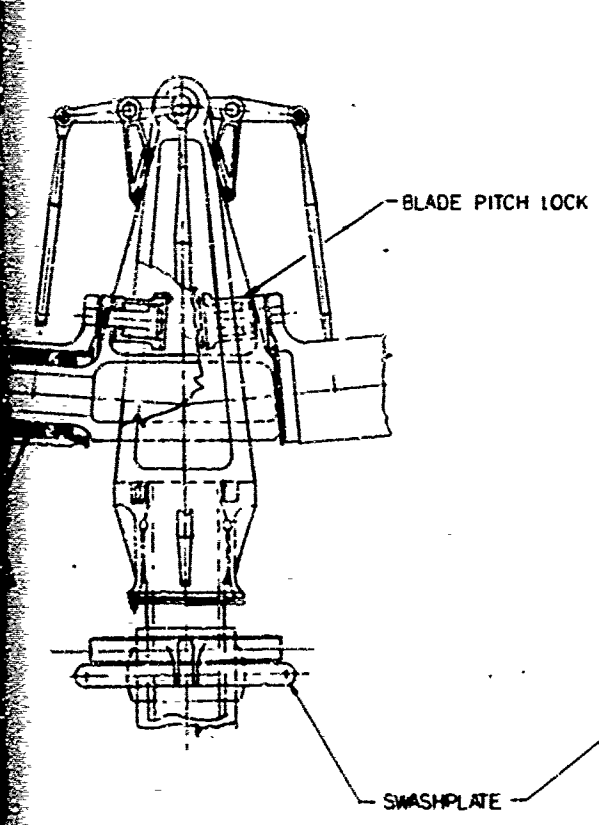

FIGURE 26

REV	DATE	BY	CHKD	APP

VARIALE DIA ROTOR STUDY  
IN-PLANE FOLD ROTOR

107

DS-507-8-3



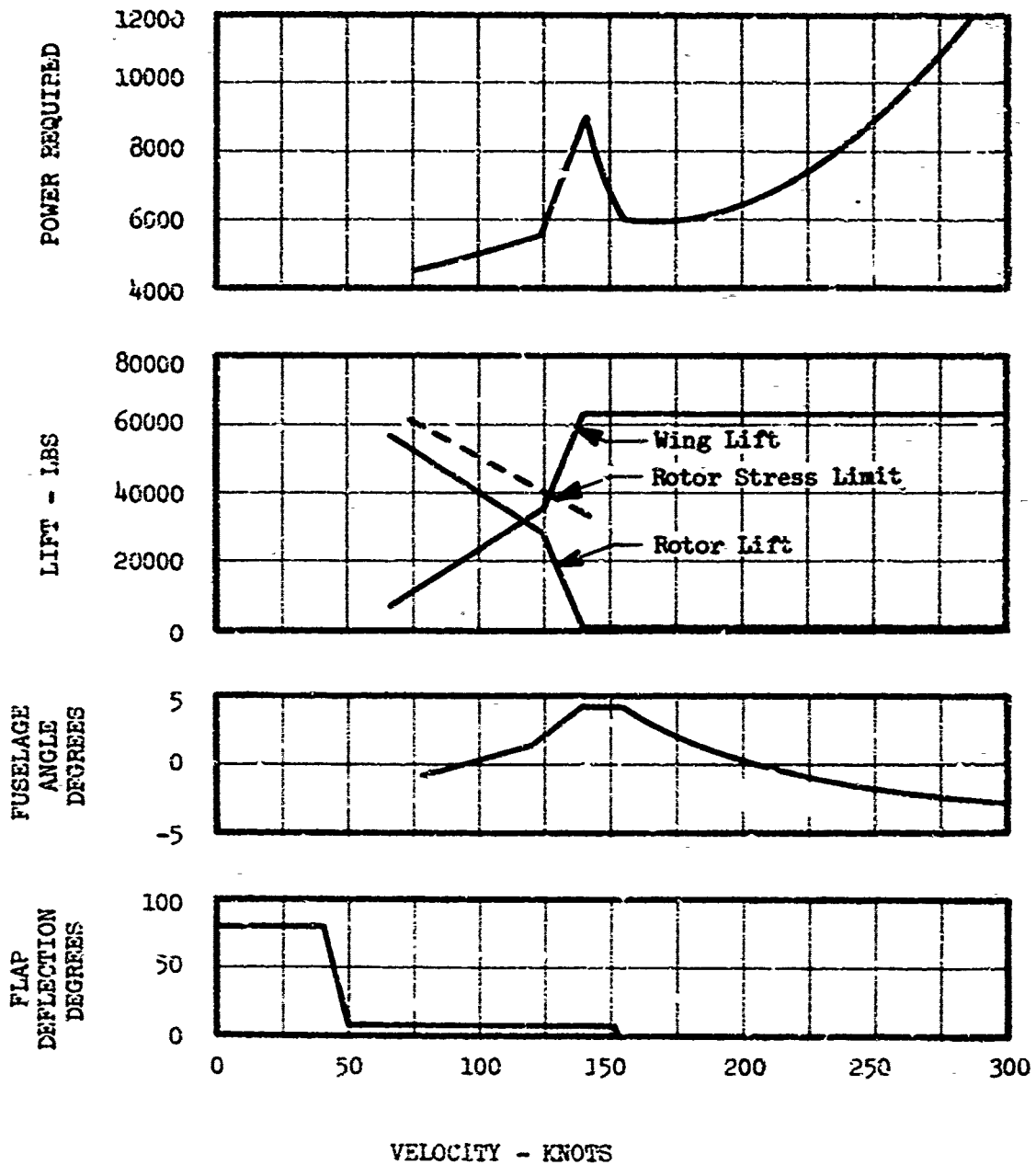

FIGURE 27  
 INPLANE FOLD ROTOR - PERFORMANCE CHARACTERISTICS  
 12000', 16°  
 62000 LBS GROSS WEIGHT  
 1080 SQ FT WING AREA

Preceding page blank

#### f. Two Segment Telescoping Rotor

The two segment telescoping rotor does not offer the high retraction ratios that can be obtained with the other concepts explored in this study. However it does offer a 1.7 to 1 retraction ratio and at a relatively lower technical risk. It is the one concept which is receiving serious attention in the industry, with Bell, Sikorsky, and others developing their own versions of it.

It was not the intent of the study to rate the various proposed two segment telescoping rotors against each other. The general concept was instead rated against the other variable diameter rotor schemes. The specific design used in the study was Sikorsky's TRAC system, which was chosen because the study team was most familiar with it. This is not to imply that any trade-off studies were performed during this program to rate the various two segment telescoping rotor systems.

The desired hovering disc loading of five pounds per square foot results in rotor diameters of over 120 feet for the size aircraft used in this study. With a retraction ratio of 1.7 to 1, the retracted diameter of the two segment telescoping rotor would still be approximately seventy feet. This was not felt to be practical and was also deviating from the original objective of this study, which was to achieve a small retracted diameter. Because of this, a hovering disc loading of 10 psf was assumed for this concept. This results in an 89.4 foot hovering diameter at 62,800 pounds gross weight, with a retracted diameter of 52 feet.

#### (1) Mechanical Design

The TRAC rotor system is shown in figure 28 and a schematic drawing of the blade is shown in figure 29. The basic mechanism is a jack-screw which serves as a primary tension member of the blade. Rotation of this screw imparts a linear retraction or extension motion to the retention nut and, through tension straps, to the outboard half of the blade which is the main lifting member. A torque tube encloses the jackscrew, transmits blade pitch control motion to the outboard blade, and carries bending moments across the sliding joint. The torque tube has an elliptical cross section to reduce aerodynamic drag when the blade is extended. When the diameter is reduced to minimum value the torque tube is enclosed by the outboard blade.

The TRAC rotor head and transmission arrangement are shown in figure 30. The rotor head is similar to a standard Sikorsky fully articulated offset hinge rotor system. Inside the rotor head is a differential gear set which is the heart of the mechanism. Both upper and lower bevel gears of this set are connected by coaxial shafts to a clutch or brake at the bottom of the transmission. Stopping the lower bevel gear with respect to the fuselage forces the pinions of the gear set to roll around the bevel gear and thus turn the jackscrews and retract the blades. Braking the upper bevel gear reverses the motion and extends the blades. The differential gears are always fully engaged and the blades

are completely synchronized. no separate power supply is required as the system is driven in both directions by the main shaft. Rotor diameter is under direct control of the pilot and is not influenced by aerodynamic forces or torques.

Use of the jackscrew provides irreversibility in the mechanism. For safety reasons, the jackscrew has been designed to operate at 50 percent dynamic efficiency. At this condition the torque of the jackscrew due to dynamic friction is equal to the useful torque required to retract the blade. Since the coefficient of static friction is greater than that for dynamic friction, the blade will remain at any degree of extension, even in the absence of a locking device, when the retraction brake is disengaged. The dynamic efficiency of 50 percent also provides for constant speed during retraction. Kinetic energy is dissipated by friction at just the rate required to cause the blade to retract. There is no tendency for the retraction speed to increase or decrease.

The outer blade has a chord of 2.92 feet and a sixteen percent thick airfoil. The inboard blade (torque tube) has a 1 foot chord and is a 33 percent thick ellipse. Two bearing blocks are utilized for the sliding contact. One is attached to the outboard end of the torque tube and one to the inboard end of the outer blade. The main structural load path is through the jackscrew and tension straps. The bearing blocks provide structural redundancy as they are also designed to carry the centrifugal loads into the torque tubes. The outer blade spar is an aluminum extrusion with a sheet aluminum and honeycomb sandwich aft section. The jackscrew and tension straps are steel. The torque tube is titanium.

## (2) Dynamic Considerations

Sikorsky Aircraft has devoted a considerable amount of analytical and experimental research into this rotor concept. The work conducted and the salient features of the investigations are discussed in detail in Reference 8. Only a brief discussion of this research will be given here.

The significant aspect of this research has been that no major problems associated with the concept have been found. One might have expected that the retraction and extension cycle may have produced blade response problems since this causes the blade natural frequencies to vary continually and to cross rotor speed harmonics. No such problems were in fact encountered, the diameter changes being performed in forward flight with low stress and minimum disturbance.

The dynamics analysis of the TRAC rotor has shown that it is completely feasible. The aeroelastic analysis of the blade indicated satisfactory stresses in all flight modes. With the relatively short total time spent in the forward flight pure helicopter (extended diameter) regime, a good fatigue life is achieved at a reasonable rotor system weight.

The unusual feature of a sliding joint mid-way along the blade and the fact that the outboard blade segment is in compression rather than tension made it necessary to develop a special computer program for aeroelastic analysis of this structure. This analysis accounted for the compressive loading of the outboard blade, the multiple load paths (torque tube and jackscrew inboard, rotor blade and straps outboard), and the different section aerodynamic characteristics of the conventional airfoil and elliptical torque tube.

The outer blade compressive loading has a very marked effect on the first blade bending mode at high tip speeds. This effect is seen first as a gradual, then as a very rapid decrease in the frequency of the mode. For the system studied the frequency reached zero at a tip speed of 1030 ft./sec. This point would correspond to buckling of the outboard section. The point actually occurred at a 50% overspeed condition. Although in this case this is well removed from the operating speed, this indicates a dynamic aspect to be considered in future designs. The accuracy of the analysis was verified by whirling a number of simple structural models until they collapsed under compressive buckling.

By retracting its diameter, the two segment telescoping rotor extends the aeroelastic boundaries of the conventional rotor system. Blade area is reduced and the blade mass is concentrated over a shorter distance. This greatly reduces the ratio of blade aerodynamic forces to inertial forces and results in improved blade flap stability at high advance ratios. Unlike all of the other systems investigated, this rotor has no dynamic instability problems within the range of speeds considered in the study. It is only concept which does not have to be stopped at some speed below 250 knots.

### (3) Aerodynamic Considerations

The two segment telescoping rotor offers improved performance with a minimum of aircraft changes. The main rotor is retracted beginning at speeds about 120 knots. This method offers large power and fuel savings at speeds from 160 to 250 knots. Transition to cruise is a continuous operation, eliminating velocities with a high power demand in the intermediate speed range. A 610 square foot wing is used to offload the rotor.

The maximum speed of the aircraft is 281 knots, using the same power that the S-65-300 baseline requires to achieve 250 knots.

The figure of merit of this rotor is .605. This is derived from a figure of merit ratio correction of .95 applied to a baseline figure of merit of .637.

Accounting for the effect that large root cutout has on minimizing vertical drag, the vertical drag of this design with its 610 square foot wing was computed at 3.6 percent of design gross weight.

The airframe is similar to that of the baseline S-65-300 so that the only parasite drag changes are for a 10% rotor head size increase and a longer fuselage length to accommodate the tail rotor. Parasite drag (excluding wing drag) was computed at 37.4 square feet. To cruise at 250 knots (the maximum speed of the baseline S-65-300) requires 8890 horsepower. This power is consumed as shown in the following breakdown.

Rotor Horsepower		20 HP
Propeller Power		
to Overcome Fuselage and Rotor Hub Parasite Drag	4495	
to Overcome Wing Induced & Profile Drag	3000	
to Overcome Rotor Rotational Drag including H Force	830	
Tail Rotor & Rotor Gearboxes		400
Accessories		100
Propeller Gearboxes		45
	TOTAL	<u>8890 HP</u>

Figure 31 shows the power requirements of the system as a function of forward flight speed. Also shown is the lift sharing, fuselage pitch attitude, and wing flap deflections necessary to sustain level flight.

#### (4) Rotor System Weight

The total weight for the rotor system is 9792 pounds, or 15.6 percent of the 62,800 pounds gross weight. This is broken down as follows:

<u>Two Segment Telescoping Blade</u>	960 LBS/BLADE	<u>3840 LBS</u>
Outboard Blade Segment	546	
Inboard Segment (Torque Tube)	414	
<u>Rotor Head</u>		
Hub	850	<u>3690</u>
Hinges	520	
Sleeves	418	
Spindles	400	
Dampers	420	
Bearings	625	
Misc.	457	
<u>Retraction Mechanism</u>		<u>2262</u>
Screw & Nut Assemblies	1340	
Drive Mechanism	855	
Misc.	67	
	TOTAL	<u>9792 LBS</u>

#### (5) Summary

In summary, the two segment telescoping rotor does not offer the high retraction ratios desired, but it does have a lower technical risk than any of the other rotors studied.

#### Advantages

- . Low technical risk
- . No dynamic instabilities to limit rotor operation at the speeds investigated in this study
- . Excellent transition characteristics with no excess power requirements in the transition range, due to the gradual diameter retraction
- . Rotor may be stopped in extended position

#### Disadvantages

- . Low retraction ratio
- . Higher downwash velocities resulting from the design disc loading
- . More difficult for application to a higher speed stopped rotor configuration than other concepts investigated in this study, due to the large rotor retracted diameter.
- . Damage to blade or tube necessitates removal for depot level overhaul
- . Difficulty in providing pilot/mechanic with blade integrity check
- . Possible damage to tube or blade in flight could prevent extension and/or retraction.

A

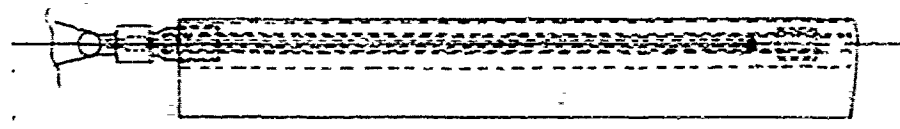
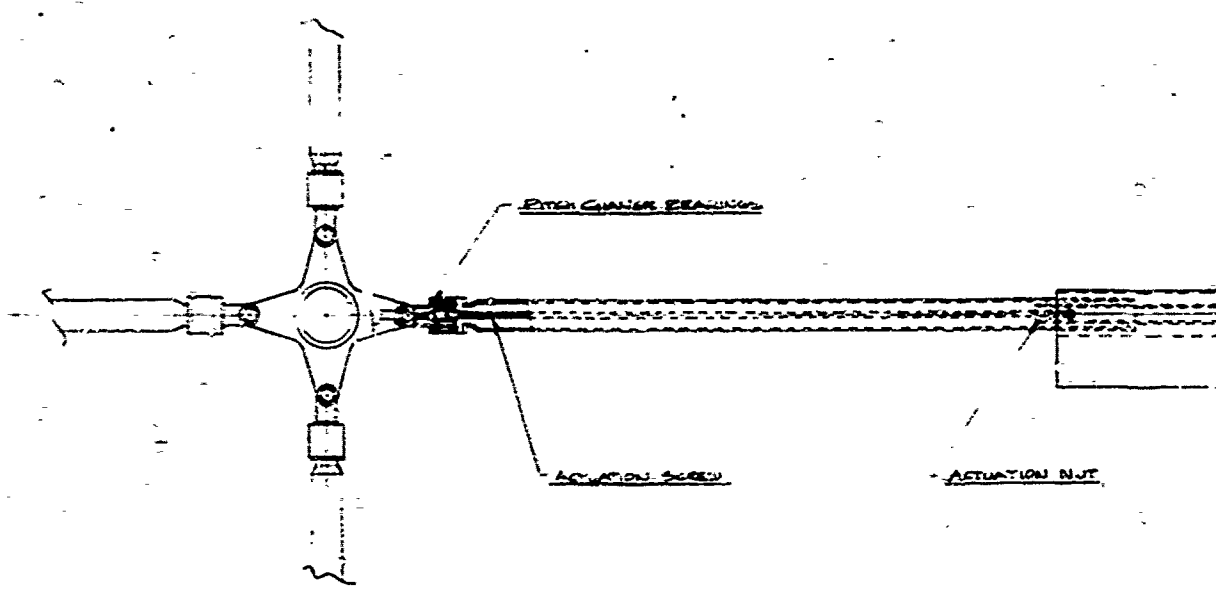

FULLY RETRACTED  
08/02 17

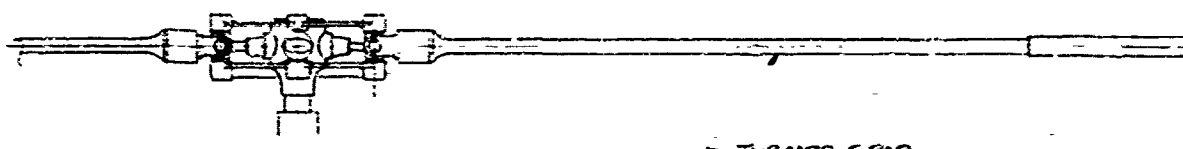

INBOARD SPAR





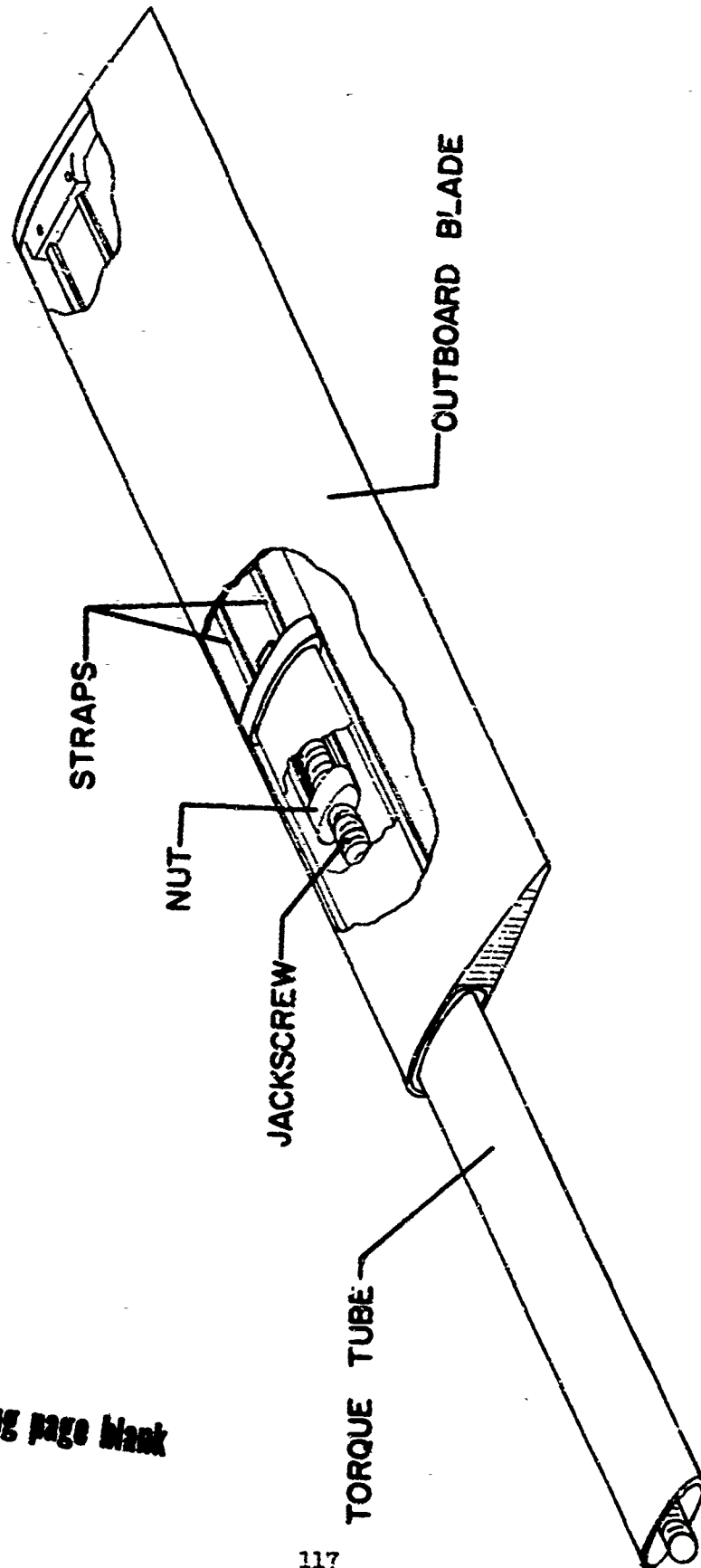

Preceding page blank

FIGURE 29 .RAC BLADE SCHEMATIC DRAWING

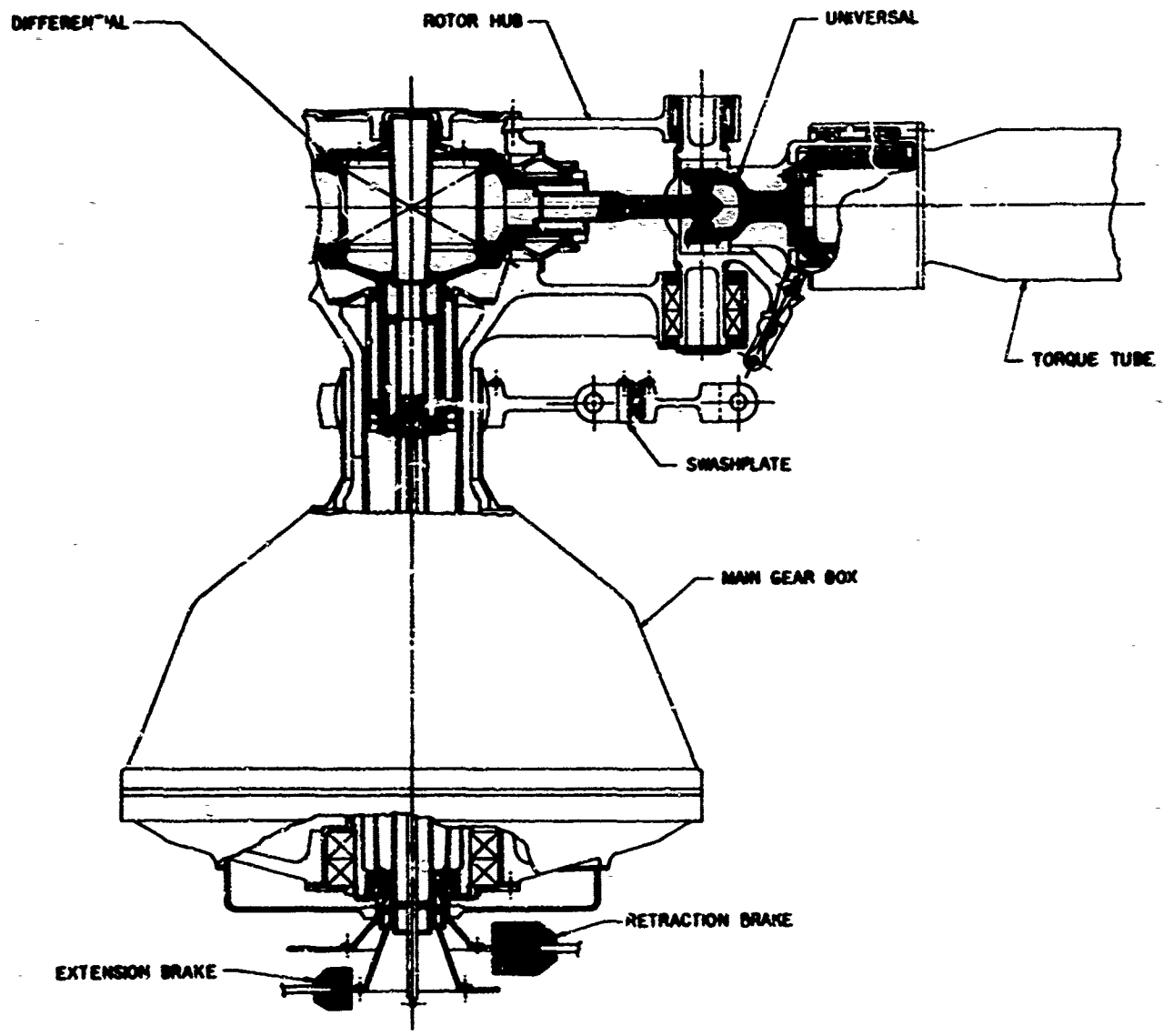

FIGURE 30 TRAC ROTOR HEAD AND TRANSMISSION SCHEMATIC DRAWING  
 118

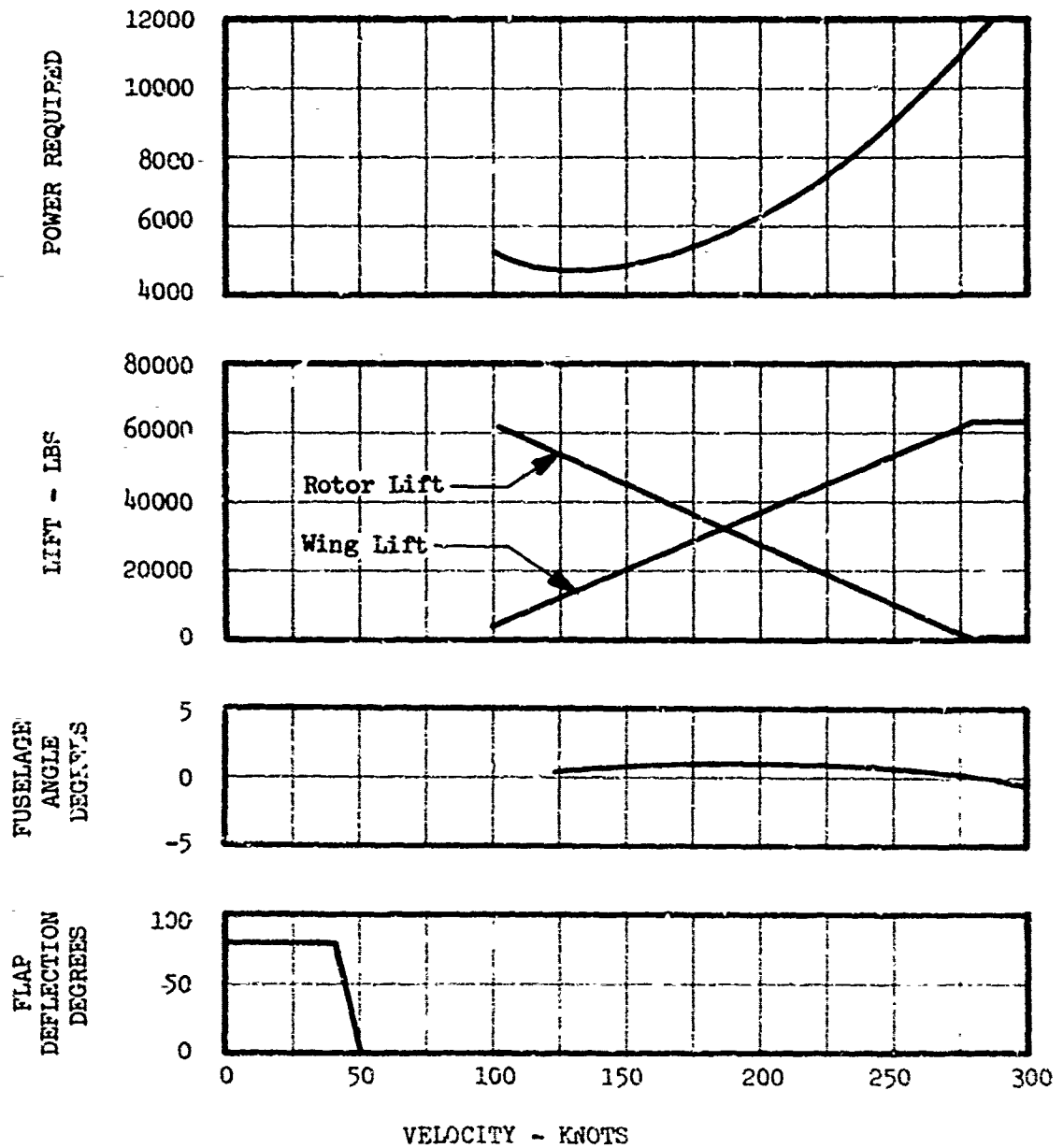

FIGURE 31  
 TWO SEGMENT TELESCOPING ROTOR - PERFORMANCE CHARACTERISTICS  
 12000', 16°  
 62800 LBS GROSS WEIGHT  
 610 SQ FT WING AREA

#### 4. COMPARATIVE RESULTS AT INITIALLY ASSUMED GROSS WEIGHTS

This section summarizes the aircraft designs at the originally assumed gross weight of 62,800 pounds. Because of the penalties associated with the variable diameter rotors, none of the aircraft can perform the S-65-300 mission at this gross weight. Therefore, each design was resized until it could perform the desired mission; this resizing effort is discussed in the next section of this report.

##### a. Aerodynamics

All aircraft were sized to perform the same mission. This included:

- . Four minutes at normal rated power, 2500 feet, 95°F, to account for warm up and take-off.
- . Climbing at 1000 feet per minute to 12000 feet at either 150 knots forward speed or maximum rotor forward speed, whichever was slower
- . Cruising at normal rated power at 12000 feet, 16.2°F
- . Descending to 2500 feet and dropping payload.
- . Returning to 12000 feet and cruising at normal rated power, returning to the original starting point
- . Landing with ten percent fuel reserves.

The mission radius was 250 nautical miles, and included the climb, cruise, and descent stages of flight.

(1) Hover

For hovering performance, the critical parameters are the figure of merit and the vertical drag of each concept. These are shown on the following table. Vertical drag values shown here assume the 475 square foot wing size of the baseline aircraft.

TABLE V HOVER PERFORMANCE FIGURE OF MERIT AND VERTICAL DRAG 62,800 LBS GROSS WEIGHT		
<u>CONFIGURATION</u>	<u>FIGURE OF MERIT</u>	<u>VERTICAL DRAG % OF GROSS WEIGHT</u>
Baseline, S-65-300	.653	6.43
Eight Segment Telescoping	.628	1.65
Roll-up Flexible Rotors		
Thin Airfoil		
Two Blades	.592	1.65
Four Blades	.598	1.95
Pneumatic Airfoil		
Two Blades	.598	1.65
Four Blades	.604	1.95
Inplane Folding Rotor	.616	1.45
Two Segment Telescoping	.605	2.80

(2) Transition

The critical parameter associated with the transition phase is the speed at which the rotors must be retracted and stopped. This is usually determined by the aeroelastic characteristics of the rotors. This requirement sizes the wing necessary to transfer lift off the rotor as the aircraft increases in forward speed. In addition to sizing the wing this way, an independent analysis was performed to determine which wing size was most cost effective for each design. The procedure for this analysis is described in Section III-5a(3).

The results of these studies are shown on the following table. The final wing size chosen was that determined by the cost effectiveness analysis, since in all cases this wing was larger than that required for transition.

TABLE VI WING SIZE 62,800 LBS GROSS WEIGHT			
CONFIGURATION	TRANSITION PERFORMANCE		MOST COST EFFECTIVE WING SIZE
	TRANSITION SPEED	TRANSITION WING SIZE REQUIREMENT	
Baseline E-65-300	-	-	475 ft <sup>2</sup>
Eight Segment Telescoping Roll-up Flexible Rotors	220 knots	630 ft <sup>2</sup>	750
Thin Airfoil	140	1050	1080
Pneumatic Airfoils	140	1050	1080
Inplane Folding Rotor	140	1050	1180
Two Segment Telescoping	275+	475	610

(3) Cruise

Cruise speed performance is affected by the parasite drag of each concept. Table VII, on page 123, gives the parasite drag summary for each aircraft.

TABLE VII PARASITE DRAG SUMMARY  
62,800 LBS GROSS WEIGHT

<u>CONFIGURATION</u>	<u>FUSELAGE</u>	<u>PYLON DELTA</u>	<u>ROTOR HEAD</u>	<u>TOTAL *</u>
Baseline S-65-300	22.1	-	10.0	35.3
Eight Segment Telescoping Rotor				
Rotating	23.4	.4	16.4	44.5
Stopped	23.4	.4	16.4	44.1
Roll-up Rotor, Two Blades				
With Inboard Pitch Control				
Rotating	23.4	1.3	8.3	36.4
Stopped	23.4	1.3	8.8	36.9
Without Inboard Pitch Control				
Rotating	23.4	1.3	4.9	32.6
Stopped	23.4	1.3	6.1	33.9
Roll-up Rotor, Four Blades				
With Inboard Pitch Control				
Rotating	23.4	2.2	12.6	42.1
Stopped	23.4	2.2	12.7	42.2
Without Inboard Pitch Control				
Rotating	23.4	2.2	10.4	39.7
Stopped	23.4	2.2	10.5	39.8
Inplane Folding Rotor				
Rotating	23.4	.3	11.9	39.2
Stopped	23.4	.3	14.6	42.2
Two Segment Telescoping Rotor				
Rotating	22.4	0	11.0	37.4

\*Includes allowance for leakage, proturbances, etc

Table VIII shows the power required at 250 knots, 12000' standard day, plus the cruise speed capability of each concept using the same installed power as the baseline aircraft. Also shown are the equivalent aircraft lift to drag ratios (defined to the product of the gross weight multiplied by the cruise speed and divided by the power required).

TABLE VIII CRUISE PERFORMANCE 12000 FT. STANDARD CONDITIONS 62,800 LRS GROSS WEIGHT				
CONFIGURATION	POWER REQUIRED AT 250 KNOTS	L/D 250 KNOTS	MAXIMUM SPEED USING 11,400 HP	L/D AT MAXIMUM SPEED
Baseline - S-65-300 Eight Segment	11400 HP	4.22	250 Knots	4.22
Telescoping	9310	5.17	275	4.65
Roll-up Flexible Rotors				
Thin Airfoil				
Two Blades	7760	6.21	295	4.98
Four Blades	8450	5.70	282	4.77
Pneumatic Airfoil				
Four Blades	8500	5.66	282	4.77
Amplified Fold	9045	5.32	233	4.78
Two Segment				
Telescoping	8890	4.41	281	4.75



b. Weights

A weight summary for the aircraft is shown below. The important parameter here is the amount of payload that can be carried with each aircraft over the S-65-300 mission profile.

Table IX Summary Weight Statements at 6,000 Pounds Design Gross Weight

	Baseline S-65-300	Roll-Up Rotors			Telescoping		Inplane Fold Rotor
		Two Thin Blades	Four Thin Blades	Four Pne- matic Blades	Two Segments	Right Segments	
Rotor Group	5191	6165	5439	4960	9792	9118	8741
Wing Group	2278	5282	5282	5202	3124	4287	5753
Tail Rotor/Fan	950	1174	1179	1.75	851	1062	1273
Tail Surfaces	937	921	921	921	927	921	921
Body Group	1219	8387	8387	8386	7219	8359	8362
Lighting Gear	2536	2549	2549	2549	2549	2549	2549
Flight Controls	1508	2112	2112	2262	1509	1661	1661
Engines & Related Items	3511	3511	3511	3511	3511	3511	3511
Fuel System	2091	1855	1952	1955	1912	1947	1957
Propeller Inst.	820	789	798	799	801	805	790
Drive System	6625	6475	6512	6444	6493	6543	6428
Miscellaneous Equipment	6384	6384	6384	6384	6384	6384	6384
Technology Saving	-1558	-2194	-2195	-2182	-1701	-2030	-2246
Contingency	+1538	+1738	+1713	+1695	+1734	+1805	+1852
Weight Empty	39990	46182	45544	44771	45084	45924	47406
Crew	720	720	720	720	720	720	720
Trapped Fluids	326	299	308	308	303	307	306
Fuel	11063	9835	10234	10757	9993	10203	10147
Payload	10701	6758	6995	7446	6701	4646	3922

c. Reliability and Maintainability

A reliability and maintainability study was performed on each rotor. Baseline reliability and maintainability values were obtained from predictions presented for the S-65-300 in Reference 10. Supplementary data necessary for this study was obtained from a 68,457 flight hour sample of H-53 data as reported by the U.S. Navy Maintenance and Material Management (3M) data collection system.

Adjustments to the baseline rotor system values for each new concept were made to take into account differences in the designs, such as the number of component parts, their size, weight, and loading conditions. Also, under consideration were the provisions for accessibility, servicing requirements, and ease of overall maintenance.

Each component of the different variable diameter rotor concepts was studied in order to arrive at predicted values for total scheduled and unscheduled maintenance, down hours per flight hour, and mission aborts per 1000 flight hours. The prediction were based on the assumptions that:

- (a) All necessary tools and aircraft support equipment were available,
- (b) All necessary spare parts and instruction manuals were available,
- (c) All maintenance men were trained in the appropriate skills, and,
- (d) There was no down time attributed to awaiting supplies or administrative reasons.

Scheduled inspections were considered to consist of preflight, postflight and phased inspections. Mean elapsed times to perform maintenance tasks were based on the 68,457 flight hour sample of Navy 3M data.

(1) The BASELINE AIRCRAFT, as presented in Reference 10, was predicted to consume 14.30 MMH/FH for the three levels of maintenance - Organizational, Field and Depot. Mean down time per flight hour was predicted to be 1.92 and the mission abort rate to be 13.2 Aborts/1000 FH.

(2) The EIGHT SEGMENT TELESCOPING ROTOR offers a slight improvement in Reliability and Maintainability values over the baseline aircraft. Its advantages and disadvantages which effect reliability and maintainability are as follows:

#### ADVANTAGES

- . Rotor head simplicity and few major components
- . Majority of non-lubricated bearings for longer life and relatively maintenance free operation

#### DISADVANTAGES

- . Rotor head components are not readily accessible
- . Blade inspection requires manual extension
- . Blade weight necessitates care in handling, special equipment, and poses a safety problem
- . Blade construction necessitates segment scrapping if major damage is sustained and means depot level repair
- . No provisions for detecting blade damage or structural failure

(3) The ROLL-UP ROTOR WITH THIN BLADES offers a significant improvement in Reliability and Maintainability values over the baseline aircraft. Its advantages and disadvantages are as follows:

#### ADVANTAGES

- . Rotor head simplicity and few major components
- . Majority of non-lubricated bearings for longer life and relatively maintenance free operation
- . Blade construction leads to ease of blade repair, possibly on the aircraft
- . Blade construction offers "throw-away" benefits with no depot level maintenance and blade handling requirements

#### DISADVANTAGES

- . Four bladed head offers poor component accessibility
- . Blade inspection requires manual extension and special handling equipment
- . Blade electrical flight control inputs must be transmitted through two rotary connections
- . Failure of the blade extension/retraction mechanism leads to safety problems during rotor shut-down

(4) The ROLL-UP ROTOR WITH PNEUMATIC BLADES again offers a significant improvement in Reliability and Maintainability values over the S-65-300. It is summarized as follows:

#### ADVANTAGES

- . Rotor head simplicity with fewer major components
- . A majority of non-lubricated bearings for longer life and relatively maintenance free operation
- . Blade construction leads to field level blade repair
- . Blade construction offers "throw-away" benefits with no depot level maintenance and blade handling requirements

#### DISADVANTAGES

- . Poor component accessibility in four bladed design
- . Blade inspection requires manual extension and special handling equipment
- . Blade electrical flight control inputs and blade pneumatics must be transmitted through rotary connections
- . Failure of the blade's extension/retraction mechanism leads to safety problems during rotor shut-down
- . Blade pneumatics must be able to provide sufficient quantities of air during autorotation with stalled engines and with blade punctures.

(5) The INPLANE FOLD ROTOR offers the largest improvements in Reliability and Maintainability values over the baseline aircraft. Its advantages and disadvantages from a reliability and maintainability viewpoint are as follows:

#### ADVANTAGES

- . Rotor head simplicity with fewer major components
- . Elastomeric bearings for longer life and relatively maintenance free operation
- . Ease of rotor head servicing and inspections
- . Blade construction leads to field level repairability

#### DISADVANTAGES

- . Head and blade torque tube are one unit and require disassembly for ease of handling
- . Dependency on hydraulic and electrical system co-ordination for safety during blade extension and retraction

(6) The TWO SEGMENT TELESCOPING ROTOR also offers a reduction in Reliability and Maintainability values over the baseline aircraft. It is summarized as follows:

#### ADVANTAGES

- . Slight reduction in major components
- . Blade construction offers load path redundancy

#### DISADVANTAGES

- . Complex in rotor head design
- . Blade inspection will require its manual extension
- . Damage to blade or tube necessitates removal for depot level overhaul - increase in overhaul activity
- . Difficulty in providing pilot/mechanic with blade integrity check

(7) FAN-IN-FIN TAIL ROTOR - The two roll-up rotor concepts, the eight segment telescoping rotor, and the inplane fold rotor were evaluated using the fan-in-fin antitorque tail rotor system. Reliability and maintainability values for this concept were based on predictions from previous design studies. These values were sized and adjusted to reflect operation on the baseline aircraft. The fan-in-fin antitorque system showed a significant improvement in reliability and maintainability relative to the S-65-300 baseline tail rotor system.

(8) PREDICTIONS - The values cited in Table X reflect predicted total air vehicle reliability and maintainability values after deletion or addition of applicable rates, maintenance manhours and downhours to the baseline data. Predictions are mature aircraft values and are not applicable to prototype systems or aircraft.

TABLE X  
RELIABILITY AND MAINTAINABILITY PREDICTIONS

<u>CONFIGURATION</u>	<u>MMH/FH</u>	<u>DH/FH</u>	<u>ABORTS/1000 FH</u>
S-65-300 Baseline Aircraft	14.3000	1.9200	13.200
Roll-up rotor			
Two thin blades	13.7924	1.7627	12.615
Four thin blades	14.0207	1.8418	12.954
Roll-up rotor			
Two pneumatic blades	13.8361	1.7649	12.702
Four pneumatic blades	14.0768	1.8459	13.070
Eight segment telescoping rotor system	14.2780	1.8170	13.000
Inplane fold rotor system	13.5283	1.7095	12.609
Two segment telescoping rotor system	14.4764	2.0079	13.344

d. Acoustics

Acoustic annoyance and detectability of the rotor concepts were compared for hovering flight. Results of this comparison are summarized in Table XI and Figure 32.

On an aural detectability basis, the conventional helicopter was less detectable than the VDR vehicles. The aural detection of both the baseline and VDR configurations is controlled by low frequency noise generated by the main lifting rotor. This low frequency noise attenuates only 6 db per doubling of distance, in contrast with high frequency noise that undergoes severe additional attenuation from molecular absorption and atmospheric scattering. At large enough distances from a helicopter, the high frequency part of the acoustic signature has attenuated sufficiently to be masked by the ambient noise around an observer while the low frequency noise from the lifting rotor is detectable above the background.

Technical data are not presently available to relate rotor noise levels, terrain, atmospheric conditions, and ambient noise to an absolute aural detection range. Detection estimates become less accurate as the frequency decreases, since human response to very low frequency noise (2 Hz to 20 Hz) has not been quantified. Although most people cannot hear noise below 20 Hz in standard audiometric booth conditions, observers in free-field surroundings can detect radiation from helicopter rotors at frequencies below 20 Hz. This detection is more by feeling than by hearing, but it still must be considered part of the aural detection problem. Aural detection of the VDR vehicles is particularly difficult to assess because of the very low frequency pure tones generated by the main rotors. These main rotors radiate noise with a fundamental frequency (blade passage frequency) of from 2 Hz to 8 Hz while the baseline rotor radiates

OCTAVE BAND LEVEL - dB (REF 0.0002 MICROBAR)

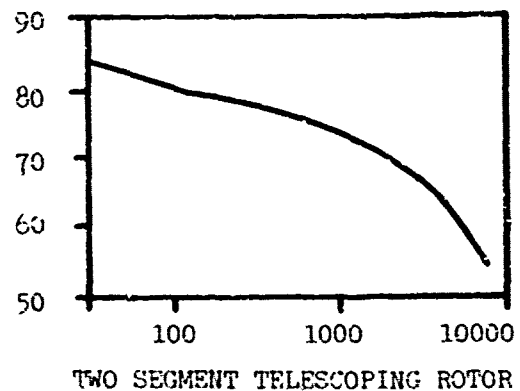
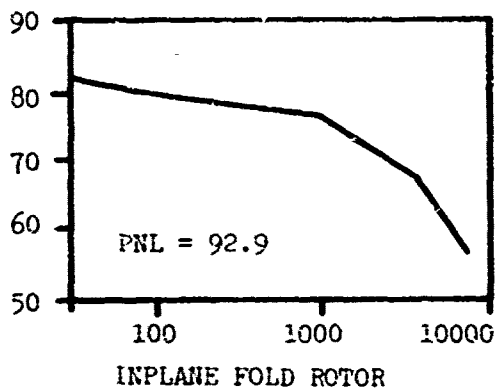
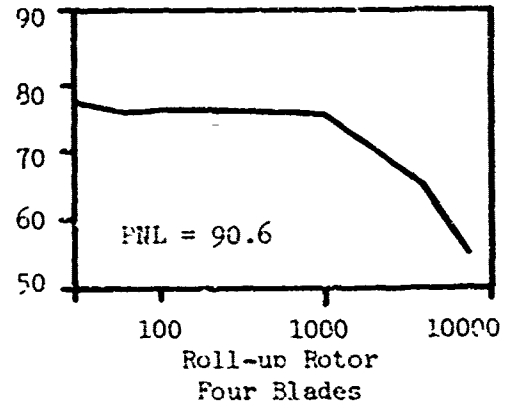
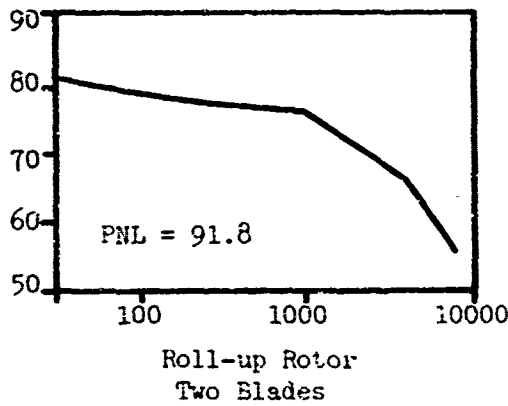
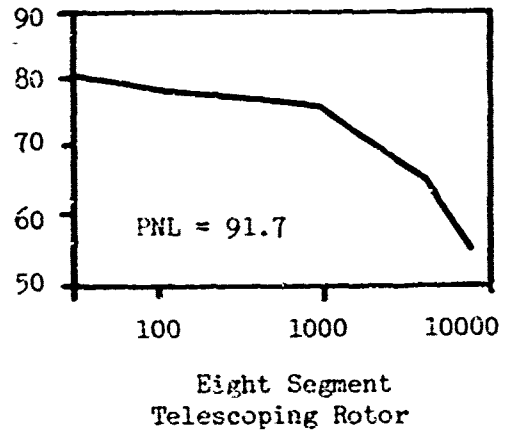
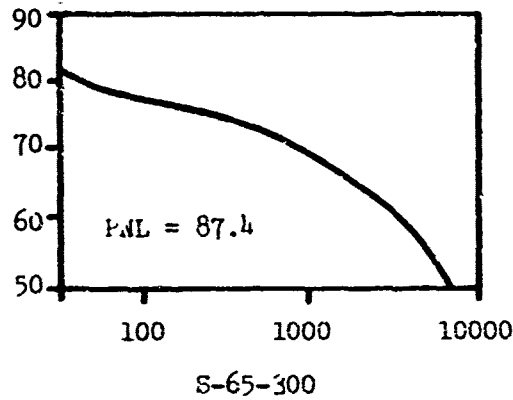

FREQUENCY IN HERTZ

FIGURE 32  
OCTAVE BAND SPECTRA @ 500 FT

noise with a fundamental frequency of 20 Hz. It is expected that rotational noise from the VDR will be detected -- felt rather than heard -- at much greater distances than the noise from the baseline rotor, so the values of Detectability Factor (detection range ratio) in Table XI are approximate at best and may grossly underestimate the relative detectability of the VDR configurations.

The conventional tail rotor was predicted to be less annoying than the anti-torque fans. The lower predicted perceived noise level (PNL) of a tail rotor relative to a fan occurs because a tail rotor radiates lower frequency noise (38 Hz blade passage frequency) and consequently contributes relatively little to the calculated PNL of the vehicle. Fan noise is higher in frequency (624 Hz blade passage frequency) with much of the acoustic energy falling in the frequency range where the human ear and PNL calculation procedure are most sensitive. This causes noise from the fan to dominate the calculated PNL for these configurations.

All of the rotor concepts were evaluated with the acoustic analysis of Lowson and Ollerhead reported in Reference 11. This particular analysis was selected for its flexibility in simulating aerodynamic interference (high frequency airloads) seen by main rotor and anti-torque system, and for its good correlation with measured data in acoustic trending studies conducted by Sikorsky Aircraft. For acoustic calculations, the airload amplitude spectrum acting on a rotor or fan blade is assumed to decay exponentially with harmonic order so that the  $N^{\text{th}}$  loading harmonic is related to the steady amplitude by  $L_n = L_0 N^{-k}$ , where the value of the exponent,  $k$ , is specified by the user of the analysis. The value of " $k$ " for a conventional helicopter rotor is 2.0. The present study used 1.9 to reflect aerodynamic blockage of the main rotor by wings and fuselage. A " $k$ " value of 1.8 was used for the anti-torque system to reflect the unsteady airflow caused by the main rotor wake in the case of a tail rotor, and to reflect noise radiation from downstream support struts in the case of the fan. This approach is believed to be valid for the trend information required to rank the configurations in the present study.

Acoustic detectability was evaluated by comparing the calculated signature in front of each configuration with a detection level criterion from Robbins and Dadson, Reference 12. This comparison resulted in the Detection Factors (detection range ratios) that give the detectability of the vehicles relative to the baseline.

TABLE XI  
PERCEIVED NOISE LEVEL AND DETECTION RANGE RATIO

<u>CONFIGURATION</u>	<u>PNL @ 500 FT</u>	<u>DETECTION RANGE RATIO</u>
Baseline S-65-300	87.4	1.00
8 Segment Telescoping	91.7	1.05
Two Bladed Roll-up	91.8	1.14
Four Bladed Roll-up	90.6	1.05
Inplane Fold	92.9	1.23
Two Segment Telescoping	91.3	1.32

e. Rotor System Dollar Costs

In order to develop the cost effectiveness values in the next section, it was necessary to estimate dollar costs for each rotor system. This was done by relating costs to a known baseline. As before, the S-65-300 was used for this purpose.

(1) Recurring Costs

To determine recurring costs, each rotor design was first broken down into weights of various materials: titanium, aluminum, fiberglass, etc. The production costs for these materials in conventional rotor applications were known from their use on production Sikorsky helicopters. These were in a dollars per pound form, and it was desired to apply them to the variable diameter rotor systems. Because the study rotors were substantially different than conventional designs, the dollars per pound values were further modified by multiplying them by "complexity factors."

The complexity factors used in the study are shown in Table XII. They were determined after the detail designs of the rotor systems had been completed, and are based on overall mechanical complexity, size of parts, and estimated fabrication difficulty. It is felt that at this point in the study sufficient knowledge of the rotor systems was available to make an assessment of overall complexity to the degree of accuracy required in a study of this depth. It is emphasized that these are qualitative judgements only.

To determine overall complexity factors, each rotor system was broken down into rotor head (including control system), blades, and retraction mechanism. Complexity for each was estimated by using three separate values - the percentage of scrapage, the total estimated fabrication time, and the total number of parts. For the heads and blades, the S-65-300 was assigned the baseline value of 1.00. For the retraction mechanism, the eight segment telescoping rotor was used for the baseline.



Table XII

## Complexity Factors Used In Recurring Cost Estimates

Configuration	Percent Scrapage	Fabrication Time	Number Of Parts	Total Overall Complexity
S-65-300				
Head	1.00	1.00	1.00	1.00
Blades	1.00	1.00	1.00	1.00
8 Segment Telescoping Rotor				
Head	.55	.41	.46	.45
Blades	1.50	2.50	4.00	2.35
Retraction Mechanism	1.00	1.00	1.00	1.00
Roll Up Rotor - Two Thin Blades				
Head	.85	1.20	.82	1.06
Blades	.10	1.00	.70	.70
Retraction Mechanism	1.05	1.10	1.05	1.08
Roll Up Rotor - Four Thin Blades				
Head	.97	1.35	1.40	1.24
Blades	.20	2.00	1.40	1.40
Retraction Mechanism	1.75	2.20	2.10	2.06
Roll Up Rotor - Four Pneumatic Blades				
Head	.97	1.35	1.40	1.24
Blades	.20	2.00	1.40	1.40
Retraction Mechanism	1.75	2.20	2.10	2.06
Inplane Fold Rotor				
Head	.55	.41	.46	.45
Blades	.90	.90	1.00	.91
Retraction Mechanism	.25	.25	.40	.27
Two Segment Telescoping				
Head	.97	.89	.89	.91
Blades	1.00	1.10	1.00	1.06
Retraction Mechanism	2.00	2.00	2.00	2.00

To combine the three measures of complexity into one overall value, each was given a weighted score. The percent scrapage was assigned thirty percent of the total and the number of parts ten percent. The fabrication time was assigned sixty percent, since it was felt that it was the most important measure of complexity. By multiplying the individual factors by these percentages and adding up the total, the overall complexity factor for each item was known. These are shown on Table XII.

As an example of how this method was used, the cost determination for the roll-up rotor using four thin blades will be illustrated. First the total overall complexity factors were found for the rotor head, blades, and retraction mechanisms. The calculation is as follows:

	<u>COMPLEXITY</u>		<u>WEIGHTING</u>		<u>WEIGHTED</u>
	<u>FACTOR</u>	x	<u>FACTOR</u>	=	<u>SCORE</u>
I. Rotor Head					
Percent Scrapage	.97	x	.30	=	.29
Fabrication Time	1.35	x	.60	=	.81
Number of Parts	1.40	x	.10	=	.14
	Total Overall Complexity				1.24
II. Rotor Blades					
Percent Scrapage	.20	x	.30	=	.06
Fabrication Time	2.00	x	.60	=	1.20
Number of Parts	1.40	x	.10	=	.14
	Total Overall Complexity				1.40
III. Retraction Mechanism					
Percent Scrapage	1.75	x	.30	=	.53
Fabrication Time	2.20	x	.60	=	1.32
Number of Parts	2.10	x	.10	=	.21
	Total Overall Complexity				2.16

The material usage in the four bladed thin roll-up rotor is as follows. These numbers are the total weights of each material in each component.

	<u>ROTOR HEAD</u>	<u>ROTOR BLADES</u>	<u>RETRACTION</u>
	<u>AND CONTROLS</u>		<u>MECHANISM</u>
Titanium	1700	-	865
Steel	497	100	770
Aluminum	1097	200	173
Lead	--	680	-
Fiberglass	--	212	-
Nylon Honeycomb	--	30	-
Polyester	--	400	-

To convert these to dollar costs, each number was multiplied by the dollar per pound value for the conventional production components. Each of these was then multiplied by the appropriate complexity factor. The resulting costs were then added to determine final dollar costs. For the present example, the rotor head was found to cost \$293,454, the blades \$63,388, and the retraction mechanism \$193,753.

These costs for all the rotor systems are illustrated in Table XIII, on the following page.

These dollar figures apply only to the rotors at the initially assumed 62,800 pound gross weight. For use in the parametric trending analysis, they were divided by the total rotor system weight to get the dollars per pound values shown in the second column of Table XIII. These were then used for all gross weights, and are the values that were used in the resizing of the aircraft, described in section III-5.

Table XIII

Recurring Cost Estimates For Variable Diameter Rotors  
Based On Assumed Design Gross Weight Of 62,800 Pounds

System/Component	Total Cost Per Aircraft (\$)	Dollars Per Pound
S-65-300		
Rotor Head	210,724	72.24
Blades	122,425	44.91
8 Segment		
Rotor Head	138,412	36.30
Blades	453,112	102.98
Retract. Mech.	124,227	60.10
Roll-Up (2 Blades)		
Rotor Head	253,988	79.05
Blades	51,175	23.67
Retract. Mech.	152,998	80.02
Roll-Up (4 Blades)		
Rotor Head	293,454	91.59
Blades	63,388	39.08
Retract. Mech.	193,763	107.17
Roll-Up (Pneumatic)		
Rotor Head	297,716	92.92
Blades	34,533	28.73
Retract. Mech.	193,763	107.17
Inplane Fold		
Rotor Head	158,227	35.35
Blades	187,362	45.41
Retract. Mech.	15,016	13.28
2 Segment Trac		
Rotor Head	239,631	62.78
Blades	170,821	37.51
Retract. Mech.	133,647	73.92

(2) Nonrecurring Costs

Nonrecurring costs consist of RDT&E costs and tooling costs. These also were determined by a baseline dollars per pound value multiplied by the rotor system weight and then multiplied by a complexity factor. The baseline S-65-300 cost for tooling was \$1500 per pound. For RDT&E, it was \$5000 per pound.

A different set of complexity factor was used for nonrecurring costs. These are also judgement values, and are based on an estimate of the overall technical risk that would be involved in reducing each concept to a final production design. These are shown below.

The total cost for each aircraft is shown at its final design gross weight in the next section.

TABLE XIV COMPLEXITY FACTORS USED IN NON-RECURRING COST ESTIMATE	
CONFIGURATION	COMPLEXITY FACTOR
S-65-300	1.00
Eight Segment Telescoping Rotor	2.30
Roll-up Rotor	
Two Thin Blades	3.60
Four Thin Blades	3.50
Four Pneumatic Blades	4.00
Inplane Fold Rotor	2.90
Two Segment Telescoping Rotor	1.25

## 5. SYSTEMS INTEGRATION

This section discusses the resizing of each aircraft, plus the final quantitative and qualitative evaluation of all the variable diameter rotor concepts.

### a. Quantitative Results

#### (1) Design Gross Weight

The program results described in the preceding sections have been concerned with the various rotor concepts sized for an aircraft with a fixed gross weight. This weight was assumed to be the 62,800 pounds of the baseline Sikorsky S-65-300 design, and was used for the dynamic, aerodynamic, and mechanical design analysis discussed in section III-3. This analysis identified the critical areas of concern for each concept and proposed methods for their solution.

Another output from this earlier part of the study was a determination of the aircraft component weights. The rotor system weight was calculated from layout drawings; wing size requirements and mission fuel were determined from aerodynamic analysis. From this, wing weight was determined. Finally, the baseline aircraft fuselage and subsystem weights were modified to reflect any unique features of each concept. Mission payload was allowed to be a variable. When all the component weights were totaled and subtracted from the assumed gross weights, the payload capability of each concept was determined. In no case could the variable diameter rotor aircraft carry as large a payload as the baseline over the design mission. This payload capability is summarized below:

<u>CONFIGURATION</u>	<u>PAYLOAD</u>
S-65-300	10,700 lbs
8 Segment Telescoping Rotor	4,650
Roll-up Rotor, Two Thin Blades	6,760
Roll-up Rotor, Four Thin Blades	7,000
Roll-up Rotor, Four Pneumatic Blades	7,450
Inplane Fold Rotor	3,930
Two Segment Telescoping Rotor	4,650

The next part of the program was involved with resizing the aircraft so they all would carry the required 10,700 pounds payload. The design gross weight now became the variable. This resizing was accomplished by parametrically describing all the aircraft with appropriate mathematical equations, and iterating the designs until the desired payload was achieved. The helicopter design computer models were used for this purpose as discussed in section III-1

From this analysis the gross weights required to achieve the desired payload were found to be as follows:

<u>CONFIGURATION</u>	<u>GROSS WEIGHT</u>
S-65-300	62,800 lbs
Eight Segment Telescoping Rotor	75,070
Roll-up Rotor, Two Thin Blades	69,760
Roll-up Rotor, Four Thin Blades	69,060
Roll-up Rotor, Four Pneumatic Blades	67,980
Inplane Fold Rotor	76,490
Two Segment Telescoping Rotor	72,070

Table xv on page 140, presents summary weight statements for each of these designs.

Table XV Summary Weight Statements at 10,700 Pounds Design Payload

	Baseline S-65-300	Roll-Up Rotors		Telescoping Rotors		Inplane Fold Rotor
		Four Thin Blades		Two Segments		
		Four Thin Blades	Four Pneu- matic Blades	Two Segments	Eight Segments	
Rotor Group	5191	5734	5038	11440	11089	10946
Wing Group	2238	5547	5419	3354	4701	6369
Tail Rotor/Fan	950	1297	1254	954	1186	1211
Tail Surfaces	937	1051	1017	1101	1152	1179
Body Group	7219	8683	8613	8093	8851	8907
Alighting Gear	2536	2849	2772	2948	3078	3139
Flight Controls	1508	2281	2388	1671	1889	1915
Engines & Related Items	3511	3511	3511	3511	3511	3511
Fuel System	2091	1943	2000	1996	2055	2033
Propeller Installation	820	797	804	810	818	805
Drive System	6625	7284	7026	7549	7985	8031
Miscellaneous Equipment	6384	6394	6392	6398	6403	6405
Technology Savings	-1558	-2316	-2305	-1900	-2224	-2486
Contingency	+1538	1840	1799	1917	2020	2075
Weight Empty	39990	47851	46770	49844	52508	54032
Crew	720	720	720	720	720	720
Trapped Fluids	326	307	315	314	321	318
Fuel	11063	10180	10558	10492	10823	10720
Payload	10700	10700	10700	10700	10700	10700
Gross Weight	62800	69757	69063	72069	75071	76490



(2) Aircraft Cruising Speed

The increased gross weight necessary to achieve the design payloads also results in increasing the aircraft power requirements. Because of this, these aircraft experience some reduction in cruise speed when using the same installed power as the S-65-300. This is summarized in Table XVI.

To give an indication of the potential of each concept for higher speeds, cruise speed was also determined assuming an arbitrary addition of twenty percent more power installed in the aircraft. This is also shown on the table. It should be noted that this added power also increases the aircraft gross weight by two or three thousand pounds.

TABLE XVI AIRCRAFT CRUISE SPEED CAPABILITIES			
CONFIGURATION	CRUISE SPEED AT 100% DESIGN POWER		CRUISE SPEED AT 120% DESIGN POWER
	AT 62,600 LB GW	AT 10,700 LBS PAYLOAD	AND 10,700 LBS PAYLOAD
S-65-300	250 Knots	250 Knots	250* Knots
Eight Segment Telescoping Rotor	275	257	279
Roll-up Rotor Two Thin Blades	295	289	308
Roll-up Rotor Four Thin Blades	282	277	297
Roll-up Rotor, Four Pneumatic Blades	282	278	298
Inplane Fold Rotor	281	271	292
Two Segment Telescoping Rotor	281	268	287

\* Limited by blade stress limits.

(3) Wing Size Trade-Off

For each design, a wing size trade-off was performed to determine the most cost effective wing area. This was then compared to the wing sizes that were required for the transition from rotor borne to wing borne flight. If the most cost effective size was larger than that required for transition, it was used. If it was not, the transition size obviously had to be used in the final designs.

To determine the most cost effective wing size, the computerized helicopter design model (described in section III-1) was again used. For each design, four or five specific wing sizes were analyzed. These varied in 100 square foot increments and were chosen to bracket the expected optimum point.

For each wing size, wing weight was determined by a parametric wing weight equation. Cruise power required was modified to reflect the wing size changes. From this, mission fuel was calculated. Minor changes were made where required in other subsystem weights to reflect the changing wing size. The sum total of the component weights were then subtracted from the gross weight to determine the mission payload capability.

Next, the computer model resized the aircraft by varying the gross weight until the desired 10,700 pound payload was achievable for all wing sizes. This provided a plot of design gross weight as a function of wing area.

The aerodynamic analysis used in this aircraft sizing had as one of its outputs mission inbound and outbound cruise speeds as functions of wing area.

At this point, the payload for all wing sizes were equal and the mission speeds were known. The only remaining variable required for the cost effectiveness analysis was the aircraft dollar cost. This was found by using the costing procedure discussed in the aircraft cost section. This used component weights, material, and complexity factors to determine unit development costs, acquisition costs, and operating costs. When these costs were combined with the payload and mission speed, the cost effectiveness was established as a function of wing size.

The entire analysis was computerized to minimize calculation time. Figures 33 through 38 show the results for each rotor type, giving the cost effectiveness, gross weight, and cruise speed variations as functions of wing size.

The transition from rotor borne to wing borne flight also influences the wing size. This was previously discussed in section III-2 of this report. Table VI of section III-4 gives the wing size requirements for transition for the baseline 62,800 pounds gross weight. The transition requirements were also determined for the final solution gross weights. These are also included in Figures 33 through 38.

Table XVII, page 146, lists the most cost effective wing size for each configuration plus the wing size requirements for the transition. The larger of the two was used for the final aircraft designs.

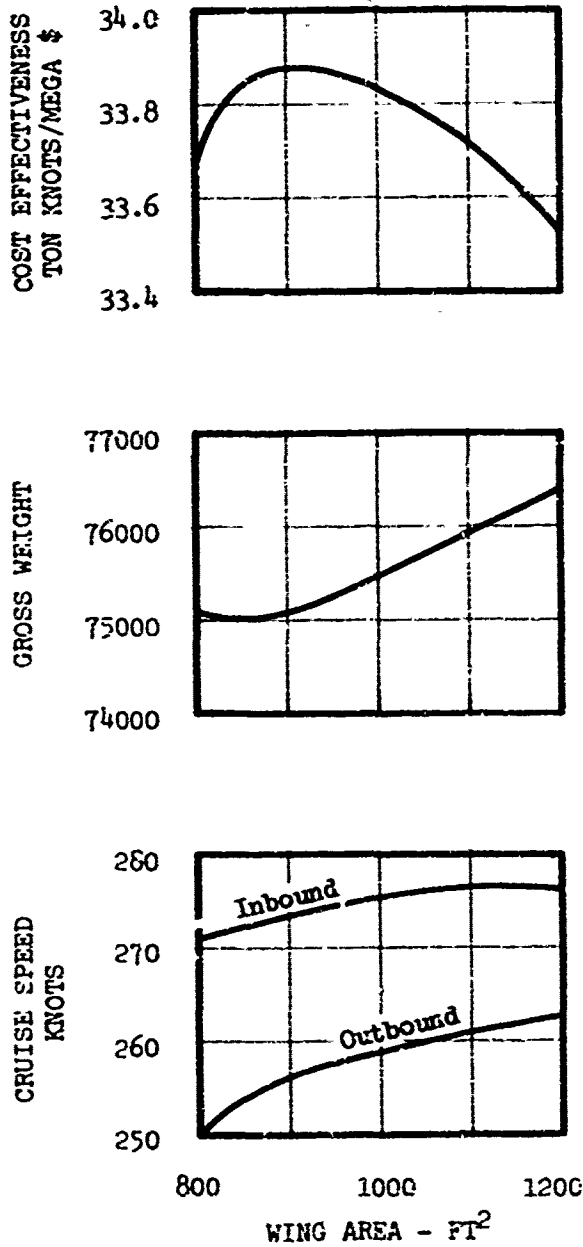

FIGURE 33  
WING SIZE TRADE OFF  
EIGHT SEGMENT TELESCOPING ROTOR

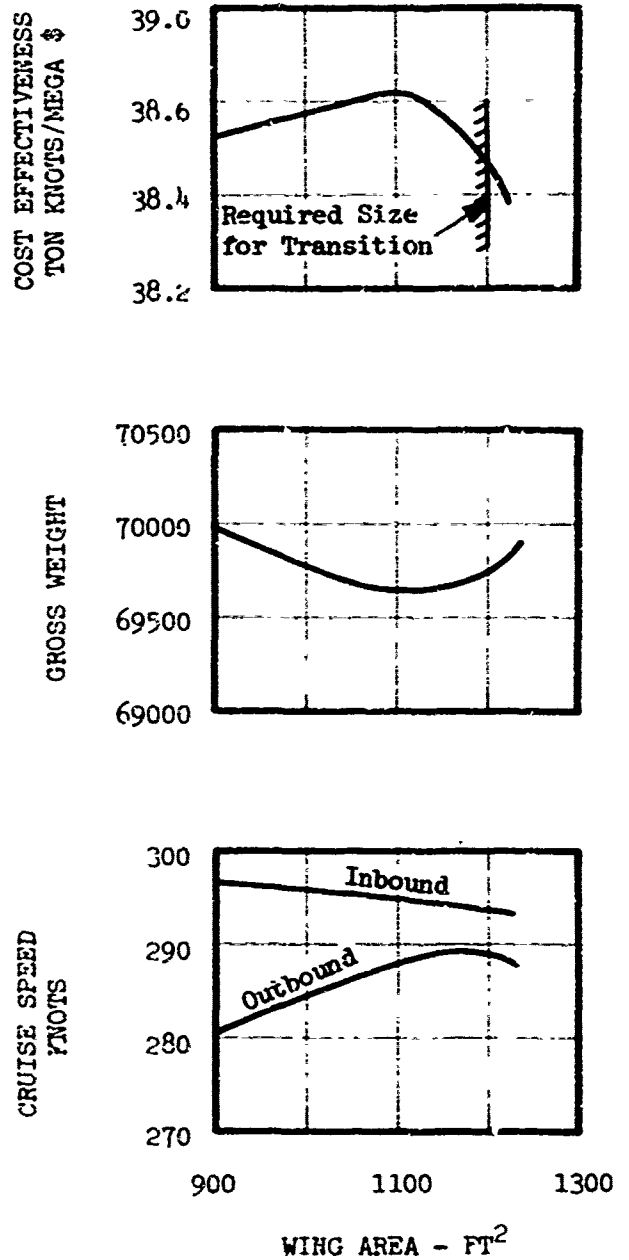

FIGURE 34  
WING SIZE TRADE OFF  
ROLL-UP ROTOR, TWO THIN BLADES

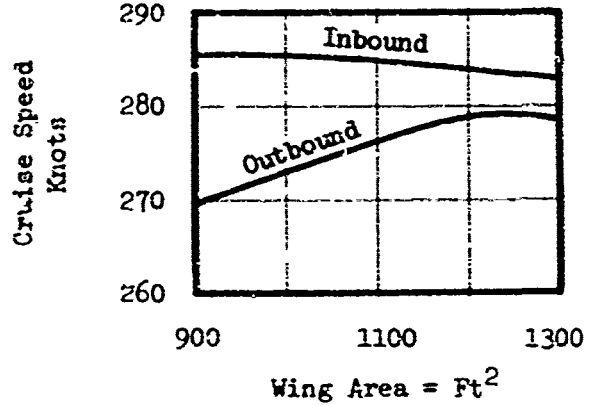
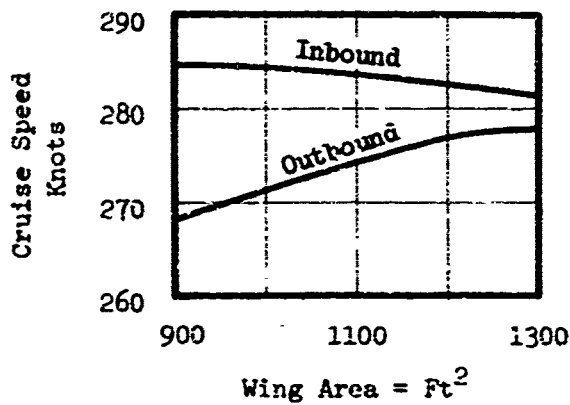
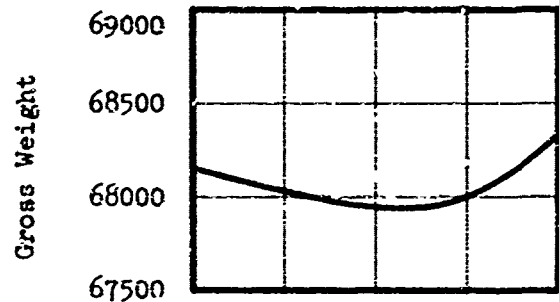
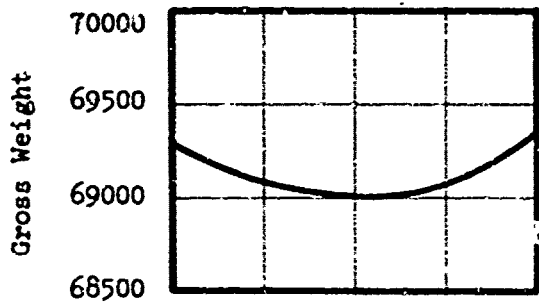
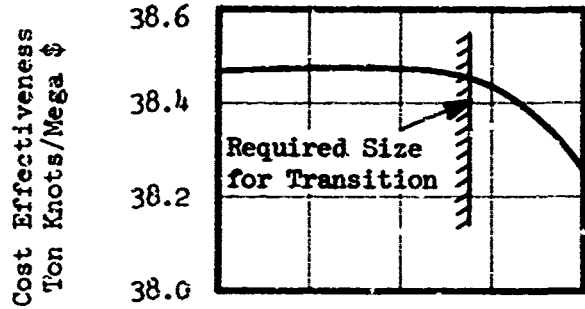
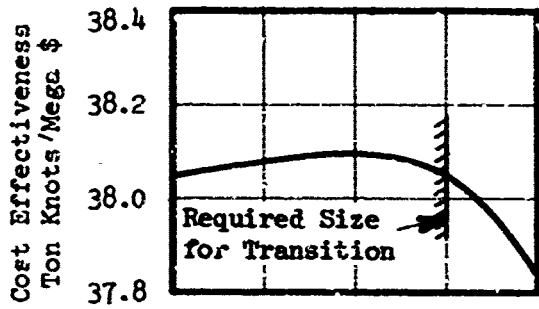

FIGURE 35  
WING SIZE TRADE OFF  
ROLL-UP ROTOR, FOUR THIN BLADES

FIGURE 36  
WING SIZE TRADE OFF  
ROLL-UP, FOUR PNEUMATIC BLADES

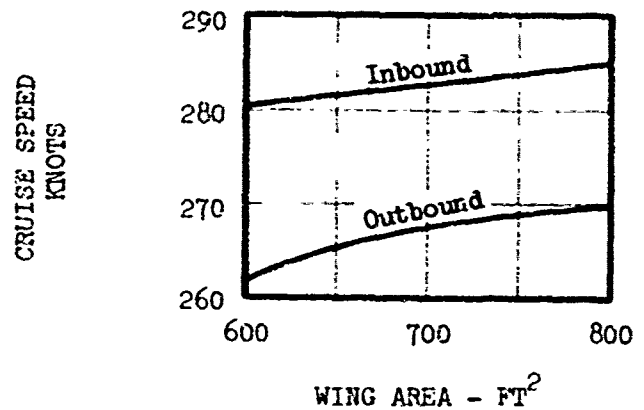
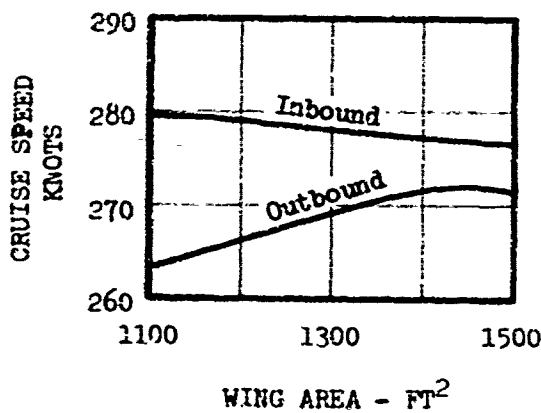
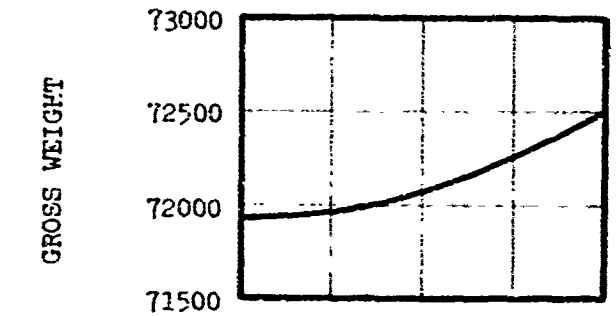
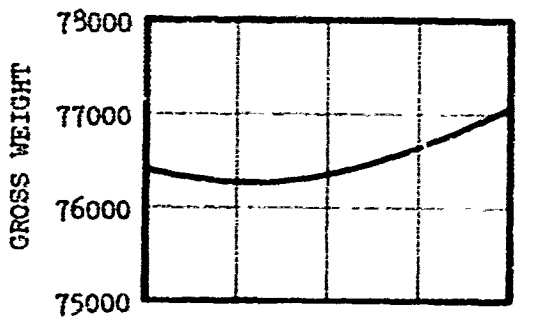
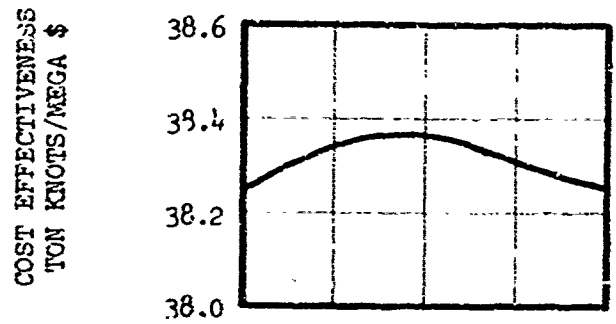
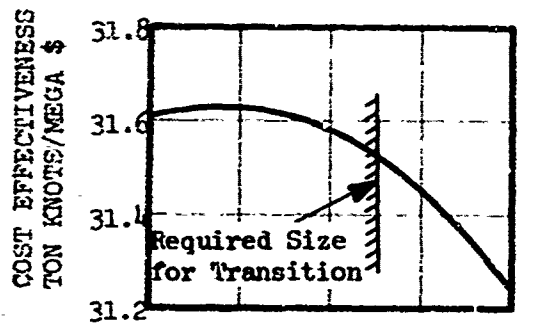

FIGURE 37  
WING SIZE TRADE OFF  
INPLANE FOLD ROTOR

FIGURE 38  
WING SIZE TRADE OFF  
TWO SEGMENT TELESCOPING ROTOR

TABLE XVII WING SIZE TRADE-OFF RESULTS

CONFIGURATION	WING SIZE REQUIRED FOR TRANSITION	MOST COST EFFECTIVE WING SIZE
Eight Segment Telescoping Rotor	880 sq. ft.	900 sq. ft.
Roll-up Rotor, Two Thin Blades	<u>1200</u>	1100
Roll-up Rotor, Four Thin Blades	<u>1200</u>	1100
Roll-up Rotor, Four Pneumatic Blades	<u>1175</u>	1000
Inplane Fold Rotor	<u>1350</u>	1200
Two Segment Telescoping Rotor	650	700

Note. Underlined values indicate wing sizes used in final aircraft designs.

(4) Mission Related Parameters

As discussed in the technical approach, Section III-1, a fleet of aircraft was defined to perform a fixed task. The fleet size was varied for each concept to account for differences in the aircraft availability and dependability. The total required fleet effectiveness was first assumed to be that of 100 aircraft performing the specific mission with 100% availability and dependability. This gives a total fleet effectiveness requirement of 57,980 ton knots. Fleet size was then determined by dividing this required fleet effectiveness by the unit mission effectiveness for each concept. Therefore, more than 100 aircraft are required in each case.

Unit mission effectiveness is a function of the aircraft cruise speed capabilities plus its availability, reliability, and survivability values. Availability and reliability were determined from the R/M analysis, discussed in the section III-4 and tabulated in Table X. Mission survivability is a judgement evaluation based on the relative impact of size and rotor configuration on vulnerability and the relative change in detectability due to the aircraft's noise signature. Table XVIII summarizes these values plus the effectiveness and total number of aircraft required for each concept.

(5) Aircraft Costs

Aircraft life cycle costs were calculated for use in the cost effectiveness analysis. Acquisition costs were found by multiplying the aircraft subsystem weights by cost factors, expressed in terms of dollar cost per pound of weight. The determination of these cost factors for the rotor systems was previously discussed in section III-4 and they were tabulated in Table XIII. For the remaining aircraft components and subsystems the cost factors used were the same as those used for the baseline S-65-300 aircraft, since all systems were similar.

Unit development costs were determined by a similar analysis; dollars per pound cost factors were applied to the final aircraft weights, with rotor development costs multiplied by complexity factors to account for their unusual development

Table XVIII Aircraft Mission Parameters

	Availability	Reliability	Survivability	Productivity Ton Knots	Effectiveness Ton Knots	Number of Aircraft Required
Baseline, S-65-300	.8948	.9725	.99950	579.76	504.25	115
Eight Segment Telescoping Rotor	.9004	.9736	.99956	591.84	518.57	112
Roll-up Rotor, Two Thin Blades	.9034	.9761	.99964	631.52	556.68	105
Roll-up Rotor, Four Thin Blades	.8991	.9746	.99966	612.49	530.52	109
Roll-up Rotor, Pneumatic Blades	.8988	.9744	.99967	614.01	537.57	108
Inplane Fold Rotor	.9063	.9749	.99942	604.25	533.57	109
Two Segment Telescoping Rotor	.8500	.9736	.99931	608.92	527.27	110

problems. These complexity factors were shown in Table XIV of section IV-4. The following table illustrates how the total unit development cost is split up between the rotor RDT&E Cost and the cost for the remaining aircraft.

	COST WITHOUT ROTOR RDT&E	+ ROTOR RDT&E =	TOTAL UNIT DEVELOPMENT COST
S-65-300	$\$2.53 \times 10^6$	$\$ .23 \times 10^6$	$\$2.76 \times 10^6$
Eight Segment Telescoping Rotor	3.34	1.41	4.75
Roll-up Rotor Two Thin Blades	3.47	1.16	4.63
Roll-up Rotor Four Thin Blades	3.27	.92	4.19
Roll-up Rotor Four Pneumatic Blades	3.26	.93	4.19
Inplane Fold Rotor	3.97	1.45	5.42
Two Segment Telescoping Rotor	3.08	.40	3.48

Operating cost is the sum of crew, replenishment spares, maintenance, and fuel, oil, and lubricants costs. Replenishment spares cost per year were assumed to be a percentage of vehicle acquisition cost. Crew cost per life cycle flight hour was assumed to be proportional to the number of officers and enlisted men in the crew. Similarly, fuel, oil, and lubricants cost per life cycle flight hour were assumed to be proportional to average mission fuel flow. Maintenance cost per life cycle flight hour was found from the product of a cost factor and the maintenance manhours per flight hour value obtained from the maintainability analysis. The cost factors, in dollars per maintenance manhour, were increased over a base rate to allow for overhead support and personnel efficiency.

Totaling the above costs gives the complete life cycle cost for each aircraft. The cost summaries are shown in Tables XX through XXVI. The total life cycle costs compare as follows:

<u>CONFIGURATION</u>	<u>UNIT LIFE CYCLE COST</u>
S-65-300	\$11,460,000
Eight Segment Telescoping Rotor	12,310,000
Roll-up Rotor, Two Thin Blades	14,470,000
Roll-up Rotor, Four Thin Blades	14,100,000
Roll-up Rotor, Four Pneumatic Blades	13,980,000
Inplane Fold Rotor	15,480,000
Two Segment Telescoping Rotor	13,340,000



Table XX			
Cost Summary			
S65-300			
Unit Development Cost			\$2,760,000
Acquisition Cost			5,036,000
Flyaway		\$3,436,000	
Airframe	\$2,958,000		
Engines	477,000		
Initial Spares		801,000	
Ground Equipment		395,000	
Training & Travel		403,000	
Operating Cost			3,662,000
Crew		530,000	
Maintenance		960,000	
Fuel, Oil, Lub		453,000	
Replenishment Spares		1,719,000	
<b>Total Life Cycle Cost</b>			<b>11,452,000</b>

Table XXI			
Cost Summary			
Eight Segment Telescoping Rotor			
Unit Development Cost			\$4,748,000
Acquisition Cost			6,380,000
Flyaway		\$4,466,000	
Airframe	\$3,988,000		
Engines	477,000		
Initial Spares		996,000	
Ground Equipment		513,000	
Training & Travel		403,000	
Operating Cost			4,176,000
Crew		530,000	
Maintenance		959,000	
Fuel, Oil, Lub		453,000	
Replenishment Spares		2,233,000	
<b>Total Life Cycle Cost</b>			<b>15,305,000</b>

Table XXII

Cost Summary  
Roll-up Rotor - Two Thin Blades

Unit Development Cost			\$4,629,000
Acquisition Cost			5,864,000
Flyaway		\$4,086,000	
Airframe	\$3,608,000		
Engines	477,000		
Initial Spares		924,000	
Ground Equipment		469,000	
Training & Travel		403,000	
Operating Cost			3,958,000
Crew		530,000	
Maintenance		926,000	
Fuel, Oil, Lub		458,000	
Replenishment Spares		2,043,000	
Total Life Cycle Cost			14,472,000

Table XXIII

Cost Summary  
Roll-up Rotor - Four Thin Blades

Unit Development Cost			\$4,193,000
Acquisition Cost			5,918,000
Flyaway		\$4,112,000	
Airframe	\$3,634,000		
Engines	477,000		
Initial Spares		929,000	
Ground Equipment		472,000	
Training & Travel		403,000	
Operating Cost			3,988,000
Crew		530,000	
Maintenance		942,000	
Fuel, Oil, Lub		459,000	
Replenishment Spares		2,056,000	
Total Life Cycle Cost			14,099,000

Table XXIV			
Cost Summary			
Roll-up Rotor - Four Pneumatic Blades			
Unit Development Cost			\$4,193,000
Acquisition Cost			5,827,000
Flyaway		\$4,043,000	
Airframe	\$3,565,000		
Engines	477,000		
Initial Spares		916,000	
Ground Equipment		464,000	
Training & Travel		403,000	
Operating Cost			3,957,000
Crew		530,000	
Maintenance		945,000	
Fuel, Oil, Lub		459,000	
Replenishment Spares		2,021,000	
<b>Total Life Cycle Cost</b>			<b>13,978,000</b>

Table XXV			
Cost Summary			
Inplane Fold Rotor			
Unit Development Cost			\$5,420,000
Acquisition Cost			6,052,000
Flyaway		\$4,215,000	
Airframe	\$3,737,000		
Engines	477,000		
Initial Spares		945,000	
Ground Equipment		484,000	
Training & Travel		403,000	
Operating Cost			4,006,000
Crew		530,000	
Maintenance		909,000	
Fuel, Oil, Lub		459,000	
Replenishment Spares		2,107,000	
<b>Total Life Cycle Cost</b>			<b>15,478,000</b>

Table XXVI

Cost Summary  
Two Segment Telescoping Rotor

Unit Development Cost			\$3,484,000
Acquisition Cost			5,861,000
Flyaway		\$4,069,000	
Airframe	\$3,591,000		
Engines	477,000		
Initial Spares		921,000	
Ground Equipment		467,000	
Training & Travel		403,000	
Operating Cost			3,991,000
Crew		530,000	
Maintenance		972,000	
Fuel, Oil, Lub		454,000	
Replenishment Spares		2,034,000	
Total Life Cycle Cost			13,336,000

(6) Summary

Table XXVII shown below summarizes the results of the quantitative part of the study. The roll-up rotors are seen to require the smallest penalty in aircraft gross weights. They require large wings, with their resultant weight penalty, but their rotor weights are comparable to the baseline S-65-300 design.

The roll up rotors also have the highest speed capability.

Table XXVII Summary of Quantitative Analysis

	S-65-300	Eight-Segment Telescoping Rotor	Roll-up Rotor Two Thin Blades	Roll up Rotor Four Thin Blades	Roll-up Rotor Four Pneumatic Blades	Impulse Field Rotor	Two-Segment Telescoping Rotor
Gross Weight, Lbs	62900	75071	69757	69063	67977	76490	73069
Disc Loading, PSF	11.8	5	5	5	5	5	10
Rotor Diameter, Ft	79.0	138.3	133.3	137.6	131.6	129.6	95.0
Wing Area	475	900	1200	1700	1175	1350	700
Outbound Mission Speed, Knots	250	257	289	277	278	271	268
Inbound Mission Speed, Knots	250	273	294	283	284	278	283
Unit Life Cycle Cost \$ x 10 <sup>5</sup>	11.86	15.31	14.47	14.10	13.98	15.48	13.24
Cost Effectiveness Ton Knots/Megawatt	44.00	33.6	31.00	38.05	35.46	34.47	39.40
Speed Capabilities at 100% Design Power:							
Outbound, Knots	250	273	308	297	298	290	287
Inbound, Knots	250	295	319	301	307	296	301

For use in the evaluation matrix, the important parameter is the overall system cost effectiveness for each concept. As discussed in the technical approach, it is used to combine all the quantitative results, and is assigned fifty percent of the total score in the evaluation. The rotor with the highest cost effectiveness is assigned a value of one, and receives 50 evaluation points. Relative values are then used for each other rotor concept. The final results are as follows.

TABLE XXVIII QUANTITATIVE EVALUATION RATING			
	COST EFFECTIVENESS	RELATIVE COST EFFECTIVENESS	EVALUATION SCORE
Eight Segment Telescoping Rotor	33.88	.857	42.9
Roll-up Rotor Two Thin Blades	38.46	.973	48.7
Roll-up Rotor Four Thin Blades	38.05	.963	48.1
Roll-up Rotor Four Pneumatic Blades	38.46	.973	48.7
Inplane Fold Rotor	34.47	.872	43.6
Two Segment Telescoping Rotor	39.52	1.000	50.0

b. Qualitative Results

The remaining fifty points of the evaluation matrix are assigned to qualitative judgements of the merit of each concept. These were felt to be necessary in addition to the quantitative cost effectiveness analysis to fully complete the evaluation. Within the limited scope of this study, no attempt is made to justify these values quantitatively.

This section discusses the rationale behind these judgements. The specific characteristics evaluated and their maximum total score are as follows:

. Technical Risk	10 points
. Off-design Performance	6 points
. Adaptability to Stowed Rotor Designs	6 points
. Growth Potential	6 points
. Handling Qualities	6 points
. Safety	6 points
. Maneuverability	3 points
. Vibration	3 points
. Hovering Downwash Severity	2 points
. Stowability/Transportability	2 points

(1) TECHNICAL RISK assesses an estimate of the relative probability that a workable production design can be developed within the timeframe assumed, and the relative magnitude of the total RDT&E effort. The maximum score of ten is assigned to the two segment telescoping rotor, because this design has fewer total problems than any of the other concepts, in addition to being the only concept which has already received a considerable development effort. This is in marked contrast with some of the other designs which have not undergone even the most basic development effort. The two segment telescoping rotor has received considerable effort by a number of helicopter manufacturers. This has included detailed aerodynamic and dynamic analysis, as well as both reduced scale and full size model tests.

Of all the concepts studied, this rotor requires the least technological advances. Its mechanism is straightforward and it has none of the dynamic and aeroelastic problems associated with the variable diameter concepts employing very flexible blades. Diameter changes can be made slowly and smoothly, as the aircraft accelerates to cruise speed. It is the only design that does not require stopping the rotor to achieve the speeds required for this study.

Of the remaining concepts, the eight segment telescoping rotor is thought to have the lowest technical risk. Its problems are mainly in the mechanical design area. These have been addressed during the quantitative analysis and have resulted in a high estimated weight for this rotor. Considerations that increase the technical risk of the rotor over the two segment telescoping rotor include the complexity of the blade and the fact that the rotor must be stopped for high speed flight. This system shares some of the advantages of the two segment rotor.

The diameter transition is smooth, and can occur slowly as the aircraft accelerates to cruise speed. The expected dynamic and aerodynamic problems are substantially less than the remaining concepts, for all modes of flight.

The eight segment telescoping rotor is assigned a technical risk score of seven. The flexible roll-up rotors are assumed to have the next highest technical risk. This is mainly because of the unusual aeroelastic problems associated with blade pitch control, ground resonance avoidance, and possible forward flight instabilities. In addition, with the thin blades there is concern about the possible distortion of the airfoil shape during gusts and other unusual loading situations. Because of this the two bladed thin airfoil rotor, with its larger blade chord and lower aspect ratio, has been assumed to have a higher risk than the four bladed rotor. It was assigned a value of five, compared to the four bladed rotor which has a value of six.

The pneumatic rotors have the further risk associated with the pneumatic system itself. Because of this the four bladed pneumatic rotor was assigned a value of 4.5.

The inplane fold rotor was assumed to have the highest technical risk of all the concepts. This is because of the unusual type of diameter retraction, which must occur quickly, rather than slowly as the aircraft accelerates. Some as yet unknown method must be found to stabilize the blade during folding, to either react or reduce loads generated during gusts or maneuvers.

The folding rotor has been assigned a technical risk score of 4.0

- (2) OFF DESIGN PERFORMANCE is a measure of the versatility of the concepts in performing other than the specific design mission. A low disc loading and high hovering efficiency would be an asset for missions requiring long hover times. Superior cruise lift to drag ratios would be an advantage for long range missions. The ability to make a gradual transition from the extended to retracted diameter positions, and to fly at intermediate diameters, might be an asset for certain other types of missions. A perfect score of six is assigned to this attribute.

The highest score of six has been given to all of the flexible roll-up rotors, since they rate high in all three of these considerations. The eight segment telescoping rotor receives a value of 4.8 due to its lower cruise lift to drag ratio. The two segment telescoping rotor receives a score of 4.2 mainly because it does not achieve the desired 5 psf hovering disc loading. The inplane fold rotor has a lower cruise lift to drag ratio than the roll-up rotors, in addition to not being able to perform its rotor retraction gradually. It receives a score of 3.6.

- (3) ADAPTABILITY TO STOWED ROTOR DEFINES rates one of the most promising aspects of some of these concepts - the fact that the rotors have been retracted to a very small size and with little added complexity, plus more installed power, substantially higher speeds are achievable. This attribute is also assigned a perfect score of six.



The two bladed flexible roll-up concept receives the highest score because it has the smallest retracted rotor size, plus the highest cruise lift to drag ratio. Following it, with scores of 5.4, are the four bladed roll-up rotors, which have larger rotor heads which would be that much harder to stow for high speed flight. Next is the eight segment telescoping rotor. It has an even larger rotor, and receives a score of 4.2. Both the inplane fold rotor and the two segment telescoping rotor have even larger retracted sizes and are consequently penalized further. With its three to one retraction ratio, the inplane fold rotor receives a score of only 2.4. The two segment telescoping rotor receives a score of 1.0. It is the only rotor analyzed in this study which has not already been stopped for the cruise mode of flight. Also, its retraction ratio of 1.7 to 1 makes it more difficult to apply to stowed rotor designs than the concepts with higher retraction ratios.

(4) GROWTH POTENTIAL measures the ability of a concept to accept design modifications, such as extended blade radius, chord increase, or improved airfoils, to enhance performance, and the degree to which engine uprating can be absorbed by the rotor system to increase gross weight capability. Six is the perfect score for this attribute also.

None of the rotors can accept all of these design modifications. All of the concepts which have a hovering disc loading of five psf can accommodate extended blade radius without any additional airframe modifications, unlike the two segment telescoping rotor which would require the extension of the tail cone for tail rotor clearance. The eight segment telescoping rotor blade would require an extensive redesign to achieve extended diameter and blade chord. It is limited in the selection of airfoils due to the requirements of the retraction mechanism. In spite of these considerations, it is still given the highest score mainly because it is able to absorb more power and therefore improve aircraft performance without any change in rotor geometry. This is because there is a large margin between the operating blade lift coefficient and the blade stall lift coefficient.

The pneumatic roll-up rotor would have a similar capability to absorb more power, although it is felt that it could not be operated at as high a blade lift coefficient as the more rigid telescoping rotors. All the roll-up rotors have the further advantage of easily being adaptable to high rotor diameters; the blade need only be made longer. Because of these considerations, the pneumatic roll-up rotor receives a score of 5.8.

The thin roll-up rotors do not have this large margin between operating and stall  $C_L$  and therefore could not accept large increases in installed power without a rotor redesign. Because of this they receive a score of 5.4.

The inplane fold rotor receives a score of five points. It can absorb more power, more diameter, and more chord. It is the only concept which permits the designer almost complete freedom in the selection of airfoil selections. It is penalized for its unusual folding requirements. It is felt that any increase in rotor diameter and blade chord would further aggravate an already difficult blade fold operation.

Finally, the two segment telescoping rotor receives the lowest score, 2.5, due to the fact that an extensive airframe redesign is required for any increase in rotor diameter.

(5) HANDLING QUALITIES measures the ease with which the pilot controls the aircraft. This attribute, which has a perfect score of six, was rated mainly on an estimate of the pilot attention required during rotor retraction and stopping, and starting and extending operations. The two segment telescoping rotor, with its smooth gradual diameter changes, and which does not have to be stopped for operation at the speeds assumed in this study, receives the highest score. The inplane fold rotor with its low speed transition, and with a transition which cannot occur gradually, receives the lowest score of only 2.0 points. The remaining concepts are in between these two extremes, and have all been given the value of 4.0.

(6) SAFETY refers to crew survivability and crashworthiness of the aircraft following a mission abort. The vulnerability of each rotor concept has already been accounted for in the mission dependability components of the cost effectiveness analysis. A perfect score of six was also assumed for this attribute.

The perfect score was assigned to both the eight segment telescoping rotor and the inplane fold rotor. They both have the five psf disc loading which leads to good autorotational characteristics, and they both have rigid rotor blades which aid in the prevention of the rotor from contacting the fuselage during an exceptionally hard landing. The flexible bladed rotors received a score of only 2.4, since it would be very hard to avoid this rotor/fuselage contact in an extreme emergency landing situation. Finally the two segment telescoping rotor receives a value of 4.8. It has rigid blades but it is penalized for its higher disc loading which does not give it as good autorotational characteristics as the other designs.

The final four attributes are not rated as important as the others, and consequently have lower perfect scores.

(7) MANEUVERABILITY, with a perfect score of three, is an attribute used to judge the maneuverability of the aircraft in the cruise configurations and during the actual diameter extension and retraction phases of the mission. Those concepts which are capable of a high retraction ratio, which stop their rotors during cruise, and which are further capable of gradual diameter changes, receive the highest score. These include the eight segment telescoping rotor and all of the roll-up rotors. The two segment telescoping rotor receives a value of 2.4 because it does not stop its rotor in cruise. This does not necessarily limit cruise maneuverability, but it may make it more difficult to program the aircraft control system for maneuvers, since both rotor controls and fixed wing controls must be manipulated. Finally, the inplane fold rotor receives the lowest score, 1.8, because it is almost impossible to maneuver the aircraft during the blade folding and unfolding operations.

(8) VIBRATION evaluates qualitatively the amount of vibration that will be felt by the airframe during rotor borne flight. A perfect score of three is assumed. Because of their flexibility the roll-up rotors receive high scores in this category. Both of the four bladed rotors are given the perfect score of three. This is reduced to 2.7 for the two bladed rotor since it would have somewhat higher vibration levels than the four bladed rotors.

Next in descending order is the two segment telescoping rotor. It has a rigid blade construction, but uses a fully articulated rotor with four blades and would, therefore, have good vibration characteristics. It is given a score of 2.1.

The lowest score, 1.5, is given to both of the two bladed rigid teetering rotor systems. They would have the highest forward flight vibration characteristics of any of the concepts studied.

(9) HOVERING DOWNWASH relates primarily to the relative disc loadings of the concepts. Since downwash severity is related to both velocity and mass flow, gross weight is also a factor. Two points is the percent score for this attribute. The lowest score of 0.4 is given to the two segment telescoping rotor since it is the only concept to use a disc loading of ten psf rather than the desired five psf. Of the remaining concepts, the score is determined by the relative gross weights required for each solution aircraft.

(10) The final two points of the evaluation matrix are assigned to STOWABILITY/TRANSPORTABILITY. This relates to the actual size of the aircraft in a folded configuration. Because of the smaller size resulting from its higher disc loading, the two segment telescoping rotor receives the full two points. All of the other concepts are assigned a value of 1.0.

c. Completed Evaluation Matrix:

The following table presents the completed evaluation matrix.

TABLE XXIX. COMPLETED EVALUATION MATRIX

	PERFECT SCORE	EIGHT SEGMENT TELESCOPIING ROTOR	ROLL-UP ROTOR TWO THIN BLADES	ROLL-UP ROTOR FOUR THIN BLADES	ROLL-UP ROTOR FOUR PNEUMATIC BLADES	INPLANE FOLD ROTOR	TWO SEGMENT TELESCOPIING ROTOR
Cost Effectiveness	50.0	42.9	48.7	48.1	48.7	43.6	50.0
Technical Risk	10.0	7.0	5.0	6.0	4.5	4.0	10.0
Off-Design Performance	6.0	4.8	6.0	6.0	6.0	3.6	4.2
Adaptability to Stowed Rotor Designs	6.0	4.2	6.0	5.4	5.4	2.4	1.0
Growth Potential	6.0	6.0	5.4	5.4	5.8	5.0	2.5
Handling Qualities	6.0	4.0	4.0	4.0	4.0	2.0	6.0
Safety	6.0	6.0	2.4	2.4	2.4	6.0	4.8
Maneuverability	3.0	3.0	3.0	3.0	3.0	1.8	2.4
Vibration	3.0	1.5	2.7	3.0	3.0	1.5	2.1
Hovering Downwash	2.0	1.4	1.8	1.8	2.0	1.4	0.4
Stowability/ Transportability	2.0	1.0	1.0	1.0	1.0	1.0	2.0
Total Score	100.00	81.1	86.0	86.1	85.8	72.3	85.4

## 6. CONCLUSIONS FROM DETAILED EVALUATION

The scores for each concept and the overall ranking of the rotor systems are as follows:

1. Roll-up Rotor, Four Thin Blades	86.1
2. Roll-up Rotor, Two Thin Blades	86.0
3. Roll-up Rotor, Four Pneumatic Blades	85.8
4. Eight Segment Telescoping Rotor	81.8
5. Inplane Fold Rotor	72.8

From the above table, it is concluded that the flexible roll-up rotors are the most promising concepts. Collectively, they rank substantially higher than the other two designs. The ranking of the three different roll-up rotors with respect to each other is not as obvious. Although the four bladed rotor using thin blades does have the highest score, the differences between the scores must be considered within the accuracy of this type of analysis. The conclusion is that although the flexible roll-up rotors are the most promising, the decision as to the particular type of flexible roll-up rotor cannot yet be made. Further analysis of the schemes, including building and testing of small scale hardware, would have to be performed to make this decision.

Because of the different ground rules used in the analyses (specifically the design disc loading) it is questionable whether the two segment telescoping rotor can be rated against the other concepts by using this evaluation score. It did achieve a score of 85.4, which is comparable with the highest scores for the other concepts. This is mainly attributed to its much lower technical risk which gave it a score in that category of three points more than any other concept. In addition, this low risk gives it the lowest RDT&E cost of any of the concepts, and this helps to improve its overall cost effectiveness to the point where it receives the highest score of 50.0 in this category. It does not achieve the desired goals of low disc loading and high retraction ratio, and it is questionable as to whether it is being correctly rated by this evaluation method. It should really be considered as a near term, interim type of solution for achieving a variable diameter rotor system.

Figure 39 shows a general arrangement drawing of how the baseline S-65-300 aircraft design would be modified to accept the thin roll-up variable diameter rotor system. The major changes include the replacement of the conventional tail rotor with a high disc loading yaw fan and the substantially larger wing which is now required. The cabin size is the same as the baseline aircraft, and the rear loading capability is retained. The general arrangement of the drive system is similar to the S-65-300; the two eleven foot diameter props are also the same as used on the baseline design.

The yaw fan is used to reduce the diameter of the anti-torque device so that it can be placed under the main rotor disc. A conventional tail rotor mounted aft of the main rotor would require a lengthening of the tailcone. This would upset the aircraft balance and require a further lengthening of the nose of the aircraft. This much longer fuselage would finally lead to an excessive airframe weight.

The wing size on the S-65-300 is 475 square feet. On that design, the wing never supports the full gross weight of the aircraft, even at the maximum cruise speed of 250 knots. With the roll-up rotor the wing must now support the full gross weight at very low speeds, since the rotor is retracted and stopped at 140 knots. The minimum size required for transition from rotor borne flight to wing borne flight at the design cruise altitude of 12000', standard conditions, is 1200 square feet. This wing is shown on Figure 39. If the transition was made at a lower altitude, a smaller wing could be used. The wing trade-off study illustrated in Figure 35 showed that the optimum wing size from both gross weight and cost effectiveness standpoints is 1100 square feet, if the transition requirement is ignored.

The gross weight for this aircraft is 69,063 pounds, 6263 pounds higher than the S-65-300. The complete weight statements for both aircraft are shown in Table XXX. Rotor weights are quite similar for both designs. The major weight increase is in the wing, with smaller additions made to the fuselage, anti-torque systems, tail surfaces, flight controls, and drive system. The mission fuel weight has decreased somewhat due to the higher cruise efficiency of the variable diameter rotor aircraft.

With the same installed power as the S-65-300, this aircraft will have a higher cruising speed due to this higher cruise efficiency. The maximum cruise speed of the S-65-300 is 250 knots. The new aircraft can cruise at 277 knots on the outbound mission leg, and this is increased on the inbound leg to 283 knots.

#### Adaptability to Stowed Rotor Designs

This study was limited to variable diameter rotors as applied to stopped rotor compounds which had the same installed power as the baseline fixed diameter design. Because of the high retraction ratio of the roll-up

rotors, they would also lend themselves to stowed rotor aircraft designs. All of the aeroelastic limits which tend to restrict the speed of compound helicopters are eliminated when the rotor is retracted and stopped. If the rotor could be stowed within the fuselage contour drag would be reduced and, with more installed power, substantially higher speeds would be achievable.

Table XXX  
Aircraft Weight Statements

	Baseline S-65-300	Variable Diameter Rotor Aircraft
Rotor Group	5191 lbs	5734 lbs
Wing Group	2238	5547
Tail Rotor/Fan	950	1280
Tail Surfaces	937	1030
Body Group	7219	8653
Alighting Gear	2536	2819
Flight Controls	1508	2265
Engine Section	752	752
Propulsion Group		
Engines as Installed	2202	2202
Air Induction	142	142
Exhaust System	39	39
Lube System	119	119
Engine Controls	66	86
Starting System	171	171
Fuel System	2091	2006
Propeller Installation	320	605
Drive System	6625	7226
Auxiliary Power Unit	246	246
Instruments	487	487
Hydraulics	155	165
Electrical	818	818
Avionics	1427	1427
Armament	55	55
Furnishings	2212	2212
Air Conditioning and Anti-Ice	625	625
Auxiliary Gear	17	16
Vibration Suppression	357	357
Technology Saving	-1558	-2075
Contingency	+1538	+1729
Weight Empty	30990	36771
Crew	710	710
Engine Oil	50	50
Usable Fuel	247	231
Fuel	11767	12558
Payload	11700	12700
Gross Weight	45844 lbs	50365 lbs



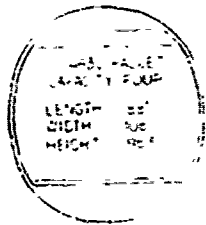

BLADE DATA  
 DIAMETER  
 BLADES  
 CHORD  
 REVERING CURVING

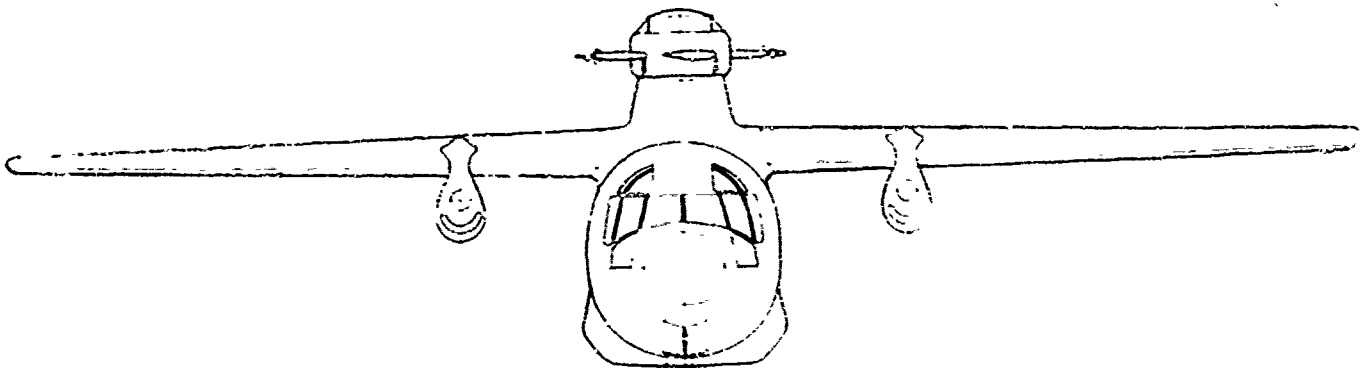

244-238

**B**

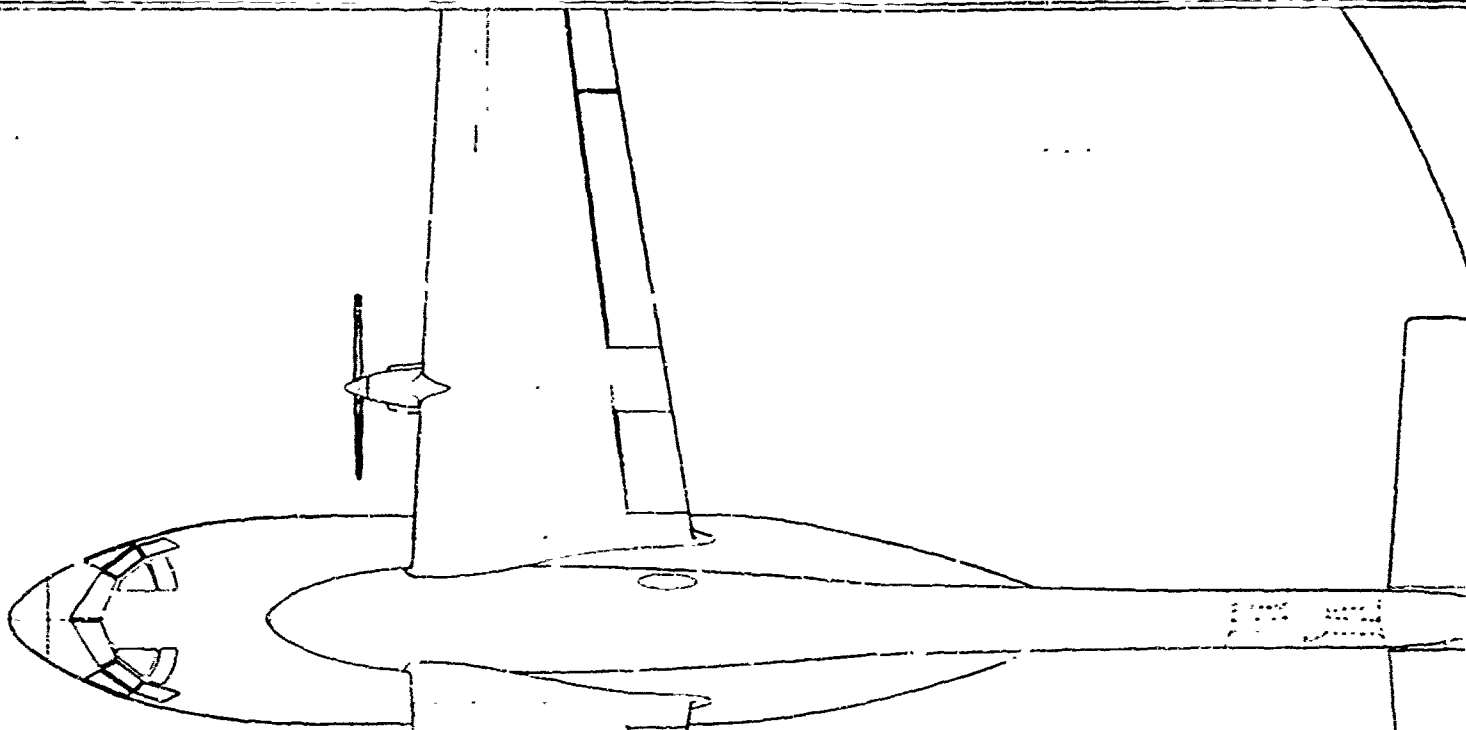

132.8  
4  
25'  
DOWING ANGLE 15'

WING DATA  
AREA 1200 ft<sup>2</sup>  
SPAN 84.85  
AR 6  
AIRFOIL NACA 63<sub>2</sub>415

WING SHOWN IN RETRACTED POSITION

11 PROP DIAMETER

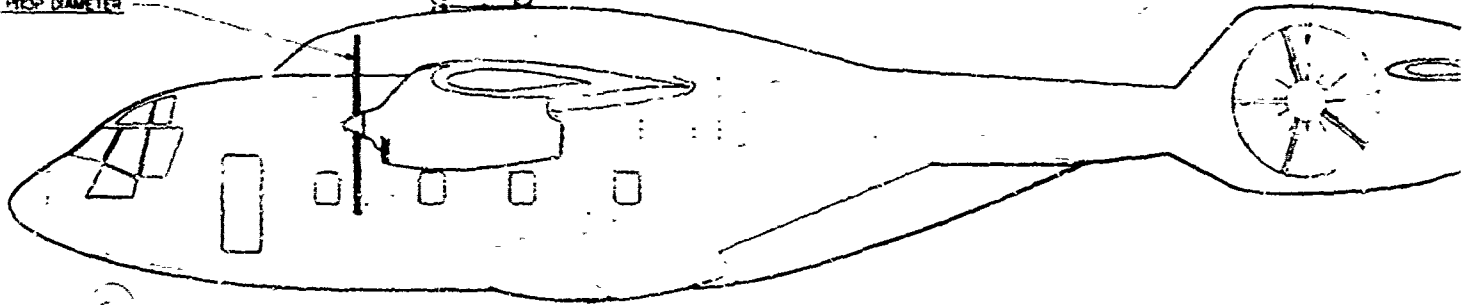

1176.1981 FUSELAGE LENGTH

- 12 94 FEB

3322

e

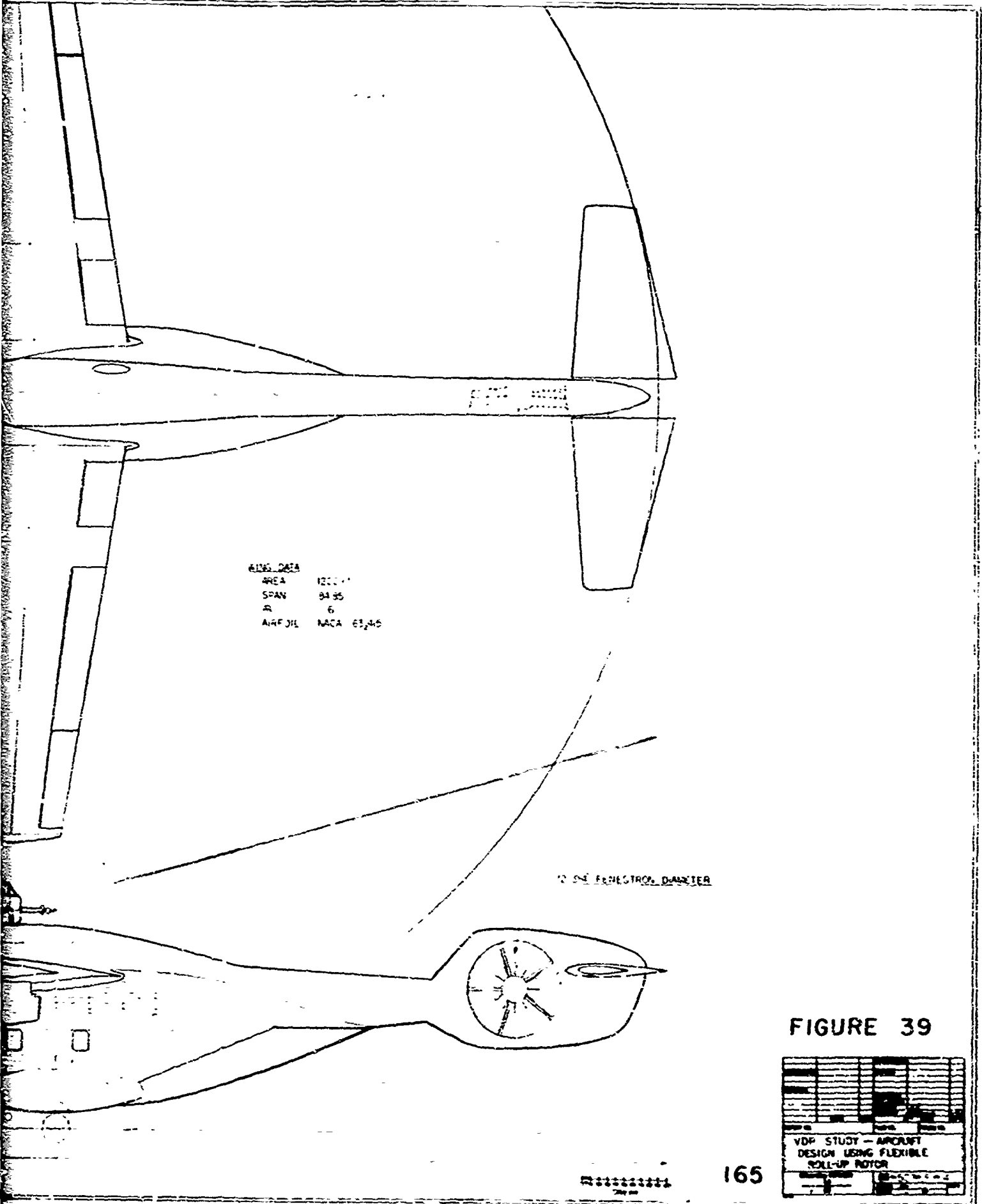

WING DATA  
AREA 122.11  
SPAN 94.95  
AR 6  
AIRFOIL NACA 63,46

CONTROL BARRIER

FIGURE 39

NO.	DESCRIPTION	DATE
1	DESIGNED	10/1/58
2	DRAWN	10/1/58
3	CHECKED	10/1/58
4	APPROVED	10/1/58
5	REVISION	
6		
7		
8		
9		
10		
11		
12		
13		
14		
15		
16		
17		
18		
19		
20		

VDP STUDY - AIRCRAFT  
DESIGN USING FLEXIBLE  
ROLL-UP ROTOR

## DEVELOPMENT PROGRAM FOR ROLL-UP ROTORS

A comprehensive program to analyze, test, develop, and substantiate the roll-up rotor concept has been formulated. The planned program begins with an investigation of fundamental system characteristics and critical hardware feasibility, and culminates in a flight demonstration program with a roll-up rotor compound aircraft. Major technical risk areas would be investigated early in the development program, and any as yet undetected fundamental problems requiring technological breakthrough will be identified early. Analytic techniques for study and optimization of the rotor system in area of performance, design, and stability, will be developed and correlated with tests.

The principle areas of technical risk investigation and critical hardware development are:

1. Investigation of the effectiveness and necessity of blade root and blade tip control systems, separately and in combination throughout the flight envelope. Determine required size of aerodynamic tip tab.
2. Investigation of blade aeroelastic response throughout the flight envelope for various blade and tip mass and elastic properties, and for various control inputs, in trimmed and untrimmed flight.
3. Investigation of various types of tip weight aerodynamic dampers, their effectiveness in eliminating ground resonance, and the study of possible flutter, buffet, or load problems they might cause.
4. Rotor stability and response during extension and retraction cycles in trimmed and untrimmed flight and in gust conditions.
5. Blade materials investigation, selection, and substantiation. Optimum blade design approach for achieving desired elastic properties with minimum production difficulty.
6. Development of concepts and materials to reduce blade erosion.
7. Determination of the aerodynamics of the reflexed airfoils, including the effects of dynamic deflection of the chord of the airfoil, and severity of change in pitching moments.
8. Investigation of blade out of track and dynamic imbalance problems associated with blade-to-blade manufacturing irregularities.
9. Development of fail-safe tip control tab actuator for high loads at high frequency of operation.
10. Rotor head drum roller design and actuation.
11. Rotor head drag reduction.

**Preceding page blank**

This program assumes the thin reflex airfoil will be used. If this is found to have difficult or insurmountable problems in one of the above areas, it is suggested that the pneumatic airfoil be substituted. At that point, a more detailed blade design effort would be made to determine if the blade could be made more stiff torsionally. This might avoid some of the more difficult problems of the reflex airfoils, although only at the cost of added total complexity.

The development program has been formalized into four distinct phases.

- Phase I

Develop first approximate analytic techniques, models, and full scale design concepts at minimum expense and in a minimum time period, to demonstrate the practicality of the concept.

- Phase II

Refine analytic and modeling techniques to optimize the rotor design, and wind tunnel test a large dynamically scaled model rotor.

- Phase III

Design, fabricate, and test a large scale flightworthy roll-up rotor equipped compound aircraft in the NASA Ames 40' x 80' wind tunnel.

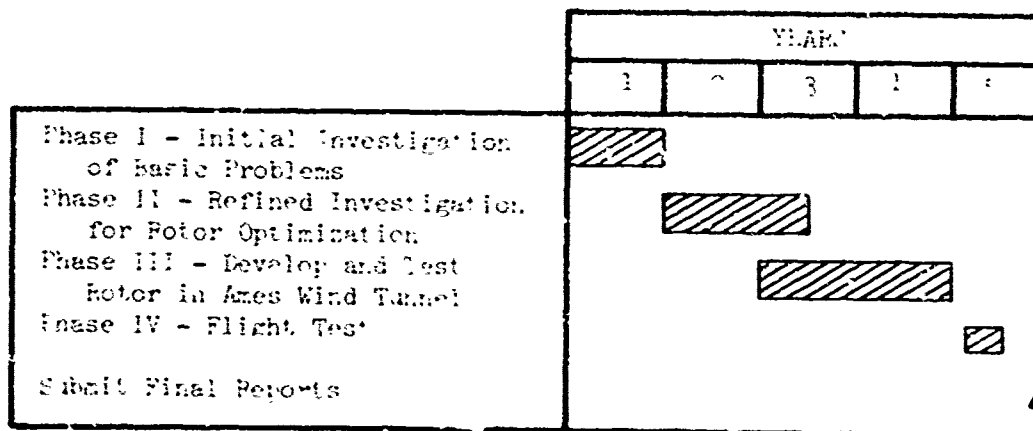

FIGURE 40  
DEVELOPMENT PROGRAM  
ROLL-UP ROTOR SYSTEM

. Phase IV

Flight test the roll-up rotor equipped compound aircraft, with rotor retraction and extension cycles at speeds up to 150 knots, and to higher speeds in the stopped rotor configuration.

Activities within the first three phases of the program have been subdivided into the following four classifications:

- A. Non-rotating aerodynamic and aeroelastic testing,
- B. Rotating system dynamically scaled testing,
- C. Analytic procedures, and
- D. Hardware design and development.

1. PHASE I

Phase I of the program, which extends over a one year period, will provide basic model test data, analytic techniques, and critical hardware concepts, to justify and potentially reorient further work on the rotor system. The approach to be taken is to develop first approximation results at minimum expense in a short time period for impact on further work.

a. Non-Rotating Aeroelastic and Aerodynamic Testing

(1) Two Dimensional Airfoil Tests

Several small scale, two dimensional blade sections will be tested at low Mach number and Reynold number for use in analytic correlation with the rotating system models which will be tested during both Phase I and Phase II. Lift, drag, and pitching moment data will be obtained. In addition, the pressure distribution over the airfoil will be obtained for use in the airfoil chordwise deflection analysis. Several of the airfoil sections to be tested will simulate the expected chord line deflection or preliminary indication of the changes in pitching moment to be expected.

(2) Model Tip Weight Tests

A geometrically scaled model of the tip mechanism (approximately 2 ft long) will be tested at relatively low speeds to investigate the aerodynamic effectiveness of the tip control tab and aerodynamic dampers. Control tab loads will be measured as well as overall tip weight lift, drag, and pitching moments. The effect of the aerodynamic damper on total lift, drag, and moment will be measured for various damper deflections, slot geometries, and flight conditions. During the latter portion of the wind tunnel test, the model would be mounted on a spring support, which simulated the impedance of the rotating blade. Dynamic damping will be measured, and any dynamic instabilities, flutter, or buffet problems would be uncovered before the first rotor test.

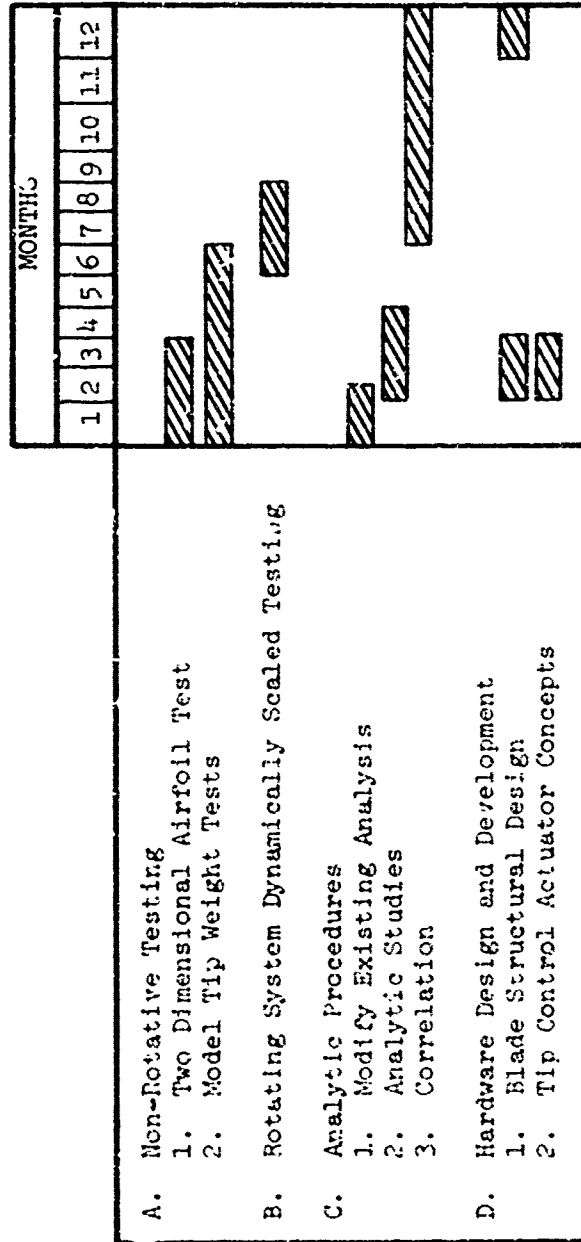

FIGURE 41  
PHASE I DEVELOPMENT PROGRAM

## b. Rotating System Dynamically Scaled Testing

A four foot diameter, non retracting model rotor will be mounted in a small low speed wind tunnel and tested at speeds which achieve an advance ratio of up to 0.3. It will be dynamically similar to the full scale design, when operated at approximately one-third full scale speeds. This reduced speed scaling greatly reduces model fabrication difficulties. Manually adjustable cyclic and collective root control and collective tip control will be provided. Variations in blade and tip weight properties will be made. Tip control tab angle and swashplate control angle will be adjusted. Overall rotor system stability and response characteristics will be obtained. Root and tip control effectiveness will be determined. Tracking and dynamic balancing irregularities, associated with blade-to-blade manufacturing differences in stiffness and airfoil contour, and resultant changes in dynamic response will be studied.

## c. Analytic Procedure

### (1) Developing Analytic Tools

Modifications to existing blade aeroelastic computer programs will be performed to include the tip control tab and aerodynamic dampers.

### (2) Analytic Studies

Analytic studies will be conducted for the rotor system in forward flight and maneuvering conditions, to define control effectiveness and blade response, and to indicate the most useful areas to be investigated during the wind tunnel program. Hovering flight will also be analyzed with the aerodynamic dampers extended, and hovering performance decrements and blade out of track phenomena will be investigated.

### (3) Correlation

Correlations with wind tunnel test results will be performed.

## d. Hardware Design and Development

### (1) Blade Structural Design

Blade design concepts will be developed. Several small scale sample blade sections will be fabricated and tested. Most promising approaches will be defined, and most useful material selected.



## (2) Tip Control Actuator Mechanism

A preliminary design of the control tab actuator will be developed. Feasibility of the design will be reexamined, after completion of the control loads investigation in the static test and the control effectiveness study in the wind tunnel tests.

## 2. PHASE II

Phase II is to be an investigation of an optimized rotor system. It covers a span of 1½ years. Critical full scale hardware will be designed and subsystems fabricated and tested. Analytic techniques will be developed and updated from Phase I results and used to optimize the rotor system. Model tests will be performed, with a dynamically scaled remotely controllable retracting rotor mounted on a compound aircraft fuselage.

### a. Non-Rotating Aeroelastic and Aerodynamic Testing

#### (1) Model Tip Weight

The same model in Phase I will be mounted in a wind tunnel capable of speeds to 0.85 Mach. Lift, drag, and pitching moment data will be reobtained with the full scale compressibility and Reynolds number effects.

#### (2) Installed Rotor Head Drag

A geometrically scaled compound aircraft design, equipped with the retracting rotor head, will be tested at speeds to 400 knots. Various rotor head fairings and pylon geometries will be tested to minimize drag.

#### (3) Two Dimensional Airfoil Tests

Two Dimensional Airfoil Tests will be conducted at full scale Mach number and Reynolds number. Lift, drag, pitching moment, and pressure distribution data will be obtained.

### b. Rotating System Dynamically Scaled Testing

#### (1) Ground Resonance Tests

The four-foot diameter model used in Phase I will be tested to further investigate ground resonance phenomena. Manually adjustable aerodynamic dampers will be added. Blade properties, such as elastic axis, C.G., stiffness, and ratio of torsional to flatwise frequency, will be varied to insure the elimination of ground resonance throughout a large range of potential rotor system aeroelastic parameters. The model will be mounted on a soft adjustable support, capable of simulating the impedance characteristics of a full scale aircraft. The support system will include an automatic locking mechanism, which greatly increases the mount's frequency should a ground resonance vibration begin.

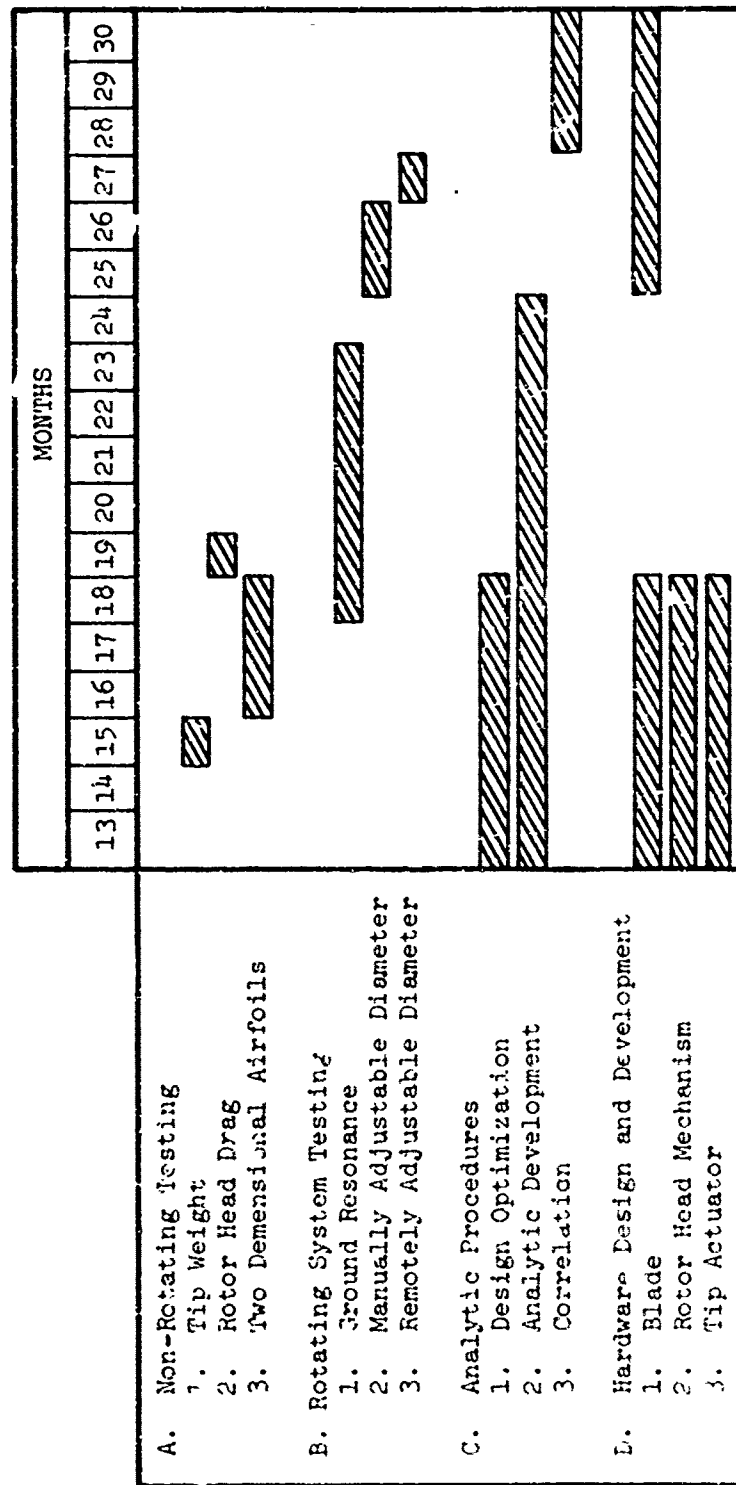

FIGURE 42  
PHASE II DEVELOPMENT PROGRAM

(2) Variable Diameter Rotating System Tests

A 12-foot diameter dynamically scaled model rotor, mounted on a compound aircraft model, will be tested up to an advance ratio of 0.3. The model will achieve dynamic similarity, when operated at one half full scale speeds. Rotor diameter will be manually adjustable, but remote blade root and tip control will be provided. Blade response and stability will be recorded, as will overall rotor and airframe loads. Trimmed and untrimmed flight conditions will be investigated for various forward speeds and rotor retraction positions. Rotor control power derivatives and overall aircraft stability derivatives will be obtained.

(3) Remotely Retracting Rotating System Test

A remotely controlled retracting rotor head will be installed in the model discussed above. Time histories of blade stress and motion during retraction will be recorded at various trimmed and untrimmed flight conditions for a range of forward speeds and wing loadings.

c. Analytic Procedures

(1) Design Optimization

Analytic techniques and test results developed in Phase I will be utilized to optimize the full scale design, and thus determine the characteristics of the Phase II models.

(2) Analytic Development

The rotor aeroelastic analysis will be modified to include a chordwise elastic mode and the interference effects caused by the close proximity wing.

(3) Correlation and Analysis

Two dimensional airfoil pressure distributions will be used to obtain more precise chordwise airfoil deflections. The information will also be used for correlation in the modified aeroelastic analysis. Wind tunnel test results will be correlated with performance and stress analytic predictions.

d. Hardware Design and Development

(1) Blade Fabrication and Materials

Investigation of full scale blade design approaches will continue. Sample blade sections will be fabricated and tested blade erosion problems will be investigated.

(2) Rotor Head Mechanism

The blade rollers, guides, and actuation mechanism for the rotor head roll-up mechanism will be designed, fabricated, and tested.

(3) Tip Control Tab Actuator

The full scale tip control tab actuator and tab mechanism will be designed and fabricated. Tests will include simulation of the high "g" field, as well as the cyclic aerodynamic and inertial loads.

3. PHASE III

A large scale flightworthy roll-up rotor system will be designed, fabricated, and tested in the NASA Ames 40 x 80 ft wind tunnel, prior to flight tests in Phase IV. Phase III would extend through the third and fourth year of the development program.

a. Non-Rotating Aeroelastic and Aerodynamic Testing

Tests of elastically scaled, two dimensional airfoil sections will continue for optimization of pitching moment characteristics, erosion prevention verification, and structural design improvement.

b. Rotating System Testing - Ames Wind Tunnel

A large scale, flightworthy roll-up rotor system will be tested on a compound aircraft airframe in the NASA Ames 40 x 80 ft wind tunnel facility. Trimmed and maneuvering flight conditions will be tested at speeds to 150 knots, with various rotor extension positions and lift sharing from the wing. Trimmed conversions from the pure helicopter to the conventional fixed wing aircraft configuration will be accomplished during rotor diameter change. Aircraft stability and control, rotor control power derivatives, blade response and stress levels, and airframe loads will be determined throughout the flight envelope. The test program will verify and expand the aerodynamic and aeroelastic data obtained during previous model tests and substantiate the rotor system and airframe for the flight test program.

c. Analytic Procedures

(1) Design Optimization

Test results and analytic techniques verified in Phase II will be used to reoptimize the rotor system design for the Phase III effort.

(2) Correlation of Wind Tunnel Tests

Analytic studies will be made of the planned wind tunnel test conditions

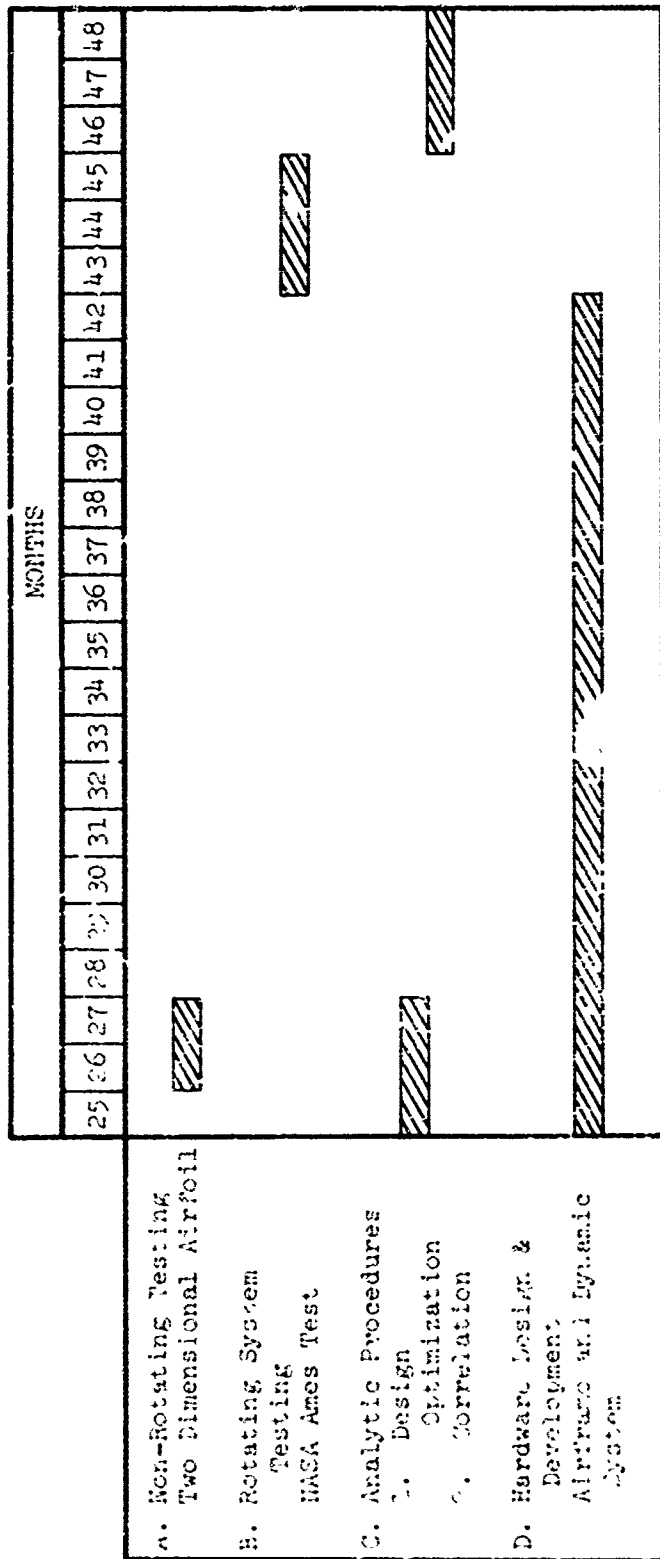

FIGURE 43  
PHASE III DEVELOPMENT PROGRAM

and used for correlation with the data.

d. Hardware Design and Development

A large scale, flightworthy roll-up rotor system will be designed and fabricated. Subsystem test and development programs will be performed. The aircraft will receive extensive ground testing to substantiate all hardware and demonstrate lack of ground resonance instabilities. Several options are available for airframe development. Use of an existing compound aircraft airframe is desirable for minimization of airframe system problems and flight characteristic unknowns. However, available airframes may not be compatible with rotor system sizing in the NASA Ames facility, in which case a totally new airframe or compounded helicopter airframe will be required.

4. PHASE IV

A flight test program will be conducted on the roll-up rotor equipped compound aircraft. Modifications to analytic techniques and/or aircraft hardware will be performed as indicated by NASA Ames wind tunnel results. Overall flight system characteristics and operational limitations will be determined. Aircraft performance and efficiency will be studied from hover, through rotor retraction, to high speed conventional fixed wing flight. Rotor blade stresses and deflections, rotor head critical component loads, airframe structure loads, and aircraft vibration levels will be determined throughout the flight envelope. Handling qualities in trimmed and maneuvering flight, with various percentages of lift sharing between wing and rotor and at various rotor retraction stages, will be studied. Transition to autorotative flight will be performed from a variety of initial flight conditions.

This flight test program will begin in month 52 and last three months. It will conclude the roll-up variable diameter rotor concept development program, and lead to incorporation of the rotor system in a large, high speed compound aircraft. The final reports will be issued by month 60.

## SECTION VI

### STUDY CONCLUSIONS

(1) There are three major types of variable diameter rotor systems that are capable of achieving large ratios of extended to retracted rotor diameter. These are classified by the type of blade construction, and include rotors using multi-segmented telescoping blades, folding blades, and very flexible blades that can be wound on drums within the rotor head. Of these three, THE FLEXIBLE ROLL-UP ROTOR IS JUDGED TO HOLD THE MOST OVERALL PROMISE. It is the lightest weight concept, and causes the fewest penalties in the aircraft design. It is capable of low disc loadings and the highest retraction ratios, both of which are particularly appealing for future high speed stowed rotor designs.

(2) All of THESE CONCEPTS INVOLVE HIGH TECHNICAL RISK, substantially higher than the two segment telescoping rotors which are presently being developed by the industry. The technical risk of the flexible roll-up rotor results from its unusual dynamic and aerodynamic characteristics. These include blade control, avoidance of ground resonance, and the possibility of dynamic instabilities during forward flight and blade retraction. These are detailed in section III-(3)b of this report, and a development program for this rotor is detailed in Section V.

In spite of this high technical risk, the study has shown that the improvements which these variable diameter rotors promise in increased aircraft capabilities and overall efficiency appear to be worth the extensive program necessary for their development.

(3) AN AIRCRAFT USING THE VARIABLE DIAMETER FLEXIBLE ROLL-UP ROTOR WOULD BE APPROXIMATELY TEN PERCENT HEAVIER THAN A CONVENTIONAL COMPOUND. When designed to carry a 5.35 ton payload over a 250 nautical mile radius mission, an aircraft using this rotor system would have a design gross weight of approximately 69,000 pounds. This compares to a gross weight of 62,000 pounds for an equivalent fixed diameter compound sized to perform the same mission. If both aircraft have the same installed power, the variable diameter aircraft could hover at higher altitudes, and it could fly the mission at higher speeds than the fixed diameter vehicle because of the improved lift to drag ratios which result when the rotor is retracted and stopped. Speeds of 280 knots would be achievable, compared to 250 knots for the baseline fixed diameter compound. This aircraft design is discussed in Section IX of this report.

(4) COMPARING THESE DESIGNS AT CONSTANT POWER RESULTS IN THE VARIABLE DIAMETER AIRCRAFT HAVING A LOWER OVERALL COST EFFECTIVENESS THAN THE BASELINE FIXED DIAMETER DESIGN. This is because its increased life cycle cost, which is due mainly to its large development cost, is not offset by the improvement in mission block time. If additional power were installed in the aircraft, higher speeds would be achievable with only minor growth in aircraft weight and cost. This could improve cost effectiveness to the point where the variable diameter compound would be superior to the baseline aircraft.

(5) THE MOST PROMISING APPLICATION FOR THE ROLL-UP ROTOR WOULD APPEAR TO BE IN A STOWED ROTOR TYPE OF AIRCRAFT DESIGN. In the compound designs investigated in this study, all of the weight and complexity penalties associated with the variable diameter rotors have been added, but large speed gains have not been made since the installed power has not been increased. The primary advantage with the roll-up rotor concept is that it has reduced rotor diameter to a point where the rotor can be stopped in flight. This eliminates the forward speed blade stress, control loads, aeroelastic, and performance boundaries which are associated with conventional high speed compounds. The aircraft would be capable of substantially higher speeds provided adequate additional power were installed. If the capability were added to stow the rotor system within the fuselage contour, the aircraft parasite drag would be further reduced. This would increase the cruise efficiency and could lead to the long sought after ideal of a high speed VTOL aircraft with low hovering disc loadings.

(6) OF THE DIFFERENT TYPES OF FOLD-UP ROTORS, THE FOUR-BLADED ROTOR USING THIN FLEXIBLE REFLEX AIRFOILS APPEARS MOST PROMISING. Certain assessments have been made in this study concerning overall feasibility and technical risk of each concept, and it is felt that this conclusion is within the accuracy limits of these assessments. There is not a substantial difference between the two-bladed and the four-bladed rotor, and between the thin reflexed airfoils and the thicker pneumatic airfoils. If after further development effort the thin reflexed airfoils are found to have more difficult problems that have been anticipated, the pneumatic blade should again be considered as a candidate system. This is particularly true in the area of torsional stiffness.

(7) THE TWO SEGMENT TELESCOPING ROTOR, although not achieving the disc loading and retraction ratio desired in this study, IS AN ATTRACTIVE INTERIM VARIABLE DIAMETER ROTOR SOLUTION FOR NEARER TERM APPLICATIONS. It has already had considerable development effort, and its technical risk is substantially lower than any of the other concepts.



## Appendix I

### U. S. Patents Applicable to Variable Diameter Rotors

1. 1,077,187 J. E. Bissel, October 28, 1913. "Propeller".  
Telescoping propeller blade, using rack and pinion retraction.
2. 1,461,733 H. E. Hawes, July 17, 1923. "Propelling Device for Aircraft". Telescoping propeller blade, using a jackscrew type of retraction.
3. 1,922,866 S. Rosenberg et al, August 15, 1933. "Rotary Airfoil".  
Initial patent on telescoping helicopter or autogyro rotors. Two and three rigid segments with retraction controlled by cables, screws, and rack and pinion gears.
4. 1,957,887 C. B. Hebbard, May 8, 1934. "Adjustable Propeller".  
Jackscrew controlled variable diameter propeller. Blade pitch automatically changes with diameter.
5. 1,969,077 J. H. Howe, August 7, 1934. "Aircraft Sustaining Unit".  
Fully articulated telescoping rotor. Rack and pinion retraction mechanism is driven through universal joint coincident with articulation hinges.
6. 2,062,712 V. H. Patriarche, May 28, 1935. "Variable Diameter Propeller". Telescoping blade with a hydraulic retraction mechanism. Mechanical links keep the blades synchronized during retraction.
7. 2,021,470 R. H. Upson, November 19, 1935. "Aircraft". Shows autogyro rotors with both telescoping and out of plane blade fold. Blade folding is proposed only for stowage purposes; it is not proposed that retraction occur during flight.
8. 2,106,245 T. Ash, Jr., February 15, 1938. "Gyratory Airplane Wing".  
Multisegmented telescoping blade, cable controlled. Cable is wound around a spring loaded drum to automatically retract blades as rotor is slowed down. Each segment is rigid; however the joints are flexible.

9. 2,110,563 Andre Thaon, March 8, 1938. "Aircraft of the Autogyro Type". Cable controlled retraction for autogyro rotors. Stowed on ground only, not during flight.
10. 2,120,168 T. Ash, Jr., June 7, 1938. "Aerodynamic Rotor". Continuation of previous patent. Multisegmented blade with each segment controlled by an individual cable. Also covers cyclicly telescoping blades for control rather than cyclicly varying pitch.
11. 2,145,413 W. A. Belfield, January 31, 1939. "Propeller". Telescoping blade with two segments; screw driven. Includes safety devices for discontinuing power to the screw mechanism when limits of extension or retraction have been reached.
12. 2,163,482 P. Cameron, June 20, 1939. "Aircraft Having Rotative Sustaining Means". Telescoping blade with two segments; screw driven through articulation hinge. Screw nut mounted flexibly to reduce bending during extension/retraction.
13. 2,172,333 T. Theodorsen and E. F. Andrews, September 5, 1939. "Sustaining Rotor for Aircraft". First to show thin flexible blades wound on a drum. Also shows many rigid segments hinged together horizontally for out of plane fold. When retracted these wind on a hexagonal drum within the rotor head.
14. 2,172,334 T. Theodorsen and E. F. Andrews, September 5, 1939. "Sustaining Rotor for Aircraft". Continuation of previous patent.
15. 2,173,291 T. L. Ash, September 19, 1939. "Aerodynamic Rotor". Continuation of patents 2,108,245 and 2,120,168 to show a counterbalanced single bladed rotor.
16. 2,226,978 R. P. Pescara, December 31, 1940. "System Including Rotary Blades". Flexible blades retracted within the rotor shaft or on drums.
17. 2,330,803 E. F. Andrews, June 14, 1937. "Aircraft". Many blade segments folded out of rotor plane onto hexagonal drum.

17. (continued)  
Extension of patents 2,172,333 and 2,172,334 to show stowed rotor application for high speed flight.
18. 2,372,350 G. H. Abeel III, March 27, 1945. "Variable Length Propeller". Telescoping rotor, two segments, hydraulically operated. Blade pitch changes with diameter.
19. 2,380,540 H. W. Mollenhauer, July 31, 1945. "Automatic Area Control Propeller". Propeller with blades splined to hub. Mechanical rods control retraction automatically with rotor torque. Small retraction ratio (Approx. 1.2).
20. 2,403,899 F. DuPont Ammen, July 16, 1946. "Propeller Pitch and Diameter Control". Two segment telescoping blade; screw driven. Small retraction ratio (Approx. 1.2).
21. 2,403,946 H. R. Noyes, July 16, 1946. "Propeller". Two segment telescoping blade; screw driven. Small retraction ratio. Patent covers mechanism to drive screws.
22. 2,404,290 W. S. Hoover, July 16, 1946. "Variable Diameter and Variable Pitch Propeller". Two segment telescoping blade. Retracted with mechanical rods. Small retraction ratio. Automatically controlled to keep drive shaft at constant speed.
23. 2,425,353 L. Spitzer, Jr., August 12, 1947. "Flexible, Variable - Diameter Propeller". Many bladed propeller with flexible blades wound on one center drum.
24. 2,442,291 C. R. Hamel, May 25, 1948. "Air Propeller with Automatically Variable Pitch and Diameter and Controlled Pitch Variation". Two segment telescoping blade. Retracted with mechanical rods. Small retraction ratio. Blade pitch changes with diameter.
25. 2,457,376 V. Isacco, December 28, 1948. "Aircraft with Rotatable Sustaining Blades". Multisegmented telescoping blade. Also includes inplane fold to further increase retraction ratio.

26. 2,457,576 J. G. Littrell, December 28, 1948. "Airplane Propeller and Means for Adjusting Same". Variable diameter propeller with small retraction ratio. Pitch changes with diameter.
27. 2,458,655 V. Issaco, January 11, 1949. "Parachute and the Like with Rotating Sustaining Blades". Continuation of patent no. 2,457,376.
28. 2,464,285 E. F. Andrews, March 15, 1949. "Aircraft with Retractable Variable - Radius Rotary Wing". Two segment telescoping blade. Segments retract beyond rotor centerline for a three to one retraction ratio. Also shows inplane folded rotor with hinge at 1/3 radius to also give a three to one retraction ratio.
29. 2,465,703 A. W. Allen, March 29, 1949. "Aircraft Sustaining Rotor". Two segment telescoping blade, retracted with cable.
30. 2,510,216 K. W. Figley, June 6, 1950. "Aircraft Propeller". Two segment telescoping propeller blade, retracted with cable. Minimum retraction ratios.
31. 2,523,216 V. Isacco, September 19, 1950. "Sustaining Propeller for Flying Machines and Parachutes". Extension of patent 2,457,376, Decemoer 28, 1948. Multisegment telescoping blade, cable controlled, combined with inplane fold to maximize retraction ratio. This patent specifically introduces bearing surfaces between the various elements for their support.
32. 2,614,636 R. H. Prewitt, October 21, 1952. "Rotor Parachute". Flexible roll-up rotor, specifically applied to non-powered rotors. Includes method to stiffen blade chordwise using longitudinal wires or straps.
33. 2,616,509 W. Thomas, November 4, 1952. "Pneumatic Airfoil". Generally covers pneumatic aerodynamic shapes, both fixed and rotary wing. Includes internal tension members to maintain specific shape under pneumatic pressure.

34. 2,637,406 V. Isacco, May 5, 1953. "Telescopic Rotor Blades and Brakes Therefor". Extension of no. 2,523,216. Multisegment telescoping blade, cable controlled. This patent introduces a brake device to limit the speed at which the blades extend under centrifugal force. This same brake can then be used to retract blades.
35. 2,640,549 V. Isacco, June 2, 1953. "Jet-Driven Sustaining Propeller for Aircraft". Extension of his previous patents to include tip driven rotors.
36. 2,684,212 E. G. Vanderlip, July 20, 1954. "Disc Rotor with Retracting Blades for Convertible Aircraft"; assigned to Piasecki Helicopter Corporation, Morton, Pa. Two segment telescoping blades, cable controlled. Telescoping segment of blades retracts into a large center disc which has a diameter of approximately one half rotor diameter. After retraction this disc becomes the wing for a high speed fixed wing mode of flight.
37. 2,713,393 V. Isacco, July 19, 1955. "Telescopic Blade for Rotating Wing Aircraft". Extension of patent no. 2,637,406. Multisegment telescoping blade, cable controlled. This patent introduces methods of balancing the blade mass about the quarter chord and certain other features to reduce blade stresses.
38. 2,717,043 V. Isacco, September 6, 1955. "Contractable Jet-Driven Helicopter Rotor". Extension of patent no. 2,457,376. Multisegment telescoping blade, cable controlled. Also includes inplane fold. This patent extends concept to include tip-driven rotors.
39. 2,749,059 D. H. Meyers et al, June 5, 1956. "Aircraft with Retractable Variable Radius Rotary Wing"; assigned to Vertol Aircraft Corporation. Telescoping blades, cable operated. Discusses method to use kinetic energy of rotor to provide retraction power. Also shows drum for cable concentric with rotor shaft.
40. 2,776,017 J. B. Alexander, January 1, 1957. "Telescoping Rotor". Multisegment telescoping blade, cable operated; Non powered rotor.

41. 2,852,207 D. K. Jovanovich, September 16, 1958. "Convertiplane". Two segment telescoping blades, telescoped beyond rotor centerline into fixed disc which becomes the wing for fixed wing flight. Center disc does not tilt with tip path plane.
42. 2,869,649 H. D. Lux, January 20, 1959. "Helicopter Rotor". Multisegment blades fold out of plane, designed for extending in flight under centrifugal force but not retracting while rotor is turning.
43. 2,967,573 W. C. Johnson, Jr., January 10, 1961. "Pneumatic Airfoil"; assigned to Goodyear Aircraft Corporation, Akron, Ohio. Pneumatic airfoil with "substantially nonextensible threads in a number between about 25 and about 200 per square inch positioned in substantially parallel relationship inside the envelope" to hold required airfoil shape when pressure is introduced.
44. 2,969,211 F. C. VonSaurma, January 24, 1961. "Inflatable-Wing Rotor". Inflatable blade with accordion fold. Applied to rotor parachutes, not helicopters.
45. 2,979,288 A. Klien, April 11, 1961. "Aircraft Propeller Arrangement and Means for Elongating Same". Variable diameter propellers using rack and pinion mechanism. Small retraction ratios.
46. 2,989,268 E. F. Andrews, June 20, 1961. "Convertible Aircraft". Extension of patent no. 2,464,285. Two segment telescoping blade with segments retracted past the rotor centerline for a 3 to 1 retraction ratio. Specifically covers tip drive for these type of rotors.
47. 2,996,121 J. A. O. Stub, August 15, 1961. "Retractable Airfoil". Flexible skinned blade, cable controlled. During retraction cables wind on drum while skin folds accordion fashion at its inboard end.

48. 3,065,799 L. C. McCarty, Jr., November 27, 1962. "Rotary Wing Aircraft". Thin flexible blades that roll on a drum within the rotor head to achieve high retraction ratios. Specifically covers these type of rotors with propulsion units on the blade tips. Discusses pitch control using control surfaces carried by the propulsion units, by control tabs on the blades themselves, by varying the angle of incidence of the tip of the blades with respect to the propulsion units, or by a combination of these. Also states that "By proper spacing of the tension filaments . . . the blade . . . may be designed to maintain an effective angle of attack . . . without the aid of a control tab . . .".
49. 3,117,630 D. T. Barish, January 14, 1964. "Rotors". Flexible blades wound on a drum.
50. 3,120,275 K. Pfleiderer et al, February 4, 1964. "Rotor Construction"; assigned to Bolkow. Flexible blades wound on a drum. Particularly applied to "Magnus rotors" which are defined as rotors which " . . . include rotor elements or blades which are substantially cylindrical and which are rotated about their longitudinal axes as well as rotated about a central rotor head axis".
51. 3,128,829 A. M. Young, April 14, 1964. "Variable Diameter Propeller". Appears to be basis for Bell Variable Diameter Rotor (VDR), although patent is not specifically assigned to Bell. Two segment telescoping rotor, cable operated. Cable drum and rotor hub are both driven by aircraft propulsion unit through planetary gearing. When the drum torque exceeds the blade centrifugal force the blade is automatically retracted. When it does not, the blade is automatically extended. The drum can also be controlled manually by the pilot, if desired.
52. 3,184,187 P. Isaac, May 18, 1965. "Retractable Airfoils and Hydrofoils". Roll up pneumatic blades. Flexible upper and lower blade surfaces with pneumatic tubes sandwiched between them. When these tubes are inflated they become the blade structural spars. Also includes blade pitch control achieved by varying the inboard blade pitch angle in conventional helicopter fashion.
53. 3,188,020 J. N. Nielsen et al, June 8, 1965. "Rotor Blade and Air Vehicles Embodying Same". Flexible blades wound on a drum. Tip weight is supported by catenary cables in leading and trailing edge of

53. (continued)  
blade. Blade chord is varied such that leading and trailing edges are concave in the plan view. This places the blade membrane in chordwise tension when centrifugal force puts the leading and trailing edge catenary cables in tension.
54. 3,249,160 W. Messerschmitt, May 3, 1966. "Rotor Blade Construction for Aircraft"; assigned to Messerschmitt AG, Augsburg, Germany. Multisegmented telescoping blade. Shows screw drive mechanism for retracting more than one segment.
55. 3,273,655 P. F. Girard, September 20, 1966. "Center Body Pivotaly Retractable Rotor"; assigned to Ryan Aeronautical Co., San Diego, California. Ryan Disc Rotor. Inplane blade fold with folding hinge at approximately one third radius. Centerbody extends beyond fold hinges so that blades are retracted within it. The blades "are counterbalanced about their swing axes to minimize retraction loads while the rotor is rotating".
56. 3,297,094 A. V. Kisovec, January 10, 1967. "Aircraft Propelling Assembly"; assigned to the Boeing Company, Seattle, Wash. Two segment telescoping blade with capability to vary blade twist with diameter; screw mechanism.
57. 3,298,142 P. Isaac, January 17, 1967. "Reelable Reversibly Flexible and Rigid Structural Members". Similar to patent 3,184,187. Roll up rotor. This patent extends the earlier one "to provide inflatable structural members which are made completely from metallic parts".
58. 3,321,020 K. Pfleiderer, et al, May 23, 1967. "Helicopter Rotor". Blade with rigid spar and flexible skin. "The blade structure is such that the outer skin and rib structure, which forms the overall blade profile when extended, may be retracted along the spar to the interior of the rotor and the exposed spar will have very little undesirable effects in respect to flight".
59. 3,362,665 A. E. Larsen, et al, January 9, 1969. "Air to Ground Descent Means". Parachute using inflatable blades coiled within the rotor head.



## APPENDIX II

### EFFECT OF VARYING DESIGN DISC LOADING

Although all designs were done with a fixed disc loading, it is instructive to determine how they would vary if disc loading was made a variable. The computer design models were used to generate new trends as functions of disc loading. These models use mathematic equations to completely describe each aircraft design, and these equations are necessarily based on certain rules and assumptions. As long as these are not changed, the equations will give accurate trends. If the original assumptions are not held, accurate results will not be obtained from the program. Because of this, the disc loadings could only be varied over a small range.

For four out of the five low disc loading concepts, the optimum was found to be within the assumed range; for one it was not. Even when the solution was found to be outside the assumed range, the analysis showed the derivatives of the trends through the design point, and this shows approximately where the optimum point should lie.

For all of the disc loading of five aircraft, the disc loading was varied between four and six psf. Beyond this range there was little confidence in the weight trending equations. The rotor weight equations, in particular, were not set up for variable disc loading, being instead developed to determine rotor weight at constant disc loading and variable gross weight.

All of these designs also use the high disc loading anti-torque fan, which is mounted under the main rotor disc. For low disc loadings, this results in the lightest aircraft gross weights. However, at higher disc loadings a tail rotor solution will be lighter. This cross over point between fans and tail rotors should occur around a disc loading of eight or nine. It is very possible that with a tail rotor these designs might optimize at a higher disc loading, and that of these two optimum points the tail rotor solution may lead to the most cost effective aircraft. This type of extended disc loading trade-off was not performed, it being considered outside the scope of this study.

Figures 44 through 49 show the results of the disc loading trade-off studies. The low disc loading concepts are summarized as follows:

	ASSUMED DISC LOADING	MOST COST EFFEC DISC LOADING
Eight Segment Telescoping Rotor	5.0	4.1
Roll-up Rotor, Two Thin Blades	5.0	4.4
Roll-up Rotor, Four Thin Blades	5.0	5.7
Roll-up Rotor, Four Pneumatic Blades	5.0	(>6)
Inplane Fold Rotor	5.0	5.0

The disc loading of the two segment, telescoping rotor was also parametrically varied from the design 10 psf down to a disc loading of 8psf. Below this its equations break down, since its tail rotor must be replaced with a fan. The conclusion is, however, that the most cost effective disc loading is not below 10 psf, but appears to be something greater than 10.

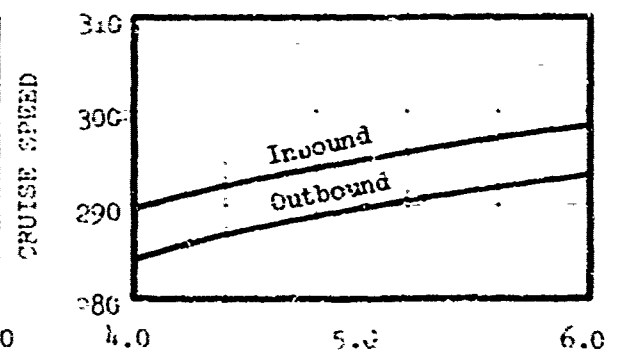
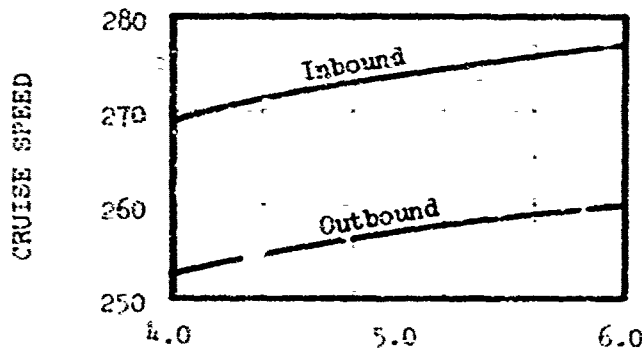
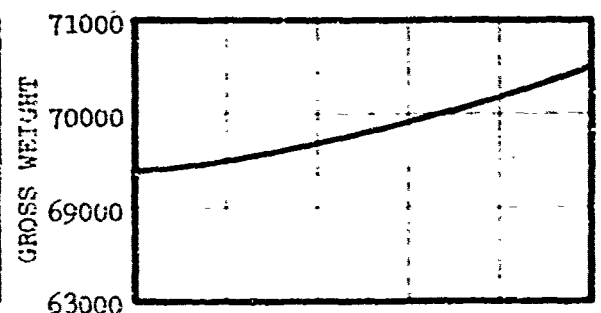
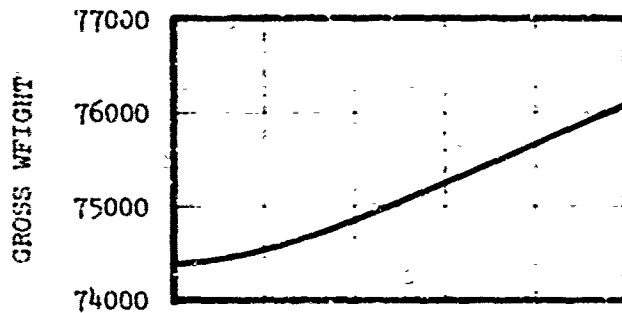
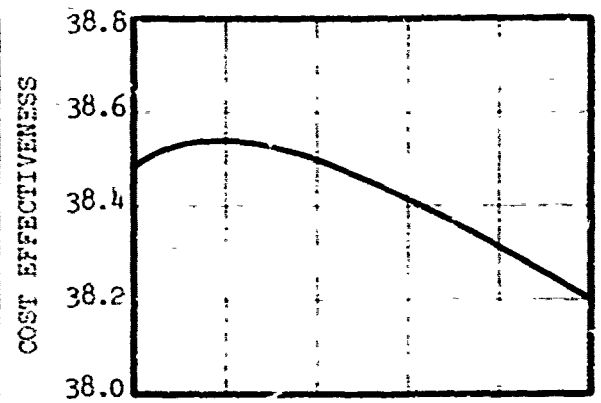
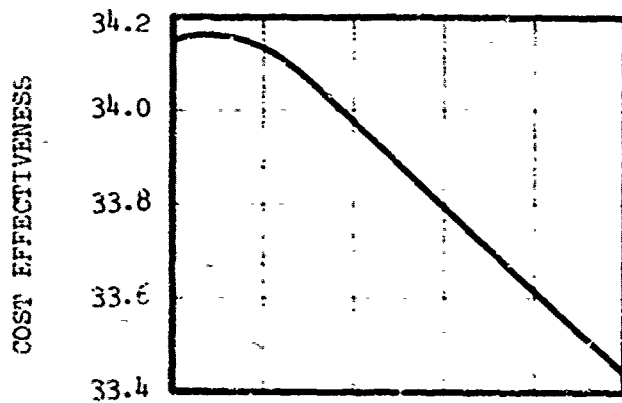

DISC LOADING - PSF

FIGURE 44  
DISC LOADING TRADE OFF  
EIGHT SEGMENT TELESCOPING ROTOR

DISC LOADING - PSF

FIGURE 45  
DISC LOADING TRADE OFF  
ROLL-UP ROTOR, TWO THIN BLADES

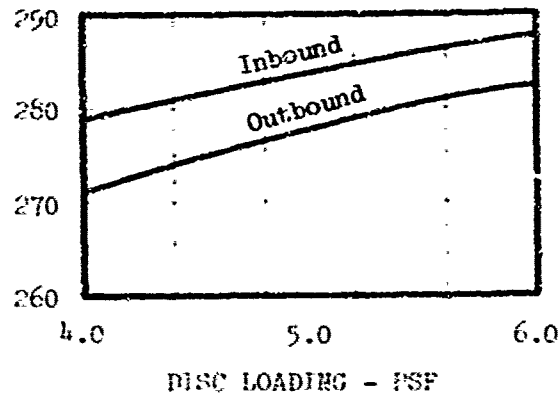
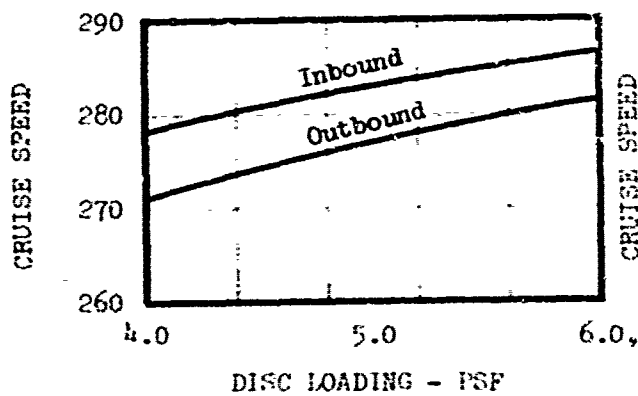
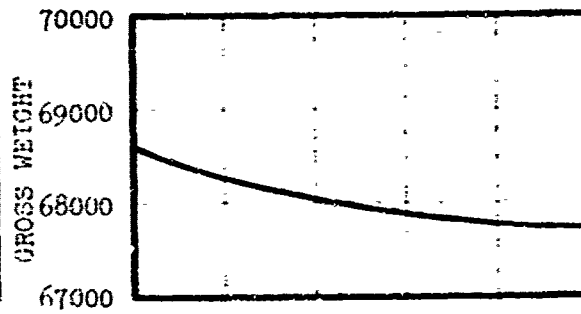
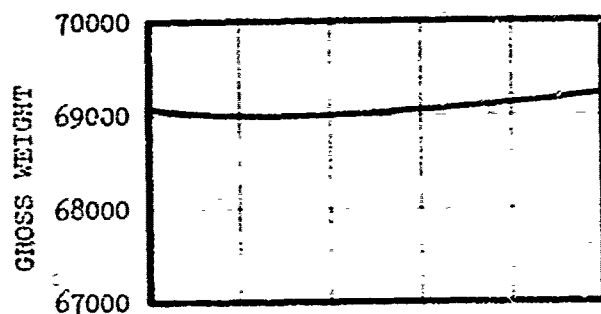
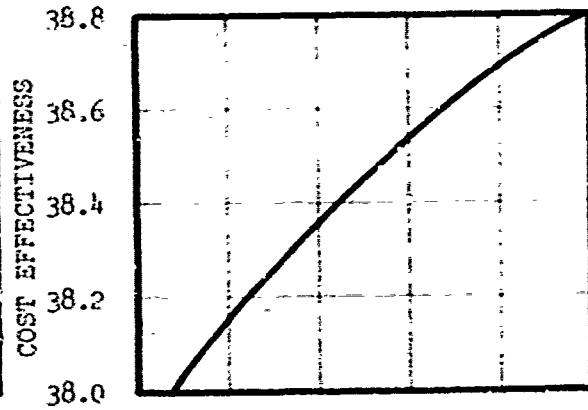
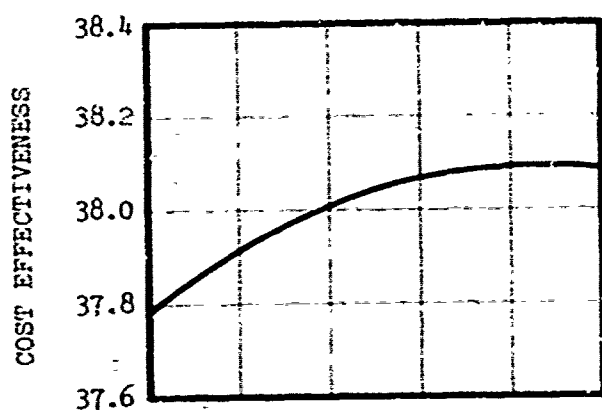
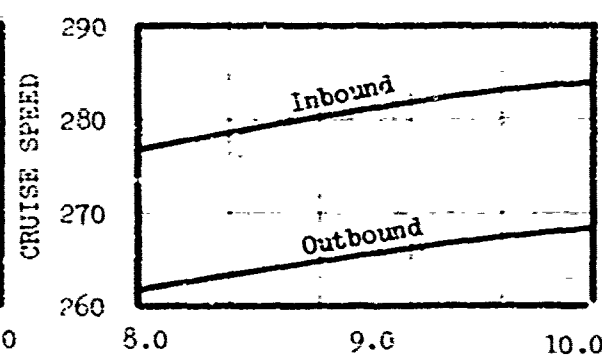
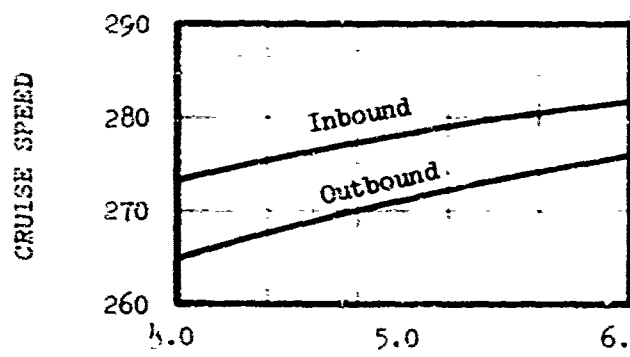
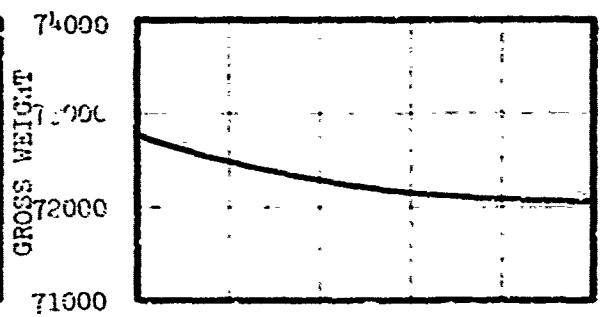
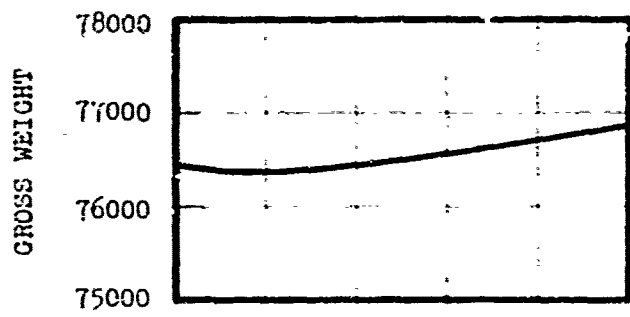
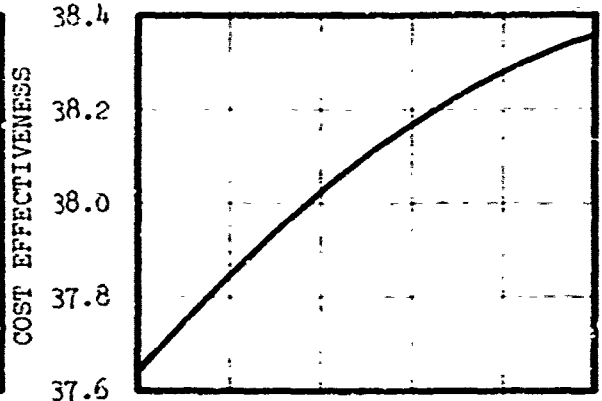
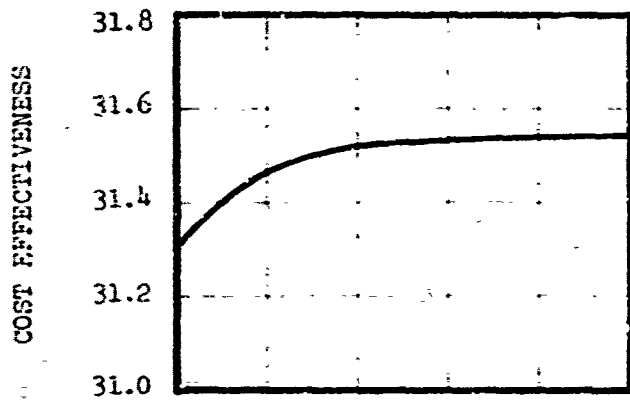

FIGURE 46  
DISC LOADING TRADE OFF  
ROLL-UP ROTOR, FOUR THIN BLADES

FIGURE 47  
DISC LOADING TRADE OFF  
ROLL-UP ROTOR, FOUR PNEUMATIC BLADES



DISC LOADING - PSF

DISC LOADING - PSF

FIGURE 48  
DISC LOADING TRADE OFF  
INPLANE FOLD ROTOR

FIGURE 49  
DISC LOADING TRADE OFF  
TWO SEGMENT TELESCOPING ROTOR

#### REFERENCES

- (1) Szustak, L.S., "Wind Tunnel Test of a 1/25th Scale Commercial Compound Helicopter Model," SER 50516, Sikorsky Aircraft, January 3, 1969.
- (2) Gerdes, W.H., and W.H. Tanner, "Generalized Rotor Performance Method," SER 50355, Sikorsky Aircraft, November 16, 1964.
- (3) Tanner, W.H., "Charts for Estimating Rotary Wing Performance in Hover and High Forward Speeds," SER 50379, Sikorsky Aircraft, August 10, 1964.
- (4) Abbot, Ira H., and Albert E. Von Doenhoff, Theory of Wing Sections, Dover Publications, Inc., New York, 1959.
- (5) Hamilton Standard, "Generalized Method of Propeller Performance Estimation," PDB6101 Rev.,A, June 1963.
- (6) Goldman, E.L., "Some Observations on the Dynamic Behavior of Extremely Flexible Rotor Blades," IAS Paper No. 60-40, IAS 29th Annual Meeting, New York, January 1960.
- (7) Arcidiacono, P.J., Landgrebe, A.J., "Status of Research Laboratories Investigation of a Novel Helicopter Rotor System Employing Blades of Extreme Flexibility," UAR Report No. C-22, February 1964.
- (8) Segel, R.M., Fradenburgh, E.A., "Development of TRAC Variable Diameter Rotor Concept," AIAA/AHS VTOL Research, Design and Operations Meeting, Atlanta, Georgia, February 1969.
- (9) Jepson, W.D., Carlson, R.G., "Wind Tunnel Investigations of High Speed Stowed Rotor Aircraft," SAE Air Transportation Meeting, N.Y., Paper 680280, April/May 1968.
- (10) Sikorsky Aircraft, "Sikorsky S-65-300, Compound V/Stol Transport," Proposal to U.S. Air Force.
- (11) Lawson, M.V., and Ollerhead, F.B., "Studies of Helicopter Rotor Noise, Wyle Laboratories;" USAAVLAES Technical Report 68-60, AD684394, U.S. Army Aviation Materiel Laboratories, Fort Eustis, Virginia, January 1969.
- (12) Robinson, D.W., and Dadson, R.S., "Threshold of Hearing and Equal-Loudness Relations for Pure Tones and the Loudness Function," Journal of the Acoustical Society of America, Volume 29, No. 12, December 1957, pages 1284-1288.

## BIBLIOGRAPHY

R. L. Goldman, The Martin Company, "Some Observations on the Dynamic Behavior of Extremely Flexible Rotor Blades". IAS Paper No. 60-44. Presented at the IAS 28th Annual Meeting, New York, New York, January 25-27, 1960.

T. Tarczynski, "Development of a Retractable Rotor", Journal of the American Helicopter Society, Vol. 2, No. 2, April 1957.

P. J. Arcidiacono and A. J. Landgrebe, "Status of Research Laboratories Investigation of a Novel Helicopter Rotor System Employing Blades of Extreme Flexibility", United Aircraft Research Laboratories report UAR-C22, February 19, 1964

D. P. Joy, "Normal Operation Aerodynamic Analysis of the Hiller Retractable Rotor System", Hiller Helicopters engineering report no. 113.0, July 15, 1954.

H. C. Carel, "Start-Stop Operation - Airloads and Flutter Analysis of the Hiller Retractable Rotor System", Hiller Helicopters engineering report no. 113.3, November 26, 1954.

A. D. Topping, "Investigation of Nylon-Reinforced Neoprene for Helicopter Rotor Blades", The Goodyear Aircraft Corporation report no. GER 8651, February 1958.

E. A. Fradenburgh, Sikorsky Aircraft, "Research and Development of Advanced Rotorcraft Concepts", paper no. ICAS 68-06, presented to the sixth Congress of International Council of the Aeronautical Sciences, München, Germany, Sept. 9-13, 1968.

R. H. Hollrock and J. J. Barzda, Kaman Aircraft Corporation, "Rotor Entry Vehicle Systems (REVS) for Safe Landings", paper no. 67-203, presented to AIAA 5th Aerospace Sciences Meeting, New York, New York, January 23-26, 1967.

E. A. Fradenburgh, Sikorsky Aircraft, "Extension of Compound Helicopter Performance by Means of the Telescoping Rotor", paper presented to the Air Force V/STOL Technology and Planning Conference, Las Vegas, Nevada, Sept. 23-25, 1959.

"Helicopter Rotor Systems, A Report Bibliography", ARB no. 048572. Defense Documentation Center, March 21, 1966.

C. Williams, "Kaman Engaged in Rotochute Development", American Helicopter, January, 1955.

"Vertiwing/Disc Rotor, Ryan Engineer Offers Two New Concepts", Ryan Reporter, Jan.-Feb., 1966.

"New Rotor Concept", Aircraft & Missiles, May, 1961. (Discusses VIDYA "FLEXI-ROTOR" utilizing "...flexible materials that can be "reeled-in" for fast forward flight".)

"Bell Develops New Variable Diameter Rotor", Rotor & Wing, December, 1968

"Flying Seat Could Save Pilot Lives", Rotor & Wing, July, 1969. (Discusses Kaman SAVER (Stowable Aircrew Vehicle Escape Rotoseat)).

R. H. Hollrock, Kaman Aircraft, "Re-Entry Rotor Tested", Verti-Flight, February, 1967.

C. M. Plattner, "Speed Studies Spur Rotary-Wing Designs", Aviation Week & Space Technology, June 24, 1968. (Discusses bell VDR, Sikorsky TRAC, Ryan Disc Rotor, and Ryan Flyball Rotor.)

R. M. Segel and E. A. Fradenburgh, Sikorsky Aircraft, "Development of the TRAC Variable Diameter Rotor Concept", AIAA Paper no. 69-221, presented at AIAA/AES VTOL Research, Design, and Operations Meeting, Georgia Institute of Technology, Atlanta, Georgia, February 17-19, 1969.

S. J. Cassarino, Sikorsky Aircraft, "Effect of Root Cutout on Hovering Performance", Technical Report AFFDL-TR-70-70, Air Force Flight Dynamics Laboratory, Wright-Patterson Air Force Base, Ohio, June 1970.

L. J. Pain and A. J. Landgrebe, "Investigation of Compound Helicopter Aerodynamic Interference Effects", Sikorsky Report SER-50474, USAAVLAES TP-67-44, November, 1967.

E. A. Fradenburgh and E. F. Kiely, Sikorsky Aircraft. "Development of Dynamic Model Blades for High Speed Helicopter Research." paper presented at the Symposium on Aeroelastic and Dynamic Modeling Technology, Wright-Patterson Air Force Base, Ohio, September 23-25, 1963.

D. S. Jenney, "On the Behavior of Extremely Flexible Rotating Beams," Doctoral Thesis, Rensselaer Polytechnic Institute, April, 1968.