

DEVELOPMENT AND PRESENTATION OF
A NATIONAL WAR COLLEGE ELECTIVE COURSE
TO DEMONSTRATE THE USE OF
QUANTITATIVE TECHNIQUES IN THE STUDY
OF INTERNATIONAL RELATIONS

AD735908

VOLUME III
INSTRUCTOR'S SUPPLEMENT

DISTRIBUTION STATEMENT A
Approved for public release;
Distribution Unlimited

CONSOLIDATED ANALYSIS CENTERS INC.

NATIONAL TECHNICAL
INFORMATION SERVICE

SEPTEMBER 1971

DEVELOPMENT AND PRESENTATION OF
A NATIONAL WAR COLLEGE ELECTIVE COURSE
TO DEMONSTRATE THE USE OF
QUANTITATIVE TECHNIQUES IN THE STUDY
OF INTERNATIONAL RELATIONS

VOLUME III
INSTRUCTOR'S SUPPLEMENT

Prepared for:
Behavioral Sciences Office
Advanced Research Projects Agency
Department of Defense

Contract No. DAHC15-70-C-0263
Amendments P00002 and P00003

CONSOLIDATED ANALYSIS CENTERS INC.

Washington, D C Offices 1815 North Fort Myer Drive, Arlington, Virginia 22209. Telephone (703) 527 8012

TABLE OF CONTENTS

	<u>Page</u>
PURPOSE OF THIS MATERIAL	i
I. LECTURE NOTES	I-1
1. Data and the International Policy-Maker	I-2
2. The Utilization of Quantitative Research in Policy Analysis: Past Examples and Future Prospects	I-21
3. Data, Computers, and Research Design.	I-38
4. Introduction to Data-File Operations	I-57
5. Concepts of National Power	I-73
6. Quantitative Aspects of National Power	I-83
7. Theories of Conflict and War.	I-94
8. Inferential Statistics and Regression	I-108
9. Quantitative Investigation of U. S. Policy Objectives and Actions in the Middle East.	I-126
10. Results of Class Work on the Middle-East Problem	I-129
11. International Alliances	I-130
12. Quantitative Investigation of the Effect of a Crisis on Alliances	I-150
13. Results of Class Work on the Alliance Problem.	I-160
14. Introduction to Simulation	I-161
15. Simulation and Planning: Presentation of NEXUS (National Executive Utility Simulation)	I-180
16. Presentation of PRINCE (Programmed International Computer Environment)	I-191

TABLE OF CONTENTS (Continued)

	<u>Page</u>
17. Student Play of Prince	I-208
18. Analytical Basis of the PRINCE Model/Post- Game Critique	I-209
19. Summary and Critique of Simulation	I-231
20. The Role and Value of Quantitative Techniques in Policy-Making	I-243
II. SAMPLE NEWSPAPER FILE ON THE PRINCE NATION AND ISSUES	II-1
The U. S. Economy and its Trade and Aid Policies	II-3
Economic Positions and Policies of the Other PRINCE Nations	II-6
Relations Among the PRINCE Nations and U. S. Foreign Policy	II-9
Issue Positions and Related Actions	II-14
U. S. Domestic Opinion	II-24
III. INSTRUCTOR'S WORKSHOP MANUAL	III-1
PURPOSE OF THIS VOLUME	III-1
SECTION I. DATA-FILE ANALYSIS	III-2
Selecting a Computer System	III-2
Preparing for the Course	III-3
Arranging to Use the Terminal System	III-3
Allocating Funds to the Student Teams	III-6
Determining the Workshop Schedule	III-8

TABLE OF CONTENTS (Continued)

	<u>Page</u>
Accounting During the Course	III-9
Checking the Student Accounts	III-9
Reallocating Funds Among Student Teams	III-10
Changing Passwords	III-11
Possible Workshop Problems	III-12
If the System Fails	III-12
Common Student Errors	III-12
SECTION II. SIMULATION: THE <u>PRINCE</u> PROGRAM	III-14
Student Use of <u>PRINCE</u>	III-14
Program Set-Up	III-16
Creation of the Data-Files	III-16
Storage of the Link-Edited Program	III-17
The Executable <u>PRINCE</u> Program	III-20
<u>PRINCE</u> Output	III-22
Suggestions for Team Organization	III-29
APPENDIX A. <u>PRINCE</u> DATA AND PROGRAM LISTINGS	III-32

PURPOSE OF THIS MATERIAL

This volume contains material that may be used by the instructor in preparing the lectures and workshops. It is divided into three parts:

- I. Lecture Notes
- II. Sample Newspaper File on the PRINCE Nations
- III. Instructor's Workshop Manual

On the basis of the experience gained during presentation of the course at the National War College, we have assembled in this volume those materials that appear to us to be most helpful to the instructor. In tailoring the course to his particular organization and student body, the instructor will, of course, exercise his own judgment about using this material as a starting point for his own course development.

LECTURE NOTES

These lecture notes are based in general on transcripts of the lectures given at the National War College. In some cases, the technical quality of the recording was so poor that very broad and liberal interpretations of the transcriptions had to be made. In other cases, new material has been added, and for all of the lectures, some editing was necessary to take an oral lecture to a written draft.

These partially edited lecture notes are included as samples of the lecture organization that might be followed. Therefore, they should be thought of only as starting points for the development of the instructor's own lectures, rather than as polished lectures ready for delivery.

In addition to these notes, the references in the Course Syllabus Volume I provide extensive material for lecture preparation.

DATA AND THE INTERNATIONAL POLICY-MAKER (Session 1)

I. Pervasive Constraints

Let us start this discussion by talking about the world as though computers had never been created, data-files never collected, and simulations never developed. If we can come to some common agreement about that world, which is a world we all know, then we can talk about why computers, data-files, and simulations might be of some interest to us. If, on the other hand, we do not agree on the nature of that world and the very severe difficulties found there, then the uses of computer-based techniques as I will discuss them will have about as much relevance for you, the decision-maker, as stamp collecting. They may be fun; they may provide a lot of intrinsic pleasure; you may enjoy the "perforations" in this world as in the stamp world, but other than providing entertainment, they will have little value.

Let us start with what I will call "pervasive constraints," those boundaries and limitations constantly encountered by the decision-makers in the higher levels of government, particularly those decision-makers dealing with international matters. These constraints may not be unique to the foreign policy sphere, but they may be more critical and difficult to deal with there.

Information and Uncertainty

The first of the pervasive constraints is related to information and uncertainty. The decision-maker is always faced with uncertainties of various kinds, and the work of high officials involves, in large part, attempting to cope with them. These uncertainties come in many forms. There may be uncertainty about the outcome and timing of expected events. For example, you may be able to predict that there will be Russian pressure on Berlin; but unless you know exactly when, the prediction may not

DATA AND THE INTERNATIONAL POLICY-MAKER (Session 1)

Lecture Outline

I. Pervasive Constraints

Information and Uncertainty
The Requirement for Action
The Need for Accuracy
Limited Resources and the Costs of Information
Correlates of High Office

II. General Implications

Response Time
Information Requirements
Information Absorption
Memory Access
Time Span
Memory Update
Information Check
Information Half-Life and Utility

III. Performances

Evaluating Policies and Programs
Monitoring Implementation
Anticipating Environments
Generating Alternatives

DATA AND THE INTERNATIONAL POLICY-MAKER (Session 1)

I. Pervasive Constraints

Let us start this discussion by talking about the world as though computers had never been created, data-files never collected, and simulations never developed. If we can come to some common agreement about that world, which is a world we all know, then we can talk about why computers, data-files, and simulations might be of some interest to us. If, on the other hand, we do not agree on the nature of that world and the very severe difficulties found there, then the uses of computer-based techniques as I will discuss them will have about as much relevance for you, the decision-maker, as stamp collecting. They may be fun; they may provide a lot of intrinsic pleasure; you may enjoy the "perforations" in this world as in the stamp world, but other than providing entertainment, they will have little value.

Let us start with what I will call "pervasive constraints," those boundaries and limitations constantly encountered by the decision-makers in the higher levels of government, particularly those decision-makers dealing with international matters. These constraints may not be unique to the foreign policy sphere, but they may be more critical and difficult to deal with there.

Information and Uncertainty

The first of the pervasive constraints is related to information and uncertainty. The decision-maker is always faced with uncertainties of various kinds, and the work of high officials involves, in large part, attempting to cope with them. These uncertainties come in many forms. There may be uncertainty about the outcome and timing of expected events. For example, you may be able to predict that there will be Russian pressure on Berlin; but unless you know exactly when, the prediction may not

be very helpful. It is easy to guess that the U. S. will eventually lose a certain foreign military base and that a given weapon system will become obsolete; the critical uncertainty is when. Frequently, it is not the date, but the outcome of an expected event that is uncertain. We know exactly the date of U. S. elections; it is the result that is of considerable doubt. Most often, however, both the date and outcome are uncertain. We may expect that one day Mao will be replaced; but when and by whom?

A related type of uncertainty is the uncertainty about the significance of patterns of events. What describes a "normal" situation that may be left alone, and what are the signs that something is heating up and may require action? What signs indicate a significant increase in hostility that may spill over into conflict? On a smaller scale, what are the early indications that a project is going to experience large cost overruns?

As troublesome as they may be, the problems of predicting specific events and understanding recurrent patterns represent only one dimension of uncertainty. Another dimension is what I will call "association versus causality." Much academic research is concerned with problems of association, based on the assumption that, if you can determine the status of one factor, you will have a relatively good chance of knowing the status of an associated factor. While this type of information has some utility for the decision-maker, he is much more interested in the problem of causality. The question is not "Can I predict the status of factor 'A' from the known status of factor 'B'?", but rather "What actions related to 'B' will bring about a desired state of 'A'?" The decision-maker is faced with much uncertainty about whether a demonstrated relationship between A and B is merely association, possibly occurring because both are related to some unknown factor C, or whether a conscious change in B will produce a predictable change in A. Implications for the decision-maker of mistaking the associative relationship for the causative one can clearly be serious.

Another type of uncertainty involves value. The decision-maker may have great uncertainty about what events and circumstances are desirable. Even if the decision-maker lived in some ideal world where he could collect accurate information and could correctly identify causal relationships, he would still face considerable uncertainty in choosing among competing goals. In a world much simpler than that of the policy-maker's, weapon system technology has progressed to the stage where, within limits, systems of almost any desired characteristics can be produced. Nevertheless, there is evidence of considerable uncertainty about whether, for example, a rifle should be easy to carry, easy to clean, very accurate, or capable of delivering fire at a very rapid rate. Rarely does a decision-maker have a clear-cut choice about how to make a given area or system the "best." Most often there are several competing systems, and instead of the possibly simpler choice of what is "best" for each individually, he must try to consider the larger "system" made up of all of them and decide what is best for it.

Uncertainty for the decision-maker has these and many other faces. A major question for him becomes, then: "How can the different types of uncertainty be handled?" The reason for going through this kind of abstract cataloging of the types of uncertainty is that computer-related techniques can help with some, but not of course with all of them. It is necessary to be as discriminating about when data-files and simulation can and cannot be of assistance as with the more customary approaches.

The Requirement for Action

Another persistent and pervasive constraint in the international sphere is the requirement for "doing something." In the academic world, it may be reasonable to obtain negative results—to discover that some actions will not produce desired results. However, the decision-maker is constrained to take some action, and, in his case, doing nothing can be a very critical form of "taking action." Knowing some things not to do is of some limited

value. It does reduce the set of courses that he must consider, and it does allow him to focus his effort on a narrower band of alternatives. But beyond narrowing the field, negative findings do not tell him what he really wants to know: namely, what to do. And that decision he cannot avoid making.

The Need for Accuracy

The next pervasive constraint I want to mention in the policy business is the need for accuracy. Tests of significance in the purely statistical and academic sense are not identical to the ones of concern to the decision-maker. By that I mean that he does not really care that a relationship is "statistically significant." That information alone is just not satisfactory. If two factors appear to be more than randomly related, that information is nice to have, but the decision-maker does not care about just beating chance if the area is important—Soviet nuclear intentions, for example. He wants a somewhat greater degree of reliability. This means that, while he may still use statistical techniques, he will treat the findings from such studies in a very different way than will academic researchers.

Limited Resources and the Costs of Information

The fourth set of pervasive constraints relates to resources and information costs. A decision-maker never has the resources to buy all the information that may be needed. It must be recognized that information is not free; in addition to money, its costs may include some unexpected items. For example, collecting information may cost the decision-maker time before he can act, and it may cost him the opportunity to collect other kinds of information. As a result, the decision-maker is always deciding about information. It may not be a positive, or even an explicit, decision; but it will be a decision, nonetheless.

A major problem in large organizations—universities, corporations, or government departments—is that decisions about spending scarce resources

are susceptible to great biasing. In the scramble for funding, information collecting is likely to get neglected because it is much easier to see the value of expanded studies, added personnel, and new hardware to an individual career and the status of an agency (or branch of the military services) than to identify the benefits of improvements in the available information about the external world. And this is likely to be true, even in those cases where the real problem of the decision-maker is a lack of information. This observation is not to imply that people are immoral, greedy, or irresponsible; it is to say that all of the pressures on them tend to push in other directions.

My purpose in enumerating the constraints and difficulties faced by the decision-maker is not to discourage you or to suggest that the situation is hopeless. I am going through all these things because they are all, it seems to me, real and persistent. But I think you can accept them all as being always there; you can recognize their great importance; and still you can find computers, data-files, and simulations to be extremely useful.

Correlates of High Office

Now I want to talk a little about some of the other pressures felt by a decision-maker who has reached a high policy-making level.

First, his responsibilities become much broader than they were at lower levels of office, increasing from country to region or from single branch of the military service to joint and combined staffs. The broader the responsibilities become, the more the problems become dependent on a plethora of factors. It is difficult for the decision-maker to focus on single problems because a multitude of them are coming at him all the time. Also, he sees a change in the relationship between responsibilities and time. He is increasingly pushed into handling matters that have very immediate impact and/or immensely long-range impact, but there is relatively little in between. He may also find that he has much less time to consider any given issue. Regardless of his estimate of its importance, he finds it shoved aside by a multitude of new, incoming problems.

In addition to the problem burden, the information burden also increases. The high-level decision-maker has access to many more sources, containing a much greater variety of information. Thus there is an increase in both the scope and the volume of the information to which he is expected to respond. The organizational pyramid works to push information up—maybe not the right information and maybe not to the right places—but the push is always up.

Another aspect of high office is the increasing importance for the decision-maker to be able to search for information privately. The reasons are quite obvious. The stakes are higher now, and the tendency of his subordinates to conform to what they think he wants to hear is greater. Various factions are deeply committed to their sides of issues, and the outcomes of his decisions are very serious and significant to large numbers of people. What this means is that it becomes relatively costly for him to indulge in public search for information. Each time the decision-maker asks for information, it is a signal to another faction and to his subordinates. He may thus find himself committed semi-officially to a position before he wants to be. Sufficient privacy in his information search might have avoided this problem.

Also, the high-level decision-maker finds that he has become even more dependent on others. Ironically, the more power he has, the more he must depend on others for information on which to base a decision and even for knowledge that a decision is required. There are all kinds of intermediaries who decide on what information comes up to him and on what goes out from him. He may make a policy decision, but he does not implement it himself. He passes it down only one step and there are many between him and the problem. One of the more cynical once said, "A bureaucrat is somebody who never writes anything he signs and never signs anything he writes." The decision-maker discovers that the "joys" of high rank involve never collecting the information on which he depends and very seldom implementing directly what he decides. This is a lot of captivity.

II. General Implications

I think that this picture is a reasonably realistic perception of what it is like to be on top. Thus, the issue is: What is the fit between the implications of these pervasive constraints and the value of computer-based data files and analysis to the decision maker? These techniques should be evaluated, not in an absolute sense, but relative to the way that the decision-maker currently works.

Response Time

One implication of the decision maker's constraints is the value of rapid response time. For a given decision, the required response time may be very short. The decision-maker thus needs a fast response from his information system; he does not have time to spend on data collection once he is presented with the problem. He has to have any collection of information done mostly beforehand, whether a computer is involved or not.

Information Requirements

And the information given to him has to be focused on his particular needs. He has too many issues, covering too great a variety, and always too little time. That means he has to have very well selected information. He has to be able to get at the essential things at once; he cannot afford to wade through the volumes which are the usual forms for vast information depots. The classic breakdown of the customary library system is best shown by the extent to which analysts rely on their own little file cabinets and not on the great common information deposits.

Thus, because his specific questions will change, and he always will want to be focused on one particular target, the data that he has available must be stored in a way that makes it easy to handle. He has to be able to take it apart and put it together in many different ways.

One of the required ways of manipulating his data involves changing quickly the level of aggregation. One characteristic of high office is, as mentioned before, that the decision-maker is asked about global matters and nitty-picky matters, and very seldom about much in between. For the grand picture he wants aggregated information and may not care about specific characteristics of individual countries; while for the nitty-picky, he does not care about global patterns or long term trends. This means that he must be able to combine pieces of information into a big picture and break it down again to get small details — both within a very short time period. Think about trying to handle 100 data files that store individual variables for each country. It is easier — maybe not instantaneous, but certainly easier — to be able to enlist computers and data-access programs to sort and assemble needed information.

Information Absorption

Also, along with the other "pleasures" of high office comes the necessity to absorb information very fast. In this business the decision-maker does not have much time; he cannot afford long study periods. Maybe he can, if he is very good at thinking while doing five other things. But however he manages his time, it is clear that he must absorb information terribly fast.

A lot is known about the conditions under which people absorb information. It has been shown that information is understood much faster from pictures or graphs than from long lists of numbers or pages of words. Now try to think about how to generate a picture from standard national intelligence reports. Try to generate a picture from most standard staff reports. It can be done, but it is hard. Now, think about trying to generate a picture from a data-file with a computer plot routine. You can easily imagine that it is far easier than creating graphs from written information.

Memory Access

The importance of private information search has already been mentioned. When he has direct access to the stored files in a computer, the decision-

maker does not have to go through an aide who goes to his subordinates, and so on down. By the time the information is delivered, everyone in the organization may have had a hand in it. That is not very private.

Compare, for example, having access to a data base via an interactive terminal that uses a simple command language with having access to the Library of Congress. For speed, convenience, and privacy, there is really no comparison.

Time Span

As mentioned before, with high office comes a curvilinear relationship to time; that is, the decision-maker is interested in matters which are either very immediate or very long-term, possibly decades or generations. Thus, he has a strong interest in both very short time-span information and very long time-span data. For some issues he will have an interest in very long time-series information perhaps covering even a century. The decision-maker should be able to think in terms of decades and centuries and not just in terms of budget cycles. On the other hand, he will sometimes have an interest in minutes and days. How does one think in terms of days and centuries? How do you get back and forth with standard kinds of information sources? Again, the computer can help with this problem by assembling just those bits of information which are required.

Memory Update

Information changes. How does the decision-maker update a book? He can update a cable by reading the next one. But maybe he does not have time to read each one; he merely wants to know how the most recent cable differs from the previous one. Think about the problems of holding in mind the contexts of all the cables that cross his desk, along with messages, phone calls, whatever, versus the problems of changing the values in a properly structured data file. This data changing or updating is immensely easier to do with certain kinds of machinery, or machine-stored information, than it is with standard sources. Changing standard sources is, of course, not impossible, but it is much harder and slower.

Information Check

One of the implications of uncertainty is that every piece of information will be poor and distorted in some way, that it will be biased in some unknown way. This is the nature of the world and probably unavoidable. What the decision-maker needs is the ability to look at and compare a variety of independent bits of information. Many decision-makers use, or think they are using, a staff in that way. Of course, there always is the risk that the staff might all get together before they talk to him. Nevertheless, there is a lot of precedent for trying to use sources in this way.

One of the ways the decision-maker can most readily combine and compare various information sources is to have available several data-sets (assuming, of course, they have been independently collected—another big assumption) in a data bank. As we have seen, a common alternative to this is picking up a piece which has already been presynthesized before it comes to him. Let us take a national estimate—it is a very presynthesized piece of paper. Or any of the JCS documents are very presynthesized pieces of paper. Compare this now with a computer-based data file, which allows the decision-maker to get beneath the pre-cut summary and closer to the raw information, in a manageable form. Then he can see for himself how it all fits together.

Information Half-Life and Utility

Since getting information is costly, and the decision-maker never has enough resources to get all the information he needs, it is important to give some consideration to how long information will be of value. What is its "half-life?" How long will it remain relevant to the decision-maker's problems?

One major way of increasing the half-life of information is to associate it with its own time period. When it no longer has value as current intelligence, then it may still have great value as a point in a time series or as

part of a recurrent pattern. In considering what kind of information is easier to place in a time series, the decision-maker will find that information structured as a computer-based data file is easier to handle than information existing in the more standard verbal format. Moving it from "current" to "historical" status may involve no more than a single code change.

The second value to consider is the extent to which information is applicable to a variety of problems, issues, and questions. These side benefits and multiple uses rest in large part on the ease with which the information can be cut and sliced. For example, a data-file containing information on European nations can be used to study aspects of the European common market, or combined with information on the U. S. , Canada, and Ireland, to look at NATO. Information on the United Kingdom can be pulled out for a look at the British Commonwealth, etc. If the decision-maker can combine pieces of information from several sources, if he can be very selective about the data he takes from each, then his ability to use the same information for a wide variety of problems is enhanced significantly. If the decision-maker is constrained from doing that, then his ability to use the same information for many different problems falls off rapidly. Information in machine-readable form lends itself to cutting and slicing and, therefore, to multiple uses at reduced costs much more readily than information arrayed in any other way.

Of course, computer-based data files do not necessarily aid in managing the constraints of high office better than customary approaches, but they do have an inherently greater chance of doing so. Whether the chance is realized depends on several factors: the decision-maker himself and his subordinates and, of course, the kind of information with which he must deal.

There is one last, interesting point I want to make before I leave this area. As a slight digression, it is worth noting some particular

differences between the public world and the academic one. In the public organizational world, there appears to be an immense priority on knowing what the organization did or said earlier. This observation is not intended to deprecate the phenomenon, merely to note its existence. It can, as any decision-maker knows, take a good deal of time because the only thing usually known with certainty is that the organization has said a great many things before, none of which were terribly clear. So, if the decision-maker or his staff must spend time finding out past organizational history, they are inherently limiting their ability to get on with their other current responsibilities. There is no doubt that it is a fairly trivial matter to set up computer-based verbal files, alphanumeric files, and alphabetical files, which can be used to find out what was said by predecessors, antagonists, and so forth. This is a very easy saving, and it is trivial in terms of the "state of the art." It is merely information retrieval, not even simple analysis.

III. Performances

It seems to me that these general constraints hold for all types of high-level decision-making, although different people at different times in their day in the public world of international matters may have somewhat different responsibilities. For convenience, work at the policy level may be roughly divided into four general tasks (or jobs or missions). One is to evaluate ongoing policies and programs. The second is to monitor implementation to find out whether anyone is actually doing what he has been told to do. The third is to anticipate problems and their environments; and the fourth is to generate some ways of handling the expected problem. The issue here is to find the fit between what is logically necessary to perform these tasks well and the kind of help the decision-maker can get from information structured into computer-based data files. This fit can be evaluated against the help he can get from information handled in the more customary manner. Obviously, the specific requirements differ for each task; yet they all fall within the framework of the pervasive constraints and implications that have already been suggested.

Evaluating Policies and Programs

A minimum requirement for evaluating a project is a before measure and an after measure. But that alone, of course, is not really enough. What is more desirable are several observations before the project began (say at $t-2$, $t-1$), information at the time it began, followed by observations after it was adopted (say, $t+1$, $t+2$). That means having comparable observations which can be lined up, one against another, to make clear what is changing, what is staying constant, and whether the trend is getting worse or better, or remaining the same. Computer based data-files lend themselves very readily to that kind of very simple comparison.

Since no one wants to throw out a policy or program for the wrong reasons, there are other factors to consider in evaluating programs. Maybe the policy or program itself is very good, but something outside makes it look bad. That sometimes happens. So the decision-maker wants to be able to compute the effect of these exogenous variables, these factors outside the policy which come ripping in to make it look bad. It may be clear that if they were not at work, and if they would disappear by tomorrow, the policy would be pretty good. The basic need here is a way of identifying and taking into account what has been happening in the environment across these time points. There are several statistical ways of doing that, which happen to be more reliable, as well as more credible, than the policy-maker's unsupported judgment. Applying statistical techniques to computer-based data allows the decision-maker to test quickly a number of factors to determine if any of them affect what is happening.

Of course, the decision-maker still has to have some ideas, since no analytical technique can replace the need for creativity. However, if he has some ideas, then computer-based techniques permit him to check them out fast. For example, if the decision-maker has a computer model of his system and its environment, then he could look at the external factor that has apparently affected his program to see what would have happened had it been, say, constant instead of increasing. He can try any number of

ideas to find out the consequences of alternative environments. It is a trivial matter, mechanically, to ask a series of "What if" questions, but this capability is certainly a great advantage to the policy-maker.

Another factor to consider in evaluating a program is the notion of a "threshold." It may well be that a program or policy will be very successful only if the resources allotted to it are above a certain point. Of course, there may be considerable disagreement about which programs belong in this category. Activities as widely disparate as saturation bombing and various social programs have been suggested as having this "threshold" characteristic. Data analysis can be helpful in exploring these areas of disagreement. It can indicate whether or not a given program has reached the threshold. If it has not, then the policy-maker can investigate when and under what conditions the threshold would be reached.

There are several actual examples of where this kind of evaluation, dealing with time points, the control of external factors, and thresholds, has been useful. For instance, there are Project Hundred Thousand (the manpower program in DOD), the Hamlet Evaluation Survey, and studies of UN voting on the admission of the Peoples' Republic of China.

Monitoring Implementation

Once a policy decision has been made, the question of monitoring the implementation of the decision arises. The problem here is that, although the decision-maker tells somebody to do something, he seldom communicates directly with the person who will have the actual responsibility for doing it. After the decision-maker has stated his policy choice to somebody who is twenty or forty steps away from the person who has to do it he, naturally, tends to assume that it is done—until he learns otherwise. Rather than be surprised unhappily, the decision-maker might think about a logic of compliance which would show by indirect measures whether or not his orders have been followed. These should be indicators

over which the supposed implementors of policy do not have control, or which, for independent reasons, they wish to keep accurate. If the decision-maker can establish this kind of "logic of compliance," then he is much more likely to find out what is, in fact, happening. For example, a famous case of non-compliance involves U. S. missiles in Turkey. We thought they had been removed at a time when they were, in fact, still there. Now, there are a number of fairly reliable indicators of missile locations maintained for a variety of reasons that may apparently have little to do with our strategic posture. An example would be records of spare parts maintenance. The logic of compliance would tell the decision-maker to look at these records some time after the missiles were ordered out of Turkey to determine if spare parts were still being shipped there. Such logistic data present a tremendous opportunity to the decision-maker, and, with a logic of compliance, may offer one of the few ways of improving control over those large organizations that are currently very marginally controlled.

Anticipating Environments

Anticipating future environments can be thought of as a third kind of performance involved in the policy process. There are several possible approaches here. One is to look at trends over time in situations of interest. Just as history is helpful in more traditional analysis, it ought to be helpful in more quantitative work. The problem of course is to find precise historical data. In spite of the difficulty in obtaining accurate, relevant data there have been several significant examples of such historical work: studies on crisis signalling, work by Bloomfield for the Arms Control and Disarmament Agency on local conflict escalation, some work on French-British-German elite attitudes on defense policy, and so forth.

Another approach which involves historical data is the identification of similar cases. When a decision-maker has a specific situation to handle, he may automatically ask himself if he has ever encountered a similar case. His first problem, of course, is to decide what is similar case.

Is Malaya similar to Vietnam? Are the Philippines analogous to Vietnam? There are arguments both for and against. So establishing what could be called "class memberships" becomes useful in dealing with historical analogs. Class membership basically says that two situations in the same class must have a lot of things in common.

Determining class membership is really a question of comparing large numbers of characteristics. Computer techniques can be very helpful in this search for similar cases since they are great "matchers." (Current examples of such uses are computer dating services, computer professional selection services, computer scoring of tests and so forth). Although computerized matching is very simple technically, it is a very powerful tool for analyzing large numbers of historical cases.

The determination that a current situation belongs in a given class, or has characteristics similar to previous cases, can be very useful in anticipating environments because it helps to identify warnings, or "leading indicators," as the economists would say. If the class membership of a situation can be established, certain indicators may appear which, at least in the past, have pointed to important changes. An example is the work on the Sino-Soviet border conflict which revealed that, historically, changes in Chinese and Soviet pronouncements are useful indicators of changes in Chinese and Soviet troop deployments.

Another way of anticipating future environments involves an investigation of constraining parameters. Some current work at RAND on forecasting is of this type. The basic thesis of this work is an admission that there is little firm data in some areas. Suppose for example that all we know about a country is that it is constrained in certain ways. For example, it cannot spend more on defense than its total economic revenue. Now let us estimate the upper and lower limits on this constraint—that is, we will estimate the maximum and minimum values of their economic revenues. We can feed these limits, along with something in the middle, into a model

of the country's budget and obtain estimates of the defense expenditures. With a computer, running these cases takes seconds—not a lot of time. With this analysis, the decision-maker has narrowed total uncertainty down to a band of possibilities. There is still much uncertainty, of course, but now the decision-maker knows a few things and has partially limited the game.

Generating Alternatives

The fourth type of task that decision-makers perform involves dealing with alternatives—especially in generating and discarding them. The main problem is to determine what really matters. What are the most sensitive factors in the system? Even without a computer, these are the questions a decision-maker asks.

With multivariate statistical techniques and sufficient data, these questions can be answered with relative ease. Regression, for example, can indicate the relative weights of various factors. It has, in fact, been used to produce interesting conclusions about land-holding equality and civilian support of guerrilla forces and about the conditions that foster revolutions. Much of this work, incidentally, has been contracted by the U.S. government.

Another way of dealing with alternatives is establishing independence of factors, rather than dependence. If a factor has no effect on anything else, then changing it is not going to accomplish much. In real life, there happen to be a lot of factors like this. For example, some interesting work done for the Air Force using Guttman scaling shows that, if a certain degree of stability is desired in a developing country, then there are some necessary stages that country must go through (note that I said necessary, not sufficient). This means that if a developing nation has not advanced to Stage 2, then carrying out those actions that help to bring about Stage 3 is totally irrelevant.

Much of a policy-maker's work is involved in searching for factors that will have a significant (and positive) effect in bringing about desired results. On this point I feel we can all reach agreement. It has been my objective in this discussion to point out to you that the use of data can be a very great aid in this process and that computer-based techniques can be a very great aid in handling and using data.

THE UTILIZATION OF QUANTITATIVE RESEARCH IN POLICY ANALYSIS:
PAST EXAMPLES AND FUTURE PROSPECTS (Session 2)

Lecture Outline

I. Past Examples

Content Analysis of the U. N. Seabed Debates
U. S. Naval Operations in Low-Level Conflict
Sino-Soviet Relations
Future Conflicts and Air Force Missions

II. Future Prospects

THE UTILIZATION OF QUANTITATIVE RESEARCH IN POLICY ANALYSIS:
PAST EXAMPLES AND FUTURE PROSPECTS (Session 2)

I. Past Examples

As the title of the presentation implies, this discussion will be divided into two parts. Initially, some examples of the use of quantitative research for actual policy purposes will be described. Subsequently, some opinions on how such techniques might be used in the future will be presented and the areas most amenable to such utilization identified. Four examples of past uses of quantitative research will be discussed. Two involve the Navy and two, the Air Force.

Content Analysis of the UN Seabed Debates*

The study for the Navy was carried out recently at the Center for Naval Analysis. It involved an investigation of the United Nations Seabed Debates and was designed to aid in preparing negotiators to take part in the formulation of an international Seabed treaty. A principal aim of the study was to discover those subjects of major concern to each nation and to analyze those subjects in light of U.S. interests. Since the debates were extensive, a technique known as computer content analysis was chosen. Using this technique, the actual statements made by delegates during the UN debates were put into machine-readable form and analyzed by computer techniques.

The entire debate was reduced to 189 separate themes, or phrases, and the frequency with which speakers from each state used the theme or phrase was recorded. The themes were then grouped under broader categories called by the analysts "variables". These variables were found to fall into 6 major subject categories:

*Friedheim, R. L., J. B. Kadane, "Quantitative Content Analysis of the United Nations Seabed Debate: Methodology and a Continental Shelf Case Study," International Organization, Vol. XXIV, No. 3, pp. 479-502, 1970.

- Seabed arms control
- Declaration of principles
- Seabed regime and/or machinery
- Continental shelf boundary delimitation
- Special needs of the developing countries in ocean exploitation
- Role of science and the international science institutions in the uses of the ocean.

Table 1 shows the variables and themes in the fourth major category, continental shelf boundary delineation. The themes under each variable are ranked on a national-international scale and are arranged in order of increasing feelings of nationalism. The rank order is then taken to be the "value" of that theme. A nation's "nationalistic" score is computed by summing the products of the number of times a speaker from that country used the theme and its "value" on the scale and then dividing by the total number of references. This produces an "average" nationalistic score and is taken by the analysts as an indication of the probable position of that country on the issue represented by the variable in question.

Figure 1 shows the scores of the various countries on variable 1 plotted against the scores on variable 2. Countries in the upper right hand corner--El Salvador, Chile, Argentina, Honduras, Philippines, South Africa, Ecuador, Peru, Columbia--show strong nationalistic tendencies. The most internationally-minded countries appear to be Iraq, the United Arab Republic, France, Czechoslovakia, Austria, Jamaica, Malta and Sweden. The U. S. was in the middle of the scale on variable 2 and slightly inclined toward the international view on variable 1. The Soviet Union did not express itself on variable 2 and thus does not appear on the figure. Values given by the authors in tables show the Soviet Union to be slightly more international-minded than the U. S. on variable 1.

The study demonstrated a fact long known about UN debates: the behavior of nations on procedural questions is similar to their behavior on substantive questions in the same area. But the study was also able to

Figure 1.*

States' Scores on Continental Shelf Issues

Variable 1—Continental Shelf Definition and
Variable 2—Continental Shelf Criteria

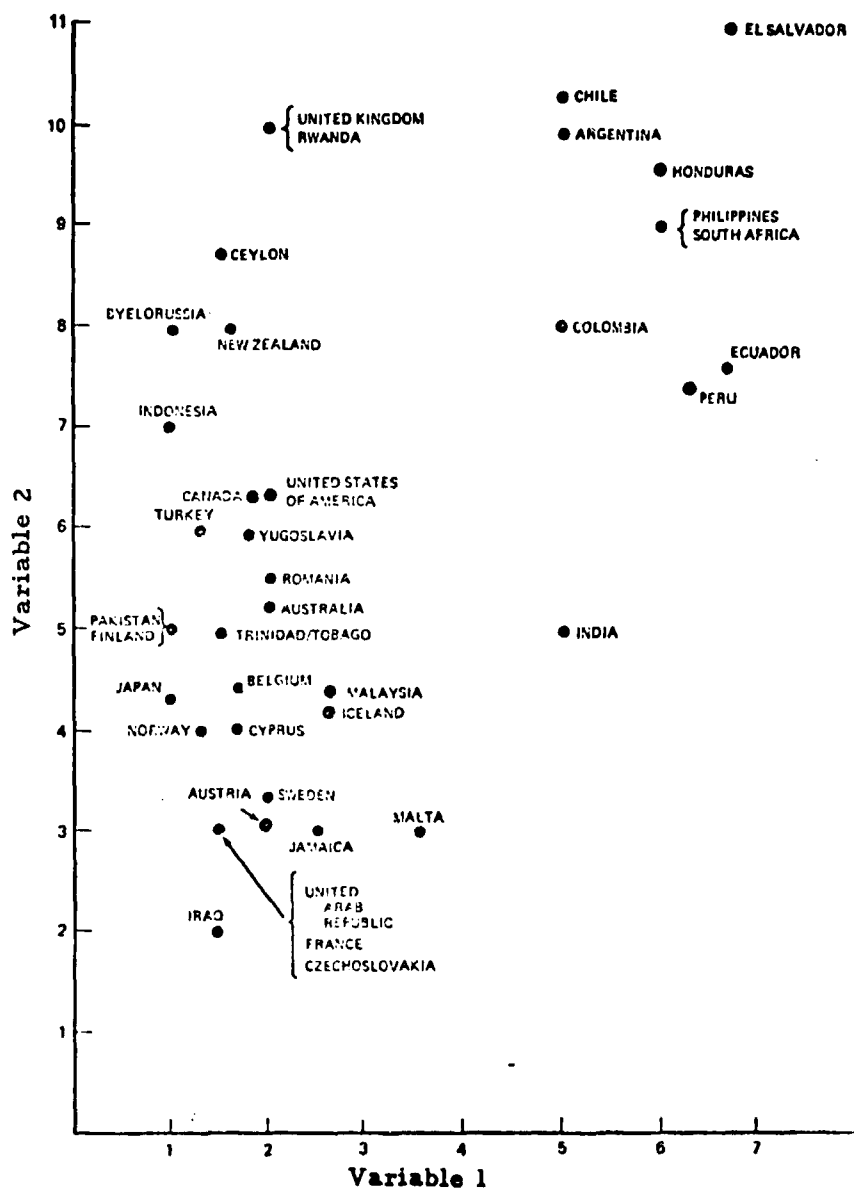

*Friedheim, *op. cit.* p. 487.

Table 1.*
Continental Shelf Themes and Topics

Variable 1: Continental Shelf Definition

1. Must define seabed area
2. Necessary to define national jurisdiction
3. Necessary to define territorial waters
4. Necessary to define continental margin
5. Not necessary to define national jurisdiction, not affected
6. Not necessary to define national jurisdiction, not alterable
7. Territorial waters not under discussion

Variable 2: Continental Shelf Criteria

1. Present international law not applicable to the seabed
2. Present international law of seabed inadequate
3. "Exploitability" invalid due to technological advances
4. Geneva convention invalid
5. Revise Geneva convention
6. Revise in accordance with international law (including Geneva conventions)
7. Revise in accordance with established conventions
8. Geneva shelf convention valid
9. Exploitability valid
10. Respect territorial integrity
11. Maintain national jurisdiction as established by practice

Variable 3: Continental Shelf Mode

1. Moratorium on claims
2. Define national jurisdiction as soon as possible
3. Define "principles" of exploitation after defining continental shelf
4. Redefine Geneva convention at third law of the sea conference
5. Define "principles" first, prior to defining seabed area
6. Define national jurisdiction after the "principles"
7. Delay redefinition of continental shelf
8. Maintain national right to extend claims

*Friedheim, op. cit., p. 485.

reach more conclusions about the attitude and probable behavior of individual nations. Their analysis of the positions of South Africa, the Philippines and Indonesia is interesting:*

The Republic of South Africa and the Philippines, found in the far northeast quadrant of both figures, are here taking stands consistent with their known policies. South Africa, with high positive transformed scores on both sets of variables, is merely conservative. It is a mineral-producing state aware of the potential value of mineral resources off its shore and wishes to bring as many of these as possible under its national jurisdiction; already, there is offshore mining activity off of South Africa. Little wonder it prefers to state that national jurisdiction is not alterable (variable 1), that "exploitability" as a criterion for shelf delimitation is adequate (variable 2), and that the redefinition of the shelf ought to be delayed and that in any case that national right to extend claims further offshore ought not be limited (variable 3).

Similar substantive positions were taken by the Philippines. It probably took these stands in order to support its "archipelago" theory. This theory would allow states like the Philippines and Indonesia, composed of many islands, to draw a line around the outer edge of the island group to mark the place where their territorial sea begins. What is most important about the archipelago theory is that it would reduce all waters inside the line to internal waters, over which the coastal state normally has a greater degree of control than the high seas or even the territorial sea. If this theory is accepted, the Philippines has little need for a continental shelf concept since most of the rights granted by this limited zone concept would be swallowed up by the swollen general purpose zone created by the archipelago theory.

What is worthy of note in these debates is the fact that Indonesia has not joined the Philippines in the protection of its traditional position. Indonesia has instead taken a mildly internationalist position on variable 1, a mildly nationalist position on variable 2, and a mildly internationalist position on variable 3. Thus it has supported the idea of defining the seabed area, attacked "exploitability," supported a moratorium on claims, and called for a third law of the sea conference. Has Indonesia given up its archipelago claim? We cannot tell from this body of data. But the data does suggest that Indonesia might not be as rigid as in the past and that some form of exploratory negotiations on the subject with Indonesia might prove fruitful.

*Friedheim, op. cit., pp. 498-499.

The authors noted that this last suggestion was upheld by the conclusion of a treaty in March 1970 between Indonesia and Malaysia delimiting their territorial sea boundaries in the Strait of Malacca in which Indonesia abandoned its archipelago theory.

U. S. Naval Operations in Low-Level Conflict

In a study by the Bendix Corporation, large amounts of data were collected and analyzed which described in a variety of ways 323 conflicts that occurred between 1945 and 1966. As part of that study, for some 85 conflicts, data were compiled which measured the deviation by the U. S. Navy and Marine Corps from normal operating schedules prior to or during politically significant conflicts. * The measures of naval operations included assigned naval missions, naval operations performed, readiness measures taken, the level of military threats assessed by the Navy, U. S. naval forces employed, access to the sea from the conflict's "center," duration, etc.

Here are some illustrative findings from the study which are of relevance to the Navy:

- (1) A show of force consisting of at least some intra-theater redeployment of U. S. Naval units to the conflict area is the most frequent operation. In decreasing order, the frequency of operations conducted were:

<u>Type of Operation</u>	<u>Number of Cases</u>
Show of force	48
Special Surveillance	20
Anticipatory Presence	19
Continuing Surveillance	17
Military Assistance	11
Evacuation	10
Combat	6
Intervention	5
Interposition	5

*For further information on the study, see: The Bendix Corporation, United States Naval Operations in Low Level Warfare (U), Final Report BSR2453, December 1968.

- (2) Although forceful opposition to the naval operations was perceived to be quite likely in at least 25 cases, operations generally were unopposed. Hostile acts were directed at U.S. naval forces only 6 times, exclusive of incidents.
- (3) While East-West tensions were a consideration in every general alert (6 cases), there had not been a general alert since 1962, and there have been 27 other cases involving East-West tensions which have resulted in only a limited alert for the Navy.
- (4) Limited operations have been carried out in 35 other cases which did not directly involve East-West tensions.
- (5) U.S. naval forces have been directly involved in only 2 colonial conflicts. In the 12 other conflicts related to colonial issues, the action taken by the Navy has been indirect and stronger than a show of force only 2 times.
- (6) Every case involving combat operations was related to intrastate conflict. Eleven out of 19 other cases where combat was considered likely, also involved internal war.
- (7) The kind of naval task organization employed included surface patrol, amphibious, or attack carrier twice as often as the other types of task organizations.

Sino-Soviet Relations

Under a contract with the Air Force Office of Concepts, Objectives and Doctrine, the Bendix Corporation, using quantitative measures, investigated several aspects of Sino-Soviet relations for the purpose of assessing its

consequences for U. S. strategic planning in the 1970's.* Four central problems were investigated using a variety of techniques:

- Describe Sino-Soviet attributes (e. g. , industrial development) and relate the differences in attributes to changes in their behavior toward each other.
- Describe Sino-Soviet behavior toward a sample of less developed countries.
- Assess the importance of ideology, nuclear strategy, and foreign policy outputs in the Sino-Soviet relationship.
- Project future Sino-Soviet behavior and assess its implications for the United States.

Two of the many findings of the study are as follows:

- During the period 1950-1967, 97 percent of the variation in Sino-Soviet mutual threat perception, border hostility and decline in economic cooperation is accounted for the differences in industrial growth between the two countries. Threat perception values were derived through content analysis of statements, notes, etc. , of top Soviet and Chinese officials.
- There is little official competition by China and the Soviet Union in the sample of less developed countries studied. Involvement was measured by various indicators of interaction including trade, aid, official and non-official contact between the nations.

* For further details on this study, see Bendix Corporation "The Sino-Soviet Rift and Its Consequences for U. S. Strategic Planning in the 1970's," Final Report, 1970.

Future Conflicts and Air Force Missions

In 1966 the Office of Research Analyses (ORA), U.S. Air Force, established the Mission Identification Program (MIP). Program objectives were:

. . . to identify future aerospace mission concepts by analyses of projected economic, sociological, political and technological environments which interact with the efforts of the United States to achieve its national goals; . . . to identify deficiencies in knowledge and techniques within the behavioral sciences which limit effective analysis of future mission requirements and present these as research opportunities; and . . . to stimulate pioneering research within the basic research community . . . by disseminating the results of the environmental studies. . . . These objectives were viewed as relevant to the Air Force long range planning function, in general, with specific applicability to the Air Force research program.*

The rationale underlying such an effort

. . . . was based on the existence of a lag between initial discovery and the translation of that discovery into operational, threat responsive systems. Such a lag in today's technological environment presents a distinct possibility that military missions towards which present research efforts are aimed will no longer be optimal for the future threat environment. This is indicated by the notion that technical considerations (which have been a significant element of the strategic equation in the past) are being replaced in importance by political facets of the international and domestic environments Thus, as Knorr and Morgenstern would summarize it, 'in the design of weapons, forces, doctrines, and strategies for future use, it is crucial to visualize, as much as possible, the politico-military environment in which these capabilities may find employment.'**

The Mission Identification Project was divided into three phases:

- (1) Assess the process of forecasting and the procedures (techniques, methodologies) available for making environmental forecasts;

*Erb, Eugene A., "The Linkage Between Conflict Events and Air Force Missions: A Preliminary Investigation," Office of Research Analysis (ORA), Office of Aerospace Research (OAR), ORA-70-0024, June 1970, p. 1.

**Erb, *op. cit.*, pp. 1-2. Knorr and Morgenstern, "Political Conjectures in Military Planning," Policy Memorandum No. 35, Center for International Studies, Princeton University, Nov. 1968.

- (2) Consider traditional concepts such as intentions, capabilities, and threat as they relate to conflict and assess the utility of an operational theory of social change for predicting the existence and degree of internal stability within nations;
- (3) With results of Phase II (list of probable future conflict events which impact on U. S. interests), address the question, "How can we improve the determination of military missions or functions which will be responsive to those events?"

For Phase I, the ORA Study completed studies in-house and contracted with outside study groups to explore forecasting methodologies and techniques. Subsequently, much of the Phase II results were reported in a study by Professor Gary Buck entitled, "A Quantitative Analysis of Modernization."^{*} The study was intended to provide a firm theoretical and empirical foundation for the Phase III effort. Specifically, that study sought to operationalize a theory of social change. In order to accomplish this task, indicators of theoretically important variables were empirically measured and then statistically manipulated. The major technique used was scalogram analysis.^{**}

Table 2 presents the analysts views of the types of military functions for which the Air Force is responsible in various types of conflict situations.^{***} Thirty-eight types of military functions are listed on the rows while nine types of conflict are arranged across the top. In the cells, an "X" has been marked in each instance where the study team felt that a specific military function was related to a given type of conflict.

^{*}G. Buck, "A Quantitative Analysis of Modernization," Office of Aerospace Research, Office of Research Analyses, Report No. ORA-69-0001A, January, 1969.

^{**}Scalogram analysis is a statistical technique used for finding patterns in distribution of descriptors (or attributes) of given entities (people, nations, etc.). See pp. 22-26 of the Buck report for a detailed description of the technique.

^{***}Table VI, p. 31 in Erb, op. cit. See that study for a detailed explanation of and several caveats about this Table.

Table 2

THE CONFLICT CLASS - MILITARY MISSION MATRIX

MILITARY FUNCTION (MISSION)	CONFLICT TYPE								
	GENERAL WAR	LIMITED WAR	OVERT INTERSTATE INTERACTION	BORDER CLASH	INCIDENT	CIVIL WAR	REVOLUTION	COUP D'ETAT	DOMESTIC TURMOIL
Destroy Enemy Weapon - Tactical Complex	X		X						
Negate Enemy Airborne Strategic Defense	X		X						
Negate Enemy Ground Strategic Defense	X		X						
Negate Enemy Airborne Theatre Defense		X							
Negate Enemy Ground Theatre Defense		X							
Negate Enemy Ground Battlefield Defense		X							
Neutralize Strategic C&C	X		X						
Neutralize Tactical C&C		X							
Negate Strategic Manned Vehicle Threat	X		X						
Negate Strategic Unmanned Vehicle Threat	X		X						
Negate Space Vehicle Threat	X		X						
Negate Tactical Manned Vehicle Threat		X							
Negate Tactical Unmanned Vehicle Threat		X							
Interdict Logistic System		X	X			X	X		
Interdict Battlefield Resources		X			X				
Fire Support of Ground Operations		X		X	X				
Pre-Strike Strategic Recon	X		X						
Post-Strike Strategic Recon	X								
Tactical Recon		X	X	X	X		X		
Battlefield Recon		X						X	X
Inter-theatre Troop (RE) supply	X		X	X		X			
Inter-theatre Materiel (RE) supply	X		X	X		X			
Inter-theatre Medevac		X				X	X		
Non-battlefield SSR		X			X				
Intra-theatre Troop (RE) supply		X				X	X		X
Intra-theatre Materiel (RE) supply		X				X			X
Intra-theatre Medevac		X				X			
Battlefield Troop (RE) supply		X						X	
Battlefield Materiel (RE) supply		X						X	
Battlefield Medevac		X							
Battlefield SSR		X							
C&C of Strategic Off-Def Forces	X		X		X				
C&C of Theatre Forces		X		X		X	X		
C&C of Battlefield Forces		X						X	X
Theatre Psy-War		X					X		
Battle Psy-War		X							
Civic Action							X		
Advisory							X		

Each class of conflict was assigned a value reflecting its impact in general on U. S. interests. The values assigned, which were only illustrative since U. S. interests are defined by civilian rather than military authorities, were:

General War	10.0
Limited War	3.0
Overt Interstate Interaction	7.0
Border Clash	.5
Incident	.7
Civil War	.1
Revolution	1.5
Coup d'etat	.1
Domestic Turmoil	1.0

The level of effort which the Air Force would anticipate expending in each of the 38 Military Function classes (Table 2) then would be the product of U. S. interest times predicted number of conflicts within which the function would be carried out. To demonstrate the calculations, projections of future conflicts calculated by the McDonnell Douglas Co. were employed. Forecasts for the decade 1975-1985 were as follows:

General War	0
Limited War	3
Overt Interstate Interaction	1
Border Clashes	2
Incident	8
Civil War	0
Revolution	8
Coup d'etat	0
Domestic Turmoil	7

Given that 8 revolutions were forecast, and that the level of U. S. interest in revolutions was set at 1.5, what is the general level of effort that should be expended on Advisory Functions (number 38 in the matrix)? The answer arrived at is $1.5 (8) = 12$. If advisory functions also were needed for border clashes, $.5 (2) = 1$ would be added to 12. Since Non-battlefield S&R are functions needed in Limited Wars and Incidents, the general level of effort which should be expended on this function is $3 (3) + .7 (8) = 14.6$.

The conclusion would be that for the period 1975-1985, Non-battlefield S&R capabilities will be more in demand than advisory functions. This is an illustrative demonstration of the way in which forecasts of future conflict situations could be useful in the planning process.

II. Future Prospects

Future uses of quantitative techniques will probably center in the area of national planning. Historically, there has been substantial concern about the planning process, but very little real effort has been expended on improving it. Thus, while there is interest in forecasting future environments, particularly the conflict environment, few resources have been allocated to it.

Strategic planning is, however, an area where quantitative techniques might be usefully applied. The move, particularly within DoD, to the use of more structured planning tools for the allocation of resources has necessitated a good deal of thinking about how one can quantify "soft" factors such as "aggressiveness," "development," "alignment," and so forth. All of these concepts and many more probably can be quantified so that more objective, accurate, and, therefore, more useful forecasts of the future conflict environment can be made.

A recent study of the use of quantitative techniques for strategic and national planning identified nine areas in which past or current quantitative research probably could be utilized*:

- Alliance Behavior and Collective Security
- Bargaining and Negotiation
- Data Handling, Information & Management Systems
- Forecasting
- Internal Stability
- International Effects of Trade and Aid
- Monitoring
- Simulation and Modeling

*Consolidated Analysis Centers Inc., Technical Report for ARPA Contract DAHC 15-71-C-0201, July 1971.

This list is by no means exhaustive, but serves to illustrate the wide range of subjects amenable to quantitative analysis. In the study cited, six ARPA-supported projects were reviewed in an attempt to locate convergence between the research conducted by members of those projects and the areas of user need identified above. Several examples of such convergence are as follows:

- Research by the World Data Analysis Program at Yale University has suggested that analysis of quantitative indices of alliance characteristics probably is useful in calculating probabilities of alliance cohesion or disintegration upon the outbreak of hostilities.
- Extensive work by the Cambridge Project at MIT and Harvard has resulted in the development of several sets of computer programs that are aimed at solving problems related to data handling and information management. Among these are:
 - (1) The ADMINS Mark III system, which allows the user the option of selecting subsets of data from large data files on the computer, then replacing the data in the original file;
 - (2) The MULTICS Social Science System which acquires cross-tabulation and display tables from the console, stores them, and retrieves them for later display;
 - (3) EFFECT, which allows the user to perform statistical operations on a large data set with only a few minutes instruction.
- Content analysis of foreign leaders' speeches by a researcher in the World Data Analysis Program appears to demonstrate a useful method for describing the intensity of foreign leaders' concerns in the area of internal development. Results such as these might well prove useful in forecasting the effects of alternative foreign military and non-military aid allocations.

- The World Event Interactive Survey at the University of Southern California project has focused considerable attention on the subject of short-term forecasts of international behavior and produced results that should prove useful to the user community. The project has investigated a wide range of problems in this area, including the systematic collection of relevant data, data storage, retrieval and analysis, and the derivation of empirical relationships useful in forecasting future international behavior.
- Some likely results of civil disorder in foreign nations have been identified by World Data Analysis Program researchers. Particular emphasis was put on the identification of those characteristics of civil disorder which may give rise to foreign intervention.
- The Cambridge Project has written computer programs designed to analyze international trade patterns with a view toward using such patterns as indices of international integration.
- Quantitative, systematic indices of international behavior patterns are continuously monitored by the World Event/Interaction Survey. The indices summarize, both on a national and a nation-pair level, trends in upper-level official international behavior. The continuous monitoring is coupled with the application of special measures to the behavior indices. These special measures provide an indication of unusual emerging patterns in international interaction. The measures have in some cases proved to be sensitive clues to oncoming crises and conflicts.

In summary, examples can be cited of the past use of quantitative techniques and arguments can be put forth for their continued and expanded use. However, until it is realized and accepted that these techniques are aids to decision-making, not replacements for expert analysts' judgments, and until they are

given a chance to prove their utility in environments not presently receptive to their use, progress in their adoption will continue at a relatively slow pace. This point is well stated in a recent research paper entitled "Quantitative Information for Strategic Decisions"*.

In the future, as management becomes more conversant with quantitative techniques and computer capabilities and as the computer becomes easier for the commander or manager to deal with, experts feel we may see more direct communication. This development of the computer is expected to proceed to direct evaluation of alternatives by the manager in about 5 years.** For the present and immediate future, the appropriate level of influence of quantitative methods is limited to the statement made in 1963 by the then Deputy Assistant Secretary of Defense Alain C. Enthoven,

'This is not to say that all matters can be reduced to numbers, or even that most can be, or that the most important aspects can be. It is merely to say that the most appropriate method for dealing with some aspects of problems of choice of weapons systems and strategies requires numbers. Non-quantitative judgment is simply not enough. What is at issue here really is not numbers or computers versus words or judgment. The real issue is one of clarity of understanding and expression.'***

*Major S. J. Yuill, USA, "Quantitative Information for Strategic Decisions," Naval War College Review, Vol. XXIII, No. 3, November 1970, pp. 16-29.

**Sherman C. Blumenthal, Management Information Systems; a Framework for Planning and Development (Englewood Cliffs, N.J.: Prentice-Hall, 1969), p. 170. As quoted in Yuill, ibid., p. 28

***Alain C. Enthoven, "Choosing Strategies and Selecting Weapon Systems," U. S. Industrial College of the Armed Forces, A Modern Design for Defense Decision (Washington: 1966), p. 141. As quoted in Yuill, ibid., p. 28.

Lecture Outline

I. Research Design

Its Purpose
Two Principal Forms

II. The "Classical" Method

Formulation of the Research Problem
Formulation and Function of Hypotheses
Operationalizing Concepts
Collecting Data
Testing the Hypotheses: The Role of the Computer

III. "Exploratory" Studies

Functions of Exploration

IV. The 1914 Crisis Study: A Classical Approach

The Research Problem
Hypothesis
Operationalization of Concepts
Test of Hypothesis and Results

V. The Sino-Indian Study: An Exploratory Approach

The Research Problem and Questions
Operationalization of Concepts
Conclusions Regarding Research Questions

VI. Summary: Data, Computers, and the Researcher

I. Research Design

Its Purpose

Since the term quantitative has to some political scientists become synonymous with computer, we should like to put aside the question of computers at once, at least temporarily. While quantitative research always involves data of some kind, it may or may not employ a computer, depending on the difficulty of the computations to be made and on the availability of computing facilities. A few years ago it was not unusual for a doctoral candidate in statistics to compute by hand a single factor analysis for his dissertation; now computers accomplish the same task in seconds. Of course, computers can do only what humans have instructed them to do, but they can do it much faster, thus leaving the researcher more time for the "thinking" aspects of his research.

"Thinking," of course, is the central component of research. No research is ever accomplished until someone thinks of a problem and of a way to attack it. A central point is that research efforts are not (or should not be) random activities. Goals require plans and this is what the discussion today will concentrate on: designs for attacking research problems. After some discussion of research design in general, two specific examples will be presented and examined in the light of the points covered in the discussion.

Two Principal Forms

Research—in the policy sciences as in the physical sciences—is far too complex to be treated as a random or haphazard activity. For each problem, there will be a great many ways to go about solving it—a large number of data sets that might be used, a multitude of quantitative techniques, and

so on. If the research is not to be purely random, then a plan or strategy is needed. In a field more familiar to you—national security planning—there are a number of steps the planner goes through to produce eventually a policy. Similarly, in research there are a number of steps that, taken together, constitute what is called "research design." In both of these activities—strategic planning and research—the purpose of formalizing the "steps" is to guide the activity toward some goal (the policy or the research results), and to insure that the stages of the activity are undertaken in some logical sequence.

Two Principal Forms

To say that there is form and structure in research is not, however, to say that there will be only one way of going about a given research problem. An important point should be made here: the type of research design chosen will depend largely on the purpose of the research. Research "strategies" can be divided roughly into two major types: the "exploratory" approach and the "classical" approach. The "exploratory" approach, while usually considered to be less formal, is not, of course, random. Suppose that the analyst has collected a set of data, but has very little idea of the rules underlying the operations described by the data. In this case, he may wish to "explore" the data, looking for significant relationships. For example, there is a data-set (which you will see later) that includes defense spending by Israel and the Arab nations, some measures of internal and external conflict experienced by these nations, and several other kinds of information. If the analyst has no idea at all of what processes these data might represent, he might choose one of the variables, say, Israeli defense expenditures, and search to see if this variable has any significant correlations with other variables. Critics have been known to refer to this as "tiptoeing through the data;" a more formal term for this activity is induction. On the other hand, the analyst may have some theoretical basis for formulating a hypothesis about the relationships among the variables in his data-set. Then, he may employ statistical techniques to test his hypothesis in a more formal way. For example, suppose theory says that leaders

take their nations into war in order to consolidate their political positions at home by strengthening their peoples' allegiance to the government. From this theory, one might hypothesize that as Arab and/or Israeli public allegiance to their respective governments declines, Mid-East hostility grows. If the data-set contains variables that can be related to internal allegiance and to external hostility, then this hypothesis can be tested. This would be more akin to the classical approach of hypothesis testing.

The "classical" method consists of a number of formal steps which will be described and discussed below. First, one should point out that there are many gradations between the "exploratory" and "classical" approach. While for the purpose of this discussion, it is convenient to make a sharp distinction between the two, it would be a mistake to assert that every research approach is one, and only one of the two.

II. The "Classical" Method

Classical research design has been described in a number of texts on research. Our discussion here will follow that in Research Methods in Social Relations by Claire Selltiz, et al.* Classical research design may be described in five major steps.

Formulation of the Research Problem

First, there is the precise specification of the research problem. Although this step appears to be an obvious beginning, it often is quite difficult to choose a specific research objective. For example, suppose you were given the responsibility for "understanding the Middle East situation." What would that mean? What questions about the Middle East would you want to try to answer?

* Claire Selltiz, et al., Research Methods in Social Relations (New York: Henry Holt & Co., Inc., 1959), ch. 2.

One of the overwhelming characteristics about the Middle East that makes it a "situation" that must be "understood" is the threat of conflict brought about by the hostility among the nations in that area. So one might want to understand something about the past conflict and present hostility. Can the past conflict levels be stated in quantitative terms? Can present hostility levels be measured? Are there any measurable characteristics of these nations with which the conflict or hostility appears correlated—Soviet aid to the Arab states, U. S. aid to Israel, guerrilla attacks on Israel, etc.? One possible research problem then, is to account for conflict in the Middle East.

Formulation and Function of Hypotheses

Having selected the questions and issues for his research, the analyst then must express these in terms of specific hypotheses that may be tested by the data. Suppose that he has decided to find out why the Soviet Union gives aid to Egypt. What data should he collect? What about measures of political stability in Iceland or population growth in Australia? The analyst would probably rule these data out at once (if, indeed, they would occur to him at all) because he thinks, or theorizes, that they have little or nothing to do with Soviet aid to Egypt. These examples were obvious; choosing precisely those factors that might "explain" Soviet aid is not that easy. It is at this point that theory becomes useful: out of the many factors that might possibly have an effect on the issue (i. e., be correlated with or "explain" in the statistical sense), theory can aid in reducing the number of factors to be considered to a manageable number. (Note that since the introduction of computers into the field of analysis, the number of variables considered "manageable" has increased considerably). One might hypothesize that Israeli conflict behavior toward Egypt is a "cause" of Soviet aid to Egypt since Egypt is, in a sense, a "client" state of the USSR. This hypothesis has thus narrowed the field of investigation down to two variables—Israeli conflict behavior toward Egypt and Soviet aid to Egypt, and has postulated a direct connection between the two. This "connection" then can be tested against the data and accepted or rejected.

Operationalizing Concepts

After stating the hypothesis to be examined, the concepts with which it deals must be "operationalized." By this, we mean the concept must be related directly to measurable factors. In the Middle East example, Israeli conflict behavior toward Egypt was one of the factors. The researcher must now specify precisely how he will measure "conflict behavior."

Shall the concept be measured by the number of military incursions into Egyptian territory by Israeli forces, by the number of Israeli flights into Egyptian airspace, by the total lethal area of the ordnance delivered by Israeli artillery into Egyptian territory? Shall "Egyptian territory" be that territory considered Egyptian by Egypt or by Israel? Now what about Soviet aid? Does this include cash actually handed to the Egyptian government, or the "value" of Soviet military equipment given to the Egyptian army? New equipment only or also replacements? Should economic aid be included? Should the estimated salaries of the Soviet technicians in Egypt be included?

Let us take another example: Consider the hypothesis that development in Latin America is directly related to UN programs in that area. There are two concepts in this hypothesis:

- Latin American "development," and
- UN programs

The question arises as to whether development should be measured by some economic indicator, for example, GNP per capita, or some other indicator, like educational levels or decrease in illiteracy. Measurement of the UN programs may also be difficult since they include many types of aid.

The major point here is that this very difficult step is, of course, crucial. Any correlations discovered in the analysis are only correlations between

the quantitative measures. The credibility of accepting or rejecting the hypothesis depends quite fundamentally on the credibility of the relationship between the concepts of the hypothesis and the measures chosen to represent them. Since the "operationalization" of the concepts defines the quantitative measures to be used, this step is obviously an early one if the data collection is to be done efficiently.

Collecting Data

After the problem has been defined, the hypothesis stated, and the concepts operationalized, then the process of data collection is fairly straightforward. There may, of course, be problems. Some of the data may be difficult, or even impossible, to find. Sources have widely varying reliability. In a highly-developed, quantitatively-oriented country like the U. S., economists think a great deal about measures like GNP and trade balance and reliable values of these quantities are relatively easy to find. But over a great part of the world, such quantities are hard to estimate and harder to translate into the same units of measure, say U. S. dollars. Sometimes missing data can be estimated—perhaps from trends or from similar cases, or from other data. When missing values cannot be estimated, then the analysis simply must ignore the missing points. Obviously, this is not desirable, and it is possible that the problems of data collection can cause the analyst to go back to his hypothesis to try to restate it in a way that is still relevant to the problem, but uses concepts that can be related to available data.

Testing the Hypothesis: The Role of the Computer

The final step is testing the hypothesis. At this stage the computer often becomes particularly relevant. You may, in fact, think of hypothesis testing as the point at which hypotheses, data and the computer merge: the data are manipulated by the computer to produce a test of the hypothesis. Implications of the hypothesis testing process may eventually become part of the theory—either supporting or contradicting old theories or possibly suggesting new ones.

It also is possible that the results fail to contribute anything at all to the store of theory. As mentioned earlier, the concept operationalization step is frequently subject to criticism. Suppose, in the UN/Latin American development example, the investigators report that they have found a high correlation between UN programs and Latin American economic development. Critics might agree that there is indeed a strong relationship exhibited in the data, but this does not indicate that the hypothesis is supported: the data may not be an appropriate measure of the concepts in the hypothesis.

Before going on to discuss an alternative way of carrying out a research project, it would be useful to summarize what has been said about the classical approach. Figure 1 indicates the general steps. The analyst starts with a fuzzy problem area that he must reduce to one or more relevant questions to be answered. With the help of whatever theory exists, he reduces these questions to a specific hypothesis. After operationalizing the concepts of his hypothesis, he collects data. With the aid of statistical techniques and, possibly, a computer, he tests the hypothesis against the data, and the implications of this result may eventually contribute something to the body of theory.

Not every research result ends as theory, of course. If the hypothesis is not verified, it means only that a relationship fails to appear in the data; it might mean that the hypothesis is untrue, or it might mean that the wrong data were collected. It is possible that the hypothesis was stated too simply: perhaps the relationship will hold in some circumstances, but not in others. For example, UN aid may contribute to the development of countries that are politically stable, but not to those that are politically unstable.

FIGURE 1
Classical Research Design

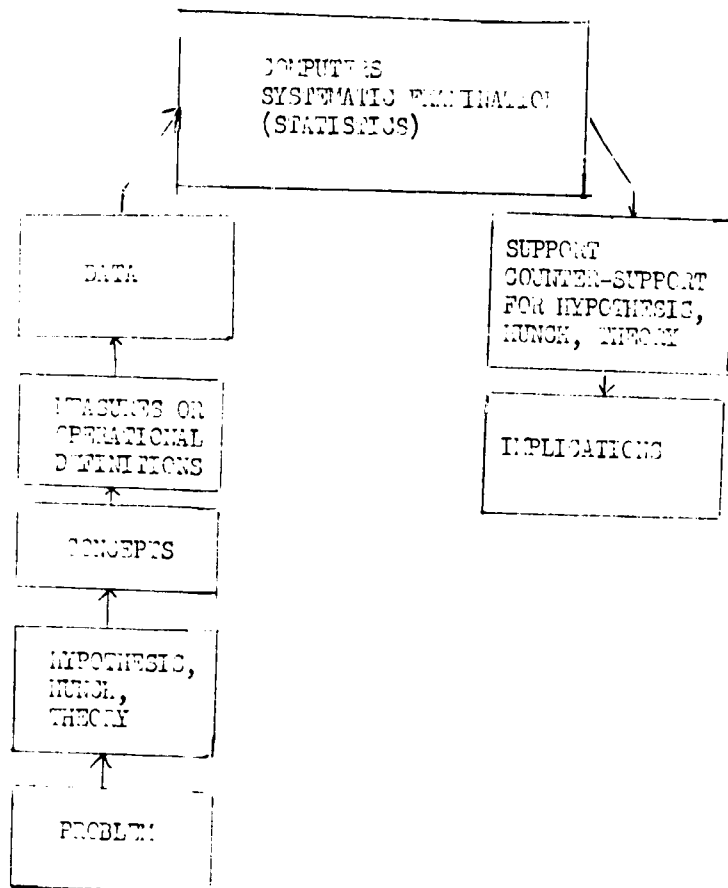

III. "Exploratory" Studies

Functions of Exploration

Suppose an analyst is working in an area where there is no theory to guide him in the choice of a hypothesis from which he can obtain concepts to operationalize?

Obviously he cannot collect and examine every piece of information available to him. When there is no specific theory to guide him, then he must turn to his own intuition and experience and to very general theoretical notions. These may lead him to expect that certain classes of variables may be relevant while others are not. Having collected the data that his insight led him to expect to be related to his area of interest, he may explore the data by such data-handling techniques as scatter-plots, curve-fitting, and the computation of correlation coefficients.

The results of such work will not be of the type that confirm or reject a hypothesis; they may, however, suggest relationships not previously suspected. In a sense, this finding may be more of a "discovery" than those obtained through the classical hypothesis testing procedure. It is clear, too, that such a discovery does not come from a totally random process: exploratory research, though less structured than more formal research design, requires thoughtful selection of concepts, careful operationalization and data collection, and detailed exploration of possibilities in the data, perhaps using the computer as a helpful tool. Any findings that are made are subject to the same criticisms as those deriving from formal research.

While abstract descriptions of research methodology may contribute to a general understanding of the research process and the role of data and computers in research, they probably do not add much to one's understanding of exactly how a research project is carried out. The best way to

achieve a deeper understanding of research is to engage in research. For that reason, one of the purposes of this course is to allow the student to carry out, on a small scale, the same steps that are part of any research process.

But, in between abstract descriptions and personal experience, an intermediate source of understanding are reports of other research projects in international relations. Therefore, two such projects will be described—one that closely follows the classical pattern and another which more closely resembles the exploratory approach.

IV. The 1914 Crisis Study: A Classical Approach

The first project is a study of some aspects of events in the summer of 1914 leading to the outbreak of World War I. The study was carried out by Holsti, North, and Brody at Stanford University.*

The Research Problem

The Stanford researchers who undertook this study hypothesized that perception is a very important component of international interaction, perhaps even more important during times of crisis and conflict. In this sense, perception refers to the way an individual, or a nation, sees his environment and the events that occur around him. It may not represent what the source of the event intends. But to the nation itself, and especially to its leaders, reality is what is perceived to be reality. The research problems undertaken in this study have been based on the model sketched in Figure 2. This model has gained popularity as the concept of perception has gained importance.

*Ole Holsti, Richard Brody, and Robert North, "Perception and Action in the 1914 Crisis," in Quantitative International Politics, edited by J. David Singer (New York: The Free Press, 1968), pp. 85-157.

FIGURE 2.
THE "PERCEPTION/REACTION MODEL"

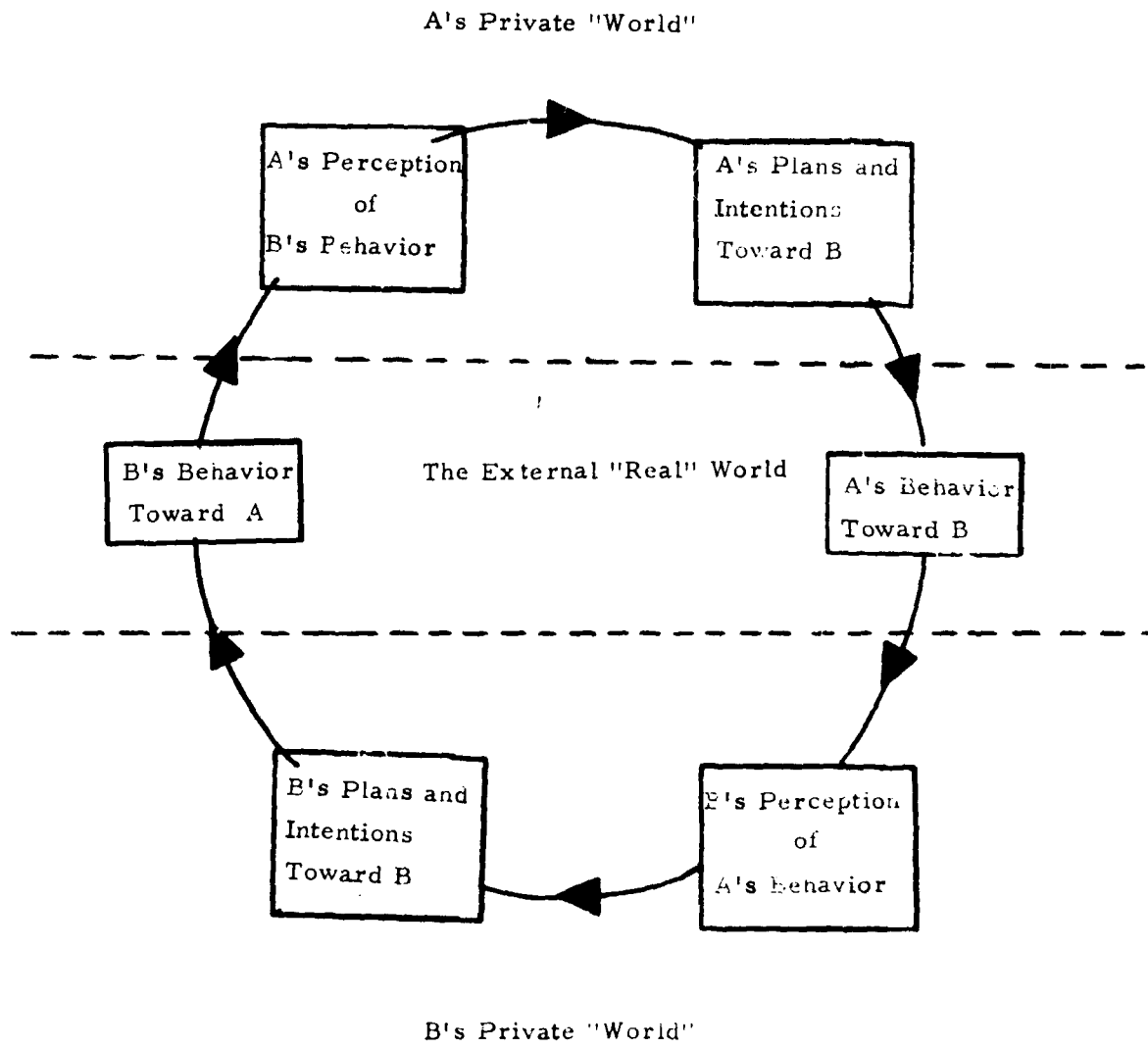

The idea behind the model is very simple. A's intentions toward B, which will be translated into his actions, are based in part on his perception of B's behavior toward him. In turn, his behavior will be perceived by B, who will formulate his plans on the basis of his perceptions. Conflict may begin to be built up when A perceives that B is acting in a hostile manner. This may influence him to respond in a hostile way, whereupon B may perceive A's hostility and respond in kind, or even escalate a little. Thus, A's original perception is reinforced and B becomes, to A, an object of hostility. Once around the circle of Figure 2 is termed a reaction cycle.

The genesis of a reaction cycle in this model may not be something that has "really" occurred (that is, B's actions may not have been intended to be, or even to appear, hostile). The reaction cycle started when B's actions appeared to A to be hostile. While stressing the importance of perception, this model is not, of course, intended to imply that all conflicts are based on mistaken perceptions of another nation's actions or intentions; but only that the possibility always exists.

Hypothesis

Holsti, Brody, and North, working with this model as their basic research model, state a number of hypotheses. For example, they hypothesize that in a situation of low involvement (i. e., low stress) perception of action will tend to be at a lower level than the actual action, whereas in a high involvement situation (i. e., high stress) perception will tend to be at a higher level than the actual action. What this says is that when there is a situation of high stress, then there are a lot of nervous ends, and people are likely to over-perceive the hostility in their environment. Over-perception leads to over-reaction, which leads to greater stress, and therefore, to greater over-perception. In this hypothesis there are three concepts. One is perception, another is actual hostility, and the third is this notion of stress. These concepts were operationalized in a study of the 1914 pre-war crisis.

Operationalization of Concepts

The nations included in this study were Austria-Hungary, Germany, Russia, Great Britain, and France. Hostility was measured according to the judgments of expert panelists who read military histories of the period.

Perceptions of hostility were obtained by analysis of the statements of key policy-makers made during this period. The source of the data was a collection of documents published after the war in which the actions and intentions as well as the perceptions and motives of the principal actors were set out.

The analysis technique employed in this study of speeches and writings is called content analysis. Categories of attitudes and actions were defined and their frequencies of occurrence in the documents determined. While earlier studies of the 1914 events had concentrated exclusively on the frequency of the occurrence of themes, this project attempted to assign an intensity measure to each. While formal procedures have been worked out for this, the actual quantitative values depend ultimately on the analyst's judgment, or perhaps the collective judgment of a panel of experts.

Levels of involvement are difficult to establish on the basis of one study. The researchers in this case simply assumed that Germany and Austria-Hungary, as the parties most concerned with the Serbian question, were in a high involvement situation, and that the Russians, French, and British were less involved with this question and therefore under less stress.

Tests of Hypothesis and Results

The time period leading up to the beginning of World War I, 27 June to 4 August, was divided into 12 periods. The difference between the

quantitative measures for perceived and actual hostility were computed for each of the nations for each of the time periods.

In this study the data were analyzed and compared in a number of ways. The table below shows the differences in the actual behavior of the one side and the perception of that behavior by their opponents. Negative differences represent "over-perceptions" of the behavior and positive differences represent "under-perception."

Table 1*

Time Period (1914)	(Actual Behavior—Perceptions of Behavior)	
	Dual Alliance (Germany and Austria-Hungary)	Triple Entente (Britain, France and Russia)
27 June - 2 July	0.40	1.58
3 - 16 July	0.45	4.25
17 - 20 July	-1.50	3.00
21 - 25 July	-1.83	2.83
26 July	-0.59	-0.62
27 July	-0.42	5.37
28 July	-0.21	5.87
29 July	-0.21	0.73
30 July	-1.55	-0.69
31 July	-0.88	-1.33
1 - 2 August	-1.50	0.11
3 - 4 August	-0.60	-1.10

This analysis thus showed that the high stress group (Germany and Austria-Hungary) did in fact continuously perceive more hostility than actually existed; that is, they "over-perceived" the hostility. The nations in the

* Holsti, et al., Table 12, op. cit., p. 154.

low stress group (England, France, and Russia) most often perceived less than the actual hostility.

This analysis appears to lend credibility to the research hypothesis. Measuring perceived and actual hostility on the same scale presents great difficulties; the definition of High vs. Low stress groups here was haphazard; and at best, all that has been shown is that the hypothesis appears to hold for a brief period during one major international crisis.

But I don't mean to stress the difficulties of this work. The results certainly are more significant than a simple assertion of an hypothesis, and this is a good example of the classical approach. The researchers defined a problem area, used existing theory to aid in formulating a hypothesis, operationalized their concepts, collected data, and examined their data to determine if they supported their hypothesis.

V. The Sino-Indian Study: An Exploratory Approach

The Research Problem and Questions

An example of the more exploratory type of work is Paul Smoker's study of Sino-Indian conflict relations.* Thus, Smoker does not state any hypothesis.

Nevertheless, as noted earlier, there are a number of steps that must be taken even in exploratory work. First, it was necessary to define the problem area. In general, Professor Smoker was concerned with the question of the degree to which national decision-makers are actually free to make choices, particularly in times of crisis and conflict. He speculated that the possibility may exist that, during a crisis, the process itself might carry a decision-maker along rather than allowing him to make conscious, reasoned choices.

* Paul Smoker, "A Time-Series Analysis of Sino-Indian Relations," Journal of Conflict Resolution, XIII (1969), 172-191.

A factor in the "carrying along" process is the possibility of information overload during a crisis. There may actually be so much information coming in to the decision-maker that it is impossible for him to react to it properly. That is, there may be such a large backlog of information that the decision-maker is not reacting to the most recent pieces. The existence of an "overload" condition may be taken as an indication that the decision-maker has lost control over the decision process. Another indication would be a loss of "freedom of decision" in the interaction process. Smoker, thus, has two major concepts to investigate: freedom of decision and information overload. For this study, he chose the Sino-Indian conflict during the six-year period from 1959 to 1965.

Operationalization of Concepts

The data source was a series of eleven "White Papers" published by the Indian Ministry of External Affairs containing all of the official correspondence between the decision-makers of India and China for the period January 1959-January 1965.

From this source he obtained the total number of notes, memoranda, and letters exchanged by China and India, aggregated by week. The table below summarizes this data base by year:

<u>Year</u>	<u>Total Messages</u>		<u>Average Number of Messages per week</u>	
	<u>From China</u>	<u>From India</u>	<u>From China</u>	<u>From India</u>
1959	38	59	.7	1.1
1960	45	44	.9	.9
1961	49	58	.9	1.1
1962	142	186	2.7	3.6
1963	135	152	2.9	2.9
1964	33	50	.5	1.0

One might judge from this that something out of the ordinary was occurring between these countries during 1962 and 1963, and that relations were back to "normal" by 1965.

Smoker associated the degree to which the number of messages in any one week could be predicted from the number in the previous week with the "freedom of decision" of the decision-makers of the country. Therefore, he "operationalized" freedom of decision as one minus the correlation coefficient of the weekly number of messages with the same time series lagged (or displaced in time) by one week. A high correlation implied to him that the process was "deterministic" and therefore not under control of the decision-maker.

The operationalization of information overload was a function of the correlation between the number of messages sent to a nation in one week and the number of messages sent out by that nation in the next. The higher this correlation, the stronger the evidence that response time is fairly long, indicating information overload.

The analysis consisted of computing these correlations from 50 week long time-series, replacing the earliest point by the next week, and so on through his 6-year period of data. Plots of the correlation coefficients indicated to him how freedom of decision and information overload were changing over this period.

Conclusions Regarding Research Questions

The author presents and discusses plots over the 6-year period of the correlation coefficients for both China and India. He concludes that it is possible to identify stable and unstable patterns of behavior using such concepts as freedom of decision, interaction, and reaction. A further conclusion is that the relationships studied change significantly over the 6 years. (Of course, a simple count of the total number of annual messages hinted at some kind of change in the relationships).

One result of his analysis was that the period of the 1962 Sino-Indian border conflict can be characterized by both low freedom of decision and high information overload. In this type of analysis one cannot say that a hypothesis has been confirmed or disconfirmed, since no hypothesis was being tested. But exploring analysis does indicate—if operationalizations are valid—that some crisis and conflict situations may be characterized by a loss of control due to information overload and loss of freedom of decision. If this is so, the policy-relevance of the findings are immediately apparent. An awareness of these problems might well contribute to their control.

VI. Summary: Data, Computers and the Researcher

In these examples of research, as in most research, neither the role of data nor the role of the computer is predominating. Each is, in a sense, a tool which increases the researcher's ability to answer his questions about how a particular part of the world works. Theory, intuition, insight and experience determine what data are relevant to the problem, what use of the computer is appropriate, and what the implications of any findings may be. The purpose of data and computers in research is not to replace human judgment, but to augment it.

INTRODUCTION TO DATA-FILE OPERATIONS (Session 4)

Lecture Outline

I. Introduction

II. Descriptive Statistics

Measures of Location

The Arithmetic Mean

The Mode

The Median

Measures of Dispersion

The Range

The Mean Deviation

The Variance and Standard Deviation

III. Form of Data

Nominal Data

Ordinal Data

Interval Data

Ratio Data

IV. Data File Operations

Cross-Sectional Files

Organization

Display, Description and Analysis

Timeseries Files

Organization

Display, Description and Analysis

V. Summary

Workshop Exercises

INTRODUCTION TO DATA-FILE OPERATIONS (Session 4)

I. Introduction

Data are the numerical material from which the quantitative political scientist constructs a representation of the international political system. Data furnish both the building material from which theory is constructed and the standards against which it is tested. In the workshops you will have an opportunity, on a small scale, to do both. You will have selected data files to explore to gain the insight which, combined with your experience and knowledge, will allow you to formulate hypotheses about operations and relationships in the international political system. Then, using statistical techniques to be presented during this course, you will test these hypotheses against the quantitative standards.

Data are sets of numerical values related to defined attributes and interactions of the actors in the international system. Principal actors include the nations, national political leaders and policy-makers, and national and international groups. Some of the attributes that have been measured (i. e., assigned numerical values) are area, population, economic development, GNP, military strength, average annual income, total national budget, number of diplomats stationed abroad, foreign aid received or given, level of internal violence, military budget, amount of hostility exhibited toward neighbors, and so on. Interactions may be measured by the yearly, or monthly or daily numbers of acts or events passing between two actors. In one of the larger data collection efforts to be described later,* international events have been divided into 63 different types and counts of events are obtained from reports in the New York Times.

* WEIS (World Event/Interaction Survey) directed by Professor Charles McClelland at the University of Southern California.

The purpose of this discussion is to introduce some relatively simple descriptive measures of quantitative data, to suggest some important distinctions among various forms of data, and to provide an initial understanding of computerized data files and their uses.

II. Descriptive Statistics*

Measures of Location

This discussion will center on descriptive statistics and will cover two types of measures. The first type are measures of location. It is desirable to have one or more summary values describing the central tendency of the data. Measures of central tendency are particularly useful for answering questions as to whether two sets of data differ "on the average". For example, are the Latin American states more or less economically developed (measured, perhaps, in terms of GNP) than the African nations?

- The Arithmetic Mean

The mean of a set of data is computed by adding all values in the data set and dividing this sum by the number of items in the data set. To simplify the example computations, assume that there are five nations in Africa and five in Latin America, and that their GNP's are represented by the following numbers:

GNP Africa	GNP Latin America
1	2
1	3
2	4
3	5
<u>4</u>	<u>6</u>
$\bar{X} = 2.2$	$\bar{X} = 4$

* See Hubert M. Blalock, Jr., Social Statistics (New York: McGraw-Hill Book Company, Inc., 1960) ch. 3, 4 and 5, pp. 25-63, for a more complete treatment of descriptive statistics.

Given these hypothetical data, the mean GNP for the African nations is $1 + 1 + 2 + 3 + 4 = \frac{11}{5} = 2.2$. The mean GNP for the Latin American nations is $2 + 3 + 4 + 5 + 6 = \frac{20}{5} = 4$. The mean value of a data set usually is denoted as \bar{X} , as in the table above.

- The Mode

Another measure of central tendency is the mode, or modal value. The mode is the value in the data set which occurs most frequently. The mode for African nations' GNP's is 1. For the Latin American nations, every value is the mode because each occurs only once.

- The Median

The median is that number in the data set, above which and below which are an equal number of cases. The median value of African GNP's is 2, since there are an equal number of nations above and below this value. Similarly, the median for Latin America is 4.

It is clear from these few simplified examples that statements about averages must specify precisely which measure of central tendency is being used. For the African nations, each of the three measures of central tendency gives a different value. Worse than this, there are other kinds of averages. There is a harmonic mean, a geometric mean, and a quadratic mean, none of which will be discussed. There is a large set of other kinds of averages used for very special purposes. It is important to know which is being used. It is also important not to use the wrong kind of averaging techniques on data. It is not correct to use the mean as an averaging technique, for example, on rates. When a data set consists of rates, speeds, or rates of change, it is not appropriate to add them up and divide by the number of cases in order to get an average rate of change. Geometric means and harmonic means are designed for that purpose.

Measures of Dispersion*

The examples above indicate also that the amount of information given by a measure of central tendency is very limited. This point may be emphasized by considering the following hypothetical data sets, which for convenience are described as data sets X_1 and X_2 . The means of the data sets are denoted by \bar{X}_1 and \bar{X}_2 :

X_1	X_2
1	4
2	5
3	5
8	5
<u>11</u>	<u>6</u>
$\bar{X}_1 = 5$	$\bar{X}_2 = 5$

The mean of each data set is 5, yet there is an obvious difference between the two sets: X_1 is far more dispersed than X_2 . Thus, it could not be concluded from the mean values that the two data sets are essentially the same. What is needed, then, is a measure of dispersion as an additional description of the data.

- The Range

The range is the simplest measure of dispersion. It represents the difference between the highest and lowest value in a data set. The range of X_1 is 1 to 11 = 10, whereas the range of X_2 is 4 to 6 = 2. The range gives additional information about a data distribution, but its value depends only on the highest and lowest values in the data. It would be more desirable to have a measure of dispersion which would take into account all of the values in the data set. The mean deviation, variance and standard deviation are intended to accomplish this task.

*For additional explanation see Blalock, ch. 6, pp. 64-75.

- The Mean Deviation

This measure of dispersion (or variability of the data) is obtained by computing the arithmetic mean of the distances of each value in the data set from some measure of central tendency of the data set, most often the mean. The signs of the deviations of the values from the mean are ignored since the sum of minus and plus deviations would be zero. The mean deviation for X_1 thus is given by:

X_1	X_1, \bar{X}_1	difference
1	4	
2	3	
3	2	
8	3	
$\bar{X}_1 = \frac{11}{5}$	$\frac{6}{18}$	

mean deviation = $\frac{18}{5} = 3.6$

- The Variance and Standard Deviation

These two are the most commonly used measures of dispersion in statistics. The reason is that the standard deviation, which is the square root of the variance, has certain very useful properties (explained below) in statistics.

The variance is similar to the mean deviation in that the difference of each value from the mean is computed. However, in the computations for the variance these differences are first squared before

they are summed and divided by the number of values. Example computations for the variance and standard deviation of X_1 follow:

X_1	$X_1 - \bar{X}_1$	$(X_1 - \bar{X}_1)^2$
1	-4	16
2	-3	9
3	-2	4
8	3	9
<u>11</u>	6	<u>36</u>
$\bar{X}_2 = 5$		74

variance = $\frac{74}{5} = 14.8$
standard deviation = $\sqrt{14.8} = 3.8$

Note that when all of the data are close to the mean, the variance and standard deviation are small; when the data are widely dispersed from the mean, the variance and standard deviation will be larger.

Now what is important about the standard deviation? It turns out that for certain types of data, so called "normal" type data, the standard deviation can be used to calculate what percentage of the observations fall into certain intervals around the mean. Let us say that these data are test scores of some sort. Very few people got close to zero; quite a few people got closer to the mean, and very few people got high grades. A distance of one standard deviation, each side of the mean, covers about 68 percent of the scores. That is to say, about 68 percent of the test scores will fall within one standard deviation each side of the mean of the test scores. A distance of two standard deviations each side of the mean covers about 96 percent of the test scores. And three standard deviations covers about 99 percent. This measure of standard deviation, in addition to saying something about the dispersion of the data, also indicates approximately where a given score is located relative to the mean. Is a score "unusual"? One would think so if it falls in a range

on the curve where only 1 percent or 5 percent of the scores lie. Much use of this property is made in statistics of the standard deviation because it allows the pinpointing of "unusual" values. This point will be discussed further in later lectures.

III. Form of Data

The number and types of descriptive measures which may be computed for a given set of data partially depends on the type of data being manipulated. For example, if a data set consists of the numbers of Catholics, Jews, and Protestants in a given city, a standard deviation or variance measure could not be computed. The reason is that the individuals are placed into classes which are not "ordered" on some scale. "Protestant" normally would not be conceived as "larger" than or "better" than another class of religion. Since there is no common scale to these measurements, a "mean religion" could not be computed, and therefore a standard deviation or variance also could not be calculated. Similarly, some measure of dispersion other than the standard deviation or variance would have to be employed in order to describe the variation in types of political systems (e. g., authoritarian, democratic) of nations, assuming that these types could not be assigned particular values on a scale of larger to smaller, better to worse, etc.

Nominal Data

The type of measurement which involves placing individuals or other units (for example, nations) into classes is called "nominal" measurement. The term derives from the operation of naming classes such as "Protestant" or "authoritarian," and counting the number of individuals falling into the class. Nominal data, then, consist of counts of the number of individuals or other units which fall into certain categories.

Ordinal Data

A second type of measurement is called "ordinal" measurement. An ordinal level of measurement involves a ranking of individuals or some other units on a common scale. For example, a panel of experts in the area of the law of the sea might rank nations according to the nations' concern with ocean pollution. One nation would be ranked as having the highest concern, another nation as having the next highest concern, another as having the third highest concern, and so on. Each nation, then, receives a ranking on this common scale, and since there is a common scale it is possible to say that nation A is "more" or "less" concerned than nation B. However, this level of measurement does not provide any information about the magnitude of differences between the nations. It gives no information, for example, about whether the distance between nations A and B is greater or larger than the distance between nations B and C.

Interval Data

"Interval" scales allow statements about the exact distances between points on the scale. For example, the distance between Fahrenheit scale measurements of 35° F and 45° F is twice as large as the distance between 45° F and 50° F. It is thus possible to compare distances between measurements on the interval scale. It is not possible, however, to compare measurements by taking their ratios. For example, 50° F is not half as warm as 100° F.

Ratio Data

In order to compare measurements by taking their ratios, a "ratio" scale which has a nonarbitrary zero point is necessary. For example, the panel of scholars on the law of the sea might have measured "concern with ocean pollution" according to the amount of monetary resources which each nation

had devoted to ocean pollution control programs during a previous year. This would be a ratio scale because it has a nonarbitrary zero point (zero funds spent on ocean pollution control). With this ratio scale data it is possible to say that a nation which spent one million dollars spent twice as much as a nation which spent one-half million dollars.

The differences among forms of data are pointed out for two reasons. First, because the forms of measurement themselves may be placed on a scale which represents "amount of information." A ratio scale contains the highest degree of information in that it contains information about the ordering of individuals or other units, the differences in distances between them, and the ratio of each to the other. An interval scale contains less information because it says nothing about the ratio of each measurement to the other. The ordinal scale contains less information than the interval scale because it does not convey information about the comparative distances between the rankings. Nominal measurements contain still less information in that the nominal categories are not ranked at all. The second reason for pointing out the differences is that certain statistical tests require certain forms of data. For example, the computations for the Pearson correlation assume at least interval-level data. A correlation may be computed using a formula which accepts ordinal-level data, and tests for relationships between variables may be conducted using only nominal data, but there is an important difference in the confidence which can be ascribed to the results of these tests. Generally, statistical tests which require higher levels of data (i. e., interval and ratio) are less likely to result in the acceptance of a hypothesis when in fact it is false than are tests requiring only a lower level of data.

IV. Data File Operations

Data of all types may be stored on computer for description, display and analysis. To understand the nature of data file operations it is useful to have an idea of what a data file consists of.

In most instances (i. e. , if the data are ordinal, interval or ratio) the basic structure of a data file is defined by its variables and its cases. A variable is simply a measured quantity which can take on varying numerical values in different cases. An example of a variable is Gross National Product. It can take on different values in different nations and at different points in time. Similarly, population size is a variable which can be measured across many nations or over time.

Cross-Sectional Files

Data in cross-sectional files are measurements taken on variables across various sections of the world at a given point in time. For example, data for the GNP and population size of 100 countries in 1970 would be cross-sectional data because the cases of measurement are sections of the world, specifically nations, at a single point in time.

• Organization

The data file consisting of GNP and population measured for 100 nations (cases) takes on this organization.

	GNP	Population
Nation 1	X	Y
2	Z	
3		
.		
.		
.		
100		

where X is nation 1's GNP, Y is nation 1's population size, Z is nation 2's GNP, and so on.

- Display, Description and Analysis

When data are stored in this form on the computer they may be displayed and analyzed in many ways. First, one might request that the computer produce a histogram of the values of GNP for all the nations. A histogram will provide some information as to the distribution of GNP across the nations. The general form of the histogram could be anticipated: most nations would be bunched up on the side of the histogram representing relatively low values of GNP, while only a few nations would be placed on the side representing relatively high values of GNP. By requesting descriptive statistics for the population variable, the computer would be instructed to compute the mean of column two (population), its variance, and so on. Beyond description of each variable there might be interest in the relationship between the two variables. By requesting a scatter-plot of the two variables the computer would be instructed to place each nation in a position in a two dimensional space defined by the axes GNP and population. If nations with higher GNP's tend to have larger populations, then the points in the scatter-plot representing the nations will reflect this pattern. Other patterns, such as in inverse relationship between the two variables, also may be detected in a scatter-plot. Correlation and regression, which are subjects of subsequent lectures, provide more condensed, statistical measures of relationships between variables. By requesting either correlation or regression analysis for the two variables, the computer is instructed to perform the appropriate calculations on the two columns in the data file.

Timeseries Files

The data in the above hypothetical data file represent measurements on variables for many "sections" of the world (nations) at one point in time. It is thus called a "cross-sectional" file and may be contrasted to a second type of file, timeseries. A timeseries file, like a cross-sectional file, is defined by its variables and cases. Its cases, however, are points in time.

- Organization

An example of a timeseries file is as follows:

	U.S. Trade with CPR	CPR-USSR Hostility
1950	X	Y
1951	Z	
.		
.		
.		
.		
1970		

- Display, Description and Analysis

The variables in the file are U.S. trade with the CPR, and CPR-USSR hostility. X represents U.S. trade with the CPR in 1950, and Y represents CPR-USSR hostility (measured by some criterion) for 1950, Z represents U.S. trade with the CPR in 1951, and so on. Each type of display, description and analysis performed using the cross-sectional file may also be performed with a timeseries file such as this. In addition to these, each variable may be plotted over time. By requesting such a plot, the computer is instructed to demonstrate the trend of the variable over time. The essential difference in the analysis of the two types of files is that in the timeseries case computations are made for descriptions of and relationships between variables across time, whereas cross-sectional files are used to produce descriptions of and identify relationships between variables that are measured for different "sections" of the world at a given point in time.

V. Summary

A data file normally is one of two types (cross-sectional, timeseries), and the data within a file may be in various forms (nominal, ordinal, interval, ratio). A useful criterion in the selection of forms of data is that the data contain as much information as possible. Ratio-level data therefore represent the most desirable form. The type of data selected depends on the purpose of the data collection. If, for example, the purpose is to search for relationships which will aid in forecasting, then timeseries data are desirable. The two types of data files have in common a basic structure which represents variables on the column headings and cases on the row headings. When the computer is instructed to display a variable, or to describe its mean, variance, etc., it is instructed to proceed to a certain column (variable) of the data file and perform the appropriate calculations. The results of these calculations (the output) are then given to the user in the form of computer printout.

WORKSHOP EXERCISES

Session 4

DISPLAY AND EXAMINATION OF DATA

General Theme:

The use of computer routines to examine a collection of data.

General Questions:

What descriptors are most useful in characterizing a time-series (i. e., a set of values associated with points in time)?

How can you quickly get an intuitive feeling for the relationships among the variables in the data collection?

Suggested Steps:

1. After signing-on to the computer system, * request the WEISDAT/T file. **
2. Choose several variables and obtain general descriptions of them.

Two routines are available in TIMESERIES that may be used for the quick examination of a data-set: DESC, which produces the mean, variance, standard deviation, and maximum and minimum values, and HIST, which plots a histogram of any specified variable.
3. Examine variables 13 (conflictual behavior toward Israel) and 16 (conflictual behavior by the U. S.). What do you observe after their means and variances? Can you explain the reason for the difference in their variances by examining their histograms?

* See "Instructions for Terminal Operations," pp. I-2 - I-5.

** This is a time-series file and, by requesting it, you have also called up the TIMESERIES statistical package.

4. Examine trends over time for several of the variables.
Trends over time can be seen by plotting the values as a function of time. Use the routine PLOT for this.
5. Plot variable 13 as a function of time. What conclusions can you draw about the trend in conflictual acts toward Israel?
6. Plot variable 16. What is the trend in U.S. conflictual acts? (Notice that the trend is much clearer for Israel than for the U.S.).
7. Relationships between two variables can be quickly determined from scatter-plots (i. e. , plots of the values of one variable against values of another). The routine SCAT will produce scatter-plots.
Plot variable 10 against variable 13.
What conclusions can you draw about conflictual acts by and toward Israel?
8. Using SCAT, plot the conflictual acts toward the Soviet Union against those by the Soviet Union. Compare this scatter-plot with the Israeli scatter -plot.

CONCEPTS OF NATIONAL POWER (Session 5)

Lecture Outline

- I. The Purpose of Politics: The Allocation of Scarce Resources

- II. Power as an Attribute

Attribute Components of Power

Some Difficulties with the Power-as-an-Attribute Formulation

- III. Power as a Relationship

The Nature of Power as a Relationship

Some Difficulties with the Power-as-a-Relationship Formulation

- IV. Problems of Operationalization

CONCEPTS OF NATIONAL POWER (Session 5)

I. The Purpose of Politics: The Allocation of Scarce Resources

Politics is an arena in which actors attempt to achieve desired goals through a value-allocating process. That is to say, actors attempt to achieve desired states of affairs by affecting the processes and institutions which allocate values and resources. When one thinks of this process, various types of domestic political systems generally come to mind. Such systems have clearly identifiable structures—courts, legislatures, administrators—which receive demands from the citizens of the political unit and make decisions about such resources and values as levels and objects of taxation, police and fire protection, zoning laws, etc. Thus, politics is generally associated with visible political and administrative structures.

It is important to realize, however, that nations also engage in an activity called politics, despite the relative lack of international institutions. This political activity involves competition over various types of international and regional resources, the outcome of which is the allocation of international and regional values and resources among nations. These values and resources might include control and exploitation of natural resources, the location of geographical boundaries, alliance partners, air rights, sea rights and so forth.

The determination of the allocation of resources within the international system or within sub-regions of that system immediately raises questions of patterns of influence and how such influence is achieved. This in turn raises the question of the nature of power and its role in international politics. It is important to stress that questions of power and influence arise in politics only because the resources and values are scarce. If

there were more of everything than everybody wanted, disputes or conflicts of interest would never arise. Because we live in a system with limited resources, however, individuals, groups, and nations come into conflict as to how those resources are to be distributed. Because such resources are scarce, actors must attempt to influence other actors either through persuasion or through the exercise of power.

Power, then, is taken to be an important element in the process of allocating resources and values among contending units. The concept occupies a central position both in the theory and practice of international relations. Hans J. Morgenthau, for example, has argued that, "International politics, like all politics, is a struggle for power." No matter what nations may pursue, whether security or a world "safe for democracy," they do so by striving for power.* Power, however, is an extremely general term which may take on a variety of meanings. Power often is viewed either as an attribute or as a relationship. In this discussion we will consider both perspectives.

II. Power as an Attribute

Suppose we think of power as a characteristic or attribute of the state itself. This is a familiar perspective which often leads to an enumeration of those attributes that contribute to power: geography, natural resources, technology, population, ideology, morale, the military base, and so on. Evidence of this conception is found in the contention that American power derives largely from military technology, or that China's large and dispersed population is a major source of its power.

Attribute Components of Power

Morgenthau suggests nine categories of attributes which should be taken into consideration in determining the power of a nation. These are listed

* Hans J. Morgenthau, Politics Among Nations: The Struggle for Power and Peace, 4th Edition (New York: Alfred A. Knopf, 1967), p. 25.

below followed by brief explanations for, or examples of, their importance, as seen by Morgenthau.*

- Geography: The geography of the Alps, for example, has made it extremely difficult to invade Central Europe from Italy, while it is much easier to invade Italy from the north, thus affecting Italy's control over her neighbors to the north.
- Natural Resources: Countries enjoying self-sufficiency in food and raw materials needn't divert their energies from their primary objectives in order to maintain a constant inward flow of food and raw materials during war.
- Industrial Capacity: Raw materials are of little use unless they are transformed into industrial products.
- Military Preparedness: Military technology, the quality of leadership and the quantity and quality of the Armed Forces are all important factors in the capability of a state to support its foreign policies.
- Population: Large populations are needed to carry out all of the functions necessary to the conduct of modern warfare including industrial production, transportation and combat.
- National Character: Cultural tastes and aversions affect nations' capabilities to maintain standing armies, to engage in conscription, to exercise authority internally, and to engage in other activity related to the national power.
- National Morale: The degree of determination with which a nation supports its government's foreign policies affects the government's ability to pursue its policies in the international arena.
- The Quality of Diplomacy: Diplomacy is the art of bringing the different elements of national power to bear upon foreign

Ibid., 106-144.

policy goals. The elements of power are of use only to the extent that diplomacy combines them into an integrated force for the attainment of the national interest.

- The Quality of Government: Government must marshal public opinion behind its policies or else other elements of national power will not be usable to their full extent.

Some Difficulties with the Power-as-an-Attribute Formulation

Since the concept of power has been central to much of international relations theory, it has been the subject of much debate. The notion of power as consisting of a series of attributes has been criticized in a number of ways. A general objection to the attribute formulation has been that it provides little clue to the likely future behavior of nations. One component of this critique is that the attribute formulation does not suggest any useful overall measures of power. The elements of power, according to this objection, play back and forth on one another so that the products of combinations of elements are difficult to assess.*

Deficiencies in natural resources, for example, may be offset by "clever technologies"; the power deriving from the leadership factor may be diminished by a particular ideology.** The definition of power as the sum of certain attributes of a nation then gives way to a far more complex, non-additive conception. The difficulties of measuring power given this complexity has led some scholars to suggest that power as an attribute cannot be measured with any precision. The attribute formulation therefore is viewed by these scholars as not useful for the purpose of making estimates of present or future power distributions in the international system.

* Charles A. McClelland, Theory and the International System (New York: Macmillan Company, 1966), p. 69.

** Ibid.

Another cause for objection has been that since the use of power is situation specific, a general notion of a nation's general power base is not very useful analytically. An example of the type of objection raised against "general" power as an organizing concept is given by the Pueblo incident. The United States "generally" is one of the most powerful nations in the international system according to almost all criteria of power, but was unable to influence or control a much smaller state's behavior in this specific situation. Similarly, the general power base of the United States seems not to have impacted upon the Vietnam conflict in the manner expected by some observers early in the United States involvement. One possible explanation is that the power base, or "capabilities", of a nation must be converted into power through a process involving selection, timing coordination and phasing.³ To the extent that the conversion process malfunctions, the raw capabilities of a nation may be of little use. The specific situational context thus appears in the past to have had an important effect on how "powerful" one nation has been in relation to another nation. This suggests, again, that the notion of power as an attribute may be of limited use in anticipating future patterns of influence among nations.

A third common criticism of the attribute formulation is that even if it were possible to measure the general capability base of a nation, this in itself would be of little value in anticipating where the nation might apply its capabilities in order to influence other nations. The concept of "intent" thus emerges as equally important as the concept of power. Knowledge of a nation's "intent" to apply power does not, however, necessarily provide information as to the outcome of a particular attempt to influence. Situational factors, the conversion process and the difficulties of measuring capabilities all complicate the task of calculating probable effects on the use of power.

³Ibid., 71.

III. Power as a Relationship

Disillusioned by the perceived inadequacies of the power-as-an-attribute formulation, some scholars have turned to definitions of power which emphasize the relational quality of the concept. One observer has given an example of the motivation behind this change in perspective. The "existence of massive power sources in one country," he notes, "sometimes causes adjacent countries to react with fear and anxiety and results in attempts to reduce the possibilities of future control by the powerful neighbor"; "power in hand" thus may limit "power to control".* The important component of power is relational, the argument goes, and the attributes of nations provide not only limited but sometimes incorrect indications of the extent to which one nation will exercise power over another.

The Nature of Power as a Relationship

A classic statement of the power-as-a-relationship formulation was given by Robert Dahl: "A has power over B to the extent that he can get B to do something that B would not otherwise do."** Morgenthau argues that political power's "essence" is "the psychological relation between two minds," which also suggests power as a relational property.*** Specifically, Morgenthau refers to the relationship as one of "control." Others have used the term "influence" to refer to the relational aspect of power.

There are various permutations within the perspective of power as a relationship, but the overriding importance of the definition of power as

* Ibid., 70.

** Robert A. Dahl, "The Concept of Power," Behavioral Science, II (July 1957), 203.

*** Morgenthau, 27.

a relationship is that it suggests looking elsewhere than the attributes of nations for evidence of the existence of power. The most prominently mentioned source of information is the series of demands and responses among nations. To the extent that nation B responds favorably to the demands of nation A, nation A might be said to have "power" over nation B. There are, however, some readily apparent difficulties with this formulation.

Some Difficulties with the Power-as-a-Relationship Formulation

The difficulty of arriving at measurements of power are not greatly lessened by the relational perspective. If A makes a demand on B, and B later carries out the action that was demanded of him, it may be that B's action was not a response to A's demand but to other pressures, perhaps of a domestic nature. A further difficulty which has been pointed out is that B, even if responding to A's demand, may not have been too unwilling to carry out the act even before A's action. In order to measure the extent to which nation A has power over nation B, it would be necessary to know the extent to which B's actions are actually responses to A's demands, and the extent to which B was opposed to taking the demanded action prior to the demand itself.

If nation A makes a demand on nation B, and B later carries out the action that was demanded, it may be that B's action was not a response to A's demand but to other pressures. For example, the People's Republic of China has for some time made certain demands of the United States regarding U. S. military presence on China's perimeter. If the U. S. should reduce that presence, then the U. S. action would be consistent with the Chinese demand. It may not, however, be a direct response to that demand, or it may be partially a response to the demand and partially a response to other considerations. Other international considerations may play a role in the U. S. action, for example a desire to strengthen Sino-American bonds as a demonstration of unity against Soviet expansion.

Domestic considerations also may be of importance, for example an American desire to reduce foreign commitments so that a greater proportion of resources might be devoted to domestic programs. A major source of difficulty in the power-as-a-relationship formulation is the inability often to know the exact sources of the actions of nations

An additional problem is that B, even if responding to A's demand, may not have been unwilling to carry out the act even before A's demand was made. The "amount" of power exercised when B responds with the demanded action when it previously had a low probability of taking the action, is greater than the "amount" of power exercised when B responds with the demanded action when it previously had a high probability of taking the action. For example, the extent to which the United States exercised power over the Soviet Union during the Cuban Missile crisis would depend on the extent to which the Soviets were willing or unwilling to withdraw the missiles prior to the U. S. demand that the missiles be removed. To know the amount of power which A has exercised over B would require knowledge of B's prior probability of taking the demanded action. Even if international decision-makers were willing to offer this type of information, its accuracy would be questionable since few policy-makers would like to admit that they had been forced to take an action against which they were totally committed.

IV. Problems of Operationalization

It is important to stress that scholars engage in such debate not because of some sterile desire to construct conceptual frameworks, but because they wish to describe, analyze and perhaps anticipate patterns of interaction among nations. It is precisely because of this desire that objections to the attribute formulation are made, and the utility of the relational perspective is questioned.

To the oft-stated question, "What is power?", it might be responded, "What difference does it make?" First of all, it makes a difference in

the description of the distribution of power among nations: who has more power than whom?; is power equally distributed among nations or unequally distributed? One definition of power will yield quite a different description than another. Given this, and the fact that descriptions are the basis for analysis, different definitions will lead to varying analytic conclusions about probable areas of conflict and other occurrences in international interaction.

Ultimately, then, the problem is one of deriving an "operational definition." An operational definition is one that exactly specifies the procedures to be carried out in measuring the concept under consideration. A simple example of an operational definition of the power concept is "population size". It is clear from this definition how to go about measuring power: count the number of individuals within each nation. A more complex operational definition of power might be "the change in B's probability of taking action Z that was caused by A's demand upon B." The ultimate concern is with operational definitions because only through operational statements are we guided as to how to measure power.

The process of operationalization is central to the quantitative study of international relations. In order to test hypotheses quantitatively, the concepts of interest must be measured in some very specific manner. A concept only vaguely defined (for example power as a demographic, economic and social attribute of a nation) needs refinement before measurement and quantitative analysis is possible.

A data set has been provided, the CAIR data file, through which the student may experiment in operationalizing the concept of power. It will be instructive to operationally define the concept of power in various ways, and then note the resulting differences in descriptions of the power distribution among nations. Specific suggested analyses are given in the Student Workshop Manual's Workshop Experiments for Session 6.

QUANTITATIVE ASPECTS OF NATIONAL POWER (Session 6)

Lecture Outline

- I. Introduction

- II. Conceptual Introduction to Correlation

- III. Computation of the Pearson Correlation Coefficient

- IV. Some Cautions in Interpretation

Workshop Exercises

QUANTITATIVE ASPECTS OF NATIONAL POWER (Session 6)

I. Introduction

The purpose of the workshop on national power is to experiment with various operational definitions of the concept to see whether and to what extent differing operational definitions would yield varying descriptions of the distribution of power among nations. Descriptive statistics, histograms and scatter-plotting already have been introduced. These techniques of data analysis will be useful in experimenting with operational definitions and the difference they make in description. The purpose of this short lecture is to introduce an additional technique—correlation—which also will be of use in testing ideas about the relationship between two distributions of data.

II. Conceptual Introduction to Correlation*

Statements about the world that are not purely descriptive in nature usually imply some relationship between one variable and another. For example, it is common to hear and read statements such as "nations exhibiting internal violence tend to engage in external violence in order to consolidate the population against an external enemy," or "the wealthier a nation, the more it will be involved in international affairs." What these two statements have in common is that they are assertions about relationships between variables.

Let us consider the first assertion, that of a relationship between internal and external violence. Further, let us take the position of an unbiased researcher and treat this assertion merely as a hypothesis. The problem

*See more detail on correlation in Hubert M. Blalock, Jr., Social Statistics (McGraw-Hill Book Company, Inc., 1960), pp. 285-301.

at hand is to show how correlation can help us decide whether or not the hypothesis is valid.

Assume that data have been collected which represent the amount of internal and external conflict which 100 nations experienced during a given period of time, say 1950-1970. We already know that the data can be scatter-plotted and that the scatter-plot will show whether there is a relationship between the two variables. The scatter-plot for these data might come out looking like Figure 1, 2, 3, or 4, depending on the collected data.

Figure 1

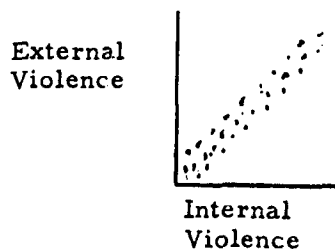

Figure 2

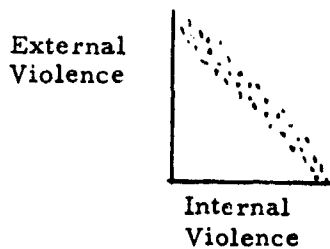

Figure 3

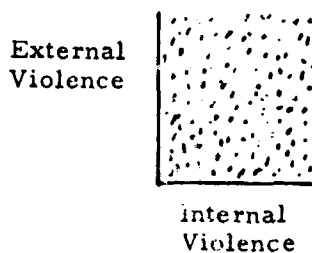

Figure 4

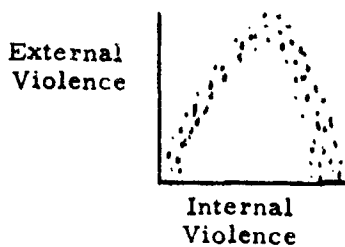

Figure 1 would suggest that external violence and internal violence are strongly related in the hypothesized direction. That is, external violence is positively related to internal violence--as one goes up, so does the other. Figure 2 would suggest that the two variables are indeed related, but inversely rather than positively--as internal violence goes up, external violence declines. Figure 3, on the other hand, indicates that the two are not related at all: given a particular level of internal violence, any level of external violence may be possible. The scatter-plot in Figure 4 suggests a complex, curvilinear relationship between external and internal violence: the more internal violence, the more external violence that is exhibited, but only up to a point beyond which higher levels of internal violence are associated with lower levels of external violence.

The Pearson correlation coefficient which is the coefficient of correlation produced by both CONSTAT and TIMESERIES is a measure of the linear association between two variables. It's values range from -1.0 (which indicates a perfect inverse relationship between the variables) and +1.0 (which indicates a perfect positive relationship). A correlation of zero means that no linear association between the variables exists in the data. The following illustrates the range of the Pearson correlation coefficient and the general interpretation of selected values.

+1.0	Perfect Positive Relationship
+ .6	Mildly Strong Positive Relationship
+ .3	Weak Positive Relationship
0	No Relationship
- .3	Weak Inverse Relationship
- .6	Mildly Strong Inverse Relationship
-1.0	Perfect Inverse Relationship

These interpretations are given only to provide a general idea of the meaning of the correlation coefficient, and should not be taken as hard and fast rules for interpretation. Quite often researchers will take a sample of data from a larger population (for example, this is done in

public opinion polling) and perform a "sample correlation" with the sample of data. Depending on the nature of the sample data, a sample correlation of +.6 might indicate that the correlation among the entire population could be anywhere between +.4 and +.8. Sampling will be discussed further in a subsequent lecture.

To get back to the main point, the Pearson correlation coefficient is a concise measure of the degree of linear relationship between variables. Thus, the data in Figure 1 would be correlated positively and fairly strongly, approaching the +1.0 level. The correlation for the data in Figure 2 also would be correlated fairly strongly, but in the inverse direction, approaching -1.0. Figure 3's data would be correlated close to 0.0 since no relationship in either direction appears. Since the data in Figure 4 are not related linearly, the Pearson correlation coefficient would not be very strong. There are other correlation coefficients designed to recognize a curvilinear relationship, but the Pearson coefficient will not. For this reason, it is important to keep in mind that the Pearson coefficient measures only linear associations, not associations in general.

III. Computation of the Pearson Correlation Coefficient

Normally it is desirable to include as many data points in the correlation calculations as possible. If the calculations are made with data sampled from a larger population (for example, as in public opinion studies), then--holding other considerations constant--the larger the sample taken the more confidence there will be that the sample correlation coefficient approximates the actual correlation in the population as a whole. For many international relations studies, however, the sampling consideration is not relevant because the correlation coefficient is calculated with the total population of data. There are approximately 130 independent political units in the international system, and often there is no need to sample these units because data will be available for all or nearly all of them. Sampling and its relationship to "inferential" statistics will be discussed further in a subsequent lecture.

The formula for computing the Pearson correlation coefficient is given by:

$$r = \frac{\sum xy}{\sqrt{(\sum x^2)(\sum y^2)}}$$

where x is the deviation of a value of variable X from the mean of variable X (the deviation is denoted as $X - \bar{X}$, where \bar{X} is the mean of X), y is the deviation of a value of variable Y from the mean of variable Y ($Y - \bar{Y}$), and x^2 and y^2 are the squares of these deviations. An example of the computations will clarify these operations. The letter r indicates that the calculations are for a Pearson correlation coefficient.

Assume two variables, X and Y , whose values are:

X	Y
1	1
2	3
3	2
4	3
5	4

We wish to know how highly correlated these two variables are. It is immediately clear that they are somewhat associated since smaller values of X are generally associated with smaller values of Y , and as X goes up Y tends to increase also although not in a one-to-one fashion. Suppose these data represented scores for five nations on internal and external violence. How highly correlated are the two concepts? The calculations

are as follow:

<u>X</u>	<u>Y</u>	$\bar{X} = 3$	$\bar{Y} = 13/5$				
		<u>X - \bar{X}</u>	<u>Y - \bar{Y}</u>	<u>(X - \bar{X})(Y - \bar{Y})</u>	<u>(X - \bar{X})²</u>	<u>(Y - \bar{Y})²</u>	
1	1	-2	-8/5	16/5	4	64/25	
2	3	-1	2/5	-2/5	1	4/25	
3	2	0	-3/5	0	0	9/25	
4	3	1	2/5	2/5	1	4/25	
5	4	2	7/5	14/5	4	49/25	
		0	0	6	10	$\frac{130}{25} = \frac{26}{5}$	

Using the formula for the correlation coefficient,

$$r = \frac{6}{\sqrt{(10) \left(\frac{26}{5}\right)}} =$$

$$\frac{6}{\sqrt{52}} =$$

$$\frac{6}{7.2} = +.83$$

The correlation coefficient for the two series of data is +.83, which indicates a fairly strong correlation in the positive direction.

IV. Some Cautions in Interpretation

Still assuming that the data were intended to measure internal and external violence for five nations, the $r = +.83$ is a measure of the linear association between the two variables as measured across five countries. Some things that the coefficient do not necessarily mean are discussed below.

- When the concepts are defined in terms of the procedures used to measure them, then it is fair to say that the concepts are related at $r = +.83$. It must be recognized, however, that other individuals might reject the particular operational measures of the concepts employed. If so, then the correlation between the data may not be recognized by these individuals as the correlation between the concepts as they would define or operationalize them.

- A strong correlation for a particular group of nations does not necessarily permit the inference that the correlation is strong among all nations. If the five nations in the example were randomly sampled from the approximately 130 nations available, then it would be possible to compute a range of correlations that might exist among all 130 nations. (Parenthetically, a correlation of $+ .83$ for a sample size of only 5 normally would not lead us to reject the possibility that the correlation in the entire population is zero). If, however, the five nations were not randomly selected from the 130—for example, if only Arab nations were selected because of some interest in that area of study—then any inference from that correlation to statements about the world in general would not necessarily be valid.

- The correlation above was computed with cross-sectional data, i. e., data collected for a series of sections of the world (nations) at a given point in time. Thus, it may be said that the nations which experienced more internal violence experienced more external violence (limiting this statement, of course, to the five nations) in the given time period. It does not necessarily follow that over time the more internal violence a particular

nation experiences, the more external violence it will experience. The distinction to be made is between cross-sectional findings and timeseries findings. Findings from cross-sectional studies are not necessarily valid in an over-time context. Further research using timeseries data would be necessary in order to state with confidence that the relationship found to exist across nations at a given point in time exists also in the over-time behavior of any given nation.

WORKSHOP EXERCISES

Session 6

QUANTITATIVE ASPECTS OF NATIONAL POWER

General Theme:

The "operationalization" of concepts.

General Question:

How can the concept of national power be operationalized? Do different definitions of power yield different rankings of the nations in terms of their power?

Suggested Steps:

1. Request the CAIR data set. *
2. Request a general description of the variables in the CAIR collection.
(DESC will produce this general description for all of the variables in the set; you cannot examine one at a time.)

How do you think your estimate about the extent to which nations vary in power would depend on your particular choice of a measure of "power"?
3. Another way to examine the variation among nations is to look at a histogram for each measure of power you are examining. (Use the routine HIST.)

What can you say about variations among nations on the basis of examination of several histograms?
4. One way to discover if any two measures of "power" would lead to different rankings is to find out the extent to which nations'

* CAIR is a collection of the values of a set of 20 attributes for 136 nations. You will have the statistical package CONSTAT available.

values of one variable are related to their values of another variable.

Choose two likely measures of power and obtain a scatter-plot for them. Would they produce the same ranking of nations on the basis of national power?

5. Correlate these two measures of power. Does the correlation coefficient indicate that the measures are highly related?
6. Perhaps given measures of "power" will be related within one set of nations and not within another. Use the GROUP routine to group the nations into regions and test your ideas about measuring power within regions instead of over all the nations. Use scatter-plots and correlation to decide whether measures of power are related differently in different regions.

THEORIES OF CONFLICT AND WAR (Session 7)

Lecture Outline

- I. Introduction
- II. What is Conflict?
- III. Methods for Studying the Causes of Conflict and War
 - The Single-Case Study
 - Comparative-Case Study
 - Inter-nation Simulation
 - Computer-Simulation Method
 - Small-Scale Laboratory Experiments
 - Surveys
 - Mathematical Modeling
- IV. Theories of Conflict and War
- V. Summary

THEORIES OF CONFLICT AND WAR (Session 7)

I. Introduction

This lecture will focus on the development of empirical theories about international conflict and war. Theory-building is a complex process that involves the selection of concepts, definitions and classifications, the development and use of various methodological techniques and careful analysis of one's results.

The field of international relations provides the researcher with a wide range of literature from which ideas, hypotheses and theoretical constructs can be selected for testing propositions about international conflict. Some work in data gathering, quantitative hypothesis-testing and model-building has been accomplished in the past decade, but the growth of empirical international relations theory about conflict has been slow. In this lecture we will attempt to achieve a conceptual understanding of international conflict by examining conceptual schemes, analytical methods and existing theories of conflict and war in the international relations field.

II. What is Conflict

Kenneth Boulding has defined conflict as "a situation of competition in which the parties are aware of the incompatibility of potential future positions and in which each party wishes to occupy a position that is incompatible with the wishes of the other."^{*} Generally speaking, conflict involves the competitive behavior of two or more parties in a system at a given point in time. In international relations, conflict can occur between individual leaders, between groups in different nations, between two or more nations in the international system, or between any combination of the three.

^{*}Kenneth Boulding, Conflict and Defense (New York: Harper and Row, 1962), p. 5.

In order to understand what conflict is in international relations, we must first consider why we study conflict at all. Karl W. Deutsch suggests that there are three reasons for studying conflict in international politics: "to identify generally those conflict situations and states which are likely to lead to war; to evaluate particular conflict situations and the probable lines along which they are likely to develop if left to themselves; and to suggest further possible techniques for controlling or containing such conflict situations so as to prevent them from breaking out into war."^{*} We are interested in identifying the sources of conflicts, understanding the dynamics of conflicts, and predicting when conflicts will occur and what will be their outcomes.

A good way to obtain an understanding of conflict in international relations is to examine the various classification schemes that international relations researchers have developed to study conflict situations. These classifications can be used to develop and test theories of international conflict. First let us look at the methods of classifying and defining conflict in international relations, and then we will turn to a discussion of theories of conflict in the field.

It is generally agreed that several levels of conflict can occur in international politics: general policy disagreement (e. g., ideological or economic quarrels); confrontation (e. g., the Cuban Missile Crisis); small-scale physical conflict (e. g., local wars); or total war. Charles A. McClelland has in some of his work made a distinction between two types of conflict—verbal conflict and physical conflict between nations. He has made a major effort to classify conflict in terms of the communications, or "event/interactions" between nations in the international system.^{**} McClelland identifies verbal conflict as hostile communications between national political leaders. Physical conflict is defined as actual physical confrontation between nations.

^{*}Karl W. Deutsch, "Mass Communications and the Loss of Freedom in National Decision-Making: A Possible Research Approach to Interstate Conflicts," Journal of Conflict Resolution, I (June, 1957), 200.

^{**}Charles A. McClelland and Gary D. Hoggard, "Conflict Patterns in the Interactions Among Nations," in International Politics and Foreign Policy, (ed.) James N. Rosenau (New York: The Free Press, 1969), pp. 711-724.

For example, if Israel accuses Egypt of prolonging the Middle East conflict, that is a verbally hostile action, but if Israel sends her planes to bomb Cairo, then that is an action of physical conflict.

Another attempt at classifying conflict is the study of Lewis Richardson on the movement of nations towards war. Richardson measured the "escalation" of conflict by examining defense expenditures of nations over time. He showed that under some circumstances, if one nation armed itself, then another nation in the international system would arm, then the first nation would arm again and so on until the process of arming would become irreversible and the arms race would end up in all-out war.* Similarly, game theorists measure conflict in terms of the utility of arming versus the utility or "payoff received" of cooperating.**

A third method for studying conflict involves the use of content analysis of communications between national leaders. Holsti, North and Brody analyzed communications between major parties to the pre-World War I crisis and fit them into a scheme for measuring perception of national leaders. They showed that perceptions of hostility on the part of the nations involved in a conflict may be partially responsible for the outbreak of the conflict. Thus, the tendency toward conflict was measured in terms of the perception of national leaders, not only by specific acts of those leaders.***

There are many other schemes for the classification of conflict between nations, but we cannot cover them all in this lecture. The above examples are major efforts in the international relations field used to develop and test theories of international politics. We will now turn to some of the specific methods used to build theory in international relations, which will illustrate how various classification schemes are put to use in the study of conflict.

* Lewis F. Richardson, Arms and Insecurity (Pittsburgh: The Boxwood Press, 1960).

** Anatol Rapoport, Strategy and Conscience (New York: Random House, 1964).

*** Holsti, Ole R., Robert C. North and Richard A. Brody, "Perception and Action in the 1914 Crisis," in Quantitative International Politics (ed.) J. David Singer (New York: The Free Press, 1968), pp. 123-158.

III. Methods for Studying the Causes of Conflict and War

International relations researchers have employed various methods to analyze international conflict and war. The most frequently used approaches are as follows: 1) the single case study, 2) comparative-case study, 3) inter-nation simulation, 4) computer simulation. 5) small-scale laboratory experiments and games, 6) survey research, and 7) mathematical modeling.*

The Single-Case Study

The single-case study probably is used more frequently than any other methodological approach to the study of international conflict. An analyst examines data about a single case involving one or more nations (e. g. , Korea, Cuba, Vietnam), and attempts to describe the conflict and to explain "why" various actions occurred. He studies the unique features of the situation and attempts to obtain a complete picture of the conflict from his information. Case studies add to the accumulated knowledge about international conflicts; however, attempts to generalize about conflict from only one study involve many risks. Each conflict has unique features that are related to the particular nations involved, the time in which the conflict occurs and the type of conflict situation. Although there may be features common to many particular types of conflicts, generalizations from one conflict to a broad range of conflicts may be misleading because of the limited information involved. This method has been used by Bruce M. Russett to investigate the Japanese decision to launch an attack on Pearl Harbor. Russett's intent was to build a theoretical framework developed from this single study to explore the Japanese foreign-policy making process. He used the framework developed from this single study to examine specific elements in common between this attack decision and other selected

*Dean G. Pruitt and Richard C. Snyder, (eds.), Theory and Research on the Causes of War (Englewood Cliffs, N. J.: Prentice-Hall, Inc., 1969), pp. 5-13.

past cases. * Holsti, North and Brody's study of events leading up to the outbreak of World War I focused on the relationship between policy makers' perceptions and the actual behavior of the nations in this specific case. **

Comparative-Case Study

The next method is the comparative-case study in which several cases are examined, or sampled for significant variables. Comparative-case studies usually have been divided into "small sample", where a minimal number of cases are systematically selected for analysis, and "large-sample" where many cases may be studied. An example of the "small-sample" study is a comparison of crises leading up to World War I and the Cuban Missile Crisis. *** The study employed content analysis to analyze historical documents from the October 1962 Cuban Missile Crisis and compare the crisis, which was resolved peacefully, with the 1914 crisis which led to the First World War. Rudolph J. Rummel's study of the relationships between the incidence of internal and external war in 69 nations **** and Raoul Naroll's comparison of twenty historical cases in six regions to identify successful and unsuccessful methods of deterring war are examples of the "large-sample" study. The latter is interesting in terms of its data sample which draws cases over a time span of 2000 years. *****

* Bruce M. Russett, "Refining Deterrence Theory: The Japanese Attack on Pearl Harbor," in Pruitt and Snyder, pp. 127-135.

** Holsti, North and Brody.

*** Ole R. Holsti, Richard Brody, and Robert North, "The Management of International Crisis: Affect and Action in American-Soviet Relations," in Pruitt and Snyder, pp. 62-79.

**** R. J. Rummel, "Some Dimensions in the Foreign Behavior of Nations," Journal of Peace Research, No. 3 (1966), 201-223.

***** Raoul Naroll, "Deterrence in History," in Pruitt and Snyder, pp. 150-164.

Inter-nation Simulation

A major international relations simulation was developed by Harold Guetzkow to test hypotheses about international politics and foreign policy decision-making. The inter-nation simulation (INS) is a model of international relations which builds an artificial laboratory world and allows human players to make national policy decisions and to interact with each other in a hypothetical international environment. Guetzkow notes that the Inter-nation simulation is an attempt "to represent social units—nations, in this case—in their inter-relations with each other... it simplifies and reduces the number of variables involved. We have used both analogies and replication in contriving the parts. Our simulation is an operating representation in reduced and/or simplified form of relations among social units by means of symbolic and/or replicate component parts."^{*}

In comparing this method with the comparative-case method, Pruitt and Snyder suggest that the INS method appears preferable as a research device for the following reasons:

- (1) The simulation environment permits greater access to the events of simulated international affairs and the policy-maker responsible for them.
- (2) The simulation method permits the investigator to create conditions of theoretical or prognostic interest that have not previously existed.
- (3) The fact that he can manipulate the simulation environment makes it possible for the investigator to unravel cause and effect.
- (4) Since the environment of the simulation is less complex than that of historical case studies, relationships between variables may be found in the former environment that would be overlooked in the latter. ^{**}

^{*} Harold Guetzkow (ed.), Simulation in Social Science (Englewood Cliffs, N. J.: Prentice-Hall, Inc., 1962), p. 84.

^{**} Pruitt and Snyder, p. 10.

The inter-nation simulation has been changed, expanded, and redirected by various researchers, and variations on the original model continue to play a primary role in training and education functions such as the World Politics Simulation (WPS) run each year at the Industrial College of the Armed Forces in Washington, D. C. *

Computer-Simulation Method

In the computer-simulation method, the experimenter builds into a computer program his own model of those aspects of the international environment which he wishes to study.

One of the first major attempts at computer-simulation of international conflict was the Technological, Economic, Military, Political, Evaluation Routine (TEMPER), a simulation of the cold-war environment developed at ABT Associates. ** A Balance of Power Simulation, developed by Zinnes, Van Houweling and Van Atta, attempted to test theories of balance of power by simulating the workings of the model computer system. *** A third computer simulation, Information Processing in a Crisis, developed by Poole and Kessler at M. I. T. and the Simulmantics Corp., is a model of the behavior of national decision-makers in an international crisis designed to test the ways in which psychological mechanisms enter into the information processing scheme used by the decision-makers. ****

* Introduction to WPS, Industrial College of the Armed Forces, Washington, D. C., 1970.

** Abt and Gordon, "Report on Project TEMPER," in Pruitt and Snyder, pp. 245-262.

*** Dina Zinnes, Van Houweling and Richard Van Atta, "A Test of Some Properties of the Balance of Power Theory in a Computer Simulation," Northwestern University, Summer 1969 (Mimeo.).

**** Ithiel de Sola Poole, and Allen Kessler, "The Kaiser, the Tsar and The Computer: Information Processing in a Crisis," The American Behavioral Scientist (May 1965), 31-38.

Small-Scale Laboratory Experiments

Small-scale laboratory experiments and games have been useful in the study of decision-making processes and bargaining and negotiation. The laboratory setting allows the researcher to test hypotheses from psychology and sociology that are relevant to the conflict behavior of nations involved in international conflicts.

H. G. Kelley and Gerald Shure, in conjunction with fellow researchers in foreign countries, conducted extensive cross-national laboratory studies of negotiation behavior which focused on comparisons of two-party bargaining relationships where each party could pursue short-term goals through non-cooperation with the other party, or pursue mutual long-term benefit by mutual agreement and cooperation.* This study was an attempt to discover under what conditions would negotiating parties pursue mutual long-term benefit.

Surveys

Survey methods utilized in the analysis of international relations are especially useful in assessing public opinions and attitudes toward wide-ranging issues in international politics. Many analysts attribute the withdrawal of President Johnson from presidential politics in 1968 to polls which showed increasing public dissatisfaction with Johnson's Vietnam Policy.** Surveys of large populations in foreign countries provide information on political variables such as party identification, and attitudes toward foreign policy issues.***

* H. G. Kelley and Gerald Shure, "Transnational Working Group on the Dynamics of Conflict," Technical Report #5. Prepared in support of Office of Naval Research Contract #N00014-69-A-0200-4003, University of California, Los Angeles, 1970.

** Seymour M. Lipset, "The President, the Polls and Vietnam," Transaction Magazine, III, (September-October, 1966), 19-24.

*** An example is Johan Galtung's survey of Norwegian public opinion on selected issues.

Mathematical Modeling

This method involves the construction of formal mathematical models to test theories of conflict. A more well-known attempt at modeling is Lewis F. Richardson's model of the development of an arms race over time. Richardson modeled the process of arms acquisition between nations prior to World War I and showed how arms competition led to war.*

The research methods we have discussed are useful for building theory about various aspects of international conflict. The next phase of this discussion will be directed toward what theories exist, and the difficulties that impede the development of valid international relations theory about conflict situations.

IV. Theories of Conflict and War

Many people argue that theory is a product of the "ivory tower" and is not relevant to the practical aspects of conflict and warfare. International relations theory is just beginning to be modeled and tested, unlike economics which is at a stage where huge computer models predict (with varying levels of accuracy) what will happen to the American economy.

There are several objections to the development of a "theory" of conflict. Some scholars contend that no two wars are alike, and therefore valid generalizations cannot be made. Others argue that war is inevitable. This misconception usually appears in the form of three arguments: (1) history repeats itself; (2) the survival of the fittest; and (3) the nature of man. The history-repeats-itself argument centers on the fact that wars have been around since history was first recorded and therefore they will always be with us. Some social scientists attempt to refute this argument by pointing to the past occurrence of various types of diseases which today have been eliminated or controlled. The second argument has been refuted on the

*Richardson, 1960.

basis that in nature, most animals compete for territory or resources, but not by engaging in organized conflict on a regular basis. It also has been suggested that war, planned and methodically executed, is not very similar to evolutionary struggles. The third argument contends that man has an aggressive nature and goes to war to relieve his frustrations. There have been a large number of social-psychological studies which bring into question this basic frustration—aggression theory.

Some theorists believe that the origins of war can be traced to one overriding cause. This argument is also known as the "single factor" explanation. One of the most popular international relations theories was Hans Morgenthau's theory of the pursuit of power. He posits that all nations will act in their own national interest and will pursue a course and policy most advantageous to them. This proposition may, in fact, be an important reason why nations go to war but it has not been shown to be the only reason. This concept tries to explain a complicated phenomenon like war or conflict on the basis of a single factor, which may be misleading. In data analysis and modeling techniques emphasis is placed upon a multi-variable explanation rather than a single variable explanation. Suppose we want to explain why at certain times there is an increase and other times a decrease in the numbers of military engagements between two nations. We can hypothesize (on the basis of theory), reasons for the increases or decreases. One explanation might be that the particular leader in power at a particular time wants to increase his political power. Another possible explanation is that the nation's economy needs stimulation. It could be that both of those are occurring simultaneously and, therefore, we have a two-factor explanation. A growing number of researchers are convinced that one-factor analysis does not have as much explanatory capability as multi-factor types of analyses.

A common misconception which usually follows the ill-conceived pattern of single-factor explanations is that there is only one answer to man's conflictual interactions. Methods for ending international conflict such as

universal socialism, alternative proposals for a unified "world" government, total and complete disarmament, and various other all-encompassing solutions are advanced as final solutions. Analysis of past history reveals that solutions for conflict, especially in international affairs, are approached guardedly. From what we've been able to learn from history and social science about the complexity of various phenomena, it appears that conflict and war are too complicated for the "single cure" approach to be effective.

Despite the proliferation of misconceptions and criticisms, a number of theories of international conflict have been advanced. The following is a list, by no means exhaustive, of theories of conflict that have gained widespread attention in the international relations field:

1. Imperialism: the policy of geographical expansion by a given nation or group of nations.
2. Contiguity: nations nearest to each other geographically tend to be involved in more conflicts than nations with a greater distance between them.
3. National "religious" zeal: a combination of events, conditions, etc., that cause a population to become aggressive against perceived "enemies."
4. Competing ideologies: the attempt by one nation representing a particular ideology to force that ideology upon other nations.
5. Natural ideological struggle: the natural historical struggle that arises between capitalist and communist systems.
6. Frustration-aggression: if a nation feels its goals have been frustrated, it will displace its hostility onto others, i. e., "scapegoats" in the form of other nations.

7. Perception of hostility: if a nation perceives hostility towards it, then that nation will be hostile to the perceived source of hostility.
8. Quest for national and material power: the attempt to increase or consolidate national power and wealth through conquest.
9. Physical conditions: the need for more territory to accommodate a population.
10. Economic competition: a need or desire to strengthen a nation's position through the possession of vital raw materials and increased economic transactions.
11. Status theory: attempts to increase the "status" of a nation in the international system.
12. Consolidation of power: the desire to unify the population of a nation behind a government by directing the population's hostility toward an outward source.
13. Minimax theory of games: it is rational to be conflictual (arm) because if one nation trusts another nation and refuses to arm itself and the other nation arms, then the first nation is at a disadvantage; therefore it is rational to arm, or be conflictual.
14. Escalation: nations are drawn into conflict by a process of escalation when it reaches a point of irreversibility.

V. Summary

This presentation has focused on several aspects of the development of theory about international conflict and war. First, various classifications and definitions of international conflict were presented, followed by a short survey of methods used to study theories of conflict. We presented some well-known theoretical explanations of international conflict.

There are numerous ways to go about studying conflict, which has been demonstrated in the last decade by the rapid growth of the use of quantitative techniques in the international relations field. Researchers have used empirical data to investigate a wide range of international conflict and conflict resolution problems. Many quantitative techniques and methods have had a great deal of attention focused upon them and many innovative techniques have suffered from a lack of development. There is a great deal of empirical theory-building currently underway in the field and many methodological developments are beginning to provide powerful tools for the analysis of international conflict.

INFERENCEAL STATISTICS AND REGRESSION (Session 8)

Lecture Outline

I. Inferential Statistics

Introduction to Estimation and Hypothesis Testing

Hypothesis Testing

Samples and Populations

The Hypothesis and the Estimator

The Null Hypothesis

II. Linear Regression

Least-Squares Method

The F-Statistic

III. Presentation of a Class Problem: U. S. Policy in the Middle East

Statement of the Problem

Description of the Middle East Data

I. Inferential Statistics*

Introduction to Estimation and Hypothesis Testing

We have covered the most elementary forms of statistics—the computation of several kinds of averages and dispersion—and one measure of association: correlation. Today we will talk about the use of data to make inferences from a sample to the larger "population" from which the sample is drawn. I will introduce linear regression in this process. For this we will need four new concepts:

- sample
- population
- hypothesis
- estimator

We will use an estimator computed from a sample of data drawn from a population to accept or to confirm an hypothesis about the "population." Before formal definitions for these terms are given, let us give some simple examples of estimation and hypothesis-testing.

Suppose that you have a bent coin and you wish to know the probability, or the proportion of times, that a toss of the coin will result in its landing with the "head" side up. Since the coin is bent, you may suspect that the answer is not so simple as "heads" one-half the time and "tails" the other half. How can you find out about this particular coin?

*Hubert M. Blalock, Jr., Social Statistics (New York: McGraw-Hill Book Company, Inc., 1960), ch. 8, pp. 89-96 provides source material for this lecture.

One approach is to estimate the probability of "heads" from an experiment with the coin. You take a sample: that is, you toss the coin, say, ten times and tabulate the results as follows:

Toss	Result
1	H
2	T
3	H
4	H
5	H
6	T
7	T
8	H
9	H
10	H

To compute an estimate of the probability of getting a "head" on a single toss, one of the natural things to do is to count the number of "heads" (7) and divide by the total number of tosses (10). Thus, 70% of the time you would expect "heads."

This is a very simple estimate of a population parameter—the probability of "heads"—that is a characteristic of the coin. Characteristics of more complex systems that you might like to estimate are the mean, a measure of the spread of the outcomes (i. e. the variance), or the correlation between two variables. Why these are referred to here as "estimates" will become clearer when we take up sample and population.

Hypothesis Testing

Now let us give a simple example of hypothesis-testing. While hypothesis-testing requires estimation, it is essentially a somewhat different process. Let us suppose that we still have the problem of the bent coin. After studying it visually, we conclude from the way it is bent, that it will almost always land "tail" side up. So we guess at the probability of "heads" as $1/4$, or 25%. This guess constitutes the hypothesis about the coin. Now

let's say that you carry out your previous experiment of tossing the coin 10 times with the following results:

Toss	Result
1	T
2	H
3	T
4	T
5	T
6	H
7	T
8	T
9	T
10	T

This second experiment yields a probability of heads of 20%. The two sets of "data" constitute two possible results from the experiment of tossing the coin ten times. From them, you may now wish to say something about your hypothesis that the probability of heads is 25%. For example, at the end of the first experiment, where you got "heads" in 70% of the tosses, you might have rejected the hypothesis. If on the other hand, you had gotten the results above, you would probably wish to accept it. That is, you have used the sample outcome of a one-time experiment—either the first one or the one above—to make a judgment about the validity of your hypothesis, which was derived originally on the basis of a visual examination of the coin. The results of experimentation—i. e., coin-tossing—were used, not to compute an estimate of a value you are willing to assign to a characteristic of the coin, but to determine your acceptance or rejection of an hypothesis about the value.

Here, you will notice that it was simply asserted that you used the results of the experiment to decide the validity of the hypothesis; it was not indicated how this is to be done. And the two sets of outcomes presented were chosen to make the decision appear obvious to you. But suppose that you had before you the results of both experiments, or suppose that the outcome had been 5 "heads" and 5 "tails." What could you say then?

In the first place, you should realize that experimenting with the coin produces merely one instance of statistical evidence (not proof, but evidence) to either confirm or to deny the hypothesis. Determination of which the evidence should cause you to do and whether or not you should feel "good" about it (that is, what confidence should be placed in your decision) is based on the following reasoning. You ask yourself this question:

"If the hypothesis is true, what are the chances of getting this result?"

If the hypothesis is true; that is, if the coin is biased in such a way that the probability of getting "heads" on one toss is $1/4$, then the chances of getting the first results are very low. So, before carrying out the experiment, you choose a criterion for accepting or rejecting the hypothesis. This criterion is the value of some parameter—here, the probability of "heads"—that can be computed from the results of the experiment. And you determine, if the computed value of this characteristic is greater than this value, to reject the hypothesis; if it is equal to, or less than, you will accept it. For the bent coin hypothesis, you may say:

"If I get more than 6 heads, I will reject the hypothesis."

Let me summarize the steps:

1. You looked at the coin, observed that it was bent, and guessed that the probability of "tails" is $1/4$.
2. You chose a criterion for accepting or rejecting the value of $1/4$.
3. You carried out an experiment and tabulated the results.
4. On the basis of the experimental results, you accepted or rejected the hypothesis.

Two types of errors are possible:

- You might have rejected a correct hypothesis, or
- You might have accepted an incorrect one.

In the terminology of statistics, these are called "Type I" and "Type II" errors. In the more colorful language of signal detection theory, they are called "missed signals" and "false alarms."

By making your criterion for accepting the hypothesis more and more constraining, you decrease your chances of making a Type II error; unfortunately, you increase, at the same time, the chances of a Type I error. Decreasing simultaneously the chances for both types of errors requires using larger samples of data, and that brings us to the subject of samples and populations.

Samples and Populations

The term population refers to the complete set of all possible cases of a measurement or of an "experiment." Here, the term experiment is being used in a very general sense. The "population" of nations is approximately 130. The opaque urn is a favorite example of statisticians. This is a container whose contents cannot be seen too well but it usually holds black and white balls or red and white poker chips or something of the kind. Let's say that this urn has poker chips numbered 1, 2, 3, 4, 5, and 6. Suppose that you have been told that numbers are written on the chips, but you have not been told what the numbers are. Now suppose that you are interested in estimating the mean of the numbers. If you had the time and resources you would pull out all the chips, write down the numbers and compute the mean directly. But suppose that, for some reason—you don't have time or it's too expensive—you can look at only one chip. From one chip, your estimate of the mean could be anything from 1 to 6. Since this

is a finite population and your sample size is finite—one, in fact—all you can do is take the value from this one chip as your estimate of the mean.

Now suppose that you have a little more time, and you can draw two chips. The lowest two numbers you could draw are 1 and 2; the highest two are 5 and 6. Your estimate of the mean, based on a sample size of two, could be as low as 1.5 or as high as 5.5. Now the omniscient analyst looking down on the drawing knows that the real mean is 3.5. So you see that by drawing two samples instead of one, we have decreased the possible error from 2.5 in the first case to 2.0 in the second.

Clearly, if you keep on drawing samples, you are going to get a better and better estimate until you have drawn all six and you're right on.

We call a set of chips like the ones in this urn a "finite population." There is a limited number, and the larger the sample drawn from the population, the more precise the estimate based on the sample.

Now the experiment described above was based on drawing a sample, recording its number and laying it aside. But suppose now, that instead of laying the chip aside, you toss it back into the urn and mix the chip up again before you draw a second time. This operation is called "sampling with replacement;" the first kind, when you did not return the chip to the urn, was "sampling without replacement."

But now when you throw the chip back into the urn after each drawing you could keep drawing a "1" each time, and your estimate of the mean could always be in error by 2.5. It isn't too likely that this will happen as you make more and more drawings, but it could. This points out that two important factors in determining how large the error in your estimate could be are the method of sampling (with or without replacement) and the size of the sample from which the estimate is made.

All of the chips in the urn constituted the "population" and the chips you drew out to look at were the "sample." Now what is the equivalent of a "population" in international relations? There are some interesting technical problems tied up with the answer to that question, depending on what you are interested in studying. Let's suppose that your unit of analysis is the "nation." The "population" in this case is the set of all the world's nations. Obtaining a "random" sample of the world's nations may sometimes be more trouble than just to collect information on all of them.

Difficulties can arise when you have data for a sample of nations—say, the nations of Western Europe. You study their behavior and attempt to make general inferences about the way nations behave from this sample. It is obvious that this is a very special kind of sample. Suppose, for example, that you are trying to answer questions about the state of U. S. relations with the rest of the world from a study of this sample. You are likely to arrive at a much brighter picture than is in fact justified by reality.

But suppose you are willing to narrow your study to the state of the relations between the U. S. and Britain. Again you may have a problem if your data covers only the years 1770-1810. If you are willing to focus your study on the state of U. S. -British relations 1770-1810 (or over whatever period your data covers), then you have a more nearly manageable problem. With the caution that the definition of "population" and the choice of a "sample" can be very critical in quantitative work in international relations, we will go on to discuss our next topic.

The Hypothesis and the Estimator

I touched briefly on the terms hypothesis and estimator before. You will remember that an hypothesis was a statement about a system, about the value of a system attribute, or perhaps, about some relationship between

system attributes. The estimator was a selected characteristic of the samples of the population. In the simple coin-tossing example introduced earlier, the estimator was the probability of getting "heads." The hypothesis was that the probability of getting heads with this particular coin was .25. From an experiment in which the coin was tossed 10 times and the probability "estimated" from the results of these 10 tosses, the hypothesis was accepted or rejected.

This simple example demonstrated the relationship between the estimator and the hypothesis; namely, the estimator is computed from experimental values and determines whether or not the hypothesis is accepted. Let's turn now to an especially useful technique for testing a hypothesis. It really amounts to testing the denial of the hypothesis you are primarily interested in.

The Null Hypothesis

The null hypothesis is the hypothesis of no change or of no difference and can be illustrated with the following example. Let's suppose that an international relations theorist has said that "a major international power will give economic aid to a smaller 'client' state to the extent that the major power's chief competitor state gives aid to the client state's antagonist; therefore, U. S. economic aid to Israel will be predictable from USSR aid to the Arab states."

However, a skeptic comes along and says "I do not believe that U. S. aid to Israel has any association with USSR aid to the Arabs." The skeptic has, in effect, stated the null hypothesis for this case; that is, he has hypothesized that Soviet aid to Arab nations has no effect on U. S. aid to the Israelis.

Let us suppose that the data for U. S. and Soviet aid are difficult to find, so that a random sample of 5 years is chosen from the period 1950-1970.

The randomly chosen years are 1951, 1958, 1961, 1968 and 1970, and the data for U. S. aid to Israel and Soviet aid to the Arabs looks like this:

<u>Year</u>	U. S. aid to Israel (millions of \$)	Soviet aid to Arabs (millions of \$)
1951	1	1
1958	3	2
1961	2	3
1968	3	4
1970	4	5

The question at hand is whether in these sample data a relationship between Soviet and American aid is exhibited, and whether the relationship is strong enough to suggest that the null hypothesis (that if all the years 1950-1970—the "population"—were taken into consideration, no relationship would be apparent) could be rejected.

Our first step is to compute the nature of the relationship between the two variables in the sample data. The sample computations will produce a sample estimator of the relationship between the two variables.

II. Linear Regression*

In an earlier lecture we discussed correlation as a measure of association. Correlating these same data, we found that the correlation was +.83, fairly strong in the positive direction. The correlation coefficient, however, does not provide us with the information needed to make statements to the effect that "a change in variable X of A units will produce a change in variable Y of B units." To make such statements, an equation which relates values of Y to values of X is needed. Linear regression is one method of producing such an equation.

* A more detailed mathematical treatment of regression may be found in Blalock, pp. 273-285.

Least-Squares Method

Let's look at the scatter-plot of our data, calling U. S. aid to Israel variable Y and Soviet aid to the Arabs variable X.

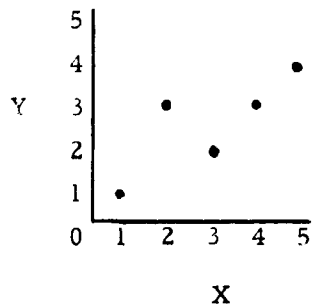

In linear regression the problem is to draw a straight line through these data which, when expressed as an equation, allows the best possible prediction of Y values given X values.

To illustrate the idea, we can draw in a hypothetical line, and indicate by dashed vertical lines how far off our predictions of Y given X would be using this line.

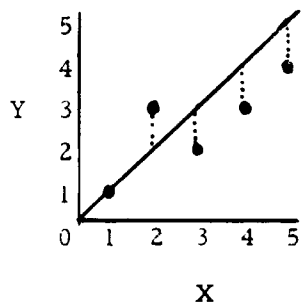

It is easy to see that the equation representing this line is

$$Y = 1X$$

Given an X of 3, using this line we would predict that Y would be equal to 3. However, the actual Y is 2, so our prediction would be in error by 1

unit of Y, as indicated by the dashed line. We can get an idea of how well this line fits the data by summing the squared differences between actual Y's and the Y's that would be predicted from this line:

<u>X</u>	<u>Predicted Y</u>	<u>Actual Y</u>	<u>Predicted-Actual</u>	<u>Predicted-Actual Squared</u>
1	1	1	0	0
2	2	3	-1	1
3	3	2	1	1
4	4	3	1	1
5	5	4	1	1
Sum of Squared Differences =				4

Another way of saying that we want an equation that gives us the best possible predictions of Y from X is to say that we want an equation that results in the smallest sum of squared differences between actual and predicted values of Y. Not unexpectedly, then, the method of producing such an equation is called "least squares." The least squares equation is of the form

$$Y = a + bX,$$

where b is the slope of the straight line, and a is the point at which the line intercepts the Y axis. We needn't engage here in the actual calculation of the parameters of the equation, since we can rely on the computer to ably accomplish this for us. But let us show the line and equation derived through least squares calculations for our data.

The equation is

$$Y = .8 + .6X,$$

which gives the line:

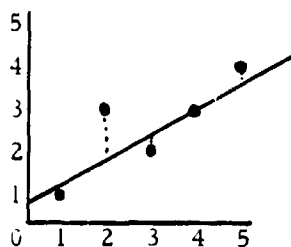

Overall, it appears that our predicted Y's will be closer to our actual Y's with this equation than with our hypothetical $Y = 1X$ equation. Let us verify this by computing the sum of the squared differences between the actual Y's and the Y's predicted from the equation

$$Y = .8 + .6X.$$

<u>X</u>	<u>Predicted Y</u>	<u>Actual Y</u>	<u>Predicted-Actual</u>	<u>Predicted-Actual Squared</u>
1	1.4	1	.4	.16
2	2	3	-1	1.00
3	2.6	2	.6	.36
4	3.2	3	.2	.04
5	3.8	4	-.2	.04

Sum of Squared Differences = 1.60

This line, the least squares line, minimizes our predictive error to the point at which the sum of the squared differences between actual and predicted Y's is 1.60. Least squares procedures, then, have maximized our ability to predict Y's from X's with a linear equation.

The term "b" in the equation is the slope of the linear relationship between X and Y. Recalling the skeptic's "null hypothesis" that X is unrelated to Y, it can be seen that his position can be restated as "the slope of the line representing the relationship of X to Y is zero," for if X and Y are unrelated, then the slope of the line will be zero.

The F Statistic

We have computed the slope in the sample data to be .6. The question now is whether, given this sample slope, the null hypothesis that the population (all the years from 1950-1970) is zero. What we would like to know is: if in the population of data the slope is zero, what is the probability of finding a slope of .6 in a random sample from that population? If certain assumptions are met (a major one is that the population of Y's for any value of X is normally distributed), then the "F statistic" will provide an answer to this question.

What is important to understand about F is that it is computed from the sample data, and that any given value of F has a probability associated with it which expresses the chance that a given slope (e. g., .6) would be obtained from sample data if in the population the slope were zero. It happens that the F computed for the sample data is 6.8, and that the probability associated with it is larger than 5%. This means that if the slope of the line in the population is zero (i. e., if the null hypothesis is true), then it would not be highly unusual (i. e., it would occur in more than 5% of random samples) to find a slope of .6 in a sample of five years from the population of 20 years. Thus, we would not reject the null hypothesis on the basis of the evidence in the sample data.

The steps that we have carried out in this problem are analogous to those carried out earlier in testing hypotheses about the probability of getting "heads" 1/4 of the time in flipping a coin. Let us summarize the steps we have taken:

1. Formulate a null hypothesis to the effect that X has no influence on Y, i. e., that the slope is zero.
2. Choose a criterion for rejecting the null hypothesis: if the probability of finding the slope exhibited in the sample of data is not too low (i. e., not less than .05) if the

population slope is zero, then do not reject the null hypothesis that the slope is zero; if the probability associated with the sample slope is low (i. e. , less than .05), then reject the null hypothesis.

3. Compute the sample slope from the sample data.
4. Depending on the probability of finding a sample slope of the computed size if in fact the population slope is zero, accept or reject the null hypothesis about the population.

The computer printout which will be obtained from running the regression program will include an F statistic and a "significance" level. The "significance" level is the probability of finding the given sample slope if in fact the population slope is zero. Since none of the data in the four data files are sample data, the usefulness of these probabilities is questionable. Such statistics as F are designed for making inferences from random samples to larger populations. Nevertheless, you may wish to look at the data as though they were randomly sampled, and then decide from the "significance" probability on the printout whether you would accept or reject the null hypothesis that the slope of the population regression line is zero.

III. Presentation of a Class Problem: U. S. Policy in the Middle East

Statement of the Problem

Six possible U. S. policy objectives in the Middle East are:

- To reduce the arms race between Israel and the Arab countries
- To increase Israel's security
- To reduce the violence between Israel and the Arab countries
- To increase the level of economic development of the Middle East nations
- To increase friendly ties between the U. S. and the Middle East nations
- To decrease Soviet influence in the Middle East

Later we may discuss whether or not these are relevant policy objectives, but your assignment now is to determine how to attain one or more of these policy objectives. Stated more specifically, the problem is to test (using the Middle East data file) your hypothesized relationships between U. S. actions and U. S. policy objectives in the Middle East.

At the same time, you may wish to investigate the limitations of U. S. actions to achieve U. S. goals by testing relationships between the policy objectives and actions over which the U. S. has no control.

The process of testing such relationships will consist of several steps. First, on the basis of previous experience and learning, state what you think the relationships are between a proposed U. S. action and the given policy objectives. Secondly, select the variables from the variable list which you think measure or operationalize the concepts in your hypothesis.

Thirdly, with the assistance of the computer and the various statistical tests which have been learned, test your propositions with the Middle East data. Then state whether or not the empirical data supported your hypothesis. You may use regression to derive linear predictive equations expressing the effects of U.S. action on selected variables. The final task will be to closely examine the strengths and weaknesses of this method for policy analysis; for example, how "good" is the data, how much confidence can we have in our tests of association?

Description of The Middle East Data

The data-file that you will be using for this exercise, MIDEAST/T, is described in your workshop manual. I want to cover briefly some important points with respect to it.

As you can see from the description in the manual, this data-file includes 45 variables, 44 of which deal with various military and economic aspects of the Arab-Israeli conflict. The other variable, No. 1, is "Time." These data are really a subset of a much larger file of over 400 variables. The data collection begins in 1948 and ends in 1967. Thus "time" runs from '48 to '67.

A few words should be said about certain variables. You will note that variables 14 through 22 measure violent conflict of one sort or another. These are merely frequencies, not absolute values. Suppose you were working with 1964 data. Then a "10" for Variable 14, Encounters between Egyptian Government Forces and Israeli Government Forces, would mean that for 10 weeks out of that year, there was at least one encounter between the Egyptians and the Israelis. It does not tell you how many encounters there were; it merely counts the number of weeks during which there were encounters. Similarly coded are variables 15-22.

One of the reasons for coding this way is that real figures on the number of encounters are very hard to come by. The data here were all gathered from two public sources—The New York Times Index and The Middle East Journal Chronology. No classified information is included at all. If classified data had been available, it might have been possible to include absolute numbers for the encounter and attack variables (#14-22). The problem of obtaining accurate figures from public sources should be kept in mind when you interpret your results.

Class Discussion of Possible Approaches

The instructor may structure the class discussion around the steps in the "classical" approach:

- Problem definition
- Hypothesis formulation
- Concept operationalization
- Data collection and analysis
- Test of the hypothesis
- Statement of the implications of the results

WORKSHOP: QUANTITATIVE INVESTIGATIONS OF U. S. POLICY
OBJECTIVES AND ACTIONS IN THE MIDDLE EAST (Session 9)

No formal lecture is given during this workshop period. The students will investigate, through the MIDEAST/T data-file, the effect of U. S. actions on policy objectives in the Middle East. Workshop exercises for this session are given on the following pages.

WORKSHOP EXERCISES

Session 9

QUANTITATIVE INVESTIGATION OF U. S. POLICY OBJECTIVES ACTIONS IN THE MIDDLE EAST

General Theme:

Formulating U. S. foreign policy toward nations in conflict.

General Questions:

What actions by the U. S. would lead toward fulfilling U. S. policy objectives in the Middle East?

To what extent is the attainment of U. S. policy objectives determined by factors outside U. S. control?

The Specific Workshop Problem:*

Given: The following U. S. foreign policy objectives:

1. To reduce the arms race between Israel and the Arab countries
2. To increase Israel's security
3. To reduce the violence between Israel and the Arab countries
4. To increase the level of economic development of the Middle East nations
5. To increase friendly ties between the U. S. and the Middle East nations
6. To decrease Soviet influence in the Middle East

*The MIDEAST/T file is used in this workshop. It is a time-series file.

Find: Actions by the U. S. that are most likely to achieve these objectives.

Actions outside U. S. control that apparently affect the attainment of these objectives.

Suggested Steps in this Study:*

For each of the policy objectives:

- State the theoretical relationship between your proposed U. S. action and the desired policy objective. This statement is your hypothesis.
- Choose variables to measure each concept in your hypothesis. This step is the operationalization of the concepts.
- Formulate hypotheses about relationships involving factors other than U. S. actions that will affect the achievement of the policy objectives.
- Operationalize these concepts.
- Test each hypothesis, using the quantitative data available in the Middle East data-file. Note the strength of statistical association and form of effect (regression coefficient) for each relationship tested.
- Decide whether or not your hypothesis is supported by the empirical evidence.
- State the implications of your investigations for U. S. Policy in the Middle East.
- Discuss your investigation, including: any reservations you have about this type of policy analysis; comparison of the strengths and weaknesses of this analysis with other methods.

*It is assumed that, by now, you are sufficiently familiar with the statistical packages and the analytical techniques, so that the choice of how the questions are to be answered can be left to you.

DISCUSSION: RESULTS OF CLASS WORK ON THE MIDDLE EAST
PROBLEM (Session 10)

No formal lecture is given during this discussion period.

The instructor may follow the outline below:

- I. Team Reports
- II. Discussion of Team Results
 - Operationalization of Variables
 - Interpretation of Findings
- III. Critique of Data File/Software Packages

INTERNATIONAL ALLIANCES (Session 11)

Lecture Outline

I. Alliance Formation

Problems for the Policy-Maker

Alliance Formation

Alliance Maintenance

Effects of the Alliance

Definition of "Alliance"

Conditions of Alliance Formation

Alliances vs. Trade Agreements and Common Market

Selection of Alliance Partners

Threats, Ideology, and Alliances

The Role of Benefits

II. Alliance Maintenance

Causes for the Weakening of Alliances

Domestic Political Change

Economic Growth

Technological Change

III. Effects of Alliances

INTERNATIONAL ALLIANCES* (Session 11)

I. Alliance Formation

Problems for the Policy-Maker

One of the things that strikes observers of human behavior, whether they are looking at individuals, groups, or nations, is the extent to which people seem to be driven toward coalescing with each other. For example, if you watch three- to six-year olds, you may observe a childhood version of alliance formation. If a third child enters an area where the two children are playing, by some process of selection, two of the three will get together and exclude the other. The two have, in effect, formed an alliance.

Similarly, in international politics we notice that nations continually form alliances with each other. Frequently, these are very formal alliances, such as NATO, where specific rules are drawn up. Occasionally, alliances are informal working agreements that are tacit rather than explicit. Whatever the form, however, alliances are a constant characteristic of international politics and policy.

There are several questions about alliances that have implications for the policy-maker:

- Alliance formation.

Why do nations form alliances? What are the advantages? What inducement to join can be offered to potential partners? What are the obstacles to alliance formation?

*Based in part on: John D. Sullivan, "Cooperation in International Politics: Quantitative Perspectives on Formal Alliances" in Behavioral International Relations, edited by Michael Haas (forthcoming; San Francisco: Chandler Publishing Co.).

- Alliance maintenance.

Once an alliance is formed, how is it retained? How can we keep our alliance partners happy, assuming that we value the alliance and want to continue it?

- Effects of the alliance.

What is the effect of an alliance on other nations? The fact that two or more nations form an alliance is likely to influence the behavior of those excluded from it. What are the most likely consequences? Will our relations with the excluded states be harmed? If so, can we take other action to improve the situation?

Definition of "Alliance"

Before we get into a discussion of these questions, I want to define an alliance and make clear just what type of international behavior we are considering. It is apparent that, in discussing alliances, we are talking about some form of cooperative behavior among nations. In general, one finds in the literature four related terms used for cooperative behavior: coalition, bloc, alliance and alignment. The term "coalition" is the most general, referring to all forms of cooperative behavior. A "bloc" is a grouping, or community, of nations sharing some set of common interests, but not necessarily bound by a formal treaty. Ties among bloc nations may vary from the fairly loose association among nations of the "Atlantic Community" to the more tightly controlled members of the "Soviet Bloc." The term "alliance" refers to a relationship characterized by a formal agreement in which both the rights and the obligations of the members are made explicit. In addition, such formal agreements frequently identify the third party toward which the alliance is directed. Finally, "alignments" are informal types of cooperation in which the nations attempt to coordinate their day-to-day behavior.

It is the alliance that we are discussing here. One of the most common forms is the military alliance, which has been defined as "a formal agreement among a limited number of countries concerning the conditions under which the members will employ military force."

A military alliance such as NATO may go much further to specify various types of peace-time cooperation attempts to standardize military hardware, the construction and maintenance of common military bases, the dissemination of technical information, the conduct of joint military field exercises, and even research and development endeavors like the SHAPE Technical Center in The Hague.

One of the most important steps in developing theory about alliances and their formation is the attempt to organize what we know about alliances into descriptions of alliance "types."

An investigation of the characteristics of 137 alliances signed between 1920 and 1957 suggested that alliances can be characterized by four principal factors:

- the degree to which one member tends to dominate the alliance,
- the amiability of the relations among the members and the duration of the alliance,
- the degree to which the alliance members are similar in military strength, and
- the degree to which the military forces of the alliance members are integrated for a defensive role.*

By investigating patterns of alliances based on these factors, definitions of alliance types can be produced.

* Nations are apparently more sensitive about joining formal alliances for offensive purposes; most alliances stress the defensive nature of the alliance objectives.

Conditions of Alliance Formation

Going on now to the first of the questions of interest to a policy-maker: Why do nations form alliances? Why are we in NATO, for example? Why were the Western European nations willing to join?

It is quite clear that in the aftermath of World War II, particularly after the Soviets moved into Eastern Europe, we perceived the need to form an alliance with the Western European nations. In this case there were clearly two major reasons:

- There was an identifiable threat.
- The war had left the European nations in a devastated state and an alliance provided a way to extend their individual defense capabilities at less cost.

Hence, in inducing them into an alliance with us, we were able to meet the threat and to play an important role in helping them to rebuild their economies.

From the example of NATO we might suppose, then, that nations tend to initiate alliances when they perceive a threat and tend to join alliances when they expect to receive a benefit. We'll go into the nature of the expected benefits later.

Alliances vs. Trade Agreements and Common Market

As was pointed out earlier, nations engage in a wide variety of cooperative behavior. In the economic area, this may range from a simple trade agreement between two nations to more ambitious attempts to develop an integrated economic system involving a group of nations, for example, the European Common Market. While all cooperative behavior among nations arises from the desire to receive a benefit of some kind, and, in the case of the Common

Market, there was also perceived to be a threat from American business, these economic agreements differ in significant respects from the formal military alliances we are discussing here. In addition to the difference in the nature of the expected benefit (primarily economic for cooperation in trade; military, political, and, only indirectly, economic for a military alliance), a major difference lies in the intent of the cooperation. A trade agreement between two countries attempts to regulate the behavior of private, commercial interests in the countries; an alliance is really an attempt to regulate the behavior of other nations—primarily nations outside the alliance. For example, although NATO may have regulated the behavior of its members to some extent, its real purpose is an attempt to regulate Soviet behavior.

Selection of Alliance Partners

Having perceived a threat that it feels inadequate to meet with its own resources, a nation looks around for alliance partners. Frequently, the nature of the threat will determine the choice of partners. NATO, for example, was composed in part of those countries not yet under Soviet control, but sufficiently close to Soviet power to perceive the possibility—that is, countries like Norway, Denmark, West Germany, France, etc.—and nations like the United States, the United Kingdom and Canada who did not wish to see Soviet domination extended. Other nations in this position chose to face the Soviet threat by remaining "neutral"—i. e., Sweden and Switzerland.

It might be expected that nations would be drawn together by similar ideologies. Again, looking at NATO, we see that the majority of the partners do show more or less similar views. And differences in ideology probably explain why Spain was not invited to join. However, it is hard to justify Portugal's membership on an ideological basis, and Iceland is a real anomaly. As the only NATO nation with a Communist government, it had no "security clearance" within NATO, at least in the '61-'63 period.

There are other hints that ideology is, perhaps, not always the most critical factor. We might expect, for instance, that, in a world characterized by a dichotomy between democratic libertarian governments and authoritarian communist regimes, there would not be much aligning across the split. In fact, for a long period this appeared to be the case; there were two fairly cohesive blocs—the East and the West. Recently, one gets the impression that these blocs have been breaking up in a very subtle way. Yugoslavia, for example, is in many ways closer to the West than to the East, and in any case, is frequently independent of either. On the other side, both France and Iceland have forced NATO bases out of their countries. Still, none of the members of either NATO or the Warsaw Pact have yet formally withdrawn from these alliances, however much they appear willing to cooperate with opposing bloc members in other ways.

There are many indications that the U. S. has not always been so sensitive to ideology in its cooperative actions—one has only to point to our basing treaties with Spain and our support of Nationalist China—neither a shining example of the democratic system.

Threats, Ideology, and Alliances

What can be said then about the relationships between threats, ideologies, and alliance formation? Suppose we think of ideologies and threats as continuums. The ideological-political spectrum would range from "right-conservative-reactionary" through "middle-of-the-road-democracy" to "left-radical-communist". The threat spectrum would range from "no threat" to a "threat of military attack and invasion". The relationship between the U. S. 's perception of the threat and its tolerance for ideological differences in its alliance partners is suggested by the figure below:

Figure 1

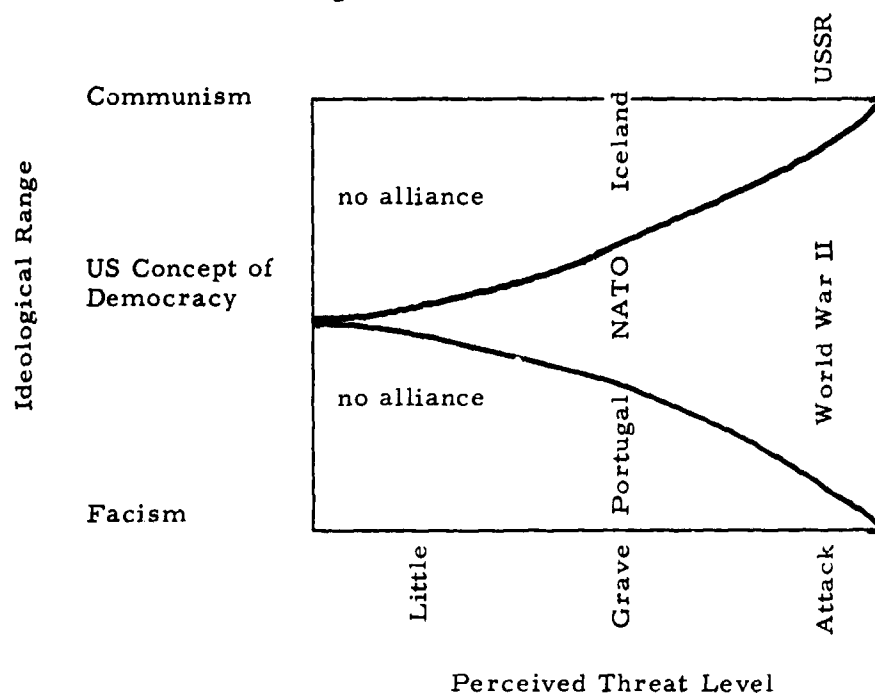

The areas marked by "no alliance" represent regions where no U. S. alliances would be formed; the remaining area indicates the region in which alliance formation is possible. Thus, the greater the threat, the greater the U. S. tolerance of ideological differences. For example, during World War II, when the perceived threat was extremely high, we aligned ourselves with communist Russia. Likewise, NATO, which was formed when threat of Russian invasion was great, encompasses a broad spectrum of political ideology—from communist Iceland to colonial Portugal.

The Role of Benefits

A third factor complicates this simple picture. When a prospective alliance partner fails to perceive a threat of the same magnitude as does the initiating nation, it may be necessary to point out to him some benefit arising from alliance membership. A hypothetical response from an

invitee might be:

"Well, if you want me to come into your alliance because you are threatened by nation Y, I'll come in. But I am not too much worried about Y, so let's work out something else for me, like a good trade relationship or a favorable border settlement."

An example of an arrangement of this type was the alliance between Bismark and Italy, whereby Bismark secured Italian military support against Austria in return for a settlement of the Italian-Austrian border dispute in Italy's favor.

The U. S. -inspired Alliance for Progress might be looked on in this light. The U. S. perceives the threat of extended Communist influence in Latin America. The Latins themselves apparently don't see this as a threat of the same gravity as the U. S. , so economic benefits must be provided to them.

Of course, alternative rationales for the "Alliance for Progress" are possible.

- We perceive the major threat as arising, not from an external source, but from internal instability in the Latin countries themselves. We attempt to improve their economic status to reduce this threat, and/or
- We feel a moral responsibility to aid less-developed countries and believe that this help will be more effective if the recipients make a contribution themselves.

Sometimes nations join an alliance more from coercion than from promises of benefits. Ostensibly, the Soviets perceived a counter-threat from the formation of NATO and decided to form an alliance of their own. While it

is doubtful that, say, Hungary and Czechoslovakia really felt threatened by the U. S. and its allies, nevertheless they did become part of the Warsaw Pact. What benefits they received from membership, they would, perhaps, find it difficult to enumerate, although they probably have a fair idea by now of what reluctance to join would have produced.

Indeed Cotrell and Dougherty* have suggested that the Warsaw Pact is merely a formalization of Soviet dominance over East Europe rather than a genuine collective security pact. Clearly, alliance formation and the choice of partners is complex and many motives are involved.

Getting back to benefits—an interesting concept developed in an attempt to formulate the benefits of an alliance is that of "collective good". Some political scientists have pointed out that, when an alliance is formed, benefits are produced which are shared by all members of the alliance, even by those who have not contributed their "fair share" to the costs of the alliance. A simple example is the ability of any resident of a city to call on the services of the city's fire department, even a citizen delinquent in his taxes.

Extending this notion to an international alliance, such as NATO, the "collective good" in this case is an effective deterrent against an attack by the Soviet Union. Even if a particular member of NATO has contributed less to the alliance than the other members consider "fair", it still will be protected. In this case, the "collective good" extends even to a non-member like Switzerland.

In analyzing alliances in terms of "collective good", it has been suggested that, all other factors being equal, nations that value the alliance highly will

* Alvin J. Cotrell and James E. Dougherty, The Politics of the Atlantic Alliance (New York: Praeger, 1964).

bear a disproportionately larger share of the cost of the alliance.* Quantitative studies of NATO appear to confirm this suggestion. However, a major difficulty arises in the attempt to "operationalize" the concept of the "value" to a member of the NATO alliance. The investigators chose a nation's GNP as a measure of the extent to which it values NATO membership, and they did find that nations with high GNP's contributed a disproportionately large share of the alliance cost.

The same results were obtained from a study of the United Nations: larger nations tended to pay their expected contributions. Explanations, other than the hypothesis that "value" and financial support are related, can be suggested:

- wealthier nations have more money to spend for luxuries—like alliances
- wealthier nations fear the loss of international prestige if they acquire a "bad credit rating" by not meeting their formal obligations
- wealthier nations have a sense of moral responsibility to smaller poorer nations that makes them willing to bear a larger share of the alliance costs.

There are more cynical explanations:

- wealthier nations are willing to aid smaller ones economically because they fear the consequences of internal unrest in the poorer countries
- since the purchases of military hardware are usually made in the larger, wealthier countries, greater contributions by them are merely indirect subsidies to their own industry.

*Mancur Olsen and Richard Zeckhauser, "Collective Goods, Comparative Advantage and Alliance Efficiency," in Issues in Defense Economics, edited by R. N. McKean (New York: Columbia Press, 1966).

Other alliances—the Arab League, for example—fail to demonstrate a relationship between defense spending and GNP. (Apparently, the investigators consider the entire military budgets of the Arab countries as the "costs" of membership in the Arab League). In order to retain the theory involving the concept of "collective good", it has been suggested that the NATO alliance is a "type" for which the theory holds and the Arab League is a "type" for which it does not. However, saying that the theory works when it works and fails to work when it fails to work does not appear particularly useful. Perhaps a more fruitful line of investigation would be to use the relative contribution of a member to the costs of an alliance as the measure of its "value" of alliance membership. Then, one could hypothesize that this "value" is related to some other factor—for example, to its perception of the external threat, possibly measured by an analysis of the content of the major speeches of the nation's leaders. Should such a relationship be demonstrated, then one would have a way of estimating roughly alliance support by the members (as long as that support is purely determined by the will of the alliance member. It is doubtful, for example, that it would help much in studying the Warsaw Pact nations).

II. Alliance Maintenance

Causes for the Weakening of Alliances

Another problem of great importance to the policy-maker is that of alliance maintenance. It may not be immediately clear why this should be a problem. Once an alliance is formed, why doesn't it go on achieving its objectives without further activity on the part of its members?

At least four basic reasons for the weakening of alliances can be identified:

- Decrease in the perceived threat
- Loss of faith in the ability of the alliance to achieve its objectives.

- Decrease in the benefits of the alliance in relationship to the costs of membership, and
- Development of internal stresses among the members.

Let's look at these reasons. First, why should the threat be perceived as less? Here, two things may happen. A nation may experience internal political changes which alter its viewpoint. As a nation's political orientation swings leftward, it may begin to feel less threatened by the Soviets. (Note here that I am not suggesting that the danger to such a nation actually becomes less; merely, that it may feel the threat to be less). Although we can't say for sure that Iceland is beginning to feel less threatened by the Soviets, it is clear that the rise of the communists there has been accompanied by an increasing reluctance on their part to cooperate with NATO.

A second thing that may happen to reduce the feeling of threat is that there may be a change in the international situation. The previously hostile nation, on whose account the alliance was formed, may begin to act less threatening, or it may begin to have troubles of its own, either internally or with a third party, which apparently decreases its capabilities to cause difficulties.

The second reason for the weakening of the alliance—the loss of alliance credibility—can in some cases come about through technological changes. One of France's reasons for weakening its NATO ties, in view of the greatly expanded Soviet nuclear capability, was its expressed doubt that the NATO nuclear shield would be adequate for Europe in the event of a Soviet ground attack. Doubting the U. S. intentions in such an event, they preferred to develop their own nuclear capability. (Even, here, they could take advantage of the "collective good" of this alliance and, regardless of their actions, still have the benefits of NATO's capabilities).

One danger that the smaller alliance members run in taking advantage of the non-selective nature of the "collective good" and reducing their contributions to an alliance, is that they will exceed the point at which the chief

contributors will continue their one-sided support. It may occur to them, after a while, that the benefits of the alliance to them no longer match their contributions close enough; the alliance is, for them, no longer "cost-effective". There are many indications that the U. S. 's NATO partners have crossed this point, and opinion is growing in the U. S. that NATO is no longer worth what the U. S. has to pay to continue it.

Finally, like all organizations of people, alliances tend to develop internal stresses that weaken the alliance ties among the members. Table 1 lists some causes of these stresses, grouped into the three categories: internal, procedural, and environmental.

These factors are generally self-explanatory but I want to go over a few of the more important.

Domestic Political Change. It has already been suggested that internal political change may cause a nation to view a threat as less serious than it once thought. Other effects of domestic change that can weaken an alliance are a growing sense of national identity, or regional identification, or a growing sense of belonging to a community larger than that represented by the alliance. Any of these can reduce the need a nation feels for alliance membership. When the region or the community has objectives that conflict with the alliance, the member may be forced to choose one or the other.

A second effect of domestic change in a nation can be modification of the attitude of the other alliance members toward that nation. The military coup in Greece is a good example. Here it was not the new Greek government that re-evaluated NATO, but some of the NATO members who began to question, largely on moral grounds, whether the alliance could afford to include Greece, and whether Greece could remain a trusted alliance member. Here, domestic political change altered, not the perceptions of the alliance member toward the alliance, but the views of the alliance toward that member.

Table 1

Causes of Intra-Alliance Stresses

Internal Factors

- Domestic Political Change
- Economic Growth

Procedural Factors

- The Organizational Structure of the Alliance
- The Decision and Bargaining Process
- Choice of the Response to a Threat
- Decision as to Alliance Jurisdiction over a Given Problem
- Contribution Expected from Each Member
- Control of the Military Capability of the Alliance
- Perceptions of the Alliance Goals

Environmental Factors

- "Spill-Over" Disputes Over Issues Outside the Alliance Jurisdiction
- Formation of Opposing Groups within the Alliance

It is not always the case, however, that domestic change affects alliances. The U. S. , for example, has had several administration changes since NATO was formed and none of them changed significantly the U. S. role in NATO. Indeed, we are accustomed to believing that—short of revolution—political changes in the U. S. are unlikely to lead to drastic changes in foreign policy. There may be grumblings, but there are not likely to be drastic revisions.

What, then, about a sudden radical change such as a coup d' etat in Latin America? Here, I think it is important to note what caused the coup. Usually, it is concerned with domestic issues and has little to do with foreign policy. I suspect that most opposition groups who find it necessary to resort to violence to remove incumbents are not fighting about foreign policy issues. In fact, once they take office, they may go to great lengths to maintain existing international ties, particularly military ones. They have the problem of reconstructing what may be a chaotic society and have neither the time nor money to institute new defense and foreign policies.

Economic Growth

When economic benefits have been a major inducement to a nation to join an alliance, it might be supposed that economic growth would tend to make alliance membership less attractive. Suppose that the world consists of one large nation and several relatively small ones. The small nations ally with each other in order to balance, or perhaps overbalance, the large nation. If one of these nations begins to grow dramatically, then it becomes less sensible for him to stay in the alliance. He may feel that he does not need his allies any more, or that they are inhibiting his actions.

Related to this is a theory of alliance formation called "the minimum winning coalition theory". In general, this theory states that coalitions will collect only the minimum number of members necessary to be successful. Let's suppose, for example, that a parliamentary-type country with a proliferation

of political parties has just held an election. The State Labor Party received 35 percent of the votes; the National Leisure Party, 16 percent; and the remaining 49 percent were divided among ten parties, not one of which received over 5 percent. To form a government, the State Labor Party and the National Leisure Party can get together. Since they don't need anyone else, the theory, as well as practical politics, says they would certainly not wish to invite anyone else in to share the power.

It has been suggested that nations form alliances on the basis of this theory. They combine only in sufficient strength to achieve whatever is the goal of the alliance. Should the alliance grow beyond this, it will disintegrate.

In support of this theory, it does appear that alliances tend to stay small. Sullivan has shown that, for example, of the 130 alliances existing between 1815 and 1939, 101 had only two members at the time of their formation. Nevertheless, control, communication, and organizational problems could also explain the preference for small alliances.

There are also more serious objections to applying the "minimum winning coalition" concept to international alliances. For one thing, it is not possible to measure "alliance strength" so precisely that only "what is needed to win" can be collected. Again, when the alliance has the objective of defending an area, then it may need the cooperation of all nations in that area, regardless of their "strength". For example, Luxembourg does not contribute overwhelming military capability to NATO. But consider the effect on NATO of Luxembourg as a member of the Warsaw Pact—complete with a Soviet military base located there.

We may summarize by saying that, in some cases, economic growth can be a disruptive effect on alliances. Nevertheless, this may not be bad. Consider the position of the U. S. if the Alliance for Progress disintegrated because all of its members became prosperous.

On the other hand, while the sizes of alliances appear to remain small, there is as yet no theory to specify exactly what the "proper" size of an alliance should be.

Technological Change

The role of technological change as a factor in modifying France's perception of NATO's ability to be sufficiently effective has been discussed. What other effects can technological change have? Apparently, the indiscriminate spread of technology can be very disruptive. Think of a world in which weapons are so cheap and readily available that every nation can develop a ground force capability, a missile capability, a nuclear capability, etc. Each nation could say to its alliance partners, "I've got everything the alliance offers; why should I stay in?" A recent, rather imaginative study of the effect of the spread of nuclear capability suggested that this is a very disruptive process. This study employed Northwestern University's Inter-Nation Simulation. College students played the roles of national decision-makers, starting with the world very much as it was in the 1950's; that is, a bi-polar world with only two nuclear powers.

The students were allowed to play a number of time periods during which the two blocs exhibited a great deal of cohesion. There was positive communication among leaders and followers in each bloc, and, at the same time, perceptions of the other side, particularly by the followers, were primarily hostile. At this point in the simulation, the game director began allowing the followers to acquire nuclear capabilities. While cohesion within the two blocs remained the same, each bloc's perception of the other changed and became much less hostile. Since a decrease in the level of perceived threat can be a factor in weakening alliances, we might suppose that, in time, the simulated blocs in this hypothetical world would tend to break up.

The message of this study for the policy-maker is not clear. It might seem to suggest that if you wish to maintain your alliance, then you must prevent your followers from developing an increased military capability. This, of course, has the effect of weakening, or at least, of not increasing, the military strength of the alliance—hardly a desirable goal. Maintaining tight control over weapons seems even less desirable when you remember that the alliance remained strong because the threat remained high. Since the purpose of the alliance was to counter the threat, a rational leader should be happy to see both the threat and the alliance disappear.

On the other hand, this study might appear to suggest that, to remove the threat, you should spread nuclear weapons around. On the whole, one might conclude that, while the college kids had a lot of fun playing with hypothetical nuclear weapons, there is not much guidance here for a policy-maker with the real thing.

Before I leave this subject, I want to suggest that it would be very interesting to know if the Chinese broke with the Russians because they had a nuclear capability of their own, or whether they felt they had to develop the capability because they did not trust the Soviet "nuclear umbrella."

III. The Effect of Alliances

I shall have least to say about what is probably the most critical of the policy-maker's alliance questions. "What is the effect of alliances on the rest of the world?" Answers to this question can range from "Crucial, decisive" to "Probably, none at all".

Some scholars claim that the alliances at the turn of the century led to World War I. They argue that the crystallization and partitioning brought about by the Triple Entente and the Triple Alliance increased hostilities and tensions to the point of making peaceful settlement of disputes impossible.

On the other hand, it has been argued that the existence of alliances, or at least one alliance, NATO, has insured stability in Western Europe. Here the argument is that the solidification of commitments has reduced the uncertainty about the U. S. response to an invasion of Western Europe. This has in turn served as a deterrent to a Soviet invasion.

On the other hand, our alliances designed to alleviate some of the world's pressing economic problems have had depressingly poor overall results.

While the question of the effect of alliances on the rest of the world is a crucial one for the policy-maker, the reverse question: "What is the effect of the rest of the world on an alliance?" is also interesting. In the next workshop session you are going to look into some aspects of this question by investigating the behavior of alliance members during an internal crisis. In addition to the intra-alliance effects, you will also investigate the behavior of the opposing bloc during this time.

QUANTITATIVE INVESTIGATION OF THE EFFECT OF A CRISIS
ON ALLIANCES (Session 12)

Lecture Outline

I. The Problem

The Czech Crisis of 1968
Why Study a Crisis?
What is a Crisis?
What are Appropriate Study Questions?

II. The Data-File

Structure of the Data-File
Content of the Workshop File (WEISAL/T)
Comparison of WEISAL/T and the Total WEIS File
Data Sources
Single Source
Interpretation Problems

Workshop Exercises

QUANTITATIVE INVESTIGATION OF THE EFFECT OF A
CRISIS ON ALLIANCES (Session 12)

I. The Problem: A Comparison of NATO and Warsaw Pact Behavior
During the Czech Crisis

The Czech Crisis of 1968

At 1:10 a. m. on a soft summer night in 1968 the Prague radio interrupted a program of music to announce that, at 11 p. m. on August 20, troops of the Soviet Union, the Polish People's Republic, the Hungarian People's Republic, the German Democratic People's Republic, and the Bulgarian People's Republic had crossed the Czech frontiers.

Within days, over 200,000 soldiers of the 5 Warsaw Pact countries streamed across the Czech borders. While the world held its collective breath, the faint efforts at Czech resistance were wiped out, and within two weeks the country struggled back to some outward appearance of its pre-invasion status.

Since that time these events have been studied and re-studied many times and we have chosen this Czech Crisis of 1968 as the background for your investigation of the effects of a crisis on an alliance.

Why Study a Crisis?

Why did we set your study of alliances against this background? As we have seen, a major reason for developing alliances is to have external support available when it is needed. The best place, then, to study the effectiveness and cohesion of an alliance is during a period of testing—that is, during a time when one of the members is involved in a crisis.

What is a Crisis?

What is a crisis anyway? In addition to the Czech crisis, we have had the Cuban Missile Crisis and the France-NATO crisis and the "dollar" crisis. How do we know these periods were crises? What factors were involved?

In the Czech and Cuban cases, the threat of war was involved but not all of these situations we term "crises" contained that threat. What else is involved in a crisis? I would suggest that a crisis arises when something happens that is very different from previous practice. Kennedy is awakened one morning at 3 a. m. and is told that there are missiles in Cuba. DeGaulle suddenly pulls France out of the military structure of NATO. Speculators begin to sell unusually large numbers of dollars to buy marks. The key words in these descriptions are "suddenly" and "unusually." These happenings became crises because they were different and unexpected and threatened to lead to unpleasant consequences, at least from the viewpoint of the U. S.

For our purposes here, we can, then, define a "crisis" as "a radical departure from existing behavior patterns that creates a sense of threat." This departure from the normal may take rather strange forms. Consider the case of Quemoy and Matsu from the mid-fifties to the early sixties. The People's Republic of China and the Nationalist forces on Taiwan exchanged firings every day, day after day. A crisis was created when one side failed to fire one day. Everyone else started wondering what they were up to. Were they going to make a peaceful move, were they going to escalate, or what were they going to do? Over time the shelling became normal and any departure became a cause for concern.

What Are Appropriate Study Questions?

The general topic on which you will focus during this workshop is alliance maintenance during a crisis. The first step in carrying out any study is to

break the general topic down into specific questions to be answered. The workshop exercises give some suggestions for questions that may be answered from the data-files available to you.

II. The Data-File

Structure of the Data-File

In this workshop you have available a subset of the World Event Interaction Survey (WEIS) data. This file, WEISAL/T, is described in your Data-File Analysis Manual. It can be pictured as a matrix in which each column corresponds to one variable. The variable names are shown across the top of the matrix and are intended to be mnemonic. For example, the first variable, SUCPCZ, is the number of Soviet Union CooPerative acts toward Czechoslovakia. The second, SUCNCZ, is the number of Soviet Union CoNflictual acts toward Czechoslovakia. The variable names are defined in the Manual. The rows in the data-file represent time expressed by year and month. For example, 6705 refers to May 1967. The data, then, are the numbers of monthly cooperative and conflictual acts directed from a single nation, or a group of nations (NATO and Warsaw Pact) toward one another. Each entry in the matrix thus represents the sum of acts over one month. A value of zero indicates that there were no acts for that month; it does not mean missing data.

These data differ in a few important ways from the original, and much larger, WEIS file. Since the workshop problem concerns alliances, the set of actors includes both nations and groups of nations, NATO and the Warsaw Pact. Furthermore, we have selected the time span from May 1967 to November 1969. This includes the fifteen months before the Soviet invasion of Czechoslovakia, and the fifteen months after. This allows you to examine the behavior of the principal actors before, during, and after a serious crisis.

The total WEIS file includes counts of 63 act types. We have arbitrarily aggregated these 63 categories into 2: cooperation and conflict. Although this makes the data more easily handled, such an aggregation loses distinctions between different kinds of conflict and cooperation acts. For example, the actual Soviet invasion of Czechoslovakia is counted as one conflict act, although in importance it is hardly equal to, say, an Albanian protest, also counted as one conflict act.

This raises the question of whether the data should be weighted, or scaled, in some way. This question, in fact, is not unique to this workshop; it has been the subject of a five year controversy. Scaling factors have been developed for WEIS data, but there are problems. What are the "most cooperative" and the "least cooperative" acts? Perhaps more important is the problem of "wiping out" data. Suppose type "1" act is the most cooperative act and is given a weight of 10. On the same scale, a type "10" is the least cooperative act and has a value of 1. One type "1" act will overshadow several type "10" acts. So, why bother to collect type 10 acts at all?

With these and other problems in mind, the director of WEIS data collection, Professor Charles McClelland, decided to collect the raw data and take up scaling as a separate matter. Thus, the codes that identify the WEIS events have no arithmetic significance—act "1" is not 1/2 of act "2."

Data Sources

The source of the WEIS data is the New York Times. Thus, "zeros" in the data indicate that, according to the New York Times, there were no acts. However, acts may in fact have occurred which the Times has not picked up. Studies by the WEIS staff comparing Times coverage with other sources—for example, the Paris newspaper, Le Monde—indicate that the Times does miss some events. However, it is clear that the Times is probably the best single source of data—at least of those published in English.

The question of how to treat the zero entries is really a problem of interpreting results. What is the "bias" of the Times compared with the "biases" of other data sources? Are there types of acts that are systematically not reported? Or, are the omissions rather evenly distributed across the categories? The WEIS staff studies treat some of these questions. For our purposes in this workshop, these questions are not so important because the data you will be using is highly aggregated.

There is, however, another question crucial to the interpretation of the results. Does a set of primarily hostile acts merely reflect a nation's diplomatic "style," or is it the result of a conscious policy? One approach to this problem is the use of past experience. For example, an increase in the number of conflict acts from Bulgaria to Czechoslovakia may have less significance than a comparable increase from Poland, since Bulgaria has traditionally acted in a more hostile manner.

Rather than depend on his memory or impressions of past behavior, a political scientist may wish to construct a quantitative measure of a nation's diplomatic "style." One such measure might be an "index of conflict," perhaps defined as:

(total number of conflict acts/total acts of all types)

Changes from this index might then be interpreted as purposeful deviations from the normal policy. You might also find that the magnitude of changes that could be considered significant varies among the nations. For example, a small increase in Polish conflict output is much more significant than even a larger increase from Bulgaria.

In general, there are two questions that you should consider in interpreting the results of data-file analysis:

- What are the limitations and biases of the data sources?
- What are the quantities represented by the data? Exactly what is being measured and what is the significance of changes and trends in the data?

Interpretation of your results will be more realistic if these and related problems are considered.

WORKSHOP EXERCISES

Session 12

QUANTITATIVE INVESTIGATION OF THE EFFECT OF A CRISIS ON ALLIANCES

General Theme:

The reaction of alliances to internal and external crisis.

General Question:

What effect did the Czech crisis have on the behavior of NATO and the Warsaw Pact?

Suggested Study Questions:

Identification of the Crisis.

1. Can you determine from the event-interaction data that a "crisis" occurred during the 31-month period covered by the data?
2. When did the crisis occur and how long did it last?
3. What data, other than the event-data, would have helped in the identification and location of the crisis?
4. The data-file that you have used covered periods both before and after the crisis. Using just the data for the period before the peak of the crisis, could you have predicted that a crisis might occur?
6. What data other than the event data would have been useful in this prediction?

Effect of the Crisis on Alliance Cohesion.

6. Can you operationalize the concept of alliance cohesion from the event data?
7. How did the cohesion of the two alliances change after the crisis?

Effect of an Internal Crisis on the Behavior of Alliance Members.

From the viewpoint of the Warsaw Pact nations, this is an internal crisis; that is, they are not facing an external threat, but an internal disagreement.

8. Develop hypotheses about the behavior during such a crisis of the alliance as a whole, the bloc leader, and the other members of the alliance.

Effect of an External Crisis on the Behavior of Alliance Members

From the viewpoint of the NATO countries, this is an external crisis. It might possibly be termed a "second-order" crisis since none of the NATO nations were threatened directly, but only in the sense that any threat, regardless of its target, threatens the peace and security of the rest of the world.

9. What would you predict about the behavior of the NATO nations, both individually, and acting as a group, during and after such a crisis?

Extension of the Analysis to Prediction.

10. These hypotheses about behavior can be checked against the data-file. Is it possible to make predictions about what might have happened if the events had been different? For example, what type of behavior would you expect from NATO and the Warsaw Pact if the crisis had involved a NATO nation?

Aid for the Policy-Maker.

11. If you had been involved in formulating U. S. foreign policy during the period immediately following the Czech crisis, would you have found this analysis helpful?
12. What additional questions would you have asked?
13. What additional data would you have liked to see?

DISCUSSION: RESULTS OF CLASS WORK ON THE ALLIANCE PROBLEM
(Session 13)

No formal lecture is given during this discussion period. The instructor may follow the outline below:

I. Reports by the Student Teams

Objectives

Approaches

Results

II. Discussions of Methodology

III. Discussion of the Data-File

Source

Completeness

INTRODUCTION TO SIMULATION (Session 14)

Lecture Outline

I. Questions about Simulation

What is Simulation?

Why is Simulation Used?

The Time Scale of the Real World is Inconvenient

The Real System Operations are too Expensive

Real System Operations are too Dangerous

The System is not Available for Experimentation

Where is Simulation Used?

II. Simulation in International Relations

All-Computer

Man-Computer

III. Model Development: Empirical vs. Judgmental Models

IV. Example of an Empirical Model

The Developer's Objective

The Variables

The Role of Judgment

The Analytical Method

Model Validation

Uses of the Model

I. Questions About Simulation

Simulation is the second of the two quantitative techniques to be presented in this course. The sessions to this point were devoted to the first: Data-File Analysis. You have seen how data can be collected, structured, analyzed, and used as an aid in investigating problems in the area of international politics.

Today we want to take a broad look at some general aspects of simulation, survey what is currently going on in the field of international relations with respect to simulation, and look closer at an example of one particular type of model.

When you are introduced to something new, whatever the subject and whatever the context, there are some pretty standard questions you want answered.

What is Simulation?

First, you want to know: What is it? Since this is a course in Quantitative techniques, you might assume that simulation is a quantitative technique. Fair enough. But a lot of things are quantitative techniques, and simulation cannot be all of them. So exactly what is simulation?

You will not be surprised to learn that analysts do not agree on how simulation should be defined. You will hear many terms—"pure simulation", "computer simulation", "computer-assisted gaming", "two-person gaming", "man-computer model", etc. For the students in our public course in the Simulation of Military Operations, I collected about 20 definitions of

simulation and modeling from the current literature. Each definition is just subtly different from the rest. One of the definitions of model includes what even the man-in-the-street thinks of as a "model." Recently I put my foot in my mouth and broke up a class at the Army War College by suggesting that the one thing that scientists, engineers, military analysts, political scientists, etc., have in common is that they all use models. After the laughter subsided, I carefully avoided the use of the word and referred to an "analytical technique."

Recognizing that there are differences in the use of the term "Simulation", I would like to define it for these discussions quite simply as the "development and use of a replica of a system rather than the system itself". This replica is then the model of the system.

Why is Simulation Used?

The second standard question, an obvious one to ask here, is: Why? If you are attempting to learn something about the real-world system, why do you build a model instead of going directly to the system? I would like to suggest some of the reasons:

The time scale of the real world system is inconvenient. In some physical systems—nuclear processes or computer operations—things happen much too fast for a human observer; in the case of international political systems, processes may be much too slow. You may wish to study international operations that occur over weeks or months or even years, but you will rarely have that long to get answers to your questions.

The real system operations are too expensive. An aircraft designer trying to decide on a wing configuration cannot afford to build and test dozens of prototypes to find the optimum design. In the international area, changing the price of gold merely to find the consequences is obviously not acceptable.

Real system operations are too dangerous. Precipitating an international crisis just to find out what causes a crisis or how to handle it is not acceptable either.

The system is not available for experimentation. Either it exists only on paper, or there is only one and the analysts cannot experiment on it. In the field of international politics, this is clearly a major reason. The real world is real and it cannot be used for experiments. (It is, of course, possible to study historical real-world operations; but then we can investigate only these phenomena that have occurred; we cannot ask hypothetical what-if type questions).

For all these reasons, most analytical investigations in a wide variety of fields involve the use of system replicas, or models.

Where is Simulation Used?

After What and Why, the next question is Where? Just where have models been used?

The earliest, and to date probably the most successful, use of models has been in the physical sciences. Indeed the whole of theoretical physics, for example, could be regarded as the development of models to be tested by experimental physics. Probably it is the success of modeling in this area that has encouraged analysts in other areas to try it.

Of course, models are widely used in engineering and, as I mentioned, in system design.

Industrial Operations Research groups use quite a large variety of models—models of warehouses, transportation systems, manufacturing processes. There are even models of hospitals, and a recent RAND study employed a model of the stock market to suggest that stockbrokers could save money by revising some of their operations.

However, you are probably most familiar with the use of modeling in the analysis of military tactics and strategies—in the form of war gaming. You may not have thought of war gaming as simulation, but it is an activity in which the analyst attempts to learn something about the behavior of a real system (a military force) by using a model of warfare, rather than resorting to warfare itself.

Among the latest fields to which simulation has been introduced are the social sciences. Its use in this area is still very new; in international relations, probably only about ten years or so. Professor Harold Guetzkow, one of the leaders in this field, has estimated that, even today, of all the political scientists, perhaps only about 10 percent are quantitatively oriented. I think you will find it interesting that of the published research papers, however, about 75 percent of them describe quantitative work.

In spite of its short lifetime, there has been a tremendous amount of work in simulation and modeling going on in the social sciences. A recently completed study by C. A. C. I. for the National War College summarizes this work. For that project around 90 or so models were surveyed. Out of the complete list, descriptions for over 50 were included in the report. Now we want to spend a few minutes looking at what is going on in this area.

II. Simulation in International Relations

Models in international relations fall into one of three categories. The first is the manual game, which is the closest to the old war game. The original manual game in International Relations is the Political Military Exercise designed by Lincoln Bloomfield and his colleagues at MIT. The Political Military Exercise involves nation teams, an umpire who is called "Control", and a scenario. The scenario, of course, depends on what the experimentors are studying. The teams vary with the scenario, but to date all the uses of PME have included the U. S. and Soviet Union. In addition

to playing the President, members of the team assume roles as representatives of specific political entities, like the National Security Council for the U. S. , or the Politburo for the Soviet Union.

PME has been used in some very interesting, policy-relevant studies. One involved an assessment of the effect of naval weapons systems on U. S. deterrent. The study involved six runs of the Political Military Exercise—three involving experienced decision-makers in both the military and political worlds, and then three runs which students, both as a control against the results with the actual decision-makers and also as a pre-test for the runs using the actual experts. The study was rather rigorously conducted. The participants were asked to fill out a questionnaire during and after the runs. The staff then conducted several follow-up interviews. As a result of the six runs, which took place over about a year and a half, the MIT group made several observations. The major conclusion was that most of the confrontations and escalations between "nations" were the result of misinterpretation of the intentions of the nations teams. The breakdown in international communications was what resulted in warfare—in the simulation anyway—rather than the actual intent of one team to be aggressive or to disrupt the international system.

All Computer

At the other end of the spectrum is the second type of simulation, the all-computer simulation. In an all-computer game, computer programs simulate the activity of nations in the international system rather than human participants. The earliest example of this form in international relations was the Simple Diplomatic Game, which was designed by Oliver Benson at the University of Oklahoma. In the Simple Diplomatic Game, a computer program simulates the activity of about eighteen nations in the international system. The user simply initiates the simulation by specifying a particular nation, an action that it takes, and the nation to which it is directing this action. He also specifies the intensity of the action on a

scale from one to nine, with one being a diplomatic protest and nine being all-out war. Then the computer program takes over. It calculates the effect of this action on the original nation's share of the world's power; it also generates a counter-response from some other nation in the system. As a result of the counter-response, it recalculates all nations' shares of the world's power.

Man-Computer

The third type of game in international relations, as you might expect, is half-way between the two. It is the man-computer simulation and it borrows the use of human participants from the manual games like PME and the computer program from the all-computer simulations like the Simple Diplomatic Game. The granddaddy of the man-computer games is the Inter-Nation Simulation (INS) which was designed by Harold Guetzkow at Northwestern. INS uses human participants, as does the Political Military Exercise. Participants assume roles as members of nation teams only these are fictitious nations. The teams interact and negotiate, conduct trade and aid agreements, and arrange military alliances. They also make domestic and budgetary decisions. At the end of each decision cycle, the computer program generates indicators of the state of the nation—such things as domestic satisfaction with the policies of the administration and military capabilities for each nation.

PRINCE, which you will be using next week, is very similar. It is a man-computer simulation like INS and, in fact, it is thought of as a third generation INS. The designer, Bill Coplin, studied under Harold Guetzkow in the early part of his career. PRINCE is different in one important way from INS. In PRINCE, the students interact directly with a computer program. The student sits at a terminal, interacting with the programmed world. In INS, team organizers handled computer output for the students, rather than allowing them experience at the terminal.

Just as there are different types of simulation—the manual, all-computer, and man-computer—there are also different purposes for which models are designed. Generally, these purposes fall into two categories, teaching and research. PRINCE, which you will play, is designed for teaching. For the teaching simulations, the intent is to create a replica of the world, let people live in it for awhile, and learn some things about the real world they might not learn otherwise—trade-off values, the tensions of crises, etc. The research simulations are slightly different. Most of them are batch programs which means that running them requires some technical knowledge of submitting programs to computers. There are, of course, exceptions. PME, which I already mentioned as the original manual game, has been used quite extensively in research and on policy poses, but has also been used in deterrent studies focusing on the effect of a second strike capability on the U. S. deterrent position, and also in more recent years, the focus on research simulations has been on an attempt to study alternative policies, to ask "what if" questions. What if we had changed our military and political strategy in Vietnam? What would have been the effect on President Johnson's popular support? We will talk later about a simulation which attempts to answer some of these questions.

III. Model Development: Empirical vs. Judgmental Models

The next thing you want to know about something to which you have been introduced, after you have been told what it is, why it is, and where it is, is How? In this case, how are models developed?

Very basically, it can be said that models are developed out of information. Let me spend a minute clarifying that apparently simplistic, almost trivial statement. If you reflect about what has gone on here for the last six weeks, it will be apparent that information—its care and handling—is what this course is all about. We discussed what constitutes information in this field, how you collect it, how you aggregate it, transform it, analyze it, and use it in making decisions.

Let me point out that information comes in the two seemingly different forms indicated in Figure 1. On the one hand, we have what we refer to as data: facts, numerical values which have come from some measuring process. Counting events in newspapers, connecting voltmeters into an electrical circuit—these processes produce numerical facts. This is the kind of information treated in the first part of this course. This kind of information can be collected into data-files. First, you learned to carry out simple statistical tests on this kind of information. You did things like plot it, computer means and variances. Then, more complex statistical techniques were introduced.

If you select a data base and if you carry out quite complex sets of statistical operations, you can pass over into what are called empirical models—that is, models which are developed by statistical techniques directly out of the data itself. Later an example of one of these models will be presented.

Now I want to go on and point out the other form that information can take. It can consist, not only of specific facts or numbers, but of all the knowledge that a person keeps in his head, the net result of everything he has learned, perhaps over a lifetime of study and experience. This form of a person's general background knowledge becomes finally his judgment or his intuition. Out of this kind of information are derived what we refer to as judgmental models. These are models based on what the developer knows about the operations of the system, although he cannot point to any specific set of data and say, "This element is in my model and the relationship between these two elements is this, because of this particular set of facts or numbers." He can say: "It is there because I know that is an important element, or because I know that is the way these elements behave in the real world."

There is a tendency that I note in some places for people to believe that a great deal more credibility can be placed in the empirical model which comes right out of the real world data, rather than one which depends solely

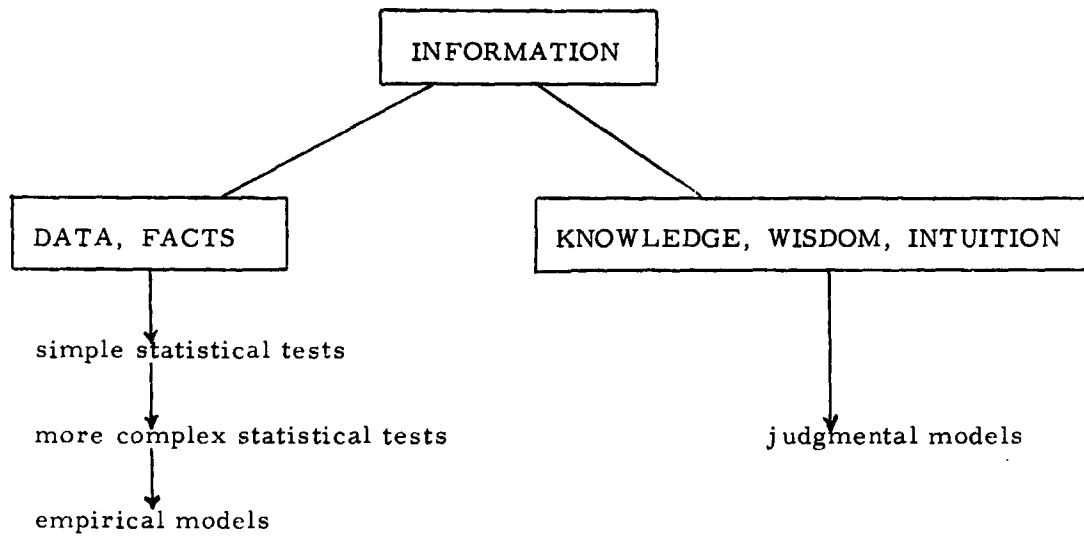

FIG. 1: THE TWO MAJOR FORMS OF INFORMATION

on somebody's judgment or intuition. Let me point out that the information base from which a judgmental model comes may indeed be far broader, far richer, than one single collection of data and one single collection of facts. If several people are involved in developing the model, it will be based on their combined experiences and can, in fact, be a very accurate representation of the way the real system operates, while the model built entirely on the data set can only reflect the range and quality of events that happened in the (usually) more limited period.

Both the NEXUS and the PRINCE models, which you will play, are judgmental models. They are based on the designers' knowledge of how international systems interact. Later on, after we have finished the play of the games, we will have a critique session in which we examine again the basis for these models, and try to see exactly what the developer has done.

IV. Example of an Empirical Model

The Developer's Objective

Now we are going back to the empirical model to discuss an example of this type.* It was developed by Jeff Milstein and William Mitchell at Stanford in 1966-67. They called it "A Model of the Vietnam War." A less all-inclusive title like "A Model of Some Aspects of the Vietnam War" might, perhaps, be preferable. Although this is an example of an empirical model developed out of data, you will see that a great deal of judgment was also involved.

*This discussion, the tables and figures shown here are taken from: Jeffrey S. Milstein and William Charles Mitchell, "Computer Simulation of International Process: The Vietnam War and the Pre-World War I Naval Race," Yale Papers in Political Science No. 38, Yale University, Office of Advanced Political Studies.

The authors' original objective in developing this model was research rather than teaching. In particular, they wanted to be able to ask "what if" questions about the Vietnam War. What if we had, instead of doing "X", done "Y"? What if we just plain had not done "Y" at all, and that particular policy or action just never happened? What might have been the effects on other aspects of the war? That was their original purpose.

The Variables

Table I shows the variables selected for the model. Each one was chosen to represent some concept. (This is the process of "operationalization" discussed earlier in this course). For example, variables such as the number of defectors and the black market value of the piastre are related to some kind of "morale" concept. Specifically, the black market piastre value was taken to be a measure of confidence in the South Vietnamese government. In addition to these "concept-related" variables, they added some "dummy" variables to represent factors such as the seasons. And for most of the variables they used not only the absolute values for accumulated, or averaged, over a month, but also month-to-month differences and month-to-month proportional changes. These additions brought the total number of variables to over forty.

The sources for the values of their variables were, principally, reports in the New York Times. For example, public opinion data came from Gallup Poll results published there. In addition, they did have access to some unclassified Department of Defense data, like number of civilians in South Vietnam killed or abducted.

The Role of Judgment

This brings us to the question: What was the role of judgment here? This model, and thus all the results and conclusions drawn from it, depend on these fifteen base variables, which were expanded to about forty by including

Table 1
Variables in the Vietnam War Model

1. The number of North Vietnamese and Viet Cong defectors.
2. The number of civilians in South Vietnam killed by the Viet Cong.
3. The number of civilians in South Vietnam abducted by the Viet Cong.
4. The margin of public opinion support for the administration's Vietnam policy (Gallup Poll approval minus disapproval).
5. The Saigon black market value of the South Vietnamese currency (piastre).
6. The monthly change in U. S. troop levels.
7. The number of battalion-size or larger U. S. ground operations.
8. The number of bombing attack sorties by the U. S. in South Vietnam.
9. The number of bombing missions by the U. S. over North Vietnam.
10. The number of U. S. troops killed in action.
11. The number of North Vietnamese and Viet Cong troops reported killed in action.
12. The number of Army of the Republic of Vietnam troops killed in action.
13. The ratio of Communist-to-allied troops killed in action.
14. Dummy variable to represent seasonal factors.
15. Dummy variable to represent the Christmas-Tet holiday period.

differences and proportional changes. Already, judgment has been exercised in deciding which variables to include and which to ignore. Very many variables might have been used; each of you could probably think of a number of additional factors you suspect might have been important. In many cases, variables were included merely because values were available; others omitted because values were not available. The main point here is that a great measure of judgment was necessary in the selection of both the variables and the sources for values of those variables.

In addition to the base variables, they also used their judgment in selecting time lags for derivative variables suspected of being related. For example, you may think that there is a relationship between U. S. bombing in the North and the number of Vietcong and North Vietnam defectors. However, this effect will not be observed instantaneously. We may carry out bombing missions today, but we will not observe any great differences in the numbers of defectors in the South today; some time lag is involved.

The Analytical Method

The mathematical techniques employed in the development of this model are based on multiple step-wise regression. Let me explain the technique with a very simple example.

A factor of major interest was the number of U. S. troops killed in action during a given month. It is suspected that this depends on the number of combat engagements and the number of U. S. bombing missions. In some cases, as many as five factors were hypothesized. The variable of main interest (here, U. S. troops killed in action) was taken to be the dependent variable, Y , and the factors contributing to it were taken to be the independent variables X_1, X_2, X_3, \dots etc., in a linear relationship of the form,

$$Y = A_0 + A_1 X_1 + A_2 X_2 + A_3 X_3 + \dots$$

A series of multiple regressions produced values of the coefficients (the A's), which measure their relative "weights", or importance in predicting the value of Y.

The "model" consists, then, of a complex set of equations of this form in which values of the coefficients are determined from regression techniques. In general, the predicted value of each base variable is a function of the previous month's values for all of the values, weighted, of course, by the computed coefficient.

Model Validation

By starting with five months of real-world data and "running" this model, out beyond these five months, one arrives at a time when the model is making pure predictions on the basis of its own internal structure. Comparison of these values predicted by the model with real-world data is a way of determining the "validity" of the model. For example, Figure 1 shows the predicted and actual values of U. S. troops killed in action during the period 1965-68.

Uses of the Model

After a series of such validations, the developers felt that the model was a fair representation of the historical relationships among the selected variables. Now they were ready to use the model to explore the consequences of historical alternatives; that is, to ask questions of the "What would have happened if...?" type.

Table 2 shows the results of a number of such explorations. From this table, the authors draw a number of conclusions relevant to U. S. policy decisions. For example,

"It appeared that the North Vietnamese and Viet Cong respond to U. S. de-escalation with their own de-escalation. They reduce the number of killings and abductions of civilians and

Figure 1

U. S. Bombing Missions Over North Vietnam, Jan., 1965-July, 1968

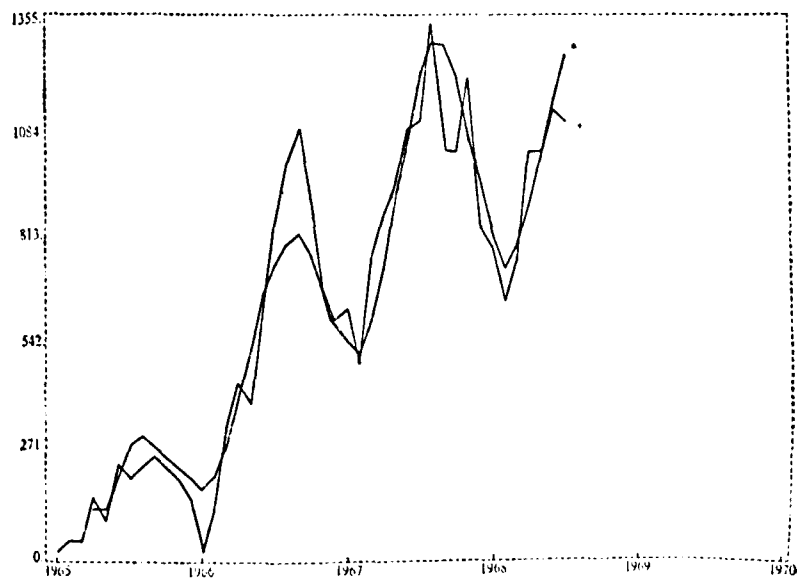

* Simulated number
† Actual number

Table 2

Results of Selected Exercises of the Computer Simulation

Dependent Variable	Halt Bombing of NV	Reduce Bombing in SV	Reduce Ground Operations	Reduce U.S. Troops
VC Defectors	More; increased in 1967, rather than decreased; continue to increase after 1967	Fewer in 1967	More; increased in 1967, not decreased	Increased last half of 1967
VC Killing of Civilians	Decrease from March, 1966, on, rather than increase	Fewer in late 1966, then increase to same level as actual values	Much fewer throughout	Decrease from mid-1967
VC Abductions of Civilians	Decrease after May, 1967, rather than increase	Fewer in late 1966, no change otherwise	Fewer throughout	Decrease from mid-1967
Popular Support for LBJ	Greater overall	Same downward trend, but greater support	No change	Greater
Piastre Value (Confidence in GVN)	First increases, then collapses to nothing	No change	No systematic change	Consistently lower, but not catastrophic
U.S. Troop Commitments	Accelerate much faster	No systematic change	Greater	—
U.S. Ground Operations	Decrease from Oct., 1966-March, 1967, then increase greatly to actual level and above	Fewer	—	Fewer in 1967
Bombing SV	Less in 1966-67; no difference in trend	—	No change	Less in late 1967
Bombing NV	—	No change	No change	Fewer missions
U.S. Killed in Action	Fewer in 1967 than actual	No systematic change	No change	Fewer, late 1967
NV -- VC KIA	Much fewer; less than U.S.	No systematic change	No change, 1966; fewer in 1967	Much fewer
ARVN KIA	More 1966, less 1967	No change	No change	No change

military offensives most when the U. S. halts the bombing of North Vietnam, and least when the U. S. reduces the bombing in South Vietnam. Communist killings and abductions of civilians are reduced following reduction of U. S. troops and of U. S. major ground operations, but the amount of reduction lies between their responses to reduction in U. S. bombing of North Vietnam on the one hand, and U. S. bombing of South Vietnam on the other hand. Moreover, reductions of U. S. ground operations seem to be a signal responded to by the Communists at the local level. Those variables changed are those over which local Viet Cong leaders have some control: fewer Viet Cong killings and abductions of civilians."

This table appears to indicate that all kinds of good things would have happened if President Johnson had halted the bombing permanently.

There would have been more VC defectors, fewer civilians killed and abducted, fewer casualties on both sides and popular support in the U. S. for the administration's policies would have been higher. There is one disturbing result: the value of the piastre would have decreased to zero. The authors interpret this to mean that "South Vietnamese confidence in their government seems to be very dependent upon U. S. military commitments to South Vietnam".

Possibly this is an appropriate conclusion for a paper delivered at a conference of the Peace Research Society.

The dangers inherent in drawing conclusions of this type of apparent here. You will remember that what actually goes to zero is the value of the piastre; it is merely an assumption of the model developer that this represents confidence in the South Vietnamese government (it is not clear precisely which governmental characteristics are in question—the government's political stability, justice, or ability to defend its people from foreign

military aggression). Let us suppose that the black market value of the piastre represents the South Vietnamese confidence that this coin will retain its purchasing power. A decrease in U. S. military support might signal to them the increased chances of a Communist take-over—which they could expect to have a disastrous effect on the piastre.

What I would like to do now is to start a general discussion about the advantages and disadvantages of this kind of model. Would anyone care to comment, for example, on whether he feels that this might be a misleading type of analysis? Is it at all useful to ask this kind of "what if" question?

(End of formal lecture period)

The remainder of the class period is devoted to a general discussion by the instructor and students of these models and the value to a policy-maker of analyses of this type.

SIMULATION AND PLANNING: PRESENTATION OF NEXUS (NATIONAL
EXECUTIVE UTILITY SIMULATION) (Session 15)

Lecture Outline

- I. Introduction
- II. NEXUS Presentation
- III. Workshop: Student Play of NEXUS
- IV. Critique and Discussion of NEXUS

SIMULATION AND PLANNING: PRESENTATION OF NEXUS (NATIONAL
EXECUTIVE UTILITY SIMULATION) (Session 15)

Introduction

Two major quantitative techniques will be presented during this course. You have already spent some weeks on the first: statistical analysis of data files. For the next few sessions you will be examining the second: simulation.

Those activities that go by the name simulation cover a very wide range. In its broadest sense simulation has been defined as: "those fields of study, training, and testing that employ a replica of the system under investigation rather than a system itself." This "replica of the system" is usually called a Model.

In our last class, we discussed the two basic ways of developing models:

- directly from specific data - the empirical models,
and
- on the basis of the modeler's knowledge of the
system - the judgmental models.

An example of an empirical model—Jeff Milstein's model of the Vietnam War—was described. Today we want to introduce an example of the judgmental model. It is—as the name implies—developed on the basis of the developer's judgment or his synthesis of other people's judgment. As I said in our last class, this does not mean that it is developed in isolation—somehow apart from the real world. On the contrary, it, too, is developed from "data"—not specific numbers that can be pointed out—but all the developer has seen, read, heard about the operation of the system.

There are literally thousands of such models being used today and, as I tried to indicate, they span a very wide range of activities. On the one hand, we have well-accepted, well-validated models of engineering and the physical sciences. Important design decisions involving millions of dollars are made on the basis of results obtained by the use of such models. There is now no longer any doubt of their value, of their ability to predict the behavior of the systems they represent.

It is hardly necessary, however, to point out to you that modeling in the social sciences has nowhere reached this state of development. There are a number of reasons for this. Let me point out just one.

Models in the physical sciences involve physical variables; i. e., those variables whose units of measurement may be reduced to the three fundamental dimensions: length, time, and mass. Both the variables and techniques to measure them have been developed over at least a couple of thousand years. When physical scientists began, with the help of computers, to build even more complex models, the necessary building blocks were at hand. Concepts—like kinetic and potential energy, momentum, potential difference—were well defined, their measurement units agreed on, and methods of producing numerical values for them were set.

Now let's look at the building blocks in the social sciences. The first readily apparent thing to strike the observer is that there are very few. Possibly, the field of economics is better off in this respect than its sister sciences. Concepts like "goods," "supply," "demand," "GNP," "labor force," "unemployed," etc. are more or less defined. At least people are used to hearing these terms and are usually willing to believe that these concepts are:

- relevant to the field of economics, and
- possible to measure

In the field of International Relations, the model-builder finds no already developed building blocks with which to work. Such concepts as he feels must be important are not defined in the same way by everyone; there is no agreement on how the critical variables can be measured—or even what units should be used to measure them. Thus, the political scientist is in the position of the house builder who can not begin his construction efforts until he has made his own bricks and also convinced the potential home owner that it is possible to build a house, and once it is built, to use it for some worthwhile purpose.

As part of this course in quantitative techniques, we want to show you some of the latest efforts in model-building in this area. Our purpose is to show you specific examples of what has been done, in order to sharpen your critical facilities in judging not only what has been done, but what might be done.

Today you are going to see NEXUS—a model in which you, the player, will assume the role of the executive decision-maker and learn some of the consequences of the decisions you will make. We are very fortunate to have for this session Mr. Roger Magowan of the Department of Defense Computer Institute. Mr. Magowan just happens to be the developer of NEXUS—and therefore the one person best qualified to present it to you.

II. NEXUS Presentation

All material for this presentation was developed by:

Mr. Roger Magowan
Department of Defense Computer Institute
U. S. Naval Station Annex
Washington, D. C. 20390

Inquiries about obtaining and using this material should be addressed to him.

The outline of Mr. Magowan's lecture is given here.

OUTLINE FOR SIMULATION FOR PLANNING

I. Types of Simulation

A. Continuous System Simulation

1. Used in weapons systems R&D and scientific studies.
2. Based on differential equations.
3. Developed by engineers and scientists.
4. Problems solved on digital or analog computers.
5. Programming done by mathematician programmers.

B. Discrete System Simulation

1. Used in weapon systems R&D and all aspects of operations analysis.
2. Based on probability and statistics.
3. Developed by operations research-simulation specialists, a class of system analysts, and functional area specialists.
4. Problems solved on digital computers.
5. Programming done by mathematician-statistician programmers who must be experienced with this class of problem.

II. Planning simulation models are simple discrete system simulation models that rely heavily on managerial judgment as opposed to firm empirical data. Intuitive judgments can be combined with well known relationships and relationships based on current analytic studies in order to develop an integrated system model. This provides a unique experimental tool for executive planning and analysis. (In a recent study of 280 chief executives, 65% identified their most important activity as long-range planning, and they indicated that they spent 44% of their time on it.)

III. Characteristics of Planning Models

- A. They are based on executive judgment.
- B. They are inherently of low accuracy (as a result of simplicity).
- C. They are often small simple models.
- D. They are easily modifiable and open-ended.
- E. They provide a significant enhancement in understanding.
- F. They may or may not include random variables.

IV. Development of Planning Models

- A. Requires only a small amount of programmer assistance.
- B. Requires only part time assistance of an operations research/simulation specialist.
- C. Requires personal involvement (2 to 50% of time) by managers responsible for planning or their staff planning specialists.
- D. Requires 1 to 6 months initial development time.

V. Uses of Planning Models

- A. Policy Analysis
- B. Budget Planning
- C. Goal Setting
- D. Long Range Strategic Planning

VI. Cost of Planning Model Development

- A. Operations research/simulation specialist assistance (\$1,000-\$3,000).
- B. Programming assistance (\$200-\$700).
- C. Manager's time (\$5,000-\$12,000).
- D. Total costs typically on the order of \$10,000.

- VII. The National Executive Utility Simulation (NEXUS) is a simplistic illustration of a planning simulation model. It touches on several aspects of national policy.
 - A. Foreign policy
 - B. Domestic policy
 - C. Military policy
 - D. Political policy
 - E. Fiscal policy

- VIII. Monte Carlo Methods are Used in NEXUS (using pseudo-random numbers).
 - A. Termination of the limited war is a stochastic event.
 - B. Initiation of a new limited war is a stochastic event.
 - C. The occurrence of a nuclear exchange is a stochastic event (the model does not simulate post-nuclear exchange events).

- IX. Monte Carlo Method Approach
 - A. Calculate a probability
 - B. Generate a pseudo-random number or insert a random number.
 - C. Compare the probability with the random number to determine the occurrence of any given event.

- X. Input Parameters (refer to worksheet in user's manual).
 - A. Note \$25 billion deficit in 1968.
 - B. Note 5% interest on national debt (added automatically).
 - C. U. S. Foreign Relations Aggressiveness.
 - 1. Influences probability of terminating war.
 - 2. Influences probability of starting war.

3. Influences probability of nuclear exchange.

4. Confrontations may be represented.

D. Taxation.

1. Influence of corporation and excise taxes on unemployment.

2. Influence of individual income taxes on voter survey.

E. Budget Allocations.

1. Military spending influences war success and cold war trend.

2. Foreign aid influences cold war trend.

3. Other expenditures influence special interest voter blocs.

XI. State of the Nation Report (refer to illustration in user's manual).

A. Budget Summary Data.

B. Unemployment Rate.

1. Corporation taxes and excise taxes.

2. Government spending.

3. Deficit or surplus.

C. War Trend.

D. Internal Unrest.

1. Unemployment rate.

2. Community development and housing, and health and welfare spending.

E. GNP.

1. Unemployment rate.

2. Growth rate.

- F. Cold War Trend.
 - 1. Aggressiveness.
 - 2. Foreign aid.
 - 3. Military spending.
- G. Voter Poll.
- H. U. S. World Influence
 - 1. Voter poll.
 - 2. Cold war trend.
 - 3. Limited war trend.
 - 4. GNP growth rate.
- I. Nuclear War Risk.

XII. Functional Relationships Chart

XIII. Success Criteria

- A. U. S. World Influence (cumulative from .5).
- B. GNP Growth Rate.
- C. Nuclear War Risk (4% normal during limited war).
- D. Voter Poll (53% is near maximum).

XIV. State of the Nation Index

- A. Components
- B. Weighting
- C. Involves explicit statement of national goals.

XV. Strategies

A. Dovish

1. Declining cold war success.
2. Declining U. S. world influence.

B. Hawkish

1. Increasing risk of nuclear exchange.
2. Declining voter support.

C. Middle-of-the-Road

1. Continuing limited war stalemate.
2. Declining voter support.

D. Mixed

XVI. Typical Results

- A. Using 1969 actual budget data.
- B. Hawkish Strategy.
- C. Mixed Strategy.
- D. Appendix A Contains 1969 and Estimated 1970 and 1971 Data.

XVII. Typical Applications Suitable for Use of Planning Models

- A. Joint Strategic Target Planning
- B. Defense Budget Planning
 1. Military personnel
 2. O&M
 3. RDT&E
 4. Procurement (Carriers, ICBMs, Polaris Subs, etc.)

- 5. Intelligence activities
- 6. Military construction
- C. Personnel Policy and Program Influence on Retention of Personnel
- D. Joint Continental Defense Systems Integration Planning
- E. Design of Future DCS
- F. Naval Air Patrol System Operations
- G. Logistic Systems
- H. Transportation System Policy
- I. Intelligence Operations
- J. Economic Policy (DRI Economic Information System)

XVIII. Conclusions

- A. Planning models are too inaccurate for automatic decision making, since many factors are omitted for simplicity's sake.
- B. The user's judgmental understanding inevitably far outdistances the sophistication of the model because he takes into consideration many variables and relationships that have not been included in the model.
- C. Development and use of planning models profoundly sharpens executive decision making.
- D. Planning simulation models generally offer the only feasible means available to the executive for experimenting with a variety of policies, budgets, and strategic plans.

PRESENTATION OF PRINCE (PROGRAMMED INTERNATIONAL
COMPUTER ENVIRONMENT) (Session 16)

Lecture Outline

I. Educational Objectives

II. Basic Model Structure

International Transactions

International Interactions

Domestic Political Reactions

III. Attitudes of the Policy-Influencing Groups

Partisan Groups

Bureaucratic Groups

Interest Groups

PRESENTATION OF PRINCE (PROGRAMMED INTERNATIONAL
COMPUTER ENVIRONMENT) (Session 16)

PRINCE is a one-sided, man-computer game in which the player assumes the responsibility of making United States foreign policy decisions. His role may be thought of as a combination of the duties of the President, the Secretary of State, and other governmental officials who deal with any phase of foreign policy. The model provides a hypothetical international environment for the player in which the actions of four other nations (USSR, FRANCE, INDIA, and PAKISTAN) are simulated by the computer program.

I. Educational Objectives

The purpose of this short briefing is to introduce you to the general nature and structure of PRINCE and the role of the player in the model. PRINCE is, like NEXUS, an example of a judgmentally developed model.

First, I want to say a few words about the educational objectives of the model. The purpose of PRINCE, at least in its current form, is to provide a set of concepts describing the real world. We do not know if these are the best concepts; we do not know if the theories on which the model is based are correct. All we can say now is that the concepts do provide a different perspective on the world. In that sense, the model represents an alternative to a book about the world. It is an interpretation, in a different medium, of the world in which we live. It has no more, but possibly no less, validity than a book.

II. Basic Model Structure

International Transactions

The term "international transactions" refers to the flow of communications,

people, goods and services across national boundaries. It is a concept employed by political scientists to refer to the totality of exchange that takes place among states and includes the transfer of capital and governmental officials as well as the flow of tourists, businessmen, mail, and military equipment. The "natural," or unrestricted, transaction flows among the PRINCE states may be altered if any one state:

- sets restrictions on the flow into the country, or
- grants foreign aid.

While the PRINCE program determines the restriction levels and the foreign aid grants of the Soviet Union, France, India and Pakistan, the player makes those decisions for the United States. During any cycle he can, within limits, set new restrictions and make new aid allocations. If he chooses not to make these changes, existing policies remain in effect. The player's decisions in this area have three effects:

- The pattern of "natural" transaction flows among the five states is modified.
- Expressions of approval or disapproval for these actions are generated among the U. S. domestic influence groups.
- Political actions by the other four nations follow indirectly as responses to these actions.

Figure 1 suggests the relationships among player decisions, actions generated by the program, and information given to the player.

International Interactions

The term "international interactions" refers to the diplomatic actions between states which, in PRINCE, are related to specific policy issues. By "policy issue" we mean a specific political, economic, or social question to which the foreign policy maker of each state directs his attention.

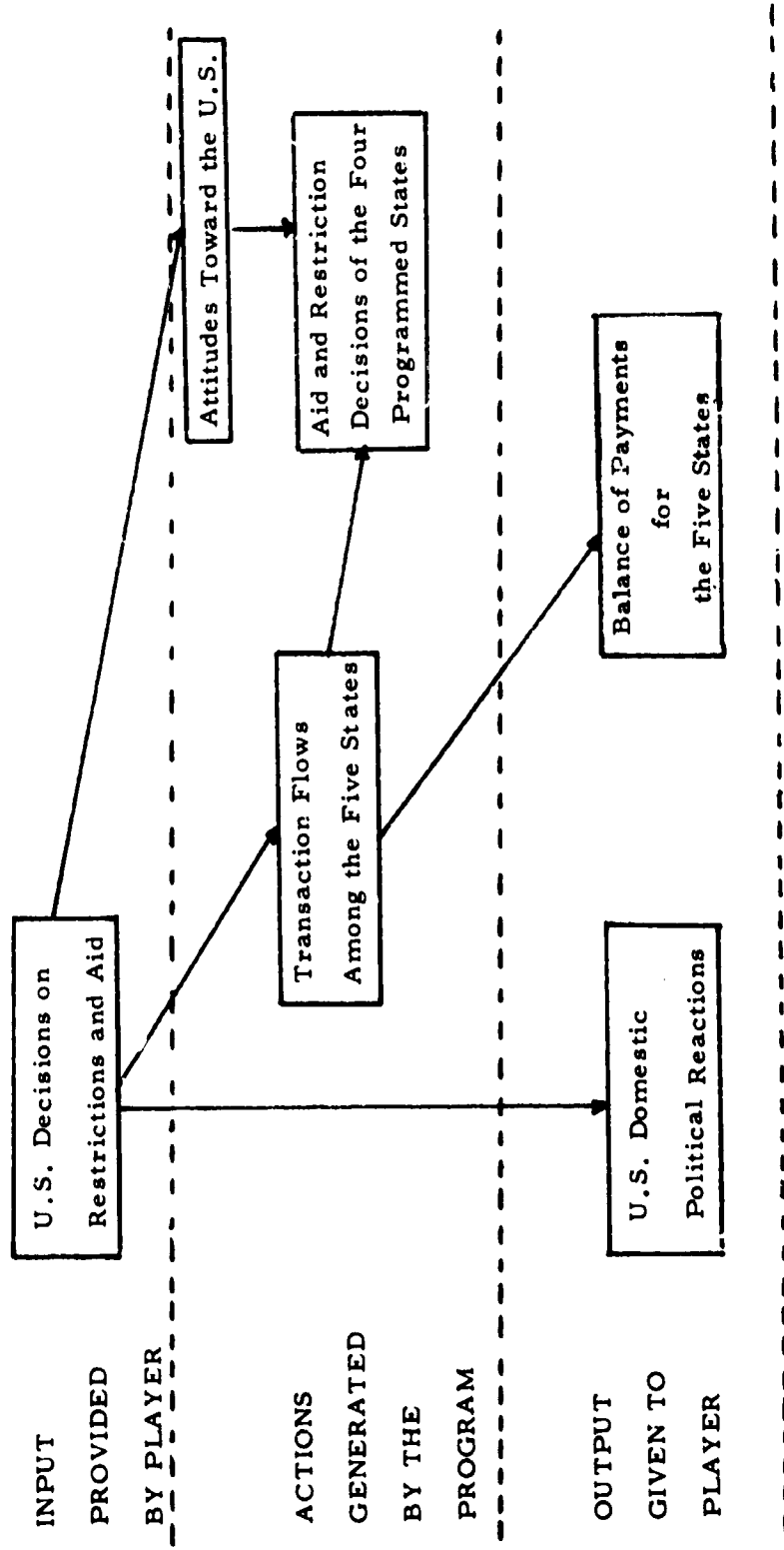

FIG. 1: IMPACT OF RESTRICTION AND AID DECISIONS

For this exercise, sixteen policy issues that are expected to be of particular interest to the five PRINCE states are selected. These issues are stated in Table 1 in the form of definite consequences or goals.

The government of each state will have an opinion on each policy issue depending on its willingness to see the goal reached. Support of the issue is expressed on a scale of -10 (representing the strongest degree of disapproval) to +10 (representing the strongest measure of support). Implications of the values on this scale in terms of action are defined in Table 2.

Having selected an issue position, each state will carry out political actions designed to exert pressure on the other nations. A "Punishment-Reward" or "PR" index represents the range of positive and negative actions that states direct at each other in this effort to resolve the policy issues to their own benefit. These actions can be viewed as mixtures of verbal statements and non-verbal actions designed to produce support through hostile or threatening actions ("Punishment") or through friendly, persuasive action ("Rewards").

These actions are represented on a PR scale of -10 (for the most hostile, negative action) to +10 (for the most positive friendly acts). Some illustrative descriptions of points on this scale are given in Table 3.

The PR values of the action taken by a state represent the state's overall foreign policy "style." The negative side of the scale represents various degrees of the "stick" or "hard-line" strategy, while the positive side represents the "carrot" or "soft-line" approach.

While United States issue positions and PR actions are chosen by the player, positions and PR actions of the other nations are computed by the PRINCE program on the basis of:

TABLE 1
THE SIXTEEN INTERNATIONAL POLICY ISSUES

1. Formal recognition of the German Democratic Republic by the NATO states, followed by the demilitarization of both East and West Germany.
2. A U.N. -sponsored plebiscite in Kashmir to decide its future.
3. Withdrawal of U.S. troops from Vietnam.
4. Continued Indian control of the border territory which China also claims.
5. Continued Russian control of the border territory which China also claims.
6. Withdrawal of Israeli troops from Arab territories occupied since the 1967 war.
7. Admission of Communist China to the United Nations as the legitimate Government of China.
8. A U.N. resolution condemning the treatment of blacks in the United States.
9. A U.N. resolution condemning the treatment of Jews in the Soviet Union.
10. General disarmament, including on-site inspection.
11. Economic boycott of South Africa.
12. Establishment of an international organization to control population growth.
13. Establishment of a commission, under the World Maritime Organization, to identify and fine states who pollute international waters.
14. A resolution committing the developed States to grant at least 1% of their annual GNP to a U.N. Aid Fund for the less developed countries.
15. A Nuclear Non-Proliferation Pact which includes provisions for the inspection of non-nuclear states.
16. An international treaty on the extradition of airplane hijackers.

TABLE 2
DESCRIPTION OF THE ISSUE POSITION INDEX

<u>Value</u>	<u>Meaning</u>
-10	Willing to lead the battle against the proposed plan or action to resolve the issue.
- 9	
- 8	
- 7	Willing to commit nation's resources against the proposed plan or action to resolve the issue.
- 6	
- 5	
- 4	Willing to help organize the fight against the proposed plan or action to resolve the issue.
- 3	
- 2	
- 1	Willing to provide verbal and symbolic opposition to the proposed plan or action to resolve the issue.
0	Indifferent
+ 1	Willing to give verbal and symbolic support to the proposed plan or action to resolve the issue.
+ 2	
+ 3	
+ 4	Willing to help organize the fight to support the proposed plan or action to resolve the issue.
+ 5	
+ 6	
+ 7	Willing to commit nation's resources to support the proposed plan or action to resolve the issue.
+ 8	
+ 9	
+10	Willing to lead the battle to support the proposed plan or action to resolve the issue.

TABLE 3
DESCRIPTION OF THE PR INDEX

	<u>Value</u>	<u>Meaning</u>
↑ Increasing "Punishment"	- 10	Threat of hostile action against a state.
	- 9	
	- 8	
	- 7	Denunciation of a state's position.
	- 6	
	- 5	
	- 4	Criticism of a state's position.
↑ Increasing "Reward"	- 2	
	- 1	Mild disapproval of state's position.
	+ 1	Mild expression of approval for state's position.
	+ 2	
	+ 3	
	+ 4	Stronger approval; promise of continued cooperation.
	+ 5	
	+ 6	
	+ 7	Promise of increased support.
	+ 8	
+ 9		
+ 10	Assurance of maximum support.	

- the importance of the policy issues to the states
- the positions of the states on the issues
- the power that can be exercised by the states on the issues

Thus, the United States foreign policy-maker will be dealing with a set of dynamically interacting states. As he attempts to convince the other four states to accept his positions, they will be attempting to influence him and the other programmed states to move closer to their positions. This process of influence interaction is indicated in Figure 2.

Domestic Political Reactions

An important part of the environment for a foreign policy-maker is the domestic pressure to which he must respond. PRINCE represents the U. S. domestic environment for the player through the opinions of eleven pressure groups, referred to as "Policy-Influencers," or PI's. The opinions of these groups are expressed on a scale of -10 (representing maximum disapproval) to +10 (representing the greatest measure of approval).

These eleven groups are divided into three groups:

- Partisan Influencers who represent the national political factions
- Bureaucratic Influencers made up of those executive departments most concerned with foreign policy formulation and execution
- Interest Influencers constituted of those groups outside government who attempt to influence U. S. foreign policy

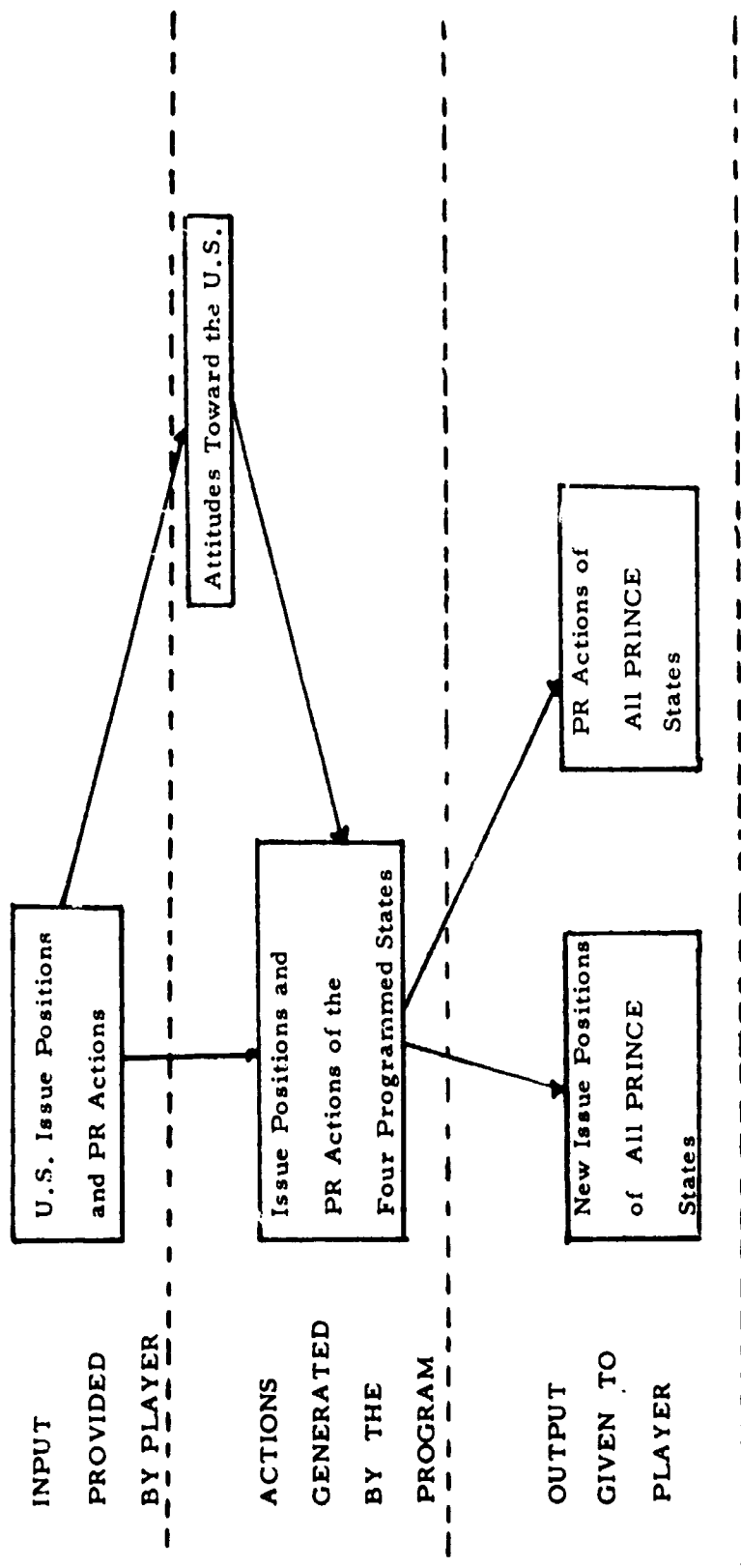

FIG. 2 : IMPACT OF ISSUE POSITION CHANGES AND PR ACTIONS

These PI Groups are abstractions of the forces within the U. S. with which the foreign policy maker must deal. Three of the groups represent the majority opinions of specific executive departments. The rest of the groups do not correspond to specific individuals, groups or organizations, but rather represent aggregations of people who share the same general attitude toward American foreign policy. The eleven PI groups represented in PRINCE are listed in Table 4 under their proper category.

Each of the three PI categories carries out a specific role in PRINCE. The Partisan PI's play what political scientists call an "interest aggregation" role. They piece together the feelings of the Interest and Bureaucratic PI's to create general political positions. Hence, their responses to policy position changes and PR actions of the player are a result of their perceptions of the positions of other PI's.

In addition to expressing their opinions of the player's actions, the Bureaucratic PI's have two unique roles:

- The State and Treasury Departments place constraints on the actions taken by the player. Should he attempt to violate these constraints, he will find his decisions modified by the program.
- The State and Treasury Departments provide the player with information about the international environment and offer suggestions on economic and political actions.

The third category is the Interest Influencers. In addition to formulating their own opinions of the player's actions, they have a share in shaping the opinions of the Partisan PI's. The attitudes of these PI's on the issues are, like those of the nations, dynamic. They start with an assigned set of ideas about international policy issues, economic acts, the "proper style" of foreign policy and the policies of the four programmed states.

TABLE 4. CATEGORIES OF U.S. POLICY-INFLUENCERS (PI'S)

PARTISAN INFLUENCERS	BUREAUCRATIC INFLUENCERS	INTEREST INFLUENCERS
● Extreme Liberals	● Treasury Department	● National Economic Groups
● Moderate Liberals	● State Department	● International Economic Groups
● Moderate Conservatives	● Defense Department	● "Hard-Line" Foreign Policy Groups
● Extreme Conservatives		● "Soft-Line" Foreign Policy Groups

However, they modify some of these ideas as a result of the actions of other states and the U. S. policies followed by the player. Thus, the domestic political environment remains fluid throughout the simulation.

Figure 3 indicates the relationship within the domestic political environment.

Reactions of the PI's are reported in two ways:

- The Presidential Advisor reports the PI group's reactions to the U. S. foreign policy decisions, and
- A public opinion poll shows the general support level for administration policies.

Although public support depends on many factors outside the sphere of foreign policy, nevertheless the degree to which foreign policy satisfies the Partisan, Interest and Bureaucratic PI's will play an extremely important role. To some extent then, the poll can be viewed as a prediction of results if a presidential election were held that particular month.

III. Attitudes of the Policy-Influencing Groups

Partisan PI's

Included in the Partisan PI category are four groups representing the U. S. domestic political factions.

- Extreme Liberals (XLIB)

This group has generally favored cooperative, rather than conflictual, foreign policies. They are committed to increasing United States aid to underdeveloped nations while opposing direct involvement in the internal affairs of those nations. They have, however, continued to oppose any

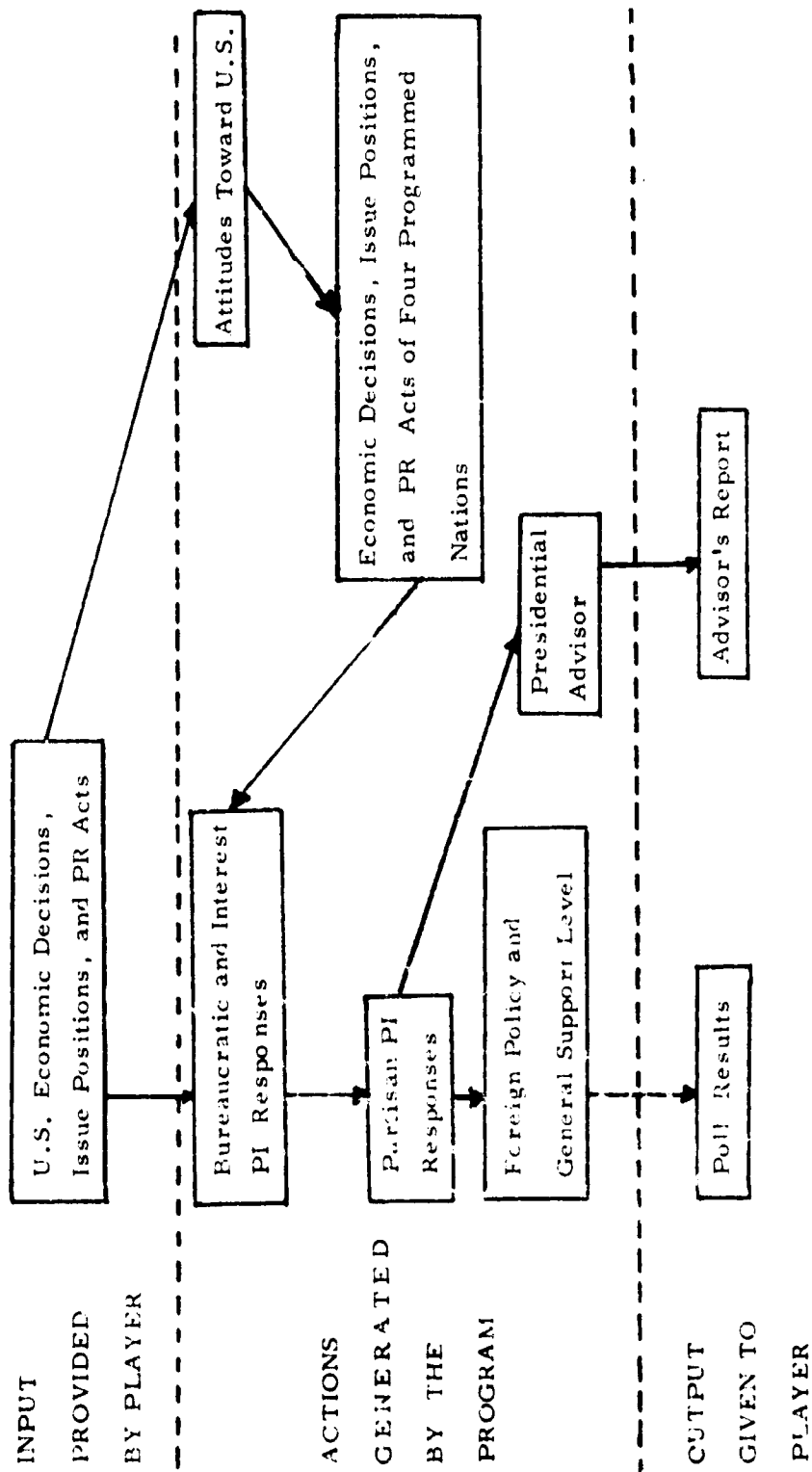

FIG. 3 - RELATIONSHIPS WITHIN THE DOMESTIC POLITICAL ENVIRONMENT

aid to autocratic political regimes. Lately, these extreme groups have been losing popular support and have begun to try to attract the more moderates.

- Moderate Liberals (MLIB)

The Moderate Liberals are flexible on most foreign policy issues. They oppose American involvement in Vietnam, although they have on occasion supported strong foreign policy actions. Generally, however, they oppose both foreign aid and the use of military force. On questions of ecology and worldwide social conditions, they tend to support positive action.

- Moderate Conservatives (MCON)

The Moderate Conservatives oppose strong foreign policy action except when American security interests are involved.

- Extreme Conservatives (XCON)

The principal concern of this group is with the threats posed by the Soviet Union and the Chinese Communists, and they favor strong action against any move either of these states might make.

Bureaucratic PI's

This category includes the three executive departments.

- Treasury Department (TREA)

The prime objective of the Treasury Department in the international area is to reduce restrictions on transaction flows while avoiding an unfavorable balance of payments position. Other factors are not considered so important.

- State Department (SD)

The State Department is very cautious in its interpretation of the policy actions of other states and tends to avoid both policy position changes and the use of threatening actions.

- Defense Department (DOD)

The attitude of the Defense Department is more flexible than that of the State Department, although it favors strong actions where it judges them to be needed.

Interest PI's

Groups outside the government make up this category.

- Nationalist Economic Groups (NAEC)

The two main interests of this group are protection of American industry and prevention of the spread of revolutionary movements.

- Internationalist Economic Groups (INEC)

Favoring increased international interdependence and stability, these groups advocate policies that stabilize the international economy, offer economic aid to the underdeveloped nations, and are cooperative rather than coercive.

- Hard-Line Foreign Policy Groups (HARD)

These groups fear the policies of the Soviet Union and Communist China and favor strong policy actions designed to prevent the spread of their influence.

- Soft-Line Policy Groups (SOFT)

These groups favor disarmament, economic aid to underdeveloped nations, and the removal of trade restrictions. In general, they prefer cooperative, rather than coercive, actions.

WORKSHOP: STUDENT PLAY OF PRINCE (Session 17)

No formal lecture is given during this workshop period.

ANALYTICAL BASIS OF THE PRINCE MODEL/ POST-GAME CRITIQUE
(Session 18)

I. Student Reports

Each team will be asked to prepare a report on their game play. While the organization of the report will be left to the team, at least the following subjects should be covered:

- National Goals of the Team
- Estimation of the Team's Success in Achieving the Goals
- Description of What Happened in the PRINCE World During Play

II. Analytical Basis of the PRINCE Model

Now that you have played the roles of decision-makers in the PRINCE world, I want to take you behind the scenes in that world to show you how and why it reacted to your decisions as it did. As indicated in Figure 1, the PRINCE computer program operates on a Data Base according to the Player's inputs and its own internal logic to produce the output that is given to the player.

The Data Base contains all of those arrays whose values constitute the PRINCE "World." During each "run" of the program (or "cycle" of play), the PRINCE program modifies the state of the world on the basis of:

- United States actions in the international political and economic areas that are selected and entered by the player at the terminal, and

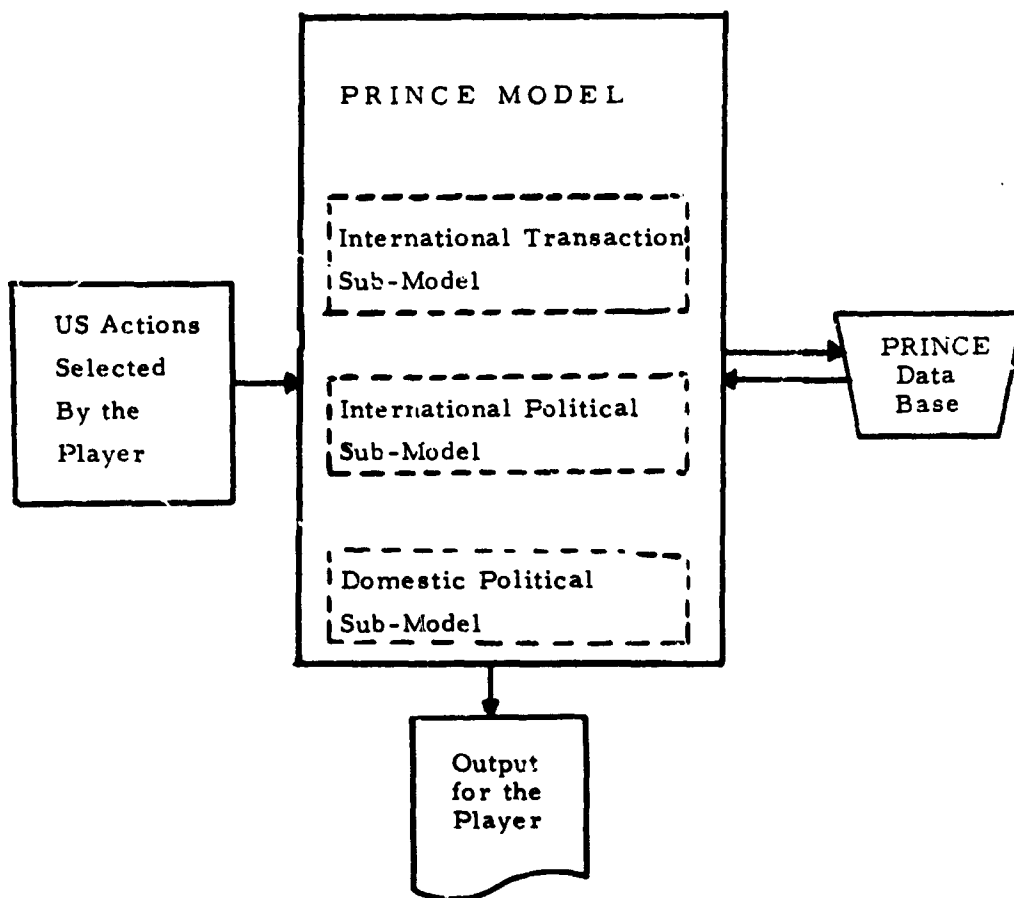

FIG. 1: PRINCIPAL ELEMENTS IN THE PRINCE PROGRAM

- acts by the other four states (the Soviet Union, France, India, and Pakistan) computed by PRINCE from programmed decision rules.

The PRINCE Data Base

Twenty-one arrays represent the state of the PRINCE world. These arrays contain variables of two basic types:

- Quantities that, although aggregated, can be measured; for example, foreign aid and transaction flows (expressed in millions of U.S. dollars), economic restrictions (percent of "natural" flows), and balance of payments (millions of dollars).

Initial values for these quantities are taken from existing data sources, such as the United Nations Statistical Yearbook.

- Quantities that represent feelings, attitudes, opinions on issues, influence, etc. These quantities have no standard units of measurement and in PRINCE are always expressed on scales of 0 to 10 or -10 to +10. In general, positive values represent friendly attitudes, approval, and persuasive actions (or "rewards"). Negative values correspond, on the other hand, to hostility, unfriendly attitudes, disapproval, and threatening actions ("punishments").

Initial values for these quantities are based on the judgment of the model designers. Research projects to develop and improve these values are in progress.

Arrays of the first type are:

AID(I, J): the amount of aid given by nation I to nation J (\$ MIL)

BAL(I): the balance of payments for nation I (\$ MIL). It includes the transaction flows between I and the rest of the world as well as between I and the other PRINCE nations.

FLOW(I, J): the actual flow of "transactions" from nation I to nation J (\$ MIL) taking into account the restrictions placed on the flow by J.

NAID(I): the amount of aid needed by nation I (\$ MIL).

RESTRI(I, J): the restrictions placed by nation J on the transactions coming to J from nation I (in percent of the "natural" transaction flows).

RNATU(I, J): the "natural" transaction flow from nation I to J, i. e., the flow that could be expected in the absence of restrictions by nation J (\$ MIL).

TREND(I, J): a constant representing the monthly growth of natural flows from nation I to nation J.

The following arrays are of the second type and are measured (except where noted) on a scale of -10 to +10.

AFFCT(I, J): the relative feeling of friendship or hostility felt by nation I toward nation J.

APOS(K): the general attitude of the Kth U.S. domestic policy influencing (PI) group toward foreign aid.

FLEX(K): relative willingness of PI group K to change its attitude toward foreign nations.

PCONG(K, L): the relative power of the interest and bureaucratic groups (K=5,11) to influence the partisan PI groups (L=1, 4)*

PELEC(K): the relative power of PI group K to determine the domestic support for the player's administration (on a scale of 0 to 10).

PIAFF(K, J): the attitude of PI group K toward nation J.

PIPOS(M, K): the position on issue M that PI group K would like to see the U. S. take. The support of PI group K for the administration is determined to a large extent by how far the player moves from these issue positions.

PISAL(M, K): the relative importance, or salience, of issue M to PI group K.

PISUP(K): the degree of support by PI group K for administration foreign policies.

POS(M, I): the position on issue M taken by nation I.

POW(M, I): the relative influence on issue M held by nation I.

RPOS(K): the attitude of PI group K toward trade restrictions.

SAL(M, I): the relative importance of issue M to nation I

SDPOS(M): the position on issue M preferred by the U. S. State Department. This position is given to the player as a "suggestion".

*The 4 partisan PI groups are listed first - Values in the PCONG array for K=1, 4 and L=1, 4 are not currently used by the program.

NRPOS(K): the type of foreign policy action preferred by PI group K.

In addition to these arrays, PRINCE stores and computes a number of other variables during the course of play. These are not defined on the basis of needed theoretical concepts, but rather as conveniences in carrying out the computations and, as such, are of interest only to the programmer.

The PRINCE Actors: Attributes and Roles

The principal actors in the PRINCE world are the five nations and the eleven domestic influence groups. The status and opinions of these groups are defined by arrays in the PRINCE data base:

NATIONS	Economic status of the nations: BAL, NAID
	Relationships of the nations to the policy issues: POW, POS, SAL
	Economic interactions among the nations: AID, FLOW, RESTI, RNATU, TREND
	Inter-nation attitudes: AFFCT
PI GROUPS	Economic attitudes of the PI groups: APOS, RPOS
	Attitudes of the PI groups on the issues: PIPOS, PISAL
	Attitudes of the PI groups toward foreign nations and foreign policy: PLAFF, NRPOS, FLEX
	Domestic political opinions, power, and influence: PELEC, PCONG, PISUP

Roles of the Actors

Actions that may be carried out by the nations include:

- (Economic) ● Setting restrictions on transaction flows into the country
- Granting foreign aid
- (Political) ● Taking positions on policy issues
- Acting to persuade or threaten other nations in an attempt to change their issue positions and attitudes.

Actions for the U. S. are chosen by the player; actions for the other four nations are computed by the program on the basis of built-in decision rules.

The domestic influence groups are essentially passive observers of the action. At the end of each cycle of play, the player is given their aggregated responses to U. S. actions.

Two of the domestic groups, the State and Treasury Departments, take a somewhat more active role with respect to the player. In addition to expressing their opinions of the U. S. decisions, they have three functions:

1. To place limits on the player's actions.
 - Aid grants may not change by more than \$5 million
 - Restriction levels may not change by more than +5%
 - Issue positions may not change by more than 2 units
2. To provide information on what has been occurring in the world.
 - A summary of the nations' issue positions
 - Lists of all economic and political acts occurring
 - Balance of payments for all the nations.
3. To make suggestions for U. S. action to be taken in the next cycle of play.
 - Economic acts
 - New issue positions
 - Political "PR" acts.

Basic Rules of the International Transaction Model

This sub-model computes the actual flows among the five PRINCE nations from the natural flows and the restrictions placed by the nations. Restrictions and aid grants for the U. S. are selected by the player within the limits allowed by the U. S. State and Treasury Departments. Aid and restriction decisions are made by the program for the other four nations on the basis of the following rules:

- Nations attempt to maintain a balance of payments within +10% of their total transaction flows plus aid. When a nation's balance of payments falls outside this range, it takes action to correct the situation.
- If the nation has an unacceptable deficit, then it will reduce its aid grants (if any) by amounts up to \$5 million per aid recipient.
- If there is still a deficit after this action, then it will increase its restrictions on transaction flows by an amount up to 5% for each country.
- A nation will attempt to correct a balance of payments surplus by increasing its aid grants to needy countries by an amount up to \$5 million per country.
- If there is still an unacceptable surplus, then it will lower its restrictions by as much as 5% per country.
- In addition to the limitation of 5% on each restriction change per country in each cycle of play, there are upper and lower limits on the restrictions that may be placed by a nation. These limits depend on the attitudes of the nation toward its trading partners.

For nation I, the limits on the restrictions it may place on transactions from nation J are:

$$\begin{aligned} \text{Upper limit: } & 60 - 4 \times [\text{AFFECT}(I, J)] \\ \text{Lower limit: } & 30 - 2 \times [\text{AFFECT}(I, J)] \end{aligned}$$

The possible ranges on these limits are shown below:

	AFFECT(I, J)	Limits	
		Lower	Upper
Maximum degree of friendship for I toward J	10	10%	20%
Neutrality	0	30%	60%
Maximum hostility of I toward J	-10	50%	100%

Thus, a completely hostile nation may not receive more than 50% of the natural flow from its target of hostility. On the other hand, a completely friendly nation cannot limit the flow to less than 80% of the natural flow.

Modification of "Natural" Flows

In addition to computing the actual flows, this sub-model increases the "natural" flows among the nations by the secular trend, modified by a normally distributed random number. Thus, RNATU(I, J), the new "natural" flow from nation I to J, is computed from:

$$\text{RNATU}(I, J) = \text{OLD} + \text{TREND}(I, J) \times [1 + V]$$

where OLD is the value of the "natural" flow for the previous month

V is a normally distributed random number with a mean of 0.

Functions of the International Political Model

This sub-model has three functions:

- To compute the punishment-reward (PR) acts that will be directed by one PRINCE state toward another,
- to determine if any PRINCE state will change its position on an issue, and
- to compute changes in the attitudes of the nations toward each other.

Both PR acts and issue position changes are computed for the United States on the basis of the same decision rules used for the other nations. However, these acts and position changes are not processed by the program, but are given to the player as "suggestions" which he may take if he wishes. Only decisions specifically entered at the terminal will be implemented by the program. Attitude changes are computed for all of the nations.

Computation of the PR Acts

Interactions among the PRINCE nations are treated in a highly aggregated manner. All of the actions directed by one nation to another on a specific issue during one month are treated in PRINCE as one "PR" action. The style, or type, of action is defined by a "PR" value assigned to it on a scale of -10 to +10.

A nation does not respond directly to PR acts of which it is a target. Such acts may, however, change its attitudes toward the initiating nation, and it is the attitudes, as well as the issue positions of both nations, which determine the range of PR actions.

Propositions underlying the generation of PR actions are:

1. A state directs general policy, or PR, acts toward other states only when an issue is sufficiently salient to it or when the influence of the target state is sufficiently great. The criterion for action by nation I toward nation J on issue M is that

$$[SAL(M, I) \times POW(M, J)] > 15$$

2. The greater the issue difference between the two states, the more hostile will be the act. Upper and lower limits on the PR acts are computed from the following equations:

$$D = |\text{POS}(M, I) - \text{POS}(M, J)|$$

where D is the absolute value of the position difference on issue M.

The upper limit is

$$\text{PRMAX} = -.045 \times D^2 + 10$$

The lower limit is

$$\begin{aligned} \text{PRMIN} = & .045 \times (20-D)^2 - 10 \\ & + \text{DEP}(I, J) \times [\text{PRMAX} - .045 (20-D)^2 + 10] / 10. \end{aligned}$$

where DEP(I, J) is a measure of the economic dependence of nation I on nation J. It is obtained by computing DPP from :

$$\text{DPP} = \frac{[\text{FLOW}(I, J)]^2 [\text{FLOW}(I, J) - 1]}{[T^2] [T - 1]}$$

where T is the total flow from nation I to the other PRINCE nations.

Then, the DEP(I, J) is constrained to lie between 0 and 10 at values of this ratio of -5 to +5 as shown below:

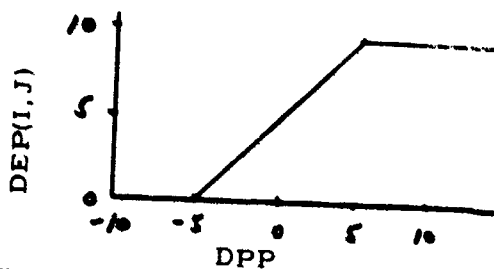

Fig 2. The Functional Dependence of DEP(I, J) on DPP

The PR of the act directed toward J by I is a randomly selected value lying somewhere between PRMAX and PRMIN. The exact value selected depends on the ratio of the importance, or salience, of the issue to I and the influence, or "power," that I has on this issue. This ratio is termed the "irresponsibility" of I on issue M.

Figures 3-5 show the scattering of PR actions as a function of the absolute value of the position differences for a "dependence" of 3 and an "irresponsibility" of 0, 4, and 8. It can be seen that the higher the "irresponsibility" of I, the closer the PR value will lie to one of the extremes (either PRMAX or PRMIN). The lower the "irresponsibility," the more likely the value is to lie at the mid-range between PRMAX and PRMIN.

Computation of Issue Position Changes

Since PKINCE is centered on the U. S. foreign policy-maker, it is designed to compute new issue positions for the other nations only for those issues of interest to the U. S. (i. e., those issues for which the U. S. salience is greater than 0). In reconsidering its position on an issue, a PRINCE nation will respond to the state of the world as defined by the attitudes of the PRINCE nations toward each other, and their positions, power, and interest in the issue. Computation of a new issue position for nation I is based on the following decision rules:

- Nation I will move toward a weighted average of the hypothetical issue positions of the other nations. The hypothetical position for nation J on issue M is computed from the following:

$$\begin{aligned} \text{If } (\text{POS}(M, I) - \text{POS}(M, J)) > 0, \text{ PP} &= \text{POS}(M, J) + \text{IDF} \\ &< 0, \text{ PP} &= \text{POS}(M, J) - \text{IDF} \end{aligned}$$

where PP is nation J's hypothetical position on issue M,

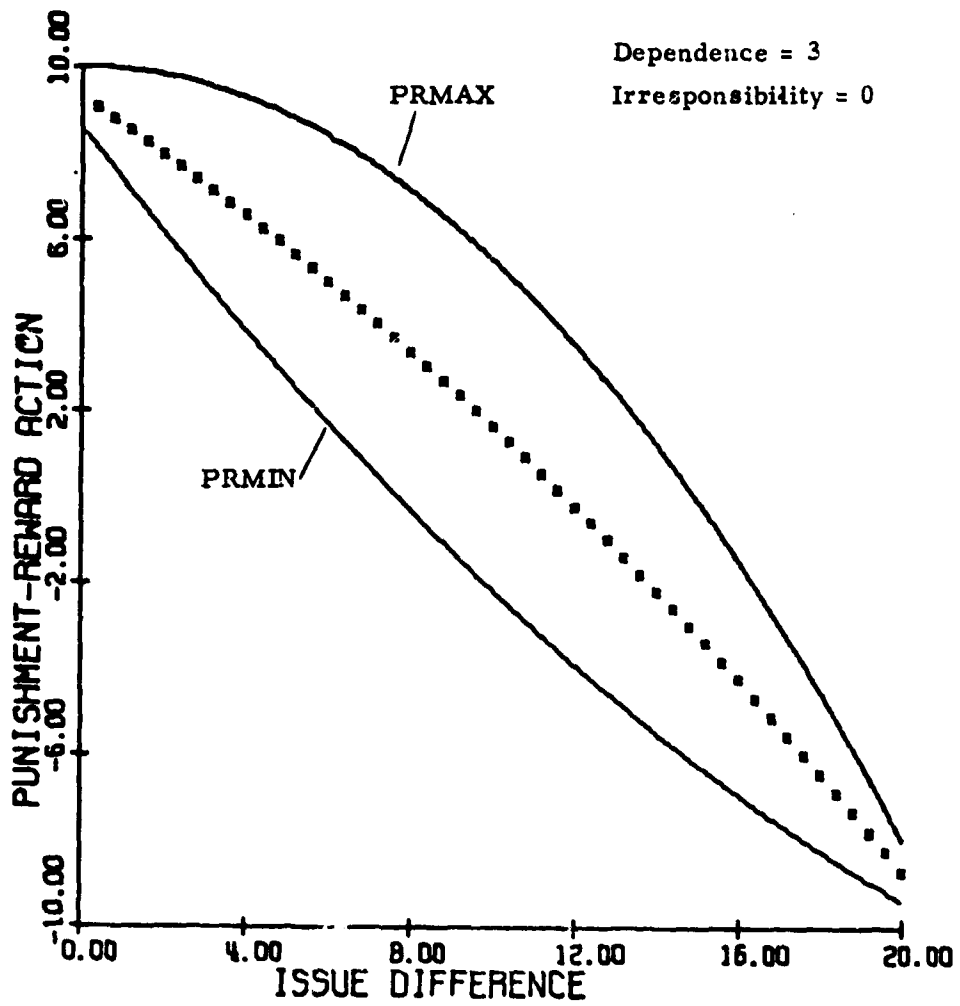

Figure 3. Distribution of PR's as a Function of Issue Difference

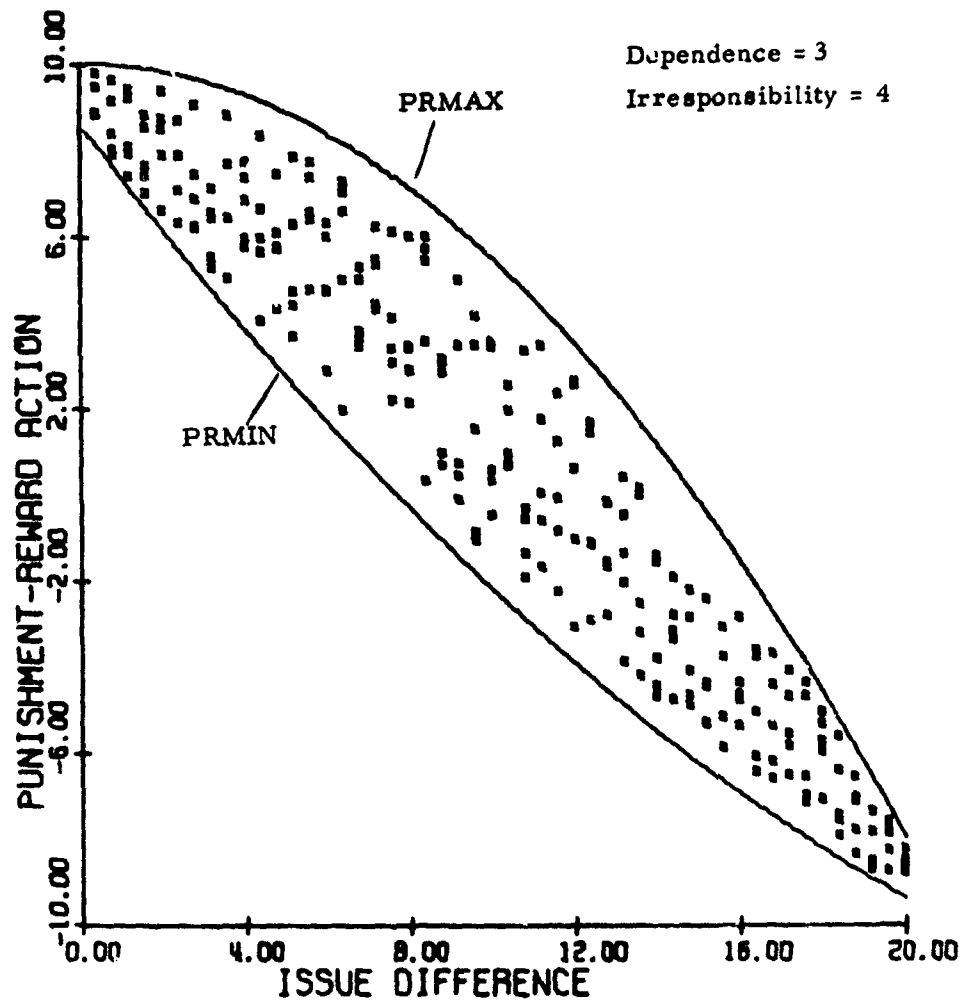

Figure 4. Distribution of PR's as a Function of Issue Difference

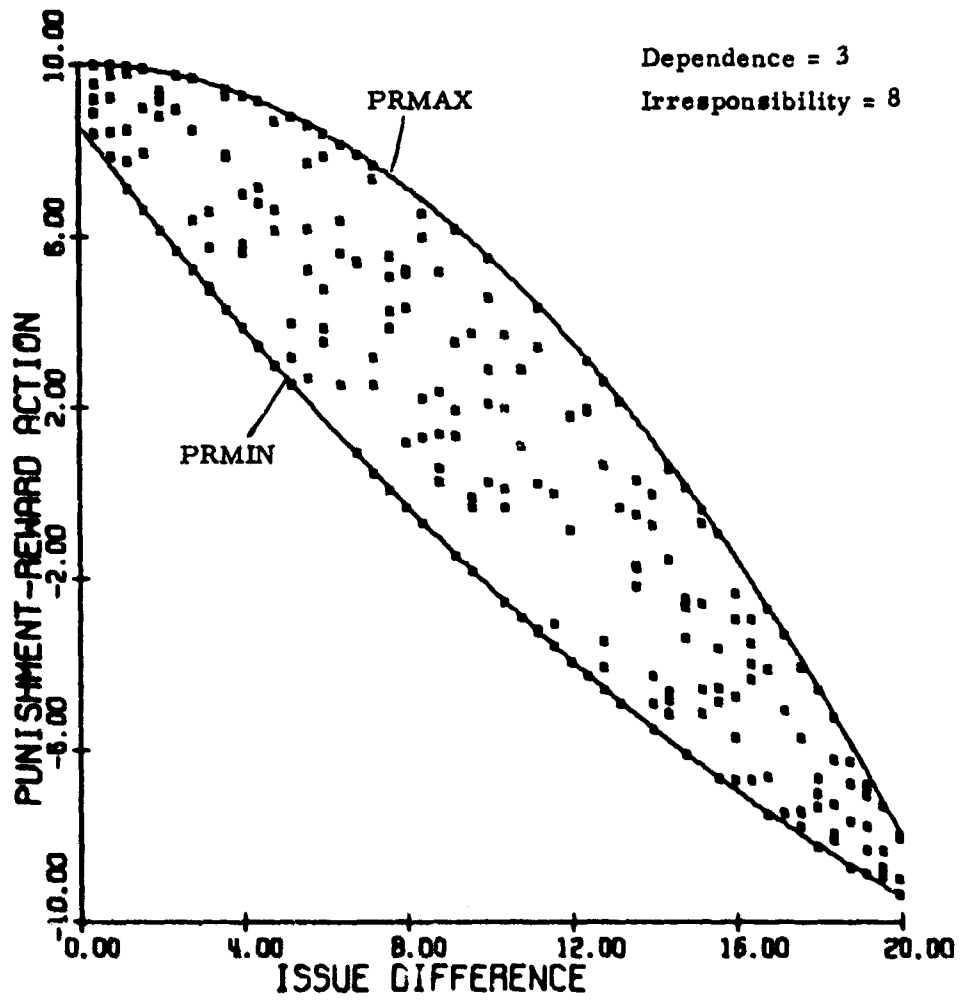

Figure 5. Distribution of PR's as a Function of Issue Difference

and IDF is computed from the following equations:

Let $S = SAL(M, I)$

$A = AFFCT(I, J)$

If $S < 5$, $IDF = -.2S^2 + \frac{8(10 - A)(S^2) + 10}{400}$

If $S > 5$, $IDF = -.2S^2 + 2S - \frac{(A - 10)(.4S^2 - 4S + 20)}{20}$

The weighting factor used in computing the average of these hypothetical positions is obtained from,

$$REF = \frac{|AFFCT(I, J)| + |AFFCT(J, I)| + SAL(M, J)}{SAL(M, I)}$$

If this factor is positive, then nation J is considered by nation I to be a "positive reference group." Conversely, a negative value represents a "negative reference group" for I.

- (1) The magnitude of the change by nation I toward (or away from) J's position on an issue is proportional to the degree of friendship (or hostility) felt for J by I.
- (2) Nation I is more likely to move on issues of high salience to J.
- (3) The magnitude of a nation's move on an issue is proportional to the importance of the issue to it.

These last two propositions are concerned with the salience of an issue to a nation. In this context, "salience" refers to the proportion of the population of the country interested in the issue. Low salience implies that the issue is of concern only to officials specifically charged with the foreign policy matters. There will be only small changes in a nation's positions on these issues. Where salience is high, the issue is of concern to wide-spread elements of the state, and, in such cases, a given level of attention by other nations is likely to produce much greater shifts in issue positions.

Computation of Attitude Changes by Nations

Although a principal reason for carrying out PR actions is to persuade (or to force) a nation to change its position on an issue, there is no direct relationship between patterns of PR actions and issue shifts. That is, a PR sent from one nation to another, even though it is related to a specific issue, will not directly change the target nation's position on the issue. Each PR act will, however, alter the opinion, or attitude, of the target nation toward the actor.

The amounts of change in the target nation's attitude caused by a given PR is determined by:

- the salience of the issue to the target nation,
- the ratio of the actor's power on the issue to the target nation's power, and
- the total number of PR acts directed by the actor toward the target during the current cycle.

Specifically, the change in the attitude of nation I toward J as a result of a PR related to issue M is computed from:

$$\text{when } A = PR \times SAL (M, I) \times \frac{POW (M, J)}{POW (M, I)} \times N$$

A is the change in I's attitude toward J

PR is the value of the PR acts directed by J toward I

SAL (M, I) is the salience of issue M to I

POW (M, J) [POW(M, I)] is the power of J [I] on issue M

N is the total number of PR acts directed toward I by J during the current cycle.

The total attitude change by nation I is the sum of changes due to the individual acts.

However, the new attitude, or opinion, is constrained to be within the range (-10 to 10).

Functions of the Domestic Political Model

This sub-model computes U. S. domestic political reactions to the results of the player's economic decisions (restrictions on flows and aid grants), positions on the issues, and political actions toward the other PRINCE nations during the current cycle of play. These reactions are expressed by eleven Policy Influencing (PI) groups that represent the partisan factions, special interest groups, and bureaucratic forces within the political structure of the United States.

Reactions of these PI groups to the player's actions are aggregated into responses in three areas:

- Economic:
responses to the restriction and aid levels set by the U. S.
- International Political:
responses to the foreign policy actions directed by the U. S. toward the other PRINCE nations.
- Issue Positions:
responses to the U. S. positions on the 16 critical international issues.

Overall support by the U. S. public is expressed by the estimated percentages answering "YES," "NO," and "NO ANSWER" to the question: "Do you agree with the general policies of this administration?"

Responses to Economic Decisions

The general propositions underlying the computation of responses to restriction and aid levels are:

- A PI group will support economic acts favoring nations toward which it has a friendly attitude (and conversely, will not support favorable actions toward a nation to which it feels hostile), but
- The support level will be modified by the opinion of the PI group toward restrictions and aid in general.

The set of equations from which the responses are computed are given below:

$$A = [APOS(K) + PIAFF(K, I)] / 3$$

$$\text{If } |A| > 1, \quad RA = A + A [\Delta AID]$$

$$\text{If } |A| < 1, \quad RA = A + \frac{A}{|A|} [\Delta AID]$$

where:

RA is the response of PI group K to aid given by the U. S. to nation I.

ΔAID is the change in U. S. aid to I from the aid given in last cycle of play.

$$B = [RPOS(K) - PIAFF(K, I)] / 3$$

$$\text{If } |B| > 1, \quad RR = B + B[RESTI(1, I)] [\Delta RES] / 60$$

$$\text{If } |B| < 1, \quad RR = B + \frac{B}{|B|} [\bar{RESTI}(1, I)] [\Delta RES] / 60$$

where: RR is the response of the PI group K to the setting of a restriction on flows from nation I

ΔRES is the change in the restriction from the last cycle of play

The aggregated response of group K to economic decisions is the average of its responses to aid and restriction levels and is scaled to lie between -10 and +10.

Responses to International Political (PR) Acts

The PI groups' reactions to each PR act by the player are based on the following factors:

- the attitude of the PI group toward the nation that is the target of the U. S. action
- the position of the PI group on the issue that is the subject of the U. S. action
- the position of the U. S. on the issue
- the position of the target nation on the issue
- the type of PR act preferred in general by the PI group.

The general propositions underlying these computations are:

- The closer the U. S. PR act to the preferred PR act of the group, the more positive the PI response.
- A more favorable response will be generated by positive PR acts directed to nations toward which the PI group feels friendly and by negative acts to nations for which they have a hostile attitude.
- A more favorable response will be generated by positive acts toward nations whose position on the issue is close to that of the group.

The sets of equations from which these responses are computed are given below:

$$P1 = NPRPOS(K) - IACT$$

$$P2 = PIAFF(K, I) \times IACT/10$$

$$D = |PIPOS(M, K) - POS(M, I)| - |PIPOS(M, K) - POS(M, I)|$$

$$P3 = D \times IACT/20$$

$$RP = [P1 |P1| + P2 |P2| + P3 |P3|]^{1/2}$$

where:

RP is the response of the PI group K to a U. S. PR act (IACT) toward nation I on issue M

IACT is the type of PR act (-10 to 10)

The aggregated response of the PI group in the international political arena is the average of its responses to all of the U. S. PR acts during the current cycle.

Responses to Issue Positions

Responses to the issue positions of the U. S. are computed from:

$$RP = [POS(M, I) - PIPOS(M, K)] [PISAL(M, K)]$$

where:

RP is the response of PI group K to the U. S. position on issue M

The aggregated response to the total U. S. issue position picture is the sum of the position differences, weighted by the salience of the issue to the group. It is scaled to range from +10 at a weighted difference of 0 to -10 at a weighted difference of 10, or greater.

SUMMARY AND CRITIQUE OF SIMULATION (Session 19)

Lecture Outline

I. Educational Goals

II. Comparison of NEXUS and PRINCE

Economic Indicators
Foreign Policy Indicators
Indicators of Domestic Approval
Summary of PRINCE
Similarities

III. Trends in Model Development

Computer Hardware Trends
Software Trends
Emphasis on Model Validation
Simulation for Planning

SUMMARY AND CRITIQUE OF SIMULATION (Session 19)

I. Educational Goals

We have come now to our last session on simulation. We want to go over what we have done to try to discover what it means to you as analysts and future decision-makers. Rather than introduce you to simulation through a series of lectures, we chose to present specific models for you to examine and get hands-on experience in using. Because of our severe time constraints, your play of these games could not be presented in such a way that the full objectives intended by the developers could be attained; i. e. :

- to learn something about the decision-making process on the executive level, or
- to investigate the effects of domestic influence groups on foreign-policy.

Our purpose in presenting these games in this course is to show you, first hand, two simulations that are currently being used. We chose, for this purpose, the two models: NEXUS (National Executive Utility Simulation) and PRINCE (Programmed International Computer Environment). This particular pair of models was selected because they are concerned with the same general problem: decision-making on the national executive level, but they approach this problem from somewhat different viewpoints. Today I want to start our discussion by spending a few minutes discussing these models—their views of the world, how they are alike, and how they differ.

II. Comparison of NEXUS and PRINCE

Figure 1 shows a comparison of the two models. In both, the input is of two types: economic and foreign policy. As you recall in NEXUS, the economic

Table 1
Comparison of NEXUS and PRINCE

INPUT	<u>NEXUS</u>	<u>PRINCE</u>
<u>Economic:</u>	U. S. Taxes	Trade restrictions (import only) by the U. S.
	U. S. Budget	Aid grants by the U. S.
<u>Foreign Policy:</u>	Index of U. S. foreign policy	Issue positions of the U. S.
	Aggressiveness	Foreign policy actions
 OUTPUT		
<u>Economic:</u>	Budget defici. (or surplus)	Trade restrictions
	% Unemployment	Aid grants
	GNP	
<u>Foreign Policy:</u>	Cold war trend	Summary of issue positions
	War trend	Summary of foreign-policy actions
	Nuclear war risk	
<u>Domestic Approval:</u>	Index of internal unrest	Opinions of the U. S. domestic policy-influencers
	U. S. Voter poll	U. S. Voter poll

decisions made by the player involve the whole range of taxes—corporation taxes, personal income taxes, excise taxes, social security taxes, etc. While the player may set general policy guidelines for himself, as far as the play of the game is concerned, he translates these guidelines into budget allocations in the general areas of military spending, foreign aid, space, health, and welfare, commerce and transportation—the categories you are accustomed to seeing.

The player's foreign policy decisions are simpler. While he has a number of economic decisions on taxes and budgets to make, his only way of expressing the U. S. attitude toward foreign policy is by selecting a value for a parameter called "the index of aggressiveness."

The NEXUS output is of three types:

Economic indicators

The player is given his budget deficit (or surplus), a computation that comes directly from his input. Then, there are estimates of the amount of unemployment and the gross national product for the year.

Foreign policy indicators

These are indices ranging in value from 0 to 1. The "Cold War Trend" measures the success of the U. S. in containing Communist expansion. The "War Trend" measures the success of the U. S. in any limited war in progress (at the beginning of the play the war in Vietnam is going on). The "normal" value of these war trends is .5. The player may judge how well he has done by whether or not these indices go above, or below, .5.

The third index measures the risk (or probability) of going to nuclear war. During each cycle, a random number determines if the limited war ends, or if there is no war, whether or not one starts. Another random number

determines if there is a nuclear exchange. Since the model is not designed to handle a nuclear war, the game stops, or the player has the option of continuing as though this had not happened.

Indicators of domestic approval

One of the indicators of domestic approval of the player's policies is the "Index of Internal Unrest," which is computed on the basis of unemployment and the spending in areas like health, welfare, and education. Again this is an index whose "normal" value is .5 and the player judges how well his policies are received by noting whether this index goes above, or below, .5. Finally, the player is given the results of a voter poll which shows the percent of people generally favoring the administration's policies.

Since each cycle of play in NEXUS represents one year, a set of 4 cycles constitutes a logically complete play of the game. At the end of 4 years, an election is held, and the player is told whether or not he is returned to office. There are no programmed constitutional limits, so (theoretically) he could stay in office 2, 3, or 4 terms.

Summary of PRINCE

The second model, PRINCE, exposes the player to a more complex world—consisting now of the U. S. and four additional countries, the Soviet Union, France, India, and Pakistan. The scope of decisions requiring the player's attention is increased significantly. He is concerned not with the U. S. taxes and budget, but he must consider U. S. trade restrictions and aid grants for each of the other PRINCE nations. He is not required, however, to worry about where the money for the aid will be obtained or what will be the effect on the domestic economy of the trade restrictions (other than the opinions of the domestic groups who judge his actions). That is, there is no computation of the effect of trade on, say, unemployment.

The player's attention is directed to 16 specific foreign policy issues. He must decide the U. S. positions on these issues and choose foreign policy actions toward the other PRINCE nations with respect to these issues. (The world environment, including the U. S. positions on these issues, is initialized to represent May 1, 1971. * Thus, if in the press of time or for some other reason, the player chooses not to think about an issue, the U. S. retains its May 1 positions).

How does the PRINCE player know what is happening in his world? Again, the output from PRINCE is of the same general type as the NEXUS output, but it is much more detailed. In the economic area, the player finds out the trade restrictions and the aid grants set by the other PRINCE nations.

In a foreign policy area, he gets a summary of the issue positions held by the countries and a list of all the PR acts occurring during the current cycle of play. (You'll remember that, in PRINCE, one cycle of play represents one calendar month).

Domestic approval is indicated in more detail than in NEXUS. The player is given the opinions of the eleven domestic influence groups in three areas: on his economic decisions, on the issue positions, and on the foreign policy actions of the U. S. during that cycle. He is also given a voter poll which tells him the percent of people agreeing with his policies, disagreeing with them, and expressing no opinion.

Similarities

Let's look at the similarities between NEXUS and PRINCE. First, the mode of play is the same. Both are man-computer games, designed to be played by one person (or one team) from a computer terminal. The player represents one set of interests—in both cases, the U. S. executive decision-maker. The computer (operating on a set of pre-programmed instructions)

* This time may be set by the instructor to be appropriate to the actual date of this course.

then plays the rest of the world.

The level of aggregation is similar. The basic entity played in both models is the nation, and the kinds of decisions which are demanded of the player are those which would be made by the chief executive and the bureaucratic organizations of which he is the head.

The concern of the player in both models is similar. He wishes to improve the position of the U. S. and increase the domestic approval for his policies.

However, most of these similarities are rather specified; there are a number of important differences. First, a minor technical difference: NEXUS requires fewer decisions by the player and is easily played by one person. PRINCE requires, perhaps, no more input from the player, but certainly consideration of more aspects of the world. It is, thus, better suited for team play.

There are more fundamental differences. The scope and detail in the models differ greatly. In NEXUS, the entire world (outside the U. S.) is represented, but in a highly aggregated way. It is not, in fact, the characteristics of the outside world that are computed, but the effect of the outside world on the U. S. The entire realm of international relations is thus represented by three indices defined from the U. S. point of view. PRINCE treats the individual actors in more detail, but reduces the scope rather drastically to five nations only.

The range of matters calling for the players' attention is rather different. NEXUS focuses primarily on spending for domestic programs. PRINCE requires that the player devote his attention to international economic issues, to foreign policy matters, and to the reactions of the people back home. NEXUS provides the player with a rigid foreign policy choice. His entire foreign policy must be reduced to one number and one budget item. The PRINCE player has a wider range of decisions to make in the foreign-

policy area, but none at all in the domestic sphere. Although, he makes economic decisions for imports that would undoubtedly (in the real world) have a profound effect on the domestic economy (GNP, unemployment, corporate profits, etc.), these effects are not part of the model, or only in a very indirect way though the degree of approval expressed by the economic interest groups.

What can we say about the models' views of what drives foreign policy? In PRINCE, it is the desire of the national executive to please domestic influence groups and to gain international support for U. S. issue positions. In NEXUS, on the other hand, the single foreign policy parameter is used only in the computation of the various "war trends," The player's attention is directed internally, rather than externally.

A closely related question is: How do the "world views" of the models differ? The primary concern of NEXUS is with domestic policies. The major components of the voter poll are unemployment rate and the ratio of individual income tax to GNP. Unemployment is a function of corporation taxes, excise taxes, and government spending in commerce, transportation, and education.

The voter groups are aggregated according to their economic preferences: The Veterans are made happier by increases in veterans' benefits; farmers, by spending for Agriculture, etc. Military spending and foreign aid influence the war trend indices and U. S. world influence.

In PRINCE, the influence groups of greatest importance in determining voter support are the moderate conservatives and the moderate liberals. The player does best when he estimates accurately the issue positions of those groups toward the positions on those issues each group considers most salient.

III. Trends in Model Development

Computer Hardware Trends

Simulation in international relations shares, of course, some of the general trends in simulation. Since the modeling of complex systems is of practical necessity tied to the use of computers, its future depends in part on what is happening with computers. Current hardware trends include interactive systems designed for less sophisticated users, faster, quieter terminals, display terminals, and an increasing use of computer-produced graphical displays.

Software Trends

Changes in software—simulation language—may be slower. As you may know, the first computer languages were strongly tied to the computer hardware and were cryptic, hard to learn, and confined to a few programming specialists. Then, FORTRAN, a far more easily learned language much closer to English, was developed and programming could be done by anyone willing to devote a week or two to its study. During this time, simulation was rapidly becoming a more important analytical tool, and between 1955-65 there were developed dozens of new computer languages specifically designed for simulation purposes.* These ranged from the extremely simple to almost FORTRAN-like complexity. There was a direct relationship between power and complexity. The very simple languages handled relatively simple situations; the more powerful languages required a larger investment in learning—but still less than FORTRAN. I don't want to say more about these languages, except that most of them have passed out of use. Experience and use by analysts has shaken the field down to about half a dozen major ones. And probably there will not be any new ones developed—at least not right away.

*See, for example, Teichroew, Daniel and John Francis Lubin, "Computer Simulation-Discussion of the Technique and Comparison of Languages," Communications of the ACM, Vol. 9, No. 10, October, 1966, pp. 723-741.

What does this mean for the field of simulation? The trend I see is for the model developer to begin to do his own programming. This has tremendous advantages in speed and ease of communication between modeler-programmer. The modeler who turns the programming over to someone else has absolutely no way of being sure that the program represents his ideas.

Emphasis on Model Validation

Another significant trend is the increased emphasis on model validation. This requires more work for the model developer and is particularly difficult for the developer of IR models. Possibly this increased desire for validation may also represent the reason for the strong opposition simulation faces from the more traditionally minded political scientists. Modeling requires precise quantitative statements about relationships. When these relationships are subjected to the cruel and objective light of quantitative testing, they may be shown to be false. The model which is described by the most agile, articulate speaker will no longer be accepted as the "best" model.

I think that I indicated in the introductory lecture on how models are developed, that I place a very high value on the judgment, experience and political wisdom of political scientists in the development of models. Unless a model operates as a man who knows the field thinks it should, there is very likely to be something wrong. But what I am saying here is that such judgment should be subjected to careful analytical testing to the limits of the data available—and then we ought to collect more data.

In addition to using data for validation of judgmental models, the idea is being tossed around that it may be possible to combine real world data collection with modeling. As to the future use of models, it is interesting

to note that simulation and modeling in fields like physics and engineering started for practical purposes—to investigate and solve real world problems, and I am not aware even now of any widespread use of simulation as a teaching device in these fields.

Simulation for Planning

In the social and political sciences, simulation started, I think, primarily as an aid to teaching. One of the earliest—the Inter-Nation Simulation—was developed by Harold Guetzkow for use in his classes at Northwestern University, and its third-generation version, PRINCE, is still used mainly for teaching purposes. I see the faint beginnings of a trend toward the use of such models by decision-makers—not to make decisions, but as aids in their exploration of problems and alternative solutions.

Looking now beyond modeling toward the use of all kinds of quantitative techniques, I see some of the better aspects of systems analysis beginning to be applied to national and international problem areas. I realize that "Systems Analysis" has, in some areas, an unfortunate and negative connotation. I would like to say that when I use the term, I am wearing a white hat like the good guys, and intend for you to understand that I am in favor only of doing all the right and good things with analytical techniques; not any of the wrong, bad things. G. H. Fisher of RAND placed systems analysis into its proper context in the following remarks at a MORS meeting in 1967:

"Contrary to what some of the more enthusiastic advocates of quantitative analysis may think, systems analysis should be visualized as playing a somewhat modest, though very significant, role in the overall decision-making process. In reality, most major long-range planning decision problems must ultimately be resolved primarily on the basis of intuition and judgment. I suggest that the main role of analysis should

be to try to sharpen this intuition and judgment through the more precise statement of problems, the discovery and outlining of alternatives, making comparisons among alternatives and the like. In practically no case should it be assumed that the results of the analysis will "make" the decision. In sum, the analytical process should be directed toward assisting the decision-maker in such a way that his intuition and judgment are better than they would be without the analysis. And in many instances a small amount of sharpening of intuition and judgment can have a high payoff."

THE ROLE AND VALUE OF QUANTITATIVE TECHNIQUES IN
POLICY-MAKING (Session 20)

Discussion Outline

I. Course Review

Perspectives

Data-File Analysis

Simulation

II. Comments for Discussion

THE ROLE AND VALUE OF QUANTITATIVE TECHNIQUES IN
POLICY-MAKING (Session 20)

No formal lecture is given in this session. It is planned as a general round-table discussion in which the students reflect on what has been presented in this course and on its possible impact on their work in the future. The instructor may start by a brief review.

I. Course Review

Perspectives

The first three lectures were designed to give the student an introduction to the use of quantitative techniques in the area of international politics. Major points covered in those lectures included:

- The pressures of policy-making at the higher levels make the use of large amounts of information necessary. Computerized data-collections contribute to the ease, speed, and privacy of data-handling.
- Quantitative techniques have been and are being used in real policy-making situations.
- While each research or policy problem has unique characteristics, the process of research and problem-solving is not a random or totally unstructured activity. There are certain more or less formal steps in the quantitative approach to a problem.

Data-File Analysis

The theme of the next part of the course was the analysis of quantitative data. The statistical techniques needed for this analysis were presented,

along with discussions of the major subject areas of international politics: national power, conflict and alliances.

Simulation

The theme of the third part of the course was simulation. Two models of aspects of the international scene were examined and played by the students. One of the models (NEXUS) emphasized the role of U. S. budget decisions; the other (PRINCE) was more dependent on decisions in the U. S. foreign policy area. Discussion periods allowed the students to compare and criticize these models.

II. Comments for Discussion

To stimulate class discussion, the instructor may present the following comments by highly placed (but intentionally unidentified*) sources:

1. First, analysis has great value in turning debates over resource allocation toward the realities and away from simple statements of noble purpose. . . . Analysis at least focuses the debate on what a particular system can accomplish and what numbers are required. The emphasis is on the real rather than the symbolic function of the system.
2. Considerable fear has been expressed that analysis will usurp the decision-making role, that the decision-maker will become passive and let analysis (implicitly) make the decisions.
3. . . . there is nothing inherent in . . . systems analysis that calls for ignoring military judgment or for relying on computers for anything other than computation . . .

*These comments are taken out of context and may not represent the complete thought of the speaker on the subject; to identify him (her) would thus be unfair. It is the concept that is of importance here.

4. Analysis is not a scientific procedure for reaching decisions which avoids intuitive elements, but rather a mechanism for sharpening the intuitions of the decision-maker.
5. The analyst should also be careful that he is not guilty of 'mechanitis', the occupational disease of one who is so impressed with modern computing machinery that he believes that a problem which he can neither solve nor even formulate can be readily answered once he has access to a sufficiently expensive machine.
6. Disciplined, orderly thought is the characterization given to analysis, but disciplined, orderly thought suggests certain traits; reflectiveness, self-criticism, and the willingness to reconsider past commitments without self-justification. However, rarely or frequently encountered in the human population, these are not the traits characteristic of the action-oriented, incisive individuals who reach policy-making decisions. Questioning and self-doubt lead to Hamlet-like decision-makers.
7. Analysis is, in the end, a method of investigating rather than solving problems... Poor or haphazard analysis may contribute to poor decisions, but good analysis by itself cannot insure good decisions.
8. Analysis has been justified with increasing frequency as part of an adversary proceeding.... One senior officer has observed, only half facetiously, that experience in debate is the most valuable training for analytic work....

II. SAMPLE NEWSPAPER FILE ON THE PRINCE NATION AND ISSUES

One way of giving the students some background on the PRINCE nations, their current attitudes toward each other and the issues that occupy the attention of their foreign policy-makers is through current newspapers. Time limitations usually prohibit an individual search of the newspaper file by each student. A compromise is the use of sets of relevant clippings collected by the instructor.

This section contains examples of such a set. The items are divided into the five general categories:

- I. The U. S. Economy and U. S. Trade and Aid Policies
- II. Economic Positions and Policies of the Other PRINCE Nations
- III. Relations Among the PRINCE Nations
- IV. Issue Positions and Related Actions
- V. U. S. Domestic Opinion

Since the news is not written with the objective of serving as PRINCE background material, the issues and policies are not always stated in precisely the same format as in PRINCE. For example, the first PRINCE issue involves the recognition of the German Democratic Republic by the NATO states, followed by the demilitarization of both East and West Germany. Currently, the principal topic of interest involving Germany, the U. S. and the USSR is the question of Berlin. Positions and attitudes on this question may be taken as hints of the attitudes on the larger question as it is stated in the list of PRINCE issues. The instructor may wish to restate the issues to match more closely the statements of current news events, or he may leave the mis-match to point up the fact that the policy-maker seldom has information in precisely the form he would like.

With the understanding that news items are no more accurate or valid for the PRINCE player than they are for the real decision-maker, such items may still serve as interesting background material to make the play of the game more vivid to the players. The following items show how news clippings may be classified according to categories related to the PRINCE model. A larger set of clippings, consisting of about 80 pages, is available and will be sent on request.

I. THE U. S. ECONOMY AND ITS TRADE AND AID POLICIES

For Huge Truck Factory Sale of Foundry Tools To Russia Approved

United Press International

The administration yesterday approved the export of \$162 million worth of foundry tools to the Soviet Union for use in building the world's largest truck factory—a step which will more than double U.S. exports to Russia and give a lift to the sluggish American machine tool industry.

With no fanfare, the Commerce Department routinely announced approval of two export licenses for foundry equipment used in the manufacture of automotive castings.

As is customary, the Commerce Department did not identify the licensee. But it said the exports would be used in the huge Russian truck facility, which will enable the Russians by 1975 to build 150,000 diesel trucks yearly—more heavy-duty trucks than the United States now produces.

Mack Trucks Inc. of Allentown, Pa., has applied for a license to export machine tools for the same plant. Although approval of the license for foundry equipment apparently signalled ultimate approval of Mack's application for a license, the department said no action has been taken on the Mack application. A spokesman said the application is "being considered at the highest levels."

See MACK, A10, Col. 1

Export of Foundry Tools to Russia For Truck Factory Given Approval

MACK, From A1
The \$1.4 billion truck plant, the largest in the world, is to be built on a six-mile by six-mile site in the Tatar Republic, about 570 miles east of Moscow.

The deal is expected to involve the export over the next two to four years of at least \$750 million worth of U.S. products. American exports to the Soviet Union last year totaled about \$120 million.

Mack Trucks and a Soviet trade delegation reached agreement on the deal last May 18 but it was contingent on Commerce Department approval of the necessary export licenses. The government agency postponed the decision several times while the pros and cons of the sale were

weighed within the administration.

Those favoring it argued it would stimulate the domestic machine tool industry, indicate to the Russians that progress on political matters—such as a disarmament—could lead to a relaxation of U.S. trade curbs and reassure the Russians that the relaxation of trade barriers with China would not come at the expense of the Soviets.

In addition, they argued, the Russians could buy from Western Europe the same technology they sought from Mack Trucks.

The Russians were negotiating with Daimler-Benz of West Germany and Renault of France while they were talking to Mack Truck officials.

The agreement carried a stipulation that the trucks and components manufactured at the Kama

River plant in Russia were to be used for industrial and agricultural purposes within the Soviet Union. This was intended to reduce political objections to the transaction in the United States.

American firms have frequently complained about U.S. export restrictions which allow Western European countries to sell to Russia and its allies goods which American firms are barred from selling to the Soviets.

The U.S. firms said the licensing practices forced them to negotiate sales to the Russians without knowing whether the required licenses would be approved. Generally, the government has sought to prevent the sale to Russia or its allies of products which could be of direct military

Table on U.S. Foreign Aid

Special to The New York Times

WASHINGTON, July 9—Following is the table released today by Senator William Proxmire listing (in thousands of dollars) United States military and economic assistance to 43 countries:

Country	Military Assistance Program	Foreign Credit Sales*	Economic Supporting Assistance	Subtotal
Cambodia	200,000		110,000	310,000
Nationalist China	19,500	45,000		64,500
Indonesia	24,990			24,990
Korea	239,400	15,000		254,400
Laos			50,550	50,550
Malaysia	134	7,500		7,634
Singapore		7,500		7,500
Thailand			40,000	40,000
South Vietnam			565,000	565,000
Greece	19,875	60,000		79,875
India		5,000		5,000
Iran	942			942
Pakistan		5,000	250	5,250
Turkey	99,770			99,770
Portugal	1,000			1,000
Spain	13,000			13,000
Congo	477	2,000	1,016	3,493
Ethiopia	12,790			12,790
Ghana			106	106
Liberia	500		203	703
Nigeria			4,400	4,400
Argentina	897	15,000		15,897
Bolivia	666		115	781
Brazil	892	20,000	174	21,066
Chile	856	5,000		5,856
Colombia	844		340	1,184
Costa Rica			198	198
Dominican Rep.	539		370	909
Ecuador	645		135	780
El Salvador	374		56	430
Guatemala	336	5,000	377	5,713
Guyana			99	99
Haiti			3,000	3,000
Honduras	467		171	638
Mexico	107			107
Jamaica			96	96
Nicaragua	568		91	659
Panama	173		203	376
Paraguay	387			387
Peru	792			792
Uruguay	400	2,000	225	2,625
Venezuela	734	15,000	200	15,934
Philippines	17,000		800	17,800
Worldwide	\$731,800	\$582,000	\$825,000	\$2,138,800

Source: U. S. State Department.
 *Estimate.
 †Previously unclassified.

II. ECONOMIC POSITIONS AND POLICIES OF THE OTHER PRINCE
NATIONS (USSR, FRANCE, INDIA, PAKISTAN)

Feud Between the Two Pakistans Has Some Economic Basis

By Charles Smith
London Financial Times

East and West Pakistan are fighting in part at least, about economic problems. And the economic plight of the East, which places it among the eight poorest countries in the world, can be partially attributed to the very fact that it is part of Pakistan.

In 1947, when the two halves of the country started out on their hazardous course as a Moslem na-

News Analysis

tion after partition from Hindu India, the East wing was actually better off than the West in a number of important respects.

Its jute crop, which to this day provides Pakistan with its biggest single source of

foreign exchange, was at that time the only product of any importance which either wing of the country had to offer to world trade. The textile mills around Dacca and Chittagong in the East constituted virtually the only industry of which Pakistan could boast and, as far as the future was concerned, East Pakistan's flat and well-watered countryside looked more promising for development than the relatively arid West.

What East Pakistan did not have, however, and has never possessed to any significant extent until today, was political power—and it was the exercise of power

by the leadership in the West that started the rot. The first blow to the East's economy was the cutting off for political reasons of trade between East Bengal (as East Pakistan had been

called before separation from India) and the neighboring Indian state of West Bengal.

The cut meant that Pakistan's jute could no longer be shipped for processing in India, and that on both sides of the frontier steps had to be taken to build up self-sufficient industries.

By the time East Pakistan had finished developing its jute processing industry in the mid 1950s, it was starting to notice the loss of its biggest single market—India—for the raw product. By that time, too, it was feeling the effects of increasing industrialization in the West.

This was based on the transfer, under exceptionally favorable tax terms, of Moslem-owned industries from Bombay to Karachi, which soon began to overtake Dacca and other cities of East Pakistan as the com-

mercial and economic heart of the divided country.

West Pakistan's industry exports its goods under a foreign exchange subsidy system which gave it a distinct advantage over agriculture—until the system was belatedly extended last year to East Pakistan jute. The West's products were dear by world standards, but they had a privileged market in East Pakistan which was thereby restrained from

buying cheap manufactured goods from international suppliers.

By the end of Pakistan's first decade, this system had produced a 20 per cent disparity in the per capita incomes of the East and West wings (arising largely out of the fact that there had been almost no increase during the 1950s in the income levels of Easterners). During the 1960s, attempts were

made to correct the imbalance, or at least they were written into such documents as the revised 1962 constitution and the successive five-year plans.

But the disparity has continued to grow and so, also, has the range of factors contributing to it. By the end of the decade there was a 47 per cent gap (according to East Pakistan figures) between the incomes of the two wings. East Pakistan's per capita income was still at the pathetically low level of around \$70 per head.

With a list of grievances like this, and with a claim that their country is in the most desperate economic

plight in the world, it is hardly surprising that East Pakistan's leaders have consistently demanded economic autonomy from the West.

French Move Closer to Building Truck Factory in Russia

By Jonathan C. Handal
Washington Post Foreign Service

PARIS, June 2 — The French and Soviet governments have inched another step toward building a giant factory in Russia capable of producing 150,000 diesel trucks annually.

For the first time since U.S. government pressures last year forced the Ford Motor Company to withdraw from the project, the Soviets spelled out just what they have in mind. They provided the nationalized French Renault firm with detailed specifications for the complex to be built on the Kama River.

Under arrangements worked out here Monday between French Finance Minister Valéry Giscard d'Estaing and Soviet Foreign Trade Minister Nikolai Patolitchev, Renault will carry out construction studies for the estimated billion dollar project.

However, French officials made it clear that the Soviets

will build their own diesel motors, an apparent departure from previous plans which at one point interested West German and British motor builders.

Joint Oil Deal

In other dealings, Giscard d'Estaing, who announced the Kama River plant study, said a joint Franco-Soviet oil refinery had reached the preparatory work stage, probably at Le Havre on the English Channel.

Giscard brushed off questions about the size of the refinery while revealing that it would be run on the French side by the state-owned Elf-Erap firm which has recently had its major source of supply in Algeria nationalized.

At present France imports only a tiny trickle of Soviet crude within its annual imports of some 100 million tons.

The French minister also said that Franco-Soviet negotiations for importing Soviet natural gas had now reached a "decisive stage." The Soviet gas would be piped in from its

present westernmost terminal in West Germany rather than an alternative outlet in northern Italy.

Last September Renault pledged \$127 million to cover both the modernization of existing Soviet truck plants and construction of the new Kama River diesel factory.

Credit terms were a generous 5.95 per cent to run for seven years after completion of all construction.

If the difficulties of Italy's Fiat in starting a passenger car plant in Russia are any indication, construction can be expected to drag on for considerably longer than originally planned.

III. RELATIONS AMONG THE PRINCE NATIONS

Unity Cited As Foreign Policy Aim

By Marilyn Berger

Washington Post Staff Writer

Secretary of State William P. Rogers said yesterday that administration policy abroad is being shaped to achieve "new national unity and purpose" at home and to overcome the "deep and destructive divisions of the 1960s."

Presenting a 617-page report on U.S. foreign policy in 1969 and 1970, Rogers noted that the administration took office "in the midst of a searching national debate on foreign affairs," a reference to divisions over Vietnam.

"Assumptions that had determined our policies for more than two decades were open to challenge and re-examination," Rogers went on. "America needed a new perception of its place in the world, a new unity and sense of purpose in its foreign affairs. That is what we are undertaking to achieve."

The administration, Rogers said, is moving out of the Vietnam war. "By ending our involvement . . . we will restore perspective. By altering the character of our involvement in the world, we hope we will reestablish a balance in the conduct of our relations."

Rogers said the legacies of the past are giving way to new forces and that policy is being adapted to new realities. "My greatest hope," he said, "is that the path we are now taking can help create among Americans a new national unity and purpose in our foreign policy, a policy no longer haunted by the past but committed freshly to the opportunities of the future."

The foreign policy report, like the secretary's introductory statement, provides a view of past policy, and in some areas, a look toward the future. It contains no new policy formulations.

It ranges all the way from the Berlin negotiations to the

problems of fisheries and wildlife, providing an idea of the scope of State Department diplomacy.

No similar report has been issued since 1898 when Secretary of State Richard Olney gave a 50-page narrative report on the state of U.S. foreign relations, with 900 pages of documentation.

The present report is being distributed to foreign embassies and U.S. posts around the world and can be purchased through the Government Printing Office for \$2.75. It provides 348 pages of narrative and charts, sketches and maps.

The report is divided by subject as well as by geographic areas and country-by-country sections. A 268-page annex provides a collection of key U.S. foreign policy papers and pronouncements for 1969 and 1970.

Throughout the report, a depiction of U.S. strength is blended with a recognition of the limitations of power, an effort to lower the American profile abroad, as prescribed by the Nixon Doctrine, while maintaining an effective role in world affairs.

The report is descriptive rather than defensive or polemic, and unlike the general run of government documents, notes some criticism of American policy.

While the facts it includes are stated candidly, others are omitted. Thus, it states that Peking canceled the May 20, 1970, meeting that was to have taken place in Warsaw. It does not say that Peking did so in protest of the combined U.S.-South Vietnamese move into Cambodia. (The White House report similarly failed to mention this fact.)

In the book's introduction Rogers calls current negotiations with the Soviet Union on strategic arms limitations "one of the most hopeful de-

velopments in contemporary world affairs." He notes that it is with Moscow that "we have made the most sustained efforts to convert disputes into negotiations," but says results have been mixed.

The U.S.S.R., Rogers wrote, has not played a constructive role in Indochina and "has continued to be North Vietnam's major arms supplier." In Berlin, he wrote, "the Soviets so far have not appeared disposed to take the realistic decisions necessary for progress."

The secretary reiterates that "a satisfactory conclusion of the Berlin talks" is necessary before wider questions of European security can be tackled.

In Asia, Rogers wrote, one of the first steps taken by the Nixon administration "was to loosen the rigidities confining U.S. China policy." But it is the U.S. relationship with Japan that is called "the most important single factor" affecting American policy in East Asia.

On the Middle East, which probably has evoked more State Department activity than any other single matter, the report details the course of negotiations as well as the arms buildup in the region. "The search for peace," the report says, "will require decisions by both Israeli and Arab leaders to move from their maximum positions . . . (and) a Soviet decision that the alternative to settlement contains dangers it does not want. It will require resoluteness on our part and a willingness to remain engaged in the area despite the risks involved."

Rogers wrote that the U.S. would "seek to preserve a relationship of confidence with Israel" and try to improve its relationship with the new Egyptian government in order to encourage acceptance of an agreed, not an imposed, settlement.

Indian Press Favors East Pakistani Rebels

By Lee Lescaze

Washington Post Foreign Service

NEW DELHI, April 1— "There are two wars in East Pakistan," a diplomat remarked today, "the war we hear about through channels and the war we read about in the Indian press."

In the first days after Pakistan's army attacked last Thursday night, Indian press reports were major source of information about the civil war. The Indian press coverage so influenced the world's initial view of what was happening in East Pakistan that it became part of the event rather than an independent commentary.

"This has not been reporting, it has been psychological warfare," an Indian official remarked of newspaper stories recounting victory after victory by Sheikh Mujibur Rahman's East Bengalis against the Pakistan army.

With the expulsion of all foreign correspondents and all regular communications with Dacca cut, it was difficult at first for observers here and elsewhere to totally discount Indian news-

paper stories. The stories fed upon and in turn increased the wave of public sympathy here for the East Pakistani cause. All Indian papers have reported the fall of Dacca to East Bengali "freedom fighters." Several newspapers, including the respected Times of India, led the way with banner headlines on Dacca's liberation in Tuesday editions. The others fell in line the next day. Most reports were attributed to the Free Bangla Radio which has been broadcasting from an unknown location since the fighting began.

However, reports that Dacca was firmly held by the Pakistan army, which were also available here, were ignored by the newspapers. Indulging in what appears to have been wishful thinking, the papers took Free Bangla Radio reports at face value and published predictions that the Bengalis would soon triumph. Retired army officers and other military analysts wrote descriptions of the tactical situation in East Pakistan which appeared

under headlines like: "Overwhelming Advantages for Bengalis."

However, as the days passed, inconsistencies began to crop up in the press. Refusing to back off their earlier reports that Dacca had been "liberated", the papers nevertheless carried stories warning that "second round" of heavy fighting was coming.

The Hindustan Times today gave its largest front page headlines to a report that "freedom fighters" remained in "complete control" of central Dacca, but carried an additional two-paragraph story saying: "The liberation movement appeared to be in reverse gear tonight in the face of sustained pressure."

But, as the civil war continued and greater variety of reports became available here, it was apparent how far from accurate the Indian press had been. On Tuesday, a group of Yugoslav technicians were striking examples of the desire to continue the impression that all was going well for Bengali forces. Several papers reported that the Yugoslavs said Dacca was burning. Others more accurately reported that everything in the East Pakistan capital had been quiet under army control when they left, but these papers played the story down, giving it far less space than accounts of Bengali successes.

The Times of India printed one Yugoslav woman's remark which seemed particularly appropriate amid the confusion here over events in East Pakistan. Asked whether foreigners in Dacca had listened to All India Radio for news of the civil war, she said they had. Her radio's coverage, she told the Times of India, "was fairly correct, although not very accurate."

Indian Mob Protests Kissinger's Visit

From News Dispatches

NEW DELHI, July 6—President Nixon's top security adviser, Henry Kissinger, arrived here today amid demonstrations protesting U.S. arms sales to Pakistan.

He was met by about 50 Indians shouting "Kissinger go home" and carrying a huge banner reading "Kissinger of death go back." Police cordoned off New Delhi airport and later dispersed protestors in front of the U.S. embassy.

About 1,500 angry Indians turned out in Bombay where the special plane carrying Vice President Spiro T. Agnew made a brief refueling stop en route to the Middle East.

Agnew, on a 10-nation goodwill tour, expressed sympathy for India's role in caring for millions of East Pakistani refugees and said the United States probably will seek to give India "the additional assistance to handle this matter."

Kissinger conferred today with U.S. officials here. He is scheduled to meet with Prime Minister Indira Gandhi and other high Indian officials Wednesday before flying to Pakistan on Thursday.

Several high Indian officials have made blunt statements about their displeasure with the U.S. arms shipments to Pakistan. Foreign ministry officials said today there was a "crisis of confidence" in In-

dia's attitude toward the United States.

There was no official indication of the thrust of Kissinger's talks with Indian leaders but informed sources believe they would be dominated by the arms issue. Kissinger is likely to also discuss problems created inside India and in her relations with Pakistan by the influx of more than 6 million East Pakistani war refugees.

U.S. officials here suggested that Kissinger's goal during his visits to India and Pakistan would center on exploring the ways to ease the diplomatic and military confrontation between the two neighbors.

Soviets, India Sign Treaty

Agreement Does Not Bind Either to Fight

From News Dispatches

NEW DELHI, Aug. 9— India and the Soviet Union signed a 20-year pact of "peace, friendship and cooperation" today.

The treaty gives India the political support of Moscow in the current India-Pakistan dispute, but it does not commit either side to automatic military aid in the event of an attack by a third country.

[At the United Nations, U.S. Secretary of State William P. Rogers, asked about the probable effect of the new treaty, said, "We hope it will have an effect for the good."]

Indian Foreign Minister Swaran Singh told a cheering Parliament, "This treaty should act as a deterrent to any powers that may have aggressive designs on our territorial integrity and sovereignty."

"It is therefore, in essence, a treaty of peace against war." Tensions between India and Pakistan have been rising steadily over the Bengali independence movement in East Pakistan and the resulting flight of some seven million refugees into India.

In briefings with newsmen, Indian officials have made it clear that they expect China—as well as the United States—to back Pakistan in case of war.

Pakistan and China have developed close ties since China's border clashes with India in 1962. Premier Chou En-lai said last April, in a message to Pakistan President Yahya Khan, "Should Indian expansionists dare to launch any aggression against Pakistan, the Chinese government and people will always firmly support the Pakistan government and people in their just struggle to safeguard their state sovereignty and national independence."

THE WASHINGTON POST *Tuesday, Aug. 10, 1971*

Washington has continued to supply President Yahya's regime with arms which it has used to suppress the Bengali uprising. This has been a major factor in the rapidly deteriorating relations between India and the United States.

In an address to a rally of nearly one million people who poured into New Delhi to express support for the government's Pakistan policy, Prime Minister Indira Gandhi said her country was not frightened by what she said were war threats that Yahya Khan had made.

Her confidence, obviously stiffened by the new Soviet pact, was seen as a counter to Yahya's recent claims that his government was "not alone" in any open conflict with India—an apparent reference to Pakistan's alliance with China.

Speaking at the same rally, India's Defense Minister Jagjivan Ram accused the United States of "trying to disturb the peace" in the Indian subcontinent and to kill the East Pakistan independence movement. "This only shows that America has wealth but not humanity," he added.

The Soviet Union is India's main supplier of arms.

The terms of the new treaty were made clear in its ninth article, which states:

"Each high contracting party undertakes to abstain from any assistance to any third party that engages in armed conflict with the other party."

"In the event of either party being subjected to an attack or a threat thereof, the high contracting parties shall immediately enter into mutual consultations in order to remove such threat and to take appropriate effective measures to ensure peace and the security of their countries."

In his speech to Parliament, just two hours after he and Soviet Foreign Minister Andrei Gromyko signed the pact, Swaran Singh said it should provide a "stabilizing factor in favor of peace" in Asia. "It is also a treaty of nonaggression," Singh said.

In the eighth article of the 1,500-word pact, each nation undertakes not to "enter into or participate in any military alliance directed against the other party."

Each also agrees "to abstain from any aggression against the other party and to prevent the use of its territory for the commission of any act which might inflict military damage on the other."

The new Soviet-Indian treaty apparently was worked out in secret negotiations concluded before Gromyko's arrival Sunday on what had appeared to be a hastily arranged visit.

Egypt and the Soviet Union signed last May a similarly titled treaty but of shorter duration. The 15-year Egyptian-Soviet pact was at the time considered unusual for a non-Communist nation.

Similarly, the 10th article bars both nations from entering "into any obligation, secret or public, with one or more states which is incompatible with this treaty."

In another article, the two countries pledge "to continue their efforts to preserve and to strengthen peace in Asia and throughout the world, to halt the arms race and to achieve general and complete disarmament, including both nuclear and conventional, under effective international control."

The treaty is to be extended automatically for successive five-year periods after the initial 20 years, unless either country wants to terminate it by giving 12 months' notice before it is due to expire.

The treaty will come into force within one month, "subject to ratification," presumably by the parliamentary organizations of each country.

In presenting the treaty to parliament Singh sought to re-

move any impression that it altered India's traditional policy of nonalignment.

"It strengthens our policy of nonalignment, respect for which is expressly mentioned in the treaty," he said.

"We sincerely hope that the policy of nonalignment will be

further strengthened and will become an effective instrument for the safeguarding of our national interests as well as an important factor in the maintenance of universal peace and international security and in the lessening tensions in the world."

IV. ISSUE POSITIONS AND RELATED ACTIONS

Issue 1. Formal recognition of the German Democratic Republic by the NATO states, followed by the demilitarization of both East and West Germany. *

Tuesday, March 30, 1971 THE WASHINGTON POST

Soviet Berlin Plan Held Nothing New

By John M. Goshko

Washington Post Foreign Service

BONN, March 29—A Soviet proposal introduced at last week's four-power meeting on Berlin contained "no new elements" and gave no sign of breaking the deadlock in efforts to find a new status for the divided city.

This was revealed today by authoritative West German government sources after it became known over the weekend that Soviet Ambassador Pyotr A. Abrasimov had offered a new position paper at the meeting Friday in Berlin. Afterward, Abrasimov had characterized the session as "important and constructive."

However, the West German sources said that the Soviet paper, while comprehensive

and detailed, consisted of nothing more than a gathering together in one document of the various proposals that the Russians have made in piecemeal fashion during earlier stages of the year-old Berlin negotiations.

Tough Position

As one source described it: "The document adds nothing to the bargaining position that Moscow had previously made clear to the Western allies. Nor does it detract from it. There are no concessions and no retreat to a tougher stance—merely an indication that the Soviets have decided on their maximum bargaining position and are sticking with it for now."

The sources described this so-called "maximum bargaining

position" as a "very tough one" that remains leagues apart from the Berlin proposals advanced by Bonn's three Western allies—the United States, Britain, and France—in a joint position paper last month.

For example, the sources said, the Soviet paper continues to insist upon a complete ending of the West German "federal presence" in West Berlin—a demand unacceptable to either Bonn or its allies.

Similarly, they added, on the crucial question of access between West Germany and West Berlin, the Soviets continue to maintain that this is a matter involving East German sovereignty and must be negotiated directly with the East German regime.

The Soviet document reportedly does repeat some hints of Communist concessions on the access question. But, the sources said, they all have been brought up in previous four-power meetings and are regarded as falling far short of the Western demand for guaranteed unimpeded access.

Soviets Unyielding

Because the Soviet position remains so unyielding, the Bonn sources said, Chancellor Willy Brandt's government has become increasingly convinced that any possible Berlin agreement lies a long way off. In fact, the sources hinted that the Bonn regime is no longer counting on an agreement being reached during 1971.

Since Moscow is well aware that the positions outlined in its new document are unacceptable to the West, the sources appeared puzzled about why Abrasimov had put on such a show of optimism when he unveiled it last week.

The sources speculated that the Moscow regime wanted to have a comprehensive set of Berlin proposals on paper in time for the Soviet party congress that begins Tuesday.

By putting the document forward at this time, the sources think, the Soviet leaders will be able to use it as a basis for making pronouncements on the Berlin question that are expected to be made during the Congress.

* As pointed out earlier, these clippings concern the Berlin question, an issue related to, but not, of course, identical with the PRINCE issue.

Washington Post : April 14, 1971

U. S. to Remain In Asia—Laird

Laird Cites 'Deterrent' After Pullout

By George C. Wilson
Washington Post Staff Writer

U. S. ships and warplanes will remain on duty in Southeast Asia after the last American soldier leaves Vietnam, Defense Secretary Melvin R. Laird indicated yesterday.

He told newsmen at a press conference at the Pentagon that these naval and air forces "would be a part of the realistic deterrent which we will maintain in Asia."

The Defense Secretary thus strengthened the impression that President Nixon is counting on warships off Vietnam and planes in Thailand to offset any diplomatic leverage he loses in Asia by the withdrawal of U.S. troops from Vietnam.

Laird said that a continued American military presence in Asia is vital to the Nixon administration effort to prevent war in the 1970s but he stressed that the United States had to be "realistic" about cost and about other world threats in deploying such forces.

Failure to maintain any force at all in Asia, Laird said would contradict the administration's expressed policy of "realistic deterrence" and mislead "any possible aggressor."

Laird declined to spell out whether the remaining force of ships and warplanes would continue to engage in combat in Indochina. "I do not believe that we should look forward to the maintenance of that kind

of warfare" was as far as he went in discussing the future role of sea and air forces in Asia.

The Defense Secretary was even more vague when newsmen tried to pin him down repeatedly on what kind of residual force of American ground troops he foresaw for Vietnam.

"I think there's a game going around here to try to divide the President from his Minority Leader," Laird complained, "and I am not going to get into that particular game because I think it gets into the question of a definition of words."

Senate Minority Leader Hugh Scott (R-Pa.) last week quoted President Nixon as telling a White House briefing for congressional leader that he intended to withdraw all forces from Vietnam before his term expires.

This was typical of several exchanges on the subject at Laird's press conference yesterday:

Q. Do you plan a Korea-type solution in Vietnam... leaving X number of Americans there as a support force indefinitely, or do you plan to get them completely out, period?

A. I think the President made that very clear in his speech.

Reminded that he had said on previous occasions that Phase 1 of Vietnamization called for turning over ground combat to the South Vietnamese by June 30, 1971, Laird said he did not mean that the remaining U.S. troops would be immune from combat to protect bases and support forces.

"They will protect the American presence," Laird said of the dwindling number of combat troops in Vietnam.

Army leaders have long

argued that even after the United States gets down to fewer than 150,000 troops on the ground in Vietnam, the combat platoons will still have to go out on patrols. The casualty rate is expected to be about 25 American battlefield deaths a week by the end of this year, although the troop presence will be way down.

Laird appeared defensive and jumpy—his hands visibly shaking at times. His usual exuberance and confidence seemed to be missing yesterday in the press conference that touched on these other points:

Laos invasion—He denied a published report that withdrawal of U.S. Air Force units from Vietnam is being slowed because Lam Son 719 fell short of its objectives. He said the current spurt of enemy attacks in Vietnam was to be expected but that the North Vietnamese would find it "almost impossible" to mount a sustained offensive.

Volunteers for Vietnam—He said that sending only volunteers to fight in Vietnam was

under study, but presented such severe difficulties that it was too early to determine whether it was feasible.

Washington Post : April 9, 1971

Israel Considers Terms for Withdrawal From Canal

By Yuval Elizur

Special to The Washington Post

JERUSALEM, April 9—Israel is convinced that under the present circumstances a partial settlement based on a limited Israeli withdrawal from the Suez Canal line is the best way to relieve Middle East tension. The Israelis are taking their time, however, about setting their terms for such a withdrawal.

Only yesterday, after the arduous three-day convention of her ruling Labor Party, was Prime Minister Golda Meir ready to sit down with her top advisors

News Analysis

to discuss under what conditions Israel would be ready to withdraw from the 60-mile-long Bar Lev line along the banks of the Suez Canal.

Observers are convinced that the majority of the Israeli cabinet favors such a partial solution, in principle. Nor are military experts fundamentally opposed to such a pullback; but from this point until the

moment when Israeli representatives will be equipped with a full Israeli position on the topic, the road may be long and full of pitfalls.

Despite the Passover holiday the Israeli government may hold a special meeting early next week to give its approval to the Israeli terms for a partial settlement and the Israeli withdrawal from the Suez Canal.

The tendency to speed up the decision on the Israeli terms of the withdrawal is mostly as a result of American pressure. The U.S. ambassador in Tel Aviv, Walworth Barbour, yesterday met, at his request, with Prime Minister Golda Meir and Foreign Minister Abba Eban probably to express U.S. feelings on this matter. Barbour is reported to have reminded the Israelis that three weeks ago they promised an answer within 10 days on U.S. ideas for a partial settlement.

U.S. officials, who feel that time is running short and that any further delay may bring a hardening of

the Egyptian position, are trying their utmost to convince the Israelis that they should speed up their decision-making process. Failure to act now, the Americans argue, may make any future settlement more difficult to achieve.

Yet experts familiar with the Israeli scene tend to agree that if the Israelis are dragging their feet it cannot be explained away by labeling it "Israeli intransigence," nor excused as merely the inevitable vacillations and infighting characteristic of any democratic regime.

In recent weeks the idea that an interim solution is needed—one which would bring about the Suez Canal's reopening and restore civilian life in the Egyptian towns along the Canal—has been gaining ground in Israel. U.S. initiative, and Israel's realization that a rejection of the demand for total withdrawal could eventually lead to the renewal of hostilities, have most likely played an important role in pushing the interim-solution idea.

In the time it took the

idea to develop from the embryonic stage, several conditions have been mentioned as prerequisites for any Israeli agreement to a partial withdrawal. Some of these may have been no more than feelers, while others may come up again as bargaining points when meaningful talks get under way. Yet observers believe that the Israelis will absolutely insist on the three following conditions:

- No Egyptian soldier will be allowed to cross the Suez Canal even after agreement on the partial settlement is reached. The Israeli forces will be pulled back 10 to 20 miles, but occasional patrols will supervise the west bank on the canal.

- The interim solution may not be considered a step in a general settlement which presupposes total Israeli withdrawal from the Sinai Peninsula.

- The partial settlement must not put an end to the Jarring mission.

Issue 7. Admission of Communist China to the United Nations as the legitimate government of China.

THE WASHINGTON POST

Saturday, July 10, 1971

**Chiang Asks Defeat
Of China U.N. Entry**

By Peter

TAIPEI, Taiwan, July 9. — President Chiang Kai-shek today appealed to all non-Communist countries to oppose Peking's admission to the United Nations.

Chiang, 83, told a rally at Taipei's city hall marking "captive nations week" that Peking's entry into the United Nations would destroy the noble spirit and great objective of the world body.

administration's overtures toward mainland China, have made the issue of nuclear weapons in the Western Pacific extremely sensitive.

This sensitivity is heightened because the Taiwan issue is crucial to future relations between the United States and Peking. The United States has taken a firm stand against the expulsion of Taiwan from the United Nations, but has not explicitly stated its new position on the question of mainland China's representation in the United Nations.

July 16, 1971

China U.N. Entry

UNITED NATIONS—A 17-nation group placed a demand on the General Assembly agenda that China be seated in the United Nations and be given the permanent seat which Taiwan now occupies in the Security Council.

The annual issue will be taken up at the assembly session beginning Sept. 21.

August 9, 1971

**Kuwait to Support
China's U.N. Entry**

KUWAIT, Aug. 8 (AP)—Kuwait will vote for the seating of China in the United Nations and the expulsion of Nationalist China, the Foreign Ministry announced today. Kuwait established diplomatic relations with China last March.

Issue 9. A U. N. resolution condemning the treatment of Jews in the Soviet Union.

Friday, May 28, 1971 THE WASHINGTON POST

Soviet-Jew Trials Denounced by U.S.

The State Department yesterday called recent trials of Soviet Jews "abhorrent" and a violation of human rights.

Department spokesman Charles W. Bray volunteered a strongly worded statement directed at the reports of trials just concluded in Riga, Latvia.

"The continued practice of trying people in secret," he said, "is a matter of deep concern to us."

Basing himself on accounts of the trials by the Soviet news agency Tass, Bray noted that the proceedings were closed to impartial observers and that foreign newsmen who had applied to cover the trials were refused admission.

According to the Tass reports, Bray said, the defendants were charged with "fabricating and circulating slanderous materials for subversive purposes."

"It would appear that the defendants were tried for an action or actions which are not even considered a crime in most countries," Bray said.

The statement continued, "We trust that the Soviet government realizes that Americans of every political persuasion and religious belief deplore the persecution of persons simply for studying a foreign language, in this case Hebrew, and for running materials off on a mimeograph machine, as seems to have been the case judging from Tass reporting of the Riga trial."

Bray said that "these trials and previous trials at Lenin-

grad are abhorrent on three grounds: the denial of the right to an open trial; persecution of people for their beliefs; the denial of the right of people freely to leave any country and to travel or reside abroad in the country of their choice."

The statement concluded, "We deeply regret these deprivations of fundamental human rights, rights that should not be in question anywhere in the second half of the 20th century."

The United States has, in the past, urged the Soviet Union to temper its policy. Last December, Secretary of State William P. Rogers sent a personal appeal to Soviet Foreign Minister Andrei A. Gromyko urging a reduction of harsh sentences growing out of the Leningrad hijacking conspiracy trial.

In February, the U.S. representative at the U.N. Human Rights Commission in Geneva, said there was widespread discrimination against Jews in the Soviet Union and urged Moscow to allow persons who wanted to leave the country to do so.

Since the beginning of 1971, the Soviet Union has been giving visas to a greater number of Jews who wished to emigrate to Israel than previously. Since the issue is a sensitive one because of Arab concern over an expanding Israeli population, numbers are kept secret.

Washington Post

March 30, 1971

Soviet ABM Bid Attracts Symington

Sen. Stuart Symington (D-Mo.) called yesterday for American acceptance of a Soviet-proposed arms control agreement limited to rival anti-missile (ABM) systems.

In a New York speech, Symington argued that an agreement limiting ABMs "could slow down, perhaps stop, this dangerous offensive-defensive merry-go-round" in the arms race. He indicated preference for banning all ABMs rather than limiting the two rival systems to protection of the Washington and Moscow areas.

A longtime foe of the America's Safeguard ABM system, Symington attacked the Washington-Moscow proposal, which is the Soviet preference, by asking, "Is the price worth the fiction of asserting we both have an ABM system?"

He has contended that the Safeguard system will not provide protection and that the existing Soviet system can be easily penetrated.

Symington's speech, at the Herbert H. Lehman College, came shortly after Sen. Henry M. Jackson (D-Wash.) delivered to the Senate his own arms-freeze proposal, made public on Sunday. Last week Sen. Hubert H. Humphrey (D-Minn.) offered his plan for an ABM ban or limitation conditioned on a future agreement to limit offensive weapons.

Jackson yesterday called Symington's proposal "dangerously unwise." Symington said Jackson's plan presented such complicated problems that it could "scuttle" hope for a SALT agreement.

At the State Department, spokesman Charles Bray avoided taking sides. He said "we welcome the constructive interest" shown by the Senators and will carefully study all suggestions.

April 8, 1971

Muskie Asks Negotiations On ABM Ban

Sen. Edmund Muskie (D-Maine) has called for accepting the Soviet proposal to negotiate an anti-missile (ABM) agreement, provided it is clearly a first step toward the control as well of offensive nuclear weapons.

He did so in a speech Tuesday night to the Philadelphia World Affairs Council. In doing so, the man generally considered the front-runner for the 1972 Democratic presidential nomination took a position similar to that of a potential rival, Sen. Hubert H. Humphrey (Minn.).

Muskie argued that the strategic arms limitation talks (SALT) are "in trouble" because new Soviet missile deployments "increase our uncertainty as to Soviet intentions" and because the United States is now deploying missiles on land and at sea with multiple warheads (MIRVs) which the Soviets do not yet have.

The senator, who is the new chairman of the Senate Foreign Relation arms control subcommittee, charged the Nixon administration with "operating on a double standard. It has called for Soviet restraint in deploying weapons; yet it is not willing to exercise comparable restraint."

Hence, he said, "if we cannot get the Soviets to agree on the United States proposal at this round (of SALT), I urge the President to try to negotiate an agreement limiting or banning" ABMs. Such an agreement "should be made with the clear understanding" that it would be the first step and both sides would have the right to reconsider if further progress were not made.

THE WASHINGTON POST Tuesday, June 22, 1971

World Court Rules Against S. Africa

From News Dispatches

THE HAGUE, Netherlands, June 21—The world court today said South Africa has violated the mandate under which it administers South-West Africa and should immediately surrender the former German colony.

The court's ruling, a 13-2 decision, with a British and a French judge voting in opposition, was a legal opinion to back up a U.N. Security Council resolution that the republic's mandate, granted by the now defunct League of Nations 50 years ago, should be revoked and that the territory now should be administered by a U.N. commission.

The opinion carries no legal weight, but it was considered an important element of international pressure on South Africa.

However, the court's ruling was expected to have no immediate effect on South Africa's control of the sparsely populated, mineral-rich territory which has about 500,000 Africans and 73,000 white settlers.

In Pretoria, Prime Minister John Vorster said South Africa had no hesitation in rejecting the world court ruling.

"An advisory opinion by its very nature has no binding force and in the present case is totally unconvincing," he said in a nationwide radio broadcast.

"It is our duty to administer South-West Africa so as to promote the well-being and progress of its inhabitants," he said.

"We have guided and administered the peoples of South-West Africa for more

than half a century in a manner which has earned their full-hearted confidence. We have set them on the way or peace, prosperity and self-determination and we do not intend to fail that trust."

South Africa has disputed the right of the United Nations to make such a decision and has continued to run the territory, an area larger than France.

It was South Africa's refusal to comply with the U.N. decision which led to the Security Council asking the International Court of Justice for a legal ruling.

This ruling, given today, was:

"The continued presence of South Africa in Namibia (the United Nations' new name for the territory) being illegal, South Africa is under an obligation to withdraw its administration immediately and thus put an end to its occupation of the territory."

To enforce its ruling, the court, also by a majority vote, called for an economic boycott on South African trade deals made on behalf of the mandated territory and asked for the withdrawal of diplomatic representatives whose appointment there had been approved by South Africa.

Issue 13. Establishment of a commission, under the World Maritime Organization, to identify and fine states who pollute international waters.

Friday, April 9, 1971 THE WASHINGTON POST

Around the World

Britain to Move Against Polluting Ships

LONDON—Britain took on itself the right yesterday to seize or sink foreign ships that threaten to pollute the country's beaches with oil—even if the ships are in the international waters.

Within hours, the Coast Guard reported that an oil tanker had collided with a Danish vessel in the English Channel, and first reports indicated that the 1,600-ton tanker Hullgate had two ruptured oil tanks and was leaking oil.

Meanwhile, a flotilla worked to break up 40-mile-long oil slicks in the channel. The slicks were believed to have come from the Liberian tanker Panther, which was aground for five days off the southeast coast of England before being freed Sunday.

British authorities had been powerless to act in the Panther's case while tug captains from several countries argued over salvage rights, since the tanker was just outside Britain's three-mile territorial waters.

Issue 16. An international treaty on the extradition of airplane hijackers.

Monday, April 12, 1971 THE WASHINGTON POST

Around the Nation

Lawyer Group Opens World Drive For Law to Stop Plane Hijacking

A Geneva-based organization of lawyers and judges, the World Peace Through Law Center, yesterday launched a campaign for worldwide adoption of laws to stop airplane hijackings.

Charles S. Rhyne, president of the center, said the organization's 40,000 members in 128 countries have been asked to petition their legislators, ministries of justice, transportation and communications, heads of government and international bodies to adopt the required legislation immediately.

"Just as the high seas were rid of piracy by the concerted action of nations, adherence to the rule of law and public indignation, so can aviation be made safe for all mankind," said Rhyne, a Washington attorney and former president of the American Bar Association.

Rhyne said member lawyers and jurists have been asked to insist upon ratification of the so-called Tokyo Convention of 1963 and Hague Convention of 1970, agreements designed to deter aircraft hijackings and to impose severe penalties on offenders.

V. U. S. DOMESTIC OPINION

March 26, 1971

The Gallup Poll

Nixon's Rating Drops to 50%

By George Gallup
PRINCETON, N. J.—Public confidence in the way President Nixon is handling his job has reached the lowest point yet recorded during his administration and the latest figures indicate that the downward trend may be leveling off.

In January of this year, Mr. Nixon's approval rating stood at 56 per cent. In February the figure had dropped to 51 per cent. And in the latest rating he receives a 50 per cent vote of confidence from the public.

Key factors in the decline in the President's popularity since the beginning of the year have been discouragement over the Vietnam war

and the state of the economy.

The high point in Mr. Nixon's popularity came in November, 1969, just after he had announced his plan for withdrawing troops from Vietnam and training the South Vietnamese to take over the fighting. At that time his approval rating reached 68 per cent.

President Johnson's low point was 35 per cent, recorded in August, 1968, when discouragement over our involvement in Vietnam had reached a new high point.

Below is the question asked in the survey. A total of 1,566 persons, 18 years of age and older, were interviewed in person between

March 19-21 in more than 300 scientifically selected localities across the nation.

Do you approve or disapprove of the way Nixon is handling his job as President?

	Approve %	Disapprove %	No Opin. %
National	50	37	13
East	49	39	12
Midwest	46	37	17
South	56	32	12
Far West	47	40	13

President Nixon's current popularity rating of 50 per cent is considerably under his overall average of 59 per cent approval, recorded over the 26 months he has been in office.

© 1971, American Institute of Public Opinion

May 9, 1971

The Gallup Poll

Popularity of Nixon Stabilizes At Low Point Reached After Laos

By George Gallup
PRINCETON, N.J.—Public confidence in President Nixon has stabilized at its low point, which was first recorded in a survey conducted immediately following the Laotian invasion in early February.

Over this 3-month period, Mr. Nixon has not been able to recoup two years of general losses in public popularity. Recent events at home and abroad, however, have not produced any further decline.

In the latest survey conducted April 23-25—at the time of the antiwar demonstrations in Washington, D.C.—50 per cent of the U.S.

voting age population gave Mr. Nixon a vote of confidence for the way he was handling his job; 39 per cent expressed disapproval, while another 13 per cent had no opinion. These findings represent virtually no change over the last three previous measurements.

The President's lowest level of public approval since taking office was 49 per cent, recorded last month. His highest popularity level, 68 per cent, was reached in November, 1969, just after he had announced his plan for staged withdrawal of U.S. troops from Vietnam.

To obtain the results reported today, personal interviews were conducted with a total of 1,566 adults in more

than 300 scientifically selected localities across the nation. This is the question which has been asked about the incumbent President since the Roosevelt years:

Do you approve or disapprove of the way Nixon is handling his job as President?

	Approve %	Disapprove %	No Opin. %
April 23-25	50	35	15
April 9-11	49	38	13
March 13-14	50	37	13
Feb. 19-21	51	36	13
Jan. 1-10	56	33	11

To identify those population groups which have contributed most to the downward trend in Nixon's popularity over the last two years, a comparison of the latest findings was made

with a Spring, 1969, survey when Mr. Nixon's rating had stabilized near its high point.

'Approval' Profile

	Spring '69 (65 Pct.)	Latest (50 Pct.)	Point Change
NATIONAL	65	50	-15
Sex			
Men	69	51	-18
Women	62	47	-15
Race			
White	67	51	-16
Non-white	52	47	-5
Education			
College	70	55	-15
High school	66	49	-17
Grade school	60	47	-13
Occupation			
Prof. & Bus.	70	57	-13
Clerical & Sales	67	51	-16
Farmers	69	47	-22
Manual	63	45	-18
Age			
21-29 years	70	49	-21
30-39 years	66	51	-15
40 & over	62	49	-13
Religion			
Protestant	69	55	-14
Catholic	60	47	-13
Jewish	51	20	-31
Politics			
Republican	81	60	-21
Democrat	55	31	-24
Independent	63	30	-33
Region			
East	61	50	-11
Midwest	66	51	-15
South	67	52	-15
West	66	44	-22

© 1971, American Institute of Public Opinion

GOP Scathes Democratic War Critics

By Spencer Rich

Washington Post Staff Writer

Republicans lashed back on the Senate floor yesterday at Democratic critics of the President's Vietnam policy, promising to put senators "on the firing line" regularly from now on to counterattack "neo-isolationists who reject the facts and vacillate."

They were led by Minority Leader Hugh Scott (Pa.), who had received a telephone call from President Nixon Tuesday night thanking him for defending the White House against criticism by Sen. Edmund S. Muskie (D-Maine).

Sen. Scott had long been considering some systematic way to respond on the floor to Democratic attacks and thereby blunt their publicity value.

Yesterday's GOP "truth squad" extolled the military operation in Laos, referred scornfully to a House Democratic resolution calling for withdrawal of U.S. troops by the end of 1972, and insisted that President Nixon is going in one direction only in Vietnam—out.

Scott vowed to respond to any further challenges of Mr. Nixon's intentions from Democratic political hopefuls. He said: "Many of these same people were talking about escalating the war" when Lyndon Johnson was President.

See DEBATE, A16, Col. 2

GOP Lashes Back At Viet War Critics

DEBATE, From A1

An array of Republicans arose to criticize Democrats for questioning the President's policies and doubting the success of the U.S.-backed incursion of South Vietnamese into Laos.

"We are on our way out, and it is somewhat disappointing—and if it weren't so political, almost humorous—to listen to the harping of some of my Democratic colleagues," said Robert Taft (Ohio).

"I am sick and tired of the war in Vietnam, and for more than two years I have been a persistent critic of our involvement in Indochina," asserted William B. Saxbe (Ohio). "One thing that distresses me even more, however, is those who continually play politics with this unfortunate war. I am also sick and tired of them."

J. Glenn Beall (Md.) declared that when he came to Congress in 1969 the Johnson administration had no plan to get this nation out of Vietnam. Now, under the Nixon administration, "we have a plan."

Others who spoke included Lowell Weicker (Conn.), William Brock (Tenn.) and Clifford Hansen (Wyo.).

Vice President Agnew developed the same theme in a speech to a Veterans Administration Volunteer Service meeting here.

Critics of the war are making veterans feel that they are fighting in a 'worthless' and 'immoral' cause, and that we ought to abandon the South Vietnamese to their enemy," Agnew declared.

This advice, Agnew said, "has come to them not from Hanoi Hannah but from some of the leading members of the U.S. Senate, prestigious columnists and news commentators, academic figures, some church organizations as well as as-so-called radicals, draft card burners and street demonstrators."

On the Senate floor the only Democratic response to the GOP attack came from Foreign Relations Committee Chairman J. W. Fulbright (Ark.), who was obviously one of the Republicans' targets though not mentioned by name.

Fulbright had told the Senate earlier this week that, on the basis of a still-secret Feb. 9 administration briefing his committee was given on the goals of the Laos operation, the incursion was clearly a failure.

"We have not been given access, we have not been consulted, we learn about the mistakes long after they have been made," Fulbright said yesterday. "It's no service to our country to . . . try to cover up what the facts are in Laos or anywhere else."

THE NEW YORK TIMES, FRIDAY, APRIL 2, 1971

400 College Leaders Condemn War Policy in Letter to Nixon

By JOHN KIFNER

More than 400 student presidents and college editors have signed an open letter to President Nixon condemning his policies in Vietnam and charging that the Administration seriously misinterprets the mood of both the campus and the countryside.

The letter, which was signed by student leaders at both prestigious and little-known colleges, attacks the President's "Vietnamization" policy, contending that "changing the color of the corpses does not end the war."

"Yet it is apparent that our policymakers have never considered the cost in Asian lives of the policies they pursue," the letter said.

The statement, to be released in Washington today, is signed by the largest number of student leaders to sign such a protest against the war.

In December, 1966, 100 student leaders sent an open letter to President Johnson expressing anxiety and doubts over the war. In the spring of 1967, 200 student leaders signed similar letter, and in April, 1969, 253 student presidents and editors signed a statement saying that they would go to jail rather than be drafted "as long as the war in Vietnam continues."

Organizers of the current drive said yesterday afternoon that they had 448 signatures and hoped to have 500 tomorrow.

The letter calls on the President to "reverse futile and immoral policies and use your authority to end the bloodshed in Vietnam"

"If not," the letter goes on, "you will have to take respon-

sibility for an intensification of public divisiveness and disunity which will further weaken the already torn moral and social fabric of American life.

"The outrage and the purposefulness emerging from beneath the surface despair on our campuses, when it is coupled with the widespread loss of public confidence in your Administration, cannot be deflected or contained."

The signers of the letter represent schools as disparate as Harvard and Grace Bible Institute; Berkeley and West Texas State; Dartmouth and Central Bible College in Missouri, and Duke University and Alaska Methodist University.

Other Schools Listed

Among the other schools represented are: Brown University, U.C.L.A., University of Colorado, Louisiana Tech, Syracuse Georgetown, Boston College, University of Iowa, University of Texas, Indiana State, Clemson, Rice, Ohio State, Sheridan College in Wyoming, Vanderbilt, Brandeis and Pawson College in Glendive, Minn.

And there were three schools where students have been slain in campus demonstrations: Kent State University, Jackson State College and South Carolina State in Orangeburg.

The campaign was organized by David Hawk, one of the organizers of last year's Moratorium and Dennis Riordan, a former student president at Colgate University. The young men, both draft resisters who are now studying at Union Theological Seminary, began drawing up the letter soon after the invasion of Laos in February.

III. INSTRUCTOR'S WORKSHOP MANUAL

PURPOSE OF THIS MANUAL

Instructions for the students are given in Volume II.

This manual is written for the instructor and contains the more detailed information about the computer operations that he may need in setting up the workshops for the students.

Section I describes some criteria useful in selecting a computer system for the data file analysis section of the course, and the instructor's specific responsibilities when the Michigan Terminal System is selected. Some potential workshop-related problems are also described.

Section II covers the use of the International Telephone and Telegraph (ITT) Reactive Terminal System (RTS) for the PRINCE simulation. This model is considered non-proprietary and may be used by any government agency or individual without further permission. The listing of the program is included here with a description of the steps taken to make it available to the students at the least cost. Sufficient information is given here to enable anyone familiar with the operation of a time-sharing system to put PRINCE into operation on another system having the required capability.

SECTION I. DATA-FILE ANALYSIS

Selecting a Computer System

The four data files, whose listings are given in the Student Manual for Data File Analysis, presently are stored on the University of Michigan computer. The data file listings may be used to create the data files on any other computer system. Unfortunately, however, the data analysis routines of CONSTAT and TIMESERIES (described in the Student Manual) are not transferrable from the Michigan System to other computer systems at this time.

The following are some of the more important criteria which led to the selection of the Michigan Terminal System and which might also be used in the process of selecting another system if the Michigan system is not used.

- The system's data analysis package(s) should be capable of accommodating data files with up to 5 variables (columns) and 150 cases (rows); this is essential in view of the sizes of the data sets.
- The data analysis package(s) should allow the student to select variables for analysis directly from the data file, rather than requiring the student to create a sub-file of just a few variables for analysis. This is not essential, but is highly desirable from the point of view of minimizing time spent on preparation for analysis, and maximizing analysis time and flexibility.
- Also to maximize analysis time, the statistical analysis package(s) should allow the student to request a new analysis immediately following the termination of the preceding one.

- A general criterion is that the analysis package(s) should require no previous programming or computer experience on the part of the user. The package(s) should prompt the user at each step, requesting him (in English) to input the necessary instructions to the computer.
- It is desirable that the analysis package(s) contain those types of analyses illustrated in the Student Manual.
- Features allowing the student to group subsets of nations or time-points for analysis are desirable.

The following information, which pertains to the responsibilities of the instructor, is intended primarily for those who will use the Michigan Terminal System for data file analysis. If another computer system is chosen, the instructor may read what follows for a general idea of the nature of his responsibilities in this portion of the course. Pre-course preparation, accounting procedures, and possible problems that may be encountered are described below.

Preparing for the Course

Arranging to Use the Terminal System. The following steps will allow a potential user to gain access to the Michigan System and to use the data-files as described.

1. Contact the Business Office of the University of Michigan Computer Center.

Access from a remote terminal to the computer at the University of Michigan and to the data-files stored there is gained by the use of identification designations and passwords issued by the Computer Center.

Arrangements to establish an account and to have ID numbers and passwords assigned for use in the course should be made through the Business Office of the Computing Center. The

address is:

Business Office
University Computing Center
University of Michigan
Ann Arbor, Michigan 48100

The Business Office telephone number is:

(313) 764-1817

These arrangements should be made at least one month before the beginning of the course to allow sufficient time for processing the application.

2. Determine the Size of the Computing Account.

The size of the account to be established with the Business Office depends on the amount of computing time required during the course. Experience has shown that the cost of computing time on the Michigan Terminal System for this course is approximately \$12 per hour for each computer terminal. Therefore, five terminals operating for one hour would cost about \$60. An overhead charge of 15 percent will be applied by the Business Office to the account. Thus, if the account is established at \$500, an overhead of \$75 will be taken, leaving \$425 to pay for actual computing time.

Funds will be deducted from the account as they are used. For example, if an account of \$425 is established, and if the first use of the computer through the terminal costs \$10, then the remaining balance in the account will be \$415. Funds remaining in the account may be checked through the procedure called PROJECTACCOUNT, explained in the next section.

3. Determine the number of student accounts needed.

Experience has shown that the students work well in teams of 3-5 members. In addition to encouraging the students to collaborate in their workshop activities, the team approach reduces the number of terminals required and is considerably less expensive than allowing each student his own terminal. Since only one terminal at a time may sign-on to the system with a given ID, there must be at least as many accounts as terminals. Thus, each team will have its own terminal, account number, and "password".

In addition to the student team ID's, a Project ID will be assigned for the purpose of allocating funds to the student account as described in the next section.

Allocating Funds to the Student Teams. Computing funds established through the Business Office will not be allocated among the Student ID's. This may be done by the instructor from a terminal through a simple procedure called PROJECTACCOUNT.* Steps in using PROJECTACCOUNT are:

- Sign-on to the Michigan Terminal System using the 'Project ID' assigned by the Business Office. (See the instructions in the Student Manual for Data-File Analysis)
- Call up the PROJECTACCOUNT program by typing:
R *PROJECTACCOUNT.

In the following example the PROJECTACCOUNT user signed-on under Project ID number IDAA (the password was NWCACI), and requested access to the PROJECTACCOUNT program. The lines typed by the user are underlined.

```
ZLD04:SIG
      MTS : ANN ARBOR (DC05-0092)
      #SIG IDAA
      #ENTER USER PASSWORD.
      ?NWCACI
      ***LAST SIGNON WAS: 16:15.44 03-02-71
      # USER "IDAA" SIGNED ON AT 14:36.53 ON 03-07-71
      #R *PROJECTACCOUNT
      #EXECUTION BEGINS
```

- A question mark (?) will be typed at the left hand margin. This question mark is the computer's way of asking what the user wishes to do. By typing STATUS PROJECT the instructor will receive a summary of the current status of the project

* This section describes the basic procedure for allocating funds to the student ID's. A more detailed description is available from the Computer Center.

accounts, as shown in the following example:

↓

	SIGNON	CHARGE	DISK SPACE	DATA CELL	TERM TIME	PLOT TIME	EXPIRE
1. PRJ		550.00	50	100	IGNORED	IGNORED	12-31-70
2.		340.00	10	20	2:00	0:00	24:00
3. REM		210.00	40	80	IGNORED	IGNORED	
4.		52.50	10	20	0:00	0:00	
5. TOT		335.00	10	20	0:00	0:00	
6.		160.00	2	5	2:00	0:00	

NOCHANGE ON FOR 0 AND OFF FOR 4 OF THE 4 PROJECT ID'S

In this output, the column indicated by the arrow contains information about the Project Funds as follows:

<u>Lines</u>	<u>Volume</u>	<u>Meaning</u>
1	550.00	Total project funds
2	340.00	Funds allocated to Student ID's
3	210.00	Unallocated project funds
4	52.50	Amounts that should be allocated to each Student ID to achieve an equal distribution of the unallocated project funds
5	335.00	Funds allocated to Student ID's through PROJECTACCOUNT*
6	160.00	Funds used by Students up to this point

The third line showing the amounts which can be allocated to Student ID's is the most important entry at this stage. The procedure for allocating these funds is illustrated below.

<u>?ADD INSTRUCTOR CHARGE</u>							
IPAN	495.00	30	100	IGNORED	IGNORED	06/30/71	
	438.55	30	21	30:11	0:00	06:00	

* Note that line 2 indicates that 340.00 has been allocated to the Student ID's, although the Instructor has been responsible for allocating only 335.00. The system will allow a student to complete a terminal session even though he over-runs his account. His over-run (\$5 in this case) is added automatically by the system to line 2.

In this example the instructor, using PROJECTACCOUNT, transferred \$50 from the project to student account IDAB. In the example, 495.00 represents the new amount which may be spent under IDAB (the old amount was 445.00), and 438.35 represents the amount which has been spent under IDAB.

After each transfer, a question mark appears and additional fund transfers may be made. PROJECTACCOUNT is terminated by typing: \$ENDFILE.

Determining the Workshop Schedule. The Michigan Terminal System schedules periodic shutdowns of its service and reserves certain times of the day for "optional" shutdown. If possible, it is best to schedule workshop sessions so that shutdown or optional shutdown periods do not coincide with the workshop sessions. The Computing Center schedule is given below:

8:00 a. m. *	System shutdown
8:15 a. m.	System back in service
10:00 a. m.	Optional system shutdown
10:15 a. m.	System back in service
12:30 p. m.	Optional system shutdown
12:45 p. m.	System back in service
5:30 p. m.	Optional system shutdown
5:45 p. m.	System back in service

The hours above are for the Eastern Standard Time (EST) Zone. Since this schedule is subject to change, the Michigan Computer Center should be contacted.

* The time marked with * is the only system shutdown time that is almost certain to occur every day.

Accounting During the Course

Checking the Student Accounts. There are several accounting tasks that must be carried out by the instructor during the course. The funds remaining in each team account should be checked periodically. If some teams are using funds at a faster rate than others, then some reallocation may be necessary. The procedure for checking the overall status of the project was described in the previous section. The following steps will allow the instructor to look at the status of individual student accounts:

- Sign-on to the Michigan Terminal System, using the Project ID, and request PROJECTACCOUNT as already described.
- Answer the computer's question mark (?) by:

STATUS xxxx, yyyy, zzzz

where xxxx, yyyy, zzzz are the account designations for which information is desired.

In the following example, the instructor wanted information on accounts IDAA through IDAE. To avoid designating sequences of accounts, the system allowed him to use:

STATUS IDAA, . . . IDAE

?STATUS IDAA,...IDAE

<u>IDAA</u>	50.00	0	0	IGNORED	IGNORED	06/30/71
	33.41	0	0	2:15	0:00	24:00
IDAB	445.00	30	100	IGNORED	IGNORED	06/30/71
	438.85	30	21	30:11	0:00	24:00
IDAC	100.00	0	0	IGNORED	IGNORED	06/30/71
	39.15	0	0	3:16	0:00	24:00
IDAD	105.00	0	0	IGNORED	IGNORED	06/30/71
	6.85	0	0	0:36	0:00	24:00
IDAE	79.00	0	0	IGNORED	IGNORED	06/30/71
	0.00	0	0	0:01	0:00	24:00

The line typed by the PROJECTACCOUNT user is underlined. All other information is printed by the terminal. The output shows that \$50 was allocated to ID number IDAA, and that \$33.41 has been used under this account number, and so on for the other account numbers.

Reallocating Funds Among Student Teams. Since ID designation IDAD looks relatively under-used (with almost \$100 left, while less than \$10 remains for IDAB), the PROJECTACCOUNT user subtracted \$50 from IDAD as shown below.

?SUBTRACT IDAD, CHARGE

<u>IDAD</u>	55.00	0	0	IGNORED	IGNORED	06/30/71
	6.85	0	0	0:38	0:00	24:00

The user made an error in the word SUBTRACT, but corrected it as described in the Workshop Manual. The subtraction of \$50 from IDAD's allocation leaves this account with \$55. The \$50 taken from IDAD becomes available for allocation to any other account number. It was given to account IDAB, as shown in the

following example:

```
?ADD IDAC,CHARGE=50
IDAB      495.00      30      100      IGNORED      IGNORED      06/30/71
          438.85      30      21      30:11      0:00      24:00
```

Through the accounting procedure, then, the PROJECTACCOUNT user may transfer funds from one account to another.

Changing Passwords. It is suggested that user passwords be changed periodically to prevent unauthorized use of project funds. A user password may be changed immediately after signing-on by typing

```
$SET PW=NEW,
```

where "NEW" is a one-to-six-character new password. The procedure is illustrated in the following example in which user IDAC signed-on under password TINWC, and then changed his password to MARY.

```
#SIG IDAC
#ENTER USER PASSWORD.
?TINWC
***LAST SIGNON WAS: 15:57.36 04-16-71
# USER "IDAC" SIGNED ON AT 15:55.38 ON 07-02-71
#$SET PW=MARY
```

The next time IDAC is signed-on, password MARY is used, as in the following example:

```
#SIG IDAC
#ENTER USER PASSWORD.
?MARY
***LAST SIGNON WAS: 15:55.38 07-02-71
# USER "IDAC" SIGNED ON AT 15:58.05 ON 07-02-71
```

Possible Workshop Problems

If the System Fails. There are several workshop related problems of which the instructor should be aware. One of the most critical that may occur during a workshop is for the Computing Center to experience technical difficulties and shut down terminal operations. If this occurs, the students will be unable to continue their work unless a back-up system to which they may shift has been prepared by the instructor in advance. The cost of such an alternate system may prohibit this solution. If no alternative is available, the instructor may wish to spend this "down" time in student discussions of the workshop problems. For an estimate of the time at which the system will return to full operation, the instructor may call:

(313) 764-2410

for a recorded message.

Common Student Errors. Experience has shown that the students will learn quickly the technical procedures of computer terminal operations and data-file analysis. A few of the more common student errors are:

- Failure to turn the terminal to the "LINE" position.
If the terminal is not turned on, or is set to the "LOCAL" position when the System telephone number is dialed, then contact with the computer will not be made.
- Failure to set the terminal to "FULL DUPLEX".
For operations with the Michigan system, using the system with the terminal at "HALF-DUPLEX" will produce unintelligible responses from the computer.
- Failure to return the carriage after a line has been typed.
The computer will not receive the line until the "CARRIAGE RETURN KEY" has been hit.

- Failure to request the data-file correctly.
As pointed out in the Workshop Manual, all teams will access the data-files in the same way:

SOURCE IDAB: "filename"

where "filename" is the name of one of the four data-files prepared for student use. The attempt to use any account designation other than "IDAB" will result in failure to access the data.

Further Information on the Michigan System

Documentation for the Computer Programs. The CONSTAT and TIME-SERIES statistical packages contain many more routines than those described in the Data-File Manual. The Data-File Manual describes only those routines used by the students in this course. Complete TIMESERIES, CONSTAT, and PROJECTACCOUNT documentation may be obtained from:

University Computer Center
University of Michigan
Ann Arbor, Michigan 48100
(313) 764-2410

Using Terminals Other than Teletypes. The "sign-on" and error-correction procedures described in the Student Manual for Data-File Analysis refers only to teletype terminals. If others (such as the IBM 2741 or DATEL 30) are to be used, then changes in the procedures are required. The following reference, which may be obtained from the Computing Center at the address above, explains the use of these terminals:

Carnahan, Bruce and James Wilkes, Introduction to Digital Computing and FORTRAN IV with MTS Applications (1971)
Chapter 4.

SECTION II. SIMULATION: THE PRINCE PROGRAM

Student Use of PRINCE

The PRINCE simulation (listed in Appendix A) can be run with probably no more than minor changes, on any interactive system with the following capabilities:

- A FORTRAN IV compiler
- At least 56,400 bytes of available core
- At least 30,000 bytes of disc storage (for one team; each additional team will require an additional 30,000 bytes)

This section will describe the way in which the program was set up on the ITT Reactive Terminal System for the use by students in Washington.

Operation of the PRINCE Program by the students is shown below:

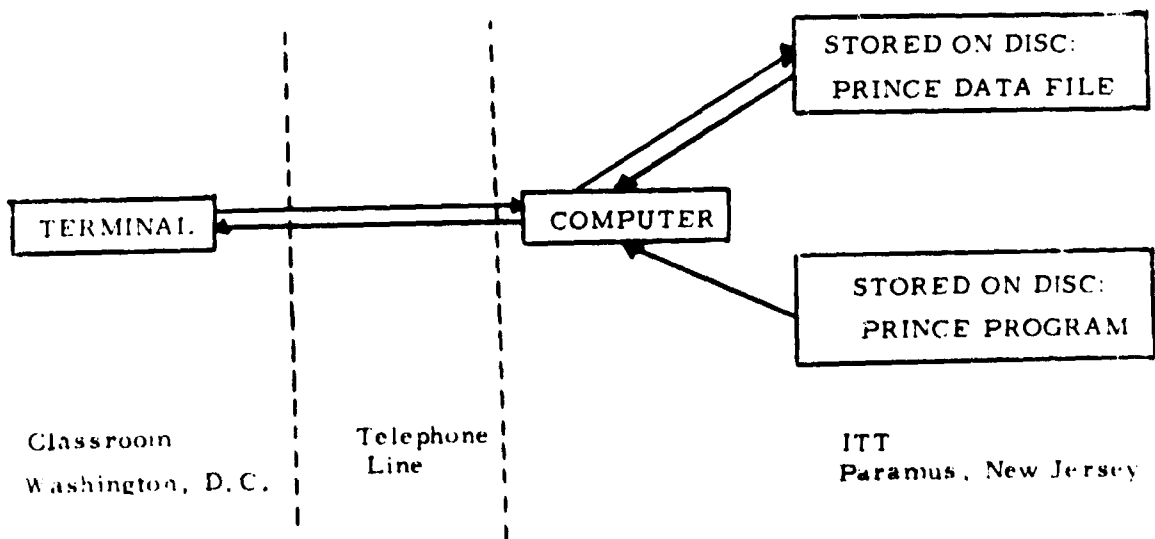

The player initiates execution of the PRINCE Program from his terminal in Washington. Copies of the PRINCE Data File and Program are drawn from disc storage into the computer's working memory. Acting on the player's decisions entered at the terminal, the PRINCE Program cycles through its instruction set for a month of game (or "simulated") time. At the end of the play period some of the arrays will have been changed as a result of the play. The new values are stored over (or replace) the old Data-File on disc.

It should be noted that the term "data-file," as used in this section on PRINCE, has a somewhat different meaning from the data-files discussed in the first section. The PRINCE "data-file" is not compiled from information about the real world intended to be subjected to the analyses described in the first section. Rather it contains values of those variables that describe, or define, the hypothetical PRINCE world. Specifically, these are the variables mentioned in COMMON statements at the beginning of each routine in the PRINCE Program. Since the play of the game changes these values, each team must store its own file.

The total PRINCE Package consists of two sections:

- The PRINCE Load Program, which creates the initial PRINCE Data File. This program reads the Data Deck (on cards) and places the values into the proper arrays before writing the arrays on the Disc File.
- The PRINCE Simulation Program, which carries out the computations of the actions and reactions of the PRINCE nations during the game. (This is the PRINCE Program shown in the diagram above).

The PRINCE Load Program is run only once when the initial Data File is created. The PRINCE Simulation Program is run once for each cycle of play.

Listings of the Data Deck, the PRINCE Load Program, and the PRINCE Simulation Program are given in Appendix A.

Program Set-Up

The steps to be carried out by the instructor to make the PRINCE Simulation available for student use are:

- Create a Data-File
- Compile the PRINCE Source Program
- Store the Link-Edited, Object Program on Disc*
- Create a Duplicate Data-File and Executable Program for each additional team

While the exact details of these steps apply only to the ITT system, they are representative of what must be done to prepare the program for execution on any system.

Creation of Data-Files

The compiled version of the PRINCE Load Program and the PRINCE Data Deck are stored in the ITT System under the names, OLOAD and PRDATA. The following instructions will execute the Load Program and produce a PRINCE data-file called AFILE.

```
/INP
/FILE DISC=1, DSNAME=AFILE, PUB=RW, DISP=NEW
/JOB GO
/INC OLOAD
/INC PRDATA
/END
/RUN
```

These instructions produce one Data-File to be used by one team. The following program prepares three additional files for the other three

-
- At execution time, this object program is read back into core for execution. It would be possible to omit these steps and execute the PRINCE object deck. The approximate cost per run would be \$13. Using the stored, link-edited version, reduces the cost to less than \$7 per run.

teams:

```
/FILE DISC=1,DSNAME=AFILE *
/FILE DISC=2,DSNAME=BFILE
/FILE DISC=3,DSNAME=CFILE,PUB=RW,DISP=NEW
/FILE DISC=4,DSNAME=DFILE,PUB=RW,DISP=NEW
/JOB GO
COMMON COM(1849),ICOM(2439)
REWIND 1
READ (1) COM,ICOM
DO 10 I=2,4
REWIND 1
WRITE (1) COM,ICOM
10 CONTINUE
STOP
END
/END
>/JOB
DSNAME = CFILE SAVED ON SYS02
DSNAME = DFILE SAVED ON SYS02
MAIN MEMORY BEGS (BYTES) 000156 HEX 000394 120
180001 STOP 0
```

Storage of the Link-Edited Version

The PRINCE Simulation (source) Program is divided into sections for convenience, and each section is compiled separately.

The compiled sections of PRINCE are stored under the names:

BJPRI
BJPR2
JANRD
BPR42
BPR5
BPR6
BPR7
BDPOL

* For this run, AFILE and BFILE were old files saved previously; CFILE and DFILE are being defined and saved for the first time.

The following program writes the link-edited version on disc under the name "PPPI."

```

L.0001 /FILE      DISC=1
L.0002 /FILE      DISC=10,1 SWAP=PPPI
L.0003 /JOB GO
L.0004 /JOB
L.0005 JOB      START 0
L.0006          EXTRN MAIN
L.0007 - WRTRNUM EQU 54 -
L.0008          BALR 12,0
L.0009          USING *+12
L.0010          LA 1,FLIST POINT TO USER PARAMETER LIST
L.0011          L 2,ACBPGR POINT TO BEGINNING OF JOB TO CHECK
L.0012          LA 3,WRTRNUM INITIALIZE THE NUMBER OF RECS TO WRITE

L.0013 WRITE    SVC 19 WRITE RECORDS
L.0014          DC X'1A52'
L.0015          DC 48'0'
L.0016          LA 2,1024(2) INCR TO NEXT PART OF JOB
L.0017          BCL 3,WRITE GO BACK FOR MORE
L.0018          SVC 0 OTHER WISE END THE JOB ... ALL LOADED
L.0019          DS OF
L.0020 ACBPGM   DC ACMAIN)
L.0021 FLIST    DC H'1024'
L.0022          DC 48'0'
L.0023          END LDF
L.0024 /INCLUDE  BPP01
L.0025 /INCLUDE  BPP02
L.0026 /INCLUDE  JANRD
L.0027 /INCLUDE  BFR4P
L.0028 /INCLUDE  BPP5
L.0029 /INCLUDE  BPP6
L.0030 /INCLUDE  BPP7
L.0031 /INCLUDE  BPP0L

```

Execution of this program produced the storage map:

```
>/XEQ CACI
DSNAME = PPI1          SAVED ON SYS02
* STORAGE MAP
IBCOM   AT 01000      FFAN#    AT 07738      CHPOS#   AT 0B770
LD#     AT 03D00      FFAN     AT 07738      CHPOS    AT 0B770
MAIN#   AT 03D38      AFFMOD#  AT 07C73      DFOL#    AT 0BFF0
MAIN    AT 03D38      AFFMOD   AT 07C78      DFOL     AT 0BFF0
ECFLOW# AT 051B0      DEF#     AT 08150      IHCFIXPR AT 0D388
ECFLOW  AT 051B0      DEF      AT 08150      FHXP#    AT 0D383
SET#    AT 05C30      FILLO#   AT 082D8      SLOG     AT 0D460
SET     AT 05C30      FILLO    AT 082D8      ALOG     AT 0D47E
CHECK#  AT 05E20      ATCHG#   AT 086B0      ALOG10   AT 0D468
CHECK   AT 05E20      ATCHG    AT 086B0      SEXP     AT 0D568
RANGE#  AT 06628      CONCL#   AT 08A28      EXP      AT 0D56C
RANGE   AT 06628      CONCL    AT 08A28      (BLANK) AT 0D688 COMMON
CEIL#   AT 06838      TREAS#   AT 08D38      XEQSAVE  AT 11988
CEIL    AT 06838      TREAS    AT 08D38      WFBUFFS  AT 12800
RANDU#  AT 06A30      DEPEND#  AT 09238      ***** AT 11A08
RANDU   AT 06A30      DEPEND   AT 09238
AMAX#   AT 06BC3      ELEC#    AT 09400
AMAX    AT 06BC8      ELEC     AT 09400
MIN#    AT 06D20      SD#      AT 09A68
MIN     AT 06D20      SD       AT 09A68
MAX#    AT 06E78      PRGEN#   AT 09E40
MAX     AT 06E78      PRGEN    AT 09E40
AKIN#   AT 06F00      RACAL#   AT 0A700
AMIN    AT 06F00      RACAL    AT 0A700
GAUSS#  AT 07128      INTEC#   AT 0A960
GAUSS   AT 07128      INTEC    AT 0A960
SQUASH# AT 072F0      INITE#   AT 0AD60
SQUASH  AT 072F0      INITE    AT 0AD60
ELIM#   AT 074C0
ELIM    AT 074C0
```

The Executable PRINCE Program

The following program, called NWCPR1, reads PRINCE into working space for execution:

```
/dis nwcpr1
L.0001 /FILE      DISC=1,DSNAME=AFILE
L.0002 /FILE      DISC=10,DSNAME=PPP1
L.0003 /JOB GO
L.0004 /BAP
L.0005 RDR        START 0
L.0006           EXTRN MAIN
L.0007 RDNUM     EQU 54
L.0008           BALR 12,0
L.0009           USING *,12
L.0010           LA 1,PLIST POINT TO USER PARAMETER LIST
L.0011           L 2,ACBPGM POINT TO BEGINNING OF PGM TO CHECKPT
L.0012           LA 3,RDNUM INITIALIZE TO NUMBER OF RECORDS TO READ
L.0013 READ     SVC 18
L.0014           DC X'1A82'
L.0015           BC 15,READA
L.0016 GOEX     L 15,ACBPGM GET ADDR OF PGM TO GO TO
L.0017           BCR 15,15 AND GO THERE
L.0018 RFADA    LA 2,1024(2) INCR TO NEXT PART OF CORE TO INIT.
L.0019           BCT 3,READ AND READ NEXT RECORD
L.0020           BC 15,GOEX OTHERWISE GOTO EXEC PGM
L.0021           DS 0F
L.0022 ACPGM    DC A(MAIN)
L.0023 PLIST    DC H'1024'
L.0024           DC 4H'0'
L.0025           END RDR
L.0026 /BAP
L.0027 MAIN     START 0
L.0028           ENTRY MAIN
L.0029           DS 5G216CL1
L.0030           END MAIN
```

To provide for simultaneous play of PRINCE by four teams, in addition to the four data-files, four copies of the executable program were stored, each program calling for one of the data-files. The executable programs were called:

NWCPR1 (National War College PRINCE, Team 1) using data-file "AFILE"
NWCPR2 (National War College PRINCE, Team 2) using data-file "BFILE"
NWCPR3 (National War College PRINCE, Team 3) using data-file "CFILE"
NWCPR4 (National War College PRINCE, Team 4) using data-file "DFILE"

Each team executed its own PRINCE program and operated on its own Data-File.

The four executable programs differed from each other only in line 1, where the name of the data-file is specified. Notice that they all use the link-edited program stored on file "PPPI." This device saves disc storage space since only one copy of the large program is stored. Each additional team requires only an additional 30 lines (and its own data-file, of course.)

PRINCE Output

A sample of the PRINCE output is given in this section. It is divided into two parts:

- the player input, which consists of information provided to the player by the program and the player's inputs
- the program output giving the player a description of the status of the PRINCE nations and the month's political and economic activity

The Player Input Section

YOU ARE NOW PLAYING PRINCE. PLEASE ENTER YOUR TEAM NUMBER(1,2,3, OF 4)

1

WOULD YOU LIKE A DESCRIPTION OF THE INPUT ? 0=NO, 1=YES

1

COUNTRY CODES ARE : 2=USSR, 3=FRANCE, 4=INDIA, 5=PAKISTAN

ENTER ECONOMIC RESTRICTIONS

INFORMATION REQUIRED :

TARGET COUNTRY (2,5) AND % RESTRICTIONS ON NATURAL FLOW OF GOODS AND CAPITAL (0,100)

EXAMPLE :

4 43

FLOW FROM INDIA IS RESTRICTED TO 43% OF THE NATURAL FLOW.

END THIS SECTION BY TYPING 00

00

ENTER ECONOMIC AID

INFORMATION REQUIRED :

TARGET COUNTRY (2,5) AND AID IN MILLIONS OF US DOLLARS (0,10000.)

EXAMPLE :

5 50

INDICATES THAT AID AMOUNTING TO \$50. MIL WILL BE GIVEN TO PAKISTAN.

END THIS SECTION BY TYPING 00

5 405

00

ENTER POSITION CHANGES
INFORMATION REQUIRED :
ISSUE (1,16) AND NEW POSITION (-10,10)
EXAMPLE :

6 -8
INDICATES THAT THE NEW US POSITION ON ISSUE 6 WILL BE -8.
END THIS SECTION BY TYPING 00

4 7
6 -7
00

ENTER PUNISHMENT-REWARD ACTS
INFORMATION REQUIRED :
TARGET COUNTRY (2,5), ISSUE (1,16), AND THE PR ACT(-10,10)
EXAMPLE :

2 4 6
INDICATES THAT ON ISSUE 4 THE US DIRECTS A PR ACT 6. TOWARD THE USSR.
END THIS SECTION BY TYPING 00

2 5 7
6 7 8
ERROR: 6 DOES NOT LIE BETWEEN 2 AND 5 ; PLEASE RE-TYPE.

a 4 6
THE SYMBOL A IS NOT RECOGNIZED. PLEASE RE-TYPE LINE.
00

WOULD YOU LIKE TO ENTER ADDITIONAL INPUT ? 0=NO, 1=YES

0

YOU HAVE ENTERED ALL THE REQUIRED PRINCE INPUT.
IT WILL BE CHECKED FOR ADMISSABILITY.

The following points about the input should be noted:

- The player's input consists entirely of numerical values separated by one or more spaces
- Alpha-numeric characters are recognized as errors and the player is given an opportunity to retype the line
- The description of the data indicates by the numbers in parentheses the limits within which the input values must fall. Values outside these ranges are recognized as errors and the player is allowed to re-enter the line.
- At the end of the input section the player is given the option of repeating this section. He may at this time enter additional acts, but he may not delete or modify any acts already entered.

The PRINCE Program Output

THE STATE DEPT WILL NOT ALLOW A POSITION ON ISSUE 4 OF 7.
THE NEW US POSITION IS 6.

THE STATE DEPT WILL NOT ALLOW A POSITION ON ISSUE 6 OF -7.
THE NEW US POSITION IS 0.0

TEAM 1 ROUND 8 AUGUST 1971

THE US STATE DEPARTMENT INTELLIGENCE REPORT

ISSUE	US	USSR	FRANCE	INDIA	PAKISTAN
1	-10.	10.	-5.	3.	-1.
2	3.	-3.	0.0	-10.	10.
3	-6.	8.	0.0	3.	-3.
4	6.	10.	-1.	10.	-10.
5	0.0	10.	-2.	4.	-6.
6	0.0	10.	9.	0.0	10.
7	-5.	4.	0.0	10.	0.0
8	-10.	0.0	-4.	5.	-3.
9	3.	-8.	-4.	0.0	9.
10	0.0	-10.	-6.	-2.	9.
11	-4.	0.0	-10.	7.	2.
12	7.	10.	10.	8.	-4.
13	0.0	4.	-10.	-4.	7.
14	1.	-1.	3.	10.	8.
15	4.	10.	8.	5.	-8.
16	6.	10.	3.	0.0	-5.

THE STATE DEPARTMENT SUGGESTS THAT YOU TAKE THE FOLLOWING
FOREIGN POLICY ISSUE POSITIONS DURING THE NEXT PERIOD

ISSUE	OLD POS	NEW POS
2	3.	2.
3	-6.	-8.
4	6.	4.
5	0.0	-1.
6	0.0	2.
7	-5.	-6.
9	3.	2.
10	0.0	1.
11	-4.	-5.
12	7.	5.
13	0.0	-1.
14	1.	0.0
15	4.	2.
16	6.	5.

YOU SHOULD ENGAGE IN THE FOLLOWING FOREIGN POLICY ACTIONS

TARGET	ISSUE	PR
USSR	1	-8
USSR	4	7
USSR	5	3
USSR	6	3
USSR	10	2
USSR	11	7
USSR	14	8
FRANCE	1	6
FRANCE	3	6
FRANCE	6	3
INDIA	4	7
INDIA	7	-2
INDIA	8	-2
INDIA	12	9
PAKISTAN	2	5
PAKISTAN	12	1

SUMMARY OF POLITICAL ACTIVITY
ISSUED FOR THE MONTH OF AUGUST ,1971

COUNTRY	TARGET	ISSUE	PP
US			
	USSR	5	7
USSR			
	US	1	-8
	US	4	7
	US	5	2
	US	6	4
	US	10	2
	US	14	8
	FRANCE	1	-2
	INDIA	2	4
	INDIA	4	8
	INDIA	7	5
	PAKISTAN	4	-5
FRANCE			
	US	1	6
	US	3	6
	US	4	6
	US	6	6
	US	11	6
	US	13	2
	US	14	8
	USSR	1	-2
	USSR	3	5
	USSR	4	4
	USSR	14	7
	INDIA	2	4
	INDIA	12	9
	PAKISTAN	2	2

INDIA	US	3	1
	US	4	6
	US	12	9
	US	14	3
	USSR	2	4
	USSR	3	7
	USSR	4	8
	USSR	5	5
	USSR	12	7
	USSR	14	2
	FRANCE	14	6
	PAKISTAN	2	-8
	PAKISTAN	4	-8
	PAKISTAN	12	1
PAKISTAN	US	2	6
	US	3	9
	US	12	1
	US	14	2
	USSR	3	1
	USSR	4	-6
	USSR	5	-2
	USSR	12	-1
	FRANCE	14	3
	INDIA	2	-8
	INDIA	4	-8
	INDIA	7	1
	INDIA	12	2
	INDIA	14	9

THE US TREASURY DEPARTMENT SUGGESTS THAT YOU ENGAGE
IN THE FOLLOWING ECONOMIC ACTIVITY FOR THE NEXT PERIOD

TARGET	ACT	AMOUNT
USSR	REST	45
INDIA	AID	880
PAKISTAN	AID	410

MONTHLY REPORT OF THE UNITED STATES TREASURY
 REPORT OF ECONOMIC ACTIVITY DURING THE PERIOD AUGUST 1971

NATION	TARGET	ACT	AMOUNT
--------	--------	-----	--------

US

	PAKISTAN AID		405
--	--------------	--	-----

USSR

FRANCE

INDIA

	US	REST	45
	FRANCE	REST	45
	PAKISTAN	REST	79

PAKISTAN

	FRANCE	REST	54
	INDIA	REST	64

BALANCE OF PAYMENTS

COUNTRY	AMOUNT
US	\$ 2387.63
USSR	\$ 140.43
FRANCE	\$ 68.37
INDIA	\$ -212.38
PAKISTAN	\$ -181.61

REPORT OF THE PRESIDENTIAL ADVISORS FOR DOMESTIC POLITICAL RELATIONS
AUGUST 1971

PI GROUP	AGGREGATED SUPPORT LEVEL		
	ECONOMIC	POLITICAL	ISSUE POSITIONS
1 XLIB	-1.	-4.	1.
2 MLIB	-2.	-5.	2.
3 MCON	3.	-10.	3.
4 XCON	6.	-10.	3.
5 TREA	7.	-9.	-8.
6 SD	-8.	-4.	2.
7 DOD	8.	-10.	-1.
8 NAEC	-9.	-4.	-10.
9 INEC	-1.	-7.	-0.
10 HARD	-0.	-2.	-3.
11 SOFT	-1.	-8.	-1.

PUBLIC OPINION POLL QUESTION :

"DO YOU AGREE WITH THE GENERAL POLICIES OF THIS ADMINISTRATION ?"
 % YES % NO % NO ANSWER
 46 29 25

IS THIS A TEST ? 1=YES, 0=NO

1
IHC0021 STOP 0

(Note: Here "IHC0021" is not an error message it indicates that the PRINCE Program has terminated as expected.)

Suggestions for Team Organization

The PRINCE players have the following responsibilities:

- Formulating of goals for the U. S.
- Translating these goals into the decisions required by PRINCE
- Initiating program execution from the terminal
- Entering the decisions at the terminal
- Waiting for PRINCE output to be printed at the terminal
- Studying the results of the current cycle and making decisions for the next round of play

Experience suggests that the teams work more efficiently if they have a formal structure, at least initially. Later, more informal team relationships may develop, depending on the individual players. The following roles are found convenient:

- President (one team member takes this role)
- Foreign Policy Advisors - the rest of the players are assigned these roles and the 16 foreign policy issues are divided among them.

These roles may be assigned by the instructor or by random selection. It is very helpful if the team member playing "President" has played at least one round before.

Suggested instructions for the President and his Policy Advisors are given in Tables 1 and 2.

Table 1.
Instructions to the President

You have selected the role of President.

Your pre-play responsibilities include:

- Formulating, with the help of your team members, foreign policy goals for the United States. These goals should be written out and submitted to the umpire for your team no later than the beginning of the second day of play. You may change your goals at any time by submitting written changes to your umpire.
- Assigning specific issues to your Foreign Policy Advisors.

Your responsibilities during play are:

- Listening to the suggestions of your Advisors.
- Making the final decisions on US actions, both political and economic, keeping in mind the US goals.
- Monitoring the reactions of the PI groups, especially the Partisan group, since your re-election depends in large part on the opinions of these groups.
- Seeing that your decisions are executed (that is, entered at the terminal). You may do this yourself, or you may delegate this responsibility.

Your post-game responsibilities:

- Preparing and delivering a 5-minute discussion of your team's goals and an evaluation of your success in meeting them.

Table 2.
Instructions to the Foreign Policy Advisor

You have selected the role of Foreign Policy Advisor. The President will assign a subset of the 16 foreign policy issues to you.

Your pre-game responsibilities include:

- Assisting the President in formulating U.S. Foreign Policy goals.
- Preparing a brief summary of the positions of the PRINCE nations on your assigned issues over the past four months.
- Formulating a strategy for handling your issues.

During game play your responsibilities are:

- Preparing recommendations for the President on positions, economic actions and PR actions with respect to your issues. You may wish to consider the suggestions of the State Department, but you need not follow them.
- Monitoring the reactions of the PI groups. If the reaction of any group appears to fall beyond acceptable limits, you may recommend actions designed to create a more favorable reaction by that group.

Your post-game responsibilities include:

- Preparation of a brief description of the U.S. actions on your issues and an evaluation of the positions and PR actions of the other nations during the game.
- Assisting the President in the preparation of his briefing on the game results.

APPENDIX A. DATA AND PROGRAM LISTINGS

A listing of the PRINCE Data Deck and Program are given here. Definitions of the COMMON variables are given in the last section.

The PRINCE Data Deck

L.0001 /DATA

2 00010026005100620067007701020113013801430187019802530528107813531364148916141639
 3 16641675180018250001003401140115011601170118011901200130013111312131213221332134
 4 21352140230023362337234723482349237424242429

L.0005	0101																			
L.0006	1AFFECT	3	5	5	1	2														
L.0007		0.	-4.	2.	5.	8.														
L.0008		-6.	0.	4.	7.	-3.														
L.0009		-1.	2.	0.	3.	-2.														
L.0010		-1.	3.	2.	0.	-5.														
L.0011		6.	-4.	-1.	-6.	0.														
L.0012	2AID	3	5	5	1	2														
L.0013		0.	0.	0.	880.	390.														
L.0014		0.	0.	0.	250.	10.														
L.0015		0.	0.	0.	20.	20.														
L.0016		0.	0.	0.	0.	0.														
L.0017		0.	0.	0.	0.	0.														
L.0018	3AID POSITION	3	11	1	1	1														
L.0019		-3.	1.	-6.	-10.	-2.	2.	-8.	2.	6	3.	2.								
L.0020	4 BAL	2	5	1	1	1														
L.0021			-380.		-360.		2420		-1040.											
L.0022	6 DEPENDENCE	2	5	5	1	2														
L.0023			0		1		4		1											
L.0024			2		0		3		1											
L.0025			6		3		0		1											
L.0026			7		3		1		0											
L.0027			9		2		1		4											
L.0028	7FLEXIBILITY	3	11	1	1	1														
L.0029		2.	6.	5.	1.	2.	3.	1.	2.	2.	3.	4.								
L.0030	8 ACTUAL FLOWS	2	5	5	1	2														
L.0031																				
L.0032					2000															
L.0033							100													
L.0034									-1000											
L.0035																				
L.0036	10CONG. POWER	3	11	4	1	1														
L.0037		0.	0.	0.	0.	2.	6.	1.	9.	1.	1.	1.								
L.0038		0.	0.	0.	0.	3.	4.	2.	7.	2.	1.	1.								
L.0039		0.	0.	0.	0.	9.	2.	6.	2.	2.	2.	4.								
L.0040		0.	0.	0.	0.	7.	1.	9.	1.	1.	2.	9.								
L.0041	11ELEC. POWER	3	11	1	1	1														
L.0042		2.	6.	7.	2.	3.	1.	2.	2.	1.	1.	1.								
L.0043	12PI AFFECT	3	11	5	1	1														
L.0044																				
L.0045		2.	5.	-2.	-8.	-3.	3.	-9.	3.	-1.	-2.	2.								
L.0046		4.	2.	-2.	-4.	-1.	-4.	-2.	2.	-1.	-1.	-2.								
L.0047		6.	4.	-4.	-1.	2.	-1.	2.	-2.	0.	1.	1.								
L.0048		-2.	0.	1.	3.	1.	1.	3.	4.	0.	6.	4.								

L.0102	18POWER	3	5	16	1	2														
L.0103		7.	8.	5.	1.	1.														
L.0104		4.	3.	1.	8.	6.														
L.0105		9.	5.	2.	1.	1.														
L.0106		8.	8.	1.	4.	2.														
L.0107		4.	10.	1.	1.	1.														
L.0108		6.	4.	2.	1.	1.														
L.0109		4.	3.	1.	6.	1														
L.0110		4.	3.	1.	5.	1.														
L.0111		4.	3.	1.	5.	1.														
L.0112		9.	9.	7.	1.	1.														
L.0113		9.	7.	5.	1.	1.														
L.0114		5.	4.	3.	8.	8.														
L.0115		8.	7.	5.	2.	1.														
L.0116		8.	8.	4.	4.	1.														
L.0117		2.	2.	1.	8.	8.														
L.0118		8.	7.	5.	1.	1.														
L.0119	19RESTI	3	5	5	1	2														
L.0120		0.	75.	40.	20.	20.														
L.0121		60.	0.	35.	22.	35.														
L.0122		48.	40.	0.	55.	55.														
L.0123		30.	30.	40.	0.	75.														
L.0124		20.	45.	35.	75.	0.														
L.0125	20NATURAL FLOW	2	5	5	1	2														
L.0126		2000.			151.	2322.						1136.								375.
L.0127		244.			200.	290.						228.								63.
L.0128		1341.			414.	171.						73.								60.
L.0129		379.			249.	64.						-842.								.4
L.0130		95.			22.6	50.						.2								-396.
L.0131	21REST. POS.	3	11	1	1															
L.0132		-3.	-1.	3.	7.	10.	-10.					9.	-9.	-2.	1.	2.				
L.0133	22SALIENCE	3	5	16	1	2														
L.0134		7.	8.	9.	1.	1.														
L.0135		4.	3.	3.	9.	9.														
L.0136		9.	4.	4.	4.	4.														
L.0137		7.	8.	2.	9.	9.														
L.0138		5.	10.	1.	3.	3.														
L.0139		8.	5.	3.	1.	1.														
L.0140		4.	3.	2.	3.	3.														
L.0141		5.	1.	1.	1.	1.														
L.0142		3.	2.	1.	1.	1.														
L.0143		2.	2.	1.	1.	1.														
L.0144		3.	1.	2.	1.	1.														
L.0145		2.	1.	2.	5.	5.														
L.0146		2.	1.	2.	1.	1.														
L.0147		2.	2.	2.	8.	8.														
L.0148		1.	1.	1.	5.	5.														
L.0149		1.	1.	1.	1.	1.														
L.0150	23 SECULAR TREND2		5	5	1	2														
L.0151			0		4						4						2			2
L.0152			3		0						2						5			3
L.0153		8.		7.		5.					1.						0.			
L.0154		8.		7.		5.					1.						0.			
L.0155		8.		2.		5.					2.						2.			
L.0156	30		1	1	1	1	1													
L.0157			5																	

L.0158	32 IOUT	1	1	1	1	1			
L.0159		6							
L.0160	33 IPASS	4	10	1	1	1			
L.0161	PRINCE								
L.0162	35	1	1	9	2	1			
L.0163	-	3	6	6	200				
L.0164	-	3	15	-4	200				
L.0165	-	4	2	5	200				
L.0166	-	4	3	-5	200				
L.0167		3	50	30	100				
L.0168		4	50	40	100				
L.0169		5	50	65	100				
L.0170	-	4	40	10	100				
L.0171		5	40	5	100				
L.0172	35	1	1	9	3	1			
L.0173	-	2	2	-7	200				
L.0174	-	2	4	-8	200				
L.0175	-	4	4	-4	200				
L.0176	-	4	5	5	200				
L.0177		2	50	50	100				
L.0178		4	50	40	100				
L.0179		5	50	65	100				
L.0180	-	4	40	10	100				
L.0181		5	40	5	100				
L.0182	35	1	1	10	4	1			
L.0183	-	2	19	8	200				
L.0184	-	2	13	-2	200				
L.0185	-	2	5	5	200				
L.0186	-	2	9	6	200				
L.0187	-	3	16	4	200				
L.0188	-	3	19	8	200				
L.0189		3	50	30	100				
L.0190		2	50	50	100				
L.0191		5	50	65	100				
L.0192		5	40	5	100				
L.0193	35	1	1	7	5	1			
L.0194		2	50	50	100				
L.0195		3	50	30	100				
L.0196		4	50	40	100				
L.0197	-	4	6	5	200				
L.0198	-	4	19	8	200				
L.0199	-	3	20	8	200				
L.0200	-	3	22	4	200				
L.0201	37 IN	1	1	1	1	1			
L.0202		1							
L.0203	38	1	1	1	1	1			
L.0204		65529							
L.0205	39 JMONT	1	1	1	1	1			
L.0206		1							
L.0207	40 JYEAR	1	1	1	1	1			
L.0208		1971							
L.0209	9 GNP	2	5	1	1	1			
L.0210		10000000		5000000		1200000	400000	110000	

L.0211	42 MES	5	8	20	1	2															
L.0212	ER01																				
L.0213	ER02																				
L.0214	ER03																				
L.0215	ER04																				
L.0216	ER05																				
L.0217	ER06																				
L.0218	ER07																				
L.0219	ER08																				
L.0220	ER09																				
L.0221	ER10																				
L.0222	ER11																				
L.0223	ER12																				
L.0224	ER13																				
L.0225	ER14																				
L.0226	ER15																				
L.0227	ER16																				
L.0228	ER17																				
L.0229	ER18																				
L.0230	ER19																				
L.0231	ER20																				
L.0232	43 MON	5	3	12	1	2															
L.0233	JANUARY				01																
L.0234	FFBRUARY				02																
L.0235	MARCH				03																
L.0236	APRIL				04																
L.0237	MAY				05																
L.0238	JUNE				06																
L.0239	JULY				07																
L.0240	AUGUST				08																
L.0241	SEPTEMRER				09																
L.0242	OCTOBER				10																
L.0243	NOVEMBER				11																
L.0244	DECEMBER				12																
L.0245	45 NATIN	5	2	5	1	2															
L.0246	US																				
L.0247	USSR																				
L.0248	FRANCE																				
L.0249	INDIA																				
L.0250	PAKISTAN																				
L.0251	46NISS	1	1	1	1	1															
L.0252		16																			
L.0253	47	1	1	1	1	1															
L.0254		11																			
L.0255	50	1	5	1	1	1															
L.0256		0	0	0	200	150															
L.0257	51STYLE	1	11	1	1	1															
L.0258		4	2	-2	-4	-1				4	-2	4	1	3	-2						
L.0259	99999	1	1	1	1	1															

(End of PRINCE Data Deck)

The line numbers (for example, L.0211) are supplied by the interactive computer system for the convenience of the user; they are not part of the PRINCE data deck. The data cards usually start in card column 1.

The PRINCE Load Program

```

L.0001 /FILE      DISC=1,DSNAME=AFILE
L.0002 /FTC SVDECK
L.0003     DIMENSION CARD(80)
L.0004     DIMENSION IDICT(51)
L.0005     DIMENSION COM(1849),ICOM(2439)
L.0006     COMMON AFFCT(5,5),AID(5,5),APOS(11),BAL(5),OLBAL(5,2),DEP(5,5),
L.0007     1FLEX(11),FLOW(5,5),GNP(5),PCONG(11,4),PELEC(11),PIAFF(11,5),
L.0008     2PIPOS(25,11),PIR(11,50),PISAL(25,11),PISUP(11),POS(25,5),
L.0009     3POW(25,5),RESTI(5,5),RMATU(5,5),RPOS(11),SAL(25,5),TREND(5,5),
L.0010     4RA(5,5),IBUF(3,11),ICARD(80),ICOUN, IEXIT, ILOC, IN, INIT, IOUT,
L.0011     5IPASS(10),IPOINT, IQUE1(5,50,4), IQUE2(5,50,4), IRND, IX, JMONT, JYEAR
L.0012     COMMON: JPOIN(5),MES(20,8),MON(12,3),NAT,NATIN(5,2),NISS,NTEAM,
L.0013     1SDPOS(25),LIM(5,5,2),NAID(5),NPRPOS(11)
L.0014     EQUIVALENCE(AFFCT(1,1),COM(1)),(IBUF(1,1),ICOM(1))
L.0015     IN=5
L.0016     READ(IN,10) IDICT
L.0017 10     FORMAT(2014)
L.0018 199   READ(IN,11,END=500) ITAM,IPT
L.0019 11     FORMAT(212)
L.0020     IOUT=6
L.0021     WRITE(IOUT,14) ITEAM,IPT . .
L.0022 14     FORMAT(@0@,@PRINCE LOAD@/@0@,'TEAM @,12,4X,@OPTION @,12<
L.0023     NTEAM=ITEAM
L.0024     GO TO (12,13),IPT
L.0025 12     DO 501 I=1,2439
L.0026     IF(I-1849) 503,503,502
L.0027 503     COM(I)=0.0
L.0028 502     ICOM(I)=0
L.0029 501     CONTINUE
L.0030     GO TO 15
L.0031 13     REWIND 1
L.0032     READ (1) COM,ICOM
L.0033 15     CONTINUE
L.0034     IOUT=6
L.0035     IN=5
L.0036 111   READ(IN,1000) IVAR,IFORM,11,12,13,IORD
L.0037     WRITE(6,1000) IVAR,IFORM,11,12,13,IORD
L.0038 1000  FORMAT(15,14X,11,415)
L.0039     IF (IVAR-13) 22,20,22
L.0040 20     DO 21 KK=1,16
L.0041 21     READ(5,1003)(PIPOS(KK,LL),LL=1,11)
L.0042     GO TO 111
L.0043 22     IF (IVAR-15) 26,24,26
L.0044 24     DO 25 KK=1,16
L.0045 25     RFAD(5,1003)(PISAL(KK,LL),LL=1,11)
L.0046     GO TO 111
L.0047 26     IF (IVAR-17) 30,28,30
L.0048 28     DO 29 KK=1,16
L.0049 29     RFAD(5,1003)(POS(KK,LL),LL=1,5)
L.0050     GO TO 111
L.0051 30     IF (IVAR-18) 34,32,34
L.0052 32     DO 33 KK=1,16
L.0053 33     READ(5,1003)(POW(KK,LL),LL=1,5)
L.0054     GO TO 111
L.0055 34     IF (IVAR-22) 38,36,38
L.0056 36     DO 37 KK=1,16
L.0057 37     READ(5,1003)(SAL(KK,LL),LL=1,5)
L.0058     GO TO 111
L.0059 38     CONTINUE

```

```

L.0060      IF(IVAR-35) 115,430,115
L.0061 115  DO 666 I13=1,I3
L.0062      DO 666 I12=1,I2
L.0063 112  IF(IVAR-51) 113,113,999
L.0064 C    READ DATA INTO PROPER BUF USING PROPER FORMAT
L.0065 113  CONTINUE
L.0066      GO TO (1,2,3,4,5),IFORM
L.0067 1    RFAD (IN,1001) (ICARD(I),I=1,I1)
L.0068 1001 FORMAT(15X,13I5)
L.0069      GO TO 100
L.0070 2    READ(IN,1002)(CARD(I),I=1,I1)
L.0071 1002 FORMAT(15X,5F10.0)
L.0072      GO TO 100
L.0073 3    READ(IN,1003)(CARD(I),I=1,I1)
L.0074      IF (IVAR-19) 100,40,100
L.0075 40   WRITE(6,1003)(CARD(I),I=1,I1)
L.0076      GO TO 100
L.0077 1003 FORMAT(15X,13F5.0)
L.0078      GO TO 100
L.0079 4    READ(IN,1004)(ICARD(I),I=1,I1)
L.0080 1004 FORMAT(80A1)
L.0081      GO TO 100
L.0082 5    READ(IN,1005) (ICARD(I),I=1,I1)
L.0083 1005 FORMAT(20A4)
L.0084 100  GO TO (2000,3000),IORD
L.0085 2000 DO 200 I11=1,I1
L.0086      I1=IDICT(IVAR)+(I11-1)+(I12-1)*I1+(I13-1)*I1*I2
L.0087      GO TO (210,220,220,210),IFORM
L.0088 210  ICOM(I1)=ICARD(I11)
L.0089      GO TO 200
L.0090 220  COM(I1)=CARD(I11)
L.0091 200  CONTINUE
L.0092      GO TO 666
L.0093 3000 DO 300 I11=1,I1
L.0094      I1=IDICT(IVAR)+(I12-1)+(I11-1)*I2+(I13-1)*I1*I2
L.0095      GO TO (310,320,320,310),IFORM
L.0096 310  ICOM(I1)=ICARD(I11)
L.0097      GO TO 300
L.0098 320  COM(I1)=CARD(I11)
L.0099 300  CONTINUE
L.0100      GO TO 666
L.0101 666  CONTINUE
L.0102      GO TO 111
L.0103 430  DO 700 I=1,I2
L.0104      READ(IN,1001)(IQUE1(I3,I,J),J=1,4)
L.0105 700  CONTINUE
L.0106      GO TO 111
L.0107 999  CONTINUE
L.0108      REWIND 1
L.0109      WRITE (1) COM,ICOM
L.0110      WRITE(IOUT,1078)
L.0111 1078 FORMAT(' END OF PRINCE LOAD')
L.0112 9999 CONTINUE
L.0113      GO TO 199
L.0114 500  RETURN
L.0115      END          (End of the Load Program)

```

The PRINCE Simulation Program

```
L.0001 /FILE DISC=1,DSNAME=AFILE
L.0002 /FTC SVDECK
L.0003 COMMON AFFCT(5,5),AID(5,5),APOS(11),BAL(5),OLBAL(5,2),DEP(5,5),
L.0004 1FLEX(11),FLOW(5,5),GNP(5),PCONG(11,4),PELEC(11),PIAFF(11,5),
L.0005 2PIPOS(25,11),PIR(11,50),PISAL(25,11),PISUP(11),POS(25,5),
L.0006 3POW(25,5),RESTI(5,5),RNATU(5,5),RPOS(11),SAL(25,5),TREND(5,5),
L.0007 4RA(5,5),IBUF(3,11),ICARD(80),ICOUN, IEXIT, ILOC, IN, INIT, IOUT,
L.0008 5IPASS(10),IPOIN, IQUE1(5,50,4), IQUE2(5,50,4), IRND, IX, JMONT, JYEAR
L.0009 COMMON JPOIN(5),MES(20,8),MON(12,3),NAT,NATIN(5,2),NISS,NTEAM,
L.0010 1SDPOS(25),LIM(5,5,2),NAID(5),NPRPOS(11)
L.0011 DIMENSION COM(1849),ICOM(2439)
L.0012 EQUIVALENCE (COM(1),AFFCT(1,1)),(ICOM(1),IBUF(1,1))
L.0013 INTEGER*2 A(9)
L.0014 REAL*8 D(3)
L.0015 INTEGER*2 IB/2H /
L.0016 A(1)=IB
L.0017 599 FORMAT('YOU ARE NOW PLAYING PRINCE. PLEASE ENTER '
L.0018 1'YOUR TEAM NUMBER(1,2,3, OR 4)')
L.0019 600 FORMAT('WOULD YOU LIKE A DESCRIPTION OF THE INPUT ?'
L.0020 1' 0=NO, 1=YES')
L.0021 601 FORMAT('COUNTRY CODES ARE :')
L.0022 1' 2=USSR, 3=FRANCE, 4=INDIA, 5=PAKISTAN')
L.0023 602 FORMAT('ENTER ECONOMIC RESTRICTIONS')
L.0024 603 FORMAT(' INFORMATION REQUIRED :')
L.0025 604 FORMAT(' TARGET COUNTRY (2,5) AND % RESTRICTIONS ON'
L.0026 1' NATURAL FLOW'/' OF GOODS AND CAPITAL (0,100)')/
L.0027 2' EXAMPLE : '/' 4 43'/' FLOW FROM INDIA IS'
L.0028 3' RESTRICTED TO 43% OF THE NATURAL FLOW.')
L.0029 605 FORMAT(' END THIS SECTION BY TYPING 00')
L.0030 606 FORMAT('ENTER ECONOMIC AID')
L.0031 607 FORMAT(' TARGET COUNTRY (2,5) AND AID IN '
L.0032 1'MILLIONS OF US DOLLARS (0,10000.)'/' EXAMPLE : '/'
L.0033 2' 5 59'/' INDICATES THAT AID AMOUNTING TO $59. MIL'
L.0034 3' WILL BE GIVEN TO PAKISTAN.')
L.0035 608 FORMAT('ENTER POSITION CHANGES')
L.0036 609 FORMAT(' ISSUE (1,16) AND NEW POSITION (-10,10)')/
L.0037 1' EXAMPLE : '/' 6 -8'/' INDICATES THAT THE NEW US'
L.0038 2' POSITION ON ISSUE 6 WILL BE -8.')
L.0039 610 FORMAT('ENTER PUNISHMENT-REWARD ACTS')
L.0040 611 FORMAT(' TARGET COUNTRY (2,5), ISSUE (1,16), AND'
L.0041 1' THE PR ACT(-10,10)')/' EXAMPLE : '/'
L.0042 2' 2 4 6'/' INDICATES THAT ON ISSUE 4 THE US DIRECTS'
L.0043 3' A PR ACT 6. TOWARD THE USSR.')
L.0044 612 FORMAT('YOU HAVE ENTERED ALL THE REQUIRED PRINCE INPUT.'
L.0045 1' IT WILL BE CHECKED FOR ADMISSABILITY.')
L.0046 IEXIT =0
L.0047 WRITE (6,599)
L.0048 1 CALL FFAN(A,D,9,NX)
L.0049 IF (A(1)-IB) 70,72,70
L.0050 70 LINE=1
L.0051 71 WRITE(6,598) A(1)
L.0052 A(1)=IB
L.0053 598 FORMAT(' THE SYMBOL ',A2,' IS NOT RECOGNIZED. PLEASE'
L.0054 1' RE-TYPE LINE.')
L.0055 GO TO (1,7,12,32,42),LINE
```



```

L.0056      72 ITEAM=D(1)
L.0057      CALL RANGE(1,4,ITEAM)
L.0058      IF (IEXIT) 3,3,1
L.0059      3 REWIND 1
L.0060      READ (1) COM,ICOM
L.0061      DO 67 I=1,50
L.0062      DO 69 J=1,4
L.0063      ICUE1(1,I,J)=0
L.0064      69 CONTINUE
L.0065      67 CONTINUE
L.0066      NTEAM=ITEAM
L.0067      IEXIT=0
L.0068      IOUT=6
L.0069      IL=1
L.0070      68 WRITE(6,600)
L.0071      7 CALL FFAN(A,D,9,NX)
L.0072      IF (A(1)-IB) 74,76,74
L.0073      74 LINE=2
L.0074      GO TO 71
L.0075      76 IEX=D(1)
L.0076      CALL RANGE(0,1,IEX)
L.0077      IF (IEXIT) 9,9,7
L.0078      9 IEX=IEX+1
L.0079      2 GO TO (6,4),IEX
L.0080      4 WRITE(6,601)
L.0081      6 WRITE(6,602)
L.0082      GO TO (10,8),IEX
L.0083      8 WRITE(6,603)
L.0084      WRITE(6,604)
L.0085      WRITE(6,605)
L.0086      10 NN=50
L.0087      MM=100
L.0088      12 CALL FFAN(A,D,9,NX)
L.0089      IF (A(1)-IB) 78,80,78
L.0090      78 LINE=3
L.0091      GO TO 71
L.0092      80 J1=D(1)
L.0093      X=D(2)
L.0094      IF (J1) 14,19,14
L.0095      14 CALL RANGE(2,5,J1)
L.0096      IF (IEXIT) 16,16,12
L.0097      16 J3=X
L.0098      CALL RANGE (0,MM,J3)
L.0099      IF (IEXIT) 18,18,12
L.0100      18 CALL SET(IL,J1,NN,J3,100)
L.0101      IL=IL+1
L.0102      IF (IL-51) 12,60,60
L.0103      19 IF (NN-50) 30,20,30
L.0104      20 WRITE(6,606)
L.0105      GO TO (22,21),IEX
L.0106      21 WRITE(6,603)
L.0107      WRITE(6,607)
L.0108      WRITE(6,605)
L.0109      22 NN=40
L.0110      MM=10000

```

```

L.0111      GO TO 12
L.0112      30 WRITE(6,608)
L.0113      GO TO (32,31),1
L.0114      31 WRITE(6,603)
L.0115      WRITE(6,609)
L.0116      WRITE(6,605)
L.0117      32 CALL FFAN(A,D,9,NX)
L.0118      IF (A(1)-1B) 82,84,82
L.0119      82 LINE=4
L.0120      GO TO 71
L.0121      84 J1=D(1)
L.0122      X=D(2)
L.0123      IF (J1) 34,40,34
L.0124      34 CALL RANGE(1,16,J1)
L.0125      IF (1EXIT) 36,36,32
L.0126      36 J2=X
L.0127      CALL RANGE(-10,10,J2)
L.0128      IF (1EXIT) 38,38,32
L.0129      38 CALL SET(IL,J1,J2,0,300)
L.0130      IL=IL+1
L.0131      IF (IL-51) 32,60,60
L.0132      40 WRITE(6,610)
L.0133      GO TO (42,41),1EX
L.0134      41 WRITE(6,603)
L.0135      WRITE(6,611)
L.0136      WRITE(6,605)
L.0137      42 CALL FFAN(A,D,9,NX)
L.0138      IF (A(1)-1B) 86,88,86
L.0139      86 LINE=5
L.0140      GO TO 71
L.0141      88 J1=D(1)
L.0142      J2=D(2)
L.0143      X=D(3)
L.0144      IF (J1) 44,60,44
L.0145      44 CALL RANGE(2,5,J1)
L.0146      IF (1EXIT) 46,46,42
L.0147      46 CALL RANGE(1,16,J2)
L.0148      IF (1EXIT) 48,48,42
L.0149      48 J3=X
L.0150      CALL RANGE(-10,10,J3)
L.0151      IF (1EXIT) 50,50,42
L.0152      50 CALL SET(IL,J1,J2,J3,200)
L.0153      IL=IL+1
L.0154      IF (IL-51) 42,60,60
L.0155      60 WRITE(6,613)
L.0156      613 FORMAT('WOULD YOU LIKE TO ENTER ADDITIONAL INPUT'
L.0157      1' ? 0=NO, 1=YES')
L.0158      61 CALL FFAN(A,D,9,NX)
L.0159      IF (A(1)-1B) 62,64,62
L.0160      62 WRITE(6,598) A(1)
L.0161      A(1)=1B
L.0162      GO TO 61
L.0163      64 IANS=D(1)+1
L.0164      GO TO (66,68),IANS
L.0165      66 WRITE(6,612)

```

```

L.0166      CALL CHECK
L.0167      CALL ECFLOW
L.0168      CALL CEIL
L.0169      DO 11 KKK=1,5
L.0170      JPOIN(KKK)=0
L.0171      11 CONTINUE
L.0172      WRITE(6,1000) NTEAM,IRND ,(MON(JMONT,J),J=1,3),JYEAR
L.0173      1000 FORMAT('0TEAM ',11,' ROUND ',12,3X,3A4,14)
L.0174      CALL CHPOS
L.0175      CALL PRGEN
L.0176      CALL SD
L.0177      CALL INTEC
L.0178      CALL TREAS
L.0179      CALL DPOL
L.0180      CALL DEPEND
L.0181      CALL AFFMOD
L.0182      DO 701 J=1,50
L.0183      DO 702 I=1,5
L.0184      DO 700 K=1,4
L.0185      IF (I-1) 743,700,743
L.0186      743 IQUE1(I,J,K) = IQUE2(I,J,K)
L.0187      IQUE2(I,J,K) = 0
L.0188      700 CONTINUE
L.0189      PIR(I,J) = 0.
L.0190      702 CONTINUE
L.0191      DO 701 I=6,11
L.0192      PIR(I,J) = 0.
L.0193      701 CONTINUE
L.0194      IF (JMONT-11) 888,8889,888
L.0195      8889 IF ((JYEAR/2)*2-JYEAR) 888,200,888
L.0196      200 CALL ELEC
L.0197      888 CALL CONCL
L.0198      STOP
L.0199      END

```

```

L.0200 /FTC SVDECK
L.0201     SUBROUTINE ECFLOW
L.0202     COMMON AFFCT(5,5),AID(5,5),APOS(11),BAL(5),OLBAL(5,2),DEP(5,5),
L.0203     1FLEX(11),FLOW(5,5),GNP(5),PCONG(11,4),PELEC(11),PIAFF(11,5),
L.0204     2PIPOS(25,11),PIR(11,50),PISAL(25,11),PISUP(11),POS(25,5),
L.0205     3POW(25,5),RESTI(5,5),RNATU(5,5),RPOS(11),SAL(25,5),TREND(5,5),
L.0206     4RA(5,5),IBUF(3,11),ICARD(80),ICOUN,IEXIT,ILOC,IN,INIT,IOUT,
L.0207     5IPASS(10),IPOIN,IQUE1(5,50,4),IQUE2(5,50,4),IRND,IX,JMONT,JYEAR
L.0208     COMMON JPOIN(5),MES(20,8),MON(12,3),NAT,NATIN(5,2),NISS,NTEAM,
L.0209     1SDPOS(25),LIM(5,5,2),NAID(5),NPRPOS(11)
L.0210     DO 5 I=1,5
L.0211     OLBAL(I,1)=RESTI(1,I)
L.0212     5 OLBAL(I,2)=AID(1,I)
L.0213     DO 10 I=1,5
L.0214     DO 11 J=1,50
L.0215     IF(IQUE1(I,J,1)) 11,11,12
L.0216     12 IF(IQUE1(I,J,4)-100) 110,13,110
L.0217     110 IF(IQUE1(I,J,4)-300) 11,111,11
L.0218     111 NN=IQUE1(I,J,1)
L.0219     PP=IQUE1(I,J,2)
L.0220     IF(I-1) 108,109,108
L.0221     108 POS(NN,I)=PP
L.0222     GO TO 11
L.0223     109 IF(ABS(POS(NN,I)-PP)-2.0) 112,112,113
L.0224     113 P=AMAX(PP,POS(NN,I)-2.0)
L.0225     P=AMIN(P,POS(NN,I)+2.0)
L.0226     WRITE(6,1003) NN,PP,P
L.0227     1003 FORMAT('THE STATE DEPT WILL NOT ALLOW A POSITION ON '
L.0228     1'ISSUE ',12,' OF ',F4.0/' THE NEW US POSITION IS ',F4.0)
L.0229     PP=P
L.0230     112 POS(NN,I)=PP
L.0231     IQUE1(I,J,2)=PP
L.0232     GO TO 11
L.0233     13 IROUT=IQUE1(I,J,2)/10-3
L.0234     INAT=IQUE1(I,J,1)
L.0235     IAMT=IQUE1(I,J,3)
L.0236     IF(I-1) 9,15,9
L.0237     9 GO TO (14,34),IROUT
L.0238     15 GO TO (16,26),IROUT
L.0239     16 IF(AID(I,INAT)+NAID(INAT)-IAMT) 40,40,36
L.0240     40 IAMT1=AID(I,INAT)+NAID(INAT)
L.0241     GO TO 19
L.0242     36 JAMT=AID(I,INAT)
L.0243     IF(IAMT-5-JAMT) 17,17,18
L.0244     18 IAMT1=5+JAMT
L.0245     19 CONTINUE
L.0246     WRITE(IOUT,1004)
L.0247     WRITE(IOUT,1001)(NATIN(INAT,K),K=1,2),IAMT,IAMT1
L.0248     1001 FORMAT(' AN AID GRANT TO ',2A4,' OF $ ',13,' MIL. IT HAS '
L.0249     1' BEEN CHANGED TO $ ',13,' .')
L.0250     1002 FORMAT(' A RESTRICTION ON IMPORTS FROM ',2A4,
L.0251     1' OF ',13,' %.'/' IT HAS BEEN CHANGED TO ',13,' %.')
L.0252     1004 FORMAT('THE STATE AND TREASURY DEPTS WILL NOT ALLOW')
L.0253     IAMT=IAMT1
L.0254     IQUE1(I,J,3)=IAMT
L.0255     GO TO 14

```

```

L.0256      17 JAMT=AID(I,INAT)
L.0257      IF (IAMT+5-JAMT) 21,14,14
L.0258      21 IAMT1=JAMT-5
L.0259      GO TO 19
L.0260      14 AID(I,INAT)=IAMT
L.0261      GO TO 11
L.0262      26 IF(IAMT-5-RESTI(I,INAT)) 27,27,28
L.0263      28 IAMT1=5+RESTI(I,INAT)
L.0264      29 CONTINUE
L.0265      WRITE (IOUT,1004)
L.0266      WRITE(6,1002) (NATIN(INAT,K),K=1,2),IAMT,IAMT1
L.0267      IAMT=IAMT1
L.0268      IQUE1(1,J,3)=IAMT
L.0269      GO TO 34
L.0270      27 IF(IAMT+5-RESTI(I,INAT)) 30,34,34
L.0271      30 IAMT1=RESTI(I,INAT)-5
L.0272      GO TO 29
L.0273      34 RESTI(I,INAT)=IAMT
L.0274      11 CONTINUE
L.0275      10 CONTINUE
L.0276      RETURN
L.0277      END

```

```

L.0001 /FTC SVDECK
L.0002     SUBROUTINE SET(I,J,K,L,M)
L.0003     COMMON AFFCT(5,5),AID(5,5),APOS(11),BAL(5),OLBAL(5,2),DEP(5,5),
L.0004     1FLEX(11),FLOW(5,5),GNP(5),PCONG(11,4),PELEC(11),PIAFF(11,5),
L.0005     2PIPOS(25,11),PIR(11,50),PISAL(25,11),PISUP(11),POS(25,5),
L.0006     3POW(25,5),RESTI(5,5),RNATU(5,5),RPOS(11),SAL(25,5),TREND(5,5),
L.0007     4RA(5,5),IBUF(3,11),ICARD(80),ICOUN, IEXIT, ILOC, IN, INIT, IOUT,
L.0008     5IPASS(10),IPOIN,IQUE1(5,50,4),IQUE2(5,50,4),IRND,IX,JMCNT,JYEAR
L.0009     COMMON JPOIN(5),MES(20,8),MON(12,3),NAT,NATIN(5,2),NISS,NTEAM,
L.0010     1SDPOS(25),LIM(5,5,2),NAID(5),NPRPOS(11)
L.0011     DIMENSION COM(1849),ICOM(2439)
L.0012     EQUIVALENCE (COM(1),AFFCT(1,1)),(ICOM(1),IBUF(1,1))
L.0013     IQUE1(1,1,1)=J
L.0014     IQUE1(1,1,2)=K
L.0015     IQUE1(1,1,3)=L
L.0016     IQUE1(1,1,4)=M
L.0017     RETURN
L.0018     END

```

```

L.0090 /FTC SVDECK
L.0091     SUBROUTINE CEIL
L.0092     COMMON AFFCT(5,5),AID(5,5),APOS(11),BAL(5),OLBAL(5,2),DEP(5,5),
L.0093     1FLEX(11),FLOW(5,5),GNP(5),PCONG(11,4),PELEC(11),PIAFF(11,5),
L.0094     2PIPOS(25,11),PIR(11,50),PISAL(25,11),PISUP(11),POS(25,5),
L.0095     3POW(25,5),RESTI(5,5),RNATU(5,5),RPOS(11),SAL(25,5),TREND(5,5),
L.0096     4RA(5,5),IBUF(3,11),ICARD(80),ICOUN, IEXIT, ILOC, IN, INIT, IOUT,
L.0097     5IPASS(10),IPOIN,IQUE1(5,50,4),IQUE2(5,50,4),IRND,IX,JMONT,JYEAR
L.0098     COMMON JPOIN(5),MES(20,8),MON(12,3),NAT,NATIN(5,2),NISS,NTEAM,
L.0099     1SDPOS(25),LIM(5,5,2),NAID(5),NPRPOS(11)
L.0100     DO 10 I=1,5
L.0101     DO 20 J=1,5
L.0102     IF(I-J) 21,20,21
L.0103     21   LIM(I,J,1)=30-AFFCT(I,J)
L.0104     LIM(I,J,2)=60-AFFCT(I,J)*4
L.0105     20   CONTINUE
L.0106     10   CONTINUE
L.0107     RETURN
L.0108     END

```

```

L.0077 /FTC SVDECK
L.0078     SUBROUTINE RANGE(LOW,LUP,N)
L.0079     COMMON COM(1849),ICOM(2439)
L.0080     EQUIVALENCE (IEXIT,ICOM(115))
L.0081     IEXIT=0
L.0082     IF(N-LOW) 10,99,11
L.0083     11   IF(N-LUP) 99,99,10
L.0084     10   WRITE(6,1000) N,LOW,LUP
L.0085     1000 FORMAT(' ERROR: ',I4,' DOES NOT LIE BETWEEN ',I4,' AND '
L.0086     1,I4,' ; PLEASE RE-TYPE. ')
L.0087     IEXIT=1
L.0088     99   RETURN
L.0089     END

```

```

L.0019 /FTC SVDECK
L.0020 SUBROUTINE CHECK
L.0021 COMMON AFFCT(5,5),AID(5,5),APOS(11),BAL(5),OLBAL(5,2),DEP(5,5),
L.0022 1FLEX(11),FLOW(5,5),GNP(5),PCONG(11,4),PELEC(11),PIAFF(11,5),
L.0023 2PIPOS(25,11),PIR(11,50),PISAL(25,11),PISUP(11),POS(25,5),
L.0024 3POW(25,5),RESTI(5,5),RNATU(5,5),RPOS(11),SAL(25,5),TREND(5,5),
L.0025 4RA(5,5),IBUF(3,11),ICARD(80),ICOUN,IEXIT,ILOC,NI,INIT,IOUT,
L.0026 5IPASS(10),IPOIN,IQUE1(5,50,4),IQUE2(5,50,4),IRND,IX,JMONT,JYEAR
L.0027 COMMON JPOIN(5),MES(20,8),MON(12,3),NAT,NATIN(5,2),NISS,NTEAM,
L.0028 1SDPOS(25),LIM(5,5,2),NAID(5),NPRPOS(11)
L.0029 DIMENSION IIP(25),IPR(25,5),IEC(2,5),ITYPE(3)
L.0030 DATA IIP/25*0/,IPR/25*1,100*0/,IEC/2*1,8*0/,ITYPE/'EC','PR','IP'/
L.0031 N=0
L.0032 ILOC=0
L.0033 DO 10 I=1,50
L.0034 1003 FORMAT(2X,4I4)
L.0035 IF (IQUE1(1,I,1)) 10,10,8
L.0036 8 CONTINUE
L.0037 9 IROUT=IQUE1(1,I,4)/100
L.0038 GO TO (11,12,13),IROUT
L.0039 11 INAT=IQUE1(1,I,1)
L.0040 IT=IQUE1(1,I,2)/10-3
L.0041 IN=IEC(IT,INAT)
L.0042 IF(IN) 21,21,99
L.0043 21 ILOC=ILOC+1
L.0044 IEC(IT,INAT)=ILOC
L.0045 GO TO 19
L.0046 12 INAT=IQUE1(1,I,1)
L.0047 IT=IQUE1(1,I,2)
L.0048 IN=IPR(IT,INAT)
L.0049 IF(IN) 22,22,99
L.0050 22 ILOC=ILOC+1
L.0051 IPR(IT,INAT)=ILOC
L.0052 GO TO 19
L.0053 13 INAT=IQUE1(1,I,1)
L.0054 IN=IIP(INAT)
L.0055 IF(IN) 23,23,99
L.0056 23 ILOC=ILOC+1
L.0057 IIP(INAT)=ILOC
L.0058 19 DO 25 J=1,4
L.0059 25 IQUE1(1,ILOC,J)=IQUE1(1,I,J)
L.0060 GO TO 10
L.0061 99 IF(N) 100,100,101
L.0062 100 WRITE(IOUT,1001)
L.0063 1001 FORMAT('THE FOLLOWING DUPLICATE ACTS ARE NOT ALLOWED'/
L.0064 1' ORIGINAL',4X,'DUPLICATE')
L.0065 1002 FORMAT(' ',A2,2X,3I3,4X,3I3)
L.0066 N=1
L.0067 101 WRITE(IOUT,1002)ITYPE(IROUT),(IQUE1(1,IN,J),J=1,3),(IQUE1(1,I,J),J
L.0068 1=1,3)
L.0069 10 CONTINUE
L.0070 ILOC=ILOC+1
L.0071 IF(ILOC-50) 111,111,999
L.0072 111 DO 1000 I=ILOC,50
L.0073 DO 1000 J=1,4
L.0074 1000 IQUE1(1,I,J)=0
L.0075 999 RETURN
L.0076 END

```

```

L.0109 /FTC SVDECK
L.0110     SUBROUTINE RANDU(YFL)
L.0111     COMMON COM(1849),ICOM(2439)
L.0112     EQUIVALENCE (IX,ICOM(2132))
L.0113     IY=IX*65539
L.0114     IF(IY) 5,6,6
L.0115     5   IY=IY+2147483647+1
L.0116     6   YFL=IY
L.0117     YFL=YFL*.465661E-9
L.0118     IX=IY
L.0119     RETURN
L.0120     END
L.0121 /FTC SVDECK
L.0122     FUNCTION AMAX(X,Y)
L.0123     AMAX=X
L.0124     IF(X-Y) 10,99,99
L.0125     10  AMAX=Y
L.0126     99  RETURN
L.0127     END
L.0128 /FTC SVDECK
L.0129     FUNCTION MIN(I,J)
L.0130     MIN=I
L.0131     IF(I-J) 99,99,10
L.0132     10  MIN=J
L.0133     99  RETURN
L.0134     END
L.0135 /FTC SVDECK
L.0136     FUNCTION MAX(I,J)
L.0137     MAX=I
L.0138     IF(I-J) 10,99,99
L.0139     10  MAX=J
L.0140     99  RETURN
L.0141     END
L.0142 /FTC SVDECK
L.0143     FUNCTION AMIN(X,Y)
L.0144     AMIN=X
L.0145     IF(X-Y) 99,99,10
L.0146     10  AMIN=Y
L.0147     99  RETURN
L.0148     END
L.0167 /FTC SVDECK
L.0168     SUBROUTINE SQUASH(XX,YY,ZZ,AA)
L.0169     ZZ=ZZ/(5.0*AA)
L.0170     IF(ZZ-1.0) 10,12,13
L.0171     13   ZZ=1.0
L.0172     GO TO 12
L.0173     10   IF(ZZ+1.0) 11,12,12
L.0174     11   ZZ=-1.0
L.0175     12   ZZ=XX+ZZ+YY
L.0176     RETURN
L.0177     END

```



```

L.0149 /FTC SVDECK
L.0150     SUBROUTINE GAUSS(IIX,S,AM,V)
L.0151     COMMON AFFCT(5,5),AID(5,5),APOS(11),BAL(5),OLBAL(5,2),DEP(5,5),
L.0152     1FLEX(11),FLOW(5,5),GNP(5),PCONG(11,4),PELEC(11),PIAFF(11,5),
L.0153     2PIPOS(25,11),PIR(11,50),PISAL(25,11),PISUP(11),POS(25,5),
L.0154     3POW(25,5),RESTI(5,5),RNATU(5,5),RPOS(11),SAL(25,5),TREND(5,5),
L.0155     4RA(5,5),IBUF(3,11),ICARD(80),ICOUN,IEXIT,ILOC,IN,INIT,IOUT,
L.0156     5IPASS(10),IPOIN,IQUE1(5,50,4),IQUE2(5,50,4),IRND,IX,JMONT,JYEAR
L.0157     COMMON JPOIN(5),MES(20,8),MON(12,3),NAT,NATIN(5,2),NISS,NTEAM,
L.0158     1SDPOS(25),LIM(5,5,2),NAID(5),NPRPOS(11)
L.0159     A=0.0
L.0160     DO 50 I=1,12
L.0161     CALL RANDU(Y)
L.0162 50    A=A+Y
L.0163     V=(A-6.0)*S+AM
L.0164     RETURN
L.0165     END

```

```

L.0178 /FTC SVDECK
L.0179     SUBROUTINE ELIM(PPOW,NN)
L.0180     COMMON AFFCT(5,5),AID(5,5),APOS(11),BAL(5),OLBAL(5,2),DEP(5,5),
L.0181     1FLEX(11),FLOW(5,5),GNP(5),PCONG(11,4),PELEC(11),PIAFF(11,5),
L.0182     2PIPOS(25,11),PIR(11,50),PISAL(25,11),PISUP(11),POS(25,5),
L.0183     3POW(25,5),RESTI(5,5),RNATU(5,5),RPOS(11),SAL(25,5),TREND(5,5),
L.0184     4RA(5,5),IBUF(3,11),ICARD(80),ICOUN,IEXIT,ILOC,IN,INIT,IOUT,
L.0185     5IPASS(10),IPOIN,IQUE1(5,50,4),IQUE2(5,50,4),IRND,IX,JMONT,JYEAR
L.0186     COMMON JPOIN(5),MES(20,8),MON(12,3),NAT,NATIN(5,2),NISS,NTEAM,
L.0187     1SDPOS(25),LIM(5,5,2),NAID(5),NPRPOS(11)
L.0188     DIMENSION IRES(3,2)
L.0189     DATA IRES/'FAVO','RABL','Y','UNFA','VORA','BLY'/
L.0190     DO 10 J=1,5
L.0191 10    SAL(NN,J)=0.0
L.0192     IF(PPOW) 11,99,12
L.0193 11    IR=2
L.0194     GO TO 13
L.0195 12    IR=1
L.0196 13    WRITE(IOUT,1001)NN,( IRES(K,IR),K=1,3)
L.0197 1001  FORMAT(@ ISSUE NO. @,12,@ HAS BEEN @,3A4,@ RESOLVED@/)
L.0198 99    RETURN
L.0199     END

```

```

L.0001 /FTC SVDECK
L.0002     SUBROUTINE AFFMOD
L.0003     COMMON AFFCT(5,5),AID(5,5),APOS(11),BAL(5),OLBAL(5,2),DEP(5,5),
L.0004     1FLEX(11),FLOW(5,5),GNP(5),PCONG(11,4),PELEC(11),PIAFF(11,5),
L.0005     2PIPOS(25,11),PIR(11,50),PISAL(25,11),PISUP(11),POS(25,5),
L.0006     3POW(25,5),REST1(5,5),RNATU(5,5),RPOS(11),SAL(25,5),TREND(5,5),
L.0007     4RA(5,5),IBUF(3,11),ICARD(80),ICOUN,IEXIT,ILOC,IN,INIT,IOUT,
L.0008     5IPASS(10),IPOIN,IQUE1(5,50,4),IQUE2(5,50,4),IRND,IX,JMONT,JYEAR
L.0009     COMMON JPOIN(5),MES(20,8),MON(12,3),NAT,NATIN(5,2),NISS,NTEAM,
L.0010     1SRPOS(25),LIM(5,5,2),NAID(5),NPRPOS(11)
L.0011     N=0
L.0012     AA=0.0
L.0013     DO 10 I=1,5
L.0014     DO 22 J=1,5
L.0015     IF(I-J)21,20,21
L.0016 21     DO 30 K=1,50
L.0017     IF (IQUE1(J,K,1)-1) 30,31,30
L.0018 31     IF(IQUE1(J,K,4)-200)30,32,30
L.0019 32     N=N+1
L.0020     II=IQUE1(J,K,2)
L.0021 1000  FORMAT(' AFFCT FROM ',I2,' TO ',I2,' WAS ',F6.2, /
L.0022     1' IT HAS BEEN CHANGED BY ',F6.2,' TO ',F6.2)
L.0023     IPR=IQUE1(J,K,3)
L.0024     POW(II,1)=AMAX(POW(II,1),1.0)
L.0025     PP=POW(II,J)/POW(II,1)
L.0026     CALL SQUASH(10.0,0.0,PP,2.0)
L.0027     AA=AA+IPR*SAL(II,1)*PP
L.0028 30     CONTINUE
L.0029     AA=AA*N
L.0030     CALL SQUASH(2.0,0.0,AA,2500.0)
L.0031     A=AFFCT(I,J)
L.0032     AFFCT(I,J)=AFFCT(I,J) +AA
L.0033     IF(AFFCT(I,J)) 50,20,51
L.0034 50     AFFCT(I,J)=AMAX(AFFCT(I,J),-10.0)
L.0035     GO TO 20
L.0036 51     AFFCT(I,J)=AMIN(AFFCT(I,J),10.0)
L.0037     20 CONTINUE
L.0038     22 CONTINUE
L.0039 10     CONTINUE
L.0040     RETURN
L.0041     END
L.0042 /FTC SVDECK
L.0043     FUNCTION DEF(A1,A2,L1,L2)
L.0044     DEF=A1
L.0045     IF (L1-L2) 10,10,99
L.0046 10     DEF=A2
L.0047 99     RETURN
L.0048     END

```

```

L.0049 /FTC SVDECK
L.0050     SUBROUTINE FILLO(K1,K2,K3,K4)
L.0051     COMMON AFFCT(5,5),AID(5,5),APOS(11),BAL(5),OLBAL(5,2),DEP(5,5),
L.0052     1FLEX(11),FLOW(5,5),GNP(5),PCONG(11,4),PELEC(11),PIAFF(11,5),
L.0053     2PIPOS(25,11),PIR(11,50),PISAL(25,11),PISUP(11),POS(25,5),
L.0054     3POW(25,5),RESTI(5,5),RNATU(5,5),RPOS(11),SAL(25,5),TREND(5,5),
L.0055     4RA(5,5),IBUF(3,11),ICARD(80),ICOUN,IEXIT,ILOC,IN,INIT,IOUT,
L.0056     5IPASS(10),IPOIN,IQUE1(5,50,4),IQUE2(5,50,4),IRND,IX,JMONT,JYEAR
L.0057     COMMON JPOIN(5),MES(20,8),MON(12,3),NAT,NATIN(5,2),NISS,NTEAM,
L.0058     1SDPOS(25),LIM(5,5,2),NAID(5),NPRPOS(11)
L.0059     DIMENSION NN(2)
L.0060     DATA NN/'AID ','REST'/
L.0061     JPOIN(NAT)=JPOIN(NAT)+1
L.0062     I1=JPOIN(NAT)
L.0063     IF(I1-50) 100,100,401
L.0064     100 IF (NAT-1) 101,490,101
L.0065     490 IF (K4-100) 499,492,499
L.0066     492 IF (K2-45) 493,401,495
L.0067     493 L=1
L.0068     GO TO 496
L.0069     495 L=2
L.0070     496 WRITE(IOUT,1002)(NATIN(K1, KK),KK=1,2),NN(L),K3
L.0071     GO TO 101
L.0072     1002 FORMAT(' ',2A4,3X,A4,3X,13)
L.0073     499 WRITE(IOUT,1001)(NATIN(K1, KK),KK=1,2),K2,K3
L.0074     1001 FORMAT(' ',2A4,3X,12,5X,13)
L.0075     101 IQUE2(NAT,I1,1)=K1
L.0076     200 IQUE2(NAT,I1,2)=K2
L.0077     300 IQUE2(NAT,I1,3)=K3
L.0078     400 IQUE2(NAT,I1,4)=K4
L.0079     401 RETURN
L.0080     END

```

```

L.0081 /FTC SVDECK
L.0082     SUBROUTINE ATCHG
L.0083     COMMON AFFCT(5,5),AID(5,5),APOS(11),BAL(5),OLBAL(5,2),DEP(5,5),
L.0084     1FLEX(11),FLOW(5,5),GNP(5),PCONG(11,4),PELEC(11),PIAFF(11,5),
L.0085     2PIPOS(25,11),PIR(11,50),PISAL(25,11),PISUP(11),POS(25,5),
L.0086     3POW(25,5),RESTI(5,5),RNATU(5,5),RPOS(11),SAL(25,5),TREND(5,5),
L.0087     4RA(5,5),IBUF(3,11),ICARD(80),ICOUN, IEXIT, ILOC, IN, INIT, IOUT,
L.0088     5IPASS(10),IPOIN,IQUE1(5,50,4),IQUE2(5,50,4),IRND,IX,JMONT,JYEAR
L.0089     COMMON JPOIN(5),MES(20,8),MON(12,3),NAT,NATIN(5,2),NISS,NTEAM,
L.C090     1SDPOS(25),LIM(5,5,2),NAID(5),NPRPOS(11)
L.0091     DO 10 IPI=1,11
L.0092     DO 15 NAT=2,5
L.0093     N=0
L.0094     ATOT=0.0
L.0095     DO 20 IRSP=1,50
L.0096     IF(IQUE1(NAT,IRSP,4)-200)20,21,20
L.0097     21 IF(IQUE1(NAT,IRSP,1)-1)20,22,20
L.0098     22 ATOT=ATOT+IQUE1(NAT,IRSP,3)*PISAL(IQUE1(NAT,IRSP,2),IPI)
L.0099     N=N+1
L.0100     20 CONTINUE
L.0101     ATOT=ATOT*N
L.0102     CALL SQUASH(FLEX(IPI),0.0,ATOT,1500.0)
L.0103     A=PIAFF(IPI,NAT)
L.0104     PIAFF(IPI,NAT)=PIAFF(IPI,NAT)+ATOT
L.0105     1000 FORMAT(' AFFECT OF PI GRP ',I2,' FOR NATION ',I2,' WAS '
L.0106     1' ',F6.2,/' IT HAS BEEN CHANGED BY ',F6.2,' TO ',F6.2)
L.0107     15 CONTINUE
L.0108     10 CONTINUE
L.0109     RETURN
L.0110     END

```

```

L.0111 /FTC SVDECK
L.0112     SUBROUTINE CONCL
L.0113     COMMON AFFCT(5,5),AID(5,5),APOS(11),BAL(5),OLBAL(5,2),DEP(5,5),
L.0114     1FLEX(11),FLOW(5,5),GNP(5),PCONG(11,4),PELEC(11),PIAFF(11,5),
L.0115     2PIPOS(25,11),PIR(11,50),PISAL(25,11),PISUP(11),POS(25,5),
L.0116     3POW(25,5),RESTI(5,5),RNATU(5,5),RPOS(11),SAL(25,5),TREND(5,5),
L.0117     4RA(5,5),IBUF(3,11),ICARD(80),ICOUN, IEXIT, ILOC, IN, INIT, IOUT,
L.0118     5IPASS(10), IPOIN, IQUE1(5,50,4), IQUE2(5,50,4), IRND, IX, JMONT, JYEAR
L.0119     COMMON JPOIN(5),MES(20,8),MON(12,3),NAT,NATIN(5,2),NISS,NTEAM,
L.0120     1SDPOS(25),LIM(5,5,2),NAID(5),NPRPOS(11)
L.0121     DIMENSION COM(1849),ICOM(2439)
L.0122     EQUIVALENCE (COM(1),AFFCT(1,1)),(ICOM(1),IBUF(1,1))
L.0123     WRITE (6,1003)
L.0124     1003 FORMAT('0IS THIS A TEST ?1=YES, 0=NO')
L.0125     READ (9,1004) IANS
L.0126     1004 FORMAT(I1)
L.0127     IF (IANS) 99,30,99
L.0128     30 IRND=IRND+1
L.0129     JMONT=JMONT+1
L.0130     IF (JMONT-12) 10,10,20
L.0131     20 JYEAR=JYEAR+1
L.0132     JMONT=1
L.0133     10 REWIND 1
L.0134     WRITE(1) COM,ICOM
L.0135     WRITE(IOUT,5000)
L.0136     5000 FORMAT(10X,'A FRIENDLY MESSAGE FROM LOCAL PRINCE CONTROL')
L.0137     ITEAM=NTEAM
L.0138     WRITE(IOUT,1002) ITEAM
L.0139     1002 FORMAT(10X,'END OF RUN   TEAM',I3)
L.0140     200 CONTINUE
L.0141     WRITE(IOUT,1000) JMONT,JYEAR
L.0142     1000 FORMAT(10X,'DATE OF NEXT JOB           MONTH:',I2,' YEAR:',I4 )
L.0143     WRITE(IOUT,1001)
L.0144     1001 FORMAT(10X,'PRINCE OFF')
L.0145     99 RETURN
L.0146     END

```

```

L.0147 /FTC SVDECK
L.0148     SUBROUTINE TREAS
L.0149     COMMON AFFCT(5,5),AID(5,5),APOS(11),BAL(5),OLBAL(5,2),DEP(5,5),
L.0150     1FLEX(11),FLOW(5,5),GNP(5),PCONG(11,4),PELEC(11),PIAFF(11,5),
L.0151     2PIPOS(25,11),PIR(11,50),PISAL(25,11),PISUP(11),POS(25,5),
L.0152     3POW(25,5),RESTI(5,5),RNATU(5,5),RPOS(11),SAL(25,5),TREND(5,5),
L.0153     4RA(5,5),IBUF(3,11),ICARD(80),ICOUN, IEXIT, ILOC, IN, INIT, IOUT,
L.0154     5IPASS(10),IPOIN, IQUE1(5,50,4), IQUE2(5,50,4), IRND, IX, JMONT, JYEAR
L.0155     COMMON JPOIN(5),MES(20,8),MON(12,3),NAT,NATIN(5,2),NISS,NTEAM,
L.0156     1SDPOS(25),LIM(5,5,2),NAID(5),NPRPOS(11)
L.0157     DIMENSION ITYP(2)
L.0158     DATA ITYP/'AID','REST'/
L.0159     WRITE(IOUT,1001)(MON(JMONT,K),K=1,3),JYEAR
L.0160 1001  FORMAT('1MONTHLY REPORT OF THE UNITED STATES TREASURY/' REPORT
L.0161     1OF ECONOMIC ACTIVITY DURING THE PERIOD ',3A4,2X,14)
L.0162     WRITE(IOUT,1002)
L.0163 1002  FORMAT('ONATION     TARGET     ACT     AMOUNT' /)
L.0164     DO 20 I=1,5
L.0165 1003  FORMAT('0',2A4/)
L.0166     WRITE(IOUT,1003)(NATIN(I,K),K=1,2)
L.0167     DO 10 J=1,50
L.0168     IF(IQUE1(I,J,1)) 10,10,12
L.0169 12     IF(IQUE1(I,J,4)-100) 10,13,10
L.0170     13 IF (IQUE1(I,J,2)-40) 52,50,52
L.0171     50 I1=1
L.0172     GO TO 54
L.0173     52 I1=2
L.0174     54 WRITE(6,1004)(NATIN(IQUE1(I,J,1),K),K=1,2),ITYP(I1),
L.0175     1IQUE1(I,J,3)
L.0176 1004  FORMAT(' ',9X,2A4,1X,A4,6X,14)
L.0177 10     CONTINUE
L.0178 20     CONTINUE
L.0179     WRITE(IOUT,1010)((NATIN(I,J),J=1,2),BAL(I),I=1,5)
L.0180 1010  FORMAT('OBALANCE OF PAYMENTS/' COUNTRY     AMOUNT'/
L.0181     14(' ',2A4,2X,'$',F10.2/))
L.0182     RETURN
L.0183     END

```



```

L.0001 /FTC SVDECK
L.0002     SUBROUTINE DEPEND
L.0003     COMMON AFFCT(5,5),AID(5,5),APOS(11),BAL(5),OLBAL(5,2),DEP(5,5),
L.0004     1FLEX(11),FLOW(5,5),GNP(5),PCONG(11,4),PELEC(11),PIAFF(11,5),
L.0005     2PIPOS(25,11),PIR(11,50),PISAL(25,11),PISUP(11),POS(25,5),
L.0006     3POW(25,5),RESTI(5,5),RNATU(5,5),RPOS(11),SAL(25,5),TREND(5,5),
L.0007     4RA(5,5),IBUF(3,11),ICARD(80),ICOUN,IEXIT,ILOC,IN,INIT,IOUT,
L.0008     5IPASS(10),IPOIN,IQUE1(5,50,4),IQUE2(5,50,4),IRND,IX,JMONT,JYEAR
L.0009     COMMON JPOIN(5),MES(20,8) MON(12,3),NAT,NATIN(5,2),NISS,NTEAM,
L.0010     1SDPOS(25),LIM(5,5,2),NAID(5),NPRPOS(11)
L.0011     CALL RACAL(FLOW(1,1))
L.0012     DO 10 NAT=1,5
L.0013     DO 20 J=1,5
L.0014     DEP(NAT,J)=RA(NAT,J)
L.0015     CALL SQUASH(5.0,5.0,DEP(NAT,J),1.0)
L.0016     20 CONTINUE
L.0017     10 CONTINUE
L.0018     RETURN
L.0019     END

```

```

L.0066 /FTC SVDECK
L.0067     SUBROUTINE SD
L.0068     COMMON AFFCT(5,5),AID(5,5),APOS(11),BAL(5),OLBAL(5,2),DEP(5,5),
L.0069     1FLEX(11),FLOW(5,5),GNP(5),PCONG(11,4),PELEC(11),PIAFF(11,5),
L.0070     2PIPOS(25,11),PIR(11,50),PISAL(25,11),PISUP(11),POS(25,5),
L.0071     3POW(25,5),RESTI(5,5),RNATU(5,5),RPOS(11),SAL(25,5),TREND(5,5),
L.0072     4RA(5,5),IBUF(3,11),ICARD(80),ICOUN,IEXIT,ILOC,IN,INIT,IOUT,
L.0073     5IPASS(10),IPOIN,IQUE1(5,50,4),IQUE2(5,50,4),IRND,IX,JMONT,JYEAR
L.0074     COMMON JPOIN(5),MES(20,8) MON(12,3),NAT,NATIN(5,2),NISS,NTEAM,
L.0075     1SDPOS(25),LIM(5,5,2),NAID(5),NPRPOS(11)
L.0076     WRITE(IOUT,1001)
L.0077     1001 FORMAT('SUMMARY OF POLITICAL ACTIVITY')
L.0078     WRITE(IJUT,1002) (MON(JMONT,K),K=1,3),JYEAR
L.0079     1002 FORMAT(' ISSUED FOR THE MONTH OF ',3A4,', ',14)
L.0080     WRITE(IOUT,1012)
L.0081     1012 FORMAT('COUNTRY          TARGET      ISSUE      PR')
L.0082     DO 10 NAT=1,5
L.0083     WRITE(IOUT,1003) (NATIN(NAT,K),K=1,2)
L.0084     1003 FORMAT(' ',2A4)
L.0085     DO 20 I=1,50
L.0086     IF(IQUE1(NAT,I,1))          10,10,11
L.0087     11 IF(IQUE1(NAT,I,4)-200) 20,100,20
L.0088     100 WRITE(IOUT,1004)(NATIN(IQUE1(NAT,I,1),K),K=1,2),(IQUE1(NAT,I,K),K=
L.0089     12,3)
L.0090     1004 FORMAT(' ',14X,2A4,2X,12,8X,13)
L.0091     20 CONTINUE
L.0092     10 CONTINUE
L.0093     RETURN
L.0094     END

```



```

L.0095 /FTC SVDECK
L.0096 SUBROUTINE PRGEN
L.0097 COMMON AFFCT(5,5),AID(5,5),APOS(11),BAL(5),OLBAL(5,2),DEP(5,5),
L.0098 1FLEX(11),FLOW(5,5),GNP(5),PCONG(11,4),PELEC(11),PIAFF(11,5),
L.0099 2PIPOS(25,11),PIR(11,50),PISAL(25,11),PISUP(11),POS(25,5),
L.0100 3POW(25,5),RESTI(5,5),RNATU(5,5),RPOS(11),SAL(25,5),TREND(5,5),
L.0101 4RA(5,5),IBUF(3,11),ICARD(80),ICOUN, IEXIT, ILOC, IN, INIT, IOUT,
L.0102 5IPASS(10),IPOIN,IQUE1(5,50,4),IQUE2(5,50,4),IRND, IX, JMONT, JYEAR
L.0103 COMMON JPOIN(5),MES(20,8),MON(12,3),NAT,NATIN(5,2),NISS,NTEAM,
L.0104 1SDPOS(25),LIM(5,5,2),NAID(5),NPRPOS(11)
L.0105 WRITE(6,100)
L.0106 100 FORMAT('OTHE US STATE DEPARTMENT INTELLIGENCE REPORT'/)
L.0107 WRITE (6,1001)(MON(JMONT,I),I=1,3),JYEAR
L.0108 1001 FORMAT(' SUMMARY OF ISSUE POSITIONS ON ',3A4,1X,14)
L.0109 WRITE(6,1002)((NATIN(I,J),J=1,2),I=1,5)
L.0110 1002 FORMAT(' ISSUE',5(1X,2A4)/)
L.0111 DO 60 NN=1,NISS
L.0112 60 WRITE(6,1003) NN,(POS(NN,I),I=1,5)
L.0113 1003 FORMAT(' ',13,5(5X,F4.0))
L.0114 WRITE(IOUT,1006)
L.0115 1006 FORMAT('OTHE STATE DEPARTMENT SUGGESTS THAT YOU TAKE '
L.0116 1'THE FOLLOWING'/' FOREIGN POLICY ISSUE POSITIONS DURING'
L.0117 2' THE NEXT PERIOD'/'OISSUE OLD POS NEW POS'/)
L.0118 N=0
L.0119 DO 31 I=1,NISS
L.0120 IF(POS(I,1)-SDPOS(I)) 25,31,25
L.0121 25 WRITE(IOUT,1007) I,POS(I,1),SDPOS(I)
L.0122 1007 FORMAT(3X,12,4X,F4.0,6X,F4.0)
L.0123 N=1
L.0124 31 CONTINUE
L.0125 IF (N) 200,200,201
L.0126 200 WRITE(6,1011)
L.0127 1011 FORMAT(6X,'NONE THIS ROUND')
L.0128 201 WRITE (6,1008)
L.0129 1008 FORMAT('OYOU SHOULD ENGAGE IN THE FOLLOWING FOREIGN POLICY'
L.0130 1' ACTIONS'/' TARGET ISSUE PR')
L.0131 N=JPOIN(1)
L.0132 DO 10 NAT=1,5
L.0133 DO 20 I=1,5
L.0134 IF(NAT-I)21,20,21
L.0135 21 DO 30 NN=1,NISS
L.0136 IF(SAL(NN,NAT)*POW(NN,I)-15)30,30,32
L.0137 32 IDF=ABS(POS(NN,NAT)-POS(NN,I))
L.0138 PRMX=-.045*IDF**2+10
L.0139 PRMN=.045*(20-IDF)**2-10
L.0140 PRMN=PRMN+DEP(NAT,I)*(PRMX-PRMN)/10
L.0141 DEL=(PRMX-PRMN)/2.0
L.0142 IF(POW(NN,NAT)) 40,41,40
L.0143 41 RESP=1000.0
L.0144 GO TO 42
L.0145 40 RESP=SAL(NN,NAT)/POW(NN,NAT)

```

```

L.0146 *2 CALL RANDU(RAND)
L.0147 RAND=RAND*.5
L.0148 PR=RAND*RESP
L.0149 CALL SQUASH(DEL,PRMN+DEL,PR,.5)
L.0150 NR=PR
L.0151 IF (NR) 103,30,102
L.0152 103 NR=MAX(NR,-10)
L.0153 GO TO 101
L.0154 102 NR=MIN(NR,10)
L.0155 101 CALL FILLQ(I,NN,NR,200)
L.0156 30 CONTINUE
L.0157 20 CONTINUE
L.0158 10 CONTINUE
L.0159 IF (N-JPOIN(1)) 203,202,202
L.0160 202 WRITE (6,1011)
L.0161 203 RETURN
L.0162 END

```

```

L.0163 /FTC SVDECK
L.0164 SUBROUTINE RACAL(DATA)
L.0165 DIMENSION DATA(5,5)
L.0166 COMMON AFFCT(5,5),AID(5,5),APOS(11),BAL(5),OLBAL(5,2),DEP(5,5),
L.0167 1FLEX(11),FLOW(5,5),GNP(5),PCONG(11,4),PELEC(11),PIAFF(11,5),
L.0168 2PIPOS(25,11),PIR(11,50),PISAL(25,11),PISUP(11),PCS(25,5),
L.0169 3POW(25,5),REST1(5,5),RNATU(5,5),RPOS(11),SAL(25,5),TREND(5,5),
L.0170 4RA(5,5),IBUF(3,11),ICARD(80),ICOUN,IEXIT,ILOC,IN,INIT,IOUT,
L.0171 5IPASS(10),IPOIN,IQUE1(5,50,4),IQUE2(5,50,4),IRND,IX,JMONT,JYEAR
L.0172 COMMON: JPOIN(5),MES(20,8),MON(12,3),NAT,NATIN(5,2),NISS,NTEAM,
L.0173 1SDPOS(25),LIM(5,5,2),NAID(5),NPRPOS(11)
L.0174 DO 10 I=1,5
L.0175 TOT=0.
L.0176 DO 20 J=1,5
L.0177 IF (I-J) 21,20,21
L.0178 21 TOT=TOT+DATA(I,J)
L.0179 20 CONTINUE
L.0180 RA(I,I)=0.
L.0181 DO 30 J=1,5
L.0182 IF (I-J) 31,30,31
L.0183 31 RA(I,J)=DATA(I,J)**2*(DATA(I,J)-1.)/TOT**2/(TOT-1)
L.0184 30 CONTINUE
L.0185 10 CONTINUE
L.0186 RETURN
L.0187 END

```

```

L.0001 /FTC SVDECK
L.0002     SUBROUTINE INTEC
L.0003     COMMON AFFCT(5,5),AID(5,5),APOS(11),BAL(5),OLBAL(5,2),DEP(5,5),
L.0004     1FLEX(11),FLOW(5,5),GNP(5),PCONG(11,4),PELEC(11),PIAFF(11,5),
L.0005     2PIPOS(25,11),PIR(11,50),PISAL(25,11),PISUP(11),POS(25,5),
L.0006     3POW(25,5),RESTI(5,5),RNATU(5,5),RPOS(11),SAL(25,5),TREND(5,5),
L.0007     4RA(5,5),IBUF(3,11),ICARD(80),ICOUN, IEXIT, ILOC, IN, INIT, IOUT,
L.0008     5IPASS(10),IPOIN,IQUE1(5,50,4),IQUE2(5,50,4),IRND,IX,IMONT,JYEAR
L.0009     COMMON JPOIN(5),MES(20,8),MON(12,3),NAT,NATIN(5,2),NISS,NTEAM,
L.0010     1SUPOS(25),LIM(5,5,2),NAID(5),NPRPOS(11)
L.0011     DO 5 I=1,5
L.0012     BAL(I)=0
L.0013     5 CONTINUE
L.0014     DO 100 I=1,5
L.0015     BAL(I)=FLOW(I,I)
L.0016     DO 100 J=1,5
L.0017     CALL GAUSS(IX,1.0,0.0,V)
L.0018     RNATU(I,J)=RNATU(I,J)+TREND(I,J)*(1+V)
L.0019     CALL GAUSS(IX,1.0,0.0,V)
L.0020     FLOW(I,J)=RNATU(I,J)*(1+V/5)*(100.-RESTI(J,I))/100.
L.0021     IF (I-J) 101,100,101
L.0022     101 CONTINUE
L.0023     BAL(I)=BAL(I)+FLOW(I,J)-FLOW(J,I)
L.0024     BAL(I)=BAL(I)- AID(I,J)+ AID(J,I)
L.0025     100 CONTINUE
L.0026     WRITE(IOUT,1006)
L.0027     1006 FORMAT('OTHE US TREASURY DEPARTMENT SUGGESTS THAT YOU'
L.0028     1' ENGAGE'/' IN THE FOLLOWING ECONOMIC ACTIVITY FOR '
L.0029     2'THE NEXT PERIOD'/' TARGET      ACT      AMOUNT')
L.0030     N=JPOIN(1)
L.0031     CALL INITE
L.0032     IF (N-JPOIN(1)) 201,200,200
L.0033     200 WRITE(6,1011)
L.0034     1011 FORMAT(' NONE THIS PERIOD')
L.0035     201 RETURN
L.0036     END

```

```

L.0037 /FTC SVDECK
L.0038 SUBROUTINE INITE
L.0039 DIMENSION REF(5)
L.0040 DIMENSION ND(5)
L.0041 COMMON AFFCT(5,5), AID(5,5), APOS(11), BAL(5), OLBAL(5,2), DEP(5,5),
L.0042 1FLEX(11), FLOW(5,5), GNP(5), PCONG(11,4), PELEC(11), PIAFF(11,5),
L.0043 2PIPOS(25,11), PIR(11,50), PISAL(25,11), PISUP(11), POS(25,5),
L.0044 3POW(25,5), REST1(5,5), RNATU(5,5), RPOS(11), SAL(25,5), TREND(5,5),
L.0045 4RA(5,5), IBUF(3,11), ICARD(80), ICOUN, IEXI, ILOC, IN, INIT, IOUT,
L.0046 5IPASS(10), IPOIN, IQUE1(5,50,4), IQUE2(5,50,4), IRND, IX, JMONT, JYEAR
L.0047 COMMON JPOIN(5), MES(20,8), MON(12,3), NAT, NATIN(5,2), NISS, NTEAM,
L.0048 1SDPOS(25), LIM(5,5,2), NAID(5), NPRPOS(11)
L.0049 DO 10 NAT=1,5
L.0050 ND(NAT)=0
L.0051 TOUT=0.0
L.0052 TIN=0.0
L.0053 TAID=0.0
L.0054 DO 11 I=1,5
L.0055 IF(NAT-J) 12,11,12
L.0056 12 TIN=TIN+FLOW(J,NAT)
L.0057 TOUT=TOUT+FLOW(NAT,J)
L.0058 TAID=TAID+AID(NAT,J)
L.0059 11 CONTINUE
L.0060 TFLOW=TOUT+TIN
L.0061 RATIO=-BAL(NAT)/TFLOW
L.0062 IF(RATIO-.1) 13,14,14
L.0063 14 IF(TAID) 9,9,40
L.0064 40 REST=BAL(NAT)/TAID*(-1)
L.0065 REST1=AMIN(REST,1.0)
L.0066 DO 41 I=1,5
L.0067 IF(NAT-I) 42,41,42
L.0068 42 IAID=AID(NAT,I)*REST1
L.0069 IAID=MIN(IAID,5)
L.0070 IF(IAID) 41,41,43
L.0071 43 IAID=AID(NAT,I)-IAID
L.0072 CALL FILLQ(I,40,IAID,100)
L.0073 BAL(NAT)=BAL(NAT)+IAID
L.0074 41 CONTINUE
L.0075 RATIO=-BAL(NAT)/TFLOW
L.0076 IF(RATIO-.1) 10,9,9
L.0077 9 REST1=-BAL(NAT)/TIN
L.0078 REST=AMIN(REST1,.05)
L.0079 DO 15 J=1,5
L.0080 I=(NAT-J) 16,15,16
L.0081 16 IREST=REST*100+REST1(NAT,J)
L.0082 IREST1=MIN(IREST,LIM(NAT,J,2))
L.0083 IF(REST1(NAT,J)-IREST1) 50,15,15
L.0084 50 CALL FILLQ(J,50,IREST1,100)
L.0085 15 CONTINUE

```

```

L.0086      IF(REST1-.25)10,17,17
L.0087      17 ND(NAT)=(REST1-.1)*TIN
L.0088      GO TO 10
L.0089      13  REST1=BAL(NAT)-.05*TFLOW
L.0090      IF(REST1) 10,10,18
L.0091      18  REST=BAL(NAT)/TIN
L.0092      REST2=AMIN(REST,.05)
L.0093      REST1=REST1-REST2*TIN
L.0094      REST2=REST2*100
L.0095      DO 30 J=1,5
L.0096      IF(NAT-J) 31,30,31
L.0097      31  IREST=REST1(NAT,J)-REST2
L.0098      IREST=MAX(IREST,LIM(NAT,J,1))
L.0099      IF(IREST-LIM(NAT,J,1)) 30,30,70
L.0100      70  CALL FILLQ(J,50,IREST,100)
L.0101      30  CONTINUE
L.0102      IF(REST1) 10,10,35
L.0103      35  TAFF=0.0
L.0104      DO 19 J=1,5
L.0105      REF(J)=0.0
L.0106      IF(NAT-J) 20,19,20
L.0107      20  IF(NAID(J)) 19,19,21
L.0108      21  IF(AFFCT(NAT,J)-1) 19,19,22
L.0109      22  IF(AFFCT(J,NAT)-1) 19,19,23
L.0110      23  REF(J)=1.0
L.0111      TAFF=TAFF+AFFCT(NAT,J)
L.0112      19  CONTINUE
L.0113      IF(TAFF) 10,10,24
L.0114      24  DO 25 J=1,5
L.0115      IF(REF(J)-1.0) 25,26,25
L.0116      26  IAID=REST1*AFFCT(NAT,J)/TAFF
L.0117      IAID=MIN(IAID,NAID(J))
L.0118      IAID=MIN(IAID,5)
L.0119      IAID=AID(NAT,J)+IAID
L.0120      CALL FILLQ(J,40,IAID,100)
L.0121      NAID(J)=NAID(J)-IAID
L.0122      25  CONTINUE
L.0123      10  CONTINUE
L.0124      DO 5 I=1,5
L.0125      5  NAID(I)=ND(I)
L.0126      RETURN
L.0127      END

```

```

L.0001 /FTC SVDECK
L.0002 SUBROUTINE CHPOS
L.0003 COMMON AFFCT(5,5),AID(5,5),APOS(11),BAL(5),OLBAL(5,2),DEP(5,5),
L.0004 1FLEX(11),FLOW(5,5),GNP(5),PCONG(11,4),PELEC(11),PIAFF(11,5),
L.0005 2PIPOS(25,11),PIR(11,50),PISAL(25,11),PISUP(11),POS(25,5),
L.0006 3POW(25,5),RESTI(5,5),RNATU(5,5),RPOS(11),SAL(25,5),TREND(5,5),
L.0007 4RA(5,5),IBUF(3,11),ICARD(80),ICOUN, IEXIT, ILOC, IN, INIT, IOUT,
L.0008 5IPASS(10), IPOIN, IQUE1(5,50,4), IQUE2(5,50,4), IRND, IX, JMONT, JYEAR
L.0009 COMMON JPOIN(5),MES(20,8),MON(12,3),NAT,NATIN(5,2),NISS,NTEAM,
L.0010 1SDPOS(25),LIM(5,5,2),NAID(5),NPRPOS(11)
L.0011 DIMENSION PPOS(5),REF(5),IDF(5)
L.0012 DO 1 I=1,NISS
L.0013 1 SDPOS(I)=POS(I,1)
L.0014 DO 50 NN=1,NISS
L.0015 IF(SAL(NN,1))50,50,10
L.0016 10 PP=0.0
L.0017 PPW=0.0
L.0018 DO 11 I=1,5
L.0019 PP=PP+POW(NN,I)
L.0020 11 PPW=PPW+POW(NN,I)*POS(NN,I)
L.0021 PPW=PPW/PP
L.0022 IF(ABS(PPW)-7)13,12,12
L.0023 12 CALL ELIM(PPW,NN)
L.0024 GO TO 50
L.0025 13 DO 25 INIT=1,5
L.0026 IDF(INIT)=0
L.0027 14 REF(INIT)=0.0
L.0028 TOTREF=0.0
L.0029 DO 20 NAT=1,5
L.0030 IF(INIT-NAT)15,20,15
L.0031 15 REF(NAT)=(ABS(AFFCT(INIT,NAT))+ABS(AFFCT(NAT,INIT))+SAL(NN,NAT))
L.0032 1/SAL(NN,INIT)-2
L.0033 REF(NAT)=AMAX(0.0,REF(NAT))
L.0034 TOTREF=TOTREF+REF(NAT)
L.0035 20 CONTINUE
L.0036 PPW=POS(NN,INIT)
L.0037 IF(TOTREF)9,25,9
L.0038 9 DO 21 NAT=1,5
L.0039 IF(INIT-NAT)16,21,16
L.0040 16 IF(SAL(NN,INIT)-5)17,18,18
L.0041 17 IDF(NAT)=SAL(NN,INIT)**2*(-.2)+(10.0-AFFCT(INIT,NAT))*8.0*
L.0042 1SAL(NN,INIT)**2/400.0+10.0
L.0043 GO TO 21
L.0044 18 IDF(NAT)=SAL(NN,INIT)**2*(-.2)+2.0*SAL(NN,INIT)-(AFFCT(INIT,NAT)
L.0045 1-10.0)*(.4*SAL(NN,INIT)**2-4.0*SAL(NN,INIT)+20.0)/20.0
L.0046 21 CONTINUE
L.0047 DO 22 NAT=1,5
L.0048 IF(POS(NN,INIT)-POS(NN,NAT))28,29,30
L.0049 28 PPOS(NAT)=POS(NN,NAT)-IDF(NAT)
L.0050 GO TO 22
L.0051 30 PPOS(NAT)=POS(NN,NAT)+IDF(NAT)
L.0052 GO TO 22
L.0053 29 CALL RANDU(RAND)
L.0054 RAND=RAND-.5
L.0055 IF(RAND-ABS(RAND))28,30,22

```

```

L.0056 22 CONTINUE
L.0057 DO 35 NAT=1,5
L.0058 35 PPW=PPW+PPOS(NAT)*REF(NAT)
L.0059 PPW=PPW/TOTREF
L.0060 PPW=PPW-POS(NN,INIT)
L.0061 PPW=AMIN(+2.0,PPW)
L.0062 PPW=AMAX(-2.0,PPW)
L.0063 IPOS=POS(NN,INIT)+PPW
L.0064 IPOS=MIN(10,IPOS)
L.0065 IPOS=MAX(-10,IPOS)
L.0066 23 IF(INIT-1)36,37,36
L.0067 37 SDPOS(NN)=IPOS
L.0068 GO TO 25
L.0069 36 NAT=INIT
L.0070 CALL FILLQ(NN,IPOS,0,300)
L.0071 25 CONTINUE
L.0072 50 CONTINUE
L.0073 RETURN
L.0074 END

```

```

L.0001 /FTC SVDECK
L.0002 SUBROUTINE DPOL
L.0003 COMMON AFFCT(5,5),AID(5,5),APCS(11),BAL(5),OLBAL(5,2),DEP(5,5),
L.0004 1FLEX(11),FLOW(5,5),GNP(5),PCONG(11,4),PELEC(11),PIAFF(11,5),
L.0005 2PIPOS(25,11),PIR(11,50),PISAL(25,11),PISUP(11),POS(25,5),
L.0006 3POW(25,5),RESTI(5,5),RNATU(5,5),RPOS(11),SAL(25,5),TREND(5,5),
L.0007 4RA(5,5),RUF(3,11),ICARD(80),ICOUN,IEXIT,ILOC,IN,INIT,IOUT,
L.0008 5IPASS(10),IPOIN,IQUE1(5,50,4),IQUE2(5,50,4),IRND,IX,JMONT,JYEAR
L.0009 COMMON JPOIN(5),MES(20,8),MON(12,3),NAT,NATIN(5,2),NISS,NTEAM,
L.0010 1SDPOS(25),LIM(5,5,2),NAID(5),NPRPOS(11)
L.0011 DIMENSION SUP(11),NBIAS(2),ITYPE(3)
L.0012 DIMENSION IPN(11)
L.0013 DATA IPN/'XLIB','MLIB','MCON','XCON','TREA','SD','DOD',
L.0014 1'NAEC','INEC','HARD','SOFT'/
L.0015 DATA ITYPE/'EC','PR','P',/NBIAS/2,4/
L.0016 K1=20
L.0017 K2=400
L.0018 K3=20
L.0019 K4=10
L.0020 K5=20
L.0021 KK1=1
L.0022 KK2=2
L.0023 KK3=1
L.0024 KK4=1
L.0025 KK5=20
L.0026 NW=0
L.0027 NTOT=0
L.0028 DO 399 IPI=1,11
L.0029 DO 400 I=1,50
L.0030 IF(PIR(IPI,I)) 400,406,400
L.0031 406 IF(IQUE1(1,I,1))400,400,407
L.0032 407 CONTINUE
L.0033 311 IROUT=IQUE1(1,I,4)/99
L.0034 GO TO(401,402,403),IROUT
L.0035 401 ITAR=IQUE1(1,I,1)
L.0036 IAREA=IQUE1(1,I,2)
L.0037 IAMT=IQUE1(1,I,3)
L.0038 IROUT=IAREA/10-3
L.0039 GO TO (520,510),IROUT
L.0040 510 A=(RPOS(IPI)-PIAFF(IPI,ITAR))/3.
L.0041 B=AMAX(1.,ABS(A))
L.0042 PIR(IPI,I)=A+A/B+IAMT*(IAMT-OLBAL(ITAR,1))/60.
L.0043 CALL SQUASH(10.,0.,PIR(IPI,I),1.)
L.0044 GO TO 400
L.0045 520 A=(APOS(IPI)+PIAFF(IPI,ITAR))/3.
L.0046 B=AMAX(1.,ABS(A))
L.0047 PIR(IPI,I)=A+A/B*(IAMT-OLBAL(ITAR,2))
L.0048 CALL SQUASH(10.0,0.0,PIR(IPI,I),1.0)
L.0049 GO TO 400
L.0050 402 IACT=IQUE1(1,I,3)
L.0051 ISSUE=IQUE1(1,I,2)
L.0052 ITAR=IQUE1(1,I,1)
L.0053 NTOT=NTOT+1
L.0054 IF(IABS(IACT)-3) 408,408,409
L.0055 409 NW=NW+1

```



```

L.0056 408 P1=NPRPOS(IPI)-IACT
L.0057 P2=PIAFF(IPI,ITAR)*IACT/K4
L.0058 DIFF=(ABS(PIPOS(ISSUE,IPI)-POS(ISSUE,1)))-ABS(PIPOS(ISSUE,IPI)-POS
L.0059 1(ISSUE,ITAR))
L.0060 P3=DIFF*IACT/K5
L.0061 PIR(IPI,1)=P1*ARS(P1)P2*ARS(P2)+P3*ABS(P3)
L.0062 CALL SQUASH(10.0,0.0,PIR(IPI,1),10.0)
L.0063 GO TO 400
L.0064 403 ISSU=IQUF1(1,1,1)
L.0065 IPOS=IQUE1(1,1,2)
L.0066 PIR(IPI,1)=10.-(IPOS-PIPOS(ISSUE,IPI))*2
L.0067 1*PISAL(ISSUE,IPI)/50.
L.0068 CALL SQUASH(10.,0.,PIR(IPI,1),1.)
L.0069 400 CONTINUE
L.0070 399 CONTINUE
L.0071 DO 501 IPI=1,11
L.0072 DO 501 I=1,50
L.0073 IF(PIR(IPI,I)) 502,501,503
L.0074 502 PIR(IPI,I)=AMAX(PIR(IPI,I),-10.0)
L.0075 GO TO 501
L.0076 503 PIR(IPI,I)=AMIN(PIR(IPI,I),10.0)
L.0077 501 CONTINUE
L.0078 507 NTOT=MAX(NTOT,1)
L.0079 W=NW*1./NTOT
L.0080 W=DEF(W,0.4,NTOT,3)
L.0081 TOT=1.-W
L.0082 508 POSPIR=0
L.0083 NPOS=0
L.0084 ECPIR=0.0
L.0085 NEC=0
L.0086 PRPIR=0.0
L.0087 NPR=0
L.0088 DO 51 IPI=1,11
L.0089 DO 50 J=1,50
L.0090 IF(IQUE1(1,J,1))53,53,52
L.0091 52 IROUT=IQUE1(1,J,4)/99
L.0092 GO TO(61,62,63),IROUT
L.0093 61 ECPIR=ECPIR+PIR(IPI,J)
L.0094 NEC=NEC+1
L.0095 GO TO 50
L.0096 62 PRPIR=PRPIR+PIR(IPI,J)
L.0097 NPR=NPR+1
L.0098 GO TO 50
L.0099 63 POSPIR=POSPIR+PIR(IPI,J)
L.0100 NPOS=NPOS+1
L.0101 50 CONTINUE
L.0102 53 NEC=MAX(1,NEC)
L.0103 NPR=MAX(1,NPR)
L.0104 NPOS=MAX(1,NPOS)
L.0105 ECPIR=ECPIR/NEC
L.0106 PRPIR=PRPIR/NPR
L.0107 POSPIR=POSPIR/NPOS
L.0108 ECPIR=DEF(ECPIR,3.,NEC,0)
L.0109 PRPIR=DEF(PRPIR,3.,NPR,0)
L.0110 POSPIR=DEF(POSPIR,3.,NPOS,0)

```

```

L.0111      SUP(IPI)=(ECPIR+PRPIR+POSPIR)/3
L.0112      CALL SQUASH(10.,0,SUP(IPI),0.1)
L.0113      312 PISUP(IPI)=TOT*PISUP(IPI)+W*SUP(IPI)
L.0114      51  CONTINUE
L.0115      DO 70 NN=1,NISS
L.0116      DO 75 IPI=5,11
L.0117      PP=999.
L.0118      IF ((PISAL(NN,IPI)-5.)*2-10) 76,75,75
L.0119      76  IF(PISAL(NN,IPI)-5.0)77,77,78
L.0120      77  IDF=PISAL(NN,IPI)**2*(-.2)+(10.0-PISUP(IPI)*8.0*PISAL(NN,IPI)
L.0121      1**2)/20.0+10.0
L.0122      GO TO 79
L.0123      78  IDF=PISAL(NN,IPI)**2*(-.2)+2.0*PISAL(NN,IPI)-PISUP(IPI)-10.0*
L.0124      1(.4*PISAL(NN,IPI)**2-4.0*PISAL(NN,IPI)+200)/21
L.0125      79  PP=PIPOS(NN,IPI)
L.0126      IF (POS(NN,1)-PIPOS(NN,IPI)) 81,82,80
L.0127      80  PPPS=POS(NN,1)-IDF
L.0128      GO TO 315
L.0129      81  PPPS=POS(NN,1)+IDF
L.0130      GO TO 315
L.0131      82  CALL RANDU(RAND)
L.0132      RAND=RAND-.5
L.0133      IF (RAND-ABS(RAND))80,81,75
L.0134      315  PPPS=PPPS-PIPOS(NN,IPI)
L.0135      PPPS=AMAX(PPPS,-2.)
L.0136      PPPS=AMIN(PPPS,2.)
L.0137      PIPOS(NN,IPI)=PIPOS(NN,IPI)+PPPS
L.0138      75  CONTINUE
L.0139      70  CONTINUE
L.0140      DO 100 I=1,4
L.0141      DO 101 NN=1,NISS
L.0142      POWTOT=0.0
L.0143      PP=PIPOS(NN,I)
L.0144      PIPOS(NN,I)=0.0
L.0145      DO 102 K=5,11
L.0146      PIPOS(NN,I)=PIPOS(NN,I)+PIPOS(NN,K)*PCONG(K,I)
L.0147      102  POWTOT=POWTOT+PCONG(K,I)
L.0148      PIPOS(NN,I)=PIPOS(NN,I)/POWTOT
L.0149      101  CONTINUE
L.0150      100  CONTINUE
L.0151      201  WRITE(IOUT,1001)
L.0152      1001  FORMAT('ORREPORT OF THE PRESIDENTIAL ADVISORS FOR '
L.0153      1'DOMESTIC POLITICAL RELATIONS')
L.0154      203  WRITE(IOUT,1003) (MON(JMONTH,K),K=1,3) ,JYEAR
L.0155      1003  FORMAT(' ',3A4,14)
L.0156      WRITE(IOUT,1007)
L.0157      1007  FORMAT('OPI GROUP ACT SPECIFICATIONS PI RESPONSE'/)
L.0158      DO 204 IPI=1,11
L.0159      N=0
L.0160      DO 205 IRSP=1,50
L.0161      IF(IQUE1(1,IRSP,1))206,205,206
L.0162      206  CALL RANDU(RAND)
L.0163      IROUT=IQUE1(1,IRSP,4)/100
L.0164      GO TO (876,877,876),IROUT
L.0165      876  PINCL=ABS(PIR(IPI,IRSP))*RAND/10.

```

```

L.0166      GO TO 878
L.0167      877 PINCL=PIR(IPI,IRSP)**2*RAND/100.
L.0168      878 IF (PIR(IPI,IRSP)) 222,222,223
L.0169      222 IF(PINCL-.5)205,210,210
L.0170      223 IF(PINCL-.1)205,210,210
L.0171      210 IF(N-1)240,241,241
L.0172      240 WRITE(IOUT,1004) IPI,IPN(IPI)
L.0173      1004 FORMAT('0',I2,2X,A4)
L.0174      N=N+1
L.0175      241 IROUT=IQUE1(1,IRSP,4)/99
L.0176      PIRESP=PIR(IPI,IRSP)
L.0177      IRESP=AMIN(10.,PIRESP)
L.0178      IRESP=AMAX(-10.,PIRESP)
L.0179      WRITE(6,1005) ITYPE(IROUT),(IQUE1(1,IRSP,K),K=1,3),IRESP
L.0180      1005 FORMAT(I2X,A4,3I4,5X,I4)
L.0181      205 CONTINUE
L.0182      204 CONTINUE
L.0183      TOTPOL=0.0
L.0184      POLWT=0.0
L.0185      DO 300 IPI=1,11
L.0186      TOTPOL=PELEC(IPI)+TOTPOL
L.0187      300 POLWT=POLWT+PISUP(IPI)*PELEC(IPI)
L.0188      TOTPOL=POLWT/TOTPOL
L.0189      NABS=TOT/3*100
L.0190      NYES=TOTPOL+60-NABS/2
L.0191      NNO=100-NABS-NYES
L.0192      WRITE(IOUT,1111) NYES,NNO,NABS
L.0193      1111 FORMAT('0PUBLIC OPINION POLL QUESTION :'/
L.0194      1'0"DO YOU AGREE WITH THE GENERAL POLICIES OF '
L.0195      2'THIS ADMINISTRATION ?"/' % YES % NO'
L.0196      3' % NO ANSWER'/6X,I2,8X,I2,12X,I2)
L.0197      CALL ATCHG
L.0198      RETURN
L.0199      END

```

```

SUBROUTINE FFAN(A,D,N,NW)
  DIMENSION A(1),D(3),K(10),IS(3),IC(3),IA(40)
  DATA K/'0','1','2','3','4','5','6','7','8','9'/
  DATA KB,KP,KM/' ','.','-'/
  INTEGER A

```

```

DO 50 I=1,3
  IS(I)=1
  IC(I)=0
  D(I)=0.
50 CONTINUE
  A(1)=KB

  READ(9,1) (IA(I),I=1,40)
1  FORMAT(40A1)
  N=1
  DO 100 I=1,40
    L=IA(I)
    IF (L-KB) 7,2,7
2  IF (I-1) 3,100,3
3  IF (IA(I-1)-KB) 5,100,5
5  N=N+1
    GO TO 100
7  IF (L-KP) 9,8,9
8  IA(I)=KB
    IF (I-1) 5,100,5
9  IF (L-KM) 11,10,11
10 IS(N)=-1
    IA(I)=KB
    GO TO 100
11 IF (L.EQ.K(1)) GO TO 20
    IF (L.EQ.K(2)) GO TO 21
    IF (L.EQ.K(3)) GO TO 22
    IF (L.EQ.K(4)) GO TO 23
    IF (L.EQ.K(5)) GO TO 24
    IF (L.EQ.K(6)) GO TO 25
    IF (L.EQ.K(7)) GO TO 26
    IF (L.EQ.K(8)) GO TO 27
    IF (L.EQ.K(9)) GO TO 28
    IF (L.EQ.K(10)) GO TO 29
    A(1)=IA(I)
  RETURN

```

```
20 L=0
   GO TO 99
21 L=1
   GO TO 99
22 L=2
   GO TO 99
23 L=3
   GO TO 99
24 L=4
   GO TO 99
25 L=5
   GO TO 99
26 L=6
   GO TO 99
27 L=7
   GO TO 99
28 L=8
   GO TO 99
29 L=9
99 IC(N)=IC(N)*10 + L
100 CONTINUE
    DO 110 I=1,3
    D(I)=IC(I)*IS(I)
110 CONTINUE
    RETURN
    END
```

Definitions of the PRINCE COMMON Variables

AFFCT	Attitude of one nation to another
AID	Aid grants
APOS	Attitudes toward aid of the PI groups
BAL	Balance of Payments
OLBAL	Previous transaction flows
DEP	Inter-nation dependence
FLEX	Willingness of the PI groups to change attitudes
FLOW	Transactions flows
GNP	Gross national products
PCONG	Power to elect congressmen of the PI groups
PELEC	Electoral power of the PI groups
PIAFF	PI groups' attitudes toward the nations
PIPOS	Issue positions of the PI groups
PIR	Responses of the PI groups
PISAL	PI groups' support for the government
POS	Issue positions of the nations
POW	Issue "power" of the nations
RESTI	Import restrictions
RNATU	"Natural" transaction flows
RPOS	Attitude of the PI groups on restrictions
SAL	Salience of an issue to a nation
TREND	Secular trend of flows
RA	Relative acceptance

Variables not used by the conversational version: IBUF, ICARD, ICOUN,
ILOC, IN, IPASS, MES

INIT	Nation initiating act
IEXIT	Input error code
IN	Input unit number (5, card input; 9, terminal input)
IOUT	Output unit number (6, terminal output)
IQUE1	Current acts
IQUE2	Future acts
IRND	Cycle (or round) number
IX	Seed for random number generator
JMONT	Current month
JYEAR	Current year
NAT	Nation responding to act
NATIN	Names of nations
NISS	Number of issues
NTEAM	Team identification number
SDPOS	Issue positions of the State Department
LIM	Limits on restrictions
NAID	Amount of aid needed by the nations
NRPOS	Preferred PR position by the PI groups

Corporate Offices: 225 Santa Monica Boulevard, Santa Monica, California 90401, Telephone (213) 451-5771
New York Offices: 2 West 45th Street, New York, New York 10036, Telephone (212) 661-7330
Washington, D.C. Offices: 1815 North Fort Myer Drive, Arlington, Virginia 22209, Telephone (703) 527-8012