

AD 728907

MRC
Medical Research Council

Royal Naval Personnel Research Committee

**USE OF CADAVER EARS IN THE ACOUSTIC
EVALUATION OF EAR PLUGS**

by

M R Forrest

and

R R A Coles

D D C
RECEIVED
SEP 3 1971
D

Report prepared

for the

HEARING SUB-COMMITTEE

of the

RNPRC

Requests for permission to publish any of the material contained in this document, and enquiries concerning patent etc., rights therein, should be addressed to the Director Naval Research and Development Administration, Ministry of Defence, quoting the NSTIC No.

October 1969

NATIONAL TECHNICAL
INFORMATION SERVICE

SUMMARY

The attenuation provided by several types of ear plug in common use, and by an experimental amplitude-sensitive plug under development at the Institute of Naval Medicine, has been examined for both pure-tones and high level impulses using cadaver-ear techniques. The objective measurements with pure tones up to 110 dB are in fair agreement with those of conventional methods. The attenuation for impulses is shown to increase with peak pressure level in the case of the experimental plug, but to remain constant in that of the ordinary V. 51R plug.

CONTENTS

	<u>Page</u>
SUMMARY	
INTRODUCTION	1
METHOD	
i. Anatomical Preparation .	2
ii. Acoustical Technique .	2
iii. Ear Plug Types used .	7
RESULTS	
i. Details of Cadavers used.	12
ii. Ear Plug Performance with Pure Tones.	12
iii. Ear Plug Performance with Impulses.	17
DISCUSSION	
i. Cadaver Ears as a Method of Ear Plug Evaluation.	17
ii. Ear Plug Attenuation Characteristics.	35
ACKNOWLEDGEMENTS	36
REFERENCES	36
FIGURES	
1 Details of Cadaver Ear Preparation	3
2a Microphone Mounting	4
2b General Arrangement of Apparatus	5
2c Apparatus for Continuous Recording of Pure Tone Attenuation	6
3 Method of Calculating Impulse Attenuation	8
4 Types of Ear Plug used	9
5 Median Values of Ear Drum Impedance	14
6 Open Ear Responses	15
7a-h Attenuation of Different Types of Plug	18-25
8 Impulse Noise Waveforms	28
9a-h Data from Cadavers	29-33
TABLES	
I Ear Drum Impedance Data	13
II Open Ear Responses to Pure Tones	16
III Attenuation of Experimental Amplitude-Sensitive Ear Plugs in dB	26
IV Attenuation of Sonex Ear Plugs, in dB	27

INTRODUCTION

With the increasing realisation of the damaging effects of noise on hearing, a considerable variety of ear protectors has become available. One much favoured type is the ear plug, fitted into the outer part of the external auditory meatus and thus reducing the noise reaching the ear drum.

When placed in an "artificial ear" coupler a solid ear plug exhibits an impressively high attenuation, as might be expected. When placed in the meatus of a real ear the attenuation appears to be very much less. This again is to be expected, as the meatus is lined with cartilage and skin which may move in response to the sound-induced movements of the pinna, or which may allow a plunger-like action of the plug as a whole; also, the plug may fail to make a good seal, in which case the resulting leak will drastically reduce the attenuation at low frequencies.

The majority of ear plug attenuation measurements have therefore been carried out using real ears. As microphones cannot be introduced into the plugged ear without doing violence to the plug or to the ear, or to the proper seal between the two, the ear drum itself is used as the measuring microphone. The subject's hearing threshold is determined, preferably binaurally in a free-field, with and without the plugs; or a loudness-balance method may be used. To allow for the many sources of error inherent in such audiometric procedures, a large number of subjects must be examined. The results are generally expressed as the mean value and standard deviation of the attenuation of each frequency used, though expression in terms of median values, interquartile and 10-90% decile ranges would be more appropriate where the number of observations justifies this.

It is usually assumed that the performance of an ear plug is linear, that is, the attenuation does not vary with sound pressure, so that results for attenuation measurements at low levels will also apply at the high levels where ear protection is needed. For the very high levels associated with, for instance, gunfire noise, this assumption cannot in fact be justified.

Thus the common approaches to measurement of ear plug attenuation are not wholly satisfactory. Artificial ears, while yielding precise results at a variety of sound pressure levels and being useful in development of plugs which give low attenuation under certain conditions, for instance frequency or amplitude-sensitive types, do not adequately simulate those properties of the meatus which limit the maximum attenuation. The use of real ears is cumbersome and is only possible at threshold or relatively low sound pressure levels.

In order to fill this gap it was decided to use ears from fresh cadavers with a small microphone introduced through the postero-superior wall of the deeper bony part of the meatus so that its sensitive surface rested flush with the meatus wall near to the intact ear drum; objective results could then be obtained, for both pure tones and impulse noises, at a wide variety of sound pressure levels. This was especially valuable as some of the types of ear plug under test were designed to be amplitude-sensitive so that the attenuation would increase at high sound pressure levels.

METHOD

i. Anatomical Preparation

Cadavers were used following the course of a normal post-mortem where the skull roof and brain are removed, thus giving access to the internal aspects of the skull.

Any cerumen in the ear canal was removed and the ear drum examined for normality of appearance and mobility. The impedance at the ear drum was measured using the acoustic bridge designed by Zwislocki^{1,2}. A metal sleeve was then inserted from within the cranial cavity through a hole drilled down and slightly anteriorly through the squamo-petrous suture so that the lower end of the sleeve was flush with the skin of the external auditory meatus just lateral to the ear drum. A strong airtight fixing was made using dental cement further surrounded by plasticine and a tightly fitting Bruel and Kjaer $\frac{1}{4}$ -inch microphone was inserted in the sleeve. The preparation is illustrated diagrammatically in Figure 1 and photographically in Figure 2a; above the actual microphone (shown in Figure 2a) is a dummy one used as an obturator during insertion of the sleeve.

ii. Acoustical Technique

A monitoring microphone was placed close to the meatus entrance, just in front of the tragus, so that a comparison of the sound pressure levels at the ear canal entrance and near the ear drum could be obtained for both pure tones and impulses, with the ear canal open or blocked by different types of plug.

Figure 2b shows the general arrangement of cadaver and apparatus in the mortuary. The experimental arrangement used for continuous automatic recording of pure tone data is shown in Figure 2c, in which a Bruel and Kjaer artificial mouth was used as a sound source. The input Sound Pressure Level was generally set at between 90 and 110 dB, maintained at a constant level by a compressor circuit between the monitoring microphone placed just in front of the tragus, and the beat frequency oscillator powering the artificial mouth. Sound pressures of

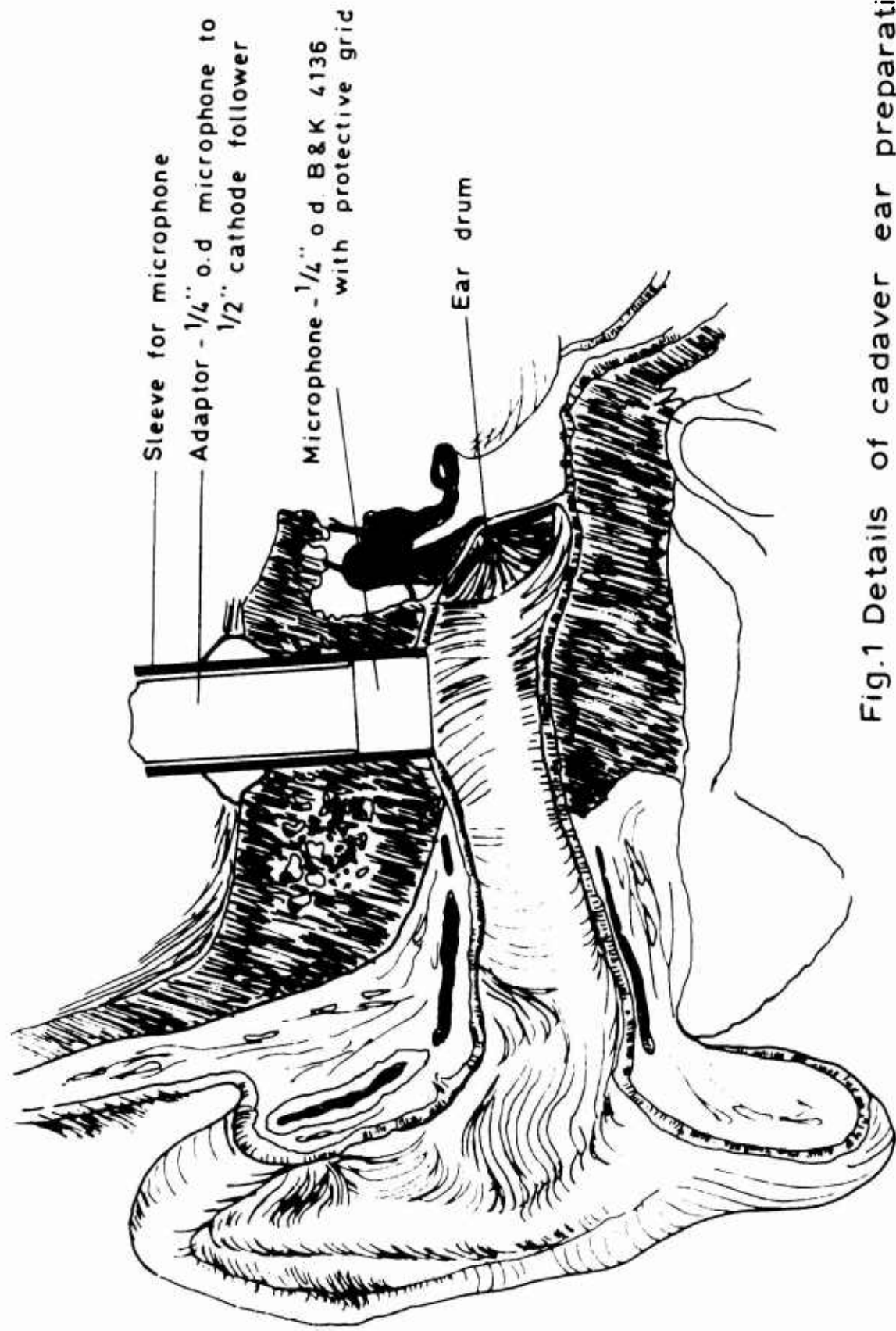

Fig.1 Details of cadaver ear preparation

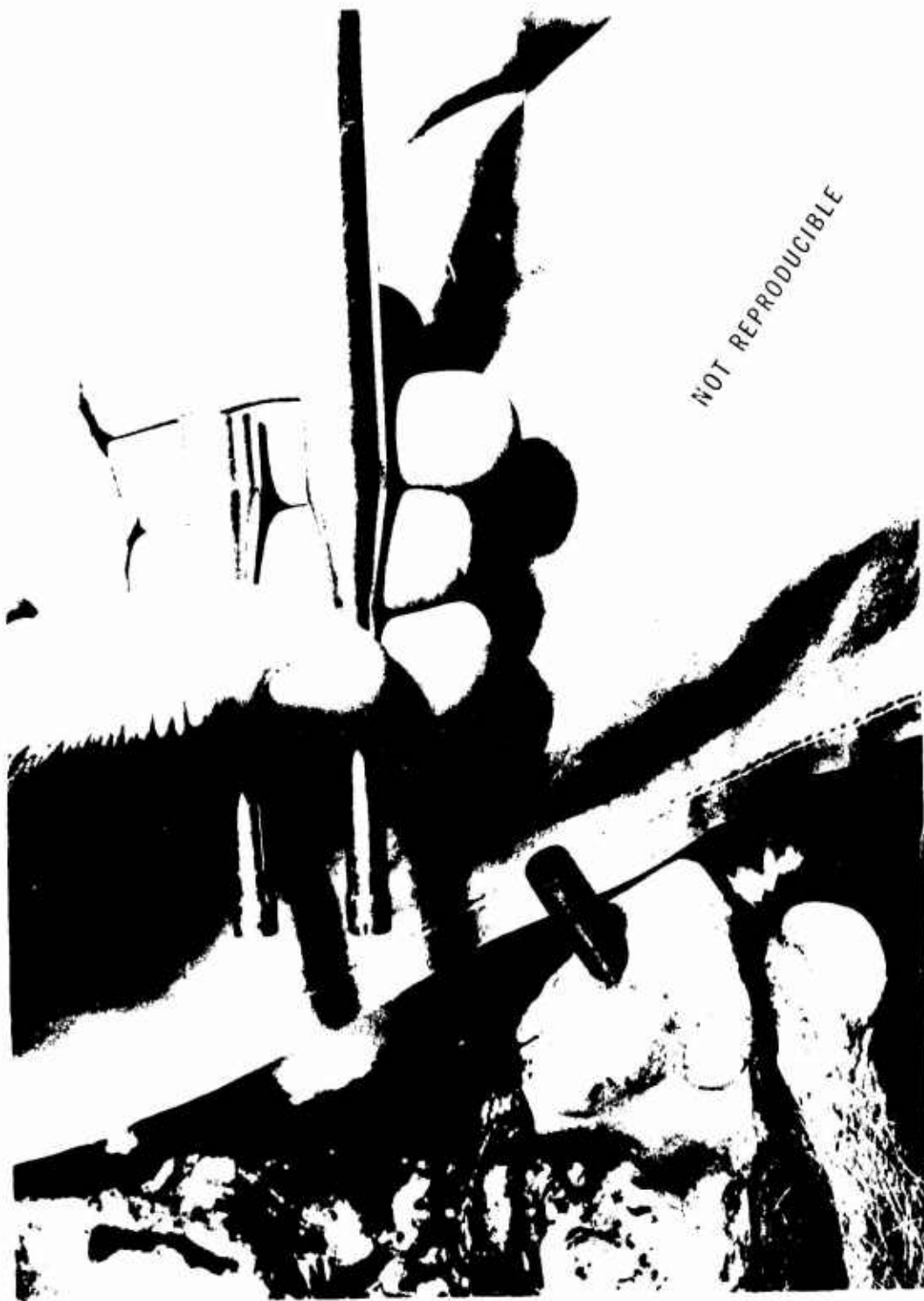

Fig. 2a Microphone mounting.



Fig. 2b General arrangement of apparatus

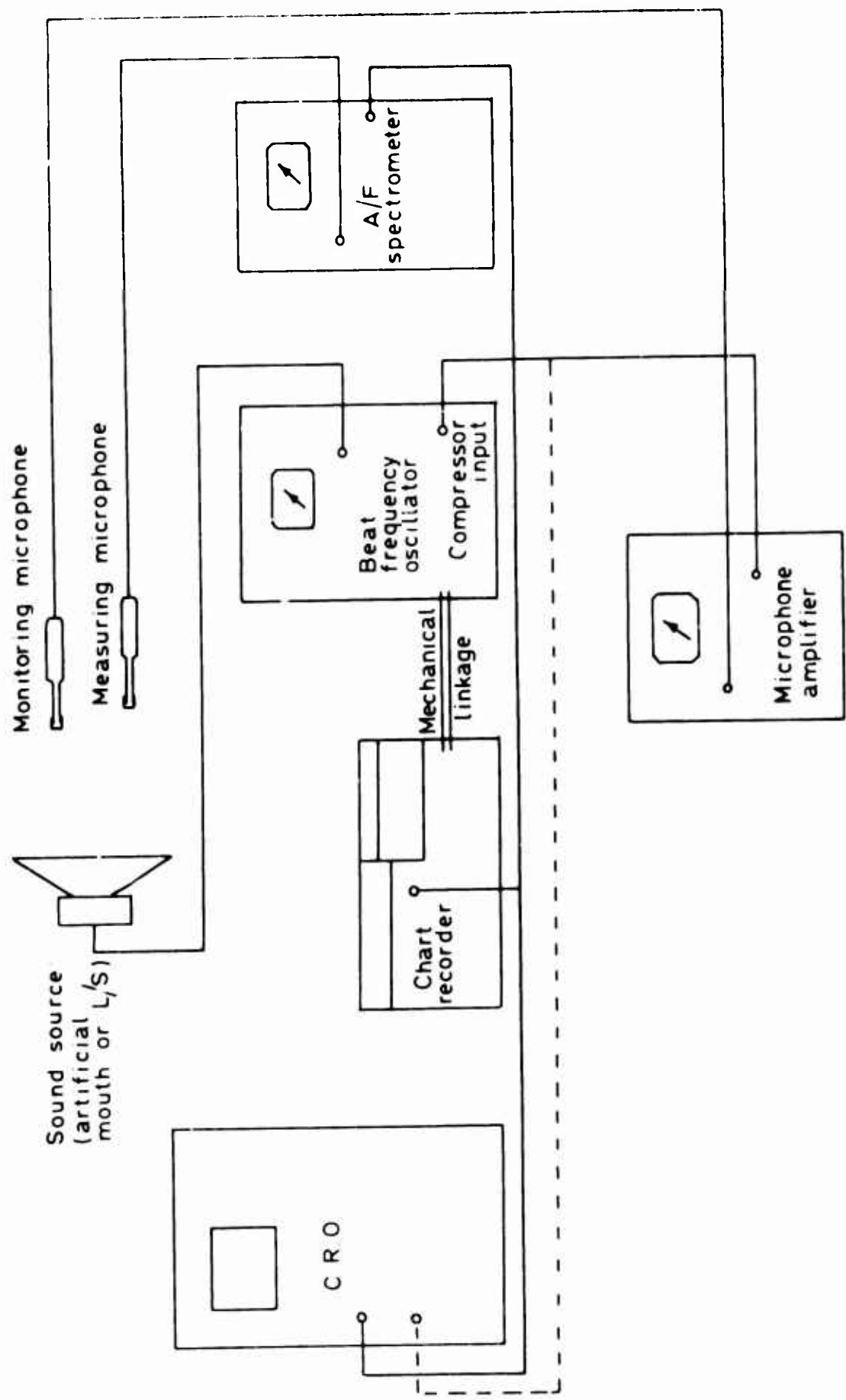

Fig. 2c Apparatus for continuous recording of pure tone attenuation

this level would not, on the basis of artificial -ear measurements, be expected to elicit any amplitude-sensitive properties in the plugs. The "raw data" therefore gave the relationship between the sound pressure at the canal entrance and at the ear drum. In deriving the attenuation of an ear plug the resonance of the open ear canal, i. e. without an ear plug, had to be taken into account also.

For cadavers 1, 2 and 3 a manual method of recording at discrete frequencies was used. For some of the subsequent ones a similar arrangement incorporating a 1/3-octave filter was used for recording at low levels.

For impulse noises a .32/.22-inch starting pistol was used as the sound source, giving peak pressure levels of 130-185 dB (ref. 2×10^{-4} dyn cm^{-2}) depending on size of cartridge and distance from the ear. A split-beam storage oscilloscope was used to record the pressure at the canal entrance and deep in the meatus simultaneously; this was necessary as the pressure waveforms produced by a given size of blank cartridge varied considerably.

The difference in pressures at the ear entrance and in the meatus was calculated using the total pressure excursion (+ to-) as shown in Figure 3, to give a more meaningful estimate of attenuation and to reduce experimental scatter.

In order to set an upper limit on the microphonic pick-up from the cathode follower of the microphone deep in the meatus, which is exposed to a sound level nearly equal to that at the ear canal entrance, the attenuation of an ear plug and ear muff combination was measured using both pure tones and impulses, and found to be comfortably higher than that for an ear plug alone. This confirmed the data in the Bruel and Kjaer handbook³ which showed that spurious microphony would probably be at too low a level to interfere with the results of attenuation measurements.

iii. Ear Plug Types used

The two ear plugs of most immediate interest were the Sonex plug and an experimental amplitude-sensitive type based on the Sonex. The opportunity was also taken to examine other types of ear plug; apart from providing a check on the results obtained using "live" and artificial ears, this also allowed some insight into their mode of operation. For instance if any particular type of plug gave much better attenuation in a given ear than other types, it would be very helpful to understand the mechanism allowing this. Most of the ear plugs are illustrated in Figure 4 and the details for each type are as follows:-

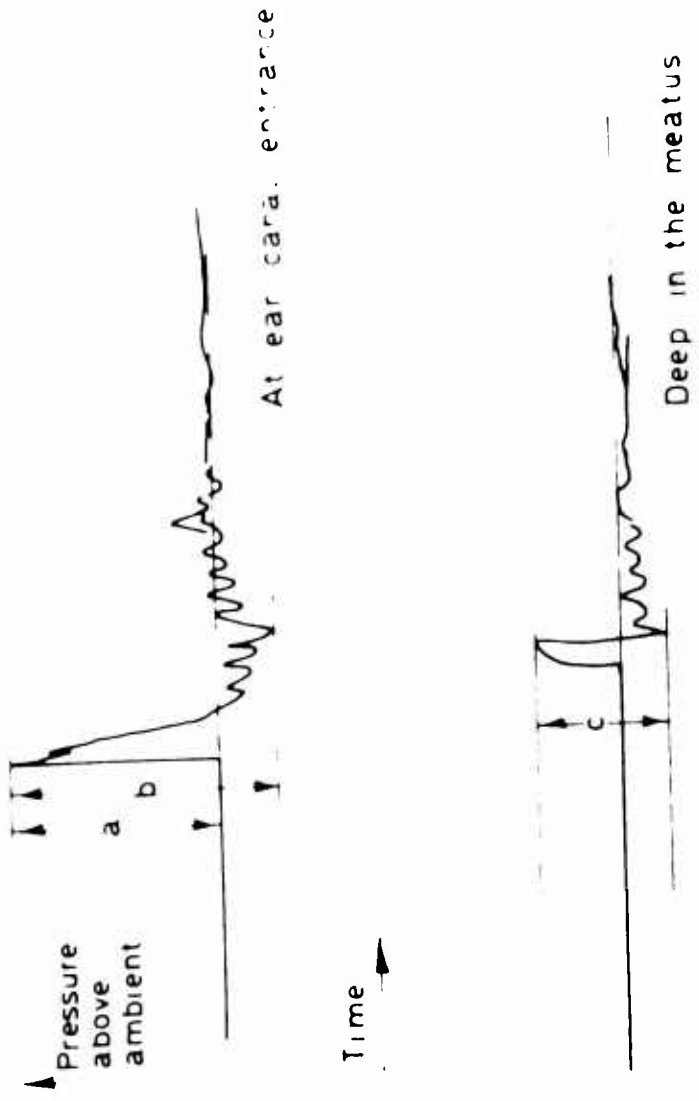
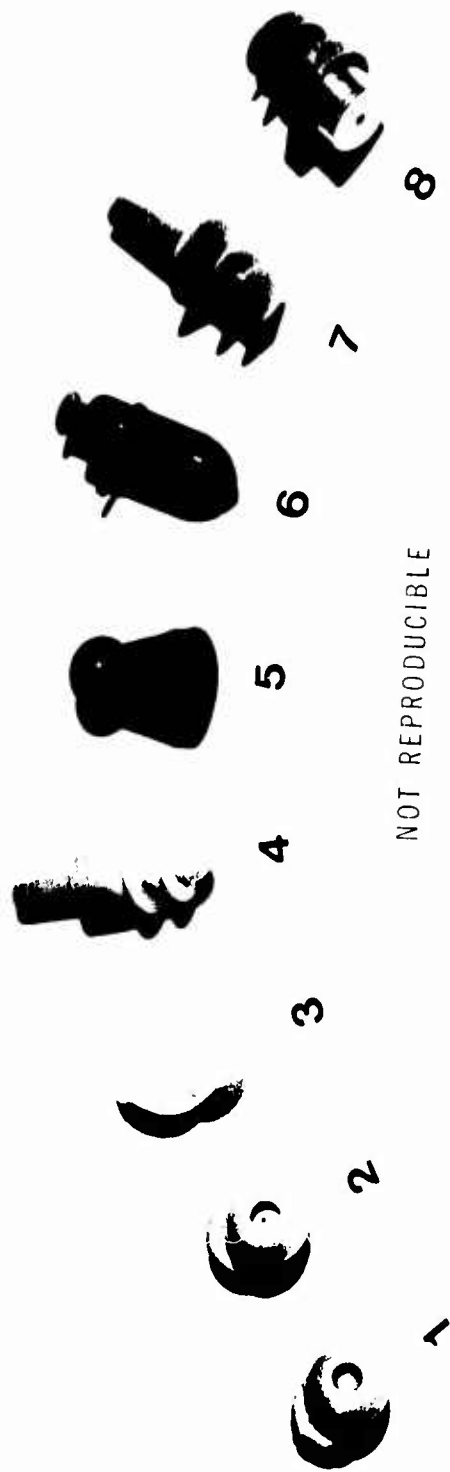

Fig 3 Method of calculating impulse attenuation
 Ratio of pressure excursions at ear canal entrance and deep in the meatus near the eardrum is calculated as 'b/c' for a peak pressure 'a' at the entrance.



NOT REPRODUCIBLE

Fig. 4 Types of ear plug used.

1. Sonex (Amplivox Ltd, Wembley, Middlesex). These are V. 51R-type pattern plugs moulded in a relatively stiff light brown plastic and currently available in three sizes. Their interest to us arose partly out of the widespread use (being a standard issue for HM Forces) and partly because they served as a basis for the experimental plugs described below.
2. Experimental Amplitude-Sensitive Ear Plugs (INM plugs). These are Sonex plugs with the core removed and replaced by a disc of 0.005 inch steel shim pierced by a 0.025 inch diameter orifice. At low sound pressure levels the attenuation is much less than for a "solid" plug like the Sonex, especially at low frequencies. At the very high levels associated with high intensity impulse noise, the flow through the orifice becomes turbulent and the resistance to flow is increased; at extremely high levels the attenuation should be comparable to that of the normal Sonex.
3. MSA (Mine Safety Appliances Inc., Pittsburgh, Pa). Like the Sonex this plug is of the V. 51R type but is made of a much softer, white plastic. It is available in five sizes.
4. Willson Sound Silencer (Richard Manufacturing Co, Van Nuys, Calif). This rather ingenious ear plug uses an air filled bung with two soft flanges in an attempt to provide a good fit for all sizes of ear canal with one size of plug.
5. Mallock-Armstrong (Anticooustic Ltd, Guildford, Surrey). This plug uses an acoustic element in the form of a thin diaphragm sandwiched between two wire mesh screens, which apparently is claimed to provide a measure of amplitude sensitivity. The body of the plug is made of a hard black plastic, the bulb at the end being made in five sizes.
6. SMR (Surgical and Medical Research Inc, Los Angeles, Calif). This torpedo-shaped plug is made of a soft black plastic cover filled with liquid, and is available in several sizes. In spite of the softness of the plug, published studies⁴ have indicated that in live ears comfort and retention are poor.
7. Com-fit (Sigma Eng Co, Los Angeles, Calif). This plug is rather similar to the Sound Silencer but without air filling of the bung. A single size of plug is fitted with three flanges and thus is intended to fit all sizes of ear canal.

8. Lee-Sonic Ear Valv (Sigma Eng Co, Los Angeles, Calif). This plug is of considerable interest as the design incorporates a flutter valve which is claimed to exclude selectively those sounds that reach a harmful intensity, that is to say, the plug is amplitude-sensitive. Sound pressures of high intensity are said to drive the valve against one or the other of two seatings, thereby affecting a seal and increasing the attenuation to that of a normal plug. Sounds of lower intensity may pass relatively freely through the apertures in the valve seatings and through the body of the plug into the meatus. Although the valve is very light and is delicately suspended on very fine coil springs it seems unlikely that its inertia would allow it to close quickly enough to be effective. Nevertheless, if the valve could be made to work satisfactorily, the plug would have important applications.

The plug itself is bulky and rather expensive, reflecting the amount of precision engineering inside it. It is made in one size only, with a double-flanged rubber fitting. The pure tone attenuation measured by free-field threshold shift⁴ is, as would be expected, rather less than that of a normal plug, especially at low frequencies, but not as low as one would like for ease of communication between impulse noises.

9. ARL Frequency-Selective Plugs. These ingenious plugs provide an effective means of protecting the ear against very narrow frequency bands while allowing normal speech communications. They have already been the subject of a separate report⁵ and will not be discussed further here; they are not shown in Figure 4.
10. Ill-Fitting "Leaky" Ear Plugs. As such plugs tend to have similar properties regardless of manufacturer they may legitimately be considered under a single heading. The low frequency attenuation of such plugs is generally poor or non-existent, being similar to that of the experimental amplitude-sensitive plug or the Lee-Sonic Valv, where the leak is introduced deliberately. Results from obviously leaky plugs have not been used in the assessment of attenuation.

RESULTS

i. Details of Cadavers used. These were as follows:-

<u>Cadaver Serial No.</u>	<u>Age at death (years)</u>	<u>Time since death (hours)</u>	<u>Sex</u>	<u>Ear Used</u>
1	77	16	F	L
2	73	16	F	L
3	64	34	F	L
4	66	57	F	R
5	72	27	M	L
6	63	40	F	L
7	59	26	M	R
8	54	50	F	L

Mean = 66

Mean = 33

The ear drum impedances measured are shown in Table I and Figure 5. It can be seen that there was considerable variation between different ears, but the median values, although indicating a rather low compliance, fell essentially within the "normal" range as determined previously using the identical Zwislocki acoustic impedance instrument.²

The open ear responses to pure tones are shown in Figure 6 as mean values with standard deviations, and individually in Table II. It can be seen that the ear canal fundamental resonance occurs at about 2 kHz, with a gain of the order of 10dB. The open ear responses to impulses, seen in Figures 9a - 9g, show a gain of approximately 4 dB.

ii. Ear Plug Performances with Pure Tones

The attenuation of "solid" ear plugs (i. e. those without deliberate or accidental leaks) are remarkably similar, especially at low frequencies where the attenuation is about 15 dB. The attenuation appears in fact to depend more on the particular ear used than on the type of ear plug. The plugs with a designed leak gave no attenuation at low frequencies, as expected, and showed a rapid increase in attenuation at about 1 kHz, but even at high frequencies this attenuation was less than that of the "solid" plugs.

Difficulty in obtaining an effective seal in the meatus was experienced with all plugs except for the Sonex and the experimental INM plugs, even though the correct size was used in each case. Provided that a good seal was obtained each time, the attenuation appeared substantially unaltered by removing and refitting the plug (except at 6000 Hz where considerable variation was found) and was independent of the sound pressure level over the range used.

TABLE I. Ear Drum Impedance Data

Frequency (Hz)	Compliance (cc of air equivalent)						Resistance (arbitrary units)					
Cadaver No.	125	250	500	750	1000	1500	125	250	500	750	1000	1500
1	0.1	0.2	0.3	0.6	0.7	1.5	5	5	10	20	25	30
2	0.4	0.4	0.4	0.5	0.6	0.7	15	20	30	5	5	35
3	0.5	0.1	0.1	0.1	0.1	0.1	6	4	8	15	18	15
4	1.2	0.8	0.8	0.5	0.6	1.2	12	13	15	15	30	25
5	0.5	0.5	0.7	1.0	1.3	2.7	15	25	30	35	35	40
6	0.3	0.3	0.2	0.3	0.7	1.1	6	10	12	15	20	23
7	0.5	0.4	1.1	1.0	1.2	0.9	14	16	21	22	21	35
8	0.5	0.4	0.5	0.5	0.8	1.2	13	16	21	24	30	37
Median	0.5	0.4	0.4	0.5	0.7	1.1	12	13	17	20	21	30

An approximate conversion of arbitrary units of resistance to acoustic ohms is included in Figure 5.

Audiology Group
 Institute of Sound and Vibration Research
 University of Southampton

Zwislocki Acoustic Bridge
 Model 3 Serial no 47
 A.G. Number

Name
 Age Sex
 Date By

Canal volume
 Right ear cc
 Left ear cc

Results:
 Right ear ○—○
 Left ear x—x
 Median ●—●

Comments

eg.
 Apparent difference in
 ear volume

eg.
 Abnormal ear canal shape

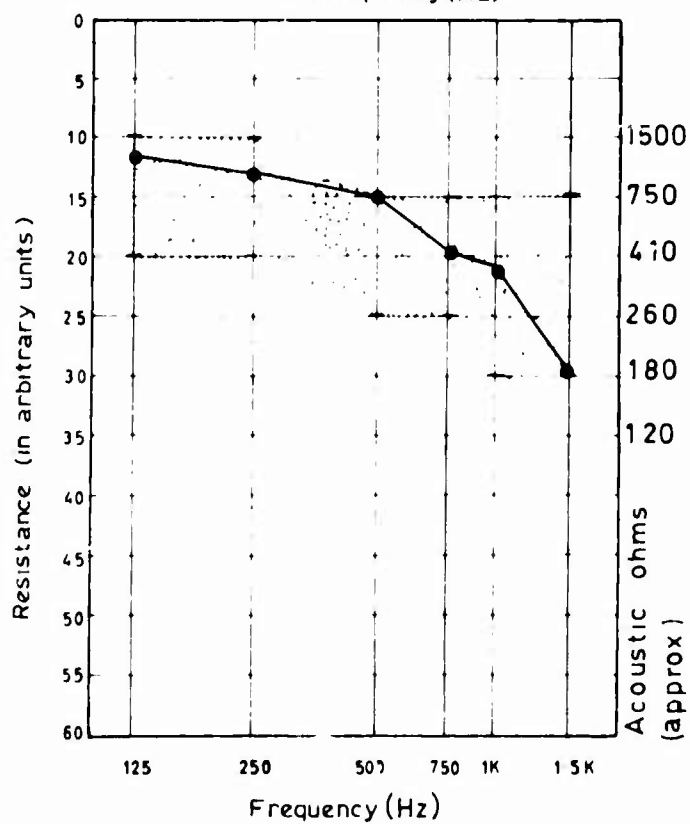
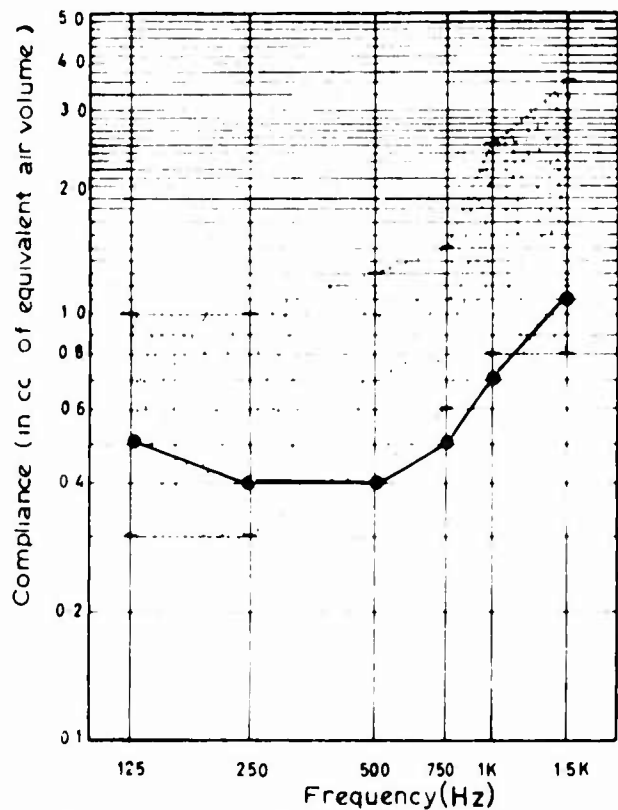

Fig 5 Median values of ear drum impedance
 Approximate 'normal' range indicated by
 stippled areas

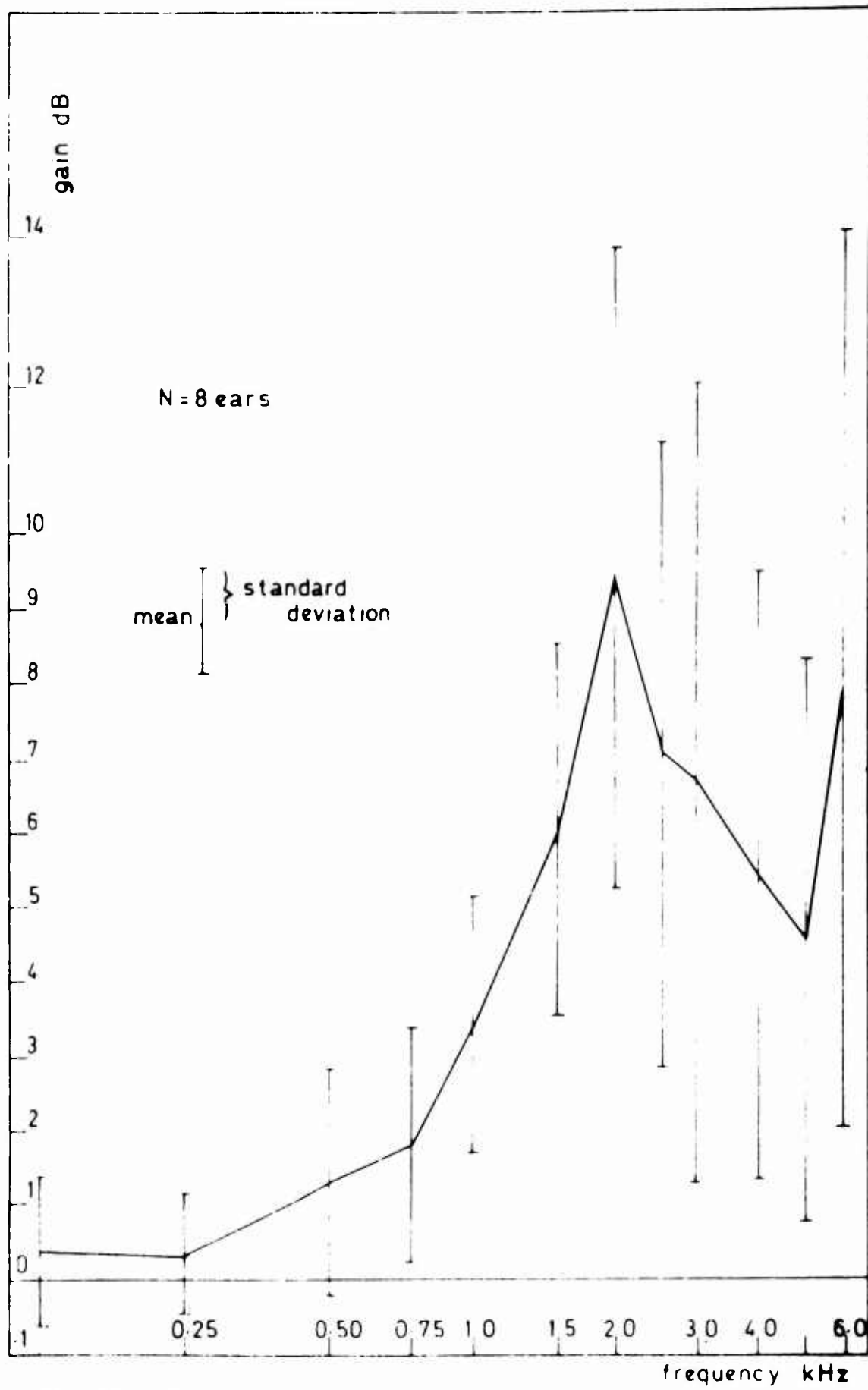

Fig 6 Open ear responses

TABLE II. Open Ear Responses to Pure Tones

Frequency (Hz)	125	250	500	750	1000	1500	2000	2500	3000	4000	5000	6000
Cadaver No.												
1	0.3	0.9	2.2	-	4.0	5.0	0.7	0.5	3.3	3.6	3.6	-
2	3.0	2.0	4.5	4.9	6.3	3.6	10.8	11.0	12.1	12.6	7.7	9.9
3	0.0	-0.5	1.0	0.3	1.7	2.2	10.6	9.7	10.3	4.0	-0.3	-0.5
4	0.0	0.0	0.2	0.8	2.0	7.0	11.0	3.0	-1.0	9.6	10.3	15.0
5	0.0	0.0	0.9	2.4	3.9	9.5	12.0	6.6	3.4	-0.6	-1.6	0.0
6	0.0	0.0	0.0	0.5	1.4	4.0	5.5	13.0	15.0	6.2	6.4	16.0
7	0.0	0.0	0.9	2.5	4.5	9.0	13.5	7.5	6.0	4.5	4.0	13.4
8	0.0	0.0	0.9	1.5	3.2	7.5	11.7	5.0	4.0	3.5	6.0	2.0
Mean	0.4	0.3	1.1	1.8	3.4	6.0	9.5	7.0	6.6	5.4	4.5	8.0
S. D.	1.0	0.8	1.6	1.6	1.7	2.7	4.2	4.2	5.4	4.1	4.0	7.3

Positive values (dB) indicate pressure increases in the meatus relative to outside the ear.

The attenuation results are given graphically in Figures 7a-h: the data for the Sonex and amplitude-sensitive plugs are shown as mean attenuation with standard deviation, and for the other plugs as individual attenuation for each cadaver. Tables III and IV show the individual results for the Sonex and the experimental amplitude-sensitive plugs.

iii. Ear Plug Performance with Impulses.

Due to the variations between cartridges giving differing impulse waveforms, the results for impulse attenuation gave considerable experimental scatter, so that a large number of individual results were required for a meaningful conclusion to be drawn. The .32-inch and the .22-inch cartridges gave similar attenuation results. Typical oscilloscope traces of the pressure waveforms are shown in Figure 8.

Impulses were not used with cadavers 5 or 6, but the results with the other cadavers, for Sonex and the experimental plugs and for open ears, are shown individually in Figures 9a-f and pooled in Figure 9g. It can be seen that the attenuation of the Sonex plug is consistent with the pure tone attenuation and independent of the impulse level, while the attenuation of the amplitude-sensitive plug increases steadily with impulse level and is about 20dB greater than for the open ear at 170 dB peak impulse level.

The Lee-Sonic Ear Valv was also examined using cadaver 7 (Figure 9h), and did give some increase in attenuation at high levels: but the rate of increase of attenuation is consistent only with the increase in air flow resistance through a small aperture, rather than the more marked effect to be expected from its advertised function, the closing of a valve. Unfortunately time did not permit a similar examination of the Mallock-Armstrong plug, but the low-level attenuation is already so high that any further attenuation would in practice be largely superfluous.

DISCUSSION

i. Cadaver Ears as a Method of Ear Plug Evaluation.

The validity of the results presented depends on the similarity between cadaver ears and real ears. Cadaver ears are suspect on two counts - whether the outer and middle ears from elderly persons are significantly different from those of the much younger subjects generally used for real-ear tests, and whether any significant difference in acoustic properties occurs at, or within two days of, death.

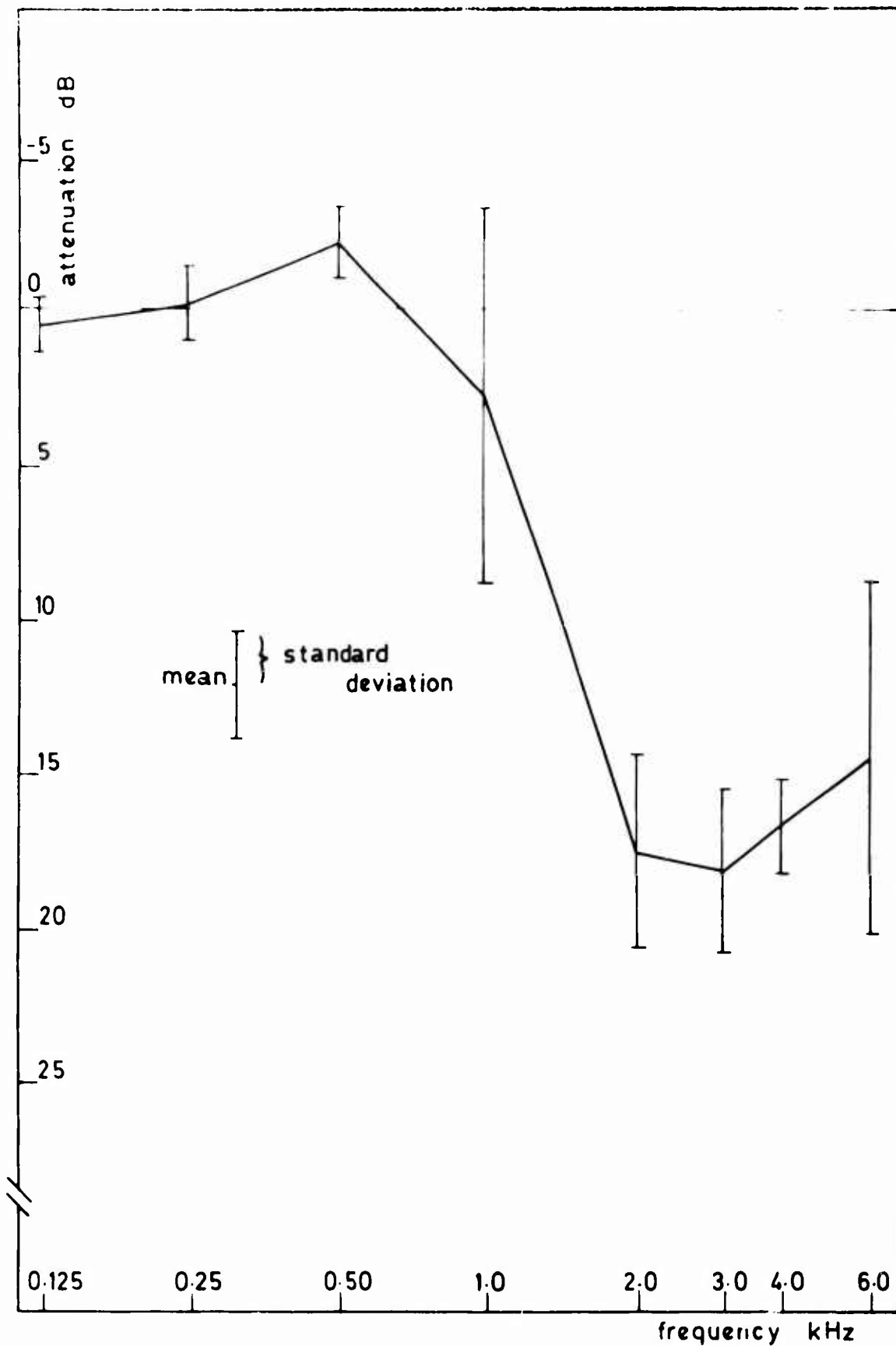

Fig. 7a Attenuation of experimental amplitude-sensitive plug.

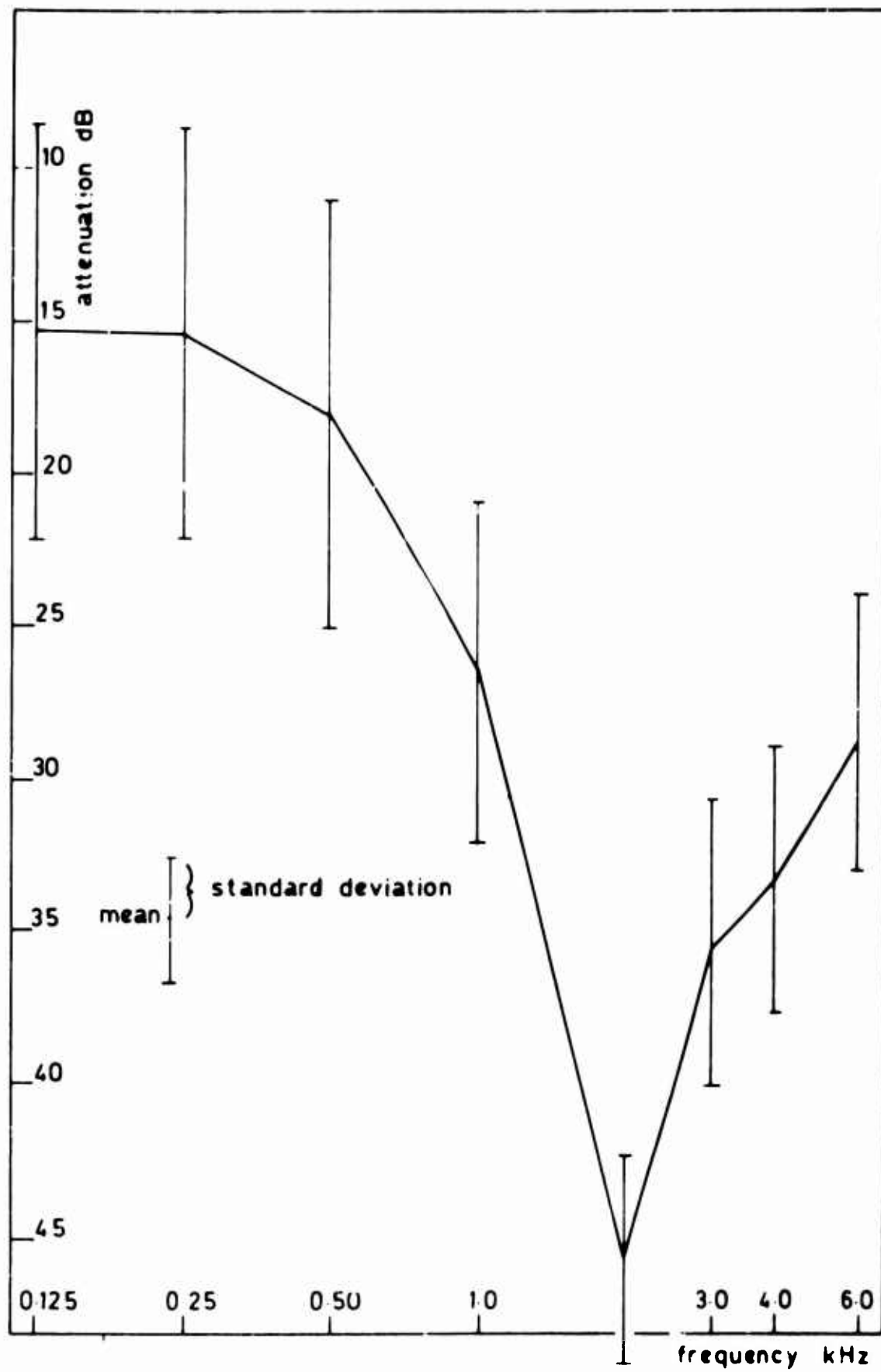

Fig 7b Attenuation of Sonex plug

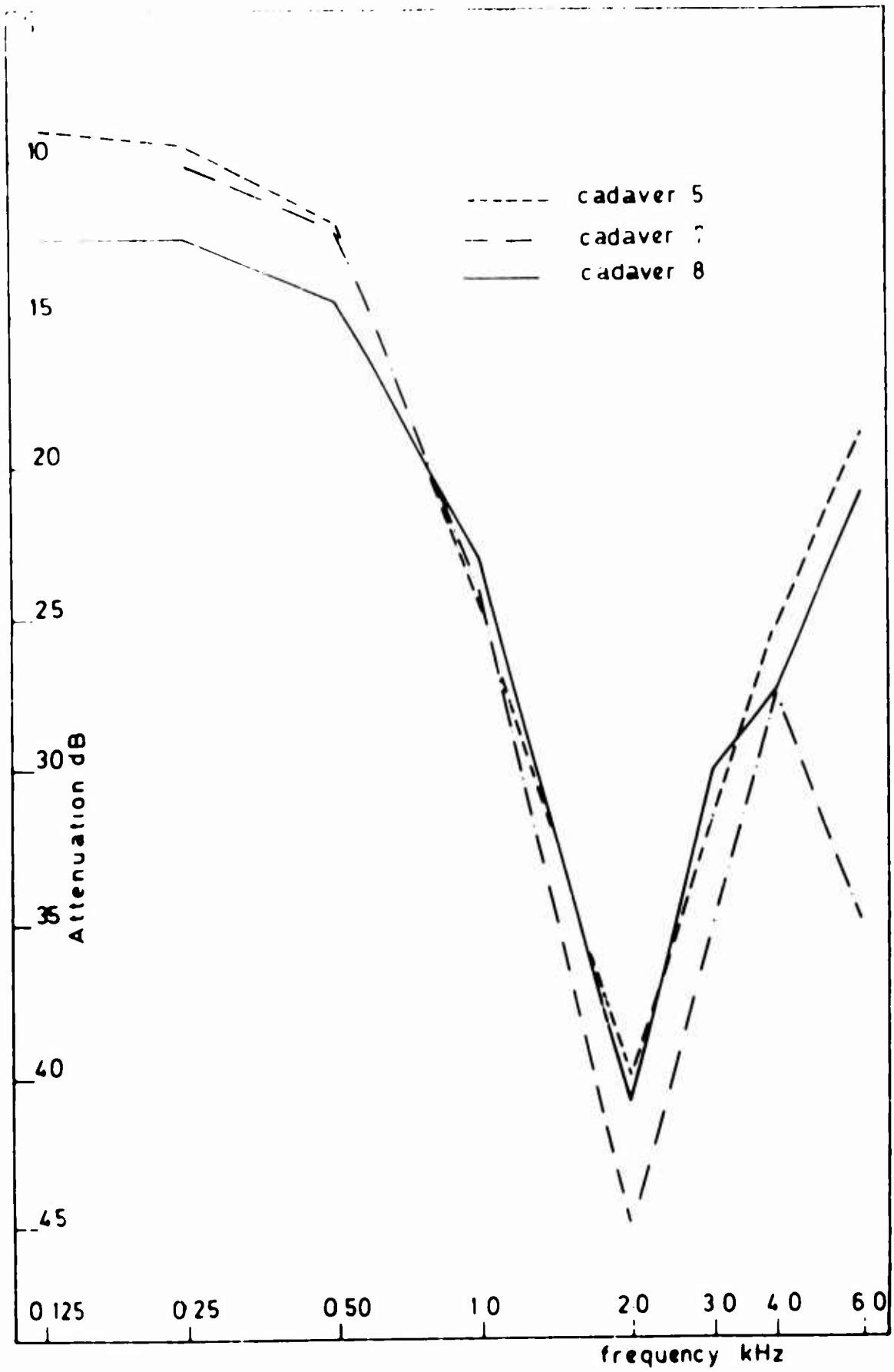

Fig 7c Attenuation of M S A plug

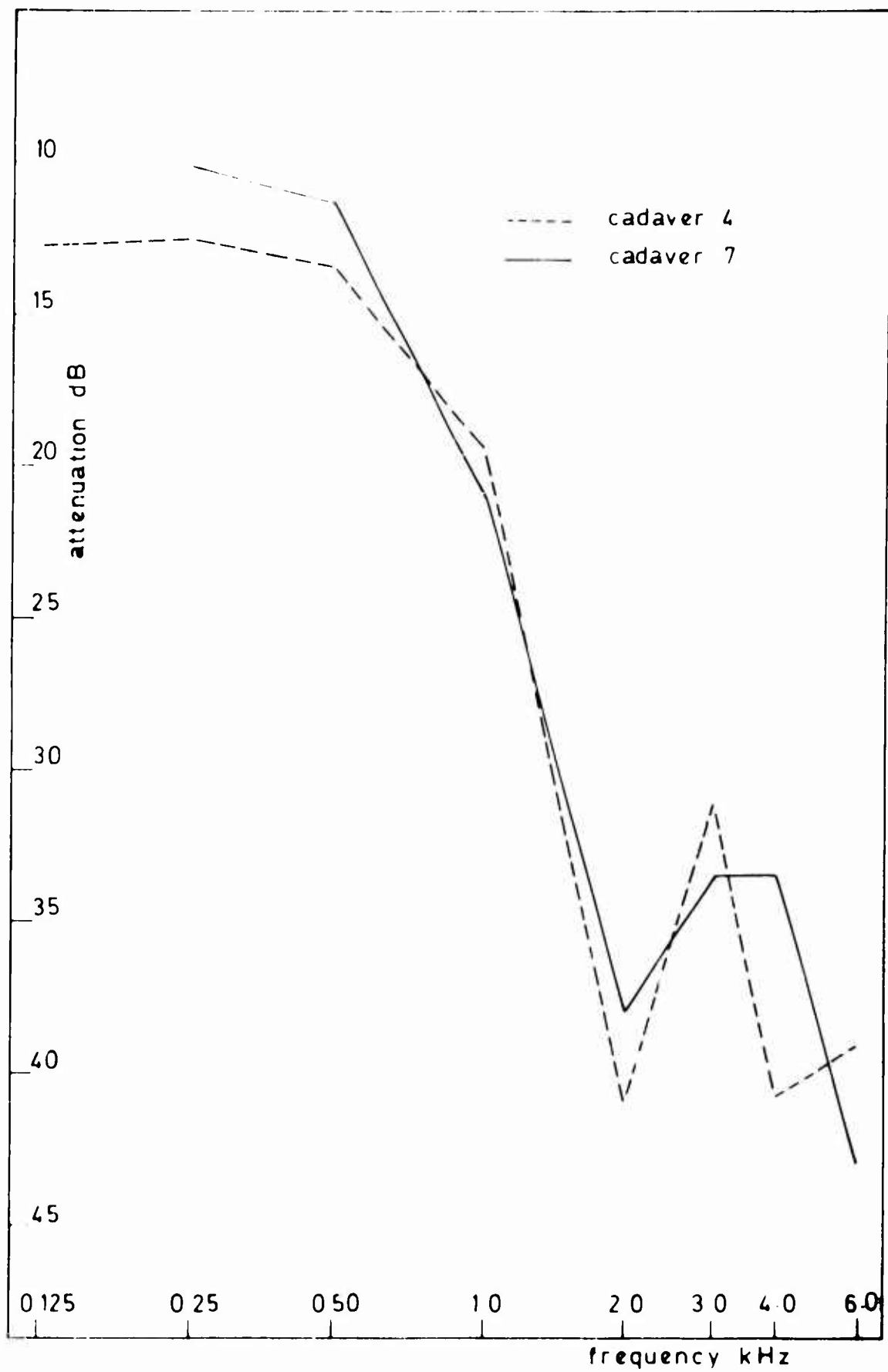

Fig 7d Attenuation of Willson Sound Silencer

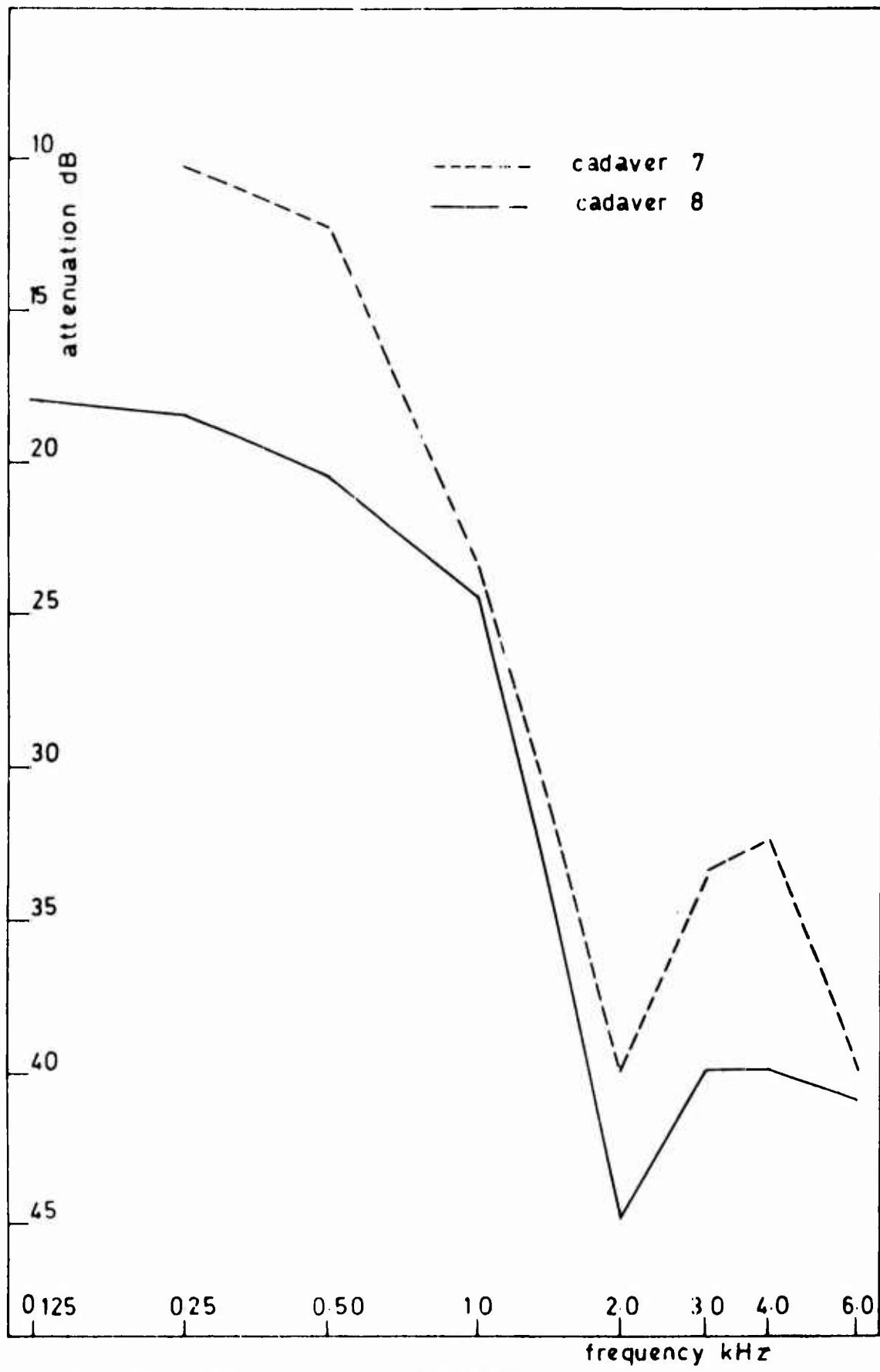

Fig 7e Attenuation of S.M.R. plug.

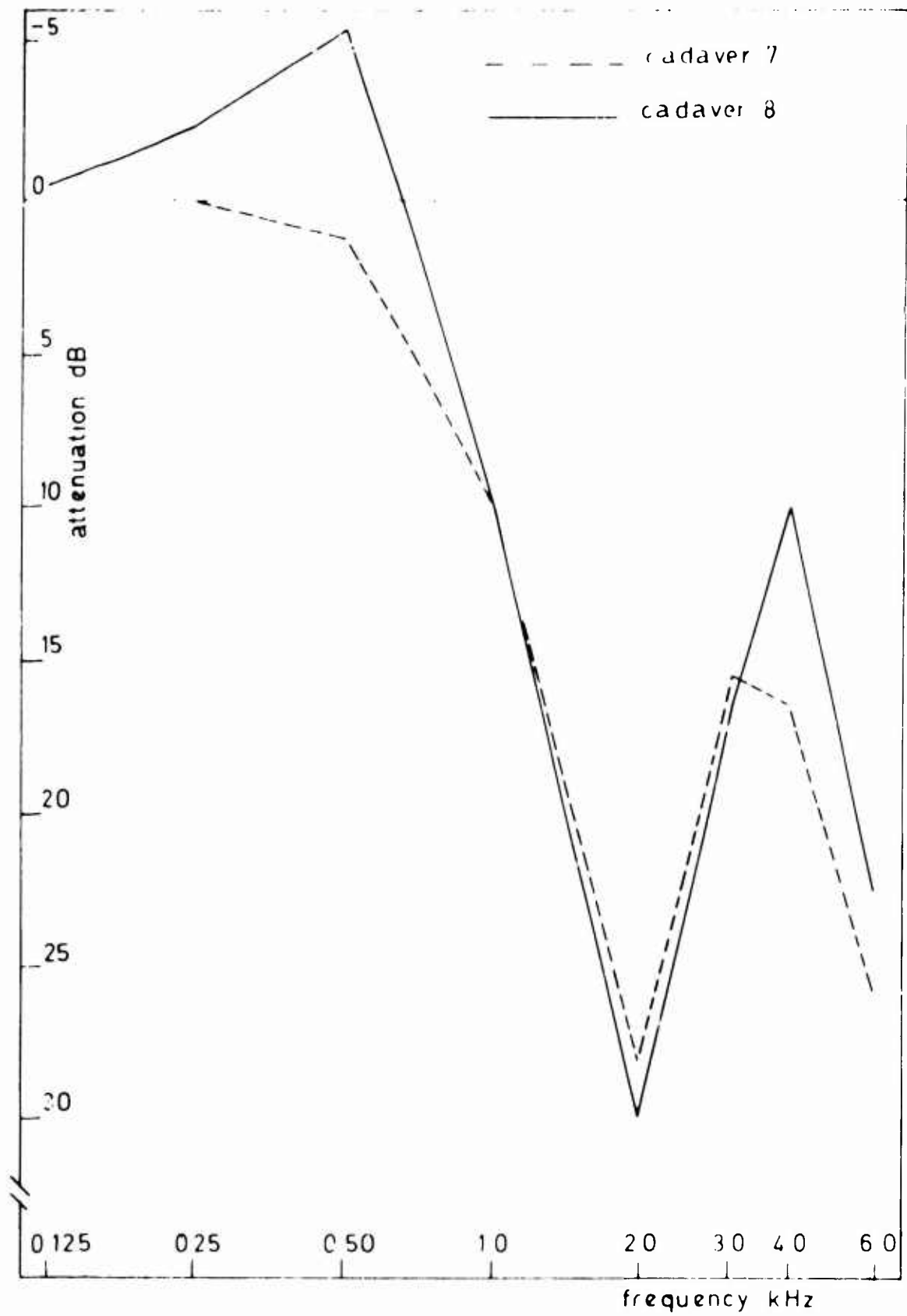

Fig 7f Attenuation of Lee Sonic Ear Valv

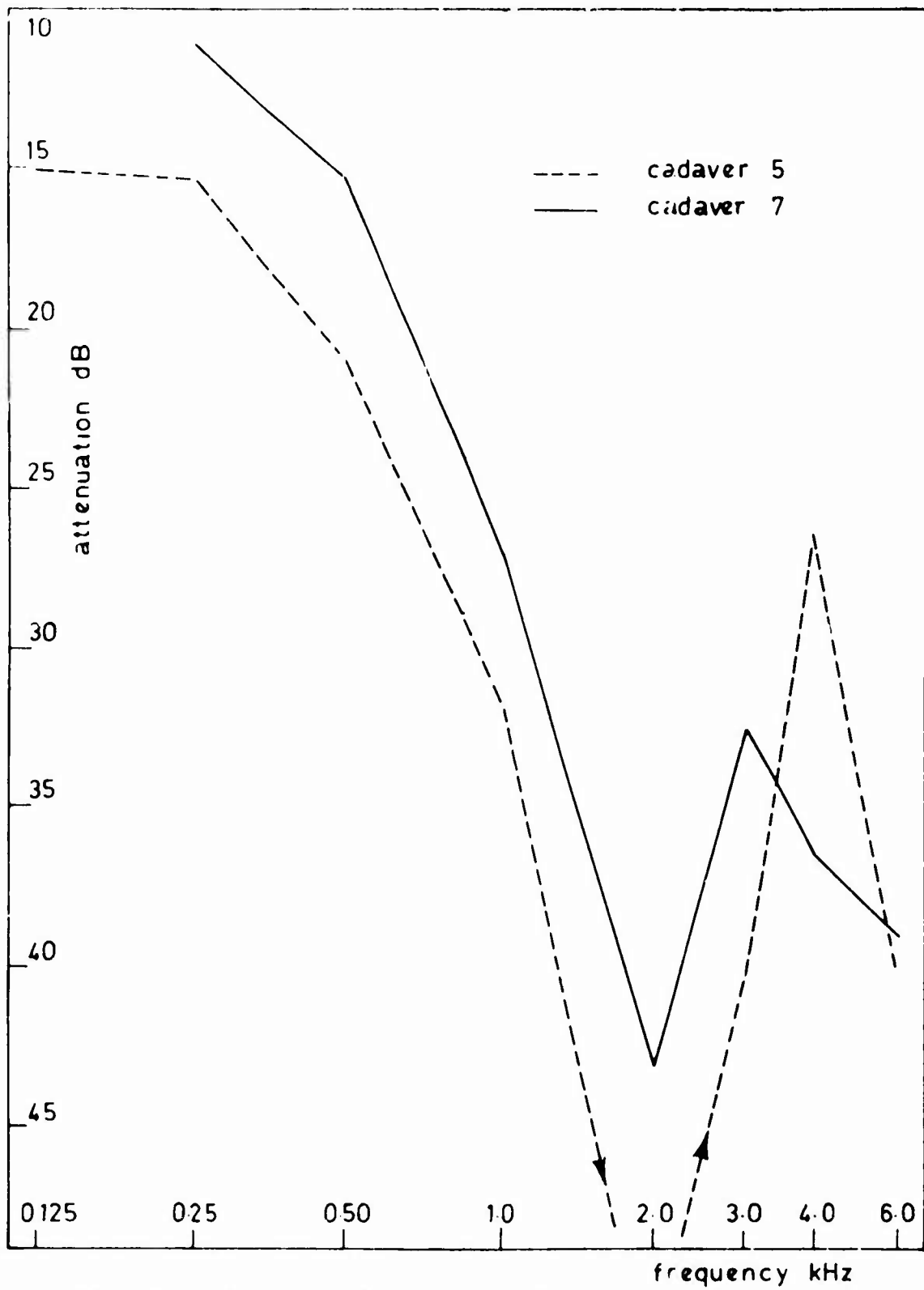

Fig 7g Attenuation of Mallock-Armstrong plug

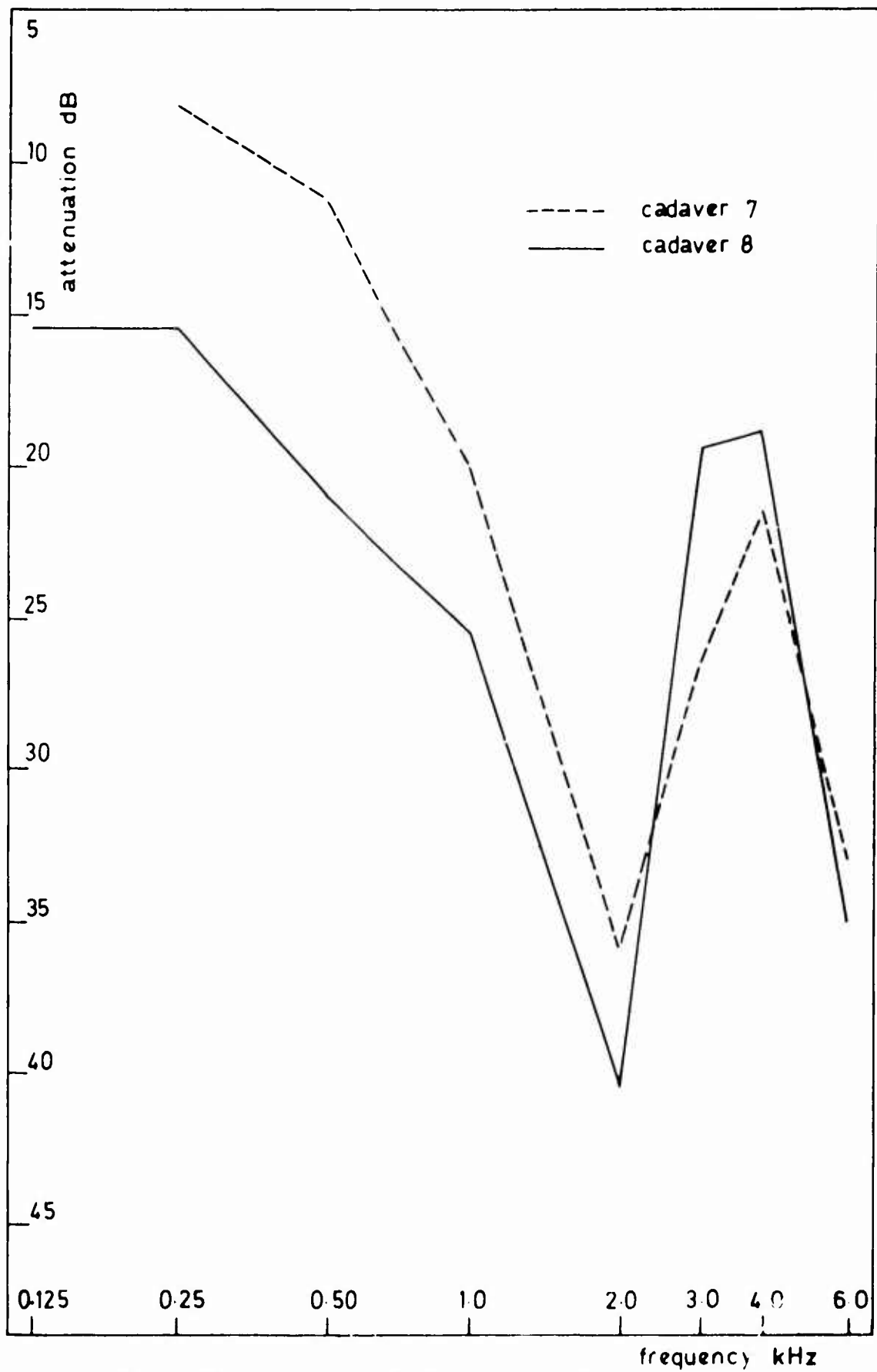

Fig. 7h Attenuation of Com-Fit plug

TABLE III Attenuation of Experimental Amplitude-Sensitive Ear Plugs, in dB

Frequency (Hz)	125	250	500	1000	2000	3000	4000	6000
Cadaver No.								
1	-0.6	-2.4	-2.6	11.3	16.0	15.0	15.8	-
2	2.5	1.6	-0.2	9.5	22.8	22.2	19.3	20.3
3	0.6	0.3	-2.2	-2.3	23.3	20.5	17.3	16.0
4	0.0	-0.3	-2.4	-4.6	21.0	15.0	18.8	13.0
5	-0.2	-1.0	-4.0	4.5	25.0	19.4	15.7	4.0
7	0	-0.2	-2.2	1.7	24.4	18.0	15.7	18.6
8	0	-1.0	3.0	-2.0	24.0	17.5	16.0	16.0
Mean	0.3	-0.4	-2.4	2.6	22.4	18.2	16.9	14.6
S. D	1.0	1.2	1.1	6.1	3.1	2.7	1.6	5.8

Positive values indicate a decreased pressure in the meatus, i. e., an attenuation

TABLE IV Attenuation of Sonex Ear Plugs in dB

Frequency
(Hz) 125 250 500 1000 2000 3000 4000 6000

Cadaver No.

1	15.6	20.3	23.4	34.2	47.6	36.2	33.5	-
2	28.5	28.5	31.5	35.0	47.4	43.0	40.0	34.0
3	9.4	11.9	15.9	23.1	50.7	35.2	28.0	34.0
4	13.0	13.0	14.5	22.5	45.5	28.8	36.5	25.0
5	11.0	11.2	12.8	25.0	46.0	39.4	35.3	23.2
7	-	9.1	12.2	23.0	41.0	32.5	28.5	28.0
8	15.0	14.7	16.3	23.0	41.7	33.2	31.0	27.0
Mean	15.4	15.5	18.1	26.5	45.7	35.5	33.3	28.5
S. D.	6.8	6.7	7.0	5.6	3.4	4.7	4.4	4.5

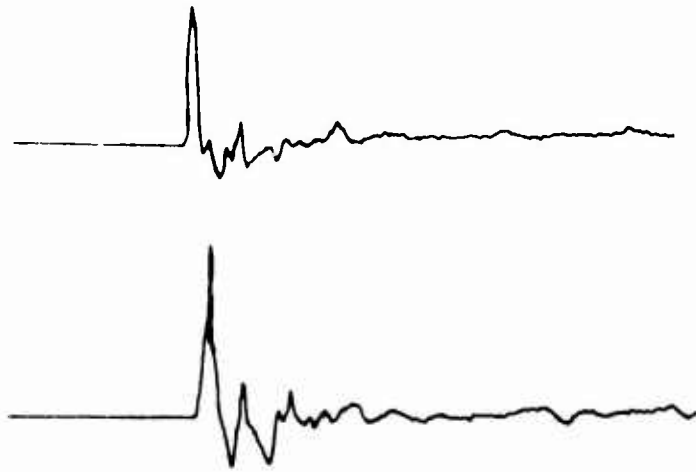

- A Open ear i.e no plug
 Upper trace - at entrance to meatus
 Peak = 158 dB ref 0.0002 dyn cm⁻²
 Lower trace - deep in meatus
 Peak = 159.6 dB
 Time scale 0.5 m sec/major div

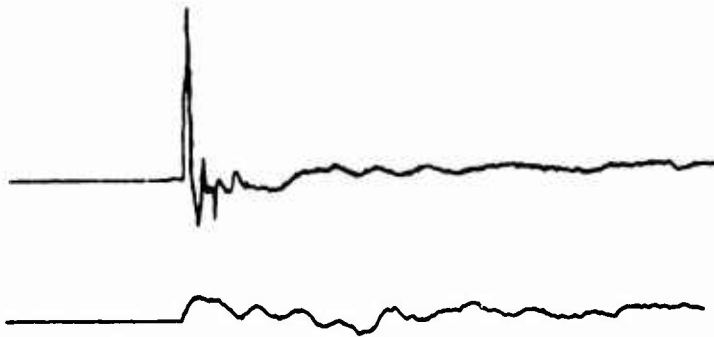

- B Sonex plug (L)
 Upper trace - at entrance to meatus
 Peak = 162 dB
 Lower trace - deep in meatus
 Peak = 126 dB
 Time scale 0.5 m sec/major div

Fig 8 Impulse noise waveforms
 Cadaver S/N1. Sound source 0.22 inch blank.
 + deflection indicates + pressure

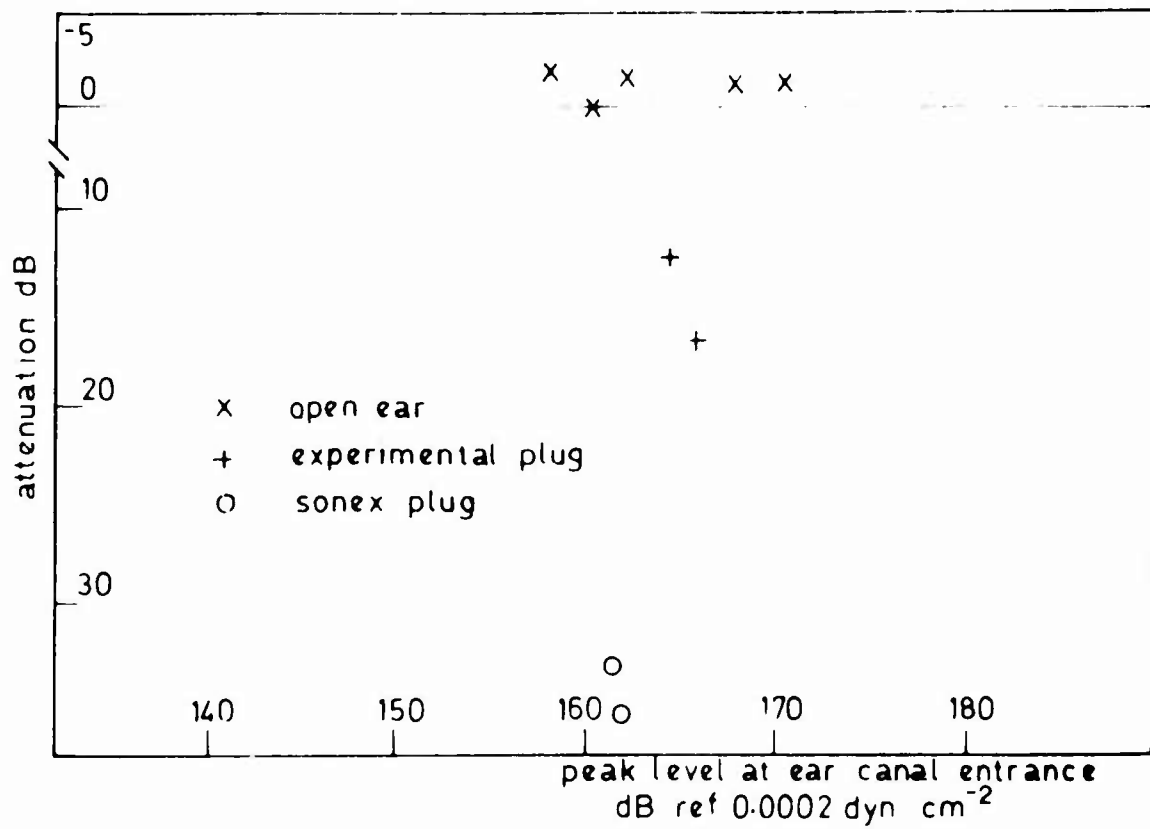

Fig 9a Cadaver 1

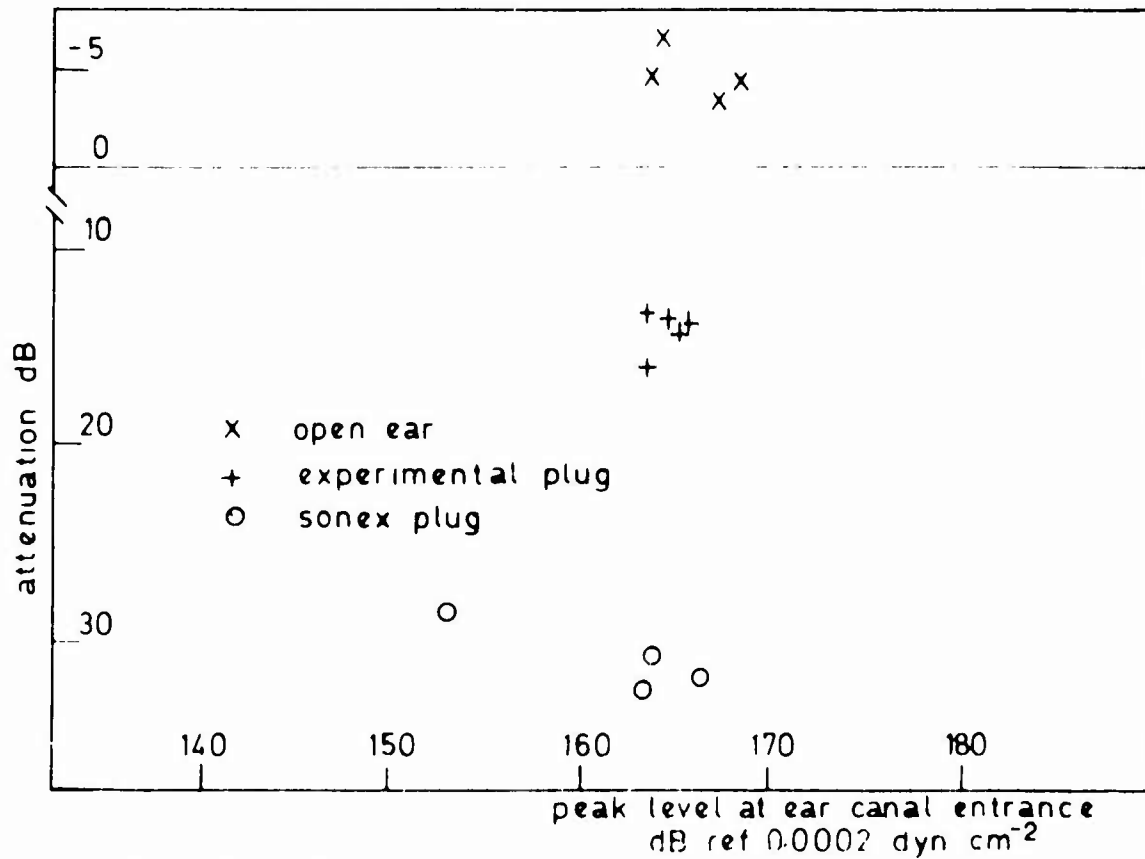

Fig 9b Cadaver 2

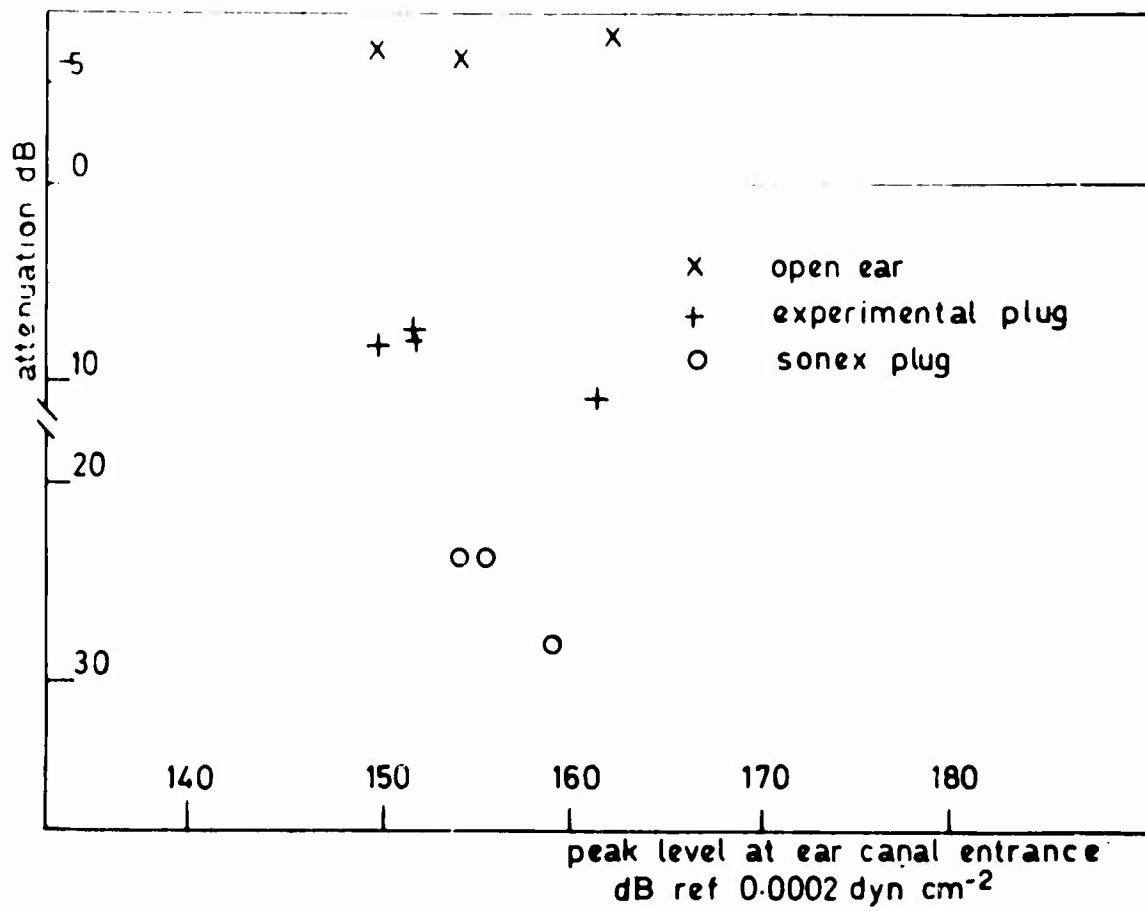

Fig 9c Cadaver 3.

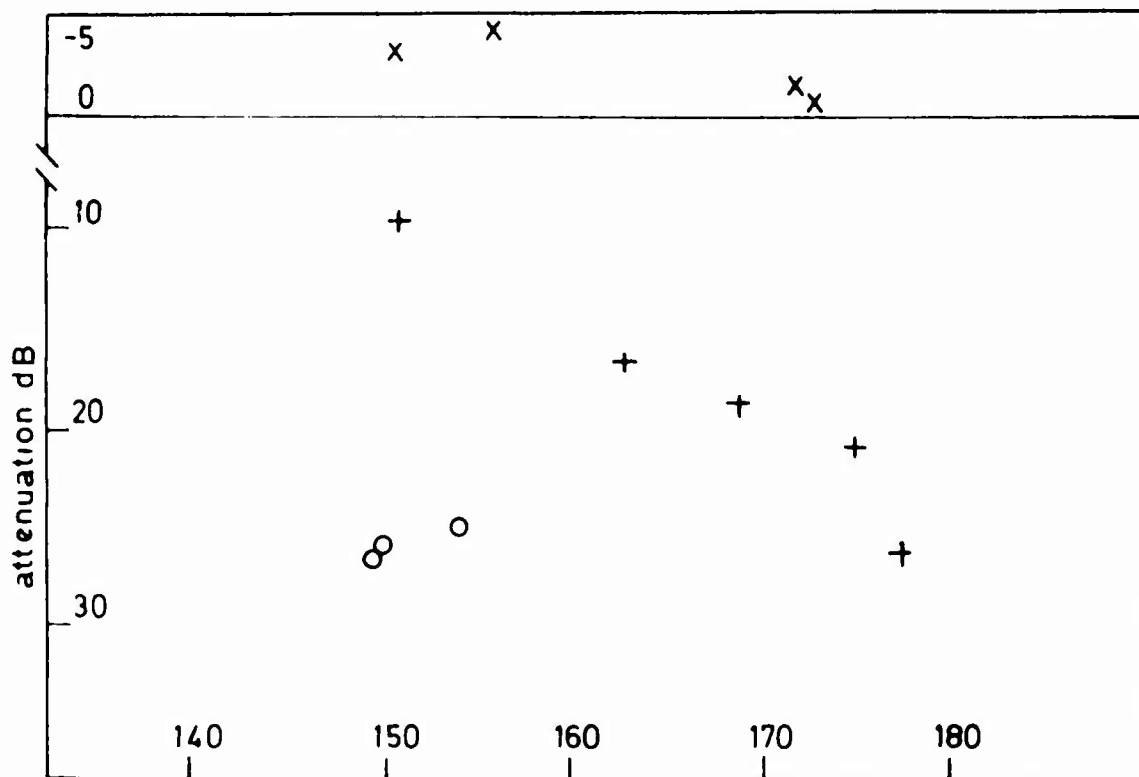

Fig 9d Cadaver 4

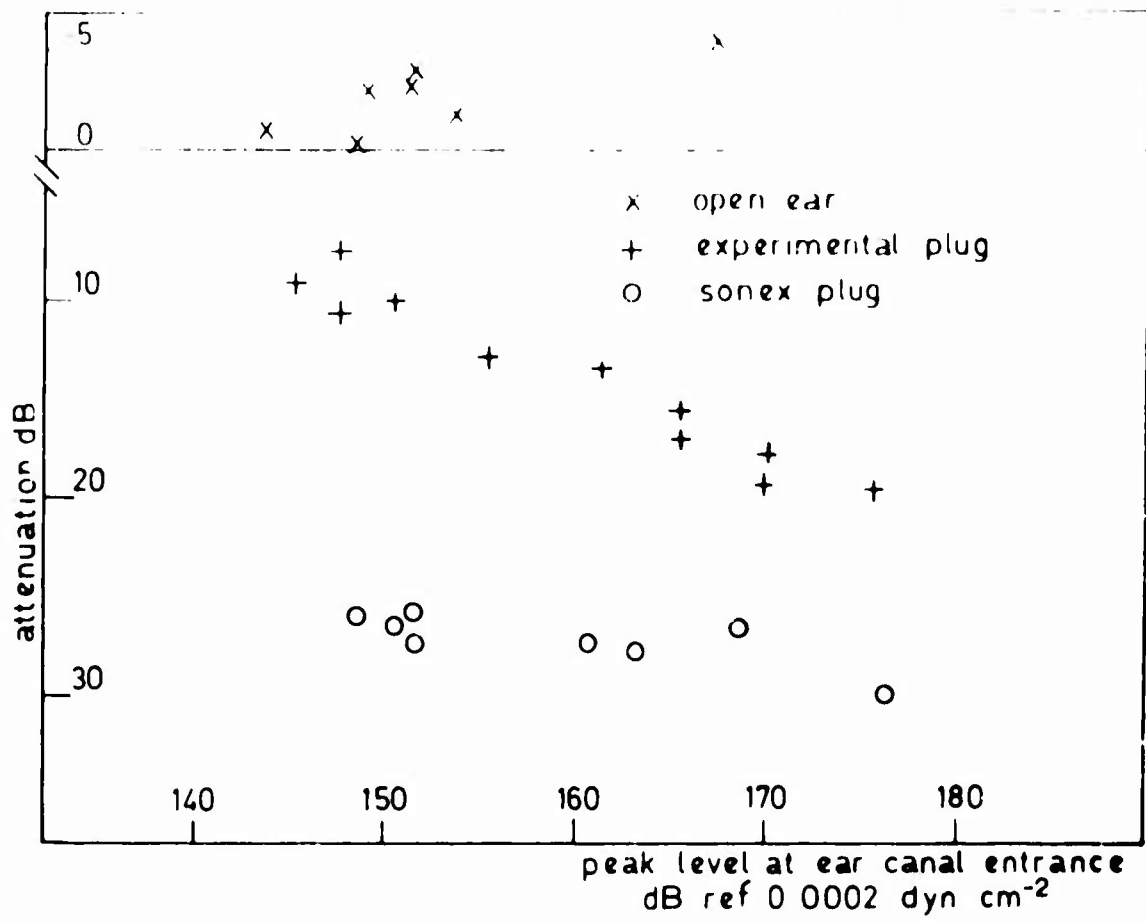

Fig 9e Cadaver 7

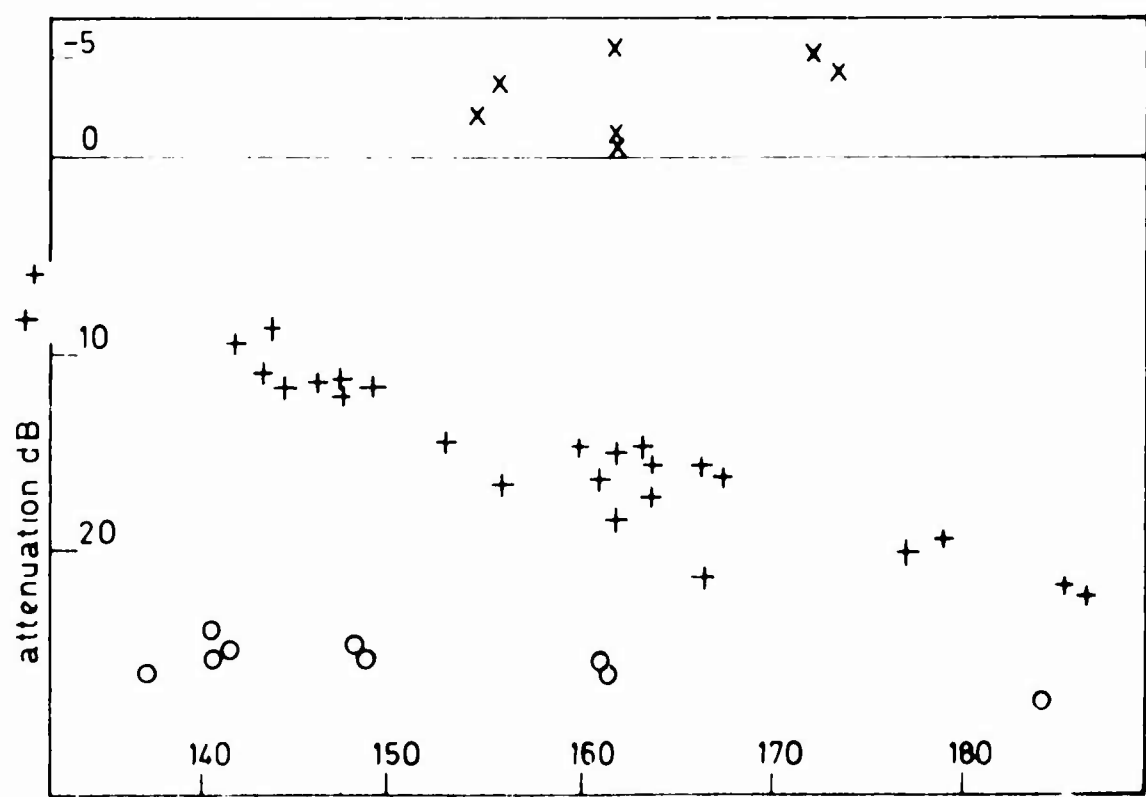

Fig 9f Cadaver 8

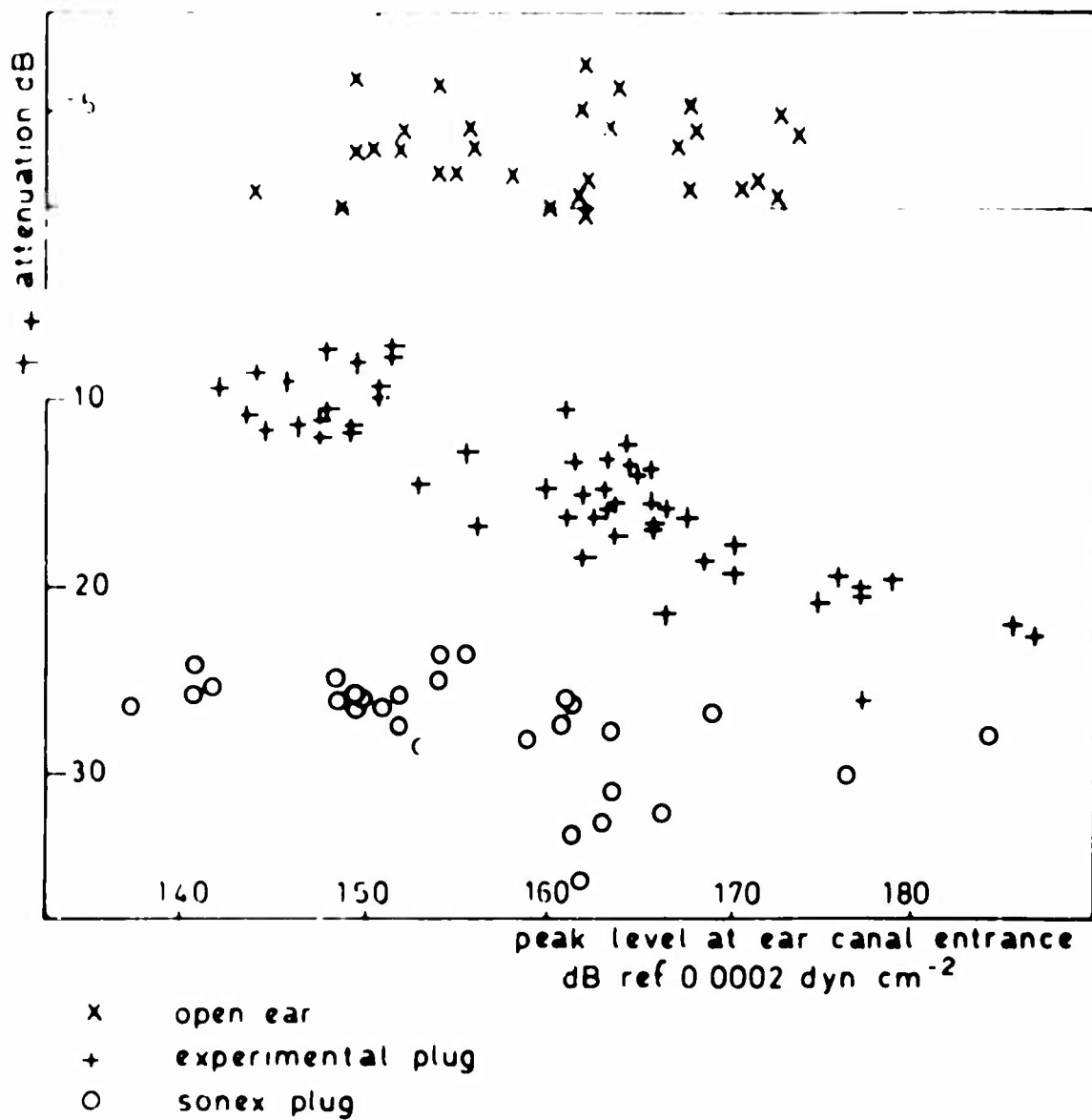

Fig 9g Pooled data from cadavers 1-4,7,8

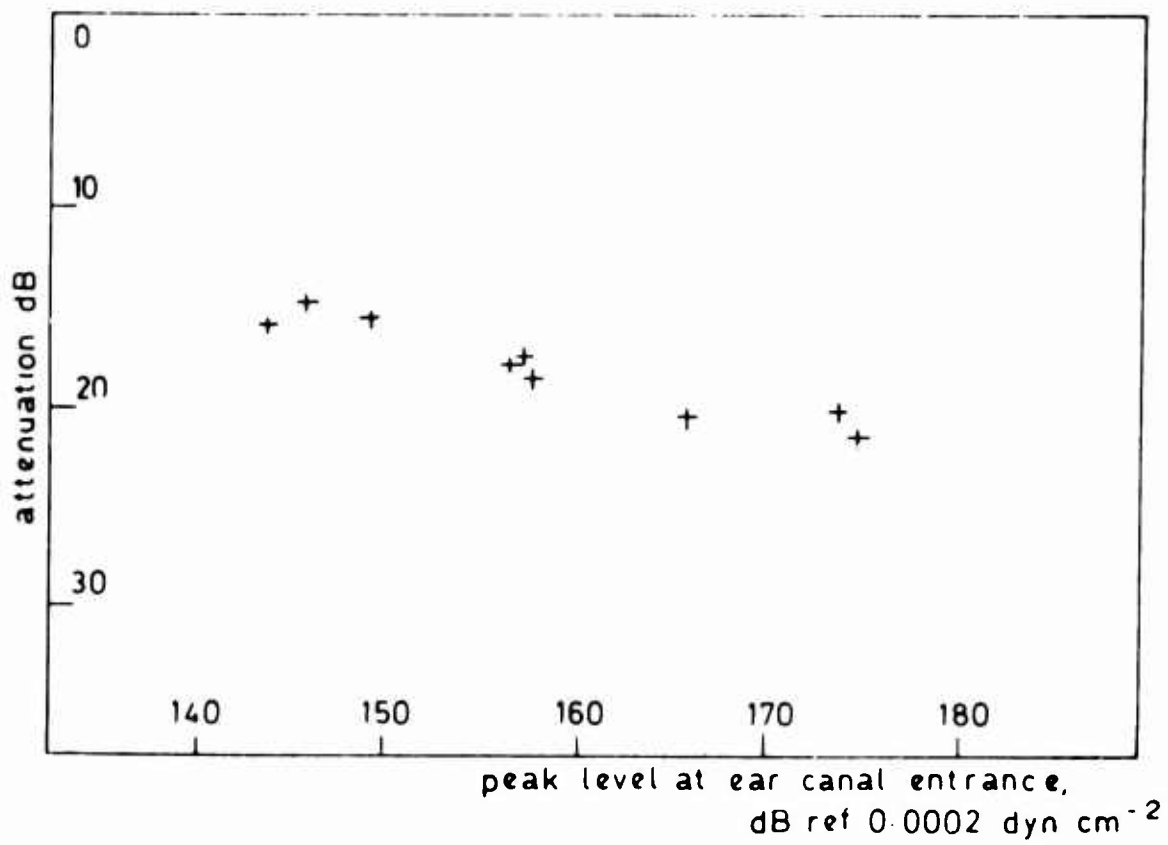

Fig. 9h Lee Sonic Ear Valve in cadaver 7

Regarding the first point, it is known that the skin loses much of its elasticity with age, and that the body fat is disposed in a less aesthetic manner, i. e. away from the subcutaneous sites. The effect of this on the mechanical properties of the pinna and meatus is uncertain. The incidence of middle ear pathology, notably fixation of the stapes and ossicular joints, might also be thought higher in an aged population than among young persons, although there is little evidence of a substantial conductive element in the deafness of old age per se.^{6, 7}

Our results using the Zwislocki bridge showed considerable variation between the acoustic impedance of the various ears, but the median values for both compliance and resistance were within or near the range covered by 95% of normal subjects, according to the earlier determination using the same instrument. On the other hand, Zwislocki and Feldman⁸ using another Zwislocki acoustic impedance bridge reported that the compliance of the drum decreased very markedly shortly after death and the resistance increases. It may be that the cadavers which Zwislocki and Feldman used were fresher than ours, although both Onchi⁶, and Elpern and Anderson⁷ consider that the properties of the middle ear do not alter rapidly after death. Some of the discrepancy may be due to the small samples used by us and by Zwislocki (N = 8 in both cases).

The resonant frequency of the meatus is of considerable interest, as the interference with this resonance contributes substantially to the attenuation characteristics of ear defenders. The most comprehensive study on this resonance appears to be that by Shaw and Teranishi⁹ who, using both real ears and a model ear together with a probe tube microphone, concluded that the resonant frequency was a little under 3 kHz with a gain of about 16 dB. They also showed how the gain, but not the resonant frequency, was affected by the drum impedance, and how the distance of the measuring microphone from the drum would affect the apparent gain without altering this frequency. They further showed that a strong resonance around 6 kHz was due to an open ended mode of the cavum conchae, and that at higher frequencies the characteristics were dependent on the shape of the pinna and on the direction to the sound source.

Wiener and Ross¹⁰, using a number of live ears, estimated the meatus resonant frequency as 4 kHz, with a gain of 12 dB; but results as low as 2 kHz have also been reported. In any case it is evident that considerable variations exist between different ears.

Our results for the cadaver ears gave the resonant frequency as about 2 kHz with a gain of about 10 dB. This rather low resonant frequency might conceivably have been due to a partial collapse of the meatus cartilage leading to a narrowing of the meatus entrance, although this would have to be quite marked to show such a large shift, and was not evident on otoscopic examination. The gain was probably slightly underestimated as the microphone was placed slightly short of the drum.

It seems that any differences in ear plug performance between our cadaver ears and normal ears are more likely to depend on changes in the resilience of the pinna and meatal tissues than on changes of acoustic impedance of the ear drum. Any changes in the resilience of the tissues are more likely to be a function of ageing than of post-mortem deterioration, as skin and cartilage are thought to alter relatively slowly after death.

The use of cadaver ears is too cumbersome to be regarded as an absolute method of determining ear plug attenuation, but nevertheless provides a useful means of comparing different types of plug and for studying their modes of operation and the effects of fit. Not only are differences between individuals not masked by the experimental error inherent in subjective threshold determinations, but measurement of attenuation at high levels, of special interest for some of the plugs in the present study, can be carried out.

ii. Ear Plug Attenuation Characteristics.

With "solid" ear plugs, provided that a good seal is obtained in the meatus, the values for attenuation obtained appear to be largely independent of the type of plug used, as was predicted by von Gierke and Warren. With ear plugs which are vented to the atmosphere (Lee-Sonic and other amplitude-sensitive types) the attenuation is reduced, depending mainly on the design of the plug, and becomes zero at low frequencies. Generally good agreement for pure tones was obtained between the results of cadaver-ear methods and of conventional threshold shift measurements.

The attenuation for high-intensity impulses shown by the Sonex plug corresponded well with that for low-level pure tones, whereas both the Lee-Sonic and the experimental amplitude-sensitive plugs showed a gradual increase in attenuation with impulse level. In the case of the experimental amplitude-sensitive plug the increase was ultimately close to the 1 dB per 2dB pressure increase that had been expected theoretically; the increase in the Lee-Sonic attenuation was rather more gradual still, presumably because of the higher initial attenuation and the more complex air passages within the plug.

The pure-tone results for all types of "solid" plugs have emphasised the crucial importance of a good fit. Of all the plug types tested, only the Sonex appeared to be reasonably satisfactory, and even this plug occasionally failed to provide an effective seal. This conclusion is in line with experience under field conditions ¹².

This means that ordinary insert type ear plugs cannot be relied on to give their normal low frequency attenuation in practice, and that where a continuous noise has hazardous components below about 1000 Hz, ear plugs may give very inadequate protection.

ACKNOWLEDGEMENTS

The authors wish to express their gratitude to the following:-

Mr W H Richardson for technical assistance at all stages, Dr R A Goodbody for facilities in the Pathology Department of Southampton General Hospital, Mr G Knebel for assistance in the mortuary, the Superintendent of the Royal Naval Physiological Laboratory for workshop services and the Director, Institute of Sound and Vibration Research, University of Southampton, for some of the instrumentation, available there under the Medical Research Council grant 965/278/C to the Institute.

REFERENCES

1. ZWISLOCKI J (1963). An acoustic method for the clinical examination of the ear. *J Speech Hear. Res* 6, 303.
2. BICKNELL M R and MORGAN N V (1968). A clinical evaluation of the Zwislocki acoustic bridge. *J Laryng* 82, 673.
3. Instructions and Applications; Quarter-inch Condenser Microphones Bruel and Kjaer Ltd, Naerum, Denmark.
4. PIESSE R A (1962). Ear Protectors. Commonwealth Acoustic Laboratory, Sydney, Australia, Report No 21.
5. FORREST M R and COLES R R A (1969). A note on the performance of ARL frequency-selective ear plugs in cadaver ears. Medical Research Council, RN Personnel Research Committee Report (unpublished).
6. ONCHI Y (1961). Mechanism of the middle ear. *J Acoust. Soc. Am* 33, 794.
7. ELPERN B S and ANDERSEN H C (1966). Experimental studies on sound transmission in the human ear - VII. The influence of age and post-mortem factors. *Acta Otolaryng.* 61, 403.
8. ZWISLOCKI J and FELDMAN A S (1963). Post-mortem acoustic impedance and human ears. *J Acoust Soc Am* 35, 1, 104.

9. SHAW E A G and TERANISHI R (1968). Sound pressure generated in an external-ear replica and real human ears by a nearby point source. *J Acoust Soc Am* 44, 240.
10. WIENER F M and ROSS D A (1946). The pressure distribution in the auditory canal in a progressive sound field. *J Acoust Soc Am* 18, 2, 401.
11. von GIERKE H E and WARREN D R (1953). Protection of the ear from noise: limiting factors. Section VIII in Benox Report "An Exploratory Study of the Biological Effects of Noise", University of Chicago, ONR Project NR 144079.
12. FORREST M R and COLES R R A (1967). Field trials of "MSA" and "Sonex" V. 51R type ear plugs. Medical Research Council RN Personnel Research Committee Report (unpublished).