

14 December 1967

3979

AD 718669
Materiel Test Procedure 5-2-519
White Sands Missile Range

U. S. ARMY TEST AND EVALUATION COMMAND
COMMON ENGINEERING TEST PROCEDURE

MOVING TARGET INDICATORS

1. OBJECTIVE

The purpose of this MTP is to detail methods of determining the electronic characteristics of Moving Target Indicator circuits (such as sensitivity, selectivity, range, and stability) and their conformity with Qualitative Materiel Requirements and Technical Characteristics.

2. BACKGROUND

Moving target indicators (MTI) are used in radar receivers to distinguish between echoes returned from moving objects and those returned from stationary targets, ground clutter, etc.

The ability of an MTI to amplify the signals reflected from moving targets while attenuating or rejecting the returns from clutter or other stationary objects determines the suitability of a receiver for moving target detection. Various attributes of the receiver may be determined during a program of testing under laboratory conditions, while others may require the use of actual or simulated field operations.

Engineers and other personnel actively engaged in testing and evaluating MTI circuits have developed, over a long period of time, certain general procedures for testing. Properly used, these procedures will determine the acceptability of an MTI for an intended use. The MTI must satisfy design parameters and equipment specifications to be accepted.

3. REQUIRED EQUIPMENT

- a. Oscilloscope
- b. Signal Generator (covering the frequency range of the radar under test)
- c. Grid Dip Oscillator (covering the desired frequency)
- d. Electronic Counter
- e. Pulse Generator
- f. Spectrum Analyzer (covering the desired frequency)
- g. Stable Local Oscillator Tester
- h. Power Meter
- i. Radar Simulator Station
- j. Noise and Field Intensity Meter
- k. Time Delay Generator
- l. Variable Delay Line
- m. Variable Attenuator
- n. Appropriate MTI shelter
- o. Target Aircraft

Best Available Copy

2004 0204 065 -1-

4. REFERENCES

- A. Terman, Fredrick E., Radio Engineering, McGraw-Hill Book Company, New York, 1959.
- B. Report on Noncoherent MTI as an Antichaff Measure, Haller, Raymond, and Brown, 1952.
- C. TR-AF-62, John Hopkins University. (TITLE AND DATE REQUIRED)
- D. AD 73 637, TR 53-431, Wright Air Development Center. (TITLE AND DATE REQUIRED)
- E. TR 57-193, Rome Air Development Center. (TITLE AND DATE REQUIRED)
- F. Massachusetts Institute of Technology, Radiation Laboratory Series, Selected Volumes, McGraw-Hill Book Company, New York, 1953.
- G. MR 16-949, Raytheon. (TITLE AND DATE REQUIRED)
- H. TM 11-750, Dept. of the Army, Electronic Counter-Countermeasures for the Operator, 20 April 1961.
- I. TM 11-751, Dept. of the Army, Electronic Counter-Countermeasures for the Technician, 20 April 1961.
- J. Facilities Branch Manual 337, "Moving Target Indicator", CAA Aeronautical Training Series.
- K. The IF TACCAR MTI System, MIT Group Report 45-28, 11 Dec. 1957.
- L. Skolnik, Merrill I., Introduction to Radar Systems, McGraw-Hill, 1962.

5. SCOPE

5.1 SUMMARY

This MTP describes in general terms the procedures required for testing MTI systems. These tests will determine whether the system will meet the design requirements.

The specific tests listed below shall be conducted under procedures contained herein:

- a. Minimum Discernible Signal Measurement -- This test determines the smallest signal amplitude which can be detected in the receiver noise by a human operator or an automatic detection circuit.
- b. Clutter Amplitude Measurement -- This test determines the relative amplitudes of extraneous signals and the minimum discernible signal.
- c. Subclutter Visibility Test -- This test determines the ability of the MTI to distinguish between weak moving target echoes and clutter.
- d. Clutter Rejection (Cancellation Ratio) Test -- This test measures the residual background signals.
- e. Blind Speed Test -- This test determines the target radial velocities at which no radar return signal is presented.
- f. Scanning Modulation Test -- This test determines the effect of antenna rotation upon the amplitude of the clutter.
- g. Nonsynchronous Signal Rejection Tests -- This test determines the ability of the MTI to reduce random signal interference.

Other tests, such as Dynamic Range, Automatic Gain Control, Automatic Frequency Control, and Local Oscillator Measurements are described in Appendix A of this MTP, and should be conducted as outlined in appropriate references and special tests as dictated by the operating requirements.

5.2 LIMITATIONS

Due to the variety of MTI circuits in use, this MTP is restricted to laboratory tests of typical configurations, and no attempt is made to describe the values or arrangements of individual components, however, the general nature of the test outlines permits their adaption to a wide range of specific units.

6. PROCEDURES

6.1 PREPARATION FOR TEST

- a. Select test equipment having an accuracy of at least 10 times greater than that of the equipment to be tested.
- b. Record the following information:
 - 1) Nomenclature, serial number(s), and manufacturer's name of the test item
 - 2) Nomenclature, serial number, accuracy tolerances, calibration requirements, and last date calibrated of the electronic test equipment selected for the tests
- c. Ensure that all test personnel are familiar with the required technical and operational characteristics of the item under test, such as stipulated in Qualitative Materiel Requirements (QMR), Small Development Requirements (SDR), and Technical Characteristics (TC).
- d. Review all instructional material issued with the test item by the manufacturer, contractor, or government, and familiarize all test personnel with the contents of such documents. These documents shall be kept readily available for reference.
- e. Thoroughly inspect the test item for obvious physical and electrical defects such as cracked or broken parts, loose connections, bare or broken wires, loose assemblies, bent relay and switch springs, and corroded plugs and jacks. All defects shall be noted and corrected before proceeding with the test.
- f. Subject all circuits of the test item to a functional test by placing appropriate switches to the normal position. Malfunctions shall be noted and corrected.
- g. Prepare record forms for systematic entry of data, chronology of test, and analysis in final evaluation.
- h. Ensure that all safety precautions are observed throughout the test.

6.2 TEST CONDUCT

NOTE: All tests shall be made under guidance of procedures contained herein. Modification of these procedures shall be made as required by technical design of the test item and availability of test equipment, but only to the extent that such modified procedures will not affect the validity of the test results.

6.2.1 Minimum Discernible Signal (MDS) Measurement

- a. Connect a signal generator into the waveguide of the receiver, through a variable attenuator and the directional coupler, as shown in Figure 1.
- b. Synchronize an A scope with the plan position indicator (PPI) sweep, and adjust the A scope sweep circuit to conform with the maximum range of the PPI.
- c. Insert a pulse of known power level from the signal generator and adjust the delay (signal generator) so that the pulse echo is located in an area of the PPI which is free from extraneous clutter. (This area, when observed on the A scope, ideally should display receiver noise only). Record the signal generator power level.
- d. Gradually attenuate the pulse until it is barely discernible in the receiver noise (grass). Record the amount of attenuation inserted in the waveguide.

6.2.2 Clutter Amplitude Measurement

- a. Insert a variable attenuator into the waveguide of the receiver, as shown in Figure 2, and adjust the attenuator to produce minimum attenuation.
- b. Point the radar antenna at the azimuth of the clutter to be measured. Place the system in the normal or non-MTI mode, and ensure that the antenna is stationary.
- c. Synchronize an A scope with the PPI sweep, and adjust the A scope sweep range to extend beyond the clutter.
- d. Gradually increase the attenuation until the clutter is reduced to the level of the residual noise of the receiver. Record the amount of attenuation which has been inserted (clutter power level relative to receiver minimum discernible power level).

NOTE: The desired clutter level must be below the point at which the receiver circuits begin to limit the signal.

- e. Ensure that the receiver is not limiting by decreasing the IF amplifier gain slightly, with no attenuation in the wave guide, while observing the clutter level on the A scope.

NOTE: If the receiver is not limiting, there will be a reduction in the level of the presentation. Increasing the gain will increase the level of the signal on the A scope until it reaches the level at which the receiver starts limiting.

6.2.3 Subclutter Visibility (SCV) Test

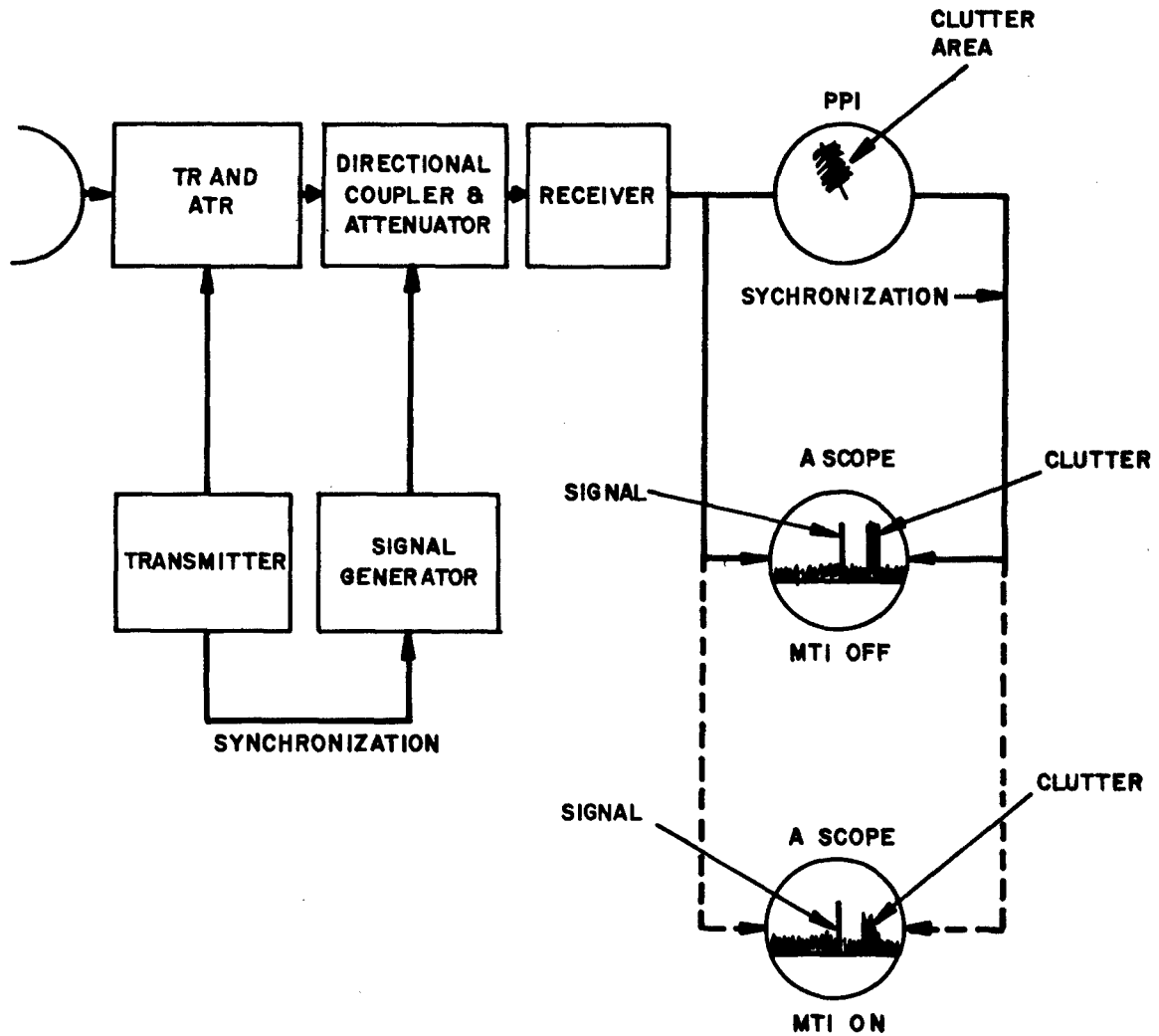

Figure 1. Signal Insertion Method of Measuring MDS and Clutter Amplitude

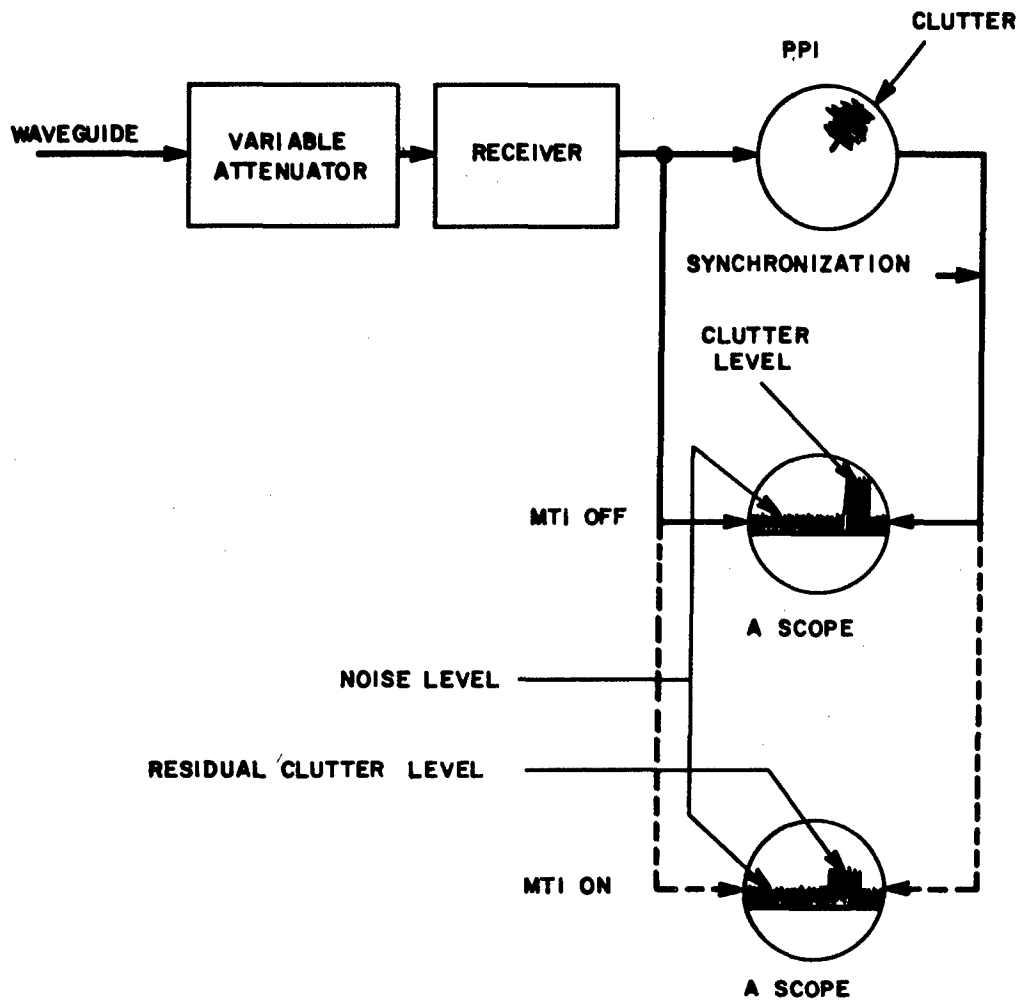

Figure 2. Signal Attenuation Method of Measuring Clutter Amplitude

- a. Insert a variable attenuator into the wave guide of the receiver, as shown in Figure 2, and adjust the attenuator to produce minimum attenuation.
- b. Point the radar antenna at the azimuth of the clutter to be measured. Place the system in the normal or non-MTI mode, and ensure that the antenna is stationary.
- c. Synchronize an A-scope with the PPI sweep, and adjust the A scope sweep range to extend beyond the clutter.
- d. Gradually increase the attenuation until the clutter is reduced to the level of the residual noise of the receiver without limiting of the receiver. Record the amount of attenuation which has been inserted.
- e. Switch the receiver to the MTI mode and connect a signal generator into the wave guide of the receiver as shown in Figure 1.
- f. Shift the signal generator delay back and forth to simulate a moving target while observing the scope presentation.
- g. Adjust the attenuation of the simulated signal until it is barely detectable on the PPI. Record the amount of attenuation which has been inserted.

6.2.4 Clutter Rejection Test

- a. Insert a variable attenuator into the wave guide of the receiver, as shown in Figure 2, and adjust the attenuator to produce minimum attenuation.
- b. Point the radar at an area of strong clutter, place the receiver in the MTI mode, and ensure that the antenna is stationary.
- c. Synchronize an A scope with the PPI sweep, and adjust the A scope sweep range to extend beyond the clutter.
- d. Adjust the receiver gain control until the clutter display is at the specified residual clutter level.

NOTE: Receiver specifications (for receivers having MTI circuits) will indicate the residual clutter level to be expected for the system under test.

- e. Measure the residual clutter level by increasing the attenuation until the residual clutter is coincident with the receiver minimum discernible signal (MDS) obtained in para. 6.2.1.
- f. Record the value of the inserted attenuation (as the level of the residual clutter above the MDS).

6.2.5 Blind Speed Test

- a. Calculate the radar blind speeds as follows:
 - 1) The first blind speed in knots equals the wavelength in meters times the PRF in cycles per second times 0.972. For example, a radar operating at 3000 megacycles (wavelength 0.1 meter) with a PRF of 500 cycles per second will have a first blind speed of $0.1 \times 500 \times 0.972 = 48.6$ knots.
 - 2) Other blind speeds occur at multiples of the first blind speed.

- b. Record the calculated blind speeds for expected target velocities.
- c. Connect a target simulator into the MTI system to provide a variable velocity target.
- d. Vary the velocity of the simulated target signal from zero to the highest target radial velocity expected.
- e. Measure and record each received blind speed interval and width.
- f. Disconnect the target simulator from the radar, and conduct flight tests during which a target aircraft is flown from its lowest reasonable velocity through as many multiples of the blind speed as possible, to the maximum velocity of the aircraft.
- g. Measure and record each received blind speed interval and width.

6.2.6 Scanning Modulation Test

- a. Locate several isolated areas of clutter on the radar presentation.
- b. Accurately measure the clutter amplitude in each area, while the antenna is rotating, in accordance with para. 6.2.2, and record on a suitable data form.
- c. Stop the antenna at the azimuth of the lowest amplitude clutter area noted.
- d. Accurately measure the clutter amplitude of this lowest area in accordance with para. 6.2.2, and record on a suitable data form.

6.2.7 Nonsynchronous Signal Rejection Test

- a. Connect a radar simulator station and radiate a random nonsynchronous pulse signal in the field of the test radar antenna.
- b. Operate the test radar in the normal or non-MTI mode with the nonsynchronous pulse displayed on the radar presentation.
- c. Measure and record the amount of pulse interference displayed on the radar presentation.
- d. Switch the test radar to the MTI mode of operation and measure and record the amount of pulse interference displayed.

6.2.8 Miscellaneous Tests

6.2.8.1 Dynamic Range

- a. Perform MTI receiver dynamic range tests in accordance with the procedures given in Reference 4 L.
- b. Record results of receiver dynamic range tests on a suitable data form.

6.2.8.2 Automatic Gain Control And Automatic Frequency Control

- a. Perform automatic gain and frequency control tests in accordance with applicable procedures given in Reference 4 L.
- b. Record results of automatic gain and frequency control tests on a suitable data form.

6.2.8.3 Local Oscillator Measurements

a. Test the stable local oscillator (STALO), coherent oscillator (COHO), and voltage tuned oscillator (VOTO) for stability, accuracy, output level, sensitivity to feedback power, and tuning range in accordance with applicable procedures contained in Reference 4 L.

b. Record results of STALO, COHO, and VOTO tests on a suitable data form.

6.3 TEST DATA

6.3.1 Preparation For Test

a. Record the following:

- 1) Nomenclature, serial number(s), and manufacturer's name of the test item
- 2) Nomenclature, serial number, accuracy tolerances, calibration requirements, and last date calibrated of the electronic test equipment selected for the tests
- 3) Deficiencies and discrepancies noted in equipment inspection prior to start of test

6.3.2 Test Conduct

6.3.2.1 Minimum Discernible Signal (MDS) Measurement

Record the signal generator power level and the amount of attenuation inserted in the waveguide in db.

6.3.2.2 Clutter Amplitude Measurement

Record the amount of attenuation inserted in the waveguide in db.

6.3.2.3 Subclutter Visibility (SCV) Test

Record the amount of attenuation inserted in both the non-MTI and MTI modes.

6.3.2.4 Clutter Rejection Test

Record the specified residual clutter level, and the attenuation inserted as the level of the residual clutter above the MDS in db.

6.3.2.5 Blind Speed Test

Record the calculated blind speeds for expected target velocities.

Record the blind speed intervals and widths obtained from both the target simulator and the target aircraft.

6.3.2.6 Scanning Modulation Test

Record the clutter amplitudes measured with the antenna rotating and the clutter amplitude measured with the antenna stationary.

6.3.2.7 Nonsynchronous Signal Rejection Test

Record the amount of radar simulator interference in the non-MTI mode and the amount of interference in the MTI mode.

6.3.2.8 Miscellaneous Tests

Record the test item indications on locally designed data forms suitable for the technical characteristics of the item under test.

6.4 DATA REDUCTION AND PRESENTATION

6.4.1 Data Reduction

6.4.1.1 Minimum Discernible Signal (MDS) Measurement

The minimum discernible signal level of the radar receiver shall be determined by subtracting the attenuation inserted in the waveguide from the signal generator output level.

6.4.1.2 Clutter Amplitude Measurement

The amplitude of the clutter above the residual noise of the receiver shall be read directly from the data form.

6.4.1.3 Subclutter Visibility (SCV) Test

The difference between the inserted attenuation in the MTI mode and the inserted attenuation in the non-MTI mode shall be determined and will be an expression of the subclutter visibility value of the MTI system. As an example, assume that the signal becomes undetectable at attenuations greater than 28 db; in this case, subclutter visibility equals 28 db.

6.4.1.4 Clutter Rejection Test

Subtract the attenuator readings for residual clutter from the maximum amplitude clutter. The difference in attenuation (expressed in db), shall be the clutter rejection or cancellation ratio of the receiver. (A typical value for the cancellation ratio is 35 db).

6.4.1.5 Blind Speed Test

The blind speed widths of the MTI as entered on the test data form shall be an expression of the system's ability to detect targets which have radial velocities differing only slightly from the blind speeds of the system.

6.4.1.6 Scanning Modulation Test

Subtract the clutter amplitude measured in db with the antenna rotating from the clutter amplitude measured with the antenna stationary. The difference shall be the effect of antenna rotation on clutter amplitude.

6.4.1.7 Nonsynchronous Signal Rejection Test

Subtract the nonsynchronous signal interference (measured in db) in the non-MTI mode from the amount of pulse interference displayed in the MTI mode. The difference shall be a measure of the ability of the MTI to reduce random signal interference.

6.4.1.8 Miscellaneous Tests

The data reduction shall be that contained in the applicable referenced procedures.

6.4.2 Presentation

Processing of raw subtest data shall consist of organizing the data under the appropriate subtest title. All test data shall be properly marked for identification and correlation to the test item in accordance with paragraph 6.3 as a minimum.

A written report shall accompany all test data and shall consist of conclusions and recommendations drawn from test results. The test engineer's opinion, concerning the success or failure of any of the functions evaluated, shall be included. In addition, equipment specifications that will serve as the model for a comparison of the actual test results should be included.

Equipment evaluation usually will be limited to comparing the actual test results to the equipment specifications and the requirements as imposed by the intended usage. The results may also be compared to data gathered from previous tests of similar equipment.

GLOSSARY

1. Area MTI: A type of MTI which utilizes scan-by-scan subtraction. This, in effect, subtracts time-spaced relief maps of the observed area and thereby displays only those objects which have changed position from one mapping operation to the next.
2. Blind Speed: A radial velocity at which the target will disappear from the radar presentation.
3. Cancellation Ratio: The ratio of fixed target return video level without MTI to fixed target return video level with MTI.
4. Clutter: Confused, unwanted signals, echos, or images on a radar display ("grass", for example).
5. Clutter Rejection: The measure of a system's ability to attenuate clutter.
6. Coherent MTI: An MTI system which depends on a coherent local oscillator (COHO) for its operation. Return signals are compared in phase to the COHO to determine whether the target has moved since the last pulse.
7. COHO: An oscillator whose phase is locked to the phase of a reference oscillator. In an MTI system, the COHO phase is locked to the STALO.
8. MDS: Minimum discernible signal. The lowest signal level detectable over the receiver noise level.
9. Noncoherent MTI: A general term which includes those MTI techniques using the clutter signal as a phase reference. No phase locking is required in the transmitter or local oscillator.
10. Optimum Speed Target: A target moving at one half of the first blind speed.
11. Scanning Modulation: Amplitude variations caused by antenna rotation.
12. SCV: The difference between the clutter and moving target levels, when the target is barely visible in the clutter.
13. STALO: An extremely stable local oscillator used to heterodyne with the return signal to produce the IF.
14. VOTO: A local oscillator tuned by changes in voltage.

APPENDIX A

MOVING TARGET INDICATORS

1. GENERAL

Moving target indicator (MTI) systems detect minute changes in the measured radial range of targets between successive radar pulses, and cancel the returns from stationary targets.

Two general categories of MTI systems are the coherent and the non-coherent. The coherent MTI may be either the intermediate frequency (IF) cancellation type shown in Figure A1, or the video cancellation type shown in Figure A2.

The IF cancellation coherent MTI system consists of three sections; the coherent signal section, the canceller section, and the automatic phase adjustment section. The video cancellation coherent MTI system consists of two sections; the coherent signal section and the video canceller section. The IF coherent system depends upon the change in phase between target returns for detection of a moving target. Nonsynchronous signals will be cancelled and will not appear on the radar presentation.

A noncoherent video cancellation MTI system, as shown in Figure A3, does not make phase measurements, as such, to detect the movement of a target. Cancellation depends upon the amplitude of one target return as compared with the amplitude of the next return. Nonsynchronous signals will be exhibited by the noncoherent system. The area MTI system is a noncoherent type which uses a storage tube for cancellation.

2. TESTING MTI SYSTEMS

Tests conducted in accordance with this MTP are made to determine whether the system meets applicable requirements. In general, the system should be tested to determine its ability to detect moving targets when not over clutter, over slow moving clutter, and over strong fixed clutter. It should be able to reject pulse type interference, when the design so requires. Blind speeds, blind speed widths, and scanning modulation residue (antenna rotation effects) also should be determined and evaluated.

The following paragraphs describe the various tests in this MTP that are performed on MTI systems in order to determine the adequacy of the equipment to meet specified requirements. Test procedures for MTI systems closely follow the test procedures for non-MTI systems. Practically all of the parameters are the same except for those circuits peculiar to the MTI.

2.1 Minimum Discernible Signal (MDS) Measurement Test

This test determines the smallest signal amplitude which can be detected in the receiver noise by a human operator or an automatic detection circuit.

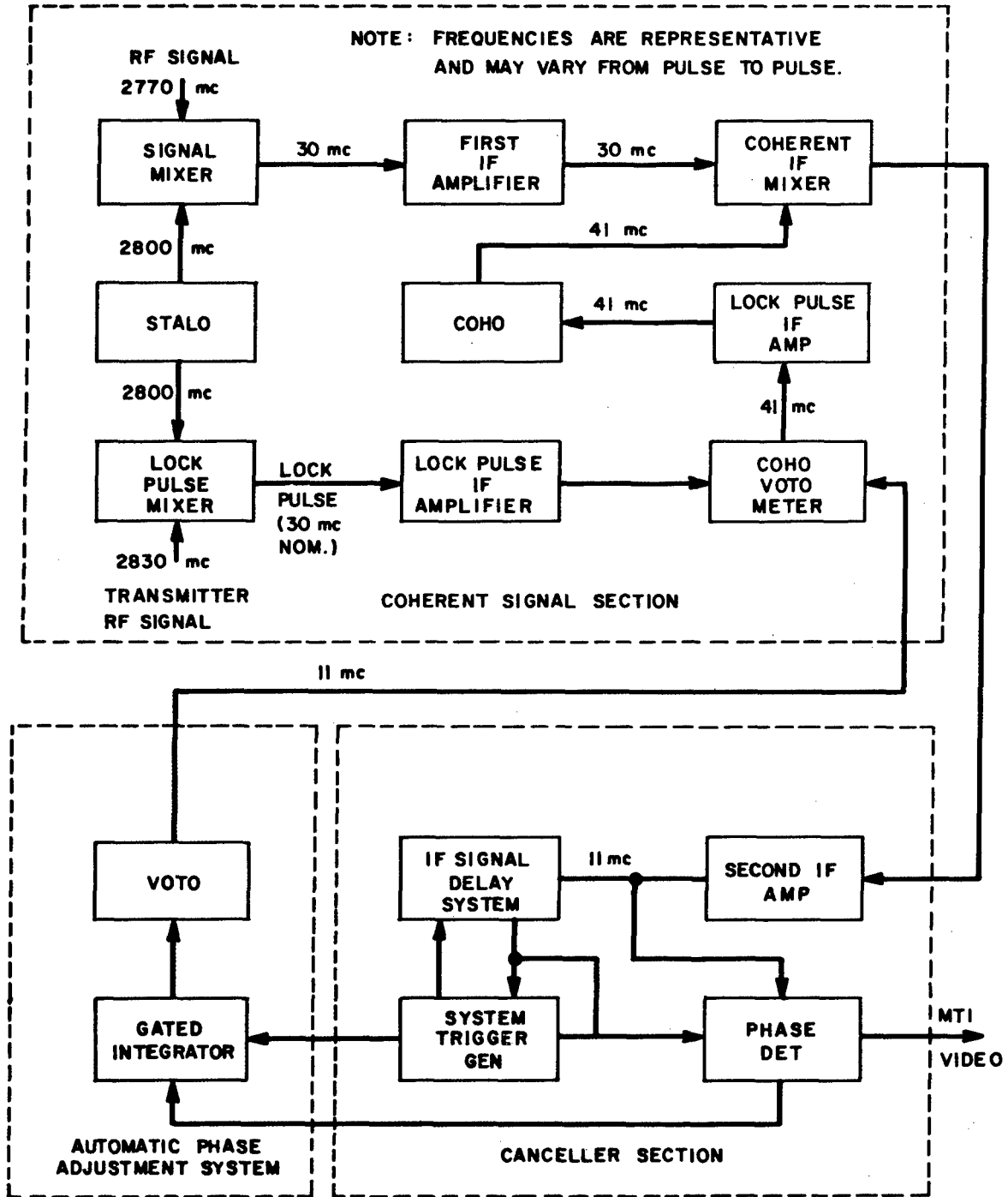

Figure A1. Coherent IF Cancellation MTI System

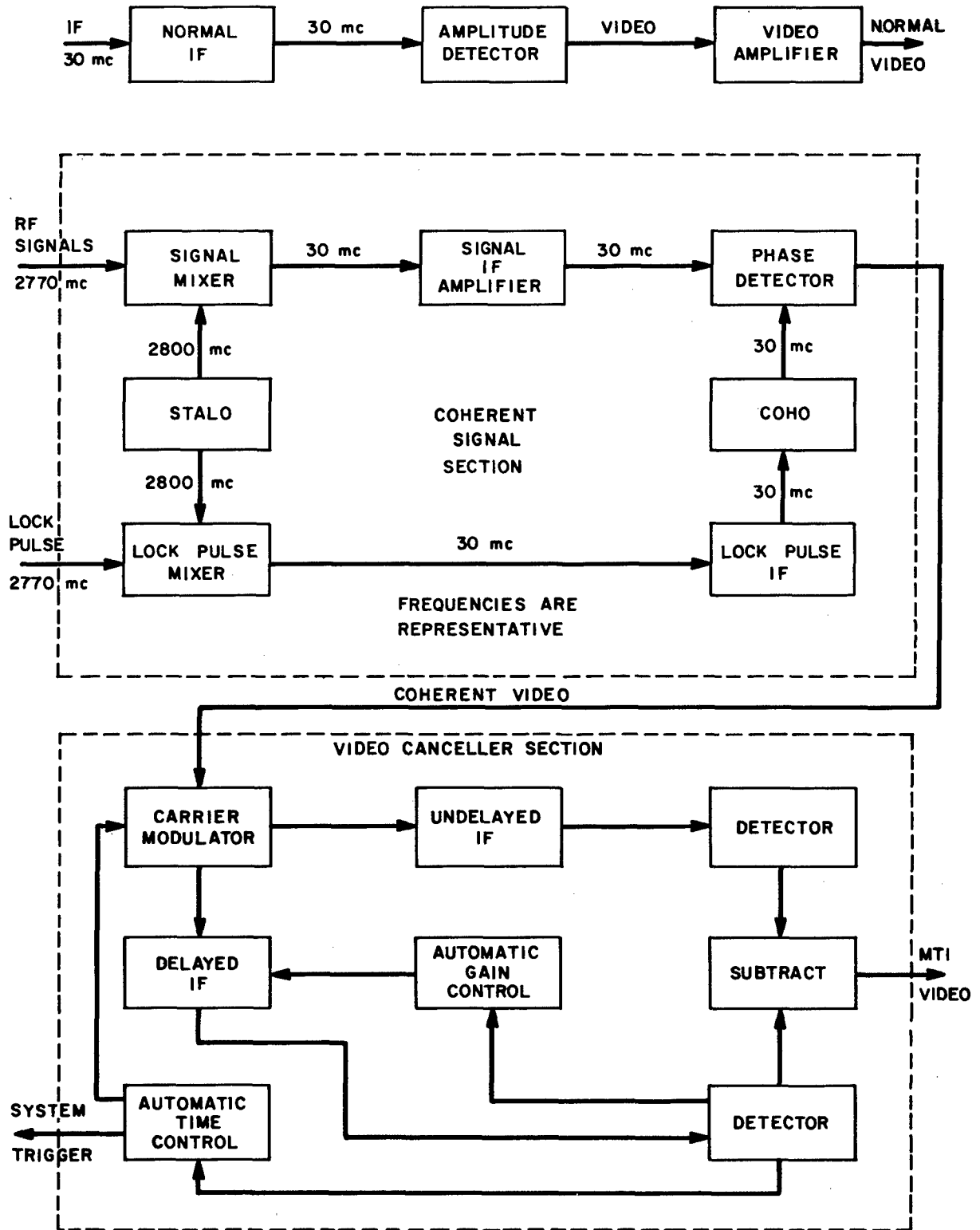

Figure A2. Coherent Video Cancellation MTI System

MTP 5-2-519
14 December 1967

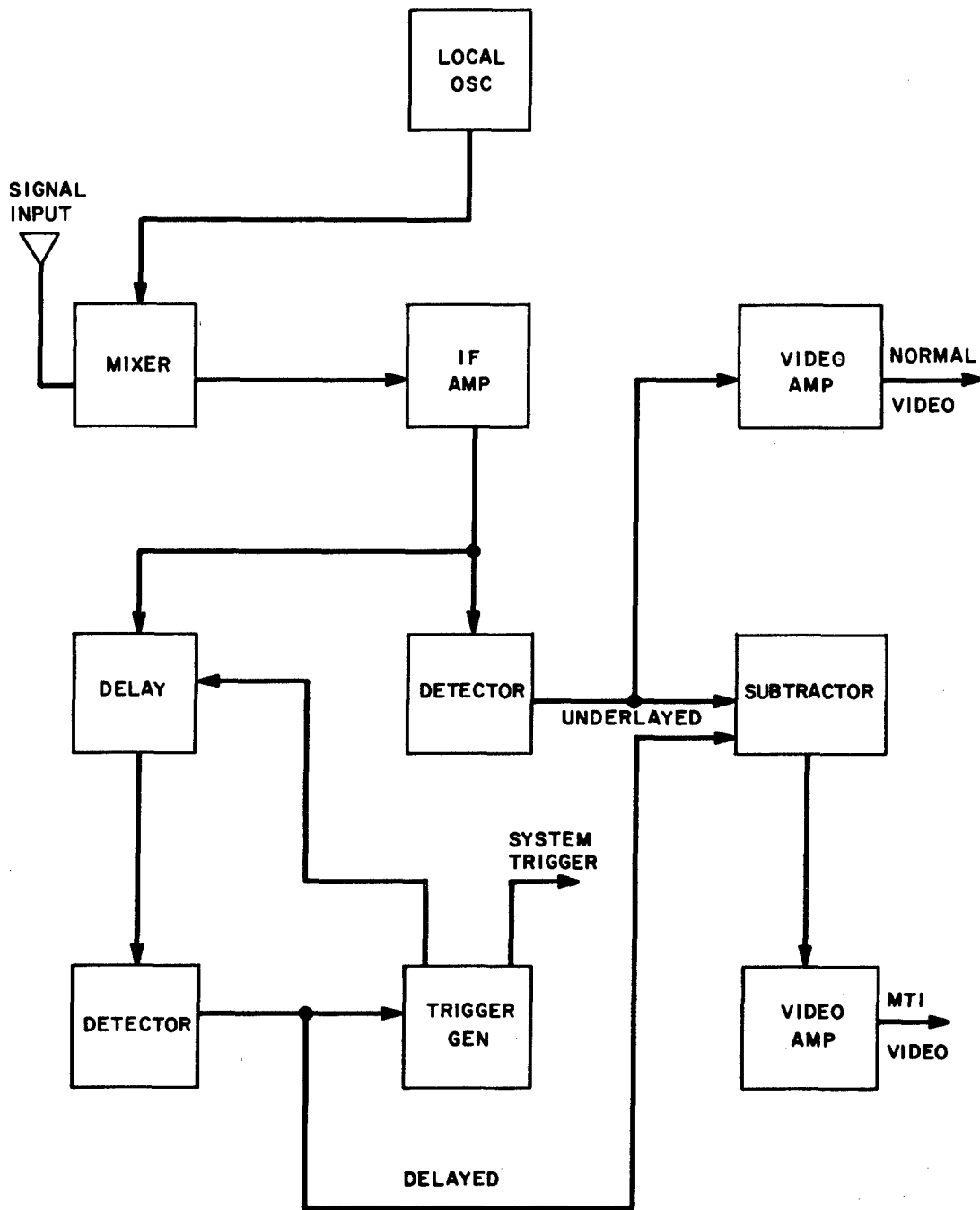

Figure A3. Noncoherent Video Cancellation MTI System

To make realistic measurements on a radar receiver, it is necessary to know the MDS level of the receiver.

The deterioration of MDS detection in the receiver will cause a serious loss of effectiveness of the radar system. MDS should be measured at regular intervals to ensure proper operation of the system. The MTI receiver may be tested for the MDS in accordance with procedures detailed in the MTP related to ground receivers, as well as with any special tests on a specific unit which may be required to assure compliance with applicable field requirements. One method of making MDS measurements is presented in this MTP for information.

2.2 Clutter Amplitude Measurement Test

This test is used to determine the relative amplitudes of extraneous signals and the minimum discernible signal.

The amplitude of clutter may be measured by any of several methods. One method may be superior when applied to a particular radar system, while the same method may be inferior when applied to a different system. The method described in this MTP is adaptable to almost any radar system.

2.3 Subclutter Visibility (SCV) Test

This test determines the ability of the MTI to distinguish between weak moving target echoes and clutter.

Subclutter visibility provides a measure of the ability of an MTI system to detect relatively weak moving targets over a clutter area while removing clutter from the radar presentation. An SCV value of approximately 25 decibels (db), or more, is reasonable. Actual design center values of SCV are specified by the equipment design requirements.

2.4 Clutter Rejection Test

This test is used to measure the residual background signals.

Clutter rejection can be measured by any of several methods. The method presented in this MTP is somewhat more accurate than other equally reliable methods. In cases where the results are extremely important, a cross check using another method is recommended. All of the methods measure the maximum clutter level in the normal mode, followed by measurement of the residual clutter plus noise in the MTI mode. When the minimum clutter is as designated in the receiver specifications, the maximum clutter is the clutter rejection figure. Receiver specifications (for receivers having MTI circuits) will indicate the residual clutter level to be expected for the system under test.

2.5 Blind Speed Test

This test determines the target radial velocities at which no radar return signal is presented.

Blind speeds are common to all contemporary single pulse repetition frequency (PRF), coherent MTI systems. Blind speed is a function of the radial velocity of a target with respect to the radar location. For example, when the radial velocity of a target aircraft is equal to that of a multiple of the first radar blind speed its echo will disappear from the radar presentation; it will reappear when the aircraft has accelerated or decelerated to a radial velocity between multiples of blind speed.

The blind speed interval is the difference between radial velocities at which blind speeds occur. The differences are discrete intervals, and their limits occur at multiples of the first blind speed.

The blind speed width is the velocity interval during which a radially accelerating or decelerating target is not visible on the radar presentation. For example, the echo of an accelerating target approaching the radar disappears as the radial velocity reaches 198 knots, and reappears when the velocity increases to 202 knots; the blind speed width in this case is four knots.

The blind speed width of an MTI system is a measure of the system's ability to detect targets which have radial velocities differing only slightly from the blind speeds of the system. A change in the blind speed width indicates a malfunction in the system parameters.

2.6 Scanning Modulation Test

This test determines the effect of antenna rotation upon the amplitude of the clutter.

The effects of antenna rotation can be determined by accurately measuring the clutter amplitude in several isolated areas on the radar presentation while the antenna is rotating, then stopping the antenna at the azimuth of the lowest clutter area noted and measuring the change in the amplitude of the clutter.

2.7 Nonsynchronous Signal Rejection Test

This test determines the ability of the MTI to reduce random signal interference.

These tests may be conducted by operating the radar in the MTI mode while radiating a nonsynchronous pulse signal in the field of the antenna. The MTI circuit will reduce the pulse interference by the rejection level of the MTI. Applicable specifications will state the exact level of interference reduction to be measured by this test.

2.8 Miscellaneous Tests

2.8.1 Dynamic Range Test

If the dynamic range of the MTI receiver does not meet operating requirements, the receiver will overload on strong signals and destroy the effectiveness of the entire system. The dynamic range is tested as outlined in referenced procedures, and in any special tests dictated by the operating requirements.

2.8.2 Automatic Gain Control and Automatic Frequency Control Tests

The automatic gain and frequency controls should be tested as outlined in referenced procedures, and in any special tests dictated by the operating requirements.

2.8.3 Local Oscillator Measurements

The stable local oscillator (STALO), coherent oscillator (COHO), and voltage tuned oscillator (VOTO), should be tested for stability, accuracy, output level, sensitivity to feedback power, and tuning range. These measurements are made as outlined in referenced procedures, and in any special tests dictated by the operating requirements.