

AD 659366

AFOSR 67-0300

R

OCT 26 1967

# afosr research

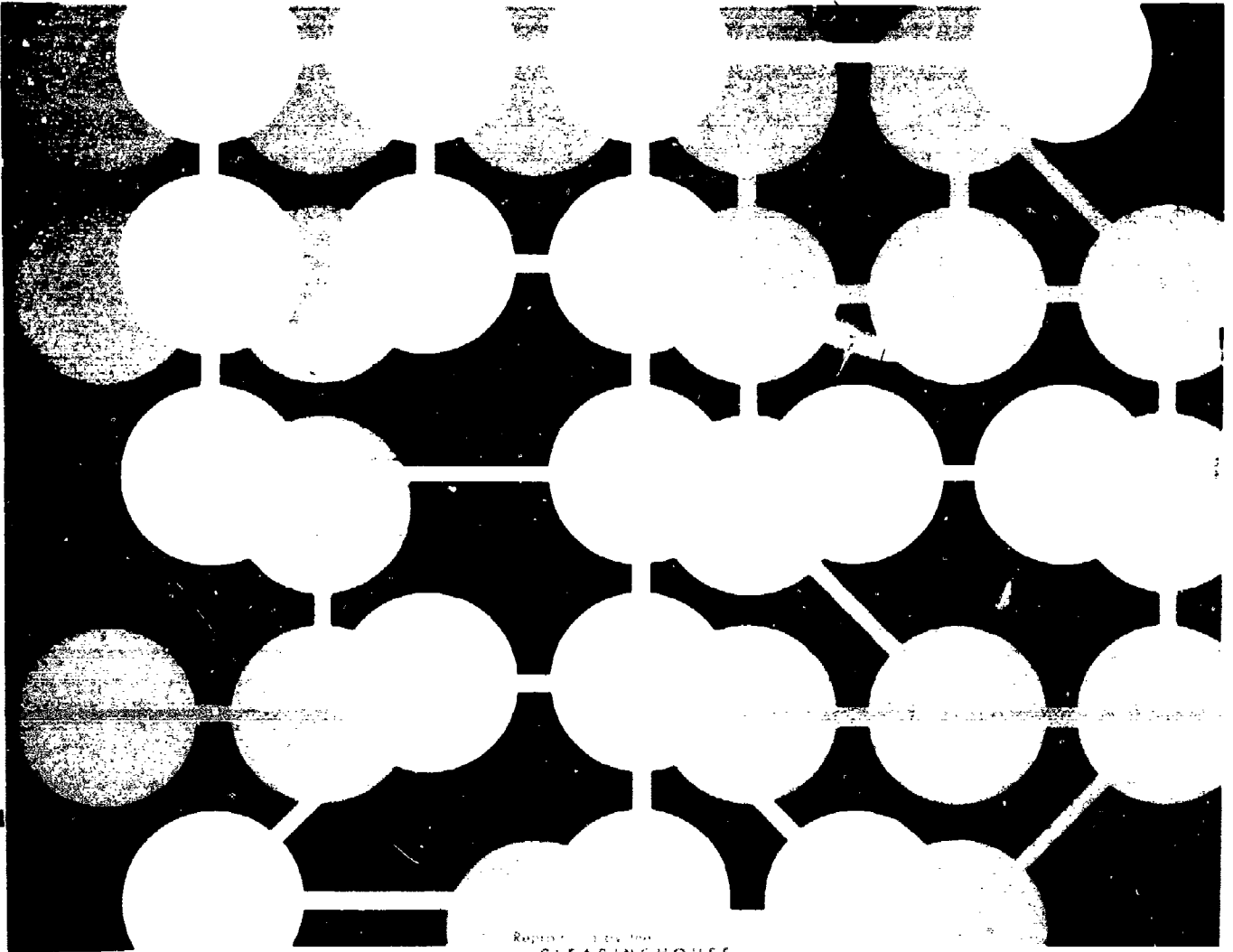

Reprinted by the  
CLEARINGHOUSE  
for Federal Scientific & Technical  
Information Springfield, Va. 22151

**AIR FORCE OFFICE OF SCIENTIFIC RESEARCH**  
**Office of Aerospace Research ☆ USAF**  
**Arlington, Va 22209**



# **afosr research**

*The Current Research Program, and a  
Summary of Research Accomplishments*

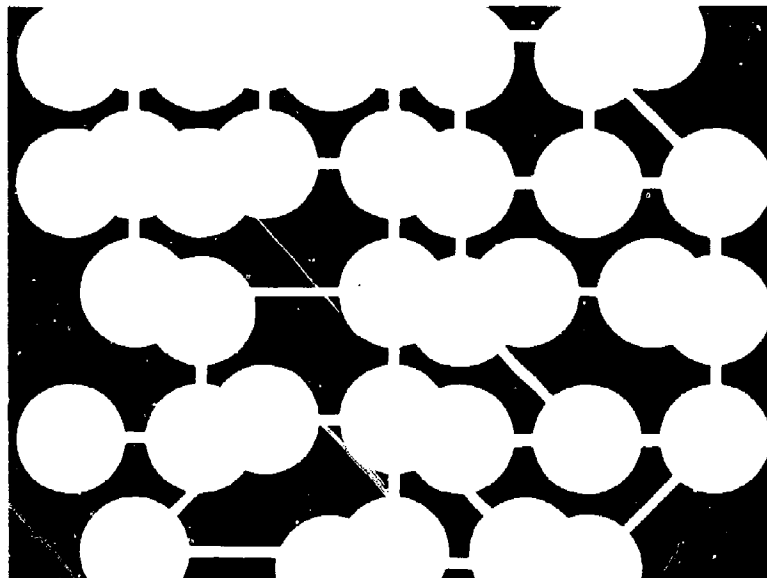

**AIR FORCE OFFICE OF SCIENTIFIC RESEARCH**

*Office of Aerospace Research, USAF  
Arlington, Va. 22209*

**AFOSR 67-0300**

## *Preface*

The Air Force Office of Scientific Research is the extramural research component of the Office of Aerospace Research, USAF, the research agency of the Air Force. OAR is commanded by Maj. Gen. Ernest A. Pinson, USAF.

AFOSR conducts a grant and contract program of phenomena-oriented research in those areas of science related most directly to needs of the future operational Air Force. AFOSR's worldwide research program requires an annual expenditure of more than \$35 million, and provides support for about 2,400 scientists. They are engaged in nearly 1,000 separate research investigations at more than 200 university, industry and other research organizations. Research is selected for support from unsolicited proposals on the basis of scientific quality and relevance to Air Force interests. Research is supported in chemistry, mathematics, electronics, mechanics, energy conversion, general physics, nuclear physics, solid state physics, astronomy-astrophysics, and the behavioral, biological and information sciences.

AFOSR also serves to provide communication between the scientific community and other Air Force and DOD organizations, thus helping to ensure the timely impact of scientific research activities on the Air Force. AFOSR serves the Air Force by providing and communicating results of pioneering extramural research to potential users, by transmitting needs for scientific information to the scientific community, by providing outside scientific advice and consultation to all parts of the Air Force requiring knowledge and interpretation of world science, and by in general maintaining and enhancing the Air Force relationship with the scientific community.

This report is designed to present the research programs of the Air Force Office of Scientific Research for the information of the users of Air Force research, for scientific investigators working in the same or in allied fields, and for the military, scientific and academic, and Government communities at large.

It is intended that this report will help provide ready access to research in progress as well as that completed and just beginning to come into the scientific literature, so that the results of these investigations will become more readily available. By making use of the list of work efforts, organized in terms of specific scientific fields, scientists and engineers in DOD laboratories and various research and development organizations can ascertain which active AFOSR programs are of interest to them. To obtain detailed information, direct contacts are encouraged with the AFOSR staff member listed as responsible for the work effort of interest.

Research managers in the DOD and other Government agencies will find this report convenient for research coordination purposes. Contractors and grantees supported by AFOSR will be able to see how their programs fit into the over-all AFOSR research program. Those within and outside the DOD who are interested in broad questions on the support of research and development should find this report useful insofar as it provides comprehensive information on the objectives, research program, and accomplishments of AFOSR.

WILLIAM J. PRICE,  
*Executive Director.*

JULY 1967.

## Contents

	Page
<b>AFOSR Organization</b>	
The Role of AFOSR, <i>Dr. William J. Price, Executive Director</i> . . . . .	3
The Relevancy of the AFOSR Research Program to the Operating Needs of the Air Force, <i>Col. Ivan C. Atkinson, Deputy Executive Director</i> . . . . .	7
AFOSR Scientific Staff and Board of Visitors . . . . .	10
AFOSR History and Chronology . . . . .	12
<b>AFOSR Research Program</b>	
Mathematical Sciences, <i>Dr. Merle M. Andrew, Director</i> . . . . .	21
Current Research Efforts . . . . .	25
Physical Sciences, <i>Dr. Lloyd A. Wood, Director</i> . . . . .	29
Current Research Efforts . . . . .	41
Chemical Sciences, <i>Dr. Amos G. Horney, Director</i> . . . . .	49
Current Research Efforts . . . . .	55
Life Sciences, <i>Dr. Harvey E. Savely, Director</i> . . . . .	59
Current Research Efforts . . . . .	61
Engineering Sciences, <i>Dr. Milton M. Slawsky, Director</i> . . . . .	66
Current Research Efforts . . . . .	69
Information Sciences, <i>Dr. Harold A. Wooster, Director, and Mrs. Rowena W. Swanson, Project Scientist</i> . . . . .	76
Current Research Efforts . . . . .	81
<b>AFOSR Research Accomplishments</b>	
Relating the Accomplishments of AFOSR to the Needs of the Air Force . . . . .	85
<i>Dr. William J. Price, Executive Director</i>	
<i>Mr. William G. Ashley, Physical Sciences Administrator, OAR</i>	
<i>Maj. Joseph P. Martino, Assistant Executive Director for     Research Communication</i>	
Mathematical Sciences	
Automata Theory, <i>Lt. Col. Barnett R. Agins</i> . . . . .	95
Control Theory, <i>Maj. John Jones, Jr.</i> . . . . .	98
Probability Theory and Mathematical Statistics, <i>Maj. John     F. Gander</i> . . . . .	102
Nonlinear Partial Differential Equations, <i>Dr. Robert G. Pohrer</i> . .	107
Physical Sciences	
Magnetic Resonance Spectroscopy, <i>Dwight L. Wennersten</i> . . . .	112
Spectroscopy in the Millimeter and Submillimeter Region of the Electromagnetic Spectrum, <i>Dr. Marshall C. Harrington</i> . .	116
Seismology, <i>William J. Best</i> . . . . .	120
Project Blue Ice, <i>Maj. Durward D. Young, Jr.</i> . . . . .	122
Observational Basis of General Relativity, <i>Dr. Erich Weigold</i> . .	126
Cosmic Ray Physics, <i>Maj. Joseph E. Gorrell</i> . . . . .	129

	Page
Theoretical Elementary Particle Physics, <i>Capt. Donald R. Lehman</i> .....	132
Crystal Nucleation and Growth, <i>Lt. Col. Ralph W. Conners</i> ...	135
Interactions of Ultrasonic Waves in Metals, <i>Max Swerdlow</i> ...	139
The National Magnet Laboratory, <i>Max Swerdlow</i> .....	143
Structural Materials for High Temperatures and Reactive Environments, <i>Dr. J. Thomas Ratchford</i> .....	147
Application of Emittance Measurements in Ablation Test, <i>Lt. Col. Randal A. Houdobre</i> .....	151
<b>Chemical Sciences</b>	
Liquid Structure, <i>Denton W. Elliott</i> .....	156
Energy-Matter Interactions, <i>Dr. Alfred Weissler</i> .....	161
Organometallic Chemistry, <i>Dr. Anthony J. Matuszko</i> .....	165
Rapid Scan Infrared Spectroscopy, <i>Dr. William J. Ruigh</i> .....	169
<b>Life Sciences</b>	
Simulation as a Social Science Research Tool, <i>Dr. Herman J. Sander</i> .....	171
Visual Perception, <i>Dr. Glen Finch</i> .....	174
Instructional Technology, <i>Maj. Laurence G. Goebel</i> .....	176
Bird-Aircraft Collisions, <i>Dan Taylor</i> .....	178
<b>Engineering Sciences</b>	
A Whistler Study of the Magnetosphere, <i>Maj. Frank H. Zander</i> .....	183
A New Dimension in Hypersonic Laboratory Simulation—The Wave Superheater Hypersonic Tunnel, <i>Milton Rogers</i> ...	186
The Effect of Vacuum and Surface Layer on the Fatigue Life of Metals, <i>Dr. Jacob Pomerantz</i> .....	194
Mass Transfer Cooling, <i>Lt. Col. George Stalk</i> .....	197
The Magneto-Plasma-Dynamic (MPD) Arc, <i>Maj. Russell G. Langlois</i> .....	201
Oxygen Atom Attack of Refractory Materials, <i>Lt. Col. Cornelius J. Donovan</i> .....	206
Electron Beam Fluorescence as a Diagnostic Tool in Low Density Gas Dynamics, <i>Paul A. Thurston</i> .....	210
Supersonic Combustion, <i>Dr. Bernard T. Wolfson</i> .....	213
<b>Information Sciences</b>	
Influences From Cybernetics on Information Sciences, <i>Mrs. Rowena W. Swanson</i> .....	217
The Computer and Its Languages, <i>Capt. Eliot Sohmer</i> .....	219
The AFOSR Coupling Program, <i>Maj. Joseph P. Martino, Assistant Executive Director for Research Communication</i> .....	223
Research Evaluation Through Citation Indexing, <i>Maj. Joseph P. Martino, Assistant Executive Director for Research Communication</i> . . .	226
AFOSR-sponsored Conferences and Symposia, 1966 .....	228
AFOSR Selected Publications List—Primary Sources of Additional Data .....	229

## FIGURES

	Page
1. Block diagram for optimal system for lunar hovering mission.....	100
2. Simplified diagram of microwave spectrograph.....	117
3. Location of seismometers at Station Inge Lehmann, Greenland....	125
4. Effect of dissolved iron on critical resolved shear strength of MgO crystals.....	150
5. Experimental setup for ablation tests.....	154
6. A representation of clathrate hydrate obtained by X-ray diffraction.	160
7. Dimerization reaction schemes.....	162
8. The triphenyl(bipyridyl)siliconium ion.....	167
9. Unit of phthalocyaninosiloxane polymer.....	167
10. Wave superheater rotor and nozzles.....	190
11. Gasdynamic processes in a single unconfined tube.....	191
12. Wave superheater reservoir map.....	192
13. Flow chart: wave superheater facility.....	192
14. Wave superheater flight simulation.....	193
15. Mass injection into boundary layer using transpiration cooling, evaporation or reacting surface.....	198
16. Effect of coolant choice on heat transfer rate.....	198
17. Thermodynamic coupling effect for helium injection through porous plate ( $2.6 < M < 4.3$ ).....	199
18. Stagnation point mass injection in hypersonic flow.....	200
19. Thermal efficiency for several cooling techniques.....	201
20. Schematic cross section of the magneto-plasma-dynamic arc.....	202
21. Filament oxidation apparatus (schematic).....	207
22. Oxidation probabilities for molybdenum.....	208
23. Oxidation probabilities for graphite.....	209
24. Oxygen atom nonequilibrium regimes during re-entry.....	209
25. Light output vs. pressure for an electron beam through air at room temperature.....	211
26. Excitation and emission paths for the $N_2^+$ first negative system ex- cited by fast electrons.....	212
27. Electron beam density and temperature measuring system in a hypersonic shock tunnel.....	213

---

## **AFOSR Organization**

---

**Preceding Page Blank**

## *The Role of AFOSR*

DR. WILLIAM J. PRICE, *Executive Director*

During the past 3 years an extensive reevaluation of the Air Force Office of Scientific Research has been in progress within AFOSR and its parent command, the Office of Aerospace Research. This examination has been directed toward further increasing the effectiveness of AFOSR in performing its mission of helping to strengthen the future operational Air Force through scientific research activities.

These studies make it abundantly clear that the Air Force is dependent on science in many ways. Thus AFOSR is challenged to carry out its business in such a manner as to optimize the benefits accruing to the Air Force from scientific research activities, whatever their nature or location.

The reevaluation has thus dealt with a variety of matters including the past accomplishments of AFOSR, the relationship of AFOSR to both user agencies and other research agencies, the type of activities sponsored, and the distribution of research efforts among the various scientific disciplines. Concurrently, we have studied the more general questions of the interaction between science and technology, and of the changing patterns in the support of research in the U.S.A., particularly trends in both roles of individual research support agencies, and in funds available for this support. We have given particular attention to the role of AFOSR in light of these various factors.

This essay summarizes some of our findings. One central theme emerges—that the current AFOSR is a highly viable organization. We find that AFOSR has an important mission to perform, that it has an excellent reputation with the scientific community as a good research agency with which to work, that it has a good record of accomplishment on which to build, and that it has a competent and dedicated staff to manage the programs of the future. We believe that any future increase in effectiveness will come from careful building upon this foundation.

## *The Interaction Between Science and Technology*

We have been carrying out studies which have provided us with a large increase in specific information showing how the Air Force has benefited from the AFOSR program. Part of this material is presented as accomplishments in this report in the form of individual subject area papers by AFOSR program managers and through the summary paper "Relating the Accomplishments of AFOSR to the Needs of the Air Force." In the course of these studies we have collected and analyzed information about the interaction between science and technology (1).

We find it is helpful in discussing the interaction between science and technology, as well as in describing AFOSR and its accomplishments, to divide research and development activity into two broad categories, phenomena-oriented science and technology. In technology, creative efforts are primarily concerned with synthesis; that is, integration of previously existing knowledge components into operational capability—for example, systems, devices, processes, methods, and materials. In contrast, phenomena-oriented science is more heavily concerned with the origins of the knowledge components themselves.

Here both applied science and engineering developments are classified as parts of technology. Applied science is so named because its goal is some sort of application of scientific principles. Thus the name comes from the goal. A phenomena-oriented scientist concerns himself with the elucidation of natural phenomena. Thus his goal is the study of phenomena, and consequently, it is reasonable to call his activity "phenomena-oriented science."

As new phenomena are understood, this new knowledge is made available to the scientific and technological communities in many ways. However, it is important to note that the new information becomes known by the peer group in the world scientific community much sooner than it is known by other groups, particularly those associated primarily with technology. Important new knowledge is known to members of the "invisible college," that is, those researchers active in the particular segment of the research front, well in ad-



vance of any formal written publication. Thus new science forges ahead, relatively independent of an ambient technology.

Similarly, technology usually feeds upon technology, in the presence of an ambient science. It has become increasingly clear, especially to the historians of science, that technology events are usually initiated within technology. This means that usually it is difficult to establish a unique correlation between an important technological event and one within phenomena-oriented science. One well-known exception is nuclear power, and its origin in the discovery of nuclear fission. Our study shows that one does not usually find phenomena-oriented research producing a new and unexpected opportunity which then stimulates a new engineering opportunity. (This observation is consistent with those of other recent studies on science and technology interaction (2, 3, 4)). Instead, we find phenomena-oriented research supporting technology in many other important ways.

Thus the gross picture is that technology usually feeds upon technology and phenomena-oriented science usually feeds upon phenomena-oriented science. However, at the same time we find that there is a strong important interaction (almost a symbiosis) between the two spheres of activity.

It is found that the science-technology interactions leading to utilization of phenomena-oriented research are usually initiated by persons who, having the urgent need for knowledge, search for the solution through prior research. The scientists who are consulted also play a very key role on their side of the dialogue, providing knowledge and interpretation from their field.

The fact that new knowledge originating in phenomena-oriented research often has implicit in it important new opportunities for exploitation means that when these can be recognized on the research side, great advantages, particularly in timing, can be realized. This is an important area for increased attention by phenomena-oriented research activities, toward the end that initiative can be successfully taken by the scientist more frequently.

Our conclusion from these studies is that the conventional picture, which emphasizes a process with unique scientific events being followed in an orderly manner by applied research, development, etc., is usually not borne out. Since that picture appears to be the exception rather than the rule, it is misleading to attempt to elucidate the contribu-

tion of phenomena-oriented science by studying this process primarily. In fact, the failure to observe a large number of such cases could lead to a nonobjective backlash in which the real (and very important) process involving the flow of an immense number of items of information across the technology-science interface is not recognized.

#### *The Role of AFOSR*

We have studied the mission which AFOSR has performed over the years, its accomplishments, and the studies which the National Academy of Sciences is making through its committee on science and public policy, particularly those studies which have dealt with the definition of the role of a research agency in a mission-oriented organization (5, 6); we have assessed the impact of the growing number of research agencies on the AFOSR mission (6); we have studied the analogy between the role of AFOSR in the USAF and that of other fundamental research activities in a mission-oriented parent organization, for example, the corporate research laboratory in a large industry (7). Particularly, we have studied the needs of the Department of Defense in view of the nature of the interaction between science and technology and the capability of the AFOSR to support the DOD. These studies have led us to describe our current role as follows.

One may think of AFOSR as a research institute made up of the AFOSR staff and various advisers as research institute managers, and the contractors and grantees performing research. This institute concept may be visualized as an activity which, by providing an interface with both the scientific community and the Air Force, improves the interaction between them. Both interfaces are of course very important.

AFOSR is well-suited to providing the required interfaces. Since it has a well-established reputation in the scientific community as a good research agency with which to work, it attracts the interest of the world's top scientific talent. At the same time, staff members of AFOSR have the mission, experience and techniques required for identifying DOD problem areas and translating them into scientific research opportunities or in reverse, in translating scientific knowledge and understanding into results for DOD users.

In this interface role between science and technology, the AFOSR research institute performs

two major functions. First, it accomplishes research, thus helping to colonize relevant scientific knowledge, and second, it provides communication between the scientific community and using agencies.

The selection of research areas in which to accomplish Air Force supported phenomena-oriented research may be motivated by helping a development group solve certain difficult classes of relatively short-term technical problems through a fuller understanding of the phenomena behind them, or as is more common, by seeking to open new fields of science holding out high promise for generating new knowledge needed to help evolve future technologies. The strategy is to attempt to colonize<sup>1</sup> those areas selected to be particularly relevant to the long-term interests of the USAF. The selection of these areas continues to be the most important challenge faced by the AFOSR.

The communication provided by the research institute is two-way—needs to the research program and scientific information to the users. We provide this communication by engaging in many types of coupling activities. For example, part of what we purchase through contracts and grants is primarily designed to provide communication. This part refers not only to the symposia we sponsor, but also to the connecting-type research which allows us to keep abreast of a variety of those scientific areas largely supported by other agencies, in which rapidly emerging scientific developments of possible importance to the Air Force are taking place.

The management responsibility for this coupling lies with the individual AFOSR program managers. This part of their function is essentially an open-ended one—that is, the opportunities are essentially limitless. It is one in which professional knowledge and ingenuity have a high premium.

Regardless of the background with which an AFOSR staff scientist comes to the job, he must keep his contacts with counterparts in the Air Force applied research-exploratory development community current. Here personal contacts are

<sup>1</sup> Colonizing may be described as increasing the chance of important discovery in an area deemed to hold promise for the Air Force by "raising the temperature" of the world's scientific activity in that field. Through judicious support of phenomena-oriented research and other activities such as symposia, the Air Force has helped colonize the activity in numerous research areas, with the result that the Air Force research support, amplified by that supported by non-Air Force funds, has affected very significantly the rate of development of important scientific areas.

made by visits, correspondence, special reports, program reviews, participation in joint task groups, etc.

Some of the most meaningful coupling activities are those which directly involve the research scientists AFOSR has under contract. We find that scientists around the country are very able and willing to participate directly in Air Force activities in many ways. The article "The AFOSR Coupling Program," elsewhere in this volume, describes the growing role which AFOSR is playing in communication between science and technology.

There are other direct roles played by the AFOSR research support which, although secondary in importance when compared with the two described above, are nevertheless important. These include education of graduate students in fields particularly relevant to the DOD; the providing of research support which makes it possible for many consultants for aerospace industries, and government to keep their expertise; and the strengthening of U.S. science by having multiple sources of support available.

AFOSR also provides the DOD with a quick reaction, program management and procurement organization for accomplishing special activities requiring the participation of the scientific community. Examples include the new scientific investigation of unidentified flying objects, the public reaction studies to sonic boom produced by the supersonic transport, the DOD Project Themis, a program to strengthen the Nation's academic institutions, and numerous projects for the Advanced Research Project Agency of the DOD.

#### **The Challenge Faced by AFOSR**

New knowledge and understanding properly utilized represent power—the possibility of bringing about effective solutions to some of society's problems on a timely basis, the competitive edge of one industry over another, or the defense of one's country against another with alien purposes. With the rapidly expanding body of both knowledge and application, the time from understanding to use has been continually decreasing and the ability of an organization to change accordingly has become a very important factor.

New scientific research is typically packaged in terms of scientific disciplines, while society's problems almost always appear in other forms. There-

fore, there are special interface problems of a particularly challenging nature which need to be worked out in providing effective communication.

Of course, engineers and others with similar responsibilities must always play a key role in the required communication; this is well recognized. However, the role of the scientific community is not recognized or understood nearly as fully. As a matter of fact, in some quarters there is still the misconception that "good" science should be "pure academic research" where the concept of purity implies a conscious and even self-righteous disengagement from utility (8).

The primary challenge to AFOSR is to help assure that the scientific part of this interface activity is performed in an optimum manner. Toward this end we are committed to the support of phenomena-oriented scientific research activities because we believe that this support brings the Air Force very direct benefits that cannot be obtained through research which is closely allied to the end items nor through fundamental science support by other agencies. We are committed to the unapologetic support of research which is admittedly strongly science-oriented. The major contribution of AFOSR is that we provide mechanisms by which highly creative science-oriented persons are involved in the Air Force program in ways which both we and they agree to be mutually beneficial. We are thus at least partially tapping this important potential for the continued strengthening of the defense of the country.

In carrying out these activities, we meet two special challenges of a continuing nature. First, how does one optimize the distribution of our effort among possible areas of interest? While the AFOSR program will always cover a wide spectrum, it is dominated by those fields clearly relevant to the Air Force. However, a narrow definition of mission relevance must not be allowed to restrict this distribution unduly.

The second challenge is to work creatively and

effectively in catalyzing the very important interaction between science and technology. For example, our studies referred to earlier indicate that although new scientific knowledge is disseminated within the scientific community quite soon after its discovery, often considerable time elapses before it becomes known to those primarily concerned with utilizing it. The results of our growing coupling program at AFOSR, which among other things is aimed at reducing this time, encourage us that this part of our mission is indeed a fruitful one.

In conclusion, I wish to state that AFOSR is managing a research program which is oriented to meet the needs of the Air Force. Whether we are choosing these areas in which to support research or whether we are promoting the all-important dialogue between the scientific community and those seeking to use science for defense purposes, our aim is to manage a research program tailored to meet the DOD needs.

#### REFERENCES

- (1) W. J. Price, *OAR Research Review* V, 10 (1966).
- (2) M. Tannenbaum and committee members, "Report of the Ad Hoc Committee on Principles of Research-Engineering Interaction" (National Academy of Sciences-National Research Council Materials Advisory Board, MAB-222-M, July 1966).
- (3) Derek de Solla Price, *Technology and Culture* 6, 4 (1965).
- (4) Project Hindsight (DOD Reports).
- (5) "Basic Research and National Goals," A Report to the Committee on Science and Astronautics, U.S. House of Representatives (National Academy of Sciences, March 1965).
- (6) Harvey Brooks, "Past Achievements and Future Foci of the Federal Government in Science" (Vicennial Convocation Address, May 1966).
- (7) "The Fundamental Research Activity in a Technology-Dependent Organization," 10th Institute on Research Administration, Center for Technology and Administration, The American University (AFOSR 65-2691, April 1965).
- (8) P. P. Medawar, *Encounter* 25, 2 (1965).

## *The Relevancy of the AFOSR Research Program to the Operating Needs of the Air Force*

COL. IVAN C. ATKINSON, *Deputy Executive Director*

The value of AFOSR to the Air Force comes through the exercise of our capability for providing an effective bridge between the needs of the Air Force and the opportunities inherent in the continually emerging frontiers of science. Our challenge is to help assure the maximum impact of new scientific activities throughout the world on the future operational Air Force. The relevancy of the AFOSR research program is a measure of the degree to which the overall impact is maximized.

### *The Key Role of AFOSR Program Managers*

AFOSR is ideally suited to provide an effective bridge between the Air Force and science. On the one hand our program managers are in an excellent position to determine the Air Force needs and to orient the scientific activities which they select to meet these needs. On the other hand, being organized as we are in terms of scientific disciplines and having the reputation as a good research agency with which to deal, we attract the interest and participation of the leading scientists, those persons who actually have their choice of sources of funds. Thus we are able to involve highly creative scientists in activities relevant to the Air Force and to do this in ways that both the Air Force and the scientific community agree to be mutually beneficial.

Guidance as to the Air Force needs comes to AFOSR in several forms. Information as to the Air Force mission in space functions, limited conflict, strategic offense, air defense, training, logistics, and other areas obtained from such sources as the document, "USAF Planning Concepts (The Plan)," and from major speeches of the Secretary of the Air Force, Dr. Brown, and the Chief of Staff, General McConnell. Many more specific needs are referred to us from higher headquarters

and by other parts of the Air Force. We establish special studies, as for example the "Seminar Series on Long-Range Problems of Limited War" and the "Workshop on Fundamental Problems of Future Aerospace Structures" to bring into better focus various parts of the Air Force research needs. We participate in the formulation of the "OAR 5-Year Plan" on an annual basis. We have inputs from the Air Force RDT&E Community through our in-house advisory committees and through the many informal visits between AFOSR program managers and the Air Force user organizations.

Through these and other mechanisms, AFOSR keeps abreast of the needs of the Air Force. Utilizing this information, the AFOSR program manager matches the needs of the Air Force and the opportunities present in emerging new science. Clearly then the AFOSR program managers serve a key role in assuring relevance.

### *The Relevant Program is the Balanced One*

In order to make the optimum contribution to its mission, AFOSR must have the proper balance in the various activities in which it engages. The preceding article discusses the various AFOSR roles in colonizing areas and in providing communication between science and users, for example. A variety of activities are equally relevant to fulfilling the AFOSR mission of providing the various elements in the proper balance. Certainly the main part of our activity must always be placed on new sciences or new aspects of sciences which show particular promise for technological application to future Air Force operations. This research attempts to colonize new fields of science holding high promise for scientific discovery from which innovations can arise. Results or their possible applications cannot be forecast with any degree of certainty. The problem is to select from a large number of possible research projects those which hold the most promise of scientific progress toward general goals of long-term Air Force interest.

Another important category of AFOSR activity is aimed at helping development groups solve certain difficult classes of relatively short term technical problems through a fuller understanding of the phenomena underlying them. The initiation

of this type of research requires a high degree of awareness of Air Force research needs on the part of both the AFOSR project scientists and the investigators. However, while the scope of the inquiry is fashioned with these interests in mind, the investigators retain a great deal of freedom as to methods of approach and otherwise bring the full force of fundamental research methods to these more applied problems.

To maintain balance, a minor but very important part of our activity must be in keeping abreast of a variety of scientific areas, largely supported by non-Air Force agencies, in which rapid and significant developments of importance to the Air Force are taking place. This is the connecting-type of support. AFOSR does this by selecting researchers not only for the quality of their work but also for their ability to provide advice and information regarding the entire field in which they are working.

By keeping these various activities in proper balance, the Air Force will be benefitted to the greatest degree. This is an area in which there is a high premium on the judgment and foresight of the program managers. There are many pressures, not the least of which being the desire of the program manager to show tangible results, which cause the program to tend toward shorter range problems areas. On the other hand, too little concern with utility works against the highly important dialogue between science and technology which AFOSR provides.

#### *The Research-Technology Interface*

A comprehensive discussion of all the aspects determining relevancy is beyond the scope of this paper. "Relating the Accomplishments of AFOSR to the Needs of the Air Force," included in this volume, is one such broad discussion. I shall restrict my remarks to relevancy of the AFOSR program to Air Force technology requirements.

The AFOSR mission statement includes the phrase "Supports programs of extramural research designed to provide new scientific knowledge and understanding in those areas of science which offer the greatest potential for improving the Air Force's present and future operational capability." This operational aspect naturally brings to mind the weapon system which can be viewed and/or read about by the taxpayer. However, because of the many steps in the complex

process of conceiving and developing a weapon system, the role research plays cannot usually be associated clearly with the development of weapon systems. In a large majority of cases research does not jump immediately into a weapon system but works its way up the triangle route whereby the complexity of the application increases as you proceed upward. The apex of the triangle is the mission. From that point downward are all the contributing areas—the weapon system, operational systems development, engineering development, and advanced development and exploratory development (including applied research). At the base of the triangle is research.

Conceptually at least one can determine the relevancy of research for supporting the operational missions by tracing through the various intermediate relationships. In practice one finds this approach to be of limited validity; there are too many uncertainties in establishing the required relationship. Perhaps the greatest limitation in developing this methodology is inherent in the nature of science and technology interactions. We find important interactions occurring between scientific research activities and technology at several levels of mission development, not just at the interface of applied research with science.

We do, however, find it meaningful to establish relationships between our scientific research activities and technology whereby technology means the broad group of applied science and engineering development activities engaged in to bring about new systems, devices, processes, and materials of use to the Air Force.

At this point it might be wise to point out that the interface between the science and technology is of a different character from those existing at other parts of the development process. The scientific research is phenomena-oriented and technology is hardware-oriented. It might be said this boundary is where orientation is given to the research results. If a too restrictive policy is applied to the support of research, this orientation process takes place sooner, and consequently the benefits which are to be derived from the more flexible approach inherent in phenomena-oriented science will be denied to the Air Force.

Often research results cannot be predicted with certainty. Relevancy cannot be determined with certainty beforehand inasmuch as pioneering research may open up or colonize a new area. Granted that this action is not in the majority of

cases, but it is the one where new and unique ideas are born. These items lead to new concepts and whole new technological worlds. If an old wording is allowed, these are breakthroughs in the real sense. Sometimes this process has to accrue exten-

sive results before the new area becomes apparent, but when it does, the scientific community usually extends its efforts in that direction. Consequently, a new and unique area is nurtured to the point where technology can benefit.

## AFOSR Scientific Staff

	Telephone (888) OX plus ext.	Telephone (888) OX plus ext.	
Dr. William J. Price, Executive Director (SRG).....	44801	Dr. Charles E. Hutchinson, Chief, Behavioral Sciences Division (SRLB).....	45045
Col. Ivan C. Atkinson, Deputy Executive Direc- tor (SRGD).....	44801	Dr. Herman J. Zander, Project Scientist	
Maj. Joseph P. Martino, Assistant Execu- tive Director, Research Communication.....	44875	Dr. Glen Finch, Project Scientist	
Lt. Col. Carl S. Jennings Jr., Assistant Ex- ecutive Director, Research Operations.....	45101	Maj. Laurence G. Goebel, Project Scientist	
Dr. Amos G. Horney, Director of Chemical Sciences (SRC).....	45337	Dr. Robert V. Brown, Chief, Biological Sciences Division (SRLA).....	45042
Denton W. Elliott, Deputy Director		Maj. Charles E. Fuller, Project Scientist	
Dr. Alfred Weissler, Project Scientist		Dr. Merle M. Andrew, Director of Mathematical Sciences (SRM).....	45263
Dr. Anthony J. Matuszko, Project Scientist		Lt. Col. Barnett R. Agins, Chief, Applied Math Division (SRMA).....	45261
Dr. William L. Ruigh, Project Scientist		Maj. John Jones Jr., Project Scientist	
Lt. Col. Edward T. Walford, Project Scien- tist		Capt. Allen Dayton, Project Scientist	
Dr. Milton M. Slawsky, Director of Engineering Sciences (SRE).....	45563	Dr. Robert G. Pohrer, Chief, Mathematics Divi- sion (SRMM).....	45264
Lt. Col. Robert B. Kalisch, Chief, Electronics Division (SREE).....	45518	Maj. John F. Gander, Project Scientist	
Maj. Frank H. Zander, Project Scientist		Dr. Lloyd A. Wood, Director of Physical Sciences (SRP).....	45451
Milton Rogers, Chief, Mechanics Division (SREM).....	45567	Dwight L. Wennersten, Chief, General Physics Division (SRPP).....	45454
Paul A. Thurston, Project Scientist		Dr. Marshall C. Harrington, Project Scientist	
Dr. Jacob Pomerants, Project Scientist		Capt. David A. Haycock, Project Scientist	
Lt. Col. George Stalk, Project Scientist		Dr. Ralph E. Kelley, Project Scientist	
Maj. Donald L. Calvert, Project Scientist		William J. Best, Chief, Geophysics Division (SRPG).....	45456
Dr. Joseph F. Masi, Chief, Propulsion Division (SREP).....	45565	Maj. Durward D. Young Jr., Project Scientist	
Dr. Bernard T. Wolfson, Project Scientist		Dr. Erich Weigold, Acting Chief, Nuclear Physics Division (SRPN).....	45581
Dr. Demetrios G. Samaras, Project Scientist		Maj. Joseph E. Gorrell, Project Scientist	
Maj. Russell G. Langlois, Project Scientist		Capt. Donald R. Lehman, Project Scientist	
Lt. Col. Cornelius J. Donovan, Project Scientist		Lt. Col. Ralph W. Conners, Chief, Solid State Sciences Division (SRPS).....	45588
Dr. Harold A. Wooster, Director of Information Sciences (SRI).....	45407	Dr. J. Thomas Hatchford, Project Scientist	
Mrs. Rowena W. Swanson, Project Scientist		Lt. Col. Randal A. Houldobre, Project Scientist	
Capt. Elliot Sohmer, Project Scientist		Max Swerdlow, Project Scientist	
Dr. Harvey E. Savely, Director of Life Sciences (SRL).....	45041	Col. Leon S. Rogan, Director of Procurement (SRK).....	45275

## *AFOSR Board of Visitors*

The AFOSR board of visitors provides the executive director with scientific and technical advice which he may employ during the planning, programing and pursuit of the AFOSR program. The group is composed of eminently qualified, distinguished members of the scientific community, who serve as members of the OAR scientific advisory group. They provide a continual outside evaluation of both the effectiveness of AFOSR activities and policies, and their impact upon the

scientific community. Members of the board of visitors are:

- Professor Leonard I. Schiff (Chairman), Department of Physics, Stanford University.*
- Dr. Lauror F. Carter, Senior Vice President and Director of Advanced Technology and Research, Systems Development Corporation.*
- Dr. Carl Kaplan, Research Fellow, Johns Hopkins University.*
- Dr. Nathan L. Kristberg, Director of Engineering, Missiles and Information Systems Division, the Boeing Co.*
- Professor Gerald M. McDonnel, M.D., Department of Radiology, Center for the Health Sciences, University of California at Los Angeles.*
- Dr. Joseph Kaplan, Professor of Physics, University of California at Los Angeles; ex officio member as Chairman, OAR Scientific Advisory Group.*



## *The History of AFOSR*

The Air Force Office of Scientific Research was officially established 11 August 1955. It had existed in recognizably similar form, however, since 29 October 1951, with its roots going back still farther to the first appearance, in February 1948, of a basic research organization at Wright-Patterson AFB.

That the Air Force entered the business of basic research when it did was due in great measure to the determination of the late Dr. Theodore von Karman, distinguished Hungarian-born aerodynamicist, who headed the Air Force's scientific advisory board during the late 1940's.

On 24 September 1949 the Ridenour report<sup>1</sup> was transmitted to Gen. Hoyt S. Vandenberg with a covering letter from Dr. von Karman, which said:

The Air Force should make fuller use of the technical talent and facilities possessed by the industries and the universities of the country. A small recurring investment in the support of fundamental scientific investigations would secure for the Air Force the enthusiastic support of the foremost scientists of the country; such men are today being substantially assisted mainly by the Office of Naval Research and the AEC. The Air Force is clearly faced by problems requiring fundamental scientific investigations; the best results in such work can be secured by direct contact between an Office of Air Research and scientists.

In February 1949, the Office of Air Research was established at Wright-Patterson under the immediate jurisdiction of the director of research and development of the Air Materiel Command, and was assigned the performance of both basic and applied research. In performing the basic research, it made use of both contractual efforts and in-house work.

On 23 February 1951, Col. Frank J. Seiler, second chief of the Office of Air Research, described

the primary mission of the Office of Air Research as "to sponsor, encourage, or take advantage of, in any way, all basic research to further Air Force ends. It is always necessary to keep in mind Air Force needs. To talk in terms of a program, one must always ask the question, what problems need study or alleviation?"

This office went out of existence in April 1951, when more basic portions of the program were transferred to Headquarters, ARDC, Baltimore, Md., and ultimately became part of the assigned mission of the Office of Scientific Research (OSR), which was organized as a headquarters staff section in October 1951.

OSR was mainly concerned with administering a research program which was largely basic rather than applied, and which was conducted entirely by means of contracts mostly with university scientists. But, as a headquarters staff section, OSR also had a supervisory role with respect to other Air Force research activities. This role, however, existed more on paper than in practice, and was later eliminated.

OSR's research program was planned along the lines of the traditional scientific disciplines, and OSR itself was organized along these lines. There were originally five functional divisions—chemistry, fluid mechanics, mathematics, physics, and the solid state sciences—each of which was headed by a division chief, usually a civilian, who was given considerable freedom in formulating a program for his division.

In February 1954, OSR's position in Headquarters ARDC was altered. At that time OSR was stripped of its staff supervisory functions and dropped down a step on the organizational ladder. The overall supervision of ARDC research was now in the hands of a newly established directorate of research (Headquarters ARDC).

In August 1955, the Office of Scientific Research became the Air Force Office of Scientific Research (AFOSR), and was given "center status," meaning that it was henceforth to be regarded not as a headquarters staff section, but as an agency on the same footing with such ARDC field organizations as the Air Force Cambridge Research Center and the Wright Air Development Center. As a measure of the organization's new-found stat-

<sup>1</sup> "Research and Development in the United States Air Force—Report of a Special Committee of the Scientific Advisory Board to the Chief of Staff, USAF." Louis N. Ridenour, committee chairman, 1949.

ure, a general officer, Brig. Gen. Don B. Flickinger, was named its commander. The resemblance to a field organization was further sharpened in July 1958 when AFOSR severed its physical connection with Headquarters ARDC by moving from Baltimore to Washington, D.C.

Officially, the granting of "center status" was designed to heighten the prestige and importance of research within the Air Force. Some AFOSR administrators felt, however, that it was really a step downward, since it placed the contractual research agency under—rather than within—command headquarters. During the following years AFOSR did, nevertheless, experience a steady growth in the size and scope of its research program.

Concurrently with the creation of AFOSR as a separate center, AFOSR was reorganized internally. This had little effect on the AFOSR program. The old divisions were either abolished and replaced by new directorates, or else directorates were superimposed upon the old divisions. The research programs continued as before, although in some cases under different men. The same general internal structure stands today.

AFOSR's new center status was accompanied by increased support. The organization's budget almost doubled from \$13.9 million in fiscal year 1956 to \$27 million in fiscal year 1959. The larger budgets permitted AFOSR to fund not only more projects but also more expensive ones, whose costs at one time had been prohibitive. Thus, the AFOSR program during the late 1950's possessed a variety, a quality, and a spark that it lacked in the earlier years.

A major review of the Air Force basic research program was set forth in the Stever committee report issued in June 1958. This was a blue ribbon committee asked to reexamine the findings of the Ridenour committee report of some 9 years earlier. The chairman was H. Guyford Stever, associate dean at MIT, and a former Air Force chief scientist (1956-57).

The Stever committee said, "The Air Force has a mission to sponsor and support exploratory research. In this way the Air Force shares with the other services the payment for research of general interest to the military. This ensures the establishment of effective lines of communication with all of the scientific community of the country, much of which will eventually but inevitably contribute

to the USAF's ability to perform its mission."

The word *mission* is used here in the nonmilitary sense, and the emphasis seems to be that set forth in DOD Directive No. 3210.1, "Policy on Basic Research," of 19 June 1952, which states:

To provide the essential foundation for the techniques of war, the DOD must assure that basic research is adequately supported in all areas where the presence of knowledge is important to the military effort \* \* \* Research in universities, non-profits \* \* \* may be of a kind which does not have specific aims but holds promise of some ultimate military application.

This directive confirmed the role of the DOD in sponsoring basic research in relation to the National Science Foundation Act of 1950. The emphasis, in this selection from the basic documents responsible for establishing the Air Force program of contract-supported basic research, has been on the nature of the research to be supported, rather than the mechanisms for administering these research contracts. The fundamental passage is that of the Ridenour report of September 1949:

A small fraction—say 2 or 3 percent—of the research and development budget of the Air Force should be consistently assigned for the research in broad general fields on problems which, without being directed toward specific goals or applications, are of potential interest to the Air Force.

The following statement, by a committee of university and industrial research scientists, is representative of the conclusions which have been reached by the vast majority of those individuals and groups, both within and outside of USAF, who have given serious thought to the place of basic exploratory research in the USAF:

The Air Force should continue and expand its support of exploratory research, originating in the ideas of working scientists, both at its in-house laboratories and through contracts, such as those administered by the Air Force Office of Scientific Research. The Air Force cannot rely upon other governmental agencies, such as the National Science Foundation, or other parts of the Department of Defense, nor upon nongovernmental agencies, to provide for its entire needs and interests in science. Neither can it rely entirely on research

which grows out of its programs of applied research and development.<sup>3</sup>

In late 1959 and early 1960, ARDC underwent an extensive reorganization. This reorganization was designed to increase the effectiveness of ARDC operations by delegating certain management functions from Headquarters ARDC to a group of functionally organized divisions. (The ARDC centers which, for the most part, were now absorbed by or subordinated to the divisions, had been organized essentially along geographic rather than functional lines, although AFOSR had been an example of a strictly functional organization even under the old system.) One new division that emerged was the Air Force research division, which included AFOSR, the European office (ARDC), the aeronautical research laboratory, and the Air Force Cambridge research laboratories—the four organizations in ARDC engaged in basic research. Basic research in the Air Force was thus now concentrated in one ARDC division.

The Air Force's research and development activities underwent another broad reorganization in April 1961. The outstanding feature of this reorganization was the combination of ARDC (minus AFRD) with those elements of the Air Materiel Command engaged in systems acquisition and related procurement functions to form the new Air Force Systems Command (AFSC). Had AFRD been allowed to remain with AFSC, its research functions would undoubtedly have been overshadowed by work on weapon systems. The Air Force decided, therefore, that it would be healthier for basic research to have its own organi-

zation apart from systems development. Thus AFRD, (still including AFOSR), was detached from ARDC, renamed the Office of Aerospace Research, and established as a separate operating agency with the procedural functions and responsibilities of a major air command. AFOSR was now an integral part of an organization devoted exclusively to research.

Following its reorganization under OAR, AFOSR began a period of internal realignments that created the present scientific directorate arrangement. Policies adopted during his period included long-term funding of grants and contracts, which tended to provide more stable support for investigators, and the AFOSR postdoctoral research program.

Later policy changes placed increasing emphasis on relating AFOSR research to Air Force technological problems, and on making this research more readily available to applied research and development scientists in Air Force laboratories. Systematic coupling was effected to provide a two-way interchange of information between the worldwide scientific community and Air Force laboratory and field development units. AFOSR project scientists functioned directly in bringing outside scientific competence to bear upon special and often urgent operating problems, and also in helping to uncover those problems susceptible to solution by the application of scientific research or research methods.

OAR's overall accomplishments were officially recognized in 1966 with the presentation of the Air Force Outstanding Unit Award, in which AFOSR shared as a component. The award was made for the period of 1 April 1964 to 31 March 1966.

<sup>3</sup> Committee on General Sciences, NAS-ARDC Study Group, "A Report by the Committee on General Sciences Relating to Long-Range Scientific and Technical Trends of Interest to the United States Air Force" (known as the "Woods Hole Report"), 1958.

## *AFOSR Chronology*

- February 1948*..... Applied Research Section (later Research Section), Engineering Division, Air Materiel Command established.
- February 1949*..... Office of Air Research, Director of Research and Development, AMC established.
- January 1960*..... Air Research and Development Command established.
- October 1961*..... Office of Scientific Research, Hq. ARDC, established with Col. Oliver G. Haywood as chief.
- September 1963*..... Col. William O. Davis named chief of OSR.
- February 1964*..... Hq. ARDC reorganized. OSR put under Directorate of Research, commanded by Col. Don D. Flickenger.
- August 1965*..... Air Force Office of Scientific Research established as a separate center of ARDC with Brig. Gen. Don Flickenger as commander.
- January 1966*..... Col. Adolf P. Gagge assumed command of AFOSR.
- March 1966*..... Brig. Gen. Hollingsworth F. Gregory designated commander of AFOSR.
- July 1966*..... AFOSR moved to Washington, D.C., from Baltimore, Md.
- September 1968*..... Congress passed Public Law 84-934, permitting all Federal agencies engaged in basic research to support their programs through a system of grants to universities and nonprofit institutions.
- November 1968*..... Brig. Gen. Benjamin G. Holzman assumed command of AFOSR.
- January 1960*..... Air Force Research Division, ARDC, established.
- January 1960*..... Col. Adolf P. Gagge named commander of AFOSR.
- October 1960*..... Dr. Knox T. Millsaps became executive director of AFOSR.
- April 1961*..... Office of Aerospace Research established with AFOSR as a component.
- September 1963*..... Dr. William J. Price named executive director of AFOSR.

---

**AFOSR Research Program**

---

**Preceding Page Blank**

## AFOSR Research Program

The AFOSR research program includes about 1,000 separate research efforts being performed at any one time at university, industrial, not for profit, and other research organizations. This section of *AFOSR Research* contains:

1. The AFOSR scientific area code, a list of those areas of science in which AFOSR supports research.

2. An explanation of the research program data elements found in the separate listings of scientific efforts.

3. A description of the scientific program of each AFOSR scientific directorate, outlining its scope and research objectives.

4. A list of all AFOSR research work efforts current as of the beginning of calendar year 1967, broken down by scientific area code, and arranged alphabetically within scientific areas by principal investigator's last name.

### AFOSR Scientific Area Code

- 1.0.0 Mathematics
  - 1.1.0 Algebra and Foundations, Analysis
    - 1.1.1 Algebras
    - 1.1.3 Mathematical Analysis
  - 1.2.0 Applied Mathematics
  - 1.4.0 Statistics and Probability
  - 1.5.0 Theory of Numbers
- 2.0.0 Physics
  - 2.1.0 Elementary Particle Physics
  - 2.2.0 Nuclear Structure Physics
  - 2.3.0 Atomic and Molecular Physics
  - 2.4.0 Low Temperature Physics
  - 2.5.0 Solid State Physics
    - 2.5.1 Theory of Solids
    - 2.5.2 Growth, Preparation and Synthesis of Solids
    - 2.5.3 Structural Characterization of Solids
    - 2.5.4 Mechanical and Thermal Properties of Solids
    - 2.5.5 Electronic, Magnetic, Optical and Electrical Properties of Solids
    - 2.5.6 Interaction Effects in Solids
  - 2.6.0 Field Physics
    - 2.6.1 Electromagnetics and Electron Physics
    - 2.6.3 Optical Physics
    - 2.6.4 Acoustics
- 2.7.0 Fluid Physics
  - 2.7.1 Plasma Physics
  - 2.7.2 Magneto Fluid Dynamics
  - 2.7.3 Structure of Gases and Liquids
- 2.8.0 Theoretical Physics
  - 2.8.1 Quantum Mechanics
  - 2.8.2 Relativity and Gravitation
- 2.9.0 Cosmic Ray Physics
- 3.0.0 Chemistry
  - 3.1.0 Analytical Chemistry and New Techniques
    - 3.1.1 Chemistry: Diffraction and Optical Methods
    - 3.1.3 Radiochemical and Nuclear Methods
    - 3.1.4 Electrochemical Methods
    - 3.1.5 New Instrumental Techniques
  - 3.2.0 Inorganic Chemistry
    - 3.2.1 Theoretical Inorganic Chemistry
    - 3.2.2 Synthetic and Descriptive Inorganic Chemistry
  - 3.3.0 Organic Chemistry
    - 3.3.1 Theoretical and Structural Organic Chemistry
    - 3.3.2 Synthesis and Properties of Organic Compounds
    - 3.3.3 Organic Chemical Materials
  - 3.4.0 Physical Chemistry
    - 3.4.1 Chemistry: Structure of Matter
    - 3.4.2 Chemistry: Interactions of Matter and Energy
    - 3.4.3 Principles Governing Chemical Reactions
    - 3.4.4 Surface Chemistry
  - 3.5.0 Chemical Kinetics and Mechanisms
    - 3.5.1 Homogenous and Heterogenous Chemical Reactions
    - 3.5.2 Energy Effects in Chemical Reactions
    - 3.5.3 Chemical Reactions of Condensed Phases
    - 3.5.4 Kinetics of Fast Chemical Reactions
  - 3.6.0 Chemical and Rheological Properties of Materials
    - 3.6.1 Chemical and Physical Properties of Pure Liquids
    - 3.6.6 Chemical and Physical Properties of Crystalline Inorganic Solids
- 4.0.0 Environmental Sciences
  - 4.1.0 Astrophysics
    - 4.1.2 Astrophysics
  - 4.2.0 Atmospheric Sciences
    - 4.2.1 Meteorology
    - 4.2.2 Atmospheric Optics
    - 4.2.3 Aeronomy
    - 4.2.4 Ionospheric Physics and Propagation
  - 4.3.0 Terrestrial Sciences
    - 4.3.2 Seismology

- 5.0.0 Biological Sciences
  - 5.1.1 Ecology
  - 5.2.1 Genetics
  - 5.2.3 Anatomy
  - 5.3.1 Immunology
  - 5.2.2 Pathology
  - 5.5.1 Microbiology
  - 5.6.1 Molecular Biology
  - 5.6.2 Biochemistry
  - 5.6.3 Biophysics
  - 5.7.1 Physiology
  - 5.7.2 Pharmacology
- 6.0.0 Social Sciences
  - 6.2.0 Economics
    - 6.3.1 Learning Processes
  - 6.5.0 Sociology
  - 6.6.0 Social Psychology
  - 6.7.0 Psychophysiology
    - 6.8.1 Engineering Psychology
    - 6.8.2 Psychometrics
- 8.0.0 Engineering Sciences
  - 8.1.0 Energy Conversion
    - 8.1.1 Magnetoplasmdynamics
    - 8.1.2 Combustion Dynamics
    - 8.1.3 Chemical Kinetics
  - 8.2.0 Mechanics of Fluids
    - 8.2.1 Fluid Dynamics (Continuum)
    - 8.2.2 Rarefied Gas Dynamics
    - 8.2.3 Boundary Layer Effects
    - 8.2.4 Plasmadynamics
  - 8.3.0 Mechanics of Solids
    - 8.3.1 Structural Mechanics
    - 8.3.2 Environmental Material Mechanics
  - 8.4.0 Engineering Chemistry
    - 8.4.1 Propellants
    - 8.4.2 Thermophysical Properties of Propellants

- 8.5.0 Information and Communication Electronics
  - 8.5.1 Systems Engineering
- 8.6.0 Physical Electronics
  - 8.6.1 Generation and Propagation of Waves
  - 8.6.2 Solid State Electronics
  - 8.6.6 Quantum Electronics
  - 8.6.7 Geo- and Astro-Electronics
- 9.0.0 Information Sciences
  - 9.1.0 Information Systems Research
  - 9.3.0 Concepts of Machine Organization
  - 9.4.0 Adaptive and Self-Organizing Systems
  - 9.5.0 Information Extraction and Classification
  - 9.6.0 Transmission of Information
  - 9.7.0 Language and Linguistic Research
  - 9.8.0 Theoretical Foundations of Information Sciences

**AFOSR Research Program Data Elements**

2.5.1<sup>1</sup> THEORY OF SOLID STATE<sup>2</sup>

BREITENBERGER E<sup>3</sup>  
 OHIO UNIVERSITY<sup>4</sup>  
 THE MANY BODY PROBLEM<sup>5</sup>  
 CONNERS R W<sup>6</sup> SRPS<sup>7</sup>

- <sup>1</sup> Scientific area code number.
- <sup>2</sup> Scientific area code name.
- <sup>3</sup> Principal investigator(s).
- <sup>4</sup> Institution or organization of P. I.
- <sup>5</sup> Title of research project.
- <sup>6</sup> AFOSR project scientist (monitor).
- <sup>7</sup> Project scientist office symbol.

## Mathematical Sciences

DR. MERLE M. ANDREW, *Director*

The AFOSR research program in the mathematical sciences is designed to create a fundamental body of mathematical techniques for broad scientific and technological application. The program also is designed to systematically exploit the newer advances in mathematical sciences and in specifically Air Force oriented problem areas.

The program is managed by two divisions, applied mathematics and mathematics. The major program objectives of the directorate are divided between them. Their functions are often complimentary. For example, basic advances in mathematics are subsequently further developed with explicit concern for their possible Air Force-oriented applications. On the other hand, Air Force interest in some contemporary applications of mathematics results in specific emphasis in the direction taken by the fundamental portions of the directorate program.

The program supports the research investigations of some 300 mathematicians, applied mathematicians and other mathematically oriented scientists by selection, together with some 225 research assistants under a program of approximately 165 grants and contracts. Contracts and grants under the directorate program may have one or more senior investigators. When a grant or contract has several senior investigators they usually work independently in the associated scientific area.

The staff of the directorate consists of seven technically trained people, the majority of whom are Air Force officers with prior experience in both the systems and operating commands of the Air Force.

To assist the directorate in its operation, two independent evaluation groups have been established. One group of some of the Nation's most outstanding mathematicians and scientists meets to discuss the overall scientific and fiscal aspects of the program. The second group includes some of the most mathematically knowledgeable civilian and military personnel in the Air Force. The

primary concern of this group is the relevance of the research and results to the Air Force and the interrelationships that exist between science and technology as applied to Air Force problems.

One of the primary products is research publications. Our current productivity rate is approximately one research publication per year per mathematician supported. That is, approximately 300 journal articles per year. On this basis, the unit cost per publication is roughly \$12,000.

The research program of the applied mathematics division is somewhat larger dollarwise than that of the mathematics division, a reflection of the importance attached to Air Force interests. The program of the applied mathematics division covers a broad spectrum of interests and applications of mathematics, in almost all areas of direct Air Force interest. It covers the contemporary problems of "classical" applied mathematics as well as the strictly contemporary developments in applied mathematics.

Approximately 30 percent of the applied mathematics budget supports research in contemporary areas of "classical" applied mathematics. These include mathematical techniques in the areas of fluid mechanics, magnetohydrodynamics, kinetic theory, relativity theory, elasticity theory, and plasticity theory. The range of Air Force-oriented problems to which such results apply include for example, those relating to the "sloshing effect" of the fuel in the tank of a rocket, the characterization of the behavior of structures under the various forces to which they are subjected, the characterization of boundary layer flow and of baroclinic (weather) flow, and the effects of aerodynamic heating on the surface of aerospace vehicles.

An additional 20 percent of the applied budget supports a substantial program in control theory designed to create mathematical models to simulate and in turn to control a physical process. Considerations include the development of mathematical techniques for the proper identification of a plant or process, and its solution. That solution involves the determination of functions which represent the optimal control for the process, with respect to criteria such as the time, energy, or total cost involved. In cases where such optimal control



is physically unrealizable, the proper solutions of such problems involves the synthesis of suboptimal control solutions. These investigations employ the advanced techniques of modern mathematics, e.g., of mathematical analysis, functional analysis, and the calculus of variations. This program in control theory is the Nation's largest and most important such program.

A third portion of the research program of the division concerns the mathematical aspects of system theory, including circuit, communication, information, and automata theory. It receives approximately 20 percent of the division's budget. A substantial portion of the research funded in this area involves the more abstract developments in modern mathematics, e.g., in algebra, topology, analysis, probability theory and statistics, precisely as they apply and can be extended to the above-stated areas. Particular concerns of this program include automatic (computer) analysis and synthesis of networks, signal design and processing, coding, and stability theory.

An additional 15 percent of the budget supports a wide-ranging program in computational analysis, an area of applied mathematics of increasing importance since the development of the general purpose, programmed, high-speed digital computer. The program emphasizes the development of techniques to provide usable, i.e., numerical solutions to problems arising in the other sciences and in engineering. Important subdivisions of the program include the areas of numerical analysis, approximation and interpolation theory, and mathematical programming. An important consideration is the development of techniques for the automatic formulation of optimal procedures, for the computer solution of problems. The nature of error propagation in long period numerical integration is another important aspect of this program.

A portion of applied mathematic's program concentrates on research in celestial mechanics and orbital dynamics. An important emphasis here is the development of complete, general mathematical theories to govern the motions of celestial bodies, both natural and artificial. Specific research directions include a concern with the problems of satellite and cislunar trajectories, the problems of reentry, rendezvous, and of space rescue.

Also supported are a select number of research seminars and symposia, designed to provide a forum for the exchange of the latest research re-

sults and ideas among scientists, and to help bridge the gap between contemporary mathematical theories and their contemporary application.

The research program of the mathematics division emphasizes the physically oriented areas of mathematical analysis and functional analysis, probability theory and statistics. Approximately 60 percent of its budget supports research in analysis and functional analysis, the mainstream of hard-core mathematics since the rise of modern science. A principal objective of this support is the qualitative theory and solution of ordinary and partial differential equations. Contemporary research in these directions includes the theory of generalized functions, different approaches to the theory of differential operators, problems in function spaces, specific techniques for strictly nonlinear phenomena, continuing concern for the local and global behavior of solutions, and the many related techniques borrowed from the calculus of variations, the theory of integral equations, many phases of topology, and the improved "abstract generalizations" of functional analysis. Many results are phrased in the appropriate conventional terms of establishing a proper mathematical model, i.e., a well-posed differential equation, to characterize physical phenomena, and corresponding, the existence, uniqueness, and stability of the resulting characteristic solution. Such determinations are essential to the subsequent successful numerical computation of the solution. Other significant modern directions in analysis are also part of this program, and include the theory of quasi-conformal mappings, Fourier analysis, harmonic analysis, and potential theory. An outstanding feature of the program is its establishment of major coordinated group efforts at many of the Nation's leading research centers. In particular, the program in the qualitative theory of nonlinear partial differential equations is a dominant and striking part of the contemporary mathematical scene.

An additional 30 percent of the mathematics division's budget supports fundamental research in probability theory and statistics. The program in probability theory is noteworthy for its emphasis on the contemporary "analytic" aspects of probability theory and their application, and the proper qualitative characterization of general stochastic processes. Results help provide general probabilistic frameworks for the characterization of many physical phenomena and on occasion the

analytic characterization of important applied problem areas, e.g., problems of mathematical physics and problems in coding theory.

The program in statistics employs contemporary mathematical bases, e.g., of finite fields, projective planes, for the realistic design and analysis of statistical experiments. It is also noteworthy in its emphasis on the modern concern for more realistic statistical techniques, i.e., leading to meaningful statistical decisions, outside the context of the older "testing of hypotheses" approach. The results are, e.g., phrased in terms of non-parametric methods, decision theory, and life testing.

A portion of the mathematics division's budget supports a number of special division programs. One of these is an unique research monograph program, to encourage the synthesis of modern research results in a form amenable to the user of mathematics, i.e., to encourage the writing of research monographs to bridge the gap between the professional journal article in mathematics and an understandable and useable form of the results. Another is a program for the support of intensified, i.e., longer term full-time research

by individual mathematicians, sometimes as part of an intensified research year at a leading research center, to concentrate on a particular area of mathematics. The last of the special programs provides for the generous encouragement and support of research symposia and conferences. The division makes special efforts to include such support for conferences in the more abstract areas of mathematics, e.g., topology, algebra, and geometry, which are not part of the division's continuing research program, but nevertheless important, in that some developments in these areas may aid specific Air Force problem areas or the application of mathematics to such areas. The division supports an annual program of full-time research visitors to the Institute for Advanced Study, Princeton, N.J. It also supports the distinguished instructorship program at the Massachusetts Institute of Technology, and will support the newly established comparable program at Yale University. Both programs attract the most promising of the Nation's younger mathematicians, and serve to keep the division abreast not only of emerging areas of mathematics but of emerging younger mathematicians.

## MATHEMATICAL SCIENCES

### 1.0.0 MATHEMATICS

ADLER R L / KONHEIM A G INTERNATIONAL BUSINESS MACHINES CORP RESEARCH IN PROBABILITY THEORY GANDER J F	SRMH	GEORGE M D UNIVERSITY OF MISSOURI NONLINEAR PARTIAL DIFFERENTIAL EQUATIONS POHNER R G	SRMH
BEURLING A INSTITUTE FOR ADVANCED STUDY SPECIAL PROGRAM IN MATHEMATICAL ANALYSIS GANDER J F	SRMH	GILBARG D STANFORD UNIVERSITY CLASSICAL AND APPLIED ANALYSIS GANDER J F	SRMH
BOH G E P UNIVERSITY OF WISCONSIN STATISTICAL MODELS GANDER J F	SRMH	HARTMAN P JOHNS HOPKINS UNIVERSITY EXISTENCE IN PROPERTIES OF SOLUTIONS OF DIFFERENTIAL EQUATIONS GANDER J F	SRMH
DIXSON R J LOCKHEED MISSILES AND SPACE CO QUADRATICALLY NONLINEAR DIFFERENTIAL SYSTEMS GANDER J F	SRMH	MU S T UNIVERSITY OF CALIFORNIA MATHEMATICAL SWITCHING THEORY GANDER J F	SRMH
GELBAUM B R UNIVERSITY OF CALIFORNIA CONFERENCE ON FUNCTIONAL ANALYSIS ANDREU M R	SRMH	JACOBSON N YALE UNIVERSITY RESEARCH IN MATHEMATICS GANDER J F	SRMH
KARLIN S STANFORD UNIVERSITY THE THEORY OF TOTAL POSITIVITY AND ITS APPLICATIONS GANDER J F	SRMH	JOHNSON G RICE UNIVERSITY ANALYSIS, FUNCTIONAL ANALYSIS AND RELATED TOPICS GANDER J F	SRMH
NITSCHKE J C UNIVERSITY OF MINNESOTA PARTIAL DIFFERENTIAL EQUATIONS AND MINIMAL SURFACES GANDER J F	SRMH	KELLER J B NEW YORK UNIVERSITY SYSTEMS OF ORDINARY DIFFERENTIAL EQUATIONS, SPECIAL FUNCTIONS AND EXISTENCE THEOREMS GANDER J F	SRMH
RAUCH M E YESHIVA UNIVERSITY COMPLEX ANALYSIS GANDER J F	SRMH	LATTA G E STANFORD UNIVERSITY DIFFERENTIAL EQUATIONS AND BOUNDARY VALUE PROBLEMS POHNER R G	SRMH
SHERMAN B NORTH AMERICAN AVIATION INC FREE BOUNDARY VALUE PROBLEMS GANDER J F	SRMH	LOUSTALMAU J O NEW MEXICO STATE UNIVERSITY COMPACT LINEAR OPERATORS IN LOCALLY CONVEX SPACES POHNER R G	SRMH
STEENROD H E PRINCETON UNIVERSITY CLASSIFYING SPACES OF TOPOLOGICAL GROUPS POHNER R G	SRMH	MARTIN N T MASSACHUSETTS INSTITUTE OF TECHNOLOGY ALGEBRA, ANALYSIS AND TOPOLOGY AND THEIR APPLICATIONS POHNER R G	SRMH
TATLISON M WASHINGTON UNIVERSITY HARMONIC ANALYSIS OF SEVERAL VARIABLES GANDER J F	SRMH	MEYER R E UNIVERSITY OF WISCONSIN MATHEMATICAL FLUID DYNAMICS GANDER J F	SRMH
		MEHARI Z CARNEGIE INSTITUTE OF TECHNOLOGY CONFORMAL AND VARIATIONAL METHODS GANDER J F	SRMH
<b>1.1.1 ALGEBRAS</b>		PROTTER M H UNIVERSITY OF CALIFORNIA PARTIAL DIFFERENTIAL EQUATIONS, OPERATOR THEORY AND APPLICATIONS POHNER R G	SRMH
NICHOLSON G E UNIVERSITY OF NORTH CAROLINA SYMPOSIUM IN COMBINATORIAL MATHEMATICS AND ITS APPLICATIONS POHNER R G	SRMH	REID V J UNIVERSITY OF OKLAHOMA CALCULUS OF VARIATIONS AND BOUNDARY VALUE PROBLEMS GANDER J F	SRMH
<b>1.1.3 MATHEMATICAL ANALYSIS</b>		ROHRL H UNIVERSITY OF CALIFORNIA COMPLEX ANALYSIS GANDER J F	SRMH
ACCOLA R D BROWN UNIVERSITY PROBLEMS IN RIEMANN SURFACES GANDER J F	SRMH	RUBEL L A UNIVERSITY OF ILLINOIS THEORY OF FUNCTIONS OF A COMPLEX VARIABLE GANDER J F	SRMH
AGMON S HEBREN UNIVERSITY TOPICS IN MATHEMATICAL ANALYSIS GANDER J F	SRMH	SELBERG A INSTITUTE FOR ADVANCED STUDY ADVANCED MATHEMATICAL RESEARCH GANDER J F	SRMH
AMFORS L V HARVARD UNIVERSITY CLASSICAL ANALYSIS GANDER J F	SRMH	SERRIN J UNIVERSITY OF MINNESOTA PARTIAL DIFFERENTIAL EQUATIONS AND CALCULUS OF VARIATIONS POHNER R G	SRMH
ANDREOTTI A UNIVERSITA DEGLI STUDI DI PISA COMPLEX ANALYSIS AND RELATED QUESTIONS IN PARTIAL DIFFERENTIAL EQUATIONS GANDER J F	SRMH	SERRIN J UNIVERSITY OF MINNESOTA PARTIAL DIFFERENTIAL EQ, CALCULUS OF VARIATIONS AND THEORET. FLUID MECH GANDER J F	SRMH
BOCHNER S PRINCETON UNIVERSITY HARMONIC ANALYSIS GANDER J F	SRMH	SHAPIRO V L UNIVERSITY OF CALIFORNIA APPLICATIONS OF LAPLACE OPERATORS GANDER J F	SRMH
BUREAU F J UNIVERSITE DE LIEGE HYPERBOLIC AND ELLIPTIC PARTIAL DIFFERENTIAL EQUATIONS POHNER R G	SRMH	THORP E D UNIVERSITY OF CALIFORNIA COMPACT LINEAR OPERATORS POHNER R G	SRMH
CESARE L UNIVERSITY OF MICHIGAN CONTINUOUS TRANSFORMATIONS AND CONTINUOUS MANIFOLDS GANDER J F	SRMH	WIDOM H CORNELL UNIVERSITY MATHEMATICAL ANALYSIS GANDER J F	SRMH
FRIEDRICHS H O NEW YORK UNIVERSITY TOPICS IN ANALYSIS AND FUNCTIONAL ANALYSIS GANDER J F	SRMH		

## MATHEMATICAL SCIENCES

### 1.1.3 MATHEMATICAL ANALYSIS

YOUNG G S  
TUULANE UNIVERSITY  
QUASI-CONFORMAL MAPPINGS AND THEIR MODULI  
POHNER R C

SRNH

### 1.2.0 APPLIED MATHEMATICS

ABRAMSON H  
UNIVERSITY OF MAHATT  
DIGITAL PROCESSING OF STOCHASTIC SIGNALS  
AGINS B R

SRNA

BALAKRISHNAN A V  
UNIVERSITY OF CALIFORNIA  
COMMUNICATION SYSTEMS THEORY  
DAYTON A

SRNA

BELTRAMI E J  
STATE UNIVERSITY OF NEW YORK  
PASSIVE SYSTEMS, DISSIPATIVE OPERATORS, AND THE THEORY OF DISTRIBUTIONS  
JONES J

SRNA

BERGEN A R  
UNIVERSITY OF CALIFORNIA  
PROGRAM OF SYSTEMS RESEARCH  
DAYTON A

SRNA

BERGMAN S  
STANFORD UNIVERSITY  
RESEARCH OF TWO-DIMENSIONAL TRANSSONIC FLOW PATTERNS OF COMPRESSIBLE FLUIDS  
AGINS B R

SRNA

BRAUER A T  
WARE FOREST COLLEGE  
BOUNDS FOR CHARACTERISTIC ROOTS OF MATRICES  
JONES J

SRNA

BUZY R S  
UNIVERSITY OF CALIFORNIA  
MODERN MATHEMATICAL CONTROL THEORY  
DAYTON A D

SRNA

CALAHAN D A  
UNIVERSITY OF MICHIGAN  
STUDIES IN THE GENERATION OF EQUIVALENT NETWORKS  
AGINS B R

SRNA

CELL J W  
NORTH CAROLINA STATE COLLEGE  
CONTINUATION OF THE APPLIED MATHEMATICS RESEARCH PROJECT  
JONES J

SRNA

CHANG S S L  
STATE UNIVERSITY OF NEW YORK  
CONTROL SYSTEMS RESEARCH  
DAYTON A

SRNA

CHENEY E M  
UNIVERSITY OF TEXAS  
BASIC RESEARCH IN APPROXIMATION THEORY  
JONES J

SRNA

CLERENCE C R  
YALE UNIVERSITY  
OPERATION OF A RESEARCH CENTER FOR CELESTIAL MECHANICS  
AGINS B R

SRNA

CLEMENT P R  
STEVENS INSTITUTE OF TECHNOLOGY  
SIGNAL ANALYSIS METHODS FOR ADAPTIVE CONTROL SYSTEMS  
DAYTON A

SRNA

COLEMAN B D  
MELLON INSTITUTE  
FLOW PROPERTIES OF NON-NEWTONIAN FLUIDS  
JONES J

SRNA

CONTOPoulos G  
UNIVERSITY OF THESSALONIKI  
RESEARCH IN THE RESTRICTED 3-BODY PROBLEM  
AGINS B R

SRNA

CURTISS J H  
UNIVERSITY OF MIAMI  
RESEARCH ON INTERPOLATION WITH POLYNOMIALS TO BOUNDARY VALUES  
JONES J

SRNA

DIAZ J B  
UNIVERSITY OF MARYLAND  
MATHEMATICAL RESEARCH IN FLUID DYNAMICS AND APPLIED MATHEMATICS  
JONES J

SRNA

DIAZ J B  
UNIVERSITY OF CALIFORNIA  
MATHEMATICAL RESEARCH IN APPLIED MATHEMATICS  
JONES J

SRNA

DRENIK R  
POLYTECHNIC INSTITUTE OF BROOKLYN  
1967 INTERNATIONAL SYMPOSIUM ON INFORMATION THEORY  
AGINS B R

SRNA

### 1.2.0 APPLIED MATHEMATICS

EDELBAUM T  
ANALYTICAL MECHANICS ASSOCIATES INC  
MONOGRAPH ON OPTIMUM SPACE TRAJECTORIES  
DAYTON A

SRNA

EMRENFELD S  
NEW YORK UNIVERSITY  
RANDOMIZATION AND FACTORIAL EXPERIMENTS  
AGINS B R

SRNA

ETIKIN B T  
UNIVERSITY OF TORONTO  
THEORETICAL INVESTIGATIONS OF THE DYNAMICS OF VEHICLES  
DAYTON A

SRNA

FLEISHMAN B A  
RENSSELAER POLYTECHNIC INSTITUTE  
STUDIES IN CONTROL THEORY AND NONLINEAR MECHANICS  
DAYTON A

SRNA

FLUGGE-LOTZ I  
STANFORD UNIVERSITY  
COMPUTATION OF LAMINAR COMPRESSIBLE BOUNDARY LAYER  
DAYTON A

SRNA

FLUGGE-LOTZ I  
STANFORD UNIVERSITY  
DETERMINATION OF OPTIMAL CONTROLS FOR SYSTEMS WITH DELAYS  
DAYTON A

SRNA

GERGEN J J  
DUKE UNIVERSITY  
CONTINUATION OF RESEARCH IN PARTIAL DIFFERENTIAL EQUATIONS  
JONES J

SRNA

GERST I  
STATE UNIVERSITY OF NEW YORK  
APPLICATIONS OF CLASS K FUNCTIONS TO PASSIVE AND ACTIVE NETWORK SYNTHESIS  
AGINS B R

SRNA

GILBERT E G  
UNIVERSITY OF MICHIGAN  
COMPUTATION OF OPTIMAL CONTROLS  
DAYTON A

SRNA

GILBERT R P  
INDIANA UNIV RESEARCH FOUNDATION  
RESEARCH IN APPLIED MATHEMATICS  
JONES J

SRNA

GILL A  
UNIVERSITY OF CALIFORNIA  
SWITCHING AND AUTOMATA THEORY  
AGINS B R

SRNA

GILLIS J  
WEIZMANN INSTITUTE OF SCIENCE  
NUMERICAL INTEGRATION OF THE EQUATIONS OF MOTION OF A VISCOUS FLUIDS  
JONES J

SRNA

GOLDSTEIN A A  
UNIVERSITY OF WASHINGTON  
RESEARCH IN NUMERICAL ANALYSIS  
JONES J

SRNA

GOLOMB S W  
UNIVERSITY OF SOUTHERN CALIFORNIA  
AUTOMATA AND COMMUNICATIONS  
DAYTON A

SRNA

GRAD H / BERNQWITE J  
NEW YORK UNIVERSITY  
RESEARCH IN KINETIC THEORY OF GASES AND MAGNETO-FLUID DYNAMICS  
AGINS B R

SRNA

GREENSPAN M P  
MASSACHUSETTS INSTITUTE OF TECHNOLOGY  
RESEARCH IN FLUID DYNAMICS  
AGINS B R

SRNA

MAKINI S L  
NORTHWESTERN UNIVERSITY  
APPLICATION OF GRAPH THEORY TO NETWORKS  
AGINS B R

SRNA

MALKIN H  
UNIVERSITY OF CALIFORNIA  
EXISTENCE THEOREMS FOR NONLINEAR OPTIMAL CONTROL THEOREMS  
DAYTON A

SRNA

MANDELMAN G M / BUICE W E  
RENSSELAER POLYTECHNIC INSTITUTE  
DYNAMICS EFFECTS ON ELASTIC SYSTEMS  
JONES J

SRNA

MARARY P  
UNIVERSITY OF MICHIGAN  
APPLICATIONS OF GRAPH THEORY  
AGINS B R

SRNA

MEIBS A E  
UNIVERSITY OF MICHIGAN  
SINGULAR INTEGRAL EQUATIONS WITH SPECIAL REFERENCE TO BOUNDARY VALUE PROBLEMS  
JONES J

SRNA

## MATHEMATICAL SCIENCES

### 1.2.0 APPLIED MATHEMATICS

HERNÉS M UNIVERSITY OF COLORADO THE STRUCTURE OF ATTAINABLE SETS DAYTON A	SRNA	HACKIE A G UNIVERSITY OF MARYLAND FREE SURFACE PROBLEMS IN FLUID FLOW JONES J	SRNA
HERRICK S UNIVERSITY OF CALIFORNIA HIGH PRECISION GEOCENTRIC INTERPLANETARY ORBITS DAYTON A	SRNA	MARCUS W/MINC M UNIVERSITY OF CALIFORNIA GENERALIZED MATRIX FUNCTIONS, COMMUTATIVITY, AND COMBINATORIAL DESIGNS JONES J	SRNA
HEJAB M A AMERICAN UNIVERSITY OF BEIRUT PAPOKOVITCH FUNCTIONS IN PROBLEMS OF ELASTICITY AGINS B R	SRNA	MC KNIGHT J D UNIVERSITY OF MIAMI THEORY OF MACHINES AGINS B R	SRNA
HIGER E D NEW YORK UNIVERSITY MODELS FOR ANALYZING INFORMATION AND COMMAND SYSTEMS AGINS B R	SRNA	NIELE A RICE UNIVERSITY OPTIMUM AERODYNAMIC SHAPES IN THE SUPERSONIC, HYPERSONIC, AND FREE-MOLECULAR FLOW REGIMES AGINS B R	SRNA
MAL T E UNIVERSITY OF TORONTO THE NUMERICAL INTEGRATION OF ORDINARY DIFFERENTIAL EQUATIONS AGINS B R	SRNA	HIRANKER M INTERNATIONAL BUSINESS MACHINES CORP MATHEMATICAL STUDIES OF NON-LINEAR CIRCUITS AGINS B R	SRNA
JAMESON M J SOCIETY FOR INDUSTRIAL AND APPLIED MATHEMATICS SUPPORT OF SYMPOSIUM ON NUMERICAL ANALYSIS, MAY 11 TO 14, 1966 AGINS B R	SRNA	MURPHY G J NORTHWESTERN UNIVERSITY RESEARCH IN MODERN CONTROL THEORY DAYTON A	SRNA
JURY E I UNIVERSITY OF CALIFORNIA STUDY OF BIOCONTROL SYSTEMS DAYTON A	SRNA	NEUSTADT L W UNIVERSITY OF SOUTHERN CALIFORNIA ADAPTIVE & OPTIMUM CONTROL OF DYNAMIC SYSTEMS AGINS B R	SRNA
KAILATH T STANFORD UNIVERSITY COMMUNICATION VIA TIME-VARIANT CHANNELS AGINS B R	SRNA	NEUSTADT L W UNIVERSITY OF CALIFORNIA CONFERENCE ON THE MATHEMATICAL THEORY OF CONTROL DAYTON A	SRNA
KALMAN R E STANFORD UNIVERSITY RESEARCH ON THE STRUCTURE OF NETWORKS AUTOMATA AND CONTROL SYSTEMS DAYTON A	SRNA	NEWCOMB R W STANFORD UNIVERSITY FUNCTIONAL NETWORK ANALYSIS AND SYNTHESIS DAYTON A	SRNA
KARNI Z TECHNION RESEARCH AND DEVELOPMENT FOUNDATION LTD THE PHYSICAL TENSOR AND APPLICATION JONES J	SRNA	PARRUS H TECHNISCHE HOCHSCHULE IN HIEN STOCHASTIC THERMAL STRESSES AGINS B R	SRNA
KEYORKTAN J UNIVERSITY OF WASHINGTON APPLICATION OF MODERN PERTURBATION THEORY TO ASTRODYNAMICS PROBLEMS DAYTON A	SRNA	PAYTON R G ADELPHI UNIVERSITY PROPAGATION OF ELASTIC WAVES IN INITIALLY STRESSED MEDIA JONES J	SRNA
KOPP R E GALUMMAN AIRCRAFT ENGINEERING CORP OPTIMIZATION THEORY AND AEROSPACE APPLICATIONS DAYTON A	SRNA	PURCELLI P LOUISIANA STATE UNIVERSITY SELECTED PROBLEMS IN APPROXIMATION THEORY JONES J	SRNA
KROHN R B KROHN-RHODES RESEARCH INSTITUTE INC THE ALGEBRAIC THEORY OF MACHINES AGINS B R	SRNA	QUINLAN P M UNIVERSITY COLLEGE THIN ELASTIC SHELLS AND BOUNDARY VALUE PROBLEMS AGINS B R	SRNA
LAGERSTROM P A CALIFORNIA INSTITUTE OF TECHNOLOGY MATHEMATICAL INVESTIGATIONS OF PHENOMENA IN DYNAMICS OF FLUIDS AND OF RIGID BODIES AGINS B R	SRNA	RAGAZZINI J R/MYERS G M NEW YORK UNIVERSITY RESEARCH INVESTIGATIONS IN SYSTEMS THEORY DAYTON A	SRNA
LASALLE J P/LEFSCHETZ S BROWN UNIVERSITY RESEARCH ON NONLINEAR DYNAMICAL SYSTEMS AGINS B R	SRNA	READ R C UNIVERSITY OF THE WEST INDIES APPLICATION OF DIGITAL COMPUTER TECHNIQUES TO COMBINATORIAL ANALYSIS AGINS B R	SRNA
LEBOVITZ M R UNIVERSITY OF CHICAGO STABILITY OF STELLAR MODELS JONES J	SRNA	RHODES J L UNIVERSITY OF CALIFORNIA ALGEBRAIC THEORY OF MACHINES AGINS B R	SRNA
LEE E B UNIVERSITY OF MINNESOTA MATHEMATICAL THEORY OF CONTROL OF NONLINEAR PROCESSES DAYTON A	SRNA	RHODES J L KROHN-RHODES RESEARCH INSTITUTE INC CONFERENCE ON ALGEBRAIC THEORY OF MACHINES AGINS B R	SRNA
LYMR C E ABHSELAEER POLYTECHNIC INSTITUTE MATHEMATICAL PROGRAMMING MORGAN B S	SRNA	RICHARDS P B GENERAL PRECISION INC RESEARCH IN THE RESTRICTED PROBLEMS OF THREE-BODY PROBLEMS DAYTON A	SRNA
LEONDES C T UNIVERSITY OF CALIFORNIA RESEARCH IN CONTROL SYSTEMS THEORY DAYTON A	SRNA	ROCKAPELLAR R T UNIVERSITY OF WASHINGTON BASIC RESEARCH ON EXTREMUM PROBLEMS INVOLVING CONVEX FUNCTIONS AGINS B R	SRNA
LEVINE S M NEW YORK STATE UNIV RESEARCH FOUNDATION MATHEMATICAL THEORY OF MOLECULAR CONTROL SYSTEMS DAYTON A	SRNA	ROMBER R A UNIVERSITY OF CALIFORNIA A THEORY FOR PRACTICAL NETWORK SYNTHESIS AGINS B R	SRNA
LORENTE G G SYRACUSE UNIVERSITY THEORY OF APPROXIMATION JONES J	SRNA	ROSENBERG P M UNIVERSITY OF CALIFORNIA VIBRATIONS OF NONLINEAR SYSTEMS WITH MANY DEGREES OF FREEDOM JONES J	SRNA
		SALTAN E J NORTHWESTERN UNIVERSITY A PROPOSAL FOR RESEARCH IN GROUP THEORY JONES J	SRNA

## MATHEMATICAL SCIENCES

### 1-2.0 APPLIED MATHEMATICS

SARACHEN P B  
NEW YORK UNIVERSITY  
CONTROL SYSTEMS RESEARCH DAYTON A SARA

SARD A  
CITY UNIVERSITY OF NEW YORK RESEARCH  
OPTIMAL APPROXIMATION AND FUNCTIONAL ANALYSIS JONES J SARA

SPOAL P G  
RESEARCH-DEVELOPMENT INSTITUTE OF TECHNOLOGY  
APPLICATIONS OF GLOBAL ANALYSIS TO MODERN THEORETICAL PHYSICS JONES J SARA

SZEPRENDSI P G  
UNIVERSITY OF FLORENCE  
NUMERICAL ANALYSIS IN NON-CONTAMINATED POLYNOMIAL FACTORIZATIONS  
IN MINI-MAX APPROXIMATIONS IN SEVERAL VARIABLES JONES J SARA

SCHEINER P R  
UNIVERSITY OF MINNESOTA  
A STUDY OF NEARLY NONLINEAR DYNAMIC SYSTEMS AND THEIR STABILITY DAYTON A SARA

SHOUBERT J J  
VON KARMAN INSTITUTE FOR FLUID DYNAMICS  
KINETIC THEORY OF GASES JONES J SARA

STEIN P H  
COLORADO STATE UNIVERSITY  
APPROXIMATIONS USING ORTHOGONAL FUNCTIONS JONES J SARA

STETTER H J  
TECHNISCHE HOCHSCHULE IN DARM  
NUMERICAL METHODS FOR PARTIAL DIFFERENTIAL EQUATIONS JONES J SARA

STONE M W  
UNIVERSITY OF CHICAGO  
RESEARCH ON THE FOUNDATIONS OF QUANTUM PHYSICS JONES J SARA

SWANSON C A/CLARK C H  
UNIVERSITY OF BRITISH COLUMBIA  
SPECTRAL PROBLEMS FOR ELLIPTIC OPERATORS JONES J SARA

TUGNER H G  
UNIVERSITY OF CALIFORNIA  
JONES J SARA

VAN WALKENBURG P E / CAUZ  
UNIVERSITY OF ILLINOIS  
RESEARCH IN SYSTEM THEORY DAYTON A SARA

WALKER G L  
AMERICAN MATHEMATICAL SOCIETY  
EVALUATION OF MATHEMATICAL SCIENCES RESEARCH PROGRAM AGINS B R SARA

WALKER G L  
AMERICAN MATHEMATICAL SOCIETY  
A SYMPOSIUM ON MATHEMATICAL ASPECTS OF COMPUTER SCIENCE JONES J SARA

WALKER G L  
AMERICAN MATHEMATICAL SOCIETY  
A SYMPOSIUM ON TRANSPORT THEORY JONES J SARA

WALKER G L  
AMERICAN MATHEMATICAL SOCIETY  
MATHEMATICS OF THE DECISION SCIENCES JONES J SARA

WOLF J R  
POLYTECHNIC INSTITUTE OF BROOKLYN  
RESEARCH INVESTIGATION IN SYSTEM THEORY DAYTON A SARA

VOELZ H  
TECHNION RESEARCH AND DEVELOPMENT FOUNDATION LTD  
NON-BINARY SWITCHING AGINS B R SARA

YUASA D C  
POLYTECHNIC INSTITUTE OF BROOKLYN  
ACTIVE TEMP-VARYING SYSTEMS AND LINEAR NETWORKS AGINS B R SARA

ZABORSKY J  
WASHINGTON UNIVERSITY  
FUNCTIONAL ANALYSIS METHODS FOR CONTROL THEORY DAYTON A SARA

ZEMANIAN A  
SOCIETY FOR INDUSTRIAL AND APPLIED MATHEMATICS  
CONFERENCE - THE APPLICATIONS OF GENERALIZED FUNCTIONS TO  
SYSTEM THEORY JONES J SARA

### 1-4.0 STATISTICS AND PROBABILITY

AZIZ A K  
GEORGETOWN UNIVERSITY  
LECTURE SERIES IN DIFFERENTIAL EQUATIONS POMER R G SARA

BARTER G F  
PURDUE UNIVERSITY  
RESEARCH IN ANALYSIS AND PROBABILITY THEORY GANDER J F SARA

CARESON R H  
UNIVERSITY OF MINNESOTA  
ANALYSIS AND STOCHASTIC PROCESSES GANDER J F SARA

CHUNG K L  
STANFORD UNIVERSITY  
STOCHASTIC PROCESSES POMER R G SARA

DAVIES I  
UNIVERSITY OF CALIFORNIA  
RESEARCH IN PROBABILITY GANDER J F SARA

DRASS H  
NORTHWESTERN UNIVERSITY  
PROBABILITY AND STATISTICS GANDER J F SARA

GEYDOR R A  
UNIVERSITY OF CALIFORNIA  
NARROW PROCESSES AND THEIR ADDITIVE FUNCTIONALS GANDER J F SARA

HANSON D L  
UNIVERSITY OF MISSOURI  
CONVERGENCE RATES FOR WEIGHTED SUMS OF RANDOM VARIABLES GANDER J F SARA

HOEL P G  
UNIVERSITY OF CALIFORNIA  
REGRESSION CURVES AND STATISTICAL TESTS GANDER J F SARA

JONES R H  
JOHNS HOPKINS UNIVERSITY  
TIME SERIES ANALYSIS AND STATISTICAL METEOROLOGY GANDER J F SARA

KALLIAMPUR G  
UNIVERSITY OF MINNESOTA  
PROBABILITY AND STATISTICS GANDER J F SARA

KULLBACK S  
GEORGE WASHINGTON UNIVERSITY  
INFORMATION THEORY, STATISTICAL APPLICATIONS GANDER J F SARA

LEADBETTER H A  
RESEARCH TRIANGLE INSTITUTE  
INVESTIGATIONS IN THE THEORY OF INFLECTIONISM AND STOCHASTIC  
PROCESSES GANDER J F SARA

LURICS E  
CATHOLIC UNIVERSITY OF AMERICA  
PROBABILITY THEORY AND MATHEMATICAL STATISTICS GANDER J F SARA

NICHOLSON G E  
UNIVERSITY OF NORTH CAROLINA  
MATHEMATICAL STATISTICS POMER R G SARA

RUDIN W  
UNIVERSITY OF WISCONSIN  
ANALYTIC FUNCTIONS OF A COMPLEX VARIABLE GANDER J F SARA

VAMBERG D E  
MANNHEIM UNIVERSITY  
STUDY OF GENERAL GAUSSIAN PROCESSES GANDER J F SARA

WALSH J L  
UNIVERSITY OF MARYLAND  
APPROXIMATION THEORY GANDER J F SARA

WOLFOVITZ J  
CONNELL UNIVERSITY  
PROBABILITY THEORY AND ANALYSIS GANDER J F SARA

## *Physical Sciences*

DR. LLOYD A. WOOD, *Director*

The physical sciences program is divided into four general subject areas, being in order of magnitude solid state, general physics, nuclear physics, and geophysics. In each of these general areas, research fields are selected of special importance to the future Air Force technology, based on studies made by the physical sciences staff and advice from a wide variety of Air Force and industrial engineers and scientists.

The staff comprises six Air Force officers and eight civilians of diverse experience in research and development, both in research performance and in research administration. Each is responsible for selection of individual investigations to be funded for support, and provides supervision and monitoring of the progress and quality of the research being supported. The total program comprises about 330 projects having an annual obligational rate of about \$20 million, including investigations managed as agent for the Advanced Research Projects Agency.

Most research investigations require several years to carry through to completion, and in the physical sciences program there are several large continuing group investigations, such as the National Magnet Laboratory, which have been created with the idea of stimulating research in a given field believed to be of special Air Force interest. In consequence, only a small fraction of the total program each year can be completely new starts. As a result the staff gives continuous careful scrutiny to the productivity of the sponsored investigations, as well as to the timeliness and probable value of the results to the Air Force. By terminating support of selected investigations at the earliest profitable time, a viable program has been maintained, with a reasonable number of new investigations being undertaken.

### *Solid State Sciences*

The research program managed by the solid state sciences division aims at fundamental in-

vestigations into the nature of solids, and has continued to be especially concerned with the rather bewildering variety of characteristics and behaviors of solids arising from the cooperative interactions of the atoms in the crystal lattices. In single atoms, electrons in the various shells, or energy levels, occupy discrete energy states, which determine their chemical and physical (non-nuclear) characteristics. When atoms are in large arrays, as crystals, the presence of neighboring atoms causes the discrete energy levels of the single atom to be expanded into energy bands, which extend throughout the crystal. Thus the electrons exhibit behavior characteristic of both the atoms and the crystal, and even more importantly the bands are drastically modified by the presence of only traces of impurities. In addition, electrons interact with crystal lattice vibrations, which further modifies their behavior.

Because of these complex interactions, crystals exhibit their astonishing range of properties, such as superconductivity, magnetism of several kinds, solid state laser, conduction, semiconduction, insulation, ferroelectricity, optical properties such as metallic lustre, color, and transparency, and transition temperatures of various kinds. Many of these are beginning to be understood, and as a result an increasing number of practical applications have been made. It is toward such study of the fundamental physics of crystals that the AFOSR solid state program has been mainly directed. In addition the problem of the gross mechanical characteristics of crystals receives attention, although it has not yet been possible to tie these to the more fundamental level of electrons and phonons of the crystal. Such questions as precipitation hardening, lattice defects of various types and their migration, and surface characteristics and their effects are the subject of active investigations.

### THE NATIONAL MAGNET LABORATORY

The largest sponsored project in the solid state research program is the National Magnet Laboratory, at the Massachusetts Institute of Technology. This laboratory is presently unique in the world,

being dedicated to the performance of research in high magnetic fields. Large spatial volumes are available for experiments at continuous field strengths up to 200,000 gauss, and in more limited volumes up to 250,000 gauss. Effort is constant to raise these limits to higher levels by research on magnet design. Because understanding the behavior of electrons in crystals is the key to most of the properties of the crystals, this laboratory is enormously valuable for solid state research, and investigators are coming to it in steadily increasing numbers to make their experiments.

The reason for the value of high magnetic fields in solid state research lies in the fact that electrons interact with the magnetic field in their movements through the crystal lattice and in their transitions among the electronic energy levels and bands of crystals. Varying the field results in changes in electrical, magnetic, and optical properties of crystals which when studied permit deduction of various fundamental characteristics of the crystals, and testing and improvements of theories on the physical laws governing these and other properties.

An astonishing discovery recently made may be cited which provides an example of the usefulness of the magnetic field in solid state research. Indium antimonide is a semiconducting crystal in which absorption of light causes electrons in the lowest energy level, or ground state, of the crystal to be excited into its conduction band. This is known as photoconduction. If the crystal is placed in a magnetic field, the conducting band splits into discrete levels, which are at various energy levels above the ground state. To excite an electron from the ground state into one of these levels, it is necessary to provide exactly the amount of energy to match the difference between the given level and the ground level. This takes place when a photon of light of the proper wavelength is absorbed. It has been recently found at the Magnet Laboratory that a laser beam of photons which have too low energy to excite the electrons of the crystal in this manner, nevertheless does excite them, but to levels at energies corresponding to twice the photon energy. It thus appears that two photons are being simultaneously absorbed, a phenomenon never previously observed or even considered as a possibility. Excitations corresponding to three photon energies have also been observed.

#### SUPERCONDUCTIVITY

A second major unsolved problem in solid state physics is the phenomenon of superconductivity. Both magnetism and superconductivity are almost surely quantum mechanical phenomena on a macroscopic scale (macroscopic here means involving a large number of crystal atoms acting in a cooperative manner). It is a curious fact of observation that these two phenomena appear to be mutually exclusive, with most metallic crystals, including compounds as well as elements, exhibiting superconductivity at low enough temperatures. Magnetic properties in contrast seem to be exhibited by a much more select group of metallic crystals. The highest temperature at which superconductivity has so far been observed is 18° K., with several examples at or very near this temperature being known. It seems possible that this might be a fundamental upper limit for superconduction, although there is no known reason for this to be so. The lowest possible temperature for a transition to the superconducting state is not known, because of the difficulty of performing experiments below 0.010° K., but the number of materials discovered which become superconducting near this temperature is very large.

Not only is superconductivity of great scientific interest in investigating the behavior of electrons in metals, but it is of considerable practical interest because high magnetic fields can be maintained at no energy cost by superconducting solenoids. Indeed commercial 100 kilogauss superconducting magnets are on the market at present for scientific use. Applications of such magnets for shielding against energetic particles in space and for obtaining magnetohydrodynamic power both from combustion and from nuclear fusion are under active industrial development at present.

It is a curious fact that the application of a magnetic field lowers the superconducting transition temperature and also the amount of superconducted current which can be carried, and it is true that a sufficiently high field has been found to destroy superconduction in almost all superconductors to 0.010° K. Certain compounds such as niobium(3)-tin and vanadium(3)-gallium, however, at a low temperature retain the superconducting property even at the highest steady field tested in the National Magnet Laboratory. Recent experiments at this laboratory have shown that niobium(3)-tin retains a useful current carrying



capacity in the superconducting state in a field of 170 kilogauss. It may be possible, by inserting a superconducting coil inside one of the large copper coils to push the upper limit for steady fields up to 300 or more kilogauss.

Superconductors are being given serious study for electrical application, as, for example, it is believed probable that with existing research knowledge, an underground superconducting power transmission line for 1,000 megawatts would be cheaper than present oil-insulated copper lines, one of which is in use at present carrying 350 megawatts. In addition, if resonant cavities or waveguides of extremely high Q are desired, superconductors may be used for the walls. Model superconducting cavities have already been tested in an exploratory research project for the Stanford University Mark III Linear Accelerator (a laboratory which also pioneered the very-high-power klystron tube development). Use of superconducting resonant cavities will permit approximate doubling of the energy which electrons can be given in the accelerator and also increase the duty cycle by tenfold or greater.

An additional, and perhaps practically valuable effect of superconductors is the so-called Josephson effect, which is the ability of superconducting electrons to tunnel through nonsuperconducting, or normal, material. This has been exploited to give an extremely sensitive magnetometer, since magnetic lines of force may pass through a normal material into the interior of the superconductor, giving rise to induced currents in the superconductor. Fluctuations in magnetic fields of radio-frequency may be sensitively detected by such a device.

The AFOSR program in superconductivity is not aimed at the production of devices, but at the fundamental understanding of the phenomenon, including the exploration of new superconducting materials. It is perhaps not an exaggeration to claim that more than about half of all known superconductors have been discovered in the last 6 years through AFOSR-sponsored research at the AFOSR Institute for the Study of Matter at the University of California (San Diego). Not only is experimental work an important part of the AFOSR program in superconductivity, but there is major support of the theoretical study of the phenomenon.

### **Physics of Particles and Fields**

The nuclear physics division of AFOSR has continued an evolutionary process through the last several years which has turned the program from the now more traditional aspects of nuclear physics into investigations into the more fundamental questions of physics. It has been AFOSR's philosophy that, based on past history, the most revolutionary impact of physical research on Air Force technology is likely to come in the long run from really new concepts arising from research into the most fundamental questions of physics. While no one expects to come up with a new idea like  $E=mc^2$  every few months, nevertheless it seems self-evident that the most drastic redirections of the courses of both science and technology result from the discoveries on the most fundamental levels. Certainly the technology of the Air Force is today drastically different from what anyone might have imagined 20 years ago at the end of World War II, due in great part to fundamental physical discoveries which were made both before and since then.

### **THEORETICAL PHYSICS**

The largest program operated by this group, which presently comprises a civilian chief and two highly qualified Air Force officers, is the theoretical program. The core of this program is a group of four projects which support the major part of the theoretical physics performed at Stanford, Princeton, Harvard, and Berkeley. Together with Cal Tech, these universities are the leading centers of theoretical physics research in the United States. In addition other smaller but important theoretical projects are supported at about 25 other universities and research institutes. It is the nature of the theoretical physicist to wish to derive from known principles the same numbers which the experimentalist obtains by his measurements, and then to go further and predict the results of experiments not yet made. The tools of his trade are the theorems and methods of mathematics, which are applied to the mathematically expressed laws and principles of physics to obtain new relationships and new laws expressing the experimental observations of physics. When observed phenomena can be explained and numerical values calculated from a limited body of fundamental principles, the theorist considers them to be "understood."

## ELEMENTARY PARTICLES

Probably the area of theoretical physics which is most exciting and fast moving at present is elementary particle physics. It is to produce and study elementary particles that the great accelerators have been constructed by many nations. In these accelerators a bewildering variety of new particles has been created, merely by causing collisions of high-speed protons or electrons with the nuclei of target atoms. In such collisions, a portion of the energy of motion of the high-velocity particle is changed into new particles which possess measurable mass (and frequently charge,) as well as a host of other characteristics. If the energy is sufficiently high, even the protons (or perhaps a neutron) may be converted into strange new particles of greater mass, which undergo a series of decays to other elementary particles, leading eventually back to a proton (or perhaps a neutron). All massive free particles except the proton and the electron (and the neutron, if it is in an atomic nucleus) have fleeting existence.

The theoretical physicist attempts to discover the rules of nature which govern these changes and to predict the characteristics of new particles which are subsequently discovered by experimentalist. Needless to say, predictions which cannot be proven by experiment do not lead to acceptance of theory. Astonishing success has been achieved in characterizing particles and in sorting out the transformations allowed by nature and those not allowed. A few years ago a brilliant prediction by Gell-Mann of Cal Tech and Ne'eman, then at Imperial College (London), now at Tel-Aviv University (and an AFOSR principal investigator), was made of the particle called the "Omega-minus." They gave so detailed a description of the Omega-minus that search of Brookhaven bubble-chamber film quickly revealed two clear examples of the particle. By an application of group theory, it was found that the properties of a particular group called  $SU_3$  were especially suited to classifying a substantial fraction of the known particles. This led to a great flurry of activity in exploring higher symmetry groups such as  $SU_6$  and  $U_{12}$  (or "U twiddle 12," as it is now universally known), but progress thus far has been slow in obtaining a completely satisfactory relativistically invariant classification scheme.

One interesting aspect which has lately received attention in the press is whether "time reversal

invariance" holds in elementary particle interactions. It is a long-accepted principle of physics that the laws of physics are invariant whether going forward or backward in time. As an example suppose that the swinging of a pendulum is photographed on movie film. If the movie film is then projected, it is found that the film may be run either forward or backward and the motion of the pendulum is observed to be the same. It is therefore not possible by watching the movie to deduce whether time is being run forward or backward in the projection since the equations for the motion of the pendulum are the same. Thus the equations of motion are said to be "time reversal invariant."

It is firmly established that the quantity known as CPT is invariant, where C, P, and T stand for certain quantum mechanical operators. C is the charge conjugation, P the parity, and T the time reversal operator. It was once believed that in any elementary particle transformation and decay C, P, and T were conserved; i.e., each operation, when applied over all the particles involved in the interaction, has the same value after as before the change. However, some years ago, it was found that P was not conserved in certain weak interactions (specifically in beta decay, a common type of radioactivity), which was surprising and disturbing to the physicist.

It was then thought probable that when P was not conserved there was a corresponding violation of C conservation such that the combined operation of CP was conserved. However, in one now well-established transformation, the decay of the kaon of zero charge into a pair of pions (one positive and one negative) it was found that CP conservation was slightly violated. The smallness of the violation was even more disturbing to theorists than a large violation would have been, because it calls into question whether the violation arises in the strong, weak, or electromagnetic interactions, or even in a new postulated "super-weak" interaction. The decay of the eta particle is known to proceed by electromagnetic interaction, and if that is responsible for CP violation, there would be an asymmetry in the energy distribution of the charged pions produced in the decay. (The eta particle, by the way, was discovered by an AFOSR-sponsored investigator, Pevsner at Johns Hopkins, several years ago.) The recent news stories reported that such an asymmetry had been observed by a Brookhaven group, but still more

recent and more extensive work at CERN showed none. Thus it presently appears that the CP violation may not be in the electromagnetic interaction. The importance of these experiments, which have all been suggested by theorists, is that if CP is not conserved, and yet the combined CPT operation is conserved, then there should be a related violation of T conservation. This would be most subversive of physical theory. On the other hand if T is conserved and CPT is violated, this would destroy most of the existing theory of elementary particle physics. An experiment to make a direct test of T invariance in electromagnetic interactions is in preparation by Fairbank in an AFOSR-sponsored investigation at Stanford, described more fully in a following discussion by E. Weigold. One may have some appreciation of the importance of these questions of reflecting that Einstein's demonstration that  $E=mc^2$  in effect overthrew other conservation laws, in certain instances at least, namely, conservation of mass and conservation of energy. His discoveries must have seemed at least as remote from practical affairs at that time as these questions seem now, but with the accelerating rate of progress of science and technology it is possible and perhaps likely that understanding of these very fundamental matters will produce rapid though presently unpredictable practical results sooner than is now foreseeable. This somewhat sketchy discussion is intended to give some notion of the "hottest" problem on the most fundamental levels of physics, and the participation of AFOSR in research to solve it.

#### FIELD THEORY

Another less rapidly moving but important area of theoretical physics is gravitational field theory including its relationship to quantum theory. The special theory of relativity announced in 1905 by Einstein set forth the principles governing the dynamics of rapidly moving bodies, from which Newton's laws of motion emerged as special cases for low velocity systems. Later in 1915 Einstein announced the general relativity theory, which gave a relativistic description of the dynamics of bodies in gravitational fields. When quantum mechanics was developed in the 1920's, it was an obvious and rapid development to originate relativistic quantum mechanics, and with the rise of accelerator

physics, very satisfactory descriptions of a wide variety of phenomena were obtained using the theory. Thus, except for certain questions on the research frontiers as illustrated above, both the special theory of relativity and quantum theory are truths essentially beyond question.

With the general theory, the situation is quite different. This gigantic concept, almost untestable and untested, still stands apart from the main body of physical theory, and yet is so extremely fundamental in its treatment of space, time, and gravitation that scientists have been disturbed and baffled by this apparent lack of connection. One of the problems is the testing of the general theory. Einstein cited three phenomena which he regarded as tests of the theory: (1) the bending of starlight in paths close to the sun; (2) the shifting of spectral lines toward the red in spectra of massive stars; and (3) the precession of the perihelion of the planet Mercury. The first of these is measurable only at the time of total eclipse, and then only inaccurately. It has been shown by Schiff, an AFOSR-sponsored investigator at Stanford University, that the second may be explained without recourse to the general theory, using only the special theory and the principle of equivalence. The third is a small effect (43 seconds of arc per century) but it has been found to agree quite accurately with the prediction of the general theory. It is thus the only satisfactory test of the validity of the general theory. It should be added that relativity specialists hold different points of view among themselves, and many regard the principle of equivalence, which is merely a statement of the experimental observation that gravitational mass and inertial mass are exactly proportional, as being a logical consequence of the general theory. Thus they regard this as being in effect a completely satisfactory experimental verification of the theory. On the other hand, it does not necessarily follow that the principle of equivalence could not be a consequence of some alternative theory of gravitation, although no such theory has been seriously proposed, probably because the general theory of relativity is so elegant and complete.

The fundamental importance of the theory, regardless of the relation of the principle of equivalence to it, is such that considerable thought has been given to further experimental test. Two new tests have been proposed and designed by AFOSR-sponsored investigators (Schiff and Fair-

bank at Stanford), which are based on the behavior of gyroscopes in the gravitational field of the earth. It has been deduced from the general theory that a gyroscope moving about the earth in a polar orbiting satellite will exhibit two types of precession of its axis caused by the gravitational field of the earth. A superconducting gyroscope has been designed which is expected to have a drift rate less than 0.01 second of arc per year. This must be housed in a magnetic field free space, to shield it from the earth's magnetic field. If successful this will be a substantial advance in gyroscope technology, and will permit the testing of the general theory. A second experiment is also being prepared which will use the nucleus of the helium isotope of atomic weight three as the gyro. This will also require the use of magnetic field free space and may be done on the earth's surface, using the rotation of the earth itself, instead of the orbiting satellite, to carry the gyro about the earth. It is also of interest to note that if an electric field is applied to the Helium-3 gyro system, and precession is found to ensue owing to this field, it will prove that the neutron has an electric dipole. This will establish that time reversal invariance is violated in electromagnetic interactions with elementary particles as discussed earlier. These experiments are in preparation under AFOSR sponsorship (1), and offer interesting illustrations of how fundamental discoveries and problems lead to advances in practical technologies, which in turn makes possible further fundamental advances.

One aspect of gravitational theory is most strange, namely that while all other physical phenomena, when discussed on a fundamental level, require recourse to quantum theory, the general theory of relativity has no clear connection with or apparent need of quantum concepts. Even magnetic fields have been discovered recently to have quantized flux. One cannot help having a suspicion that the position of the general theory with respect to gravity may be analogous to that of Maxwell's equations with respect to electricity and magnetism, which also required no resort to quantum concepts. It was not until the discovery of the electron, the special theory, and much later the quantum theory, that the reasons for the validity of Maxwell's equations were understood on a more fundamental level. It is thus natural for relativists to become engrossed in attempts to quantize gravitation, in order to seek a similar

understanding of the general theory equations. It is quite possible to postulate a "graviton," with a role perhaps analogous to the photon in electromagnetic interactions, and which would be a kind of quantum of the gravitational interaction. The nature and the characteristics of the graviton emerge from the theoretical deductions, which might tell the experimentalists where and how to look for this "particle." Since all particles in motion have associated with them a characteristic wavelength the concept of the graviton immediately suggests the possibility of gravity waves, and several experiments have been and are being studied or conducted in a search for them. Thus far, no evidence of their existence has been experimentally observed.

#### **General Physics**

The program of the general physics division, as the name suggests, is a diversified research program in many fields of physics of importance to the Air Force. It is administered by a staff comprising three civilians and one military officer, and has an annual expenditure rate of about \$4.8 million per year, including ARPA funds. The major portion of the program deals with atomic and molecular physical phenomena, including quantum electronics. Other aspects include investigations in plasma physics, both in the laboratory and with astrophysical techniques: space physics, including ionospheric and astronomical studies; statistical mechanics and studies of nonequilibrium thermodynamics; and quantum optics and coherent radiation.

#### **STELLAR INTERFEROMETRY AND COHERENCE**

One of the exciting investigations which has had a major impact in modern optics is the Brown-Twiss stellar interferometer, located in Narrabri, Australia. The ordinary Michelson stellar interferometer gathers the light from a star at two separate apertures, and by a system of mirrors brings the light together so that an interference pattern is created. This is physically similar to the interference pattern when light passes through two slits, creating interference fringes on a screen behind the slits: the narrower the slits, the sharper the fringes on the screen. Similarly, the Michelson type of stellar interferometer causes the light from

the star to interfere such that fringes are produced, with their sharpness depending on the apparent diameter of the star. In practice, a Michelson interferometer has not been found very useful, because all but a very few stars are so far away that it is not possible to get the two light-gathering apertures sufficiently far apart so that stars appear as other than point sources. The reason for this is that the base line distance between the two apertures must have a ratio to the light wavelength of the approximate order of magnitude as the ratio of the distance to the star to the length of the baseline. When the baseline is made this long, there is sufficient variation in the optical path length owing to thermal and mechanical disturbances, that clear fringes cannot be formed. Brown and Twiss, two radio astronomers then at Jodrell Bank, England, discovered a way to avoid this problem by a radically new approach, of such basic importance that it has created an entirely new field of research, not only in optics, but in radio technology as well.

This consisted of gathering light from a given star on two large mirrors some distance apart and focussing it upon photomultiplier tubes. The electrical outputs of the tubes were then multiplied together so that the fluctuations were correlated against each other. While it is a well-known fact that stars twinkle, owing to atmospheric effects, it is not these twinkling fluctuations which are measured! Instead it is the fluctuations due to the basic coherent characteristics of the light from a weak point source. If the star being observed is very far away, the light arriving at the earth fluctuates in intensity, in such a way that the fluctuations at one point of observation are exactly the same as at another. The light is then said to be completely coherent. If a nearby star is observed, and the two points of observation are sufficiently far apart, then it is found that the fluctuations are not identical at the two points, because the light is only partially coherent. The degree of incoherence may be measured by cross-correlation of the intensity fluctuations measured at the two points. This means that the star no longer appears to such an intensity interferometer as a point source, but instead has a measurable diameter which can be computed from the degree of incoherence. The Brown-Twiss Interferometer at Narrabri, sponsored by AFOSR, has mirrors 24 feet in diameter, mounted on a circular railway such that they can be separated as much as 600

feet. The Australian location was selected because many more stars are within range in the southern hemisphere than in the northern. By cross-correlating fluctuations over a 100-megacycle bandwidth, the atmospheric scintillation is a negligible fraction of the total, and introduces no error.

The importance of this discovery lies not so much in the astronomical data which will be obtained on the 100 or 200 stars which the instrument can resolve, although it is quite true that the results are of enormous interest to astronomers, and particularly to those astrophysicists concerned with the nuclear processes by which stars derive their energies. Instead it is the wholly new outlook of the behavior of coherent and partly coherent light and the wholly new field of quantum statistics of radiant sources which is being developed to understand and explain this behavior. Practically, there is of course an obvious extension of the theory to radar observations of objects too distant to be resolvable by conventional techniques. It is more than mildly astonishing that what now seems an obvious extension of quantum theory of electromagnetic radiation so long escaped attention not only of optical physicists but of radio physicists as well.

#### LASERS

This remarkable expansion of the horizons of the properties of light is of enormous importance in laser theory, for of course lasers produce light of a high degree of coherence. Fundamental papers on laser theory were published several years ago by two AFOSR-sponsored investigators: A semi-classical treatment by Lamb, and a quantum mechanical treatment by Glauber. These papers dealt with the mechanism of the stimulated emission phenomenon, from their respective points of view. Lasers have two characteristics of both scientific and practical interest: They produce light which has a high degree of coherence, and the light has very high intensity, which if desired may be emitted in extremely short pulses. It is the latter property on which practical interest has so far mostly been centered, although it is the coherence property which is responsible for the highly collimated nature of the laser beam, that makes possible the practical use of the high intensity. It is the coherence property, however, which suggests the potential use in communication, with the first

obvious idea being merely the modulation of the extremely narrow spectral line, as in radio transmission of information. Indeed an AFOSR-sponsored investigator, Holzhauser, has shown how to use amplitude modulation of laser beams in a practical way, and beat frequency studies with two independent laser beams have been made by other AFOSR-sponsored investigators as well, including Siegman and Mandel. While not perhaps casually evident, it is a fact that all these modulations and interference effects, like the Brown-Twiss experiment, involve quantum mechanical fluctuations, including the stimulated emission process itself and the spectral line width of the emitted radiation. The Brown-Twiss ideas essentially opened the door to these new concepts.

Masers, both optical and microwave, operate because certain atoms have transitional probabilities for certain of their electronic energy levels such that an "inverted population" of electrons can be produced. This requires that energy can be easily absorbed by or "pumped" into the atom such that electrons are raised to a high energy level, and then drop into an intermediate level which has a naturally low probability of transition back to the normal ground level. With such atoms, given sufficiently rapid pumping by optical, radiofrequency, or even chemical means it is possible to elevate and temporarily store a large percentage of the ground state electrons in the higher energy, meta-stable level. These energized atoms may be either in the gaseous, liquid, or solid state in various masers which have been made. In nearly all masers, it is necessary in practice to have them in a resonant cavity, in the instance of optical masers, or lasers, consisting of two plane mirrors at each end of the cylinder containing the energized atoms. When the mirrors are made parallel (called Q-switching), light is then reflected back and forth between the mirrors, making possible a standing wave optical field pattern in the laser material. The presence of this field influences the transition probability for the electrons in the excited state to return to the ground state, by giving off their stored energy as light quanta. Depending on the phase and intensity of the electric or magnetic field of the light quanta traveling back and forth between the two mirrors, the transition probabilities are raised or lowered in such a way that the transitions are stimulated or inhibited in just such a manner that the newly emitted photon is in phase with the standing wave train between the mirrors,

thus adding to the intensity of the wave. This buildup of intensity is extremely rapid, and by having a small hole in one mirror, or having it only partially silvered, the pulse of light is allowed to leak out as the laser beam. Pulses of enormous intensity may be generated, which when properly focused will even punch holes in diamonds, simply by vaporizing the diamond. Continuously operating lasers of lower intensity may also be made by continuously pumping suitable atoms, which emit their spectral line (or lines) at steady intensity. It is clear that to obtain a laser beam of a desired wavelength, it is necessary first to discover atoms (or molecules) which have the appropriate energy levels as described above. These are readily investigated by studying atomic and molecular spectra since each spectral line is only a manifestation of the energy difference between two levels, and the line intensity is related to the probability of transition between these levels. Because of the great practical interest in masers, both microwave and optical, there has been a substantial increase in spectroscopic research, in which the AFOSR program is well represented. Indeed AFOSR-sponsored research has played a major role in the development of laser technology, since not only has much of the theory of laser action been developed as discussed above, but many of the laser crystals have been products of the solid state program. In addition the knowledge of rare earth element spectra gained by the late Professor Dieke of Johns Hopkins made available many of the dopants used in laser crystals under AFOSR sponsorship.

#### IRREVERSIBLE PROCESSES AND STATISTICAL MECHANICS

An important program in the AFOSR general physics research is the theoretical program on nonequilibrium processes. Heisenberg once termed the understanding of turbulence "the aristocrat of physics problems" because of its intractability. It might once have been more appropriate to apply this accolade to nonequilibrium processes, for turbulence is only one example of such processes, but this is no longer true, for in recent years theoretical physicists have succeeded in reducing this aristocrat more to the level of at most the upper middle class. To quote the U.S. National Academy of Sciences (2):

"The more complex problems of the fundamentals of irreversible statistical mechanics have been attacked successfully only recently by Prigogine and colleagues at the University of Brussels. The understanding of the nature of the approach to equilibrium developed by the Prigogine school represents a contribution to the statistical theory of matter comparable in importance to the work of Gibbs."

Commenting to AFOSR on this remarkably complimentary statement, Professor Prigogine said that "this development was only possible through the continuous support of the U.S. Air Force," which was from AFOSR through the European Office of Aerospace Research.

The understanding of all physical processes in the final analysis must discuss the behavior of the individual particles involved in the process. In fluid physics this requires discussing the movements of molecules, in plasma physics, of ions and electrons, in nuclear physics, of nucleons; in elementary particle physics, the various ordinary and strange particles involved. If the system of particles is in macroscopic equilibrium, then the details of the particle behavior may usually be discussed using a rather simple kind of average behavior, known as Boltzmann statistics. The proper use of this body of theory leads to the equations of equilibrium thermodynamics, thus providing a microscopic understanding of why the laws of thermodynamics hold. When any physical or chemical change takes place, however, ordinary thermodynamics has nothing to say regarding the rates of change, nor does the ordinary statistical mechanics. The reason is that the kind of averaging processes developed by Boltzmann and Gibbs is not successful in systems which are not at equilibrium, except on a microscopic scale at best. Thus new kinds of statistical approaches have had to be developed, and since 1935 advances in the understanding of nonequilibrium processes has proceeded at an accelerating rate. The basic theory is known as the N-body problem, which must take into account the rate processes of the mechanical interactions between the many bodies involved, transport processes, and hydrodynamic processes. The AFOSR program in this field sponsors, in addition to Prigogine, a number of other outstanding theorists, including Lebowitz, Siegel, Lieb, and Watson.

#### RADAR STUDIES OF THE IONOSPHERE AND PLANETS

One major project now world famous is managed by AFOSR for the Advanced Research Projects Agency, called the Arecibo Ionospheric Observatory, located in a natural bowl near Arecibo, P.R. This observatory is really a gigantic radar, with a reflecting dish 1,000 feet in diameter, and with the 430 megacycle radiofrequency feed suspended about 500 feet above the dish, which rests on the earth in the bowl. Unlike most radars, the emitted beam of radiation is steered by moving the feed while the dish remains immobile. This novel arrangement was first worked out by an AFCRL scientist, Sletten, and permits steering about 20° from the vertical in all directions. To accomplish this, the dish must have a spherical surface instead of the usual parabolic surface, and the feed must be a line feed, instead of the horn feed (quasi-point source) of a parabolic reflector. The problem of this novel feed has led to an interesting practical advance in antenna design, which must be mentioned as an example of how scientific research leads to unexpected practical side results. The original feed is a tapered rectangular tube 90 feet long, having slotted openings spaced along each side. The radar signal at 2.5 megawatts peak power is pulsed into the feed, and by emerging from the slots as it passes down the feed, illuminates the dish such that the phases of the waves reflected from the different regions of the dish combine to produce a plane wave upward parallel to the feed. By pointing the feed in different directions, the beam is steered in the desired direction. In the early operation of the dish, it was disappointingly revealed that the arrangement was only about 40 percent efficient in getting the radiation energy into the beam, as compared with about 60 percent efficiency of a parabolic reflector with a simple horn feed. Further analysis and experimentation has led to a new design which can be readily made to give an efficiency above that of the parabolic antenna. It seems possible that this discovery could lead to major changes in future antenna designs.

The design of the observatory was dictated by the requirements for studying the ionosphere, which is done by sending a high-intensity pulse through the ionosphere, which is essentially transparent to 430 megacycles. The radiofrequency field causes the electrons and ions to oscillate in syn-

chronism with it, and as a result of this movement they reradiate, since they are accelerated charges. A portion of this energy arrives back at the dish, and is measured by it in phase and amplitude. The interval between the time the pulse is originally broadcast and the time the returning radiation is received is a measure of the distance, since the signal travels at the finite speed of light. The analysis of the phase and amplitude of the signal yields the concentration and temperature of the particles at that distance. Thus the ionosphere may be mapped in a broad region above the observatory. It has been found that charged particles move in clouds across the ionosphere, and their characteristics are studied, along with their diurnal variation.

Because of the high power of the transmitter, radar astronomy of the nearer planets is possible, and the rates of rotation of both Mercury and Venus have been accurately measured. Mercury was previously thought to have only one face to the Sun, as the Moon has to the Earth, but has been established to rotate in the retrograde direction (opposite to the Earth's rotation) on its axis once every two-thirds Mercurial year. The radar reflection characteristics of the lunar surface are also presently being mapped for NASA.

Because of the large area of the dish, it has the greatest sensitivity in the world for receiving signals from space. The most interesting part of the radio spectrum is the 21-centimeter (1430 megacycles) line emitted by hydrogen, which is received from very distant galaxies among other sources. It has been possible to true the surface of the dish sufficiently so that about 600 feet of the diameter is effective for receiving this wavelength. A suitable feed is being designed and built for efficient reception of this frequency, and when this is in operation the observatory will become first in importance among the dishes in the world for radio-astronomy.

#### **Geophysics—Seismology**

The AFOSR geophysics division, comprising one civilian and one officer, operates a basic research program in seismology on behalf of the Advanced Research Projects Agency, as a part of the underground nuclear test detection program of ARPA. The AFOSR program comprises about 40 projects mainly carried out by universities, and includes research in instrumentation, seismic data

processing and interpretation of the structure of the earth, and exploration of sites at a number of locations around the earth.

The basic problems of underground explosion detection are the detection of the seismic signal of the explosion in the background of seismic noise, and then the analysis of the event to determine whether it was caused by an earthquake or an explosion. If the explosion is large, then neither of these is difficult, but for very small explosions the signal may be lost in the noise, and small earthquakes are so numerous that even for identifiable signals the uncertainty of interpretation is large.

The enlargement of the signal to noise ratio can be promoted in three ways, by moving the observing station close to the explosion (which is possible for the Nevada test site but not for others), by locating the observing station in regions with the minimum noise level, and by using arrays of seismometers and processing the signals so that advantage can be taken of the directionality and coherence of the seismic signal. It is of interest to note that in the past summer the center of the Greenland icecap has been found to be an excellent low noise area, to the surprise of most seismologists. This was learned by an expedition organized by the Arctic Institute of North America, supported and flown in by the Alaskan Air Command from Thule Air Force Base. A second site of good quality is a station near Abeche, Chad, in the center of Africa, where a station is operated under supervision of Rocard of the University of Paris in cooperation with Anderson of Columbia University. Both sites are far from the ocean, a well-known source of seismic noise, much of which has been shown to come from waves on certain beaches. Another investigation by Bradner of the University of California at San Diego has included ocean bottom measurements at many points in the southern and central Pacific Ocean, at depths as great as 14,000 feet. It does not appear that the ocean bottom has low noise characteristics.

#### **Relevance**

The preceding discussions by no means include all the interesting subjects in AFOSR physical sciences research, but are only a sampling of the program. All sponsored investigations are basic in nature, for it has been standard practice to refer applied research investigators to the appropriate laboratories of the Air Force Systems Command's



research and technology division. In selecting proposals for support, the physical sciences staff has attempted to choose the most original and important research which its experience and imagination leads it to believe will be fundamental to future Air Force technology. Importance is measured by an assessment of how much understanding of the physical phenomena being investigated is likely to be gained if the outcome is successful. Probability of success is also a factor which is weighed.

The question is often asked as to why the Air Force, or even the Defense Department, operates a program of this type. Why should not the National Science Foundation be the exclusive Federal agency to support basic research? There are undoubtedly reasonable arguments on both sides of the question, but it should be remembered that the Air Force on balance benefits from its involvement in the basic research activity of the Nation. The more connection the Air Force has with basic research, the more interaction there is between the Air Force and scientific thought and scientists. The Air Force is the largest consumer of basic knowledge, because of the vastness and complexity of the technology used. Research and science also benefit from interaction with defense technology and its needs, and each reinforces the other. While basic research is beneficial to the general level of national technology, it is essential to Air Force technology, which rapidly assimilates new discoveries and usually applies them far in advance of commercial exploitation, in order to maintain the most advanced level of aerospace technology.

It is rare that a given basic research discovery can be demonstrated as having been taken directly through applied research, and technical and operational development to hardware. Instead, there is a complexity of movement on all fronts, from very fundamental research to perhaps only a slightly improved gadget, which are all important, with

each reinforcing all others. If any of the movement is lacking, then all are affected, and technological progress is slowed in producing new and complex systems.

It is strange to a scientist that managers will often ask for a prediction as to what will be the effect on future developments if basic research is diminished, or even discontinued. This is asking what will be the effect of the lack of an idea which no one has yet conceived. This can be answered for a certain number of ideas in the past originating from basic research, but even there it is not usually possible to trace an explicit chain of events leading to an important system of hardware. From such history, it must be concluded that innovation must be continuous in any technological organization. It is the opposite of stagnation, and stagnation is fatal, whether it be in military, commercial, or any other enterprise. Innovation only comes from ideas, and in technologies, ideas come from basic research activities more than from any other.

It has been the aim of the physical sciences program to strive for the novel, the original, and the fundamental. While such judgments are far from infallible, the record of Air Force participation in the really new research ideas has been exceptional. It is the prime objective to keep it that way.

#### REFERENCES

- (1) See also the paper in this volume by E. Weigold "Observational Tests of General Relativity" or the paper entitled "From Quantized Flux to a Free Precession Nuclear Gyro," by Fairbank et al., in the *Proceedings of the OAR Research Applications Conference*, 5 Apr 1966, Office of Aerospace Research.
- (2) *Publication 1292D*, par. 2, p. 12, of the National Academy of Sciences National Research Council, Washington, D.C. (1966)

PHYSICAL SCIENCES

2.0.0 PHYSICS

2.1.0 ELEMENTARY PARTICLE PHYSICS

BARUT A D  
UNIVERSITY OF COLORADO  
QUANTUM FIELD THEORY AND ELEMENTARY PARTICLES  
LEHMAN D R SRPN

EDEH R J  
CAMBRIDGE UNIVERSITY  
THEORETICAL RESEARCH IN FUNDAMENTAL PARTICLE PHYSICS  
LEHMAN D R SRPN

ERSPONG G  
STOCKHOLMS UNIVERSITET  
ANTIPROTON AND OTHER ELEMENTARY PARTICLES RESEARCH  
GORRELL J E SRPN

FURINI S  
UNIVERSITA DEGLI STUDI DI TORINO  
THEORETICAL STUDY IN QUANTUM FIELD THEORY AND ELEMENTARY PARTICLES  
LEHMAN D R SRPN

GARTENHAUS E  
PURDUE RESEARCH FOUNDATION  
THEORETICAL STUDY OF NUCLEAR STRUCTURE AND INTERACTIONS  
LEHMAN D R SRPN

GLAUBER R J  
HARVARD UNIVERSITY  
THEORETICAL STUDIES OF THE INTERACTIONS OF PARTICLES AND FIELDS  
LEHMAN D R SRPN

HARPLUS R  
UNIVERSITY OF CALIFORNIA  
THEORETICAL PHYSICS OF ELEMENTARY PARTICLES  
LEHMAN D R SRPN

LEVISSETTI R  
UNIVERSITY OF CHICAGO  
HYPERNUCLEI AND RESONANT STATES OF ELEMENTARY PARTICLES  
GORRELL J E SRPN

LEWIS R R  
UNIVERSITY OF MICHIGAN  
THEORY OF WEAK INTERACTIONS AND ELECTRODYNAMICS  
LEHMAN D R SRPN

MUWIR B A  
OHIO UNIVERSITY  
BASIC RESEARCH IN HIGH ENERGY PHYSICS  
GORRELL J E SRPN

NE-EMAN Y  
TEL-AVIV UNIVERSITY  
ALGEBRAIC APPROACH TO ELEMENTARY PARTICLE DYNAMICS  
LEHMAN D R SRPN

OPPENHEIMER R  
INSTITUTE FOR ADVANCED STUDY  
THEORETICAL ASPECTS OF MODERN NUCLEAR PHYSICS  
LEHMAN D R SRPN

ROMAN P  
BOSTON UNIVERSITY  
STUDIES IN PARTICLE PHYSICS  
LEHMAN D R SRPN

SCHIFF L I  
STANFORD UNIVERSITY  
THEORETICAL STUDIES IN PARTICLES, NUCLEAR AND LOW TEMPERATURE  
PHYSICS  
LEHMAN D R SRPN

SUCHER J  
UNIVERSITY OF MARYLAND  
FOUNDATIONS OF SCATTERING THEORY AND APPLICATIONS TO PHYSICAL  
PROBLEMS  
LEHMAN D R SRPN

SUSSKIND L  
YESHIVA UNIVERSITY  
STRONG INTERACTION DYNAMICS  
LEHMAN D R SRPN

THIRRING W E  
TECHNISCHE HOCHSCHULE IN WIEN  
HIGH ENERGY PHYSICS  
LEHMAN D R SRPN

TOLL J S  
STATE UNIVERSITY OF NEW YORK  
AXIOMATIC QUANTUM FIELD THEORY AND SCATTERING OF ELEMENTARY  
PARTICLES  
LEHMAN D R SRPN

WJCICKI S/NOJICIKI S  
STANFORD UNIVERSITY  
ANALYSIS TO DETERMINE PARAMETERS OF NEUTRAL KAON DECAY AND  
INTERACTION  
GORRELL J E SRPN

2.2.0 NUCLEAR STRUCTURE PHYSICS

BLATT J H  
UNIVERSITY OF NEW SOUTH WALES  
NUCLEAR THREE-BODY PROBLEM  
WEIGOLD E SRPN

BODENSTEDT E  
UNIVERSITAT BONN  
EXTRANUCLEAR EFFECTS IN GAMMA-GAMMA ANGULAR CORRELATIONS  
WEIGOLD E SRPN

BREIT G  
YALE UNIVERSITY  
ELECTRON NUCLEAR INTERACTIONS AND RELATED PROBLEMS  
WEIGOLD E SRPN

CLAYTON D D  
RICE UNIVERSITY  
THEORETICAL NUCLEAR ASTROPHYSICS  
WEIGOLD E SRPN

DAVIS R H  
FLORIDA STATE UNIVERSITY  
RESEARCH IN EXPERIMENTAL AND THEORETICAL LOW ENERGY NUCLEAR  
PHYSICS  
WEIGOLD E SRPN

GAMMEL J L  
TEXAS A AND M RESEARCH FOUNDATION  
THEORETICAL STUDIES IN NUCLEAR PHYSICS  
WEIGOLD E SRPN

GREEN A E S  
UNIVERSITY OF FLORIDA  
STUDIES WITH VELOCITY DEPENDENT POTENTIALS  
WEIGOLD E SRPN

GREEN A E  
UNIVERSITY OF FLORIDA  
INTERNATIONAL CONFERENCE ON THE NUCLEON-NUCLEON INTERACTION  
WEIGOLD E SRPN

MC CARTHY E E  
UNIVERSITY OF DREGON  
STUDIES OF NUCLEAR REACTIONS AND STRUCTURE  
WEIGOLD E SRPN

MURSER R H  
UNIVERSITY OF ROCHESTER  
EXPERIMENTS IN NUCLEAR PHYSICS USING A BEAM PULSING AND  
TIME OF FLIGHT SYSTEM  
WEIGOLD E SRPN

SALA C  
UNIVERSIDADE DE SAO PAULO  
DEUTERON AND PROTON REACTIONS AT 3.5 MEV.  
WEIGOLD E SRPN

SCOTT B L  
CALIFORNIA STATE COLLEGE AT LONG BEACH  
APPLICATIONS OF SEPARABLE, NONLOCAL POTENTIALS TO PHYSICAL  
PROBLEMS  
WEIGOLD E SRPN

VAN PATER D H  
FRANKLIN INSTITUTE  
PROPERTIES OF MEDIUM WEIGHT NUCLEI  
WEIGOLD E SRPN

VAN PATER D H  
FRANKLIN INSTITUTE  
A GAMMA RAY DETECTING SYSTEM  
WEIGOLD E SRPN

WEINZIERL P/PAUL N  
AUSTRIAN ATOMIC ENERGY STUDY GROUP  
BETA SPECTRUM OF NEUTRON DECAY IN COINCIDENCE WITH RECOIL PROTONS  
WEIGOLD E SRPN

WERNITZ C  
CATHOLIC UNIVERSITY OF AMERICA  
THEORETICAL STUDIES OF LIGHT NUCLEI  
WEIGOLD E SRPN

2.3.0 ATOMIC AND MOLECULAR PHYSICS

BATLEY I L/THOMAS B S  
UNIVERSITY OF FLORIDA  
LOW-ENERGY IONIC COLLISIONS  
WENNERSTEN G L SRPN

BROUT R  
UNIVERSITE LIBRE DE BRUXELLES  
THEORY OF MANY BODY PROBLEMS AND PARTICLE PHYSICS  
WENNERSTEN G L SRPN

CARVER J H  
UNIVERSITY OF ADELAIDE  
ATOMIC AND MOLECULAR PHOTODISINTEGRATION  
WENNERSTEN G L SRPN

CHISHOLM J S R  
UNIVERSITY OF RENT  
RESEARCH ON PADE APPROXIMANTS AND QUANTUM FIELD THEORY  
WENNERSTEN G L SRPN

## PHYSICAL SCIENCES

### 2.3.0 ATOMIC AND MOLECULAR PHYSICS

COOH J O  
TEXAS A AND M RESEARCH FOUNDATION  
ELECTRONIC SPECTRA OF SIMPLE MOLECULES  
WENNERSTEN G L SAPP

DE GROOT S R  
UNIVERSITY OF LEUVEN  
THERMODYNAMICS OF IRREVERSIBLE PROCESSES  
WENNERSTEN G L SAPP

DEWON J H  
NEW ENGLAND INSTITUTE FOR MEDICAL RESEARCH  
RESEARCH ON POSITRONIUM  
HARRINGTON H C SAPP

GROSS E P  
BRANDEIS UNIVERSITY  
MANY BODY THEORY AND QUANTUM FLUIDS  
HAYCOCK D A SAPP

HENKE D  
POMONA COLLEGE  
PHYSICS OF LOW ENERGY X-RAYS AND BETA RAYS  
HARRINGTON H C SAPP

HENKE D L  
UNIVERSITY OF HAWAII  
LOW ENERGY X-RAYS AND ELECTRONS IN THE 100 TO 1000 VOLT RANGE  
HARRINGTON H C SAPP

MAST R D  
STATE UNIVERSITY OF NEW YORK  
EFFECTS OF EXTERNAL MAGNETIC AND ELECTRIC FIELDS ON SMALL  
MOLECULES  
HAYCOCK D A SAPP

KELLER J D / PERLUS J R  
NEW YORK UNIVERSITY  
MANY-BODY PHYSICS  
WENNERSTEN D L SAPP

KUSCH P  
COLUMBIA UNIVERSITY  
PHYSICS AND CHEMISTRY OF GASES AT HIGH TEMPERATURES  
HARRINGTON H C SAPP

LANDER H S / WHITEHEAD W D  
UNIVERSITY OF VIRGINIA  
DETERMINATION OF THE DEGREE OF IONIZATION OF GAS ATOMS AS A FUNCTION  
OF X-RAY ENERGY  
WENNERSTEN D L SAPP

LARKIN D R  
UNIVERSITY COLLEGE  
MICROWAVE SPECTROSCOPY IN THE MILLIMETER REGION  
HARRINGTON H C SAPP

LEONITZ J  
YESHIVA UNIVERSITY  
STATISTICAL MECHANICS OF EQUILIBRIUM, NON-EQUILIBRIUM AND QUANTUM  
MANY-BODY PROCESSES  
WENNERSTEN D L SAPP

LEUW H  
UNIVERSITY  
MOLECULAR FORCES AND BASIC PROBLEMS OF QUANTUM  
MECHANICS  
HARRINGTON H C SAPP

REIJER P H / ETAMARA  
CATHOLIC UNIVERSITY OF AMERICA  
STATISTICAL MECHANICS AND IRREVERSIBLE THERMODYNAMICS  
WENNERSTEN G L SAPP

MONDI D S  
MONT STATE UNIVERSITY  
SINGLE QUANTUM ANNIHILATION OF POSITRONS IN VARIOUS ATOMIC SHELLS  
HARRINGTON H C SAPP

NEUBERG R E  
WASHINGTON UNIVERSITY  
SOLID AND LIQUID RARE GASES  
WENNERSTEN D L SAPP

PRIGOGINE I  
UNIVERSITE LIBRE DE BRUXELLES  
NON-EQUILIBRIUM STATISTICAL MECHANICS  
HAYCOCK D A SAPP

SCHEWEN L E  
UNIVERSITY OF MINNESOTA  
TRANSPORT AND TRANSFORMATION IN CONTINUA  
HAYCOCK D A SAPP

SARIBAN J  
UNIVERSITY COLLEGE OF NORTH MALES  
SUB-MILLIMETER WAVE GENERATION AND SPECTROSCOPY  
HARRINGTON H C SAPP

SIEGEL A  
BOSTON UNIVERSITY  
THEORETICAL STUDIES IN STATISTICAL AND QUANTUM MECHANICS  
WENNERSTEN D L SAPP

SOLTYSEK E A  
UNIVERSITY OF MASSACHUSETTS  
POLARIZATION OF LIGHT RESULTING FROM THE EXCITATION OF ATOMS BY  
ELECTRONS  
WENNERSTEN D L SAPP

WALSON R H  
UNIVERSITY OF CALIFORNIA  
ATOMIC PHYSICS AND MANY-PARTICLE INTERACTIONS  
HAYCOCK D A SAPP

WEISLER G L  
UNIVERSITY OF SOUTHERN CALIFORNIA  
SOFT X-RAY PHYSICS BETWEEN 5 AND 110 ANGSTROMS  
HARRINGTON H C SAPP

WOLF P A  
SAN DIEGO STATE COLLEGE  
ION-MOLECULE AND CHARGE TRANSFER REACTIONS  
WENNERSTEN D L SAPP

### 2.4.0 LOW TEMPERATURE PHYSICS

BREWER D F  
UNIVERSITY OF SUSSEX  
THERMAL AND MAGNETIC PROPERTIES OF ADSORBED PHASES OF H<sub>2</sub> AND He  
AT LOW TEMPERATURES  
WENNERSTEN G L SAPP

DONNELLY A J  
UNIVERSITY OF OREGON  
VORTICITY IN SUPERFLUID HELIUM  
WENNERSTEN D L SAPP

KIDDER J N  
SMITHSONIAN COLLEGE  
HYDRODYNAMICS OF SUPERFLUID HELIUM WITH QUANTIZED  
VORTICITY AND PHASE CORRELATION  
WENNERSTEN D L SAPP

LOPESKI J J / DOMHAUSER E  
BROWN UNIVERSITY  
STUDIES OF PHONON DIFFRACTION IN LIQUID HELIUM  
WENNERSTEN D L SAPP

### 2.5.0 SOLID STATE PHYSICS

LASTER M  
UNIVERSITY OF MARYLAND  
REVIEW AND EVALUATION OF PHYSICAL SCIENCES PROGRAMS  
COMBERS R W SAPP

### 2.5.1 THEORY OF SOLIDS

ANDERSON E E  
CLARKSON COLLEGE OF TECHNOLOGY  
MAGNETIC EXCHANGE INTERACTIONS  
HOUIDGARE R A SAPP

BREITENBERGER E  
OHIO UNIVERSITY  
THE MANY BODY PROBLEM  
COMBERS R W SAPP

CARRERA R  
UNIVERSITY OF VIRGINIA  
THEORY OF SCATTERING FROM SOLID SURFACES  
SHERIDON H SAPP

CATANIELLO E R  
UNIVERSITA DEGLI STUDI DI NAPLES  
FIELD-THEORETICAL METHODS IN MANY-BODY PHYSICS  
COMBERS R W SAPP

CUTLER P H  
PENNSYLVANIA STATE UNIVERSITY  
THEORETICAL INVESTIGATION OF THE SURFACE AND BULK ELECTRONIC  
PROPERTIES OF METALS  
RATCHFORD J T SAPP

DE MATTE P D  
UNIVERSITY OF TEXAS  
CALCULATIONS OF DYNAMIC PROPERTIES OF SOLIDS  
COMBERS R W SAPP

DOHNER D L / RINDI R S  
UNIVERSITY OF ROCHESTER  
THEORY OF ELECTRONIC PROPERTIES OF SOLIDS  
SHERIDON H SAPP

DUNWALL G E  
WASHINGTON STATE UNIVERSITY  
SHOCK WAVES IN SOLIDS  
HOUIDGARE R A SAPP

FENRELL R C  
UNIVERSITY OF MARYLAND  
THEORY OF INTERACTING ELEMENTARY EXCITATIONS IN SOLIDS  
COMBERS R W SAPP

FOHLER H R  
LEHIGH UNIVERSITY  
THEORY OF ELECTRONIC STATES IN INSULATING CRYSTALS  
RATCHFORD J T SAPP

GOLDBERG M  
NEW YORK STATE UNIV RESEARCH FOUNDATION  
ATOM-ENVIRONMENT STUDY BY THE EXPANDED HAMILTONIAN  
COMBERS R W SAPP

PHYSICAL SCIENCES

2.5.1 THEORY OF SOLIDS

MANDLER G S UNIVERSITY OF GEORGIA STATISTICAL THEORY OF ELECTRONIC ENERGIES SHERDLON H	SAPS
HARTMANN W NEW YORK UNIVERSITY PHENOMENA AND THEIR INTERACTIONS WITH ELEMENTARY EXCITATIONS SHERDLON H	SAPS
MORART R H BATTELLE MEMORIAL INSTITUTE THEORY OF THE METALS STRESS MCUIODORE R A	SAPS
MORTON C A RUTGERS UNIVERSITY LOW TEMPERATURE THERMAL AND ELECTRICAL PROPERTIES OF CRYSTALS CONNERS R W	SAPS
KERAN R P BATTELLE MEMORIAL INSTITUTE THEORY OF FERROMAGNETISM IN INSULATORS CONNERS R W	SAPS
KJELDGAAS T POLYTECHNIC INSTITUTE OF BROOKLYN THEORY OF INTERACTION OF HIGH-FREQUENCY SOUND WAVES AND ELECTRONS CONNERS R W	SAPS
KLEINMAN L UNIVERSITY OF SOUTHERN CALIFORNIA RESEARCH IN THEORETICAL SOLID STATE PHYSICS RATCHFORD J T	SAPS
KORRINGA J OHIO STATE UNIV RESEARCH FOUNDATION STUDY RESPONSE OF A LARGE SYSTEM TO A TIME-DEPENDENT EXTERNAL FIELD CONNERS R W	SAPS
LEVY P R YALE UNIVERSITY THEORY OF THE MAGNETIC BEHAVIOR OF INSULATORS CONNERS R	SAPS
MACHLUP S WESTERN RESERVE UNIVERSITY LOW MOBILITY ELECTRONS IN SOLIDS SHERDLON H	SAPS
MARADUDIN A A UNIVERSITY OF CALIFORNIA THEORETICAL STUDIES OF PROBLEMS IN DEFECT LATTICE DYNAMICS RATCHFORD J T	SAPS
MATTIS D C YESHIVA UNIVERSITY THEORY OF MAGNETIC AND ELECTRONIC PROPERTIES OF SOLIDS RATCHFORD J T	SAPS
MELFORD F J BATTELLE MEMORIAL INSTITUTE THEORY OF PARA- AND DIA-MAGNETIC PROPERTIES OF SOLIDS CONNERS R W	SAPS
NARDELLI G F UNIVERSITA DEGLI STUDI DI MILANO LOCAL MODES AND RESONANCE SCATTERING IN CRYSTALS CONNERS R W	SAPS
PEROVICH J UNIVERSITY OF NEW MEXICO TWELFTH AFOSR SCIENCE SEMINAR ARA D L	SAPS
PINES D UNIVERSITY OF ILLINOIS THEORY OF SOLIDS AND CONDENSED MATTER CONNERS R W	SAPS
SARKIS M T COLUMBIA UNIVERSITY THEORETICAL STUDIES OF DISLOCATION BEHAVIOR IN CRYSTALS CONNERS R W	SAPS
SMITH D W UNIVERSITY OF FLORIDA INTERNATIONAL SYMPOSIUM ON ATOMIC, MOLECULAR AND SOLID-STATE THEORY CONNERS R W	SAPS
STEPHEN R J YALE UNIVERSITY PROPERTIES OF TYPE II SUPERCONDUCTORS SHERDLON H	SAPS
SUMI H UNIVERSITY OF CALIFORNIA THEORY OF SOLIDS SHERDLON H	SAPS
WEINER J H COLUMBIA UNIVERSITY THEORETICAL STUDIES OF DEFECT MOTION IN CRYSTALS RATCHFORD J T	SAPS

2.5.2 GROWTH, PREP, SYNTHESIS OF SOLIDS

WRODS J L SOUTHERN ILLINOIS UNIVERSITY SINGLE CRYSTALS UNDER THERMAL GRADIENTS CONNERS R W	SAPS
BEER A C BATTELLE MEMORIAL INSTITUTE HIGH-MOBILITY LOW-MELTING-POINT III-V COMPOUND AND ALLOYS SEMI-CONDUCTORS SHERDLON H	SAPS
CANUT R L SOUTHERN ILLINOIS UNIVERSITY 2-DIMY STUDIES ON MOLECULAR FREE OR HINDERED ROTATION IN PLASTIC CRYSTALS CONNERS R W	SAPS
CARR E P UNIVERSITY OF MAINE ORDERING OF MOLECULES IN THE ANISOTROPIC LIQUID PHASE OF LIQUID CRYSTALS MCUIODORE R A	SAPS
GAUMBAUM E UNIVERSIDAD DE CHILE GROWTH AND STRUCTURE OF SINGLE CRYSTAL FILMS RATCHFORD J T	SAPS
POUND G H STANFORD UNIVERSITY HETEROGENEOUS NUCLEATION IN VAPOR DEPOSITION MCUIODORE R A	SAPS
STICKNANN E F UNIVERSITY OF IDAHO COLOR CENTERS AND THE REFRACTIVE INDEX OF CALCIUM AND STRONTIUM OXIDE MCUIODORE R A	SAPS
SIENKO M J CORNELL UNIVERSITY NEW SOLID STATE DEFECT STRUCTURES SHERDLON H	SAPS
STEINFINK M/WEISS C J UNIVERSITY OF TEXAS CRYSTAL CHEMISTRY OF THE SYSTEMS RARE EARTHS-GROUPS V AND VI ELEMENTS MCUIODORE R A	SAPS
TILLER W A STANFORD UNIVERSITY CRYSTALLIGENESIS SHERDLON H	SAPS
WEINZIERL P AUSTRALIAN ATOMIC ENERGY STUDY GROUP ATOMIC VIBRATIONS IN STRESSED CRYSTAL LATTICES BY INELASTIC SCATTERING OF NEUTRONS CONNERS R W	SAPS

2.5.3 STRUCTURAL CHARACTERIZATION OF SOLIDS

AUSTIN A E BATTELLE MEMORIAL INSTITUTE DISTRIBUTION OF SOLUTES IN DILUTE SOLID SOLUTIONS MCUIODORE R A	SAPS
BETTLER P C UNIVERSITY OF NEVADA FIELD EMISSION STUDIES OF SURFACE MIGRATION OF REFRACTORY METALS CONNERS R W	SAPS
BLAKELY J H CORNELL UNIVERSITY DEFECTS AND DIFFUSION ON IONIC CRYSTAL SURFACES SHERDLON H	SAPS
NIELSON G P OHIO-ILLINOIS GLASS CO NUCLEATION PHENOMENA IN GLASS-CERAMIC MATERIALS MCUIODORE R A	SAPS
POUND G H CARNegie INSTITUTE OF TECHNOLOGY THEORY OF NUCLEATION IN CONDENSATION PROCESSES MCUIODORE R A	SAPS
RHOEN T CORNELL UNIVERSITY BINDING AND MOBILITY OF METAL ATOMS ON CRYSTAL SURFACES SHERDLON H	SAPS
SEEGEL B B CORNELL UNIVERSITY OXIDATION OF METAL SURFACES STUDIED BY ELECTRON DIFFRACTION AND MICROSCOPY SHERDLON H	SAPS
SMELTZER M W/BERNALDY J S MCMASTER UNIVERSITY IONIC DIFFUSION IN SOLID METAL OXIDES MCUIODORE R A	SAPS

## PHYSICAL SCIENCES

### 2.5.3 STRUCTURAL CHARACTERIZATION OF SOLIDS

STEIN R H  
POLYTECHNIC INSTITUTE OF BROOKLYN  
SURFACE INVESTIGATIONS BY SLOW ELECTRON AND PHOTO-ELECTRON  
SPECTROSCOPY  
SHERDLow M SRPS

WEBB M B  
UNIVERSITY OF WISCONSIN  
SURFACE STUDIES BY SLOW ELECTRON DIFFRACTION  
SHERDLow M SRPS

### 2.5.4 MECHANICAL AND THERMAL PROPERTIES OF SOLIDS

ALLEN C W  
UNIVERSITY OF NOTRE DAME  
STRAIN ENERGY AND METASTABILITY OF THREE DIMENSIONAL DISLOCATIONS  
ARRAYS  
MCUIDDRE R A SRPS

ANSSELL G S  
REMSELER POLYTECHNIC INSTITUTE  
EFFECT OF ATMOSPHERES ON THE MECHANICAL PROPERTIES OF CRYSTALS  
CONNERS R W SRPS

DODD R A  
UNIVERSITY OF WISCONSIN  
MECHANISM OF STRESS CORROSION CRACKING IN FACE-CENTERED CUBIC  
METALS  
MCUIDDRE R A SRPS

EDINGTON J  
BATTELLE MEMORIAL INSTITUTE  
EFFECTS OF HIGH STRAIN RATES ON THE FLOW STRESS & DEFECT STRUCTURE  
OF METALS  
MCUIDDRE R A SRPS

EL-SADEN M R  
CALIFORNIA STATE COLLEGE AT FULLERTON  
BASIC STUDIES OF COUPLED TRANSPORT PROCESSES  
RATCHFORD J T SRPS

FINE M E  
NORTHWESTERN UNIVERSITY  
PHASE TRANSFORMATION AND PRECIPITATION STUDIES IN CERAMICS  
SHERDLow M SRPS

GUILD R W  
UNIVERSITY OF FLORIDA  
INFLUENCE OF GP ZONES ON THE MECHANICAL PROPERTIES OF  
ALUMINUM ALLOYS  
MCUIDDRE R A SRPS

HELET L A  
MICHIGAN TECHNOLOGICAL UNIVERSITY  
DEFECT BEHAVIOR IN SEMICONDUCTOR CRYSTALS  
CONNERS R W SRPS

LIEBERMAN D S  
UNIVERSITY OF ILLINOIS  
POINT DEFECTS IN CSD ORDERED ALLOYS AND OTHER  
INTERMETALLIC COMPOUNDS  
RATCHFORD J T SRPS

MARTIN M C  
CLARKSON COLLEGE OF TECHNOLOGY  
HEAT TREATMENT EFFECTS ON SOME PHYSICAL PROPERTIES OF METALLIC  
SINGLE CRYSTALS  
MCUIDDRE R A SRPS

MC COLLUM D C  
UNIVERSITY OF CALIFORNIA  
SPECIFIC HEATS OF ARSENIC, ANTIMONY, BISMUTH AND DILUTE  
BISMUTH ALLOYS  
RATCHFORD J T SRPS

MILLER M G  
CLEVSON UNIVERSITY  
STUDY OF THE DISLOCATION MULTIPLICATION PROCESSES IN AGL  
MCUIDDRE R A SRPS

MITCHELL I A  
CASE INSTITUTE OF TECHNOLOGY  
MECHANICAL PROPERTIES OF BODY-CENTERED CUBIC REFRACTORY METALS  
SRPS

PITT C M  
UNIVERSITY OF UTAH  
RECRYSTALLIZATION AND GRAIN GROWTH IN DILUTE ALLOYS OF MAGNESIUM  
AND ZINC  
MCUIDDRE R A SRPS

ROBINSON M M  
CARNEGIE INSTITUTE OF TECHNOLOGY  
DISLOCATION ARRAYS IN FCC METALS  
MCUIDDRE R A SRPS

SLIFKIN L M  
UNIVERSITY OF NORTH CAROLINA  
IMPERFECTIONS AND ELECTRICAL PROPERTIES OF IONIC CRYSTALS  
RATCHFORD J T SRPS

SMITH R W  
BIRMINGHAM UNIVERSITY  
STABILITY OF THE BODY CENTERED CUBIC STRUCTURE IN METALS AND  
ALLOYS  
MCUIDDRE R A SRPS

THOMSON R P / PROBLAND T J  
UNIVERSITY OF ILLINOIS  
IMPERFECTIONS IN SOLIDS  
CONNERS R W SRPS

### 2.5.4 MECHANICAL, THERMAL PROPERTIES OF SOLIDS

TINDER R F  
WASHINGTON STATE UNIVERSITY  
FACTORS AFFECTING THE INITIAL PLASTIC BEHAVIOR OF CLOSE PACKED  
METAL SINGLE CRYSTALS  
MCUIDDRE R A SRPS

VASSARILLET L F  
REIUN INSTITUTE  
STACKING FAULTS IN FACE-CENTERED CUBIC ALLOY PHASES  
MCUIDDRE R A SRPS

VENABLES J A  
UNIVERSITY OF SUSSEX  
ELECTRON MICROSCOPIC OBSERVATIONS OF DEFECTS IN CRYSTALS  
RATCHFORD J T SRPS

WERT C  
UNIVERSITY OF ILLINOIS  
PROPERTIES OF SOLID SOLUTIONS IN METALS  
MCUIDDRE R A SRPS

### 2.5.5 ELECTRON, MAG, OPT, ELEC PROP OF SOLIDS

BECKMAN D  
ROYAL UNIVERSITY OF UPSALA  
BAND STRUCTURE INVESTIGATIONS BY ULTRASONIC, SUSCEPTIBILITY AND  
GALVANOMAGNETIC MEASUREMENTS  
CONNERS R W SRPS

BESHAY A  
AMERICAN UNIVERSITY OF CAIRO  
DIFFERENT FACTORS AFFECTING SEMICONDUCTING PROPERTIES IN GLASSES  
MCUIDDRE R A SRPS

BLAKEMORE J S  
UNIVERSITY OF FLORIDA  
RECOMBINATION STUDIES AND RADIATIVE TRANSITIONS IN SEMICONDUCTORS  
CONNERS R W SRPS

BLING R  
NUCLEAR INSTITUTE  
NATURE OF THE FERROELECTRIC TRANSITIONS IN H-BONDED FERROELECTRIC  
CRYSTALS  
MCUIDDRE R A SRPS

BOMM HV/IEDLER R  
WAYNE STATE UNIVERSITY  
MEGACYCLE AND KILOMEGACYCLE ULTRASONIC ATTENUATION IN METALS  
TEMPERATURES  
CONNERS R W SRPS

BOK J  
ECOLE NORMALE SUPERIEURE  
PLASMA EFFECTS IN SOLIDS  
RATCHFORD J T SRPS

BULEF D J  
WASHINGTON UNIVERSITY  
ELECTRON SPIN-PHONON INTERACTIONS IN METALS AND SEMICONDUCTORS  
MCUIDDRE R A SRPS

BUNFEGLIOTE G  
ISTITUTO ELETTRONTECNICO NAZIONALE  
INORGANIC CRYSTALLINE LUMINESCENCE  
RATCHFORD J T SRPS

BRITTAIN J G  
NORTHWESTERN UNIVERSITY  
STRUCTURE SENSITIVE PROPERTIES OF INTERMEDIATE SOLID SOLUTIONS  
RATCHFORD J T SRPS

BROWN F  
WILLIAMS COLLEGE  
NONLINEAR OPTICAL EFFECTS IN METALS  
CONNERS R W SRPS

BURNS J  
NORTHWESTERN UNIVERSITY  
EXCITED ELECTRONIC STATES IN SOLIDS  
SHERDLow M SRPS

CALLAWAY J/WILD R L  
UNIVERSITY OF CALIFORNIA  
TRANSPORT AND OPTICAL PROPERTIES OF LOW MOBILITY SOLIDS  
RATCHFORD J T SRPS

CELLI V  
UNIVERSITY OF VIRGINIA  
MAGNETIC AND SUPERCONDUCTING PROPERTIES OF SOLIDS  
SHERDLow M SRPS

CHARPLEIN R S  
UNIVERSITY OF MINNESOTA  
MICROWAVE STUDIES OF SEMICONDUCTOR CRYSTALS  
MCUIDDRE R A SRPS

ERLBACH E  
CITY COLLEGE OF NEW YORK  
INFRARED ABSORPTION IN STRAINED GERMANIUM AND SILICON  
RATCHFORD J T SRPS

PHYSICAL SCIENCES

2.6.6 ELECTRONIC, MAGNETIC, OPTICAL AND ELECTRICAL PROPERTIES OF SOLIDS

FIESCHI R  
UNIVERSITA DEGLI STUDI DI MILAN  
IONIC THERMOCONDUCTIVITY AND PROPERTIES OF DIELECTRICS  
CONNERS R M SRPS

FRETZSCHER M  
UNIVERSITY OF CHICAGO  
ELECTRONIC PROPERTIES OF SOLIDS  
SWERDLOW M SRPS

GARDNER J H  
BRIGHAM YOUNG UNIVERSITY  
CYCLOTRON ABSORPTION IN BISMUTH-ANTIMONY  
MCQUIDORE R A SRPS

GORDON W/BECK TG  
CASE INSTITUTE OF TECHNOLOGY  
THE FERMI SURFACE OF METALS AND OF DILUTE ALLOYS OF BERYLLIUM  
RATCHFORD J T SRPS

HOFSTADTER R  
STANFORD UNIVERSITY  
X-RAY DETECTION IN SEMICONDUCTORS AND SCINTILLATORS  
SWERDLOW M SRPS

JENSEN M A  
UNIVERSITY OF PENNSYLVANIA  
DILUTE MAGNETIC IMPURITIES IN NORMAL METALS  
SWERDLOW M SRPS

KEPPER F  
UNIVERSITY OF PITTSBURGH  
ELECTRON AND NUCLEAR SPIN INTERACTIONS IN SOLIDS  
SWERDLOW M SRPS

KEMP J C  
UNIVERSITY OF OREGON  
MICROWAVE AND OPTICAL PROPERTIES OF CRYSTALS  
MCQUIDORE R A SRPS

KRYANE C J  
ARIZONA STATE UNIVERSITY  
ELECTRICAL PROPERTIES OF OXIDES OF LANTHANIDE RARE EARTH ELEMENTS  
SWERDLOW M SRPS

KIP A F  
UNIVERSITY OF CALIFORNIA  
ELECTRONIC STRUCTURE OF METALS  
RATCHFORD J T SRPS

LAING R A  
TULANE UNIVERSITY  
EFFECTS OF PARAMAGNETIC IMPURITIES ON NUCLEAR SPIN-LATTICE INTERACTIONS IN SOLIDS  
RATCHFORD J T SRPS

LAMBERT L M  
UNIVERSITY OF VERMONT  
ENERGY BAND QUANTIZATION IN HIGH ELECTRIC FIELDS  
RATCHFORD J T SRPS

LAPEYRE G J  
MONTANA STATE COLLEGE  
PHOTODEMISSIVE STUDIES OF THE BAND STRUCTURE OF SOLIDS  
CONNERS R M SRPS

LUTY F  
UNIVERSITY OF UTAH  
PARAELECTRIC AND PARAELASTIC BEHAVIOR OF DIPOLE CENTERS IN CRYSTALS  
MCQUIDORE R A SRPS

MAHENDROO P P  
TEXAS CHRISTIAN UNIVERSITY  
PRESSURE IMPLICITY AND VACANCY EFFECTS ON NUCLEAR MAGNETIC RELAXATION IN SOLIDS  
RATCHFORD J T SRPS

MC KELVEY J P  
PENNSYLVANIA STATE UNIVERSITY  
SEMICONDUCTOR PHYSICS  
CONNERS R M SRPS

MERGERTAN D  
WESTINGHOUSE ELECTRIC CORP  
HIGH FREQUENCY PARAMAGNETIC RESONANCE STUDIES  
CONNERS R M SRPS

MORAN P R  
UNIVERSITY OF WISCONSIN  
EXPERIMENTAL SOLID STATE PHYSICS EMPLOYING NUCLEAR MAGNETIC RESONANCE  
RATCHFORD J T SRPS

MUELLER R H  
DEMOX CORP  
TRANSPORT PROPERTIES IN GRAIN BOUNDARIES  
CONNERS R M SRPS

MACHTEBER M H  
UNIVERSITY OF CHICAGO  
ELECTRON PROPERTIES OF MOLECULAR SOLIDS AND HIGH PRESSURES  
SWERDLOW M SRPS

PARKS R O  
UNIVERSITY OF ROCHESTER  
POSITRON ANNIHILATION IN METALS  
MCQUIDORE R A SRPS

POOLE C P  
UNIVERSITY OF SOUTH CAROLINA  
OPTICAL AND MAGNETIC RESONANCE STUDY OF TRANSITION METAL MIXED CRYSTALS  
RATCHFORD J T SRPS

RAYNE J A  
CARNEGIE INSTITUTE OF TECHNOLOGY  
ELECTRONIC SPECIFIC HEAT OF NOBLE AND TRANSITION METAL ALLOYS  
SWERDLOW M SRPS

SAH C T  
UNIVERSITY OF ILLINOIS  
INTERFACE AND BULK PHENOMENA IN SOLID STATE SCIENCE  
RATCHFORD J T SRPS

SARACHIN M P  
CITY UNIVERSITY OF NEW YORK RESEARCH  
LOCALIZED MOMENTS AND TRANSPORT PROPERTIES IN DILUTE ALLOYS  
MCQUIDORE R A SRPS

SCAIFE B R P  
TRINITY COLLEGE  
PRESSURE DEPENDENCE OF DIELECTRIC PROPERTIES AND SOLIDS  
CONNERS R M SRPS

SCHWARTZ C M  
BATTELLE MEMORIAL INSTITUTE  
PRESSURE EFFECTS ON CHARGE-TRANSPORT PHENOMENA IN METAL OXIDES  
MCQUIDORE R A SRPS

STERN E A  
UNIVERSITY OF WASHINGTON  
ELECTRONIC STRUCTURE OF DISORDERED ALLOYS  
MCQUIDORE R A SRPS

STILLWELL E P  
CLEMSON UNIVERSITY  
ELASTIC STRAIN EFFECTS ON GALVANOMAGNETIC AND SUPERCONDUCTING PROPERTIES OF METALS  
RATCHFORD J T SRPS

TAMIZUNA C T  
UNIVERSITY OF ARIZONA  
PHYSICAL PROPERTIES OF SOLIDS AT HIGH PRESSURE  
MCQUIDORE R A SRPS

TRIVISONNO J  
JOHN CARROLL UNIVERSITY  
MAGNETO-ACOUSTIC ABSORPTION IN SOLIDS  
MCQUIDORE R A SRPS

WERTZ J E  
UNIVERSITY OF MINNESOTA  
ELECTRONIC PROPERTIES OF OXIDE INSULATORS  
MCQUIDORE R A SRPS

WHEELER R C  
YALE UNIVERSITY  
SPECTROSCOPY OF INSULATING CRYSTALS AT LOW TEMPERATURES  
RATCHFORD J T SRPS

WILLIAMS G A  
UNIVERSITY OF UTAH  
WAVE PROPAGATION IN SOLID STATE PLASMAS  
MCQUIDORE R A SRPS

WITTRY D B  
UNIVERSITY OF SOUTHERN CALIFORNIA  
ELECTRON PROBE ANALYSIS OF SEMICONDUCTORS  
SWERDLOW M SRPS

YAQUB M  
OHIO STATE UNIVERSITY  
TRANSPORT PHENOMENA IN METALS AT LOW TEMPERATURES  
SWERDLOW M SRPS

ZIMMERMAN G O  
BOSTON UNIVERSITY  
INVESTIGATION OF SOLID HELIUM THREE IN HIGH MAGNETIC FIELDS  
RATCHFORD J T SRPS

2.6.6 INTERACTION EFFECTS IN SOLIDS

CHANDRASEKHAR B S  
WESTERN RESERVE UNIVERSITY  
SUPERCONDUCTIVITY IN ALLOYS AND THIN FILMS AND SUPERFLUIDITY  
RATCHFORD J T SRPS

GAPPEL J R  
OHIO STATE UNIVERSITY  
MAGNETIC PROPERTIES OF THE SOLID HYDROGENS AT VERY LOW TEMPERATURES  
CONNERS R SRPS

HOLLER P  
BRANDEIS UNIVERSITY  
CRITICAL POINT PHENOMENA IN MAGNETISM  
RATCHFORD J T SRPS

## PHYSICAL SCIENCES

### 2.6.6 INTERACTION EFFECTS IN SOLIDS

LAMBERT M  
UNIVERSITE LIBRE DE BRUXELLES  
SUPERCONDUCTING PROPERTIES OF DISORDERED METALS  
RATCHFORD J T SAPS

LAX B  
MASSACHUSETTS INSTITUTE OF TECHNOLOGY  
NATIONAL MAGNET LABORATORY  
SHERDLON R SRP

LEVY M  
UNIVERSITY OF CALIFORNIA  
ULTRASONIC INVESTIGATION OF SUPERCONDUCTING PHASES AND  
MICLEAR SPIN WAVES IN SOLIDS  
SHERDLON R SAPS

LOUNASMAA D V  
TECHNICAL UNIVERSITY OF HELSINKI  
DETERMINATION OF MAGNETIC AND QUADRUPLE PARAMETERS IN METALS  
AND ALLOYS  
CONNERS R M SAPS

MASOCCI V A  
STATE UNIVERSITY OF NEW YORK  
MAGNETORESISTANCE EFFECT IN SINGLE-CRYSTAL THIN FILMS  
SHERDLON R SAPS

MATTHIAS B T  
UNIVERSITY OF CALIFORNIA  
SUPERCONDUCTIVITY, FERROMAGNETISM, FERROELECTRICITY AND MELTING  
POINTS IN SOLIDS  
SHERDLON R SRP

MITCHELL E M  
UNIVERSITY OF NORTH CAROLINA  
SUPERCONDUCTING TUNNELING IN SINGLE CRYSTAL THIN FILMS  
CONNERS R SAPS

MOULTON W C  
FLORIDA STATE UNIVERSITY  
STUDIES OF SOLIDS AT LOW TEMPERATURES  
RATCHFORD J T SAPS

MORBERG R E  
WASHINGTON UNIVERSITY  
APPLICATION OF MAGNETIC RESONANCE TO SOLID STATE PHYSICS  
CONNERS R M SAPS

ORZEFFE A  
ARIZONA STATE UNIVERSITY  
SEMICONDUCTING PHENOMENA IN PURE AND GOPED COPPOUS OXIDE  
SHERDLON R SAPS

REICHERT J F  
WESTERN RESERVE UNIVERSITY  
ELECTRIC FIELD EFFECTS IN ELECTRON-NUCLEAR DOUBLE RESONANCE  
SPECTROSCOPY  
RATCHFORD J T SAPS

REYNOLDS C A  
UNIVERSITY OF CONNECTICUT  
ELECTRICAL AND THERMAL PROPERTIES OF IMPURE, SINGLE CRYSTALS OF  
SEMICONDUCTORS  
MOULDOBRE R A SAPS

SPENCE R D  
MICHIGAN STATE UNIVERSITY  
MAGNETIC ORDERING AT LOW TEMPERATURES  
SHERDLON R SRP

TAYLOR K H R  
UNIVERSITY OF DURHAM  
ELECTRONIC PROPERTIES OF DILUTE ALLOYS AND SUBSTITUTED COMPOUNDS  
OF RARE EARTHS  
RATCHFORD J T SAPS

TEANEY D J  
INTERNATIONAL BUSINESS MACHINES CORP  
BASIC ANTIFERROMAGNETIC STUDIES  
SHERDLON R SAPS

TEBBL R S  
UNIVERSITY OF SHEFFIELD  
MICROWAVE RESONANCE IN RARE EARTH METALS AND ALLOYS  
RATCHFORD J T SAPS

THOMPSON E D  
CASE INSTITUTE OF TECHNOLOGY  
MAGNETIC PROPERTIES IN FERROMAGNETIC METALS  
CONNERS R M SAPS

TOTH L E  
UNIVERSITY OF MICHIGAN  
SUPERCONDUCTING PROPERTIES AND BONDING CHARACTERISTICS OF METAL  
CARBIDES AND NITRIDES  
CONNERS R M SAPS

TROUSDALE N I  
WESLEYAN UNIVERSITY  
MOSSBAUER EFFECT IN THE STUDY OF SOLIDS  
MOULDOBRE R A SAPS

ZAMLAN A B  
AMERICAN UNIVERSITY OF BEIRUT  
DYNAMICAL BEHAVIOR OF THE ELECTRON  
RATCHFORD J T SAPS

### 2.6.6 FIELD PHYSICS

#### 2.6.1 ELECTROMAGNETICS AND ELECTRON PHYSICS

BENNETT W A  
YALE UNIVERSITY  
RELAXATION MECHANISMS AND GAS LASER MEDIA  
MAYCOCK D A SRPP

BYACEMELL R N  
STANFORD UNIVERSITY  
RADIO ASTRONOMY RESEARCH  
HARRINGTON M C SAPP

BRANNEN E  
UNIVERSITY OF WESTERN ONTARIO  
MM AND SUBMILLIMETER ELECTROMAGNETIC RADIATION  
WENNERSTEN D L SAPP

BRIGGS B H/ELFORD M G  
UNIVERSITY OF ADELAIDE  
MEDIUM FREQUENCY IONOSPHERIC AND METEOR OBSERVATIONS USING A LARGE  
ANTENNA ARRAY  
HARRINGTON M C SAPP

COHEN R H  
UNIVERSITY OF CALIFORNIA  
HIGH RESOLUTION STUDIES OF DISCRETE RADIO SOURCES  
HARRINGTON M C SRPP

COLEMAN P D  
UNIVERSITY OF ILLINOIS  
ELECTROMAGNETIC PROPERTIES OF MATERIALS IN THE INFRARED-  
SUBMILLIMETER RANGE  
HARRINGTON M C SAPP

EVERHART E  
UNIVERSITY OF CONNECTICUT  
COINCIDENCE STUDIES IN VIOLENT ATOMIC COLLISIONS  
MAYCOCK D A SRPP

FELLERS R G  
UNIVERSITY OF SOUTH CAROLINA  
NON-WAVE GUIDE METHODS OF MILLIMETER WAVE TRANSMISSION  
WENNERSTEN D L SAPP

GOLD T  
CORNELL UNIVERSITY  
THEORETICAL RESEARCH IN ASTROPHYSICS  
HARRINGTON M C SAPP

GORDY M  
DUKE UNIVERSITY  
MICROWAVE-MILLIMETER AND RADIO FREQUENCY SPECTROSCOPY  
HARRINGTON M C SRPP

MOULT D P  
PENNSYLVANIA STATE UNIVERSITY  
TURBULENCE IN THE ATMOSPHERE BETWEEN 30 AND 150 KM  
HARRINGTON M C SRPP

HUGHES V W/LAMB W E  
YALE UNIVERSITY  
ATOMIC, MOLECULAR AND PLASMA PROPERTIES  
WENNERSTEN D L SAPP

KRAUSE L  
UNIVERSITY OF WINDSOR  
OPTICAL PUMPING IN ALKALI METAL VAPORS  
HARRINGTON M C SRPP

LASSETTE E M  
MELLON INSTITUTE  
ELECTRONIC COLLISION CROSS SECTION  
WENNERSTEN D L SRPP

MARTIN D W/MCDANIEL  
GEORGIA INSTITUTE OF TECHNOLOGY  
MASS SPECTROMETRIC STUDY OF MOBILITY, DIFFUSION AND REACTIONS OF  
IONS IN GASES  
WENNERSTEN D L SAPP

MOZT M  
OXFORD UNIVERSITY  
WAVES IN ANISOTROPIC MEDIA  
WENNERSTEN D L SRPP

ST JOHN R M/LIN C C  
UNIVERSITY OF OKLAHOMA  
OPTICAL EXCITATION CROSS-SECTIONS IN ATOMIC COLLISIONS  
WENNERSTEN D L SRPP

STURROCK P A  
STANFORD UNIVERSITY  
PLASMA PHYSICS AND PLASMA PHENOMENA OF ASTROPHYSICS  
MAYCOCK D A SRPP

WHITEHURST R M  
UNIVERSITY OF ALABAMA  
SUBMILLIMETER RADIATION FROM RELATIVISTIC ELECTRONS  
WENNERSTEN D L SRPP

PHYSICAL SCIENCES

2.6.3 OPTICAL PHYSICS

CROSSMITE H N / KERR D E  
JOHNS HOPKINS UNIVERSITY  
SPECTRA OF DOUBLY AND TRIPLY IONIZED RARE EARTHS  
HARRINGTON M C SRPP

GUNG M  
UNIVERSITY OF ROCHESTER  
INTENSITY CORRELATION INTERFEROMETRY FOR ASTRONOMICAL OBSERVATION  
HARRINGTON M C SRPP

HOLMES J R  
UNIVERSITY OF HAWAII  
PROPERTIES OF GAS LASERS  
HARRINGTON M C SRPP

HOLSHOUSE D F / GADDO D  
UNIVERSITY OF ILLINOIS  
MODULATION AND DEMODULATION OF COHERENT OPTICAL RADIATION  
HARRINGTON M C SRPP

KAPAMY M S  
OPTICS TECHNOLOGY INC  
DIFFRACTION AND COHERENCE PHENOMENA IN OPTICAL WAVEGUIDES  
HARRINGTON M C SRPP

MANDEL L  
UNIVERSITY OF ROCHESTER  
INTERACTIONS AND CORRELATIONS OF ELECTROMAGNETIC FIELDS  
HARRINGTON M C SRPP

STEGMAN A E  
STANFORD UNIVERSITY  
OPTICAL PHYSICS AND NONLINEAR OPTICAL EFFECTS  
HARRINGTON M C SRPP

STRONG J D  
JOHNS HOPKINS UNIVERSITY  
FAR INFRARED SPECTROSCOPY  
HARRINGTON M C SRPP

TEEGARDEN H J  
UNIVERSITY OF ROCHESTER  
BASIC RESEARCH IN OPTICS  
HARRINGTON M C SRPP

MULF E  
UNIVERSITY OF ROCHESTER  
EFFECTS OF COHERENCE IN ELECTROMAGNETIC RADIATION  
HARRINGTON M C SRPP

2.6.4 ACOUSTICS

NYBORG N L  
UNIVERSITY OF VERMONT  
NONLINEAR SONIC PHENOMENA  
WENNERSTEN D L SRPP

2.7.0 FLUID PHYSICS

2.7.1 PLASMA PHYSICS

BARACH J P  
VANDERBILT UNIVERSITY  
PLASMA FRONT STUDIES  
HAYCOCK D A SRPP

BOLEY F B  
DARTMOUTH COLLEGE  
HYDROMAGNETIC WAVE-PARTICLE BEAM INTERACTIONS  
HAYCOCK D A SRPP

BURNHAM D  
STANFORD UNIVERSITY  
INTERACTION BETWEEN RADIATION AND BOUNDED MEDIA  
HAYCOCK D A SRPP

CHEN S Y  
UNIVERSITY OF OREGON  
SPECTRA FROM HOT COMPRESSED GASES  
HAYCOCK D A SRPP

GARRIDO L R  
UNIVERSIDAD DE BARCELONA  
OPERATIONAL DEVELOPMENT OF CLASSICAL MECHANICS AND APPLICATION TO  
PLASMA PROBLEMS  
HAYCOCK D A SRPP

KURSUMGLU B  
UNIVERSITY OF MIAMI  
STOCHASTIC PROCESSES IN A PLASMA  
HAYCOCK D A SRPP

LUCE J S  
AERONAUTICAL RESEARCH  
ANALYTICAL AND DIAGNOSTIC RESEARCH IN HIGH TEMPERATURE  
PLASMAS  
WINGERTSON R C SRPP

SEXTON M C  
UNIVERSITY COLLEGE  
MICROWAVE STUDIES OF IONIZATION PHENOMENA IN GASEOUS DISCHARGES  
HAYCOCK D A SRPP

SPITZER L / GOTTLIEB M B  
PRINCETON UNIVERSITY  
RESEARCH IN THE ASTROPHYSICAL SCIENCES  
HAYCOCK D A SRPP

WONG A Y  
UNIVERSITY OF CALIFORNIA  
JOINT EXPERIMENTAL AND THEORETICAL INVESTIGATIONS IN PLASMA  
PHYSICS  
HAYCOCK D A SRPP

2.7.2 MAGNETO FLUID DYNAMICS

MACKEYE R R  
UNIVERSITY OF CALIFORNIA  
PLASMA DYNAMICS AND INTERACTIONS WITH HIGH FREQUENCY FIELDS  
HAYCOCK D A SRPP

SPITZER E  
NEW YORK UNIVERSITY  
STELLAR FLUID DYNAMICS  
HAYCOCK D A SRPP

2.7.3 STRUCTURE OF GASES AND LIQUIDS

WILLSAPS R  
UNIVERSITY OF FLORIDA  
AN EXPERIMENTAL DETERMINATION OF THE TRANSITION TO TURBULENCE  
USING THE DOUBLE LAYER  
WENNERSTEN D L SRPP

WEINZEL R  
UNIVERSITÄT WIEN  
DYNAMICS OF LIQUIDS  
WENNERSTEN D L SRPP

2.8.0 THEORETICAL PHYSICS

2.8.1 QUANTUM PHYSICS

DESER S  
BRANDEIS UNIVERSITY  
QUANTUM FIELDS, PARTICLE THEORY, AND GENERAL RELATIVITY  
LEHMAN D H SRPP

GOLDREGER A L  
PRINCETON UNIVERSITY  
FUNDAMENTAL CONCEPTS IN THEORETICAL PHYSICS  
LEHMAN D H SRPP

KURSUMGLU B  
UNIVERSITY OF MIAMI  
FOURTH CORAL GABLES CONFERENCE ON SYMMETRY PRINCIPLES AT HIGH  
ENERGY  
LEHMAN D H SRPP

KURSUMGLU B  
UNIVERSITY OF MIAMI  
THEORETICAL STUDIES ON SYMMETRY PRINCIPLES AT HIGH ENERGY  
LEHMAN D H SRPP

SALAN A  
IMPERIAL COLLEGE OF SCIENCE AND TECHNOLOGY  
HIGH ENERGY PHYSICS AND ELEMENTARY PARTICLE THEORY  
LEHMAN D H SRPP

ZIMMERMAN A L  
UNIVERSITY OF OREGON  
STUDIES IN QUANTUM FIELD THEORY  
LEHMAN D H SRPP

2.8.2 RELATIVITY AND GRAVITATION

BERGMANN P G  
SYRACUSE UNIVERSITY  
IRREVERSIBLE PROCESSES AND GENERAL RELATIVITY  
WEIGOLD E SRPP

CHEN M/OZSWATH E  
GRADUATE RESEARCH CENTER OF THE SOUTHWEST  
GENERAL THEOREMS ON SPATIALLY HOMOGENEOUS COSMOLOGICAL MODELS  
WEIGOLD E SRPP

DE HITT B / SYVAN DARR H  
UNIVERSITY OF NORTH CAROLINA  
BASIC RESEARCH ON GRAVITATION  
WEIGOLD E SRPP

FAIRBANK H H  
STANFORD UNIVERSITY  
NUCLEAR GYRO TEST MOUNT AND ZERO MAGNETIC FIELD EQUIPMENT  
WEIGOLD E SRPP

KOMAR A B  
YESHIVA UNIVERSITY  
GENERAL RELATIVITY  
WEIGOLD E SRPP



## PHYSICAL SCIENCES

### 2.0.2 RELATIVITY AND GRAVITATION

MOONAN T N  
UNIVERSITY OF NORTH CAROLINA  
PUBLICATION OF M.P. ROBERTSON'S RELATIVITY LECTURE NOTES  
MEIGOLD E SRPN

WEBER J  
UNIVERSITY OF MARYLAND  
DETECTION AND GENERATION OF GRAVITY WAVES  
MEIGOLD E SRPN

### 2.0.0 COSMIC RAY PHYSICS

ANILKUMAR M S  
UNIVERSIDAD MAYOR DE SAN ANDRES  
COSMIC RAY INTENSITY VARIATIONS DURING A PERIOD OF INCREASING  
SOLAR ACTIVITY AT CHACALTAYA  
GORRELL J E SRPN

BRADY H  
MASSACHUSETTS INSTITUTE OF TECHNOLOGY  
BOLIVIAN AIR SHOWER JOINT EXPERIMENT/ CERENKOV LIGHT EXPERIMENT  
GORRELL J E SRPN

BROWN R B  
UNIVERSITY OF CALIFORNIA  
PARTICLE BOMBARDMENT OF THE POLAR ATMOSPHERE  
GORRELL J E SRPN

CONAN C L  
CATHOLIC UNIVERSITY OF AMERICA  
BASIC RESEARCH IN COSMIC NEUTRINO PHYSICS  
GORRELL J E SRPN

GEISS J F  
UNIVERSITÄT BERN  
RADIATION EFFECTS IN SPACE  
GORRELL J E SRPN

GREISEN K  
CORNELL UNIVERSITY  
STUDY OF COSMIC GAMMA RADIATION  
GORRELL J E SRPN

HAYNES R C  
RICE UNIVERSITY  
RADIOACTIVITY OF SOME UNUSUAL CELESTIAL ENERGY SOURCES  
GORRELL J E SRPN

LAPORTE H  
UNIVERSITY OF MARYLAND  
BOLIVIAN AIR SHOWER JOINT EXPERIMENT  
GORRELL J E SRPN

MANLEY D P  
AMERICAN SCIENCE AND ENGINEERING INC  
POTENTIAL MODELS OF CELESTIAL X-RAY SOURCES  
GORRELL J E SRPN

MC CUSKER C B A  
UNIVERSITY OF SYDNEY  
ULTRA HIGH ENERGY COSMIC RADIATION  
GORRELL J E SRPN

PORTER N A  
UNIVERSITY COLLEGE  
RADIO AND OPTICAL EMISSION FROM HIGH ENERGY COSMIC RAYS  
GORRELL J E SRPN

SIMPSON J A  
UNIVERSITY OF CHICAGO  
COSMIC AND SOLAR RADIATION STUDIES AND THEIR ASTROPHYSICAL  
CONSEQUENCES  
GORRELL J E SRPN

TREFFALL M  
UNIVERSITY OF BERGEN  
X-RAY AND PARTICLE RADIATIONS AT HIGH ALTITUDES IN THE  
ALPINE ZONE  
GORRELL J E SRPN

VON FRIESEN S  
LUND UNIVERSITY  
HEAVY PARTICLES IN PRIMARY COSMIC RADIATION  
GORRELL J E SRPN

WOLFENBUELE A H  
UNIVERSITY OF DURHAM  
ANALYSIS OF COSMIC RAY EXPERIMENTS  
GORRELL J E SRPN

### 4.0.0 ENVIRONMENTAL SCIENCES

#### 4.1.0 ASTROPHYSICS

#### 4.1.2 ASTROPHYSICS

ALLER L H  
UNIVERSITY OF CALIFORNIA  
CHEMICAL COMPOSITIONS OF GASEOUS NEBULAE AND PECULIAR STARS  
HAYCOCK D A SRPN

ALLER L H  
UNIVERSITY OF CALIFORNIA  
TWO CO-ORDINATE MICROPHOTOMETER COMPARAYON  
HAYCOCK D A SRPN

BROWN R H  
UNIVERSITY OF SYDNEY  
STELLAR INTENSITY INTERFEROMETRY  
HARRINGTON P C SRPN

ELLYETT C D  
NEWCASTLE UNIVERSITY COLLEGE  
RIFMETER STUDIES OF THE INTERRELATIONS OF RADIO NOISE AND  
ABSORPTION  
HAYCOCK D A SRPN

GREENSTEIN J  
CALIFORNIA INSTITUTE OF TECHNOLOGY  
STELLAR COMPOSITIONS AND NUCLEAR PROCESSES  
HAYCOCK D A SRPN

HECHT F  
TECHNISCHE HOCHSCHULE IN WIEN  
CHEMICAL COMPOSITION AND TRACE ELEMENT CONTENT OF METEORITES  
HAYCOCK D A SRPN

HENYEV L  
UNIVERSITY OF CALIFORNIA  
COMPUTATIONAL RESEARCH IN ASTROPHYSICS  
HAYCOCK D A SRPN

MCTE L  
COLUMBIA UNIVERSITY  
THE STRUCTURE & EVOLUTION OF STARS BETWEEN GO AND FO ALONG THE  
MAIN SEQUENCE  
HAYCOCK D A SRPN

SAHAG J  
UNIVERSIDAD NACIONAL DE LA PLATA  
RESEARCH IN STELLAR SPECTROSCOPY  
WENNERSTEN G L SRPN

MULTJER L  
COLUMBIA UNIVERSITY  
MAGNETIC FIELDS IN STARS AND GALAXIES  
HAYCOCK D A SRPN

#### 4.2.0 ATMOSPHERIC SCIENCES

GLUNDON E/COOK S/ROACH F  
UNIVERSITY OF COLORADO  
SCIENTIFIC STUDY OF UNIDENTIFIED FLYING OBJECTS  
RATCHFORD J T SRPN

#### 4.3.0 TERRESTRIAL SCIENCES

#### 4.3.2 SEISMOLOGY

SCHREIBER F  
COLUMBIA UNIVERSITY  
MEASUREMENT OF P / S VELOCITIES UNDER PRESSURE ON  
LAB MODELS OF THE EARTH'S MANTLE  
YOUNG D D SRPN

SMITH S  
CALIFORNIA INSTITUTE OF TECHNOLOGY  
RESEARCH IN GEOPHYSICS  
BEST W J SRPN

WILSON J T  
UNIVERSITY OF MICHIGAN  
CONTRACTORS RESEARCH AND EVALUATION PANEL FOR GEOPHYSICS  
BEST W J SRPN

## Chemical Sciences

DR. AMOS G. HORNEY, *Director*

The directorate of chemical sciences, with an annual budget of approximately \$3.3 million, sponsors basic research in areas of chemistry of immediate and of long-range interest to the Air Force. The funds are provided by congressional appropriation, via the Department of Defense and the Office of Aerospace Research. As a report to the taxpayers—our stockholders—the directorate of chemical sciences each year prepares "Chemistry Program Review." This document, which is available upon request, gives many interesting statistical and timely scientific details about our program.

The directorate of chemical sciences has six senior scientists, one military, who select and manage the program. Each of our approximately 150 research efforts generally has a 4-year active life span with the funds being made available for consecutive 2-year periods. The average cost of each research effort is about \$25,000 per year, although they range from \$5,000 to \$165,000.

The chief investigators and their unsolicited proposed research programs are carefully selected. Scientific merit, probable return per dollar in Air Force areas of interest, and the investigator's infectious enthusiasm and dedication for his proposed research play important roles in the selection process.

The chemistry research program consists of a balanced research effort of a fundamental nature in chemistry and closely related areas (1) as a foundation for meeting the more direct and varying needs—recognized and unrecognized—of the military, and (2) research in specific recognized areas where the aim is discovering new understanding that will open the way both to new science and to satisfying defense needs within a foreseeable timespan.

The first includes selected research in the basic disciplines of chemistry which are likely to produce information leading to new or improved materials and their applications to military structures, military powerplants, military armaments, and

military communication systems. Crucial military problems exist in limited war or in global war. Present military problems and undoubtedly those of year 2000 involve structures, powerplants, armaments, communication systems, and people. The disciplines of chemistry relevant to these military objectives and our program include the following.

*Synthesis*, usually according to a rational plan, is the construction of complex substances by the combination of simpler ones. The projected construction of a molecule of a substance must be by a design, a sequence of steps, some of which may never have been performed before. The projected plan of synthesis must be fashioned in accordance with analogy and theory, since simple trial and error is too costly in time and effort. Dr. Anthony J. Matuszko of our staff in a later section of this report discusses organometallic chemistry and gives a clear picture of the problems and successes of synthesizing new substances containing carbon-metal bonds and at the same time points out the Air Force stake in this exciting area of chemistry.

*Structural chemistry and physical properties* are important in all areas of our chemistry program. The unit of structure may be the molecule or crystal, or it may be part of a molecule, e.g., a group of atoms, or even a single electron or a single atomic nucleus. The qualitative understanding of chemistry is almost always in terms of structural units. When a chemical reaction occurs, it is the changes in physical properties which permit the chemist to decide which structural units of the molecule have changed.

The following is quoted from the Westheimer Report, "Chemistry: Opportunities and Needs," published in 1965 by the National Academy of Sciences:

The more we know about the molecular structures of chemical compounds, the more readily we can transform them in predictable ways and the more readily we can understand transformations that we cannot predict. Nothing less than a "total" approach serves for the kinds of problems that are now being attacked: every possible measurement that can yield a clue is required. This manner of

approach to molecular structures has led to a marked change in chemistry.

The tools that have made this change possible include new searching equipment for detecting and measuring spectra of various kinds: Infrared, microwave, radiofrequency, ultraviolet, visible, Raman, Mossbauer, X-ray, nuclear, magnetic resonance, electron-spin, resonance, nuclear quadrupole, and mass spectra. Furthermore, electronic digital computers have been especially useful. We can now achieve rapid and detailed characterization of physical properties, many of which either were completely unknown 10 years ago or could be determined only with precision lower by several orders of magnitude than is now attainable. The new information on structure has led to development in theories of intermediates in reaction mechanisms, of geometrical and electronic structural units, of spectra, of stereospecific synthesis, of biological activity, and particularly of electronic binding and chemical transformation.

The modern experimental chemist has a laboratory full of sophisticated electronic gear. The computer is fast becoming an essential tool for both the chemical experimentalist and theoretician. Other important tools and emerging techniques (in addition to those mentioned above) on the exploding frontiers of chemistry in which our program is involved include: Molecular beams, shock-tube chemistry, high-pressure techniques, vapor phase calorimetry and vapor phase chromatography, high-energy lasers.

\* \* \* we are not yet able to predict what new chemical and physical phenomena will be found. \* \* \* we are only beginning to know what properties of a molecule and its environment we need to find to follow its reactions; and we are almost totally ignorant of the nature of chemical structure and transformation under extreme conditions of temperature, pressure, electric and magnetic fields, and combinations of these. (Westheimer report.)

*Chemical dynamics*, a major area of our research program, is concerned with such questions as: How do reactions occur? What forces drive them? Why are they so fast, or so slow? Most useful reactions do not take place in a single simple step. The basic task in the study of chemical dynamics is to under-

stand the elementary processes in a sequence or network of cooperative and competitive steps. For example, the reaction between hydrogen and chlorine to produce hydrogen chloride is not simple but is a complex network of elementary steps and a chain of reactions. Some of these take place thousands of times until the chain is broken. Innumerable chains constitute the process. Chain reactions occur in flames, explosions, burning of propellants, and in the making of polymers.

What is the velocity of each separate elementary step in a network of chemical reactions? What is the nature of the mechanical and chemical energy transfers that are taking place during the reaction? Obtaining and understanding the answers to these kinds of questions are important to the progress of chemical dynamics. Dr. Alfred Weissler of our staff discusses the energy matter interface, its place in the AFOSR chemistry program, and its relevancy to Air Force in this report. G. C. Pimentel (University of California at Berkeley) under AFOSR sponsorship discovered a method of making the first chemical laser using the reaction between hydrogen and chlorine, described by Dr. William L. Ruigh in his article "Rapid Scan Infrared Spectroscopy."

Chemical reactions take place in solids, in liquids, and in gases. *Surface chemistry* involves chemical reactions at interfaces separating two states of matter. These latter reactions at interfaces or heterogeneous reactions are of extreme importance to the Air Force, to the chemical industry, and the science of chemical dynamics. For example: Corrosion and crack propagation of metals, synthesis of high-octane gasoline, manufacture of nitric acid, of sulfuric acid, of ammonia, of butadiene for synthetic rubber, and numerous other chemicals. Most of these processes are still not understood.

In *heterogeneous catalysis*, chemical reactions take place between molecules of a liquid or gas that are adsorbed on a surface. The substances formed are then replaced by new molecules of the reactants. "Dirty surfaces"—that is, surfaces on which there are unwanted foreign substances—have stymied fundamental work on catalysis until recently. Ultra-high vacuum is now making it possible to work with "atomically clean" surfaces. One fine new tool for studying molecules on surfaces is the field-emission microscope. Using this instrument technique, Gert Ehrlich of General Electric is studying for us the kinetics of the ad-

sorption of hydrogen on such semiconductor surfaces as germanium.

Another important *surface chemistry* area is *electrochemistry*, which deals with reactions that take place at the interface between solutions and electrodes when an electric current passes through the solution. The chemical dynamicists are fascinated by electrochemical processes and reactions, not only because of their inherent importance, because they provide precision tools for the study of many other kinds of chemical reactions. Electrochemists have made available a large variety of measurements for application to practical as well as research problems. Electrochemical dynamics plays an important role in both military and civilian economy. Batteries and the electrochemical industries, fuel cells and communication systems, illustrate the importance of the interconversions of chemical and electrical energy and the increasing technical importance of the field. Both in the past and in the present our program has given careful attention to this important chemistry research area.

Many of the better understood chemical reactions take place in solution where the reacting substances are dissolved in liquids. A study of a variety of reactions by dynamic methods in solution have led to an understanding of reaction mechanisms and have supplied the ideas and generalizations essential to the successful practical synthesis of complicated compounds. For example, M. E. Kenny (Case Inst. Tech.) synthesized phthalocyaninosiloxane polymers and D. Seyferth (MIT) devised a new method of generating the subsequent synthesis of fluorinated cyclopropane derivatives. Dr. Matuszko discusses the contributions of these investigators to our program.

Many reactions take place in steps with the formation of *transient intermediates*. These short-lived substances are consumed almost as fast as they are formed. Some exist in solution for time intervals as short as a billionth of a second. Free radicals are examples of these substances, which were being studied in our program in the 1950's by F. O. Rice at Catholic University, H. P. Broida at NBS, and G. C. Pimentel at Berkeley using the matrix-isolation techniques. Out of these researches grew the DOD million-dollar-plus NBS Free Radical Program headed by Dr. Broida.

In an attempt to latch on to an exotic new fuel the study of *transient intermediates* has opened up rich new areas of chemical science important

in syntheses of new substances, understanding of kinetics of reactions, the understanding of molecular rearrangements and of reaction mechanisms. Several of our investigators are exploring this promising research area. For example, P. Skell (Penn State) is studying  $C_1$ ,  $C_2$ , and other single atom species as synthetic agents and Libby (UCLA) hopes to add single atoms of carbon in high vacuum to clean surfaces of solid carbon crystals (diamond). Growing such crystals should be a natural for a manned orbital laboratory.

Accompanying each chemical change there is also an energy change. This phenomenon and the energy content of each individual chemical species and the energy level of each of its electrons are also of primary importance to the chemical dynamicists. Note Dr. Weissler's discussion of photochemistry radiation chemistry in this report.

*Solids* are the principal components of all military structures, military powerplants, military armaments, and military communication systems. The chemical behavior of solids has been important in modern technology for a long time. The serious work on the chemistry of solid state, however, has not been commensurate with the importance of the subject. Why? Have the ARPA interdisciplinary laboratories been highly productive in solving significant military problems associated with materials? Is neglect of solid-state chemistry by ARPA laboratories, as well as the general neglect of the subject, because it is so very difficult? Is it because of the lack of vision of its importance or the lack of funds for its support? Although chemical reactions in solids are more difficult to study than in any other medium and the problems are exceedingly complex, our program does contain numerous research efforts involving solid-state chemistry. Much of the fine work recently done in solid-state physics actually lies in the overlapping area of chemistry and physics. Progress to date in understanding the solid state has been made primarily by physicists who are concerned with the description of those properties of matter that are not sensitive to the nature of the particular system—that is they are concerned with mathematical descriptions of isolated units. Future progress is more appropriately in the hands of chemists because they are concerned with system-sensitive aspects of matter—that is, with units of matter in a real environment, even though many such problems now seem impossible.

It has often been said that the crystalline state and the gaseous state of matter are well understood and that very little is known about the liquid state. We in chemistry have given some attention to the liquid state since the early days of our program. Denton W. Elliott discusses "Liquid Structure" as well as "Why should the Air Force be interested in the structure of liquids?"

Even a short discussion of basic disciplines of chemistry important to the Air Force must include theoretical chemistry. All aspects of chemistry already discussed is the concern of theoretical chemistry. Our past program, our present program and our future will be concerned with theoretical chemistry. I wish to quote from the theoretical chemistry panel report prepared for the Westheimer committee:

The theoretical chemist invents, tests, and develops new theoretical concepts and new theoretical methods; he applies theories already established to newly discovered chemical phenomena; he relates different chemical phenomena and data by examining the connections among them required by theory; he provides a theoretical framework for discussion of data; he tries to qualify; he tries to predict. Above all else, he tries to understand. The ultimate theoretical treatment is solely in terms of the laws of nature, but this is rarely achieved; the most valuable chemical theory often falls far short of being a set of inviolate mathematical deductions from physical principles.

In chemistry, theory and experiment interact strongly and continually. When new phenomena are discovered, theory is used in order to understand and organize the data, and to relate the data to what is already known. In the next stage, the organization provides guidance for new experiments. Predicting the results of new experiments is a final stage of theory, and established theory has predictive value for engineering.

Technology is in large measure the end product of old theories. Chemical thermodynamics was for decades the province of the theoretical chemist, but today it is a major resource of the engineer. Considered in this light, modern statistical mechanics and quantum mechanics can be confidently expected to evolve into everyday tools of future engineers.

Even today, theoretical chemistry is playing a dynamic role in technological research.

This brief treatment of synthesis, structure, reactions, surfaces, liquids, solids, solutions, electrochemistry, and theoretical chemistry are all illustrative of chemical disciplines likely to produce information which will serve as a foundation for the varying needs of the Air Force. It is illustrative of the consideration of the first part of our program in chemistry.

The consideration of the second part of our program are the specific recognized areas, as previously suggested, where the aim is discovering new understanding that will open the way both to new science and to satisfying defense needs within the foreseeable timespan. Here, we are concerned with the chemistry in extremes in environment, such as high pressure, high vacuum, high and low temperatures. We are concerned with radiation effects on substances, novel synthesis of certain kinds of substances, and with novel or improved techniques for sensing and measuring minute concentrations and chemical changes taking place. We are concerned with an improved understanding of the real nature of selected substances of scientific and military importance.

This second part of our program may be illustrated by a series of queries which plague the minds of our investigators:—

How does the form, structure, and stability of a polymer change with the degree of crystallization (Flory—Stanford)?

At room temperature at pressures from 10-200 atmospheres, what is the nature of the solvent action of liquified gases such as carbon dioxide, ammonia, and noncarbon flourides (Peacock—Birmingham University)?

How can one pure species of the nitrogen atoms contained in the upper atmosphere be prepared in the laboratory? What is its chemistry when it reacts with other substances? (Lichten and Hoffman—Boston University)?

What is the nature of germanium-carbon, tin-carbon, rhenium-carbon bonds? How do you synthesize substances containing these bonds? How do these bonds react chemically (Stone—Bristol University)?

What are the steps in the decomposition of hydrogen peroxide decomposition? Why does it take place so rapidly? Can a radioisotope labeling technique be used in answering these questions (Edwards—Brown University)?

What kinds of molecules will efficiently absorb the harmful effects—to living and nonliving substances—of ultraviolet light or high-energy nuclear radiation (Hammond—Cal Tech)?

How do you synthesize triple strand polymers with frequent ties between strands which may be thermally stable (Butler—University of Florida)?

How can flame spectrometry and gas chromatography be used to make ultrasensitive and selective detectors for the detection and analysis of vapors and gases, including toxic ones (Winefordner—University of Florida)?

What structural changes take place when selected substances such as semiconductor materials are subjected to pressures up to and over 2 million pounds per square inch (Kasper—General Electric)?

How does one synthesize compounds of transition metals—such as iron, cobalt, and nickel—with nitrogen, phosphorus, and sulfur? What will be their structure and chemistry (King—University of Georgia)?

How can the structure—and thus the chemistry—of minute single crystals of unknown substances be determined by X-ray diffraction and computer techniques (Gougoutas—Harvard)?

What is the nature of the solid-solid reactions of onium salts with amine complexes of cobalt, nickel, chromium and copper, etc., at elevated temperatures and high pressures as revealed by the use of thermoanalytical techniques (Wendlandt—University of Houston)?

What really happens to all the energy in an exothermic chemical reaction from a molecular point of view, since an appreciable amount has not yet been made useful for propulsion or in explosives (Bair—Indiana University)?

How can the many quantum chemistry electronic computer programs, which are so expensive in scientific manpower and dollars, be made available to other investigators who need the same program as a step in their own researches? A partial answer is provided by Harrison Shull (Indiana

University) who operates the AFOSR quantum chemistry program—now starting its fourth year with over 361 active participants at home and abroad.

How can electrochemical techniques, such as polarographic and electrodeposition methods, be used for the separation and determination of such metals as zirconium, hafnium, tantalum, niobium, titanium, and rare earth metals such as scandium? Can novel nonaqueous solvents, for example, acetonitrile, be used for these separations and determinations (Oliver—University of Massachusetts)?

Is it possible to get a better understanding of the chemical structure of oxide glasses such as alkali-alkaline earth aluminum-silicate systems, using irradiation techniques, by a systematic study of localized defects states in parallel with the same systems in crystalline form? Will the study be more fruitful by varying the chemical composition (Mackey—Mellon Institute)?

How can I build a device which will accelerate neutral molecules to a high speed, each molecule to have the same energy content, in order to test current theories of inelastic collisions and to more profoundly understand the nature of gas-phase chemical reactions, as well as the nature of gas-liquid and gas-solid collision processes (Wharton—University of Chicago)?

These are examples of questions which our chemistry investigators are attempting to answer. The answers may open up whole new areas of science and will undoubtedly answer questions relevant to Air Force interests.

"The natural sciences, such as physics, chemistry, and mathematics, assume a very great significance in contemporary military affairs. Only on the basis of these sciences can one reliably and objectively evaluate the new principles which govern different forms of military material." (*Science and Technology in Contemporary Wars.* Soviet Maj. Gen. G. I. Pokrovsky.)

Why should the Air Force support basic research in chemistry? The answer is simple and short: It pays.

CHEMICAL SCIENCES

3.0.0 CHEMISTRY

EARLEY J E  
GEORGETOWN UNIVERSITY  
RESEARCH EVALUATION CONTRACT/ CHEMISTRY  
ELLIOTT D M SRC

3.1.1 CHEMISTRY - DIFFRACTION AND OPTICAL METHODS

DUNCAN J F  
VICTORIA UNIVERSITY OF WELLINGTON  
USE OF THE MOSSBAUER EFFECT IN CHEMISTRY  
ELLIOTT D M SRC

EYRING E H  
UNIVERSITY OF UTAH  
LASER TEMPERATURE-JUMP RELAXATION STUDIES  
RUIGH W L SRC

FRAENKEL G R  
COLUMBIA UNIVERSITY  
ELECTRON SPIN RESONANCE OF FREE RADICALS  
ELLIOTT D M SRC

HANNA H W  
UNIVERSITY OF COLORADO  
NMR STUDIES OF INTRA- AND INTERMOLECULAR INTERACTIONS  
WALFORD E T SRC

MERTER R H  
MELLON INSTITUTE  
KINETIC SPECTROSCOPY IN THE INFRARED  
RUIGH W L SRC

JOHNSON W H / VESTAL M L  
WILLIAM H JOHNSON LABS INC  
COINCIDENCE MEASUREMENTS OF MOLECULE-ION REACTIONS  
MCERNEY A G SRC

RASPER J S  
GENERAL ELECTRIC CO  
CRYSTAL CHEMISTRY OF NEW HIGH PRESSURE PHASES  
RUIGH W L SRC

ROGGER F A  
UNIVERSITY OF SOUTHERN CALIFORNIA  
ELECTROCHEMISTRY OF SOLIDS  
WALFORD E T SRC

LIBBY W F  
UNIVERSITY OF CALIFORNIA  
THE AFOSR PROGRAM FOR SPACE CHEMISTRY AT UCLA  
MCERNEY A G SRC

MARGERUM D W / PARQUE H L  
PURDUE UNIVERSITY  
STUDY OF KINETIC METHODS OF CHEMICAL ANALYSIS  
ELLIOTT D M SRC

PINGS C J  
CALIFORNIA INSTITUTE OF TECHNOLOGY  
AFOSR PROGRAM FOR RESEARCH ON LIQUID STRUCTURE  
WALFORD E T SRC

ROBINSON D H  
JOHNS HOPKINS UNIVERSITY  
HIGH RESOLUTION STUDIES IN THE FAR INFRARED  
RUIGH W L SRC

WHARTON L  
UNIVERSITY OF CHICAGO  
DEVELOPMENT OF A MOLECULAR BEAM ACCELERATOR  
WALFORD E T SRC

WINEFORDNER J  
UNIVERSITY OF FLORIDA  
FLAME SPECTROMETRY AND GAS CHROMATOGRAPHIC DETECTORS  
RUIGH W L SRC

3.1.3 RADIOCHEMICAL AND NUCLEAR METHODS

SCHMIDT-BLEER F  
PURDUE UNIVERSITY  
HOT ATOM CHEMISTRY OF OXYGEN AND NITROGEN  
WEISSLER A SRC

3.1.4 ELECTROCHEMICAL METHODS

SCATHOFF I H  
UNIVERSITY OF MINNESOTA  
ACID-BASE EQUILIBRIA AND TITRATIONS AND ELECTROCHEMICAL EQUILIBRIA  
IN ACETONITRILE  
WEISSLER A SRC

MASON J G  
VIRGINIA POLYTECHNIC INSTITUTE  
OXIDATION OF ARSENIC (III) AND ANTIMONY (III)  
ELLIOTT D M SRC

OLVER J W  
UNIVERSITY OF MASSACHUSETTS  
ELECTROCHEMISTRY OF TRANSITION METAL IONS IN ACETONITRILE  
RUIGH W L SRC

3.1.5 NEW INSTRUMENTAL TECHNIQUES

ODD C G  
OWENS-ILLINOIS GLASS CO  
X-RAY ABSORPTION-EDGE FINE-STRUCTURE SPECTROMETRY OF GLASS AND  
GLASS-CRYSTAL MATERIALS  
RUIGH W L SRC

GOUGOUTAS J Z  
HARVARD UNIVERSITY  
X-RAY CRYSTALLOGRAPHIC METHODS  
RUIGH W L SRC

3.2.0 INORGANIC CHEMISTRY

3.2.1 THEORETICAL INORGANIC CHEMISTRY

BODINOSI D R  
UNIVERSITY OF WESTERN ONTARIO  
SOME THERMOCHEMICAL STUDIES BY MASS SPECTROMETRY  
RUIGH W L SRC

BUCHANAN A S  
UNIVERSITY OF MELBOURNE  
PHOTOLYTIC AND PYROLYTIC FREE RADICALS  
RUIGH W L SRC

DAML L P  
UNIVERSITY OF WISCONSIN  
STRUCTURAL CHEMISTRY AND BONDING IN INORGANIC COMPOUNDS  
ELLIOTT D M SRC

DOYLE J R / BAENZIGER N C  
STATE UNIVERSITY OF IOWA  
REACTIONS AND STRUCTURES OF METAL-OLEFIN COMPLEXES AND RELATED  
SUBSTANCES  
WALFORD E T SRC

GILLESPIE R J  
MCMASTER UNIVERSITY  
INORGANIC NMR SPECTROSCOPY  
RUIGH W L SRC

GRIM S D  
UNIVERSITY OF MARYLAND  
PHOSPHORUS COORDINATION COMPOUNDS  
RUIGH W L SRC

HAAS T E  
TUFTS UNIVERSITY  
INORGANIC APPLICATIONS OF NUCLEAR QUADRUPOLE RESONANCE  
SPECTROSCOPY  
RUIGH W L SRC

MILL T T  
ROCHESTER INSTITUTE OF TECHNOLOGY  
BIBLIOGRAPHIC FILE OF ABSTRACTS ON PHOTOGRAPHIC SCIENCE  
MCERNEY A G SRC

MORADOKS W D  
PRINCETON UNIVERSITY  
INORGANIC STRUCTURE AND SPECTRA  
RUIGH W L SRC

LAPPERT M F  
UNIVERSITY OF SÜSSE  
MASS SPECTROMETRIC THERMOCHEMICAL AND RELATED STUDIES ON SERIES  
OF INORGANIC COMPOUNDS  
RUIGH W L SRC

LARSEN E H  
GORDON RESEARCH CONFERENCES INC  
GORDON RESEARCH CONFERENCE ON INORGANIC CHEMISTRY  
RUIGH W L SRC

MACKENZIE J D  
RENSSELAER POLYTECHNIC INSTITUTE  
VISCOSITY FLOW AND COMPRESSIBILITY OF MOLYB DEN BORATES AT HIGH  
PRESSURE  
RUIGH W L SRC

MACHRY J H  
MELLON INSTITUTE  
DEFECT STATES AND STRUCTURES OF OXIDE GLASSES  
RUIGH W L SRC

OGLE P R  
OTTERBEIN COLLEGE  
AN INVESTIGATION OF THE MECHANISM OF THE REACTION BETWEEN  
BORON TRIFLUORIDE AND NITROGEN (III, IV, V) OXIDES  
WEISSLER A SRC

PGPE H F  
GEORGETOWN UNIVERSITY  
METALLOPOLY COMPOUNDS OF GROUP VB ELEMENTS  
ELLIOTT D M SRC

SYMONS W C  
UNIVERSITY OF LEICESTER  
METALS IN NON-METALLIC SOLVENTS  
WALFORD E T SRC

## CHEMICAL SCIENCES

### 3.2.1 THEORETICAL INORGANIC CHEMISTRY

TODIAS R S  
UNIVERSITY OF MINNESOTA  
POLYNUCLEAR HYDROXO COMPLEXES  
RUIGH W L SRC

BLICK J E  
UNIVERSITY OF VIRGINIA  
THEORETICAL STUDIES ON THE STRUCTURE OF INORGANIC AND  
ORGANOMETALLIC COMPOUNDS MURPHY A W SRC

DENAM R J S  
UNIVERSITY OF TEXAS  
ORGANIC CHEMICAL PHYSICS NATUSZKO A J SRC

### 3.2.2 SYNTHETIC AND DESCRIPTIVE INORGANIC CHEM

CROSBY D A  
UNIVERSITY OF NEW MEXICO  
FUNDAMENTAL INVESTIGATIONS OF LUMINESCENT MATERIALS  
RUIGH W L SRC

HEES E L  
UNIVERSITY OF NOTRE DAME  
QUANTITATIVE CONFORMATIONAL ANALYSIS  
NATUSZKO A J SRC

LERING M L  
UNIVERSITY OF WISCONSIN NATUSZKO A J SRC

EARLEY J E  
GEORGETOWN UNIVERSITY  
REACTIONS OF METALLIC IONS ELLIOTT D M SRC

GOLDFARB T D /BOIKESS R S  
STATE UNIVERSITY OF NEW YORK  
PHOTOCHEMICALLY GENERATED VALENCE FLUCTUATIONS  
WEISSLER A SRC

EDWARDS J O  
BROWN UNIVERSITY  
ISOTOPE STUDY OF THE DECOMPOSITION OF INORGANIC PEROXIDES  
ELLIOTT D M SRC

GUGGOUTAS J Z  
HARVARD UNIVERSITY  
INSTRUMENT GRANT FOR CHEMICAL STRUCTURE DETERMINATION  
RUIGH W L SRC

FERNELIUS W G  
NATIONAL ACADEMY OF SCIENCES  
RESEARCH ON INORGANIC CHEMICAL NOMENCLATURE  
WALFORD E T SRC

HAMMOND G S  
CALIFORNIA INSTITUTE OF TECHNOLOGY  
TRANSFER OF EXCITATION IN SOLUTION  
WEISSLER A SRC

GREENWOOD N W  
UNIVERSITY OF NEWCASTLE UPON TYNE  
CHEMISTRY OF DECABORANE COORDINATION CHEMISTRY OF GROUP III  
ELEMENTS RUIGH W L SRC

MISLOW K  
PRINCETON UNIVERSITY  
STUDIES IN STEREOCHEMISTRY NATUSZKO A J SRC

KACZMARECZYK A  
DARTMOUTH COLLEGE  
THE SOLUTION CHEMISTRY OF POLYHEDRAL BICENTRIC HYDROGEN IONS  
RUIGH W L SRC

MILVANEY J E  
UNIVERSITY OF ARIZONA  
CHEMISTRY OF ORGANOLITHIUM COMPOUNDS AND ACETYLENES  
NATUSZKO A J SRC

KING R B  
UNIVERSITY OF GEORGIA  
TRANSITION METAL COMPLEXES CONTAINING NITROGEN, PHOSPHORUS OR  
SULFUR ELLIOTT D M SRC

SKELL P S  
PENNSYLVANIA STATE UNIVERSITY  
ATOMIC CHEMISTRY NATUSZKO A J SRC

KOCHER J K  
CASE INSTITUTE OF TECHNOLOGY  
PHOTO-INDUCED REDOX REACTIONS WEISSLER A SRC

STRIETWIESER A  
UNIVERSITY OF CALIFORNIA  
QUANTUM ORGANIC CHEMISTRY NATUSZKO A J SRC

KOENLER M C  
OAK RIDGE NATIONAL LABORATORY  
SEVENTH RARE EARTH RESEARCH CONFERENCE NATUSZKO A J SRC

### 3.2.3 SYNTHESIS AND PROP. OF ORG. COMPOUNDS

MACDIARMID A G  
UNIVERSITY OF PENNSYLVANIA  
HIGH PRESSURE 73-5 KB./ INORGANIC AND  
ORGANOMETALLIC SYNTHESIS RUIGH W L SRC

BATTISTE M A  
UNIVERSITY OF FLORIDA  
MULTICHARGE AROMATIC IONS NATUSZKO A J SRC

MACDONALD D J  
UNIVERSITY OF NEVADA  
KINETICS OF TRANSITION-METAL IONS OF d<sup>8</sup> ELECTRONIC CONFIGURATION  
ELLIOTT D M SRC

BENKESER R A  
PURDUE UNIVERSITY  
ELECTROLYTIC REDUCTION OF ORGANIC COMPOUNDS  
WALFORD E SRC

MC DONALD R L  
UNIVERSITY OF MARIETTA  
THE SOLVENT EXTRACTION BEHAVIOR OF INORGANIC COMPLEXES  
ELLIOTT D M SRC

BLY R S  
UNIVERSITY OF SOUTH CAROLINA  
THE SOLVOLYTIC REACTIVITY OF PI-COMPLEXED COMPOUNDS  
NATUSZKO A J SRC

NACHTRIEB W H  
UNIVERSITY OF CHICAGO  
STRUCTURE IN MOLTEN SALTS AND GLASSES  
ELLIOTT D M SRC

BUCHANAN G L  
UNIVERSITY OF GLASGOW  
STUDIES IN RING EXPANSION NATUSZKO A J SRC

STONE F G A  
BRISTOL UNIVERSITY  
ORGANOMETALLIC CHEMISTRY ELLIOTT D M SRC

BUTLER G B  
UNIVERSITY OF FLORIDA  
SYNTHESIS OF TRIPLE STRAND POLYMERS NATUSZKO A J SRC

WENDLANDT W W  
UNIVERSITY OF HOUSTON  
TRANSITION METAL AMINE COMPLEXES AT HIGH PRESSURES AND  
TEMPERATURES ELLIOTT D M SRC

HULSE M O  
MASSACHUSETTS INSTITUTE OF TECHNOLOGY  
THE CHEMISTRY OF CARBANIONS NATUSZKO A J SRC

### 3.3.0 ORGANIC CHEMISTRY

PHYER M A  
LOUISIANA STATE UNIVERSITY  
REACTIONS OF FREE RADICALS NATUSZKO A J SRC

### 3.3.1 THEORETICAL AND STRUCTURAL ORG. CHEM.

BERSON J A  
UNIVERSITY OF WISCONSIN  
STERIC EFFECTS IN CONJUGATED SYSTEMS NATUSZKO A J SRC

SEYFERTH D  
MASSACHUSETTS INSTITUTE OF TECHNOLOGY  
ORGANOMETALLIC SYNTHESIS OF REACTIVE INTERMEDIATES  
NATUSZKO A J SRC

BERSON J A  
UNIVERSITY OF WISCONSIN  
CHEMISTRY OF STRAINED OLDFINS NATUSZKO A J SRC

TRAYLOR T G  
UNIVERSITY OF CALIFORNIA  
CARBONIUM ION RADICALS AND CRY RADICALS  
NATUSZKO A J SRC

WEST R C  
UNIVERSITY OF WISCONSIN  
NOVEL ORGANOMETALLIC COMPOUNDS NATUSZKO A J SRC



## CHEMICAL SCIENCES

### 3.3.3 ORGANIC CHEMICAL MATERIALS

BERLIN R D  
OKLAHOMA STATE UNIVERSITY  
NUCLEOPHILIC DISPLACEMENTS ON TRIVALENT PHOSPHORUS  
RUIGH W L SRC

BOROWITZ I J  
YESHIVA UNIVERSITY  
NUCLEOPHILIC DISPLACEMENTS BY ORGANOPHOSPHORUS COMPOUNDS  
RUIGH W L SRC

### 3.4.0 PHYSICAL CHEMISTRY

#### 3.4.1 CHEMISTRY- STRUCTURE OF MATTER

BEALOET A A  
UNIVERSITY OF SOUTHERN CALIFORNIA  
MICROWAVE SPECTROSCOPY OF BICRON COMPOUNDS  
RUIGH W L SRC

DUNCAN J F  
VICTORIA UNIVERSITY OF WELLINGTON  
USE OF MOSSBAUER EFFECT IN CHEMISTRY  
ELLIOTT D W SRC

MYLLEBAAS E A  
UNIVERSITY OF OSLO  
ELECTRONIC STRUCTURE AND ENERGY LEVELS OF MANY ELECTRON ATOMS  
ELLIOTT D W SRC

JAKOBSEN R J  
BATTELLE MEMORIAL INSTITUTE  
FAR INFRARED STUDIES OF THE HYDROGEN BOND  
ELLIOTT D W SRC

MURRAY R W/REILLY C W  
UNIVERSITY OF NORTH CAROLINA  
ELECTROCHEMICAL STUDIES OF KINETICS, ADSORPTION, AND EXCITED ELECTRONIC STATES  
ELLIOTT D W SRC

OVEREND J  
UNIVERSITY OF MINNESOTA  
VIBRATIONAL ANHARMONICITY AND ROTATION-VIBRATION INTERACTION IN POLYATOMIC MOLECULES  
WEISSLER A SRC

PETRUCCI S  
POLYTECHNIC INSTITUTE OF BROOKLYN  
KINETICS OF ION-COMPLEX FORMATION IN MIXTURES OF FUSED SALTS STUDIED BY ULTRASONIC ABSORPTION  
WEISSLER A SRC

PICE S A  
UNIVERSITY OF CHICAGO  
THEORETICAL AND EXPERIMENTAL STUDIES IN CHEMICAL PHYSICS  
WEISSLER A SRC

SHULL H  
INDIANA UNIVERSITY  
QUANTUM CHEMISTRY PROGRAM EXCHANGE  
HALFORD E T SRC

SHULL H/ HAGSTROM S A  
INDIANA UNIVERSITY  
ELECTRONIC COMPUTER CALCULATIONS ON SIMPLE DIATOMIC AND POLYATOMIC MOLECULES  
ELLIOTT D W SRC

STEEL C  
BRANDEIS UNIVERSITY  
PHOTOCHEMISTRY OF AZO COMPOUNDS AND STUDIES IN UNIMOLECULAR REACTIONS  
WEISSLER A SRC

#### 3.4.2 CHEMISTRY-INTERACTIONS OF MATTER AND ENERGY

SWAR M  
WEIZMANN INSTITUTE OF SCIENCE  
MECHANISM OF NITROGEN FIXATION BY ULTRASONIC RADIATION IN WATER  
ELLIOTT D W SRC

BATR E J  
INDIANA UNIVERSITY  
KINETIC SPECTROSCOPY OF CHEMICALLY ACTIVE SYSTEMS  
WEISSLER A SRC

BATES R D  
UNIVERSITY OF CALIFORNIA  
LIGHT EMITTED BY ATOMIC FLAMES  
WEISSLER A SRC

BURNS G  
UNIVERSITY OF TORONTO  
KINETICS OF ATOMIC ASSOCIATION REACTIONS USING FLASH PHOTOLYSIS OVER A WIDE TEMPERATURE RANGE  
WEISSLER A SRC

DOVE J E  
UNIVERSITY OF TORONTO  
KINETICS OF ION FORMATION DURING CHEMICAL REACTION IN SHOCK WAVES  
RUIGH W L SRC

DUMM T M  
UNIVERSITY OF MICHIGAN  
THE EXCITED STATES OF URANIUM AND HEAVY METALS  
ELLIOTT D W SRC

EYRING L  
UNIVERSITY OF RHODE ISLAND  
GORDON RESEARCH CONFERENCE ON HIGH TEMPERATURE CHEMISTRY  
WEISSLER A SRC

FENG P Y  
IIT RESEARCH INSTITUTE  
CHEMICAL REACTIONS OF SECONDARY ELECTRONS  
RUIGH W L SRC

FLETCHER W H  
UNIVERSITY OF TENNESSEE  
HIGH RESOLUTION RAMAN SPECTROSCOPY  
ELLIOTT D W SRC

GESSER M  
UNIVERSITY OF MANITOBA  
SURFACE STABILIZED RADICALS  
RUIGH W L SRC

HISATSUNE I L  
PENNSYLVANIA STATE UNIVERSITY  
SPECTROSCOPIC STUDIES OF CHEMICAL REACTIONS IN THE SOLID STATE  
ELLIOTT D W SRC

HYDE B G  
UNIVERSITY OF WESTERN AUSTRALIA  
SOLID, NON-STOICHIOMETRIC OXIDE PHASES OF THE INNER AND OUTER TRANSITION METALS  
ELLIOTT D W SRC

JAMES H M  
VANDERBILT UNIVERSITY  
COORDINATION, LIGAND REACTIVITY, AND CATALYSIS  
HALFORD E T SRC

KOSKI M S  
JOHNS HOPKINS UNIVERSITY  
UPPER ATMOSPHERE ION-MOLECULE REACTIONS  
ELLIOTT D W SRC

LIBBY W F  
UNIVERSITY OF CALIFORNIA  
THE AFOSR PROGRAM IN SPACE CHEMISTRY AT UCLA  
HALFORD E T SRC

LEIGHTON N N/HOFFMAN M  
BOSTON UNIVERSITY  
N<sub>2</sub> A-TRIPLET-SIGMA STATE GENERATED BY 1849 ANGSTROM ULTRAVIOLET MERCURY PHOTOSENSITIZATION  
WEISSLER A SRC

LUVALLEY J E  
SOCIETY OF PHOTOGRAPHIC SCIENTISTS AND ENGINEERS  
COLLOQUIUM ON THE PHOTOGRAPHIC INTERACTION BETWEEN RADIATION AND MATTER  
HALFORD E T SRC

LYONS L E  
UNIVERSITY OF QUEENSLAND  
CHARGE AND ENERGY TRANSFER IN ORGANIC SYSTEMS  
ELLIOTT D W SRC

MATSON G J  
UNIVERSITY OF DETROIT  
PLASMA PINCH FLASH PHOTOLYSIS  
WEISSLER A SRC

MOYER M A  
UNIVERSITY OF TEXAS  
REACTIONS OF MOLECULES IN EXCITED ELECTRONIC STATES WITH PARAMAGNETIC GASES  
MATUSZAK A J SRC

PACKER J E  
UNIVERSITY OF ABERLAND  
CHEMISTRY OF RADIATION PROTECTING AGENTS  
ELLIOTT D W SRC

PIRENTEL G C  
UNIVERSITY OF CALIFORNIA  
ULTRARAPID-SCAN INFRARED SPECTROSCOPY  
ELLIOTT D W SRC

RABINOVITCH B S  
UNIVERSITY OF WASHINGTON  
INTERMOLECULAR ENERGY TRANSFER  
WEISSLER A SRC

ROBINSON G W  
CALIFORNIA INSTITUTE OF TECHNOLOGY  
HIGH RESOLUTION SPECTROSCOPY OF SMALL MOLECULES IN THE GASEOUS STATE  
ELLIOTT D W SRC

SCHLAG E H  
NORTHWESTERN UNIVERSITY  
ENERGY TRANSFER IN HDI MOLECULES  
WEISSLER A SRC

TURRO D J  
COLUMBIA UNIVERSITY  
CHEMISTRY OF STRAINED RING COMPOUNDS  
WEISSLER A SRC

## CHEMICAL SCIENCES

### 3.4.2 CHEMISTRY, INTERACTIONS OF MATTER AND ENERGY

WEINER E R  
UNIVERSITY OF DENVER  
KINETIC ENERGY OF IONIC PRODUCTS FROM ELECTRON AND ION-MOLECULE REACTIONS  
HALFORD E T SRC

YEARER E  
ELECTROCHEMICAL SOCIETY OF AMERICA 196  
SYMPOSIUM ON ELECTRODE PROCESSES  
RUIGH N L SRC

### 3.4.3 PRINCIPLES GOVERNING CHEMICAL REACTIONS

ALLEN L C  
PRINCETON UNIVERSITY  
CHEMICAL ELECTRONIC STRUCTURE THEORY  
WEISSLER A SRC

BONHAM R A  
INDIANA UNIV RESEARCH FOUNDATION  
THEORETICAL AND EXPERIMENTAL ANALYSIS OF ELECTRON SCATTERING FROM ATOMS AND MOLECULES  
WEISSLER A SRC

DEBYE P J  
CORNELL UNIVERSITY  
CONCENTRATION FLUCTUATIONS IN THE VICINITY OF THE CRITICAL POINT  
WEISSLER A SRC

FLOSS R M  
YALE UNIVERSITY  
INSTRUMENT GRANT FOR ELECTROLYTIC CONDUCTANCE  
RUIGH N L SRC

MARGRAVE J L  
NATIONAL ACADEMY OF SCIENCES  
CONFERENCE ON CURRENT AND FUTURE PROBLEMS IN CHEMISTRY AT HIGH TEMPERATURES  
ELLIOTT D M SRC

MYBURG S  
UNIVERSITY OF TORONTO  
MOLECULAR INTERACTIONS AND CRYSTAL STRUCTURES AT LOW TEMPERATURES  
HALFORD E T SRC

PHILLIPS L F  
UNIVERSITY OF CANTERBURY  
GAS PHASE REACTIONS OF ATOMS, RADICALS AND SIMPLE MOLECULES  
WEISSLER A SRC

STENGLE T R/LANSFORD  
UNIVERSITY OF MASSACHUSETTS  
RATES OF EXCHANGE OF SOLVENT MOLECULES WITH PARAMAGNETIC IONS  
RATUSZKO A J SRC

TAMMUT F D  
REED COLLEGE  
REACTION RATE STUDIES OF GASEOUS UNIMOLECULAR ISOMERIZATIONS  
ELLIOTT D M SRC

WHITMAN D R/CARLSON R O  
CASE INSTITUTE OF TECHNOLOGY  
ELECTRONIC STRUCTURE OF MOLECULES BY VARIATIONAL METHODS AND CORRELATION CORRECTIONS  
WEISSLER A SRC

WILSON D J/BALTERS  
UNIVERSITY OF ROCHESTER  
UNIMOLECULAR DECOMPOSITION OF CYCLOHEPTANE DERIVATIVES AT HIGH PRESSURE  
WEISSLER A SRC

### 3.4.4 SURFACE CHEMISTRY

BURNELL R I  
NORTHWESTERN UNIVERSITY  
HETEROGENEOUS CATALYSIS IN LIQUID SYSTEMS  
ELLIOTT D M SRC

ENRLEIGH G  
GENERAL ELECTRIC CO  
ATOMIC AND MOLECULAR KINETICS ON SOLID SURFACES  
RUIGH N L SRC

MORSON H C  
VIRGINIA INSTITUTE FOR SCIENTIFIC RESEARCH  
CHEMICAL CHARACTERIZATION OF MOLECULES ADSORBED ON A FOREIGN SOLID  
WEISSLER A SRC

ZWERNER R N  
LANCASHIRE UNIVERSITY  
SURFACE STATES IN PURE PALLADIUM  
SPRUEBEL R D SRC

### 3.5.0 CHEMICAL KINETICS AND MECHANISMS

### 3.5.1 HOMOGENEOUS AND HETEROGENEOUS ION REACTIONS

JANZEN E W  
UNIVERSITY OF GEORGIA  
EPR THERMAL DECOMPOSITION STUDIES OF NITROAROMATIC COMPOUNDS AND INORGANIC SALTS  
RATUSZKO A J SRC

QUEJA S M  
UNIVERSIDAD DE CHILE  
SALT EFFECTS ON SEVERAL ACIDITY FUNCTIONS  
RATUSZKO A J SRC

PINCOCK R E  
UNIVERSITY OF BRITISH COLUMBIA  
CHEMICAL REACTIONS IN FROZEN SOLUTIONS  
RUIGH N L SRC

SHINE H J  
TEXAS TECHNOLOGICAL COLLEGE  
ION-RADICALS OF ORGANIC SULFUR SELENIUM TELLURIUM AND PHOSPHORUS COMPOUNDS  
RATUSZKO A J SRC

### 3.5.2 ENERGY EFFECTS IN CHEMICAL REACTIONS

LACHER J R/PARK J D  
UNIVERSITY OF COLORADO  
VAPOR PHASE CALORIMETRY  
HALFORD E T SRC

MARGERUM J D  
MAGNES RESEARCH LABS  
ACID-BASE CHARACTERISTICS OF PHOTOTROPIC  
WEISSLER A SRC

SCHUBERT H W  
UNIVERSITY OF WASHINGTON  
MEDIUM EFFECTS ON ACID CATALYZED REACTIONS  
AQUEOUS ACIDS  
RATUSZKO A J SRC

### 3.5.3 CHEMICAL REACTIONS OF CONDENSED PHASES

THORNTON E B  
UNIVERSITY OF PENNSYLVANIA  
SOLVENT ISOTOPE EFFECTS FOR CH<sub>3</sub>OH VS. CD<sub>3</sub>OH  
RATUSZKO A J SRC

TSUTSUMI M  
NEW YORK UNIVERSITY  
SIGNA PI REARRANGEMENT  
RATUSZKO A J SRC

### 3.5.4 KINETICS OF FAST CHEMICAL REACTIONS

PADNA A  
STATE UNIVERSITY OF NEW YORK  
PHOTOCHEMICAL GENERATION OF DIVALENT CARBON DERIVATIVES  
WEISSLER A SRC

### 3.6.0 CHEM AND RHEOLOGICAL PROPERTIES OF MATERIALS

#### 3.6.1 CHEMICAL AND PHYSICAL PROPERTIES OF PURE LIQUIDS

ADAMSON A W  
UNIVERSITY OF SOUTHERN CALIFORNIA  
PHYSICAL ADSORPTION OF VAPORS  
WEISSLER A SRC

BLUCHE A N  
GENERAL ELECTRIC CO  
SIXTH INTERNATIONAL SYMPOSIUM ON THE REACTIVITY OF SOLIDS  
MORREY A G SRC

CAMPFIELD F B  
OKLAHOMA UNIV RESEARCH INSTITUTE  
DENSITY OF CRYOGENIC LIQUID MIXTURES  
HALFORD E T SRC

CROWELL A D  
UNIVERSITY OF VERMONT  
INTERACTION OF MOLECULES WITH SOLID SURFACE  
WEISSLER A SRC

SCHMID G W  
UNIVERSITY OF FLORIDA  
DIFFERENTIAL ELECTRICAL DOUBLE LAYER CAPACITIES ON LIQUID AND SOLID ELECTRODES  
HALFORD E T SRC

#### 3.6.2 PROPERTIES OF CRYSTALLINE INORG. SOLIDS

FLORY P  
STANFORD UNIVERSITY  
MACROMOLECULAR RESEARCH  
RATUSZKO A J SRC

## *Life Sciences*

DR. HARVEY E. SAVELY, *Director*

In this directorate two divisions, biological sciences and behavioral sciences, have a broad charter to support studies in these fields of potential Air Force interest. However, since these programs are small, both in relation to others in AFOSR as well as in the Nation as a whole, only a limited number of areas can be selected for support. This selection takes into account areas judged to be of particular long-range interest to the Air Force, and the pattern of research support already available in the military and in other agencies such as NSF and NIH.

The life sciences directorate provides the Air Force with a "window on the universities" by selecting carefully projects for support proposed by investigators who can also give authoritative technical advice to the Air Force on critical life science problems as they arise. Air Force acquaintance with foremost scientists and knowledge of current scientific achievements are accomplished by the directorate's lending support to research symposia and national and international scientific meetings.

In the biological sciences division a decision was taken, at least 10 years ago, to emphasize certain aspects of research on the nervous system. At that time, the most effective way of accelerating this field seemed to be to give support to key European laboratories which were still having difficulty rebuilding after World War II. It now seems fair to say that the regrowth and vigor of neurobiology in Europe has been significantly affected by AFOSR's program and has led to a fuller exchange with American scientists both through travel and exchange of scientific workers. Studies in neurobiology are now showing close support of relevance to Air Force and NASA technologies. Some of the areas involved are: Sleep; brain waves as indicators of states of alertness; sensory physiology of vision and olfaction; nature of membranes; endocrine studies relevant to toxicology; tolerance to stress, and to behavior. Other areas, such as photosynthesis, biochemistry, im-

munology, and molecular biology are on the borders of current military interests in exploratory developments and may well find direct applications within the next decade.

The orientation of a significant portion of the biological program to studies relevant to problems of living in the tropics and other stressful environments is now underway. Now that research in the biomedical sciences has expanded so greatly in the last decade, it becomes even more important for AFOSR to look critically on how its small program (about \$1.7 million) can have the maximum impact on research problems that are of Air Force interest and which need special emphasis. In view of the military strategic situation, it seems clear that problems of limited warfare are likely to be of continuing importance. The reorientation toward problems in the tropics is intended to contribute to these problems. While a well planned order of priorities is not yet at hand, it seems clear that problems of epidemiology, and environmental physiology will rank high. Ecological studies of environments should be an important aspect of these interests, and can have meaning not only for medical problems but nutritional, economic, and sociological problems as well, all of which are now becoming a part of the larger problem of developing nations in which limited warfare is a potentiality.

Continuing studies on the nervous system are emphasizing those that help to gain a comparative analysis of nervous mechanisms underlying motor and sensory systems in animals. The applications of this knowledge will be in the bionics, and in studies of automata and control systems.

Our program has included from its beginning the support of studies in ethology, a name given in Europe to the study of animal behavior with emphasis on behavior in natural conditions. This area is now expanding in the United States where the approach is finding application to problems of bird-strikes by aircraft. It is anticipated that such studies can also lead to significant findings useful in the control of animal vectors and reservoirs of diseases.

The life sciences directorate will increasingly emphasize research of an interdisciplinary charac-

ter in the general area of the biological science-behavioral science interface.

The behavioral sciences division concentrates its effort on support of basic research that promises to contribute to the solution of problems of human adaptation and performance that arise from the operational requirements imposed by Air Force mission assignments. Basic behavioral research findings provide the foundations upon which may be built technological developments to improve personnel classification; training; leadership; morale; communication; man-machine systems; adaptation to exotic environments; decision and information processes; work under stress; target location and acquisition; teamwork; and management of large organizations.

The disciplines supporting this program are experimental, physiological, and social psychology; sociology; political science; anthropology; and computer science.

Specifically, research projects are being supported on complex decisionmaking; short- and long-term memory; perception under adverse environmental conditions; organizational effectiveness; communication with foreign populations; and behavioral compensation for stressful situations.

Increased relevance to Air Force needs is being achieved by concentrating effort on problems concerned with human inputs required for the orderly development of aerospace capabilities.

Studies have been and are being conducted on sleep and arousal, and on optimal work-rest cycles. Basic conditions of psychophysiological adaptation to fatigue and to environmental stress are being studied.

The behavioral sciences division is responsive to guidance from Department of Defense and Headquarters USAF as to areas of need to which basic research can be most relevant in current and future applications of findings.

In the areas of strategy and concept development there is a growing need for refined forecasts of future military environments; for improving planning processes; and for developing better methods for translating plans into functioning organizations, systems, and strategies. Research in these areas has been undertaken in response to Hq. USAF guidance. Particular emphasis is being placed on studies appraising military, technological, political, and economic factors in both Communist and non-Communist countries. Such studies include: Appraisal of world situations likely to affect warfare and military strategy during the next 15 to 20 years; projected assessments of the capacities of U.S. science and technology to contribute to systems development for future needs; elaboration of concepts for the employment of aerospace forces; forecast of the long-range capability objectives of the Air Force throughout the spectrum of support, threat, and conflict; and identification of capabilities inherent in the Air Force for achieving national objectives.

LIFE SCIENCES

5.0.0 BIOLOGICAL SCIENCES

CAIRNS J  
COLD SPRING HARBOR LABORATORY OF QUANTITATIVE BIOLOGY  
XIII SYMPOSIUM ON QUANTITATIVE BIOLOGY  
FULLER C E  
SRLA

COULIDGE M J  
NATIONAL ACADEMY OF SCIENCES  
ELEVENTH PACIFIC SCIENCE CONFERENCE  
FULLER C E  
SRLA

COHAN R G  
SMITHSONIAN INSTITUTION  
CONFERENCE ON STUDIES IN TROPICAL BIOLOGY  
BROWN R V  
SRLA

DECARLO M B  
NATIONAL ACADEMY OF SCIENCES/NATIONAL RESEARCH COUNCIL  
US NATIONAL COMMITTEE FOR THE INTERNATIONAL BIOLOGICAL PROGRAM  
SAVELY H E  
SRLA

LEVI-MONTALCINI R  
WASHINGTON UNIVERSITY  
ACTION OF NERVE GROWTH FACTOR  
LEVENTHAL J R  
SRLA

WILES G H  
NORTH STAR RESEARCH AND DEVELOPMENT INSTITUTE  
EFFECTS OF PHYSIOLOGICAL RHYTHMS ON PERFORMANCE  
BROWN R V  
SRLA

WILBER C G  
UNIVERSITY OF FLORIDA  
CARDIOVASCULAR PATHOLOGY RESULTING FROM ENVIRONMENTAL STRESS  
BROWN R V  
SRLA

5.1.1 ECOLOGY

BOUDREAL G B  
SARITA BETA TECHNOLOGY INC  
INVESTIGATE AND EVALUATE ACCIDENTAL BIRD CONTROL PROCEDURES  
FULLER C E  
SRLA

BUECHNER M R  
SMITHSONIAN INSTITUTION  
ECOLOGICAL STUDY IN KUBRA  
SAVELY H E  
SRLA

BUECHNER M R  
SMITHSONIAN INSTITUTION  
RESEARCH PROBLEMS IN ENVIRONMENTAL PHYSIOLOGY AND ECOSYSTEM  
ECOLOGY  
FULLER C E  
SRLA

GOULD E  
JOHNS HOPKINS UNIVERSITY  
ECOLOGICAL STUDIES OF SOME INSECTIVORES  
FULLER C E  
SRLA

GRESSITT J L  
BERNICE P BISHOP MUSEUM  
STUDIES OF AIR-BORNE ORGANISMS RETRIEVED BY LARGE AIRCRAFT  
FULLER C E  
SRLA

HAMILTON W J  
UNIVERSITY OF CALIFORNIA  
FLOCKING MECHANISMS IN BIRDS  
FULLER C E  
SRLA

LEWIS W M  
MISSOURI BOTANICAL GARDEN  
BOTANICAL STUDIES IN THE HECTARE  
BROWN R V  
SRLA

LILL A C  
NEW YORK ZOOLOGICAL SOCIETY  
ETHNOLOGY OF SOME TROPICAL BIRDS  
BROWN R V  
SRLA

MEDINA A  
UNIVERSIDAD NACIONAL DE TRUJILLO  
THE ROLE OF CATECHOLAMINES AND SERITANIN IN THE PROCESS OF  
ADAPTATION TO HIGH ALTITUDE  
BROWN R V  
SRLA

SMITH W J  
UNIVERSITY OF PENNSYLVANIA  
STUDIES OF ANIMAL COMMUNICATION  
BROWN R V  
SRLA

5.2.1 GENETICS

BARNETT B  
DRYDEN HARM COLLEGE  
GENETIC MECHANISMS UNDERLYING BIOLOGICAL RHYTHMS  
BROWN R V  
SRLA

WELER E C  
MUS CORP  
IMPERITABLE OF XANTHINE DEHYDROGENASE IN SACROPHILA MELANOGASTER  
BROWN R V  
SRLA

RENN W S  
UNIVERSIDADE DE SAO PAULO  
INTERNATIONAL SYMPOSIUM OF GENETICS  
FULLER C E  
SRLA

5.2.0 ANATOMY

OLMINK J  
JOHNS HOPKINS UNIVERSITY  
DEVELOPMENT OF THE PRIMATE RETINA  
BROWN R V  
SRLA

LARSEN J R  
UNIVERSITY OF ILLINOIS  
ANATOMY OF INSECT CENTRAL NERVOUS SYSTEMS  
BROWN R V  
SRLA

SOFFEL R J  
INSTITUTO DE INVESTIGACION DE CIENCIAS BIOLÓGICAS  
ELECTRON MICROSCOPE STUDY OF MEIOTIC CHROMOSOMES  
BROWN R V  
SRLA

TRUJILLO-GONZ D  
INSTITUTO DE INVESTIGACION DE CIENCIAS BIOLÓGICAS  
COMPARATIVE ANATOMY OF THE A THROPOD VISUAL SYSTEM  
FULLER C E  
SRLA

5.3.1 IMMUNOLOGY

SELA W  
HEIZMANN INSTITUTE OF SCIENCE  
SYNTHETIC POLYPEPTIDE ANTIGENS  
BROWN R V  
SRLA

5.3.2 PATHOLOGY

GIBSON J B  
UNIVERSITY OF HONG KONG  
PATHOLOGY OF CLONORCHIS SINENSIS  
BROWN R V  
SRLA

5.5.1 MICROBIOLOGY

FLYNN R J  
ALYONNE NATIONAL LAB  
PREPARATION OF MANUSCRIPTS FOR THE COMPANION REFERENCE BOOKS ON  
LABORATORY ANIMAL DISEASES  
FULLER C E  
SRLA

GOULD J R  
GENERAL ELECTRIC CO  
DETECTION OF PATHOGENS  
BROWN R V  
SRLA

5.6.1 MOLECULAR BIOLOGY

COMMER B  
MICHIGAN UNIVERSITY  
INTERDISCIPLINARY STUDIES IN MOLECULAR BIOLOGY  
BROWN R V  
SRLA

DE ROBERT S E  
CONSEJO NACIONAL DE INVESTIGACIONES CIENTÍFICAS  
ULTRASTRUCTURE AND FUNCTION IN LATE CYCLAMINE CONTAINING SYSTEMS  
BROWN R V  
SRLA

HEIST M E  
MURVELL INC  
OXYD SENSING CELL ULTRASTRUCTURE BY ELECTRON MICROSCOPY  
BROWN R V  
SRLA

LEDERBERG J  
STANFORD UNIVERSITY  
MOLECULAR BIOLOGY: APPLICATIONS OF MASS SPECTROMETRY  
BROWN R V  
SRLA

5.6.2 BIOCHEMISTRY

ANTONINI E  
UNIVERSITA DEGLI STUDI DI ROMA  
STRUCTURAL ASPECTS OF HEMOGLOBIN FUNCTION  
BROWN R V  
SRLA

CAMESSA-FISCHER H  
UNIVERSIDAD DE CHILE  
BIOCHEMICAL PROFILE OF SOLED ARON MEMBRANS  
BROWN R V  
SRLA

ZOMBER R H  
MASSACHUSETTS INSTITUTE OF TECHNOLOGY  
ISOLATION OF THE SODIUM-POTASSIUM-ACTIVATED ATPASE  
SAVELY H E  
SRLA

GAFFRON H  
FLORIDA STATE UNIVERSITY  
PHOTOBIOLOGY AND PHOTOCHEMISTRY  
BROWN R V  
SRLA

KAPLAN N O  
BRANDEIS UNIVERSITY  
STRUCTURE AND PROPERTIES OF MULTIPLE ENZYME FORMS  
FULLER C E  
SRLA

## LIFE SCIENCES

### 5.4.4 BIOCHEMISTRY

- RATCHALSKIE E  
WEIZMANN INSTITUTE OF SCIENCE  
BIOLOGICAL SIGNIFICANCE OF HIGH MOLECULAR WEIGHT PEPTIDES  
BROWN R V SALA
- RUPPLAN S V  
HARVARD UNIVERSITY  
BIOCHEMICAL STUDIES ON THE NERVOUS SYSTEM  
BROWN R V SALA
- LAVALLA R  
CENTRE D'ENSEIGNEMENT ET DE RECH. LAB. 2ND ALIMENT ET CHIM.  
REGULATION OF RNA SYNTHESIS  
BROWN R V SALA
- LIMO L  
UNIVERSITY OF OREGON MEDICAL SCHOOL  
LIPID METABOLISM STUDIES  
BROWN R V SALA
- LUNBY R  
UNIVERSITY OF MINNESOTA  
RELATION OF STRUCTURE TO FUNCTION IN HEMOGLOBIN  
SAVELLY M E SALA
- MASON P L  
HARVARD UNIVERSITY  
HYPOTHALAMIC SECRETORY FACTOR FOR ADRENOCORTICOTROPIC HORMONE  
BROWN R V SALA
- RABINOWITZ E  
UNIVERSITY OF ILLINOIS  
FLUORESCENCE DURING PHOTOSYNTHESIS  
BROWN R V SALA
- ROSENBERG J L  
UNIVERSITY OF PITTSBURGH  
FLASH SPECTROSCOPY AND FLASH FLUORESCENCE IN PHOTOSYNTHETIC  
STUDIES  
LCHWENTHAL J R SALA
- SHIGEMAN P E  
UNIVERSITY OF MINNESOTA  
ALTERATIONS OF BRAIN BIOCHEMISTRY AND DEVELOPMENT OF BEHAVIOR  
BROWN R V SALA
- TAMIYA H  
TORONTO UNIVERSITY  
STRUCTURE OF SEA SHARK VENOUS  
BROWN R V SALA

### 5.4.5 BIOPHYSICS

- BALCHEN M A  
SENSORY SYSTEMS LAB  
EXPLORATORY USES OF TELEMETRY IN SENSORY STUDIES  
BROWN R V SALA
- BUSHEL R G  
ECOLE NORMALE SUPERIEURE  
SYMPOSIUM ON BIONIC MODELS OF THE ANIMAL SONAR SYSTEM  
FULLER C E SALA
- JALILAN F J  
RETINA FOUNDATION  
FORCE VELOCITY AND SARCOMERE LENGTH IN MUSCLE  
BROWN R V SALA
- RATCHALSKIE E  
WEIZMANN INSTITUTE OF SCIENCE  
MECHANISM-CHEMISTRY OF COUPLED CONTRACTILE AND CHEMICAL RATE  
PROCESSES  
BROWN R V SALA
- LEWIS E R  
GENERAL PRECISION INC  
SIMULATION OF NEURAL BEHAVIOR  
BROWN R V SALA
- MATAMORA M R  
UNIVERSIDAD DE CHILE  
ANATOMICAL BASIS OF PATTERNS OF ACTIVITY  
BROWN R V SALA
- MORRISON R B  
UNIVERSITY OF CONNECTICUT  
DATA PROCESSING IN THE OPTIC GANGLIA OF COMPOUND EYES  
BROWN R V SALA
- PICLARD B F  
WASHINGTON UNIVERSITY  
PROPERTIES OF ELECTRICALLY EXCITABLE MEMBRANES  
BROWN R V SALA
- PROCTOR L D  
EDSEL B FORD INSTITUTE FOR RESEARCH  
INTERNATIONAL SYMPOSIUM-BIOCYBERNETICS OF THE CENTRAL NERVOUS  
SYSTEM  
BROWN R V SALA
- PYE J D  
KINGS COLLEGE  
ECHolocation AND ULTRASONIC MECHANISMS IN BATS AND INVERTEBRATES  
BROWN R V SALA

- RUSEM R  
UNIVERSITY OF CHICAGO  
RELATIONAL APPROACH TO BIOLOGY  
BROWN R V SALA
- STEVENS R B  
NATIONAL ACADEMY OF SCIENCES  
U S NATIONAL COMMITTEE FOR PURE AND APPLIED BIOPHYSICS  
FULLER C E SALA
- STEVENS R B  
NATIONAL ACADEMY OF SCIENCES  
20 INTERNATIONAL BIOPHYSICS CONGRESS  
FULLER C E SALA
- TEORRELL T  
ROYAL UNIVERSITY OF UPPSALA  
GENESIS OF ACTION POTENTIALS IN EXCITABLE TISSUE  
BROWN R V SALA
- WEBSTER F A  
SENSORY SYSTEMS LAB  
SOUND GENERATION IN BATS IN RELATION TO ECHolocation  
BROWN R V SALA
- WEIS-FOGH T  
CAMBRIDGE UNIVERSITY  
STRUCTURING OF RESILIN AND ELASTOMERS IN INSECTS  
BROWN R V SALA

### 5.7.1 PHYSIOLOGY

- ALVAREZ J  
CATHOLIC UNIVERSITY OF CHILE  
NERVOUS CONNECTIONS IN THE VESTIBULAR SYSTEM  
SAVELLY M E SALA
- ARDIHI A  
UNIVERSITA DEGLI STUDI DI PARMA  
PHYSIOLOGY OF CENTRAL VISUAL PATHWAYS  
BROWN R V SALA
- BALUNIN M A  
SENSORY SYSTEMS LAB  
APPLICATION OF TELEMETRY TECHNIQUES TO PHYSIOLOGY  
BROWN R V SALA
- BENNETT M V L  
COLUMBIA UNIVERSITY  
ELECTROSENSORY SYSTEMS IN ELECTRIC FISH  
SAVELLY M E SALA
- BERNHARD C G  
KAROLINSKA INSTITUTE  
BIOPHYSICAL AND ELECTROPHYSIOLOGICAL STUDIES OF SENSORY MECHANISMS  
BROWN R V SALA
- BROOKS V B  
NEW YORK MEDICAL COLLEGE  
INPUT-OUTPUT RELATIONS OF SENSORIMOTOR CENTER  
BROWN R V SALA
- BULOCK T H  
UNIVERSITY OF CALIFORNIA  
BIOLOGICAL SENSORS OF ELECTRICITY  
BROWN R V SALA
- CARLSSON A  
GÖTEBORGS UNIVERSITET  
METABOLISM OF BIOLOGICALLY ACTIVE AMINES  
BROWN R V SALA
- CURTIAN R R  
UNIVERSIDADE DE SAO PAULO  
ROLE OF VARIOUS BRAIN STRUCTURES ON PHYSIOLOGICAL FUNCTION  
BROWN R V SALA
- DAHL E  
LUND UNIVERSITY  
LOCALIZATION OF DOPAMINE AND 5-HYDROXYTRYPTAMINE IN NERVOUS TISSUE  
BROWN R V SALA
- DE ADELINA A F  
INSTITUTO CAJAL  
NEURONAL PATTERNS ASSOCIATED WITH AFFECTIVE RESPONSES  
BROWN R V SALA
- ELUL R  
UNIVERSITY OF LONDON  
SYNAPTIC TRANSMISSION AS RELATED TO SURFACE CHEMISTRY  
SAVELLY M E SALA
- ESTABRO C  
INSTITUTO DE INVESTIGACION DE CIENCIAS BIOLÓGICAS  
NEURON REGENERATION AND NEUROPHYSIOLOGY  
BROWN R V SALA
- FESTARD A C  
MONTREAL ET BIOLOGIA  
NERVOUS PROCESSES UNDERLYING BEHAVIOR AND LEARNING  
BROWN R V SALA
- FORTIER C  
LAVEL UNIVERSITY  
NEUROHORMONAL CONTROL OF THYROTROPIC ACTIVITY  
BROWN R V SALA

LIFE SCIENCES

6.11 PHYSIOLOGY

FRONZ S UNIVERSIDAD DE CHILE FORM AND FUNCTION INVARIANTS IN THE VISUAL SYSTEM SAVELY H E	SALA	MONAHAN O C CLARK UNIVERSITY ODOR-INDUCED ACTIVITY IN THE OLFACTORY SYSTEM BROWN R V	SALA
GOLDSTEIN H H JOHNS HOPKINS UNIVERSITY PERIPHERAL CODING OF ACOUSTIC STIMULI BROWN R V	SALA	NEWCASTLE V B JOHNS HOPKINS UNIVERSITY STATISTICS OF CNS NEURON ACTIVITY FULLER C E	SALA
MAGUIWARI S UNIVERSITY OF CALIFORNIA MICROPHYSIOLOGICAL STUDIES OF NERVE AND MUSCLE UNITS FULLER C E	SALA	PERL E B UNIVERSITY OF UTAH PERIODICITY IN THE AUTONOMIC DISCHARGE BROWN R V	SALA
MARKER J E CAMBRIDGE UNIVERSITY BIOLOGICAL CLOCKS AND THEIR INTERACTIONS IN INSECTS BROWN R V	SALA	PETRE-GLADENS O BOHRN HOMER FOUNDATION DEVELOPMENT OF SLEEP PATTERNS IN THE YOUNG BROWN R V	SALA
MUNG S K YONSEI UNIVERSITY METABOLIC ADAPTATION TO COLD SAVELY H E	SALA	PICKFORD R UNIVERSITY OF EDINBURGH SMOOTH MUSCLE RESPONSES AS ALTERED BY MUNDANE BACKGROUND BROWN R V	SALA
MURER F COLOGNE UNIVERSITY NEW SPECIES FOR STUDIES IN COMPARATIVE NEUROPHYSIOLOGY BROWN R V	SALA	PITRODINI P INSTITUTE OF OCCUPATIONAL HEALTH MATHEMATICAL AND ELECTRICAL ANALOGUES OF HEAT TRANSFER IN MAN BROWN R V	SALA
MYDEN H GUTENBERG UNIVERSITÄT INTRACELLULAR MECHANISMS FOR INFORMATION STORAGE BROWN R V	SALA	PITTERDORF C S PRINCETON UNIVERSITY PHYSIOLOGICAL STRESS IN RELATION TO IMMATE DAILY RHYTHMS NERVOUS CONTROL OF CIRCADIAN RHYTHMS BROWN R V	SALA
JOUVET R UNIVERSITE DE LYON NEUROPHYSIOLOGICAL MECHANISMS IN CONDITIONING AND LEARNING BROWN R V	SALA	PRINGLE J B S DUPOND UNIVERSITY OSCILLATORY CONTRACTILE MECHANISM OF INSECT FLIGHT MUSCLE SAVELY H E	SALA
KATSUKI Y TOKYO MEDICAL AND DENTAL UNIVERSITY NEURAL MECHANISMS IN HEARING AND PACEMAKER NEURONS BROWN R V	SALA	PROCTOR L D EDSEL B FORD INSTITUTE FOR RESEARCH DYNAMICS OF RETICULAR AND LIMBIC POST-STIMULUS DISCHARGE BROWN R V	SALA
KENNEDY D STANFORD UNIVERSITY PHYSIOLOGY OF CRUSTACEAN INTERNEURONS BROWN R V	SALA	REICHMANN V MAX PLANCK INSTITUT FÜR BIOLOGIE INFORMATION PROCESSES IN BIOLOGICAL SYSTEMS BROWN R V	SALA
LETTVIN J Y MASSACHUSETTS INSTITUTE OF TECHNOLOGY ELECTROPHYSIOLOGICAL CORRELATES OF VISION BROWN R V	SALA	ROSSI G F UNIVERSITA DEGLI STUDI DI GENOVA RELATION BETWEEN THE BRAIN STEM AND ELECTROCORTICAL ACTIVITY FULLER C E	SALA
LETTVIN J Y MASSACHUSETTS INSTITUTE OF TECHNOLOGY VISUAL INFORMATION IN THE SUPERIOR COLLICULUS BROWN R V	SALA	ROSWELL G M F MANHATTAN UNIVERSITY COLLEGE NEURAL CONTROL SYSTEMS OF INVERTEBRATES FULLER C E	SALA
LICKER R D STATE UNIVERSITY OF NEW YORK VISUAL SYSTEM ANALYSIS BROWN R V	SALA	SATO M KUMAMOTO UNIVERSITY NEURAL ORGANIZATION OF SENSORY INFORMATION FOR TASTE LOWENTHAL J R	SALA
LILLY J C COMMUNICATION RESEARCH INSTITUTE COMMUNICATIONS STUDIES ON TURSIGUS TRUNCATUS AND OTHER DELPHINIDS BROWN R V	SALA	SEHENIA E UNIVERSITÄT ZÜRICH SUGAR AND PEPTIDE INTESTINAL DIGESTION AND ABSORPTION BROWN R V	SALA
LILLO J V CATHOLIC UNIVERSITY OF CHILE STUDIES IN SYNAPTIC MECHANISMS BROWN R V	SALA	SHARE L WESTERN RESERVE UNIVERSITY CONTROL OF BLOOD FLOW OF VASOPRESSIN BROWN R V	SALA
MARAZZI A S UNIVERSITY OF MINNESOTA CHEMICAL CHANGES IN LEARNING BROWN R V	SALA	SPYROPOLOUS C S UNIVERSITY OF CHICAGO TRANSPORTATION PHENOMENA IN ACHAL NEURONES SAVELY H E	SALA
NEEMAN J P UNIVERSITY OF SOUTHERN CALIFORNIA THE ROLE OF VAGUS NERVE AFFERENTS IN CIRCULATION CONTROL BROWN R V	SALA	STEVENS J C JOHN B PIERCE FOUNDATION OF CONNECTICUT PSYCHOPHYSICS OF SAIN SENSES BROWN R V	SALA
NELLO R K MASSACHUSETTS GENERAL HOSPITAL MECHANISMS OF COLOR DISCRIMINATION - A BEHAVIORAL ANALYSIS BROWN R V	SALA	STREIBERER P CALIFORNIA INSTITUTE OF TECHNOLOGY LEARNING IN NEURONS BROWN R V	SALA
NEMANER H UNIVERSITY OF TEXAS CARDIAC RESPONSES BEFORE, DURING AND AFTER HIBERNATION BROWN R V	SALA	TARAJI S F GUJARAT UNIVERSITY NEUROPHYSIOLOGICAL STUDIES ON THE OLFACTORY RECEPTIVE MECHANISM BROWN R V	SALA
NIDDLERSON S UNIVERSIDAD DE CHILE CORTICO-HYPOTHALAMIC INTERACTIONS BROWN R V	SALA	TARAJI S F GUJARAT UNIVERSITY NEUROPHYSIOLOGICAL STUDIES ON THE OLFACTORY RECEPTIVE MECHANISM SAVELY H E	SALA
NORLIZZI G UNIVERSITA DEGLI STUDI DI PISA COMPARATIVE NEUROPHYSIOLOGY OF VISION SPORN I V	SALA	TERZAGHI C A UNIVERSITY OF MINNESOTA SYSTEMS ANALYSIS OF SENSORY AND MOTOR SYSTEMS SAVELY H E	SALA
		TEINBERGER D DUPOND UNIVERSITY BRAIN STEM STIMULATION AND ETHOLOGICAL STUDIES IN BIRDS BROWN R V	SALA

**LIFE SCIENCES**

**5.7.1 PHYSIOLOGY**

YONITA T  
ARIZONA UNIVERSITY  
COMPARATIVE STUDY OF THE VERTEBRATE ELECTROLYTIC PROGRAM  
BROWN R V  
SALA

VON EULER L S  
KARDOLINSKA INSTITUTE  
DISTRIBUTION OF BIOLOGICALLY ACTIVE COMPOUNDS IN THE BODY  
BROWN R V  
SRLA

WATERMAN T M  
YALE UNIVERSITY  
RETINAL FIBER STRUCTURE AND VISUAL ORIENTATION  
SAVELY H E  
SRLA

WELCH B L  
UNIVERSITY OF TENNESSEE  
NEUROENDOCRINE ADAPTATION  
BROWN R V  
SRLA

WERNER G  
UNIVERSITY OF PITTSBURGH  
VESTIBULAR FUNCTION AND SPATIAL ORIENT ATION  
BROWN R V  
SRLA

WILSON O H  
UNIVERSITY OF CALIFORNIA  
NERVOUS COORDINATION OF ANIMAL LOCOMOTION  
FULLER C E  
SRLA

YOUNG J Z  
UNIVERSITY COLLEGE  
ANATOMICAL LOCALIZATION OF TARGET LEARNING AND MEMORY  
SAVELY H E  
SALA

ZAMBETTI A  
UNIVERSITA DEGLI STUDI DI MILANO  
BRAIN STEM SYSTEMS AND BEHAVIOR  
BROWN R V  
SRLA

**5.7.2 PHARMACOLOGY**

HILTON J G  
UNIVERSITY OF TEXAS  
POSTGANGLIONIC CHOLINERGIC MEDIATION OF SYMPATHETIC NERVES  
BROWN R V  
SRLA

MURWITZ J  
UNIVERSIDAD DE CHILE  
EPIDEMIOLOGICAL STUDIES ON NEUROPSYCHIATRIC DISORDERS  
BROWN R V  
SRLA

KALSER S C  
UNIVERSITY OF PITTSBURGH  
ATROPINE DETOXICATION DURING HYPOXEMIA BY THE ISOLATED PERFUSED RAT LIVER  
BROWN R V  
SRLA

LEVINE R R  
BOSTON UNIVERSITY  
LYMPHATIC ABSORPTION OF DRUGS  
BROWN R V  
SRLA

MARANZO P  
UNIVERSIDAD CENTRAL DEL ECUADOR  
PSYCHOTROPIC PLANTS OF ECUADOR  
BROWN R V  
SRLA

ROCHA-T-SILVA H  
UNIVERSIDADE DE SAO PAULO  
III INTERNATIONAL PHARMACOLOGICAL CONGRESS  
FULLER C E  
SRLA

**6.0.0 SOCIAL SCIENCES**

**6.2.0 ECONOMICS**

SPENCER D L  
MICHIGAN UNIVERSITY  
TRANSFER OF TECHNOLOGY UNDER MILITARY AND RELATED CONDITIONS, JAPAN AND OTHER COUNTRIES  
MUTCHINSON C E  
SRLB

**6.3.1 LEARNING PROCESSES**

ADAMSON R E  
FLORIDA ATLANTIC UNIVERSITY  
A MODEL FOR STIMULUS RELEVANCE  
FINCH G  
SRLB

ATTNEAVE F  
UNIVERSITY OF OREGON  
ELEMENTARY PROCESSES IN PATTERN PERCEPTION  
FINCH G  
SRLB

DE LOUVO V  
UNIVERSITY OF WESTERN AUSTRALIA  
A SYSTEMATIC INVESTIGATION OF CONTRAST EFFECTS RELATED TO VIGILANCE TASKS  
FINCH G  
SRLB

EDWARDS M  
UNIVERSITY OF MICHIGAN  
RESEARCH ON INTERFERENCE INVOLVING COMPOUND AND SIMPLE HYPOTHESES  
FINCH G  
SRLB

HUBLE C E  
UNIVERSITY OF GEORGIA  
HUMAN SELECTIVE LEARNING  
GCEBEL L G  
SRLB

ROBINSON J A  
UNIVERSITY OF LOUISVILLE  
TRANSFORMATION PROCESSES IN MEMORY  
GCEBEL L G  
SRLB

**6.5.0 SOCIOLOGY**

BIERMAN A D  
BUREAU OF SOCIAL SCIENCE RESEARCH FAC  
AEROSPACE POWER AND BEHAVIORAL KNOWLEDGE  
SANDER H J  
SRLB

BOWERS R V  
UNIVERSITY OF ARIZONA  
IMPACT OF TECHNOLOGICAL CHANGE ON PROFESSIONAL CAREERS IN MILITARY AND CIVILIAN ORGANIZATIONS  
SANDER H J  
SRLB

DAY R C  
WASHINGTON STATE UNIVERSITY  
EFFECTS OF SUPPORTIVE, CISCSE AND PUNITIVE STYLES OF SUPERVISION  
GCEBEL L G  
SRLB

EISENSTADT S M  
HEBREW UNIVERSITY  
INNOVATION, SOCIAL EXCHANGE AND INSTITUTIONALIZATION  
SANDER H J  
SRLB

FRENCH R L  
TUFTS UNIVERSITY  
INNOVATION IN TASK ORIENTED COMMUNICATION  
FINCH G  
SRLB

GARFINKEL H  
UNIVERSITY OF CALIFORNIA  
DECISION MAKING IN SITUATIONS OF PRACTICAL ACTION  
MUTCHINSON C E  
SRLB

HAYS J E  
OHIO STATE UNIVERSITY  
SIMULATION STUDIES OF ORGANIZATIONAL BEHAVIOR UNDER STRESS  
SANDER H J  
SRLB

HILL R J  
PURDUE UNIVERSITY  
A STUDY IN SOCIAL SCIENCE DECISION MAKING  
SANDER H J  
SRLB

KELLEY H H  
UNIVERSITY OF CALIFORNIA  
PERSUASIVE COMMUNICATION IN FUNCTIONAL ORGANIZATIONS  
GCEBEL L G  
SRLB

RAMO F C  
UNIVERSITY OF MICHIGAN  
LEADERSHIP, ORGANIZATIONAL EFFECTIVENESS, AND HUMAN RESOURCES  
GCEBEL L G  
SRLB

MC GRATH J E  
UNIVERSITY OF ILLINOIS  
SOCIAL PSYCHOLOGICAL ASPECTS OF STRESS  
SANDER H J  
SRLB

ROSE B R/ROSE S C  
SYSTEM DEVELOPMENT CORP  
EXECUTIVE DECISION MAKING IN ORGANIZATIONS UNDER STRESS AND CRISIS  
SANDER H J  
SRLB

VOLLMER H H  
STANFORD RESEARCH INSTITUTE  
CRITERIA FOR THE DESIGN OF NEW FORMS OF ORGANIZATION  
SANDER H J  
SRLB

WOODHOUSE C E/ LYNCH P D  
UNIVERSITY OF NEW MEXICO  
INFLUENCE OF CAMPUS ENVIRONMENT ON STUDENT COMMITMENT TO THE USAF ROTC  
MUTCHINSON C E  
SRLB

**6.6.0 SOCIAL PSYCHOLOGY**

BARTOS O J  
UNIVERSITY OF HAWAII  
PREDICTIVE MODEL FOR INTRA-GROUP NEGOTIATION  
SANDER H J  
SRLB



LIFE SCIENCES

6.6.6 SOCIAL PSYCHOLOGY

COOK S W  
UNIVERSITY OF COLORADO  
MEASUREMENTS OF ANXIETY AND ATTITUDE CHANGE  
GEBEL L G SALB

MCNEEL W C  
OHIO STATE UNIVERSITY  
AN ANALYSIS OF GROUP FEEDBACK EFFECTS  
GEBEL L G SALB

LANZETTA J T  
YARVOUTH COLLEGE  
STUDIES OF UNCERTAINTY, INFORMATION SEARCH AND DECISION-MAKING  
FINCH G SALB

MC GRATH J E  
UNIVERSITY OF ILLINOIS  
NEGOTIATION AND DECISION-MAKING IN COMPLEX ORGANIZATIONS  
SANDER M J SALB

MEIER D L  
WASHINGTON UNIVERSITY  
SIMULATION OF COMMUNICATION AND INTERACTION  
SANDER M J SALB

MULDER H  
STATE UNIVERSITY OF UTRECHT  
EXPECTATIONS OF MOTIVATIONS RELATED TO POWER DIFFERENCES  
WITHIN GROUPS  
GEBEL L G SALB

TAJFEL H  
OXFORD UNIVERSITY  
STUDY OF COGNITIVE AND AFFECTIVE ATTITUDES  
SANDER M J SALB

WILLIAMS R W  
CORNELL UNIVERSITY  
AN EXPERIMENTAL STUDY OF THE DEVELOPMENT OF CONSENSUS  
SANDER M J SALB

ZANDER A F  
UNIVERSITY OF MICHIGAN  
DESIRE FOR GROUP ACHIEVEMENT ORIGINS AND EFFECTS  
GEBEL L G SALB

6.7.0 PSYCHOPHYSIOLOGY

BARCH N B  
HOUSTON STATE PSYCHIATRIC INSTITUTE  
PSYCHOPHYSIOLOGICAL CORRELATES OF HUMAN INFORMATION PROCESSING  
SANDER M J SALB

DAILEY J T  
GEORGE WASHINGTON UNIVERSITY  
ANALYSIS OF EXPERIMENTS IN LIFE SCIENCES  
SANDER M J SALB

ERMAN G  
STOCKHOLMS UNIVERSITET  
PSYCHOPHYSICAL RELATIONS IN PERCEPTION OF SPACE, TIME AND VELOCITY  
FINCH G SALB

PROFFER S J  
TUFTS UNIVERSITY  
MOVEMENT AND PERCEPTUAL MOTOR PERFORMANCE DURING ATYPICAL INPUT  
CONDITIONS  
FINCH G SALB

WILGAMM B B  
STANFORD UNIVERSITY  
STUDIES IN THE PARAMETERS OF HYPNOSIS  
FINCH G SALB

JERISON M J  
ANTIOCH COLLEGE  
COMPARATIVE STUDIES OF ANXIANCE  
AGARSEN R T SALB

RUGELMASS S  
HEBREW UNIVERSITY  
MEASUREMENT OF REACTIONS TO STRESS  
FINCH G SALB

LOGAN F A  
UNIVERSITY OF NEW MEXICO  
OPERATIONAL ANALYSIS OF THE LAWS OF LEARNING  
FINCH G SALB

MULTERMAN J M  
PRINCETON UNIVERSITY  
PERCEPTION OF TIME-VARYING STIMULUS MAGNITUDES  
FINCH G SALB

ONE A T  
UNIVERSITY OF PENNSYLVANIA HOSPITAL  
RELATIONSHIPS BETWEEN SLEEP AND HYPNOSIS  
SANDER M J SALB

TAUB Z  
JEWISH CHRONIC DISEASE HOSPITAL  
MOVEMENT AND LEARNING FOLLOWING DEAFFERENTIATION IN MONKEYS  
FINCH G SALB

VERPLANK N S  
UNIVERSITY OF TENNESSEE  
OPERATIONAL ANALYSIS OF BEHAVIORAL SITUATIONS  
FINCH G SALB

6.8.1 ENGINEERING PSYCHOLOGY

GREGORY R L  
CAMBRIDGE UNIVERSITY  
VISUAL PERCEPTION OF MOVEMENT  
FINCH G SALB

6.8.2 PSYCHOMETRICS

MORONITZ H  
WAKE FOREST COLLEGE  
DECISIONS AND DECISION-MAKERS/ THE EFFECTS OF CONFIDENCE, SOCIAL  
RISK AND COMMITMENT  
GEBEL L G SALB

## *Engineering Sciences*

DR. MILTON M. SLAWSKY, Director

The directorate of engineering sciences selects and supports phenomena-oriented research the Air Force needs (1) to reduce the level of empiricism in the development of both hardware and software, (2) to extend the understanding of the behavior of simple physical systems to more complex physical systems, and (3) to discover or to create new principles and concepts to be used as building blocks for developing generic solutions to engineering problems.

The directorate consists of three divisions, electronics, mechanics, and propulsion.

Research in electronics is carried out under the joint services electronics program (JSEP), under which 11 universities receive Army-Navy-Air Force support, and under the smaller electronics program which serves as a catalyst for aspects of JSEP. Included here are information, communications and electronic engineering sciences, in response to mission requirements of better sensing, transmitting, ranging, receiving, processing, information display, and controlling of related equipment.

Studies are conducted in systems in which the individual electrons and photons play the dominant role, including basic physics studies such as the measurement of critical opalescence with laser beams as a test of theories of phase transitions, the extent of the equality of electron and proton charge, relation between inverse Faraday effect and Raman scattering, and determination of plasma instabilities from the computer analysis of particle trajectories. Other areas are electromagnetics, quantum electronics, electro-optics, electro-acoustics, solid state electronics, and electro-dynamics.

Environmental electronics involves theoretical and experimental investigations of phenomena associated with the earth, atmosphere, ionosphere, and outer space. Research topics include an experimental determination of the constancy of the Newtonian gravitational constant, an experimental test of the Freundlich cosmological red-shift hy-

pothesis, and an experimental test of Einstein's curved-space interpretation of gravity.

Two topics in bioelectronics are electromechanical simulation of biological processes to improve the biological specimen's capabilities, and analog analysis of biological subjects to enhance electronics design. Interest in and the importance of bioelectronics is steadily increasing.

Communication sciences studied under this program include system theory, information theory, control and feedback problems, network and circuit considerations, pattern recognition, artificial intelligence, data processing, linguistics, and threshold logic. The common trait of these fields is that they may be treated as a study of the correspondence between two sets of data. In this scheme inputs and outputs from an unknown network might be the data sets so that the notion is quite general. Communication science, within this framework, focusses on the general properties of the correspondence and the attendant transfer functions.

The mechanics division is mainly concerned with the motion of a body through a medium, and the laws relating this motion to causes and effects. One such area of study is the external and internal flow phenomena involved in the design of advanced low- and high-speed aircraft missiles and space vehicles. These studies are directed toward providing a more thorough understanding of the mechanics of continuum fluid motion. Included are the effects of temperature, viscosity, pressure gradients, compressibility, entropy, and gravity on the fluid motion. One goal of this research is better understanding of hypersonic flow phenomena associated with slotted wings for potential hypersonic high lift-drag ratio wings.

A second major focus of the mechanics division is boundary layer research. This concerns the layer of fluid or gas adjacent to a body moving through a medium, and may be thought of as laminar or turbulent. Solutions to laminar flow can be obtained for some conditions by usually straightforward conservation equations. In turbulent flow, the number of variables outnumbers the equations now available. Other areas of interest are the stability of the boundary layer and the time-depend-

ent displacement of the external flow by the boundary layer in hypersonic flow.

When the motion and the structure of the fluid interact, the problems become those of aerophysics. In this area AFOSR has played an important role in stimulating and supporting much of the understanding underlying hypersonic flight, for example, and has provided the bulk of the support at times in aerophysics. Aerophysics is the study of the mechanisms of vibrational and rotational relaxation, of dissociation and ionization, of radiation of energy, and a determination of the relevant relaxation times. These effects bear on observable properties of fluid flow, such as shock wave thickness, and are studied by both the fluid dynamicist and the physicist. Here also are found chemists and aerodynamicists using flow phenomena to identify complex and intermediate reactions, and using this knowledge to compute flows in nozzles, through shocks and around bodies.

There are important areas of fluid mechanics where the particulate structure of the fluid must be recognized in any technologically helpful theory of its behavior. The aerodynamics of flight at altitudes above 50 miles and the behavior of instruments for measuring airspeed and ambient pressure at such altitudes are examples which are important from an Air Force point of view. At such altitudes the distance traveled by molecules between collisions is comparable in size to some of the aerodynamic features of the vehicle, with the result that events on the molecular scale cause the flow to deviate significantly from the continuum behavior. For these reasons a portion of the program is comprised of research on the mechanics of intermolecular collisions, the mechanics of collisions between molecules and solid surfaces, and on the analytical techniques required for the prediction of flows dominated by these events.

Structural mechanics is concerned with the static and dynamic behavior of structural components of vehicles under varying aerothermodynamic conditions in flight. AFOSR research is providing new and improved theoretical methods of analysis of stresses, deformations, and stability of structures. Also of interest are problems in the areas of dynamic stability, vibrations of structures, the effect of random vibrations, aeroelasticity, wave propagation, and fatigue. Great advantages are to be gained particularly from better understanding of the fatigue mechanism leading to improved designs or improved nondestructive means

for detection and measurement of the progress of fatigue damage in metals. The program also considers the mechanical response of structural materials to environmental conditions and includes the fundamental understanding of materials derived from subjecting them to low pressure, high-speed impact, temperature extremes, different gaseous environments, and triaxial stress under high pressure.

The propulsion division supports research in the detailed mechanisms, physical and chemical processes of release, transformation and transport of energy. Included are the interrelated effects of combustion fluid dynamics, magnetohydrodynamics and heat transfer phenomena in gas, liquid, and solid and hybrid systems. Research efforts in this program have a direct relation to air-breathing, liquid, solid, and hybrid rocket combustion, and magnetoplasma dynamics related to release of energy by nuclear fusion, generators of electric power and mechanical thrust.

AFOSR has also provided important portions of the research in the area of supersonic combustion, both detonative and diffusional, rocket combustion instability phenomena, plasma acceleration, magnetoplasma dynamic power generation, and in high temperature plasma behavior.

Fundamental studies are selected for the exploration of molecular and atomic sources of energy so as to provide new information leading to increased Air Force capability in chemical propulsion. Investigations of thermophysical properties provide precise data on the structure, spectra, thermodynamic, and transport properties of selected molecules that form the reactants or combustion products of present and future chemical propellants. Chemical kinetics concerns the rates and mechanisms of reactions involving light energetic molecules, to understand processes taking place in the combustion of chemical rocket propellants.

About 40 percent of the propulsion division program is devoted to research on problems associated with interaction of plasmas with electromagnetic fields. The program is oriented toward generic phenomena found in efforts to build a sound basis for exploratory development of controlled thermonuclear reactors, MHD electric power generators, and plasma accelerators. This research area is divided for administrative purposes into high temperature plasmas; low temperature, low density

plasmas; and high density partially ionized plasmas. The general problems that occur in almost every case are related to the description and understanding of instabilities, conductivity, collision probabilities, charge exchange, and other physical properties. In addition to this, research is being conducted on the parameters describing laminar and turbulent flow of plasmas.

This research program is designed to cover the most important problems in magnetoplasmadynamics.

Research concerned with the thermodynamic properties of chemical species is important for solid rocket propulsion and is studied from both a theoretical and experimental viewpoint. Combustion dynamics of solids involves the studies of the complex processes taking place in the combustion of solid propellants, the understanding of which is essential for rational approaches to propellant formulation and rocket design. One of the particular approaches most studied under this project is that of acoustic, or resonant instability.

## ENGINEERING SCIENCES

### B.O.O ENGINEERING SCIENCES

KELLY M C  
NATIONAL ACADEMY OF SCIENCES  
THE AFOSR POSTDOCTORAL RESEARCH PROGRAM  
ARM D L

SREP

JEN M C  
NEW YORK UNIVERSITY  
NON-LINEAR INTERACTIONS OF PLASMA TURBULENCE  
SAMARAS D G

SREP

### B.1.0 ENERGY CONVERSION

#### B.1.1 MAGNETOPLASMA DYNAMICS

BUSTICH M H  
STEVENS INSTITUTE OF TECHNOLOGY  
MECHANISM AND DYNAMICS OF COAXIAL PLASMA ACCELERATION  
SAMARAS D G

SREP

HEBERBRACK J L  
MASSACHUSETTS INSTITUTE OF TECHNOLOGY  
CONDUCTION IN IONIZED GAS-SURFACE INTERACTIONS  
SAMARAS D G

SREP

CAMBL A B  
NORTHWESTERN UNIVERSITY  
THERMOPHYSICAL PROPERTIES OF PLASMAS  
LANGLEIS R G

SREP

LESSEN M / LUBIN M  
UNIVERSITY OF ROCHESTER  
MHD SHOCK WAVES IN COLD-DISSIPATIVE 2 FLUID PLASMA  
LANGLEIS R G

SREP

CAP F  
INNSBRUCK UNIVERSITY  
PLASMA INSTABILITIES  
LA GLEIS R G

SREP

LUCE J  
AEROSPACE GENERAL NUCLEONICS  
HIGH TEMPERATURE PLASMA RESEARCH  
LANGLEIS R G

SREP

COLIN P E  
VON KARMAN INSTITUTE FOR FLUID DYNAMICS  
EXPERIMENTAL AERODYNAMICS  
LANGLEIS R G

SREP

WARDLE F E  
CALIFORNIA INSTITUTE OF TECHNOLOGY  
GROWTH OF BOUNDARY LAYERS IN PLASMA ACCELERATORS  
SAMARAS D G

SREP

DATLEY C L  
TRM INCORPORATED  
PROPERTIES OF ACCELERATED PLASMAS  
SAMARAS D G

SREP

MC MER M D  
SPERRY RAND RESEARCH CENTER  
CONFINEMENT OF SIMULATED HOT PLASMAS  
SAMARAS D G

SREP

DEMETRIADES S T  
STD RESEARCH CORP  
COLLISION CROSS SECTIONS FOR MOMENTUM TRANSFER IN PLASMAS  
LANGLEIS R G

SREP

MEASURES R M  
UNIVERSITY OF TORONTO  
INVESTIGATION OF HALL-CURRENT ACCELERATION  
LANGLEIS R G

SREP

DEGATE A C  
GIAMINI SCIENTIFIC CORP  
LOSSES IN PLASMA ACCELERATION  
SAMARAS D G

SREP

PATRICK R M  
AVCO CORP  
PROPERTIES OF COLLISIONLESS PLASMAS  
LANGLEIS R G

SREP

DIMM H / LUBIN M J  
UNIVERSITY OF ROCHESTER  
MHD SHOCK WAVES IN LASER PRODUCED PLASMAS  
LANGLEIS R G

SREP

POOL M L  
OHIO STATE UNIVERSITY  
RESEARCH ON ROTATING R-F FIELD PLASMA  
SAMARAS D G

SREP

EUSTIS R  
STANFORD UNIVERSITY  
BOUNDARY PHENOMENA IN EQUILIBRIUM MHD GENERATORS  
LANGLEIS R G

SREP

RUSKISZEMSKI J J  
GENERAL DYNAMICS CORP  
IGNITING FACTORS IN PLASMA ACCELERATORS  
AND GENERATORS  
SAMARAS D G

SREP

FAM L  
KANSAS STATE UNIVERSITY  
HEAT TRANSFER TO A MHD FLUID FLOW  
SAMARAS D G

SREP

SELLEN J N  
TRM INCORPORATED  
INTERACTION OF PLASMA STREAMS WITH MAGNETIC FIELDS  
SAMARAS D G

SREP

FELNER T M  
GENERAL DYNAMICS CORP  
NON-LINEAR THEORY OF PLASMA DYNAMICS  
LANGLEIS R G

SREP

SHERMAN A  
GENERAL ELECTRIC CO  
FLOWING MHD SYSTEMS AND NON-EQUILIBRIUM IONIZATION  
LANGLEIS R G

SREP

GEFFEN M  
TECHNION RESEARCH AND DEVELOPMENT FOUNDATION LTD  
MAGNETIC HYPERCRITICAL FLOW WITH SHOCKS  
LANGLEIS R G

SREP

HELLS D R  
UNIVERSITY OF MIAMI  
INJECTION AND TRAPPING OF PLASMA VORTEX STRUCTURES  
LANGLEIS R G

SREP

GLOERSEN P  
GENERAL ELECTRIC CO  
DENSITY PROFILE MEASUREMENTS  
SAMARAS D G

SREP

#### B.1.2 COMBUSTION DYNAMICS

GROSS R A  
COLUMBIA UNIVERSITY  
HYDROMAGNETIC PLASMA RESEARCH  
LANGLEIS R G

SREP

ANDRADE C A  
MARTIN CO  
COMBUSTION CHEMISTRY OF HIGH ENERGY FIELDS  
WOLFSON B T

SREP

GUDERJAHN K A  
NORTH AMERICAN AVIATION INC  
ELECTRODELESS DISCHARGES IN MOVING GAS MIXTURES  
SAMARAS D G

SREP

BASYREK K  
ARTHUR D LITTLE INC  
SOLID PROPELLANT IGNITION STUDIES  
WOLFSON B T

SREP

HENWICKS C D  
UNIVERSITY OF ILLINOIS  
CHARGED COLLOIDAL SIZED PARTICLES FOR PROPULSION  
SAMARAS D G

SREP

BEACHMEL H C  
UNIVERSITY OF DELAWARE  
COMBUSTION CHARACTERISTICS OF CRYSTALLINE OXIDIZERS  
WOLFSON B T

SREP

HICKOK R L  
SOCOBY MOBIL OIL CO INC  
PLASMA PROBING USING HIGH ENERGY BEAMS  
LANGLEIS R G

SREP

BONDEN F P  
CAMBRIDGE UNIVERSITY  
GROWTH OF BURNING TO DETONATION IN LIQUIDS AND SOLIDS  
WOLFSON B T

SREP

JAMES G S  
AVCO CORP  
PLASMA PROPULSION  
LANGLEIS R G

SREP

BRAY K N  
NORTHERN RESEARCH AND ENGINEERING CORP  
IGNITION AND SUSTAINING OF COMBUSTION BY ENERGY ADDITION IN  
TURBULENT SUPERSONIC FLOWS  
WOLFSON B T

SREP

CURDS L P  
NORTH AMERICAN AVIATION INC  
PRESSURE WAVE GROWTH IN A HOMOGENEOUS HOMOGENEOUS SPRAY  
GAS MIXTURE  
WOLFSON B T

SREP

## ENGINEERING SCIENCES

### 6.1.2 COMBUSTION DYNAMICS

COURTNEY H C  
TRIBBOL CHEMICAL CORP  
DEPOSITION OF ULTRA-SMALL COLLOID PARTICLES  
WOLFSOHN B T SREP

DA RINA E  
INSTITUTO NACIONAL DE TECNICA AEROSPACIAL  
DIFFUSION FLAMES AND SUPERSONIC COMBUSTION  
WOLFSOHN B T SREP

DAMERMAN L  
NEW YORK UNIVERSITY  
SOLID PHASE REACTIONS IN SOLID PROPELLANT IGNITION AND  
COMBUSTION WOLFSOHN B T SREP

DICKINSON L A  
STANFORD RESEARCH INSTITUTE  
RESPONSE OF BURNING PROPELLANT SURFACE TO ERODIVE TRANSIENTS  
WOLFSOHN B T SREP

DISE D  
OHIO STATE UNIV RESEARCH FOUNDATION  
COMBUSTION PHENOMENA IN SUPERSONIC COMBUSTION  
WOLFSOHN B T SREP

EVANS H W  
STANFORD RESEARCH INSTITUTE  
DETONATION CHARACTERISTICS OF LOW DENSITY GRANULAR MATERIALS  
WOLFSOHN B T SREP

FERRI A  
GENERAL APPLIED SCIENCE LABS INC  
HIGH SPEED COMBUSTION AT LOW PRESSURES  
WOLFSOHN B T SREP

GERSTEIN M  
DYNAMIC SCIENCE CORP  
COMBUSTION CHEMISTRY AND MIXING IN SUPERSONIC FLOW  
WOLFSOHN B T SREP

GLASSMAN I  
PRINCETON UNIVERSITY  
COMBUSTION PROCESSES IN LIQUID PROPELLANT ACCKET MOTORS  
WOLFSOHN B T SREP

HERNANDEZ C E  
UNIVERSITY OF WATERLOO  
FUNDAMENTAL PROCESSES IN SOLID PROPELLANT IGNITION  
WOLFSOHN B T SREP

MORTON R D  
BRIGHAM YOUNG UNIVERSITY  
EXTINCTION OF BURNING SOLID PROPELLANT BY PRESSURE DECREASES  
WOLFSOHN B T SREP

LEVY H  
VITRO LABS  
PHOTOCHEMICAL IGNITION OF LOW PRESSURE FUEL-AIR MIXTURES  
WOLFSOHN B T SREP

LEWIS B  
COMBUSTION INSTITUTE  
ELEVENTH INTERNATIONAL COMBUSTION SYMPOSIUM  
WOLFSOHN B T SREP

LEIBY P A - WELLS J F A  
UNIVERSITY OF CALIFORNIA  
TURBULENT FLOWS WITH CHEMICAL REACTIONS  
WOLFSOHN B T SREP

MC CONNACK P D  
DARTMOUTH COLLEGE  
MECHANICALLY DRIVEN COMBUSTION INSTABILITY IN LIQUID ROCKET  
MOTORS WOLFSOHN B T SREP

MC LAIN W H  
UNIVERSITY OF DENVER  
PYROLYSIS AND COMBUSTION OF METALS AND METAL HYDRIDE  
PARTICLES WOLFSOHN B T SREP

OPPENHEIM A K  
UNIVERSITY OF CALIFORNIA  
WAVE DYNAMIC STUDIES IN EXPLOSIVE GASEOUS MIXTURES  
WOLFSOHN B T SREP

RYAN H D / BAER A D  
UNIVERSITY OF UTAH  
IGNITION AND BURNING OF SOLID PROPELLANT  
WOLFSOHN B T SREP

RYAN H Y / BAER A D  
UNIVERSITY OF UTAH  
COMBUSTION IRREGULARITIES OF SOLID PROPELLANTS  
WOLFSOHN B T SREP

SAPC H A  
UNIVERSITY OF SANTA CLARA  
PRESSURE EFFECT ON IGNITION AND COMBUSTION  
WOLFSOHN B T SREP

SCHNEZ J A  
UNIVERSITY OF MARYLAND  
VAPORIZATION AND DIFFUSION OF LIQUID HYDROCARBONS IN A SUPERSONIC  
AIR STREAM WOLFSOHN B T SREP

SHANNON L J  
UNITED TECHNOLOGY CENTER  
IGNITION AND COMBUSTION MECHANISMS OF SOLID PROPELLANT SYSTEMS  
WOLFSOHN B T SREP

SHINWAR R/RATZ S  
CITY COLLEGE OF NEW YORK  
COMPLEX MIXING MODELS FOR CHEMICAL REACTION SYSTEMS  
WOLFSOHN B T SREP

STREHLER R A / BARTHEL H O  
UNIVERSITY OF ILLINOIS  
DETERMINATIVE MACH STERNS WOLFSOHN B T SREP

SUMMERFIELD W  
PRINCETON UNIVERSITY  
PROPELLANT IGNITION AND IGNITION CHARACTERISTICS  
WOLFSOHN B T SREP

SUMMERFIELD W  
PRINCETON UNIVERSITY  
RESEARCH ON SOLID PROPELLANT COMBUSTION INSTABILITY  
WOLFSOHN B T SREP

SMITHENBANK J  
UNIVERSITY OF SHEFFIELD  
FUNDAMENTAL STUDY OF SUPERSONIC COMBUSTION FOR HYPERSONIC JET  
WOLFSOHN B T SREP

TARIFA C S  
INSTITUTO NACIONAL DE TECNICA AEROSPACIAL  
COMBUSTION AND FLAME PROPAGATION IN HETEROGENEOUS SYSTEMS  
WOLFSOHN B T SREP

YOUNG T Y  
MASSACHUSETTS INSTITUTE OF TECHNOLOGY  
SHOCK-INITIATED SUPERSONIC COMBUSTION USING HIGH VELOCITY MISSILE  
TECHNIQUES WOLFSOHN B T SREP

TORRA T P  
ILLINOIS INSTITUTE OF TECHNOLOGY  
OSCILLATIONS IN ROCKET MOTOR BURNER CAVITIES  
WOLFSOHN B T SREP

WIM ELBE G  
ATLANTIC RESEARCH CORP  
DEFLAGRATION OF HIGH-ENERGY OXIDIZERS  
WOLFSOHN B T SREP

ZUCROW R J / OSBORN J R  
PURDUE UNIVERSITY  
PARAMETRIC STUDY OF ROCKET MOTOR INSTABILITY  
WOLFSOHN B T SREP

### 6.1.3 CHEMICAL KINETICS

BALDWIN R R  
UNIVERSITY OF MLLL  
KINETICS OF THE HYDROGEN-OXYGEN AND HYDROCARBON-OXYGEN REACTIONS  
DONOVAN C J SREP

BARTEY C  
ROCKET POWER INC  
ION REACTIONS IN MATRICES DONOVAN C J SREP

BOLDART P  
STANFORD UNIVERSITY  
REACTIONS BETWEEN METALS AND HYDROCARBONS  
DONOVAN C J SREP

CASES P  
UNIVERSIDAD DE CHILE  
STUDY OF CYCLOPROPANE DERIVATIVES CONTAINING FLUORINE  
DONOVAN C J SREP

DECRETS J H  
UNIVERSITY OF TORONTO  
DISTRIBUTION OF ENERGY IN ELECTRICAL DISCHARGES  
DONOVAN C J SREP

BRISQON T A  
IIT RESEARCH INSTITUTE  
CHEMICAL REACTION IN A NONTHERMAL FIELD  
DONOVAN C J SREP

FENG P  
IIT RESEARCH INSTITUTE  
ION MOLECULE REACTIONS IN FLAMES  
DONOVAN C J SREP

GORDON J S  
ASTROSYSTEMS INTERNATIONAL INC  
SPECTRA OF FLAMES AND COMBUSTION GASES  
DONOVAN C J SREP

HENRISEN R  
UNITED AIRCRAFT CORP  
COMBUSTION OF METALLIC BERYLLIUM  
DONOVAN C J SREP

LAPORTE O  
UNIVERSITY OF MICHIGAN  
PLASMAS OF MERCURY IN A PRESSURE-DRIVEN SHOCK TUBE  
DONOVAN C J SREP

LEIDENFROST W  
PURDUE RESEARCH FOUNDATION  
PRECISE DETERMINATIONS OF PROPERTIES OF FLUIDS  
DONOVAN C J SREP

## ENGINEERING SCIENCES

### 8.1.3 CHEMICAL KINETICS

LEVY J B ATLANTIC RESEARCH CORP HYDROGEN-FLUORINE REACTION DONOVAN C J	SREP	FINSTON M MASSACHUSETTS INSTITUTE OF TECHNOLOGY MARE STUDIES USING MAGNETIC SUSPENSION STALK G	SREN
NATLA R R UNIVERSITY OF MICHIGAN COMBUSTION KINETICS OF TETRAFLUOROETHYLENE DONOVAN C J	SREP	GREGORY P C MARTIN CO STABILITY OF SUBMERGED JETS STALK G	SREN
PETERSON E E UNIVERSITY OF CALIFORNIA DECOMPOSITION KINETICS OF AMMONIUM PERCHLORATE DONOVAN C J	SREP	HALL J G CORNELL AERONAUTICAL LABORATORY INC NON-EQUILIBRIUM EFFECTS IN SUPERSONIC FLOWS ROGERS R	SREN
ROBERTSON H M UNIVERSITY OF TEXAS PHYSICS OF METASTABLE SYSTEMS DONOVAN C J	SREP	JONES R T AYCO CORP HYDRODYNAMIC EFFECTS ON CLOTTING STALK G	SREN
ROSHER D E AEROSOL RESEARCH LABS INC INTERFACIAL RATE PROCESSES IN FLOW SYSTEMS DONOVAN C J	SREP	LIEPMANN H W CALIFORNIA INSTITUTE OF TECHNOLOGY ROTATIONAL FLOW OF FLUIDS STALK G	SREN
ROSHER D E AEROSOL RESEARCH LABS INC OXIDATION OF METALS BY PARTIALLY DISSOCIATED GASSES DONOVAN C J	SREP	LIMLEY J L PENNSYLVANIA STATE UNIVERSITY MATHEMATICAL FOUNDATIONS OF TURBULENCE THEORY STALK G	SREN
ROTHE E W GENERAL DYNAMICS CORP INTERMOLECULAR POTENTIAL ENERGIES BY A MOLECULAR BEAM SCATTERING METHOD DONOVAN C J	SREP	MALMUTH B NORTH AMERICAN AVIATION INC SURFACE DISTORTION EFFECTS ON HYPERSONIC FLOW FIELDS STALK G	SREN
SANTER R P UNIVERSITY OF CALIFORNIA NON-EQUILIBRIUM COMBUSTION PRODUCTS DONOVAN C J	SREP	MARTINEZ E GIANNINI CONTROLS CORP INTERNAL AERODYNAMICS OF SENSITIVE PLANS STALK G	SREN
SCHMIDT H J CONSEJO NACIONAL DE INVESTIGACIONES CIENTIFICAS Y TECNICAS KINETICS AND MECHANISM OF REACTION AND FLUORINE CHEMICALS DONOVAN C J	SREP	MAZELSKY B AEROSPALS RESEARCH ASSOCIATES INC LIFT DRAG RATIO STUDIES OF BLUNT DELTA WINGS AT HYPERSONIC VELOCITIES STALK G	SREN
SIMONS R F VICTORIA UNIVERSITY OF MANCHESTER INHIBITION OF THE THERMAL REACTION BETWEEN HYDROGEN AND OXYGEN DONOVAN C J	SREP	NILLO-CHRISTENSEN E MASSACHUSETTS INSTITUTE OF TECHNOLOGY TURBULENT THERMAL CONVECTION STALK G	SREN
SKINNER H A VICTORIA UNIVERSITY OF MANCHESTER HIGH TEMPERATURE REACTION CALORIMETRY DONOVAN C J	SREP	NAPOLITANO L G UNIVERSITA DEGLI STUDI DI NAPLES NON-EQUILIBRIUM TRANSONIC FLOWS ROGERS R	SREN
SMITH J N GENERAL DYNAMICS CORP CHEMICAL REACTIONS USING MODULATED ATOMIC BEAM TECHNIQUES DONOVAN C J	SREP	OG BATH S CALIFORNIA INSTITUTE OF TECHNOLOGY EFFECT OF BODY FORCES ON THE MOTION AND HEAT TRANSFER OF COMBUSTING FLUIDS STALK G	SREN
SOKOLON I J FIT RESEARCH INSTITUTE ADVANCED OXIDIZER CHEMISTRY DONOVAN C J	SREP	RESLER E L/BAUER S M CORNELL UNIVERSITY KINETICS OF CHEMICAL REACTIONS IN SHOCK TUBES ROGERS R	SREN
VAN TIGGELEN A UNIVERSITE CATHOLIQUE DE LOUVAIN EXPERIMENTAL AND THEORETICAL STUDY OF COMBUSTION DONOVAN C J	SREP	ROTHEILD F POLYTECHNIC INSTITUTE OF BROOKLYN RESEARCH EVALUATION SERVICES STALK G	SREN

### 8.2.8 MECHANICS OF FLUIDS

#### 8.2.1 FLUID DYNAMICS /CONTINUUM/

BLACK H D/NERODE A CORNELL UNIVERSITY AUTOMATA AND THEIR APPLICATION TO ENGINEERING SYSTEMS ROGERS R	SREN	SACKS A M ITER CORP DYNAMICS OF NON-NEWTONIAN FLUIDS NEAR COMPLIANT SURFACES STALK G	SREN
BLOOM H M / CRESCI B J POLYTECHNIC INSTITUTE OF BROOKLYN HYPERSONIC FLOWS OVER LIFTING VEHICLES STALK G	SREN	SHAPIRO G WESTINGHOUSE ELECTRIC CORP SYMPOSIUM ON SIMULATION AND SIMULATORS OF DYNAMIC SYSTEMS ROGERS R	SREN
DONALDSON C D AERONAUTICAL RESEARCH ASSOCIATES OF PRINCETON INC INTERACTION PHENOMENA IN ROTATIONAL STREAMS CALVERT D L	SREN	SLACK L NATIONAL ACADEMY OF SCIENCES SYMPOSIUM ON BOUNDARY LAYERS AND TURBULENCE ROGERS R	SREN
EMICH R J LEHIGH UNIVERSITY 6TH INTERNATIONAL SHOCK TUBE SYMPOSIUM ROGERS R	SREN	SALEPCEVICH C M OSI GAZOVA UNIV RESEARCH INSTITUTE A UNIFIED APPROACH TO TRANSPORT PHENOMENA BASED ON ENGINEERING THERMODYNAMICS STALK G	SREN
FERNI A / TING LU NEW YORK UNIVERSITY AERODYNAMIC STUDIES OF WING BODY CONFIGURATIONS WITH MODERATE ASPECT RATIO ROGERS R	SREN	VAN DYKE M STANFORD UNIVERSITY HYPERSONIC AND VISCOUS FLOW THEORY STALK G	SREN
		VIDAL R J CORNELL AERONAUTICAL LABORATORY INC NON-ISOTHERMAL GAS DYNAMICS ROGERS R	SREN
		VINCENTI M G STANFORD UNIVERSITY INVESTIGATIONS OF NONEQUILIBRIUM FLOWS ROGERS R	SREN

## ENGINEERING SCIENCES

### 8.2.2 RAREFIED GAS DYNAMICS

BRUNDIN C L  
DEPAUL UNIVERSITY  
FIFTH INTERNATIONAL SYMPOSIUM ON RAREFIED GAS DYNAMICS  
ROGERS N SREN

CARICIONANI C  
APPLICAZIONI RICERCHE SCIENTIFICHE  
RAREFIED GAS DYNAMICS THURSTON P A SREN

FERRARI C  
POLITECNICO DI TORINO  
RESEARCH ON RAREFIED GAS DYNAMICS, HYPERSONIC AND ROTATING STALL  
STALL STALL SREN

GLASS I I  
UNIVERSITY OF TORONTO  
AEROPHYSICAL INVESTIGATIONS AT HYPERVELOCITIES  
ROGERS N SREN

HARRIS T J  
UNIVERSITY OF ILLINOIS  
WALL TURBULENCE CALVERT D L SREN

LAUFER J  
UNIVERSITY OF SOUTHERN CALIFORNIA  
FUNDAMENTAL PROBLEMS IN RAREFIED GAS DYNAMICS  
THURSTON P A SREN

LAURMAN J A  
TRC, INC  
LEADING EDGE FLOWS IN HYPERSONIC RAREFIED GASES  
THURSTON P A SREN

ROBER T P  
BRAND UNIVERSITY  
KINETIC MODEL EQUATIONS IN RAREFIED GAS DYNAMICS  
THURSTON P A SREN

MAJTE E P  
GENERAL ELECTRIC CO  
DIRECT MEASUREMENTS OF THE MOLECULAR VELOCITY DISTRIBUTION  
FUNCTION ROGERS N SREN

MYERSON A L  
CORNELL AERONAUTICAL LABORATORY INC  
BOUNDARY LAYERS IN HIGH TEMPERATURE FLOWS  
ROGERS N SREN

PARKER M W / RUMHAY A R  
UNIVERSITY OF VIRGINIA  
LOW DENSITY FLOW AERODYNAMIC CHARACTERISTICS USING ELECTRO  
MAGNETIC SUSPENSION SYSTEM STALK G SREN

PATTERSON G N  
UNIVERSITY OF TORONTO  
TRANSFER OF MASS, MOMENTUM AND ENERGY IN FREE MOLECULE SYSTEMS  
THURSTON P A SREN

SLINNER G T  
CORNELL AERONAUTICAL LABORATORY INC  
MOLECULAR INTERACTIONS AT HIGH TEMPERATURE  
THURSTON P A SREN

SMITH J R  
GENERAL DYNAMICS CORP  
INTERACTIONS BETWEEN HYDROGEN AND OXYGEN ATOMS AND SURFACES  
THURSTON P A SREN

SHOLDEREN J J  
VON KARMAN INSTITUTE FOR FLUID DYNAMICS  
LOW DENSITY HIGH TEMPERATURE GAS DYNAMICS  
THURSTON P A SREN

TALBOT L  
UNIVERSITY OF CALIFORNIA  
PLASMA WIND TUNNEL RESEARCH THURSTON P A SREN

THOMAS A B  
UNIVERSITY OF MISSOURI  
ENERGY EXCHANGE BETWEEN SOLIDS AND GASES  
THURSTON P A SREN

TRILLING L  
MASSACHUSETTS INSTITUTE OF TECHNOLOGY  
GAS-SOLID SURFACE INTERACTION THURSTON P A SREN

ZIERING S  
SPACE SCIENCES INC  
DRAG IN RAREFIED GASES THURSTON P A SREN

### 8.2.3 BOUNDARY LAYER EFFECTS

ARNOLD L/WERNER J  
NEW YORK UNIVERSITY  
HEAT TRANSFER HYDRODYNAMIC INSTABILITY  
STALK G SREN

BARDI J A  
MASSACHUSETTS INSTITUTE OF TECHNOLOGY  
HIGH SPEED HEATING AND RADIATING FLOWS  
CALVERT D L SREN

BLACKSTOCK D T  
UNIVERSITY OF ROCHESTER  
INTERACTION BETWEEN HIGH INTENSITY SOUND AND VISCOUS MEDIA  
CALVERT D L SREN

CORREIA SYRANSTHAY L S  
JOHNS HOPKINS UNIVERSITY  
SHEAR FLOWS CALVERT D L SREN

CRIMBLE W D  
PRINCETON UNIVERSITY  
INTERACTION OF FLUID MOTION  
CALVERT D SREN

FAURE A  
UNIVERSITY OF AIX-MARSEILLE  
STATISTICAL INVESTIGATIONS OF TURBULENT GASES  
STALK G SREN

GENOUE J J  
VON KARMAN INSTITUTE FOR FLUID DYNAMICS  
LAMINAR SEPARATION IN HYPERSONIC FLOWS  
CALVERT D L SREN

HILL J A P  
METRIS INC  
CONVECTION VELOCITY OF TURBULENCE IN HYPERSONIC WAKES  
STALK G SREN

HOLT R  
UNIVERSITY OF CALIFORNIA  
RESEARCH IN AERODYNAMICS AND AERODELASTICITY  
CALVERT D SREN

KLINE S J  
STANFORD UNIVERSITY  
BASIC STRUCTURES AND STABILITY OF TURBULENT SHEAR FLOWS  
CALVERT D L SREN

LANDAUER R /ASHLEY H  
MASSACHUSETTS INSTITUTE OF TECHNOLOGY  
UNSTEADY GASODYNAMIC PROBLEMS RELATED TO FLIGHT VEHICLES  
STALK G SREN

LEES L  
CALIFORNIA INSTITUTE OF TECHNOLOGY  
VISCOUS EFFECTS OF HEAT TRANSFER IN SEPARATED FLOWS  
CALVERT D L SREN

RESHOTKO E  
CASE INSTITUTE OF TECHNOLOGY  
TIME-DEPENDENT HYPERSONIC VISCOUS INTERACTIONS  
STALK G SREN

RIBNER H S  
UNIVERSITY OF TORONTO  
AERODYNAMICALLY GENERATED SOUND  
CALVERT D SREN

RUSE M G  
UNIVERSITY OF VIRGINIA  
TURBULENT SHEAR FLOWS RESEARCH  
CALVERT D L SREN

YAGLO-LAURIN R  
NEW YORK UNIVERSITY  
HYPERSONIC ATMOSPHERIC FLOWS  
THURSTON P A SREN

YAN DRIEST E R  
NORTH AMERICAN AVIATION INC  
STABILITY AND TRANSITION OF LAMINAR BOUNDARY LAYER  
CALVERT D L SREN

### 8.2.4 PLASMA DYNAMICS

BIRD G A  
UNIVERSITY OF SYDNEY  
NUMERICAL STUDIES IN GAS DYNAMICS  
THURSTON P A SREN

BURGERS J R  
UNIVERSITY OF MARYLAND  
HYPERSONIC FLOW PHENOMENA THURSTON P A SREN

CHANG C C  
CATHOLIC UNIVERSITY OF AMERICA  
THEORETICAL AND EXPERIMENTAL STUDIES IN MAGNETOHYDRODYNAMICS AND  
PLASMA PHYSICS THURSTON P A SREN

DE LEEUW J H  
UNIVERSITY OF TORONTO  
PLASMA DYNAMICS AND MAGNETOHYDRODYNAMICS  
THURSTON P A SREN

DOFFMAN J /PAPE S I  
UNIVERSITY OF MARYLAND  
PHENOMENA SURROUNDING HIGH SPEED PLASMA  
THURSTON P A SREN

FOY J B  
MASSACHUSETTS INSTITUTE OF TECHNOLOGY  
HEAT TRANSFER IN A PLASMA THURSTON P A SREN



## ENGINEERING SCIENCES

### 0.2.4 PLASMA DYNAMICS

LASHINSKY M  
UNIVERSITY OF MARYLAND  
NONLINEAR MECHANICS OF UNSTABLE PLASMAS  
THURSTON P A SREN

LON M  
HEBREN UNIVERSITY  
OPTICAL AND ACOUSTICAL MEASUREMENTS BEHIND SHOCK WAVES  
ROGERS R SREN

ONG B S B  
UNIVERSITY OF MICHIGAN  
RELAXATION TIMES OF A DILUTE PLASMA  
THURSTON P A SREN

PAI S J  
UNIVERSITY OF MARYLAND  
J.N. BURGESS 70TH ANNIVERSARY SYMPOSIUM ON THE  
DYNAMICS OF FLUIDS AND PLASMAS  
THURSTON P A SREN

RESLER E L  
CORNELL UNIVERSITY  
FLUID MECHANICS RESEARCH  
THURSTON P A SREN

SANDRI G  
AERONAUTICAL RESEARCH ASSOCIATES OF PRINCETON INC  
NON-EQUILIBRIUM STATISTICAL MECHANICS  
THURSTON P A SREN

SCALA S R  
GENERAL ELECTRIC CO  
THEORETICAL STUDIES OF HYPERSONIC RAREFIED PLASMA FLOW  
ROGERS R SREN

SEARS M R  
CORNELL UNIVERSITY  
HIGH SPEED AERODYNAMICS  
THURSTON P A SREN

SHEER E  
COLUMBIA UNIVERSITY  
DIAGNOSTIC STUDY OF THE FLUID TRANSFER ARCH  
THURSTON P A SREN

TRAUOGOTT S C  
MARTIN CO  
MODEL FOR A NON GREY RADIATING GAS  
THURSTON P A SREN

WEHRMAN M D  
UNIVERSITY OF ROCHESTER  
ELECTRON AND ION DENSITY IN SHOCK WAVES  
THURSTON P A SREN

### 0.3.0 MECHANICS OF SOLIDS

CHAPPEL R E  
OKLAHOMA STATE UNIVERSITY  
STRESSES IN IRREGULARLY SHAPED MEMBRANES  
POMERANTZ J SREN

HEBENHANN G  
NORTHWESTERN UNIVERSITY  
DYNAMIC BEHAVIOR AND STABILITY OF SLICIS  
POMERANTZ J SREN

### 0.3.1 STRUCTURAL MECHANICS

BELL J F  
JOHNS HOPKINS UNIVERSITY  
PLASTIC WAVE PROPAGATION IN METALS AT ELEVATED TEMPERATURES  
POMERANTZ J SREN

BIOT R A  
M A BLOT  
MECHANICS OF INCREMENTAL DEFORMATIONS AND RELATED THERMODYNAMICS  
POMERANTZ J SREN

BUCKERS P  
UNIVERSITE CATHOLIQUE DE LOUVAIN  
INFLUENCE OF STRUCTURAL ELASTICITY ON ATTITUDE STABILITY AND DRIFT  
OF SPACE CRAFT  
POMERANTZ J SREN

DILLON D W  
UNIVERSITY OF KENTUCKY RESEARCH FOUNDATION  
THERMAL EFFECTS IN SOLIDS  
POMERANTZ J SREN

DONALDSON N L  
SOUTHWEST RESEARCH INSTITUTE  
NON DESTRUCTIVE EVALUATION OF METAL FATIGUE  
STALK G SREN

DOUGLASS J  
MASSACHUSETTS INSTITUTE OF TECHNOLOGY  
AEROTHERMELASTICITY  
POMERANTZ J SREN

FUNG Y C  
UNIVERSITY OF CALIFORNIA  
CONTINUUM MECHANICS OF BIOMECHANICAL SYSTEMS  
POMERANTZ J SREN

HEBENHANN G  
NORTHWESTERN UNIVERSITY  
INTERNATIONAL CONFERENCE ON DYNAMIC STABILITY OF STRUCTURES  
POMERANTZ J SREN

HEFFERTY W  
STANFORD UNIVERSITY  
GENERAL SOLUTION FOR THE ELASTIC QUADRANT SPACE  
POMERANTZ J SREN

HUFF N J  
STANFORD UNIVERSITY  
AIRCRAFT AND MISSILE STRUCTURES OPERATING AT HIGH TEMPERATURES  
POMERANTZ J SREN

MARTON W  
STANFORD UNIVERSITY  
EFFECTS OF PLASTICITY ON THE BUCKLING AND POSTBUCKLING OF  
CYLINDRICAL SHELLS  
STALK G SREN

MEADOLT J C  
AERONAUTICAL RESEARCH ASSOCIATES OF PRINCETON INC  
EXCEEDANCES OF STRUCTURAL INTERACTION BOUNDARIES FOR RANDOM  
EXCITATION  
POMERANTZ J SREN

JANJAZEBI W  
PENNSYLVANIA STATE UNIVERSITY  
THERMAL STRESSES IN MICRO-STRUCTURES IN CONTINUUM MECHANICS  
POMERANTZ J SREN

JU F D  
UNIVERSITY OF NEW MEXICO  
BEHAVIOR OF METALLIC MATERIALS UNDER LOW-CYCLE DYNAMIC LOADING  
STALK G SREN

KARNOFF D C  
MASSACHUSETTS INSTITUTE OF TECHNOLOGY  
RANDOM VIBRATION IN AEROSTRUCTURES  
POMERANTZ J SREN

KEMNER J  
POLYTECHNIC INSTITUTE OF BROOKLYN  
PLATES AND SHELLS UNDER EXTERNAL LOADING AND ELEVATED TEMPERATURES  
POMERANTZ J SREN

KERR A D  
NEW YORK UNIVERSITY  
VARIATIONAL METHODS IN NONLINEAR SHELL PROBLEMS  
POMERANTZ J SREN

MAZELSKY B  
AEROSPACE RESEARCH ASSOCIATES INC  
ENERGY ABSORBING STRUCTURES  
POMERANTZ J SREN

MILLER J W DOUGLAS M  
GIAMINI CONTROL CORP  
PRESSURIZED, INFLATABLE, AND FILAMENT-WOUND STRUCTURES  
POMERANTZ J SREN

NASH M A  
UNIVERSITY OF FLORIDA  
RESPONSE OF STRUCTURES TO RANDOM NOISE  
STALK G SREN

PIAN T H H  
MASSACHUSETTS INSTITUTE OF TECHNOLOGY  
STATIC AND DYNAMIC NONLINEAR STRUCTURAL PROBLEMS  
POMERANTZ J SREN

PRAGER W NACHBAR W  
UNIVERSITY OF CALIFORNIA  
DYNAMIC RESPONSE OF THIN SHELLS TO SUDDENLY APPLIED LOADS  
POMERANTZ J SREN

REISBACH W  
STATE UNIVERSITY OF NEW YORK  
FORCED VIBRATION AND DYNAMIC RESPONSE OF CYLINDRICAL SHELLS  
POMERANTZ J SREN

SINGER J  
TECHNICON RESEARCH AND DEVELOPMENT FOUNDATION LTD  
BUCKLING OF SHELLS UNDER COMBINED LOADING AND THERMAL  
STRESSES  
POMERANTZ J SREN

STEARMAN R O  
RIDGEMONT RESEARCH INSTITUTE  
PANEL FLUTTER OF CYLINDRICAL SHELLS  
STALK G SREN

STEARMAN R O  
UNIVERSITY OF TEXAS  
VIBRATION CHARACTERISTICS OF CYLINDRICAL SHELL STRUCTURES WITH  
CYCLIC STIFFENING  
STALK G SREN

ZISFELD B  
FRANKLIN INSTITUTE  
AEROSPACE STRUCTURES  
POMERANTZ J SREN

## ENGINEERING SCIENCES

### 0.3.2 ENVIRONMENTAL MATERIALS MECHANICS

ANDERSON H B  
SOUTHWEST RESEARCH INSTITUTE  
RESPONSE OF STRUCTURAL MATERIALS TO HIGH INTENSITY PURE THERMAL  
RADIATION  
STALK G SAEN

BOHNER J A  
TECHNION RESEARCH AND DEVELOPMENT FOUNDATION LTD  
DYNAMIC ELASTIC BEHAVIOR OF MATERIALS  
POMERANTZ J SAEN

FRY L H  
PENNSYLVANIA STATE UNIVERSITY  
EFFECTS OF UNIAXIAL STRESSES ON MECHANICAL PROPERTIES OF METALS  
UNDER HIGH PRESSURE  
STALK G SAEN

LARSEN R C  
PENNSYLVANIA STATE UNIVERSITY  
DISPERSION HARDENING  
STALK G SAEN

KRAMER E R  
MARTIN CO  
EFFECT OF VACUUM ENVIRONMENT ON MECHANICAL BEHAVIOR OF MATERIALS  
POMERANTZ J SAEN

QUONAN E  
MASSACHUSETTS INSTITUTE OF TECHNOLOGY  
PHYSICAL BASIS OF ADHESION  
POMERANTZ J SAEN

SALTSBURG H R  
GENERAL DYNAMICS CORP  
SYMPOSIUM ON FUNDAMENTALS OF GAS-SURFACE INTERACTIONS  
ROGERS H SAEN

WILSON J  
MASSACHUSETTS INSTITUTE OF TECHNOLOGY  
MECHANICAL BEHAVIOR OF METAL COMPOSITES  
POMERANTZ J SAEN

### 0.4.0 ENGINEERING CHEMISTRY

#### 0.4.1 PROPELLANTS

ADAMS R R  
GEORGE COLLEGE  
SYNTHESIS OF BORON HYDRIDES  
DONOVAN C J SAEP

SHELSON A  
ITT RESEARCH INSTITUTE  
CHEMICAL EQUILIBRIA AND RAMAN SPECTROSCOPY USING MATRIX ISOLATION  
TECHNIQUE  
DONOVAN C J SAEP

#### 0.4.2 THERMO PHYSICAL PROP. OF PROPELLANTS

BECKETT C H  
NATIONAL BUREAU OF STANDARDS  
THERMODYNAMICS OF LIGHT-ELEMENT COMPOUNDS  
DONOVAN C J SAEP

BRINER J  
REDHIST RESEARCH INSTITUTE  
DETERMINATION OF NEAR VIRIAL COEFFICIENTS  
DONOVAN C J SAEP

CUMMINGHAM J  
UNIVERSITY OF DUBLIN  
ENERGY TRANSPORT IN IRRADIATED SYSTEMS  
DONOVAN C J SAEP

CURTIS E C  
NORTH AMERICAN AVIATION INC  
HYDRATION FROM VIBRATIONAL FREQUENCIES AND FORCE CONSTANTS  
DONOVAN C J SAEP

DOULIN D R  
BUREAU OF WEAPONS  
THERMODYNAMICS OF ORGANIC DERIVATIVES OF THE LIGHTER ELEMENTS  
DONOVAN C J SAEP

GROSS P  
PALMER RESEARCH INSTITUTE LTD  
HEATS OF FORMATION OF METAL-METAL COMPOUNDS  
DONOVAN C J SAEP

KALPHAN J  
MARTIN CO  
THEORETICAL AND QUANTUM CHEMISTRY OF BORON, BERYLLIUM AND ALUMINUM  
COMPOUNDS  
DONOVAN C J SAEP

MILNE T  
REDHIST RESEARCH INSTITUTE  
ELECTRIC DEFLECTION OF MOLECULAR BEAMS  
DONOVAN C J SAEP

OPPENHEIM U P  
TECHNION RESEARCH AND DEVELOPMENT FOUNDATION LTD  
QUANTITATIVE HIGH TEMPERATURE INFRARED SPECTROSCOPY  
DONOVAN C J SAEP

POTTER H D  
PHILCO CORP  
THERMODYNAMIC PROPERTIES OF PROPELLANT COMBUSTION PRODUCTS  
DONOVAN C J SAEP

WILLIAMSON H A  
UNITED AIRCRAFT CORP  
CALCULATION OF CROSS SECTIONS FOR ELECTRON-ATOM COLLISIONS  
DONOVAN C J SAEP

### 0.5.0 INFORMATION AND COMMUNICATION ELECT

ANGELARD D J / HENNERY J  
UNIVERSITY OF CALIFORNIA  
BASIC RESEARCH IN ELECTRONICS /JSEP/  
KALISCH R B SREE

COMMANDING OFFICER  
ARMY ELECTRONICS COMMAND  
BASIC RESEARCH IN ELECTRONICS /JSEP/, MIT, COLUMBIA U., ILLINOIS  
U., STANFORD U., HARVARD U.  
KALISCH R B SREE

BOGAL A A  
UNIVERSITY OF TEXAS  
BASIC RESEARCH IN ELECTRONICS /JSEP/  
KALISCH R B SREE

KAPRIELIAN Z A  
UNIVERSITY OF SOUTHERN CALIFORNIA  
BASIC RESEARCH IN ELECTRONICS /JSEP/  
KALISCH R B SREE

SHOSTAK A  
OFFICE OF NAVAL RESEARCH  
BASIC RESEARCH IN ELECTRONICS /JSEP/, PURDUE UNIVERSITY  
KALISCH R B SREE

### 0.5.1 SYSTEMS ENGINEERING

WEBER E  
POLYTECHNIC INSTITUTE OF BROOKLYN  
MICROWAVES, ELECTROMAGNETIC THEORY AND INFORMATION PROCESSES  
KALISCH R B SREE

### 0.5.2 PHYSICAL ELECTRONICS

#### 0.5.2.1 GENERATION AND PROPAGATION OF WAVES

CULLEMAN P D  
UNIVERSITY OF ILLINOIS  
LASER STUDIES IN 100 TO 1000 MICRON RANGE  
ZANDER F H SREE

NAIRAN C S  
RITRAS INC  
RESONANT HARMONIC GENERATION AND NON-LINEAR OPTICS  
ZANDER F H SREE

PAPAS C M  
CALIFORNIA INSTITUTE OF TECHNOLOGY  
SELECTED PROBLEMS IN THE THEORY OF ELECTROMAGNETIC RADIATION  
ZANDER F H SREE

#### 0.5.2.2 SOLID STATE ELECTRONICS

MORTMAN J J  
RESEARCH TRIANGLE INSTITUTE  
EFFECT OF STRESS WAVES ON P-N JUNCTIONS  
ZANDER F H SREE

#### 0.5.2.3 ELECTRO-OPTICS

SMITH C B  
NORTH AMERICAN AVIATION INC  
THIN FILM OPTICAL TRANSMISSION LINE  
ZANDER F H SREE

SMITH G F  
HUGHES RESEARCH LABS  
INTERACTION OF COHERENT LIGHT WITH SOLIDS AND WITH TURBULENT  
ATMOSPHERES  
ZANDER F H SREE

WANNER A H  
ADVANCED KINETICS INC  
INTERACTION OF LIGHT AND PARTICLE BEAMS  
ZANDER F H SREE

## ENGINEERING SCIENCES

### 8.6.5 PLASMA AND ELECTRIC BEAMS

GAARD R W  
CALIFORNIA INSTITUTE OF TECHNOLOGY  
PLASMA DYNAMICS  
ZANDER F H

SREE

SUTHERLAND A G  
UNIVERSITY OF FLORIDA  
ELECTRON BEAM-PLASMA INTERACTION  
ZANDER F H

SREE

CHODRON H  
STANFORD UNIVERSITY  
INTERACTION OF ELECTROMAGNETIC AND ACOUSTIC WAVES IN SOLIDS  
ZANDER F H

SREE

GEORGE B  
CALIFORNIA INSTITUTE OF TECHNOLOGY  
LASER ELECTROMAGNETICS  
ZANDER F H

SREE

HACHELLAN R S  
UNIVERSITY OF SOUTHERN CALIFORNIA  
OPTICAL CATHODE  
ZANDER F H

SREE

### 8.6.6 QUANTUM ELECTRONICS

BULGIANO L P  
UNIVERSITY OF DELAWARE  
QUANTUM LIMITATIONS TO ELECTROMAGNETIC SIGNAL MEASUREMENTS  
ZANDER F H

SREE

### 8.6.7 GEO- AND ASTRO-ELECTRONICS

MELTWELL R A  
STANFORD UNIVERSITY  
WAVE PARTICLE INTERACTIONS IN THE MAGNETOSPHERE  
ZANDER F H

SREE

## *Information Sciences*

DR. HAROLD A. WOOSTER, *Director*  
and ROWENA W. SWANSON, *Project Scientist*

The information sciences try to apply the scientific method of inquiry to an understanding of all the factors that go to make up paths. Perhaps the most obscure is the one man has spent the most time on—the one concerned with an understanding of himself, how he thinks, how he comes to understand, how he learns, what he wants his goal to be, and why. Perhaps the least obscure is the comparatively new route being paved by modern technology. Man has harnessed the computer and many other machines, complex concatenations of many components, to sense and process signals that he knows about but cannot see or hear or touch.

Information science may be this generation's contribution to science. It is invading this discipline and that, extracting an idea here and an equation there, and it is beginning to weave the pieces into a pattern. It is beginning to show features dealing with the acquisition and coding of information, the communication process, and recall of information, and how information is and can be used.

The selection of areas and projects for funding is a product of many factors. The directorate has turned its attention to studies in depth of some of the fundamental principles that must be explored and understood to advance basic concepts of information representation and processing. At this stage in the evolution of the information sciences, these studies fortuitously are often efforts of one person or small teams. Though this is a familiar pattern in science, it must be remembered that this is but one pattern in science.

Emphasis in the late 1950's with a much smaller budget was on such library-oriented topics as indexing and classification and the applicability of machines to information center operations. Gradual shift to the present program has resulted as much from an awareness of engineers, physiologists, physicists, psychologists, mathematicians, linguists, and philosophers that they were dealing

with information science problems as it did from an awareness of the directorate that problems in many disciplines are basically information problems. The tasks within the program are: (1) information systems research, (2) information identification and classification, (3) transmission of information, (4) adaptive and self-organizing systems, (5) language and linguistics research, and (6) theoretical foundations of information sciences.

These tasks do not encompass all of the information sciences, nor could they form the given budget. Several major areas excluded concern studies of materials, hardware components and assemblies, structure and behavior of biological systems, and large-scale man-machine and time-sharing interactions. Most of the excluded areas are included in other AFOSR and DOD programs.

A further remark may be appropriate with respect to inclusion and exclusion. Given \$1 million and a mission—for the directorate, to help assure the timely impact of information science on the future operational Air Force—selections have been made which are identified with technological problems of Air Force interest.

### *Information systems research*

Information systems research looks at the structure and operation of entire systems or of units within a system viewed in the framework of the entire system. Efficiency and effectiveness of methods and tools for the input, throughput, dissemination, and use of information are principal topics for investigation.

Information systems abound. They are used for document control, data control, logistics, management and command, and intelligence within military and civilian contexts. Many existing systems are based on ad hoc planning and have suffered explosive, unanticipated growth. Frequently mechanization or other changes have been introduced to alleviate some information processing difficulties, but the effects are usually far from optimal.

Questions must be asked about systems in the abstract. What are possible information flow patterns? With what configurations of men and machines can each be achieved? What is the match

between pattern and purpose of the system? What effect does the environment have on the system? Who feeds the system? Who uses it? Who could feed it or use it? What are the tradeoffs for a given system for a given purpose?

Questions must be asked about existing systems. Existing structures and operations must be quantitatively and realistically analyzed. The effects of perturbations must be examined in the abstract and tested in simulations and in ongoing operations. Live data under perturbations are invaluable but difficult to obtain.

Systems research is slow-producing research. There are many variables, and they are difficult to isolate, control, and test. They pertain to the behavior of men as well as to machines. They must, however, be studied, which means that ways must be found for studying them.

#### **Information Identification and Classification**

The problem of selecting appropriate descriptors of information and organizing them into a structure was originally thought of as a library problem. It is still a crucial problem of information services activities handling the technical document literature. Conventional library classification schemes are not readily amenable to frequent and major modifications of narrow subject areas which must be accessed in specificity and depth as research expands knowledge of them. Conventional library indexing practices can similarly not readily accommodate to current requirements for many terminological access points to the subject content of documents.

The problem of identification and classification has, however, been aggravated by a technology that has produced computers and sensors. Machines that can read printed and handwritten characters and can look at maps and photographs need instructions to tell them how to recognize a pattern and how to differentiate one pattern from another. This raises the question of how to describe a pattern. What are the information-bearing parameters in a line drawing, in a letter of the alphabet, in an aerial photograph? Are the bits that are significant to a human significant to a machine? Can rules or algorithms be developed that can give machines the intelligence to identify patterns they haven't seen before and to separate signals from noise?

Projects concerned with both categories of prob-

lems pertaining to classification are included in this task. Descriptor structures for document systems are frequently related to other aspects of total system organization and operation. As methods are perfected for mechanizing useful indexing procedures, new approaches to input, search and retrieval can be explored and incorporated in systems. Work with natural language may also lead to abstractions pertaining to syntactic and semantic structures in language. Rules that characterize the process must describe procedures by which machines can learn from experience and can adjust or adapt to new inputs. How patterns are coded also bears on information content and information loss in their transmission.

The possibility exists that models for characterizing patterns will also describe concepts represented by clusters of word descriptors.

#### **Transmission of information**

Many mechanisms exist by which information is transmitted. A simple organism can have a multiplicity of sensors for orientation in and adaption to its environment. Man has mechanisms within mechanisms compounded by his higher animal abilities of perception, awareness, and thought. Physical systems display order, a balancing of cause and effect, and adaption that suggest other mechanisms.

Living systems present a challenge to man's understanding of information processing. In packages smaller than he can fabricate, complex processes occur that he cannot yet model. What are the algorithms for seeing, for hearing, for remembering, for forgetting, for integrating one bit of information with another, for making quantum jumps in thought that lead to creative synthesis? How are impulses sensed, sorted, coded, transmitted, stored, recalled, evaluated? How are judgments made and decisions reached? How do organisms communicate with each other, and, in particular, how effectively does man communicate with man? Inquire into information transmission mechanisms ranges from studies of interactions at the subcellular level to those among men and between men and machines.

This task principally sponsors connecting research. However, other sponsors are not necessarily concerned with information science objectives that seek isolation of information-bearing parameters, models of information processing

mechanisms, and techniques for improving communication processes. Since the range is broad and the budget is small, only a few projects can be supported. They highlight the difficulties that are inherent in attaining information science objectives.

#### ***Adaptive and self-organizing systems***

Man, the information processor, intrigues man, the circuit designer, and man, the model builder. Man's nervous systems is a fascinating structure, its operation a subject for conjecture. Some of man's sensory systems, his eye, his ear, are better understood and offer existence proofs to the engineer. Beyond what man can see are processes he calls perception, consciousness, and thought. Will he be able to find neural networks or molecules he can associate with these processes? Where and how is experience stored to provide for memory and recall?

Man and lower living systems embody principles of structure and performance which far surpass equations that he has been able to formulate and hardware he has been able to build. Man has repeatedly built machines exceeding his own physical capabilities. But, except to minor degrees, he has not yet built devices he can work with as extensions of himself in the way that he can work with other men. He has not built machines he can send into hostile and adverse environments that can report back to him selectively and reliably the information he would want to know. He has built machines which record vast quantities of data about the physical universe, yet few machines can distinguish the significant bits from the rest.

In information science terms, research to understand and model the dynamic processes of living systems is variously termed artificial intelligence, the field of adaptive and self-organizing systems, and when the construction of hardware is involved, bionics. The term cybernetics is sometimes used, because these systems incorporate control and feedback mechanisms that adjust their performance toward specific goals.

Research on adaptive systems may produce spectacular results over the short range, but such results can only be a first and gross approximation to what the long range holds. The mechanical eye or hand, the computer that voices the words "Bravo!" or "Come again!", the tracker that finds a target embedded in noise go part of the way.

Mechanical devices with more and higher level features of human intelligence and adaption could teach and train man. Machines might not only help accelerate learning, but could also be used to stimulate and enhance man's inventiveness and creativity if more were known about his memory and thought processes. The equations by which man discriminates, makes decisions, integrates disjoint bits into a whole greater than the sum of its parts can be successively approximated. It would be shortsightedness, however, to consider first approximations as more than precisely that.

Engineers, mathematicians, and perhaps administrators, tend to get carried away with the potential prospects of the intelligent machine. It is error to ignore data bases. The neurophysiologist knows something about the nervous system, but he has a lot more to discover. The psychiatrist and psychologist know something about behavior, but only a little something. The molecular biologist knows compound composition and structure, but what is the explanation for memory? Optimum results over the long range can only come from close cooperation across the range of disciplines that contribute pieces to the puzzle. The generalist and the specialist are both needed in the various fields, and they must be able to exchange ideas. Science is becoming one again as it simultaneously increases in specialization.

#### ***Language and linguistics research***

Language consists of groups of symbols arranged according to a set of rules. Viewed this way, "language" includes both the languages people speak and all synthetic symbol systems. So language is viewed in this task.

Language is a tool. It is a device for representation. Information science is concerned with its use for representing concepts, relationships among concepts, models for automata, and instructions for processing devices.

Natural language has proved tractable with difficulty. Structure or syntax has been amenable to modeling, but the number of grammatically correct sentences that can be meaningless is for practical purposes, indefinite. Major emphasis is now on semantics, to elicit rules for recognizing meaning and generating meaningful sentences. Research on natural language was originally sponsored (not by AFOSR) to develop procedures for machine translation. Machine production of trans-

lations, indexes, and abstracts, and other machine manipulations of natural language text are requirements if achievable, because man's capacity to assimilate bits of information is limited. As document volume increases, automatic methods that intelligently select the significant bits appear mandatory for efficient handling of information. Results are slow in coming because the data is large, large-scale projects are expensive, and perhaps creative ideas are few.

Work on synthetic or artificial languages can be roughly subdivided into work on machine and programming languages and work on languages for representing concepts and procedures simulating intelligent processes. The directorate program has not included much programming language research. An area of directorate interest is in translators and compilers which make machines accessible to non-programmer scientist and manager users.

Language for game playing and theorem proving suggest approaches to the representation and association of concepts that may be approximations to characterizing thought processes. Considerable progress has been made, some under AFOSR sponsorship, on languages for problem-solving procedures. Enough may now be known about some languages for automata to permit generalizations on useful procedures that can be accomplished on computers.

#### ***Theoretical Foundations of Information Sciences***

Most of the studies in this task concern developments in symbolic logic. We were not thinking of the new mathematics called for by von Neumann to describe intelligent activities when we established the task. Our sponsored projects in multi-

valued logics increasingly suggest this as a possible route. Since the McCulloch-Pitts logical calculus of 1943, procedures have been sought for expressing such "ideas immanent in nervous activity" as learning and recognition and the ability of automata to function reliably under duress, with unreliable components, and with incomplete information. Space flight and hostile environments now impose requirements on logical elements of adaptation and self-repair.

Automata theory is another route for building intelligent systems. The use of algebraic methods to describe the language and behavior of automata may lead to machines that are both fundamental and behavioristically simple. Combinatorial algebras may give useful models for information retrieval systems. Techniques for simplifying proof procedures offer possibilities of eliminating exhaustive enumerations that are time consuming and can exceed machine capacities. Questions concerning algorithmic unsolvability and other problems in recursive function theory (the theory of computability) are amplifying notions of constructibility, decidability, consistency, and completeness.

The logic models supply formal approaches that can be applied to problems in the structuring and processing of information and language. The precise descriptions of automata are models of realizable networks and define bounds on their performance. Automata are beginning to be assessed for the solution of natural language problems. However, it is expected that applications to information problems will await further examination of such questions as complexity, equivalence, and the behavior of automata with and without restrictions on time and space.

## INFORMATION SCIENCES

### 9.0.0 INFORMATION SCIENCES

#### 9.1.0 INFORMATION SYSTEMS RESEARCH

BOHNET L B  
C. E. R. INC.  
DEVELOPMENT OF A STANDARDIZED LANGUAGE FOR DESCRIBING  
DOCUMENTATION SYSTEMS  
SWANSON R SRI

BROTHMAN A A  
UNIVERSITY OF PENNSYLVANIA  
EVALUATION OF INFORMATION SCIENCES RESEARCH PROGRAM  
SWANSON R SRI

GOFFMAN W  
WESTERN RESERVE UNIVERSITY  
SEARCH STRATEGY FOR INFORMATION RETRIEVAL  
SWANSON R SRI

KLEMPNER E H  
COLUMBIA UNIVERSITY  
DIFFUSION OF ABSTRACTING SERVICE MEDIA FROM GOVERNMENT  
SPONSORED RESEARCH  
SWANSON R SRI

PARKS W C  
GORDON RESEARCH CONFERENCES INC.  
GORDON RESEARCH CONFERENCE ON DEVELOPING INFORMATION SYSTEMS  
SWANSON R SRI

RUBINOFF W  
UNIVERSITY OF PENNSYLVANIA  
INFORMATION SYSTEM DESIGN FOR THE INFORMATION PROCESSING FIELD  
SCHMER E SRI

SPRU A B  
RUTGERS UNIVERSITY  
SCIENTIFIC BASES FOR INFORMATION PROCESSING  
SWANSON R SRI

SHER E H  
INSTITUTE FOR SCIENTIFIC INFORMATION  
ANALYSIS OF DOD SPONSORED RESEARCH PUBLICATIONS  
MARTINO J P SRI

TAYLOR R S  
LEHIGH UNIVERSITY  
STUDY OF THE MAN-SYSTEM INTERFACE IN LIBRARIES  
RETRIEVAL STUDIES  
SWANSON R SRI

#### 9.2.0 CONCEPTS OF MACHINE ORGANIZATION

BAGLEY P R  
UNIVERSITY CITY SCIENCE CENTER  
GENERALIZATION AND EXTENSION OF PROGRAMMING LANGUAGE CONCEPTS  
SCHMER E SRI

#### 9.4.0 ADAPTIVE AND SELF-ORGANIZING SYSTEMS

GLISE E E  
UNIVERSITY OF ILLINOIS  
EVOLUTIONARY AND MULTILEVEL INFORMATION PROCESSING NETWORKS  
SWANSON R SRI

JOHNSON D L  
UNIVERSITY OF WASHINGTON  
MACHINE LEARNING FOR GENERAL PROBLEM SOLVING  
SCHMER E SRI

KILMER W L  
MICHIGAN STATE UNIVERSITY  
A SPATIO-TEMPORAL RETICULAR FORMATION MODEL THAT LEARNS  
SWANSON R SP

PASH G  
SYSTEM RESEARCH LTD  
CYBERNETIC INVESTIGATION OF LEARNING AND PERCEPTION  
SWANSON R SRI

VON FOERSTER W  
UNIVERSITY OF ILLINOIS  
THEORY AND APPLICATION OF COMPUTATIONAL PRINCIPLES IN COMPLEX  
INTELLIGENT SYSTEMS  
SWANSON R SRI

#### 9.5.0 INFO. EXTRACTION AND CLASSIFICATION

BROWN C R/MOORE V  
LIBRARY OF CONGRESS  
AIR FORCE SCIENTIFIC RESEARCH BIBLIOGRAPHY  
JENNINGS C S SRI

BRYANT E C  
MFSAT RESEARCH ANALYSIS INC.  
THEORETICAL FOUNDATIONS FOR ASSOCIATIVE RETRIEVAL  
BURGESS T H SRI

FAITHORNE R A  
HERRER AND CO  
UNIFICATION OF THEORY AND EMPIRICISM IN INFORMATION RETRIEVAL  
SCHMER E SRI

FREEMAN M  
NEW YORK UNIVERSITY  
DIGITAL COMPUTER PROCESSING OF GRAPHICAL DATA  
SWANSON R SRI

GORNER J G  
BELL AEROSYSTEMS CO  
LINEAR NETS WITH PREPROCESSORS AND CASCADED COMBINATIONS  
SWANSON R SRI

GROVES G/ WALD A T  
UNIVERSITY OF MASSACHUSETTS  
LINEAR NETWORK THEORY AND PATTERN RECOGNITION  
BURGESS T H SRI

MILLMAN D J  
LEHIGH UNIVERSITY  
A FORMAL THEORY OF CONCEPTUAL AFFILIATION FOR DOCUMENT  
RECONSTRUCTION  
SWANSON R SRI

JAMODA G  
FLORIDA STATE UNIVERSITY  
ANALYSIS OF PERSONAL INDEX STRUCTURES AND USRS  
SWANSON R SRI

KGTZ S  
UNIVERSITY OF TORONTO  
COMPENDIUM OF THE DISTRIBUTIONS OF MATHEMATICAL STATISTICS AND  
APPLICATIONS  
SWANSON R SRI

LOVELL D J  
UNIVERSITY OF MICHIGAN  
A STUDY OF THE DEVELOPMENT OF IMPAIRED SENSITIVE DETECTORS  
MARTINO J P SRI

PETERSON W L/SHOUP J  
SPEECH COMMUNICATION RESEARCH LAB INC.  
SPEECH COMMUNICATION AND AUTOMATIC SPEECH RECOGNITION  
SCHMER E SRI

SELVE M /CABBIANI C  
UNIVERSITY OF MONTREAL  
ANALYSIS OF INFORMATION STORAGE, SEARCH AND RETRIEVAL PROCESSES  
SWANSON R SRI

SHER I  
INSTITUTE FOR SCIENTIFIC INFORMATION  
CITATION INDEX STUDIES FOR INFORMATION CONTROL  
SWANSON R SRI

HAYABARA H S  
UNIVERSITY OF HAWAII  
SELECTION OF VARIABLES IN CLUSTERING AND PATTERN RECOGNITION  
SCHMER E SRI

#### 9.6.0 TRANSMISSION OF INFORMATION

BEKEY G A/MCGHEE R B  
UNIVERSITY OF SOUTHERN CALIFORNIA  
ASYNCHRONOUS AUTOMATA AND DISCRETE-TIME SYSTEMS  
SWANSON R SRI

EGAN J P  
INDIANA UNIVERSITY  
AUDITORY SIGNAL DETECTION, CORRELATION AND TRANSMISSION  
SCHMER E SRI

KAILATH T  
ROCKFORD RESEARCH INSTITUTE  
STATISTICAL DETECTION THEORY IN COMMUNICATION SYSTEMS  
SWANSON R SRI

KAUTZ W H  
STANFORD RESEARCH INSTITUTE  
ASSESSMENT OF PROGRESS IN CODING THEORY IN THE USSR  
SWANSON R M SRI

MYERS J H  
RAYTHEON CO  
TRANSFORMATION-GENERATING PRINCIPLES IN BIOLOGICAL SYSTEMS  
SWANSON R SRI

TAMMER W P  
UNIVERSITY OF MICHIGAN  
THEORETICAL FRAMEWORKS FOR PATTERN  
RECOGNITION PROBLEMS  
SWANSON R SRI

VON FOERSTER W/NATURAMA H  
UNIVERSITY OF GEORGIA  
INTEGRATION OF THEORY AND EXPERIMENT INTO A UNIFIED CONCEPT OF  
VISUAL PERCEPTION  
SWANSON R SRI

#### 9.7.0 LANGUAGE AND LINGUISTICS RESEARCH

AMARAL S  
RADIO CORP OF AMERICA  
PROBLEMS IN MACHINE PROBLEM SOLVING  
SWANSON R SRI



## INFORMATION SCIENCES

### 9.7.0 LANGUAGE AND LINGUISTIC RESEARCH

**BAMERJI A / BERNST C**  
 CASE INSTITUTE OF TECHNOLOGY  
 PROBLEM SOLVING AND PATTERN RECOGNITION LANGUAGES  
 SUMNER E SRI

**BURNS J B**  
 SIMON COLLEGE  
 CRITERIA FOR EXCLUSIONS AND CORRELATIONS FOR AUTOMATIC LANGUAGE  
 ANALYSIS SHANSON R SRI

**CARACCIOLO DI TORINO A**  
 UNIVERSITA DEGLI STUDI DI PISA  
 LANGUAGES FOR AUTOMATIC PROGRAMMING TOOLS SHANSON R M SRI

**CLAPP L C**  
 COMPUTER RESEARCH CORP  
 SURVEY OF ON-LINE COMPUTER LANGUAGES AND SYSTEMS SHANSON R M SRI

**EMMONSON H P**  
 UNIVERSITY OF CALIFORNIA  
 STUDIES IN MATHEMATICAL AND COMPUTATIONAL LINGUISTIC RESEARCH SHANSON R SRI

**GALLER B A**  
 UNIVERSITY OF MICHIGAN  
 AUTOMATIC PROGRAMMING BURGESS T K SRI

**GINSBURG S**  
 SYSTEM DEVELOPMENT CORP  
 THEORY OF PROGRAMMING /ALGORITHMIC/ LANGUAGES SHANSON R M SRI

**GLASERSFELD E V**  
 P E C RESEARCH ASSOCIATES INC  
 AUTOMATIC ENGLISH SENTENCE ANALYSIS SHANSON R M SRI

**KELLER A**  
 CONNECTICUT COLLEGE  
 A STUDY OF CERTAIN PHILOSOPHICAL INTRUSIONS INTO CURRENT  
 LINGUISTIC THEORY SHANSON R M SRI

**RAPHAEL B**  
 STANFORD RESEARCH INSTITUTE  
 SURVEY OF COMPUTER LANGUAGES FOR SYMBOLIC AND ALGEBRAIC  
 MANIPULATION SHANSON R SRI

**SOMMERS P Y**  
 NEW YORK RESEARCH GROUP INC  
 ANALYSIS OF STRUCTURES OF HUMAN COMMUNICATION SYSTEMS SHANSON R SRI

**ZIFRER S**  
 UNIV. NACIONAL DE TRUJILLO  
 COMPARATIVE ANALYSIS OF FOUR LANGUAGES IN RELATION TO  
 THEIR DEPTH HYPOTHESIS SHANSON R SRI

### 9.8.0 THEORETICAL FOUNDATIONS OF INFORMATION SCIENCES

**ARID R A**  
 STANFORD UNIVERSITY  
 RESEARCH IN AUTOMATA THEORY AND ITS MODELING APPLICATIONS SHANSON R M SRI

**BING A**  
 PENNSYLVANIA POLYTECHNIC INSTITUTE  
 SYSTEMS OF NATURAL DEDUCTION WITHOUT ESSENTIAL RESTRICTIONS ON  
 VARIABLES SHANSON R M SRI

**BRICH D B**  
 INFORMATION RESEARCH ASSOCIATES INC  
 APPLICATION OF WIENER CANONICAL EXPANSIONS TO PATTERN RECOGNITION SHANSON R SRI

**COHN R / HANSON M M**  
 SPERRY RAND CORP  
 STUDIES IN LOGIC ON INFORMATION CAPACITY AND COMMAND HIERARCHIES SHANSON R SRI

**DAVIS M / D'PUTINA H**  
 NEW YORK UNIVERSITY  
 THE EXISTENCE AND USE OF ALGORITHMS SHANSON R SRI

**GAID E R**  
 INSTITUTE FOR FORMAL STUDIES  
 A FORMAL THEORY AND ALGORITHMS FOR INTELLIGENT ACTIVITIES SHANSON R SRI

**GANTNER C**  
 UNIVERSITY OF ILLINOIS  
 INFORMATION, COMMUNICATION, MANY-VALUE LOGIC, AND MEANING SHANSON R SRI

**HANSON M M**  
 PHYSICS ENGINEERING AND CHEMICAL RESEARCH ASSOCIATES INC  
 LOGIC AND RATIONAL PROCESSING IN SCIENTIFIC DISCOVERY SHANSON R SRI

**KALLICH B**  
 NORTHWESTERN UNIVERSITY  
 THEOREM PROVING BY COMPUTER SHANSON R SRI

**MCROBBE R A / RAHLER T W**  
 UNIVERSITY OF GEORGIA  
 CONFERENCE ON INTELLIGENCE AND INTELLIGENT SYSTEMS SHANSON R SRI

**RANDOLPH J**  
 UNIVERSITY OF ROCHESTER  
 LOGIC FOR SELF-ADAPTING AUTOMATA AND UNIVERSAL ELEMENTS SHANSON R SRI

**SCHUTZENBERGER M / PAILLOT R**  
 ASSOC POUR L'ETUDE ET LA RECH EN TRAITEMENT DE L'INFORMATION  
 ALGEBRAIC METHODS IN AUTOMATA THEORY SHANSON R SRI

**SHULLYAN R M**  
 YESHIVA UNIVERSITY  
 SYMBOLIC LOGIC AND RECURSIVE FUNCTION THEORY SHANSON R SRI

**STERN A L**  
 WAYNE STATE UNIVERSITY  
 A BRAIN MODEL USING MULTI-VALUED LOGIC SHANSON R SRI

**WILKS Y**  
 INSTITUTE FOR FORMAL STUDIES  
 COMPUTABLE SEMANTIC DERIVATIONS AND THEIR EMPIRICAL BASIS IN  
 LANGUAGE SHANSON R SRI

---

## **AFOSR Research Accomplishments**

---

**Preceding Page Blank**

## *Relating the Accomplishments of AFOSR to the Needs of the Air Force*

DR. WILLIAM J. PRICE, *Executive Director*  
WILLIAM G. ASHLEY, *Physical Sciences Administrator, OAR*  
MAJ. JOSEPH P. MARTINO, *Assistant Executive Director for Research Communication*

Recently AFOSR conducted a survey designed to trace the utilization of scientific research coming from the Air Force Office of Scientific Research program. The results of this survey are of broad interest in that they help develop a model<sup>1</sup> of interaction between science and technology, a matter of great importance in the transfer of technical information. Equally significant, these results help underline the key role which a science-oriented activity can play in support of a technology-dependent, mission-oriented parent organization (1, 2) and at the same time they provide further insight to AFOSR and other managers seeking to optimize the effectiveness of this type of research program.

### **General Accomplishments of AFOSR**

It is generally recognized that the AFOSR program has been successful over the years in helping provide the broad scientific base, as well as the scientific and technical manpower, needed by the Air Force. For example, we have always had a high degree of payoff on our research investment measured in terms of the quality and quantity of the research results coming from the AFOSR support. A bibliography of these results, including abstracts of the articles and reports, is published by AFOSR (3). A close examination of these publications shows that this AFOSR accomplishment alone demonstrates very good value received for the money expended.

The scientific importance of the work which AFOSR has supported can be established in vari-

ous ways such as by noting the number of AFOSR-supported researchers who have been among the leaders in the continually emerging important fields of science. The quality of the work, as well as the AFOSR role as an alternate source of funds for creative scientific programs, can also be appreciated by some statistics on our own proposal activity. We support only those proposals which pass vigorous screening for scientific importance, competence of the investigators, and potential importance to defense. We receive many thousands of informal proposals each year. Currently each year about 2,500 of this much larger group of informal proposals become formal proposals and only less than 500 are finally supported.

AFOSR is also playing a significant role in technical education. At any given time our research program is providing at least partial support for the doctoral research of more than 1,000 graduate students. The overall importance of this support is quite substantial but hard to measure; however, it can be appreciated by recognizing that these students are among the top strata of the Nation's graduate students and they are receiving their education in areas particularly relevant to the DOD. This can be illustrated by the following example. A recent short course on the "Status of Modern Control Systems Theory" at UCLA utilized a total of 10 guest lecturers who presented specific topics to the class. Of these 10, four had received their Ph. D. degrees as a result of AFOSR support, one had received direct support from AFOSR, and an additional three had received both Ph. D. and postdoctoral support from AFOSR grants. The two remaining had received support from other Air Force agencies. Much of the material presented by these lecturers was based on the results they had obtained under AFOSR sponsorship (4).

Thus the impact of the AFOSR research support on scientific research and education is generally recognized. However, it is realized too seldom that the Air Force is benefited directly by this admittedly science-oriented activity, both because the talents of very capable scientists are brought to bear on scientific fields holding particular promise to the Air Force, and what is perhaps just as important, the Air Force support of

<sup>1</sup> This model is discussed in "The Role of AFOSR" in this volume.

scientists provides these persons channels by which they can contribute more directly to the defense of the country through consulting and similar activities.

#### **More Direct Benefits to the Air Force**

AFOSR has played a primary role in colonizing many scientific fields that are very important to the Air Force. Some of these fields are:

Turbulent boundary layer research.  
Blunt body hypersonic flow.  
Hypersonic laboratory simulation.  
Plasma dynamics.  
Shock-tube techniques.

Combustion research on high-energy fuels and oxidants.  
Combustion instability.  
Supersonic combustion.  
Structural materials for high temperature and other reactive environments.  
Mass transfer cooling.

Magneto hydrodynamic energy conversion.  
Electric propulsion.  
Interactions of ultrasonic waves in metals.  
High-temperature arc research.  
Rarefied gas flow.

Fluid physics.  
Cosmic ray physics.  
Seismology.  
Masers and lasers.  
Crystal growth.

Compound semiconductors.  
Superconductivity.  
High magnetic field research.  
Very low temperature physics.  
Cryogenic pumping.

Magnetic resonance spectroscopy.  
Millimeter and submillimeter spectroscopy.  
Ultrasoft X-ray spectroscopy.  
Microwave spectroscopy.  
Field ion emission microscopy.

Quasi-optics.  
Collisional phenomena in ionized gas.  
Quantum electrodynamics.  
Statistical mechanical studies of microscopic materials.

Materials studies by application of EPR, NMR, and Mossbauer effect.  
Matrix isolation techniques.  
Precipitation Hardening.  
High-temperature X-ray techniques.

Structure of polymers.  
High-temperature chemistry.  
High-pressure chemistry.  
Chemistry of the upper atmosphere.

Ladder-type polymers.  
Chemical kinetics.  
Energy transfer phenomena in molecules.  
Rapid scan infrared spectroscopy.  
Chemistry of photographic processes.

Structure of liquids.  
Orbital and celestial mechanics.  
Nonlinear dynamical systems.  
Nonlinear partial differential equations.

Automata theory.  
Probability theory and mathematical statistics.  
Optimum control theory.  
Sampled-data control systems.  
Statistical filtering theory.

Theory and application of digital filtering.  
Nonlinear circuit theory.  
Computer design of electric networks.  
Pattern recognition.  
Statistical approach to information theory.  
Man-machine interfaces.

Information retrieval.  
Error correcting codes in information theory.  
Cybernetics and information theory.  
Computer languages.  
Biological lens studies including compound eyes.  
Research in instructional technology.  
Simulations of international relations.

Role of RNA in memory.  
Visual perception.  
Prisoner of war stress research.  
Biological rhythm.  
Gas chromatography for identification of bacteria.  
Nervous and sensory physiology.  
Performances of organizations under stress.

Since these accomplishments are documented elsewhere (4-24) and are not the primary consideration in this paper, they will not be reviewed here. Illustrations of these activities include:

Probability and statistics, to which AFOSR programs have made outstanding contributions, not only to better understanding of these fields, but also to such Air Force interests as communication theory, decision theory, war gaming, reliability theory, and meteorological forecasting (4, 5).

Improved education and training methods research. An AFOSR-sponsored conference in 1958, and publication of the proceedings (6), provided the impetus for subsequent rapid progress in the field. These and other AFOSR activities have had very significant impact on teaching machines development and on military education and training techniques in general.

Fast chemical reaction research. Important increases in understanding, including the development of a greatly improved rapid scan spectrometer for the infrared region, have not only opened up important new areas for fuller knowledge of many fast-chemical reactions but have also led to the exciting development of chemical lasers (7) and new space flight instrumentation.

Visual perception by moving observers. Studies stimulated by AFOSR have led to important productive research activities in a previously neglected area. Through study of perceptual functions in dynamic situations, including reduced or distorted perceptual cues, important human capabilities and limitations can be identified (8).

Seismology research. Technically managed by AFOSR and funded by ARPA, this program has colonized research in this area of vital importance to solid earth geophysics. This research provided many unique and

significant contributions in instrumentation and techniques for studying and analyzing seismic sources, for discriminating between natural events such as earthquakes, and nuclear explosions, and for pointing the way toward earthquake prediction (9).

High magnetic field research at the AFOSR-sponsored National Magnet Laboratory at the Massachusetts Institute of Technology. Research at NML is stimulating an entire new branch of science. Started in 1960, this laboratory is rapidly adding to the important understanding of the structure solids in several hitherto unreachable aspects, is stimulating research with high magnetic fields throughout the world, and is already making several important direct applied contributions to the defense effort and to technology in general (10).

Combustion research, which has been continually supported by AFOSR, has had broad impact on such important areas as fuels and oxidants for high-energy missile propulsion, and combustion stability in operating rocket engines (11, 12).

Hypersonic research, including hypersonic facilities studies, is a broad based program in which AFOSR has played a key role. Of course, its overall impact on Air Force operational systems is widely recognized (13).

Low-temperature physics research which, made possible by fundamental understanding of the nature of absolute zero, and further stimulated by the goal of designing an experiment to check Einstein's Theory of General Relativity, has established both through theory and experiment the principles required to make improved gyros and magnetometers (14).

Information handling and retrieval studies including man-machine interface problems were pioneered by AFOSR. This field of research, which is growing rapidly both in importance and breadth of support, has already led to the computerized management control data systems in use by various Department of Defense agencies and currently being adopted by other governmental and non-governmental organizations (15).

The large AFOSR activity in providing communication between the scientific community and the Air Force using agencies—through symposia

specifically designed to bring new science to users through oral and written state-of-the-art reviews, by AFOSR-sponsored consultants traveling to Air Force installations, and by other related AFOSR programs (14, 16, 21, 23)—is also making important identifiable contributions. We know also that many scientists supported by AFOSR are performing consultation for DOD in-house and industrial activities under non-AFOSR auspices. It is very significant that AFOSR support helps these persons achieve and maintain their expertise while they are continually helping the DOD in a myriad of direct ways. For example, Project Jason, a long-standing group which has continually made in-depth studies for the DOD, has always included several AFOSR-sponsored scientists. In fact, Dr. M. L. Goldberger, Project Jason's chairman of long standing, is supported by AFOSR in theoretical high-energy physics.

Finally, we have always believed that there are many other instances where the research results coming from our program have directly benefited the military forces, in terms of specific applications. Although many of these uses were known to us, and some have been documented elsewhere (4-22), we also believe that there was a large amount of specific utilization of our research about which we had little or no information.

Since the dissemination of the results from the research program can take place in many ways spaced over a long span of time—through reports of journal articles, through presentations at scientific meetings, and particularly through any one of numerous less formal channels—the research results receive wide distribution, and may be used by someone totally unknown to the research scientist. The diversity in the methods of flow of information is at the same time a source of great strength in the research program and the primary reason for the existence of the problem in tracing the specific utilization of research. Even in cases where the user has to make some contact with the author, there is often still little feedback. For instance, an AFOSR contractor, Dr. D. A. Calahan, then at the University of Kentucky, devised a computer program for designing electrical networks. The user could specify the desired network characteristics, and the computer would then design the network, including component sizes and places in the network. He sent card decks containing the computer program to nearly a hundred

people who requested them. Even though Dr. Calahan received feedback from a number of recipients it was still not possible to point to specific weapon systems which benefited directly from it, even though it actually was a major step forward in design technique.

Furthermore, even in cases where the research scientist does learn of an application for his research, he may not always inform the sponsoring agency. The application typically does not come until several years after the completion of the research. The research scientist may now be receiving support from a different agency. He may not even realize that his sponsors want to learn of applications of his work. So the small number of cases where the scientists learn of applications of their work is further reduced in relaying word of these applications to his sponsoring agency.

#### *The Current Study of Specific Applications*

In order to obtain more objective data, AFOSR recently embarked on a number of projects to obtain information about how basic research results get used in military technology, and how this process might be improved. In one of these projects we attempted to reduce the number of failures to report known applications, by directly asking our researchers if they knew of applications of their research.

A brief one-page questionnaire was sent to a small sample of scientists who had been associated with AFOSR in the past. The intent was to collect a body of examples of applications, which would then be useful in drawing conclusions about what kind of research results get use, what they get used for, and the channels through which they get used. The analysis of the questionnaires is not complete (a partial analysis and compilation has been made (24)), but some interesting information has emerged from the study. In particular, we obtained over 100 good examples of applications of research which AFOSR has sponsored.

We found that the utilization came about in a wide variety of ways. These were broadly categorized as "weapon systems", "instrumentation", "design techniques", "manufacturing methods", and the remainder which were simply grouped as "other". Some of the examples are given below, as well as some additional information obtained from the questionnaires.

### Weapon Systems Applications

Three examples of weapon system applications will be cited, two involving a missile application and one an aircraft application.

One missile application was concerned with reentry vehicle design. One of the design problems of reentry vehicles is to assure that they are unstable in all but the nose-first attitude. If a reentry vehicle were capable of stable flight in some other attitude, and reentered in that attitude, the heat shield, which is thickest on the nose, would offer insufficient protection and the vehicle would burn up. One of the early model reentry vehicles for ballistic missiles was designed to be unstable in all but the nose-first attitude, in atmosphere of normal density. However, it was found that the vehicle was stable flying tail-first in rarefied gases. The company designing the vehicle found that for some years AFOSR and the Office of Naval Research had sponsored research in rarefied gas aerodynamics at the University of California at Berkeley and other places and that the results of this research were directly applicable to their problem. The company was able to make use of the results of this research to redesign the reentry vehicle so that it was no longer stable in the tail-first attitude, even in rarefied gas flow.

The aircraft application involves so-called favorable interference. Dr. Antonio Ferri, AFOSR contractor at Polytechnic Institute of Brooklyn, has developed a theory known as "three dimensional interference effects", which shows that by properly positioning protuberances on an aircraft, or even creating protuberances where necessary, the airflow disturbances from one can be caused to interfere with the airflow disturbance of the other, canceling out effects that would otherwise be deleterious to aircraft performance. This concept was applied by Grumman Aircraft Co. to design the air inlet for the F11F-1F aircraft resulting in a considerable increase in the power available from the jet engines. Dr. Ferri was a consultant to Grumman during the design of this aircraft.

Finally, we find that Kalman's linear filter theory, developed under AFOSR support in 1959 under a contract entitled "The Study of Non-linear Mechanics", is finding broad application in the control and navigation systems currently being employed for USAF and NASA space launches.

### Instrumentation

A sizeable share of the applications turned out to be in the field of instrumentation. In some cases AFOSR was supporting the work in order to obtain the new test instrument. In other cases, an instrumentation technique was developed by a research scientist who was looking for something else, but who realized the significance of what he had discovered.

A striking example of research directed toward a new instrument is the wave superheater hypersonic wind tunnel, at Cornell Aeronautical Laboratory. AFOSR research at Cornell University, Cornell Aeronautical Laboratory and other places, designed to provide fundamental understanding of hypersonic flow and of methods for producing laboratory simulation, evolved this concept of this type of wind tunnel. AFOSR supported CAL for the design and fabrication of a pilot model wave superheater, intended to demonstrate the feasibility of obtaining a continuous stream of high-temperature air. With the successful demonstration of the pilot model, the presently used full-scale wave superheater was designed and built, with initial support from AFOSR, and later support from other agencies. This device has proved to be of tremendous importance in design of reentry vehicles, since it provides an opportunity to test full-sized reentry vehicles, at reentry speeds and temperatures, at much lower cost than for a missile flight, and with much more detailed measurements taken of heat shield behavior. The tunnel has already been used for several full-scale tests of developmental reentry vehicles.

AFOSR supported two programs of phenomena-oriented research in the infrared properties of molecules at high temperatures with reasonable expectation that utilization might be achieved if the research were successful. This research, accomplished primarily at the Warner Swazey Research Laboratory, did, indeed, lead to applications of interest to both DOD and NASA. One of these programs was for research in the use of "band models" to represent the transmittance of infrared bands of molecules at high temperatures. From it evolved spectroscopic techniques which were quickly applied to the problem of determining the concentration of water vapor in a supersonic nozzle and the determination of CO<sub>2</sub> concentrations in shock-heated gases. The other research program was to determine the temperature distribution in a hot

gas from measurements of the infrared spectrum of the gas. Results from this program led to a method for calculating spectral transmittance in an applied research program for NASA. This applied research program combined the results of the two basic research efforts and produced a method for predicting the radiant heating of the base of the Saturn rocket. Further, the results of this basic research have been applied to calculation of the radiance from a missile plume.

An example of instrumentation which arose from research originally aimed at other purposes involves the use of superconductivity in metallurgical analyses. AFOSR has continuously supported a major fraction of U.S. research in superconductivity, together with the Army Research Office and the AEC, which supported work on superconducting magnets. The intent of this research program, at a number of universities, was to gain more understanding of the phenomenon of superconductivity. Among other things, it was learned that the presence of minute traces of impurities, imperfections, and lack of homogeneity in metal samples can alter the superconducting behavior of metals to a measurable degree. This fact has been put to use by at least one aircraft manufacturer as a nondestructive testing technique for the analysis of new titanium alloys for aircraft structures.

Another example of an unexpected application came from Butler's search for understanding of the alternating intra-inter molecular chain propagation mechanism for the formation of linear polymers from nonconjugated diene monomers. This theory led to the concept and synthesis of ladder polymers. A polymer derived from this process has shown excellent potential as a flocculating agent with the capability of converting surface water to potable water, and the Army is using this material in a portable unit for water purification which is awaiting adoption by the Army Medical Corps.

Still another example is that of the blood-glucose measuring instrument. Dr. H. V. Malmstadt, of the University of Illinois, applied for AFOSR support for research in the field of spectrophotometric titration procedures. In these procedures, the concentration of some chemical in a solution is determined by adding another chemical which will neutralize or otherwise react with the chemical to be measured. The neutralizing chemical is added slowly and continuously until just enough has been added to completely remove from the

solution the chemical to be measured. The endpoint of this process is signaled by a change in the color of the solution. Since the amount of neutralizing chemical which has been added to the solution is known, it is then possible to calculate the amount of the chemical to be measured which was originally present. The drawbacks to this process are that it is time consuming, and the exact time of color change (endpoint) is often a matter of judgment, since the solution may be only faintly colored well before the endpoint. Dr. Malmstadt investigated the use of photoelectric devices for determining the endpoint, and succeeded in devising techniques which allowed determination of the amount of certain metals present in a solution, with much more precision than had been possible before. He then turned his attention to other materials, including glucose in blood. He found that a modification of the procedure already used on metals could be used for determination of blood glucose, and that the entire process could be automated using a combination of commercially available instruments. The process he devised is much more rapid than those previously used, it used a less expensive chemical for addition to the glucose solution, and its precision is considerably higher. The method has been adopted in a number of hospitals and clinical laboratories.

#### **Design Techniques**

Another important category of applications was that of design techniques. These covered a wide range of subjects, from differential correction of orbits to design of solid propellant rocket engines.

In the case of correction of orbits, S. Herrick of UCLA, with AFOSR support, has developed theories of differential correction of orbits. His theories were applied by Aeronutronic to the design orbit of the Mercury capsule. In this case, the application of the research result arose from the fact that Dr. Herrick was a consultant to Aeronutronic Division of Philco.

P. D. McCormack, of the University of Dublin, under AFOSR sponsorship, was doing research on the effects of vibration on stability of combustion in the engine. He presented his results at an AFOSR-sponsored symposium which was attended by specialists in the field of combustion dynamics. Personnel from Rocketdyne, who were concerned with design of a medium-sized rocket engine for NASA, were present at the meeting.



They recognized that McCormack's results provided a solution to a problem of combustion instability which had arisen during tests of the NASA engine. They applied his results successfully, and eliminated the instability.

Another example involves the design of a restartable solid propellant rocket. Under the direction of Drs. N. W. Ryan and A. D. Baer, at the University of Utah, a concept had been originated regarding the relation between ignition temperature and initial temperature of a solid propellant. Some time after publication of their results, they attended a symposium and heard a paper presented by an industrial group which related that their concept had been applied successfully. The concept had made possible a significant reduction in the number of low-temperature test firings required during development of a restartable engine.

#### **Manufacturing Methods**

The manufacturing methods which had resulted from the application of AFOSR research ranged from methods for producing a few ounces of low-defect materials to methods for producing tonnage quantities of high-purity materials.

Two examples of small-scale manufacturing methods both involve solid state electronics. AFOSR-supported research at Westinghouse on dendritic growth of semiconductors, resulted in a detailed understanding of the nature of the dendritic growth mechanism and led to methods for producing high-quality germanium and silicon ribbons for use in transistors. Similarly, AFOSR-sponsored research at Stanford University has led to means for production of large, relatively defect free, sapphire crystals which are in great demand, for use as substrates for integrated circuits.

Two other examples involve large-quantity production of materials for applications requiring a high degree of purity. AFOSR-sponsored research at Columbia University on chemical reactions in the tail flame of a high intensity arc has led directly to a process for producing uranium monocarbide, a process which is superior to those previously used, and which has been used commercially, producing UC in many-ton lots for use in nuclear reactors. Another example is a process for producing tonnage quantities of high-purity aluminum, which grew out of AFOSR-

sponsored research on the effect of stirring during freezing on the purification of materials.

Two further examples show where phenomena-oriented research at the University of Illinois resulted in improved manufacturing methods for semiconductor devices. Studies of diffusion in heavily doped silicon and germanium provided valuable data for the fabrication of devices, particularly integrated circuits, by the diffusion method. Similarly, basic studies of semiconductor surfaces have been of importance to those concerned with the reliability of semiconductor devices.

#### **Other Applications**

After the examples were grouped into the categories described above, we were left with a collection of disparate examples which could not be categorized easily. One of these will be cited here because we feel it has considerable significance. Drs. Tiffany and Kikuchi were working at the University of Michigan in 1955, under a joint-service funded Project Michigan, which was investigating infrared equipment. They wanted to investigate a phenomenon called electron spin resonance in certain solid materials. Because of the pressure on Project Michigan to produce hardware, it was difficult for them to get support for this investigation, as it was considered too "basic". They applied for and received AFOSR support to continue their investigations. In the course of their research they studied various crystals including the ruby. Almost incidentally, they observed that the ruby had properties which would make it useful in microwave amplification. They grasped the significance of their observations, and made the results available to others who developed the ruby as the basis for the first practical solid state maser.

In addition to the direct application of research results to weapon systems, or to means for designing, testing or manufacturing weapon systems, many other benefits of a service-sponsored basic research program were illustrated by this survey. Consultations with aerospace manufacturers is an important example which demonstrates how AFOSR-sponsored research is transmitted directly to users. While some certainly would have been involved in these activities even without AFOSR support, some made the positive statement that it was AFOSR support that made them interested enough in Air Force problems to be willing to engage in these activities.

### **Summary of Findings**

The examples cited above illustrate some of the findings of our investigation of applications of AFOSR-supported research. Analysis of the findings is not complete, and additional efforts are being made to get more examples. However, based on the information we do have, we have already reached some conclusions.

First of all, it is abundantly clear that much of the phenomena-oriented research we have supported has had a significant impact on military technology. Our success in finding utilization through this survey shows us that a large amount of such information could be accumulated.

Second, we find that research is often applied quite rapidly. Although much of the utilization which we discovered in this survey came from results produced in the first 10 years of our 15-year history, we are already seeing important utilization of the last 5 years of research results. Clearly, one does not have to wait until research results are condensed into the books to be taught to the next generation of engineers before it is utilized.

Third, since the interactions bridging scientific research activities with technological utilization occur in many diverse and important ways, any specific study of the R&D management process must recognize the possibility of missing very important facets of this interaction. On the one hand, examples are found where phenomena-oriented research provided the key idea from which application proceeded. On the other hand, we find many more cases of utilization where highly essential understanding and other support was provided technology activities in a large variety of ways which usually are not even mentioned when the origin of application is being discussed.

Fourth, the phenomena-oriented research leading to the applications which we are finding was not generally started to support the specific purpose for which it was ultimately used. Rather, it was initiated by the AFOSR project manager who selected it because it supported the overall program for which he was responsible and, as such, met appropriate standards of Air Force relevance and scientific promise. As new knowledge and understanding grew, related technology progressed along with it. In other words, we are finding a large amount of utilization of research of the type which is typically performed in universities,

under the sponsorship of capable agency program managers.

Fifth, we found that one of the important roles performed by organizations like AFOSR is to support phenomena-oriented research in laboratories (such as industrial laboratories) which are sometimes reluctant to conduct research not directly related to their technical program. This support permits investigators in such laboratories to perform a thorough investigation of some phenomenon or approach instead of stopping when they have enough information to meet the specifications on the development program which brought a problem to light. The additional information thus gained often turns out to be very useful in solving or sidestepping a more complex form of the same problem in a later development program.

Sixth, our findings confirm the widely accepted belief that carefully designed special purpose symposia and scientific meetings, and other means of communicating which provide opportunities for personal contact, are very important channels for transmission of research results from researcher to user, and equally important for transmission of needs from the user to the researcher, thus assuring their dynamic and positive interaction to forestall the usual time lapse of years as when reliance is left solely to publication.

### **Conclusions**

We are quite pleased with the results which have come out of this study so far. They have confirmed our earlier confidence that the research which AFOSR has sponsored has been of great benefit to the Air Force, and to the other military services.

The contribution to our knowledge of the way in which phenomena-oriented science and technology interact is particularly significant in that it brings the interface role served by AFOSR into clearer focus both from the standpoint of its importance and its function. This understanding is vital in choice of research areas for colonization and in the conduct of activities designed to provide effective interaction between phenomena-oriented science and technology. Further study of those successful techniques for selecting research in the past is providing additional insight into ways of further optimizing the research management procedures used in the future.

## REFERENCES

- (1) *The Fundamental Research Activity in a Technology-Dependent Organization*. Tenth Institute on Research Administration, Center for Technology and Administration, The American University (AFOSR 65-2891, April 1965).
- (2) Howard Reiss and Jack Balderson, *International Science and Technology* 53 (1966).
- (3) *Air Force Scientific Research Bibliography* I (1959), II (1961), III (1964), IV (1966).
- (4) *OAR Research Review* III, 10 (1964).
- (5) *Ibid.* IV, 6 (1965), IV, 7 (1965).
- (6) *Automatic Teaching, the State of the Art*, ed. by F. Galanter (Wiley & Sons, New York, 1959).
- (7) *Scientific American* (April 1966).
- (8) *Nature* 207, 4992 (1965).
- (9) *Vela Uniform Research in Seismology, 1961-1965* (AFOSR 65-2867, 1965).
- (10) *Scientific American* (April 1965).
- (11) *OAR Research Review* III, 12.
- (12) *Ibid.* IV, 1.
- (13) *Ibid.* IV, 6.
- (14) *Proceedings of OAR Research Applications Conference*, OAR Washington, D.C., April 1966. Also, "Applications of Cryogenic Zero Magnetic Field to Nuclear Gyroscope and Magnetometers," Hughes Aircraft Co.
- (15) *Computers in the Research Administration Process*. Eleventh Institute on Research Administration, Center for Technology and Administration, The American University (AFOSR 66-0653, April 1966).
- (16) *OAR Research Review* (monthly since February 1962).
- (17) *U.S. Air Force Achievements in Research*, Office of Aerospace Research, USAF, Washington, D.C. (1965).
- (18) *Annual Report*, Office of Aerospace Research, USAF (1964).
- (19) *OAR Progress '65*, Office of Aerospace Research (1965).
- (20) *Case History of Scramjet Development*, Final Scientific Report, University of Oklahoma (AFOSR 1044-66, November 1966).
- (21) *Sciences in the Sixties*, Proceedings AFOSR Summer Scientific Seminar, New Mexico University Press (1965).
- (22) Elsewhere in this volume.
- (23) *A Summary of AFOSR Coupling Activities* (1965, 1966).
- (24) *A Study of the Impact of Air Force Research on Defense*, AFOSR (April 1966).
- (25) Jack Morton, "Innovation as a Systems Process," National Planning Association Conference on Technology Transfer and Innovation (1966).
- (26) Jack Goldman, "The Role of Science in Innovation," National Planning Association Conference on Technology Transfer and Innovation (1966).
- (27) Harvey Brooks, "Past Achievements and Future Foel of the Federal Government in Science," Official Proceedings of the Vicennial Convocation, Office of Naval Research (May 1966).
- (28) Howard Reiss, personal communication.

## Mathematical Sciences

### *Automata Theory*

LT. COL. BARNETT R. AGINS

The development of the digital computer heralded a new era in science and technology and has had an impact on all phases of modern existence. It is used as a tool for computation and as an integral part of systems development ranging from automobile production to guidance of space vehicles. Yet there are severe limitations on a computer's capabilities. Although there have been many technological advances, such as the design of smaller components and better memory techniques, the fundamentals have not changed in the past 25 years due to a lack of the related mathematical formalism we call automata theory. However, results of the AFOSR-supported program in automata theory promises to lead to a wide range of new theoretical advances in computer technology.

Automata theory began in 1939 with the classical work of Shannon on switching circuits. The theory of sequential machines, where time plays an essential role, was established in the McCulloch and Pitts paper of 1943. Thereafter, theory developed slowly because no mathematical formalism was available.

Almost concurrently with the theory, digital computers were developed. These are finite state sequential machines. The approach to the construction of computer hardware was the intuitive one. The engineer, confronted with the problem of realization of any particular sequential circuitry, and knowing how many registers, words of memory, etc., were required in the past to construct similar devices, used his experience and ingenuity to connect the chosen components in the most advantageous manner. Frequently, after the machine was in operation, a considerable redundancy was discovered. Whole blocks of components could be eliminated without in any way impairing the desired operation. Even though there were a number of techniques for dealing with nonsequential circuit design, it was an art to which long experi-

ence in practical problems was the sole initiation. The situation was similar to that existing in classical mechanics before the introduction of the Hamilton-Lagrange methods. Obviously, what was required in sequential machine design was a canonical representation furnishing a technique by which a complete set of irredundant equations characterizing the desired system could be obtained almost mechanically. In addition to the immediate design application, such schemes could constitute a general structure theory of sequential machines, leading to a really profound understanding of finite state sequential systems in general.

In 1962, the first basis of an algebraic theory of finite sequential machines appeared. It established that the needed mathematics was the theory of finite semigroups, and the one new idea, that of a relative measure of the computing power of finite machines, was introduced. This was a key to the decomposition of finite machines into a natural set of irreducible component machines.

The algebraic theory of machines came to the attention of AFOSR even before publication. An evaluation of the theory indicated that it was based on sound mathematics, and had the potential to develop the needed mathematical formalism. Two goals were envisioned: First, to furnish an automatic, programable technique for minimal physical realization of finite-state machines; and second to provide fundamental understanding of the essential notion of finite state systems in general. A wide range of applications was anticipated. Machines could be designed automatically by computers without human intervention. Special purpose computers, such as those required for onboard space vehicle systems, could be realized with minimum weight and cost. Many systems with finite state representations, e.g., long chain molecules and biological systems, could be studied carefully. At the very least, the research would yield more efficient programming methods which should save more than the cost of the investigation. Based on these factors, a research program in automata theory was initiated.

The algebraic theory of machines is a complete structural study using algebraic methods, in par-

ticular, those of the theory of groups. This allows, for the first time, the application of the enormous fund of sophisticated results of classical and modern algebraists to computer engineering. The most elementary use of the theory is to construct, given the input-output relation desired, the minimal finite state machine realizing this relation.

To understand the ideas, we need a few definitions. Machine  $A$  is said to *divide* machine  $B$  if and only if any calculation  $A$  can do can be done by  $B$ , possibly aided by memoryless input-output codes. A *semigroup* is a set of elements closed under an associative operation. Semigroup  $A$  divides semigroup  $B$  if and only if  $A$  is a homomorphic subimage of  $B$ , i.e., intuitively, if and only if  $A$  is algebraically simpler than  $B$ .

The initial observation is that machine  $A$  divides machine  $B$  if and only if  $A$ 's semigroup divides  $B$ 's semigroup. Here we have an engineering property which is difficult to establish equivalent to an easily verified algebraic property.

A machine is called prime if, whenever it divides a series-parallel (loop-free) network of other machines, it divides one of them. That is, a machine is prime if it can never profitably be loop-free constructed out of weaker ones. In view of the stringency of the definition, it is not clear that any prime machines exist. A very long algebraic construction and proof shows that there is, in fact, an infinite number of them and gives a complete characterization of the primes. It is well known that any integer can be represented as a product of the primes that divide it. For example, the number 200 is divisible only by two primes, 2 and 5 and can be expressed as  $2^3$  and  $5^2$ . It is amazing that a corresponding fact is true for the much more complicated set of computing machines. This construction immediately allows solution of the state assignment problem for a wide category of cases.

Suppose an engineer wishes to realize in hardware a given  $N$  state sequential machine  $M$  (i.e., the abstract logical formulation of the circuit). Assume that flip-flops, cores or any other binary elements are the basic memory objects.

In the literature, this is the sole case treated. It should be noted here that the approach via the algebraic theory of machines leads to a method equally applicable to  $n$ -ary elements for any  $n$  greater than 1.

The engineer proceeds to select an integer  $k$  such that  $2^k$  is equal to or greater than  $N$ . He then assigns to each state of the machine  $M$  a configura-

tion ( $k$ -tuple) of elements such that two different configurations correspond to two different states. Once this assignment is made, the diode logic of the hardware is uniquely determined by the sequential machine  $M$ . In general, the next state of each binary element is dependent upon both the present input and the last state of all the binary elements. In this arbitrarily bad state, we may measure the complexity of the diode logic by saying that there are  $k^2$  dependencies. In general, dependencies of the order of  $\frac{4k^2}{5}$  are considered excellent, using the foregoing techniques.

However, using the algebraic theory of machines,  $M$  is decomposed into a series-parallel network of prime machines, where the product of the number of states of the component machines is equal to the number of states of the original machine  $M$ . States are assigned to the component machines arbitrarily. This operation, through the connecting codes of the decomposition, automatically induces a state assignment for  $M$ . Now, it is clear that we can number the component machines 1 to  $q$ , so that in all, between the  $i^{\text{th}}$  machine and the input to the network there are no more than  $i-1$  intermediate machines. The logic of the 1st machine will depend only on the binary elements which realize this machine, and the logic of the  $i^{\text{th}}$  machine will depend only on its binary elements and the  $i-1$  machines which precede it. Consequently, the number of dependencies is of the order of  $1+2+\dots+k = \frac{k^2}{2}$  (approximately.)

Thus, in this application, the complexity of the machine  $M$  is reduced in the ratio 8:5.

In general, the theory of machines can be regarded as a theory of optimum coordination of phase spaces, where phase space is the set of states of machines whose outputs are the same as the current state. In fact, the precise notion of what is meant by the term "physical theory" is just a transparent coordination of the phase space over which the theory operates. Problems in mechanics, for example, lead directly to the correct choice of generalized coordinates, and the seven integrals of motion are seen to correspond to the first machine and the machine decomposition of phase space. It is in the case of discrete phase space where the techniques of differential equations are not applicable that important breakthroughs are anticipated using this algebraic theory.

A new method for generating Boolean func-

tions has been developed. A fixed simple abelian group machine  $M$  is used, and any Boolean function  $B$  can be realized by  $M$  with the aid of a storage sequence depending on  $M$  and  $B$ . This means that one finite state machine can be used to realize all Boolean functions involved in a given operation with only a storage unit required for each Boolean function. This could lead to significant new techniques in the optimization of design of computer components.

A system for determining semigroup isomorphisms (equivalences) has been programmed to Project MAC. The program required 20 seconds to find an isomorphism of the cyclic group of order 12 with the direct product of the cyclic groups of orders three and four. Decomposition of semigroup of order 64! has been achieved.

A study of the application of the theory to biology has been initiated. A state input model for metabolic processes has been developed whereby a semigroup can be found underlying a given multi-enzyme system. The theory proves that the semigroup of any enzyme system can be represented by a system of simpler components. Information theory indicates that the components which are biologically significant are those known as simple non-Abelian groups (SNAG's), all others being insufficiently adaptive to maintain vital functions in the fluctuations of environment to which living organisms are subject.

This program represents the first application of nonlinear mathematical modes to biology. There are considerable implications for medical research inherent in the theory, in that it provides insight into pathological processes.

Work has been started, using the techniques of the theory of machines, to attempt to clarify the theory of elementary particles.

The pioneering aspect of the algebraic theory of machines, which to a large extent was sponsored by AFOSR, will be concluded by bringing together a number of investigators, whose results in various aspects of automata theory and applications will be discussed. The proceedings of this conference will be published and form a cohesive reference for future research.

There are three major aspects for the continuing research: (1) Pure research to develop a complete structure in the theory itself; (2) immediate applications to computer sciences, languages, and related fields; and (3) use of the theory as a tool

for better understanding of biological and physical systems.

Concurrent with the support of the algebraic (structure) theory of machines research, the applied mathematics division has funded other approaches to automata theory. These include the reliability of sequential machines, the synthesis of time varying sequential circuits, linear sequential circuits, error correcting codes and nonbinary switching and logic.

There are two approaches to the effects of errors in sequential machines. One is to assume that the machine has somehow arrived at the wrong internal state and then the effect of these errors is considered. The second is to consider the effects of errors on the inputs. In this model, one specifies input words which may be in error by giving an error relation on the class of input words. In the investigation, both internal errors (incorrect state transitions) and external errors (inputs which are not received properly) were considered. One result was obtained by the study of the class of automata which correct a prescribed set of input errors. It was found that there is an exchange between the error correcting capabilities of a machine and the time necessary for correction.

Another part of the program is to develop a general theory through which any linear sequential circuit can be analyzed and synthesized. In particular, the investigation is concerned with the characterization and design of stable circuits, where any error input vanishes in a finite time, and quasi-stable circuits, where input error produces a perpetual but constant response. These circuits, which are singular, have been largely ignored in the past, but can be used to advantage in error correcting and detecting systems. Techniques for constructing minimal forms of linear modular sequential circuits and for singular circuits have been developed very recently.

An examination of the problem of minimization of Boolean functions through graph theoretical methods is being pursued. It may be that this approach to minimal synthesis is preferable to existing algorithms.

In most automata, the logic is two valued, based on binary switching theory. There appears to be considerable potential in multivalued logic for automata, so the development of nonbinary switching theory is another area into which the program in automata theory reaches. Ternary algebras have been developed and synthesis techniques for mini-

mum cost ternary switching circuits were derived in the context of available technology. Efforts are now underway to establish design techniques for nonbinary cellular arrays as well as for nonbinary nonlinear sequential circuits.

AFOSR has thus developed a broad based program on research in automata theory which encompasses both the structural and the programing approaches. There are, necessarily, overlaps and interchanges between these approaches and between automata theory and other areas such as information theory and biology. These interchanges are encouraged with the objective of advancing the frontiers of all the involved sciences and their eventual application to the needs of the Air Force and the United States.

## *Control Theory*

MAJ. JOHN JONES, JR.

Modern control theory is a branch of applied mathematics under strenuous development by AFOSR to help obtain solutions to problems related to high-speed aircraft, aerospace vehicle systems, and advanced space systems.

The starting point for these theoretical developments were based upon the assumption of a mathematical model of the system to be controlled in one form or another. Although the main objective of nearly all control problems is maximization or minimization of a certain specified performance index, their complexity and the methods of approach depend on the forms of the assumed mathematical model, in particular, the form of the system equations and the associated constraints.

Most of the recent research efforts in control theory have been devoted to problems involved in obtaining solutions to adaptive and optimum control problems. Theoretical investigations on optimum and adaptive control have been carried out for the following classes of systems: dynamical systems governed by ordinary differential equations; distributed parameter dynamical systems governed by partial differential equations, integral equations, and functional differential equations;

integral equations; and dynamical systems with uncertainties

Optimum control problems have occupied the attention of researchers for several years. Methods used for their solution have included those based on the calculus of variations and on Pontryagin's maximum principle. Another approach is based upon the work of Krein who established conditions for the existence of linear functionals which transform given elements of a normed linear space into given points on the real line, and which, in addition, have norms of value less than or equal to a constant  $L$ . When the conditions are used to define a minimum value for  $L$ , a minimization problem is defined. The application of Krein's work to automatic control optimization problems has been made by several scientists.

The solution of optimum control problems requires that the desired result be a development of design procedures for the controller of a manufacturing facility which optimized that plant's performance in some sense. The cost of control or of deviation of the plant's state from the desired state is expressed as a cost function and this cost function is to be minimized. In addition, constraints on the operation of the plant are also present. A group headed by Leondes at UCLA is investigating such a functional analysis approach to control problems for linear plants. The cost functions and constraints correspond mathematically to norms of linear functionals defined on a normed linear function space. The output of a linear system at a specific time  $T$  is related to the input time function by a convolution integral. This integral is a linear functional which transforms the system weighting function into a real number, the output. Each new input time function defines a new functional. Thus, the control system optimization problem corresponds to a mathematical problem of finding a linear functional with minimum norm which satisfies certain constraints.

In order to completely solve the problem, one needs to find the functional and the type of norm which corresponds to the physical problem being solved. The control signal must be formed as a function of time or of the state variables physically available for measurement. The controller must be designed for either open-loop or closed-loop control of the plant.

During the last decade, control theory has advanced quite rapidly. This is due largely to the

fact that control engineers have been called upon to deal with increasingly complex systems. As the problems become more stringent, the theory of optimal control systems has received increasing attention by engineers and mathematicians. Historically, the optimal control problem arose first as the "time optimal" control problem, the problem of bringing some components of the system state vectors to desired states from a given set of initial states as quickly as possible, while satisfying certain constraints on the means of controlling the system. Since then, a large number of research papers have appeared on various other types of optimal control problems as well as on time optimal control problems and the theory of optimal control has reached a rather high level of development.

The optimal way of controlling a given system with respect to the given criterion of performance will be called the optimal control policy. Optimal control policies may be given as a function of "state" of the control systems or as a function of time. In the former case, they represent a closed-loop control of the system whereas in the latter they represent an open-loop control.

A way of controlling the system in some non-optimal way for the given criterion of performance will be called a suboptimal control policy. There are several reasons why one must consider suboptimal policies. First, because of the scale and complexity of systems it may be impossible to solve optimal control problems exactly even if optimal policies are assumed to exist and in certain cases optimal policies may not even exist. Also, if optimal policies whose existences are assumed are too complex either from the standpoint of analysis or engineering implementation, then various approximate solutions of the optimal control problems must be considered. Original complex problems may, on the other hand, be sufficiently simplified to allow exact solutions. In any case one desires good suboptimal policies to approximate optimal policies.

Another fact which must be considered is that rarely are criteria of performances designed to include all pertinent factors in optimal system designs, thus it is necessary to consider not only optimal policies but suboptimal policies to allow engineering and or economical considerations in the construction of systems.

The problem of optimally controlling a class of linear control systems which are disturbed by random noise and the probability distribution

function of the noise is known or where the distribution function is known only as a member of a given class of distribution functions, is known as a stochastic control problem in the first case, and as an adaptive control problem in the latter case.

Another example of an optimal control problem is that of designing a system such that certain components of the system state vector follow some desired or given functions of time as accurately as possible during the control period. One may refer to desired functions of time as desired trajectories and actual or realized functions of time produced by the system as actual trajectories of the systems. Optimization problems consist in choosing control vectors and other system parameters at the disposal of system designers in such a way that some given criterion of closeness of fit is minimized for given desired trajectories and realized system trajectories.

An important result used in control theory is the Pontryagin maximum principle introduced in 1956. An especially appealing feature of this principle from the control system designer's viewpoint is its utility in establishing certain properties of optimum controls with a minimum of mathematical manipulation.

Let us consider an example of the maximum principle applied to a lunar hovering mission. Assume that a space vehicle is in the terminal descent phase of a lunar mission and is descending vertically. We desire to program the thrust so that the vehicle will achieve zero terminal velocity at some specified altitude, say approximately a few hundred feet and with a minimum expenditure of fuel. Once this terminal condition is achieved, the vehicle can hover by applying a thrust acceleration of one lunar gravity  $g$ . Such a mission permits inspection of a lunar surface and subsequently aiding in the choice of a landing site if so desired.

It has been shown for this above problem that there is at most one switching during the descent and that the switching is from "off" to "on." That is, the optimal thrust program consists of either full thrust from the initiation of the mission until the desired hovering altitude is achieved, or a period of zero thrust or free-fall followed by full thrust until the desired hovering altitude is achieved. Because of the relative simplicity of the optimal thrust program, it can be synthesized by developing an appropriate switching function. Development of a switching function consists in determining a relation such that if the thrust is



turned on when this relation is first satisfied, and left on, the desired terminal conditions are achieved.

The optimal thrust program is then implemented by sensing the altitude and velocity during descent by a radar altimeter and doppler radar, respectively, initiating thrust when a given relation is satisfied and continuing thrust until the desired terminal conditions are achieved.

Fundamentally speaking, all physical systems are intrinsically distributed in nature. However, in many physical situations, the system's spatial energy distribution is sufficiently concentrated or invariant in form during the course of motion so that an approximate lumped parameter description may be adequate. However, on the other hand, the spatial energy distribution of many practical physical systems are widely dispersed. It is desired to maintain precise control of certain spatially distributed physical variables. This generally requires the direct consideration of distributed parameter mathematical models which are in the form of partial differential equations or integral equations. Typical examples include distillation processes, nuclear and chemical reactors.

The basic approach underlying almost all existing works on the control of distributed parameter systems has been based on first approximating the distributed model by a corresponding spatially discretized model, and then designing a control system via the established theory for lumped parameter systems.

The notion of controllability is associated with the ability of steering one system state to another in a finite amount of time by means of certain admissible class of controls. This concept was first introduced by Kalman. He derived precise mathematical conditions for the controllability of finite dimensional linear dynamical systems. For dy-

namical systems governed by nonlinear ordinary differential equations, results pertaining to local controllability in Kalman's sense have been obtained by Lee and Markus. Also, they have established a relation between complete controllability and asymptotic stability. Many other phases of control theory have been investigated including a study of optimal control for systems described by difference equations, control problems with state vector measurement errors and on line computer control techniques and their application to reentry aerospace vehicle control.

Over the past 25 years a great body of knowledge has been built up on the subject of feedback control of linear, time-invariant dynamic systems. This knowledge plays an important role in our technology, and engineering schools recognize this fact by teaching courses in this area. However, many dynamic systems, particularly aerospace systems, are nonlinear and/or time-varying and the techniques for analysis and design of linear, time-invariant control systems are, in general, not applicable to these more complicated systems. This fact was particularly noted by AFOSR in the early fifties and it has since pioneered in the development of theories applicable to the design of realistic aerospace systems.

The appearance of practical, high-speed digital computers in the 1950's provided an essential tool for dealing with nonlinear and time-varying systems. It also required a great understanding and the development of a theory of sampled-data systems. Such systems which are also referred to as discrete systems are those in which information is available only at discrete intervals of time. A telemetry system is another prime example of a discrete system. It is, therefore, quite obvious why the first program of AFOSR support of research in control theory was in sampled-data systems. This program at Columbia University had as its

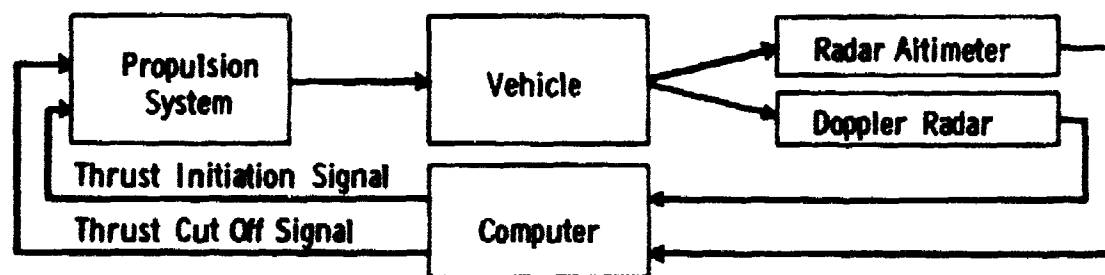

FIGURE 1.—Block diagram for optimal system for lunar hovering mission.

principal investigators John Ragazzini (now dean of engineering, New York University) and Lotfi Zadeh (now head of the Department of Electrical Engineering, University of California, Berkeley). The program was extremely successful. It provided the fundamental theory essential for the use of digital computers in guidance and control systems. Specific applications have been made to the design of digitally controlled aircraft intercept systems (SAGE), guided missile control systems, and trajectory and rendezvous control of space vehicles. It should also be noted that both the oil industry and chemical industry are prolific users of sampled-data control systems and the results of this program are used extensively there also. Although the theory with its manifold applications was extremely significant, its greatest achievement was the development of trained researchers in theory and design of control theory. These people have all had and are still having significant impact on the development of the theory and its application to aerospace as well as other engineering problems. These are E. I. Jury, now professor, University of California, Berkeley; R. E. Kalman, now professor, Stanford University; J. Bertram, now responsible at IBM for development of the next series of advanced scientific computers; H. Friedman, now professor, New York University; A. Bergen, now professor, University of California, Berkeley; P. Sarachik, now professor, New York University; G. Kranc, now professor, City University of New York; G. Franklin, now professor, Stanford University; B. Friedland, now director control group, General Precision Corp.; J. Sklansky, now at RCA and contractor of ASD, Wright-Patterson AFB; W. Nelson, Bell Telephone Laboratories. This program in sampled-data systems at Columbia University was quickly supplemented by support of its first research associate to receive a degree, E. I. Jung at the University of California, Berkeley. He subsequently has contributed significantly to discrete system theory, most recently in the design of a rendezvous radar. Doctoral students trained in that AFOSR program are now playing significant roles in industry; one example is in developing satellite communication systems at Comsat.

Another early program was on time-varying systems with John Truxal at the Polytechnic Institute of Brooklyn. This program particularly stimulated the research in adaptive control systems and many of its developments and results were ap-

plied in the design of the adaptive autopilot for the X-15 aerospace vehicle. It also led to considerable fundamental research on sensitivity or the effects of changes in a system's parameters.

AFOSR was also a pioneer in the support of research in nonlinear systems. The largest and most successful was the support of the Research Institute of Applied Science (RIAS). (Over 100 technical papers and six books resulted from this program.) The program under the direction of S. Lefshetz and J. LaSalle emphasized the mathematical aspects of nonlinear systems and the application to design of control systems. Important additions to basic theory resulted from their study of stability of nonlinear systems, in particular the use of Liapunov's second method. When they began the study there were relatively few mathematicians in this country acquainted with the method and even fewer scientists and engineers who realized how it could be applied. This was in sharp contrast to the situation in the Soviet Union where Liapunov's second method was the primary tool used in solving linear and nonlinear stability problems of all types. Today, Liapunov's second method is being used in the United States. It is a standard topic in the training of control engineers and is being applied by the aerospace industry.

Also at RIAS an AFOSR sponsored program under R. E. Kalman (trained in the Columbia group) with R. Bucy, made extremely significant discoveries in developing and applying statistical filtering theory. The theoretical results were obtained by a new look at the similar problem considered by Norbert Wiener in the theory of signal detection and aircraft course prediction. One of the theoretical results was to show that the simple mathematical operation of taking an average, and other operations of a similarly simple nature, can be employed in a large number of cases to obtain statistical performance that is optimum, or close to it. Such operations are easily realized or closely approximated by simple devices constructed of standard electronic components. In situations where the use of digital computers is indicated, the simple, averaging type of operations make very modest demands on computer speed, memory capacity, and arithmetic capabilities.

One direct application of the theoretical results is now occurring at Patrick Air Force Base. Here, Republic Aviation is studying the redesign of devices to predict missile impact points; the previous design was quite elementary and unsophisti-

cated with a rather poor performance index. Improved designs, using a proper balance of analog computer and digital computer techniques, will yield close to theoretically optimum performance, high reliability, and, what is perhaps most impressive, will cut costs by about \$2 million. The capability of the theory to solve the point-of-impact problem has already been amply demonstrated by its success in a related area, that of the point-of-intercept problem solved in the Discoverer series of nosecone intercepts.

Further applications of the theory have been made to the problem of estimating position and velocity on board a lunar orbiting vehicle. Studies of this problem, based on the research supported by the Air Force, have been conducted by NASA at the Ames Research Center. Other outgrowths of the theory have been applications to the general problem of astronomical guidance. Direct application of the theory has been made by Autonetics for the Navy to optimize the performance of their ships inertial navigation system (SINS).

## *Probability Theory and Mathematical Statistics*

MAJ. JOHN F. GANDER

Coincidences, in general, are great stumbling blocks in the way of that class of thinkers who have been educated to know nothing of the theory of probability: that theory to which the most glorious objects of human research are indebted for the most glorious of illustrations.

EDGAR ALLAN POE,  
"The Murders in the Rue Morgue"

The world we live in confronts us with events that are not strictly predictable yet we are required to make what we hope will be favorable decisions. For example, just about anyone would be willing to wager in favor of the proposition that the sun will rise tomorrow. However, what assurance does one really have to guarantee the occurrence of such an event? To justify the act of the sun rising tomorrow on the basis that today was a beautiful day to visit the beach or that the sun has followed the same habit since the dawn of recorded history is no real assurance that we will be blessed by that event tomorrow.

Unfortunately, the mathematician has not developed methods for handling such propositions—the best advice that one can give for situations of this type is to advise the concerned individual to follow the "old and reliable" gambler's rule, i.e., never bet against a winner \* \* \*.

Fortunately, not all events of man, nature and science exhibit such singular unpredictable characteristics as depicted by the example cited above. Hence, the mathematician has been able to develop methods for transforming extremely large classes of what seem to be strictly unpredictable events into predictable events. These methods form the mathematical disciplines generally referred to as probability theory and mathematical statistics. These disciplines have found important applications in such different fields of endeavor as agriculture, criminology, economics, engineering, medicine, psychology and sociology. They have proved their worth to the Air Force through extensive use in many areas of Air Force interest, including communication theory, decision theory, war gaming, reliability theory and meteorological forecasting.

Pierre Simon deLaplace (1749-1827), generally considered the father of probability theory, gave the following elementary definition of probability: If an event can result in  $n$  equally likely outcomes, then the probability of such an event  $E$  is the ratio of the number of outcomes favorable to  $E$  to the total number of outcomes. Obviously, this definition is somewhat restrictive in nature and does not begin to adequately describe the full potential of modern probability theory.

Fortunately, it is much easier to show what probability theory does by examples than to try to define and explain probability theory per se. For, even though probability theory is a distinct and separate discipline of mathematics, it is clearly a branch of analysis and in a narrow sense a branch of measure theory. Its most rudimentary parts, and probably those parts that are most familiar to the vast majority of people, find their origin in combinatorial analysis. In fact, combinatorial analysis affords us with a good elementary example of probability theory. For instance, what is the probability of drawing three red balls from an urn which contains four red balls and three white balls? According to Laplace's definition, we would like to know the ratio of the number of ways we can get three of the four red balls in the container to the total number of ways one can pick

three balls (of either color) out of the container. Now there are four possible ways to get three red balls out of the container while there are 35 possible ways to pick three balls of either color. To demonstrate this, suppose we number the balls one through seven and let the first four be red and the remaining three white. There are four ways to choose the numbered balls one through four taken three at a time, while there are 35 ways to choose the numbered balls one through seven taken three at a time. Finally, the desired probability is seen to be  $\frac{4}{35}$ .

Because we shall make use of the theory demonstrated by this example, let us develop it further. One could just as easily have asked for the probability of getting none, one or two red balls drawing three balls at a time from the container. Simple calculations show that these probabilities are  $1/35$ ,  $12/35$  and  $18/35$ , respectively. To further aid developing our example, let us associate some commonly used names with the concepts that we have been discussing. The number of red balls appearing in the sample (in this example the sample, or more specifically the sample size, refers to the set of three balls drawn from the container) is a quantity whose value is determined by the results of the random selection of the sample. It is usually referred to as the random variable. With each possible value  $d$  of the random variable  $RV$  (again, in this example 0, 1, 2, or 3 are the possible values that the random variable may assume) we associate the probability  $P(RV=d)$  that the value  $d$  will occur. A mathematical expression which gives this probability is referred to as a probability distribution function or simply a distribution function. In this example the distribution function happens to be a discrete probability distribution function. It is often helpful to have a mathematical formula that expresses these probabilities as a function of any given value  $d$  in the domain space (the space of all possible values  $d$  can assume) of the random variable. To this end, let the total number of balls in the container be  $N$  (here  $N$  is generally referred to as the population size), suppose that the population contains  $r$  red balls (here again the  $r$  red balls could represent any special event we wish to single out, e.g., defective transistors, improperly tempered turbine blades, below-standard mixing valves, etc.) and  $(N-r)$  non-red balls. Further, suppose that the sample size is  $s$ . We wish to find an efficient way of expressing the distribution of

the random variable  $RV$ . In the above example  $N=7$ ,  $r=4$  and  $s=3$ . A straightforward calculation gives the distribution function

$$P(RV=d) = \frac{\binom{r}{d} \binom{N-r}{s-d}}{\binom{N}{s}} \quad (\#)$$

where  $\binom{a}{b}$  stands for the binomial coefficient

$$\binom{a}{b} = \frac{a!}{b!(a-b)!}$$

$a$  and  $b$  are integers and  $a! = 1 \cdot 2 \cdot 3 \cdots a$ . The function  $(\#)$  in this example is sometimes called the hypergeometric distribution  $(N, r, s)$ .

With the aid of this example we shall now give an acceptable definition of mathematical statistics as well as shed light on how inextricably mathematical statistics and probability theory are related. Modern mathematical statistics studies methods of drawing conclusions about a population on the basis of data that ordinarily is collected from only a sample of the population. To clarify the relation as well as to make a distinction between mathematical statistics and probability theory, consider the following problem.

Suppose that a field commander is interested in the percentage of a boatload of bullets that conform to a specific quality standard, e.g., how many bullets can be expected to misfire. Obviously, he would not want to fire each bullet to ascertain the number of bullets suitable for combat use, so he chooses a random sample for examination. Suppose that there are  $N$  bullets in this shipment of which  $r$  are below standard, that  $s$  of them are examined and that  $RV$  of those examined are below standard. Note how this problem corresponds to the previous example. Recall that we calculated the probability that  $RV$ , the random variable, will assume one of its possible values  $d$  to be  $(\#)$ . This is a typical result of probability theory.

Such a result stops short of giving the field commander a usable answer. Obviously we need  $r$  in order to compute  $(\#)$ , but if we know the value of  $r$  we do not need to make any inspection. Actually,  $(\#)$  gives only the probability that  $RV$  will take on various values, while the field commander will observe during combat the actual value of  $RV$ . Hence, the problem is not to find the distribution of  $RV$  knowing  $r$ , but rather to draw some conclusion about  $r$  after observing  $RV$ . This is a statistical problem: to draw a conclusion about a population on the basis of a sample. From these examples it appears as though statistics and probability work in opposite directions. Indeed, proba-

bility theory investigates a known population in order to derive distributions related to a sample from the population, while, as we have just seen, statistics investigate the observed sample in order to draw conclusions about some unknown feature of the population.

In the above example there is in the probability model a quantity (i.e.,  $r$  in this example) generally referred to as a parameter. Knowledge of the value of this parameter completely specifies the distribution. Statistics is intensely concerned with developing methods of drawing conclusions about parameters on the basis of the observed values of random variables whose distributions depend on the parameters. Although statistics depend heavily on probability theory to specify the distribution corresponding to various values of the parameters, it goes far beyond probability theory in order to deal with the more delicate questions that arise when the fundamental distributions are not completely specified.

The disciplines of mathematical statistics and probability theory are far more extensive than the above examples indicate. Although the study of distribution functions, random variables, and sampling methods are central topics of consideration for the advancement of these disciplines, they are by no standard the only topics of importance. Any attempt to list all of the areas of current research interest is doomed, for the subject matter of these disciplines is growing at a spectacular rate—a rate which is resulting in a flow of new research results with which no single article of this nature can adequately describe. However, some subjects of current research interest deserve to be mentioned. These subjects of research interest are: limit theorems, stochastic processes, Markov processes, estimation theory, the test of statistical hypothesis, parametric and nonparametric statistical methods, the analysis of variance and transformations in the analysis of variance, the design and analysis of experiments, decision theory, multi-stage decision procedures, sequential analysis, multivariate analysis, multiple comparison tests, information theory, communication theory, reliability theory, and operational analysis. They all have one thing in common which is to aid mankind in one way or another in his selection of the appropriate course of action to be followed in real world events. For example, decision theory was developed to replace the theory of testing statistical

hypothesis for it was felt that that theory was inadequate to describe many of the problems arising in statistical investigations.

The research objectives of AFOSR's program in probability theory and mathematical statistics are to discover new theories and to develop techniques which will ultimately yield new and improved test methods for scientific, engineering, and management problems wrought by our pressing national defense interests.

A substantial portion of AFOSR's mathematics support is for major projects in some of the above-mentioned areas. It includes group efforts at many of the leading research centers as well as singular efforts performed by outstanding research personnel at both leading universities and aerospace corporations.

A major group effort at the University of North Carolina under the leadership of G. E. Nicholson, Jr., A. Barlotte, R. C. Bose, I. M. Chakravorte, W. Hoeffding, and N. L. Johnson has made outstanding contributions in mathematical statistics, the design of experiments, communication theory, nonparametric inference, and the design or analysis of multifactor multiresponse experiments under various models. Three major achievements of this leading group are described here. Each achievement has made its singular contribution, be it mathematical eloquence, useful application, or exceptional future potential.

The first of these results is significant primarily because of its mathematical eloquence and it demonstrates the outstanding research caliber of the personnel involved. R.C. Bose and S.S. Shrikhande created a sensation in the mathematical community by establishing the falseness of one of Leonard Euler's (1703-83) classical conjectures. Euler conjectured that there do not exist pairwise orthogonal Latin squares of order  $4t+2$  ( $t$  a natural number). Recall that the Latin square is a prime tool in certain experimental designs. To illustrate further what a Latin square is, consider the following example. Suppose we wish to compare effects of five types of bombs delivered by five types of aircraft flown by each of five pilots. First we make a 5 by 5 square array (i.e., a matrix consisting of five rows and five columns) matching the pilots against the type of aircraft flown in such a way that each pilot flies once and only once in each aircraft. We then make this configuration into a Latin square by assigning the types of bombs to be dropped at random in such a way

that each type of bomb is used once and only once by each aircraft and each pilot during the experiment. Now the Latin square is a practical experimental design when dealing with small sets of events but the labor of analysis rapidly becomes excessive as the size increases. This labor is considerably less for a particular type of Latin squares, orthogonal Latin squares. The results of Bose and Shrikhande outline ways of developing an infinite number of orthogonal Latin squares of size  $4t + 2$  thus disproving Euler's conjecture while at the same time giving to science an improved method for solving real significant problems.

Another contribution which has proved to be of considerable use involves error correcting codes in information theory. R. C. Bose is the world's foremost authority on error-correcting codes. Recall that information theory is concerned with the reliable transmission of information in a communication system. Discrepancies between the transmitted and the received messages occur and are generally attributed to noise. The central problem is to assure that the transmitted and received messages are as nearly alike as possible commensurate with time, cost, and operating procedures. A logical solution to this problem is to invent an error-correcting code—a short error-correcting message transmitted with the original message—which points out errors and corrects them. Bose and his colleagues have made singular outstanding contributions in this direction. However, the kernel of Bose's results is a real mathematical achievement apart from its obvious applications. His results prove that error-correcting codes and fractionally replicated statistical designs are in essence the same mathematical problem, thus accelerating advancement in both subjects by opening avenues of cross-fertilization. Bose and the group at the University of North Carolina are currently working on methods of devising rules for obtaining check digits for checking message sequences in such a way that errors which are more likely to occur can be corrected or detected with the least amount of checking. Such results will find extensive use in modern digital computers as well as space communication.

The third achievement of the group is significant not only because of its contemporary and unusual scientific importance but also because of its exceptional future potential. W. Hoeffding considered tests of simple and composite hypothesis for multinormal distributions. In particular, he

showed that the Chi-square tests of simple and of some composite hypothesis are inferior to the corresponding likelihood ratio tests. In addition, he demonstrated that certain Bayesian tests share the same properties of a likelihood ratio test. The outstanding feature of this research is that it abandons the currently used device of analyzing infinitely close alternatives to the hypothesis being tested and uses for the first time the theory of large deviations in deducing optimal tests. Jerzy Neyman says of these research results: " \* \* \* Hoeffding's paper goes further than merely proving the superiority of a particular test. In fact, it is my expectation that his paper is the first section of a new and a very important chapter in the theory of statistics." In addition he states, " \* \* \* Hoeffding's paper clearly indicates that the potential of the device of infinitely close alternatives as a means of deducing optimal tests is already spent, and that it should be replaced by some other more effective device, and 'probabilities of large deviation' seems an excellent promise." The results of this research are also of considerable interest to the user of statistics.

Another outstanding research effort in probability theory and mathematical statistics is under the leadership of J. Wolfowitz at Cornell University. Wolfowitz' primary fields of study are mathematical statistics and information theory. His current research interests are directed toward improving the existing theory of generalized maximum likelihood estimators in several important respects; e.g., finding relatively weak sufficient conditions for the existence of asymptotically efficient estimators, developing routine methods for finding generalized maximum likelihood estimators, and obtaining significant results for the multiparameter case. He is also investigating some aspects of information theory; e.g., two-way channels, estimation of the exponential error bound as well as problems connected with Markovian channels, fidelity criterion, and sequential decoding. Space, or more precisely, limited space, will only allow us to single out several of the outstanding achievements of Wolfowitz and his colleagues being supported by AFOSR.

In a joint research effort Wolfowitz and Kiefer laid the foundation of the modern theory of design of regression experiments. Recall that in regression analysis we distinguish between an independent variable and a dependent variable. We assume that corresponding to each value of the independ-

ent variable is normally distributed and that the mean value of the dependent variable is given as a function of the independent variable; e.g., a polynomial expression. Regression analysis techniques give us a method for determining the variance of the dependent variable as well as the parameters of the function expressing the mean of the dependent variable; i.e., in this case, the coefficients of the above-mentioned polynomial.

Wolfowitz has also made outstanding contributions to information theory. C. Shannon originally formulated and conjectured many of the results that are now termed information theory. The definitive development of this entire area: the mathematics of information theory, on a rigorous basis has been accomplished for the first time by Wolfowitz. The results are summarized in a recent publication ("Coding Theorems of Information Theory," J. Wolfowitz; Springer-Verlag). There he describes and proves most of the known existence theorems of information theory. He treats various types of information channels, e.g., general discrete channels, channels with memory and without memory, channels with stochastically determined states, etc.

Recently Professor Wolfowitz has given a new and very sweeping method of solution for the problem of asymptotic efficiency of estimators. His method solves the problem for all classical cases and many other problems for which no solution has ever been given.

Space limits us to singling out only a few results for detailed analysis although there are many equally outstanding research projects in SRMM's statistics and probability theory support portfolio. We shall give brief mention of only a few. For example, at the University of Minnesota there are several noteworthy projects. Professor Orey, while working on potential theory for recurrent Markov chains, introduced the idea of a Martin boundary for recurrent chains. Professor Rubin has made substantial contributions to the general theory of multivariate birth and death processes in which the stochastic interaction between the various states (stages of a disease, different employment groups, etc.) can be represented by a single fundamental parameter. He developed a method of estimating this parameter from the observed fluctuations in time of the "densities" of individuals in the various states. He also made contributions in statistical mechanics concerning the fluctuation of colloidal and gas molecule concen-

trations under diffusion equilibrium. Specifically, he studied the fluctuation of component cell concentrations.

Hoel at the University of California at Los Angeles has made substantial contributions to the classical theory of linear regression. He has worked on the problem of optimum design for polynomial regression and on the problem of determining the effects of correlation on interpolation and extrapolation by means of polynomial regression. He has obtained optimum designs for both one and higher dimensional polynomial regression and for trigonometric regression on the sphere.

In conclusion it seems appropriate, indeed necessary, to include the research accomplishments and directions of K. L. Chung of Stanford University. Chung is one of the country's, if not the world's, outstanding probabilists. He is one of the principal developers of the theory of Markov processes (for an excellent example of a Markov process see "Theory of Markov Processes," E. B. Dynkin, Prentice-Hall, Inc., 1961). Chung's current research interests include the study of boundary theory for Markov chains where sudden exits to infinity are possible as well as the study of probabilistic potential theory and the application of probability theory to the extended Dirichlet problem for multiplying superharmonic functions.

This article briefly describes the important disciplines of probability theory and mathematical statistics in an effort to convey some feeling for the subjects, what they involve, how they are related, what they can and cannot do for us, and to point out some of the significant achievements of the past few years. Reliability theory is becoming an important area of consideration for the Air Force and national defense. It is common knowledge that the development of missile and space technology has brought about substantial progress in the practice of reliability and reliability growth analysis. This work has stimulated activities in many directions, including the development of more sophisticated failure distributions. Mathematicians have not extensively cultivated the problem of the statistical estimation from test data of parameters such as empirical descriptions and optimizations of reliability growth during engineering development programs, or the formulation of explicit probabilistic growth models based on on-site statistical descriptions. The next logical step is to stimulate a definitive development of the mathematics of reliability theory.

## *Nonlinear Partial Differential Equations*

Dr. ROBERT G. POHREK

The qualitative theory of partial differential equations is an important part of contemporary, physically oriented mathematics. AFOSR supports a major research program in this area, including efforts at many of the Nation's leading research centers by leading research mathematicians. A special feature of this program is its concern for the solution of quasi-linear and (strictly) nonlinear equations.

Generally speaking, all phenomena of our "physical environment" can be described mathematically. This description can take the form of a differential equation. Consequently, and in this context, the so-called mathematical model of any physical phenomenon is a differential equation. The differential equation itself is simply a stated relation between certain physical observables or representations of them and the changes which occur among them over a period of time. It is a mathematical expression which, in its "statement," relates the mathematical representations of the observations.

The solution of a differential equation is another (second) mathematical expression related to the first, which describes a single one of the observables, explicitly, in terms of the others. The difference between an ordinary differential equation and a partial differential equation can be simply stated. The former includes a single independent observable, and a single dependent one which varies (in some way) with or dependent upon the independent variable. On the other hand, a partial differential equation includes more than one independent observable with which a dependent one varies. This simple difference, which can be described as a mathematical difference involving independent and dependent variables, has a significant physical counterpart. That counterpart is an important dichotomy in the manner in which physical phenomena can be viewed.

In the first case, a physical process is viewed as being composed of elementary particles which, while they may change position in a space-time framework, are themselves unaffected in the process. The process is described by an ordinary differential equation. It is the classical description of

Newtonian mechanics. A contemporary example is the description of the path of a ballistic missile in which time is the independent variable and the distance traveled is the dependent variable.

The alternate description of physical phenomena is exemplified by the field theory in physics, in which physical processes are determined by field quantities which depend not only upon time but upon three additional independent space coordinates, or a total of four independent variables. It is the classical description of electromagnetic phenomena and optics. A contemporary example is the description of the vibration of a membrane or a portion of the surface of an aircraft. The vibration of a two-dimensional membrane is described in terms of time and two additional independent space coordinates for a total of three independent variables; the dependent variable is the displacement or distortion of the membrane from its point of equilibrium or rest.

Another major and important classification of differential equations is according to their linearity or nonlinearity. When the dependent variable and its derivatives (i.e., mathematical expressions for the change of one observable with respect to another) occur to the first degree or power only in a differential equation, and not as higher powers or products (with one another), the equation is termed linear. Otherwise it is termed nonlinear. A reasonably important class of nonlinear partial differential equations is termed quasi-linear. A quasi-linear equation is one in which the highest order derivatives of the dependent variable are linear (and by implication other derivatives or parts of the equation are not).

Generally speaking, linear and nonlinear differential equations and mathematical methods for their solution differ, often to a marked degree. And again, the physical phenomena which give rise to each, which may be termed linear and nonlinear phenomena, also differ, again often to a marked degree.

The formulation of a differential equation as a mathematical model for physical phenomena, and the invention of techniques for its solution, first occurred (more or less) with the invention of the calculus, and a formalism for treating mathematical variables and the observable changes of one variable with respect to another (the derivative of one variable with respect to another).

Throughout the years mathematical concern for the proper formulation and solution of partial



differential equations has continued. While a general theory or perhaps a body of theory was created for the solution of ordinary differential equations, comparable developments for the solution of partial differential equations did not occur. The interest of mathematicians in the latter problems never waned, was on occasion directed to the formulation of general theories, and on occasion directed to the study of specific equations, in particular as the latter arose in physical contexts. But an appropriate overall framework for their formulation and solution was not evolved.

A dramatic change began in the latter 1940's, with the development of the theory of distributions or generalized functions in the context of the modern theory of topological vector spaces.

The distinguished history of mathematical invention is characterized by certain broad and general trends, one of which is most often attributed to the mathematician D. Hilbert (1862-1943). It is to generalize and simplify. Mathematicians, faced with seemingly intractable problems, often generalize and to the mathematical outsider enlarge their problem. In a manner of speaking, they consider not one problem but an entire series of somewhat similar problems, simultaneously. Again in a manner of speaking, the essential and major difficulties, in this fashion, become clearer. As one result, the initial and intractable problem, in its individual and intractable context, is solved in a broader, clearer, and more simple context, stripped of all but its essential features.

The price which a mathematician willingly pays for this is "abstraction," the creation of new areas of mathematics which seem, again to the mathematical outsider, to be further and further removed from the physical problems which initiated the original concern. That impression is naive and incorrect. For the reward of this activity is the solution of not only an initial physical problem but of a wide range of physical problems. Since they all can be solved in a single new (and admittedly abstract) context, they can be solved thus more simply.

A distribution or generalized function is what the latter words imply, a more general type of mathematical function which includes the older type and definition of function. (A function is a mathematical expression involving mathematical variables). In its older context, a generalized function is a certain type of functional (which will not be defined here).

A topological vector space is (again) a generalization and an abstraction. Its earliest and most primitive forebearer is the space of elementary analytic geometry. Extend such a space to a vector space: extend the properties of the "real line" coordinate system to, simply, continuity in space (i.e., a topological space). The end result, in very unmathematical terms, is a topological vector space.

The solution of a partial differential equation, by a generalized function solution in a topological vector space thus initiated, in 1950-51, one of the most dramatic developments of modern mathematics.

What has happened in this area since the initial breakthrough includes, more or less, the definitive and complete qualitative solution of partial differential equations with constant coefficients of arbitrarily high order.

Qualitative solution refers to the formulation of precise mathematical models, differential equations, which have a solution. (A mathematical expression which includes variables and derivatives need not necessarily apply to the given or any physical phenomenon, nor have any solution). That solution must be unique (mathematical characterizations of a physical phenomenon may be too general, and include a wide range of similar physical phenomena distinguished by detail overlooked in the initial mathematical formulation). Furthermore, that solution must be stable. The latter phrase is an important one in particular for all physical applications of the equation and its solution. It involves the following considerations. Applications of mathematical results to physical phenomena involve quantitative measurements: i.e., numbers. If the initial quantitative measurements, or judgments, which resulted in the formulation of the differential equation were, somehow, inessential and in a manner of speaking divorced from basic, major, stable quantities, relatively minor changes in their numerical values often result in major changes in the numerical values of the solution, and render that solution valueless for application to problems of the real world.

An important point and one worth repeated emphasis: Unless the qualitative theory of partial differential equations is mathematically established (mathematically proved) in all these particulars, the numerical calculation of the solution, which very often is achieved by use of a modern high-speed computer, will involve the following:

(1) if the solution does not exist, the computer may "spin its wheels" endlessly in attempting to calculate it; (2) if a solution is not unique, the computer may single out one (incorrect) solution or combine the data from a range of solutions and render the results meaningless; or, (3) if the solution is not stable, slight fluctuations in the data result in inaccuracies in the solution which again render it meaningless, and make it necessary to begin all over again in formulating the problem to obtain a correct solution.

A partial differential equation in contemporary notation appears as  $Du=0$ , where  $D$  is a differential operator and  $u$  is the dependent variable referred to previously. A contemporary problem is the search for properties of  $D$  or rather of its associated characteristic polynomial which are intrinsic, in the sense that they are more or less equivalent to properties of the solution. The first complete results are due to I. Petrovsky. Among other results, he proved that the existence of analytic solutions for the above equation is equivalent to a certain condition on the characteristic polynomial, for differential operators with constant coefficients.

L. Schwartz, the creator of the theory of distributions or generalized functions, pointed out that these two conditions were equivalent if  $u$  were assumed to be a generalized function. The exploitation of these ideas, in particular, by L. Hörmander but including a number of other mathematicians, has resulted in the more or less definitive solution of systems of partial differential equations with constant coefficients of arbitrarily high order: in particular, the qualitative establishment of the existence and uniqueness of their solutions.

This rather surprising statement would have stretched the credibility of most mathematicians, some 25 or less years ago. Nor is that the extent of progress in these directions. The important solution of linear elliptic differential equations, and still more recently of quasi-linear elliptic differential equations, is to all intents and purposes essentially complete. Similar powerful and abstract methods in modern analysis, functional analysis, and topology again proved surprisingly effective. This is illustrated by just one series of developments.

AFOSR sponsored a summer seminar in applied mathematics, held at the University of Colorado in the summer of 1957. At that time, the theory of linear elliptic differential equations was ap-

proaching its essentially complete solution. At about the same time, E. DiGiorgi and J. Nash independently achieved significant breakthroughs in the solution of quasi-linear elliptic equations in divergence form. The successful extension of their results, in particular through the intimate connection between the divergence form of the equation and the calculus of variations, was a dominant feature of the AFOSR Symposium in Differential Equations at the University of California, Berkeley, in April 1960. The still more recent solution of quasi-linear elliptic equations in the more directly stated nondivergence form has been essentially achieved by O. Ladyzhenskaya and N. Ural'tseva, two Soviet mathematicians (1964), and by N. Trudinger, a research assistant under the AFOSR group program at Stanford University (1966).

Other research directions in partial differential equations evidenced at the Berkeley symposium, and their subsequent development, were examined in depth at the Symposium in the Applications of Nonlinear Partial Differential Equations in Mathematical Physics, in New York City, in April 1964. Their importance, and the extent of the mathematics division's commitment to their continued exploitation, cannot be overemphasized.

An interesting historical perspective of these developments is provided by the following observation. In an era (the last 20-25 years) now being called the golden age of mathematics, the developments described above: i.e., the solution of partial differential equations by generalized functions in the context of topological vector spaces, is thought by many mathematicians to be the single most important physically-reliable development in all of mathematics.

To such ends, AFOSR encourages and supports major group efforts, coordinated and relatively large programs, at leading research centers in this country in this research area. These include the Courant Institute of Mathematical Sciences at New York University, the University of Minnesota, the University of California at Berkeley, and Stanford University. This is the most significant national program by any Federal agency in this research area. It is also interesting to reflect that all of the AFOSR European program, contracts and grants administered through EOAR, include investigators making significant contributions to this same research area.

Recent AFOSR research projects include L.

Nirenberg of the Courant Institute, one of the world's foremost authorities in these developments. His most recent research interests include a refinement of the theory of singular integrals of A. Calderon and A. Zygmund, precisely as such techniques can be applied to establish the existence of solutions of partial differential equations. His investigations also include consideration of abstract differential equations in a Banach space. In conjunction with S. Agmon (Hebrew University), he is considering certain convexity inequalities, employing the techniques of functional analysis and complex function theory. A third major direction is his consideration of the stability of difference schemes for the numerical calculation of the solutions of partial differential equations, in conjunction with P. Lax. A fourth is the study of non-elliptic boundary value problems. He has obtained and is continuing to obtain significant results in all these investigations.

K. G. Friedrichs of the same institution, in conjunction with P. Lax, is examining certain symmetrizable systems of partial differential equations, part of a continuing major research concern of the investigators. He is also continuing to investigate the formulation of well-posed problems in mathematical physics; i.e., the proper partial differential equation model for physical problems. His recent published results in these areas include the development of theories for the solution of arbitrary; i.e., not specifically elliptic, parabolic, or hyperbolic, but general, partial differential equations, related boundary value problems and conditions which guarantee the unique generalized function solution of such equations. He has also shown that many problems of mathematical physics may be expressed and solved in terms of the theory of the symmetric positive systems so developed, although in many cases the result will not be simple.

J. Serrin of the University of Minnesota is continuing his research in the calculus of variations and the solution of partial differential equations, in particular as the two areas are related. His recent publications concern various aspects of the calculus of variations. In particular they include an elementary method for obtaining an a priori estimate which can be used to solve a Dirichlet problem (i.e., a boundary value problem for a partial differential equation) under exceptional boundary conditions. A series of three papers on quasi-linear and nonlinear second order elliptic

partial differential equations extends the techniques of Nash and DiGiorgi (above) and J. Moser, to describe the general behavior of the solutions of such equations. In particular, he examines the a priori majorization of solutions, the nature of removable singularities, and the behavior of a possible solution in the neighborhood of an isolated singularity. There are remarkable differences in the latter behavior, as they concern nonlinear versus linear partial differential equations.

J. C. C. Nitsche of the same institution is investigating the structure of the solutions of general nonlinear partial differential equations, by examining the structure of the solutions of the highly nonlinear minimal surface equation. He has established the possibility of formulating and solving Dirichlet's boundary value problem for partial differential equations in a convex domain under unusual boundary conditions. With these results and the determination of a new general maximum principle, he has been able to examine questions concerning the removability of isolated singularities. He has established some results concerning the nonsolvability of Dirichlet's problem in non-convex domains. He has further investigated certain implications of nonlinearity upon the behavior of the solutions of certain quasi-linear elliptic equations and parabolic equations. These results relate to those of R. Finn (Stanford University), H. Jenkins, and D. Aronson, all with AFOSR support. A final principal concern is the numerical solution of elliptic equations by difference methods, including a number of related problems in the theory of polynomial approximation.

M. H. Protter of the University of California, Berkeley, has continued his extensive examination of partial differential equations, as generalized to partial differential inequalities. He has, in addition, continued his research to establish upper and lower bounds for eigenvalues of elliptic operators. In conjunction with H. Weinberger, a number of applications of the maximum principle for elliptic partial differential equations have been examined. Their recent results include the solution of certain elliptic inequalities, which in turn relate to the solution of elliptic equations. He has extended certain of his earlier results on the asymptotic behavior of the solutions of hyperbolic equations, and succeeded in sharpening the results on asymptotic decay, in particular when the hyperbolic operator is specialized to the wave operator.

T. Kato of the same institution has continued

his related investigations concerning many different aspects of the theory of linear operators, in Banach spaces, with general types of spectra. An important application relates such results to partial differential operators and singular integral operators. Some of his most recent results concern the similarity of perturbed and unperturbed operators in general contexts. He is also continuing his research in nonlinear analysis. By employing the methods of functional analysis, he is able to examine abstract (ordinary) differential equations, with specific attention to the application of such results to the Navier-Stokes equations and other nonlinear equations of mathematical physics. Other recent results concern the singular behavior of singular equations; i.e., equations governed by special in particular nonlinear criteria.

H. O. Cordes of Berkeley has been concerned with the establishment of so-called zero order a priori estimates for solutions of elliptic differential equations. He has also continued to examine the generalized Fredholm theory of partial differential operators. Particular directions here include major aspects of the theory of singular integral operators, of linear partial differential operators, of the Fredholm properties of the oblique derivative and related problems.

D. Gilbarg of Stanford University is continuing his previous research on nonlinear elliptic equations and on problems in fluid dynamics. Recent developments indicate that many results which are important for the theory of elliptic equations hold for a wide class of nonlinear equations of divergence form, which class is similar to but distinct from elliptic equations. He intends to extend his preliminary results in these directions to formulate a theory of nonlinear equations of divergence form, analogous to the existing elliptic

theory. Recent specific results concern boundary value problems for nonlinear elliptic equations in  $n$  variables, examined under different ellipticity hypotheses.

R. Finn, also of Stanford, continues to pursue the research interests referred to above in conjunction with Nitsche's work. Questions relating to the structure of minimal surfaces, and, more generally, of surfaces of constant mean curvature, are important for the resolution of many associated questions related to the solution of partial differential equations. In addition, he is interested in extending his previous results on problems in the theory of partial differential equations as they specifically relate to problems of hydrodynamics. These investigations include questions on the existence, asymptotic behavior, and of the singular perturbation related to the exterior stationary problem for the Navier-Stokes equations. He is particularly interested in the possibility of obtaining stationary solutions as the limit of nonstationary ones.

The foregoing discussion is representative of the research program of AFOSR in this area. It is by no means exhaustive. The important research investigations of many illustrious mathematicians working in the same general and related directions under the four major group efforts described above have not been included, nor have the important research investigations of many other illustrious mathematicians working in the same area under other contracts and grants of the mathematics division.

This article or similar articles could not be exhaustive, even in relatively restricted research areas of the division's program. No special significance should be attached to the inclusion or exclusion of the research work of any individuals, nor to the chronological order in which the items chosen for discussion were presented.

## Physical Sciences

### *Magnetic Resonance Spectroscopy*

DWIGHT L. WENNERSTEN

The historical roots of magnetic resonance spectroscopy are buried in optical, infrared and ultraviolet spectroscopy and in the magnetic cooling (adiabatic demagnetization) experiments conducted in the 1920's. However, the main branch of magnetic resonance spectroscopy comes from critical experiments designed and accomplished by Stern and Gerlach in the early 1920's and in 1938 by I. I. Rabi, one of Stern's many distinguished students. These two experiments demonstrate, respectively, space (laboratory coordinate) quantization and energy state quantization. The Stern-Gerlach experiment is an example of the detection of space quantization as measured for a single valence-electron atom, silver. The experiment verifies the quantum mechanical prediction that such an atom has a net angular momentum vector which assumes one of two possible directions, up or down, relative to a magnetic (or electric) field direction, and secondly, that there is in addition a net deflection up or down in a magnetic field with a high gradient, or rate of change of strength. With properly shaped pole faces there is a large change in the intensity of the magnetic field at various points in the space between the magnets. The two patches of silver deposited duplicate the slit outline approximately and show the predicted separation into roughly equal numbers of atoms deflected up and down corresponding to the orientation of the various atoms' angular momentum vectors. The second experiment by Rabi combined two oppositely arranged magnets with an intervening cylindrical electrode to permit introducing a radio frequency field at right angles to the direction of the static magnetic field.

In simple terms, an arrangement of oven, slit, and vacuum chamber produced a thin ribbon of molecules or atoms which progressed through a magnet splitting into two ribbons dependent on the right or left random orientation of the angular momentum vector of the incoming particles. In the central region a half-slit or knife edge elimi-

nates one of the ribbons by intercepting its path. When the RF loop is unenergized, the unintercepted beam ribbon will enter another magnet, experiencing an opposite deflection due to the reversed gradient of this magnetic field and reach the collector, usually a coated, hot-wire detector (with shield) and produce a measurable signal. When the RF loop is driven with a megacycle-per-second signal transverse to the static magnetic field direction, frequencies can be found for which the beam intensity measured at the collector decreases or vanishes. Additionally, the beam can be "refound" if the collector is moved to a position at twice the deflection distance from the axis of the instrument produced by the first magnet alone. So evidently, the RF frequency has reversed or "flipped" the angular momentum vector direction of the beam in the central region. This is a demonstration of quantum state selection quite different from the space quantization of the earliest Stern-Gerlach arrangement. In other words, the atoms in the beam absorbed microwave energy and re-oriented their spin vectors to that of a higher energy state.

This, then, was the state of magnetic resonance spectroscopy just before World War II. It is true that microwave spectroscopy's first experimental finding, the inversion spectrum of ammonia, had been made in 1934 by Cleeton and Williams, but the field was largely dormant because of instrumental electronic difficulties and hence the uncertainties in observed data.

At the end of the war, magnetic resonance research based on electronic and radar advances gave significant improvements, particularly instrumental versatility and stability. The types of instruments multiplied and diversified. The measurement techniques developed in the same family with atomic beam magnetic resonance spectroscopy were microwave spectroscopy, nuclear magnetic resonance, and electron spin resonance.

P. Kusch (1) in tracing the history of magnetic resonance investigations reports that the atomic or molecular beam magnetic resonance method "is to some degree the parent of almost every technique of modern spectroscopy—the nuclear magnetic resonance method, microwave spectroscopy,

optical pumping, paramagnetic resonance (ESR) and still other spectroscopic methods."

As can be expected, each of the experimental techniques has particular strengths for certain types of investigations. Microwave spectroscopy flowered and reached full maturity first by transferring World War II electronic techniques with imagination but with only moderate further development.

This technique was particularly appropriate to and used for a wide variety of investigations of molecular structural or geometric configuration studies. A more detailed review of this area is covered elsewhere in this volume. A possibly more elegant description was offered by H. C. Longuet-Higgins (2) in his introduction to the first session of the 19th meeting of the Faraday Society at Cambridge, in 1955, where he said, "microwave spectroscopy provides, in fact, the most accurate method for determining the geometry of simple molecules, and is becoming increasingly useful (to the chemist) as a tool for measuring internal barriers to internal rotation."

Additional developments included adaptation of the heavy water, HDO, microwave oscillator as an inexpensive frequency standard by AFOSR contractor Y. Beers of New York University in the late 1950's for an urgent Navy need. The short-term frequency stability was about 1 in  $10^6$  with much less auxiliary equipment required than the ammonia or cesium atomic clocks of that period.

It is interesting to note that microwave spectroscopy is an absorption process, where energy is absorbed in exciting low-lying states near the ground state at ordinary temperatures. The inverse process, stimulation of energy release by excited molecular states in returning to the ground state, provides a mechanism for controlled, coherent oscillation or amplification. This is obviously the maser. AFOSR helped support the work of Charles Townes through the joint services electronics program and, later, on the application of the maser to the amplification of radio astronomy microwave signals, and a test of this low-noise temperature device on a radio astronomy dish at the Naval Research Laboratory. This effort was made with the encouragement and approval of the Navy in sort of an inverse process to that involved in Yardley Beers' research on the medium-accuracy clock mentioned earlier.

Nuclear magnetic resonance spectroscopy was also supported widely by AFOSR. This technique,

discovered independently in the United States and U.S.S.R. just after the war, uses a very homogeneous magnetic field in the thousands-of-gauss region and radio frequencies in the megacycles-per-second range. It is useful for determining nuclear moments, nuclear spins, nuclear quadrupole (electric) moments, nuclear-lattice coupling in crystals, nuclear spin-lattice relaxation times, and—by calculation—molecular bond lengths, bond strengths, and geometry. It is a particularly sensitive tool for determining structural and local molecular environments relating to hydrogen atoms in molecules so rapidly became a useful tool that moved from physics to chemistry.

Electron spin resonance (e.s.r.) or electron paramagnetic resonance as the Oxford group named it, followed hard on the heels of n.m.r. This spectroscopic technique deals with resonance phenomena of unpaired or spin uncompensated electrons in molecular ions, free radicals and transition element atoms. Since the magnetic dipole moment of the electron is nearly equal to that of the proton with a mass of one eighteen-hundredths as much, strong magnetic fields and higher radio, really microwave, frequencies are required to observe electron resonances. Typically, the parameters are 10,000 gauss fields and gigacycle ( $10^9$ ) frequencies. Such research efforts were conducted frequently by an association among scientists of different disciplines. One of the more productive groups supported by AFOSR was at Washington University, St. Louis. Studies there (3) were accomplished jointly by physicists and chemists with the sometime participation of life scientists. Separate chemical and life science programs are supported now by sponsors other than AFOSR.

This sort of transition of a tool from one scientific discipline to another raises management or administrative problems for a government sponsor. In p.m.r./e.s.r. research, the interdisciplinary trained groups "measured" and interpreted almost anything that gave a good signal, initially. This was understandable as the early development period of a new technique is an appropriate time for proof of the experimental stability and sensitivity of the equipment by all possible means. In addition, the validity of simple theoretic models first was substantiated along with the various selection rules of quantum mechanics that had grown up in the art of optical spectroscopy. Soon a point was reached when proposals were being received by federal monitors where there was a serious ques-

tion as to whether requests for sponsorship of new instrumentation and research support was reaching "cookbook" or engineering handbook phase. Such proposals came in considerable numbers from recent Ph. D.'s trained under the initial groups and from other scientists in related endeavors. The program monitor then had a real problem in selecting, from this point, only those specific proposals actually falling within his scientific areas of responsibility.

In 1957 General Physics accepted its last proposal to manufacture or wind a strong electromagnet. The art was at a stage that even with the availability of graduate students it was more economical in real project dollar costs to buy a ready-built magnet. In this atmosphere, the fields of p.m.r. and e.s.r. reached full maturity around 1958. With hundreds of investigations underway in the 1950's, it is difficult to rank major advances even among the modest fraction of those programs of atomic and molecular physics supported by AFOSR. Representative advances can be found in each of many group researches.

For instance, James Burgess became interested in the theoretical models for the complex interactions occurring among magnetic vectors and spins during his doctoral program at Washington University. He developed the first applications of density matrices to spin resonances there, then extended the density matrix work at Stanford, again with AFOSR support, to include application to spin couplings—a more complex situation. Its solution was required before the full potential of e.s.r. could be used in interpreting complex spectra being obtained as instrumental sensitivity was increased.

G. Pake, former physics advisory group member and contractor, assesses (4) the e.s.r. studies of free radicals conducted by S. I. Weissman and associates as having one of the more importantly significant impacts on physics and chemistry of the late 1950's. This group, which started with ONR support and was then AFOSR supported from 1958, predicted and discovered the techniques of measuring and identifying the hyperfine splittings of the electron resonances of free radicals that arise from nuclear hyperfine interactions with the unpaired electron. This proved that intermediates in reactions could be identified and additionally that minute amounts of rare or impurity nuclei down to about 1 part per billion could be quantitatively identified. A further accomplish-

ment under AFOSR support included a significant theoretical improvement. It was the finding that liquid solutions of normally crystalline materials could be used to average away anisotropic hyperfine couplings for free radicals and thus provide clearer data from the simplified or uncomplicated splittings to calculate the magnitude of the electron wave function at the nucleus. This was of great significance to both theoretical atomic and molecular physics and reaction rate chemistry, particularly to the direct measurement by e.s.r. techniques of reaction rates by identifying the relative concentrations of the molecules and molecular ions where the reaction goes on in solution. Physical biologists had used electron transfer mechanisms with free radical intermediates in their theoretical models of many life processes at molecular level. ESR now provided a technique for identifying some of the simpler ones, particularly photosensitive processes. Additionally, some animal tissue studies were made by the Washington University group (5). Here minute samples of human liver were obtained by nonsurgical, needle biopsies and tested in glucose solution for e.s.r. Large signals were found to indicate a form of jaundice where operative procedures would be of help to the patient.

Tremendous improvements were made in the postwar period on atomic and molecular beam magnetic resonance techniques and instrumentation starting about 1950. These were based on two fundamental discoveries. First was the Lamb shift in 1947, that the displacement of the resonance point of a bound state energy level due to radiative corrections did not follow the Dirac predictions. The second was Kusch's verification in 1948 that the spin magnetic moment of the electron is 0.01 percent higher than expected, 1,0011 Bohr magnetons. These two advances allowed the full six-figure accuracy of experiments to be applied to precision energy state measurements and identification using atomic or molecular beams. Two such studies can be cited to support this thesis.

The University of California, Berkeley, has a large AEC-supported program in fusion and fission research. One group under Nierenberg and Shugart identified the first atomic parameters of the transuranic element plutonium-239 for AEC in 1957. Others have followed. Parameters such as nuclear spin, magnetic moments, quadrupole moments and hyperfine structure separation of many transuranic elements have been measured. From

1958 to 1964, AFOSR supported a users program on these facilities at modest cost. The program dealt in a large part with the atomic characteristics, spin, moments, and fine structure of the radioactive isotope series such as copper in the Cu 61 and Cu 67 atomic weight series (6). Copper 63 and Cu 65 are the stable isotopes normally found in the abundance ratio of 2-to-1 respectively. Two things were sought, the physical data themselves as a check on atomic and nuclear physics theory of structure and properties, and additionally, verification that atomic beam magnetic resonance measurements could be made on all five of the radioactive species including the two with half lives of less than 10 minutes. All of these objectives were met during the planned program which actually was completed nearly 1 year ahead of the original time estimates.

The second example is taken from the atomic beam magnetic resonance studies which are part of the Hughes and Lamb project at Yale University supported by AFOSR. This is a very subtle study of the foundations of elementary particle physics and quantum mechanics. It concerns muonium, one of the three lightest atoms which are hydrogen, muonium, and positronium. The heaviest of these three is atomic hydrogen consisting of a proton and an orbital electron. Muonium is next with a positive mu-meson nucleus and one orbital electron. The third and lightest is positronium consisting of a negative electron and its antiparticle, a positive electron, orbiting about each other. Positronium was discovered in 1953 at MIT and has been investigated quite thoroughly by a score of groups under various sponsorships including General Physics. In brief, positronium has now become a chemical probe in recent times with AEC the principal supporter of related research. Muonium has had more interest to physics but has proved more stubborn in yielding its characteristics. It consists of a positive muon,  $\mu^+$ , which has 207 times the "weight" of an electron. Its combination with an electron is hypothesized to result in a "light hydrogen" atom equivalent with properties scaled from hydrogen where the proton in hydrogen is 1836 times the mass of the electron. There are other interesting points: In positronium, the positive and negative electrons are antiparticles to each other and annihilate each other to produce intense gamma rays; the electron and  $\mu^+$  are not antiparticles and do not annihilate each other; the  $\mu^+$  has a magnetic moment 3.18 times that of the proton;

and, last, nuclear physics has established that  $\mu^+$  itself is unstable and decays in 2.2 microseconds into a positron and two neutrinos have various energies up to 52 million electron volts by a weak interaction mechanism without conservation of parity.

The subtlety mentioned earlier consists in using these properties in the design of an atomic beam experiment to get unequivocal data that: (1) Measurements are made on muonium atoms, not something else; (2) that hyperfine energy level splittings consistent with a "light" hydrogen atom are induced; and, (3) the decay products (positron and/or neutrinos) are identifiable and give consistent statistics.

The first two objectives were met in 1960 (7) by a users program on the Nevis Synchrocyclotron at Columbia. A pion-muon beam was filtered through a carbon pion absorber with  $\mu^+$  entering an atomic beam resonant chamber equipped with 5 scintillation counters disposed around a reaction chamber filled with pure argon gas. A static magnetic and a transverse microwave field are also provided. In operation, counters 1 and 2 indicate coincident arrival of  $\mu^+$ , counter 3 measures loss of  $\mu^+$  from the "through" muon beam. Counters 4 and 5 with a proper absorber identify positron,  $e^+$ , arrival and delay times at right angles to the original beam. A separate microwave resonant circuit identifies the muonium atom and the hyperfine-structure level separation at 4463 megacycles per second. The argon gas acts as a target for the  $\mu^+$ , also furnishing an electron to form the  $(\mu^+e^-)$  atom when the muon slows sufficiently to capture one. Further buffer collisions provide the necessary time to avoid wall collisions before the decay into a positron and two neutrinos. Experimental refinements produced measurements on approximately one muonium atom per second.

A popular version of the research appears in reference 8 along with the results of recent experiments on muonium chemistry which detail reaction measurements with molecular oxygen,  $O_2$ ; nitric oxide, NO; and nitrogen dioxide,  $NO_2$ . Hughes speculates that a rich field of muonium chemistry is now open for exploration.

With the preceding recital, one view of the recent course of magnetic resonance spectroscopy has been presented. From the frequent reference to "user" programs it is apparent that many experiments now require access to extensive, expensive facilities as the frontiers of this class of spectro-



scopic experiments are planned and accomplished. It is also fair to say: (1) That emphasis has moved back to optical and IR spectroscopy using the laser as an intense radiation field generator; (2) that p.m.r. and e.s.r. have moved to solid state sciences and chemistry for present studies; and finally (3) that as the body of scientific knowledge of magnetic interactions grows so rapidly as it does, few practitioners in one scientific discipline can do or follow the related progress in more than one other discipline. Such is progress and the natural change in viewpoint as to what are the present frontiers in science.

#### REFERENCES

- (1) P. Kusch, *Phys. Today* 19, 2 pp. 23-35 (1966).
- (2) H. C. Longuet-Higgins, *Trans. Faraday Soc.* (1955).
- (3) Washington University Report 42 to AFOSR (1962). Also, Y. Deguchi, *Bull. Chem. Soc. Japan* 35, pp. 261-264 (1962).
- (4) G. E. Pake, Joseph Henry Lecture (1963). Also, *Bull. Phil. Soc. Wash.* 16, 3, pp. 296-297 (1964).
- (5) J. L. Ternberg and B. Commoner, *J. Am. Med. Soc.* 183, p. 339 (1963).
- (6) B. Dodsworth, "Nuclear Spins of Copper and Iron Isotopes," (Univ. Cal., UC-34 Physics, 18 Apr. 1963).
- (7) *Phys. Rev. Letters*, 5, p. 63 (1960) and 6, pp. 19-21 (1961).
- (8) V. Hughes, *Sci. Am.* 214, 4, pp. 93-100 (1966).

## *Spectroscopy in the Millimeter and Submillimeter Region of the Electromagnetic Spectrum*

DR. MARSHALL C. HARRINGTON

Research in microwave spectroscopy by AFOSR and its predecessor organizations began in 1953 when the field of short microwaves seemed particularly attractive because of the gap which existed between microwaves and the infrared. It was suspected then and subsequently shown that this spectral range was to be extremely fruitful in a variety of ways.

The earliest contract was with Walter Gordy of Duke University. He and his associates were pioneers in many aspects of microwave research and have contributed papers in the field continually. This group is, in fact, one of the more prolific ef-

forts now supported by the General Physics Division.

During the time that Gordy has been supported by the Air Force 50 young scientists have received the Ph. D. degree under his direction and about an equal number have gained from 1 to 3 years of additional experience in postdoctoral research in microwaves. Essentially all are now in positions where they contribute directly or indirectly to the country's defense. Some of them have been supported by AFOSR in their present locations. Thus, AFOSR in supporting the research at Duke has had an important influence in expanding and extending the field of microwave spectroscopy in all of its aspects—in equipment and techniques, in data and theory, and in important applications in science and technology.

Spectroscopy has had a long and successful history in the formulating and testing of ideas of the structure and behavior of matter in its various forms. Yet until a few decades ago, there was a region in the middle of the electromagnetic spectrum which was largely unavailable for spectroscopic research. This region lay between short radio waves and the far infrared. The first fruitful work in the region appeared in the middle thirties with the experiments of Cleeton and Williams (1) of the spectrum of ammonia. However, the lack of convenient and powerful equipment prevented further exploitation of the method until about 10 years later. The extensive activity in microwave radar during World War II for the first time led to the development of suitable methods and instruments. Since that time the field has expanded rapidly, and now the gap between microwaves and the far infrared regions of the spectrum has been closed.

The microwave region of the electromagnetic spectrum lies between the far infrared and the conventional radio frequency region. In wavelength, this is from about 0.5 mm to 30 cm and in frequency from about 600,000 Mc/s to 1000 Mc/s. This region extends over approximately eight octaves of the electromagnetic spectrum. In contrast, the visible part of the optical region covers only about 1 octave.

Since the microwave region lies between radio waves on one side and the far infrared on the other, this field may be considered as an extension of either of the adjacent regions. There are, however, reasons for treating microwave spectroscopy as an independent subject. The devices for generating, transmitting, and measuring microwaves

are different from those used in ordinary radio work, such as vacuum tubes, coils, resistors, capacitors, etc. Thus, the development of specialized equipment in the past several decades has permitted closing the gap in spectroscopic methods between those of short radio waves and the infrared. Optical methods have continually extended observations toward the longer wavelengths of the submillimeter regions, but there is a practical limit to use of optical elements, such as gratings, interferometers, and detectors in pushing lower into the infrared region of the spectrum. On the other hand, some progress has recently been made in extending the laser into the infrared. For instance, Gebbie (2) et al. report work on the CN line at 0.377 mm. However, there are still gaps in the laser region because the device is not, in general, tunable. Consequently, it does not at present provide a practical source for absorption spectroscopy. Efforts may soon be fruitful in overcoming this deficiency.

The millimeter and submillimeter range is particularly interesting because in this range many atoms, molecules, and crystals have sharp, strong spectral lines that now can be measured with high resolution and precision. Thus, information is found which usually cannot be ascertained by observations in any other region of the spectrum, for instance, constants which determine the spectra of molecules, and of solids or molecular crystals. Ro-

tational spectra of molecules are particularly amenable to microwave techniques. Stark and Zeeman effects in rotational spectra have been observed only in the microwave region. The methods and results developed in these studies have had wide application in science and engineering.

The chief instrument used by Gordy is the microwave spectroscope. In its simplest version this instrument consists of: (1) A tunable source of electromagnetic radiation; (2) a frequency meter; (3) an absorption cell and associated equipment for introducing the gas to be measured; (4) a detector of the radiation; (5) an amplifier; and (6) an indicator.

With this equipment measurements were first made in the centimeter range of wavelengths. Later the wavelength attained was shortened to a few millimeters.

High resolution microwave spectroscopy now has been extended from the 5 mm region down to a wavelength of 0.43 mm or a frequency of 691,472 Mc/sec. This has enlarged the range available by a factor of 10. Specially designed crystal harmonic generators energized by klystrons provided the energy, and crystal diodes were used as detectors. Klystrons were preferred to other alternative sources of microwave radiation because they provide a narrower bandwidth at any one setting. One essential requirement in the equipment was the

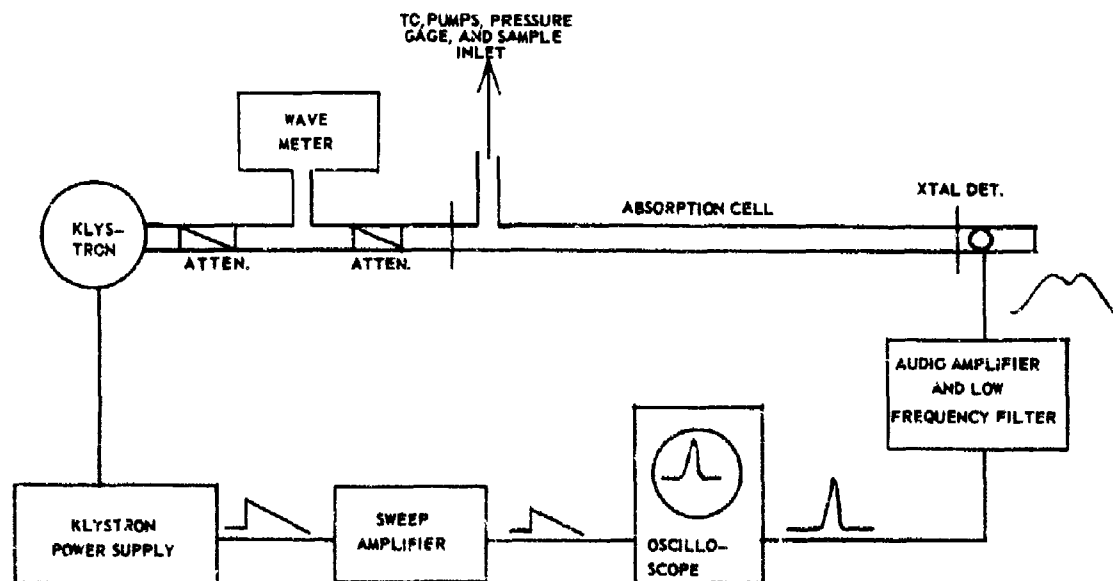

FIGURE 2.—Simplified diagram of microwave spectrograph.

ability to sweep the frequency of the microwave beam continuously through a range of frequencies. Thus, narrow absorption lines could be revealed. Several ranges of frequencies were provided by using the different harmonics produced by the crystal generator. Determination of the frequency was made by comparison with the standard signals broadcast by station WWV of the U.S. Bureau of Standards. Thus, standard frequencies, accurate to at least eight significant figures, were obtained by multiplication via a harmonic chain from the megacycle or kilocycle frequencies of the Bureau of Standards station. Early measurements at Duke in the range 4 to 2 mm were made with multiplier and detector crystals in coaxial mounts with K-band klystrons which had a 1.23 cm fundamental.

In an effort to extend the range below 2 mm the size of the crystals was reduced and they were mounted directly into the waveguide.

Subsequent designs and methods have remained substantially the same since that time but waveguide sizes were reduced as the wavelength region was lowered. Better crystals and improved klystrons also permitted extending the range to 0.77 mm and later to 0.43 mm. Further work now in progress may extend the range to 0.3 mm or below.

A wide band of frequencies may be covered in a single sweep of the klystron because useful energy is available from many harmonics above the cutoff frequency of the wave guide. (Harmonics to the 20th and higher are often employed.) In a molecule under consideration the lines may have frequencies which fall into an approximate but not an exact harmonic series. The klystron harmonics on the other hand, are exact multiples of the fundamental frequency. Hence, two of the molecular absorption frequencies may be displayed with different harmonics by sweeping the klystron frequency over a small range. The spacing of the lines permits calculation of certain molecular constants. Ambiguity is avoided by measuring the line again with another harmonic. This method is superior to that in which the generator of the energy is employed only with its fundamental frequency. For the shorter waves suitable sources are not available, but in the ranges in which they are, the high total power which they often provide is not advantageous. For high-resolution spectroscopy one must avoid the broadening of the spectral lines which would arise because of saturation of the sample. Furthermore, it is not the

total power that is important, but the power within the bandwidth required for the measurement. For this reason, a generator of reasonably short wavelength is chosen and so arranged that its frequency may be swept continuously through a selected range. The crystal harmonic generator then provides many harmonics, each of which is swept in step with the frequency of the generating klystron.

One byproduct of this research has been an indirect measurement of the velocity of light. Certain molecular constants of  $\text{HC}^{35}$  had been evaluated from data obtained with a precision grating (6). The results were expressed in wavelength units; the limit of error involved was comparable with that for the velocity of light. Professor Gordy and his colleagues measured the same constant in frequency units of error still smaller. The ratio of the two values of the constant provides a new evaluation of the velocity of light. This is  $299,792.8 \pm 0.4$  km/sec. The result is in agreement with and is of accuracy comparable with the best values obtained by more direct methods.

The millimeter range of the spectrum is a good one for measurements of the Stark effect. This is the splitting of the spectral lines into components due to an applied electric field. The observations provide measurements of the electric dipole moments of the molecule. At the wavelengths employed here, the Stark effect is easy to explore with electric fields of moderate strength. The apparatus needed involves a special absorption cell. Two types of cells have been devised.

One type consists of a length of standard waveguide fitted with a conducting strip in its center. The strip is held in place by insulating spacers. Measurements are taken with and without an electric field between the center strip and the walls of the waveguide. In 1948, Gordy proposed a parallel plate cell (7) for use with horns so designed as to send the beam of microwaves through the space between the plates of the cell. To provide a focusing effect Teflon lenses were installed in the horns. This type of cell is sometimes called a "free space" absorption cell. The cell and horns are enclosed in a vacuum chamber with suitable arrangements for introducing the gas to be measured. This second type of cell was found to yield more accurate values.

An adaptation of the free-space absorption cell makes it suitable for the study of free radicals and other unstable species of which the molecular con-

stants are difficult to measure. In this case, the gaseous free radicals are produced by a glow discharge in a chamber below and connected to the cell. Other unstable molecular species have been measured with this arrangement also. A modification of this arrangement has been constructed to study unstable species at higher temperatures. The free-space cell is placed in a metallic enclosure of which the temperature can be raised. Measurements have been made on such unstable species as AIF.

Another modification of the equipment permits measurement of absorption spectra of collimated, high-temperature molecular beams which traverse the radiation path.

This method has been particularly valuable for the measurements of the molecular constants for the alkali halides. The samples are heated in the oven forming a beam which traverses the cell. Measurements of these high-temperature molecular beams in the wavelength region between about 4 and 0.89 mm have yielded results which cannot be achieved by observation of spectra in the optical region. Furthermore, the method is superior to that in which the cell containing the sample is heated as a whole because under such an arrangement the absorption lines would be broadened by the Doppler effect and by pressure.

The microwave spectrograph is particularly well suited as far as resolution is concerned for the study of molecules containing atoms of which there are several isotopes. The lines of such molecules are separated so well in most cases that there is no overlapping. For example, the two molecules  $O^{16}C^{32}S^{32}$  and  $O^{16}C^{32}S^{34}$  may easily be distinguished. In this case the two molecules differ only by having sulfur atoms of atomic weights of 32 and 34 respectively. The concentrations of the several isotopic molecules in a gas may be determined quantitatively from intensity measurements. Thus, the method is valuable for the study of isotopic mixtures.

Identification of unknown gases is possible. Thus, methods of qualitative and quantitative analysis of mixtures of gases have been devised to complement those of infrared spectroscopy. Wherever it can be applied, microwave spectroscopy is superior because of its greater resolving power which permits definite identification and accurate intensity measurements.

For possible future applications in radio, radar, or missile guidance, the pioneering efforts of

Gordy's laboratory in microwave techniques down to 0.4mm. wavelength will be helpful. For example, they have shown that solid-state detectors and harmonic generators are practical at these short wavelengths for measurements on the absorptions of atmospheric gases in the shorter millimeter wave range of the spectrum. The results will be useful in designing equipment for communication at these short wavelengths.

Microwave spectroscopy also contributes to the study of certain aspects of liquids and solids, particularly the measurement of closely spaced energy levels in paramagnetic substances, and the structure of certain crystals.

Since 1955 this group has applied its methods to the study of radiation damage in critical biological matter, such as protein and nucleic acids (ENA and RNA). This work has influenced the initiation of many investigations employing the same techniques in medical research centers. The results with the nucleic acids DNA and RNA have been most significant (5). Modified forms of these molecules may eventually have applications as memory storage units, or circuit elements, in computers or other devices. Such applications must await further information about their properties.

Since 1955, Gordy's group has also applied its methods to the study of radiation damage in simple organic substances which are used in making synthetic plastics and fibers (e.g. teflon). These studies led to the wide usage now made of the techniques for radiation studies in the laboratories of chemical and electrical industries. The increasing potential for exposure of materials and human beings to ionizing radiation in the space age makes the solution of such problems relevant to the present space effort.

Other applications have been found. One is the stabilization of a microwave oscillator by coupling it to a spectrum line. (6) It appears now to be possible to stabilize the frequency of a klystron oscillator to much better than one part in a million. There are obvious advantages in having stable oscillators for frequency comparisons, and for indirect measurements of time and distance.

The results of this research have in general increased the store of precise information about sizes, shapes, and properties of atoms, molecules, and atomic nuclei, primarily from their interactions with microwave radiations. The review articles cited in the bibliography list papers in which data and interpretation are presented. In some

cases, the information was supplementary to that derived from observations made in the optical region of the spectrum, but for many molecules the data could not otherwise have been found.

#### REFERENCES

- (1) C. E. Cleeton and N. H. Williams. *Phys. Rev.* **45**, p. 235 (1934).
- (2) H. A. Gebbie, N. W. B. Stone and F. D. Findlay. *Nature* **202**, p. 685 (1964). Also, G. W. Chantry, H. A. Gebbie and J. E. Chamberlain. *Nature* **205** (1965).
- (3) W. Gordy, "Proceedings of the Eighth European Congress on Molecular Spectroscopy," p. 129 ff., Copenhagen (1959).
- (4) W. Gordy, *Rev. Mod. Phys.* **20**, p. 668 (1948).
- (5) R. A. Patten and W. Gordy. *Nature* **201**, p. 361 (1964).
- (6) W. W. Smith, J. L. Garcia de Quevedo, R. L. Carter, and W. S. Bennett, *J. Appl. Phys.* **18**, p. 1112 (1947). Also, J. L. Garcia de Quevedo and W. V. Smith, *J. Appl. Phys.* **19**, p. 831 (1948).

## Seismology

WILLIAM J. BEST

A program of basic research in seismology, funded by the Advanced Research Projects Agency of the Department of Defense under the VELA UNIFORM program, has been scientifically monitored and administered since 1961 by the Air Force Office of Scientific Research through its geophysical division.

In that time 46 research efforts have been initiated through grants and contracts with leading universities and research institutions in the United States and abroad. The program's objective is to improve the capability to distinguish seismically between nuclear explosions and natural geological events.

Research efforts have been applied in areas of identification techniques, data processing, array configuration, deep-hole and ocean bottom detection, instrumentation techniques, magnitude-energy scale relationships, noise studies, earth seismicity, explosion and earthquake source mechanism studies, crustal studies, and theoretical studies.

The entire research program through the end of 1965 is summarized in the AFOSR publication *VELA UNIFORM Research in Seismology* (AFOSR 65-2667), published in January 1966.

The research program is directed toward four general major problems associated with the detection and identification of underground nuclear explosions. These are (a) the nature of the source and its mechanisms for generating seismic wave energy; (b) the propagation paths including the crust and mantle of the earth; (c) the receiver site or sites including instruments and arrays for signal to noise enhancement; and (d) data analysis techniques for the detection, identification, and source location of seismic signals.

More recently, significant contributions have been in the areas of improved traveltime curves, refining the accuracy of locating explosion sources, and in establishing large arrays, serving to enhance the signal-to-noise ratio of smaller events.

From these has come the realization that the mantle, especially the upper mantle under the source or receiver sites, cannot be assumed to be layered, homogeneous, isotopic, etc. The upper mantle can now be visualized as a corrugated surface with large horizontal variations in temperature, density, compositions, and pressure at a given depth below a given geographic region. Therefore, to accurately locate a seismic event the source corrections have to be known as well as the propagation paths corrections, and azimuthal variations in the stations corrections. The source corrections caused by the corrugated variation in the upper mantle means that the complicated regions of the world have to be calibrated to determine their source corrections for the upper mantle.

Regional variations for the Aleutian Islands are were calibrated by ARPA's Project Long Shot during the fall of 1965. This underground nuclear explosion confirmed that the upper mantle has large regional variations that affects the accuracy of source locations and the distortion of seismic waves propagating through these regions. Therefore, since seismology provides the most direct and accurate data for interpreting the structure of the interior of the earth, AFOSR's basic research programs have made contributions in developing techniques to refine this interpretation.

Seismic techniques provide the only readily available data on the mantle of the earth (depths greater than about 30 km.). From knowledge of the velocities of propagation of *P* and *S* waves, attempts have been made to infer interior properties such as chemical compositions, density thermal properties, temperature, crystal structure and

orientation, and creep rate. To provide satisfactory interpretation of this seismic data, results from high-pressure temperature research must be utilized along with theoretical considerations. Recent results from experimental seismology have shown that this data, in addition to seismic velocities profiles, can provide other information such as density and anelasticity. These determinations when combined with elastic properties are providing an approach to make a direct estimate possible for the composition and temperature profile for the mantle. There is a possibility of using seismic anisotropy to determine crystal orientation within the mantle. This reopens the question of phase changes to explain the various discontinuities existing in the upper mantle.

Recent improvements have been made in long-period instrumentation for recording the long-period surface waves and free oscillations of the earth. These improvements have enabled seismologists to refine their interpretation of the earth's interior and to develop two new independent parameters, density and anelasticity. Density bears directly on the problem of determining the composition of the earth. Anelasticity has important bearing on the problems of temperature and phase changes in the mantle, and may even be appropriate in explaining long-term deformations of the earth.

These lateral variations in the crust and upper mantle are now well established. New results, especially from surface wave data, indicate that regional variations extend in the mantle even deeper than 400 km. The gross features of the mantle, such as low velocity zone and sharp upper mantle discontinuities, seem to exist on a world-wide basis. Extra details differ for geographic regions. ARPA's worldwide calibration program, such as Project Long Shot, will provide the basic data to refine our interpretation of selected geographic regions. These new results will aid in the accuracy of locating and identifying events. These results are from basic research in seismology being conducted at California Institute of Technology, Columbia University, University of California at Berkeley, Southern Methodist University, and Massachusetts Institute of Technology.

In addition to the basic research program in seismology, AFOSR was responsible for three specialized projects for the Department of Defense, each of which demonstrated a high degree of coordination and cooperation with many domestic

and foreign research and governmental organizations. These projects were Blue Ice, described elsewhere in this volume, Early Rise, and Infrasonics.

Project Early Rise was another in a series of summer seismic field experiments designed to understand and evaluate the method by which seismic energy is propagated and modified by the inhomogeneities in the crust. The project consisted of a series of forty 5-ton chemical explosions detonated at a fixed shot point repeatedly occupied and fairly centered in Lake Superior. Two shots were fired each night at 0330 and at 0430, under the overall direction of the crustal studies branch of the U.S. Geological Survey, Department of the Interior, Menlo Park, Calif.

Thirteen seismic radial arrays emanated from the shot point and uniformly covered the entire North American continent. The seismic field parties occupying each of the arrays was composed of seismic recording crews from universities and industry as well as the USGS. Of the 13 radial recording lines, 10 were under the direction of the AFOSR geophysics division. The seismic experimental field methods required that each team move out radially from the shot point after each successful night's shooting. There were a maximum of only 20 nights of shooting which precluded re-occupancy of the same stations for more or hopefully better data.

The shooting program involved the use of the U.S. Coast Guard cutter *Woodrush*. A special underwater demolition team was assigned to the *Woodrush* for loading and firing of the explosive—a nitrocarbonitrate compound. The exact time of detonating each shot was recorded electronically on records which also contained WWV time signals. Communications between the shot point and all field teams were made by single sideband radio systems and by rapidly changing telephone networks. Two of the seismic profile lines in north and northeast Canada required the use of pontoon-equipped aircraft and experienced Canadian bush pilots to place the teams in the remote areas where roads do not exist. Experience gained in charge composition and optimum depth location of the charge from previous summer programs has resulted in the best overall extensive seismic program ever conducted under the VELA UNIFORM project. Usable data has been obtained by nearly all participants out to the extreme limits of their planned traverses. From the analysis and compilation of these data will undoubtedly be produced

the most comprehensive seismic velocity and structure analysis maps of the North American continent ever known. The results will be compiled by the USGS and will be issued as USGS technical reports.

Project Infrasonics is a joint program with the geoaoustics branch of ESSA and supported by ARPA, in which two infrasonic array stations have been established in Bolivia and in Peru. Several source mechanisms, natural and artificial, on or under the surface of the earth, are known to excite acoustic, acoustic-gravity, and shock wave in the troposphere.

Recent research has shown that these acoustic gravity waves are directly correlated with such source mechanisms as earthquakes, tornados, meteors, volcanos, and solar particles impinging on the ionosphere. Even explosions in the atmosphere, if large enough and near enough, will be recorded by infrasonic equipment. This interplay of acoustics gravity waves with other geophysical phenomena in the troposphere and ionosphere is opening up a whole new area of geophysical research. The station at Penas, Boliva, operated by San Calixto Observatory, is conducting experimental research on the interplay between earthquakes recorded at the seismic station and acoustic gravity waves recorded by the infrasonics station. The station at Huancayo, Peru, operated by Instituto Geofisico del Peru, will conduct research to determine interaction of acoustic gravity waves with the preturbations detected in the ionosphere.

In addition, a grant has been issued to Brown University for Dr. Dave Harkrider to conduct theoretical research on acoustic gravity waves. Such research will cover the type of source models to represent the artificial and natural source mechanisms, investigate the applicability of plane stratified atmospheric models, and calculate the effects of viscosity, winds, thermal gradients, and gravity.

### *Project Blue Ice*

MAJ. DURWARD D. YOUNG, JR.

Seismologists the world over are eternally in quest of that magic set of conditions best described

as a "quiet site." In real life such seismic laboratory locations free of background noise, far from cultural noise source, yet strategically located with respect to the world's major seismically active areas, simply do not exist. However the search for the best goes on. Prior to the present decade, seismologists had to be content with observatories located in close proximity to educational and governmental institutions for both technological and financial support. This changed rapidly early in 1961 with the inception of the Advanced Research Projects Agency's VELA UNIFORM project.

Activities under the project ranged from basic theoretical research to seismic instrumentation design and development. Under this charter the entire earth's surface was considered the laboratory for investigation for the best seismic recording locations. It is fairly safe to state that no part of the free world was excluded from investigation for the quietest possible location for seismic studies. Concurrent with these worldwide background noise studies a large number of research programs were instigated in universities and research institutions in this country, Canada, South America, and Europe. AFOSR alone directed over 50 research efforts in basic research in seismology. The state of the art of recording instrumentation was greatly stimulated and many new techniques and processes for data analysis were evolved. Simultaneously the theory involved in interpretations of seismic data was advanced by orders of magnitude.

The cumulative results of such massive efforts in the science have advanced seismology to the present state in which the detection and identification of seismic events is limited only by the natural seismic background noise mixed with and masking the incoming signal. A unique application of this new knowledge is now manifest in the design and installation of the large aperture seismic array located near Miles City, Mont. This 525-element array was commissioned in the late fall of 1965 and has been operated fairly continuously since that date.

LASA, designed as an experimental model of a large seismic detection array, was not necessarily designed as a prototype for future array design. However, it was immediately evident (from other studies also) that arrays such as LASA offered powerful methods for time series analysis of incoming signals with resultant marked increase

in signal to noise ratios. With the objective of locating the quietest feasible sites for possible duplication of the instrument cluster concept of the Montana LASA system, AFOSR was directed by ARPA in February of 1966 to take another look at the seismic noise level of the interior of the Greenland icecap. Several such studies have been performed by seismic field teams in the intervening years since 1961. A review of the data collected by these teams did not generate a great amount of enthusiasm for another icecap investigation in Greenland; however, several unique innovations made the new survey interesting and worthwhile.

The field effort, code named Project Blue Ice, had a distinct technical advantage over the others. The project was to be placed in the very center of the uninhabited cap with the latest and possibly the best event detection seismometers and recording instrumentation and know-how available in the seismic community. The original Blue Ice plan was to move into the center of the Greenland icecap as early as possible in the summer of 1966 and establish the station in sufficient time to permit at least 1 month of data to be recorded before the arctic night made later occupation too hazardous. The station was to be closed in mid-September and reoccupied in the early spring of 1967 for a week to 10 days of additional recording. The project would end with a final 2 weeks of recording in July 1967 which would provide a 12-month seasonal sampling of background noise on the icecap.

Field operations began in March of 1966 when the Arctic Institute of North America in Washington, D.C., was awarded a contract to establish and operate a base field camp to support the seismic program. The exact location was not initially important but was to be selected such that maximum distance from all sources of cultural and natural noises would be obtained. This part of the operation was under the able direction and leadership of Ralph Lenton, of the Arctic Institute of North America, who effectively put the camp together from a plan stage to full operation in less than 6 months. The site of the seismic station was arbitrarily first picked at latitude  $78^{\circ}$  N. and longitude  $40^{\circ}$  W.

Air logistic support from Thule, Greenland, to the interior of the icecap was provided by Headquarters Alaskan Air Command from Elmendorf AFB, Alaska, using ski-equipped C-130 Hercules

aircraft operated by the 17th Troop Carrier Squadron. The initial fly in required that the lead aircraft depart Thule with adequate survival gear for the initial landing on a unprepared open area of the icecap.

The lead aircraft could not make visual surface contact at the dead-reckoned coordinates of  $78^{\circ}$  N.,  $40^{\circ}$  W. A break came when the abandoned British 1952-54 North Ice Station was sighted thru the cloud cover. The site-selection aircraft then flew under the low cloud cover approximately 14 miles and upon landing established the Inge Lehman Station at  $77^{\circ}56'48''$  N. and  $39^{\circ}11'$  W. These coordinates were verified by 50 theodolite sunshots and are accurate to  $\pm 1$  km. This location error is considered within the acceptable limits for event detection studies.

The initial touchdown was accomplished on 19 July 1966. The camp nucleus then consisted of one skid-mounted trailer and six scientific personnel. This landing party was rapidly augmented to a full station complement of 10 and approximately 60 tons of camp and scientific gear. Approximately eight missions (round trips) were required for the Hercules C-130's to establish the basic camp. This was completed in 6 days without serious incident except for the loss of one engine when a propeller dug into a sastrugi ridge. The aircraft was airborne again with a replacement engine changed on the icecap within 72 hours.

The seismic array consisted of four downhole short-period seismometers located at the center and apices of an equal angular triangle as illustrated. A three component short-period surface station completed the instrumentation. The base camp consisted of two 20-foot-long skid-mounted trailers positioned to provide an 18-foot covered vestibule work space between them. One trailer served as a cook, messing, and recreation facility. The other housed four personnel, the scientific recording equipment, and also contained a shower which doubled as a darkroom. A Jamesway hut extending from the vestibule served as a dormitory.

The exact thickness of the ice at the site is not known but from available data appears to be approximately 2.8 km. The terrain is monotonously uneventful and devoid of animal or plant life. Drilling began as soon as the minimum requirements of the base camp installation were satisfied. The instrument hole depths were predicated upon the depth required to reach an ice density of 0.83.



This was found to occur at each instrument location at a depth of approximately 180 feet. All instruments are therefore approximately 180 feet below the surface. The holes were core drilled which permitted excellent density/depth control. The upper portions were cased with an 8-inch fiberglass pipe down to depths of 60 feet. The lower portions of the holes were unsupported and showed no visible evidence of closure during the first 6 months of operation. Drilling was accomplished by a portable ski-mounted Acker Hillbilly powered by a Perkins diesel engine. Selected cores were depth logged and encased in plastic bags for additional studies. Instrumentation, operation, and maintenance of the array was accomplished by personnel of the Geotech Division of Teledyne, Inc., Garland, Tex.

On 17 August 1966, the Project Blue Ice site was officially dedicated as the Inge Lehmann Station. The name was selected to honor Dr. Inge Lehmann, a noted Danish seismologist, who has performed considerable seismic research in the United States. Dr. Lehmann presently resides in Copenhagen, Denmark.

There were a total of four independent scientific measurement programs under the project. The seismic program was accomplished under a joint activity arrangement between the Danish Geodetic Institute and the Air Force Office of Scientific Research. Dr. Eric Hjortenbergt of the Danish Geodetic Institute, Copenhagen, Denmark, worked in collaboration with Dr. Eduard Douze, the Geotech/AFOSR contractor in processing and analyzing the seismic data.

The seismic instrumentation was a packaged "suitcase" system assembled and field tested by Geotech. The short-period down-hole instruments were Geotech model 20171A moving coil seismometers designed to operate in shallow holes at pressures up to 500 p.s.i. and at tilt angles as great as 10 degrees. The instrument is capable of long-term operation at temperatures up to 120° F. (49° C.) and demonstrated satisfactory operation at bottomhole temperatures encountered at minus 33.2° F. It has a natural frequency response adjustable from 0.75 to 1.05 hertz and a natural period adjustable from 1.33 to 0.95 second. For Blue Ice the period was set at 1 second. A three-component surface seismic station was installed 2,250 feet to the NNW (326°) of the base camp in a vault approximately 12 feet below the surface. All cabling was accomplished using REA PE23, a

six-pair telephone cable suitable for direct burial. This is the same cable used in the Montana LASA. Available weather records of the area indicated no lightning protection would be required and an uneventful summer validated the decision to eliminate the protectors. Recording was accomplished on a battery-operated Geotech 14-channel IRIG slow-speed analog tape recorder. This recorder has a capability for continuous operation for 33 days; however, the speed was adjusted to 0.03 inches/second for a 7-day operation. Two tapes were flown out on each biweekly resupply air mission. These were continuously processed during the summer by the Geotech division which permitted the data analyst to recommend different gain settings and adjustments via radio contact with the site upon receipt of each tape. Each of the four vertical down-hole seismometers were operated at dual-gain levels. The surface verticals were operated also at a dual level, but because of channel limitation the two horizontals were recorded at one gain level only. The remaining two tape channels were used to record station timing and WWV. This method of recording requires minimum power and magnetic tape but it is limited to dynamic range of 35 db (peak-to-peak) on each channel and a total peak signal range of 50 db (peak-to-peak) on each channel and a total peak signal range of 50 db (peak-to-peak) using dual-level recording. The upper data frequency limit was 5 hertz.

The magnetics measurement program was under the supervision of Johannes Wilhelm of the Danish Meteorological Institute in Copenhagen.

Wilhelm maintained a magnetic laboratory located adjacent to the base camp in which he recorded daily variations in the earth's magnetic intensity and declination. These data were supplemented by data from several fixed observation sites in an array projecting east and west of the base camp.

A third program involved the measurement of the specific activity of the cosmic-ray-produced  $Si^{32}$ . One ton of ice below the 6-meter depth (from the pre-hydrogen bomb testing era beginning in 1953) were collected and flown to Thule AB for analysis by scientists from the University of Copenhagen. The purpose of this investigation was to check whether or not the fallout of naturally produced  $Si^{32}$  is influenced by a continental effect. Comparison with a similar sample collected at Camp Century, 500 km. west of Inge Lehmann station, should give the answer to this question,

which is important for the possible use of  $Si^{22}$  for dating of ice.

For the fourth program, selected ice cores were preserved for crystallographic studies by personnel from the U.S. Army Cold Regions Research and Engineering Laboratories in Hanover, N.H.

In addition, daily synoptic weather observations were recorded on precipitation, wind direction and velocity, barometric pressure, temperature, cloud/sky conditions.

Initial analysis of the data has been directed at determining the nature and character of the seismic background noise. It was obvious from the beginning that the noise level at this particular location was especially low. As each new hole was completed they were immediately instrumented and adjusted for maximum gain. Gains were rapidly increased to as high as 106 but were leveled off at approximately 1 million, which was an order of magnitude higher than anticipated. With the completion of the entire array, it became obvious that this was an unusual seismic environment: there was no evidence of noise due to ice flow, cracking, wind, and other expected sources.

Power spectra of the vertical seismographic data show that the noise level at the 1 cps detection interest frequency is slightly less than  $1 \mu^2/\text{cps}$ . This is true for down-hole verticals as well as the surface vertical instrument. The power in the

spectra increases rapidly for periods greater than 1 second and shows peaks at 2.8 and 4.5 seconds. The expected 6.0 second microseism peak common at continental recording stations is seen at Inge Lehmann only when major storms are active in the North Atlantic. The power peak at 2.8 seconds is always present but is noted to change in value as a function of time. For periods less than 1 second the spectra decreases rapidly. The surface instrument is sensitive to wind noise at these short periods but the down-hole instruments showed little response to summer winds as high as 35 knots. Measurement of the coherence of the noise within the four element array shows that for periods of less than 1.5 seconds the noise is apparently uncorrelated.

To check this particular result of the spectral analysis the power spectra of all four seismographs were summed at the 1-second period. The power was increased by almost exactly a factor of four indicating absence of noise correlation. This summing was done to eliminate other possible causes for low coherence. For example, the low coherence at 3.5 seconds as seen by the notch in the power spectrum, could be caused by averaging of the 2.8 and 4.5 second spectral peaks which are due to seismic phases traveling at different velocities and quite possibly from different directions, i.e., ocean waves generated noise from the east and west

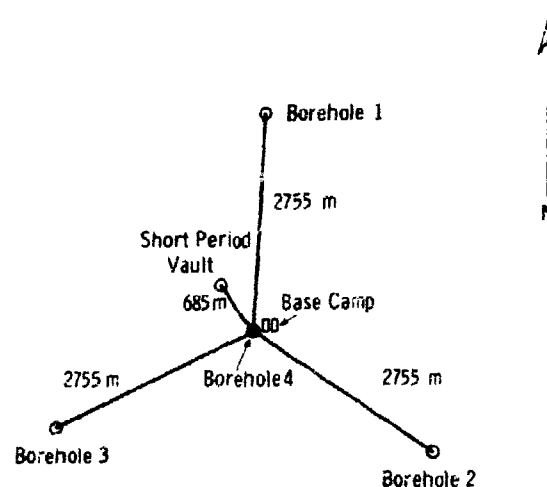

FIGURE 3.—Location of seismometers at Station Inge Lehmann, Greenland.

coasts of Greenland. Much work remains to be done with the station data but low noise quantities are already quite apparent.

Because of the uniquely low background noise associated with the Project Blue Ice data, it was decided to continue manned operations throughout the winter until summer of 1967. Logistic operations began immediately to prepare the station for the 4 months of isolated winter operations. On 15 October 1966, four station contractor personnel were rotated into the Inge Lehmann station to operate the array during the winter period. A rudimentary emergency lighting airstrip was hastily installed to provide for any emergency evacuation.

Seismic event reports are issued daily by radio to Thule and relayed by teletype to the USCGS at Rockville, Md., for inclusion in the standard ESSA seismic event bulletin. A new crew will operate the station until mid-1967.

## Observation Basis of General Relativity

Dr. ERICH WEIGOLD

AFOSR has supported studies in gravitational physics for approximately a decade. Although these studies have not loomed prominently in the nuclear physics program, the investigations have been both interesting and varied. They have, for instance, dealt with cosmological solutions of Einstein's equations, efforts to quantize the general theory of relativity, studies concerning the gravitational collapse of stars as possible explanations for the behavior of quasars, and efforts to test the general theory of relativity experimentally.

Although the general theory of relativity has a clear conceptual superiority over Newtonian gravitation, it has been difficult to establish the experimental superiority of the theory. In this respect it differs markedly from the special theory of relativity, which has been amply verified by experiment within its domain of validity. In order to verify the general theory, phenomena must be observed in moderate gravitational fields at high speeds (in terms of the velocity of light) or in strong gravitational fields at moderate speeds. The relevant gravitational parameter is  $\frac{GM}{c^2 r}$  where

$G$  is the Newtonian constant of gravitation,  $c$  the speed of light,  $M$  the mass of the gravitating object, and  $r$  the distance from its center. Even at the surface of the sun this parameter is only of the order of  $10^{-6}$ , while at the surface of the earth it is roughly  $10^{-9}$ . Thus the available gravitational fields are extremely weak and the Newtonian theory can be used to a high degree of approximation.

There are, however, three well-known tests of the theory: The gravitational red shift, the deflection of starlight by the sun, and the precession of the perihelion of the orbit of Mercury. The first of these "tests" was shown by Einstein (1) to be independent of the formalism of general relativity and to follow directly from any theory consistent with the well-established (2) equivalence principle. The deflection of starlight passing close to the sun has been measured and the results, although not completely consistent, are in rough agreement with the predictions of the general theory of relativity. The situation is better with regard to the third test. The observed precession of the perihelion of the orbit of the planet Mercury agrees with the predicted value to within 2 percent. On the other hand, Dicke (3) has proposed that the precession of the perihelion of the inner planets could in part be due to a very small flattening of the sun.

In order to remedy this paucity of observational evidence, a new experimental test was proposed by L. I. Schiff and W. M. Fairbank of Stanford's Department of Physics. Some years ago, Schiff (4), under AFOSR sponsorship, showed that a perfect gyroscope, subject to no external torques and orbiting the earth in a satellite, will experience an "anomalous" precession with respect to the fixed stars as it travels around the earth. For an orbit of moderate altitude, the predicted shift of the direction of the axis of rotation of such a gyroscope is only 7 seconds of arc per year. A measurement of this precession, which arises as a result of the earth's mass "distorting space-time" in its neighborhood, would provide a test of the general theory of relativity essentially equivalent to, but more sensitive than, the deflection of light test. A second much smaller anomalous precession (of the order of 0.05 second per year) is due to the difference, according to Einstein's theory, between the gravitational fields of a rotating and nonrotating body.

William Fairbank and his colleagues W. Hamilton and F. Everitt have been working for sometime toward a gyroscope that will be able to detect these very small rates of precession. This work, supported by AFOSR, is now rapidly progressing toward the point of being tried in practice. The gyroscope under construction should be capable of being read to 0.01 seconds of arc and should have a drift rate due to all external torques of less than 0.01 second of arc per year. The experiment should give a completely new check to the general theory of relativity.

The technical problems are enormous and can only be solved by placing the gyroscope in a satellite, where it is possible to reduce the effective gravitational field sufficiently to reduce the support torques to the required level. To reduce the drift from the gravity gradient torques, which exist on any nonspherical gyroscope whether it is in a satellite or on the surface of the earth, it is necessary to have the gyroscope as perfectly spherical as possible. This, unfortunately, presents a severe readout problem since normal readouts require knowing the position of the axis of rotation with respect to the ball. For a perfectly spherical ball the moments of inertia of all the axes of the ball are equal and it is impossible to anticipate about which axes the gyroscope will spin.

Fairbank realized, however, that the so-called London moment could provide a unique way of solving this readout problem. London's (5) theory of superconductivity predicted that a spinning superconductor would spontaneously develop a magnetic moment of  $10^{-20}$  gauss along its axis of spin, where  $\omega$  is the frequency of rotation of the body. The existence of the London moment was demonstrated in 1964 by Bol and Fairbank (6), supported by AFOSR, as well as by Hildebrandt (7), and by King, Hendricks, and Rorschach (8). The London moment is very small and to achieve the required readout accuracy, a superconducting magnetometer with a sensitivity of  $10^{-10}$  gauss was developed at Stanford (9). This would allow an accuracy in readout of 0.1 second of arc for a superconducting ball spinning at a frequency of 4,000 radians per second (38,000 rev/minute). The sensitivity can be increased to at least the required 0.01 second of arc by averaging over a year or by reducing the noise temperature in the amplifier to liquid helium temperatures.

Since external magnetic fields would interact with the London moment causing a precession of the gyroscope much larger than the desired level, all external magnetic fields must be excluded from the vicinity of the gyro. This has been made possible by another unique feature of superconductors also predicted by London. He suggested (5) that the flux in a superconducting ring might be quantized in units of  $4 \times 10^{-7}$  gauss  $\text{cm}^2$  due to the long-range order in the momentum of electrons. In 1961 Deaver and Fairbank (10) at Stanford and Doll and Näbauer (11) in Germany, discovered that the flux trapped in a superconducting ring was indeed quantized, but in units of  $2 \times 10^{-7}$  gauss  $\text{cm}^2$ . This factor of 2 is due to the pairing of electrons in a superconductor and it provided a very substantial verification of the theory of Bardeen, Cooper, and Schrieffer (12). This discovery made possible for the first time the attainment of regions in which the magnetic field is truly zero. Deaver and Fairbank observed that the flux trapped in the hole in a small superconducting cylinder is zero if the cylinder is made superconducting in a magnetic field of such size that the flux in the hole of the cylinder is below half a flux unit. The Stanford group has used this unique property of superconductors to design a zero magnetic field facility (9) in which the ambient magnetic field will be less than half a flux unit. An experiment where it is desired to obtain zero magnetic field can therefore be surrounded by a superconducting shield, placed in the zero magnetic field facility, and then cooled below the transition temperature of the shield. When the magnetic shield becomes superconducting, it will trap no flux and inside the shield there will be a region of zero magnetic field.

The actual gyroscope will consist of a very homogeneous and spherical quartz ball, 1.5 inches in diameter and coated with a thin layer of niobium. The ball, electrostatically supported across a supporting space of 1.5 thousandths of an inch, is spun up in vacuum when in the superconducting state by helium gas jets. The entire gyroscope is surrounded by a superconducting 4-inch diameter spherical magnetic shield from which the last quantum of flux has been excluded. The superconducting loop of the readout magnetometer (9) introduces essentially no losses in the ball. The gyroscope and readout loop are made an integral part of a quartz telescope, which will

be used to compare the axis of the gyroscope with the position of the stars. Both the telescope and gyro will be operated at liquid helium temperatures. The complete satellite experiment, supported by NASA after initial AFOSR support, will include four gyroscopes, two checking the larger effect due to the satellite's motion around the earth and two for checking the earth's rotation effect of 0.05 second of arc per year. The experiment will be kept cold for more than 1 year by approximately 75 pounds of liquid helium.

If the gyroscope is at rest in an earthbound laboratory, the earth's rotation carries the gyroscope through the earth's gravitational field, and the magnitude of the first "anomalous" precession would be roughly 0.4 second of arc per year, rather than 7 seconds per year. However, due to support torque problems, none of the existing gyroscopes are anywhere near sensitive enough to carry out an earthbound experiment. At this stage, the Stanford group revived the well-known idea that a spinning nucleus is a gyroscope which suffers none of the usual torques caused by the necessity of supporting the gyroscope against gravity forces. However, there is one serious difficulty with a free precession nuclear gyro, and that is the overwhelming torque due to external magnetic fields. Since a nucleus is very light and produces a relatively large magnetic field along its axis of spin, a very weak external field can make the nucleus precess at a high rate. For instance, a  $\text{He}^3$  nucleus will precess at a rate of 20,000 radians per second per gauss if the external field is at right angles to the  $\text{He}^3$  magnetic moment. Calculations show that in order to do the relativity experiment with a  $\text{He}^3$  nuclear gyro, the external magnetic field would have to be reduced to at least  $3 \times 10^{16}$  gauss. Previous attempts to make free precession nuclear gyroscopes have failed because of the impossibility of making the ambient magnetic field sufficiently small. The discovery of quantized flux has suddenly changed all this.

The Stanford group under Fairbank and supported by AFOSR has designed such a free precession  $\text{He}^3$  gyroscope.<sup>(9)</sup> It is necessary that the relaxation time of the  $\text{He}^3$  nuclei be longer than a year. This can be satisfied by diluting pure liquid  $\text{He}^3$  in  $10^7$  parts of the completely nonmagnetic  $\text{He}^4$ . The  $\text{He}^3$  nuclei must also be polarized so that essentially all their spins are pointing in

the same direction. This can be achieved either by optical pumping or by cooling them to  $0.01^\circ \text{K}$ . in the field of 100 kilogauss. The magnetic field produced by the polarized  $\text{He}^3$  nuclei, although an order of magnitude smaller than that produced by the superconducting gyro discussed previously, will have its direction monitored by a detection circuit basically the same as that used for the superconducting gyro. Modifications are introduced into the detection circuit in order to prevent it producing a magnetic disturbance which can react significantly back on the  $\text{He}^3$  nuclei. (These modifications are discussed in some detail in reference 9.) The  $\text{He}^3$  gyro, approximately 0.2 inches in diameter, is shielded by a carefully constructed superconducting magnetic shield  $1\frac{1}{2}$  inches in diameter. Even if care is taken to eliminate all ferromagnetic materials, it is estimated that the magnetic field due to the  $\text{He}^3$  nuclei and reflected from the spherical shield back on the nuclei will have a disturbing effect equivalent to somewhat less than  $10^{14}$  gauss. Therefore, the apparatus presently under construction will not be sufficiently perfect to perform the relativity experiment, the expected drift rate being of the order of 0.07 second of arc per day.

Although the apparatus will not be sensitive enough to perform the relativity experiment, the nuclear gyro will make possible a new important test of one of the fundamental symmetry laws in physics. This symmetry law, the principle of time reversal invariance, has been considered valid for all the interactions found in physics. Recently, however, high-energy experiments<sup>(13)</sup> have shown that time reversal invariance may be violated in the weak interactions or in the electromagnetic interactions. Now a nucleus with a non-zero angular momentum, such as  $\text{He}^3$ , will have a permanent electric dipole moment only if the principle of time reversal invariance is violated. (For a simple classical argument demonstrating this, see Schiff,<sup>14</sup>) However, should  $\text{He}^3$  have an electric dipole moment, a strong electric field applied across the gyro should cause the  $\text{He}^3$  nuclei to precess. The Stanford experiment, planned by Fairbank and Hamilton, will be a direct and extremely sensitive test of the principle of time reversal invariance.

In conclusion, as Fairbank<sup>(9)</sup> has said:

\* \* \* we see that the basic discovery of one of the fundamental properties of super-

conductors, the property of macroscopic flux quantization, has led to the possibility of making a truly zero magnetic field region and a readout such that a free precession nuclear gyro can be made which in principle has very much smaller drift rates than any known man-made gyroscope and which is unaffected by linear accelerations. The peculiar properties of a superconductor with respect to a magnetic field developed along its rotating axis and the associated perfect magnetic shields give rise to the possibility of a gyro in space which is more sensitive than any existing gyroscope. These two gyroscopes in turn make it possible for the first time, a test of the equations of motion in Einstein's general theory of relativity, and a new test of the fundamental symmetry law of time-reversal invariance. So we have come full sweep, a fundamental experiment makes possible a practical application, which in turn makes possible a still more fundamental experiment.

#### REFERENCES

- (1) A. Einstein, *Ann. Physik*, **35**, p. 808 (1911).
- (2) R. V. Eotvos, D. Pekar, and E. Fekete, *Ann. Physik*, **68**, p. 11 (1922).
- (3) R. R. Dicke, *Phys. Today* **20**, 1, p. 55 (1967).
- (4) L. I. Schiff, *J. Soc. Indust. Appl. Math.* **10**, p. 796 (1962).
- (5) F. London, *Superfluids, I* (John Wiley and Sons, N.Y., 1950. and Dover Publications Inc., N.Y. 1961).
- (6) M. Bol and W. M. Fairbank, "Proceedings of IX Conference on Low Temperature Physics," 1964, p. 471 (Plenum Press 1965).
- (7) A. F. Hildebrandt, *Phys. Rev. Letters* **12**, p. 190 (1964).
- (8) A. King, Jr., J. B. Hendricks, and H. E. Rorschach, Jr., "Proceedings of IX Conference on Low Temperature Physics," p. 406 (Plenum Press 1965).
- (9) W. M. Fairbank, W. O. Hamilton, and C. W. F. Everitt, "Proceedings of the OAR Research Applications Conference," p. 153 (5 Apr. 1966).
- (10) B. S. Deaver, Jr. and W. M. Fairbank, *Phys. Rev. Letters* **7**, p. 43 (1961).
- (11) R. Doll and M. Nabauer, *Phys. Rev. Letters* **7**, p. 51 (1961).
- (12) J. Bardeen, L. N. Cooper, and R. Schrieffer, *Phys. Rev.* **108**, p. 1175 (1957).
- (13) J. H. Christenson, J. W. Cronin, V. L. Fitch and R. Turlay, *Phys. Rev. Letters* **13**, p. 138 (1964).
- (14) L. I. Schiff, *Physics* **1**, p. 209 (1965).

## Cosmic Ray Physics

MAJ. JOSEPH E. GORRELL

Cosmic rays were discovered in 1912, but little cosmic ray research was accomplished for the next two decades. Then as man's knowledge of nuclear physics increased and better scientific instrumentation became available, research in cosmic ray physics substantially increased. During this early period, most research was directed primarily toward the determination of the composition, origin, and energy spectrum of the cosmic rays. These areas are still under study today.

In recent years, however, cosmic ray research has received additional emphasis because of its relationship to other scientific fields. For instance, the Air Force and NASA desire to know the cosmic ray hazard to manned space flight. High-energy physicists wish to use cosmic rays to learn more about the elementary particles. (Indeed, many of the elementary particles were first discovered in cosmic ray research.) Also, the cosmologist is interested in cosmic rays as a means of providing information useful in the formulation and verification of cosmological theories.

AFOSR has supported cosmic ray research since 1952. During this time the funds allotted to cosmic ray research have increased from approximately \$150,000 per year to \$650,000 per year. Initially support was limited to projects which used cosmic rays for the study of elementary particles. However, after the launching of the first manmade satellite additional funds were allocated to support research in the space environment aspects of cosmic radiation. Today the AFOSR program supports research in most areas of cosmic ray research that are of relevance to the Air Force and of current scientific interest.

Perhaps the best way to indicate the contribution of AFOSR-sponsored cosmic ray research to man's knowledge is to discuss briefly the work of a few of the scientists supported in the AFOSR program. One group at the Enrico Fermi Institute for Nuclear Studies at the University of Chicago has been supported for many years and has made valuable contributions to science. This group is directed by John A. Simpson and has been interested primarily in the low-energy components of cosmic radiation, i.e., particles of less than 1 BeV.

Initially the Chicago group was interested in

obtaining data on the neutron intensity in cosmic radiation. Instrumentation was carried aloft in high-flying aircraft and also placed in ground laboratories at various altitudes and latitudes. The ground stations ranged from Chicago to Huan-cayo, Peru, and were later expanded to include European stations and shipboard stations. The neutron detector used was designed by the Chicago group and was adopted as a standard detector for worldwide measurement in the International Geophysical Year.

Starting in 1959 this group entered the satellite program by placing scientific instrumentation on NASA satellites. The direction of research also was modified toward obtaining charged particle spectra and fluxes encountered in orbit. This program has led to several major accomplishments. One was the careful mapping of the earth's outer magnetic field as opposed to surface measurements of the magnetic field. By establishing that large differences exist between geomagnetic coordinates at ground level and those in the outer field, it was possible to clear up many seeming anomalies that had existed in the data on cosmic ray intensity distribution.

Another notable accomplishment of the Chicago group was the gathering of the most definitive data known on the cosmic radiation associated with the giant solar flare of 23 February 1956. That produced the fifth and largest major increase in cosmic radiation since the first observation of this phenomenon in 1942. Extensive data were taken from all the ground measurement stations, and, because of an alarm system developed by the researchers, they were able to release a balloon that reached 90,000 feet over Chicago to gather data during the time of intense cosmic ray activity. The insight gained by the analysis of this solar flare data has led to a greater recognition of the solar contribution to primary cosmic ray flux. For example, it was determined that the Forbush decrease (a sharp intensity and spectral change in cosmic radiation that occurs during magnetic storms) is of solar origin. It had previously been thought that this decrease was associated with the earth's magnetic field in some way. As this example suggests, cosmic ray research often produces important new knowledge about other related fields. In this case the cosmic rays serve as a magnetic field probe and the data obtained have direct application on radio communication studies and space vehicle guidance and radiation hazards.

The most recent accomplishments of the Chicago group concern the experiments placed aboard four satellites: Interplanetary Monitor Platform III (IMP-III), Orbiting Geophysical Observatory II (OGO-II), Pioneer 6 deep space probe, and Mariner IV. The instruments placed aboard these spacecraft are obtaining information as to the composition and abundance of cosmic rays. This information is proving to be of great value to many areas of science. For example, Mariner IV, looking for trapped radiation near Mars, determined that the magnetic field of Mars is less than one one-thousandth the earth's field.

Another group that has produced significant results under AFOSR sponsorship is at the University of Rochester under the direction of M. F. Kaplan. This group has collected data from balloons and ground-based equipment and has been concerned primarily with the high-energy components of cosmic radiation. (This is the part of the cosmic ray spectrum of most interest for the study of nuclear interactions.) The early work of this group helped establish the fact that light element nuclei (lithium, beryllium, and boron) were present in the cosmic rays. Whether the light elements are primary cosmic rays or are produced as fragments from nuclear interactions is still not known.

In recent years the Rochester group has been studying the energy spectrum, the composition, and, where possible, the isotopic structure of the charged primary cosmic rays. This is accomplished by using balloon and satellite-borne lithium-drifted solid-state detectors, scintillators, and Cerenkov light detectors. The charge composition is a very useful parameter since the existence of rare components such as H<sup>2</sup>, He<sup>3</sup>, Li, Be, and B are used in formulating models suggesting the origin of cosmic rays.

Also of importance is the work done by the Rochester group in the detection of high-energy primary gamma rays. By means of a gamma ray telescope carried aloft by balloon, it was found that very few, if any, high-energy gamma rays were emitted by the Crab Nebula, a celestial body that could conceivably be a source for such radiation. Their experiment yielded the lowest value for an upper limit on the high-energy gamma flux from that nebula.

The AFOSR cosmic ray research program has included several foreign projects. One such project is the partial support of a cosmic ray laboratory on top of Mount Chacaltaya near La Paz, Bolivia.

This mountaintop laboratory is the highest such facility in the world (17,200 ft.) and is located within four degrees of the geomagnetic equator. Since the laboratory is accessible year round and the wind velocities are rather low, this facility is quite suited for cosmic ray research. AFSOR has supported research directly at the laboratory on cosmic ray intensity variation studies in addition to supporting a large experiment conducted there by a group at MIT under the direction of George Clark.

The intensity variations research under Ismael Escobar collected data for several years on the cosmic ray intensity as well as temperature and pressure data taken by radiosonde equipment. Those data supplied evidence that the source of daily variations in cosmic ray intensity was due to extraterrestrial effects.

The MIT group established special equipment on Mount Chacaltaya to study extensive air showers. (A shower of particles is caused by a high-energy cosmic ray particle interacting with the atmosphere and producing a cascade of many secondary particles that impinge upon the earth over a large area.) The equipment consisted of an array of symmetrically arranged scintillation detectors connected to a common recording station. This air-shower array was the highest elevation array ever established. The results of the data obtained from this array showed that the structure of air showers at this altitude varied markedly from that at sea level. This led to a much better understanding of air-shower development and how elementary particles interact at extremely high energies.

This air-shower experiment led to another experiment called the Bolivian Air Shower Joint Experiment (BASJE) which had the primary objective of gathering data on the high-energy gamma ray component of primary cosmic radiation. Very high energy gamma rays are hard to detect but are of interest because they are uncharged (unlike most cosmic radiation) and are therefore not influenced by interstellar magnetic fields. They should travel directly from their source to the earth. Hence, if their arrival direction is obtained, the direction of the source of the cosmic rays can be determined. Also, since the production of high-energy gamma rays is likely to occur only under very special conditions, the source of such rays can tell something of the nature of stellar processes. Another reason gamma ray astronomy may be of value is that it could provide information about the

center of our own galaxy. Optical telescopes cannot view the center of our galaxy because of the great amount of interstellar dust which makes this region opaque to visible light. High-energy gamma rays, however, can penetrate this dust.

The BASJE experiment is still in progress and the data is being analyzed. Results thus far indicate that there are air showers of low muon content that appear to be produced by primary gamma rays. A search is being made to determine if these showers are produced by gamma rays emanating from certain regions in the celestial sphere. The results of this experiment will be of great value to cosmologists and other scientists.

Another foreign research project supported by AFOSR is a project located in Australia which is under the direction of C. B. A. McCusker. This experiment has the purpose of investigating extensive air showers. One part of the experiment is designed to study the core of the air shower. A 60-square-meter array of 60 plastic scintillators is used for this purpose. The results thus far indicate that the core of an air shower varies according to the type of primary particle which produces the shower. A primary proton will produce one concentrated area of secondary shower particles with a diminishing number of particles extending outward from this central point. However, a primary cosmic ray deuteron will break up into two particles upon entering the atmosphere and will produce a shower pattern of two concentrations of secondary particles. Indeed, if the primary particle is an iron nucleus one would expect that the core of the shower would contain approximately 56 concentrated areas of secondary particles, each as a result of the 56 nucleons in the iron nucleus being torn apart upon impact with atmospheric nuclei. These results of the nature of air shower cores was first published by the Sydney group and other groups throughout the world are confirming them.

The second part of this experiment is a study of shower size and energy spectrum. The largest air-shower array in the world is being constructed in Australia to detect showers produced by particles of a  $10^{20}$  eV. (100 billion billion electron volts). This array of detectors will be spread over an area of 100 square miles. It is anticipated that an upper limit may be found for cosmic ray particles and that these extremely high-energy particles will originate from certain areas of the celestial sphere, since particles of this energy are



not much deflected by magnetic fields. The results of this experiment will be of great scientific value and they will be unique, for no other array of this size is under construction or even contemplated at this time. In addition, this array will provide a unique facility to calibrate other air-shower experiments such as those that detect the radio emission, Cerenkov light, or scintillation light produced by an air shower.

The preceding examples of AFOSR-sponsored cosmic ray research do not, of course, give a complete picture of the work being accomplished by these groups. In a report of this scope, it is impossible to mention all those supported by AFOSR who are contributing to scientific knowledge in general and to the Air Force mission indirectly. AFOSR program has made unique and valuable contributions to the knowledge of cosmic rays and to the related fields of space physics, elementary particle physics, astronomy, and cosmology. Without Air Force support, there is no doubt that knowledge in these fields would be significantly less than it is today.

## *Theoretical Elementary Particle Physics*

CAPT. DONALD R. LEHMAN

For the past 14 years, the Air Force has played a significant role in the support of scientists working in the area of elementary particle physics. Initially, the primary emphasis was experimental elementary particle physics; but in the early sixties, due to increased costs in the accomplishment of experiments and relatively stationary budgets, emphasis shifted to a program primarily involving theoretical efforts. Today, the subjects of these projects range over the spectrum of topics on the forefront of elementary particle physics research.

The purpose of this article is to discuss in a broad manner the main avenues of research in elementary particle physics and to give examples of work completed or presently being pursued by AFOSR grantees and contractors in these areas. The text is divided according to the methods of

approach to the elementary particle problem; namely, quantum field theory, S-matrix theory, and symmetry principles or the algebraic approach. Following a brief description of each particular approach, an example of work in that area sponsored by AFOSR is described.

The goal of theoretical particle physics is to formulate a theory to account for and classify the proliferation of elementary particles which have been experimentally detected in the past 5 years. The problem of finding a single theory to explain the properties of and to account for the 100 or more elementary particles is pursued by the methods mentioned in the previous paragraph: Quantum field theory, S-matrix theory, and symmetry principles. To be absolutely correct, one cannot in the strict sense call any of these a theory, because none has succeeded in doing more than yielding an understanding of some small area of theoretical particle physics. Furthermore, they are not mutually exclusive, but overlap in many ways.

The three main approaches described above have as their foundation the principles of quantum mechanics and special relativity, neither of which seems to be challenged by experiment to date. Within this framework, the desire is to find a unified description of the four types of interactions which are responsible for the physics of the elementary particles and their properties. These interactions are classified according to their relative strengths: strong, 1; electromagnetic,  $10^{-2}$ ; weak,  $10^{-14}$ ; and gravitational  $10^{-39}$ . Primarily, effort is centered on the development of a theory of the strong and weak interactions, since quantum electrodynamics seems at present to be an adequate theory for the description of the electromagnetic interaction, and the gravitational interaction is too weak to be considered of importance at this stage of investigation.

### *Quantum Field Theory*

The use of the concepts of relativistic quantum field theory to describe the strong and weak interactions has its background in the success of quantum electrodynamics. Quantum electrodynamics is the quantum version of the classical field theory of electromagnetism. It ascribes to the electromagnetic force. The photon is a particle of zero-mass itself in the photon, the carrier of the electromagnetic force. The photon is a particle of zero-mass and the electromagnetic interaction or force is long range.

The application of quantum field theory to describe the strongly and weakly interacting particles is accomplished through analogy with quantum electrodynamics. The theory is based on a number of basic "matter-fields" to describe the particles and their interactions. These basic fields are then raised to quantum status by means of certain mathematical relations and from this, the particle interpretation emerges just as in the case of the photon. However, the force carrying particles are massive and as a consequence, the short-range character of the strong and weak forces is obtained.

The concepts of quantum field theory are used in many different problems. Recently, J. Sucher of the University of Maryland and G. Feinberg of Columbia University studied the long-range forces acting between pairs of particles, at least one of which is neutral and spinless (i.e., it has no angular momentum). This work (1), supported in part by the nuclear physics division of AFOSR, was pursued to establish whether or not such long-range forces are presently observable in particle physics. It turned out that for the particle physics problem they considered, namely, the long-range force between K-mesons, the long-range effects were not detectable. However, another interesting result was obtained from this work concerning the long-range forces between two neutral molecules, called van der Waals forces, which determine the macroscopic properties of matter such as surface tension, viscosity, and solubility.

The first quantitative theory of van der Waals forces was advanced by the German physicist, Fritz London, in 1930 (2). In this theory, a particular dynamical model is assumed and the intermolecular forces arise from the electrostatic interaction between two dipoles. The energy of the interaction turns out to be proportional to  $r^{-6}$  and the force to  $r^{-7}$ , where  $r$  is the distance between the bodies. London's approach is not valid at large separations due to the neglect of the retardation effects in the interaction between the two neutral systems. The retardation effects were first considered by the Dutch physicists, H. G. B. Casimir and D. Polder in 1948 (3). Casimir and Polder found that, at relatively large distances, the interaction energy and the force are proportional to  $r^{-7}$  and  $r^{-8}$ , respectively, in contradiction to the London expressions.

The more comprehensive quantum field theory calculations of Sucher and Feinberg yielded a more general result. Their work proved that the result of

Casimir and Polder concerning van der Waals forces is independent of the detailed dynamical models for the individual interacting systems. However, due to the binding of atoms by electromagnetic interactions, there is an exponential term in the expression for the interaction energy which may dominate the interaction potential for many atomic radii before the  $r^{-7}$  terms become of importance.

#### S-Matrix Theory

The S-matrix theory, or scattering-matrix theory, approach does not deal with the elementary particle problem at nearly the basic level as the quantum field theory approach. The aim is to rely on empirical results of one experiment to predict the results of another, while learning about the various interactions without making assumptions concerning their nature beforehand. Experimental quantities, such as cross sections, are used to learn about the properties of the interactions and to deduce their nature. Of course, the hope is that this "black box" approach will ultimately give the clues for development of the correct theory to describe the elementary particles and their interactions.

One technique employed to carry out the above program is the use of dispersion relations. Dispersion relations (4) had their first applications in optics, where through such a relation, the index of refraction is related to the absorption coefficient of a given medium. Similarly, in the description of a particle scattering from a scattering center, one can utilize the wave character of the particle to relate the scattered wave to the wave describing the particle before interaction with the medium. This is called a single-dispersion relation. In 1959, the single-dispersion relation was extended to a double-dispersion relation by Stanley Mandl, who was a member of a theoretical group sponsored by AFOSR at the University of California, Berkeley. This work made it possible to consider more complicated particle interactions. It is also interesting to note that these same techniques have applications in the propagation of radiation in the atmosphere, shielding problems and electrical systems.

One theoretical physicist who has played an important role in the development and application of dispersion relations in particle physics is Marvin Goldberger who is principal investigator on

an AFOSR contract at Princeton. The Mandelstam dispersion techniques permitted Goldberger and his associates to relate such things as scattering amplitudes of certain physical processes to the absorption amplitudes of related processes. These results allowed many inferences to be drawn concerning the properties of the interactions. Accordingly, such topics as the electromagnetic structure of the nucleon were studied exhaustively.

More recently, dispersion techniques have been used in conjunction with the algebraic approach to the elementary particle problem.

#### **Symmetry Principles**

The symmetry principles approach embodies the attempt at finding algebraic principles and approximate conservation laws as an aid to discovering what the correct elementary particle theory may be like. The experimentalist classifies particles and particle resonances into a multiplet structure (similar to atomic spectra multiplets) according to some conserved quantum property like parity. This data permits the theoretical physicist to identify a possible mathematical group to represent the invariance group of the underlying dynamics. Once this is accomplished, results which can be verified by experiment are calculable.

The algebraic method involves the use of Lie groups and their representations. Lie groups were developed in the 19th century by the Norwegian mathematician Sophus Lie. The basic concept, the group, is defined as a set of operations possessing the property that any two of them performed in succession are together equivalent to another operation belonging to the set. A representation of a group is a set of numbers and a rule of transformation of these numbers such that each operation of the group produces a well-defined transformation of these numbers. With these two basic ideas, the theoretical physicist, aided by the work done by mathematicians on group theory, is prepared to apply group theory to physical problems. This is possible since the laws of quantum mechanics require that whenever a physical object has a symmetry, there is a well-defined group of operations that preserve the symmetry, and the possible quantum states of the object are then in exact correspondence with the representations of the group.

The algebraic approach has been very successful in permitting the elaboration and prediction of

numerous symmetry properties of the elementary particles. The existence of families of related strongly interacting particles, charge multiplets and supermultiplets, as well as mass splitting rules within the families have been predicted and verified by experiment. Selection and intensity rules for the production of the particles and their decays through strong interactions have been derived. However, some of the most recent and important results have been obtained by combination of the algebraic method with dispersion techniques best known as the algebra of currents.

The use of dispersion methods in the study of symmetries was first developed (5) in 1964-65 by G. Furlan (Institute of Physics—University of Trieste) and S. Fubini (Institute of Physics—University of Torino) under an AFOSR grant and was later extended to a relativistic formulation independently by S. Adler, W. Weisberger (6), and S. Fubini, G. Furlan and C. Rossetti (7). Recently, another application of these methods to higher symmetry schemes has been pursued by G. Segre, S. Fubini, and J. D. Walecka (8) in collaboration. Walecka is a member of a theoretical group at Stanford University which is sponsored by AFOSR. Many other applications have occurred in the past year also.

The impact of the current algebra approach in elementary particle physics has been particularly significant in the theory of weak interactions and in giving the physicist a deeper understanding of the symmetry properties of elementary particles. The scheme is based on a postulate which was proposed by Murray Gell-Mann (9) and can be used to derive "sum rules" involving only experimental quantities. The first application of this new approach is due to Adler and Weisberger (6) who derived a sum rule relating the weak interaction ratio of the renormalized axial-vector and vector-coupling constants of  $\beta$ -decay to experimental quantities appearing in pion-nucleon scattering. The result is in excellent agreement with the experimental value. Further, Fubini, Furlan, and Rossetti (7, 10) have obtained relations between the isoscalar and isovector anomalous moments of the nucleon and the corresponding photopion production amplitude. These relations also are in excellent agreement with the experimental values. In addition to these results, many other interesting applications have been completed or are in progress.

## REFERENCES

- (1) G. Feinberg and J. Sucher, *Phys. Rev.* **39**, p. 1619 (1965).
- (2) F. London, *Z. Phys.* **60**, p. 491 (1930).
- (3) H. G. B. Casimir and D. Polder, *Phys. Rev.* **73**, p. 360 (1948).
- (4) References to the work described in this article and a discussion of the basic ideas of dispersion theory can be found in ch. 10 of *Collision Theory* (John Wiley and Sons, New York, 1964) written by M. L. Goldberger and K. M. Watson.
- (5) S. Fubini and G. Furlan, *Physica* **1**, p. 229 (1965).
- (6) S. Adler, *Phys. Rev. Letters* **12**, p. 1051 (1965). Also, W. Welsberger, *Phys. Rev. Letters* **14**, p. 1047 (1965).
- (7) S. Fubini, G. Furlan, C. Rossetti, *Nuovo Cimento* **40**, p. 1171 (1965).
- (8) S. Fubini, G. Segre, J. D. Walecka, *Ann. Phys.* **39**, p. 381 (1966).
- (9) M. Gell-Mann, *Physica* **1**, p. 63 (1964).
- (10) S. Fubini, G. Segre, J. D. Walecka, *Nuovo Cimento* **43**, p. 161 (1966).

## Crystal Nucleation and Growth

LT. COL. RALPH W. CONNERS

Since the early 1960's AFOSR has supported selected programs to study the process of crystal nucleation and growth; techniques of purification; mechanisms of impurity segregation, and density and distribution of impurities; techniques for forming precisely known compounds and structural imperfections of crystals. This broad program has as its objective better understanding of the crystal growth mechanisms and techniques in order to advance the science and develop the technology for making materials with the optimum microstructure for certain desirable physical properties of materials. In the past, much of the work in the area of crystal growth was empirical and a few scientists became experts growing certain selected crystals for their own use.

AFOSR has supported a program with William A. Tiller, Stanford University, from 1961, first at Westinghouse Research Laboratories and later Stanford University. This program, entitled "Crystallogenics," stands for crystal genesis or the birth and growth of crystals. Progress has been made in the area of nucleation, atomic kinetics, solute manipulation, controlled fluid flow, inter-

face morphology control, physical imperfections, phase equilibria, and property and perfection studies.

In the area of nucleation, the effect of electromagnetic stirring during solidification has been demonstrated as a practical means of achieving an isotropic fine-grain texture in alloys (1). This grain refinement produces a material with greater homogeneity and increase in the physical properties. In the area of atomic kinetics several new techniques have been devised for investigating the difference between the possible atomic mechanisms during growth from the melt (2, 3). In the area of solute manipulation a quantitative analysis was made of the effect of an electric field on the redistribution of solute atoms during freezing and a technique proposed for measuring the effective ionic mobility of solute atoms in the melt (2, 3). In the area of controlled fluid flow, it has been shown that by application of electromagnetic energy to a liquid melt, both the melt temperature and its motion may be controlled. An analysis was made on the influence of convection on the redistribution of solute during the freezing process and a consistent mathematical formulation developed (2, 3). In the area of interface morphology control, two dominant principles that determine particular interface morphologies were postulated. Some experimental support for these postulates was also determined. (4). In the area of physical imperfections several mechanisms for dislocation generation during crystal growth were postulated and experimental support found. Sophisticated X-ray techniques are being developed for more exacting tests (5, 6, 7). In the area of phase equilibria, solidification techniques were developed for determining the partition coefficients, tie-lines and liquidus surfaces in multicomponent systems. In the area of property and perfection studies they have been able to show that a high probability exists for the rearrangement of dislocation tangles, at slip-plane intersections in a metal, to a lower energy array resembling a twin. This has considerable significance relative to the fracture stress of metals and to the estimation of stress from basic data (8).

The product of the above studies has been largely scientific understanding but has contributed to the beginnings of some practical applications of the freezing process to (a) ingot structure control, (b) preparation of large polymer single crystals, and (c) the ultra purification of water.

It can be predicted from the study of the freezing process coupled with electromagnetic stirring of molten metals and alloys that improved ingot structure, improved ingot yield, and lower production costs through well controlled and automated processes will come about and replace the somewhat backward ingot practice and foundry technology existing today.

Another product of the freezing process was a method of growing large single crystals of selenium, an elemental semiconductor which fails to grow at adequate rates under conventional laboratory conditions. The selenium molecule in the liquid has polymer-like properties, and whatever the method of crystallization, the experimentalist must deal with the fact that the molecules in the liquid medium ahead of the crystal may be in the form of chains of varying length, and varying degrees of kinkiness or in the form of closed rings of eight selenium atoms. In order to grow a single crystal, the interface must be able to select the appropriate molecular entity length from this mélange. At room temperature the selection process is sluggish, and the crystal grows slowly. To speed up the growth of single crystal selenium a different approach was taken. This process involved the use of pressure and higher temperatures in a closed system. After extended experimentation, it was found that a pressure of about 5,000 atmospheres was needed. At this pressure and a temperature of 342°C. the researchers were successful in growing a single crystal of selenium of about 1 centimeter and 10 centimeters in length. These crystals are of ample size that solid state scientist: (9) now have a material with which they can perform reproducible experiments and controlled measurements of the electronic structure and the semiconducting properties of selenium.

A program under the direction of F. P. Jona, International Business Machines, had as its objective improving the fundamental understanding of the various mechanisms that are at work when a crystal grows from the vapor phase by way of one or several chemical transport reactions. This work is divided into equilibrium studies, vapor transport studies, and surface studies.

The specific vapor-growth systems chosen were ZnS-I, Si-HCl and Ge-I or Ge-Br systems. In addition, considerable effort was expended to simpler, solvent-free vapor-growth systems such as Ge-Ga-As and Si-Si. A simple method was developed for the determination of chemical equilibria

that involves weightless measurements. The method was tested successfully on the Ge-I system and then used to elucidate the Ge-Br system (10). The equilibrium behavior of the Si-HCl system was elucidated from published thermodynamic data and found to explain satisfactorily a number of experimental facts (11). Also studied was the equilibrium in the Ge-Ga-I system which is used for the growth of heavily doped epitaxial layers (12).

Kinetic measurements of the transport rate were carried out in the system ZnS-I and the effects of temperature, pressure, and geometry were investigated. Diffusion-controlled vapor transport theory was tested successfully and the onset of convective effects demonstrated (13). Vapor-transport theory was confirmed also by the experiments with the systems Ge-Ga-I, which provided useful rules for the growth of heavily doped germanium (14). Further confirmation of vapor transport theory was provided by kinetic measurements in the Ge-I system, whereas some surface effects were detected in the Ge-Br system (15).

The interaction between diffusion limitations and surface effects was elucidated theoretically, and orientation-dependent growth rates even demonstrated experimentally (16). However, all attempts at measuring the dependence of growth rate upon supersaturation failed. No experimental technique was developed that would allow measurement of both temperature and thickness of a substrate growing under surface-limited conditions. Consequently, quantitative studies of the effects of poisoning agents upon the growth rate could not be carried out. Since the study of measuring the dependence of growth rate upon supersaturation failed, their direction was changed to the nature and crystallographic characteristics of semiconductor surfaces and to the measurement of this chemical reactivity. For the former study, a new display-type low-energy electron diffraction (LEED) equipment was used to develop techniques of preparation of atomically clean surfaces (17). The crystallographic characteristics of several semiconductor surfaces were elucidated (18) and this led to a study of the nature of surfaces of semimetals.

A program under the direction of A. C. Beer at Battelle Memorial Institute studying high-mobility low-melting-point group III-V compound semiconductors has been supported since 1960. These investigations have provided:

Reasonably conclusive identification of the

of  
pr  
er  
  
cr  
ex  
in,  
  
st  
ea:  
eff  
cr  
ha  
the  
tri  
me  
sol  
It  
tio  
tha  
dec  
ma  
cha  
anc  
pre  
me:  
of t  
to t  
and  
sho

residual defect in GaSb as a type of antistructure, e.g., Ga atoms in Sb sites.

Development of special techniques which enable preparation of GaSb crystals having an order of magnitude lower concentration of the residual acceptors, with large increases in the hole mobility.

Achievement of relatively uncompensated n-type crystals of GaSb exhibiting a room-temperature mobility of  $6,300 \text{ cm}^2/\text{volt-sec.}$ , a value substantially larger than has been reported elsewhere.

Elucidation of scattering mechanisms in the above n-type material, which illustrate the importance of effects arising from the subsidiary conduction band, including screening of Coulomb interaction.

Analysis of electronic scattering in moderately doped InSb which revealed the influence of electron-electron interactions and the non-parabolicity of the conduction band.

The success achieved in growing single crystals of GaSb from nonstoichiometric melts now permits production of improved GaSb with electrical properties superior to these previously attainable.

The ability of improved GaSb should also increase its usefulness in device applications. For example, interesting studies are appearing regarding acousto-electric properties of GaSb.

H. Steinfink at the University of Texas has been studying crystal chemistry of the systems rare earth—groups V and VI elements. The aim of this effort is directed toward the correlation between crystal-chemical parameters and the physical behavior of the materials. An initial step to study the connections existing between structure and electrical conductivity was carried out with the intermediate phases of  $\text{LaTe}_2$  (19) and  $\text{NdTe}_2$ , and the solid-solution series existing for this composition. It was shown that the stoichiometric 1:2 composition has the highest electrical conductivity and that it decreases as the tellurium concentration decreases. A detailed X-ray structure study was made to see what relation exists between the changes in the structure as the tellurium is removed and the physical behavior. The first step was a precise structure determination of the stoichiometric composition and involved the measurement of three-dimension X-ray diffraction data. This led to the ambiguous assignment of the rare earth ions and of the metallic ions in the structure. It was shown that one of the crystallographically inde-

pendent tellurium atoms displayed interatomic contacts which could be reconciled with an essentially metallic-type atom and the other tellurium position were filled by an atom with ionic characteristics.

The analysis of three-dimensional data obtained from a crystal with composition of  $\text{NdTe}_{1.8}$  (20) showed that the tellurium deficiency was created by the statistical omission of the metallic-type tellurium atoms. Thus, the removal of this type of atom explains the observed decrease in electrical conductivity and also explains the observed decrease in the "a" and increase in the "c" lattice constants.

At the Virginia Institute for Scientific Research, J. F. Kirn has been studying methods of crystal growth of elements on which little work has been done. Crystals of the alkali metals, sodium, potassium, lithium, and rubidium have been grown by the Czochralski technique both under high vacuum and in purified argon. Rubidium crystals have also been pulled under a blanket of oil in an effort to reduce strain on the crystal seed by means of buoyancy. A technique for growing alkali metals to specific orientations has been developed.

Cobalt has been deposited epitaxially on large surfaces of cobalt substrate by the reduction of cobalt sulfate solution with hydrogen. Previous problems of random nucleation have been overcome by control of pH, agitation, and the addition rate of the reducing agent. Areas as large as 1 square centimeter have been achieved free of spurious growth. Twinning still remains to be a problem, but with some modifications to the equipment the twinning may be overcome.

E. F. Carr at the University of Maine is studying ordering of molecules in the anisotropic phase of liquid crystals. The primary objective of this investigation is to obtain a better understanding of the effect due to external electric and/or magnetic fields. The most significant contributions thus far have been determination that the degree of molecular alignment which can be obtained in the anisotropic liquid phase using an external electric field is the same as that which can be obtained using a magnetic field. This comparison was made with fields of such magnitudes that the molecular alignment was saturated. A comparison of the electric and magnetic fields by producing molecular alignment shows the presence of another aligning process which is a function of the electric or magnetic field. This process is not asso-

ciated with the anisotropy in the electric constant or the permeability. Although this new process cannot be justified theoretically, the experimental results show that it can be described by an empirical equation involving the electric and magnetic fields. Serious consideration will be given to the possibility of obtaining molecular alignment in the solid phase by cooling from the anisotropic liquid phase in the presence of electric and magnetic fields.

At the University of Idaho, E. F. Sieckmann has been studying color centers in single crystals of alkaline earth oxides. Single crystals of the alkaline earth oxides are difficult to produce synthetically because of their high melting points and are not found in nature due to their chemical reactivity with water. Sieckmann has been able to produce single crystals of these substances and has measured the refractive indices of CaO and SrO in the visible spectrum at six different wavelengths (21).

Attempts to produce color center in these crystals at room temperature by means of X-rays have not been successful, but he will attempt to radiate the crystals at liquid nitrogen temperature in hopes that color centers can be formed at the lower temperature. Electrolytic coloration of crystals of CaO has been successful, and an optical absorption band thus produced centered at about  $6,500\text{\AA}$  has been observed.

R. Roy at the Pennsylvania State University Materials Research Laboratory has investigated reaction mechanisms and kinetics in solid phase reaction from 1,500–3,000°C. The most novel single contribution has been the unambiguous experimental establishment of the change of a vacancy model defect solid to an interstitial model phase shown for  $\text{ZrO}_2\text{-CaO}$ . Another contribution was that the occupancy of the interstitial sites in  $\text{CaF}_2\text{-YF}_3$  solution has been confirmed by Fouries' map techniques and final least squares refinements were run on the IBM 7074 computer. Densities of natural and synthetic yttrifluorites have been determined by means of a gradient tube with Clerici's solution. The density clearly shows that charge neutrality is maintained mainly by the introduction of anion vacancies.

The topotactic mechanism in the precipitation reaction of  $\text{Ga}_2\text{O}_3$  from a spinel crystalline solution has been verified and quantitatively determined. It has been shown that the oxygen content within equivalent transformation volumes in the

matrix and the precipitate is constant, supporting the topotactic nature of the exsolution. This is further substantiated by the close similarity of the oxygen packing in the  $\text{MgAl}_2\text{O}_4$  and  $\text{-Ga}_2\text{O}_3$  structures (22). The novel approach to topotaxy has been the study of the reaction of single crystals of  $\beta\text{-Ga}_2\text{O}_3$  (grown to 1 cm size) with MgO in various selected orientations to form the spinel  $\text{MgGa}_2\text{O}_4$ . This is also an example of the preparation of single crystals of complex oxides by subsolidus solid state reactions.

AFOSR programs in crystal growth have provided the scientific community with new knowledge making it possible for researchers to grow single crystals of known composition to perform experiments.

#### REFERENCES

- (1) W. C. Johnston, G. R. Kotter, and W. A. Tiller, *Trans AIME* **227**, p. 890 (1963).
- (2) J. J. Kramer and W. A. Tiller, *J. Chem. Phys.* **37**, p. 841 (1962).
- (3) J. J. Kramer and W. A. Tiller, *J. Chem. Phys.* **42**, p. 257 (1965).
- (4) W. A. Tiller and R. F. Sekerka, *J. Appl. Phys.* **35**, p. 2726 (1964).
- (5) R. W. Armstrong and J. M. Schultz, *Acta Cryst.* **17**, p. 1214 (1964).
- (6) R. Stickle and R. W. Armstrong, *J. Appl. Phys.* **35**, p. 3061 (1964).
- (7) G. F. Bolling, *Rev. Sci. Instr.* **34**, p. 706 (1963).
- (8) R. W. Armstrong, "Proceedings of Deformative Twinning Conference AIME," p. 356, Gainesville, Fla. (1963).
- (9) D. E. Harrison, *J. Chem. Phys.* **41**, p. 844 (1964).
- (10) F. Jona, R. F. Lever, and H. R. Wendt, *J. Electrochem. Soc.* **111**, p. 413 (1964).
- (11) R. F. Lever, *IBM J. Res. Develop.* **8**, p. 460 (1964).
- (12) R. F. Lever, *J. Phys. Chem. Solids* **26**, p. 1629 (1965).
- (13) F. Jona and G. Mandel, *J. Phys. Chem. Solids* **25**, p. 187 (1964).
- (14) R. F. Lever, op cit.
- (15) F. Jona, *J. Chem. Phys.* **42**, p. 1025 (1965).
- (16) R. F. Lever and F. Jona, *Am. Inst. Chem. Engrs.* (in press).
- (17) F. Jona, *Appl. Phys. Letters* **6**, p. 205 (1965).
- (18) F. Jona, *IBM J. Res. Develop.* **9**, p. 375 (1965).
- (19) T. E. Ramsey, H. Steinfink, and E. J. Weiss, *J. Appl. Phys.* **34**, p. 548 (1965).
- (20) W. Lin, H. Steinfink, and E. J. Weiss, *Inorg. Chem.* **4**, p. 877 (1965).
- (21) E. F. Sieckmann and G. E. Pynchon, *Bull. Am. Phys. Soc. II* **10**, p. 109 (1965).
- (22) G. Katz and R. Roy, *J. Am. Ceram. Soc.* **48**, p. 450 (1965).

## *Interactions of Ultrasonic Waves in Metals*

MAX SWERDLOW

In the past decade a considerable effort has been put forth in the field of solid-state physics to investigate the dynamic properties of conduction electrons in metals at very low temperatures. From the point of view of fundamental physics, experimental investigations under carefully controlled environmental conditions are essential to the development of a refined understanding of the detailed interactions of these electrons with the host ionic lattice of the metal. Apart from this primary purpose it is not difficult to envision the impact which such thorough investigation might have on the successful prediction of macroscopic transport properties of metals or alloys.

A somewhat more specific objective has been the study of superconductivity, an effect known experimentally for over 50 years, but one where man's understanding of the phenomenon has progressed rapidly only in the last 10 years. Truly systematic studies of superconducting properties have been possible only since the development of the first adequate theory of superconductivity by Bardeen, Cooper, and Schrieffer (BCS) in 1957 (1). Since then, theoretical and experimental progress has been rapid, and as superconductivity has become better understood there have been advances of an applied nature as well. Chief among these has been the development of extremely high critical field superconducting alloys (type II) from which have been fabricated wires used in the construction of high field (100 kilogauss) solenoids for laboratory use (2). Other potential applications include such things as high-speed switching circuits and memories for computers, perfect diamagnetic shields, d.c. transmission of very large electronic power, a.c.-d.c. power converters with superconducting rectifiers, very sensitive magnetometers, and frictionless bearings, gyroscopes, and accelerometers.

An important colonizing role has been played by AFOSR in stimulating the rapid growth of techniques and utilization of ultrasonic attenuation in research on the behavior and properties of solids. Shortly after the first observations of electronic attenuation of ultrasound in metals by Bommel (3) and by MacInnon (4), R. W. Morse initiated a

program of research on the electronic properties of metals using ultrasonic techniques (5). AFOSR sponsored the program at Brown University. Because of the pioneering nature of this research, Morse and his collaborators made important practical contributions toward the development of experimental procedures and design of the necessary electronic equipment needed for generating, regulating ultrasonic waves, and detecting their interactions with the electronic structure of metals. Apart from the activity in the physics department AFOSR also sponsored a group under the direction of R. Truell in the Applied Mathematics Division at Brown University. In 1956, the measurement of fatigue in metallic structures was begun using the methods of ultrasonic attenuation. In the accomplishments that followed, Truell and his collaborators developed a scheme for measuring the degree of fatigue and predicting the fracture and probable failure of aircraft structures.

Before summarizing the scientific contributions of Morse's group at Brown University, as well as describing the continuing research in this field at Wayne State University and at the National Magnet Laboratory at the Massachusetts Institute of Technology, both sponsored by AFOSR, a brief résumé of the people involved will perhaps give some indication of the manner in which sustained university research support can influence the growth of one particular area of scientific investigation. The first Ph. D. from Morse's group at Brown University was H. V. Bohm, who subsequently formed his own research group at Wayne State University, also with AFOSR sponsorship. There followed an additional six Ph. D.'s from Brown University (J. D. Gavenda, M. T. Walker, L. T. Claiborne, J. R. Leibowitz, M. S. Said, and R. L. Thomas) and all but one has continued research investigations of ultrasonic attenuation in metals at other laboratories. R. L. Thomas is currently associated with the Wayne State group. There were, in addition, three visiting research associates (T. Olsen, A. Myers, and R. Peverley) at Brown University from foreign countries. All of these scientists are currently working in this area of research.

The early work of the Morse group stimulated much activity; many other ultrasonic groups were established and much theoretical and experimental work was started in this country and abroad (6). Among the new groups supported by AFOSR was one at the Polytechnic Institute of



Brooklyn under the direction of T. Kjeldaas, Jr. who is concerned with the theory of the interactions of high-frequency sound waves and electrons. Another group in this country is at the National Magnet Laboratory at MIT working under the direction of B. Lax are Y. Shapira (who received his Ph. D. under B. Lax) and L. J. Neuringer. It is, perhaps, of interest that the NML group and the Wayne State University group have recently been collaborating on a study of antiferromagnetic chromium (?).

The Wayne State group has produced four Ph. D.'s (V. J. Easterling, G. Kamm, and N. H. Horowitz). Norman Tepley joined this group in 1963 after receiving his Ph. D. from MIT and is currently coprincipal investigator with H. V. Bohm. L. Mackinnon of the University of Essex, England, joined the Wayne State group under an NSF senior foreign scientist fellowship in 1963-64.

A fundamental aspect in the study of electrons in metals is the role of the periodic atomic lattice structure. The interaction between the conduction electrons and the spectrum of thermal, elastic vibration of this ionic lattice ("phonon spectrum") are the keys to an understanding of the basic properties and behavior of metallic conductors. In any attempt to study these interactions through macroscopic transport phenomena (e.g. thermal and electrical conductivity), the entire vibrational spectrum, as well as the entire conduction electron distribution must be taken into account. The experimental technique of ultrahigh frequency sound propagation (or attenuation) and detection provides the physicist with a nondestructive, powerful probe for studying electron interactions with monoenergetic lattice vibrations. Under certain conditions, it is possible to insure that the ultrasonic wave interacts with a spatially selective group of conduction electrons.

The selective electron-phonon interaction can be studied as a function of several experimental parameters such as temperature, external magnetic field strength, lattice impurity, etc. The experiments which will be summarized in this article utilized frequencies ranging from 10 megacycles per second (Mc/s) to 10 gigacycles per second (1 Gc/s = 10,000 mc/s). In all cases the measured physical quantity was the ultrasonic attenuation coefficient. In order that sound scattering be confined primarily to conduction electrons, most experiments were performed at 4.2° K. or below on

samples of high purity. In metals at very low temperatures, the attenuation of ultrasonic-frequency sound waves is very large. The interesting feature is that the attenuation is caused by interaction of the sound wave and the conduction electrons. Because of this, the attenuation has a strong dependence on the magnitude of an applied external magnetic field. Variations of the attenuation as a function of applied magnetic field and/or temperature, can be interpreted to give information about the Fermi surface of a metal and/or about the superconducting properties of a metal or alloy.

The dynamics of the conduction electron system are generally visualized in terms of an abstract constant-energy surface in momentum space called the Fermi surface. This concept derives from the fact that electrons obey Fermi-Dirac statistics, which require that the allowed energy corresponding to a given momentum vector gives rise to only two quantum states. If one fills the allowed (quantized) energy states in order of increasing energy until all of the electrons per unit volume occupy an energy state, to a first approximation, all the states up to the Fermi energy are filled, all those above the Fermi level are empty electrons. Thermal excitations smear this clean distribution of electrons demarked by the Fermi surface. In fact, those electrons which are within the thermal energy range of the Fermi surface are the only ones which take part in transport processes, other transitions within the filled "sphere" being forbidden by the Pauli exclusion principle. In many real metals the effect of the periodic atomic lattice structure is to replace the simple Fermi sphere approximation by multiply connected surfaces; for metals with more than one valence electron per atom, there exist several separate pieces of Fermi surface.

When Bragg reflection of X-rays by electrons takes place in a periodic lattice structure, it is visualized in momentum space by means of Brillouin zone boundaries. The Brillouin zone is an abstract concept pictured in the same momentum space as the Fermi surface. It is represented by a polyhedron which can often be constructed in "k-space" from considerations of the wave vectors of the various electronic states characteristic of the energy band theory of solids, the crystal lattice and its symmetry. In the study of complex metals and alloys, where there may be several overlapping energy bands, the geometry of the zones plays an important role. If one considers the set of planes in momentum space corresponding to the lowest

order Bragg reflections, there results a closed polyhedron characteristic of the particular crystal structure of the metal. Wherever the Fermi sphere interacts with the first Brillouin zone, some boundary portions of the Fermi surface lie in higher order zones and often one attempts to map the extra segments into the first zone in the so-called reduced zone scheme. Without going into the intricate details of fermiology here, it may be noted that even though such a model is helpful, and much progress has been made in recent years with machine theoretical calculation of the topology of such surfaces, the true structure of the Fermi surface must still be determined experimentally. The ultrasonic technique is a powerful, but not the only means of measuring the Fermi surface. Other experimental techniques which yield both overlapping and complementary information include the de Haas-van Alphen effect (extremal cross sectional areas), cyclotron resonance (surface curvature and effective mass), magnetoresistance (areas of contact with Brillouin zone boundaries), anomalous skin effect (surface curvature and area), positron annihilation (number of electron in a given cross section), and Gantmakher effect (extremal linear dimensions) (8).

Historically, the first metals which were studied by ultrasonic techniques were superconductors. After Bommel's (3) work first demonstrated a sharp decrease in the attenuation coefficient at the superconducting transition temperature,  $T_c$ , in lead, Morse and Bohm (9) showed that the fall-off in attenuation below the transition in tin and indium was in agreement with the behavior predicted by the BCS theory of superconductivity (1). According to the BCS theory, it is energetically favorable for electrons to exist in bound pairs below  $T_c$ . The bound electron pairs (in Cooper pairs, the constituent electrons have opposite momenta and spin and hence are paired in momentum space rather than in coordinate space) do not take part in sound scattering, leaving only the unpaired ("normal") electrons to interact with the sound waves (phonons). For weak interaction between electrons and phonons, the limiting energy gap is given as  $3.5 K T_c$  (where  $K$  is Boltzmann's constant and  $T_c$  the critical temperature) by the BCS theory for superconductors. The first experimental evidence obtained by Morse and Bohm (9) was in good agreement with the energy gap, predicted by BCS theory and thus confirmed a fundamental

physical parameter in the theory of superconductors.

The ultrasonic attenuation in a pure metal at liquid helium temperature has been shown to vary periodically as the reciprocal of an applied magnetic field. There are three distinct types of such oscillations which may be related to separate, yet complementary features of the Fermi surface. These oscillations, referred to as geometric resonances, quantum oscillations, and ultrasonic cyclotron resonances, yield linear dimensions, cross sectional areas, and curvatures of the Fermi surface respectively. In addition, a fourth, nonperiodic magnetoacoustic effect, the so-called Kjeldaas effect (10, 11), yields values for the extremal Fermi velocity in the direction of the magnetic field. AFOSR currently sponsors a theoretical study of the interaction of high-frequency sound waves and electrons at the Polytechnic Institute of Brooklyn under the direction of Terje Kjeldaas, Jr. In the summers of 1960 and 1961, Kjeldaas worked with H. E. Bommel at the Bell Telephone Laboratories. Prior to that time, while at the Westinghouse Research Laboratories, he collaborated with T. Holstein, and F. Keffer, at the University of Pittsburgh where he earned his Ph. D. It was out of this joint interest in the theory of solids supported by AFOSR at the University of Pittsburgh that his theory of ultrasonic cyclotron resonance in metals (10) and the theory of the oscillatory magnetoacoustic effect in metals (11), that the Kjeldaas effect was predicted.

Geometric resonances occur when a magnetic field is applied in a direction perpendicular to the direction of ultrasonic propagation. Since the velocity of an electron at the Fermi surface is roughly 500 times that of the sound wave, the electron in its helical path about the magnetic field "sees" a spatially periodic electric field due to the lattice wave which is effectively stationary for many orbits of the electron. Extrema in the ultrasonic attenuation occur when the electron orbit diameter just matches an integral number of acoustic half wavelengths. Thus, geometric resonances provide a caliper of the linear dimensions of the Fermi surface. Applying this technique, Easterling and Bohm (12) experimentally confirmed and refined the model of the Fermi surface of silver which had been suggested by Pippard (13) on the basis of anomalous skin effect measurements. Fermi surface investigations by acoustic geometric resonance have been reported for a large number of metals.

The phenomenon of quantum oscillations is somewhat a more difficult concept to visualize than geometric resonance. Because a rather high magnetic field is needed generally, this effect has been studied for only a limited number of metals by Shapira, Lax, and Neuringer at the National Magnet Laboratory (14, 15). Acoustic quantum oscillations have much in common with the de Haas-van Alphen effect and as such provide measurements of extremal cross sectional areas of the Fermi surface. When the rules of quantum mechanics are applied to electron orbits on the Fermi surface in the presence of a magnetic field, one consequence is that the position of the Fermi surface coincides with an allowed (quantized) energy level only for a discrete set of magnetic field values. As the magnetic field is increased, successive energy levels pass through the Fermi surface. In the presence of a sound wave, the laws of conservation of momentum and energy yield the values of magnetic field for which the electron-acoustic phonon scattering process can take place; i.e. where the ultrasonic attenuation is maximized. Thermal broadening of the energy levels leads to symmetrical oscillations, but the detailed theory indicates that under certain circumstances the oscillations become very large and spike-like. These are called giant quantum oscillations. The importance of this effect lies in the fact that it provides information about the non-extremal as well as the extremal Fermi surface cross sectional areas, and also about the carrier cyclotron mass,  $M_c$ , and magnetic  $g$ -factor.

For an ultrahigh purity metal, microwave ultrasonic frequencies can satisfy the very stringent requirement for acoustic cyclotron resonance absorption. When this condition is satisfied, the sound wave can be made to stay in resonance with the electron for its entire helical trajectory between collisions. The relevant physical parameter obtained from acoustic cyclotron resonance is  $m_c$ , the extremal value of the cyclotron mass. So far, only gallium crystals have been grown of sufficient purity for acoustic cyclotron resonance observations. In pure gallium, usually all three of the oscillatory magnetoacoustic effects are observed in a single experiment. Much of the current experimental work of isolating these effects and relating them to the gallium Fermi surface is being carried out by N. Tepley of the Wayne State group. Giant quantum oscillations in gallium have been reported

by the National Magnet Laboratory group utilizing high magnetic fields. Because of the relatively low driving frequencies employed; these oscillations were of the type which correspond to extremal orbits. At 9 Gc/sec it should be possible to induce transitions which give information about nonextremal orbits. Through the use of ultrasonic waves of frequencies from 10 Mc/s to 10 Gc/s (a range believed wider and higher than that available at present in any other laboratory) the Wayne State University group hope to observe interactions of the electrons in nonextremal orbits. In addition to earlier work on zinc by Bohm and Mackinnon and the gallium work by Tepley, quantum oscillations have been seen and are currently being investigated in chromium and mercury by the Wayne State group. Wallace, Tepley, Bohm in collaboration with Shapira at the National Magnet Laboratory have reported preliminary results on chromium obtained with a 110-kilogauss solenoid. Chromium, an antiferromagnet, was studied ultrasonically after being cooled from its Néel temperature (312° K.) both in the presence of a large 60–80-kg magnetic field and with zero external magnetic field. Although chromium has cubic crystal symmetry, after being "field-cooled," the periods of quantum oscillation were found to exhibit tetragonal symmetry of the crystal lattice, a fact which can be used to gain further information about the spin density wave character of the electronic ground state of this metal. Such studies promise to shed light on the physical origins of antiferromagnetism in metals—a present-day mystery in solid-state physics.

A recent set of experiments by Shapira and Neuringer on the effects of high-magnetic fields on the ultrasonic velocity and attenuations in niobium-zirconium alloys, demonstrate that the ultrasonic technique also gives information about very impure metals and indeed alloys and sheds much light upon the behavior of high-field superconductors. These experiments may very well lead to a coherent theory of impure metals or alloys at low and high temperatures as well as molten metals.

Only several highlights have been cited of the great progress that has been made in the last decade, toward a better understanding of the fundamental properties of metals. Ultrasonics is by no means the only technique that has been used to obtain present knowledge, but it is a powerful probe and versatile tool for experimental research.

It is noteworthy that a large fraction of the ultrasonic research in metals during this decade has been accomplished under the sponsorship of the AFOSR. The applied uses of the fundamental knowledge obtained are rarely, if ever, clearly traceable; but it is clear that there exists a strong coupling between the enormous variety of new metallic alloys synthesized in the last decade for a host of different applications and the increasingly detailed understanding of the transport properties of some of the constituent metals comprising these alloys. The phenomena of superconductivity in alloys has already been harnessed for the generation of very-high magnetic fields; other possible uses in the area of communications, computer technology, and aerospace applications are presently beginning to be exploited. Perhaps more easily discernable are the aerospace adaptations of various cryogenic techniques first developed in the research laboratory, some in connection with the work described above.

#### REFERENCES

- (1) J. Bardeen, L. N. Cooper and J. R. Schrieffer, *Phys. Rev.* **108**, p. 1175 (1957).
- (2) C. Laverick, *Nuclonics* **24**, p. 48 (1966).
- (3) H. E. Bommel, *Phys. Rev.* **98**, p. 220 (1954).
- (4) L. Mackinnon, *Phys. Rev.* **98**, p. 1181 abs. Q49 (1955).
- (5) A summary of much of this work may be found in a review article by R. W. Morse, *Progr. Cryo.* **1** (Heywood & Co., Ltd, London 1959).
- (6) For a review of investigations of the electronic structure of metals using ultrasonic techniques see N. Tepley, *Proc. IEEE*, **53**, p. 596 (1965).
- (7) W. D. Wallace, N. Tepley, H. V. Bohm, and Y. Shapira, *Phys. Letters* **17**, p. 184 (1965).
- (8) See A. R. MacIntosh, *Sci. Am.* **209**, p. 110 (1963). For significance of the Fermi surface, see "The Fermi Surface," edited by W. A. Harrison and M. B. Webb (John Wiley & Sons, N.Y., 1960).
- (9) R. W. Morse and H. V. Bohm, *Phys. Rev.* **106**, p. 1004 (1957).
- (10) T. Kjeldaa Jr., *Phys. Rev.* **111**, p. 1473 (1959).
- (11) T. Kjeldaa Jr., and T. Holstein, *Phys. Rev. Letters* **2**, p. 340 (1959).
- (12) V. J. Easterling and H. V. Bohm, *Phys. Rev.* **125**, p. 812 (1962).
- (13) A. B. Pippard, *Proc. Roy. Soc. (London)* **A257**, p. 165 (1960).
- (14) Y. Shapira and B. Lax, *Phys. Letters* **1337**, p. 133 (1963).
- (15) Y. Shapira and L. J. Neuringer, *Phys. Rev.* **140**, p. A1638 (1965); *Phys. Rev. Letters* **15**, p. 724 (1965); *Phys. Rev. Letters* **17**, p. 81 (1966); *Phys. Rev.* **148**, p. 231 (1966).

## The National Magnet Laboratory

MAX SWERDLOW

In 1960, a need existed in physics to fully and promptly exploit the significant scientific and important technological potentials of the special properties and the unique behavior of materials in very high magnetic fields. Recognizing that tomorrow's Air Force operational and technological capabilities depend directly upon the new knowledge and concepts gained from today's research, AFOSR awarded a contract to the Massachusetts Institute of Technology in Cambridge, Mass., to construct a high magnetic field facility and to establish a basic research laboratory on a scale much larger than any in existence.

On 1 July 1960 Francis Bitter and Benjamin Lax, who conceived the original idea, undertook the unprecedented task of designing and constructing a 10-megawatt facility capable of generating magnetic fields of a quarter-million gauss, and conducting a diversified research program to investigate the properties of matter in very intense magnetic fields. On 30 April 1963, the research facility was formally dedicated by the former Assistant Secretary of the Air Force for Research, Development, and Engineering, Dr. Brockway McMillan. It was officially designated as the National Magnet Laboratory, to serve as a national center for the scientific research community and the permanent staff at the Laboratory. At present, the NML is the only research facility of its kind in the world. It is a vital national and world center for research in the generation and utilization of intense continuous magnetic fields in excess of a quarter of a million gauss.

An intense magnetic field is a most powerful tool for research because it can nondestructively penetrate and interact with the electrons and magnetic nuclei that are key constituents of matter. The need for more intense magnetic fields to serve as extremes in environments for research is shared by almost all the major divisions of physics: solid-state physics, high-energy physics, plasma physics, geophysics, and even biophysics. In many ways the need for more higher magnetic fields is akin to the need for higher resolving power in microscopes and telescopes. In its ability to advance any one of several fields of physics, as well as other areas of

science and technology and in terms of operation, magnitude, inherent capability, flexibility, and as a research parameter; the National Magnet Laboratory may be compared to modern high-energy accelerator, reactor, or large computer installations. If emulation is any mark of success, it can be pointed out that several other countries are following our lead in establishing their own high-magnetic field research facilities. The Soviet Union is building a 16-megawatt laboratory, Great Britain is planning a 16-megawatt power supply, and France is planning a 14-megawatt facility (there is already a 3.4-megawatt laboratory at Grenoble. There is talk of a high-magnetic field facility in Canada and West Germany.

#### **The NML Facility**

The facility is housed in a converted bakery building at 170 Albany Street in Cambridge, Mass., adjoining the campus at MIT and adjacent to the MIT nuclear reactor. It was built on the early experience gained in the 2-megawatt magnet laboratory built by Bitter at MIT in 1936. The power for the NML magnets is a 10-megawatt continuous d.c. supply with various overload capacities up to 32 megawatts for 2-second pulses. The power supply was planned on a block concept so that it could be conveniently divided and controlled to supply four simultaneous experiments at the 100-kilogauss level, two simultaneous experiments at the 150-175-kg region, or with all four blocks coupled in parallel to supply the very highest field magnets. Power from each of the four independent generators is deliverable to 10 experimental stations. Eight of these can accommodate two magnets and two larger stations can accommodate up to four experiments simultaneously. All routing of power and water to various experimental stations is controlled from a central location to allow rapid and effective time-sharing of the power generators by the various operating magnets. Cooling water for the magnets is supplied from a closed system of clean, de-ionized water which is heat exchanged with water taken from the nearby Charles River via a 4-foot diameter conduit. The cooling system is capable of delivering water at the rate of 4,000 gallons per minute at a pressure of 200 pounds per square inch. The power supply consists of two motor generator sets each consisting of a pair of generators, synchronous motor, and flywheel; a.c.

power up to 16,000 kva is purchased from the Cambridge Electric Light Co. The pulse power of 32 megawatts for as long as 2 seconds is supplied by the rotational energy in the pair of 84-ton flywheels.

#### **Water-Cooled Magnets**

The 16 high-power water-cooled magnets now in use in the NML facility represent a wide range of field characteristics, working volumes, and orientations. Because of the wide variety of experiments and the ever-changing role that the magnets are called upon to play, the magnets require both flexible design and mode of installation to serve different experiments. Magnets in use fall into two broad categories, straight bore solenoids, varying in dimensions and field strengths, and solenoids with access not only along the field direction but at right angles to the field direction. The bore sizes range from 0.01-inch diameter for the 255 kilogauss magnitude requiring 10 megawatts of d.c. power to the 14-inch bore diameter for the 50-kg magnet requiring only 2.5 megawatts of electric power. The quarter-million gauss magnet is particularly worthy of note here; not only because it achieved the world's highest continuous magnetic field, but because it illustrates several important points about a high field facility. The magnet is designed as a composite of three nested coils mainly to allow the current density and the resultant stresses to be controlled. With a 2¼-inch bore it can develop fields of 205 kg using 10 megawatts of power. By inserting conical iron pole pieces fields of 255 kg are generated in a cylindrical space of 0.01 inches in diameter and 0.010 inches high. When in operation the magnet monopolizes the entire power supply and water-cooling system of the facility. No other magnet may be used simultaneously. Therefore it is necessary that only the most important experiments be done with this magnet and that preliminary experiments be done in lower field magnets first. The 250-kg magnet has become a useful device for pointing the way to even higher field magnets of the future.

#### **Superconducting Magnets**

The 250-kg water-cooled magnet has already made unique contributions in permitting, for the first time, actual measurements on very high field superconductors. The upper critical field of ni-

bium-tin, niobium-zirconium, and niobium-titanium have been a matter of theoretical speculation before magnetic fields above 200 kg were available. These measurements indicate that a superconducting magnet of 175 kg is technically feasible, but still rather expensive in cost of materials (\$100,000 for a 1-inch solenoid).

These high field studies have played an important part in understanding how superconducting wire behaves at very low temperatures and at high critical fields and current densities. The NML is building a 1-inch bore 100-kg superconducting magnet utilizing several unique and promising innovations. Combination water-cooled and superconducting magnets for special uses are being designed. Contemplated is a large external copper magnet surrounding a smaller superconducting magnet to form a composite magnet of high field capability (180 kg) but of lower cost than all superconducting magnets of 1-inch bore.

#### **Pulse Magnets**

Pulsed magnetic fields up to 750 kilogauss are available using the NML 100-kilojoule capacitor bank and a variety of pulsed coils. Recently, fields up to 500 kilogauss for milliseconds have been produced in a new type of beryllium-copper solenoid with a  $\frac{3}{4}$ -inch diameter working volume. A new system for providing repetitive (synchronous) field pulses of this magnitude in larger volumes will greatly facilitate the acquisition of data in types of experiments that require longer pulse times coupled with higher repetition rates. The magnets will be driven with a half cycle of 60 cycle a.c. power and pulse once every second. This half cycle alternating current can be supplied by allowing the flywheels to drive the synchronous motors as synchronous generators. The magnet itself will be constructed as a flux concentrator which is a specialized single turn transformer type of winding developed at the NML. It will represent a versatile test facility and experimental aid for investigating higher field d.c. magnets in the future.

#### **Significance of Research Accomplishments**

The generation of high-magnetic fields is an intriguing research and development area of science in its own right. However, the motivation for achieving higher fields is mainly to provide a means for investigating physical phenomena in

matter. Consequently, the availability of nondestructive high continuous magnetic fields of the order of several hundred thousand gauss and pulsed fields of one-half million gauss or more in workable volumes have been achieved. Such fields have made it possible to perform a large variety of new experiments in solid-state physics, low-temperature physics, plasma physics, quantum electronics, and applications including electron beam devices. The most extensive and most active research area in the utilization of high-magnetic fields has been solid-state physics. The total number of solid-state research investigations conducted at the NML since it began full-time operation is too large to describe in detail in this report. The following, therefore, is only a selected but representative sample of some of the more recent and current work.

The areas of solid-state physics that have been investigated at the NML include transport phenomena, such as the galvanomagnetic and thermomagnetic effects, susceptibility of metals and semiconductors which exhibit oscillatory phenomena, such as the de Haas-van Alphen effect. These oscillatory transport techniques have now been extended to include ultrasonic propagation, the use of magnetoplasma waves in the limit, and the optical de Haas-Shubnikov effect at the magnetoplasma edge. The ultrasonic techniques as well as d.c. conductivity and susceptibility measurements have been the principal techniques for studying the behavior of high field, type II superconductors. These experiments were aimed at characterizing the critical high-field parameters as well as exploring the physical phenomena which limit the high-field properties in the region of 200,000 gauss or more. One of the most extensively explored areas has been that of the more recently discovered magneto-optical phenomena in semiconductors and semimetals. With the availability of good single crystals for research, low temperatures and high-magnetic fields, the quantum phenomena of Bloch electrons in a crystal have shed considerable light on the behavior of current carriers in these solids. The phenomena can be characterized as *intra-band* in which cyclotron resonance and propagation of magnetoplasma waves are two of the more striking aspects. The phenomena may also be characterized as *inter-band* in which magnetoabsorption and magnetoreflexion in the presence of quantized levels have provided

quantitative information on energy band parameters, Fermi surface, and exciton levels in solids. Most recently the combined use of high-magnetic fields and lasers in the far and near infrared are extending these investigations into the submillimeter region of the electromagnetic spectrum. These studies have suggested a new area of research which is called nonlinear magneto-optics.

The other areas of high-magnetic field research which are of increasing importance for the future are those involving ultra low temperature in which adiabatic demagnetization techniques can take full advantage of intense magnetic fields. With superconducting magnets and water-cooled magnets providing fields in excess of 100,000 gauss. Mössbauer measurements to study nuclear Zeeman effect and as a delicate probe for the study of hyperfine interactions in solids; quantitative investigations of the fundamental mechanism involved in magnetism may be undertaken.

Plasma physics, both in solids and in ionized gases, may be studied with the aid of high magnetic field. Investigations of helicon and Alfvén waves in multicarrier systems can be undertaken. Interactions of electrons and ions in both states of matter in which the coupling of electromagnetic waves and phonons can be explored. High intensity, coherent, narrow beam sources from lasers combined with intense magnetic fields makes possible a new region for high-resolution spectroscopy of solids. The behavior of lasers and masers in high-magnetic fields can utilize, advantageously, fields in excess of 100 kilogauss. This is not restricted to solidstate lasers or gaseous lasers but is readily extended to electron beam devices as well.

The national character of the NML is well illustrated by the fact that more than 100 visiting scientists and a similar number of students have conducted parts of their research programs at the facilities of the NML. Many of them from universities, governmental laboratories, and DOD contractors. Although many of these came from the Boston area because of the high density of scientists in the region, many others came from distant parts of this country as well as from abroad. They have used and are continuing to use the unique facilities of the NML to perform experiments that can be done nowhere else.

The visiting scientists account for about half of the total "magnet time" in the present 16-hour day, 5-day week operating schedule. The continu-

ing need of the unique high-magnetic field facilities at the NML is further emphasized by the steadily increasing number of requests for magnet time. The waiting list for new experiments is now 3 months and can be expected to lengthen. Many of the visiting scientists' programs involve research on the electronic properties of solidstate materials. Quite irrespective of the investigators' affiliation, a considerable amount of new information has been obtained and reported on metals, semimetals, semiconductors, superconductors, and magnetic materials. All of which is of considerable importance to the AFOSR program of research in the solidstate sciences. In the 6-year period 1 July 1960 to 1 July 1966, the average number of full-time staff members at the NML has grown to 41. Although full-time operation of the facility did not actually begin until November 1963, the NML staff have published or submitted for publication (as of 1 July 1966) approximately 227 papers in scientific journals and books, and have given approximately 285 talks at scientific meetings.

#### **Potential Applications and Technological Implications**

Although applications and practical devices which might result from basic research in high-magnetic fields at the NML are not the principle mission of the laboratory, potential technological implications are not overlooked. Basic research into the special properties of matter in intense magnetic fields can be expected to discover new phenomena which can lead to new ideas for embodiment into practical devices. Better understanding of the structure and behavior of solids could lead to new or improved electronic solid state electronic devices such as transistors, diodes, computer memory elements, lasers, masers, etc. Diodes and masers have already been investigated in high-magnetic fields and have demonstrated unique properties which could extend or open new applications. The tuning of maser frequencies by variable magnetic fields is an example. The possibility of developing new maser devices, such as cyclotron resonance and magneto-optical masers is dependent upon the use of high-magnetic fields.

The use of high-magnetic fields in nuclear and magnetic resonance permits greater sensitivity of detection of these phenomena and therefore enhances the possibilities of more sensitive inertial

guidance systems which utilize atomic or electron-nuclear resonance.

High fields can be exploited for the development of high-intensity millimeter and submillimeter wave generation. Because of their short wavelengths, these radiations permit the development of a new radar and communication technologies in a part of the electromagnetic spectrum not yet explored in a practical way by scientists and engineers.

The use of ferrites as microwave components is already widespread. Further studies of the properties of ferrites and antiferromagnetic materials in high-magnetic fields may provide new and more efficient microwave components.

Another new area of research in which high-magnetic fields play an important role is that of ultrasonic propagation and attenuation in solids. In particular, it has been shown theoretically that high-magnetic fields permit the possibility that devices can be built with semimetals and semiconductors which will amplify ultrasound and alter the velocity of sound in these solidstate materials. Devices based on these two physical phenomena may be important for delay lines used in present radar and communication systems.

Basic studies of the properties of superconductors in high-magnetic fields, available only at the NML, have resulted in the development and fabrication of new superconducting alloys. These new materials which can be used to produce high-magnetic fields in large volumes, show promise for applications with important technological implications. For example, the confinement of plasmas in a thermonuclear reactor and the direct conversion of heat into electric power by a magnetohydrodynamic generator both require moderately intense magnetic fields in large volumes.

Potential space applications of superconducting magnets include the inductive storage of electric energy in superconducting coils (to replace storage batteries) and the shielding of space travelers by the magnetic deflection of high-energy charged particles (to replace massive shielding walls). Inertial-guidance navigation systems may ultimately make use of magnetically suspended frictionless gyroscopes employing currents in a superconductor. The loss-free generation, transformation (d.c.-a.c.) and transmission of electric power by superconductors may someday revolutionize the entire power industry.

## *Structural Materials for High Temperatures and Reactive Environments*

DR. J. THOMAS RATCHFORD

When solid objects move in and through the atmosphere at high speeds, a serious problem may arise from the high temperatures engendered by the frictional losses involved. This is a boundary condition which must be faced by the designer of the space reentry vehicle, since serious trouble may be caused by frictional heating in supersonic and subsonic aircraft as well. For both cases it is fairly obvious that there is a wide selection of methods available for protecting men and equipment against the high temperatures resulting from large heat influxes encountered.

For subsonic and supersonic aircraft and lifting bodies, careful aerodynamic design can reduce frictional losses. Not only is this desirable to reduce the heat influx, but it is desirable for other reasons such as weight and range considerations. With reentry vehicles, the problems are vastly more formidable and their solution may require many of the techniques which are available. The use of ablative coatings is well known, where the latent heat of evaporation (or sublimation) is used to dissipate the unwanted heat. Here one requires an ablative material which goes through the proper change of phase at a suitable temperature under operational conditions.

The heat capacity of the vehicle itself may be increased, thus reducing the temperature rise for a given heat input. The obvious way to do this is to thicken the outer skin, but the penalty resulting from the increased weight of the outer skin, insulation, and cooling equipment is high.

Internal coolants which regulate the internal temperature can be useful. For example, a substance can be made to undergo a change of phase while constrained between the inner and outer walls. A serious limitation is the rate at which heat can be transferred to the coolant from the outer skin.

Perhaps the most attractive alternative for most applications is insulation of the outer skin surface. If the high-temperature material used for this is also suitable for structural members the advantages become even more pronounced. Such a



material increases the efficiency of radiative transfer immensely, since radiative energy losses vary as the fourth power of the absolute temperature. At the same time the influx of heat to the inner wall is greatly reduced, making the internal cooling problem much simpler.

It is appropriate to mention a concomitant problem which must be faced in practical situations. This is the fact that in an oxidizing environment metals rapidly corrode. Thus it would be advantageous if a material that is already an oxide could be used for high-temperature structural applications.

AFOSR has recognized the importance of protecting men and equipment from high temperatures, and has actively supported a basic research program in this area from the very beginning of its existence as an organization. The complex nature of the problem was evident from a perusal of the engineering data available. Various options in solving the problem were available, and the solution has been sought from basic studies which might be described as interdisciplinary in nature. The following discussion will emphasize two approaches in finding high-temperature structural materials. First we consider ways of protecting currently used materials from the deleterious effects of high temperatures. Then the possibilities of developing completely new structural materials are discussed in regard to basic research which holds high promise.

The biggest problem one faces with most structural materials at high temperature is oxidation. This is basically a chemical reaction. However, the current status of knowledge concerning the chemistry of materials at very high temperatures is in a very crude state. Scientifically we lack basic data in the form of equilibrium diagrams, crystallographic data, and mechanisms of reactions. Without such basic information one cannot even properly and quantitatively describe the problem of high-temperature oxidation; therefore prescribing a solution is very difficult. A problem of such magnitude does not lend itself easily to empirical solution as other more simple ones have done in the past.

Rustum Roy of the Pennsylvania State University has been studying basic reaction mechanisms and kinetics in solid phase reactions at very high temperatures with AFOSR support since 1961. Since a metal with an oxide protective coating is an example of two solid phases in equilibrium,

this study is attacking the basic scientific problems involved. Furthermore, efforts to obtain strong materials for such applications as jet engine rotors are leading to carbides, borides, and oxides. The interreaction of solids is frequently used to prepare these materials, rather than reactions using a melt or liquid.

Reactions between solids are determined to a large extent by the nature and concentration of point defects in the system, because diffusion of ions is dependent upon point defects. The influence of the crystal structure on solid-state reactions is also very important, and must be understood in order to be able to predict reaction properties. Roy has made significant contributions in explaining these high-temperature solid phase reactions, and use of his results by those involved in design and production of useful high-temperature materials should be extensive.

The basic research on diffusion in crystals by C. E. Birchenall exemplifies another approach to the same fundamental problem of high-temperature materials.

Oxidation of metals and alloys not only offers protection against structural degradation in high temperatures and more reactive environments, but is also a logical outgrowth of research on the nature of atomic and ionic transport processes in crystals. AFOSR has supported this research since 1953, during Birchenall's tenures first at Princeton and later at the University of Delaware.

This research includes detailed investigations of some of the component parts of the oxidation process. At elevated temperatures metals and alloys form solid oxides at rates controlled by the diffusion of ions in the oxides as noted above. In order for this diffusion to occur, point defects must exist. However these defects and their behavior are not the same in all types of crystals. To understand their differences and derive general methods for describing their behavior, many examples with different kinds of binding forces must be studied, such as metals, oxides, and covalent semiconductors. Of particular importance is surface diffusion on metals. A mechanism for self diffusion (diffusion by atoms of the same kind chemically as the crystal itself) on iron crystals was developed in some detail, and has been valuable in the explanation of diffusion on certain metallic crystal surfaces. This "vacancy model" uses the properties of missing atoms (vacancies) on the surface to show how diffusion occurs. The weight of experi-

mental evidence supports this model, and it has been a necessary step in the progressive understanding of the phenomenon.

This investigation of diffusion is still underway, with more and more complex questions asked. For instance, the effect of saturation magnetic fields on volume self-diffusion in ferromagnetic iron is being checked, and chemical interdiffusion is being examined in certain alloys. Answers to these problems will fill in still further the matrix of information necessary to produce optimum materials with surfaces exhibiting the necessary properties.

Surprisingly or not, an explanation of the nature of scaling processes would help in design of high-temperature components as well as in the more commonly thought of marine applications. It is a very complex kinetic reaction of great technological importance, and the research results of both Roy and Birchenall have made and are making contributions to its ultimate solution.

Perhaps the most attractive avenue open for developing high-temperature structural materials is to find ways to strengthen the well-known ceramics, which already have many of the desired high-temperature characteristics. As we know from their uses in industrial furnaces (firebrick), bathroom fixtures and floors and ancient art masterpieces, ceramics have attractive physical properties. Contrast the results in dropping ceramic and metal flower vases however, and one realizes some of their seemingly inherent disadvantages. Effective methods for strengthening ceramics are needed in order for their use to flourish as a structural material in the space age.

Since 1955, AFOSR has sponsored one of the pioneering efforts in this field at Northwestern University. Here, Morris E. Fine has translated his extensive knowledge of strengthening mechanisms in metals to this unexploited area of ceramics. It is now known that hardened fine steels, some known since the days of antiquity, depend for their strength on the fact that very fine particles are dispersed in a matrix of iron. This is known as "precipitation hardening," since the tiny particles are precipitated during the manufacture of the material. This basic phenomenon has quite wide application, since we find that bones in vertebrate animals, including man, also are hardened by a dispersion of tiny precipitates. Clearly more knowledge is needed concerning the phenomenon and its application to ceramic systems.

Fine has undertaken to understand better the

important factors involved in precipitation hardening in metals, and their application to ceramics. His first work in this almost completely unexploited field was with sodium chloride crystals, ordinary table salt. Hardening by precipitation of potassium chloride increased its strength by a factor of 10. It was shown that instead of the usual smooth cleavage faces found in sodium chloride, the material with precipitates cleaved with very rough faces. The precipitates had interfered with the cleavage process and increased the strength of the material proportionately. Although table salt probably will not have extensive technological uses as a structural material, these experiments did establish a basic principle and yield useful quantitative data.

Experiments with magnesium oxide and iron precipitates yielded much basic and useful information. The iron was diffused into the samples at high temperatures and variation in oxygen pressure was found to vary the proportion of trivalent to divalent iron. This turns out to be quite important, since wustite ( $\text{FeO}$ ) is completely soluble in magnesium oxide but hematite ( $\text{Fe}_2\text{O}_3$ ) is not. Thus with proper treatment one finds the trivalent iron precipitating, as magnesioferrite ( $\text{MgFe}_2\text{O}_4$ ), resulting in significant strengthening. Divalent iron on the other hand does not strengthen, indicating the reason behind the importance of the oxygen pressure during the manufacturing process.

One knows that metals are strengthened by dissolving one metal in another. An example is zinc dissolved in copper to produce brass, which is stronger than either component. In ionic crystals the alloying element must have a different valence from the ion in order to increase the strength of the crystal. One can see in the accompanying graph that trivalent iron (here maintained in solution by very rapid cooling) increases the strength of the magnesium oxide sixfold. Thus we find there are two ways to strengthen ceramics: alloying and precipitation. In precipitation strengthening there is another variable to consider, the number and size of the particles. In a typical sample in Fine's studies, there are a hundred thousand trillion particles per cubic inch, and the number and size may be controlled by processing conditions. These precipitates also impart another interesting property to the magnesium oxide. The magnesioferrite precipitate is ferrimagnetic, with many potential uses such as high-frequency transformers and memory cores for computers. This technological "fallout" in the

form of interesting magnetic properties is being considered as a broad-band radar absorber for potential application to Air Force systems.

These important basic research studies are continuing with other oxide systems, such as aluminum oxide with titanium precipitates. Here preliminary results show a significant increase in strength for the aluminum oxide containing precipitates. The overall results to date show that Fine's fertile research on the strength of ceramics has been and will continue to be productive and of great importance to the Air Force in the years ahead.

A broad spectrum of basic knowledge is needed to meet requirements for structural materials useful in high temperature, reactive environments. As these basic scientific questions are answered, the engineer and design specialist will have a greater choice of materials to aid him in overcoming the

increasingly complex demands of aerospace technology.

#### BIBLIOGRAPHY

- C. E. Birchenall, *Proc. of the 4th Int. Conf. on Reactivity of Solids*, p. 24 (Elsevier, Amsterdam, 1961).  
 C. E. Birchenall, *Trans. Met. Soc. AIME* **227**, p. 784 (1963).  
 John Dash and M. E. Fine, *Acta. Met.* **3**, 1949 (1961).  
 M. E. Fine, in *Proceedings of the OAR Research Applications Conference*, OAR, Washington, D.C. (1966).  
 M. E. Fine, in *National Physical Laboratory Symposium* No. 15, p. 290 (HMSO, London, 1963).  
 G. W. Groves and M. E. Fine, *J. Appl. Phys.* **35**, p. 2587 (1964).  
 W. Kobes and M. E. Fine, *J. Appl. Phys.* **37**, p. 704 (1966).  
 Rustom Roy, in *Reactivity of Solids*, p. 321 (Elsevier, Amsterdam, 1965).  
 International Union of Pure and Applied Chemistry, Commission on High Temperature and Refractories, publishes on a regular basis bibliographies on high temperature chemistry and physics of materials in the condensed state.

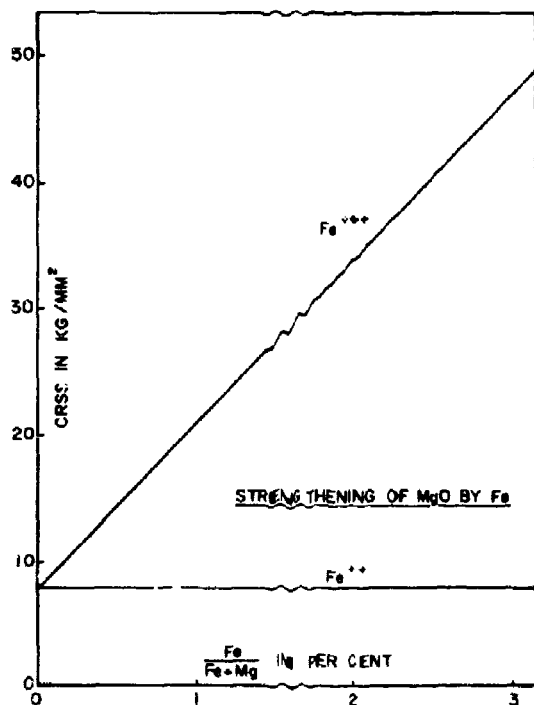

FIGURE 4.—Effect of dissolved iron on critical resolved shear strength of  $MgO$  crystals.

## Application of Emittance Measurements in Ablation Test

Lt. Col. RANDAL A. HOUIDORRE

The emergence of hypersonic aircraft and space flight has created a need for materials which are suited to extreme environments. One important environmental factor is high temperature. Since the temperatures encountered in these environments occasionally exceed the melting points of conventional materials and in most instances are in regions where material strength becomes very low, it has become necessary either to reduce temperature or to find new materials which are capable of withstanding these temperatures. A development which grew out of this necessity was application of the ablation principle. In general, this principle is considered to be that by which material is sacrificed for protection of some underlying structure. In other words, mass is traded for heat.

For a typical organic ablator, during the initial phase of heating the body acts as a heat sink (i.e. the heat transferred to the body simply increases the surface temperature). Then, at the material decomposition temperature gases are evolved and a char layer forms. As the process continues the boundary between the char and the virgin material moves inward and decomposition gases flow outward through the porous char. These gases act as a transpiration coolant for the surface. As the char thickens, the rate at which heat reaches the interface decreases; the rate of inward movement of the char boundary decreases; and the transpiration cooling effect decreases. Thus, the surface temperature rises and, in a stable system, a steady-state char thickness is maintained.

For charring ablator systems operated at high temperatures and for purely radiative thermal protection systems, the radiation controlled processes are of major importance. Thus, a thorough knowledge of emittance of materials is a necessity. The surface temperatures of such systems will approach, and in some instances, may exceed 2,000° C.

In recognition of the need for high-temperature emittance data, the Air Force Office of Scientific Research supported the investigations of Tabor S. Laszlo at the research and advanced development

division of Avco Corp. from June 1962 through October 1964. This support materially assisted Laszlo's group in obtaining high-temperature emittance data.

Prior to Laszlo's work (1), emittance data for materials at temperatures above 2,000° C. were very scarce and there were no really satisfactory methods for obtaining such data. The methods for obtaining emittance data in general usage relied on the comparison of the emittance of the sample with that of a blackbody at the same temperature. These methods become increasingly difficult to apply as the temperature approaches 2,000° C. As the temperature is increased problems connected with furnace material strength and reaction between the sample and its holder become very difficult. Conventional furnaces are limited to an operating temperature of about 1,800° C. Induction furnaces are capable of producing very high temperatures in the sample, but there are problems in connection with the use of these furnaces. These problems are mainly connected with contamination of the sample. Usually, a susceptor or a crucible must be in contact with the sample. In such cases reaction between the sample and the material of the crucible and/or susceptor are almost impossible to avoid.

In 1957, Laszlo (2) proposed an approach for measuring the emittance of materials above 2,000° C., through the use of a solar furnace. Later, Blau (3) and Comstock (4) attempted to use solar and carbon arc-image furnaces for emittance measurements based on this approach, but until Laszlo's work, success of this method was rather limited. The AFOSR sponsored investigation was concerned with the development of the necessary mathematical equations, instrumentation, and techniques for high-temperature emittance measurements with a calibrated solar furnace.

The basic approaches generally used in the measurement of emittance may be classified as direct and indirect methods. In the direct method, the radiant energy emitted by the sample is compared with that emitted by a blackbody at the same temperature as the sample. Whereas, in the indirect method, the reflectance of the sample is measured and the emittance is calculated from Kirchoff's law. This method is applicable only to opaque bodies or bodies of known transmittance.

Both of these methods present considerable experimental difficulties. Measurement of surface

temperature is one of the greatest problems. Above the operating range of thermocouples, optical or radiation pyrometers are generally used. However, use of these instruments requires a prior knowledge of the surface emittance.

There also exist problems connected with reference blackbodies. Since reference blackbody radiators are available only for temperatures below 1,500° C., an even lower temperature limit is set. The use of a reference blackbody cavity in the specimen also presents difficulties. The most serious of which is the requirement of maintaining the same temperature on the specimen surface as in the cavity. This is particularly true when the specimen is heated by radiation.

Further difficulties are encountered in connection with the controlled heating of a sample to high temperatures. Beyond the range of electric resistance furnaces, induction heating can be used if the specimen is a susceptor. If it is not, an auxiliary susceptor can be used. However, reactions between the sample and the susceptor may occur and distort the data.

In an image furnace, any sample, regardless of its magnetic susceptibility, can be heated to high temperatures without contamination from its surroundings. In a solar furnace, heat fluxes corresponding to a blackbody temperature of approximately 4,500° C. can be reached (5). The special characteristics of a calibrated solar furnace also make it possible to measure the surface temperature with an optical pyrometer without previous knowledge of the emissivity.

The use of an image furnace does, however, impose some difficulties. There are such things as: The need to separate the radiation emitted by the surface from that reflected by the surface, the small size of the radiating area, and the nonuniformity of the heat flux impinging on the specimen. These difficulties have been overcome by Laszlo and his group and emittance measurements have been performed in the solar furnace.

Emittance data for a number of different materials including heat shield materials were obtained. Of specific interest were the unexpected data obtained during the high-temperature emittance measurement of oxides (6). Rods of alumina, magnesia and zirconia were heated in the solar furnace. The incident flux was known from calibration data; the temperature of the samples and the emitted flux were measured for each incident flux level. The temperature of the zirconia rose steeply,

continuously with the flux increase. In contrast to this behavior the magnesia and alumina behaved in an unexpected and interesting manner. At the beginning of the heating process, the temperature of these materials rose very slowly or not at all with a large increase of the incident flux. Suddenly, it rose very rapidly with only a slight increase in flux.

From the large temperature increase it appears that a much larger fraction of the incident flux was absorbed by the magnesia and alumina slightly above their melting points than slightly below it. Emittance data supply confirmation of this statement. The emittance of alumina increased from 0.6 to 1.0. However, the emittance of zirconia, although it rose from 0.52 to 0.92 before melting, dropped to 0.82 after melting.

The flux emitted by the samples showed the same sudden increase when the melting point of the alumina and magnesia was reached, but no such phenomenon was observed with zirconia. The flux emitted by the zirconia samples varied in the expected manner.

These observations indicate a simultaneous increase in emittance and temperature. An explanation for these sudden changes in temperature and emittance at the melting point is not readily apparent. However, Laszlo (6) proposes the following mechanism:

The abrupt changes in the magnitude of observed temperature can be explained by the low solar absorptance of the white alumina and magnesia samples. Since only a very small fraction, approximately 10 percent of the concentrated solar radiation is absorbed, a large increase in the incident flux causes only a small increase in absorbed energy and thus, a small increase in temperature increase is not easily detected by this method since, in such a case, the magnitude of the reflected energy component is much larger than the emitted component. Thus, the specimen temperature measurement is insensitive to small changes in emitted radiation. When melting occurs, these conditions are suddenly reversed if the solar absorptance of the sample increases considerably. Thus, not only will the increase of incident flux cause a large temperature increase, but the method becomes very sensitive to small increases in the incident concentrated solar radiation since the emitted and reflected flux are of the same order of magnitude.

He also proposes several possible causes for the sudden increase in apparent solar absorptance are

given. These include: The formation of a liquid lens; emission from both the surface and the volume; the failure of the assumption that transmittance is zero; and a difference in thermal conductivity.

Emittance measurements on alumina, magnesia, and zirconia are of particular importance in view of possible use of these ceramics as heat shields. Investigation of the characteristics of porous alumina and zirconia impregnated with resins has been performed (7) and these materials have been found valuable because they combine the low thermal conductivity, high specific heat and mass transfer effects of the plastics with the heat resistance and thermal stability of the ceramics.

The results of emittance measurements on specific ceramics constitute only one example of the utility of this emittance measurement method. The immediate application of this method to developmental problems is in the area of heat shield ablation measurements.

The importance of emittance measurements was pointed out in the introduction to a paper (8) presented at the symposium on thermal radiation of solids in March of 1964.

The design and performance of future space systems will depend to a great extent upon radiant heat transfer characteristics of surfaces exposed to high-energy and high-temperature environment. Reentry systems following a wide range of trajectories will encounter high heat flux environments and when operating at high temperatures will dissipate large amounts of energy through radiation transport. In addition, heat transfer from leading edges and rocket nozzles will be a function of the radiation characteristics of their surfaces. In these and other cases the overall system temperature may often be established by surface emittance values. For example, space radiator size and weight is generally universally related to surface emittance.

In many cases, reported emittance data is contradictory or, as with many new coating systems of interest to the Air Force, this data is entirely unavailable. Currently, data obtained by different investigators on the same material have varied by more than 50 percent in some instances. These differences may have been due to poor experimental techniques, improper preparation of samples, inadequate

definition of experimental conditions, or poor instrumentation.

Knowledge of the high-temperature emittance characteristics of materials will play an important role in the selection of materials for hypersonic aircraft surfaces which will be exposed to high temperatures. There are indications that the "hot structure" concept (i.e., the structure is not cooled, insulated or ablated) must be used for hypersonic aircraft (9). If such a concept is used surface temperatures on some areas of the aircraft will be above 1,700° C. For these areas tantalum and tungsten alloys are being considered. The emittance of these alloys can be determined by the Laszlo approach.

Much of the testing of ablative and other heat-shield materials has been performed in plasma-arc facilities, (10, 11). In these facilities convective and radiative effects occur simultaneously and independent regulation of the magnitude of the components is difficult. This is particularly true for test conditions which require a high-radiant component (i.e., high surface temperatures). In view of this difficulty, Laszlo and his coworkers decided to determine the effects of each process separately. They then proceeded to study the radiant heating effects by use of solar image furnace (12). In this study the methods previously developed (1) for emittance measurements were used. Ablation testing was performed with a 60-inch solar furnace as a radiant energy source. The concentrated flux was adjustable to any value in the range from 59 to 1000  $\text{cal/cm}^2\text{sec}$ .

The experimental arrangement is shown. The solar radiation, concentrated by the paraboloidal mirror [17] is adjusted to the desired level by the flux control screen [1]. The sample [4] is mounted on an arm controlled by a rotary solenoid [3]. In the normal position the sample is out of the focal plane. When the solenoid is energized, the arm is rotated and the front surface of the sample is brought into the focal plane. At the end of the exposure, the solenoid is deenergized and the sample is removed. The exposure time is controlled by an electrical timer in the solenoid energizing circuit. A single-frame movie camera [24] is used to make photographs during the test. A 12-foot flexible fiber-optics light pipe [11] is used to transfer the image of the sample profile, as reflected by the 45° plane mirror [25], through the proper lens systems [13, 12] into the camera. The emitted and reflected radiation is separated by use of rotating

1. FLUX CONTROL SCREEN
2. SAMPLE HOLDER
3. ROTARY SOLENOID
4. SAMPLE
5. DRIVE MOTOR
6. MONOCHROMATIC RADIATION SENSOR ( $J_{\lambda}$  AND  $J_{\lambda}'$ )
7. TWO-POSITION MIRROR
8. POS 1
9. AMPLIFIER
10. RECORDER
11. 12' LIGHT PIPE
12. LENS SYSTEM FROM LIGHT PIPE INTO CAMERA
13. LENS SYSTEM INTO LIGHT PIPE
14. OPTICAL PATH
15. ROTATING RADIATION SHIELD
16. FIXED COLLIMATOR TUBE
17. SOLAR FURNACE MIRROR
18. ROTATING DISC
19. SPRING LOADED DISC
20. POS 2
21. TOTAL RADIATION SENSOR ( $J_{NT}$ )
22. AMPLIFIER
23. RECORDER
24. SINGLE FRAME MOVIE CAMERA
25. PLANE MIRROR

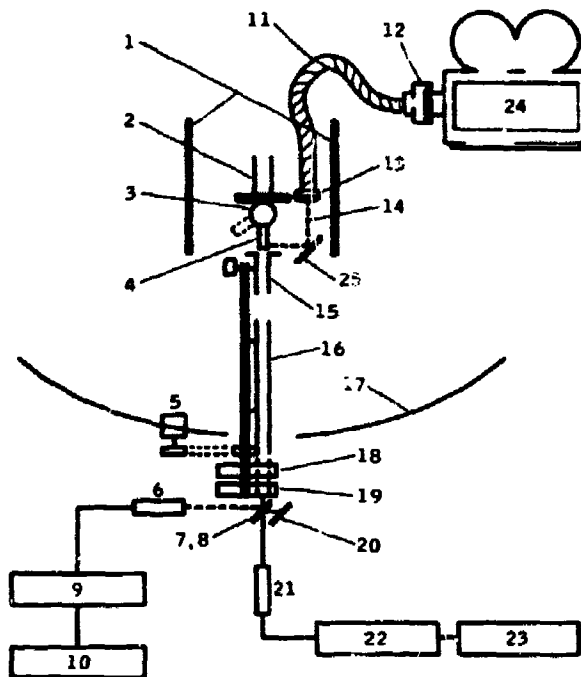

63-7062-A

FIGURE 5.—Experimental setup for ablation tests.

radiation shield [15]. When the shield is in front of the sample, no solar radiation impinges. Thus, only the radiation emitted by the sample passes through the fixed collimator tube [16]. Thus, both emitted and reflected radiation pass through the fixed collimator tube towards the radiation sensors.

The samples were  $\frac{1}{8}$ -inch diameter rods, 1.5 inches long. These were mounted in a graphite cylinder which was attached to the rotary solenoid. After the entire assembly was precisely aligned, the furnace was focused on the sun and the guidance system started. The desired flux level was established by adjusting the flux control screen [1] and the solenoid was activated for a specific time.

Because of the high rate of ablation, each of the three measurements (i.e. the emitted radiation, the sum of emitted and reflected radiation, and the total emitted radiation) were performed on new, but identical samples. For the first measurement the two-position mirror [7] was placed in position 1, thus reflecting the radiation emitted by the sample into monochromatic radiation sensor [6]. The generated signal was amplified by amplifier [9] and was displayed on recorder [10]. In the

second stage, the instrumentation was the same except that the spring loaded disc [19] was retarded and a fresh sample was used. Thus, the sum of emitted and reflected radiation was recorded on [10]. In the third stage, the two-position mirror [7] was moved into position 2. The radiation emitted by the sample was then received by total radiation sensor [21], amplified by amplifier [22] and recorded on a high-speed Sanborn recorder [23]. This value represented the total radiation emitted by the sample. During these exposures, the radiant flux was held constant. The shape of the ablating surface, the length of the sample and the thickness of the hot front layer versus time were determined from the photographic record. An alumina radiation shield was used to protect the stainless-steel sample holder [2] and the front surface of this shield was used as the reference in the measurement of the change in length of the sample.

Various ablating materials were tested by this method. Among these materials were heat-shield materials and prospective heat-shield materials. The data obtained from these tests were material

thickness decreases, surface temperatures and radiated fluxes for specific incident fluxes. From these data the dependence of recession rates, surface temperatures and emitted fluxes upon incident flux was obtained.

These results of ablation tests indicate that the radiative properties of the ablator are very important parameters in the evaluation of its performance. Since these properties can be altered within certain limits to change the reflected and emitted radiant flux, a thorough knowledge of them is a necessary step in the design of highly effective heat shields.

Design requirements for heat shields under hypersonic flight and reentry conditions stimulated interest in the high-temperature thermal characteristics of materials. Results of early investigations indicated that some of the fundamental radiant properties were not known at the requisite temperatures and fluxes. Thus, methods for the determination of these parameters were sought. One of the most important of these parameters, the emittance, was almost completely unknown above temperatures of approximately 1,500°C. Emittance data in this temperature region had not been obtained because a reliable measurement technique was not developed.

With the impetus of need for high-temperature data, Laszlo and his coworkers developed techniques applicable to solar furnace measurements. These techniques produced reliable emittance data

which, in turn, facilitated the development of testing methods for heat-shield materials. Thus, investigations of a fundamental nature in the determination of high-temperature emittance characteristics have led to techniques and methods which materially assist the engineer who is assigned the task of heat-shield design.

#### REFERENCES

- (1) T. S. Laszlo, R. E. Gannon, and P. J. Sheehan, *Solar Energy* 8, p. 105 (1964).
- (2) T. S. Laszlo, *Solar Energy* 1, p. 78 (1957).
- (3) H. Blau Jr., in "Proceedings of an International Symposium on High-Temperature Technology" p. 45 (McGraw-Hill, New York, 1960).
- (4) F. Comstock, *Temperature—Its Measurement and Control in Science and Industry*, p. 1063 (Reinhold, New York, 1962).
- (5) T. S. Laszlo, *Science* 124, p. 797 (1956).
- (6) T. S. Laszlo, P. J. Sheehan, and R. E. Gannon, "Recent Results of Ablation Studies," presented at 1966 Solar Energy Society Meeting (in press).
- (7) E. L. Strauss, *Aerodynamically Heated Structures*, p. 7 (Prentice-Hall, Edgewood Cliffs, N.J., 1962).
- (8) D. F. Stevison and M. L. Minges, *High-Temperature Emittance* (Preprint of Symposium on Thermal Radiation of Solids, Session V, p. 1, 1964).
- (9) M. G. Childers, *Space/Aeronautics* 46, p. 86 (1966).
- (10) T. K. Pugmire et al. (*General Electric Co. Report MNVD 3519708* 1963).
- (11) J. H. Bonin and C. F. Price, *Conference on Extremely High Temperatures*, p. 237 (Wiley & Sons, New York, 1958).
- (12) P. T. Sheehan, R. E. Gannon, and T. S. Laszlo, *Solar Energy* 9, p. 141 (1965).



## Chemical Sciences

### *Liquid Structure*

DENTON W. ELLIOT

Air Force Office of Scientific Research support of research in liquid structure is a long-standing program stemming from an Air Force interest in such processes as welding, casting, wetting, and in liquid flow and other related phenomena.

A lack of good working theory for the behavior of liquids has its frustrating and expensive consequences at the practical level. The modern-day engineers and scientists, for all of their knowledge of atoms and molecules, cannot make a straightforward prediction of the elementary properties of even the simplest liquids. Such things as densities, viscosities, and boiling points, needed for the design and intelligent operation of chemical plants, oil refineries, and liquid-fueled rockets, cannot be reliably estimated from theory and must be measured in the laboratory and pilot plant.

It is apparent that continued lack of full understanding of the behavior of liquids in general and solutions in particular will stand as a barrier to full insight of many other basic problems. Chemical kinetics in the liquid phase is currently at a standstill, in contrast to the significant gains in gas-phase kinetics in the past 10 years.

Among the participants in the early part of the AFOSR program were Dr. Howard Ritter of Miami University of Ohio and Dr. Donald Andrews of Johns Hopkins University. Dr. Ritter succeeded in assembling a special X-ray diffraction apparatus for studying special liquids (barium iodide in water) and developed a computer program to fit his liquid structure problems.

At that time there were no mathematical equations to express the theoretical relations comparable to what we had for crystals and gases. For this reason there existed a real need to obtain more data on pure liquids and binary and ternary problems. In order to develop a theory for the liquid state there is a need to know about the spatial order of molecules, their thermal motions, and the forces acting between them, both in pure liquids and in solutions. The importance of this type of infor-

mation to the Air Force for understanding and perfecting heat transfer liquids, hydraulic fluids, fluid flow, and lubricants cannot be overstressed. With this in mind a project was supported with Dr. Andrews in which he constructed a new type of calorimeter that embodied an automatic recording and computing system which made measurements of the high accuracy required for theoretical calculations. It has been used for the study of heat capacities and heats of fusion of a number of compounds and multicomponent systems. New concepts were developed which aided in setting up more suitable generalized coordinates for liquid systems and permitted the simplification of the calculations.

At Caltech, Cornelius J. Pings, associate professor of chemical engineering, has been studying the fundamental behavior of liquids for the past 8 years with support by the Air Force Office of Scientific Research.

Pings and his group are attempting to learn more about how atoms and molecules behave in the liquid state at various temperatures and pressures and how microscopic forces lace them together in the informal, shifting way characteristic of liquids.

"Although the molecules of solids are arranged in orderly rows and those in gases in perfect disorder, the molecules in liquids comprise a moving interlocked mess, a sort of ordered chaos," Dr. Pings explains. "In liquids, each atom is affected by thousands of surrounding atoms whose positions in relation to each other are constantly changing."

This is an example of a many-body problem, a name given to a number of problems involving the simultaneous interaction of a large number of particles, atoms, or molecules. The biggest digital computers are not powerful enough to solve these problems by brute-force arithmetic. Although they are currently the focus of much activity by theoretical physicists and chemists, progress is slow, and a general solution to these many-body problems is not yet in sight. Pings and his co-workers are interested in determining the behavior of very simple liquids at a wide variety of temperatures and pressures. The group hopes to obtain

enough data to provide a sound framework for a comprehensive, overall theory. The team is making observations of molecules and their forces in liquids with several techniques.

The first such technique is X-ray diffraction, which enables investigators to measure the average number of neighboring atoms and the distance they sit from each other. A beam of X-rays is directed at the liquid being studied and the atoms in the fluid diffract the X-rays. The diffracted radiation is detected by scintillation counters. Mathematical analysis of the diffraction data yields direct information about the average configurations in the system of moving liquid molecules.

One set of completed experiments on liquid nitrogen has revealed that each nitrogen molecule on the average is surrounded by a "shell" of 15 neighboring molecules at a distance about 5 percent greater than the shell of nearest neighbors in the crystal lattice.

The second experimental technique is a study of the refractive index of the fluids. This is the measurement of how much a beam of light is bent as it goes through a liquid. The amount of bending is indicative of the electrical environment in the immediate vicinity of a molecule in the liquid.

These measurements have been made on methane, carbon tetrafluoride, and argon. Argon measurements have been mainly of the liquid up to 100 atmospheres, but have also included some studies of both gaseous and solid argon. Of particular interest in this study is the Lorentz-Lorenz theory, which postulates a quite simple relationship between the dielectric constant (or refractive index) and the density of a substance. The experimental work has indicated that the theory seems to be quite good for nonpolar gases, liquids, and solids. This may be of some significance, since very few properties can be predicted for all three states of matter by a single theory or model.

The third experimental technique is ultrasonic absorption. Ultrasound pulses disturb the liquid slightly, causing its structure to change. The rate at which the liquid's forces pull its molecules back to their original position could provide information that may lead to a theory of predicting viscosity and other transport properties.

Much of the investigation is concentrated at the critical region of a liquid, the borderline region between liquid and gas. Theoreticians still have no satisfactory explanation for the very strange behavior of a fluid at its critical state. It is known

that very large clumps form in liquids in this region. The clumps often are so large that they cause light to scatter. In some instances an otherwise colorless liquid looks brown from the scattering.

There is considerable theoretical and practical interest in this region. Practically, there is much interest in the fact that heat capacity and thermal conductivity increase as much as ten times. The thermal conductivity properties suggest that liquids in the critical state may provide a very effective heat transfer medium for boilers and chemical processing equipment, and the heat capacity properties may be useful for heat control, as a sort of heat buffer.

On the theoretical side, the critical region seems to be sort of a promised land for the theoretician interested in many-body problems. A key to the critical region might very well also turn the lock of the whole liquid-state problem.

The use of advanced mathematical theories in explaining the properties of matter is a valuable supplement to the traditional chemical approaches. Interesting work in this field has been accomplished by Bernard D. Coleman at the Mellon Institute under an AFOSR contract.

Coleman used mathematical treatments of the mechanical behavior fluids, including such complications as sheer-dependent viscosity and gradual stress relaxation. His general theory of "simple fluids with fading memory," developed in collaboration with Dr. Walter Noll, is based on mathematical definitions of these concepts.

Translated into ordinary language, a simple fluid is one which has no intrinsic preference for a particular configuration out of a class of configurations of equal volume; that is, it takes the shape of the confining vessel. Similarly, the principle of fading memory states that deformations which occurred in the distant past should have less effect on the present value of the stress than deformations which occurred in the recent past.

The theory obtained by mathematical reasoning from these concepts was found to be broadly applicable to fluids. Even complex systems such as molten polymers or polymers in solution were found by the theory to show ideal or "Newtonian" behavior in the limit of very slow flow, and linear viscoelastic behavior in the limit of infinitesimal deformations.

In developing the theoretical aspects of liquid structure none has been more productive under AFOSR support than Stuart A. Rice at the Uni-

versity of Chicago. From his studies of the statistical theory of transport phenomena, he has published "Statistical Mechanics of Simple Liquids" (John Wiley & Sons, Inc., N.Y. 1965). In this book he summarizes his approach to the theory of transport in liquids with an extensive comparison of theory and experiment.

Rice has published several papers on the kinetic theory of dense fluids. One paper deals with the shear viscosity of liquid argon. The theory of Rice and Allnat leads to predictions of the temperature dependence of the shear viscosity under conditions of constant volume. These predictions are in good agreement with experimental results.

In another paper a formula for the bulk viscosity of a simple liquid has been obtained from the solutions of the kinetic equations proposed by Rice and Allnat. The theory unambiguously predicts that the ratio of bulk to sheer viscosity for liquid argon, at a density of 1.12 g/cm<sup>3</sup> and temperatures between 125° and 185° K, should be approximately 1.3.

Dr. Rice's experimental and theoretical studies of the electronic structures of disorganized systems were published as "Electron Mobilities in Liquid Argon and Krypton". Measurements were reported on the drift velocity of electrons in liquid argon and krypton as a function of temperature, pressure, and electric-field strength. It was demonstrated that an elementary scattering theory provides a reasonable zeroth order description of the mobility in the low-field region. The theory incorporates the effects of coherence in the electron scattering from nearby atoms into the cross section of a modified Boltzmann equation. The magnitude of the mobility and the pressure and temperature dependence of the mobility are all reproduced to better than a factor of two. It is found that the electron velocity distribution is not thermal and that the mean electron energy may be as large as 0.5 electron volt even when the electric-field strength is as low as 100 volts/cm. Under these conditions, a dilemma for zero field calculation is posed by the fact that the nonthermalized electron distribution leads to nonlinearity of the drift velocity with respect to the electric-field strength.

In "Theoretical Studies of Solvated Electrons", published in "Advances in Chemistry Series", Rice and Jortner considered the metastable excess electron states in polar and nonpolar liquids. They discussed the general questions: (1) What

is the form of the general dispersion curve describing the momentum-energy relationship for a quasi-free electron in a liquid? (2) What are the conditions which lead to the localization of an excess electron in a liquid? (3) What is the nature of the transition to the metallic state in a liquid containing high density of excess electrons? (4) What information can be extracted from studies of the behavior of excess electrons in liquids about the dynamical and statistical geometry of the liquid state?

A neglected area of research, but one which could play a major role in the liquid structure picture, is that of liquid crystals. These form a curiously neglected state of matter, intermediate between crystalline solids and "normal" isotropic liquids. They are formed by certain compounds with elongated, relatively polar molecules whose mutual attraction tends to orient them with their long axes parallel. Such materials first melt to an anisotropic liquid in which the molecules are free to move about only so long as they remain parallel to one another. At a higher temperature the melt undergoes a sharp transition to a normal liquid. Certain substances exist in not one but two distinct liquid crystalline phases. These on fusion give first a smectic phase in which the molecules are not only constrained to be parallel, but are also arranged in layers; at a higher temperature they undergo transition to the nematic phase when this extra constraint is lost; and then at a still higher temperature the nematic phase changes to a normal liquid. Certain substances are even claimed to exist in two or more distinct smectic phases.

Liquid crystals therefore behave mechanically as liquids, but they preserve some of the order of crystalline solids. If a material whose molecules are rod-shaped is dissolved in a liquid crystal, we may expect the solute molecules to be oriented parallel to the molecules of the solvent. The resulting geometrical constraint should have obvious and interesting physical and chemical consequences, and so liquid crystals should show very unusual solvent properties.

A general type of liquid crystal is composed of certain cholesterol ester derivatives with eccentric molecular structure. This substance flows like water but has the optical properties of rigid crystals. Through their chameleon-like color changes, liquid crystals portray gradation of mechanical

stress, electromagnetic radiation, and chemical composition, as well as temperature. For this reason they have found a variety of industrial uses, particularly in the testing of delicate space instruments.

In the area of medicine, liquid crystals are also offering unexpected, exciting, and imaginative application. Bizarre substances are being tested experimentally and clinically for cancer detection and analysis, for monitoring the status of newborn infants, and for checking on the patency of vascular grafts.

As a research tool, the prospects of liquid crystals are even more sweeping. They may yield important information on the diseases that cause peripheral vasomotor disabilities. They could greatly magnify the efficiency of entire diagnostic procedures. Ultimately, they may shed light on the basic mechanics of sight and other senses.

As liquid crystals are sensitive to response of external electrical magnetic fields, in addition to having unique thermal and optical properties, they have direct relevance to Air Force problems in the area of detection devices. For this reason, AFOSR supported the first International Liquid Crystal Conference, held at Kent State University, Kent, Ohio, 15-20 August 1965. This conference was attended by more than a hundred scientists with varied backgrounds from the United States and a dozen foreign countries to exchange views on the present knowledge of the liquid crystalline state.

Another structure problem that is intertwined with the liquid structure dilemma is that of glassy materials. This subject has created as much controversy as that of ordinary liquids. This is no doubt due to the unique character of a material in the glassy state, in that it possesses many of the mechanical properties of crystalline solids and yet structurally resembles a liquid in its random distribution of molecules.

Since the liquid and glassy structure behaviors appear to have the potential of throwing light on each other and because any information on these important materials may be of Air Force significance, AFOSR has included in its overall program some investigations on the fundamental properties of the glassy or vitreous state.

J. D. Mackenzie of Rensselaer Polytechnic is studying the relationship between flow properties

and structure of glass-forming oxide melts. He is measuring the viscosity and compressibility of  $B_2O_3$  and binary metal oxide-boron oxide melts, as well as the solid glasses at high pressures and temperatures. These measurements permit one to evaluate viscosity values at constant volume. These data are extremely valuable, since the contribution of thermal expansion to the flow process can then be separated.

John Mackey and his group at Mellon Institute are doing a study of localized defect states in oxide glasses. They are concentrating on the relationship of glass structure to the structure of crystalline compounds in the same region of the phase diagram, using defect studies as a tool. In addition, they are studying the role of structural changes in defect behavior due to annealing and thermal and chemical factors and the existence of phase or composition boundaries in glass systems and their effect upon electronic properties.

Chemical reactions, whether adding to knowledge in the laboratory, to profit in the chemical industries, or to life and growth in the human body, most often take place in solution. Most of these solutions contain water as their prime solvent. Water occupies a unique place as a solvent, because it is cheap, available, dissolves so many substances, and exists as a liquid over our usual temperature range.

In spite of being the most familiar and the most abundant, liquid water is an atypical liquid and its structure has presented a challenge to theoreticians for decades. There is a pressing need for a structure model of liquid water adequate for quantitative interpretation of its anomalous properties, such as maximum density at 4° C., the high-dielectric constant, heat capacity, viscosity, thermal conductivity, critical temperature, and the differences from deuterium oxide.

Archimedes in his day was aware that there are only four strictly regular polyhedra, the tetrahedron, cube, octahedron and icosahedron. All other polyhedra, such as the 12-sided dodecahedron, are not strictly regular. At an international conference held appropriately enough at Athens, Greece, G. A. Jeffrey of the University of Pittsburgh reported on the importance of this ancient observation to a perennial problem of great military and civilian importance: an adequate supply of drinkable water.

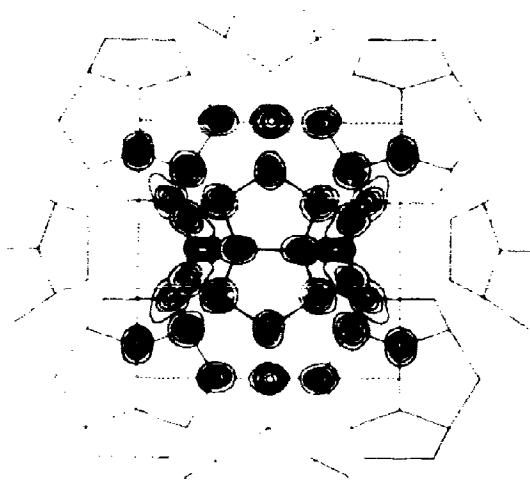

FIGURE 6.—A representation of clathrate hydrate obtained by X-ray diffraction.

Water forms a very interesting series of molecular compounds called clathrate hydrates, in which a cage structure made of water molecules is found to trap or enclose a different species of molecule. The association between host and guest molecules does not require primary chemical binding, so that the two types can be separated at little cost in energy. In research supported by AFOSR, Dr. Jeffrey has demonstrated that the basic structural unit for some 30 quaternary alkyl ammonium and phosphonium salt hydrates is the  $H_{20}O_{20}$  regular dodecahedron, made up of 20 water molecules linked together by hydrogen bonds. These results tie in with current work on the structural theory of liquids by J. D. Bernal of the University of London, who has suggested that structures of fivefold symmetry are quite important in nonperiodic arrays, and dodecahedra with axes of fivefold symmetry may be significant units in liquids.

The  $(H_2O)_{20}$  dodecahedron also occurs in the natural gas hydrates, clathrate compounds containing lower hydrocarbons as guest compounds. Because it is a noncrystallographic solid with regular pentagon faces on the unit structure, it does not form a close-packed crystalline array. Structures with this basic unit must therefore contain nonregular "holes" which are themselves polyhedra with hexagonal as well as pentagonal faces.

Dozens of clathrate hydrates are known. Some involve the inert gases such as  $6 Ar \cdot 46 H_2O$ ; other examples are:



Such compounds are generally crystalline, can be easily recrystallized, and have possible application in purification processes. In fact, the propane hydrate is the basis of a water desalination procedure. Consequently, this project was transferred to the Office of Saline Waters.

In conclusion it can be said that the scientific understanding of liquid structure is trailing far behind the knowledge of the gaseous and solid states. The apparent reason for this lag is found in the fact that liquids do not have either the geometrical regularity of solids or the complete randomness of gases. Theoretical and experimental developments have recently shown encouraging progress toward some understanding of the problem. But it is only through persistent, continuous effort on the part of the investigators and those who are supporting the research, that there will be any positive far-reaching progress made on understanding the complexities of liquid structure.

#### REFERENCES

- (1) J. A. Barker, *Lattice Theories of the Liquid State* (Pergamon Press, New York, 1963).
- (2) B. D. Boleman, "Problems in Rheology and Physical Chemistry" (Final Report AFOSR 5126).
- (3) F. Frank, *Quarterly Review* 20 (1966).
- (4) P. Gray and S. A. Rice, *J. Chem. Phys.* 41 (1964).
- (5) N. Hart and S. A. Rice, *J. Chem. Phys.* 42 (1965).
- (6) K. Kiroike, N. R. Kestner, S. A. Rice and J. Jortner, *J. Chem. Phys.* 43 (1965).
- (7) J. Wiley, *Molecular Theory of Gases* (Hirschfelder, Curtiss and Bird).
- (8) T. J. Hughel, *Liquids: Structure, Properties and Solid Interactions* (Elsevier Publishing 1965).
- (9) J. Jortner, N. R. Kestner, S. A. Rice, and M. H. Cohen, *J. Chem. Phys.* (in press).
- (10) B. A. Lowry, S. A. Rice, and P. Gray, *J. Chem. Phys.* 40 (1964).
- (11) J. D. Mackenzie, *Modern Aspects of the Vitreous State* (Butterworth London, 1960).
- (12-14) P. G. Mikolaj and C. J. Pings, *J. Chem. Phys.* (in press).
- (15) C. J. Pings and H. H. Pallman, *Mol. Phys.* 5, N5, 531 (1962).
- (16) S. A. Rice and P. Gray, *Statistical Mechanics of Simple Liquids* (John Wiley & Sons, New York, 1965).
- (17) S. E. Rodriguez and C. J. Pings, *Rev. Sci. Instr.* 33, 12 (1962).

## Energy-Matter Interactions

DR. ALFRED WEISSLER

Research on the problems of energy-matter interactions is the key to solving a whole host of vital Air Force problems. They include atmospheric reentry of aerospace vehicles, navigation by lasers, malfunction of systems and personnel due to intense sound and vibration, deterioration of structural and circuitry materials under unscreened solar radiation in the upper atmosphere, the hope of squeezing some precious extra thrust out of the hot exhaust gases of a jet engine, and many others.

Partly for this reason, many of the chemists in the world devote their lives to this pivotal chemical research problem. Sometimes the aim is to control undesirable breakdown processes. Other times, it is to create a new plastic or rocket fuel or cause another desirable process to occur.

In the past, thermal energy was just about the only type available for changing one form of matter into another: The chemist would mix his starting materials, apply heat for a period of time, and fish the wondrous new stuff out of the brew. But recently chemists have diversified their armamentarium, and now can bring about specific chemical transformations by injecting into molecules other forms of energy such as ultraviolet, gamma rays, and ultrasonic waves.

A large fraction of the AFOSR chemistry program is devoted to the rapidly growing field of energy-matter interactions. A few examples are discussed below, using the researcher's own language in some places. The purpose is not only to show the military relevance, but also to convey the excitement of life on the scientific frontier.

### Exposure in the Ultraviolet

Fortunately for us, the most destructive component of the sun's rays (the far ultraviolet) is screened out by the protective layers of the atmosphere. In the aerospace environment, however, materials are subjected to merciless bombardment by high-energy short-wave ultraviolet. Many of them—especially the organic substances—undergo deterioration.

One important effect of far ultraviolet irradiation has been discovered by G. Oster of the Polytechnic Institute of Brooklyn: Plastics such as mylar and saran lose their insulating properties

and become photoconductors. Inasmuch as mylar is used as a dielectric, control systems in aerospace vehicles may thereby be compromised. During this work, Oster found that the ultraviolet rays also cause discoloration of saran, due to a molecular change of splitting out chlorine.

A related study by P. DeMayo of the University of Western Ontario has shown that exposure to ultraviolet causes deep-seated changes in the molecules of many organic materials. In some cases a ring structure is broken as in the elegant synthesis of maleimide from pyrrole. In other cases, such as a mixture of cyclohexene and acetylacetone, a new precursor is formed photochemically.

### Photochemistry vs. Radiation Chemistry

Twenty years ago there was a flurry of activity in which both radiation chemists and photochemists sought correlations among the chemical results of the two kinds of excitation. The initial observations led to such confusion that the attempts at correlation were abandoned in most laboratories. During the past year G. S. Hammond at Caltech and coworkers have obtained results that seems to provide the basis for a much more optimistic outlook. Essentially simultaneously, similar reports have come from a number of other laboratories although, at least momentarily, the Caltech team seems to have the most extensive results.

Their approach has been the use of energy transfer as a monitor of the kind of electronic excitation appearing in a sample exposed to gamma-irradiation. They have gamma-irradiated solutions of various photochemically reactive substrates in aromatic solvents such as benzene and toluene. The choice of solvent is important, because efficient cascade to nondissociative excited states must occur if the excitation delivered is to reach the same state as is obtained by absorption of ultraviolet light. When the reactive substrates are isomerizable olefins such as stilbenes,  $\alpha$ -methylstilbenes,  $\alpha$ ,  $\beta$ -dimethylstilbenes, or piperylenes, the same pattern of response is observed as is seen in photosensitized cis-trans isomerization. This similarity in behavior suggests that excited solvent molecules decay to their lowest triplet states and then transfer triplet excitation to solute molecules.

The use of radiation-induced isomerization as a means of counting triplet excitations immediately comes to mind. In fact, others have used this

method, with the 2-butenes as triplet counters. However Hammond finds that the G values (yield of molecules per 100 electron volts of energy absorbed) for isomerization are much higher (around 13) than previously reported. The high values occur at high-solute concentrations. The upturn in G values for isomerization at high-substrate concentrations resembles closely the rise in G values of scavengeable radicals at high-scavenger concentrations in the radiolysis of aqueous solutions. The results are probably due to bimolecular destruction of triplets in the region of high-excitation density within radiation spurs.

The radiation-induced dimerization of 1,3-cyclohexadiene shows an additional startling feature. Dimeric products are formed with high G values. However, two sets of dimers are produced, those formed in photosensitized reactions and those produced by thermal dimerization at high temperatures. The Caltech workers have demonstrated that the two sets have different precursors. Addition of isopropyl alcohol selectively inhibits formation of the "thermal" dimers and addition of azulene (a good triplet scavenger) reduces the yields of both sets but represses the formation of the "photo" dimers most strongly. Clearly, one type of excitation that is conveyed to the solute molecules is triplet in character. Cross-comparison with experiments in which cyclohexadiene is irradiated directly indicates that the thermal dimers are not formed from singlet excitations. The only other attractive alternatives are positive ions and negative ions. Since carbon tetrachloride, a good electron scavenger, has only a mild repressive effect on dimerization, they infer that the active intermediates are not anion radicals derived from the substrate, and by elimination are led to prefer a mechanism in which cation radicals are intermediates. This is consistent with the inhibitory effect of isopropyl alcohol.

Increasing the concentration of cyclohexadiene increases the yield of photo dimers much more than the yield of thermal dimers; this suggests that the precursors to the thermal dimers are not destroyed by diffusion-controlled bimolecular reactions within spurs. Because the G values for dimerization are rather high, it seems that the thermal products must be produced by a chain reaction. Tentatively, the following overall mechanism has been formulated.

These studies and their interpretation lead to the hypothesis that the steps in excitation degrada-

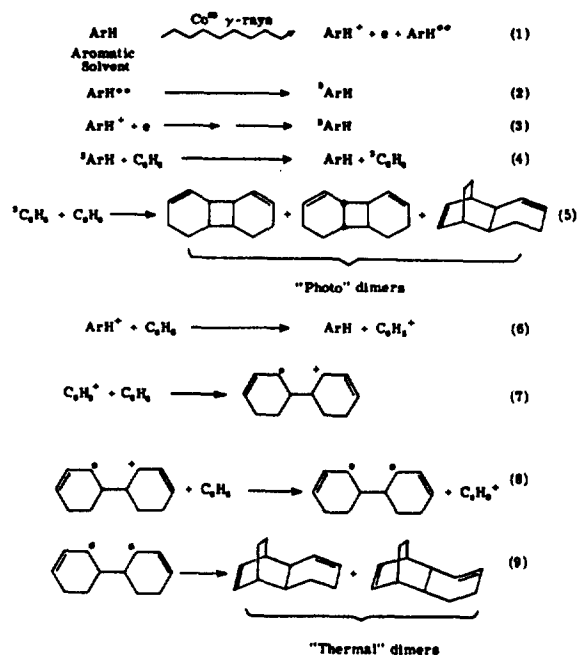

FIGURE 7.—Dimerization reaction schemes.

tion, following production of Compton electrons, do not occur in a definite sequence. In the region of high-excitation density, bimolecular reactions between excitations may lead to production of high-energy excitations from those of lower energy.

Hammond is enthusiastic about the prospect of using chemical monitoring as a means of dissecting the mechanism of excitation decay in radiation chemistry. The work may have a number of attractive applications, including development of new and effective methods for the protection of materials against radiation damage. It is also entirely possible that chemical means of characterization of different kinds of radiation can be based upon linear energy transfer effects, which may have major influences on the course of induced chemical reactions.

#### Sound Chemistry

Sound chemistry or "sonochemistry" is the name given to the study of molecular disintegrations caused by exposure to intense sound or ultrasound waves. AFOSR is supporting the research of one of the leaders in this esoteric field, Michael Anbar at the Weizmann Institute of Science in Rehovoth, Israel.

For over 30 years, it has been known that when water is exposed to intense mechanical vibrations it breaks down to give hydrogen, hydrogen peroxide, and eventually oxygen. Volatile compounds dissolved in water may be broken down, too, under these conditions; and nonvolatile substances, although not broken down, may react with the decomposition products of water, namely hydrogen atoms and hydroxyl (OH) radicals. Decomposition of water in this way was known to depend on two things—the presence of a permanent gas or some other highly volatile component dissolved in the system, and the occurrence of cavitation.

Cavitation is the formation and collapse of microscopic bubbles in a liquid when it is subjected to transient tensile stresses. These bubbles, or cavities, can be seen in daily life around the propellers of speed boats or ocean liners, as well as in hydroelectric turbines and pumps. Very intense cavitation can be generated in liquids by ultrasonic generators, of the kind used in ultrasonic cleaners and cell disintegrators, at frequencies up into the megacycle range. Cavitation, as we shall see, is a characteristic feature of any sonochemical reaction.

Recently it was shown by a team consisting of Anbar, Israel Pecht, and Alfred Weissler of AFOSR that the phenomenon of sonolysis can be demonstrated in a variety of liquids other than water. In nonaqueous systems, sound waves not only decompose the solvent itself but bring about chemical reactions with dissolved gas, as well as secondary reactions with nonvolatile substances in solution.

What, then is the mechanism of sonochemical reaction? How, in other words, is the mechanical energy of sound waves converted into chemical energy?

Energy may be transferred to a molecule by three pathways. First, mechanical energy may be acquired by collision with another, fast-moving molecule. If energetic enough, this process may eventually transfer enough kinetic energy into the molecule to produce vibrational excitation, leading to cleavage of chemical bonds. As the available mechanical energy of molecules depends on temperature, this is the classical, thermal method of inducing chemical reactions.

Secondly, electromagnetic energy (in the form of photons of an energy that is characteristically absorbed by a given molecule) can serve to excite

the molecule and, in certain cases, to disrupt it, in which case we speak of the reaction as photolysis and the molecules as photosensitive.

In a third process, the energy of fast-moving charged particles, such as electrons or protons, may be transferred by electrical interaction with the electrons of molecules, causing excitation and ionization. Ionization, which implies the release of an electron, is itself a chemical reaction; in a suitable solvent the electron itself will dissolve as a hydrated or solvated electron. The electronic excitation may then be transformed into vibrational excitation, leading to the breaking of chemical bonds. This third process, then, is the mechanism of radiolysis of molecules by fast electrons or other charged particles.

Anbar has shown that in the sonolysis of aqueous solutions there is an absence of hydrated electrons, while photosensitive materials in solution show no particular instability. These results seem to exclude both the photolytic and the radiolytic pathways in the sonochemical process, leaving us with the first, the classical thermal pathway, to explain the reactions caused by sound.

It still remains to explain how the mechanical energy of an ultrasonic wave (which, when expressed in terms of pressure, amounts merely to a few atmospheres) can accelerate individual molecules to velocities so high that a collision will break a strong chemical bond like the O-H bond in water. Kinetic energy of this order corresponds to temperatures of several thousand degrees, or pressures of many thousands of atmospheres.

The clue can be found in cavitation—in the microscopic cavities formed throughout a liquid by the action of sound waves. As noted earlier, no sonolysis is observed unless cavitation is also present. If a bubble containing some gas or vapor is formed in the liquid and is then compressed very rapidly, the gas within it will be heated to an instantaneous temperature of thousands of degrees. The hot gas, which will also contain any volatile components in the system, may now undergo rapid chemical reactions. Thus we can see why volatile substances in solution undergo extensive sonolytic decomposition, while nonvolatile ones (which will not be present in the cavities) are involved only in secondary reactions with some of the reactive products formed within the cavities.

We may now describe the sonochemical behaviour of water in greater detail. Water is chosen as an example because it is the liquid which has



been studied most thoroughly, but analogous behaviour is to be expected from any other liquid undergoing sonolysis. Let us first consider pure water containing argon, a chemically inert gas, in solution. Once cavitation has been initiated by mechanical vibrations, bubbles begin to form and collapse. The lifetime of each bubble is equal to the duration of a single cycle—10 microseconds in the case of an ultrasonic wave of 100 kilocycle/sec. frequency.

If we follow the life cycle of one of these bubbles, we find that it grows from an initial diameter of a fraction of a micron to a final size a hundred times larger. During this period argon, together with some water vapor, diffuses into the bubble, which initially was a vacuum. By the time the expansion half-cycle is over, the bubble has grown to its maximum size while building up some internal pressure of gas.

During the second half-cycle compression takes place, and as the time interval is so short the buildup of pressure, which may amount to thousands of atmospheres, is accompanied by a precipitous rise in temperature. The time of compression is much too brief to allow dissipation of the excess heat.

At such high temperatures the water vapor inside the bubble heats up to such an extent that it partially decomposes to hydrogen and oxygen atoms, as well as to OH radicals. Most of these fragments recombine rapidly to give water, molecular hydrogen, hydrogen peroxide and molecular oxygen. Some of the hydrogen and OH fragments do not manage to recombine before the cavity reaches the point of collapse and are therefore released into the bulk of the liquid.

These fragments are extremely reactive, and they will react rapidly with any substance in solution, organic or inorganic, that is capable of oxidation. Thus one may oxidize formate ions ( $\text{HCO}_2^-$ ) to carbon dioxide, ferrous to ferric iron, or cuprous to cupric copper; or one may disrupt amino acids or hydroxylate aromatic compounds.

If now the water is first saturated with a reactive gas or volatile compound, before sonolysis, this will participate in the high-temperature reactions taking place with the cavities. Thus oxygen will produce  $\text{HO}_2$  radicals and ozone molecules; nitrogen will yield  $\text{NO}$ ,  $\text{NO}_2$  and  $\text{NOH}$  radicals, which lead in turn to nitrogen fixation in the form of nitrites and nitrates; carbon dioxide will yield formate ions; and so on. Volatile organic com-

pounds undergo complete fragmentation under the same conditions; thus methanol may yield hydrogen, carbon monoxide and carbon dioxide, as well as methane and ethane.

We may thus picture a sonolysed liquid as a heterogeneous system wherein small centers of very high temperature exist in transient gas bubbles dispersed in a liquid medium. Ordinarily, the primary chemical processes take place only in the gas, and are therefore of a transient nature; whereas slower secondary reactions may eventually follow in the liquid.

There is, however, a specific case where sonochemical processes take place directly in the bulk of the liquid. It is in the degradation of high polymers, which are split up into polymers of lower molecular weight by ultrasonic action—most probably by the direct mechanical stresses of the violent implosions that occur when the cavities eventually collapse.

When sonolysis is carried out on a small laboratory scale, with an ultrasonic power input in the range of 100 watts into a volume of roughly 100 ml., the chemical yield of the various products is rather small, of the order of millimoles per liter per minute. Thus, the efficiency of conversion from mechanical to chemical energy is quite low. Although this poor efficiency may be discouraging from a practical standpoint as a means of synthesis, sonochemistry nevertheless has far-reaching implications.

The outstanding feature of sonochemical processes is the occurrence of chemical reactions at extremely high temperature in a gas phase that remains within a liquid environment at ordinary temperatures. The combination of high-temperature shock waves with free radical chemistry in solution—each a method of synthesis in its own right—has no equivalent in the world of chemistry. Moreover, the extremely short interval between the sharp rise in temperature inside the cavity and its total collapse provides a remarkably effective means of trapping or “freezing” a substantial part of the transient products of the hot gas in the much colder liquid.

These conditions, which are not available to the chemist in ordinary circumstances, lead to unusual results. The oxidation of molecular nitrogen by water is an outstanding example of a reaction which is a feasible sonochemical process but which has never been demonstrated under ordinary thermal or even radiolytic process conditions. This

is, in fact, a case of a reaction that is thermodynamically impossible at room temperature, but is made possible by the rapid freezing of a system that is at equilibrium at a temperature around 6,000° C. Sonochemistry is by no means just a chemical process in a system heated by a transducer instead of a bunsen burner.

What, then, is the importance of the current research on sonochemistry? It might well be said that an understanding of sonochemistry is the key to the understanding of numerous chemical changes which take place around us in everyday life. Sonochemistry is indeed a common phenomenon, not a laboratory curiosity. The conversion of mechanical into chemical energy, although rather inefficient, is much more commonplace than are, say, radiolytic processes.

There are many instances where mechanical agitation of a medium induces cavitation. Outstanding examples are provided by sea waves and waterfalls which, it has recently been suggested, are responsible for nitrogen fixation—a matter of great significance for life in the oceans and rivers. It appears that a substantial fraction of atmospheric nitrogen undergoes fixation by sonochemical processes in addition to the classical methods of bacterial fixation. A significant portion of the hydrogen peroxide found in natural waters may also be of sonochemical origin.

Another commonplace example of sonochemistry at work can be found in the intense corrosion and erosion caused by cavitation on the propellers of ships. Furthermore, the sonolysis of pure organic liquids indicates that hydraulic and lubricating fluids which are subjected to intense mechanical vibration, may be broken down. Indeed, sometimes sonolysis may be the major factor in the deterioration of these fluids, a subject of considerable importance to the Air Force. Although the mechanochemical conversion efficiency is low, enormous amounts of mechanical energy are involved over the long period of service of such fluids.

In the case of fluids which are inherently highly unstable, such as liquid explosives, sonolysis induced by mechanical agitation may contribute substantial amounts of free radicals, which in turn may act as chain initiators and thus lead to explosion. The invention of dynamite by Alfred Nobel was a way of avoiding the disastrous consequences of sonolysis in nitroglycerin, by absorbing it in a solid medium.

Most of the examples given above tend to show sonolysis in destructive roles. But it has interesting possibilities as a means of synthesis. For example, sonolytically induced polymerization may, in certain cases, compete with chemically induced processes. A second example is the production of halogen atoms from pure halocarbons and their use in inorganic synthesis of special anhydrous halides. It seems very likely, too, that sonochemistry will provide us with means of making hitherto unknown inorganic compounds.

We have seen that mechanically induced chemical reactions may take place in liquids under conditions which have never been suspected. Who would expect nitric acid to be formed in air-saturated tap water when flowing rapidly through a pipe system? Although the concentrations of nitric acid formed in such a continuously flowing system are generally far below the sensitivity of existing analytical methods, we can be confident that nitric acid and hydrogen peroxide will indeed be produced whenever cavitation takes place in air-saturated water. Sonochemistry is in fact as old as the waves of the ocean and it is hard to understand why so little attention has been paid to this extraordinary chemical effect.

## *Organometallic Chemistry*

DR. ANTHONY J. MATYSZKO

The upsurge of interest in organometallic chemistry in the past 10 to 15 years has attracted many of the leading young research chemists in this country and abroad. The discovery of the highly stable ferrocene system (an iron atom "sandwiched" between two cyclopentadiene rings) in 1951 initiated intense research activity in transition metal organic chemistry. Extensive worldwide efforts in the area of catalytic applications of organometallic compounds followed the discoveries by Karl Ziegler in Germany and Giulio Natta in Italy that olefins could be polymerized in a stereospecific manner using organometallic catalysts. These developments together with the continued interest in the versatility of organosilicon compounds stimulated much of the inquiry by research scientists into the chemical character,

structure and reactivity of the organometallic system of compounds.

The Air Force has a stake in this increased research into organometallic chemistry. Compounds with metal to carbon bonds are important not only as reaction intermediates in the synthesis of new polymeric materials, which will withstand the extremes of temperature, pressure and radiation of the aerospace environment, but also as laser materials, lubricants, semiconductors, and high-energy propellant ingredients. Improved theories of carbon to metal bonding are vital to the selection of stronger adhesives for metal-to-metal bonding in the building of supersonic aircraft and missiles. There are many other perhaps less obvious, but still significantly important Air Force applications to which basic research in organometallic chemistry is highly pertinent. Recognizing the need for and significance of research in this area, AFOSR has encouraged and supported research by a number of organic, inorganic and physical chemists who have sought to uncover the mysteries of this rapidly emerging field of chemistry.

Historically speaking, compounds with metal-to-carbon bonds have been known for more than a century. In 1849, Edward Frankland set out to prepare the free ethyl radical,  $C_2H_5$ , using zinc to remove iodine from ethyl iodide, but obtained instead diethylzinc in the first recorded synthesis of an organometallic compound. A few years later, in 1863, Friedel and Crafts reported the preparation of tetraethylsilane, the first organosilicon compound. By the turn of the century a few more organometallics were synthesized. In 1938, in his first volume of "Organic Chemistry, An Advanced Treatise," Henry Gilman summarized the then existing knowledge about organometallic chemistry in less than 90 pages. In contrast, it took 300 pages to cover some of the highlights of research published in 1964, in volume I of "Annual Surveys of Organometallic Chemistry" written by Dietmar Seyferth of MIT and R. Bruce King of Mellon Institute (both are currently AFOSR research investigators). Seyferth is also editor of "The Journal of Organometallic Chemistry," a monthly publication of current research results. Two other AFOSR investigators, F. G. A. Stone of Bristol University and Robert West of University of Wisconsin, are coeditors of "Advances in Organometallic Chemistry" of which the first two volumes were published in 1964. These emerging publications, together with the several international sym-

posia during the past year devoted to this area of chemistry, are an indication of the research interest in organometallic chemistry.

A great deal of effort has gone into the chemistry of organosilicon compounds. Although silicon is a metalloid (intermediate between a metal and nonmetal), organosilicon compounds are usually included in discussions of organometallic chemistry. Silicon substances have achieved commercial importance as polysiloxane fluids, lubricants, rubbers and resins. During the past few years, with AFOSR support, Robert West at the University of Wisconsin has made noteworthy contributions to this area of chemistry. One of his research accomplishments was the synthesis and characterization of the remarkably stable azidotriphenylsilane,  $(C_6H_5)_3SiN_3$ . Although azide compounds, particularly those used as initiators and explosives, are generally sensitive to heat and shock, this azide derivative only partially decomposed when heated to over  $200^\circ C$ . West attributes this stability to a particular type of bonding (dative pi bonding) between the nitrogen and silicon atoms, made possible by contributions of electrons in the  $d$  orbitals of silicon. Subsequently, West, as well as another AFOSR investigator, Grant Urry at Purdue University, prepared the azidotrimethylsilane  $(CH_3)_3SiN_3$ , and other researchers have since reported the synthesis of polyazidosilanes. Azide compounds, which contain high percentages of nitrogen and can be handled safely, are of interest as gas generators since they produce nitrogen gas on decomposition.

West and his coworkers at the University of Wisconsin have prepared and characterized  $C_3Li$ , the first organic perlitium compound which they have named "perlitliopropyne". The compound, a red-brown solid, is prepared from methylacetylene and *n*-butyllithium.  $C_3Li$  has potential application as a catalyst for polymerization of diolefins to make synthetic rubbers and as an intermediate in the synthesis of a variety of organic compounds through substitution of the lithium atoms on the molecule. One reaction which has been successfully carried out is the following:

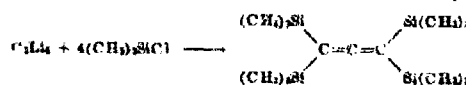

It is hoped that  $C_3Li$  is the first of a family of completely lithiated hydrocarbons. Further work in this area of research is actively being pursued.

In still another phase of the AFOSR-sponsored research at the University of Wisconsin, the first pentacoordinate species of silicon (five groups of atoms bonded to each silicon atom) bonded to three organic groups was prepared. The triphenyl (bipyridyl)siliconium ion formed (see fig. 8) might be considered as being analogous to the important carbonium,  $R_3C^+$  in organic chemistry. This pentacoordinate siliconium species should be useful in the synthesis of novel organosilicon compounds.

In another AFOSR-sponsored project on organosilicon chemistry, Malcolm Kenney at Case Institute of Technology discovered a new series of phthalocyaninosiloxane polymers in which there are six chemical bonds to the silicon atom. These hexacoordinate compounds have silicon bonded to four planar ring nitrogens in the center of a phthalocyanino ring, and two oxygens, one on either side and perpendicular to the ring.

The Si-O-Si backbone is buried in the center of the phthalocyanino ring and is well protected from attack thus accounting for the high stability of this unique polymeric material. It is not attacked when treated with concentrated sulfuric acid and it doesn't decompose at 520° C. in a vacuum. Dr. Kenney has prepared similar compounds in which aluminum as well as silicon are both incorporated into the same polymeric structure. Use is now being made of this research by the Aerospace Group of General Precision, Inc., in an effort directed toward the development of practical high-temperature polymers for the Bureau of Ships under a U.S. Navy contract.

Organometallic chemical research by Dietmar Seyferth at Massachusetts Institute of Tech-

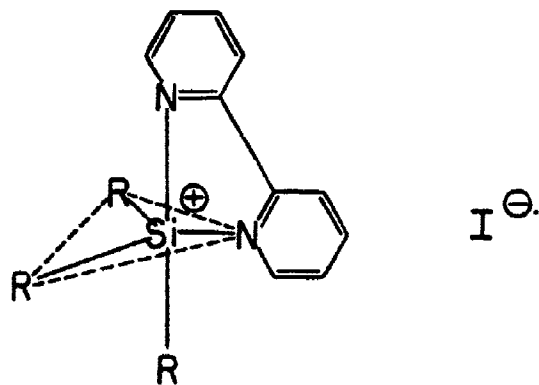

FIGURE 8.—Triphenyl (bipyridyl) siliconium ion.

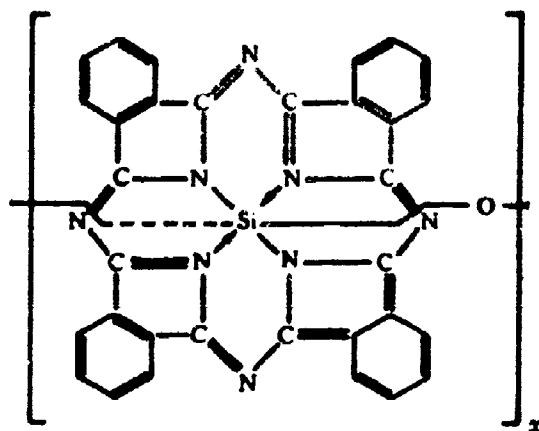
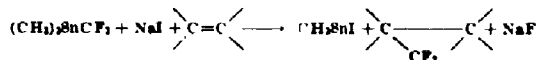

FIGURE 9.—Unit of phthalocyaninosiloxane polymer.

nology has resulted in the generation of difluorocarbene,  $CF_2$ , under the mildest conditions reported thus far. The generated  $CF_2$  reacts in the presence of olefins to form *gem*-difluorocyclopropanes in very good yield. (The *gem*-difluoro refers to the attachment of both fluorines to the same carbon atom). MIT researchers are studying the chemistry of the "extrusion reaction" which involves the decomposition of organometallic compounds containing halogenated organic substituents in which the organic portion separating a metal atom and a halogen is extruded either thermally or photochemically. For example, in the formation of  $CF_2$ , trimethyl(trifluoromethyl) tin (I) decomposes at 80° C. and  $CF_2$  reacts with the olefin in the reaction mixture to form a *gem*-difluorocyclopropane.



Sodium iodide serves to release  $CF_2$  in the reaction. The yields of product exceeded 70 percent with the olefins tried. Similar reactions tried with organomercurials, such as  $C_6H_5HgCl$ , and olefins at 30° C. gave dichlorocyclopropane derivatives in yields of more than 90 percent.

The reactions carried out by the MIT group were done in a nonbasic medium. This is particularly significant since basic conditions (or higher temperatures) are generally used in the generation of halocarbenes. However, many organic and inorganic reactants and reaction products are not stable to basic conditions. Hence the organometallic decomposition leading to these reactive

species have important advantages and should prove valuable in the synthesis of new materials, especially in the preparation of *gem*-difluoro derivatives. The mild conditions for reaction could find useful Air Force application in the dihalomethylation of residual olefinic bonds in polymers to increase their thermal stability.

At Pennsylvania State University Philip Skell and his coworkers have devised methods of selectively producing monoatomic and triatomic carbon,  $C_1$  and  $C_3$ , in the ground and excited states and reacted these various forms of carbon with organic molecules such as olefins and alcohols. This research has suggested to Skell that other molecular and atomic metastable states could be produced by low-energy electron bombardment and that the chemical properties of these substances could be studied by the techniques employed for carbon. In the carbon research the carbon was vaporized into an arc plasma in high vacuum and the labile species of carbon were trapped on the walls of the reaction vessel at liquid nitrogen temperatures. The  $C_1$  or  $C_3$  generated in this manner was then reacted with an olefin (or alcohol), and the stereochemical character of the products indicated the triplet or singlet state of the reactant carbon. Experiments with nickel and silicon indicate the feasibility of extending to other atomic species the experimental techniques which were successful in studying carbon vapor. Atomic silicon has been treated with trimethylsilane to give a preliminary indication that the expected hexamethyltrisilane,  $(CH_3)_3Si-SiH_2-Si(CH_3)_3$ , is one of the reaction products. The reactions with atomic nickel appear equally encouraging. The research is continuing and Skell hopes to study the chemical character and reactivity of the atomic species of several other metallic elements.

At the University of Pennsylvania Alan MacDiarmid is applying high pressures to the synthesis of new organometallic and inorganic compounds. Among his recent developments has been a new noncatalytic method for the preparation of  $HSiF_3$ , a useful intermediate for the synthesis of organometallics. Using pressures in the 45 atmosphere range, a purer and stabler  $HSiF_3$  can now be prepared, since the product is no longer contaminated by  $SbCl_3$  catalyst, which was used in a previous synthesis. The  $HSiF_3$  has been used by MacDiarmid to synthesize the first

example of a hydrofluorosilicate which is surprisingly stable thermally.

These are only a few examples of the many accomplishments under the organometallic research program sponsored by the directorate of chemical sciences. In a broader coverage of the subject one would include the research and accomplishments of Bruce King, formerly at the Mellon Institute and now at the University of Georgia, who has developed an international reputation as a researcher who can synthesize novel complex organometallic systems when others have tried and failed. Larry Dahl at the University of Wisconsin has done extensive work on structure identification of organometallic systems. Glenn Crosby's researches at the University of New Mexico on rare earth and transition metal chelates have been referenced on numerous occasions by scientists working on lasers; scientists at the Air Force Rome Air Development Center are interested in Crosby's work and have contributed to AFOSR's support of his research program. Also, the Air Force Avionics Laboratory has worked out an agreement with Crosby to test some of his laser materials which are of interest to the Avionics Laboratory. Norman Greenwood at the University of Newcastle and F. G. A. Stone at the University of Bristol are contributing significantly in their synthesis and mechanism studies of organometallic compounds. Several others, too numerous to mention in this report, are doing important and useful organometallic research in solution coordination chemistry, organoboron chemistry, etc. Concurrently with the AFOSR-supported research program in organometallic chemistry, it seems appropriate to mention that significant research on metal chelates and organosilicon chemistry is being carried on at the OAR Aerospace Research Laboratories at Wright-Patterson AFB.

The Air Force with its encouragement of highly knowledgeable research investigators has played an important role in the rapidly increasing store of knowledge about the chemistry of organometallic compounds. The benefits to the Air Force are many. Some of the research is already playing its proper role in technological developments. But even more important the AFOSR-supported research will have an important bearing on the solution of Air Force problems of the future. For it is from the systematic basic approach to the understanding of chemical systems, such as the organo-

metallics, that important technological breakthroughs evolve.

## Rapid Scan Infrared Spectroscopy

DR. WILLIAM L. RUGH

AFOSR has from its inception supported work in the area of chemical spectroscopy, one of the most powerful tools available to elucidate the structure of molecules. Very soon after the formation of the directorate of chemical sciences, support was given to such investigators as Kasha and Crosby at the University of Florida; Simpson, Cross, and Eggers at the University of Washington; Hexter at the Mellon Institute; Dows at UCLA, and Pimentel of the University of California at Berkeley. Pimentel wished to study the spectra of molecules, particularly those which could be dissociated by ultraviolet flash photolysis to give ionized or excited atoms. Pimentel was one of the first investigators to use the technique of "matrix isolation." In this technique the active molecules were frozen out in a matrix of intensely cold, solid, rare gas such as xenon.

Even using the technique of matrix isolation many reactive species decayed before an infrared spectrum could be obtained. The "free radicals" isolated on the matrix were of interest to the Air Force which at that time was supporting a large "free radical" project hoping to get more active species for propulsion.

To study better the infrared spectra of these species, Pimentel began to investigate the possibility of a "rapid scan" infrared spectroscopy. After several years he achieved a breakthrough in this area by utilizing the principle of a rotating Littrow mirror. This enabled Pimentel to study not only the comparatively slow reactions in the matrix but also the infrared spectra of explosive reactions.

Pimentel, studying the flash photolysis of methyl iodide, noticed "spikes" in the infrared spectra. These he reasoned were due to the formation of a population of active iodine atoms from the dissociation of methyl iodide. Thus in an article on "Atomic Photo-Dissociation Laser," by Kasper and Pimentel, "Applied Physics Letters," 5, 231

(1964), they explain the lasing effect by showing that the energy from the reaction came from an intense high-energy xenon flash. The excited methyl-iodide molecules dissociated with bond rupture, and the resulting excited atomic iodine atoms in the  $^2P_{1/2}$  state were produced in sufficient excess over those in the  $^2P_{3/2}$  ground state to permit stimulated emission or actual coherent laser light when reacted in a suitable laser cavity.

Pimentel and his associates have uncovered evidence of laser emission in the photolysis of six other alkyl iodides. The principle of a "photodissociation laser" is that stimulated emission occurs as the result of bond rupture, although the initial energy from the photoflash is utilized to supply the energy for the excited inverted population and the resulting burst of coherent stimulated emission. In other words, the excited molecule of methyl iodide acts as a temporary reservoir for the flash energy, and the dynamics of bond rupture determine the population inversion.

The methyl iodide photolysis was then made to actually lase in a conventional laser cavity.

The explosive reaction of hydrogen and chlorine to form HCl was also found capable of lasing. In the case of the hydrogen-chlorine reaction, the energy is essentially derived from the heat of the chemical reaction itself and not the flash.

The two chemical lasers discovered by Pimentel resulted from the use of a new tool or instrument he and his colleague, K. C. Herr, developed. This instrument is the rapid-scanning infrared spectrophotometer constructed by Pimentel with AFOSR funds. The heart of the instrument is an extremely sensitive, ultrafast-response, zinc-doped, germanium detector and a highspeed (10,000 r.p.m.) rotating Littrow mirror. These elements, combined with a conventional Perkin-Elmer spectrograph and an oscilloscope display tube have achieved scan rates of  $1,000 \text{ cm}^{-1}$  per 100 microseconds through the region  $5,000\text{--}650 \text{ cm}^{-1}$ .

The spectrophotometer makes possible for the first time infrared studies of extremely fast reactions occurring after flash photolysis. hitherto studied only in the ultraviolet, visible, and near-infrared due to limitations of the photographic plate. The fastest previously described infrared spectrometers either scanned an equivalent region at a rate 100 times slower, or a narrow region of 30 to 40  $\text{cm}^{-1}$  in a comparable time.

This instrument has successfully demonstrated its applicability to rapid-scan infrared spectroscopy.

copy in studies of transient phenomena. Both the identification of short-lived chemical intermediates, produced photolytically, and the kinetic study of systems reacting on a microsecond time scale have been studied. Preliminary emission spectra give promise of chemiluminescence scans prior to equilibration of vibrational degrees of freedom. A variety of other possibilities suggest themselves, such as the investigation of transient species produced by the fast mixing of reactants, by shock waves, and by flash heating techniques. Currently, important problems of intermolecular energy and intramolecular energy transfer can also be attacked by this new technique.

The most spectacular effort to which the rapid-scanning infrared spectrophotometer has been applied is the discovery of the chemical lasers already discussed. The use of this tool in surveying chemical reactions for their laser potentialities depends upon suddenly developing a peak under certain conditions where coherent light emission occurs.

After stimulated emission is indicated, the reaction can be made to take place in a suitable laser cavity, and true coherent laser emission obtained.

The advantage of an efficient chemical laser to the Air Force is obvious. It frees the airborne or spaceborne from the tremendous weight penalty necessary to utilize ordinary flash-activated lasers. Electrical flash-operated lasers need ponderous banks of condensers and heavy electrical generating systems necessary to supply the flash energy. Now that the chemical laser is a reality, it remains for further applied research to find either more powerful laser-producing reactions, or to discover chemical reactions which can give multiple flashes for other practical applications of Air Force interest.

#### REFERENCES

- (1) Kasper and Pimentel. *Appl. Phys. Letters* 3, 1, p. 231 (1964).
- (2) Pimentel. *Sci. Am.* (6 Apr. 1965).

## Life Sciences

### *Simulation as a Social Science Research Tool*

DR. HERMAN J. SANDER

Simulation as a social science research tool for studying complex organizations in a laboratory setting has come into its own since the late 1950's. A simulation is a model, and may be thought of as a social science activity seeking to create representations of complex systems, as for example, an international or social system.

A model may represent a system or process pictorially, as by a diagram, flow, or organizational chart; verbally, through a system of interrelated propositions; mathematically, through a symbolic set of relationships; and through simulation (1). The simulation model differs in that it is an operating model. Once the variables have been selected for representation, and the relations between them are specified, the model is put into operation. It may operate by having people play roles and interact with each other, by means of a computer, or a combination of both.

Some of the better known subjects are electoral systems, simulation of small groups or units in training or action, simulation of organizations or suborganizations under stress or crisis management, and simulation of international systems. Simulation is more than an instructional method; it is proving useful in helping build a body of knowledge of social and international systems and processes. It is helping social scientists to formulate theories that explain and predict group behavior, and to permit study of an operating system whose concepts cannot be tested experimentally, as for example, national organization.

Two types of highly useful simulation have been pioneered with AFOSR support. These are the Inter-Nation Simulation (INS) at Northwestern University under the direction of Harold Guetzkow and his associates, and now called Simulated International Processes; the other is work under Eugene Haas at Ohio State for laboratory study of organizations under crisis stress.

Although the early pilot run of the INS in 1958 was privately supported, AFOSR gave basic support from 1959 to 1964 (2). INS was an operating, live model of people and computer programs designed to represent the interactions between a world of five or more fictitious nations. In the simulation, a "nation" is created by setting up programmed characteristics and resources plus a number of defined roles and people to fill them. Three such roles are central decisionmaker (chief of state), external decisionmaker (foreign minister), and internal decisionmaker (congressional leader). The CDM is the leader of the nation, but he may be replaced if his policies and practices do not satisfy a validating index supplied by a computer program. Other computer programs provide economic constraints and levels of technological development for each nation. In each run of a simulation, the people who occupy the roles of the various decisionmakers are allowed to operate with considerable freedom and carry out plans and strategies over a wide range of alternatives. They may form alliances, found international organizations, become aggressive or conciliatory as they wish. They are able, within realistic constraints, to determine their own fate and that of their nation in the international arena.

A simulation run operates on compressed time in which days may represent years. There are established rules set up by the experimenter in each nation for the relationship between the satisfaction of its population and the possibility for the decisionmakers to stay in office, but there are no fixed rules as to when international suspicion and tension will lead to war. The relations between nations are thus heavily influenced by the internal states of the nations. Some decisionmakers may try to increase the wealth of their nation by trade. Others may emphasize national power and prestige through military technological build-up and aid. By exchanging notes and holding conferences, the states develop alliances and treaties. Through a "world newspaper" the heads of state make pronouncements, favorable or denunciatory, about the actions of other nations.

The sense of realism provided by this type of simulation has been affirmed by many types of participants. Over the years of its operation and



development under AFOSR support, and more recently under ARPA support, INS has conducted experimental runs in which college students, foreign service trainees, foreign graduate students, military academy students, journalists, military staff officers, and foreign and U.S. diplomats were used as decisionmakers. From the reports of the investigators, these participants have generally become intensely involved and concerned with the outcome of each run.

During the development and improvement of this simulation method, various efforts have been made to use it and validate its use in a predictive way. This has been done by controlling certain inputs such as nuclear capability, or by replaying the events with actual historical inputs which resulted in a crisis.

Richard Brody adapted INS to simulate the effects of the spread of a nuclear weapons capability (3). He differentiated between nuclear and conventional weapons, whereas the standard runs had not done so. The number of participating nations was increased to seven, divided into two alliances, each dominated by a major nuclear power. During the course of the simulation the spread of nuclear capability was given to the smaller nations in each alliance by experimental intervention. His study found that after the spread of nuclear weapons the cohesion of the alliances was markedly reduced. Nations formerly partners in one alliance increased their transactions with nations in the opposing alliance, and the influence of the leading nation in the alliance was reduced. The parallels between these and what transpired between France and the United States and between China and the Soviet Union after the diffusion of nuclear capability into France and China are striking. The parallels are even more impressive when account is taken of the relative simplicity of the experimental situation, the nature of the participants, and the fact that these experiments were conducted in 1960.

Another variant of INS was used by Charles F. and Margaret G. Hermann to check the model's output and correspondence to the real world by using masses of historical data on the period prior to World War I, and simulating the events prior to the outbreak of the War (4). A related study was performed by Dina A. Zinnes of Indiana University from the historical data assembled by Robert North and his associates at Stanford University. Zinnes compared the results of 13 hy-

potheses generated by INS runs at Northwestern University with similar hypotheses utilizing the Stanford World War I data. Correspondence was found for nine of the 13 hypotheses compared, using the two data sources (5).

Under AFOSR support Dorothy Meier, Washington University, St. Louis, is currently using the Later-Nation Simulation in a contemporary events project to test the predictive power of the model. The general strategy of the study involves "setting" the model of INS to correspond to the real world situation at a concurrent point in time, and then running the simulated system ahead on a telescoped time dimension.

Since late 1964, Guetzkow and his associates at Northwestern have been conducting a further development of simulation research under ARPA support.

These studies are attempting to relate and compare the effectiveness of the INS model with other, more computerized simulations and with verbal foreign policy theories. This will include further efforts toward validation of simulation methods with the use of historical data and such techniques as have been developed by Olaf Helmer at the Rand Corp. on the use of experts for the prediction of future events.

As Guetzkow and Jensen have indicated in a recent article: "Whether or not we go to a new generation of simulation models, our understanding of the coherence and validity of existing models must be much improved. The Simulated International Processes project at Northwestern hopes that it can contribute at least in some small measure, to the unending need of tying together 'islands of theory' generated by verbal and simulation research." (6)

INS is receiving increasing attention as an effective training technique for those who participate as decisionmakers for the interacting nations, both inside and outside the federal government. In major educational institutions, the simulation method is being used in the teaching of international relations and the graduate instruction of foreign service trainees. Some military service academies and war colleges are experimenting with adaptations of it for the training of senior cadets and staff officers. A special kit has recently been published which was designed for high school and college undergraduate instruction in international relations (7).

Thus the early AFOSR sustained support of the program at Northwestern University has made possible the development of a man-computer social science research technique which will have wide application in education and research as it is further adapted and developed in the years to come.

Initial support was given in 1964 to Eugene Haas and his associates (T. E. Drabek and E. L. Quarantelli) at Ohio State University for study of organizations under crisis stress. Traditionally, field studies had been the major research device used by social scientists for analyzing complex organizations, whether these were operating under normal conditions or under the demand of a disaster situation. Such field studies (supported by OGD-Army) are also conducted by the Ohio State Disaster Research Center. Emergency research teams were assembled and trained in 1963. These have moved into disaster areas as soon after the event as possible to interview organizational leaders.

The early postdisaster field studies indicated that the stress on organizations in a community immediately after a disaster is due to the fact that increasing demands upon certain organizations such as the fire, police, or public works departments, will exceed their capability to meet the demands. As organizations attempted to cope with sudden change in demands and capability brought about by disaster, it was noted that there were certain changes in performance structure. For example, following the Alaskan earthquake in 1964 the decisionmaking pattern in the Anchorage Public Works Department was significantly modified. Many decisions were made at much lower levels than they would normally have been. Lines of authority were "breached" as upper echelon officials went directly to specialists or foremen for current information and advice.

In order to test experimentally how certain organizations respond to various levels of demand in a crisis situation, and how their performance pattern changes, Haas and his associates contrived an instrumental laboratory setting for the simulation of a crisis situation in which all factors could be under control, observed, and recorded. The communication system of a metropolitan police department was selected as the system to be simulated. All three shifts of personnel from the police radio room participated in three normal laboratory sessions, in which demands on the sys-

tem were markedly changed through a simulated report of the "crash of a large aircraft into an apartment house complex." The experimenters trained a special group of assistants to take positions of cruiser operators and telephone callers using language identical to that to which police officers in a headquarters were accustomed. Exact replication of the characteristics of input calls, skill in the use of police radio jargon, and the physical layout of the laboratory, created a simulate which behaved exactly as its real counterpart. The principal investigator reported personally to the writer that the police group found the stress situation so real that they could think of nothing else for several hours after the simulation session.

Although this was the first attempt at this type of simulation by the Ohio State University DRC or, for that matter, by any other research organization, the results are considered quite encouraging. The laboratory simulation method used was found to be feasible and the experimental setting was surprisingly realistic. Substantively, the major hypothesis was supported: If there is organizational stress, then there will be change in organizational performance structure. Furthermore, the four types of change in: rate of task performance, priority order of task selection, rate of decisionmaking and frequency of interpersonal contact, were found to correspond roughly to the predictions made from postdisaster field observations.

Theoretical refinement of this type of simulation and analysis of organizational response to crisis stress will continue under AFOSR support. It is anticipated that by continual testing of the results of future experiments against the real world: further revising, refining, and retesting, a theoretical model will emerge that may permit an increasingly better prediction of organizational responses to various forms of stressful situations.

#### REFERENCES

- (1) H. Guetzkow, C. F. Alger, R. L. Brody, R. C. Noel, and R. Snyder, "Simulation in International Relations: Developments for Research and Teaching," p. 190 (Prentice-Hall Inc., 1963).
- (2) *Ibid.*, Acknowledgments.
- (3) R. A. Brody, "The Spread of Nuclear Weapons and Alliance Stability: An Experiment" (AFOSR 5507, February 1963).
- (4) C. F. and M. G. Hermann, "The Potential Use of Historical Data for Validation Studies of the International Simulation: The Outbreak of World War I

as an illustration" (Northwestern Univ., August 1962).

- (5) D. A. Zinnes, *World Politics* 18 (1966).
- (6) H. Guetzkow and L. Jensen, *Background* 9 (1966)
- (7) H. Guetzkow and C. Cherryholmes, "Inter-Nation Simulation Kit" (Chicago: Science Research Associates 1966).
- (8) T. E. Drabeck, "Laboratory Simulation of a Police Communications System Under Stress" (AFOSR 65-1714).

## Visual Perception

DR. GLEN FINCH

When walking, man is provided with information through a number of sensors about how fast he is moving, whether he is speeding up, slowing down, going uphill or downhill, how rapidly he is approaching an object, or how fast he is closing with a moving object, estimation of relative size and distance of objects, appreciating which direction is up and which direction is down, as well as identifying many other features of his environment. With mechanical transport, some of the sensory inputs previously available are rendered ineffectual. He can no longer make effective use of the sensory organs of the muscles, joints, and skin. Under conditions of weightlessness, the utility of the vestibular input is greatly lessened. In an automobile, airplane, or spaceship, man must depend largely upon vision, audition, or upon electronic or mechanical sensors for knowledge about his movement through space and about his relationship to objects.

Until recently very little work had been done on studying perception in moving observers. One reason for this is that apparatus required to do controlled studies and to obtain objective data is quite elaborate and complex. Basic knowledge about man's capabilities of perceiving objects while moving, compensating for distortions, making judgments about size, speed, time, velocity, and acceleration is most important in designing equipment for efficient human operation. High-speed aviation and aerospace travel impose on the human operator perceptual requirements of a different order than those encountered when man moves at slower speeds. A man-machine transportation system should be designed so that man's

perceptual inadequacies can be compensated for with mechanical-electronic devices and optimal use made of his perceptual-motor capabilities. It is only by study of perceptual functions in dynamic situation and with reduced or distorted perceptual cues that important human capabilities and limitations can be identified. Engineers, if supplied with specific information about man's capabilities and limitations, can develop devices that can enable man to function effectively under extreme conditions. One danger that has to be avoided is the providing of the operator with unneeded information, information that the operator cannot process, and to which he cannot react.

The behavioral sciences division of AFOSR has supported a number of related research projects in the area of perception. Six of these will be described:

(1) Richard Gregory, Cambridge University, is doing research on the perceptual efficiency of man under movement conditions.

(2) Sanford J. Freedman, Tufts University, is doing research on the effects of prolonged and unusual stimulus conditions on human performance.

(3) Joseph M. Notterman, Princeton University, is studying the effects of spatial and temporal cues on the detection of differences in velocity and rates of acceleration.

(4) Gosta E. Olsson of the University of Stockholm, is attempting to derive the relations between subjective estimates of space, time, and velocity.

(5) Franz Thurner, University of Innsbruck, is studying artificially disturbed sensory coordination in man.

(6) Edward Taub, Isaac Albert Research Institute, is studying the effects of surgically eliminating body, muscle, and joint sensitivity in Rhesus monkeys.

Gregory has constructed an electrically driven carriage running on rails in a dark tunnel. Subjects can be moved on this carriage at a constant speed. He also uses a large parallelogram swing which can introduce horizontal acceleration forces (1).

The research so far has involved the measurement of visual size constancy during movement (2). A simple shape, such as a circle, which can be continuously adjusted in size, is presented to the subject. Its size is varied as the observer is carried on the swing or railway away or toward it, and it is changed so as to appear to him constant in size. If there were no size constancy operating,

the display would have to be increased in size, with increasing observer distance, so that the retinal image would remain constant in size. This would require a reciprocal function. If the size constancy were perfect, no change in the display size would be required for it to appear constant. Any kind of added information about his movement increases the subject's constancy index and reduces variability of the measures. In the case of complete darkness and no acceleration, there is no evidence of any constancy and the variability is high. Under these conditions, observers are unreliable—and these are essentially the conditions prevailing for the astronaut. Very slight increase in information (proprioceptive or visual) of observer movement improves constancy dramatically.

Size constancy is greater for forward than for backward movement. Constancy is affected by the subject's perception of what is moving—the viewed objects or the observer. Largest objects are usually perceived as stationary. In space conditions, the apparently largest objects may be surrounding equipment or other astronauts. If they are perceived as stationary, it may be anticipated that considerable errors in judgment of size and distance may occur.

A person's perception may be misleading if the cues are contradictory. Under such conditions, impossible geometric figures may appear as real objects. As an example, a cube made of wire, painted with luminous paint, suspended on a cord, and viewed in total darkness, will be perceived in various ways that do not correspond to the true physical stimulus. The front and back faces of the cube will seem to alternate in position; sometimes the nearer face will seem to be farther away and the farther one will seem nearer. The same sort of spatial distortion is likely to happen to astronauts viewing the structural elements of their space station. They would receive no more cues to the distance of different parts than one receives from the luminous wire cubes.

Depth perception can become reversed when cues are limited. When this occurs, objects become distorted. For example, a cube might be perceived as a truncated pyramid. Conditions of limited stimuli may lead to the perceiving of optical illusions and impossible geometrical figures.

Freedman has conducted studies that show that adaptive compensation for misleading information transmitted through one sense modality may lead to temporarily maladaptive behavior mediated by

another (3). This suggests that spatial orientation is a function of the central nervous system. Manipulation of one channel of information may so disrupt the orientation function that effects occur in behavior control led by another sensory channel. Loading the visual inputs with rearranged information, and forcing compensation, may produce a visual-motor shift by disturbing the orientation function as a whole; therefore, effects appear in auditory direction finding as well.

Notterman has worked for the last 8 years on a program of research on the perception of dynamic stimuli. The major objectives of this research have been to provide some understanding of the capability of organisms to perceive stimulus magnitudes that vary as a function of time. The basic datum is the precision of discrimination of time-derivative changes in stimulus magnitudes. Of primary concern is whether any generalizations may be made regarding these processes across various stimulus modalities and dimensions.

The specific objectives of Notterman's research revolve around several basic questions. The first is concerned with a comparison of the levels of precision in the perception of time variant changes for two major classes of stimuli: Topographic and kinetic.

Second, the research is not restricted to examination of discriminative acuity for first time-derivative stimulus changes (velocity). Information is also being collected on how difference thresholds are affected at higher time-derivatives of stimulus magnitudes (acceleration). Rate discrimination depends upon rate of change, duration, and total stimulus change. Information is also being collected on the influence of cultural variables.

Ekman's research focuses on psychophysical relations in adaptation processes (5). His research has resulted in numerous published research reports which are widely recognized as important contributions to the body of scientific material in the fields of perception. His work has dealt with dark adaption (6), olfactory adaptation (7), perceptual dimensionality (8), subjective distance and emotionality (9), subjective scales of number (10), discrimination of roughness and smoothness (11), psychophysical scaling (12), and discrimination and preferences of saltiness and sweetness (13).

Thurner, a young psychologist working in the Institute for Experimental Psychology at the University of Innsbruck, Austria, received his Ph. D. at Innsbruck but is also American trained (A.M.,

University of Georgia). The Innsbruck Institute is recognized as one of the most productive European psychological research institutes. Its director is the distinguished psychologist, Ivo Kohler. Thurner is collecting data on difference-thresholds for visual-motor coincidences, orientation learning of displaced perceptual systems, and ability as related to adjustments to disturbances of the visual systems.

Taub (14), experimenting with monkeys as subjects, has collected data that call into question many of the theories about the significance of bodily sensory input (from skin, muscles, joints, and internal body). Dr. Taub has demonstrated that monkeys can be retrained, after being deprived of these sensory channels, to walk, climb, pick up small pellets, and even to compensate in reaching for food when his hands are masked and when the visual image of the food is displaced by his looking through prisms.

Taub's research may lead to important applications in the retraining of persons who have undergone spinal and other nerve injury, and in the development of new physical therapy techniques. Perhaps more important, this research is leading to a better understanding of the way in which the components of the total sensory system interact.

The program of research on perception that is sponsored by AFOSR is leading to the discovery of many principles and new data that are important to the design of Air Force weapon systems in which the operators' perceptual capabilities and limitations must be correctly assessed in order to achieve an optimal integration of man and machine.

#### REFERENCES

- (1) R. L. Gregory, *Nature* 207, p. 16 (1965).
- (2) R. L. Gregory and H. E. Ross, "Perceptual and Motor Skills" 18, p. 3 (1964).
- (3) R. Held and S. J. Freedman, *Science* 142, p. 455 (1963).
- (4) F. J. Mandriota, D. E. Mintz, J. M. Notterman, *Science* 133, p. 437 (1962).
- (5) G. Ekman, *Vision Research* (to be published, 1966).
- (6) G. Ekman, J. Hosman, B. Berglund, *Rep. Psychol. Lab., U. Stockholm* (in press, 1966).
- (7) G. Ekman, B. Berglund, U. Berglund, T. Lindvall, *Rep. Psychol. Lab., U. Stockholm* (in preparation, 1966).
- (8) G. Ekman, *AFEOAR 62-76 Final Report* (1965).
- (9) G. Ekman and O. Brattisch, *Acta Psychologica* 24, p. 430 (1965).
- (10) G. Ekman, *J. Psychol.* 45, p. 287 (1958).

- (11) G. Ekman, J. Hosman, B. Lindstrom, *J. Exper. Psychol.* (in press).
- (12) G. Ekman (in W. A. Rosenblith, Ed., *Sensory Communication*, p. 35, New York: Wiley (1965)).
- (13) G. Ekman and C. Akesson, *Scand. J. Psychol.* (in press).
- (14) E. Taub, S. J. Ellman, A. J. Berman, *Science* 151, p. 503 (1966).

## Instructional Technology

MAJ. LAURENCE G. GOEBEL

In the indoctrination and training of military personnel a continuing search has been made over the years for better and more efficient techniques of instruction. Unquestionably, our existing methods and material have been effective in producing well-trained airmen and officers; however, we have always been aware that through research we might be able to exploit a great deal more of the military man's potential performance capability, while at the same time reducing the amount of time required to bring him to peak performance. In the Air Force, where more than 500,000 people are being trained in about 2,000 courses annually, reduction of training time by as little as a week could provide a tremendous additional pool of available, contributing manpower without increase in personnel strength. (1).

The foundations of Air Force research on improved instructional technology were laid during World War II in the Army aviation psychology research program when the critical needs for trained officers and airmen stimulated rapid development of instructional devices such as training films, film strips, simulators, mock-ups, models, and abbreviated training manuals. Although certainly significant, much of this development was more opportunistic than scientific—designed to meet the needs of the moment and, essentially, based only on modifications of the existing known technology. Following World War II, opportunity was provided to initiate and apply a more systematic research approach to military education and training problems. An extensive basic research program in learning, together with a well-planned applied research effort on training devices gradually evolved.

During the period 1950 to 1957 the Training Research Laboratory of the Air Force Personnel and Training Research Center was a fountainhead of creative research and technical development in the areas of learning and instructional technology. Scientists such as A. A. Lumsdaine, R. Gagne, N. Crowder, L. Briggs, R. French, and others developed a whole series of instructional devices, including the "subject-matter trainer," which is often cited as one of the first teaching machines (2). During this period, while studying the problems of training for electronic troubleshooting, N. Crowder developed his system of instructional programming called "intrinsic programming," one of the two fundamental techniques now used in programmed instruction materials. The productivity of this training research laboratory is attested to by the professional reports which were issued. Of the 224 papers listed by Lumsdaine and Glaser in their 1960 compilation of reports on teaching machines and programmed instruction, 28 percent were products of the Air Force laboratory (3).

When the Air Force Personnel and Training Research Center was discontinued in 1957, responsibility for applied research in training was assigned to Wright-Patterson AFB. The Air Force Office of Scientific Research, Directorate of Life Sciences, assumed responsibility for supporting the more fundamental studies of learning and related processes in human performance.

AFOSR developed a discriminating approach to its selection of contract and grant proposals which would insure that the studies supported would not only contribute significantly to a scientific development of military education and training techniques, but would also promise early payoffs. One of the most outstanding actions was AFOSR sponsorship of a symposium on the art and science of teaching verbal and symbolic skills which was held at the University of Pennsylvania in December 1958.

Prior to the University of Pennsylvania symposium very little attention had been given outside of the applied research and development on military training devices to an instructional technology approach in education and training research. A majority of the research being conducted was oriented to studies within the framework of existing learning theory. Until 1958 only about 15 articles had appeared in professional journals discussing the possibility of restructuring the instructional situation through technological innovation

to exploit known principles of learning. Most of these articles had been written by S. Pressey and his students at Ohio State, and two of them were discussions by B. F. Skinner of Harvard.

At the September 1958 meeting of the American Psychological Association in Washington, D.C., a conference was held on research on teaching machines. Papers were read by Pressey, Skinner, Crowder, Lumsdaine, and others. These papers and the discussions which followed provoked the idea that this instructional technology approach in research might prove to be a most fruitful avenue to more efficient education and training. The AFOSR decided to sponsor a symposium which might serve as a soundingboard for these new ideas.

Funded by AFOSR, the symposium was held on 8 and 9 December 1958 at the University of Pennsylvania, with Eugene Galanter acting as chairman. Among the participants were S. L. Pressey of Ohio State; B. F. Skinner, J. G. Holland, D. Porter, and S. R. Meyer of Harvard; R. M. Gagne of Princeton; L. Homme and R. Glaser of the University of Pittsburgh; A. A. Lumsdaine of the American Institute for Research, and many others. Galanter edited the papers which issued from this symposium and published them in book form.

Galanter's book, "Automatic Teaching: The State of the Art," (4) was the first major publication dealing with research on teaching machines and programmed instruction. It proved to be a best-seller, stimulating a tremendous activity among educators and research workers. The papers included served as a catalyst to new thinking on the problems of improving education and training. Interest was generated in all the military services, Federal agencies, industry, and academic institutions. Research studies increased from a handful to hundreds of individual projects throughout the country.

Following the success of this symposium AFOSR continued to support selected research efforts which showed promise of contributing to advances in military training. Among these was a contract with the American Institute for Research for studies on cueing and prompting techniques. This contract alone produced 14 professional papers and reports by Angell, Lumsdaine, and Guthrie. Gagne and Bolles, under another AFOSR contract, made an intensive study of the factors influencing the efficiency of learning

and developed three major reports which have been extensively referenced in the professional literature. Knowledge of results, which is a primary feature of the concepts underlying teaching machines and programed learning, was studied by W. I. Smith and J. W. Moore under an AFOSR grant. The results of this research formed the basis of a chapter in their book, "Programed Learning", (5) in addition to being reported in the professional literature.

#### REFERENCES

- (1) C. W. Lead, in *National Society for Programed Instruction Journal*, 5, 7 (1966).
- (2) A. A. Lumsdaine and R. Glaser, *Teaching Machines, and Programed Learning* (N.E.A., Washington, D.C., 1960).
- (3) S. V. Martorana, *The Air Force-OAR Contribution to Programed Instruction* (OAR, 1964).
- (4) E. Galanter, *Automatic Teaching: is The State of the Art* (John Wiley & Sons, Inc., New York, 1969).
- (5) W. I. Smith and J. W. Moore, *Programed Learning* (Van Nostrand, Princeton, 1963).

## Bird-Aircraft Collisions

DAN TAYLOR

The conflict between man and his environment can be a lethal affair for an Air Force pilot.

On 13 October 1966 a T-37B aircraft operating from Reese Air Force Base, Tex., performed a local weather check en route to an auxiliary field. Flying at 1,200 feet and 220 knots, the aircraft struck a large bird, which penetrated the windscreen and struck one of the pilots in the head, killing him instantly.

In March last year a fully loaded C-130 en route to Vietnam lifted off at McClellan Air Force Base, Calif. A second later it passed through a flock of starlings crossing the runway. Two of the prop-jet engines ingested birds, lost power, and shut down although the pilot managed to land safely.

These incidents highlight the growing menace of bird-aircraft collisions, which are costing the Air Force well in excess of \$10 million each year, injuries and loss of lives, interruptions of opera-

tions, and vast numbers of man-hours devoted to repair.

#### Bird Strike Characteristics

Air Force collisions with birds must be reported to the directorate of aerospace safety when damage is sufficient to classify the occurrence as an aircraft accident. The number was 53 in 1962, 70 in 1963, and 145 in 1964. In 1965, and for that year only, all bird strikes were made reportable regardless of whether damage resulted. The total was 839, nearly six times the number for the previous year. The change in the reporting procedure was made to provide a more representative history, and to obtain statistical information of value in current research programs directed at reducing the hazard. (1).

The preliminary total for 1966 is 291 bird strikes classified as accidents, following the upward trend and bearing out the grim fact that bird-aircraft collisions are increasing in frequency and cost. While separate cost accounting is not presently being performed, there are ample indications to support the \$10 million estimate. Seventy-five engines were replaced in 1965 because of bird ingestion. Damage reports cite a constant toll of windscreens, canopies, air intakes, radomes, wing and fuselage panels, flaps and landing gear, and particularly jet engines. The number of man-hours required to repair a duck impact on a B-52 wing leading edge, for example, can run as high as 100, indicating severe damage to electrical and other systems. A single bird can reduce a jet engine, costing several hundred thousand dollars, to a pile of scrap in an instant, if compressor blades are broken off and further ingested.

Using data for 1965, these patterns in bird-strike incidents are observed: (1) The birds were infrequently observed prior to impact and in almost half the incidents the kind of bird involved was not known. Small birds such as blackbirds, starlings, sparrows, and doves were most frequently encountered near airfields. Seagulls, starlings, and blackbirds were the most frequently identified species, (2) more strikes involved transports than any other type aircraft, with trainers second, (3) most encounters occurred below 1,000 feet, with a quarter of these being on the airfield itself, (4) of 839 strike incidents, 138 were on the airfield,

and 243 were within 1 mile. Of the remainder, 149 were during low-level training missions, including radar-evasion, gunnery, and navigation practice runs, (5) 109 engine ingestions were reported, requiring 26 shutdowns and 75 replacements; windscreens and canopies were involved in 178 incidents, with eight penetrations and four cases of minor injuries, (6) 694 incidents occurred within the continental United States, with 70 percent in the southern half of the country. The highest 2-month period was September-October, with March-April next highest. These periods coincide with bird migratory activity, (7) increasing numbers of windscreen penetrations in the especially vulnerable T-37 and T-38 aircraft reflect increased pilot training schedules and are receiving special attention.

While the Air Force has a mandatory reporting system, commercial and private aircraft operators may, but are not compelled, to report bird strikes. During 1966, the Federal Aviation Agency was notified of about 650 such hits. In recent years, an airliner was downed with the loss of 17 persons when it hit a swan causing a stabilizer to fail. Another airliner's engines ingested starlings on takeoff and crashed, killing 62. U.S. airlines in past years have reported an average of about 300 bird collisions a year. In 1965, as a result of FAA stress on these reports, about 650 were filed by U.S. airlines. One Canadian airline has reported that virtually every jet engine in its fleet has ingested birds (2).

Bird-aircraft collisions are definitely increasing as aircraft get larger and faster, and fly more miles each year. The problem portends even graver consequences with extremely large aircraft such as the C-5A transport entering the inventory. Supersonic aircraft add another dimension to the question, particularly the F-111, which will fly considerable portions of its mission "on the deck".

#### Countermeasures

There are many approaches to the problem. The brute force method provides birdproof windshields for aircraft ranging from the C-47 to the C-141. These will protect the pilot from hits of 4-pound birds at 500 knots. The supersonic strike is still largely an unresolved question, but there is no question about what happens when a large bird hits a small aircraft, and as yet no way has been

found to birdproof a jet engine without paying a stiff penalty in aerodynamic efficiency.

Another approach is "If you don't see them they aren't there." This may take several forms. There exists a puzzling reluctance on the part of many who fly to admit the magnitude and sometimes existence of the bird-aircraft collision problem. Pilots dislike having to make detailed bird-strike reports. Airlines dislike alarming the public. Base commanders dislike having to curtail flying schedules. Traffic controllers dislike having their screens obscured by clouds of migrating birds. More than one airport control radar has been re-engineered to reduce the return from birds when these unwanted "angels" were found to interfere with aircraft control. And in an age when a bare-footed rifleman can bring down a multimillion-dollar aircraft with a single shot, it is sometimes difficult to be concerned about seemingly non-urgent problems.

At one training base, T-37's regularly flew through flocks of blackbirds. These birds occupy a winter roost with a population estimated at 5 million, a few hundred yards from the main runways. In view of extremely tight training schedules, the toll of engines, windscreens, landing lights, and wing and tail surfaces was accepted for a time, but flying at that base has since been curtailed during the birds' travel to and from the roost at dawn and dusk. However, a more important lesson to be learned from this example is that the base was built adjoining the roost, which has existed as long as the oldest residents of the area can remember. In the New York City area, one of the sites being evaluated for a possible new jetport is located in a major waterfowl refuge.

Since most incidents occur on or near airfields, an effective approach is habitat manipulation to make airfields less attractive for birds. Standard measures, advocated by the FAA and the Air Force, include harassment from liquid propane-fueled noisemakers, shotgun shell explosive crackers, and recorded distress calls of birds; draining marshes, using herbicides and insecticides, cutting trees and grass; trapping crows and owls; and eliminating dumps and other refuse. But these are all only partially effective in view of the fact that most airfields are located in areas naturally attractive to birds, such as filled areas near water, agricultural land, and woods and forest.



### **Role of Research**

Consequently, the best hope of workable, effective solutions lies in acquiring better knowledge of the birds themselves. Bird-aircraft collisions can never be prevented entirely as long as aircraft and birds are in the air together, but the probability of such collisions can be reduced markedly. As with most conflicts arising from man's relationship with his environment, answers can come only from better understanding of the nature of the problem, and from new knowledge provided by scientific research.

The life sciences program of the Air Force Office of Scientific Research has included many studies of bird metabolism and such activities as breeding and nesting, feeding, migratory and other movements, and navigation. Other research has been sponsored on species interactions and distributions. This long-standing program provides an interesting example of the relevance of basic research to Air Force operations, and particularly of the role of scientific research in support of a technology-dependent and oriented organization such as the Air Force. While bird research has been at relatively modest program levels, the scope has been broad, and has established the Air Force as a pivotal point of support in scientific research related to the collision problem. This support also has provided AFOSR, through its researchers and membership in interagency committees, with access to the best of current research being carried on by other Federal and State agencies, universities, and private groups. Close coordination is effected with other elements of the Air Force through the Special Assistant for Natural Resources Conservation, Deputy, The Inspector General, who provides scientific liaison for Air Force wildlife management problems.

The Air Force Office of Scientific Research supports research by Dr. William J. Hamilton III at the University of California at Davis. Dr. Hamilton generally is studying the basic biology of the starling, and specifically the highly organized social and group activity of its flocking, travel, roosting, feeding, and other activities. Understanding the entire ecosystem of a given species makes it possible to learn how to manipulate it and other species more successfully. It may be said that the problem of bird-aircraft collisions is ultimately one of bird ecology.

The starling's particular refuging and dispersal activity offers insights into some of the basic mechanisms determining the movements of birds in general. The daily radiative dispersal from the roost is a pattern observed in many animals in which the population occupies a concentrated core area from which they emerge and radiate to nearby feeding areas. Because starlings flock to mutual advantage, they do not aggressively defend space, but concentrate on feeding. The same individual does not go to the same place each day, but varies the location on the basis of past successes and dietary need.

Starling populations were traced by Dr. Hamilton and his graduate students to a giant roost in the Sacramento River, from which the birds radiated each day as far as 50 miles, affecting Travis Air Force Base as well as McClellan, near Sacramento. This 50-acre roost sheltered 2 million starlings and about the same number of blackbirds. Checkpoints at 10-mile intervals revealed that concentrations of passing starlings declined gradually to 50 miles and then tailed off sharply. The starlings were found to adopt deployment strategies designed to use and gain energy efficiently. Birds which go 50 miles, taking an hour and 40 minutes each way, must obtain more energy in the form of food than those which go only 5 miles. However, the further the bird disperses, the less the competition from other starlings, and it is able to gain available food at a greater rate. This balances the extra energy cost of the greater distance traveled. At a certain distance, competition ceases, and there is no reason for birds to go further. Basic understanding of the core as a very stable, radiative system is a major step in being able to predict the biosystem problems that may arise in connection with bird dispersal, and may make it possible to cope with problems such as bird-aircraft collision in a more effective fashion, or to avoid problems before they arise. (3)

Coloration is the major difference in the heat absorption ability of all animals. Recent research by Dr. Hamilton and Frank Heppner indicates that an animal's black color may function primarily to promote the absorption of solar energy, reducing the energy "cost" of maintaining body temperature, and thus be an important advantage to an animal such as the starling which must work hard by day, but can seek shelter by night.

In an experiment to test this view, white zebra finches' energy expenditure was measured with and

without artificial sunlight. Then the same birds were dyed black and again compared. The dyed birds under light were found to use an average of 20 percent less energy, by measurement of their oxygen consumption, than when they were white, or when they were either color and lacked artificial sunlight. The same evidence is applicable to man. Dark skin coloration may increase the absorption of solar radiation in situations where energy must be expended, as at dawn and dusk in otherwise hot climates. (4)

Dr. Hamilton's work also indicates that certain aspects of bird population dynamics may be approached by computer simulation. These analyses could be based on available extensive banding and recovery data. Such investigations may lead to mathematical models that can deal with the complexity of ecological systems and suggest the relative wisdom of various control strategies. By this technique control programs can be evaluated in advance and their possible effect upon the ecosystem as a whole can be predicted. Better understanding has been obtained of factors that contribute to explosive population growth of a single species, particularly among animals that have been introduced into already established ecosystems, as was the starling in 1890. The research program also indicates that there are other introduced species that could create greater problems for aviation and agriculture than the starling, and better knowledge is needed to evaluate these species and determine factors that could trigger their population growth.

The first working conference held by ecologists on research related to the bird-aircraft collision problem was sponsored by AFOSR, and conducted by Dr. Hamilton at Davis 31 May to 3 June 1966. Attendees included administrators and research scientists viewing the question from the standpoint of the interlocking web of phenomena and processes common to most animals. They agreed that beyond the immediate scope of tactical alterations of environment and birds must come a vigorous and sustained effort involving long-range analyses of complete ecological systems. Systems analysis, including the interpretation of the role and trends of environmental manipulation by man, should be considered, with special emphasis on the trends of bird populations that may interact with potential air-travel operations.

The conference also advised that a forecast capability be developed based on studies of the timing

and characteristics of bird migration. Radar studies can provide one basis for analysis of bird movements. Modern data acquisition and reduction systems are required to permit monitoring bird movements on a continental basis. By challenging the problem with weather data, perhaps from satellites, by radar data, and information from birds that can be monitored directly, it should be possible to interpret and predict periods of maximal aircraft hazard and the location and altitude where they are most likely to occur. (5)

Work also has been supported by AFOSR on the effects of sound on bird flocks. This investigation has been carried out by G. W. Boudreau of Santa Rita Technology, Inc., using blackbird flocks. Birds have been noticed to become severely disoriented by the sounds of jet engines. Tests were performed using both jet engines and sounds created in the laboratory from statistical analysis of recorded jet engine sounds. These were observed to divert flocks of blackbirds, causing string-like flocks to break and swirl in a characteristic whirlpool action. Some birds are known to be sensitive to radar emissions as well, and both these techniques offer bird control potential.

To stimulate scientific interest in the bird-aircraft collision problem, as well as public understanding, AFOSR held an extensive display on the topic at the annual meeting of the American Association for the Advancement of Science, held 26-30 December 1966, in Washington, D.C. The exhibit was seen by a major share of the 8,000 university, government, and industrial scientists and engineers attending, and considerable press, radio, and TV coverage resulted. Included in the exhibit were a number of aircraft parts damaged by birds, together with numerous photographs. Subsequently, this display was shown to Air Force Systems Command (RTD) lab directors at a special briefing held for them on the AFOSR research programs, and the University of California at Davis has requested it for use during its annual open house.

A brochure, "Bird/Aircraft Collisions" (6), has been provided both with the exhibit and on request to a number of organizations. These include the Air Training Command, which is distributing them to each of its bases; the Assistant Surgeon General for Veterinary Services, which is sending them to each base medical and public health unit throughout the Air Force; the AFSC F-111 Systems Office; the National Research Council of

Canada, and a number of foreign nation air attaches.

There is no complete solution to the bird-aircraft collision problem. All that can be achieved is a statistical solution, a reduced probability that such collisions will occur. In all approaches to this complex question we have in fact reached the limits of our knowledge. Before further progress can be achieved, detailed studies must be made of the biology of species which have become pests and hazards, and of the economics of controls suggested by biological research. What most research thus far has shown is that man can learn to live with the problem if he can minimize it as far as practicable.

The big question mark is the birds themselves, and much more data is required, particularly of bird migration. For example, the 1960 Maryland airliner crash was caused by a whistling swan. Yet, according to one researcher, virtually nothing was known before the crash of this bird's migration to the Chesapeake Bay area, and very little has been learned since. Formerly, it was believed that birds follow rather well-defined migratory pathways. Now there is increasing evidence that birds in general, like aircraft, fly the weather, taking advantage of winds and pressure fronts, and shifting

courses to avoid disturbances and unfavorable winds. Thus migratory bird flight patterns may well be open to prediction with sufficient biological and weather information.

These are the various facets of a serious and growing Air Force and general aviation operating difficulty that today is only beginning to yield to scientific investigation, and to receive the public concern it deserves.

#### REFERENCES

- (1) "USAF Aircraft Collisions with Birds", Study Nos. 14-66, 14-65, 20-64, 21-63. Directorate of Aerospace Safety. Deputy The Inspector General. USAF.
- (2) Bird, W. H., "Bird Strike Hazards Can Be Reduced", Engineering Research and Development Dept., Air Canada.
- (3) Hamilton, W. J., F. H. Heppner, W. M. Gilbert, and R. J. Planck, "Strategies of Starlings Dispersing From a Winter Roost," in press.
- (4) Hamilton, W. J., and Frank Heppner, "Radiant Solar Energy and the Function of Black Homeotherm Pigmentation: An Hypothesis," *Science*, 13 January 1967.
- (5) "Proceedings of the AFOSR Conference on Ecological Studies in Support of the Bird-Aircraft Collision Problem," 31 May to 3 June 1966, Davis, Calif.
- (6) "Bird/Aircraft Collisions," AFOSR (SRGC), December 1966.

## Engineering Sciences

### *A Whistler Study of the Magnetosphere*

MAJ. FRANK H. ZANDER

Whistlers result from the dispersive propagation over very long paths of very-low frequency electromagnetic waves radiated by lightning impulses. The signals follow approximately the horseshoe-shaped paths of the earth's magnetic field lines. Whistlers echo from one hemisphere to the other via the outer ionosphere extending from about 100 kilometers to roughly 10 earth radii in the geomagnetic equatorial plane.

When detected, amplified, and monitored aurally, a whistler is heard as a gliding tone, usually descending in frequency and lasting about a second. The peculiar frequency versus time behavior of whistlers is the result of dispersion produced along the whistler path by the effect of free electrons acting in the presence of the earth's magnetic field.

The originating flash that produces a whistler also radiates an impulsive signal that travels without dispersion between the earth and the lower boundary of the ionosphere. Since this signal, the causative atmospheric, propagates at the speed of light and appears on the spectrographic records along with the resultant whistler, it serves as an indication, accurate to within several milliseconds, of the time of origin of the whistler. Whistlers are detected and recorded both in the hemisphere of the originating flash and in the opposite hemisphere. In the latter case the causative atmospheric signal travels thousands of miles and appears weakly defined but still indicates the time of whistler origin accurately.

Several aspects of whistler spectrographs are extremely important to geophysicists. The time delay, that time between the causative atmospheric signal and the leading edge of the whistler signal, is a measure of both the magnetospheric path electron density and the strength of the earth's magnetic field encountered. The leading edge of the whistler, that tone initially recorded, serves as an indicator of the geomagnetic latitudes at which

the whistler entered and exited the magnetosphere. As the magnetosphere is inaccessible by conventional sounding techniques, the whistler has become a powerful tool for investigating various aspects of this enormous region of space. It is suspected that the magnetosphere plays a vital role in the development of magnetic storms and auroras, the details of which still remain among the outstanding mysteries of the atmosphere.

Whistlers were first reported in 1919 by Barkhausen who observed them while eavesdropping on Allied telephone conversations during World War I. They may actually have been observed as early as 1888 by J. Fuchs of the Sonnblick High Altitude Observatory in Austria. The association of whistlers with various atmospheric phenomena and a positive correlation between their rate of occurrence and solar activity were reported by Eckersley of the Marconi Co. in 1928. Eckersley also reported an observation by Tremellen indicating an association of whistlers with visible lightning. The first quantitative measurement of the frequency-time relationship in a whistler was made and reported in 1933 by Burton and Boardman from a whistler recorded in Ireland. Eckersley, in 1935, derived a dispersion law which explained the variation of whistler frequency with time and demonstrated that Burton and Boardman's published analysis agreed closely with the new theory.

Interest in whistlers then lagged for about 15 years until Storey began his doctoral studies at Cambridge in 1951. He made a detailed experimental study of whistlers and related atmospheric signals, and identified short whistlers which were not associated with loud clicks (causative atmospheric) and long whistlers which were always preceded by a loud click. From spectrum analysis, Storey showed the difference between multiflash whistlers, each of which resulted from separate causative atmospheric, and multiple-path whistlers which resulted from a single causative atmospheric but traversed separate paths of propagation. From a theoretical study of ray paths, Storey discovered that whistler energy should be guided approximately by the lines of force of the earth's magnetic field. This led him

to postulate that these were indeed the paths of propagation.

The simultaneous observations of whistlers at spaced stations was begun by R. A. Helliwell in 1951 at Stanford and Seattle. About 25 percent of the whistlers observed were coincident at the two stations, whose separation of 1120 kilometers corresponded to the area coverage predicted by Storey. His predicted relationship between causative atmospherics in the Southern Hemisphere and short whistlers in the Northern Hemisphere was confirmed by Helliwell in 1954. Simultaneous observations of whistler echo trains at Unalaska and at Wellington and Dunedin, New Zealand, near its geomagnetic conjugate point, were made in 1955 by Morgan and Allcock. Their results fully confirm the predicted behavior. The predicted absence of whistlers on the geomagnetic equator was confirmed by Koster and Storey in 1955.

AFOSR began support of Helliwell at Stanford in 1956. The numerous results are of continuing importance to both the scientific and military communities. With a theory of propagation developed by J. J. Brandstatter and a set of calculations of whistler ray paths formulated by Irving Yabroff (both of the Stanford Research Institute), a basis was provided for explaining the absence (nondetection) of whistlers which propagate into the ionosphere along paths which are not aligned with the earth's magnetic field. The new theory predicted that such signals may deviate appreciably from preferred directions and be unfavorably oriented for repenetration of the subionospheric region. Such whistlers would not be expected to be observed at ground stations. This theory is well supported by observations of artificially triggered whistler signals.

A study of whistler sources was based on the impulses produced by nuclear explosions. From 1953 to 1962 Stanford made broadband very low frequency recordings during detonations of a large number of nuclear devices. In five cases a bomb-excited whistler was recorded at one or more receiving stations. It was found that nuclear sources produce whistlers similar in all measurable respects to those produced by natural lightning and that a whistler can be excited by a nuclear explosion located in the hemisphere opposite to that of the entrance to the whistler path. It was also discovered that nuclear explosions which take place above the lower edge of the ionosphere produce signals similar to those arising from subiono-

spheric explosions. This meant that the source of the electromagnetic impulse was in fact between the earth and the ionosphere and not at the location of the bomb itself.

In 1959 a theory was developed by R. L. Smith, Helliwell, and I. Yabroff regarding the trapping of whistlers. This important work postulated that a slight (5 to 10 percent) increase in the density of electrons in columns aligned with the earth's magnetic field was sufficient to trap completely the waves entering the ionosphere from the middle geomagnetic latitudes, hence under certain conditions whistlers would travel in preferred or discrete paths. The concept of the discrete path led to a reexamination of data recorded during the IGY. A search was conducted for "hybrid" whistlers, those which had been excited from both ends of one of the postulated paths. Several examples of hybrid whistlers were found. The theory was further confirmed by the relatively precise data obtained from two of the nuclear explosions.

The analysis of whistler spectra themselves presented many problems. The most difficult was the identification of the atmospheric source. Methods based on the use of multiple records and multiple stations were developed whereupon it became possible to achieve a relatively high degree of reliability in the identification of the source. Further, this correlation of data led to the remarkable discovery that each whistler trace provided sufficient information to define the latitude of the magnetospheric path and one parameter describing the distribution of ions and electrons along the path. Many such measurements taken at different latitudes provided a basis for constructing a model of the magnetospheric electron density distribution.

A major accomplishment by Angerami and Carpenter, under AFOSR support, was the first description of the detailed variation of electron density and total tube (field aligned column) electron content near the "knee", a region where the electron density drops from relatively high to extremely low values. For the first time it was realized that the knee involves an extremely abrupt decrease in electron density and that this decrease is essentially field aligned at about four earth radii. This implies the existence of a three-dimensional boundary or "plasmopause" in the magnetosphere, a doughnut-like shell extending around the earth and separating a dense inner region from a tenuous outer region. The presence of such an abrupt three-dimensional boundary came as a total sur-

prise to scientists since no previous theory had predicted its existence. Recently there has been confirmation of the plasmopause from satellite experiments. Measurements show that on the night-side of the equatorial plane the plasmopause electron density changes by a factor of 20 to 100 within the relatively short distance of 0.15 earth radii. Further analysis shows that this abrupt profile is normally unchanged for about 18 hours per day, there being a 6-hour period of rapid radial variation and less precise definition.

The more precise description of the plasmopause now makes it possible to identify major regions of geophysical activity in the magnetosphere, i.e., the plasmopause is also a boundary defining certain regions of noise generation both in the ionosphere and the magnetosphere. Passage through the plasmopause involves drastic variation in the noise detected by certain types of spacecraft antennas recording at very low frequencies and also affects the interpretation of certain on-board sensors. The improved knowledge of the plasmopause provides a new viewpoint on the coupling between the ionosphere and the region above.

Of no less significance is the discovery that whistlers can be used to detect magnetospheric motions. There exists no experimental method other than whistlers to map magnetospheric motions on a large scale. The whistler technique has provided the first direct experimental evidence that the inner magnetosphere approximately corotates with the earth. Recent studies have also shown that, as predicted by theory, there are radial motions in the outer magnetosphere, driven by large-scale electric fields. A number of measurements have been made of these motions, revealing inward motion of plasma on the nightside of the earth and outward motion on the dayside. A continuation of these studies should make it possible to establish an important link between the solar wind, the corpuscular flow from the sun, and the inner magnetosphere.

One of the most spectacular areas of growth in whistler research concerns the general theory of electromagnetic signal propagation in a medium such as the ionosphere, containing electrons, protons, and other species of charged particles. From a beginning in 1964 on a number of individual topics, Helliwell has developed an overall theoretical understanding that makes it possible for him to explain a wide range of phenomena, including

proton whistlers, the low frequency cutoff of common whistlers, and some anomalous behaviors of whistlers. The success of the overall theory in explaining new phenomena has led to active programs of study at the Defence Research Telecommunications Establishment in Ottawa, Carleton University (also Ottawa), and the State University of Iowa.

An important extension of previous ground-based observations was the recent experiment of Stanford University on the OGO-1 satellite which provided measurements of whistler mode signals in the outer ionosphere at altitudes greater than 1,000 kilometers. These new data yield information on total path attenuation rates. It is believed that this research will be of value in determining the usefulness of whistler mode propagation as a means of communication.

As man seeks to fly higher and communicate farther, the scientist strives to gain a better understanding of the magnetospheric medium—its physical composition, its predictable time variations, and its anomalous behaviors. The whistler provides a means for attaining this goal.

#### REFERENCES

- (1) L. R. O. Storey, *Phil. Trans. Roy. Soc. A.*, **246**, p. 113 (London, 1953).
- (2) J. H. Crary, R. Helliwell and R. F. Chase, *J. Geophys. Res.*, **61**, p. 35 (1956).
- (3) R. A. Helliwell and M. G. Morgan, *Proc. IRE*, **47**, **2**, p. 300 (1959).
- (4) R. L. Smith, R. A. Helliwell, and I. W. Yabroff, "A Theory of Trapping of Whistlers in Field-Aligned Columns of Enhanced Ionization" (TR 3, Radioscience Laboratory, Stanford Electronics Laboratories, 31 Dec. 1959).
- (5) R. L. Smith and D. L. Carpenter, "Extension of Noise Whistler Analysis" (TR 8 Radioscience Laboratory, Stanford Electronics Laboratories, 28 Apr. 1961).
- (6) D. L. Carpenter, "The Magnetosphere During Magnetic Storms: A Whistler Analysis" (TR 12, Radioscience Laboratory, Stanford Electronics Laboratories, June 1962).
- (7) R. A. Helliwell, "Whistlers and Related Low Frequency Radio Wave Phenomena" (Final report).
- (8) D. L. Carpenter and R. L. Smith, *Rev. Geophys.*, **2**, **3**, p. 415 (1964).
- (9) D. L. Carpenter, *J. Geophys. Res.*, **71**, **3**, p. 693 (1966).
- (10) R. A. Helliwell, "A Study of Wave Particle Interactions in the Magnetosphere and a Complementary Study of the Propagation Characteristics of Whistlers and Related Phenomena" (Final report).

# *A New Dimension in Hypersonic Laboratory Simulation—The Wave Superheater Hypersonic Tunnel*

MILTON ROGERS

As children we learn that shooting stars are actually small meteorites burning and evaporating as they fall at hypersonic velocities into the earth's dense atmosphere. Today, the problems of hypersonic flight through the atmosphere present great challenges to man's ingenuity.

An intercontinental ballistic missile, for example, enters the atmosphere at the end of its flight path with sufficient kinetic energy to vaporize 10 times its weight in water. If such a body is to survive atmospheric reentry, most of its energy must be transferred to the surrounding air. Successful reentry depends upon a delicate balance between heat absorption and dissipation (1).

The history of applied science and engineering is really a history of simulation—searching for methods of observing a priori the behavior of engineering systems and of varying the parameters of such systems in order to seek optimum results. The approach of the pure scientist seeking to explain observable phenomena likewise leans heavily on simulation and analogs (2). Thus from the days of Kitty Hawk to the mid-1950's man's explorations and conquests in flight were normally preceded by extensive ground test evaluation of the flight vehicle. Aerodynamic stability, performance, structural and material strength were among the many factors realistically simulated on the ground (3). However, when jet propulsion, through its ability to provide great power in a small package, exploded the power barrier to high velocities it was found that the available ground test facilities proved inadequate to realistically simulate the hyperthermal environment characteristic of very high speed passage of a body through the atmosphere (4).

It is obvious that the most direct way of testing a machine, particularly a missile or an aircraft, is to build a prototype, fly it and observe its behavior by techniques involving telemetry and recovery after each test. This is, however, a tedious, costly and frequently frustrating procedure, and al-

though this direct approach, circumventing the need for simulation, is costly in time and money, much flight research and development was successfully accomplished.

With increased velocities of atmospheric flight testing came a host of concomitant problems: telemetry blackout from the ionized plasma sheathing the vehicle, heating of structural materials, degradation of stability and control by ablation, and loss of visual contact with vehicles because of the radiance of the boundary layer and wake. Moreover, mistakes of procedure usually destroyed the effectiveness of the test or the vehicle itself. If the conditions of hypersonic flight could be brought into the laboratory, scientists and engineers would have instruments to study the problems directly.

## *Hypersonic Simulation*

The chief tool of the aeronautical engineer for the study of flight is the wind tunnel. By use of the converging-diverging nozzle, expansion of a test gas to supersonic velocities in the laboratory can be readily achieved. However, great cooling occurs in expanding gases to the very high velocities required for simulation of hypersonic flight. Cooling is so severe that actual condensation of the air to a fog of liquid air may occur. To delay this condensation, the air must be heated before it is expanded. However, the amount of heating for the expansion necessary to reach these extreme velocities without liquifaction produces gas temperatures higher in the plenum than the melting point of practical materials.

Further, temperatures required to simulate true free flight approach those of the sun surface. At mach 16 at 60,000 feet, temperatures of about 6,000° K. exist at the nose of a missile. A completely new concept of wind tunnel was required to study hypersonic flight.

The question might be asked why such high temperatures must be simulated. Does the temperature of the gas itself affect the proposed design? The answer is yes: at the temperatures encountered, near the body of a missile, air is no longer an ideal gas. It breaks down from a relatively simple mixture of nitrogen and oxygen molecules to nitrogen and oxygen atoms and molecules, oxides of nitrogen, ions, and electrons. These constituents directly affect the aerodynamics and raise many new problems in the proposed design.

Since true hypersonic flight is to be studied, it has been necessary to find techniques to simulate these conditions in the laboratory. In recent years the researcher has been offered a relatively simple tool which creates these conditions in the laboratory for a brief instant. This device is the shock tube.

Like many things which we regard as the latest innovation, it is actually quite an old discovery dating back to 1899. However, its potentialities for heating gases to extremely high temperatures have been exploited only recently. It has been established by several scientific research groups that temperatures even higher than three times that of the surface of the sun may be achieved in the shock tube.

Essentially the shock tube consists of a relatively long pipe divided into two parts, the low-pressure and high-pressure chamber. When the experiment is ready to proceed, a thin diaphragm which separates the high-pressure and low-pressure regions is destroyed. Driver gas in the high-pressure chamber then explosively rushes into the low-pressure chamber forcing the gas in the low-pressure chamber to compress suddenly, and a shock wave develops in this gas.

This shock wave speeds down the tube ahead of the onrushing driver gas, compressing and accelerating the gas in the low-pressure tube. If high enough pressure is used in the driver gas, an extremely strong shock wave can be generated. If the tube can be made long enough (in some practical applications tubes of over 50 feet in length have been employed), a "pocket" of gas which increases in size with the length of the shock tube develops ahead of the rushing driver gas.

Temperatures far in excess of those needed for hypersonic flight testing may be generated in this pocket. The temperature, pressure and velocity of the gases in the shock tube may be known to considerable accuracy. This point is important in precise physical measurement. However, the gas is still not useful for hypersonic testing, for while it is very hot its mach number is low, usually between two and three, since the speed of sound increases with increasing temperature.

An expanding nozzle at the end of the shock tube allows the gas to expand to the proper mach number. Expansion cools the test section to the desired level as the gas accelerates. Thus the gas in the test section may simulate the conditions of free hypersonic flight in the upper atmosphere. This device is called a shock tunnel.

Temperature, because of the aerophysics involved, is by no means the only important simulated parameters in hypersonic research. In most instances, pressure and density simulation are equally important. In these respects too the shock tunnel is outstanding, since after expansion of the shock-heated, shock-compressed gas through a hypersonic nozzle to a test section, it has sufficient pressure and density to simulate correctly many hypersonic flight conditions.

The chief drawback to the shock tunnel, as with "hot-shot" tunnels, is the brief testing time available (of the order of milliseconds).

#### **Hypersonic Test Facilities**

Not only is the hypersonic regime more difficult to simulate than the subsonic and supersonic regimes, but there is also an essential difference in the application of test results to the actual vehicle. In the subsonic and supersonic flight regimes, extrapolation of the results of scale-model wind tunnel testing to an actual vehicle has been accomplished very successfully by means of aerodynamic scaling laws. In the hypersonic regime, however, the aerodynamic scaling laws are more complex and often secondary to other aerophysical effects.

To complicate matters, these effects cannot be scaled in the same manner. Thus the theorists must learn how to evaluate correctly the aerophysical effects in which they are interested, using one or several test facilities. Then they must predict composite effects on a vehicle under actual trajectory conditions.

Until the development of the wave-superheater facility at Cornell Aeronautical Laboratory (CAL) the aerodynamic and aerostructural problems of very high speed vehicles had been investigated in bits and pieces. No single test facility had been able to simulate completely a hypersonic airstream so that a relatively large-scale model could be studied in detail at close range for relatively long times under precisely controlled conditions. Researchers had to laboriously piece together bits of isolated data to form a "grossly correct" picture of hypersonic flight. The wave superheater now provides a means of getting much more detailed information.

Hypersonic test facilities currently in operation fall into four general classes (5).



"Cold" hypersonic shock tunnels, in which a high-pressure gas drives a shock wave through a monatomic gas such as helium, create a hypersonic flow condition over a model for a few thousandths of a second. Mach numbers of 20 to 25 can be achieved in these tunnels. They are valuable in fundamental studies involving phenomena such as the interactions between the boundary layer and the shock waves on a vehicle. Their great limitation is that they do not produce the proper "real gas" effects, because their atmosphere is monatomic, with only one atom per molecule. Air, the gas in which we are practically interested, is diatomic, with its molecule shaped like a dumbbell. When it is heated, the air molecule not only moves about rapidly, but also absorbs considerable energy by spinning. At some point enough energy is absorbed to break up the molecule into separate atoms. Finally the atoms become ionized when an electron is broken away. These "real gas" effects, which alter the heat transfer characteristics of the airflow and cause chemical reactions (erosion) between the air and a vehicle's surface, are the primary differences between hypersonic and the slower-speed flows.

Heated nitrogen tunnels, simulate the flow of air more closely than does the helium tunnel. These facilities operate with a stagnation gas temperature of around 4,000° F.

"Hot" hypersonic shock tunnels use air as the working atmosphere and "real gas" effects are produced. The maximum test mach number of most of these facilities is 10 to 12, but some reach mach 17 or so. Testing time in this type of tunnel is measured in thousandths of a second, as it is in the "cold" tunnels, but this is long enough to record very accurate force and moment data, dynamic stability information, and heat-transfer measurements. Fast response pressure transducers, thermocouples, and other sophisticated instrumentation have been in operation long enough to build up an unassailable performance record. The larger "hot" shock tunnels have test sections around 6 feet in diameter, and they will accommodate fairly large models. The stagnation temperature of the air in these tunnels is 9,000° F. or more. The great limitation of these facilities is their short test time, which does not allow a study of air chemistry, structural ablation, and the effect these have on thickening the boundary layer, altering the heat-

transfer characteristics, or otherwise disturbing the flow around a vehicle.

Arc-jet tunnels produce a very high energy, high-temperature flow for many seconds at a time. They are widely used to study structural ablation, heating effects in large segments of actual structure, and the properties of materials in high-temperature air streams. These facilities will accommodate large models and will reproduce the temperature and heat transfer conditions which will be encountered by many types of reentry vehicles over a large portion of their reentry flight paths. The limitation of the arc-jet tunnels is that their gas streams are contaminated when their electrodes burn away. The exact chemistry of their flow is not known at any given point at any given time. Therefore, there is always a question as to whether the "real gas" chemistry is being simulated accurately.

Each of these devices has a serious test inadequacy in either time, pressure, or medium when compared to hypersonic ground simulation requirements.

#### **Wave Superheater Development**

The idea of using the wave engine, the so-called COMPLEX (6, 7) originally proposed by the Brown-Bovari Co., as the hot gas source of a wind tunnel (8) was born at the Cornell Aeronautical Laboratory in the late 1950's. The potential capability of this device for producing large flow rates of high energy, high pressure, pure air on a continuous basis was realized from the beginning and was the intent of the program.

The early calculations, performed as an internal research effort at CAL, showed such promise that the AFOSR sponsored a program (February 1956–October 1958) to build and evaluate a small prototype device. A pilot wave superheater, dubbed Little Rollo and designed to heat air to 3,000° R. (or argon to 5,500° R.), was built and tested (9). It is interesting to note that the first run with Little Rollo yielded more shock tube flow time than had been obtained with all the shock tubes in the world up to that time.

The success of Little Rollo prompted the Air Force Office of Scientific Research to initiate a full-sized wave superheater program (November 1956–May 1958). The wave superheater was de-

signed to heat air to 9,000° R. using supply air and driver helium preheaters. The AFOSR contract funded the cycle design, the rotor design and the design and purchase of the pebble bed supply gas preheaters. These programs validated the basic principles and resulted in the decision in 1959 by the Advanced Research Projects Agency to sponsor (using AEDC as the responsible agency) design and construction of the full-scale wave superheater hypersonic tunnel at the Cornell Aeronautical Laboratory (10, 11). This facility was operational in 1962 and at present is operated by Cornell Aeronautical Laboratory on a use-charge basis.

Today, the wave superheater delivers a 270 megawattsecond stream of pure air at pressures up to 100 atmospheres for test periods of 15 seconds three times a day, to a hypersonic tunnels system. Tests in the tunnels can be conducted with wind speeds up to 7,500 miles per hour (11,000 ft./sec.) over a density altitude range from 50,000 to 200,000 feet using models from 1.5 to 15 inches in diameter. The value in a ground test facility of this kind is that the gasdynamic, thermal, plasma, and optical mechanisms active in hypersonic flight situations are recreated on the ground for experimental examination, for sufficient duration to establish the conditions of equilibrium needed to check aerodynamics, aerophysical, and aerostuctural interactions.

The wave engine as conceived by the Brown-Bovari Co. of Switzerland in its COMPRES pressure exchanger is basically a compressor. The wave superheater is also a compressor wherein modern shock tube technology has been applied to a large number of shock tubes mounted on a rotating drum. The essential feature of a shock tube is that a very high speed gas piston does acceleration and compressive work on a working gas. In a shock tube, this event happens once, initiated by the rupturing of a diaphragm hence releasing the high pressure piston or driver gas, and the flow time of a shock tunnel is in the micro-to millisecond range. The energy pressures, flow rates, and gas purity are ideally suited however for simulating hypersonic flight, but the test duration is extremely short. The problem is then to extend the duration while maintaining the realized gas condition. The COMPRES concept introduces the idea of rapidly inserting, between the driver

gas supply and the hypersonic nozzle, the shock tube driven section. In the wave superheater, this is achieved by replacing the driven tube with a rotor which transports 288 driven tubes. At a high rotational speed, the rotor replaces the driven tube, preloaded with air, at a rate of 6,000 to 10,000 per second. As it turns out, about 10 shock tubes are functioning simultaneously, with each shock wave about 6 inches behind the one adjacent to it. Each shock heated parcel of air is longer than 12 inches so that the parcels, as they emerge from the rotor, lay along side each other (fig. 10). Since the only disturbance in the flow is the tube boundary layer, the flow is steady and rapidly becomes smooth as the flow expands in the nozzle (fig. 11). The fore and aft ends of the individual parcels are, of course, appropriately disposed of and are not included in the nozzle flow. After a tube has discharged its contents, it receives a coolant followed by another charge of air as it returns to the shock event. The cycle currently employed in the wave superheater is capable of continuous operation. However, the tremendous consumption of preheated, pressurized gas (50 pounds per second of helium and 12 pounds per second of air) restricts the maximum duration to 15 seconds. Four hours are then required to reactivate the system. The wave superheater can process any gas and deliver the processed gas pure and in chemical-physical equilibrium.

When operating with air, the effective reservoir, as generated, is shown in figure 12 by the solid line. A pressure loss up to 30 percent is inherent in the gas collection of the rotor discharge. The resultant effective reservoir for the tunnel systems is shown by the broken line. A gas supply flow chart is given in figure 13. To demonstrate its flight simulation capability, the free stream Reynolds number and stagnation point heat transfer to a sphere are shown in figure 14. The "flight corridor" is included to provide a base for comparison. To be sure, certain aspects of flight require the duplication of that flight condition in the facility. However, these applications require detail not possible in this brief review.

Measurements on models at test conditions have been made of forces, moments, surface pressures, surface temperatures and heat transfer, static and dynamic stability, boundary layer and wake radiation, electron concentrations, and flow structure

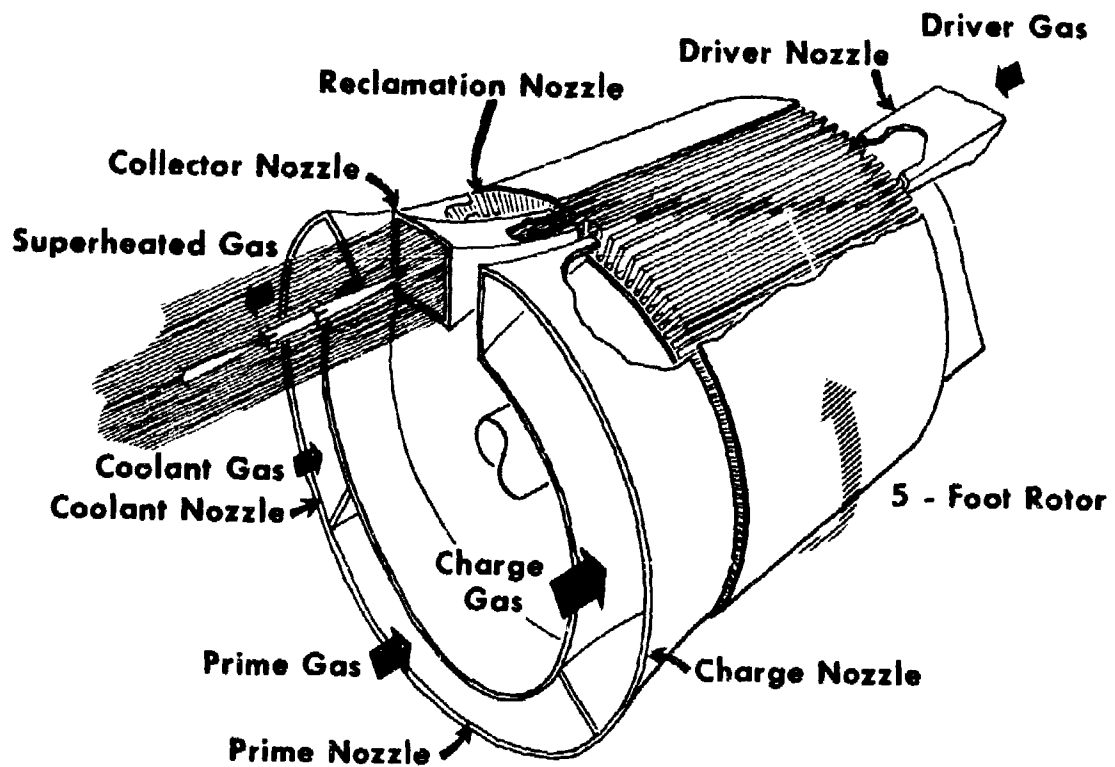

FIGURE 10.—Wave superheater rotor and nozzles.

and material ablation rate and distribution. The following table indicates measurement ranges:

Reservoir temperature.....	3,000 to 7,000° R.
Reservoir enthalpy.....	800 to 2,300 B.t.u./lb.
Model stagnation pressure....	$10^{-2}$ to 85 atm.
Free stream mach number.....	1.5 to 14.
Free stream velocity.....	3,500 to 11,000 ft./sec.
Model nose radius.....	0.1 to 6.0 inches.
Model nose heat transfer.....	10 to 7,000 $\frac{\text{BTU}}{\text{ft}^2 \text{ sec.}}$
Aerodynamic shear stress....	0.5 to 300 lb./ft. <sup>2</sup>

The test programs have been conducted both on customer funds and customer prime contracts with the Air Force, the Navy, and the Army. Among the many users of the wave superheater hypersonic tunnel have been: AVCO Rad, Boeing Aircraft Co., Conduction Co., Douglas Aircraft Co., General Electric Co., Lincoln Laboratories of M.I.T., Lockheed Missile and Space Co., Martin Co., McDonnell Aircraft Co., NASA, Sandia Corp., Union Carbide Corp., and the Whitaker Corp. More than a dozen different weapon systems and

research applications have been checked in the wave superheater.

While this list of experiments, customers, and programs is impressive, it does not show the progressive dependency of the technical community on this particular facility.

To date, the wave superheater has logged approximately 1,400 runs and since the first contract test in November of 1962, 920 contract runs for a total test time of 4,500 seconds have been obtained in it. This averages out to a typical run time of 5 seconds per run and represents a total accumulated stream power of about 22 megawatt-hours. It is interesting to note that in developing and enlarging its proficiency in the use of the facility, CAL has performed one test of shake-down-calibration type (paid for with CAL funds) for every two contract tests.

Of the 920 contract runs, 820 (about 90 percent) have been material ablation tests. About 3,700 seconds of test time were utilized in this effort.

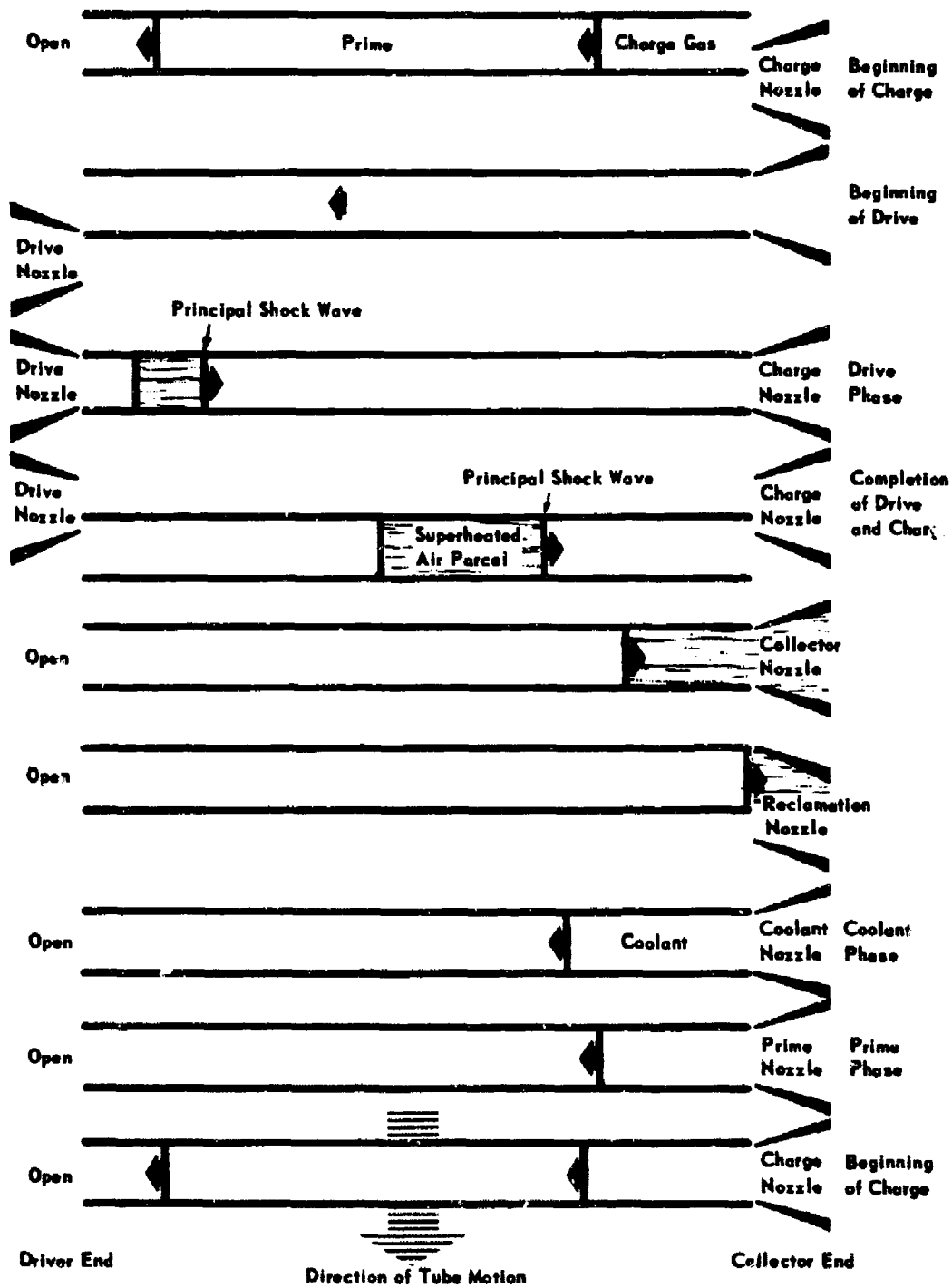

FIGURE 11.—Gas dynamic processes in a single unstricted tube.



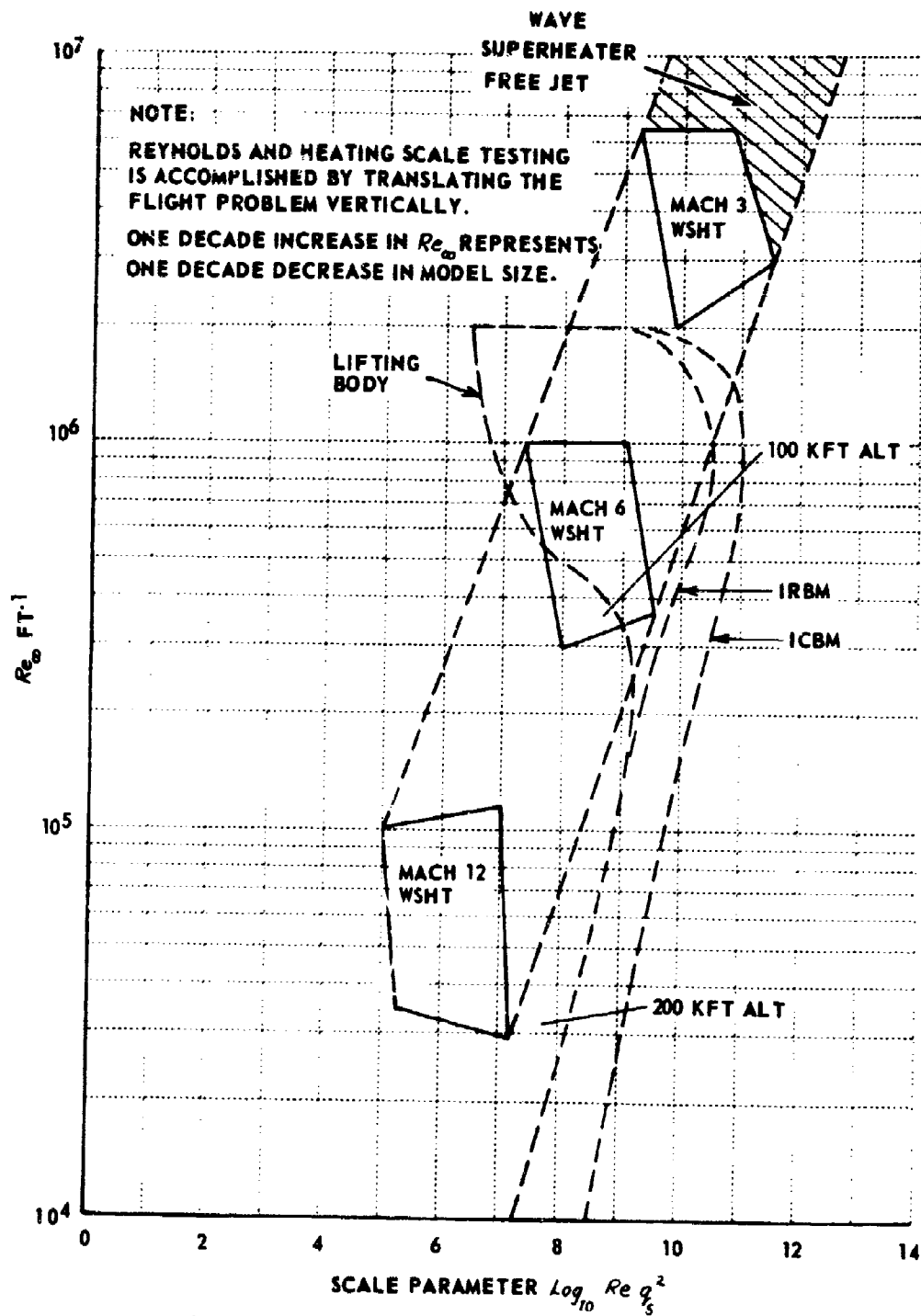

FIGURE 14.—Wave superheater flight simulation.

Approximately 69 percent of all ablation tests have been concerned with graphitic materials and 15 percent with refractories. The remaining 20 percent were devoted to the taffons, reffrasil, quartz, etc. BSD, through its various contractors, has supported about 50 percent of the ablation tests.

As determined by experience and contact with the technical community, the time has come to exploit the growth potential of the wave superheater facility and its concept. The existing facility was designed to provide a continuous flow of air at high temperature and pressure, with a design limit of 9,000° R. in air. As it became operational it became evident that maximum operation of the current facility was to be 7,000° R. in air. In the near future, this deficit in output will be surmounted in an upgrading program.

It has also become apparent that, of all the devices for heating air, only the wave superheater approach has the potential capability to generate and contain stream power density levels significantly exceeding 20 megawatts per square inch of flow area for sustained periods of time.

Due to its cyclic operation, no single material element of the facility is required to be consistently exposed to the superheated test medium. The nominal exposure time of any element is about 200 microseconds. All other devices conceived for hyperthermally heating air have components which are directly and continuously exposed to the heated medium. On this basis, it is clear that the wave superheater type of test facility is unique in its inherent growth potential.

Its suitability has been proven for the ground testing of all the aspects of flight within its present capabilities. Experiments have been conducted in all of the major flight sciences: aerodynamics, material ablation, dynamic and static stability (including the effects of ablation), boundary layer and wake plasma, and turbulent flow.

At present, in the operation of the wave superheater hypersonic tunnel, two new major experimental program areas have been entered. One is the measurement and study of wake structure and chemistry of ablating models, and the other is the measurement and study of hyper-velocity propulsion systems. The power, size, and duration available in the facility make it an ideal test bed for wake probe experimentation and scramjet whole-engine testing. To be sure, no facility on earth is suitably large and powerful to make possible full

scale testing of the largest forms of either of these programs, but because common practice is to begin small and work up, the ideal place to begin is in the wave superheater.

#### REFERENCES

- (1) R. C. Weatherston, *Research Trends*, 7, 2.
- (2) R. L. Bisplinghoff, *Perspective* (Second Qtr. 1965).
- (3) J. E. Carpenter, *Research Trends* (Second Qtr. 1963).
- (4) A. Hertzberg, *Research Trends*, 3, 2.
- (5) J. S. Butz, Jr., "Breaking the Wind Tunnel Barrier" (*Air Force Magazine*, December 1962).
- (6) C. Seippie, U.S. Patent 2,390,394 (1946).
- (7) A. Meyer, *Electrical World*, 127 (1947).
- (8) R. C. Weatherston, A. L. Russo, W. E. Smith, and P. V. Marrone, "Gasdynamics of a Wave Superheater Facility for Hypersonic Research and Development" (AFOSR TN 59-107, AO 210-233, 1959).
- (9) W. E. Smith and R. C. Weatherston, "Studies of a Prototype Wave Superheater Facility for Hypersonic Research" (AFOSR TN 58-158, Univ. of Calif. HF-1056-A-1, 1958).
- (10) J. E. Carpenter, "Wave Superheater Hypersonic Tunnel Fifth Semi-Annual Report" (1 Jan.-1 July 1962, AD-1345-W-8).
- (11) J. E. Carpenter, "Wave Superheater Hypersonic Tunnel Sixth and Final Semi-Annual Report" (1 Jan.-1 July 1962, AD-1345-W-8).

## *The Effect of Vacuum and Surface Layer on the Fatigue Life of Metals*

DR. JACOB POMERANTZ

Since the middle of the 19th century the failure of metals by fatigue has been recognized as an important technological problem. Failure by fatigue is the fracture of a structure subjected to alternating stress over a period of time, even if the maximum stress is well below the maximum load capability of the structure under static conditions. Failures in practically all moving parts are so prevalent that it may be said unequivocally that more money and effort has been expended in an effort to overcome and understand fatigue than any other single problem in solid mechanics.

Failures by fatigue were realized as early as 1858 by A. Wohler (1) who suggested that the metal changed from a fibrous texture to a crystalline structure. Although later work was to prove this concept to be incorrect, the failure of metals by fatigue is still not understood. The designer and engineer is therefore faced with a situation wherein he cannot accurately predict the fatigue life and therefore must resort to the concept of "overdesign." It is not uncommon therefore to have a part 300-400 percent stronger than required by static considerations. This "overdesign" concept leads to a large increase in weight, which is especially critical in aircraft construction where weight is important.

During the past 5 years a new approach to the fatigue problem was undertaken by I. R. Kramer at the Martin Co. under the sponsorship of both the Air Force Office of Scientific Research and the Air Force Systems Command. In approaching the fatigue problem a research team was formed wherein both the practical and basic research aspects of the problem area were considered. The research team decided for the most part to abandon the earlier and more conventional concepts used to explain fatigue failure and embark upon a new approach. Whereas previously it was generally considered that fatigue failure was due to damage in the bulk of the metal, the Martin team found that fatigue was associated with metallurgical changes which took place in a narrow region at the surface (2, 3). This surface region which extends to a depth of about 0.003 inch is formed whenever a metal is plastically deformed and contains many crystal imperfections known as dislocations. It is the reaction of these dislocations in the surface region which govern the fatigue behavior of metals.

It has been known that fatigue damage is not merely a stress phenomenon; it is strongly influenced by the environment in which the fatigue process is taking place. Studies of environmental effects were therefore undertaken for two reasons. Because of the practicality of high altitude missions under conditions where the amount of oxygen, water vapor and other chemical reactive species are greatly reduced, it is important to know how the fatigue life would be affected. Secondly, it was considered that the results from these studies would be very helpful in elucidating the fatigue phenomena. The Martin research team under Kramer was indeed able to uncover impor-

tant parameters affecting the improvement in fatigue life in a vacuum (4, 5).

Attempts had been made to explain the increase in fatigue life in vacuum solely in terms of the reduction in the rate of formation of the oxide film. It had been proposed (6, 7) that the freshly formed, exposed surface in the crack region is able to heal more easily during the compression or reverse half cycle as the oxidation rate is decreased. Such a mechanism would predict that the fatigue life in vacuum should increase with the frequency of the stress amplitude because the time available per cycle for the formation of an oxide layer at the crack is decreased with increasing frequency. Tests conducted by Kramer on the fatigue life as a function of frequency at a constant stress showed that the opposite of this prediction was true (8). The number of cycles to failure (fatigue life) was determined for frequencies of 49 and 76 c.p.s. over a range of pressures from 760 torr (one atmosphere) to  $10^{-5}$  torr. All this was first performed at a maximum stress of 9,700 p.s.i. and then repeated at 11,700 p.s.i. It was found that: (1) the fatigue life at both frequencies remains more or less constant as the pressure is decreased until the pressure is reduced to a value in the neighborhood of  $3 \times 10^{-2}$  torr; (2) the fatigue life then begins to increase rapidly as the pressure is decreased further; (3) the improvement in fatigue life appears to reach a limiting value at pressures less than  $10^{-5}$  torr; (4) the average vacuum fatigue life for specimens tested at 49 c.p.s. is greater than that of specimens tested at 76 c.p.s.—the difference increasing with decreasing pressure; and (5) the number of cycles to failure was decreased at all pressure levels as the stress was increased from 9,700 to 11,700 p.s.i. However, if the vacuum effect is expressed in terms of the ratio between the fatigue life at any vacuum pressure and the fatigue life at the atmospheric pressure, then the vacuum effect is actually greater at the higher stress.

Aside from the above experimental evidence against explaining the fatigue life in vacuum solely in terms of the reduction in the rate of formation of the oxide film, it is known that the healing or rewelding can be impaired by the surface distortion resulting from a redistribution of stress at the surface as well as by an oxide film. Moreover, the probability of healing is farther reduced by the continuous shear action which occurs in the crack region during the test. It therefore appears that the increase in fatigue life in



vacuum or in an inert atmosphere cannot be entirely due to the reduction in the rate of oxide formation.

In the course of his investigations of the effect of surfaces on the mechanical behavior of metals, Kramer showed that the surface exerts a marked influence on the plastic behavior of metals (2, 9-11). Also, a specimen with an oxide film is more resistant to plastic flow (12-16). And furthermore, results obtained from surface removal experiments (2, 9-11) have shown that besides the effect from the oxide surface film, the mechanical properties of metals are also influenced by a so-called "debris" layer, which contains a higher concentration of dislocations, formed at the surface of the specimen during plastic deformation. After removing this surface layer by electropolishing, it was found that the workhardening coefficient was decreased during plastic deformation (less actual stress was needed to produce a given strain). These effects may be explained in terms of the rate of escape of dislocations through the surface. The rate of formation of this "debris" layer depends upon the ease with which the dislocation can escape through the surface. Strong obstacles, such as oxide films, impede the egress of dislocations and enhance the rate of formation of this layer. Kramer proposed that the "debris" layer plays an important role in the fatigue process (17) and later showed that the concept of a debris layer is useful in explaining the results of the investigation into the fatigue life of an aluminum specimen in vacuum given above in the fourth paragraph. He was thus able to uncover two important features of fatigue; the surface layer effect and the environment effect. Although the research effort is not completed, it appears that these two effects are not completely independent and the environmental conditions affects the build up of the imperfections in the surface layer.

As in many cases when both the practical and the fundamental aspects of a natural phenomenon are understood, solution to other important problems are found also. Such was the case in these studies. It was found that the surface layer concept not only helped in elucidating the fatigue problem, but was very helpful in the understanding of the creep, stress-rupture and brittle fracture behavior of metals. For the first time, it was demonstrated in many cases that this surface layer controls the creep and stress-rupture behavior of metals and it was possible to improve these

characteristics. The improvement was accomplished by the very simple expedient of alloying the surface of the metal to modify the surface layer (18). The surface treatment improved the stress-rupture life by 100 percent and decreased the creep rate by 600 percent.

Closely coupled with this work was the Martin development of a process for the improvement of the fatigue, corrosion, and stress-corrosion behavior of aluminum alloys (19). Again by a very simple surface treatment, the fatigue life was improved manifold. For example, at a stress level of 25,000 p.s.i. a normally treated aluminum alloy (7075) has a fatigue life of about 500,000 cycles; the Martin process improved the life such that no failures occurred in 10 million cycles. The endurance limit, that is the stress level below which no fatigue failure is supposed to occur, was also increased by about 30 percent by the Martin process. Not only was the fatigue life improved but the corrosion and stress-corrosion resistance was enhanced. Whereas structural aluminum alloys failed from corrosion in about 5,000 hours in a salt spray test, the specimens treated by the Martin Co. process withstood over 20,000 hours with any corrosion whatsoever. This same type of improvement was experienced when specimens were subjected to other corrosion tests, including outdoor tests at an ocean site. A similar improvement in behavior was also experienced in the stress-corrosion life of structural aluminum alloys. Often the stress-corrosion life was improved by a factor of 10. Specimens exposed at an ocean site (Kire Beach) did not fail after 1 year exposure when the imposed stress level was 80 percent of the yield stress. Normally treated specimens usually failed in a much shorter time and experience shows that never before have specimens lasted this long in this test environment.

#### REFERENCES

- (1) A. Wohler, *Z. Bauwesen*, p. 8 (1853).
- (2) I. R. Kramer and L. D. Demer, *Trans. Met. Soc. AIME*, 221, p. 780 (1961).
- (3) I. R. Kramer, "Effect of Surface on the Mechanical Properties of Metals" (Air Force Report ASD-TRD-65, 1965).
- (4) H. Shen and I. R. Kramer, "Effect of Vacuum on the Mechanical Behavior of Metal" (AFOSR Report 64-2509, 1964).
- (5) H. Shen, S. E. Podlaseck, and I. R. Kramer, *Trans. Met. Soc. AIME*, 233, p. 1963 (1965).
- (6) N. J. Wadsworth, *Phil. Mag.* 3-34, p. 1154 (1958).

- (7) K. U. Snowden, *Acta Met.* 12, p. 295 (1964).
- (8) H. Shen, S. E. Podlaseck and I. R. Kramer, *Acta Met.* 14, p. 341 (1966).
- (9) I. R. Kramer, *Trans. Met. Soc. AIME*, 221, p. 969 (1961).
- (10) I. R. Kramer, *Trans. Met. Soc. AIME*, 227, p. 1003 (1963).
- (11) I. R. Kramer, *Trans. Met. Soc. AIME*, 230, p. 991 (1964).
- (12) R. Roscoe, *Nature* 133, p. 912 (1934).
- (13) A. H. Cottrell and D. F. Gibbons, *Nature* 162, p. 488 (1948).
- (14) S. Harper and A. H. Cottrell, *Phys. Soc.* 63, p. 331 (1960).
- (15) J. Takamura, *Mem. Fac. Eng. Kyoto Univ.* 18, p. 255 (1966).
- (16) I. R. Kramer and S. E. Podlaseck, *Acta Met.* 11, p. 70 (1963).
- (17) I. R. Kramer, *Proc. of 10th Segamne Conference* (Syracuse Univ. Press, 1964).
- (18) I. R. Kramer, "Improvement in Stress—Rupture Life and Creep Resistance by a Surface Coating" (Air Force Report ASD-TDR-64, pt. 3).
- (19) Private communication.

## Mass Transfer Cooling

LT. COL. GEORGE STALK

Recognition of the thermal problem in high-speed flight, whether for reentry conditions or sustained hypersonic flight in the atmosphere, has long been realized, and its scope is quite apparent from the simplest concepts of gas dynamics. In the early 1950's the immediate problem centered about structural weakening at temperatures on the order of only a few hundred degrees. Since then attainable speeds have increased by more than an order of magnitude. The gas temperature adjacent to vehicles operating at these speeds can be of the order of 50,000° R. The result is a vehicle which may be thermally somewhat akin to a meteorite, with both the temperature and energy input rate to the surface now of interest. Moreover, the engineering solution to control and prediction of the surface, thermal and geometric history, in many cases, has a marked resemblance to meteorite behavior—namely, the acceptance of a mass loss from the vehicle to achieve an optimum and practical design. The present state-of-the-art, which is still undergoing improvement for advanced ma-

terials and vehicles, is the result of relatively recent efforts of the last 15 years.

Thermal equilibrium is virtually impossible at hypersonic speeds due to the relatively low melting temperatures of all materials. Energy transmitted from the airstream to the vehicle must be either absorbed or reemitted in some fashion. Mechanisms allowing absorption, for instance, are a change of phase, an endothermic chemical reaction, or most simply, an allowed temperature rise through a large mass of material. Reemission mechanisms are radiation or the passage of a coolant from the vehicle to the stream through which it is passing. A combination of techniques is possible, and occurs naturally. Most important is an understanding of the role of each mechanism, and especially of those over which there is some measure of control and which may beneficially reduce the magnitude of the problem.

Since distortion of the boundary layer so as to decrease heat transfer was foreseen from some earlier work done by NACA (1), an intensive study of mass efflux into the boundary layer (fig. 15) was initiated during the mid 1950's under support of the Air Force Office of Scientific Research. The research organizations included the Massachusetts Institute of Technology, under the guidance of J. R. Baron, and the University of Minnesota, under the guidance of E. R. G. Eckert. It should be recalled that at that time the aerodynamicist was primarily concerned with the perfect gas dynamics of a fictitious medium known as "air," and that widespread use of digital computing machinery was not yet applied to boundary layer problems. Analysis of a mass transfer situation required a (then) complex description of a flowing mixture, and fundamental physical properties were not readily available for the kinds of coolants envisioned as being useful. Quantitative information was sought for the effects of Mach number, geometry and type of injected coolant. It was not clear that suitable porous surfaces were to be found for transpiration schemes. Most important, virtually no experimental evidence was available, and special techniques, such as concentration probing in a thin boundary layer, required development simply to evaluate the theoretical concepts.

Injection of a chemically inert coolant into a supersonic boundary layer revealed analytically a possible strong control over both heating rate and the ultimate equilibrium temperature of a system

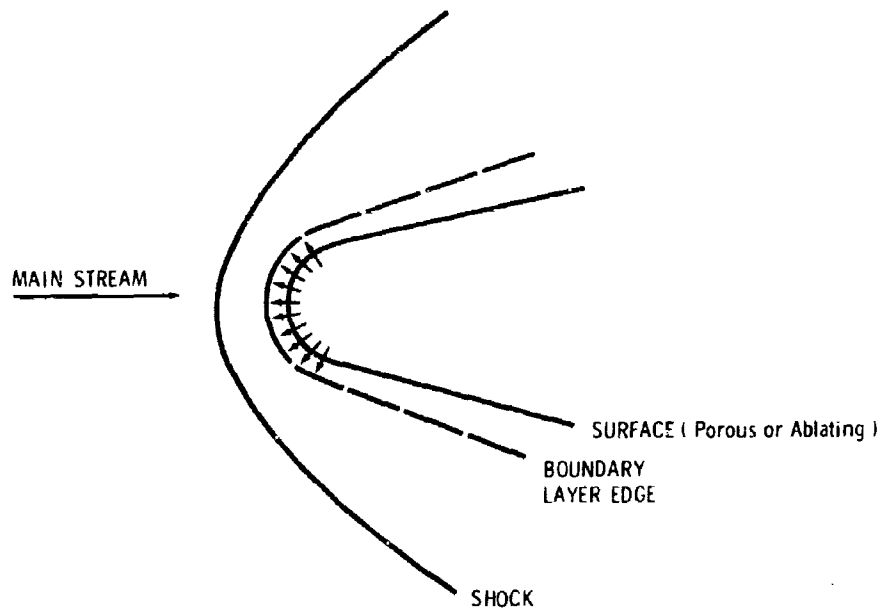

FIGURE 15.—Mass injection into boundary layer using transpiration cooling, evaporation or reacting surface.

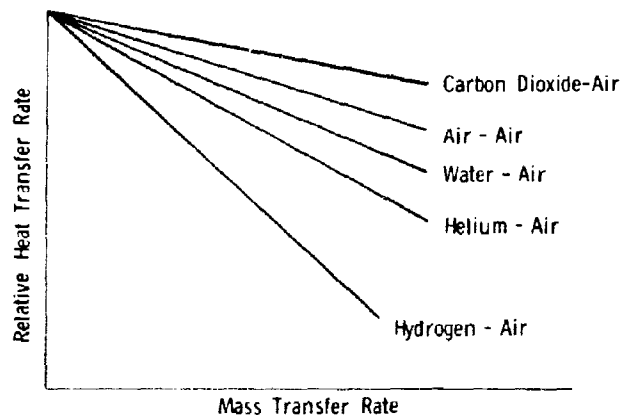

FIGURE 16.—Effect of coolant choice on heat transfer rate.

(2, 3). Consideration of various coolants led to a simplifying rule for the effect of coolant molecular weight on the energy transfer rate, now used to some extent in ablation work with associated vaporization (fig. 16). Certain classes of gases of large thermal capacity proved quite efficient as simultaneous absorbers of energy while reducing the heating load. The conjecture that injection would induce a turbulent condition into the boundary layer and thus negate any possible cooling benefits by affecting the stability of the laminar boundary layer proved ill founded (4).

The related experimental efforts required precise simulation of mass transfer under wind tunnel conditions. However, sintered (porous) materials technology proved to be far from adequate. Even if data were corrected for off-design conditions, which would be quite difficult, the practical need for hypersonic flight required a large improvement in quality control of the product. A byproduct of wind tunnel model specifications and demands was improved metallurgical control. Close uniformity was achieved where required, and specific permeability distributions were obtained with both uniform and variable thickness materials. Still further, new base materials such as stainless steel and nickel were introduced with the capability of withstanding high and prolonged temperatures.

Some serious discrepancies between theory and experiment were in evidence, however, but showed a consistency amongst the work of several investi-

gators (fig. 17). Even though the available analysis disagreed somewhat with each other, none came close to agreeing with the experimental data. The discrepancy existed despite the development of machine computation programs capable of "exact" solutions for mass transfer, mixture problems. The final resolution of the question was of special interest. A hitherto neglected phenomena in aerodynamics, namely a coupling between mass and energy transfer on a microscopic scale of interactions, proved responsible for the discrepancies (5, 6).

A mass transfer approach somewhat different than those described above was also studied. This involved a point injection into the stagnation region so as to produce a relatively thick inner layer of gas between the body and the hot shock layer (fig. 18). With proper contouring of the injection orifice it proved possible to simulate an "effective" hemispherical interface as seen by the incoming flow resulting in greatly reduced surface temperatures (7, 8).

For the most part the above brief review stems from research efforts conducted for the Air Force Office of Scientific Research by groups at the Massachusetts Institute of Technology under J. R. Baron and the University of Minnesota under E. R. G. Eckert. Mass transfer studies were also conducted by NASA, with emphasis on turbulent conditions (9), by the Naval Ordnance Laboratory, with emphasis on stability and experimental

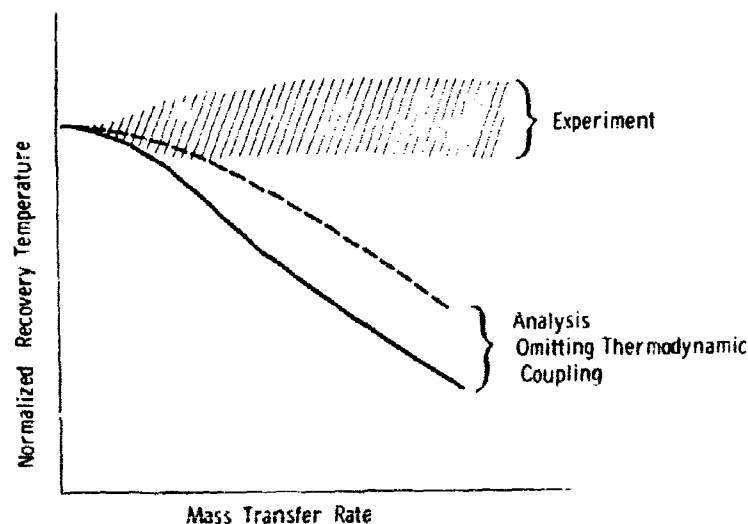

FIGURE 17.—Thermodynamic coupling effect for helium injection through porous plate ( $2.6 < M < 4.3$ ).

verification, and by industry (AVCO, General Electric) in connection with gas phase injection of ablation products (10, 11).

Extensions of the initial studies, in the 1960's, considered multicomponent, reacting, boundary layers which arise due to various surface chemistry reactions and simply the high temperature behavior characteristics of a real gas (dissociation, etc.) (12, 13). Upon inclusion of surface chemistry the mass transfer process becomes coupled to the diffusion and reaction rates in combination. In fact, distinct regimes (reaction, diffusion, sublimation) of control are now found in the case of a graphite surface and presumably are present with other materials. At present such surface coupling is under consideration for a variety of new refractory materials (borides, zirconium, and hafnium carbides, etc.). This recent effort underscores the need for fundamental physical properties of "new" gaseous components, in close correspondence to the original difficulties in the earlier binary, inert gas studies. In a fashion very much like closing the circle, the refractory materials now can involve mass deposition due to solid oxide formations with or without simultaneous injection of other surface reaction products into the airstream.

Mass transfer cooling techniques are required and used by military weapon systems which obtain hypersonic or reentry velocities. Likewise, these techniques are used in the NASA Man in Space Effort (Gemini, Apollo) and are well publicized. Internal aerodynamics has also made use of the concept in the form of rocket engine liners and compressor blade cooling for supersonic and advanced VSTOL jet engines. Sustained operation for long periods of time of supersonic and/or hypersonic vehicles, such as a space plane, suggest either exceptionally good ablators or a transpiration technique to hold to geometric specifications (fig. 19) (14). For flight times of the order of an hour (such as might be associated with a hypersonic transport) one would expect that transpiration cooling techniques would be the logical choice for reduced heat transfer rates.

One further outgrowth of the Air Force Office of Scientific Research program is somewhat aside from any direct contributions to knowledge of mass transfer behavior and aerodynamic phenomena. The research investigators have instilled in their graduate students interest in high speed thermal problems. AFOSR support is necessary both to attract able students in the field of hypersonic research and to furnish the relevant knowl-

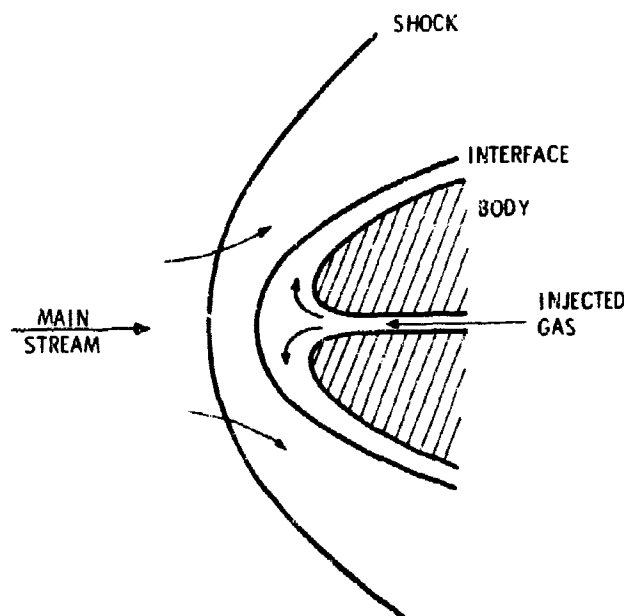

FIGURE 18.—Stagnation point mass injection in hypersonic flow.

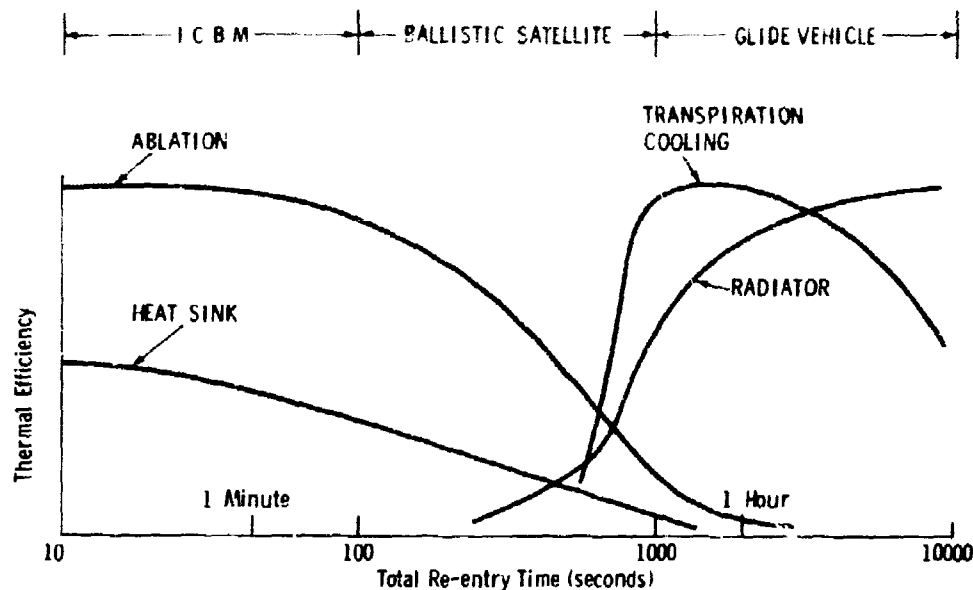

FIGURE 19.—Thermal efficiency for several cooling techniques.

edge and literature needed by upcoming scientists and engineers for the design of advanced high-performance weapon systems.

#### REFERENCES

- (1) W. B. Brown and P. L. Donoughe, "Tables of Exact Laminar Boundary-Layer Solutions When the Wall is Porous and Fluid Properties are Variable" (NACA TN 2479, 1951).
- (2) J. R. Baron, "The Heterogeneous Laminar Boundary Layers" (Rand-AFOSR Symposium on Mass Transfer Cooling for Hypersonic Flight, 1957).
- (3) J. F. Cross, J. P. Hartnett, D. J. Masson, and C. Gazley, *Int. J. Heat and Mass Transfer* 3, 3, p. 198 (1961).
- (4) E. C. Covert, "The Stability of Binary Boundary Layers" (AFOSR TN 57-389, 1957).
- (5) J. R. Baron, *J. Am. Rocket Soc.* 32, 7, p. 1053 (1962).
- (6) E. M. Sparrow, C. J. Scott, R. J. Forstrom, and W. A. Ebert, *J. Heat Transfer*, 86 (1964).
- (7) J. R. Baron and J. Alzner, *J. Fluid Mechanics*, 15, 3, p. 442 (1963).
- (8) O. Y. Wang, *J. Am. Inst. Aeron. Astronaut*, 2, 1, p. 178 (1964).
- (9) C. C. Pappas and A. F. Okuro, "Measurement of Heat Transfer and Recovery Factor of a Compressible Turbulent Boundary Layer on a Sharp Cone with Foreign Gas Injection" (NASA TN D-2230, 1964).
- (10) Mac C. Adams, *J. Am. Rocket Soc.* 29, 9, p. 625 (1959).
- (11) S. M. Scala and W. F. Ashley, "Mass Addition

Effects on Hypersonic Heat Transfer to a Two Dimensional Body" (G.E. R605D491, 1960).

- (12) L. Lees, "Convective Heat Transfer with Mass Addition and Chemical Reactions, Third Combustion and Propulsion Colloquium" (AGARD, NATO, Palermo, 1958).
- (13) S. M. Scala and L. M. Gilbert, "Aerothermodynamic Behavior of Graphite at Elevated Temperatures" (G.E. R645D55, 1964).
- (14) N. S. Disconis, J. B. Fauucci, and G. W. Sutron, "Heat Protection Potential of Several Ablation Materials for Satellite and Ballistic Reentry into Earth's Atmosphere" (G.E. R595D423, 1959).

## The Magneto-Plasma-Dynamic (MPD) Arc

MAJ. RUSSELL G. LANGLOIS

The magneto-plasma-dynamic arc is an axisymmetric device in which an electrical arc discharge takes place between the anode and cathode to produce an ionized plasma. This flowing plasma then interacts with the magnetic field caused by the arc current and the external applied magnetic field  $B$  to accelerate the plasma. The

interaction of the various components of such a discharge has been the subject of widespread attention and the present discussion is oriented at elucidating the contributions that have been made to date. Several of the basic problem areas have been supported by the AFOSR and in fact the significant developments which have followed are directly attributable to this early work. This review covers not only AFOSR sponsored research, but work at other Air Force laboratories and at other government agencies as well, including the Aerospace Research Laboratories and the Aerospace Propulsion Laboratory.

The great deal of attention that has been focused in the past years on the development of MPD arcs is due mainly to the application of this class of accelerator for use as an electric thruster for space flight. Investigators who have been involved in these studies are a group at Electro Optical Systems (EOS), directed by G. Cann; a group at Plasmadyne (now Giannini Scientific) directed by Ducati; a group at NASA Langley, directed by R. V. Hess; a group at Avco-RAD, directed by R. John; and a group at Avco-Everett, directed by R. M. Patrick. This is a summary of the results obtained by these groups in the period 1959 to the present.

The MPD arc today is an outgrowth of the work done on conventional arc jets and the work done on very low density plasma accelerators which was sponsored by AFOSR. In 1958 many of the investigators were working with conventional arc jets. Ducati, R. John, and others approached the MPD arc jet by lowering the plasma density in their accelerators and applying an external bias field. On the other hand, some of the other investiga-

tors, Cann, and Hess, et al., were studying devices where the plasma density was very low. These investigators approached the MPD arc by raising the plasma density in their accelerators to the density of interest. The work at Avco-Everett was divided into two parts, the first directed by G. S. Janes, investigating the low density plasma regime with a goal of containing and accelerating the plasma by confining the electrons in the plasma and accelerating the ions by an electric field which maintains charge neutrality in the plasma. A parallel effort at Avco-Everett was carried out by Patrick, who investigated a magnetic annular arc (MAARC) which operated with a plasma at an intermediate density (the same as present MPD arcs). Hall effects were present in this device and the goal was to try to minimize heat transfer to the side walls due to hot electrons, and also to use Hall currents to produce containment and acceleration.

In early 1958 there were three classes of plasma accelerators being investigated. The first and oldest were the conventional arc jets. The primary work directed towards space propulsion was carried on independently by Ducati and R. John. This type of an accelerator depends on viscous containment to retain the energy in the plasma and achieve low wall losses. These requirements led to the development of very small devices with high densities. Reasonable thrust efficiencies were obtained by employing hydrogen as a working fluid to velocities which corresponded to specific impulses equal to 1,100 seconds.

The second class of accelerators which were developed in the beginning of this period consisted of the rectangular  $E \times H$  accelerator and the MAARC. Intermediate plasma densities were used and  $w.t.$  (electron gyro frequency collision time) in most cases was the order of unity. The conventional  $E \times H$  accelerator depended on the  $j \times B$  acceleration of a relatively low temperature plasma to achieve high thrust efficiency. It was found by several investigators during this period that the side walls of such accelerators (parallel to the direction of the applied field) act as a short circuit for the applied electric field. This became known as the Hartmann boundary layer effect, where the gas near the wall has an insufficient velocity to generate a large enough  $v \times B$  voltage to prevent large currents from flowing in this region. This resulted in large wall losses. At this time the MAARC experimental studies were

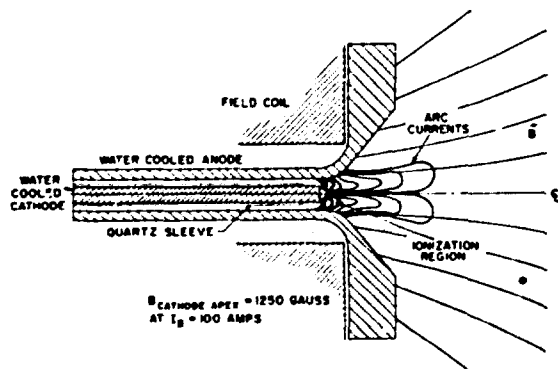

FIGURE 20.—Schematic cross section of the magneto-plasma-dynamic arc.

started in an effort to eliminate these wall losses and to try to achieve  $j \times B$  acceleration with a coaxial geometry. Although the original  $E \times H$  accelerator does not look very attractive for propulsion applications, extensive research is now under way to use this device as a wind tunnel driver where heat transfer and electrode erosion do not limit the concept.

The third class of accelerators being investigated in this period were the low-density accelerators, a typical example of which is the traveling wave accelerator of Janes, et al. A large accelerator using a magnetic field configuration with stationary cusps was also studied by Cann at EOS. The plasma conditions in these accelerators corresponded to very low densities under sufficiently strong magnetic fields so that large Hall currents could flow, i.e.,  $w.t. \gg 1$ . The hope for containment and elimination of wall losses was based on pure magnetohydrodynamic containment of the plasma. Concurrently, Hess at NASA Langley was investigating a device with a geometry very similar to the present MPD arc configuration in this very low-density regime. This configuration using Hall currents to contain the plasma, is probably the first publication of the MPD arc concept. During this period the groups working with the low-density plasma accelerators began to discover that one could not predict the current distribution in these plasmas, assuming classical diffusion for the electrons and ions. This led to decreased interest in utilizing this type of accelerator as a propulsion device because of the high wall losses.

The group at Avco-Everett investigated a coaxial arc discharge with an axial magnetic field (MAARC). The effect of tensor conductivity on the properties of a coaxial arc was studied. It was found that this type of discharge possessed unique voltage characteristics and the voltage was strongly dependent on the magnetic field intensity. The existence of Hall currents in this geometry caused the radial currents to flow in a more extended region downstream from the electrodes than that obtained in conventional arcs. It was further shown that this type of discharge in a partially ionized plasma was stable, which eliminated many of the difficulties encountered in high density arc jets. This early study led to the development of the present MAARC geometry, where the extension of the currents from the electrodes in the flow and magnetic field direction was used

to cause currents to flow in an expanded region in a nozzle with a hope that Hall currents flowing in the expanded portion of the nozzle would produce containment and acceleration in a stable manner.

Concurrently, a radiation-cooled arc jet was developed at Avco-RAD which could operate continuously with power levels up to 50 kw. This advance in technology greatly enhanced the development of MPD arcs since the geometry of both devices is very similar.

During the period from 1960 to 1964 it was shown by Janes and Hess that plasma turbulence was generated in the low density accelerator. This impaired the use of Hall currents in these devices for containment and acceleration, and severely limited the ability of one to predict their performance. At the same time the group at EOS under Cann changed from using a low-density plasma to a higher density plasma and began to study only the exit portion of their accelerator. The group at EOS discovered that when the plasma density was increased in a single cusp magnetic field, a large increase in the apparent thrusts and efficiencies was obtained with a dramatic decrease in wall losses. This was the beginning of the MPD arc development at EOS.

Meanwhile, at Plasmadyne, Ducati had performed experiments indicating that a specific impulse of up to 10,000 seconds could be obtained at low mass flow. This achievement attracted a great deal of attention, since the "arc jet" could now compete with the much more complicated ion engine. Ducati investigated various conventional arc jet configurations and studied a large range of mass flows and configurations and discovered when the mass flow was reduced the apparent exit velocities (specific impulses) increased to velocities much higher than had been obtained before with conventional arc jets. These results were obtained by measuring the thrust and input power and mass flow. At this time the bias magnetic field was applied by wrapping the leads to the arc jet around the device. These modifications improved the electrode performance, with the apparent attainment of higher specific impulses. These results focused a great deal of attention on the development of arc jets with an axial bias field. Since results were obtained with a thrust stand a great deal of enthusiasms was generated because the results showed that a simple extrapolation of arc jet technology might furnish a simple accelerator which could be very useful for space propulsion.



During this period, the Avco-Everett group studied the flow in a MAARC nozzle, reporting thrust efficiency as high as 35 percent, and showed the role of Hall currents in reducing wall losses. Conventional continuum diagnostics were used (pitot tubes, etc.) which limited the study only to mass flows sufficiently high to insure the validity of using these continuum diagnostic tools. This placed a limit on the energy per particle and thrust velocity obtained in this research to velocities corresponding to specific impulses below 600 seconds. This forced this group to develop simple diagnostics other than a thrust stand which would give local properties and be useful for free molecule flow conditions in the exhaust.

After Ducati reported his achievement of high specific impulse, other groups investigated low mass flows to evaluate their devices with the possible use of MPD arcs for electric propulsion at power levels between 20 and 50 kw. The group at EOS developed a MPD arc which used a condensable metal vapor as propellant. The argument for this choice of propellant is that it can be easily pumped by condensing the exhaust in a vacuum chamber. This allows the best simulation of the very low back pressure encountered in space. The EOS group obtained results which indicated that very high thrust efficiency with lithium as a propellant could be attained. Later the group at Avco-RAD (John, et al.) tested MPD arcs using metal vapor propellants. The result of their work showed that the construction and operation of MPD arcs with lithium used as a propellant was very difficult. Because of the complicated design features this group was forced to abandon many of the simple features of the conventional arcs and MPD arcs which have made this class of accelerator so attractive. The introduction of insulating surfaces close to the discharge region eliminated one of the most attractive features of the MAARC and MPD geometries. These restrictions have limited the development of MPD arcs using condensable metal vapors as propellants.

As a separate effort the group at Avco-RAD studied geometries very similar to those used by Ducati and investigated the effect of a bias magnetic field on the nozzle flow and electrode performance with the main effort directed toward increasing thrust efficiency. It was discovered by Ducati about this time that his MPD arc could be run with no mass flow throughput with very little thrust change. This fact made his earlier results appear

questionable, since he had obtained high specific impulses by dividing the thrust obtained with his thrust stand by the measured mass flow throughput. When R. John of Avco-RAD confirmed these results in his own experiments the situation became very confused. It was felt that either the background gas in the vacuum system was being recirculated through the arc jet (back pressure in the vacuum system not low enough) or that stray magnetic or electric fields to the tank walls (a conductor) were responsible for the phenomenon. The back pressure in the vacuum system has been reduced as low as possible without noticeable effect on the thrust level. A spectroscopic analysis of the products in the tank and various regions of the arc was conducted at TRW and indicated no recirculation of background gas. This was a cursory examination over a limited range of variables and it is felt that it was not conclusive. It has been proposed to use nonconducting tank walls for the vacuum system to eliminate stray magnetic effects. Electrostatic or sheath effects would still remain. No results of these experiments have been reported. It was concluded that the simple measurement of thrust on a thrust stand is an incomplete diagnostic to be used in the development of plasma accelerators.

During this time, Hess at NASA Langley had increased the mass flow in his early device. Since he used mostly argon as propellant, with a relatively large atomic weight, the plasma densities were characteristically lower than those studied by the other investigators. He frequently reported unstable arc characteristics and noise produced by the discharge.

The group at Avco-Everett studied the characteristics of their MAARC, using a small thrust plate developed to measure the low thrust density in the collision-free exhaust and also carried out an extensive study of the voltage characteristics of the device. The results of this study showed that the voltage was proportional to the magnetic field, the cathode, anode spacing, and the Alfvén ionization velocity of the propellant. The effect of varying the magnetic field shape and intensity on the thrust profile was obtained. These measurements indicated the effect of the Hall currents forcing the flow nearer the axis of the accelerator. This result verified some of the earlier speculations that Hall currents could act to contain the plasma and reduce the heat loss of the high enthalpy plasma to the anode.

The group at NASA Lewis used a very large vacuum facility to study these accelerators. This facility was capable of producing back pressures two to three orders of magnitude lower. The early results obtained with a conventional MPD arc, using either hydrogen or ammonia as propellants showed that the measured thrust efficiency with a thrust stand was greater than 100 percent. This focused more attention on the validity of thrust stand measurements and also focused the attention of the investigators on the position of the arc currents in these devices, and the question was asked whether they were confined to flow in the immediate vicinity of the nozzle or could they flow out into a large volume in the tank. This would account for large thrust with no mass flow throughput. The current distribution in the nozzle region of this class of accelerator was investigated by the group at EOS, Avco-RAD, and Avco-Everett and it was shown that the major portions of the arc currents flowed well upstream in the nozzle. Later it was discovered at NASA that an error had been made in measuring the mass throughput, giving an erroneous value for the thrust efficiency. The present status of this development is that the most attractive propellant is ammonia. It is very easy to store for space missions and produces a reasonably high operating voltage because the energy required to ionize and dissociate ammonia is large. A high voltage in the plasma minimizes wall losses, and most important, there are strong indications from all of the data accumulated by all of the groups investigating MPD arcs that the thrust efficiency is limited only by wall losses. An accelerator very similar to the MAARC geometry is being developed at Avco-RAD which is to use ammonia as a propellant and operate in the power range between 10 and 50 kw. At the present time the group at NASA Lewis is studying an EOS engine which uses a lithium metal vapor propellant, but because of the extreme difficulty in operating this type of engine no results have been obtained to date.

The determination of the thrust efficiency of these devices has been made difficult by the aforementioned effects, but one thing appears to be clear, that this type of device will transfer electrical energy into plasma energy with a very high efficiency, i.e.: very low wall loss.

Much more research remains to be done to clearly understand the transfer process by which electrical energy is converted to kinetic energy. Moreover, new diagnostics must be developed to

correlate experimental results. It has already been demonstrated that reliance on a single method of measurement can not only produce the wrong answer, but can confuse the issue regarding the basic phenomena under investigation. To this end the AFOSR will continue support of the energy conversion process and associated diagnostics.

Although the MPD arc looks very attractive for space propulsion, other applications are now being considered. Some of these are: As a plasma wind tunnel driver producing a stream of high-velocity collision-free plasma for example, used in solar wind simulation. Another application which has been suggested is in high-speed shock tubes as a driver. As a facility for ablation testing it will permit the identification of the failure mechanisms which exist in high-speed reentry. Such a facility will duplicate free-stream conditions which are far in the future because considerable advances are required in present testing facilities even on a pulsed basis.

In conclusion it can be seen that an early interest by AFOSR in arc jet phenomena has served as a stimulant to the scientific community in understanding the phenomena and has led the technologist to develop these devices as important candidates for future deep-space missions. The extent to which the Air Force will participate in deep-space missions is not yet known. However, based on the record such an important contribution should not be overlooked.

#### BIBLIOGRAPHY

- (1) A. C. Ducati, E. Muehlberger, and G. Giannini, "High Specific Impulse Thermo-Ionic Accelerator," AIAA 64-688 (August-September 1964).
- (2) A. C. Ducati, G. Giannini, and E. Muehlberger, "Recent Progress in High Specific Impulse Thermo-Ionic Accelerator," AIAA 65-96 (January 1965).
- (3) W. E. Powers and R. M. Patrick, "A Magnetic Annular Arc" (2d Symposium on the Engineering Aspects of Magnetohydrodynamics, Univ. of Penn., Philadelphia, (March 1961).
- (4) W. E. Powers and R. M. Patrick, *Phys. Fluids* 5, p. 1108 (1962).
- (5) A. M. Schneiderman and R. M. Patrick, "Optimization of the Thermal Efficiency of the Magnetic Annular Arc" (AIAA 66-115, 1966).
- (6) G. L. Cann, R. W. Ziemer, and G. L. Mariotte, "The Hall Current Plasma Accelerator" (AIAA 63011, 1963).
- (7) G. L. Cann and G. L. Mariotte, *AIAA J.* 2, p. 1234 (1964).

- (8) G. L. Cann, "Annular Magnetic Hall Current Accelerator" (AIAA 64-679, 1964).
- (9) R. D. Buhler and R. E. Stribling, "Power Conversion and Conditioning for 300-1200 KW Plasma Propulsion Systems" (AIAA 64-679, 1964).
- (10) R. Werlock and R. A. Moore, "Electrical Propulsion Ground Testing" (AIAA 65-478).
- (11) R. R. John, S. T. Bennett, and J. F. Connors, "Experimental Performance of a High Specific Impulse Arc Jet Engine" (AIAA 64-660, August-September 1964).
- (12) R. R. John and S. T. Bennett, "Recent Advances in Electrothermal and Hybrid Electrothermal Electromagnetic Propulsion," 4th Symposium on Advanced Propulsion Concepts (1965).
- (13) S. T. Bennett, G. Enos, R. R. John, and A. Tuchman, "Cesium Fueled MPD Arc Jet Engine Performance" (AIAA 65-296, 1965).
- (14) W. P. Powers, "Measurements of the Current Density Distribution in the Exhaust of an MPD Arc Jet" (AIAA 66-116, 1966).
- (15) R. V. Hess, "Experiments and Theory for Continuous Acceleration of Low Density Plasmas," XI National Astronautical Congress, Stockholm (1960).
- (16) W. Grossman, R. V. Hess, and H. A. Hassan, "Experiments with a Co-Axial Hall Current Plasma Accelerator," AIAA 64-700.
- (17) A. C. Ducati, G. M. Channini, and E. Muehlberger, AIAA J. 2 (1964).

## Oxygen Atom Attack of Refractory Materials

LT. COL. CORNELIUS J. DONOVAN

While conventional subsonic aircraft produce negligible chemical changes in the air through which they move, the kinetic energy of a hypersonic vehicle, as for example, a reentering spacecraft, is comparable to the dissociation energy of oxygen molecules naturally present in the earth's atmosphere. As a result, near such vehicles large oxygen atom concentrations are produced, even though dissociation levels in undisturbed air are negligible in the altitude range of greatest aerodynamic interest (below, say, 200,000 ft.). On thermodynamic grounds one might expect that these O atoms, produced where the gas temperatures typically exceed 3,000° K. (4,940° F.), would recombine to form stable O<sub>2</sub> molecules in the gas wetting the cooler vehicle surfaces. However, recombination takes time (i.e., many atomic collisions)

and, as a result of rapid gas motion and their diffusion, O atoms can survive to bombard the vehicle surfaces. What are the effects on material loss or degradation due to oxidation? In view of the meager experimental data on high-temperature surface reactions, even for stable gas molecules, it is necessary to question whether existing materials design and test procedures adequately take these recently encountered atom attack processes into account.

With these questions in mind, in 1962 Daniel E. Rosner of AeroChem Research Laboratories proposed to AFOSR that a basic research program be established to investigate the oxidation behavior of refractory materials in well-defined, dissociated gas environments. Previously, Rosner (1, 2) and others (3, 4) had developed prediction techniques which accounted for the important aerodynamic heating consequences of atom recombination on surfaces. But when an O atom strikes a high-temperature surface the probability of oxidation (and consequent material loss or degradation) may greatly exceed the probability of surface-catalyzed atom recombination. To guide future advances in the attainment of hypersonic flight, an understanding of the rates and consequences of such chemical attack was therefore needed. This can be obtained most accurately, and, incidentally, economically, by carrying out reaction rate experiments in the laboratory at O atom bombardment rates comparable to those attained during atmosphere reentry, under conditions such that the oxidation probability per collision can be determined without ambiguity. This chemical kinetic information can then be combined with an aerodynamic analysis of the air/reaction product boundary layer to enable rational predictions of oxidation rates under the diverse conditions encountered locally during reentry.

Such a program was initiated at AeroChem by AFOSR in November of 1962. By mobilizing several experimental methods used in recent corrosion and physical chemistry research, Rosner and his collaborator, H. Donald Allendorf, successfully developed a unique apparatus and method (5-9) which satisfied the above requirements and, moreover, allowed direct comparison of the O atom reaction probabilities with those of the corresponding O<sub>2</sub> reactions. The method combines the conditions of low total pressure, high gas velocity, and small specimen size and uses a microwave discharge cavity to dissociate oxygen.

As depicted (fig. 21), noble gas/O<sub>2</sub> mixtures are passed through the microwave discharge cavity, downstream of which the partially dissociated gas encounters the specimen—an electrically heated filament. For surface reactions forming volatile (nonprotective) products, the voltage drop across the central portion of the specimen is continuously monitored using spring-loaded contacts leading to a recording potentiometer. During an experiment the filament is maintained at constant temperature by altering the measured heating current in accord with an optical pyrometer or thermocouple output, thereby allowing the decrease in filament diameter caused by the reaction to be related to the increase in electrical resistance. The absolute value of the filament temperature is determined either from its resistivity or from the corrected pyrometer reading and O atom concentrations at the specimen location are obtained using a luminescent titration technique. By combining the observed rate of material loss at each temperature with the prevailing O atom concentration, one can then calculate the probability,  $\epsilon$ , that an incident O atom will lead to material removal (i.e.,  $\epsilon=1$  would mean every incident atom is successful in removing a substrate

atom). In all cases, possible complications due to local oxygen depletion as well as the difference between the incident gas (atom or molecule) temperature and the surface temperature, are ruled out experimentally on the basis of the absence of gas flow rate—and carrier gas identity—effects on the observed reaction rates. Complications due to the possible presence of excited atoms and molecules in the electrical discharge products have also been experimentally shown to be negligible (9). The method has considerable range and flexibility. Thus far, it has been used to study a large class of O atom/solid reactions (5-9) at surface temperatures between 300° K. and 3,000° K. and O atom partial pressures from  $2 \times 10^{-4}$  to  $5 \times 10^{-2}$  Torr (1 Torr =  $1.32 \times 10^{-3}$  atm). By substituting microscope size measurements time-lapse photographs for determining the diameter change of the specimen, the method has been extended to electrically nonconducting materials (e.g., boron nitride) by depositing them on conducting substrates (e.g., tungsten). By adding a second microwave discharge cavity and feedline, the method has also been generalized to study the reactivity of dissociated gas mixtures, such as mixtures of O and N atoms.

63-848

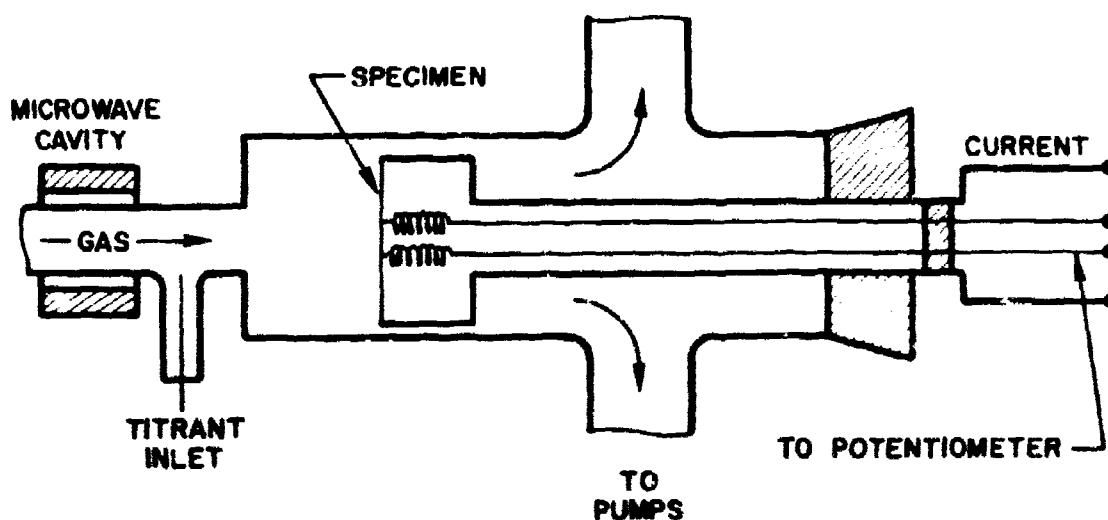

FIGURE 21.—Filament oxidation apparatus (schematic).

Capabilities of the approach and method are perhaps best illustrated by considering recent experimental results on two refractory materials of major interest to the Air Force: molybdenum (5, 9) and graphite (6, 7, 10).

Fig. 22 shows the temperature dependence of the oxidation probability of molybdenum subjected to atomic or molecular oxygen at a partial pressure representative of those encountered by vehicles with aerodynamic lift entering the Earth's atmosphere. The quantity,  $\epsilon$ , which measures the probability that a molybdenum atom will be removed from the solid for each oxidizer collision is seen to be considerably different, depending upon whether the oxidizer is atomic or diatomic oxygen. For example, at about 1,200° K. the reaction probability for O atoms is greater than that for O<sub>2</sub> by a hundredfold. Aside from their large absolute values and relatively weak temperature dependence, another interesting aspect of the O atom reaction probabilities is their remarkable invariance under a 500-fold change in O atom pressure. The simplicity of the O atom reaction kinetics, attributed (5, 9) to the fact that many gas-phase O atoms collide directly with absorbed oxygen (on the surface) leading directly to oxidation, makes it possible to extrapolate these data with greater confidence to the wide range of conditions of aerospace interest.

In contrast to the O-atom data shown, corresponding experiments (9) covering a 10,000-fold

O<sub>2</sub> pressure range reveal that when diatomic oxygen strikes high-temperature molybdenum the reaction probability (already lower than that for O atoms) decreases markedly as the O<sub>2</sub> pressure is increased. The complex behavior revealed for the O<sub>2</sub> reaction is a reflection of the less direct route to oxidation (in which oxygen dissociation must first occur on the surface) when the oxidizer is diatomic.

These are the first data available comparing the rates of O-atom and O<sub>2</sub> attack of molybdenum at elevated temperatures. They indicate that the presence of O atoms in the reentry environment would greatly increase the rate of oxidation of exposed molybdenum surfaces.

As a second example, data have been obtained on the O atom attack of several kinds of graphite (6, 7, 10) since graphite and graphite composites have been used as leading edge materials for lifting hypersonic reentry vehicles (11); moreover, many ablation heat shield materials form carbonaceous outer char layers. In particular, pyrolytic (high density, anisotropic) graphite has been viewed as a leading edge/nose cap material with considerable aerospace promise, partly because it is more oxidation-resistant than more porous grades of graphite. While this is true, Rosner and Allendorf have recently found that differences between the two grades of graphite are not so striking when the oxygen is dissociated.

Shown (fig. 23) are data for pyrolytic (dark circles) and a commercially available graphite (open circles) in both atomic and diatomic oxygen corrected to an oxygen pressure of  $3 \times 10^{-2}$  Torr. It is seen that the improvement in oxidation resistance offered by pyrolytic graphite diminishes considerably when it is exposed to atomic oxygen. Moreover, the O atom oxidation probability near 2,000° K. is quite high ( $\approx 1/3$ ) compared to the corresponding value (less than  $1/100$  for O<sub>2</sub> attack of the same pyrolytic graphite surface. In both the United States (12, 13) and Russian (14) aerospace literature these impressive differences in oxidation rate have until now been neglected, the common assumption being that O atoms and O<sub>2</sub> will oxidize graphite with comparable effectiveness at high temperatures. In many cases the experimental results obtained in the present program on graphites and refractory metals will strongly influence future designs for both unprotected graphite and graphite coated with refractory noble metals (15).

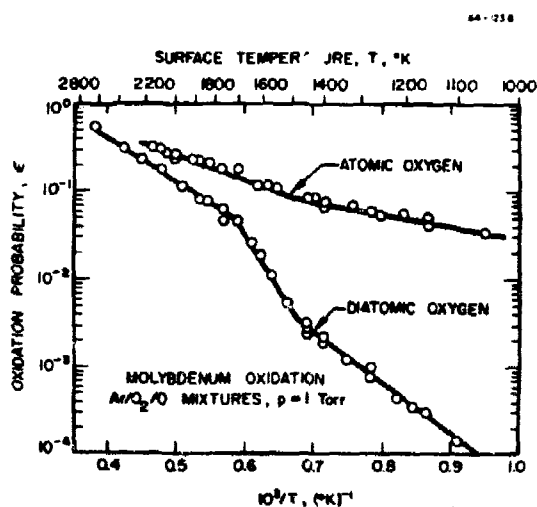

FIGURE 22.—Oxidation probabilities for molybdenum.

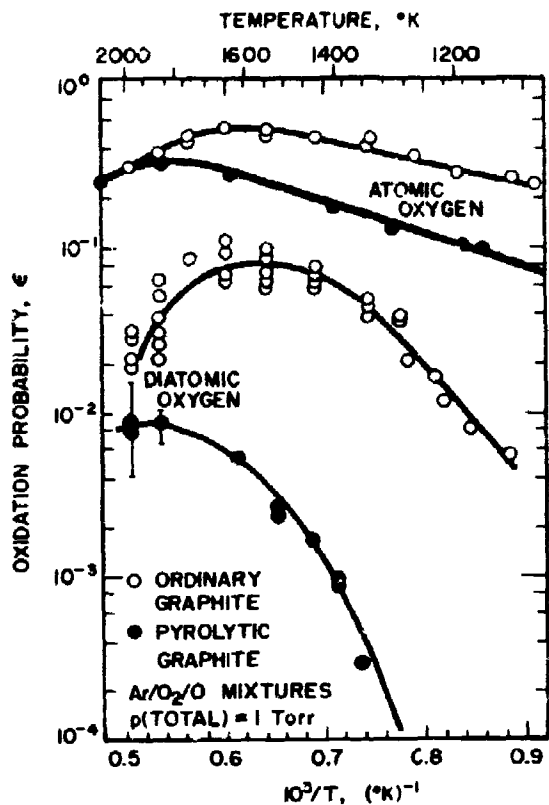

FIGURE 23.—Oxidation probabilities for graphite.

Much remains to be done before a comprehensive understanding of the effects of atomic oxygen on reentry materials is obtained, and oxidation probabilities can be reliably extrapolated or predicted. As already indicated, it is also necessary to combine, in a self-consistent manner, this chemical kinetic information with a knowledge of transport phenomena in the gaseous boundary layer which envelops reentry vehicles. Thus, owing to the establishment of steep concentration and temperature gradients in the boundary layer, due account must be taken of the fact that actual O atom partial pressures experienced at vehicle surfaces will depend strongly on the altitude-velocity "trajectory" of a particular vehicle, its overall size, and its heat-protection scheme. Typical trajectories for several classes of reentry vehicles are shown (fig. 24) together with (a) regions (shaded) in which one can rule out appreciable O atom concentrations at the surface for various reasons, and (b) points (open circles) on each trajectory at

which the conditions of aerodynamic heating are most severe. This figure, a more detailed version of which is discussed from the point of view of aerodynamic heating in (1), displays the trajectories of two ballistic (without aerodynamic lift) vehicles, earth satellite (S) and intercontinental ballistic missile (ICBM), and two lifting vehicles, glide (GV) and lunar lifting (LLV), differing widely in initial entry speed. In the odd-shaped shaded region to the left (low velocity) the vehicle kinetic energy is insufficient to thermodynamically produce appreciable oxygen atom concentrations at the prevailing pressures. In the upper (high altitude) shaded region the vehicle energies are sufficient, but the rates of O<sub>2</sub> dissociation are inadequate for vehicles in the size range of aerospace interest. In the lower (low altitude-high density) shaded region, O atoms produced in the high temperature regions of the flow undergo a sufficient number of molecular encounters in the cooler gas regions near the surface to recombine (reforming O<sub>2</sub>) in the gas phase. Note that for the vehicles shown, all but the ICBM experience peak heating rates under conditions such that high nonequilibrium oxygen atom concentrations will be present near the vehicle surfaces.

In particular, for hypersonic glide vehicles in the region of peak heating, there is sufficient time for the dissociation of diatomic oxygen behind the bow shock and in the high-temperature regions of the gas boundary layer, yet the density levels are

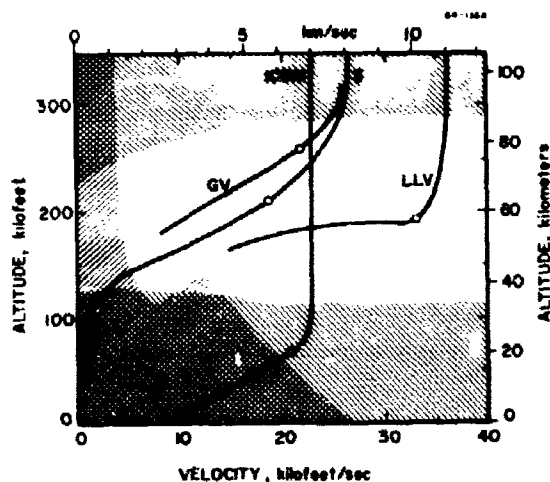

FIGURE 24.—Oxygen atom nonequilibrium regimes during reentry.

inadequate to allow complete oxygen atom recombination to occur in the cooler portions of the flow adjacent to the surface. For a lifting reentry vehicle with a wing loading of, say, 80 psf, the oxygen atom mole fraction at the time of peak heating can reach about 30 percent at stagnation pressure levels somewhat less than  $10^{-1}$  atm. Moreover, peak surface temperatures will be close to 2,000° K. Under these conditions, Rosner and Allendorf have experimentally found that the effective rate constant for graphite attack by O atoms is more than ten times larger than the corresponding rate constant for O<sub>2</sub> attack. Based on these data, estimates of the prevailing O atom concentrations and available predictions of the total weight of graphite heat shield material ablated due to O<sub>2</sub> oxidation during reentry, Rosner estimates that neglect of the dissociation effect could lead to errors as large as 50 percent. Because of the sensitivity of payload and booster size predictions to predicted heat shield weight, effects of this magnitude will bear careful reexamination and inclusion in future designs.

In current extensions of this work at AeroChem, data are being obtained on the O atom attack of tungsten, tungsten alloys, rhenium, boron, boron nitride, and related refractory materials to establish patterns and infer the reaction mechanism, both in the presence and absence of additional gaseous constituents (e.g., N atoms). While the translation of these basic studies into aerospace engineering practice via improved test and design procedures will require additional effort on the part of applied research agencies and Government contractors, the present program provides an excellent illustration of the basic research supported by AFOSR and the Air Force mission in the field of hypersonic aerodynamics.

#### REFERENCES

- (1) D. E. Rosner, *ARS J.* **29**, p. 215 (1969). Also, *AIAA J.* **1**, p. 1560 (1963).
- (2) D. E. Rosner, "Proceedings of Symposium on Supersonic Flow, Chemical Processes and Radiative Transfer" (Pergamon, London 1964).
- (3) R. J. Goulard, *ARS J.* **28**, p. 737 (1958).
- (4) R. J. Goulard, *ARS J.* **28**, p. 737 (1958).
- (5) D. E. Rosner and D. A. Allendorf, *J. Chem. Phys.* **46**, p. 3441 (1964).
- (6) D. E. Rosner and H. D. Allendorf, *AIAA J.* **3**, p. 1522 (1965).
- (7) D. E. Rosner and H. D. Allendorf, *TANSO* **3**, p. 153 (1965).

- (8) D. E. Rosner and H. D. Allendorf, *J. Chem. Phys.* **69**, p. 4200 (1965).
- (9) D. E. Rosner and H. D. Allendorf, *Aero Chem.* TP-140 (1969). Also, *J. Electrochem. Soc.* (in press).
- (10) D. E. Rosner and H. D. Allendorf, "Kinetics of the O-Atom Attack of Pyrolytic Graphite at High Temperature" (in preparation).
- (11) H. E. Bartlett, *ASSET 2* (Air Force Flight Dynamics Lab. 65-31. 2, AF 4-2 426, April 1966).
- (12) S. M. Scala and L. M. Gilbert, "Aerothermochemical Behavior of Graphite at Elevated Temperatures" (General Electric Co. Report R08D99, November 1963).
- (13) J. A. Moore and M. Zlotnick, *ARS J.* **31**, p. 1388 (1961).
- (14) B. V. Alekseyev, "Laminar Boundary Layer on a Sublimable Surface" (AFSC, FTD, MT 65-145, AD 634 832, 17 Jan. 1966).
- (15) J. M. Criscione, H. F. Volk, and A. W. Smith, *AIAA J.* **4**, p. 1791 (1966).

## Electron Beam Fluorescence as a Diagnostic Tool in Low Density Gas Dynamics

PAUL A. THURSTON

Low-density aerodynamics, or rarefied gas dynamics, is roughly speaking the study of the flow of gases containing less than one one-thousandth the number of molecules per unit volume as ordinary air at sea level. The 1960's are seeing a rapid advance in this area which until now has lagged several decades behind the comparable advance in continuum aerodynamics. This current burst of new knowledge in low-density aerodynamics is undoubtedly due in part to the fact that man's activities in space and the upper atmosphere have occasioned an urgent need for this knowledge; but for a need to be filled, it must coincide with a suitable opportunity for its filling. This article describes how an important opportunity for progress in the experimental aspects of low density aerodynamics has been provided through a decade of research by scientists in three different countries. AFOSR financial support has aided substantially in bringing this work to fruition.

Wind tunnel experiments in low density aerodynamics are impeded by the very small size of

the forces and pressures involved in the flow of a gas so light that a pound of it would occupy at least the volume of an ordinary dwelling house. Any macroscopic measuring instrument inserted into such a flow radically disturbs the quantity being measured. A further serious difficulty is that at the densities of interest the various modes of energy storage in the gas are often not in thermodynamic equilibrium. For this as well as other reasons, the properties of the gas from one point to another in the flow are not nearly as simply related as in the case of the inviscid flow of an equilibrium gas. For a detailed and accurate interpretation of experimental results, it is necessary that the state of the gas can be determined at any point in the flow, independently of upstream conditions. The solution to this problem in a large variety of experiments is the electron beam fluorescence technique.

A well-collimated beam of electrons about the diameter of the lead of a pencil is passed through the gas flow. In the gas density range being discussed, a beam of 40 kilovolt electrons is not significantly attenuated over a distance of a few inches. If the gas is air, the beam is visible as a thin line of fluorescence. By optical means, any place along the beam length can be selected for observation, and a "point" measurement of the beam emission can be accomplished. The emission can be used to measure directly the local state of the gas. Electron beam fluorescence has a spectrum peculiar to the composition and temperature of the gas being observed. It resembles the emission from a low density gas discharge tube for a gas of similar composition. A gas species density is obtained from the intensity of light emitted at a selected wavelength characteristic of the species. The emitted intensity is linearly proportional to the density in the density range of interest here. Figure 25 shows the dependence of intensity upon density found by Gadamer (1) in preliminary experiments with electron beam fluorescence. The linear region is close to the origin on the scale of figure 25.

If the gas used is nitrogen, the molecular emission bands can be used to obtain vibrational and rotational temperatures. This is done by measuring the relative intensities in the vibrational and rotational fine structure of the nitrogen  $N_2$  negative system emission band. The measurements

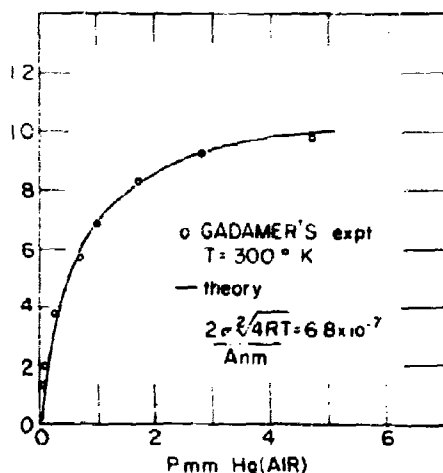

FIGURE 25.—Light output vs. pressure for an electron beam through air at room temperature.

represent a direct static temperature determination which is an extremely difficult quantity to obtain in many flow situations. Figure 26 shows the excitation-emission paths which have been used for nitrogen temperature measurements (2). It is important to the accuracy of the temperature measurements that the 18-electron volt ionizing excitation occurs without disturbing the rotational or vibrational state of the original nitrogen molecule.

Besides these capabilities, the technique can be used to measure flow velocity and translational temperatures by making use of the Doppler shift and broadening of a suitable spectral line. The versatility of the technique has been a spur to the recent rapid growth of its use in experimental gas-dynamics. Figure 27 shows a schematic drawing of an electron beam fluorescence density and temperature measuring system in a hypersonic shock tunnel (3).

Early interest in the fluorescence excited in a gas by a beam of energetic electrons derived from a desire to investigate the applicability of wave mechanics to collision phenomena (4-6). The application of electron beam excitation to the measurement of gas density was suggested in 1955 by B. W. Schumacher and A. E. Grun (7) in the form of a German patent application which was based on work performed at the Hechingen High Voltage Laboratory of the Max-Planck Institute for



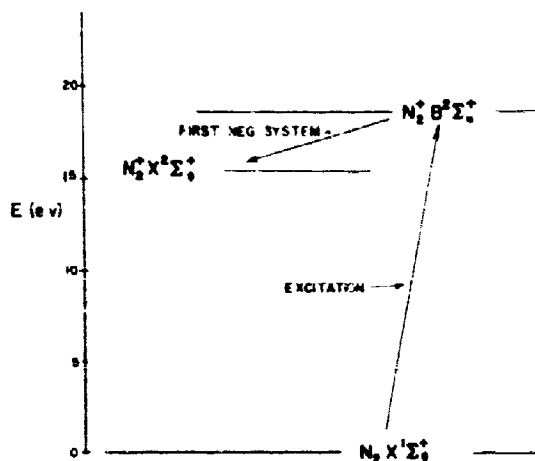

FIGURE 26.—Excitation and emission paths for the  $N_2$  first negative system excited by fast electrons.

Physics of the Stratosphere. At about this time Schumacher became associated with the Ontario Research Foundation, Toronto, Ontario, and at the same time AFOSR initiated a contract with Grün and colleagues at the Hechingen laboratory for further research into the mechanism by which gas molecules absorb energy from a beam of electrons. The results of this work were published in 1957 (8).

Meanwhile, in 1956 Gordon Patterson, Director of the University of Toronto Institute of Aerophysics, decided to undertake the development of the electron beam as a density and temperature diagnostic device. Acting for Patterson, I. I. Glass and J. G. Hall of UTIA carried out discussions with Schumacher and the Ontario Research Foundation. From that time on, a series of AFOSR contracts and grants have supplemented the support of the Defence Research Board of Canada for the group under Patterson in its research on the electron beam fluorescence technique.

E. O. Gadamer (1), working with Schumacher's design for the electron gun, showed by a simple set of experiments the feasibility of obtaining local density measurements anywhere in a flow field without disturbing the flow. E. P. Muntz (2) extended the technique to the measurement of vibrational and rotational temperatures in nitrogen and airflows. Muntz took the important step of introducing the use of electron guns commercially available at low cost from the television industry in place of the sophisticated, cumbersome, and ex-

pensive design supplied earlier by Schumacher. Muntz later became associated with the Valley Forge Space Technology Center of the General Electric Company, where he extended the electron beam technique to the measurement of the molecular velocity distribution function (9).

Use of the electron beam fluorescence technique is rapidly growing. It is being used, refined, and extended to new uses in many laboratories in the United States, both for basic research in rarefied gasdynamics and for applied research. The first applied research use was by Zempel and Muntz (3) under contract to the Air Force Ballistic Systems Division.

The future applications of electrons beam fluorescence in both applied research and in basic fluid physics will no doubt continue to proliferate. As the requirements of defense systems become more sophisticated, more details of the flow fields must be known. The fluorescence technique is an excellent device for gathering this information. It is expected that with considerably more technique development, it will be applied to chemical nonequilibrium flows. Fundamental fluid physics, particularly in basic kinetic theory of nonequilibrium flows with rotational, vibrational, and translational degrees of freedom, should be advanced. Flows of gas mixtures will also be studied extensively. Two items of great interest to applied research projects will be quantitative flow visualization and velocity measurements using the Doppler shift method. Upper atmosphere research will also benefit from electron beam fluorescence. Rocket payloads being prepared at the present writing contain electron beam packages for measuring density and rotational temperature at satellite altitudes.

#### REFERENCES

- (1) B. W. Schumacher and E. O. Gadamer, *Can. J. Phys.* **36**, p. 659 (1958).
- (2) E. P. Muntz, "Measurement of Rotational Temperature, Vibrational Temperature, and Molecular Concentration in Non-Radiating Flows of Low Density Nitrogen" (UTIA report 71, AFOSR 60-490, April 1961).
- (3) R. Zempel and E. P. Muntz, "Slender Body Near Wake Density Measurements at Mach Numbers 13 and 18" (GE R63SD55 1963).
- (4) J. J. Thomson, "Conduction of Electricity Through Gases II" (Cambridge University Press, London and New York 1933).
- (5) N. F. Mott and H. S. W. Massey, "The Theory of Atomic Collisions" (Oxford University Press 1962).

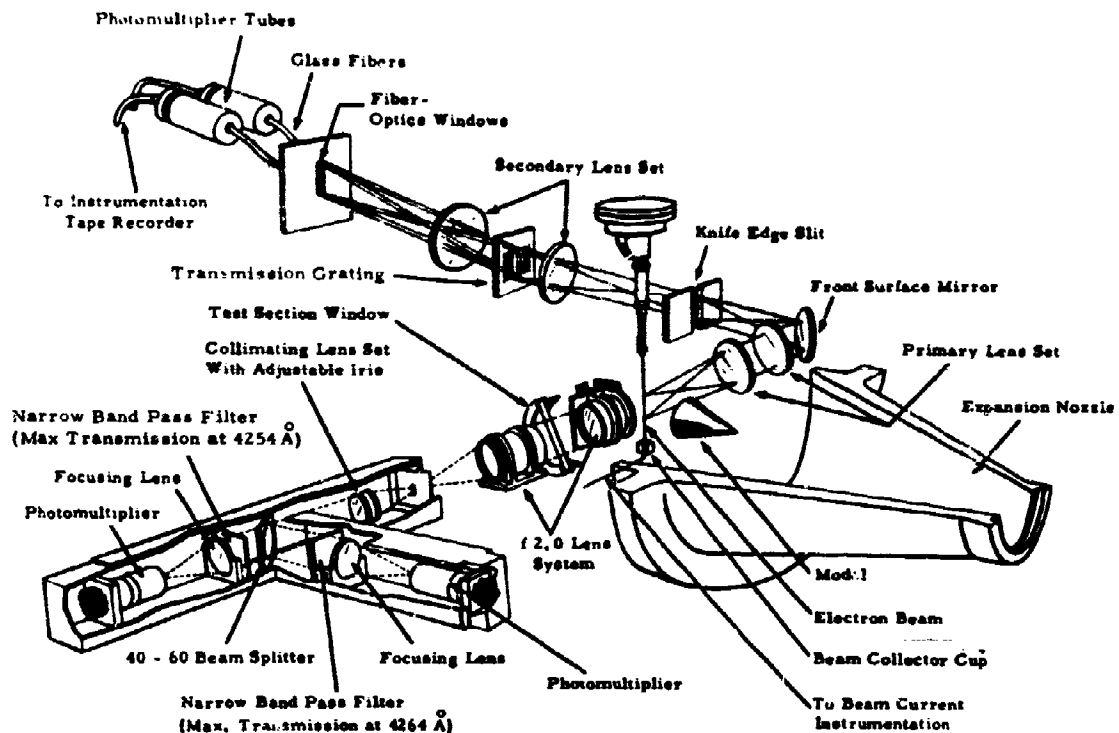

FIGURE 27.—Electron beam density and temperature measuring system in a hypersonic shock tunnel.

- (6) H. S. W. Massey and E. H. Burhop, "Electronic and Ionic Impact Phenomena" (Oxford University Press, 1952).
- (7) B. W. Schumacher and A. E. Grün, "Apparatur für die Messung der örtlichen Gasdichten innerhalb eines ausgedehnten Beobachtungsraumes, Deutsche Patentanmeldung" (Sch. 18144 IX 142-1 June 1955).
- (8) A. E. Grün, "Measurement of Air Density by Electron Absorption," AFOSR 57-58, AD 136515 (1957). Also, "Zeitschrift für Naturforschg." 12a (1957).
- (9) E. P. Muntz, "Direct Measurement of Velocity Distribution Functions" (GE R64SD59, 1964).

## Supersonic Combustion

DR. BERNARD T. WOLFSON

A long-standing program of fundamental research has been supported by AFOSR directed at Air Force technical problems concerned with

combustion dynamics. Many of these supporting type studies are basic to the eventual attainment of supersonic combustng ramjets that will be required for flight in the Mach 8 and faster range.

The program provides new knowledge leading to solution of problems in ignition and extinction, steady-state combustion, control of combustion instability, detonation and sensitivity, and supersonic combustion. These research efforts directly involve air-breathing, liquid and solid rocket combustion and propulsion. The work will eventually influence advanced development in hypersonic ramjets, aerospace aircraft, recoverable boosters, advanced air-breathing cycle engines, ignitors, air-augmented and large chemical rockets, and advanced aircraft propulsion systems such as VTOL.

This program has in the past and is now playing an important role in pioneering research in the areas of supersonic combustion, both detonative and diffusional type; of rocket combustion instability phenomena, and of ignition and extinction of propellants and motors.

In the broad area of homogeneous or gaseous combustion, investigations are supported in the general area of supersonic combustion, both shock initiated or detonative, and shock-free or diffusional supersonic combustion.

As late as 1952 there were large unknowns in the chemical kinetics of combustion and the theoretical limits of the amount of heat produced by combustion within a ramjet. Early design work on supersonic combustion ramjets indicated that the length of a combustion chamber necessary to produce the required space heating and resultant thrust would be determined by the rate of combustion of the fuel-air mixture in a very high speed airflow. In a Mach 5 airstream combustion must take place in less than 1 millisecond if the burning is to occur within a 5-foot chamber. Reaction rates for premixed fuel-air mixtures were rather well known as functions of temperatures and pressures. Interrelated effects were known for mixing and reaction rates, but the extent of the effect for hypersonic speed ranges was unknown. It was reasoned that the reaction times for unmixed gases were necessarily longer than for mixed gases, however, so the shortest possible combustor would be one in which premixed gases were burned.

Premixing was one of the conditions necessary in the shock-initiated combustion ramjet engine suggested by Ledue in 1946. A normal shock would supply sufficient heat for combustion. A great deal of the kinetic energy of a ducted flow of air is lost over a normal shock wave in the form of heat rather than pressure rise. This heat tends to dissociate the molecules of the gas and thereby inhibit reaction. In order to maintain supersonic flow throughout the engine and still utilize shock-initiated combustion, supersonic (or oblique) rather than normal shock waves are necessary.

Among the first to do extensive research into shock-initiated combustion was Dr. Robert A. Gross, then at Fairchild Aircraft. He concluded that in hypersonic ranges any air breather that reduced airflow velocity to subsonic speeds before adding fuel would have such high diffuser temperatures that the fuel would dissociate and absorb heat rather than add heat to produce thrust. Although the Air Force in general was not urgently interested in new air-breathing propulsion schemes, AFOSR began to support Gross in 1955. Under this support Gross demonstrated an ignition device applicable to supersonic flow combustion. This consisted of a cylindrical tube through

which a supersonic flow of a hydrogen-air mixture was ducted. Small wedges were placed opposite one another in the flow to cause oblique shock waves to be formed at either side. At the intersection of these shock waves a small normal shock wave formed, producing an area of heat sufficiently intense to produce spontaneous combustion. Although the flow is reduced to subsonic values over a normal shock, the normal shock area is relatively small in this case. By placing a divergent nozzle just behind the shock wave the flow could be re-accelerated to supersonic values. Photographs of the standing normal shock showed the flame front and the shock wave to be coincidental, indicating no time delay for ignition. The implications were very favorable to the shock ignition scheme of design.

In 1955 AFOSR gave support to J. A. Nicholls, working on detonation at the University of Michigan. Nicholls thought shock-induced combustion could be applied to propulsion in an intermittent shock wave within a pulse jet. He also considered the possibility of shock-induced combustion in a ramjet if the shock could be made to stand still. He was able to produce a standing detonation wave in apparatus which consisted of a converging channel with a sonic throat followed by a diverging supersonic nozzle. The position of the standing wave could be controlled by varying the pressure of the fuel-air mixture.

At the same time Alexander Weir at Michigan was working on gas flow through sharp-edged orifices at supercritical pressure ratios. He photographed the flow pattern vented into the atmosphere and found a normal shock forming at some distance from the orifice. This phenomenon could not be explained by existing theory and became known as the "shock bottle effect." Nicholls and Weir teamed and derived an explanation and a method of calculating where the shock wave would sit. Nicholls applied this to the flow patterns of rocket exhausts, and was given AFOSR support for further studies. Under Nicholls a student named Roger Dunlap calculated the performance of a ramjet using the principle of a standing detonative wave, published in 1958, and subject of much industry attention. The apparatus consisted of a converging nozzle which brought the flow to mach 1; fuel was added at the throat and the mixture accelerated to supersonic speeds in a diverging duct; downstream a center wedge produced a standing shock wave.

The temperature rise produced by the shock wave ignited the mixture with an accompanying rise in temperature and pressure. It was concluded that the performance of a detonative wave ramjet would be less than that of a conventional ramjet below mach 5 but would peak at mach 7 where the conventional type would be ineffective. The ideal detonative wave concept seemed to be the standing detonative wave, which formed without mechanical flow diverters and could be made to stand just ahead of a diverging channel so as to keep the subsonic portion of the air flow at a minimum length. Since the position of this standing wave had been shown to be a function of the inlet pressure, some means of metering the inlet pressure would have to be incorporated in the engine design. This consideration seemed to indicate a need for a variable-geometry inlet or exhaust or both.

In 1955 Marquardt Corp., with Aero Propulsion Laboratory (AFSC) support, demonstrated continuous autoignition of hydrogen in a shock-free, mach 2 airstream. Lack of immediate interest was attributed by the investigators to the prevailing opinion that any ramjet needed some flame holding device to maintain continuous combustion. With APL support in part, Arthur Mager and Charles Lindley began work in the newly formed Astro Division. They were convinced that Eugene Perchenok, also at Astro, had demonstrated shock-free supersonic combustion while at NACA in 1947. Mager and Lindley did thermodynamic cycle analysis on a hypothetical, shock-free, supersonic combustion ramjet and concluded in 1958 that such an engine would be efficient up to orbital velocities. Lindley is credited with coining "scramjet."

Parallel and independent work was being done by Antonio Ferri of the General Applied Science Laboratory (GASL), in which he demonstrated at Polytechnic Institute of Brooklyn steady combustion without strong shocks in a supersonic airstream. As early as 1958 he said that he had accomplished shock-free diffusion controlled combustion in a mach 3 airstream, the diffusion process being a means of control of mixing and reaction. Ferri's research was supported by AFOSR in its very early, fundamental stages in 1956 and 1957, and later support for engine-oriented research came from APL. The proposed engine would incorporate a shock-free supersonic intake to a throat where hydrogen fuel would be added tangent to the flow and at approximately the same temperature and velocity. Adding hydrogen under these

conditions would prevent the generation of shock waves in the throat. The hydrogen gas would then diffuse in the airstream which would be above the temperature at which spontaneous ignition would occur. The channel would be divergent to prevent unwanted temperature extremes which would cause such dissociations of ions as to absorb heat and interfere with heat releasing chemical reaction. In 1964 Dr. Ferri stated that the detonation wave engine likely would require variable geometry inlets. He preferred that hydrogen fuel be injected hot and at high speeds into the airflow as it enters the combustion area of the engine. This combustion would be gradual and stable because the flow would remain supersonic. His concepts differ from those of many who favor the detonation wave engine in that Ferri, unlike the others, is designing with goals of mach 12 and up in mind. In these numbers he proposes to nullify the possible high combustion chamber temperatures by quenching with an excess of hydrogen over the stoichiometric ratio. Ferri maintains that the cooling capacity of the hydrogen fuel is more than sufficient up to mach 23.

Low mach supersonic speeds with diffusion control also appear possible to Ferri. In answer to criticisms based upon mixing considerations, he maintains that in conditions of high temperature the reaction rate is sufficiently high in comparison to the mixing rate that it can be neglected and the mixing process can be considered, for the purpose of analysis, to be a problem in equilibrium flow. A slight difference in the velocities of inner and outer jets will produce turbulent mixing rapid enough to finish the process in sufficiently short distances to use the diffusion process as the control mechanism for supersonic combustion. Combustion can be maintained in supersonic flow below the flash point of hydrogen in air by admitting a core of very hot gas, say hydrogen, into the mixture behind the mixing jets. The reaction can be maintained by heat convection from the chemical reactions associated on the boundary of this central pilot jet. Thus the range of operation of the supersonic combustion can be extended into the lower supersonic mach regimes. He indicates that combustion is completed in  $10^{-6}$  seconds in conditions of initial static temperature of 2,000° Rankin. The length of combustion area required would be on the order of a quarter of an inch in a flow of 20,000 feet per second. Ferri also indicates that the most difficult problem is not related to the construction

of the engine but to the construction of facilities for ground testing the engine as a whole. GASL has obtained contracts with NASA for a test engine, and with the Air Force Systems Command, in conjunction with Marquardt, for a prototype to be flown on a rocket booster. Greatest applicability seems at present to be for a recoverable space launch vehicle (RSLV).

Recent studies by Ferri and his GASL group show that high altitude and low supersonic performance in a fixed geometry engine using hydrogen or selected hydrocarbon fuels can be extended by use of external ignition sources and a special means for inducing mixing. In addition they found that the total length required for completion of

combustion could be substantially reduced below that predicted by stream tube calculations by combining conveniently located ignition sources with pressure gradients induced by the combustion process itself.

The theory and data obtained by this research are of direct and immediate concern to the Air Force because of the new insights into prediction and control of gas flows in which finite rate chemical processes are important. Further, there is direct applicability to the design and operation of a multitude of new Air Force concepts such as high-speed manned observation and reconnaissance and missile systems, and first stage boost systems for space.

## Information Sciences

### *Influences From Cybernetics on Information Sciences*

ROWENA W. SWANSON

Norbert Wiener popularized the word "cybernetics" through his book, "Cybernetics or Control and Communication in the Animal and the Machine" (1), and thus brought into vogue an area of research that has been difficult to define precisely because of the diverse reaches of its possible influence. Wiener originally associated the word with the entire field of control and communication theory in machines and animals. After initially condemning the field as a tool of capitalists and the bourgeoisie, scientists in the USSR adopted the term and began to ascribe to the field the power to revolutionize human activity through the optimal use of men and machines. (2) Sensationalism presaging an age of robot control of man also became associated with the word, cybernetics, and introduced a period, particularly in the United States and England, during which scientists were loathe to use it. This period seems to be gradually ending, but a prevalent view is that an informative description of particular areas of inquiry would simultaneously be more meaningful and obviate need for use of the word.

From the vantage point of 1966, the cybernetics banner appears to have been productively useful, principally, perhaps, because of its unifying influences. It appears representative of a trend in modern science toward multidisciplinary approaches to problem solving. It has stimulated team efforts for the co-joint investigation of control, communication, and the mechanisms and methods used by man that result in what is considered intelligent behavior. A beneficial byproduct is the broadening by scientists of their individual perspectives to admit increasingly wider areas beyond those of their original specialization.

A recent analysis of cybernetics by I. A. Akchurin in *Voprosy filosofii* indicates the conceptual and practical ranges of activity encompassed by cybernetics (3). His taxonomy isolates three principle areas: theoretical cybernetics, applied cyber-

netics, and technical cybernetics. To theoretical cybernetics he assigns research in information theory, programing theory, the theory of automatic machines, and game theory. Applied cybernetics pertains to the solution of specific problems of control that arise in such widely diverse fields as biology, linguistics, sociology, and military science. Technical cybernetics refers to reductions to practice of designs and devices such as the synthesis of switching circuits, determinations of component and system reliabilities, the construction of adaptive systems of sensors, and the development of interactive man-machine communication networks. The links that unify these areas Akchurin calls "the information concept" and generalized "neomathematical structures." Informational data, by initial input and feedback, determine the possible, probable, or actual behavioral characteristics of elements of a system and overall system structure and performance. Mathematical structures, derived theoretically or based on observation and experimentation, pertain not only to complex systems of regulation and control but also to abstract axiomatizations that emphasize approaches to optimization and economy (e.g., codes, strategies) independent of anthropomorphic implications.

In the foregoing context, accomplishments of particular investigations in the cited subject areas are meaningful as accomplishments of cybernetics. In this context, a large portion of the basic research program of the Directorate of Information Sciences, AFOSR, is cybernetics oriented. For example, M. P. Schutzenberger and M. P. Nivat of Institut Blaise Pascal are investigating the use of algebraic methods in automata theory for describing machines that are both fundamental and behavioristically simple. A theory they formulated for incompletely specified automata has yielded solutions to the general problem of approximating any event by some regular one. They are currently examining several basic conjectures in coding theory to gain a better understanding of combinatorial problems and the meaning of unique decipherability problems. F. B. Cannonito of Hughes Aircraft Co. has observed a relationship between basic abstract structural features of a library and the structures of some semigroups that

are finite semilattices. He is extending studies in combinatorial algebra to the design and simulation of a model combinatorial information retrieval system. At the University of Hawaii, A. T. Ewald has been trying to discover better differentiating descriptors to improve the identification process in pattern recognition. Employing primarily linear techniques, his algorithm tested against recorded data of nonlinear tsunami wave patterns has been able to predict the maximum tsunami wave height in one locale from the wave record in another, a first for this type of prediction. His results are also furnishing information (as well as raising questions) on how classes should be categorized. He plans to test the predictive capability of the algorithm against other sets of data such as magnetic anomaly data, earthquake wave transmissions, and radar patterns.

Foundational studies in mathematical logic are relevant to cybernetics in that they are providing answers to such questions as: what are the limits on computability, and how can computable procedures be explicitly described. H. Putnam, for example, culminated 5 years of research in hierarchy theory with the construction of a hierarchy of degrees of unsolvability that extends the Spector hierarchy to all sets of integers that are "constructible" in the sense of Gödel. This result amplifies knowledge on problems of relative recursiveness, on constructive models for analysis, and on systems of notations for ordinal numbers. Putnam is now examining new methods for proving theorems for an infinitely axiomatized system of first-order number theory. R. M. Smullyan at Yeshiva University is developing new and simplified methods for translating proofs in one proof-procedure system to proofs in another. He formulated a specific unifying principle in set theory that is furnishing fundamental insight into the relation between the well ordering theorem, the transfinite recursion theorem, and several theorems on ordinal numbers. Results include some new characterizations of the ordinals, and a generalization of the notion of ordinal number. Smullyan has introduced a new notion of nest structure and of an isomorphic tree structure that simplify proof procedures. He is also investigating procedures that can constructively demonstrate the consistency of various mathematical systems.

Logical representations, such as those being devised for automatic theorem proving, are also indicative of ways that machines can be instructed

to perform operations usually associated with human intelligence. For example, B. Kalliek at Northwestern University is exploring the development of efficient theorem-proving algorithms via the Herbrand theorem through expressions of denial of the theorem as a prenex formula of predicate calculus and generation of an inconsistent set of instances of this formula. His comparison of a generalization of a decision procedure of J. Friedman with a proof procedure of J. A. Robinson resulted in a reformulation of the generalization procedure in terms of conjunctive normal form matrices rather than disjunctive normal form matrices. The reformulation provides economies in computation. It eliminates the need of special techniques for matrix amplification and is most amenable to proof procedure applications when the conjunction of a set of axioms with a theorem's negation yields a matrix that, in disjunctive form, is large and contains many non-relevant terms.

A basic understanding of how to analyze and represent various types of problems is an essential first step to developing efficient and effective procedures for problem solving by machine. At RCA's David Sarnoff Research Center, S. Amarel has been examining theory formation processes, heuristic problem solving procedures, and methods for realizing them. He has developed a conceptual framework for ordering a variety of problem types for machine solution. In an analysis of a specific problem of transportation scheduling, the "missionary and cannibals" problem, Amarel evaluated the effects of alternate formulations to the expected efficiency of mechanical procedures for solving it, and the processes that are involved in a transition from one formulation to a better one. Integrated, goal-oriented routines that specify macrotransitions enabled a substantial reduction in problem-solving effort: a macrotransition is an expression of knowledge about the probability of realizing particular sequences of transitions. Research on representational models such as Amarel's is relevant to industrial and military problems concerned with reasoning about actions as arise, for example, in logistics and operations planning.

The word, cybernetics, thus, is not a descriptor for a single discipline but is, rather, a term for characterizing a conceptual orientation in various fields of study. The orientation is that of extracting from experimental data on biological, social, and

even philosophical, systems, principles pertainin, to regulation, control, communication, and optimization. The state of the art strongly suggests that model building and testing well integrated with real-world systems data could, then, achieve the goal of revolutionizing human activity, both of the individual and of the organization, through an understanding of how to optimize configurations of men and machines.

#### REFERENCES

- (1) Norbert Wiener, "Cybernetics or Control and Communication in the Animal and the Machine." M.I.T. Press (and John Wiley & Sons, Inc., Cambridge, Mass., 2d ed., 1961).
- (2) A. Berg, "Cybernetics and Technical Progress." Joint Publications Research Service, JPRS-11, (926), 11 Jan. 62. (Translation from *Pravda*, 10 Nov. 61).
- (3) I. A. Akhburin, "The Development of Cybernetics and Dialectics." TT-65-32287, JPRS-31,792, August 65. (Translation from *Voprosy filosofii*, No. 7, 1965).

## *The Computer and Its Languages*

CAPT. ELIOT SOHMER

What is a computer and what can it do for me? This is a question that is constantly being asked by many people today, and it will continue to be asked for many years.

Computer sciences is a young and dynamic art that those outside the computer field view with confusion and awe. Headlines such as "Computer Lands Gemini Automatically" (11) and popular magazine articles ascribing human characteristics to computer programs (10) are frequent occurrences. These reports contribute to a popular notion that the computer is a "giant brain" capable of indefinite "intelligence." An almost equally popular notion is that a computer is "a pile of nuts, bolts, and electronic gear that is nothing more than a fast adding machine."

The computer is, in fact, revolutionizing our lives and our society. In a memorandum issued 28 June 1966 to heads of departments and agencies, President Johnson expressed his concern that the electronic computer be properly utilized and managed. He stated: "The electronic computer is having a greater impact on what government does and

how it does it than any other product of modern technology. The computer is making it possible to send men and satellites into space; make significant strides in medical research; add several billions of dollars to our revenue through improved tax administration; administer the huge and complex social security and medicare programs; manage a multibillion dollar defense logistics system; speed the issuance of G.I. insurance dividends at much less cost; save lives through better search and rescue operations; harness atomic energy for peaceful uses, (and) design better but less costly highways and structures. In short, computers are enabling us to achieve progress and benefits which a decade ago were beyond our grasp.

"The technology is available. Its potential for good has been amply demonstrated, but it remains to be tapped in fuller measure. I am determined that we take advantage of this technology by using it imaginatively to accomplish worthwhile purposes.

"I therefore want every agency head to give thorough study to new ways in which the electronic computer might be used to provide better service to the public, improve agency performance, (and) reduce costs. But, as we use computers to achieve these benefits, I want these activities managed at the lowest possible cost." (6)

There are at least 2,600 computers in use in the Federal Government today and 71,000 people employed in their operation. The Department of Defense operates 2,000 of these and employs 51,000 of the personnel. Since the Air Force is the world's largest user of computers from the viewpoint of number of machines in service, as well as in the number and variety of applications (1), the Air Force is committed to a leading role in furthering computer technology. It is apparent that the digital computer is invading the realm of Air Force operations and management. In the near future most staff personnel will require a working familiarity with computer and data processing techniques. Anomalously, computer capabilities have not become apparent to the great majority of management and operations personnel. (3) The cause for the anomaly, and hopefully the cure, may lie in accessibility of the computer to the noncomputer trained user.

How does a person use a computer? Basically, he must have the ability to "speak" to the machine. However, the means of communication must be such that the computer will "understand" the ideas



that the user wishes to convey. The user would have no difficulty if he could speak to the computer in a "natural" language (such as English) and be understood. However, computer technology has not progressed far enough to allow the free use of a natural language as a means of communication.<sup>1</sup>

Therefore, one of the primary goals in computer research is the development of computer languages so that people who are relatively unfamiliar with scientific terminology and methods can use the computer to solve problems in languages familiar to them. Let us briefly review computer language development since the advent of the computer.

With the early machines, all communication was accomplished using what is known as "machine language." For most computers, these languages consist of sequences of zeros and ones and were undesirable, since they were slow and tedious for a human to use and subject to many bothersome human errors in coding. Their greatest fault, however, is their complete unnaturalness for the human communication process.

"Assembly language" was the next development. This type of language permitted the user to communicate with a machine through a mnemonic-type structure<sup>2</sup> that was translated by the computer itself into machine language. This development eased the communication problem but did not remove the restriction of use of computers to scientifically oriented specialists.

The next major development in automatic programming languages was "one-to-many" translation. Whereas assembly language is basically a "one-to-one" translation (i.e., one sentence such as "ADD 13" is translated into one machine command), "one-to-many" languages permit the user to shift the responsibility of tedious coding tasks to the computer. For example, a person familiar with high school arithmetic would have the ability to communicate with the computer by saying such things as "5\*(10+2)" and expect to receive the answer 60. This development eased the task of expressing in assembly language each of the necessary instructions to arrive at the same result. Thus, one "sentence" could now be used to generate a series of "machine sentences." One important limit-

ing factor on all of these languages is that each inherently depends on the particular computer being used. Thus, as computers advanced in speed and capacity, new languages had to be written and old languages had to be reprogrammed.

At this stage of computer language development, an attempt was made to produce languages that were independent of the particular machine being used. Fortran (*FOR*mula *TRAN*slation) and Algol (*ALG*orithmic *O*riented *L*anguage) were developed toward this objective, and although they have eased the programming problem considerably, they fall short of being truly machine-independent.

The discussion thus far has centered around scientifically-oriented languages, developed by scientists for themselves. What about the problems of the manager and administrator? How could they communicate with the computer when they had no understanding of scientifically-oriented languages? It was readily apparent that the great speed of the computer could be well utilized for tedious bookkeeping and administrative tasks. These tasks contain features that are completely different from those of scientific problems. Business-oriented languages began to be developed for these problems. For example, Cobol (*C*ommon *B*usiness *O*riented *L*anguage) provides a language familiar to the business and management oriented person. Snobol (a language developed for the manipulation of strings of symbols) eases the problems of text searching, making additions and deletions, and other secretarial-type tasks. These tasks could have been expressed in scientifically oriented languages, but this would have been inefficient and costly, and, of greater importance, this would have been completely unnatural to the user. Analogously "string-processing" and business-oriented languages are inefficient when used for simple arithmetic computations.

Perhaps the most glamorously used and least understood of the languages that have been developed are the "list-processing" languages, which are frequently employed in "problem-solving" tasks such as game playing (8, 9) and question-answering programs (2). This area of application holds great promise for the future advancement of "machine intelligence."

A person who wants to use one of today's computers must learn a language understood by the computer and structured to handle the data format of the problem. For example, a numerical analyst

<sup>1</sup> The "natural language problem" is very complex and is being studied intensively. Its scope is not restricted to computer sciences, but cuts across a wide spectrum of disciplines such as linguistics, physiology, and mathematics.

<sup>2</sup> For example, a programmer would have the ability to say "ADD 13" rather than "00110000001011".

would waste his time trying to solve his problems using a string-processing rather than a scientifically oriented language. How may this burden of learning a computer language be alleviated? How may computer technology be made available to more people with widely divergent interests? These are some of the questions being investigated by research presently being sponsored.

Under AFSOR sponsorship, Peter Ingerman has developed a particular computer language translator. Ingerman first developed his translator as a graduate student at the University of Pennsylvania's Moore School of Electrical Engineering in 1963 under an AFSOR contract. He was later sponsored at Westinghouse Electric Corp.

The latter effort resulted in a recently published monograph entitled "A Syntax-Oriented Translator" (4). A computer translator is a processor that accepts as input a message in one language (the language used by the programmer) and outputs a message in another language (the computer's language) with the requirement that there exist one common meaning for the two messages. The classical translator normally is a relatively efficient structure that can provide any desired balance between fast translation and fast machine code. However, the maintenance required for the translator to incorporate changes in this balance is at best tedious work and at worst may effect a complete redevelopment of the translator. Also, the production of a new translator for a new language or for a different computer can at best make limited use of the old translator. On the other hand, a syntax-oriented translator is completely independent of the programming language that is to be translated, as long as sufficient means exist for describing the properties of the programming language. Ingerman presents a method of producing various computer languages that depends only on a system programmer's ability to specify the rules of his own language. Ingerman, in effect, has devised a method that minimizes the time delay between the conception of a new language and its availability to users of a wide variety of computers.

Philip Bagley is investigating the possibility of developing a programming language that essentially separates the task of programming into two distinct phases. The first phase involves writing the program in an algorithmic or logical language that is completely independent of the characteristics of a specific computer. The second phase, which may be replaced by a mechanical device involves

specifying in an implementation language the manner in which the program will be executed on a specific computer. Bagley is attempting to incorporate a variety of data structures into his language to satisfy a variety of needs within the structure of one language. The success of this research would be a step closer to an ability to use more natural languages in communications with computers.

Another contribution toward freeing users from computer language restrictions has its origins in AFOSR-sponsored research in information retrieval. Calvin Mooers of the Rockford Research Institute had been exploring ways of manipulating natural language text so that computers could aid, and in part replace, catalogers and reference librarians in storage and retrieval operations. Mooers and Peter Deutsch developed the language they called TRAC (*Text Reckoning And Compiling*) that is a general tool for text manipulation. (7) One of TRAC's outstanding features is that it gives the user the power to formulate a large number of well-defined procedures with a small repertoire of primitive functions. TRAC is operational in a time-shared computer environment, and is thus immediately useful in the third-generation computer systems now being installed.

As the Air Force continues to incorporate computers into its operations, and as computer-based Air Force systems continue to grow in complexity, research such as that of Ingerman, Bagley, and Mooers becomes increasingly relevant. Ingerman's contribution coupled with the success of Bagley's work, for example, may effect great savings in time, effort, and cost through their use in modifying existing operational programs and in conversions from one computer system to another. This research is only exemplary of that being sponsored by AFOSR, other Air Force laboratories, and other agencies. It does indicate, however, areas in which study was, and continues to be, needed, to most effectively integrate computers and allied hardware into the most efficient Air Force systems man and machine can combine to create.

#### REFERENCES

- (1) *Air Force Policy Letter for Commanders*. (Office of Secretary of the Air Force, Washington, D.C., 15 Aug. 1965).
- (2) B. F. Green, "Baseball: An Automatic Question-Answerer," (Proceedings Western Joint Computer Conference, 1961).

- (3) J. E. Hughes, *Air University Review*, 17, p. 4 (1966).
- (4) P. Z. Ingerman, "A Syntactically-Oriented Translator." (Academic Press, 1966).
- (5) H. R. Johnson, *Air University Review*, 17, 1 (1966).
- (6) L. B. Johnson, "White House Memorandum" to Heads of Departments and Agencies, Washington, D.C., 28 June 1966.
- (7) C. N. Mooers and L. P. Duetsch, "TRAC, A Text Handling Language" (Proceedings 20th National Conference).
- (8) A. Newell, J. C. Shaw, and H. A. Simon *IBM J. Res. Develop.* 2, 4 (1958).
- (9) A. L. Samuel, *IBM J. Res. Develop.* 3, 3 (1959).
- (10) *Time Magazine*, 88, 15 (1966).
- (11) *Washington (D.C.) Post* (Friday, 16 Sept. 1966).
- (12) H. H. Zschirnt, *Air University Review*, 16, 1 (1964).

## *The AFOSR Coupling Program*

MAJ. JOSEPH P. MARTINO, *Asst. Exec. Dir. for Research Communication*

The importance which AFOSR places on coupling has been pointed out several times in this report. In fact, all AFOSR program managers have coupling as a primary concern. In addition, AFOSR has a staff office, the Office of the Assistant Executive Director for Research Communications, which assists in these functions.

Choosing the appropriate areas of science, choosing the relative emphasis to be given to each, and insuring that the results of the research are of benefit to the Air Force, requires that the AFOSR research program be carefully coupled to the Air Force. Information must be obtained on what needs and problems the Air Force has and is likely to have in the future, and the results of research must be made available quickly to Air Force activities.

AFOSR coupling is also concerned with providing scientific advice and consultation to all parts of the Air Force and in otherwise bringing about constructive involvement of research scientists in Air Force problems. This is a particularly fruitful activity because it serves to make scientists more knowledgeable of Air Force problems and at the same time it serves to bring to the Air Force knowledge and understanding from the much broader area of world science with which the scientists supported by AFOSR are in intimate contact. This article summarizes briefly these coupling activities. More details can be found in other published reports (1, 2, 3).

Coupling the output of research to the research user is all too frequently spoken of in terms of "coupling science to technology." This is too narrow a viewpoint. Inherent in this viewpoint is the assumption that there is a natural chain of progression from a scientific discovery, through a technological advance, to a major improvement in weapon system capability. The overwhelming impact of the transistor and nuclear weapons have fostered this assumption. However, when one looks for other examples, they tend to be scarce. Despite

the magnitude of their impact, the transistor and the nuclear weapon are statistical anomalies which give a misleading impression of the relation between science and technology. In fact, most technological advance is built on previous technology.

This is not to say that science does not contribute to technology. It is to say, rather, that science may contribute at any stage. It may contribute not only at the point of technological advance, but during manufacturing, operation, maintenance, and operator training as well.

In the Air Force the customer of research is not just the technological innovator. AFOSR research can and should be of direct benefit to every organization and agency in the Air Force. With this thought in mind, we will examine the means by which AFOSR couples its research to the Air Force.

Some of the means for coupling science to the Air Force are described below. Most important are journals, books, and reports. Others, not necessarily in the order of importance, are sponsorship of symposia, membership on interservice and inter-agency committees, attendance at meetings sponsored by other organizations to discuss their areas of interest, and individual action by the AFOSR project scientist.

During 1966, AFOSR sponsored the publication of approximately 1,500 journal articles, 700 reports, and several dozen books. These will receive widespread distribution through the journal publication system, through agencies such as DDC, and through direct distribution to persons known to be interested in the contents.

In the case of journal articles, it is difficult, if not impossible, to verify that the material in them has been used. Only if someone later makes reference to an article sponsored by AFOSR is it possible to verify that the material in the article was of value to someone. However, a secondary measure of the impact of these articles can be obtained. The Office of Scientific and Technical Information, Headquarters Office of Aerospace Research, conducted a survey to determine the extent to which journals containing articles reporting OAR-sponsored research are to be found in defense-oriented libraries. Since well over half of the total OAR-sponsored journal articles are sponsored by

AFOSR, the results of this survey should provide a good measure of the distribution of AFOSR-sponsored articles. Using a weighted average which took into account the number of articles in a journal during a 5 year period, and the number of libraries out of the total sample which carried a given journal, it was determined that on the average, each library was exposed to nearly half the total articles published. Thus it appears that in fact AFOSR-sponsored journal articles do reach those who can make use of them.

In the case of reports, a more direct measure is available. AFOSR obtained from DDC a report showing which AFOSR-sponsored reports in DDC had been requested during 1965, and by whom they had been requested. The total was too great for full analysis, but a manual analysis of a small sample showed that AFOSR-sponsored reports are requested by agencies which have an obvious requirement for the information contained in the reports. While again no proof of use can be obtained, it is safe to assume that reports are not requested unless someone has a need for them, since making a request does take a certain amount of effort. Thus based on the examination of requests to DDC, it appears that reports generated under AFOSR grants and contracts do reach impressive numbers of research users who can make use of them.

There is no measure of the extent to which books are effective in reaching those users of research who need the information they contain. Books produced under AFOSR sponsorship are either selected as representing a significant summary of research in some field, presented in a manner suitable for the users of that research, or they are produced as a byproduct of some other effort, such as a symposium. These books provide a valuable source of information about some field of science at a particular time. Especially in the case of state-of-the-art summaries, they provide a benchmark by which future progress in a field of science can be judged, and provide the research user with a consolidated source of all important information currently available in that field.

Symposia are a very important means for coupling research to users. Not only do the papers provide information on the latest research results in a field of science, but symposia are attended by large numbers of both producers and users of research in a particular field. This provides ample opportunity for an exchange of information be-

tween those attending, with researchers being in direct contact with the users of their research. In 1966, AFOSR sponsored a total of 53 symposia.

One important symposium was Simulation and Simulators of Dynamical Systems. This meeting brought together persons interested in mathematical, mechanical, and computer simulation of various dynamical physical or biological systems. Systems to be simulated ranged from astronauts undergoing extravehicular activity to the human circulation system under the action of an artificial heart. The intent of the meeting was to illustrate the similarities behind simulations of all types of dynamical systems.

Another important symposium was the International Symposium on Combustion, attended by scientists and engineers interested in all aspects of combustion, a subject of major importance to the design of jet and rocket engines. This symposium provided American specialists in combustion with an opportunity to meet with persons of similar interests from throughout the world. The Americans present were thus able to tap the scientific knowledge of the entire world on the subject of combustion.

The final symposium to be discussed here was the Conference on Hazards of Birds to Aircraft. Specialists on all ecological phases of the subject were able to exchange information on various aspects of the problem, such as the location of airfields to reduce incidence of impacts.

Interservice and interagency committees of various types provide a very important means for transferring results of AFOSR-sponsored research to users. The meetings of these committees bring together representatives of research-sponsoring agencies such as AFOSR, and representatives of users of research, to discuss some particular problem, or problem area. Some of the groups on which AFOSR is represented are:

Security Equipment Working Group, an Air Force group responsible for advising AFSC on approaches to the problem of airfield security in remote areas, particularly against insurgent infiltration; Nuclear Weapons Effects Research Medical Advisor Group of the Defense Atomic Support Agency; and Foreign Area Research Committee, which includes representatives of the Army, Navy, Air Force, and State Department.

During the year various Air Force agencies sponsor meetings at which their problems are discussed with representatives of research laboratories

and technology laboratories. A small sampling of such meetings attended by AFOSR representatives during 1966 follows:

Ballistic Systems Division-Research and Technology Division (AFSC) Coupling Meeting; Research and Technology Division-Electronic Systems Division (AFSC) Coupling Meeting; Air Force Tenth Technology Review, sponsored by Research and Technology Division, AFSC; Anti-Missile Research Advisory Council meeting, sponsored by Advanced Research Projects Agency; and Research and Technology Division--Industry Technology Reviews at several industries.

Individual actions by AFOSR project scientists represent a significant portion of the total coupling effort of the organization. The position description of each professional staff member of AFOSR includes a statement of coupling as one of the major responsibilities of the position. This is a reflection of the very personal interest in coupling demonstrated by AFOSR scientists, and the position of the AFOSR management that coupling is an essential part of the AFOSR job.

AFOSR project scientists seek to establish communication with persons throughout the Air Force interested in the research activities for which they are responsible. They initiate many such contacts and also welcome inquiries. The following are illustrative areas of such coupling.

In some of these cases specific research results which make possible the solution of a problem are too new to have reached a wide audience through normal channels of dissemination. When these problems are identified and located, information in the form of available written reports or special oral reports are made available to the organization responsible for solving the problem. In many cases the important action is not that AFOSR-sponsored research is transmitted to some user, but that the very existence of the AFOSR program, with its resultant wide array of contacts in the scientific community, makes it possible to bring together a specialist in some area and a technology-oriented user of research. The specialist then is able to bring the entire range of this knowledge to bear on a specific problem. A few of the examples of such coupling actions are:

Arranging for a contractor to visit Air Force Missile Development Center to provide technical consulting in connection with the Air Launched Scramjet Orbital Booster Study.

Arranging for several contractors to consult with a Department of Defense panel studying the military retirement system.

In response to a request from Air Force Missile Development Center, arranged to transmit to AFMDC information on filtering methods.

Arranging for contractors to help improve the specifications for the engineering development of a General Purpose Automatic Test Set for the Middletown Air Materiel Area.

Arranging for contractor to advise the Directorate of Armament Development, RTD, AFSC, on wing-flutter prediction for aircraft carrying external stores.

In a number of instances joint activities have been instituted. For example, AFOSR's Propulsion Division and Air Force Rocket Propulsion Laboratory personnel assist each other in evaluating proposals. Seventeen different Air Force organizations are represented on AFOSR "in house" advisory groups. AFOSR and Air Force Aeropropulsion Laboratory cosponsor research in high temperature plasma at Aerojet General Nuclonics and there are many similar instances of common contracting with other Air Force organizations.

AFOSR program managers participate widely in IR&D reviews of the aerospace industries. They participate in ad hoc studies such as the scramjet study, the special air warfare study, and the prisoner of war studies. They arrange for special state-of-the-art reviews such as the AFIT monthly lecture series. They make numerous visits to Air Force installations either as individuals or in scheduled groups.

More examples of the types given above could be cited to illustrate that coupling is a very important function of AFOSR, and that it is exploited by the AFOSR staff. Furthermore, the considerable effort invested in the activity brings about a significant coupling of the AFOSR research to the Air Force as a whole. Through these activities we are insuring that the AFOSR research program is oriented to meet the needs of the Air Force.

#### REFERENCES

- (1) "A Summary of AFOSR Coupling Activities" (AFOSR, May 1964).
- (2) "A Summary of AFOSR Coupling Activities" (AFOSR, 1965).
- (3) "AFOSR Coupling Activities" (AFOSR, 1966).

## Research Evaluation Through Citation Indexing

MAJ. JOSEPH P. MARTINO

One of the problems in managing a research program is that of evaluating the quality of the research done. This problem is particularly severe for organizations whose function is that of supporting extramural research. While considerable effort is made to select quality researchers in the first place, it is desirable to have means for checking on the quality of the research done under support.

Previous research has indicated that one important measure of the quality of a scientific paper, published in the journal literature, is the number of citations, i.e., the number of times that later authors make reference to the paper. While this can be used only as an after-the-fact check on a single researcher, it is of far more value in evaluating a program as a whole, since policies which led to support of research papers which have high (or low) citation rates tend to persist over time.

Unfortunately, the citation rate as a measure of research quality has not been widely used, because

of the difficulty of examining the literature and tracing citations by manual means. As with so many other functions of management, however, the advent of the digital computer has completely changed the picture. The digital computer now makes it possible to search through hundreds of journals, published over a several-year period, to locate citations to one or several previously-published papers. At least one commercial organization, the Institute for Scientific Information, provides search services to its subscribers on a routine basis. ISI currently indexes the articles in over a thousand scientific journals, and in particular, identifies the previous articles which each article cited.

AFOSR entered into a contract with ISI, under which ISI was to determine the number of citations to articles published in 1964 and which resulted from research sponsored by AFOSR, Office of Naval Research, and the Army Research Office. The citation rate for these sponsored articles was to be compared with the citation rate for the literature at large, and for a statistical sample of articles matching the AFOSR-sponsored articles in journal and month of publication. A statistical summary of the results obtained by ISI follows (see table).

TABLE.—Frequency of citation in 1965 and first three quarters in 1966 of 1,535 AFOSR-sponsored research papers published in 1964, compared with control sample and with Science Citation Index total file

	Cited in 1965		Cited in 1966, 1st quarter		Cited in 1966, 2d quarter		Cited in 1966, 3d Quarter	
	AFOSR	Control	AFOSR	Control	AFOSR	Control	AFOSR	Control
1. Number of papers (unique authored items).....	1, 535	106	1, 535	106	1, 535	106	1, 535	106
2. Number of times papers in (1) were cited.....	3, 370	173	921	39	851	54	881	49
3. Average number of citations per paper.....	2. 19	1. 63	0. 60	0. 37	0. 55	0. 51	0. 57	0. 46
4. Number of papers cited at least once.....	941	63	509	29	487	36	502	32
5. Average number of citations per paper cited at least once.....	3. 59	2. 72	1. 80	1. 35	1. 75	1. 50	1. 76	1. 53
6. Total number of papers in SCI file cited at least once in 1965—1,617,000.								
7. Average number of citations per paper cited at least once, total SCI file, 1965—1.65.								

ISI found 1,535 articles sponsored by AFOSR, 332 sponsored by ARO, and 1,508 sponsored by ONR, and published in 1964. In addition, a control sample of 106 articles, matching the AFOSR-sponsored articles in terms of month and journal of publication, was selected at random. Citations to these articles were located in articles published in 1965, and in each of the first three quarters of 1966. The analysis shows that the average number of citations (that is, total citations divided by total number of articles being cited) is higher for the sponsored articles than for the control sample or for the general run of the literature, as represented by the total Science Citation Index (SCI) file. The

data in the ISI files were further examined, looking only at those articles cited at least once. Here again, those sponsored articles cited at least once had a higher citation rate than similar articles among the control sample or the general run of the literature.

While additional analysis of the data will be performed, to gain as much additional knowledge as possible on such things as patterns of citations over time, the analysis presented here clearly indicates that scientific work sponsored by AFOSR, ARO and ONR is definitely of higher-than-average quality.



## AFOSR-sponsored conferences and symposia, 1966

The following conferences and symposia were held during 1966 with funds provided in part or wholly by AFOSR as a means of furthering areas of scientific research of particular interest to the Air Force.

*Lecture Series in Differential Equations*, Joint Graduate Consortium of area universities (September 1965 to July 1967, Washington, D.C.).

*International Symposium on Animal Toxins*, Los Angeles County Hospital (8-11 Apr. 1966, Atlantic City, N.J.).

*Conference on Current and Future Problems in Chemistry at High Temperatures*, National Academy of Sciences (26 Jan. 1966, Houston, Tex.).

*Third Coral Gables Conference on Symmetry of Principles at High Energy*, University of Miami (20-22 Jan. 1966, Coral Gables, Fla.).

*International Symposium on Information Theory*, Institute for Electrical and Electronics Engineers (31 Jan.-2 Feb. 1966, UCLA).

*Gordon Research Conference on The Formulation of Research Policies*, AAAS (31 Jan.-4 Feb. 1966, Santa Barbara, Calif.).

*Williamsburg Conference on Intermediate Energy Physics*, College of William and Mary (10-12 Feb. 1966, Williamsburg, Va.).

*International Conference on Isobaric Spin in Nuclear Physics*, Florida State University (17-19 Mar. 1966, Tallahassee, Fla.).

*Mathematical Aspects of Computer Science*, American Mathematical Society (5-7 Apr. 1966, New York, N.Y.).

*Symposium on Generalized Networks*, 16th Microwave Research Institute, Polytechnic Institution of Brooklyn (12-14 Apr. 1966, New York, N.Y.).

*Symposium on Electrode Processes*, The Electrochemical Society (1-6 May 1966, Cleveland, Ohio).

*Symposium on Numerical Analysis*, Society for Industrial and Applied Mathematics (11-14 May 1966, Iowa City, Iowa).

*Fifth U.S. National Congress of Applied Mechanics*, University of Minnesota (14-16 June 1966, Minneapolis, Minn.).

*Conference on Air S. -like Hazard to Aircraft*, University of California (7-9 June 1966, Davis, Calif.).

*Cold Spring Harbor Symposium on Quantitative Biology*, Cold Spring Harbor Laboratory of Quantitative Biology (June 1966, Cold Spring Harbor, N.Y.).

*Symposium on Simulation and Simulators of Dynamic Systems*, Westinghouse Defense and Space Center (June 1966, Baltimore, Md.).

*Topics in Celestial Mechanics and Applications to Space Research*, NATO (27 June-15 July 1966, Driebergen, Netherlands).

*Fifth International Symposium on Rarefied Gas Dynamics*, Oxford University (4-8 July 1966, Oxford, England).

*Gordon Conference on Developing Information Systems (National and International Networks)*, AAAS (18-22 July 1966, New Hampton, N.H.).

*Gordon Conference on High Temperature Chemistry*, AAAS (22-29 July 1966, New Hampton, N.H.).

*Systems Theory in Anthropology*, Wenner-Gren Foundation for Anthropological Research (23-31 July 1966, Almuenster, Austria).

*Symposium on the Biota of the Amazon Basin*, Association of Tropical Biology (6-11 June 1966, Belem, Para, Brazil).

*Second Rochester Conference on Coherence and Quantum Optics*, University of Rochester (22-24 June 1966, Rochester, N.Y.).

*The Eleventh Combustion Institute of the International Symposium on Combustion*, The Combustion Institute (14-19 Aug. 1966, University of California, Berkeley, Calif.).

*International Symposium of Genetics*, Brazilian Society of Genetics (25-31 July 1966, Sao Paulo, Brazil).

*1966 Linguistic Institute Conference on Linguistic Method*, University of California (1-3 Aug. 1966, Los Angeles, Calif.).

*Gordon Research Conference on Inorganic Chemistry*, AAAS (8-12 Aug. 1966, New Hampton, N.H.).

*The Application of Generalized Functions to System Theory*, Society for Industrial and Applied Mathematics (25-26 Aug. 1966, Stony Brook, N.Y.).

*Eleventh Pacific Science Conference*, National Academy of Sciences (22 Aug.-19 Sept. 1966, Tokyo, Japan).

*Second International Biophysics Congress*, National Academy of Sciences (5-9 Sept. 1966, Vienna, Austria).

*Conference on Algebraic Theory of Machines with Applications*, University of California (29 Aug.-8 Sept. 1966, Pacific Grove, Calif.).

*Boundary Layers and Turbulence Including Geophysical Applications*, National Academy of Sciences (19-24 Sept. 1966, Kyoto, Japan).

*Bionic Models of the Animal Sonar System*, NATO (26 Sept.-3 Oct. 1966, Villa Falconieri, Frascati, Rome, Italy).

*Conference on Sensitivity Synthesis*, University of Illinois (4 Oct. 1966, Urbana, Ill.).

*Conference on Learning, Remembering and Forgetting*, Stanford University (9-12 Oct. 1966, Santa Ynez Inn, Pacific Palisades, Calif.).

*Colloquium on the Photographic Interaction Between Radiation and Matter*, Society of Photographic Scientists and Engineers (26-27 Oct. 1966, Washington, D.C.).

*Tropical Biology*, Smithsonian Institution (6-9 Nov. 1966, Panama City, Panama).

*Fundamentals of Gas-Surface Interactions*, General Atomic (Dec. 1966, San Diego, Calif.).

## AFOSR Selected Publications List—Primary Sources of Additional Data

The following AFOSR publications are listed to indicate sources of information on the organization and its functions, contract and grant procedures, research program, objectives and research results. Not included here are the volumes of proceedings that result from about 50 conferences and symposia held each year with AFOSR support, and from the numerous AFOSR contractor meetings.

William G. Ashley, *A Study of the Impact of Air Force Research on Defense* (AFOSR 66-2882). Examination of the effect on technology of selected AFOSR research. *The Active Research Program of AFOSR by Scientific Area*. A series of reports summarizing at intervals the entire AFOSR research program.

*AFOSR Achievements, 1966*. One of a series of reports documenting selected results of AFOSR research of immediate significance to the Air Force.

*AFOSR Chemistry Program Review, 1966*. Twelfth in a series of annual reports of the research supported by the directorate of chemical sciences.

*AFOSR Contracts for Basic Research*. A guide to the preparation and administration of AFOSR contracts.

*AFOSR Coupling Activities 1966*. One of a series of reports on AFOSR activities to make results of AFOSR research available to Air Force activities and their contractors.

*AFOSR Grants for Basic Research*. A guide to the preparation and administration of AFOSR grants.

*AFOSR Programs*. A summary of the organization, its objectives and the program areas in which AFOSR sponsors scientific research.

*AFOSR 12th Science Seminar*. Objectives, abstracts and program for the 1967 AFOSR summer seminar, Albuquerque, N. Mex.

*Air Force Research Objectives (OAR)*. One of a series of publications outlining the scope and objectives of the OAR research program, including that of AFOSR.

*Air Force Research Résumés*. Complete listing with scientific abstracts of the AFOSR research program. 1965 in press; 1964 and later lists complete OAR extramural program; 1963; 1961-62, 1960, and 1959 are entitled "Basic Research Résumés."

*Air Force Scientific Research Bibliography*. I, 1950-56 (1961); II, 1957-58 (1964); III, 1959 (1965); IV, 1960 (1967); V, in preparation. Abstracts of publications produced through AFOSR research support.

*Information Sciences 1965*. Third in a series of annual reports of the research supported by the AFOSR Directorate of Information Sciences.

Maj. Carl S. Jennings and William J. Price, "Computers in

the Research Administration Process" (AFOSR 66-0658).

*LORE, List of OAR Research Efforts by State and Country*. Basic listing of OAR grants and contracts as well as inhouse efforts to facilitate coupling between research activities and exploratory and system-development programs. (1966)

*OAR Progress, 1966*. One of a series of reviews of activities, including AFOSR research, of the Office of Aerospace Research.

*OAR Research Review, 1-5*. Monthly review of research results, including AFOSR program.

William J. Price, "The AFOSR as an Air Force Activity to Utilize the Extramural Science-Oriented Community," in *The Fundamental Research Activity in a Technology-Dependent Organization*, Tenth Institute on Research Administration, The American University (AFOSR 65-2091).

William J. Price, *The R. & D. Organization's Fundamental Research Activity as a Window Between Science and Technology* (AFOSR 65-0664, AD 616834).

William J. Price, *The Importance of Properly Describing the Objectives of the AFOSR Program* (AFOSR 66-0191).

*Proceedings of the OAR Research Applications Conference* (OAR, 1966; 1967). Includes AFOSR research presentations of significant DOD interest.

*Science in the Sixties* (AFOSR, 1965). A collection of articles by AFOSR-supported researchers and originally presented as lectures at the Tenth Anniversary AFOSR Science Seminar, Cloudcroft, N. Mex., June 1965.

*Science and the Air Force*. A history of the Air Force Office of Scientific Research, Office of Aerospace Research (OAR 66-7).

Rowena W. Swanson, *Cybernetics in Europe and the USSR—Activities, Plans and Impressions* (AFOSR 66-0579). National policies and resources to aid communication.

Rowena W. Swanson, *Information System Networks . . . Let's Profit From What We Know* (AFOSR 66-0673). A systems engineering approach to information systems.

*U.S. Air Force Achievements in Research* (OAR, 1965). Selected OAR research results, including more than 50 from the AFOSR program since 1956.

*VELA UNIFORM Research in Seismology*. A review of the 48 research efforts scientifically monitored and administered since 1961 by AFOSR Geophysics Division for the Advanced Research Projects Agency (1965).

Harold A. Wootter, *As Long As You're Up Get Me a Grant—the Preparation of Unsolicited Research Proposals* (AFOSR 65-0392). A guide to proposal writing techniques.

Security Classification

DOCUMENT CONTROL DATA - R & D		
<i>(Security classification of title, body of abstract and indexing annotation must be entered when the overall report is classified)</i>		
1. ORIGINATING ACTIVITY (Corporate author)		2a. REPORT SECURITY CLASSIFICATION
Air Force Office of Scientific Research Office of Aerospace Research, USAF Arlington, Virginia 22209		UNC
2. REPORT TITLE		2b. GROUP
AFOSR Research		
4. DESCRIPTIVE NOTES (Type of report and inclusive dates)		
Scientific special		
3. AUTHOR(S) (First name, middle initial, last name)		
Dan Taylor, Editor		
6. REPORT DATE	7a. TOTAL NO. OF PAGES	7b. NO. OF REFS
1967	229	--
8a. CONTRACT OR GRANT NO.	8b. ORIGINATOR'S REPORT NUMBER(S)	
8. PROJECT NO.		
61445014		
c.	9b. OTHER REPORT NO(S) (Any other numbers that may be assigned this report)	
d.	AFOSR 67-0300	
10. DISTRIBUTION STATEMENT		
1. DISTRIBUTION OF THIS DOCUMENT IS UNLIMITED		
11. SUPPLEMENTARY NOTES		12. SPONSORING MILITARY ACTIVITY
TECH, OTHER		AFOSR (SRGC) 1400 Wilson Boulevard Arlington, Virginia 22209
13. ABSTRACT		
<p>The organization, program and research accomplishments of the Air Force Office of Scientific Research, a unit of the Office of Aerospace Research, USAF, are described. Emphasis is placed upon the role of AFOSR in procuring and managing a program of basic research in the sciences, carried out at university, industrial and non-profit research organizations worldwide, in response to current and long range Air Force technological interests and requirements. The research program is presented to enable Air Force user organizations and DOD research administrators and managers to gain immediate access to on-going research of direct and related interest, and to gain more detailed understanding of all AFOSR activities, and particularly those designed to couple research and research applications.</p>		

DD FORM 1 NOV 66 1473

Security Classification

Security Classification

14 KEY WORDS	LINK A		LINK B		LINK C	
	ROLE	A*	ROLE	A*	ROLE	A*
Air Force Office of Scientific Research Office of Aerospace Research, USAF basic research mathematical sciences nuclear physics solid state sciences general physics geophysics chemical sciences behavioral sciences biological sciences electronics mechanics propulsion research accomplishments coupling relevancy conferences and symposia						

Security Classification