

AD656501



THE EFFECT OF CARBON BLACK SURFACE PROPERTIES
ON THE STABILITY OF POLYETHYLENE

John T. Moynihan,
Acheson Dispersed Pigments Company,
2250 E. Ontario Street,
Philadelphia 34, Pa.

FIFTH ANNUAL SYMPOSIUM ON
"TECHNICAL PROGRESS IN
COMMUNICATION WIRFS AND CABLES",
ASBURY PARK, N. J.

December 4, 1956

RECEIVED

AUG 21 1967

CFSTI

This document is approved
for public release and sale; its
distribution is unlimited.

DDC
REGISTERED
AUG 11 1967
UNCLASSIFIED
C

THE EFFECT OF CARBON BLACK SURFACE PROPERTIES
ON THE STABILITY OF POLYETHYLENE

Introduction

Carbon black has been found to be the most effective stabilizer for polyethylene plastic with respect to degradation due to light and weathering (1, 2). This stability is very important when the material is subjected to exposure to sunlight and weathering over long periods of time such as in electrical cable sheathing applications (3) and in plastic pipe. A study of the interrelation between the plastic and the carbon black surface is important so that future increases in stability may result. For example, the distribution of the carbon black surface within the polyethylene mass is an important consideration for stability.

One obvious characteristic of carbon black as a light stabilizer in polyethylene is that it absorbs light throughout the entire range of the spectrum and so protects the interior of the plastic into which it is incorporated from the penetration of high energy photons. The solar spectrum at the surface of the earth does not extend effectively, that is with appreciable intensity, below a wavelength, in the ultraviolet of 280 millimicrons. Above 300 millimicrons, the intensity increases rapidly with increasing wavelength (4). Thus, in considering the photochemical degradation of polyethylene, we must look for structures which absorb energy at wavelengths greater than 300 millimicrons.

Tables 1 and 2 compare the energy per mole of photons (one einstein) at various wavelengths with the bond energies present in unfilled polyethylene plastic (5).

<u>Table 1</u>		<u>Table 2</u>	
<u>Wavelength</u>	<u>Energy</u>	<u>Bond</u>	<u>Energy</u>
300 millimicrons	95.3 Kcal/einstein	C-C	62.77
400 millimicrons	71.5 Kcal/einstein	C-H	85.56
500 millimicrons	57.2 Kcal/einstein		

It is apparent that the energies present at greatest intensity on the surface of the earth are those likely to cause breakage of the carbon-carbon bonds and degradation of the polymer.

Wavelengths much in excess of 400 millimicrons do not have sufficient energy to cause damage to the polymer. In the presence

of oxygen, carbon-oxygen bonds may form in a chain terminating reaction before the polymer segments have a chance to reform or cross-link. This serves to explain the presence of aldehydes, ketones, and acids in the degradation products of polyethylene degraded in the presence of oxygen (6). On the other hand, hydrocarbons result when the polymer is degraded in the absence of oxygen (7). The preponderance of chain terminating steps in the reaction in the presence of oxygen helps explain the accelerated deterioration of polyethylene during weathering, that is, in the presence of atmospheric oxygen. When carbon black and polyethylene are subjected to even higher energies than those presented in Table 1, such as those from a van der Graaf generator, the physical stability of the material is preserved due to the presence of carbon black. Here, because of increased energy penetration, the distribution of carbon black surface within the plastic is also very important. The dispersed surface provides greater opportunity for interaction with polymer radicals to form connecting links of the polymer-carbon-polymer type.

It is apparent from the previous discussion that energy may break carbon-carbon bonds or carbon-hydrogen bonds with the formation of polymer free radicals, activated or reactive polymer molecules, methyl radicals, hydrogen radicals and other radicals (8). Szwarc (9), among others, has recently pointed out how the carbon surface may take up free radicals before they may react with additional polymer and degrade it. Let us now examine the carbon black surface in more detail. Fig. 1 (10) shows a schematic diagram of a typical soft carbon surface which is composed of condensed aromatic rings in the stacked planes characteristic of a graphite structure. In between the graphite areas are hard carbon regions which are disordered arrangements of carbon atoms. Fig. 2 shows how the sigma and π electrons are located at the edges of the condensed aromatic structure and also the π electron within the condensed structure.

In actual fact, the carbon black surface is not entirely π and sigma electrons as shown, but many of the edge positions are saturated with hydroxyl, carboxyl, phenolic, aldehyde and quinone type oxygen-containing groups and also hydrogen (11), which serve to take up some of these electrons. The amount of oxygen occupying the surface at the edges will vary with the conditions of carbon black manufacture.

The carbon black in the polyethylene will, then, stabilize by two mechanisms, light absorption and free radical reaction first at active edge positions of the graphite planes and also in a secondary reaction with π electrons within the condensed aromatic structure. Certainly the ability of the carbon black surface to absorb light and to accept free radicals will be a function of the amount of surface which is exposed to the plastic, that is a function of the degree of dispersion. If the amount of

dispersion of the carbon black is improved then it follows that the stability of the plastic will improve.

Results

Schaeffer, et al. (12), have shown how the chemisorbed oxygen can be removed from the carbon black surface by heat treatment to 1000°C in a vacuum. Consequently, a channel black with an average particle size of 17 millimicrons was subjected to heat treatment while being evacuated so that the oxygen content of the surface would vary. The material was then immediately dispersed at 2% concentration in polyethylene. This polyethylene had a melt index of 0.3 and a density of 0.92. The temperature was controlled at 235°F ± 5°F.

The method for measuring the degree of dispersion attained was by the use of an optical density comparison scale of 0 to 30, the zero representing the finest possible degree of colloidal dispersion as viewed microscopically at 100 power magnification. The 30 represents essentially no dispersion. The correlation with the proposed ASTM D20-Subcommittee VII optical density method, is shown in Fig. 3. Here a visual daylight filter was employed with a mercury vapor lamp in a microphotometer. The absorptivity, a , is defined as follows:

$$a = \frac{A}{bc}$$

$$A = \text{absorbance} = \log \frac{1}{T} = \text{optical density}$$

T = transmittance

b = thickness of the specimen (cm.)

c = concentration of carbon black (grams/cc.)

$$\log = \log_{10}$$

The more arbitrary optical scale comparison method was used because all the samples were dispersed at the same concentration, shear and temperature, so that a microscopic evaluation in an approximately linear manner afforded greater speed. Nevertheless, the ASTM method is more reproducible especially when smaller differences in dispersion are encountered than those which were obtained in making large surface changes in carbon black in this study.

Constant shear was employed because of the effect of this variable, shown in Fig. 4. All of the above conditions were controlled to make certain that the dispersion obtained would be a function of the carbon surface itself.

The effect of varying the surface oxygen content on the degree of dispersion is shown in Figs. 5 and 6. Treatments with hydrogen, ethylene and other materials are shown in Fig. 7. The change in surface area following evacuation was relatively small as shown by iodine adsorption values on the pigment. It is to be expected that with increasing surface area of the pigment the degree of dispersion obtained under the same conditions will be less. This is because of the greater energy required to cover this increased surface. However, if two pigments are compared as in Fig. 8, which vary greatly in surface area, the presence of surface oxygen seems to overcome the factor of increased surface area in comparison to a pigment where the surface is primarily hydrogen groups.

Discussion

Fig. 9 is a schematic drawing of what seems to occur in plastic dispersion. From a consideration of the above data, it appears likely that at constant temperature, rate of shear, surface area as calculated from electron-microscope measurement, and time of dispersion, the effect of the carbon black surface on the degree of dispersion as measured by optical density may be described by the following semi-empirical relation:

$$(1) \quad d = k \frac{E_{cp}}{E_{cc}}$$

where

d = the degree of dispersion as measured by optical density

k = the fraction of oxygen on the carbon surface

E_{cp} = the bond energy of the carbon-polymer bonds

E_{cc} = the bond energy of the carbon-carbon bonds

The carbon-carbon bond is undoubtedly a van der Waals bond of the hydrogen bond type, the energies of which decrease in the following order between hydrogen and another atom which may be fluorine, oxygen, nitrogen, chlorine or sulfur (13). The bond between a CH containing surface and another CH containing surface is so weak as to be negligible. Therefore, since the bonds formed between carbon particles are between carbon oxygen groups which have a bond energy of 8 kilocalories and the bond between the carbon surface and the polymer may be a chemical bond, C-O-R (Polymer), of 75 kilocalories, a plot of these energies in the above equation versus the degree of dispersion assuming an equal chance for carbon-polymer bonds and carbon-carbon bonds to form, is shown in Fig. 10. The bond energies, E_{cp} and E_{cc} , would each

be modified by a factor n, equal to the number of bonds, if the distribution of bonds could be evaluated. Since the number of carbon-polymer bonds has not been determined, the exact relationship is still not known. However, the calculation appears related to the observed degrees of dispersion.

Another possible chemical bond is that between a polymer scission fragment broken off during dispersion at high shear which combines with the electrons of the carbon surface in a carbon-polymer bond.

Although the representation or model presented by the above equation may help explain some of the observations by the mechanism of a carbon to polymer chemical bond, an explanation on the basis of van der Waals forces alone is possible. The carbon particles are small spheres. In the aggregated condition the points of contact between spheres is confined to a small area as shown in Figure 11. Since the van der Waals attraction decreases by a factor of $1/r^7$ as the distance, r, between the surface atoms increases, it is readily seen that the number of the van der Waals bonds between the carbon particles will be small in comparison to the number of bonds between the carbon and the polymer. The more deformable, mobile polymer should establish a greater number of bonds with which to overcome the carbon-carbon attraction. Assuming that the van der Waals attraction is negligible after a distance along the radius of curvature of the particle equal to 30 angstrom units, a ratio of the area available on each particle for carbon-polymer bonds to that available for carbon-carbon bonds both at 8 kilocalories per mole is roughly 30 to 1. These areas are represented in Fig. 11, in addition to a typical van der Waals bond between carboxyl and hydroxyl groups on adjacent carbon particles. Insertion of these modifications into equation (1) yields the following revision:

$$(2) \quad d = \mathcal{L} \, kr \frac{E_{cp}}{E_{cc}} + b$$

where \mathcal{L} = a proportionality constant for the dispersion scale employed

k = the fraction of oxygen on the carbon surface

r = the ratio of the areas of carbon-polymer attraction and carbon-carbon attraction

kr is a constant for any one carbon black dispersion

$E_{cp} = E_{cc} = 8$ for O---H bonds, or $d = \mathcal{L} \, kr$

b = the intercept

A plot of this equation, kr versus d, produces a line with a slope similar to Fig. 10.

The actual situation in plastic dispersion may be a composite of these two models, with the latter model always present and the chemical bond model also present to a degree dependent on dispersion conditions.

LITERATURE CITED

1. Dannenberg, E.M., Jordan, M.E., and Stokes, C.A., *India Rubber World* - 122, 663-671 (1950)
2. Haibauer, A.E., and Myers, C.S., *Polyethylenes*. *Transactions of the Electrochemical Society* - 90, 341 (1946)
3. Wallder, V.T., Clarke, W.J., DeCoste, J.B. and Howard, J.B., *Weathering Studies in Polyethylene for Wire and Cable Applications*, paper presented before the Division of Paint, Varnish and Plastics Chemistry of the A.C.S., Detroit, April 1950.
4. Gusman, S. and Stroup, J.D. *Deterioration of Synthetic Enamels I. Absorption of Solar Energy*. Paper presented at the Cincinnati Meeting A.C.S., Division of Paint, Plastics and Printing Ink Chemistry, April 1955.
5. Syrkin, Y.K., and Dyatkina, M.E., Structure of Molecules and the Chemical Bond, 240 - Interscience, New York 1950.
6. Beachell, H.C., and Nemphros, S.P., *J. Polymer Science*, 21, 116 (1956)
7. Madorski, S.L., *Rates of Thermal Degradation of Polystyrene and Polyethylene in a Vacuum*. Circular 525, 221-235, Nov. 1953. U.S. National Bureau of Standards.
8. Sun, K.H. *Effects of Atomic Radiation on High Polymers*. *Modern Plastics*, p. 146, Sept. 1954.
9. Szwarc, M. *The Action of Carbon Black in Stabilizing Polymeric Materials*. *J. Polymer Science*, 29, 589 (1956)
10. Loebner, E.E. *Thermoelectric Power, Electrical Resistance and Crystalline Structure of Carbons*. Dissertation, Graduate School, University of Buffalo, May 1955.
11. Studebaker, M.L., Huffman, E.W.D., Wolfe, A.C., and Nabors, L.G. *Oxygen-Containing Groups on the Surface of Carbon Black*. *Industrial & Engineering Chemistry* - 48, 162 (1956)
12. Schaeffer, W.D., Smith, W.R., and Polley, M.H. *Structure and Properties of Carbon Black. Changes Induced by Heat Treatment*. *Industrial & Engineering Chemistry* - 45, 1724 (1953)
13. Syrkin, Y.K. - *ibid.* (5) p. 276

FIG. 1 SOFT CARBON - AFTER LOEBNER.

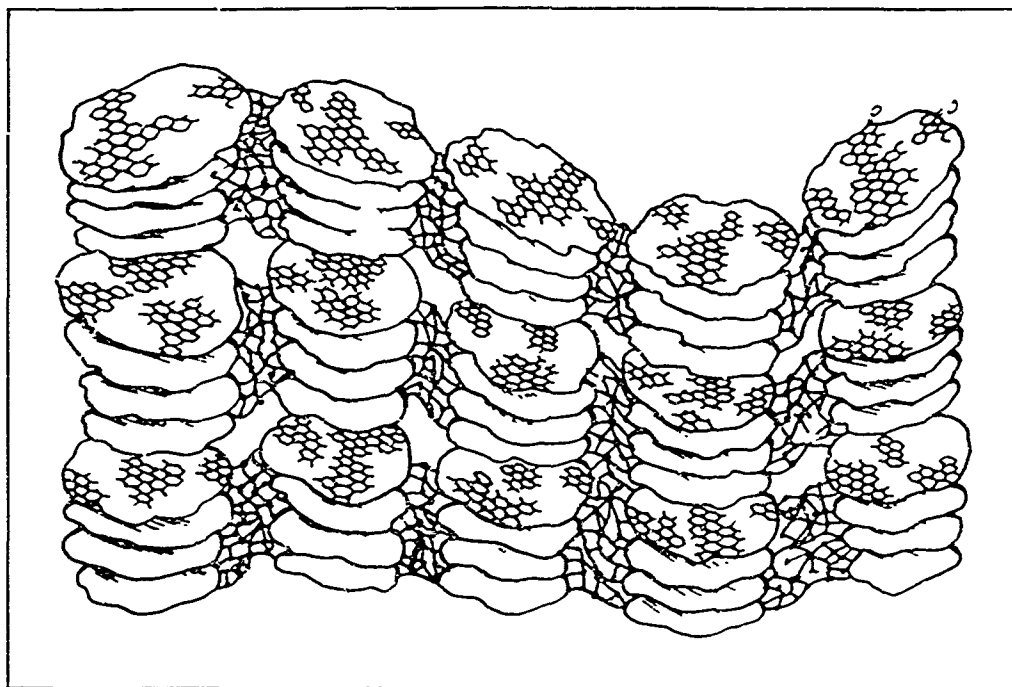

FIG. 2 SCHEMATIC DRAWING OF ELECTRON DISTRIBUTION FOR CARBON SURFACE

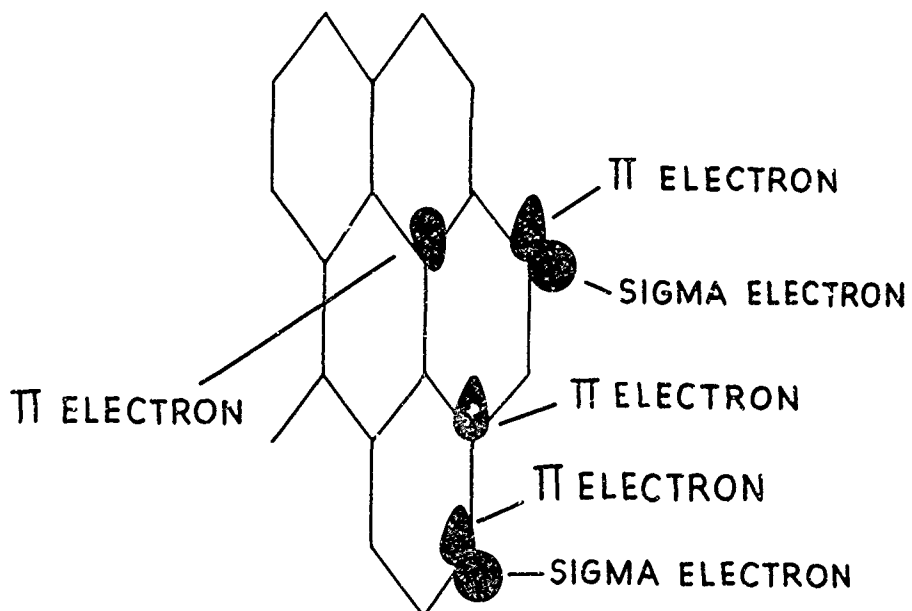

FIG. 3. CORRELATION OF DISPERSION RATING SCALE WITH ABSORPTIVITY

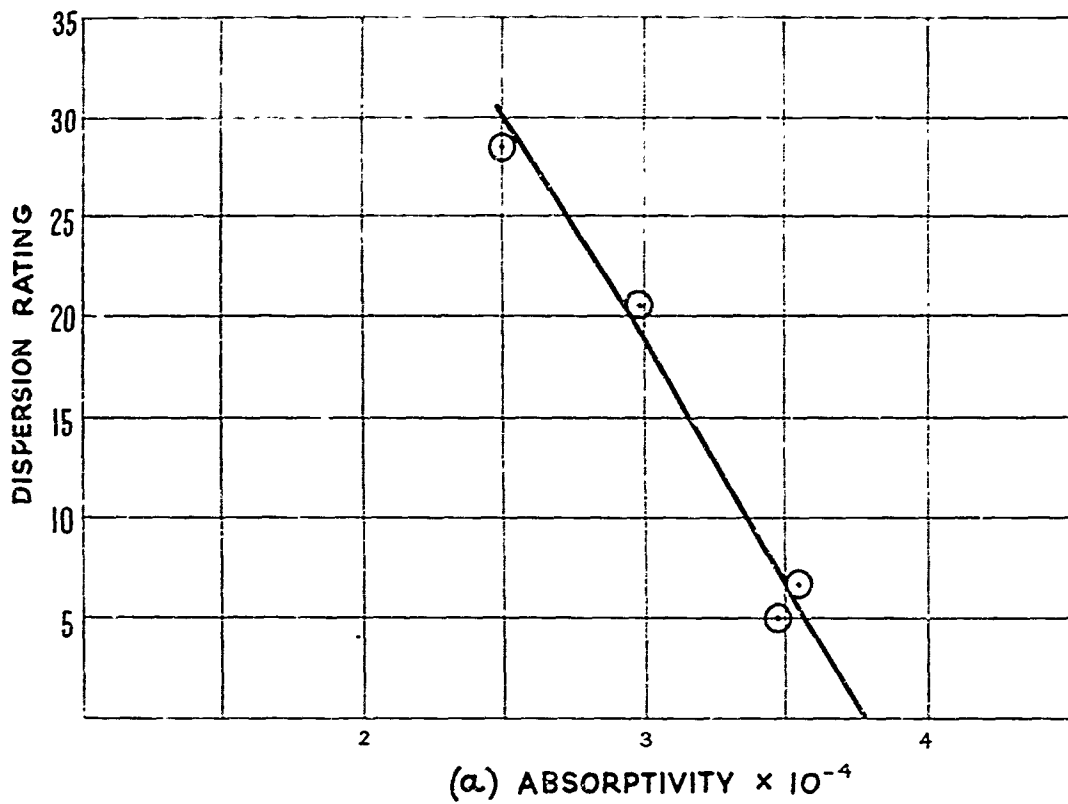

FIG. 4 VARIATION IN DEGREE OF DISPERSION WITH CHANGING RATE OF SHEAR

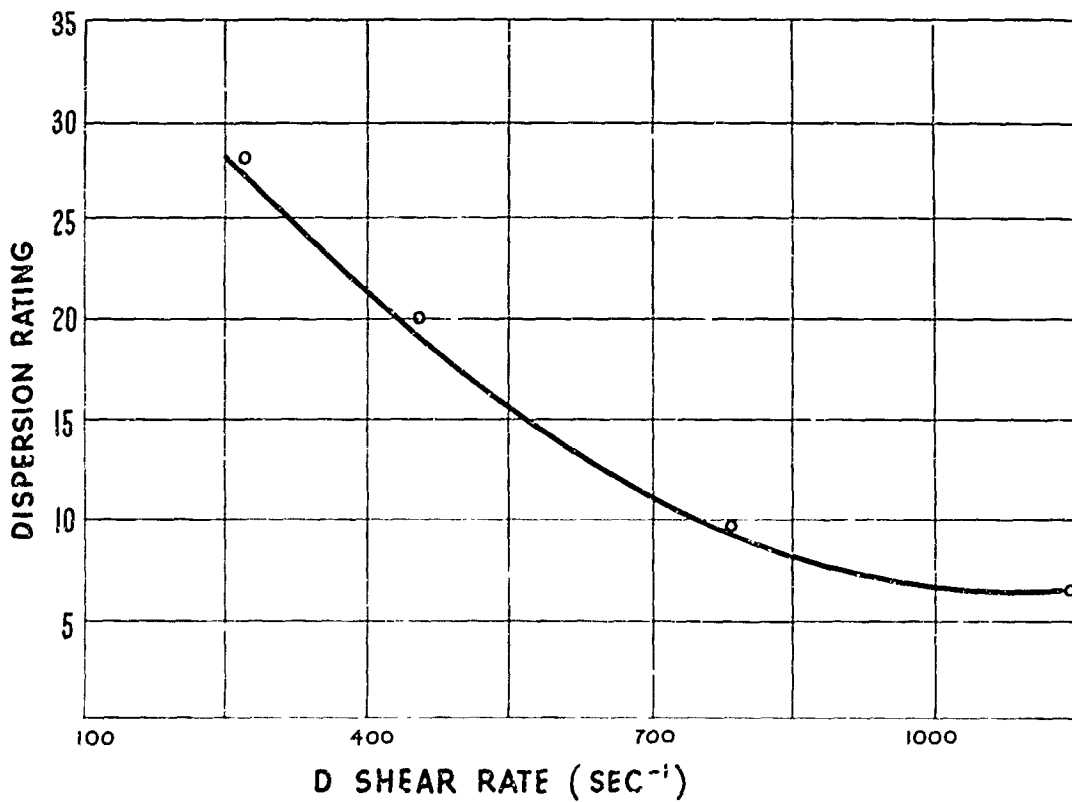

FIG. 5 CHANGE IN DEGREE OF DISPERSION WITH HEAT TREATMENT

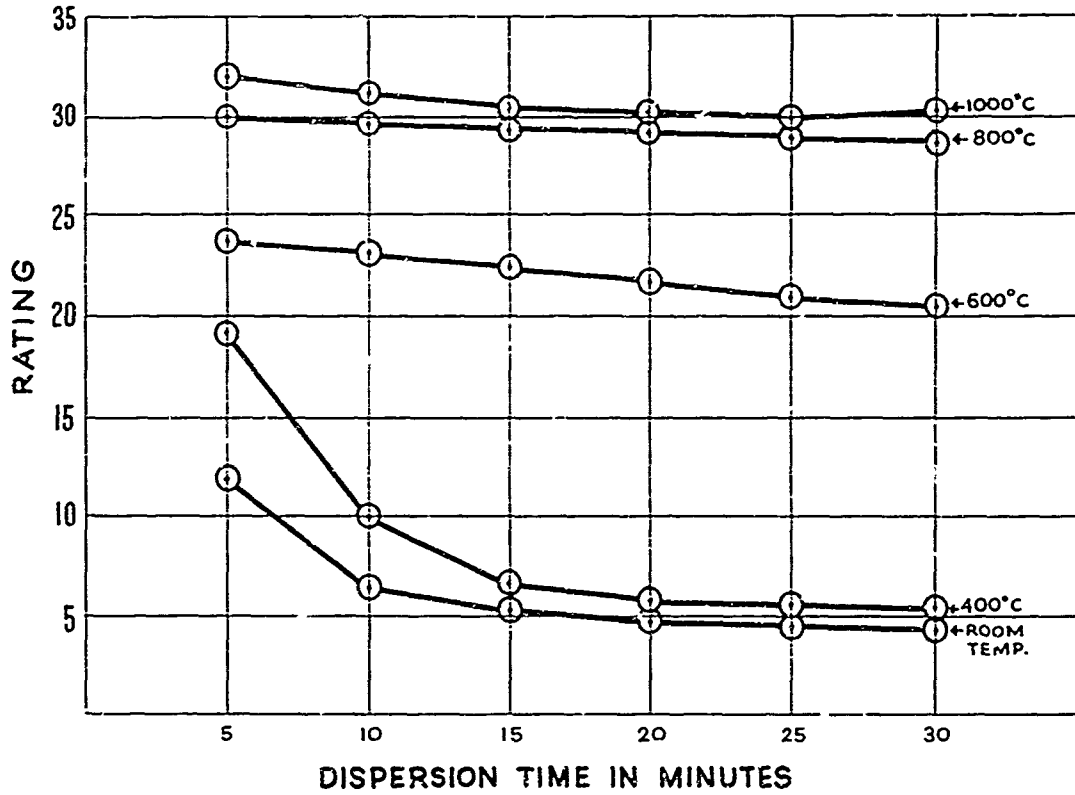

FIG. 6 VARIATION IN DEGREE OF DISPERSION WITH CHANGING SURFACE OXYGEN CONTENT

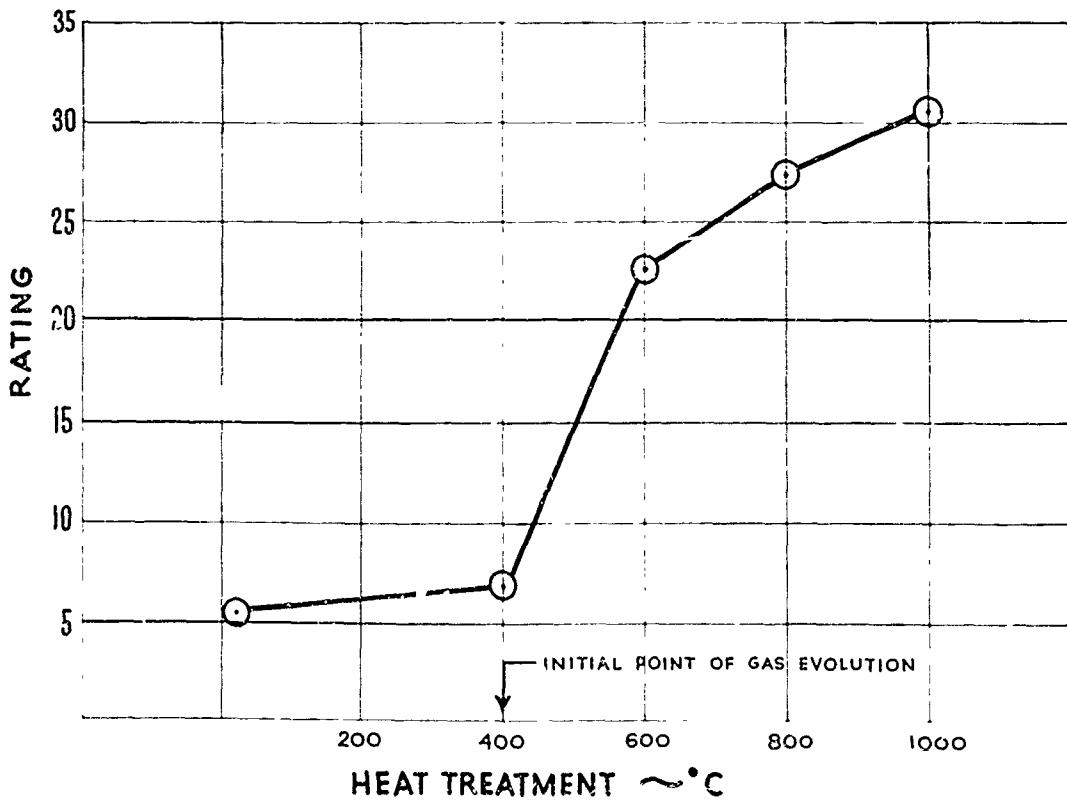

FIG. 7 EFFECT OF CARBON SURFACE TREATMENTS ON DEGREE OF DISPERSION

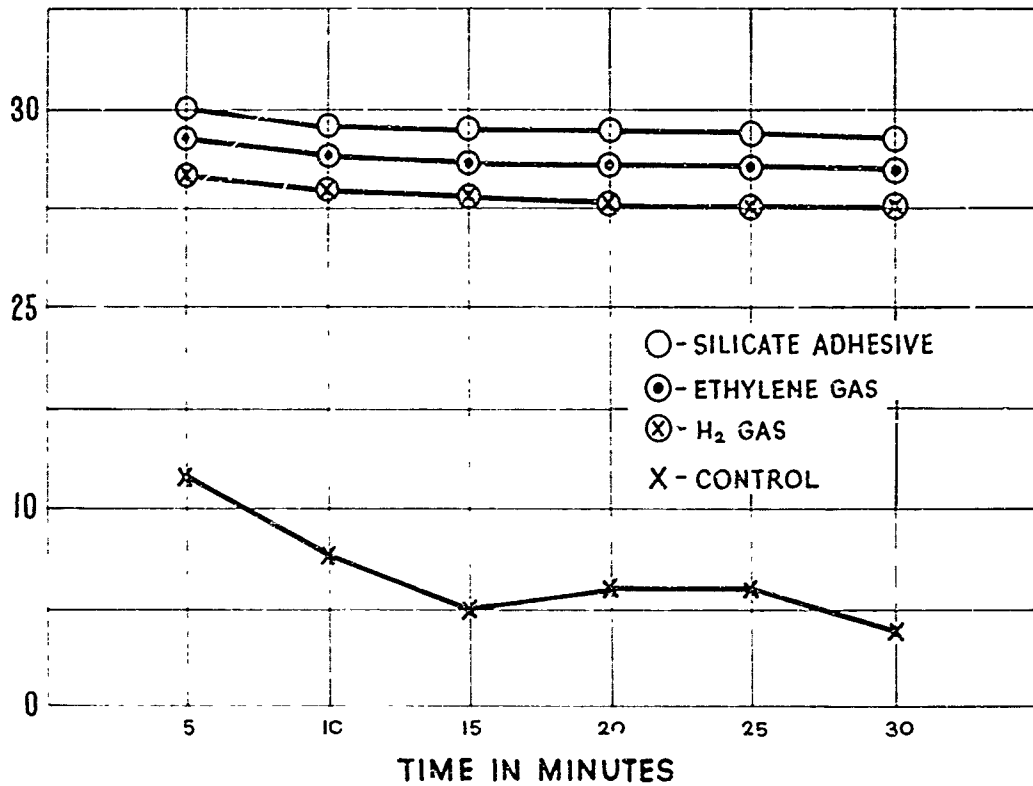

FIG. 8 COMPARISON OF DISPERSIONS FOR CARBON BLACKS OF DIFFERENT SURFACE AREAS AND SURFACE OXYGEN CONTENTS

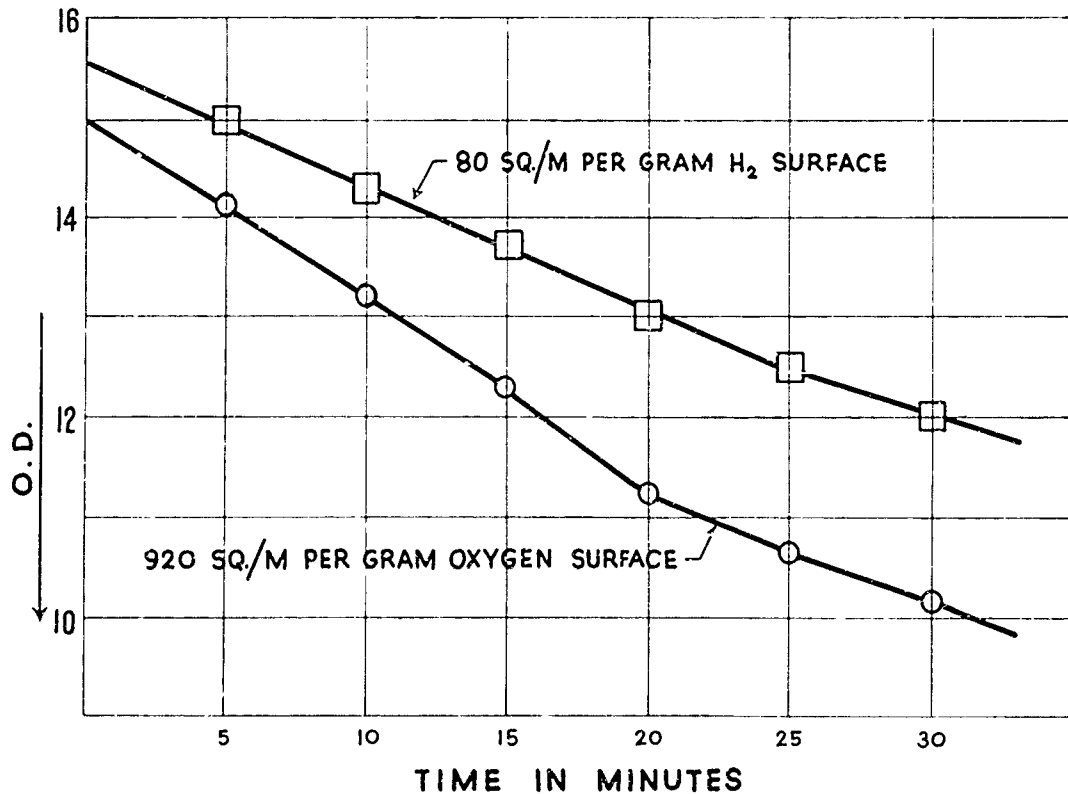

FIG. 9 SCHEMATIC DRAWING
OF TWO CARBON PARTICLES UNDERGOING
PLASTIC DISPERSION

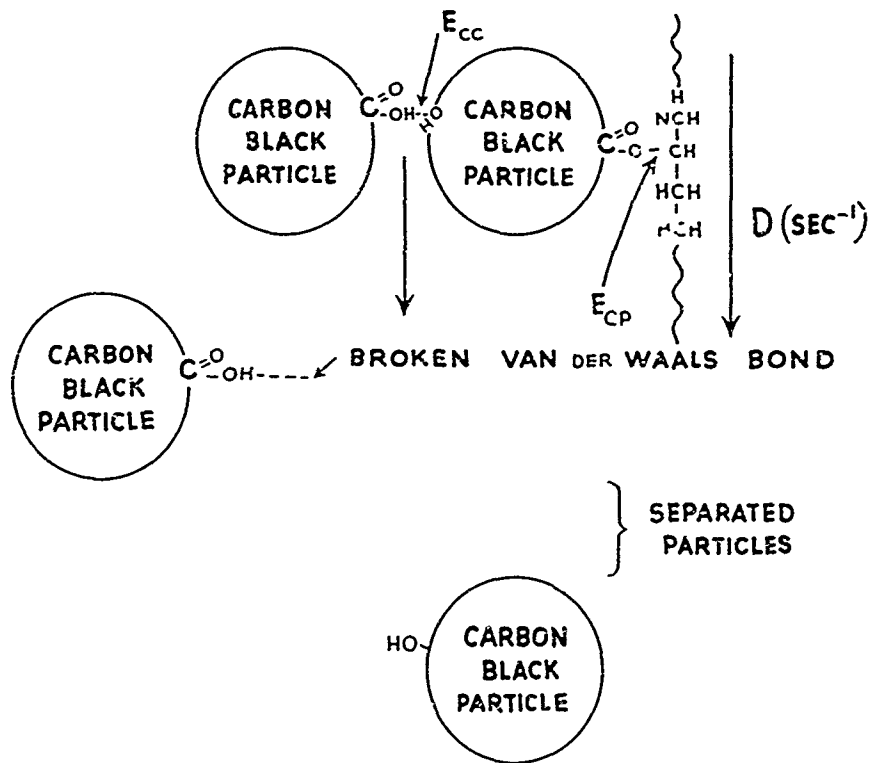

FIG. 10. PLOT OF DEGREE OF DISPERSION
(vs) RELATIVE BOND ENERGIES

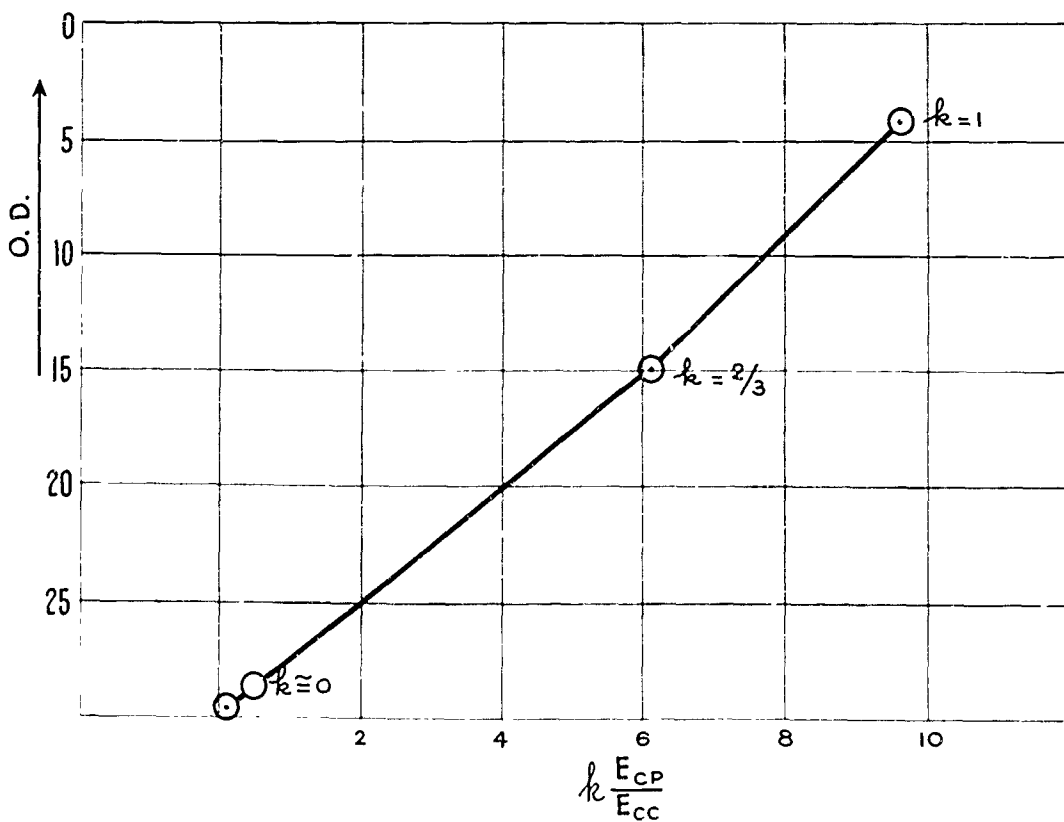

FIG. II

SCHMATIC COMPARISON OF
VAN DER WAALS FORCES FOR TWO CONTACTING
CARBON PARTICLES

