

AD 605 372

DMIC Report 203

May 8, 1964

COPY <u>1</u> OF <u>3</u> <sup>72p.</sup>	
HARD COPY	\$ .3.00
MICROFICHE	\$ .0.75

## EXPLOSIVE FORMING OF METALS

DEFENSE METALS INFORMATION CENTER

Battelle Memorial Institute

Columbus, Ohio 43201

The Defense Metals Information Center was established at Battelle Memorial Institute at the request of the Office of the Director of Defense Research and Engineering to provide Government contractors and their suppliers technical assistance and information on titanium, beryllium, magnesium, aluminum, refractory metals, high-strength alloys for high-temperature service, corrosion- and oxidation-resistant coatings, and thermal-protection systems. Its functions, under the direction of the Office of the Director of Defense Research and Engineering, are as follows:

1. To collect, store, and disseminate technical information on the current status of research and development of the above materials.
2. To supplement established Service activities in providing technical advisory services to producers, melters, and fabricators of the above materials, and to designers and fabricators of military equipment containing these materials.
3. To assist the Government agencies and their contractors in developing technical data required for preparation of specifications for the above materials.
4. On assignment, to conduct surveys, or laboratory research investigations, mainly of a short-range nature, as required, to ascertain causes of troubles encountered by fabricators, or to fill minor gaps in established research programs.

Contract No. AF 33(615)-1121  
Project No. 8975

*Roger J. Runck*

Roger J. Runck  
Director

"The information in this report came from many sources, and the original language may have been extensively quoted. Quotations should credit the original authors and the originating agency. Where patent questions appear to be involved, the usual preliminary search is advised before making use of the material, and where copy-righted material is used, permission should be obtained for its further publication."

**COPIES AVAILABLE FROM OTS \$ .....**

DMIC Report 203  
May 8, 1964

**EXPLOSIVE FORMING OF METALS**

by

**D. E. Strohecker, R. J. Carlson,  
S. W. Porembka, Jr., and F. W. Boulger**

to

**OFFICE OF THE DIRECTOR OF DEFENSE  
RESEARCH AND ENGINEERING**

**DEFENSE METALS INFORMATION CENTER  
Battelle Memorial Institute  
Columbus, Ohio 43201**

TABLE OF CONTENTS

	<u>Page</u>		<u>Page</u>
SUMMARY . . . . .	i	Transmission Mediums . . . . .	26
INTRODUCTION . . . . .	1	Liquid Mediums . . . . .	26
EXPLOSIVES AND THEIR CHARACTERISTICS . . . . .	1	Solid Mediums . . . . .	28
Characteristics of Some Secondary		Shock-Wave Transmission . . . . .	28
High Explosives . . . . .	2	CURRENT APPLICATIONS OF	
TNT (Trinitrotoluene) . . . . .	3	EXPLOSIVE FORMING . . . . .	29
Tetryl (Trinitrophenylmethylnitramine) . . . . .	3	Sheet Forming . . . . .	29
RDX (Cyclotrimethylenetrinitramine) . . . . .	3	Tooling Considerations . . . . .	29
PETN (Pentaerythrite Tetranitrate) . . . . .	3	Size Limitations . . . . .	30
Nitrostarch, Nitrocellulose, Guncotton . . . . .	3	Tolerances . . . . .	30
NG, Nitroglycerin . . . . .	4	Placement of Explosive Charges . . . . .	31
Composition B . . . . .	4	Formability Limits of Sheet Materials . . . . .	31
Compositions C-3 and C-4 . . . . .	4	Economic of Explosive Sheet Forming . . . . .	32
Dynamites . . . . .	4	Examples of Explosively Formed	
Detasheet A and C (EL-506) . . . . .	5	Sheet Materials . . . . .	33
MFXP Explosive . . . . .	5	Plate Forming . . . . .	35
MFX Explosive . . . . .	5	Tooling Considerations . . . . .	35
Aerex Liquid Explosive . . . . .	5	Formability of Plate Materials . . . . .	35
Detonating Fuse . . . . .	5	Explosive-Charge Placement . . . . .	36
Detonators . . . . .	6	Economics of Explosive Plate Forming . . . . .	36
Selection Based on Explosives . . . . .	6	Examples of Explosively Formed	
Selection Based on Function . . . . .	6	Plate Materials . . . . .	36
EXPLOSIVE-FORMING TECHNIQUES . . . . .	7	Tube Forming . . . . .	39
Systems . . . . .	7	Tooling Considerations . . . . .	39
Reflectors . . . . .	9	Formability of Tube Materials . . . . .	40
Holding the Charge in Position . . . . .	9	Explosive-Charge Placement . . . . .	40
Charge Preparation . . . . .	9	Economics of Explosive Tube Forming . . . . .	40
Connection of Blasting Caps . . . . .	9	Examples of Explosively Formed Tubes . . . . .	40
Preparation of Material Prior to		Forming Welded Sheet-Metal Preforms . . . . .	41
Explosive Forming . . . . .	9	Tooling Considerations . . . . .	42
Edge Preparation . . . . .	10	Formability of Welded Assemblies . . . . .	42
Thermal Treatments . . . . .	10	Explosive-Charge Placement . . . . .	42
Forming of Welds . . . . .	11	Economics of Forming Welded	
EXPLOSIVE-FORMING FACILITIES . . . . .	11	Sheet Assemblies . . . . .	43
Location of a Facility . . . . .	11	Examples of Explosively Formed	
Safety . . . . .	11	Welded Blanks . . . . .	43
Local Regulations . . . . .	12	RESPONSE OF MATERIALS TO HIGH-	
Economics . . . . .	13	VELOCITY FORMING . . . . .	45
Layout of Operations . . . . .	13	Critical Impact Velocity . . . . .	45
Flow of Material . . . . .	14	Effects on Microstructures . . . . .	46
Safety Control . . . . .	14	Formability . . . . .	46
Building Construction . . . . .	14	Mechanical Properties During Forming . . . . .	47
Explosive-Forming Facility Designs . . . . .	15	Static Mechanical Properties of Materials	
Equipment Requirements . . . . .	15	After Explosive Forming . . . . .	47
Water Tank . . . . .	16	Stress-Corrosion Properties of	
Crane . . . . .	17	Explosively Formed Materials . . . . .	50
Vacuum Pump . . . . .	18	THE FUTURE FOR EXPLOSIVE FORMING . . . . .	50
Detonating Circuit . . . . .	18	REFERENCES . . . . .	51
Auxiliary Equipment . . . . .	19		
Safety Considerations . . . . .	20	APPENDIX A	
DIE SYSTEMS AND MATERIALS . . . . .	21	METHODS OF DETERMINING PEAK	
Die Considerations . . . . .	21	PRESSURES AND ENERGY REQUIREMENTS . . . . .	A-1
Hold-Down Ring Design . . . . .	23	Calculation of Peak Pressures . . . . .	A-1
Materials for Solid Dies . . . . .	24	Use of Nomograms . . . . .	A-1
Materials for Composite Dies . . . . .	25	Peak Pressure and Energy Requirements . . . . .	A-3
Lubricants . . . . .	26	References . . . . .	A-5

# EXPLOSIVE FORMING OF METALS

## SUMMARY

In view of the current high level of interest in explosive-metalworking processes, this report has been prepared to review the status of forming materials with high explosives. The information presented has been obtained from the open literature and from firms active in explosive-forming operations. In most cases the process is applied to large or unusual shapes which cannot be readily fabricated by conventional means.

Explosive-metalworking operations can generally be classified as either confined or unconfined systems. The confined system has distinct advantages for the forming of thin materials to close tolerances; however, the nature of the operation imposes a size limitation. Unconfined systems are less efficient because only a small portion of the total energy from the explosive is utilized in the forming operation. This method is particularly attractive, especially for very large pieces, since tooling requirements are greatly simplified.

A wide variety of explosives and detonators used in explosive-forming operations are discussed with emphasis on the secondary high explosives. Both commercial and military types of explosives have been used in forming operations to date. The military types have been employed to a lesser extent and it has been noted that their continuity is not as good as the commercial types. Characteristics of these materials relating to their handling and storage are briefly reviewed. The versatility and wide use of Primacord in explosive operations is particularly noteworthy.

Positioning of the explosive in the proper relation to the workpiece can be achieved by a number of routine methods. In order to prevent misfires and deflagration of the explosive it is necessary to employ the proper size blasting cap and method of attachment as recommended by the explosive manufacturers. Depending on the material to be formed, protection from blasting cap fragments or corrosive action by the water transfer media may be required.

Materials are generally formed in the annealed condition with explosives at ambient temperatures. Intermediate anneals may also be employed between successive forming operations and are determined by prior experience with the particular material. In some cases such as those involving extensive work hardening, stress-relieving treatments are required immediately after forming to prevent delayed cracking due to

residual stresses. For titanium and refractory metals, forming at elevated temperatures is desirable.

Location of an explosive-forming facility must be based on considerations of safety, local regulations, economics, and community relations. Both the initial use and projected future uses must be factored into the decision in order that continued operation may be assured. The layout of operations within such a facility should serve to provide a smooth flow of materials through the work area and permit close control of the operations for maximum safety.

The design of dies for explosive-forming operations is dependent on the peak pressure to be developed during detonation. Once this value is established, conventional methods of stress analysis may be applied to the designs. Die materials in past and current operations have included heat-treated alloy steels, Kirksite, aluminum alloys, ductile iron, reinforced concrete, plastic, ice, and composite materials.

Explosive forming has been used most widely for producing parts from sheet metal. The maximum size of parts which can be formed is limited only by the size of tooling that can be constructed. Tolerances as close as  $\pm 0.001$  inch can be achieved on small parts, but working tolerances are normally 0.010 inch. The nature of various investigations concerning the formability of sheet materials has not yielded quantitative information on formability limits since the efforts have been directed toward specific parts. It has been generally observed that both austenitic and precipitation-hardening stainless steels and aluminum alloys have been formed with very little difficulty. Work-hardened stainless steels are also readily formed with explosives, and through proper scheduling of prior work and annealing, optimum mechanical properties can be obtained after forming. In contrast, carbon steels can withstand only limited deformation.

Increases in strength similar to those resulting from the same amount of deformation in conventional forming have been noted in explosively formed materials. Limited data indicate a decrease in fatigue strength in such materials; however, more detailed studies are required to establish this effect. Similarly, only limited data are available on the effects of explosive forming on stress-corrosion resistance.

## INTRODUCTION

Explosive forming is best described as a process in which metal parts are formed by the high pressures resulting from the detonation of chemical explosives. During the course of development of new forming methods a number of high-energy-rate techniques have been categorized as explosive forming. These methods have included the use of chemical low and high explosives, pneumatic systems, electrical discharge systems, and magnetic devices. In this summary, however, explosive forming will be defined as that relating to chemical high explosives since this approach has been perhaps the most widely investigated and applied.

Interest in this forming method was initiated around the turn of the nineteenth century when it was noted that the energy released from an explosive charge could be used for deforming metals into a useful shape. Some of the earliest English patents on this subject concerned the explosive expanding of tubing in attachment fittings to fabricate bicycle frames. (1)\* Gun-emplacements shields were explosively formed by the French prior to World War II. In the United States, explosive forming of sheet metal was described in a patent issued in 1909. (2) After the initial interest as evidenced by the patent literature little advance was made in explosive forming until more recent years. A more recent United States patent describes the ranges of operating conditions in more detail in terms of process parameter and is presently considered one of the more important patents in this area. (3) In particular, the high-alloy materials and aerospace metals prompted a reevaluation of nonconventional forming methods. As a result the Air Force initiated a comprehensive study of explosive-forming principles in 1957. (4) Further studies in this area have been sponsored by the Air Force, Army, Navy, and NASA.

Along with other recent interests in explosive forming, its use as a production tool has been established. The Moore Company of Marceline, Missouri, has produced Monel metal fan hubs by this technique since 1950, and currently uses the process for small-quantity production lots of large fan hubs. (5) Similarly other firms have

\*References are given on page 51.

accomplished production forming of wheel covers and tank ends. These products represent short-run specialty items. Of particular advantage in these short-run applications are the short lead times required and minimum expenditures for tooling.

Although a considerable amount of effort has been expended in the development of explosive forming, the process has not been widely accepted for commercial manufacturing. Most companies do not have an area available where explosives can be handled. To maintain such an isolated area may increase shipping costs and offset potential economic advantages of the process. In many cases, large-quantity production of parts are involved which can also be fabricated by existing conventional equipment, and the replacement of such equipment is not economically desirable until it becomes obsolete. Therefore, current applications have been concerned with those items which are difficult to fabricate with conventional equipment.

The purpose of this summary is to present a review of the status of explosive forming with chemical high explosives. Available information, as obtained through the open literature and discussions with firms active in this area, serves as a basis for this review. The general aspects of explosives and their application to explosive metalworking have been well summarized in the recent work of Pearson and Rhinehart. (6) Admittedly further information exists but is considered proprietary by the individual firms. To provide a wide scope and maximum usefulness of this summary, information ranging from the characteristics of various chemical explosives to the properties of explosively formed materials has been included.

## EXPLOSIVES AND THEIR CHARACTERISTICS

There are many types of explosives available which might be considered for explosive-forming operations. Both commercial and military types have been used. Military types have been limited to companies which have Government contracts and to companies which have managed to obtain limited amounts on

a Government surplus basis. Although both types have been shown to answer the requirements of a wide range of explosive-forming operations, the availability of the military types is not as good as that of the commercial types. On the other hand, it is highly desirable to minimize to the greatest possible extent the variety of commercial explosives employed because the cost per pound of commercial explosives is closely related to volume purchased per order of each type and form. Most types of explosives do not have unlimited shelf life and the destruction of deteriorated explosives is expensive.

In selecting explosives it is well to keep in mind handling and storage characteristics. Sensitivity to shock and heat, tendency to be hygroscopic, and effect of storage time and conditions on homogeneity, as well as the more obvious characteristics of behavior upon detonation and suitability of physical form should be considered. Although consideration of the cost of explosives can be important under some circumstances, in many, if not most, instances the explosive cost is but a small fraction of the total expense of the operation.

In the discussions which follow, low explosives and primary high explosives are not included because these materials are of very limited interest in explosive-forming operations. Those interested in low explosives and primary high explosives will find comprehensive discussions on these subjects in References 7 and 8.

#### Characteristics of Some Secondary High Explosives

The general characteristics of a number of commonly used and representative explosives are given in Tables 1 and 2. Among the properties

TABLE 2. COMPOSITIONS AND CHARACTERISTICS OF DYNAMITES(7, 8)

	Strength of Dynamite, per cent <sup>(a)</sup>				
	20	30	40	50	60 100
<b>Straight Dynamites</b>					
Nitroglycerin	20.2	29.0	39.0	49.0	56.8
Sodium Nitrate	59.3	53.3	45.5	34.4	22.6
Carbonaceous Fuel	15.4	13.7	13.8	14.6	18.2
Sulfur	2.9	2.0			
Antacid	1.3	1.0	0.8	1.1	1.2
Moisture	0.9	1.0	0.9	0.9	1.2
Rate of Detonation, ft/sec			14,500	17,000	19,400
TNT Equivalent (Ballistic Pendulum Test)			94.5%	102.5%	114%
<b>Ammonia Dynamites</b>					
Nitroglycerin	12.0	12.6	16.5	16.7	22.5
Sodium Nitrate	57.3	46.2	37.5	25.1	22.5
Ammonium Nitrate	11.8	25.1	31.4	43.1	50.3
Carbonaceous Fuel	10.2	8.8	9.2	1.0	8.6
Sulfur	6.7	5.4	3.6	3.4	1.6
Antacid	1.2	1.1	1.1	0.8	1.1
Moisture	0.8	0.8	0.7	0.9	0.7
Rate of Detonation, ft/sec	8,900		10,800	12,800	15,200
TNT Equivalent (Ballistic Pendulum Test)	81%		91%	99%	109%
<b>Gelatin Dynamites</b>					
Nitroglycerin	20.2	25.4	32.0	40.1	49.6 91.0
Sodium Nitrate	60.3	56.4	51.8	45.6	38.9
Nitrocellulose	0.4	0.5	0.7	0.8	1.2 7.9
Carbonaceous Fuel	8.5	9.4	11.2	10.0	8.3
Sulfur	8.2	6.1	2.2	1.3	
Antacid	1.5	1.2	1.2	1.2	1.1 0.9
Moisture	0.9	1.0	0.9	1.0	0.9 0.2
Rate of Detonation, ft/sec	13,100	15,100	17,000	18,400	20,200
TNT Equivalent (Ballistic Pendulum Test)	74%	79%	84.5%	90.5%	99%
<b>Ammonia Gelatin Dynamites</b>					
Nitroglycerin	22.9	26.2	29.0	35.3	
Sodium Nitrate	54.9	49.6	32.0	33.5	
Ammonium Nitrate	4.2	8.0	13.0	20.1	
Nitrocellulose	0.3	0.4	0.4	0.7	
Carbonaceous Fuel	8.3	8.0	8.0	7.9	
Sulfur	7.2	5.6	3.4		
Antacid	0.7	0.8	0.7	0.8	
Moisture	1.5	1.4	1.6	1.7	
Rate of Detonation, ft/sec	14,500	16,000	17,400	18,700	
TNT Equivalent (Ballistic Pendulum Test)	83%	88%	92%	97.5%	

(a) This used to mean the percentage of nitroglycerin present. It now only indicates the relative strength of the dynamite within specific types.

TABLE 1. CHARACTERISTICS OF EXPLOSIVES(7, 8)

Explosive	Relative Power From Trauzl Lead-Block Test (% TNT)	Method of Charge Preparation	Detonation Velocity, ft/sec	Storage Life	Detonator	Safety Risk	Sensitivity to Impact (2-Kg Weight), PA RAP <sup>(a)</sup> , in.	Source From Which Explosive is Available
TNT	100	Cast	22,600	Medium	Special	Fumes toxic	14	U.S. Government
PETN	170	Pressed <sup>(b)</sup>	27,200	Excellent	No. 6	Internal toxic	6	U.S. Government
RDX	170	Pressed <sup>(b)</sup>	27,400	Very good	No. 6	Nontoxic	8	U.S. Government
Tetryl	129	Pressed <sup>(b)</sup>	25,750	Excellent	Special	Toxic to skin	8	U.S. Government
An-Fuel Oil	--	Loose mix	11,050	Good	Special	Toxic fumes	--	Du Pont
Comp B	130	Cast	25,600	Good	Special	Toxic fumes	13	U.S. Government
Comp C-3	115	Hand shaped	35,000	Fair	No. 6	Slightly toxic	14	U.S. Government
Comp C-4	130 <sup>(c)</sup>	Hand shaped	26,400	Good	No. 6	Nontoxic	19	U.S. Government
Detasheet A <sup>(d)</sup>		Cut to shape	23,600 <sup>(e)</sup>	Good	Special	Internal toxic	6, 22 <sup>(e)</sup>	
Detasheet C <sup>(d)</sup>		Cut to shape	23,000	Very good	Special	Internal toxic	5 <sup>(e)</sup>	Du Pont
MFX		Pressed <sup>(b)</sup>	22,000		No. 6			Hercules
MFXP		Hand shaped	21,780		No. 8			Hercules
AEREX liquid		Liquid measure	21,000		No. 8			Aerojet
AEREX solid		Hand shaped			No. 8			Aerojet

(a) Picatinny Arsenal test apparatus. (b) Depends on density of loading. (c) Estimated, no data available. (d) Available in a range of thicknesses. (e) 3-kg drop test.

included in Table 1 are relative power and sensitivity. Actually there are a number of more or less standard test methods which are used for the determination of each of these properties. For the most part, data generated by the various test methods are in general agreement in terms of the relative power or relative sensitivity of the various explosives. The values reported in Table 1 for these properties were selected because it was felt that the test methods utilized in obtaining them best reflected the conditions of interest in explosive forming. The details of the various test methods and the values for the test methods not reported in Table 1 can be found in the References 7 and 8.

#### TNT (Trinitrotoluene)(7)

This is a military explosive and is used as a standard (with a rating of 1.00) in measuring the power of other explosives. It has a detonation rate of 22,600 fps. It is relatively insensitive to shock although it may sometimes be detonated by a rifle bullet. It is only very slightly soluble in water and can be used for underwater work without a moistureproof wrapping. This explosive should not be used in closed spaces, because its detonation produces poisonous gases. TNT can be initiated with a Number 8 blasting cap, although the presence of moisture reduces the sensitivity of TNT and a cap more powerful than a Number 8 will greatly increase the reliability of initiation.

#### Tetryl (Trinitrophenyl-methyltriamine)(7)

Tetryl is a more sensitive explosive than TNT and as such is primarily used as a booster charge for the initiation of less sensitive explosives. It is a military explosive and is not available commercially. The explosive is used in a pressed pellet form and its density depends on the pressure at which it was pressed. The pressure of compaction also determines the detonation velocity of the explosive; the velocity is greater for higher compacting pressures. The explosive is very slightly soluble in water at room temperature and is hygroscopic to the extent of only 0.04 per cent in a 90 per cent humidity at 30 C. The sensitivity of tetryl to shock and friction has not been found sufficient to necessitate packing in a wet condition, as is required with pure PETN or RDX. The equivalent power of tetryl is about 129 per cent of TNT, depending on the density of the loading. The storage life of this explosive is excellent. "Tetryl has a strong coloring action on the human skin and can cause a dermatitis. The use of a cold cream containing 10 per cent sodium perborate has been found to minimize these effects. Inhalation of tetryl dust has recognized toxic effects, and the suggested permissible

maximum concentration of the dust in air is 1.5 milligrams per cubic meter. (7)

#### RDX (Cyclotrimethylene-trinitramine)(7)

Pure RDX melts at 204.1 C and has a crystal density of 1.816. It may be cast or pressed to obtain higher densities. Although this is primarily a military explosive it is used in combination with a number of other explosives or binders in commercial forms. Some types of detonating fuses are loaded with this explosive. RDX is slightly soluble in water and is non-hygroscopic. Its sensitivity to detonation is decreased when wet so it is shipped wet in the pure state. The equivalent explosive power of RDX is about 170 per cent of TNT but will vary depending on its density of loading. It has a detonation velocity of approximately 27,400 ft/sec.

RDX does not appear to be markedly toxic, and cleanliness is the only precaution prescribed.

#### PETN (Pentaerythrite Tetranitrate)(7)

Pure PETN melts at 141.3 C and the crystals have a density of 1.765 grams/cc. The explosive is very slightly soluble in water and is nonhygroscopic although wetting the explosive will tend to desensitize it. PETN is primarily a military explosive used in combination with other explosives. Special loadings of PETN are found commercially in sheet explosive and in detonating fuse. This explosive has an equivalent power of 170 per cent of TNT. It has an excellent storage life but should be kept dry for most consistent results. It has a detonation velocity of 27,200 ft/sec.

PETN is not unduly toxic, since it is nearly insoluble in water. Small doses of PETN taken internally cause a decrease in blood pressure and larger doses cause dyspnea and convulsions.

#### Nitrostarch, Nitrocellulose, Guncotton(7)

These are all similar explosives and are used primarily in mixtures with other explosives. Some dynamites contain nitrocellulose but its primary use is in the preparation of propellants for the military and in the preparation of small-arms ammunition or smokeless powders. It has not been used by itself as an explosive in explosive-forming operations. The explosive is somewhat hygroscopic and absorbs moisture up to 3 per cent. The absorption of moisture will change the properties of the explosive and make



it unpredictable; this is the primary reason for its limited use as an explosive. The dry explosive is very sensitive to impact, friction, heat, and spark. It is never handled dry in bulk for this reason. The rate of detonation is 24,000 ft/sec and it has very poor storage characteristics. The characteristics of this explosive make it unsuitable for use by itself as an explosive-forming energy source.

#### NG, Nitroglycerin<sup>(7)</sup>

Nitroglycerin is the primary explosive in a number of dynamites. In its pure state it is a colorless liquid and extremely sensitive to impact. It has no application in its pure state in an explosive-forming operation due to the extreme care required in handling it. This explosive has a detonation rate of 25,200 ft/sec when properly initiated. It has an explosive power of 185 per cent of TNT. The explosive is stable at room temperatures and has a low solubility in water. It will not cause corrosion of metals with which it may come in contact. Any contamination in the explosive may cause rapid decomposition.

"Nitroglycerin is readily absorbed through the skin into the circulatory system of the human body and vapors inhaled are absorbed by the blood. The effect is a severe and persistent headache, from which some relief can be obtained with strong black coffee or caffeine citrate. Workers in constant contact with nitroglycerin usually develop an immunity that can be maintained only by almost daily contact."<sup>(7)</sup> The toxicity of nitroglycerin does not cause organic deterioration even with long-time exposures. All explosive compositions which contain nitroglycerin will cause the headaches mentioned above.

#### Composition B<sup>(7)</sup>

This is strictly a military explosive and is not available commercially. It is composed of 55.2 per cent RDX, 40 per cent TNT, 1.2 per cent polyisobutylene, and 0.6 per cent wax. It is normally used in the cast state as a eutectic mixture which freezes at 79 C. The solid Composition B is slightly more sensitive than TNT but less than RDX in impact. The power of this explosive is 130 per cent as great as TNT. The detonation velocity of the cast explosive is 25,600 ft/sec. Several variations of this explosive are used in the military which have slightly different impact sensitivity and equivalent power. The explosive is practically nonhygroscopic and it is very stable in long-time storage at moderate temperatures. The main advantage in using Composition B is the ability to cast charges to shape and size providing the equipment is available for melting and handling it. Some of this explosive has been used in explosive-forming operations although its use has

been very limited due to special requirements for charge-preparation equipment and the fact that it is not available commercially.

#### Compositions C-3 and C-4<sup>(7)</sup>

These are plastic explosives which may be molded by hand to the desired shape. C-4 is only available from the military; however, limited quantities of surplus C-3 can now be obtained commercially. The C-3 explosive is a mixture of about 77 per cent RDX and 23 per cent explosive plasticizer, containing mononitrotoluene. It is a yellowish puttylike solid that has a density of 1.60 grams/cc. It is much less sensitive to impact than RDX and about equal in sensitivity to impact as TNT. It has a detonation rate of 25,000 ft/sec and it is about 115 per cent as powerful as TNT. It is slightly hygroscopic to the extent of 2.4 per cent but its power is unaffected by immersion in water. Composition C-3 is not unduly toxic, but it should be handled in a similar manner to tetryl.

Composition C-4 is less sensitive to impact than the C-3 but can still be initiated with a No. 8 blasting cap. It has a detonation rate of 26,400 ft/sec and has a TNT power equivalent of about 120 per cent. It has a better storage life than C-3 and is nonhygroscopic. It is also nontoxic so that no special precautions need be used in handling it. C-3 and C-4 have been used in explosive-forming operations and are well suited to this purpose because they can be readily shaped by hand to any configuration and size of charge.

#### Dynamites<sup>(8)</sup>

The straight dynamites are mixtures of nitroglycerin and some inert agent such as wood pulp. Some contain sodium nitrate and others contain ammonium nitrate. Some dynamites have the nitroglycerin replaced with nitrostarch to remove some of the objectionable qualities of the straight dynamites. Blasting gelatins are obtained by colloidizing nitrocellulose with nitroglycerin which makes the mixture waterproof. The cost of glycerin and the tendency of nitroglycerin to freeze at some atmospheric temperatures prompted the partial replacement of nitroglycerin by nitrated diglycerin, sugars, and glycols. Antacid materials, such as calcium carbonate or zinc oxide, have been added to most dynamite compositions to neutralize any acidity developed during storage.

Most of the commercial dynamites are described by strength designations on a percentage basis. This used to mean the percentage of nitroglycerin present. It now only indicates the relative strength of the dynamite within specific types.

Characteristics of the various dynamites have been given in Table 2. Use of this table requires knowledge of the compositions of the dynamites available commercially from the manufacturers.

The use of dynamites for explosive-forming operations is not recommended because their instability in storage tends to preclude reproducibility. All dynamites tend to exude nitroglycerin when stored for 6 months or more and become soft. The nitroglycerin which is exuded makes the dynamites very sensitive to impact and toxic to handle. Although some companies have used dynamites in explosive-forming operations by re-packing to the size and shape required, this practice can not be justified as a general practice.

#### Detasheet A and C (EL-506)(9)

Detasheet is essentially (PETN) explosive combined with other ingredients to form a tough flexible sheet which is supplied in the convenient size of 10 by 20-inch sheets. It is available from Du Pont. Several different compositions are available although the C series is preferred due to its greater flexibility and long shelf life before drying out and becoming brittle. This explosive is waterproof and can be used as direct contact charges or can be cut and shaped to the desired charge size for standoff operations. Various thicknesses of sheet are available with loadings up from 1/2 gram/in<sup>2</sup> in the C series. Various layers of the sheet may be placed together to build up to the charge size required. This explosive should be initiated only with special high-powered caps since it is rather insensitive. This becomes even more critical as the thickness of the sheet explosive is reduced. The explosive may be glued onto a backup material for charge shaping if desired. A good all-purpose adhesive which may be used is Minnesota Mining and Manufacturing Company Adhesive CTA-11 (thinned with naphtha). This explosive is one of the safest on the market commercially, but the cost is still rather high due to the limited quantity produced. It was developed and mainly used for operations in the explosive-forming and -hardening field. It has a detonation velocity of 23,600 ft/sec for Type A and 23,000 ft/sec for Type C. The thicker the sheet the higher the detonation velocity. Type C has recently been given a military designation and with increased production, its price can be expected to become more reasonable.

A special shape of this explosive is available as a line-wave generator and consists of a triangular-shape sheet which has been perforated in such a manner that initiation at any one apex of the triangle generates a line wave at the opposite side of the triangle.<sup>(10)</sup> The sheets can be obtained in thicknesses of 0.050 and 0.168 inch. Since the explosive is flexible the line-wave generator

should only be considered for applications in which it is essential that an explosive charge be initiated simultaneously across a long section. The explosive is also available in standard cord and ribbon geometries. Other extruded shapes are available on special order.

#### MFXP Explosive<sup>(11)</sup>

This is a putty type of explosive which can be hand molded to shape. It is available from Hercules Powder Company. The explosive requires a No. 8 cap for consistent detonation and has a detonation velocity of 21,000 ft/sec.

#### MFX Explosive<sup>(11)</sup>

This is the designation applied to pressed charges made to order by Hercules Powder Company. They are available in various sizes (cylindrical in shape with a well to receive a blasting cap). The explosives may be detonated with a No. 6 blasting cap.

#### Aerex Liquid Explosive<sup>(12)</sup>

Another specialty explosive made specifically for explosive-forming operations is Aerex liquid explosive made by the Aerojet-General Corporation. The unique feature of this explosive is that it is stored as two separate liquids, neither of which is explosive by itself. The explosive charge is prepared by mixing the two liquids in the proper proportions. Since it is liquid, shaping of the explosive charge is no problem, as it will take the shape of the container. Plastic or glass containers may be used. It has a detonation velocity of 20,000 to 22,000 ft/sec and has about 80% of the power of TNT. It is sold in minimum quantities of 5 gallons and it is one of the less expensive explosives. A solid Aerex explosive is also now available. It consists mainly of the liquid explosive with the addition of ammonium nitrate to obtain a solid. The solid Aerex explosive is slightly less powerful than the liquid.

#### Detonating Fuse<sup>(13)</sup>

Most people in the explosive industry now call detonating fuse by the trade name Primacord. It was originally developed for initiation of multiple charges of explosives by using only one cap. Its versatility because of ease of hand shaping the desired charge has resulted in its extensive use in explosive-forming operations. Primacord consists of a small filament of an explosive material, normally PETN or RDX, and a protective coating of plastic or some water-repellent material. The explosive is sensitive to water and the ends should be protected when underwater operations are contemplated. A roll of Primacord held in storage

for some time may become damp near the ends. In starting a new operation it is best to cut at least 6 inches off the end of the roll to be assured of consistent quality in the explosive. Failure to take this precaution or to seal the ends from water when immersed may result in misfires, especially if a No. 6 cap is used.

Mild detonating fuse (MDF) is a line explosive available in charge loadings between 20 and 1 grain per foot. In order to obtain consistent detonation with an explosive charge this small, it is necessary to encase the explosive in a metallic shield. Lead is normally used for the shielding material. Although MDF was developed specifically for aircraft armament work, it has been used extensively in explosive-forming operations where a very small charge is required. The bulging of small-diameter tubing is one example of this application.

Most of the Primacords available may be cut to length with a knife. They should not be cut with pliers since a buildup of the explosive may occur in the joints of the pliers and cause an accident at a later time. End priming should be used for the smaller Primacords while parallel priming may be satisfactory with the larger loadings above 100 grains/ft. Primacord may also be used for connecting separated charges or may be used as the charge itself.

Specific information on the various types of detonating fuse available commercially are given in Table 3. Different types of detonating fuse with

TABLE 3. DETONATING FUSE<sup>(13)</sup>

Trade Name <sup>(a)</sup>	Explosive Loading, grains/ft	Coating	Detonation Velocity, ft/sec	Initiation Cap Size No.	Diameter, in.
Detacord	40	Cotton	20,800	6	0.175
PETN No. 30	30		20,800	8	0.155
PETN No. 40	40	Polyethylene	20,800	6	0.180
PETN No. 50	50		20,800	6	0.198
PETN No. 50	50	Reinforced	20,800	6	0.202
PETN No. 50	50	Plastic	20,800	6	0.200
PETN No. 60 HV	60	Polyethylene	22,600	6	0.200
PETN No. 60	60	Plastic wire	20,800	6	0.238
PETN No. 100	100	Polyethylene	20,800	6	0.242
PETN No. 150	150	Polyethylene	20,800	6	0.285
PETN No. 175	175	Polyethylene	20,800	6	0.305
PETN No. 200	200	Polyethylene	20,800	6	0.325
PETN No. 400	400	Polyethylene	20,800	6	0.426
RDX No. 70	70	Vinyl	20,800	8	0.197
RDX No. 100	100	Vinyl	20,800	8	0.234
<b>Mild Detonating Fuse</b>					
MDF Type A-1	PETN, 1 grain/ft	Metal	21,000	8	0.040
MDF Type A-2	PETN, 2 grain/ft	Metal	23,000	8	0.040
MDF Type A-5	PETN, 5 grain/ft	Metal	22,000	8	0.073
MDF Type A-10	PETN, 10 grain/ft	Metal	24,000	8	0.15

(a) The trade names given are for Du Pont explosives. Similar explosive-detonating fuse sometimes called Primacord is sold by other explosive manufacturers.

similar loadings may be available in different localities. It is therefore suggested that the local explosives distributor be contacted to determine the types and prices of explosives available. Primacord is normally sold in rolls.

### Detonators

A wide variety of detonators are available which can be utilized in an explosive-forming operation. The selection of a detonator depends first upon the requirements of the explosive to be initiated and then upon secondary characteristics of the detonator itself such as electric or non-electric activation, sensitivity to stray currents, etc.

### Selection Based on Explosives

Explosives have an initiation sensitivity which requires not only that a sufficient force be applied but that the application be sufficiently brisant in character to assure detonation of the explosive. It is possible to use less powerful caps on the less sensitive explosives if an intermediate booster is used between the cap and the explosive. Using a booster, however, is normally undesirable since it complicates the explosive setup. The best approach appears to be to select a cap which has sufficient power for the direct initiation of the explosive. A Number 6 cap, one of the least powerful caps in commercial use, is primarily utilized for the initiation of dynamites and PETN Primacord. A Number 8 cap should be used with RDX Primacord and most of the military explosives. For the detonation of sheet explosive, special caps which have a heavy charge should be considered. For specific capabilities of the various caps in common use in explosive-forming operations see Table 4.

TABLE 4. DATA ON BLASTING CAPS<sup>(14, 15)</sup>

Detonator	Explosive	Loading, grains	No Fire Current	Explosive Used With
No. 6	PETN	4.9	0.28	Dynamite and PETN Primacord
No. 8	PETN	6.9	0.28	Dynamite and RDX Primacord
E-83 engineers <sup>(a)</sup>	PETN	13.5	0.21	Sheet explosive TNT, C-4
E-78 <sup>(a)</sup>	PETN	13.5	0.21	Extra-strength application
E-84 <sup>(a)</sup>	RDX	7.0	0.30	Crimp end for Primacord
E-94 EB <sup>(a)</sup>	PETN	13.5	0.50	Sheet explosive
EBW-XBC-1 <sup>(b)</sup>	PETN	4.23	(c)	Equivalent to No. 8 cap

(a) Trade designations of Du Pont.

(b) Trade designations of Librascope.

(c) No fire with 500 v from 1-microfarad capacitor.

### Selection Based on Function

There are various types of delay caps available, some of which have been used to a very limited extent in explosive-forming operations. They might be considered where a delayed initiation at various points is desired. Normally the

delay times available in such caps are too short for practical applications in explosive forming due to the small distance over which the charges are separated.

Another aspect which might be considered when selecting blasting caps is the sensitivity of the cap to stray current. Most of the commercial caps available have a no-fire current of 0.32 amp. Special caps with higher no-fire currents can be obtained but the quantity required is normally not sufficient to obtain a competitive price. One technique which appears to be workable is to shield the lead wires of the cap with a grounded metal sleeve when the caps must be used in a high-RF-radiation area; however, it is best not to attempt to use electric caps under these circumstances.

A number of companies have examined the use of exploding-bridge wire systems for the direct initiation of explosive, thereby eliminating the need for the blasting cap. One company has marketed a high-energy detonation system based on the exploding-bridge wire concept but the price of the individual units far exceeds the price of conventional caps. (14) If the demand for this type of detonator increases, it is possible that the cost of a system completely safe in an RF field would be competitive. A number of companies have not waited for this reduction in cost and have developed their own high-energy-rate detonation systems. The development was not always based on the need for a safer cap but in most cases developed through a requirement for line-front detonations which could not be obtained without the use of an explosive line-wave generator. A line initiation from an exploding-bridge wire provides a linear detonation front without the use of auxiliary explosive components which may be prohibitive in some operations.

Consistent detonation across a wide front of explosives can also be obtained with waveguide explosive generators. The size of the waveguides available today limits the application to approximately a 10-inch front length. Exploding-bridge wires offer possibilities for extending the length of front which could be detonated successfully and consistently with a high-energy-rate source. Most of the setups which have been used for a high-energy-rate detonation of explosives have been limited to homemade devices since none is available commercially at a price within range of the blasting caps.

## EXPLOSIVE-FORMING TECHNIQUES

### Systems

Explosive-metalworking operations can generally be classified as either confined or unconfined systems. The confined or closed system as

illustrated in Figure 1 consists of a die completely enclosing the energy source. This system has been used with propellant charges and for some small-diameter tube forming and piercing operations with high explosives. (16) The closed system has distinct advantages for the forming of thin materials to close tolerances because the sustained pressure tends to set the material to the die. The confined system with explosive charges has been used for some close-tolerance sizing operations on thin-wall tubing. However, limits on the maximum part size which can be produced, die erosion, and possible hazards of operation have been prime factors limiting its use. As part size is increased with a closed-die system, the thickness of the die wall must be increased proportionately and a point of uneconomical die construction is reached very quickly, usually at around 2 inches for a tubular section. When forming a part with a shape other than tubular, the critical size will be reached at an even smaller size. Deterioration of the die cavity is common with closed-die systems as a result of continued gas erosion. In addition, die failure in a closed-die system is much more likely to result in a shrapnel hazard from the fragmented die than in an unconfined system. Since the confined system has had limited use up to now, its future does not look promising. This report deals largely with the unconfined system, which is in widespread use.

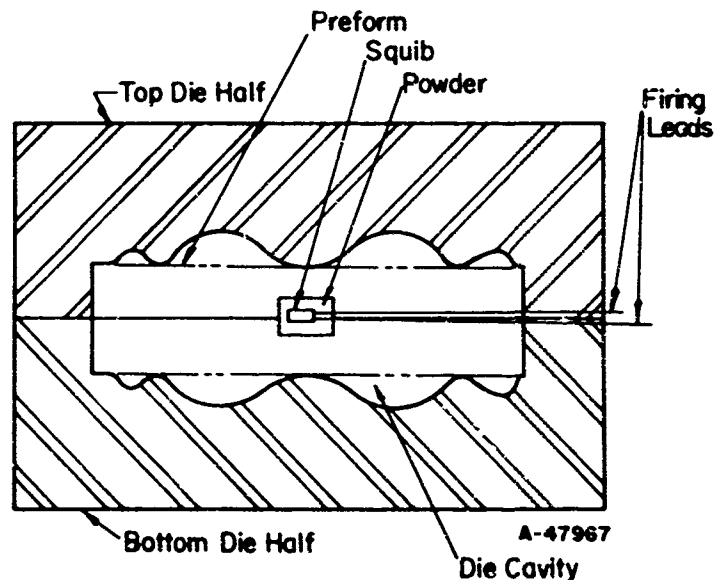
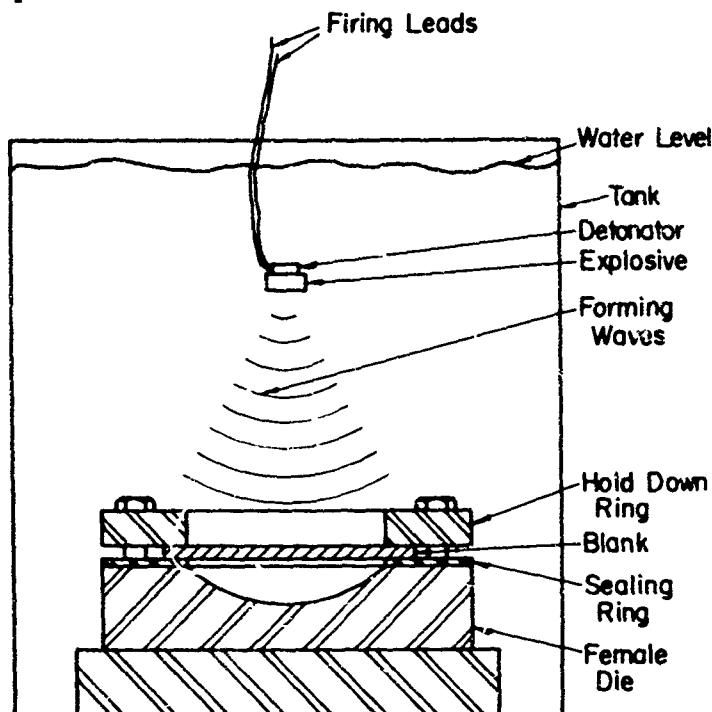

FIGURE 1. CONFINED SYSTEM OF EXPLOSIVE FORMING<sup>(5)</sup>

Courtesy of Olin  
Mathieson Chemical  
Corporation.

The unconfined system, illustrated by Figure 2, consists of a single female die with a blank held over it and an explosive charge suspended at a predetermined position over the blank. The complete assembly may be immersed in a water tank, or a plastic bag filled with water may be placed over the blank.



A-47968

FIGURE 2. UNCONFINED SYSTEM OF EXPLOSIVE FORMING<sup>(5)</sup>

Courtesy of Olin Mathieson Chemical Corporation.

The unconfined system is inherently inefficient because only a small portion of the total energy released from the explosive is used in the forming operation. With explosive forming the explosive force acts equally in all directions, sending out shock waves radially from the charge. Although the unconfined system may be inefficient in the utilization of energy, it has other advantages which make it economically attractive.

Tooling for explosive forming can be made simple, with a reduction in cost of up to 80 per cent over that for tooling required to perform the same operation by conventional techniques. The tooling is simplified since only the female member of a die set is required, with the explosive shock waves acting as a punch. The tooling is loaded in compression to a greater extent than in tension. Since most die materials can sustain a much greater load in compression than in tension, lighter dies can be utilized. The cost of the explosive is normally very small in comparison with die costs, so that an economic advantage is generally obtained through the use of the unconfined system. Simplicity of operation also contributes to the economy of the system.

The medium within which the explosive is detonated plays an important part in determining the efficiency of the system. As the density of the medium increases, the efficiency of the system increases. This can be readily illustrated by comparing the results of a cup test in air and under water using the same explosive charge and standoff distance. Under these circumstances the underwater test will, in all cases, draw a much deeper cup and may even rupture it.

Under normal operating conditions it is best to detonate explosive charges as far below the surface of the water as possible. This reduces the amount of water which is thrown by the explosion and the amount of energy lost through venting the gas bubble to the atmosphere. Adequate efficiency is obtained provided the distance from the charge to the surface of the water is at least twice the standoff distance. When a charge is fired under water, a shock wave moves out from the explosive and is followed by the expansion of a gas bubble from the detonating charge. If the gas bubble vents to the surface before it impinges on the part being formed, a considerable amount of energy will be lost. With charges sufficiently deep in the water, several cycles of expansion and contraction of the gas bubble can be noted. Each time a bubble expands, an additional pressure pulse is transmitted to the part being formed, but these pulses are not severe enough to require consideration in the explosive-forming process.

The variations in energy level delivered from various shapes of charges are small when fired in a water medium, providing the standoff distance is 1 foot or more. When charges are placed closer to a part, within 1 or 2 inches, energy-transfer mechanisms from the explosive to the workpiece change. An example of these effects is shown in Figure 3.

In standoff operations in water or in air, the amount of energy or peak pressure delivered can be readily calculated from standard formulas. The optimum location of the charges for forming of most parts is a matter of diverse opinions. However, generally speaking, a cylindrical charge or point charge is located near the center line of the part and at a distance from the part which is related to the span of the workpiece over the die cavity. This can vary according to the shape of the shock wave desired. In large parts, it is generally impractical to use a point-type charge. In forming large hemispheres or end closures for rocket motors, Primacord, shaped in a large loop and located close to the outer periphery of the part, is usually used.

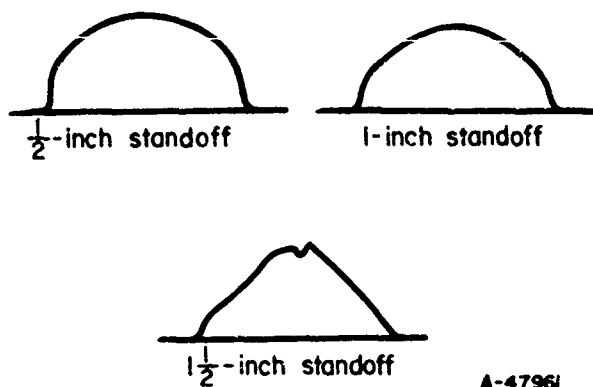

FIGURE 3. EFFECT OF STANDOFF ON CUP PROFILE(32)

Material 2024-0 aluminum:explosive disk EL 506A:media water.

Many producers using the process prefer to have a smaller number of charges, if possible, and, if at all practical, to use a single charge. Others have found that the use of small charges and a number of shots for the forming of one part will permit the use of lighter dies and more consistent control of the process.

#### Reflectors

In some cases, the use of reflectors for explosive charges has proved to be very helpful. However, predicting the amount of peak pressure obtainable from a reflected charge is rather difficult at the present state of the process. In some cases, the amount of localized work has been doubled by using reflectors over certain areas of parts. Reflectors are only used when a greater amount of energy is required, as in certain areas of nonconcentric parts. In the forming of nonconcentric parts, it is also possible to locate charges off-center to obtain a greater amount of force in the areas where it is desired.

#### Holding the Charge in Position

Normally, wire or masking tape is used to hold the charge in proper position relationship to the workpiece while it is immersed in the water. The only requirement on such holding devices is that the charge be maintained in its proper location and not displaced by water flowing in and around the charge as the die is immersed in the water tank.

#### Charge Preparation

Many of the explosives used in explosive-forming operations must be modified slightly from the commercial form in which they are

obtained. The amount of modification which is utilized in the explosive-forming depends on the specific type of charge required. The use of Primacord is quite widespread throughout the industry due to the ease of handling and the varieties of loading densities available commercially. Sheet explosives have been used to give plane waves over larger areas, although they have limited applications in sheet-metal forming. The flexibility of the sheet explosive also simplifies charge preparation. Some of the other types of explosives, such as Composition C-3 or C-4 plastic explosives, can be readily molded by hand into a ball or other type of shape. Compacting of charges from powdered explosives on the site has normally been avoided. The castable military explosives such as Composition B or TNT have not been used to any great extent mainly due to the requirement for special facilities for melting and casting of charges from these explosives. Some of the commercial explosives such as dynamite have been recompacted, or the sticks of dynamite cut to give the size of charge desired. Handling of dynamite for recompacting is generally avoided due to the possibility of assimilation of nitroglycerine by processing personnel. Also, commercial dynamite, in storage, tends to segregate and when the individual sticks are broken up, it is very difficult to obtain reproducible charges.

#### Connection of Blasting Caps

Table 4 gives some information on blasting caps. The proper blasting cap should be selected for the explosive which is to be detonated; an improper-size cap often results in misfires or deflagration of the explosive and pieces of the undetonated explosive charge broken up by the cap will accumulate in the water. This, of course, should be avoided. The blasting cap should be affixed to the explosive charge in such a manner as to eliminate any possibility of the cap coming loose during immersion in the water. It is sometimes necessary with the less sensitive explosives to bury the cap in the explosive charge itself to assure consistent results. Specific information on methods for placing the cap on the explosive charge should be obtained from the explosive manufacturers. Electric blasting caps are in use in all explosive-forming operations today.

#### Preparation of Material Prior to Explosive Forming

Some materials should be prepared for metal forming in order to protect their surface finish or to insure maximum formability. To protect the surface, consideration must be given to possible damage from a blasting cap or other material which may be projected against the workpiece and to the possibility of corrosion

during or after forming. The type of protection necessary will vary according to the material under consideration. Titanium alloys and aluminum alloys normally require a protective covering in order to prevent damage from fragments from a blasting cap. Other metals, such as stainless steels, do not appear to be adversely affected by such flying fragments. In addition, a few materials, such as most of the magnesium alloys, require protection from corrosion in an underwater forming operation. This can be accomplished by waxing or by covering the blanks with thin polyethylene sheets.

Normally the same type of defects which adversely affect the formability of materials in conventional forming are also deleterious in explosive forming. Material with a ground surface frequently has less ductility than the same material with an as-rolled surface. Material with directional properties should also be avoided. The purchase of cross-rolled material for explosive-forming operations is desirable.

#### Edge Preparation

Edge preparation to smooth out rough edges is more critical in some types of explosive-forming operation than in others. Edge preparation is normally not required for blanks which are to be formed by deep drawing with a hold-down ring. When forming parts without a hold-down ring, as in driving a blank into a tapered die, edge preparation may be essential. Similarly, polishing of edges is sometimes necessary for parts to be formed on a conventional hydropress, but not for parts which are formed by deep drawing on presses. The edges produced by sawing, blanking, and shearing operations are normally satisfactory for explosive forming, although some materials such as titanium are more sensitive to edge conditions. In general, special polishing on the edges of blanks to be explosively formed is not warranted, but excessively rough edges are undesirable. Burrs left on the surface of the material can cause erratic effects especially when the hold-down rings are being utilized. Such burrs should be removed, possibly by filing, prior to explosive forming of the pieces.

#### Thermal Treatments

Most materials are explosively formed in the annealed condition. In some sizing operations, the materials may be formed in the hardened condition. The forming of materials in the hardened condition is generally limited to very small amounts of stretching, in the neighborhood of 1 or 2 per cent.

Some materials must be formed at elevated temperatures in order to obtain the desired

amount of ductility. For titanium and refractory metals, elevated temperatures should be considered for explosive-forming operations. Most of the other materials, such as aluminum alloys, stainless steels, mild or low-alloy steel, copper, nickel-base alloys, and most of the high-strength alloys can be explosively formed without the use of special heating devices in the forming operation.

It is sometimes desirable, when deep forming is required, to conduct the forming operation in a number of steps rather than to attempt to form the part with one explosive charge. In some cases the materials will retain enough ductility so that this can be accomplished without intermediate anneals. At other times the material will work harden to an extent that further forming is not possible and it will be necessary to anneal the material prior to continuing with the forming operation. Standard annealing treatments for the material should be utilized in this case. The number of intermediate anneals which may be required will be dependent on the material characteristics and the severity of the deformation. Some materials, such as the precipitation-hardening stainless steels, do not display the same work-hardening characteristics in explosive forming as they do in conventional forming; however, normally, conventional-forming operations may be used as guidelines in determining the amount of deformation that can be obtained between intermediate annealing steps by explosive forming. Sometimes stainless steel alloys may be deep drawn by explosive forming in a number of shots without intermediate anneals, whereas spinning requires intermediate anneals for the same part. In most cases the determination of the requirement for intermediate anneals must be determined by experience in the particular forming operation because information is lacking on the response of materials in explosive-forming operations.

With some materials, such as the precipitation-hardening stainless steels, the explosive-forming operation may be considered an integral part of the thermal treatment. The precipitation-hardening stainless steels are normally solution annealed, deep-freeze treated, and then aged to develop the full properties. By explosive forming materials in the solution-annealed condition, the deformation will tend to transform most of the austenite to a martensitic type of structure. Any retained austenite can then be subsequently transformed to martensite by the deep-freeze treatment and then aged to develop the full properties of the material. By the use of this technique the solution-annealed treatment may be eliminated from the final thermal-processing cycle. There are some indications that this technique increases the tensile strength and ductility

of the precipitation-hardening stainless steels.<sup>(17)</sup> At the present time it is not known whether the same type of processing would be useful for conventional forming of the same materials, or not.

It is necessary to stress relieve some materials immediately after explosive-forming operations to prevent delayed cracking due to residual stresses. This is especially true of the materials which have been work hardened close to the upper limit of their mechanical properties. Stress-corrosion cracking may also occur in some of the materials if high residual stresses are not relieved. The susceptibility of parts that have been explosively formed to stress-corrosion cracking has been found to be greater than that of parts that have been formed the same amount by conventional forming techniques. Therefore techniques must be considered to eliminate the possibility of stress-corrosion cracking in explosively formed parts.<sup>(18)</sup>

#### Forming of Welds

Any time that parts must be explosively formed from blanks which have weld beads, special considerations should be given to the weld area. It is desirable that parts requiring welding be designed to place the weld in an area where the least amount of deformation will occur. The welds may be expected to stand approximately 5 to 10 per cent less deformation than the parent material before failure occurs. Once a welded part has been explosively formed it is very unlikely that any difficulty will be encountered with the welds in later processing, or during the service life of the structures. The quality of the welds should be good and of uniform characteristics so that maximum weld ductility is obtained for the explosive-forming operation. Use of automatic welding equipment can be useful in this regard. Explosive forming will serve as an excellent inspection technique on the welds since any defects usually show up as cracks. Welding, of course, introduces a cast structure into the blank and most cast structures are rather sensitive to impact-type loading. It is therefore advisable to use roll planishing which breaks down the cast structure of the weld beads to a more ductile wrought condition on welded blanks and preforms which are to be explosively formed. Very little difficulty has been found in the explosive forming of tubular parts made from welded and drawn tubing, for the welds have been worked sufficiently to eliminate the cast structure.

If weld beads are not planished, the surface of the bead should be at least ground flush so that the blank will lie smooth against the die during the forming operation and the bead itself will not cause bulging. Although weld beads are often ground, improper grinding practices can introduce

residual stress in the weld area and this may be detrimental to the forming operation. To avoid poor ductility at or near the joint it is often desirable to anneal, or otherwise heat treat, preforms between the welding and forming operations.

When parts with weld beads in critical high-stress areas must be explosively formed it is sometimes useful to use a buffer material, such as rubber, over the weld area. The use of a rubber pad will decrease the loading rate and result in less severe impact conditions on the weld. The buffer material must be placed tightly against the surface prior to forming since water between the buffer and the part will result in erratic behavior and possibly in failure of the blank at that point.

### EXPLOSIVE-FORMING FACILITIES

Since explosive-forming facilities are of a highly specialized nature, particular attention must be given to their location, design, equipment, and operation. The need for close safety control is emphasized in each of these categories and is perhaps the dominant factor in the facilities that exist today. As in other production-oriented operations the economics of production are important. Continued operational experience has resulted in improved process economics while a high level of safety has been maintained. Considering that the explosive-forming industry is still in a stage of rapid growth and development the information presented is intended to provide only a general review of the factors influencing the location and design of explosive-forming facilities and their equipment and operations.

#### Location of a Facility

There are four primary considerations in the location of an explosive-forming facility; safety, local regulations, economics, and community relations. Decisions based on these factors should include the anticipated initial use of the facility and projected future requirements in order that continued operation may be maintained. The influence of these factors is treated in more detail in the subsequent discussions.

#### Safety

From the standpoint of safety, the important points to be considered when locating a facility are the case of eliminating outside hazards and of controlling access to the area. Where large or extensive operations are contemplated, all considerations except possibly economics suggest that an isolated area is the best location for an explosive-forming facility. Control of the area should be maintained with a security fence. The hazard zone should be cleared so that a visual



check can be readily made during any time the facility is in operation. The operation may also require room for the placement of remote explosive storage magazines.

The location of a facility in an arid region has definite advantages on the basis of an outside operation for the reduction of facility cost, but safety can be a problem with regard to the build-up of static-electric charges on the operating personnel. Static charges can initiate electric blasting caps; therefore, operations under such conditions must have some provision for eliminating the static charge from the personnel. The use of conductive shoes or spurs to give contact between the personnel and a metal floor plate will provide the required protection. Even with the grounding of the personnel, it is best to secure the operation if the wind velocity exceeds 15 miles per hour.

The location of an explosive-forming facility within close range of any electromagnetic radiators such as radio, TV, FM, or radar installations of any type should be avoided, since RF energy can fire electric blasting caps. A graph for obtaining safe operating distances from transmitters of various power outputs is given in Figure 4. It should be emphasized that mobile transmitters mounted on vehicles are even more dangerous, since their whereabouts in the area is not always known until it is too late. To eliminate the possibility of danger from RF energy, a facility should not be located within 7000 feet of any transmitter. If it is found necessary to operate a facility within close range of a transmitter, it is best to consider the erection of a metal shield which would reduce the hazard involved. A sheet-metal building will serve this purpose or the use of shielding over the blasting-cap wires may also be used. Explosive-forming facilities have been operated within close range of transmitters for several years now without incident, although the hazard is still there if proper precautions are not maintained.

A strong induction field should also be avoided, since under certain conditions, it can result in the premature firing of blasting caps. When precautions are taken to eliminate the hazard from RF energy, a possible mishap from an induction field becomes more likely. The shielding of wires or grounding of one lead wire to the cap can establish a circuit in the cap leads which makes it ideal for receiving current of an inductive nature. Induction fields are obtained only when there is a large amount of current flowing through a conductor in the area. Areas with underground cables, or even areas in which a current is applied to pipelines to prevent corrosion, should be avoided. A simple circuit can be prepared to check the area for both inductive

field and RF energy prior to the installation of a facility to determine if these hazards exist. After a facility is in operation, an electronic signalling device can be constructed to warn of RF energy in the area emanating from passing aircraft or mobile transmitters; also, small devices can be obtained from explosive manufacturers which will fire when exposed to a low level of RF energy. To be effective, these should be placed at intervals around the periphery of the facility.

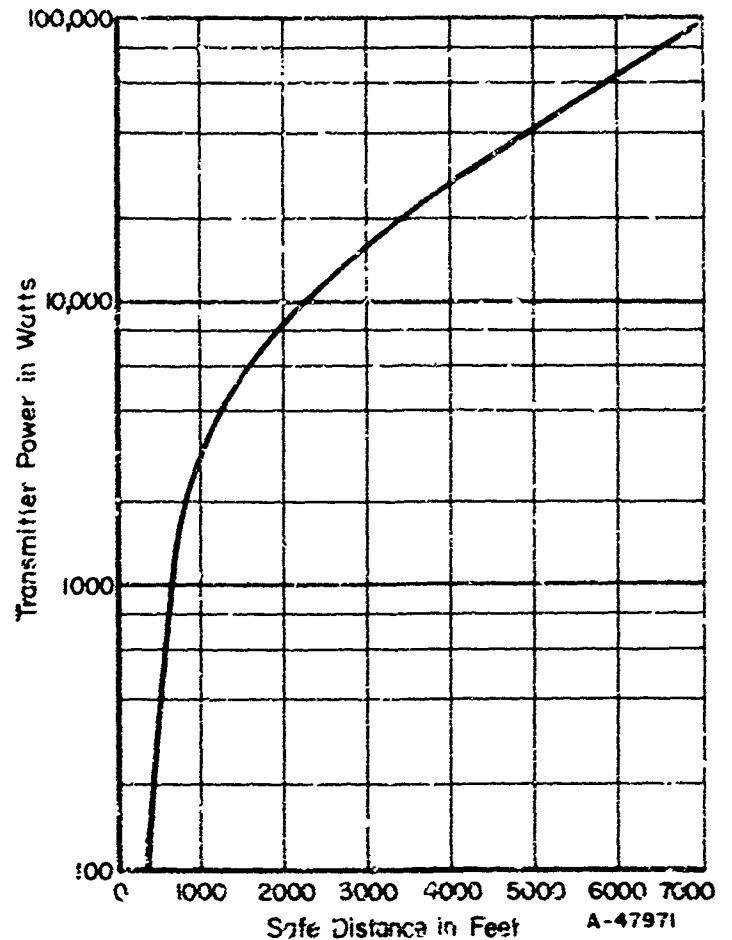

FIGURE 4. TRANSMITTER POWER VERSUS SAFE EXPLOSIVE OPERATING DISTANCE(20)

Institute of Makers of Explosives,  
1956

#### Local Regulations

Each area of the country has different local regulations which must be examined before the selection of a site for an explosive-forming facility. The regulations may be in the form of zoning codes, laws by local and state governments, or even national laws, although the latter deal mainly with interstate transportation of explosives. The attitude of the community within which the facility is to be operated might cause difficulties either prior to establishing the facility or in the future when the need for expansion

arises. Where there are no laws restricting the use of explosives, some basic steps should be taken to assure that the shipping, storing, and handling of explosives will comply with the interstate commerce safety regulations. The Blaster's Handbook,<sup>(19)</sup> safety bulletins published by the Institute of Explosive Manufacturers,<sup>(20)</sup> and military documents<sup>(21)</sup> may also be useful.

In general, most regulations apply to the possible noise nuisance of an explosive-forming operation and most of the noise can be eliminated by firing underwater. The safe storage of explosives to prevent unauthorized access is normally a regulation which is necessary and should be strictly observed. Each year, there are numerous accidents resulting from stray blasting caps falling into the hands of children. Lawsuits can result, if it is proven that the explosive material was not properly secured.

When selecting a site for present production capabilities, the future applications should be also reviewed. Although the initial operation may be within the local regulations, expansion in the future may be prohibited. A good example of this might be a requirement to produce large parts which could not be handled in the present facility due to size of the necessary charge. The expansion needed to meet production requirements could very well be prohibited. The selection of a site which does not allow for expansion should be avoided.

Closely related to local regulations is the possibility of lawsuits arising from the operation of an explosive-forming facility. Suits can take the form of actual damages or implied damages, either of which can result in a considerable loss of time and money. A suit of this type may be very difficult to prove one way or the other. Several incidents of this nature have been reported.

#### Economics

The economics involved in the location of a facility will probably be of prime consideration to a manufacturer. If a facility is located in an isolated area, as is desirable, it may be so far removed from other related manufacturing as to be impractical. This may well occur unless the facility can be a completely integrated operation, including both die and material preparation. Even with an integrated operation, the cost of shipping materials to and from the facility may make the operation uneconomical.

The location of a facility near other manufacturing operations may also have its disadvantages. The shock wave in the surrounding ground from the explosive-forming operation may have

deleterious effects on the operation of other manufacturing equipment. Most electronically controlled equipment such as controllers for heat-treating equipment or automatic welding equipment are very sensitive to shock vibration. A geological survey of the underground rock strata can pinpoint possible areas of difficulty prior to the start of an installation and can result in a considerable saving of time and money, due to improper location of a facility. In operations where equipment such as drop hammers or heavy presses are in use, the amplitude of the resulting shock waves often exceeds the amplitude of a shock wave from a high explosive charge. If the water-table level is close to the surface of the ground, a greater amount of shock-wave energy will be transmitted than if the ground is dry. Good drainage around the explosive-forming water tanks can, therefore, aid in reducing the energy of a transmitted shock wave.

Labor cost is one of the major items in the operation of an explosive-forming facility. Hazard pay may be requested by employees working in the area, and due to the nature of the operation, it is best to consider only properly trained personnel for working with the explosive charges. Hiring personnel with experience in explosive operations will provide the required know-how for the explosive charges, but the metalworking knowledge may be lacking. The explosive-forming industry has not grown to the point where there is an excess of personnel trained in its operation. Consequently, obtaining trained personnel appears unlikely unless a high premium is paid. The alternative is on-the-spot training of personnel.

The management of facilities which are presently under operation varies. Some companies have established separate departments to carry out the explosive-forming function, while others have attempted to integrate the operation into the regular manufacturing sequence. It is interesting to note that the leading companies in this field have maintained the operation under engineering control, and have staffed it with high-caliber personnel. The ratio of engineers to technicians is sometimes as high as 1 to 1. The high percentage of technically trained personnel being utilized in the operations of explosive-forming facilities is probably due to the trial-and-error state of the process. Probably this percentage will decrease as more information on the process and better training of personnel is made possible through continuing operations.

#### Layout of Operations

There are two primary factors which should be considered in the layout of a facility. The first is smooth flow of material through the work area

for maximum efficiency, and the second is proper control of the operations on the basis of safety. Generally, operations conducted with limited access serve to aid in achieving both of these factors.

### Flow of Material

In general, the factors affecting the flow of material in a conventional manufacturing plant should also be considered in an explosive-forming facility. The quantity of items to be manufactured and the variety of parts to be made will determine to a great extent the layout and area required. According to the nature of the operations, the following areas might be considered in an integrated facility: incoming-material storage, material-preparation rooms, die-preparation room, charge-preparation area, loading area for the die, loading area for the charge, firing area, die-unloading area, inspection area, finished part storage, and shipping area. A number of these areas can be combined according to the number of personnel working and the volume of production contemplated. One of the chief considerations in such operations should be the separation of the areas where explosives are being handled from the other operational areas. It is, therefore, advisable to have much of the conventional type of work as possible performed on the material before the loaded die is brought into the firing room for attachment of the explosive charges.

The flow of explosive materials from the magazine to a charge-preparation area and subsequently to the firing area must be closely controlled. Charges can be prepared in the firing area, provided production schedules permit, but should never be prepared in the magazine. A minimum type of operation might consist of one building for firing and a magazine for external storage of explosive materials. This could then be expanded according to the needs of the facility. Crowding of the firing area should be avoided, since this will hamper the proper control of the area.

### Safety Control

The safe control of an explosive-forming operation requires that the man in charge of the operation be able to see and to know the location of all personnel during the operation. If only the personnel required to perform the operation are permitted in the areas where explosives are being handled, the amount of time the supervisor must devote to safety is considerably reduced, and he can apply his time more efficiently to production. The stacking of dies or erection of other obstacles to his vision within the firing area should be avoided. When the operation

becomes large enough to require additional personnel, consideration should be given to multiple firing areas with barricade separation between them for better control and a more efficient operation. Three men in the firing area at any time will supply the required manpower provided the maximum amount of nonexplosive type of preparation has been carried out in some other part of the facility.

The following jobs or duties should be allotted to each man so that they can work as a team: one man in charge of the operation who is qualified to assist in any of the operations required, a man to set the charges, and possibly a man to operate the crane. Two men can operate the facility satisfactorily if the desired output is not too large. It should be a standard rule that no explosives are to be handled within a facility unless two men are present in the facility, preferably not operating in the same area. In case of an accident, one man would be able to summon help.

### Building Construction

The method of construction of an explosive-forming facility is a matter of local choice. Some facilities have been constructed using sheet-metal exteriors, while in other climates, no building was required. The firing area is the only area which requires special attention in the construction of an inside facility for explosive forming. Since this area should be separated from the rest of the facility, the use of reinforced concrete walls as a separator is advisable. Some explosive-forming facilities have special blow-off-type roofs to relieve the pressure inside a building in the event of an accident without disturbing the walls of the building. Most industrial-type buildings will withstand an overpressure on the building of 10 psi. A 1-pound charge of TNT fired in the center of a room 40 feet in diameter would apply a 10-psi overpressure to the walls of the building. A reinforced concrete wall will withstand a considerably greater force, depending on its thickness.

An excellent barrier for outside facilities is a ring of railroad ties set into the ground on end. The arrangement is referred to as a "bull pen" when the ties are set in a circle. A 30-foot-diameter ring of this kind is adequate for firing up to a 10-pound charge of TNT at the center. Additional support could be obtained with such a facility by piling dirt against the outside of the railroad ties.

The use of a building has an advantage for an explosive-forming facility where close neighbors might be disturbed, because it reduces the amount of noise reaching the outside. Also some

type of building is normally required for material preparation or die work. Connecting a cover over an explosive-forming firing area to the die-preparation building should not be too difficult, providing proper precautions are taken to assure the safety of the operation through the construction of barricades. The facility layout shown in Figure 5 is given as a suggestion and should not be considered as recommendation. The ideal arrangement depends on the purpose and requirements of each individual facility.

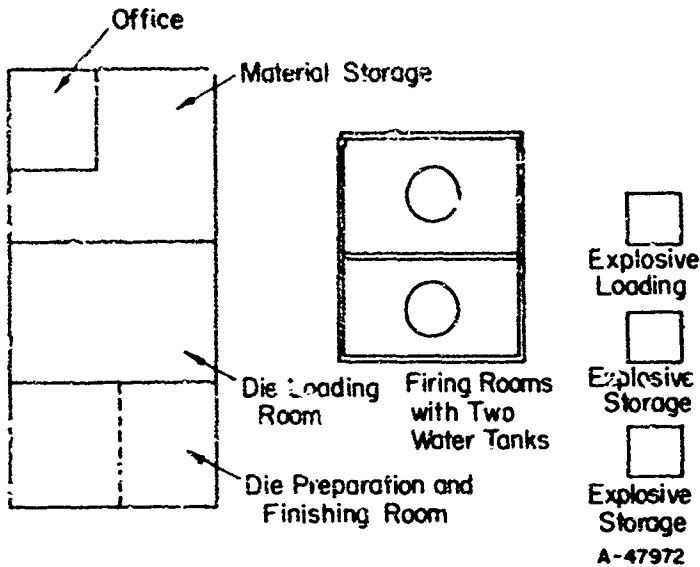

FIGURE 5. LAYOUT OF A HIGH-PRODUCTION EXPLOSIVE-FORMING FACILITY

#### Explosive-Forming Facility Designs

A number of facilities have been installed around the country for the specific purpose of conducting explosive-forming operations. Most of these are located in the western part of the country, where outside operations are possible. The facility shown in Figure 6 consists of one concrete tank 12 feet in diameter by 10 feet deep with 1-foot-thick walls. The tank is equipped with a bubble curtain and 1-pound charges have been fired in it without damage to the tank. A slightly different type of facility is shown in Figure 7. Here, the water tank is completely above ground and an air curtain is used to reduce stresses in the steel tank wall. The water tank is 13 feet in diameter and 13 feet deep. The tank is instrumented and has indicated a stress in the tank wall of 28,000 psi when a 320-gram charge was fired in the middle of the tank.

The two facilities have been shown to provide an indication of the various types presently in use. The most desirable type of facility depends on the local conditions and needs estimated for present and future production requirements.

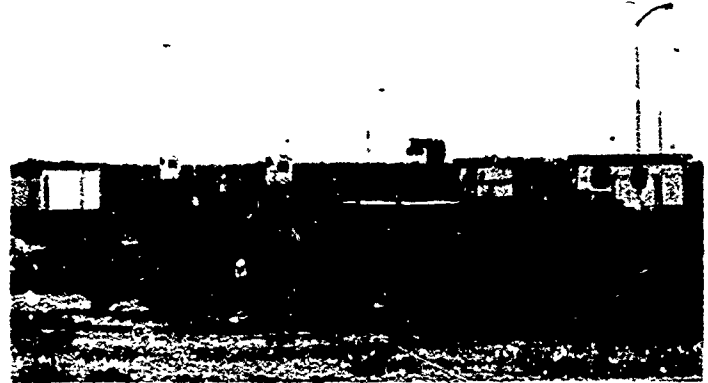

FIGURE 6. PRODUCTION FACILITY FOR EXPLOSIVE FORMING

Courtesy of Astronautics Division of General Dynamics Corporation.



FIGURE 7. ELEVATED WATER TANK FOR EXPLOSIVE FORMING ON A PRODUCTION BASIS

Courtesy of Lockheed Aircraft Corporation.

#### Equipment Requirements

The equipment requirements depend to a great extent on the volume of production to be carried out in the facility. The primary equipment consisting of a water tank, crane, vacuum

pump, and detonator will be considered first. Auxiliary equipment which is desirable but not essential to the explosive-forming operation will be considered as a group. Such items as water pumps, filtration systems, and other special equipment fall in this category.

### Water Tank

A water tank is considered essential for a production operation of explosive forming, although work could be conducted in air or even by placing the explosive charges in plastic bags filled with water and placing them on the material to be formed. The latter two methods have serious disadvantages from both the standpoint of noise and ease of operation, although they work quite well. A water tank must be able to withstand the repeated impacts of the explosive shock without rupturing. Tanks are often designed to be large enough so that the shock reaching the walls of the tank from a centrally located explosive charge is considerably reduced. As the tank diameter is increased, the load it will withstand is decreased for an equal wall thickness. The stress in the wall of a tank can be determined as a function of the internal pressure, the diameter of the tank, and the wall thickness of the tank. A graph of the stress in a tank wall as a function of the radius of the tank for a 1-lb charge of TNT and constant wall thickness of 1 inch is given in Figure 8. As can be seen from the graph, an

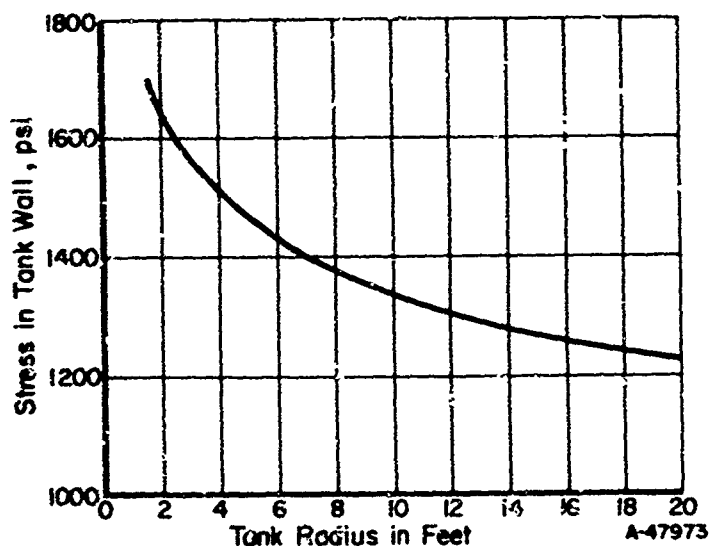

FIGURE 8. TANK WALL STRESS VERSUS DISTANCE FROM CHARGE

Based on unit tank-wall thickness and on a unit charge of TNT.

increase in the diameter of the tank from 4 to 40 feet only lowers the stress level in the tank wall from 1650 psi to 1225 psi, or a decrease of only 26 per cent. At the same time, the weight of

material which must be used to construct the tank wall has increased by a factor of ten. Obviously, increasing the diameter of a tank to obtain a reduction in the thickness of the tank wall required is not an economically practical solution.

Water tanks with sloping sides have been used for explosive-forming operations. The stress analysis of a tank with a sloping wall indicates that the stress in the vertical direction is reduced by a function of the angle which the sloping wall makes with a vertical wall. The stress in the vertical direction of a tank, considering a constant pressure in the tank, is always one-half of the hoop stress in the tank at any point. Such a design requires an increase of material for construction of the tank wall over a straight-wall tank, similar to that found necessary by increasing the diameter of the tank, considering equal design pressures.

One of the best approaches to the problem is to moderate the pressure shock wave before it strikes the tank wall. Experiments at Lockheed have indicated that the stress in the wall of an explosive-forming water tank can be reduced considerably by several techniques.<sup>(4)</sup> Figure 9 depicts the use of inflated rubber tubing for the

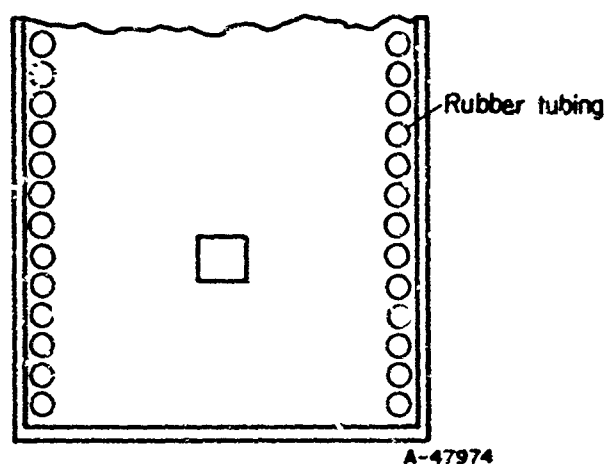
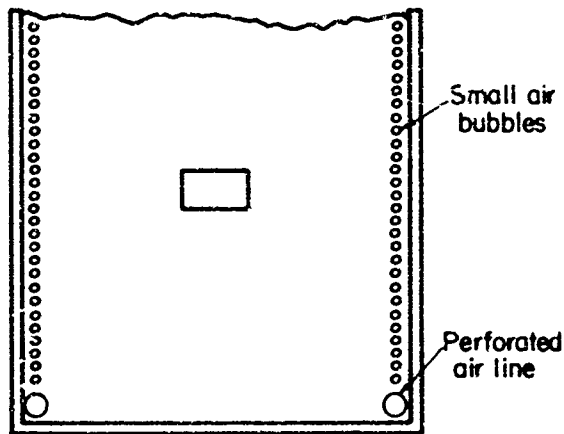

FIGURE 9. CROSS SECTION OF AN INFLATED-AIR-TUBE WALL TANK<sup>(4)</sup>

Stress level in tank wall reduced by 83 per cent. Tubing was 1.5-inch-diameter 0.25-inch-thick continuous coil rubber. The air pressure was sufficient to maintain inflation under the pressure of the tank water head.

reduction of the stress in the tank walls. The rubber tubing acted as a cushion and provided a reduction in stress of 83 per cent. To use this technique in a large tank, a considerable amount of tubing would be required and difficulties would be experienced in maintaining the position of the tubing and in preventing damage to the tubing

during explosive-forming operations. The use of an air-bubble curtain as shown in Figure 10 appears to offer one of the best solutions to the problem of low-cost water-tank construction. To be effective, a uniform and closely spaced curtain of bubbles must be obtained along the walls of the water tank. This is controlled by the size of holes through the air tubes at the base of the tank and by the distribution of holes in the air hose. A maximum charge size of 70 grams of TNT explosive has been fired in an 8-foot-diameter tank of this design with no visible signs of difficulty when the bubble curtain is operating.



A-47975

FIGURE 10. CROSS SECTION OF BUBBLE CURTAIN TANK(4)

Stress level in tank wall reduced 83 per cent with 2.18 cubic foot of air per minute per foot of air line. Stress reduction is dependent on rate of air flow. Air line was 2-inch diameter with 0.07-inch-diameter holes placed 0.50 inch on centers.

Some tanks constructed from reinforced concrete have given poor results and they are not recommended for production operations. Concrete has good properties when loaded in pure compression, but has very poor properties when loaded in tension as would be the case for the wall of a water tank. Spalling of the concrete surface and general cracking and finally disintegration of the wall has been experienced when attempting to use this type of construction.

The base of the tank is also important, since it takes the same amount of impact as the tank walls, if not more. Placing the tank in solid rock where possible, is often advantageous. A heavy base of reinforced concrete can be used provided that a heavy steel plate is used to evenly distribute the stresses striking the concrete to prevent localized high tensile stresses. Another useful method consists of placing a shock-absorbing material between the concrete and the

steel base plate. A sheet of rubber with a Shore A hardness of about 60 will provide some stress reduction, provided the thickness of the rubber is properly chosen. The use of a rubber hose coiled between the base plate and the base may also be used with good results. The hose should be closely spaced and inflated with only enough air to support the base plate and the water head above it. Overinflation will result in greater stress-wave transmission and possibly frequent damage to the tubing due to overpressurization. The stresses which the base will experience can be reduced by about 80 per cent.

The problems of sealing the base to the tank wall must also be overcome. Welding has been utilized at some facilities, but has not been altogether satisfactory. Since the joint is at a corner, the maximum stress concentration occurs at this location. Seals with resilient plastics have provided satisfactory results and are easy to repair in case of a leak. A plastic manufacturer should be consulted for the type of plastic to be used, since there are several types available.

In the design of water tanks, a safety factor of four should be used for a production facility. Mild steel has been one of the most commonly used materials for construction and fabrication by welding. Corrugated steel drainage pipe could be used for the tank walls. The base plates are generally made of 1-inch-thick mild steel plate.

#### Crane

A crane of some type is required to move material around the facility and also in and out of the water tank. Ideally, the crane should be air operated to eliminate electric power lines within the firing area. The capacity of the crane required will depend on the size and weight of the dies to be handled. One of the largest dies reported, which was used in an explosive-forming operation, weighed 21,000 pounds. A picture of this die is shown in Figure 11. It probably represents one of the largest dies that would ever be considered for movement in and out of a water tank. Larger stationary dies have been made.

All of the standard crane types have been used; the main consideration in the erection of a crane is that it have adequate capacity for expected requirements of the facility. Enough room should be provided between the crane and the top of the tank, so that adequate slings of proper length may be used to lift the dies and place them on the bottom of the water tank.

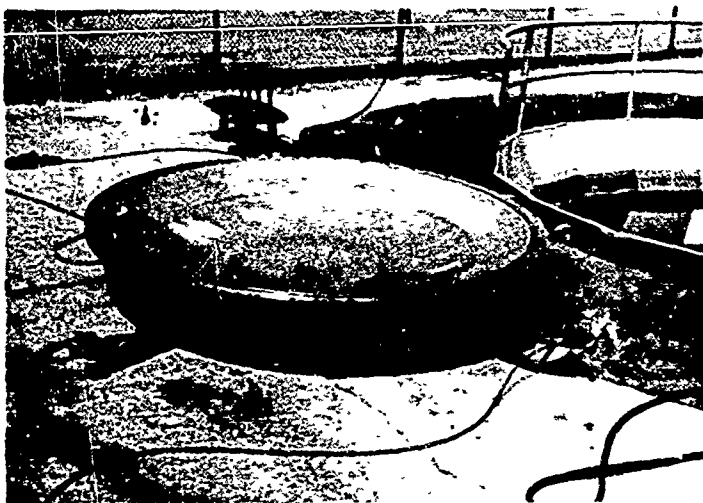

FIGURE 11. LARGE KIRKSITE DIE FOR FORMING ANTENNA REFLECTOR

Courtesy of North American Aviation, Inc., Columbus Division.

#### Vacuum Pump

A vacuum pump will probably be required for most explosive-forming operations when parts are formed under water. It is possible to construct dies in a manner which will eliminate the requirement for a vacuum between the part and the die. These are special cases and not commonly encountered in a production explosive-forming operation. Several types of vacuum pumps may be suitable for this application. If the firing area is to be maintained with a minimum of electric lines, a venturi pump which will operate on water pressure will work satisfactorily. A mechanical electrical pump may be used, and the vacuum lines brought into the area from a pumping site remote from the firing area. The electric pump is preferred, since it has a considerably greater capacity than the venturi pump and is probably more economical to operate. In a high-production facility where the application of a vacuum may be time consuming, a storage tank in the vacuum line will greatly assist the operation. If it is found necessary to operate an electrically driven vacuum pump in the firing area, it should have shielded wiring and a sealed motor unit. When using a mechanical pump, it is important to eliminate any possibility of water entering the pump. This can occur if the vacuum line becomes disconnected from the die during firing operations. To prevent this, a storage tank between the pump and the line should be used to trap any water which may enter the line. The tank can then be drained periodically to eliminate the water.

#### Detonating Circuit

Under ideal conditions, the detonator for the electric blasting caps is the only electric circuit which should be permitted in the area where explosives are being handled. Several types of detonating machines available from explosives manufacturers for regular blasting operations can be used for explosive-forming operations. Most of these lack positive control, an important feature for safe operation of an explosive-forming facility. It is reassuring to the person responsible for handling and setting of charges to know that he is the only one who can arm and fire the circuit. This can only be done by permitting him to maintain in his possession at all times an important part of the detonating circuit which can, in no way, be replaced by some other means.

Possibly, a detonating circuit constructed especially for the purpose of explosive-forming work would provide the best results. A detonator should be constructed on the "fail safe" principle, so that any malfunction will immediately cause the circuit to be disarmed. The following characteristics are believed to be desirable in the design of a detonator for explosive-forming work:

- (1) The device should be operable only with a key which can be carried by the individual setting the charges,
- (2) When the device is not armed with the key, this fact should be visually discernable from the work area,
- (3) The lead wires to the cap should always be shorted when the circuit is not armed,
- (4) When the circuit is armed with the key, both a visual and an audible warning of its armed condition should be activated automatically,
- (5) A method of checking the continuity of the blasting circuit should be an integral part of the detonator.

A schematic diagram for a detonator which meets these requirements is shown in Figure 12.

A continuity meter is a meter sensitive enough to read a current flow which is too small to fire a blasting cap. Most caps have a maximum no-fire level of about 0.25 amp. If an ohmmeter were used to check a blasting cap, this much current could be obtained and the blasting cap would be fired. A special circuit arrangement is, therefore, required. The use of a 1.5-volt battery connected in series with a 10,000-ohm

resistor and a microammeter will serve the purpose. The resistor will reduce the current flow below the safe limits for firing a blasting cap.

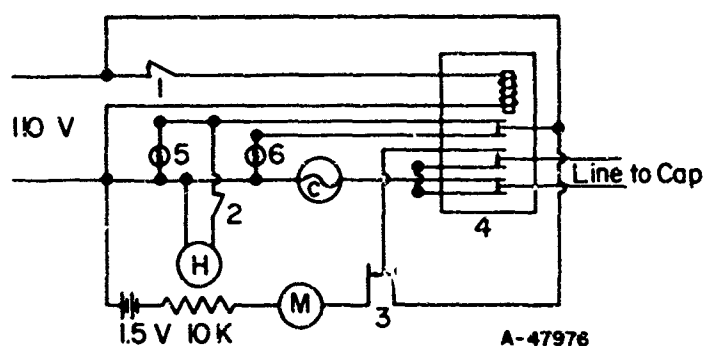

- 1 Key Switch, Single Pole, Single Throw
- 2 Horn Switch, Single Pole, Single Throw, Momentary Off Operation
- 3 Continuity and Firing Switch, Single Pole, Double Throw
- 4 Relay, Three Pole, Double Throw
- 5 Armed Warning Light
- 6 Safe Warning Light
- C 5-Amp Circuit Breaker
- H 110-V Horn
- M Microammeter

FIGURE 12. SCHEMATIC OF A SAFE DETONATOR FOR PRODUCTION IN EXPLOSIVE FORMING

The current for firing the blasting caps can be obtained from a 6-volt battery or directly from a 110-volt line. If a 110-volt line is used, it is best to use some type of circuit breaker in the circuit for protection of the lines in case of a short during firing.

#### Auxiliary Equipment

During the operation of an explosive-forming facility, debris will probably collect on the surface of the water or be distributed throughout the water tank, depending on its density. Since this result hampers the operation, some method for removing the debris is desirable. Skimming equipment, such as that used for swimming pools, will serve very well for the removal of material which is floating on the surface. Material which is distributed throughout the water will have to be removed by a filtration system. Again, standard swimming pool filtration equipment can be used. It should be remembered,

however, that any explosive material collected in the water tank will be pumped through the filtration lines and possibly into the pump where it may collect and cause an accident at some later date. Pumps may also be required to drain the tanks from time to time for cleaning or for painting the tank to prevent corrosion. A venturi pump is considered safe to use in an operation. A mechanical pump may be used if a filter is located between the pump and the water tank.

In locations where water is plentiful, the tanks are emptied by gravity flow and refilled quite frequently, while in other areas, the same water must be used over and over again. The dumping of tank water, especially into sewer lines, should be avoided, since any explosive in the water may be trapped and build up to a concentration which might cause a serious accident in the future. The buildup of explosive in the water tank should not occur, if everything is operating properly, but experience has shown that some misfires do occur and result in undetonated explosive in tanks. Normally, a misfire can be readily detected and then attempts should be made to recover as much of the undetonated explosive as possible for later destruction. A log of operations will indicate approximately how much undetonated explosive might be expected in the tank and this will simplify any subsequent precautions which need to be taken. A filter should be used ahead of the pump to trap any explosive material in the water. The filter material should be handled as explosive material when it is emptied.

It may be desirable to add some chemicals to the water to prevent the growth of algae. It has been noted that some constituents of the explosive compound cause algae to thrive in an explosive-forming water tank. The algae are not objectionable on the basis of operating efficiency, but they are objectionable on the basis of appearance.

An air compressor can be a useful tool in the operation of an explosive-forming facility. It is handy for cleaning surfaces of the dies, insuring that the vacuum lines in the dies are clear, and for operating pneumatic hand tools. An air compressor might also be required for the operation of a bubble curtain in the water tank or for the operation of an air wrench on the crane. If an air compressor is installed, it is best located away from the firing area. Location in the firing area would require shielded wiring and shielded motors. All hose connections should be of the quick-change type for a pressure system.

This discussion of equipment has been limited to the most general types of equipment



which might be used in an explosive-forming facility, strictly for the support of the explosive-forming operation. Additions to this list might include special equipment for die preparation or material preparation.

### Safety Considerations

Since explosives are being used within the facility, additional safety requirements for the elimination of any fire-producing or spark-producing equipment are necessary. In addition, to prevent accidental detonations, precautions should include the collection of all matches or lighters from all personnel entering any building where explosives are present. An area safe for smoking should be designated away from any explosive-containing buildings. Electric lighters should be provided at such areas if smoking is to be permitted.

During operations only persons absolutely necessary to carry out the operation should be present when any explosives are within the area. Segregation of areas with blastproof partitions is an asset in maintaining good production output with a minimum number of employees actually handling or exposed to the explosive charges. This separation of areas and use of only an essential number of employees is required to minimize the effect of an accident.

Often, an explosive-forming facility becomes a major point of interest to management and to other personnel in the area. Many visitors can, therefore, be expected, and unless a firm set of rules has been established with the means for their enforcement, a considerable amount of responsibility is placed on the man in charge. He will not only be responsible for the routine operation, but will be concerned with visitors in the area and their control.

The amount of explosive stored within the facility should always be kept to a minimum and preferably should not exceed the supply required for 1 day's operation. For temporary storage of explosives within the facility, a small storage container can be made from a discarded refrigerator. The caps should be stored in one and the explosives in another. The main storage of explosives for the operation should be at some distance from the facility.

Various types of explosive magazines can be constructed, depending on the amount of explosive to be stored at any one time. An igloo-type magazine should be used where the quantity of explosive stored exceeds 500 pounds. Where less than this amount will be stored, a less expensive wood or sheet metal magazine can be constructed. Specific instructions for the construction of magazines

may be obtained from explosive authorities.<sup>(19,20)</sup> The magazine serves two primary functions; it secures the explosives from unauthorized tampering, and it protects the explosives from the elements.

Misfires during an operation, which can result from a number of causes, are extremely hazardous and time consuming. It is, therefore, necessary that established procedures be followed carefully, so that the possibility of a misfire is held to a minimum. Improper connections to caps can be detected by the use of a continuity meter in the firing circuit. Only an approved meter should be used for this purpose, since a standard ohmmeter can cause premature detonation of blasting caps. A continuity meter will only supply information as to the completeness of the circuit and will not indicate if the lines are shorted. Precautions should, therefore, be taken to make sure that a short does not occur during the immersion of the setup for firing in the water tank. Incorrect placement of the blasting cap or use of an improper size of blasting cap may result in the firing of the cap but not the explosive charge. This will result in the cap breaking up the explosive charge and distributing it throughout the water tank. The hazards of explosives in the water tank were discussed earlier under equipment.

Precautions to be taken after the firing circuit has been energized and the charge does not detonate include a check of the continuity of the circuit, and if the circuit is good, another attempt to fire the charge should be made. If this fails, the firing circuit should be disconnected from the power source and the power source checked for proper output. If no difficulty is found with the power source, the lead wires in the firing circuit can be checked visually from a distance to determine if any shorts have occurred. Under no circumstances should the charge be brought to the surface for examination until fifteen (15) minutes have elapsed from the last time attempts were made to fire the charge. All personnel should leave the area during this waiting period. This requirement is necessary due to the possibility of a "hang fire" in the cap. After the specified time has elapsed, the charge should be brought to the surface and a new cap placed on it. The charge can then be fired in the normal manner.

When defective blasting caps are found, they should be destroyed with any other scrap explosive at the close of operations each working day. The scrap explosive should be accumulated at some point other than with the new explosive material. The scrap material, provided the quantity is not too great, can be destroyed by placing it in a plastic bag. The bag can then be

wound with Primacord and immersed in the production water tank for detonation.

The exudation from dynamite presents a problem in its use. When the explosive becomes soft, it should be destroyed, since the nitroglycerin which is coming out of solution and causing the softening is as sensitive to shock as the raw nitroglycerin. When dynamite is used in an explosive-forming operation, a maximum storage time of 6 months should not be exceeded. If some of the dynamite does become soft, it should be destroyed by burning in an approved area. The sticks should be opened and spread over a flammable material such as excelsior in a long line. Additional flammable material is then spread from the line to act as a fuse, so that sufficient time is available for the personnel to leave the area before the flame reaches the explosive. Any such area used for the burning of explosives should be considered a contaminated area and should be secured from unauthorized admittance.

In the operation of an explosive-forming facility, safety is one of the primary considerations and should be practiced as a full-time job. One man who has demonstrated that he is safety conscious should be in complete charge of the operation. His management should make sure that he has complete authority over the facility and its operations. Operations where large quantities of explosives are used every day have demonstrated an excellent safety record with an accident frequency rate about one-half that of all industry. By following the practices which have been established over years of experience with explosives, an explosive-forming operation can achieve an equally good safety record.

### DIE SYSTEMS AND MATERIALS

One of the main economic advantages in using explosive forming is that only one tool component is required. The force or shock wave generated from the explosive charge acts as the punch for this system, and through design of the shape of the explosive and selection of the transmitting medium the characteristics of the force applied to the workpiece can be modified. The geometry of explosive charges is related to the specific shapes to be formed. This relationship is discussed in more detail in subsequent discussions of current explosive-forming applications. Tooling concepts and transmission mediums as applied to explosive-forming operations are described in this section.

#### Die Considerations

Basic differences in tooling concepts for explosive-forming operations arise from the type

of loading which the material in the die must be able to withstand. The high-impact loads associated with the transmission of shock waves through the material lead to unusual types of stress patterns within the material and as a result corners should be eliminated where possible. This procedure minimizes the possible reinforcement of the stress wave resulting at corners and the resulting failures. An example of this phenomenon is found when an explosive charge is detonated inside a cylindrical cavity of a part with a square outside configuration. Under static loading conditions, the material fails at the thinnest cross section of the tube; under explosive loading conditions, the material fails at the corners or the heaviest cross section. Figures 13 and 14 show the modes of failure for

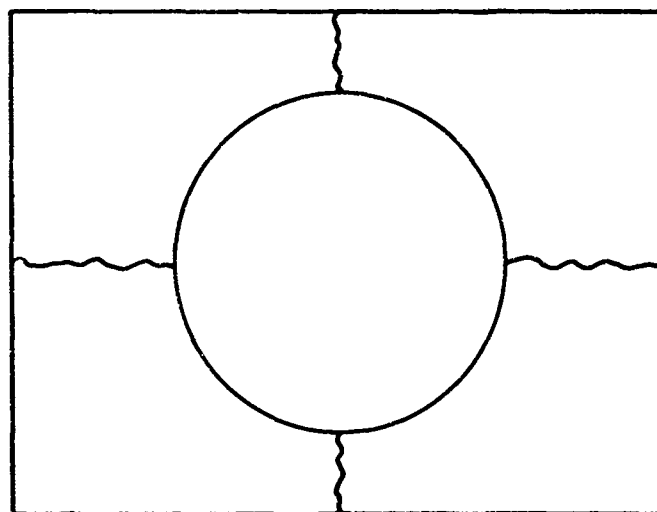

A-47977

FIGURE 13. MODE OF FAILURE UNDER STATIC INTERNAL-LOADING CONDITIONS

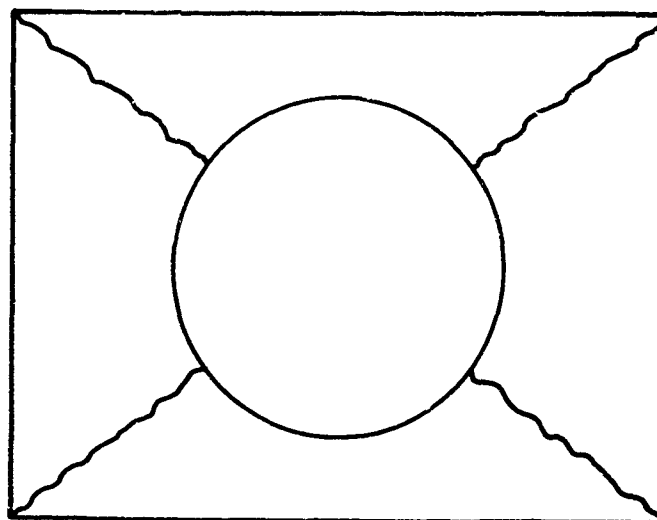

A-47978

FIGURE 14. MODE OF FAILURE UNDER DYNAMIC INTERNAL-LOADING CONDITIONS

the conditions of static loading and dynamic loadings. Failures of this kind are more likely when the safety factor is lowered to conserve the

weight of dies. It is also an important factor in materials, such as concrete, which are characterized by high compressive strengths but low tensile strengths. In such materials, the reflection of or reinforcement of stress waves may change the stress from compressive to tensile and cause failure.

The surface of the dies should be as smooth as the surface desired on the parts to be made. Due to the high loading, characteristic of the explosive-forming process, excellent surface reproduction from the die will occur on the part. Although this may be desirable in some cases, it generally requires that the die have a good finish. Where a die must be split to facilitate the removal of a completed part, it should be expected that some marking of the part at the parting line will occur. The forces involved will, in most cases, be sufficient to open the die slightly under heavy loading conditions and result in the extrusion of material into the crack between die sections.

In determining the strength of dies required, the peak pressure which is to be used for the forming operation is the primary consideration. Once the peak pressure value has been established, conventional methods of stress analysis may be applied to the die design. The yield strength of the die material is normally taken as the working-strength level and a safety factor of four is applied to obtain the design stress level to be considered in the die design. If some uncertainty exists as to the peak pressure which will be used on the final production run, some estimate should be made of the maximum peak pressure which might be required, and this in turn used for calculating the die requirement.

The wall thickness of the die needed for a drawing operation can be determined by considering that the die acts as an end closure of a high-pressure tank. The maximum stress occurs near the upper edge of the die, since the bottom of the dies are normally flat and equally supported. The formula for stress concentration in a heavy-wall cylinder can, therefore, be used as a good approximation of the thickness of material required in the die wall. The thickness in the base of the die should be equal to that used in the die wall for proper stress distribution under shock-loading conditions.

At one time, "dieless" explosive forming was expected to offer major advantages; however, the technique has since been relegated to experiments for establishing basic material behavior patterns.<sup>(22)</sup> Dieless forming consists of simply supporting the outside edge of the parts to be formed and letting the peak pressure determine

the amount of forming obtained. Some typical tooling used for dieless-formability studies is shown in Figure 15. The tolerances and reproducibility obtainable in a dieless-forming operation are poor and for this reason the process has very limited application to production. The process is further limited to forming simple concentric shapes such as bulging cylinders or forming dish-shape parts. The dieless-explosive-forming technique is potentially most useful in the forming of heavy members which must be machined after forming, or for very large concentric parts which do not require a close tolerance.

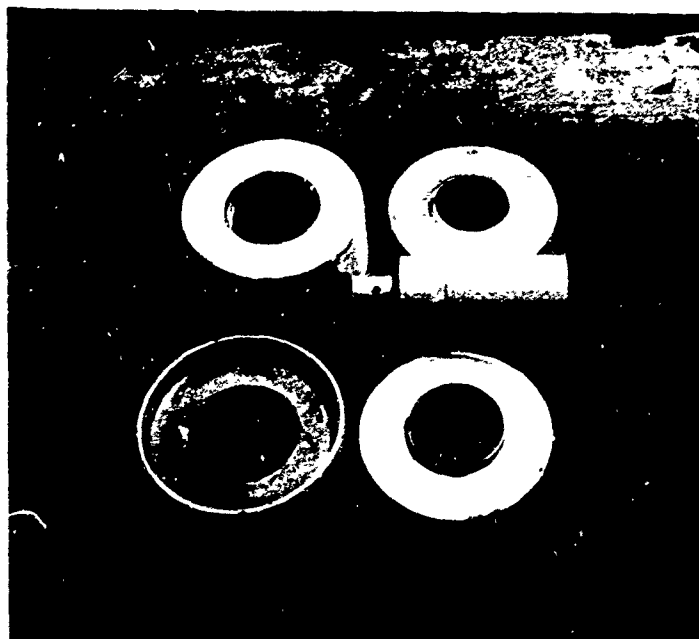

FIGURE 15. TOOLING FOR EXPERIMENTAL DIELESS FORMING

Upper left corner: ring die  
 Lower lefthand corner: loose hold-down ring for blank positioning  
 Center right: wood and paper tube Prinacord charge holder  
 Upper and lower right, respectively: parted and complete formed flange test parts  
 Courtesy North American Aviation, Inc., Columbus, Division.

Most explosive-forming operations have been performed in dies where a vacuum is applied between the blank to be formed and the die surface. Where possible, some method of sealing should be made an integral part of the die. In many cases the use of rubber with a Shore hardness of about A-60 projecting 1/16 inch above the die surface has provided the necessary sealing function. Since the explosive-forming process causes the metal to pick up detail from the die, the vacuum port in the die should be kept small

and located in an area of the die where it can be removed from the part in subsequent trimming operations. If this is not possible, then the vent hole should be located in an area of the part in which it would not be detrimental to form a dimple.

#### Hold-Down Ring Design

A hold-down ring of some type is generally required to prevent wrinkling of the part as the blank is drawn into the die. The size of the hold-down ring and the clamping pressure required depend on the material being formed. With a soft material, such as annealed aluminum, very little hold-down pressure is required, while materials like stainless steel require high pressures to prevent wrinkling. The hold-down ring should be made of a material strong enough to withstand repeated impacts without deforming. The die shown in Figure 16 was used to explosively form 0.040-inch-thick Type 350 stainless steel tank ends. The 1-inch-thick hold-down ring on the die warped upward in the center after approximately 50 impacts and this prevented adequate control of the hold-down pressure on the blank. A new hold-down ring that was 2 inches thick received over 100 impacts without showing any signs of warping. (17)

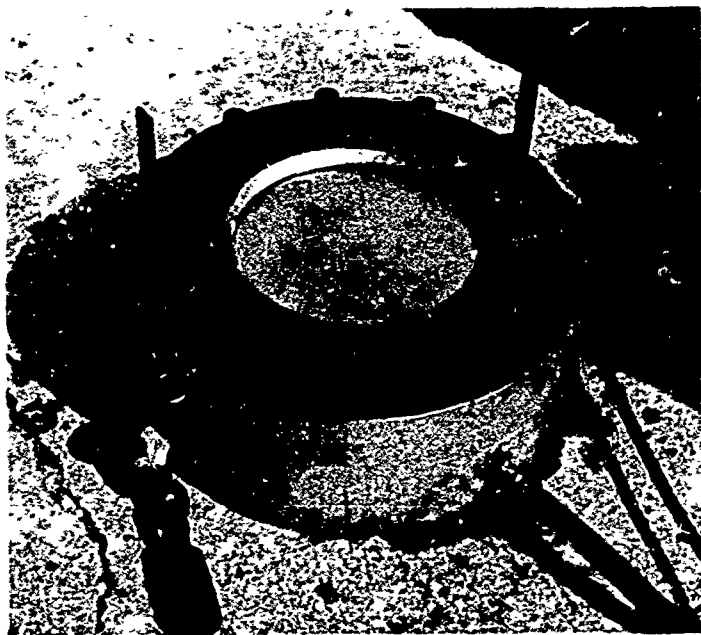

FIGURE 16. HOLD-DOWN RING WHICH WAS UNSATISFACTORY BECAUSE IT WAS TOO THIN

Courtesy of North American Aviation, Inc., Columbus Division.

As illustrated in the photograph, bolts are often used to clamp the hold-down ring to the blank and die. The use of bolts is inefficient on

the basis of time required to load and unload a die, but is probably the most efficient on the basis of applying holding force. Various clamping loads can be obtained from standard bolts at various torque levels; a 1-inch bolt with 900 ft-lb of torque will apply a clamping load of approximately 50,000 pounds. To obtain this same amount of loading with a hydraulic activation device operating on a 3000-psi system would require a cylinder diameter of more than 4.5 inches. Each jack for clamping would then require a spacing minimum of 10 inches to obtain the same loading at each jack clamp as a 1-inch-diameter bolt. The bolts could be placed on a spacing of 2 inches, however, which means that on the basis of clamping force, the bolts could be five times more efficient than a hydraulic clamping jack. For materials such as aluminum, which do not require high clamping forces in the hold-down ring, hydraulic clamping jacks can be a very efficient time saver for loading and unloading the dies. A heavy-duty hydraulic clamp used in explosive-forming operations is shown in Figure 17.

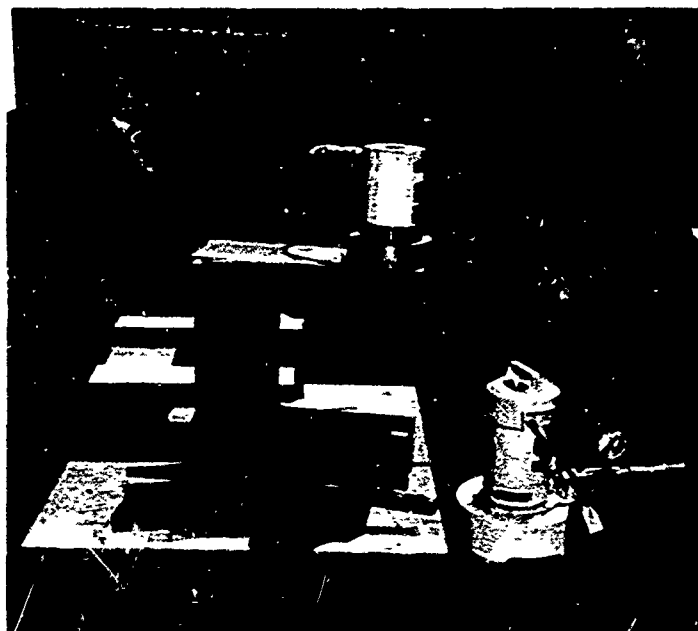

FIGURE 17. HYDRAULIC JACK FOR CLAMPING HOLD-DOWN RINGS ON EXPLOSIVE-FORMING DIES

Courtesy of Astronautics Division, General Dynamics Corporation.

Force is applied to a hold-down ring to prevent wrinkling of the blank as it is drawn into the die. In order to accomplish this, enough force must be applied to prevent buckling in the flange, but not enough to produce tensile failures in the regions being ironed or stretched. A graphic analysis of the holding force required and the range within which it should operate is presented in Figure 18 where (23)

A = the minimum pressure required to prevent flange buckling

B = the ideal pressure required to produce maximum formability where flange buckling and ironing is permitted

C = a low pressure such that the ironing raises the cup wall tension excessively.

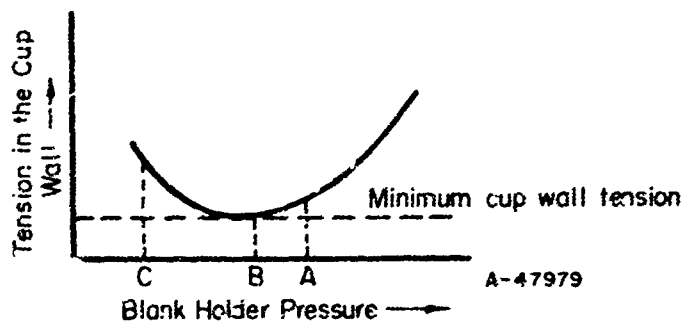

FIGURE 18. CUP WALL TENSION VERSUS BLANK HOLDER PRESSURE<sup>(23)</sup>

In some special cases where the parts to be made are concentric, it is possible to eliminate the requirement for a hold-down ring. The die shown in Figure 19 was used for forming titanium ring channels at room temperatures. The blank was positioned so that it was supported both on the plug taper at the center of the die and on the taper at the outside of the die. As



FIGURE 19. DIE FOR FORMING WITHOUT A HOLD-DOWN RING

Courtesy of North American Aviation, Inc., Columbus Division.

the blank was driven into the die, all of the edges remained under a compressive stress so that the greater amounts of forming could be obtained. The holes at the bottom of the die served as vents, so that a vacuum was not required. The same technique has been used for forming cones,<sup>(24)</sup> where the blank is situated on a taper leading into the die. This technique can provide savings when aboveground operations are utilized. If it is necessary to fire in a water tank then sealing and a vacuum would be required, along with some type of a hold-down ring.

#### Materials for Solid Dies

Solid dies made from heat-treated alloy steel maintain contour, surface finish, and dimensional accuracy for a relatively long time. To avoid brittle fracture when slight overloads are experienced, only steels with good toughness and impact resistance should be used for explosive forming dies, thus a maximum hardness of 50 Rockwell C is normally desirable. Steel dies are normally limited to applications where simple machining operations can be used to sink the die or where a high strength and long life are required. The utilization of steel dies for large parts is sometimes limited by the size of raw material available or the capacity of equipment which can machine or heat treat large dies. Steel inserts can be used to reduce the cost of die preparation. Where lettering or special details are required, the shapes can be machined in flat sheet stock which is then formed to fit the contour of the die. Anchoring of the inserts can be accomplished by either spot welding or flush riveting the inserts to the die surface.

Some of the steels which might be considered are the AISI 4100 and 4300 grades as well as the tool-steel Grades S-1 through S-5. Where the need for long life and good surface finish does not justify the cost of tool steels, mild steels such as the AISI 1010 or 1020 steels may be good alternative choices. In practice, a light coat of lubricating oil over the steel die surface after each forming operation will provide sufficient protection from rusting. In addition, steel dies should be dried and coated with oil at the close of each day's operation.

Kirkosite, which has been widely used in explosive forming, is a castable zinc-base alloy, containing about 95 per cent zinc and small amounts of aluminum and manganese. This material, which melts at 717 F and has a density of 6.7 grams per cubic centimeter, provides for good shock-wave transmission through the die material. The ultimate strength of Kirkosite in tension is 35,000 psi and the ultimate compressive strength is 75,000 psi. Tooling made from this material may be cast to a rough configuration

to reduce the cost of finishing operations or it may be used in composite tooling. Kirksite tooling is generally used when the loading levels on the die are too low to cause plastic deformation and dimensional changes, being usually reserved for production quantities not exceeding 100 parts. One of the largest single-piece dies known to have been made of this material is shown in Figure 11. The main reason for the popularity of Kirksite as a die material in explosive-forming operations is that most aircraft companies have facilities for casting it. Kirksite has been a standard material for drop-hammer dies in the aircraft industry and it may be readily reclaimed by melting when a job is completed.

Aluminum has been used for dies to a very limited extent in explosive-forming operations. It does not appear to have any particular advantage over other die materials which would warrant its use other than ease of machining. Tooling life is low due to the low yield strength of the material, and it appears to have very limited applications for the future.

The use of ductile iron dies appears to have stemmed from the desire for a stronger material which was relatively easy to cast and machine. It has a tensile yield strength of 45,000 psi and a compressive yield strength of about 55,000 psi. It can be considered for low-cost, elevated-temperature tooling, since it maintains a yield strength of about 35,000 psi at 800 F. Ductile iron holds a good surface finish under repeated impacts and retains its shape without the growth often associated with Kirksite dies. Dies made of nodular iron have worked quite well in production and as a result it is believed to be one of the better tooling materials for explosive forming. This material is more expensive to use as a die material than Kirksite due to its high melting temperature and poorer machinability. It does, however, have very excellent qualities for long life in an explosive-forming operation which will often offset the initial additional cost of using this material.

Reinforced concrete has been considered for the construction of large dies exceeding the machining capabilities of all-metal dies. The ease of producing large concrete dies is one of its primary advantages, although its disadvantages include a low tensile strength. About 3000-psi ultimate strength in tension is the maximum design strength for concrete. The use of reinforcement will increase this strength level according to the amount of reinforcement used. The compressive strength of concrete is about 30,000 psi and as long as the die can be designed to accept its maximum stress in compression, it can be used quite satisfactorily. Caution should be used, however, in judging the gross strength

of concrete dies, since it is quite easy to exceed the tensile strength of the surface by shock-wave reflections, even though the die is initially loaded in compression.

The use of solid plastic dies has not been very successful. The low strength of the material coupled with its low density make it unsuitable for more than several impacts before cracking. Porosity in the plastic may also contribute to its instability under impact-loading conditions. Another drawback is the disparity between the modulus of elasticity of the plastic and the metals being formed; a large mismatch will permit overforming to occur. Surrounding the plastic in a strong steel case has helped to overcome some of these difficulties, but the cost of the case is normally so high that a cheaper die could have been made at less cost from solid metal.

Plaster has been used for one-shot dies when only one piece is required. The reason that a brittle material such as plaster can be used for a die in explosive-forming operations is related to the speed of impact. Since the rate of loading is very fast, the imprint of a brittle material can be transferred to a metal surface before the die crumbles. Applications for cheap plaster dies appear to be very limited, although they might be considered where only a few parts are required. As with plastics, better results are obtained if the plaster die is contained by a metal container so that the plaster is loaded in compression to the greatest extent possible. Cases should be cylindrical in shape to minimize stress concentrations.

One company has recently reported the use of ice as a die for explosive forming. (25) The advantages listed for the use of ice include its low compressibility, ease of cutting and shaping, and simplicity of repair. Although the dies are rather inexpensive to prepare, the auxiliary equipment for freezing the water and maintaining the dies in a frozen state can be rather expensive. Since ice has a low tensile strength but a high compressive strength, the concepts of tooling design for materials such as concrete should also be applied to the use of ice.

#### Materials for Composite Dies

Epoxy facings have been used successfully on concrete dies. (20,21) The epoxy may contain reinforcing glass cloth or may simply be a smoothing agent. The use of this material with concrete is of particular interest since it is easy to apply, provides a smooth surface, and by minimizing shock-wave irregularities it helps to maintain a compressive-stress state in the concrete. The epoxy may be applied directly to the

surface of the concrete and then swept to the desired contour, a procedure which should be considered for very large dies. Alternatively, a glass-reinforced plastic laminate may be made from a master and then backfilled with plastic in the concrete dies. Experience has indicated that where heavy loading is encountered, the life of a plastic laminate is about 25 parts before it starts to crack and requires replacement. Due to the low cost of replacement this is not considered a serious disadvantage.

The use of plastic laminates in Kirksite dies of complex shapes will provide a considerable savings in die-sinking time. The Kirksite die body is cast roughly to shape and then a plastic laminate which has been made from a plaster master is seated into the die by backfilling with a resilient plastic. The amount of resilient plastic should be maintained at a minimum, since reflected tensile waves set up by the difference in density between the laminate and the metal die body can cause separation at the interface.

Since most concrete dies will withstand at least one impact without disintegrating, it is quite feasible to sweep a concrete die slightly oversize by the thickness of the metal liner which is to be installed. The metal liner is installed by explosive forming it into the die and then the liner serves as the die surface for all subsequent operations. The tolerances of a die prepared by this technique depend on the tolerances obtained in the sweeping operation as well as on the tolerances on the thickness of the metal liner which is placed into the die. The main advantages of this type of die construction are the ability to obtain a smooth die surface by polishing the liner in the flat before placing it into the die and the die will possess a longer life than that of plastic liners. Difficulty has been experienced with pulverization of the concrete behind the metal liner which will result in progressively deteriorating tolerances if many parts are required.

#### Lubricants

Lubricants are seldom employed in explosive-forming operations because the contact area between tooling and workpiece is small. The total contact area in explosive forming may be only a tenth of that for conventional forming operations with punches. Under certain conditions, however, welding may occur between the part and the die, requiring reworking of the dies. Suitable lubricants would be expected to prevent seizing, galling, and welding in these operations and are only used when initial forming tests indicate their need. Although rare, such difficulties are most likely to be encountered in forming

aluminum or in sizing operations with high explosive-shock pressures.

Some of the standard conventional deep-draw lubricants such as Hevi-Draw Liquid Lubricant, Shell Deep-Draw Lubricant, Shell STP, Dow Corning Silicon Lubricant, Dow Corning No. 4, Vaseline, and wax have been used in explosive-forming operations. In general the lubricants appear to be desirable when heavy plates are involved. The benefits derived from lubricants used by various investigators are not known.

Since refractory metals must be formed at elevated temperatures, lubricants used in explosive-forming operations of these materials must be able to withstand the elevated temperature involved. The work which has been conducted on the explosive forming of refractory metals has not defined the requirements for a lubricant in this operation. (28) Glasses which have been used as lubricants for refractory metals in conventional metalworking operations may be satisfactory. (29)

#### Transmission Mediums

The transmission medium serves as the connecting link between the explosive charge and the part which is to be formed. The energy from the explosive is transmitted in the form of a shock wave and is attenuated as a function of the characteristics of the medium and explosive. Most of the early work in explosive forming was performed in air, which provided very high peak pressures for very short time periods, usually a few microseconds. Consequently, the total impulse available for forming was less than that for a liquid medium which provides slightly greater confinement of the charge and higher efficiencies in terms of total impulse. (4) The size of charge required for forming a given part in water is reduced approximately 80 per cent as compared to a charge which would be required if the forming was accomplished in air. Further reductions in noise can be achieved through the use of transmission media denser than water.

#### Liquid Mediums

An explosive generates two types of energy which can be harnessed to perform a forming operation. The shock wave, which travels above the speed of sound in the medium, reaches the workpiece first. It is followed by the pressure wave generated by the gas bubble expanding from the site of the explosion. By equalizing the pressure and increasing the dwell time, this wave assists in forming thin materials and those which are sensitive to springback. (30, 31) The shapes

of shock waves and gas bubbles generated by detonating charges with different shapes, in water, are shown in Figure 20.

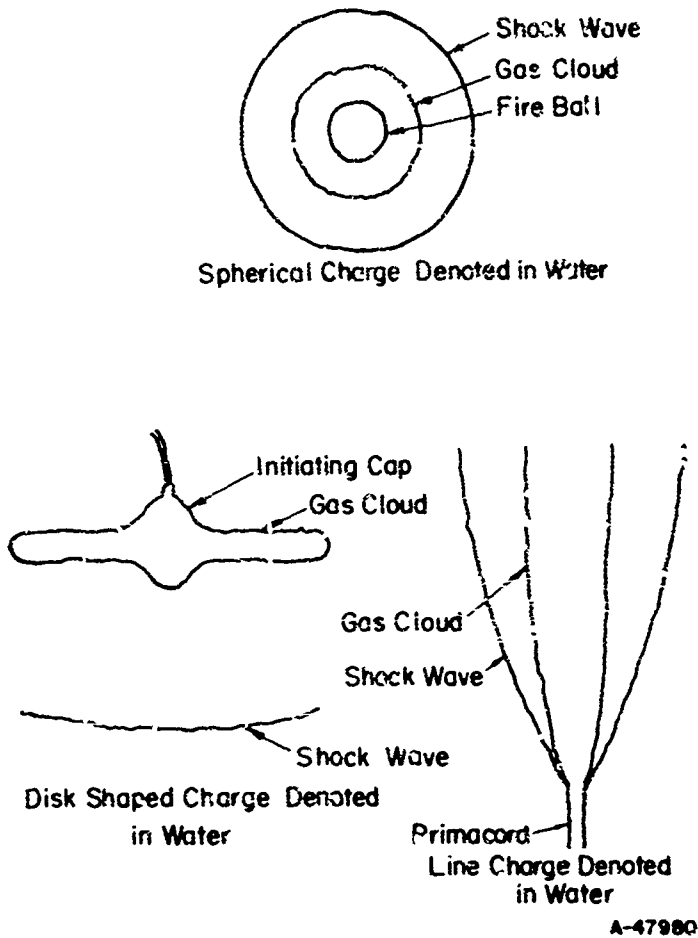

FIGURE 20. SHAPES OF SHOCK WAVES PRODUCED BY EXPLOSIVES OF DIFFERENT SHAPES<sup>(32)</sup>

Water has proved to be one of the best mediums for explosive-forming operations because it is readily available in most locations, inexpensive to use and produces excellent results. Since the energy absorbed by a medium is related to its density, it would be expected that considerably more energy would be lost by waves transmitted through a liquid than through air. This apparent loss of energy is, however, more than compensated for by the additional confinement of the explosive charge and the lengthening of the pulse duration due to the trapped energy. The net result is an increase in total impulse available in a liquid over that obtained in a gas for the same charge size and standoff distance. When a charge is confined in a liquid medium and the charge is sufficiently far from the surface of the water, several pulses may be obtained due to the overexpansion and overcompression of the gas bubble from the explosive charge. The greater confinement of the explosive by the water tends

to even out the pulse distribution and to maintain a positive pressure for a period of time measured in the millisecond range. The graph shown in Figure 21 depicts the difference in the pressure-time profile and the resultant integrated increase in total energy delivered between water and air mediums.

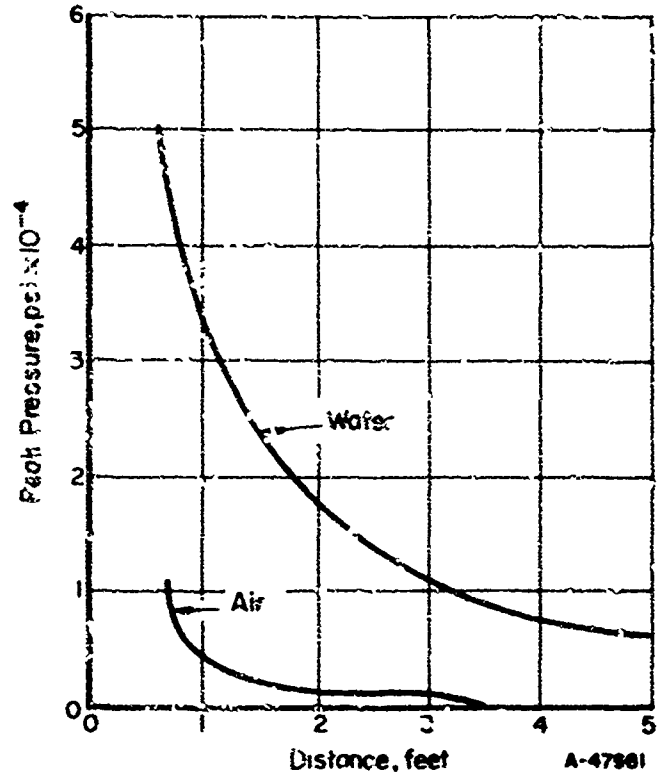

FIGURE 21. PEAK PRESSURE VERSUS DISTANCE<sup>(33)</sup>

Four-pound TNT charge.

Other liquids, such as oil, have been used for transmission mediums with good success. They act in the same general manner as water depending on their density, but water is generally preferred because of easier handling. Higher density liquids, such as mercury, are considered too expensive for general use. Some additional materials which have been used include talc, clay, fuller's earth, and combinations of solids suspended in water. These materials did not exhibit any particular advantages.

The differences in the shock-wave profiles with different mediums are illustrated in Figure 22 by the cup shapes which were obtained in air and in various liquids with a constant explosive charge and a standoff distance of 1/2 inch.<sup>(32)</sup> The pointed characteristics of the cup formed using air as the medium indicates the sharp, short-duration shock wave which is generally obtained in air.



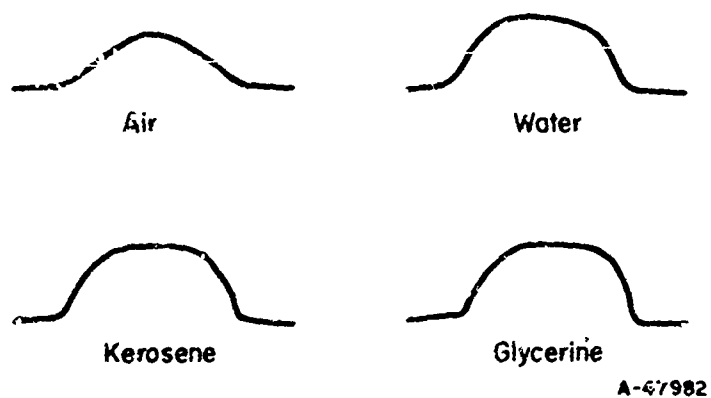

FIGURE 22. EFFECT OF MEDIA ON CUPPING PROFILE<sup>(32)</sup>

Explosive EL 506A constant  
charge size  
Standoff 1/2 inch  
Material 1015 steel

#### Solid Mediums

The use of a solid medium will protect the surface of the part being formed. Sometimes small slivers of metal projected from the blasting cap or any other material such as wire which is used to attach the charge may strike the surface of the part and result in scrap. Difficulty may also be experienced from slight irregularities in the explosive charge which cause the formation of jets. The jet effect is smaller under water and will normally only cause difficulty at very small standoff distances. Probably one of the most beneficial characteristics of a solid medium is the uniform distribution of pressure over the surface of the part being formed.

Solids in the form of rubber sheets, cast plastics, or even metals are sometimes used in explosive-forming operations. Plastics and rubber materials with Shore hardnesses below 60 on the A scale have been found to improve formability of some metals. The use of a plastic transmission medium has proven especially useful in the close-tolerance sizing of tubing details. The plastic tends to maintain the pressure for a sufficient time at the high-pressure level to minimize springback and at the same time does not hold the pressure level for a time sufficient to exceed the delayed yield strength of steel dies.

The use of solid metal plugs in the forming of shell configurations has also resulted in better formability.<sup>(34)</sup> It is postulated that energy trapped within a medium imparts a momentum to the medium which will in turn do work on the part to be formed. A similar effect occurs in trapped rubber-forming operations on a drop hammer. A solid medium will also tend to even out the stress-wave distribution before it enters the part

to be formed, resulting in better formability because unequal stress distributions are held to a minimum.

Elevated-temperature operations require the use of some inexpensive medium which will maintain its characteristics at elevated temperature and will not transmit heat to the explosive charge. Several materials including sand and small glass beads have been used for this purpose.<sup>(35)</sup> If sand is used, some buffer material should be placed over the part to prevent imbedding the sand into the part or marking the surface. It is believed that the shock waves are transmitted through fine-particle solids in a manner similar to the transmission in liquids, although a suitable method of determining this has not yet been described.

#### Shock-Wave Transmission

It has been found that shock waves travel through a medium at a velocity that is related to the speed of sound in the medium, indicating that good acoustical properties are associated with high efficiencies in shock-wave transmission.<sup>(36)</sup> When a minimum of energy loss is desired at an interface between two different mediums, a close acoustical impedance match should be obtained between them. Since the acoustical impedance is a function of the density of the medium, as a first approximation, matching the densities of the mediums helps to increase the efficiency of the system. The effect of placing an intermediate medium, such as a sheet of rubber, over a part on the depth of draw obtained is shown in Figure 23. The increase in rubber thickness lowers the maximum depths of draw but may assist in obtaining a greater amount of draw due to the shape of the cup profile obtained. The use of a solid intermediate medium permits more material to draw from under the hold-down ring without wrinkling and without rupture of the cup at the apex.

The same reasoning applies for the impedance between the explosive charge and the medium in which it is detonated. By obtaining a reasonable impedance match between the explosive and the medium, only weak reflections occur between the explosive and the transmission medium while the stronger reflections occur at the surface of the medium container. If the container walls are shaped properly, the reflections can be used to reinforce the shock wave which strikes the workpiece. They may also be directed to areas of the workpiece which require greater amounts of energy for forming. Although most shock-wave reflections are undesirable, they can be made to perform a useful function in forming of nonconcentric parts. Any reflectors which are used

should be made of steel and be rigidly supported since they will receive a high load.

### Sheet Forming

Explosive forming has been used most widely for producing parts from sheet metal. Most of the early work was done with concentric shapes, which are characterized by symmetry, but more emphasis is currently being devoted to nonconcentric shapes. With concentric parts the tooling and charge placement are relatively simple, thus requiring a minimum of experience to produce successful shapes. Nonconcentric forms such as beaded panels, electrode forms, and other nonsymmetrical configurations, involve techniques using uneven force distributions, reflectors, and shaped charges. Through experience, a better understanding of control in such systems has been developed and as a result the use of explosive forming for fabricating such shapes has increased.

### Tooling Considerations

Tooling requirements for the two types of configurations vary considerably due to the geometries involved. For concentric parts, fairly simple techniques such as casting or lathe machining can be used. The more complex dies required for nonconcentric parts necessitate hand finishing or the use of profile milling. In both cases, however, only a female die is required since a properly designed explosive charge provides the appropriate forming force. Special features can be incorporated into both types of tooling to control metal deformation and minimize buckling effects.

In simple drawing operations buckling is prevented by the pressure applied to a draw ring. With concentric parts an equal draw-ring pressure is required around the circumference, whereas variations in draw-ring pressures are needed with nonconcentric parts to accommodate variations in depth of draw. Pressures can be estimated for concentric configurations, but a trial-and-error system must be used to establish the required pressure patterns for nonconcentric forms. In such systems it has been generally observed that the pressure level for the minimum depth of draw should be decreased 2 to 4 per cent for areas of maximum draw<sup>(17)</sup>. Control of metal movement during forming can also be accomplished by using a bead around the die to induce more friction between the blank and die. This approach is much less flexible, particularly when a trial-and-error approach is required in the initial forming work.

Forming of thin sheet materials can be assisted by slowly drawing a vacuum between the blank and the die and working out wrinkles with a plastic mallet as they form. This procedure represents a partial forming, and often sufficient

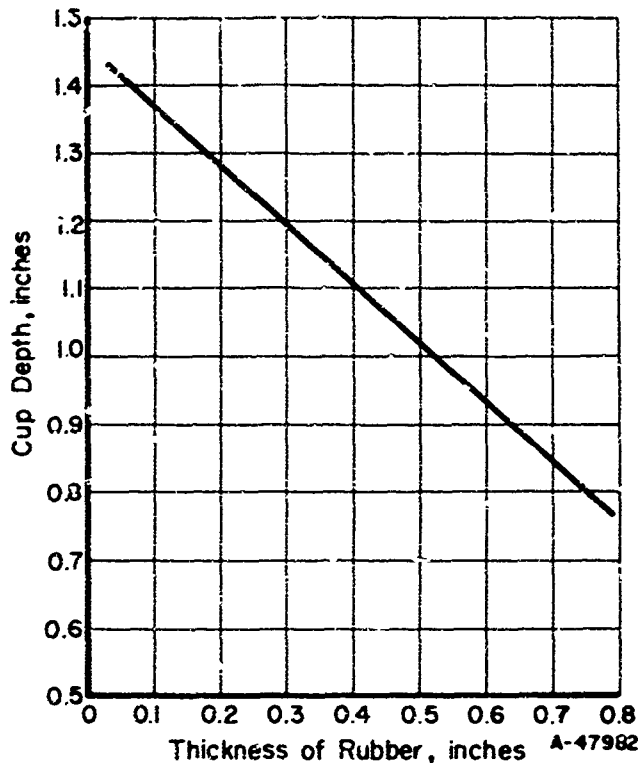

FIGURE 23. EFFECT OF INTERMEDIATE MEDIA

Test was conducted on a 4-inch-diameter cup die without hold-down pressure on 0.064-inch-thick PH-15-7Mo SS in the annealed condition. Standoff distance was 3 inches. Sixty inches of 100-grain Primacord was wrapped around a 2-inch-diameter tube to make a cylindrical charge. Rubber hardness was Shore A 60.

### CURRENT APPLICATIONS OF EXPLOSIVE FORMING

The potential of explosive forming in fabricating shapes to close tolerances has been the basis of current applications work in this area. In this respect forming operations involving sheet, plate, and tube have received major emphasis. In many instances large parts which would otherwise require extreme conventional-press capacities or parts which have complex geometries are the objects of interest.

deformation is achieved so that only a light explosive charge is necessary to complete the forming.

A "plug cushion" technique has been developed to provide additional mass in regions where greater stretching is desired in order to yield a more uniform distribution of stresses during explosive forming. (34) This method which permits greater depths of draw, results in better control of part shape and more uniform thickness than the direct explosive-forming approach. A comparison of the two techniques is depicted in Figure 24. Specific information has not been published on this technique but critical parameters have been identified as chamber angle, density, and thickness of plug.

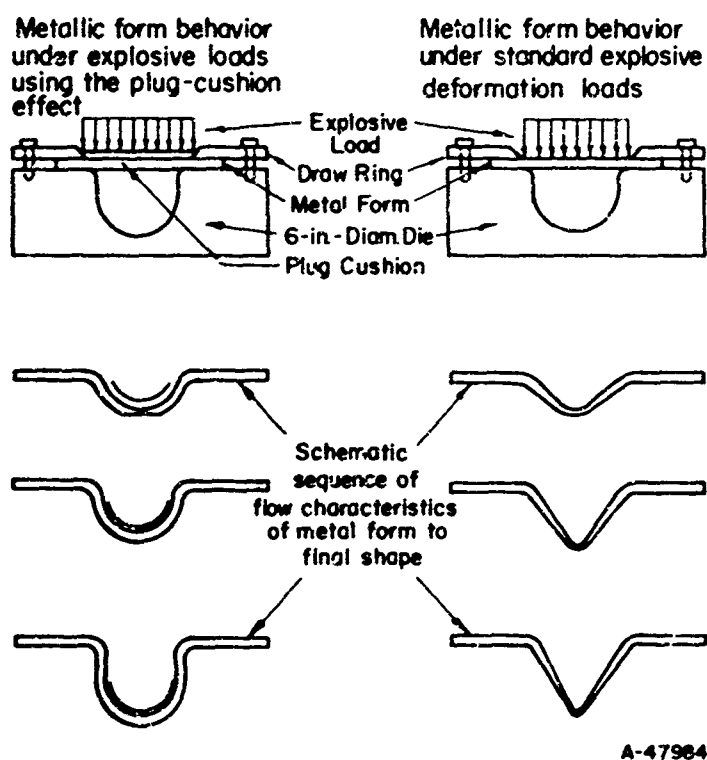

FIGURE 24. COMPARISON OF FORMING USING THE PLUG-CUSHION EFFECT AND STANDARD EXPLOSIVE-FORMING TECHNIQUES<sup>(34)</sup>

#### Size Limitations

The maximum size of parts which can be formed explosively is limited only by the size of tooling which can be constructed. Probably a more significant limitation on part size will be the method of shipping large parts after they are formed. It is quite possible in the future that the very large parts will be formed on the site where they will be used so that shipping is held to a minimum. The process would be ideal for this type of operation because of the comparatively low capital cost involved in setting up a facility for producing large parts. The only drawback is

that it may be undesirable to fire heavy explosive charges in some areas.

Recently, work has been initiated on the forming of 33-foot-diameter tank ends for the Saturn missile. (37) These will be the largest parts on which explosive forming has been used to date. The successful application of explosive forming to parts of this size will provide the information needed to perform even larger forming operations.

#### Tolerances

Tolerances as close as  $\pm 0.001$  inch have been obtained on small parts by explosive forming, but working tolerances are normally 0.010 inch. The tolerances are directly related to the amount of pressure utilized in the forming operation, up to a point where die failure will occur. The use of plastic or rubber fillers over parts also has a considerable bearing on the tolerance obtained. Since filler materials decrease the total pressure imposed on the part but maintain the pressure for a longer period of time, the increase in total impulse tends to improve conformation to the die and minimize springback. In general there are very few instances where explosive forming cannot equal or better tolerances obtained by conventional forming.

Measurements on large parts by standard methods are difficult where contoured surfaces are involved. The method of holding the part while the measurements are being taken can affect the measurement readings. These values are particularly sensitive to variations in room temperature and slow creep of the material due to its own weight. Another factor which is often overlooked on large parts is that the dimensions measured at the forming site may be correct and within specification; however, these values may be changed slightly after handling and shipping.

The type of tooling used in the explosive-forming process also influences the tolerances obtainable. Probably steel tooling is the most satisfactory for holding close tolerances for long production runs. Tooling materials such as Kirksite or plastics will flow under repeated impacts at high loads and cause a gradual increase in part dimensions during the production run.

A new area for explosive forming is in the forming of plastics. Most plastics have a very excellent memory for their original shape and tend to return to this shape after being formed by conventional equipment. A plastic seal made of Kel-F plastic by propellant forming in boiling water has demonstrated the usefulness of explosive forming methods. (38) This part was formed

to a tolerance of  $\pm 0.001$  inch and maintained that tolerance after storage for a year.

### Placement of Explosive Charges

In general, explosive-forming operations require that the explosive charges be at some standoff distance from the parts to be formed. In contrast, a contact charge supplies too high a peak pressure (above 1,000,000 psi) and can result in rupturing of the blank although more recent work with explosives of controllable detonation velocities and peak pressures have been successful.<sup>(39)</sup> Positioning of the explosive charges can be performed by a number of techniques provided several conditions are met: (1) the method of positioning should be substantial enough that immersion of a part in a water tank for firing will not displace the charge out of position, (2) the rigging for the charge should not result in flying projectiles which might damage the workpiece, and (3) any debris from the rigging should be easily recoverable from the water tank so that the operation can proceed in an orderly manner.

To meet these requirements, various types of rigging materials have been used. For large parts small-gage wire is used which generally is retrieved with the die. With smaller parts, masking tape is normally preferred for locating the explosive charge because it is easy to handle. Permanent steel rigging can also be used provided that the charge is separated from the rigging by at least 2 inches. Cardboard tubes work well for separating the charge from the rigging provided that the tube is not immersed in the water longer than 5 minutes before the charge is fired. For longer immersion times the tubes should be sprayed with a plastic coating.

Often it is possible to obtain the same results with different types of charges. For instance, tank ends can be formed with cylindrical charge or with an equal weight of Primacord wrapped on a cardboard tube.<sup>(17)</sup> Similar results are obtained if the diameter of the Primacord charge does not exceed twice the diameter of the solid cylindrical charge. Consequently when the supply of one type of explosive has been depleted, it is often possible to utilize another type which may be on hand.

Special types of explosive charges are generally required for the forming of nonconcentric shapes. These charges may be shaped in a manner which will provide a variation of shock-wave intensity so that the areas of the part which require a greater amount of energy will be properly loaded. The development of such charge shapes are especially difficult requiring extensive trial-and-error tests. Energy transmission to

the part can also be varied through the use of a rubber blanket covering those areas which require the least forming. In this case relatively simple charge configurations can be used. The most widely used technique involves the use of multiple charges to work the metal into the die in steps.

Shock-wave reflectors are suitable for producing parts which require a deeper draw in one particular region. They become very complicated, however, if there is more than one such region in a part. Generally trial-and-error testing must be employed since little information on the use of shock reflectors in sheet forming is available.

### Formability Limits of Sheet Materials

The nature of various investigations concerning the formability of sheet materials by explosive techniques has not yielded quantitative information on formability limits. Generally, the data obtained have been related to the types of configurations that can be formed and the relative behavior of the specific materials studied during forming. In contrast to these studies, applications of explosive forming have involved specific materials and configurations with the development effort devoted to process parameters. As a result, the wide range of shapes, tooling, and process variations represented in past work do not permit definite conclusions as to formability limits of the materials investigated. Observations of forming behavior do, however, provide a comparison of the relative ease of forming.

It has been generally observed that both austenitic and precipitation-hardening stainless steels can be readily formed into shapes of intricate geometry and those requiring extensive elongations.<sup>(40)</sup> Properly finished welds of these materials will also withstand similar deformations. Work-hardened stainless steels are readily formed with explosives and through proper scheduling of prior work and annealing, optimum mechanical properties can be obtained after forming. In contrast, carbon steels can withstand only limited deformation without splitting and cracking.

Aluminum alloys including both heat-treatable and work-hardening types have been formed with very little difficulty.<sup>(40)</sup> It has been found desirable to conduct initial forming operations in the annealed condition to minimize springback. Final forming can then be accomplished in the required condition as in more conventional forming.

The metals molybdenum, titanium, zirconium and their alloys are difficult to form at ambient temperatures. (40) Preheating to temperatures on the order of 800 to 1200 F has been found to minimize the cracking and splitting behavior normally experienced. Very little data has been reported on explosive forming the remaining refractory metals; however, it is expected that their relative behavior will parallel that in conventional forming.

#### Economics of Explosive Sheet Forming

Only limited information has been published on cost comparison of conventional forming and explosive forming. It has been generally found that simple shapes readily formed by conventional methods should not be considered for explosive forming since an economic advantage will not be realized. More complex shapes and materials with special properties such as the work-hardening characteristics of stainless steels and the new classes of high-temperature alloys lend themselves to explosive fabrication. Size considerations must also be taken into account since extremely large sizes may be formed explosively that would be impractical by conventional techniques.

A cost analysis conducted by Lockheed demonstrates the variability of both conventional and explosive-forming costs with specific parts. (4) This study involved the fabrication of five parts by both methods in sufficient quantity to establish the desired cost information. These parts which are shown in Figure 25 include a side-panel jet pod, collar-outlet housing, tailpipe ring, pan-fire shield, and an engine bellmouth tailpipe. The results of the cost analysis are summarized in Table 5 where it is evident that three of the parts examined were fabricated less expensively by explosive forming.

Further considerations in the economics of explosive forming sheet materials must include the availability of equipment and personnel. In many cases conventional equipment and trained personnel are already available and a change in production method must yield sufficient savings to offset the unused life of present equipment and the cost of retraining personnel. The quantity of parts to be produced will affect these economic factors. Although explosive forming has generally been regarded as applicable to short production runs, competitive production of 20,000 parts has been observed. (41)

TABLE 5. COMPARISON OF MANUFACTURING COSTS: CONVENTIONAL VERSUS EXPLOSIVE FORMING(4)

	Total Cost, dollars		Increase (+) or Decrease (-) Over Conventional Form, %	Total Cost, dollars		Increase (+) or Decrease (-) Over Conventional Form, %
	100 Qty. Basis			500 Qty. Basis		
	Conventional	Explosive	Conventional	Explosive		
Side-Panel-Jet Pot	80.64	89.91 81.29(a)	+11.5 +0.8	35.44	55.03 49.23(a)	+55.3 +38.9
Collar-Outlet Housing	6.77	12.99 10.79(a)	+91.9 +59.4	2.18	6.12 4.60(a)	+180.7 +111.0
Tailpipe Ring	80.63	53.22 50.72(a)	-34.0 -37.1	38.40	21.68 20.00(a)	-43.5 -47.9
Pan-Fire Shield	66.91	40.08 36.19(a)	-40.1 -45.9	22.80	19.19 16.58(a)	-15.8 -27.3
Bellmouth-Engine Tailpipe	161.47	133.54 128.48(a)	-17.3 -20.4	57.82	52.75 49.34(a)	-8.8 -14.7

(a) Denotes predicted cost of explosive forming as a production operation. First figure based on actual cost for experimental forming of parts.

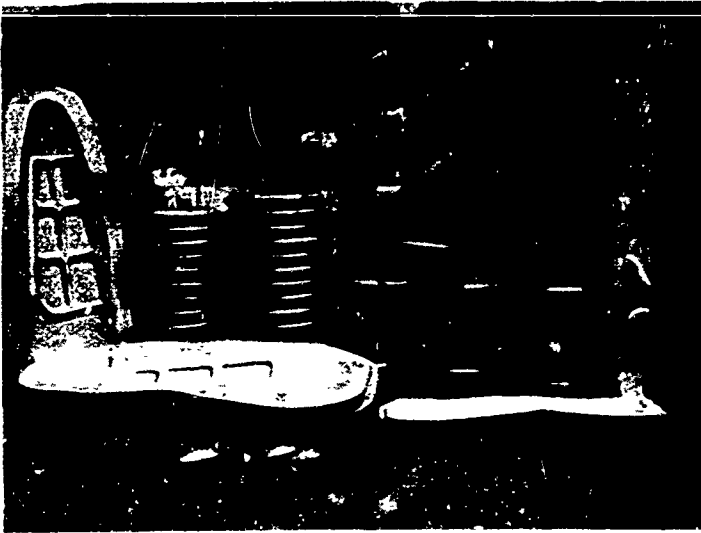

FIGURE 25. EXPLOSIVE-FORMED PARTS USED IN COST COMPARISON STUDY

Courtesy of California Division of Lockheed Aircraft Company.

#### Examples of Explosively Formed Sheet Materials

A variety of sheet materials and shapes representing both concentric and nonconcentric configurations have been formed with explosives. In each case the process parameters have been optimized for the particular part in question; consequently only the basic features of explosive forming are common to all of these applications. In reviewing the parts currently being formed it is evident that variations in die materials, types of explosives, and methods of charge placement are preferred as related to the particular part being formed. It is intended that the examples presented in the subsequent discussion will demonstrate these variations and the types of applications in current practice.

Forming of hemispherical shapes with a centrally located explosive charge has been the most widely investigated application of explosive forming. In forming large hemispheres of the type shown in Figure 26 a number of explosive operations are generally required.<sup>(42)</sup> In this case the 44-inch diameter shape of the 0.071-inch-thick 6061 aluminum alloy was formed in six operations with one intermediate anneal. The shell-die concept consisted of a fiber-glass-reinforced plastic shell of the desired contour which was sealed to a heavy-wall steel container. Additional reinforcement was supplied to the shell by filling the container with water before sealing the shell to it. This tooling was used to form the subject parts. This type of die assembly is considered unusual when compared to other single-component hemispherical forming dies.

The explosive consisted of a 30-inch-diameter ring of Primacord (25 g) in the first operation and similar charges located 11 inches above the center in subsequent detonations. This procedure produced a finished part of 57 per cent total stretch with tolerances of  $\pm 0.008$  inch on the contour and 0 to 0.005 inch in thickness. A similar technique involving three annular charges of Primacord and using a Kirksite die has been employed in forming 5086 aluminum alloy domes of 94-inch diameter and 0.281-inch thickness.<sup>(43)</sup>

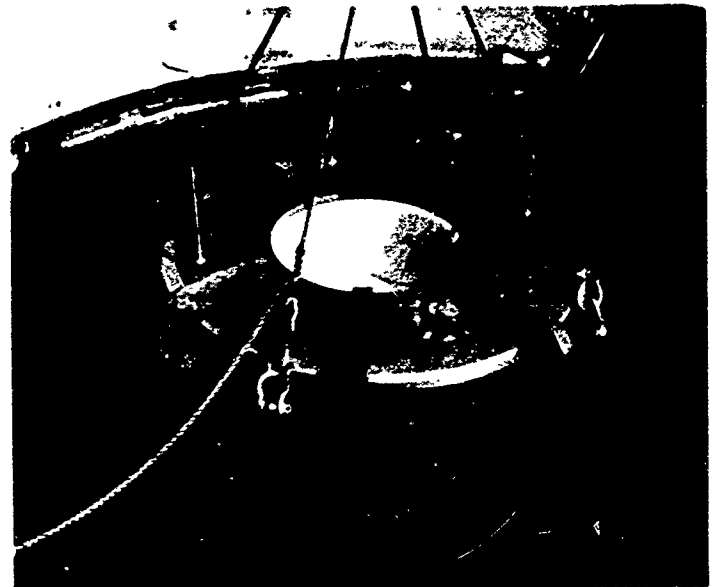

FIGURE 26. HEMISPHERICAL PART IN THE DIE AFTER THE FIRST FORMING STEP

Courtesy of General Dynamics/Astronautics.

A Z-ring blank explosively formed from 0.020-inch-thick Type 321 stainless steel is illustrated in Figure 27.<sup>(44)</sup> For this part a single forming operation involving a 4130 steel die with hold-down rings and a 9-inch-diameter winding of two strands of Primacord (approximately 25 g) was required. Subsequent detonations and annealing treatments were not needed because of the relatively shallow draw in forming. The part as shown requires trimming to complete the fabrication of the desired ring configuration.

Techniques for explosive forming at elevated temperatures were required in forming domes from tungsten sheet.<sup>(12)</sup> Prior to detonation the tungsten blank was heated to approximately 1250 F in a bath of molten aluminum by the device shown in Figure 28. The explosive was contained in an insulated tube in order that premature detonation would not occur. To form tungsten domes of 4.5-inch diameter by 0.125-inch thickness, a 12-g charge of Composition C-4 explosive and an AISI 4130 steel die was used in the assembly described. A dome height of

approximately 1 inch with a tolerance of  $\pm 0.003$  inch resulted from a single operation of this type.

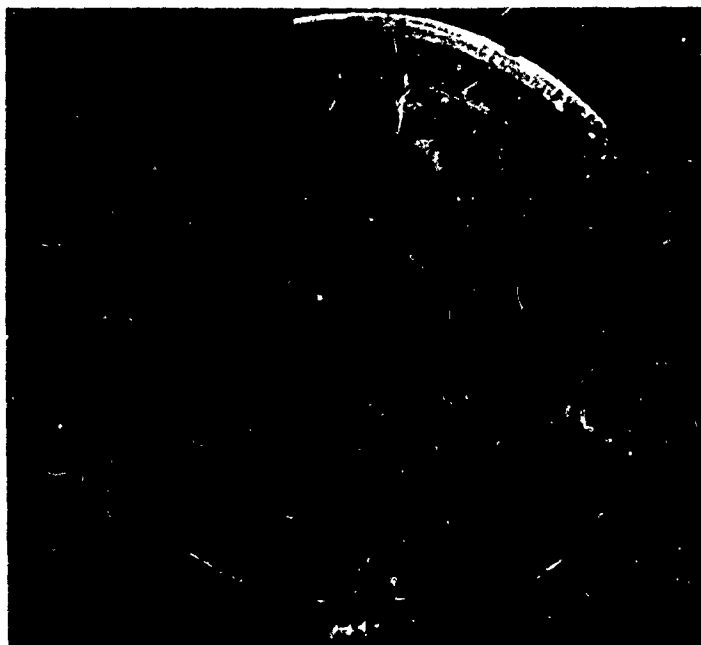

FIGURE 27. CLOSEUP OF PART READY FOR TRIMMING TO FORM THE Z-RING

Courtesy of McDonnell Aircraft Corporation.

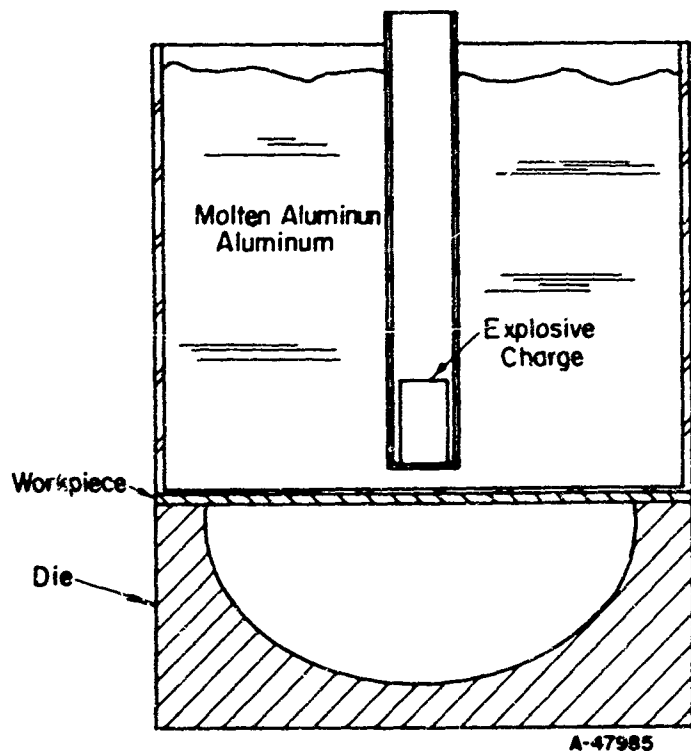

FIGURE 28. ARRANGEMENT FOR EXPLOSIVE FORMING AT ELEVATED TEMPERATURE

Courtesy of Aerojet-General Corporation.

Since nonconcentric parts are considerably more difficult to produce, forming of such items has been restricted to those that are small or require only limited deformation. Beaded panels represent examples of these parts which have been formed both by drop hammers and explosives. The panel shown in Figure 29 was explosively formed from a 0.020-inch-thick sheet of a columbium-1 per cent zirconium alloy. (44) Sheet explosive at a 5-inch standoff distance and a 4130 steel die were used to form the part in a single operation. The final tolerances realized in this part were approximately  $\pm 0.000$  inch. Similar panels of Type 321 stainless steel have also been formed by this method.

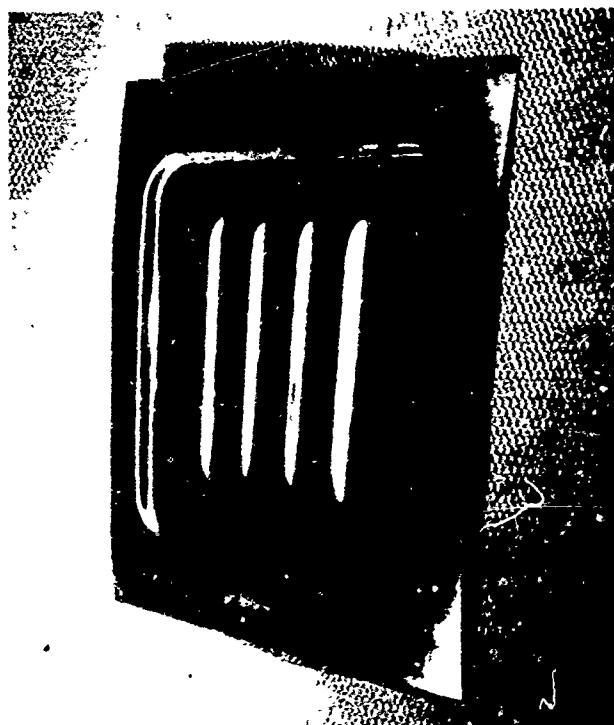

FIGURE 29. BEADED PANEL MADE FROM Cb-1Zr ALLOY SHEET

Courtesy of McDonnell Aircraft Corporation.

The forming of a L-605 stainless steel shingle for the Mercury capsule illustrates a deep-drawing operation on a nonconcentric part. (44) The shingle which is shown in Figure 30 was formed in two explosive-forming steps using flat helical coiled charges of PETN Primacord at a 10-inch standoff distance and Kirksite dies. This part which was formed from a 0.010-inch-thick starting blank 10 by 12 inches yielded minimum tolerances of 0.0075 inch of the final configuration.

A larger nonconcentric part with a shallow contour which was formed with explosives is a honeycomb facing sheet. (45) This part formed from a PH-15-7 stainless steel blank measuring 24 by 120 inches in a single operation is shown in Figure 31. In this application a 4-lb charge of

60 per cent nitroglycerin dynamite at a 24-inch standoff distance and a Kirksite die was employed. The die was assembled on a heavy wood support and an inclined track was used to lower the assembly into the water tank. In the final configuration tolerances of  $\pm 0.010$  inch were achieved. This application represents a case where only a few parts with close tolerances were required and explosive forming served as the most economic means of fabrication.

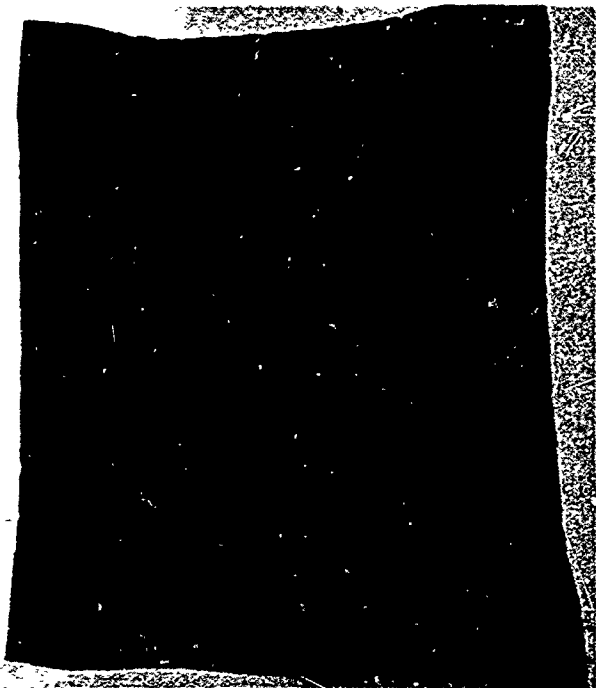

FIGURE 30. SHINGLE AFTER FORMING AND BEFORE TRIMMING

Courtesy of McDonnell Aircraft Corporation.



FIGURE 31. FINISHED DOUBLE-CONTOURED PART AFTER FORMING

Courtesy of Georgia Division, Lockheed Aircraft Corporation.

### Plate Forming

Concentric shapes similar to those described for sheet-metal parts can be explosively formed from plate. The limiting bend radii, of course, are larger since they depend on both the thickness and the mechanical properties of the workpiece. Explosive forming of plate materials has been employed because presses large enough to form heavy plates are generally not available. Economic advantages are realized when a forming operation, prior to machining of thick parts, can reduce the subsequent machining time and the weight of raw material required. Explosives have also been used to blank or pierce holes in heavy shapes. This operation requires a wave guide with the appropriately positioned and sized holes for placing over the workpiece. It has been generally noted that placement of the wave guide is critical and extreme care is needed to prevent irregular blanking.

### Tooling Considerations

In order to support the higher loads characteristic of explosive forming plate materials, the tooling must be of heavier construction than that used for sheet forming. Although the same basic methods for determining die designs are employed in both cases, plate-forming tooling is generally less complex. Usually plates are not formed to close tolerances, particularly since they are often machined in a later operation. A vacuum system is not necessary in these operations because the plates are heavy enough to withstand bulging from the gas pressure created in unvented dies; where the dies are vented, marking of the workpiece is removed in the final machining. The mass of hold-down rings required for plate forming is too large to be practical; consequently forming is generally accomplished in free-forming dies such as shown in Figure 32.

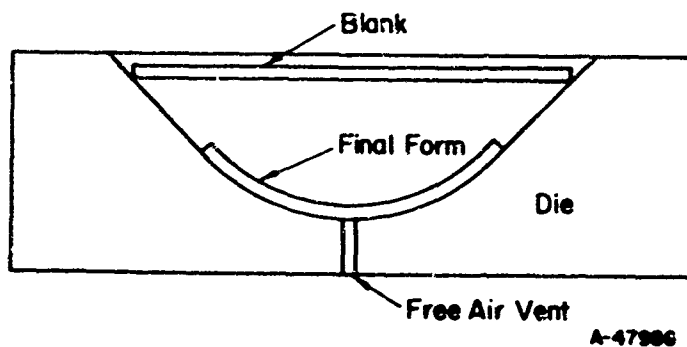

FIGURE 32. TAPERED-ENTRANCE DIE

### Formability of Plate Materials

As in other explosive-forming operations, limitations on the size of parts that can be



fabricated from plate materials are imposed by factors related to the process rather than to the basic features of the method. As parts become larger, or heavier plates are used, the required explosive charge becomes larger and may approach the maximum charge which can be used in a particular facility. These same factors would necessitate larger and more heavily constructed tooling which would be more difficult and expensive to fabricate. Without these restrictions there is no theoretical limit to the size of parts that can be formed from plate materials with explosives.

Tolerances obtainable in explosively formed plate materials are the same as those noted for sheet materials, namely  $\pm 0.010$  inch. Normally, considerably greater tolerances than these are accepted on parts made from plate since subsequent machining operations are customary. With free-formed plate materials, tolerances as great as  $\pm 0.250$  inch have been considered acceptable. In order to realize the greatest economic potential of preforming plates with explosives, relaxation of tolerances is generally experienced.

There are no specific data on the formability limits of plate materials in explosive-forming operations. In most cases to date only limited deformation, on the order of 10 per cent, has been required in forming these plate configurations. It is likely that greater deformations could be obtained if desired, but these have not been required in current applications. Also, efforts in this area of explosive forming have been limited to a relatively small number of materials and applications with the result that the relative forming behavior of the plate materials examined cannot be well established.

#### Explosive-Charge Placement

The explosive arrangement for plate forming is similar to that for sheet forming except for the scaled-up size of tooling, workpiece, and explosive charges. Since water is the preferred transmission medium in these operations, containment in large water tanks or firing above ground using a water-filled bag is required. In each approach the explosive energy is transmitted to the workpiece through water; however, aboveground firings create a considerable noise problem which may have to be reconciled with public-relation policies.

Because of the relatively simple configurations involved in plate forming, charge shapes and placement are less complex. Normally, centrally located charges and ring charges positioned at the desired standoff distance are employed. Consideration of charge containment in

water and the rigging required for positioning are essentially the same as those in sheet forming. However, since final machining is often required some marking of the formed piece can be tolerated.

#### Economics of Explosive Plate Forming

The economics of plate-forming operations using explosives has not been established through specific cost comparisons with more conventional fabrication methods. It is generally considered that the greatest savings would be expected in preforming heavy parts prior to finish machining. This operation compared to machining the same component from solid stock would provide a savings in both the required machining time and the total stock removed as waste. Particular advantages would be realized with materials that are expensive and inherently difficult to machine. Such savings, of course, would be required to offset the costs of the explosive-preforming operation.

Economic advantages may also be gained in explosive forming plate materials in short production runs where conventional equipment is not available. In such cases the cost of procuring a heavy press for the limited forming required would be prohibitive and the capital costs required for establishing an explosive-forming facility and the related tooling would appear particularly attractive.

#### Examples of Explosively Formed Plate Materials

In forming plates with explosives concentric configurations have received the most interest particularly where forming to final shapes has been involved. Present applications have been limited to plate thicknesses of 1/2 inch or less because of the component sizes of interest and not because of process limitations. In addition to the free-forming approach which has been widely used with plate materials, step-forming operations, and stretch forming have also been employed. These variations and typical applications are demonstrated in the subsequent discussion.

Free forming dome shapes from plate stock with explosives has proven to be highly successful. A dome resulting from explosive forming a 0.19-inch-thick by 25.6-inch-diameter Type 321 stainless steel blank is shown in Figure 33.(46) In this case three charges of Powertol 7A (200, 600, and 600 grains) with no intermediate anneals were required. Forming was accomplished over a mild steel ring die with centrally located, spherical, explosive charges at a standoff distance of 2 inches. Similar techniques were used in

forming a 2014 aluminum alloy dome which is shown in Figure 34 after attachment of a skirt by welding.<sup>(46)</sup> Six explosive-forming operations were used in producing this 1/5-scale Titan dome from a blank 0.100-inch thick and 33.6 inches in diameter. The mild steel die components employed in this case included a die ring and hold-down ring.

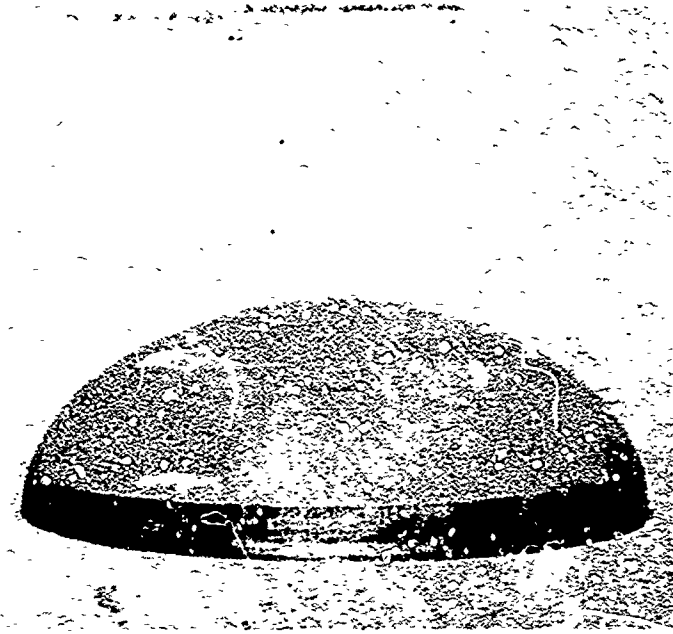
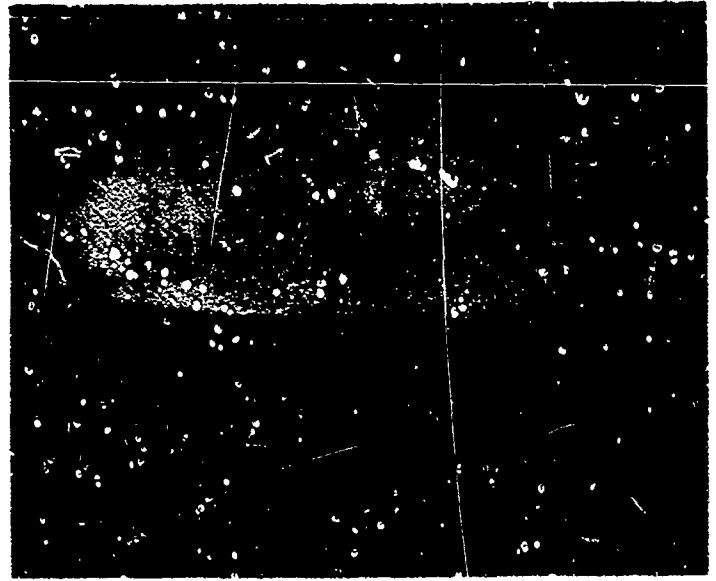

**FIGURE 33. TRANSLATION ROCKET PART FORMED BY DIE-LESS TECHNIQUES**

Diameter	14.4 inches
Initial Thickness	0.100 inch
Final Thickness	0.080 inch
Thickness Variation	20 per cent

Courtesy of Martin Company,  
Denver Division.

The production of a hyperbolic reflector by multiple explosive-forming operations has been demonstrated with a 6061-O aluminum alloy. Ten steps were required to form this shape from annealed plate measuring 3/8-inch thick and 135 inches in diameter.<sup>(47)</sup> Explosive charges for each operation consisted of loops of Primacord arranged in a decreasing diameter. This procedure resulted in progressive stretching to form the shape, starting from the periphery of the part and finishing at the central portion. The final shape which is shown in Figure 35 was formed in a Kirksite die in a water transfer medium and represented a total stretch of approximately 15 per cent and tolerances of  $\pm 0.032$  inch. This approach to forming plate materials has the advantages that the small charges are less likely to damage the die and forming of large shapes can be conducted in a limited facility.



**FIGURE 34. FRONT VIEW OF 1/5-SCALE MODEL TITAN DOME WITH ATTACHED SKIRT**

Formed by free-forming techniques using the "plug cushion" concept; final thickness at apex = 0.097 in.; thickness variation 4.9%; Courtesy of Martin Company, Denver Division.

Explosive plate forming has been used to a considerable extent for commercial production of heavy dished heads for steel tanks<sup>(12)</sup>. The tank ends which are shown in Figure 36 after forming and trimming were fabricated from 77-inch-diameter AISI 4340 blanks of variable thickness. The procedure used involved two underwater explosive-forming steps in a 4340 steel die with a liquid Aerex explosive. The explosive charges consisting of 3210 g were in a spherical shape and located at a 7-inch standoff. In the final parts deflections of 20 inches were attained with tolerances of 0.006 inch on the thickness and 0.025 inch on the contour. The high degree of uniformity in wall thicknesses was in part due to pre-machining the thick plates to the appropriate shape.

The general procedures for drawing large parts in explosive operations differ from stretching in that a greater number of steps are required. This procedure permits a greater control of metal flow to avoid excessive thickening or thinning. Often rubber inserts are placed in the die for deformation control in the early forming operations. A 70-inch-diameter hemisphere formed in this manner is shown in Figure 37.<sup>(48)</sup> In this case a 100-inch-diameter blank of Type 4086 aluminum alloy was formed in 10 explosive operations using PETN Primacord charges varying from 50 to 150 g. A cast mild steel die was employed. Standoff distances were varied from 6 to 10 inches the blank was held hydraulically



**FIGURE 35. COMPLETED HYPERBOLIC REFLECTOR**

Note slight elongation of holes in part rim due to pull in against the bolts. The circular mark on the contour was picked up from a scribe line on the die surface which indicates the detail possible with the process even on plate material.

Courtesy of North American Aviation, Inc., Columbus Division.

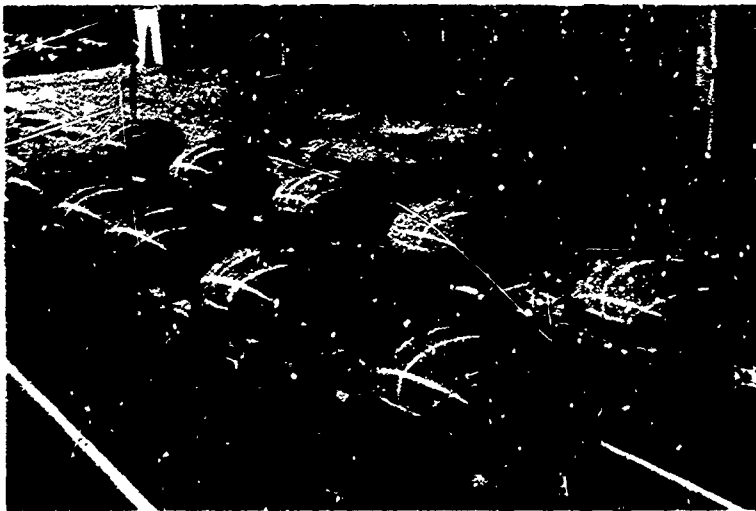

**FIGURE 36. COMPLETED STEEL TANK ENDS AFTER FORMING AND TRIMMING**

Courtesy of Aerojet-General Corporation.



**FIGURE 37. COMPLETED 70-IN. EXPLOSIVELY FORMED ALUMINUM TANK END**

Courtesy of Ryan Aeronautical Company.



**FIGURE 38. BLANKS AFTER EXPLOSIVE FORMING**

Courtesy of General Dynamics/Fort Worth.

with a force of 200 tons. The final configuration resulted in a 35 per cent stretch at the center and 10 per cent shrink at the periphery with a tolerance of  $\pm 0.030$  inch.

Preforming of heavy plate prior to machining, which has been noted as a potential economic advantage, is demonstrated in Figure 38<sup>(49)</sup>. This forming was accomplished on an aluminum 7075 alloy plate in the T-6 condition measuring 40 inches in diameter by 2 inches thick. Two explosive operations using 38 and 24 ounces of commercial dynamite and a Kirksite die in a water system were required. The final component exhibited a stretch of approximately 18 per cent with a tolerance of  $\pm 0.06$  inch. This preforming resulted in a saving of 766 pounds of material per part when compared to direct machining from an 11-inch slab. In addition the machining time required was greatly reduced although no direct comparisons were made.

Forming nonconcentric parts from plate materials is more difficult and as a result has not been widely investigated. The greater complexity of such forming was demonstrated in the fabrication of a torus ring from René 41<sup>(38)</sup>. This nonconcentric part which is shown in Figure 39 required three forming steps using 700-g charges of Composition C-3 at a 4-inch standoff distance and a Kirksite die. The initial annealed blank which measured 54 inches in diameter by 0.25-inch thick yielded 30 per cent stretch and tolerances of  $\pm 0.010$  inch in the final configuration. Wrinkling near the nonconcentric bulge was the major difficulty in this forming; however, the use of point charges located at the difficult areas eliminated the forming problems.

#### Tube Forming

Explosive forces have also been utilized successfully in tube-forming operations. This process has permitted the formation of many unique tubular shapes by beading and bulging the initial workpiece in selected areas. In addition, the extremely close tolerances that can be achieved have been found particularly advantageous. Since the basic geometry employed in these operations is a tube, it is generally necessary to use split dies and line explosive charges to achieve the desired forming. These features of explosive tube forming represent a major difference between this forming method and sheet and plate forming.

#### Tooling Considerations

In order to facilitate removal of the completed tubular configurations it is necessary to use either split dies or split tapered die inserts depending on the particular part to be formed.

The use of split dies makes evacuation more difficult in that rubber seals are required between the die halves. The parting lines between the die segments will often leave undesirable marks on the formed part. This marking effect can be reduced by either reducing the explosive charge and employing multiple operations or increasing the strength of the die. Where heavy loads are involved, modifying the strength of the die has little effect.

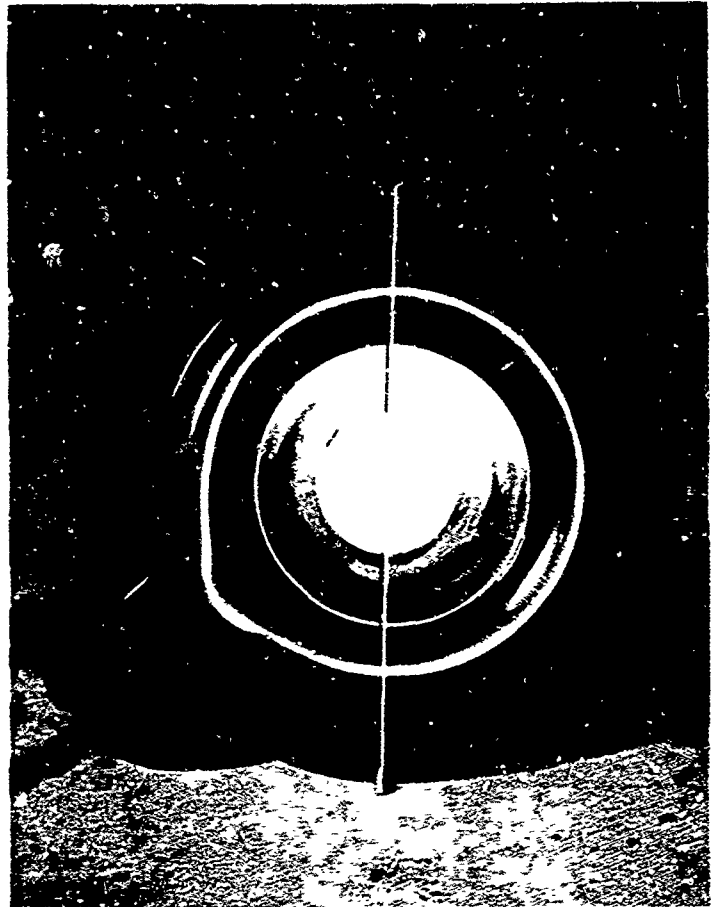

FIGURE 39. NONCONCENTRIC TORUS RING

Explosively-formed from René 41.  
Courtesy of Rocketdyne, a Division of  
North American Aviation, Inc.

Some control of the amount of bulging can be obtained through the use of end plugs to supply some restraining force to prevent drawing-in from the ends of the tube. This detail can be critical in thin-gage tubing where wrinkling will occur if the ends of the tube are not restrained.

Shock-wave reflectors can be incorporated in the tooling for explosive-forming operations on tubing. They find the best applications in tooling for nonconcentric shapes or where reentrant angles are desired. With the use of special reflectors the charge can be placed at one end of the tube and a reflector inside the tube to concentrate the shock wave in certain areas. Very large bulges (350 per cent of tube

diameter) have been produced with the use of reflectors, intermediate anneals, and step-forming operations. The reflectors can vary considerably in design, ranging from a solid filler with an angled cut (to concentrate the energy on one side of the tube) to exponential shapes for reentrant angles. To date, most of the work with reflectors has been performed with propellants in closed systems rather than with explosives.

### Formability of Tube Materials

As with sheet and plate forming any limitations on the size of tubes that can be formed explosively are dependent on factors such as facility capabilities, difficulties in die construction, and handling. Forming operations have been conducted on tubes ranging from 1/4-inch diameter with a 0.010-inch wall to 40-inch diameter with a 5-inch wall. As the size of the workpiece is increased, greater quantities of explosives are required which may approach the limits that can be handled safely in an existing facility.

Tolerances on small-diameter tubes have been maintained as low as  $\pm 0.001$  inch, but tolerances on the order of  $\pm 0.010$  inch are generally accepted. This consideration is based on economics since the extremely close tolerances require the construction of heavy, accurate dies which will withstand the repeated heavy loading in the production of the desired parts. With the relaxed tolerance, less expense is involved in the die fabrication and slight deformations through use can be accommodated.

From existing data it is difficult to establish formability limits and relative behavior for the various tube materials formed explosively. In most operations material is drawn into the forming area in addition to the diametral expansion at that point; thus a measurement of the diametral expansion alone does not give a true evaluation of the formability of the material. An illustration of this effect is demonstrated in forming a tubular compound component where a 350 per cent increase in diameter was recorded at a point where the wall thickness was reduced only 20 per cent. (41) Usually only information on the diameter increase as a result of forming or the diameter at fracture has been recorded. It is generally regarded, however, that explosive-forming limits for simple bulging are probably similar to conventional bulge forming on the same material.

### Explosive-Charge Placement

The setup for tube forming requires the use of line charges placed on center line of the tube.

This requirement holds for parts which have lengths greater than their diameters. Alignment of the charge is critical since the tube provides some reflective characteristics to the shock wave, and misalignment can result in extreme pressures in areas of the tube closest to the charge. Proper location of the charge can be insured by thin spacers placed in the tube or by an exterior fixture which applies some tension to the explosive charge. A rigid plastic tube can also be used to cover the explosive charge and to keep the flexible charge straight.

Normally a die is required when a specific configuration is required. As with plate forming, however, the process can be used for preforming a tube which is to be machined. Simple bulges can be formed in heavy-wall tubes without a die but tolerances can not be held very closely on either the diameter or on the contour of the bulge. This technique sometimes offers advantages for parts which are to be finish machined.

### Economics of Explosive Tube Forming

Although no specific data are available on the economics of tube-forming operations, it appears that considerable savings are possible. This opinion is based on the large production quantities of explosively formed tubular parts which have been made in isolated cases. One example is the sound-suppressor tubes used on all commercial jet aircraft, an application which has involved the production of more than 10,000 parts. The main economic advantage in this application is derived from the close tolerances obtainable. Such components are often assembled in other operations requiring close tolerances (brazing, etc.) which previously involved considerable hand work on conventionally formed tubes.

### Examples of Explosively Formed Tubes

Both commercially available seamless and welded tubing have been employed in explosive-forming operations with no apparent difference in forming behavior. Applications to date have involved forming various materials to configurations with both longitudinal and diametral ribs. The general procedures used have been similar with only minor modifications appropriate to the part being formed. The following examples demonstrate the variations in forming that have been achieved.

Some of the less complex tube-forming operations have involved the forming of square, fluted, and hexagonal tubes. (38, 49) A typical item which was formed from a 5-inch-diameter

Type 321 stainless steel tube measuring 38 inches long with a 0.020-inch wall is shown in Figure 40. This part was fabricated in a single operation using 6 ounces of Primacord in a water medium and an AISI-4340 die. The final configuration represented a stretch of approximately 20 per cent with finished tolerances of +0.000 and -0.010 inch.

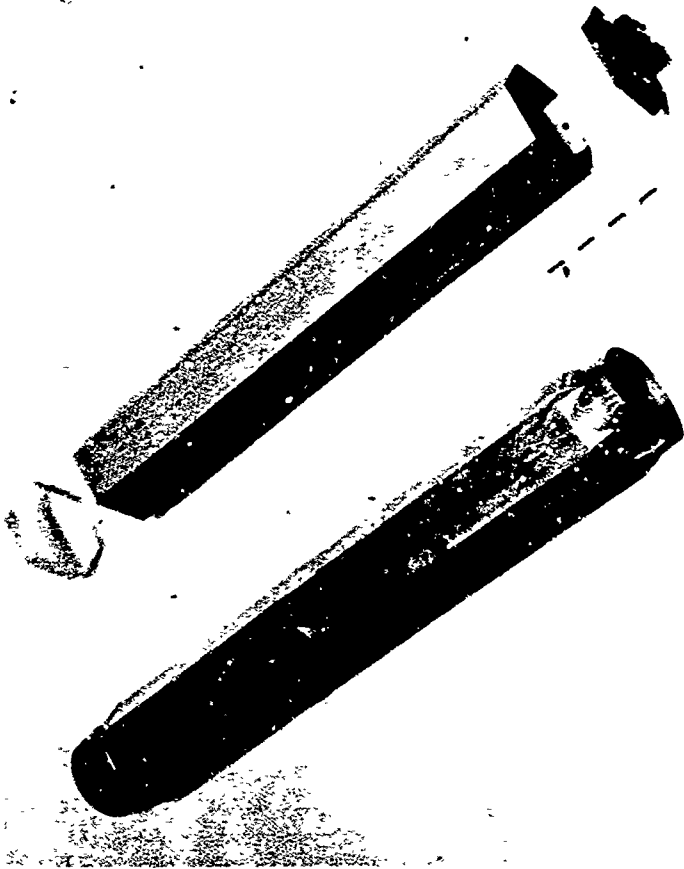

FIGURE 40. EXPLOSIVE-FORMED HEXAGONAL TUBE BEFORE AND AFTER TRIMMING

Courtesy of General Dynamics/  
Fort Worth

Explosive forming has also been applied to the formation of inner and outer thrust-chamber liners. The spiral grooves such as shown on the outer thrust-chamber shell in Figure 41 demonstrate the variations in explosive tube-forming operations that may be considered practical. This part was formed in a single operation with 150 grains of PETN Primacord and a Solar tool-steel die in a water medium. The initial 4-inch-diameter Type 321 stainless steel tube with a 0.063-inch wall yielded an approximate 7 per cent stretch with finish tolerances of  $\pm 0.0005$  inch on the inside diameter.

Pressure-vessel segments of 6061 aluminum have been fabricated in single explosive-forming operations by similar techniques.<sup>(43)</sup>

The sectioned segment shown in Figure 42 was formed from an 18-inch length of a 4-inch-diameter tube with a 0.078-inch wall using a 15-inch length of PETN Primacord (75 grams) and a mild steel die. The resulting part achieved a stretch of 15 per cent and a tolerance of within 1.003 inch of the die dimensions. As can be noted in the photograph a small amount of thinning was experienced in the bulged areas of the formed part.

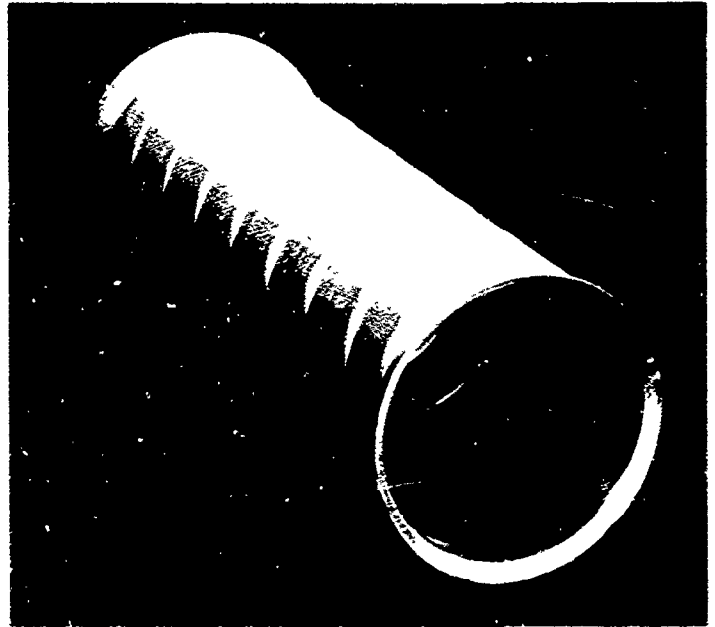

FIGURE 41. END VIEW OF OUTER THRUST CHAMBER SHELL

Courtesy of Rocketdyne, a  
Division of North American  
Aviation, Inc.

The bulging of a curved fuel-line tube by explosive methods is illustrated in Figure 43.<sup>(43)</sup> This part was initially curved by conventional methods from a 2-inch-diameter 30-inch-long 321 cold-rolled steel tube with a 0.065-inch wall. Three explosive-forming operations, as indicated in the figure, using a 4340 forged steel die were required. Formation of this part represented a maximum stretch of 50 per cent and tolerances of +0.005 to 0.003 inch on the diameter.

#### Forming Welded Sheet-Metal Preforms

Explosive-forming methods have been used in forming components from welded preforms. Such preforms are required when the initial tube size is larger than that obtainable commercially or when a specialized starting shape is needed. Since subsequent forming operations will be conducted, it is necessary that good quality ductile welds be employed in preform fabrication. Generally the welds are planished and the blanks annealed prior to forming. Also, where possible, the welds are located in areas where a minimum

stretching is expected to reduce the possibility of weld failures during the forming operation.



FIGURE 42. COMPLETED SEGMENTED PRESSURE VESSEL AND CROSS SECTION

Courtesy of Chance Vought Corporation, a Division of Ling-Temco-Vought.

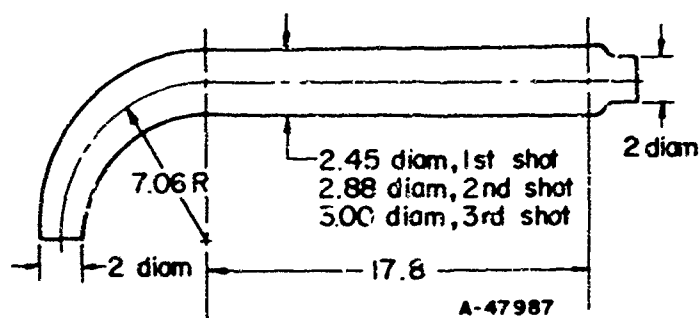

FIGURE 43. F8U FUEL-LINE TUBE

Courtesy of Chance Vought Corporation, a Division of Ling-Temco-Vought.

### Tooling Considerations

The size of parts may in some cases limit the use of split dies and in turn limit the process to applications where natural draft will permit the removal of the part from the die. No other special considerations are necessary for tools unless very thin parts are to be formed which may result in wrinkling when a vacuum is applied between the part and the die. Wrinkles can be avoided by the use of sandwich blanks or removed by hammering with a mallet if they form during the time the vacuum is applied.

### Formability of Welded Assemblies

As with other explosive-forming operations, the size of parts which can be produced from welded blanks is limited only by external factors. The maximum die size is smaller than for sheet or plate forming because the shape of the parts usually results in higher tensile stress components. In addition, the charge size is limited in the same manner as that noted for sheet and plate, namely the capability of the facility to be used.

Tolerances for parts explosively formed from welded sheet can be held to  $\pm 0.010$  inch although a more practical tolerance of  $\pm 0.032$  inch is normally specified. The higher forces that would be necessary to obtain closer tolerances would shorten die life and result in higher die costs for a given production run. Close tolerances would also require a higher degree of weld finishing prior to forming. Because of these factors the tolerances for forming welded sheet-metal preforms are generally considered somewhat larger than those for forming sheet metal of the same thickness.

The formability of welded sheet-metal preforms in explosive forming would be the same as that for the individual sheet metal. This direct comparison, of course, assumes that the welds have been properly finished and annealed to insure adequate ductility. Otherwise, the weld joints or heat-affected areas would impose limitations on the forming operation. Often it is necessary to test the welds in tension to provide a comparison of their ductility with that of the parent metal.

### Explosive-Charge Placement

The type and placement of explosive charges in forming welded sheet assemblies depends on the final configuration of the part desired. Line charges positioned at the axis of the assembly are used for long right cylindrical shapes. With a cone-shape part a point charge positioned toward the base of the assembly may be desired.

Combinations of the two types of charges and reflectors can also be utilized as noted in the previous discussion on tube forming. As with other explosive-forming operations, set-up details are still based to a great extent on individual experience with similar starting shapes and explosive-forming assembly designs.

#### Economics of Forming Welded Sheet Assemblies

Economic advantages that may be realized in explosive forming welded sheet-metal assemblies are dependent on the complexity of the part designs and the number and types of operations required in conventional fabrication. In addition, material factors such as ease of forming, welding, and machining will influence the comparison. As with other types of explosive forming economic analyses are quite limited. One economic comparison concerning the forming of welded sheet preforms is summarized in Table 6. (50) This analysis involving bulging, floturning, and explosive forming considers the forming of a complete skin section made of 6061 and 5086 aluminum alloy. The final formed part was to be 31 inches long with a 12-inch diameter at one end and a 5-inch diameter at the other end.

TABLE 6. RELATIVE MANUFACTURING COSTS OF A CONICAL ALUMINUM SKIN

	Bulging	Floturn	Explosive Forming
Part Cost	0.89	1.00	0.77
Tooling	3.60	1.00	2.40
Facilities	2.30	4.00	1.00

The analysis shows an economic advantage in favor of explosive forming for this particular part.

#### Examples of Explosively Formed Welded Blanks

A wide variety of tubular and conical shapes has been fabricated by explosive-forming welded-sheet assemblies. In most cases relatively thin sheet has been used, but the effectiveness of this forming method on thicker assemblies has also been demonstrated. Depending on the geometry in question, line charges, point charges, and split charges have been employed. Also variations in die designs have been used with particular emphasis on minimizing die costs. The following examples present some of the shapes and explosive-forming practices that are characteristic of current applications.

Complex conical shapes generally require multiple forming operations with possible intermediate anneals. The truncated cone shown in Figure 44 was formed in this manner from a 22-inch-long Type 321 stainless steel preform measuring 4-1/2 inches in diameter at the small end

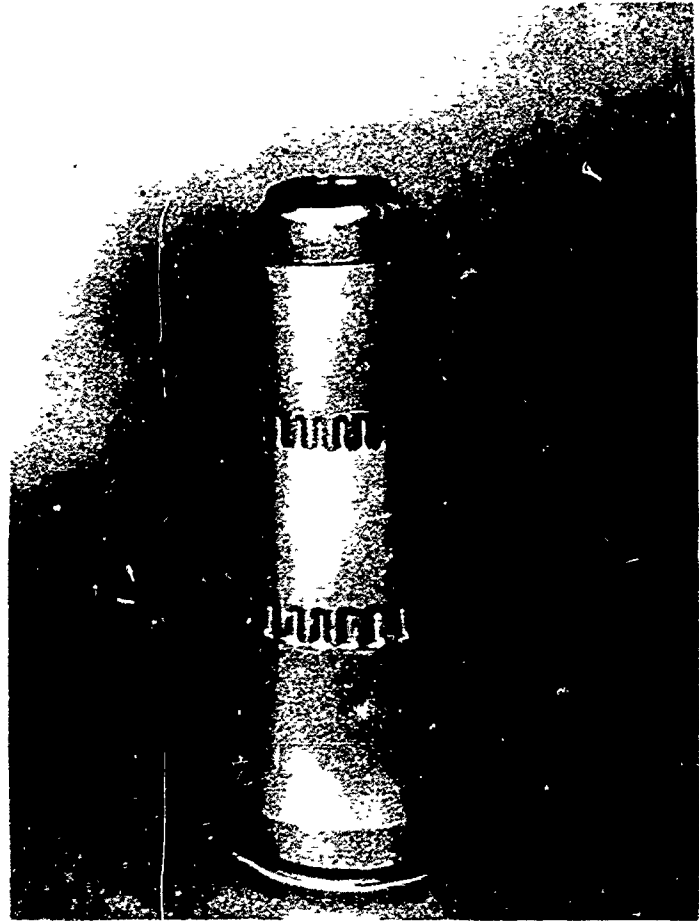

FIGURE 44. COMPLETED TRUNCATED CONE

Courtesy of Ryan Aeronautical Company.

and 11-1/2 inches in diameter at the large end. (48) Five forming stages were required using ball shaped 60 per cent Nitro Dynamite charges of 5 to 16 g positioned at the center of the cone. A Kirksite die with steel inserts for forming the bosses and a clamp ring represented the tooling in this operation. During the course of forming this part, one intermediate anneal was necessary. Tolerances of -0.010 inch from the die dimensions were achieved with the material undergoing 20 per cent stretch. Similar techniques have also been used to fabricate the rocket shroud shown in Figure 45. (38)

The usefulness of the separation of explosive charges to achieve a bell-shape component of K-Monel is demonstrated in Figure 16. (42) The initial rolled and welded 0.040-inch-thick cone preform measuring 24 inches long with a diameter tapering from 4 to 20 inches was formed in three operations. Spherical charges of 4 g and



15 g located at the top and bottom of the assembly, respectively, were used in each step with one intermediate anneal. A Kirksite die with bolts to provide a hold-down force was used in a water medium in this forming operation. A total stretch of 19 per cent with a finished tolerance of  $\pm 0.010$  inch was achieved. It was noted that a considerable amount of drawing occurred during the operation requiring the accommodation of the change of length in the part.



FIGURE 45. EXPLOSIVELY FORMED ROCKET SHROUD

Courtesy of Rocketdyne, a Division of North American Aviation, Inc.

Explosive forming of large-diameter welded-sheet tube preforms has been accomplished in dies consisting of stacked and bolted plates of steel.<sup>(5)</sup> The fan hub shape formed in this manner is shown in Figure 47. These configurations have been fabricated from Monel, carbon steel, Types 304 and 316 stainless steel, and silicon bronze from 10 to 14-gage preforms ranging from 16 to 36 inches in diameter. In all cases, charges of dynamite were centrally located in the assembly to achieve the desired forming.

Explosive forming heavy-wall tube preforms has been successful in fabricating 6061 aluminum components.<sup>(51)</sup> The part shown in Figure 48 was formed in a single operation from

a 1-1/4-inch-thick preform 32 inches in diameter and 16 inches long. A 260-g Composition C-3 explosive charge located at the center of a ductile-iron split-die assembly was utilized for this forming. The approximate stretch achieved in this case was 5 per cent.

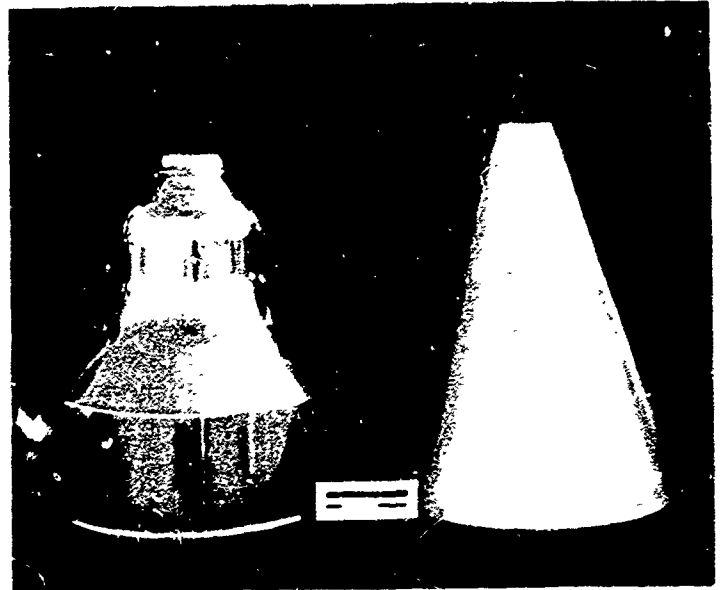

FIGURE 46. STARTING BLANK CONE AND FINISHED EXPLOSIVE FORMED PART

Courtesy of General Dynamics Astronautics.

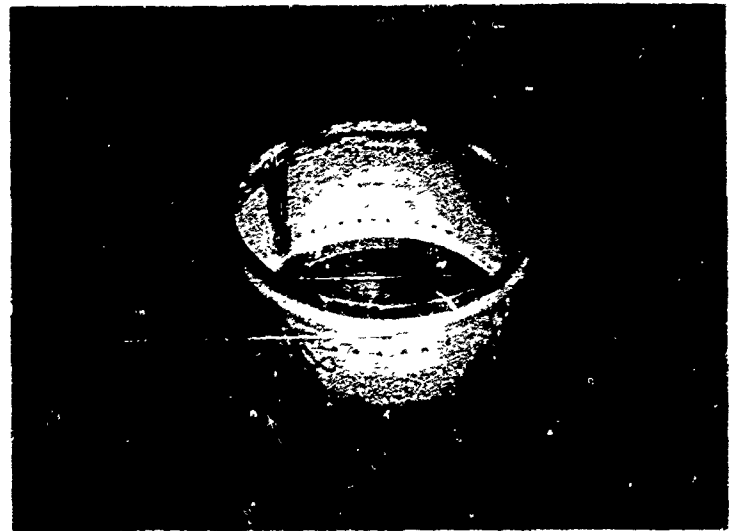

FIGURE 47. FINISHED MONEL FAN HUB

Courtesy of the Moore Company.

Final sizing of a closed end shape is demonstrated by the pylon door for a large missile system shown in Figure 49.<sup>(38)</sup> Blanks for this configuration were initially formed by drop-hammer forging 6061-aluminum alloy segments. Subsequent welding and heat treating resulted in

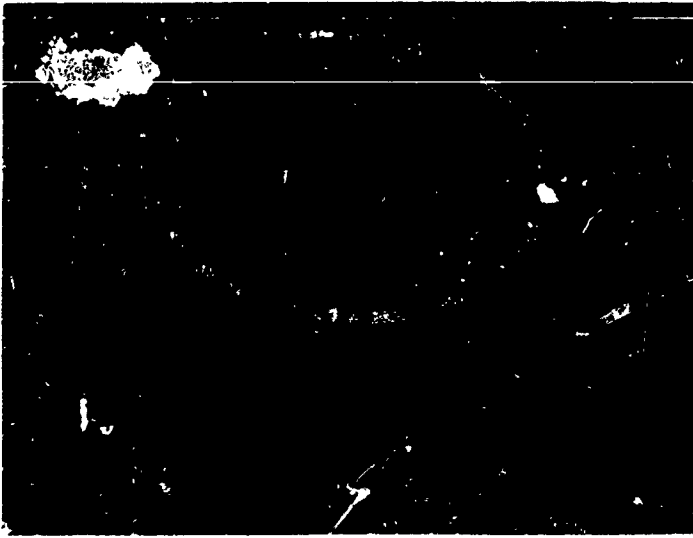

FIGURE 48. HEAVY-WALL TUBE AFTER FORMING

Courtesy of California  
Division of Lockheed Aircraft  
Corporation.

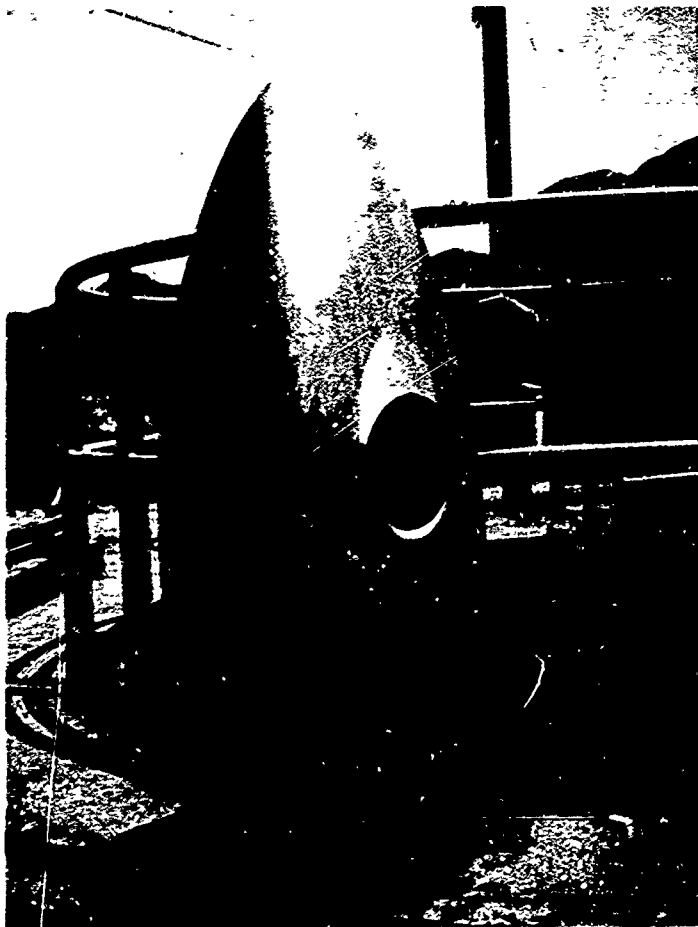

FIGURE 49. COMPLETED PYLON

Courtesy of  
Rocketdyne, a  
Division of North  
American Aviation,  
Inc.

considerable distortion of the preform for the final sizing operation. This sizing was accomplished by three explosive-forming steps using 400 grain/ft PETN Primacord centrally located in a ductile-iron split die. The die assembly in this case was opened and closed hydraulically. The final part which measured 4 feet by an 18-inch-diameter base with a 0.063-inch wall yielded final tolerances of  $\pm 0.010$  inch with a maximum of 20 per cent stretch. Over 100 parts were made in this manner with the same die setup.

#### RESPONSE OF MATERIALS TO HIGH-VELOCITY FORMING

Among the factors of interest in an explosive-forming system are critical impact velocity, particle velocity, rate of propagation of elastic and plastic waves, longitudinal and transverse wave propagation, transmitted and reflected waves, and compression and tension waves. Many of these considerations, however, apply only to contact operations where very high pressures are obtained from the detonation of the explosive charge. Since explosive forming is normally conducted with standoff charges which produce considerably lower pressures, most of the aforementioned factors can be disregarded. Thus, for practical applications of explosive forming it is most important that the critical impact velocity of the material is not exceeded.

#### Critical Impact Velocity

The critical impact velocity is a function of the material which is represented by the limiting condition for differences in relative velocity between two adjacent elements under dynamic conditions. If all parts of a material were moving at the same velocity there would be no critical impact velocity until some reaction tended to stop the motion of a part of the material while other parts attempted to continue at the initial velocity. The reverse condition is obtained in explosive forming where the material is initially at rest and on detonation some part of it is accelerated while other parts of it are restricted and remain at rest. The critical impact velocity is important because it limits the maximum strain rate at which a material still exhibits some ductility and, in effect, imposes a limit on formability.

Table 7 lists the critical impact velocities reported for various materials and includes both experimental and theoretical values. (52) It is important to note that these velocities are lower for cold-worked materials than the corresponding material in the annealed condition. Therefore, in step-forming operations without intermediate anneals, the permissible velocity imparted to the

material in the second and subsequent stages is less than that which can be used in the initial operation.

TABLE 7. CRITICAL IMPACT VELOCITIES OF SOME MATERIALS

Material	Condition	Critical Impact Velocity, ft/sec	
		Experimental	Theoretical(a)
<b>Aluminum alloys</b>			
2002	Annealed	200+	176
2002	1/2 H	110	36
2024	Annealed	200+	174
2024	ST	200+	290
<b>Magnesium alloys</b>			
Dow F	As received	200+	232
Dow J	As received	200+	303
Copper	Annealed	200+	232
Copper	Cold rolled	50	42
Ingot iron	Annealed	100	(b)
<b>Steels</b>			
SAE 1022	Annealed	160	(b)
SAE 1022	Cold rolled	100	95
SAE 4130	HT	235	(b)
SAE 1095	Normalized	200+	232
SAE 1095	Annealed	160	231
Stainless 302	As received	200+	490
Hadfield steel	As received	200+	750

(a) Computed from engineering stress-strain curves.

(b) Existence of yield point prevents computation of critical velocity.

### Effects on Microstructures

In materials which undergo a phase transformation due to changes in temperature, a phase transformation may also occur when the pressure applied to the material reaches a high level. Steel is an alloy which behaves in this manner. A phase transformation is believed to occur at a pressure level of about 130 kilobars, which is equivalent to approximately 2,000,000 psi.<sup>(53)</sup> This opinion is supported by the deviation in the equation-of-state curve for iron shown in Figure 50. Even without an initial pressure impulse of this magnitude, interaction of the stress waves within a material may cause transformation to occur. A material called "white martensite", because of its metallographic appearance, is often found in steel at areas where maximum shear has occurred. The hardness of the material has been found to be greater than the normal untempered martensite found in the specimens, although it reacts to tempering in a fashion similar to the normal martensite. The appearance metallographically of this material is that of massive carbide formations but the hardness is lower than expected for carbides.

There are several theories concerning the formation of the white martensite but they have not been substantiated. Probably the most widely accepted theory is that the material has been heated, by internal friction, above the austenite

transformation temperature and then very rapidly quenched by the surrounding material to form the white martensite. It should be noted, however, that this system does not represent equilibrium, and phase diagrams based on equilibrium conditions cannot be applied. Examination of steel specimens containing white martensite has indicated a preference for cracks to propagate through or along the streaks of white martensite. This indicates that the material must have been formed prior to the initiation of the crack, for the free energy of a crack after it has been formed is much too low to account for the formation of the white martensite.

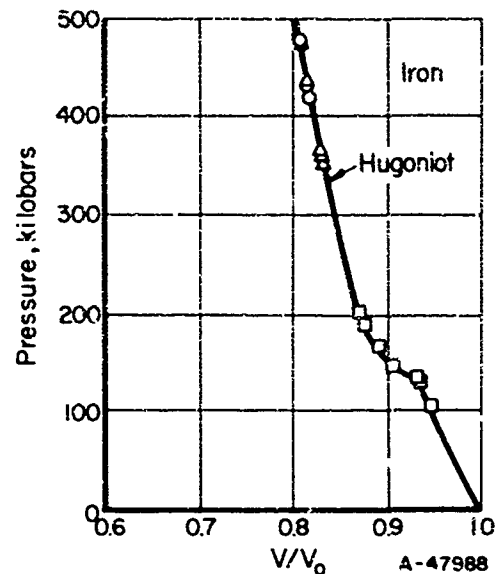

FIGURE 50. HUGONIOT CURVE FOR IRON<sup>(53)</sup>

White martensite has been formed by deformation processes other than explosive impacting. Hammer heads and other tooling subjected to impact loads have shown traces of this material. It may, therefore, be concluded that the two essential factors are impact loading and localized high deformation. There has not been any correlation to date of the impact speed required to obtain this material although one of the newer studies may provide the needed information on its mechanism of formation.<sup>(54)</sup>

### Formability

In normal explosive-forming operations the major material factors are ductility and toughness. It is general practice not to exceed the elongation as determined by tensile testing in forming a part from the same material. Toughness criteria cannot be as readily applied since the forming operation represents biaxial and triaxial stressing as compared to uniaxial stressing in the tensile test. Therefore, the area under the engineering stress-strain curve, which is usually taken as a measure of toughness, must be considered a relative value to be used in

conjunction with formability tests and past experience. In addition it should be noted that tooling design can influence the apparent formability of a material.

Comparisons of formability of various materials on explosive forming are subject to the particular experimental design under which they are tested. As a result, absolute values of formability are not obtained, but relative behavior for use in other explosive-forming operations can be established. A comparison of materials using annealed 1100 aluminum as the basis is shown in Figure 51.<sup>(55)</sup> It should be noted that the apparent formabilities shown may be increased through modified tooling design in other operations. Also, increasing the forming temperature will provide obvious forming advantages.

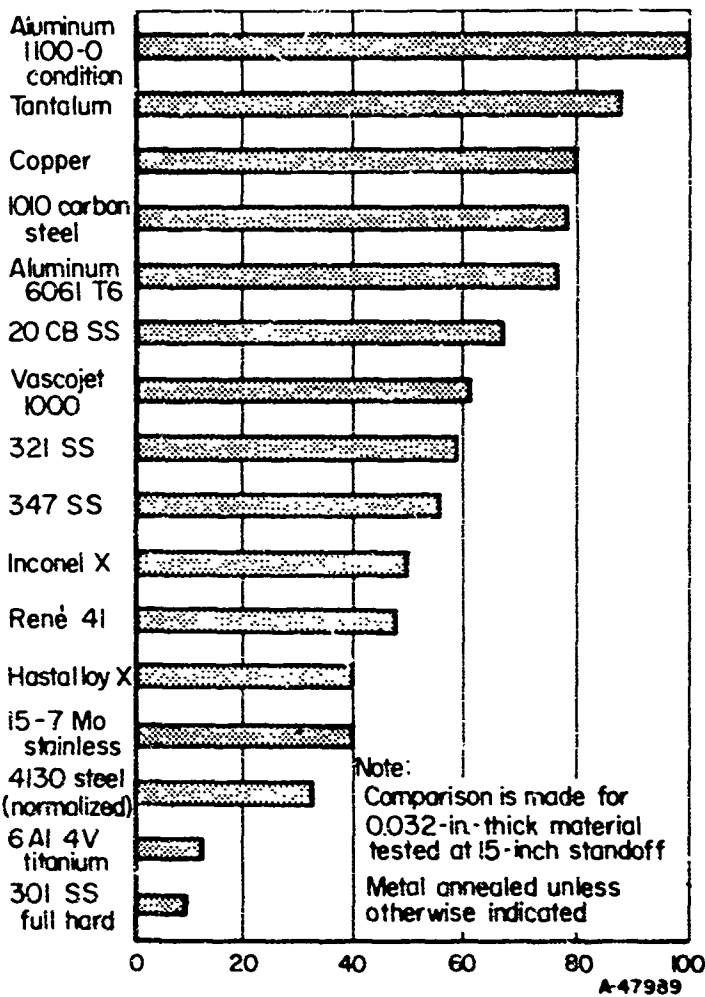

FIGURE 51. RELATIVE FORMABILITY OF METAL WITH EXPLOSIVE<sup>(55)</sup>

Many cases of reduced springback in explosive-forming operations have been reported. This unusual effect is generally attributed to the extreme pressures involved in this fabrication method, being several orders of magnitude higher than those in conventional methods. Of particular interest is the elastic strain that may be induced in the die during

forming and the degree to which this may match normal springback of the formed part. Where these two values match closely little apparent springback would be observed. As more forming experience is accumulated it is apparent that minimal springback and die wear are related, indicating that the "overdriving" effect noted above is the likely mechanism. The degree of springback is also related to the explosive parameters and die design as evidenced by the contrasting occurrence of normal springback in operations involving small charges and heavily constructed dies.

Mechanical Properties During Forming

An indication of the properties and behavior of materials during high-velocity loading was obtained in early mechanical testing programs.<sup>(52)</sup> The most striking effect was found in materials with a delayed yield point such as iron. It was found that the materials could be loaded beyond their yield point and held for a small time without the initiation of deformation. Only materials exhibiting an upper and lower yield point in conventional tensile tests were found to show this type of behavior. In explosive forming, a material of this type would sustain more of the total impulse before actual movement of the material started. The consequences of this type of loading are not completely understood although experiments have indicated that except for slightly higher loading such materials deform like those which do not display this behavior.

In all materials, the dynamic ultimate strength is considerably above the static ultimate strength as indicated in Figure 52.<sup>(52)</sup> This means that the pressure required to deform a metal will be greater under explosive-forming conditions than that required if the pressure were supplied at a lower rate. The exact dynamic yield strength of a material is a function of the strain rate and the work-hardening characteristics of the material. All values for the dynamic yield of materials have been derived empirically and they are usually reported as multiples of the static yield strength. The speed effect is normally taken into account with a number of other controlling factors so that one factor is obtained for all of the variables. This simplifies the procedure of establishing pressure requirements for any new material or configuration.

Static Mechanical Properties of Materials After Explosive Forming

Increases in strength similar to those expected from the same amount of deformation by conventional forming methods have been found in

explosively formed materials. There have also been some indications of abnormally high increases in strength levels<sup>(17)</sup> as given in Table 8, although they have been limited to specific alloys. Some indications of increased ductility at a given strength level have also been reported for multiple-step forming operations where no intermediate anneals have been used.<sup>(17)</sup> In these cases the strength of the material after the first intermediate forming operation would indicate that the ductility is insufficient for completing forming operations although the parts were made successfully by forming without intermediate anneals. This indicates that the explosively formed parts exhibited unexpected good ductility at a higher strength level. Certainly more work is required to determine the conditions affecting this behavior.

TABLE 8. THE EFFECT OF HIGH-VELOCITY DEFORMATION (AND ASSOCIATED THERMAL TREATMENTS) ON THE AVERAGE PROPERTIES OF 350 STAINLESS STEEL<sup>(17)</sup>

Treatment	Ultimate Tensile Strength, 1000 psi		Tensile Yield Strength, 1000 psi		Elongation in 2 Inches, per cent	
	Long.	Trans.	Long.	Trans.	Long.	Trans.
Explosively deformed and aged	225	225	202	199	17.5	18.0
Explosively deformed, refrigerated, and aged	229	228	201	203	18.0	17.0
Explosively deformed, process annealed, refrigerated, and aged	205	204	162	161	23.0	20.5
AMS Specification 5548 requirements for CRT condition	185 minimum		150 minimum		10.0 minimum	
Allegheny Ludlum typical properties						
90 HT Condition	201		158		12.0	
CRT Condition	190		160		17.0	
20% cold reduction	225		195		13.0	

(a) Reference North American Aviation Report NA61H-76, dated May 4, 1961.

(Data are for standard tensile specimens removed from the rim area of a 0.040-inch-thick explosively formed dome end which had been impacted twice during forming. Starting material prior to forming was in the annealed condition.)

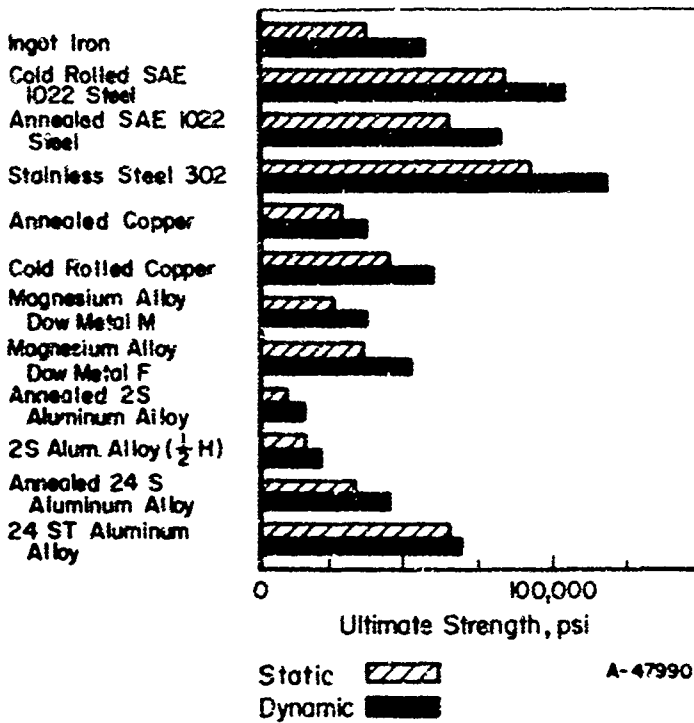

FIGURE 52. STATIC AND DYNAMIC VALUES OF THE ULTIMATE STRENGTH OF SEVERAL METALS<sup>(52)</sup>

Impact velocity 200-250 ft/sec.

Aluminum alloys show very little strengthening from explosive forming. The ultimate strength of the material remains almost constant and there is only a slight increase in the yield strength of the material.<sup>(56)</sup> Figure 53 compares the ultimate and yield strengths, as well as the per cent elongation values, of 2014 aluminum alloy in both the 0 and the T-6 conditions after the materials had been explosively formed on a 6-inch-diameter cupping die to varying depths. The tests were conducted on 0.063-inch-thick sheet.

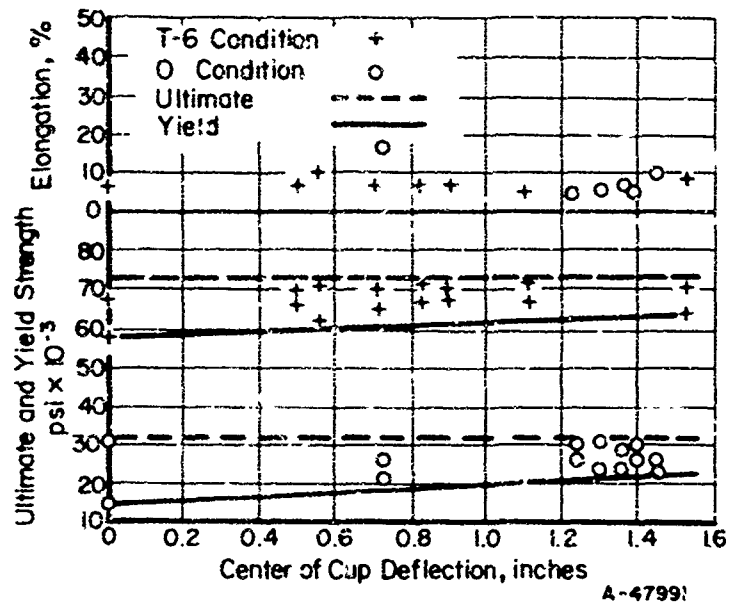

FIGURE 53. MECHANICAL PROPERTIES OF 2014 ALUMINUM ALLOY AFTER EXPLOSIVE FORMING ON A 6-INCH-DIAMETER DIE<sup>(56)</sup>

Some types of materials, such as the precipitation-hardening stainless steels, are austenitic at room temperature but transform to martensite upon deformation. Since the explosive-forming operation applies uniform loading to the parts being formed, the martensite which is formed is fairly evenly distributed and some ductility is still retained in the material. The procedure can be considered similar to ausforming since the material is worked in the austenitic condition prior to transformation to martensite. To obtain the full benefits of the process it is necessary to chill the material to eliminate the

retained austenite and then to reheat to temper the martensite and to precipitate additional strengthening carbides. This procedure has been found to produce increases up to 20 per cent in ultimate and yield strengths and ductility over properties obtained by the typical heat treatment of solution treating, deep freezing, and aging.<sup>(17)</sup>

Other materials do not appear to gain any significant increase in strength by explosive forming over that obtained from the same amount of deformation by conventional processes. This opinion is supported by data in Table 9. The amount of strengthening is strictly a function of the work-hardening characteristics of the material. Materials which work harden much more rapidly than others require intermediate anneals just as they do in a conventional forming process.

TABLE 9. COMPARISON OF MECHANICAL-PROPERTIES FOR EXPLOSIVELY FORMED AND SHEET METALS<sup>(4)</sup>

Material	Spec. Obtained From <sup>(a)</sup>	Grain Direction	Hardness, R <sub>C</sub>	F <sub>tu</sub> , ksi	F <sub>ty</sub> , ksi	Elongation, %
VJ-1000	Formed part	Long.	39	232	187	5.0
	Formed part	Trans.	45	233	189	5.3
	Sheet	Long.	45	242	198	6.3
	Sheet	Trans.	45	249	207	6.0
Ti-6Al-4V	Formed part	Long.	115 R <sub>b</sub>	151	143	8.7
	Formed part	Trans.	110 R <sub>b</sub>	158	134	7.5
	Sheet	Long.	110 R <sub>b</sub>	147	140	14.5
	Sheet	Trans.	105 R <sub>b</sub>	146	137	14.5
350 SS	Formed part	Long.	41	195	165	12.0
	Formed part	Trans.	37	195	165	12.0
	Sheet	Long.	40	207	175	11.3
	Sheet	Trans.	41	205	177	10.0

(a) Formed part means tensile specimens were obtained from parts which had been explosively formed, heat treated, and explosively sized before the specimens were removed. Sheet material means that the specimens were prepared from sheet material without any forming after the sheet had been heat treated.

Data indicating that explosive working lowers the fatigue strength of materials have been reported as shown in Figures 54, 55, and 56. (4) The fatigue specimens for these tests were taken from an explosively formed part which had been stretched about 7 per cent. The formed parts were heat treated after forming and then explosively sized before the fatigue specimens were removed for testing. About 1 per cent stretch was produced in the final sizing operation. All fatigue specimens were obtained from the same parts as the specimens which were used to generate the data for the mechanical-property values listed in Table 9 and the stress-corrosion data listed in Table 10.

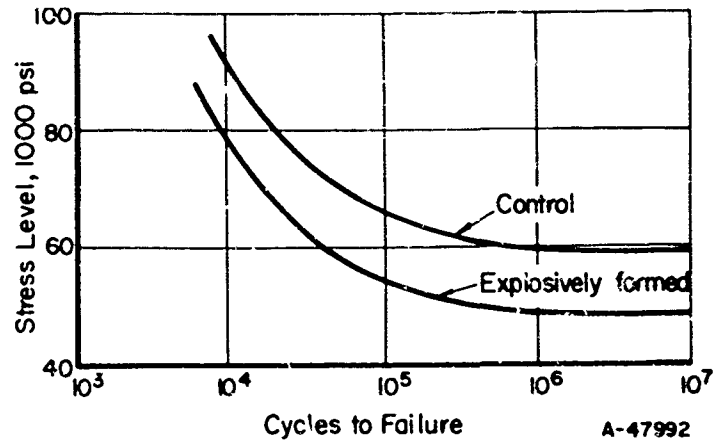

FIGURE 54. S-N-CURVE-.025 HT VASCOJET 1000

Range Ratio - 0.1  
 Test Temperature - Room  
 Grain Direction - Long.

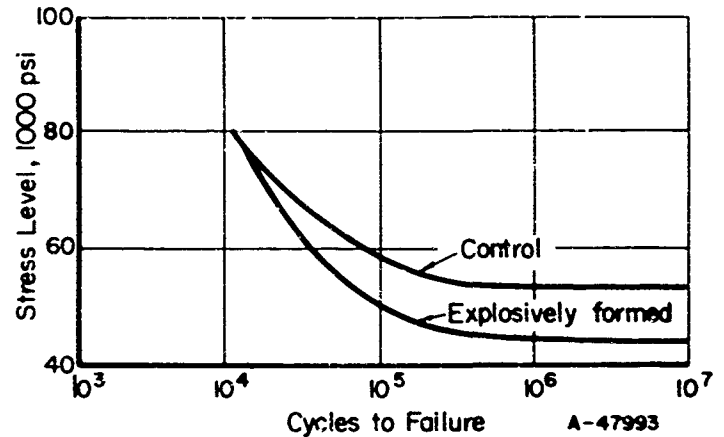

FIGURE 55. S-N-CURVE-.025 HT AM 350

Range Ratio - 0.1  
 Test Temperature - Room  
 Grain Direction - Long.

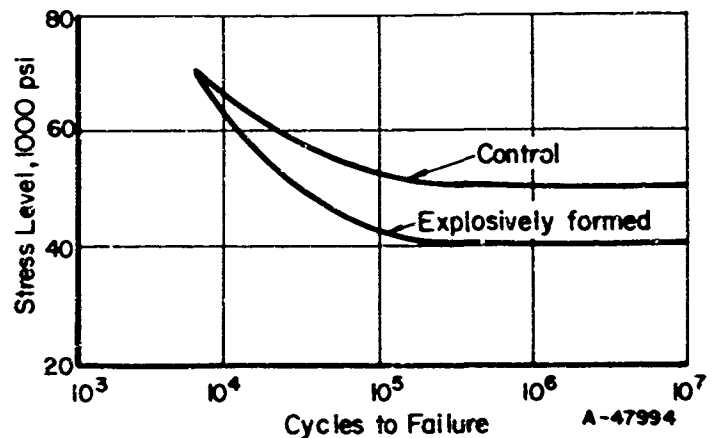

FIGURE 56. S-N-CURVE- .025 ANNEALED 8Mn TITANIUM

Range Ratio - 0.1  
 Test Temperature - Room  
 Grain Direction - Long.

TABLE 10 STRESS-CORROSION DATA FOR SPECIMENS REMOVED FROM EXPLOSIVELY FORMED PARTS AND FROM SHEET MATERIALS<sup>(4)</sup>

Material	Spec. Obtained From <sup>(a)</sup>	Grain Direction	Hardness, R <sub>c</sub>	F <sub>ty</sub> (Avg) (ksi) (.75)	Deflection, inch	Thickness, inch	Hours to Failure, Range
UJ-1000	Formed part	Long.	45	139.8	0.275	.0247	48-170
	Formed part	Trans.	44	141.5	0.279	.0237	56-144
	Sheet	Long.	42	148.3	0.293	.0246	80-170
	Sheet	Trans.	41	155.3	0.307	.0246	80-144
6Al-4V	Formed part	Long.	105 R <sub>b</sub>	107.0	0.143	.0655	No failure
	Formed part	Trans.	110 R <sub>b</sub>	100.2	0.134	.0655	No failure
	Sheet	Long.	115 R <sub>b</sub>	104.9	0.141	.0710	No failure
	Sheet	Trans.	94 R <sub>b</sub>	102.5	0.137	.0701	No failure
350 SS	Formed part	Long.	40	124.4	0.241	.0275	8-32
	Formed part	Trans.	37	124.0	0.240	.0274	No failure
	Sheet	Long.	38	132.0	0.254	.0245	No failure
	Sheet	Trans.	34	132.5	0.257	.0245	No failure

(a) Specimens obtained from formed parts which had been explosively formed, heat treated, and explosively sized. Specimens obtained from sheet material which had been heat treated but not deformed. Bend specimens were exposed to Salt Spray Test per Federal Standard Method 151, Method 811 (170 hours' exposure time).

Comparison with fatigue data for control specimens cut from sheet material which had not been formed indicates a reduction in the properties for the explosively formed specimens.<sup>(4)</sup> It is quite possible that a comparison with material which had been deformed to the same configuration by conventional forming methods would have not shown any significant difference in properties. Fatigue properties of explosively formed materials still require additional investigation and could be considered an urgent matter since hardware made by explosive forming is now being used in areas of critical stress on aircraft and missiles.

Some studies now in progress have indicated a change in the formation of dislocations as the velocity of forming changes.<sup>(57)</sup> This effect would be expected to influence the mechanical properties and the characteristics of a material's reaction to fatigue. More definitive study in this area may establish the effects of explosive forming on fatigue properties.

#### Stress-Corrosion Properties of Explosively Formed Materials

Information available on the effects of explosive forming on the stress-corrosion resistance of materials is very limited. Table 10 compares the stress-corrosion characteristics of several materials in salt-spray tests on bend specimens. A decrease in stress-corrosion resistance was found for explosively formed material compared to material which had not been deformed.<sup>(4)</sup> The stress-corrosion characteristics of explosively formed materials have also been shown to be poorer in magnesium chloride tests than those of materials formed by conventional equipment.<sup>(18)</sup> Therefore, the use of explosively formed materials must involve considerations of these effects and of techniques for their improvement. More detailed study is required in this area of research.

#### THE FUTURE FOR EXPLOSIVE FORMING

Over the past few years, explosive fabrication has gained the respect of materials

fabricators as another useful technique which complements older and more conventional forming methods. There is little question now that there are useful applications of the explosive-forming approach. At the same time, explosive forming is no longer selected because of its novelty alone.

While there is no single set of circumstances that can be stated as being controlling criteria in the decision to apply explosive or more conventional techniques, there are certain generalizations which, although somewhat controversial, can be made. Simply stated, these are (1) as the size and or complexity of configuration increases, the attractiveness of explosive techniques increases and (2) as the required production rate increases, the attractiveness of explosive techniques decreases. Therefore, it seems to be apparent that the application of explosive forming will continue to grow as a function of the increasing size and complexity of aerospace hardware requirements and that explosive forming will gradually, as the technology matures, move into fields and applications now dominated by other techniques where hardware weight is an important consideration.

#### REFERENCES

- (1) Johnson, Walter C. , "A Method of Generating Fluid Pressure for Tube Joining or Embossing, Stamping, of Metal Sheets and Such Like Operations", British Patent No. 21840 (September 23, 1897).
- (2) Jones, I. N. , "Method of Forming Sheet-Metal Bodies", U. S. Patent No. 939,702 (November 9, 1909).
- (3) Drexelius, V. W. , "Metal Forming", U. S. Patent No. 3,036,373, Assigned to Olin Mathieson Corporation (May 29, 1962).
- (4) Piper, F. C. , Rardin, G. N. , and Richter, W. L. , "High Energy Rate Metal Forming", Final Technical Engineering Report (October 18, 1957 to August 1, 1960), AMC TR 60-7-588, Lockheed Aircraft Corporation, California, Contract No. AF 33(600)-35543, AMC Project No. 7-588 (October, 1960).
- (5) Letter from R. D. Moore, The Moore Company, to D. E. Strohecker (September 11, 1962).
- (6) Rinehart, J. S. , and Pearson, J. , Explosive Working of Metals, The Macmillan Company, New York (1963).
- (7) Military Explosives, Department of the Army Technical Manual, TM 9-1910 (April, 1955).
- (8) "Explosives and Demolitions", FM 5-25, Department of the Army (September, 1954).
- (9) Du Pont EL-506 Flexible Sheet Explosive, E. I. du Pont de Nemours and Company, Incorporated, Wilmington, Delaware.
- (10) Du Pont Line-Wave Generators, Bulletin No. ES-58-2, E. I. du Pont de Nemours, Incorporated, Wilmington, Delaware.
- (11) Brochure from Hercules Powder Company, Explosive Department, Wilmington, Delaware.
- (12) Personal communication with I. Lieberman, Aerojet-General Corporation, Downey, California.
- (13) "Data Sheet - Primacord Detonating Fuze", E. I. du Pont de Nemours and Company, Incorporated, Wilmington, Delaware.
- (14) "Librascope EBW Systems", Brochure from Librascope Division of General Precision, Incorporated, Glendale, California.
- (15) "Data Sheet - Electric Blasting Caps", E. I. du Pont de Nemours and Company, Incorporated, Wilmington, Delaware.
- (16) "Metal Forming", Brochure from Olin Mathieson Chemical Corporation, New Haven, Connecticut (1958).
- (17) Strohecker, D. E. , "Deep Drawing Without Presses", Report No. NA 61H-76, North American Aviation, Incorporated, Columbus, Ohio (May 4, 1961).
- (18) Verbraak, C. A. , "Explosive Forming Can Cause Problems... A Dutch Report", Metal Progress, 83 (1), pp. 109-112 (January, 1963).
- (19) Blasters' Handbook, Fourteenth Edition, E. I. du Pont de Nemours and Company, Incorporated, Wilmington, Delaware.
- (20) "Rules for Storing, Transporting and Shipping Explosives", Pamphlet No. 5, Institute of Makers of Explosives, New York (1956).
- (21) War Department Technical Manual, TM 9-1900 and Ordnance Corps Manual ORD M7-224 (1951).



- (22) Philipchuk, V., "Dieless High Energy Rate Forming and Production Parts for H. E. R. F.", ASTME Report No. SP 60-162, presented at the Creative Manufacturing Seminars (1960-1961).
- (23) Wood, W. W., et al, "Theoretical Formability - Volume II - Application", TR 61-191 (II) for the United States Air Force, Chance Vought Corporation, United Aircraft Corporation, Fort Worth, Texas, Contract No. AF 33(616)-6951 (August, 1961).
- (24) Tardif, H. P., "Explosive Forming in Canada", *Metal Progress*, 17 (1), pp. 128-130 (January, 1960).
- (25) "Lowest Cost Tooling Material", *The Tool and Manufacturing Engineer*, 48 (6), p. 9 (June, 1962).
- (26) Orr, J. P., "Explosive Forming Has Many Advantages: One Big Disadvantage", *SAE Journal*, 69 (6), pp. 57-59 (June, 1961).
- (27) Bryan, B. J., "Epoxy Dies for Explosive Forming", *The Tool Engineer*, 44 (2), pp. 97-102 (February, 1960).
- (28) "Explosive Forming of Refractory Metals", Final Technical Report for the Navy Bureau of Weapons, Contract No. NOas 59-6265-c (December 31, 1960).
- (29) Preliminary information, Westinghouse Electric Corporation, under an Air Force contract (April, 1962).
- (30) Peterson, A. H., "High Energy Rate Forming", *High Energy Rate Metal Forming*, American Society for Metals Pamphlet, pp. 21-29 (1958).
- (31) Fairlie, J., "Explosive Welding and Forming Open Another Door for Industry", *Welding Engineer*, 44 (1), pp. 61-64 (April, 1959).
- (32) Douglass, J. J., "Forming Practices with High Explosives", Technical Information on Du Pont Explosive Specialties, E. I. du Pont de Nemours and Company, Incorporated, Wilmington, Delaware.
- (33) Rinehart, John S., "High Energy Rate Forming via Explosives", ASTME Report No. SP 60-138, presented at Creative Manufacturing Seminars (1960-61).
- (34) Ida, Noble N., "Explosive-Forming Techniques at Martin-Denver", ASTME Report No. SP 62-84, presented at Creative Manufacturing Seminars (1961-1962).
- (35) Cox, F. A., Shevlin, R. C., Orr, J. P., Paynter, A. L., and Magclich, E., "Explosive Forming of M-1 Helmets", Report No. 61B073 for the United States Army, Ryan Aerospace, San Diego, California, Contract No. DA 19-129-QM-1540 (July 24, 1961).
- (36) Person, John, "The Explosive Working of Metals", Paper presented at the Society of Aircraft and Materials Engineers Symposium, Dayton, Ohio (March 9-10, 1960).
- (37) "Explosive Forming Saturn V Tank Ends", *American Machinist*, 108 (1), pp. 70-71 (January 6, 1964).
- (38) Personal communication with E. E. Lockwood, Rocketdyne, Division of North American Aviation, Incorporated.
- (39) Savitt, J., "Direct Contact Explosives Metalforming", Final Technical Documentary Report for the United States Air Force, ASD-TDR-62-1035, Explosiform, Incorporated, Park Forest, Illinois, Contract No. AF 33(657)-9631 (October, 1962).
- (40) Adams, D. S., Harrison, V. S., and Orr, J. P., "High Energy Forming of Metallic Sheet Materials", Report No. 61B073 for the United States Army, WAL TR 624.5/1, Ryan Aeronautical Company, San Diego, California, Contract No. DA 04-495-ORD-1921 (February, 1961).
- (41) Personal communication with G. C. Caldwell, Rohr Manufacturing Company, Chula Vista, California.
- (42) Personal communication with W. C. Wilson, General Dynamics/Astronautics, San Diego, California.
- (43) Personal communication with D. J. Brooks, Jr., and C. E. Rheinbold, Astronautics Division of Ling-Temco-Vought, Dallas, Texas.
- (44) Personal communication with G. Fugua and R. A. Schoppman, McDonnell Aircraft Company, St. Louis, Missouri.

- (45) Personal communication with R. C. Stewart, Lockheed-Georgia Company, Marietta, Georgia.
- (46) Personal communication with J. Ida and A. A. Ezra, Martin Company, Denver, Colorado.
- (47) Personal communication with D. Ross, North American Aviation, Incorporated, Columbus, Ohio.
- (48) Personal communication with J. B. Orr, Ryan Aeronautical Company, San Diego, California.
- (49) Personal communication with W. O. Sunafrank, General Dynamics/Convair, Fort Worth, Texas.
- (50) House, A. M., "Process Development Program for the Explosive Forming of T54E1 Missile Skins", Final Summary Report for the United States Army, Technical Document 42060, Minneapolis-Honeywell Regulator Company, Hopkins, Minnesota, Contract No. DA 11-022-501-ORD-2662 (June 21, 1960).
- (51) Personal communication with G. N. Rardin, Lockheed Aircraft Corporation, Burbanks, California.
- (52) Clark, D. S., and Wood, D. S., "The Impact Properties of Some Metals and Alloys", Transactions of the American Society for Metals, 42, pp. 45-74 (1950).
- (53) Walsh, J. M., Rice, M. H., McQueen, R. G., and Yarger, F. L., "Shock-Wave Compressions of Twenty-Seven Metals. Equations of State of Metals," Physical Review, 108 (2), pp. 196-216 (October 15, 1957).
- (54) Silverman, S. M., Godfrey, L., Hauser, A. H., and Seaward, E. T., "The Effect of Shock-Induced High Dynamic Pressures on Iron-Base Alloys", ASD-TDR-62-442 for the United States Air Force, Pratt and Whitney Aircraft Division, United Aircraft Corporation, Contract No. AF 33(616)-8190 (August, 1962).
- (55) Lockwood, E. E., and Glyman, J., "The Explosive Formability of Metals", ASTM Report No. SP 62-09, presented at the Creative Manufacturing Seminars (1961-1962).
- (56) Ida, N., and Burkhart, J., "Metallurgical Effects on Residual Properties of Explosively Formed 2014 Aluminum Alloy", Report No. R-61-7, The Martin Company, Denver, Colorado (May, 1962).
- (57) Personal communication with G. T. Hahn, Battelle Memorial Institute, Columbus, Ohio.

APPENDIX A

METHODS OF DETERMINING PEAK PRESSURES  
AND ENERGY REQUIREMENTS

## APPENDIX A

METHODS OF DETERMINING PEAK PRESSURES  
AND ENERGY REQUIREMENTS

The forces from an explosive charge can be estimated from the basic laws of physics. The difficulty in the application of these laws is that the forming takes place in such a short time interval that it is difficult to measure parameters to determine which laws are to be applied. Although direct measurement is impossible in most cases, methods for indirect measurement have been established. Since the basic laws of conservation of energy are obeyed, scaling laws are applicable. Measurements taken at a distance, with low-pressure measuring devices, can then be used to determine the energy impulse in close proximity to an explosive charge. This information may be used for small charges and standoff distances, provided the distance in the explosive operation is not less than 2 inches.

Calculation of Peak Pressures

Experiments have shown that the peak pressures developed by detonating an explosive under water decrease in a regular manner with detonation velocity and with distance. The relationship, for point charges, can be expressed by the following equation, modification of one suggested by Roth(A-1)\*.

$$P = \sqrt{6.9 \times V} \times \left( \frac{W^{1/3}}{R} \right)^{1.13} \times 10^2, \quad (A-1)$$

where

P = peak pressure, psi

V = detonation velocity, meters/second

W = weight of explosive, pounds

R = standoff distance, feet

The value of 6.9 is an average of the factors determined for a variety of explosives with detonation velocities ranging from 2000 to 7400 meters/second. Data reported by several investigators for different explosives and standoff distances indicate that the conversion factor is constant within 6 per cent.

If a particular type of explosive and shape of charge is to be used frequently, an appropriate nomogram simplifies calculations of peak pressures for different charge sizes and standoff distances. For example, substituting the appropriate detonation velocity of 6750

\*References are given on page A-5.

meters/second for TNT in the above formula yields the following equation:

$$P = 2.16 \times 10^4 \left( \frac{W^{1/3}}{R} \right)^{1.13}. \quad (A-2)$$

Values obtained from that equation were used to construct the nomogram in Figure A-1 after converting the units to inches of distance and grams of charge. Those units are more commonly employed in explosive-forming operations. Similar nomographs can be constructed for point charge of other explosives from known detonation velocities.

Figure A-1 can be used to predict peak pressures and energies developed by point charges of this particular explosive, TNT, at different standoff distances. The information is for detonations produced in water.

The nomogram in Figure A-2 can be used similarly for line charges of PETN explosive. Two scales for standoff distance are given on the chart. One is for use when the line charge is located along the axis of a cylinder. In this case the diameter of the cylinder is the governing parameter. The other scale is used when line charges are used to deform flat blanks.

Use of Nomograms

A line on the nomograph connecting the desired peak pressure with the point for a certain standoff distance intersects the "charge weight" scale at a value indicating the required weight of explosive.

To use the nomograms, the peak pressures required to form the particular part must first be determined. The estimates can be made by the methods described in the section "Peak Pressure and Energy Requirements". Then the standoff distance is selected on the basis of the size and shape of the part and the type of loading desired. Increasing the standoff distance lowers the amplitude of the initial impact but increases the time duration of pressure application. Consequently, greater standoff distances are used for forming than for sizing operations. The amount of energy available for transfer to the workpiece varies inversely with the distance between the explosive charge and the work.

It should be noted that the nomographs in Figures A-1 and A-2 are for specific explosives

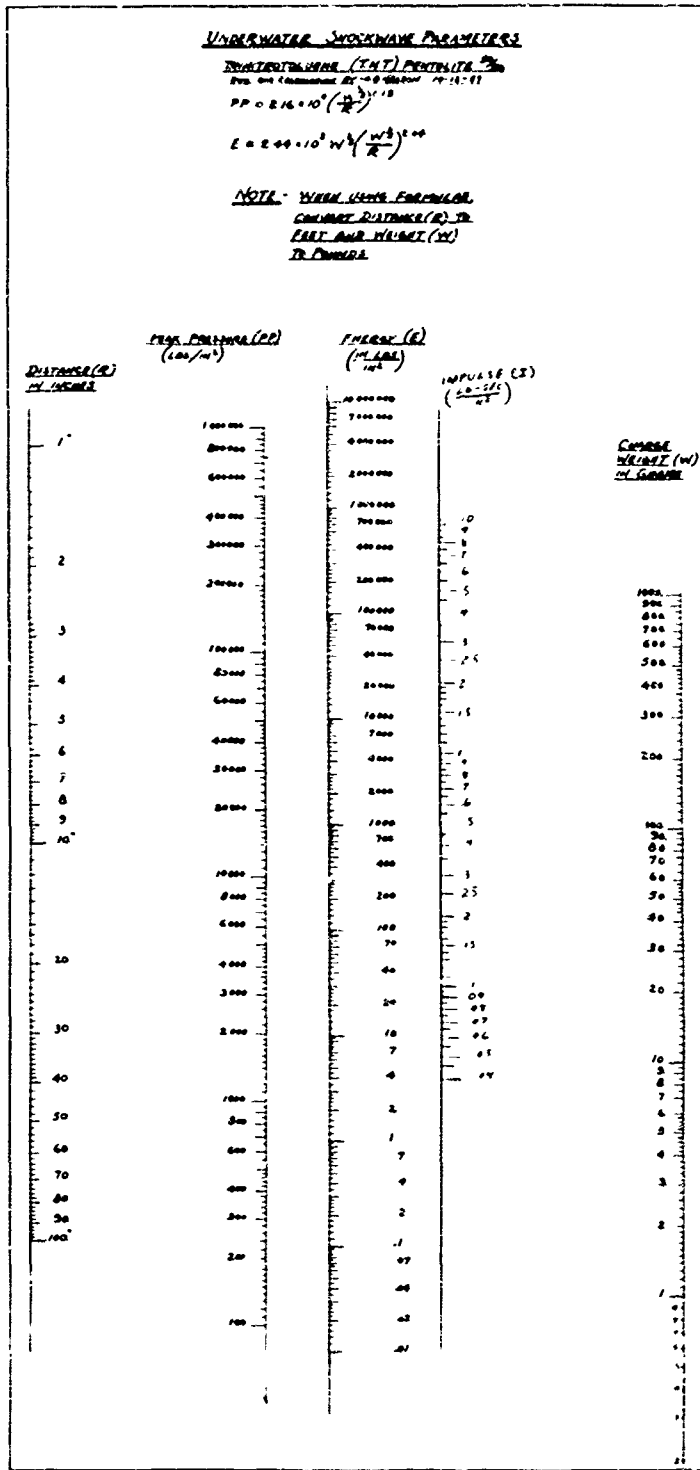

FIGURE A-1. NOMOGRAPH SHOWING PEAK PRESSURES AND ENERGY VALUES AS A FUNCTION OF STANDOFF DISTANCES AND WEIGHTS OF TNT POINT CHARGES IN WATER

and charge shapes detonated in water and do not apply to other conditions.

In calculating the amount of explosive required for a particular job, the amount of explosive in the blasting cap should be included

UNDERWATER SHOCK PRESSURE FOR LINE CHARGES OF PETN EXPLOSIVES  
 (FOR OTHER EXPLOSIVES USE TNT EQUIVALENTS x LOADING)

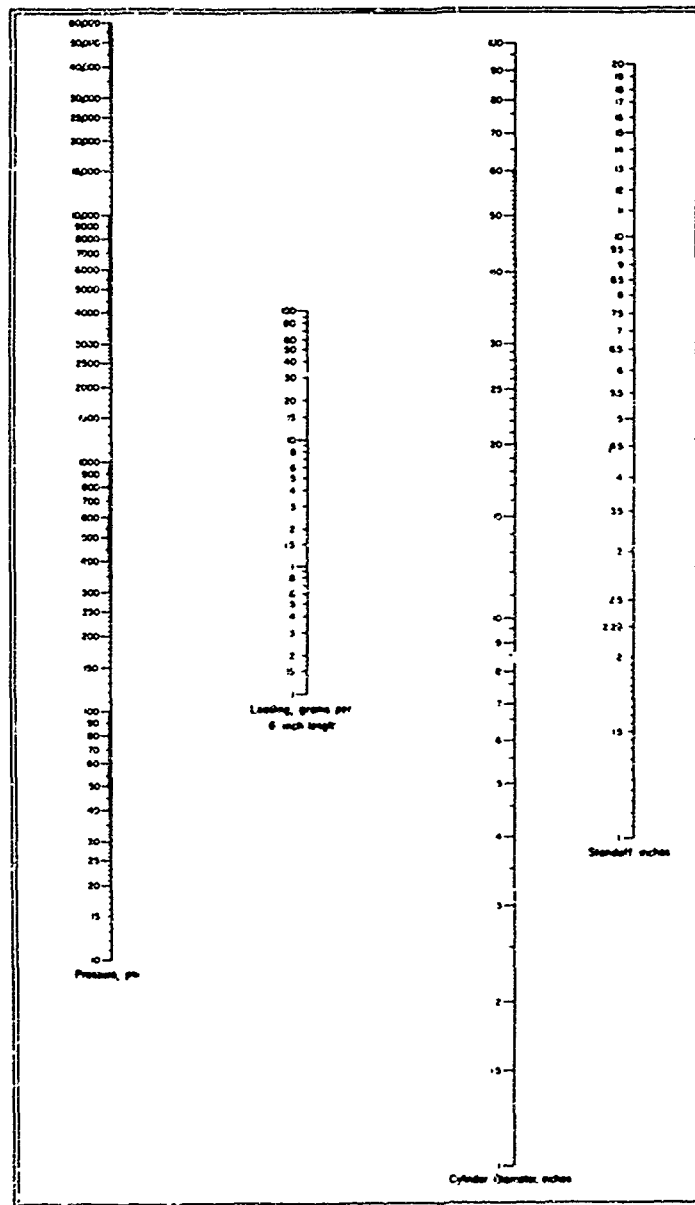

FIGURE A-2. NOMOGRAPH SHOWING PEAK PRESSURE AS A FUNCTION OF STANDOFF DISTANCE AND WEIGHT OF LINE CHARGES OF PETN EXPLOSIVE IN WATER

if the total charge size is less than 50 grams. Most blasting caps contain less than 1 gram of explosive so the error, which would result from not taking the cap into consideration, will be small when large weights of explosives are utilized but could be significant for small charges. The empirical data presented in the nomograms are accurate within approximately 10 per cent.

Errors resulting from slight variations in explosive weight are not as significant as those caused by variations in standoff distances. This effect can be seen readily from the formula which indicates that the explosive-charge weight affects the peak pressure by the cube root whereas the

standoff distance is essentially directly related to the peak pressure. The accuracy obtained by using the nomograms has been found to be adequate for most explosive-forming operations. More sophisticated calculations can be made but normally they do not significantly reduce the error. Therefore, it is reasonable to expect that this information will provide an excellent starting point for any particular explosive-forming operation.

The two nomographs do not hold for forming operations on "sandwiches" or for mediums other than water. It is unfortunate that very little quantitative information is available on the effects of various plastic or rubber mediums on peak pressure delivered through them. It is known, of course, that the larger explosive charges are required to produce the same amount of forming when rubber is used over a part and that the amount of charge or peak pressure must be increased as the rubber thickness is increased. The use of plastic or rubber mediums in forming operations will certainly receive more research attention in the future and is an area which promises to have significant advancements in the state of the art in explosive-forming technology.

#### Peak Pressure and Energy Requirements

A considerable amount of information is available on energy requirements for conventional metalworking operations. This information can be used where it applies and modified by simple coefficients when empirical data indicate that it is necessary. The differences are concerned mainly with the response of materials to dynamic loading. Some of the work performed by Wood and Clark<sup>(A-3)</sup> has shown that materials are stronger or exhibit higher yield and ultimate strengths under dynamic loading than under slow loading. The increase depends on the material and the rate of stress application. Since very high loading rates occur in explosive-forming operations, it is reasonable to expect that a dynamic yield stress should be used in the determination of pressure or energy requirements for deforming materials. This is a difficult property to measure since it requires a large amount of testing at various rates of load application, and special equipment is necessary to obtain the high rates of stress application. Some materials such as steel complicate the determination of dynamic yield strength even further by having a delayed yield point. The effect of this characteristic on explosive-forming operations is not known although it is expected that it will result in a different type of derivation of dynamic yield strength from materials which do not have an upper and lower yield point.

Due to the many variables which must be evaluated in order to estimate the dynamic yield strength of a material, most of the information available on this characteristic of materials has been derived empirically. The variations in types of devices used to obtain empirical data make it difficult, if not impossible, to interpret this information for other types of equipment or operations.

The equations which determine the operation of explosive forming can be established on the basis of energy requirements or peak pressure requirements.

Considering the pressure requirements for the initiation of deformation for various geometries of parts the following equations are obtained<sup>(A-4)</sup>:

For elliptical flat plates with simple supported edges

$$P = St^2a/(3a-2b) b^2, \quad (A-3)$$

where

$P$  = static pressure in lb/in.<sup>2</sup>

$S$  = maximum stress in lb/in.<sup>2</sup>, equal to dynamic yield strength

$t$  = thickness of blank in inches

$2a$  = major axis of blank in inches

$2b$  = minor axis of blank in inches.

For square flat plate simply supported

$$P = 8St^2/b^2 \quad (A-4)$$

where

$b$  = one side of the square in inches.

For circular plates with edges simply supported

$$P = 8St^2/3R^2 (3 + m) \quad (A-5)$$

where

$R$  = radius of blank in inches

$m$  = Poisson's ratio; approximately 0.3 for steel.

For circular plates with fixed edges, the formula for maximum stress at center should be used since rupture normally occurs at the center of a blank. The formula is

$$P = 8St^2/2R^2 (1 + m) \quad (A-6)$$

for maximum stress at center of blank

For bulging thin-walled tubing:

$$P = 2t S_c d \quad , \quad (A-7)$$

where

$P$  = static pressure in pounds/square inch

$t$  = wall thickness in inches

$d$  = diameter of tube OD in inches.

For bulging thick-walled cylinders:

$$P = T(R_2^2 - R_1^2)/R_2^2 \quad , \quad (A-8)$$

where

$T$  = shear stress

$R_1$  = internal radius of cylinder in inches

$R_2$  = external radius of cylinder in inches.

To apply these equations, it is necessary to know the dynamic yield strength of the material. Cold work increases the yield strength of metals and must be taken into account when determining the dynamic yield strength of the material. Because of the variables involved, it is best to utilize a first approximation to the solution of the problem and then adjust conditions based on experience for the first several parts. This approach to the problem, which is better than trial and error, is based on the empirical relationship found between static and dynamic pressures causing equal amounts of deformation. The relationship has the form

$$K = a\sqrt{e} \quad , \quad (A-9)$$

where

$K$  = a factor indicating the ratio between the conventional and dynamic yield strengths and the pressures required for fast and slow forming.

$e$  = mean diametral stretch required to form the part, per cent

$a$  = a factor dependent on the work hardening characteristic of the material,  $a = 1.58$  for stainless steels and about 1.25 for mild steel and aluminum.

A graph of "K" as a function of percentage of stretch is given in Figure A-3, for Type 301 stainless steel. The curve would be shifted to the left for materials like aluminum or mild steel which are less sensitive to strain hardening than stainless steel.

It should be emphasized that these equations provide only a starting point and may not result

in a satisfactory part without some changes of the setup during the initial trials.

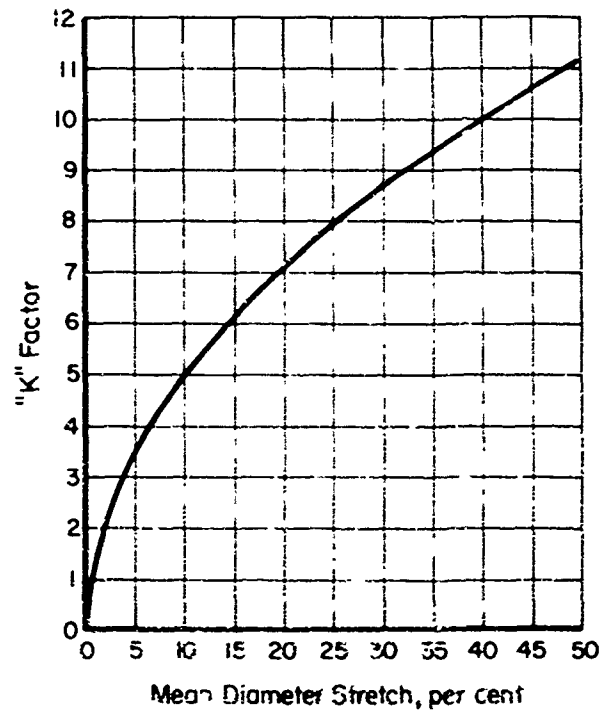

A-47970

FIGURE A-3. EFFECT OF STRAIN ON THE RATIO OF PRESSURES REQUIRED FOR FAST AND SLOW FORMING OF TYPE 301 STAINLESS STEEL(A-2)

Another method which may be used in establishing initial conditions is based on the energy requirements(A-1). This approach may be used for free-forming operations where the size of the charge controls the depth of draw. The following equation has been found to provide fair correlation with experience in free-drawing operations:

$$d = D(E_u/2St)^{1/2} \quad , \quad (A-10)$$

where

$d$  = depth of draw in inches

$D$  = cup diameter in inches

$E_u$  = energy required per unit area in in-lb/in.<sup>2</sup>

$S$  = dynamic yield strength of material in lb/in.<sup>2</sup>

$t$  = thickness of material in inches.

The energy available from a TNT charge at a given standoff distance can be determined from the following formula:

$$E_u = 2.41 \times 10^3 \times W/R^{1/3} \quad , \quad (A-11)$$

where

$E_u$  = energy required per unit area in  
in-lb/in.<sup>2</sup>

W = explosive weight in pounds

R = explosive standoff in feet.

The energy available from TNT and other explosive charges follows the relationship<sup>(A-5)</sup>

$$E_u = A W^{1/3} \left( \frac{W^{1/3}}{R} \right)^B, \quad (A-12)$$

where

E = energy per unit area in  
ft-lb/ft<sup>2</sup>

W = weight of explosive charge in  
pounds

R = standoff distance in feet

A and B = constants determined  
empirically.

There are a number of additional factors which enter into any calculations for the energy or peak pressure requirements for the forming of parts explosively. (1) The ratio of the blank diameter to the finished part diameter is important because ironing restrains the flow of material into the die and increases the energy required for drawing. (2) The hold-down clamping force will have a very significant effect on the amount of energy required for forming. (3) The pressure between the blank and the die during forming which may result from entrapped gases should also be considered. The initial pressure as well as the final fit of the formed blank to the die will determine the pressure between the part and the die during forming. In addition to creating a back pressure, burning or discoloration of die and part surface can result from high temperatures developed during rapid compression of the trapped gas. In a free-forming system, or where the part is not completely formed to the die, these difficulties should not occur provided the volume occupied by the formed part is not more than half of the total die volume available.

#### References

- (A-1) Roth, Julius, "Metal Deformation by Explosives", Hercules Powder Company, Research Center, Wilmington, Delaware, July, 1961.

(A-2) Strohecker, D. E., "Deep Drawing Without Presses", Report No. NA61H-76, North American Aviation Inc., Columbus Division (May 4, 1961).

(A-3) Clark, D. S., and Wood, D. S., "The Impact Properties of Some Metals and Alloys", Transactions of the American Society for Metals, 42, pp. 45 (1950).

A-4) Eshbach, O. W., Handbook of Engineering Fundamentals, 2nd Edition, John Wiley and Sons Inc., New York; pp. 5-55 (1952).

(A-5) Cook, M. A., The Science of High Explosives, Reinhold Publishing Company, New York (1958).



LIST OF DMIC TECHNICAL REPORTS ISSUED  
DEFENSE METALS INFORMATION CENTER  
 Battelle Memorial Institute  
 Columbus, Ohio 43201

Copies of the technical reports listed below may be obtained from DMIC at no cost by Government agencies, and by Government contractors, subcontractors, and their suppliers. Others may obtain copies from the Office of Technical Services, Department of Commerce, Washington, D. C. 20230 (See FB or AD numbers and prices in parentheses.)

Number	Title
46D	Department of Defense Titanium Sheet-Rolling Program - Uniform Testing Procedure for Sheet Materials, September 12, 1958 (FB 121649, \$1.25)
46E	Department of Defense Titanium Sheet-Rolling Program - Thermal Stability of the Titanium Sheet-Rolling-Program Alloys, November 25, 1958 (FB 151061, \$1.25)
46F	Department of Defense Titanium Sheet-Rolling Program - Status Report No. 4, March 20, 1959 (FB 151065, \$2.25)
46G	Department of Defense Titanium Sheet-Rolling Program - Time-Temperature-Transformation Diagrams of the Titanium Sheet-Rolling Program Alloys, October 19, 1959 (FB 151075, \$2.25)
46H	Department of Defense Titanium Sheet-Rolling Program - Status Report No. 5, June 1, 1960 (FB 151087, \$2.00)
46I	Statistical Analysis of Tensile Properties of Heat-Treated Ti-4Al-3Mo-IV Sheet, September 16, 1960 (FB 151095, \$1.25)
46J	Statistical Analysis of Tensile Properties of Heat-Treated Ti-4Al-3Mo-IV and Ti-2.1Al-16V Sheet.
*106	Beryllium for Structural Applications, August 15, 1958 (FB 121648, \$3.00)
107	Tensile Properties of Titanium Alloys at Low Temperature, January 15, 1959 (FB 151062, \$1.25)
108	Welding and Brazing of Molybdenum, March 1, 1959 (PB 151063, \$1.25)
109	Coatings for Protecting Molybdenum From Oxidation at Elevated Temperature, March 6, 1959 (FB 151064, \$1.25)
110	The All-Beta Titanium Alloy (Ti-13V-11Cr-3Al), April 17, 1959 (PB 151066, \$3.00)
111	The Physical Metallurgy of Precipitation-Hardenable Stainless Steels, April 20, 1959 (FB 151067, \$2.00)
112	Physical and Mechanical Properties of Nine Commercial Precipitation-Hardenable Stainless Steels, May 1, 1959 (FB 151068, \$3.25)
113	Properties of Certain Cold-Rolled Austenitic Stainless Sheet Steels, May 15, 1959 (FB 151069, \$1.75)
114	Ductile-Brittle Transition in the Refractory Metals, June 25, 1959 (FB 151070, \$2.00)
115	The Fabrication of Tungsten, August 14, 1959 (FB 151071, \$1.75)
116R	Design Information on 5Cr-Mo-V Alloy Steels (H-11 and 5Cr-Mo-V Aircraft Steel) for Aircraft and Missiles (Revised) September 30, 1960 (FB 151072-R, \$1.50)
117	Titanium Alloys for High-Temperature Use Strengthened by Filters of Dispersed Particles, August 31, 1959 (PB 151073, \$2.00)
118	Welding of High-Strength Steels for Aircraft and Missile Applications, October 12, 1959 (FB 151074, \$2.25)
119	Heat Treatment of High-Strength Steels for Aircraft Applications, November 27, 1959 (PB 151076, \$2.50)
120	A Review of Certain Ferrous Castings Applications in Aircraft and Missiles, December 19, 1959 (FB 151077, \$1.50)
121	Methods for Conducting Short-Time Tensile, Creep, and Creep-Rupture Tests Under Conditions of Rapid Heating, December 20, 1959 (PB 151078, \$1.25)
122	The Welding of Titanium and Titanium Alloys, December 31, 1959 (PB 151079, \$1.75)
123	Oxidation Behavior and Protective Coatings for Columbium and Columbium-Base Alloys, January 15, 1960 (FB 151080, \$2.25)
*124	Current Tests for Evaluating Fracture Toughness of Sheet Metals at High Strength Levels, January 29, 1960 (PB 151081, \$2.00)
*125	Physical and Mechanical Properties of Columbium and Columbium-Base Alloys, February 22, 1960 (FB 151082, \$1.75)
126	Structural Damage in Thermally Cycled René 41 and Astroloy Sheet Materials, February 29, 1960 (FB 151083, \$0.75)
127	Physical and Mechanical Properties of Tungsten and Tungsten-Base Alloys, March 15, 1960 (FB 151084, \$1.75)
*128	A Summary of Comparative Properties of Air-Melted and Vacuum-Melted Steels and Superalloys, March 29, 1960 (FB 151085, \$2.75)
129	Physical Properties of Some Nickel-Base Alloys, May 20, 1960 (FB 151086, \$2.75)
130	Selected Short-Time Tensile and Creep Data Obtained Under Conditions of Rapid Heating, June 17, 1960 (FB 151088, \$2.25)
*131	New Developments in the Welding of Metals, June 24, 1960 (FB 151089, \$1.25)
132	Design Information on Nickel-Base Alloys for Aircraft and Missiles, July 20, 1960 (FB 151090, \$3.00)
133	Tantalum and Tantalum Alloys, July 25, 1960 (PB 151091, \$5.00)
*134	Strain Aging of Refractory Metals, August 12, 1960 (FB 151092, \$1.75)
135	Design Information on FH 15-7 Mo Stainless Steel for Aircraft and Missiles, August 22, 1960 (FB 151093, \$1.25)
136A	The Effects of Alloying Elements in Titanium, Volume A: Constitution, September 15, 1960 (FB 151094, \$3.50)
136B	The Effects of Alloying Elements in Titanium, Volume B: Physical and Chemical Properties, Deformation, and Transformation Characteristics, May 29, 1961 (AD 260226, \$3.00)
137	Design Information on 17-7 PH Stainless Steels for Aircraft and Missiles, September 23, 1960 (FB 151096, \$1.00)
138	Availability and Mechanical Properties of High-Strength Steel Extrusions, October 26, 1960 (FB 151097, \$1.75)
139	Melting and Casting of the Refractory Metals Molybdenum, Columbium, Tantalum, and Tungsten, November 18, 1960 (PB 151098, \$1.00)
*140	Physical and Mechanical Properties of Commercial Molybdenum-Base Alloys, November 30, 1960 (PB 151099, \$3.00)
141	Titanium-Alloy Forgings, December 19, 1960 (PB 151100, \$2.25)
142	Environmental Factors Influencing Metals Applications in Space Vehicles, December 27, 1960 (FB 151101, \$1.25)
143	High-Strength-Steel Forgings, January 5, 1961 (PB 151102, \$1.75)
144	Stress-Corrosion Cracking - A Nontechnical Introduction to the Problem, January 6, 1961 (PB 151103, \$0.75)
145	Design Information on Titanium Alloys for Aircraft and Missiles, January 10, 1961 (PB 151104, \$2.25)
*146	Manual for Beryllium Prospectors, January 18, 1961 (PB 151105, \$1.00) Obsolete

\* DMIC supply exhausted; copies may be ordered from OTS.

116

Number	Title
147	The Factors Influencing the Fracture Characteristics of High-Strength Steel, February 6, 1961 (PB 151106, \$1.25)
148	Review of Current Data on the Tensile Properties of Metals at Very Low Temperatures, February 14, 1961 (PB 151107, \$2.00)
149	Brazing for High-Temperature Service, February 21, 1961 (PB 151108, \$1.00)
*150	A Review of Pending Methods for Stainless Steel Tubing, March 2, 1961 (PB 151109, \$1.50)
151	Environmental and Metallurgical Factors of Stress-Corrosion Cracking in High-Strength Steels, April 14, 1961 (PB 151110, \$0.75)
152	Binary and Ternary Phase Diagrams of Columbium, Molybdenum, Tantalum, and Tungsten, April 28, 1961 (AD 257739, \$3.50)
153	Physical Metallurgy of Nickel-Base Superalloys, May 5, 1961 (AD 258041, \$1.25)
154	Evolution of Ultrahigh-Strength, Hardenable Steels for Solid-Propellant Rocket-Motor Cases, May 25, 1961 (AD 257976, \$1.25)
155	Oxidation of Tungsten, July 17, 1961 (AD 263598, \$3.00)
156	Design Information on AM-350 Stainless Steel for Aircraft and Missiles, July 28, 1961 (AD 262407, \$1.50)
157	A Summary of the Theory of Fracture in Metals, August 7, 1961 (PB 181081, \$1.75)
*158	Stress-Corrosion Cracking of High-Strength Stainless Steels in Atmospheric Environments, September 15, 1961 (AD 266005, \$1.25)
*159	Gas-Pressure Bonding, September 25, 1961 (AD 265133, \$1.25)
160	Introduction to Metals for Elevated-Temperature Use, October 27, 1961 (AD 268647, \$2.50)
161	Status Report No. 1 on Department of Defense Refractory Metals Sheet-Rolling Program, November 2, 1961 (AD 267077, \$1.00)
162	Coatings for the Protection of Refractory Metals from Oxidation, November 24, 1961 (AD 271384, \$3.50)
163	Control of Dimensions in High-Strength Heat-Treated Steel Parts, November 29, 1961 (AD 270045, \$1.00)
164	Semiaustenitic Precipitation-Hardenable Stainless Steels, December 6, 1961 (AD 274805, \$2.75)
165	Methods of Evaluating Welded Joints, December 28, 1961 (AD 272088, \$2.25)
166	The Effect of Nuclear Radiation on Structural Metals, September 15, 1961 (AD 265839, \$2.50)
*167	Summary of the Fifth Meeting of the Refractory Composites Working Group, March 12, 1962 (AD 274804, \$2.00)
168	Beryllium for Structural Applications, 1958-1960, May 18, 1962 (AD 278723, \$3.50)
169	The Effect of Molten Alkali Metals on Containment Metals and Alloys at High Temperatures, May 18, 1962 (AD 278654, \$1.50)
170	Chemical Vapor Deposition, June 4, 1962 (AD 281887, \$2.25)
171	The Physical Metallurgy of Cobalt-Base Superalloys, July 6, 1962 (AD 283356, \$2.25)
172	Background for the Development of Materials to be Used in High-Strength-Steel Structural Weldments, July 31, 1962 (AD 284265, \$3.00)
173	New Developments in Welded Fabrication of Large Solid-Fuel Rocket-Motor Cases, August 6, 1962 (AD 284829, \$1.00)
174	Electron-Beam Processes, September 15, 1962 (AD 287433, \$1.75)
175	Summary of the Sixth Meeting of the Refractory Composites Working Group, September 24, 1962 (AD 287029, \$1.75)
176	Status Report No. 2 on Department of Defense Refractory Metals Sheet-Rolling Program, October 15, 1962 (AD 288127, \$1.25)
177	Thermal Radiative Properties of Selected Materials, November 15, 1962, Volume I (AD 294345, \$3.00), Volume II (AD 294346, \$4.00)
178	Steels for Large Solid-Propellant Rocket-Motor Cases, November 20, 1962 (AD 292258, \$1.00)
179	A Guide to the Literature on High-Velocity Metalworking, December 3, 1962 (AD 403493, \$3.50)
180	Design Considerations in Selecting Materials for Large Solid-Propellant Rocket-Motor Cases, December 10, 1962 (AD 294695, \$1.00)
181	Joining of Nickel Base Alloys, December 20, 1962 (AD 296174, \$2.00)
182	Structural Considerations in Developing Refractory Metal Alloys, January 31, 1963 (AD 419383, \$1.00)
183	Binary and Ternary Phase Diagrams of Columbium, Molybdenum, Tantalum, and Tungsten (Supplement to DMIC Report 152), February 7, 1963 (AD 407987, \$2.75)
184	Summary of the Seventh Meeting of the Refractory Composites Working Group, May 30, 1963 (AD 413567, \$1.75)
185	The Status and Properties of Titanium Alloys for Thick Plate, June 14, 1963 (AD 421029, \$1.50)
186	The Effect of Fabrication History and Microstructure on the Mechanical Properties of Refractory Metals and Alloys, July 10, 1963 (AD 423952, \$1.75)
187	The Application of Ultrasonic Energy in the Deformation of Metals, August 16, 1963 (AD 423562, \$2.25)
188	The Engineering Properties of Columbium and Columbium Alloys, September 6, 1963 (AD 426255, \$3.50)
189	The Engineering Properties of Tantalum and Tantalum Alloys, September 13, 1963 (AD 426344, \$2.50)
190	The Engineering Properties of Molybdenum and Molybdenum Alloys, September 20, 1963 (AD 426264, \$4.00)
191	The Engineering Properties of Tungsten and Tungsten Alloys, September 27, 1963 (AD 425547, \$2.75)
192	Hot-Cold Working of Steel to Improve Strength, October 11, 1963 (AD 425948, \$2.00)
193	Tungsten Research and Development Review, October 23, 1963 (AD 425474, \$1.50)
194	A Discussion of the Physical Metallurgy of the 18 Per Cent Nickel Maraging Steels, November 15, 1963 (AD 430082, \$0.75)
195	Properties of Coated Refractory Metals, January 10, 1964 (AD 433782, \$2.25)
196	Hydrogen-Induced, Delayed, Brittle Failures of High-Strength Steels, January 20, 1964 (AD 421124, \$3.00)
197	Cracking in High-Strength Steel Weldments - A Critical Review, February 7, 1964 (AD 438432, \$2.50)
198	The Mechanical Properties of the 18 Per Cent Nickel Maraging Steels, February 24, 1964 (AD 600427, \$2.75)
199	The Application of High Pressure in Metal-Deformation Processing - Report of an Informal Symposium of the Metalworking Process and Equipment Program, March 2, 1964 (AD 437328, \$2.00)
200	Vacuum Degassing in the Production of Premium-Quality Steels, March 11, 1964 (AD 600088, \$2.25)
201	U. S. Government Metalworking Processes and Equipment Program, March 18, 1964 (AD 600088, \$2.25)
202	The Effects of High-Pressure, High-Temperature Hydrogen on Steel, March 26, 1964 (AD 600088, \$2.25)

\* DMIC supply exhausted; copies may be ordered from OTS.

DOCUMENT CONTROL DATA - R&D

(Security classification of title, body of abstract and indexing annotation must be entered when the overall report is classified)

1 ORIGINATING ACTIVITY (Corporate author) Battelle Memorial Institute Defense Metals Information Center 505 King Avenue, Columbus, Ohio 43201		2a REPORT SECURITY CLASSIFICATION Unclassified	
		2b GROUP	
3 REPORT TITLE Explosive Forming of Metals			
4 DESCRIPTIVE NOTES (Type of report and inclusive dates) DMIC Report			
5 AUTHOR(S) (Last name, first name, initial) Strohecker, D. C., Carlson, R. J., Porembka, S. W., Jr., and Boulger, F. W.			
6 REPORT DATE May 8, 1964	7a TOTAL NO. OF PAGES 59	7b NO. OF REFS 62	
8a. CONTRACT OR GRANT NO. AF 33(615)-1121	9a ORIGINATOR'S REPORT NUMBER(S) DMIC Report 203		
b. PROJECT NO. 8975	9b. OTHER REPORT NO(S) (Any other numbers that may be assigned this report)		
c. —			
d. —			
10. AVAILABILITY/LIMITATION NOTICES Copies may be obtained from DMIC at no cost by Government agencies and by Government contractors, subcontractors, and their suppliers. Others may obtain copies from the Office of Technical Services, Washington, D. C. 20230			
11. SUPPLEMENTARY NOTES		12. SPONSORING MILITARY ACTIVITY United States Air Force Research and Technology Division Wright-Patterson Air Force Base, Ohio 45433	
13 ABSTRACT In view of the current high level of interest in explosive metal-working processes this report has been prepared to review the status of forming materials with high explosives. The information presented has been obtained from the open literature and from firms active in this work. Explosives and their characteristics are described along with discussions of general explosive-forming techniques. More detailed treatment is given to descriptions and requirements of facilities, die designs and materials, and current applications and practice in the forming of sheet, plate, and tubular products. In addition, the response of materials to high velocity forming is described in terms of effects on microstructures, formability, and mechanical properties. Methods of determining peak pressures and energy requirements are presented in an appendix along with appropriate nomographs. (Author)			

A

14. KEY WORDS	LINK A		LINK B		LINK C	
	ROLE	WT	ROLE	WT	ROLE	WT
Explosive forming						
Explosives (high)						
Detonators						
Edge preparation						
Thermal treatment						
Facilities						
Equipment						
Die designs						
Sheet						
Plate						

INSTRUCTIONS

1. **ORIGINATING ACTIVITY:** Enter the name and address of the contractor, subcontractor, grantee, Department of Defense activity or other organization (*corporate author*) issuing the report.
- 2a. **REPORT SECURITY CLASSIFICATION:** Enter the overall security classification of the report. Indicate whether "Restricted Data" is included. Marking is to be in accordance with appropriate security regulations.
- 2b. **GROUP:** Automatic downgrading is specified in DoD Directive 5200.10 and Armed Forces Industrial Manual. Enter the group number. Also, when applicable, show that optional markings have been used for Group 3 and Group 4 as authorized.
3. **REPORT TITLE:** Enter the complete report title in all capital letters. Titles in all cases should be unclassified. If a meaningful title cannot be selected without classification, show title classification in all capitals in parenthesis immediately following the title.
4. **DESCRIPTIVE NOTES:** If appropriate, enter the type of report, e.g., interim, progress, summary, annual, or final. Give the inclusive dates when a specific reporting period is covered.
5. **AUTHOR(S):** Enter the name(s) of author(s) as shown on or in the report. Enter last name, first name, middle initial. If military, show rank and branch of service. The name of the principal author is an absolute minimum requirement.
6. **REPORT DATE:** Enter the date of the report as day, month, year, or month, year. If more than one date appears on the report, use date of publication.
- 7a. **TOTAL NUMBER OF PAGES:** The total page count should follow normal pagination procedures, i.e., enter the number of pages containing information.
- 7b. **NUMBER OF REFERENCES:** Enter the total number of references cited in the report.
- 8a. **CONTRACT OR GRANT NUMBER:** If appropriate, enter the applicable number of the contract or grant under which the report was written.
- 8b, 8c, & 8d. **PROJECT NUMBER:** Enter the appropriate military department identification, such as project number, subproject number, system numbers, task number, etc.
- 9a. **ORIGINATOR'S REPORT NUMBER(S):** Enter the official report number by which the document will be identified and controlled by the originating activity. This number must be unique to this report.
- 9b. **OTHER REPORT NUMBER(S):** If the report has been assigned any other report numbers (*either by the originator or by the sponsor*), also enter this number(s).
10. **AVAILABILITY/LIMITATION NOTICES:** Enter any limitations on further dissemination of the report, other than those

imposed by security classification, using standard statements such as:

- (1) "Qualified requesters may obtain copies of this report from DDC."
- (2) "Foreign announcement and dissemination of this report by DDC is not authorized."
- (3) "U. S. Government agencies may obtain copies of this report directly from DDC. Other qualified DDC users shall request through \_\_\_\_\_."
- (4) "U. S. military agencies may obtain copies of this report directly from DDC. Other qualified users shall request through \_\_\_\_\_."
- (5) "All distribution of this report is controlled. Qualified DDC users shall request through \_\_\_\_\_."

If the report has been furnished to the Office of Technical Services, Department of Commerce, for sale to the public, indicate this fact and enter the price, if known.

11. **SUPPLEMENTARY NOTES:** Use for additional explanatory notes.
12. **SPONSORING MILITARY ACTIVITY:** Enter the name of the departmental project office or laboratory sponsoring (*paying for*) the research and development. Include address.
13. **ABSTRACT:** Enter an abstract giving a brief and factual summary of the document indicative of the report, even though it may also appear elsewhere in the body of the technical report. If additional space is required, a continuation sheet shall be attached.

It is highly desirable that the abstract of classified reports be unclassified. Each paragraph of the abstract shall end with an indication of the military security classification of the information in the paragraph, represented as (TS), (S), (C), or (U)

There is no limitation on the length of the abstract. However, the suggested length is from 150 to 225 words.

14. **KEY WORDS:** Key words are technically meaningful terms or short phrases that characterize a report and may be used as index entries for cataloging the report. Key words must be selected so that no security classification is required. Identifiers, such as equipment model designation, trade name, military project code name, geographic location, may be used as key words but will be followed by an indication of technical context. The assignment of links, rules, and weights is optional.