

UNCLASSIFIED

AD NUMBER
AD487893
NEW LIMITATION CHANGE
TO Approved for public release, distribution unlimited
FROM Distribution: Further dissemination only as directed by Department of the Army, Attn: Public Affairs Office, Washington, DC 20310, FEB 1961, or higher DoD authority.
AUTHORITY
DAMA ltr, 13 May 1975

THIS PAGE IS UNCLASSIFIED

THIS REPORT HAS BEEN DELIMITED  
AND CLEARED FOR PUBLIC RELEASE  
UNDER DOE DIRECTIVE 5200.20 AND  
NO RESTRICTIONS ARE IMPOSED UPON  
ITS USE AND DISCLOSURE.

DISTRIBUTION STATEMENT A

APPROVED FOR PUBLIC RELEASE  
DISTRIBUTION UNLIMITED.

✓

# HumRRRO

This document may be further distributed by any holder only with specific prior approval of the Chief of Research and Development, Department of the Army.

487893

(2)

DDC  
AUG 31 1966

B

**U.S. Army Armor Human Research Unit  
Fort Knox, Kentucky**

*Under the Technical Supervision of*

**The George Washington University  
HUMAN RESOURCES RESEARCH OFFICE  
operating under contract with  
THE DEPARTMENT OF THE ARMY**

US Army Armor Human Research Unit  
Fort Knox, Kentucky

This document may be further distributed  
by any holder only with specific prior  
approval of the Chief of Research and  
Development, Department of the Army.

Human Factors Evaluation of the Tank, Combat  
Full Tracked: 105mm Gun, M60

Donald F. Haggard  
Albert R. Wight

Consulting Report  
February 1961

A report of work done in connection with Subtask VIII, FIREPOWER, Task 11-26,  
"Methods for Improving Performance in Tank Gunnery"

*Norman Willard Jr.*

NORMAN WILLARD, JR.  
Director of Research

*Edwin W. Reynolds*

EDWIN W. REYNOLDS  
Lt Col, Armor Chief

Research under the technical supervision of  
HUMAN RESOURCES RESEARCH OFFICE  
The George Washington University  
Operating under contract with  
The Department of the Army

## TABLE OF CONTENTS

List of Figures	ii
Abstract	iii
Introduction	1
Procedure	1
Results	3
Driver's Compartment	4
Work Space	4
Entry and Exit	5
Primary Driving Controls and Seating	7
Seating	7
Accelerator Pedal	9
Brake Pedal	10
Steering Wheel	11
Transmission Shift Lever	12
Vision Devices	13
Auxiliary Driving Instruments	14
Loader's Section	16
Work Space	16
Loader's Gun Safety Switch	17
Ammunition Racks	17
Loader's Seat	18
Turret Traverse Lock	19
Replenisher Cylinder Indicator Tape	19
Suggested Periscope	19
Gas Mask Connection	20
Loader's Hatch	20
Gunner's Section	21
Work Space	21
Gunner's Seat	22
Periscope M31, Infinity Sight M44C, and Telescope M105C	22
Gunner's Control Assembly	23
Elevation Hand Pump	23
Hand Traversing Assembly	24
Power Switch Box	25
Ballistics Computer ML3A1D	25
Azimuth Indicator	26
Elevation Quadrant M13	26
Portable Fire Extinguisher	26
Tank Commander's Section	27
Work Space	27
Tank Commander's Seat Assembly	27
Commander's Control Handle	29
Tank Commander's Cupola	30
Equipment External to the Hull	30
Exterior Interphone Connection	30
End Connectors	30
Headlight Mounting Bracket	30
Tail Lights	30
Aluminum	31
Seals on Stowage Boxes	31
Track Connecting Fixture	31
Application of Results	31
References	33
Appendix: Human Factors Check List for the M60 Tank	35

## LIST OF FIGURES

- Figure 1: Posture of Driver, Operating with Hatch Closed
- Figure 2: Driver's Posture after Relocation of Accelerator Pedal
- Figure 3: Location of Brake Pedal and Linkage
- Figure 4: Location of Steering Wheel in Relation to Periscope and Hull
- Figure 5: Driver's Line of Sight over the Center Periscope When the Seat Is Adjusted to Maximum Height
- Figure 6: Minimum Visual Angle over Front of Hull, Showing Interference of Periscope with Vision of Driver
- Figure 7: Driver's Line of Sight over Center Periscope When the Maximum Height Is Increased 2.5 Inches
- Figure 8: Suggested Schema for Speedometer - Odometer
- Figure 9: Suggested Schema for Tachometer - Hour Meter
- Figure 10: Position of Loader Between Breech Operating Handle and Ammunition Rack
- Figure 11: Ammunition Rack Retainer Assembly, Dropped into Turret Ring
- Figure 12: Loader's View of Replenisher Cylinder Indicator Tape
- Figure 13: Work Space Provided for the Gunner
- Figure 14: Gunner's Operating Position Showing Relative Control Locations and Proximity to the Tank Commander's Station
- Figure 15: Suggested Designs for Manual Elevating Handle
- Figure 16: Interference of Ammunition Selector Handle with Gunner Operation of Hand Traversing Assembly
- Figure 17: Interference of Mirror with Lighting for Level Vial of Elevation Quadrant
- Figure 18: Position of TC in Relation to TC Controls and Gunner's Section
- Figure 19: Position of TC When He Uses the Seat for Footing During Operation with the Hatch Open
- Figure 20: Obstruction of Seated TC's View by the Cupola
- Figure 21: Obstruction of Standing TC's View by the Cupola
- Figure 22: Interference of Seat Handle When Commander Stands on Platform
- Figure 23: Position of Back Rest of Commander Seat When He Uses Cupola Periscope
- Figure 24: Seated Position of TC for Using the Cupola Vision Devices
- Figure 25: Adduction and Abduction at Wrist in Relation to Positioning Requirements of the TC's Control Handle
- Figure 26: Relation of Commander's Control Handle and His Hand During Operation with Hatch Open and Head Out

ABSTRACT

A human factors evaluation of the M60 tank was conducted by the Armor Human Research Unit through observation of crew performance, interviews with tank crewmen, and measurement of layout of crew work space. Design deficiencies which would reduce operational effectiveness were found in each of the four crew positions. The findings were submitted to Continental Army Command and to Ordnance Tank-Automotive Command for review. Approved changes will be reflected in future production of the M60 series tanks.

## Human Factors Evaluation of the Tank, Combat, Full Tracked, 105-MM Gun, M60

### INTRODUCTION

The primary measure of a weapon system's value is its operational effectiveness in a combat application. An important factor in achieving operational effectiveness is the degree to which the human operator is integrated into the relevant components of the system. Component characteristics which violate the requirements for efficient operation of the system (by humans) compromise the operational capabilities of the entire system.

Recognizing these facts, Continental Army Command<sup>1</sup> advised the US Army Armor Center to consult with the US Army Armor Human Research Unit in conducting the troop evaluation of the M60, 105-MM Gun Tank. The Armor Center therefore requested the Unit to participate.<sup>2</sup> The purpose of this part of the evaluation was to determine human factors problem areas likely to be encountered with component systems of the M60. Armor Human Research was to specify those components for which avoidable safety or human engineering deficiencies appeared to decrease system efficiency.

### PROCEDURE

Several handbooks are available in which the results of a large number of human engineering studies are collated in summary form; the collation indicates the critical requirements which determine optimum operating and safety requirements for man-machine systems (e. g., 3, 7, 8, 17, 18). On the basis of the information contained in these handbooks, a list of human factors which are critically related to the safety, ease, and accuracy of operation of various types of equipment was developed. These factors were

---

<sup>1</sup>Letter, ATPNG-D&R 451.6/18 (C), 2 May 1960, Hq USCONARC, subject, "Troop Evaluation of the M60 Tank" (U).

<sup>2</sup>Letter, AIBK-SBA, 25 June 1960, US Army Armor Center, subject, "Troop Evaluation of the M60 Tank."



then applied in check list form to each component of the M60 tank (4) which was relevant to crew functioning.<sup>3</sup> The resulting "Human Factors Check List for the M60 Tank" was intended for use as a guide for completing the human factors analyses. Appendix A is a copy of this check list.

The analysis of the M60 tank was conducted in three phases. During the first phase, Armor Human Research personnel reviewed equipment characteristics and their relation to known human engineering principles. This review included making physical measurements of the crew work space and completing the human factors check lists. All physical measurement was referenced to anthropometric measures of armor personnel (2).

Percentile points were used as the most practicable elaboration of anthropometric statistics. A percentile point is a value on the measurement scale below which any given percentage of the cases fall. For example, the 95th percentile is the point below which 95 per cent of the measurements fall. For this analysis it was assumed that all hardware dimensions should accommodate at least 90 per cent of the armor personnel. Minimum dimensions were thus referenced to the 5th percentile anthropometric measure (that which would be exceeded by 95 per cent of the armor personnel), and maximum dimensions were referenced to the 95th percentile anthropometric measure (that which be exceeded by only 5 per cent of the armor personnel). For illustrative purposes the measurement which would best illustrate the degree of deficiency was used.

The second phase of the evaluation included both observing and interviewing operating crews during and directly after vehicle operation for the troop

---

<sup>3</sup>Equipment components which were not furnished with the initial M60 models used during the troop evaluation (e. g., cupola machine gun, communication system, etc.) were not included in the analysis.

evaluation conducted at Ft. Hood, Texas. Both observation and interview were referenced to the human factors check lists.

The results of these two phases were combined in an integrated compilation of safety and human engineering deficiencies. This list was then checked against the available troop evaluation reports (15), and all items which duplicated those in the report were eliminated because they had already been reported. The remaining deficiencies were reviewed with representatives from the US Army Armor Board to eliminate any other item which did not seem to reflect a degree of deficiency that would warrant modification of equipment.

#### RESULTS

The purpose of this study was to determine avoidable engineering deficiencies which might compromise the operating efficiency, safety, or comfort of the tank crew. The results of the study therefore emphasize inadequacies, although if a comparative study between this and other vehicles were made, as many good points could probably be listed. In fact, most of the interviews and observations indicated that a number of improvements over the M48A2 had been made, but that additional changes would greatly increase the crew's operating efficiency. These changes were the subject of the analysis reported here.

Some of the changes recommended as a result of the analysis involve only slight modification of the present equipment. Others, however, involve more extensive modification or the use of other equipment. Many of these deficiencies appear insignificant, considered individually; but together they could result in a considerable loss in efficiency. Further justification for modification of the present vehicle will have to be established, since there has been no attempt to determine either the exact degree of operational

decrement, or the cost of a proposed change in relation to the increase in operating efficiency which is expected to result from that change. It should be stressed, however, that most of these deficiencies could have been avoided had more attention been given to human factors requirements during the initial stages of equipment development.

Driver's Compartment:

The driver's compartment of the M60 is too small for optimum comfort and efficiency, but it could not be enlarged without changing the profile of the tank. Obviously this condition can also be expected in future tanks, with the increased emphasis on lower profiles and more supporting equipment. It is therefore imperative that the controls within the compartment be arranged so the driver can utilize the available work space advantageously and operate the tank efficiently. Instances in which this could be accomplished in the present M60 by rearrangement of control layout or substitution of alternate types of control will be emphasized in the following sections. However, several deficiencies cannot be eradicated simply by rearrangement or substitution. Where these deficiencies severely hamper operation, a major modification may be required.

Work Space. One of the more severe deficiencies restricts head space during operation with the hatch closed. The vertical distance from the driver's seat in its lowest position to the closed hatch cover should be sufficient to enable 95 per cent of the drivers, wearing a tanker's helmet and with maximum expected clothing thickness, to operate while they are sitting erect. In the M60 this vertical distance measures 37 inches; whereas the sitting height of the 95th percentile man (without tanker's helmet or heavy clothing) is 38.5 inches. While the effective working height of the driver is between 1.5 and 2 inches less than his statistical anthropometric

height, vertical space is still less than that required for efficient driving. The resulting cramped posture which the driver must assume (as shown in Figure 1) severely limits the length of time he is able to operate efficiently with the hatch closed.

Another deficiency is the amount of dust and mud which enter the driver's compartment. With the models used during the troop evaluation, both tracks threw dirt and mud over the front of the fender and through an opening between the hull and fender. Drivers estimated that they could not drive over ten minutes with the hatch closed before the periscopes were covered with mud, or twenty minutes with the hatch open before the instruments were covered with mud. An equipment modification has since extended the fenders and filled in the hull-fender space, thereby reducing the amount of mud which enters the compartment. However, driving with the hatch closed is still hampered by mud and dust on the periscope. A method of protecting or periodically cleaning the periscope faces should therefore be provided.

Padding around the driver's hatch, particularly in the rear, is insufficient. The bouncing and jolting of the driver during cross country operation might cause serious injury. The only way the driver can steady himself is to use the steering wheel as a brace, or if the hatch is open, to brace one arm on the edge of the hatch. Neither method provides sufficient stability, and both methods interfere with driving. It is therefore recommended that some method of securing the driver, such as seat belts and shoulder straps with a quick release device, be provided and that heavier padding be used to line the rim of the hatch.

Entry and Exit. The driver's compartment has two hatches for entry and exit—a driver's hatch over the driver's seat, used for normal entry and exit, and an escape hatch directly beneath the driver's seat, used for

emergency exit by the crew.

The driver's hatch is semicircular; it measures approximately 28.5 inches across the base and 15.5 inches in radius. This size is sufficient for normal use, although the depth would be somewhat restrictive for the arctic soldier with a clothed chest and hip depth of approximately 16 inches (9).

The cover for the driver's hatch slides along a cross bar which is mounted at the rear of the hatch and which is therefore behind the driver's head. To operate this cover, the driver must first grasp the handle and pull the cover to a half open position, then turn, and grasping the handle with the other hand, complete the movement along the cross bar. While this operation is awkward, it does not seem to offer any particular difficulty which would warrant modifying equipment. However, operation depends on easy traverse along the cross bar; when this bar becomes covered with mud and debris, the cover will not traverse. Normally the cross bar can be wiped clean periodically; but under combat conditions quick operation would be required, and the driver could not take the time to wipe the cross bar before closing the hatch. For this situation some sort of protection for the cross bar should be provided.

Mud and dirt on the hatch seal also interfere with closing the hatch. After a short period most drivers can not close the hatch without outside help. Since quick one-man operation is required, this situation should be corrected.

Handles for the hatch cover are considered not large enough for easy operation. The handle at the front of the hatch, used to close the cover, is not large enough to provide a good grip; the lock handle is so light that it bends whenever it is forced. These handles should be enlarged.

The location of the turret pressure gage near the end of the cross bar

also interferes with closing the hatch. Whenever the hatch cover is closed rapidly, the driver's hand hits the gage, injuring his hand and sometimes breaking the gage. This gage should be relocated.

Another deficiency in the present hatch system is the size of the driver's escape hatch. The diameter of the circular escape hatch is 18 inches. This is sufficient for a man dressed in the fatigue uniform but the arctic soldier measures approximately 28, 23 and 25 inches in the respective widths of shoulder, chest, and hip (9). Thus, when they wear the arctic uniform none of the crew are able to use the escape hatch for emergency exit. Since the performance requirements of this vehicle provide for operation in temperatures which would not permit unbuttoned operation without arctic gear, and which would not enable the man to remain without arctic clothing for the length of time necessary to exit, find cover, and put on clothing, it would seem imperative that all hatch dimensions be made to conform to the spatial dimensions of the arctic soldier.

Also, since the driver's escape hatch cover is concave, water collects in the cover and rusts the controls until they are inoperative. The cover is awkward and difficult to remove each time it fills with water; so some method of draining should be provided.

Primary Driving Controls and Seating. The position and mode of operation of the gear shift, steering wheel, accelerator, and brake, and the position of the vision devices and instruments, all in relation to the seated position of the driver, have an important bearing on his ability to control the vehicle. Within the limited space of the M60 driver's compartment, planning for accessibility and operability of controls increases in difficulty as well as in importance.

Seating. For optimum efficiency the driver should be able to

lean back slightly while he is driving. But with the hatch open and the seat in its most forward position, the driver must lean forward to get his head out of the hatch. He must lean forward even more over the middle periscope to see close enough to the front of the tank for safe driving. When the hatch is closed, the driver must lean forward to see close to the front of the tank through the periscope. Relocating the central point of fore and aft adjustment forward would thus greatly increase the comfort of the driver's position and decrease his postural strain and fatigue in driving for an extended period of time.

Also the support bar for the driver's seat is not sturdy enough to withstand the forces exerted by the driver in driving cross country. Many seats were bent down during the first few miles of operation. A sturdier support should be provided.

The wire mesh driver's seat is to be replaced by the M48A2 seat (15), but comments and observations pertaining to this seat should be considered for future seat design. Also, if this type of seat is retained for the other crew members, these comments would apply to all other seating in the vehicle. Since the seat mount will be unchanged, its functioning and relation to other equipment should still be considered.

Most drivers preferred the wire mesh seat to the usual canvas-covered seat because of its ease of maintenance. The wire seat can simply be sprayed off to clean, and no breaks or tears were expected. In contrast, a canvas covered seat must be scrubbed often and it rips and tears easily. But ease of maintenance was the only support given for use of the wire seat. It was thought to be hard and uncomfortable since it is not resilient enough to provide an adequate seating surface or to enable the man to sit anywhere except in the center of the seat, regardless of the relation of this position to the controls he is operating. It does not absorb the vibrations of the tank, but transmits

all the jolts and jars to the man's body. Lack of resiliency added to bounciness could be expected to result in a high consumption of energy and loss in visual acuity over extended periods of operation (6, 11, 12, 16).

The backrest for the driver's seat was also considered to be inadequate. It is the chief support for the driver when he is braking, or bracing himself for bumpy terrain. While the backrest is large enough to provide adequate support, the lack of padding results in scraped and bruised backs during cross country operation. Also the back adjustment lock is not sturdy enough to withstand the bracing; so it does not hold the back in position.

Accelerator Pedal. The location of the accelerator pedal directly forward of the seat causes a very cramped posture when the driver is operating with the hatch closed. (See Figure 1.) In addition, the near vertical mounting of the pedal results in a sharp ankle angle, especially for slow speeds. When the hatch is open and the seat is up, the forward distance to the pedal is not very critical, but the vertical mounting of the pedal requires that the driver operate it by holding his foot on the upper edge with no anchor point on which to rest his foot. In both positions the accelerator is extremely difficult to operate, almost impossible when the driver is wearing overshoes or arctic boots.

One solution to this problem would be to move the pedal approximately six inches forward; this change would also raise the height of the pedal about four inches. Operation with the hatch closed and with the pedal relocated forward is depicted in Figure 2. It can be seen by comparing this figure with Figure 1 that this solution alleviates the difficulty somewhat without requiring a drastic modification.

The operating angle of the present accelerator pedal requires that drivers of different statures apply force from different angles of the lower leg and that they use whatever is available as a heel rest (some drivers use the linkage,



POSTURE OF DRIVER, OPERATING WITH HATCH CLOSED

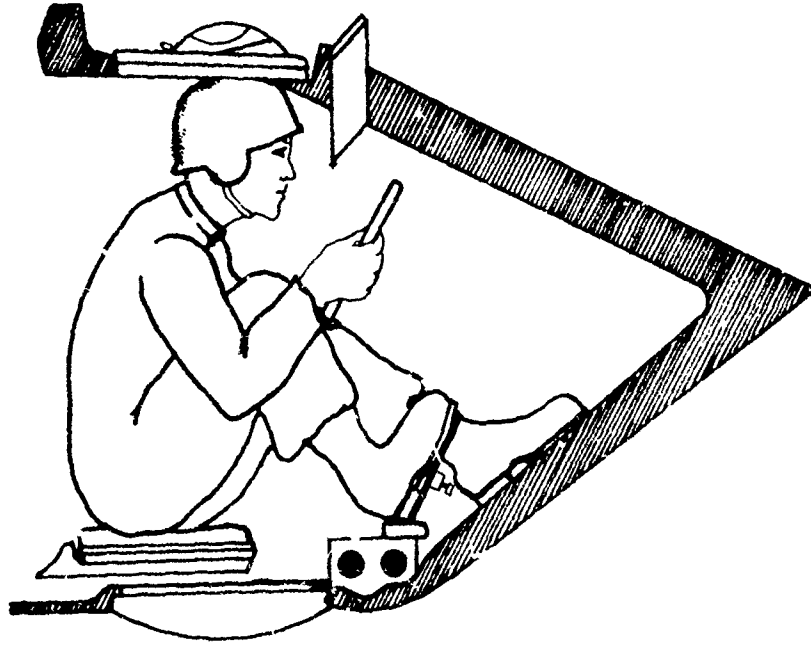

Figure 1

DRIVER'S POSTURE AFTER RELOCATION OF ACCELERATOR PEDAL

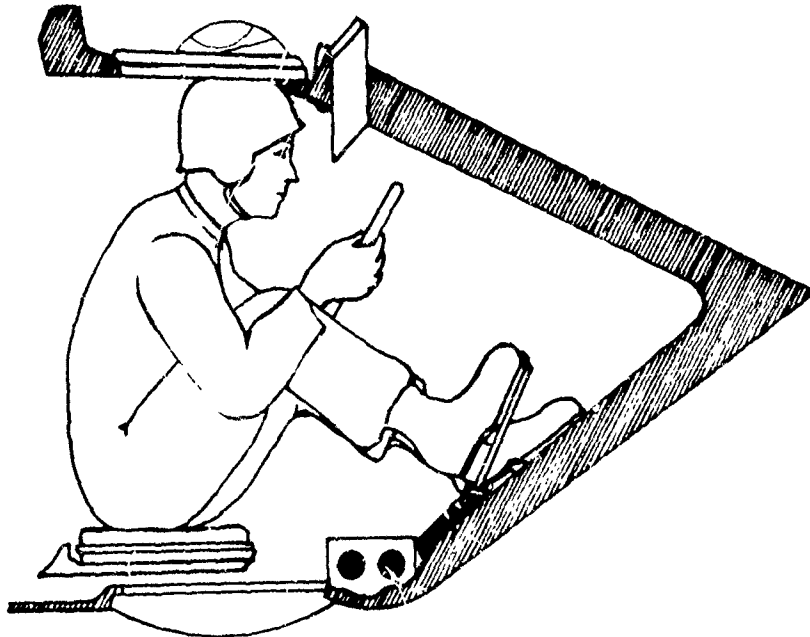

Figure 2

others the hull, and still others the base of the pedal). The pedal angle should nevertheless conform to the configuration of the sole of the driver's boot and offer enough resistance to offset the weight of the foot. The present pedal satisfies neither requirement. The shape of this pedal is based on the driver's position in an obsolete tank and does not conform to any operating requirement of the M60 tank. It is split vertically into two levels for operation when the hatch is closed and open, but neither level is angled correctly for M60 positions, or is wide enough to hold the driver's boot. Nor does pedal resistance offset the weight of the driver's foot; so he has to support his foot in a position which becomes tiring after a short time. This pedal should be modified to provide a comfortable operating angle for operation with the hatch both closed and open, and sufficient width and resistance to support the driver's boot.

The surface of the pedal has a smooth texture which, when the pedal becomes covered with mud and oil, allows the foot to slide back and forth. This sliding is fatiguing and results in erratic acceleration during cross country driving. This condition could be eliminated by covering the pedal with a durable corrugated material.

Brake Pedal. The location of the brake pedal, high on the hull and directly behind the steering wheel, requires most drivers to bend their leg around the wheel to brake. This requirement and the force necessary to operate the pedal make braking extremely difficult. Obviously the brake pedal should be relocated, but to what position is not readily apparent.<sup>4</sup> Relocation

---

<sup>4</sup>Relocation of the brake pedal raises a question that can not be answered without further research. Separation of brake and accelerator pedals reduces the possibility of accelerating when one intends to brake. However, it might be more advantageous if both the accelerator and brake in the present vehicle were operated by the same foot. Sufficient separation could still be achieved. When the accelerator is on the right side of the steering wheel and the brake

is further complicated by the large amount of linkage required to operate the present braking system. (See Figure 3.) This linkage restricts not only the number of possible pedal locations, but also the location and operation of the other controls. Some method of assisted braking, such as hydraulic brakes, which would reduce the amount of linkage required, would greatly reduce clutter and interference and allow for proper location of the braking controls.

Steering Wheel. The focus of many layout problems in the driver's compartment is the steering wheel.

It has already been noted that the wheel blocks direct access to the brake pedal. Covering a fairly large area directly in front of the driver, the wheel blocks access to much of the forward area and, without stricter assembly tolerances, is prone to malfunction. (See Figure 4.) On some vehicles the wheel is mounted directly under the middle periscope, so that the wheel must be removed before the periscope can be removed or replaced. On other vehicles the wheel is mounted so near the hull that the driver bangs his knuckles or binds the wheel against the hull in making a sharp turn. Undoubtedly better quality control would solve some of these problems, but a better over-all solution might be to use a type of steering control which would not offer much of a blocking problem: for example, a T-Bar or wobble stick. Most of the drivers interviewed who had operated vehicles in which other types of controls were used, expressed a definite preference for the T-Bar or wobble stick. Other studies have indicated that control preference is directly related to the amount of past experience with that control (10),

---

on the left, the driver has a tendency to brace one foot on the accelerator when he is braking. This tendency is particularly true for trainees, but also occurs with experienced drivers. In one instance a driver hit both brake and accelerator pedals when a tank in front of him stopped suddenly. This situation could be avoided if both pedals were operated by the same foot (as in an automobile). A study would be necessary, however, to determine the comparative operating efficiency of the two arrangements.



---

Figure 3:

Location of Brake Pedal and  
Linkage

---

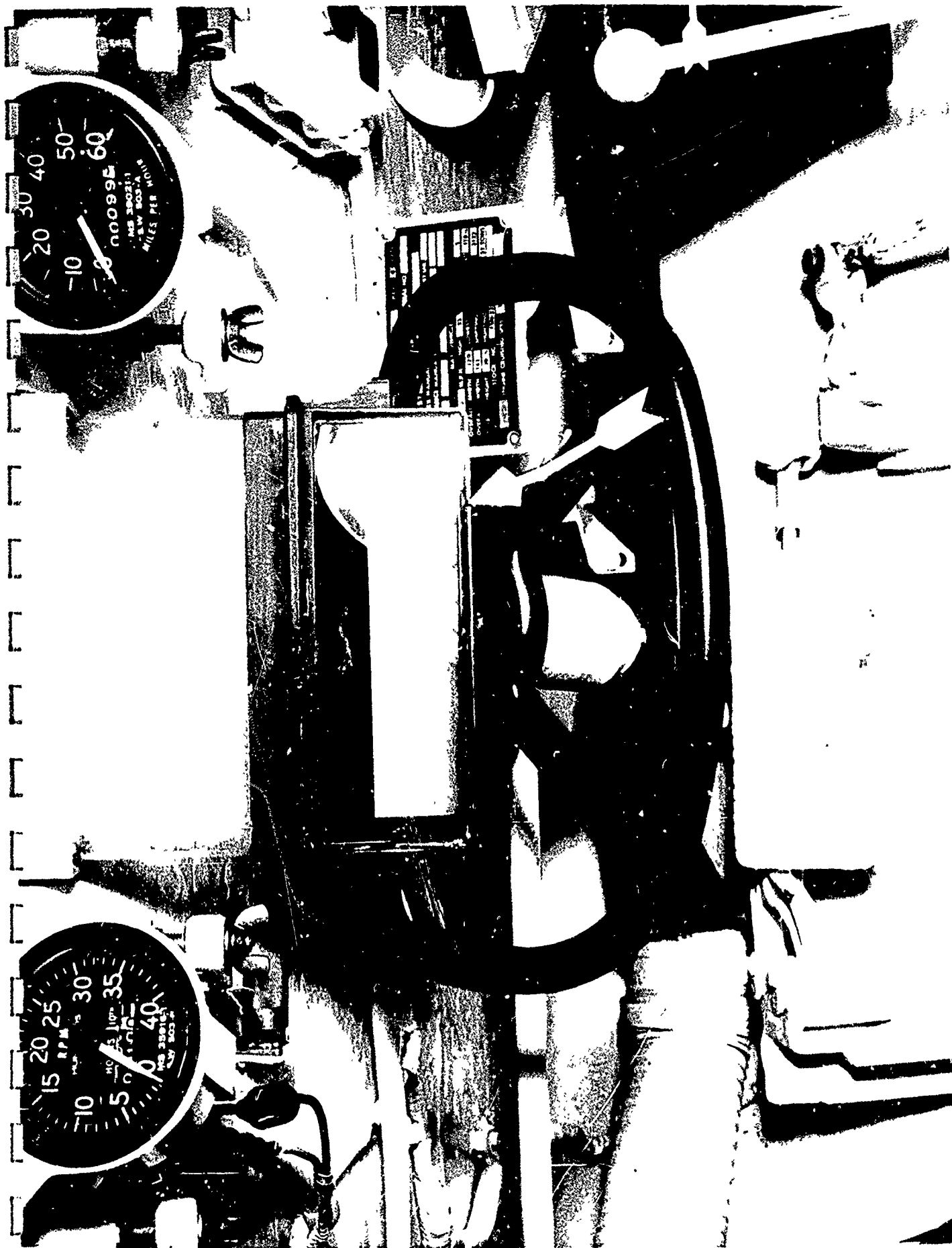

Figure 4:  
Location of Steering Wheel in  
Relation to Periscope and Hull

but further investigation of control space requirements and operating ease and accuracy should be considered, the objective being to determine the optimum type of control for use in restricted compartments. A study in progress at the Army Ordnance Human Engineering Laboratory should provide much of this information (10, p. 7).

The present steering column of the M60 does not seem to be rugged enough to withstand more than normal driving force. Several drivers reported bending of the steering column when the wheel was used for support over rough terrain. Support handles for the driver as suggested earlier, would lessen use of the steering wheel as a brace, but the steering column should still be strong enough to withstand any normal leverage which might be applied.

Transmission Shift Lever. The gear shift lever is so located that shorter drivers have difficulty reaching the farthest position, the starting position. Some of these drivers say they operate the lever with their foot rather than their hand. This procedure could cause a number of malfunctions; it could easily be stopped if the shift control were moved several inches closer to the driver's seat, or if the starter were located on the driver's instrument panel.

A recurring problem is the requirement that the radio be turned off before starting the tank.<sup>5</sup> Despite considerable emphasis on this requirement during training, countless radio tubes are destroyed by drivers who forget or ignore the requirement. It would cost very little to place a RADIO-ON warning light near the starter, or better still, to incorporate a breaker switch which would take care of the sudden surge of current or turn the radio off while the starter is in operation.

---

<sup>5</sup>This operation is not necessary when fully transistorized radios are used. But since such equipment is not yet available, the problem should be considered.

Emphasizing the lettering of control positions, and supplying an instruction plate outlining the starting procedure, might aid inexperienced drivers or emergency operation by another member of the crew. The present lettering to indicate shift positions is in sunken relief, the same color as the surround. Positions are very difficult to read under dim illumination. They could be made more legible if they were painted a contrasting color. The starting procedure is available only in the tank manual.

Vision devices. Two types of vision devices are provided for the driver during operation with the hatch closed. Three vision blocks centered directly in front of the driver are used for daylight driving. An infrared periscope which can be inserted through the driver's hatch affords night vision.

The three vision blocks seem to afford adequate vision for the driver; however, the location of the central vision block causes several operating difficulties. First, the device is located so far forward from the driver that when the hatch is closed, he must assume a crouched position to view terrain which is directly in front of the tank. This position is fatiguing even for a short period of operation. Adding an angled, longer block directly in front of the present one, or an adjustable periscope head, would enable the driver to view the immediate terrain from a normal driving position. Second, the present spacing above the vision block and around the cushion is not great enough to allow the driver a close view while he is wearing the tanker's helmet.

Third, the vertical distance from the top of the driver's seat to the tops of the vision blocks is 29 inches. This distance will be increased when the M48A2 bucket-type seats are used. Since the eye level of the 75th percentile man in a normal sitting position is only 30.4 inches, the majority of drivers cannot now observe the immediate frontal area when they are

operating with the hatch open. (See Figures 5 and 6.) To increase frontal vision, the driver must either remove the block or use some method of increasing the height of the seat (some drivers use seat cushions; others drill an extra hole at the top of the seat adjustment bar). Removal of the block would not be permitted in a combat situation where a quick change from hatch-open to hatch-closed operation might be necessary. Raising the seat raises the driver enough that he might be accidentally hit by the gun shield. One suggested solution is a quick adjusting up-down case for this vision block. Another suggestion is to increase seat height (as shown in Figure 7), and add a device to protect the driver from the gun shield.

The infrared periscope used for night driving can be locked in place, but most drivers prefer to leave it unlocked so that they can turn it to the side, particularly when they turn the vehicle, or swing it up to look ahead when they are going up a hill. A scope handle would thus facilitate control in driving. Also the infrared scope cannot be used with the tanker's helmet, and better spacing should be provided for this purpose.

Auxiliary Driving Instruments. The speedometer and tachometer are located directly in front of the driver, well within his field of view; but the location of the indicator gage panel and the master control panel to his side requires that he interrupt his observation of the terrain whenever he has to read a dial or manipulate a control. This interference with the driver's primary duty could be lessened if both panels were located in front of the driver. The horseshoe arrangement used in the T92 light tank (1) was considered very satisfactory during the equipment test; it might well form the basis for instrument layout in the M60.

Drivers use the tachometer very little, relying mainly on the speedometer. One reason is that the driver seldom remembers the correct RPM for various



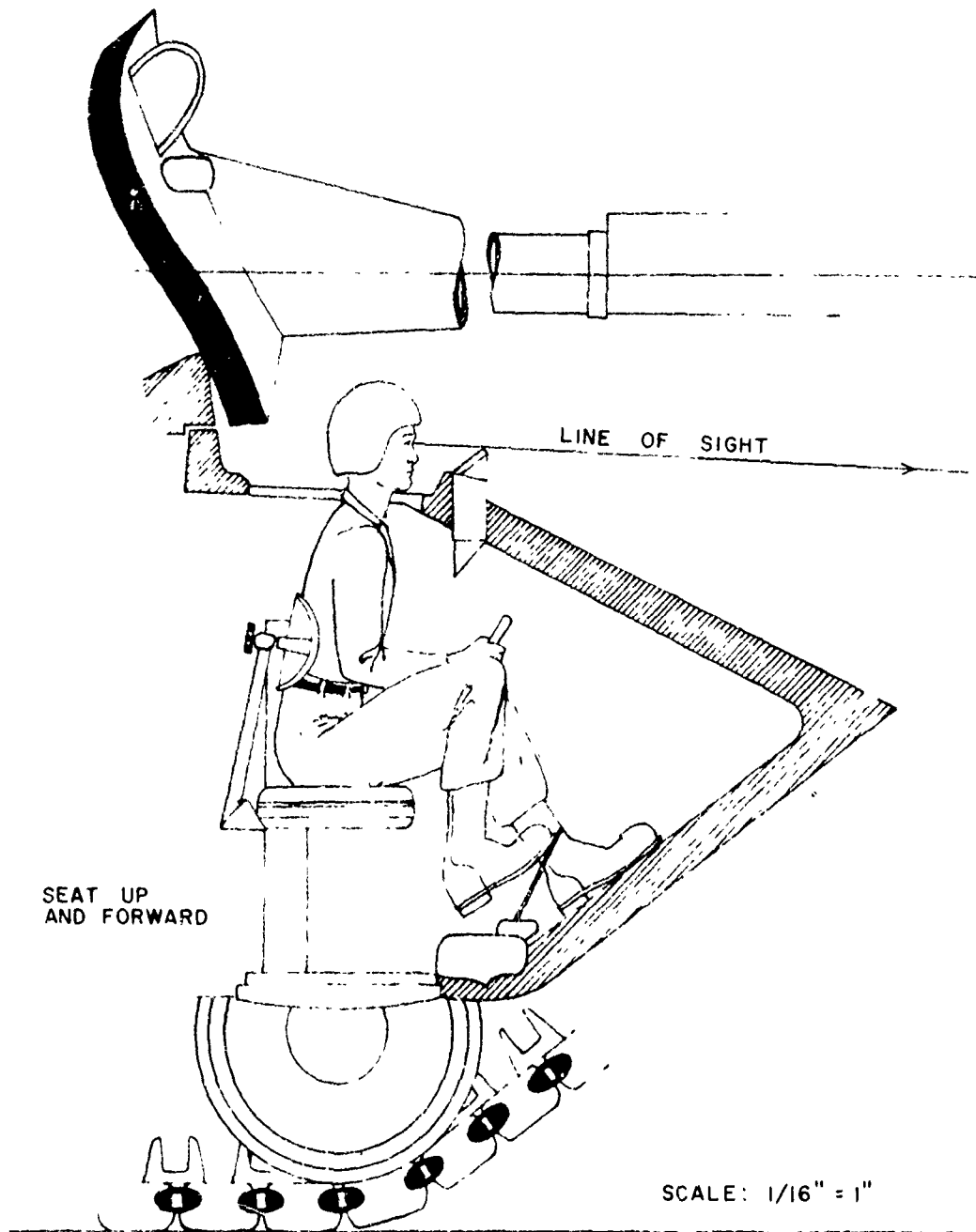

5<sup>th</sup> PERCENTILE DRIVER

Figure 5

Figure 5:

Driver's Line of Sight over the  
Center Periscope When the Seat Is  
Adjusted to Maximum Height

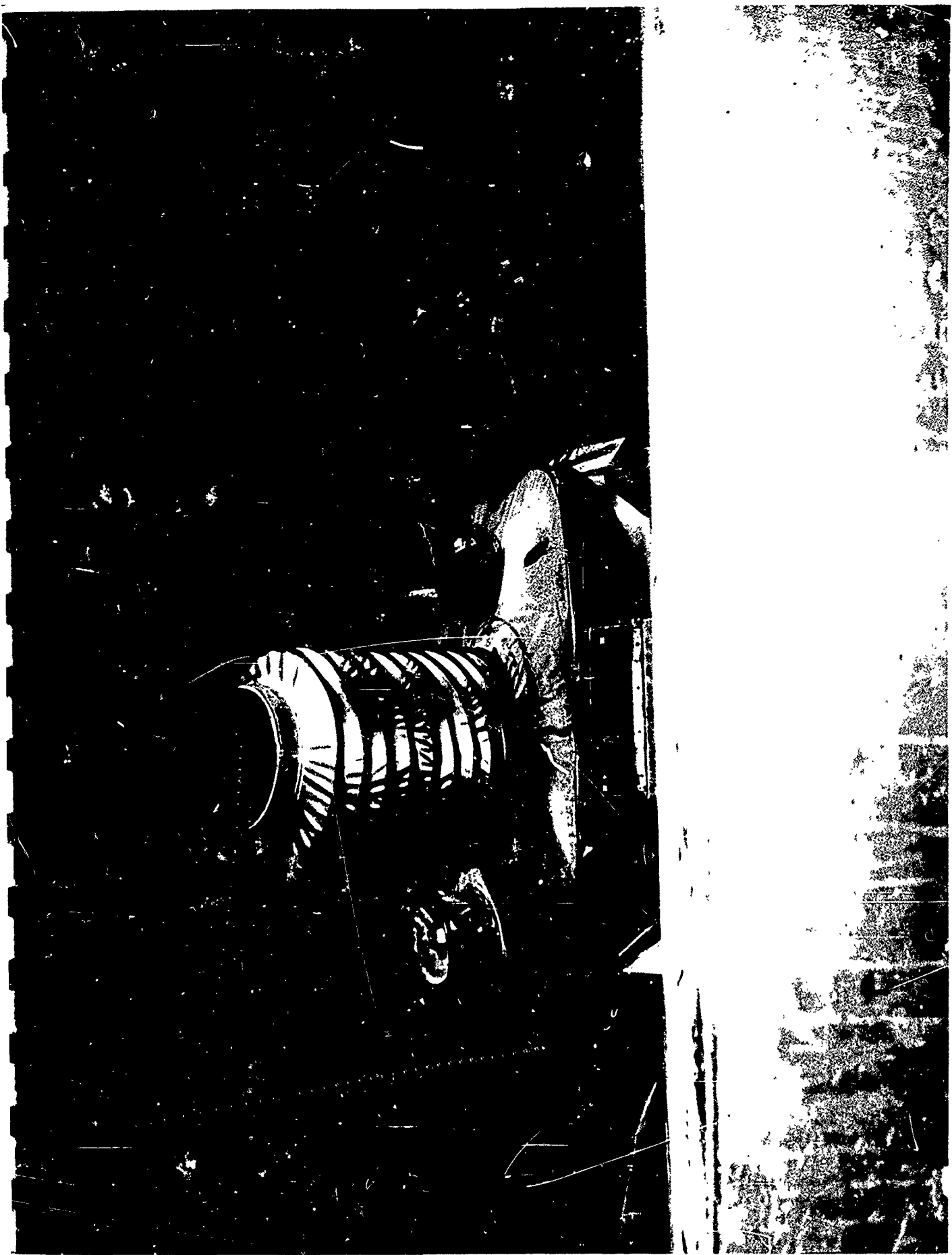

---

Figure 6

Minimum Visual Angle over Front  
of Hull, Showing Interference of  
Periscope with Vision of Driver

---

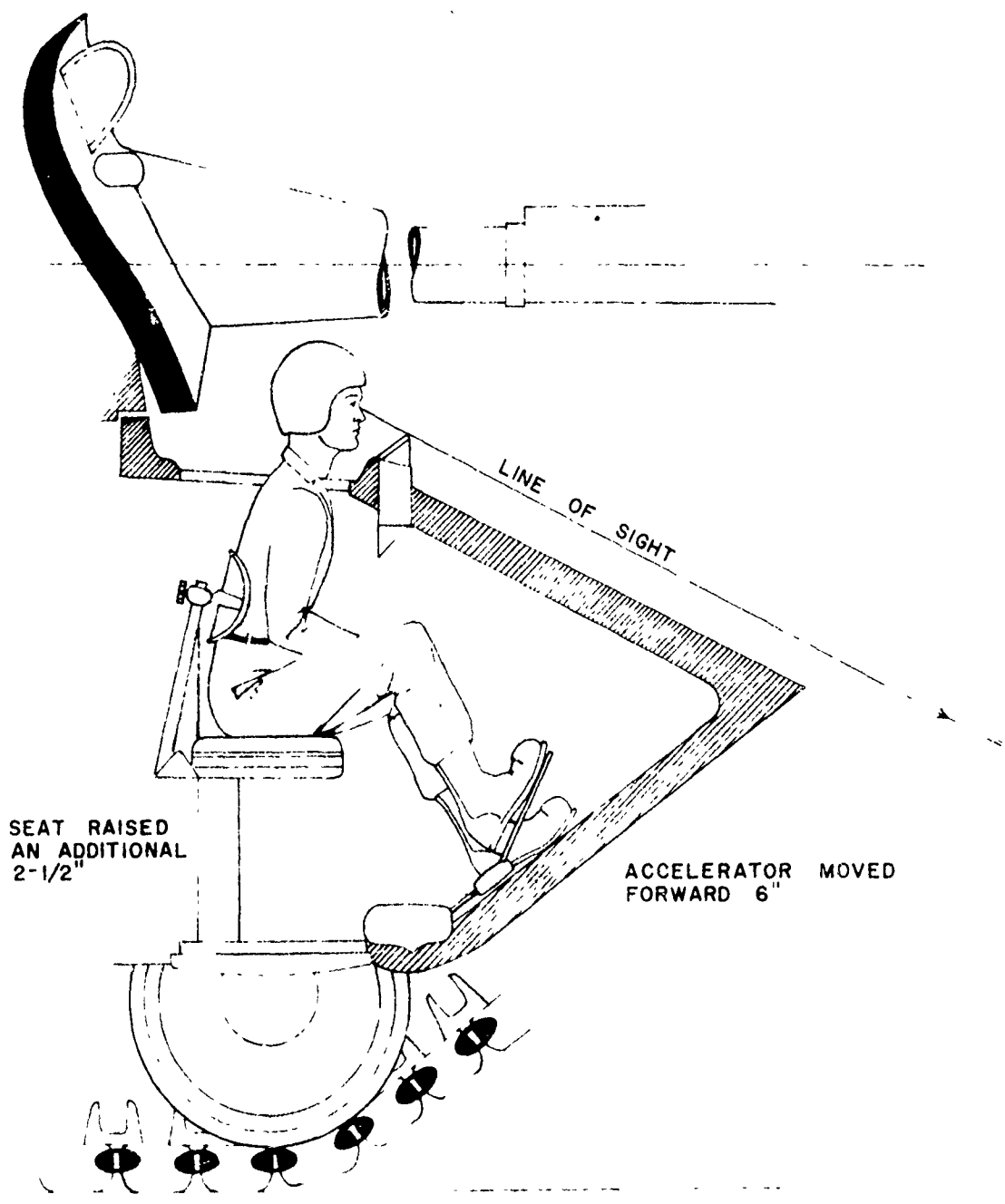

5<sup>th</sup> PERCENTILE DRIVER

Figure 7

Figure 7:  
 Driver's Line of Sight over the  
 Center Periscope When the Maximum  
 Height Is Increased 2.5 Inches

operations. Color zoning could be added to the tachometer as an aid. One possible schema, shown in Figure 9, includes a separation or distinctive marks between zones—one at 1000 RPM for operation before shutting the engine off, a color zone for the 1600 to 1800 RPM area for engine warm-up, a mark or separation at 3000 RPM to indicate that brakes should be applied in negotiating a steep down grade, and perhaps a zone in the 2000 to 2100 RPM area to indicate the optimum RPM for normal operation.

Zones or distinctive marks could also be added to the speedometer to identify critical speeds. One possible schema, shown in Figure 8, provides for a distinction at the 4 MPH position for towing, at 5 MPH for traveling in reverse or for ascending or descending steep grades, between 6 and 12 MPH for shifting from low to high or from high to low and for showing maximum speed in low gear, and at 30 MPH for showing maximum speed on a hard surface.

Also numerals on both dials have been moved outside the calibration markings where they can be more easily and accurately read. Both dials should also have internal illumination. These dials are now hard to read at night even when the dome light is illuminated.

Color zoning has already been added to the dials on the indicator gage panel, but this was evidently an *afterthought*, as the zones are painted on the outside rim of the dial. For quick and accurate reading, the zones should be painted on the faces of the dials. For optimum readability, none of the dial pointers should cover the marks or numbers as some present pointers do.

For all coding, colors which are discriminable under daylight, white light, and red light should be used—not including the reds which are frequently used, for these reds wash out under red light. A report of research conducted by the Armor Human Research Unit (13) specifies the hues which are most discriminable under both white and red light. These hues should be used for

---

Figure 8:  
Suggested Schema for  
Speedometer - Odometer

---

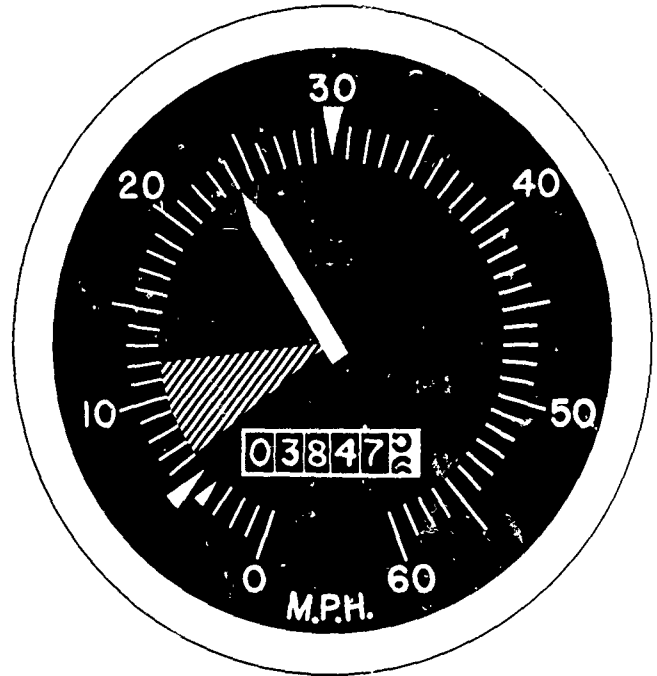

SPEEDOMETER — ODOMETER  
Figure 8

---

Figure 9:  
Suggested Schema for  
Tachometer - Hour Meter

---

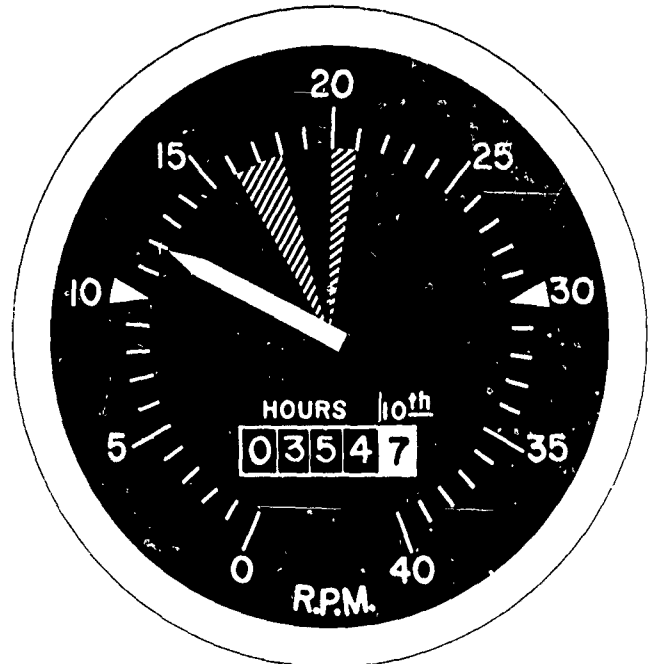

TACHOMETER — HOUR METER  
Figure 9

all color coding within the tank.

All switch and control positions are fairly well marked, the main exception being the lighting control, for which the control switches cover the markings and labeling. However, detents are pronounced enough to indicate positioning, and it might be difficult to design a more efficient control without additional space.

In view of the relative importance of the master control switch, it might well be made more imposing: a larger switch rather than an ordinary toggle switch like the others. This would greatly reduce the possibility of mistaking this switch for the adjacent main engine fuel switch.

#### Loader's Section:

Work Space. Adequate work space in the loader's section is very important because of the amount of body movement required to complete loader tasks and because of the number of potential safety hazards near the loader.

In the present turret, work space is severely limited by the arrangement for ammunition stowage and the increased size of the round. Very little space is available between the breech and the vertically stowed ammunition (about 16 inches at the widest point). Space is further limited during firing, because ejected cartridge cases which strike the ammunition boxes projecting into the floor area behind the breech are thrown into the area around the loader's feet. The loader therefore usually prefers to twist into the space beside the gun, where there is little clearance between him and the breech operating handle which recoils with the breech. (See Figure 10.) A safety bar, similar to that for the gunner and tank commander but redesigned so as not to interfere with the loading operation, is needed to protect the loader from stepping or falling behind the breech, and to afford some protection from the breech operating handle. Furthermore, if the fire extinguisher mounted under the

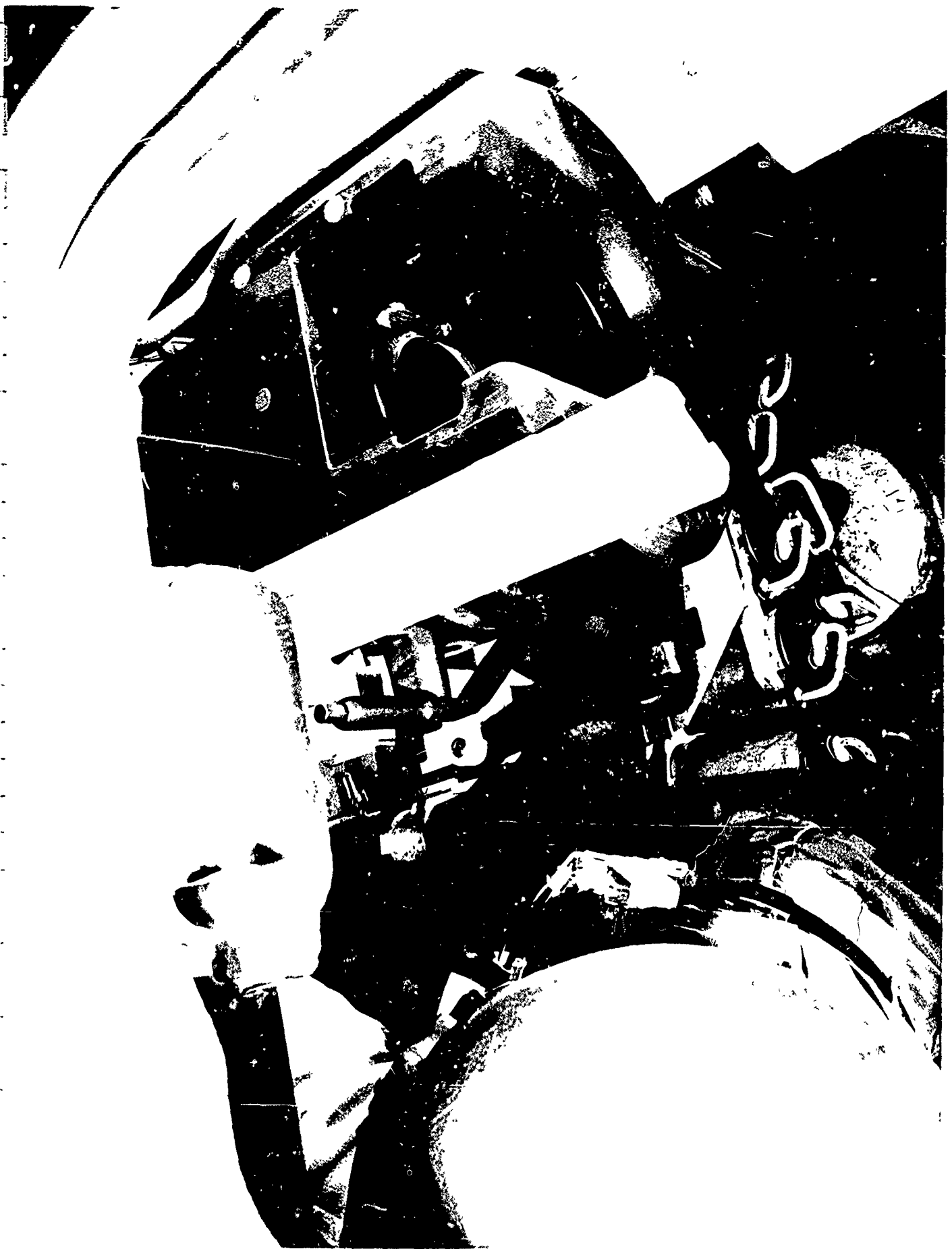

---

Figure 10:

Position of Loader Between  
Breech Operating Handle and  
Ammunition Rack

---

gunner's seat (and inaccessible where it is) is relocated, the ammunition boxes could be moved further into the gunner's area, thereby clearing the floor behind the breech. These two changes do not increase the loader's work space, but they do increase his safety while he is loading.

Another very potential safety hazard in the loader's section is that equipment projects into the area around the loader's head. Hooks, lights, the seat stowage rack, the stowed seat, and stowage cases all project from the turret wall and are all mounted at head height. During normal movement around his section, the loader is constantly bumping his head on projections. When he is riding over rough terrain or reacting to the recoil of the gun, the loader could be seriously injured by such a bump. This danger is increased because the height of the turret is not sufficient to enable the loader to operate effectively when he is wearing the tanker's helmet; so he will most likely perform his job without wearing a protective helmet. Therefore, equipment mounted on the turret wall and ceiling should be rearranged to afford a cleared area around the loader's head, with sufficient tolerance for anticipated reactions to jolts and recoil.

Loader's Gun Safety Switch. This switch is located so far forward on the breech that the loader must lean forward, over the breech operating handle and the edge of the breech, to operate it. Operating it after the ammunition is loaded places the loader in an off-balance, unguarded position when the gun might be fired. Moving the switch to a protected position farther to the rear, as on the loader's safety bar, would remove this hazard.

Ammunition Racks. The retainer assembly on some of the ammunition racks falls back into the turret ring (as shown in Figure 11), and is bent and chewed when the turret is traversed. Stops should be placed on the bars to prevent this.





---

Figure 11:

Ammunition Rack Retainer  
Assembly, Dropped into Turret  
Ring

---

The third vertical row of ammunition tubes to the driver's left is in line with the turret basket. The ammunition retention bars on these tubes, not spring loaded, therefore fall into the basket. When the turret is traversed, the bars catch in the basket and are bent or torn off. Spring loading would prevent this damage.

Some of the stowage tubes are too short to hold the longer rounds. It would be advisable to identify these tubes or racks by painting them a different color.

Loader's Seat. The loader's seat is the most uncomfortable seat in the M60. Besides having the same inadequacies as the driver's seat, it is much too small; it is angled so that it keeps the loader pitched forward instead of slightly back; and it has a backrest which is hard, too low, too small, unadjustable, and poorly contoured. Like the other seats in the M60, this seat should be replaced.

In his limited workspace the loader cannot perform his duties with the seat in place. Before he can load a round, he must remove the seat and place it in a stowage rack on the turret wall. Doing so in a combat situation would cause too much delay; so he would most likely flip it onto the floor behind the breech where it would soon be bent and become inoperable, leaving him without a seat. There should be a better method of removing the seat, possibly—if a flatter seat were used—a dump arrangement which would immediately drop the seat flush with the turret basket wall.

His seat is the only platform available for the loader to stand on when he is operating with his head out of the hatch. It should therefore be rugged and large enough to stand on safely. The present seat is too small for this purpose, and the support bar is not strong enough to support the loader's weight during operation. Most of the seats have already been

bent down out of position.

Turret Traverse Lock. Before traversing the turret, the tank commander or gunner must check that the turret lock is off. In previous turrets this lock has been located between the tank commander and gunner where it could be easily checked and where it served as a fair reminder to perform the check. Despite its location, the turret was sometimes operated with the lock on.

In the M60 the lock is located in the loader's section where it is usually not visible to the gunner, and the tank commander always has to make a verbal check before the turret is traversed. This check may be considered a safety factor, which prevents injury to the loader by unexpected turret traverse; it nevertheless takes time and invites error. There have been many attempts to traverse the turret in power while the lock was on. Also, in its present position the lock cannot be operated when the HE or HEP round is in the vertical stowage rack nearest the lock. This condition either limits using the lock or decreases the possible ammunition load. It would therefore be advisable to relocate the turret lock in its previous position. If equipment mounted along the turret ring between the tank commander and the gunner cannot be adjusted to provide space for the lock, adopting the smaller lock type used in the M48 should be considered.

Replenisher Cylinder Indicator Tape. Before, during, and after firing, the loader should check the indicator tape marking to insure the correct fluid level. With the tape in its present position, the markings are not visible to the loader (as shown in Figure 12), and when the ammunition racks are full, the markings cannot be readily checked by feel. However, if the replenisher cylinder were moved several inches to the right, the loader would have an unobstructed view of the tape markings.

Suggested Periscope. During operation in a combat area, all crew members

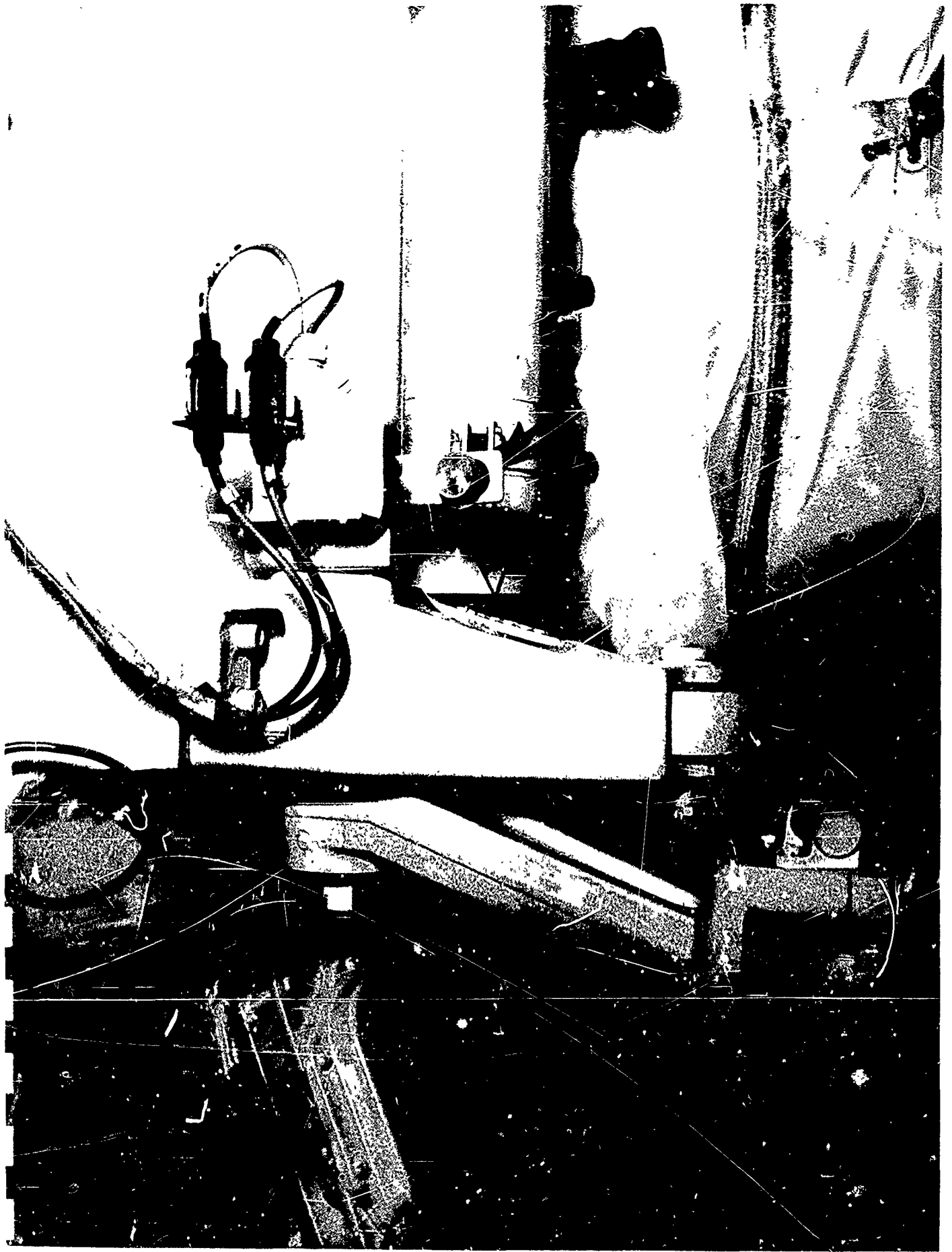

---

Figure 12:

Loader's View of Replenisher  
Cylinder Indicator Tape

---

should help the tank commander search the terrain for possible enemy locations. Such a procedure increases the probability that enemy targets will be detected as early as possible. In the past such operations were performed with the hatches open, and the hatches were closed only when the tank came under enemy fire or when enemy fire was probable. In this situation the loader could frequently use the opened loader's hatch as an observation point. With the increasing expectation of long periods of operation while the hatch is closed, the loader can no longer be used to help detect targets, and detection probability might decrease accordingly.

Also, many studies have indicated that rather severe motion sickness results after only short periods of riding in vehicles when visual contact with the surround is not maintained. Thus, loader performance in the present turret could be expected to decrease during operation with the hatches closed.

It is suggested that a periscope be made available to the loader to alleviate both of these conditions. An adjustable periscope, such as the driver's infrared periscope, mounted in the loader's hatch, would be advantageous if it could be designed so as not to interfere with the loader's movements (e. g., a collapsible mirror base).

Gas Mask Connection. The connection for the loader's gas mask is located under the breech of the main gun. Connection at this point may hamper the loader's performance. The hose interferes with ammunition handling, and there is constant danger that the hose will become entangled in some part of the breech. If it were entangled, the hose would be torn or would pull the loader into the breech during recoil. A study should be made of possible positions on the turret wall or ceiling, to determine the most efficient and safe connection point.

Loader's Hatch. The loader's hatch is a semicircle 22.5 inches across

the base, and 15 inches in radius. This size is sufficient for normal use, but it would be very restrictive for a soldier in arctic clothing. The hatch should be enlarged to afford entry and exit under all expected clothing conditions.

Entry and exit are also hampered by the lack of handholds and steplike projections in this area. Movement through the hatch, especially when the loader's seat is stowed, is slow and awkward. It is recommended that handholds mounted outside the turret, and a small step on the turret wall, be provided.

The hatch cover is hinged in such a way that the loader must grasp it near the far end and exert considerable force to close it. The amount and time of body exposure during this operation is excessive. Furthermore, the lack of a handle on the under side of the cover, and of body support for the loader in this position, makes it likely that he will fall back into the turret, bang his head with the closing cover, or smash his fingers under it. This cover should be redesigned to provide better balance and a handle for closing.

#### Gunner's Section:

Work Space. The work space provided for the gunner is extremely limited. (See Figure 13.) The gun shield is only a few inches from his left elbow. The ballistic computer is flush against his right hip. He can lean back only slightly because the tank commander's knees are directly behind his back and the range finder is behind his head. And he cannot move very far forward, for equipment is mounted directly in front of him. Restricted to this position, he would suffer from fatigue and cramped muscles after even short periods of operation. The resulting decrement in speed and accuracy of manual performance should be significant. It would be very costly to relocate equipment in the present turret, and to modify linkages and connections; but sufficient operating space for the gunner should be a primary consideration in planning equipment layout for future turrets.

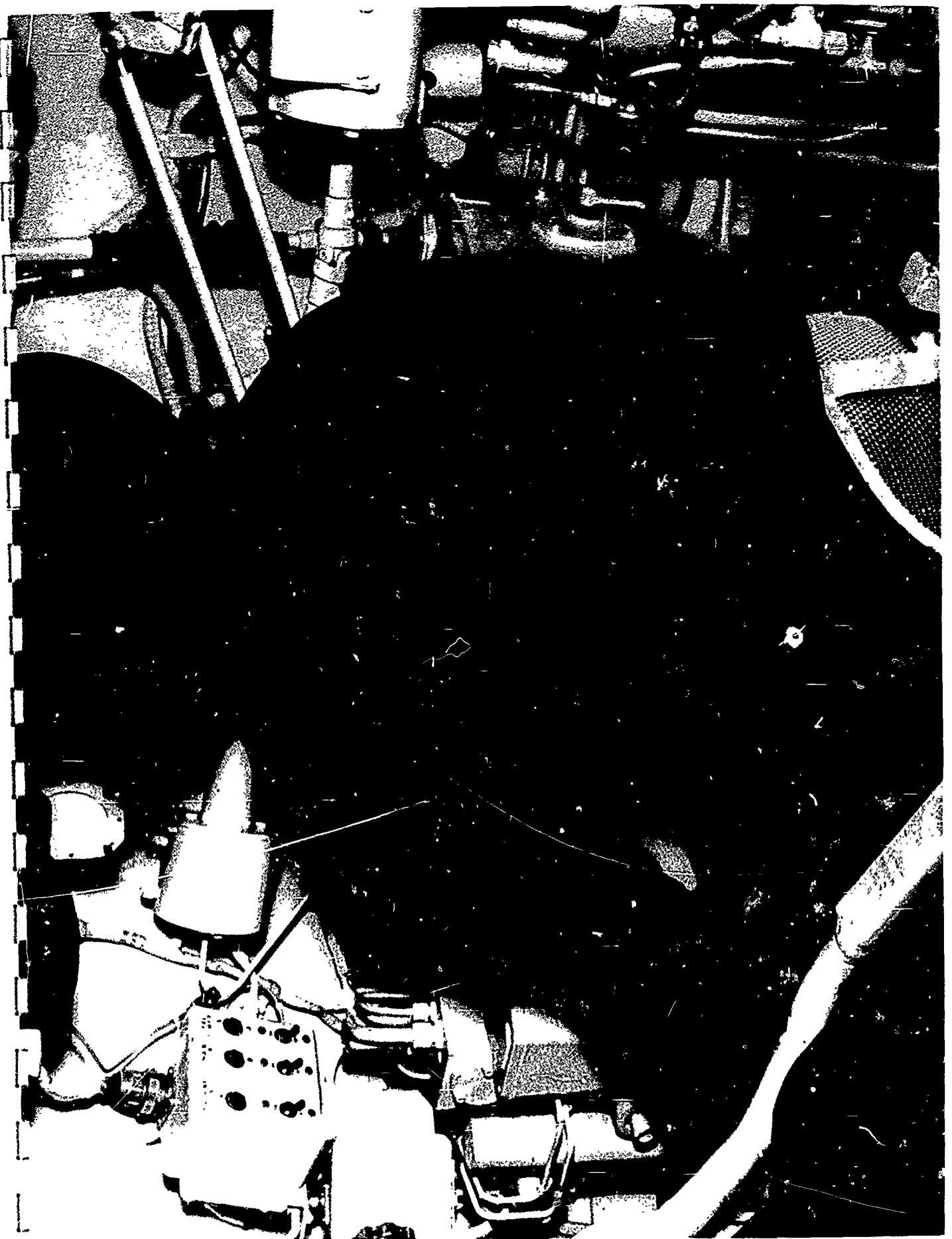

---

Figure 13:

Work Space Provided for the  
Gunner

---

Entry to the gunner's position, and exit from it, are extremely difficult. Gunners often support themselves by holding on to the range finder, conceivably throwing the instrument out of adjustment. Modifications recommended later for the gunner and tank commander seat assemblies should increase the ease of entry and exit.

The support which is provided for the gunner's legs by the footrest is inadequate. A larger footrest which gives more support, particularly to the right foot, should be provided.

Gunner's Seat. The wire mesh seat provided for the gunner exemplifies all the inadequacies specified for this type of seat in the driver's compartment. The seat is also difficult for one man to raise and lower, but it would seldom have to be adjusted, since it would require a vertical change only when gunners are changed.

The seat and the backrest hamper entry to the gunner's position and exit from it. It is recommended that a dump-type backrest or a swivel seat be considered.

The present backrest is not adjustable enough vertically to provide adequate support for the gunner. A longer post which permits higher adjustment should be used.

Periscope M31, Infinity Sight M44C, and Telescope M105C. The height and mounting angle of all the sights, and their distance from the gunner, provide him a good, comfortable view. However, the tanker's helmet cannot be worn when the gunner is using the sights because the brow pads interfere. All brow pads should be redesigned for use with the tanker's helmet.

The brow pad for the infinity sight and the M31 periscope does not slide easily from one sight to the other. But the left side of the brow pad could be shortened about one inch and left in position for use with the M31 periscope.



In this position it would not block vision through the infinity sight and could still be used as a forehead rest in using this sight.

Glasses cannot be worn to view through the periscope because of the set eye relief distance. Nor is the range of diopter adjustment great enough for men who wear glasses. This problem is common to most sights now in use, and its importance for good gunnery suggests that a prompt solution is necessary.

Gunner's Control Assembly. The control assembly is mounted to the right of the midline of the gunner's seat, directly under the periscope. This position requires a dissymmetry of movement of the gunner's arms in tracking. In using the telescope, the gunner must lean to the left for viewing and reach to the right with both hands to operate the control handles. If the control handles were mounted along the midline of the seat, the resulting symmetry would, if anything, increase the precision of tracking with the periscope, and the ease and precision of tracking with the telescope.

The width of the control handles, including the brake release, is about 2.5 inches too large to afford a good, comfortable grip. It is recommended that the width of the control assembly handles be reduced to about 2 inches.

Many studies have indicated the superiority of a trigger operated by the thumb over one operated by any other finger. In depressing a trigger with the index finger, there is a tendency to jerk the control and to alter its position (i. e., gun elevation with the present control assembly). This tendency has been shown to be less when the trigger is depressed with the thumb. It is therefore recommended that a thumb trigger be used with the control assembly.

Elevation Hand Pump. Controls which must be operated from a fixed operator position, as when the gunner views through the sights, should be within an arc of 28 inches measured from the individual's shoulder position. The position

of the elevation hand pump is now located too far from the gunner; this distance requires maximum reach for most gunners, so that the arm is almost fully extended at the far side of the arc. (See Figure 14.) At this point the gunner can apply very little leverage to the pump and cannot maintain continuous smooth operation. At its present height the control also hits the gunner's knee; he is therefore required to move his leg to the left during operation. If the control were moved closer to him, his leg would give much more interference during operation. There is room, however, to raise the pump handle. The control handle should therefore be positioned so that the far arc is no more than 28 inches from the gunner's shoulder, and so that the bottom arc of the hand clears the gunner's leg.

The resistance offered by the pump is too great for its 3.5-inch radius; either it should be reduced or the radius of operation should be increased. The radius - force relation necessary for smooth, precise operation should be determined.

The configuration of the pump handle and its mode of operation are awkward. Also, the handle turns freely so that it may come to rest with the firing button in any position. This condition requires the gunner to position the handle before gripping it. A handle which more closely conforms to the normal grasp (as illustrated in Figure 15), and one which is weighted so as to remain in a ready position, should be used.

Hand Traversing Assembly. The hand traversing assembly also requires too much force for precise tracking and laying, considering the present operating radius. The radius - force relation determined for the elevation hand pump should also be used for the hand traversing assembly.

Operation of the crank, in its present location and plane of movement, is hampered by its proximity to the ballistic computer. During normal operation

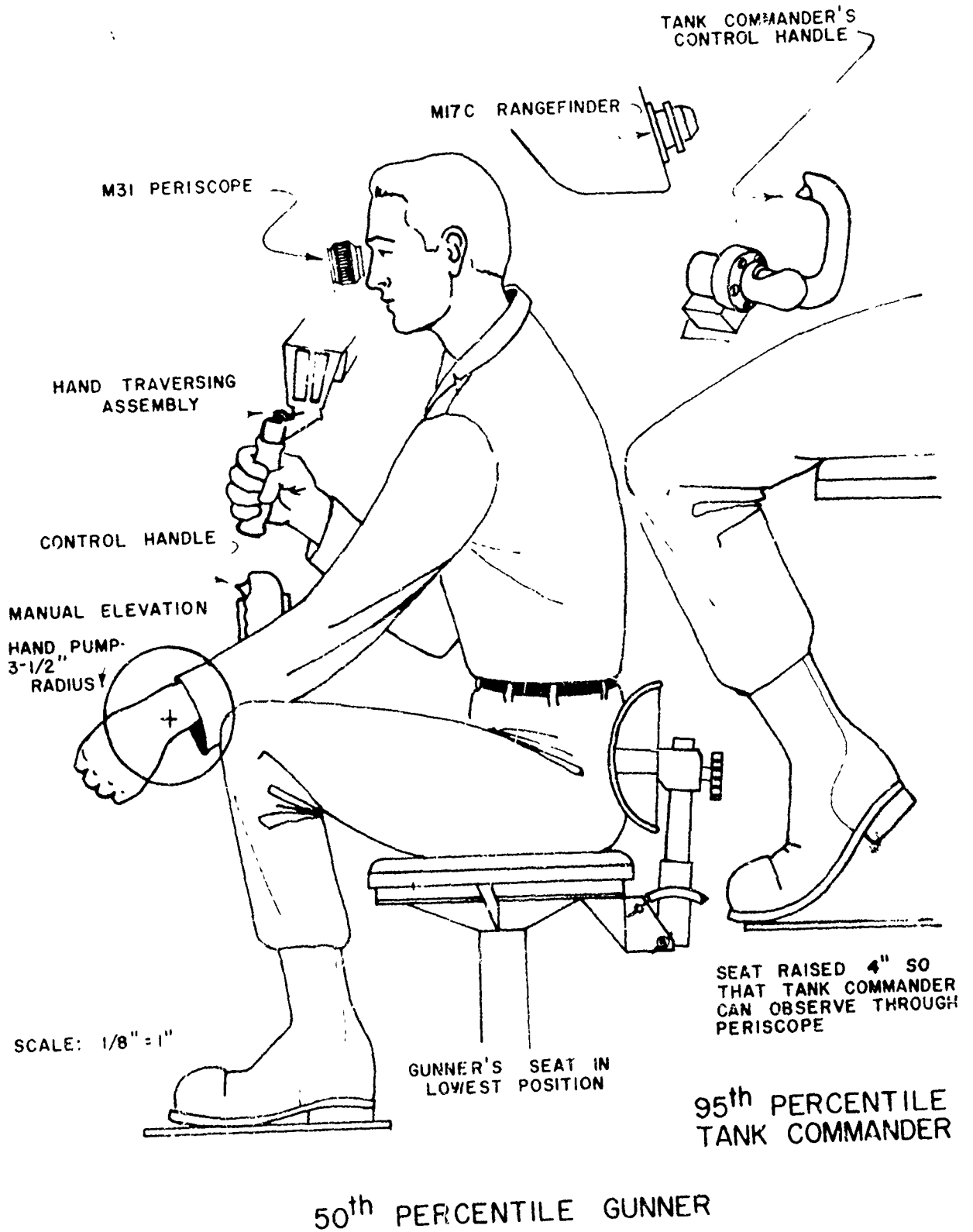
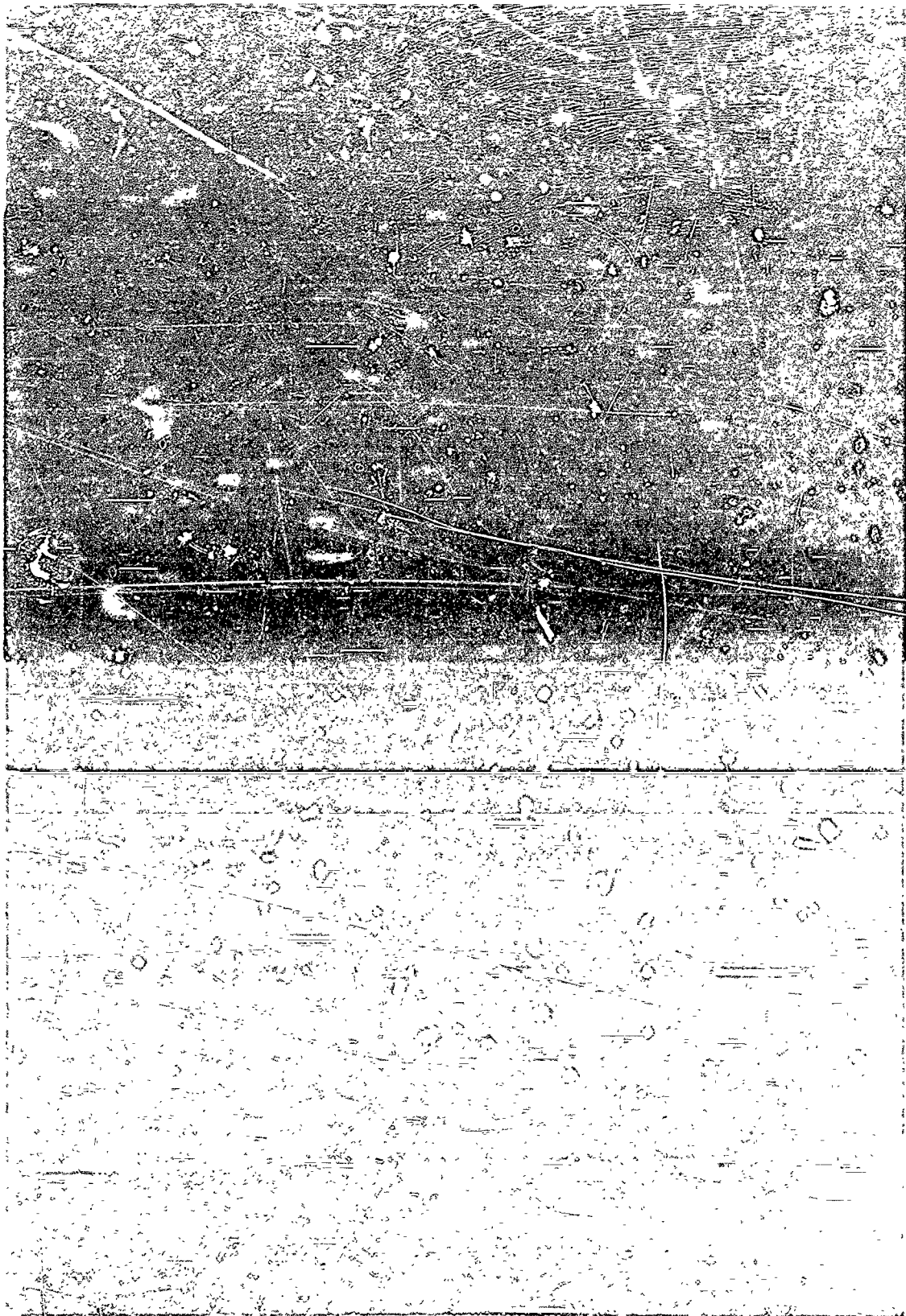

Figure 14

Figure 14:

Gunner's Operating Position  
 Showing Relative Control Locations  
 and Proximity to the Tank  
 Commander's Station



# MANUAL ELEVATION HAND PUMP HANDLE

(Operated with Left Hand)

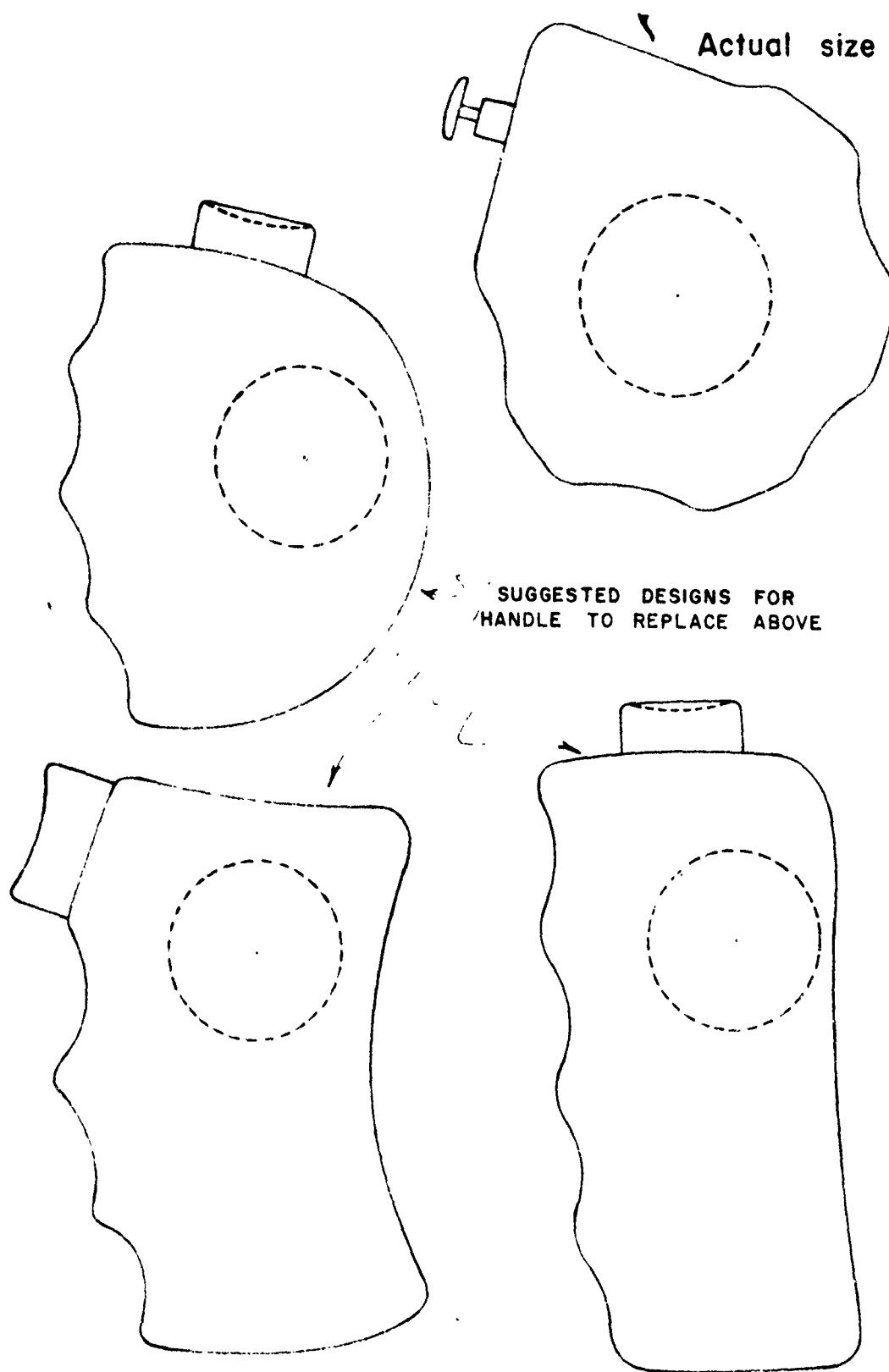

Figure 15

Figure 15:

Suggested Designs for Manual  
Elevating Handle

the gunner's elbow locks against the ammunition selector handle. (See Figure 16.) This condition forces the gunner to operate with his elbow lowered, increasing the difficulty of turning the crank smoothly and precisely. Since the space available precludes relocation of the assembly, a different plane of movement should be adopted.

Power Switch Box. As most gunners operate these switches with the left hand, the switches are mounted on the box in reverse order of frequency of use. The switch used most frequently, turret power, should be on the left, and the one used least frequently, machine gun, on the right.

The box is poorly lighted, and the switches are fairly close together so that mistakes in switch selection might be made easily during operation under reduced illumination. Coding by size or shape would decrease the possibility of error.

Ballistics Computer M13A1D. The ballistics computer is too close to the gunner's side, and too far back to be operated with ease. (See Figure 16.) The gunner must turn to the right and lean back to operate the ammunition selector handle, and must assume a very awkward position to read the dials. The superelevation dial is especially difficult to read. The computer should be located farther forward, and angled towards the normal line of sight in a position which would facilitate operating the controls and reading the dials.

The superelevation dial has too few calibrations. It is calibrated in even tenths, whereas odd tenths must also be read. Also, there is no immediate indication as to whether the tenths scale should be read up or down. Since the dial is not used frequently, even experienced gunners have difficulty reading it. A dial with precise calibrations and directional indicators should be designed.

The superelevation hand crank must be held in while it is being rotated.



Figure 16:

Interference of Ammunition  
Selector Handle with Gunner  
Operation of Hand Traversing  
Assembly

It is difficult to turn through the vertical plane and at the same time apply force in the horizontal plane. The force required increases as the crank stiffens with use. A large hand knob with a detent button would greatly improve the speed and ease of operation.

Azimuth Indicator. The azimuth indicator is mounted parallel to the floor, rather than perpendicular to the gunner's line of sight. Hence there is some error due to visual parallax, and the control knob blocks the view of part of the inner dial. Vision is also obstructed by the linkage for the commander's control handle, and by the computer circuit breaker. Both parallax error and obstruction would be reduced if the indicator were mounted farther forward, perpendicular to the gunner's line of sight.

Elevation Quadrant M13. Illumination of the quadrant is very poor. A mirror, mounted between the light and the level vial, blocks all light to the vial and a flashlight is needed to read the quadrant. (See Figure 17.) The ballistic drive light assembly should be moved to a position where it fully illuminates the level vial.

Since the quadrant is located at some distance from the gunner, the level vial bubble is difficult to see. It would be easier to read if a mirror which would magnify the image were used.

There is considerable confusion in reading the micrometer scale of the quadrant, because both plus and minus readings are taken from the same scale markings. The quadrant should have two dials, one to the left for minus and one to the right for plus, corresponding to the plus and minus of the elevation scale.

Portable Fire Extinguisher. The extinguisher is located under the gunner's seat where it is difficult to reach and release. It should be mounted in a position which is readily accessible to both gunner and tank commander.



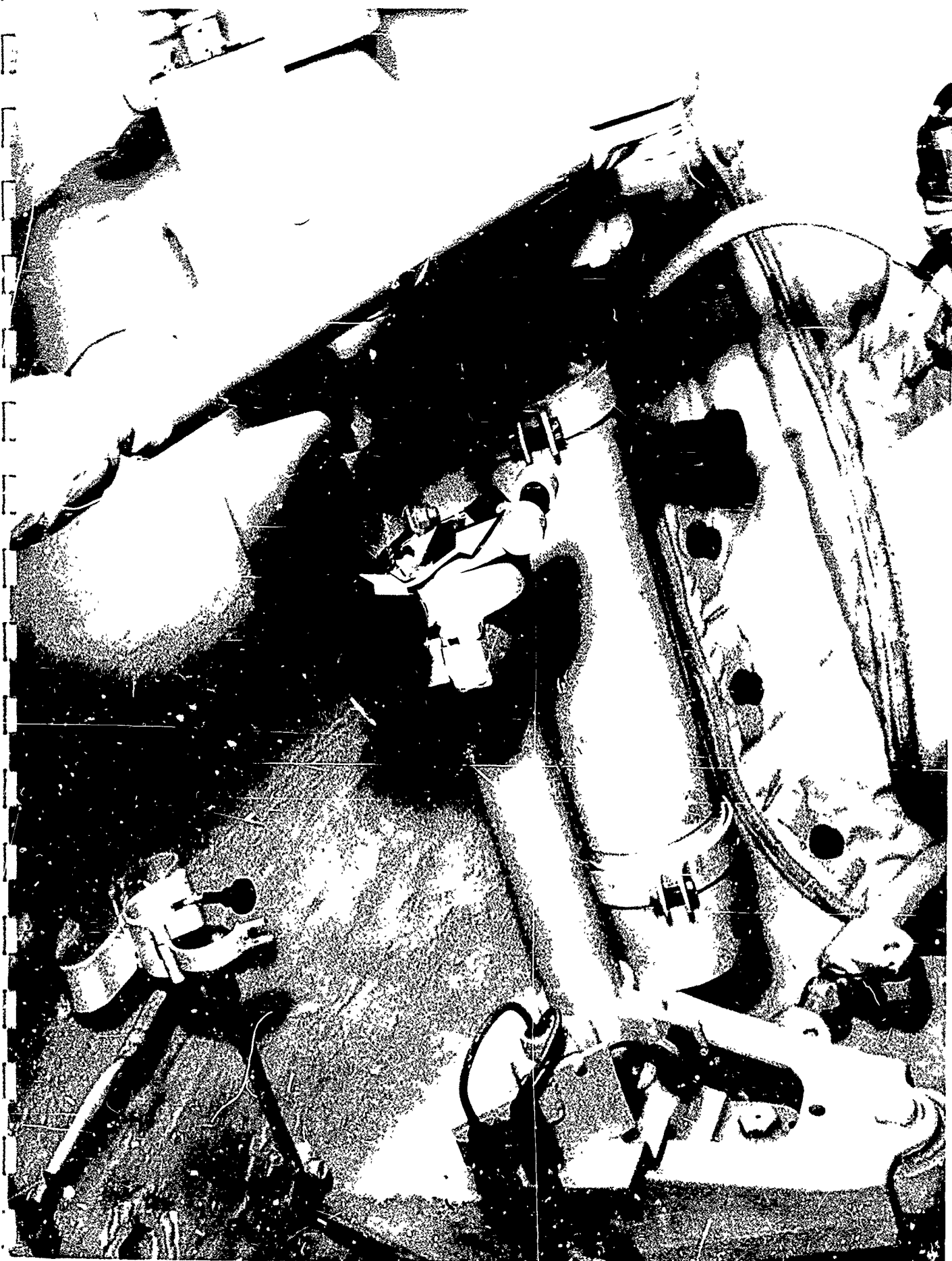

---

Figure 17:

Interference of Mirror with  
Lighting for Level Vial of  
Elevation Quadrant

---

### Tank Commander's Section:

Work Space. By virtue of his location above the main armament, the tank commander has sufficient space for movement. Since his position in this area is determined by the location of the seat assembly, deficiencies in the area primarily involve seating.

Tank Commander's Seat Assembly. The wire mesh seat provided for the tank commander suffers from all the inadequacies specified above for the driver's seat. Also, the seat and platform are so far forward that when he is seated the commander's knees are in the gunner's back. (See Figures 13 and 18.) Both the seat and platform are forward from the cupola hatch so that the commander does not have a firm footing on either, during operation with the hatch open, head out. (See Figure 19.) There is enough room behind the commander to move his seat back several inches, allowing more room between him and the gunner, placing the seat directly under the cupola hatch, and decreasing interference from the seat when he stands on the platform.

Vertical adjustment of the seat is sufficient for use with the range finder (the lean required is not extreme, considering the short periods of range finder operation). Vertical seat adjustment is also sufficient for use with cupola periscope and vision blocks. However, when the seat is adjusted to the highest position, the commander cannot see over the top of the cupola, and must stand to observe during operation with the hatch open. (See Figure 20.) Standing is very tiring and results in decreased efficiency. If a seat were provided, however, it would have to be possible to lower it easily and quickly if the tank came under fire. This requirement will be referred to later in relation to the backrest.

The commander's platform is of little help. It is 24.5 inches below the seat so that only the man's toes touch it. (See Figure 18.) At its highest

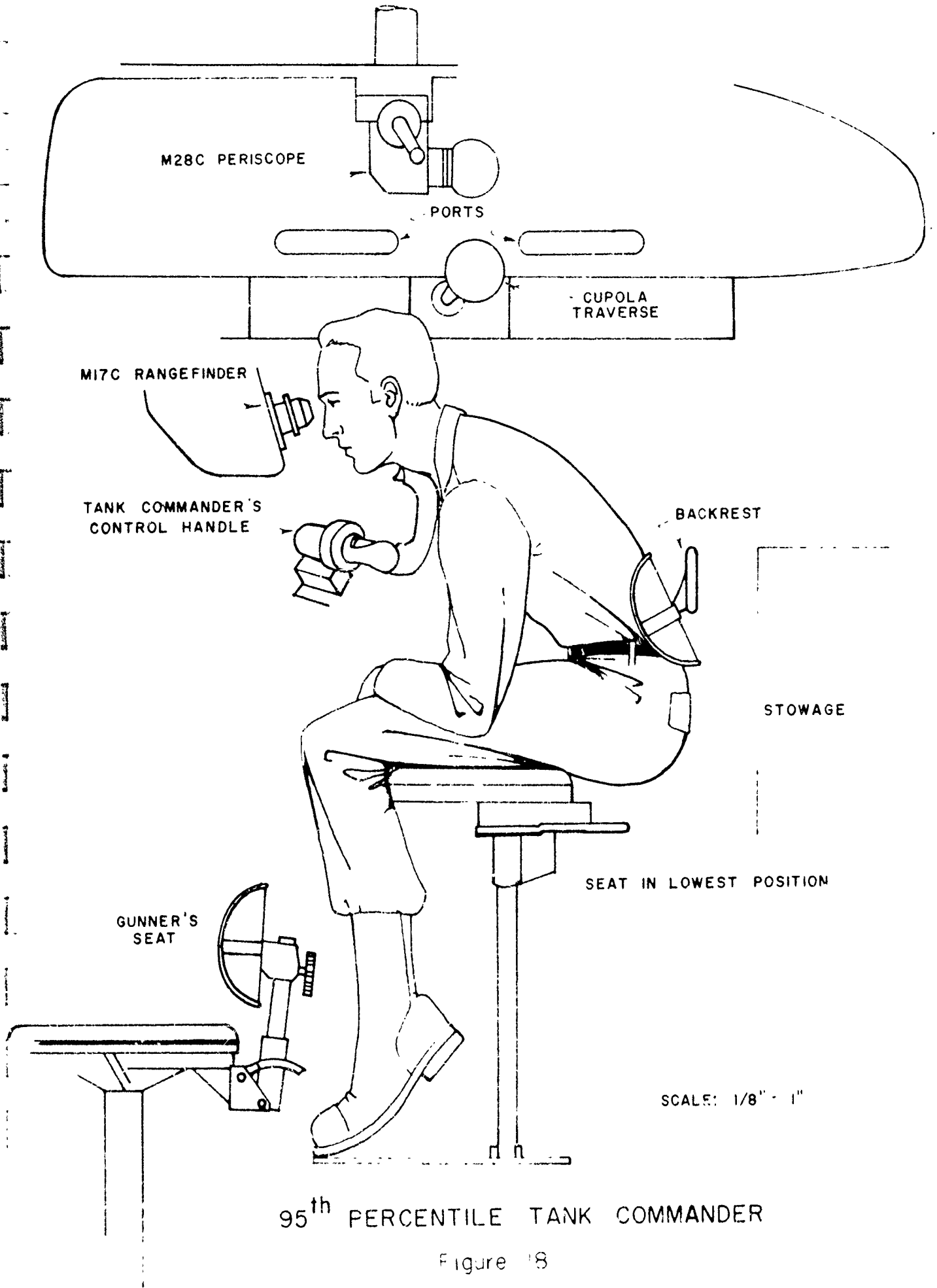
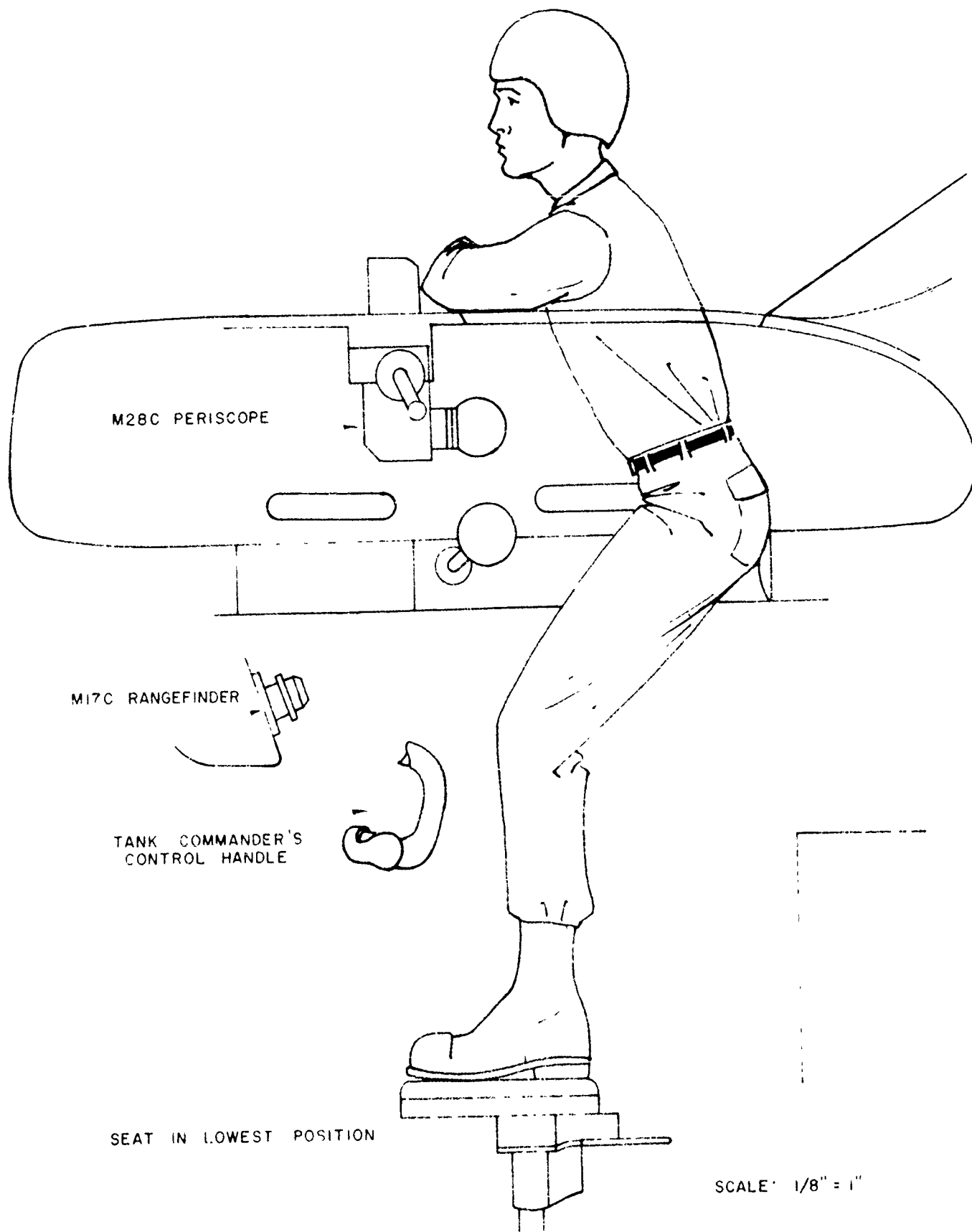

Figure 18:



95<sup>th</sup> PERCENTILE TANK COMMANDER

Figure 19

Figure 19:

Position of TC When He Uses the  
Seat for Footing During Operation

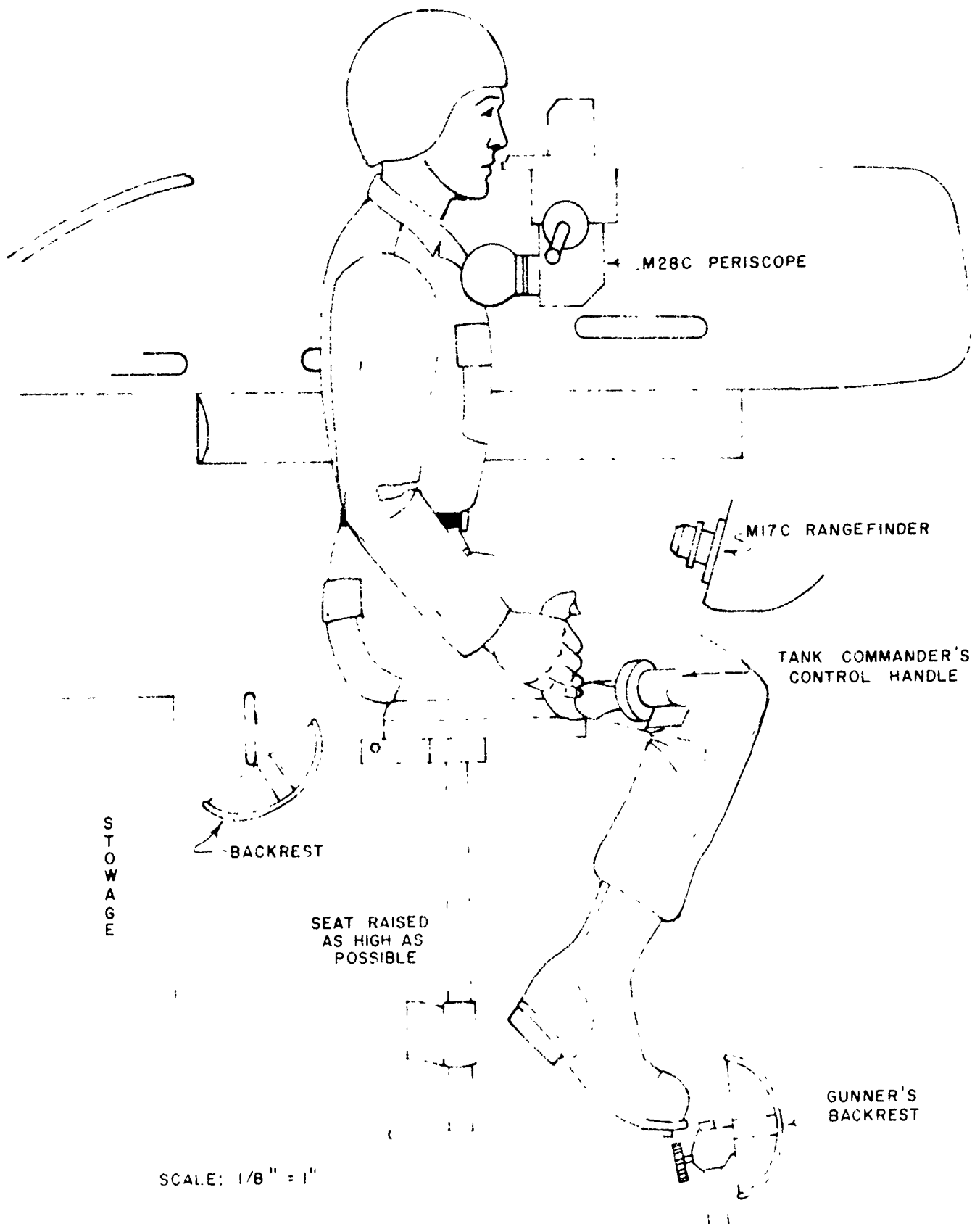

95<sup>th</sup> PERCENTILE TANK COMMANDER

Figure 20

Figure 20:

position, the commander can barely see over the top of the cupola and cannot see terrain close enough to the front of the tank to aid the driver during night operation. (See Figure 21.) It is therefore recommended that the platform be moved to 16 - 18 inches below the seat; at this distance the platform would provide support for the feet. Also the added six to eight inches in maximum height would aid the commander during operation with the hatch open.

The adjustment mechanism for the seat assembly is very difficult to operate, and the seat handle interferes with standing on the platform. (See Figure 22.) The commander must be off of the seat and platform before they can be raised, and should be off of them when they are lowered. Furthermore, the locking pin does not insert securely; it is apt to release when the commander's weight is applied to it. Again, supports for the seat and platform are not sturdy enough to withstand the force applied over rough terrain. Both seat and platform are likely to be bent down. It is therefore recommended that a method be devised to raise and lower the seat assembly while the commander is on it, that the assembly be rugged enough to withstand the forces exerted during cross-country operation, and that there be a means of locking it safely in position.

The commander's backrest is of little use; in its present position it provides support only during range finder operation. When he is using the cupola periscope it is far behind the commander's back; so that it tilts forward, and could cause serious back injury during firing. (See Figure 23.) During operation with the hatch open and the commander's head out, the backrest is too low to provide support. (See Figure 20.) Furthermore, the backrest must be placed in a stowed position whenever the commander wishes to raise the seat level or fold up the seat. (See Figure 21.)

The present backrest serves virtually no purpose, but probably should not be eliminated altogether. Riding for an extended time without back support can

5<sup>th</sup> PERCENTILE TANK COMMANDER  
Standing Erect on Footrest Fully Raised

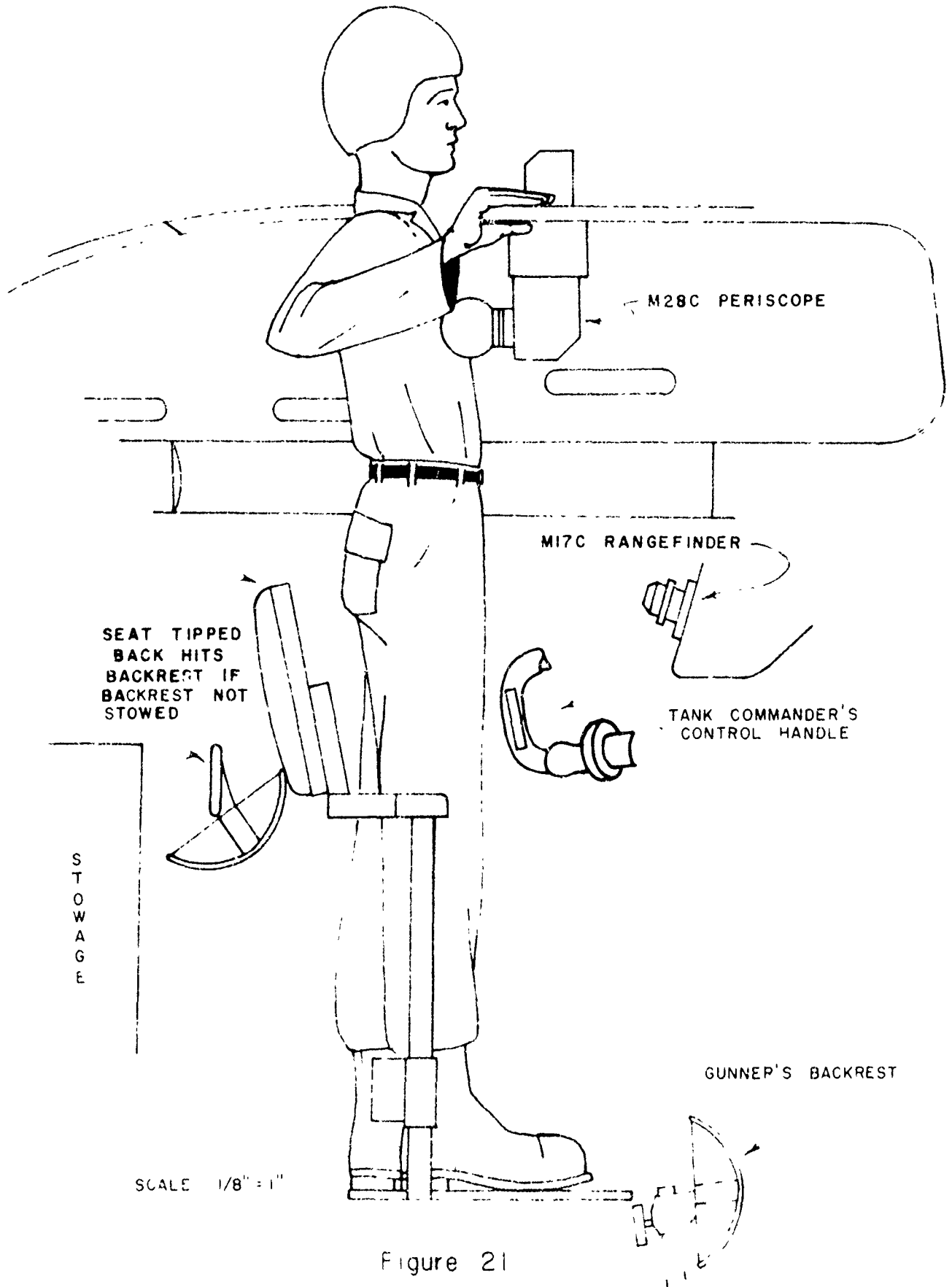

Figure 21



Figure 22:

Interference of Seat Handle When  
Commander Stands on Platform





be very tiring. It would seem advisable that a new backrest be designed which can be raised and lowered with the seat and adjusted in relation to it. It would also be useful to design the backrest so that it could be locked in a horizontal position to use as a seat during operation with the hatch open.

Commander's Control Handle. The commander's control handle is poorly located for operation from any of the three positions the commander assumes. First, when he is using the range finder, the commander must lean far forward so that the handle is close to his shoulder, and movements to increase elevation must be made by twisting his elbow around behind his back. (See Figure 18.) The result is jerky and imprecise tracking. The position of the handle is most satisfactory when the commander is in the second position, for viewing through the cupola ports and periscope. (See Figure 24.) In this position, the handle is near his elbow level, but because of the limited movement of the wrist in abduction as compared with adduction, the handle would be easier to operate if it were mounted higher in the turret. (See Figure 25.) For the third position, head out, during operation with the hatch open, the top of the handle is at the limit of the commander's reach. (See Figure 26.) It would therefore be advisable to locate the handle where it is easily accessible from any operating position. Raising it about eight inches would place it where it could be operated with little difficulty from all three positions.

Again, the use of a thumb-operated trigger would increase the accuracy of handle operation.

Also, some of the control handles have weak springs which let them fall over to the left instead of holding them upright. In this position, they are easy to step on by anyone who enters through the commander's hatch. The result might be broken handles or, if the turret power is on, slewing the turret. Better quality control would insure that springs of sufficient

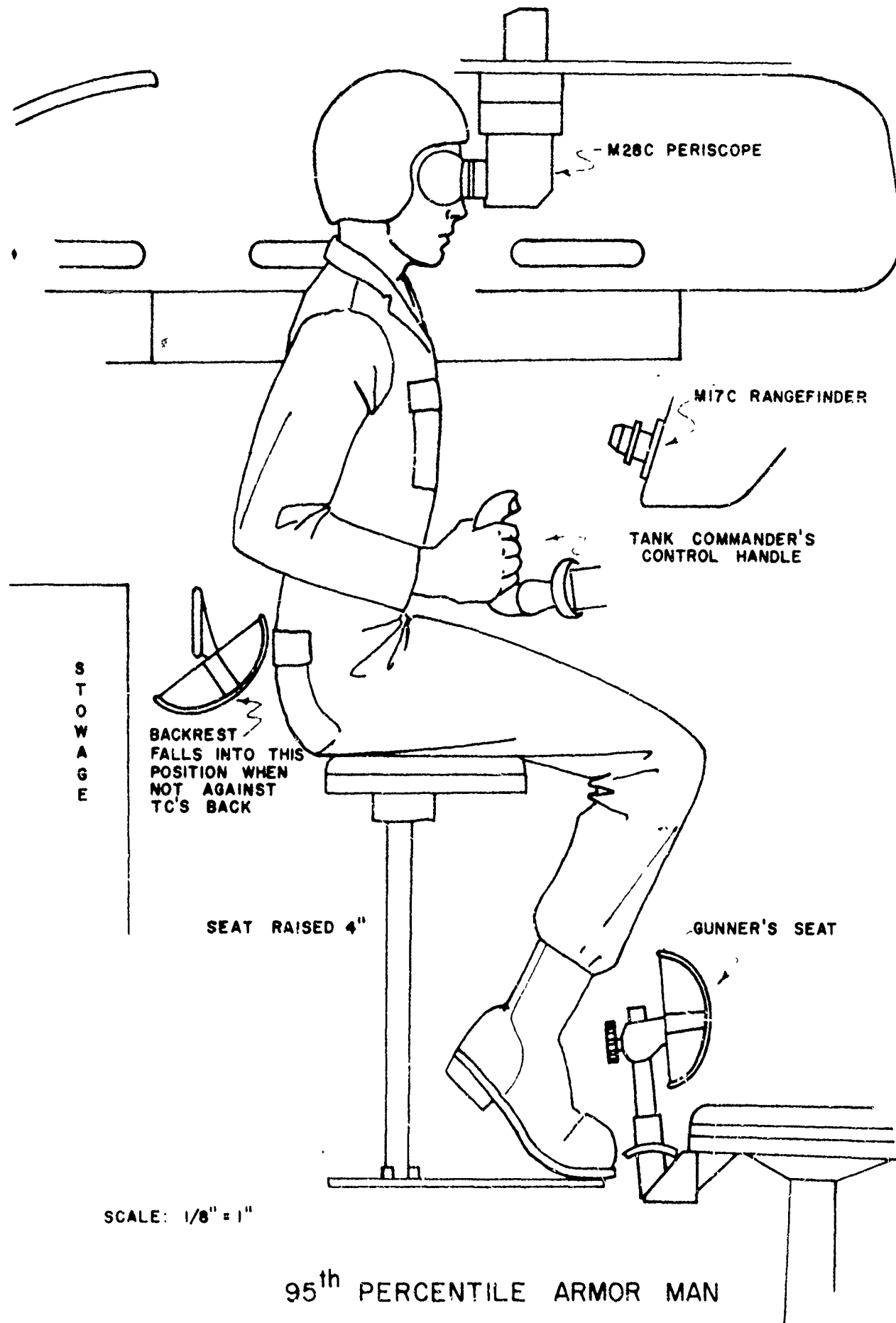
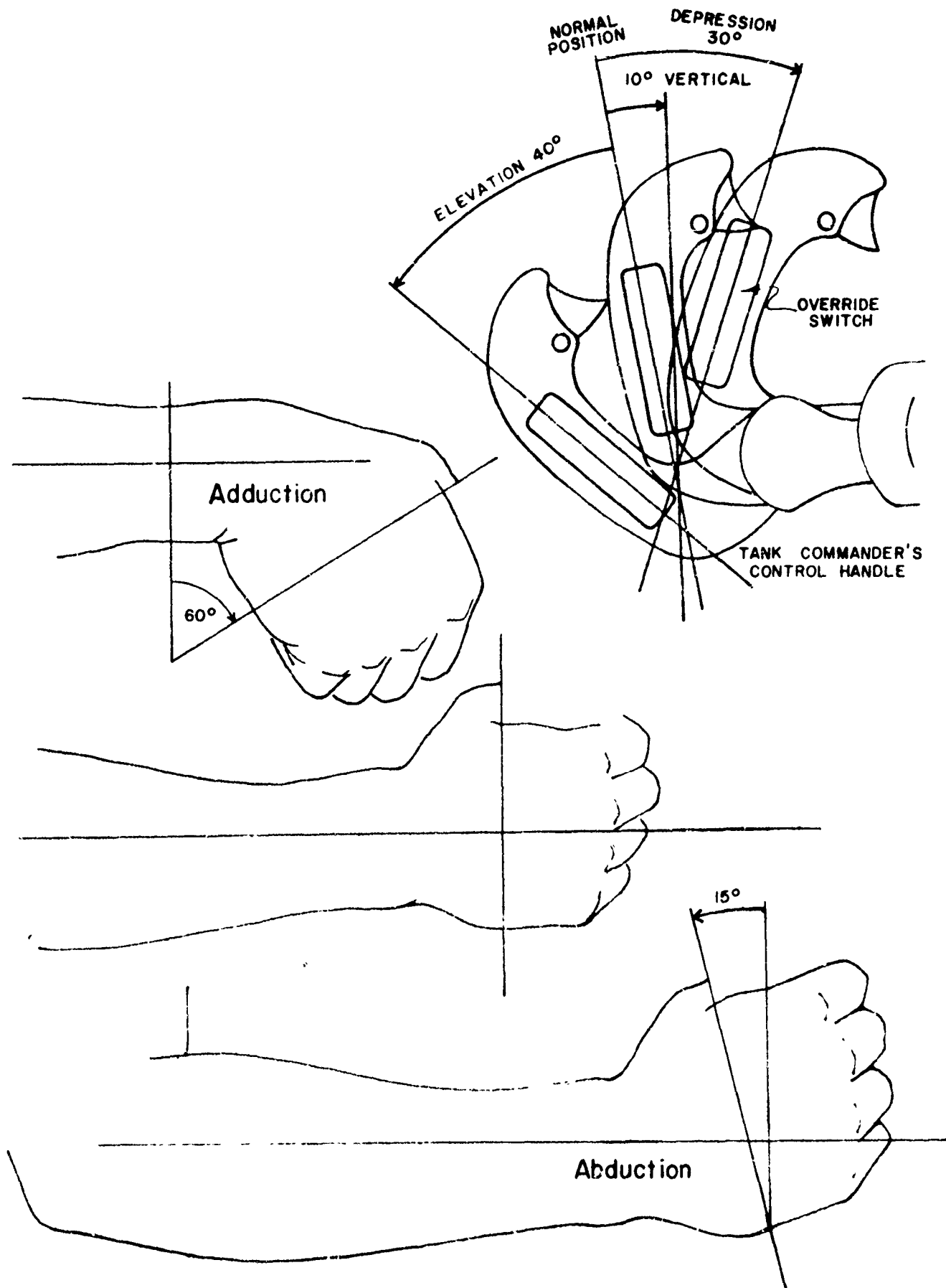

Figure 24

Figure 24:

Seated Position of TC for Using  
the Cupola Vision Devices



ADDUCTION AND ABDUCTION AT WRIST

Figure 25

Figure 25:

Adduction and Abduction at the Wrist  
 in Relation to the Positioning  
 Requirements of the TC's  
 Control Handle



Figure 26

Relation of Commander's Control

strength are used in these handles.

Tank Commander's Cupola. The elevating handle in the cupola is hard to operate. This type of control results in jerky movement and binding. A handle of better design should be used.

The cupola traversing handle is not long enough to accommodate the average hand width, and the end plate is much larger than is necessary. The only purpose of the plate is to hold the hand in place; in doing so the plate interferes with operation of the handle. A knobbed handle or one of different design should be used.

#### Equipment External to the Hull:

While the primary objective of this study was concerned with crew operation within the driver's compartment and turret, some comments referenced to external equipment were made; they are reported here for information to those interested.

Exterior Interphone Connection. The phone is supplied with six feet of line; but most uses would require a longer line (e. g., a spotter should stand at least ten feet to the side of the tank, because of obscuration). A longer line should be supplied.

End Connectors. The hull and tow hooks block access to the end connectors on the hull side of the track. These connectors are only accessible one at a time, near the road wheel rather than the compensating idler wheel as prescribed in TM 9-2350-215-10 (p. 143). The use of reverse wedges, if they are practicable, would alleviate this condition.

Headlight Mounting Bracket. The brackets reflect light, causing a glare which interferes with viewing and increases eye fatigue. Brackets should be backed with a nonreflecting material.

Tail Lights. The increased smoke from the diesel engine obscures the

tail lights, particularly during black-out driving. This condition is a safety hazard, particularly during a column formation. Tail lights should be located higher on the hull where they will not be obscured by diesel exhaust.

Aluminum. Aluminum parts are not considered satisfactory where heavy impact can be expected. Aluminum stowage boxes and fenders bend and tear easily. Bends are difficult to straighten as the metal tears if it is rebent cold and buckles if it is heated. Welds are not holding; apparently personnel or facilities for welding at battalion level are insufficient. On some tanks, fenders are slivering when they are hit by the track end connectors, and these slivers could cut a man badly if he brushed against them.

It was felt that both the boxes and fenders could be made of steel without a significant increase in weight. If not, boxes could be braced with steel rods, and fenders could be skirted with steel channeling similar to that used on the M48.

Seals on Stowage Boxes. The seals for stowage boxes mounted on the fenders are not tight. Dust and water filter into the boxes.

Track Connecting Fixture. The fixture is mounted on the left rear fender. During operation, it becomes covered with dirt and must be cleaned after every operation. It was felt that a protective container should be supplied for stowing the fixture.

#### APPLICATION OF RESULTS

The Results reported above were presented for consideration by the M60 Task Force in October 1960. The presentation resulted in the establishment of an advisory group whose mission was to assist OTAC and Ordnance in correcting the deficiencies noted. The advisory group consisted of representatives from the Armor Human Research Unit, the Armor Board, and the Armor School.

Subsequent group meetings (5) and work sessions held with Chrysler and OTAC resulted in the fabrication of new mock-ups of a driver's compartment and turret compartment. The mock-ups reflected changes in the braking system, interior lighting, periscope adjustments, location and type of controls, location of indicators and panels, seats and seating arrangements, ammunition stowage, addition of a loader's periscope, and stowage of OEM and crew equipment.

The mock-ups were reviewed by CONARC during the OTAC Week-Project Review (5-8 December 1960), and it was agreed to accept for future production models the changes recommended (14).



## REFERENCES

1. Aircraft Armaments. Notes of Development Type Materiel, 76mm Gun Tank, T92 (U). Center Line (Michigan): Detroit Arsenal, 1957 (CONFIDENTIAL).
2. Army Medical Research Laboratory. Anthropometric and Other Data. Fort Knox: US Army Medical Research and Development Command, 1 February 1943.
3. Bradley, J. V., and R. A. Wallis. Spacing of On-Off Controls. II: Toggle Switches. TR 58-475. Wright-Patterson AFB: WADC, March 1959.
4. Defense Operations Division. Notes on Development Type Materiel and Preliminary Technical Manual (TM 9-2350-215-10), Part I: Operators manual, Tank, Combat, Full Tracked: 105MM Gun, M60. Center Line (Michigan): Chrysler Corporation, 15 October 1959.
5. Defense Operations Division. Human Engineering Evaluation Meeting, M60E1. Center Line (Michigan): Chrysler Corporation, 25 October 1960.
6. Dennis, J. P. The Effect of Vibration on a Visual Acuity Task, CSEE Report 104. London: Ministry of Supply, 1955.
7. Dunlap and Associates. Human Engineering Seminar. Stamford (Connecticut): Dunlap, May 1960.
8. Ely, J. H., R. M. Thomson, and J. Orlansky. Layout of Workspaces. TR 56-171. Wright Patterson AFB: WADC, September 1956.
9. Kobrick, J. L. Quartermaster Human Engineering Handbook Series. I: Spatial Dimensions of the 95th Percentile Arctic Soldier. Natick (Massachusetts): Quartermaster Research and Development Command, September 1956.
10. Kurke, M. I., and J. A. Stephens. Systems Evaluation of the Tank, 76mm Gun, M41A1, TM 1-57. Aberdeen Proving Ground: Human Engineering Laboratory, 1957.
11. Loeb, M. A Preliminary Investigation of the Effects of Whole-Body Vibration and Noise, Report 145. Fort Knox: US Army Medical Research Laboratory, 1954.
12. Loeb, M. A Further Investigation of the Influence of Whole-Body Vibration and Noise on Tremor and Visual Acuity, Report 165. Fort Knox: US Army Medical Research Laboratory, 1954.
13. Miller, K. R. Absolute Identification of Munsell Hues under Red Illumination, Working Paper. Fort Knox: US Army Armor HRU, February 1961.
14. Ordnance Tank Automotive Command. OTAC Week-Project Review. Center Line (Michigan): Detroit Arsenal, 21 December 1960.

15. OTAC Engineering Division. Agenda for M60 Task Force Meeting Number 5.  
Center Line (Michigan): Detroit Arsenal, 2 May 1960.
16. Stevens, S. S., "The Effect of Vibration on Visual Acuity," III, 2 in  
C. E. Waring, Transmission and Reception of Sounds Under Combat  
Conditions, Summary TR, Division 17. Washington: National Defense  
Research Committee, 1940.
17. Tufts College, Institute of Applied Experimental Psychology. Handbook  
of Human Engineering Data, second edition, TR 199-1-2. Port  
Washington (New York): USNTDC, 1 November 1952 (revised).
18. Woodson, W. E. Human Engineering Guide for Equipment Designers.  
Berkeley: California Press, 1954.

APPENDIX: Human Factors Check List for the M60 Tank.

(When this check list was administered, space was provided for comment, by inserting blank lines after each item.)

## Human Factors Check List for the M60 Tank

### I. DRIVER'S SECTION

#### A. Work Space:

1. Is there sufficient space for the driver to perform his job duties effectively over extended operating periods?
2. Is there sufficient space for the driver to perform his job duties effectively when wearing arctic clothing?
3. Are there any projections from the hull or turret, other than equipment, that might interfere with normal operation or be considered a safety hazard?
4. Are there any noxious fumes during operation that might decrease performance?
5. Is there excessive dust during operation that might decrease performance?
6. Is the work space protected from mud thrown up by the tracks?
7. Is the work space occupied during unbuttoned operation protected from extensions from the turret?
8. Is space provided for storing canteens, arctic clothing, etc.?
9. Other deficiencies:

#### B. Driver's Seat:

1. Does the shape and size of the seat cushion provide comfortable support for the body for extended periods of operation?
2. Does the seat cushion absorb movement and firing shock?
3. Does the seat cushion absorb engine vibration that interferes with visual or manual operating requirements?
4. Does the shape and size of the backrest provide comfortable support?
5. Is the backrest on a pivot permitting fitting to the driver's back as he changes position?
6. Can all seat and backrest adjustments be made quickly and easily during operation and without requiring the use of special tools?
7. Do the adjusting knobs and pins secure the seat under maximum expected shock during operation?
8. Is the minimum height adjustment of the seat low enough to permit normal operation of foot pedals by all drivers?
9. Is the minimum height adjustment of the seat low enough to permit head clearance for all drivers when wearing the tanker's helmet during buttoned-up operation?
10. Is the maximum height adjustment of the seat high enough to permit normal unbuttoned operation by all drivers?
11. Is the number of height adjustments for the seat enough to accommodate all drivers in relation to vision devices and operating controls?
12. Is the range of adjustments for the backrest enough to provide comfortable support for all drivers?
13. Is the range of fore and aft adjustments of the seat enough to allow all drivers comfortable access to all controls and vision devices?
14. Other deficiencies:

#### C. Periscope M27:

1. Is the height of the periscopes near the eye level of the driver in his normal buttoned-up position?

2. Are the periscopes located at a distance from the driver that allows full viewing without requiring any change, other than head movement, in the driver's normal seated position?

3. Do any pieces of equipment inside the turret interfere with direct viewing through the periscopes?

4. Do any pieces of equipment outside the turret obstruct the field of view?

5. Is the horizontal and vertical field of view sufficient for daytime buttoned-up driving?

6. Is the horizontal and vertical field of view sufficient for night black-out driving?

7. Do any lights glare on the inside face of the periscopes thereby interfering with viewing?

8. Are the external windows of the periscopes adequately protected from rain and accumulations of dust or mud?

9. Can all periscope heads be replaced quickly and easily?

10. Do any other pieces of equipment interfere with the operations necessary to replace any periscope head?

11. Other deficiencies:

D. Periscope M24 (Infrared):

1. Can the M24 periscope be installed quickly and easily?

2. Do any other pieces of equipment interfere with installation?

3. Is the brow pad centered perpendicular to the center of the driver's seat?

4. Is the brow pad located at a distance from the driver that allows viewing without requiring him to lean forward over a distance that causes postural strain during long operating periods or that interferes with other activities such as steering or shifting?

5. Can the brow pad be adjusted for comfortable viewing?

6. Does the brow pad absorb engine vibration?

7. Does the brow pad absorb vehicle movement and firing shock?

8. Does any other piece of equipment interfere with making focus adjustments?

9. Do any pieces of equipment outside the turret obstruct the field of view?

10. Is the horizontal and vertical field of view sufficient for acceptable driving speed and accuracy?

11. Does the periscope provide sufficient visibility for acceptable driving speed and accuracy?

12. Can the periscope be used when wearing the tanker's helmet?

13. Other deficiencies:

E. Indicator Gage Panel, Tachometer, Odometer:

1. Is the angle of sight to dials and warning lights satisfactory when driving buttoned-up and unbuttoned?

2. Does any piece of equipment obstruct the view of any dials or warning lights when driving buttoned-up or unbuttoned?

3. Are all dials labeled meaningfully?

4. Are all dials adequately illuminated?

5. Can all dials be read quickly?

6. Can all dials be read accurately?

7. Are dial markings legible under daylight, white light, red light?

8. Does glare from other light sources interfere with dial reading?
9. Are any dials calibrated more accurately than necessary?
10. Are danger points on dials clearly indicated?
11. Are changes in dial indication easy to detect?
12. Is the illumination of warning lights noticeable under red light?
13. Other deficiencies:

F. Master Control Panel:

1. Are controls located within normal reach distance of the driver in the buttoned-up and unbuttoned position?
2. Do any other pieces of equipment obstruct access to any controls when driver is in buttoned-up and unbuttoned position?
3. Is control panel illumination adequate?
4. Are control functions clearly labeled?
5. Are control positions clearly labeled?
6. Is all labeling visible under daylight, white light, and red light?
7. Are any controls located where they are likely to be operated accidentally while performing other operations?
8. Is enough space allowed between controls so that controls aren't operated accidentally when reaching for, or operating, another control?
9. Is enough space allowed between controls so that controls won't be operated accidentally when reaching for, or operating, another control when the driver is wearing arctic mittens?
10. Can controls be operated easily?
11. Is the illumination of indicator lights noticeable under red light?
12. Can the utility outlet covers be removed and replaced easily when wearing arctic mittens?
13. Other deficiencies:

G. Steering Wheel:

1. Is the height of the steering wheel satisfactory for both buttoned-up and unbuttoned driving?
2. Is the wheel diameter large enough to make precise settings and to hold settings over extended periods of operation?
3. Is the angle of the steering wheel to the seat, during both buttoned-up and unbuttoned operation, an optimum compromise for both force and velocity of wheel turning?
4. Is there adequate clearance between the seat cushion and the wheel during both buttoned-up and unbuttoned operation? when wearing arctic clothing?
5. Is the sensitivity of the wheel sufficient to allow fast and accurate changes in position?
6. Is the distance from the seat cushion forward to the center of the wheel optimum for comfortable operation by all drivers?
7. Do any other pieces of equipment interfere with operation of the wheel?
8. Other deficiencies:

H. Transmission Shift Lever:

1. Is the lever within normal reach distance of the driver during both buttoned-up and unbuttoned operation?
2. Is lever accessibility or operation obstructed by other pieces of equipment during either buttoned-up or unbuttoned operation?

3. Are all lever positions clearly labeled?
4. Can the lever be operated easily into all positions?
5. Is the lever located so that it might be operated accidentally when performing other duties?
6. Other deficiencies:

I. Accelerator Pedal and Brake Pedal:

1. Is the pedal located at a comfortable distance and angle from the seat cushion for both buttoned-up and unbuttoned operation?
2. Does any other equipment obstruct or interfere with operation of the pedal?
3. Could other equipment be operated accidentally if foot is not squarely on the pedal or if the foot slipped?
4. Is a heel rest provided on the pedal to help anchor the foot over long periods of operation?
5. Is too much force required to operate the pedal for short periods of time?
6. Is too much force required to operate the pedal over long periods?
7. Is too little force required to operate the pedal so that vehicle movement causes changes in settings?
8. Is the pedal large enough for the entire foot to rest on it and apply force to it?
9. Is the pedal covered with a ribbed material to prevent foot slippage?
10. Does any of the accelerator pedal angle, between the idling position and full acceleration, induce ankle strain when operating for long periods in a buttoned-up or unbuttoned position?
11. Other deficiencies:

J. Dimmer Switch (Driving Lights):

1. Is the pedal located at a comfortable distance for operation in both the buttoned-up and unbuttoned position?
2. Is access to the switch obstructed by any other pieces of equipment?
3. Can the switch be easily and quickly located during operation?
4. Can the switch be operated easily?
5. Other deficiencies:

K. Hull Drain Valves Control Lever, Throttle Locking Lever, Fixed Fire Extinguisher Control Handles, Fuel Shut Off Valve Handle, and Turret Seal Manual Pump:

1. Are the handles, or levers, within normal reach distance of the driver?
2. Is access to the handle, or lever, obstructed by other pieces of equipment?
3. Is too much force required for operation?
4. Is the handle, or lever, located where it might be operated accidentally when performing other duties?
5. Does the lever remain locked in place during operation?
6. Other deficiencies:

L. Purge Pump and Manifold Heaters Starter Button:

1. Is the handle within normal reach distance of the driver?

2. Is access to the handle or button obstructed by other pieces of equipment?
3. Is too much force required for operation of the handle or button?
4. Is the handle or button located where it might be operated accidentally when performing other duties?
5. Is too little force required to operate the handle or button so either could be easily operated accidentally?
6. Other deficiencies:

M. Turret Seal Pressure Gage:

1. Is the angle of sight to the gage satisfactory?
2. Does any other piece of equipment obstruct the view of the gage?
3. Is the gage adequately illuminated?
4. Are dial markings legible under daylight, white light, and red light?
5. Are danger points on the dial clearly indicated?
6. Can the bleeder valve be operated accidentally when performing other duties?
7. Other deficiencies:

N. Auxiliary Power Receptacles:

1. Are receptacles easily accessible?
2. Does use of the receptacles interfere with the performance of other duties?
3. Can the receptacle cap be removed and replaced easily? when wearing arctic mittens?
4. Can connections be made easily? when wearing arctic mittens?
5. Other deficiencies:

O. Headlamp Stowage Bracket:

1. Is the stowage bracket easily accessible?
2. Can the lamps be removed easily? when wearing arctic mittens?
3. Other deficiencies:

P. Dome Light:

1. Is the light switch within normal reach of the driver during buttoned-up and unbuttoned operation?
2. Is access to the light switch obstructed by any other piece of equipment?
3. Are switch positions clearly labeled?
4. Is the light located so it illuminates all necessary areas?
5. Is illumination of any area obstructed by the driver or by other pieces of equipment?
6. Does the red light provide enough illumination for operation?
7. Does the red light reduce dark adaptation of the driver?
8. Does light glare on any panels so as to interfere with legibility of markings?
9. Does the light adversely affect vision through the periscopes either by glare or by providing too much background illumination?
10. Other deficiencies:



Q. Driver's Hatch:

1. Can the hatch control be operated easily by driver? when wearing arctic mittens?
2. Can the hatch cover be moved open and closed easily?
3. Can the hatch be locked open securely?
4. Is a foot step available to aid in exit through the hatch?
5. Does any other piece of equipment interfere with entry or exit through the hatch?
6. Is the hatch large enough to allow exit and entry when wearing arctic clothing?
7. Does the hatch position allow direct exit without twisting and turning body?
8. Other deficiencies:

R. Driver's Escape Hatch:

1. Can the hatch lever be operated easily? when wearing arctic mittens?
2. Can the hatch be removed easily?
3. Does any other piece of equipment interfere with exit through the hatch?
4. Is the hatch large enough to allow exit when wearing arctic clothing?
5. Other deficiencies:

## II. LOADER'S SECTION

### A. Work Space:

1. Is there sufficient space for the loader to perform his job duties effectively?
2. Is there sufficient space for the loader to perform his job duties effectively when wearing arctic clothing?
3. Are there any projections from the turret, other than equipment, that might interfere with normal operation or be considered a safety hazard?
4. Are safety devices included to ensure that the loader is not within the recoil and brass ejection path of the main armament during firing?
5. Are there any noxious fumes during operation that might decrease performance?
6. Is there excessive heat or dust during operation that might decrease performance?
7. Is space provided for storing canteens, arctic clothing, etc.?
8. Other deficiencies:

### B. Loader's Seat:

1. Does the shape and size of the seat cushion provide comfortable support for the body for extended periods of operation?
2. Does the shape and size of the backrest provide comfortable support?
3. Can the height of the seat cushion and backrest be adjusted to accommodate all loaders?
4. Do the adjusting knobs and pins secure the seat under maximum expected shock during operation?
5. Other deficiencies:

### C. Breech Operating Handle:

1. Does any other piece of equipment interfere with access to or operation of the handle?
2. Can the handle be operated easily? when wearing arctic mittens?
3. Is the handle located where it is likely to be operated accidentally while performing other operations?
4. Does operation of the handle place the loader in an unsafe position?
5. Other deficiencies:

### D. Loader's Safety Switch:

1. Does any other piece of equipment obstruct the accessibility of the switch?
2. Can the switch be operated easily? when wearing arctic mittens?
3. Is the switch located where it could be operated accidentally while performing other operations?
4. Is the switch located so that the loader must be completely out of the recoil and brass ejection path of the main armament to operate it?
5. Other deficiencies:

### E. Turret Traverse Lock:

1. Does any other piece of equipment obstruct access to or interfere with the operation of the lock handle?

2. Can the lock handle be operated easily? when wearing arctic mittens?
3. Does the lock hold securely?
4. Other deficiencies:

F. Replenisher Cylinder Indicator Tape:

1. Does any other piece of equipment interfere with the view of or access to the tape?
2. Is the tape adequately illuminated?
3. Are tape markings distinct enough to be easily discriminable tactually?
4. Other deficiencies:

G. Ventilating Blower and Accessory Outlet:

1. Does any other piece of equipment obstruct the accessibility of the switch?
2. Can the switch be operated easily? when wearing arctic mittens?
3. Is the switch located where it could be operated accidentally while performing other operations?
4. Can the accessory outlet cover be removed and replaced easily? when wearing arctic mittens?
5. Does use of the accessory outlet interfere with the performance of other duties?
6. Other deficiencies:

H. 7.62mm Machine Gun:

1. Are adjusting screws readily accessible?
2. Are special tools required to adjust the screws?
3. Are the adjusting screws adequately illuminated for performing the adjustment operation?
4. Is the portion of the weapon that must be disassembled for boresighting easily accessible?
5. Can the receiver assembly be detached and removed from the mounting block assembly, and replaced, easily and without requiring the use of special tools?
6. Can the receiver assembly be detached and moved out of the way, and replaced, by one man?
7. Is the barrel of the gun accessible for use with the binocular for boresighting?
8. Can the cartridge case bag be installed and removed easily by one man without requiring the use of special tools?
9. Can the charger handle be pulled to the rear easily with one hand?
10. Can the cover be opened and closed easily with one hand?
11. Is the safety device clearly labeled?
12. Can the safety device be moved to all settings easily with one hand?
13. Is the safety device located where it might be operated accidentally while performing other operations?
14. Can one man insert the cartridge belt and position the first round in the slot of the feed tray easily and without requiring the use of special tools?
15. Is the electrical firing cable from the gunner control box long enough for easy connection to the solenoid?
16. Can the electrical connecting plugs be joined easily?

17. Is the manual trigger readily accessible?
18. Can the manual trigger be easily activated with one hand?
19. Is the manual trigger located where it might be accidentally operated while performing other operations?
20. Can all operations be performed while wearing arctic mittens?
21. Other deficiencies:

I. Ammunition Racks:

1. Are all racks easily accessible?
2. Does the location of any rack require lifting the shell into an awkward position?
3. Is ammunition held in place securely?
4. Can ammunition be removed from the rack easily?
5. Can ammunition be released from the rack accidentally while performing other operations?
6. Are the racks located so that ammunition can be transferred easily?
7. Other deficiencies:

J. Loader's Escape Hatch:

1. Can the hatch control be operated easily? when wearing arctic mittens?
2. Can the hatch cover be moved open and closed easily?
3. Can the hatch be locked open securely?
4. Is a foot step available to aid in exit through the hatch?
5. Does any other piece of equipment interfere with entry or exit through the hatch?
6. Is the hatch large enough to allow exit and entry when wearing arctic clothing?
7. Does the hatch position allow direct exit without twisting and turning the body?
8. Other deficiencies:

### III. GUNNER'S SECTION

#### A. Work Space:

1. Is there sufficient space for the gunner to perform his job duties effectively over extended operating periods?
2. Is there sufficient space for the gunner to perform his job duties effectively when wearing arctic clothing?
3. Are there any projections from the turret, other than equipment, that might interfere with normal operation or be considered a safety hazard?
4. Are there any noxious fumes during operation that might decrease performance?
5. Is there excessive dust during operation that might decrease performance?
6. Is space provided for storing canteens, arctic clothing, etc.?
7. Other deficiencies:

#### B. Gunner's Seat:

1. Does the shape and size of the seat cushion provide comfortable support for the body for extended periods of operation?
2. Does the seat cushion absorb movement and firing shock?
3. Does the seat cushion absorb engine vibration that interferes with visual or manual operating requirements?
4. Does the shape and size of the backrest provide comfortable support?
5. Is the backrest on a pivot permitting fitting to the gunner's back as he changes position?
6. Can all seat and backrest adjustments be made quickly and easily during operation and without requiring the use of special tools?
7. Do the adjusting knobs and pins secure the seat under maximum expected shock during operation?
8. Is the minimum height adjustment of the seat low enough to permit normal operation of all job duties by all gunners?
9. Is the maximum height of the seat high enough to permit normal operation of all job duties by all gunners?
10. Is the number of height adjustments for the seat enough to accommodate all gunners in relation to vision devices and operating controls?
11. Is the range of adjustments for the backrest enough to provide comfortable support for all gunners?
12. Is the range of fore and aft adjustments of the seat enough to allow all gunners comfortable access to all controls and vision devices?
13. Other deficiencies:

#### C. Periscope M31, Infinity Sight M44C, Gun Ready Light:

1. Is the browpad centered perpendicular to the center of the gunner's seat?
2. Is the brow pad located at a distance from the gunner that allows viewing without requiring him to lean forward over a distance that causes postural strain or that interferes with other activities such as operation of the turret traverse and gun elevation controls?
3. Can the brow pad be adjusted for comfortable viewing?
4. Does the brow pad absorb engine vibration?

5. Does the brow pad absorb vehicle movement and firing shock?
6. Does the brow pad obstruct access to other instruments or observation of other displays?
7. Does any other piece of equipment interfere with viewing?
8. Is the range of diopter settings provided great enough to accommodate all gunners (note especially those gunners who normally wear glasses)?
9. Is enough eye relief provided to compensate for turret response during firing?
10. Can the brightness of all scales shown in the eyepiece of the M31 be adjusted over a sufficient range?
11. Can the brightness of the M44C reticle be adjusted over a sufficient range?
12. Can the instrument be used when wearing the tankers helmet?
13. Does glare from any other light sources interfere with viewing?
14. Do any other pieces of equipment obstruct access to the boresight knobs?
15. Is illumination of the boresight knobs adequate?
16. Can the boresight knobs be operated when wearing arctic mittens?
17. Are the boresight knob calibrations legible?
18. Are the boresight knobs located where they are likely to be operated accidentally while performing other operations?
19. Are locking devices provided to secure the position of the boresight knobs?
20. Is the gun ready light located where it is visible to the gunner without requiring him to move his head from the M31 periscope?
21. Does illumination of the gun ready light interfere with visibility through the M31 periscope?
22. Is illumination of the gun ready light noticeable under both white light and red light?
23. Other deficiencies:

D. Telescope M105C:

1. Does the height and distance of the telescope from the gunner's seat allow viewing without requiring a position that causes postural strain?
2. Is the telescope located so as to allow smooth and accurate operation of the manual and power elevation and traversing controls while sighting?
3. Does any other piece of equipment interfere with access to the telescope?
4. Is the shape and angle of the brow pad consistent with the head angle required during viewing?
5. Does the brow pad absorb engine vibration?
6. Does the brow pad absorb vehicle movement and firing shock?
7. Is the range of diopter settings provided great enough to accommodate all gunners (note especially those gunners who normally wear glasses)?
8. Is enough eye relief provided to compensate for turret response during firing?
9. Can the brightness of all scales shown in the eyepiece be adjusted over a sufficient range?
10. Can the instrument be used when wearing the tanker's helmet?
11. Does glare from any other light sources interfere with viewing?
12. Are the boresight knobs and levers easily accessible?
13. Does any other piece of equipment obstruct access to the boresight knobs?

14. Are the boresight knob calibrations legible?
15. Is illumination of the boresight knobs adequate?
16. Can the boresight knobs and levers be operated when wearing arctic mittens?
17. Do the locking levers secure the position of the boresight knobs?
18. Are the boresight knobs located where they are likely to be operated accidentally while performing other operations?
19. Is the gun ready light located where it is visible to the gunner without requiring him to move his head from the telescope?
20. Does illumination of the gun ready light interfere with visibility through the telescope?
21. Other deficiencies:

**E. Azimuth Indicator:**

1. Does the angle of sight to the indicator allow the gunner a full view of the dial face from his normal seated position?
2. Is the indicator within normal reach distance of the gunner?
3. Are all dial markings legible from the gunner's seated position?
4. Do any pieces of equipment obstruct the gunner's view of the dial?
5. Is the dial adequately illuminated?
6. Can the dial be read quickly?
7. Can the dial be read accurately?
8. Are dial markings legible under both white light and red light?
9. Does glare from any other light sources interfere with dial reading?
10. Can the resetter knobs be depressed easily? when wearing arctic mittens?
11. Can the resetter knob be operated quickly and accurately? when wearing arctic mittens?
12. Other deficiencies:

**F. Ballistics Computer M13A1D:**

1. Does the angle of sight to the face of the panel allow the gunner a full view of the panel from his normal seated position?
2. Does any other piece of equipment obstruct the view of any dials or access to any controls?
3. Does any other piece of equipment interfere with the operation of any controls?
4. Are all dials labeled meaningfully?
5. Are all dials adequately illuminated?
6. Can all dials be read quickly?
7. Can all dials be read accurately?
8. Are dial markings legible under both white light and red light?
9. Are any dials calibrated more or less accurately than necessary?
10. Does glare from any other light sources interfere with dial reading?
11. Is illumination of the indicator pilot light noticeable under both white light and red light?
12. Are all controls located within the normal reach distance of the gunner?
13. Are any controls located where they are likely to be operated accidentally while performing other operations?
14. Is enough space allowed between controls so that controls won't be operated accidentally when reaching for, or operating another control? when wearing arctic mittens?

15. Can controls be operated easily? when wearing arctic mittens?
16. Is the direction of control movement compatible with the direction of dial movement?
17. Other deficiencies:

G. Elevation Quadrant M13:

1. Is the angle of sight to the quadrant satisfactory when the gunner is in his normal seated position?
2. Is the quadrant within normal reach distance of the gunner?
3. Does any other piece of equipment interfere with viewing or adjusting the quadrant?
4. Is quadrant illumination adequate?
5. Can the quadrant be read quickly and accurately?
6. Are quadrant calibrations legible?
7. Can quadrant calibrations be read under both white light and red light?
8. Does glare from other light sources interfere with quadrant reading?
9. Can the quadrant knob be adjusted easily and accurately? when wearing arctic mittens?
10. Other deficiencies:

H. Power Switch Box and Emergency Firing Control Box:

1. Are controls located within normal reach distance of the gunner?
2. Is the angle of sight to the indicator lights satisfactory when the gunner is in his normal seated position?
3. Does any other piece of equipment obstruct the view of the indicator lights or access to any controls?
4. Are controls located where they are likely to be operated accidentally while performing other operations?
5. Is enough space allowed between controls so that controls aren't operated accidentally when reaching for, or operating, another control? when wearing arctic mittens?
6. Can controls be operated easily? when wearing arctic mittens?
7. Is the illumination of indicator lights noticeable under both white light and red light?
8. Are controls labeled meaningfully?
9. Are control labels legible under both white light and red light?
10. Other deficiencies:

I. Gunner's Control Assembly:

1. Is the assembly located to allow smooth, fast and accurate operation when using the M31 periscope or the M105C telescope?
2. Does depression of the firing button interfere with operation of the handle?
3. Can the handles be operated independently in azimuth and elevation; that is, can the gunner speedily set in an azimuth change without also inadvertently setting in some change in elevation and vice versa?
4. Is the assembly sensitive enough to allow small but accurate changes in azimuth and elevation?
5. Could the assembly be operated effectively when the gunner is wearing arctic mittens?



6. Other deficiencies:

J. Elevation Hand Pump and Hand Traversing Assembly:

1. Is the handle located to allow smooth, fast and accurate operation when using the M31 periscope or the M105C telescope?
2. Does depression of the firing button (or locking lever) interfere with operation of the handle?
3. Can the handle be operated easily? when wearing arctic mittens?
4. Is the handle sensitive enough to allow small but accurate changes in elevation (or azimuth)?
5. Does any other piece of equipment interfere with operation of the handle?
6. Is the direction of control movement compatible with the direction of turret (or gun) movement?
7. Is the firing button located where it is likely to be depressed accidentally while performing other operations?
8. Other deficiencies:

X. Accumulator Pressure Gage:

1. Is the angle of sight to the gage satisfactory?
2. Does any other piece of equipment obstruct the view of the gage?
3. Is the gage adequately illuminated?
4. Are dial markings legible under both white light and red light?
5. Are danger points on the dial clearly indicated?
6. Other deficiencies:

L. Power Pack Oil Level Gage:

1. Is the gage easily accessible?
2. Can the gage be removed easily? when wearing arctic mittens?
3. Are gage calibrations meaningful?
4. Are gage calibrations legible?
5. Other deficiencies:

#### IV. TANK COMMANDER'S SECTION

##### A. Work Space:

1. Is there sufficient space for the TC to perform his job duties effectively over extended operating periods?
2. Is there sufficient space for the TC to perform his job duties effectively when wearing arctic clothing?
3. Are there any projections from the turret, other than equipment, that might interfere with normal operation or be considered a safety hazard?
4. Are there any noxious fumes during operation that might decrease performance?
5. Is there excessive dust during operation that might decrease performance?
6. Are safety devices included to ensure that the TC is not within the recoil and brass ejection path of the main armament during firing?
7. Does the operation of any piece of equipment require that the TC enter the recoil and brass ejection path of the main armament?
8. Is space provided for storing canteens, arctic clothing, etc.?
9. Other deficiencies:

##### B. Commander's Seat:

1. Does the shape and size of the seat cushion provide comfortable support for the body for extended periods of operation?
2. Does the seat cushion absorb movement and firing shock?
3. Does the seat cushion absorb engine vibration that interferes with visual or manual operating requirements?
4. Does the shape and size of the backrest provide comfortable support?
5. Is the backrest on a pivot permitting fitting to the TC's back as he changes position?
6. Can all seat and backrest adjustments be made quickly and easily during operation and without requiring the use of special tools?
7. Do the adjusting knobs and pins secure the seat under maximum expected shock during operation?
8. Is the minimum height adjustment of the seat low enough to permit normal operation of all job duties by all TCs?
9. Is the maximum height adjustment of the seat high enough to permit normal seated operation by all TCs when operating in an unbuttoned position?
10. Is the maximum height adjustment of the seat high enough to permit normal viewing by all TCs when using the commander's cupola?
11. Is the number of height adjustments for the seat enough to accommodate all TCs in relation to vision devices and operating controls?
12. Is the range of adjustments for the backrest enough to provide comfortable support for all TCs?
13. Is the range of fore and aft adjustments of the seat enough to allow all TCs comfortable access to all controls and vision devices?
14. Other deficiencies:

##### C. Commander's Control Handle:

1. Is the handle located to allow smooth, fast and accurate operation in a buttoned-up and unbuttoned position?

2. Is the handle located to allow smooth, fast and accurate operation when vision devices are used concurrently?

3. Does depression of the override switch interfere with operation of the handle?

4. Does depression of the firing button interfere with operation of the handle?

5. Can the handle be operated independently in azimuth and elevation, that is, can the TC speedily set in an azimuth change without also inadvertently setting in some change in elevation and vice versa?

6. Is the control sensitive enough to allow small but accurate changes in azimuth and elevation?

7. Could the control be operated effectively when the TC is wearing arctic mittens?

8. Other deficiencies:

#### D. Rangefinder M17C:

1. Is the brow pad centered perpendicular to the center of the TC's seat?

2. Is the brow pad located at a distance from the TC that allows viewing without requiring him to lean forward over a distance that causes postural strain during long operating periods or that interferes with other activities such as operating the commander's control handle?

3. Can the brow pad be adjusted for comfortable viewing?

4. Does the brow pad absorb engine vibration?

5. Does the brow pad absorb vehicle movement and firing shock?

6. Does any other piece of equipment interfere with viewing?

7. Is the range of diopter settings provided great enough to accommodate all TCs (note especially those TCs who normally wear glasses)?

8. Is enough eye relief provided to compensate for turret response during firing?

9. Is the horizontal and vertical field of view acceptable for use during surveillance?

10. Does the eyepiece provide sufficient visibility for quick and accurate ranging?

11. Can the brightness of all scales shown in the eyepiece be adjusted over a sufficient range?

12. Do any scales shown in the eyepiece interfere with ranging?

13. Do any scales shown in the eyepiece interfere with surveillance?

14. Can the instrument be used when wearing the tanker's helmet?

15. Is the range scale adequately illuminated?

16. Can the range scale be read quickly and accurately?

17. Is the range scale legible under daylight, white light, red light?

18. Does glare from any other light sources interfere with range scale reading?

19. Are all rangefinder controls located within normal reach distance of the TC with relation to concurrent activities?

20. Do any other pieces of equipment obstruct access to any controls?

21. Is the illumination of controls adequate?

22. Are control functions clearly labeled?

23. Are control positions clearly labeled?

24. Is all labeling visible under daylight, white light, and red light?

25. Are any controls located where they are likely to be operated accidentally while performing other operations?

26. Is enough space allowed between controls so that controls aren't operated accidentally when reaching for, or operating, another control? when wearing arctic mittens?

27. Can all controls be operated quickly and accurately? when wearing arctic mittens?

28. Is the sensitivity of all controls great enough for the degree of adjustment accuracy required?

29. Can control locks be operated quickly and easily? when wearing arctic mittens?

30. Do control locks hold securely?

31. Can control and spare lamp covers be opened and closed quickly and easily? when wearing arctic mittens?

32. Other deficiencies:

E. Commander's Cupola:

1. Are the vision blocks located at a distance from the TC that allows full viewing without requiring any change, other than head movement, in his normal operating position?

2. Do any pieces of equipment inside the cupola interfere with direct viewing through the vision blocks?

3. Do any pieces of equipment outside the cupola obstruct the field of view?

4. Is the horizontal and vertical field of view sufficient for buttoned-up surveillance?

5. Is the horizontal and vertical field of view sufficient when aiding the driver during buttoned-up operation?

6. Do any lights glare on the inside face of the vision blocks thereby interfering with viewing?

7. Are the external windows of the vision blocks adequately protected from rain and accumulations of dust or mud?

8. Is normal observation through the vision blocks possible when wearing the tanker's helmet?

9. Can the cupola traversing lock handle be operated quickly and easily? when wearing arctic mittens?

10. Do any other pieces of equipment interfere with the operation of the cupola traversing lock handle?

11. Does the cupola traverse lock hold securely?

12. Are the elevating and traversing cranks located in an optimum position for operation?

13. Can the elevating and traversing cranks be operated quickly and easily? when wearing arctic mittens?

14. Are the elevating and traversing cranks sensitive enough to allow small but accurate changes in azimuth and elevation?

15. Can safety latches and lock and drag handles be operated quickly and easily? when wearing arctic mittens?

16. Do control latches and locks hold securely?

17. Can the hatch control be operated easily? when wearing arctic mittens?

18. Can the hatch cover be moved open and closed easily?

19. Can the hatch be locked open securely?

20. Is a foot step available to aid in exit through the hatch?

21. Does any other piece of equipment interfere with entry and exit through the hatch?

22. Is the hatch large enough to allow entry and exit when wearing arctic clothing?

23. Does the hatch position allow direct exit without twisting or turning the body?

24. Are hand holds available to help steady the TC when operating from an unbuttoned position?

25. Other deficiencies?

F. Searchlight Switch:

1. Is the switch located within reach distance of the TC in the buttoned-up and unbuttoned position?

2. Does any other piece of equipment obstruct the accessibility of the switch?

3. Is the switch located where it could be operated accidentally while performing other operations?

4. Could the switch be operated easily and accurately when wearing arctic mittens?

5. Other deficiencies: