

UNCLASSIFIED

AD NUMBER
AD483172
NEW LIMITATION CHANGE
TO Approved for public release, distribution unlimited
FROM Distribution authorized to U.S. Gov't. agencies and their contractors; Critical Technology; MAY 1966. Other requests shall be referred to Air Force Systems Command, Space Systems Division, Los Angeles, CA 90045.
AUTHORITY
SAMSO USAF ltr, 17 Jan 1972

THIS PAGE IS UNCLASSIFIED

27 May 1966

Report SSD-TN-65-161-1

TITAN II - AUGMENTED ENGINE IMPROVEMENT PROGRAM

SUPPLEMENTAL FINAL REPORT

DEVELOPMENT OF A TURBOPUMP GEARBOX  
LUBRICANT FOR TITAN FAMILY ENGINES

Contract AF 04(694)-464

Best Available Copy

Prepared for

SPACE SYSTEMS DIVISION  
Air Force Unit Post Office  
Los Angeles, California 90045

"This document is subject to special export controls,  
and each transmittal to foreign governments or foreign  
nationals may be made only with prior approval of,"

Hq. Space Systems Division (AFSC)  
Air Force Unit Post Office  
Los Angeles, California 90045  
Attn: Gemini System Program Office (SSVL)

4493T

**AEROJET-GENERAL CORPORATION**  
A SUBSIDIARY OF THE GENERAL TIRE & RUBBER COMPANY

AD 483172

FOREWORD

This supplemental final report is prepared by the Aerojet-General Corporation, Sacramento, California, in accordance with the requirements outlined in AFSCM 310-1B, S-17-12.0-1, Technical Report, and describes the results of the program conducted to develop a turbopump gearbox lubricant for the Titan family engines.

This technical report has been reviewed and is approved.

ABSTRACT

The development of a turbopump gearbox lubricant for the Titan II family engines was undertaken to formulate a new lubricant, which would replace presently used Bryco 880 Conojet (MIL-L-7808D(1)) oil. Naphthenic mineral oil was selected for the base because it has excellent storage life and propellant compatibility. Several additives were admixed to provide oxidation stability, good aeration characteristics, and a high load-carrying capacity. The task was completed with the selection of Humble 3156 gear lubricant, which is being proposed for engine qualification testing. Specifications covering all the particulars of this new lubricant have been written and are attached to this report. The development program encompassed the following tasks:

1. Selection of basic candidates.
2. Optimization of additives
3. Selection of final candidate lubricant

TABLE OF CONTENTS

	<u>Page</u>
I. Introduction	1
II. Summary	3
III. Conclusions and Recommendations	7
A. General Conclusions	7
B. Specific Conclusions	9
C. Recommendations	11
IV. Technical Discussion	13
A. Gearbox Lubrication System	13
B. Selection of Basic Prospective Formulations	13
C. Optimization of Additives	17
D. Selection of Final Prospective Lubricant	25
E. Evaluation of Final Prospective Lubricant	28
F. Future Qualification of New Oil for Titan Engines	47
V. References	51

APPENDICES

<u>Appendix</u>		<u>Page</u>
I	Aerojet-General Corporation Gear Lubricant Specification AGC-44209	53
II	Ryder Gear Test Procedure and Test Results	69
III	Properties of Humble 3156 Gear Lubricant	75
IV	Solvent Compatibility Studies	79
V	Draining and Flushing Procedures	83

LIST OF TABLES

<u>Table</u>		<u>Follows Page</u>
I	Optimization Tests with Anti-Corrosive Additive Ortholeum 535	23
II	Ryder Gear Machine, Load-Sequence-Simulating Gearbox	31
III	Ryder Gear Machine, Simulating-Gearbox Operation	31
IV	Tests of Load-Carrying Capacity	32
V	Variables Affecting Gear Scuffing	33
VI	Tests Using Oil per MIL-L-7808D(1)	34
VII	Tests Using Batch 41 Oil	35
VIII	Tests Using Batch 41 Oil and 2% Oil per MIL-L-7808D(1)	36
IX	Schedule for Lubrication Jet Reduced Pressure Tests Using MIL-L-7808D(1) Oil	36
X	Ryder Gear Test Results	36
XI	Filter Plugging Test	40
XII	Spindle Corrosion Tests	45
XIII	Metal Corrosion Tests	45
XIV	DuPont Humidity Cabinet Tests	45
XV	Long-Term Storage Tests	46
XVI	Results of Long-Term Storage Tests with Gearbox Parts	46
XVII	Storage Stability Tests at 185°F	46

Appendix III

XVIII	Properties of Humble 3156 Gear Lubricant	77
-------	--	----

Appendix IV

XIX	Solvent Compatibility Tests	82
-----	-----------------------------	----

LIST OF FIGURES

<u>Figure</u>		<u>Follows Page</u>
1	Lubrication System	13
2	Turbopump Assembly (Cutaway View)	13
3	Condition of DDP	19
4	DDP Crystalline Structure	19
5	DDP Sample C	19
6	DDP Comparison Between Batches B and C	19
7	Ryder Gear Value (Side A Only) vs Blend Neutralization Number, 3-Centistoke Base Oil	20
8	Ryder Gear Value (Sides A and B) vs Blend Neutralization Number, 3-Centistoke Base Oil	20
9	Ryder Gear Values vs DDP Concentration, 3-Centistoke Base Oil	20
10	Ryder Gear Value vs DDP Concentration, 4-Centistoke Base Oil	20
11	Ryder Gear Value vs Ortholeum 162, 3-Centistoke Base Oil	20
12	Ryder Gear Value vs Ortholeum 162 with Ortholeum 535, 3-Centistoke Base Oil	20
13	Aeration Time vs Percent of Monsanto PC-1244 (0.20% Ortholeum 162)	22
14	Aeration Time vs Percent of Monsanto PC-1244 (Dicresyl Phosphate Additive)	22
15	Aeration Time vs Percent of Monsanto PC-1244 (Didodecyl Phosphate Additive)	22
16	Aeration Time vs Percent of Monsanto PC-1244, Batch 21	22
17	Aeration Time vs Percent of Monsanto PC-1244, Batch 22	22
18	Aeration Time vs Percent of Monsanto PC-1244, Average Values	22
19	Aeration Time vs Percent of Monsanto PC-1244, Batches 22 and 41	22
20	Aeration Time vs Percent of Monsanto PC-1244, Batch 41	22
21	Corrosion Resistance Test	24
22	Ryder Gear Values and Percent Relative Rating	30
23	Pinion Gear SN 1049 (4720 sec in Oil per MIL-L-7808D(1))	35
24	Pinion Gear SN 1848 (4720 sec in 4720 Gear Lubricant)	35
25	Involute Profile (Oil per MIL-L-7808D(1))	35
26	Involute Profile (3156 Lubricant)	35

LIST OF FIGURES

(Continued)

<u>Figure</u>		<u>Follows Page</u>
27	Involute Profile	35
28	Involute Profile after Tests of 4720 and 2800 sec	35
29	Pinion Gear SN 1049 after Test with 3156 Lubricant and 2% (Oil per MIL-L-7808D(1))	36
30	Ryder Gear Test Results	36
31	First-Stage Gearbox after Pinion Failure, View 1	36
32	First-Stage Gearbox after Pinion Failure, View 2	36
33	Pinion Gear after Test	36
34	Gear Train after Test	36
35	Lubrication Oil Flow to Gearbox vs Gearbox Test Run Time	37
36	Western Gear Scuff Test	37
37	Filter Plugging Test, Flow Schematic	39
38	Filter Plugging Test Setup	39
39	Filter Plugging Test, Pressure Drop across Filter vs Time	40
40	Filter Plugging Test, Before and after Views of Filter	40
41	Aeration Test, 440 sec, First-Stage Gearbox	44
42	Aeration Test, 250 sec, Second-Stage Gearbox	44
43	Aeration Test, 440 sec, AEIP Gearbox	44
44	Residual Oil per MIL-L-7808D(1) in Gearbox vs Number of Flushes (with A1 Motor Spin)	46
 <u>Appendix II</u> 		
45	Erdco Universal Tester, Ryder Gear Method	71
46	Cross-Section of Ryder Gear Machine	71
47	Slave Gears	71
48	Test Gears Installed	71
49	Support and Load Oil System	71
50	Gear Teeth Inspection Data Sheet	71
51	Plot and Calculations Sheet	71



## I.

INTRODUCTION

Turbopump gearboxes for Titan rocket engines are presently lubricated with a di-ester lubricant formulated by the Bray Oil Company, Los Angeles, California, to meet a now-obsolete military specification (MIL-L-7808D(1)). This synthetic lubricant was initially selected for the Titan II Weapon System (WS107A) in 1956 because its load-carrying ability was slightly higher than other available lubricants having acceptable viscosity limits. However, several problems associated with the use of this oil have motivated the Air Force and Aerojet-General Corporation to seek an improved lubricant. These problems are:

(1) Soap-like deposits are formed by lubricant-propellant incompatibility. These deposits which necessitate turbopump disassembly and cleaning are found in a cavity formed by the pump and gearbox dynamics seal.

(2) A gum-like substance is formed as a result of incompatibilities of lubricant-gas generator gases; this gummy substance plugs the lubrication oil filter causing high pressure losses and results in marginal lubrication.

(3) Incipient gear teeth scuffing is caused by the lack of load-carrying capacity under certain severe operating conditions.

(4) Logistics problems result from the short storage life of esters; the quality of this lubricant is difficult to control because its composition is not known and the lubricant is supplied by a single source and is formulated in accordance with an obsolete specification.

In a previous program (Ref 1), commercially available lubricants potentially useful for this application were screened and found to be incompatible with the Titan system propellants and gas generator products. At the conclusion of this earlier program, three prospective additive formulations in a propellant-compatible mineral base oil were shown to be worthy of further development. These formulations differed in the type of load-carrying additive employed and are described below:

Candidate No.	Load-Carrying Additive	Oxidation Inhibitor	Anti-Foam Additive
1	0.25% Didodecyl Phosphate	0.5% Ethyl 702	0.01% Monsanto PC-1244
2	0.50% Dicresyl Phosphate	0.5% Ethyl 702	0.01% Monsanto PC-1244
3	0.20% Ortholeum 162	0.5% Ethyl 702	0.01% Monsanto PC-1244

I, Introduction (cont.)

The purpose of this report is to present the results of a program conducted to (1) optimize the concentrations of the above additive formulations, (2) evaluate each candidate by laboratory and component testing, and (3) select the best candidate for possible qualification in the TPA.

Specific program objectives are as follows:

- (1) Load Capacity: Ryder Gear test value of 3000 lb/in. of tooth width. Good characteristics of boundary lubrication and "break-in" performance.
- (2) Compatibility: No reaction with AeroZINE 50; no solid sludge forming a precipitate with  $N_2O_4$  or turbine hot gases; and no reaction with the present lubricant.
- (3) Operational Characteristics: Good coolant capacity (minimum aeration) and a maximum viscosity of 4 centistokes at 210°F.
- (4) Storability: Ten-year storage life without corrosiveness to metals or loss in basic oil properties.
- (5) Quality Assurance: Detailed composition specification.

The work to accomplish the above objectives was performed in accordance with the following program plan: (1) select basic choices of formulations from previous work, (2) establish the optimum concentration of additives in each formulation, (3) select a final choice of lubricant, (4) perform comprehensive laboratory and component evaluations of the final candidate relative to the present lubricant, and (5) establish test objectives for new lubricant qualification programs if a promising candidate is developed.

For the convenience of the reader who is not familiar with the requirements of the lubricant, the first part of the technical discussion contains a description of the Titan gearbox lubrication system. The remaining portion of the technical discussion presents the results of the program.

II.

SUMMARY

A new lubricant for potential use in Titan II engine gearboxes has been developed as a result of laboratory and component tests. The quality of this lubricant can be easily controlled through the use of a composition specification such as is presented in Appendix . . . Table I lists specific program objectives and corresponding accomplishments. This table shows that all initial objectives have been satisfactorily achieved except the requirements for noncorrosiveness.

It was found that the extreme pressure additive (alkyl acid phosphate) reacts with alloy steels (except stainless steels) to form an iron phosphate coating. This coating appears as a light gray tarnish in the absence of water and is a gray-black tarnish in the presence of 0.2% water (the present oil specification limit). The coating does not affect the dimensions of the steel parts and is expected to be a boundary lubricant for bearings and a mild antirust film for all steel parts.

Although the Ryder Gear rating objective of 3000 lb/in. was achieved in standard Ryder Gear tests, it was found that when black iron oxide (currently used on production gears) is placed on the gears as a coating, the load capacity of the new lubricant is reduced from 3000 to approximately 1500 lb/in. To better understand the meaning of this data, the following discussion is devoted to a summary of black oxide, why it is used in the Titan gearbox, and the mechanisms by which the two lubricants act.

Black oxide was originally coated on gears to provide a mild rust inhibition and to slightly increase load capacity. The load capacity of the present di-ester-type lubricant depends on the formation of oxides and is therefore assisted by the presence of a black oxide coating and the presence of an oxidizing environment. The load capacity of the new lubricant is provided by the acid phosphate additive, which reacts with the iron surfaces, apparently independently of the environment, to form iron phosphate. This iron phosphate is known to possess a low shear strength and, thereby, prevents asperity welding (scuffing). The presence of a black oxide coating prevents the beneficial action of this additive. The acid phosphate coating is approximately 30% more effective than the oxide formation with respect to load capacity and about equal in corrosion inhibition.

Ryder Gear test results have shown that the load capacity of the present lubricant is degraded when the oxygen in the gearbox is displaced by gas generator products (a turbine seal leakage) or an inert atmosphere. The load capacity of the present lubricant as measured by a Ryder Gear test, decreased from 2200 to 1400 psi when oxygen was replaced by gaseous nitrogen in the Ryder Gear tester. The new lubricant, however, was not affected by the exclusion of oxygen; this is understandable because the formation of iron phosphate does not depend upon the presence of oxygen.

II, Summary (cont.)

Laboratory gearbox tests conducted at Western Gear Corporation show that the new lubricant performs satisfactorily in gearboxes containing black oxide coating gears at extended test durations and at loads up to 137% of the normal value. The new lubricant produced slightly more abrasive wear than the present lubricant, but this is not considered to be a problem within the life requirements of field units. These tests were conducted at lubrication oil jet pressures in excess to 20 psi.

As a result of the above test data, a reduction in the lubricant load capacity requirements of the Titan first-stage gearbox was made. It has been determined that the most severe gearbox scuffing conditions occur at low oil pressure and with the gearbox pressurized with gas generator exhaust products. Under these conditions, the new lubricant is expected to perform at least as well as the present lubricant in the presence of black oxide coating. Previously, it had been assumed that scuffing took place with an oil that had a load-carrying capacity of 2000 ppi at the time that scuffing occurred.

The conclusion reached is that the load-carrying requirements are significantly lower than previously estimated. The present conclusion regarding scuffing conditions is supported by the absence of scuffing in tests performed with the present lubricant under extreme loading conditions, low oil pressure, and an oxidizing environment, as well as the pressure of scuffing on a unit subject to nominal load, low oil pressure, and an environment containing exhaust products.

The relative performance of these oils under the severe scuffing condition described above is needed before the new lubricant is used in production units containing black-oxide-coated gears. In new gearboxes where the black oxide can be omitted, excellent antisuff performance at all gearbox conditions is predicted from laboratory tests.

The following is a summary of program objectives and accomplishments:

<u>Objectives</u>	<u>Accomplishments</u>
Gear load-carrying ability of 3000 lb/in. of tooth width as measured by the Ryder gear test.	More than 4000 ppi at EPPI Precision Inc.; 2590 and 2900 ppi at Southwest Research Institute; 3040 ppi at Alcor Laboratories Inc.
No reaction with AeroZINE 50.	No reaction with AeroZINE 50 in a 50-50% mix after 72 hr.
No sludge forming or solid precipitate with N <sub>2</sub> O <sub>4</sub> .	No sludge forming or solid precipitate with N <sub>2</sub> O <sub>4</sub> in a 50-50% mix after 72 hr.

II, Summary (cont.)

<u>Objectives</u>	<u>Accomplishments</u>
No sludge forming or solid precipitate when exposed to gas generator products.	No sludge forming or solid precipitates when exposed to NH <sub>3</sub> and water (active constituents of gas generator products) at concentrations and exposure times exceeding an engine firing. No detectable filter plugging under conditions simulating those which solidly plug the filter with the present lubricant.
Equal performance to present lubricant when contaminated with 2% of the present lubricant.	Load-carrying ability, filter plugging, propellant compatibility, and other laboratory tests indicate performance equal or better than the present lubricant. A color change from yellow to blue-green catalyzed by ultraviolet light has no effect on performance.
10-yr storage life.	Data on each constituent of the new lubricant blend show that at least a 10-yr storage life in plastic-lined containers can be expected. A blend containing the same additives at nearly the same concentrations shows no degradation after 2 yr.
No corrosion to gearbox parts.	No corrosion of gearbox parts except tarnishing of non-stainless-steel parts, such as AISI 52100 bearings and AISI 1025 bearing sleeves.
Pass aeration test by a clearing of bubbles in 4 min after violent agitation for 1 min in a Waring Blendor.	Bubbles clear in 39 sec.
Aeration performance equal to present lubricant as measured by bearing temperature rise in a 440-sec gearbox test.	New lubricant equals present lubricant.
Pass ASTM foaming test.	Pass ASTM foaming test.
Maximum viscosity of 4 centistokes at 210°F.	Three centistokes at 210°F.

## III.

CONCLUSIONS AND RECOMMENDATIONS

This section is divided into three subsections: "general conclusions," "specific conclusions," and "recommendations." Following each specific conclusion, a reference is given to portions of the technical discussion where verification of this statement is given. The conclusions presented in this section are based upon the results of laboratory and component tests which comprise Phase I of the new oil development. Phase II consists of qualification testing under actual engine operating conditions.

## A. GENERAL CONCLUSIONS

The following general conclusions were made:

(1) Laboratory and component testing have shown the following new lubricant to be the best of several candidates considered:

Base oil: 3-centistoke viscosity (at 210°F)  
naphthenic base mineral oil

Extreme pressure agent: 0.3% Ortholeum 162

Oxidation inhibitor: 0.5% Ethyl 702

Antiaeration agent: 0.1% Monsanto

Corrosion exhibitor: 50 ppi Ortholeum 535

(2) A comprehensive evaluation of this lubricant relative to the present Bray Oil used has shown that the new lubricant is superior in many areas and, therefore, warrants the further testing under actual turbopump operating conditions. Such a program could be structured to serve as a qualification program. (Advantages and disadvantages of the new lubricant are listed following these conclusions.)

(3) The most severe gear scuffing conditions for current production gearboxes with the present lubricant are low oil pressure and the displacement of oxygen by gas generator exhaust products. Under these conditions and with black-oxide-coated gears, the new lubricant should perform at least as well as the present lubricant. The new lubricant will provide double the load-carrying capacity in new gearboxes where the black oxide coating is not applied to the gear teeth surfaces. In Titan II standard production gearboxes previously run with MIL-L-7808D(1) lubricant, conversion to the new lubricant should provide equal or better performance to the MIL-L-808D(1) lubricant.

(4) A specific qualification program is not presented in this report. Program planning criteria are present, however, which outline possible problem areas that should be explored under conditions simulating those of engine firing. It is concluded that the planning philosophy for qualification programs should not be one of statistical selection of random gearboxes, but one in which the selection of test

III, A, General Conclusions (cont.)

gearboxes is made on the basis of unit histories which stress the lubricant in a manner desired.

(5) An Aerojet-General composition-type lubricant specification has been prepared defining the base stock and additives of the new lubricant formulation. Variation limits in the composition of the extreme pressure additives (Ortholeum 162 by DuPont) have been explored by Aerojet-General and DuPont, and no differences in performance were noted. DuPont agreed to perform special quality control tests on batches of this additive supplied for Aerojet-General to ensure that subsequent batches fall within the limits of the batches tested. Laboratory tests will certify the quality of each batch.

The advantages and disadvantages of new oil are summarized as follows:

<u>Advantages</u>	<u>Disadvantages</u>
1. No filter plugging	1. Cost of qualification program
2. No seal cavity deposits	2. Exhibits characteristics with unknown effects:
3. Logistics	a. Gray tarnish on AISI 52100 and soft steel parts in absence of water
a. Known composition (guaranteed future duplicate composition and performance)	b. Gray-black tarnish on AISI 52100 and soft steel parts in presence of water
b. Greater than 10-yr container storage life	c. Formation of white emulsion at water concentrations above 0.2%
4. Twice the load capacity in absence of black oxide coating on gears	3. Only equal load capacity for production black oxide coated gears
5. Load capacity is not degraded by inert gaseous atmosphere	4. Special plastic-lined oil cans are required
6. Prevention of rust on steel in presence of water	
7. Less lacquer formation on bearings	

III, Conclusions and Recommendations (cont.)

B. SPECIFIC CONCLUSIONS

The following specific conclusions were made:

(1) Laboratory test results indicate that the new lubricant warrants further testing under actual turbopump operating conditions. Such a program could be structured to serve as a qualification program.

(2) The lubricant load-capacity requirements of Titan first-stage gearboxes are significantly lower than previously estimated:

(a) Gear loads 37% greater than normal sustained for 4700 sec will not produce scuffing with either the new oil or present oil with black-oxide-coated gears. With black-oxide-coated gears, the present oil rates 2300 ppi, and the new oil rates 1500 to 2300 ppi in the Ryder gear tests.

(b) In an inert gaseous atmosphere (simulating a turbine seal leak), the present lubricant rates only 1400 ppi in the Ryder Gear test.

(c) In an oxidizing atmosphere, the reduction in lubricant flow to increase the scuffing tendency resulted in a structural failure (overheating) of the pinion teeth rather than a scuffing failure.

(d) A gear tooth profile change (tip relief) accomplished in 1960 has virtually eliminated scuffing at normal lubrication jet pressures.

(e) A combination of low lubrication jet pressures and a turbine seal leak is required to produce moderate scuffing in a 200-sec test. This is the most severe gear-scuffing condition.

(3) The load capacity of the new lubricant is not degraded by an inert atmosphere because its boundary lubrication properties depend upon the formation of iron phosphate, which does not require an oxidizer.

(4) Black-oxide-coated gears are detrimental to the load-carrying capacity of the new lubricant because the oxide coating prevents the formation of iron phosphate; in standard Ryder Gear tests, a drop from more than 4000 to 1500 ppi was observed; in Ryder Gear tests with Titan II gear materials, a drop to 2300 ppi was observed.

(5) Black oxide coating increases the Ryder Gear rating of the present lubricant from 2100 to 2300 ppi in an oxidizing atmosphere.



III. B, Specific Conclusions (cont.)

(6) Ortholeum 162 is the best extreme pressure additive of the three additives considered; didodecyl phosphate proved to be insoluble at low temperatures in concentrations required to produce a Ryder Gear rating of 3000 ppi; dicosyl phosphate gave poor Ryder Gear results.

(7) Extremes in the composition of Ortholeum 162 do not affect the Ryder Gear rating.

(8) Contamination of the new lubricant or present lubricant with 0.2% water and 0.1% AeroZINE 50 does not affect their performance in the Ryder Gear test.

(9) The usefulness of the Ryder Gear test in predicting the load capacity of experimental lubricants is limited by poor repeatability; the Ryder Gear rating of the new lubricant varied from 2590 to more than 5200 when it was extensively tested by three different laboratories.

(10) The new oil will not cause filter plugging; the present oil reacts with products from the gas generator to form ammonium azelate which quickly plugs gearbox filters.

(11) The aeration and foaming characteristics of the present and new oils are equal.

(12) The preservative properties of the present and new oils are equal, but both are poorer than those of preservative oils (such as oils meeting Specifications MIL-C-8199C and MIL-H-6083B).

(13) The new oil produces no solid precipitates when exposed to propellants, gas generator products, oil meeting Specification MIL-L-7808D(1), or water.

(14) The long-term storage of the new oil is estimated to be greater than 10 years, compared to 18 months for MIL-L-7808D(1) oil.

III, Conclusions and Recommendations (cont.)

C. RECOMMENDATIONS

The following recommendations were made:

(1) The mineral base lubricant developed in this program should be qualified for all Titan engine applications by performing turbopump assembly gearbox tests under conditions producing (1) a maximum tendency to plug filters, (2) a severe scuffing propensity, and (3) maximum contamination by foreign substances.

(2) The black oxide should be omitted on the gear tooth surfaces of all new production gearboxes to realize the full potential of the new lubricant.

(3) Although Ortholeum 162 is a satisfactory load-carrying additive for this application, research should be continued to isolate an acid phosphate compound, or mixture of acid phosphate compounds, which provide the optimum compromise between load-carrying ability and corrosiveness. It appears that both mono-acid and di-acid alkyl phosphates are needed. The molecular structure of the alkyl group should be larger than  $C_{12}$  to avoid problems of insolubility at low temperatures.

Report SSD-TR-65-161-1

IV.

TECHNICAL DISCUSSION

This section contains the following subsections: (1) description of gearbox lubrication system; (2) selection of the basic prospective formulation; (3) optimization of additives; (4) selection of a final choice of prospective lubricant; (5) evaluation of the final choice of oil; and (6) future qualification requirements for the new oil. Detailed data is given on all candidate oils considered in order to document information of value to the science and art of gearbox lubricant development.

A. GEARBOX LUBRICATION SYSTEM

The lubrication system used for cooling and lubricating the load carrying elements in the gearbox consists of a lubrication pump located in the oil reservoir, oil passages to the lubrication oil jets within the gearbox and to an oil cooler coupled to the reservoir (Figure 1). The reservoir is mounted to the accessory drive pad on the gearbox input side (turbine side) and the lubrication pump is driven by the pump gear off the accessory drive pinion. A sectional view of the first-stage turbo-pump showing this arrangement is shown in Figure 2.

The lubrication oil pressure pump identified by Number 11 Figure 1 discharges oil through Port 5 to the lubrication oil passages of the gearbox. Oil jets within the gearbox direct lubrication oil to the unmeshing teeth of each gear mesh. A drain cover, located on the lower part of the input housing and oil drain passages direct oil to the lubrication pump scavenge elements through Ports 2, 3, 6, and 7. The scavenge pumps circulate the drain oil through the oil cooler to the lubrication oil reservoir where it flows, by gravity, through the 40-micron filter element (screen) 15 to inlet 13 of the lubrication oil pressure pump 11.

B. SELECTION OF BASIC PROSPECTIVE FORMULATIONS

1. Introduction

A previous AEIP oil program was concluded with the selection of a 4 centistoke naphthenic lubricant designated Humble 3155 (Ref 1). The shortcomings of this lubricant were excessive aeration and marginal corrosiveness. Subsequently, however, two alternative load-carrying capacity additives have been synthesized, which showed a promising reduction in corrosiveness. New prospective oils having these two additives plus the Humble 3155 formulation modified with an improved anti-aeration additive were proposed as new candidates. These three initial candidates were as follows:

Candidate No. 1: 4-centistoke naphthenic base lubricant  
0.25% didodecyl phosphate (Monsanto)  
0.5% Ethyl TOE  
0.01% Monsanto PC-1244

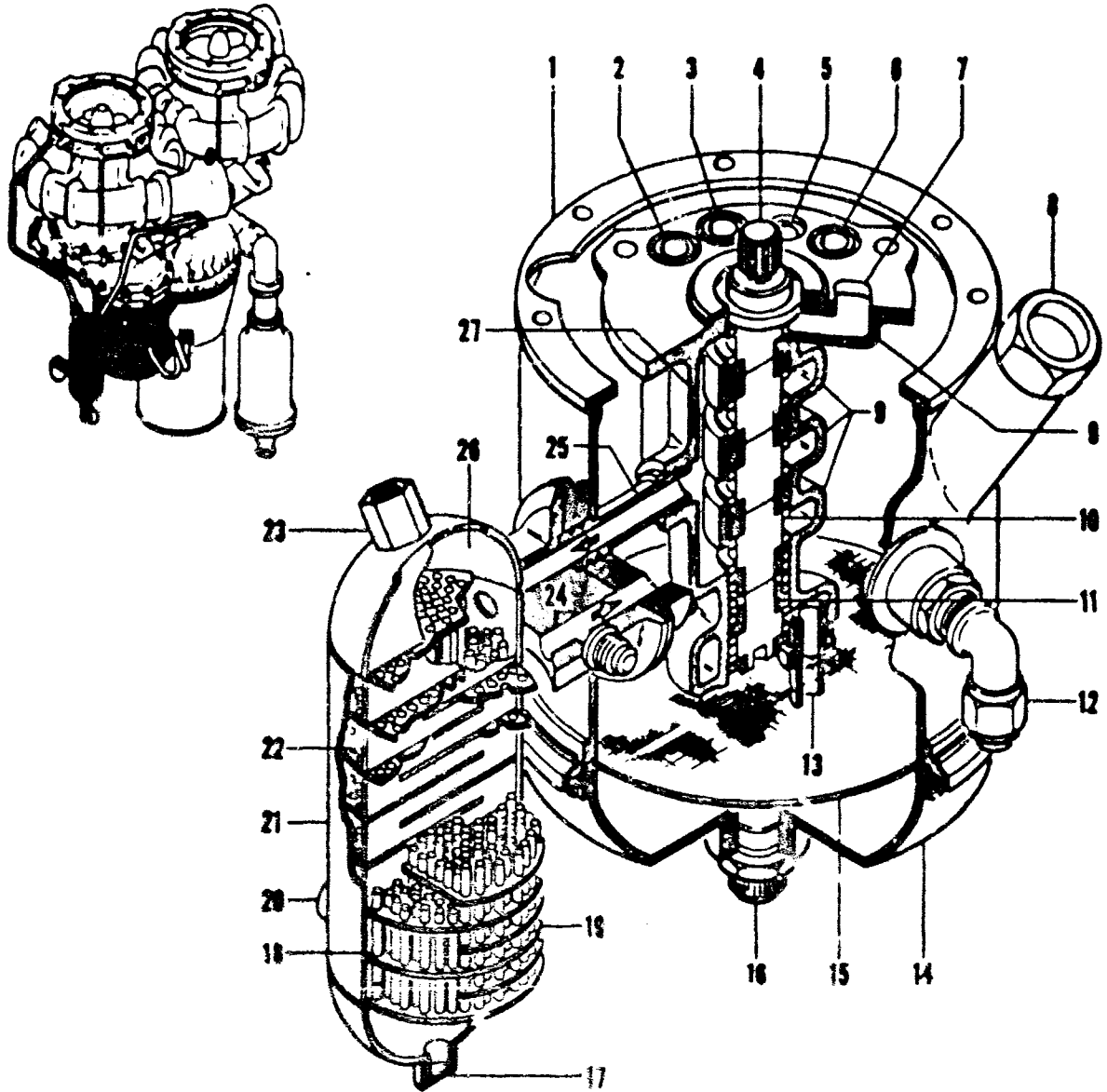

- |                                       |  |
|---------------------------------------|--|
| 1. OIL RESERVOIR ASSEMBLY             | 15. OIL SUMP FILTER ELEMENT                      |
| 2. NO. 4 SCAVENGE PUMP INLET PORT     | 16. OIL SUMP DRAIN                               |
| 3. NO. 3 SCAVENGE PUMP INLET PORT     | 17. FUEL DRAIN PORT                              |
| 4. LUBE PUMP DRIVE SHAFT              | 18. FUEL (COOLANT) TUBE BUNDLES                  |
| 5. PRESSURE PUMP DISCHARGE PORT       | 19. OIL BAFFLES                                  |
| 6. NO. 2 SCAVENGE PUMP INLET PORT     | 20. OIL DRAIN PORT                               |
| 7. NO. 1 SCAVENGE PUMP INLET PORT     | 21. OIL COOLER                                   |
| 8. FILLER PLUG                        | 22. OIL SEPARATION PLATE                         |
| 9. SCAVENGE PUMP INLET MANIFOLDS      | 23. FUEL OUTLET PORT                             |
| 10. SCAVENGE PUMPS (TYPICAL 4 PLACES) | 24. OIL COOLER DISCHARGE LINE                    |
| 11. PRESSURE PUMP                     | 25. OIL COOLER INLET LINE                        |
| 12. PRESSURIZATION INLET PORT         | 26. FUEL (COOLANT) OUTLET CHAMBER                |
| 13. PRESSURE PUMP INLET PORT          | 27. COMMON DISCHARGE MANIFOLD FOR SCAVENGE PUMPS |
| 14. OIL SUMP                          |  |

Figure 1. Lubrication System

### 87-5 TURBOPUMP ASSEMBLY (CUTAWAY VIEW)

- |   |                                   |
|---|-----------------------------------|
| 1 OXIDIZER PUMP ASSEMBLY (REF)          | 12 TURBINE ASSEMBLY               |
| 2 FUEL PUMP ASSEMBLY (REF)              | 13 TURBINE (INPUT) SHAFT          |
| 3 FUEL GEARBOX SEAL ASSEMBLY            | 14 ROLLER BEARING (TYPICAL)       |
| 4 FUEL (OUTPUT) SHAFT                   | 15 GEARBOX (INPUT) HOUSING        |
| 5 GEAR (FUEL SHAFT)                     | 16 DRIVE GEAR                     |
| 6 ACCESSORY GEAR (LUBRICATION OIL PUMP) | 17 GEAR (OXIDIZER SHAFT)          |
| 7 OIL COOLER                            | 18 GEARBOX (OUTPUT) HOUSING       |
| 8 FILTER SCREEN                         | 19 BALL BEARING (TYPICAL)         |
| 9 LUBRICATION OIL PUMP                  | 20 OXIDIZER (OUTPUT) SHAFT        |
| 10 LUBRICATION OIL RESERVOIR            | 21 BEARING RETAINER (TYPICAL)     |
| 11 IDLER GEAR                           | 22 OXIDIZER GEARBOX SEAL ASSEMBLY |

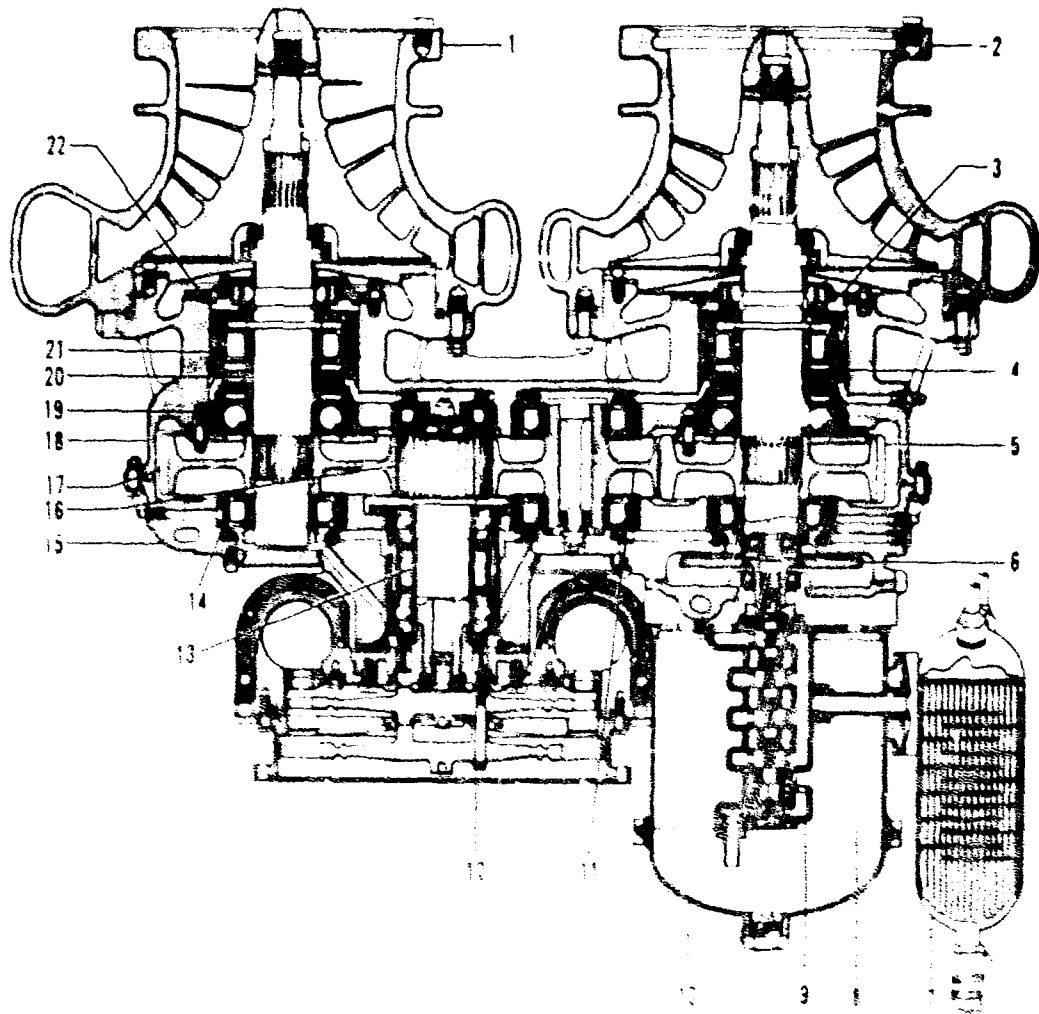

Figure 2. Turbopump Assembly (Cutaway View)

## IV, B, Selection of Basic Prospective Formulations (cont.)

Candidate No. 2: 4-centistoke naphthenic base lubricant  
 0.5% dicresyl phosphate (Monsanto)  
 0.5% Ethyl 702  
 0.01% Monsanto PC-1244

Candidate No. 3: 4-centistoke naphthenic base lubricant  
 0.20% Ortholeum 162 (DuPont)  
 0.5% Ethyl 702  
 0.01% Monsanto PC-1244

The selection of basic formulations involved the choice of the number, types, and amounts of additives for a mineral base oil. Major effort was directed toward the selection of the extreme pressure additives, since the proper balance between scuffing limit and lubricant corrosiveness is of major importance. Tentative amounts of each additive in the three new candidate lubricants were selected by judgement and experience.

## 2. Base Lubricant Selection

The base lubricant selected is a super-refined naphthenic base mineral oil made by Humble Oil Company and designated 3153. The mineral base oil provides a large improvement in chemical compatibility with AeroZINE 50 and nitrogen tetroxide. This base stock has a proven 20-year storage life and has good low-temperature properties. This lubricant is manufactured by processes developed at Pennsylvania State University for the U.S. Air Force by Drs. M. R. Fenske and E. E. Klaus (Ref 2).

The term "super-refined" refers to additional processing beyond that normally employed in the manufacture of conventional lubricant. Super-refining improves the physical and chemical properties by removing undesirable nitrogen- and oxygen-bearing compounds and chemically modifying or removing the aromatics. It is unavoidable that this process also removes a few desirable components, such as natural oxidation inhibitors and anti-wear agents, but this is offset by an increased susceptibility to desirable additives. As with any mineral oil, a pressurized system blanketed with nitrogen will greatly increase the temperature capabilities of the lubricant by minimizing oxidation and evaporation.

The Humble 3153 base stock can be described as the lubricant with a low viscosity and a low viscosity index. The pour point is about -30°F. It is a high-temperature-resistant fluid for use in the temperature range of -30 to +350°F. Its properties are as follows:

Specific Gravity at 60°F	0.863 ± 0.005
Flash Point, COC, °F, min.	325
Fire Point, COC, °F, min.	360
Water Content, Karl Fischer, % Max.	0.01
Pour Point, °F Max.	-30
Distilled at 330°F, 10-mm Pressure	5% Max.
Kinematic Viscosity at 100°F, cstk	14.2 ± 0.7

## IV, B, Selection of Basic Prospective Formulations (cont.)

Kinematic Viscosity at 210°F, cstk	3.10 ± 0.15
Viscosity Index Min.	67
Keut. No.	0.03
Molecular Weight	296
Storage Life	20 Years
Corrosiveness	Negligible

Two different viscosities (3 and 4 centistokes at 210°F) of this mineral oil base were considered. The 4-centistoke base provides slightly better load-carrying capacity, and the 3-centistoke has better anti-aeration characteristics. It was previously determined that 4-centistoke oil was the maximum viscosity which could be used in this application because of high oil pump pressure at the start-up in the gearbox at temperatures below +15°F.

3. Selection of Additives

Selection of additives was a rather complex problem because the interaction of the additives with the gearbox materials and propellants must be considered, as well as the performance requirements of high load capacity, low aeration characteristics and good thermal stability. In formulating a new prospective oil, the number of additives was to be kept at a minimum.

The additives that appear in each batch consist of extreme pressure additives (alkyl acid phosphates), an anti-oxidant agent (Ethyl 702), a defoamer and anti-aeration agent (Monsanto PC-1244).

An anti-corrosive additive (Ortholeum 535) was considered for certain blends.

a. Extreme Pressure Additives

High-load-capacity lubricants frequently require an additive to develop lubricating films which are more resistant to rupture than the film strength of the base oil. The anti-scuff properties of the prospective oils depend upon the surface reaction of the extreme pressure additives with gear materials (Ref 3, 4, 5, and 6). It is believed that the mechanism of additive anti-scuff action is the formation of a low-shear compound which allows asperities to be worn away in an orderly manner rather than welding together and causing scuffing. The surface activity must be a correct balance between corrosion and anti-scuff activity. The interaction of all of the above influences on additive anti-scuff behavior are not completely understood; however, many commercial lubricants use extreme pressure additives to enhance load carrying capacity.

The availability of a low-viscosity mineral oil for lubrication of high-speed gearboxes, such as those used in the Titan II engine, is limited by the commercial availability of a boundary lubrication additive which will provide the required anti-scuff properties at a low viscosity. The initial requirement of this program was that an extreme pressure (E.P.) additive for Titan II application should

IV, B, Selection of Basic Prospective Formulations (cont.)

give a Ryder Gear rating of 3000 lb/in. and not be corrosive to silver-plated bearing cages and other gearbox materials. The Ryder Gear rating requirement was based on the assumption that the present MIL-L-7808D(1) oil, which had a rating of 2000 lb/in., was responsible for an incipient scuffing condition which was present in the gearbox.

On the basis of previous work conducted (Ref 1), it has been determined that the impurities in tricresyl phosphate are the active species in providing anti-scuff properties. It would appear, therefore, that the synthesis of these impurities to a high degree of purity should provide a reliable method of increasing the load capacity of low viscosity mineral oils. To this end, two new additives--didodecyl phosphate and dicresyl phosphate--were synthesized and evaluated, besides the existing anti-scuff Ortholeum 162 additive.

Ortholeum 162\* is a commercial product which can be used to provide gear anti-scuff performance. This additive is a mixture of mono- and di-acid phosphates at an approximate 50:50 ratio. It has been found that both mono- and di-acid phosphates are required for good extreme pressure activity. This commercial product of DuPont is readily available at a reasonable cost. Its properties are:

Acid No. ASTM. D-664	270
Phosphorus % by Weight	10
Solubility in Mineral Oil	In all proportions
Decomposition Temperature	355°F

b. Anti-Oxidant

Ethyl 702 oxidation inhibitor was jointly agreed upon between Aerojet and Dr. Beerbower from the Esso Research Product Division. Other major oil companies have also had good experience with the Ethyl 702 additive in similar applications.

This additive is used to prevent formation of lacquer or varnish deposits on hot running gearbox parts. Its chemical structure is as follows:

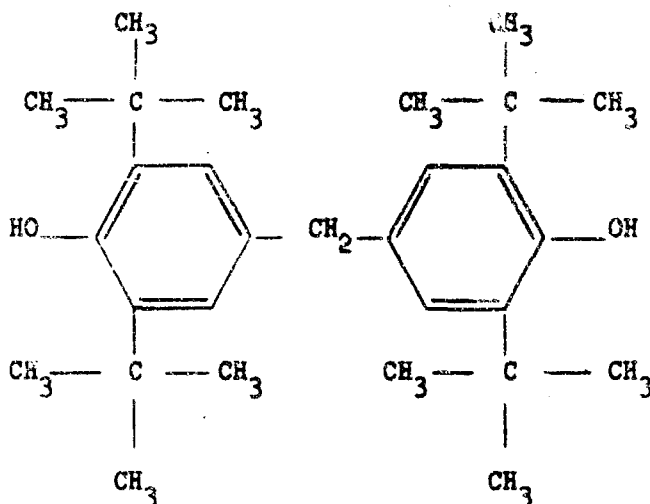

\*Du Pont registered trademark



IV, B, Selection of Basic Proprietary Formulations (cont.)

4, 4 Methylenebis (2,6 - di-tert-butylphenol)

Properties:

Form	Powder
Color	Light yellow
Molecular Weight	424
Flash Point	424°F
Solubility in Mineral Oil at 0°F	1.0 to 1.5% by weight

c. Anti-Aeration Additive

An anti-aeration additive, Monsanto PC-1244, was introduced to improve the "coolant" characteristics of the mineral base lubricant by reducing the number of air bubbles entrapped in the lubricant during gearbox operation. This additive was successfully used in England to solve aeration problems with turbojet engines. It is produced by the Monsanto Chemical Company under the name of PC-1244 Defoamer. This proprietary organic polymer is highly effective in acidic or neutral mineral base oils. It is completely soluble in mineral oils within the recommended dosage of 1 ppm to 0.2% by weight and has a long storage life.

d. Corrosion Inhibitor

To prevent the formation of a "Vaseline-type" deposit formed on the low-alloy steels in the presence of water and to reduce the degree of gray tarnish on similar steels, Ortholeum 535,\* alkyl ammonium mixed alkyl acid phosphate was introduced. Its properties are:

Solubility in Hydrocarbons	Completely miscible
Phosphorous Content	6.8% by weight
Acid No. ASTM D-664	187

C. OPTIMIZATION OF ADDITIVES

The purpose of this section is to present results of tests performed to establish the best concentration of each of the additives for each of the basic formulations described in Section IV,B.

1. Anti-scuff Additives

Considerable effort was spent on the optimization of the anti-scuff additives because these additives play the most important part in formulation of the candidate oils.

The estimated amounts of each three E.P. additives required to give a Ryder Gear value of 3000 ppi are shown below:

\*Du Pont registered trademark.

## IV, C, Optimization of Additives

Candidate No. 1: 0.25 Didodecyl phosphate 0.0181%P  
 Candidate No. 2: 0.50 Diclesyl phosphate 0.0562%P  
 Candidate No. 3: 0.25 Ortholeum 162 0.0262%

Three different amounts of each E.P. additive were evaluated in each basic formulation.

The following Ryder Gear tests have been conducted on each of the three prospective E.P. additives:

Batch No.	Oil, cstk	DDP, <sup>(1)</sup> %	DCP, <sup>(2)</sup> %	Orth. 162, <sup>(3)</sup> %	Ethyl 702, %	Monsanto PC-1244	Ryder Gear Value, ppi <sup>(4)</sup>
10	4	---	---	0.15	0.50	0.01	3043
11	4	---	---	0.20	0.50	0.01	4175
12	4	---	---	0.25	0.50	0.01	5135
13	4	0.20	---	---	0.50	0.01	7610
14	4	0.35	---	---	0.50	0.01	8015
15	4	0.50	---	---	0.50	0.01	7950
16	4	---	0.20	---	0.50	0.01	1525
17	4	---	0.35	---	0.50	0.01	1190
18	4	---	0.50	---	0.50	0.01	1385

(1) DDP = Didodecyl phosphate

(2) DCP = Diclesyl phosphate

(3) Ortholeum 162

(4) ppi = lb/in.

The test revealed extreme weakness of diclesyl phosphate which did not change the strength of the oil despite its heavy concentration of 0.5% by weight. This additive has also shown a very poor stability when reacting with ammonia, which is one of the constituents of the products of combustion. A solid yellow precipitate has been found in the test tube. This type of precipitate would have caused great damage to filter and nozzles of the gearbox in case of leakage of the products of combustion into the gearbox. Therefore, it has been decided to eliminate diclesyl phosphate from the oil program. The other two additives favorably passed chemical compatibility tests and were selected for further Ryder Gear evaluation.

While the Ortholeum 162 E.P. additive in the prospective oil gave steady Ryder Gear values, didodecyl phosphate gave erratic results. Investigation of this inconsistency showed that each batch of didodecyl phosphate was different from one another. Oil containing the first batch (designated Batch A) of this additive passed all of the qualification tests. The second batch (designated Batch B) of this additive was found to produce low Ryder Gear values and high metal corrosiveness. Monsanto Company produced a third batch in two portions (designated Batches C & D) which demonstrated their ability to synthesize a product of reasonable repeatability.

## IV, C, Optimization of Additives

The following summary gives data for the batches of DDP as screened by Aerojet in chemical and physical tests:

<u>DDP Batch</u>	<u>Melting Point, °C</u>	<u>Neutralization No. KOH mg/gr</u>	<u>Crystalline Structure</u>	<u>Corrosion Test</u>	<u>Ryder Gear Test</u>
A	43 to 50	341	Central	Passed	Passed
B	47 to 49	432	Parallel	Failed	Failed
C	43 to 47	331	Central	Passed	Passed
D	43 to 50	340	Central	Passed	Passed

Tests were performed to investigate the difference between the above batches and also to establish an acceptance specification for the additive. The following conclusions can be made based on the laboratory investigation:

(1) Infrared spectra of samples from Batches A and B were found to be essentially identical to each other. Minor differences between the spectra can be contributed to water. Both samples contain water; however, Batch A contains more water than Batch B. Since both samples behaved differently, the infrared spectrum analysis was considered inconclusive.

(2) A portion of Batches A and B was heated at 110°C at atmospheric pressure for 2 hr. Batch B developed an amber color while Batch A showed only slight discoloration. This is possible due to the stabilizing effect of absorbed moisture by Batch A.

(3) The melting points of Batches A and B are different.

(4) Neutralization number of Batch A is 341 mg KOH per gram of oil, while Batch B shows a neutralization number as high as 432. This number is very important in the determination of the chemical activity. It is believed that the high neutralization number of Batch B resulted from a different synthesis method employed by Monsanto Research Laboratory.

Photographs (X33) No. 1, 2, 3, and 4 of Figure 3 show different conditions of Batches A and B. Whereas Batch A shows an amorphous melted mass, Batch B shows granular material structure.

Microphotographs No. 5, 6, 7, and 8 of Figure 4 indicate a very different crystalline structure. Batch A has centrally oriented crystals, while Batch B shows parallel oriented structure. Microphotographs of Batch C show similarity with Batch A. (Figure 5). A comparison of granular appearance between Batches B and C is shown in shown in Figure 6.

Thin-layer chromatography revealed that the major difference between Batch A and Batch B was purity. Batch A contained about 5% mono-acid phosphate and 95% di-acid phosphate, while Batch B contained all di-acid phosphate (DDP). Extra

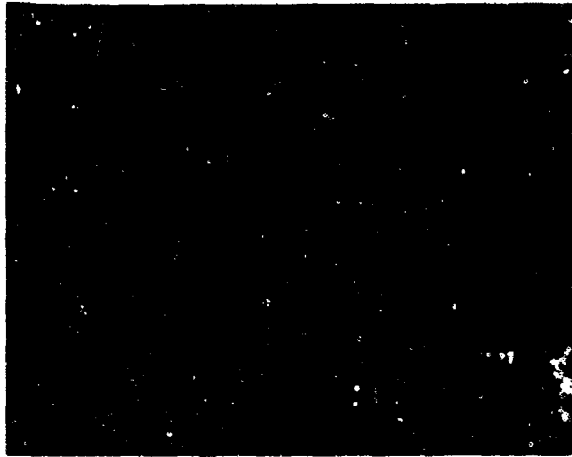

1

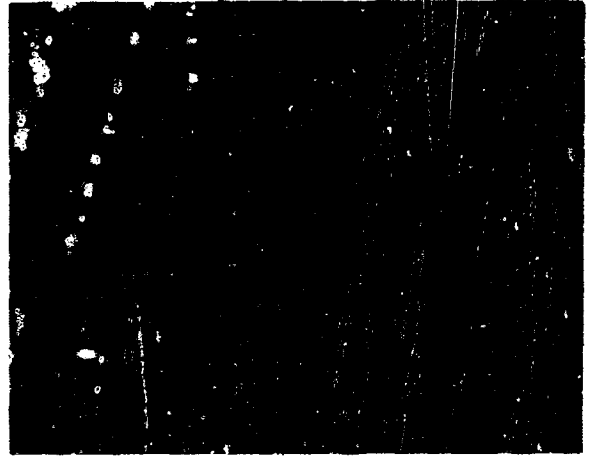

2

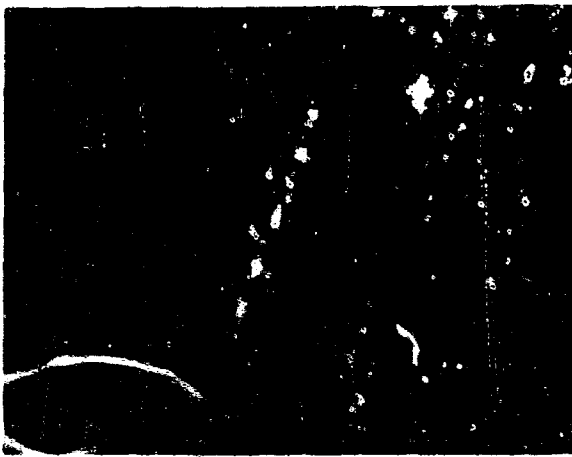

3



4

Magnification 33X

<u>Photo No.</u>	<u>Remarks</u>
1 and 3	Of original material as received, sample marked A.
2 and 4	Of original material as received, sample marked B.

NOTE: Photographs show a difference between Sample A and Sample B.

Figure 3. Condition of DDP

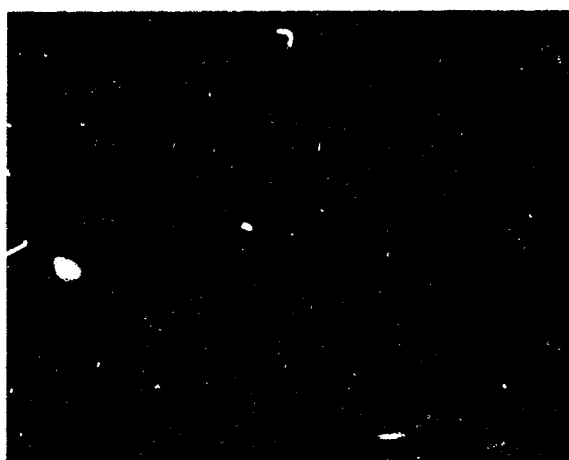

5

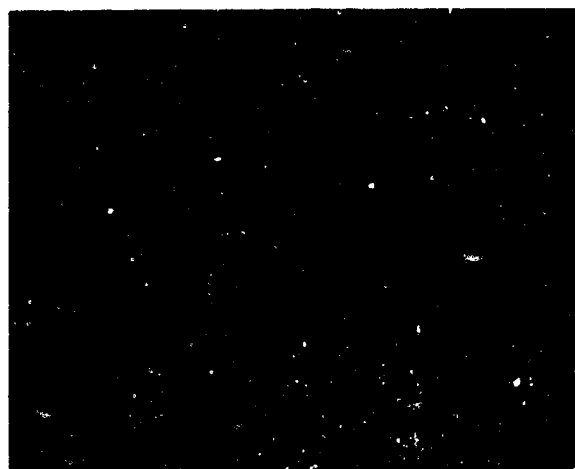

6



7

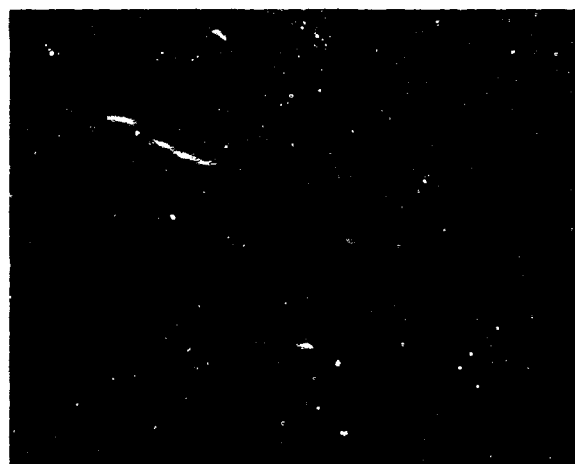

8

Magnification 84X

Photo No.	Remarks
5 and 7	Crystallization from a melt of Sample A using crossed polarizers at a magnification of 84X.
6	Crystallization from a melt of Sample B using crossed polarizers at a magnification of 84X.
8	Crystallization from a gradient melt of Samples A and B.

NOTE: Photographs show a difference between Sample A and Sample B. However both samples show an amount of eutectic melt remaining after crystallization, an indication of impurities.

Figure 4. DDP Crystalline Structure



Sample as received  
Magnification 33X

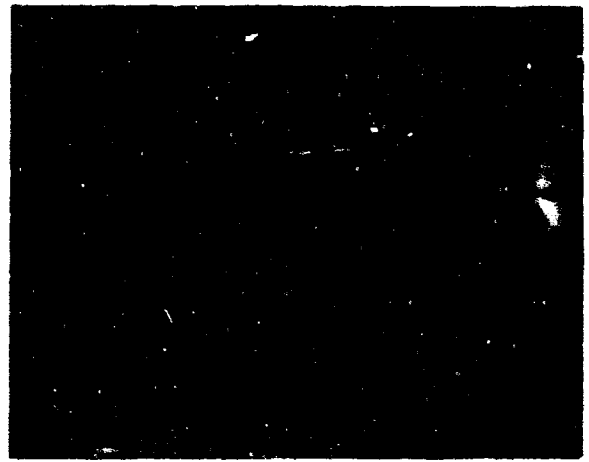

Magnification 84X  
Crystallization from melt  
taken between crossed polars.

Figure 5. DDP Sample C

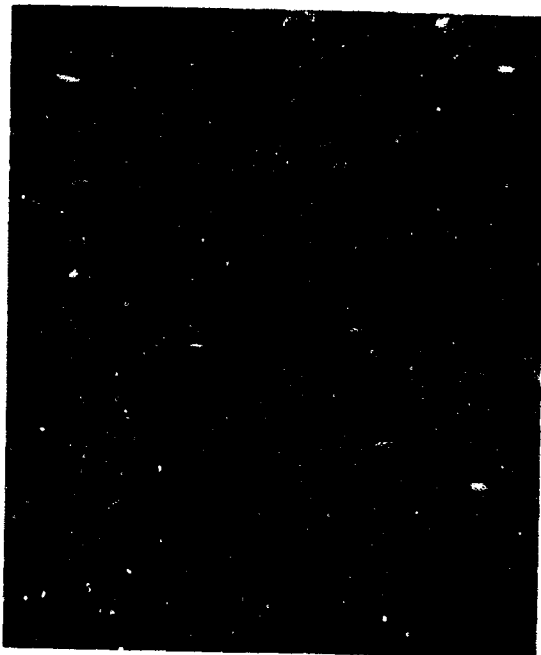

Top small spherical particles are white  
This is SAMPLE B



Lower large lumps of material are creamy in  
color. This is SAMPLE C

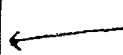

Sample B

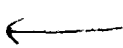

Sample C

Figure 6. DDP Comparison between Batches B and C

IV, C, Optimization of Additives (cont.)

purification steps employed in the synthesis of Batch B apparently removed the 5% mono-acid phosphate, while Batch B contained all di-acid phosphate (DDP). Extra purification steps employed in the synthesis of Batch B apparently removed the 5% mono-acid phosphate which occurred as an impurity. It is interesting to note that, contrary to initial assumptions, the presence of both mono- and di-acids are required to provide good extreme pressure lubrication.

To more readily compare and analyze data for the different E.P. additives, a neutralization number (KOH) was selected as common denominator for both E.P. additives. This number indicates the number of mg of potassium hydroxide required to neutralize acidity in one gram of oil. Ryder Gear test results with side A of the test gears is shown in Figure 7. Sides A and B test results, excluding results which differ more than 800 ppi, are shown in Figure 8.

In order to establish the required concentration didodecyl phosphate, Ryder Gear values were plotted against percent DDP in Figure 9. The characteristic response curves transposed from the KOH versus Ryder Gear value previously described are placed on this curve. According to this curve, a concentration of 0.4% DDP would be required to meet the 3000 ppi requirement in 3-centistoke base oil. It was established that 0.30% of didodecyl phosphate is the solubility limit of this additive at lower temperatures. Therefore, the optimum concentration of DDP is 0.30%, which provides a Ryder Gear value of about 2400 ppi. In the 4-centistoke oil, values of Ryder Gear were erratic but generally higher than in the 3-centistoke blend (see Figure 10).

The characteristic response curve of the 3-centistoke Ortholeum 162 oil is shown in Figure 11. This graph shows that a concentration of 0.3% is required to achieve repeatable results above the 3000-ppi level. Figure 12 shows similar results with blends containing 50 ppm (Ortholeum 535 in conjunction with Ortholeum 162). The concentration of Ortholeum 162 is selected at the minimum value meeting the Ryder Gear requirement of 3000 ppi to minimize corrosiveness to metals.

2. Oxidation Inhibitor

Ethyl 702 was selected as an oxidation inhibitor upon the recommendation and experience of the oil industry. The concentration of this additive, based upon industry experience, was established at 0.5% by weight. This inhibitor effectively prevented formation of varnish or lacquers on the gearbox parts when heated in the oil at 347°F for five days.

3. Optimization of Monsanto PC-1244 Defoamer

The optimization of Monsanto PC-1244 defoamer was accomplished with several blends of both 3- and 4-centistoke viscosity oil. Optimization test data on the 4-centistoke base oil with various amounts of E.P. additives and Monsanto PC-1244 are shown below:



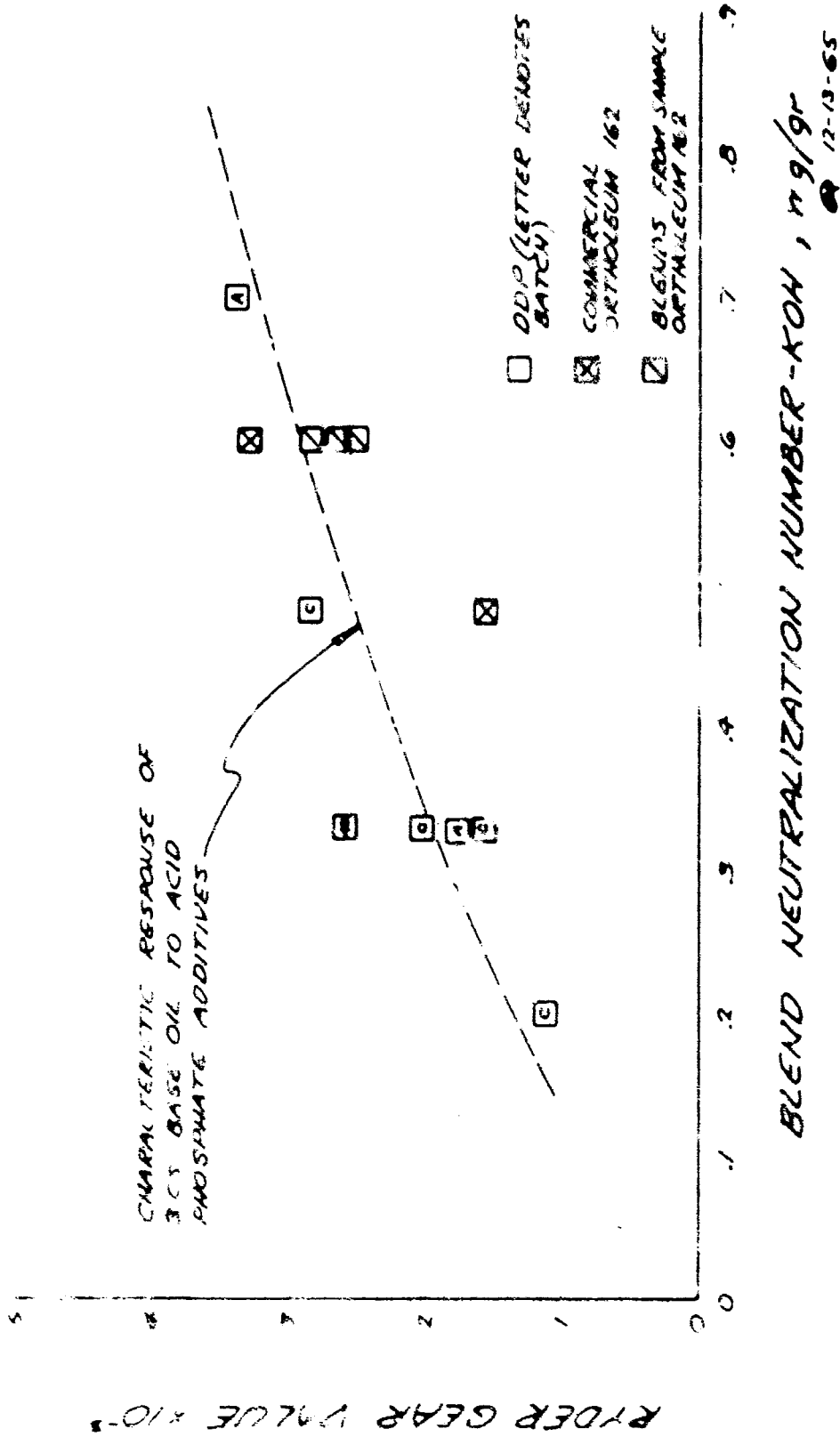
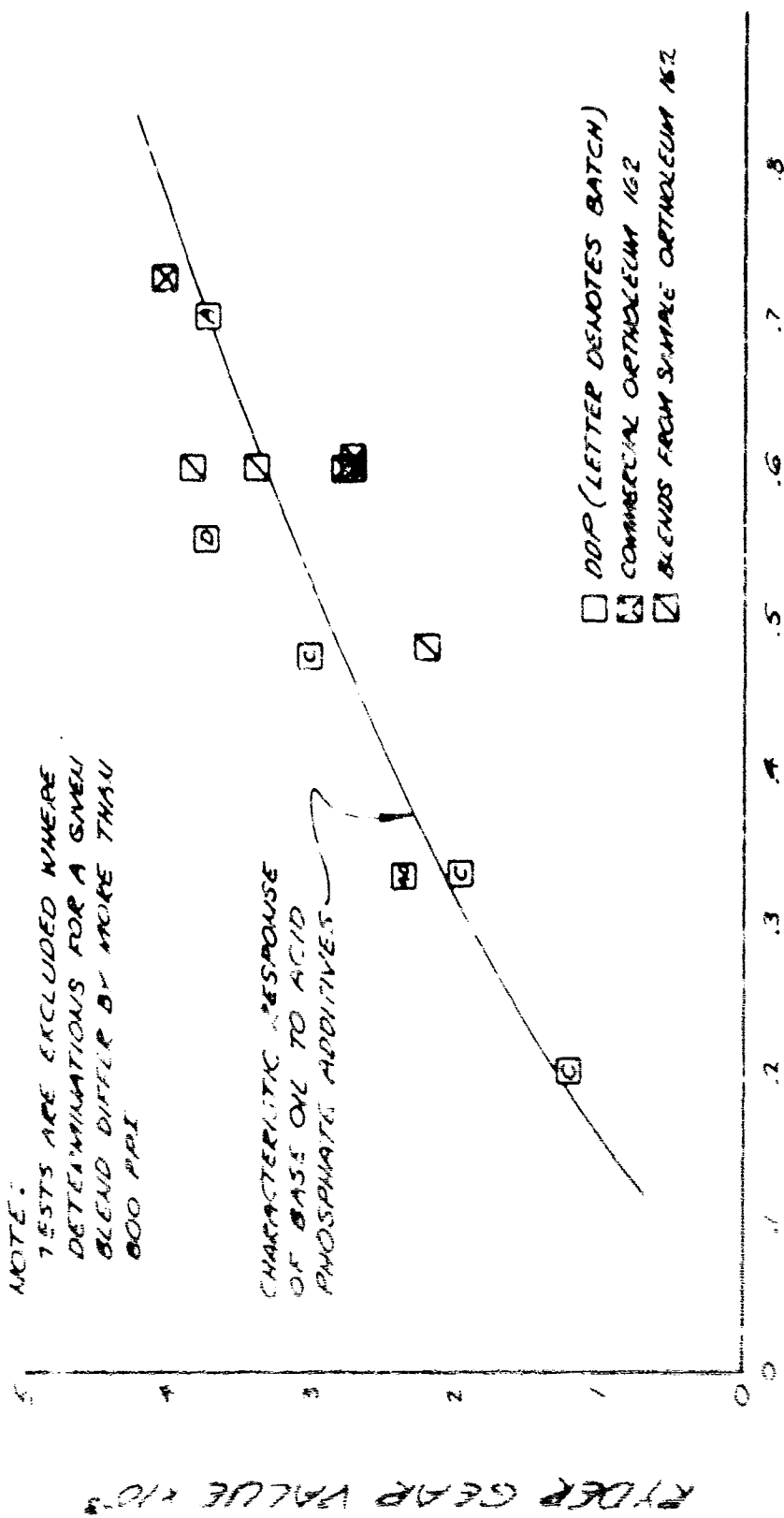

Figure 7

Ryder Gear Value (Side A Only) vs Blend Neutralization Number,  
3-C3 Base Oil

BLEND NEUTRALIZATION NUMBER-KOH, mg/9r

12-13-65



BLEND NEUTRALIZATION NUMBER - NON, mg/gr  
 CA 12-16-65

Ryder Gear Value (Sides A and B) vs Blend Neutralization Number  
 3 25 Base Oil

80 41184

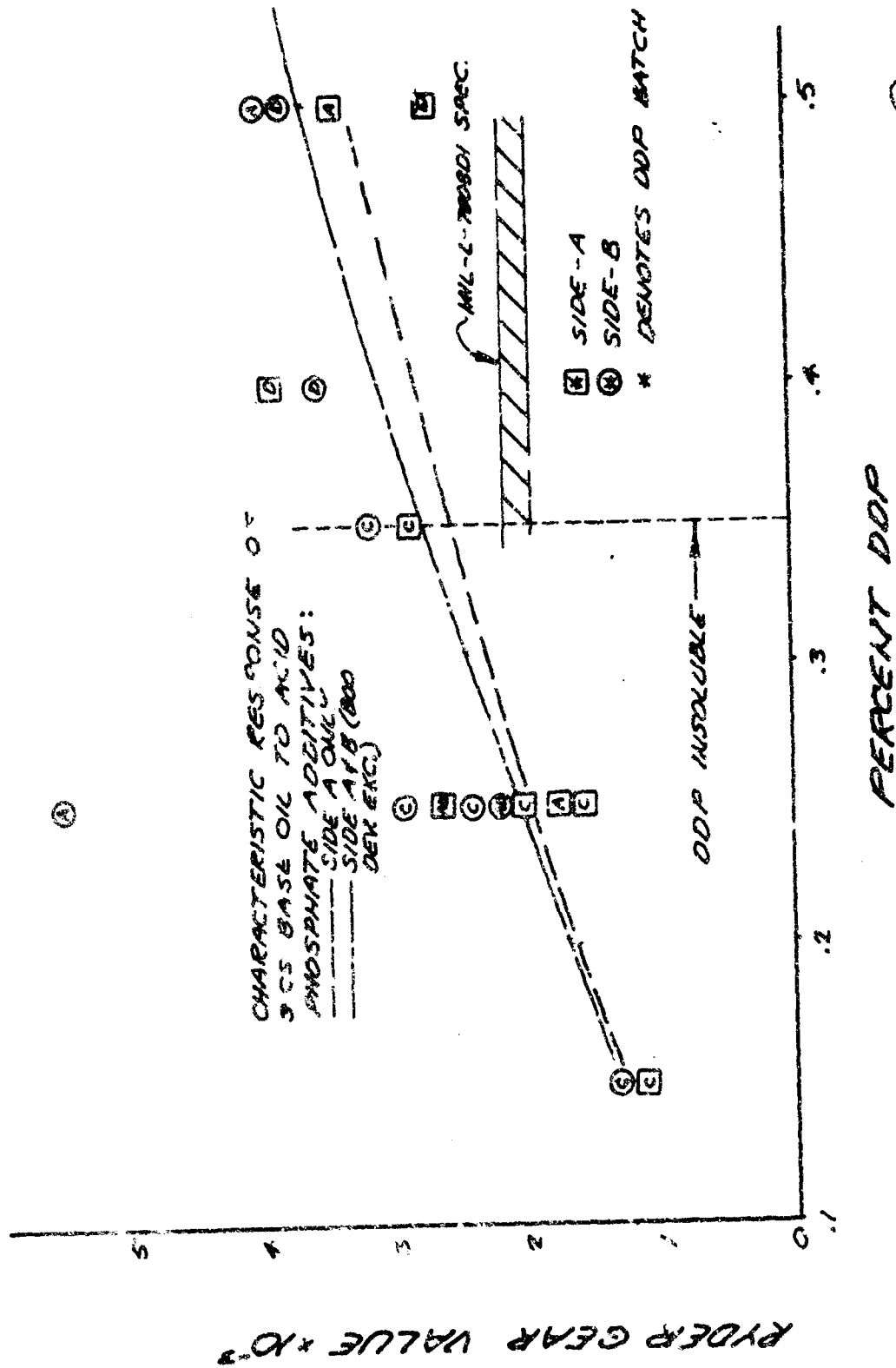

12-14-65

Figure 9

Kyder Gear Values vs DDP Concentration, 3-Centistoke Base Oil

NOTE:  
 LETTER ADJACENT  
 TO SQUARE OR  
 CIRCLE DENOTES  
 DDP BATCH.

CHARACTERISTIC RESPONSE OF 3CS  
 BASE OIL TO ACID AND/OR SODIUM ADDITIVES:  
 --- SIDE A ONLY  
 - - - - - SIDE A/B (500 DEV. ETC.)

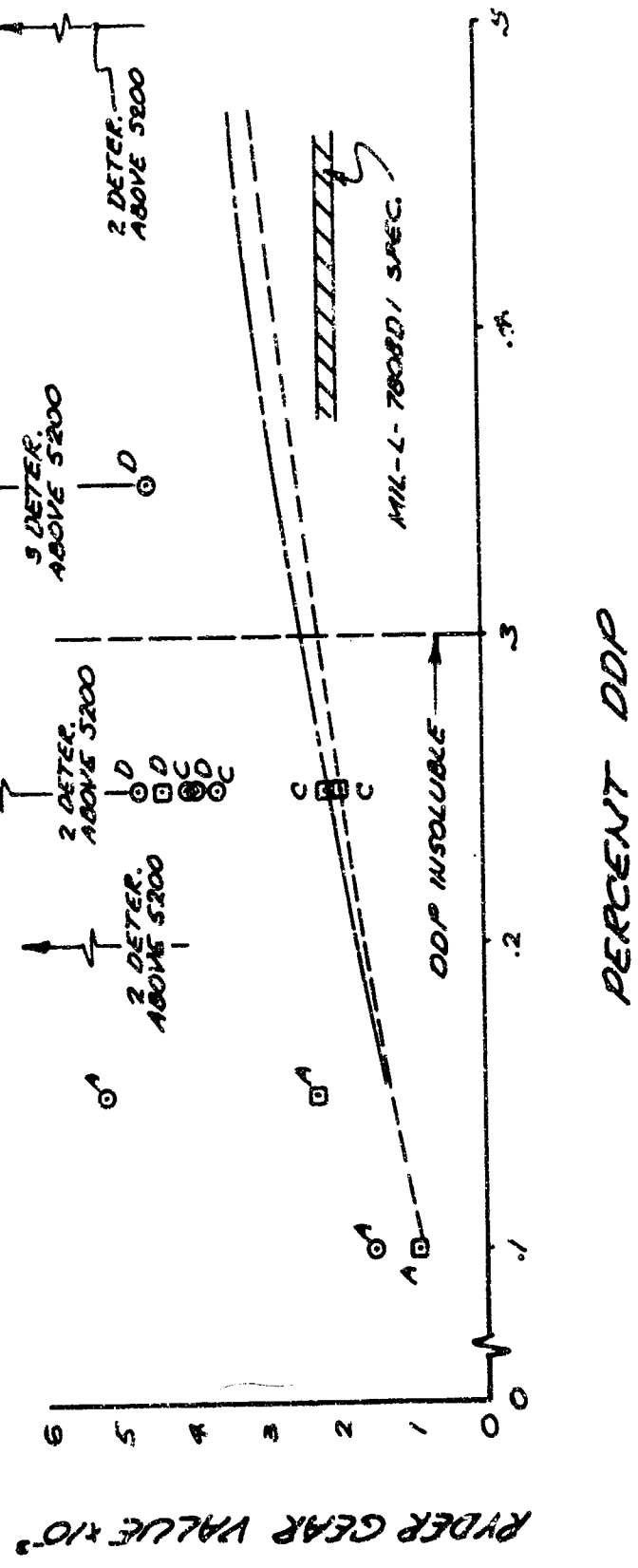

Figure 10.

1-17-66

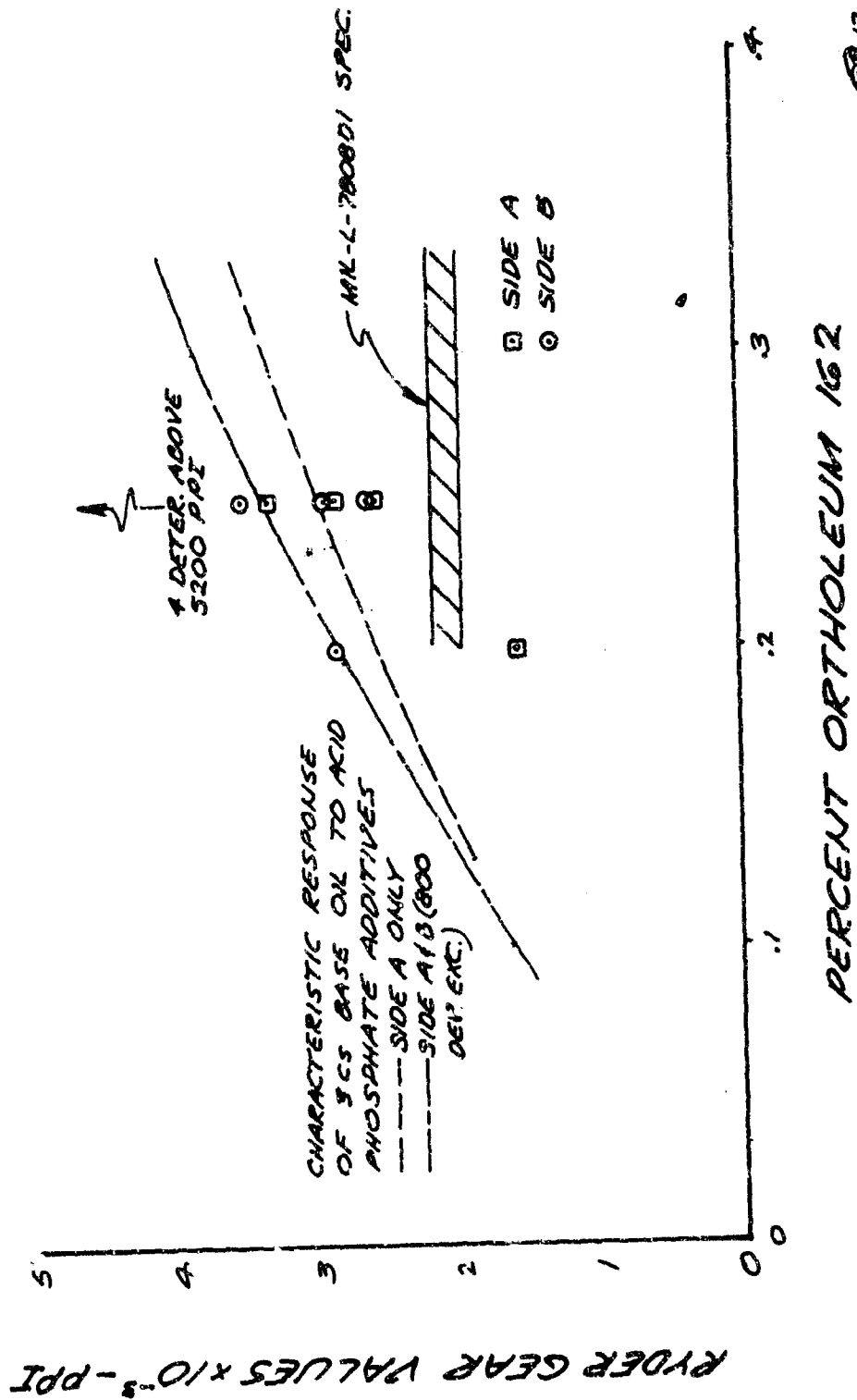
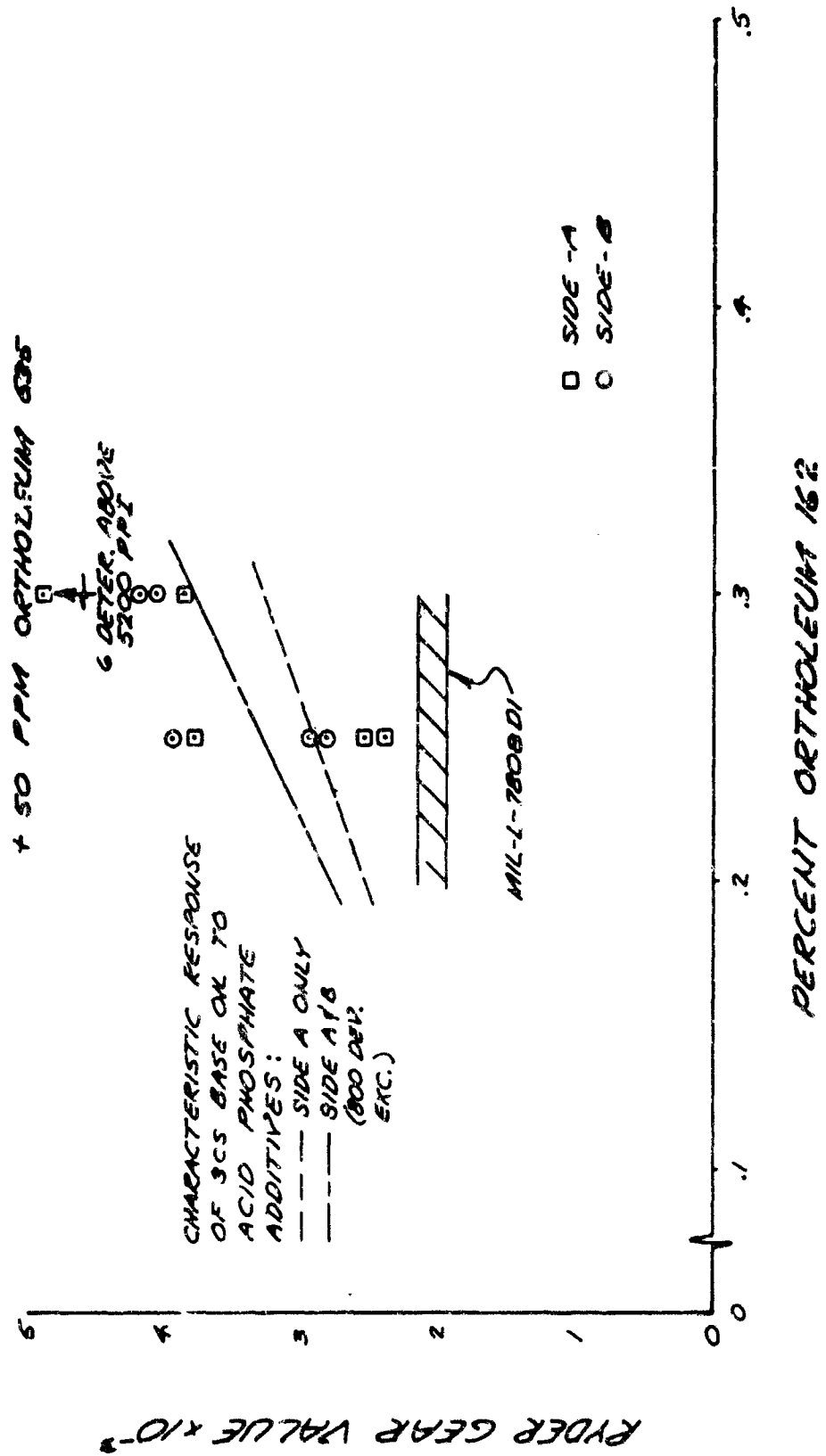

Figure 11



12-15-68

Ryder Gear Value vs Ortholeum 162 with Ortholeum 535, 3-Centistoke Base Oil

Figure 12

## IV, C, Optimization of Additives (cont.)

<u>%</u> By Weight, E.P.	<u>%</u> by Weight, Ethyl 702	<u>%</u> By Weight, Mons. PC-1244	<u>Aeration,</u> sec	<u>Foam to</u> <u>Collapse,</u> sec
0.5 DCP	---	---	67	63
0.5 DCP	0.5	---	80	55
0.5 DCP	0.5	0.005	91.6	55
<u>Candidate No. 2</u>				
0.5 DCP	0.5	0.01	81	49
0.5 DCP	0.5	0.015	94	60
0.5 DCP	0.5	0.02	92	53
0.25 DCP	---	---	90	47
0.25 DCP	0.5	---	71	55
0.25 DCP	0.5	0.005	86.8	47
0.25 DCP	0.5	0.010	81	47
0.25 DCP	0.5	0.015	75	37
0.25 DCP	0.5	0.02	87.5	43
<u>Candidate No. 1</u>				
0.25 DDP	0.5	0.01	280	200
0.25 DDP	0.5	0.005	341	175
0.25 DDP	0.5	0.010	284	207
0.25 DDP	0.5	0.015	724	260
0.25 DDP	0.5	0.02	468.7	214
0.20 Orth 162	0.5	0.005	724	107
<u>Candidate No. 3</u>				
0.20 Orth 162	0.5	0.010	1012.9	132
0.20 Orth 162	0.5	0.015	1207.6	82
0.20 Orth 162	0.5	0.02	1224.9	158
0.20 Orth 162	0.5	0.025	1337	69

Aeration tests were performed according to the Aerojet-General test method, wherein 200 ml of oil are heated to 100°F and agitated at high speed in a Waring-type blender for one min. The oil is then transferred into the 250-ml graduated cylinder, and the time (aeration sec) is recorded when the oil is clear enough to see the cylinder graduation located on the far side. The foam thickness and the time of foam collapse (foam to collapse sec) is also observed.

The 4-centistoke base oil has the rather poor aeration clearing time of 512 sec, while the 3-centistoke oil needs only 71 sec to clear. Because the three prospective oils, Candidates No. 1, 2, and 3 were made from 4-centistoke base oil, an optimized value of Monsanto PC-1244 was required to keep aeration at the lower value. The results of the aeration tests conducted with the 4-centistoke base oil can be summed up as follows:

IV, C, Optimization of Additives (cont.)

1. Base oil with dicresyl phosphate E.P. additive:  
-- excellent aeration characteristics
2. Base oil with didodecyl phosphate E.P. additive:  
-- marginal aeration characteristics
3. Base oil with Ortholeum 162 E.P. additive:  
-- unsatisfactory aeration characteristics

(Maximum allowable aeration time is 240 sec)

Over 20 additional aeration tests were performed with the oil containing Ortholeum 162, the negative results of which can be seen in Figure 13.

Test results with 4-centistoke oil containing dicresyl phosphate E.P. additive are plotted in Figure 14 and show excellent aeration characteristics. Satisfactory aeration characteristics of the 4-centistoke oil containing didodecyl phosphate, with the amount of Monsanto PC-1244 increased to 0.10%, are shown in Figure 15.

Above tests pointed out problems existing with Candidate No. 3, which contains Ortholeum 162 E.P. additive, while both Candidates No. 1 and 2 have shown good aeration characteristics.

Therefore, a decision was made to change the base oil from 4 to 3 centistokes and to increase the Ortholeum content from 0.20% to 0.25% by weight. The results of the aeration tests conducted with 3-centistoke base oil and the new amount of Ortholeum 162 are shown in Figure 16. The beneficial action of Monsanto PC-1244 is clearly seen in these tests, and its amount was established at 0.10% by weight.

Introduction of Ortholeum 535 to suppress corrosiveness of the oil further reduced aeration time of the 3-centistoke Ortholeum 162 blend (Figure 17). Comparative aeration test results are shown in Figure 18.

Details of the aeration test performed on 3-centistoke Ortholeum 162 oil (with Ortholeum 535) are shown in Figure 19. The present prospective oil, Batch No. 41, is a direct result of the above tests and has shown excellent aeration characteristics.

Final optimization of 3-centistoke oil with its additives is shown in Figure 20. The influence of Monsanto PC-1244 is clearly seen. The improvement of this blend with the addition of Ortholeum 535 anti-corrosive additive has been demonstrated. With the content of Monsanto PC-1244 at zero, the aeration exceeded the required value of 240 sec. Gradual increase of this additive helped to drop aeration time from over 700 sec to an acceptable value of 90 sec.



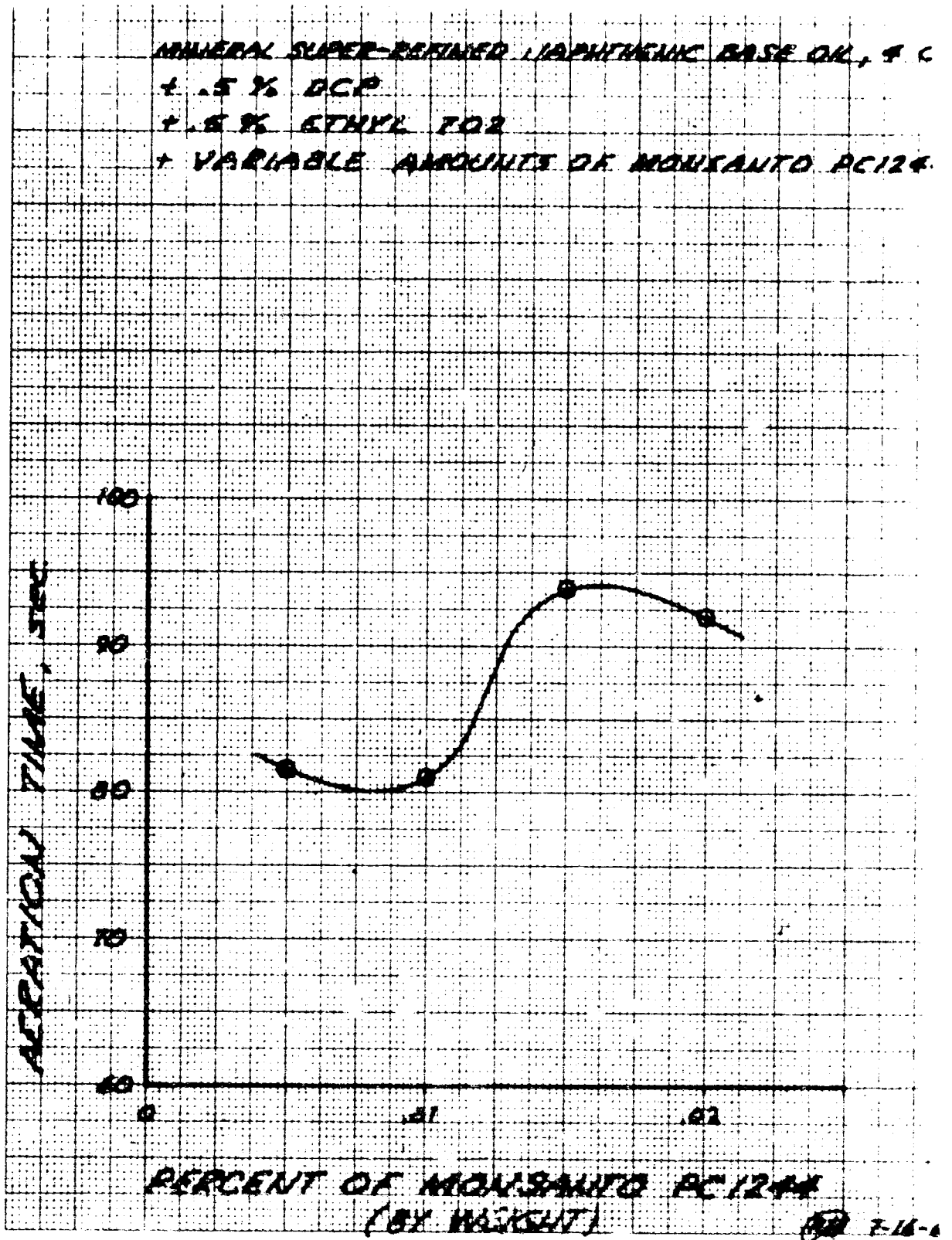

Aeration Time vs Percent of Monsanto PC-1244 (0.20% Ortholeum 162)

Figure 13

MINERAL SUPER REFINED 4CS NAPHTHENIC  
BASE OIL  
+.25% DIDODECYL PHOSPHATE  
+.50% ETHYL 702  
+ VARIABLE AMOUNTS OF MONSANTO PC-1244

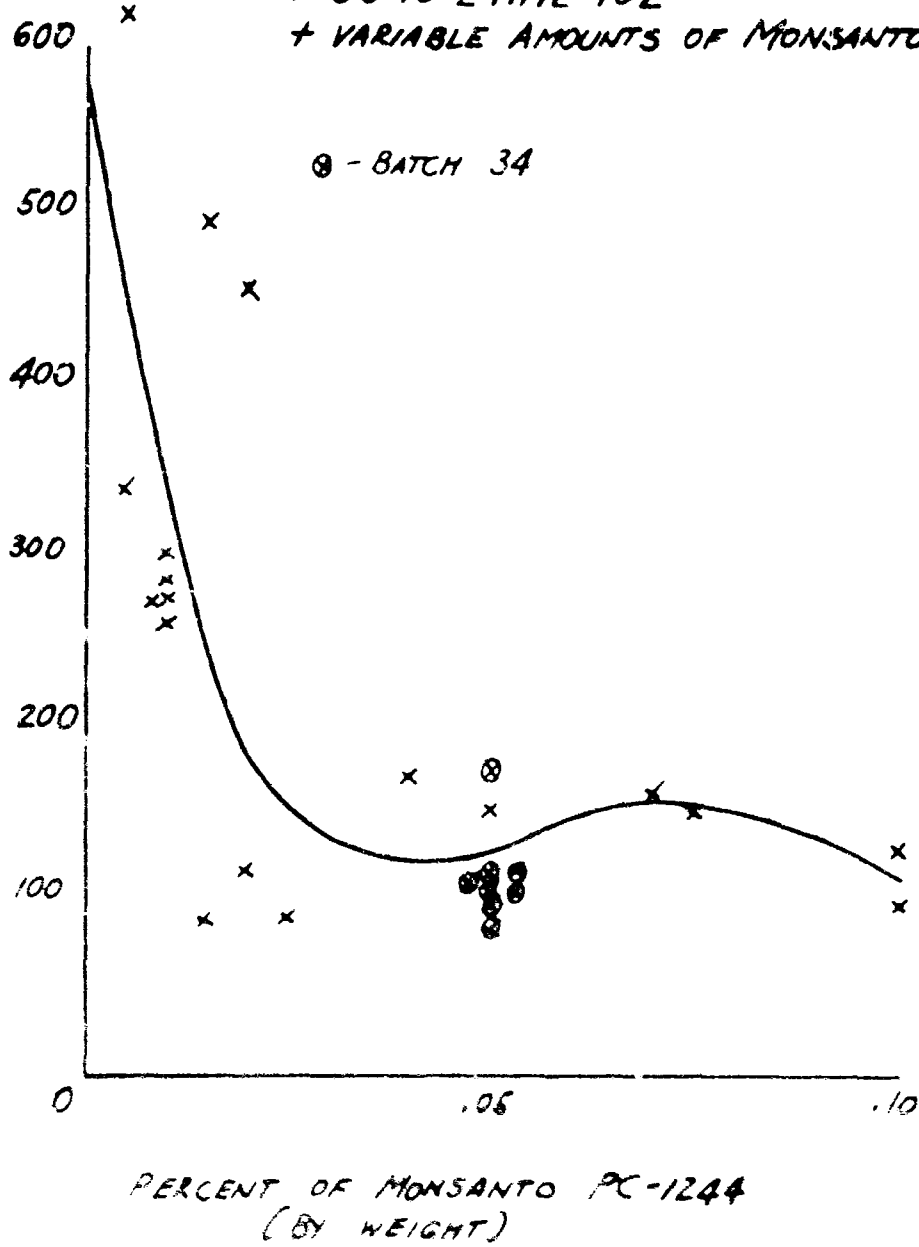

Aeration Time vs Percent of Monsanto PC-1244  
(Dioctyl Phosphate Additive)

figure 14

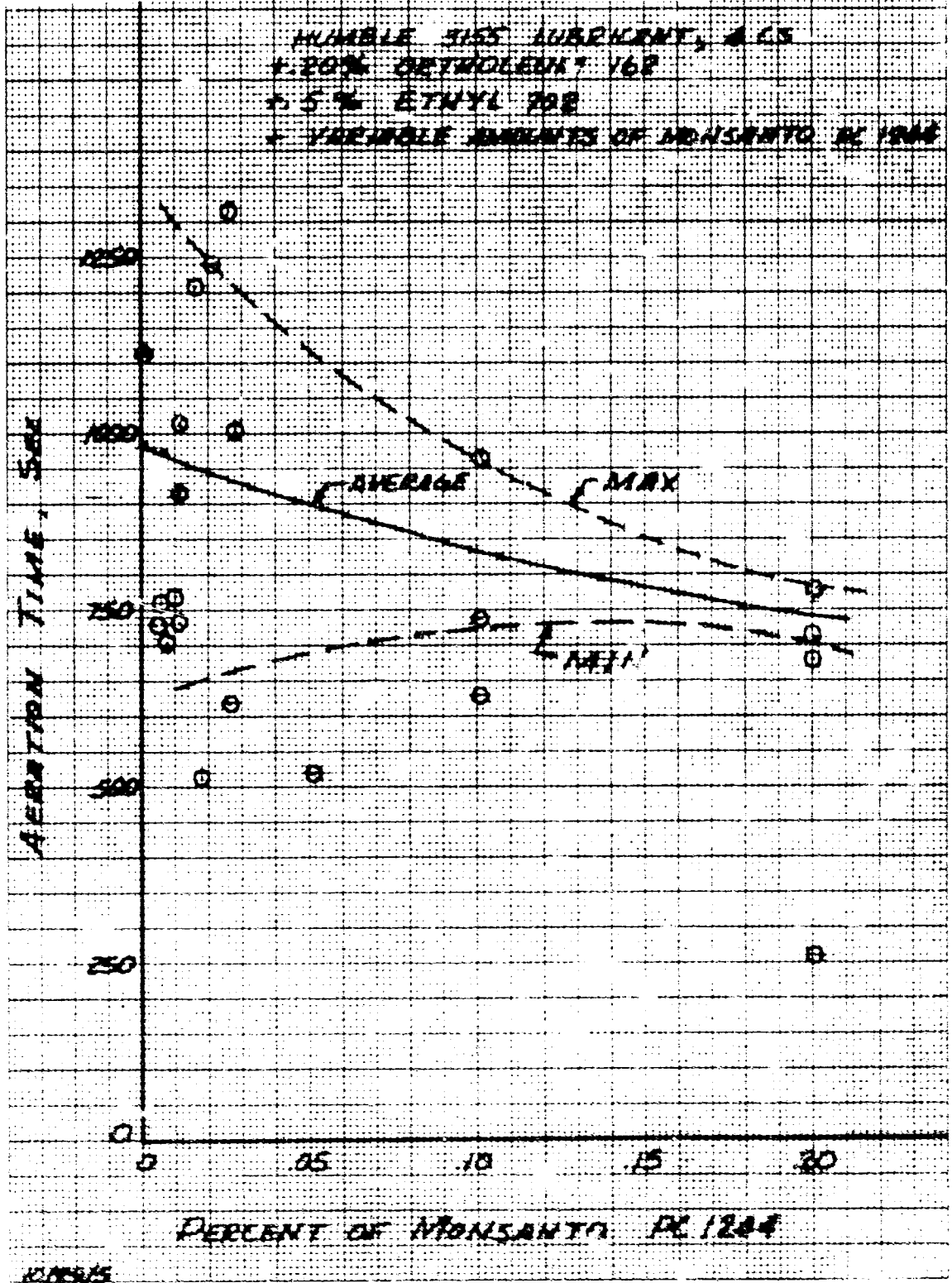

Aeration Time vs Percent of Monsanto PC-1244  
(Didodecyl Phosphate Additive)

Figure 15

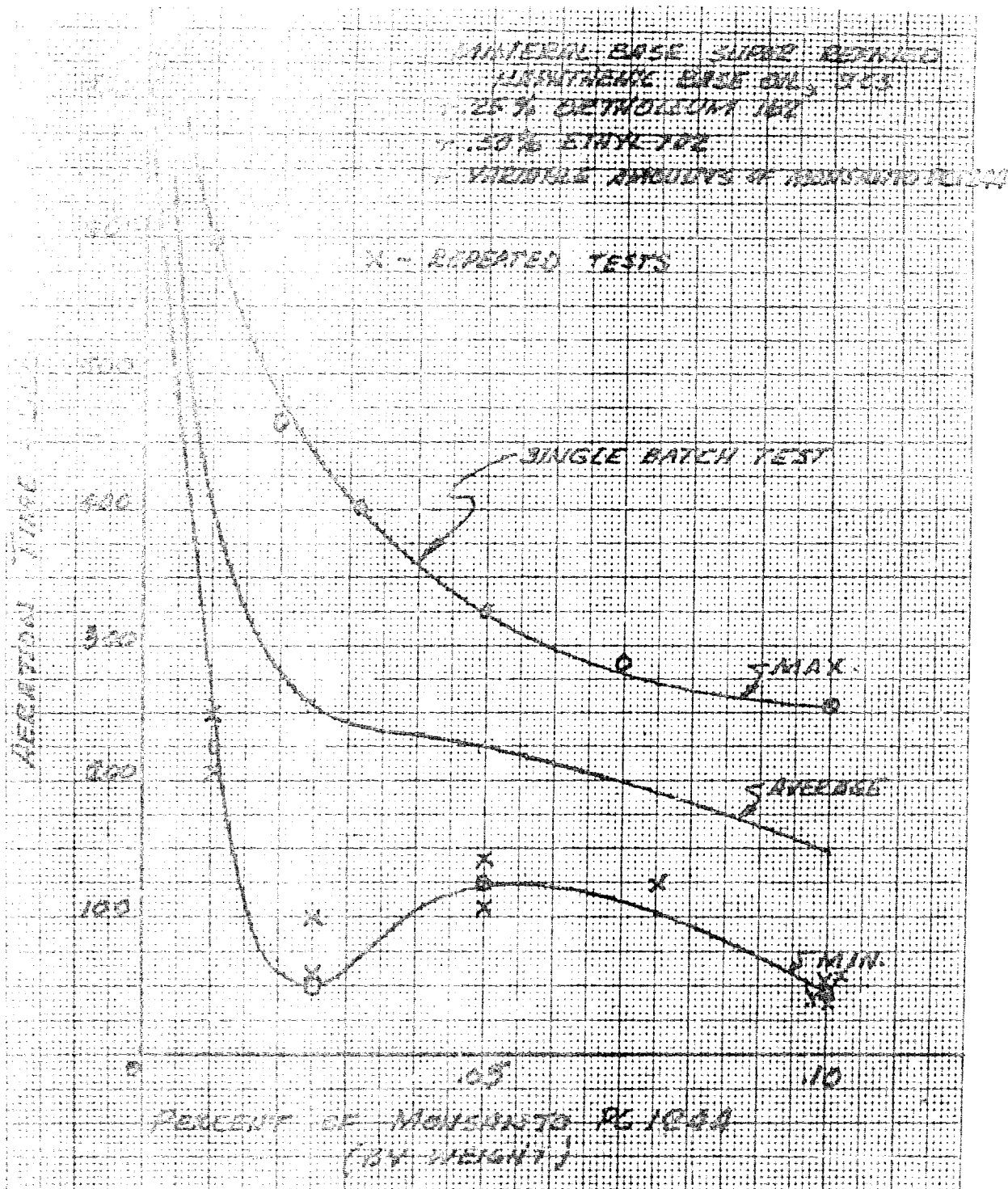

Agitation Time vs Percent of Monsanto PC-1244, Batch 21

Figure 16

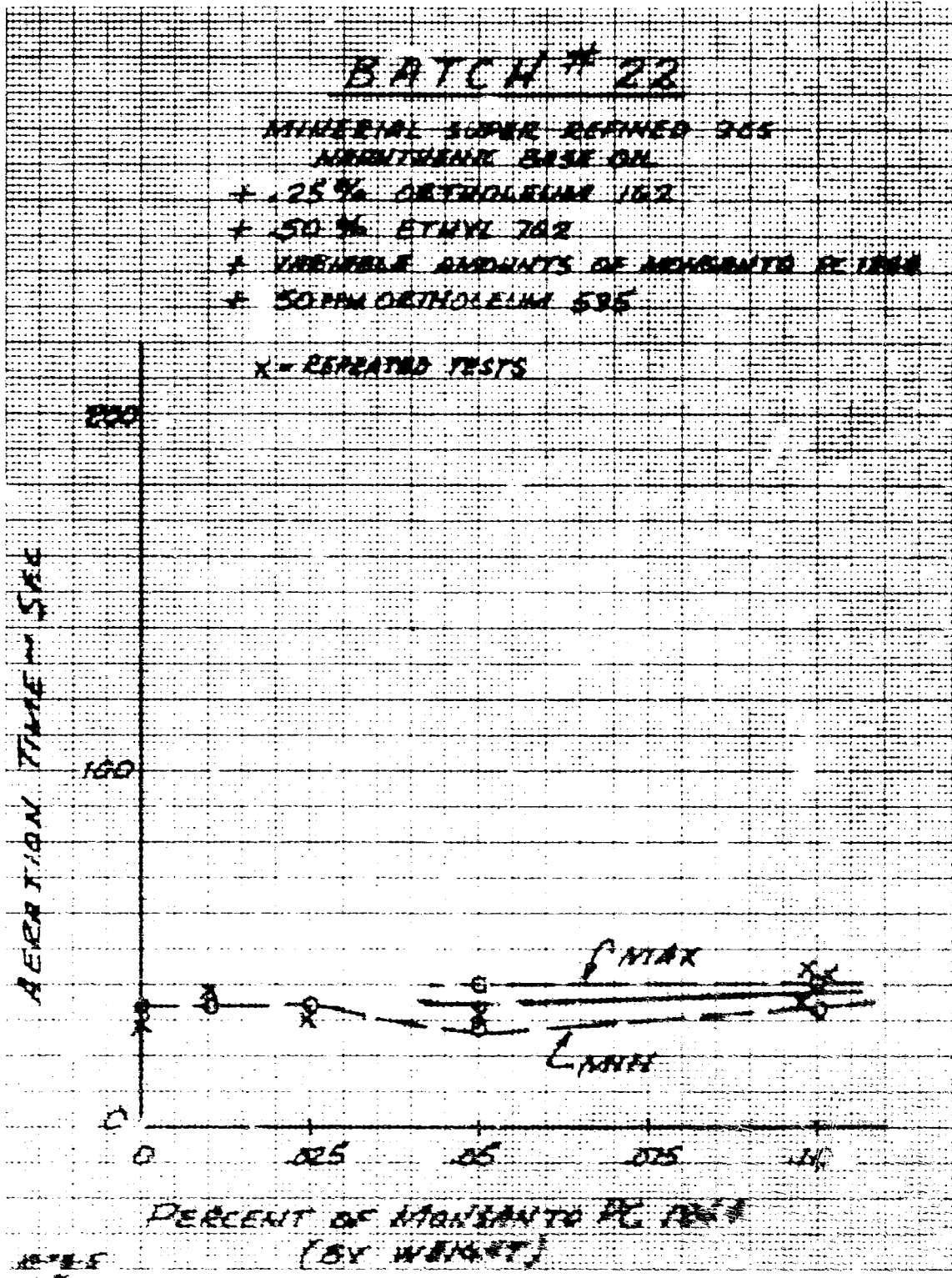

Aeration Time vs Percent of Nonsanto PC 104, Batch 22

Figure 17

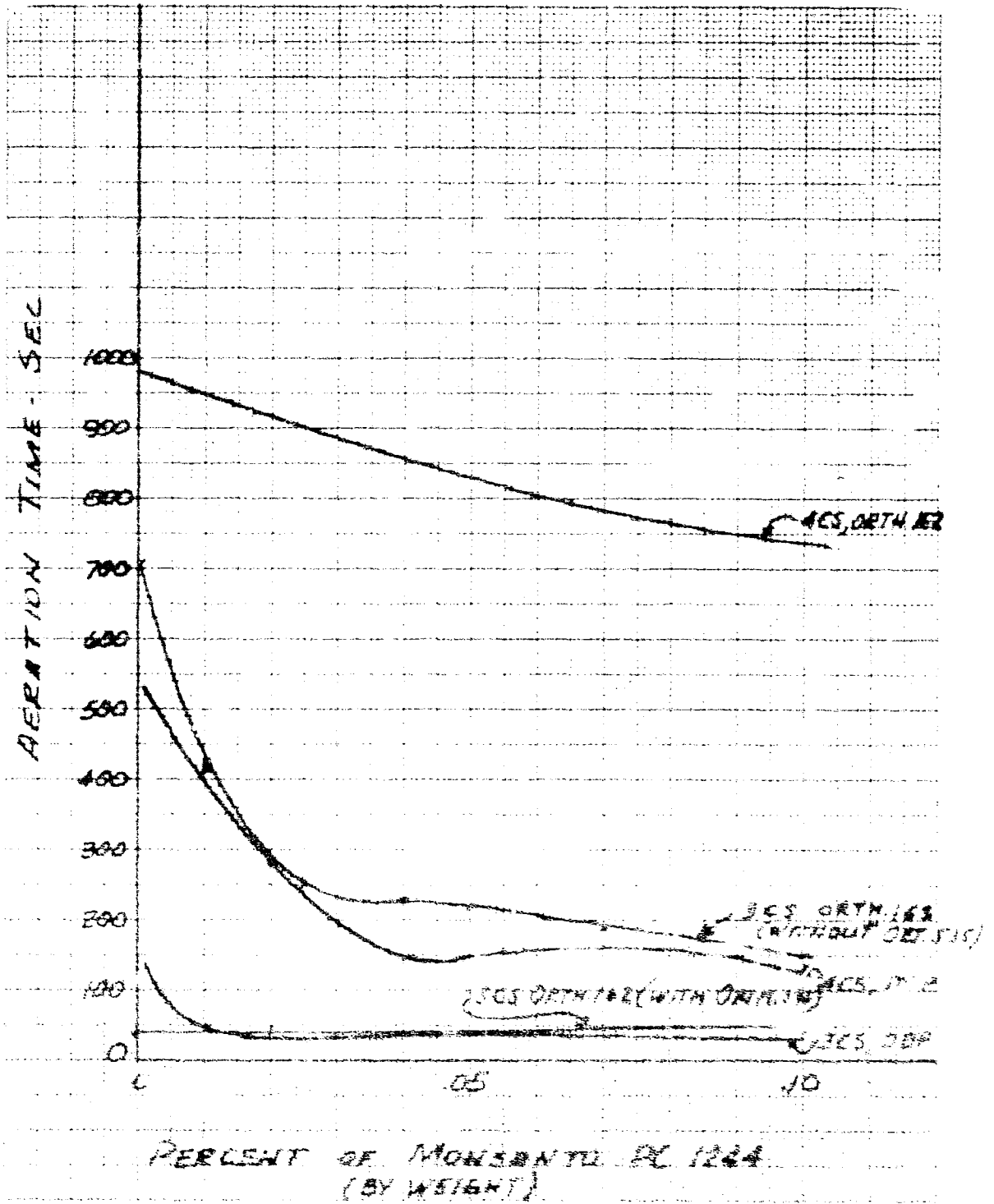

Aeration Time vs Percent of Monomers of DC 1244 - Average values

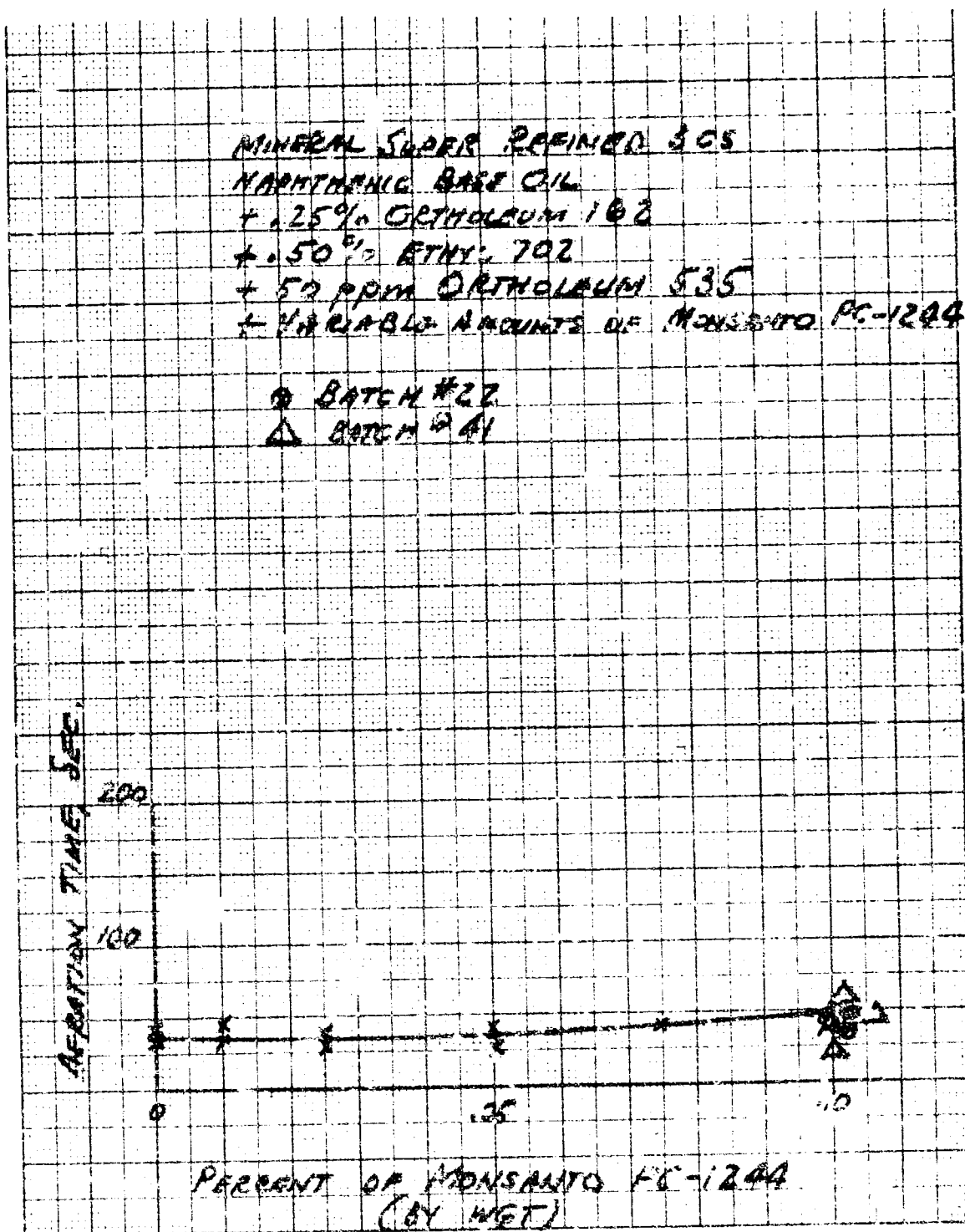

Aeration Time vs Percent of Monsanto PC-1244, Batches 22 and 41

Figure 19

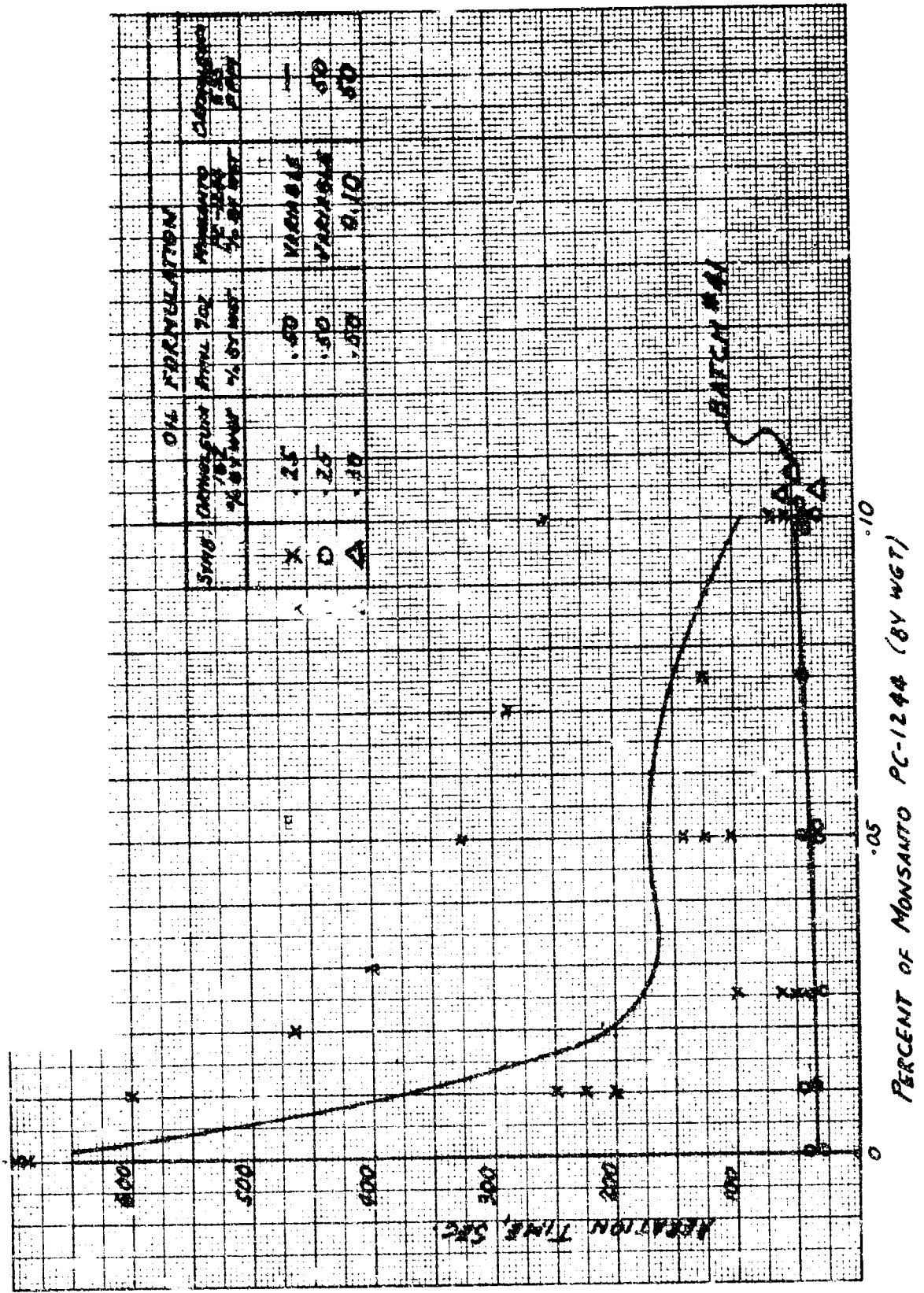

Figure 20



Report SSD-TR-65-161-1

## IV, C, Optimization of Additives (cont.)

The strong anti-aeration properties of the anti-corrosive additive (Ortholeum 535) suggests that Monsanto PC-1244 may not be required. The decision was made to keep PC-1244 in the blend because the mechanism of the Ortholeum 535 action is probably based on surface active properties, and its effect may not be lasting.

4. Optimization of Ortholeum 535 Anti-Corrosive Additive

This additive was introduced to combat corrosion and excessive formation of colorless precipitates on the soft steel in the presence of water. Table I illustrates test results conducted to establish the needed amount of this additive.

The above tests show that anti-corrosive additive is effective with the oil containing DDP additive and highly efficient when added to the 3-centistoke oil containing Ortholeum 162.

Further optimization of Ortholeum 535 was conducted using 3-centistoke oil with Ortholeum 162 additive. Data from this effort are summarized below:

## Base Formulation (Batch 41):

3-centistoke Super-refined naphthenic base lubricant  
0.25% Ortholeum 162  
0.5% Ethyl 708  
0.1% Monsanto PC-1244

Spindle: SAE 1020 Polished to 6 to 10 rms

Amount of Water: 0.2%

Five-day test, three determinations

Batch 21	Room Temperature		140°F	
	Spindle	Vaseline Formation	Spindle	Vaseline Formation
Neat	Black Gray	Heavy	Dull Gray	Very Light
+ 25 ppm Ortholeum 535	Gray	Light	Gray	None
+ 50 ppm*	Dull	None	Dull	None
+ 75 ppm	Dull	None	Dull	None
+ 100 ppm	Dull	None	Dull	None

\*ppm = part per million

A mixture containing 50 ppm of Ortholeum 535 was selected because any further increase of this additive did not make any noticeable changes. Because the minimum required amount of each additive was considered to be the best solution, the above amount was accepted in the lubricant formulation.

TABLE I

## OPTIMIZATION TESTS WITH ANTI-CORROSIVE ADDITIVE ORTHOLEUM 535

Spindle Test, 1/2 Diameter, SAE 1020 at 140°F for Five days with 0.2% Water

<u>4-cstk DDP Oil, Heat</u>	Corroded and discolored dark gray, no ppt
+ 25 ppm PL-535	Dull, grayish, no ppt
+ 50 ppm PL-535	Slightly dull, no ppt
+ 75 ppm PL-535	Slightly dull, no ppt
+100 ppm PL-535	Spindle stained slightly, no ppt
<u>3-cstk DDP Oil, Heat</u>	Slight dull discoloration, no ppt
+ 25 ppm PL-535	Slight stains, no ppt
+ 50 ppm PL-535	Slightly dull, no ppt
+ 75 ppm PL-535	Slightly dull, no ppt
+100 ppm PL-535	Spindle slightly dull, no ppt
<u>3-cstk Orth. 162 Oil, Heat</u>	Spindle slightly dull, oil hazy
+ 25 ppm PL-535	Spindle slightly discolored, no ppt
+ 50 ppm PL-535	Spindle dull, no ppt
+ 75 ppm PL-535	Spindle dull, no ppt
+100 ppm PL-535	Spindle slightly dull, oil clear, no ppt

Table I

## IV, C, Optimization of Additives (cont.)

The protective action of Ortholeum 535 is also demonstrated by the results of a corrosion resistance test summarized below. The posttest coupons are shown in Figure 21.

SAE 1008 coupons for four hours in 250° lubricant  
Dipped in 1% saline solution for 10 min  
Observations after 24 hr.

<u>Batch No.</u>	<u>Observations after 24 Hours</u>
MIL-L-7808D(1)	Badly corroded
Batch 21 (without Ortholeum 535)	Spots of corrosion
Batch 41 (with Ortholeum 535)	No corrosion
Batch 34 (DDP Lubricant without Ortholeum 535)	Badly corroded

Favorable aeration results obtained when Ortholeum 535 was added to existing blends are shown below:

	<u>Oil</u>	<u>Aeration</u>	<u>Foam</u>	<u>Foam Thickness, in.</u>
<u>Batch 13:</u>	Neat	380	239	1/2
	With 25 ppm PL-535	125	87	1/2
	With 50 ppm PL-535	56	37	1/4
<u>Batch 26:</u>	Neat	106	64	3/4
	With 25 ppm PL-535	44	None	None
	With 50 ppm PL-535	33	20	1/4
<u>Batch 33:</u>	Neat	46	15	1/4
	With 25 ppm PL-535	31	27	1/2
	With 50 ppm PL-535	31	28	3/4

5. Summary

Attempts to optimize the concentration of DCP showed that this additive does not have sufficient lubrication activity under extreme pressure. The optimum concentration of DDP based upon a compromise between E.P. activity and solubility is 0.3% by weight. The best concentration of Ortholeum 162 based upon a compromise between corrosiveness and the Ryder Gear requirement of 3000 ppi is 0.3% by weight. The best concentration of Monsanto PC-1244 is 0.1% when used in Ortholeum 162 blends and 0.05% when used in DDP blends. The optimum concentration of Ortholeum 535 is 50 ppm in Ortholeum 162 blends.

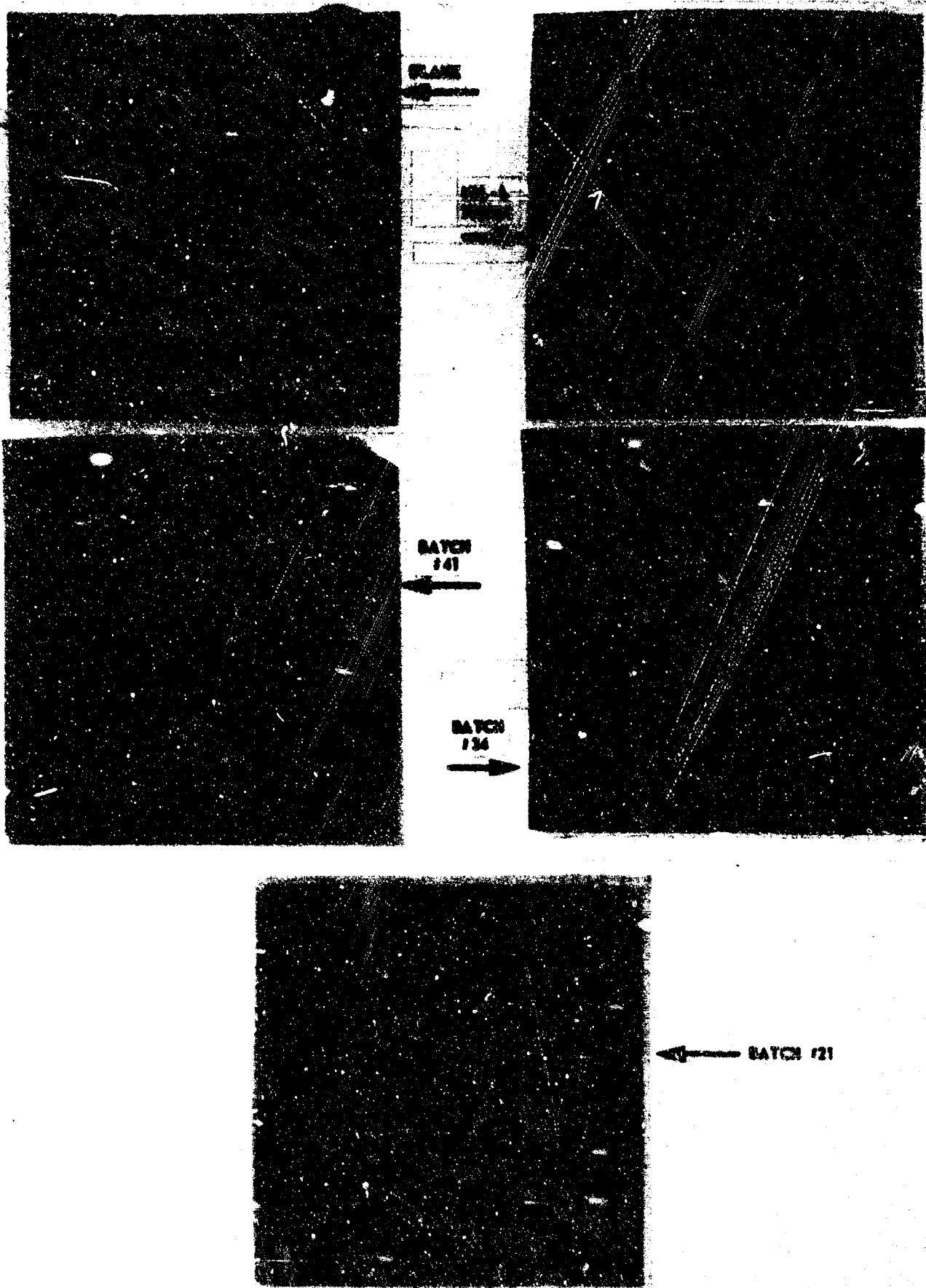

Figure 21. Corrosion Resistance Test

IV, Technical Discussion (cont.)

D. SELECTION OF FINAL PROSPECTIVE LUBRICANT

Selection criteria for the new prospective oil consist of the program objectives outlined in the introduction of this report. A large number of blends shown in Table X were tested in laboratory and component tests and nearly all have shown better performance than the MIL-L-7808D(1) lubricant. Five of the most promising lubricants were selected as candidates for the final lubricant. Each candidate was screened against the following tests:

1. Ryder Gear rating
2. Oxidation stability
3. Corrosiveness with soft steel
4. Aeration tendency
5. Chemical compatibility
6. Filter plugging test
7. Solubility
8. Western Gear aeration test
9. Quality assurance

The five prospective oil blends were as follows:

Batch No.	Oil, cstk	E.P., Additives		Anti-Oxidant	Anti-Corr.	Defoamer
		Orth. 162, %	BDP, %	Ethyl 702, %	Ortho. 535, ppm	Monsanto PC-1244, %
20	3	---	0.25	0.5	---	0.05
21	3	0.25	---	0.5	---	0.10
22	3	0.25	---	0.5	50	0.10
34	4	---	0.25	0.5	---	0.05
41	2	0.30	---	0.5	50	0.10

Relative performance of each of candidate oils after the screening tests can be summed up as follows:

## IV, D, Selection of Final Prospective Lubricant (cont.)

<u>Tasks</u>	<u>Batch No.</u>				
	<u>20</u>	<u>21</u>	<u>22</u>	<u>34</u>	<u>41</u>
Ryder Gear Rating	Pass	Pass	Pass	Pass	Pass
Oxidation Stability	Pass	Pass	Pass	Pass	Pass
Corrosiveness with Soft Steel	Pass	Failed	Pass	Pass	Pass
Chemical Compatibility	Pass	Pass	Pass	Pass	Pass
Filter Plugging	Pass	Pass	Pass	Pass	Pass
Aeration	Pass	Pass	Pass	Pass	Pass
Western Gear Aeration Tests	Pass	Pass	Pass	Pass	Pass
Solubility of E.P. Additive	<u>Failed</u>	<u>Pass</u>	<u>Pass</u>	<u>Failed</u>	<u>Pass</u>
Total Score	<u>Failed</u>	<u>Failed</u>	<u>Pass</u>	<u>Failed</u>	<u>Pass</u>

Failure of Batches 20 and 34 was caused by the poor solubility of DDP at low temperature. This could be solved by the synthesis of an alkyl phosphate in the C<sub>14</sub> range rather than C<sub>12</sub>; however, the availability of favorable candidates illuminated the need for this approach.

Batch 21 was eliminated because of its higher corrosiveness against the AISI 52100 steel and mild steel (such as SAE 1020). It is also prone to build colorless, Vaseline-like precipitates on the mild steels at room temperature.

Batch 22 differs from Batch 41 in the amount of Ortholeum 162. An increase from 0.25 to 0.30% by weight was made to meet the Ryder Gear rating of 3000 ppi.

On the basis of the above comparison, Batch 41 was selected as the final prospective lubricant. Humble Oil and Refining Company, which was very instrumental in the development of this gearbox lubricant, suggested that Batch 41 be called 3156 Gear Lubricant.

The final formulation of the selected prospective lubricant is as follows:

<u>Base Lubricant:</u>	Humble 3153 naphthenic super-refined mineral 3-centistoke (at 210°F) lubricant	
<u>Additives:</u>	0.30% Ortholeum 162	E.P. additive
	0.50% Ethyl 702	Anti-oxidant
	0.10% Monsanto PC-1244	Defoamer
	50 ppm Ortholeum 535	Anti-corrosive additive

General properties of the final prospective lubricant are compared with the properties of the MIL-L-7808D (1) lubricant:

	Esso 3156	Bryco 880 MIL-L-7808D(1)
Viscosity at 100°F, cstk	14.2	11.0
Viscosity at 210°F, cstk	3.10	3.0
Pour Point, °F	-30	-75

## IV, D, Selection of Final Prospective Lubricant (cont.)

	<u>ESSO 3156</u>	<u>Bryco 880 MIL-L-7808D(1)</u>
Auto-Ignition Temperature, °F	735	740
Neutralization No., mg/KOH/gr Sample	0.80 ± 0.15	0.39
Color	Light yellow	Yellow
Ryder Gear Rating, ppi	2500 to 4000	1800 to 2200
Oxidation Stability	Excellent	Excellent
Corrosiveness Iron	Forms light gray film	None
Other Gearbox Metals	None	None
Aeration Tendency	Very low	Very low
Foaming	Very low	Very low
Chemical Compatibility with Propellants and Products of Combustion	Pass	Failed
Filter Plugging	Pass	Failed
Storage Life	Est. 10 years	Pass - 18 months

All the additives of the new formulation are "off-the-shelf" items and have undergone excessive research by the vendors. No special request was made to specifically blend any of the additives, which have shown their consistency throughout the development and testing.

IV, Technical Discussion (cont.)

E. EVALUATION OF FINAL PROSPECTIVE LUBRICANT  
(With Respect to Present Lubricant)

1. Introduction

As discussed in the previous section, the final prospective lubricant was selected from among several candidates on the basis of its performance with regard to the program objectives. Following this selection, the performance of the candidate lubricant was further evaluated relative to present lubricant. Many of the tests were conducted on a parallel basis to provide an accurate comparison.

This section contains descriptions of the following laboratory and component tests:

- a. Load-carrying tests (Ryder Gear Tests)
- b. Gearbox tests at Western Gear Corporation
- c. Filter plugging
- d. Propellant compatibility tests
- e. Aeration tests
- f. Corrosion tests
- g. Compatibility with MIL-L-7808D(1) oil
- h. Storage test

2. Load-Carrying Capacity

The load-carrying capacity of the new oil was evaluated by comparing the results of Ryder Gear tests and gearbox performance test with the results obtained in duplicate tests with MIL-L-7808D(1) oil. Standard Ryder Gear testing procedure, delineated in Appendix II, was varied in special tests to more nearly duplicate the Titan II first-stage gearbox operating conditions. Special high-load gearbox tests were also conducted at Western Gear Corporation on the new oil and MIL-L-7808D(1) oil.

a. Ryder Gear Tests

(1) Standard Ryder Gear Tests

The standard Ryder Gear value unit is pounds per inch (ppi) of tooth width and is a measure of the load-carrying capacity of an oil at a particular set of test conditions. Each test oil is evaluated at the same conditions as specified in Federal Test Method Standard 791a, Method 6508 (Ref 7).



Report SSD-MR-65-161-1

IV, E, Evaluation of Final Prospective Lubricant (cont.)

Standard Ryder Gear tests are conducted with case-hardened gears made of AMS-6260 steel, and the tooth load is increased 370 ppi at each successive 10-min run. In this report, the above gear material is referred to as "standard Ryder gears" and the loading sequence as "standard loading."

To correlate Ryder Gear data obtained by different testing laboratories, each laboratory periodically tests a reference oil, and all Ryder Gear values are rated according to the reference oil in terms of relative rating percentage as follows:

$$\% \text{ Relative Rating} = \frac{\text{Test Oil Average Rating}}{\text{Reference Oil Average Rating}} \times 100$$

Therefore, the higher relative ratings indicate higher load-carrying capacities.

The following table gives the average Ryder Gear value and relative ratings for MIL-L-7808D(1) oil and the new oil, obtained by the various testing laboratories. Each tabulated value is an average of the tests or determinations by a testing laboratory.

<u>Testing Laboratory</u>	<u>Ryder Gear Value in ppi</u>	<u>% Rel. Rating</u>	<u>Number of Determinations</u>
<u>MIL-L-7808D(1) Oil:</u>			
EPPI Precision Products, Inc.	2070	70.6	2
South West Research Institute	2204	<u>82.0</u>	4
		152.6	
		Average Relative Rating - 76.3%	
<u>Batch 41 Oil:</u>			
EPPI Precision Products, Inc.	5200	179	7
South West Research Institute	2590	96	9
Alcor Laboratories	3040	<u>106</u>	3
		381	
		Average Relative Rating - 127%	

A relative rating improvement over MIL-L-7808D(1) oil of 50% was attained.

## IV, B, Evaluation of Final Prospective Lubricant (cont.)

All standard Ryder Gear data obtained from the three testing laboratories is shown in Figure 22. Based on all the data obtained, the average relative rating of Batch 41 oil is 144%. The 127% rating is conservative and is based on the most repeatable values obtained. It excludes test data extrapolated beyond the 5500-ppi capacity of the standard testing rig.

In evaluating Ryder Gear data, it should be understood that low ratings may result from gear variations, such as tooth spacing and tooth surface finish. However, high values can only be obtained with oils that provide high film strength and scuff resistance.

## (2) Special Ryder Gear Tests

A previous investigation of Ryder Gear tests shows that caution should be used when evaluating an oil for use with gear materials other than AMS-6260 steel or operating conditions other than those that can be produced in a Ryder Gear machine. The following is an excerpt from a report on Ryder Gear tests by South West Research Institute on USAF Contract 33(616)-7223:

"On the basis of the load-carrying capacity determinations of ten lubricants, it was found that no organized correlation existed between the results obtained with one gear material under a given set of operating conditions and those obtained with another gear material under another set of operating conditions."

It may be concluded that the test results obtained from standard Ryder Gear tests, per Federal Test Method Standard 791a, Method 6508, provide statistical data for oil comparison. However, more representative conclusions should be based on the results of tests tailored, as near as practicable, to the actual gear-box operating conditions. In order to preserve data continuity, the standard Ryder Gear testing was changed in two phases: (1) gear material and (2) sequence of loading increments and duration of test at each load.

In Phase I, the gear material was not actually changed but simply black-oxide-coated per Specification MIL-C-13924, Class 1, the same as the Titan II production gears. The following summary shows the results of the standard load sequence tests conducted by EPPI Precision Products, Inc.:

<u>Test Oil</u>	<u>Ryder Gear Value in ppi</u>	<u>% Relative Rating</u>	<u>Number of Determinations</u>
MIL-L-7808D(1)	2315	76	4
Batch 41	1430	47	4

The relative rating of Batch 41 oil is 39% lower with the black oxide coating.

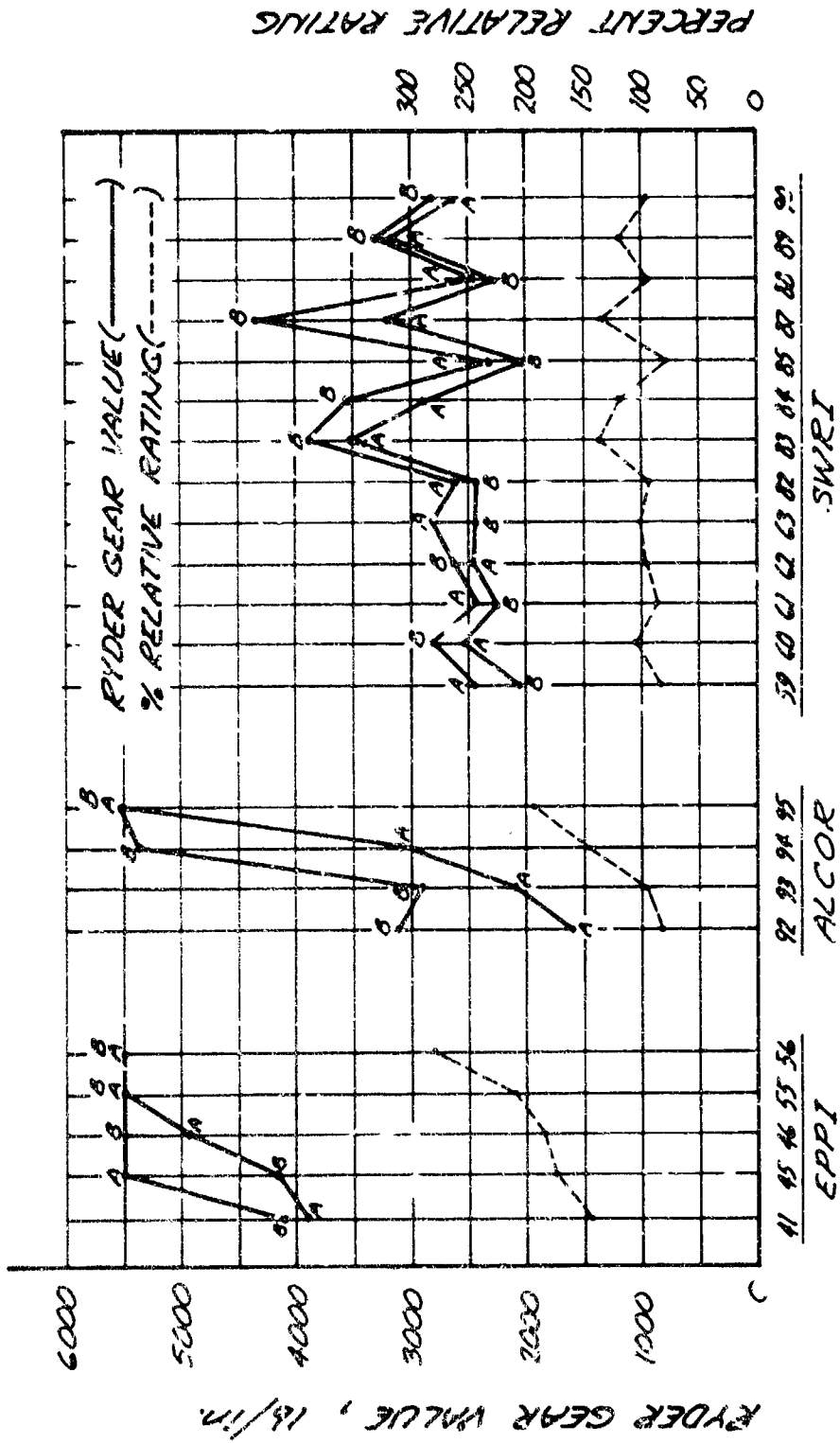

Figure 22

OIL BATCH NUMBER  
TESTING LABORATORY

Ryder Gear Values and Percent Relative Rating

## IV, E, Evaluation of Final Prospective Lubricant (cont.)

In Phase II, standard gears were black-oxide-coated as above, and the sequence of loading was modified. The initial load sequence and duration was based on normal operating cycle of the Titan II first-stage gearbox. At loads simulating the normal gearbox load, the duration of the Ryder Gear test would approach the life of the gears and the data for comparison would be in terms of time. The number of tests required makes the time procedure impractical; therefore, the load increments were established to simulate the gearbox break-in load, full-load, and turbopump assembly tests. Subsequent load increments were designed to obtain rating data in ppi (pounds per inch).

The loading sequence for these tests is given in Table II and the Ryder Gear values obtained with black oxide standard gears are listed below:

<u>Test Oil</u>	<u>Ryder Gear Value in ppi</u>	<u>% Relative Rating</u>	<u>Number of Determinations</u>
MIL-L-7808D(1)	2360	77	4
Batch 41	1632	54	4

In order to simulate gear conditions in the field, the break-in runs were with MIL-L-7808D(1) oil; the test procedure was modified as shown in Table III to evaluate Batch 41 oil at these conditions. MIL-L-7808D(1) oil was used during the first two break-in runs and then the tests were continued with Batch 41 oil, plus 2% MIL-L-7808D(1) oil. The 2% MIL-L-7808D(1) oil was added to simulate the residual oil remaining in the gearbox in the silo after draining and flushing. The procedures for draining and flushing as well as for refilling with the new oil, are given in Appendix V of this report.

The results of these tests are given below:

<u>Test Oil</u>	<u>Ryder Gear Value in ppi</u>	<u>% Relative Rating</u>	<u>Number of Determinations</u>
MIL-L-7808D(1) break-in followed by Batch 41 plus 2% MIL-L-7808D(1)	2187	71.7	4

This is more than a 42% improvement over the two previous series of tests and shows the adverse effect black oxide has on the E.P. (extreme pressure) additives in Batch 41 oil. Therefore, the test was repeated, except after the break-in with MIL-L-7808D(1) oil; the black oxide was removed with phosphoric acid; and the test continued as above with the following results:

<u>Test Oil</u>	<u>Ryder Gear Value in ppi</u>	<u>% Relative Rating</u>	<u>Number of Determinations</u>
Batch 41 plus 2% MIL-L-7808D(1)	3915	129	2

TABLE II

RYDER GEAR MACHINE, LOAD-SEQUENCE-SIMULATING GEARBOX

<u>Test No.</u>	<u>Tooth Load, ppi</u>	<u>Test Duration, minutes</u>
1	435	32
2	870	16
3	1750	16
4	1750	16
5	1750	32
6	1900	16
7	1900	16
8	2100	16
9	2100	16
10	2270	16
11	2270	16
12	2270	24
13	2450	16
14	2450	16

Table II

TABLE III

## RYDER GEAR MACHINE, SIMULATING-GEARBOX OPERATION

<u>Test No.</u>	<u>Tooth Load, ppi</u>	<u>Test Duration, minutes</u>
<u>(Test oil per MIL-L-7808D(1))</u>		
1	435	16
2	1730	16
<u>(Flush - Continue test with Batch 41 oil + 2% MIL-L-7808D(1) oil)</u>		
3	1950	16
4	1950	16
5	1950	32
6	1950	32
7	1950	32
8	1950	32
9	2320	16
10	2700	16
11	3100	16
12	3480	16
13	3860	16
14	4230	16
15	4600	16

Table III

IV, E, Evaluation of Final Prospective Lubricant (cont.)

This is a 79% improvement over the last test series and a 150% improvement over black-oxide-coated gears with no break-in with MIL-L-7808D(1) oil.

Titan II gears are made of black-oxide-coated 4620 and 9310 steel; therefore, these materials were evaluated by the standard Ryder gear load sequence, with and without black oxide coating, with the following results:

<u>Test Oil</u>	<u>Ryder Gear Value in ppi</u>	<u>% Relative Rating</u>	<u>Number of Determinations</u>
<u>With Black Oxide</u>			
MIL-L-7808D(1)	2385	78.2	2
Batch 41	2330	76.2	2
<u>Without Black Oxide</u>			
Batch 41	3865	127	2

A relative rating improvement of 67% without black oxide was attained.

The Ryder Gear machine was used to evaluate both MIL-L-7808D(1) and Batch 41 oils contaminated with water, AeroZINE 50, and extremes of E.P. additives.

Tabulated results of these tests, shown in Table IV, indicate that these contaminants are ineffective at the allowable limits of gearbox contamination.

In turbopump tests where a turbine seal leak occurs, the atmospheric environment in the gearbox is one of inert or reducing gases. This condition also exists during flight because the turbine exhaust gases are used to pressurize the lubricating oil system to minimize vaporization; therefore, a series of Ryder Gear tests was conducted using a gaseous nitrogen atmosphere, with the following results:

<u>Test Oil</u>	<u>Ryder Gear Value in ppi</u>	<u>% Relative Rating</u>	<u>Number of Determinations</u>
MIL-L-7808D(1)	1407	53.0	2
Batch 41	2830	106.3	2

TABLE IV

## TESTS OF LOAD-CARRYING CAPACITY

Standard Ryder Gear Tests by SWRI

New oil at extremes of Ortholeum 162 composition

	<u>Ave. Ryder Gear Value, ppi</u>	<u>% Ave. Rel. Rating</u>	<u>Number of Determinations</u>
Max. mono-acid	2900	107	6
Min. mono-acid	2900	107	6
<u>Standard Test except Nitrogen Blanketing</u>			
Batch 41 oil	2830	106.3	2
MIL-L-7808D(1) oil	1407	53.0	2
<u>Reduced Flow Test</u>			
Batch 41 oil at 50%	2197	82.7	2
at 25%	916	34.5	2
MIL-L-7808D(1) oil at 50%	1575	59.4	2
at 25%	1569	59.0	2

Special Ryder Gear TestsGearbox load sequence with MIL-L-7808D(1) oil break-in  
Black oxide by EPPI on Titan II gear materials

	<u>Ave. Ryder Gear Value, ppi</u>	<u>% Ave. Rel. Rating</u>	<u>Number of Determinations</u>
Batch 41 oil + 2%	A = 1880	96	2
MIL-L-7808D(1) oil	B = 3980		
Batch 41 oil + 0.2% water	1730	56.7	2
+ 0.1% A-50			
MIL-L-7808D(1) oil + 0.2% water	2575	84.5	2
+ 0.1% A-50			

Standard Ryder Gear Tests

Batch 1 oil + 0.1% water (Drop in KOH from 0.65 to 0.57)	3915	129	2
---	------	-----	---

Table IV



## IV, E, Evaluation of Final Prospective Lubricant (cont.)

The effect of oxygen on the new and present oils can be seen when the above data are compared to the following data from the same test with an air atmosphere:

<u>Test Oil</u>	<u>Ryder Gear Value in ppi</u>	<u>% Relative Rating</u>	<u>Number of Determinations</u>
MIL-L-7808D(1)	2204	82	4
Batch 41	2590	96	9

The Ryder gear value of the present oil, MIL-L-7808D(1), was reduced 36% by the neutral atmosphere, while the value for the new oil was slightly increased. It is concluded that the present ester-base oil requires oxygen to provide the scuff resistance indicated by the standard Ryder Gear values. The new oil provides high scuff resistance without the presence of oxygen by the formation of iron phosphate on the gear tooth surfaces at operating temperatures and is, therefore, not adversely affected by turbine exhaust gases in the gearbox.

Tests were also conducted to show a comparison of load-carrying capacities of the new and present oils at reduced oil supply in an inert atmosphere. The results of these tests are graphically illustrated in Figure 30, showing Ryder Gear values vs percentages of normal oil supply. These tests show that the new oil is superior to the present oil above 35% of normal oil supply. Complete Ryder Gear test results are shown in Table X.

## b. High Load

The initial evaluation of load-carrying and scuff resistance provided by Batch 41 oil was made from Ryder Gear values. As previously noted, Ryder Gear values are not directly applicable to gears where the gear material, tooth forms and dynamic conditions are not identical to those in the Ryder Gear test arrangement. The more significant differences between the standard Ryder Gear machine and the Titan II gearbox operating conditions are listed in Table V. Therefore, the load-carrying capacity of Batch 41 oil was further evaluated in Titan II gearbox tests.

These tests were conducted at the gearbox production test facilities maintained by Western Gear Corporation in Lynwood, California. The test schedule was designed to establish the maximum load carrying capacity of MIL-L-7808D(1) oil in terms of gear tooth surface wear; i.e., scoring and scuffing so that Batch 41 oil could be evaluated by comparing gear tooth surfaces of the pinion gears after being operated at the same test conditions. These tests are referred to as high-load scuffing tests to distinguish them from production tests.

TABLE V

**VARIABLES AFFECTING GEAR SCUFFING**

Scuffing Parameters      Titan II 87-5 G/S      Ryder Gears      MIL-L-7808D(1)      Humble 3152

Operational

Lubricant and gear surface temperatures      Sump = 250° max.      Sump = 165° max.

Pitch line velocity (speed), ft/sec      290      153

Lubricant flow, ml/min      1970      270

Applied tooth load      2500 FPI      Variable

Applied load (tooth sharing)      2500/1.8      Variable/1.5

Lubricant Properties

Viscosity      3.0 cstk at 210°F      3.0 cstk at 210°F

Aeration (coolant capacity)      Good      Good

Extreme pressure activity (P, CL, or S content)      Slight      High

Content of long-chain fatty acids      Trace      None

Gear Design

Sliding velocity, ft/sec      75.9      42.8

Tooth tip relief      Yes      None

Tooth spacing and eccentricity tolerances      0.005      0.0010

Surface finish      25      35

Gear material      9310 on 4620      6260

Number of teeth in contact (AVG)      1.8      1.5

Table V

IV, E, Evaluation of Final Prospective Lubricant (cont.)

(1) Test Equipment

All scuff tests on both oils were conducted with a Titan II first-stage gearbox assembled with new bearings and gears to test each oil. The first-stage gearbox was selected in preference to the second stage because:

(1) The tooth contact stresses in the first stage are higher than in the second stage.

(2) The pinion gear teeth are loaded twice per revolution.

These and other factors cause the wear rate of the pinion gear teeth of the first-stage gearbox to be the highest of all the gears in both stages, and, therefore, this was the gear selected to be inspected after each test run.

To achieve an overload condition on the gear teeth within the operating range of the test equipment, the width of the pinion gear was reduced to provide 30% tooth overload at normal operating input torque. This loading is based on the average effective width (1.953 in.) of the oxidizer and idler gear and the effective width (1.512 in.) of the reduced width pinion. Because the test stand can be safely operated at 10% above normal rated load, it was possible to simulate tooth loads equivalent to 42% overload.

In order to control the lubrication oil pressure to the gearbox, a by-pass line and control valve was installed in the lubrication oil circuit between the lubrication pump discharge and the lubrication oil reservoir. The lubrication oil pressure to the gearbox was controlled by varying the flow in the by-pass line. It is significant that the oil flow in the by-pass line did not enter the gearbox. This method provided adequate control of lubrication oil pressure to the gearbox during all five test runs.

The conditions of this test were maintained to obtain scuff data at reduced lubrication oil flow to the gearbox and should not be construed to represent all conditions of low oil pressure recorded during a TPA test. In these tests, the pressure to the gear was reduced by an external by-pass, whereas in a TPA, the oil flow to the gearbox is relatively constant and pressure decay is attributed to thermal expansion of components and subsequent internal leakage.

(2) Scuff Test with MIL-L-7808D(1) Oil

The first scuff test was conducted with MIL-L-7808D(1) oil in accordance with the load conditions given in Table VI. After each test run of 200 or more sec, the working side of the pinion gear teeth were visually inspected through the speed transducer port. Gear tooth surface disturbances and changes in surface conditions observed during the visual inspections are also tabulated, adjacent to each test run. After 4720 sec of operation, the gearbox was disassembled for detail inspection and macrophotographing of the pinion gears. The test time-load schedule for this test is shown graphically in Figure 36.

TABLE VI

## TESTS USING OIL PER MIL-L-7808D(1)

<u>Test No.</u>	<u>% Design Load</u>	<u>Duration, sec</u>	<u>Inspection Results</u>
1	25	400	Two light scratches 0.025 in. apart 3/16 in. from upper end of all 31 teeth.
2	50	200	No change
3	100	200	No change
4	100	400	Very light scratches on addendum near O.D. No scuffing.
5	115	200	Very light scratches. No scuffing.
6	115	200	Light abrasion.
7	115	200	Slight increase in light abrasion.
8	125	200	No change
9	125	400	Superficial scuffing near involute profile. Modification in addendum.
10	125	400	Noticable increase in width of light scuff pattern.
11	137	200	Wide superficial scuff marks visible at Test 10 are less distinctive due to fine abrasive action.
12	137	200	No scuffing. Slight increase in abrasion and previous scuff marks worn away.
13	137	320	Black oxide in addendum of working surface appears lighter.
14	137	400	Light abrasion. No appreciable change.
15	137	400	Slight roughness in addendum near center of tooth width.
16	137	400	Slight increase in roughened area. No other significant change.
Total run time		4720 sec	

Table VI

IV, E, Evaluation of Final Prospective Lubricant (cont.)

(7) Scuff Tests with Batch 41 Oil

(a) Test Conditions

The second test was conducted with Batch 41 oil in the same gearbox assembled with new bearings and gears identical to those used in the first scuff test. The test time and load schedule for these tests are shown graphically in Figure 36 as Tests 1 and 2.

All operating conditions and inspection procedures of the first scuff test were repeated. The pertinent operating conditions and inspection results are tabulated in Table VII.

(b) Initial Scuff Data Discussion

Visual inspection of the pinion gears after the above tests revealed that the gear tested with the new oil had more wear than the gear tested with MIL-L-7808D(1) oil. The black oxide coating on the gear tested with the new oil had been removed, and there were more radial scratches in the addendum of the teeth than on the gear tested with MIL-L-7808D(1) oil. Photographs of these pinion gears are shown in Figures 23 and 24.

It should be noted that the original grind marks are visible on both gears but are more pronounced in Figure 23 (the gear tested with MIL-L-7808D(1) oil), because it has retained most of the black oxide coating. The light area at the left side of Figure 24 (the gear tested with the new oil) is the result of the grinding asperity wear. The abrasive wear to the right is little more than superficial because the depth is equal to or less than the original grind marks. Alternate light and dark areas at the left of Figure 24 give an inverted illusion of waviness that does not actually exist.

Gear tooth wear is determined by comparing the involute profile tracer before and after the test. Involute traces of the gear tested with MIL-L-7808D(1) oil are shown in Figure 25 and show a very moderate wear of 0.0001 in. Figure 26 shows the involute traces of the gear tested with the new oil and shows that the wear is less than 0.002 in. on the working surface.

Figure 27 are sample traces labeled to illustrate more clearly the significance of the forging figures. Figure 27b shows the new gear involute limits superimposed on the traces of Figure 26b. The position numbers located near the bottom of the traces pertain to areas of the tooth where the trace is made. Positions 1 and 3 correspond to locations approximately 1/8 in. from the ends of the tooth (measured parallel to the axis of the gear) and Position 2 to the center of the tooth.

It should be noted that, except for tip wear resulting from heavy overloading, the working surfaces of both gears are still within new gear limits after 4720 sec of run time (Figure 28). Therefore, on the basis of these tests, it can be concluded that both oils perform acceptably.

TABLE VII

## TESTS USING BATCH 41 OIL

<u>Test No.</u>	<u>% Design Load</u>	<u>Duration, sec</u>	<u>Inspection Results</u>
1	25	400	Black oxide on working surface is gray.
2	50	200	Fine abrasion near tip of teeth.
3	100	200	No change. Working surface still gray.
4	100	400	Very light scratches at tip PM (profile modification).
5	115	200	Light scratches.
6	115	200	Slight increase in scratches at tip PM. Light scratches noted in addendum.
7	115	400	Scratches surfaces appear as fine abrasion.
8	125	200	No apparent change.
9	125	400	Abrased area increased slightly at tip PM.
10	125	400	Abrasion increased.
11	137	200	Abrasion coarser.
12	137	200	No apparent change in abrasion. Working surface roughness increased near pitch diameter. Two or three light score lines in addendum of each tooth.
13	137	320	Scoring slightly increased. Working surface burrished.
14	137	400	Light scoring and abrasion line near the tip at center of teeth has increased in length to within 3/8 in. from the end of the teeth.
15	137	400	Line of abrasion increased in length to within 1/4 in. of the end of the teeth.
16	137	400	Line of abrasion increased to full width of teeth.
Total run time		4720 sec	

Table VII



Figure 23. Finion Gear SN 1049 (4720 sec in Oil per MIL-L-7808D(1))

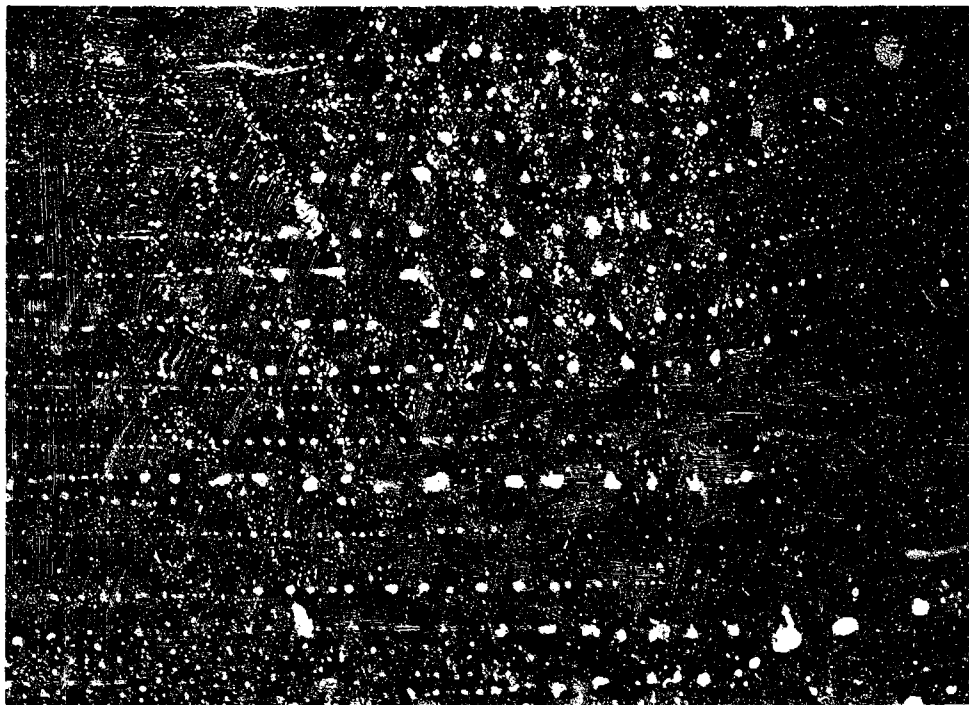
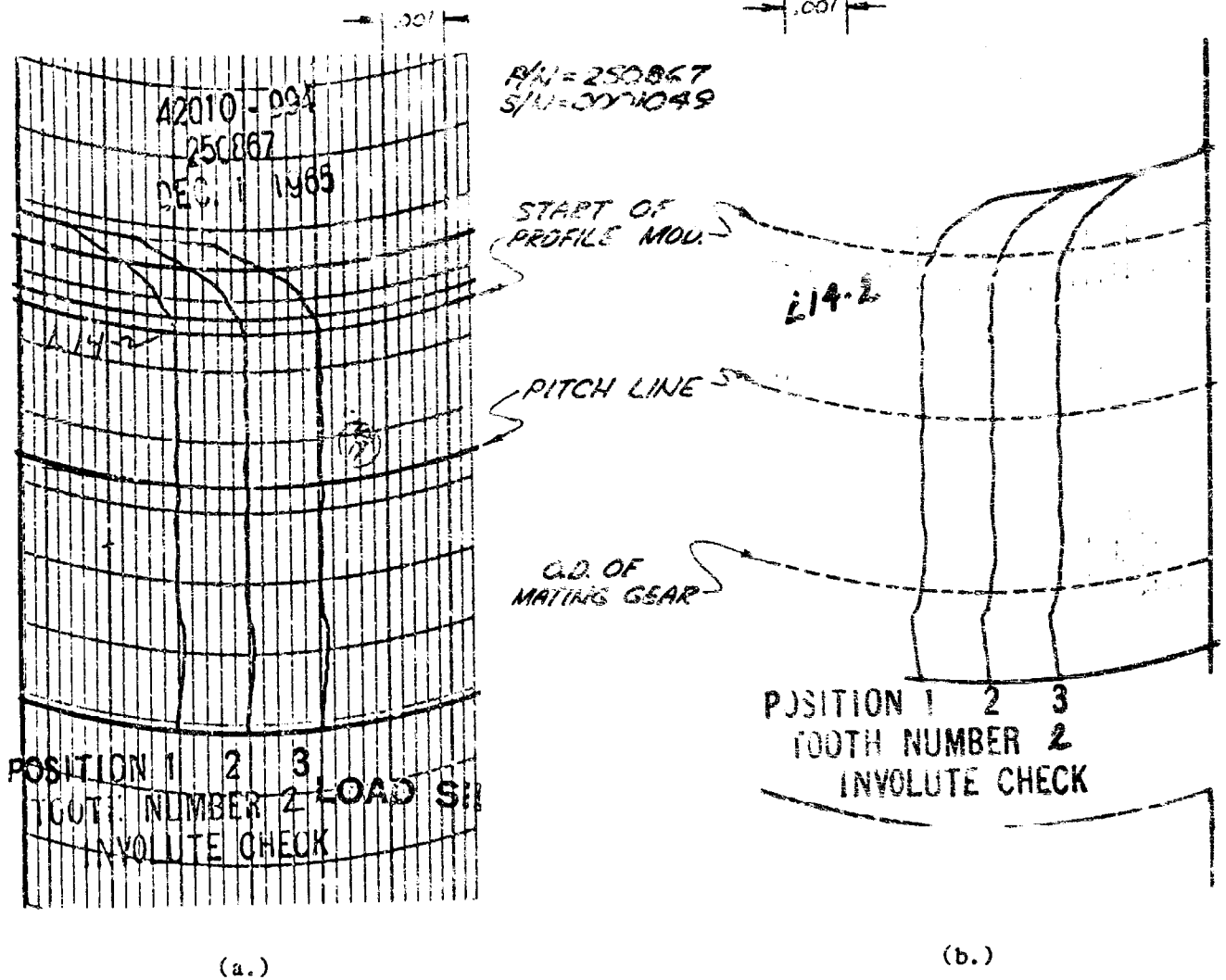

Figure 24. Finion Gear SN 1848 (4720 sec in 4720 Gear Lubricant)

NEW GEAR PROFILE

AFTER RUNNING 4720 SBC IN OIL  
per (MIL-L-7808D(1))



Involute Profile (Oil per MIL-L-7808D (1))

Figure 25



NEW GEAR PROFILE

AFTER RUNNING 4720 SEC  
IN BATCH 41 OIL

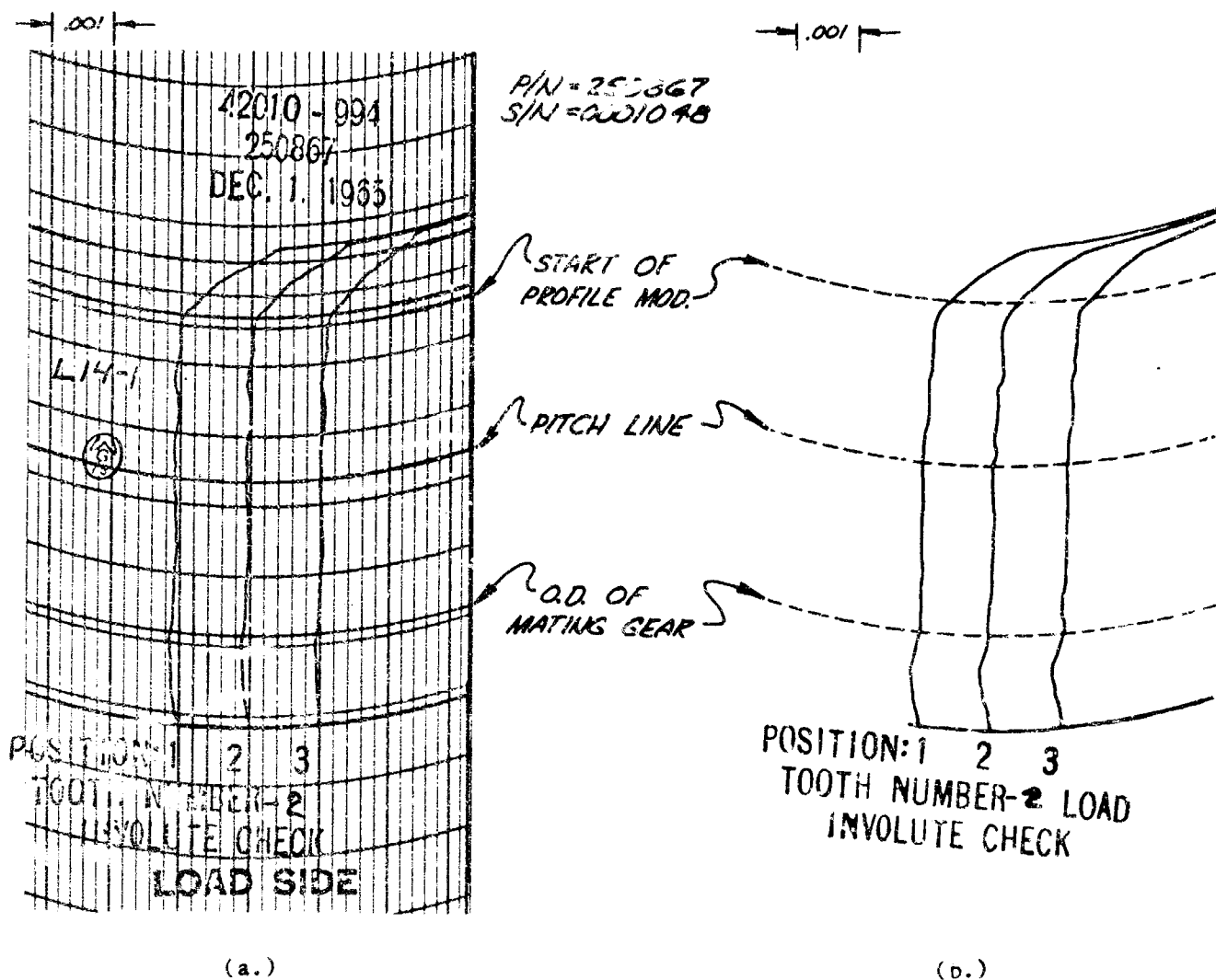

Involute Profile (3156 Lubricant)

Figure 26

EXAMPLE OF 0.0003-in. WEAR  
ON NEW GEAR PROFILE

AFTER RUNNING 4720 SEC  
IN BATCH 41 OIL

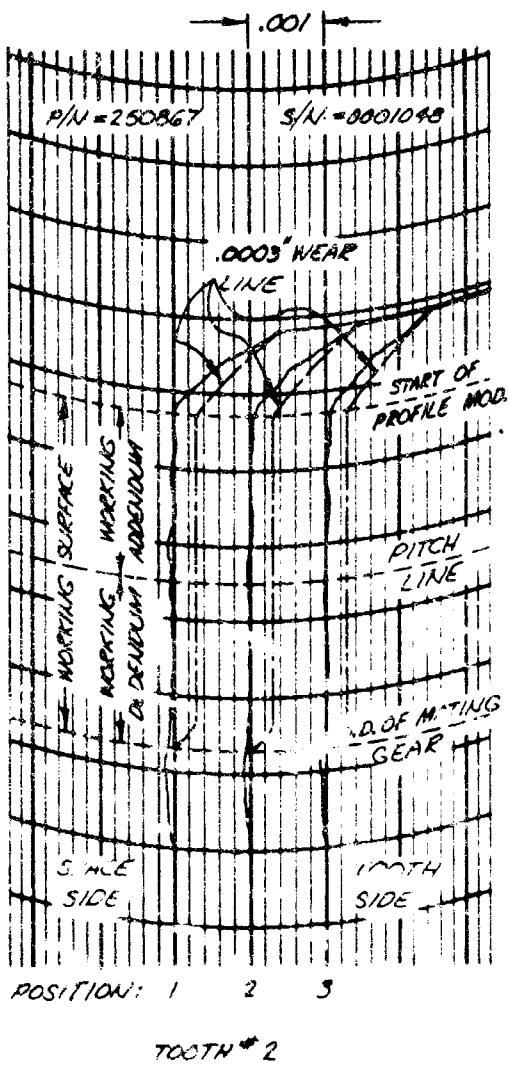

(a.)

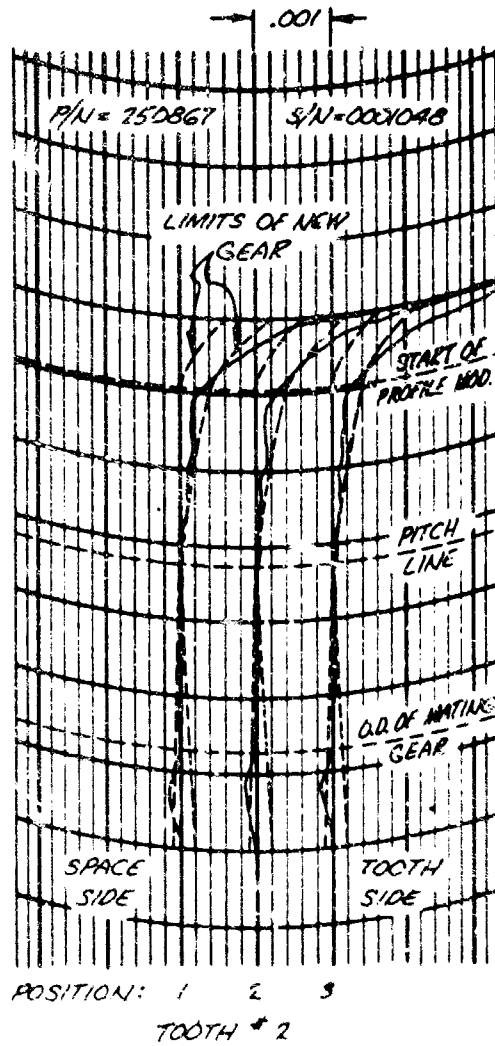

(b.)

Involute Profile

Figure 27

AFTER RUNNING 4720 SEC IN MIL-L-7808 D(1) THEN 2800  
SEC IN MIL-L-7808 D(1) OIL AND 2% OIL PER MIL-L-7808 D(1)

P/N = 250867

S/N = 0001049

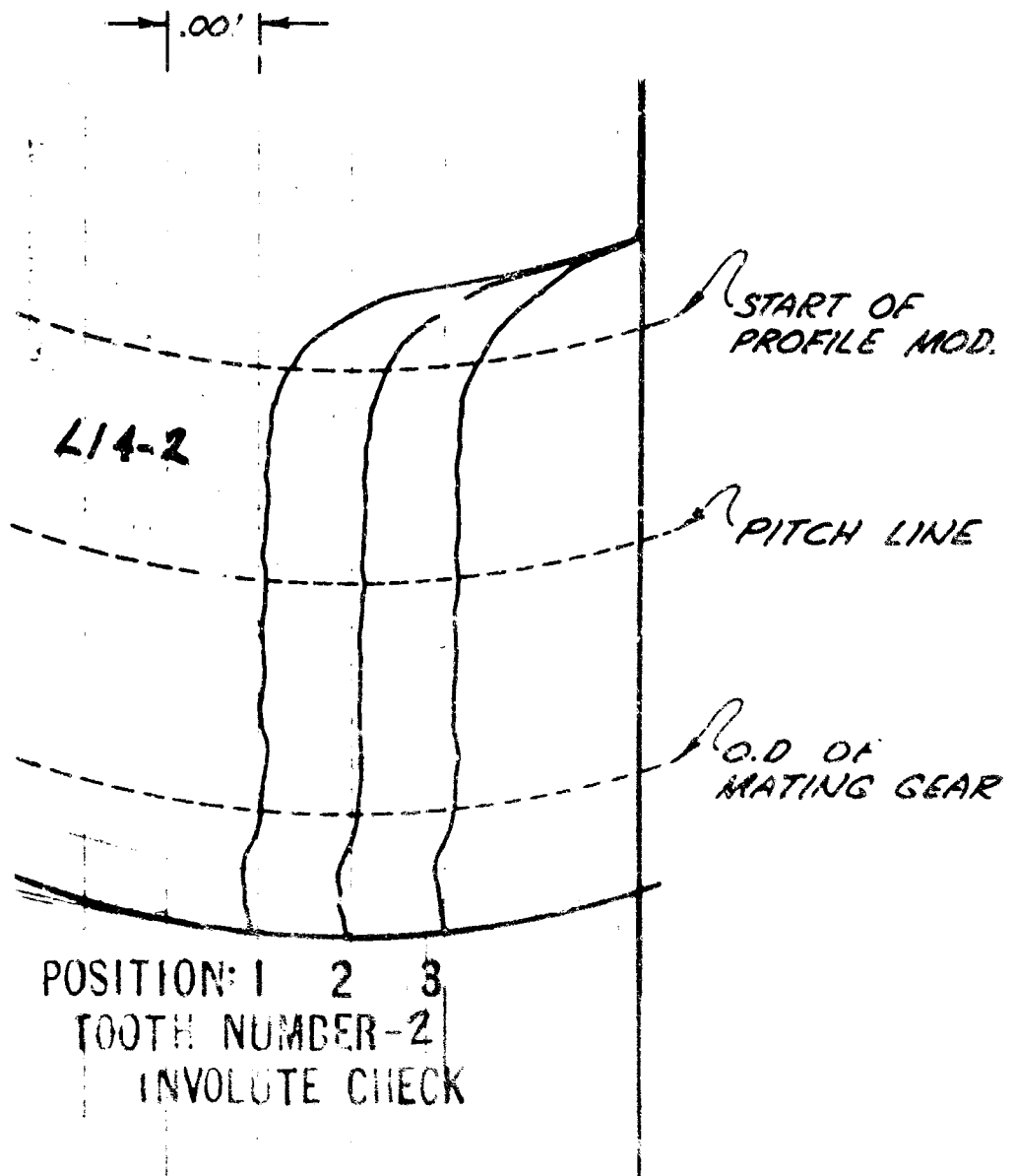

Involute Profile after Tests of 4720 and 2800 sec

Figure 28

IV, E, Evaluation of Final Prospective Lubricant (cont.)

(4) Scuff Test Simulating Field Gearbox

A third test was conducted to determine the scuff resistance provided by the new oil on gears in the field; i.e., gears previously run for prolonged periods with MIL-L-7808D(1) oil. This test was conducted using the same gearbox and components that were used in the 4720-sec test with MIL-L-7808D(1) oil (see Table VIII). When a gearbox in the field is drained and flushed in accordance with the draining and flushing procedure given in Appendix V of this report, the amount of MIL-L-7808D(1) oil remaining in the gearbox will be less than 2% by weight; therefore, this test was conducted using the new oil plus 2% MIL-L-7808D(1) oil. The operating conditions of this test are given in Table VIII.

The inspection results after each test run show no scuffing occurred during the eight runs, which totaled 2800 sec at 20% overload. This pinion gear now has a total run time of 7520 sec, with 4720 sec with MIL-L-7808D(1) oil prior to this test. The test load and run duration of Test 3 is graphically illustrated in Figure 36. The photograph taken after Test 3 is shown in Figure 29. It shows a light scored pattern through which the original grind marks are still visible. The full working surface of these teeth is bright metal with no black oxide coating. The lighting for this photograph was intentionally adjusted to accentuate the light areas shown.

The gear tooth wear during the last 2800 sec is determined by comparing the involute profile traces shown in Figure 28, with the profile traces shown in Figure 25b, which were made after the 4720 sec test with MIL-L-7808D(1) oil. The wear during the last test was uniform and less than 0.002 in.

It may be concluded that Batch 41 oil contaminated with 2% MIL-L-7808D(1) oil provides adequate scuff resistance for Titan II gearboxes previously operated with MIL-L-7808D(1) oil.

(5) Scuff Test at Reduced Lubrication Jet Pressure

A fourth gearbox test was conducted with MIL-L-7808D(1) oil to determine if the loss of lubrication oil jet pressure (PLD-GGB) to the gears is the major cause of scuffing. This test was conducted with the same gearbox used in the previous scuff tests assembled with a set of new bearings and gears. The pinion gear for this test was also a reduced width pinion. The conditions of this test are given in Table IX and are graphically illustrated in Figure 36 as Test 4.

After 195 sec of the fifth test, the pinion gear failed, and the test was stopped. The condition of the gearbox after the pinion failure is shown in Figures 31 and 32. All teeth of the pinion gear failed, and two teeth of the idler gear are broken as shown in Figures 33 and 34. The hardness of the oxidizer, idler, and fuel gear teeth (measured at the tip) showed a reduction of 15 to 20% due to overheating. It should be noted that, while the pinion gear failed completely, there was no visible scuffing on any of the other gear teeth.

TABLE VIII

TESTS USING BATCH 41 OIL AND 2% MIL-L-7808D(1) OIL  
 (On the Same Gears Used for Tests shown in Table I)

<u>Test No.</u>	<u>% Design Load</u>	<u>Duration, sec</u>	<u>Inspection Results</u>
1	120	200	Abrasion in addendum is coarser than in previous test following gearbox split.
2	120	200	Above abrasion finer. Width of wear pattern increases near center of tooth width.
3	120	400	No significant change.
4	120	400	Line of abrasion just below the tip profile modification and at the extreme tip is more distinct.
5	120	400	Fine radial lines in addendum near the center of teeth. Grind marks are visible through black oxide on full working surface of all teeth.
6	120	400	Fine line radial scratches diminished; working surface appears to be polishing near center of tooth.
7	120	400	No major change; fine radial lines in addendum still visible except at center of tooth.
8	120	400	No major change.
		-----	
		2800	
	16 previous runs	4720 (see Table I)	
		-----	
	Total run time	7520 sec	

Table VIII

TABLE IX

SCHEDULE FOR LUBRICATION JET REDUCED PRESSURE TESTS  
WITH MIL-L-7808D(1) OIL

<u>Test No.</u>	<u>% Design Load</u>	<u>Duration, sec</u>	<u>Initial Jet, psi</u>	<u>Final Jet, psi</u>	<u>Inspection Results</u>
1	25	200	45	30	Abrasion in addendum due to foreign particles.
2	50	200	40	28	Abrasion in addendum appears finer than Test 1. Black oxide appears thinner than on gears tested earlier.
3	115	200	20	14	No scuffing. Bright spot 0.030 x 0.050 in. in addendum at end of each tooth.
4	115	200	10	6.5	Bright spot at end of teeth increased in axial length. Bright area has polished scuff pattern.
5	115	195	10	7	Pinion gear failed.

Table IX

Report SSD-TR-65-161-1

TABLE X

RYDER GEAR TEST RESULTS

Test Lab	Test Ref No.	AGC Batch No.	Oil Visc., cstx at 210°F	DDP, %	DDP Batch Symbol	Ortho. 162, %	Ortho. 535, ppm	Ethyl 702, %	Monsanto PC-1244, %	DCP, %	Ryder Gear Value, Side A	Ryder Gear Value, Side B	Value, Ave.	Ref OIL	Ave. Rel. Rating, Sides A And B, %	Black Oxide Finish
	7	7	4	0.25	A	---	---	0.50	0.01	---	---	---	---	---	---	---
	8	8	---	---	---	---	---	---	---	0.50	---	---	---	---	---	---
	9	9	---	---	---	0.20	---	---	---	---	---	---	---	---	---	---
	10	10	---	---	---	0.15	---	---	---	---	---	3140	3140	---	---	---
EPPI	10	10	---	---	---	0.15	---	---	---	---	2020	4990	3505	2889	121.3	No
	11	11	---	---	---	0.20	---	---	---	---	4000	4350	4175	2889	144.5	No
	12	12	---	---	---	0.25	---	---	---	---	4020	6250	5135	2889	177.7	No
	13	13	0.20	A	---	---	---	---	---	---	6870	8350	7610	2889	263.4	No
	14	14	0.35	A	---	---	---	---	---	---	6650	9380	8015	2889	277.4	No
	15	15	0.50	A	---	---	---	---	---	---	7650	8250	7950	2889	275.2	No
	16	16	---	---	---	---	---	---	---	0.20	1500	1500	1525	2889	52.8	No
	17	17	---	---	---	---	---	---	---	0.25	1050	1330	1190	2889	41.2	No
	18	18	---	---	---	---	---	---	---	0.50	1290	1480	1385	2889	47.9	No
	19	19	4	0.30	A	---	---	---	---	0.20	(Not run)		---	---	---	---
	20A	20A	3	0.15	B	---	---	---	---	---	1270	1180	1225	2920	42.0	No
	20A	20A	---	0.20	B	---	---	---	---	---	680	1010	845	2920	28.9	No
	20A	20A	---	0.25	B	---	---	0.01	---	---	1040	1430	1235	2920	42.3	No
	20	20	---	0.25	1.5A+1D	---	---	0.05	---	---	2600	2190	2395	2920	82.0	No
	21	21	---	---	---	0.25	---	0.10	---	---	2850	2690	2770	2920	94.9	No
	21	21	---	---	---	0.25	---	0.10	---	---	2560	2840	2700	2920	92.5	No
	21	21	---	---	---	0.25	---	0.10	---	---	7050	6900	6975	3071	227.1	No
	21	21	---	---	---	0.25	---	0.10	---	---	6770	5440	6105	3071	198.8	No
	21	21	3	---	---	0.25	---	0.10	---	---	6690	6690	6690	3071	217.8	No
	22	22	3	---	---	0.25	50	0.10	---	---	3800	3980	3890	2840	137.0	No
	22	22	3	---	---	0.25	50	0.10	---	---	2400	2860	2630	2920	90.0	No
EPPI	22	22	3	---	---	0.25	50	0.50	0.10	---	2550	2900	2725	2920	93.3	No
	23	23	3	0.50	A	---	---	0.01	---	---	3430	4000	3715	2810	132.2	No
	24	24	4	0.10	A	---	---	0.01	---	---	920	1270	1095	2810	39.0	No
	25	25	4	0.15	A	---	---	0.01	---	---	2030	5170	3600	2810	128.1	No
	26	26	3	0.25	A	---	---	0.01	---	---	1780	5520	3650	2810	129.9	No
	27	27	3	---	---	0.20	---	0.10	---	---	1570	2870	2220	2840	79.2	No
	28	28	4	0.20	A	---	50	0.01	---	---	1665	3000	2332	2840	82.1	No
EPPI	29	29	3	0.25	A	---	50	0.50	0.01	---	1890	2640	2265	2840	79.8	No
	31	31	3	0.25	A	---	---	0.50	0.05	---	1750	2360	2055	2840	72.4	No
	32	32	3	---	---	0.25	---	0.05	---	---	1490	1780	1635	2840	57.6	No
	33	33	3	---	---	0.25	---	---	---	---	3300	3500	3400	2840	121.2	No
	34	34C	4	0.25	C	---	---	---	---	---	2040	3610	2825	2920	96.7	No
	34	34C	4	0.25	C	---	---	---	---	---	2010	4080	3045	2920	104.3	No
	35	35C	3	0.15	C	---	---	---	---	---	1130	1280	1205	2920	41.3	No
	36	36C	3	0.35	C	---	---	---	---	---	2870	3170	3020	2920	103.4	No
	37D	37D	3	0.50	D	---	---	---	---	---	2700	3680	3190	2880	110.8	No
	38C	38C	3	0.25	C	---	---	---	---	---	2040	2900	2407	2920	82.4	No
	38C	38C	3	0.25	C	---	---	0.50	0.05	---	1590	2390	1990	2920	68.2	No
	MIL-L-7906	---	3	---	---	---	---	---	---	---	2120	2020	2070	2920	70.9	No
	39D	39D	4	0.35	D	---	---	0.50	0.05	---	5590	4520	5055	2880	175.5	No
	40D	40D	3	0.40	D	---	---	0.05	---	---	3930	3570	3750	2880	130.2	No
	41	41	3	---	---	0.30	50	0.10	---	---	3900	4070	4025	2880	139.8	No
	42	34D	4	0.25	D	---	---	0.05	---	---	2580	3910	3245	2880	112.7	No
	43	34D	4	0.25	D	---	---	0.05	---	---	5750	5970	5860	2880	203.5	No
	44	34D	4	0.25	D	---	---	0.05	---	---	4380	5700	4540	2880	157.6	No
	45	41	3	---	---	0.30	50	0.10	---	---	6060	4100	5080	2880	176.4	No
	46	41	3	---	---	0.30	50	0.50	0.10	---	4950	5640	5295	2880	183.8	No
	47	40D	3	0.40	D	---	---	0.05	---	---	(Not run)		---	---	---	---
	48	40D	3	0.40	D	---	---	0.05	---	---	(Not run)		---	---	---	---
	49	37D	3	0.50	D	---	---	0.05	---	---	(Not run)		---	---	---	---
	50	37D	3	0.50	D	---	---	0.05	---	---	(Not run)		---	---	---	---
	51	22	3	---	---	0.25	50	0.10	---	---	(Not run)		---	---	---	---
	52	22	3	---	---	0.25	50	0.10	---	---	(Not run)		---	---	---	---
EPPI	55	41	3	---	---	0.30	50	0.10	---	---	7220	6470	6845	3071	222.9	No
	56	41	3	---	---	0.30	50	0.10	---	---	7450	9470	8460	3071	273.5	No
	57X	41	3	---	---	0.30	50	0.10	---	---	1300	1440	1415	3044	46.5	Yes
EPPI	58E	41	3	---	---	0.30	50	0.50	0.10	---	1460	1430	1445	3044	47.5	Yes

**TABLE X (cont.)**

Test Lab	Ref	ADC Batch No.	Oil		BDP Batch Symbol	Ortho. 162, %	Ortho. 535, PPA	Ethyl 702, %	Monsanto PC-1244, %	DCP, %	Ryder Gear Value, psi Ref			Ave. Rel. Rating, Sides A And B, %	Gear Metl.	Black Oxide Finish	
			Visc., cSt at 150°F	Cost at 150°F							Side A	Side B	Ave. Oil				
EWRI	59	41	3	---	---	0.30	50	0.50	0.10	---	2410	2100	2255	2685	84.0	Std.	No
	60	41	3	---	---	0.30	50	0.50	0.10	---	2780	2835	2807	2685	104.5	Std.	No
	61	41	3	---	---	0.30	50	0.50	0.10	---	2482	2205	2343	2685	87.3	Std.	No
	62	41	3	---	---	0.30	50	0.50	0.10	---	2570	2582	2576	2685	96.0	Std.	No
SWRI	63	41	3	---	---	0.30	50	0.50	0.10	---	2877	2574	2725	2685	101.5	Std.	No
EPPI	64	70	3	0.15	A+B	---	---	0.5	0.05	---	1470	1380	1425	3044	46.8		Yes
											1870	2920	2390	2906	82.2		Yes
EPPI	65																
	66																
	67																
	68	41	3	---	---	0.30	50	0.5	0.1	---	1520	1870	1695	3067	55.3		Yes
EPPI	69	41	3	---	---	0.30	50	0.5	0.1	---	1610	1530	1570	3067	51.2		Yes
	70A																
	71X	41	3	---	---	0.30	50	0.5	0.1	---	4450	3280	3865	B		4620/9310	No
	72	41	3	---	---	0.30	50	0.5	0.1	---	1840	2820	2330	B		4620/9310	Yes
	73																
	74	41	3	---	---	0.30	50	0.5	0.1	---	1940	2830	2385	B		4620/9310	Yes
	75	41	3	---	---	0.30	50	0.5	0.1	---	975	1610	1293	B		4620/9310	Yes
	76																
	77																
	78																
	79																
	80																
EPPI	81																
SWRI	82	41	3	---	---	0.30	50	0.5	0.1	---	2540	2440	2540	2710	93.8	Std.	No
	83	41	3	---	---	0.30	50	0.5	0.1	---	3520	3933	3726	2710	137.5	Std.	No
	84	41	3	---	---	0.30	50	0.5	0.1	---	2930	3575	3252	2710	120.0	Std.	No
	85	41	3	---	---	0.30	50	0.5	0.1	---	2275	2040	1257	2710	79.5	Std.	No
	86 x	41	3		Nitrogen Blanketing	0.30	50	0.5	0.1	---	2790	2870	2830	2830	100.0	Std.	No
	87	41	3	---	---	0.30	50	0.5	0.1	3	3220	4286	3753	2710	138.5	Std.	No
	88	41	3	---	---	0.30	50	0.5	0.1	---	2520	2440	2480	2655	93.2	Std.	No
	89	41	3	---	---	0.30	50	0.5	0.1	31	3180	3180	3180	2655	119.7	Std.	No
	90	41	3	---	---	0.30	50	0.5	0.1	---	2320	2775	2547	2655	95.8	Std.	No
	91 x				MIL-L-7808D(1) Nitrogen Blanketing						1420	1395	1407	2655	53.0	Std.	No
	92 x				MIL-L-7808D(1) Flow Reduced 50%						1400	1750	1575	2655	59.4	Std.	No
	93 x	41	3	---	---	0.30	50	0.5	0.10	---	2135	2260	2197	2655	82.7	Std.	No
	94 x				MIL-L-7808D(1) Flow Reduced 50%						1697	1442	1569	2655	59.0	Std.	No
SWRI	95 x	41	3	---	---	0.30	50	0.5	0.1	---	725	1108	916	2655	34.5	Std.	No
EPPI	21	21	3	---	---	0.25	---	0.5	0.10	---	1560	1680	1620	3044	53.2		Yes
	34	34	4	0.25	C	---	---	0.5	0.05	---	2270	2480	2375	3044	78.0		Yes
											2060	2450	2255	3044	74.1		Yes
											2490	1830	2160	3044	71.0		Yes
SWRI											2244	2356	2300	2685	85.6	Std.	No
											2150	2170	2160	2685	80.3	Std.	No
ALCOR	92	41	3	---	---	0.30	50	0.5	0.1	---	1670	3040	2355	2880	81.6	Std.	No
	93	41	3	---	---	0.30	50	0.5	0.1	---	2250	3050	2650	2880	92.0	Std.	No
	94	41	3	---	---	0.30	50	0.5	0.1	---	3000	5500	4250	2880	147.5	Std.	No
ALCOR	95	41	3	---	---	0.30	50	0.5	0.1	---	5500	5500	5500	2880	190.9	Std.	No



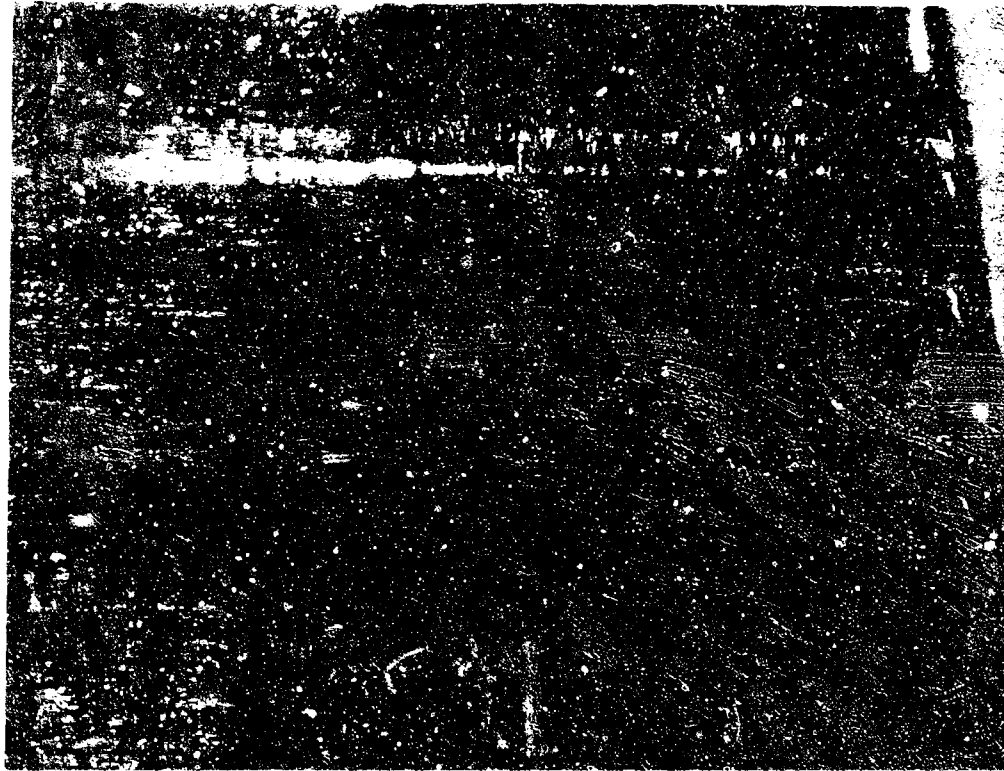

Passion Gear SN 1049 After Test with 3156 Lubricant  
and 2% (Oil per MIL-L-7808D(1))

Figure 29

(STANDARD GEAR MATERIAL AND LOAD SEQUENCE)

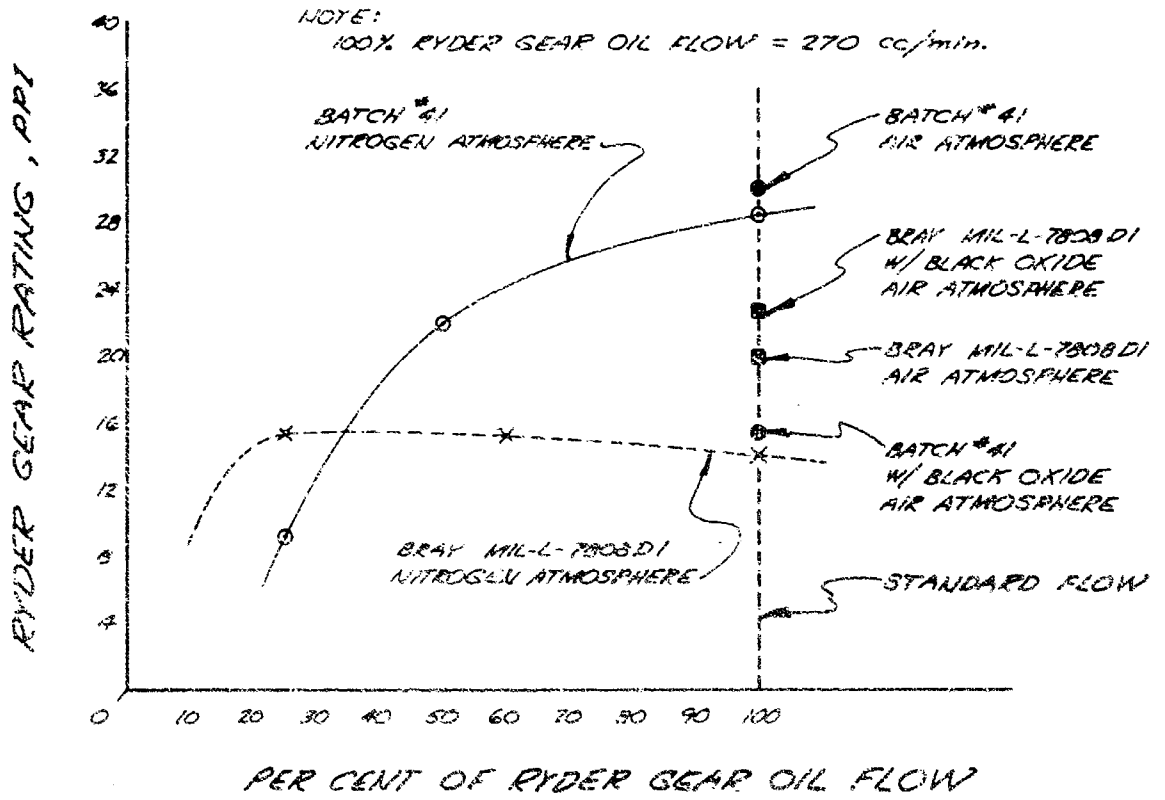

Ryder Gear Test Results

Figure 30

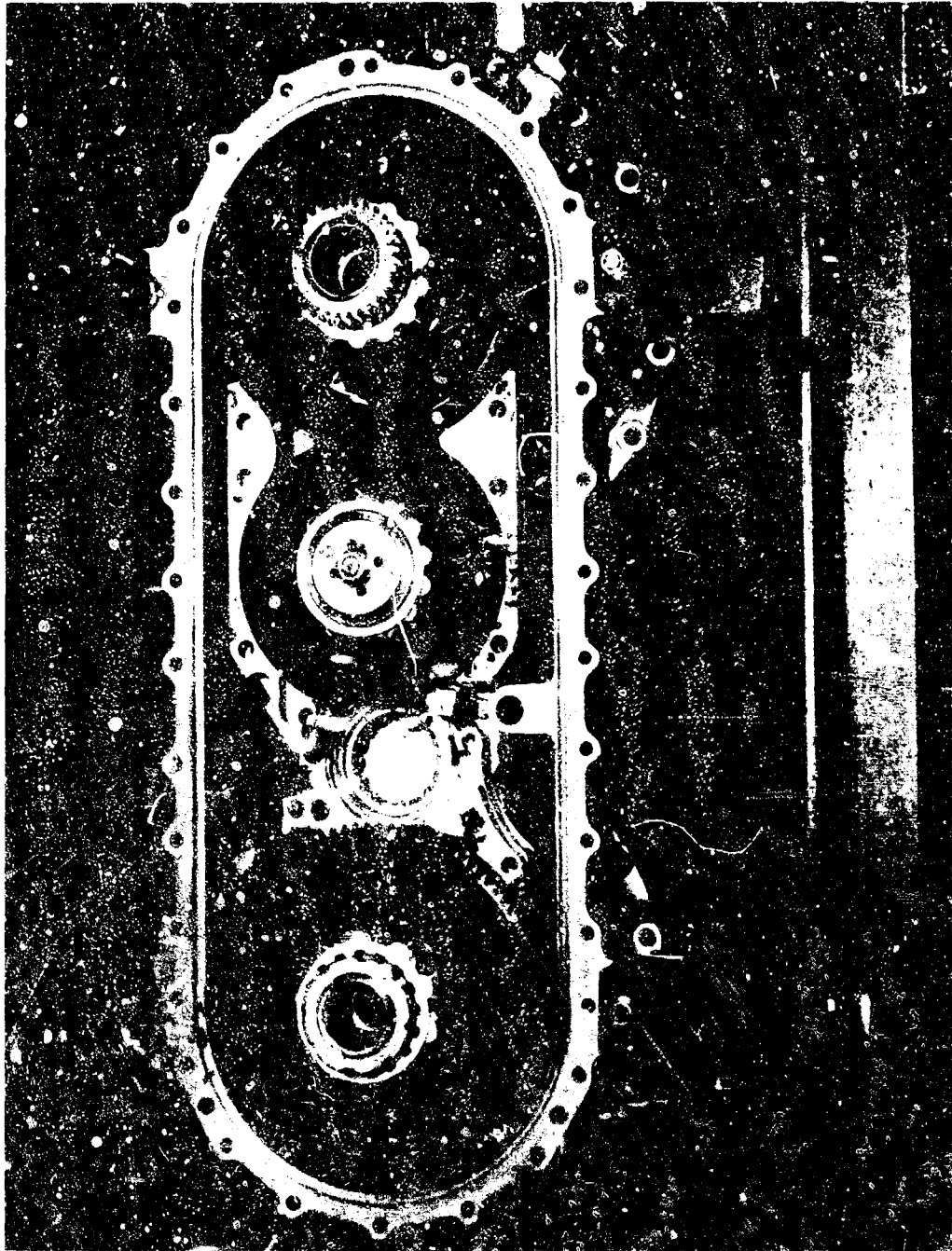

First-Stage Gearbox After Pinion Failure, View 1

Figure 31



First-Stage Gearbox After Pinion Failure, View 2

Figure 32

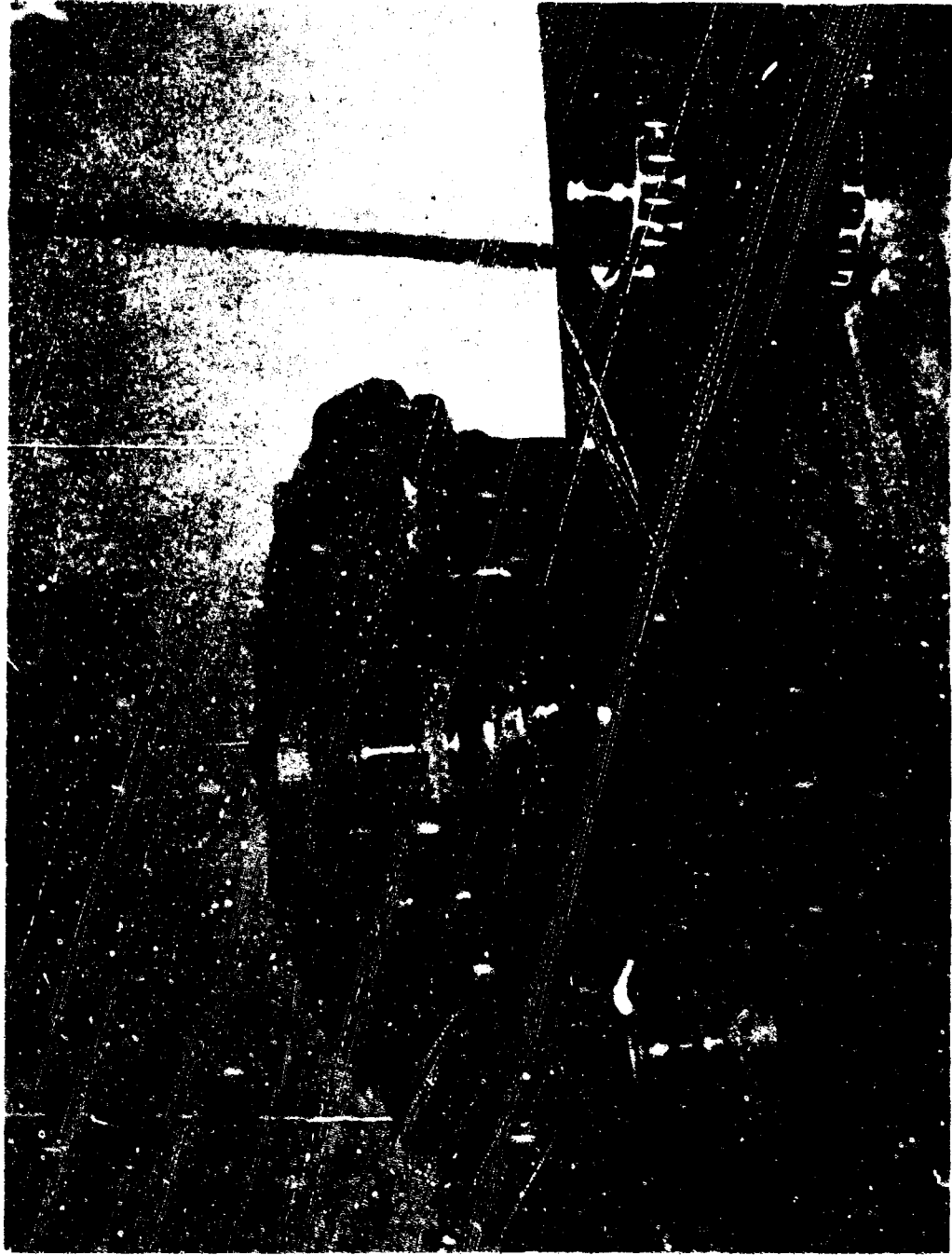

Pinion Gear After Test

Figure 33

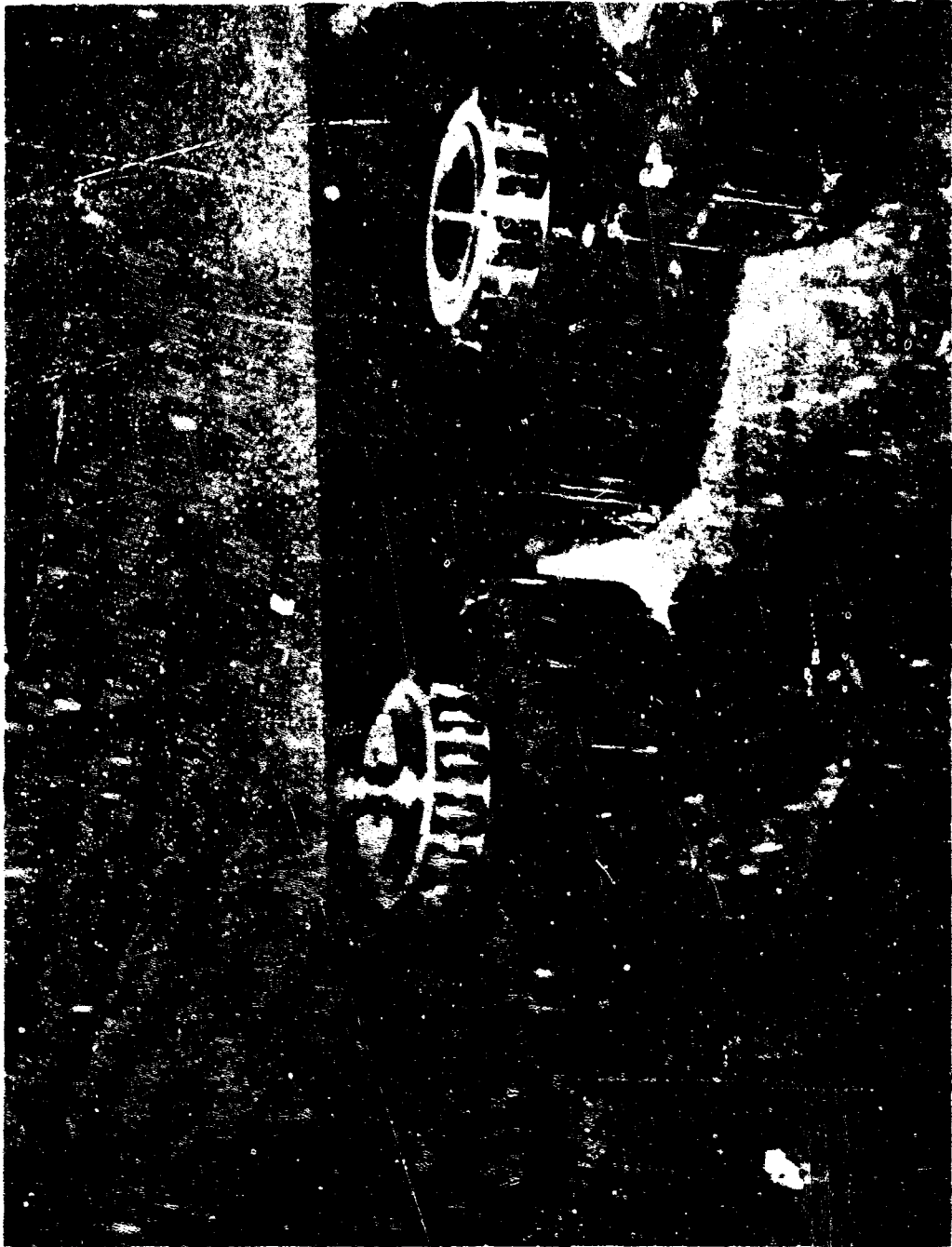

Gear Train After Test

Figure 34

IV, E, Evaluation of Final Prospective Lubricant (cont.)

Lubrication oil flow data recorded during this test is shown in Figure 35, along with similar data from first-stage turbopump hot firing tests. Curve 1 shows the flow rate and total oil delivered to the gearbox during a normal 200-sec turbopump production test, in which no visible gear teeth wear occurred. Curve 2 shows data recorded during a test in which approximately 60% of the oil was lost to the atmosphere through the gearbox relief valve due to a hot gas leak. The conditions of this turbopump test are similar to the conditions of the reduced flow test at Western Gear Corporation, except the atmosphere in the gearbox was air (oxidizing) at Western Gear Corporation and turbine gas (reducing) in the turbopump test.

Curve 3 shows the flow rate and total flow to the gearbox during the third reduced flow test at Western Gear Corporation, in which no scuffing occurred. Curve 4 shows the conditions of the last two tests. After the first of these two tests, only one bright spot was noted at the upper end of the gear near the tip of the teeth, and then complete failure occurred at 195 sec of the last test.

It may be concluded that during gearbox tests; i.e., with no turbine gas in the gearbox, the present oil provides adequate scuff resistance for 200 sec when the lubrication oil flow rate to the gearbox is greater than 2.25 gpm.

It may also be concluded that turbine gas, which is a reducing atmosphere, inhibits the formation of oxidizer, which, in turn, reduces the scuff resistance of black oxidized gears provided by the present oil. This fact is evident, because during this test, in which the gearbox was run until failure occurred, the oxidizer, idler, and fuel gear did not scuff. And, in the turbopump test described above in which turbine gas was in the gearbox, scuffing occurred on all gears without structural failure.

c. Summary and Conclusions

The usefulness of Ryder Gear test data for predicting the load capacity of experimental lubricants is limited by poor repeatability.

Standard and special Ryder Gear tests of plain and black-oxide-coated gears, made of standard Ryder Gear material (AMS-6260) and Titan II gear materials (AISI 4620 and 9310) show the following:

(1) The Ryder gear value of the new oil is 3500 ppi and that of the present oil is 2137 ppi.

(2) The black oxide coating on Titan II gear materials reduces the Ryder Gear value from 3900 to 2300 ppi, and on 6260 from 4000 to 1500 ppi.

(3) Black oxide coating improves the Ryder Gear rating of the present oil from 2100 to 2300 ppi.

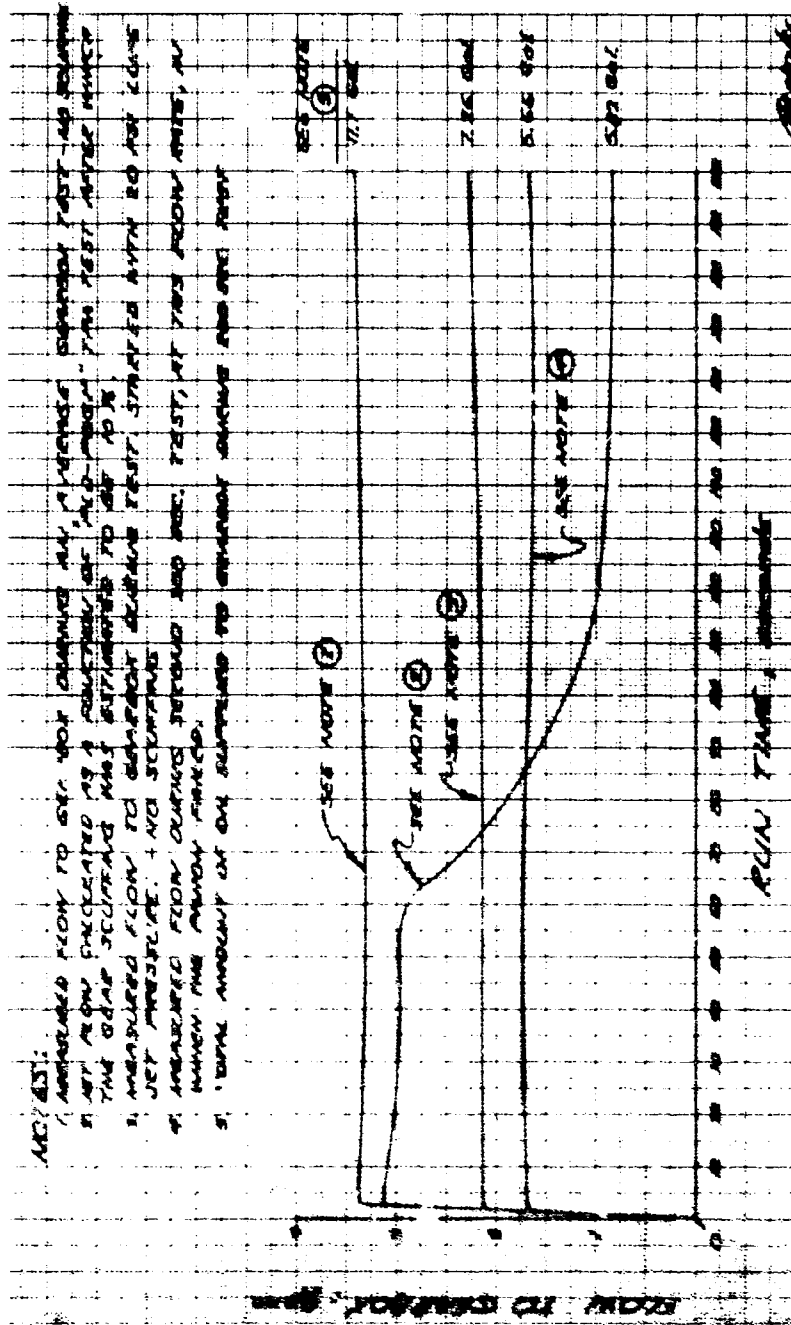

Figure 35



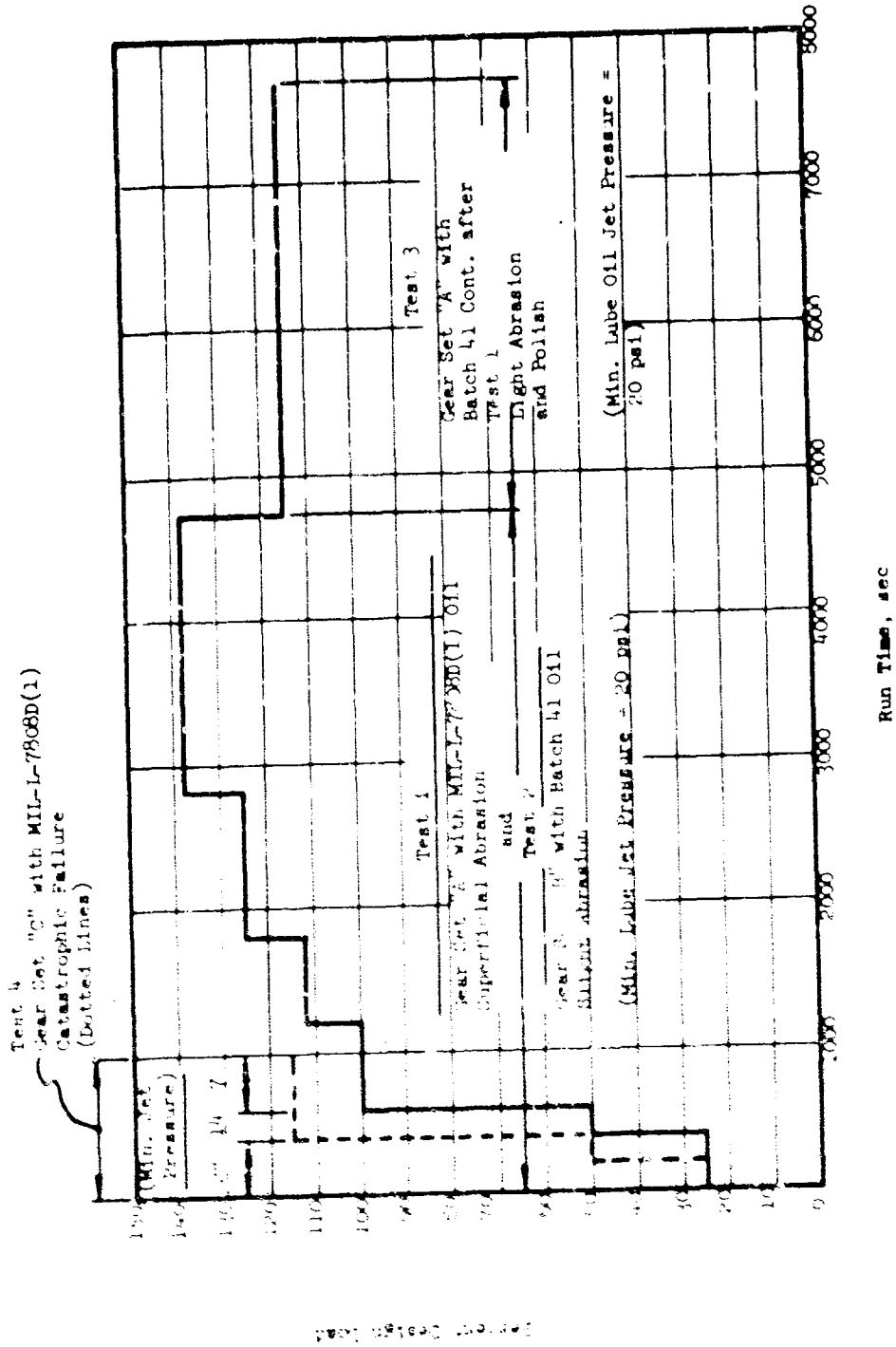

Figure 36

IV, E, Evaluation of Final Prospective Lubricant (cont.)

(4) In an inert gaseous atmosphere (simulating gearbox conditions of a turbine seal leak), the present lubricant rates are 1400 ppi; the new oil is unaffected.

(5) Contamination of the new oil with 0.2% water and 0.1% AeroZINE 50 does not affect their performance in Ryder Gear tests.

Gearbox tests at Western Gear show that both the present oil and the new oil provide adequate lubrication to black-oxide-coated gears during tests equal to 1-1/2 times the design life of the gears at conditions up to 37% overload. It is concluded from these tests that, although the full potential of the new oil is not realized on black-oxide-coated gears, it does provide adequate lubrication for the Titan II gearbox application.

3. Filter Plugging Tests

Filter plugging tests were conducted in order to duplicate flow conditions across the filter screen of the prospective lubricant under simulated gearbox conditions. The present gearbox lubricant itself has previously shown to be a source of contamination if exposed to the products of generator gases.

The filter plugging test setup has been designed in order to screen the lubricant deposits formed as the results of interaction between the lubricant and the products of combustion only. The products of combustion contain water and ammonia, which have been found to be the main cause of filter plugging. A typical composition of the products of combustion of the first-stage gearbox is as follows:

<u>Products of Combustion - First Stage</u>	
Hydrogen (H <sub>2</sub> )	52%
Nitrogen (N <sub>2</sub> )	30%
Methane (CH <sub>2</sub> )	12%
Ammonia (NH <sub>3</sub> )	0.21%
Carbon Monoxide (CO)	4%
Water (H <sub>2</sub> O)	1.07%
Solid Carbon	Traces

An explanation of the reactions is needed to understand formation of deposits in the lubricant. The presently used lubricant (Bryco 880 Conojet, which meets Specification MIL-L-7808B(1)) has been found to be prone to the filter plugging phenomenon. The super-refined mineral oil base used for the new lubricant shows a minimal tendency to plug the filter during the long hour filter tests.

IV, E, Evaluation of Final Prospective Lubricant (cont.)

A theory was advanced (and later confirmed by the tests) explaining chemical reactions taking place in the MIL-L-7808D(1) lubricant if exposed to products of combustion.

The composition of Bryco 880 Conojet lubricant (MIL-L-7808D(1)) is as follows:

Composition of Bryco 880 Conojet

47.5% Di-isooctyl azelate	- di-ester base
47.5% Dipropyleneglycol dipelargonate	
0.5% Phenathiazine NF, purified	- oxidation inhibitor
4.5% Tri-cresyl phosphate (TCP)	- E.P. additive

The following reaction occurs between Bryco 880 Conojet and the products of combustion:

- (1) Di-isooctyl azelate +  $H_2O$  = azelaic acid + isooctyl alcohol
- (2) Azelaic acid + ammonia = ammonium azelate

Both ammonium azelate and azelaic acid have been identified in the filter sludge.

a. Test Setup

A schematic of the test setup is shown in Figure 37. The oil is contained in the stainless steel sump and can be heated to  $200 \pm 2^\circ F$ . The sump has a coil with small orifices to bubble gaseous ammonia at the determined rate. Oil is circulated by the small positive displacement pump at the rate of 0.1 gpm through the flow control valve and filter screen which simulates actual TPA operating oil flow for the equivalent filter area. The temperature of lubricant in the sump is monitored, and any pressure built up across the filter screen is shown on the upstream and downstream mounted pressure gages.

To exclude any metal contamination, such as copper and zinc, which might have reacted with Bryco Conojet lubricant, the whole circulating system was made from stainless steel and plastic tubing. A separate system supplies the required amount of ammonia. A photograph of this setup is shown in Figure 38.

b. Test Procedure and Results

The test procedure used was to take two quarts of lubricant and blend them at high speed with a determined percent of water for one minute. Gaseous ammonia was bubbled through the oil during the test.

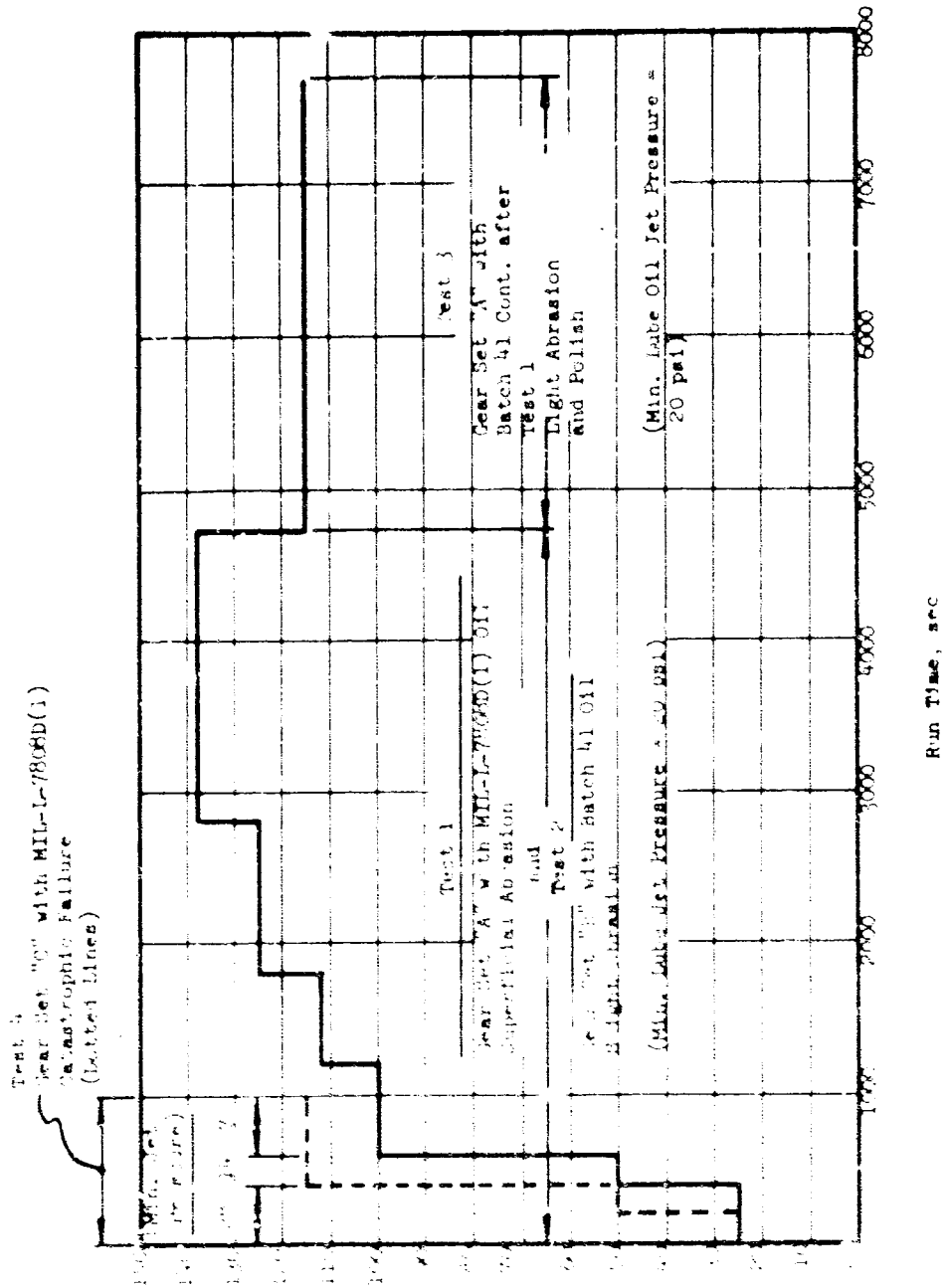

Figure 38

AEIP GEARBOX LUBRICANT DEVELOPMENT  
FILTER PLUGGING TEST

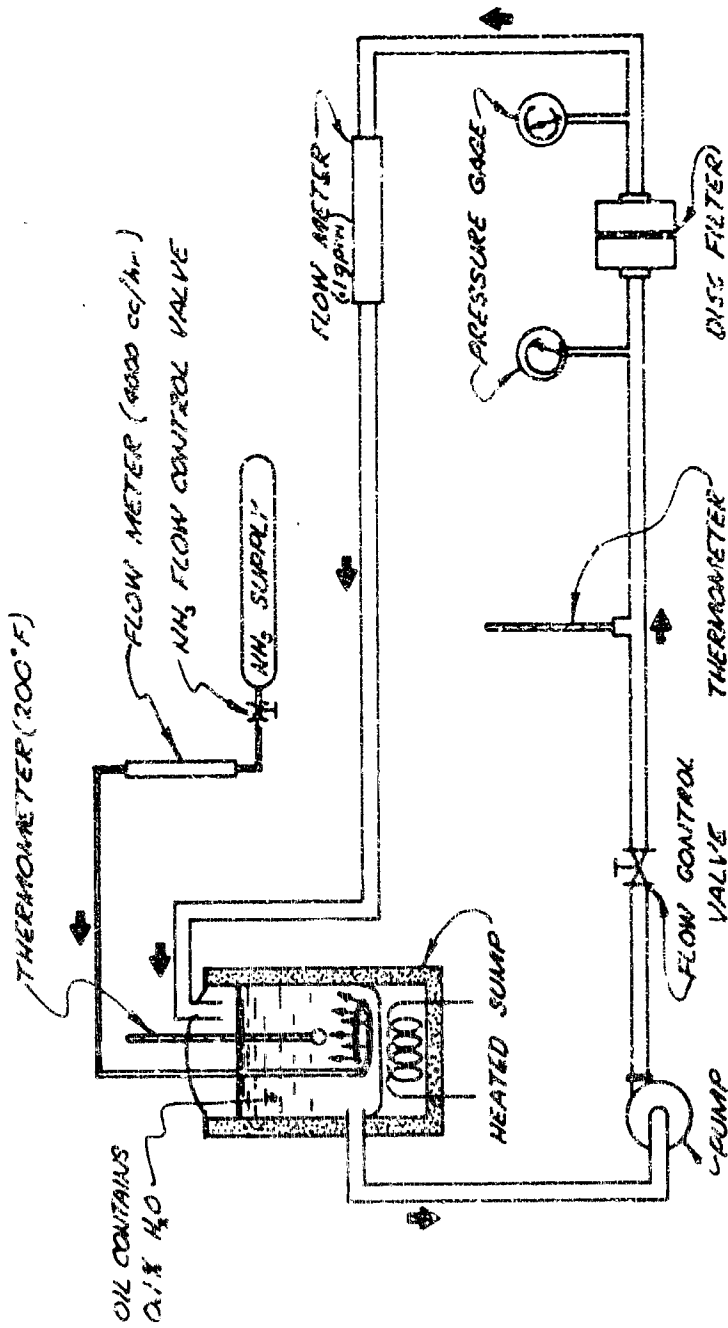

Figure 37

Report SSD-TR-63-161-1

## IV, E, Evaluation of Final Prospective Lubricant (cont.)

A theory was advanced (and later confirmed by the tests) explaining chemical reactions taking place in the MIL-L-7808D(1) lubricant if exposed to products of combustion.

The composition of Bryco 880 Conojet lubricant (MIL-L-7808D(1)) is as follows:

Composition of Bryco 880 Conojet

47.5% Di-isoctyl azelate	- di-ester base
47.5% Dipropyleneglycol dipelargonate	
0.5% Phenathiazine NF, purified	- oxidation inhibitor
4.5% Tri-cresyl phosphate (TCP)	- E.P. additive

The following reaction occurs between Bryco 880 Conojet and the products of combustion:

- (1) Di-isoctyl azelate + H<sub>2</sub>O = azelaic acid + isoctyl alcohol
- (2) Azelaic acid + ammonia = ammonium azelate

Both ammonium azelate and azelaic acid have been identified in the filter sludge.

a. Test Setup

A schematic of the test setup is shown in Figure 37. The oil is contained in the stainless steel sump and can be heated to 200 ± 2°F. The sump has a coil with small orifices to bubble gaseous ammonia at the determined rate. Oil is circulated by the small positive displacement pump at the rate of 9.1 gpm through the flow control valve and filter screen which simulates actual TPA operating oil flow for the equivalent filter area. The temperature of lubricant in the sump is monitored, and any pressure built up across the filter screen is shown on the upstream and downstream mounted pressure gages.

To exclude any metal contamination, such as copper and zinc, which might have reacted with Bryco Conojet lubricant, the whole circulating system was made from stainless steel and plastic tubing. A separate system supplies the required amount of ammonia. A photograph of this setup is shown in Figure 38.

b. Test Procedure and Results

The test procedure used was to take two quarts of lubricant and blend them at high speed with a determined percent of water for one minute. Gaseous ammonia was bubbled through the oil during the test.

## IV, E. Evaluation of Final Prospective Lubricant (cont.)

(4) In an inert gaseous atmosphere (simulating gearbox conditions of a turbine seal leak), the present lubricant rates are 1400 ppi; the new oil is unaffected.

(5) Contamination of the new oil with 0.2% water and 0.1% AeroZINE 50 does not affect their performance in Ryder Gear tests.

Gearbox tests at Western Gear show that both the present oil and the new oil provide adequate lubrication to black-oxide-coated gears during tests equal to 1-1/2 times the design life of the gears at conditions up to 37% overload. It is concluded from these tests that, although the full potential of the new oil is not realized on black-oxide-coated gears, it does provide adequate lubrication for the Titan II gearbox application.

### 3. Filter Plugging Tests

Filter plugging tests were conducted in order to duplicate flow conditions across the filter screen of the prospective lubricant under simulated gearbox conditions. The present gearbox lubricant itself has previously shown to be a source of contamination if exposed to the products of generator gases.

The filter plugging test setup has been designed in order to screen the lubricant deposits formed as the results of interaction between the lubricant and the products of combustion only. The products of combustion contain water and ammonia, which have been found to be the main cause of filter plugging. A typical composition of the products of combustion of the first-stage gearbox is as follows:

#### Products of Combustion - First Stage

Hydrogen (H <sub>2</sub> )	52%
Nitrogen (N <sub>2</sub> )	30%
Methane (CH <sub>2</sub> )	12%
Ammonia (NH <sub>3</sub> )	0.21%
Carbon Monoxide (CO)	4%
Water (H <sub>2</sub> O)	1.07%
Solid Carbon	Traces

An explanation of the reactions is needed to understand formation of deposits in the lubricant. The presently used lubricant (Eryco 880 Conojet, which meets Specification MIL-L-7808D(1)) has been found to be prone to the filter plugging phenomenon. The super-refined mineral oil base used for the new lubricant shows a minimal tendency to plug the filter during the long hour filter tests.

IV, E, Evaluation of Final Prospective Lubricant (cont.)

A theory was advanced (and later confirmed by the tests) explaining chemical reactions taking place in the MIL-L-7808D(1) lubricant if exposed to products of combustion.

The composition of Bryco 880 Conojet lubricant (MIL-L-7808D(1)) is as follows:

Composition of Bryco 880 Conojet

47.5% Di-isooctyl azelate	- di-ester base
47.5% Dipropyleneglycol dipelargonate	
0.5% Phenathiazine NF, purified	- oxidation inhibitor
4.5% Tri-cresyl phosphate (TCP)	- E.P. additive

The following reaction occurs between Bryco 880 Conojet and the products of combustion:

- (1) Di-isooctyl azelate +  $H_2O$  = azelaic acid + isooctyl alcohol
- (2) Azelaic acid + ammonia = ammonium azelate

Both ammonium azelate and azelaic acid have been identified in the filter sludge.

a. Test Setup

A schematic of the test setup is shown in Figure 37. The oil is contained in the stainless steel sump and can be heated to  $200 \pm 2^\circ F$ . The sump has a coil with small orifices to bubble gaseous ammonia at the determined rate. Oil is circulated by the small positive displacement pump at the rate of 0.1 gpm through the flow control valve and filter screen which simulates actual TPA operating oil flow for the equivalent filter area. The temperature of lubricant in the sump is monitored, and any pressure built up across the filter screen is shown on the upstream and downstream mounted pressure gages.

To exclude any metal contamination, such as copper and zinc, which might have reacted with Bryco Conojet lubricant, the whole circulating system was made from stainless steel and plastic tubing. A separate system supplies the required amount of ammonia. A photograph of this setup is shown in Figure 38.

b. Test Procedure and Results

The test procedure used was to take two quarts of lubricant and blend them at high speed with a determined percent of water for one minute. Gaseous ammonia was bubbled through the oil during the test.



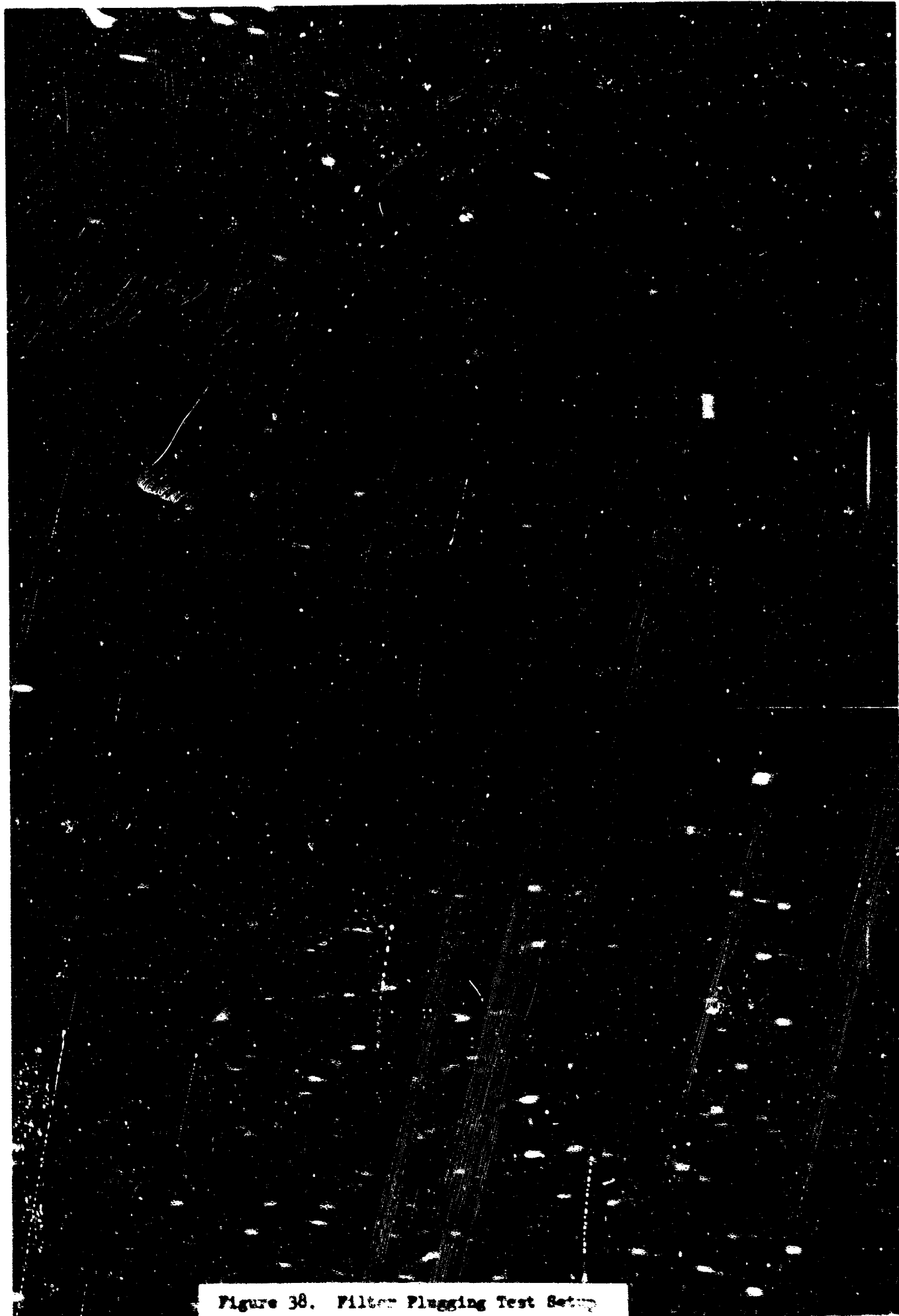

Figure 38. Filter Plugging Test Setup

IV, E, Evaluation of Final Prospective Lubricant (cont.)

The increase of the pressure across the filter was recorded vs time and was plotted (Figure 39). As can be seen from the graph, the plugging time between MIL-L-7808D(1) oil, which is Bryco Conojet 380 lubricant, and the mineral oil differs considerably. The MIL-L-7808D(1) lubricant showed a pressure buildup across the filter between 5 to 25 min; the 3156 mineral oil (Batch 41) lubricant has shown a considerable stability with the tests run between 8 to 16 hr without a significant increase of the pressure.

The above tests have been performed at various temperature levels and water content. The significant results are shown in Table XI. It can be seen that the addition of 2% of MIL-L-7808D(1) lubricant to the 3156 lubricant would not greatly influence filter plugging; however, the time to achieve a 5-psi filter pressure is shorter as compared with the neat 3156 lubricant.

Synthetic di-ester lubricant, such as Bryco 880 Conojet, was found to plug the filter within 25 min. A pressure differential of 5 psi was recorded at 5, 12, and 15 min.

A significant test was performed with 3156 lubricant to check on the filter-plugging tendency of a white emulsion-type precipitate formed when this lubricant is subjected to water at a concentration of 0.2% or greater.

A large quantity of this precipitate was extracted by centrifuging from the 3156 lubricant, and this concentrated precipitate was packed on the filter screen. The cold lubricant was pumped while, at the same time, the heat was turned on at the sump. No pressure change was noticeable throughout the test. When the lubricant reached 200°F, the test was terminated, and the pressure across the filter was steady at 3/4 psi. The test lasted 41 min, during which time no pressure drop was noted across the filter, and the lubricant became crystal-clear (the melting point of the precipitate is 159°F) at the end of the test (see Figure 40).

The tests have confirmed that the synthetic MIL-L-7808D(1) lubricant subjected to the products of combustion will readily plug the gearbox filter. The 3156 mineral oil, even with 2% MIL-L-7808D(1) lubricant, will not plug the filter in a 200-sec run. Neat 3156 mineral oil will not plug the filter even after 8 hr.

Residue is found on the filter screen when circulating 3156 lubricant with 0.1% water and ammonia for 8 hr. This residue increases the pressure across the filter to 5 psi at the end of 400 min. Chemical analysis of this precipitate revealed the following:

(1) The X-ray diffraction pattern obtained from the sample was not conclusive; the best match for the pattern would conform to the pattern for ammonium hydrogen phosphate:  $(\text{NH}_4)_2 \cdot \text{HPO}_4$ .

(2) Emission spectrographic analysis indicated 14% phosphorous content.

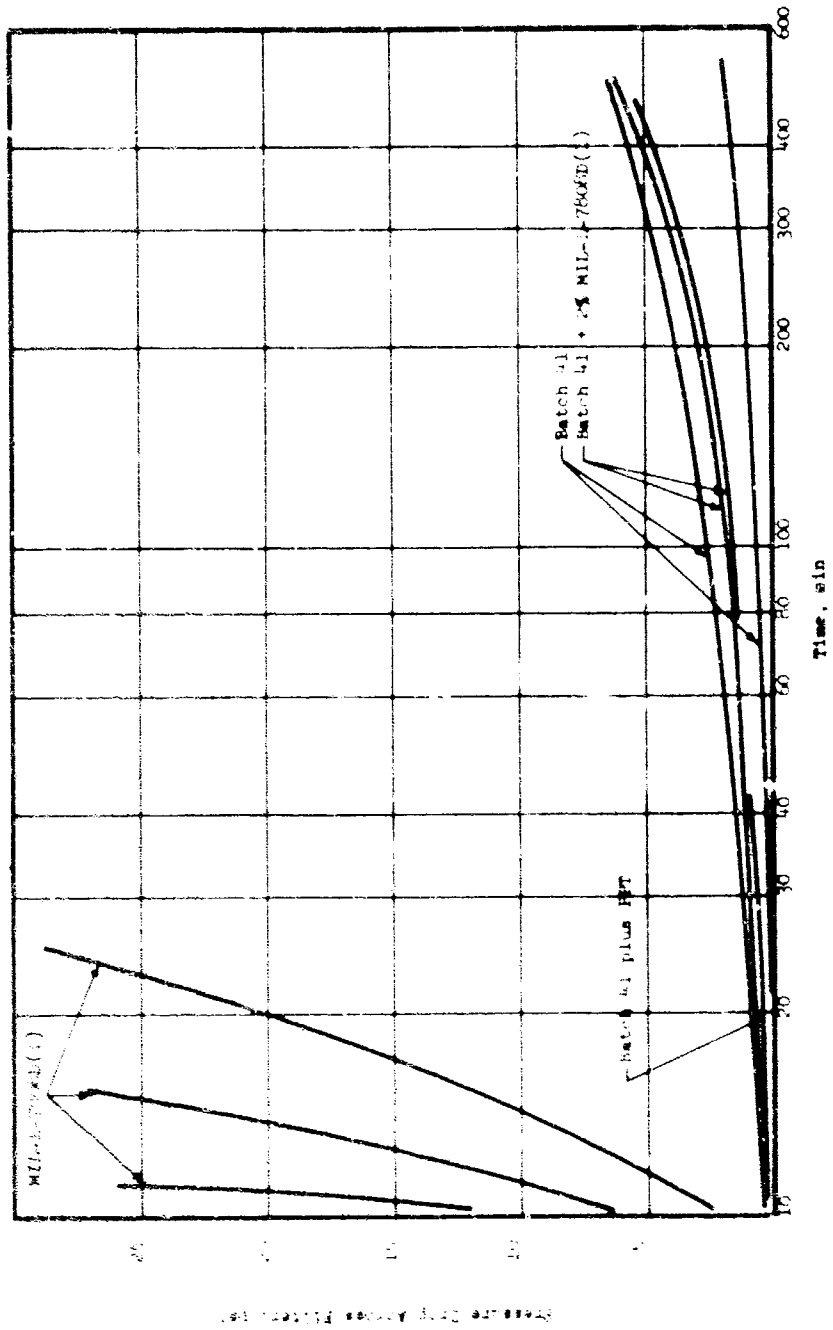

Figure 39

Filter Plugging Test, Pressure Drop across Filter vs Time

*BATCH #41 FILTER FILLED UP  
WITH PRECIPITATE FROM EMULSION*



*FILTER BEFORE TEST*



*FILTER AFTER TEST*

Filter Plugging Test. Before and After Views of Filter

Figure 40

TABLE XI

## FILTER PLUGGING TEST

<u>Oil Composition</u>	<u>Temp., °F</u>	<u>Ammonia, cc/hr</u>	<u>Water, % by Wt.</u>	<u>MIL-L-7808D(1) Oil, % by Wt.</u>	<u>Time for 5 psi ΔP across the filter, minutes</u>
Batch 41	RT	---	---	---	Over 8 hr
Batch 41	200	4000	0.1	---	400
Batch 41	RT	---	0.2	---	Over 8 hr
Batch 41	RT	4000	0.2	2	Over 8 hr
Batch 41	200	---	---	---	Over 8 hr
Batch 41	200	4000	0.1	2	330
Batch 41	RT	---	0.1	2	420
Batch 41	RT	---	0.1	2	370
MIL-L-7808D(1)	200	4000	0.1	---	12
MIL-L-7808D(1)	200	2000	0.1	---	5
MIL-L-7808D(1)	200	4000	0.1	---	15
Batch 41 with ppt	RT to 200	---	---	---	1-3/4 after 41 min

Table XI

IV, E, Evaluation of Final Prospective Lubricant (cont.)

(3) The infrared spectrum of chloroform-washed material indicated the presence of  $(\text{NH}_4)_2 \cdot \text{HPO}_4$ . It is believed the presence of ammonium hydrogen phosphate can be explained by the following reactions:

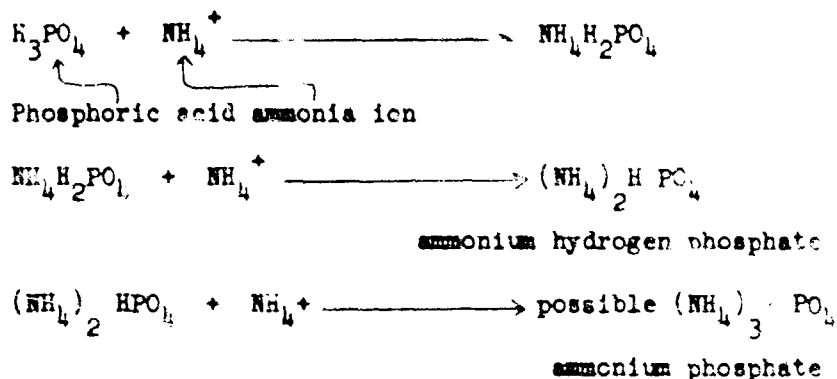

In conclusion, the newly developed 3156 mineral oil is much more stable, and is not expected to plug filters within the service life of a gearbox. The deposit found on the filter after an extended time is derived from the extreme pressure additive (Ortholeum 162).

4. Compatibility with Propellants, MIL-L-7808D(1) Oil and Water

The greatest need for a new lubricant results from the fact that the presently used MIL-L-7808D(1) lubricant is incompatible with the propellants and the products of combustion from the gas generator. The chemical environments of the gearbox impose severe requirements on the lubricant and tend to change its composition which, in turn, has a related action on the performance of the gearbox. The fuel, AeroZINE 50, which is a mixture of 50% hydrazine ( $\text{N}_2\text{H}_4$ ) and 50% unsymmetrical dimethylhydrazine  $(\text{CH}_3)_2\text{N}_2\text{H}_2$  reacts strongly with MIL-L-7808D(1) lubricant. The oxidizer, nitrogen tetroxide ( $\text{N}_2\text{O}_4$ ), also reacts with the lubricant to form a sludge. The products of combustion (water and ammonia) acting upon the lubricant can cause the filter to plug.

The following is a summary of chemical compatibility tests with three determinations and observations after 72 hr:

<u>Agent</u>	<u>Humble 3155-41</u>	<u>MIL-L-7808D(1)</u>
50/50 $\text{N}_2\text{O}_4$	No solid ppt	Traces of solid ppt Dark viscous residue
50/50 AeroZINE 50	No ppt	Solid ppt
Ammonia for 4 hours at 250°F	No ppt	Traces of solid ppt
3% Water for 4 hours at 210°F	No solid ppt	No solid ppt
2% MIL-L-7808D(1)	No ppt	---

IV, F, Evaluation of Final Prospective Lubricant (cont.)

The mixture of MIL-L-7808D(1) oil and 3156 mineral oil will rapidly change color if exposed to the sunlight; a very slow change takes place in the dark room. Color tests were performed on different mixtures of the two lubricants. No precipitate could be obtained after several hours of centrifuging. The results are summarized as follows:

<u>% MIL-L-7808D(1)</u>	<u>3156 Mineral Oil with MIL-L-7808D(1) Oil</u> <u>Observations at 1 and 24 hours</u>
0	No Change
0.025	Very light green
0.05	Very light green
0.10	Light green
0.20	Medium green
1.0	Black green
2.0	Black green
3.0	Black green

Dark Room Test

Batch 41 with 2% MIL-L-7808D(1) oil

Observations: Light green color after 30 days. The color change of the mixture did not change basic characteristics of Humble 3156 lubricant.

The compatibility of Batch 41 oil with MIL-L-7808D(1) oil was demonstrated as follows:

Combination Test

Batch 41 with 2% MIL-L-7808D(1) oil and 0.2% Water 168 Hours Test at 221°F

3 Determinations

Results ppt less than 0.005 mg/200 ml oil clear

## IV, E, Evaluation of Final Prospective Lubricant (cont.)

The water emulsion tests were performed with 3156 mineral oil, which showed that the lubricant would yield white flakey precipitate above 0.1% of the water admixed. This precipitate is caused by the hydrolysis of the Ortholeum 162 additive, which absorbs the free water preventing the formation of red rust at oil-water-iron interfaces. These tests are summarized as follows:

<u>% Water</u>	<u>Observations</u>
0.025	No change
0.050	No change
0.100	No change
0.200	Light white viscosity ppt
1.00	White viscosity ppt
2.0	White viscosity ppt

Depletion of E.P. additive was established when the neutralization number (milligrams of potassium hydroxide per gram of lubricant) was measured of the neat and contaminated 3156 mineral oil:

<u>Mixture</u>	<u>Neutralization Number KOH mg/gr</u>	
	<u>Original</u>	<u>After 30 Days</u>
Humble 3156, Batch #1	0.65	0.65
Batch #1 + 0.1% water*	---	0.57
Batch #1 + 0.2% water	---	0.46
+ 1% MIL-L-7808D(1) oil	---	
* all gearbox parts		

\*Hyder Gear rating at 0.1% water: 3915 psi

These water emulsion tests show that no significant depletion of the extreme pressure additive (Ortholeum 162) occurs when it is exposed to a water concentration allowed by the current operation specifications (0.1% water).

The good chemical compatibility of the new oil will eliminate problems of the filter plugging and the seal cavity deposits. It may be used in the gearbox, from which the MIL-L-7808D(1) lubricant has been drained and the remaining 2% mixed up without deteriorating effect to the new lubricant.



IV, E, Evaluation of Final Prospective Lubricant (cont.)

5. Aeration and Cooling Behavior

The aeration (or air entrapment) performance of a lubricant for a high-speed gearbox is very important because it affects the lubricant's ability to act as a coolant. The entrapped bubbles cause a drop in the lubricant's specific heat, and, accordingly, poor heat dissipation results. Pumping of the lubricant also becomes more difficult.

Previous tests have shown that a lubricant of poor aeration characteristics is not acceptable for the high-load, high-speed gear training of the Titan II gearboxes. For example, the 4-centistoke mineral oil originally developed for the AEIP lubrication development program was not acceptable because the temperatures in the gearbox were about 50°F higher than with MIL-I-7808D(1) lubricant.

While there are many foam depressing agents, the aeration agents are few. One of them, Monsanto PC-1244, was developed specifically for British turboprop engines. This additive was successfully applied to the new lubricant. It was established that 0.1% of Monsanto PC-1244 could almost entirely suppress aeration of the 5-centistoke oil. The anti-corrosion additive used in the present lubricant under the name of Ortholeum 535 has shown to be another anti-aeration suppressant. The viscosity of the base lubricant also influences the aeration of the finished products. The 3-centistoke base lubricant gave significantly better results with Ortholeum 162 than the 4 centistoke oil.

After the optimum anti-aeration additive was selected for the final prospective oil in laboratory Waring Blendor tests (see Section C), the lubricant was tested at Western Gear Corporation using the first- and second-stage Titan II production gearboxes. The fuel shaft lower bearing was selected for the graph, because this bearing has one of the highest temperatures recorded within the gearbox. As can be seen from Figures 41, 42, and 43, the 3156 mineral oil showed identical temperature distribution as the MIL-L-7808D(1) lubricant, which is known for its good anti-aeration stability.

6. Corrosiveness and Preservative Characteristics

The new lubricant was formulated to maintain its high anti-scuffing characteristics, which is made possible by the anti-scuff additive (Ortholeum 162). The selection of anti-scuff additive is difficult because good gear-loading capacity must be balanced with low-corrosion values. The anti-scuff action of most load-carrying additives relies on the corrosive attack of an active compound. Therefore, a mild corrosive action is to be expected.

Out of three available anti-scuff groups, which contain sulphur, chlorine, and phosphorus, a phosphorus-containing additive has been selected. Sulphur-containing additives could not be considered because they would attack silver lining of the bearing cage. Chlorine-containing additives are not compatible with the propellants. The Ortholeum 162 acid phosphate additive will attack the tin lining of oil cans and mild steel in presence of water. The following metals have been found to be affected by the selected additive:

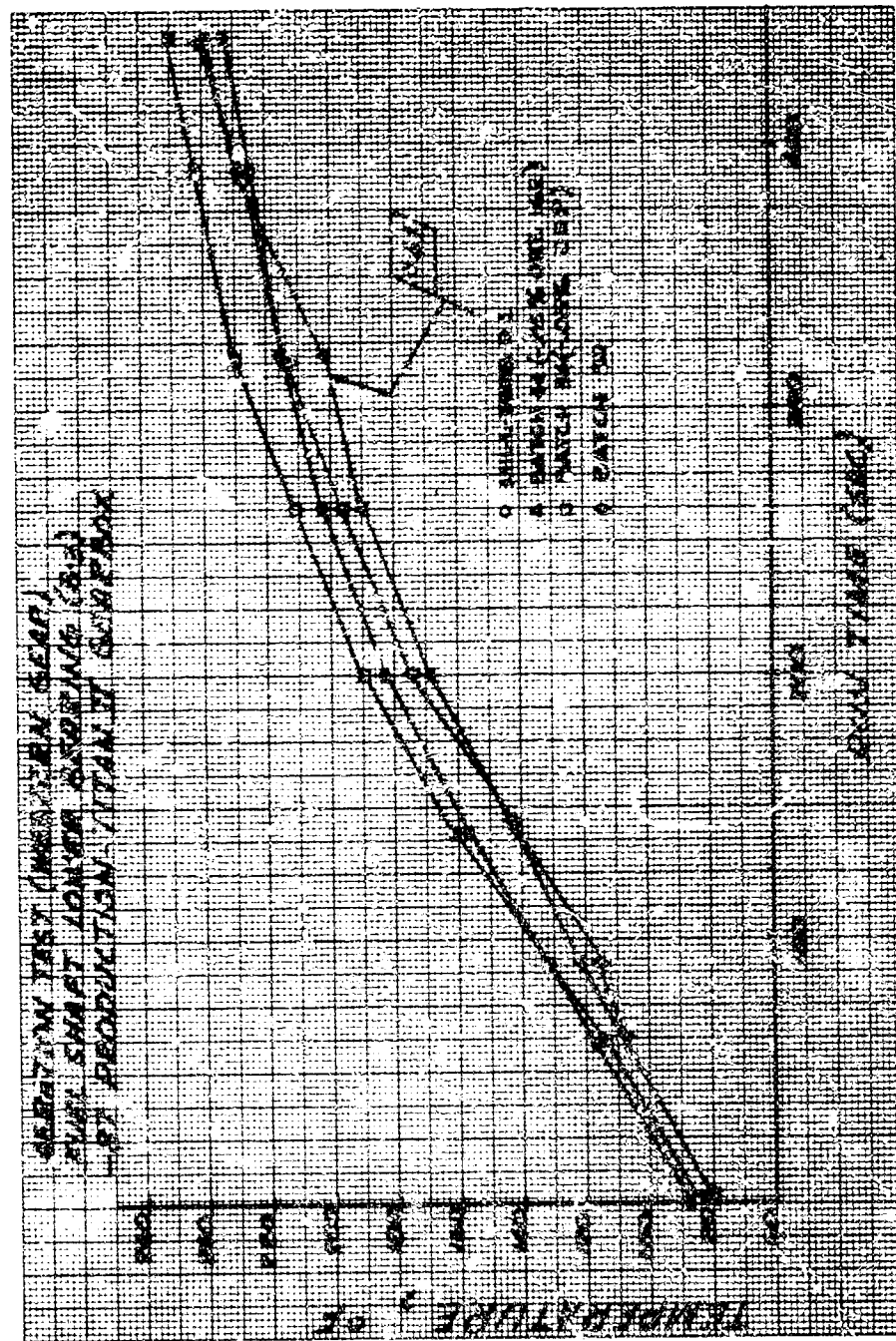
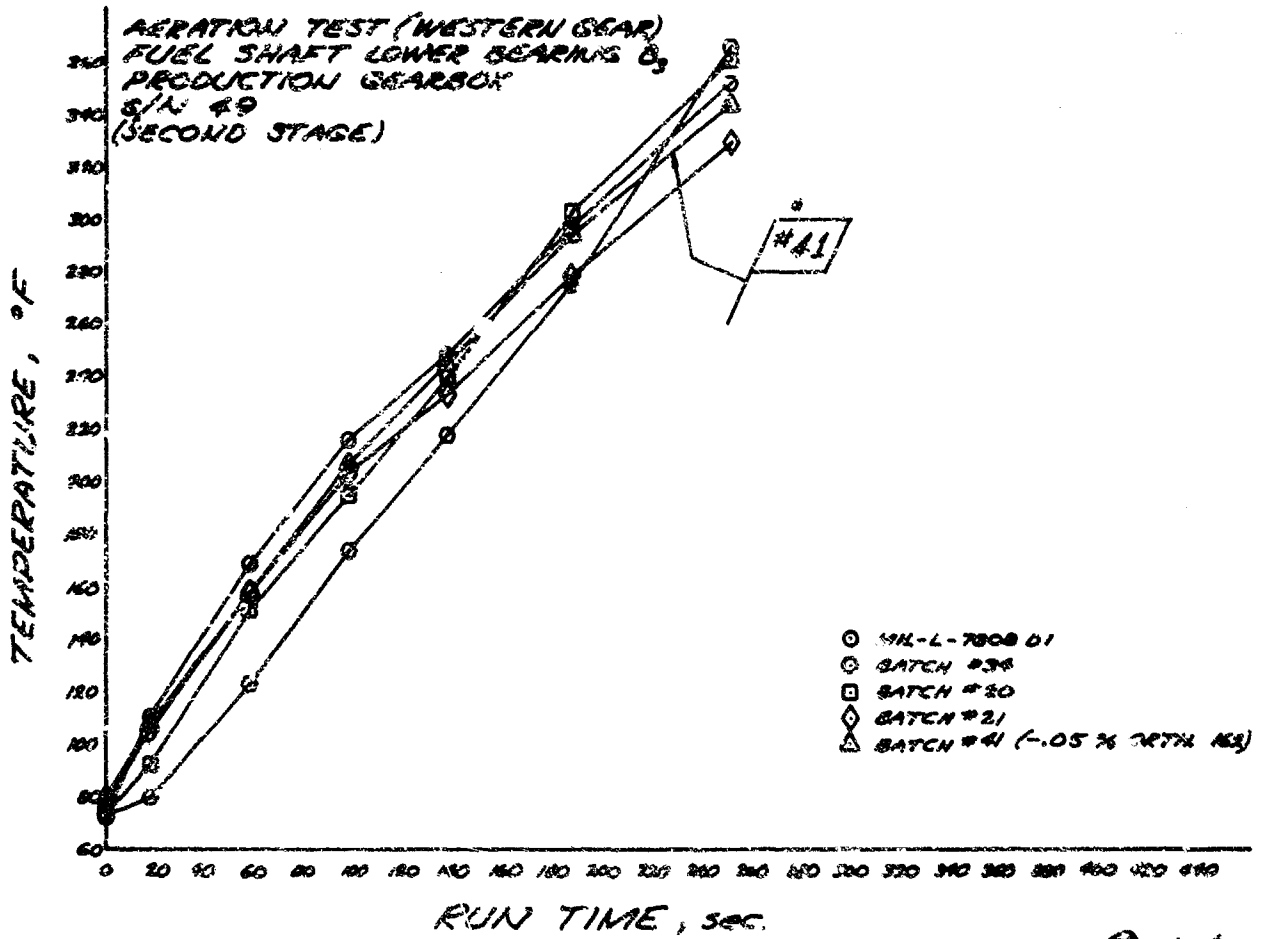
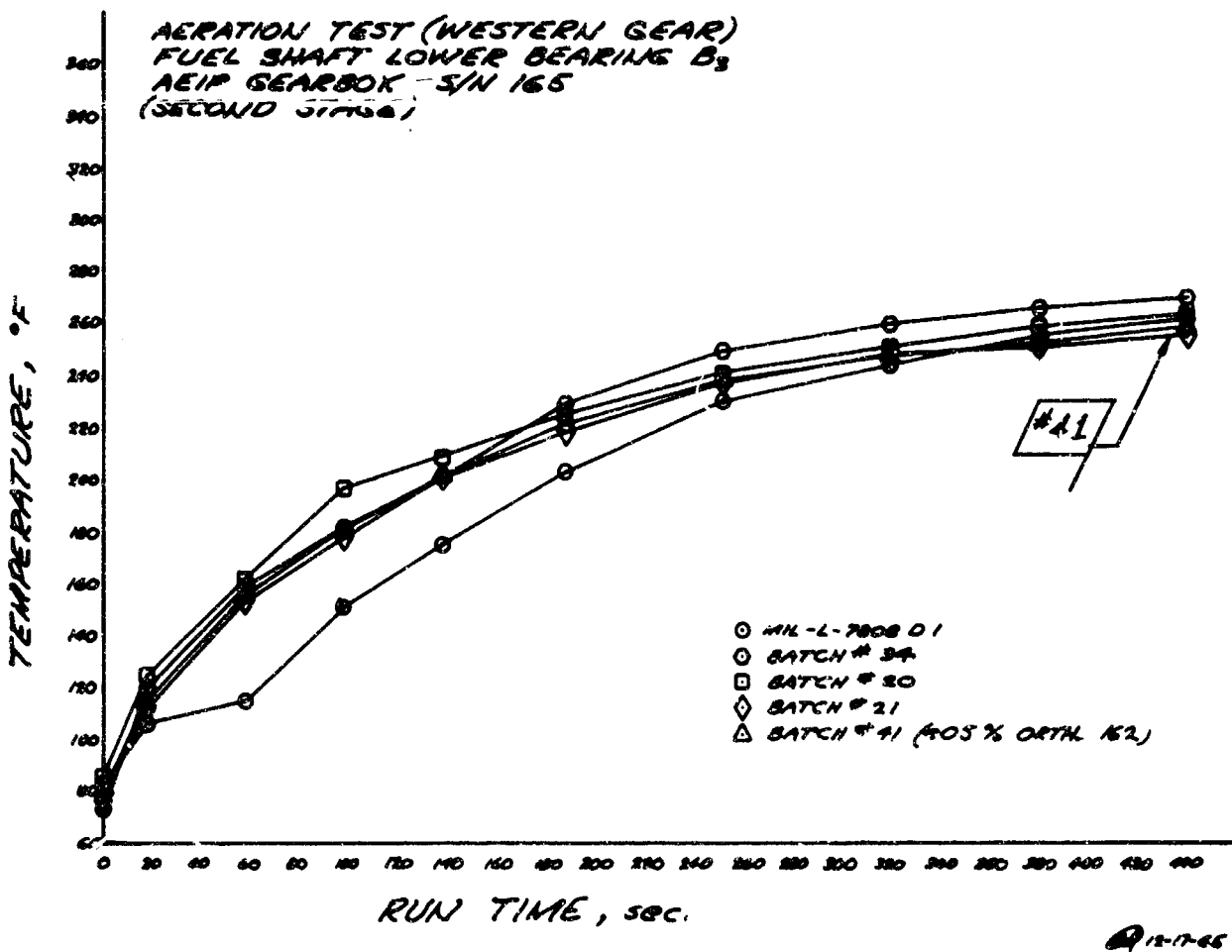

Figure 41



Aeration Test, 250 sec, Second-Stage Gearbox

Figure 42



Aeration Test, 440 sec, AFIP Gearbox

Figure 43

## IV, E, Evaluation of Final Prospective Lubricant (cont.)

<u>Material</u>	<u>Presence of Water</u>	<u>Heat Oil</u>	<u>Observation</u>
52100 steel	---	Yes	Formation of colorless coating (Vaseline)
SAE 1025 steel	Yes	---	Slightly dull
Brass	---	Yes	Discoloration
4140 steel	---	Yes	Dark gray discoloration
Bronze	---	Yes	Slight discoloration

The lubricant will also dissolve black oxide coating of the gear ( $Fe_3O_4$ ) within 30 days.

To explore corrosiveness of the candidate lubricant, tests were performed on the standard SAE 1020 spindles at different concentrations of water and different temperatures. No ill effect (corrosion) was established; however, the formation of colorless coating was established in the presence of water at room temperature.

The established allowable water content in the lubricant is 1.5% by weight. At room temperature, with a 0.2% concentration of water, the SAE 1020 spindle would become dull with some colorless precipitation on its surface. The same test conducted at 140°F shows no precipitate formation and only slight dullness of the spindle.

Table XII shows corrosion test results obtained with two extremes of Ortholeum 162 delivered for this purpose by DuPont.

Table XIII contains results of the metal corrosion tests performed with different metals at 347°F for a test duration of 24 hours. As can be seen in this table, the metal corrosion is below corrosive limits as set forth for the new lubricant in Specification AGC-44209.

The conclusion drawn from the above tests indicates that the discoloration and colorless precipitate on some of the metals is the balance between the extreme pressure additive and the corrosive action of E.P. additive and that this balance should be maintained to have strong lubricant to protect the gears from the scuffing. Addition of an anti-corrosive agent such as Ortholeum 535 has improved considerably the corrosiveness of the new lubricant in the presence of water.

MIL-L-7808D(1) oil and 3156 mineral oil were tested for their preservative action on the metal surfaces in DuPont humidity cabinet tests, shown in Table XIV. Both of the lubricants failed in preventing rust formation.

TABLE XII

SPINDLE CORROSION TESTS

Extreme Values of Ortholeum 162

Three Determinations

SAE 1020, Spindle at Room Temperature and 140°F for 5 Days and 0.2% Water

	Mono-Acid Phosphate Content			
	Minimum		Maximum	
	Room Temperature	140°F	Room Temperature	140°F
Oil	Slightly cloudy	Clear	Clear	Clear
Spindle	Dull	Dull	Dull	Dull
Vaseline-like formation	Very light	None	Very light	None
ppt	Very light (Viscous)	None	None	None
Scum	Traces	Traces	Traces	Traces

Table XII

TABLE XIII

METAL CORROSION TESTS

(At 347°F for 24 hr)

<u>Metals</u>	<u>Allowable</u>	<u>Weight Change, mg/cm<sup>2</sup></u>
Iron	0.2	+0.02
Aluminum	0.2	+0.02
Silver	0.2	-0.02
Copper	1.5	-1.29

Table XIII

TABLE XIV

## DuPONT HUMIDITY CABINET TESTS\*

Humidity Box Test per JAN-H-792:

122°F, 100% relative humidity

<u>Formulation</u>	<u>% Area Rusted</u>	
	<u>20 hr</u>	<u>144 hr</u>
Bray Oil Co. MIL-L-7808D(1)	45	75
Batch 41	18	98
Base oil + 0.3% Ortho. 162	21	98
+ 0.005% Ortho. 535		
Base oil'	61	98
Base oil + 5% Ortho. 535	0	22
MIL-H-608313**	0	

\*Specified in Specification MIL-C-8188C

\*\*Trace rust spots at 144 hr



## IV, E, Evaluation of Final Prospective Lubricant (cont.)

7. Long-Term Storage

The 3156 lubricant was developed so as to permit no precipitation, separation, turbidity, or any other deterioration for a minimum period of 18 months at the outside extreme temperatures between -65 to +160°F. Several cycling tests at these temperatures failed to show any deteriorating effect of these extreme temperatures. No separation or precipitation of the additives was observed and the lubricants remained clear as before the tests.

Eight samples were placed in storage in January 1966, as shown in Table XV. Water and MIL-L-7808D(1) oil were added to the prospective lubricant to observe whether any deterioration would occur during the 18-month storage time. The gearbox samples were added to the neat and contaminated lubricant. All the metal samples were made from original parts. One side of the sample was polished to 4-6 RMS. Observations are being made each month; first-month observations are shown in Table XVI.

Since the reported content of the MIL-L-7808D(1) oil in the gearbox after the gearbox spin test has been established at about 2% (see Figure 44), the new lubricant is added to the Titan II gearbox, which may contain 2% of the presently used lubricant. The mixture will have to be stable in the gearbox during 18 months at least. It is anticipated that the water content may be between 0.1 to 0.2% when a turbine seal leak is encountered.

An accelerated storage test is being made at 185°F where the lubricant is observed for any neutralization number change. Copper corrosion is being established at intervals of 0, 7, and every 15 days until the depletion of lubricant (one gallon). This test results are shown in Table XVII.

8. Summary on the Evaluation of Final Prospective Lubricant

The following summary shows a comparison of the performance of the new lubricant with the one presently used:

<u>Test</u>	<u>Humble 3156-1</u>	<u>MIL-L-7808D(1)</u>
Load-Carrying Ability (Ryder Gear Test) lb/in.	2500 to 3000	2000 to 2200
Filter Plugging	Pass	Failed
Compatibility with Propellants	Pass	Failed
Aeration	Pass	Pass
Corrosion	Pass	Pass
Long-Term Storage (18 months)*	Unknown	Pass

\*Neat Lubricant Only

TABLE XV

LONG-TERM STORAGE TESTS

1. Batch 41 oil + 0.1% water
2. Batch 41 oil + 0.1% water  
+ 2% MIL-L-7808D(1) oil
3. Batch 41 oil + 0.1% water  
+ 2% MIL-L-7808D(1) oil  
+ gearbox parts
4. Batch 41 oil + gearbox parts
5. Batch 41 oil + 0.2% water  
+ 2% MIL-L-7808D(1) oil  
+ gearbox parts
6. Extended storage test (Heat oil)
7. Accelerated storage test at 185°F
8. Humidity chamber test with gearbox parts

Storage Requirements

No change observed after cycling oil between -65 and +160°F

TABLE XVI

## RESULTS OF LONG-TERM STORAGE TESTS WITH GEARBOX PARTS

Observation after One Month, Batch 41 Oil, Heat

<u>Material</u>	<u>Observation</u>
I-Si-bronze	Shiny
4620 steel	Shiny
9370 steel	Shiny
Type 347 stainless steel	Shiny
356-T6 aluminum	Dull
Type 440 stainless steel	Shiny
Brass	Dull
6061-T6 aluminum	Dull
1010 mild carbon steel	Dull
52100 bearing	Gray tarnish
AM350	Shiny
Bronze	Dull
O-Ring	N/C
Gasket	N/C
Carbon CDJ-83	N/C
Filter screen	N/C

Table XVI

TABLE XVII  
STORAGE STABILITY TESTS AT 185°F

<u>Days</u>	<u>Copper Corrosion,</u> <u>mg/cm<sup>2</sup></u>	<u>KOH,</u> <u>mg/gt</u>
0	-0.8	0.69
	-0.75	
	-0.65	
7	-2.9	0.59
	-2.5	
	-2.4	
14	-3.9	0.60
	-3.9	
	-2.8	
28	-2.9	0.51
	-3.0	
	-3.2	
42	-2.95	0.38
	-3.7	
	-3.1	
56	-3.8	0.35
	-3.9	
	-3.7	

Table XVII

PERCENT OF MIL-L-7808D(1) IN DRAINED ESSO S155 OIL

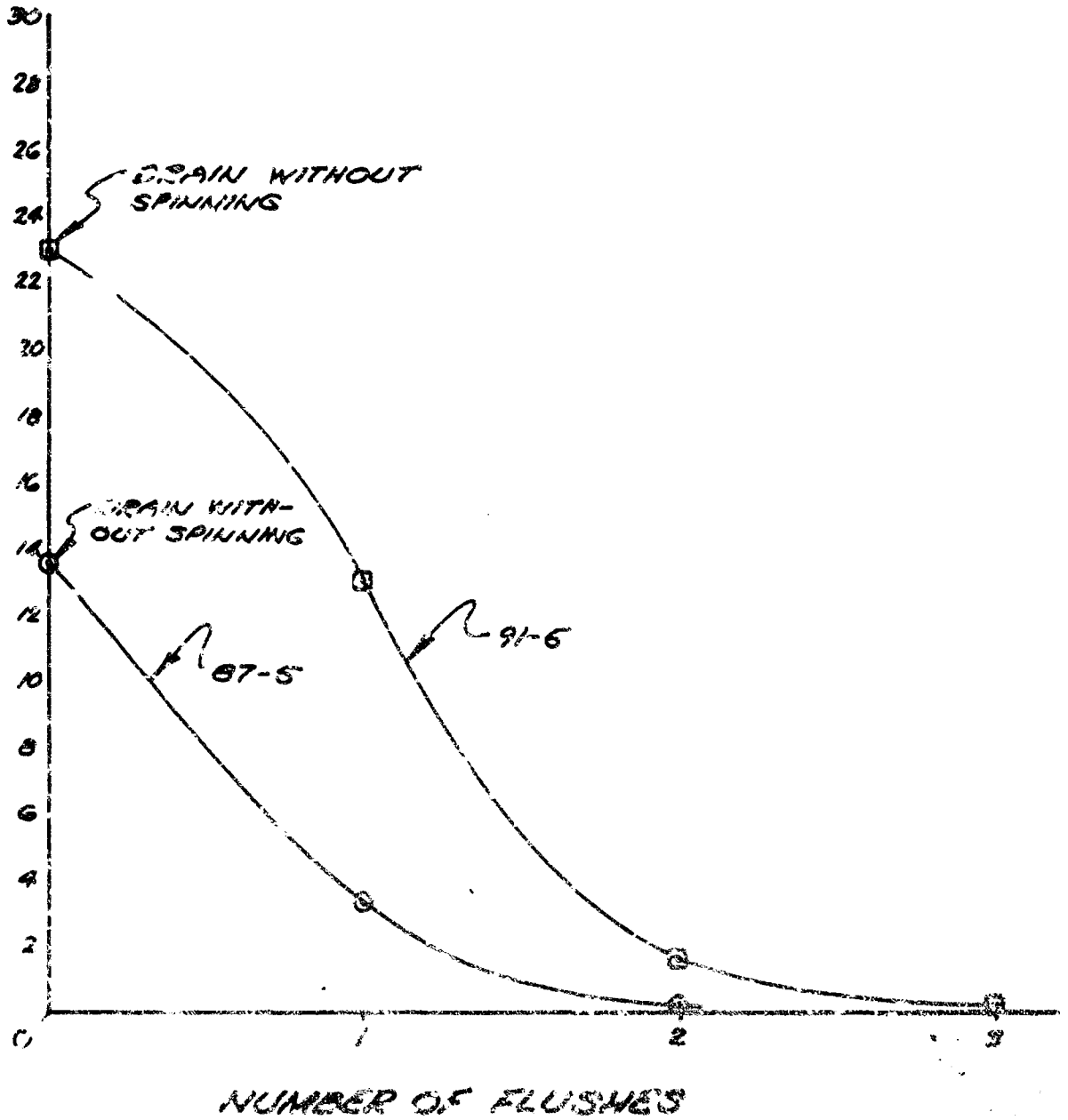

1-18-66

Residual Oil per MIL-L-7808D(1) in Gearbox vs Number of Flushes (With Air Motor Spin)

Figure 44

## IV, E, Evaluation of Final Prospective Lubricant (cont.)

The new lubricant has its definite advantage over the Bryco 880 Conojet lubricant. The load-carrying ability of the new lubricant is considerably higher when the clean metal surfaces are exposed to beneficial action of the E.P. additive. It is superior to the presently used lubricant when the lubricant is tested in the nitrogen-blanketed environments. It is a known fact that the ester-base lubricant would lose its lubricity in the absence of oxygen. The tests confirmed that MIL-L-7807D(1) oil loses about 50% of its load-carrying ability in the neutral atmosphere while the new candidate lubricant will remain unchanged.

Tests run with the gears coated with the black oxide have shown that the 3156 mineral oil performed between 30 and 50% of its demonstrated clean gear capacity, while the 880 Conojet (Bryco) lubricant was not affected. Detailed discussion of the black oxide problem can be found under "Load-Carrying Ability," Section E,2. An unknown characteristic of the 3156 mineral oil is that it forms white flaky precipitate in the presence of more than 0.1% of water. The filter-plugging tests, however, have shown that this precipitate will not plug the filter and would melt at 159°F, and at or above this temperature, the lubricant becomes clear (Figure 40). In addition, the contamination specification limits the water content to 0.16%.

Excellent chemical stability of the candidate lubricant was proven in the numerous tests and makes this lubricant desirable for the Titan II family gearboxes.

Foaming and aeration of both lubricants are about the same. Accordingly, the cooling effect of the critical hot areas within the gearbox is the same for both.

Long-duration storage tests to date show that in the presence of water the protective action of the Humble 3156 lubricant prevents rust formation on the gearbox parts. Red rust was found on the same parts when they were exposed to Bryco 880 Conojet lubricant containing 0.2% of water. The preservative properties of the present and new oils judged by humidity cabinet tests are equal, but both are poorer than those of preservative oils (such as meet Specifications MIL-C-8188C and MIL-H-6083E).

## F. FUTURE QUALIFICATION OF NEW OIL FOR TITAN ENGINE

The oil designated Humble 3156, developed on this program, has been thoroughly evaluated at the laboratory and component level and has been found superior to the present oil in nearly all areas. All turbopump operational conditions cannot be effectively or economically reproduced at the laboratory and component level. Therefore, further evaluation is required at the turbopump assembly (TPA) cold flow and engine test level.

The qualification program objectives should be aimed at proving the capabilities of the new oil in a turbopump assembly, under the most adverse operating conditions normally encountered during the life of such a unit. It is also desirable

IV, F, Future Qualification of New Oil for Titan Engine (cont.)

to evaluate the new oil in a TPA at conditions that accentuate the problems encountered with the present oil. Other problem areas to be considered that were encountered in laboratory screening tests with the new oil are as follows:

- (1) A white gelatinous precipitate caused by excessive water in the lubrication oil.
- (2) A tendency to form a Vaseline-like substance on soft steel components at room temperature.
- (3) Discoloration or gray tarnish formed on bearings and low carbon steel components.
- (4) A decrease in load-carrying ability in the presence of black-oxide-coated gears.
- (5) Degradation of black oxide coatings on nonwearing surfaces.

1. Qualification Testing

To explore all the conditions in which the new oil may be expected to provide lubrication, the qualification testing should be accomplished in three phases with the following units:

1. Titan II field units
2. Titan II production components, except with no black oxide on the gears.
3. Titan II components

Phase 1 tests should evaluate the new oil at the following conditions:

1. Maximum allowable contaminants of 0.15% water, 0.10% AeroZINE 50, no  $N_2O_4$ , and 2% MIL-L-7808D(1) oil.
2. Maximum hot gas leak to the gearbox of 30 psia (to simulate flight conditions).

It should be established that the new oil is acceptable at these conditions by performing a series of full-duration tests on a TPA that has exhibited high temperatures, a high lubrication jet pressure decay, and turbine seal leakage.

In Phase 2, these tests should be repeated without black oxide on the gears.

In Phase 3, these tests should be conducted with Titan III components.

IV, F, Future Qualification of New Oil for Titan Engine (cont.)

2. Posttest Qualification Data

For a lubrication oil inspection, the oil drained from the lubrication system after each cold flow or engine test is to be analyzed for the following:

- a. Viscosity
- b. KOH (neutralization number)
- c. Precipitate
- d. Compatibility (tendency to stratify)
- e. Aeration (entrained gases)
- f. Water content
- g.  $N_2O_4$  content
- h. AeroZINE-50 content
- i. Filter screen deposit analysis

The gearboxes are to be disassembled and the components inspected after each test or at such intervals deemed necessary by engineering to establish wear or degradation characteristics of all affected components.

Inspection record data is to be kept on, but is not limited to, the following:

1. Inspection of bearings per Specification AGC-46322.
2. Visual inspection of all gear teeth and preparation of involute profile charts on Teeth 1, 2, and 3 of the pinion gears of both stages.
3. Recording of the condition of the seal cavity relative to contamination from lubrication oil and listing of postfire leak check data.
4. Inspection of all components for varnish-like deposits.
5. Inspection of the interior of the gearbox for any deposits that may be attributed to the new oil.



Report S8D-TR-65-161-1

V.

REFERENCES

1. Development of a Petroleum Base Lubricant for Titan II Engine Turbopump Gearboxes, Aerojet-General Report 464-TN65-1, Contract AF 04(694)-464, 16 July 1965.
2. Klaus E.E., Tewksburg E.J., and Fenske, M.R., "Preparation, Properties, and Some applications of Super-Refined Mineral Oils," ASLE Transactions, Volume 8, 1, 1962.
3. Sakurai, T., and Sato, K., "Study of Corrosivity and Correlation between Chemical Reactivity and Load-Carrying Capacity of Oils Containing Extreme Pressure Agents," ASLE Transactions, Volume 9, 1 November 1966.
4. Barcraft, F.T., "A Technique for Investigating Reactions between E.P. Additives and Metal Surfaces at High Temperatures," WEAR, Volume 3, Page 440, 1960.
5. Godfey, D., "Chemical Changes in Steel Surfaces during Extreme Pressure Lubrication," ASLE Transactions, Volume 5, 57, 1962.
6. Rounds, F. G., "Some Environmental Factors Affecting Surface Coating Formation with Lubricating Oil Additives," ASLE Transactions, Volume 9, 88, 1966.
7. Lubricants, Liquid Fuels, and Related Products, Methods of Testing, Federal Test Method Standard 791a, 25 September 1963.

PREVIOUS PAGE WAS BLANK, THEREFORE NOT FILLED

Report BSD-TR-65-161-1

APPENDIX I

AEROJET-GENERAL CORPORATION GEAR LUBRICANT SPECIFICATION ACC-44209

## Report SSD-TR-65-161-1, Appendix I

## 1. SCOPE

1.1 This specification establishes the minimum requirements for a petroleum (naphthene type) base, high temperature lubricating oil suitable for use in gearboxes for extended storage periods of 18 months, minimum, (see 6.1).

## 2. APPLICABLE DOCUMENTS

2.1 Department of Defense documents.-- Unless otherwise specified, the following documents, listed in the issue of the Department of Defense Index of Specifications and Standards in effect on the date of invitation for bids, shall form a part of this specification to the extent specified herein.

## SPECIFICATIONS

Military

MIL-L-7808D, Amendment 1 9 September 1961	Lubricating Oil, Aircraft Turbine Engine, Synthetic Base
---	---

MIL-S-13282	Silver
-------------	--------

## STANDARDS

Federal

Federal Test Method Standard 791	Lubricants, Liquid Fuels, and Related Products; Methods of Testing
--	---

(Copies of documents required by contractors in connection with specific procurement functions should be obtained as indicated in the Department of Defense Index of Specifications and Standards.)

2.2 Other documents.-- Unless otherwise specified, the following documents, of the issue in effect on the date of invitation for bids, shall form a part of this specification to the extent specified herein.

## STANDARDS

American Society for Testing and Materials

ASTM D92	Method of Test for Flash and Fire Points by Cleveland Open Cup
ASTM D97	Method of Test for Cloud and Pour Points
ASTM D270	Sampling Petroleum and Petroleum Products
ASTM D286	Autogenous Ignition Temperatures of Petroleum Products

ASTM D287	Method of Test for API Gravity of Petroleum Products, Hydrometer Method
ASTM D445	Method of Test for Kinematic Viscosity
ASTM D664	Neutralization Number by Potentiometric Titration
ASTM D892	Method of Test for Foaming Characteristics of Lubricating Oils
ASTM D1160	Distillation of Petroleum Products
ASTM D1744	Water in Liquid Petroleum Products by Karl Fischer Reagent

(Copies of ASTM standards may be obtained from the American Society for Testing and Materials, 1916 Race Street, Philadelphia 3, Pennsylvania.)

2.3 Aerojet-General Corporation documents.- Unless otherwise specified, the following documents, of the latest issue in effect, shall form a part of this specification to the extent specified herein.

#### SPECIFICATION

AGC-44041

AeroZINE 50

#### 3. REQUIREMENTS

3.1 Qualification.- The product furnished under this specification shall be a product which has been tested and has passed the qualification tests specified herein and has been listed on, or approved for listing on, the applicable qualified products list.

3.1.1 Regualification.- Regualification may be required in the event any change is made in quality, composition, source of ingredients, or source of manufacture of the finished lubricant.

3.2 Material.- The lubricant shall consist of a base stock of naphthene type oil containing additives for the improvement of oxidation resistance, foaming, load-carrying and anticorrosion characteristics.

3.2.1 Petroleum base stock.- The properties of the petroleum base stock, before the addition of any other ingredient, shall be as follows:

<u>Property</u>	<u>Requirement</u>	<u>Test Method</u>	
		<u>FTMS-791a</u>	<u>ASTM</u>
Specific gravity at 60°F	0.863 ± 0.005	401	D-287
Flash point, COC, °F, Min.	325	1103	D-92
Fire point, COC, °F, Min.	360	1103	D-92
Color, Saybolt, Min.	+30	101	D-156
Precipitation number, Max.	0.03	3101	---
Water content, Karl Fischer, % Max.	0.01	3253	---
Pour point, °F, Max.	-30	201	D-97
Distillate at 330°F, 10mm Hg	5% max.	---	D-116
Viscosity, kinematic,			
cstks at 100°F	14.2 ± 0.7	305	D-445
cstks at 210°F	3.00 ± 0.15	305	D-445
Neutralization number mgKOH/gr Max.	0.03	5105	D-664

3.2.2 Additives.-- The only additives added to the base stock oil shall be the following for the achievement of antioxidant, antiwear, antifoam and anticorrosion characteristics.

3.2.2.1 Antioxidant.-- The antioxidant to be added shall be 0.50 ± 0.05 percent by weight of 4,4'-methylenebis (2,6-ditert-butylphenol as manufactured by Ethyl Corporation, or equivalent).

3.2.2.2 Antiwear.-- The antiwear compound to be added shall be 0.30 ± 0.02 percent by weight of Ortholeum\* 162 lubricant assistant as manufactured by E. I. DuPont de Nemours and Company.

3.2.2.3 Antifoam.-- The antifoam compound to be added shall be 0.10 ± 0.02 percent by weight of PC-1244 Defoamer as manufactured by Monsanto Chemical Company.

3.2.2.4 Anticorrosive.-- The anticorrosive to be added shall be 50 ± 5 ppm of Ortholeum\* 535 as manufactured by E. I. DuPont de Nemours and Company.

3.3 Physical and chemical properties.-- The finished oil shall have the following properties:

\*DuPont Registered Trademark

<u>Property</u>	<u>Requirement</u>	<u>Test Method</u>	
		<u>FIMS 791</u>	<u>ASTM</u>
Viscosity at 100°F, estks	14.2 ± 0.7	305	D445
Viscosity at 210°F, estks	3.00 ± 0.15	305	D445
Pour point, °F, Max.	-30	201	D97
Flash point, °F, Min.	325	1103	D92
Sp. Gr. at 60°F/60°F	0.863 ± 0.005	401	D287
Neutralization number, mg KOH/g	0.600 ± 0.050	5105	D664
Distillate, at 330°F, 10 mm Hg, Max.	5%	1001	D86
Autoignition temp, °F, Min.	735	1152	D1160
Water content, % by wt, Max.	0.01	3253	D1744

### 3.4 Corrosion and oxidation stability.-

3.4.1 Corrosion.- When tested in accordance with this specification, test samples of carbon steel, aluminum, and silver, shall not experience a weight change in excess of +0.2 mg/cm<sup>2</sup> of surface area. A test sample of copper shall not have a change in weight in excess of +2.5 mg/cm<sup>2</sup> of surface area. There shall be no pitting, etching, or visible corrosion on the surface of any of the metals when viewed under a magnification of 20 diameters. Staining of the metals is permitted.

3.4.2 Oxidation stability.- The viscosity of the lubricating oil measured after the corrosion test (3.4.1) shall not have changed more than -5 to +15 percent from the original viscosity at 100°F. The maximum allowable neutralization number after the corrosion test shall be 2.20. Darkening of the lubricating oil during the test is permitted.

3.5 Swelling of synthetic rubber.- Swelling of standard synthetic rubber "H" by the lubricating oil shall not exceed 10 percent change in volume.

3.6 Load-carrying ability (gear test).- The load-carrying ability requirement shall depend on the number of gears tested as shown below:

<u>No. of Tests</u>	<u>Load-Carrying Requirements (lb/in., minimum)</u>	<u>Average Relative Rating* (percent, minimum)</u>
2	3000	107
4	2800	100
6	2650	95
8	2500	89

\*Average Relative Ratings are based on reference oil having a rating of 2800 lb/in.

3.7 Foaming characteristics.- When tested in accordance with this specification, the lubricating oil shall not exceed the following foam volume values for the indicated test method sequence. Complete foam collapse shall occur before the end of each sequence time period.

<u>Sequence Number</u>	<u>Foam Volume (ml, Max)</u>	<u>Sequence Time Period</u>
1	100	5 min + 10 sec
2	25	3 min + 10 sec
3	100	5 min + 10 sec

3.8 Aeration.- The clearing time for the lubricating oil when tested in accordance with this specification shall be 90 sec, maximum.

3.9 Compatibility.- When tested in accordance with the compatibility procedures of this specification the lubricating oil shall meet the following requirements.

3.9.1 Nitrogen tetroxide, N<sub>2</sub>O<sub>4</sub>.- No solid precipitation at end of 72 hour test period.

3.9.2 AeroZINE 50.- No solid precipitation at end of 72-hour test period. A temperature rise of 1°C is permissible. After centrifuging, a slight cloudiness of the oil layer is permissible.

3.9.3 Moist Ammonia.- No solid precipitation at end of 72-hour test period. Cloudiness of the oil layer is permitted.

3.9.4 Water.- No solid precipitation at end of 72-hour test period.

3.9.5 MIL-L-7808D(1) oil.-

3.9.5.1 After 168 hours.- The mixture of lubricant and 2.0 + 0.1 percent MIL-L-7808D(1) oil shall show no sign of separation or precipitation when maintained at a temperature of 221 + 5°F for 168 + 0.5 hours. After centrifuging, the mixture shall not be turbid or have more precipitate than 0.005 ml/200 ml of oil.

3.9.5.2 After 18 months.- The mixture of lubricant and 2.0 + 0.1 percent of MIL-L-7808D(1) oil shall show no signs of separation and meet the extended storage stability requirements when stored in a dark room for 18 months at 75 + 5°F.

3.10 Extended storage stability.- The lubricant, when tested for extended storage stability in accordance with this specification, shall show no signs of separation (stratification or precipitation) after 18 months. In addition, the lubricant shall meet the requirements of the following properties when tested after the 18-month period:

- (a) Viscosity at 100°F
- (b) Flash point
- (c) Pour point
- (d) Corrosion and oxidation stability at 347°F
- (e) Foaming
- (f) Aeration
- (g) Neutralization number

3.11 Cycling effect.— The lubricant shall not show any sign of separation, turbidity, or precipitation when tested between the time and temperatures specified in Section 4.14.

3.12 Filterability.— When mixed and filtered as specified in Section 4, the increase in the pressure drop through the filter shall not exceed 8.0 psi.

3.13 Quality.— The lubricant shall be homogeneous and contain no mixture of resin, rubber, soaps, gums, fatty oils, oxidized hydrocarbons, or other additives (except as specified herein).

3.14 Temperature limitation.— At no time during the lubricant blending process, or operations subsequent thereto, shall the temperature of the lubricant or its components exceed 300°F.

#### 4. QUALITY ASSURANCE PROVISIONS

##### 4.1 Supplier responsibility.—

4.1.1 Inspection.— Unless otherwise specified, the supplier is responsible for the performance of all inspection requirements as specified herein and may use any facilities acceptable to the Aerojet-General Corporation (AGC). The supplier shall submit a certified test report showing the material conforms to all requirements of this specification prior to qualification. The supplier shall submit a certified test report with each lot of material offered for acceptance showing that the material conforms to the acceptance tests specified herein.

4.1.2 Processing changes.— The supplier shall make no change in processing techniques or other factors affecting the quality of the product, after qualification has been granted, without prior notification to AGC.

4.1.3 Rejection.— A lot of material shall be subject to rejection if a single sample from that lot fails to satisfy all of the acceptance tests specified herein. In the event a sample fails to satisfy an acceptance test, a resample and retest shall be permitted prior to rejection of a lot.



4.2 Inspection lots.-

4.2.1 Batch.- An indefinite quantity of a homogeneous mixture of material manufactured by a single plant run through the same processing equipment with no change in ingredient material.

4.2.2 Lot.- An indefinite number of identical size and type unit packages offered for acceptance and filled with a homogeneous mixture of material manufactured by a single plant run through the same processing equipment with no change in ingredient material.

4.3 Classification of tests.- The inspection and testing of the lubricant shall be classified as follows:

- (a) Qualification tests.- Qualification tests are those tests conducted on samples of material to be considered for qualification as a satisfactory product prior to an invitation for bid.
- (b) Acceptance tests.- Acceptance tests are those tests accomplished on material manufactured and submitted for acceptance under contract.

4.4 Qualification testing.- Qualification testing shall consist of the following tests performed in the order below:

- (a) Acceptance tests
- (b) Base stock certification
- (c) Flash point
- (d) Pour point
- (e) Distillate
- (f) Autoignition temperature
- (g) Swelling of synthetic rubber
- (h) Compatibility tests
- (i) Extended storage stability
- (j) Cycling
- (k) Filterability

4.5 Acceptance testing.- Acceptance testing shall consist of the following tests:

- (a) Viscosity at 100°F
- (b) Viscosity at 210°F
- (c) Specific gravity, 60°F/60°F
- (d) Aeration
- (e) Neutralization number
- (f) Water content
- (g) Foaming
- (h) Corrosion and oxidation stability at 347°F
- (i) Load-carrying ability (Ryder Gear Test)
- (j) Certification of concentration and brand names of additives used (3.2.2)

4.6 Sampling.-

4.6.1 Sampling plan.- The sampling plan and method used for acceptance shall be in accordance with Publication ASTM D-270.

4.6.2 Qualification test sample.- The qualification test sample shall consist of 10 gallons of finished lubricating oil taken from each of three batches. Samples shall be taken in accordance with the method specified in Publication ASTM D-270, identified as required, and forwarded to the testing laboratory approved by AGC.

4.7 Test methods.-

4.7.1 Chemical and physical tests.- Unless otherwise specified, the tests of Table I shall be made in accordance with the test methods described in Federal Test Method Standard 791.

4.7.2 Corrosion and oxidation stability test.- The corrosiveness and oxidation stability of the product shall be determined by Federal Test Method Standard 791, Method 5308, with the following exceptions:

- (a) Temperature shall be  $347 \pm 1^\circ\text{F}$ .
- (b) Length of test shall be 24 hours.
- (c) Silver (MIL-S-13282) shall be substituted for magnesium.

(d) Teflon shall be substituted for cadmium plated steel to give rigidity to the assemblage.

(e) The following sequence of test specimen assembly shall be used:

(1) Copper, Iron, silver and aluminum with a teflon spacer placed diagonally.

4.8 Swelling of synthetic rubber test.- The swelling of standard synthetic rubber "H" shall be determined by Federal Test Method Standard 791, Method 3604.

4.9 Load carrying ability test.- The load carrying ability of the product shall be determined by Federal Test Method Standard 791, Method 6508. Eight determinations shall be made for qualification testing. A minimum number of determinations shall be made for acceptance testing to satisfactorily pass the lubricant gear test requirements.

4.10 Foaming characteristics.- The foaming of the product shall be determined by Federal Test Method Standard 791, Method 3212, except that the settling periods shall be 5, 3, and 5 minutes, respectively.

4.11 Aeration test.- Preheat a sample of the product to  $100 \pm 2^\circ\text{F}$ . Transfer  $200 \pm 2$  ml to a Waring-type blender and mix at high speed for one minute. Transfer the sample to a 250-ml graduated cylinder. Observe the time required for the sample to clear enough for all graduation marks to be visible when viewed through the lubricant against a dark background. The first two readings shall be disregarded. Three determinations are required to establish a value.

4.12 Compatibility tests.- The propellants used in the compatibility tests are extremely hazardous and should be handled with the precautions prescribed in 6.3.

4.12.1 Nitrogen tetroxide,  $\text{N}_2\text{O}_4$ .- Place  $20.0 \pm 0.5$  ml of lubricant in a 100-ml beaker and cool to approximately  $12^\circ\text{F}$ . Place a magnetic stirring bar in the beaker and place the beaker on a magnetic stirrer. Suspend a thermometer in the lubricant so that the bulb is covered. Pour a sample of  $\text{N}_2\text{O}_4$  (98 percent minimum) into a second beaker. When the lubricant has warmed to the temperature of the  $\text{N}_2\text{O}_4$ , turn on the magnetic stirrer, and slowly add  $20.0 \pm 0.5$  ml of  $\text{N}_2\text{O}_4$ . Record the temperature during mixing and observe the mixture after 72 hours for precipitate formation.

NOTE: 50/50 mixture of the oil and nitrogen tetroxide will detonate if heated to  $155^\circ\text{F}$ .

4.12.2 AeroZINE 50.- Place  $20.0 \pm 0.5$  ml of lubricant in a 100-ml beaker. Place a magnetic stirring bar in the beaker and place the beaker on a magnetic stirrer. Suspend a thermometer in the lubricant so that the bulb is covered. Turn on the magnetic stirrer and slowly add  $20.0 \pm 0.5$  ml of AeroZINE 50 (per AGC-44041). Continue mixing for one minute and centrifuge for 10 minutes at  $70 \pm 5$  gravity units to break the emulsion. Observe the mixture for precipitate formation after 72 hours.

4.12.3 Moist ammonia.- Place 120 ml of test lubricant in a clean dry three-necked, 500-ml distilling flask. Connect a 300-ml reflux condenser to the center opening. Attach cooling water to the condenser. Place a thermometer, secured through a rubber stopper, in one of the flask's side openings and immerse in the lubricant until the thermometer bulb is covered. Insert a length of one-fourth inch outside diameter pyrex tubing through a rubber stopper in the remaining flask opening and extend to the bottom of the flask. Connect the other end of the tubing to an anhydrous ammonia (99.9 percent minimum) supply so that the ammonia passes through two scrubbers (primary absorber with fritted glass disc) before reaching the lubricant. Add 50 ml of ammonium hydroxide, reagent grade, to each scrubber. Attach a tube to the upper end of the condenser and vent off excess ammonia into an exhaust hood. Heat the lubricant to  $250 \pm 5^\circ\text{F}$  with a heating mantle (Glass-Col, Series M) and bubble ammonia through the lubricant at a rate of  $4.5 \pm 0.45$  gm/hr for four hours. Check the mixture for a precipitate or other visible changes after 72 hours.

4.12.4 Water.- Mix three percent of water by volume with the lubricant and heat to  $200 \pm 5^\circ\text{F}$ . After maintaining this temperature for four hours, allow to cool to ambient temperature. Check the mixture for a precipitate or other visible changes after 72 hours.

4.12.5 MIL-L-7808D(1) oil.- Mix  $2.0 \pm 0.1$  percent by volume of MIL-L-7808D(1) oil with the lubricant following the same procedure and tests as for the "extended storage stability test." The 168-hour test shall be performed in accordance with the requirements of 3.10.5.1.

4.13 Extended storage stability test.- Place one five-gallon can and one quart clear glass container of the test lubricant in a dark room, maintained at a temperature of  $75 \pm 5^\circ\text{F}$ . At 3, 6, 12, and 18 months, the lubricant in the clear glass container shall be visually inspected for evidence of separation, either in the form of stratification or precipitation. Samples shall be taken from the five-gallon container at the end of 18 months at which time the following tests shall be performed on the sample.

- (a) Viscosity at  $100^\circ\text{F}$
- (b) Flash point
- (c) Pour point
- (d) Corrosion and oxidation stability at  $347^\circ\text{F}$
- (e) Foaming
- (f) Aeration
- (g) Neutralization number

4.14 Cycling test.- The lubricating oil shall be cycled between  $-65^\circ\text{F}$  and  $+160^\circ\text{F}$  for 24 hours. A minimum of four cycles shall be made. Inspection for separation, turbidity and precipitate shall be at room temperature.

4.15 Filterability test.- Blend two quarts of lubricant containing  $0.1 \pm 0.2$  percent by weight distilled water in a Waring-type blender at high speed for one minute. Circulate at  $0.10 \pm 0.01$  gpm and  $200 \pm 5^\circ\text{F}$  through a steel or plastic piping system consisting of a pump, reservoir, filter, thermometer, control valve and flow meter. While circulating the lubricant mixture, bubble into the reservoir  $400 \pm 100$  cc/hr of gaseous ammonia. The filter through which the ammonia contaminated lubricant shall pass shall be a 40-micron, stainless steel one with an effective filtering area of two square inches. Filter the mixture for eight hours. After this period of time, measure the pressure increase across the filter.

5. PREPARATION FOR DELIVERY

5.1 Packaging and packing.- The packaging and packing of the lubricating oil shall be in accordance with the following:

5.1.1 Containers.- The size of the containers shall be one quart cans. Containers shall be made of a plastic which is non-reactive with the lubricant. Before filling, all containers shall be thoroughly cleaned and inspected. Containers shall be completely absent of water.

5.1.2 Filling.- The lubricant shall be filtered through a suitable filter assembly rated at 10 microns or finer, situated as close to the container filler equipment as may be feasible.

5.2 Marking.- Each unit package and each packing container shall be marked as follows:

5.2.1 Unit package.- Each unit package shall be marked as follows:

- (a) AGC-44209
- (b) 3156 Gear Lubricant
- (c) Manufacturer's Identification Code
- (d) Batch Number

In addition, the following warning note shall appear:

"WARNING" DO NOT MIX WITH ANY OTHER FLUID OR OIL

5.2.2 Packing container.- Each packing container shall be marked as follows:

- (a) AGC-44209
- (b) 3156 Gear Lubricant
- (c) Manufacturer's Identification Code
- (d) Date of Manufacture
- (e) Batch Number

6. NOTES

6.1 Intended use.- This product is to be used for the lubrication of high speed gears when under heavy load at temperatures up to 350°F and stored for a period in excess of 18 months.

6.2 Qualification.- Procurement contracts will be awarded only for such products that, prior to the closing date for receipt of quotations, have been tested and approved for inclusion on the applicable qualified products list (QPL). The attention of suppliers is called to this requirement, and they are urged to have the products that they propose to offer to AGC tested for qualification in order that they may be eligible to be awarded contracts for the products covered by this specification. The activity responsible for the QPL is AGC.

6.3 Safety.-

6.3.1 Compatibility.-  $N_2O_4$  and AeroZINE 50 should not be present in the laboratory at the same time. The compatibility tests of oil and propellants should be carried out in a laboratory hood equipped with forced air ventilation. AeroZINE 50 and  $N_2O_4$  compatibility tests should be done behind a safety shield consisting of a double thickness of safety glass held in place by an aluminum or other metal framework. The safety glass should be approximately 2 feet by 2-1/2 feet. The propellant should be added to the oil by reaching around the side of the safety shield and slowly adding the propellant to the oil. An asbestos glove and a face shield should be worn while performing this operation.  $N_2O_4$  is a strong oxidizer and must be kept away from all oxidizable substances. The hood used to carry out tests with  $N_2O_4$  should be thoroughly cleaned before use.

6.3.2  $N_2O_4$  hazards.- The fumes or vapors from  $N_2O_4$  are extremely toxic and capable of producing acute poisoning. A concentration of only five parts per million is the maximum allowable concentration (continuous exposure during an eight hour period). Although acid fumes containing this amount of  $N_2O_4$  are usually detectable by odor, vapors from liquid  $N_2O_4$  are more deceptive and may reach dangerously high concentrations before throat irritation occurs. The exact threshold of poisoning from  $N_2O_4$  probably varies with individuals and acute or fatal poisoning may occur with little or no warning to the victim at the time of inhalation. The toxicity symptoms and over-exposure effects from  $N_2O_4$  are almost identical with those for nitric acid. The symptoms of poisoning by the inhalation of the oxides of nitrogen or nitric acid vapors are determined by the relative concentrations of the toxic substances in the vapor, the duration of exposure, the total vapor concentration, and, to some extent, the susceptibility of the individual. Upon inhaling nitric acid vapor or nitrogen oxide fumes, little warning is given as to the degree of exposure. In case of over-exposure, the usual burning sensation of the nose and throat will subside shortly after exposure, only to be followed in five to eight hours by symptoms of nitric acid poisoning, coughing, burning of the chest and difficulty in breathing, varying in intensity with the degree of over-exposure. In other cases excessive inhalation of the oxides of nitrogen presents a distinctly different appearance characterized by dizziness, faintness and lowered blood pressure. Should any of the above symptoms be noticed, report immediately to first aid. Should the first symptoms occur after working hours, contact a physician or call first aid for instructions.

6.3.3 AeroZINE 50 hazards.- AeroZINE 50 is a blend of hydrazine and unsymmetrical-dimethylhydrazine (UDMH). Both of these materials are toxic and can cause poisoning by contact, inhalation or ingestion. Both are caustic and cause irritation of the skin or injury to the eyes or mucous membranes. Hydrazine is explosive in the vapor state. It is a strong reducing agent and if spilled on such material as wood, paper, rags or rusty iron, should be washed away at once with large amounts of water. If AeroZINE 50 comes into contact with the skin or eyes or other parts of the body, it should be washed away at once with large amounts of clean water and first aid or medical attention should be obtained immediately. The presence of AeroZINE 50 in the air is detectable by the ammonia-like odor. The presence of this odor is warning of the presence of harmful concentrations. The maximum allowable concentration (MAC) for hydrazine is 1.0 part per million; for UDMH the MAC is 0.5 part per million. Due to the higher volatility of UDMH, the vapor existing over liquid AeroZINE 50 is essentially all UDMH and the MAC of 0.5 ppm should be observed.

PREVIOUS PAGE WAS BLANK, THEREFORE NOT FILMED

Report SSD-TR-65-161-1

APPENDIX II

RYDER GEAR TEST PROCEDURE AND TEST RESULTS



## Report SSD TR-65-161-1, Appendix II

The load-carrying ability of lubricating oils with reference to gears is measured in pounds per inch. The pounds is a measure of the force transmitted from the driving teeth to the driven gear teeth. Since the contact area of these teeth at any instant is virtually a line, the inch units is the measure of the length of this line or, in general, the axial width of the gear tooth.

The load-carrying capacities of oils are investigated by testing each oil in a machine in which all operating conditions are constant except the transmitted load. One such machine is the Erdco Universal Tester, Ryder Gear Method, shown in Figure 45. A detailed procedure for the operation of this machine is given in Federal Test Standard 791a, Method 6508. (Figures 45 through 51 in this appendix have been extracted from FTMS 791a.)

For the purpose of this report, a brief discussion of the "four square" principle, test gears, and test oil chamber will suffice.

Figure 46 is a cross-sectional view of the Ryder Gear Machine, see Item A in Figure 45. The upper shaft is driven at the right end by components B, C, D, and E in Figure 45. The test gears T and U, Figure 3, are mounted on the shafts in the test oil chamber marked TOC. Note the helical slave gears, shown in Figure 47, and the location of the ring grooves near the shoulders marked "P".

#### A. STANDARD TEST PROCEDURE

##### 1. Installation of Test Gears

Test gears are installed, as shown in Figure 48, with the serial numbers outward for the first test and the working side is arbitrarily called Side A. The support and load oil system is arranged as shown in Figure 49. The test sequence is as follows:

- a. Side A is tested with a pressure P of 5 psig for 10 min.
- b. The test is stopped, the working surface of every tooth on the narrow test gear is examined for scuffing, and the results are tabulated as indicated in Figure 50.
- c. Pressure P is then increased to 10 psig, and steps (a) and (b) are repeated.
- d. The pressure P is increased in increments of 5 psig until the average percent gear scuff is approximately 40%.

The test is then stopped and the test gears are turned over on their respective shafts; i.e., with the serial numbers away from the viewer. After the test oil chamber and circuit (see Figure 49) has been cleaned and flushed with test oil and finally refilled with test oil, the above sequence is repeated. Rearranging the gears causes the load to be applied to new tooth surface on both gears. This second side is called Side B.

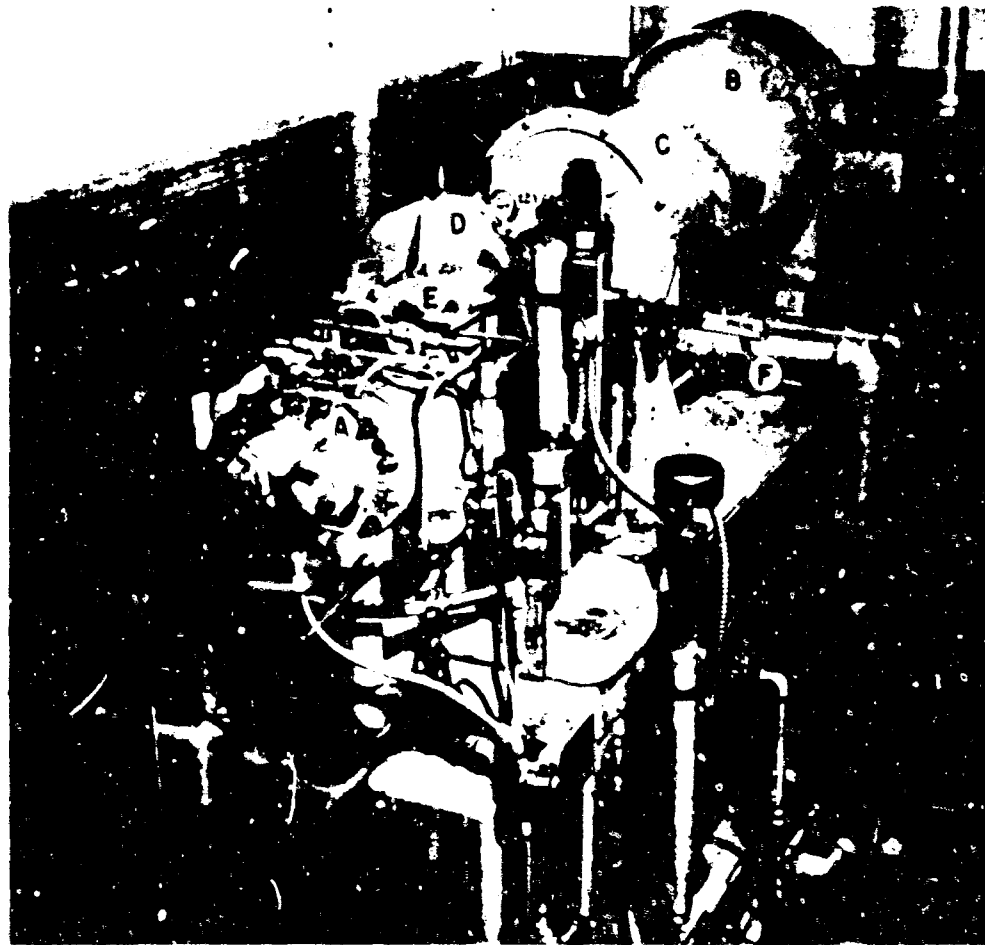

A. Ryder gear machine  
B. Drive motor

C. Dynamic coupling  
D. Step-up gear box

E. Adaptor  
F. Indexing catchet

Ercco Universal Tester - Ryder Gear Method

Figure 45

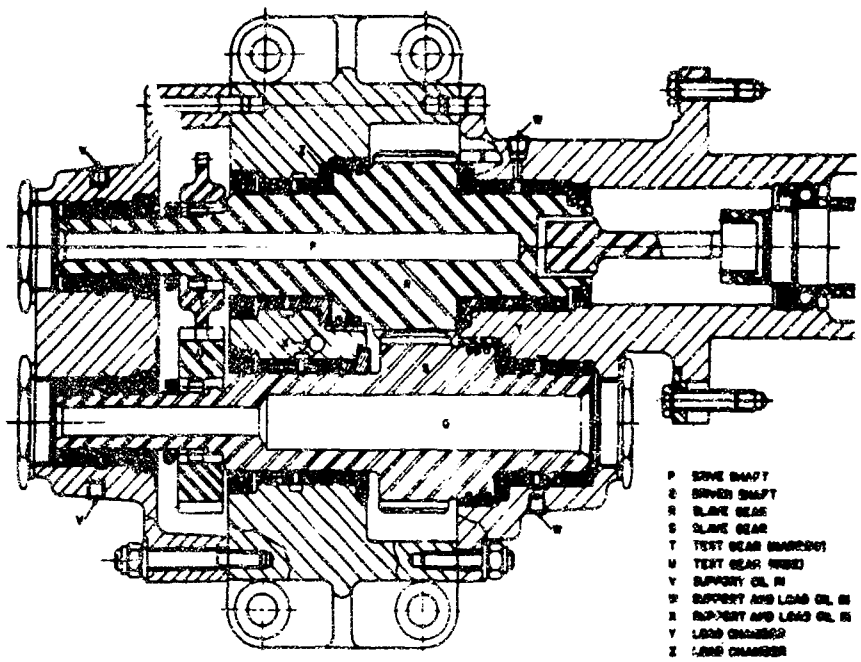

Figure 46. Cross-Section of Ryder Gear Machine

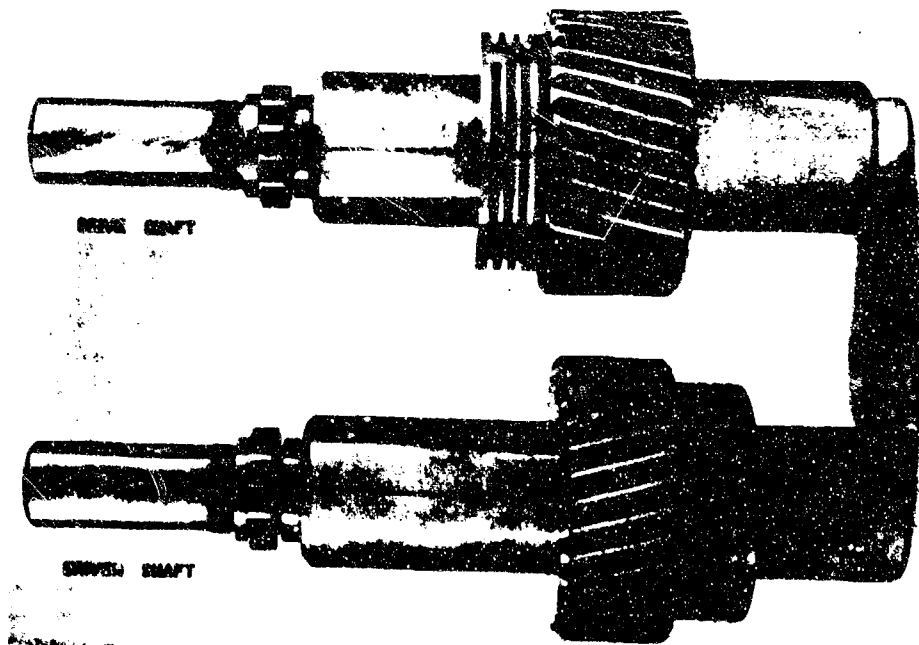
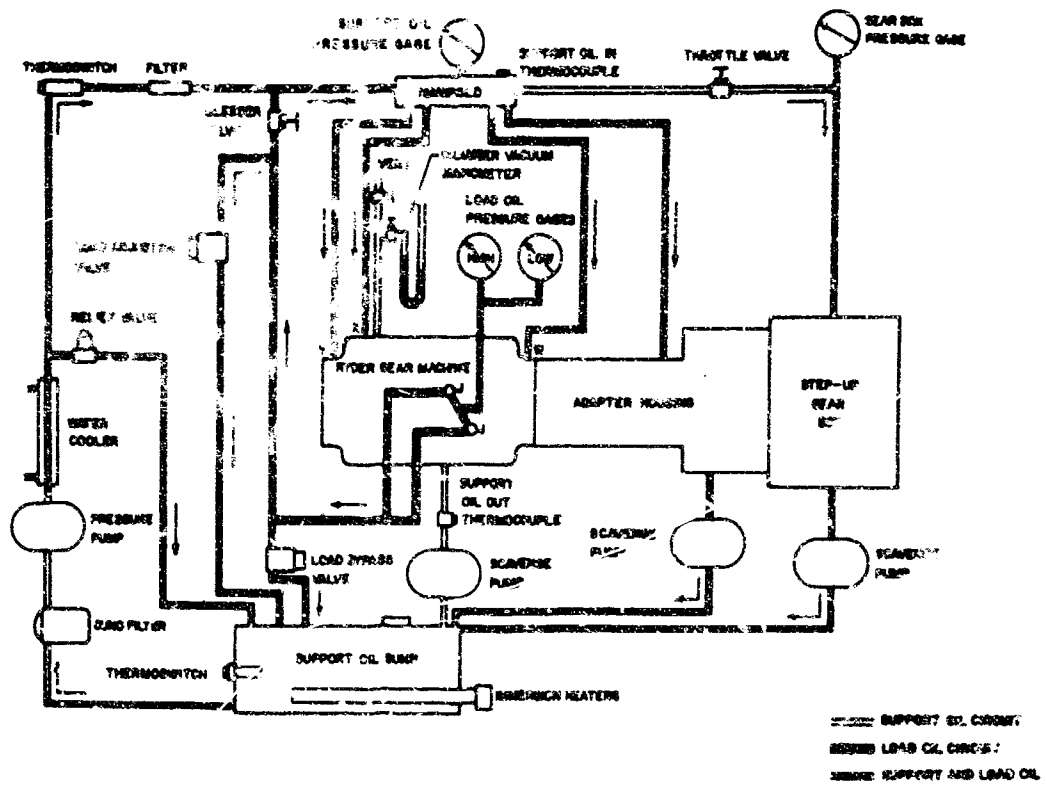

Figure 47. Slave Gears



Figure 48. Test Cells Installed



Support and Load Oil System

Figure 49

Test No. \_\_\_\_\_  
 Sheet No. \_\_\_\_\_

**LOAD-CARRYING ABILITY TEST  
 GEAR TEETH INSPECTION DATA SHEET**

OIL CODE \_\_\_\_\_ TEST SPECIFICATION \_\_\_\_\_

DATE \_\_\_\_\_ OPERATOR \_\_\_\_\_

GROSS TOOTH WIDTH \_\_\_\_\_ INCHES GEAR SIDE \_\_\_\_\_ "A" SIDE

PERCENT EFFECTIVE TOOTH WIDTH \_\_\_\_\_ "B" SIDE

Tooth No.	Percent of Tooth Area Scuffed at Low Oil Pressure (psia) of														Photo-graphs	
	5	10	15	20	25	30	35	40	45	50	55	60	65	70		75
1																
2																
3																
4																
5																
6																
7																
8																
9																
10																
11																
12																
13																
14																
15																
16																
17																
18																
19																
20																
21																
22																
23																
24																
25																
26																
27																
28																
Sum of Percent																
Average Percent																

Gear Teeth Inspection Data Sheet

Figure 50

TEST NO \_\_\_\_\_  
 SHEET NO 3

**LOAD CARRYING ABILITY TEST  
 PLOT AND CALCULATIONS SHEET**

OIL CODE \_\_\_\_\_ TEST SPECIFICATION \_\_\_\_\_  
 DATE \_\_\_\_\_ ENGINEER \_\_\_\_\_

A SIDE

B SIDE

EFFECTIVE TOOTH WIDTH, INCHES \_\_\_\_\_  
 LOAD OIL PRESSURE AT 22.5% SCUFF, P<sub>22.5</sub> \_\_\_\_\_  
 LOAD-CARRYING ABILITY, LB/INCH \_\_\_\_\_

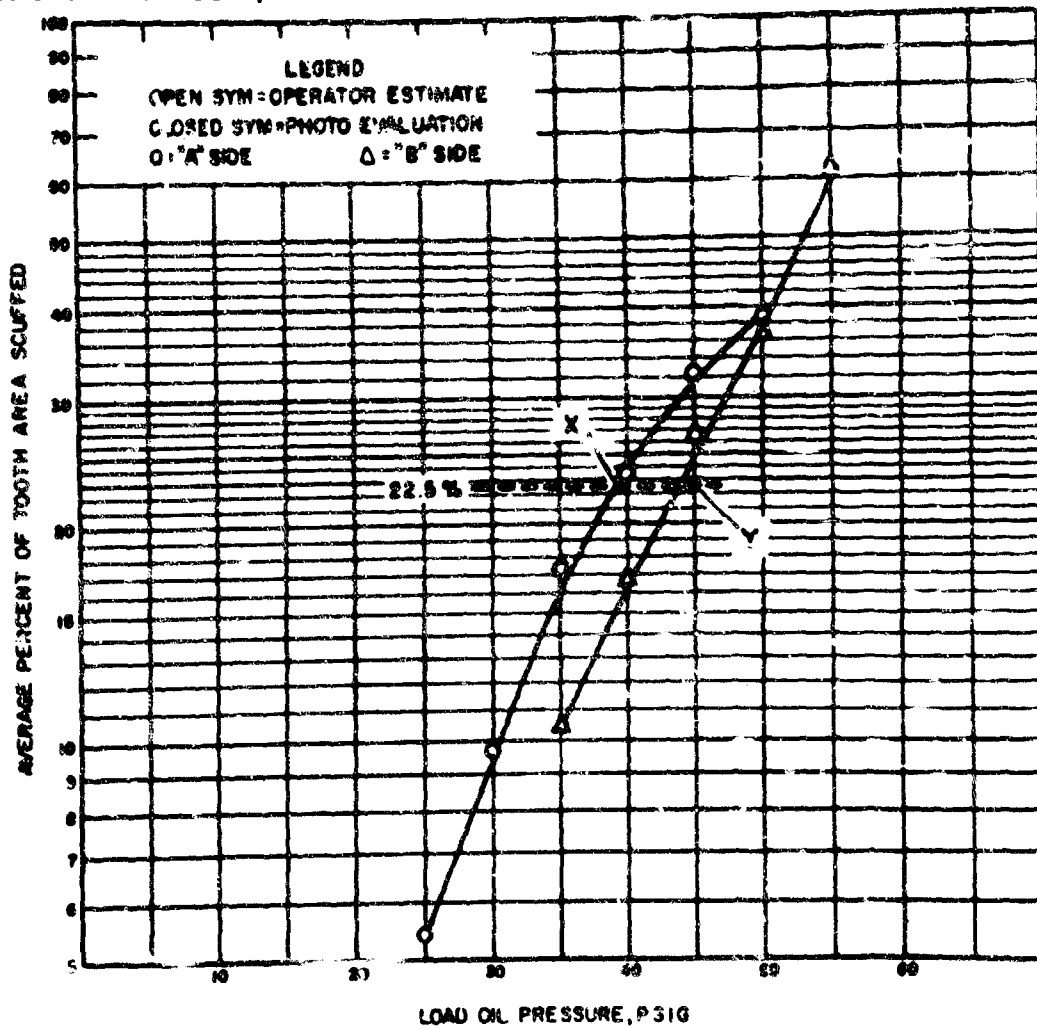

Plot and Calculations Sheet

Figure 51

## A, Standard Test Procedure (cont.)

2. Conditions of Tests

During the test run, test oil is sprayed on the gear teeth at the rate of 270  $\pm$  5 ml/min. The spray jet is directed at the gear teeth as they are unmeshing.

Assembled as shown in Figure 46, both the slave gears and test gears are engaged to form a "square." The housing and seal arrangement is such that lubricating oil pressure from a secondary source, not test oil, can be supplied to the shoulders of the shafts in the direction indicated by the arrows in Figure 47. Pressure applied at the shaft shoulders tends to translate the shafts axially in opposite directions. The resulting "four square" principle can be more readily understood if the lower shaft (Figure 47) is considered rigid, i. e., non-rotatable, and translates the upper shaft to the right. Note that the slave gears are helical gears with approximately 25° helix angles and that this translation would cause the upper shaft to rotate when the slave gears are engaged.

When the shafts and gears are assembled as in Figure 46, the test gears resist this tendency to rotate. The forces resisted by the test gears is proportional to the pressure applied at P on the upper shaft in Figure 47. Pressure is applied at P on the lower shaft to produce an equal and opposite force to that of the upper shaft. The only drive power required then is that necessary to overcome the frictional losses in the radial bearings and gears. Since the pressure P can be varied during operation, it follows that the loads on the test gears can be increased in specific increments.

Standard Ryder Gear tests are conducted at a constant speed of 10,000 rpm and 165  $\pm$  5°F and test oil temperature.

3. Plotting of Data

The data obtained for both Sides A and B during the above tests are plotted on semilog graph paper (as shown in Figure 51), and the 22.5% line is drawn through both curves. The intercept of the 22.5% line and the data plot for Side A is marked "X," and that for Side B is marked "Y." The 22.5% line is an arbitrary standard degree of scuffing used throughout the industry in the evaluation of all oil. Figure 51 curves are plotted for each batch number oil tested for AGC.

4. Calculating Load-Carrying Ability

The load-carrying ability of each gear set is calculated as follows:

$$L = \frac{KP}{W_2}$$

L = Load-carrying ability (or scuff limited load) of the lubricant, lb/in.

A. Standard Test Procedure (cont.)

K = Ryder Gear Machine constant (approximately value 18.55)

P = Load-oil pressure, psig

$W_2$  = Effective tooth width, in. (narrow test gear only)

Here the load-oil pressure P is the value corresponding to the "X" or "Y" intercepts of the curves in Figure 51.

B. STANDARD REFERENCE OIL

In order to establish that the Ryder Gear Machine is performing within its design limits, a series of tests are conducted using a standard reference oil. The oil used is SAE 50, which has a viscosity of 20 centistokes at 210°F. The following values were recorded for such a test:

<u>Oil</u>	<u>Side A</u>	<u>Side B</u>
Reference	2540	2540
	2850	2500
	2660	2720
	2860	2650
	2260	2260
	3160	2780
	3380	2850
	<u>19,710</u>	<u>19,300</u>
		14
		<u>19,710</u>
		<u>38,010</u>

Average load-carrying capability 2715 lb/in.

After each 20 determinations on test oils (10 sets of gears), two determinations (one set of gears) are made on the standard reference oil. The two oldest determinations of the eight previous reference tests are dropped, and the latest two values are used to determine the new averaging rating. This value is used to establish a rating for test oils relative to SAE 50 and is calculated as follows:

$$\text{Relative Rating \%} = \frac{\text{Test Oil Average Rating}}{\text{Reference Oil Average Rating}} \times 100$$



PREVIOUS PAGE WAS BLANK, THEREFORE NOT FILLED

Report SSD-TR-65-161-1

APPENDIX III

PROPERTIES OF HUMBLE 3156 GEAR LUBRICANT

Report SSD-TR-65-161-1, Appendix III

The properties of Humble 3156 gear lubricant are summarized in Table XVIII.

TABLE XVIII

PROPERTIES OF HUMBLE 3156 GEAR LUBRICANT  
(Base Oil: Humble 3153 3-Centistoke Super-Refined Naphthenic Oil)

Item No.	Test	Batch 41	Test By:		Method		
			AGC	Esso	FIMS 791a	ASTM	Other
1	Viscosity at 210°F, cs	3.10		X	305	D-445	
2	Viscosity at 100°F, cs	14.2		X	305	D-445	
3	Pour Point, °F	-30		X	201	D-97	
4	Flash Point, °F	325		X	1103	D-92	
5	Autoignition Temperature, °F	735		X	1152	D-286	
6	Specific Gravity at 60/60°F	0.863		X	401	D-287	
7	Acid Number, mg/gr KOH	0.60 to 0.85	X	X	5105	D-1160	
8	Distillate at 330°F, 10 mm pressure	5%		X			
9	Corrosion & Oxidizer Stability		X	X			MIL-L-7808D(1)
	Copper	mg/cm <sup>2</sup>	-1.29		Similar		
	Soft Steel	mg/cm <sup>2</sup>	-0.12		to		
	Aluminum	mg/cm <sup>2</sup>	+0.10		5308.4		
	Silver	mg/cm <sup>2</sup>	-0.07				
10	Foaming Characteristics			X			MIL-L-9708D(1)
	Sequence 1 (5/5)	Pass			Similar	Similar	
	Sequence 2 (5/3)	Pass			to	to	
	Sequence 3 (5/5)	Pass			3211.2	D-892-63	
11	Water Content, % by wgt, Max. (Karl Fisher)	0.01		X			
12	Spindle Corrosion Test			X			AGC
	140°F for 5 days	Pass					
	Room Temperature for 5 Days	Pass					
13	Storage Stability			X			MIL-L-8708D(1)
14	Extended Storage Stability			X			AGC

Table XVIII, Page 1 of 2

Report SSD-TR-65-161-1, Appendix III

TABLE XVIII (cont.)

Item No.	Test	Batch 41	Test By:		Method		
			AGC	Eso	FMS 791a	ASTM	Other
15	Long-Duration Corrosion and Material Compatibility Test			X			AGC
16	Chemical Compatibility Tests:						AGC
	N <sub>2</sub> O <sub>4</sub>	Pass					
	Aerozine	Pass					
	Ammonia	Pass					
	Water	Pass					
17	Compatibility with (MIL-L-7808D(1))	Pass		X		Similar to 3403	AGC
18	Swelling of Synthetic Rubber	Pass			X	3604	
19	Load Carrying Ability, lb/in.	3000		X		6508	
20	Aeration Test, sec	39		X			AGC
21	Specific Heat at:						
	100°F	0.493					
	150	0.518					
	200	0.543					
	300	0.592					
	350	0.618					
22	Precipitation Number, mg/200 ml	Less than 0.005		X		3004/4	MIL-L-7808D(1)
23	Vapor Pressure at 300°F, mm Hg	2.6			X	1201	
24	Filter Plugging Test	Pass		X			AGC

APPENDIX IV

SOLVENT COMPATIBILITY STUDIES

Report SSD-TR-65-161-1, Appendix IV

Solvent compatibility of the prospective oil, 3156 gear lubricant, and Bryco Conojet 800 (MIL-L-7808D1) lubricant was investigated in the AGC laboratory.

Three solvents were used for the tests:

1. Freon TF
2. Trichloroethylene
3. Solvent 250 (Chevron)

Freon TF is used for the gearbox proper and is highly volatile. Trichloroethylene is used for cleaning rolling contact bearings in the gearbox. Solvent 250 is used by the Western Gear Corporation for degreasing of the gears. It is highly volatile, which reduces chance of contamination. Small amounts of trichloroethylene were found in the bearing cavities.

In order to test above two lubricants for chemical compatibility with the solvents, 5 and 0.1% of each solvent were added to the oil. Metal corrosion and viscosity change have been recorded.

From the test results, which are shown in Table XIX, no reaction could be observed with either oil. Also, no free chloride ions have been detected. Aluminum, soft steel and silver showed no signs of corrosion. It is concluded that both oils are solvent compatible.

TABLE XIX

## SOLVENT COMPATIBILITY TESTS

Lubricant	Solvent wgt.	Observations						
		Water, % wgt.	Metal Corrosion, mg/cm <sup>2</sup>		SAE 1008	Vis- cosity Change %	ppt, mg/200 ml	Others
			Silver	Aluminum				
MIL-L-7808D(1)	5% TF <sup>(1)</sup>	---	-0.039	-0.039	-0.031	+10.9	None	Oil Clear
MIL-L-7808D(1)	0.1% TF	---	-0.024	-0.039	-0.031	+ 3.9	None	Oil Clear
MIL-L-7808D(1)	5% TCE <sup>(2)</sup>	---	-0.024	-0.039	-0.085	+11.7	None	Oil Clear
MIL-L-7808D(1)	0.1% TCE	---	0	-0.031	-0.016	+ 9.3	None	Oil Clear
MIL-L-7808D(1)	5% TF	0.15	+0.031	-0.024	-0.16	+ 6.9	None	Light ppt
MIL-L-7808D(1)	0.1 TF	0.15	0	-0.039	-0.46	+ 4.7	None	Light ppt
MIL-L-7808D(1)	5% TCE	0.15	-0.047	0.038	-0.047	+ 5.0	None	Light ppt
MIL-L-7808D(1)	0.1% TCE	0.15	-0.015	-0.036	-0.047	+ 3.5	None	Light ppt
MIL-L-7808D(1)	5% S-250 <sup>(3)</sup>	0.15	-0.015	-0.030	-0.039	+ 7.6	None	Light ppt
Esso 3156	5% TF	---	-0.070	-0.015	-0.039	0	None	Oil Clear
Esso 3156	0.1% TF	---	-0.031	0	-0.015	- 5.8	None	Oil Clear
Esso 3156	5% TCE	---	-0.023	0	-0.047	0	None	Slightly Turbid
Esso 3156	0.1%	---	0	-0.015	-0.047	- 2.6	None	Clear
Esso 3156	5% TF	0.15	-0.062	-0.039	-0.100	- 2.9	None	Hazy
Esso 3156	0.1% TF	0.15	-0.054	-0.015	-0.070	- 4.3	None	Clear
Esso 3156	5% TCE	0.15	-0.062	0	-0.054	- 4.0	None	Hazy
Esso 3156	0.1% TCE	0.15	0	0	-0.047	- 3.9	None	Slightly Hazy
Esso 3156	5% S-0.15	0	0	0	+ 2.3	None	Clear	

(1) Freon TF

(2) Trichloroethylene

(3) Solvent 250 by Chevron

Table XIX

Page 40

APPENDIX V

DRAINING AND FLUSHING PROCEDURE  
FOR TITAN II GEARBOX

The following draining and flushing procedures should be used in the field to minimize the amount of residual MIL-L-7808D(1) oil in the Titan II gearboxes prior to refilling with the new oil.

A. 87-5 (FIRST-STAGE GEARBOX)

1. Drain lubrication oil per Engineering Test Directive (ETD) 2.1-3.65.
2. Remove the drain plug from the oil side of the lubrication oil heat exchanger and rotate the turbine shaft 800 to 1000 rpm for one minute with an air motor adapted to the turbine rotor.
3. Introduce new oil at the PLD connection at 20 psi while rotating the turbine shaft at 800 to 1000 rpm and drain per Steps 1 and 2 above.

B. 91-5 (SECOND-STAGE GEARBOX)

Drain, flush, and reflush per the 87-5 procedure above, except that rotating the turbine shaft during draining is not required, and the applicable Engineering Test Directive is ETD 2.1-3.66.



Unclassified

Security Classification

DOCUMENT CONTROL DATA - R&D		
<small>(Security classification of title, body of abstract and indexing annotation must be entered when the overall report is classified)</small>		
1 ORIGINATING ACTIVITY (Corporate author) Aerojet-General Corporation P.O. Box 15847, Sacramento, Calif. 95813		2a REPORT SECURITY CLASSIFICATION Unclassified
		2b GROUP Not Applicable
3 REPORT TITLE Titan II - Augmented Engine Improvement Program Supplemental Final Report		
4 DESCRIPTIVE NOTES (Type of report and inclusive dates) Supplemental Final Report		
5 AUTHOR(S) (Last name, first name, initial)  Aerojet-General Corporation		
6 REPORT DATE 27 May 1966	7a TOTAL NO OF PAGES 85	7b NO OF REFS 7
8a CONTRACT OR GRANT NO. AF 04(694)-464	8b ORIGINATOR'S REPORT NUMBER(S) SSD-TR-65-161-1	
9 PROJECT NO	9a OTHER REPORT NO(S) (Any other numbers that may be assigned this report) Not Applicable	
10 AVAILABILITY/LIMITATION NOTICES  None		
11 SUPPLEMENTARY NOTES  None	12 PERSONS OR ORGANIZATIONS TO WHOM THIS REPORT IS DEDICATED Space Systems Division Air Force Systems Command Air Force Unit Post Office Los Angeles California 90845	
13 ABSTRACT  Development of a turbopump gearbox lubricant for the Titan II family engines was undertaken to formulate a new lubricant, which would replace presently used Bryco 890 Conojet (MIL-L-7808D(1)) oil. Naphthenic mineral oil was selected for the base because it has excellent storage life and propellant compatibility. Several additives were admixed to provide oxidation stability, good aeration characteristics, and a high load-carrying capacity. The task was completed with the selection of Humble 3156 gear lubricant, which is being proposed for engine qualification testing. Specifications covering all the particulars of this new lubricant have been written and are attached to this report. The development program encompassed the following tasks:		
<ol style="list-style-type: none"> <li>1. Selection of basic candidates.</li> <li>2. Optimization of additives</li> <li>3. Selection of final candidate lubricant</li> </ol>		

DD FORM 1473

Unclassified

Security Classification

Unclassified  
Security Classification

14 KEY WORDS	LINK A		LINK B		LINK C	
	ROLE	WT	ROLE	WT	ROLE	WT
Titan II Augmented Engine Improvement Program Supplemental Final Report						

INSTRUCTIONS

1. **ORIGINATING ACTIVITY:** Enter the name and address of the contractor, subcontractor, grantee, Department of Defense activity or other organization (*corporate author*) issuing the report.

2a. **REPORT SECURITY CLASSIFICATION:** Enter the overall security classification of the report. Indicate whether "Restricted Data" is included. Marking is to be in accordance with appropriate security regulations.

2b. **GROUP:** Automatic downgrading is specified in DoD Directive 5200.10 and Armed Forces Industrial Manual. Enter the group number. Also, when applicable, show that optional markings have been used for Group 3 and Group 4 as authorized.

3. **REPORT TITLE:** Enter the complete report title in all capital letters. Titles in all cases should be unclassified. If a meaningful title cannot be selected without classification, show title classification in all capitals in parenthesis immediately following the title.

4. **DESCRIPTIVE NOTES:** If appropriate, enter the type of report, e.g., interim, progress, summary, annual, or final. Give the inclusive dates when a specific reporting period is covered.

5. **AUTHOR(S):** Enter the name(s) of author(s) as shown on cover of the report. Enter last name, first name, middle initial. If military, show rank and branch of service. The name of the principal author is an absolute minimum requirement.

6. **REPORT DATE:** Enter the date of the report as day, month, year, or month, year. If more than one date appears on the report, use date of publication.

7a. **TOTAL NUMBER OF PAGES:** The total page count should follow normal pagination procedures, i.e., enter the number of pages containing information.

7b. **NUMBER OF REFERENCES:** Enter the total number of references cited in the report.

8a. **CONTRACT OR GRANT NUMBER:** If appropriate, enter the applicable number of the contract or grant under which the report was written.

8b, c, & 8d. **PROJECT NUMBER:** Enter the appropriate military department identification, such as project number, subproject number, system numbers, task number, etc.

9a. **ORIGINATOR'S REPORT NUMBER(S):** Enter the official report number by which the document will be identified and controlled by the originating activity. This number must be unique to this report.

9b. **OTHER REPORT NUMBER(S):** If the report has been assigned any other report number (either by the originator or by the sponsor), also enter its number(s).

10. **AVAILABILITY/LIMITATION NOTICES:** Enter any limitations on further dissemination of the report, other than those

imposed by security classification, using standard statements such as:

- (1) "Qualified requesters may obtain copies of this report from DDC."
- (2) "Foreign announcement and dissemination of this report by DDC is not authorized."
- (3) "U. S. Government agencies may obtain copies of this report directly from DDC. Other qualified DDC users shall request through \_\_\_\_\_."
- (4) "U. S. military agencies may obtain copies of this report directly from DDC. Other qualified users shall request through \_\_\_\_\_."
- (5) "All distribution of this report is controlled. Qualified DDC users shall request through \_\_\_\_\_."

If the report has been furnished to the Office of Technical Services, Department of Commerce, for sale to the public, indicate this fact and enter the price, if known.

11. **SUPPLEMENTARY NOTES:** Use for additional explanatory notes.

12. **SPONSORING MILITARY ACTIVITY:** Enter the name of the departmental project office or laboratory sponsoring (paying for) the research and development. Include address.

13. **ABSTRACT:** Enter an abstract giving a brief and factual summary of the document indicative of the report, even though it may also appear elsewhere in the body of the technical report. If additional space is required, a continuation sheet shall be attached.

It is highly desirable that the abstract of classified reports be unclassified. Each paragraph of the abstract shall end with an indication of the military security classification of the information in that paragraph, represented as (TS), (S), (C), or (U).

There is no limitation on the length of the abstract. However, the suggested length is from 150 to 225 words.

14. **KEY WORDS:** Key words are technically meaningful terms or short phrases that characterize a report and may be used as index entries for cataloging the report. Key words must be selected so that no security classification is required. Identifiers, such as equipment model designation, trade name, military project code name, geographic location, may be used as key words but will be followed by an indication of technical context. The assignment of links, roles, and weights is optional.

Unclassified  
Security Classification