

UNCLASSIFIED

AD NUMBER
AD458476
NEW LIMITATION CHANGE
TO Approved for public release, distribution unlimited
FROM Distribution authorized to U.S. Gov't. agencies and their contractors; Administrative/Operational Use; May 1961. Other requests shall be referred to Aeronautical Systems Div., Wright-Patterson AFB, OH 45433.
AUTHORITY
ASD USAF ltr, 3 Feb 1975

THIS PAGE IS UNCLASSIFIED

WADC TECHNICAL REPORT 57-126  
PART V

AD0458476

OFFICIAL FILE COPY

File Copy  
ASRCNP

D-14

## PHOSPHINOBORINE POLYMERS

ROSS I. WAGNER  
AMERICAN POTASH & CHEMICAL CORPORATION

ANTON B. BURG  
UNIVERSITY OF SOUTHERN CALIFORNIA

DARWIN L. MAYFIELD  
LONG BEACH STATE COLLEGE

MAY 1961

This report is not to be announced  
or distributed automatically  
to foreign governments  
(AFR 205-43A, paragraph 6d).

**BEST AVAILABLE COPY**

AERONAUTICAL SYSTEMS DIVISION

20040224153

# DISCLAIMER NOTICE

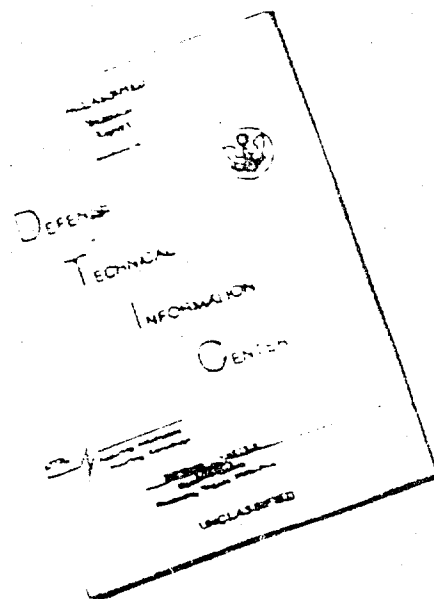

THIS DOCUMENT IS BEST  
QUALITY AVAILABLE. THE COPY  
FURNISHED TO DTIC CONTAINED  
A SIGNIFICANT NUMBER OF  
PAGES WHICH DO NOT  
REPRODUCE LEGIBLY.

REPRODUCED FROM  
BEST AVAILABLE COPY

## NOTICES

When Government drawings, specifications, or other data are used for any purpose other than in connection with a definitely related Government procurement operation, the United States Government thereby incurs no responsibility nor any obligation whatsoever; and the fact that the Government may have formulated, furnished, or in any way supplied the said drawings, specifications, or other data, is not to be regarded by implication or otherwise as in any manner licensing the holder or any other person or corporation, or conveying any rights or permission to manufacture, use, or sell any patented invention that may in any way be related thereto.

ASTIA release to OTS not authorized.

Qualified requesters may obtain copies of this report from the Armed Services Technical Information Agency, (ASTIA), Arlington Hall Station, Arlington 12, Virginia.

Copies of ASD Technical Reports and Technical Notes should not be returned to the Aeronautical Systems Division unless return is required by security considerations, contractual obligations, or notice on a specific document.

WADC TECHNICAL REPORT 57-126  
PART V

## PHOSPHINOBORINE POLYMERS

ROSS I. WAGNER  
AMERICAN POTASH & CHEMICAL CORPORATION

ANTON B. BURG  
UNIVERSITY OF SOUTHERN CALIFORNIA

DARWIN L. MAYFIELD  
LONG BEACH STATE COLLEGE

MAY 1961

MATERIALS CENTRAL  
CONTRACT No. AF 33(616)-6913  
PROJECT No. 7340

AERONAUTICAL SYSTEMS DIVISION  
AIR FORCE SYSTEMS COMMAND  
UNITED STATES AIR FORCE  
WRIGHT-PATTERSON AIR FORCE BASE, OHIO

## FOREWORD

This report was prepared by Dr. Ross I. Wagner, American Potash & Chemical Corporation, Research Department, Whittier, California, Dr. Anton B. Burg, University of Southern California, Los Angeles, California, and Dr. Darwin L. Mayfield, Long Beach State College, Long Beach, California, under USAF Contract No. AF 33(616)-6913. This contract was initiated under Project No. 7340, "Non-metallic & Composite Materials," Task No. 73404, "New Chemicals & Methods." The report was administered under the direction of Materials Central, Directorate of Advanced Systems Technology, Wright Air Development Division, with Lt. W. K. Musker acting as project engineer.

This report covers work conducted from January 1960 through December 1960.

The work at American Potash & Chemical Corporation Laboratories was carried out under the direction of Dr. D. R. Stern, Manager, Research, Dr. K. R. Eilar, Assistant Manager, Research, and Head, Organic Chemistry Section, and Dr. Ross I. Wagner who acted as project leader. Boron-Phosphorus Polymers work was performed by Messrs. Frederick F. Caserio, Jr., John J. Cavallo, Gordon F. Dierks, Earl M. Evleth, Marvin H. Goodrow, Howard N. Hammar, Harley J. Rockoff, and Richard H. Suess. Boron-Nitrogen Polymers work was performed by James L. Bradford and John J. Cavallo. New Approaches to Thermally Stable Polymers were carried out by Roger A. Baldwin and Franklin A. Billig under the direction of Robert M. Washburn. Physical Chemistry work was performed by Robert G. Adler and Rodger W. Baier under the direction of Robert D. Stewart.

The work at the University of Southern California was carried out under the direction of Dr. Anton B. Burg under Subcontract No. AF 6913-1 and is reported in Appendix I. Dr. Burg was assisted by Messrs. Louis R. Grant, James E. Griffiths, Kamalakant K. Joshi, and Louis K. Peterson.

The work at Long Beach State College was carried out under the direction of Dr. Darwin L. Mayfield under Subcontract No. AF 6913-2 and is reported in Appendix II. Dr. Mayfield was assisted by Messrs. Allan Bike and Robert Flath.

## ABSTRACT

Boron-Phosphorus Polymers. Treatment of triethylamine stabilized P-dimethylborophane polymer with a variety of reagents resulted in increased thermal stability. N-Halosuccinimides have been shown to be quite useful in synthesizing completely or partially B-halogenated borophane compounds, which could be readily substituted by reaction with certain organometallic reagents. Conditions for substitution of B-halogens with cyano radicals were also developed.

Boron-Nitrogen Polymers. On pyrolysis unsymmetrically substituted borazenes showed significant disproportionation but no indication of linked-ring borazene polymers which were prepared by coupling reactions as were polyborazyl oxides.

Two pseudoaromatic compounds were pyrolyzed in an effort to prepare linear borazene polymers.

New Approaches to Thermally Stable Polymers. Prototype P-N bonded compounds were prepared from aniline, phenyl-, and diphenylphosphonyl chlorides, when diphenylphosphonyl azide, a polymer precursor, was found to be unexpectedly thermally stable.

Polymers having Si-O-P, Si-O-C<sup>O</sup>- and CB(NC)<sub>2</sub> skeletons were prepared.

Physical Chemistry. Neumayer thermistor and microbullimetric molecular weight apparatuses and differential thermal analysis equipment have been used to characterize and evaluate new compounds.

Inorganic Polymer Components. New CF<sub>3</sub>-P-O compounds and a new PCCP diphosphine have been made as possible polymer precursors. The new alkyltrifluoromethylphosphines and polyphosphines offer the opportunity to seek new kinds of R<sub>2</sub>P-B-H polymers.

Thiosiloxane Polymers. Attempts have been made to synthesize high molecular weight linear thiosiloxanes from the cyclic trimer, hexaphenylcyclotrithiosiloxane, by thermal and chemical ring opening reactions as well as reactions of silanethiols with chlorosilanes.

## PUBLICATION REVIEW

This report has been reviewed and is approved.

FOR THE COMMANDER:



A. M. LOVELACE  
Chief, Polymer Branch  
Nonmetallic Materials Laboratory  
Materials Central

## TABLE OF CONTENTS

	PAGE
I. INTRODUCTION . . . . .	1
II. BORON-PHOSPHORUS POLYMERS. . . . .	2
A. Discussion . . . . .	2
1. Borophanes . . . . .	2
2. Phosphine Borines. . . . .	16
3. Phosphines . . . . .	18
B. Experimental . . . . .	20
1. Borophanes . . . . .	20
2. Phosphine Borines. . . . .	57
3. Phosphines . . . . .	58
III. BORON-NITROGEN POLYMERS. . . . .	65
A. Discussion . . . . .	65
1. Borazene Polymer Syntheses . . . . .	65
2. Borazene Intermediates . . . . .	68
3. Pseudoaromatic Boron-Nitrogen Compounds. . . . .	71
B. Experimental . . . . .	74
1. Borazene Polymer Syntheses . . . . .	74
2. Borazene Intermediates . . . . .	86
3. Pseudoaromatic Boron-Nitrogen Compounds. . . . .	98
IV. NEW APPROACHES TO THERMALLY STABLE POLYMERS. . . . .	104
A. Discussion . . . . .	104
1. Phosphorus-Nitrogen Chemistry. . . . .	104
2. Silicon-Oxygen Chemistry . . . . .	107



TABLE OF CONTENTS (cont'd.)

	PAGE
3. Boron-Nitrogen Chemistry . . . . .	108
B. Experimental . . . . .	110
1. Phosphorus-Nitrogen Chemistry. . . . .	110
2. Silicon-Oxygen Chemistry . . . . .	117
3. Boron-Nitrogen Chemistry . . . . .	119
V. PHYSICAL CHEMISTRY . . . . .	121
A. Discussion . . . . .	121
1. Molecular Weight Determinations. . . . .	121
2. Differential Thermal Analysis Studies. . . . .	121
B. Experimental . . . . .	123
1. Molecular Weight Determinations. . . . .	123
2. Differential Thermal Analysis Studies. . . . .	128
VI. SUMMARY AND CONCLUSIONS. . . . .	138
VII. BIBLIOGRAPHY . . . . .	140
APPENDIX I. CHEMISTRY OF INORGANIC POLYMER COMPONENTS. . . . .	142
I. THE BIS(PHOSPHINO)ACETYLENE $(CF_3)_2PC\equiv CP(CF_3)_2$ . . . . .	142
II. THE BORINE ADDUCTS OF TETRAMETHYLBIPHOSPHINE . . . . .	146
III. THE PHOSPHINOUS ACID $(CF_3)_2POH$ AND ITS DERIVATIVES . . . . .	150
IV. TRIFLUOROMETHYLPHOSPHONOUS ACID AND ITS ESTERS . . . . .	166
V. ALKYL FLUOROCARBON MONO-PHOSPHINES . . . . .	174
VI. CHEMISTRY OF NEW POLYPHOSPHINES. . . . .	184
VII. SUMMARY. . . . .	190
VIII. BIBLIOGRAPHY FOR APPENDIX I. . . . .	192

TABLE OF CONTENTS

	PAGE
APPENDIX II. THIOSILOXANE POLYMERS . . . . .	194
I. DISCUSSION. . . . .	194
II. EXPERIMENTAL. . . . .	198
III. BIBLIOGRAPHY FOR APPENDIX II. . . . .	204
APPENDIX III. NEW COMPOUNDS . . . . .	205
BIBLIOGRAPHY FOR TABLE XLV. . . . .	234

LIST OF FIGURES

FIGURE	PAGE
1. Chromatogram of P-Hexamethyltriborophane, P-Octamethyltetra- borophane and P-Nona- methylbicyclo[4.4.0]pentaborophane . . . . .	17
2. Ebulliometer Bridge Circuit. . . . .	126
3. Ebulliometer Calibration . . . . .	130
4. Ebulliometer Calibration - Low Solute Concentrations. . . . .	131
5. Differential Thermal Analysis Cell Holder. . . . .	132
6. Differential Thermal Analysis Sample Holder. . . . .	133
7. Differential Thermal Analysis Temperature Recording Circuit. . . . .	134
8. Infrared Spectra of $(CF_3)_2P=O$ Compounds. . . . .	157
9. Comparison Spectra of $(CF_3)_2P=$ and $(CF_3)_2P-$ Compounds in the P=O Stretching Region. . . . .	163

0

LIST OF TABLES

TABLE		PAGE
I	Illustrative Examples of Borophane Nomenclature . . . . .	3
II	B-Organ-substituted Triborophane Yields from B-Halo-substituted Tri- borophanes and Organometallic Reagents . . . . .	10
III	Relative Yields of Partially B-Halogenated P-Hexamethyltriborophanes with Organo- metallic Reagents. . . . .	13
IV	Thermal Decomposition of Treated and Untreated P-Dimethylborophane Polymer. . . . .	23
V	Preparation of Secondary Phosphine Borines . . . . .	59
VI	Preparation of Methyl-n-alkylphosphines. . . . .	60
VII	Pyrolytic Disproportionation Products from the Isomeric Pentamethylborazenes . . . . .	75
VIII	Preparation of N-Methyl-B-trimethylborazenes . . . . .	87
IX	Distillation of N-Methyl-B-trimethylborazenes. . . . .	89
X	Preparation of N-Trimethyl-B-methylborazenes . . . . .	91
XI	Fractionation of N-Trimethyl-B-methyl-B-dichloroborazene. . . . .	94
XII	Infrared Absorptions of Products Derived from Boronic Acids and 3,3',4,4'-Tetraaminobiphenyl . . . . .	109
XIII	Calibration of Neumayer Molecular Weight Apparatus . . . . .	125
XIV	Ebulliometer Calibration . . . . .	129
XV	Differential Thermal Analysis Furnace Calibration . . . . .	136
XVI	Differential Thermal Analyses of Various Borophanes . . . . .	137
XVII	Synthesis of $(CF_3)_2PC\equiv CP(CF_3)_2$ . . . . .	143

LIST OF TABLES (cont'd.)

TABLE		PAGE
XVIII	Vapor Tensions of $(CF_3)_2PC\equiv CP(CF_3)_2$ . . . . .	144
XIX	Vapor Tensions of the Less Volatile Product . . . . .	145
XX	Infrared Spectrum of $P_2(CH_3)_4 \cdot 2BH_3$ . . . . .	148
XXI	Rough Vapor Tensions of Liquid $P_2(CH_3)_4 \cdot BH_3$ . . . . .	149
XXII	Vapor Tensions of $(CF_3)_2POCH_3$ . . . . .	151
XXIII	Vapor Tensions of $(CF_3)_2POC_4H_9$ . . . . .	152
XXIV	Vapor Tensions of Liquid $C_4H_9(CF_3)_2PO$ . . . . .	153
XXV	Vapor Tensions of Liquid $CH_3(CF_3)_2PO$ . . . . .	154
XXVI	Vapor Tensions of Liquid $(CF_3)_2POBr$ . . . . .	156
XXVII	Infrared Spectra of $(CF_3)_2POX$ Type Compounds. . . . .	158
XXVIII	Infrared Spectra of $(CF_3)_2P(O)X$ Type Compounds. . . . .	161
XXIX	Calculated Electronegativities of the $CF_3$ Group . . . . .	162
XXX	Vapor Tensions of Liquid $(CH_3O)_2PCF_3$ . . . . .	167
XXXI	Vapor Tensions of Liquid $CF_3P(OH)_2$ . . . . .	169
XXXII	Vapor Phase Equilibrium of Trifluoromethylphosphonous Acid . . . . .	170
XXXIII	The Infrared Spectrum of " $CF_3P(OH)_2$ " at $75 \pm 5^\circ C$ . . . . .	171
XXXIV	Vapor Tensions of the $C_2H_4O_2PCF_3$ Monomer. . . . .	173
XXXV	The $CH_3I-(CF_3P)_n$ Reaction . . . . .	177
XXXVI	Formation of Two Trifluoropropyl-Phosphines . . . . .	181
XXXVII	Vapor Tensions of $(CF_3)_2PC_2H_4CF_3$ . . . . .	182
XXXVIII	Vapor Tensions of $CF_3P(C_2H_4CF_3)_2$ . . . . .	182
XXXIX	Vapor Tensions of $(CF_3)_2PC_2H_5$ . . . . .	183

LIST OF TABLES (cont'd.)

TABLE		PAGE
XL	Vapor Tensions of $C_2H_5PHCF_3$ . . . . .	184
XLI	Synthesis of $CH_3HPP(CF_3)_2$ . . . . .	185
XLII	Vapor Tensions of $CH_3HPP(CF_3)_2$ . . . . .	186
XLIII	Vapor Tensions of $CH_3P\overline{P}(CF_3)_2/2$ . . . . .	189
XLIV	Preparation of Hexaphenylcyclotriithiosiloxane . . . . .	195
XLV	New Compounds . . . . .	206

## I. INTRODUCTION

The primary objective of this program is research in the field of borophane and borazene compounds leading toward the synthesis of polymeric materials which are basically inorganic in nature and are capable of development into elastomers, adhesives and/or fluids having extreme chemical and thermal stability. Also under investigation are a number of screening reactions which should lead to new thermally stable polymers involving P-N, B-N, Si-O-P, Si-O- $\overset{\text{O}}{\underset{\text{H}}{\text{C}}}$  bonding systems.

The borophanes offer a promising field of study since as a class these compounds are unusually resistant to thermal decomposition and to oxidative and hydrolytic attack.

The two basic approaches to the problem of preparing useful borophane compounds are (1) altering the substituents on the boron and phosphorus atoms, and (2) changing the degree of polymerization. The changes in physical or chemical properties resulting from varying substituents or changing degree of polymerization are to be compared with the properties of P-hexamethyltriborophane,  $\left[ (\text{CH}_3)_2\text{PBH}_2 \right]_3$ , as the reference standard.

In the borazene work the immediate goal is the preparation of a polymer comprising a chain of borazene nuclei.

Initial efforts are being directed toward the reactions of diphenylphosphonyl azide, phosphonanilides, and polymers derived from terephthalic acid and phenylphosphonyl dichloride with diphenyldiacetoxysilane.

Improved techniques for determination of the molecular weight and thermal stability of polymers are being investigated.

Manuscript released by authors 30 March 1961 for publication as a WADC Technical Report

## II. BORON-PHOSPHORUS POLYMERS

### A. Discussion

#### 1. Borophanes

Beginning with this report a new system of nomenclature for compounds containing the monomer units  $R_2PBR_2$  and  $RPBR$  has been adopted. The old name, phosphinoborane polymers, will be replaced by the new term borophane polymers. Thus, cyclic phosphinoborane trimers and tetramers, and linear polymers will be named tri- and tetra-, and polyborophanes, respectively. The new system also provides an adequate means of describing the analogous boron-phosphorus compounds having polycyclic fused ring structures. Within the framework of the new nomenclature several names for a single compound are possible, the simplest consistent with lack of ambiguity being preferred. Illustrative of the new system are the examples listed in Table I.

#### a. Linear Borophane Polymers

##### (1) Reaction of P-Dimethylborophane Polymer with Nickel Carbonyl

Although the nature of the end groups in P-dimethylborophane polymer is still obscure there is reasonable possibility that the phosphorus moiety remains uncoordinated. Two preliminary experiments were made in which the polymer was treated with nickel carbonyl, known to form strong complexes with phosphines. Quantities were adjusted so that an increase in the molecular weight would be observed if reaction occurred. In one experiment so little gas was released as to place doubt as to whether any reaction occurred other than thermal decomposition of the nickel carbonyl. Molecular weight data suggest that reaction did occur increasing the degree of polymerization by 25-30% presumably according to a combination of the equations:

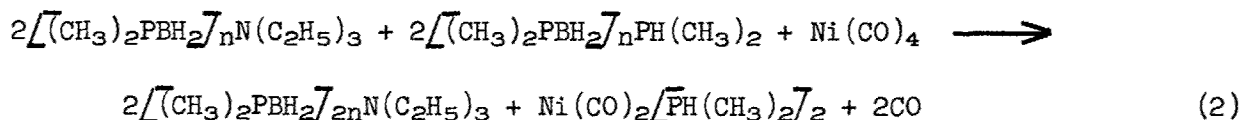
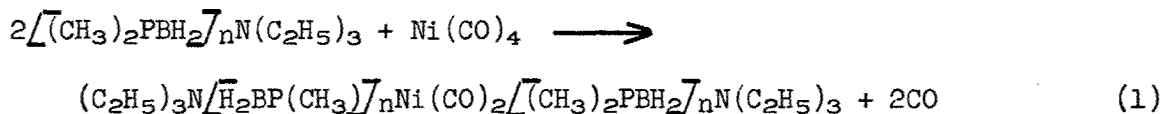

The thermal stability of the product is recorded in another section (vide infra).



TABLE I

Illustrative Examples of Borophane Nomenclature

Example	Structural Formula	Names
1.		<p>P-Hexamethyltriborophane</p> <p>1,1,3,3,5,5-Hexamethyltriborophane</p>
2.		<p>1,2,3,4,5,6-Hexamethyl-1,3,5-triethyltriborophane</p>
3.		<p>P-tris(cyclotetramethylene)-triborophane</p> <p>Trispiro[triborophane-1,1':-3,1":5,1"-tris(cyclotetramethylenephosphine)]</p>

TABLE I (Cont'd.)

Illustrative Examples of Borophane Nomenclature

Example	Structural Formula	Names
4.		<p>P-Hexaethyl-B,B'-dibromotri- borophane</p> <p>1,1,3,3,5,5-Hexaethyl-2,4- dibromotriborophane</p>
5.		<p>1,1,3,3,7,7,9,9-Octamethyl-5- phenyl-2-iodo-bicyclo[4.4.0]- pentaborophane</p>
6.	$\left[ \text{C}_2\text{H}_5(\text{CH}_3)\text{PBH}_2 \right]_n$	<p>P-Methylethylborophane polymer</p> <p>Poly-P-methylethylborophane</p>

(2) Reaction of P-Dimethylborophane  
Polymer with Basic Reagents

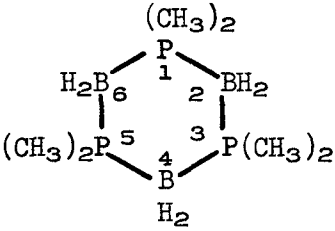
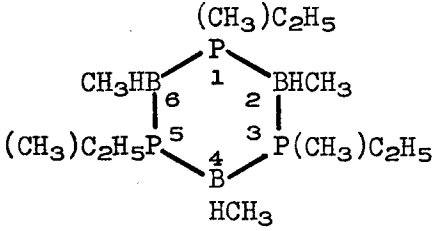
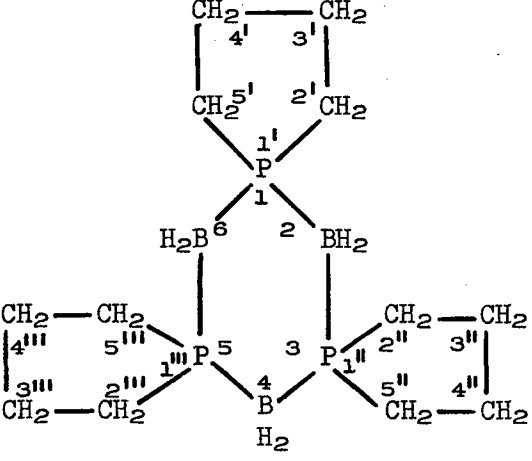
Replacement of the coordinated base at the boron end of the P-dimethylborophane polymer chain by a stronger base might increase the stability of the polymer. Both triethylenediamine and butyllithium were used to replace the triethylamine end group. With the former difunctional base where a significant increase in molecular weight would be expected, only a slight increase was observed in one experiment and a decrease in another. Thermal stabilities of these reaction products are recorded in another section (vide infra).

(3) Reaction of P-Dimethylborophane  
Polymer with Acidic Reagents

The end groups in P-dimethylborophane polymer are assumed to be a tetracoordinate  $\text{-BH}_2\text{:base}$  and a tricoordinate  $\text{-P(CH}_3)_2$ . If the phosphorus end were made tetracoordinate by treatment with an acidic reagent without affecting the boron end, the thermal stability should be enhanced.

In separate experiments the P-dimethylborophane polymer was treated with acetic acid-acetic anhydride, acetic anhydride-sulfuric acid and maleic anhydride. The possibility of increasing the molecular weight and simultaneously introducing some cross-links makes use of maleic anhydride particularly attractive. The thermal stabilities of these reaction products are recorded in another section (vide infra).

(4) Thermal Decomposition of Treated and  
Untreated P-Dimethylborophane Polymer

Acid treated, base treated and untreated P-dimethylborophane polymer samples were subjected to thermal decomposition at either  $202^\circ\text{C}$ . or  $260^\circ\text{C}$ . In all cases samples treated with hydrogen chloride, acetic anhydride-acetic acid, sulfuric acid, maleic anhydride, nickel carbonyl, or butyllithium were found to be more thermally stable than the untreated polymer. The untreated polymer decomposed  $27 \pm 4\%$  at  $202^\circ\text{C}$ . during 1.0 hr. whereas all treated polymers (with the exception of that treated with triethylenediamine) decomposed less than 6% under identical conditions. It was also observed that the rate of decomposition decreased with time suggesting that thermal decomposition occurs at the ends of the polymer chain. The polymer treated with acetic anhydride-acetic acid was found to be the most thermally stable, decomposing less than 30% at  $260^\circ\text{C}$ . in 1.0 hr. Also the improved mechanical properties of the residue from acetic acid-acetic anhydride and nickel carbonyl treated polymers were in contrast with those of all other residues.

Although the nature of the above tests are admittedly crude, guides have been established for future experiments.

(5) Preparation of Linear  
P-Diethylborophane Polymer

Pyrolysis of a mixture of diethylphosphine borine and triethylamine containing 19 mole % of the amine at  $200^\circ\text{C}$ . produced P-diethylborophane

polymer in an unexpectedly low yield with a complementary high yield of the cyclic P-hexaethyltriborophane.

(6) Preparation of P-Dimethyl-B-dichloroborophane Polymer

P-Dimethyl-B-dichloroborophane polymer was obtained in nearly quantitative yield by heating P-dimethylborophane polymer under reflux with excess N-chlorosuccinimide in carbon tetrachloride. The product was found by chlorine analysis to have been only 92.4% halogenated. A weak B-H absorption in the infra-red spectrum confirmed that the polymer had not been completely halogenated. An attempt to increase the extent of halogenation by increasing the amount of N-chlorosuccinimide and increasing the reaction time proved unsuccessful.

(7) Attempt to Prepare P-Dimethyl-B-dimethylborophane Polymer

Treatment of P-dimethyl-B-dichloroborophane polymer with trimethylaluminum at 100°C. for 1 hr. followed by a methanol wash resulted in complete decomposition of the polymer. Since both the B-hexamethyl- and B-hexachloro-derivatives of P-hexamethyltriborophane are stable toward trimethylaluminum and methanol it is quite probable that one or both of these reagents reacted with the end groups of the polymer resulting in an unzipping depolymerization and methanolysis.

b. Cyclic Borophane Polymers

(1) B-Fluoro Borophane Derivatives

P-Hexamethyl-B-hexafluorotriborophane was prepared in 84% yield for use as an intermediate by the previously reported<sup>1</sup> reaction of P-hexamethyltriborophane and hydrogen fluoride according to the equation:

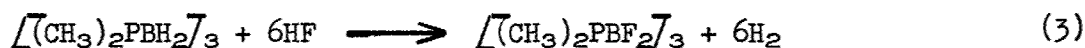

An attempt to prepare P-hexaphenyl-B-hexafluorotriborophane by the analogous reaction of P-hexaphenyltriborophane with hydrogen fluoride at room temperature was unsuccessful. Addition of benzene, in which both reactants are soluble, did not promote a reaction.

(2) B-Chloro Borophane Derivatives

N-Chlorosuccinimide and P-hexamethyltriborophane in a ratio in excess of 6:1 under reflux for 7 hrs. in carbon tetrachloride gave a 72% yield of P-hexamethyl-B-hexachlorotriborophane according to the equation:



A lesser amount of substitution than indicated by equation (4) may be effected by using a lesser stoichiometric quantity of the halogenating agent.

Equimolar quantities of P-hexamethyltriborophane and N-chlorosuccinimide in carbon tetrachloride stirred at room temperature gave 100.8% of the theoretical succinimide and a mixture of products containing 4.2% P-hexamethyltriborophane, 92.4% P-hexamethyl-B-chlorotriborophane, and 3.4% P-hexamethyl-B,B'-dichlorotriborophane after one crystallization. Partial separation was accomplished by fractional sublimation in high vacuum; starting material and the monochloro-derivative were volatile at room temperature where the dichloro-derivative had virtually no vapor pressure. Fractional crystallization from ethanol-water then afforded pure materials.

In a second, larger scale preparation performed in an analogous manner the crude product was found to consist of 15.2% starting material, 61.4% monochloro-derivative, 17.8% dichloro-derivative and four other components (5.6%). Preparative vapor phase chromatography was used to separate and collect the B-monochloro- and B,B'-dichloro-derivatives which were recrystallized to afford analytical samples for definitive characterization of these two new compounds.

### (3) B-Bromo Borophane Derivatives

P-Hexamethyltriborophane was heated under reflux with N-bromosuccinimide in a 6:1 ratio (equation 4) in either benzene or heptane solution to give P-hexamethyl-B-hexabromotriborophane in 27% and 42% yields, respectively. An attempt made to improve the 42% yield of P-hexamethyl-B-hexabromotriborophane using methylene bromide as solvent resulted in a 23% yield. Since the highly brominated triborophanes were only partially soluble in both solvents and the N-bromosuccinimide and succinimide were also only slightly soluble, considerable difficulty was encountered in determining when reaction was complete, perhaps accounting for the low yields of perbrominated triborophane. A larger steric requirement may also be decreasing the reaction rate.

Previous attempts<sup>2,3</sup> to prepare P-hexamethyl-B-tribromotriborophane using elemental bromine gave material of broad melting range but correct elemental analysis. It was thought that N-bromosuccinimide might be of a more selective nature and facilitate the preparation of a pure P-hexamethyl-B-tribromotriborophane isomer from either P-hexamethyltriborophane or from P-hexamethyl-B,B'-dibromotriborophane. However, materials isolated from these reactions by standard, although not exhaustive, recrystallization techniques, had broad melting ranges indicating mixtures.

A strong structural similarity exists between the cyclohexane and triborophane ring systems. The possible existence of cis-trans and axial-equatorial stereoisomers as well as a geminal dihalide configuration gives rise to a considerable number of compounds in the di-, tri-, and tetra-B-halogenated P-hexamethyltriborophanes. In the present case it is concluded that the material obtained in both reactions is primarily an isomeric mixture of P-hexamethyl-B-tribromotriborophanes.

P-Hexamethyltriborophane was treated with two equivalents of N-bromosuccinimide to give in 58% yield the previously known<sup>2</sup> P-hexamethyl-B,B'-dibromotriborophane which assayed 99.4% by vapor phase chromatography.

Three different brominating agents were used in a series of experiments to prepare P-hexamethyl-B-bromotriborophane. The reaction of equimolar quantities of P-hexamethyltriborophane and N-bromosuccinimide gave the monobromo-derivative in 62% yield. Elemental analysis and molecular weight confirm the structure. Using mercuric bromide the same monobromo-derivative was obtained in two experiments in 44% and 14% yields, respectively. The reaction follows the stoichiometry:

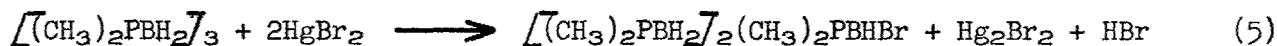

The reaction of equimolar quantities of bromine and P-hexamethyltriborophane in methylene bromide or acetic acid yielded a complex mixture of brominated products rather than the monobromo-derivative. Fractional crystallization, sublimation, or solution chromatography failed to afford any significant degree of separation. The only compound characterized was the previously known<sup>2</sup> P-hexamethyl-B,B'-dibromotriborophane.

In attempting to replace the methyl hydrogens in dodecamethyltriborophane with bromine and hence arrive at a new compound with a functional substituent, the fully methylated compound was heated under reflux in carbon tetrachloride with N-bromosuccinimide. After a 4 hr. heating period the black solution, on work-up, yielded no succinimide, but only recovered starting material (76%).

#### (4) B-Iodo Borophane Derivatives

Six equivalents of N-iodosuccinimide and P-hexamethyltriborophane heated under reflux for 16 hrs. in methylene iodide gave a dark brown residue from which none of the expected P-hexamethyl-B-hexaiodotriborophane (equation 4) could be separated. The failure of this reaction is in keeping with the observed trend of decreasing yield with increasing atomic number of the halogen attributed to decreasing solubility of the halogenated products and to increasing steric requirements of the halogen.

P-Hexamethyl-B-iodotriborophane was obtained in 65% crude yield from equimolar quantities of P-hexamethyltriborophane and N-iodosuccinimide in benzene at room temperature. Purification was accomplished by fractional sublimation at 40-50°C. followed by crystallization from alcohol-water. A larger scale preparation gave an 85% crude yield which, after purification, provided pure material in 74% yield.

N-Iodosuccinimide reacted with P-nonamethylbicyclo[4.4.0]-borophane to give a mixture from which two iodinated derivatives, a microcrystalline solid and a transparent crystalline solid were isolated. Repeated crystallization of the transparent product gave a pure monoiodo-derivative suitable for structure elucidation by X-ray crystallography. The differing infrared spectra and melting points of the two products, and the similar elemental analyses suggest that they are position isomers.

(5) Reactions of B-Halo-Derivatives  
of P-Hexamethyltriborophane  
with Organometallic Compounds

A new method for preparing B-organo-substituted triborophanes has been developed and is outlined by equation (6).

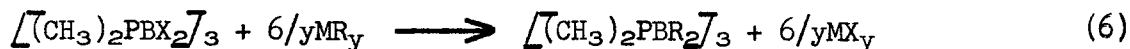

Each of the halogens can be used with varying degrees of success with respect to yield obtained and amount of starting material recovered depending in part on the organometallic reagent used.

From the limited amount of data the generalization can be made that B-fluoro-compounds give lower yields of B-organo-substituted triborophanes accompanied by degradation of the triborophane nucleus than did the other B-halo-derivatives. The data are summarized in Table II. Dodecamethyltriborophane has been prepared from P-hexamethyl-B-hexafluorotriborophane and trimethylaluminum at 100°C. in 55% yield and an attempt to improve the yield was unsuccessful. The strong pungent odors frequently encountered in the preparation and occasionally in reaction mixtures of P-hexamethyl-B-hexafluorotriborophane strengthened the supposition that the triborophane ring was undergoing decomposition. A high 87% yield of dodecamethyltriborophane was prepared from P-hexamethyl-B-hexafluorotriborophane and trimethylborine at 100°C. Similarly, triethylborine and P-hexamethyl-B-hexafluorotriborophane at 125°C. gave an unresolvable mixture the infrared spectrum of which was indicative of the ethyl group, but also contained B-H absorption. A second experiment conducted with a seven-fold longer reaction time provided a crystalline product after tedious purification. The small amounts of material precluded definitive characterization, although spectroscopic evidence offered support for the expected product, P-hexamethyl-B-hexaethyltriborophane. Dimethylzinc at 125°C. resulted in complete decomposition of the B-hexafluoro-derivative while at lower temperatures no reaction or only partial decomposition occurred allowing recovery of the unreacted triborophane. Organotin compounds also had a pronounced tendency to decompose P-hexamethyl-B-hexafluorotriborophane. After 6 hrs. at 100°C. with tetramethyltin only 11% of the starting material was recovered; none of the expected dodecamethyltriborophane was detected. Tetravinyltin completely destroyed the hexafluoro- compound at 125°C. (4.5 hrs.) leaving a voluminous brightly colored solid residue. Tetraphenyltin, although it decomposed most of the hexafluoro- compound, did provide a detectable quantity of crude product, the infrared spectrum of which displayed bands characteristic of the triborophane nucleus and the mono-substituted phenyl ring. Triphenylaluminum proved equally effective as the tin derivative in decomposing P-hexamethyl-B-hexafluorotriborophane. A small quantity of partially arylated material was obtained, but this too resisted purification by conventional methods. Finally, P-hexamethyl-B-hexafluorotriborophane and ethereal methyllithium at room temperature reacted to give a large quantity of methane but none of the expected B-methylated product and only a small amount of the starting material could be recovered.

TABLE II

B-Organosubstituted Triborophane Yields from  
B-Halo-substituted Triborophanes and Organometallic Reagents

Organometallic Reagent	B-Organotriborophane Yields from B-Halo-substituted P-Hexamethyltriborophanes, $(\text{CH}_3)_6\text{P}_3\text{B}_3\text{H}_6\text{-nX}_n$						
	$\text{B}_3\text{F}_6$	$\text{B}_3\text{Cl}_6$	$\text{B}_3\text{Br}_6$	$\text{B}_3\text{H}_3\text{Br}_3$	$\text{B}_3\text{H}_4\text{Br}_2$	$\text{B}_3\text{H}_5\text{Br}$	$\text{B}_3\text{H}_5\text{I}$
$(\text{CH}_3)_3\text{Al}$	55	95	95	85(a)	61(a)	-	25(a)
$(\text{C}_2\text{H}_5)_3\text{Al}$	-	(b)	-	-	-	-	-
$(\text{C}_6\text{H}_5)_3\text{Al}$	(b)	-	-	-	-	-	-
$(\text{CH}_3)_3\text{B}$	87	-	-	-	-	-	-
$(\text{C}_2\text{H}_5)_3\text{B}$	20	(b)	-	-	-	-	-
$(\text{CH}_3)_2\text{Hg}$	-	(c)	-	-	-	-	1(a)
$(\text{CH}_3)_2\text{Cd}$	-	-	-	-	-	-	68(a)
$(\text{CH}_3)_2\text{Zn}$	0	92	-	-	-	-	42(a)
$(\text{C}_2\text{H}_5)_2\text{Zn}$	-	(b)	-	-	-	-	-
$(\text{C}_6\text{H}_5)_2\text{Zn}$	-	-	-	-	-	57	-
$(\text{C}_2\text{H}_5)_4\text{Pb}$	-	(c)	-	-	-	-	-
$(\text{CH}_3)_4\text{Sn}$	0	-	-	-	-	-	0
$(\text{CH}_2=\text{CH})_4\text{Sn}$	0	-	-	-	-	-	-
$(\text{C}_6\text{H}_5)_4\text{Sn}$	0	-	-	-	-	-	-
$(\text{C}_6\text{H}_5)_2\text{Mg}$	-	-	-	-	-	-	34(a)
$\text{C}_6\text{H}_5\text{MgBr}$	-	-	-	-	-	-	(c)
$\text{CH}_3\text{Li}$	0	-	-	-	-	-	-

(a) Disproportionation products also isolated.

(b) Partial substitution but no products characterized.

(c) No reaction.



In marked contrast to the B-fluoro-substituted triborophane, P-hexamethyl-B-hexachlorotriborophane gave high yields of dodecamethyltriborophane on reaction with trimethylaluminum (95% yield at 125°C.) and dimethylzinc (92% yield at 125°C.). With diethylzinc at 125°C. none of the desired product, P-hexamethyl-B-hexaethyltriborophane, was obtained. Instead only partially ethylated products were formed accompanied by decomposition of the diethylzinc into zinc, ethylene and ethane. P-Hexamethyl-B-hexachlorotriborophane was much more resistant toward reaction with triethylborine than the analogous hexafluoro-derivative. After heating at 200°C. for 16 days, 83% of the triborophane was recovered. The small amount of ethyl-containing product proved unresolvable. P-Hexamethyl-B-hexachlorotriborophane with triethylaluminum at 125°C. gave a small amount of crude P-hexamethyl-B-hexaethyltriborophane (not yet fully characterized) but was unreactive with either tetraethyllead at 125°C. (86% recovery) or with dimethylmercury at temperatures up to 160°C. for prolonged periods of time (96% recovery).

In extending the scope of this reaction to include the B-bromo-substituted triborophanes, P-hexamethyl-B-hexabromotriborophane and trimethylaluminum were heated at 125°C. giving dodecamethyltriborophane in 95% yield. P-Hexamethyl-B,B',B''-tribromotriborophane and trimethylaluminum at 125°C. gave a 95% yield of product thought to be an inseparable isomeric mixture of P-hexamethyl-B,B',B''-trimethyltriborophanes contaminated with an impurity containing a BH<sub>2</sub> grouping which was later also found to contaminate the starting material. However, this supposed isomeric mixture was shown by vapor phase chromatography to contain only 90% of the B-trimethyl products. A more definitive reaction of the partially halogenated P-hexamethyltriborophanes with trimethylaluminum was that of pure P-hexamethyl-B,B'-dibromotriborophane where product analysis proved that alkylation is nonspecific, failing to follow the stoichiometry

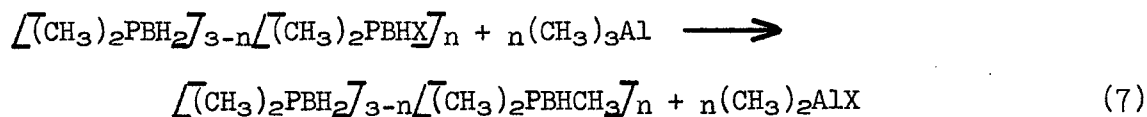

The product on vapor phase chromatographic analysis was shown to be a mixture of unsubstituted, mono-, di-, tri-, and tetra-B-methylated P-hexamethyltriborophanes. To explain the further methylation of product an attempt to methylate P-hexamethyltriborophane with trimethylaluminum during 8 hrs. at 100°C. was made but proved to be unsuccessful (98% recovery) as was an attempt under more drastic conditions; during 18 hrs. at 200°C. the trimethylaluminum completely decomposed while 97% of the triborophane was recovered unchanged. Since trimethylaluminum alone does not react with triborophanes, further methylation of the triborophane nucleus most probably arises by abstraction of an hydridic hydrogen by the by-product dimethylaluminum halide from either the starting triborophane or the primary methylation product (equation 8). The resulting halogen derivative may then be methylated by trimethylaluminum (equation 7) while the dimethylaluminum hydride can reduce any of the halogenated compounds to the parent triborophane or its methyl derivatives (equation 9). The data are summarized in Table III.

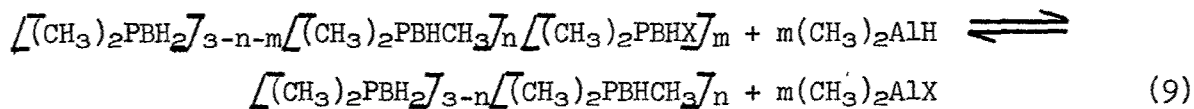
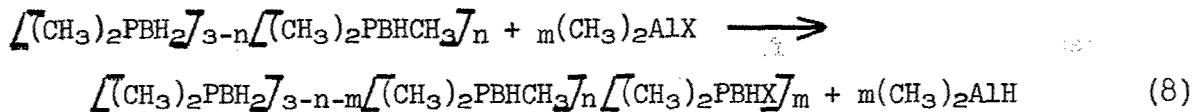

Treatment of P-hexamethyl-B-bromotriborophane with diphenylzinc at 125°C. for 17 hrs. has produced the first pure and fully characterized B-phenyl substituted borophane compound in 57% yield. The infrared spectrum, as expected, was quite similar to the spectra of the monohalogenated triborophanes and also contained all the absorption bands characteristic of the phenyl group. A minor second constituent was also encountered, the infrared spectrum of which was strikingly similar to that for the monophenyl-derivative. This material might be the B,B'-diphenyl-derivative but the small sample size precluded a careful examination.

Confirmation of the non-stoichiometric nature of the alkylation of partially B-halo-derivatives of P-hexamethyltriborophane on reaction with organometallic reagents was observed using pure P-hexamethyl-B-iodotriborophane and at the same time the utility of B-iodo-derivatives in this reaction was demonstrated. In this reaction with trimethylaluminum the distribution of products was even more pronounced than when B-bromo-derivatives were used; lesser but still appreciable quantities of by-products were observed when dimethylzinc, dimethylcadmium, and dimethylmercury were used. Tetramethyltin failed to alkylate the triborophane nucleus. The zinc and cadmium reagents provided preparative yields of the B-monomethyl-derivative whereas only a small yield was obtained with dimethylmercury under much more drastic conditions. The data listed in Table III show that with increasing atomic number of the metal the reaction proceeds with decreasing amounts of reduction (equation 9) as would be expected from the decreasing thermal stabilities of the respective metal hydrides. P-Hexamethyl-B-iodotriborophane, when treated with a refluxing ethereal solution of phenylmagnesium bromide, failed to give the expected monophenyl-derivative and instead 96% of the triborophane was recovered. However, halide-free diphenylmagnesium did react with the monoiodo-derivative to give P-hexamethyl-B-phenyltriborophane together with some unsubstituted and B-diphenyl-substituted derivatives. Presumably in the absence of magnesium halide which coordinates strongly with diphenylmagnesium, the organometallic reagent may coordinate with the B-halo-substituent as a first step toward B-arylation.

(6) Reactions of B-Halo-derivatives  
of P-Hexamethyltriborophane with  
Other than Organometallic Reagents

(a) Preparation of B-cyano-derivatives

The cyanogenation of the triborophane ring, which heretofore proved unsuccessful with such exotic reagents as cyanogen<sup>4</sup> and cyanogen bromide,<sup>4</sup>

TABLE III

Relative Yields of Partially B-Halogenated  
P-Hexamethyltriborophanes with Organometallic Reagents

Reagent		Reaction		No. of B-Methyl Groups in $(\text{CH}_3)_6\text{P}_3\text{BH}_{6-n}(\text{CH}_3)_n$				
		Time, hrs.	Temp., °C.	0	1	2	3	4
Triborophane	Organometallic							
P-Hexamethyl-B,B'B''-tri-bromotriborophane	$(\text{CH}_3)_3\text{Al}$	18	125 ± 2	0.1	0.3	2.5	90.1	3.9
P-Hexamethyl-B,B'-di-bromotriborophane	$(\text{CH}_3)_3\text{Al}$	18	125-155	0.9	7.2	80.2	10.0	1.7
P-Hexamethyl-B-iodo-triborophane	$(\text{CH}_3)_3\text{Al}$	9	100 ± 2	11.1	33.8	54.7	0.3	0.1
P-Hexamethyl-B-iodotri-borophane	$(\text{CH}_3)_2\text{Zn}$	9	100 ± 2	6.6	74.4	18.7	0.3	-
P-Hexamethyl-B-iodotri-borophane	$(\text{CH}_3)_2\text{Cd}$	9	125-135	2.2	78.9	16.4	2.5	-
P-Hexamethyl-B-iodotri-borophane	$(\text{CH}_3)_2\text{Hg}$	8	175-250	29.3	9.2	56.9	2.3	-
P-Hexamethyl-B-iodotri-borophane	$(\text{C}_6\text{H}_5)_2\text{Mg}$	24	125 ± 5	4	34*	11*	-	-

\* Phenyl

and only partial successful using potassium mercuricyanide (vide infra), has now culminated in a high yield reaction using sodium cyanide. Treatment of the B-bromo- and B,B'-dibromo-derivatives of P-hexamethyltriborophane with sodium cyanide in dimethylformamide has provided the corresponding monocyano- and dicyano-derivatives in 89% and 55% yields, respectively. However, P-hexamethyl-B-hexachlorotriborophane failed to react with sodium cyanide under similar conditions.

The use of ethanol as solvent proved as successful as dimethylformamide in preparing P-hexamethyl-B-cyanotriborophane from P-hexamethyl-B-iodotriborophane suggesting that this solvent may be useful for other displacement reactions.

The early successful effort to prepare a B-cyano-derivative of a triborophane consisted of reaction of P-hexamethyl-B,B',B''-tribromotriborophane with potassium mercuricyanide in either dimethylformamide or acetonitrile. In the experiments using dimethylformamide a definite reaction occurred. In one of these experiments bromide ion was formed in 54.2% yield and is compelling evidence for replacement of bromine on boron by some reactive species from potassium mercuricyanide. The dissociation products of the complex cyanide appeared to be the most probable reactive species and accordingly were investigated; the simple alkali metal salt proved to be useful in replacing halogen (vide supra), while mercuric cyanide was found to be very poor cyanoating agent (vide infra).

#### (b) Miscellaneous

P-Hexamethyl-B-bromotriborophane and potassium fluoride in dimethylformamide failed to give the anticipated P-hexamethyl-B-fluorotriborophane. Rather, a carbonyl compound of unknown structure was obtained in good yield and presumably arose from interaction of the borophane with the solvent. The infrared spectrum, displaying strong absorption bands at 8.29 and 5.80  $\mu$ , is indicative of a formate group, assumed to be on boron. Vapor phase chromatography confirmed the existence of a new compound assaying 78.4%. The small quantity of material precluded more careful examination. Accordingly, this reaction will be repeated and the structure of the product elucidated. Starting material containing only a small amount of a carbonyl compound was obtained when lithium fluoride was substituted for potassium fluoride.

Since P-hexamethyl-B,B',B''-tribromotriborophane appears to contain a relatively labile bromine as evidenced by its reaction with potassium mercuricyanide, an attempt was made to react this triborophane with diethylamine to see if a B-diethylamino-derivative would form by elimination of hydrogen bromide. However, no reaction occurred when the reagents were mixed and heated at 85°C. for 0.5 hr. with excess amine as solvent. Similarly, the reaction of P-hexamethyl-B-bromotriborophane with pyrrolidine yielded only a small amount of a solid, possibly a B-pyrrolidyl-substituted triborophane. Other than hydrogen the products of the reaction were not defined. The residue from the reaction yielded an undetermined amount of phosphine derivatives on hydrolysis indicating at least partial destruction of the triborophane nucleus.

The attempted displacement of bromide ion from P-hexamethyl-B-bromotriborophane with hydroxide ion in methanol failed to give an identifiable product. Analysis for bromide ion indicated that only 13% of the bromotriborophane had reacted.

An experiment designed to replace the fluoro atoms with acetate groups in P-hexamethyl-B-hexafluorotriborophane, utilizing mercuric acetate resulted in decomposition of the triborophane ring and the formation of metallic mercury.

(7) Reactions of  
P-Hexamethyltriborophane

P-Hexamethyltriborophane was found to react with mercuric acetate. Aside from mercury metal isolated in 90% yield the products of the reaction were obscure. A small amount of an oily liquid was isolated, the infrared spectrum of which indicated it to be a triborophane containing both hydroxy and carbonyl functions. In another experiment using less mercuric acetate only mercury metal and impure starting material were isolated.

P-Hexamethyltriborophane failed to react with either neutral or acidic aqueous hydrogen peroxide at room temperature. No significant reduction of peroxide occurred and the triborophane was quantitatively recovered.

The attempted mild oxidation of P-hexamethyltriborophane with silver oxide at 200°C. failed. Although silver metal was isolated the triborophane was recovered in 98.5% yield suggesting complete oxidative degradation of the remaining 1.5% of the starting material.

Elemental sulfur and P-hexamethyltriborophane react at 130-150°C. to yield a colorless nonvolatile solid and hydrogen. No hydrogen sulfide was detectable until the solid was exposed to atmospheric moisture. In another experiment the two reagents were heated in carbon disulfide at 125°C. without apparent reaction and the P-hexamethyltriborophane and sulfur were recovered in 91% and 86% yields, respectively.

In order to test the interaction of radicals with P-hexamethyltriborophane, a mixture of azo-bis-isobutyronitrile and the triborophane was heated at  $90 \pm 10^\circ\text{C}$ . for 4 hrs. A very small amount of a volatile liquid tentatively identified as isobutyronitrile was isolated along with a crystalline solid which sublimes at 60°C. and a small amount of soft colorless residue. The volatile solid is the major product and appears from its infrared spectrum to be a mixture of P-hexamethyltriborophane and tetramethylsuccinonitrile. From these data it would appear that only a minor amount of a hydrogen abstraction process has occurred because of the formation of the volatile liquid nitrile.

Essentially no reaction occurred between P-hexamethyltriborophane and cyanogen in the presence of catalytic amounts of aluminum chloride since most of the starting cyanogen and triborophane were recovered unchanged.

In contrast to the halogenation of P-hexamethyltriborophane with mercuric bromide the reaction of mercuric cyanide yielded only trace amounts (0.5%) of P-hexamethyl-B-cyanotriborophane.

The reaction of hydrogen cyanide with ethereal lithium borohydride to form lithium monocyanoborohydride as reported by Wittig and Raff<sup>5</sup> proceeds smoothly but in the two attempts to obtain P-hexamethyl-B,B',B''-tricyanotriborophane by reaction with dimethylphosphonium chloride, the product obtained appeared to have neither hydrolytic nor thermal stability. The limited data obtained from these experiments do not give conclusive evidence that the product obtained was the B-cyano-substituted triborophane.

In an attempt to prepare triethylamine cyano- or dicyanoborane as an intermediate in the synthesis of B-cyanoborophanes, triethylamine borane and cyanogen were allowed to interact for 3 days at room temperature and produced an intractable black solid with recovery of 59.7% of the starting cyanogen. A similar result was obtained when triethylamine borane and hydrogen cyanide were heated together at 75°C. for 4 hrs. to give an unidentified black solid and about 67.7% recovery of the starting amine borane.

The separation of P-nonamethylbicyclo[4.4.0]pentaborophane from P-hexamethyltriborophane and P-octamethyltetraborophane as well as the partial separation of the latter two compounds from each other has been accomplished by solution chromatography. Several combinations of adsorbent, solvent and eluent have been tried including silica gel, alumina and Linde Molecular Sieve 13X as adsorbents, cyclohexane and benzene as solvents, and isopropanol, cyclohexene, dioxane, benzene and cyclohexane as eluents. Preliminary experiments indicate that on an alumina column the tri- and tetraborophanes are eluted best with a 1:1 cyclohexene--cyclohexane mixture. P-Nonamethylbicyclo[4.4.0]pentaborophane is more strongly adsorbed and required a 3:7 benzene--cyclohexane solution (introduced after elution of the monocyclic borophanes) for elution in a reasonable time. The chromatogram (Figure 1) suggests that two isomeric P-nonamethylbicyclo[4.4.0]pentaborophanes are present confirming results obtained by fractional crystallization of this material<sup>6</sup> from methanol. Fractions comprising the first peak (Sections I and II, Figure 1) generally had broad melting points in the range 86-93°C. and those fractions comprising the second peak (Sections III and IV) melted in the range 93-101°C. Similar fractions from five runs without admixed monocyclic borophanes were combined into four samples indicated by Sections I-IV in Figure 1 to be rechromatographed.

## 2. Phosphine Borines

### a. Preparation of Diethyl-, Methylphenyl- and Methyl-n-alkylphosphine Borines

A number of methyl-n-alkyl phosphine borines were prepared as intermediates in the preparation of the corresponding polyborophanes which are being prepared to determine the effect of the length of the alkyl groups on the physical properties of the polymer. In addition, diethyl- and methylphenylphosphine borines were prepared as intermediates. Each of the adducts was liquid at room temperature.

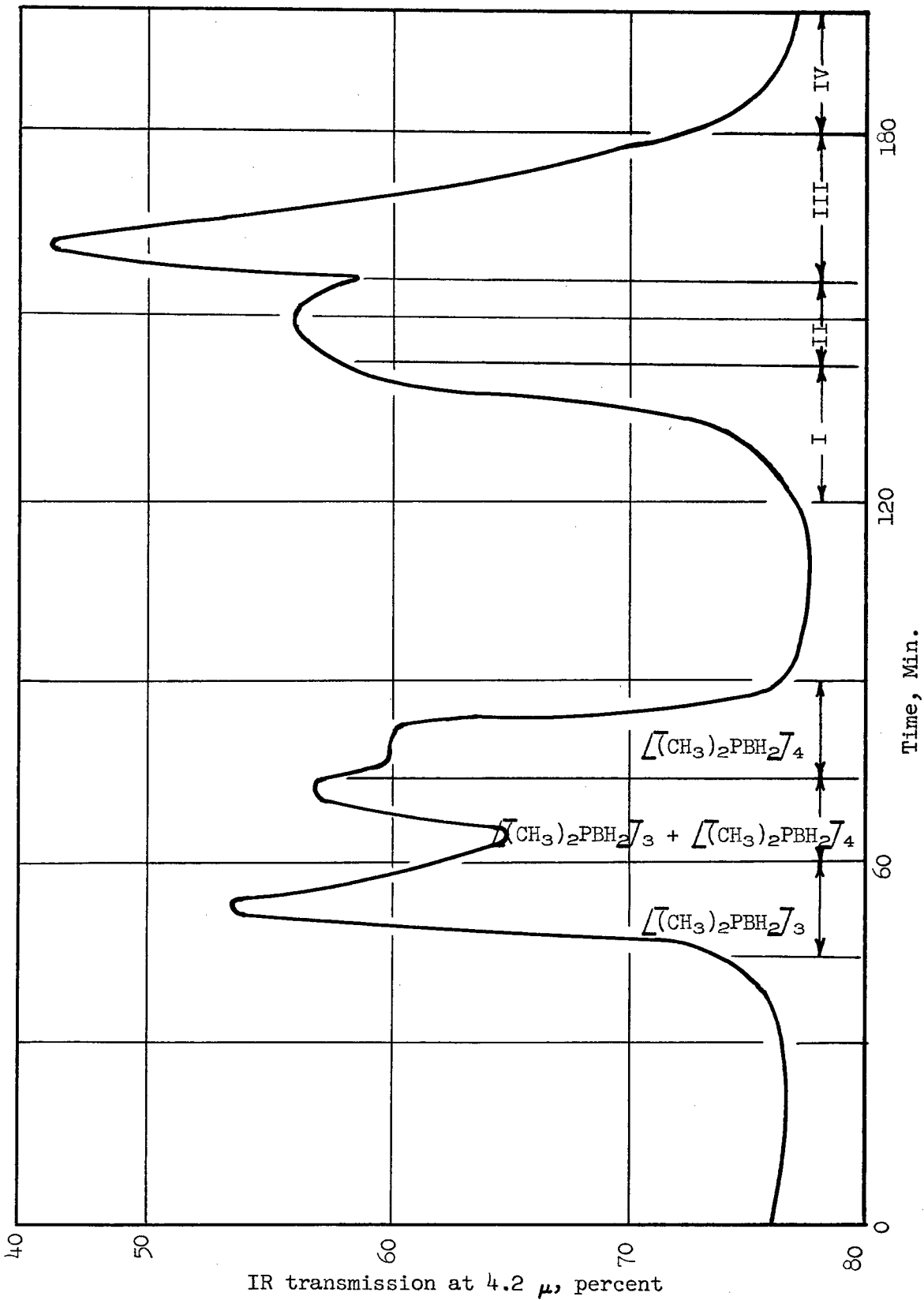
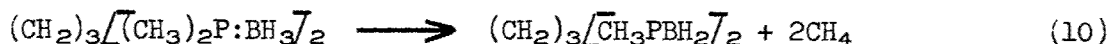

Figure 1. Chromatogram of P-Hexamethyltriborophane, P-Octamethyl-tetraborophane and P-Nonamethylbicyclo[4.4.0]pentaborophane

b. Preparation and Pyrolysis of 1,3-Tri-  
methylene-P,P'-bis(dimethylphosphine borine)

1,3-Bis(dimethylphosphino)propane was converted to the borine adduct with diborane and pyrolyzed at 200°C. for extended periods resulting in only slight decomposition of the adduct. The 0.21 mole of hydrogen and 0.023 mole of methane obtained per mole of adduct suggests that dissociation of the adduct followed by decomposition of the boron moiety was the principal reaction rather than borophane formation according to the equation



That this ditertiary phosphine borine did not undergo polymerization confirms earlier evidence<sup>7</sup> that tertiary phosphine borine adducts do not lead to borophane polymers on pyrolysis.

3. Phosphines

a. Preparation of  
Methyl-n-alkylphosphines (C<sub>3</sub>-C<sub>8</sub>)

The series of secondary phosphines having the general formula CH<sub>3</sub>RPH, where R represents n-butyl through n-octyl, was prepared in good yield according to the following equations:<sup>8</sup>

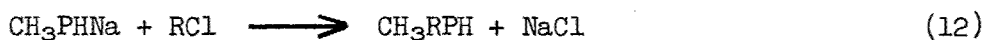
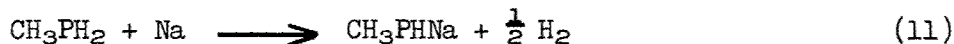

A lower yield obtained in the preparation of methyl-n-propylphosphine is attributable in part to a less efficient extraction from the reaction mixture and in part to the higher volatility of the product. The less efficient extraction resulted indirectly from a deficiency of methylphosphine which required addition of water to convert unused sodium metal to the gelatinous hydroxide.

b. Preparation of Diethylphosphine

Diethylphosphine was prepared from sodium phosphinide, ethyl chloride and sodium in liquid ammonia<sup>8</sup> in 22% yield. The poor recovery was probably due to partial volatilization of diethylphosphine during removal of the solvent ammonia.

c. Preparation of  
1,3-Bis(dimethylphosphino)propane

1,3-Bis(dimethylphosphino)propane, synthesized by basifying the phosphonium salt obtained from 1,3-bis(methylphosphino)propane and methyl iodide, was prepared for use as an intermediate.



d. Preparation of Ethyldichlorophosphine

The reaction of tetraethyllead and phosphorus trichloride<sup>9</sup> at 110°C. for 24 hrs. resulted in a mixture of low boiling products. Further heating for 16 hrs. led to isolation of 88% of impure ethyldichlorophosphine which was stored without purification for subsequent use as an intermediate.

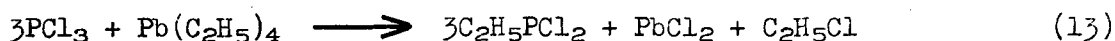

e. Preparation of o-Bromobenzyl Methyl Ether as an Organophosphine Intermediate

Several minor modifications of the previously described procedure<sup>10</sup> for preparation of o-bromobenzyl methyl ether resulted in an improvement of the yield from 71.3% to 90.0%. Probably the most significant modification was removal of a larger amount of the methanol before water washing the product and repeated extraction of product from the water washes with diethyl ether. The reaction time as well as the time required to add the reagents was also markedly decreased.

This compound is one of a series of intermediates in the synthesis of 2,3-benzocyclotrimethylenephosphine.

f. Preparation of Dimethylaminomethylchlorophosphine

The compound dimethylaminomethylchlorophosphine was conveniently prepared by the partial aminolysis of methyldichlorophosphine with dimethylamine. This intermediate will be used in the synthesis of methylarylphosphines.

g. Purification of p-Bis[bis(dimethylamino)phosphino]benzene

A sample of p-bis[bis(dimethylamino)phosphino]benzene was purified by sublimation for an analytical sample.

h. Attempt to Prepare Diphosphinomethane

Two attempts to prepare diphosphinomethane from sodium phosphinide and methylene chloride in ammonia were unsuccessful. Phosphine, methylphosphine, and an unidentified mixture containing P-H and C-H bonds were the only observed reaction products.

i. Attempt to Prepare Methylcyanophosphine

Two attempts to isolate methylcyanophosphine, from the direct reaction of cyanogen bromide with methylphosphine did not lead to the desired

product. Approximately half of the cyano groups were recovered as hydrogen cyanide. On heating the solid reaction products with triethylamine, two solids were isolated, one of which was identified as triethylammonium bromide. In a third experiment cyanogen bromide was added to a hexane solution of methylphosphine yielding 63% of the cyano groups as hydrogen cyanide. No attempt was made to characterize the solid products.

## B. Experimental

### 1. Borophanes

#### a. Linear Borophane Polymers

##### (1) Reaction of P-Dimethylborophane Polymer with Nickel Carbonyl (57W-17-128, 129)

In a preliminary experiment 0.2683 g. (3.63 mmoles as monomer) of P-dimethylborophane polymer, (MW 3080) 0.03 cc. (0.001 mmole) of nickel carbonyl and 4 ml. of benzene was heated in a sealed 5 ml. bomb tube at 60°C. for 107 hrs. The tube was cooled, opened and the benzene removed under high vacuum. The white amorphous solid residue, m.p. 167-169°C. was found to have an ebullioscopic molecular weight of 3990 in benzene.

A sealed 50 ml. bomb tube containing 0.7211 g. (9.762 mmoles as monomer) of P-dimethylborophane polymer, (MW 3080) 1.68 cc. (0.075 mmole) nickel carbonyl and 25 ml. benzene was heated at 80°C. for 45 min. Since the reaction mixture began to darken the temperature was lowered to 65°C. and heated an additional 18 hrs. On cooling and opening to the vacuum line 0.60 cc. of noncondensable gas (presumably CO) was collected. Solvent and excess nickel carbonyl were removed at room temperature leaving a light gray amorphous solid, m.p. 166-168°C. This material was dissolved in benzene, filtered to remove nickel and recovered by evaporation of the filtrate as a light gray solid which was found to have an ebullioscopic molecular weight of 3790 in benzene.

##### (2) Reaction of P-Dimethylborophane Polymer with Triethylenediamine (1361-92)

To 0.9538 g. (12.91 mmoles as monomer) of P-dimethylborophane (MW 3080), in a nitrogen-filled 25 ml. glass tube was added 5 ml. of dry benzene and 0.0195 g. (0.174 mmole) of triethylenediamine (resublimed, m.p. 154.6°C.). The benzene solution was degassed and the sealed tube heated at 80°C. for 17 hrs. The benzene was evaporated leaving a white solid which had an ebullioscopic molecular weight of 3230 in benzene.

A second experiment was done simultaneously using 0.9795 g. (13.26 mmoles as monomer) of P-dimethylborophane polymer (MW 3080) and 0.0111 g. (0.0989 mmole) of triethylenediamine. An ebullioscopic molecular weight determination of the resulting polymer in benzene gave a value of 2480.

(3) Reaction of P-Dimethylborophane  
Polymer with Butyllithium (1361-94)

To 0.2168 g. (2.934 mmoles as monomer) of P-dimethylborophane polymer (MW 3080) in a 5 ml. tube containing 3 ml. of dry benzene was added 0.3840 g. of a 15% hydrocarbon solution of butyllithium. The mixture was degassed and the sealed tube heated at 80°C. for 5 hrs. resulting in formation of a white precipitate. The tube was opened to the vacuum system and benzene was removed. A portion of the residual solid upon exposure to the atmosphere spontaneously ignited. The remaining material was water washed, dissolved in hot benzene, filtered and recovered after evaporating the solvent. An ebullioscopic molecular weight determination in benzene gave a value of 3250.

(4) Reaction of P-Dimethylborophane  
Polymer with Acidic Reagents

(a) Acetic Acid-Acetic Anhydride (1388-2)

A 1.249 g. (16.90 mmoles as monomer) quantity of P-dimethylborophane polymer (MW 3080) was suspended in a mixture of 25 ml. glacial acetic acid and 25 ml. acetic anhydride and refluxed for 4 hrs. The cooled mixture was diluted with water and the solid material isolated by filtration and vacuum dried. A total of 1.112 g. (89%) of an amorphous powder, m.p. 165-167°C. was obtained having an ebullioscopic molecular weight of 3200 in benzene.

(b) Sulfuric Acid-Acetic Anhydride (1388-3)

A 1.2798 g. (1733 mmoles as monomer) quantity of P-dimethylborophane polymer (MW 3080) was dissolved in 50 ml. of acetic anhydride containing 0.44 mmoles of sulfuric acid. This solution was refluxed (140°C.) for 2 hrs. The cooled reaction mixture was diluted with 200 ml. of water and the resulting thick paste was filtered, and vacuum dried to yield 0.955 g. (75%) of slightly colored polymer, m.p. 150-155°C. having an ebullioscopic molecular weight of 3060 in benzene.

(c) Maleic Anhydride (1388-7)

In a preliminary experiment, 0.0616 g. (0.834 mmole as monomer) of P-dimethylborophane polymer (MW 3080) and 0.0821 g. of freshly sublimed maleic anhydride heated 15 min. at 185°C. yielded a dark red brittle glass.

In a larger scale experiment 0.4027 g. (5.447 mmoles as monomer) of P-dimethylborophane polymer (MW 3080) and 0.0141 g. (0.144 mmoles) of freshly sublimed maleic anhydride were heated in a sealed tube 1.5 hrs. at 170-180°C. The reaction mixture became dark and viscous at this temperature. The material solidified on cooling to a brittle amber glass, m.p. 165-167°C., somewhat tougher than those polymer samples treated with other acidic reagents. The ebullioscopic molecular weight of this product was found to be 3200 in benzene.

(5) Thermal Decomposition of Treated and Untreated P-Dimethylborophane Polymer (57W-17-142-146, 1388-47, 48)

A small amount (0.050-0.300 g.) of P-dimethylborophane polymer was weighed into a 10 mm. tube equipped with a trap. The apparatus was evacuated with the trap cooled to  $-78^{\circ}\text{C}$ . and the polymer sample was heated to  $202^{\circ}\text{C}$ . using a cold finger bath maintained at constant temperature with refluxing acetophenone. The polymer sample was heated for a fixed time, after which it was cooled and the contents of the  $-78^{\circ}\text{C}$ . trap weighed. In all cases the volatile material appeared to be mixtures of tri- and tetraborophane compounds. Representative volatile samples, analyzed by vapor phase chromatography, proved to be principally P-hexamethyltriborophane with only about one-third the amount of P-octamethyltetraborophane usually found when this mixture of cyclic borophanes is prepared from dimethylphosphine borine.

If the polymer was observed to be sufficiently stable (less than 15% decomposition at  $202^{\circ}\text{C}$ . in 1.0 hr.) the residue was heated an additional hour at  $260^{\circ}\text{C}$ . (refluxing diphenyl ether). The results are summarized in Table IV.

(6) Preparation of Linear P-Diethylborophane Polymer (1371-50)

A 46.0 g. (0.442 mole) quantity of diethylphosphine borine was placed in a 1100 ml. stainless steel bomb with 8.5 g. (0.084 mole) of triethylamine. The bomb was heated for 1.5 hrs. at  $200^{\circ}\text{C}$ . at which temperature a pressure of 250 psig. was developed. The bomb was cooled to ambient temperature and the gas at 225 psig. was bled from the reactor through a trap at  $-196^{\circ}\text{C}$ . and measured by a wet test meter as 9.97 liters (STP 0.445 mole or 101% of the theoretical hydrogen).

The bomb was opened and found to contain a clear colorless viscous liquid and a white granular solid. The solid was filtered, washed with ether, vacuum dried and weighed 4.1 g. (0.040 mole as monomer). The yield of linear P-diethylborophane polymer was 9.0%.

Ether was removed from the filtrate using a rotary evaporator leaving 46.3 g. of liquid which was passed during 5 hrs. through a molecular still at  $50^{\circ}\text{C}$ . The distillate obtained weighed 23.9 g. and had an average molecular weight (Neumayer) of 292.8 (calcd. for  $[(\text{C}_2\text{H}_5)_2\text{PBH}_2]_3$ , 305.8). The residual material was again passed through the still during 2 hrs. to obtain an additional 12 g. of distillate. The combined distillates were refluxed overnight with 100 ml. of methanol containing 0.5 ml. of 12N HCl. Removal of methanol from the mixture left a colorless liquid containing white crystalline solid shown by infrared analysis to be triethylammonium chloride. Most of the solid was filtered from an ether solution of the trimer which was then washed three times with water to remove the remaining salts. The ether was removed at reduced pressure and the residual liquid was then passed through the molecular still at  $50^{\circ}\text{C}$ . to obtain 26.7 g. of distillate. Re-running the residue through the still yielded an additional 3.6 g. to give a total of 30.3 g. (0.099 mole, 67.2%) of P-hexaethyltriborophane which was shown to be pure by vapor phase chromatographic analysis. The pure liquid had an  $n_D^{25}$  1.5293,  $d_{25}$  0.914, and a Neumayer molecular weight 305.5 (calcd. 305.8).

TABLE IV  
 Thermal Decomposition of  
 Treated and Untreated P-Dimethylborophane Polymer

Reagent	Temp., °C.	Time, hrs.	Decomposition, wt. %	Physical Appearance of Residual Polymer	Pyrolyzate Composition	
					Triborophane, %	Tetraborophane, %
None	202	1	34.4 (a)	brittle colorless glass	-	-
None	202	1	30.2 (a)	brittle colorless glass	97.9	2.1
		2	42.1			
None	202	7	64.7	brittle colorless glass	97.0	3.0
		1	21.8 (a)			
None	202	3	36.1	brittle colorless glass	-	-
		7	51.0			
None	202	1	25.8 (a)	brittle colorless glass	-	-
		1	24.0 (a)			
Hydrogen chloride	202	1	2.9	brittle colorless glass	97.5	2.5
	260	1	89.7			
Hydrogen chloride	202	1	1.0	brittle colorless glass	-	-
	260	1	56.8			
Acetic acid- acetic anhydride	202	1	3.4	tough colorless glass	95.9	4.1
	260	1	29.2			
Acetic anhydride- sulfuric acid	202	1	5.4	brittle colorless glass	-	-
	260	1	67.5			
Maleic anhydride	202	1	5.4	brittle light amber glass	96.2	3.8
	260	1	66.1			

TABLE IV (Cont'd.)  
 Thermal Decomposition of  
Treated and Untreated P-Dimethylborophane Polymer

Reagent	Temp., °C.	Time, hrs.	Decomposition, wt. %	Physical Appearance of Residual Polymer	Pyrolyzate Composition	
					Triborophane, %	Tetraborophane, %
Nickel carbonyl	202	1	4.4	tough black glass	-	-
	260	1	53.2			
Butyllithium	202	1	4.1	light amber gum	-	-
	260	1	76.0			
Triethylene- diamine	202	1	23.4	brittle colorless glass	-	-
	202	1	24.9			

(a) Average weight percent decomposition after 1 hr. at 202°C., 27 ± 4%.

(7) Preparation of P-Dimethyl-B-dichloroborophane Polymer (1357-193, 1385-2)

To 0.5002 g. (6.77 mmoles as monomer) of P-dimethylborophane polymer in 40 ml. of carbon tetrachloride (in which the polymer is only slightly soluble), was added 1.8971 g. (14.21 mmoles) of N-chlorosuccinimide (crystallized from benzene). The mixture was heated under reflux with vigorous stirring for 18 hrs. A white flocculent solid remained, most of which floated to the surface. The solvent was removed on a rotary evaporator at reduced pressure and the white residue was thoroughly washed with two 25 ml. portions of water. After thorough drying over calcium sulfate there was obtained 0.9535 g. (99%) of P-dimethyl-B-dichloroborophane polymer, m.p. 234.5-238°C. (under N<sub>2</sub>). Anal. calcd. for (C<sub>2</sub>H<sub>6</sub>BPCl<sub>2</sub>)<sub>x</sub>: Cl, 49.67. Found: Cl, 45.9. The infrared spectrum was identical with that for the previously reported polymer,<sup>11,12</sup> except for weak absorption at 1710 cm.<sup>-1</sup> indicative of a carbonyl function presumably arising from adhering succinimide and/or N-chlorosuccinimide. The carbonyl impurity was completely removed by thorough washing of the product with methanol without significant change in the melting point (235-236.5°C.), or chlorine analysis (45.9%). Weak absorption in the B-H region of the infrared spectrum confirmed the incomplete chlorination of the polymer suggested by the chlorine analysis.

In a second experiment, 1.0053 g. (13.61 mmoles as monomer) of P-dimethylborophane polymer and 4.3017 g. (32.21 mmoles) of N-chlorosuccinimide in 60 ml. of carbon tetrachloride were heated under reflux for 12 hrs. whereafter an additional 0.5000 g. (3.74 mmoles) of N-chlorosuccinimide was added and the heating continued for another 12 hrs. The solvent was removed in a stream of argon and the solid residue thoroughly washed twice with 25 ml. portions of water followed by two washes with 25 ml. portions of methanol. After thorough drying there was obtained 1.7917 g. (92%) of P-hexamethyl-B-dichloroborophane polymer, m.p. 237-240°C. (under N<sub>2</sub>), analyzing 45.6% chloride (theoretical, 49.67). A weak B-H absorption at 2400 cm.<sup>-1</sup> was observed in the infrared spectrum.

(8) Attempt to Prepare P-Dimethyl-B-dimethylborophane Polymer (1385-5)

In a 5 ml. heavy-wall tube was placed 0.2149 g. (1.505 mmoles as monomer) of P-dimethyl-B-dichloroborophane polymer and 2.40 ml. (1.81 g., 25.0 mmoles) of trimethylaluminum was condensed into the evacuated tube. Approximately one-third of the polymer dissolved at room temperature and solution was complete after heating the sealed tube at 125 ± 2°C. for 1 hr. No precipitate formed on cooling. The tube was opened in vacuo and a small amount of methane was observed. The trimethylaluminum was removed. After 6 hrs. in high vacuum some pyrophoric material still remained in the viscous residue. Upon decomposition of the residual trimethylaluminum with a dilute solution of methanol in petroleum ether a strong characteristic phosphine odor was noted and a voluminous white precipitate formed. The contents of the tube were extracted with 50 ml. of hot benzene. The extractant yielded no product on evaporation to dryness. Extraction with hot methanol likewise gave no product. Since the residue would not burn in a flame it is presumed to be aluminum oxide.

b. Cyclic Borophane Polymers

(1) B-Fluoro Borophane Derivatives

(a) Preparation of P-Hexamethyl-B-hexafluorotriborophane (1358-43)

A 500 ml. polyethylene bottle cooled to  $-78^{\circ}\text{C}$ . was charged with 10.0 g. (44.9 mmoles) of P-hexamethyltriborophane and 300 ml. of anhydrous hydrogen fluoride. The mixture was allowed to react as the mixture warmed to room temperature. After evaporation of the hydrogen fluoride, the crude residue was slurried with water, separated by decantation and dried in vacuo. Purification by sublimation in high vacuum at  $60^{\circ}\text{C}$ . followed by crystallization from cyclohexane gave 12.50 g. (37.8 mmoles, 84%) of white crystalline product, m.p.  $126.5-128^{\circ}\text{C}$ .

(b) Attempt to Prepare P-Hexaphenyl-B-hexafluorotriborophane (1357-57, 61)

To 0.300 g. (0.505 mmole) of P-hexaphenyltriborophane contained in a 10 ml. polyethylene tube cooled to  $-78^{\circ}\text{C}$ . was added 5 ml. of anhydrous hydrogen fluoride. The tube was warmed to room temperature in a hood. Since the triborophane would not dissolve, the mixture was stirred occasionally with a stainless steel spatula. After 3 hrs. most of the hydrogen fluoride had evaporated; the remainder of the volatile material was removed at aspirator pressure. The residual white solid was recrystallized from benzene-ethanol to provide 0.2902 g. (97%) of recovered starting material which was identified by its infrared spectrum.

A second experiment utilizing 0.2160 g. (0.364 mmole) of P-hexaphenyltriborophane, 3 ml. of anhydrous hydrogen fluoride and 5 ml. of benzene in which both components are somewhat soluble was equally unsuccessful. The run, under the same conditions and work-up procedure, provided a crude product, m.p.  $177-179^{\circ}\text{C}$ ., which, after crystallization, gave a 90% recovery of starting material (identified by infrared spectrum).

(2) B-Chloro Borophane Derivatives

(a) Preparation of P-Hexamethyl-B-hexachlorotriborophane (1357-97)

A magnetically stirred mixture of 0.1310 g. (0.591 mmole) of P-hexamethyltriborophane, and 0.5207 g. (3.90 mmoles) of N-chlorosuccinimide (purified by recrystallization from benzene) in 10 ml. of carbon tetrachloride was heated to reflux for 7 hrs. in a 50 ml. flask. It was observed that the insoluble solid N-chlorosuccinimide at the bottom of the flask was replaced by a solid floating on the surface of the solvent (succinimide is insoluble in carbon tetrachloride and less dense). The mixture was cooled in an ice-salt bath and filtered. The white insoluble precipitate was heated with 15 ml. of boiling water, filtered and dried. There was obtained 0.2041 g. (81%) of crude P-hexamethyl-B-hexachlorotriborophane, m.p.  $361-374^{\circ}\text{C}$ . Recrystallization from chloroform gave pure material, m.p.  $384-385^{\circ}\text{C}$ ., the infrared spectrum of which was identical with that of authentic material.



(b) Preparation of P-Hexamethyl-  
B-chloro- and P-Hexamethyl-  
B,B'-dichlorotriborophanes (1357-136, 157)

To a stirred solution of 0.5015 g. (2.26 mmoles) of P-hexamethyltriborophane in 10 ml. of carbon tetrachloride was added 0.3021 g. (2.26 mmoles) of N-chlorosuccinimide (purified by recrystallization from benzene). After 2 hrs. it was obvious that reaction was taking place since the solid N-chlorosuccinimide, only slightly soluble and more dense than carbon tetrachloride, rose to the surface of the solution upon being converted to succinimide, which is only slightly soluble and less dense than carbon tetrachloride. After stirring at room temperature overnight, all of the insoluble material was floating or suspended in solution.

The solid succinimide collected on a Büchner funnel and thoroughly dried weighed 0.2260 g. (100.8%) and had a m.p. 117-119°C. On crystallization from ethanol the melting point was raised to 123-125°C. The filtrate was evaporated to dryness at aspirator pressure to give 0.5832 g. of a white solid, m.p. 60.5-66°C. Mats of fine needles, m.p. 64-69°C., were obtained on crystallization from ethanol-water (9:1) which proved to be a mixture of 4.2% P-hexamethyltriborophane, 92.4% P-hexamethyl-B-chlorotriborophane, and 3.4% P-hexamethyl-B,B'-dichlorotriborophane when chromatographed in the vapor phase on a silicone oil/Celite column. Since additional recrystallizations did not improve the purity significantly, the filtrates were combined, evaporated to dryness and sublimed in high vacuum at room temperature to give a product, m.p. 67.5-70°C., which now contained only P-hexamethyltriborophane and the monochloro-derivative. Crystallization from ethanol-water (4:1) provided mats of fine needle-like crystals of P-hexamethyl-B-chlorotriborophane (0.1827 g.), m.p. 69-71°C.

The sublimation residue gave a second sublimate at a bath temperature of 75-100°C., which on crystallization from ethanol-water (9:1), gave approximately 0.002 g. of fine needle-like crystals presumed to be P-hexamethyl-B,B'-dichlorotriborophane.

In a larger scale preparation carried out in the same manner, 2.7860 g. (20.86 mmoles) of N-chlorosuccinimide was added 4.5322 g. (20.45 mmoles) of P-hexamethyltriborophane in 60 ml. of carbon tetrachloride and stirred at room temperature for 8 hrs. There was obtained 2.2843 g. (23.05 mmoles, 113%) of crude succinimide, m.p. 114-117°C., and 5.1382 g. of white crystalline partially chlorinated P-hexamethyltriborophanes. Vapor phase chromatographic analysis on Apiezon L/Celite, showed the crude product to consist of 15.2% P-hexamethyltriborophane, 61.4% P-hexamethyl-B-chlorotriborophane, 17.8% P-hexamethyl-B,B'-dichlorotriborophane and four other components (5.6%) of unknown structure. A benzene solution containing approximately 0.2 g. of this mixture was chromatographed on a preparative vapor phase apparatus and the mono- and dichloro-derivatives were collected separately. A benzene solution of the monochloro-derivative was evaporated to dryness in a stream of argon to yield 0.1004 g. of product, m.p. 72.5-74°C., analyzing 99.9%, but contaminated with 0.1% P-hexamethyltriborophane. An analytical sample was prepared by fractional sublimation.

Anal. calcd. for  $C_6H_{23}B_3P_3Cl$ : C, 28.14; H, 9.05; M.W., 256.1. Found: C, 28.37; H, 9.10; M.W. (Neumayer), 261.6. The infrared spectrum was identical with the spectrum of the analogous monobromo-derivative and very similar to that of the monoiodo-derivative (vide infra).

A benzene solution of the P-hexamethyl-B,B'-dichlorotri-borophane was evaporated to dryness in a stream of argon and the residue, m.p. 86-97°C., was fractionally sublimed. The sublimate collected at a bath temperature of 45-65°C. analyzed 97.5% P-hexamethyl-B,B'-dichlorotriborophane by vapor phase chromatography. Three recrystallizations from ethanol-water (4:1) provided an analytical sample, m.p. 117-118°C. Anal. calcd. for  $C_6H_{22}B_3P_3Cl_2$ : C, 24.80; H, 7.63. Found: C, 25.27; H, 7.81.

### (3) B-Bromo Borophane Derivatives

#### (a) Preparation of P-Hexamethyl-B-hexabromotriborophane (1357-86, 92, 114)

To 0.2000 g. (0.903 mmole) of P-hexamethyltriborophane dissolved in 10 ml. of benzene in a 50 ml. flask equipped with a Teflon covered magnetic stirring bar and a condenser leading to a mercury bubbler was added 0.9638 g. (5.415 mmoles) of N-bromosuccinimide (purified according to Daubin and McCoy,<sup>13</sup> procedure Aa). As the reaction slurry was heated to reflux under a nitrogen atmosphere, the solution took on a red-orange color which disappeared after one-half hour. Refluxing was continued for an additional hour whereafter the slurry was cooled. The insoluble white solid was collected, washed thoroughly with benzene, extracted with 20 ml. of hot water (in which both N-bromosuccinimide and succinimide are soluble) and dried. There was obtained 0.0315 g. of crude P-hexamethyl-B-hexabromotriborophane contaminated with a very small amount of impurity containing a B-H function as determined by infrared analysis.

The benzene filtrate was evaporated to dryness leaving a white crystalline mixture which was found by infrared analysis to contain P-hexamethyl-B-hexabromotriborophane and carbonyl-containing compounds. The mixture was refluxed with 20 ml. of methanol. The methanol insoluble solid, 0.1383 g., was found to be primarily P-hexamethyl-B-hexabromotriborophane contaminated with a small amount of unknown material containing a B-H function. The total crude yield of  $[(CH_3)_2PBBBr_2]_3$  was thus 0.1698 g. (27%).

Employing the same equipment as in the above experiment, a second experiment was performed with slight modifications. To 0.2056 g. (0.928 mmole) of P-hexamethyltriborophane in 10 ml. of heptane was added 1.0900 g. (6.12 mmoles) of N-bromosuccinimide. Heating under reflux for 2.5 hrs. caused the solution to turn light brown. After cooling, the insoluble material was collected, extracted with 15 ml. of boiling methanol, filtered and dried to give 0.4091 g. (63%) of crude P-hexamethyl-B-hexabromotriborophane. The infrared spectrum showed a very small amount of contaminant containing a B-H function. Crystallization of the product from methylene bromide provided 0.2720 g. (42%) of pure material as shown by its infrared spectrum.

Using the same equipment and experimental conditions described in the second experiment, 0.2151 g. (0.971 mmole) of P-hexamethyltriborophane and 1.2960 g. (9.19 mmoles) of N-bromosuccinimide in 20 ml. of methylene bromide were heated under reflux for 6 hrs. After removing the solvent at aspirator pressure, the brown residue was washed with two 20 ml. portions of hot water to remove succinimide and excess N-bromosuccinimide. The resulting light brown colored solid, 0.5565 g., was recrystallized twice from methylene bromide-cyclohexane to yield 0.1575 g. (23%) of pure P-hexamethyl-B-hexabromotriborophane characterized by its infrared spectrum.

(b) Preparation of P-Hexamethyl-  
B,B',B''-tribromotriborophane (57W-17-126, 131)

A total of 1.4757 g. (6.659 mmoles) of P-hexamethyltriborophane was dissolved in 140 ml. of benzene. Into a Soxhlet thimble was weighed 3.5705 g. (20.06 mmoles) of N-bromosuccinimide. The benzene solution was brought to reflux and the entire amount of N-bromosuccinimide was added by Soxhlet reflux during 24 hrs. The cooled reaction mixture was evaporated to dryness and extracted twice with 50 ml. portions of hot i-hexane and filtered leaving 1.860 g. (94%) of succinimide, m.p. 122-124°C. The filtrate yielded the following fractions on progressive concentration: (1) 0.883 g., m.p. 100-125°C.; (2) 1.416 g., m.p. 90-100°C.; (3) 0.273 g., m.p. 80-92°C., and (4) a residue, 0.183 g. Fraction (1), after several recrystallizations from i-hexane, yielded a material, m.p. 130-145°C. Fractions (2) and (3) were separately recrystallized several times from i-hexane yielding material melting between 100-110°C. Mechanical separation of individual crystals and recrystallization from i-hexane yielded material, m.p. 102-109°C. The inability to isolate pure material conveniently by recrystallization prompted storage of the products until a more convenient means of purification is available.

In a second experiment 0.4006 g. (2.23 mmoles) of N-bromosuccinimide in 75 ml. of benzene was added to a stirred solution of 0.8450 g. (2.20 mmoles) of P-hexamethyl-B,B'-dibromotriborophane in 25 ml. of benzene at room temperature. The reaction mixture was heated rapidly to 80°C., refluxed 10 hrs. and cooled. The solvent was removed at reduced pressure and the residue extracted twice with 50 ml. portions of hot i-hexane. Gradual evaporation of the i-hexane yielded 1.015 g. white solid, m.p. 95-110°C., in the following five fractions: (1) m.p. 150-168°C.; (2) 145-165°C.; (3) m.p. 103-110°C.; (4) 95-105°C., and (5) a residue, m.p. 80-95°C. This apparent mixture of bromo-derivatives of P-hexamethyl-B-triborophane was stored without further purification since previous experience had shown recrystallization of these complex mixtures failed to afford any significant separation of the components.

(c) Preparation of P-Hexamethyl-  
B,B'-dibromotriborophane (57W-17-118)

To a stirred solution of 1.6068 g. (7.2509 mmoles) P-hexamethyltriborophane in 50 ml. benzene was added 2.5901 g. (14.55 mmoles) of N-bromosuccinimide dissolved in 100 ml. of hot benzene. After about half the material was added, a bromine color developed which gradually disappeared over a period of several minutes. Following the addition of the N-bromosuccinimide the

reaction mixture was refluxed for 5 min. After cooling to room temperature the reaction mixture was evaporated to dryness under reduced pressure and the residue extracted three times (30 ml. each) with hot i-hexane. On evaporation the extract gave 2.72 g. of crystalline solid, m.p. 105-125°C., which after several recrystallizations from i-hexane, gave 0.648 g. of pure P-hexamethyl-B,B'-dibromotriborophane, m.p. 129-131°C., mixed melting point with authentic sample not depressed. Vapor phase chromatographic analysis showed this material to be 99.4% pure. An additional 0.964 g. of material, m.p. 127-130°C. were obtained from the mother liquors to give a total yield of 58%.

(d) Preparation of P-Hexamethyl-B-bromotriborophane

[1] Using N-Bromosuccinimide (57W-17-106, 108)

To a stirred solution of 0.3830 g. (1.733 mmoles) of P-hexamethyltriborophane was added dropwise a benzene solution of 0.3101 g. (1.742 mmoles) of recrystallized N-bromosuccinimide. The reaction mixture was stirred at room temperature for 2 hrs. and then heated to reflux for 10 min. The reaction mixture was then evaporated to dryness and extracted with 20 ml. of hot i-hexane. The residue proved to be succinimide, 0.165 g. (96%), m.p. 124-125°C. The i-hexane extract on evaporation yielded 0.518 g. (99.5%) of crude product, m.p. 71-75°C., which after several recrystallizations yielded needles, m.p. 76-78°C. Anal. calcd. for  $C_6H_{23}P_3B_3Br$ : C, 23.98; H, 7.71; M.W., 300.55. Found: C, 24.43; H, 7.84; M.W., 295.6 (Neumayer).

In a second experiment 3.112 g. (17.48 mmoles) of N-bromosuccinimide in 100 ml. benzene, was added to a stirred solution of 3.8407 g. (17.39 mmoles) of P-hexamethyltriborophane dissolved in 50 ml. benzene. The reaction mixture was stirred for 0.5 hr. at 45-50°C. and then heated to 75°C. for 1 hr., cooled, and solvent removed at reduced pressure. The residue was extracted with i-hexane and filtered yielding 1.563 g. (90%) succinimide, m.p. 124-125°C. as residual solid. The filtrate on evaporation yielded 5.23 g. (100%) needles of crude product, m.p. 70-75°C., which on recrystallization from pentane yielded 2.766 g. needles (m.p. 76-78°C.) as first crystal crop. Analysis by vapor phase chromatography showed this material to be 98.0% P-hexamethyl-B-bromotriborophane containing 1.1% P-hexamethyltriborophane and 0.9% unknown material of intermediate volatility. Recrystallization of the additional material obtained from the mother liquors yielded 0.470 g. needles, m.p. 75-77°C., giving a total yield of 62%. The mother liquors were evaporated to dryness and the residue was stored for future use.

[2] Using Mercuric Bromide (57W-17-91, 110)

A 0.2089 g. (0.9427 mmole) quantity of P-hexamethyltriborophane and 2.4997 g. (6.935 mmoles) of mercuric bromide were weighed into a 25 ml. bomb tube together with 15 ml. of redistilled dimethoxyethane. The tube was degassed, sealed, and contents dissolved and then heated for 70 hrs. at 100°C. During the course of reaction, a large amount of precipitate formed. The cooled tube was opened and the contents filtered to yield 1.055 g. solid which analyzed Hg 64.4% and Br, 29.7% suggesting it to be crude mercurous bromide. The filtrate was evaporated and the residue extracted twice (25 ml. each) with hot pentane.

The 1.064 g. residue was shown by its infrared spectrum to be mercuric bromide. Evaporation of the pentane solution yielded 0.386 g. of solid material. Recrystallization proved difficult but eventually there was obtained 0.124 g. (44%) of impure P-hexamethyl-B-bromotriborophane, m.p. 55-70°C., identified by infrared analysis and 0.231 g. of a mixture of mercuric bromide and boric acid.

In a second experiment 0.2089 g. (0.9427 mmoles) of P-hexamethyltriborophane, 1.4146 g. (3.925 mmoles) mercuric bromide and 6.5 ml. dimethoxyethane were weighed into a 25 ml. bomb tube. The mixture was degassed, sealed, dissolved and heated 21 hrs. at 100°C. During the course of reaction a moderate amount of precipitate was formed. On opening the tube 0.28 cc. of non-condensable gas was obtained. The dimethoxyethane was removed by distillation at reduced pressure and was shown to contain 0.077 mmoles bromide ion (presumably as hydrogen bromide, 8.2% yield). Sublimation for 20 hrs. at 65°C. under high vacuum yielded 0.2251 g. of crystalline solid, m.p. 70-85°C. condensed at -78°C. Vapor phase chromatography showed this sublimate to be a mixture of 82.8% P-hexamethyltriborophane and 17.2% P-hexamethyl-B-bromotriborophane representing a 14% yield.

### [3] Using Bromine (57W-17-79, 96)

A 7.297 g. (45.65 mmole) quantity of bromine in 25 ml. methylene dibromide was added dropwise with stirring to 10.051 g. (45.68 mmoles) of P-hexamethyltriborophane dissolved in 100 ml. methylene dibromide at room temperature. The solvent was removed under reduced pressure to yield 14.09 g. of a colorless crystalline solid. Recrystallization and progressive concentration of mother liquors yielded the following fractions: (1) 3.113 g., m.p. 70-90°C., (2) 3.684 g., m.p. 85-100°C., (3) 3.68 g., m.p. 55-80°C., (4) 1.08 g., m.p. 50-75°C., and a small amount of residue. Infrared spectra showed fractions (1), (3), and (4) to be largely starting material, and fraction (2) to be polybrominated material which on fractional sublimation under high vacuum yielded, in turn, two materials: (a) 1.119 g., m.p. 103-115°C. (subliming 60-80°C.) and (b) 2.001 g., m.p. 95-120°C. Several recrystallizations of (a) from i-hexane finally yielded 0.385 g. of the previously known<sup>2</sup> P-hexamethyl-B,B'-dibromotriborophane, m.p. 129.5-130.0°C. Anal. calcd. for C<sub>6</sub>H<sub>22</sub>P<sub>3</sub>B<sub>3</sub>Br<sub>2</sub>: C, 18.99; H, 5.97; M.W., 379.46. Found: C, 18.65; H, 5.84; M.W., 374.4 (Neumayer). Recrystallizations of (b) failed to yield any sharp melting fractions as did resublimation. Chromatography of (b) on alumina with i-hexane-benzene also failed to effect separation. All samples were stored until such time as a preparative vapor phase chromatograph is available.

In a second experiment acetic acid was used in place of methylene bromide as the reaction solvent. To a stirred solution of 0.5274 g. (2.388 mmoles) of P-hexamethyltriborophane in 10 ml. of glacial acetic acid was added 0.3894 g. (2.436 mmoles) of bromine at room temperature. The acetic acid was removed through a trap at 0°C. under high vacuum and the residue fractionally sublimed for 16 hrs. at room temperature and 24 hrs. at 50-60°C. Four fractions were obtained: (1) 0.087 g., m.p. 83-86°C., condensed at -78°C., (2) 0.269 g., m.p. 55-70°C., condensed at 0°C., (3) 0.230 g., m.p. 65-92°C., condensed at room temperature, and (4) residue, 0.110 g., m.p. 125-145°C. Several recrystallizations of (3) from i-hexane yielded material melting at 120-125°C. Fraction (4) on recrystallization from i-hexane yielded a material, m.p. 171-179°C. Both of these products appear to be polybrominated derivatives.

(e) Attempt to React P-Dodecamethyl-triborophane with N-Bromosuccinimide (1357-159)

In a 50 ml. flask equipped with a reflux condenser was placed 0.3105 g. (1.015 mmoles) of P-dodecamethyltriborophane, 1.0842 g. (6.09 mmoles) of N-bromosuccinimide (purified according to Daubin and McCoy,<sup>13</sup> procedure Aa) and 15 ml. of carbon tetrachloride. On heating under reflux for 4 hrs., the solution gradually became dark red and eventually black. Unlike the normal reaction, no succinimide was observed floating in the solution, however, a black residue adhered to the sides of the container. The filtered solution was evaporated in a stream of nitrogen and crystallized from methanol-water (3:1) to recover 0.2350 g. (76%) of starting material characterized by its m.p. 333-337°C. and infrared spectrum.

(4) B-Iodo Borophane Derivatives

(a) Attempt to Prepare P-Hexamethyl-B-hexaiodotriborophane (1357-134)

A 1.8700 g. (8.311 mmoles) quantity of N-iodosuccinimide was added to a well stirred solution of 0.3056 g. (1.379 mmoles) of P-hexamethyltriborophane in 12 ml. of methylene iodide. The resulting light yellow colored slurry turned a deep red on heating slowly to 60-65°C. where it was maintained for 16 hrs. and finally became darker red-brown in color. The small amount of brown residue adhering to the sides of the flask was removed by filtration. Repeated attempts to obtain a solid product by fractional crystallization from a number of solvents including hydrocarbons and alcohols proved unsuccessful.

(b) Preparation of P-Hexamethyl-B-iodotriborophane (1357-141, 179)

To a well stirred solution of 0.4004 g. (1.807 mmoles) of P-hexamethyltriborophane in 10 ml. of benzene was added 0.4065 g. (1.807 mmoles) of N-iodosuccinimide. The slightly pink colored solution on stirring for 7 hrs. turned to a deep red and on standing overnight became dark brown. After removal of the benzene in a stream of nitrogen, the reaction mixture was extracted with petroleum ether (b.p. 40-60°C.) leaving 0.1960 g. (109%) of crude succinimide, which on crystallization twice from absolute ethanol, gave 0.1038 g. (58%) of pure material, m.p. 122-124°C.

The extract was evaporated to dryness to yield 0.4078 g. (65%) of crude light yellow colored P-hexamethyl-B-iodotriborophane, m.p. 70-74°C. Repeated recrystallizations from ethanol-water (4:1) raised the melting point to 82-84°C., however, a satisfactory carbon and hydrogen analysis could not be obtained until the material had been fractionally sublimed at 40-50°C. and again recrystallized from ethanol-water (4:1), m.p. 82.5-84°C. (corr.). Anal. calcd. for  $C_6H_{23}B_3P_3I$ : C, 20.73; H, 6.67. Found: C, 20.57; H, 6.76.

In a second preparation a mixture of 2.5356 g. (11.44 mmoles) of P-hexamethyltriborophane and 2.6054 g. (11.58 mmoles) of N-iodosuccinimide in 25 ml. of benzene was stirred for 16 hrs. at room temperature. The solvent

was removed in a stream of argon and the light brown residue was triturated twice with 20 ml. portions of water followed by a 20 ml. water wash containing several crystals of sodium thiosulfate, then with water and finally dried. High vacuum fractional sublimation at room temperature provided 0.2238 g. of material, m.p. 55-65°C., (presumably a mixture of starting material and product), and at a bath temperature of 50-75°C., 3.0836 g. (85%) of P-hexamethyl-B-iodotriborophane, m.p. 79-81.5°C. One crystallization from 7:3 ethanol-water provided 2.716 g. (74%) of fine white needles, m.p. 80.5-82°C., M.W., 348.6 (calc. for  $C_6H_{23}B_3P_3I$ : 347.6).

(c) Preparation of P-Nonamethyl-B-iodobicyclo[4.4.0]pentaborophane (1357-189)

To a solution of 0.3680 g. (1.041 mmoles) of P-nonamethyl-bicyclo[4.4.0]pentaborophane, m.p. 96-98°C., in 12 ml. of benzene was added 0.2576 g. (1.145 mmoles) of N-iodosuccinimide. With stirring under a nitrogen atmosphere, the solution took on a pink color which gradually darkened as the reaction progressed. After 4 hrs. of stirring at room temperature, the mixture was allowed to stand overnight. The mixture, now brown in color, was evaporated to dryness in a stream of argon. The resulting viscous oil, after trituration with 10 ml. of water containing three crystals of sodium thiosulfate followed by a water wash (10 ml.), afforded a light yellow colored solid product, 0.4673 g. (94% of theoretical P-nonamethyl-B-iodobicyclo[4.4.0]pentaborophane), m.p. 99-118°C. The infrared spectrum of the crude product was significantly changed from the starting material. Particularly important was the absence of a shoulder on the  $BH_2$  absorption band at  $9.04 \mu$  which appears in the P-nonamethylbicyclo[4.4.0]pentaborophane spectrum.

The crude product was fractionally crystallized from methanol at approximately -10°C. concentrating the solution to the volumes listed below after collecting the precipitates.

<u>Fraction</u>	<u>Approx. Vol. of solution, ml.</u>	<u>Wt., g.</u>	<u>Softening Point, °C.</u>	<u>Melting Point, °C.</u>	<u>Form</u>
1	17	0.0697	none	147-148.5	micro-crystalline powder
2	15	0.0986	127	130.5-133	needles
3	10	0.0500	128	131.5-133.5	needles
4	7	0.0078	127	132-133.5	needles
5	4	0.0169	128	130.5-133	needles

Combined fraction 2-5 (0.1733 g., 0.3616 mmole, 34.7% yield) were dissolved in 10 ml. of methanol and allowed to evaporate partially at room temperature to give as the first crop a single large transparent crystal (0.0568 g.), the interfacial angles of which were measured. A second crop of transparent crystals (0.0802 g.) was obtained at -10°C. An additional recrystallization of these two combined

fractions gave 0.1037 g. (0.2164 mmole, 20.8%) of pure P-nonamethyl-B-iodobicyclo-[4.4.0]borophane, m.p. 136.0-137.0°C. Anal. calcd. for C<sub>9</sub>H<sub>35</sub>B<sub>5</sub>P<sub>5</sub>I: C, 22.55; H, 7.36. Found: C, 22.32; H, 7.38.

Fraction 1, m.p. 147-148.5°C. had an infrared spectrum which differed considerably from that of the other product, m.p. 136-137°C., but elemental analysis indicated it to be an isomeric monoiodo-derivative. Anal. calcd. for C<sub>9</sub>H<sub>35</sub>B<sub>5</sub>P<sub>5</sub>I: C, 22.55; H, 7.36. Found: C, 22.22; H, 6.98. The 0.0697 g. (0.1454 mmole) sample represents a 14.0% yield.

(5) Reactions of B-Halo-Derivatives  
of P-Hexamethyltriborophane with  
Organometallic Compounds

(a) B-Fluoro Derivatives

[1] P-Hexamethyl-B-hexafluorotri-  
borophane and Trimethylaluminum (1357-23, 99)

Into a 7.5 ml. heavy-walled glass tube containing 0.1081 g. (0.328 mmole) of P-hexamethyl-B-hexafluorotriborophane was condensed 1.0 ml. (0.75 g., 10.4 mmoles) of trimethylaluminum. The sealed tube was heated for 2 hrs. at 100-105°C., cooled and opened on the vacuum line. No volatile gases were observed. The trimethylaluminum was distilled out and the remaining white residue sublimed in vacuo (75-100°C.) to yield 0.0550 g. (55%) of dodecamethyltriborophane, m.p. 333-335°C. Recrystallization of the sublimate from methanol gave long needles, m.p. 334-336°C. A mixed melting point with authentic material was not depressed.

In a second experiment following the same procedure, 0.1079 g. (0.327 mmole) of P-hexamethyl-B-hexafluorotriborophane and 0.70 ml. (0.526 g., 7.30 mmoles) of trimethylaluminum were heated at 100 ± 2°C. for 6 hrs. On sublimation of the solid residue at 100-160°C. after removal of the more volatile components of the mixture, there was obtained 0.0932 g. of crude product (m.p. > 400°C.) which, after crystallization from methanol, gave 0.0551 g. (55%) of dodecamethyltriborophane, m.p. 332-335°C. (uncorr.). A very strong odor of phosphine accompanying the crude reaction product and the same low yield of product suggest that decomposition of the triborophane nucleus occurred during the reaction.

[2] P-Hexamethyl-B-hexafluorotri-  
borophane and Triphenylaluminum (1357-127)

A sealed, evacuated, 5 ml. heavy-wall tube containing 0.0950 g. (0.288 mmole) of P-hexamethyl-B-hexafluorotriborophane, 0.1562 g. (0.605 mmole) of triphenylaluminum and 2.0 ml. of degassed benzene was heated at 100 ± 2°C. for 15 hrs. A light yellow solid phase had formed in the hot solution; a second, colorless solid phase precipitated on cooling. The tube was opened, the benzene was removed and the contents were sublimed in high vacuum. There was obtained what was thought to be two sublimates, 0.0176 g. at a bath temperature of 90-110°C. and 0.0196 g. at 125-175°C. However, infrared spectra of each being



very similar, suggested that they were mixtures of partially arylated products. Efforts to crystallize a pure component employing methanol and hydrocarbon solvents proved futile.

[3] P-Hexamethyl-B-hexafluorotri-  
borophane and Trimethylborine (1357-130, 133)

In a 5 ml. heavy-wall bomb tube was placed 0.1203 g. (0.365 mmole) of P-hexamethyl-B-hexafluorotriborophane. A seal-off tip was attached and 471 cc. (21.0 mmoles) of trimethylborine was added from the vacuum line. The sealed tube was heated at 100°C. for 144 hrs. whereafter a crystalline product formed on cooling to room temperature. Permanent gases were not observed when the tube was opened. After removal of the volatile components there remained a white solid residue. Sublimation of the residue in high vacuum at 85-125°C. gave 0.0971 g. (87%) of dodecamethyltriborophane, m.p. 333-335°C. (uncorr.). The mixed melting point with authentic material was 336-337°C. (uncorr.).

In a preliminary experiment, 0.1114 g. (0.338 mmole) of P-hexamethyl-B-hexafluorotriborophane and 157.1 cc. (7.01 mmoles) of trimethylborine were heated in a sealed tube at 125°C. for 39 hrs. Under these conditions the trimethylborine was entirely vaporized giving a two-phase reaction medium. On workup as described above, 0.0329 g. (32%) of crude dodecamethyltriborophane, shown to be slightly impure by infrared analysis, was obtained. Crystallization from methanol yielded 0.0045 g. (4%) of pure material, m.p. 331-333°C. (uncorr.).

[4] P-Hexamethyl-B-hexafluorotri-  
borophane and Triethylborine (1357-108, 117)

To 0.1190 g. (0.361 mmole) of P-hexamethyl-B-hexafluorotriborophane contained in a 7 ml. bomb tube equipped with a seal-off tip was added 1.0 ml. (0.693 g., 7.07 mmoles) of triethylborine from the vacuum line. After heating at 125 ± 2°C. for 12 hrs. the insoluble solid trimer dissolved and would not precipitate on cooling to 0°C. No noncondensable gas was found when the tube was opened. The volatile material was removed and found to be mainly boron trifluoride and triethylborine by infrared analysis. On sublimation of the residue at 75-100°C. in high vacuum, there was obtained 0.1015 g. of a white solid, m.p. 44-70°C., the infrared spectrum of which suggested that it was a mixture of partially B-ethylated derivatives. Attempted purification by fractional crystallization employing either methanol or aqueous acetic acid was unsuccessful.

In an analogous second experiment, 0.1095 g. (0.332 mmole) of P-hexamethyl-B-hexafluorotriborophane and 1.00 ml. (0.693 g., 7.07 mmoles) of triethylborine were heated at 125 ± 2°C. for 86 hrs. Sublimation of the residue after removal of the volatile components gave 0.1170 g. of a white solid at 125-200°C. which crystallized from methanol as needles, m.p. 195-202°C. (0.0255 g., 0.065 mmole, 20%). The infrared spectrum of this material was in accord with the expected product, P-hexamethyl-B-hexaethyltriborophane. An additional crystallization from methanol raised the melting point to 197-204°C. but reduced the quantity to an amount insufficient for further purification or characterization.

[5] P-Hexamethyl-B-hexafluorotri-  
borophane and Dimethylzinc (1357-48, 66, 70)

To 0.1183 g. (0.359 mmole) of P-hexamethyl-B-hexafluorotriborophane in a 7 ml. bomb tube was added 0.5 ml. (0.69 g., 7.2 mmoles) of dimethylzinc in vacuo at  $-196^{\circ}\text{C}$ . As the sealed tube was warmed to room temperature the triborophane dissolved to give a clear solution. A white gelatinous precipitate formed after heating at  $100^{\circ}\text{C}$ . for 15 hrs. The tube was opened (no noncondensable gas was observed) and the volatile material was removed. The white solid residue was heated to  $175^{\circ}\text{C}$ . in high vacuum. None of the expected dodecymethyltriborophane was found. A small amount of a highly volatile solid thought to be methylzinc fluoride condensed in a trap at  $0^{\circ}\text{C}$ . but was inadvertently lost.

In a second experiment 0.5 ml. (0.69 g., 7.2 mmoles) of dimethylzinc was added in vacuo to 0.1062 g. (0.322 mmole) of P-hexamethyl-B-hexafluorotriborophane in a 7 ml. bomb tube to which was attached a double seal-off tip. The sealed tube was warmed slowly to room temperature where the triborophane dissolved. After standing for 90 hrs. the tube was opened on the vacuum line, the volatile material removed and the tube partially immersed in an oil bath. The white residue commenced to sublime at  $55^{\circ}\text{C}$ . to the upper part of the tube and moved rapidly at  $70-75^{\circ}\text{C}$ . Since this material was obviously starting material, the dimethylzinc was replaced, the tube sealed and heated at  $50-55^{\circ}\text{C}$ . for 12 hrs. The tube was again opened (no noncondensable gas observed) and the volatile material removed. Sublimation of the white solid residue gave 0.0939 g. (88% recovery) of P-hexamethyl-B-hexafluorotriborophane (identified by its infrared spectrum).

In a third experiment conducted as above, 0.1000 g. (0.303 mmole) of P-hexamethyl-B-hexafluorotriborophane and 0.5 ml. (0.69 g., 7.2 mmoles) of dimethylzinc were heated at  $75 \pm 2^{\circ}\text{C}$ . for 15 hrs. After removal of the volatile material the gray-white residue was sublimed in vacuo to yield only one sublimate, P-hexamethyl-B-hexafluorotriborophane (0.0449 g., 50% recovery), m.p.  $125-129^{\circ}\text{C}$ . (further identified by its infrared spectrum). The residue, which was nonvolatile at the highest bath temperature of  $175^{\circ}\text{C}$ ., was further investigated by infrared analysis. This spectrum offered no information as to the fate of the remaining 50% of the starting material.

[6] P-Hexamethyl-B-hexafluorotri-  
borophane and Tetramethyltin (1357-144)

P-Hexamethyl-B-hexafluorotriborophane, 0.1191 g. (0.361 mmole) and 1.00 ml. (1.29 g., 7.22 mmoles) of tetramethyltin (prepared by the method of Edgell and Ward<sup>14</sup>) were heated at  $100 \pm 2^{\circ}\text{C}$ . in a sealed, evacuated 5 ml. bomb tube for 6 hrs. resulting in formation of a reddish-brown residue. The tube was opened on the vacuum line and no noncombustible gas was observed. After removal of the volatile components the brown solid residue was sublimed in high vacuum at  $65-120^{\circ}\text{C}$ . to give 0.0138 g. (11% recovery) of crude starting material, m.p.  $118-121^{\circ}\text{C}$ ., identified by its infrared spectrum. No other sublimate was obtained at temperatures up to  $175^{\circ}\text{C}$ .

[7] P-Hexamethyl-B-hexafluorotri-  
borophane and Tetravinyltin (1357-110)

Into a 6 ml. bomb tube containing 0.1146 g. (0.348 mmole) of P-hexamethyl-B-hexafluorotriborophane, was condensed 1.0 ml. (containing 1.08 g., 4.76 mmoles) of tetravinyltin, (VPC assay 86.7%) from the vacuum line. The sealed tube was heated at  $125 \pm 2^\circ\text{C}$ . for 4.5 hrs. whereafter it was noted that extensive decomposition had occurred as evident from the voluminous brown and gray colored residue. No permanent gas was observed on opening the tube on the vacuum line. After removal of unreacted tetravinyltin there remained a yellow-brown colored solid residue. On attempted sublimation in high vacuum at temperatures up to  $190^\circ\text{C}$ . only a trace amount of a clear liquid was observed to be volatile. This liquid was observed at a bath temperature of  $125$ - $150^\circ\text{C}$ . and could not be induced to crystallize. An infrared spectrum of the yellow residue was not interpretable.

[8] P-Hexamethyl-B-hexafluorotri-  
borophane and Tetraphenyltin (1357-118)

To 0.1033 g. (0.313 mmole) of P-hexamethyl-B-hexafluorotriborophane and 0.9448 g. (2.212 mmoles) of tetraphenyltin in a 5 ml. bomb tube was added 2.5 ml. of benzene from the vacuum line. The sealed tube was heated at  $125^\circ\text{C}$ . for 17 hrs. After opening the tube on the vacuum line and observing no permanent gas, the volatile components were removed leaving a white crystalline residue. Sublimation of this residue in high vacuum gave two fractions. The first, 0.0433 g., at a bath temperature of  $110$ - $125^\circ\text{C}$ ., melted at  $192$ - $214^\circ\text{C}$ ., was a white amorphous material and was presumed to be a mixture of partially arylated trimer as inferred from its infrared spectrum which displayed bands characteristic of the triborophane nucleus and mono-substituted phenyl ring. A sharp melting product could not be obtained on fractional crystallization of this material from methanol. The second fraction, 0.0845 g., which sublimed slowly at a bath temperature of  $140$ - $200^\circ\text{C}$ . melted at  $158$ - $216^\circ\text{C}$ . and proved to be crude tetraphenyltin by comparison of its infrared spectrum with a reference spectrum.

[9] P-Hexamethyl-B-hexafluorotri-  
borophane and Methyllithium (1357-31)

In an 80 ml. nitrogen-filled bomb tube containing 3.0 ml. of 1.35M ethereal methyllithium (4.05 mmoles) was placed 0.1823 g. (0.553 mmoles) of P-hexamethyl-B-hexafluorotriborophane contained in thin-walled capillary tubes. The tube was evacuated, sealed, allowed to warm to room temperature where gas evolution commenced as the triborophane dissolved in the solution after breaking the capillary tubes. After standing at ambient temperature for 72 hrs. there remained a colorless solution over a white precipitate. The tube was opened and 27.9 cc. of methane removed. After removing the ether, careful hydrolysis of the contents with water was attended by vigorous gas evolution. The residue was extracted with three 10 ml. portions of ether and the combined ether extract was evaporated to dryness leaving a solid residue which was sublimed. Approximately 0.002 g. of material was obtained as the only sublimate which was shown to be P-hexamethyl-B-hexafluorotriborophane by infrared analysis. The solid residues to which was added 10 ml. of water were again exhaustively extracted with ether from which no solid product could be obtained.

(b) B-Chloro Derivatives

[1] P-Hexamethyl-B-hexachlorotri-  
borophane and Trimethylaluminum (1357-29)

Into an 8 ml. heavy-walled bomb tube containing 0.1012 g. (0.236 mmole) of P-hexamethyl-B-hexachlorotriborophane was condensed (in vacuo) 3.0 ml. (2.25 g., 31.2 mmoles) of trimethylaluminum. The sealed tube was heated in an oven at 125°C. for 16 hrs. after which the solution was clear and colorless. The tube was opened on the vacuum line and a trace amount of noncondensable gas, presumably methane, was observed. The trimethylaluminum was removed leaving a white residue which was sublimed at 90-100°C. There was obtained a 95% yield of dodecamethyltriborophane, m.p. 336-338°C. The mixed melting point with authentic material was undepressed; the infrared spectrum was identical with a reference spectrum.

[2] P-Hexamethyl-B-hexachlorotri-  
borophane and Triethylaluminum (1357-74)

In a 5 ml. bomb tube was placed 0.1211 g. (0.283 mmole) of P-hexamethyl-B-hexachlorotriborophane and 0.5 ml. (0.35 g., 3.1 mmoles) of triethylaluminum (85% pure) was distilled into the tube from the vacuum line. The sealed tube was heated at 125 ± 2°C. for 12 hrs. and opened on the vacuum line. No noncondensable gas was observed. After distilling the volatile material at a bath temperature of 60-65°C., there remained a viscous clear liquid which distilled at a bath temperature of 135-160°C. to give 0.0836 g. of a viscous material that could not be induced to crystallize on cooling. Crystallization from methanol yielded 0.0130 g. of crude P-hexamethyl-B-hexaethyltriborophane, m.p. 68-76°C., mol. wt. 403.5 (calcd. for  $[(CH_3)_2PB(C_2H_5)_2]_3$ , 389.97). The infrared spectrum was consistent with the expected P-hexamethyl-B-hexaethyltriborophane displaying C-CH<sub>3</sub> absorption at 7.30 μ. Absorption at 4.30 μ indicated that the contaminant contained B-H probably arising from the 3-6% diethylaluminum hydride in the triethylaluminum which could replace halogen with hydrogen in the chlorinated triborophane. Also, the 3-6% tributylaluminum impurity may be responsible for the high molecular weight found for this material if the triborophane had been partially substituted by butyl groups. Lack of material terminated further purification.

[3] P-Hexamethyl-B-hexachlorotri-  
borophane and Triethylborine (1357-89)

A sealed 6 ml. bomb tube containing 0.1230 g. (0.287 mmole) of P-hexamethyl-B-hexachlorotriborophane and 1.00 ml. (0.693 g., 7.07 mmoles) of triethylborine was heated at 150 ± 2°C. for 12 hrs. and 200 ± 5°C. for 16 days. The triborophane, which was virtually insoluble cold, dissolved very slowly during the prolonged heating period. On opening the tube in vacuum noncondensable gas was not observed. The volatile contents were distilled leaving a white solid residue. Sublimation of the residue yielded 0.0114 g. of a white solid at a bath temperature of 150-160°C. and 0.1026 g. (83% recovery) of P-hexamethyl-B-hexachlorotriborophane (identified by its infrared spectrum) at 175-185°C. Absorption bands at 6.85 and 7.30 μ in the infrared spectrum of the more volatile

sublimate confirmed the presence of an ethyl group in the molecule. The remainder of the spectrum however, was similar to the reference spectrum of the starting material suggesting that only partial ethylation had occurred.

[4] P-Hexamethyl-B-hexachloro-triborophane and Dimethylzinc (1357-41)

In a 7 ml. heavy-walled bomb tube was placed 0.1224 g. (0.286 mmole) of P-hexamethyl-B-hexachlorotriborophane and 0.5 ml. (0.69 g., 7.2 mmoles) of dimethylzinc was condensed in from the vacuum line. The sealed tube was heated at 125°C. for 16 hrs. whereafter a clear colorless solution was observed when hot. A crystalline precipitate formed when cooled to room temperature. The tube was opened on the vacuum line and the volatile material removed. The resulting white residue was sublimed in high vacuum to provide 0.0800 g. (92%) of dodecamethyltriborophane, m.p. 337-339°C. The infrared spectrum was identical with that of authentic material; the mixed melting point was undepressed.

[5] P-Hexamethyl-B-dichloro-triborophane and Diethylzinc (1357-59, 62)

In a 5 ml. heavy-walled bomb tube was placed 0.1218 g. (0.284 mmole) of P-hexamethyl-B-hexachlorotriborophane and 0.5 ml. (ca. 1.5-2.0 mmoles) of a 25% diethylzinc in heptane solution in vacuo. The trimer was insoluble at room temperature and only slightly soluble at 125°C. where it was maintained for 21 hrs. After observing that no noncondensable gas had been formed, the volatile material was removed from the tube and the white solid residue was sublimed in high vacuum to obtain at a bath temperature of 140-160°C. 0.0535 g. of a liquid which eventually crystallized to a white waxy solid. The infrared spectrum suggested the presence of  $BH_2$  (absorption bands at 4.2, 4.3 and 9.0  $\mu$ ) and ethyl (bands at 6.85 and 7.30  $\mu$ ) groups in the molecule. A second sublimate weighing 0.0564 g. was obtained at 180-200°C. and was proved by infrared analysis to be P-hexamethyl-B-hexachlorotriborophane.

The volatile liquid removed from the reaction tube was passed through a condenser tube maintained at -100°C. The material which did not condense was investigated by infrared and found to be an approximate 1:1 mixture of ethylene and ethane. Since metallic zinc was also observed as a residue in the reaction tube, it is probable that these products resulted from the thermal decomposition of the diethylzinc.

A second experiment was designed to include a solvent in which the dimethylphosphinodichloroborine trimer was more soluble. To 0.1000 g. (0.233 mmole) of P-hexamethyl-B-hexachlorotriborophane was added 1.0 ml. (ca. 3-4 mmoles) of a 25% diethylzinc in heptane solution and 1.0 ml. of cyclohexane (dried over calcium hydride). The triborophane was only slightly soluble even at the elevated reaction temperature of 125°C. where it was heated for 16 hrs. The mixture was further heated at 175°C. for 4 hrs. at which temperature it was later found that the diethylzinc decomposed rapidly as evidenced by the large amount of metallic zinc residue. The residue was sublimed in vacuo to give 0.0258 g. of a waxy solid at 140-155°C., 0.0200 g. of a white solid at 160-175°C.,

and 0.0198 g. of crystalline starting material at 180-200°C. The infrared spectrum of the intermediate fraction suggested that some of the halogens on the triborophane nucleus had been substituted with ethyl (absorption at  $7.35 \mu$ , characteristic of the ethyl group and negligible absorption in the B-H regions).

[6] P-Hexamethyl-B-hexachlorotri-  
borophane and Dimethylmercury (1357-82, 84)

To 0.1107 g. (0.258 mmole) of P-hexamethyl-B-hexachlorotriborophane in a 6 ml. bomb tube was added 0.50 ml. (1.48 g., 6.4 mmoles) of dimethylmercury from the vacuum line. The sealed tube was heated at  $100 \pm 2^\circ\text{C}$ . for 15 hrs.,  $125 \pm 2^\circ\text{C}$ . for 6 hrs. and finally at  $145\text{-}160^\circ\text{C}$ . for 15 hrs. After each interval it was noted that the triborophane remained undissolved in the hot solvent, precipitating only a small amount of solid upon cooling. The tube was then opened in vacuo, the volatile material removed after observing a small amount of methane, and the resulting white residue was sublimed. There was obtained 0.1070 g. (97% recovery) of P-hexamethyl-B-hexachlorotriborophane identified by its infrared spectrum.

To overcome the solubility problem encountered in the first experiment, 1.0 ml. methylene chloride was used in this experiment as a common solvent for 0.1194 g. (0.279 mmole) of P-hexamethyl-B-hexachlorotriborophane and 0.20 ml. (0.59 g., 2.56 mmoles) of dimethylmercury. The reaction mixture was heated at  $130^\circ\text{C}$ . for 3 hrs. and  $145\text{-}160^\circ\text{C}$ . for 15 hrs. and worked up as before yielded with some mechanical losses 0.0745 g. (62% recovery) P-hexamethyl-B-hexachlorotriborophane (identified by its infrared spectrum) as the only triborophane compound.

[7] P-Hexamethyl-B-hexachlorotri-  
borophane and Tetraethyllead (1357-77)

In a 5 ml. heavy-wall bomb tube was placed 0.1180 g. (0.276 mmole) of P-hexamethyl-B-hexachlorotriborophane and 1.0 ml. (1.7 g., 5.3 mmoles) of tetraethyllead. The tube was evacuated, sealed and heated at  $125 \pm 2^\circ\text{C}$ . for 12 hrs. whereafter it was noted that the solid triborophane did not dissolve appreciably. Additional heating (72 hrs.) at  $125^\circ\text{C}$ . resulted in decomposition of the tetraethyllead as evident from the large amount of a solid gray residue. The tube was opened, the volatile components, presumably a mixture of ethane and ethylene (v.p., 140 mm. at  $-112^\circ\text{C}$ .) were removed. The residue was sublimed in vacuo to give an 86% recovery of crude P-hexamethyl-B-hexachlorotriborophane identified by its infrared spectrum.

(c) B-Bromo Derivatives

[1] P-Hexamethyl-B-hexabromotri-  
borophane and Trimethylaluminum (1357-101)

To 0.2176 g. (0.313 mmole) quantity of P-hexamethyl-B-hexabromotriborophane in a 6 ml. bomb tube equipped with a seal-off tip was added 0.90 ml. (0.68 g., 9.43 mmoles) of trimethylaluminum from the vacuum line. The sealed tube was heated at  $125 \pm 2^\circ\text{C}$ . for 20 hrs. after which time all

the solid material had dissolved. There was observed a small amount of methane after opening the tube on the vacuum line. The volatile components were removed leaving a white solid product which sublimed in vacuo at 95-150°C. The solid was identified by its infrared spectrum as dodecamethyltriborophane (0.0912 g., 95% yield), m.p. 333.5-335°C. (uncorr.). A mixed melting point with authentic material was undepressed.

[2] P-Hexamethyl-B,B',B''-tribromotri-  
borophane and Trimethylaluminum (1357-38)

In a 7 ml. bomb tube was placed 0.1217 g. (0.265 mmole) of P-hexamethyl-B,B',B''-tribromotriborophane and 1.1 ml. (0.83 g., 11.5 mmoles) of trimethylaluminum was condensed into the tube. The sealed tube was heated at 125°C. for 18 hrs., opened, and found to contain no noncondensable gas. The condensable material was removed leaving a clear viscous liquid which after distillation at a bath temperature of 60-80°C. eventually solidified on standing. There was obtained 0.0595 g. of a waxy solid which was analyzed vapor phase chromatographically on an Apiezon L/Celite column at 300°C. The results, included in Table III, indicate P-hexamethyl-B,B',B''-trimethyltriborophane to be the principal product containing lesser amounts of the unsubstituted, B-methyl-, B,B'-dimethyl-, and B,B,B',B''-tetramethyl-derivatives. An infrared spectrum confirmed the presence of a BH<sub>2</sub>-containing derivative which may have been formed in part by reduction but which was also found later to have been a contaminant of the starting material.

[3] P-Hexamethyl-B,B'-dibromotri-  
borophane and Trimethylaluminum (57W-17-139)

A 0.2003 g. (0.5274 mmole) of P-hexamethyl-B,B'-dibromotriborophane (99.4% pure) was heated with 1.45 ml. (1.09 g., 15.1 mmoles) trimethylaluminum for 18 hrs. at 125-155°C. The reaction product was sublimed to yield 0.1007 g. of a semi-solid which was analyzed by vapor phase chromatography. The results, listed in Table III, show P-hexamethyl-B,B'-dimethyltriborophane to be the principal product but also show that a considerable amount of apparent disproportionation had occurred.

[4] P-Hexamethyl-B-bromotri-  
borophane and Diphenylzinc (1357-155)

In a 5 ml. heavy-wall bomb tube was placed 0.1045 g. (0.348 mmole) of P-hexamethyl-B-bromotriborophane and 0.2795 g. (1.273 mmoles) of freshly distilled diphenylzinc. The tube was evacuated, sealed and heated at 125 ± 3°C. for 17 hrs. On cooling to room temperature a white crystalline material formed suspended in the viscous reaction medium. The tube was opened and 3 ml. of water added cautiously to decompose excess diphenylzinc and form a white flocculent precipitate of zinc hydroxide which dissolved on acidification with 6N hydrochloric acid. The insoluble material, 0.0837 g., was collected, dried and fractionally sublimed in high vacuum. P-Hexamethyl-B-phenyltriborophane, 0.0590 g. (57%), m.p. 101-102°C., was obtained at a bath temperature of 65-75°C. after first removing unreacted starting material at room temperature. A second product of unknown structure, 0.0105 g., sublimed at 90-100°C. as a wax-like

solid which eventually turned to a hard solid, m.p. 171-181°C., the infrared spectrum of which confirmed the presence of the triborophane nucleus and a mono-substituted aromatic ring. Vapor phase chromatographic analysis indicated a four-component mixture containing in order of decreasing volatility 0.7% unknown, 0.6% P-hexamethyl-B-phenyltriborophane, 11.1% unknown, and 87.6% unknown but none of the less volatile P-hexamethyl-B,B'-diphenyltriborophane.

An analytical sample of P-hexamethyl-B-phenyltriborophane was prepared by resublimation and crystallization from ethanol-water (1:1) to yield mats of fine white needles, m.p. 101-101.5°C. Anal. calcd. for  $C_{12}H_{28}B_3P_3$ : C, 48.40; H, 9.48; M.W. 287.7. Found: C, 48.99; H, 9.56; M.W. 305.9 (Neumayer). The infrared spectrum contained all the absorption bands of P-hexamethyl-B-bromotriborophane plus all the bands associated with the monosubstituted benzene ring.

(d) B-Iodo Derivatives

[1] P-Hexamethyl-B-iodotriborophane and Trimethylaluminum (1385-1)

To 0.3192 g. (0.918 mmole) of P-hexamethyl-B-iodotriborophane in a 5 ml. bomb tube was added 1.00 ml. (0.752 g., 10.43 mmoles) of trimethylaluminum from the vacuum line. The sealed tube was heated at  $100 \pm 2^\circ\text{C}$ . for 9 hrs., cooled and opened on the vacuum line. No noncondensable gas was observed. After removal of the excess trimethylaluminum there remained a viscous oil which was distilled at room temperature and condensed at  $0^\circ\text{C}$ . to give a white solid which melted on warming to room temperature and reacted when exposed to air (presumably some trimethylaluminum still remaining). After this slight reaction subsided the resulting solid residue was sublimed in vacuo at  $40-60^\circ\text{C}$ . to yield only one fraction, 0.1592 g., m.p.  $35-60^\circ\text{C}$ . On vapor phase chromatographic analysis on an Apiezon L/Celite column at  $300^\circ\text{C}$ ., the product was found to consist of a spectrum of B-methyl derivatives, as listed in Table III, with the B-methyl- and B,B'-dimethyl derivatives as the major products, the latter in greatest amount.

[2] P-Hexamethyl-B-iodotriborophane and Dimethylmercury (1385-89, 93, 103)

Experiment 1. P-Hexamethyl-B-iodotriborophane, 0.3172 g. (0.913 mmoles), and 0.60 ml. (1.772 g., 7.68 mmoles) of dimethylmercury were heated in an evacuated 5 ml. tube at  $125 \pm 4^\circ\text{C}$ . for 9 hrs. On opening the tube, no noncondensable gas was observed. On high vacuum sublimation of the residue obtained after removal of the unreacted dimethylmercury, 0.3145 g. (99.1%) of P-hexamethyl-B-iodotriborophane, m.p.  $79-82^\circ\text{C}$ . (softened at  $77^\circ\text{C}$ .) was recovered and shown to be free of contaminants by vapor phase chromatography.

Experiment 2. In the same manner, 0.1803 g. (0.519 mmole) of P-hexamethyl-B-iodotriborophane and 0.60 ml. (1.772 g., 7.68 mmoles) of dimethylmercury were heated at  $175-250^\circ\text{C}$ . (malfunctioning thermostat) for 8 hrs. That extensive decomposition had occurred was obvious from the large globule of mercury in the tube and the 47.4 cc. of methane obtained when the tube was opened. Sublimation of the residue recovered after removal of most of unreacted



dimethylmercury gave 0.0192 g. of a viscous material analyzing 82.5% dimethylmercury, 5.1% P-hexamethyltriborophane, 1.6% P-hexamethyl-B-methyltriborophane, 9.9% P-hexamethyl-B,B'-dimethyltriborophane, 0.4% P-hexamethyl-B,B'B''-trimethyltriborophane and 0.4% P-hexamethyl-B-iodotriborophane by vapor phase chromatography.

Experiment 3. Treatment of 0.2330 g. (0.670 mmole) of B-hexamethyl-B-iodotriborophane with 0.80 ml. (2.36 g., 10.2 mmoles) of dimethylmercury for 9 hrs. at  $175 \pm 5^\circ\text{C}$ . yielded 5.05 cc. of methane and 0.1772 g. of sublimate after removal of the excess dimethylmercury. Vapor phase chromatography showed the sublimate to consist of 71.0% recovered P-hexamethyl-B-iodotriborophane, 0.6% P-hexamethyltriborophane, 0.2% P-hexamethyl-B-methyltriborophane, and 28.2% of poorly resolved and unidentified materials.

[3] P-Hexamethyl-B-iodotriborophane  
and Dimethylcadmium (1385-87)

A solution of 0.3345 g. (0.962 mmole) of P-hexamethyl-B-iodotriborophane in 1.00 ml. (1.985 g., 13.9 mmoles) of dimethylcadmium in an evacuated 5 ml. sealed bomb tube was heated at  $125-135^\circ\text{C}$ . for 9 hrs. On cooling to room temperature a transparent crystalline material was deposited. The tube was opened on the vacuum line and 4.11 cc. of methane removed. After removal of the unreacted dimethylcadmium, the viscous gray residue was sublimed in high vacuum at bath temperatures up to  $70^\circ\text{C}$ . The 0.1944 g. sublimate was found by vapor phase chromatography to consist of a spectrum of B-methyl-derivatives as listed in Table III with the B-monomethyl-derivative predominating.

[4] P-Hexamethyl-B-iodotriborophane  
and Dimethylzinc (1385-73)

To 0.3198 g. (0.920 mmole) of P-hexamethyl-B-iodotriborophane in a 5 ml. heavy wall tube was added 228.6 cc. (10.21 mmoles) of dimethylzinc from the vacuum line. The sealed tube was heated at  $100 \pm 2^\circ\text{C}$ . for 9 hrs. whereafter it was opened in vacuo and the noncondensable gas (1.2 cc. methane, v.p. 12 mm. at  $-196^\circ\text{C}$ .) was measured. After removal of the unreacted dimethylzinc there remained a viscous residue which was sublimed in high vacuum. Vapor phase chromatographic analysis of the 0.1745 g. sublimate indicated that it was a mixture of B-methyl-derivatives as listed in Table III, with B-monomethyl the principal product.

[5] P-Hexamethyl-B-iodotriborophane  
and Tetramethyltin (1385-99)

To 0.2013 g. (0.579 mmole) of P-hexamethyl-B-iodotriborophane in a 5 ml. heavy-wall tube was added 1.00 ml. (1.29 g., 7.22 mmoles) of tetramethyltin from the vacuum line. The evacuated tube was heated at  $125 \pm 5^\circ\text{C}$ . for 9 hrs. and  $175 \pm 5^\circ\text{C}$ . for another 9 hrs. After cooling and opening on the vacuum line there was obtained 2.20 cc. of methane. Excess tetramethyltin was removed; the white solid residue was sublimed at a bath temperature of  $30-100^\circ\text{C}$ . in high vacuum through a U-trap at  $-78^\circ\text{C}$ . to give 0.1910 g., of a white solid, m.p.  $80-83^\circ\text{C}$ . shown by vapor phase chromatography to be 62.3% recovered P-hexamethyl-B-iodotriborophane and a mixture of unknown and poorly resolved materials.

[6] P-Hexamethyl-B-iodotriborophane and Diphenylmagnesium (1385-111, 113)

Experiment 1. To the side arm of a 5 ml. heavy-walled tube was introduced 0.0974 g. (0.280 mmole) of P-hexamethyl-B-iodotriborophane. The tube was evacuated and filled with nitrogen. Employing a long needle syringe, 2.00 ml. (1.62 mmoles) of 0.81M ethereal diphenylmagnesium solution (prepared according to Strohmeier<sup>15</sup>) was introduced. The tube was immediately evacuated after cooling to  $-196^{\circ}\text{C}$ . and the ether was cautiously distilled while maintaining the side arm at about  $-20^{\circ}\text{C}$ . to prevent loss of the iodotriborophane. A light brown viscous residue which retained the ether of coordination remained. To the residue was added 1.0 ml. of benzene (in vacuo). The tube was then sealed above the side arm and removed from the vacuum line. After thoroughly washing the iodo compound from the side arm into the reaction tube, the latter was sealed below the side arm. On warming the mixture to room temperature a solution was obtained which after standing for several hours contained a light gray flocculent precipitate.

After heating at  $125 \pm 5^{\circ}\text{C}$ . for 20 hrs. the tube was opened on the vacuum line and the material volatile at room temperature was removed. The tube was then sealed onto a U-trap and subjected to high vacuum sublimation. The first fraction (0.0200 g.) sublimed at  $25-80^{\circ}\text{C}$ . and was found by vapor phase chromatography to be a mixture consisting of biphenyl, P-hexamethyltriborophane and P-hexamethyl-B-iodotriborophane. A second sublimate (0.0764 g.), obtained at a bath temperature of  $100-230^{\circ}\text{C}$ ., was crystallized from absolute ethanol and provided 0.0350 g. (34%) of white needles, P-hexamethyl-B,B'-diphenyltriborophane, m.p.  $161-163^{\circ}\text{C}$ . which analyzed by vapor phase chromatography on silicone grease/Celite at  $340^{\circ}\text{C}$ . as 1.2% P-hexamethyl-B-phenyltriborophane and 98.8% P-hexamethyl-B,B'-diphenyltriborophane. An analytical sample was prepared by two crystallizations from absolute ethanol, m.p.  $163-164^{\circ}\text{C}$ . Anal. calcd. for  $\text{C}_{18}\text{H}_{32}\text{B}_3\text{P}_3$ : C, 57.83; H, 8.63; M.W. 373.8. Found: C, 58.43; H, 8.63; M.W. 379.0. The infrared spectrum was similar to that for P-hexamethyl-B-phenyltriborophane except for minor variations in the "finger-print" region (appearance of bands at 685 and  $835\text{ cm}^{-1}$  and disappearance of a band at  $706\text{ cm}^{-1}$ ).

Experiment 2. Employing the same type tube described in the first experiment, 0.1305 g. (0.375 mmole) of P-hexamethyl-B-iodotriborophane was placed in the side arm and 3.00 ml. (2.43 mmoles) of 0.81M diphenylmagnesium was added from a syringe to the nitrogen-filled tube. After removal of the ether in high vacuum the tube was sealed above the side arm. The iodotriborophane was then sublimed into the reaction tube (cooled to  $-78^{\circ}\text{C}$ .) and the tube sealed. The mixture was heated for 24 hrs. at  $125 \pm 5^{\circ}\text{C}$ . at which temperature it was completely homogeneous. On cooling to room temperature the viscous yellow mass eventually solidified. After opening on the vacuum line and removing a small amount of volatile liquid the residue was sublimed in high vacuum through a  $-78^{\circ}\text{C}$ . bath. The first fraction (0.0267 g.) sublimed at a bath temperature of  $60-80^{\circ}\text{C}$ . and was found by vapor phase chromatography to consist of 11.8% P-hexamethyltriborophane, 85.3% biphenyl, 0.05% P-hexamethyl-B-iodotriborophane and 2.85% P-hexamethyl-B-phenyltriborophane.

The second sublimate (0.0638 g., m.p. 95-130°C.) collected at a bath temperature of 100-160°C., was resublimed. There was obtained 0.0273 g. (24%) of P-hexamethyl-B-phenyltriborophane, m.p. 100-101°C. at a bath temperature of 50-75°C. The sublimation residue (0.0247 g.) analyzed by vapor phase chromatography (silicone grease/Celite at 340°C.) contained 38.2% P-hexamethyl-B-phenyltriborophane and 61.8% P-hexamethyl-B,B'-diphenyltriborophane.

Calculation of total yields on basis of the chromatographic data and the weights of the sublimes gave the following results: P-hexamethyltriborophane, 4%; P-hexamethyl-B-iodotriborophane, trace; P-hexamethyl-B-phenyltriborophane, 34%; P-hexamethyl-B,B'-diphenyltriborophane, 11%.

[7] P-Hexamethyl-B-iodotriborophane  
and Phenylmagnesium Bromide (1385-23)

In a 50 ml. two-necked flask equipped with a water condenser vented through a mercury bubbler and with a dropping funnel with a nitrogen inlet was placed 0.4420 g. (1.27 mmoles) of P-hexamethyl-B-iodotriborophane and 10 ml. of anhydrous ether. In a nitrogen atmosphere and with vigorous stirring, 0.8 ml. of ethereal 3M phenylmagnesium bromide (2.4 mmoles) was added during 15 min. After heating under reflux for 3 hrs. the reaction mixture was allowed to stand overnight at room temperature before it was decomposed with 3 ml. of ca. 3N aqueous hydrochloric acid solution. The ether layer was separated, washed with three 5 ml. portions of water and dried over calcium sulfate. On evaporation of the ether in a stream of argon there remained 0.4282 g. of a light yellow solid. P-hexamethyl-B-iodotriborophane weighing 0.3623 g. was recovered (96%) as three separate fractions by sublimation in high vacuum at a bath temperature of 40-75°C. Each fraction melted sharply within the 79-82°C. range. A second yellow colored product of unknown composition, was obtained at a bath temperature of 75-90°C., 0.0135 g., m.p. 65-70°C.

(6) Reactions of B-Halo-derivatives of  
P-Hexamethyltriborophane with Other  
Than Organometallic Reagents

(a) Preparation of B-Cyano-derivatives

[1] P-Hexamethyl-B,B',B''-tribromotri-  
borophane and Potassium Mercuricyanide  
(1369-4, 11, 12, 14, 15)

Preparation of Potassium Mercuricyanide. Following the procedure of Dickinson<sup>16</sup> 5.4 g. (0.025 mmole) of mercuric oxide was added to 6.8 g. (0.104 mmole) of potassium cyanide dissolved in 15 ml. of water. The mixture was warmed until a slightly turbid colorless solution was obtained. The solution was filtered and the product crystallized at 0°C. Recrystallization from water and drying in vacuum at room temperature yielded 3.9 g. (0.0102 mmole, 41%) of potassium mercuricyanide. The infrared spectrum of the product showed a trace of bound water but heating in vacuum at 100°C. caused discoloration and only negligible loss of weight.

Experiment 1. A sealed, evacuated, 5 ml. heavy-wall tube containing 0.1017 g. (0.2219 mmole) of P-hexamethyl-B,B',B''-tribromotriborophane, 0.2757 g. (0.7201 mmole) of potassium mercuricyanide and 2.0 ml. of dimethylformamide (dried by azeotropic distillation with benzene) was heated at  $153 \pm 2^\circ\text{C}$ . for 1 hr. The initial almost clear, colorless solution turned yellow and a gray precipitate formed during heating. The tube was opened under nitrogen and the supernatant solution removed. The precipitate was washed consecutively with two 1 ml. portions of dimethylformamide and two 1 ml. portions of diethyl ether. The ether washes were discarded and the precipitate was dried after which a small amount of metallic mercury was removed mechanically. The precipitate weighed 0.0601 g. and contained 0.0430 g. (54.2%) of potassium bromide as determined by bromide analysis.

The yellow dimethylformamide solution and washes were evaporated in high vacuum (ca. 2 days) and the soft orange residue was extracted with two 1 ml. portions of diethyl ether. The ether was evaporated and 0.0339 g. of an orange oil was obtained which slowly crystallized. Recrystallization from water yielded 0.0151 g. of pale yellow solid, m.p. ca.  $125-147^\circ\text{C}$ ., having sharp absorptions at 2190 and 2410  $\text{cm}^{-1}$  in the infrared corresponding to CN and BH, respectively. Attempted hydrolysis of this solid in 80% sulfuric acid led only to detection of sulfur dioxide by odor. Digestion with concentrated sulfuric or nitric acid, dilution with water and treatment with stannous chloride precipitated no mercury. Analysis of 0.0073 g. of the pale yellow solid showed  $1.7 \pm 1.7\%$  bromine.

The residue from the ether extraction was triturated with three 2 ml. portions of water to leave 0.0120 g. of residue, A, m.p. ca.  $150-166^\circ\text{C}$ . (dec.), which had absorptions in the infrared at 2195 and 2410  $\text{cm}^{-1}$ . This material was insoluble in hot and cold diethyl ether, dimethylformamide, acetone, benzene, chloroform, water and 6N sodium hydroxide but was soluble in 6N hydrochloric acid and gave a precipitate when strongly basified with sodium hydroxide. About half of the precipitate was dried in high vacuum and the remainder triturated with acetone with most of it dissolving. The acetone solution was evaporated giving a white solid. The infrared spectra of both the above solids were quite similar and the acetone treated solid had bands at 2175 and 2380  $\text{cm}^{-1}$  while the untreated solid had bands at 2175 and 2400  $\text{cm}^{-1}$  (broad).

To the combined water washes of residue A was added 4 ml. of 6N hydrochloric acid which caused almost immediate precipitation of a white solid, 0.0200 g., m.p. ca.  $160-204^\circ\text{C}$ . (dec.) after drying. The solid had absorptions in the infrared at 2185 and ca. 2375  $\text{cm}^{-1}$  (broad). An attempt to sublime this solid resulted in isolation of only a small ( $< 1$  mg.) amount of volatile solid which was discarded. The hydrochloric acid mother liquor was strongly basified with sodium hydroxide and an orange solid precipitated. The mixture was reacidified with concentrated hydrochloric acid and several crystals of stannous chloride were added. Elemental mercury formed almost immediately.

Experiment 2. A sealed evacuated tube containing 0.0978 g. (0.2133 mmole) of P-hexamethyl-B,B',B''-tribromotriborophane, 0.2473 g. (0.6459 mmole) of potassium mercuricyanide and 2.0 ml. of dimethylformamide was

allowed to remain at room temperature overnight. No reaction appeared to take place and the tube was heated at  $100 \pm 2^\circ\text{C}$ . for about 6 hrs. A gray precipitate formed after about 0.5 hr. The tube was opened and no permanent gas or material more volatile than solvent was detected. The solvent was removed in high vacuum (24 hrs.) leaving a yellow viscous syrup, gray precipitate and metallic mercury which was triturated with two small portions of water. The yellow syrup dissolved leaving the gray precipitate and mercury which were discarded. The yellow solution was treated with 4 drops of 6N hydrochloric acid giving a copious white precipitate which was isolated, washed with water and dried in high vacuum. The solid, 0.0870 g., m.p.  $138\text{-ca. } 147^\circ\text{C}$ . (dec.), had infrared absorptions at 2190 and  $2400\text{ cm.}^{-1}$  (broad). On standing the acidic mother liquor slowly precipitated more white solid which was collected in three successive batches over a 6 day period. This solid weighed a total of ca. 0.024 g. and had absorptions in the infrared at 2180 and  $2370\text{ cm.}^{-1}$  (broad). The spectrum of the last collected batch was much less resolved than the first and all were slightly different in the  $900\text{-}950\text{ cm.}^{-1}$  region. The mother liquor was basified and ammonia was detected by odor and its basic reaction with moist indicator paper.

The original 0.0870 g. of solid was heated with 1.5 ml. of 50% sulfuric acid at  $100^\circ\text{C}$ . for 8 hrs. but did not entirely dissolve. The mixture was diluted and the solid isolated, m.p. ca.  $305\text{-}390^\circ\text{C}$ . (dec.). The infrared spectrum was very poorly resolved and the B-H and CN absorptions were almost indistinguishable from background noise.

Experiment 3. A sealed, evacuated tube containing 0.1513 g. (0.3952 mmole) of potassium mercuricyanide, 0.1026 g. (0.2238 mmole) of P-hexamethyl-B,B',B''-tribromotriborophane and 1 ml. of dimethylformamide was heated at  $85 \pm 2^\circ\text{C}$ . for 2 hrs. The reactants dissolved quickly and in about 0.5 hr. a white precipitate formed which later turned gray. The tube was opened under nitrogen and the solvent removed in high vacuum. The gray solid and clear liquid residues were triturated with three 2 ml. portions of diethyl ether. Most of the gray solid remaining was accidentally lost but what remained was extracted with water and the solid residue discarded. Acidification of the aqueous solution with 6N nitric acid caused a white precipitate to form which after isolation had m.p.  $160^\circ\text{C}$ . (soften) but did not completely melt at  $260^\circ\text{C}$ . (dec.). The infrared spectrum was poorly resolved but had weak bands at 2200 and  $2400\text{ cm.}^{-1}$  (broad).

The ether solution was evaporated to give 0.0928 g. of clear liquid, the infrared spectrum of which had bands at 2120 and  $2420\text{ cm.}^{-1}$  and also strong dimethylformamide bands. The infrared sample was recovered in ether, the ether evaporated and solvent eliminated from the residual liquid by pumping in high vacuum for 3 days. The sticky product, 0.0524 g., was partially crystalline and had a phosphine-like odor after this treatment. The infrared spectrum ( $\text{CHCl}_3$  solution) had bands at 2125 and  $2430\text{ cm.}^{-1}$  but still showed strong dimethylformamide bands.

Experiment 4. A sealed evacuated tube containing 0.1960 g. (0.5119 mmole) of potassium mercuricyanide, 0.0971 g. (0.2118 mmole) of P-hexamethyl-B,B',B''-tribromotriborophane and 2.0 ml. acetonitrile was heated 1 hr. at  $85 \pm 2^\circ\text{C}$ . then 8 hrs. at  $105 \pm 2^\circ\text{C}$ . The solid phase only partially dissolved

and no reaction appeared to occur so the temperature was raised to  $127 \pm 2^\circ\text{C}$ . for about 17 hrs. The solid phase did not dissolve but changed appearance. The tube contents consisted of an orange solution, colorless powdery solid, metallic mercury and only a trace of permanent gas after the heating period. The solvent was removed in high vacuum and residual orange and white solid was extracted with three 2 ml. portions of diethyl ether. The colorless ether solution was evaporated leaving 0.0434 g. of colorless powder, m.p.  $108-114^\circ\text{C}$ . (uncorr.), (m.p. of starting trimer,  $112-115^\circ\text{C}$ .), which had absorptions in the infrared at 2190 and  $2420\text{ cm}^{-1}$  (weak).

The orange residue from the ether extraction was extracted with three 1 ml. portions of methanol to give an orange solution and a small amount of colorless powder which did not contain bromine. The methanol solution was evaporated to leave 0.1583 g. of a tan powder which had one sharp infrared absorption at  $2160\text{ cm}^{-1}$  which is indicative of potassium mercuricyanide.

[ 2 ] P-Hexamethyl-B-hexachlorotri-  
borophane and Potassium Mercuricyanide (1369-7)

Into a 5 ml. heavy-wall bomb tube cooled to  $-78^\circ\text{C}$ . and containing 0.1071 g. (0.2635 mmole) of P-hexamethyl-B-hexachlorotriborophane and 0.3190 g. (0.8333 mmole) of potassium mercuricyanide was placed 2.0 ml. of dimethylformamide (dried by azeotropic distillation with benzene). The tube was degassed, sealed and heated at  $130 \pm 2^\circ\text{C}$ . for 8-10 hrs. The tube contents consisted of a yellow solution and a gray-white precipitate. The tube was opened and no permanent gas was present nor was any material more volatile than solvent detected. The precipitate was separated, washed with two 1 ml. portions of solvent and dried in high vacuum to give 0.0775 g. of impure starting triborophane as shown by its infrared spectrum. The yellow solution and washes were combined and evaporated in high vacuum leaving 0.3369 g. of buff colored powder, 0.1188 g. of which was triturated first with 10 ml. of water, then 5 ml. of methanol and the remaining solid dried in high vacuum. The solid weighed 0.0146 g. and its infrared spectrum showed it to be impure starting material (total accounted for is 0.1189 g., 110%).

In a second experiment, 0.1024 g. (0.2496 mmole) of P-hexamethyl-B-hexachlorotriborophane, 0.3214 g. (0.8394 mmole) of potassium mercuricyanide and 2.0 ml. of dimethylformamide were heated in a sealed evacuated 5 ml. heavy-wall tube at  $153 \pm 2^\circ\text{C}$ . for 7 hrs. The tube was opened and contained no permanent gas but did contain 0.34 cc. of gas condensable at  $-196^\circ\text{C}$ . but not at  $-78^\circ\text{C}$ . The solvent was removed in high vacuum (24 hrs. required) and about 2 ml. of water was added to the dark brown residue giving a dark brown solution and a gray precipitate. The aqueous solution was extracted with ether, the ether dried and evaporated yielding an oily film which was discarded. The precipitate was washed with two 1 ml. portions of water, three 2 ml. portions of methanol and dried in high vacuum to yield 0.0914 g. (89.3%) of impure starting triborophane as identified by its infrared spectrum.

[3] P-Hexamethyl-B-chloro-, P-Hexamethyl-B-bromo- and P-Hexamethyl-B-iodotriborophanes and Sodium Cyanide. Preparation of P-Hexamethyl-B-cyanotriborophane

(1357-147, 1385-22, 47)

To a solution containing 0.2005 g. (0.666 mmole) of P-hexamethyl-B-bromotriborophane in 6 ml. of dimethylformamide (dried by azeotropic distillation with benzene) was added 0.0684 g. (1.396 mmoles) of sodium cyanide which only partially dissolved. Upon heating on the steam bath the solution became light yellow in color as more of the sodium cyanide dissolved. Heating was continued for 5 hrs. during which time the small amount of material which sublimed to the neck of the container was washed back with small amounts of dimethylformamide. On dilution with 25 ml. of distilled water a fine, white, needle-like crystalline precipitate formed. The solid was collected on a filter, and washed thoroughly with additional distilled water. The entire aqueous filtrate was found to contain 0.752 mmole (113% of theory) of bromide ion.

After thorough drying there was obtained 0.1456 g. (89%) of P-hexamethyl-B-cyanotriborophane, m.p. 106.5-108°C., which on admixture with P-hexamethyl-B-bromotriborophane (m.p. 76-78°C.) melted at 78-90°C. When chromatographed in the vapor phase on silicone oil/Celite at 200°C., the product was found to contain 0.9% P-hexamethyltriborophane, 2.1% unknown material, and 97% P-hexamethyl-B-cyanotriborophane. As further evidence for this new compound, a synthetic mixture with P-hexamethyl-B-bromotriborophane was chromatographed on Apiezon L/Celite at 300°C. The two observed peaks were the monocyano-derivative with a retention time of 7.4 min. and the monobromo-derivative at 8.2 min., the same retention time found for the pure monobromo-derivative under identical chromatographic conditions. An analytical sample was prepared by three crystallizations from alcohol-water (3:2) followed by sublimation. Anal. calcd. for  $C_7H_{23}B_3P_3N$ : C, 34.08; H, 9.40; M.W., 246.7. Found: C, 34.34; H, 9.66; M.W., 257.2.

Treatment of 0.1307 g. (0.510 mmole) of P-hexamethyl-B-chlorotriborophane with 0.1003 g. (2.05 mmoles) of sodium cyanide in 8 ml. of dimethylformamide at 100°C. for 7 hrs. with constant stirring followed by cooling and diluting with 20 ml. of water yielded 0.1112 g. (0.451 mmoles, 88%) of P-hexamethyl-B-cyanotriborophane, m.p. 106-108°C. The mixed melting point with authentic material (prepared from the monobromo-derivative, vide supra) was undepressed.

A mixture consisting of 1.0153 g. (2.921 mmoles) of P-hexamethyl-B-iodotriborophane and 0.2862 g. (5.84 mmoles) of sodium cyanide in 15 ml. of absolute ethanol was heated under reflux for 8 hrs. After cooling to room temperature the solids were removed by filtration with the aid of an additional 10 ml. of ethanol. Dilution of the ethanol filtrate with 25 ml. of water formed a fine, white crystalline precipitate of P-hexamethyl-B-cyanotriborophane, m.p., 104-107°C., which after thorough drying weighed 0.6740 g. (2.733 mmoles, 93.6%). Vapor phase chromatographic analysis showed no impurities.

[4] P-Hexamethyl-B,B'-dibromotriborophane and Sodium Cyanide. Preparation of P-Hexamethyl-B,B'-dicyanotriborophane (1357-166)

To a solution of 0.1004 g. (0.264 mmole) of P-hexamethyl-B,B'-dibromotriborophane in 3.0 ml. of dimethylformamide was added 0.0510 g. (1.040 mmoles) of sodium cyanide. The mixture was heated for 6 hrs. on the steam bath during which time the sodium cyanide dissolved slowly. On dilution with 10 ml. of water a white, flaky, crystalline precipitate formed and was separated by filtration. The aqueous filtrate, acidified with nitric acid and boiled to expel hydrogen cyanide, gave a voluminous yellow precipitate of silver bromide. On thorough drying there was obtained a 55% (0.0397 g.) yield of crude P-hexamethyl-B,B'-dicyanotriborophane, m.p. 122.5-125°C. A mixed m.p. with P-hexamethyl-B,B'-dibromotriborophane (m.p. 129-131°C.) was 121-127°C. The infrared spectrum was strikingly similar to that for the dibromo-derivative with an additional absorption band at 4.56 $\mu$  indicative of the cyano group.

Sublimation in high vacuum at room temperature removed the 1.9% P-hexamethyl-B-cyanotriborophane (determined by vapor phase chromatography); P-hexamethyl-B,B'-dicyanotriborophane was obtained on heating the residue at 95-105°C. An analytical sample was prepared by crystallization from ethanol-water which yielded fine white needles, m.p. 127-128°C. Anal. calcd. for  $C_6H_{22}B_3P_3N_2$ : C, 35.37; H, 8.16. Found: C, 35.74; H, 8.63.

[5] P-Hexamethyl-B-hexachlorotriborophane and Sodium Cyanide (1357-173)

Utilizing the general reaction and conditions which proved successful in replacing chlorine, bromine or iodine in the partially halogenated derivatives of P-hexamethyltriborophane, 0.2108 g. (0.492 mmole) of P-hexamethyl-B-hexachlorotriborophane and 0.2947 g. (6.10 mmoles) of sodium cyanide in 4.0 ml. of dimethylformamide were heated on the steam bath for 12 hrs. The resulting milky slurry was diluted with 7 ml. of water resulting in the formation of a fine white precipitate. After washing with water and thorough drying there was obtained 0.1807 g. (86%) of unreacted P-hexamethyl-B-hexachlorotriborophane, m.p. 372-374°C. (uncorr.) whose infrared spectrum was identical with that of authentic material.

(b) Attempt to Prepare P-Hexamethyl-B-fluorotriborophane (1357-174, 180)

In a 5 ml. heavy-wall tube was placed 0.1227 g. (0.408 mmole) of P-hexamethyl-B-bromotriborophane, 0.0793 g. (1.365 mmoles) of potassium fluoride and 3.0 ml. of dimethylformamide. The sealed evacuated tube was heated at 100  $\pm$  2°C. for 15 hrs. whereafter it was opened on the vacuum line. There were obtained 2.62 cc. of hydrogen and 0.09 cc. of methane. The tube contents were removed and the tube washed with 1 ml. of dimethylformamide. On dilution of the dimethylformamide solution with 8 ml. of water a copious white precipitate formed and the characteristic phosphine odor was noted suggesting at least partial decomposition of the triborophane ring had occurred. There was obtained 0.0122 g. of



product which melted sharply at 45°C. but still contained a small amount of material which eventually melted at 60°C. A second precipitate, 0.0285 g., m.p. 46.5-47.0°C., was obtained after dilution of the aqueous filtrate with an additional 5 ml. of water. The infrared spectra of the two fractions were essentially identical and very similar to that of P-hexamethyl-B-bromotriborophane except for additional absorption bands at 9.35  $\mu$  (w.), 8.29  $\mu$  (s.) and 5.80  $\mu$  (vs.). This combination of absorption bands is indicative of a formate function (presumably on boron) in the molecule. Vapor phase chromatographic analysis on an Apiezon L/Celite column at 300°C. showed this second precipitate to be a mixture consisting of 1.7% P-hexamethyltriborophane (retention time, 2.9 min.), 78.4% "formate" derivative (5.6 min.) and 19.9% P-hexamethyl-B-bromotriborophane (7.4 min.).

In a second experiment, 0.3207 g. (1.067 mmoles) of P-hexamethyl-B-bromotriborophane was heated at 100  $\pm$  2°C. for 6 hrs. in a 5 ml. heavy-wall tube with 0.1021 g. (3.936 mmoles) of lithium fluoride and 2.0 ml. of dimethylformamide. The tube was opened on the vacuum line and found to contain a trace (0.3 cc.) of noncondensable gas. The dimethylformamide solution was removed from the tube and diluted with 10 ml. of water which caused the precipitation of 0.3085 g. of fine white needles. The infrared spectrum of this crude material showed weak absorption bands at 1725 and 1205  $\text{cm}^{-1}$ , suggesting the presence of a small quantity of a carbonyl-containing impurity. Recrystallization from 4:1 ethanol-water gave 0.1880 g. (59%) of recovered P-hexamethyl-B-bromotriborophane, m.p. 77-78°C. (mixed m.p. with authentic material was 75.5-77°C.).

(c) Miscellaneous Reactions

[1] P-Hexamethyl-B-bromotriborophane and Pyrrolidine (57W-17-122)

Into a 3 ml. bomb tube was weighed 0.0747 g. (0.249 mmole) of P-hexamethyl-B-bromotriborophane and 0.2738 g. (3.850 mmoles) of pyrrolidine. The tube was evacuated, sealed, and heated 15.5 hrs. at 130-150°C. The tube was cooled and opened to the vacuum line. A total of 14.6 cc. (0.652 mmole) of hydrogen was obtained. A total of 0.1681 g. of volatile material (assumed to be pyrrolidine) was obtained on vacuum distillation at room temperature. The residue dissolved easily in water yielding a strong phosphine odor. The aqueous solution was extracted with two 3 ml. portions of *i*-hexane which on evaporation yielded only 0.018 g. of shiny plates, m.p. 85-100°C. The infrared spectrum of this material indicated it to be a triborophane different than starting material but insufficient material prevented further characterization.

[2] P-Hexamethyl-B,B'B''-tribromotriborophane and Diethylamine (1369-16)

A sealed, evacuated, 2 ml. heavy-wall tube containing 0.1840 g. (2.516 mmoles) of diethylamine and 0.0469 g. (0.1023 mmole) of P-hexamethyl-B,B',B''-tribromotriborophane was heated at 85  $\pm$  2°C. for 0.5 hr. giving a clear solution. After remaining two days at room temperature, the tube was opened and the starting materials were almost quantitatively recovered.

[3] P-Hexamethyl-B-bromotri-  
borophane and Hydroxide Ion (57W-17-112)

A solution of 0.0451 g. (1.13 mmoles) potassium hydroxide and 0.1079 g. (0.359 mmole) of P-hexamethyl-B-bromotriborophane in 5 ml. methanol was allowed to stand overnight at room temperature and then refluxed for several hours. The reaction mixture was poured into water and resulting solid was extracted into *i*-hexane. The aqueous layer analyzed 0.048 mmoles (13%) bromide ion. A total of 0.057 g. (0.190 mole, 53%) of starting material (m.p. 75-77°C.) was recovered.

[4] P-Hexamethyl-B-hexafluorotri-  
borophane and Mercuric Acetate (1357-125)

In a 5 ml. heavy-wall tube were placed 0.1181 g. (0.358 mmole) of P-hexamethyl-B-hexafluorotriborophane, 0.3374 g. (1.058 mmoles) of mercuric acetate and 3 ml. of dimethoxyethane (purified by distillation from calcium hydride) was added from the vacuum line. The sealed tube was heated at 125°C. for 15 hrs. whereafter there was observed a red colored solution, a viscous oil and metallic mercury. The tube was opened; no noncondensable gas was obtained. After removal of the solvent, 0.1448 g. of mercury (representing 68% of the mercuric acetate) was removed mechanically. An attempt to sublime the residue at temperatures up to 200°C. proved unsuccessful as did attempts to crystallize a product from hydrocarbon, halogenated hydrocarbon and alcohol solvents.

The infrared spectrum suggested the presence of a fluoroborate function which must have resulted from decomposition of the triborophane ring. The expected carbonyl absorption was essentially absent.

(7) Reactions of P-Hexamethyltriborophane

(a) With Mercuric Acetate (57W-17-80, 81)

To a stirred solution of 1.240 g. (5.613 mmoles) of P-hexamethyltriborophane in 50 ml. of hot methanol was added 1.7284 g. (5.423 mmoles) of mercuric acetate in 50 ml. methanol. Within 30 sec. a crystalline solid began to form followed by a gradual darkening of the solution and precipitation of mercury metal. After refluxing 3 hrs., the reaction mixture was cooled and filtered to yield 0.984 g. (90.4%) of mercury globules. Accidental loss of part of the filtrate occurred at this point. Concentration of the remaining filtrate yielded a semi-solid residue having a strong odor of acetic acid. This was extracted twice (10 ml. each) with cyclohexane to give a crude separation into two fractions; (a) 0.134 g. of an insoluble oily liquid, and (b) 0.560 g. of a cyclohexane soluble material. Fraction (a) on high vacuum distillation at 100-120°C. yielded 0.0852 g. of an oil nonvolatile at room temperature. The infrared spectrum indicated it was a triborophane containing both hydroxyl and carbonyl functional groups. On high vacuum sublimation at 50°C. fraction (b) yielded 0.099 g. of a greasy solid, nonvolatile at room temperature, and 0.222 g. of a broad melting solid (65-75°C.) retained in a trap at -78°C. Resublimation of this latter material yielded 0.185 g. of a greasy solid, m.p. 80-85°C. shown by infrared analysis to be impure starting material.

In a second experiment 0.1772 g. (0.8023 mmole) of P-hexamethyltriborophane, 0.1255 g. (0.3939 mmole) of mercuric acetate and 4.5 ml. anhydrous methanol were sealed under vacuum in a 15 ml. bomb tube and heated for 2 hrs. at 65°C. Upon opening the tube, 0.68 cc. of noncondensable gas was measured. By filtration 0.0710 g. (90%) of mercury metal was isolated. The filtrate on cooling to -78°C. yielded 0.035 g. needles, m.p. 75-80°C. Evaporation of the filtrate to dryness yielded 0.140 g. of oily solid, m.p. 50-65°C. (which on sublimation under high vacuum yielded 0.1211 g. of solid, m.p. 50-60°C.) condensed at -78°C. and a small amount of oily liquid (0.0097 g.). The major fraction showed only a weak infrared absorption at 5.85  $\mu$ . (carbonyl function) and the principal absorption bands were those of starting material.

(b) With Aqueous Hydrogen Peroxide (57W-17-89)

A solution of 0.6831 g. (3.09 mmoles) of P-hexamethyltriborophane dissolved in 20 ml. cyclohexane was shaken with 7.00 ml. of an 0.847N solution of hydrogen peroxide for 5 min. Titration of a 1.00 ml. aliquot with 0.1N potassium permanganate showed the aqueous solution to be 0.843N in hydrogen peroxide. A 1.00 ml. quantity of 1N H<sub>2</sub>SO<sub>4</sub> was added to the aqueous phase and shaken for an additional 5 min. A 1.00 ml. aliquot titrated 0.698N in hydrogen peroxide (calcd. 0.726N). The cyclohexane phase was separated and evaporated to dryness to yield 0.681 g. colorless crystalline solid indicated by m.p. 85-87°C. to be starting material.

(c) With Silver Oxide (57W-17-113)

A mixture of 0.0779 g. (0.353 mmole) of P-hexamethyltriborophane and 0.0733 g. (0.316 mmole) of silver oxide were sealed in an evacuated 10 ml. bomb tube and heated at 200°C. for 1.5 hrs. The reaction mixture was no longer black and a silver mirror was noted. Upon opening the tube, no measurable noncondensable gas was observed. A small amount of condensable gas (0.5 cc.) was measured, apparently carbon dioxide originally present as silver carbonate. The residue was sublimed under high vacuum to yield 0.0767 g. (98.5% recovery) of starting material, m.p. 85-88°C. The gray residue was digested 2 hrs. with dilute perchloric acid to yield 0.0630 g. of light gray solid which fused under flame to bright metallic droplets.

(d) With Sulfur (57W-17-82, 85)

A mixture of 0.0425 g. (0.192 mmole) of P-hexamethyltriborophane and 0.0129 g. (0.402 mmole) of flowers of sulfur were heated in an evacuated 5 ml. bomb tube for 64 hrs. at 130-150°C. By the end of the heating period a considerable amount of colorless solid had formed. On opening the bomb tube, 4.80 cc. of hydrogen but no methane, hydrogen sulfide or other volatile material was observed. High vacuum sublimation of the residue at temperatures up to 210°C. yielded 0.0237 g. (56% recovery) of P-hexamethyltriborophane, m.p. 85-86°C. and 0.0012 g. of an unknown material, m.p. 85-110°C. The residue which weighed 0.0274 g. hydrolyzed rapidly on exposure to air to give a noticeable odor of hydrogen sulfide.

In a second experiment, a solution of 0.4180 g. (1.892 mmoles) of P-hexamethyltriborophane and 0.0321 g. (1.00 mmole) of sulfur in 7.398 g. carbon disulfide was sealed in an evacuated 50 ml. bomb tube. The solution was heated 36 hrs. at 125°C. The yellow sulfur did not disappear. On opening the tube, 0.47 cc. of noncondensable gas was measured and 7.4028 g. (100.1%) carbon disulfide, v.t. at 22°C. = 320 mm. (Lit. 321 mm.) was recovered. High vacuum sublimation of the residual material yielded 0.381 g. (91% recovery) of starting material, m.p. 87-89°C. and 0.0275 g. (86%) of a light yellow solid, m.p. 117-120°C. assumed to be sulfur.

(e) With Azo-bis-isobutyronitrile and Cyanogen (1369-1, 5, 6)

Into a 5 ml. heavy-walled bomb tube containing 0.1662 g. (0.7495 mmole) of P-hexamethyltriborophane and 0.0219 g. (0.133 mmole) of azo-bis-isobutyronitrile was condensed 97.3 cc. (4.34 mmoles) of cyanogen. The tube was sealed and heated at 80 ± 1°C. for 4 hrs. The tube was opened and a total of 2.89 cc. (0.129 mmole, 97.0%) of permanent gas, presumably nitrogen, and 92.7 cc. (4.14 mmoles, 95.3%) of cyanogen containing a trace of hydrogen cyanide (infrared analysis) were collected. The brown solid residue in the tube was sublimed to give 0.1457 g. (0.6593 mmole, 87.7%) recovery of pure P-hexamethyltriborophane (infrared analysis).

In a second experiment, a sealed, evacuated 5 ml. heavy-walled bomb tube containing 0.0455 g. (0.201 mmole) of P-hexamethyltriborophane and 0.1761 g. (1.072 mmoles) of azo-bis-isobutyronitrile was heated at 92 ± 1°C. for 4 hrs. The tube was opened and 23.9 cc. (1.07 mmoles, 99.6%) of permanent gas, presumably nitrogen was collected. The contents of the tube were sublimed at 60°C. in high vacuum to give 0.0166 g. of volatile liquid, 0.1357 g. of volatile colorless crystals and 0.0329 g. of soft colorless residue. The infrared spectrum of the liquid is consistent for isobutyronitrile, that of the volatile solid appears to show a mixture of starting triborophane and a nitrile, and that of the residue shows both BH<sub>2</sub> and CN functional groups.

A third experiment used 0.0560 g. (0.253 mmole) of P-hexamethyltriborophane and 0.3010 g. (1.83 mmoles) of azo-bis-isobutyronitrile. The tube was heated 4 hrs. at 105 ± 1°C. The tube was opened and 41.3 cc. (100.5%) of permanent gas was obtained. The contents were sublimed to give 0.0325 g. of a colorless volatile liquid, 0.0791 g. of colorless solid, m.p. 69-70°C. (uncorr.) volatile at 30°C., 0.1689 g. of colorless solid, m.p. 70-74°C. (uncorr.) volatile at 60°C. and 0.0244 g. of yellow gummy solid residue. The infrared spectra of the latter three substances all showed B-H and -CN absorptions. The two middle fractions were combined and treated with 4 ml. of hot 75% sulfuric acid to give 0.0135 g. of pure insoluble starting triborophane. The poor recovery is attributable to mechanical loss shown by a blank in which 0.0361 g. was recovered from sulfuric acid treatment of 0.0727 g. of P-hexamethyltriborophane. Dilution of the original acid solution caused 0.0221 g. of a solid nitrile to precipitate which had an infrared spectrum identical to that obtained by pyrolysis of azo-bis-isobutyronitrile alone and subsequent isolation of the solid volatile product, m.p. 168.4°C. (corr.), presumably tetramethylsuccinonitrile.

(f) With Trimethylaluminum (1357-36, 94)

Into a 6 ml. heavy-walled bomb tube containing 0.0940 g. (0.424 mmole) of P-hexamethyltriborophane was condensed 1.0 ml. (0.75 g., 10.4 mmoles) of trimethylaluminum. The tube was sealed and warmed to room temperature whereupon the triborophane quickly dissolved accompanied by a vigorous apparent evolution of a gas. The tube was heated at 100°C. for 8 hrs., cooled, opened in vacuo and found to contain 0.24 cc. of a noncondensable gas (presumably methane). The condensable material was removed leaving 0.0917 g. (98% recovery) of P-hexamethyltriborophane, m.p. 87.5-88.5°C.

In a second experiment, 0.1126 g. (0.508 mmole) of P-hexamethyltriborophane and 0.60 ml. (0.45 g., 6.25 mmoles) of trimethylaluminum were heated at 200°C. for 18 hrs. whereafter it was noted that only a single solid phase remained. After removal of methane (v.p., 11.5 mm. at -196°C.), the residue was sublimed in vacuo to give 0.1087 g. (97% recovery) of P-hexamethyltriborophane, m.p. 83-86°C. The mixed melting point with authentic material was 84-87°C.

(g) With Cyanogen and Aluminum Chloride (1369-2)

Into a 5 ml. heavy-walled bomb tube containing 0.1178 g. (0.5313 mmole) of P-hexamethyltriborophane and 0.0121 g. (0.091 mmole) of aluminum chloride was condensed 69.7 cc. (3.11 mmoles) of cyanogen. The tube was heated at 90 ± 2°C. for 3.5 hrs. The reaction mixture became black during this time. The tube was opened and 66.4 cc. (2.96 mmoles, 95.3%) of essentially pure (infrared analysis) cyanogen was recovered. The reaction solids were sublimed and 0.0723 g. (0.0327 mmole, 62.4%) of starting triborophane was recovered. Recovery was poor because of some mechanical losses.

(h) With Mercuric Cyanide (57W-17-140)

A sealed 20 ml. heavy-wall tube containing 0.3245 g. (1.464 mmoles) of P-hexamethyltriborophane, 0.7622 g. (3.017 mmoles) of mercuric cyanide and 9.5 ml. absolute methanol was heated 95 hrs. at 100-115°C. after which a considerable amount of metallic mercury was noted. No measurable noncondensable gas was observed upon opening the tube. Methanol was distilled from the tube and was shown to contain 0.837 mmoles of volatile cyanide. Sublimation of the residue for 1.5 hrs. at 90°C. yielded 0.2925 g. of crystalline material, m.p. 80-86°C. Analysis by vapor phase chromatography shows this material to be 99.2% P-hexamethyltriborophane (0.290 g., 89.4% recovery), 0.6% P-hexamethyl-B-cyanotriborophane (0.002 g., 0.5% yield) and 0.2% unknown.

(8) Attempt to Prepare P-Hexamethyl-B,B',B''-tricyanotriborophane (1358-32, 37)

Into one leg of a reaction vessel, consisting of two seal-off tubes of approximately 80 cc. capacity joined together at the necks by a tube containing a fritted glass filter, was introduced 0.19 g. (8.71 mmoles) lithium borohydride (ca. 94% purity) in thin-walled capillary tubing. Into the evacuated reaction tube was condensed 30 ml. of diethyl ether and an estimated 80 mmoles of

hydrogen cyanide (prepared by reaction of sulfuric acid and sodium cyanide). The sealed tube was then shaken violently to break the capillary tubing and the mixture allowed to react for one day at room temperature. After reaction, the mixture was filtered through the fritted disc into the other leg of the reactor, the residue was washed three times with ether. The excess hydrogen cyanide was removed by vacuum distillation and dioxane was added to the solution whereupon a white precipitate formed. This precipitate was filtered and dried in vacuo at 100°C. A lithium analysis indicates this compound corresponds to the formula  $\text{LiCNBH}_3 \cdot 0.91\text{-C}_4\text{H}_8\text{O}_2$ .

To 0.1774 g. (1.4 mmoles) of this solvated salt in an 80 ml. bomb tube was added 20 ml. of dioxane and 1.7 mmoles of dimethylphosphonium chloride (prepared from stoichiometric quantities of  $(\text{CH}_3)_2\text{PH}$  and  $\text{HCl}$ ) and the mixture was allowed to react for one day at 45°C. The hydrogen evolved was then collected by means of a Sprengel pump and found to be 10.8 cc. (34% yield). The solid mixture remaining after removal of the dioxane hydrolyzed very rapidly making analysis of the product impossible.

A second experiment was made in approximately the same manner, with the following exceptions: (1) The hydrogen was measured after reaction of lithium borohydride and hydrogen cyanide and found to be 105% of the theoretical amount; (2) No dioxane was used and the dimethylphosphonium hydrochloride was added while the lithium monocyanoborohydride was in ether solution. The mixture was heated to 60°C. for one hour during which time only 17% of theoretical hydrogen was produced; (3) The ether was removed and the remaining solid was heated to 90°C. in an attempt to polymerize the adduct. The resulting product also hydrolyzed rapidly. The infrared spectrum, however, indicated the presence of both  $\text{C}\equiv\text{N}$  and  $\text{BH}$  bonds.

(9) Reaction of Triethylamine  
Borane and Cyano Compounds (1369-3, 17)

(a) Cyanogen

Into a 5 ml. heavy-walled bomb tube containing 0.1313 g. (1.151 mmoles) of triethylamine borane was condensed 54.6 cc. (2.44 mmoles) of cyanogen. The tube was sealed and allowed to remain at room temperature for 3 days during which time the liquid contents turned dark brown and viscous. The tube was opened and no permanent gas had formed but 32.7 cc. (1.46 mmoles, 59.7%) of cyanogen containing a trace of hydrogen cyanide was recovered. The dark reaction mixture was extracted with 3 ml. of benzene and 6 ml. of diethyl ether leaving a black solid residue. The ether was discarded and the benzene evaporated to give about 0.010 g. of essentially pure triethylamine borane. The black solid was intractable and did not melt in a flame but did appear to change on heating.

(b) Hydrogen Cyanide

A sealed evacuated 5 ml. heavy-wall tube containing 0.1270 g. (1.114 mmoles) of triethylamine borane and 32.3 cc. (1.44 mmoles) of hydrogen cyanide was allowed to warm to room temperature from -78°C. The solids melted and appeared to react immediately giving a yellow color which faded rapidly

as a white precipitate formed. The tube remained at room temperature overnight, then was opened and yielded 0.68 cc. of permanent gas. The tube was resealed and heated at  $75 \pm 2^\circ\text{C}$ . for about 4 hrs. after which the tube contents were dark brown. The tube was opened and 6.79 cc. (27.2% of the expected hydrogen) of permanent gas was collected. A total of 0.0860 g. (67.7%) of impure triethylamine borane was separated in high vacuum from 0.0533 g. of an unidentified black fluffy solid which was partially soluble in methanol.

(10) Solution Chromatography of P-Hexamethyltriborophane, P-Octamethyltetra-borophane and P-Nonamethylbicyclo[4.4.0]pentaborophane Mixtures

(1358-77, 83, 87, 91, 93, 98, 100, 103, 108, 111, 115, 122, 126, 135, 138)

The chromatographic column was a 10 mm. i.d. Pyrex tube surmounted by a 125 ml. bulb to hold the eluent. The column was packed dry with 60-200 mesh alumina (activated at  $200^\circ\text{C}$ . overnight) which was settled on a glass wool support plug to a height of 80 cm. by gentle tapping for 15 min. Approximately 0.5 g. of borophanes could be placed on the column. A second column 17 mm. i.d. x 117 cm. surmounted by a 500 ml. eluent reservoir was used for samples weighing up to about 1.5 g.

The column was wetted with cyclohexane prior to introduction of a concentrated cyclohexane solution of the borophane mixture (ca. 1 g./20 ml.). A convenient flow rate of liquid through the column was maintained under a nitrogen pressure of 10 psi. The sample solution was washed onto the column with an approximately equal volume of cyclohexane divided into two portions before the reservoir was filled with eluent solution (approximately 1000 ml./g. required). The eluate passed through a glass wool filter and a 0.2 mm. infrared cell connected to the column by polyethylene tubing into sample vials. The infrared spectrophotometer set at  $4.2 \mu$  was used as a detector by measuring percent transmittance as a function of time. Elution of P-hexamethyltriborophane and P-octamethyltetra-borophane was accomplished using a 1:1 cyclohexane--cyclohexane mixture. After removal of these components from the adsorbant the eluent solution was replaced by a 3:7 benzene--cyclohexane mixture to displace the presumably isomeric mixture of P-nonamethylbicyclo[4.4.0]pentaborophanes. A typical chromatogram is shown in Figure 1.

Analysis of the eluate fractions was made either by vapor phase chromatography or melting point of the solids recovered on evaporation of the solutions to dryness (except the volatile P-hexamethyltriborophane) at ambient temperatures.

## 2. Phosphine Borines

### a. Preparation of Diethyl-, Methylphenyl- and Methyl-n-alkylphosphine Borines ( $\text{C}_3\text{-C}_8$ )

(1371-48, 52, 53, 54, 55, 58, 82, 86)

Since each of the secondary phosphine borine adducts was prepared as previously reported,<sup>17</sup> only a brief general description will be given here. Each

of the secondary phosphines was sampled in a closed system and analyzed by vapor phase chromatograph and infrared spectrophotometer. A sample of suitable purity of each phosphine was treated with diborane to give the corresponding adduct. Diborane was purified by passing it through a stainless steel cold trap at  $-120^{\circ}\text{C}$ ., at a pressure not exceeding 25 mm. This diborane was collected at  $-196^{\circ}\text{C}$ . and stored at  $-78^{\circ}\text{C}$ . in a stainless steel bomb until used. On each adduct sample, densities were determined at  $25^{\circ}\text{C}$ . using a pycnometer calibrated at  $25^{\circ}\text{C}$ . with distilled water and infrared spectra were determined for reference. The data are summarized in Table V.

b. Preparation and Pyrolysis of 1,3-Tri-  
methylene-P,P'-Bis(dimethylphosphine Borine) (1350-127)

A 0.7 g. (4.3 mmoles) quantity of crude 1,3-bis(dimethylphosphino)propane was treated with 3.557 mmoles of diborane to yield crude 1,3-trimethylene-P,P'-bis(dimethylphosphine borine). The crude borine adduct was sublimed and then recrystallized from toluene to yield white crystalline platelets, m.p.  $162-163^{\circ}\text{C}$ . Part of the borine adduct, 0.1606 g. (0.837 mmoles), was transferred into a 38 ml. glass bomb tube equipped with a double seal-off tip and evacuated. The sealed tube was heated at  $200^{\circ}\text{C}$ . for 24 hrs. and opened on the vacuum line. The gas was collected and found by combustion over cupric oxide to consist of 1.374 cc. (0.0613 mmole) of hydrogen and 0.0114 cc. (0.00051 mmole) of methane. The bomb tube was resealed and again heated at  $200^{\circ}\text{C}$ . for an additional 174 hrs. producing an additional 2.5954 cc. (0.1159 mmole) of hydrogen and 0.0186 cc. (0.00083 mmole) of methane.

3. Phosphines

a. Preparation of Methyl-n-  
alkylphosphines ( $\text{C}_3\text{-C}_8$ ) (1371-4, 6, 8, 16, 21, 24)

A series of secondary phosphines was prepared from sodium methylphosphinide and a n-alkyl chloride in liquid ammonia<sup>5</sup> using approximately 1000 ml. of solvent per mole of sodium salt. In the preparation of methyl-n-propyl and methyl-n-butylphosphines only, hexane was added to reduce the partial vapor pressure of the phosphines before allowing the ammonia to evaporate. The residual solids were extracted with either toluene (for the three higher boiling compounds) or with hexane. Since each of the preparations was done in a similar manner only the synthesis of methyl-n-butylphosphine will be described in detail. Data for all the preparations are summarized in Table VI.

A nitrogen-swept 2000 ml. cylindrical six-neck flask fitted with a glass stirrer, Dry Ice condenser, two 100 ml. pressure equalized addition funnels and gas addition tube was used. The off-gases were vented through a mercury bubbler to a flare. A 24.9 g. (1.08 moles) quantity of sodium was cut under oil, washed with hexane, and placed in the reaction vessel. The system was then evacuated, filled with nitrogen and 100 g. (1.08 moles) of butyl chloride was placed in the addition funnel under a nitrogen flow. Approximately 1000 ml. of liquid ammonia was then added to the flask giving the characteristic deep blue colored solution. Gaseous methylphosphine was added as rapidly as possible (about 2 hrs.) until the



TABLE V

Preparation of Secondary Phosphine Borines

CH <sub>3</sub> RPH Reagent		CH <sub>3</sub> RPHBH <sub>3</sub> Product	
R	Purity, % <sup>(a)</sup>	Wt. g.	d <sup>25</sup> , g./ml.
C <sub>2</sub> H <sub>5</sub> <sup>(b)</sup>	94.4	46.6	-
n-C <sub>3</sub> H <sub>7</sub>	96.0	16.7	0.778
n-C <sub>4</sub> H <sub>9</sub>	99.9 <sup>+</sup>	30.1	0.784
n-C <sub>5</sub> H <sub>11</sub>	98.7	28.9	0.788
n-C <sub>6</sub> H <sub>13</sub>	98.0	30.6 <sup>(c)</sup>	0.793
n-C <sub>7</sub> H <sub>15</sub>	99.5	25.0 <sup>(d)</sup>	0.798
n-C <sub>8</sub> H <sub>17</sub>	99.9	21.5	0.804
C <sub>6</sub> H <sub>5</sub>	97.8	27.9	0.944

(a) By vapor phase chromatographic analysis.

(b) Diethylphosphine with hydrocarbon impurities only.

(c) Molecular weight; found 149.0, calcd. 146.0.

(d) Molecular weight; found 162.7, calcd. 160.1.

TABLE VI  
Preparation of Methyl-n-alkylphosphines

Na		Reagents			CH <sub>3</sub> RPH Product				
Wt. g.	Moles	R	n-RCl		Wash Solvent, ml.	Wt. g.	Moles	Yield (a), %	Approximate b.p., °C./mm.
			Wt. g.	Moles					
29.3 (b)	1.27	C <sub>3</sub> H <sub>7</sub>	62	0.79	hexane, 600	18.5	0.21	26.0 (b)	65°/400
24.8	1.08	C <sub>4</sub> H <sub>9</sub>	100	1.08	hexane, 450	74.1	0.71	65.9	63°/144
21.6	0.94	C <sub>5</sub> H <sub>11</sub>	100	0.94	hexane, 400	91.5	0.77	82.6	70°/74
19.1	0.83	C <sub>6</sub> H <sub>13</sub>	100	0.83	toluene, 350	83.2	0.63	75.9	90°/82
17.1	0.74	C <sub>7</sub> H <sub>15</sub>	100	0.74	toluene, 450	94.3	0.65	86.8	117°/100
15.5	0.67	C <sub>8</sub> H <sub>17</sub>	108	0.73	toluene, 300	91.7	0.57	91.6	81°/10

(a) Yield based on alkyl chloride.

(b) 17.5 ml. of conc. NH<sub>4</sub>OH (0.67 mole H<sub>2</sub>O) added to destroy excess sodium;  
 yield 48% based on sodium.

color of the solution changed to yellow. The butyl chloride was added dropwise, followed by 100 ml. of hexane. The ammonia was allowed to evaporate overnight and the residual slurry was pressure siphoned to a sintered glass filter with the aid of an additional 50 ml. of hexane. The reaction vessel and residual solids were washed with three 100 ml. portions of hexane.

Hexane was distilled from the colorless filtrate through a 3/4" x 24" column packed with 0.16" x 0.16" stainless steel protruded packing and the remaining material was fractionated on a spinning band column at 2050 RPM yielding the following fractions: (1) 31 g., b.r. 50-58°C./403 mm.; (2) 2.7 g. forerun, b.r. 53-63°C./144 mm.; (3) 74 g. methyl-n-butylphosphine, b.r. 63-64°C./144 mm. and 3.4 g. residue. A 1.0 g. center cut was taken from fraction (3) for a reference sample. Each of the fractions with the exception of the solvent was sealed in an ampoule.

b. Preparation of Diethylphosphine (1371-31)

Diethylphosphine was prepared from sodium, ethyl chloride, and phosphine in liquid ammonia following the procedure previously outlined,<sup>8</sup> and using 52 g. (2.26 moles) of sodium in the first step and 49.5 g. (2.15 moles) of sodium in the second step. The quantities of phosphine and ethyl chloride used were not measured but addition of these reagents to the reaction mixture was governed by color changes. Phosphine for the reaction was generated by addition of water to a dioxane slurry of 755 g. of magnesium aluminum phosphide.<sup>18</sup> Before the ammonia was allowed to evaporate 270 ml. of hexane was added to the slurry to reduce the volatility of the diethylphosphine and to facilitate its separation from the solid salts. The salts were filtered, washed and discarded. The hexane solution was fractionated at 727 mm. on a spinning band column at 2050 rpm. yielding: 48 g. forerun, b.r. 69-81°C.; 19 g., b.r. 81.5-82.5°C. (87% diethylphosphine by VPC); 28.8 g., b.p. 82.5°C. (99.3% diethylphosphine by VPC); and 3.3 g. residue. The 45.1 g. (0.50 mole) of product corresponds to a yield of 22.1%.

c. Preparation of 1,3-Bis-  
(dimethylphosphino)propane (1350-111)

A 3.107 g. (22.83 mmoles) quantity of 1,3-bis(methylphosphino)propane was added to 50 ml. of n-pentane in a closed, magnetically stirred reactor vented through a mercury bubbler. A 5.7 ml. (91.51 mmoles) quantity of methyl iodide was added dropwise to the phosphine solution. The solvent and excess methyl iodide were removed from the white phosphonium salt under vacuum. The salt was dissolved in distilled water, transferred to a separatory funnel containing 20 ml. of n-pentane, and neutralized with aqueous 50% potassium hydroxide. The organic phase was washed three times with slightly basic water. The combined water extracts were exhaustively extracted with n-pentane. The extracts and the organic phase were combined, concentrated to about 15 ml., and dried over magnesium sulfate. Crude 1,3-bis(dimethylphosphino)propane (assaying 93.0% by vapor phase chromatography) was obtained by vacuum stripping the residual n-pentane.

d. Preparation of Ethyldichlorophosphine (1369-8)

The directions of Kharasch, et al.<sup>9</sup> were followed in this preparation. To 137 g. (1.0 mole) of phosphorus trichloride contained in a 500 ml. round-bottomed flask, fitted with a reflux condenser protected by a mercury bubbler, dropping funnel, argon inlet and small Vigreux column with take-off, was added dropwise 100 g. (0.3 mole) of tetraethyllead. The system was agitated by gently swirling the whole apparatus during addition which took about 15 min. The homogeneous solution was heated at 100°C. for 24 hrs. A white precipitate formed during the heating period. Part of the mixture was distilled from the reaction vessel and had b.p. 90-105°C. The distillate was returned to the flask and the mixture refluxed another 16 hrs. The reaction mixture was then distilled at atmospheric pressure giving four fractions: (1) b.p. to 105°C., 35.0 g.; (2) b.p. 105-109°C., 23.0 g.; (3) 109-111°C., 14.7 g.; (4) 111-112.5°C., 43.4 g. The infrared spectra of these fractions showed less than 1% POCl<sub>3</sub> and lines at 1283, 1239 and 969 cm.<sup>-1</sup> which are not present in pure ethyldichlorophosphine.<sup>19</sup> The amount of unreacted phosphorus trichloride could not be determined by infrared analysis.

e. Preparation of o-Bromobenzyl Methyl Ether as an Organophosphine Intermediate (1350-82)

The method previously described<sup>10</sup> was employed with slight modification. A 922.3 g. (3.690 moles) quantity of o-bromobenzyl bromide was added to 1182.2 g. (36.90 moles) of refluxing methanol containing 213.3 g. (5.332 moles) of sodium hydroxide over a period of 40 min. After removing 691 g. (58%) of the methanol by distillation, the concentrated mixture was washed three times with 1000 ml. portions of water. The combined water extracts were exhaustively washed with diethyl ether. The combined ether and methanol solutions were dried over magnesium sulfate, filtered, and fractionated through a 2 ft. spinning band column to give 667.7 g. (3.321 moles, 90.0%) of o-bromobenzyl methyl ether, b.p. 98-100°C./15-16 mm., assaying 99.96% by vapor phase chromatography.

The forerun, 20.3 g., b.p. 96-98°C./15-16 mm., and afterrun, 38 g., b.p. 100-101°C./15-16 mm. also were analyzed chromatographically and found to contain an additional 55.0 g. of product thus providing an over-all reaction yield of 97.4%

f. Preparation of Dimethylaminomethylchlorophosphine (57W-17-125)

To a stirred solution of 39.2 g. (0.335 mole) of methyldichlorophosphine in 500 ml. of anhydrous ether was added 30.2 g. (0.670 mole) of dimethylamine during 3 hrs. while the reaction mixture was maintained between 0°C. and 20°C. After warming to room temperature the reaction mixture was filtered to remove the dimethylammonium chloride. Fractional distillation of the filtrate at atmospheric pressure yielded, after removal of ether, the following fractions: (1) 1.0 ml., 35-125°C., (2) 4.5 ml., 125-142°C., (3) 22.0 ml., 142-142.5°C., (4) 5.5 ml. residue. Fraction (3) analyzed 28.1% Cl; calcd. for C<sub>3</sub>H<sub>9</sub>ClNP: Cl, 28.2%.

g. Purification of  
p-Bis[bis(dimethylamino)phosphino]benzene (57W-17-116)

An impure crystalline sample of p-bis[bis(dimethylamino)phosphino]benzene<sup>20</sup> sublimed at 125°C. under high vacuum. The colorless crystalline material had a melting point 146-148°C. Anal. calcd. for C<sub>6</sub>H<sub>4</sub>(P[N(CH<sub>3</sub>)<sub>2</sub>]<sub>2</sub>)<sub>2</sub>: C, 53.49; H, 8.98. Found: C, 53.16; H, 9.06.

h. Attempt to Prepare \*  
Diphosphinomethane (1350-142)

A 0.8652 g. (37.62 mmoles) quantity of sodium, 2.8 ml. of anhydrous ammonia, and 900 cc. (40.18 mmoles) of phosphine were introduced into the reactor at -78°C. on the vacuum line. After formation of sodium phosphinide, all of the solvent containing excess phosphine was removed and replaced with about 28 ml. of fresh ammonia. Over a two-hour period 1.5920 g. (18.74 mmoles) of methylene chloride was introduced below the liquid surface at -78°C. The solution in the reactor remained a pale yellow and a white solid precipitated. No formation of the characteristic orange residue common to polymeric residues containing P-P bonding was observed. The portion of the reaction mixture that was volatile at -78°C. was passed through an anhydrous zinc sulfate trap at 0°C. When about three-fourths of the material had passed into the zinc sulfate trap, the trap broke and water was drawn into the trap and the reactor. However, the portion of material which had passed the zinc sulfate and collected at -196°C. was saved. The collected material was separated into three fractions identified by their infrared spectra as 270.2 cc. (12.1 mmoles) of phosphine, 38.22 cc. (1.71 mmoles) of methylphosphine, and 22 cc. (1.0 mmole) of methylene chloride. In addition, 11.8 cc. (0.53 mmole) of unidentified two-phase liquid mixture was obtained showing C-H and P-H in its infrared spectrum.

For a second experiment the reactor was modified so that it could be inverted to filter the reaction slurry before passing the vaporized filtrate through the zinc sulfate trap. In the manner described in the first experiment, the following reagents were combined: 0.8631 g. (37.53 mmoles) of sodium, 885.4 cc. (39.53 mmoles) of phosphine, 30 ml. of ammonia, 1.5934 g. (18.76 mmoles) of methylene chloride. A noncondensable gas (6.06 cc.) observed on completion of the reaction was found after combustion over cupric oxide to consist of 5.01 cc. (0.224 mmole) of noncombustible permanent gas and 0.05 cc. (0.0023 mmole) of gas volatile at -78°C. The reduction in volume is most readily explained by the assumption that oxygen was depleted from a small quantity of air which leaked into the system.

The reactor was inverted and the receiving bulb placed in a -78°C. bath. As the pale yellow liquid passed through the sintered glass disc an orange, apparently polymeric, material formed in the filter. When the filtration was about half completed, the filter became clogged and the top portion of the apparatus blew off. The filtrate was quickly placed on the vacuum line and frozen. The filtrate was vaporized and slowly passed through a zinc sulfate trap at 0°C. The material that passed through the zinc sulfate was found, by fractional condensation, to contain small amounts of phosphine, methylphosphine, and a trace of the same

unidentified mixture of compounds containing P-H and C-H bonds. The major product, however, was water believed to have been displaced by ammonia from the incompletely dehydrated zinc sulfate.

i. Attempt to Prepare  
Methylcyanophosphine (1361-58, 61, 67)

Into an evacuated 10 ml. tube were condensed 0.1636 g. (1.54 mmoles) of cyanogen bromide and 35.82 cc. (1.55 mmoles) of, previously purified (99.9% by VPC) methylphosphine. The sealed tube was warmed to room temperature and a vigorous reaction ensued forming a white solid. The tube was opened and 18.3 cc. (0.82 mmole) hydrogen cyanide and 0.0184 g. of solid, m.p. 161-210°C. was removed, after which 0.1103 g. (1.09 mmoles) of triethylamine was condensed onto the remaining solid. The sealed tube was heated for 4 hrs. at 100°C. with noticeable yellowing of the reaction mixture. A small quantity (0.0731 g.) of an unidentified volatile liquid was removed and the remaining solid (0.1909 g.) from which an 0.0110 g. sample was removed, m.p. 161-211°C., was subjected to high vacuum sublimation (150-165°C.) yielding 0.0746 g. (0.41 mmole) triethylammonium bromide identified by its infrared spectrum, m.p. 210-236°C., and 0.0728 g. of unidentified yellow residue, m.p. 142-166°C.

Similar results were obtained in a second experiment using 0.2380 g. (2.25 mmoles) cyanogen bromide and 50.18 cc. (2.24 mmoles) methylphosphine and following the same procedure except that the reaction solids were heated with excess triethylamine.

A third experiment was attempted by slowly adding to a 5 ml. hexane solution (95 mole %) of 130.9 cc. (5.85 mmoles) of methylphosphine, 0.6194 g. (5.84 mmoles) of cyanogen bromide in 5 ml. hexane from a side arm of a 100 ml. sealed tube. Immediate reaction occurred forming a white flocculent solid, m.p. 140-182°C. (0.3206 g.), and 82.88 cc. (3.70 mmoles) hydrogen cyanide. The solids were fractionally sublimed under high vacuum (180-200°C.) yielding three unidentified fractions.

### III. BORON-NITROGEN POLYMERS

#### A. Discussion

##### 1. Borazene Polymer Syntheses

##### a. Pyrolyses and Copyrolysis of the Isomeric Pentamethylborazenes

The previous attempt<sup>21</sup> to prepare decamethyl-B,N'-biborazyl (I) by pyrolytic dehydrogenation was repeated on a larger scale but again was concluded without positive result. The attempted reaction indicated by equation (14) appears to play only a minor part in the pyrolysis reaction which is better represented as the series of disproportionation reactions indicated by equations (15-17).

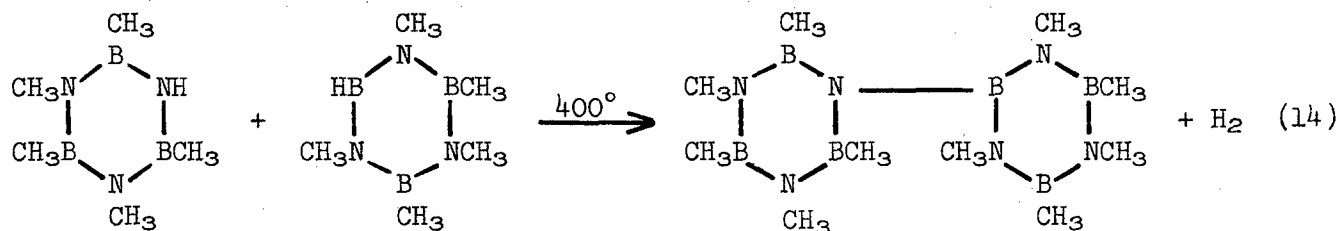

I

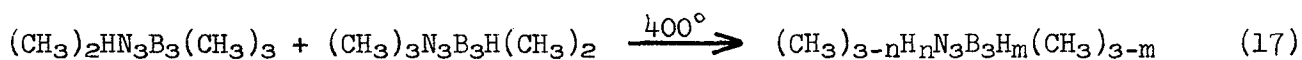
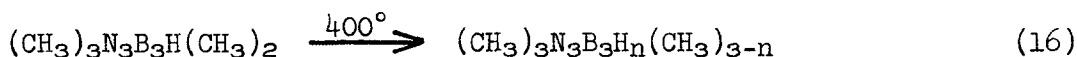
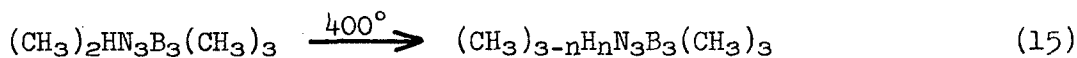

The products of the independent pyrolyses of the two isomeric pentamethylborazenes (equations 15 and 16) showed very little decomposition, if any, based on outward appearances and lack of significant gas evolution. However, infrared and vapor phase chromatographic analyses demonstrated that considerable disproportionation to tri-, tetra- and hexamethylborazenes had occurred but indicated that exchange of substituents took place only if those substituents were bonded to like atoms and not between boron and nitrogen substituents.

The condensation of two borazene nuclei to prepare decamethyl-B,N'-biborazyl (I) was successfully accomplished by the elimination of lithium chloride from an equimolar mixture of N-lithiopentamethyl- and B-chloropentamethylborazenes.

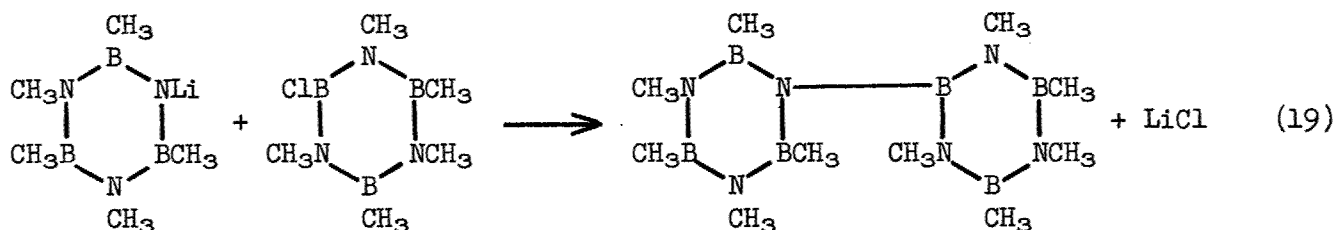

I

Extension of this type reaction to multifunctional borazene derivatives led to the preparation of two isomeric diborazylborazenes (II), one of the isomeric tri-borazylborazenes (III), and finally a diborazylene polymer (IV).

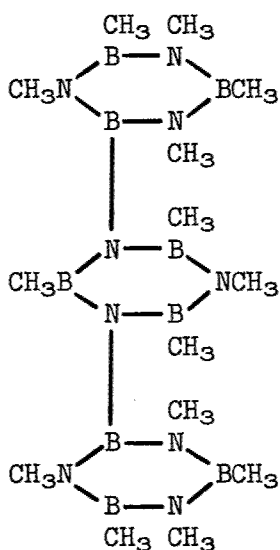

IIa

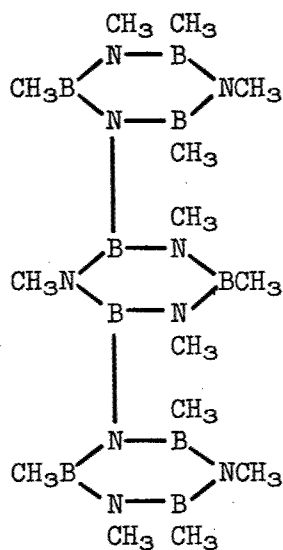

IIb

An attempt to prepare N-triborazylborazene (IIIa) gave decamethyl-diborazyl oxide (V) as the principal product. Presumably the intermediate N-trilithio-B-trimethylborazene is unstable or reacts with the solvent and is thus unavailable for reaction with pentamethyl-B-chloroborazene.



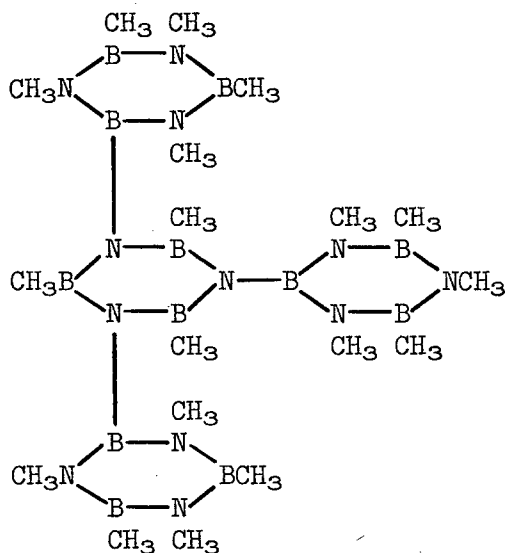

IIIa

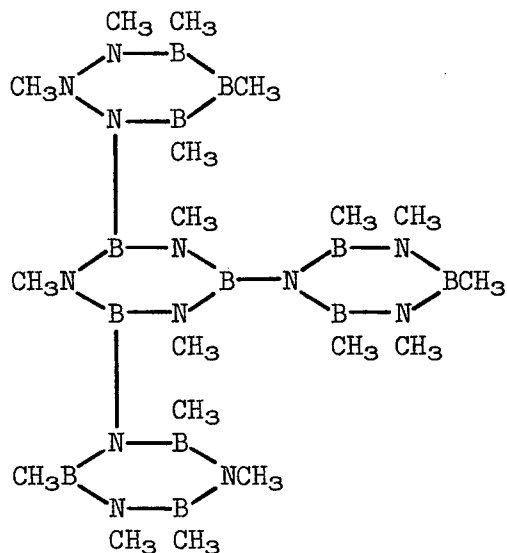

IIIb

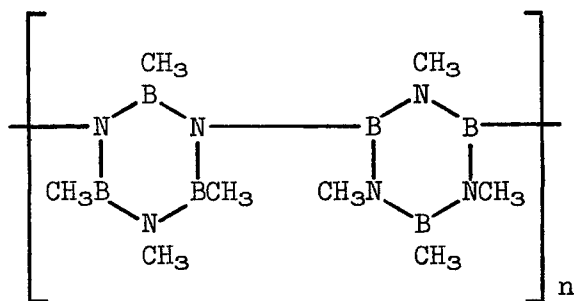

IV

A third approach to the synthesis of decamethyl-B,N'-biborazyl and related polymers was tried and appeared at first to be successful. In eight separate experiments, equimolar mixtures of N-dimethyl-B-trimethylborazene and N-trimethyl-B-dimethyl-B-chloroborazene were dehydrohalogenated with either triethylamine, pyridine, or triethylenediamine giving a crystalline product at first believed to be decamethyl-B,N'-biborazyl but subsequently characterized as decamethyl-B,B'-diborazyl oxide in yields as high as 67%. The yield of this by-product was markedly reduced in experiments done in sealed tubes or if shorter reaction times were used in the experiments done under an "inert" atmosphere. No identifiable products were obtained in an attempt to prepare 2,4-bis(2',3',4',5',6'-penta-methyl-1'-borazyl)-1,3,5,6-tetramethylborazene (IIb) by a dehydrohalogenation reaction.

The partial hydrolysis of N-trimethyl-B-dimethyl-B-chloroborazene has been shown to result in the coupling of two borazyl radicals through an oxygen atom to give decamethyl-B,B'-biborazyl oxide (V).

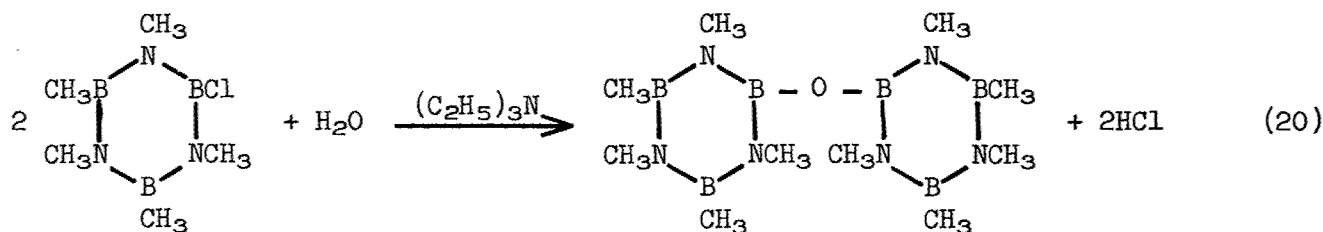

V

Partial hydrolysis of mixtures of mono- and dihalo-substituted borazene derivatives gave a series of products (VI) with an increasing number of borazene rings in the chain while hydrolysis of the dihaloborazene derivative alone gave a polymeric chain of rings (VII) with a degree of polymerization of approximately 23.

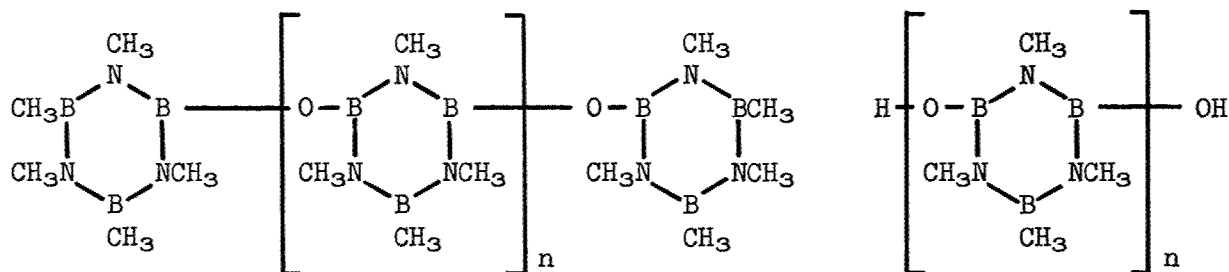

VI

VII

Only with the simplest compound (V) was characterization definitive. With the more complex materials indicated by the idealized formula (VI) three different compounds may be formed if the terminal ring (or rings) were derived from the dichloro- rather than the monochloroborazene derivative. Terminal rings of this origin carry a B-hydroxy functional group as indicated in formula (VII).

## 2. Borazene Intermediates

### a. Preparation of N-Dimethyl-B-trimethyl- and N-Methyl-B-trimethylborazenes

Following a published method<sup>22</sup> for the synthesis of N-methyl-substituted borazenes, a mixture of 299 g. of four B-trimethylborazenes with varying amounts of N-methyl substitution was prepared by coprolysis of a mixture of methylamine trimethylborine and ammonia trimethylborine<sup>23</sup> as indicated in equation (21)



Considerable difficulty was encountered in securing a high pressure seal in each of the three pyrolysis runs due to a faulty gasket seat. However, the 62% yield of crude product was fractionated to yield both N-methyl-B-trimethyl- and N-dimethyl-B-trimethylborazenes.

N-Alkylation of B-trimethylborazenes was also accomplished by treating the newly discovered N-lithio-derivatives with methyl iodide (equation 18). N-Lithio-N-dimethyl-B-trimethylborazene gave hexamethylborazene and N-lithio-B-trimethylborazene gave primarily N-methyl-B-trimethylborazene with lesser quantities of the N-dimethyl-B-trimethyl- and hexamethylborazenes on alkylation with methyl iodide. Although experimental conditions were not optimised the latter reaction provides a convenient synthetic method for unsymmetrically or partially N-substituted borazene derivatives.

b. Preparation of N-Trimethyl-B-methyl- and N-Trimethyl-B-dimethylborazenes

The methylation of N-trimethylborazene with one or two moles of methylmagnesium iodide appears to be the most direct approach in the preparation of these B-dimethyl derivatives.<sup>24</sup>

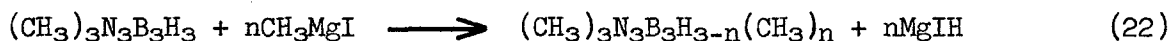

Accordingly a supply of N-trimethylborazene was prepared in good yield by pyrolysis of methylaminoborine trimer<sup>25</sup> according to the equation,

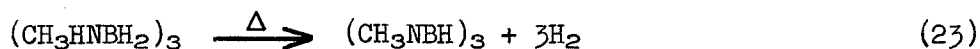

Infrared analysis of the distillation forerun detected a compound which from volatility and solubility considerations is most probably dimethylaminoborine arising from an impurity in the methylamine used as starting material.

A critical part of the preparation of B-alkyl derivatives by the Grignard method is the quantity of saturated aqueous ammonium chloride used to decompose the Grignard complex, as an excess causes loss of product by hydrolysis<sup>25</sup> whereas a deficiency causes incomplete extraction of the product from the complex. Fieser<sup>26</sup> suggests generally 150 to 170 ml. of saturated aqueous ammonium chloride per mole of magnesium salts; however, we have found that 125 ml./mole (or perhaps even less) is sufficient to decompose the complex.

In order to avoid the hydrolysis problem entirely, the use of anhydrous tertiary amines was proposed and found by experiment to be successful in complexing the magnesium salts and allowing the separation of the borazene product in fairly good yield. Additional experiments along these lines would undoubtedly result in other refinements in the preparative method.

c. Preparation of Partially  
B-Halogenated Borazene Derivatives

N-Trimethyl-B-dimethyl-B-chloroborazene was prepared in about 50% yield by the alkylation of N-trimethyl-B-trichloroborazene with two equivalents of methyllithium.<sup>27,28</sup> A similar alkylation with one equivalent of methyllithium produced N-trimethyl-B-methyl-B-dichloroborazene in about 38% yield. In another experiment using 100% excess of the borazene derivative the yield was raised to about 55%. Separation of the B-chloroborazene derivatives in a reasonable state of purity by fractional sublimation of the reaction mixtures has proved to be a tedious process. Therefore a better means of either purification or synthesis was sought.

A series of four chlorinating agents were tried in an effort to find a reagent which would replace a hydrogen on boron in N-trimethyl-B-dimethylborazene with chlorine in high yield and allow facile isolation of a high purity product.

When N-trimethyl-B-dimethylborazene was treated with one equivalent of hydrogen chloride in a sealed tube at 130°C., N-trimethyl-B-dimethyl-B-chloroborazene and hydrogen were produced in very high yields (>95%). The borazene derivative was characterized by chlorine analysis, melting point, and infrared spectrum. This much simpler method of preparation was extended to the chlorination of N-trimethyl-B-methylborazene with equally successful results. When N-trimethyl-B-methylborazene was treated with two equivalents of hydrogen chloride in a sealed tube at 150°C., N-trimethyl-B-methyl-B-dichloroborazene and hydrogen were produced in very high yields (>95%). The by-product hydrogen was identified by combustion over hot copper oxide and the borazene derivative was characterized by chlorine analysis, melting point, and infrared spectrum. It appears that selective elimination of hydrogen rather than methane from 1:1 or 2:1 adducts of hydrogen chloride with partially B-methylated N-trimethylborazenes is readily accomplished as might be predicted from the work of Wiberg<sup>29</sup> on the 3:1 adducts of hydrogen chloride with either N-trimethylborazene or hexamethylborazene where the B-H and B-CH<sub>3</sub> functions are in separate molecules. The mono- and di-substituted bromine analogs were prepared similarly using hydrogen bromide.

Two experiments were carried out in which N-trimethyl-B-dimethylborazene and carbon tetrachloride were heated together in equimolar amounts without any evidence of a halogenation reaction. In one experiment a trace of aluminum chloride was used in an attempt to catalyze the reaction. No evidence of chloroform formation was detected in either experiment.

Two unsuccessful attempts were made to chlorinate N-trimethyl-B-trimethylborazene with N-chlorosuccinimide in carbon tetrachloride. In both attempts, considerable amounts of dark, tarry residue were formed, and no evidence of B-Cl bond formation was found, although only part of the borazene derivative was recovered.

An unsuccessful attempt was made to chlorinate N-trimethyl-B-dimethylborazene with cupric chloride in acetonitrile in the presence of a deficiency of ammonia. A very small yield of a borazene compound was isolated which appeared to be neither the starting material nor the chloro-derivative.

### 3. Pseudoaromatic Boron-Nitrogen Compounds

Two pseudoaromatic boron-nitrogen compounds, one of them a new compound, have been prepared and pyrolyzed in an attempt to prepare a linear borazene polymer. With both compounds steric requirements of substituent groups prevent cyclization to a hexatomic ring.

#### a. Preparation and Pyrolysis of 7-Methyl-8-bora-7,9-diazaro-peri-naphthene

The reaction of N-methyl-1,8-diaminonaphthalene successively with boron trichloride and lithium aluminum hydride (equations 24 and 25) gave 7-methyl-8-bora-7,9-diazaro-peri-naphthene in 75% yield. After extensive purification the product analyzed correctly for carbon and hydrogen, yielded almost the theoretical amount of hydrogen on methanolysis, had the correct molecular weight, but did not have a sharp melting point.

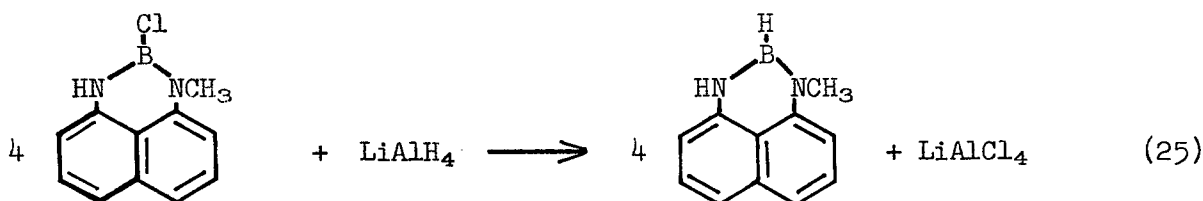
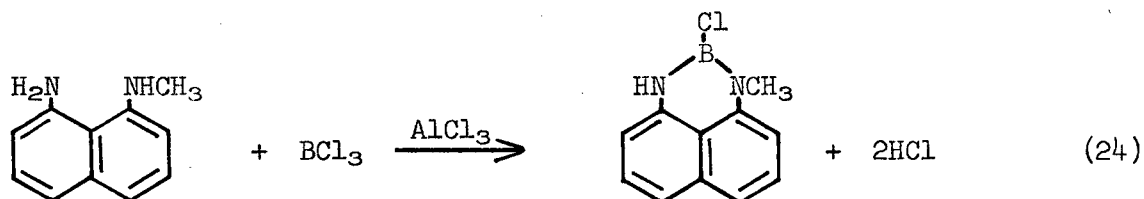

An attempt to prepare 7-methyl-8-bora-7,9-diazaro-peri-naphthene by successive reactions of 8-bora-7,9-diazaro-peri-naphthene<sup>30</sup> with methyllithium and methyl iodide (equations 26 and 27) gave a very poor yield of an unidentified product which had no B-H absorption in its infrared spectrum.

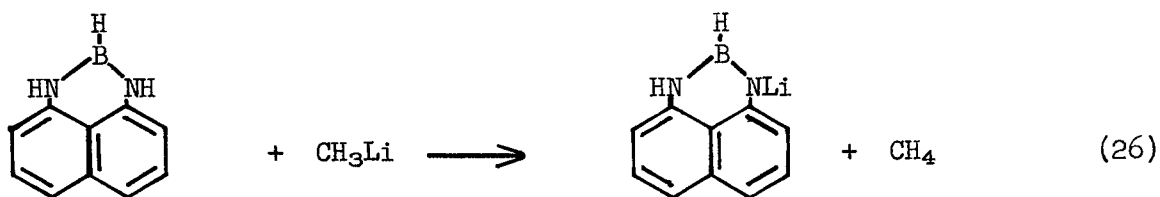

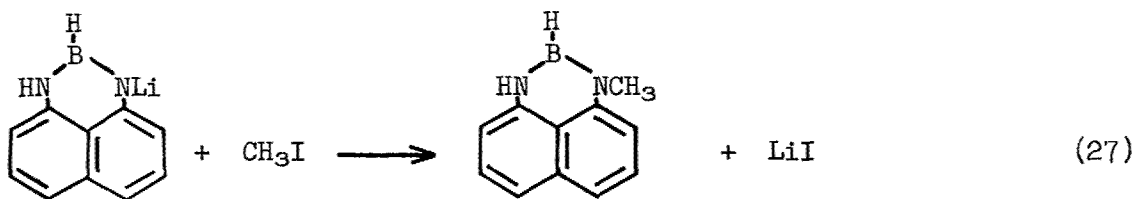

A sample of 7-methyl-8-bora-7,9-diazaro-peri-naphthene was pyrolyzed in an attempt to determine whether a linear borazene polymer would result according to equation (28).

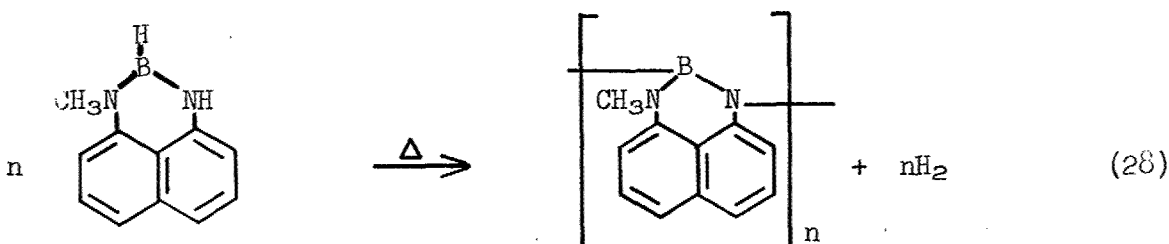

A preliminary small scale pyrolysis of 7-methyl-8-bora-7,9-diazaro-peri-naphthene yielded only 28% of the theoretical hydrogen. Infrared analysis of the pyrolysis mixture showed the presence of unchanged starting material and other unidentified substances. In a second experiment the hydrogen liberated during 77 hrs. at 360°C. was only 83% of the theoretical suggesting incomplete polymerization. However, an attempt to remove any unreacted 7-methyl-8-bora-7,9-diazaro-peri-naphthene by sublimation proved unsuccessful. An infrared spectrum showed N-H but no B-H bands suggesting perhaps another mode of decomposition.

b. Preparation and Pyrolysis of 10,9-Borazarophenanthrene

Following a procedure described by Dewar<sup>31</sup> 2.8 g. of pure 10,9-borazarophenanthrene were prepared in 16% yield. Pyrolysis of this material at 350-450°C. for 3-5 days produced 70-94% of the hydrogen expected according to equation (29).

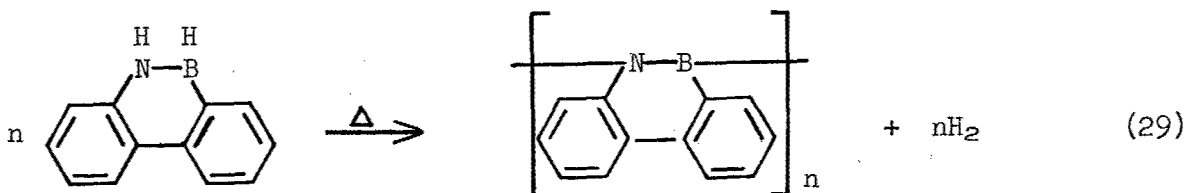

The degree of polymerization of the residual solid was not established conclusively but it appeared to be low.

c. Preparation of 8-Phenyl-8-bora-7,9-diazaro-peri-naphthene

8-Phenyl-8-bora-7,9-diazaro-peri-naphthene has been prepared in 64% yield by reaction of 1,8-diaminonaphthalene and phenyldichloroborane in benzene solution.

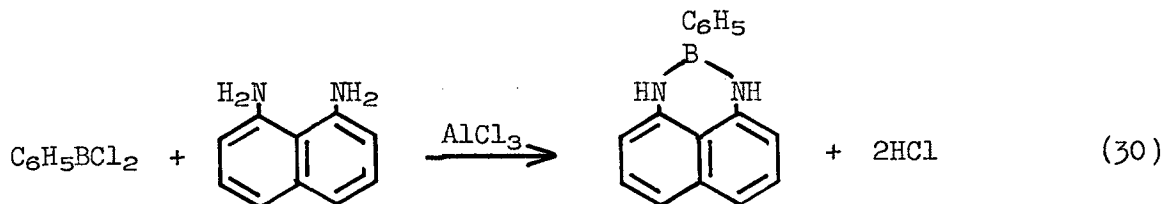

The structure of the product was assigned on the basis of its method of preparation, infrared spectrum and correct carbon and hydrogen analyses. Treatment of this compound by 2.7M sodium hydroxide in 50% aqueous ethanol and 1.9M hydrochloric acid in 50% aqueous ethanol resulted in about 83 and 66% hydrolysis, respectively after 16 hrs. at 80°C. One of the identified hydrolysis products was 1,8-diaminonaphthalene. The relative ease with which 8-phenyl-8-bora-7,9-diazaronaphthene was hydrolyzed suggests a lesser aromatic character than similar heterocyclic compounds.<sup>32</sup>

d. Preparation of N-Methyl-1,8-diaminonaphthalene

The reaction of 1,8-diaminonaphthalene successively with freshly prepared methyllithium and methyl iodide in ether produced crude N-methyl-1,8-diaminonaphthalene in 69% yield. Characterization was accomplished by its method of preparation, infrared spectrum and, following extensive purification, carbon and hydrogen analyses. Possible by-products in the crude product are N,N- and N,N'-dimethyl-1,8-diaminonaphthalene.

4. Miscellaneous Boron-Nitrogen Compounds

a. Attempt to Prepare Tetrakis(dimethylamino)diboron

Following the method of Skinner and Smith<sup>33</sup> for the preparation of bis(dimethylamino)chloroborane, the intermediate bis(dimethylamino)bromoborane was prepared in yields of 80.0%, 29.5% and 61.5%. The product from the third preparation assayed high for boron and nitrogen.

This intermediate was used following the method of McCloskey, et al.<sup>34</sup> in two unsuccessful attempts to prepare tetrakis(dimethylamino)diboron. The product obtained was contaminated with compounds which could not be removed by treatment with dimethylamine or by distillation. The purity of the distilled product

was not determined since it appeared to decompose extensively upon vapor phase chromatographic analysis using a silicone oil/Celite column.

Accordingly an alternate synthesis described by McCloskey, et al.<sup>34</sup> was begun with the synthesis of tris(dimethylamino)borane in 67.0% yield. Vapor phase chromatographic analysis of the product using a silicone oil/Celite column showed extensive decomposition during the analysis.

## B. Experimental

### 1. Borazene Polymer Syntheses

#### a. Pyrolyses and Copyrolysis of the Isomeric Pentamethylborazenes (1364-55, 58, 59)

##### (1) N-Dimethyl-B-trimethylborazene

A 0.5058 g. (3.357 mmoles) sample of N-dimethyl-B-trimethylborazene (assay 99.3%) after pyrolysis in a 5 ml. bomb tube for 16 hrs. at 400°C. appeared essentially unchanged and yielded only 0.90 cc. of noncondensable gas identified as predominantly methane. However, infrared and vapor phase chromatographic analyses summarized in Table VII indicated that considerable disproportionation had occurred yielding all four of the possible disproportionation products,  $H_n(CH_3)_{3-n}N_3B_3(CH_3)_3$ .

##### (2) N-Trimethyl-B-dimethylborazene

A similar pyrolysis of 0.4426 g. (2.938 mmoles) N-trimethyl-B-dimethylborazene (assay 99.9%) in a 5 ml. bomb tube under the same conditions as before resulted in the formation of a slight trace of noncondensable gas (0.01 cc.), with no visible evidence of sample decomposition. The results of infrared and vapor phase chromatographic analyses showing considerable disproportionation to the series of four products,  $(CH_3)_3N_3B_3H_n(CH_3)_{3-n}$ , are summarized in Table VII.

##### (3) N-Dimethyl-B-trimethyl- and N-Trimethyl-B-dimethylborazenes

A mixture of 0.2219 g. (1.473 mmoles) N-trimethyl-B-dimethylborazene (assay, 99.9%) and 0.2291 g. (1.521 mmoles) N-dimethyl-B-trimethylborazene (assay, 99.3%) after pyrolysis in a 5 ml. bomb tube for 33 hrs. at 400°C. had turned slightly amber colored and produced 13.96 cc. of methane and 4.69 cc. of hydrogen (14.2% of theoretical). That portion of the mixture volatile at room temperature in high vacuum was distilled from 0.0189 g. of brown residue. Vapor phase chromatographic analysis of the distillate showed that considerable disproportionation into tetra- and hexamethylborazenes had occurred. The analytical results are presented in Table VII together with the results obtained from the independent pyrolyses of the two pentamethylborazene isomers.



TABLE VII

Pyrolytic Disproportionation Products  
from the Isomeric Pentamethylborazenes

Compound	Pyrolysis		Product Composition	
	Time, hrs.	Temp., °C.	No. of Methyl Groups	Percent (a)
N-Dimethyl-B-trimethylborazene	16	400	3	0.40
			4	5.48
			unknown	0.17
			5	88.8
			6	5.12
N-Trimethyl-B-dimethylborazene	16	400	3	0.03
			4	5.18
			5	88.4
			6	6.35
Equimolar mixture of penta- methylborazene isomers	33	400	3	-
			4	15.3
			4? (b)	2.46
			5	74.9
			6	7.37

(a) Vapor phase chromatographic analyses.

(b) Unknown, but possibly N-dimethyl-B-dimethylborazene isomers.

b. Lithium Chloride Elimination Reactions

(1) Preparation of N-Lithio-N-dimethyl-B-trimethylborazene (1364-156)

Into a 6 ml. nitrogen-filled bomb tube was placed 0.2704 g. (1.795 mmoles) N-dimethyl-B-trimethylborazene (assay 99.3%). The borazene was cooled to  $-196^{\circ}\text{C}$ ., a layer of degassed ether was added and frozen above it and then 1.90 ml. of 0.95M ethereal methyllithium (1.805 mmoles) was added from a syringe and the tube sealed under vacuum at  $-196^{\circ}\text{C}$ . Upon warming to room temperature, considerable effervescence of the mixture was noted. The tube was then warmed briefly to  $50^{\circ}\text{C}$ . and allowed to stand overnight. From the opened tube 40.14 cc. (99.8% of theoretical) of noncondensable gas ( $\text{CH}_4$ ) was removed. To further characterize the product, 0.2598 g. (1.830 mmoles) of methyl iodide was added to the degassed N-lithiopentamethylborazene-containing mixture at  $-196^{\circ}\text{C}$ . and the tube was resealed. After heating briefly to  $50^{\circ}\text{C}$ . with shaking, the tube was cooled to  $-196^{\circ}\text{C}$ . and opened. A trace of noncondensable gas and the solvent ether were removed through a  $-30^{\circ}\text{C}$ . trap which retained the major volatile product. After purification by sublimation the product was identified by infrared analysis as hexamethylborazene. Analysis of the 0.5016 g. sublimation residue indicated it was predominantly lithium iodide with a trace of boron-containing impurity. Anal.  $\text{Li}^+$ , 2.99 m.eq.;  $\text{I}^-$ , 2.45 m.eq.; B, 0.21 m.eq.

(2) Preparation of Decamethyl-B,N'-biborazyl. (I) (1364-146, 152, 161)

Experiment 1. Into a nitrogen-filled 6 ml. bomb tube was syringed 0.2219 g. (1.473 mmoles) of N-dimethyl-B-trimethylborazene (assay 99.3%). The tube was cooled to  $-196^{\circ}\text{C}$ . under nitrogen, and 1.475 mmoles of ethereal methyllithium was added from a syringe. The tube was sealed under vacuum, allowed to warm to room temperature, and briefly heated to  $50^{\circ}\text{C}$ . to complete reaction. The tube was then cooled to  $-196^{\circ}\text{C}$ . and 32.44 cc. of noncondensable gas (98.5%) was removed. The tube was warmed to room temperature and 0.2745 g. (1.483 mmoles) of N-trimethyl-B-dimethyl-B-chloroborazene dissolved in 1.5 ml. ether was syringed into the N-lithiopentamethylborazene solution through a rubber septum closure on the tube. Gentle agitation of the mixture produced general cloudiness and evolution of heat. Finally the mixture was shaken vigorously and then centrifuged. The supernatant liquid was withdrawn by syringe and the solids washed with 1 ml. of ether and vacuum dried to yield 0.1300 g. of fine powder analyzing  $\text{Li}^+$ , 0.87 m.eq.;  $\text{Cl}^-$ , 1.09 m.eq.; B, 0.15 m.eq. The residue obtained on evaporation of the ether solution was extracted with 10 ml. of petroleum ether (b.r.  $30-60^{\circ}\text{C}$ .) leaving 0.0993 g. of fine powder analyzing  $\text{Li}^+$ , 0.54 m.eq.;  $\text{I}^-$ , 0.49 m.eq.; B, 0.09 m.eq. Sublimation of the petroleum ether extract residue yielded at  $50^{\circ}\text{C}$ . 0.0490 g. (0.265 mmole, 17.8%) of unreacted N-trimethyl-B-dimethyl-B-chloroborazene and at  $100^{\circ}\text{C}$ . 0.2324 g. of sublimate leaving 0.1072 g. of residue. Recrystallization of the sublimate from i-propylamine followed by resublimation at  $100^{\circ}\text{C}$ . yielded 0.1840 g. (0.617 mmole, 42%) of needles, m.p.  $172-174^{\circ}\text{C}$ ., which were characterized by elemental analyses and Neumayer molecular weight. Anal. calcd. for  $\text{C}_{10}\text{H}_{30}\text{B}_6\text{N}_6$ : C, 40.13; H, 10.10; M.W., 299.3. Found: C, 40.05; H, 10.19; M.W., 291.8. An infrared spectrum showed characteristic bands for C-H stretching at  $3.40\ \mu$ , C-H bending at  $6.92\ \mu$  and B-N ring vibrations at  $7.2\ \mu$ .

Experiment 2. A second preparation was made in a similar manner except the reverse order of addition of reagents was used. Into a 250 ml. bulb 1.5433 g. (10.24 mmoles) of N-dimethyl-B-trimethylborazene (assay 99.3%) was syringed and diluted with 10 ml. of ether. The mixture was frozen at  $-196^{\circ}\text{C}$ . and then 10.5 ml. of 0.95M ethereal methyllithium (9.98 mmoles) was syringed slowly into the bulb. The bulb was attached to the vacuum line, evacuated and allowed to warm to room temperature, where reaction liberating methane occurred. A total of 207.0 cc. (92.7%) of methane was collected, but the collection was incomplete because of inadvertent admission of air to the bulb while degassing the mixture.

Into a nitrogen-filled 100 ml. septum bottle containing a magnetic stirring bar was placed 1.8580 g. (10.04 mmoles) of N-trimethyl-B-dimethyl-B-chloroborazene and 15 ml. of ether. The N-lithiopentamethylborazene slurry was syringed slowly into the stirred solution in the septum bottle during 10 min. The exothermic reaction caused a slight rise in pressure which was released by momentarily inserting a second syringe needle through the septum. The supernatant liquid was decanted and the solids were washed with 10 ml. of ether and dried to yield 0.3908 g. of salts analyzing  $\text{Li}^+$ , 6.70 m.eq.;  $\text{Cl}^-$ , 8.44 m.eq.;  $\text{I}^-$ , 0.09 m.eq.; B, 0.12 m.eq. The residue obtained on evaporation of the ether solution was extracted with two 25 ml. portions of petroleum ether (b.r.,  $30-60^{\circ}\text{C}$ .) to separate 1.7858 g. of salts analyzing  $\text{Li}^+$ , 7.66 m.eq.;  $\text{I}^-$ , 9.68 m.eq.;  $\text{Cl}^-$ , 0.21 m.eq.; B, 0.66 m.eq. Evaporation of the petroleum ether extract followed by sublimation of the residue yielded at  $50^{\circ}\text{C}$ . 0.0530 g. of moist white sublimate (shown by infrared analysis to be principally the same as the major sublimate with a small B-O impurity), at  $120^{\circ}\text{C}$ . 2.2150 g. of white sublimate leaving 0.2400 g. of glassy residue. Recrystallization of the second sublimate from i-propylamine followed by resublimation at  $110^{\circ}\text{C}$ . yielded 1.6660 g. of solid, m.p.  $155-173^{\circ}\text{C}$ ., which on further sublimation at  $100^{\circ}\text{C}$ . yielded 1.5132 g. (5.05 mmoles, 50.6%) of decamethyl-B,N'-biborazyl, m.p.  $168-172^{\circ}\text{C}$ . Anal. calcd. for  $\text{C}_{10}\text{H}_{30}\text{B}_6\text{N}_6$ : C, 40.13; H, 10.10; M.W., 299.3. Found: C, 40.31; H, 10.07; M.W., 305.2 (Neumayer).

Experiment 3. In this preparation standard glassware and normal precautions to exclude moisture were employed. Into a 500 ml. nitrogen-swept flask fitted with stirrer, condenser and addition funnel was placed 200 ml. of ether containing 1.5200 g. (10.09 mmoles) N-dimethyl-B-trimethylborazene (assay 99.3%), and 50 ml. of ethereal methyllithium (10.03 mmoles) were added dropwise with stirring during 15 mins. The mixture was refluxed for 2 hrs. and allowed to stand overnight whereupon a brown, gelatinous precipitate separated from the clear, yellow solution. The mixture was reslurried, and 1.8534 g. (10.01 mmoles) of N-trimethyl-B-dimethyl-B-chloroborazene dissolved in 50 ml. of ether was added dropwise with stirring during 15 mins. After refluxing an additional 2 hrs., the mixture was filtered at room temperature and the solids were washed with 50 ml. of ether and vacuum dried. The 0.4927 g. of salts analyzed  $\text{Li}^+$ , 7.46 m.eq.;  $\text{Cl}^-$ , 8.38 m.eq.;  $\text{I}^-$ , 0.26 m.eq.; B, 0.48 m.eq. The ether solution was vacuum evaporated and the residue extracted with 100 ml. of n-hexane leaving 1.2454 g. of salts analyzing  $\text{Li}^+$ , 6.19 m.eq.;  $\text{I}^-$ , 7.57 m.eq.;  $\text{Cl}^-$ , 0.35 m.eq.; B, 1.29 m.eq. The n-hexane extract was vacuum evaporated and the residue was heated at  $50^{\circ}\text{C}$ . to recover 0.6757 g. (44.5%) of N-dimethyl-B-trimethylborazene. On further heating to  $100^{\circ}\text{C}$ . 1.3550 g. of cream-colored sublimate and 0.300 g. of brown residue were obtained. Recrystallization of the sublimate from i-propylamine followed by resublimation at  $100^{\circ}\text{C}$ . (again

leaving a 0.0096 g. residue) yielded 0.8800 g. (2.791 mmoles, 13.9% yield) of product, m.p. 128-134°C., the infrared spectrum of which had several bands in addition to those present in the spectrum of decamethyl-B,N'-biborazyl. The material was characterized as a new borazene derivative, decamethyl-B,B'-diborazyl oxide (vide infra).

(3) Preparation of 1,3-Bis(1',3',4',5',6'-pentamethyl-2'-borazyl)-2,4,5,6-tetramethylborazene. (IIa) (1364-168)

Into a 250 ml. nitrogen-filled bulb was placed 0.6892 g. (5.044 mmoles) of N-methyl-B-trimethylborazene (assay 99.4%) and 5 ml. of ether. The solution was cooled to -196°C. and 10.6 ml. of 0.95M ethereal methyllithium (10.1 mmoles) was added from a syringe slowly. The bulb was attached to the vacuum line, cooled to -196°C. and evacuated quickly. On warming to room temperature a vigorous gas evolution was observed. Completion of the reaction was insured by briefly heating the mixture to 50°C. After 226.3 cc. (100.3%) of methane was removed an additional 10 ml. of ether was introduced in an unsuccessful attempt to dissolve the entire solid phase. A solution of 1.8674 g. (10.09 mmoles) of N-trimethyl-B-dimethyl-B-chloroborazene in 15 ml. of ether was slowly added to the agitated slurry of N-dilithiotetramethylborazene. Considerable heat evolution was evident, and the bulk volume of the solid phase was reduced markedly. The 0.4112 g. of isolated solids were washed with 10 ml. of ether, vacuum dried, and analyzed Li<sup>+</sup>, 9.18 m.eq.; Cl<sup>-</sup>, 8.87 m.eq.; I<sup>-</sup>, 0.15 m.eq.; B, 0.18 m.eq. Evaporation of the ether solution followed by two extractions with 40 ml. and 20 ml. portions of petroleum ether (b.r. 30-60°C.) left 1.4840 g. of salts analyzing Li<sup>+</sup>, 11.03 m.eq.; I<sup>-</sup>, 10.63 m.eq.; B, 0.51 m.eq. Sublimation of the residue obtained from the petroleum ether extract yielded the following sublimates: at 50°C., 0.3313 g., m.p. 85-95°C.; at 100°C., 0.3204 g., m.p. 103-117°C., and at 140°C. 1.2724 g., m.p. 192-206°C. Resublimation of the highest melting material for 2 hrs. at 100°C. and 1.5 hrs. at 120°C. yielded 0.1151 g. of white, powdery sublimate, m.p. 141-196°C. Further heating at 140°C. for 2 hrs. delivered 1.0190 g. of powdery sublimate (m.p. 196-209°C.) and 0.0580 g. of fluffy residue. Recrystallization of the latter sublimate from i-propylamine yielded 0.8690 g. (two crops) of needles which on resublimation yielded at 120°C. during 2 hrs. 0.1170 g. of white sublimate, m.p. 198-206°C. and 140°C. during 3 hrs. 0.6074 g. (1.400 mmoles, 27.8% yield) of sublimate, m.p. 207-210°C., the infrared spectrum of which showed the characteristic C-H absorption at 3.4 and 6.9 μ, B-N absorptions at 7.2 μ and no B-O band at 10.6 μ. Anal. calcd. for C<sub>14</sub>H<sub>42</sub>B<sub>9</sub>N<sub>9</sub>: C, 38.75; H, 9.76; M.W., 433.9. Found: C, 39.04; H, 9.77; M.W., 433.9 (Neumayer).

(4) Preparation of 1,3,5,6-Tetramethyl-2,4-bis(2',3',4',5',6'-pentamethyl-1'-borazyl)borazene. (IIb) (1364-179)

A 1.5122 g. (10.04 mmoles) quantity of N-dimethyl-B-trimethylborazene (assay 99.7%) followed by 6 ml. of ether were syringed into a nitrogen-filled 250 ml. bulb and cooled to -196°C. under nitrogen. Then 10.3 ml. of 0.95M ethereal methyllithium (9.79 mmoles) was slowly added and the bulb containing the stratified, frozen mixture was attached to the vacuum line and evacuated. After

allowing reaction to proceed at room temperature 220.9 cc. (100.8%) of methane was collected. The degassed N-lithiopentamethylborazene solution was warmed to room temperature, and 1.0045 g. (4.887 mmoles) of N-trimethyl-B-methyl-B-dichloroborazene dissolved in 10 ml. ether was added dropwise with agitation. On completion of the addition, the salts were freed of supernatant liquid and washed with 10 ml. of ether. The dry solids weighed 0.4040 g. and analyzed  $\text{Li}^+$ , 9.02 m.eq.;  $\text{Cl}^-$ , 8.62 m.eq.;  $\text{I}^-$ , 0.21 m.eq.; B, 0.18 m.eq. The ether solution was vacuum evaporated and the residue extracted with 45 ml. and 25 ml. portions of petroleum ether (b.r. 30-60°C.) leaving 1.2130 g. of tan, amorphous powder analyzing  $\text{Li}^+$ , 9.79 m.eq.;  $\text{I}^-$ , 8.47 m.eq.;  $\text{Cl}^-$ , 0.68 m.eq.; B, 0.36 m.eq. The residue from the combined petroleum ether extracts was sublimed yielding at 100°C. 0.2470 g. of solid, m.p. 100-111°C., and 1.1144 g. of sublimate which was recrystallized from i-propylamine. The first two crystal crops were resublimed to yield at 100°C. 0.1545 g. of syrupy material and at 140°C. 0.5550 g. (1.279 mmoles, 26.2% yield) of sublimate, m.p. 135-138°C., leaving 0.1600 g. of residue. The infrared spectrum of the final sublimate showed the characteristic C-H absorptions at 3.4 and 6.9  $\mu$ , B-N absorptions at 7.2  $\mu$ , and no B-O band at 10.6  $\mu$ . Anal. calcd. for  $\text{C}_{14}\text{H}_{42}\text{B}_3\text{N}_9$ : C, 38.75; H, 9.76; M.W., 433.9. Found: C, 39.13; H, 9.79; M.W., 443.0.

(5) Attempt to Prepare 1,3,5-Tris(1',3',4',5',6'-  
pentamethyl-2'-borazyl)-2,4,6-trimethylborazene (1364-190, 197)

Into a nitrogen-filled 250 ml. bulb fitted with a rubber septum was syringed 0.4076 g. (3.32 mmoles) of B-trimethylborazene and 5 ml. of ether. In the same manner 10.5 ml. of 0.95M ethereal methylolithium (10.0 mmoles) were added slowly with agitation. When the methane which was vented through a hypodermic needle had ceased to evolve, 1.8502 g. (9.99 mmoles) of N-trimethyl-B-dimethyl-B-chloroborazene in 15 ml. of ether was added with agitation, necessitating intermittent cooling to remove the heat of reaction. On completion of the addition, the mixture was shaken vigorously and allowed to stand until a fine, white precipitate settled out of the clear, colorless solution. The precipitate was isolated by washing twice with 5 ml. portions of ether and vacuum drying to yield 0.3132 g. of powder, presumably crude lithium chloride. The ether extracts were evaporated and re-extracted with two 50 ml. portions of petroleum ether (b.r. 30-60°C.). The residual solids were vacuum dried yielding 1.4070 g. of powder, presumably crude lithium iodide. Evaporation of the petroleum ether extracts yielded a translucent, colorless, viscous liquid containing a very small quantity of solids, which when heated for 4 hrs. under high vacuum at 100°C. yielded only a trace of volatile liquid tentatively identified as B-trimethylborazene. Continued heating at 160°C. for 3 hrs. volatilized the major portion of the material as a moist white sublimate weighing 0.9780 g., leaving 0.3680 g. of dark brown residue. The sublimate was recrystallized from i-propylamine yielding 0.4778 g. of slightly moist crystals and 0.2866 g. of viscous mother-liquor residue, which set to a crystalline semi-solid mass. An analytical sample was prepared by twice crystallizing the moist looking product from methylamine in a Schlenk tube. Rapid crystallization produced needles but on slow cooling large rhombs, m.p. 133-135°C., were formed. Anal. calcd. for  $\text{C}_{18}\text{H}_{54}\text{B}_{12}\text{N}_{12}$ : C, 38.03; H, 9.57; M.W., 568.5; calcd. for  $\text{C}_{10}\text{H}_{30}\text{B}_3\text{N}_6\text{O}$ : C, 38.09; H, 9.59; M.W., 315.3. Found: C, 38.26; H, 9.81; M.W., 318.4. The compound, decamethyldiborazyl oxide, had only slight solubility in liquid ammonia at 25°C.

A second experiment only served to confirm the results of the first.

- (6) Preparation of 1,3,5-trimethyl-2,4,6-tris-(2',3',4',5',6'-pentamethyl-1'-borazyl)borazene (1364-194)

Into a nitrogen-filled 250 ml. bulb fitted with a rubber septum was syringed 1.5340 g. (10.18 mmoles) of N-dimethyl-B-trimethylborazene and 5 ml. of ether. Then 10.8 ml. of 0.95M ethereal methyllithium (10.3 mmoles) were added slowly in the same manner with agitation following which the mixture was heated slightly to insure completion of the reaction. The methane produced was allowed to escape intermittently through a hypodermic needle. To this clear solution was added slowly with agitation 0.7626 g. (3.39 mmoles) of N-trimethyl-B-trichloroborazene dissolved in 10 ml. of ether. The exothermic reaction required intermittent cooling. Following the addition, a white precipitate settled from the clear, yellow solution. The precipitate was isolated by decantation and washing with two 5 ml. portions of ether followed by vacuum drying to yield 0.3365 g. of powder, presumably crude lithium chloride. The ether extracts were evaporated to dryness, re-extracted with two 50 ml. portions of petroleum ether (b.r. 30-60°C.) and vacuum dried to yield 1.4348 g. of tan powder, presumably crude lithium iodide. Evaporation of the petroleum ether extracts left a viscous residue which failed to deliver any volatile material during 4 hrs. heating at 100°C. under high vacuum. Continued heating at 175°C. yielded 0.9030 g. of white glassy sublimate, m.p. 189-229°C., during 3 hrs. leaving 0.4084 g. of dark brown residue. The molecular weight of the sublimate was determined to be 565.6. Recrystallization from methylamine in a Schlenk tube yielded needles, m.p. 236-245°C. Anal. calcd. for  $C_{18}H_{54}B_{12}N_{12}$ : C, 38.03; H, 9.57; M.W., 568.5. Found: C, 38.29; H, 9.72; M.W. 593.2.

- (7) Preparation of Poly-1',2,3',4,5,5',6,6'-octamethylbiberazylene. (IV) (1364-173)

A 0.7516 g. (5.061 mmoles) quantity of N-dilithio-N-methyl-B-trimethylborazene in 15 ml. of ether was prepared in a 250 ml. bulb by the action of 10.16 mmoles ethereal methyllithium on 0.6916 g. (5.061 mmoles) of N-methyl-B-trimethylborazene. Then 1.0417 g. (5.068 mmoles) of N-trimethyl-B-methyl-B-dichloroborazene in 10 ml. of ether was syringed slowly into the agitated suspension of the N-dilithiotetramethylborazene. The 0.3890 g. of salts resulting from the exothermic reaction were isolated by decantation, washed with 10 ml. of ether, and analyzed  $Li^+$ , 8.80 m.eq.;  $Cl^-$ , 8.41 m.eq.;  $I^-$ , 0.14 m.eq.; B, 0.15 m.eq. Extraction of the residue from the ether solution with 40 ml. and 20 ml. portions of petroleum ether (b.r. 30-60°C.) left 1.3983 g. of salts analyzing  $Li^+$ , 10.54 m.eq.;  $I^-$ , 9.57 m.eq.;  $Cl^-$ , 0.39 m.eq.; B, 0.39 m.eq. The residue from the petroleum ether extract on heating under vacuum at 150°C. delivered no measurable sublimate, although the 1.3128 g. (96.5%) of clear, yellow glassy resin had become more friable. The infrared spectrum was quite similar to previously prepared B,N'-linked borazene derivatives, but was less resolved as would be expected. The ebulliometric molecular weight in benzene was found to be 1356. The melting range of the resinous material was very wide and was approximately 140-160°C. A large portion of the product was reheated at 215°C. under vacuum, and delivered a very small

amount of viscous material. The residual material now had a molecular weight of 1382 corresponding to a D.P. of 5 or a chain of ten rings. The melting range of the material, 163-168°C. (softened at 155°C.) was still quite broad. Anal. calcd. for  $(C_4H_{12}B_3N_3)_n$ : C, 35.69; H, 8.98; B, 24.11; N, 31.22; M.W.,  $(134.62)_n$ ; calcd. for  $C_{40}H_{120}B_{30}N_{30}LiCl$ : C, 34.60; H, 8.71; B, 23.38; N, 30.26; Li, 0.50; Cl, 2.55; M.W., 1388.6. Found: C, 34.91; H, 8.90; B, 22.3; N, 29.1; Cl, 0.76; M.W., 1382.

c. Dehydrohalogenation Reactions

(1) N-Dimethyl-B-trimethylborazene and  
N-Trimethyl-B-dimethyl-B-chloroborazene

(a) Using Triethylamine (1364-70, 75, 111, 143)

Into a 500 ml. nitrogen-swept flask fitted with stirrer, Friedrichs condenser and 100 ml. addition funnel was placed 1.9598 g. of crude N-trimethyl-B-dimethyl-B-chloroborazene (assay, 85.9% by chlorine analysis; 9.10 mmoles monochloro-, 0.134 mmole of dichloro-derivative) dissolved in 100 ml. anhydrous ether. To this stirred solution was added dropwise 100 ml. anhydrous ether containing 1.6080 g. (10.67 mmoles) N-dimethyl-B-trimethylborazene (assay, 99.3%) during 10 min. The resultant mixture was refluxed for 2 hrs., cooled to room temperature, and then 50 ml. anhydrous ether containing 1.0908 g. (10.78 mmoles) triethylamine (recovered; may have contained  $(C_2H_5)_3CH_3NCl$ ) was added dropwise with vigorous stirring during 1.5 hrs. without noticeable heat evolution. The reaction slurry was stirred for an additional 0.5 hr. and then filtered in an enclosed filter. The clear filtrate, deposited additional precipitate, which was collected. The combined 1.1540 g. of solid was dried and identified by infrared analysis as triethylammonium chloride (8.38 mmoles; 78.5%).

The filtrate was evaporated at reduced pressure leaving a light brown wet solid with an odor closely resembling that of N-dimethyl-B-trimethylborazene. By placing the residue under high vacuum, 0.440 g. of crude N-dimethyl-B-trimethylborazene (by infrared analysis) was recovered, corresponding to 27.4% of the starting material (assuming 100% purity). The residual solid was sublimed under high vacuum yielding the following fractions: at 90°C., 0.3192 g. of a moist, cream-colored solid condensed at 0°C.; at 130°C., 0.4525 g. of white crystalline material condensed at 0°C.; and at 160°C., 0.4940 g. of greasy, cream-colored material condensed at 10°C., leaving a 0.3960 g. tarry residue which had to be removed with cleaning solution. The second sublimate, m.p. 105-120°C. was found by infrared analysis to contain little if any of the original borazenes or hexamethylborazene, but there was definite evidence for the presence of the borazene ring structure. Recrystallization from i-propylamine gave 0.0440 g. (3.1% yield) of needles, m.p. 132-33°C., tentatively characterized by elemental analysis, Neumayer cryoscopic molecular weight determination in benzene, and infrared spectrum which showed characteristic C-H bands at 3.4 and 6.9  $\mu$ , B-N ring at 7.2  $\mu$ , and a band at 10.6  $\mu$  attributed to B-O. Anal. calcd. for  $C_{10}H_{30}B_3N_3$ : C, 40.13; H, 10.10; M.W., 299.3; calcd. for  $C_{10}H_{30}B_3N_3O$ : C, 38.09; H, 9.59; M.W., 315.3. Found: C, 37.95; H, 9.62; M.W., 317.0.

In a second experiment using 1.9026 g. N-trimethyl-B-dimethyl-B-chloroborazene (assay, 85.9%, 8.826 mmoles monochloro-, 1.305 mmoles

dichloro-derivative), 1.5858 g. (10.52 mmoles) N-dimethyl-B-trimethylborazene, and 1.0763 g. (10.64 mmoles) triethylamine was carried out in benzene solution which was refluxed for 2 hrs. after mixing the reagents. The insoluble portion of the reaction mixture weighed 1.2 g. (85% yield assuming triethylammonium chloride). Anal. calcd. for  $C_6H_{16}NCl$ : N, 10.2; Cl, 25.8. Found: N, 10.4; Cl, 26.2; B, 0.18.

The filtrate was vacuum evaporated and 0.97 g. (64%) of crude N-dimethyl-B-trimethylborazene identified by infrared analysis was recovered. The residue was sublimed under high vacuum and yielded at 80°C. 0.2720 g. of white semi-crystalline material; at 120°C., 1.0058 g. of waxy cream-colored material and about 0.7 g. of brown tarry residue which was discarded. The 1.0058 g. sublimate was twice recrystallized from i-propylamine to give 0.2306 g. (0.7704 mmole, 16.6% yield) of needles, m.p. 132-133°C. Elemental analysis and a molecular weight determination gave the results: C, 38.36; H, 9.86; M.W., 320.6. The material was resublimed at 50-65°C. during 140 hrs. and the determinations were repeated on the sublimate: Anal. calcd. for  $C_{10}H_{30}B_3N_6$ : C, 40.13; H, 10.10; M.W., 299.3; calcd. for  $C_{10}H_{30}B_3N_6O$ : C, 38.09; H, 9.59; M.W., 315.3. Found: C, 37.75; H, 9.61; M.W., 313.0 (Neumayer).

In a third experiment 2.2386 g. (12.09 mmoles) N-trimethyl-B-dimethyl-B-chloroborazene (assay, 99.0% by chlorine analysis) 1.8806 g. (12.48 mmoles) N-dimethyl-B-trimethylborazene (assay 99.3%) and 200 ml. anhydrous benzene were placed in a nitrogen-swept 500 ml. flask fitted with stirrer, 50 ml. addition funnel and condenser. The mixture was stirred to produce a clear solution and then 50 ml. benzene containing 1.7266 g. (17.06 mmoles) triethylamine (assay, 99.9%) was added dropwise at room temperature during 30 min. The initially clear solution became cloudy as the insoluble by-product triethylammonium chloride formed. The slurry was refluxed overnight with stirring. An attempt to follow the progress of the reaction by infrared spectroscopic analysis slurry samples was unsuccessful at the low reactant concentrations. The mixture was filtered under nitrogen and the solids washed with two 25 ml. portions of benzene, dried first in a stream of nitrogen and finally on the vacuum line to yield 0.9027 g. (54%) of triethylammonium chloride, identified by infrared analysis and low (0.06%) boron content. The solvent was removed from the filtrate leaving 3.6 g. of crude borazene derivatives which were dried further on the vacuum line by removing 0.2700 g. (1.79 mmoles, 14.3%) N-dimethyl-B-trimethylborazene. High vacuum sublimation of the resultant residue yielded at 55°C., 0.5556 g. (3.00 mmoles, 24.8%) of recovered N-trimethyl-B-dimethyl-B-chloroborazene and at 100°C. 1.0318 g. of sublimate leaving 0.2030 g. of a dark brown greasy residue which was discarded.

Recrystallization of the second sublimate from i-propylamine gave 0.7265 g. of vacuum-dried white crystals and a mother liquor residue of 0.1966 g. The crystals were resublimed at 100°C. to yield 0.6647 g. (46.3% based on unrecovered B-chloro-derivative) of white crystalline sublimate, m.p. 133-134°C. and 0.0098 g. of tan, fluffy residue. Anal. calcd. for  $C_{10}H_{30}B_3N_6$ : C, 40.13; H, 10.10, M.W., 299.32; calcd. for  $C_{10}H_{30}B_3N_6O$ : C, 38.09; H, 9.59; M.W., 315.3. Found: C, 36.91; H, 9.49; M.W., 288.4 (Neumayer).

A fourth experiment was made in a sealed 80 ml. bomb tube using 1.7341 g. (9.367 mmoles) N-trimethyl-B-dimethyl-B-chloroborazene, 1.4606 g.



(9.694 mmoles) N-dimethyl-B-trimethylborazene and 0.9716 g. (9.601 mmoles) triethylamine in 20 ml. benzene at 150°C. for 6 hrs. Triethylammonium chloride, 0.1464 g. (1.064 mmoles, 11.4%), was separated from the benzene soluble material which was fractionally sublimed yielding 0.4830 g. (3.206 mmoles, 33%) of recovered N-dimethyl-B-trimethylborazene, 1.6418 g. (8.869 mmoles, 95%) of recovered N-trimethyl-B-dimethyl-B-chloroborazene, and 0.1246 g. of cream-colored sublimate, m.p. 90-100°C. The 100°C. sublimate was not considered worth working up due to the extremely low yield (ca. 4%).

(b) Using Pyridine (1364-126, 131, 149)

Into a nitrogen-swept 500 ml. flask fitted with Hershberg stirrer, 50 ml. addition funnel and Friedrichs condenser was placed 200 ml. dry benzene, 1.9090 g. (10.31 mmoles) N-trimethyl-B-dimethyl-B-chloroborazene, and 1.5982 g. (10.61 mmoles) N-dimethyl-B-trimethylborazene. A solution of 0.8192 g. (10.35 mmoles) pyridine in 50 ml. of benzene was added dropwise during 30 mins. to the mixture with simultaneous precipitation of pyridinium chloride. The mixture after stirring under reflux for 17 hrs. was filtered in an enclosed filter to yield 0.3030 g. (2.622 mmoles, 25.4%) of pyridinium chloride, identified by infrared analysis. The residue obtained on vacuum evaporation of the filtrate was sublimed to yield at 50°C. 0.4620 g. (2.496 mmoles, 24.2%) of recovered N-trimethyl-B-dimethyl-B-chloroborazene (identified by infrared analysis) and at 100°C. 1.3286 g. of white, crystalline product leaving 0.4450 g. of brown, greasy residue. Recrystallization of the latter sublimate from i-propylamine yielded two crops of crystals weighing 0.9579 g.; the mother liquor yielded a 0.2615 g. residue. The crystalline material was resublimed at 100°C. to yield 0.8246 g. (2.615 mmoles, 66.9%) of sublimate, m.p. 132-133°C., and 0.0670 g. of residue. Anal. calcd. for  $C_{10}H_{30}B_3N_6$ : C, 40.13; H, 10.10; M.W., 299.3; calcd. for  $C_{10}H_{30}B_3N_6O$ : C, 38.09; H, 9.59; M.W., 315.3. Found: C, 37.82; H, 9.86; M.W., 316.1 (Neumayer).

From the density, 1.05 g./cc., determined by floatation at 25°C. and the cell dimensions\* of the orthorhombic crystals,  $a = 14.27 \pm 0.07\text{\AA}$ ,  $b = 11.63 \pm 0.03\text{\AA}$ ,  $c = 12.20 \pm 0.03\text{\AA}$ ,  $Z = 4$ , the molecular weight was calculated to be 320.0.

A second experiment was performed in a manner similar to that described above using 1.5742 g. (8.504 mmoles) N-trimethyl-B-dimethyl-B-chloroborazene, 1.3504 g. (8.963 mmoles) N-dimethyl-B-trimethylborazene, and 0.6779 g. (8.570 mmoles) pyridine in benzene solution with 20 hrs. reflux. Isolation of 0.1759 g. (1.522 mmoles, 18.0%) of pyridinium chloride, 0.2474 g. (1.642 mmoles, 18.6%) of recovered N-dimethyl-B-trimethylborazene, 0.2517 g. (1.360 mmoles, 16.0%) of recovered N-trimethyl-B-dimethyl-B-chloroborazene, and 0.7782 g. (2.468 mmoles, 58.0%) of recrystallized and resublimed product, m.p. 132-133°C. and M.W., 332.8 (Neumayer), indicated a similar course of the reaction.

A third experiment in a sealed 80 ml. bomb tube used 1.7790 g. (9.61 mmoles) N-trimethyl-B-dimethyl-B-chloroborazene, 1.4690 g.

\* It is a pleasure to acknowledge the work of Drs. Joseph R. Schwartz, Loyola University of Los Angeles and Kenneth N. Trueblood, University of California at Los Angeles.

(9.75 mmoles) N-dimethyl-B-trimethylborazene, and 0.7843 g. (9.91 mmoles) pyridine in 30 ml. benzene. The tube was heated at 150°C. for 85 hrs. after which only a trace of solid (pyridinium chloride) was observed. The solid obtained on evaporation of the solvent was sublimed to yield at 50°C. 1.2480 g. (6.742 mmoles, 70.3%) of recovered N-trimethyl-B-dimethyl-B-chloroborazene and 0.4900 g. (3.252 mmoles, 33.3%) of recovered N-dimethyl-B-trimethylborazene and at 100°C. 0.3362 g. of light yellow sublimate. The final sublimate smoked and appeared to react on attempted recrystallization from i-propylamine suggesting the material was predominantly the original chloroborazene derivative. No further attempt to isolate a pure material was made.

(c) Using Triethylenediamine (1364-136)

A final experiment was made by treating 1.1456 g. (6.19 mmoles) of N-trimethyl-B-dimethyl-B-chloroborazene and 0.9838 g. (6.52 mmoles) of N-dimethyl-B-trimethylborazene in 250 ml. benzene solution with 0.6995 g. (6.24 mmoles) resublimed triethylene diamine and refluxed for 17 hrs. From the reaction mixture 0.6572 g. of tan powder was isolated, the infrared spectrum of which indicated it to be an organoammonium salt. Sublimation of the benzene soluble residue yielded at 50°C. 0.2482 g. (1.341 mmoles, 21.6%) of unreacted N-trimethyl-B-dimethyl-B-chloroborazene and at 100°C. 0.9250 g. of sublimate leaving 0.0677 g. of brown residue. Recrystallization of the sublimate from i-propylamine yielded two crops of needles weighing 0.6800 g., which were resublimed to give 0.5892 g. (1.869 mmoles, 60.4%) of solid characterized only by its m.p. 128-132°C.

(2) N-Trimethyl-B-methyl-B-dichloroborazene and N-Methyl-B-trimethylborazene (1364-117)

Into a nitrogen-swept 500 ml. flask fitted with stirrer, condenser, and 50 ml. addition funnel was placed 200 ml. of benzene containing 2.0908 g. (10.17 mmoles) N-trimethyl-B-methyl-B-dichloroborazene (assay, 98.4% by chlorine analysis). To this solution was added 1.4455 g. (10.58 mmoles) N-methyl-B-trimethylborazene (assay 99.4%) and the resultant solution was stirred for 0.5 hr. From the addition funnel was added dropwise with stirring 50 ml. of benzene containing 2.0892 g. (20.65 mmoles) triethylamine (assay 99.8%). The solution became turbid upon addition of the amine. The mixture was refluxed with stirring for 6 hrs. and a light brown viscous liquid separated from the clear liquid. After standing for two days the mixture was refluxed an additional hour, then filtered hot and the insoluble solid washed with two 50 ml. portions of hot benzene. The white, crystalline solid, after drying on the vacuum line, weighed 0.9933 g. (35.5%) and was identified by infrared spectroscopy as predominantly triethylammonium chloride. The filtrate was vacuum evaporated leaving a brown, greasy residue, which was sublimed in high vacuum at 60°C. to yield 0.4058 g. of a white, crystalline solid which appears on the basis of volatility and infrared spectrum to be recovered N-trimethyl-B-methyl-B-dichloroborazene. The 1.7524 g. of light brown sublimation residue was re-extracted with 20 ml. benzene, and 0.2605 g. of an insoluble tan powder was separated by centrifuging and vacuum dried. Infrared analysis identified the material as largely triethylammonium chloride but containing some non-borazene impurity.

The benzene extract was evaporated to yield a syrupy liquid containing a crystalline solid which could not be isolated. The mixture was freed of benzene by high vacuum evaporation followed by recrystallization from *i*-propylamine. A small quantity of white crystals, m.p. 148-152°C. was obtained and tentatively identified by infrared analysis as *i*-propylammonium chloride free of borazene derivatives.

d. Hydrolyses of B-Chloroborazene Derivatives

(1) N-Trimethyl-B-dimethyl-B-chloroborazene (1364-158)

Into a nitrogen-filled 15 ml. centrifuge cone fitted with a rubber septum was placed 0.3931 g. (2.12 mmoles) of N-trimethyl-B-dimethyl-B-chloroborazene and 3 ml. of ether. An estimated 0.39-1.06 mmoles of distilled water was added by mixing 0.25 ml. with 10 ml. of ether and adding 0.77 ml. of this mixture to the agitated borazene solution which deposited a white, milky solid. An evolution of heat was observed when 0.2145 g. (2.12 mmoles) of triethylamine was added to the mixture from which 0.1826 g. of impure triethylammonium chloride was obtained. From the residue obtained on evaporation of the ether solution was sublimed at 50°C. 0.1630 g. (0.881 mmoles, 41.5%) of recovered N-trimethyl-B-dimethyl-B-chloroborazene and at 100°C. 0.0791 g. of solid leaving 0.0124 g. of glassy residue. The latter sublimate, when recrystallized from *i*-propylamine and resublimed, had a m.p. 125-129°C. However, the infrared spectrum was identical with that of decamethyl-B,B'-diborazyl oxide (m.p. 133-134°C.) isolated from attempted dehydrohalogenation experiments (vide supra). The mixed melting point of these two materials was 126-130°C.

(2) N-Trimethyl-B-methyl-B-dichloro-  
and N-Trimethyl-B-dimethyl-B-  
chloroborazene Mixture (1364-165)

Into a nitrogen-filled 100 ml. septum bottle containing a stirring bar was placed 1.1146 g. (6.021 mmoles) of N-trimethyl-B-dimethyl-B-chloroborazene, 0.6186 g. (3.010 mmoles) of N-trimethyl-B-methyl-B-dichloroborazene and 15 ml. of ether. To the stirred solution was added a solution of 0.1081 g. (6.003 mmoles) of distilled water and 1.2520 g. (12.373 mmoles) of triethylamine. The slurry was then diluted with 20 ml. of ether and stirred for 2 hrs. The solids, which were removed by filtration, were washed with three 5 ml. portions of ether and vacuum dried to yield 1.4232 g. of crude triethylammonium chloride by infrared analysis. Evaporation of the ether filtrate yielded a clear, colorless viscous liquid from which at 50°C. 0.0526 g. of solid, m.p. 115-124°C. (presumably N-trimethyl-B-dimethyl-B-chloroborazene) was sublimed. Continued sublimation at 100°C. yielded 0.2102 g. (0.6667 mmoles, 22.1% yield) of white sublimate, m.p. 126-131°C., identified by infrared analysis as decamethyl-B,B'-diborazyl oxide. Further sublimation of the original residue at 140°C. yielded 0.2051 g. (0.4402 mmoles, 26.2% yield) of a colorless, sticky sublimate, m.p. 133-155°C. with an infrared spectrum quite similar to that of decamethyl-B,B'-diborazyl oxide. Anal. calcd. for  $C_{14}H_{42}B_9N_9O_2$ : C, 36.09; H, 9.09; M.W., 465.9; calcd. for  $C_{13}H_{40}B_9N_9O_3$ : C, 33.34; H, 8.62; M.W., 467.9; calcd. for  $C_{12}H_{38}B_9N_9O_4$ : C, 30.67; H, 8.15; M.W., 469.9. Found: C, 30.80; H, 8.69; M.W., 478.6.

The 0.4460 g. sublimation residue was a clear yellow liquid which became a brittle glass on cooling. The infrared spectrum of this material was similar (although somewhat less resolved) to the lower molecular weight homologs. Anal. calcd. for  $C_{22}H_{66}B_{15}N_{15}O_4$ : C, 34.48; H, 8.68; M.W., 766.2; calcd. for  $C_{21}H_{64}B_{15}N_{15}O_5$ : C, 32.79; H, 8.39; M.W., 769.2; calcd. for  $C_{20}H_{62}B_{15}N_{15}O_6$ : C, 31.15; H, 8.10; M.W., 771.1; calcd. for  $(C_4H_{12}B_3N_3O)_n$ : C, 31.89; H, 8.03; M.W., (150.6)<sub>n</sub>. Found: C, 32.94; H, 8.60; M.W., 734.5.

(3) N-Trimethyl-B-methyl-B-dichloroborazene (1364-183)

Into a 100 ml. nitrogen-filled septum bottle equipped with a stirring bar were placed 2.2805 g. (11.10 mmoles) of N-trimethyl-B-methyl-B-dichloroborazene and 50 ml. of ether. A 0.200 ml. (11.11 mmoles) quantity of distilled water was slowly syringed into the stirred borazene solution, producing a voluminous white precipitate. Addition of 2.2774 g. (22.51 mmoles) of triethylamine resulted in considerable evolution of heat. The stirring was continued for 1 hr., after which the solids were filtered, washed with two 10 ml. portions of ether, and vacuum dried to give 2.6060 g. (18.93 mmoles, 86.7%) of tan, amorphous powder, characterized by infrared and elemental analyses as predominantly triethylammonium chloride. Anal. calcd. for  $C_6H_{16}NCl$ : N, 10.18; Cl, 25.76. Found: N, 10.58; Cl, 24.37; B, 2.87. Very little, if any, volatilization of material from the ether extract at 150°C. resulted on attempted vacuum sublimation. The residual light brown glass weighing 1.0790 g. (7.164 mmoles as monomer, 64.7%) melted over the range 180-200°C. The infrared spectrum of the material in KBr was poorly resolved but in  $CS_2$  solution bands characteristic of C-H ( $3.4 \mu$ ), B-N ( $7.2-7.4 \mu$ ) and B-O ( $10.5 \mu$ ) were apparent. Anal. calcd. for  $(C_4H_{12}N_3B_3O)_n$ : C, 31.89; H, 8.03; M.W., (150.6)<sub>n</sub>. Found: C, 29.17; H, 8.13; M.W., 3512.

2. Borazene Intermediates

a. Preparation of N-Dimethyl-B-trimethyl- and N-Methyl-B-trimethylborazenes

(1) Copyrolysis of Methylamine Trimethylborine and Ammonia Trimethylborine (1364-22)

The results of three similar copyrolyses of the trimethylborine adducts of ammonia and methylamine in an 1100 ml. Aminco high pressure steel bomb are summarized in Table VIII and accordingly only one experiment is described in detail. Into the nitrogen-swept bomb were placed 100.5 g. (1.38 moles) of ammonia trimethylborine and 162 g. (1.86 moles) of methylamine trimethylborine. The sealed bomb was then heated slowly to 220°C. where an exothermic reaction occurred raising the temperature to 262°C. and the pressure to 3000 psig. at which pressure the bomb began to leak. After cooling overnight, 4.75 moles (73%) of methane were vented through a wet test meter, and the bomb was resealed and reheated to 375-380°C. for 6 hrs. Upon cooling again, 0.81 mole (13%) of methane gas had been produced bringing the total yield of methane to 86%. The crude light brown liquid product was recovered in 74% yield (118 g.) by pressure siphoning it into a 1000 ml. distillation flask.

TABLE VIII  
Preparation of N-Methyl-B-trimethylborazenes

Expt. No.	Reagents						Reaction Time, hrs.	Products		
	$\text{NH}_3:\text{B}(\text{CH}_3)_3$		$\text{CH}_3\text{NH}_2:\text{B}(\text{CH}_3)_3$		Temp., °C.	CH <sub>4</sub>		Crude Products		
	g.	moles	g.	moles		moles		Yield, %	Wt., g.	Yield, %
1	100.5	1.38	162	1.86	380	6	5.56	86	118	74
2	103.0	1.41	158	1.82	380	6	4.67	72	75	47
3	112.0	1.53	152	1.75	380	2	4.62	70	107	67
Total	315.5	4.32	472	5.43	-	-	14.85	76	300	65

Following an unsuccessful attempt to distill the combined crude product in a spinning band column due to seizure of the tantalum band, the mixture was fractionated in a 2 ft. x 1 in. distillation column packed with 0.16 x 0.16 in. protruded stainless steel packing. The atmospheric distillation (766 mm.) yielded the six fractions summarized in Table IX. Vacuum sublimation of the distillation residue at 80°C. yielded 15 g. (5%) of white crystalline hexamethylborazene identified by its infrared spectrum. Infrared analysis of each of the six fractions and the sublimate and residue was made and the densities were determined by weighing to three decimal places the amount of sample delivered by a 1 ml. TD pipette.

## (2) Alkylation of B-Trimethylborazene (1364-185, 188)

Into a nitrogen-filled 80 ml. bomb tube was syringed 1.2416 g. (10.13 mmoles) of B-trimethylborazene (assay 99.9%) and 5 ml. of anhydrous ether. From a syringe 10.7 ml. of 0.95M ethereal methyllithium (10.2 mmoles) were added slowly with agitation with accompanying gas evolution. When the addition was complete, 1.4710 g. (10.36 mmoles) of methyl iodide in 10 ml. of ether was added to the clear solution, which turned cloudy and a solid phase settled out on standing. The tube was then attached to the vacuum line, evacuated, sealed and heated for 3 hrs. at 80-90°C. The tube was opened and the contents were concentrated on a rotary evaporator to a vapor pressure of 60 mm. at 20°C. The 13.0 g. of evaporated solvent was trapped at -196°C. and found by vapor phase chromatographic analysis to contain 0.53% methyl iodide (0.48 mmole, 4.6% recovery). To the residual product mixture was added 25 ml. of petroleum ether (b.r. 30-60°C.) and the solvent was again evaporated on a rotary evaporator to a vapor pressure of 80 mm. at 20°C. The residue was twice extracted with 50 ml. portions of petroleum ether leaving 2.5010 g. of powder analyzing 5.61% Li<sup>+</sup>, 90.8% I<sup>-</sup> and 0.27% B. The petroleum ether extract was concentrated on a rotary evaporator to a volume of about 2 ml. (1.4254 g.) and this concentrated solution was analyzed vapor phase chromatographically as follows: 16.8% B-trimethylborazene, 25.0% N-methyl-B-trimethylborazene, 10.0% N-dimethyl-B-trimethylborazene, and 0.96% hexamethylborazene. These data correspond to yields of 31.9% tetra-, 11.6% penta-, and 0.98% hexamethylborazenes based on unrecovered B-trimethylborazene (0.240 g., 1.95 mmoles recovered).

A preliminary experiment on the same scale (10.25 mmoles B-trimethylborazene) followed the same procedure except that the reaction was allowed to proceed at room temperature and the product was distilled directly from the reaction mixture without preliminary solvent extraction. Under these conditions only a 1.8% yield of N-methyl-B-trimethylborazene was obtained based on 6.61 mmoles of B-trimethylborazene not recovered.

### b. Preparation of N-Trimethylborazene (1364-18)

The pyrolysis of 702 g. (5.46 moles) of methylaminoborane trimer to form N-trimethylborazene was performed in two runs in an 1100 ml. Aminco high pressure steel bomb. In the first run, 354 g. (2.75 moles) of the trimer was placed in the nitrogen-swept bomb and the sealed bomb was then heated slowly. At about 180°C. an exothermic reaction was observed to occur and the pressure and temperature rose to 5500 psig. and 245°C., respectively. Heating was resumed when the temperature dropped to 225°C. and was continued for 5 hrs. at this temperature. The by-product

TABLE IX  
Distillation of N-Methyl-B-trimethylborazenes

Fraction	Component	Boiling Range, °C.	Density, g./ml. at 25°C.	Weight, g.	Yield, % of Crude Product
1	Methylaminodimethylborine	40-42	0.65	17.5	5.8
2	B-Trimethylborazene (crude)	45-130	0.72	32.5	10.8
3	N-Methyl-B-trimethylborazene (crude)	131-155	0.84	22	7.4
4	N-Methyl-B-trimethylborazene	157-159	0.86	75.5	25.2
5	N-Dimethyl-B-trimethylborazene (crude)	160-185	0.87	13	4.3
6	N-Dimethyl-B-trimethylborazene	187.5-188.5	0.88	66	22.0
Residue	Hexamethylborazene + Tar	-	-	15 58.5*	5.0 19.5*

\* By difference.

hydrogen, measured by venting the cooled bomb through a wet test meter, amounted to 5.82 moles (71%). A total of 334 g. (99%) of crude product was removed from the bomb by pressure siphon.

In a similar manner the remaining 347 g. (2.71 moles) of trimer were pyrolyzed at 225°C. for 4.5 hrs. (maximum pressure, 6000 psig.). From the cooled bomb, 7.82 moles (96%) of hydrogen gas was measured and 331 g. (100%) of crude product was recovered.

The combined batches of crude N-trimethylborazene (665 g.) were distilled from a 2000 ml. flask through a 2 ft. x 1 in. insulated column packed with 0.16 x 0.16 in. protruded stainless steel packing. The forerun (b.p. 97-130°C.) contained a considerable quantity of a solid material, which was removed from the head by moderate warming. The main fraction, b.p. 130.5-131.5°C., (lit.<sup>22</sup> 134°C.) was characterized as pure N-trimethylborazene by comparison of its infrared spectrum with an authentic sample; yield 568 g. (4.63 moles, 85%). The solid material in the forerun was not the starting material, methylaminoborane trimer, and probably is dimethylaminoborane dimer (m.p. 75°C.) from a dimethylamine impurity in the methylamine.

c. Preparation of N-Trimethyl-B-methyl- and N-Trimethyl-B-dimethylborazenes (1364-32,37,39,42,45,47,121)

A series of six experiments were conducted in an effort to optimize the yield of N-trimethyl-B-dimethylborazene from the reaction of a 2:1 mole ratio of methylmagnesium iodide with N-trimethylborazene. The procedure followed was essentially that of Smalley and Stafiej<sup>24</sup> with several variations, which together with yield figures are presented in Table X. Experiment 4, which afforded the best yield, is described below in detail together with a larger scale preparation using the same reaction conditions.

A 12.4 g. quantity (0.101 mole) of N-trimethylborazene was pipetted into 500 ml. of anhydrous n-hexane contained in a nitrogen-swept 2000 ml. flask fitted with a Hershberg stirrer, Friedrichs condenser, 250 ml. addition funnel, dial thermometer and nitrogen inlet. To the ice water-cooled borazene solution were added dropwise with vigorous stirring 250 ml. of 0.83M (0.207 mole) methylmagnesium iodide in ether during 1.5 hrs. Stirring was continued for two additional hours at room temperature and then the mixture was allowed to stand overnight. The resultant two-phase system, consisting of a clear, light yellow liquid and a dark brown solid, was cooled in an ice-bath while 25 ml. of degassed saturated aqueous ammonium chloride solution was added dropwise with vigorous stirring. Resultant decomposition of the Grignard complex was accompanied by evolution of heat, gas, and precipitation of a white, pasty solid on the walls of the flask. The mixture was warmed to room temperature and the organic phase was decanted and filtered through anhydrous sodium sulfate in an enclosed medium-porosity filter. The wet solids in the reaction flask were washed with three 50 ml. portions of anhydrous n-hexane, which were combined with the filtrate. The initially clear filtrate, which became cloudy on standing, was evaporated to a volume of approximately 35 ml. on a rotary evaporator, and this concentrated mixture was placed in a 50 ml. distillation flask and the evaporation of solvent completed at 38 mm. through a water-cooled condenser. The crude borazene mixture was then distilled through a vacuum-jacketed Vigreux column



TABLE X

Preparation of N-Trimethyl-B-methylborazenes

Expt. No.	Reagents (a)		Experimental Conditions			Borazene Product (CH <sub>3</sub> ) <sub>3</sub> N <sub>3</sub> B <sub>3</sub> H <sub>3</sub> -n(CH <sub>3</sub> ) <sub>n</sub>			
	(CH <sub>3</sub> NBH) <sub>3</sub> moles	500 ml. solvent	Reflux time, hrs.	Decomp. Medium	Extraction solvent, ml.	n	Wt., g.	Moles	Yield(b), %
1	0.104	Ether	2	10 ml. aqueous NH <sub>4</sub> Cl	15 ml. benzene	1	4.04	0.0296	28.4
2	0.101	Ether	2	None	500 ml. n-hexane, followed by 100 ml. benzene	1	2.29	0.0168	16.6
3	0.100	Hexane	2	30 ml. aqueous NH <sub>4</sub> Cl	none	2	2.28	0.0151	15.0
4	0.101	Hexane	0	25 ml. aqueous NH <sub>4</sub> Cl	none	3	1.08	0.0066	6.5
5	0.103	Hexane	0	125 ml. anhydrous (C <sub>2</sub> H <sub>5</sub> ) <sub>3</sub> N	none	1	2.81	0.0206	20.6
6	0.102	Hexane	0	250 ml. anhydrous (C <sub>2</sub> H <sub>5</sub> ) <sub>3</sub> N	none	2	7.10	0.0472	47.2
						3	3.61	0.0213	21.3
						1	3.49	0.0256	25.3
						2	7.53	0.0500	49.5
						3	2.75	0.0167	16.5
						1	3.25	0.0238	23.1
						2	6.32	0.0420	40.8
						3	2.02	0.0123	11.9
						1	2.87	0.0210	20.6
						2	4.79	0.0318	31.2
						3	2.18	0.0132	13.0

(a) 250 ml. of ethereal CH<sub>3</sub>MgI (0.207 mole) were used in each experiment.

(b) Yields based on vapor phase chromatographic analyses.

with a Whitmore-Lux head. An over-all borazene recovery of 91.4% was realized, including a 25.3% yield of N-trimethyl-B-methylborazene and a 49.6% yield of N-trimethyl-B-dimethylborazene based on vapor phase chromatographic analysis.

The combined borazene products from the six experiments were redistilled at 38 mm. through an 8 in. fractionating column packed with protruded stainless steel to yield pure samples of N-trimethyl-B-methylborazene (9.9 g., assay 99% m.p. -14.5°C., b.p. 76.2°C./38 mm.,  $d^{25}$  0.85) and N-trimethyl-B-dimethylborazene (21.8 g., assay 99.9%, m.p. 32.8°C., b.p. 101.2°C./38 mm.,  $d^{35}$  0.87).

In a large scale experiment 2000 ml. of anhydrous n-hexane (assay 95+) and 125.0 g. (1.02 moles) of N-trimethylborazene (99.9%) was placed in a 5000 ml. nitrogen-swept flask fitted with stirrer, condenser, and 1000 ml. addition funnel. One liter of 2.06M ethereal methylmagnesium iodide was added dropwise to the stirred borazene solution at room temperature during 2 hrs. During the addition formation of a dark brown sludge which made stirring difficult was observed. After standing overnight, the mixture was hydrolyzed by dropwise addition during 2.5 hrs. of 250 ml. of saturated aqueous ammonium chloride to the stirred slurry at 0°C. The hydrolysis was accompanied by considerable gas evolution (presumably hydrogen) and transformation of the hard brown deposits to a white, pasty mass. The organic phase was decanted and immediately filtered through a 1.5 in. layer of anhydrous granular sodium sulfate supported on a medium porosity filter and the filter cake was washed with 250 ml. hexane.

The clear, yellow filtrate, which upon standing turned cloudy, was concentrated under reduced pressure to a volume of 200 ml. The concentrate was freed of residual solvent and fractionally distilled at 36 mm. through a 20 x 200 mm. column of protruded stainless steel packing, yielding five fractions including N-trimethyl-B-methylborazene (39.5 g., 0.289 moles, 28.3%, b.p. 74°C./36 mm.) and N-trimethyl-B-dimethylborazene (72.9 g., 0.484 moles, 47.4%, b.p. 97.5°C./36 mm.). Approximately 18 g. (0.11 mole, 11%) of hexamethylborazene was also obtained.

d. Preparation of Partially  
B-Halogenated Borazene Derivatives

(1) Methylation of N-Trimethyl-B-trichloroborazene

(a) Preparation of N-Trimethyl-  
B-dimethyl-B-chloroborazene (1364-62)

Into a nitrogen-swept 2000 ml. flask fitted with a Hershberg stirrer, Friedrichs condenser and 250 ml. addition funnel was added 11.3550 g. (50.2 mmoles) N-trimethyl-B-trichloroborazene in 750 ml. anhydrous ether. A 110 ml. quantity of 0.906M ethereal methylolithium (99.7 mmoles) was diluted to 250 ml. in the addition funnel and added dropwise during 3 hrs. to the vigorously stirred borazene solution at 0°C. The resultant light yellow slurry was filtered in an enclosed medium fritted glass filter under nitrogen pressure, and the precipitate was washed with two 50 ml. portions of ether. Solvent was removed from the filtrate on a rotary film evaporator, leaving a yellow solid residue which was slurried in 500 ml. of petroleum ether (b.r. 20-40°C.). The insoluble lithium salts were filtered as before and washed with two 70 ml. portions of petroleum ether. The

filtrate was again evaporated to dryness yielding 9.5 g. of crude yellow product which was sublimed at 80-90°C. from residual lithium salts. The sublimate was fractionally resublimed to yield 4.9557 g. of crystalline product, m.p. 120-129°C. analyzing 21.31% chlorine (calc. for  $C_5H_{15}B_3N_3Cl$ : 19.15%). From the chlorine analysis an assay of 85.9% N-trimethyl-B-dimethyl-B-chloroborazene (45.8% yield) and 14.1% N-trimethyl-B-methyl-B-dichloroborazene was calculated.

(b) Preparation of N-Trimethyl-B-methyl-B-dichloroborazene (1364-82, 93)

An 11.3568 g. (50.26 mmoles) sample of N-trimethyl-B-trichloroborazene was dissolved in 750 ml. of anhydrous ether in a 2000 ml. flask fitted with a Hershberg stirrer, Friedrichs condenser and 250 ml. addition funnel. The stirred solution was cooled to 0°C. and 155 ml. of 0.341M ethereal methyllithium (50.3 mmoles) was added dropwise during 1 hr. After standing overnight the mixture was filtered under nitrogen and the solids washed with two 50 ml. portions of ether. The filtrate was evaporated to dryness at reduced pressure and the residue was slurried in 500 ml. of petroleum ether (b.r. 20-40°C.), filtered, and the solids washed with two 50 ml. portions of petroleum ether. The filtrate was evaporated to dryness leaving 9.2 g. of crude product which was sublimed at 170°C. to remove an additional 2.1 g. of lithium salts. Resublimation of the crude product in high vacuum gave at 60°C. 3.0927 g. of crystalline material and at 80°C. an additional 2.4750 g. of crystalline material leaving 0.8493 g. of brown, tarry residue.

Analyses of the two volatile fractions are summarized below and are compared with pure N-trimethyl-B-methyl-B-dichloroborazene.

<u>Fraction</u>	<u>% C</u>	<u>% H</u>	<u>% Cl</u>	<u>Assay, %</u>	<u>m.p., °C.</u>
1	20.68	5.60	37.8	74.0	146-148
2	20.48	5.40	38.8	66.9	148-150
$(CH_3)_3N_3B_3(CH_3)Cl_2$	23.37	5.89	34.5	-	-

Another similar preparation was made except that 100% excess borazene and simultaneously addition of ethereal reagent solutions, were used with high speed agitation. N-trimethyl-B-trichloroborazene (250 ml. containing 99.69 mmoles) and methyllithium (500 ml. containing 50.3 mmoles) solution were added dropwise during 1 hr. maintaining a 2:1 ratio to 300 ml. ether in an ice-cooled 2000 ml. Morton flask.

In the same manner as described in the first experiment the product was freed of 6.3 g. inorganic salts analyzing  $Li^+$ , 26.6 m.eq.;  $X^-$ , 27.6 m.eq.; B, 1.71 m.eq. The 21 g. of crude product which fumed on contact with moist air was sublimed at 90°C. in high vacuum. Fractional resublimation of this material at a series of ascending temperatures gave four fractions which had the melting points and analyses summarized in Table XI. The yield of N-trimethyl-B-methyl-B-dichloroborazene based on chloride analyses of the mixed di- and trichloro-

TABLE XI

Fractionation of  
N-Trimethyl-B-methyl-B-dichloroborazene

Fraction	Wt., g.	Sublimation Temp., °C.	M.P., °C.	Chloride, %	$(\text{CH}_3)_3\text{N}_3\text{B}_3(\text{CH}_3)\text{Cl}_2$ Assay, %
1	2.4528	35	123-143	39.4	61.1
2	2.7202	50	148-150	43.1	31.8
3	4.3510	65	147-157	43.3	30.2
4	6.1658	80	147-157	42.9	33.4
Residue	0.4403	-	-	22.7	-
	<u>16.1301</u>				

derivatives was 5.74 g. (27.9 mmoles) corresponding to 55.5% yield. Of the excess N-trimethyl-B-trichloroborazene 9.95 g. (41.5 mmoles, 88.4%) was recovered.

(2) Halogenation of N-Trimethyl-B-dimethyl-  
and N-Trimethyl-B-methylborazenes

(a) Preparation of N-Trimethyl-  
B-dimethyl-B-chloroborazene (1364-100, 109, 139)

Into an evacuated 5 ml. bomb tube was condensed 0.1445 g. (0.959 mmole) N-trimethyl-B-dimethylborazene (assay 99.9%) followed by 20.66 cc. (0.922 mmole) hydrogen chloride (99+%). The tube was sealed off under vacuum at -196°C., after which it was allowed to warm to room temperature, then heated at 130°C. for 16 hrs. After cooling to -196°C. the tube was opened and 21.11 cc., (0.943 mmole, 102%) of hydrogen was obtained. Sublimation of the white, crystalline solid phase yielded 0.1560 g. (0.843 mmole, 91.4%) of N-trimethyl-B-dimethyl-B-chloroborazene, m.p. 127-129°C. Absence of absorption in the B-H region, in an infrared spectrum of the product in cyclohexane showed it to be free of any starting material.

In a second preparation, 6.0989 g. (40.48 mmoles) of melted N-trimethyl-B-dimethylborazene (assay 99.9%) was syringed into an 80 ml. nitrogen-filled bomb tube which was then fitted with a seal-off tip and degassed at -196°C. Hydrogen chloride derived from 2.1802 g. (40.75 mmoles) of ammonium chloride and excess concentrated sulfuric acid was condensed into the tube. The sealed bomb was warmed slowly to room temperature and then heated at 130°C. for 2 hrs. to produce 897.5 cc. (40.07 mmoles, 99%) of hydrogen and 7.6075 g. of crude product which was transferred in an inert atmosphere to a sublimation apparatus. High vacuum sublimation at 50°C. yielded 7.2195 g. (39.00 mmoles, 96.3%) of N-trimethyl-B-dimethyl-B-chloroborazene, m.p. 127-128°C. Anal. calcd. for  $C_5H_{15}B_3N_3Cl$ : Cl, 19.15. Found: Cl, 19.3.

In a third and larger scale preparation 13.5333 g. (89.82 mmoles) of N-trimethyl-B-dimethylborazene were syringed into 125 ml. of anhydrous carbon tetrachloride in a 250 ml. flask fitted with manometer, vacuum, and hydrogen chloride inlets. The pressure was reduced to that of carbon tetrachloride and then 3.3560 g. (94.62 mmoles) of anhydrous hydrogen chloride was added from a 10 ml. cylinder and absorbed at the maximum rate permitted by pressure rise in the borazene solution cooled in an ice bath. As the addition was completed, the appearance of a precipitate was noted and the pressure returned to that of carbon tetrachloride. Nitrogen was admitted to atmospheric pressure, and the flask contents were observed to have no odor of hydrogen chloride. Vacuum evaporation of the solvent left 16.3390 g. (96.7%) of a milky, semi-crystalline colorless residue, which on standing overnight completely solidified. The adduct was transferred to the glass liner in a 43 ml. steel pressure vessel and heated at 160°C. for 4 hrs., during which time the pressure rose to 1200 psi. When the product had cooled to room temperature the by-product hydrogen, vented through a wet test meter, was measured as (1900 ± 28 cc.) or 98% of the theoretical. The white crystalline product was sublimed at 75°C. and left 0.2810 g. of amorphous residue and gave 14.9522 g. (90.0%) of sublimate. The low chlorine analysis (19.1%; calcd., 19.15%) and broad melting range (120-128°C.) suggested the presence of unreacted starting material. Retreatment of the sublimate

with 167.3 cc. (7.46 mmoles) hydrogen chloride in an 80 ml. bomb tube for 4 hrs. at 130°C. yielded an additional 43.4 cc. (1.94 mmoles, 2.2%) of noncondensable gas. The 14.8180 g. of product was resublimed at 70°C., yielding 14.3302 g. (77.41 mmoles, 86.3%) of N-trimethyl-B-dimethyl-B-chloroborazene, m.p. 127-128.5°C. Anal. calcd. for  $C_5H_{15}B_3N_3Cl$ : Cl, 19.2. Found: Cl, 19.4.

(b) Preparation of N-Trimethyl-B-methyl-B-dichloroborazene (1364-102, 104, 177)

Into a nitrogen-filled 5 ml. bomb tube was syringed 0.1466 g. (1.073 mmoles) N-trimethyl-B-methylborazene (assay 99.7%). The sample was degassed at -196°C., 46.10 cc. (2.057 mmoles) hydrogen chloride (99%) added, and the tube sealed off and warmed to room temperature. Upon heating to 70-80°C., the reaction mixture began to effervesce, indicating the evolution of hydrogen. After 16 hrs. at 125°C., the tube was cooled to -196°C., opened and 44.25 cc. (1.98 mmoles, 96.0%) of hydrogen (identified by combustion over copper oxide) was obtained. A 0.1948 g. (0.948 mmole, 92.2%) quantity of white crystalline product, m.p. 134-140°C., was recovered upon sublimation of the solid material. The infrared spectrum showed a small B-H absorption band suggesting incomplete chlorination.

A second larger scale preparation was made in a similar manner except that a small excess of hydrogen chloride was used. The reagents used were 3.4368 g. (25.15 mmoles) of N-trimethyl-B-methylborazene (assay 99.7%) and hydrogen chloride derived from 2.9605 g. (55.34 mmoles) of ammonium chloride and excess concentrated sulfuric acid. The sealed 120 ml. bomb tube was heated at 150°C. for 3 hrs. to obtain 1139.4 cc. (101%) of hydrogen (identified by combustion over copper oxide) and a white solid which was sublimed in high vacuum at 70°C. to yield 5.0613 g. (24.62 mmoles, 97.9%) of N-trimethyl-B-methyl-B-dichloroborazene, m.p. 145-146°C. Anal. calcd. for  $C_4H_{12}B_3N_3Cl_2$ : Cl, 34.50. Found: Cl, 34.7. Infrared spectra of the sublimate obtained in both carbon disulfide and cyclohexane solution, showed no absorption in the B-H region.

In a third preparation similar to that just described, 5.870 g. (42.97 mmoles) of N-trimethyl-B-methylborazene (assay 99+%) was treated with 1983 cc. (88.48 mmoles) of hydrogen chloride in a 190 ml. bomb tube for 16 hrs. at 150°C. The hydrogen was inadvertently lost on opening the tube. The crude product was sublimed at 75°C. to yield 8.5034 g. (41.37 mmoles, 96.3%) of white crystalline N-trimethyl-B-methyl-B-dichloroborazene, m.p. 144-146°C. Anal. calcd. for  $C_4H_{12}B_3N_3Cl_2$ : Cl, 34.50. Found: Cl, 34.55.

(c) Attempt to Chlorinate  
N-Trimethyl-B-dimethylborazene

[1] With Carbon Tetrachloride (1364-61)

A mixture of 0.4498 g. (2.985 mmoles) N-trimethyl-B-dimethylborazene (assay 99.9%) and 0.5257 g. (3.417 mmoles) carbon tetrachloride was heated for an hour at 80°C. in a sealed nitrogen-filled ampoule. Infrared analysis of the resultant mixture failed to reveal any traces of chloroform. Reheating for another hour at 80°C. in the presence of a trace amount of anhydrous aluminum chloride was without result.

[2] With N-Chlorosuccinimide (1364-86, 88)

A 1.6400 g. (12.28 mmoles) quantity of solid N-chlorosuccinimide was added to 125 ml. of a carbon tetrachloride solution of 1.6344 g. (10.85 mmoles) of N-trimethyl-B-dimethylborazene contained in a 250 ml. flask. The mixture was stirred magnetically under reflux for 1.5 hrs., after which a dark, tarry residue began to separate out, and heating was discontinued. The clear solution was separated from the residue with a filter stick and evaporated to dryness at reduced pressure. Sublimation of the filtrate residue yielded 0.6 g. (36%) of a lavender crystalline solid which was identified by infrared analysis as predominantly N-trimethyl-B-dimethylborazene containing a small amount of a carbonyl-containing impurity, presumably a succinimide derivative.

A second experiment run similar to the first but at 6.6 times higher dilution gave essentially the same results (40% recovery of crude N-trimethyl-B-dimethylborazene).

[3] With Cupric Chloride (1364-98)

A 0.75 g. (4.98 mmoles) quantity of N-trimethyl-B-dimethylborazene was added to a 30 ml. acetonitrile slurry of 0.67 g. (4.98 mmoles) of anhydrous cupric chloride and 0.17 g. (9.99 mmoles) of anhydrous ammonia contained in a 100 ml. bomb tube. The tube was evacuated at  $-196^{\circ}\text{C}$ ., degassed, and sealed off. The deep blue color of the slurry changed to brown and the borazene appeared to react when the mixture warmed to room temperature. The tube was opened under nitrogen, filtered, and the filtrate evaporated to yield a green residue. Sublimation of this residue yielded a very small amount of white crystalline material which was found by infrared analysis to be a borazene compound, but no B-H or B-Cl absorption bands were observed.

(d) Preparation of N-Trimethyl-B-dimethyl-B-bromoborazene (1364-128)

Into a 6 ml. bomb tube containing 0.3313 g. (2.20 mmoles) of N-trimethyl-B-dimethylborazene (assay 99.8%) was condensed 51.6 cc. (2.30 mmoles) of hydrogen bromide at  $-196^{\circ}\text{C}$ . The tube was sealed, heated at  $180^{\circ}\text{C}$ . for 2 hrs., cooled to  $-196^{\circ}\text{C}$ . and opened to obtain 49.6 cc. of hydrogen (100.6%) and 0.5070 g. (100.4%) of crude product. The solid was vacuum sublimed at  $70^{\circ}\text{C}$ . to yield 0.4585 g. (2.00 mmoles, 90.9%) of white, crystalline N-trimethyl-B-dimethyl-B-bromoborazene, m.p.  $127-129^{\circ}\text{C}$ . (mixed m.p. with chlorine analog,  $110-115^{\circ}\text{C}$ .). Infrared analysis showed the product to be free of starting material and to have a spectrum identical with that of the chlorine analog except for shifts of the absorption bands at  $7.26$ ,  $9.24$  and  $9.96\ \mu$  to  $7.28$ ,  $9.32$  and  $10.05\ \mu$ , respectively. Anal. calcd. for  $\text{C}_5\text{H}_{15}\text{B}_3\text{N}_3\text{Br}$ : Br, 34.8. Found: Br, 35.2.

(e) Preparation of N-Trimethyl-B-methyl-B-dibromoborazene (1364-134)

In a manner similar to that described for N-trimethyl-B-dimethyl-B-bromoborazene (vide supra), 0.8040 g. (5.88 mmoles) of N-trimethyl-B-methylborazene (assay 99.7%) was treated with 270.0 cc. (12.05 mmoles) of hydrogen

bromide in a sealed 25 ml. bomb tube at 220°C. for 2 hrs. As the tube was opened at -196°C. a leak occurred and only 165.7 cc. (62.8%) of the theoretical hydrogen were collected. The 1.6735 g. (96.7%) of crude product, was sublimed at 70°C. to yield 1.6163 g. (5.489 mmoles, 93.4%) of white crystalline N-trimethyl-B-methyl-B-dibromoborazene, m.p. 140-142°C. (mixed m.p. with chlorine analog, 136-140°C.). Infrared analysis showed the product to be free of starting material and to have a spectrum identical with that of the chlorine analog with the exception that bands at 7.25, 9.24 and 10.03  $\mu$  were shifted to 7.30, 9.29 and 10.13  $\mu$ , respectively, and a band at 15.22  $\mu$  was absent. Anal. calcd. for C<sub>4</sub>H<sub>12</sub>B<sub>3</sub>N<sub>3</sub>Br<sub>2</sub>: Br, 54.3. Found: Br, 54.8.

### 3. Pseudoaromatic Boron-Nitrogen Compounds

#### a. Preparation of 7-Methyl-8-bora-7,9-diazaro-peri-naphthene

##### (1) From N-Methyl-1,8-diaminonaphthalene (1365-16, 19, 37)

To a solution of 1.45 g. (8.4 mmoles) of crude N-methyl-1,8-diaminonaphthalene in 60 ml. of dry benzene in a 250 ml. Morton flask equipped with a high speed stirrer, 50 ml. equalized dropping funnel, argon inlet tube, and Dry Ice condenser vented through a mercury bubbler, was added dropwise 0.94 g. (8.0 mmoles) of boron trichloride in 20 ml. of benzene. The slightly exothermic addition of boron trichloride resulted in an immediate precipitation of a yellow solid which gradually changed to brown as the addition proceeded. After the addition was complete, the reaction mixture was refluxed 5 hrs. About two-thirds of the benzene was removed at aspirator pressure and was replaced by 100 ml. of dry ethyl ether. Next, 7.0 ml. (8.4 mmoles) of ethereal lithium aluminum hydride was added dropwise and the reaction mixture was refluxed for 2 hrs. Excess hydride was hydrolyzed with 20 ml. of water and the ether layer was separated. The water layer was extracted with two 50 ml. portions of ether. The combined ethereal solutions were dried over magnesium sulfate, filtered, and evaporated at reduced pressure to yield a bright yellow crystalline solid. Sublimation at 90-100°C. under high vacuum and three recrystallizations from n-hexane produced 0.5562 g. (36%) of slightly pink crystalline solid, m.p. 56-66°C. An infrared spectrum of the solid showed B-H, and N-H, and aliphatic and aromatic C-H absorption bands. Methanolysis of 0.1198 g. (6.5 mmoles) of this product yielded 14.6 cc. of hydrogen (theor. 14.8 cc.). The elemental analyses were poor, possibly indicating interference of boron with the carbon and hydrogen analyses. Anal. calcd. for C<sub>11</sub>H<sub>11</sub>N<sub>2</sub>B: C, 72.57; H, 6.09; M.W., 182.0. Found: C, 71.85; H, 7.84; M.W., (Neumayer) 182.5. Further purification by sublimation was unsuccessful.

In another experiment, 4.79 g. of 7-methyl-8-bora-7,9-diazaro-peri-naphthene was prepared in 75% yield using 6.02 g. (34.9 mmoles) of N-methyl-1,8-diaminonaphthalene (assay 98%), 4.1 g. (35.0 mmoles) boron trichloride and 1.3 g. (35.0 mmoles) of lithium aluminum hydride in 40 ml. of ether. The product was purified by two high vacuum sublimations (80-110°C.) and four crystallizations from n-hexane and had an m.p. 57-67°C. Anal. calcd. for C<sub>11</sub>H<sub>11</sub>N<sub>2</sub>B: C, 72.58; H, 6.09. Found: C, 72.49; H, 6.02.



A preliminary experiment carried out similarly used 2.1 g. (12.0 mmoles) of crude N-methyl-1,8-diaminonaphthalene, 1.4 g. (12.0 mmoles) of boron trichloride and 10 ml. (12.0 mmoles) of lithium aluminum hydride solution. The only significant difference in the experimental procedure was the use of ethyl acetate to destroy the excess hydride. High vacuum sublimation at 95-100°C. and crystallization from n-hexane gave 0.30 g. (14%) of slightly pink crystalline solid which had the same melting point and infrared spectrum as the product from the first experiment.

(2) From 8-Bora-7,9-diazaro-peri-naphthene (1365-21, 28)

In an experiment patterned after that previously reported,<sup>30</sup> 3.32 g. of 8-bora-7,9-diazaro-peri-naphthene was prepared in 54% yield. The apparatus and isolation procedure were as described for the preparation of 7-methyl-8-bora-7,9-diazaro-peri-naphthene (vide supra). The amounts of reagents used were 5.74 g. (36.2 mmoles) of 1,8-diaminonaphthalene, 4.24 g. (36.2 mmoles) of boron trichloride and 36.2 mmoles of lithium aluminum hydride in 30 ml. of ether. The product was purified by two sublimations (95-100°C.) under high vacuum and two crystallizations from n-hexane and had m.p. 97.5-99°C. (uncorr.). A Neumayer cryoscopic molecular weight determination gave the value 176.0 (theoretical, 168.0).

To a solution of 1.04 g. (6.18 mmoles) of 8-bora-7,9-diazaro-peri-naphthene in 80 ml. of anhydrous ether was added dropwise 12 ml. (6.2 mmoles) of freshly prepared methyllithium in ethyl ether. During the methyllithium addition a gas, presumably methane, was constantly evolved and the solution became yellow-brown in color. After addition of the methyllithium, the reaction was refluxed for 1 hr., cooled and 0.88 g. (6.19 mmoles) of methyl iodide in 10 ml. of ethyl ether was added during 15 min. The mixture again was refluxed for 8 hrs., cooled, and processed as described in the first experiment using N-methyl-1,8-diaminonaphthalene as the starting material (vide supra). After removal of the ether in vacuo, a dark reddish-brown solid remained which yielded, after two sublimations under high vacuum at 90-100°C., 0.1602 g. of a white crystalline solid. The infrared spectrum of this unidentified product showed N-H and aliphatic and aromatic C-H, but no B-H adsorption.

b. Pyrolysis of 7-Methyl-8-bora-7,9-diazaro-peri-naphthene (1365-29, 40)

A 0.1001 g. (0.540 mmole) sample of 7-methyl-8-bora-7,9-diazaro-peri-naphthene was placed in a sealed, evacuated 5 ml. heavy-wall tube and heated at 185°C. for 15 hrs. forming only 0.45 cc. (0.02 mmole) hydrogen. The tube was resealed and heated for 8 hrs. at 240°C. and then 20 hrs. at 300°C. The hydrogen produced during this heating period was found to be 3.31 cc. (0.15 mmole). The total hydrogen evolved was 28% of theoretical assuming one mole of hydrogen per mole of 7-methyl-8-bora-7,9-diazaro-peri-naphthene. The tube contained a clear pink solid on the bottom and a yellow solid on the walls. The pink solid had an infrared spectrum identical with that of starting material and the spectrum of the yellow solid showed N-H but very little B-H absorption.

A second sealed tube containing 0.119 g. (0.65 mmoles) of 7-methyl-8-bora-7,9-diazaro-peri-naphthene was heated for 77 hrs. at 360°C. The 12.6 cc. of noncondensable gas evolved was analyzed by combustion over copper oxide as 12.1 cc. (0.54 mmole) hydrogen (83% of theoretical) and 0.51 cc. (0.021 mmole) methane.

An attempt to recover the starting material by sublimation of the pyrolysis residue at 100-150°C. proved unsuccessful. An infrared spectrum of the polymeric residue showed N-H but no B-H absorption bands.

c. Preparation of  
10,9-Borazarophenanthrene (1365-44)

In an experiment patterned after that described by Dewar,<sup>31</sup> 12.1 g. (0.103 mmole) of boron trichloride in 50 ml. of dry benzene was added dropwise to a vigorously stirred solution of 17.4 g. (0.103 mmole) of 2-aminobiphenyl in 350 ml. of dry benzene. Upon completion of the addition the reaction mixture was refluxed for 10 hrs. before the benzene was removed under reduced pressure. A 1.2 g. (9.0 mmoles) quantity of anhydrous aluminum chloride was added to the dark brown solid residue and heated at 170°C. for 7 hrs. Without exposure to the atmosphere, the dark solid mixture was sublimed at 160-180°C. under high vacuum to give a white crystalline sublimate which was transferred to another reactor as an ethyl ether solution. To this ether solution, 2.0 g. (2.7 mmoles) of lithium aluminum hydride in 100 ml. of ethyl ether was added dropwise with vigorous agitation and then refluxed for 1 hr. The excess hydride was destroyed by the addition of 15 ml. of ethyl acetate, after which the mixture was filtered and placed on a rotary evaporator to remove the solvent. The residual yellow solid was then purified by three high vacuum sublimations (60-100°C.) and three crystallizations from *n*-hexane to yield 2.8 g. (15.7%) of a white crystalline product, m.p. 69-70°C. (uncorr.). Anal. calcd. for C<sub>12</sub>H<sub>10</sub>NB: C, 80.50; H, 5.63; M.W., 179.0. Found: C, 80.64; H, 5.62; M.W., 177.2 (Neumayer). The infrared spectrum showed the characteristic N-H and B-H bands.

d. Pyrolysis of  
10,9-Borazarophenanthrene (1365-48, 51)

A 0.1082 g. (0.60 mmole) sample of 10,9-borazarophenanthrene was heated in a sealed, evacuated 5 ml. heavy-wall tube at 300-350°C. for 134 hrs. The evolved hydrogen was collected and measured as 9.5 cc. (0.424 mmole, 70% of the theoretical). The residue was a clear colorless glass, which after removal of a trace of unchanged starting material by sublimation (80-100°C.), showed no N-H or B-H absorption bands in the infrared and had a molecular weight of 295.9 (Neumayer).

In a second experiment 0.1072 g. (0.598 mmole) of 10,9-borazarophenanthrene was pyrolyzed at 400-450°C. for 84 hrs. in the same manner. The pyrolysis produced a yellow crystalline solid and 12.54 cc. (0.561 mmole) of hydrogen or 94% of the theoretical. The presence of N-H or B-H adsorption bands was not observed in the infrared spectrum of the product. The molecular weight of the product was not determined because of its low solubility in benzene.

The polymeric solids obtained from each of the pyrolysis experiments softened in the range 95-100°C. and were completely liquid only above 340°C.

e. Preparation and Hydrolytic Stability of  
8-Phenyl-8-bora-7,9-diazaro-peri-naphthene (1365-31, 1369-18, 19)

A solution of 4.34 g. (27.3 mmoles) phenyldichloroborane in 40 ml. of dry benzene was added slowly at room temperature from a 50 ml. equalized dropping

funnel with stirring to a solution of 4.22 g. (26.7 mmoles) of 1,8-diaminonaphthalene in 150 ml. of benzene, contained in a 500 ml. Morton flask equipped with a high speed stirrer, condenser and argon inlet. A reddish-yellow solid was formed during addition. The mixture was refluxed for 3 hrs. The solvent was removed under aspirator pressure, and the residue was sublimed twice at 160-180°C. under high vacuum to give 4.1659 g. (64%) of a yellow solid. An infrared spectrum showed aromatic C-H, N-H and mono-substituted phenyl absorption bands. The product was further purified by sublimation at 125-130°C. under high vacuum, two recrystallizations from 1:1 cyclohexane--n-hexane, and one crystallization from 4:1 cyclohexane--n-hexane followed by another sublimation to give pale yellow microcrystals, m.p. 92.5-93.5°C. (corr.). Anal. calcd. for C<sub>16</sub>H<sub>13</sub>N<sub>2</sub>B: C, 78.72; H, 5.37. Found: C, 78.78; H, 5.33.

A sealed evacuated tube containing 0.0492 g. (0.18 mmole) of 8-phenyl-8-bora-7,9-diazaro-peri-naphthene and 1 ml. of degassed 2.7M sodium hydroxide in 50% aqueous ethanol was heated at 80 ± 1°C. for 16 hrs. The tube was opened under nitrogen and 2 ml. of water was added producing a cloudy solution which was acidified with 1 ml. of 6N hydrochloric acid. A precipitate formed which was isolated and weighed 0.0135 g. The infrared spectrum of this material showed it to be a mixture of 1,8-diaminonaphthalene and 1,8-diaminonaphthalene hydrochloride containing about 38% starting material. The aqueous solution was strongly basified with sodium hydroxide and 0.0257 g. of solid impure 1,8-diaminonaphthalene containing about 12% starting material was isolated. From qualitative infrared analyses, about 83% of the starting material was hydrolyzed.

A second sealed evacuated tube containing 0.0561 g. (0.24 mmole) of 8-phenyl-8-bora-7,9-diazaro-peri-naphthene and 1 ml. of degassed 1.9M hydrochloric acid in 50% aqueous ethanol was heated at 80 ± 1°C. for 16 hrs. The tube was opened under nitrogen and 0.0272 g. of insoluble 1,8-diaminonaphthalene hydrochloride containing about 8% starting material by qualitative infrared analysis was isolated. The mother liquor was diluted with 3 ml. of water causing 0.0174 g. of starting material to precipitate. Strong basification of the mother liquor resulted in no further precipitate. From qualitative infrared analyses, about 66% of the starting material was hydrolyzed.

f. Preparation of  
N-Methyl-1,8-diaminonaphthalene (1365-11, 32)

To a solution of 5.2 g. (32.7 mmoles) of 1,8-diaminonaphthalene (recrystallized three times from 95% ethanol) in 100 ml. of diethyl ether, in a 500 ml. Morton flask equipped with high speed stirrer, argon inlet tube, 50 ml. pressure equalized dropping funnel, and condenser vented through a mercury bubbler, was added dropwise 34.2 ml. (32.6 mmoles) of freshly prepared ethereal methyllithium solution. During addition of the methyllithium the temperature of the mixture rose from 20°C. to 25°C. with constant evolution of gas (presumably methane) and formation of a small amount of brown precipitate. After addition of the methyllithium, the reaction mixture was refluxed for 1 hr. The mixture was cooled to room temperature and 4.6 g. (32.4 mmoles) of methyl iodide in 25 ml. ether was added dropwise in 15 min., The reaction mixture was then refluxed for 8 hrs. after which 50 ml. of water was added dropwise resulting in an exothermic evolution of gas. The layers were separated and the solids and aqueous layer washed with two 50 ml. portions of ether. The combined reddish-brown ether extracts were washed with two 100 ml.

portions of water. The ether layer was dried over magnesium sulfate, filtered, and evaporated at reduced pressure to yield 5.3 g. of a dark reddish-brown liquid which was twice distilled from zinc dust and charcoal under high vacuum (140-170°C./10<sup>-5</sup> mm.). The 3.9 g. (69%) of light yellow liquid distillate analyzed poorly for carbon. The material was distilled again (160°C.) under high vacuum and the center fraction of the distillate was redistilled to give, in turn, the pale yellow center fraction used for the analytical sample. Anal. calcd. for C<sub>11</sub>H<sub>12</sub>N<sub>2</sub>: C, 76.71; H, 7.02. Found: C, 76.95; H, 7.39. An infrared spectrum showed aliphatic and aromatic C-H, and possibly NH<sub>2</sub> bands.

In a second experiment 13.3 g. (0.077 mole) of N-methyl-1,8-diaminonaphthalene was prepared in 48% yield using 25.0 g. (0.158 mole) of 1,8-diaminonaphthalene, 172 ml. (0.158 mole) of an ethereal methyllithium solution and 23.0 g. (0.16 mole) of methyl iodide. The product was purified by distillation (124-125°C., 0.1 mm.) through an 18" tantalum spiral column. Anal. calcd. for C<sub>11</sub>H<sub>12</sub>N<sub>2</sub>: C, 76.71; H, 7.02; M.W., 172.2. Found: C, 76.37; H, 6.98; M.W., 173.4 (Neumayer). Vapor phase chromatographic analysis indicated the material to be 98% pure.

#### 4. Miscellaneous Boron-Nitrogen Compounds

##### a. Preparation of Bis(dimethylamino)bromoborine (1361-69, 79, 80)

To a solution of 100.2 g. (0.40 mole) of boron tribromide in 400 ml. benzene (dried over sodium) in a 2000 ml. Morton flask fitted with stirrer, reflux condenser, and gas addition tube was added 18.5 g. (0.40 mole) dimethylamine while cooling with an ice-bath. A thick white slurry was formed to which was added one-half of an 81.0 g. (0.80 mole) solution of triethylamine in 135 ml. of benzene. The resulting slurry was diluted with 300 ml. of benzene and treated in the same manner as above with a second equivalent of dimethylamine, 18.5 g. (0.40 mole), and the remaining half of the triethylamine solution. The precipitate was filtered and washed with 300 ml. of benzene. The solvent was distilled from the combined filtrate and washings through a spinning band column and the residual liquid was fractionated under reduced pressure, to give 37.6 g. (0.32 mole) of bis(dimethylamino)bromoborine, b.p. 52-56°C./12-18 mm. in 80% yield.

Following the same procedure a second preparation using 198.0 g. (0.79 mole) boron tribromide, 164.0 g. (1.62 moles) triethylamine and 74.0 g. (1.64 moles) dimethylamine produced 42.0 g. (0.236 mole) of bis(dimethylamino)bromoborine, b.p. 63-73°C./26-29 mm. in 29.5% yield.

Similarly a third preparation using 199.1 g. (0.79 mole) boron tribromide, 74.0 g. (1.64 moles) dimethylamine (added as liquid) and 161.0 g. (1.59 moles) of triethylamine, provided an additional 87.0 g. (0.49 mole) bis(dimethylamino)bromoborine, b.p. 65-72°C./30 mm., in 61.5% yield. Anal. calcd. for C<sub>4</sub>H<sub>12</sub>N<sub>2</sub>BBR: B, 6.05; Br, 44.67; N, 15.7. Found: B, 6.39; Br, 47.6; N, 17.5.

##### b. Attempt to Prepare Tetrakis(dimethylamino)diboron (1361-74, 85)

A dispersion of 9.30 g. (0.45 mole) of sodium in 400 ml. of toluene (dried over sodium) was prepared using 0.8 ml. oleic acid as dispersing agent in a

2000 ml. Morton flask fitted with stirrer, stainless steel condenser flushed with argon and vented through a mercury bubbler. A solution of 57.6 g. (0.32 mole) of bis(dimethylamino)bromoborane in 50 ml. toluene, was added dropwise. The violet reaction mixture was refluxed for 45 min., cooled, and the supernatant liquid removed by pressure siphon through a glass wool filter stick. The solid residue was washed with two 100 ml. portions of toluene which was stripped from the combined filtrate and washings through a 40 cm. Vigreux column. The residual liquid was fractionally distilled through a spinning band column to give three fractions boiling in the range 35-37°C./1.5-3.5 mm. (reported<sup>34</sup> for tetrakis(dimethylamino)diboron, 55-57°C./2.5 mm.); each fraction precipitated white solids on standing. The liquid portions of these three fractions were combined and treated with excess dimethylamine, 20 g. (0.445 mole) in benzene. An exothermic reaction ensued forming white solids which were filtered from the solution. The benzene was distilled from the filtrate under reduced pressure and from the remaining liquid which appeared to decompose upon continued distillation. Two fractions were collected: 6 ml. at 81-89°C./18-20 mm. and 0.6 ml. at 90-93°C./18-20 mm. (reported<sup>34</sup> for tetrakis(dimethylamino)diboron, 100°C./18 mm.) each of which still precipitated white solids on standing.

Following the same procedure a second attempt was made to prepare tetrakis(dimethylamino)diboron using 5.20 g. (0.276 mole) of sodium in 400 ml. of toluene and 37.0 g. (0.207 mole) of bis(dimethylamino)bromoborane. The reaction mixture was refluxed for 2.5 hrs. and the liquid products were fractionally distilled through a 16 cm. tantalum spiral column. Four fractions were collected arbitrarily in the range 57-78°C./2.5-3.0 mm., each of which precipitated white solids on standing. Redistillation (127-139°C./90 mm.) gave the same results. Vapor phase chromatographic analysis of the material boiling 138-139°C./90 mm., showed extensive decomposition on a silicone/Celite column but indicated perhaps some tetrakis(dimethylamino)diboron,  $(\text{[(CH}_3)_2\text{N]}_2\text{B)}_2$ , may be present.

c. Preparation of  
Tris(dimethylamino)borane (1361-87)

To a solution of 1020 g. (22.7 moles) of dimethylamine in 2000 ml. of pentane (95 mole %) cooled with an ice-salt bath in a 5000 ml. round-bottom flask fitted with Dry Ice condenser, stirrer and gas delivery tube was added 266.5 g. (2.27 moles) of boron trichloride. A very exothermic reaction occurred forming a thick white slurry from which the excess amine was allowed to evaporate during three days at room temperature. The salts were filtered and washed with 2500 ml. of pentane. The solvent was stripped from the combined filtrate and washings through a 30 cm. Vigreux column and the residual liquid was fractionated through a spinning band column giving 217.5 g. (1.51 mole) tris(dimethylamino)borane, in 67% yield, b.p. 144-147°C./700-716 mm.

#### IV. NEW APPROACHES TO THERMALLY STABLE POLYMERS

##### A. Discussion

A number of new approaches to thermally stable polymer systems are being screened; these include P-N, Si-O-P, Si-O-C<sup>O</sup>, and B-N.

##### 1. Phosphorus-Nitrogen Chemistry

##### a. Phosphorus Azides

Diphenylphosphonyl azide has been prepared as a possible precursor for the preparation of thermally stable P-N polymers. It can be prepared from sodium azide and diphenylphosphonyl chloride in up to 87% yield using dry pyridine, benzene, or acetonitrile as the reaction solvent. The azide was found to be unexpectedly thermally stable; it was obtained as a colorless, slightly viscous liquid when purified by distillation at reduced pressures (137-140°C./0.05 mm.). This stability is in contrast to the ready thermal rearrangement of carboxylic azides (Curtius reaction<sup>35</sup>). The azide undergoes ready hydrolysis which is also in contrast to the hydrolytic stability of the carboxylic azides which may be prepared by treating acid hydrazides in cold, aqueous solution with nitrous acid or via aqueous sodium azide and acid chloride.<sup>35</sup> The infrared spectrum showed a strong azide stretching absorption at about 4.65  $\mu$  which corresponds to an acyclic form as contrasted to a possible oxatriazole heterocycle.<sup>36</sup>

An attempt to prepare and then thermally rearrange the azide in dimethylformamide resulted in the evolution of nitrogen but yielded a water-soluble product. Acidification of the aqueous solution gave a precipitate of diphenylphosphonic acid. Apparently then, although nitrogen was lost, no rearrangement resulted since both phenylphosphonic acid and aniline would be the expected hydrolysis products.

An attempt to prepare the azide from aqueous sodium azide and a chloroform solution of the acid chloride, diphenylphosphonic chloride, followed by a sulfuric acid catalyzed rearrangement of the azide in chloroform,<sup>35</sup> likewise, yielded only diphenylphosphonic acid. In view of the observations on the hydrolytic sensitivity of the azide, this result is not surprising. Diphenylphosphonic acid was also obtained on attempted sulfuric acid catalyzed rearrangement of the azide in benzene solution.

Thermolysis of the azide at 220-250°C. or higher for 4-16 hrs. gave black residues and half the theoretical quantity of nitrogen, based on equation (31):

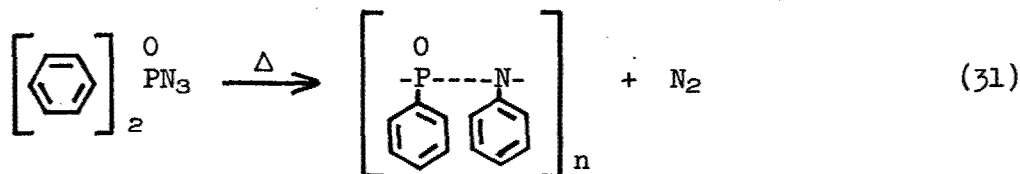

Again, there was not any evidence for any rearranged material; some diphenylphosphonic acid was recovered. There was not any indication of hydrazoic acid or of ammonia during the workup of the residues which would be expected from unreacted azide or any unsaturated nitrogen systems which might be present.

Diphenylphosphonyl azide reacts with triphenylphosphine in ether solution to smoothly liberate nitrogen and provide a 74% yield of a thermally and hydrolytically stable compound (I) according to equation (32).

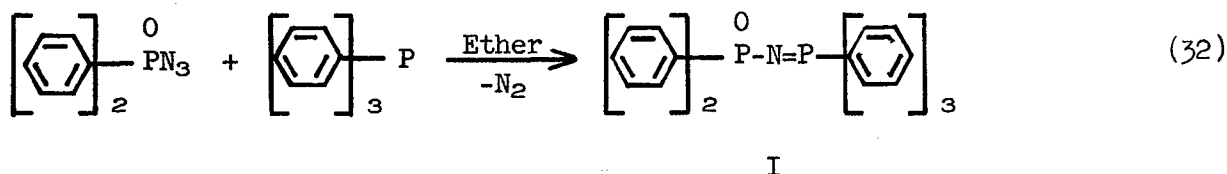

In order to further investigate the P=N-P bond system present in I, bis-1,4-(diphenylphosphino)benzene (II) was caused to react with diphenylphosphonyl azide. Although 98.2% of the nitrogen was obtained based on equation (33), the product was a yellow gummy material from which a stable product was not obtained using the work-up procedure which was successful in isolating I.

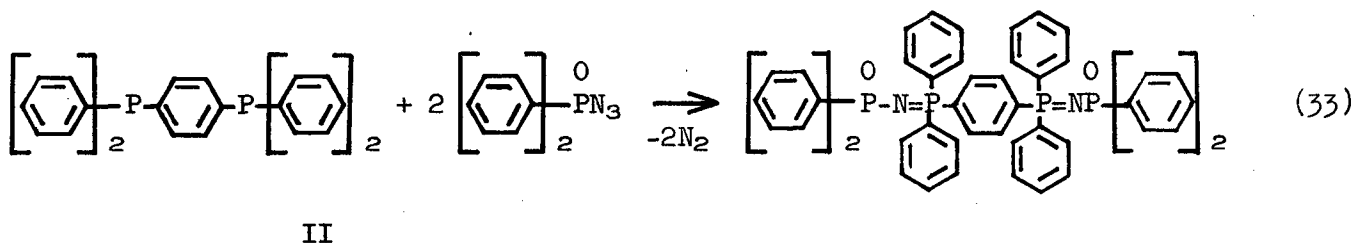

A portion of the gummy reaction product was extracted with ammonium hydroxide and then acidified to yield diphenylphosphonic acid. Examination of a portion of the product in the infrared indicated the absence of bands at  $7.9\mu$  and  $13.0\mu$  which were present in I.

In an attempt to further define the scope of the reaction of diphenylphosphonyl azide and tertiary phosphorus compounds, the reaction of phenyldimethylphosphine and diphenylphosphonyl azide was run and in contrast to the reaction leading to I, was found to be extremely rapid. The resulting nitrogen evolution was so vigorous that both the addition funnel and condenser were blown out of the flask. The product was hydrolytically decomposed to give diphenylphosphonic acid.

The reaction of diphenylphosphonyl azide and triethylenediamine was investigated to determine the effect of a strong nitrogen base. There was an immediate formation of a white, water soluble material without the evolution of

nitrogen. Infrared examination of this material did not show a band at  $4.65\mu$ , characteristic of the azide group. However, there was a strong broad absorption at  $4.5\mu$ , characteristic of a phosphorus-ammonium salt. The material melted at  $172-180^{\circ}\text{C}$ . and was soluble in ethanol. When the water solution was acidified, diphenylphosphonic acid was recovered.

It appears that the loss of nitrogen or of azide from diphenylphosphonyl azide is influenced in part by the nucleophilic character of the phosphorus or nitrogen of the attacking species, and in part by the phosphorus d-orbitals. The more basic the phosphorus compound, the greater the rate of reaction with the azide. On the other hand, there is no nitrogen evolution with nitrogen bases such as the strongly basic triethylene diamine and the azide is best prepared in pyridine solvent. However, strong nitrogen bases appear to cause azide displacement, whereas no azide displacement was observed with the phosphines.

Other similar azides will be prepared to determine their polymerizability and to investigate the properties of the new bonding system,  $\text{P-N=P}$ .

#### b. Phosphorus Amides

Phenylphosphonyl dichloride undergoes reaction with aniline in the presence of pyridine to provide an 85% yield of phenylphosphondianilide (III). The dianilide underwent reaction with diphenylphosphonyl chloride in the presence of triethylamine to yield a thermally and hydrolytically stable phenyl-substituted prototype P-N compound which might be either IVa or IVb (equation 34).

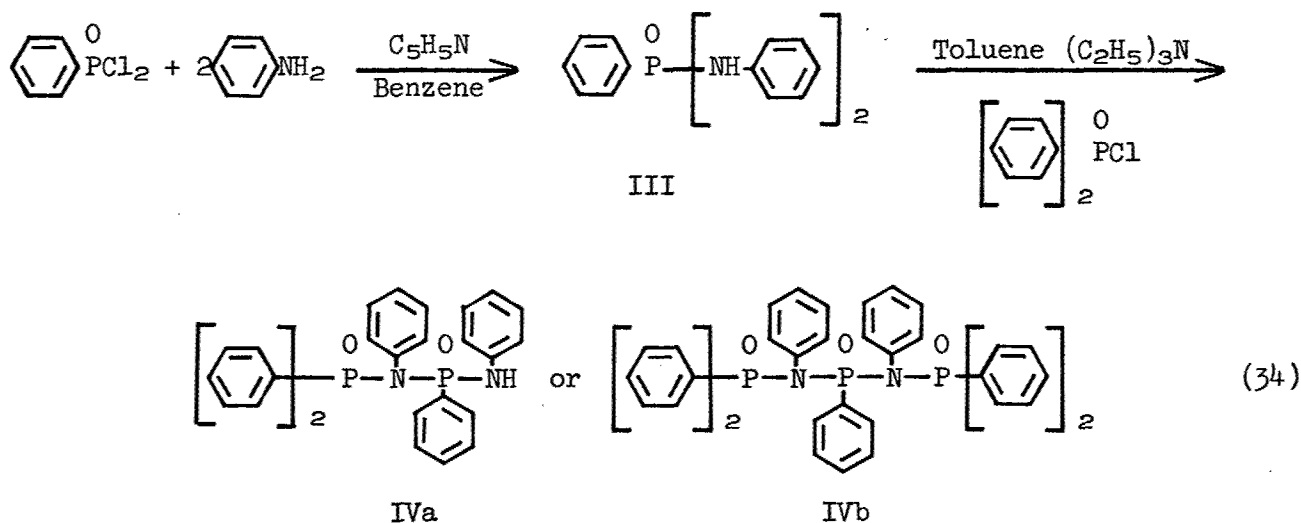

On substituting either pyridine and benzene or triethylenediamine and benzene for triethylamine and toluene in the second step (equation 34) no reaction occurred and starting materials were recovered.

The attempted direct preparation of P-N compounds from phenylphosphonic acid and aniline in dimethylformamide yielded two isolable materials, one of which was proved by infrared to be a monoanilinium salt. The other product appeared to be different, but it was probably not a P-N bonded compound since it was water



soluble. A monoanilinium salt was the only product isolated when the reaction solvent was xylene, and appeared by infrared to be the same as the monoanilinium salt isolated from the dimethylformamide run.

An attempt to prepare P-N compounds by the reaction of diphenylphosphonyl chloride and sym-dimethylurea in benzene yielded instead a material which did not exhibit carbonyl absorption and which was partially soluble in water. Thus, it appears that an ammonium salt of the phosphonic acid was obtained. The stability of the phosphorus anilides indicates that polymers based on this type of P-N-P bonding system are worthy of investigation.

## 2. Silicon-Oxygen Chemistry

An attempt to prepare a polymeric material from diphenyldiacetoxysilane and phenylphosphonyl dichloride by the elimination of acetyl chloride gave a brown glass which was thermally stable but was very sensitive to moisture (equation 35).

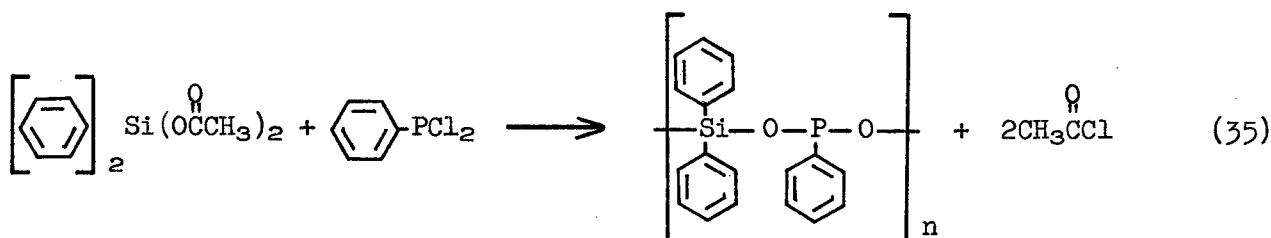

An apparent molecular weight of about 724 suggests that the product might be a dimer.

The elimination of acetic acid from terephthalic acid and diphenyldiacetoxysilane gave a thermally stable tan-colored brittle solid which was insoluble in common organic solvents and which was only very slowly attacked by boiling water (equation 36).

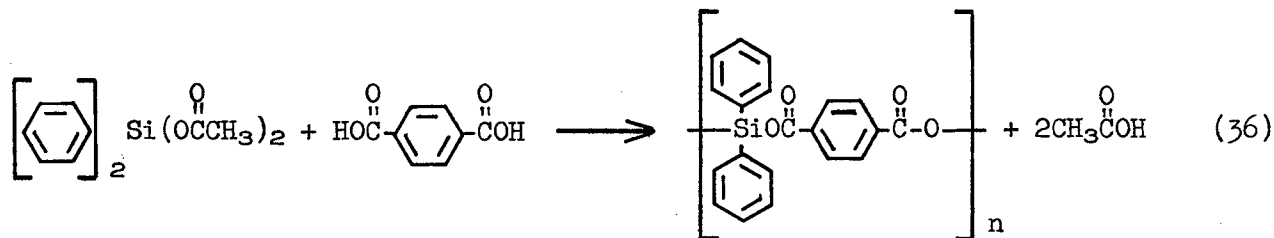

Acetyl chloride was also eliminated during the reaction of diphenyldiacetoxysilane and tetrachloroterephthaloyl chloride in p-xylene or without a solvent. Both reactions eventually yielded a black, shiny glass which was only slightly attacked by boiling water and base and which burned only slowly when placed in a Bunsen flame. The loss of acetyl chloride was much slower in these reactions than in the corresponding reactions with terephthalic acid. Tetrachloroterephthalic acid was

prepared from the acid chloride for further studies in this area. The general inertness and ready preparation of polymers based on the  $-\text{Si}-\text{O}-\overset{\text{O}}{\parallel}{\text{C}}-$  bonding system indicate that they are worthy of further investigation.

### 3. Boron-Nitrogen Chemistry

In a prototype experiment, a hydrolytically and thermally stable bis(borimidazoline) (V) was obtained from 3,3',4,4'-tetraaminobiphenyl and benzeneboronic acid (equation 37).

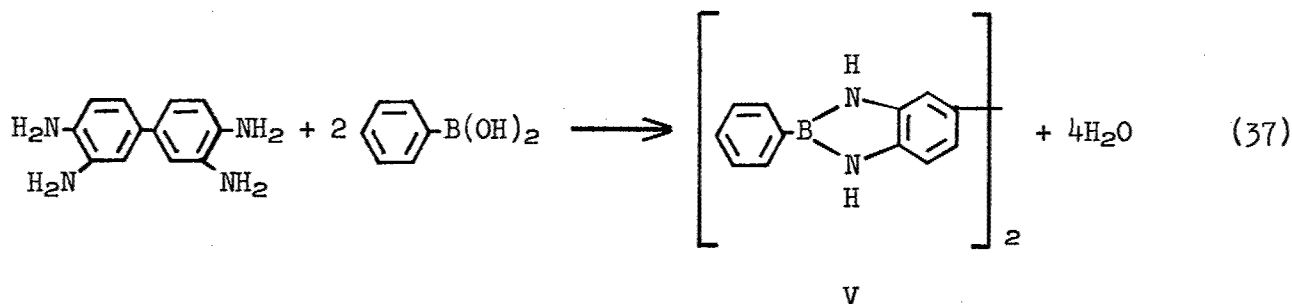

The high melting point (338-340°C.) and general inertness suggested that this B-N system would be worthy of further development. Therefore, benzene-1,3- and benzene-1,4-diboronic acids and tetra-n-butylbenzene-1,4-diboronate were prepared and caused to react with 3,3',4,4'-tetraaminobiphenyl in an attempt to prepare a polymer having the repeating unit shown in VI. Products from all of these reactions appeared to be thermally and hydrolytically stable brown solids (m.p. > 360°C.), soluble in sulfuric acid and insoluble in common organic solvents.

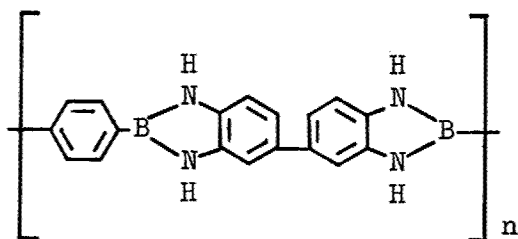

The analytical data for these products indicate some intermediate degree of polymerization. The boron analyses which are more accurate than the nitrogen analyses suggest that the reaction of the tetraamine and benzene-1,4-diboronic acid gave a product involving approximately three moles of tetraamine and two moles of diboronic acid. The boron analyses for the product obtained from the reaction of tetraamine and tetra-n-butylbenzene-1,4-diboronate indicate a product intermediate between the material obtained when the diboronic acid was used and a product

TABLE XII

Infrared Absorptions of Products Derived  
from Boronic Acids and 3,3',4,4'-Tetraaminobiphenyl

Product	N-H 2.9 $\mu$	B-N 6.9-7.1 $\mu$	Trivalent B 7.25-7.4 $\mu$	Aryl Substitution Band 9.8-9.9 $\mu$
IV	strong sharp	strong sharp	strong <sup>(a)</sup> sharp	medium sharp
(b)	strong sharp	strong sharp	medium sharp	strong sharp
(c)	strong sharp	strong sharp	strong sharp	strong sharp
(d)	strong <sup>(e)</sup> broad	very weak <sup>(f)</sup> sharp	very weak	none

- (a) Absorbs at 7.2-7.3  $\mu$  .  
 (b) Product from reaction of tetraamine and benzene-1,4-diboronic acid.  
 (c) Product from reaction of tetraamine and tetra-n-butyl benzeneboronate.  
 (d) Product from reaction of tetraamine and benzene-1,3-diboronic acid.  
 (e) Broadness and shoulder due to hydrogen bonded N-H.  
 (f) Absorbs at 7.05-7.15  $\mu$  .

derived from two moles of tetraamine and one mole of diboronate. The infrared data listed in Table XII support these conclusions. The infrared data for the product obtained from the benzene-1,3-diboronic acid-tetraamine reaction indicate that little, if any, condensation product was obtained.

A slight excess of either reactant would act as an effective chain stopper. It has been observed previously that areneboronic acids undergo deboronation<sup>37</sup> in the presence of nucleophilic reagents. A trace of benzene was formed during these reactions and could account for the isolation of products of intermediate degree of polymerization.

## B. Experimental

### 1. Phosphorus-Nitrogen Chemistry

#### a. N,N-Diethylamidodichlorophosphate (1323-198)

To a solution of 1227 g. (8.00 moles) of phosphorus oxychloride and 808 g. (8.00 moles) of triethylamine in 1000 ml. of ether were slowly added 584 g. (8.00 moles) of diethylamine over a 3 hr. period with external cooling by means of a large ice-bath. After stirring overnight, the mixture was siphoned into a large closed glass sintered funnel which contained glass wool. The filtration under argon was rapid. The solid on the funnel was washed with additional fresh ether until the solid was no longer colored.

After removal of the ether through an 18 in. Vigreux column, distillation at 20 mm. pressure yielded 1090.5 g. (5.74 mole, 71.7%) of colorless N,N-diethylamidodichlorophosphate boiling at 107-110°C. (lit. 99-100°C./15 mm.<sup>38</sup>),  $n_D^{20}$  1.4639. Anal. calcd. for  $C_4H_{10}NPOCl_2$ : Cl, 37.0. Found: Cl, 35.7.

#### b. Preparation of Diphenylphosphonic Acid (1323-109, 110)

A solution of 266 ml. of ethereal phenylmagnesium bromide (0.8 mole) dissolved in 500 ml. of ether was slowly added with stirring and external cooling to 80 g. (0.52 mole) of phosphorus oxychloride dissolved in 1500 ml. of ether. At the end of the addition period (2.75 hrs.), the reaction mixture became very difficult to stir and a large ball of tacky solid material had formed. After decanting the ether and washing the solid with 1000 ml. of water (little reaction observed), 1000 ml. of 3N sodium hydroxide solution was gradually added. The mixture was filtered (extremely slow) and the aqueous filtrate on acidification yielded 45 g. (0.206 mole, 51.6%) of diphenylphosphonic acid as a white powder, m.p. 192-195°C. (lit.<sup>39</sup> 190-192°C.).

A 17.2 g. (0.0619 mole, 23.1%) quantity of triphenylphosphine oxide was recovered by treatment of the solids obtained from the earlier filtration with hydrochloric acid followed by recrystallization from an ethanol-water mixture.

In a second experiment using the same quantities of reagents but using benzene as the reaction solvent, a yield of only 38.2 g. (0.17 mole, 33.5%) of the acid was obtained. An analytical sample, recrystallized from ethanol, had a neutralization equivalent of 217 (calcd. for  $(C_6H_5)_2POOH$ , 218).

c. Bis-p-tolylphosphonic Acid (1134-2, 9)

To the gently refluxing Grignard solution prepared from 24.3 g. (1.00 mole) of magnesium turnings and 171 g. (1.00 mole) of p-bromotoluene in 500 ml. of anhydrous ethyl ether in an argon atmosphere was added 90 g. (0.474 mole) of N,N-diethylamidodichlorophosphate at a rate sufficient to maintain reflux. Heating was continued for 2.5 hrs. after the addition had been completed, and then the mixture was cooled and hydrolyzed with 53 g. (1.0 mole) of ammonium chloride in 500 ml. of water. The ether layer was removed and concentrated to give a yellow semi-crystalline mass which was refluxed for 6 hrs. with concentrated hydrochloric acid. After basifying with 5N sodium hydroxide solution and treating with Norite A, acidification with concentrated hydrochloric acid gave a yellow gum which partially solidified on cooling. Repeated crystallization from ethanol-water mixtures gave a white solid, which on air-drying had m.p. 55-60°C. The equivalent weight, 274, corresponds to a one and one-half hydrate.

When the same sample was vacuum-dried for 4 hrs., the melting point was found to be 132-134°C. (reported for bis-p-tolylphosphonic acid, 130-132°C.<sup>40</sup>; equivalent weight: calcd., 246; found, 247; yield, 38 g., 30.8%.

A second run involving the addition of the N,N-diethylamidodichlorophosphate to the Grignard solution at ice-bath temperature gave 32.2 g. (0.139 mole, 29.3%) of the bis-p-tolylphosphonic acid.

d. Preparation of  
Diphenylphosphonyl Chloride

(1) From Diphenylphosphonic Acid and Phosphorus Pentachloride (1323-124)

To a solution of 70 g. (0.32 mole) of diphenylphosphonic acid in 99 g. of phosphorus trichloride at 40°C. was added 66.6 g. (0.32 mole) of phosphorus pentachloride in small portions during 1.25 hrs. The mixture was warmed for 0.5 hr. after completion of the addition and then allowed to stand overnight. The heating was resumed for 2.5 hrs. (to 85°C.) before the excess phosphorus trichloride was removed through a 12 in. Vigreux column. Distillation of the liquid residue yielded 58.6 g. (0.248 mole, 77.4%) of a colorless liquid, b.p. 148-151°C. at about 0.1 mm. (lit.<sup>41</sup> 135-137°C. at 0.07 mm.).

(2) By Air Oxidation of Diphenylchlorophosphine (1323-127, 138)

A slow stream of air was passed in series through Drierite, sodalime and sulfuric acid into 66.2 g. (0.30 mole) of diphenylchlorophosphine dissolved in 200 ml. of benzene for 8 hrs. at 40°C. After removal of the solvent, distillation of the liquid residue yielded (1) 25.9 g. of forerun, b.p. 84-115°C. at 0.01-0.05 mm. and (2) 36.4 g. (0.153 mole, 51.2%) of diphenylphosphonyl chloride, b.p. 138-144°C. at 0.1 mm.

A second run using the same quantities but at 60°C. for 12 hrs. yielded 33.5 g. (0.14 mole, 47.2%) of the phosphonyl chloride, b.p. 119-123°C. at 0.01 mm.

(3) Attempted Preparation from Diphenylphosphonic Acid and Thionyl Chloride (1323-111)

A 5.5 g. (0.025 mole) quantity of diphenylphosphonic acid was refluxed with 18 ml. (29.9 g., 0.25 mole) of thionyl chloride for 2 hrs. No diphenylphosphonic chloride was obtained on distillation of the reaction mixture at about 0.05 mm.

e. Bis-p-tolylphosphonyl Chloride (1134-14)

Thionyl chloride, 80 ml., was dropped slowly onto 72 g. (0.293 mole) of bis-p-tolylphosphonic acid with immediate evolution of hydrogen chloride and sulfur dioxide. The reaction mixture soon became fluid and was then heated under reflux for 4 hrs. After removal of excess thionyl chloride, b.p. 75-76°C., distillation through a short Vigreux column at 0.05 mm. gave 61.1 g. (0.231 mole, 78.7% yield) of viscous oil boiling at 164-167°C. On standing, the oil solidified to a white solid which softened at 45°C. and melted at 52-54°C. Anal. calcd. for  $C_{14}H_{14}POCl$ : P, 11.70; Cl, 13.39. Found: P, 11.76; Cl, 13.26.

f. Diphenylphosphonyl Azide

(1) Pyridine Solvent (1323-146, 149, 160, 166)

In an atmosphere of argon, 69.99 g. (0.297 mole) diphenylphosphonyl chloride and 20.88 g. (0.32 mole) of sodium azide in 200 ml. of pyridine (distilled from calcium hydride) was refluxed with stirring for 18 hrs. The solids were removed by filtration. The solvent was removed from the filtrate at reduced pressure to yield a dark, viscous oil which was distilled at 0.05 mm. to yield 63.1 g. (87.4%) of colorless azide boiling at 137-140°C. The infrared spectrum showed a strong azide stretching absorption at about 4.65  $\mu$  which corresponds to an acyclic form as contrasted to a possible oxatriazole heterocycle.<sup>36</sup> Anal. calcd. for  $C_{12}H_{10}N_3OP$ : N, 17.28. Found: N, 17.2; Cl, 0.19. Anal. of solids, calcd. for  $NaCl$ : Cl, 65.8;  $NaN_3$ ; N, 64.6. Found: Cl, 55.1; N, 10.1.

Exposure of the azide to water resulted in the hydrolysis to and recovery of diphenylphosphonic acid, m.p. 192-196°C., and in a positive azide test.<sup>42</sup>

(2) Acetonitrile Solvent (1323-144)

The interaction of 2.4 g. (0.01 mole) of diphenylphosphonyl chloride and 0.65 g. (0.01 mole) of sodium azide in 20 ml. of impure acetonitrile (1.8% water) at reflux for 5 hrs. yielded diphenylphosphonic acid, 0.49 g. (22.4% recovery) and 0.85 g. (38.9% yield) of crude diphenylphosphonyl azide. The crude azide contained only 0.63% chloride, gave a positive azide test<sup>42</sup> and showed an azide band at 4.65  $\mu$  in an infrared spectrum.

g. 1,4-Bis(diphenylphosphino)benzene (II) (1323-184)

A solution of 36.7 g. (0.155 mole) of p-dibromobenzene in 250 ml. of anhydrous tetrahydrofuran was added over a period of 30 min. to 7.5 g. (0.31 mole) of magnesium turnings. After the p-dibromobenzene had been added, the mixture was

refluxed with stirring for 7 hrs. with the amount of yellow colored solid increasing as the reaction progressed. Diphenylchlorophosphine, 68.4 g. (0.31 mole), in 250 ml. of tetrahydrofuran was added slowly with the reaction mixture clearing and becoming dark orange in color. The mixture was refluxed for an additional hour, and 250 ml. of saturated ammonium chloride solution was added to the cooled solution. The organic layer was separated and the water layer extracted successively with 100 ml. of tetrahydrofuran and 100 ml. of diethyl ether. The combined organic extracts were dried over anhydrous sodium sulfate before the solvent was removed to yield a yellow-white solid which was digested with isopropyl alcohol to remove the yellow color. The white powder, which softened at 155°C. and melted over the range 167-172°C. weighed 40.7 g. (0.091 mole, 58.7% yield). Anal. calcd. for  $C_{30}H_{24}P_2$ : P, 13.82. Found: P, 13.3.

A quantity of the crude product was sublimed at 160-180°C. and 10<sup>-4</sup> mm. to give a white powder, m.p. 166-168.5°C. Anal. calcd. for  $C_{30}H_{24}P_2$ : P, 13.82; M.W., 446.5. Found: P, 13.7; M.W., 436.6.

An attempt to prepare a bis(tribromoborane) adduct from 1.0 g. (2.33 mmoles) of 1,4-bis(diphenylphosphino)benzene and 1.2 g. (4.66 mmole) of tribromoborane resulted in the complete recovery of the diphosphine.

h. 1,4-Bis(diphenylphosphonyl)benzene (1323-183)

To the Grignard solution prepared from 36.7 g. (0.155 mole) of p-dibromobenzene and 7.5 g. (0.31 mole) of magnesium in 250 ml. of tetrahydrofuran (vide supra) was added 68.4 g. (0.289 mole) of diphenylphosphonyl chloride dissolved in 100 ml. of tetrahydrofuran with the resulting color changes: colorless to green to black to orange-yellow. The mixture was refluxed for 1 hr., cooled, and treated with 250 ml. of saturated ammonium chloride solution to obtain a gummy solid. Ammonium hydroxide was added to basify the solution before attempting an unsuccessful ether extraction. The liquid was decanted from the gummy material and it was dried by azeotropic distillation with 250 ml. of toluene. A yellow powder was obtained which had a strong P-O band at 8.4  $\mu$ . Recrystallization of the powder from dimethylformamide gave 29.5 g. (0.062 mole, 74.2% yield) of 1,4-bis(diphenylphosphonyl)benzene as a white powder, m.p. 297-302°C. Anal. calcd. for  $C_{30}H_{24}O_2P_2$ : P, 12.16. Found: P, 12.2.

i. Attempted Acid Catalyzed Rearrangement of Diphenylphosphonyl Azide in Benzene (1323-136)

Sodium azide, 2.0 g. (0.031 mole) and 7.4 g. (0.031 mole) of diphenylphosphonyl chloride were refluxed with stirring in 100 ml. of dry benzene for 8 hrs. After standing overnight, 5 ml. of concentrated sulfuric acid was added with stirring. The mixture was allowed to stand over the weekend before the benzene was decanted from the semi-solid sulfuric acid layer. The solvent was removed at reduced pressures on a rotary evaporator to yield only a small quantity of a brown oil which hydrolyzed to diphenylphosphonic acid. The sulfuric acid layer was diluted with water to yield a white solid which was recrystallized from ethanol (Norite) to give 5.1 g. (0.023 mole, 74.2%) of white needles of diphenylphosphonic acid, m.p. 193-195°C.

j. Attempted Preparation and Thermal Rearrangement of Diphenylphosphonyl Azide in Dimethylformamide (1323-137)

An immediate evolution of nitrogen occurred when 10.6 g. (0.045 mole) of diphenylphosphonyl chloride and 2.9 g. (0.045 mole) of sodium azide were mixed in dimethylformamide. Heating was gradually increased over about 7 hrs. until approximately 1000 cc. of gas had been collected. (Theory: 1008 cc.). The dark red solution was poured into water to yield a clear solution. Acidification with concentrated hydrochloric acid again precipitated diphenylphosphonic acid as indicated by its melting point, 194-198°C., and infrared spectrum.

k. Thermolysis of Diphenylphosphonyl Azide (1323-168, 170)

Experiment 1. A sealed pressure tube containing 0.5697 g. (2.39 mmoles) of diphenylphosphonyl azide was heated at 200-280°C. for 6 hrs. The tube, containing a black, low melting residue, was opened on a high vacuum line and 28.98 cc. (1.294 mmoles, 55.1%) of nitrogen was collected. The tube was resealed and returned to the furnace for an additional 16 hrs. at 300°C. A negligible amount, 0.85 cc., of additional nitrogen was collected. The black shiny residue was insoluble in benzene, cyclohexane, 20-40°C. petroleum ether, and ethyl acetate and soluble in ethanol and chloroform. A gray powder obtained from chloroform-petroleum ether was dissolved in ammonium hydroxide and precipitated with hydrochloric acid. The gray powder had a wide melting range, 170-200°C.

Experiment 2. A larger quantity of diphenylphosphonyl azide, 9.3 g. (0.042 mole), was heated at 220-250°C. for 3 hrs. in a sealed tube to yield 463 cc. (0.0206 mole, 49%) of nitrogen. The black contents of the tube were successively extracted with 65-110°C. petroleum ether (3 x 50 ml.), methylcyclohexane (2 x 50 ml.), and 50 ml. of benzene; the benzene dissolved all remaining material. The first three solvents yielded small quantities of white, gummy material which soon turned yellow, slowly reacted with water, and dissolved in ammonium and sodium hydroxide solutions. The basic solutions from each extraction were acidified to yield diphenylphosphonic acid, 2.0 g. (21.9%) total weight. There was not any evidence of ammonia from the reaction material on basification with sodium hydroxide or of any hydrazoic acid on acidification of the basic solutions.

l. Reaction of Diphenylphosphonyl Azide and Triphenylphosphine (1323-153, 164)

To 1.28 g. (5.26 mmoles) of diphenylphosphonyl azide dissolved in 15 ml. of ether was added 1.38 g. (5.26 mmoles) of triphenylphosphine. When the mixture was heated under reflux for 4 hrs. there was a slow precipitation of a white solid. The solid was removed by filtration to give 1.9 g. (75.7%) of a white powder (I) which melted at 149-150°C. A mixed melting point with triphenylphosphine oxide, melting point of 152-153°C., was found to be 112-122°C. This product was unaffected by boiling water and boiling ammonium hydroxide solution. Anal. calcd. for  $C_{30}H_{25}NOP_2$ : P, 12.98; M W., 477.5. Found: P, 12.8; M.W., 487.9.



m. Reaction of Diphenylphosphonyl Azide and 1,4-Bis(diphenylphosphino)benzene (1323-189)

A 2.6790 g. (0.010 mole) quantity of diphenylphosphonyl azide in 10 ml. of ethyl ether was slowly added to 2.2358 g. (0.005 mole) of 1,4-bis-(diphenylphosphino)benzene dissolved in 35 ml. of ethyl ether with no apparent reaction. When after 2 hrs. reflux there was still no evidence of any reaction the ether was removed by distillation while adding 50 ml. of tetrahydrofuran. At reflux, a slow gas evolution began with a small quantity of solid appearing. The volume of gas collected was approximately 220 cc. (theory, 224 cc.).

Removal of the solvent left a yellow gummy residue with some crystalline solid at the edge of the gum. A portion of the gum was extracted with ammonium hydroxide with part of the material dissolving. Acidification of the ammonia extract after filtration gave a white solid which on recrystallization from ethanol had a melting point of 190-192°C. (diphenylphosphonic acid). Attempts to cause the gum to crystallize were unsuccessful. Examination of the more crystalline portion by infrared spectroscopy gave a spectrum which lacked the bands at 7.9  $\mu$  and 13.0  $\mu$  which were present in the triphenylphosphine adduct of diphenylphosphonyl azide.

n. Reaction of Phenyl dimethyl phosphine and Diphenylphosphonyl Azide (1323-186)

To 9.0 g. (0.065 mole) of phenyl dimethyl phosphine in 25 ml. of anhydrous ether were added several drops of the diphenylphosphonyl azide (15.8 g., 0.065 mole) with an extremely vigorous gas evolution which blew out both the condenser and dropping funnel. Although the remaining azide was diluted with 10 ml. of ethyl ether before resuming the addition to the cold phenyl dimethyl phosphine solution, the reaction again got out of control with loss of nitrogen. The white solid which formed was tacky and when placed in ammonium hydroxide, liquidified and the odor of phenyl dimethyl phosphine was quite strong. When the basic aqueous layer was acidified with concentrated hydrochloric acid, diphenylphosphonic acid, m.p. 192-194°C. was recovered.

o. Reaction of Triethylenediamine and Diphenylphosphonyl Azide (1323-200, 1134-6)

The addition of 1.9 g. (7.8 mmoles) of diphenylphosphonyl azide in 10 ml. of diethylene glycol dimethyl ether to a refluxing solution of 0.95 g. (7.8 mmoles) of triethylenediamine in 10 ml. of the same solvent resulted in the immediate formation of a white solid but there was no evolution of nitrogen. The solid dissolved in water to give a clear solution which precipitated diphenylphosphonic acid on acidification with concentrated hydrochloric acid. The solid, melting range 172-180°C. in a sealed tube, when examined in the infrared did not have the strong azide band at 4.65  $\mu$  but there was a strong, broad absorption at 4.5  $\mu$  characteristic of a phosphorus-ammonium salt.

p. Attempted Polymerization of Phenylphosphonic Acid and Aniline (1323-140)

A solution containing 15.8 g. (0.10 mole) of phenylphosphonic acid and 9.3 g. (0.10 mole) of aniline dissolved in 200 ml. of dimethylformamide was slowly distilled over 18 hrs. to remove approximately 150 ml. of the solvent. An aliquot of the mixture was removed and diluted with water to give white plates melting from 168-182°C. after two recrystallizations from ethanol (Norite); the infrared spectrum showed an amine salt absorption. This was not further characterized. The remainder was placed on a rotary evaporator to remove the solvent. As the solvent evaporated, a yellow-brown gum formed. The gum solidified in isopropyl alcohol and could be recrystallized from ethanol (Norite) to give white crystals melting at 175-190°C. The infrared spectra of these two substances are dissimilar and unlike the starting acid. However, the infrared spectrum proved the former solid to be the monoanilinium salt of diphenylphosphonic acid (vide infra).

q. Attempted Preparation of the Dianilide of Phenylphosphonic Acid (1323-143)

A mixture of 15.8 g. (0.10 mole) of phenylphosphonic acid and 18.6 g. (0.20 mole) of aniline in 250 ml. of xylene was slowly distilled to remove water azeotropically. After removal of 50 ml. of the solvent an additional 100 ml. of xylene was introduced and distillation continued. After distillation of an additional 100 ml. of xylene, the reaction mixture was cooled and a portion of the mixture was filtered to give a water and ammonium hydroxide soluble white powder melting from 170-190°C.

Solids from the entire mixture were removed by filtration and added to 18.6 g. (0.20 mole) of aniline and 200 ml. of tetraethylene glycol dimethyl ether. Distillation over 4 hrs. to a head temperature of about 190°C. and a pot temperature of about 250°C. gave a tan solid in the reaction flask. After filtration, the tan solid was twice recrystallized from ethanol (Norite) to give white platelets melting at 183-186°C. The infrared spectrum shows amine salt bands at 3.5-4.0  $\mu$  and proved the material to be the same as that isolated in the dimethylformamide run (vide supra). Anal. calcd for  $C_{12}H_{14}NO_2P$ : C, 57.37; H, 5.61; N, 5.57; equivalent weight, 125.5. Found: C, 57.25; H, 5.69; N, 5.82; equivalent weight, 132.0. The infrared spectrum and analysis support the formulation of this material as the monoanilinium salt of diphenylphosphonic acid.

r. Preparation of Phenylphosphondianilide (III) (1323-145)

A reaction mixture of 19.5 g. (0.1 mole) of phenylphosphonyl dichloride, 27.9 g. (0.30 mole) of aniline, and 15.8 g. (0.20 mole) of pyridine dissolved in 300 ml. of benzene was heated under reflux for 3 hrs. with the formation of a white solid. The solid was removed by filtration, washed twice with 400 ml. portions of distilled water, and dried at reduced pressure over anhydrous sodium sulfate. Recrystallization from ethanol yielded 28.8 g. (93.5%) of phenylphosphondianilide as a white, fluffy solid which melted at 213-214.5°C. (lit.<sup>43</sup> 211°C.).

s. Preparation of N,N'-Bis(diphenylphosphonyl)phenylphosphondianilide (IV) (1323-148, 156, 157)

Diphenylphosphonyl chloride, 4.8 g. (0.02 mole), dissolved in 25 ml. of toluene was slowly added to 3.1 g. (0.01 mole) of phenylphosphondianilide and 2 ml. of triethylamine dissolved in 50 ml. of toluene. The mixture was heated under reflux for 2.5 hrs. and then cooled. The cream-colored needles removed by filtration had a melting point of 235-250°C. and appeared to be crude diphenylphosphonanilide, m.p. 242-244°C.<sup>44</sup>

From the mother liquors, a second white solid was recovered by filtration which was washed with water and vacuum-dried. The melting point of this material was 191-193°C. and gave with diphenylphosphonic acid a mixed melting range of 160-165°C. The weight of the second fraction was 3.5 g. (50%). Anal. calcd. for C<sub>30</sub>H<sub>26</sub>N<sub>2</sub>O<sub>2</sub>P<sub>2</sub> (IVa): C, 70.86; H, 5.15; N, 5.51; M.W., 508; calcd. for C<sub>42</sub>H<sub>35</sub>N<sub>2</sub>O<sub>3</sub>P<sub>3</sub> (IVb): C, 71.18; H, 4.98; N, 3.95; M.W., 708. Found: C, 70.74; H, 5.27; N, 5.72; M.W., 649.

The use of benzene as solvent and pyridine as the base resulted in only recovered starting materials. The same result was obtained using benzene and triethylenediamine.

t. Attempted Reaction of *sym*-Dimethylurea and Diphenylphosphonyl Chloride (1323-158)

A 4.7 g. (0.02 mole) quantity of diphenylphosphonyl chloride was reacted with 0.9 g. (0.01 mole) of *sym*-dimethylurea in 30 ml. of benzene and 3 ml. of triethylamine. After 2.5 hrs. reflux the mixture was cooled, filtered, and the white solid washed with ether. The solid was partially soluble in water, insoluble in ammonium hydroxide, and rather soluble in ethyl acetate. An infrared spectrum indicated the presence of a salt and the absence of a carbonyl group.

Unreacted diphenylphosphonyl chloride was recovered from the filtrate and hydrolyzed to diphenylphosphonic acid.

## 2. Silicon-Oxygen Chemistry

a. Preparation of Diphenyldiacetoxysilane (1323-163)

The interaction of 46.1 g. (0.182 mole) of diphenyldichlorosilane, 37.1 g. (0.364 mole) of acetic anhydride and 1 ml. of triethylamine in 100 ml. of p-xylene resulted in an orange-brown colored reaction mixture from which only one-half the theoretical amount of acetyl chloride distilled. Removal of excess reactants and solvent at reduced pressure gave a viscous brown oil from which 41.7 g. (76.9%) of diphenyldiacetoxysilane as a viscous oil, boiling point 132-136°C./0.02 mm. was obtained, (lit.,<sup>45</sup> 176-178°C./3.0 mm.).

b. Tetrachloroterephthalic Acid (1323-193)

Fifteen grams (0.044 mole) of tetrachloroterephthaloyl chloride was refluxed with 50 ml. of 2N sodium hydroxide and 75 ml. of water for 16 hrs. It was

necessary to occasionally wash down the solid from the walls of the flask. Unreacted acid chloride, 2.8 g. (0.0082 mole), was recovered by filtration. Acidification of the basic solution with concentrated hydrochloric acid gave a white solid, m.p. 333-336°C., dec., (lit.,<sup>46</sup> 343-345°C.). The yield of the tetrachloroterephthalic acid was 8.5 g. (0.028 mole, 78.2%).

c. Reaction of Diphenyldiacetoxysilane and Phenylphosphonyl Dichloride (1323-172)

When 13.4 g. (0.045 mole) of diphenyldiacetoxysilane and 7.4 g. (0.045 mole) phenylphosphonyl dichloride were warmed, acetyl chloride (5 ml.) readily distilled from the mixture. The resulting brown colored liquid was aspirated for 30 min. before the pressure was reduced to about 0.5 mm. It was necessary to warm the mixture frequently to maintain a fluid reaction mixture during the 2 hrs. at the lower pressure. On cooling, a brittle, brown glass was obtained which was soluble in benzene and in ethanol and which reacted rapidly with water. A Neumayer molecular weight determination in benzene was erratic but gave a value of about 724. This value suggests a dimer product (theory 754.5).

d. Reaction of Terephthalic Acid and Diphenyldiacetoxysilane (1323-174)

Terephthalic acid, 7.97 g. (0.048 mole) and 14.4 g. (0.048 mole) diphenyldiacetoxysilane were heated under reflux in 50 ml. of p-xylene for 1 hr. before an azeotrope of acetic acid and p-xylene was distilled at 122-127°C. Three 15 ml. fractions were collected before the excess solvent and reactants were removed at reduced pressures. On cooling, a cream-colored brittle glass was obtained, which did not melt up to 255°C., only appearing to soften at about 185-190°C. This material which was only slightly affected by boiling water was hot-pressed into a translucent brittle film. The opaque glass gave a clear melt in a Bunsen flame without apparent decomposition.

e. Reaction of Diphenyldiacetoxysilane and Tetrachloroterephthaloyl Chloride (1323-191, 192)

Under an argon atmosphere, 8.0 g. (0.027 mole) of diphenyldiacetoxysilane and 9.2 g. (0.027 mole) of tetrachloroterephthaloyl chloride were slowly warmed to distill out 2.5 ml. (theory, 3.8 ml.) of acetyl chloride during 4.5 hrs. During this period the color of the reaction mixture gradually darkened and toward the end of the heating period there was considerable fuming. The reaction mixture was aspirated while warm. The cooled material was a shiny black glass which was soluble in chloroform and in carbon tetrachloride. Boiling water had little effect on the glass and it burned only when heated strongly in a Bunsen flame.

An attempt to cause the elimination of acetyl chloride in a solvent, p-xylene, was not successful with only p-xylene distilling from the mixture. After removing the solvent, further heating yielded the same shiny black glass which had been obtained previously.

### 3. Boron-Nitrogen Chemistry

#### a. Preparation of Benzene-1,4-diboronic Acid (1377-25, 34)

The general procedure for preparing benzene-1,4-diboronic acid is given below.

Under an argon atmosphere, freshly distilled methyl borate (1479 g., 14.23 moles) and 1,4-dichlorobenzene (280.5 g., 1.91 moles) were placed in a Morton flask and sodium (180 g., 7.85 g.-atoms) dispersed in 350 ml. xylene was added at such a rate that the temperature remained between 35-38°C. The reaction mixture was cooled when necessary with a kerosene-Dry Ice bath and was stirred for 6-8 hrs. Excess methyl borate was removed by distillation up to a pot temperature of 107°C. The viscous syrupy reaction mixture was then hydrolyzed with 3N sulfuric acid to give a slightly acidic (pH 5-6) yellow mixture. The solids were collected on a filter (mainly boric acid) and the organic layer separated and evaporated leaving crude benzene-1,4-diboronic acid. The concentrated saline aqueous layer was extracted with several portions of acetone and the extracts evaporated leaving crude benzene-1,4-diboronic acid contaminated with boric acid. The boric acid was removed as methyl borate by heating the crude solids in excess methanol and distilling. Evaporation of the residual methanol solution gave benzene-1,4-diboronic acid in 45% yield.

#### b. Preparation of Benzene-1,3-diboronic Acid (1505-167, 179, 185)

Boron tribromide (568 ml./25°C.; 1505 g., 6.0 moles) and 10 g. of anhydrous aluminum chloride were brought to a mild reflux and benzene (177 ml./25°C.; 156 g., 2.0 moles) then was added slowly over 2 hrs. The mixture was refluxed gently for 24 hrs. and the excess unreacted boron tribromide removed at atmospheric pressure with the pot temperature reaching 130°C. at which temperature the distillation was terminated. The reaction mixture was cooled and slowly added to 500 ml. chilled 0.2N HCl. The mixture was then filtered and the crude reaction material collected, treated with charcoal, and recrystallized from water to give benzene-1,3-diboronic acid in 10% yield.

#### c. Reaction of Benzeneboronic Acid and 3,3',4,4'-Tetraaminobiphenyl (1323-134)

A mixture of 2.4 g. (0.02 mole) of benzeneboronic acid and 2.1 g. (0.01 mole) of 3,3',4,4'-tetraaminobiphenyl in 50 ml. of benzene was heated under reflux for 12 hrs. The mixture was filtered to yield a dark brown powder which was insoluble in ethanol, chloroform, and methanol and sparingly soluble in ethyl acetate. After several recrystallizations from ethyl acetate, a small quantity of a powder melting at 338-340°C. was obtained. Anal. calcd. for C<sub>24</sub>H<sub>20</sub>B<sub>2</sub>N<sub>4</sub>: C, 74.66; H, 5.22. Found: C, 74.23; H, 5.32.

d. Reaction of Benzene-1,4-diboronic Acid and 3,3',4,4'-Tetraaminobiphenyl (1377-49)

A mixture of 3.8 g. (0.023 mole) benzene-1,4-diboronic acid and 5.0 g. (0.023 mole) of 3,3',4,4'-tetraaminobiphenyl in 50 ml. toluene was heated for 72 hrs. removing 0.8 g. water (calcd., 0.83 g.) as a toluene-water azeotrope. The mixture was filtered to yield a brown powder, apparently insoluble in methanol, acetone, ethyl acetate, chloroform, benzene and slightly soluble in warm dioxane. Vacuum drying at 99°C./0.5 mm. for 196 hrs. gave a material melting above 360°C. Anal. (see discussion) calcd. for  $C_{48}H_{42}B_4N_{12}$ : B, 5.21; N, 20.24. Found: B, 4.98; N, 12.77.

Vapor phase chromatographic analysis of the toluene used to azeotropically remove water of reaction indicated the presence of a trace of benzene.

e. Reaction of Tetra-n-butyl Benzene-1,4-diboronate and 3,3',4,4'-Tetraaminobiphenyl (1377-52)

In a similar manner, reaction occurred between tetra-n-butyl benzene-1,4-diboronate, formed in situ from benzene-1,4-diboronic acid (0.023 mole) and n-butanol (0.092 mole), and 3,3',4,4'-tetraaminobiphenyl to give brown solids, m.p., >360°C. Anal. (see discussion) calcd. for  $C_{30}H_{28}B_2N_8$ : B, 4.14; N, 21.46; calcd. for  $C_{48}H_{42}B_4N_{12}$ : B, 5.21; N, 20.24. Found: B, 4.46; N, 16.73. A trace of benzene was found in the solvent by vapor phase chromatographic analysis.

f. Reaction of Benzene-1,3-diboronic Acid and 3,3',4,4'-Tetraaminobiphenyl

Reaction between 0.023 mole benzene-1,3-diboronic acid and 0.023 mole 3,3',4,4'-tetraaminobiphenyl in toluene in the manner described previously gave 0.8 g. water as the toluene-water azeotrope. Anal. calcd. for  $C_{18}H_{14}B_2N_4$ : B, 7.04; N, 18.19. Found: B, 6.67; N, 14.17.

Infrared analysis indicated that little or none of the desired reaction occurred (see discussion).

## V. PHYSICAL CHEMISTRY

### A. Discussion

#### 1. Molecular Weight Determinations

##### a. Neumayer Thermistor Method<sup>47</sup>

The vapor pressure of a solution of a non-volatile solute is depressed below that of the pure solvent by an amount defined, in the ideal case, by Raoult's Law,  $P = (1-N) P_0$  where  $N$  is the mole fraction of solute and  $P_0$  is the vapor pressure of pure solvent. When a solution is exposed to an atmosphere saturated with pure solvent vapor, equilibrium can be attained in two ways. The solution can be heated above the ambient temperature, thus increasing the vapor pressure to equal that of the pure solvent at ambient or the solution can be diluted (ultimately to infinite dilution) to raise its vapor pressure.

In this method both effects are present. Solvent vapor condenses on the solution and in doing so releases its latent heat of vaporization to raise the temperature. It is this temperature increase, amounting to value from a few hundredths to a tenth of a degree that is measured and related to the concentration of the solution. From this the molecular weight of the solute is calculated.

Thermistors are used as sensitive temperature sensing elements. What is actually measured is the temperature difference between a drop of pure solvent and a drop of solution in an atmosphere saturated with solvent vapor.

##### b. Microbullimetric Method

As polymers of increasing molecular weight are prepared, it has become necessary to design equipment that will be able to measure the higher molecular weights obtained. A set of microbullimeters similar to that described by Dimbat and Stross<sup>48</sup> has been constructed and is now in use for the routine determination of molecular weights. The apparatus allows determination of molecular weight by the boiling point elevation of dilute solutions. Accurate determinations have been made on compounds of low molecular weight. Lack of ideality encountered in polymer solutions results in difficulty in determining values with a reproducibility better than about  $\pm 5\%$ . Alterations in molecular weight of a polymer during treatment amounting to 10% or more may be determined.

#### 2. Differential Thermal Analysis Studies

##### a. Equipment

During the development of a DTA furnace suitable for studying borophanes up to 500°C. the importance of excluding all traces of oxygen and oxides became apparent. P-octamethyltetraaborophane was found to react with both alumina and silica (diatomaceous earth) powders which were screened through a 100 mesh sieve and retained on a 200 mesh sieve. Although the alumina was evacuated to  $10^{-4}$  mm. pressure before the test, enough adsorbed water may have been present to cause the

degradation. The use of carbon powder, however, was found to eliminate these exotherms even when the powder was exposed to laboratory atmosphere. A sample holder fabricated from the most dense commercially available graphite (National Carbon Code 82) was found to be porous enough to hold significant amounts of air. A sample holder was therefore made of 303 stainless steel to replace the graphite holder. Bare Chromel-Alumel thermocouple wires appeared to be inert and their calibration did not change after measuring borophanes and material evolving water.

b. Procedure

The procedure specified in the following section for DTA measurements can be modified to suit the material under test. As an example, Dry Ice may be placed on the lid of the sample holder just before assembling in the cell holder to establish a linear heating rate at a lower temperature. The carbon dioxide may then be pumped out and replaced with dry nitrogen. These steps allow the system to be stabilized and portions of the differential temperature-time curve obtained below a temperature of about 20°C.

c. Calibration

Precision obtained for the calibration of thermocouples and sample holder is adequate to allow the determination of both the amount of heat change and the temperature at which such change occurs. This temperature can be measured within 5°C. of the true temperature in the range 0-500°C. Variations in areas measuring endotherms are large and typical of thermal measurements in heterogeneous systems. The stainless steel sample holder was found to have a calibration constant of  $3.82 \pm 0.64$  cm.<sup>2</sup>/cal. on Range 3 of the Range Standard (0.49°C./cm. deflection with Chromel-Alumel thermocouples). Within this variation no significant difference in calibration constant could be found when the heating rate was changed by a factor of 2 and the atmosphere was changed from air to nitrogen.

d. DTA Measurements of Various Borophanes

Fusion and vaporization endotherms of the various borophanes measured coincide very closely with other physical test results. The fusion endotherms begin within 5°C. of measured melting points and the vaporization endotherms for P-hexamethyltriborophane and P-octamethyltetraborophane peak at 890 and 1200 mm. partial pressure respectively based on extrapolated vapor pressure data.<sup>7</sup>

The polyborophanes show other heat effects taking place such as the small exotherms superimposed on both fusion and vaporization endotherms. Although the fusion endotherms correspond to reported melting points for P-methylethylborophane and P-dimethylborophane polymers, the vaporization endotherms of these polymers have peaks corresponding to P-octamethyltetraborophane. A possible explanation would be that these polymers break down into a mixture of the tri- and tetraborophanes (or into monomers from which these are rapidly formed), which vaporize at the rate at which they are formed and coincidentally produce an endotherm similar in shape and position to that observed with the pure tetraborophane.

A comparison of treated and untreated P-dimethylborophane polymers (vide supra, Table IV) shows a slight stabilizing effect of the treatment and the addition of an exotherm preceding vaporization.



e. DTA Study of P-Hexamethyltriborophane  
in a Special Evacuated Sample Holder

The vapor phase decomposition of P-hexamethyltriborophane was measured in sealed glass tubes containing the thermocouple and evacuated to  $10^{-5}$  mm. pressure. This decomposition was exothermic and occurred between  $450^{\circ}\text{C}$ . and  $480^{\circ}\text{C}$ . The temperatures are not precise, since the system was not calibrated for these exploratory experiments.

B. Experimental

1. Molecular Weight Determinations

a. Neumayer Thermistor Method

Equipment. Except for minor modifications, the equipment was essentially the same as designed by Neumayer.<sup>47</sup> The chamber is immersed in a constant-temperature water bath thermostated at about  $30 \pm 0.01^{\circ}\text{C}$ . The thermistors are incorporated into a Wheatstone Bridge circuit. The solvent and solutions are maintained at the bath temperature by storing in the bath in the vessel stoppered with droppers to add solution or solvent quickly to the thermistors in the vapor chamber.

Operational Procedure. Solvent is added to the cell until there is enough to saturate the paper lining the inside wall of the cell and cover the bottom to a depth of about one centimeter. The cell is immersed in the bath and permitted to come to equilibrium, at which point the thermistors and supports are wiped free of condensed solvent with a tissue-wrapped piece of wire. Solvent is then applied through a hole in the Bakelite cap to both platinum wire coils covering the thermistors and the switch is turned on. The system is permitted to reach equilibrium which takes about 5 mins., and the circuit is balanced. One of the thermistors is then rinsed with 0.1-0.2 ml. of solution and the circuit is balanced using a potentiometer. Approximately 5 mins. are required for the solution to reach its maximum temperature. The maximum resistance of the potentiometer is recorded and used to determine the molecular weight of the solute. The solution thermistor is then rinsed with solvent and the potentiometer returned to zero. The above procedure is then repeated for the next analysis. If desired, the sample may be recovered from the crucible within the cell.

Calculations. Thermistor resistance varies logarithmically with temperature but less than 1% of the total resistance of one of the thermistors is used in these experiments. Therefore,  $\Delta T$  (the change in the temperature of the sensing thermistor) is essentially proportional to  $\Delta R$  (the change in its resistance). Also

$$\Delta R = K \times MF \quad (38)$$

in which MF is the mole fraction of the solute in the solution and K is a proportionality constant. Substituting the appropriate terms for MF and rearranging yields the equation

$$MW_{\text{solute}} = \frac{(\text{g. solute})(MW_{\text{solvent}})(K - \Delta R)}{(\text{g. solvent}) \Delta R} \quad (39)$$

Calibration. Benzene (Eastman, Spectro Grade, dried over sodium) when used as solvent gave very stable operation and reproducible results. The apparatus was calibrated using benzene solutions of azobenzene and naphthalene (each of which had been purified by vacuum sublimation). From the slope of a plot of the mole fraction and change in resistance data listed in Table XIII the value for K of 74,360 ohms was determined.

However when methanol (Baker and Adamson, Reagent) was employed, results were very erratic. Even using methanol which had been distilled from calcium hydride did not improve the stability.

#### b. Microebulliometric Method

Equipment. Except for minor modifications, the ebulliometers are of the same design as those used by Dimbat and Stross.<sup>4B</sup> Two ebulliometers are in use; one for the sample solution and one for pure solvent as a reference. The vapor jackets supplying most of the heat to the ebulliometers are also of the same design, except that instead of sealing the heating coil into the bottom of the jacket, the jacket is provided with a well which accomodates a 660-watt heating element. The boilers are heated by means of 50-watt Chromalox C-201C cartridge heaters inserted into brass heat transfer blocks, the ends of which are turned down to fit into heater wells extending into the bottoms of the boilers. Each jacket and boiler heating element is supplied with power from a variable transformer adjusted to give a desirable boiling rate.

The temperature-sensing devices employed are Veco thermistors No. 51A1 having resistances of approximately 105,000 ohms at room temperature and 11,000 ohms at the boiling point of benzene. Because of the difficulty of obtaining thermistors with matched resistances and thermal coefficients of resistance, the ebulliometers are maintained at constant pressure. This eliminates small errors which might result from changes in atmospheric pressure. Pressure is maintained at slightly above one atmosphere by means of a Moore Nullmatic pressure regulator, Model 40-2. The equipment described above is enclosed in a light-tight box to prevent light from affecting the thermistors.

The electrical circuitry, basically a Wheatstone Bridge, is given in Figure 2. The Helipot is equipped with a Duodial, so that resistances may be measured to 0.025 ohm. The range is extended beyond the 25 ohms available on the Duodial through the use of a decade switch (L & N 31-3-0-1) which connects 25 ohm resistors (Cinema Engineering Corp. precision resistors, No. CE 207, 25 ohm  $\pm$  0.1%). The null detector is a Leeds and Northrup galvanometer No. 2430E (sensitivity 0.001 microamp./mm.).

All work to date has been performed using Baker and Adamson Reagent Grade benzene as the solvent. Initial tests performed with Eastman Spectro Grade

TABLE XIII

Calibration of Neumayer  
Molecular Weight Apparatus

Standard	Molality	MF	$\Delta R$ (ohms.)
Azobenzene	0.01797	0.001402	100.0
	0.03804	0.002962	211.6
	0.06306	0.004901	371.2
	0.1208	0.009347	699.9
Naphthalene	0.08894	0.006899	501.9
	0.1138	0.008810	661.7
	0.1349	0.01043	771.7

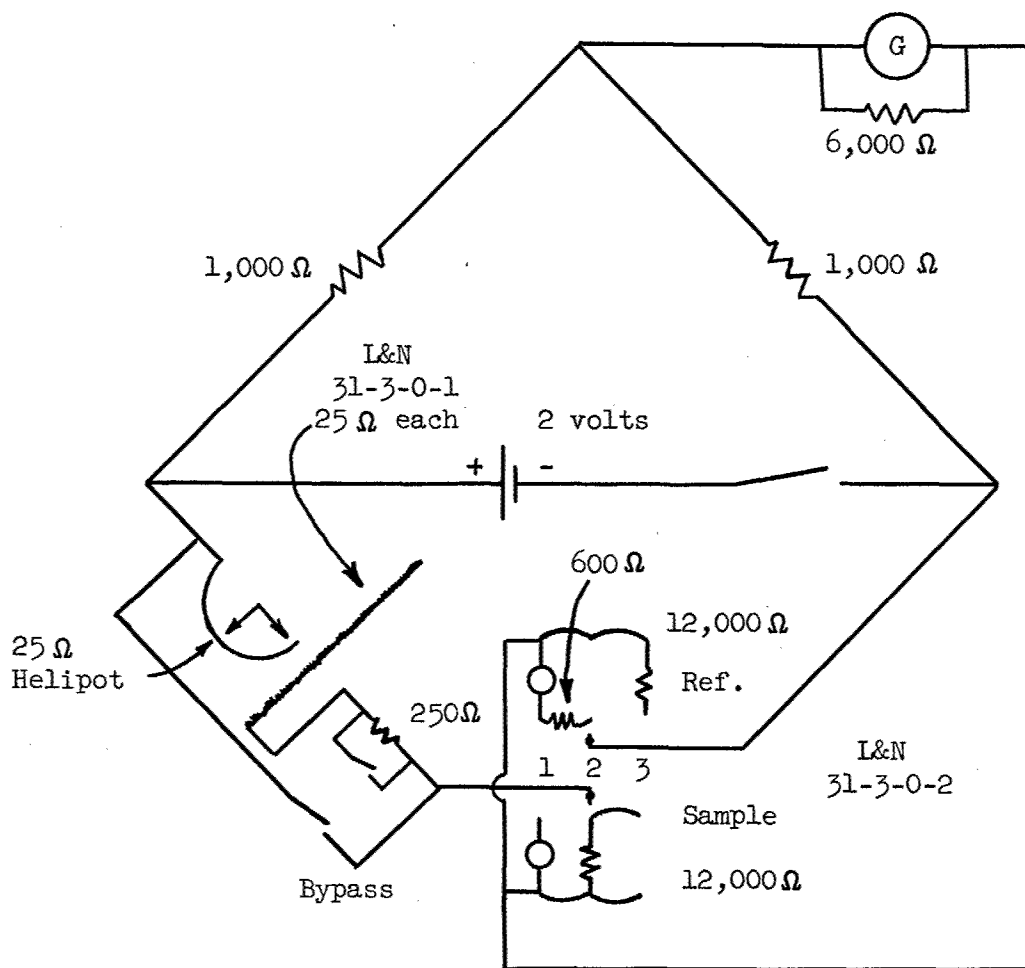

Figure 2. Ebulliometer Bridge Circuit

benzene gave erratic behavior. The apparatus appears to be quite sensitive to the solvent being used. Stability may vary from lot to lot of benzene.

Operational Procedure. Into each ebulliometer 10 ml. of benzene is pipetted. If the ebulliometers are permitted to warm up slightly before benzene addition, superheating is eliminated. Once vigorous boiling has begun, the system is left for several hours to insure equilibrium before a run is begun.

Before a measurement is taken, the pressure is adjusted. Switch L & N 31-3-0-2 is turned to position 2 and the decade circuit bypass switch is closed. The galvanometer is adjusted to zero to compensate for any thermal EMF. The power switch is turned on, the galvanometer brought to zero by adjusting the pressure regulator, the power shut off, and the bypass switch opened. The system is now ready for a measurement. Switch 31-3-0-2 is turned to position 1, the galvanometer set at zero, and the power turned on. The decade system is brought into balance, allowing a few minutes for equilibrium to be attained. A reading is taken and the power is then shut off. The sample ebulliometer is disconnected from the pressurizing system, the weighed sample added, the ebulliometer reconnected, and the above procedure repeated. Several separate sample additions are made for each material analyzed.

Calculations. From Raoult's Law and the Clausius-Clapeyron equation, the equation

$$\Delta T = x \frac{RT_0^2}{L} \quad (40)$$

- $\Delta T$  = the increase in the boiling point
- $x$  = the mole fraction of solute
- $T_0$  = the boiling point of the solvent
- $L$  = the heat of vaporization of the solvent

may be obtained. This equation describes the rate of increase in boiling point with concentration and holds at low concentrations when solutions are nearly ideal.

To simplify calculations, the apparatus is calibrated in terms of the increase in Duodial reading per micromole of compound added to the 10 ml. of benzene in the sample ebulliometer. This may be done since the increase in Duodial reading is directly proportional to the increase in temperature over the small temperature range used, and is equal to  $5.7 \times 10^{-5}^\circ\text{C}$ . per Duodial unit.

Compounds of low molecular weight give nearly ideal solutions, the temperature increase with concentration is linear, and the molecular weight can be estimated to within 1% in the case of a compound of molecular weight 200 using a 0.050 g. sample. The higher the molecular weight, the greater the amount of material required. In the case of polymers, the proportionately larger quantities of materials cannot be used, due to small amounts of material available, low solubility, lack of ideality of the resulting solutions, and foaming. Analyses using up to 0.200 g. of material with a molecular weight of 3500 have been made, although accuracy is reduced to  $\pm 5\%$ . In some cases lack of ideality has resulted in a

change in observed molecular weight with concentration; in these cases, the molecular weight has been determined by plotting the observed molecular weight versus concentration and extrapolating to zero concentration.

Calibration. The apparatus was calibrated initially by adding 0.020 g. increments of azobenzene to the sample ebulliometer and recording the Duodial reading. Each increase of one unit on L & N switch 31-3-0-1 was recorded as 1000 Duodial units. The data are given in Table XIV and plotted in Figure 3. The apparatus constant was determined as 0.1902 micromole/Duodial unit. It was soon realized, however, that molar concentrations of polymer solutions would be very small and that it would be desirable to calibrate the system for very low concentrations. This was done by adding 1 ml. portions of dilute solutions of azobenzene in benzene to the sample ebulliometer. The data also are given in Table XIV and plotted in Figure 4. The equation

$$\mu \text{ moles} = 0.2042 \Delta R + 1.65 \quad (41)$$

(in which  $\Delta R$  is the increase in Duodial reading) was obtained from the plot. This plot has a different slope than the previous one, and does not pass through the origin. However, more consistent data were obtained using it than the calibration obtained at higher concentrations.

## 2. Differential Thermal Analysis Studies

### a. Equipment

A vacuum tight sample cell holder (Figure 5) was designed which permits reproducible positioning of a sample cell (Figure 6) relative to the heating element. The heating element consists of 13.5 feet of 25 gauge Nichrome wire wound around the cell holder and electrically insulated from it by mica sheets. The assembly is fitted into a metal can, also insulated by mica, which holds the heating element in place when the assembly is lifted in and out of a thermally insulated chamber. Chromel-Alumel 24 gauge thermocouples are positioned in the lid of the 303 stainless steel sample cell with Pyrex glass sleeves and are connected to recording equipment as illustrated in Figure 7. A Flexatallic gasket (316 ss and Blue African asbestos) is compressed between the upper flange and lid of the sample cell holder with eight bolts. Either vacuum or inert gas may be applied to the sample through the vent shown in Figure 5. The thermocouple wires are sealed vacuum tight from the atmosphere with EC 801 sealant (Minnesota Mining and Manufacturing Co.). A fibre glass and asbestos board split-lid covers the top of the cell holder and fits around the vent line carrying the thermocouple leads. Metal rings and ears on the sample cell and lid allow the sample to be hung from the thermocouple leads and lowered into position.

### b. Procedure

A 0.25 g. portion of minus 100, plus 200 mesh carbon powder, which was degassed at 200°C. and 10<sup>-5</sup> mm. pressure and stored under nitrogen, is added to the reference compartment of the sample cell. Approximately 0.08 g. of sample (particle size between 100 and 200 mesh) is weighed to the nearest milligram and diluted with about 0.2 g. of the same carbon powder, mixed thoroughly and placed in

TABLE XIV

Ebulliometer Calibration

Azobenzene Added per mm., g. (a)	Total Azobenzene Added (a)		Decade System Reading Increase per Run, $\Delta R$	Total $\Delta R$
	g.	$\mu$ moles		
0.0178	0.0178	97.7	513	513
0.0191	0.0369	202.5	540	1053
0.0200	0.0569	312.3	582	1635
0.0185	0.0754	413.8	541	2176
0.0215	0.0969	531.8	625	2801
(0.00311)	(0.00311)	17.04	80.2	80.2
(0.00285)	(0.00596)	32.70	70.4	150.6
(0.00264)	(0.00860)	47.17	72.6	223.2
(0.00164)	(0.00164)	8.98	34.6	34.6
(0.00150)	(0.00314)	17.21	39.4	74.0

(a) Parenthetical values calculated in terms of weight of azobenzene per 10 ml. benzene.

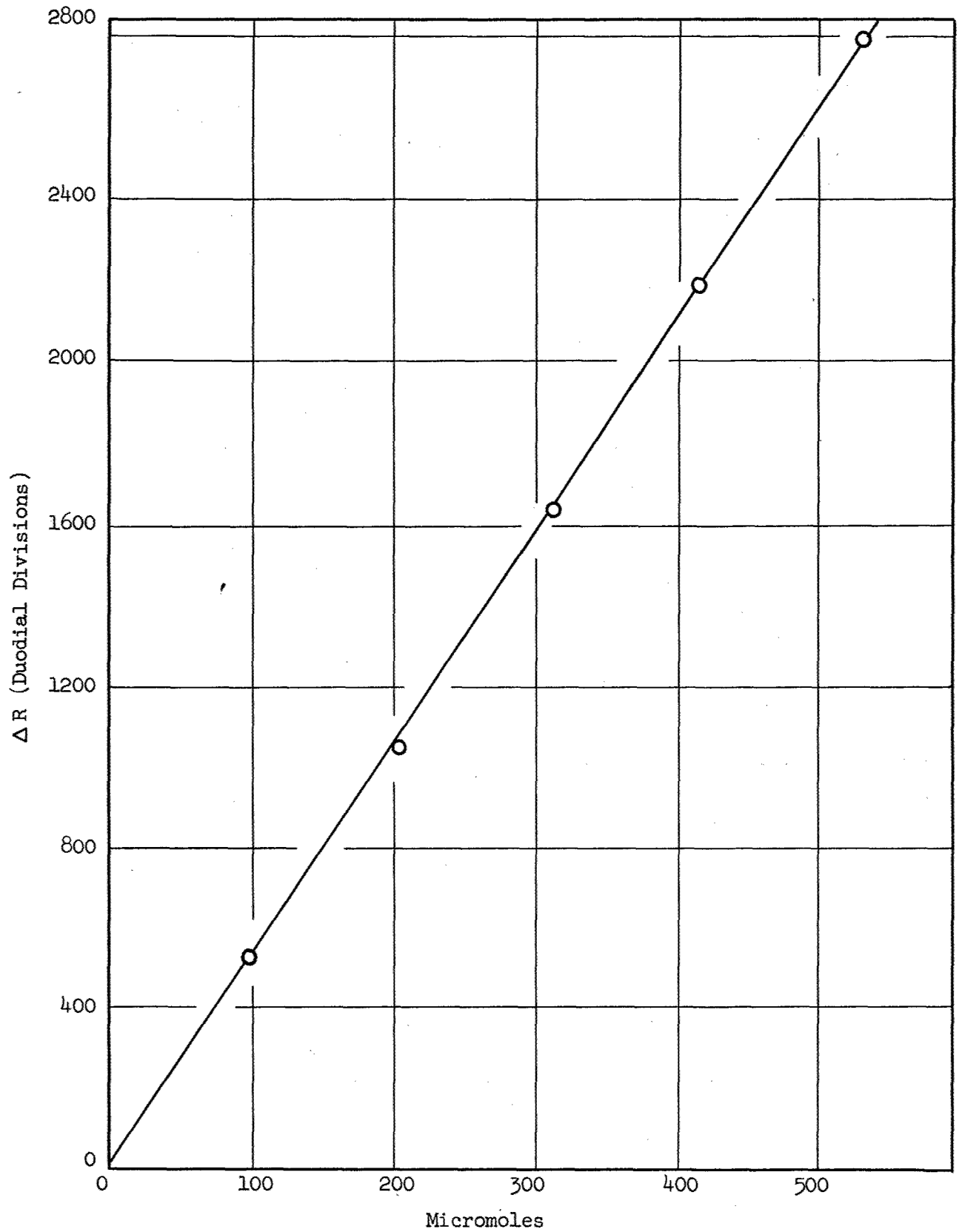

Figure 3. Ebulliometer Calibration



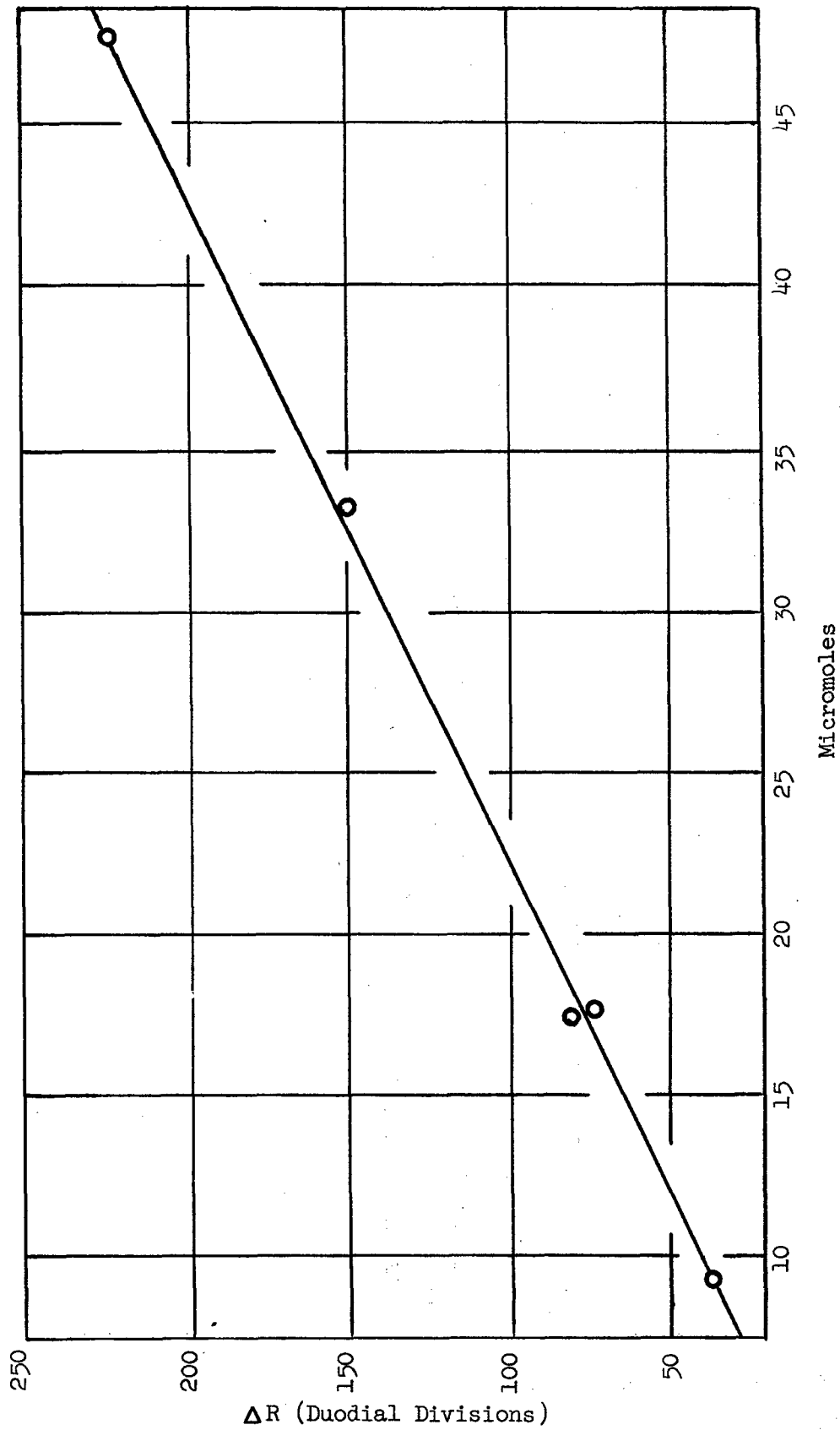

Figure 4. Ebulliometer Calibration - Low Solute Concentrations

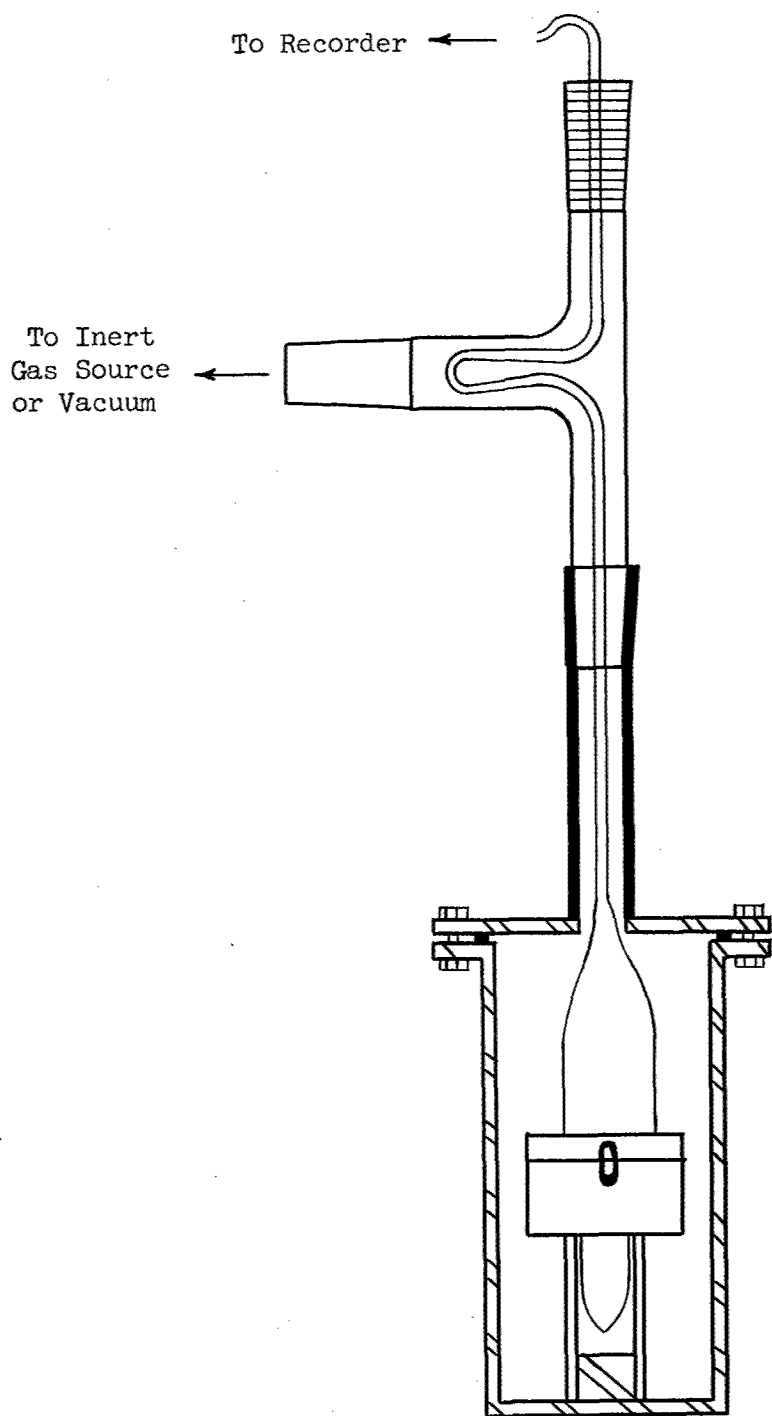
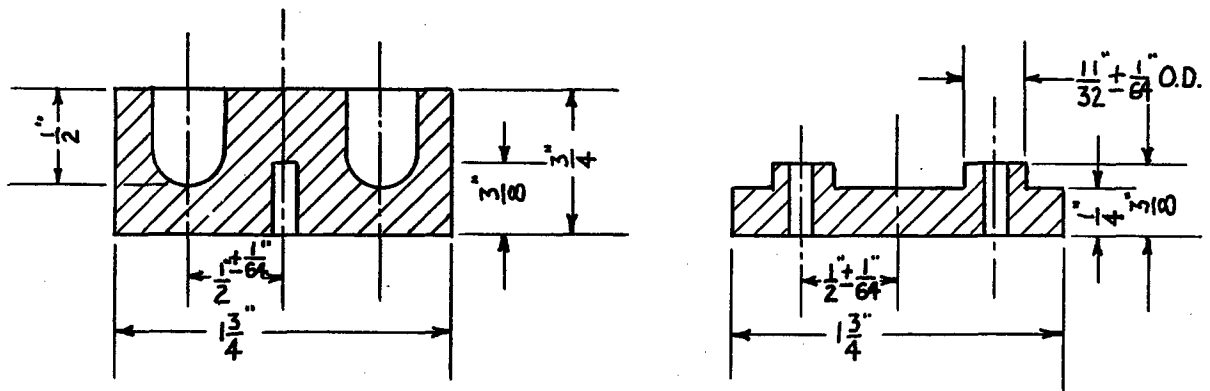
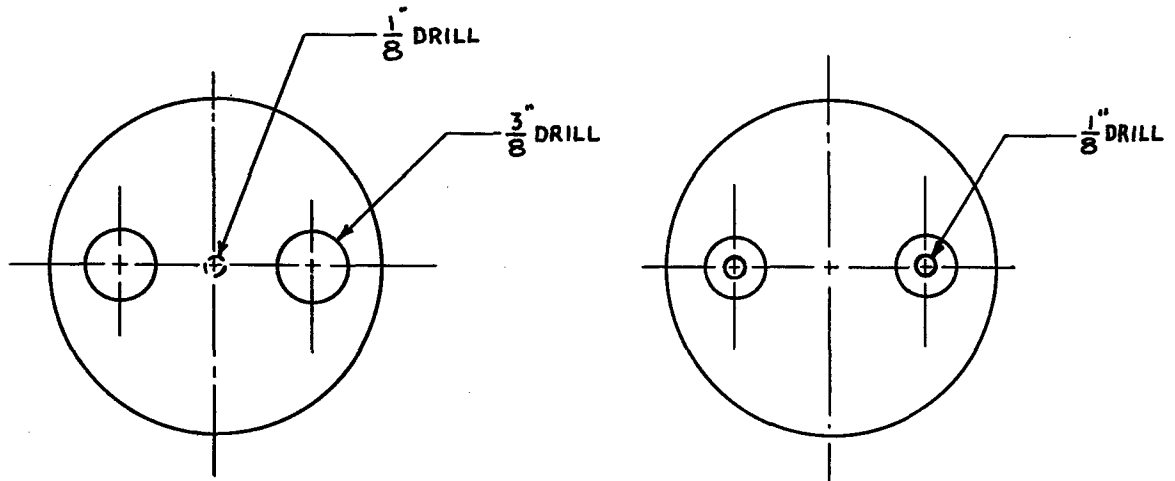

Figure 5. Differential Thermal Analysis Cell Holder



Tolerances  $\pm \frac{1}{32}$ " on all dimensions not specified

Sample Holder

Lid

Figure 6. Differential Thermal Analysis Sample Holder

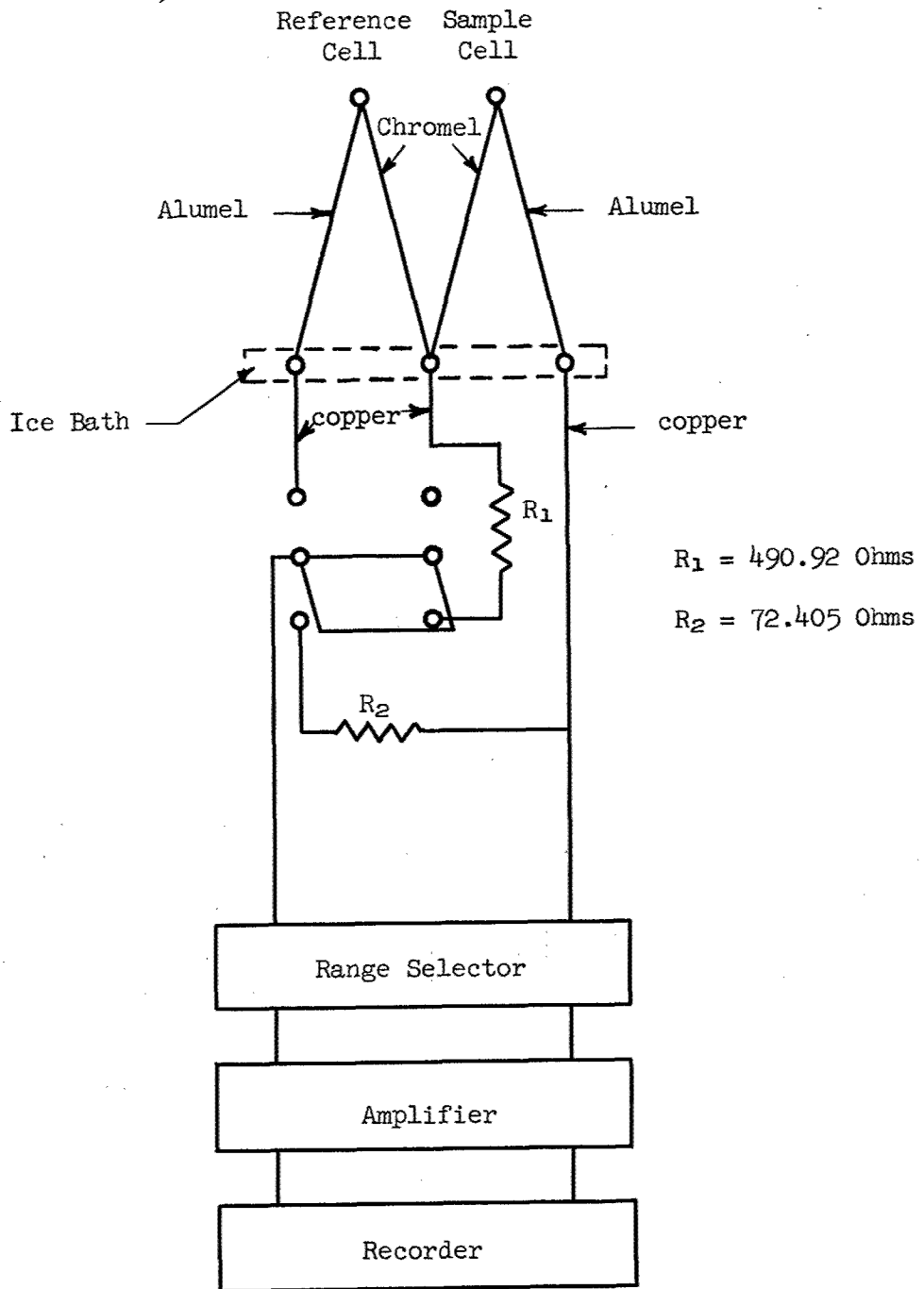

Figure 7. Differential Thermal Analysis Temperature Recording Circuit

the sample compartment of the sample cell. The body of the sample cell is hooked to the lid such that the thermocouple entering the sample is connected to the voltage divider to allow absolute temperature measurements to be made on the sample. The assembly is then lowered into position and the lid is bolted to the cell holder, the Flexatallic gasket providing a gas-tight seal. The cell holder is then covered with insulation, evacuated, and filled with nitrogen having less than 20 ppm. oxygen. Evacuation and filling is repeated two more times before the heater is turned on. A linear heating rate is achieved by manual adjustment of the variable transformer according to a predetermined program. A transformer setting of 100 volts initially is reduced to 95 volts after 15 min. and returned to 100 volts after 25 min. This program was found satisfactory for a heating rate of 10-12°C./min. A heating rate of 6°C./min. was obtained with 100 volts initially, reduced to 70 volts after 5 min., 80 volts after 45 mins. and 90 volts after 70 mins. Differential temperatures are continuously recorded, interrupted only by taking absolute temperature readings every 5 mins. by switching the sample couple in series with its 0°C. cold junction and allowing the pen to record a short flat trace on the chart.

#### c. Calibration

The electrical system was calibrated by a constant D.C. potential from a Leeds and Northrup Type K-3 Universal potentiometer to the input of the range standard and measuring deflection of the pen from its hose line. A full scale (100 mv.) deflection on Range 6 corresponding to an absolute temperature of 465°C. was obtained in this manner.

Endothermic peak areas corresponding to the dehydration of  $\text{CuSO}_4 \cdot \text{H}_2\text{O}$  were used to calibrate the sample holder. Changes in atmosphere and heating rate were made in a systematic manner to evaluate their effect on the calibration. These results are summarized in Table XV and indicate a calibration of  $3.82 \pm 0.64 \text{ cm.}^2/\text{cal.}$  on Range 3 of the Range Standard. Statistical evaluation of furnace atmosphere and heating rate show these variables have no effect at a 95% significance level.

#### d. DTA Measurements of Various Borophanes

The equipment and procedure described above was used to make DTA measurements of five different borophanes. Characteristic features of these traces are summarized in Table XVI.

#### e. DTA Study of P-Hexamethyltri-borophane in Evacuated Sample Holder

A 0.1099 g. sample of P-hexamethyltriborophane was mixed with 0.5051 g. of Norblack carbon, both powders being minus 100 plus 200 mesh screen fractions, and placed in a 9 mm. Pyrex tube 4 cm. long and fitted with a thermocouple pushed into a central position through molten glass at one end. An identical tube was made up and filled with 0.4573 g. carbon. Both tubes were evacuated to  $10^{-5}$  mm. pressure, sealed and supported in the center of the DTA furnace by their respective thermocouple wires. The furnace was then heated at the rate of 12°C. per minute. Essentially no variation from the base line occurred after 166°C. and until 450°C. when a large exotherm began and terminated with an explosion at 480°C.

TABLE XV

Differential Thermal Analysis Furnace Calibration (a)

Run No.	Specific Area cm. <sup>2</sup> /gm.	Calibration Const. (b) cm. <sup>2</sup> /cal.	Variables (c)
72	228	3.25	AH
73	248	3.54	AL
79	281	4.01	NL
80	268	3.82	NH
81	268	3.82	NH
82	279	3.98	AH
83	271	3.87	AL
84	301	<u>4.30</u>	NL
		Ave. 3.82 ± 0.64	

(a) On Range 3 of Range Standard (0.49°C./cm. deflection).

(b) 17,500 cal./g.-mole at 264°C. - N.B.S. Circ. 500, p. 212.  
A 0.3048 g. sample of  $\text{CuSO}_4 \cdot 5\text{H}_2\text{O}$  weighed 0.1948 g. after heating to approximately 500°C. in air. (Theory 0.1948 g.)

(c) A = Air Atmosphere  
N = Nitrogen Atmosphere  
L = Low Heating Rate  
H = High Heating Rate

TABLE XVI

Differential Thermal Analyses of Various Borophanes

Run	Sample	Peak Temps., °C. (a)	Heating Rate °C./min.	Remarks
85	P-hexamethyltri- borophane	95, 255	6.2	-
86	P-hexamethyltri- borophane	95, 255	11.7	-
87	P-octamethyltetra- borophane	168, 316	11.9	-
88	P-octamethyltetra- borophane	162, 321	6.0	-
90	P-methylethylboro- phane polymer <sup>(b)</sup>	107, <u>200</u> , 326	13.3	Exotherm superimposed in lower temperature endotherm.
91	P-methylethylboro- phane polymer <sup>(b)</sup>	112, <u>210</u> , 324	10.4	Exotherm superimposed in lower temperature endotherm.
92	P-methylethylboro- phane polymer <sup>(b)</sup>	116, 323	9.8	Exotherm superimposed in lower temperature endotherm. Exo- therm disappeared on 2nd and 3rd melting cycles.
93	P-dimethylborophane polymer <sup>(c)</sup>	171, 299 ± 20	11.5	-
94	P-dimethylborophane polymer <sup>(d)</sup>	171, <u>197</u> , 321	11.5	Last endotherm began 36°C. higher than that of Run 93.

(a) Exotherms are underscored.

(b) MW 2430

(c) MW 3080

(d) Treated with an acetic acid-acetic anhydride mixture. (MW 3200).

## VI. SUMMARY AND CONCLUSIONS

The thermal stabilities of linear P-dimethylborophane polymer samples were determined before and after treatment with a variety of reagents including acetic acid, acetic anhydride, maleic anhydride, sulfuric acid, hydrogen chloride, nickel carbonyl, butyllithium and triethylenediamine. Each of these reagents with the exception of the last improved the thermal stability of the polymer as measured by the decreased decomposition during one hour at 200°C. from  $27 \pm 4\%$  to less than 6%. An improved halogenation process for borophanes using N-halosuccinimides was developed and used to prepare P-dimethyl-B-dichloroborophane polymer.

In the course of development of the reaction of borophanes with N-halo-succinimides a variety of new B-halo-derivatives were prepared, characterized and subsequently used in studying their reaction with organometallic reagents and inorganic salts. Fourteen new P-dimethyltriborophane derivatives were prepared as a consequence of the investigation of these reactions.

A series of methyl-n-alkylphosphine borines (alkyl = C<sub>3</sub>-C<sub>8</sub>) have been prepared for use as intermediates to evaluate the effect of alkyl chain length on the properties of P-methyl-n-alkylborophane polymers.

The principle of coupling borazene nuclei has been demonstrated with the preparation of decamethyl-B,N'-biborazyl by the elimination of lithium chloride from N-lithiopentamethylborazene and N-trimethyl-B-dimethyl-B-chloroborazene. This coupling reaction has been extended to prepare di- and triborazylborazenes as well as a biborazylene polymer. The N-lithio-derivatives are new synthetically useful borazene compounds. A renewed attempt to couple borazene nuclei by pyrolytic dehydrogenation of an equimolar mixture of the isomeric pentamethylborazenes resulted instead in considerable disproportionation to other methyl-substituted borazenes. Attempts to prepare B-N linked borazene compounds by dehydrohalogenation of B-Cl and N-H functions yielded only starting materials and B-O-B compounds formed by hydrolysis of the B-Cl function. The same oxygen linked borazene compounds and related polymers were prepared by direct hydrolysis of chloroborazene derivatives. A new synthesis for the B-mono- and dichloro-substituted N-trimethylborazenes was developed.

The pseudoaromatic compounds, 7-methyl-8-bora-7,9-diazaro-peri-naphthene and 10,9-borazarophenanthrene, were prepared and pyrolyzed to give what appeared to be low molecular weight linear borazene polymers.

The thermally stable diphenylphosphonyl azide, prepared as a possible precursor to P-N polymers, was found to react with triphenylphosphine to yield nitrogen and a thermally stable P-N=P compound. Other prototype P-N bonded compounds showing hydrolytic and thermal stability were prepared from phenyl and diphenylphosphonyl chlorides on reaction with aniline.

A hydrolytically unstable Si-O-P polymer was obtained on reaction of phenylphosphonyl dichloride with diphenyldiacetoxysilanes. A more hydrolytically stable



and thermally stable  $-\text{Si}-\text{O}-\overset{\text{O}}{\parallel}{\text{C}}-$  polymer was obtained from the latter reagent and terephthalic acid.

Bis(borimidazoline) was prepared as a prototype material for B-N polymers by reaction of 3,3',4,4'-tetraaminobiphenyl and benzenboronic acid.

The construction and operation of a Neumayer thermistor molecular weight apparatus and a microebulliometer has expedited the characterization of polymers and intermediate compounds. Preliminary differential thermal analyses of borophane polymers confirm other thermal stability data and may provide a means of rapid evaluation of new polymer systems.

## VII. BIBLIOGRAPHY

1. R. I. Wagner, et al., WADC Technical Report 57-126, Part I, March 1957, p. 22.
2. R. I. Wagner, et al., WADC Technical Report 57-126, Part I, March 1957, p. 25.
3. R. I. Wagner, et al., WADC Technical Report 57-126, Part III, March 1959, p. 38.
4. R. I. Wagner, WADC Technical Report 57-126, Part IV, March 1960, p. 28.
5. G. Wittig and P. Raff, Z. Naturforsch., 6b, 225 (1951).
6. R. I. Wagner, et al., WADC Technical Report 57-126, Part III, March 1959, p. 33.
7. A. B. Burg and R. I. Wagner, J. Am. Chem. Soc., 75, 3872 (1953).
8. R. I. Wagner, et al., WADC Technical Report 57-126, Part I, March 1957, p. 34.
9. M. S. Kharasch, E. V. Jensen and S. Wernhouse, J. Org. Chem., 14, 429 (1949).
10. R. I. Wagner, WADC Technical Report 57-126, Part IV, March 1960, p. 36.
11. R. I. Wagner, et al., WADC Technical Report 57-126, Part III, March 1959, p. 31.
12. R. I. Wagner, WADC Technical Report 57-126, Part IV, March 1960, p. 23.
13. H. J. Daubin and L. L. McCoy, J. Am. Chem. Soc., 81, 4863 (1959).
14. W. F. Edgell and C. H. Ward, J. Am. Chem. Soc., 76, 1169 (1954).
15. W. Strohmeier, Ber., 88, 1218 (1955).
16. R. G. Dickinson, J. Am. Chem. Soc., 44, 774 (1922).
17. R. I. Wagner, et al., WADC Technical Report 57-126, Part I, March 1957, p. 30.
18. M. M. Rauhut, et al., J. Am. Chem. Soc., 81, 1103 (1959).
19. L. W. Daasch and D. C. Smith, Anal. Chem., 23, 862 (1951).
20. R. I. Wagner, et al., WADC Technical Report 57-126, Part II, February 1958, p. 33.
21. R. I. Wagner, WADC Technical Report 57-126, Part IV, March 1960, p. 40.
22. H. I. Schlesinger, D. M. Ritter and A. B. Burg, J. Am. Chem. Soc., 60, 1296 (1938).
23. R. I. Wagner, WADC Technical Report 57-126, Part IV, March 1960, p. 38.
24. J. H. Smalley and S. F. Stafiej, J. Am. Chem. Soc., 81, 582 (1959).
25. R. I. Wagner, WADC Technical Report 57-126, Part IV, March 1960, p. 40.

26. L. F. Fieser, "Experiments in Organic Chemistry," 3rd Ed., D. C. Heath and Co., Boston (1955), p. 270.
27. R. I. Wagner, et al., WADC Technical Report 57-126, Part III, March 1959, p. 57.
28. R. I. Wagner, WADC Technical Report 57-126, Part IV, March 1960, p. 41.
29. E. Wiberg and A. Bolz, Ber., 73, 209 (1940).
30. R. I. Wagner, WADC Technical Report 57-126, Part IV, March 1960, p. 44.
31. M. J. S. Dewar, V. P. Kubba and R. Pettit, J. Chem. Soc., 1958, 3073.
32. M. J. S. Dewar and V. P. Kubba, Tetrahedron, 7, 213 (1959).
33. H. A. Skinner and N. B. Smith, J. Chem. Soc., 1954, 2324.
34. A. L. McCloskey, et al., WADC Technical Report 59-761, December 1959, p. 33.
35. P. A. S. Smith, Organic Reactions, Volume III, John Wiley & Sons, Inc., New York, N.Y., 1946, p. 337-449.
36. F. L. Scott, Experientia, 13, 275 (1957).
37. R. M. Washburn, F. A. Billig, M. Bloom, C. F. Albright, and E. Levens, 131st National ACS Meeting, San Francisco, Calif., April 1958; In press, Advances in Chemistry Series.
38. A. Michaelis, Ann., 326, 181 (1902).
39. G. M. Kosolapoff, J. Am. Chem. Soc., 64, 2982 (1942).
40. G. M. Kosolapoff, J. Am. Chem. Soc., 71, 369 (1949).
41. W. A. Higgins, P. W. Vogel, and W. G. Craig, J. Am. Chem. Soc., 77, 1864 (1955).
42. F. Fiegel, Spot Tests, Volume I, Elsevier Publishing Co., New York, N.Y., 1954, p. 268.
43. A. Michaelis, Ann., 293, 215 (1896).
44. B. B. Hunt and B. C. Saunders, J. Chem. Soc., 1957, 2413.
45. H. H. Anderson, J. Am. Chem. Soc., 74, 2371 (1952).
46. N. Rabjohn, J. Am. Chem. Soc., 70, 3518 (1948).
47. J. J. Neumayer, Anal. Chim. Acta, 20, 519 (1959).
48. M. Dimbat and F. H. Stross, Anal. Chem., 29, 1517 (1957).

I. The Bis(phosphino)acetylene  $(CF_3)_2PC\equiv CP(CF_3)_2$ 

The new diphosphine  $(CF_3)_2PC\equiv CP(CF_3)_2$  has been made as an especially promising component for phosphorus-containing boron hydride resins. It absorbs two  $BH_3$  groups

at the triple bond to make an  $H_2B-R-BH_2$  type of compound, which probably is a 

bridged polymer. A similar reaction between the triple bond and the polyborane residues which accompany the removal of  $BH_3$  groups from  $B_5H_9$  would give a C-C connected polyborane resin, with the possibility of further condensation through the removal of  $CF_3$  groups as  $HCF_3$  as the temperature is raised.

A. Synthesis

The successful method of synthesizing the new diphosphine was based upon the acidity of acetylene. It was argued that  $HC\equiv CH$  should react with a  $(CF_3)_2PX$  compound to eliminate  $HX$ , which could be removed by a tertiary base such as trimethylamine. The initial experiment used  $(CF_3)_2PI$ , but this was not the best choice because it reacted with trimethylamine to form unintelligible solid material. Better for the purpose was  $(CF_3)_2PCL$ , which reacted more cleanly and gave good yields of the desired product. In the first experiment the mixture of  $(CF_3)_2PCL$ ,  $C_2H_2$ , and  $(CH_3)_3N$  failed to react in the vapor phase during 18 hours at  $62^\circ C.$ , but the reaction was quite extensive when the containing tube was small enough to maintain a liquid phase and the heating was extended to 92 hours at  $62^\circ C.$  In the second experiment with a similar mixture, the reaction was almost equally extensive during 23 hours at  $91^\circ C.$ , again in a sealed tube small enough to maintain a liquid phase. The data of these two experiments are presented in Table XVII. It is of interest that the reactants consumed were in the ratio 1.00:1.79:2.20 for  $C_2H_2:(CF_3)_2PCL:(CH_3)_3N$  in the first experiment, and 1.00:1.82:2.33 in the second experiment. Thus there was a persistent deficiency in the use of  $(CF_3)_2PCL$  and some excess consumption of  $(CH_3)_3N$ , relative to the ideal equation:

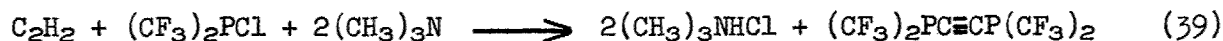

It is worthy of mention that no  $HCF_3$  appeared in either experiment, although the base might have been expected to induce its formation at the expense of protons from acetylene.

In each of these experiments the acetylene was recovered by fractional condensation methods and identified by its vapor tension at  $-112^\circ C.$  (66 mm.) and molecular weight (found, 26.4 or 26.8; calcd., 26.04). The trimethylamine was taken out as the hydrochloride and weighed, making it possible to isolate the  $(CF_3)_2PCL$ : vapor tension at  $0^\circ C.$ , 208 or 209 mm.; mol. wt. 205.3 or 203.0 (calcd., 204.5).

TABLE XVII

Synthesis of  $(CF_3)_2PC\equiv CP(CF_3)_2$ 

(Quantities in millimoles unless otherwise stated)

Substance	First Experiment				Second Experiment			
	Start	End	Used	% Yield	Start	End	Used	% Yield
$C_2H_2$	2.341	0.518	1.823	-	2.151	0.412	1.739	-
$(CF_3)_2PCl$	4.481	1.155	3.326	-	4.157	1.038	3.119	-
$(CH_3)_3N$	4.363	0.105	4.258	-	4.459	0.632	3.827	-
$\llbracket (CF_3)_2PC\equiv \rrbracket_2$	-	1.183	-	71.1	-	1.045	-	67.0
Unknown (slightly volatile)	-	109.4 mg.	-	-	-	60.5 mg.	-	-

### B. Proof of Formula

The new diphosphine was purified by high-vacuum fractional condensation and then gave the molecular weight values 361.9 and 362.4 (calcd., 362.06). A 77.6 mg. sample was analyzed for  $\text{CF}_3$  groups by heating with 737 mg. of iodine for 3 days at  $300^\circ\text{C}$ . The resulting 0.867 mmole of  $\text{CF}_3\text{I}$  represented 4.04  $\text{CF}_3$  groups per molecule, in accord with the formula  $(\text{CF}_3)_4\text{P}_2\text{C}_2$ .

### C. Volatility

The highly purified acetylenic diphosphine showed vapor tension values (Table XVIII) which were correlated by the equation  $\log_{10}P_{\text{mm}} = 8.0001 + 1.75 \log_{10} T - 0.00740 T - 2594/T$ . This indicates the normal b.p. to be  $107.0^\circ\text{C}$ . and the Trouton constant 21.2 cal./deg. mole. The m.p. could not be observed because the substance formed a glass at low temperatures.

TABLE XVIII

Vapor Tensions of  $(\text{CF}_3)_2\text{PC}\equiv\text{CP}(\text{CF}_3)_2$

t ( $^\circ\text{C}$ .)	0.00	23.9	31.2	37.0	43.0	49.0	56.6
$P_{\text{mm}}$ (obsd.)	5.60	24.99	37.29	49.91	67.8	89.9	126.3
$P_{\text{mm}}$ (calcd.)	5.59	25.01	37.31	49.92	67.8	90.0	126.3

### D. Ultraviolet Spectrum

The absorption spectrum of the new diphosphine was recorded by a Cary Model 14 spectrophotometer, showing a maximum at 2285 Å. ( $\epsilon = 1840$ ) and a minimum at 2240 Å. ( $\epsilon = 1710$ ). There was also evidence of a shoulder between 2340 and 2380 Å. By comparison with the previously-described  $(\text{CF}_3)_2\text{P}(\text{C}_2\text{H}_2)\text{P}(\text{CF}_3)_2$  (maximum at 2295 with  $\epsilon = 3560$ , and minimum at 2115 with  $\epsilon = 2600$ ; Cf. Ref. 5, p. 111), it seems that the triple bond shifts the over-all spectrum toward higher wave lengths and lesser intensity. Such a result would correspond to a slightly greater freedom of the pi electrons and this would correlate with somewhat greater base-strength for the phosphorus lone-pair electrons.

### E. The Addition of Diborane

The retention of the triple bond in the acetylenic diphosphine was confirmed by its absorption of one  $\text{B}_2\text{H}_6$  per molecule. The 0.139 mmole sample consumed 0.135 mmole of  $\text{B}_2\text{H}_6$  from a 0.425 mmole sample, during 18 hours at room temperature. The resulting light-yellow non-volatile viscous oil was destroyed by an HCl-methanol mixture at  $100^\circ\text{C}$ . (16 hours), yielding 0.526 mmole of  $\text{H}_2$ . This would mean 3.90 B-H bonds per  $\text{B}_2\text{H}_6$  absorbed, demonstrating the hydroboration of the triple bond by two

BH<sub>3</sub> groups to form two C-H and two C-BH<sub>2</sub> bonds. The resulting structure could have either a B-C-C-B chain with phosphine side-groups or a B-C-B chain with a C(P)<sub>2</sub> type of side group, the latter being somewhat favored by the consideration that the first boron draws the second pair of pi electrons toward itself. In either case, the non-volatile oily character of the material suggests polymerization through B  $\begin{matrix} H \\ | \\ B \end{matrix}$  bridge bonding, since the alternative use of the phosphine units for P-B dative bonding would most probably lead to a monomer or dimer rather than a material which seems to be more polymeric.

#### F. Resistance to Biphosphine Addition

Like the ethylenic diphosphine (CF<sub>3</sub>)<sub>2</sub>P(C<sub>2</sub>H<sub>2</sub>)P(CF<sub>3</sub>)<sub>2</sub>, the acetylenic diphosphine fails to react with the biphosphine (CF<sub>3</sub>)<sub>2</sub>PP(CF<sub>3</sub>)<sub>2</sub>, even during a week at 110°C. with iodine as a possible catalyst-- conditions which effected the addition of the same biphosphine to acetylene itself (Ref. 5, p. 109). The reluctance of P-C=C-P and P-C≡C-P chains to accept the biphosphine and form a tetraphosphine might be ascribed to a delocalization of the carbon pi electrons into the phosphorus 3d orbitals, but steric hindrance also could be an important factor. Using a system of atomic models we find that a  $\left[ \begin{matrix} (CF_3)_2P \\ | \\ C=C \\ | \\ P(CF_3)_2 \end{matrix} \right]_2$  could exist in a close-packed manner permitting no rotation of any groups about their bonding axes, but such a snug situation surely would not be favorable as the goal of a reasonable reaction mechanism.

#### G. By-Products of the Synthesis

The formation of the -C≡C- connected diphosphine was accompanied by production of some brown-solid non-volatile material and a slightly volatile liquid (mentioned as "unknown" in Table XVII), the purest samples of which had molecular weight values of 238.4 and 238.6. The uniformity of this material was demonstrated by its vapor tensions (Table XIX), which determined the equation  $\log_{10} p_{mm} = 8.0571 - 2426/T$ . This would give the Trouton constant as 23.7 cal./deg. mole. Assuming the normal 21.0 for the Trouton constant, the b.p. would be estimated as 209°C. The

TABLE XIX

Vapor Tensions of the Less Volatile Product

t (°C.)	25.0	35.0	44.9	54.7	64.2	75.0
p <sub>mm</sub> (obsd.)	0.84	1.54	2.70	4.56	7.22	12.29
p <sub>mm</sub> (calcd.)	0.84	1.53	2.70	4.58	7.36	12.30

compound showed some tendency to change to a non-volatile glass on standing. The most reasonable molecular formula for this substance would seem to be (CF<sub>3</sub>)<sub>2</sub>PCH=CHCl (calcd. mol. wt. 230.5). Such a material would be the obvious result of a direct addition of (CF<sub>3</sub>)<sub>2</sub>P-Cl to acetylene. However, no analysis has yet been attempted.

## II. The Borine Adducts of Tetramethylbiphosphine

The earlier work on the single and double borine adducts  $P_2(CH_3)_4 \cdot BH_3$  and  $P_2(CH_3)_4 \cdot 2BH_3$  (Ref. 3, pp. 13-16) was directed primarily toward their conversion to phosphinoborine polymers, with only a passing glance at the properties of the adducts themselves. Within the past year there has been a new study of these adducts, with results having some interest from the viewpoint of fundamental chemistry. A 24 page manuscript covering all of our work on tetramethylbiphosphine and its chemical consequences has been submitted for publication in the Journal of the American Chemical Society.

### A. The Two Crystal Forms of the Double-Borine Adduct

There had been a discrepancy in regard to the volatility of the adduct  $P_2(CH_3)_4 \cdot 2BH_3$ , for the earliest sample had nearly all sublimed away during some hours under high vacuum at room temperature (Ref. 3, p. 14), whereas the vapor tensions of a later sample in the range 63-93°C. had given an equation from which the vapor tension at 25°C. would be calculated as  $2 \times 10^{-4}$  mm.-- far too slight for appreciable sublimation. By microscopic examination, however, an unheated sample of this adduct was found to be a mixture of irregular striated-lump crystals and well formed needles or flat blades. The needles often extended from common centers to form spiny clusters. They sublimed under high vacuum at 25°C., condensing as lumps at room temperature and as needles just above a trap at 0°C. Under static heating, the needles converted entirely to the lump form, and accordingly it was this less volatile form which gave the observed vapor tensions. However, when the lump form was sublimed (very slowly at 60°C. under high vacuum) the sublimate formed lump-crystals near the warm zone and needles in the cooler regions farther down the tube. Thus it appeared that the two crystal forms interconverted through the vapor phase. Both forms proved to be birefringent, for microscopic observation between crossed polaroids showed delicate blue-green and red fringes on the needles and sometimes the same colors on the lumps, which mostly appeared golden-yellow.

Neither with the pure lump-crystals nor with a mixture of the two forms was it possible to reproduce the 106°C. m.p. given by Nöth for  $P_2(CH_3)_4 \cdot 2BH_3$ .<sup>6</sup> In fact, no melting occurred when a sealed tube containing the crystal-mixture was immersed suddenly in oil at 112°C.; all that happened was that the needles lost their linear shape and became striated, evidently converting to the less volatile form. The lumps finally melted at 194°C. (in a sealed 1 ml. tube), but then the evolution of hydrogen indicated enough formation of the  $(CH_3)_2PBH_2$  trimer and tetramer to account for a solution effect.

The two crystal forms of the double-borine adduct evidently do not differ in regard to molecular formula, for the molecular weight of a sample of the mixed crystals was determined in solution. The 25.2 mg. sample lowered the vapor tension of 15.34 mmoles of diethyl ether by 3.59 mm. from the pure-ether value of 328 mm. at 12.5°C. Hence the apparent molecular weight was 156 (calcd., 149.7), a good result for the nearly saturated solution.



## B. Infrared Spectrum of the Double Adduct

A possible reason for the two differently-volatile crystal forms of  $P_2(CH_3)_4 \cdot 2BH_3$  would be a stabilization of the rotational isomers (one trans and two asymmetric  $60^\circ$ -cis, or gauche, forms) through interaction of the dative-bond dipoles in the solid state. Evidence bearing upon this hypothesis was sought through a relatively detailed study of the infrared spectra of the two samples, one consisting wholly of the stabler and less volatile lump form and one in which the less stable and more volatile needle form seemed to predominate. In some regions the two samples showed virtually identical absorption bands, whereas in other regions there was just enough difference to admit the possibility of rotational isomers. But the different crystal-field effects (especially relating to the P-B dative-bond dipoles) in the different crystal structures might alone account for the observed differences. Hence the stabilization of rotational isomers in the solid state remains an interesting hypothesis, requiring a different basis for decision.

Table XX describes the spectra of both samples, with mention of the observable differences. Except where the Infracord instrument is mentioned, the bands were recorded at high resolution by a Perkin-Elmer Model 13 spectrophotometer, using sodium chloride optics. The air-stable (acetone-soluble) samples were insoluble in Nujol, in which they could be pulverized to make mulls of similar crystal-size, for mounting between salt-windows. The predominantly needle-sample was obtained as a high-vacuum sublimate far from the hot region, and under the 160-power microscope it seemed to contain about 30% lump-crystals. The stable lump-crystals were taken as the sublimate nearest to the  $100^\circ C$ . bath, and seemed to contain none of the needle form.

The bands in which one would seek differences due to the stabilization of rotational isomers would be those representing B-H bending and  $BH_3$ -group rocking, for these aspects would be different for trans and gauche placement of the  $BH_3$  groups. No differences would be expected for the methyl groups, since both trans and gauche relations between methyl groups occur in both kinds of rotational isomers. And in fact, the bands concerning the methyl groups are identical in shape (with only slight differences of intensity of some shoulders), whereas noticeable qualitative differences occur in the B-H bending bands. For example, the high shoulder indicating a submerged peak at  $1057\text{ cm.}^{-1}$  is noticeably broader for the pure-lump sample than for the 70% needle sample, as though it might not be found at all for pure needles. However, the three peaks at 768, 759, and 731 are identically related to each other in shape and intensity for the two samples, only showing somewhat less over-all intensity for the needle-crystal sample. One may well consider that the crystal-field effects might be most important for the groups which are associated with dipoles, namely the dative-bonded  $BH_3$ .

## C. The Single-Borine Adduct

The initial experiment on the synthesis of  $P_2(CH_3)_4 \cdot BH_3$ , employing the reactants in the ratio  $2P_2(CH_3)_4$  to one  $B_2H_6$ , gave a mixed product in which 14% of the biphosphine was unused, even after heating for 20 minutes at  $100^\circ C$ . (Ref. 3, p. 15). Hence it seemed that about 14% of the initially-formed  $P_2(CH_3)_4 \cdot BH_3$  had reacted further to make the double-adduct  $P_2(CH_3)_4 \cdot 2BH_3$ , which resisted reaction with the unused biphosphine. However, we now have found that the reaction

TABLE XX

Infrared Spectrum of  $P_2(CH_3)_4 \cdot 2BH_3^*$ 

Frequency ( $cm.^{-1}$ )	Intensity and Character	Interpretation
2920 2880	Very strong doublet	C-H stretching (Infracord)
2220	Medium peak	Uncertain; probable $CO_2$ effect
2345 2315	Strong doublet	B-H stretch, affected by $CO_2$
1400	Broad medium peak	C-H bending, $\delta$ -e
1305	Weak peak	Probably a Nujol effect
1297	Weak shoulder	Uncertain
1286	Sharp medium peak	C-H bending, $\delta$ -a
1150	Broad weak peak	(Present only for lump-form)
1125	Medium peak	B-H bending, $\delta$ -e
1101	Weak shoulder	(Present only for lump-form)
1068	Medium shoulder (submerged peak)	Uncertain; more evident for the needle-form
1057	High shoulder on 1049 peak	Uncertain; more evident for the needle-form
1049	Strong peak	B-H bending, $\delta$ -a
945 895	Med. strong peak Strong peak	$CH_3$ group rocking (Infracord)
849	Weak peak	Uncertain
834	Weak peak	Uncertain
768	Weak peak	Could represent the three peaks expected for gauche- $BH_3$ rocking, but not surely.
759	Weak peak	
731	Med. peak	
722	Medium peak	Probably a Nujol effect
693	Weak peak	Probably P-C stretch
681	Weak peak	

\* It is a pleasure to acknowledge valuable aid by Dr. David A. Dows in the recording and interpretation of these data.



can be brought quantitatively to completion by sufficient heating with a small excess of  $\text{P}_2(\text{CH}_3)_4$ , thus making it possible to produce stoichiometrically clean samples of the single-borine adduct.

In one such experiment 0.413 mmole of  $\text{P}_2(\text{CH}_3)_4 \cdot 2\text{BH}_3$  and 62.5 mg. of  $\text{P}_2(\text{CH}_3)_4$  (0.512 mmole) were heated together in a closed tube at  $80^\circ\text{C}$ . for four hours, after which 11.3 mg. of  $\text{P}_2(\text{CH}_3)_4$  could be recovered. Thus 0.419 mmole of the biphosphine had reacted, and the yield of  $\text{P}_2(\text{CH}_3)_4 \cdot \text{BH}_3$  would be estimated as 0.830 mmole. The stability of the product was tested by a series of 4 to 7 hour heatings at  $80^\circ\text{C}$ ., each liberating a trace (0.005 to 0.001 mmole) of  $\text{P}_2(\text{CH}_3)_4$ , but each time less than before. It was not quite possible to decide whether any of the biphosphine came from a reversal of the above reaction.

Although  $\text{P}_2(\text{CH}_3)_4 \cdot \text{BH}_3$  could be made in stoichiometrically pure form by this reaction, all attempts to observe its melting point and to measure its vapor tensions were seriously disturbed by its sensitivity to stop-cock greases (forming traces of dimethylphosphine) and by behavior suggesting more than one solid form. An opaque-crystalline sublimate, taken by high-vacuum fractional condensation in a U-tube at  $0^\circ\text{C}$ ., developed less than 0.02 mm. pressure during 20 minutes at  $25^\circ\text{C}$ .; and to sublime away this 0.2 mmole sample under high vacuum required 5 hours at  $28^\circ\text{C}$ . But when the same crystals were resublimed by briefly heating the closed U-tube at  $50^\circ\text{C}$ ., the more transparent sublimate now could be sublimed out in a half-hour at  $28^\circ\text{C}$ . The opaque form was largely converted to the more volatile transparent form during a day-long warming from  $10^\circ\text{C}$ . to  $19^\circ\text{C}$ . A melting range of  $41\text{-}45^\circ\text{C}$ . was fairly typical, but might correspond to a mixture including some of the yet unconverted low-temperature form.

Consistent vapor-tension measurements could not be obtained for the solid  $\text{P}_2(\text{CH}_3)_4 \cdot \text{BH}_3$ , but roughly useful values (Table XXI) could be obtained for the liquid by subtracting 0.40 mm. from each measurement, to correct for the  $(\text{CH}_3)_2\text{PH}$  which was later isolated and measured. Thus  $\log_{10} p_{\text{mm}} = 8.37 - 2744/T$ ; Trouton constant 25 cal./deg. mole. With a normal Trouton constant of 21 the b.p. would be estimated as  $255^\circ\text{C}$ . (equation,  $226^\circ\text{C}$ .).

TABLE XXI

Rough Vapor Tensions of Liquid  $\text{P}_2(\text{CH}_3)_4 \cdot \text{BH}_3$

t ( $^\circ\text{C}$ .)	54.0	61.0	68.6	78.2	85.0
$p_{\text{mm}}$ (corr.)	0.99	1.44	2.10	3.63	5.18
$p_{\text{mm}}$ (calcd.)	0.96	1.44	2.19	3.63	5.12

#### D. New Synthesis of Tetramethylbiphosphine Dioxide

The biphosphine dioxide  $P_2(CH_3)_4O_2$ , previously indicated as a product of the  $(CH_3)_2PH-(CF_3)_2POP(CF_3)_2$  reaction (Ref. 5, p. 81), now has been sought by an independent method. A rapid room-temperature reaction between 0.965 mmole of  $P_2(CH_3)_4$  and 1.79 mmoles of HgO formed white crystals and metallic mercury. After two days 0.204 mmole of  $(CH_3)_3P$  and 0.221 mmole of  $P_2(CH_3)_4$  were isolated, indicating that some 27% of the consumed biphosphine had undergone methyl-group transfer, presumably forming some compound of the  $CH_3P$  group. However, a reasonable yield of a white solid melting at 132.2-132.8°C. was obtained, differing from the earlier sample of supposed  $P_2(CH_3)_4O_2$  (m.p. 132.5-132.7°C.) only in minor details of the infrared spectrum. A quantitative yield without impurities would have been too much to expect, for the HgO- $(CH_3)_3P$  reaction gave only 80% yields of  $(CH_3)_3PO$ , based upon a 37% consumption of  $(CH_3)_3P$  during 30 minutes at 40°C.

In relation to this synthesis it is interesting that no reaction occurred when a mixture of dimethylphosphine with the phosphinic amide  $(CH_3)_2PN(CH_3)_2$  was heated during ten days at 100°C. The expected reaction would have been the formation of  $(CH_3)_2NH$  and  $(CH_3)_2P-P(CH_3)_2$ , in the manner of the successful synthesis of tetramethylbiphosphine from the corresponding aminophosphine. Presumably the biphosphine monoxide would have disproportionated to the biphosphine and the biphosphine dioxide; but this route to the biphosphine dioxide evidently is barred by the absence of the initial reaction.

#### III. The Phosphinous Acid $(CF_3)_2POH$ and its Derivatives

The chemical character of the phosphinous acid  $(CF_3)_2POH$  and its esters and anhydride, including rearrangement tendencies or the absence thereof, must be understood as a part of the scientific information needed for the development of polymers based upon  $-P-O-(CH_2)_n-P-$  or  $-P-O-(CF_2)_n-P-$  skeletons. Within the past year there has been considerable progress in regard to rearrangements of the methyl and tert-butyl esters. Infrared spectroscopy has been used to prove the molecular structures of such esters and the corresponding phosphine oxides; and fuller interpretations have been sought in terms of the electronegativity of the  $CF_3$  group. This electronegativity weakens the base-action of the lone-pair electrons on phosphorus, explaining an unusual reaction in which a material purporting to be  $(CF_3)_2HPO$  converts to  $(CF_3)_2POH$ , opposite to the normal direction of the Arbuzov-type rearrangement. Various other interesting reactions were observed in relation to the main course of this work; for example, an efficient and convenient new synthesis of the useful reagent  $Hg(CF_3)_2$  was found through an attempt to make  $(CF_3)_3PO$  by the reaction between  $(CF_3)_3P$  and HgO. Some studies concerning the oxygen chemistry of the  $(CH_3)_2P$  group also are described in the present section, since the results offer interesting contrasts or similarities to the oxygen chemistry of the  $(CF_3)_2P$  group.

A. Esters of the Type (CF<sub>3</sub>)<sub>2</sub>POR

1. The Methyl Ester

Our initial work on the action of methanol on P<sub>2</sub>(CF<sub>3</sub>)<sub>4</sub> (Ref. 3, p. 33) had discouraged this approach to the synthesis of (CF<sub>3</sub>)<sub>2</sub>POCH<sub>3</sub>, but later attempts to make it by the action of P<sub>2</sub>(CF<sub>3</sub>)<sub>4</sub> on NaOCH<sub>3</sub> led to an unpleasant explosion when the process was tried in a static system, and to unresolved mixtures when a flow system was tried. Hence the methanol reaction was tried again and found to be controllable, giving virtually quantitative yields of (CF<sub>3</sub>)<sub>2</sub>PH and (CF<sub>3</sub>)<sub>2</sub>POCH<sub>3</sub>.

The equimolar mixture of 1.767 mmoles of P<sub>2</sub>(CF<sub>3</sub>)<sub>4</sub> with 1.812 mmoles of CH<sub>3</sub>OH reacted very slowly during 13 hours at 0°C., and then proceeded smoothly at room temperature. The mixture was resolved by fractional condensation under high vacuum, showing 0.02 mmole of recovered methanol, 1.849 mmoles of (CF<sub>3</sub>)<sub>2</sub>PH (104.5% yield, not fully explained), and 1.671 mmoles of (CF<sub>3</sub>)<sub>2</sub>POCH<sub>3</sub> (94.6% yield). The ester was purified by passage over fresh P<sub>4</sub>O<sub>10</sub>, since CaSO<sub>4</sub> proved unsuitable on account of too much adsorption of the desired product. The infrared spectrum of the ester showed no P=O stretching, demonstrating the absence of any rearrangement to the phosphine oxide form.

The pure (CF<sub>3</sub>)<sub>2</sub>POCH<sub>3</sub> melted within 0.1°C. of -78.5°C. Its uniformity was further demonstrated by the very consistent set of vapor tensions shown in Table XXII. These determined the equation  $\log_{10} p_{\text{mm}} = 7.6794 + 1.75 \log_{10} T - 0.008107 T - 2147.7/T$ , which gives the normal b.p. as 55.2°C. and the Trouton constant as 21.1 cal./deg. mole.

TABLE XXII

Vapor Tensions of (CF<sub>3</sub>)<sub>2</sub>POCH<sub>3</sub>

t (°C.)	-63.8	-45.3	-30.7	-23.1	0.00	7.0	12.1	15.8
P <sub>mm</sub> (obsd.)	0.63	3.42	10.85	18.19	73.68	106.1	136.6	162.2
P <sub>mm</sub> (calcd.)	0.61	3.42	10.72	18.24	73.68	106.2	136.6	162.8

The vapor-phase molecular weight of pure (CF<sub>3</sub>)<sub>2</sub>POCH<sub>3</sub> was determined as 200.1 or 200.0 (calcd., 200.0). A 21.9 mg. sample was heated in a sealed tube with 1.5 ml. of 10% NaOH solution (36 hours at 100°C., although less drastic conditions would have been adequate), yielding 15.3 mg. of HCF<sub>3</sub> (calcd., 15.3 mg.; 93.5 mm. at -111.6°C. vs. calcd. 94 mm.). These results, taken with the nearly quantitative synthesis, leave no doubt of the formula (CF<sub>3</sub>)<sub>2</sub>POCH<sub>3</sub>.

## 2. The Ethyl Ester

Although not a new compound, the ester  $(\text{CF}_3)_2\text{POC}_2\text{H}_5$  was made by us as an aid in interpretation of the infrared spectra of other esters of the same type. Instead of the original method of synthesis (alcoholysis of the chlorophosphine)<sup>7</sup> we chose alcoholic cleavage of  $\text{P}_2(\text{CF}_3)_4$ , partly for convenience and partly to augment the supply of the equal by-product,  $(\text{CF}_3)_2\text{PH}$ . The process began during a 12-hour storage of a mixture of 0.718 mmole of  $\text{P}_2(\text{CF}_3)_4$  and 0.739 mmole of  $\text{C}_2\text{H}_5\text{OH}$  at  $0^\circ\text{C}$ ., continued during 27 hours at  $25^\circ\text{C}$ ., and was brought surely to completion by a four-hour heating at  $60^\circ\text{C}$ .. The yield of  $(\text{CF}_3)_2\text{PH}$  (mol. wt., 169.3; calcd., 170.0) was 0.719 mmole, or 100.1%. The yield of  $(\text{CF}_3)_2\text{POC}_2\text{H}_5$  (mol. wt., 214.0, as calcd.) was 0.707 mmole, or 98.5%, after removal of the last trace of  $\text{C}_2\text{H}_5\text{OH}$  by passage across a bed of  $\text{P}_4\text{O}_{10}$ .

## 3. The Tertiary-Butyl Ester

The initial synthesis of the ester  $(\text{CF}_3)_2\text{POC}_4\text{H}_9$  by the tert.- $\text{C}_4\text{H}_9\text{OH}$  cleavage of  $\text{P}_2(\text{CF}_3)_4$  (Ref. 3, p. 33) was repeated, using 2.971 and 2.973 mmole samples of the respective reactants. The reaction was incomplete after 80 hours at  $25^\circ\text{C}$ ., but reached 98.8% completion during a further eight days. The yield of  $(\text{CF}_3)_2\text{PH}$  was 2.937 mmoles; of  $(\text{CF}_3)_2\text{POC}_4\text{H}_9$ , 2.826 mmoles-- respectively 100.0 and 96.3%, based upon the consumed biphosphine. The ester was purified by passage across a fresh bed of  $\text{P}_4\text{O}_{10}$ , which did not cause any of the rearrangement which had been observed earlier, when the  $\text{P}_4\text{O}_{10}$  was not so fresh (Ref. 3, p. 33).

The highly purified ester sample melted within  $0.1^\circ\text{C}$ . of  $-26.1^\circ\text{C}$ .. Its uniformity was further demonstrated by the very consistent set of vapor tensions shown in Table XXIII. These determined the equation  $\log_{10} P_{\text{mm}} = 7.3042 + 1.75 \log_{10} T - 0.00686 T - 2421.1/T$ , which gives the normal b.p. as  $110.3^\circ\text{C}$ . and the Trouton constant as 20.5 cal./deg. mole. The sample had the correct vapor-phase molecular weight (242.0 as calcd.) and the alkaline hydrolysis of 82.6 mg. of it gave 47.4 mg. of  $\text{HCF}_3$  (calcd., 47.8 mg.).

TABLE XXIII

Vapor Tensions of  $(\text{CF}_3)_2\text{POC}_4\text{H}_9$

t ( $^\circ\text{C}$ .)	0.00	11.5	25.0	30.0	41.7	56.7	67.0
$P_{\text{mm}}$ (obsd.)	6.79	13.82	29.53	38.21	67.18	128.7	192.4
$P_{\text{mm}}$ (calcd.)	6.79	13.82	29.51	38.21	67.20	128.6	192.4

#### 4. The Deuterated Acid

The acid  $(CF_3)_2POD$  was made as an aid to identification of infrared bands, to avoid confusion between P-O stretching and O-H deformation vibrations. Since a sharp decrease of intensity corresponding to O-H bands would be sufficient for the purpose, the available 90% deuterated water was considered a suitable source of deuterium. It was converted to DCl by reaction with  $BCl_3$  and used in that form to cleave the diphosphoxane  $(CF_3)_2POP(CF_3)_2$ , as had been done before with HCl (Ref. 5, p. 77). The cleavage was performed during 72 hours of heating at  $100^\circ C.$ , in a sealed tube which could be attached to the high-vacuum system by a magnetic breaker, thus avoiding any stop-cock greases and vacuum waxes. In this way it was possible to obtain a 100% yield of the deuterated phosphinous acid, along with an equal yield of  $(CF_3)_2PCl$ . The 90% deuterated compound melted at  $-19.3$  to  $-19.2^\circ C.$ , vs.  $-21.3$  to  $-21.1^\circ C.$  for the pure  $(CF_3)_2POH$  meaning that pure  $(CF_3)_2POD$  would melt at  $-19.0^\circ C.$  A similar extrapolation of the  $0^\circ C.$  vapor tension would give 53.22 mm. vs. 50.58 mm. for  $(CF_3)_2POH$  at  $0^\circ C.$

#### 5. Arbuzov Rearrangements to Phosphine Oxides

As mentioned above, it was not found possible to repeat the conversion of  $(CF_3)_2POC_4H_9$  to the phosphine oxide  $C_4H_9(CF_3)_2PO$  by contact with fresh phosphoric anhydride; but this reaction did go very well in the presence of methyl iodide as a catalyst. In one experiment 0.515 mmole of  $(CF_3)_2POC_4H_9$ , heated with 0.516 mmole of  $CH_3I$  for two hours at  $70-80^\circ C.$ , was 85% converted to the phosphine oxide form. The  $CH_3I$  was virtually all recovered; 0.513 mmole, having mol. wt. 141.6 (calcd., 141.9). The recovered ester amounted to 18.8 mg. (vapor tension 6.8 mm. at  $0^\circ C.$ ; Cf. Table XXIII), or 15.1% of the original sample. The less volatile phosphine-oxide isomer was trapped out in vacuo at  $-30^\circ C.$  Its molecular weight was determined as 242.0, as calcd., in the vapor phase at 92.0 mm. and  $91.8^\circ C.$  Its vapor tensions (Table XXIV) showed the mutual consistency expected for a pure substance, determining the equation  $\log_{10}P_{mm} = 8.0011 - 2304.6/T$ . Since this would give a high value for the Trouton constant (23.4 cal./deg. mole), the b.p. is estimated from the highest vapor-tension value on the basis of a normal Trouton constant of 21, the result being  $188^\circ C.$  instead of the  $177^\circ C.$  from the equation.

TABLE XXIV

Vapor Tensions of Liquid  $C_4H_9(CF_3)_2PO$

t ( $^\circ C.$ )	0.00	13.8	25.0	35.5	43.3	49.9	78.1
$P_{mm}$ (obsd.)	0.37	0.94	1.88	3.43	5.24	7.39	27.62
$P_{mm}$ (calcd.)	0.37	0.93	1.88	3.39	5.24	7.38	27.63

The strictly catalytic behavior of methyl iodide in this rearrangement would be difficult to understand in terms of the usual idea of the Arbuzov rearrangement, according to which the methyl group would have been captured by phosphorus and the t-butyl group would have been taken off as the iodide. In this connection it is interesting that the ester  $(CF_3)_2POCH_3$  is far harder to rearrange; a mixture of this ester with  $CH_3I$ , heated in a small sealed tube to maintain the liquid phase, showed no reaction at temperatures below  $130^\circ C.$ , and only 4% rearrangement occurred during 196 hours at that temperature. After 144 hours at  $148^\circ C.$ , the yield of the phosphine oxide  $CH_3(CF_3)_2PO$  still was only 8.5%. Thus one might speculate that the first reaction between  $(CF_3)_2POC_4H_9$  and  $CH_3I$  is a reversible exchange of alkyl groups on oxygen; then the resulting  $(CF_3)_2POCH_3$  cannot react with more  $CH_3I$  in the Arbuzov manner to make  $CH_3(CF_3)_2PO$  nearly so easily as it reacts with  $C_4H_9I$  to make  $CH_3I$  and  $C_4H_9(CF_3)_2PO$ . Thus all of the initially-used  $CH_3I$  would be restored and the only phosphine oxide would be  $C_4H_9(CF_3)_2PO$ . The reason for an easier attachment of t- $C_4H_9$  to phosphorus would be the lower C-I bond energy in t- $C_4H_9I$  than in  $CH_3I$ .

#### 6. Methyl-Bis(trifluoromethyl)-Phosphine Oxide

The initial failure to accomplish the rearrangement of the ester  $(CF_3)_2POCH_3$  raised the question whether the phosphine oxide form might be less stable than its isomer. Accordingly a sample of  $CH_3(CF_3)_2PO$  was made directly, by the reaction between 1.557 mmoles of  $CH_3P(CF_3)_2$  and 1.246 mmoles of  $HgO$ , first during 45 minutes at  $95^\circ C.$  (34% progress) and then for 16 hours at  $80^\circ C.$  The consumption of the ester then was 1.128 mmoles (90.5% use of the  $HgO$ ) and the yield of  $CH_3(CF_3)_2PO$  was 219.9 mg., representing 97.5% of the consumed ester. The other products were metallic mercury and traces of solids, including a slightly volatile material which might have been  $Hg(CF_3)_2$  (see below). There was no trace of  $(CF_3)_2POCH_3$  at any stage of the reaction.

The purity of the new phosphine oxide was indicated by its sharp m.p. ( $-27.0$  to  $-26.8^\circ C.$ ) and the consistent set of vapor tensions shown in Table XXV. These determined the equation  $\log_{10} P_{mm} = 8.5815 + 1.75 \log_{10} T - 0.00802 T - 2828.1/T$ ; b.p.  $128.7^\circ C.$ ; Trouton constant  $20.9$  cal./deg. mole. The formula was confirmed by the molecular weight (201.2 vs. calcd. 200.0) and an infrared spectrum clearly showing the P=O stretching vibration. It showed no tendency to convert to the ester-isomer.

TABLE XXV

#### Vapor Tensions of Liquid $CH_3(CF_3)_2PO$

t ( $^\circ C.$ )	0.00	15.8	29.5	40.1	44.6	50.2	59.5
$P_{mm}$ (obsd.)	2.01	6.08	14.24	25.80	32.62	43.25	66.5
$P_{mm}$ (calcd.)	2.01	6.09	14.22	25.61	32.62	43.16	67.0



7. Acid-Base Chemistry of the Esters and Phosphine Oxides

It was not possible to form any adduct of boron trifluoride with either the ester  $(\text{CF}_3)_2\text{POCH}_3$  or the phosphine oxide  $\text{C}_4\text{H}_9(\text{CF}_3)_2\text{PO}$ . In both cases we may consider that the lone-pair electrons of oxygen are largely assigned to pi-bonding through the use of phosphorus 3d orbitals, and that the effect is especially strong because the  $\text{CF}_3$  groups make phosphorus especially electronegative without supplying any electrons for competitive pi-bonding.

The ester  $(\text{CF}_3)_2\text{POCH}_3$  also failed to form a trimethylamine adduct, in contrast to the ability of  $(\text{CF}_3)_2\text{POP}(\text{CF}_3)_2$  to form a weakly bonded 1:1 adduct with trimethylamine (Ref. 5, p. 74). The difference may be ascribed to a three-atom delocalization of pi-bonding electrons from oxygen in the diphosphoxane, so that the electron density on each phosphorus is less than in the ester.

This methyl ester also proved to be inert toward  $(\text{CH}_3)_2\text{PH}$  at room temperature, but reacted to some extent during 24 hours at  $80^\circ\text{C}$ . However, the reaction was not in the direction of making the desired  $(\text{CH}_3)_2\text{P-P}(\text{CF}_3)_2$ , but rather seemed to be more like a basic hydrolysis, giving  $\text{HCF}_3$  representing 13% of the  $\text{CF}_3$  groups in the ester. A dark non-volatile oil was the by-product.

When alkaline hydrolysis was tried for the analysis of the phosphine oxide  $\text{C}_4\text{H}_9(\text{CF}_3)_2\text{PO}$ , the formation of  $\text{HCF}_3$  amounted only to 1.38 per molecule after 65 hours at  $100^\circ\text{C}$ . It has been noted before that  $\text{CF}_3$ -phosphines having a hydrocarbon group on phosphorus are more difficult to hydrolyze to give  $\text{HCF}_3$ , and it is probable that the  $\text{P}=\text{O}$  linkage also helps to inhibit the process leading to  $\text{HCF}_3$ . Accordingly a bromination process was tried as a means of determining the  $\text{CF}_3$  groups in  $\text{C}_4\text{H}_9(\text{CF}_3)_2\text{PO}$ . However, the result was not a new analytical method for  $\text{CF}_3$  groups but a synthetic method for the new compound  $(\text{CF}_3)_2\text{POBr}$ , as next described.

A mixture of 0.1632 mmole of  $\text{C}_4\text{H}_9(\text{CF}_3)_2\text{PO}$  with 0.949 mmole of  $\text{Br}_2$  was heated in a sealed tube for 20 hours at  $100^\circ\text{C}$ . (forming 0.340 mmole of  $\text{HBr}$ ) and for six days longer at  $130^\circ\text{C}$ . The final result was 0.611 mmole of  $\text{HBr}$ , a black tar, and 0.0844 mmole (51.5% yield) of the new volatile compound  $(\text{CF}_3)_2\text{POBr}$ . It seems that a  $\text{CF}_3$ -phosphine oxide does not react with bromine in the manner of a phosphine to cleave off the  $\text{CF}_3$  groups,<sup>8</sup> and in the present case the easier reaction was removal and bromination of the t-butyl group. The new phosphinic-acid bromide was shaken with mercury to remove bromine, and purified by a slow high-vacuum distillation through a trap at  $-78^\circ\text{C}$ . Its m.p. was  $-35.5^\circ \pm 0.3^\circ\text{C}$ . Its vapor tensions (Table XXVI) determined the equation  $\log_{10}P_{\text{mm}} = 7.962 - 1772/T$ , which gives the Trouton constant as 23.2 cal./deg. mole. On the basis of a normal Trouton constant of 21.0, the b.p. would be estimated as  $82^\circ\text{C}$ ., rather than  $76^\circ\text{C}$ . as given by the equation.

TABLE XXVI

Vapor Tensions of Liquid  $(CF_3)_2POBr$ 

t ( $^{\circ}C.$ )	-23.8	-5.3	0.00	6.1	10.2	16.5
$P_{mm}$ (obsd.)	7.1	22.2	29.9	41.6	51.2	70.0
$P_{mm}$ (calcd.)	7.2	22.2	29.9	41.4	51.2	70.0

The formula of this new acid bromide was confirmed by its vapor-phase molecular weight (264.3 vs. calcd. 264.9) and by an alkaline hydrolysis of the whole 0.0844 mmole sample to give 0.086 meq of bromide and 0.0834 mmole of  $HCF_3$ . This conversion of half of the  $CF_3$  groups to  $HCF_3$  (during 16 hours at  $100^{\circ}C.$ ) is consistent with the known behavior of the expected initial hydrolysis-product, the phosphinic acid  $(CF_3)_2POOH$ . Before the analysis, the sample was employed for recording its infrared spectrum, with results consistent with the acid-bromide formula and the estimated electronegativity of the  $CF_3$  group.

#### B. Infrared Spectra of $(CF_3)_2P-O$ Compounds

The successful assignment of infrared frequencies for the trifluoromethyl halides,<sup>9,10</sup> with the recent extension to compounds of the  $CF_3S-$  group,<sup>11</sup> makes it feasible to extend the existing correlations of group frequencies in  $(CF_3)_2P$  compounds, especially since their  $CF_3$ -vibrational spectra are decidedly similar. Moreover, the paucity of infrared spectral data for molecules having a reasonably isolated P-O single bond with trivalent phosphorus, makes such a correlation valuable. For the immediate purposes of the present project, the primary value is in the sure confirmation of the structures of the phosphinous acid derivatives and the corresponding phosphine oxides.

##### 1. The Oxyphosphines

The spectra of six compounds having in common the  $(CF_3)_2P-O-$  grouping were recorded over a broad range of frequencies by means of a Perkin-Elmer Infracord instrument. Tracings of the spectra are compared in Figure 8, illustrating the constancy of certain group frequencies and the gradual changes in the P-O stretching frequency as the groups D,  $CH_3$ ,  $C_2H_5$ ,  $t-C_4H_9$ , and  $P(CF_3)_2$  are substituted for H on oxygen. The numbers on the curves represent the pressures of the vapor in mm., in a cell of 71 mm. path length. The windows were single-crystal potassium bromide, although the instrument itself had sodium chloride optics.

For greater accuracy and higher resolution, the most significant details of the spectra of these compounds were recorded by means of the Perkin-Elmer Model 13 spectrophotometer. The detailed data are presented in Table XXVII. The frequency assignments here must sometimes be regarded as tentative, because of considerable coupling of vibrations.

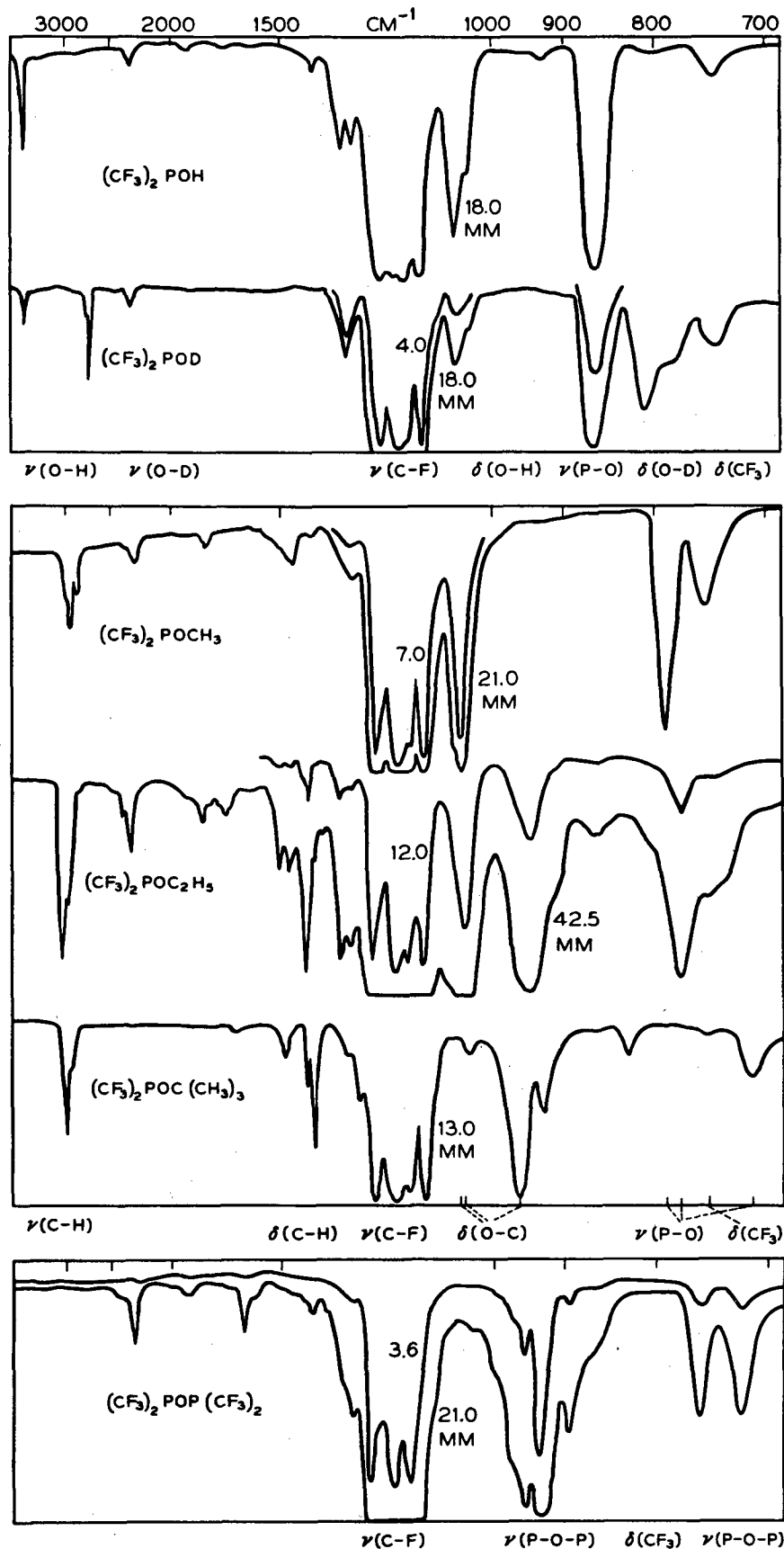

Figure 8. Infrared Spectra of  $(\text{CF}_3)_2\text{P-O}$  Compounds

TABLE XXVII

Infrared Spectra of  $(CF_3)_2POX$  Type Compounds

Assignment	X=H	D	CH <sub>3</sub>	C <sub>2</sub> H <sub>5</sub>	t-C <sub>4</sub> H <sub>9</sub>	P(CF <sub>3</sub> ) <sub>2</sub>
$\nu$ (O-H)	3620 s	3620 vw	-	-	-	-
$\nu$ (C-H)	{ - - -}	- - -	2935 m 2850 w	3000 m 2915 m 2860 vw	3008 s	- - -
$\nu$ (O-D)	{ - -}	2680 vw 2640 m	- -	- -	- -	- -
c	2365 vw	-	2365 vw	2350 vw	2385 vw	-
c	2270 vw	2270	-	2280 vw	-	2240
c	-	-	-	1820 vw	-	-
c	-	-	-	1710 vw	1655 vw	1630 vw
$\delta$ (CH <sub>3</sub> ) ASYM.	{ - -}	- -	1475 w 1458 w	1490 w 1455 w	1475 w	- -
$\delta$ (CH <sub>3</sub> ) SYM.	{ - -}	- -	1380 w	1400 m	1395 w 1375 w	- -
c	1305 w	1295 w	-	1305 m	-	-
c	1282 w	-	1280 w	1275 w	1255 w	1280 w
$\nu$ (C-F)	{ 1203 vs 1170 vs 1137 vs 1103 vs}	1210 vs 1170 vs 1140 vs 1120 vs	1222 vs 1172 vs 1135 vs 1105 vs	1225 vs 1175 vs 1145 vs 1115 vs	1218 vs 1172 vs 1135 vs 1103 vs	1222 vs 1181 vs 1140 vs -
$\delta$ (O-H)	{ 1054 s 1033 ssh}	1055 w 1040 ssh	- -	- -	- -	- -

TABLE XXVII (cont'd.)

Assignment	X=H	D	CH <sub>3</sub>	C <sub>2</sub> H <sub>5</sub>	t-C <sub>4</sub> H <sub>9</sub>	P(CF <sub>3</sub> ) <sub>2</sub>
$\nu$ (C-O)	-	-	1044 vs	1040 vs	952 s	-
$\nu$ (c-c), r(CH <sub>3</sub> )	-	-	-	939 m	917 mw	-
$\nu$ (P-O-P) ASYM.	}	-	-	-	-	950 w
		-	-	-	-	925 s
		-	-	-	-	885 w
$\nu$ (c-c) (?)	-	-	-	860 vw	850 vw	-
t-C <sub>4</sub> H <sub>9</sub> (?)	-	-	-	-	819 vw	-
	-	-	-	-	767 vw	-
$\nu$ (P-O)	854 vs	858 vs	780 s	770 m	705 w	-
$\delta$ (O-D)	-	805 ms	-	-	-	-
	-	780 msh	-	-	-	-
$\delta$ (CF <sub>3</sub> ) SYM.	743 w	742 w	745 m	745 msh	744 w	745 w
$\nu$ (P-O-P) SYM.	-	-	-	-	-	715 w
	572 m	↑	574 m	↑	568 ms	↑
546 w	549 w		550 w			
$\delta$ (c-c)	-	N.I.	-	N.I.	489 w	N.I.
	465	↓	459 s	↓	458 s	↓
$\nu$ (PC <sub>2</sub> ) ASYM.	(?)407 vw		407 vw		415 vw	

s = strong, m = medium, w = weak, v = very, sh = shoulder,  $\nu$  = stretching,  
 $\delta$  = deformation, c = combination or overtone, r = rocking, N.I. = not investigated.

The vibrations of the  $(CF_3)_2P$  group evidently are little affected by the P-O linkage. The C-F stretching vibrations appear as four intense absorption bands in the usual range (1100 to 1225  $cm^{-1}$ ),<sup>8,12</sup> although one band is often difficult to observe because it occurs as a shoulder (1135 to 1145  $cm^{-1}$ ) on the neighboring central band (see Figure 8). Deformation modes of the  $CF_3$  group are assigned to the bands near 745  $cm^{-1}$  (symm.) and 565-575  $cm^{-1}$  (asymm.) by analogy to the spectra of similar compounds.<sup>11,12</sup>

In alkyl phosphines the P-C stretching vibration occurs in the range 650-750  $cm^{-1}$ ,<sup>13</sup> but in  $CF_3$ -phosphines and in  $CF_3S$ -compounds the P-C and S-C stretching vibrations are observed at far lower frequencies.<sup>11</sup> With the  $(CF_3)_2P-O$ -group, the C-P-C asymmetric stretching vibration apparently occurs as a strong band near 460  $cm^{-1}$ . A very weak band near 410  $cm^{-1}$  may be due to the symmetric vibration within the  $PC_2$  triangle. Other vibrations, such as the P-C bending modes, would occur at lower frequencies, beyond the range of our instruments.

The P-O stretching vibrations showed the expected trend to lower frequencies with heavier groups occupying the other valence of oxygen. From  $(CF_3)_2POH$  to  $(CF_3)_2POD$  the change was scarcely observable, but the frequency was far lower for  $(CF_3)_2POCH_3$ . Then the ethyl group led to a slightly lower frequency, while the t-butyl group lowered the frequency of this P-O stretching by a much wider margin. Finally, the two P-O-P modes are seen as two equally prominent bands in the low-frequency region.

The O-H stretching frequency is unique at 3620  $cm^{-1}$ , and still is present as an impurity in the spectrum of  $(CF_3)_2POD$ . A very slight shoulder on the O-H band cannot be ascribed to an overtone of the C-F stretching, for the same kind of shoulder is more obvious on the O-D stretching band at 2645  $cm^{-1}$ . The 1054 band for  $(CF_3)_2POH$  must represent O-H deformation, for it shifts to 805  $cm^{-1}$  for the deuterated compound. This leaves 854  $cm^{-1}$  to be assigned to P-O stretching in both compounds. It is interesting that both the O-H and O-D deformation bands have very obvious shoulders on the low-frequency side.

The shift of the C-O stretching mode in the alkyl esters is much as expected; 1044  $cm^{-1}$  for the methyl compound, 1040 for ethyl, and 952 for t-butyl. These bands, along with the P-O stretchings, as well as the C-C stretching and methyl-group rocking, are all useful for identification purposes.

The absorption bands associated with the methyl, ethyl, and t-butyl groups all occur in the expected regions (Cf. Table XXVII) and have been discussed elsewhere.<sup>14,15</sup>

## 2. The Phosphine Oxides and Acid Halides

The frequencies and assignments of the absorption bands for the  $(CF_3)_2POX$  compounds (where X is Cl, Br,  $CH_3$ , or t- $C_4H_9$ ) are given in Table XXVIII, except that frequencies above 1500  $cm^{-1}$  are omitted. Those would only represent C-H stretching and possibly some persistent combinations and overtones of the C-F stretching modes. The spectra were recorded mostly by the Infracord instrument, but the Model 13 was used with a KBr prism and windows for the spectra of the chloride and the methyl ester down to 400  $cm^{-1}$ . The spectra of the less volatile

TABLE XXVIII

Infrared Spectra of (CF<sub>3</sub>)<sub>2</sub>P(O)X Type Compounds

Assignment	X = Cl	Br	CH <sub>3</sub>	t-C <sub>4</sub> H <sub>9</sub>
δ (CH <sub>3</sub> ) ASYM.	-	-	1411 vw	1470 w
t-C <sub>4</sub> H <sub>9</sub>	-	-	-	1400 vw 1270 s
ν (P=O)	1330 s	1312 s	1316 s	1282 s
c	1295 m	1250 w	-	-
δ (CH <sub>3</sub> ) SYM. or c	-	-	1295 w	-
ν (C-F)	{ 1204 vs 1143 s 1122 msh 1098 w	1202 vs	1205 vs	1197 vs
		1162 s	1180 vs	1172 vs
		-	1132 vs	1150 s
		1047 w(?)	1098 vw	1128 s 1026 vw(?)
r(CH <sub>3</sub> )	-	-	887 s	-
t-C <sub>4</sub> H <sub>9</sub>	-	-	-	812 w
δ (CF <sub>3</sub> ) SYM.	759 m	753 m	775 m	745 w
r(CH <sub>3</sub> ) or ν (P-CH <sub>3</sub> )	-	-	732 m	-
ν (P-Cl)	615 s	↑	-	↑
δ (CF <sub>3</sub> ) ASYM.	{ 581 sh 563 s 536 sh	N.I.	581 sh	N.I.
			543 m	
			-	
ν (P-CH <sub>3</sub> ) ASYM.	498 s	↓	495 s	↓
ν (P-CF <sub>3</sub> ) SYM(?)	-		430 m	

s = strong, m = medium, w = weak, v = very, sh = shoulder,  
 ν = stretching, δ = deformation, c = combination, r = rocking,  
 N.I. = not investigated.

alkyl phosphine oxides were taken at the highest vapor-pressures possible at room temperature but lower pressures were employed also when necessary to resolve the more intense bands. As before, the 71-mm. gas cell was used.

The P=O stretching frequencies were very near to those of a CF<sub>3</sub> combination and the methyl-group deformation, so that it could be identified in two cases only by comparison with the corresponding oxygen-free phosphines, as shown in Figure 9. The comparison was important for (CF<sub>3</sub>)<sub>2</sub>POCl and the methyl-bis(trifluoromethyl)phosphine oxide; and fortunately it was not necessary for the butyl-phosphine oxide, for which the corresponding phosphine was not available.

The shift in the position of the P=O stretching band with a variety of groups or atoms on phosphorus has been used recently as a basis for calculating the effective electronegativity of the CF<sub>3</sub> group.<sup>16</sup> The result,  $x = 3.3$  on the Pauling scale, seemed to be qualitatively correct and agreement with other spectral and thermochemical data lent confidence to the result. Thus it appeared that the equation  $\nu_{P=O} = 918 + 41.3 \sum x$ , where  $\sum x$  represents the sum of the electronegativity values of the groups on phosphorus (on the Pauling scale) and  $\nu_{P=O}$  is the stretching frequency for the P=O bond, could be used to estimate the electronegativity of any group on phosphorus when those of the other groups are known. However, our new P=O compounds gave an opportunity to test the equation again, for somewhat less symmetrical compounds.

The results of this test, shown in Table XXIX were deduced from the equation, using the accepted Pauling values of  $x$  for Cl and Br, and calculating  $x$  for the CH<sub>3</sub> group from the equation by the use of the P=O stretching frequency in (CH<sub>3</sub>)<sub>3</sub>PO.<sup>17</sup>

TABLE XXIX

Calculated Electronegativities of the CF<sub>3</sub> Group

Compound	(CF <sub>3</sub> ) <sub>2</sub> POCl	(CF <sub>3</sub> ) <sub>2</sub> POBr	(CF <sub>3</sub> ) <sub>2</sub> POCH <sub>3</sub>
P=O (cm. <sup>-1</sup> )	1330	1312	1316
Calcd. $x$	3.5	3.4	3.5

Although these results are slightly higher than the earlier 3.3, the difference is within the error of the electronegativity concept itself; for no such simple idea can apply quantitatively to the wave-mechanical complexities of electronic behavior.

The CF<sub>3</sub> vibrational modes in the P=O compounds are like those in the corresponding phosphines, although some frequency shifts are observed. The C-F stretching vibrations appear in the expected range (1100 to 1205 cm.<sup>-1</sup>) but those



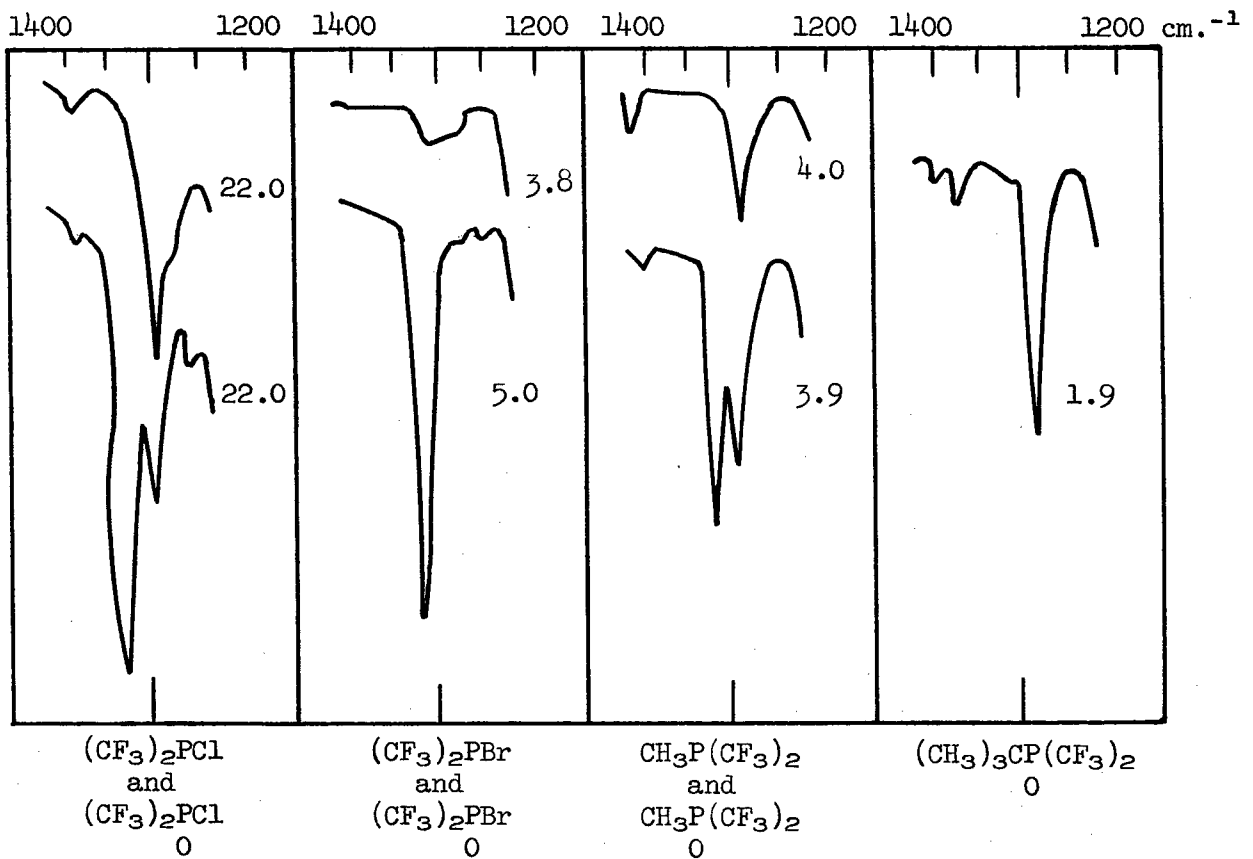

Figure 9. Comparison Spectra of  $(CF_3)_2P(=O)-$  and  $(CF_3)_2P(=O)-$  Compounds in the P=O Stretching Region

on the low-frequency side are considerably less intense than those of higher frequency. The symmetric  $\text{CF}_3$  deformation band for  $(\text{CF}_3)_2\text{POCH}_3$  is shifted to  $770 \text{ cm.}^{-1}$  from the 742-745 range of the trivalent phosphorus compounds in Table XXVIII. Another upward shift occurs in the P-C<sub>2</sub> asymmetric stretching frequencies: 498 to  $485 \text{ cm.}^{-1}$  for the P=O compounds versus 465 to 458 in Table XXVIII. The asymmetric  $\text{CF}_3$  deformation vibration appears at a somewhat lower frequency than observed for the phosphinous acid esters. These small shifts evidently arise from minor changes in electronic behavior for trivalent versus pentavalent phosphorus compounds, leading to differences of force constants.

The P-Cl stretching vibration in  $(\text{CF}_3)_2\text{POCl}$  is recognized as a strong band at  $615 \text{ cm.}^{-1}$ , not found for the corresponding methyl phosphine oxide. A strong band at  $855 \text{ cm.}^{-1}$  for this methyl compound can be attributed to a  $\text{CH}_3$  rocking mode, by comparison with a number of other phosphines and phosphine oxides.<sup>13,17,18</sup> A medium-intensity band in the spectrum of this methylphosphine oxide, at  $732 \text{ cm.}^{-1}$ , might also arise from a  $\text{CH}_3$  rocking mode, but is more probably due to a P- $\text{CH}_3$  stretching vibration which would be expected in the  $650\text{-}750 \text{ cm.}^{-1}$  region. Other absorption bands characteristic of the alkyl groups appear in the expected regions, and require no further comment.

### 3. Ultraviolet Spectra of Two Phosphinous Esters

The ultraviolet spectra of  $(\text{CF}_3)_2\text{POCH}_3$  and  $(\text{CF}_3)_2\text{POC}_4\text{H}_9$  were recorded by the Cary Model 14 spectrophotometer. For the methyl ester, the wave length of the maximum was 2071 Å., with molar extinction coefficient 2045; the minimum occurred at 1945 Å., with molar extinction coefficient 684. For the t-butyl ester the corresponding data were 2051 Å. (ext. coeff. 3240) and 1929 Å. (ext. coeff. 1160). The maxima are attributed to a pi-bond type of electronic delocalization between P and O, using phosphorus 3d orbitals. The relatively low wave lengths of the maxima would accord with a considerably shorter electronic path than in the diphosphoxane  $(\text{CF}_3)_2\text{POP}(\text{CF}_3)_2$  (maximum at 2110 Å.; see ref. 5, p. 73).

### C. An Anti-Arbuzov Rearrangement

Unlike its esters, the phosphinous acid  $(\text{CF}_3)_2\text{POH}$  has shown not the slightest tendency to rearrange into the secondary-phosphine-oxide form.<sup>19</sup> The reason for this high stability as a phosphinous acid doubtless is the inability of the phosphorus atom to employ its lone-pair electrons in the base-sense to hold the proton. This idea now gains further support from a reaction which seems to be the opposite to a rearrangement in the Arbuzov manner, namely the new process represented by equation (41). This seems to be the first case of such a reaction.

#### 1. Synthesis of the Secondary-Phosphine Oxide

Mercuric oxide was used to attach an oxygen atom to phosphorus in the phosphine  $(\text{CF}_3)_2\text{PH}$ , in a reaction which proved to be spontaneous and quite exothermic, giving white fumes and metallic mercury. The initial experiment, in a static reaction-tube, gave some  $(\text{CF}_3)_2\text{POH}$  and  $(\text{CF}_3)_2\text{POOH}$ , along with recovered  $(\text{CF}_3)_2\text{PH}$ . Thus it could be argued that the initially-formed but unstable  $(\text{CF}_3)_2\text{HPO}$  had partly disproportionated into  $(\text{CF}_3)_2\text{PH}$  and  $(\text{CF}_3)_2\text{POOH}$ , while a similar amount had rearranged into  $(\text{CF}_3)_2\text{POH}$ .

In order to check this idea more neatly, the synthesis was done in a flow system, so that the 0.702 mmole sample of  $(CF_3)_2PH$  flowed at a pressure of 6 mm. over a bed of HgO (at 60-65°C. to minimize adsorption) and was led into a series of evacuated traps at -45°, -96°, and -196°C. Then the HgO tube was sealed off to prevent further contact with the volatile products. The -196°C. trap had caught 0.128 mmole of unused (or regenerated)  $(CF_3)_2PH$  and the -96°C. trap held 0.03 mmole of  $(CF_3)_2POH$ . Neither of these could have been an important component of the slightly volatile liquid in the -45°C. trap. However, during a 14-hour storage at 25°C. this liquid generated 0.129 mmole of  $(CF_3)_2PH$  and 0.128 mmole of  $(CF_3)_2POH$ , while forming 0.088 mmole of the slightly volatile  $(CF_3)_2POOH$  (analyzed by alkaline hydrolysis to form one  $HCF_3$  per molecule.<sup>20</sup> These results are interpreted in terms of the existence and decomposition of the unstable phosphine oxide  $(CF_3)_2HPO$ , as argued below.

## 2. The Rearrangement and Disproportionation

The above results could be understood only in terms of the parallel reactions:

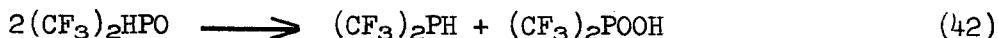
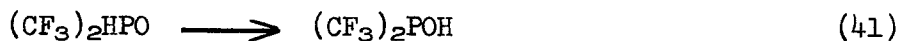

for  $(CF_3)_2POH$  would not have disproportionated in the manner of the second reaction even if much of it had been present in the -45°C. condensate. Also, the  $(CF_3)_2POOH$  could not have reacted with  $(CF_3)_2PH$  to form the observed  $(CF_3)_2POH$ , since this reverse-disproportionation was shown not to occur at 60°C. For use in this experiment, the  $(CF_3)_2POOH$  was made by quantitative oxidation of  $(CF_3)_2PH$ , using excess HgO in situ. Since the yield of  $(CF_3)_2POOH$  by this method was close to 100%, it is concluded that  $(CF_3)_2POH$  is directly oxidized by HgO; for otherwise some of the  $(CF_3)_2P$  groups would have appeared as  $(CF_3)_2POH$ .

## 3. Synthesis of the Dimethylphosphine Oxide

For a direct comparison with the HgO-synthesis of  $(CF_3)_2HPO$ , the analogous process with  $(CH_3)_2PH$  was carried out. The 1.504 mmole sample of  $(CH_3)_2PH$ , with 1.062 mmoles of HgO, reacted spontaneously in a water-cooled static reaction tube attached to the high-vacuum system. Within three minutes metallic mercury began to appear, along with a viscous liquid. After 20 minutes at 70°C. the reaction had given a 98% yield of mercury (1.040 mmoles); but the amount of unrecovered  $(CH_3)_2PH$  was only 0.778 mmole. Further heating of the viscous liquid (12 hours at 100°C.) yielded 0.236 mmole of  $(CH_3)_2PH$ ; and now the presence of 0.523 mmole of  $(CH_3)_2POOH$  (m.p. 91°C.; known, 91-92°C.) was demonstrated by titration to pH 6.0.<sup>21</sup> Thus the whole process could be summarized by the empirical equations:

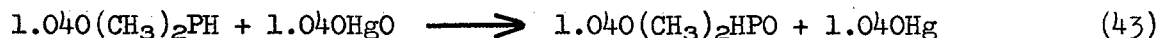

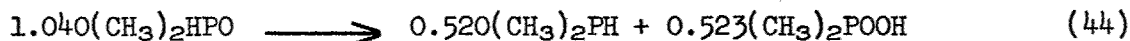

Hence it seems that  $(\text{CH}_3)_2\text{HPO}$  has finite existence but can only disproportionate to  $(\text{CH}_3)_2\text{PH}$  and  $(\text{CH}_3)_2\text{POOH}$ , having strictly no tendency toward the anti-Arbuzov type of rearrangement. The same disproportionation was reported last year (Ref. 5, p. 80) as a consequence of the reaction between  $(\text{CH}_3)_2\text{PH}$  and  $(\text{CF}_3)_2\text{POH}$ .

#### D. The HgO Reaction of $(\text{CF}_3)_3\text{P}$

A sample of the phosphine oxide  $(\text{CF}_3)_3\text{PO}$  was desired for comparison purposes, and accordingly the oxidation of  $(\text{CF}_3)_3\text{P}$  by HgO was tried. However, the result of this attempt was the discovery of the interesting and nearly quantitative reaction

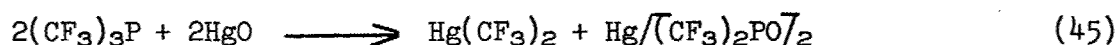

whereby a 96% yield of the rare and useful reagent  $\text{Hg}(\text{CF}_3)_2$  was obtained. The accompanying non-volatile product has not been fully investigated; in particular, it is not known whether it is a mercury phosphinite (Hg-O-P bonded) or an Hg-P bonded phosphine oxide derivative. The latter interpretation may be better, since the substance did not react with hydrogen chloride to make  $(\text{CF}_3)_2\text{POH}$ ; however, it is not sure that the compound is as simple as either formulation. The new synthesis of  $\text{Hg}(\text{CF}_3)_2$  now has been published.<sup>22</sup>

#### IV. Trifluoromethylphosphonous Acid and Its Esters

The phosphonous acid  $\text{CF}_3\text{P}(\text{OH})_2$  and more especially its esters are closely related to the possibility of making long-chain polymers of the phosphinic polyester

type, such as  $(-\overset{\text{O}}{\text{P}}-\text{C}_2\text{H}_4\text{O}-)_n$ , by rearrangements of the Arbuzov type. Hence it was

considered appropriate to learn the most significant properties of the free acid (a previously unknown substance) and some of its esters. The free acid itself proved to be very interesting, for there is evidence that it exists in the form of the dimer of the phosphinic acid  $\text{CF}_3\text{HPOOH}$ . This would indeed suggest that the glycol ester  $\text{C}_2\text{H}_4\text{O}_2\text{PCF}_3$  has energetic reasons for rearranging to the phosphinic-ester-polymer form indicated above, as has been suggested before (Ref. 4, pp. 103-104). The glycol ester now has been made and partially studied, but as yet its rearrangement has not been investigated.

##### A. Synthesis and Properties of the Dimethyl Ester

###### 1. Synthesis

The reaction of a pure sample of  $\text{CF}_3\text{PCl}_2$  with methanol slightly in excess was essentially complete after 42 hours at room temperature. The formation of the desired ester  $(\text{CH}_3\text{O})_2\text{PCF}_3$  was nearly quantitative, but the presence of a trace of  $\text{CH}_3\text{Cl}$  indicated the onset of the secondary reaction whereby HCl converts

the ester to the phosphonous acid. The reaction mixture was resolved into its components by means of high-vacuum fractional condensation. The stoichiometry (mmoles) was thus:

$$\text{CF}_3\text{PCl}_2 + 2\text{CH}_3\text{OH} \longrightarrow (\text{CH}_3\text{O})_2\text{PCF}_3 + 2\text{HCl} + \overline{\text{CF}_3\text{P}(\text{OH})_2} + 2\text{CH}_3\text{Cl} \quad (46)$$

Taken	1.877	3.959	-	-	-	-
Found	nil	0.030	1.797	3.592	0.082	0.164
Used	1.877	3.929	-	-	-	-
% Yield	-	-	95.7	95.7	4.3	4.3

The phosphonous ester was purified by passage over fresh phosphoric anhydride. Its infrared spectrum demonstrated it to be a dimethoxy-phosphine rather than the phosphinic ester  $\text{CH}_3\text{CF}_3\text{POOCH}_3$ , to which it might conceivably rearrange.

## 2. Volatility

The highly purified phosphonous ester proved to be a liquid at  $-78^\circ\text{C}$ . forming a glass at lower temperatures (such as  $-196^\circ\text{C}$ .), so that its m.p. could not be determined; however its uniformity was demonstrated by the consistent set of vapor tensions shown in Table XXX. These determined the equation  $\log_{10}P_{\text{mm}} = 5.1521 - 0.0035 T + 1.75 \log_{10} T - 1983.3/T$ , which gives the b.p. as  $88.6^\circ\text{C}$ . and the Trouton constant as 22.8 cal./deg. mole.

TABLE XXX

Vapor Tensions of Liquid  $(\text{CH}_3\text{O})_2\text{PCF}_3$

t ( $^\circ\text{C}$ .)	-36.2	-22.8	0.00	16.0	24.9	30.4	35.3	44.4
$P_{\text{mm}}$ (obsd.)	1.29	3.56	15.83	38.85	61.1	79.7	100.0	148.9
$P_{\text{mm}}$ (calcd.)	1.29	3.57	15.85	38.84	61.1	79.6	99.9	149.2

## 3. Confirmation of the Formula

The vapor-phase molecular weight of the supposed  $(\text{CH}_3\text{O})_2\text{PCF}_3$  was measured as 162.0 (calcd., 162.0), and checked to the same value after the vapor-tension measurements. For analysis, a 45.9 mg. sample was heated with 1.6 ml. of 15% NaOH solution in a sealed tube for 18 hours at  $80^\circ\text{C}$ ., to give 19.9 mg. of  $\text{HCF}_3$  (calcd., 19.84 mg.). These results, taken with the nearly quantitative synthesis, leave no doubt of the formula  $(\text{CH}_3\text{O})_2\text{PCF}_3$ , which agrees also with the infrared spectrum.

B. The Phosphonous Acid CF<sub>3</sub>P(OH)<sub>2</sub>

1. Synthesis from the Dibromophosphine

The reaction of CF<sub>3</sub>PBr<sub>2</sub> with methanol slightly in excess went more than 75% toward completion during 85 minutes at room temperature, and was virtually complete after 16 hours. After resolution of the mixture by high-vacuum fractional condensation, the following stoichiometry could be demonstrated (quantities in mmoles).

	$\text{CF}_3\text{PBr}_2 + 2\text{CH}_3\text{OH}$	$\longrightarrow$	$\text{CF}_3\text{P(OH)}_2 + 2\text{CH}_3\text{Br}$	(47)
Taken	1.297    2.800		-        -	
Found	0.002    0.134		1.274    2.543	
Used	1.295    2.666		-        -	
% Yield	-        -		98.4    98.3	

The phosphonous acid was isolated as a water-white, slightly volatile liquid.

2. Synthesis from the Phosphonous Ester

The dramatically different results of the room-temperature methanolyses of CF<sub>3</sub>PCl<sub>2</sub> and CF<sub>3</sub>PBr<sub>2</sub>-- one giving a 96% yield of (CH<sub>3</sub>O)<sub>2</sub>PCF<sub>3</sub> during 42 hours and the other a 98% yield of CF<sub>3</sub>P(OH)<sub>2</sub> during 16 hours-- could be understood in terms of the initial formation of (CH<sub>3</sub>O)<sub>2</sub>PCF<sub>3</sub> in both cases, followed by a far more rapid cleavage of this by HBr than by HCl. This interpretation was confirmed by an experiment in which HBr was permitted to attack (CH<sub>3</sub>O)<sub>2</sub>PCF<sub>3</sub> during 24 hours at room temperature. The results are represented stoichiometrically as follows in mmoles.

	$(\text{CH}_3\text{O})_2\text{PCF}_3 + 2\text{HBr}$	$\longrightarrow$	$\text{CF}_3\text{P(OH)}_2 + 2\text{CH}_3\text{Br}$	(48)
Taken	0.301    0.602		-        -	
Found	0.004    0.003		0.297    0.595	
Used	0.297    0.599		-        -	
% Yield	-        -		98.8    98.8	

In the synthesis of the ester from methanol and CF<sub>3</sub>PCl<sub>2</sub>, the product was in contact with HCl for the major part of the 42 hours at room temperature, giving only a 4.3% yield of CH<sub>3</sub>Cl and CF<sub>3</sub>P(OH)<sub>2</sub>. Thus we find that the far higher rate of ester-cleavage by HBr accounts for the high yield of CF<sub>3</sub>P(OH)<sub>2</sub> from the methanolysis of CF<sub>3</sub>PBr<sub>2</sub>, in contrast to the high yield of (CH<sub>3</sub>O)<sub>2</sub>PCF<sub>3</sub> from the methanolysis of CF<sub>3</sub>PCl<sub>2</sub>.

### 3. Volatility

The phosphonous acid  $\text{CF}_3\text{P}(\text{OH})_2$ , having two hydroxyl groups per monomer molecule, is only very slightly volatile at room temperature, showing the vapor-tension data of Table XXXI. These determine the equation  $\log_{10} p_{\text{mm}} = 3.7328 - 0.001374 T + 1.75 \log_{10} T = 2381.8/T$ , indicating the b.p. as  $214.1^\circ\text{C}$ . and the Trouton constant as  $22.8 \text{ cal./deg. mole}$ . This value of the Trouton constant would imply that the liquid and vapor phases have nearly the same degree of association. In fact, we next present evidence indicating that the saturated vapor is dimeric, with very little dissociation to the monomer. Hence presumably the liquid also is composed of the dimer form.

TABLE XXXI

Vapor Tensions of Liquid  $\text{CF}_3\text{P}(\text{OH})_2$

t ( $^\circ\text{C}$ .)	0.00	23.1	40.2	58.8	80.2	98.1
$p_{\text{mm}}$ (obsd.)	0.08	0.41	1.17	3.33	9.66	20.18
$p_{\text{mm}}$ (calcd.)	0.08	0.41	1.18	3.34	9.26	20.18

### 4. The Dimer-Monomer Equilibrium

Pressure measurements on 0.2565 mmole of trifluoromethylphosphonous acid, in an immersible tensimeter of known volume and with internal compensation for mercury vapor, were used to investigate the variation of associated character of this acid in the vapor phase at six different temperatures. The acid was made directly in the tensimeter by the  $(\text{CH}_3\text{O})_2\text{PCF}_3\text{-HBr}$  reaction, in order to avoid the small losses of the sample by absorption in stopcock grease during transfer, which would seriously affect the results.

The data were interpreted in terms of a monomer-dimer equilibrium because a molecular weight determination at  $118.5^\circ\text{C}$ . approached the dimer value (263.8 vs. calcd. 268.0), and also because an infrared spectrum of the liquid and saturated vapor showed no evidence of the monomer. If the equilibrium showed significant proportions of a trimer form, an average molecular weight near that of the dimer would demand the presence of a similar proportion of the monomer. In such a case, however, one would expect a Trouton constant far higher than the observed  $22.8 \text{ cal./deg. mole}$ .

Accordingly, the data of Table XXXII are used to calculate equilibrium constants for the dissociation of a dimer to a monomer. The good conformity of the resulting K values to the van't Hoff equation further justifies the assumption of a pure monomer-dimer equilibrium. During all of the measurements there was

no evidence of any instability such as the formation of  $\text{CF}_3\text{PH}_2$  by the disproportionation

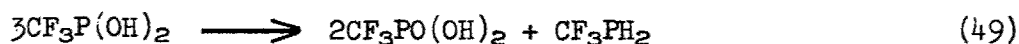

The dry acid thus is far stabler than the aqueous solution obtained by the hydrolysis of  $\text{CF}_3\text{PI}_2$ .<sup>23</sup>

TABLE XXXII

Vapor Phase Equilibrium of  
Trifluoromethylphosphonous Acid

t (°C.)	P <sub>mm</sub>	V (cc.)	Mol. wt. (obsd.)	Degree of Dissozn.	K <sub>eq</sub> (atm.) Obsd.	x 10 <sup>3</sup> calcd.
134.1	15.81	224.4	246.0	0.090	0.680	0.655
142.5	16.29	225.5	242.4	0.106	0.975	0.973
150.1	16.85	225.5	238.6	0.123	1.362	1.380
158.0	17.50	225.6	234.0	0.145	1.978	2.009
165.3	18.12	225.6	229.8	0.166	2.700	2.673
174.0	19.01	225.6	224.5	0.193	3.870	3.811

These data determined the equation  $\log_{10} K = 5.400 - 3496/T$ , meaning that  $\Delta F^\circ = 16.00 - 0.0247 T$  kcal./mole of dimer. Now the intermolecular bonding can only be of the hydrogen-bonding type, as in the dimer of a carboxyl acid; and the 16.00 kcal. of bonding energy would account for two hydrogen bonds involving bi-coordinate oxygen, but not three or four hydrogen bonds of any kind. Thus we are

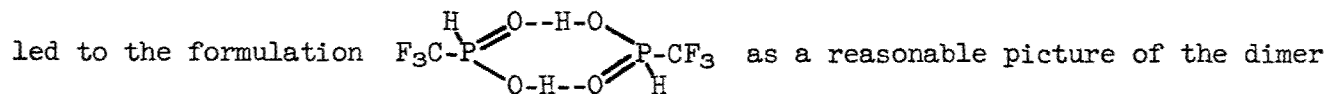

molecule. The energy of each O--H-O bond, namely 8.00 kcal., compares reasonably with values near 7.00 kcal. for similar bonds in acetic acid and in trifluoroacetic acid. On the other hand, if the data of Table XXXII were interpreted in terms of a trimer-monomer equilibrium, the highest estimate of the energy per hydrogen bond would be only 3.2 kcal., which would scarcely compete with van der Waals forces.



## 5. The Infrared Spectrum

The above phosphinic-acid dimer pattern for the phosphonous acid agrees also with the infrared spectrum of the substance. Its low volatility made it difficult to obtain a good record of the spectrum, but it seemed important to learn as much as possible by this means. Lacking a cell designed for work at elevated temperatures, we used an ordinary 10-cm. cell with an infrared heat lamp directed perpendicularly to the line of the beam through the spectrophotometer. Thus much of the sample was in the vapor phase, although there was some condensation on the NaCl windows and the general background absorption was high enough to be troublesome. However, the results (Table XXXIII) do show clearly the P=O--H-O-P bridging and most probably also a P-H stretching vibration. There is no evidence of any simple O-H stretching (frequency near 3600  $\text{cm.}^{-1}$ ), which would be required for a monomeric  $\text{CF}_3\text{P}(\text{OH})_2$  or a doubly H-bridged dimer with the non-bridging H atoms on O instead of P. The monomeric phosphinic-acid form  $\text{CF}_3\text{HPOOH}$  also could not have been present in sufficient optical density to be observed.

TABLE XXXIII

The Infrared Spectrum of " $\text{CF}_3\text{P}(\text{OH})_2$ " at  $75 \pm 5^\circ\text{C}$ .

Frequency ( $\pm 10 \text{ cm.}^{-1}$ )	Intensity and Shape	Assignment
2980	medium broad	O-H stretch in O-H--O
2440	very weak	P-H stretch or 2 x 1225
1285	medium, broad	P=O stretch
1225	medium	C-F stretch
1165	strong, broad	C-F stretch
1069	medium	
1035	medium shoulder	O-H bending
1000	medium	
955		P-O stretch

Here the least certain assignment is the P-H stretch at 2440  $\text{cm.}^{-1}$ , the apparent weakness of which should be judged with due regard for the high background-absorption. The P-H stretch ordinarily should be considerably more intense than the overtone of the 1225  $\text{cm.}^{-1}$  C-F stretch, which probably would not emerge

above the background. But even if there were no discernible P-H stretching vibration, its absence need not be significant, since the polarity of the P-H bond in this situation is not easy to predict. The assignments of the C-F, P=O, O-H bending, and P-O stretching vibrations all are justified by known cases bearing an analogy close enough for the purpose. Taken together, the infrared evidence quite strongly favors the phosphinic-acid dimer formula for the so-called phosphinous acid.

## 6. The Basic Hydrolysis

Although the quantitative synthesis left no real doubt of the empirical formula  $\text{CF}_3\text{P}(\text{OH})_2$ , this was rechecked by a basic hydrolysis in which a 40.4 mg. sample of the nearly pure compound was shaken with 20% aqueous NaOH during 30 minutes at room temperature. The resulting 0.3005 mmole of  $\text{HCF}_3$  was just as calculated. This clean result was obtained only by forming the sample directly in the tube destined for the hydrolysis experiment, so that there were no losses during transfer.

### C. The Glycol Ester $\text{C}_2\text{H}_4\text{O}_2\text{PCF}_3$

#### 1. Synthesis

The initial approach to  $\text{C}_2\text{H}_4\text{O}_2\text{PCF}_3$ , through the action of ethylene-glycol upon  $(\text{CF}_3\text{P})_4$  in a solvent, indicated the promise of interesting polymers through its rearrangement, but the method was too difficult and tedious for repetition on a sufficient scale for useful further work. The work on the synthesis of  $(\text{CH}_3\text{O})_2\text{PCF}_3$  had shown a better way forward, and in the same manner a mixture of 0.941 mmole of  $\text{CF}_3\text{PCl}_2$  with 0.943 mmole of  $\text{C}_2\text{H}_4(\text{OH})_2$  was warmed from  $-196^\circ\text{C}$ . to room temperature in a weighed tube attached through a stop-cock to the high-vacuum system. The formation of HCl indicated 75% progress of the reaction during the first 45 minutes, and 99.9% completion during 16 hours. However, the presence of polymeric alternates to the desired monomer was indicated: there were far less volatile products, seen as a sirupy liquid and a crystalline solid. The relatively volatile monomer was removed by fractional condensation (passing a trap at  $-35^\circ\text{C}$ .) and obtained in 58% yield. Its physical properties are described in a later section.

The less volatile material (trapped out at  $-35^\circ\text{C}$ .) was resolved into two fractions. The first was a mixture of a volatile liquid and a sublimable solid. The basic hydrolysis of a 22.1 mg. portion (20% NaOH, room temperature, 15 minutes) so easily gave the expected  $\text{HCF}_3$  (found, 9.4 mg.; calcd., 9.7 mg.) as to indicate low polymers of the  $\text{CF}_3\text{P}-\text{O}-\text{C}_2\text{H}_4-\text{O}-$  unit rather than the Arbuzov-rearranged type with a P- $\text{CH}_2$  linkage.

The final fraction was non-volatile at room temperature but sublimed under high vacuum under gentle warming. Its basic hydrolysis was delayed by a failure to dissolve immediately, but after two hours with mild warming it gave the calculated amount of  $\text{HCF}_3$ . Hence this material evidently also was built up of glycol-ester units rather than  $\text{CF}_3\text{PO}-\text{C}_2\text{H}_4\text{O}-$  units. It represented 27% of the glycolysis product, while the more volatile polymer amounted to 15%.

The glycolysis process could be represented stoichiometrically as follows:

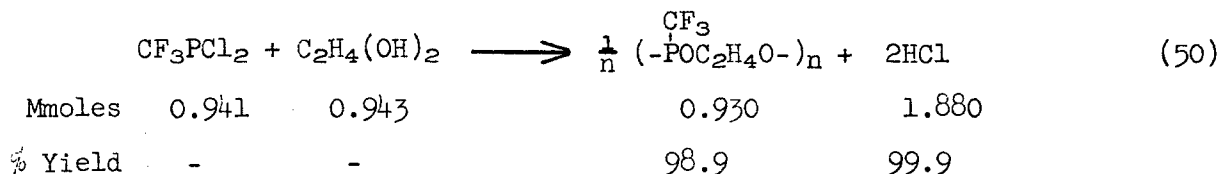

## 2. Physical Properties of the Monomer

The purified sample of  $\text{C}_2\text{H}_4\text{O}_2\text{PCF}_3$  melted sharply in the range  $-33.2$  to  $-33.0^\circ\text{C}$ . and its uniformity was further demonstrated by the consistent set of vapor tensions shown in Table XXXIV. These determined the equation  $\log_{10}P_{\text{mm}} = 8.105 - 1986/T$ , which would slightly underestimate the b.p. as  $107^\circ\text{C}$ . and give a high value for the Trouton constant,  $23.9 \text{ cal./deg. mole}$ .

TABLE XXXIV

Vapor Tensions of the  $\text{C}_2\text{H}_4\text{O}_2\text{PCF}_3$  Monomer

t ( $^\circ\text{C}$ .)	-22.7	-4.7	0.00	10.7	14.4	20.6
$P_{\text{mm}}$ (obsd.)	1.5	5.1	6.9	12.9	15.9	22.1
$P_{\text{mm}}$ (calcd.)	1.5	5.1	6.9	12.9	15.9	22.2

The infrared spectrum of the substance in the gas phase proved to be consistent with the presumed ethylenedioxyphosphine ring, but is not here recorded because the assignment of frequencies has not yet been completed.

## 3. Confirmation of the Monomer Formula

The vapor-phase molecular weight of the most volatile glycol-ester was measured as 160.2; calcd. for the monomeric  $\text{C}_2\text{H}_4\text{O}_2\text{PCF}_3$ , 160.0. The basic hydrolysis of a 17.2 mg. sample (13 hrs. at  $25^\circ\text{C}$ .) gave just the calculated 7.5 mg. of  $\text{HCF}_3$ , again demonstrating the absence of  $\text{P-CH}_2$  bonding, which has been shown to

inhibit the formation of fluoroform. Hence the ring formulation  $\begin{array}{c} \text{H}_2\text{C-O} \\ | \\ \text{H}_2\text{C-O} \end{array} \text{PCF}_3$  seems

entirely justified. As yet there has been no attempt to cause a rearrangement in the Arbuzov manner, to form polymers having the  $(\text{-P-C}_2\text{H}_4\text{-O})_n$  skeleton. Before this is tried, there should be a study of how to rearrange phosphonous esters such as  $(\text{CH}_3\text{O})_2\text{PCF}_3$  in the desired manner.

D. Attempt to Make  
Tris(trifluoromethyl)triphosphoxane

The anhydride of the phosphonous acid  $\text{CF}_3\text{P}(\text{OH})_2$  should be  $(\text{CF}_3\text{PO})_n$  polymers, of which the trimer may be expected to be the stablest. Its synthesis has been attempted twice, using  $\text{CF}_3\text{PI}_2$  with  $\text{Ag}_2\text{CO}_3$ , a combination which was too hard to control either in a static or a flow system. The question whether it will be a stable substance remains interesting.

V. Alkyl Fluorocarbon Mono-Phosphines

Considerable effort has been devoted to the synthesis of  $\text{RCF}_3\text{P}$ - compounds for possible application to the development of new polymers in at least three interesting ways, namely, (1) the use of  $\text{RCF}_3\text{PH}$ ,  $\text{RCF}_3\text{PF}$ , or  $(\text{RCF}_3\text{P})_2$  compounds to make  $\text{RCF}_3\text{PBH}_2$  polymers of yet-unpredictable degree of polymerization; (2) the use of such compounds to make C-C, C=C, and  $\text{C}\equiv\text{C}$  linked diphosphines for use with boron hydrides to make resins. Here the elimination of  $\text{HCF}_3$  on heating would lead to more cross-linking, so that the main mass would become stabler with increase of temperature; (3) the use of  $\text{RP}(\text{CF}_3)_2$  compounds with polyboranes to make resins have the  $\text{ECF}_3$ -evolution feature but no C-C bonding. Resins of the  $\text{R}_3\text{PB}_x\text{H}_y$  class would convert to the  $\text{R}_2\text{PB}_x\text{H}_y$  class, with mixed intermediate stages.

New methods discovered during the past year have led to 85% yields of  $\text{CH}_3\text{CF}_3\text{PI}$ , as demonstrated by its quantitative conversion to  $(\text{CH}_3)_2\text{NPCH}_3\text{CF}_3$ . It is now possible also to make  $\text{CH}_3\text{CF}_3\text{PH}$  in yields approaching 40%. Thus there is good reason to hope that the diphosphine  $(\text{CH}_3\text{CF}_3\text{P})_2$  can be made with high efficiency from these  $\text{CH}_3\text{CF}_3\text{P}$ -compounds, and then be applied effectively along the lines of item (2) above. The discovery of the especially interesting new diphosphine,  $\text{CH}_3\text{HP}-\text{P}(\text{CF}_3)_2$  and the completely-substituted triphosphine  $(\text{CF}_3)_2\text{P}-\text{P}(\text{CF}_3)_2$  (the first members of their classes) will be described in section VI.

A. Synthesis of  $\text{CH}_3\text{CF}_3\text{PI}$  and  $(\text{CH}_3)_2\text{NPCH}_3\text{CF}_3$

The synthesis of  $\text{CH}_3\text{CF}_3\text{PI}$  and the corresponding amino derivative  $(\text{CH}_3)_2\text{NPCH}_3\text{CF}_3$  succeeded by two new methods and did not succeed when two other new approaches were tried. These efforts are described in the following sections.

1. The Iodination of Methyl-  
bis(trifluoromethyl)phosphine

The tertiary phosphine  $\text{CH}_3\text{P}(\text{CF}_3)_2$  is easily obtained either by the exchange reaction of methyl iodide with  $(\text{CF}_3)_3\text{P}^{24}$  or by the action of dimethylzinc on the iodophosphine  $(\text{CF}_3)_2\text{PI}$ . It was considered possible that  $\text{CH}_3\text{P}(\text{CF}_3)_2$  would react with ammonia to form  $\text{HCF}_3$  and  $\text{CH}_3\text{CF}_3\text{PNH}_2$ , but when this was tried during 14 hours at  $25^\circ\text{C}$ ., no reaction occurred at all. It is possible that a higher temperature would produce the desired result, but then an attack upon the second P- $\text{CF}_3$  would become probable. Hence a different manner of employing  $\text{CH}_3\text{P}(\text{CF}_3)_2$  was tried: its reaction with iodine. This method led to the desired  $\text{CH}_3\text{CF}_3\text{PI}$  and the corresponding amino compound in fairly satisfactory yields.

The sample of  $\text{CH}_3\text{P}(\text{CF}_3)_2$  was made by the reaction of  $(\text{CF}_3)_2\text{PI}$  with  $\text{Zn}(\text{CH}_3)_2$  present in slight excess; yield, 81%; mol. wt., 183.8 (calcd., 184.0). Then a 1.58 mmole sample of this tertiary phosphine was heated with 1.69 mmoles of  $\text{I}_2$  for 38 hours in a sealed tube at  $196^\circ\text{C}$ . The formation of  $\text{CH}_3\text{CF}_3\text{PI}$  was indicated by the action of dimethylamine upon the reaction mixture, to form 0.21 mmole of  $(\text{CH}_3)_2\text{NPCH}_3\text{CF}_3$ . Next the excess dimethylamine was separated from the unused  $\text{CH}_3\text{P}(\text{CF}_3)_2$  by treatment with an amount of  $\text{HCl}$  calculated from the average molecular weight of the mixture, permitting recovery of 1.12 mmoles of pure  $\text{CH}_3\text{P}(\text{CF}_3)_2$ . Thus the 0.21 mmole yield of the aminophosphine represented 46% of the consumed 0.46 mmole of  $\text{CH}_3\text{P}(\text{CF}_3)_2$ . The yield of  $\text{CF}_3\text{I}$  was 0.15 mmole. Other products were not recognized.

In sum, then, it appears that the reaction

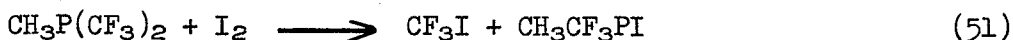

can be used effectively to make the desired methyl-trifluoromethyl-iodo-phosphine, although side or secondary reactions made the method considerably less than quantitative. The possible conversion of this iodophosphine to  $\text{CH}_3\text{CF}_3\text{PH}$  by reaction with  $\text{PH}_3$  seems worth considering, but has not yet been tried.

### 2. The $\text{CF}_3\text{I}-(\text{CH}_3)_2\text{NP}(\text{CH}_3)_2$ Reaction

It was proposed that the reaction

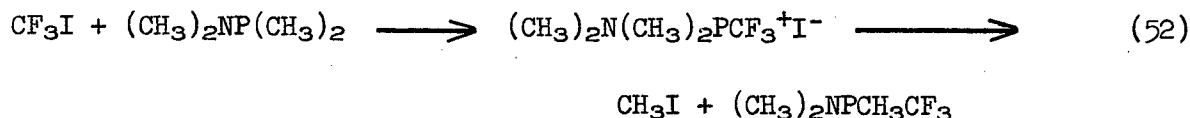

might occur and lead to a good yield of the desired aminophosphine. In the actual experiment, 2.66 mmoles of  $(\text{CH}_3)_2\text{NP}(\text{CH}_3)_2$  and 1.51 mmoles of  $\text{CF}_3\text{I}$ , warming from  $-15^\circ\text{C}$ . to room temperature during an overnight period, gave 0.55 mmole of  $\text{HCF}_3$  and 0.68 mmole of  $\text{CH}_3\text{I}$ . Thus it appeared that the desired replacement of  $\text{CH}_3$  by  $\text{CF}_3$  on P might have occurred, but none of the desired aminophosphine could be found. Aside from the mentioned volatile components, the main product was an orange-colored solid, the character of which was not obvious. The extensive formation of fluoroform evidently was a signal of the destruction of the desired material.

### 3. Depolymerization of $(\text{CF}_3\text{P})_n$ by Methyl Iodide

The cleavage of the  $(\text{CF}_3\text{P})_4$  and  $(\text{CF}_3\text{P})_5$  ring polyphosphines by various agents, such as  $(\text{CH}_3)_3\text{P}$  or  $(\text{CH}_3)_3\text{N}$  to form monomeric  $\text{CF}_3\text{P}$  complexes, or water and alcohols to make P-O and P-H bonds, led to the hope that methyl iodide also would break down these rings, to form  $\text{CH}_3\text{CF}_3\text{PI}$ . This hope was justified by the results of an initial experiment, wherein a tetramer-pentamer mixture amounting

to 21.58 mmoles of  $\text{CF}_3\text{P}$  monomer was heated with 41.50 mmoles of  $\text{CH}_3\text{I}$ , with consumption of 16.29 mmoles of  $\text{CF}_3\text{P}$  and 20.09 mmoles of  $\text{CH}_3\text{I}$ , to give 2.84 mmoles of  $\text{CH}_3\text{CF}_3\text{PI}$ , which now was actually isolated for the first time; yield, 17.4%. It was purified by high-vacuum fractional condensation (passing  $-45^\circ\text{C}$ . but trapping at  $-55^\circ\text{C}$ ., and showed 11 mm. vapor tension at  $25^\circ\text{C}$ . It proved to be very reactive toward mercury, as expected. The formula was verified by conversion of 0.929 mmole of it to 0.925 mmole of  $(\text{CH}_3)_2\text{NPCH}_3\text{CF}_3$  (previously characterized: see Ref. 5, p. 98), with consumption of 1.860 mmoles of  $(\text{CH}_3)_2\text{NH}$  and formation of 0.930 mmole of  $(\text{CH}_3)_2\text{NH}_2\text{I}$ . The aminophosphine was identified by its mol. wt. (159.4; calcd., 159.1), its 12.1 mm. vapor tension at  $0^\circ\text{C}$ ., and its infrared spectrum.

This initial experiment was promising, but an uncertainty in the temperature of the process (due to a faulty oven-control) led to the need for more extensive study, leading to better yields. It seemed important to eliminate the side-formation of  $\text{CF}_3\text{PI}_2$  (5.54 mmoles in the above initial experiment) and to seek possible catalysts so that the temperature need not be so high. Accordingly nine more experiments were done, with the conditions and results shown in Table XXXV. All of these experiments were done in 10 ml. sealed tubes, so that the pressure varied with the amount of material. It is evident that the best yields (based upon  $\text{CF}_3\text{P}$ -material consumed) appear long before the major part of the  $\text{CF}_3\text{P}$ -material is used up, suggesting that prolonged heating causes destruction of the desired product. The proposed catalysts obviously were not at all effective. Possibly further experiments with more careful control of the numerous variables would lead to better results, but the results of Expt. 8 would be regarded as highly useful, even though implying the inconvenience of recovering the unused reactants for recycling.

The listed yields of  $\text{CH}_3\text{CF}_3\text{PI}$  were determined by conversion to  $(\text{CH}_3)_2\text{NPCH}_3\text{CF}_3$ , which again was identified by its mol. wt., and infrared spectrum. Expt. 3 was preceded by a demonstration that  $(\text{CH}_3)_2\text{O}$  has no tendency to depolymerize  $(\text{CF}_3\text{P})_n$ , either at room temperature or at  $-78^\circ\text{C}$ .

#### 4. Synthesis and Use of the Monomer Complex $(\text{CH}_3)_3\text{NPFCF}_3$

The initial use of the monomer-complex  $(\text{CH}_3)_3\text{PPCF}_3$  for the series of reactions

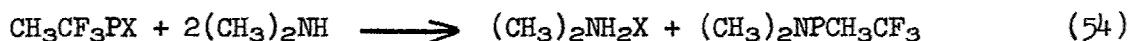
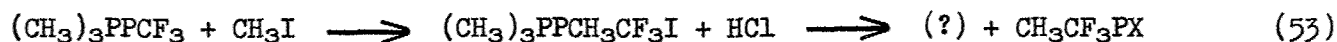

(Ref. 5, pp. 97-98) led to attempts to carry through the same kind of series for the corresponding trimethylamine complex  $(\text{CH}_3)_3\text{NPFCF}_3$ . The formation of this complex was done in a more closely quantitative manner than before (Ref. 4, p. 97), but the two attempts to convert its  $\text{CH}_3\text{I}$  adduct to  $\text{CH}_3\text{CF}_3\text{PI}$  were not at all successful. Further attempts along that line may be made.

TABLE XXXV

The CH<sub>3</sub>I-(CF<sub>3</sub>P)<sub>n</sub> Reaction

Expt. No.	Reactants (mmoles)		Possible Catalyst	Temp. (°C.)	Time (hrs.)	% Yield of CH <sub>3</sub> CF <sub>3</sub> PI based on used CF <sub>3</sub> P	Remarks
	CF <sub>3</sub> P unit	CH <sub>3</sub> I					
1	7.28	18.45	trace I <sub>2</sub>	104	12	nil	100% recovery
2	7.28	18.45	trace I <sub>2</sub>	130	15	46	-
3	1.03	1.06	1.05 Me <sub>2</sub> O	110	12	nil	100% recovery
4	0.98	1.98	0.05 Me <sub>3</sub> N	110	30	nil	CF <sub>3</sub> P 91% gone
5	11.81	24.90	trace Hg	110	24	nil	CF <sub>3</sub> P 13% gone
6	13.17	26.34	none	110	36	52.5	16% reaction
7	2.83	2.62	none	150	2	31	28% reaction
8	3.97	7.05	none	148	5	85	34% reaction
9	10.14	20.30	none	150	16	13	100% reaction; formed tars and 1.3% CF <sub>3</sub> PI <sub>2</sub>

In the first experiment a  $\text{CF}_3\text{P}$ -tetramer-pentamer mixture amounting to 3.92 mmoles of  $\text{CF}_3\text{P}$  units was treated with 11.12 mmoles of  $(\text{CH}_3)_3\text{N}$  in a sealed tube during 12 hours at  $25^\circ\text{C}$ . The excess amine (6.98 mmoles) was recovered by high-vacuum distillation at  $-78^\circ\text{C}$ ., leaving 4.14 mmoles apparently combined in the solid product; amine: $\text{CF}_3\text{P}$  ratio, 1.056. Similarly, 1.625 mmoles of  $\text{CF}_3\text{P}$  units combined with 1.626 mmoles of amine (of the original 11.018 mmoles); ratio, 1.002. In both experiments the room-temperature solution appeared as two phases, the denser of which had a deeper orange color. Evidently the lower layer represented liquefaction of the solid complex by absorption of excess amine, while the upper layer was a saturated solution of the complex in the amine.

The 3.92 mmole sample of  $(\text{CH}_3)_3\text{NPCF}_3$  was treated at room temperature with 15.35 mmoles of  $\text{CH}_3\text{I}$ , of which 3.83 mmoles combined to form the solid adduct. This product was dissolved in 10.45 mmoles of liquid sulfur dioxide, forming a deep-red-brown solution. This was kept for 12 hours at  $0^\circ\text{C}$ ., and then the  $\text{SO}_2$  was wholly recovered by distillation (10.44 mmoles), showing that no reaction had occurred; the known complex  $(\text{CH}_3)_3\text{NSO}_2$ <sup>25</sup> had not formed. The reestablished  $\text{SO}_2$  solution was treated with 6.62 mmoles of  $\text{HI}$  in an attempt to form the compound  $\text{CH}_3\text{CF}_3\text{PI}$  in a clean manner; however, the mixture exploded on warming from  $-78^\circ$  to  $-45^\circ\text{C}$ ., and the experiment has not been tried again.

The quantitatively clean 1.625 mmole sample of  $(\text{CH}_3)_3\text{NPCF}_3$  absorbed 1.626 mmoles of  $\text{CH}_3\text{I}$ , thus cleanly forming the adduct written as  $(\text{CH}_3)_3\text{NPCH}_3\text{CF}_3\text{I}$ . The solid sample was treated with 3.69 mmoles of  $\text{HI}$ , of which 2.80 mmoles combined (1.73  $\text{HI}$  per formula unit, instead of 2.00 as hoped). However, there was no yield of  $\text{CH}_3\text{CF}_3\text{PI}$ ; only a brown non-volatile product was formed.

## B. Synthesis of $\text{CH}_3\text{CF}_3\text{PH}$

The important phosphine  $\text{CH}_3\text{CF}_3\text{PH}$  could be obtained only in a very slight yield by the thermal decomposition of the borine adduct  $(\text{CH}_3)_2\text{NPCH}_3\text{CF}_3\cdot\text{BH}_3$ -- in contrast to the good yields of secondary phosphines from the borine adducts of  $(\text{CH}_3)_2\text{NP}(\text{CH}_3)_2$ <sup>26</sup> and  $(\text{CH}_3)_2\text{NPC}_4\text{H}_8$ .<sup>27</sup> However, the desired  $\text{CH}_3\text{CF}_3\text{PH}$  has been obtained in quite promising yields by the addition of  $\text{CF}_3\text{I}$  to  $\text{CH}_3\text{PH}_2$ . As a preliminary to this process, the addition of  $\text{CF}_3\text{I}$  to  $(\text{CH}_3)_2\text{PH}$  was tried and led to a good yield of the tertiary phosphine  $(\text{CH}_3)_2\text{PCF}_3$ .

### 1. Decomposition of the Aminophosphine Borine

The adduct formed from 0.423 mmole of  $\text{B}_2\text{H}_6$  and 0.855 mmole of  $(\text{CH}_3)_2\text{NPCH}_3\text{CF}_3$  was heated for 96 hours at  $125^\circ\text{C}$ . giving 0.366 mmole of presumed  $\text{H}_2$  and 0.03 mmole of a gas roughly conforming to the properties expected for  $\text{CH}_3\text{CF}_3\text{PH}$  (passed a high-vacuum trap at  $-78^\circ\text{C}$ .; mol. wt. a little over 100). The further products were a white solid which would not volatilize under high vacuum at  $60^\circ\text{C}$ ., and a volatile mixture of liquid and solid presumed to contain  $\left[ (\text{CH}_3)_2\text{N} \right]_2\text{BH}$  and  $(\text{CH}_3)_2\text{NBH}_2$ . This mixture was heated with  $\text{B}_2\text{H}_6$  to yield 0.32 mmole of  $(\text{CH}_3)_2\text{NB}_2\text{H}_5$  and 0.55 mmole of  $(\text{CH}_3)_2\text{NBH}_2$ , accounting for all of the  $(\text{CH}_3)_2\text{N}$  groups. The non-volatile solid must have contained some B-H material, and the absence of anything volatile enough to be a trimer of the  $\text{CH}_3\text{CF}_3\text{PBH}_2$  unit would again encourage the idea that this unit may incline toward a higher degree of polymerization.



## 2. The Addition of CF<sub>3</sub>I to (CH<sub>3</sub>)<sub>2</sub>PH

A mixture of 2.17 mmoles of (CH<sub>3</sub>)<sub>2</sub>PH and 1.11 mmoles of CF<sub>3</sub>I showed no reaction at -78°C. but reacted quickly at 0°C., forming a white solid. After 24 hours the volatile components were sealed in a small glass tube and left for 48 hours at room temperature. The recovery of CF<sub>3</sub>I was 0.04 mmole (4%) and the main volatile product was 0.96 mmole of (CH<sub>3</sub>)<sub>2</sub>PCF<sub>3</sub> (mol. wt., 130.4 vs. calcd., 130.0; vapor tension 115.2 mm. at 0°C. vs. calcd., 117 mm.), representing a 90% yield in terms of the equation:



## 3. The Addition of CF<sub>3</sub>I to CH<sub>3</sub>PH<sub>2</sub>

A mixture of 2.71 mmoles of CH<sub>3</sub>PH<sub>2</sub> and 1.40 mmoles of CF<sub>3</sub>I reacted on warming to room temperature, immediately forming a white solid. However, the process seemed quite limited in extent, and could be pushed forward only by transferring the volatile components each day to a fresh reaction tube. After six such daily restartings, the volatile mixture consisted of 0.65 mmole of HCF<sub>3</sub>, 1.08 mmoles of a CH<sub>3</sub>PH<sub>2</sub>-CF<sub>3</sub>I mixture, and 0.35 mmole of the previously unknown compound CH<sub>3</sub>CF<sub>3</sub>PH. This new phosphine was identified by its mol. wt. (115.7 vs. calcd., 116) and an infrared spectrum showing the characteristic peaks for one P-H, one P-CH<sub>3</sub>, and one P-CF<sub>3</sub> linkage. Its vapor tension at -78°C. was observed as 3 mm. The yield represented 35% of the consumed CF<sub>3</sub>I, the rest of which accounted for the fluoroform.

Although the final yield of the desired CH<sub>3</sub>CF<sub>3</sub>PH in the above experiment seemed quite attractive, the requirement of numerous repetitions to achieve adequate amounts of reaction was a serious disadvantage. The hope of improvement through removing the by-product HI more effectively than as CH<sub>3</sub>PH<sub>3</sub>I, as by the use of mercury or a tertiary amine, was not fulfilled, for the process did not go well in the presence of mercury, and either (CH<sub>3</sub>)<sub>3</sub>N or (C<sub>2</sub>H<sub>5</sub>)<sub>3</sub>N led to larger yields of HCF<sub>3</sub> and slightly volatile solids; the yields of CH<sub>3</sub>CF<sub>3</sub>PH were minimal. For example, when triethylamine was used, the following equation could be written, with the mmole quantities shown below.

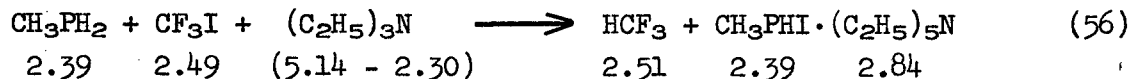

Thus the only volatile product was HCF<sub>3</sub>, the rest of the material appearing as a slightly yellow solid.

For better results it was argued that the reaction might reach a more favorable equilibrium at an adequate speed at low enough temperatures to avoid HCF<sub>3</sub> formation, by proceeding in the liquid phase. Accordingly it was tried at -78°C. with good results when enough time was allowed. For this purpose a sample of CH<sub>3</sub>PH<sub>2</sub> (generously supplied to us from the Whittier Research Laboratory of the

Prime Contractor) was highly purified by a reflux column at  $-78^{\circ}\text{C}$ ., then showing a 336.0 mm. vapor tension at  $-35.9^{\circ}\text{C}$ . Then a 2.33 mmole portion of this phosphine was sealed off with 1.22 mmoles of  $\text{CF}_3\text{I}$  and the mixture was kept at  $-78^{\circ}\text{C}$ . for 48 hours. Since the reaction occurred only slightly during that time, the period was extended for a further 14 days at  $-78^{\circ}\text{C}$ . The resulting 1.044 mmole of crude gas was treated with  $\text{HCl}$  to remove 0.47 mmole of  $\text{CH}_3\text{PH}_2$  as the  $\text{HCl}$  salt (consumed, 1.86 mmoles of  $\text{CH}_3\text{PH}_2$ ) and permitting the recovery of 0.242 mmole of  $\text{CF}_3\text{I}$  (used, 0.98 mmole). Then it was possible to isolate 0.36 mmole of the presumed  $\text{CH}_3\text{CF}_3\text{PH}$  (mol. wt., 118; calcd., 116.0). There was no  $\text{HCF}_3$  at all. Thus in terms of the equation

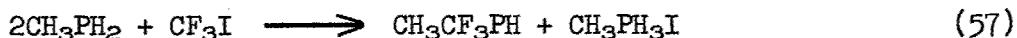

the yield of the desired phosphine was 39% of that expected in terms of the consumed  $\text{CH}_3\text{PH}_2$  or 37% of the consumed  $\text{CF}_3\text{I}$ . The slow rate of the method was not regarded as a disadvantage from the laboratory viewpoint, since the process required very little attention.

### C. The Addition of Phosphines to Ethylene

The formation of new phosphines by the addition of known phosphines to ethylene was tried originally in order to develop a better understanding of the side reactions occurring when one adds biphosphines to ethylene, tetrafluoroethylene, and acetylene (Ref. 4, pp. 90-93 and Ref. 5, pp. 102-120). The same approach also has been found useful for making new tertiary monophosphines of the type considered in point 3 of the introduction to the present section, as well as a secondary phosphine,  $\text{C}_2\text{H}_5\text{CF}_3\text{PH}$ , from which mixed alkyl-trifluoromethyl-phosphinoborine polymers might be made.

#### 1. Tris(trifluoromethyl)phosphine

The formation of  $\text{CF}_3\text{C}_2\text{H}_2\text{-P}$  compounds from  $(\text{CF}_3)_3\text{P}$  and acetylene (Ref. 5, p. 109) has its parallel in the addition of  $(\text{CF}_3)_3\text{P}$  to ethylene to make  $(\text{CF}_3)_2\text{PC}_2\text{H}_4\text{CF}_3$  and  $\text{CF}_3\text{P}(\text{C}_2\text{H}_4\text{CF}_3)_2$ . These same substances were first indicated as minor by-products of the addition of  $\text{P}_2(\text{CF}_3)_4$  to ethylene, and their fuller study now confirms the assumption that their formation had implied a transfer of  $\text{CF}_3$  groups from one phosphorus atom to another. The conditions and results of three experiments on the addition of  $(\text{CF}_3)_3\text{P}$  to ethylene are shown in Table XXXVI.

Here Expts. 1 and 2 represent early explorations dating back to November, 1959, when knowledge of the products was too meagre for inclusion in Reference 5. The recent Expt. 3 was the main basis for a fuller characterization of the new trifluoropropyl-phosphines.

The melting points of these compounds could not be observed because they formed glasses at low temperatures. The ultra-violet spectrum of  $(\text{CF}_3)_2\text{PC}_2\text{H}_4\text{CF}_3$  showed no structure, meaning that there was no P-P bonding. Its vapor tensions, shown in Table XXXVII, determined the equation  $\log_{10}P_{\text{mm}} = 4.2158 + 1.75 \log T - 0.00140 T - 1895/T$ , giving the b.p. as  $83.8^{\circ}\text{C}$ . and the Trouton constant as 22.3 cal./deg. mole.

TABLE XXXVI

Formation of Two Trifluoropropyl-Phosphines

Expt. No.	Reactants (mmoles)					Products (mmoles)*	
	(CF <sub>3</sub> ) <sub>3</sub> P	C <sub>2</sub> H <sub>4</sub>	Catalyst	Temp. (°C.)	Time (hrs.)	(CF <sub>3</sub> ) <sub>2</sub> PT <sub>p</sub>	CF <sub>3</sub> PT <sub>p2</sub>
1	2.00	2.00	none	104	69	(nil reaction)	
	[0.205 Consumed]	[0.204 Consumed]	none	160	168	0.174	(not obsd.)
2	1.821	1.968	tr. I <sub>2</sub>	112	120	0.817	0.255
	[1.086 Consumed]	[1.502 Consumed]					
3	3.965	4.040	tr. I <sub>2</sub>	120	168	2.025	0.392
	[2.690 Consumed]	[3.606 Consumed]					

\* The symbol T<sub>p</sub> is used as an abbreviation for -C<sub>2</sub>H<sub>4</sub>CF<sub>3</sub>.

TABLE XXXVII

Vapor Tensions of  $(CF_3)_2PC_2H_4CF_3$ 

t (°C.)	0.00	6.4	17.9	26.1	31.6	48.8	60.6
P <sub>mm</sub> (obsd.)	14.5	21.2	40.8	63.0	82.9	185.3	307.2
P <sub>mm</sub> (calcd.)	14.5	21.3	40.8	62.9	82.9	185.6	307.3

For  $CF_3P(C_2H_4CF_3)_2$  the vapor tensions shown in Table XXXVIII determined the equation  $\log_{10} P_{mm} = 4.0142 + 1.75 \log_{10} T - 0.001010 T - 2216/T$ , giving the b.p. as 144.7°C. and the Trouton constant as 22.2 cal./deg. mole.

TABLE XXXVIII

Vapor Tensions of  $CF_3P(C_2H_4CF_3)_2$ 

t (°C.)	0.00	24.3	33.9	39.8	48.0	54.7	64.0	72.5	81.6
P <sub>mm</sub> (obsd.)	0.78	3.98	6.98	9.60	15.03	21.18	33.5	49.8	74.6
P <sub>mm</sub> (calcd.)	0.78	3.92	6.93	9.67	15.05	21.25	33.5	49.8	74.6

The molecular weight of the compound purporting to be  $(CF_3)_2PC_2H_4CF_3$  was determined as 265.8 (calcd., 266.1); and for the presumed  $CF_3P(C_2H_4CF_3)_2$  the result was 294.4 (calcd., 294.1).

2. Bis(trifluoromethyl)phosphine

The addition of  $(CF_3)_2PH$  to  $C_2H_4$  required ultraviolet radiation, to which the mixture was exposed for 18 hours at room temperature. The source was a water-cooled quartz lamp operating at 15,000 volts (220 VA). However, the shorter wave lengths were mostly eliminated, for the mixture was in a sealed Pyrex tube. The reaction consumed 1.436 mmoles of  $(CF_3)_2PH$  (from a 2.379 mmole sample) and 1.429 mmoles of  $C_2H_4$  (from 1.555). The yield of  $(CF_3)_2PC_2H_5$  was 1.423 mmoles, representing more than 99% of each reactant in the equation

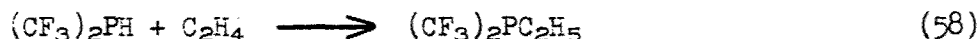

Thus only the molecular-weight results (198.7 and 199.8) were needed to prove the formula (calcd. value, 198.1). However, the material was analyzed for  $\text{CF}_3$  groups by the iodine method (49 hours at  $300^\circ\text{C}.$ ), giving 99.6% of the expected result.

Supercooling prevented the observation of the m.p. of this new tertiary phosphine, but its vapor tensions, shown in Table XXXIX, were satisfactory, determining the equation  $\log_{10}P_{\text{mm}} = 5.8688 + 1.75 \log_{10} T - 0.005269T - 1900/T$ . This gives the b.p. as  $64.0^\circ\text{C}.$  and the Trouton constant as 21.1 cal./deg. mole.

TABLE XXXIX

Vapor Tensions of  $(\text{CF}_3)_2\text{PC}_2\text{H}_5$

t ( $^\circ\text{C}.$ )	-26.0	-21.4	-16.0	-10.6	0.00	5.1	14.6	22.8
$P_{\text{mm}}$ (obsd.)	11.7	15.8	22.1	30.4	54.8	71.4	113.2	163.0
$P_{\text{mm}}$ (calcd.)	11.6	15.8	22.1	30.4	54.8	71.3	113.2	164.1

3. Trifluoromethylphosphine

The phosphine  $\text{CF}_3\text{PH}_2$  also added to  $\text{C}_2\text{H}_4$  under ultraviolet irradiation, but with more difficulty (possibly for lack of a condensed phase such as was present in the preceding case) and with some conversion of the ethylene into polymeric by-products. The 1.823 mmole sample of  $\text{CF}_3\text{PH}_2$  was made from  $\text{CF}_3\text{PI}_2$  by reaction with  $\text{PH}_3$ , and mixed with 1.826 mmoles of  $\text{C}_2\text{H}_4$  in a sealed Pyrex tube. After 176 hours of irradiation by the 220 VA, 15,000-volt lamp, the destruction of  $\text{CF}_3\text{PH}_2$  amounted to 0.741 mmole; of  $\text{C}_2\text{H}_4$ , 1.047 mmoles. The yield of the new phosphine  $\text{C}_2\text{H}_5\text{PHCF}_3$  (mol. wt., 129.9; calcd., 130.1) was 0.625 mmole, representing 84% of the consumed  $\text{CF}_3\text{PH}_2$ . The missing 16% of the consumed  $\text{CF}_3\text{PH}_2$  evidently went to make a 0.12 mmole by-product (11 mm. at  $0^\circ\text{C}.$ ) having a roughly measured molecular weight of 148 and purporting to be mostly the new  $(\text{C}_2\text{H}_5)_2\text{PCF}_3$  (calcd. mol. wt. 158). This leaves 0.180 mmole of consumed ethylene, the polymerization of which would account for the observed solid film on the tube-wall.

The vapor tensions of  $\text{C}_2\text{H}_5\text{PHCF}_3$  (Table XL) determined the equation  $\log_{10}P_{\text{mm}} = 7.6040 - 1516/T$ , giving the b.p. as  $47.8^\circ\text{C}.$  and the Trouton constant as 21.6 cal./deg. mole. The substance formed a glass at low temperatures, and the m.p. could not be observed.

This new secondary phosphine was analyzed for  $\text{CF}_3$  groups by the iodine method; the 32.1 mg. (0.247 mmole) sample was heated in a sealed tube with 500 mg. of  $\text{I}_2$  for 81 hours at  $300^\circ\text{C}.$  The main volatile product was 0.417 mmole of gas having average mol. wt. 53.5, corresponding to 59 mole percent  $\text{HCF}_3$  with 41 mole percent  $\text{C}_2\text{H}_6$ . This interpretation would indicate 0.246 mmole of  $\text{HCF}_3$  (calcd.,

0.247 mmole). The basic hydrolysis of a 0.140 mmole portion of the ethyl-trifluoromethyl-phosphine (10% KOH, 36 hours at 100°C.) gave 0.129 mmole of HCF<sub>3</sub>, or 92% of the calcd. amount. Thus the formula C<sub>2</sub>H<sub>5</sub>PHCF<sub>3</sub> appears to be correct. Synthesis of the corresponding phosphinoborine polymer may be both possible and interesting.

TABLE XL

Vapor Tensions of C<sub>2</sub>H<sub>5</sub>PHCF<sub>3</sub>

t (°C.)	-36.4	-31.4	-25.5	-17.3	-12.1	0.00
p <sub>mm</sub> (obsd.)	15.9	21.6	30.5	47.9	62.6	113.5
p <sub>mm</sub> (calcd.)	15.9	21.6	30.5	47.9	62.8	113.5

## VI. Chemistry of New Polyphosphines

A natural extension of our use of methylphosphine was its reaction with (CF<sub>3</sub>)<sub>2</sub>P-X compounds to make two very interesting new compounds: the first monoproctic biphosphine, CH<sub>3</sub>HPP(CF<sub>3</sub>)<sub>2</sub>, and the first completely substituted triphosphine, CH<sub>3</sub>P/P(CF<sub>3</sub>)<sub>2</sub>/<sub>2</sub>. The new biphosphine is stable enough for purification and characterization, but can be decomposed fairly easily to make (CF<sub>3</sub>)<sub>2</sub>PH and material purporting to be a polymeric CH<sub>3</sub>P. Thus it would seem that this chemistry provides a new approach to materials in the class of (CH<sub>3</sub>P)<sub>4</sub> (which was indicated in the work of Dr. Ross I. Wagner in our laboratories in the year 1953), although the different physical character of the present material would suggest a different degree of polymerization. Another recent aspect of our polyphosphine studies is the reaction of (CF<sub>3</sub>P)<sub>5</sub> with an equimolar proportion of methanol, with monitoring of the reaction by the determination of the average molecular weight in solution in an inert solvent. However, this aspect is not yet fully understood, and must be reserved for a later report. The feasibility of work with the CF<sub>3</sub>P pentamer has been considerably improved by a discovery privately reported by Dr. Walter Mahler (at the Experimental Station of E.I. duPont de Nemours & Co.), of a new way to obtain high yields from the synthesis of this pentamer.

### A. 1-Methyl-2-bis(trifluoromethyl)biphosphine

#### 1. Synthesis

The initial approach to the synthesis of the biphosphine CH<sub>3</sub>HPP(CF<sub>3</sub>)<sub>2</sub> was through reactions of the type



in ether solution with an equimolar proportion of trimethylamine to remove the hydrogen halide. However, the phosphinolysis process did not stop at the first stage, so that the yields of the triphosphine  $\text{CH}_3\text{P}(\overline{\text{P}}(\text{CF}_3)_2)_2$  (vide infra) considerably exceeded those of the desired biphosphine. For example, 2.93 mmoles each of  $(\text{CF}_3)_2\text{PCl}$ ,  $\text{CH}_3\text{PH}_2$ , and  $(\text{CH}_3)_3\text{N}$ , reacting during 15 hours in 10 ml. of  $(\text{C}_2\text{H}_5)_2\text{O}$  at  $-78^\circ\text{C}$ ., gave only 0.46 mmole (15.8% yield) of  $\text{CH}_3\text{HPP}(\text{CF}_3)_2$  and considerably more of the slightly volatile liquid which later proved to be the triphosphine. When 4.31 mmoles of  $(\text{CF}_3)_2\text{PI}$  was left with 4.42 mmoles of  $\text{CH}_3\text{PH}_2$  and 4.51 mmoles of  $(\text{CH}_3)_3\text{N}$  in 6 ml. of ether at  $-78^\circ\text{C}$ . for 16 hours, the yield of  $\text{CH}_3\text{HPP}(\text{CF}_3)_2$  was only 0.40 mmole (9.0% of the  $\text{CH}_3\text{PH}_2$ ), while the yield of triphosphine was nearly 50%.

In the hope of avoiding the secondary reaction, an attempt was made toward phosphinolysis of  $(\text{CF}_3)_3\text{P}$  by  $\text{CH}_3\text{PH}_2$ , but these compounds failed to react on standing together at room temperature and higher temperatures were not tried because the desired biphosphine was known to be unstable. A reaction between the hydrochloride of  $\text{CH}_3\text{PH}_2$  and  $(\text{CH}_3)_2\text{NP}(\text{CF}_3)_2$ , in ether during 14 hours at  $-78^\circ\text{C}$ . progressed well enough but the reaction products were all non-volatile.

The final method, leading to a quantitative synthesis of  $\text{CH}_3\text{HPP}(\text{CF}_3)_2$ , went according to the equation:

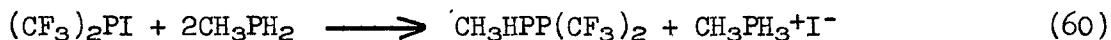

Three experiments based upon this process, using sealed 15 ml tubes at  $-78^\circ\text{C}$ . with reaction occurring completely during an overnight period, are summarized by Table XLI.

TABLE XLI

Synthesis of  $\text{CH}_3\text{HPP}(\text{CF}_3)_2$

Expt. No.	Reactants (mmoles)		$\text{CH}_3\text{HPP}(\text{CF}_3)_2$		Remarks
	$(\text{CF}_3)_2\text{PI}$	$\text{CH}_3\text{PH}_2$	mmoles	% Yield	
1	2.32	5.30	1.80	77.6	Yield per $(\text{CF}_3)_2\text{PI}$
2	7.49	15.84	7.12	95.1	Recovered 1.44 mmoles of $\text{CH}_3\text{PH}_2$
3	1.059	2.196	1.058	99.9	Proof of formula

For best results, it was important to make sure that the reactants were well mixed during the early stages of reaction. The desired biphosphine was isolated by high-vacuum fractional condensation, passing a trap at  $-45^\circ\text{C}$ . and condensing at  $-63^\circ\text{C}$ .

## 2. Proof of the Formula

The composition of the new biphosphine was determined by the quantitative stoichiometry of Expt. 3. The recovery of 0.076 mmole of  $\text{CH}_3\text{PH}_2$  meant that the reaction ratio had been 2.002  $\text{CH}_3\text{PH}_2$  per  $(\text{CF}_3)_2\text{PI}$ . The slightly volatile yellow residue reacted with 1.061 mmole (out of 2.146) of  $(\text{C}_2\text{H}_5)_3\text{N}$  to give 1.046 mmoles of  $\text{CH}_3\text{PH}_2$ , or 98.8% of the amount calculated from the original equation for the phosphinolysis. The recovered  $\text{CH}_3\text{PH}_2$  was identified by its vapor tension at  $-78^\circ\text{C}$ . (28.4 mm. vs. calcd. 28.8) and mol. wt. (48.2 vs. calcd. 48.0). Thus equation (60) was strictly quantitative, and no analysis of the resulting biphosphine was required. Its molecular weight was determined in the vapor phase, as 215.2 (calcd., 216.0).

## 3. Volatility

The vapor tension data shown in Table XLII are consistent enough to demonstrate a high degree of purity, even though glass-formation prevented observation of a melting point. These vapor tension measurements were made difficult by the instability of the biphosphine in a glass-mercury system; hence for good results it was necessary to use a freshly-cleaned containing tube and a freshly purified sample for each measurement. The results conformed well to the equation  $\log_{10}P_{\text{mm}} = 6.1043 + 1.75 \log_{10} T - 0.00500T - 2146/T$ , which gives the normal b.p. as  $91.6^\circ\text{C}$ . and the Trouton constant as 21.8 cal./deg. mole.

TABLE XLII

Vapor Tensions of  $\text{CH}_3\text{HPP}(\text{CF}_3)_2$

t ( $^\circ\text{C}$ .)	-45.6	-37.3	-30.7	-23.3	0.00	12.0	18.2
$P_{\text{mm}}$ (obsd.)	0.53	0.94	1.64	2.92	13.98	28.3	39.2
$P_{\text{mm}}$ (calcd.)	0.46	0.99	1.64	2.90	14.00	28.1	39.3

## 4. Spectroscopy of the Biphosphine

The ultraviolet spectrum of  $\text{CH}_3\text{HPP}(\text{CF}_3)_2$  showed a well defined peak at  $2170 \text{ \AA}$ . (molar extinction coefficient 7804) and a minimum at  $2025 \text{ \AA}$ . ( $\epsilon = 6280$ ). Thus the maximum was close to that for  $\text{P}_2(\text{CF}_3)_4$  ( $2160 \text{ \AA}$ .), but considerably displaced from the one for  $(\text{CH}_3)_2\text{PP}(\text{CF}_3)_2$  ( $2330 \text{ \AA}$ .) (Ref. 4, p. 85), which might have been expected to be more similar in electronic behavior.

The infrared spectrum (recorded by the Infracord instrument) showed three strong peaks characteristic of a  $(\text{CF}_3)_2\text{P}$  groups, namely C-F stretchings at 1195, 1163, and  $1134 \text{ cm}^{-1}$ . Another strong peak at 1120 could represent P-H bending.



The P-H stretching near 2350 was recognizable although fairly weak. The C-H stretching near 3000 was discernible but very weak; the C-H bending modes were somewhat stronger, with  $\delta$  -e at 1440 and  $\delta$  -a as one of a pair of peaks at 1304 and 1294  $\text{cm}^{-1}$ . The  $\text{CH}_3$  group rocking modes would be represented by two fairly strong peaks at 1004 and 900  $\text{cm}^{-1}$ , although they are somewhat farther apart than is usual for these modes. Of two peaks at 775 (medium weak) and 748 (medium strong) it is difficult to say which represents the P- $\text{CH}_3$  stretching and which the C-F deformation. On the whole, however, the spectrum is consistent with the formula  $\text{CH}_3\text{HPP}(\text{CF}_3)_2$ , with the expected peaks recognizable and nothing extraneous which is difficult to rationalize.

#### 5. Decomposition of the Biphosphine

A 0.384 mmole sample of  $\text{CH}_3\text{HPP}(\text{CF}_3)_2$  was heated in a sealed tube for 6 hours at 160°C. The resulting volatile product proved to be pure  $(\text{CF}_3)_2\text{PH}$ , as shown by its molecular weight, vapor tension at -78°C., and infrared spectrum. The yield of 0.380 mmole, or 99.0% of the amount calculated from the equation:

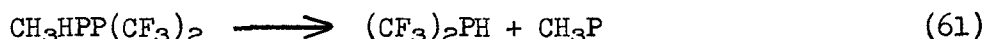

Thus the non-volatile by-product had the composition of a polymer of the  $\text{CH}_3\text{P}$  unit.

Another sample of the biphosphine (1.799 mmoles) in a sealed Pyrex tube was exposed to bright sunlight during two sunny days, at room temperature. The recovery of  $\text{CH}_3\text{HPP}(\text{CF}_3)_2$  was 0.146 mmole, meaning that 1.653 mmole had been destroyed. The yield of  $(\text{CF}_3)_2\text{PH}$  was 1.630 mmoles (98.6%), the only other product being a viscous non-volatile liquid. Evidently the same equation (61) applied, as for the thermal decomposition.

The biphosphine also seemed to be catalytically affected by mercury and by tertiary amines, although the decomposition products in these cases have not been fully investigated.

The supposed  $(\text{CH}_3\text{P})_x$  polymer, appearing as a colorless and highly viscous liquid, was regarded as a likely candidate for conversion to  $\text{CH}_3\text{CF}_3\text{PI}$  by additive depolymerization, using  $\text{CF}_3\text{I}$ . However, there was no such reaction when this polymer was heated with  $\text{CF}_3\text{I}$ , in one experiment for 16 hours at 80°C. and in another for 12 hours at 100°C. The  $\text{CF}_3\text{I}$  was wholly recovered in each case, but the polymer had turned to an orange color and become even more viscous than before.

#### 6. The Reaction with Iodotrifluoromethane

Although it was not found possible to obtain  $\text{CH}_3\text{CF}_3\text{PI}$  by adding  $\text{CF}_3\text{I}$  to  $(\text{CH}_3\text{P})_x$ , it did prove possible for  $\text{CF}_3\text{I}$  to intercept the  $\text{CH}_3\text{P}$  unit from the decomposing  $\text{CH}_3\text{HPP}(\text{CF}_3)_2$ , giving in the first experiment a 54% yield of  $\text{CH}_3\text{CF}_3\text{PI}$ . It is possible that the first step of the process was a  $\text{CF}_3\text{I}$ -addition to  $\text{CH}_3\text{HPP}(\text{CF}_3)_2$  to form HI and the yet-unknown biphosphine  $\text{CH}_3\text{CF}_3\text{PP}(\text{CF}_3)_2$ , which would be cleaved by HI to make the observed products,  $(\text{CF}_3)_2\text{PH}$  and  $\text{CH}_3\text{CF}_3\text{PI}$ . The first step would be like the addition of  $\text{CF}_3\text{I}$  to  $\text{CH}_3\text{PH}_2$  to form  $\text{CH}_3\text{CF}_3\text{PH}$  and HI, as

described in Section V, and the second step would be like known biphosphine cleavages (e.g. Ref. 4, p. 86), one more of which is described in the following sub-section 7. Such a mechanism would account for the enhanced rate of decomposition of  $\text{CH}_3\text{HPP}(\text{CF}_3)_2$  during the  $\text{CF}_3\text{I}$  reaction, but is not necessarily the only way in which this could happen.

In the actual experiment 0.463 mmole of  $\text{CH}_3\text{HPP}(\text{CF}_3)_2$  and 0.582 mmole of  $\text{CF}_3\text{I}$  were left together in a sealed 10 ml. tube for 36 hours at room temperature. The yield of  $(\text{CF}_3)_2\text{PH}$  was 0.144 mmole, and a yield of 0.250 mmole of  $\text{CH}_3\text{CF}_3\text{PI}$  was shown by conversion to  $(\text{CH}_3)_2\text{NPCH}_2\text{CF}_3$ , as described in Section V. It is possible that the yield of  $(\text{CF}_3)_2\text{PH}$  was limited by some addition of  $\text{CF}_3\text{I}$  to make  $(\text{CF}_3)_3\text{P}$  and  $\text{HI}$ , but further experiments would be required to demonstrate this. In any case, the over-all process shows great promise of becoming the best route to the desired  $\text{CH}_3\text{CF}_3\text{PI}$ , since  $\text{CH}_3\text{HPP}(\text{CF}_3)_2$  can be made by a quantitative process.

## 7. The Cleavage by HCl

The reaction

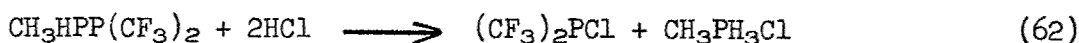

occurred quite completely during 20 hours at  $-78^\circ\text{C}$ ., with no side reaction such as the thermal or photochemical decomposition. The 1.121 mmole sample of biphosphine reacted with 2.27 mmoles (of a 2.37 mmole sample) of  $\text{HCl}$ , to give 1.119 mmoles of  $(\text{CF}_3)_2\text{PCL}$  and 1.122 mmoles of  $\text{CH}_3\text{PH}_3\text{Cl}$ , all quantitatively in accord with the equation. At room temperature ( $25^\circ\text{C}$ .), however, there was a nearly perfect 50:50 bifurcation into the  $\text{HCl}$  cleavage and the independent thermal decomposition, during 24 hours. The 1.664 mmole sample of the biphosphine consumed 1.645 mmole (out of a 2.568 mmole sample) of  $\text{HCl}$ , yielding 0.835 mmole of  $(\text{CF}_3)_2\text{PH}$  with 0.853 mmole of  $\text{CH}_3\text{P}$  units as polymer, plus the cleavage products 0.835 mmole of  $(\text{CF}_3)_2\text{PCL}$  with 0.811 mmole of  $\text{CH}_3\text{PH}_3\text{Cl}$ .

For the above experiments the  $(\text{CF}_3)_2\text{PH}$  and  $(\text{CF}_3)_2\text{PCL}$  were isolated and identified by their characteristic molecular weights, vapor tensions at specific temperatures, and infrared spectra. The  $\text{CH}_3\text{PH}_3\text{Cl}$  was wholly dissociated in the vapor phase, showing an average mol. wt. of 42.3 (calcd., 84.5/2); and in the first experiment the  $\text{CH}_3\text{PH}_2$  itself was isolated and found to represent 56.95% of the volatile solid hydrochloride (calcd., 57.14%). The  $-78^\circ\text{C}$ . experiment probably owed much of its clean completion to the formation of the  $\text{CH}_3\text{PH}_3\text{Cl}$ , which would be entirely stable at that temperature. It may be remarked further that this low-temperature  $\text{HCl}$  cleavage reaction represents a full confirmation of the formula  $\text{CH}_3\text{HPP}(\text{CF}_3)_2$  for the biphosphine.

Two experiments were devoted to the possibility of cleaving  $\text{CH}_3\text{HPP}(\text{CF}_3)_2$  by diborane, but in both cases (one with excess  $\text{B}_2\text{H}_6$  and the other with a deficiency), there was no important reaction. In one case the mixture was left for 16 hours at  $25^\circ\text{C}$ ., and there was some slight diminution in the amounts of diborane and biphosphine, but the only volatile product was 0.01 mmole of non-condensable gas, from 50 times as much diborane. It seems that there was not even

any adduct formation between diborane and the biphosphine, for both were fully separated and isolated by cooling the mixture to  $-116^{\circ}\text{C}$ . and distilling off the diborane one hour later.

B. 2-Methyl-1,1,3,3-tetrakis-(trifluoromethyl)triphosphine

1. Synthesis

The initial experiment on the reaction of  $\text{CH}_3\text{PH}_2$  with  $(\text{CF}_3)_2\text{PI}$  in the presence of trimethylamine (see above) gave so much more of the new triphosphine than the biphosphine  $\text{CH}_3\text{HPP}(\text{CF}_3)_2$  as to suggest that the second stage of phosphinolysis occurred more readily than the first. Hence it seemed quite reasonable to make the triphosphine by the secondary process.

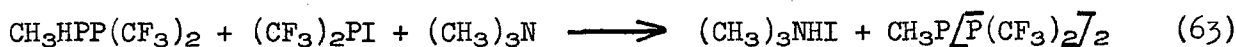

Accordingly, 142.4 mg. (0.659 mmole) of  $\text{CH}_3\text{HPP}(\text{CF}_3)_2$  and 196.0 mg. (0.662 mmole) of  $(\text{CF}_3)_2\text{PI}$  were first allowed to stand together in vacuo at  $-78^{\circ}\text{C}$ ., without evolution of HI; then 0.665 mmole of  $(\text{CH}_3)_3\text{N}$  was added and the reaction tube was sealed off. After 14 hours at room temperature, the mixture yielded a trace of material passing a trap at  $-45^{\circ}\text{C}$ . The main volatile component passed a trap at  $-36^{\circ}\text{C}$ . and condensed at  $-45^{\circ}\text{C}$ ., during the high-vacuum fractional condensation. The yield was 234.2 mg., or 92.4%, interpreted as the triphosphine  $\text{CH}_3\text{P}(\overline{\text{P}}(\text{CF}_3)_2)_2$ . This formula was confirmed by the molecular weight (385.1 vs. calcd., 384.0), along with the virtually quantitative synthesis.

2. Volatility of the Triphosphine

A carefully purified sample of the triphosphine gave the vapor tension measurements shown in Table XLIII. These determine the equation  $\log_{10} p_{\text{mm}} = 6.3722 + 1.75 \log_{10} T - 0.00500T - 2509.1/T$ , from which the normal b.p. is calculated as  $136.2^{\circ}\text{C}$ . and the Trouton constant as 21.2 cal./deg. mole. The m.p. could not be observed on account of glass formation.

TABLE XLIII

Vapor Tensions of  $\text{CH}_3\text{P}(\overline{\text{P}}(\text{CF}_3)_2)_2$

t ( $^{\circ}\text{C}$ .)	-23.3	0.00	8.8	23.2	25.0	35.0	42.6	50.5	57.3	65.2
$p_{\text{mm}}$ (obsd.)	0.19	1.21	2.25	5.67	6.20	11.11	16.60	24.7	34.3	49.2
$p_{\text{mm}}$ (calcd.)	0.19	1.21	2.25	5.65	6.25	11.11	16.64	24.8	34.4	49.2

### 3. Infrared Spectrum

The Infracord record of the spectrum of the new triphosphine shows the expected C-F stretching modes at 1130, 1158, and 1180  $\text{cm}^{-1}$ , all with high intensity. A spectrum in which these are within the chart shows the C-H stretching only as a very slight peak, scarcely distinguishable from the normal aberrations of the instrument. The C-H deformations at 1200 and 1430  $\text{cm}^{-1}$  are more distinct. A very weak peak at 1000 may well represent methyl-group rocking; and a composite peak at 743-746 probably includes the symmetrical C-F deformation and the P-CH<sub>3</sub> stretching. No other bands are strong enough to be recognized. Thus the main features expected for  $\text{CH}_3\text{P}(\overline{\text{P}}(\text{CF}_3)_2)_2$  are present, and there are no peaks foreign to the expected pattern.

### 4. The Ultraviolet Spectrum

The spectrum of the triphosphine was recorded by the Cary ultraviolet spectrophotometer, at a pressure of 0.75 mm. and with a 10-mm. path length. It showed a very flat, broad band with the maximum at  $2200 \pm 30 \text{ \AA}$ . The adjacent minimum was equally broad and flat, occurring at  $2100 \pm 20 \text{ \AA}$ . The molar extinction coefficient of the maximum was calculated as 3980, versus 3900 for the minimum. Such a spectrum could be interpreted in terms of the behavior of two kinds of phosphorus lone-pair electrons. The lone-pair on the central phosphorus atom would be much like the pi electrons of oxygen in  $(\text{CF}_3)_2\text{POP}(\text{CF}_3)_2$ , which account for a maximum at 2110  $\text{\AA}$ ., corresponding to a relatively limited three-atom delocalization. The lone-pair electrons on the end P atoms of  $(\text{CF}_3)_2\overset{\cdot\cdot}{\text{P}}-\overset{\cdot\cdot}{\underset{\text{CH}_3}{\text{P}}}-\overset{\cdot\cdot}{\text{P}}(\text{CF}_3)_2$  would be more like

the oxygen pi electrons of  $(\text{CF}_3)_2\text{POH}$ , which would have a two-atom range accounting for  $\lambda = 2025 \text{ \AA}$ . (Ref. 5, pp. 73 and 79). Thus it would not be unreasonable to suppose that the relatively weak peak due to the two-atom end electrons would occur in the region of the minimum adjacent to the stronger peak for the central electrons, thus accounting for a spectrum in which the minimum is nearly cancelled out.

## VII. Summary

The new diphosphine  $(\text{CF}_3)_2\text{PC}\equiv\text{CP}(\text{CF}_3)_2$  (b.p. est.  $107^\circ\text{C}$ .; ultraviolet maximum at 2285  $\text{\AA}$ .) resulted from the reaction of acetylene with  $(\text{CF}_3)_2\text{PCl}$  in the presence of trimethylamine. A by-product of this synthesis probably is  $(\text{CF}_3)_2\text{PC}_2\text{H}_2\text{Cl}$  (b.p., est.  $207^\circ\text{C}$ .). The new diphosphine saturates its triple bond by absorbing  $\text{B}_2\text{H}_6$  to make a  $\text{H}_2\text{B-R-BH}_2$  type of compound, which may be  $\text{BH}_2\text{B}$ -bridge polymerized.

The air-stable adduct  $\text{P}_2(\text{CH}_3)_4 \cdot 2\text{BH}_3$  (m.p.,  $194^\circ\text{C}$ . dec.) forms slightly volatile crystal needles which convert on heating to a stabler and less volatile crystal-lump form; but the two forms are interconvertible by vacuum sublimation. Their slightly different infrared spectra do not decide whether the two forms represent solid-state stabilization of rotational isomers. The  $2\text{BH}_3$  adduct reacts quantitatively with  $\text{P}_2(\text{CH}_3)_4$  to make the adduct  $\text{P}_2(\text{CH}_3)_4 \cdot \text{BH}_3$ , which is air-reactive, relatively volatile, and interconvertible between two crystal forms. The dioxide  $\text{P}_2(\text{CH}_3)_4\text{O}_2$  has been made by a new method: the action of  $\text{P}_2(\text{CH}_3)_4$  with  $\text{HgO}$ .

Esters of the type  $(\text{CF}_3)_2\text{POR}$  were made by alcoholysis of  $\text{P}_2(\text{CF}_3)_4$ , and studied in regard to the Arbuzov-type rearrangement. Thus  $(\text{CF}_3)_2\text{POCH}_3$  (b.p. est.  $55^\circ\text{C}$ .)

with  $\text{CH}_3\text{I}$  as catalyst in the liquid phase is very slow to change at  $140^\circ\text{C}$ . into  $\text{CH}_3(\text{CF}_3)_2\text{PO}$  (b.p. est.  $129^\circ\text{C}$ .; m.p.,  $-27^\circ\text{C}$ .), whereas  $(\text{CF}_3)_2\text{POC}_4\text{H}_9$  with  $\text{CH}_3\text{I}$  as catalyst changes fairly quickly at  $80^\circ\text{C}$ . into  $\text{C}_4\text{H}_9(\text{CF}_3)_2\text{PO}$  (b.p. est.  $188^\circ\text{C}$ .). The infrared spectra of the esters  $(\text{CF}_3)_2\text{POCH}_3$ ,  $(\text{CF}_3)_2\text{POC}_2\text{H}_5$ , and  $(\text{CF}_3)_2\text{POC}_4\text{H}_9$  have been compared with those of  $(\text{CF}_3)_2\text{POH}$ ,  $(\text{CF}_3)_2\text{POD}$ , and  $(\text{CF}_3)_2\text{POP}(\text{CF}_3)_2$ , with assignment of virtually all observed bands. The infrared spectra of four related  $\equiv\text{P}=\text{O}$  compounds have been compared, leading to a new estimate of the electronegativity of the  $\text{CF}_3$  group.

Materials which seem to be  $(\text{CF}_3)_2\text{HPO}$  and  $(\text{CH}_3)_2\text{HPO}$  have been made by the action of the corresponding phosphines upon  $\text{HgO}$ . The former partly disproportionates to  $(\text{CF}_3)_2\text{PH}$  and  $(\text{CF}_3)_2\text{POOH}$ , and partly rearranges to the stabler  $(\text{CF}_3)_2\text{POH}$ . On the other hand,  $(\text{CH}_3)_2\text{HPO}$  only disproportionates to  $(\text{CH}_3)_2\text{PH}$  and  $(\text{CH}_3)_2\text{POOH}$ . An attempt to oxidize  $(\text{CF}_3)_3\text{P}$  to  $(\text{CF}_3)_3\text{PO}$  by means of  $\text{HgO}$  led instead to the use of one-third of the  $\text{CF}_3$  groups to make the useful reagent  $\text{Hg}(\text{CF}_3)_2$ .

The phosphonous acid written formally as  $\text{CF}_3\text{P}(\text{OH})_2$  (b.p. est.  $214^\circ\text{C}$ .) has been isolated for the first time, and seems to exist mainly as the dimer of the isomeric form  $\text{CF}_3\text{HPOOH}$ . The infrared spectrum agrees with this phosphinic acid dimer form, the dissociation of which to monomer was studied:  $F^\circ = 16.00 - 0.0247 T$  kcal. for the formation of two moles of monomer. The ester  $\text{CF}_3\text{P}(\text{OCH}_3)_2$  (b.p.  $89^\circ\text{C}$ .) was made by the action of methanol on  $\text{CF}_3\text{PCl}_2$ , whereas the analogous  $\text{CF}_3\text{PBr}_2$  reaction led at once to the phosphonous acid itself, for the initially-formed  $\text{HBr}$  is far more effective than  $\text{HCl}$  for cleaving the ester. The reaction of  $\text{CF}_3\text{PCl}_2$  with  $\text{C}_2\text{H}_4(\text{OH})_2$  forms  $\text{C}_2\text{H}_4\text{O}_2\text{PCF}_3$  (m.p.  $-33^\circ\text{C}$ .; b.p.,  $107^\circ\text{C}$ .) and its polymers, apparently composed of  $\text{CF}_3\text{POC}_2\text{H}_4\text{O}$ - units. Initial attempts to make  $(\text{CF}_3\text{PO})_n$  polymers have not succeeded.

The desired phosphine  $\text{CH}_3\text{CF}_3\text{PI}$  has been made in good yields by two methods: The additive depolymerization of  $(\text{CF}_3\text{P})_4$  and  $(\text{CF}_3\text{P})_5$  by  $\text{CH}_3\text{I}$  (yields up to 85%) and replacment of one  $\text{CF}_3$  in  $\text{CH}_3\text{P}(\text{CF}_3)_2$  by the action of iodine (46% yield). A third way, in which  $\text{CF}_3\text{I}$  adds to the  $\text{CH}_3\text{P}$  unit during the decomposition of the new  $\text{CH}_3\text{HPP}(\text{CF}_3)_2$ , also has great promise. Another desired phosphine,  $\text{CH}_3\text{CF}_3\text{PH}$ , has been obtained in yields approaching 40% by a slow but clean addition of  $\text{CF}_3\text{I}$  to  $\text{CH}_3\text{PH}_2$  at  $-78^\circ\text{C}$ .

The addition of  $(\text{CF}_3)_3\text{P}$  to  $\text{C}_2\text{H}_4$  (with  $\text{I}_2$  as catalyst at  $112$ - $120^\circ\text{C}$ .) gives high yields of  $(\text{CF}_3)_2\text{PC}_2\text{H}_4\text{CF}_3$  (b.p.  $84^\circ\text{C}$ .) and some  $\text{CF}_3\text{P}(\text{C}_2\text{H}_4\text{CF}_3)_2$  (b.p.,  $145^\circ\text{C}$ .). The phosphines  $(\text{CF}_3)_2\text{PH}$  and  $\text{CF}_3\text{PH}_2$  add to  $\text{C}_2\text{H}_4$  during ultraviolet irradiation, forming respectively  $\text{C}_2\text{H}_5\text{P}(\text{CF}_3)_2$  (b.p.,  $64^\circ\text{C}$ .) and  $\text{C}_2\text{H}_5\text{HPCF}_3$  (b.p.,  $48^\circ\text{C}$ .).

The new biphosphine  $\text{CH}_3\text{HPP}(\text{CF}_3)_2$  was made quantitatively by the reaction of  $(\text{CF}_3)_2\text{PI}$  with  $2\text{CH}_3\text{PH}_2$ . Its b.p. is  $92^\circ\text{C}$ . Its ultraviolet and infrared spectra correspond to expectations. With heating or in sunlight it decomposes cleanly to  $(\text{CF}_3)_2\text{PH}$  and apparently  $(\text{CH}_3\text{P})_x$ ; or in the presence of  $\text{CF}_3\text{I}$  it goes to  $(\text{CF}_3)_2\text{PH}$  and a 54% yield of  $\text{CH}_3\text{CF}_3\text{PI}$ . At  $-78^\circ\text{C}$ .  $\text{HCl}$  cleaves it cleanly to  $(\text{CF}_3)_2\text{PCl}$  and  $\text{CH}_3\text{PH}_3\text{Cl}$ , whereas at room temperature there is thermal decomposition independent of the cleavage. It reacts with  $(\text{CF}_3)_2\text{PI}$  (with trimethylamine to remove the resulting  $\text{HI}$ ), almost quantitatively forming the new-type triphosphine  $\text{CH}_3\text{P}(\overline{\text{P}}(\text{CF}_3)_2)_2$  (b.p.,  $136^\circ\text{C}$ .). The infrared spectrum of this is in accord with expectations, while its ultraviolet spectrum is unusual but explainable.

### VIII. Bibliography for Appendix I

The following references are numbered in the order of first appearance of the corresponding reference superscripts at various points in the main text-- except that references 1-5 are here placed first because they represent a series of long earlier reports from the present project. For easier reference, these will be indicated in the text in parentheses with page-numbers rather than by the usual superscripts.

1. A. B. Burg, et al., WADC Technical Report 56-82, Part I (1956).
2. A. B. Burg, et al., WADC Technical Report 56-82, Part II (1957).
3. A. B. Burg, et al., WADC Technical Report 56-82, Part III (1958).
4. A. B. Burg, et al., Appendix II of WADC Technical Report 57-126, Part III (1959).
5. A. B. Burg, et al., Appendix II of WADC Technical Report 57-126, Part IV (1960).
6. H. Nöth, Z. Naturforsch., 15b, 328 (1960).
7. H. J. Emeléus and J. D. Smith, J. Chem. Soc., 1959, 380.
8. A. B. Burg and J. E. Griffiths, J. Am. Chem. Soc., 82, 3514 (1960)
9. E. K. Plyler and W. S. Benedict, J. Res. Natl. Bur. Standards, 47, 202 (1951).
10. W. F. Edgell and C. E. May, J. Chem. Phys., 22, 1808 (1954).
11. S. N. Nabi and N. Sheppard, J. Chem. Soc., 1959, 3439.
12. F. W. Bennett, H. J. Emeléus, and R. N. Haszeldine, J. Chem. Soc., 1953, 1565.
13. M. Halman, Spectrochimica Acta, 16, 407 (1960) and other references there cited.
14. L. J. Bellamy, The Infrared Spectra of Complex Molecules, Methuen & Co., Ltd., London, 2nd ed., 1958, Chapter 1.
15. N. Sheppard and D. M. Simpson, Quart. Rev., 7, 19 (1953).
16. J. J. Lagowski, Quart. Rev., 13, 233 (1959).
17. J. Goubeau and W. Berger, Z. anorg. allgem. Chem., 304, 147 (1960).
18. L. W. Daasch and D. C. Smith, Anal. Chem., 23, 853 (1951).
19. J. E. Griffiths and A. B. Burg, J. Am. Chem. Soc., 82, 1507 (1960).
20. H. J. Emeléus, R. N. Haszeldine, and R. C. Paul, J. Chem. Soc., 1954, 563.

21. A. B. Burg and R. I. Wagner, J. Am. Chem. Soc., 75, 3872 (1953).
22. J. E. Griffiths and A. B. Burg, J. Am. Chem. Soc., 82, 5759 (1960).
23. F. W. Bennett, H. J. Emeléus, and R. N. Haszeldine, J. Chem. Soc., 1954, 3899.
24. R. N. Haszeldine and B. O. West, J. Chem. Soc., 1956, 3631.
25. A. B. Burg, J. Am. Chem. Soc., 65, 1629 (1943).
26. A. B. Burg and P. J. Slota, Jr., J. Am. Chem. Soc., 80, 1107 (1958).
27. A. B. Burg and P. J. Slota, Jr., J. Am. Chem. Soc., 82, 2148 (1960).

## APPENDIX II - THIOSILOXANE POLYMERS

### I. Discussion

#### A. Preparation of Hexaphenylcyclotrithiosiloxane

Preparation in 71% yield of the cyclic trimer,  $[(C_6H_5)_2SiS]_3$ , has been described in an earlier report.<sup>1</sup> More recent work has shown that the trimethylchlorosilane admixed with the starting diphenyldichlorosilane in 1:3 mole ratio is not necessary to obtain the cyclic trimer by reaction of hydrogen sulfide and diphenyldichlorosilane in the presence of pyridine.

The utilization of small amounts of trimethylchlorosilane for chain termination was proposed originally in attempts to obtain linear polymeric materials by reaction of diphenyldichlorosilane with hydrogen sulfide. Only the cyclic trimer has been identified among the products of the reaction which include small amounts of a viscous oil which to date has resisted efforts at further characterization. Infrared spectra show no evidence of methyl groups or of methyl-silicon bonds in the oil or in the cyclic trimer.

When no trimethylchlorosilane is used, the crystalline cyclic trimer is produced in lower yields (55%) with about the usual amount of oily residue. Slow concentration of a hexane-benzene solution of the cyclic trimer has resulted in formation of large monoclinic crystals (1-1.5 cm. on an edge) of the trimer. No detectable amount of the crystalline cyclic dimer described by Moody<sup>2</sup> has resulted from any of our experiments although experimental conditions similar to those used by Moody have resulted in low yields (22%) of the cyclic trimer.

Table XLIV summarizes three typical experiments in which trimethylchlorosilane was not utilized. Experiment 1 attempted to duplicate conditions outlined in the Moody patent and Experiments 2 and 3 describe conditions which produced a satisfactory yield of the cyclic trimer.

#### B. Pyrolysis of Hexaphenylcyclotrithiosiloxane

##### 1. Attempts to Separate and Identify Components of Pyrolyzed Material

When hexaphenylcyclotrithiosiloxane is heated in an atmosphere of nitrogen or at reduced pressure to 350-400°C. for 2-6 hrs., it is converted to a viscous clear brown glass. The weight loss on heating is 10-15%. The glass hardens on standing at room temperature and becomes very brittle over a period of a few weeks. It has no definite melting range. During the heating of the trimer some viscous liquid collects in the cool upper part of the tube and solidifies to light yellow crystals when cooled. This crystalline material melts at 155-165°C. after twice recrystallizing from benzene and gives a cryoscopic molecular weight of 534. The glass is much less soluble in benzene so that a molecular weight determination in this solvent is difficult. Attempts to separate the glass into its components by reduced pressure distillation, molecular distillation, fractional crystallization and column chromatography have been unsuccessful to date.



TABLE XLIV

Preparation of Hexaphenylcyclotrithiosiloxane

No.	Reactants				Products Isolated						
	$(C_6H_5)_2SiCl_2$		$C_5H_5N$		$C_5H_5N \cdot HCl$		Unidentified Liquid Residue	Crystalline $[(C_6H_5)_2SiS]_3$			
	Wt. g.	Moles	Wt. g.	Moles	Wt. g.	Moles		Wt. g.	Moles	m.p., °C.	% Yield
1*	18.75	0.063	9.90	0.125	15.1	0.120	2.1	3.04	0.005	188-189	22.6
2	31.63	0.125	22.9	0.29	26.6	0.25	4.1	14.7	0.023	186-188	54.9
3	31.63	0.125	22.9	0.29	20.5	0.18	4.4	14.2	0.022	186-188	53.0

\* In Experiment 1, no external heating was applied whereas in Experiments 2 and 3 a temperature of 50-55°C. was maintained for at least two hours.

2. Investigation of Pyrolyzed Material  
as Bonding Agent for Metals

Investigation of the possible use of the glass resulting from pyrolysis of the cyclic trimer as a bonding agent for stainless steel has shown that bonding results on heating the steel strips and pyrolyzed trimer to 250-450°C. but that the bond can be ruptured by slight to moderate manual pressure, the break coming in the bonding agent. Blending 10% by weight of sulfur into the softened glass at 150-200°C. and applying it as a bonding agent under similar conditions resulted in no increased bonding strength.

C. Attempts to Promote Linearization  
of Hexaphenylcyclotriithiosiloxane

1. Action of Lewis Acids on Cyclic Trimer

It has been proposed that action of a Lewis acid on sulfur in hexaphenylcyclotriithiosiloxane might cause ring opening which then could lead to further ring opening and polymerization of the polar intermediates. However, the trimer has been recovered unchanged after standing at room temperature and after refluxing with catalytic amounts of fuming sulfuric acid in ether or with boron trifluoride in anhydrous benzene.

2. Action of Phenyllithium on Cyclic Trimer

Gilman and Lichtenwaller<sup>3</sup> have reported that  $(C_6H_5)_3SiSCH_3$  reacts with phenyllithium according to the following equation:

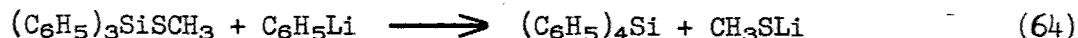

Such a reaction suggests that phenyllithium might open the ring of hexaphenylcyclotriithiosiloxane.

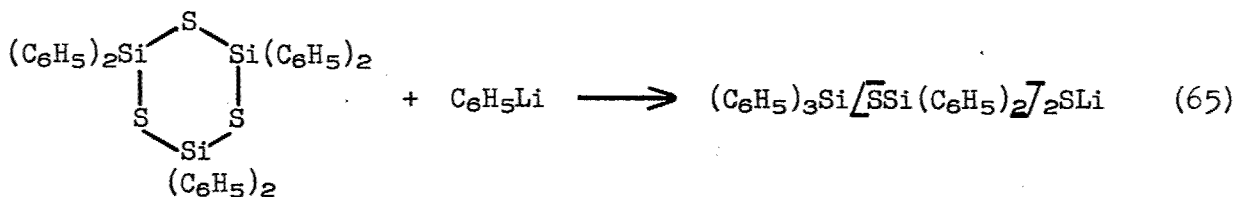

Should this reaction result without further action of phenyllithium on the silicon-sulfur bonds of the opened ring, it is reasonable to suggest that further reaction with  $R_3SiX$ ,  $R_2SiX_2$ ,  $RSiX_3$  or  $SiX_4$  might take place. For example, diphenyldichlorosilane should give a polymeric material with seven  $(C_6H_5)_2SiS$ -units.

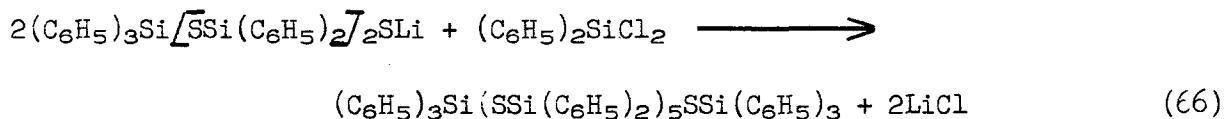

When refluxed in ether, a 1:3 mole ratio of phenyllithium to cyclic trimer resulted in reaction of the starting trimer. The yellow crystalline product partially melted over a range of 160-240°C. with evolution of hydrogen sulfide. Recrystallization from a hexane-benzene solvent did not change the melting characteristics. The solid gave a qualitative test for sulfur, a positive Zerewitinoff test with  $\text{CH}_3\text{MgBr}$  and a cryoscopic molecular weight of 401. The flame test for lithium was strong. No unreacted trimer was recovered although when solutions with 1:10 and 1:50 mole ratios of phenyllithium to cyclic trimer were allowed to stand at room temperature, essentially all trimer was recovered unchanged.

Reaction of a 1:1 mole ratio of phenyllithium to cyclic trimer could lead to breakdown of the trimer to small molecules. Such a possibility is being investigated as are the further reactions of the product from the 1:3 mole ratio reaction.

#### D. Preparations and Reactions of Silanethiols

##### 1. Preparation of Certain Silanethiols and Disilthianes

The only compounds of general formulas  $\text{R}_3\text{SiSH}$  and  $(\text{R}_3\text{Si})_2\text{S}$  which have been reported are those in which R is ethyl or propyl.<sup>4</sup> They have been prepared by reaction of  $\text{R}_3\text{SiNH}_2$  with hydrogen sulfide. After reaction, the thiols were distilled at reduced pressure accompanied by some evolution of hydrogen sulfide resulting in formation of the corresponding hexaalkyldisilthianes.

In this work we have prepared  $(\text{C}_2\text{H}_5)_3\text{SiSH}$ ,  $(\text{C}_6\text{H}_5)_2\text{CH}_3\text{SiSH}$  and  $(\text{C}_6\text{H}_5)_3\text{SiSH}$  by reaction of the corresponding monohalosilanes with excess hydrogen sulfide in the presence of an organic base. Usually the product has not been purified beyond filtration of the precipitated amine hydrochloride and evaporation of the solvent at room temperature and reduced pressure. Both the silanethiol and disilthiane are formed in the reaction but distillation results in reaction of some thiol to form disilthiane and hydrogen sulfide. Thiol content is estimated by the Zerewitinoff procedure for active hydrogen content.

##### 2. Reactions of Silanethiols with Halosilanes

Silanethiols have been caused to react with  $(\text{C}_6\text{H}_5)_2\text{SiCl}_2$ ,  $(\text{C}_2\text{H}_5)_2\text{SiCl}_2$  and  $\text{C}_6\text{H}_5\text{SiCl}_3$  by refluxing in ether or benzene in the presence of sufficient organic base to react with all hydrogen chloride evolved. The following equation summarizes the sort of reaction that has been attempted:

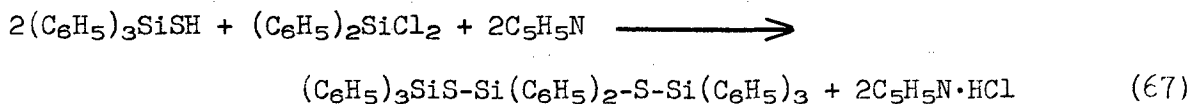

A number of experiments have been attempted in an effort to get the indicated product in good yield but to date products have all been viscous oils which have not been successfully separated into pure components. Should general conditions for such a reaction be developed, it is suggested that linear silicon-sulfur polymers of relatively low molecular weight may be prepared by building chains one unit at a time (or two units if both ends of the chain are utilized) by alternating conversion of a chlorosilane to a silanethiol followed by reaction of the thiol with an excess of a dichlorosilane thus leaving a terminal chlorine which can be again converted to the thiol.

Among the compounds with a five-membered silicon-sulfur chain whose preparations have been attempted but which have not been isolated or identified in the reaction products resulting from the attempted syntheses, are the following substances:

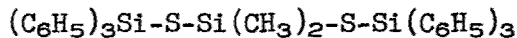
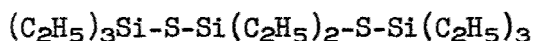

Limited investigation has been carried on as to the possibility of the existence of silanedithiols such as  $(\text{C}_6\text{H}_5)_2\text{Si}(\text{SH})_2$  or of chlorosilanethiols such as  $(\text{C}_6\text{H}_5)_2\text{ClSiSH}$ . To date no evidence of the formation of such compounds has been obtained.

## II. Experimental

### A. Preparation of Hexaphenylcyclotriithiosiloxane

#### 1. Reaction of Diphenyldichlorosilane and Hydrogen Sulfide with No External Heating (Exp. 1, Table XLIV)

Anhydrous hydrogen sulfide was bubbled for one-half hour into a solution of 18.75 g. (0.063 mole) of redistilled diphenyldichlorosilane and 9.90 g. (0.125 mole) of pyridine (dried over  $\text{CaH}_2$ ) contained in a 250 ml. 3-neck flask fitted with stirrer, gas introduction tube and reflux condenser protected by a calcium chloride tube. During this period the temperature rose to  $52^\circ\text{C}$ . and the mixture became difficult to stir due to precipitation of pyridine hydrochloride. Stirring was facilitated by addition of 50 ml. of benzene after which stirring and hydrogen sulfide introduction were maintained for an additional 2 hrs. The temperature during this period remained within five degrees of room temperature ( $26\text{-}31^\circ\text{C}$ .). The pyridine hydrochloride (15.1 g., 0.12 mole) was separated by filtration in a nitrogen filled dry box. Material volatile to  $240^\circ\text{C}$ . was distilled from the filtrate and the yellow oily residue partially crystallized on standing. The material was twice recrystallized from a benzene-hexane mixture giving 3.04 g.

(0.005 mole, 22.6% yield) of hexaphenylcyclotriithiosiloxane (m.p. 188-189°C.). Evaporation of the filtrate left a tan oil (2.1 g.) which did not crystallize further.

2. Reaction of Diphenyldichlorosilane and Hydrogen Sulfide at 50-55°C. (Exps. 2 and 3, Table XLIV)

In a 1-l., 3-neck flask fitted with a thermometer, gas introduction tube, magnetic stirrer, dropping funnel and reflux condenser was placed 100 ml. of dry benzene and 22.9 g. (0.29 mole) of anhydrous pyridine. The flask was flushed with nitrogen after which anhydrous hydrogen sulfide was bubbled slowly into the solution while redistilled diphenyldichlorosilane (31.63 g., 0.125 mole) was added dropwise over a period of one-half hour. The temperature rose to 45°C. during the addition. When the silane introduction was complete, an additional 150 ml. of benzene was added and the temperature was maintained at 50-55°C. for 2 hrs. while slow introduction of hydrogen sulfide was continued. The mixture was filtered in a dry box, the precipitate washed once with 50 ml. of hexane (dried over Na) and the wash combined with the filtrate. Material volatile to 240°C. was distilled from the filtrate. The pot residue was dissolved in 150 ml. of boiling hexane and a minimum amount (about 40 ml.) of benzene and allowed to cool and crystallize. There were obtained 11.2 g. of the cyclic trimer (m.p. 186-188°C.). A second crop (3.5 g., m.p. 186-188°C.) was obtained by concentration of the mother liquor. Complete evaporation of volatile material from the filtrate after recovery of a second crop of cyclic trimer crystals left a viscous yellow oil (4.1 g.) that did not crystallize.

B. Pyrolysis of Hexaphenylcyclotriithiosiloxane

1. Attempts to Separate and Identify Components of Pyrolyzed Material

A total of 11.0 g. (0.017 mole) of hexaphenylcyclotriithiosiloxane (m.p. 186-188°C.) was placed in a 100 ml. Pyrex tube sealed at one end and fitted with a ground glass joint at the other end. The Pyrex tube fit snugly into an insulated ceramic tube wound with resistance wire. The solid was melted and heated in this furnace at 350-400°C. for 5 hrs. during which time a nitrogen atmosphere was maintained in the tube. The furnace was turned off and, when the temperature had dropped to 300°C., the flask was evacuated with an oil pump to a pressure of about 1 mm. Quantities of a white vapor were drawn into the Dry Ice trap and a thick colorless liquid crept up to the cooler portions of the tube. When the system had reached room temperature a trace of colorless liquid was found in the trap. The liquid which had collected in the upper portions of the tube had solidified to light yellow crystals (3.2 g., m.p. 127-150°C.). Two recrystallizations from benzene raised the melting range to 155-165°C. and a cryoscopic molecular weight determination in benzene gave a value of 534. The residual clear brown glass (6.4 g.) was viscous on first cooling and became brittle on standing. It did not distill at a pot temperature of 350°C./1 mm. and spattered on warming in an attempted molecular distillation when connected to a mercury diffusion pump. It was not sufficiently soluble in hot benzene to permit fractional crystallization and did not crystallize from 3-pentanone in which it was soluble. Likewise no

satisfactory separation, based on change in refractive index, was obtained on washing a solution of the glass dissolved in 3-pentanone through a chromatographic column (packed with 5% Nuchar, 45% anhydrous  $Al_2O_3$  and 50% sand by weight).

## 2. Investigation of Pyrolyzed Material as Bonding Agent for Metals

A number of stainless steel strips (2 cm. by 15 cm.) were polished with steel wool and a buffing wheel. A 6 cm. overlap on each pair of strips was coated with a layer of the pyrolyzed trimer prepared as outlined in 2.a. and each pair was clamped together with two laboratory screw clamps. Pairs of treated strips were heated to 250°, 300°, 350°, 400°, and 450°C. for one-half hour each in a furnace. On cooling, the strips were found to be bonded by the pyrolyzed material but the bond could be ruptured by slight to moderate manual pressure, the break coming in the bonding agent. No difference in bonding strength was detected as a result of heating to various temperatures. On warming to 125°C. a pair of strips originally bonded at 400°C., the bond parted under the weight of the unsupported strip.

A similar experiment using as bonding agent the pyrolyzed trimer into which 10% by weight of sulfur had been worked at 150-200°C. was attempted. Results were essentially the same as those for the glass without sulfur.

## C. Attempts to Promote Linearization of Hexaphenylcyclotrithiosiloxane Polymer

### 1. Action of Lewis Acids on Cyclic Trimer

#### (a) Fuming Sulfuric Acid

A total of 0.59 g. (0.0009 mole) of hexaphenylcyclotrithiosiloxane and one drop (0.04 g., 0.0002 mole) of fuming sulfuric acid were dissolved in 40 ml. of ether (dried over Na). The solution remained at room temperature for 24 hrs. and was then evaporated to a volume of about 5 ml. Anhydrous ammonia was passed into the solution and the precipitated ammonium sulfate filtered off. The ether was completely evaporated and the residue recrystallized from a benzene-hexane mixture. The product weighed 0.51 g. (m.p. 184-188°C.).

In another experiment using the same amounts of starting materials, 2 hrs. of refluxing in ether did not alter the amount of starting material recovered.

#### (b) Boron Trifluoride

In 10 ml. of benzene (dried over Na) was dissolved 0.38 g. (0.0006 mole) of hexaphenylcyclotrithiosiloxane (m.p. 187-188°C.). Boron trifluoride was bubbled into the solution for 3 min. and the material was allowed to stand at 25°C. for 18 hrs. On workup, 0.34 g. of starting trimer (m.p. 185-187°C.) was recovered.

In a second experiment, boron trifluoride was bubbled into the benzene solution containing 0.38 g. of cyclic trimer for 6 min. and the solution was refluxed for 2 hrs. Most of the starting material, 0.32 g., was recovered.

## 2. Action of Phenyllithium on Cyclic Trimer

In the dry box, 1.73 g. (0.0027 mole) of hexaphenylcyclotriethio-siloxane (m.p. 187-189°C.), 25 ml. of anhydrous ether, 25 ml. of dry benzene and 2 ml. of an ether solution containing 0.001 mole of freshly prepared phenyllithium were placed in a 125 ml. flask fitted with a reflux condenser. The solution was refluxed for 45 min. and then evaporated to a volume of 10 ml. Precipitation of white crystals started at this stage and 50 ml. of hexane (dried over CaH<sub>2</sub>) was added immediately. A deposit of light yellow crystals formed on standing (m.p. 180-240°C., gas evolution). These crystals were separated and recrystallized from hexane-benzene (1.16 g., m.p. 160-240°C., H<sub>2</sub>S evolution and incomplete melting). The solid burned with a smoky flame and the residue gave a flame color typical of lithium. The solid contained sulfur and gave a positive Zerewitinoff test. An earlier experiment involving 1 hr. reflux in benzene of a solution of 9.2 g. (0.014 mole) of cyclic trimer and 0.38 g. (0.0046 mole) of phenyllithium resulted in recovery of only 0.4 g. of solid material (m.p. 143-150°C., decomp.).

In rather similar experiments using 1:10 and 1:50 mole ratios of phenyllithium with 2.0 g. (0.003 mole) of hexaphenylcyclotriethiosiloxane, 80% and 90%, respectively of the starting trimer were recovered unchanged. In the case of the 1:10 mole ratio experiment, 0.3 g. of a viscous oil containing sulfur was also recovered.

## D. Preparations and Reactions of Silanethiols

### 1. Preparation of Certain Silanethiols and Disilthianes

#### (a) Preparation of Triethylsilanethiol

The reaction of 20.0 g. (0.1 mole) of redistilled triethylbromosilane and 16.4 g. (0.21 mole) of pyridine dissolved in 150 ml. of dry ether with anhydrous hydrogen sulfide gas (bubbled into the stirred reaction mixture over a period of one hour at 25-30°C.) resulted in precipitation of 16.2 g. (0.1 mole) of pyridine hydrobromide. The major part of the ether solvent was evaporated from the filtrate with a stream of dry nitrogen and the remainder was removed with a Rinco evaporator connected through a calcium chloride tube to a water aspirator. The residue was a light yellow liquid which gave positive tests for sulfur and active hydrogen. Distillation at reduced pressure gave 8.14 g. of a clear liquid boiling at 67-71°C./6 mm. The residue was a yellow liquid (3.67 g.) which contained sulfur and no active hydrogen. It is probably hexaethyldisilthiane. The distillate amounted to 0.055 moles (55% yield based on triethylsilanethiol). Molecular weight of distillate (Zerewitinoff): calcd. for C<sub>6</sub>H<sub>16</sub>SSi: 148. Found: 141.

(b) Preparation of Triphenylsilanethiol

A total of 6.6 g. (0.025 mole) of triphenylchlorosilane (prepared by reaction of diphenyldichlorosilane and phenyllithium) and 2.5 g. (0.025 mole) of anhydrous triethylamine dissolved in 150 ml. of dry benzene were stirred in a 3-neck, 500 ml. flask while anhydrous hydrogen sulfide gas was slowly bubbled into the reaction mixture for a period of one hour. The temperature was maintained at 25-30°C. while stirring was continued for an hour after hydrogen sulfide addition was terminated. A white crystalline solid separated and was filtered in the dry box. The solid appeared to be triethylamine hydrochloride. The filtrate turned light yellow and white crystals slowly precipitated on standing in the refrigerator for 2 days. The material was evaporated using a Rinco apparatus and more solid settled out. When the volume had been reduced to about one-fourth the original, the solution was filtered in the dry box. The precipitate was washed with hexane and dried. The weight was 3.79 g. of a white crystalline solid melting at 129-132°C. and the yield was 58.3% assuming a formulation of triphenylsilanethiol. When heated to the melting point the solid evolved hydrogen sulfide as evidenced by both odor and a test with lead acetate paper. However, no gas evolution was noted visually until a temperature of 200°C. was reached at which point the material frothed and turned dark brown. Anal. calcd. for  $C_{18}H_{16}SSi$ : Si, 9.59, molecular weight, 292. Found: Si, 9.03, molecular weight (Zerewitinoff), 280.

(c) Preparation of  
Tetraphenyldimethyldisilthiane

To 290 ml. of benzene containing 2.78 g. (0.087 mole of dissolved hydrogen sulfide (determined gravimetrically by PbS precipitation) in a 3-neck flask fitted with a dropping funnel, reflux condenser, nitrogen inlet tube and magnetic stirrer was added 14.22 g. (0.18 mole) of anhydrous pyridine. To the stirred solution under an atmosphere of dry nitrogen and held at room temperature in a water bath was added dropwise during 30 min. a total of 25 g. (0.09 mole) of redistilled diphenylmethylbromosilane. A white precipitate formed during the addition which was filtered after standing at room temperature for 24 hrs. The dry white precipitate weighed 12.74 g. and melted at 214-216°C. Evaporation of the filtrate at room temperature on a rotary evaporator resulted in an oily yellow residue from which colorless crystals settled. The oil was washed from the crystals with 10 ml. of dry ether. The dried crystals weighed 1.46 g. (m.p. 110-112°C.). A second crop (1.30 g., m.p. 108-110°C.) was obtained on concentrating the ether filtrate and a third (0.98 g., m.p. 103-110°C.) on further concentration. All crops gave a positive qualitative test for sulfur and a negative Zerewitinoff test. Anal. calcd. for  $[(C_6H_5)_2CH_2Si]_2S$ : Si, 13.15, molecular weight, 427. Found: Si, 13.02, molecular weight (cryoscopic benzene), 424.

The filtrate on standing at room temperature in the dry box slowly produced more crystals which appeared similar to those already isolated.

2. Reactions of Silanethiols with Halosilanes

A number of experiments have been directed toward preparing compounds which can be named octaalkyl- or aryltrisilthianes by reaction of two moles of triethyl- or triphenylsilanethiol with one mole of diethyl-, dimethyl- or



diphenyldichlorosilane in the presence of at least two moles of pyridine or triethylamine. Reaction temperatures used have been those of refluxing benzene or ether. Pyridine hydrochloride and triethylamine hydrochloride have been isolated in amounts approaching that of the calculated values. The reaction products consist of viscous oils which have not been satisfactorily purified or characterized to date.

III. Bibliography for Appendix II

1. R. I. Wagner, WADC Technical Report 57-126, Part IV, March 1960, p. 47.
2. L. S. Moody, U.S. 2,567,724 (Sept. 11, 1951).
3. H. Gilman and G. D. Lichtenwalter, J. Org. Chem., 25, 1064 (1960).
4. E. Larsson and R. Mårin, Acta Chem. Scand., 5, 964 (1951).

### APPENDIX III - NEW COMPOUNDS

Listed in Table XLV are the new compounds prepared during the past five years (1956 through 1960) under Air Force Contracts AF 33(616)-2743, 3506, 5435, and 6913. References to WADC Technical Reports listed at the end of the table are designated by a letter and page number while published material is designated by a number only.

TABLE XLV

New Compounds

Name	Formula
<u>PHOSPHINES</u>	
1,3-Diphosphinopropane	$H_2P(CH_2)_3PH_2$
1,4-Diphosphinobutane	$H_2P(CH_2)_4PH_2$
p-Diphosphenobenzene	$p-H_2PC_6H_4PH_2$
Methyltrifluoromethylphosphine	$CH_3(CF_3)PH$
Ethyltrifluoromethylphosphine	$C_2H_5(CF_3)PH$
Methylpropylphosphine	$CH_3(C_3H_7)PH$
Methylallylphosphine	$CH_3(C_3H_5)PH$
Methylbutylphosphine	$CH_3(C_4H_9)PH$
Methylamylphosphine	$CH_3(C_5H_{11})PH$
Methylhexylphosphine	$CH_3(C_6H_{13})PH$
Methylheptylphosphine	$CH_3(C_7H_{15})PH$
Methyloctylphosphine	$CH_3(C_8H_{17})PH$
Dicyclohexylphosphine	$(C_6H_{11})_2PH$
Methyldodecylphosphine	$CH_3(C_{12}H_{25})PH$
Cyclotetramethylenephosphine	$\underline{CH_2(CH_2)_3PH}$
3,3-Dimethylcyclotrimethylenephosphine	$(CH_3)_2C\underline{CH_2PHCH_2}$
1,3-Bis(methylphosphino)propane	$CH_3HP(CH_2)_3PHCH_3$
p-Bis(methylphosphino)benzene	$p-CH_3HPC_6H_4PHCH_3$
Bis(trifluoromethyl)ethylphosphine	$(CF_3)_2PC_2H_5$
Bis(trifluoromethyl)-3,3,3-trifluoropropylphosphine	$(CF_3)_2PCH_2CH_2CF_3$

M.p., °C.	B.p., °C./mm.	Remarks	Reference
-	140 (calc.)		A34, B18
-	-	Liquid	A34
69-70.5	226 (calc.)		B35
-	18	Glass at low temp.	E178
-	48		E183
-	65/400		A34, E58
-	80.9 (calc.)	Polymerizes on standing	C46, D30
-	63/144		E58
-	70/74		E58
-	90/82		E58
-	117/100		E58
-	81/10		E58
-	72-73/0.2		C52
-	117-119/3		C46
-88	105 (calc.)		A34, C78, F11, 12
-	190 (calc.)	Polymerizes on standing	D30
-	184 (calc.)		B21
-	-	Liquid	C54
-	64		E182
-	84		E180

Name	Formula
Trifluoromethyl-bis(3,3,3-trifluoropropyl)phosphine	$\text{CF}_3\text{P}(\text{CH}_2\text{CH}_2\text{CF}_3)_2$
Bis(trifluoromethyl)-3,3,3-trifluoropropenylphosphine	$(\text{CF}_3)_2\text{PCH}=\text{CHCF}_3$
1,2-Bis(dimethylphosphino)ethane	$(\text{CH}_3)_2\text{P}(\text{CH}_2)_2\text{P}(\text{CH}_3)_2$
1,2-Bis[bis(trifluoromethyl)phosphino]ethane	$(\text{CF}_3)_2\text{P}(\text{CH}_2)_2\text{P}(\text{CF}_3)_2$
1,2-Bis[bis(trifluoromethyl)phosphino]-1,1,2,2-tetrafluoroethane	$(\text{CF}_3)_2\text{P}(\text{CF}_2)_2\text{P}(\text{CF}_3)_2$
1,2-Bis[bis(trifluoromethyl)phosphino]ethylene	$(\text{CF}_3)_2\text{PCH}=\text{CHP}(\text{CF}_3)_2$
1,3-Bis(dimethylphosphino)propane	$(\text{CH}_3)_2\text{P}(\text{CH}_2)_3\text{P}(\text{CH}_3)_2$
p-Bis(diphenylphosphino)benzene	$p\text{-(C}_6\text{H}_5)_2\text{PC}_6\text{H}_4\text{P}(\text{C}_6\text{H}_5)_2$
Trifluoromethyl-bis- $\beta$ -[bis(trifluoromethyl)phosphinoethyl]phosphine	$\text{CF}_3\text{P}[\overline{\text{CH}_2\text{CH}_2\text{P}(\text{CF}_3)_2}]_2$
Trifluoromethyl-bis- $\beta$ -[bis(trifluoromethyl)phosphinoethenyl]phosphine	$\text{CF}_3\text{P}[\overline{\text{CH}=\text{CHP}(\text{CF}_3)_2}]_2$
Trifluoromethyldifluorophosphine	$\text{CF}_3\text{PF}_2$
Trifluoromethyldibromophosphine	$\text{CF}_3\text{PBr}_2$
Cyclohexyldichlorophosphine	$\text{C}_6\text{H}_{11}\text{PCL}_2$
p-Bis(dichlorophosphino)benzene	$p\text{-Cl}_2\text{PC}_6\text{H}_4\text{PCL}_2$
Dimethylchlorophosphine	$(\text{CH}_3)_2\text{PCL}$
Methyltrifluoromethylchlorophosphine	$\text{CH}_3(\text{CF}_3)\text{PCL}$
Methyltrifluoromethyliodophosphine	$\text{CH}_3(\text{CF}_3)\text{PI}$

M.P., °C.	B.p., °C./mm.	Remarks	Reference
-	145		E180
-	74 (calc.)	Glass at low temp., IR indicates cis-trans	D110, D115
0	168 (calc.)		C91, D65
-51.3	135		C91, D102
-49.6	ca. 127		D105
-54	ca. 122		D109
-	-	Liquid	E61
166-168.5	-		E112
-	24/0.2		D103
	203 (calc.)	Glass at low temp.	D110, D116
-132	-47 (calc.)		C105, F27, G34
-	87 (calc.)	Glass at low temp.	D88, 13
-	45-50/1		C50
58-60	-		B35
-1	71 (calc.)		F18, G5, 3
-	51 (calc.)	Glass at low temp.	D99
-	25/11		E174

Name	Formula
Bis(trifluoromethyl)fluorophosphine	$(CF_3)_2PF$
Bis(trifluoromethyl)bromophosphine	$(CF_3)_2PBr$
Dicyclohexylchlorophosphine	$(C_6H_{11})_2PCl$
Dimethylaminotrifluoromethylchlorophosphine	$(CH_3)_2NPClCF_3$
Dimethylaminocyclohexylchlorophosphine	$(CH_3)_2NPClC_6H_{11}$
Dimethylaminophenylchlorophosphine	$(CH_3)_2NPClC_6H_5$
Bis(dimethylamino)chlorophosphine	$\overline{\overline{(CH_3)_2N}}_2PCl$
Dimethylaminomethyltrifluoromethylphosphine	$(CH_3)_2NP(CH_3)CF_3$
Dimethylaminomethylphenylphosphine	$(CH_3)_2NP(CH_3)C_6H_5$
Dimethylaminodicyclohexylphosphine	$(CH_3)_2NP(C_6H_{11})_2$
Dimethylamino-p-bromophenylphenylphosphine	$(CH_3)_2NP(p-BrC_6H_4)C_6H_5$
Dimethylaminodi-p-tolylphosphine	$(CH_3)_2NP(p-CH_3C_6H_4)_2$
Dimethylaminocyclotetramethylene-phosphine	$(CH_3)_2NP(\underline{CH_2})_3CH_2$
Bis(dimethylamino)methylphosphine	$\overline{\overline{(CH_3)_2N}}_2PCH_3$
Bis(dimethylamino)phenylphosphine	$\overline{\overline{(CH_3)_2N}}_2PC_6H_5$
p-Bis[bis(dimethylamino)phosphino]-benzene	$p-\overline{\overline{(CH_3)_2N}}_2PC_6H_4P\overline{\overline{N(CH_3)_2}}_2$
Tris(dimethylamino)phosphine	$\overline{\overline{(CH_3)_2N}}_3P$



M.p., °C.	B.p., °C./mm.	Remarks	Reference
-149.6	-12		C105, F37, G36, 5
-	42 (calc.)	Glass at low temp.	D87, 13
-	108-110/1		C51
-	115 (calc.)		D101
-	56-61/1		C50
-	78-80.5/1		C53
-	93-97/48		B26
-	99 (calc.)	Glass at low temp.	D98, E175
-	66-70/1		C54
-	134-136/3		C51
-	124-150/1		C55
-	85/10 <sup>-5</sup>		B27
-	170 (calc.)		F5, 12
-	64-67/49		D35
-	42-44/0.02		B29
146.5-147.5	-		B33
-	60-61/18		B35

Name	Formula
<u>POLYPHOSPHINES AND RELATED MATERIALS</u>	
1,2-Bis(trifluoromethyl)biphosphine	$\text{HCF}_3\text{PPCF}_3\text{H}$
1-Methyl-2,2-trifluoromethylbiphosphine	$\text{HCH}_3\text{PP}(\text{CF}_3)_2$
Tetramethylbiphosphine	$(\text{CH}_3)_2\text{PP}(\text{CH}_3)_2$
1,1-Dimethyl-2,2-bis(trifluoromethyl)-biphosphine	$(\text{CH}_3)_2\text{PP}(\text{CF}_3)_2$
1,2-Dimethyl-1,2-bis(trifluoromethyl)-biphosphine	$\text{CH}_3(\text{CF}_3)\text{PP}(\text{CF}_3)\text{CH}_3$
Tetrakis(trifluoromethyl)biphosphine bis(nickel tricarbonyl)	$(\text{CO})_3\text{Ni}(\text{CF}_3)_2\text{PP}(\text{CF}_3)_2\text{Ni}(\text{CO})_3$
1,2,5,6-Tetrakis(trifluoromethyl)-1,2,5,6-phosphacycloocta-3,7-diene	$\text{CF}_3\text{PCH}=\text{CHPCF}_3$ $\text{CF}_3\text{PCH}=\text{CHPCF}_3$
1,2,3-Tris(trifluoromethyl)triphosphine	$\text{HCF}_3\text{PP}(\text{CF}_3)\text{PCF}_3\text{H}$
2-Methyl-1,1,3,3-tetrakis(trifluoromethyl)triphosphine	$(\text{CF}_3)_2\text{PP}(\text{CH}_3)\text{P}(\text{CF}_3)_2$
Tetrakis(trifluoromethyl)cyclotetra-phosphine	$(\text{CF}_3\text{P})_4$
Polymer from $(\text{CF}_3\text{P})_4$ and $\text{Ni}(\text{CO})_4$	$\left[ (\text{CF}_3\text{P})_4\text{Ni}(\text{CO})_n \right]_x$
Pentakis(trifluoromethyl)cyclopenta-phosphine	$(\text{CF}_3\text{P})_5$
Poly(trifluoromethyl)phosphine	$(\text{CF}_3\text{P})_x$

M.p., °C.	B.p., °C./mm.	Remarks	Reference
-	69 (calc.)		C82, C99, G30, 6
-	92 est.	Unstable	E184
-2.1	140 (calc.)		A36, B24, C72, D64, G6, 8
-79	117 (calc.)	Unstable above 65°	C84
-	129 (calc.)		D96, D100
105	20/5	Red-black crystals	G37, 4
-	220 (calc.)	Glass at low temp.	D117
-	124 (calc.)		C98, 6
-	136 est.		E189
66	135 (calc.)	$d^{25} = 2.0$ $d^{66} = 1.54$	C105, F25, G24, 1, 6
-	-	Not well characterized	G38, 4
-32	190 (calc.)	$d^{25} = 1.60$	C105, F26, G24, 1, 6
-	-	Greenish-yellow	C94, 6

Name	Formula
<u>PHOSPHINE BORINES</u>	
Ethylphosphine borine	$C_2H_5PH_2:BH_3$
Methylethylphosphine borine	$CH_3(C_2H_5)PH:BH_3$
Methylallylphosphine borine	$CH_3(C_3H_5)PH:BH_3$
Methylpropylphosphine borine	$CH_3(C_3H_7)PH:BH_3$
Methyl-i-propylphosphine borine	$CH_3(i-C_3H_7)PH:BH_3$
Diethylphosphine borine	$(C_2H_5)_2PH:BH_3$
Cyclotetramethylenephosphine borine	$\underline{CH_2(CH_2)_3}PH:BH_3$
Methylbutylphosphine borine	$CH_3(C_4H_9)PH:BH_3$
Methylamylphosphine borine	$CH_3(C_5H_{11})PH:BH_3$
Methylphenylphosphine borine	$CH_3(C_6H_5)PH:BH_3$
Methylhexylphosphine borine	$CH_3(C_6H_{13})PH:BH_3$
Methylheptylphosphine borine	$CH_3(C_7H_{15})PH:BH_3$
Methyloctylphosphine borine	$CH_3(C_8H_{17})PH:BH_3$
Diphenylphosphine borine	$(C_6H_5)_2PH:BH_3$
Dicyclohexylphosphine borine	$(C_6H_{11})_2PH:BH_3$
Methyldodecylphosphine borine	$CH_3(C_{12}H_{25})PH:BH_3$
1,3-Trimethylene-P,P'-bis(methylphosphine borine)	$H_3B:CH_3HP(CH_2)_3PHCH_3:BH_3$
Dimethyl( $\beta$ -dimethylphosphinoethyl)phosphine borine	$(CH_3)_2P(CH_2)_2P(CH_3)_2:BH_3$
1,2-Dimethylene-P,P'-bis(dimethylphosphine borine)	$H_3B:(CH_3)_2P(CH_2)_2P(CH_3)_2:BH_3$

M.p., °C.	B.p., °C./mm.	Remarks	Reference
-	-	Liquid	A21
-	-	Liquid	A31
-	-	Unstable liquid	C33, D22
-	-	Liquid $d^{25} = 0.778$	C27, E57
-	-	Liquid	B13
-	-	Liquid	C26, E57
-	-	Liquid	C27, C34
-	-	Liquid $d^{25} = 0.784$	E57
-	-	Liquid $d^{25} = 0.788$	E57
-	-	Liquid $d^{25} = 0.944$	C28, E57
-	-	Liquid $d^{25} = 0.793$	E57
-	-	Liquid $d^{25} = 0.798$	E57
-	-	Liquid $d^{25} = 0.804$	E57
49-52	-		C35
74-77	-		C34
-	-	Liquid	C27, C32
-	-	Solid	B13
-	-		D67
> 150	-		C92, D67

Name	Formula
1,3-Trimethylene-P,P'-bis(dimethylphosphine borine)	$H_3B:(CH_3)_2P(CH_2)_3P(CH_3)_2:BH_3$
Dimethylaminodimethylphosphine borine	$(CH_3)_2NP(CH_3)_2:BH_3$
Dimethylaminomethyltrifluoromethylphosphine borine	$(CH_3)_2NPCH_2CF_3:BH_3$
Tetramethylbiphosphine borine	$(CH_3)_2PP(CH_3)_2:BH_3$
1,1-Dimethyl-2,2-bis(trifluoromethyl)biphosphine borine	$(CF_3)_2PP(CH_3)_2:BH_3$
Tetramethylbiphosphine bis(borine)	$H_3B:(CH_3)_2PP(CH_3)_2:BH_3$
<u>TRIBOROPHANES</u>	
P-Hexakis(trifluoromethyl)triborophane	$[(CF_3)_2PBH_2]_3$
P-Hexaethyltriborophane	$[(C_2H_5)_2PBH_2]_3$
P-Tris(cyclotetramethylene)triborophane	$[\underline{CH_2(CH_2)_3}PBH_2]_3$
1,3,5-Trimethyl-1,3-diethyl-5-i-propyltriborophane	$[\underline{CH_3(C_2H_5)PBH_2}]_2CH_3(i-C_3H_7)PBH_2$
1,3,5-Trimethyl-1-ethyl-3,5-di-i-propyltriborophane	$CH_3(C_2H_5)PBH_2[\underline{CH_3(i-C_3H_7)PBH_2}]_2$
1,3,5-Trimethyl-1,3,5-tri-i-propyltriborophane	$[\underline{CH_3(i-C_3H_7)PBH_2}]_3$
P-Hexacyclohexyltriborophane	$[(C_6H_{11})_2PBH_2]_3$
P-Hexa-p-tolyltriborophane	$[(p-CH_3C_6H_4)_2PBH_2]_3$
1,3,5-Trimethyl-1,3,5-tridodecyltriborophane	$[\underline{CH_3(C_{12}H_{25})PBH_2}]_3$

M.p., °C.	B.p., °C./mm.	Remarks	Reference
162-163	-		E58
9.5-12	> 200 (calc.)		F15, 11
-21	> 164 (calc.)		D99
45	54/1		G15, 8
-30	-		C87
> 194	102.5/1		G13
30.4	177 (calc.)		F38, G42, 5
-7 to -6	134/1.5	$n_D^{25} = 1.5293$ ; $d^{25} = 0.914$	E22, F3, 11
169	-		C34, C79, F9, G18, 12
-	-	Liquid	B16
-	-	Liquid	B16
-	-	Glass at low temp., $n_D^{20} = 1.5291$	B13
256-258	-		C28, C34
199-203	-		B13
-	-	Semi-solid	C32

Name	Formula
1,3,3,5,5-Pentamethyl-1- $\beta$ -(1,3,3,5,5-pentamethyl-1-triborophyl)propyl/triborophane	$\text{CH}_2(\text{CH}_2(\text{CH}_3)\text{PBH}_2\text{[(CH}_3)_2\text{PBH}_2\text{]}_2)_2$
P-Hexamethyl-B-methyltriborophane	$\text{[(CH}_3)_2\text{PBH}_2\text{]}_2(\text{CH}_3)_2\text{PBHCH}_3$
P-Hexamethyl-B,B'-dimethyltriborophane	$(\text{CH}_3)_2\text{PBH}_2\text{[(CH}_3)_2\text{PBHCH}_3\text{]}_2$
P-Hexamethyl-B,B',B''-trimethyltriborophane	$\text{[(CH}_3)_2\text{PBHCH}_3\text{]}_3$
P-Hexamethyl-B,B,B',B''-tetramethyltriborophane	$\text{[(CH}_3)_2\text{PBHCH}_3\text{]}_2(\text{CH}_3)_2\text{PB}(\text{CH}_3)_2$
P-Hexamethyl-B-phenyltriborophane	$\text{[(CH}_3)_2\text{PBH}_2\text{]}_2(\text{CH}_3)_2\text{PBHC}_6\text{H}_5$
P-Hexamethyl-B,B'-diphenyltriborophane	$(\text{CH}_3)_2\text{PBH}_2\text{[(CH}_3)_2\text{PBHC}_6\text{H}_5\text{]}_2$
1,2,2,3,4,4,5,6,6-Nonamethyl-1,3,5-triphenyltriborophane	$\text{[(CH}_3)_2\text{PB}(\text{C}_6\text{H}_5)\text{]}_3$
P-Hexamethyl-B-cyanotriborophane	$\text{[(CH}_3)_2\text{PBH}_2\text{]}_2(\text{CH}_3)_2\text{PBHCN}$
P-Hexamethyl-B,B'-dicyanotriborophane	$(\text{CH}_3)_2\text{PBH}_2\text{[(CH}_3)_2\text{PBHCN}\text{]}_2$
P-Hexamethyl-B-hexafluorotriborophane	$\text{[(CH}_3)_2\text{PBF}_2\text{]}_3$
P-Hexamethyl-B-chlorotriborophane	$\text{[(CH}_3)_2\text{PBH}_2\text{]}_2(\text{CH}_3)_2\text{PBHCl}$
P-Hexamethyl-B,B'-dichlorotriborophane	$(\text{CH}_3)_2\text{PBH}_2\text{[(CH}_3)_2\text{PBHCl}\text{]}_2$
P-Hexamethyl-B-hexachlorotriborophane	$\text{[(CH}_3)_2\text{PBCl}_2\text{]}_3$
1,3,5-Trimethyl-1,3,5-triethyl-2,2,4,4,6-pentachlorotriborophane	$\text{CH}_3(\text{C}_2\text{H}_5)\text{PBHCl}[\text{CH}_3(\text{C}_2\text{H}_5)\text{PBCl}_2\text{]}_2$
1,3,5-Trimethyl-1,3,5-triethyl-2,2,4,4,6,6-hexachlorotriborophane	$\text{[(CH}_3(\text{C}_2\text{H}_5)\text{PBCl}_2\text{]}_3$
P-Hexamethyl-B-bromotriborophane	$\text{[(CH}_3)_2\text{PBH}_2\text{]}_2(\text{CH}_3)_2\text{PBHBr}$
P-Hexamethyl-B,B'-dibromotriborophane	$(\text{CH}_3)_2\text{PBH}_2\text{[(CH}_3)_2\text{PBHBr}\text{]}_2$



M.p., °C.	B.p., °C./mm	Remarks	Reference
121-122	-		B15
-	-		E43
-	-		E41
-	-		E41
-	-		E41
101-102	-		E41, E44
160-162	-		E44
167-174	-		C36
106.5-108	-		E49
127-128	-		E50
127-129	-		A22, D29
72.5-74	-		E27
117-118	-		E27
377-378	-		A22, E26
-	-	Solid	A25
210-211	-		C42
76-78	-		E30
129-131	-		A25, E29

Name	Formula
P-Hexamethyl-B,B',B''-tribromotri- borophane	$\left[ (\text{CH}_3)_2\text{PBHBr} \right]_3$
P-Hexamethyl-B-hexabromotriborophane	$\left[ (\text{CH}_3)_2\text{PBBR}_2 \right]_3$
P-Hexamethyl-B-iodotriborophane	$\left[ (\text{CH}_3)_2\text{PBH}_2 \right]_2 (\text{CH}_3)_2\text{PBHI}$
P-Hexamethyl-B-hexaiodotriborophane	$\left[ (\text{CH}_3)_2\text{PBI}_2 \right]_3$
<u>TETRABOROPHANES</u>	
P-Octakis(trifluoromethyl)tetra- borophane	$\left[ (\text{CF}_3)_2\text{PBH}_2 \right]_4$
1,3,5,7-Tetramethyl-1,3,5,7-tetra-i- propyltetraborophane	$\left[ \text{CH}_3(\text{i-C}_3\text{H}_7)\text{PBH}_2 \right]_4$
1,3,5,7-Tetramethyl-1,3,5,7-tetra- dodecyltetraborophane	$\left[ \text{CH}_3(\text{C}_{12}\text{H}_{25})\text{PBH}_2 \right]_4$
P-Octamethyl-B-"hexa"chlorotetra- borophane	$\left[ (\text{CH}_3)_2\text{P} \right]_4 \text{B}_4\text{H}_2\text{Cl}_6$
<u>MONOCYCLIC BOROPHANE POLYMERS</u>	
Polymer from 1,3-Trimethylene-P,P'- bis(methylphosphine borine)	$\left[ \text{H}_2\text{BP}(\text{CH}_3)(\text{CH}_2)_3(\text{CH}_3)\text{PBH}_2 \right]_x$
Copolymer from 1,3-Trimethylene-P,P'- bis(methylphosphine borine) and Dimethylphosphine borine	$\left[ \text{H}_2\text{BP}(\text{CH}_3)(\text{CH}_2)_3(\text{CH}_3)\text{PBH}_2 \right]_x -$ $\left[ (\text{CH}_3)_2\text{PBH}_2 \right]_y$

M.p., °C.	B.p., °C./mm.	Remarks	Reference
-	-	Solid	A25, E29
>411 dec.	-		A25, E28
82.5-84	-		E32
>411 dec.	-		A25
116	98.4/4		G50, 5
-	-	Liquid	B13
-	-		C32
320-323	-	Crude mixture of isomers	A24
-	-	Solid	B13
-	-	Solid	B15

Name	Formula
<u>POLYCYCLIC BOROPHANE POLYMERS</u>	
P-Nonamethylbicyclo[4.4.0]penta- borophane	$\left[ (\text{CH}_3)_2\text{PBH}_2 \right]_4 \text{CH}_3\text{PBH}$
P-Dimethylborophane--P-Methyldehydro- borophane Copolymer	$\left[ (\text{CH}_3)_2\text{PBH}_2 \right]_x (\text{CH}_3\text{PBH})_y$
P-Ethylborophane--P-Ethyldehydro- borophane Copolymer	$\left[ \text{C}_2\text{H}_5\text{HPBH}_2 \right]_x (\text{C}_2\text{H}_5\text{PBH})_y$
P-Methylethylborophane--P-Methyl- dehydroborophane Copolymer	$\left[ \text{CH}_3(\text{C}_2\text{H}_5)\text{PBH}_2 \right]_x (\text{CH}_3\text{PBH})_y$
P-Methylethylborophane--P-Ethyldehydro- borophane Copolymer	$\left[ \text{CH}_3(\text{C}_2\text{H}_5)\text{PBH}_2 \right]_x (\text{C}_2\text{H}_5\text{PBH})_y$
P-Methylethylborophane--P-Phenyl- dehydroborophane Copolymer	$\left[ \text{CH}_3(\text{C}_2\text{H}_5)\text{PBH}_2 \right]_x (\text{C}_6\text{H}_5\text{PBH})_y$
P-Nonamethyl-B-iodobicyclo[4.4.0]- pentaborophane	$\left[ (\text{CH}_3)_2\text{PBH}_2 \right]_3 \left[ (\text{CH}_3)_2\text{PBHI} \right] \text{CH}_3\text{PBH}$
1,1,3,3,5,7,7,9,9-Nonamethyl-2,2,4,4,- 6,6,8,8-Octachlorobicyclo[4.4.0]- pentaborophane	$\left[ (\text{CH}_3)_2\text{PBCL}_2 \right]_4 \text{CH}_3\text{PBH}$
<u>LINEAR POLYBOROPHANES</u>	
P-Methyl-B-dimethylborophane polymer	$\left[ \text{CH}_3\text{HPB}(\text{CH}_3)_2 \right]_x$
P-Dimethylborophane polymer	$\left[ (\text{CH}_3)_2\text{PBH}_2 \right]_x$
P-Methylethylborophane polymer	$\left[ \text{CH}_3(\text{C}_2\text{H}_5)\text{PBH}_2 \right]_x$
P-Diethylborophane polymer	$\left[ (\text{C}_2\text{H}_5)_2\text{PBH}_2 \right]_x$
P-Methylpropylborophane polymer	$\left[ \text{CH}_3(\text{C}_3\text{H}_7)\text{PBH}_2 \right]_x$

M.p., °C.	B.p., °C./mm.	Remarks	Reference
98-99	-		C34
-	-	Glass	C33
-	-	Glass	A21
-	-	Viscous liquid and glass	A30
-	-	Viscous liquid and glass	A31
-	-	Glass	B18
136-137 147-148.5	- -	M.p. and IR indicate two isomers	E33
272-273	-		C42
-	-	Glass at low temp.	A21
170-172	-	Depolymerizes at high temp.	C25, D20, E20, 8, 9
118-126	-	Depolymerizes at high temp.	C26, D20
263-267	-		C26, D21, E22
-	-	Viscous liquid	C27

Name	Formula
P-Methyl-i-propylborophane polymer	$\overline{[\text{CH}_3(\text{i-C}_3\text{H}_7)\text{PBH}_2]_x}$
P-Methylphenylborophane polymer	$\overline{[\text{CH}_3(\text{C}_6\text{H}_5)\text{PBH}_2]_x}$
P-Methyldodecylborophane polymer	$\overline{[\text{CH}_3(\text{C}_{12}\text{H}_{25})\text{PBH}_2]_x}$
P-Dimethyl-B-dichloroborophane polymer	$\overline{[(\text{CH}_3)_2\text{PBCl}_2]_x}$
P-Dimethylborophane--P-Methyldodecylborophane copolymer	$\overline{[(\text{CH}_3)_2\text{PBH}_2]_x \overline{[\text{CH}_3(\text{C}_{12}\text{H}_{25})\text{PBH}_2]_y}}$
<u>BORAZENES</u>	
N-Dimethyl-B-trimethylborazene	$\text{H}(\text{CH}_3)_2\text{N}_3\text{B}_3(\text{CH}_3)_3$
N-Lithio-B-trimethylborazene	$\text{LiH}_2\text{N}_3\text{B}_3(\text{CH}_3)_3$
N-Dilithio-B-trimethylborazene	$\text{Li}_2\text{HN}_3\text{B}_3(\text{CH}_3)_3$
N-Dilithio-N-methyl-B-trimethylborazene	$\text{Li}_2\text{CH}_3\text{N}_3\text{B}_3(\text{CH}_3)_3$
N-Lithio-N-dimethyl-B-trimethylborazene	$\text{Li}(\text{CH}_3)_2\text{N}_3\text{B}_3(\text{CH}_3)_3$
N-Trimethyl-B-dimethyl-B-chloroborazene	$(\text{CH}_3)_3\text{N}_3\text{B}_3(\text{CH}_3)_2\text{Cl}$
N-Trimethyl-B-methyl-B-dichloroborazene	$(\text{CH}_3)_3\text{N}_3\text{B}_3\text{CH}_3\text{Cl}_2$
N-Trimethyl-B-dimethyl-B-bromoborazene	$(\text{CH}_3)_3\text{N}_3\text{B}_3(\text{CH}_3)_2\text{Br}$
N-Trimethyl-B-methyl-B-dibromoborazene	$(\text{CH}_3)_3\text{N}_3\text{B}_3\text{CH}_3\text{Br}_2$
Decamethyl-B,N'-biborazyl	$\overline{[(\text{CH}_3)_3\text{N}_3\text{B}_3(\text{CH}_3)_2]_2} \overline{[(\text{CH}_3)_2\text{N}_3\text{B}_3(\text{CH}_3)_3]_3}$
1,3-Bis(pentamethyl-2'-borazyl)-2,4,5,6-tetramethylborazene	$\overline{[(\text{CH}_3)_3\text{N}_3\text{B}_3(\text{CH}_3)_2]_2} \overline{2\text{CH}_3\text{N}_3\text{B}_3(\text{CH}_3)_3}$
1,3,5,6-Tetramethyl-2,4-bis(pentamethyl-1'-borazyl)borazene	$(\text{CH}_3)_3\text{N}_3\text{B}_3\text{CH}_3 \overline{[(\text{CH}_3)_2\text{N}_3\text{B}_3(\text{CH}_3)_3]_2}$
1,3,5-Trimethyl-2,4,6-tris(pentamethyl-1'-borazyl)borazene	$(\text{CH}_3)_3\text{N}_3\text{B}_3 \overline{[(\text{CH}_3)_2\text{N}_3\text{B}_3(\text{CH}_3)_3]_3}$

M.p., °C.	B.p., °C./mm.	Remarks	Reference
-	-	Viscous liquid	C27
-	-		C28
-	-		C27
215-225	-		C31, D23, E25
122-125	-		C30
-	187.5-188.5	$d^{25} = 0.88$	D37, E86
-	-		E88
-	-		E88
-	-		E78
-	-		E76
127-128.5	-		C58, D41, E92
145-146	-		E95
127-129	-		E97
140-142	-		E97
172-174	-		E76
207-210	-		E78
135-138	-		E78
236-245	-		E80

Name	Formula
Poly-1',2,3',4,5,5',6,6'-Octamethylbi-borazylene	$(\overline{[(CH_3)_3B_3N_3CH_2]} \overline{[CH_3B_3N_3(CH_3)_3]})_x$
Decamethyl-B,B'-diborazyl oxide	$\overline{[(CH_3)_3N_3B_3(CH_3)_2]}_2O$
Poly(1,3,5,6-tetramethyl-2,4-borazylene oxide)	$(\overline{[(CH_3)_3N_3B_3CH_2]O})_x$
<b>MISCELLANEOUS BORON-NITROGEN COMPOUNDS</b>	
Trimethylamine difluoroborine	$(CH_3)_3N:BHF_2$
Triethylenediamine borine	$N(C_2H_4)_3N:BH_3$
Triethylenediamine bis(borine)	$H_3B:N(C_2H_4)_3N:BH_3$
Aminodimethylborine trimer	$\overline{[H_2NB(CH_3)_2]}_3$
8-Bora-7,9-diazaro- <u>peri</u> -naphthene	$(C_{10}H_6)NHBHNH$
8-Methoxy-8-bora-7,9-diazaro- <u>peri</u> -naphthene	$(C_{10}H_6)NHB(OCH_3)NH$
8-Phenyl-8-bora-7,9-diazaro- <u>peri</u> -naphthene	$(C_{10}H_6)NHB(C_6H_5)NH$
7-Methyl-8-bora-7,9-diazaro- <u>peri</u> -naphthene	$(C_{10}H_6)N(CH_3)BHNH$
5'-(2'-Phenylborobenzimidazolyl)-2-phenylboro-5-benzimidazole	$\overline{[(C_6H_5)B(NH)_2(C_6H_3)]}_2$
Polymer from Benzene-1,4-diboronic acid and 3,3',4,4'-Tetraaminobiphenyl	$\overline{[C_6H_4B(NH)_2(C_6H_3)_2(NH)_2B]}_x$
<b>MISCELLANEOUS PHOSPHORUS COMPOUNDS</b>	
Trifluoromethyltetrafluorophosphorane	$CF_3PF_4$



M.p., °C.	B.p., °C./mm.	Remarks	Reference
163-168	-	Resinous	E80
133-134	-		E81, E85
180-200	-	Glass	E86
>74	58.6/1		G45, 5
164-165	-		D19
> 390 dec.	-		D19
124.5-125	-		A21
97-99	-		D44
115-120	-		D44
92.5-93.5	-		E100
57-67	-		E98
338-340	-		E119
> 360	-		E120
-113	-39		G34

Name	Formula
Trifluoromethyltetrachlorophosphorane	$\text{CF}_3\text{PCl}_4$
Trifluoromethyltetrabromophosphorane	$\text{CF}_3\text{PBr}_4$
Bis(trifluoromethyl)trifluorophosphorane	$(\text{CF}_3)_2\text{PF}_3$
Bis(trifluoromethyl)tribromophosphorane	$(\text{CF}_3)_2\text{PBr}_3$
Tris(trifluoromethyl)dibromophosphorane	$(\text{CF}_3)_3\text{PBr}_2$
Methyl bis(trifluoromethyl)phosphinite	$(\text{CF}_3)_2\text{POCH}_3$
t-Butyl bis(trifluoromethyl)phosphinite	$(\text{CF}_3)_2\text{POC}_4\text{H}_9$
$\beta$ -Bis(trifluoromethylphosphino)ethyl bis(trifluoromethyl)phosphinite	$(\text{CF}_3)_2\text{POCH}_2\text{CH}_2\text{P}(\text{CF}_3)_2$
Bis(trifluoromethyl)phosphinous acid	$(\text{CF}_3)_2\text{POH}$
Bis(trifluoromethyl)phosphinous acid-d	$(\text{CF}_3)_2\text{POD}$
Dimethyl trifluoromethylphosphonite	$\text{CF}_3\text{P}(\text{OCH}_3)_2$
Cycloethylene trifluoromethylphosphonite	$\text{CF}_3\text{P}(\text{OCH}_2\text{CH}_2\text{O})$
Ethylene trifluoromethylphosphonite polymer	$(-\text{P}(\text{CF}_3)\text{OCH}_2\text{CH}_2\text{O}-)_x$
Trifluoromethylphosphonous Acid	$\text{CF}_3\text{P}(\text{OH})_2$
Dimethylphosphine oxide	$(\text{CH}_3)_2\text{PHO}$
Bis(trifluoromethyl)phosphine oxide	$(\text{CF}_3)_2\text{PHO}$
Bis(trifluoromethyl)methylphosphine oxide	$(\text{CF}_3)_2\text{CH}_3\text{PO}$

M.p., °C.	B.p., °C./mm.	Remarks	Reference
-52	20/10		G27, G36, 6
28	-	Orange-yellow	D89, 13
-76	-4.7 (calc.)		G34
9	-		D89, 13
-	-	Liquid	D89, 13
-78.5	55 (calc.)		E151, E157, E164
-26	110 (calc.)		E152, E157, E164
5	202 (calc.)		D75
-21.1	61 (calc.)		D77, E157, 10
-19.2	-		E153, E157
<-78	88 (calc.)	Glass at low temp.	E166
-33	107 (calc.)		E172
-	-	Mixture of liquid and solid	E172
-	214 (calc.)	Principally dimer	E168
-	-	Viscous easily decomposed liquid	E165, 17
-	-	Slightly volatile easily decomposed liquid	E164, 17
-27	129 (calc.)		E154, E161

Name	Formula
Bis(trifluoromethyl)-t-butylphosphine oxide	$(CF_3)_2t-C_4H_9PO$
1,4-Bis(diphenylphosphonyl)benzene	$(C_6H_5)_2P(O)C_6H_4P(O)(C_6H_5)_2$
Tetramethylbiphosphine dioxide	$(CH_3)_2P(O)P(O)(CH_3)_2$
Tetrakis(trifluoromethyl)diphosphoxane	$(CF_3)_2POP(CF_3)_2$
Polymer from oxidation of Cyclo-tri-fluoromethylphosphines	$(CF_3PO_2)_x$
Diphenylphosphonyl azide	$(C_6H_5)_2PON_3$
Triphenylphosphine diphenylphosphonyl azide	$(C_6H_5)_2PON_3 \cdot P(C_6H_5)_3$
Trimethylphosphine adduct of Cyclo-tri-fluoromethylphosphine monomer	$(CH_3)_3PPCF_3$
Trimethylamine adduct of Cyclo-tri-fluoromethylphosphine monomer	$(CH_3)_3NPCF_3$
Polymer from Diphenyldiacetoxysilane and Phenylphosphonyl dichloride	$\left[ (C_6H_5)_2SiOP(O)C_6H_5 \right]_x$
Nickel dicarbonyl bis(trifluoromethylphosphine)	$\left[ (CF_3)_3P \right]_2Ni(CO)_2$
Lithium tris(dimethylphosphino)aluminumhydride	$LiAlH \left[ P(CH_3)_2 \right]_3$
Dimethylphosphinoaluminane dimethylphosphine	$(CH_3)_2PALH_2 \cdot (CH_3)_2PH$
Dimethylphosphinodichloroaluminane	$\left[ (CH_3)_2PALCl_2 \right]_x$
Bis(dimethylphosphino)chloroaluminane	$\left[ (CH_3)_2P \right]_2AlCl$
Nitrilophosphoric dimethylamide chloride	$\left[ (CH_3)_2NPNC l \right]_3$
Polymer from Nitrilophosphoric chloride trimer and Sodium acetylde	$\left[ (NP)_3Cl_5(C_2H)_{1.6} \right]_x$

M.p., °C.	B.p., °C./mm.	Remarks	Reference
-	177 (calc.)		E153, E163, G33
297-302	-		E113
133	-		D81, E150
-52	78 (calc.)		D71, 10
-	-	Series of polymers	G28, 6
-	137-140		E112
149-150	-		E114
-	-	Unstable solid	C95, D95
-	-	Unstable yellow solid	C97, E176
-	-		E118
-31	0/1		G37, 4
-	-	Non-volatile solid	G19, 14
-	-	Non-volatile	G19, 14
-	-	Non-volatile	G20, 14
-	-	Non-volatile	G22, 14
-	-		G53, 7
-	-		G55, 7

Name	Formula
<u>MISCELLANEOUS</u>	
Trifluoromethyldifluoroborine	$\text{CF}_3\text{BF}_2$
Dimethylaminotrifluoromethyl sulfide	$(\text{CH}_3)_2\text{NSCF}_3$
Tetraphenyldimethyldisilthiane	$\left[ (\text{C}_6\text{H}_5)_2\text{CH}_3\text{Si} \right]_2\text{S}$
Polymer from Diphenyldiacetoxysilane and Terephthalic acid	$\left[ (\text{C}_6\text{H}_5)_2\text{SiOCC}_6\text{H}_4\text{COO} \right]_x$
Polymer from Diphenyldiacetoxysilane and Tetrachloroterephthalic acid	$\left[ (\text{C}_6\text{H}_5)_2\text{SiOCC}_6\text{Cl}_4\text{COO} \right]_x$

M.p., °C.	B.p., °C./mm.	Remarks	Reference
-	-78/5		C107, F52, G60, 16
-98.8	56 (calc.)		C107, 16
110-112	-		E202
> 255	-		E118
-	-		E118

Bibliography for Table XLV

- A. R. I. Wagner, et al., WADC Technical Report 57-126, Part I, March 1957.
- B. R. I. Wagner, et al., WADC Technical Report 57-126, Part II, February, 1958.
- C. R. I. Wagner, et al., WADC Technical Report 57-126, Part III, March 1959.
- D. R. I. Wagner, et al., WADC Technical Report 57-126, Part IV, March 1960.
- E. R. I. Wagner, et al., WADC Technical Report 57-126, Part V, January 1961.
- F. A. B. Burg, et al., WADC Technical Report 56-82, Part II, May 1957.
- G. A. B. Burg, et al., WADC Technical Report 56-82, Part III, April 1958.
1. W. Mahler and A. B. Burg, J. Am. Chem. Soc., 79, 251 (1957).
2. A. B. Burg and W. Mahler, J. Am. Chem. Soc., 79, 4242 (1957).
3. A. B. Burg and P. J. Slota, Jr., J. Am. Chem. Soc., 80, 1107 (1958).
4. A. B. Burg and W. Mahler, J. Am. Chem. Soc., 80, 2334 (1958).
5. A. B. Burg and G. Brendel, J. Am. Chem. Soc., 80, 3198 (1958).
6. W. Mahler and A. B. Burg, J. Am. Chem. Soc., 80, 6161 (1958).
7. A. B. Burg and A. P. Caron, J. Am. Chem. Soc., 81, 836 (1959).
8. A. B. Burg, J. Inorg. Nucl. Chem., 11, 258 (1959).
9. R. I. Wagner and F. F. Caserio, Jr., J. Inorg. Nucl. Chem., 11, 259 (1959).
10. J. E. Griffiths and A. B. Burg, J. Am. Chem. Soc., 82, 1507 (1960).
11. A. B. Burg and P. J. Slota, Jr., J. Am. Chem. Soc., 82, 2145 (1960).
12. A. B. Burg and P. J. Slota, Jr., J. Am. Chem. Soc., 82, 2148 (1960).
13. A. B. Burg and J. E. Griffiths, J. Am. Chem. Soc., 82, 3514 (1960).
14. A. B. Burg and K. Mödritzer, J. Inorg. Nucl. Chem., 13, 318 (1960).
15. J. E. Griffiths and A. B. Burg, J. Am. Chem. Soc., 82, 5759 (1960).
16. T. D. Parsons, E. D. Baker, A. B. Burg and G. L. Juvinall, J. Am. Chem. Soc., 83, 250 (1961).
17. J. E. Griffiths and A. B. Burg, Proc. Chem. Soc., 1961, 12.



UNCLASSIFIED

AMERICAN POTASH & CHEMICAL CORPORATION, Whittier, California, PHOSPHINOBORINE POLYMERS, by R. I. Wagner, A. B. Burg and D. L. Mayfield, May 1961. 234p. incl. illus. and tables (Project 7340; Task 73404) (WADC TR 57-126 Pt V)  
(Contract AF 33(616)-6913)  
Unclassified report

In continuing research toward the development of thermally stable polymers based on the boron-to-phosphorus bond system, experiments were conducted to find means of improving the thermal stability of linear phosphinoborine (borophane) polymers, and

UNCLASSIFIED

( over )

UNCLASSIFIED

UNCLASSIFIED

AMERICAN POTASH & CHEMICAL CORPORATION, Whittier, California, PHOSPHINOBORINE POLYMERS, by R. I. Wagner, A. B. Burg and D. L. Mayfield, May 1961. 234p. incl. illus. and tables (Project 7340; Task 73404) (WADC TR 57-126 Pt V)  
(Contract AF 33(616)-6913)  
Unclassified report

In continuing research toward the development of thermally stable polymers based on the boron-to-phosphorus bond system, experiments were conducted to find means of improving the thermal stability of linear phosphinoborine (borophane) polymers, and

UNCLASSIFIED

( over )

UNCLASSIFIED

to introduce a variety of boron substituents into the linear and cyclic polymers. An investigation of the boron-to-nitrogen bond system led to two series of polycyclic borazene polymers one directly bonded and the other bonded through oxygen. Screening experiments on thermally stable polymers systems based on phosphorus-to-nitrogen, phosphorus-to-oxygen-to-silicon, and carbon-to-oxygen-to-silicon bond systems were conducted.

UNCLASSIFIED

UNCLASSIFIED