

UNCLASSIFIED

AD 281 804

*Reproduced
by the*

**ARMED SERVICES TECHNICAL INFORMATION AGENCY
ARLINGTON HALL STATION
ARLINGTON 12, VIRGINIA**



UNCLASSIFIED

NOTICE: When government or other drawings, specifications or other data are used for any purpose other than in connection with a definitely related government procurement operation, the U. S. Government thereby incurs no responsibility, nor any obligation whatsoever; and the fact that the Government may have formulated, furnished, or in any way supplied the said drawings, specifications, or other data is not to be regarded by implication or otherwise as in any manner licensing the holder or any other person or corporation, or conveying any rights or permission to manufacture, use or sell any patented invention that may in any way be related thereto.

**Best
Available
Copy**

281804

281804

① FC

THE LORAN-C SYSTEM OF NAVIGATION

AD NO. —
ASTIA FILE COPY

FEBRUARY 1962

ASTIA
RECORDED
AUG 9 1962



JANSKY & BAILEY

A Division of Atlantic Research Corporation
Washington, D. C. Alexandria, Va.

NO OTS

THE LORAN-C SYSTEM OF NAVIGATION

February 1962

Prepared for the U.S. Coast Guard

by

Jansky & Bailey

Washington, D. C.

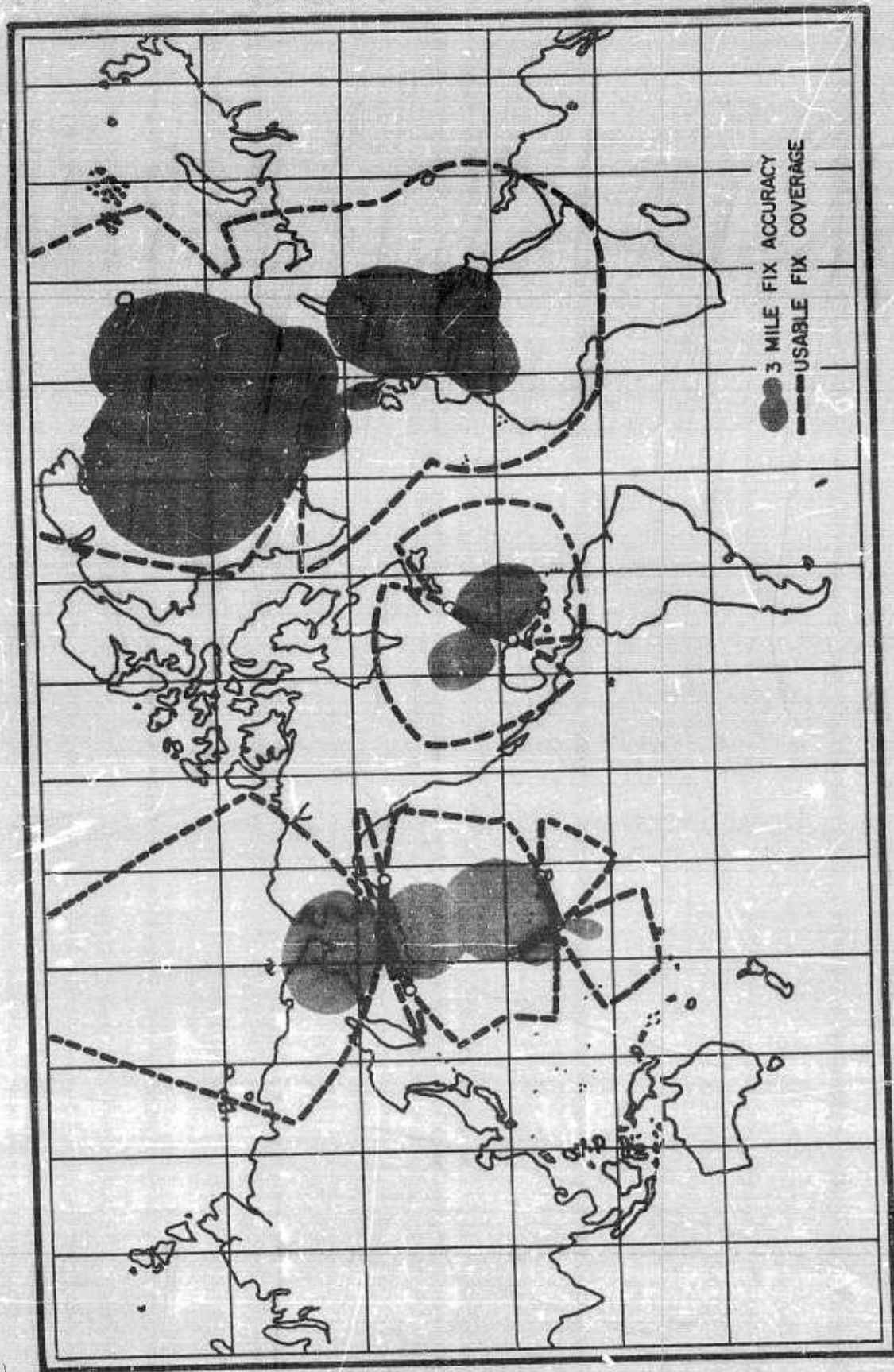

PRESENT (1961) LORAN-C COVERAGE WITH 17 STATIONS

PREFACE

The purpose of this report is to present, in a single volume, a condensation of LORAN-C information of interest to management, operational and engineering personnel. *is presented.* ~~The report is divided into two parts. Part I~~ *is provided* a general description of the LORAN-C system, its history, its operational capabilities as a radio navigation system, and its collateral uses. ~~Part II contains technical information~~ *is also provided.* on the system engineering aspects.

FOREWORD

The term LORAN, an acronym derived from the descriptive phrase Long Range Navigation, encompasses pulsed hyperbolic radio aids to navigation. Expansion of the original LORAN concept to meet operational requirements for greater accuracy and greater service range has resulted in the development of three related systems now designated as LORAN-A, LORAN-B, and LORAN-C.

All LORAN systems provide navigational-fix data in the form of hyperbolic lines-of-position determined by the time-difference between the reception of pulse signals from widely separated shore transmitting stations.

The technical principle that distinguishes the various versions of LORAN from the other hyperbolic radio navigation systems is the use of pulse emissions. This permits the non-ambiguous measurement of time-differences of signals from different stations and further provides the means for discrimination at the receiving location between groundwave and skywaves. The ability to select and utilize a particular transmission mode provides maximum fix accuracy consistent with the inherent system geometric accuracy.

TABLE OF CONTENTS

PART I - THE LORAN SYSTEM

<u>CHAPTER</u>		<u>PAGE</u>
1	HISTORY OF LORAN	3
1.1	Basic Principle of Hyperbolic Radio Navigation System	3
1.2	Historical Background of Hyperbolic Systems	4
	Early Hyperbolic Sound Systems	4
	The GEE System	6
1.3	Historical Background of the LORAN Systems	6
	Standard LORAN System (LORAN-A)	6
	Skywave Synchronized LORAN	8
	MF/HF Long Baseline LORAN	9
	Early Efforts Toward an LF LORAN System	9
	CYCLAN	11
	NAVAGLOBE/FACOM/NAVARHO	12
	CYTAC/LORAN-C	13
	Status of LORAN-C Transmitting Station Installations	14
1.4	Regulatory History of LORAN	16
	General	16
	Status of LORAN-A Under the Cairo Regulations (1938)	17
	LORAN and The Atlantic City Radio Regulations (1947)	18
	Effect of Action by the Provisional Frequency Board (PFB) and the Extraordinary Administrative Radio Conference (EARC) on LORAN-C	19
	U.S. Proposal to the Geneva Radio Conference (1959)	20

TABLE OF CONTENTS
(Continued)

<u>CHAPTER</u>		<u>PAGE</u>
1	1.5 The Present International and National Regulatory Status of LORAN-C	21
	Introduction	21
	International Regulatory Considerations	21
	1.6 Policies and Programs for LORAN-C	27
	General	27
	Operational Requirements	28
	National Regulatory Considerations	31
	Future LORAN Systems Planning	32
2	PRINCIPLES OF LORAN-C	35
	2.1 Introduction	35
	2.2 Basic Principles of the LORAN-C System	35
	LORAN System Geometry	38
	Defective Operation and Temporary Suspension of Service	38
	Pulse Repetition Rates	38
	Terminology	39
	Signal Characteristics	40
	Groundwave Range	40
	Skywave Range	43
	2.3 Identification and Use of LORAN-C Signals	43
	General	43
	Plotting Lines-of-Position	44
	LORAN Tables Provide Greater Accuracy	45

TABLE OF CONTENTS
(Continued)

<u>CHAPTER</u>		<u>PAGE</u>
2	2.4 Transmission Characteristics	45
	2.5 Over-all System Accuracy	47
	Instrumentation of User Equipment	47
	System Accuracy	49
	2.6 Accuracy of LORAN Fixes	50
3	CHARTS, TABLES AND CORRECTIONS	53
	3.1 General Information Concerning Use of Charts and Tables	53
	LORAN-C Navigation Charts	53
	LORAN-C Tables	54
	3.2 Corrections Applied to Time-Difference Readings	55
	Skywave Corrections	55
	Transmission Delay Curves	56
	Conventional Corrections	57
	Special Corrections	57
	Application of Correction for Matching Groundwaves to Skywaves	59
4	ADDITIONAL USES OF LORAN-C	61
	4.1 Introduction	61
	4.2 Location of Geographic Positions	61
	4.3 Distance Measuring	62
	4.4 Timing	62
	4.5 Homing	66
	4.6 Propagation Studies	66

TABLE OF CONTENTS
(Continued)

<u>CHAPTER</u>	PART II - LORAN-C SYSTEMS ENGINEERING	<u>PAGE</u>
5	CONSIDERATIONS AFFECTING THE CHOICE OF LORAN-C CHARACTERISTICS	73
	5.1 Basic System Types	73
	5.2 Choice of Optimum Frequency	74
	5.3 Comparison of Pulse and Continuous-Wave Radio Navigation Systems	74
	5.4 Total Bandwidth Required by a Pulse System	78
	5.5 Over-all Spectrum Utilization Efficiency	84
6	LORAN-C PRINCIPLES OF OPERATION	87
	6.1 Hyperbolic Principle	87
	6.2 Synchronization of Signals for Time Measurements	87
	6.3 Pulse Operation	88
	6.4 Time Spacing of Master and Slave Signals	91
	6.5 Identification of a Particular Group of Master and Slaves	92
	6.6 Special Features of LORAN-C Relative to Corresponding Features of LORAN-A	93
7	SYSTEM OPERATION AND CALIBRATION	97
	7.1 Operation of a LORAN-C Triad	97
	7.2 Monitoring and Calibrating Operations	99
	7.3 Operation of a LORAN-C Receiver for Obtaining a Position Fix	101
8	TECHNICAL DESCRIPTION OF COMPONENTS OF LORAN-C SYSTEM	105
	8.1 LORAN-C Ground Station Equipment	105

TABLE OF CONTENTS
(Continued)

<u>CHAPTER</u>		<u>PAGE</u>
8	8.2 Technical Description of LORAN-C Receiving Equipment	117
9	LORAN-C PERFORMANCE	129
	9.1 Introduction	129
	9.2 Partition of System Errors	129
	9.3 Effects of Geometry on LORAN System Error	129
	9.4 Groundwave Performance	132
	Groundwave Prediction Error	133
	Groundwave Propagation Anomalies	134
	System Area Monitors	134
	Geographic Accuracy	135
	LORAN-C Position Measurement Repeatability and Instrumental Errors	135
	9.5 Skywave Performance of LORAN-C	138
	Skywave Discrimination	138
	Skywave Corrections	140
	9.6 Use of LORAN-A Receivers for Making Measurement of LORAN-C Signals	140
	9.7 Summary of Observed Performance of LORAN-C	143
	9.8 LORAN-C Coverage	143
10	LORAN-C SYSTEM PLANNING AND IMPLEMENTATION	145
	10.1 Introduction	145
	10.2 Noise Considerations	145
	10.3 Signal Considerations	146
	10.4 Geometric Considerations	148

TABLE OF CONTENTS
(Continued)

<u>CHAPTER</u>		<u>PAGE</u>
10	10.5 Reconciliation of Geometric and Signal Considerations	149
	10.6 Monitor Stations	149
	10.7 Initial Studies of Potential Transmitting Sites	150
	10.8 Physical Considerations of the Site	150
	10.9 Site Antenna Considerations	151
	10.10 Environmental Considerations	152
	10.11 Topographic and Geographic Considerations	153
	10.12 Site Ownership Considerations	154
	10.13 Photography in Site Planning	154
	10.14 Operational Considerations	155
	10.15 Site Survey Report	157
	10.16 Planning Group Duties	158
	10.17 Calibration of the System	159
	10.18 Calibration of Team Composition and Tasks	160
	10.19 Normal Operation of the LORAN-C Chain	163
	10.20 Further Improvement in Service	164

LIST OF ILLUSTRATIONS

<u>FIGURE</u>		<u>PAGE</u>
1	A Hyperbolic Audio Location System	4
2	The Basic Hyperbolic Radio Navigation Principle	5
3	Estimated and Observed CYTAC Fix Errors	13
4	ITU Regions	25
5	Fix From a Triad Configuration	37
6	Propagation Paths	41
7	LORAN-C Star Chain	48
8	Tabulated Limits of Groundwave to Skywave Corrections	58
9	LORAN-C Clock	64
10	Slaved Versus Independent Clocks	65
11	LORAN-C Pulse	81
12	LORAN-C Ideal Spectrum	82
13	LORAN-C Spectrum	83
14	Time-Sharing Operation of LORAN-C Triad	95
15	LORAN-C Chart	103
16	A Typical LORAN-C Transmitting Station	106
17	A 625-foot Guyed LORAN-C Transmitting Antenna	107
18	Typical LORAN-C Station	108
19	AN/FPN-41 LORAN-C Timer-Synchronizer	111
20	AN/FPN-42 LORAN-C Transmitter	112
21	LORAN-C Station Equipment	113
22	LORAN-C Master Station Functional Block Diagram	114
23	LORAN-C Slave Station Functional Block Diagram	116
24	Receiver Block Diagram	118

LIST OF ILLUSTRATIONS
(Continued)

<u>FIGURE</u>		<u>PAGE</u>
25	LORAN-C Receiver AN/SPN-29	123
26	LORAN-C Receiver AN/SPN-30	124
27	LORAN-C Receiver AN/SPN-32	125
28	Automatic Airborne LORAN-C Receiver	126
29	Automatic LORAN-A/C Receiver AN/APN-145	127
30	Nomogram for Computing Contours of Constant Geometric Accuracy	130
31	Constant Geometric Accuracy Contours	131
32	Effect of Interference on Performance of a Typical LORAN-C Receiver (AN/SPN-28)	137
33	Nighttime Skywave Field Intensity	139
34	Present (1961) LORAN-C Coverage with 17 Stations	142
35	Groundwave Field Intensity	147
36	Secondary Phase Factor of Groundwave at 100 kc/s	162

LIST OF TABLES

<u>TABLE</u>		<u>PAGE</u>
1	High Power Transmitting Stations and Area Coverage of LORAN-C Chains	15
2	Frequency Allocations to Services	22
3	Navigation Ranges and Requirements	29
4	Pulse Repetition Rates	39
5	Expected Groundwave Range	42
6	Pulse Repetition Rates (Microseconds)	92

PART I

THE LORAN SYSTEM

CHAPTER 1

HISTORY OF LORAN

1.1 BASIC PRINCIPLE OF HYPERBOLIC RADIO NAVIGATION SYSTEMS

All hyperbolic radio navigation systems are based on the principle that radio frequency energy is propagated through space with a finite and known velocity. A measurement of the difference in times of arrival of radio signals from two points by a receiver provides an accurate measure of the difference in the distance of the propagation paths involved. By definition, the locus of points with a constant difference in distance from two reference points is a hyperbola. Measurement of constant time-differences and, hence, constant distant differences places the receiver on a hyperbolic line-of-position.

The reference signals may be transmitted and received by any feasible means (sound or radio) but radio frequency energy is the only present means which provides accurate long range information. Transmissions ranging from unmodulated continuous waves to short pulses may be used. The basic principle of position determination, however, remains the same. Since the readout of hyperbolic navigation systems consists of time-difference readings from a particular set of ground stations, means must be provided to convert the time-difference readings to geographic position.

Special charts, tables, or computers are utilized to interpret the measured time delays in terms of lines of geographical position. Charts for general navigation have representative hyperbolic lines corresponding to various time delays from the pairs of stations in addition to the ordinary latitude and longitude lines and other navigational data.

1.2 HISTORICAL BACKGROUND OF HYPERBOLIC SYSTEMS

Early Hyperbolic Sound Systems

The first known practical application of the principle of position determination by measurement of the relative time of arrival of signals involved the use of sound waves rather than radio waves. One such system used during World War I for locating the position of hidden cannon is shown in Figure 1. Since this is a good example of what is now called Inverse LORAN, it will be briefly described.

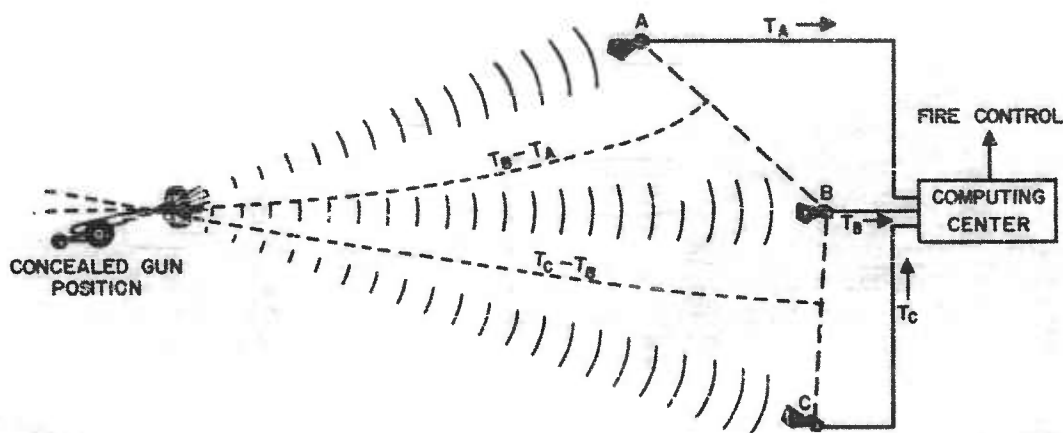

FIGURE 1
A HYPERBOLIC AUDIO LOCATION SYSTEM

The exact times of arrival of the sound blast from the cannon at receiving stations A, B, and C were determined using a Chronograph at the "computing center." Comparison of T_A , T_B , and T_C indicated how much farther the source of sound was from receiver B than from receiver A and how much farther it was from receiver C than from receiver B. This information was then used to draw two hyperbolas, $T_B - T_A$, $T_C - T_B$ with A and B as one pair of reference points and B and C as the second pair. Intersection of

these hyperbolas fixed the location of the sound source.

The basic limitations in this system were the short range of the sound waves and the limited accuracy with which the relative time of arrival of the sound could be measured.

During World War II, radio frequency generators were developed which were capable of producing a peak power output of hundreds of kilowatts. Through the development of equipment capable of measuring relative time to an accuracy of one millionth of a second, hyperbolic radio systems became technically feasible. A number of systems were implemented to meet urgent operational requirements for all-weather navigational aids. The two hyperbolic systems most widely used during the World War II were GEE and LORAN. The basic hyperbolic principles of GEE and LORAN are the same and may be seen in Figure 2.

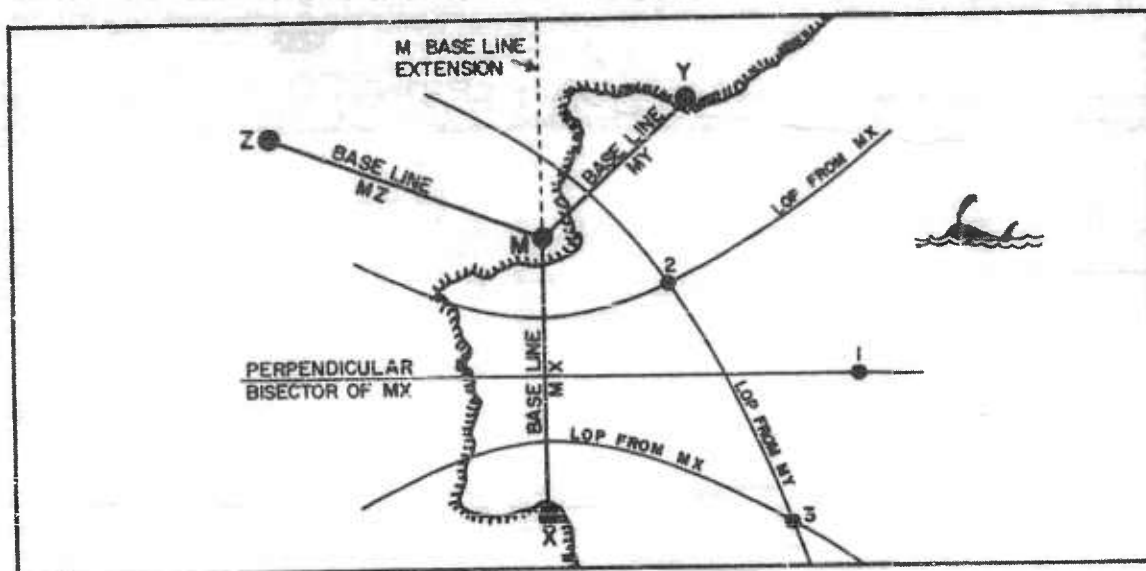

FIGURE 2
THE BASIC HYPERBOLIC RADIONAVIGATION PRINCIPLE

The GEE System

The first practical hyperbolic radio navigation system was put into operation in England during 1942. This system, called GEE, was extensively used during World War II by the Air Forces of the Allies. The GEE system used during World War II involved the transmission of short radio frequency pulses of about 2-10 microseconds duration in synchronism from three, or sometimes four, ground transmitting stations separated by about 75 miles. The difference in times of arrival of the pulses from ground stations is measured by utilizing a special receiver indicator unit. Measurements with an accuracy of better than one microsecond were made possible by use of a cathode ray oscilloscope with its electronic trace (or time base) calibrated by markers derived from a highly stable oscillator.

The accuracy of the system varied from a few hundred yards near the baselines to about five miles at maximum range. In most of the service area, the fix accuracy was generally 2-3 miles.

1.3 HISTORICAL BACKGROUND OF THE LORAN SYSTEMS

Standard LORAN System (LORAN-A)

In 1940, the U. S. National Defense Research Committee (NDRC) was assigned a project to develop a long-range, precision aircraft navigation system. Operational specifications for the system called for an accuracy of about 1000 feet at a range of 200 miles. To meet these requirements, it was planned to use synchronized pairs of pulse-type transmitting stations separated by distances of several hundred miles. Transmitters radiating a peak power of about 1 1/2 million watts were contemplated.

The original system concepts involved the use of groundwave signals only. However, during the course of the system development, measurements

were made of the timing stability of pulses (with frequencies from about 2 Mc/s to 8 Mc/s) received via reflections from the ionosphere and, contrary to what was generally believed at the time, the stability of the E-layer reflected signal was found to be quite good. Computations based on these measurements indicated that a long-range system using a combination of groundwaves and skywaves would provide a "fix" accuracy of better than five miles at a range of 1500 miles. The possibilities of a navigational system with this range and accuracy were so great that the original concept was dropped and all efforts were concentrated toward this new goal. The revised project was assigned to the Radiation Laboratory of the Massachusetts Institute of Technology in the summer of 1941 and experimental transmitting stations were located at Coast Guard facilities near Montauk Point, N.Y., and Fenwick Island, Delaware.

In January 1942, the first skywave accuracy tests were made and a radio frequency band selected. Trials in moving vehicles were undertaken in June. By October, a four-station chain was inaugurated for extended field trials by the Navy. About forty receiver indicators were installed in naval vessels during the next four or five months.

On 1 January 1943, the administration of the new program (LORAN) was turned over to the U. S. Navy. The U. S. Coast Guard and the Royal Canadian Navy were assigned responsibility for operation of the transmitting stations. The LORAN system became fully operational in the spring of 1943 when charts for the four-station North Atlantic chain were made available. The first chain comprised the two test stations at Montauk, N.Y., and Fenwick Island, Delaware, plus two new stations at Baccaro and Deming, Nova Scotia. The Fenwick station was first moved to Bodie Island, North

Carolina, and later to Cape Hatteras, North Carolina. The Montauk station was moved to Nantucket Island, Massachusetts. By March 1943, LORAN had proved to be a useful system and the transition to large scale procurement, installation, and training had begun.

This first version of LORAN which operated on channels in the 1800-2000 kc/s band was originally called Standard LORAN to distinguish it from the other experimental versions of LORAN then being evaluated. Standard LORAN, now known as LORAN-A, is widely implemented throughout the world.

Skywave Synchronized LORAN

The most successful variation of Standard LORAN during World War II was known as Skywave Synchronized (SS) LORAN. SS LORAN also operated at 2 Mc/s, but, as its name implies, the stations maintained synchronization by using skywaves rather than the groundwave. Coverage of this system was available only during night time because of propagation conditions. SS LORAN was first tested on the night of 10 April 1943 between Fenwick Island, Delaware, and Bonavista, Newfoundland, 1100 miles away. Observations at the Radiation Laboratory near Boston revealed a line-of-position probable error of about 0.5 miles. By the fall of 1943, two SS LORAN pairs were in operation with transmitting stations in East Brewster, Massachusetts, Gooseberry Falls, Minnesota, Montauk Point, N.Y., and Key West, Florida. Extensive evaluation flights by U. S. and Allied Forces revealed an average position-fixing error of 1-2 miles.

In the early spring of 1944, the four SS LORAN stations in the U. S. were dismantled and the equipment was installed in Europe and North Africa. Stations were located in Scotland, Tunisia, Algeria, and Libya. This system

became operational in October 1944 and was used extensively for night bombing operations. The combination of very long baselines (approximately 950 miles) and favorable baseline orientation gave night time service over virtually all of Europe with an accuracy of 1-2 miles. SS LORAN systems were also operated successfully in Southeast Asia. Lack of daytime coverage was the major drawback of SS LORAN.

MF/HF Long Baseline LORAN

Skywave Long Baseline LORAN was tested by the Coast Guard shortly after World War II. It was similar to SS LORAN but operated at 10.585 Mc/s daytime and at 2 Mc/s night time for synchronization purposes. In order to provide normal 2 Mc/s service, 2 Mc/s transmitters were operated during the day as well as at night, being controlled by the synchronization on 10.585 Mc/s in daytime.

Preliminary tests were conducted between Chatham, Massachusetts, and Fernandina, Florida, in May 1944. These tests were followed by additional tests between Hobe Sound, Florida and Point Chinato, Puerto Rico, in December-January of 1945-46. Results of these tests showed the basic concepts to be sound, but the difficulty in obtaining a suitable frequency allocation terminated development.

Early Efforts Toward an LF LORAN System

It was recognized early in the program that a low frequency LORAN system would provide improved accuracy and greatly extended navigational coverage during the day and night with fewer transmitting stations. The first experimental low frequency LORAN system (operating at 180 kc/s and called LF LORAN) was placed in operation in 1945 with transmitting stations at Cape Cod, Massachusetts, Cape Fear, North Carolina, and Key Largo, Florida.

Monitor stations for overwater observations were installed at Bermuda, the Azores, Puerto Rico, and Trinidad. Overland signals were observed at monitor stations in Ohio and Minnesota and aboard specially equipped aircraft.

The LF LORAN system was basically an extension of the techniques of 2 Mc/s LORAN to the lower frequency. However, the LF stations operated in synchronized triplets instead of pairs, and in addition to pulse envelope matching, the individual RF cycles of the master and slave pulses were displayed on the user's receiver-indicator. The receivers were designed to provide for visual match of pulses and cycles. A rough match was made first using the envelopes of the two pulses (as in 2 Mc/s LORAN) and then a fine measurement made by matching selected RF cycles within each pulse.

In 1946, all equipment installed in the experimental East Coast LF LORAN system was transferred to the northwest section of Canada where it served the requirements of special Arctic maneuvers in the area. Upon completion of the maneuvers, a joint Canadian-United States project was initiated to evaluate the system. Nine fixed-monitor stations and a number of specially equipped aircraft were placed in operation and comprehensive tests were carried out over a period of many months. These operational tests, together with results of the East Coast tests, showed that the LF system could operate with substantially longer baselines than was feasible with the 2 Mc/s system and that the 24-hour service coverage over land would be of the order of two-thirds of that of sea water (as against an almost negligible overland coverage provided by the existing 2 Mc/s LORAN). The accuracy achieved was equivalent to an average LOP error of 160 feet at

750 miles. Beyond 750 miles, accuracy deteriorated rapidly due to skywave interference.

On the other hand, operators found they could not select the correct pair of RF cycles more than about 75 per cent of the time without prior knowledge of the correct pulse envelope delay. The resulting positional ambiguities were operationally unacceptable and the system was judged unsatisfactory for general purpose navigation. To correct these positional ambiguities, work was begun in 1946 on the development of cycle-identification and phase-measuring techniques. This work was carried out jointly by government and industry and culminated in the field tests of a low frequency, cycle-matching LORAN system called CYCLAN. (CYCLE matching LORAN).

CYCLAN

CYCLAN was the first fully automatic LORAN system. The cyclic ambiguity problem was solved through the use of pulse transmissions on two frequencies 20 kc/s apart (180 and 200 kc/s were used at first, followed by operation on 160 and 180 kc/s). Slope matching on the first 50 microseconds of the pulse was followed by cycle matching within the pulse envelope for precise determination of arrival time-differences. Incorrect cycle-matching at one frequency was readily apparent by an obvious mismatch at the second frequency utilized. CYCLAN coverage was limited to the groundwave region and gave a range of about 1000-1500 miles (depending on local noise). Operational tests with CYCLAN were complicated by serious interference problems involving broadcast stations and aeronautical radio beacons on adjacent frequencies. The tests did show, however, that the RF cycle-identification problem could be solved. Very significant progress

was also made in the area of instrumentation. It became necessary to seek another solution when the Atlantic City (1947) Radio Conference designated the 90-110 kc/s band (20 kc/s bandwidth) for the development of long range navigational systems CYCLAN required a total bandwidth of approximately 40 kc/s.

NAVAGLOBE/FACOM/NAVARHO

An early system investigated as a potential LF system operating within the band 90-110 kc/s was called NAVAGLOBE. Work on this system started in 1945. The directional characteristics were obtained from a configuration of three vertical antennas placed at the corners of an equilateral triangle. The antennas were excited alternately in pairs so that three overlapping figure-eight patterns were obtained. The ratio of the fields produced by the three patterns were determined and displayed on an ADF type meter. This indication was the mobile units bearing (Theta) from the NAVAGLOBE station. Cross bearings (Theta-Theta) were required to establish position. To obtain range information, parallel development of a distance measuring system called FACOM was carried out. This system also operated in the 90-110 kc/s band in the following manner:

1. Coarse distance data (RHO) were developed by comparing the phase of a low frequency modulating tone on a local oscillator with the phase of a similar tone on the CW signal from the FACOM ground station.
2. Fine distance measurements were made on the RF cycles in the carrier.

The NAVAGLOBE-FACOM systems were combined, called NAVARHO, and extensively evaluated during 1957. The program was discontinued because

the over-all system performance was unsatisfactory.

CYTAC/LORAN-C

In 1952, work began under government contract on a long range, automatic, ground-reference tactical bombing system known as CYTAC. A pulsed, hyperbolic navigation system operating in the 90-110 kc/s band was an integral part of the CYTAC system. Equipment development was completed by 1955 and three transmitting stations were constructed at Forestport, N.Y., Carolina Beach, N.C., and Carrabelle, Florida. Tests with the navigational component of the system throughout 1956 showed that automatic instrumentation could solve the RF cycle identification problem and could measure time-difference in a hyperbolic system with an average error of a few tenths of a microsecond. The coverage area extended from the Atlantic Ocean to the Mississippi River and from the Great Lakes to the Gulf of Mexico. Monitor stations installed at widely separated locations collected data during a year of testing. The average errors at six fixed-monitor sites are shown in Figure 3. The lines are "constant

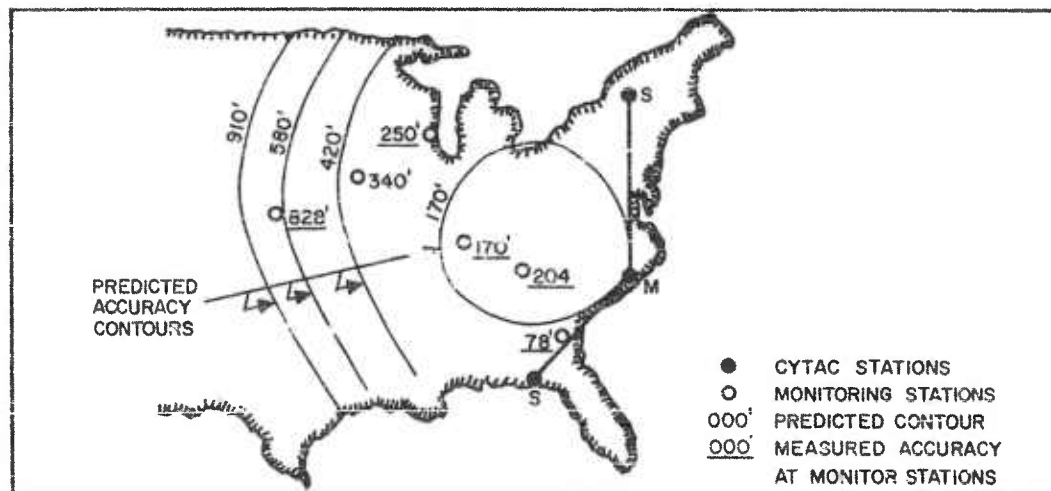

FIGURE 3
ESTIMATED AND OBSERVED CYTAC FIX ERRORS

accuracy contours" and were based on predictions made prior to manufacture of the equipment. The results of the tests demonstrated that the system was not only capable of a high degree of precision, but also that the laws controlling its accuracy were sufficiently well known to permit sound predictions of accuracy prior to installation. For operational reasons, the CYTAC concept (the control of tactical aircraft from a ground-reference system) was abandoned. Its use as a navigational aid was immediately apparent.

An operational requirement was developed for a highly accurate long range maritime radio navigation aid in 1957. The stated accuracy and range requirements were considerably in excess of the capabilities of existing LORAN-A equipment. On the basis of the results of the CYTAC tests referred to above, it was believed that this requirement could be satisfied by implementing the CYTAC concepts as well as some of the CYTAC equipment. Consequently, equipment from stations at Forestport, N.Y., and Carrabelle, Florida, was transferred to new stations - Martha's Vineyard, Massachusetts, and Jupiter, Florida, respectively. These stations, operating in conjunction with the existing station at Carolina Beach, N.C., were placed in operation in 1957. The U. S. Coast Guard in accordance with U. S. Federal Laws assumed responsibility for operation of the stations in August 1958. Comprehensive tests by both surface and airborne units showed that the original concepts were sound. The new system, designated LORAN-C, was at that time placed on operational status.

Status of LORAN-C Transmitting Station Installations

The initial system installation at Cape Fear, North Carolina; Carrabelle, Florida, and Forestport, New York was extensively evaluated over the

eastern part of the United States during the period 1952-1955. The results indicated that it was possible to obtain a fix repeatability within 250 feet or less over an area of more than one million square miles.

In 1956-57, the chain was re-oriented to provide its best geometry toward the sea. The master station remained at Cape Fear but the two slave stations were moved, one to Jupiter on the east coast of Florida and the other to Martha's Vineyard, Massachusetts. Evaluation of this chain was conducted in 1958 over an area roughly defined by Natal, Brazil, Trinidad, the Bahamas and Newfoundland. For peak radiated powers of 60 kw, the groundwave and first hop skywave ranges were approximately 1500 and 2300 miles, respectively. Second, third, and fourth hop skywaves were monitored at various distances up to 3435 miles.

Table 1 gives the locations of higher power transmitting stations

TABLE 1

HIGH POWER TRANSMITTING STATIONS AND AREA COVERAGE OF LORAN-C CHAIN

AREA COVERED BY CHAIN	LOCATION OF TRANSMITTING STATIONS
Mediterranean Sea	Italy (Master) Turkey Libya Spain
Norwegian Sea	Norway Jan Mayen Island Iceland Faeroes (Master)
Bering Sea	Attu Sitkinak St. Paul (Master) Pt. Spencer
Hawaii	Island of Hawaii Johnston Island (Master) Kure Island

and area coverage of LORAN-C chains which have been set up since 1958 and are now operational.

1.4 REGULATORY HISTORY OF LORAN

General

LORAN-A was brought to full operational status during a period which required that virtually all other considerations be subordinated to the basic objective of providing the Allied Armed Forces with the best and most reliable long range radio navigational aid that the state-of-the-art would allow. The decision as to the general portion of the radio spectrum in which LORAN transmitters would operate was based on the results of propagation experiments. Basic LORAN system parameters; such as, radiated power, pulse width, pulse rise time, repetition frequency, etc., were established almost exclusively on the basis of the effect each would have on over-all system performance. During this period, little consideration was given to minimizing the radio frequency bandwidth occupied by the LORAN emissions or to the effect these emissions might have on other users of the spectrum.

With the cessation of hostilities, it became apparent that a radio navigation system originally developed solely to meet the urgent requirements of a global war could very effectively serve peace time navigational needs. The decision was made, therefore, which called for the continued use of LORAN. For the first time, there arose the aspect of LORAN as one of an ever-growing number of telecommunication services that must be accommodated in a finite radio frequency spectrum. The task of bringing LORAN operations into conformity with international regulations began.

In order to appreciate the magnitude of this task, it is necessary to review briefly the international regulatory background against which the LORAN system developed.

Status of LORAN-A under the Cairo Regulations (1938)

The International Radio Regulations (Cairo, 1938) which were "in effect" during the period of LORAN development made no provision for the operation of a relatively broad-band radio navigation service in frequency bands suitable for LORAN. When it became known from propagation studies that a frequency band of the order of 2 Mc/s was near optimum for LORAN (as then conceived), the U. S. War Communication Board through the Interdepartment Radio Advisory Committee (IRAC) assigned three frequencies (1750, 1850 and 1950 kc/s) to the system. Nationally, the band 1700-2000 kc/s was allocated to the Amateur Service which was suspended in this country during the war. Internationally, the band was principally used for small-boat radiotelephone communications and for short-range fixed operations; both of which had been sharply curtailed in most areas during the war. During its early years, LORAN-A enjoyed fairly wide and relatively clear radio frequency channels.

At the end of World War II, the majority of the international radio services which transmitted on frequencies in or near the LORAN frequency band began to go back into operation. Unfortunately, this caused serious interference problems in certain areas. This interference was due mainly to the continued service of wartime developed LORAN transmitters which radiated a broad radio frequency spectrum. The problem was further complicated by the unfavorable frequency and geographical juxtaposition of a high powered, pulsed radio navigation system (i.e. LORAN) and a low powered, ship/shore radiotelephone service used by the general public.

Subsequently, it was found possible through the application of technical and operational measures either to eliminate or to reduce the LORAN interference to tolerable levels in most cases. The initial impression concerning pulsed systems by these interference problems lingers to this day and has had a significant bearing on the obtaining of suitable frequency allocations for LORAN at subsequent international conferences.

LORAN and the Atlantic City Radio Regulations (1947)

At the Atlantic City Conference in 1947, the United States proposed world-wide allocation of the band 1800-2000 kc/s for Standard LORAN. Largely, as a result of the interference problems previously mentioned, this proposal met with determined and effective opposition from a number of European Delegations. With respect to the European area (ITU Region 1), a compromise was finally reached which allocated the band 1605-2000 kc/s to the fixed and mobile services and provided for continued operation of the European LORAN stations then in existence. In other areas of the world, Standard LORAN System was given "priority status" in the band 1800-2000 kc/s.

On the basis of experience with LF LORAN and other systems, the United States delegation to the Atlantic City Conferences also proposed that a "segment of the frequency band 200-280 kc/s be allocated on a world-wide basis for the ultimate long distance navigational aid." This proposal was not acceptable to the European Administrations, due largely to opposition in behalf of the Broadcasting Service. When it became apparent that the original U. S. proposal would not be accepted and that no similar proposal involving frequencies between 155 and 1560 kc/s would be acceptable, the situation was reviewed and the band 90-110 kc/s was selected as the best compromise between the conflicting technical and

operational considerations involved. The modified United States proposal was conditionally accepted by the Conference and the band 90-110 kc/s was allocated to the (a) fixed, (b) maritime mobile, and (c) radio navigation services. The manner in which provision for the development of a new world-wide service was made in a band which was authorized for world-wide use by other services is most interesting. This was set forth in the following footnote (112) to the Allocation Table.

"The development of long distance radio navigation is authorized in this band which will become exclusively allocated wholly or in part for the use of any one such system as soon as it is internationally adopted. Other considerations being equal, preference should be given to the system requiring the minimum bandwidth for world-wide service and causing the least harmful interference to other services.

If a pulse radio navigation system is employed, the pulse emissions nevertheless must be confined within the band, and must not cause harmful interference outside the band to stations operating in accordance with the Regulations.

During the experimental period prior to the international adoption of any long distance radio navigation system in this band, the rights of existing stations operating in this band will continue to be recognized."

The influence of the interference problems involving LORAN-A, previously mentioned, is clearly seen in the first and second paragraphs of the footnote.

Effect of Action by the Provisional Frequency Board (PFB) and the Extraordinary Administrative Radio Conference (EARC) on LORAN-C

In accordance with the decision of the Atlantic City Radio Conference (1947) to draw up a new International Frequency List in the bands between 10 kc/s and 30 Mc/s, seven international conferences were held during the period 1948-1951. The task of drawing up a draft "Frequency Allotment Plan" for the bands between 14 kc/s and 150 kc/s was given to the Provisional Frequency Board (PFB) which met in Geneva from January 1948 to February 1950.

On 31 January 1950, the PFB adopted a "draft world-wide plan of frequency assignments to fixed and coast stations in the band 14-150 kc/s." As in the case of many other frequency bands, the Board found that the spectrum space available was insufficient to accommodate all the stated frequency requirements of the various administrations. In an effort to meet some of these requirements, the Board was forced to adopt very narrow channel spacing; i.e., in the vicinity of 100 kc/s, a spacing of only 350 cps was provided between adjacent assignable frequencies. Thus, 58 assignable frequencies were available between 90-110 kc/s (89.75 - 90.1, 90.45 109.7 - 110.05, etc.) and the Board made 158 discrete assignments on these frequencies to the fixed and maritime mobile stations of 51 separate administrations.

The Extraordinary Administrative Radio Conference convened in Geneva in 1951 for the purpose of developing a procedure whereby the Atlantic City Table of Frequency Allocations would be brought into force. Among other things, the EARC adopted the Draft Frequency List for the band 14-150 kc/s prepared by the PFB thereby giving International Registration Status to the approximately 160 frequency assignments made by the Board in the band 90-110 kc/s. Under the Atlantic City Regulations, a frequency assignment with Registration Status "shall have the right to international protection from harmful interference."

U. S. Proposal to the Geneva Radio Conference (1959)

The LORAN-C system was brought to operational status during the period 1952-1956. The first operational chain was installed along the east coast of the United States in 1957. Subsequently, LORAN-C chains were constructed in the Eastern Mediterranean Sea and in the Northeast Atlantic.

In view of the rapid expansion taking place, the United States Delegation to the Geneva Radio Conferences (1959) proposed that the frequency band 90-110 kc/s be allocated on a world-wide basis to the radio navigation service. For a number of technical, political, and economic reasons, this proposal was unacceptable to a few administrations and it was necessary again to seek a compromise. After lengthy consideration of the matter, it was agreed that the basic allocation of the band to fixed, maritime mobile, and radio navigation services remain unchanged. In ITU Region 2, (North and South America) the Radio Navigation Service was designated the "primary service." In ITU Regions 1 and 3, the three services have equal rights.

1.5 THE PRESENT INTERNATIONAL AND NATIONAL REGULATORY STATUS OF LORAN-C

Introduction

In this section, the LORAN-C system is examined with respect to:

1. Its international and national regulatory status as a specific type of one of these general services authorized to operate in the frequency band 90-110 kc/s.
2. Its status as a basic policy of the United States with respect to long distance aids to navigation.
3. Its status as a basic component in the United States system of radio aids to maritime navigation.

International Regulatory Considerations

The frequency allocation table of Article 5 of Geneva (1959) Radio Regulations for the frequency band 90-110 kc/s is shown in Table 2.

With reference to Regulation 166, it should be noted that the language shown is that appearing in the document signed by the United States Delegation in Geneva in December 1959. In the final printed version of the

TABLE 2
FREQUENCY ALLOCATIONS TO SERVICES

REGION 1	REGION 2	REGION 3
90-110 FIXED MARITIME MOBILE 158 RADIO NAVIGATION 163 166 167	90-110 RADIO NAVIGATION Fixed Maritime Mobile 158 166 167	90-110 FIXED MARITIME MOBILE 158 RADIO NAVIGATION 166 167

NOTE: Primary services in capital letters.

163) In Albania, Bulgaria, Hungary, Poland, Roumania, Czechoslovakia, and the USSR, the band 80-150 kc/s is allocated on a secondary basis to the aeronautical and land mobile services while within and between these countries these services shall have equal right to operate.

166) The development and operation of long distance radio navigation systems are authorized in this band, which will become exclusively allocated, wholly or in part, to the radio navigation service for the use of any one such system as soon as it is internationally adopted. Other considerations being equal, preference should be given to the system requiring the minimum bandwidth for world-wide service and causing the least harmful interference to the other services. If a pulse radio navigation system is employed, the pulse emissions shall nevertheless be confined within the band 90-110 kc/s and shall not cause harmful interference outside the band to stations operating in accordance with the Regulations. In Regions 1 and 3, during the period prior to the international adoption of any long distance radio navigation system, the operation of specific radio navigation stations shall be subject to arrangements between administrations whose services, operating in accordance with the Table, may be affected. Once established under such arrangements, radio navigation stations shall be protected from harmful interference.

Radio Regulations (the so-called "green book"), the word "agreement" has been substituted for the word "arrangement" in the last and in the next-to-last sentence. A few words concerning this point appear to be in order.

In consideration of the safety of life aspect involved, the U. S. Delegation at the Geneva Conference took the position that the radio navigation service should either have "exclusive" or "primary service" status in a band. In general, this concept was supported by the majority of the delegation. However, due to the large number of existing fixed and maritime mobile operations in the bands between 70 and 130 kc/s and the fact that this agreement on a "single system of radio navigation" had not been reached, a majority of the delegations representing Region 1 and Region 3 was unwilling to give the radio navigation service either exclusive or "primary service" status in the band 90-110 kc/s. Nevertheless, in recognition of the safety aspect involved, it was agreed that the operation of specific radio navigation should be subject to arrangement between administrations involved and that having been established, pursuant to such arrangements, these radio navigation stations should be protected from harmful interference. The arrangements envisaged by the U. S. participants were bi-lateral understandings at the technical level similar to those under which provision had been made for operation of the then-existing European LORAN-C stations and the Canadian Decca chains.

To avoid confusion with the formal ITU mechanism known as a "special agreement" which is defined in the Telecommunications Convention and for which special procedures are prescribed in the Radio Regulations, the word "arrangement" was selected by the drafters of Regulations 164 and 166. Subsequent to the signing of the "white document," a special editorial

committee appointed by the conference retained the word "arrangement" in Regulation 164 which provides for radio navigation in Region 2 in the bands 70-90 kc/s and 110-130 kc/s but substituted the word "agreement" for the word "arrangement" in Regulation 166. It was not the intent of the Editorial Committee to change the meaning of a regulation; therefore, it has been assumed that the two words are synonymous. From the foregoing, the basic regulatory status of LORAN-C operation in the band 90-110 kc/s in various areas of the world may be summarized as follows:

1. In ITU Region 2 (see Figure 4), the radio navigation service is the primary service. Therefore, LORAN-C operations are entitled to protection from harmful interference from the other authorized services (fixed and maritime mobile).
2. In ITU Regions 1 and 3, the frequency band is equally shared by stations of the fixed, maritime mobile, and radio navigation services (the order of listing is alphabetical and does not indicate relative priority). However, Footnote 166 is applicable to the entire band 90-110 kc/s and stipulates that "in these regions during the period prior to the international adoption of any long distance radio navigation system, the operation of specific radio navigation stations shall be subject to agreements between administrations whose services may be affected."

In addition to the general requirement (Article 47 of the Convention), that "all stations must be established and operated in such a manner as not to result in harmful interference to the radio services of other administrations," Footnote 166 imposes an additional requirement on pulse system

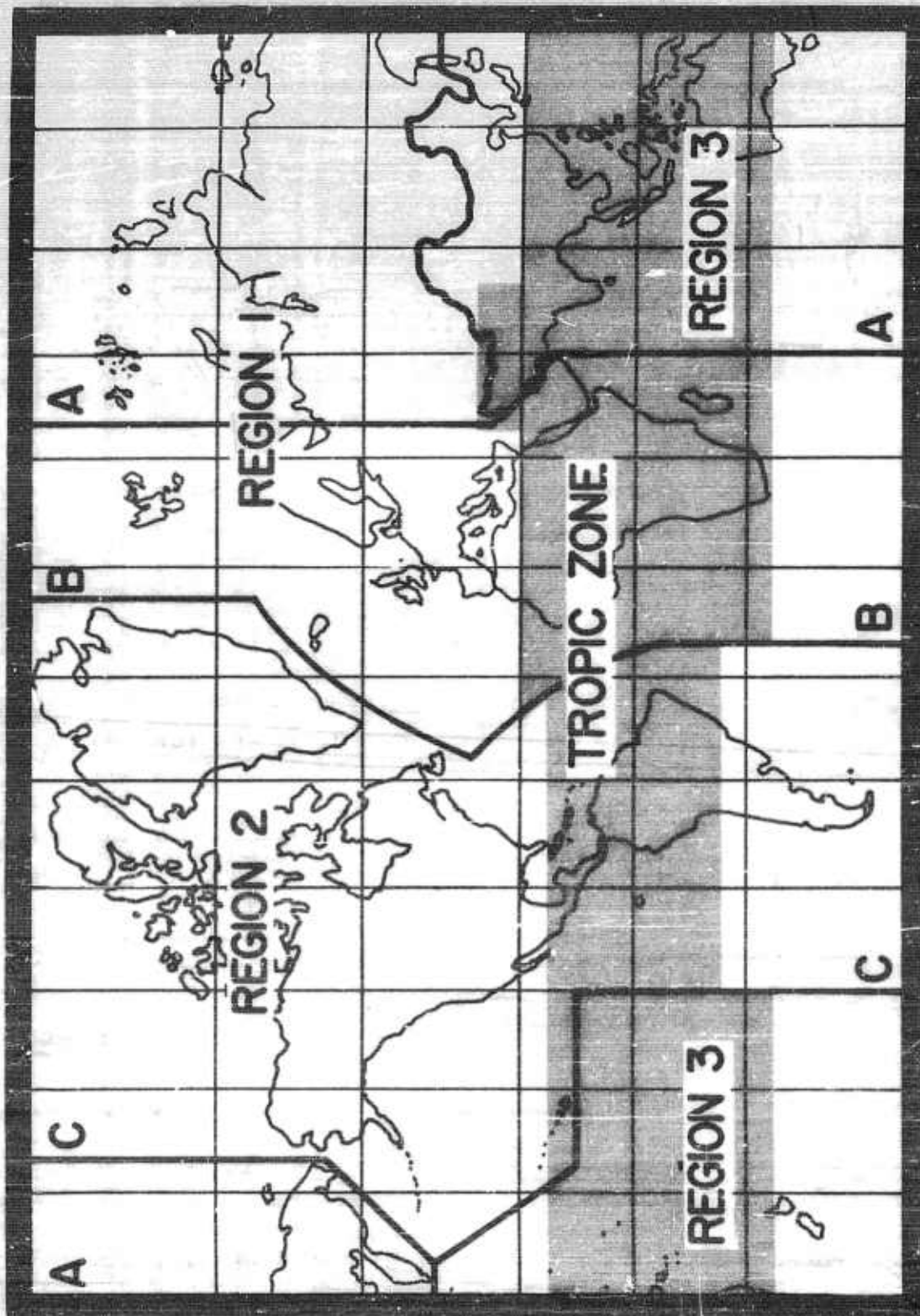

FIGURE 4
ITU REGIONS

operation in the band 90-110 kc/s by stipulating that "emissions from transmitters of such systems must be confined within the band and shall not cause harmful interference to stations outside the band." The phrase "emissions must be confined within the band" must be reasonably interpreted to mean that not more than one per cent of the total energy radiated shall be outside the band 90-110 kc/s. That is, the "occupied bandwidth" as defined by the Radio Regulations shall not exceed 20 kc/s since a strict literal interpretation of this phrase would, per se, preclude the operation of any pulse system in the band. On the other hand, the phrase "shall not cause harmful interference outside the band ..." clearly imposes a limitation on pulse systems over and above that imposed by the definition of "occupied bandwidth." For reference purposes, pertinent definitions from the Radio Regulations, Geneva, 1959, Article 1, Section III, Technical Characteristics, have been extracted and are given below.

85-Assigned Frequency: The centre of the frequency band assigned to a station.

89-Assigned Frequency Band: The frequency band the centre of which coincides with the frequency assigned to the station and the width of which equals the necessary bandwidth plus twice the absolute value of the frequency tolerance.

90-Occupied Bandwidth: The frequency bandwidth such that, below its lower and above its upper frequency limits, the mean powers radiated are equal to 0.5 per cent of the total mean power radiated by a given emission. In some cases, for example multi-channel frequency-division systems, the percentage of 0.5 per cent may lead to certain difficulties in the practical application of the definitions of occupied and necessary bandwidth; in such cases a different percentage may prove useful.

91-Necessary Bandwidth: For a given class of emission, the minimum value of the occupied bandwidth sufficient to ensure the transmission of information at the rate and with the quality required for the system employed, under specified conditions. Emissions useful for the good functioning of the receiving equipment as, for example, the emission corresponding to the carrier or reduced carrier systems, shall be included in the necessary bandwidth.

Under the U. S. Communications Act of 1934, radio communication stations operated by agencies of the federal government are excluded from the licensing authority of the Federal Communications Commission (FCC). The regulation of federal government radio communication facilities is the responsibility of the President. By Executive Order, the President has directed that frequency assignments and basic regulations governing federal government radio communication facilities shall be made in his behalf by the Interdepartment Radio Advisory Committee (IRAC). In accordance with this directive, all operating U. S. LORAN-C stations have been duly authorized by the Interdepartment Radio Advisory Committee to operate in the frequency band 90-110 kc/s. All other U. S. operations in this band are on a secondary basis.

1.6 POLICIES AND PROGRAMS FOR LORAN-C

General

The LORAN-C system offers great promise as a standard long range aid to navigation. It is capable of great accuracy at extended ranges when used with a precision LORAN-C receiver. Less accuracy can be obtained with less precise equipment, consistent with the needs of the user. Receiver outputs are suitable as inputs to any type of readout device.

A total of 17 stations are now operating and future planning encompasses expansion as requirements become known. A system on the order of 40 to 50 stations would provide world-wide coverage with accuracies consistent with the needs of a variety of users. The United States policy, as stated in this chapter, is to encourage standardization without stifling development. As of early 1962, LORAN-C is the only operational system which can meet both U. S. and international long range navigational aid requirements.

Operational Requirements

It is virtually impossible to obtain complete agreement among a large group of potential users with respect to the detailed operational requirements that the ultimate long distance navigation system should satisfy. Nevertheless, it is generally agreed that a long distance aid should:

1. Be suitable for implementation and use in any area of the world during day and night, all seasons, over extensive sea areas, and in all kinds of weather
2. Provide omni-directional navigational data that are free of operationally-significant ambiguities within the area of intended coverage at least 95 per cent of the time
3. Be freely available to all who desire to use it
4. Serve an unlimited number of users in a manner compatible with the operational performance characteristics of their vessels
5. Provide fail-safe indication of system malfunctions
6. Be compatible with the currently effective International Radio Regulations.

With respect to the required position-fixing accuracy, the report of Special Committee 30 of the Radio Technical Commission for Marine Services (RTCM) states: "In the ocean areas, a position fixing system with an accuracy of five miles or one per cent of the distance from danger, whichever is the lesser, is required." With respect to aviation requirements, the report of Special Committee 67 of the Radio Technical Commission for Aeronautics (RTCA) states: "As an immediate goal, fix errors in 95 per cent of

the readings up to 2000 nautical miles from the most remote station contributing to the fix shall be less than plus or minus five nautical miles or plus or minus 1 per cent of the distance, whichever is greater."

The International Meeting on Radio Aids to Marine Navigation (IMRAMN) put forth the following ranges of navigation and requirements:

TABLE 3

NAVIGATION RANGES & REQUIREMENTS

RANGES	FUNCTIONS	DISTANCE (n.mi.) TO NEAREST SOURCE OF DANGER	ACCURACY	TIME AVAILABLE TO ESTABLISH POSITION
Long	Transocean navig.	More than 50	$\pm 1\%$	15 minutes
Medium	Aid to approaching land, to coasting and general port approach	50-3	$\pm 1/2$ n.mi. to 200 meters	5 1/2 minutes
Short	Aids to harbors and entrance	Less than 3	± 50 meters	Immediate

ICAO has stated (ICAO Document 7625) that irrespective of time or weather, a range of the order of 1500 miles is desirable. The accuracy must be such that the position fixing error will not exceed 10 miles on at least 95 per cent of the occasions. The U.S. statement on aviation operational requirements is contained in the Air Coordinating Committee Paper ACC 58/9.1, May 27, 1957. In this paper, it is stated that the accuracy should be within plus or minus 3 miles 95 per cent of the time in the operational area being covered and the system must be reliable 95 per cent of the time. Committee Paper ACC 58/9.1 should be referred to for complete details on aviation operational requirement.

The above requirements range from plus or minus 50 meters to plus or minus 10 miles in fix accuracy and from several miles to 2000 miles in range. LORAN-C can meet all these requirements with only minor qualification.

On the baseline connecting a master and each of its slave stations, a single line-of-position (LOP) is available with a constant accuracy of plus or minus 16.2 yards. Another master-slave combination would be necessary at right angles to the first to provide a fix (two lines-of-position) of this accuracy. To fulfill the specific requirements for all harbor entrances, large numbers of short baseline LORAN-C networks would be needed.

The longer range navigational requirements listed above, which may be summarized as fix accuracy of plus or minus 200 yards at medium ranges and plus or minus 3 miles at 1500-2000 miles, are presently fulfilled by LORAN-C in those areas where coverage exists.

The need for world-wide fix coverage is difficult to meet. There are vast water masses in the southern hemisphere that in certain cases provide no land upon which to place transmitting stations. As a result, complete ground-wave coverage may not be possible, but most of these groundwave voids will be covered by skywaves.

If LORAN-C is fully implemented, the following range, accuracies, and coverage may be expected (keeping in mind that the accuracy is a function of the geometrical configuration of each chain and the receiver's location in the service area).

<u>RANGE</u>	<u>ACCURACY</u>
Up to 400 miles - - - - -	Better than 0.25 nautical miles
400 to 1200 miles - - - - -	Approximately 0.25 nautical miles
1200 to 2500 miles - - - - -	From 0.25 to 3.0 nautical miles
<hr/>	
Total coverage, if fully implemented, will be 80 per cent of the earth's surface with a minimum accuracy of plus 3 miles.	

National Regulatory Considerations

The basic policies^{1/} of the United States with respect to long distance aids to navigation are:

1. "To promote, as a continuing goal, national and international standardization of a single type of ground-based, long distance radio aid to navigation suited to the needs of all users (air, surface, and sub-surface). In the meantime, to standardize on the minimum number of types of aids necessary to meet the requirements of the various users.
2. "To recognize the complementary relationship between ground-based short distance and long distance, and self-contained aids in the system of navigation and traffic control.
3. "To promote the scientific and technical evaluation of all aids, domestic and foreign, and to support the development and operational evaluation of those which are economically feasible and potentially capable of meeting recognized operational requirements. The United States will not advocate or accept any standard which would entail any monopolistic or exclusive advantage to any one country or to any one business enterprise or group of enterprises.
4. "To encourage and promote the international exchange of technical information concerning long distance aids to navigation.
5. "To support and promote national and international standardization of the essential characteristics of and test standards for the standardized aid.

^{1/} Document 58/12.1E of the Air Coordinating Committee, dtd 30 Dec. 1959.

6. "To exercise sound planning in facility implementation and deployment in the interest of frequency conservation, over-all economies, and avoidance of unnecessary duplication.
7. "To install aids to meet the requirement of the various users, as far as practicable, until a standard aid is accepted and implemented. The current types of long distance ground-based radio aids to navigation upon which present plans will be based are: LORAN-A, LORAN-C, non-directional beacons, and consol.
8. "To support and promote the international adoption and implementation of such aids or systems of aids which more adequately meet requirements of users and which can be technically, operationally, and economically justified until a single national and international ground-based long distance radio navigation aid is accepted and implemented."

Statutory responsibility for maritime navigational aids is covered by Section 81 of Title 14, United States Code. Under this regulation, the U. S. Coast Guard is responsible for the establishment, maintenance, and operation of maritime navigational aids required by the Armed Forces and United States commerce. Pursuant to this statutory authority, the U. S. Coast Guard has adopted LORAN-C as a standard element in the United States system of radio aids to maritime navigation.

Future LORAN Systems Planning

The United States National Policy is to standardize on the minimum number of navigational aids necessary to meet the needs of the various users until a standard aid is accepted and completely implemented. With this policy

in mind, a Coast Guard study was undertaken to determine the compatibility of LORAN-A and LORAN-C and the eventual transition to one system. The outcome indicated that these two LORAN systems could be integrated but it would require a long time period.

The Coast Guard planning studies show that the LORAN-A and LORAN-C systems can be integrated to provide an orderly transition to the LORAN-C system. LORAN-C would then provide greater navigational fix coverage than is presently provided by the two systems now in operation. The first phase of the integration progress was started in 1958 by arranging LORAN-A and LORAN-C stations so that both LORAN-A and LORAN-C data can be transmitted from a single site. Presently (1961), eight allocated LORAN-A/C stations are in operation. Co-location provides for reduction in site occupation, costs, station personnel, logistic support, and administrative control.

Future planning consists of a progressive realignment of the existing facilities without materially reducing interim navigational coverage. Implementation would be coordinated with new area requirements and curtailment of existing services coupled with modernization programs and necessary rebuilding due to destruction by natural forces.

Military and commercial applications have been given due consideration in the future planning studies. Particular regard has been given to the availability and cost of user equipment. With these factors in mind, it can be seen that certain areas are more susceptible to primary conversion from LORAN-A to LORAN-C; whereas, in other areas, LORAN-A and LORAN-C may both be used to meet specific requirements.

CHAPTER 2

PRINCIPLES OF LORAN-C

2.1 INTRODUCTION

LORAN-C is a hyperbolic system of radio navigation similar to LORAN-A (Standard LORAN) and is available throughout the areas shown on the coverage diagram. Ships and aircraft can use it in all weather conditions over land and sea to obtain higher accuracy position information at greater distances than those obtained in the LORAN-A system.

The inherent accuracy capabilities of the system make it suitable for general purpose or precise radio navigation and for a wide variety of radiolocation purposes. The range capabilities of the system make it particularly desirable in remote areas where suitable transmitting sites are limited and where coverage of vast ocean areas is required.

Recent studies by the National Bureau of Standards^{1/} show that the LORAN-C system has the capability of being used for other purposes in addition to navigational service without requiring the use of additional spectrum space. Several of these additional functions are:

1. A long range time distribution system with an accuracy in the order of one microsecond.
2. Microsecond-order relative time standardization between widely separated receiving locations.
3. Electromagnetic wave propagation studies.

2.2 BASIC PRINCIPLES OF THE LORAN-C SYSTEM

One ground station in a LORAN network is designated as the "master" station in the network. This station transmits groups of pulses which

^{1/} Timing Potentials of LORAN-C, R. H. Doherty et al, Proceedings of the IRE, Vol. 49, No. 11, November, 1961.

are disseminated in all directions. Several hundred miles away in different directions, two or more "slave" stations receive the master pulse groups and transmit similar groups of pulses which are accurately synchronized with the signals received from the "master" station. The constant time-differences between the reception of the master pulses and the corresponding slave pulses establish the LORAN line-of-position (LOP).

The line joining two transmitters is called the "baseline" and its perpendicular bisector is called the "centerline" (see Figure 5). If both master and slave pulses are transmitted simultaneously, they will be received simultaneously on the centerline, and the corresponding time-difference will be zero. On either side of the centerline, the pulse from the nearer station is received first. The farther the receiver is removed from the centerline, the greater will be the time-difference between reception of the pulses.

In the present LORAN system, the master and slave station pulses are not transmitted simultaneously. Each slave transmission is delayed a controlled amount so that the master station pulse is always received first. Therefore, time-differences increase from a minimum value at the slave station to a maximum at the master station.

Data defining the lines of constant time-difference for each pair of stations are computed and made available to the user in the form of LORAN-C tables or charts. When obtaining navigational information from the LORAN system, the navigator measures the time-difference between the receipt of the master and slave signals on his receiver, consults the charts or tables, and interpolates between the tabulated lines-of-position to determine the line-of-position corresponding to the measured time-difference.

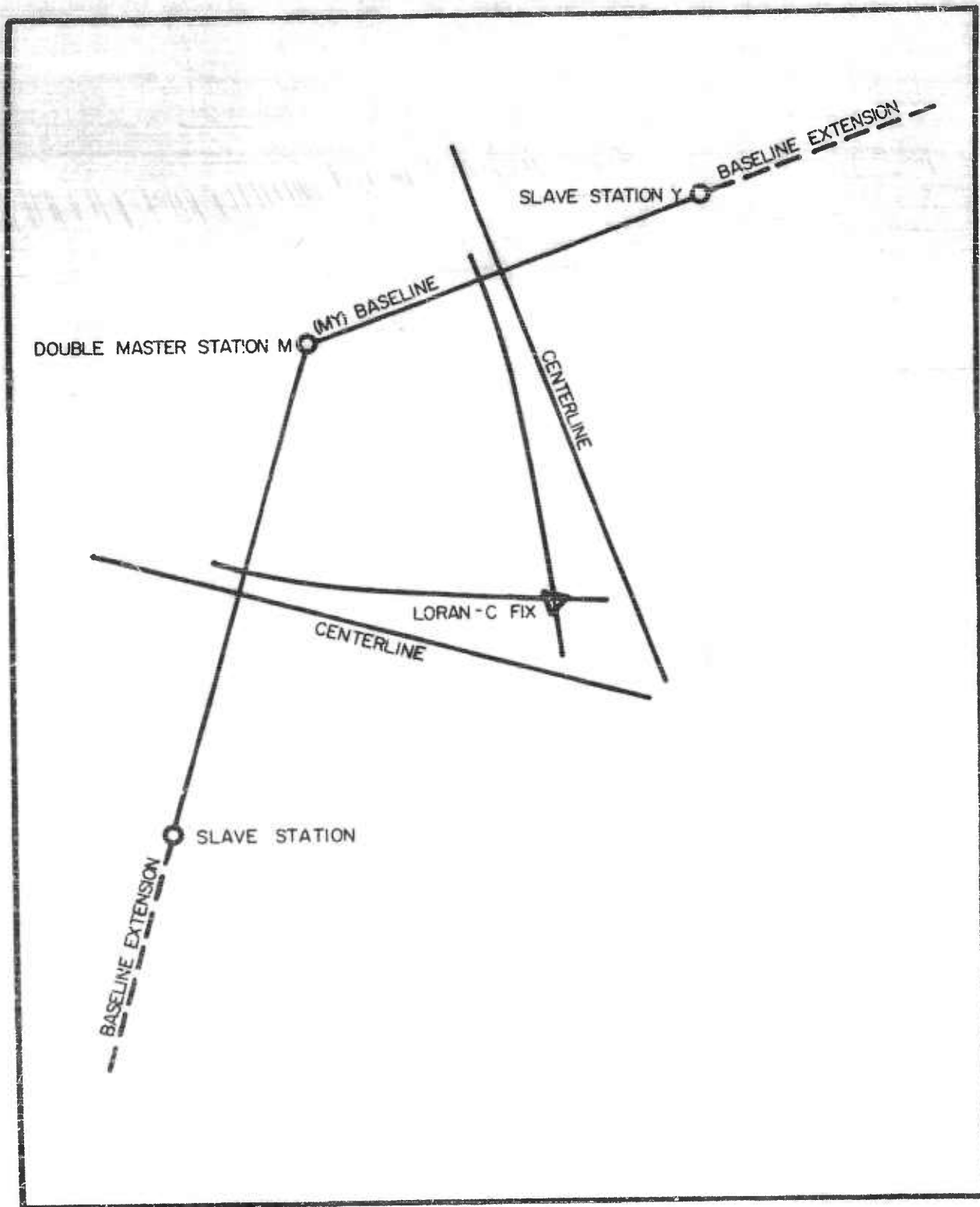

FIGURE 5
FIX FROM A TRIAD CONFIGURATION

LORAN System Geometry

LORAN stations are located so that signals from two or more pairs of stations may be received in desired coverage areas, and thus a LORAN fix may be obtained by crossing two or more lines-of-position as indicated in Figure 5. The transmitting stations may be arranged in triads, stars, or squares to provide optimum geometric accuracy of position fixing in the desired coverage area. Slave stations are normally 500 to 700 miles from the master station.

Defective Operation and Temporary Suspension of Service

The accuracy of LORAN-C depends upon the transmitting stations keeping their signals correctly timed or synchronized. When synchronization of the transmitters is lost, the ninth pulse of the master station blinks or shifts back and forth. Equipment instruction books describe the exact manner in which blink is shown by the set in use.

Pulse Repetition Rates

Most of the LORAN-C repetition rates are compatible with the LORAN-A system, and for these rates, LORAN-A receivers can be modified to permit reception of 100 kc/s signals for envelope matching of the signals in the conventional LORAN-A manner. (See Table 4.) To make all of the rates compatible requires more extensive modification of present LORAN-A receiving equipment. In any case, it must be remembered that LORAN-A receivers do not incorporate the capability of measuring "fine" time-differences as do LORAN-C receivers, and as a result, less accuracy is obtained.

TABLE 4

PULSE REPETITION RATES

SPECIFIC PRR	BASIC PRR					
	SS	SL	SH	S	L	H
0	100,000	80,000	60,000	50,000	40,000	30,000
1	99,900*	79,900*	59,900*	49,900	39,900	29,900
2	99,800	79,800	59,800	49,800	39,800	29,800
3	99,700*	79,700*	59,700*	49,700	39,700	29,700
4	99,600	79,600	59,600	49,600	39,600	29,600
5	99,500*	79,500*	59,500*	49,500	39,500	29,500
6	99,400	79,400	59,400	49,400	39,400	29,400
7	99,300*	79,300*	59,300*	49,300	39,300	29,300

* Not compatible for reception on LORAN-A receivers converted for radio frequency only.

Terminology For Use With Tables

Following are abbreviations and symbols used in the LORAN-C system:

T Tabulated reading in microseconds
T_g Reading of groundwave match
T_s Reading of skywave match
T_{gs} Reading of master groundwave, slave skywave match
T_{sg} Reading of master skywave, slave groundwave match

The combination of numbers and letters in the designation of a LORAN-C line indicates the basic pulse repetition rate, the specific pulse repetition rate, station type designator of a particular station pair, and the time-difference in microseconds found on charts, tables, and indicators.

BASIC PULSE REPETITION RATES (LORAN-C FREQUENCY - 100 KC/S)

H 33-1/3 pulses per second
L 25 pulses per second
S 20 pulses per second
SH 16-2/3 pulses per second
SL 12-1/2 pulses per second
SS 10 pulses per second

Specific Pulse Repetition Rates assigned for identification (following H, L, S, SH, SL, or SS): 0, 1, 2, 3, 4, 5, 6, 7.

Station Type Designators (not station letter designators) and Transmission Sequence: M — Master, X — Slave, Y — Slave.

For example, the complete legend SO-X-13300 denotes the following: basic pulse repetition rate, 20 pulses per second; specific pulse repetition rate, 0; station type designator, slave X; and micro-second reading, 13300.

Signal Characteristics

LORAN-C operates in the band centered around a carrier frequency of 100 kc/s with a spectrum contained within the band of 90 to 110 kc/s. The slave stations in a particular LORAN-C network transmit eight pulses to a group on a specific group repetition rate. For visual identification, the master station transmits a ninth pulse in its group. Station identification in automatic search operation is accomplished by phase coding the master and slave groups.

Groundwave Range

Radio energy released as signals from each transmitter emanates in all directions from the point. A portion of the LORAN-C radio energy travels out from each transmitting station parallel to the surface of the earth. This is known as the groundwave. Another portion of the radio energy travels upward and outward, encounters an electrified layer of the atmosphere known as the ionosphere and is reflected back to the earth. Reflections from the ionosphere are known as skywaves. (See Figure 6.)

LORAN-C groundwave coverage extends to approximately 1200 nautical miles. During periods of good propagation, this range may be greater and during periods of high noise and interference, it may be less. However,

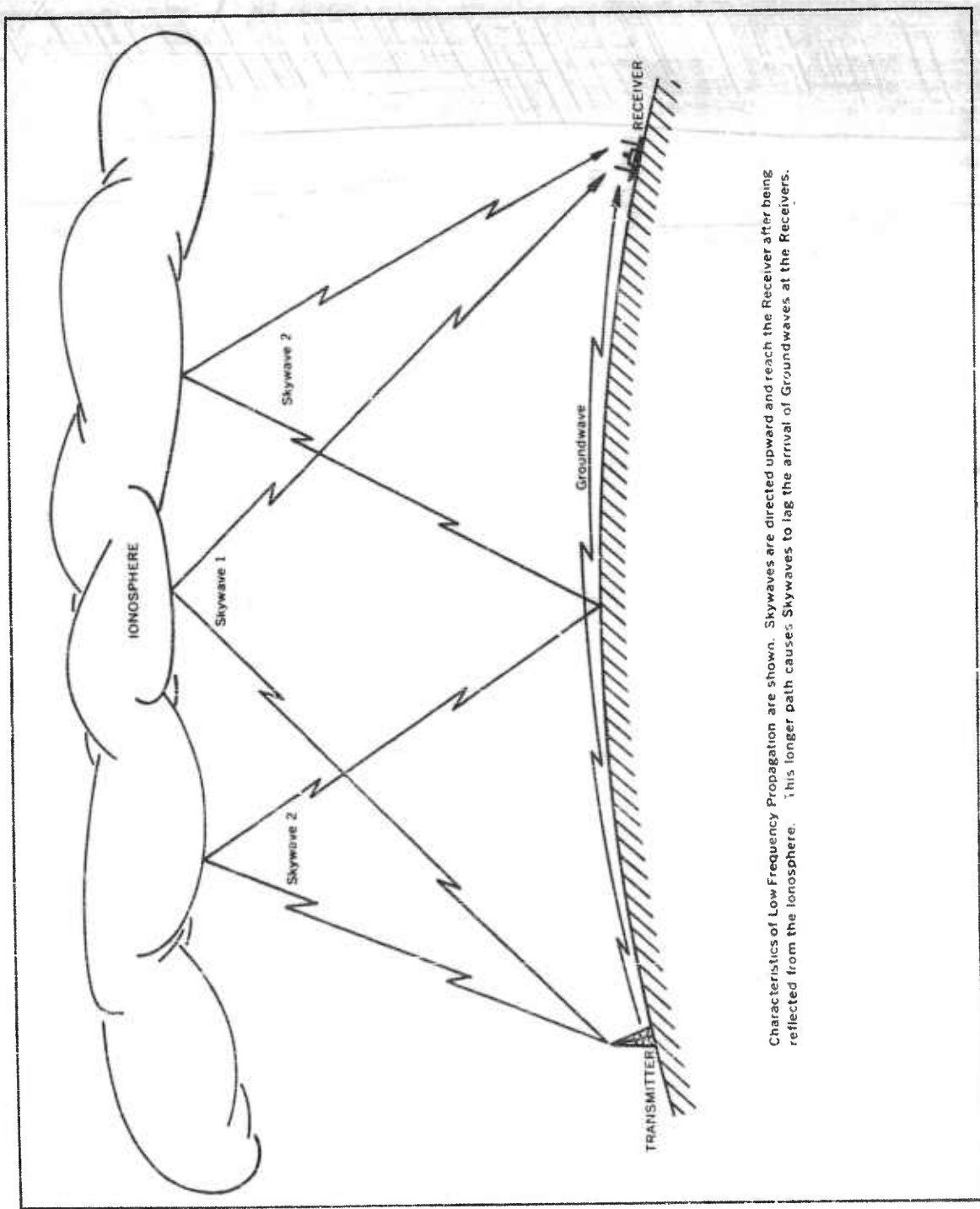

Characteristics of Low Frequency Propagation are shown. Skywaves are directed upward and reach the Receiver after being reflected from the ionosphere. This longer path causes Skywaves to lag the arrival of Groundwaves at the Receivers.

FIGURE 6
PROPAGATION PATHS

based on current noise and interference information, it is considered that 1200 nautical miles is a reasonable estimate of the reliable groundwave range of LORAN-C signals from a station having 300 Kw peak pulse power.

The ability of the LORAN-C receiver to indicate accurate time-difference readings is dependent upon the relative strength of the received signals and the level of the noise interference also received by the equipment. As the ratio of signal-to-noise decreases, the time-difference reading accuracy of the receiver decreases. As a result, the accuracy of the navigational information deteriorates as the receiver moves away from the stations. In Table 5, are listed several geographic areas and the expected groundwave range for these areas. Each area has five ranges listed in order of decreasing accuracy. The value at the top of the table shows the standard deviation in microseconds of the time difference readings and under each is the range in nautical miles at which this standard deviation can be expected. New LORAN-C stations have increased power and hence better corresponding signal-to-noise ratio.

TABLE 5

EXPECTED GROUNDWAVE RANGE

Geographic Area	Noise Factor (db/1 μ v)	Groundwave Range in Nautical Miles for Standard Deviations (μ sec)				
		0.10	0.15	0.20	0.25	0.30
North Atlantic (Summer)	35	1480	1600	1680	1780	1880
North Atlantic (Winter)	40	1300	1460	1560	1660	1760
Central Pacific	45	1160	1280	1380	1480	1580
Mediterranean	50	1060	1150	1250	1350	1450
Atlantic (Equatorial)	55	900	1060	1120	1220	1320

Based on 100 kw output. Reception estimated for 95 per cent of time.

Skywave Range

At frequencies near 100 kc/s, the stability of the refracting medium, the ionosphere, is comparatively high. Frequently there is little or no evidence of either fade or appreciable phase variation for periods of an hour or more. The well-known skywave "splitting" so common and useful in LORAN-A does not occur from a practical standpoint at 100 kc/s.

Usable first-hop E-layer skywaves have been observed during both daylight and darkness for ranges of as much as 2300 nautical miles and the second-hop waves have been observed as far away as 3400 nautical miles.

Multi-hop skywaves have been monitored solidly out to ranges of 3435 nautical miles with every indication that useful signals are available at even further distances. An almost complete darkness path between the user and the transmitting station is required for stable, night time, multi-hop operation. At the present time, the use of multi-hop skywaves is not recommended for high-accuracy navigation.

Skywave accuracy is dependent upon stability of the ionosphere. As a general rule, expected skywave stability is approximately plus or minus one microsecond and is usable for general navigation.

2.3 IDENTIFICATION AND USE OF LORAN-C SIGNALS

General

The LORAN-C indicator provides a reading regardless of whether groundwave or skywave pulses are matched. To obtain the correct reading, the proper pulses must be selected. This is a critical part of LORAN-C operation and must be carefully performed. Instruction books for the particular equipment and coverage charts for the area should be consulted to assist in determining which mode of signal is being received.

If groundwaves can be received from two stations of a pair, they should always be used. If no groundwave is received from either station of a pair, the first-hop skywaves should be matched and a skywave correction applied. If a groundwave is received from only one station of the pair, the usual procedure is to ignore it, match the first-hop skywave from each station and apply the skywave correction as above. In some instances, however, a special correction is provided for matching the groundwave from one station to the first-hop skywave of the other.

The skywave correction compensates for the fact that the first-hop skywave path is longer than the groundwave path. LORAN lines-of-position as given in tables and on charts are computed on the assumption that signals travel via the groundwave. The skywave correction reduces the skywave time-difference reading to the equivalent groundwave reading in order that both groundwave and skywave lines-of-position can be determined from a single set of charts or tables.

Skywave corrections are usually tabulated for those areas in which one-hop reception is probable. Extension of skywave corrections into areas not covered by tabulated values should not be attempted.

Plotting Lines-of-Position

When using a receiver designed specifically for LORAN-C, it is not necessary to advance or retard LORAN-C lines-of-position because all of the readings are taken simultaneously. A single LORAN-C observation provides readings which establish lines-of-position for all of the pairs within the particular network being used. In general, these lines-of-position will not coincide with those shown on the chart, and the navigator must draw lines properly spaced and aligned between the printed LORAN lines. Readings taken

with a modified LORAN-A set will require the usual advance or retardation if the interval between observations, the speed, and the chart scale warrant it.

LORAN Tables Provide Greater Accuracy

When greater accuracy than that provided by LORAN charts is desired, the tables should be used. From each table corresponding to the pertinent rate and readings observed, the latitude and longitude of two points are obtained. In general, points are computed sufficiently close to permit drawing a straight line through two consecutive points to determine the LORAN line. The line drawn through these points is the line-of-position of the observation. All tables are computed for groundwave observations.

2.4 TRANSMISSION CHARACTERISTICS

Substantially increased ranges are achieved by transmitting LORAN-C pulses in the 90-110 kc/s frequency band as compared with LORAN-A pulses in the 2 Mc/s band. The synchronization of LORAN signals between transmitting stations and the propagation of the signals over land masses, as well as over large bodies of water, extend radio navigation services to areas not covered by LORAN-A. The improved LORAN-C system geometry provides more accurate fixes due to the increase in distance between stations and increased precision in measuring time-difference using cycle comparison techniques.

The basic principle of LORAN is extended by improved instrumentation techniques to include measurement of the carrier phase of the pulse signals. This technique provides an effective vernier for increasing the accuracy of time-difference. Continuous wave systems operating in this frequency range provide comparable accuracies at short ranges, but the accuracy deteriorates at medium and long ranges because the groundwave signal becomes contaminated

by skywave propagated energy. LORAN-C as a pulsed-type system retains groundwave accuracy and stability since it is possible to resolve the groundwave energy from the delayed skywave by proper time-sampling.

Following are additional features of the LORAN-C system:

1. Low frequency transmissions (100 kc/s) give extended range over both land and sea at all altitudes.
2. Pulse envelope measurement allows "coarse" time-difference measurement. Measurement of the radio frequency cycle phase provides an accurate "fine" time-difference measurement.
3. Automatic instrumentation can provide continuous position indication in time-difference coordinates. Automatic search as well as automatic tracking can be provided.
4. The use of pulse groups increases average power.
5. Phase reversals between the pulses prevent interference between pulses in the event of extended skywave delay, assist in rejecting interfering signals, and facilitate proper group matching of the pulses from the paired stations.
6. Advanced engineering techniques, defined as cross-correlating and narrow banding, enable the equipment to operate with high accuracy despite low signal strengths.

Propagation of the low frequency radio signal has been studied by the National Bureau of Standards (NBS Report 7204 - J. Ralph Johler) and the particular case of the propagation of a groundwave pulse was considered in detail. A stretching in the form or shape of the pulse was noted as a result of the filtering action of the propagation medium and the particular case of a signal transmitted between two points on the earth's surface was considered from the viewpoint of propagation in the time domain. The conclusions reached

were that "low frequencies exhibit properties which are quite favorable to high reliability and precision radio navigation-timing. In particular, the groundwave signal is especially favorable at distances less than 2,000 statute miles (3,200 kilometers), i.e., the pulse type transmission resolve or sort out the individual propagation rays. At greater distances, the signals propagated via ionospheric propagation rays also exhibit favorable properties provided again that the individual ionospheric propagation rays are sorted in the time domain. The detailed investigation of these properties is now required as a result of the economic and scientific importance of the navigation-timing and communications systems operating at low frequency."

2.5 OVER-ALL SYSTEM ACCURACY

Instrumentation of User Equipment

Equipment developed for use with the LORAN-C system has been designed to take full advantage of the accuracy and coverage capability of the system and to provide automatic presentation of time-difference readings. Such equipment provides a direct numerical readout of as many as three time-differences (for three lines-of-position) received from paired stations. These readings change automatically and continuously as the navigating craft moves. Reference to a chart permits immediate determinations of position. Initial signal search and match is accomplished semi-automatically. Instrumentation can be provided for transmitting information to a course computer which shows "course to steer" and "distance to go" and to a position recorder which shows the chart position of the craft.

A less expensive equipment which will provide moderate accuracy and coverage as compared to the automatic receiver is now being developed. This system will operate on all LORAN-C rates, will involve the use of visual envelope and cycle matching, and will be equipped with narrow band-pass filters

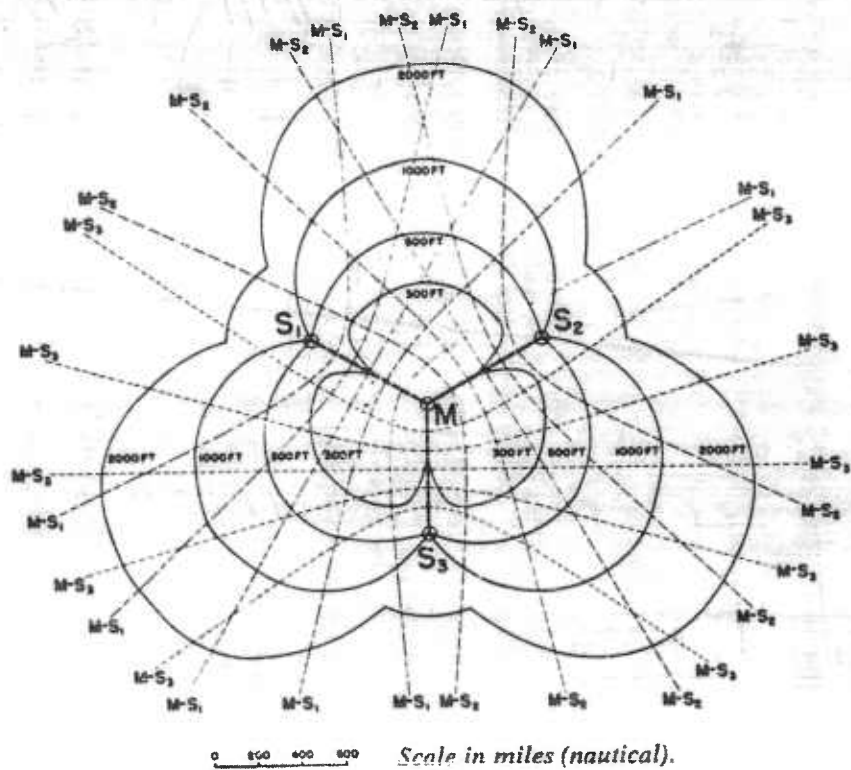

FIGURE 7

LORAN-C STAR CHAIN

and other features intended to facilitate the taking of LORAN-C data in the presence of noise and interference. It will be of particular value to those who desire to take advantage of the improved coverage of LORAN-C but do not require the full automatic features for obtaining the maximum accuracy capabilities of the system.

System Accuracy

Over-all system accuracy is a function of the following three major factors:

1. Geometrical Accuracy - Geometrical accuracy of the system is dependent upon the positioning of the ground stations. This can be reduced to terms of nautical miles per microsecond of time-difference (or feet per one-tenth of a microsecond) for 99 per cent of the individual observations. (These prediction errors can be reduced to 0.05 microsecond by local calibration.)
2. Instrumentation Accuracy - The inherent measurement capability of the system has been determined to be less than 0.05 microsecond.
3. Propagation Accuracy
 - a. Variations which occur in groundwave propagation are less than 0.1 microsecond over a 1000-mile sea water path.
 - b. Variations which occur in skywave propagation are nominally 1 to 1.5 microseconds from a mean predicted value, except at sunrise and sunset, at which times large and rapid variations occur.

Figure 7 shows the coverage and accuracy attainable with a typical LORAN-C star-configured chain.

2.6 ACCURACY OF LORAN FIXES

The accuracy of a LORAN fix depends on the accuracy of the individual lines-of-position used to obtain a fix and the crossing angles of the lines-of-position. Accuracy of an individual line-of-position depends on the following factors:

1. Synchronization of transmitting stations.
2. Operational or receiver accuracy.
3. Skywave correction (when skywaves are used).
4. Position of ship relative to transmitting stations (function of system geometry).
5. Accuracy of tables and charts.
6. Timing and positional uncertainties.

If the error in synchronization of the transmitting stations exceeds the tolerable limits (usually set for the envelope at plus or minus 3.0 microseconds for one minute or longer or for the greater part of two minutes, and for the phase greater than plus or minus 0.15 microseconds for one minute or longer or for the greater part of two minutes) the proper ninth-pulse code or blinking procedures will be initiated.

When a synchronization discrepancy exists, the master station and/or one or more slave stations alter their normal pattern of transmission to warn the users and the other station in the pair that the system is temporarily unusable. The warning is in accordance with the master ninth-pulse code procedure and the slave blink procedure.

The actual accuracy of the area receiver is dependent upon the variations of signal-to-noise ratio, operator skill, and instrumentation. For the most part under average conditions and considering all errors, the accuracy of the

fixes determined by the receiver is well within 1500 feet 95 per cent of the time. Actual designed receiver errors are negligible.

Due to the fluctuating height of the ionosphere, the skywave corrections represent arithmetic averages of corrections taken at various times of the day. The skywave delay changes from the night time to the daytime values in a period of from one to two hours before ground sunrise. In the afternoon, the delay begins to increase near sunset; but, the change is more gradual, sometimes continuing to increase slowly for several hours after ground sunset. At distances of 800 miles or more, carefully made skywave readings with the proper correction will generally be accurate within three nautical miles 95 per cent of the time. At lesser distances the uncertainty increases. As a general rule, expected skywave stability is approximately plus or minus one microsecond.

The accuracy of a geographical position determined by LORAN is dependent upon the system geometry regardless of the precision of the measuring equipment used. As is evident from a LORAN navigational chart, the separation between two lines (each labelled with a specific time-difference) varies throughout the coverage area. From a standpoint of minimum separation, the most favorable position is on the baseline between the two transmitters generating the lines. In the areas behind the transmitters on the baseline extensions, the separation is greatest and thus a small error in time-difference measurement results in a larger position fixing error. However, normal LORAN-C synchronization accuracy and the precision of the receivers make it possible to obtain general navigational information in these unfavorable areas.

There are three contributing factors to the error that may be present when a LORAN-C position is determined. These are system synchronization errors,

receiver errors, and propagation errors. The first of these is held to a minimum by the use of very precise transmitting station equipments. The second can be controlled to some extent by receiver design. However, noise and interference conditions can influence the readings. This error can be minimized by measuring time-differences over a period of time at a definite location and thus determining a most probable time-difference reading. This method may not be possible under some operational conditions. The third factor is the result of the variation in the propagation of the radio wave as it passes over the earth's surface. Considerable research has been done in this regard and propagation behavior can be predicted to minimize the error.

Since LORAN-C has such high precision capability, the geographical position of the LORAN-C transmitting antennas must be determined to a high order of accuracy. Any errors in designation of the geographical positions of the transmitting antennas will be reflected in an error in the navigational coverage area.

The LORAN-C system uses repetition rates which are the same as those which are standard for LORAN-A and rates which are one-half the "standard" rates. Consequently, a LORAN-A receiver which is equipped with a 100 kc/s to 2 Mc/s (approximately) frequency converter can be used to obtain envelope matches of LORAN-C signals in the conventional manner. At extended ranges, these converted LORAN-A receivers can utilize LORAN-C skywaves in the same manner as LORAN-A skywaves are used. At intermediate ranges, however, the leading edge of the groundwave and skywave overlap. This can result in erroneous visual measurements of leading-edge time-differences, depending on the amount of overlap. Use of LORAN-C signals with a converted LORAN-A receiver in this mid-range area is dependent upon the user's accuracy requirements.

CHAPTER 3

CHARTS, TABLES AND CORRECTIONS

3.1 GENERAL INFORMATION CONCERNING USE OF CHARTS & TABLES

The U. S. Navy Hydrographic Office publishes charts and tables for the LORAN-C system. In following these charts and tables, the navigator merely interpolates between plotted or tabulated lines-of-position to determine the line corresponding to the observed readings: thus determining latitude and longitude of the point obtained. The lines drawn between two interpolated values for a line-of-position are for all practical purposes straight lines. The curvature of the hyperbolic time-difference line is negligible over short distances; but, in some cases, the curvature is significant, for example, near the station. When there is some doubt, three points are plotted to determine the amount of curvature for each line-of-position.

An advantage in using a LORAN-C receiver is that all time-difference readings are taken simultaneously and no advancing or retarding lines-of-position is necessary.

LORAN-C Navigation Charts

LORAN-C navigation charts are provided for use aboard ships and aircraft. Groundwave lines-of-position from the various station pairs are printed in distinctive colors and are further identified by legends. The colors used are blue and magenta. The lines-of-position are shown at the closest interval of T satisfactory for the scale of the chart. This is 100 microseconds on the H.O. Charts.

The LORAN-C air/surface charts which show isogonic lines are presently available only in one scale; i.e., 30 nautical miles to the inch at mid-latitudes. This is the VLC 30 series. Skywave correction factors

are not available on these charts.

LORAN-C Tables (See Page 39 for Terminology)

LORAN-C tables supply the coordinates necessary for the construction of LORAN-C lines-of-position. These tables are supplied to navigators to obtain fixes on most kinds of charts. There is a separate table for each station pair. The columns are headed by tabulated readings in microseconds represented by T, the groundwave reading. These are separated by 10 microsecond intervals.

A theoretical LORAN-C two-line fix coverage diagram is included in each volume of LORAN-C Tables. This diagram is shown in Figure 5. Due to the relative newness of LORAN-C, its systems are being changed for various reasons. In the Mediterranean Area, a fourth station is being built which will increase the coverage area. LORAN-C charts and tables on this area will have to be brought up-to-date when the station is completed.

The coverage area is depicted by points listed at intervals of one degree of latitude or longitude except in areas close to the transmitting stations. In this case, additional points are listed at intervals of fifteen minutes. In using the tables, navigators can feel safe in using a straight line joining any two adjacent tabulated points. However, within twenty nautical miles of a transmitting station, the curvature of the lines is excessive and straight line segments will introduce appreciable errors. If the navigator is in doubt about the accuracy of the lines-of-position with regard to curvature, he may plot a third point to ascertain the amount of error present. The chartlet preceding each table indicates the tabulated coverage areas.

Interpolation may be necessary if the required value of T is not tabulated. A rate of change of latitude or longitude per microsecond (Δ) is given in hundredths of minutes of arc for each tabulated point. The nearest tabulated value of T should be used for this interpolation. To interpolate, multiply the difference of the actual reading T_g and T by the value of Δ and add the product algebraically to the tabulated value of latitude or longitude given in the column under T . Note that either Δ or $T_g - T$ may be negative. Computations involving baseline extensions do not follow the same rules because T no longer changes in direct proportion to distance. Δ values have been omitted in those regions. Reference to H.O. Misc. 11,691 will provide a special non-linear interpolation for lines-of-position due to the baseline extensions. However, the interpolator for skywave readings should never be used.

3.2 CORRECTIONS APPLIED TO TIME-DIFFERENCE READINGS

Skywave Corrections

Whenever two skywaves or a skywave and a groundwave are matched, it is necessary to use skywave corrections. These are available for the coverage area in the form of transmission delay curves and precomputed values. The transmission delay curves represent the delay time required for a skywave to reach a specific area as compared to a groundwave. By carefully taking into consideration the location of the receiver with respect to the system and applying the skywave correction in the correct direction under the specific circumstance, the skywave reading can be accurately reduced to the proper wave reading and a fix can be obtained. An explanation precedes the lists of skywave corrections in H.O. Pub. 221 for any LORAN-C pair.

The only tables now available for LORAN-C navigation are:

H.O. Pub. No. 221 (1001)
Pair SO-X

H.O. Pub. No. 221 (1002)
Pair SO-Y

Transmission Delay Curves

Skywave corrections can be obtained from the skywave transmission delay curves. The transmission delay curves show the average time delay required for a signal to travel via the one-hop-E reflection path rather than via the groundwave path.

The skywave correction for a LORAN-C pair is zero if the receiver is on the centerline equidistant from the two stations of a pair. The skywave time-difference reading is the same as the groundwave time-difference reading because the skywaves from both stations of a pair are delayed on the average by the same amount. In general, the skywave correction is equal to the difference in the skywave transmission delays corresponding to the distances from the receiver to each station.

Since time-difference is measured from the master station pulse to the slave station pulse, the skywave correction is added if the receiver is nearer the master station and subtracted if it is nearer the slave. For example, assume that the receiver is 400 nautical miles from the master station and 800 nautical miles from the slave station. At night, the skywave transmission delay curve corresponding to an ionosphere height of 91 km. shows the delay at 400 nautical miles to be 85 microseconds and the delay at 800 nautical miles to be 59 microseconds. The desired skywave correction is the difference between these two delays ($85 - 59 = 26$), and it is added to the skywave reading.

Conventional Corrections

Since all skywave readings (T_g) must be corrected to the equivalent groundwave readings (T_g) corrections of this type have been precomputed for the navigator. These "Skywave Corrections" precede the main part of each LORAN-C table. For each pair of stations, the corrections are tabulated in microseconds. Values are listed for points separated by whole degrees of latitude and longitude. Limits are indicated in Figure 8.

Special Corrections

Do not use conventional skywave corrections when matching groundwaves to skywaves. This type of match requires a special correction. This correction, required either when land weakens one signal or when the transmitters of a LORAN pair are far apart, consists of the skywave transmission delay. The skywave transmission delay is added to or subtracted from the indicator reading. Following are the two rules which apply.

1. ADD if matching a master station skywave to a slave station groundwave.
2. SUBTRACT if matching a master station groundwave to a slave station skywave.

The special "Groundwave to Skywave Correction" also precedes the main part of each LORAN-C table.

Matching two one-hop-E skywaves is usually more reliable than matching a groundwave to a skywave. When matching two skywave signals, variations of skywave travel time caused by ionospheric fluctuations will affect both signals by comparable amounts. Errors will be caused by the variation in the difference of the two corrections and will tend to cancel each other. This is not true when matching a groundwave to a skywave since only one signal travels via the ionosphere.

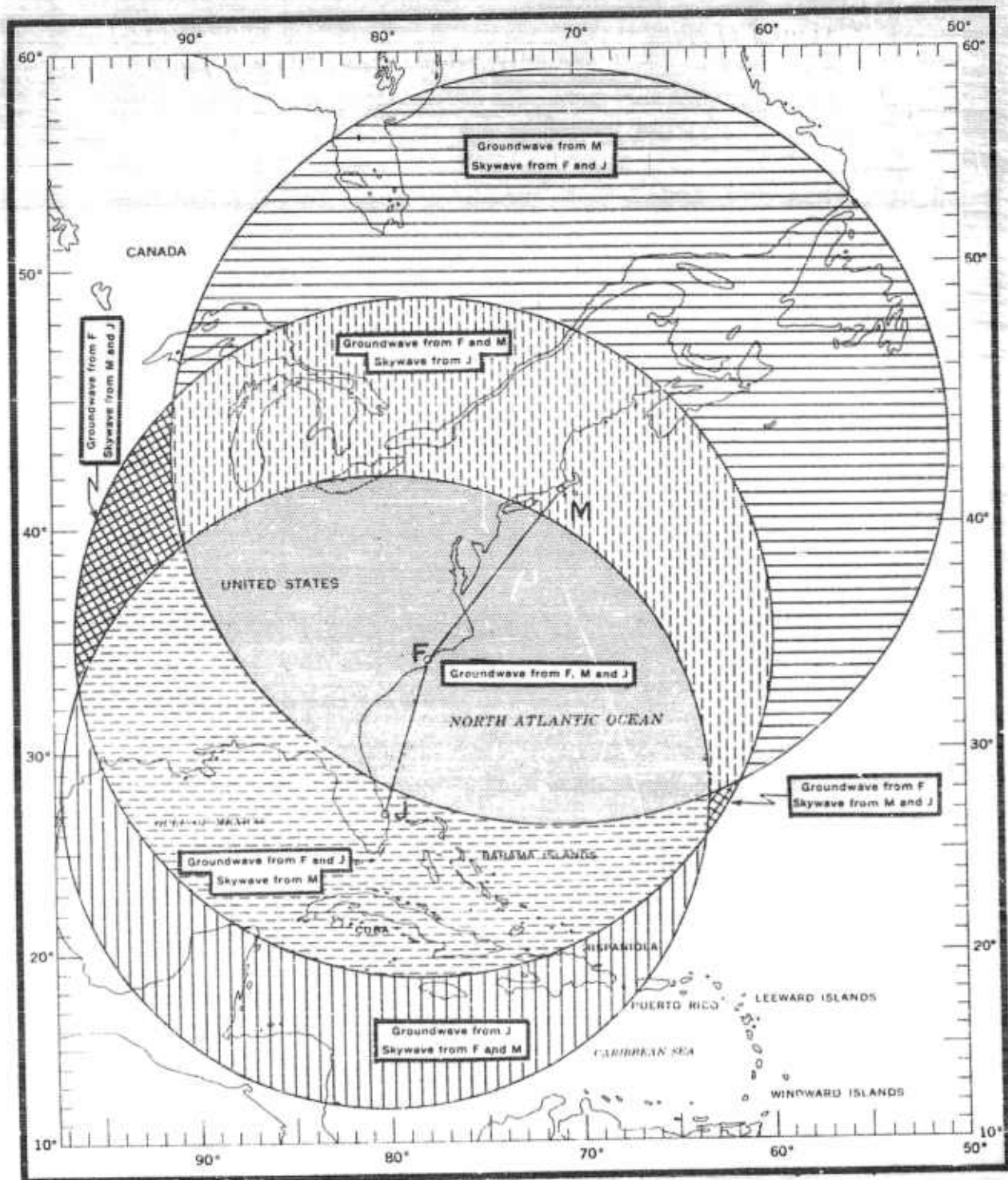

FIGURE 8
TABULATED LIMITS OF GROUDWAVE TO SKYWAVE CORRECTIONS

Application of Correction for Matching Groundwaves to Skywaves

When receiving a skywave signal from one LORAN-C station and large groundwaves and skywaves from a second LORAN-C station, the only practical procedure is to match the skywave from the first station to the groundwave of the second station. This situation would be encountered when the receiver is located far from one station and near to the second. The use of an all skywave match may cause additional errors because of large uncertainties in the near station skywave correction.

The skywave to groundwave match correction is obtained and used in the same manner as a conventional skywave correction. Enter the table with latitude and longitude nearest to the DR position. Apply the tabulated correction as indicated by the sign to the time-difference reading. Sometimes interpolation within the table may be necessary. Do not use conventional dual skywave match corrections when matching groundwaves to skywaves.

When it is possible to match two groundwaves, never match a groundwave with a skywave. Under the best conditions for matching groundwaves to skywaves, the value obtained may be uncertain by an amount equivalent to several miles in position. As with matching two skywaves, the error may be very large when the DR position is within 200 microseconds of the baseline extensions.

CHAPTER 4

ADDITIONAL USES OF LORAN-C

4.1 INTRODUCTION

While LORAN-C is primarily a radio navigation system, the inherent accuracy, range, and reliability of the system have made it particularly attractive for a number of other functions such as the precise geographic positioning, distance measuring, homing, timing, and propagation investigations.

4.2 LOCATION OF GEOGRAPHIC POSITIONS

The stability of the LORAN-C system's transmissions makes it suitable for determining precise geographic positions. LORAN-C's coverage capabilities make it attractive for this use in areas where a large number of suitable transmitter sites cannot be found for shorter range systems presently being employed. Oceanographers and meteorologists thus can have precise positioning data for their data-collecting instruments.

A report ^{1/} by the Woods Hole Oceanographic Institution of Woods Hole, Massachusetts describes how use was made of the LORAN-C East Coast network to track instrumented floats over a period of days. The Oceanographic Institution determined a course position to within 4 microseconds of the LORAN-C grid by other means and then a LORAN-C phase match was made for the precise reading. Use of this technique was made over a period of a year in the vicinity of Bermuda, a distance of approximately 650 nautical miles from the master station with uncertainties of position

^{1/}"An Interim LORAN-C Receiving System," Woods Hole Oceanographic Institution, Woods Hole, Mass., July 1961, Robert G. Walden.

of 420 feet on the southern station pair and 102 feet on the northern station pair. This accuracy was obtained with the use of a visual cycle matching receiver.

4.3 DISTANCE MEASURING

In a report entitled "Application of LORAN-C To Intercontinental Surveying" (Air Armament Division, Sperry Gyroscope Company, Scientific Report No. 1, December 1959) a prediction on the accuracy of utilizing LORAN-C for distance measuring is presented. This report predicts, for an over-all water propagation path, an error of 32 feet at 435 nautical miles and 42 feet at 1000 nautical miles. These predicted errors include small errors in calculating the velocity of propagation. The principal errors are random time measurement errors which are associated with the electronic equipments. These vary with changes in signal-to-noise ratio. Over a 26-day monitoring period, the standard deviations based on daily averages were 32.8 feet at a range of 435 nautical miles over sea water. For a propagation path of 1000 miles, part over land and part over sea water, the standard deviations were 118 feet.

The large error for the part-land path is due to a drift in the data associated with this particular path. It is felt that this drift is a natural phenomenon correlated with variations in temperature, humidity, and other weather factors over the land path. To date, no accepted theories explain this observed phenomenon. However, with continued research it may be possible to compensate for much of the error.

4.4 TIMING

The high order of stability achieved in the LORAN-C system has

generated considerable interest in its use for time-measurement. The National Bureau of Standards and the U. S. Naval Observatory have indicated that emissions from a LORAN-C system provide the capability of synchronizing and setting clocks to an accuracy of better than 1 microsecond in an area covered by the ground wave of a LORAN-C transmitter. Such timing information is approximately 1000 times better than the service presently available by other means. When sufficient LORAN-C networks are available and all are properly synchronized, one microsecond accuracy timing information can be maintained on a world-wide basis. A LORAN-C clock (see Figure 9) capable of resolving time to one microsecond has recently been constructed for general laboratory use by the National Bureau of Standards.

The comparison of a LORAN-C clock with independent clocks running from oscillators of different qualities is shown in Figure 10. This comparison assumes that two independent clocks are drifting apart at a drift rate equal to the maximum rate indicated. The independent clocks must be initially synchronized and must run continuously without interruption. A LORAN-C clock may be interrupted and resynchronized without affecting its accuracy.

The capability of LORAN-C for improving time-measurement accuracy over wide areas enhances the feasibility of the following applications:

1. The synchronization of LORAN networks; allowing time-difference measurements to be made by using one station from each of two synchronized networks.
2. The location and guidance of space vehicles.
3. Determination of the position of high-altitude aircraft

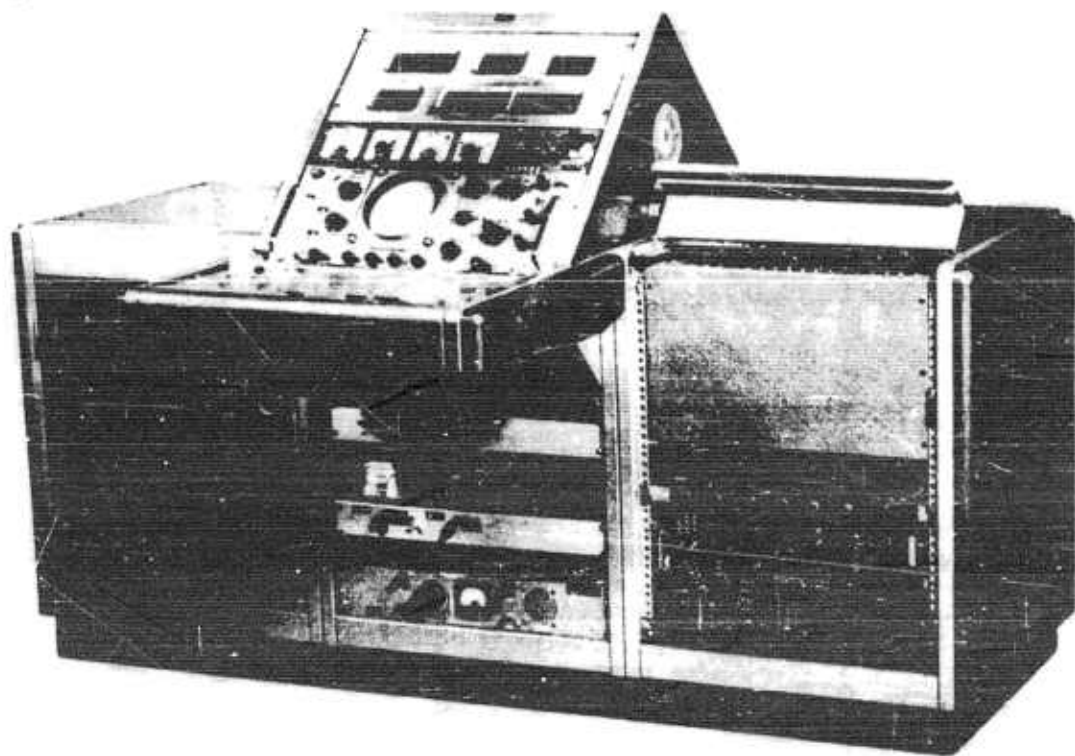

FIGURE 9
LORAN-C CLOCK

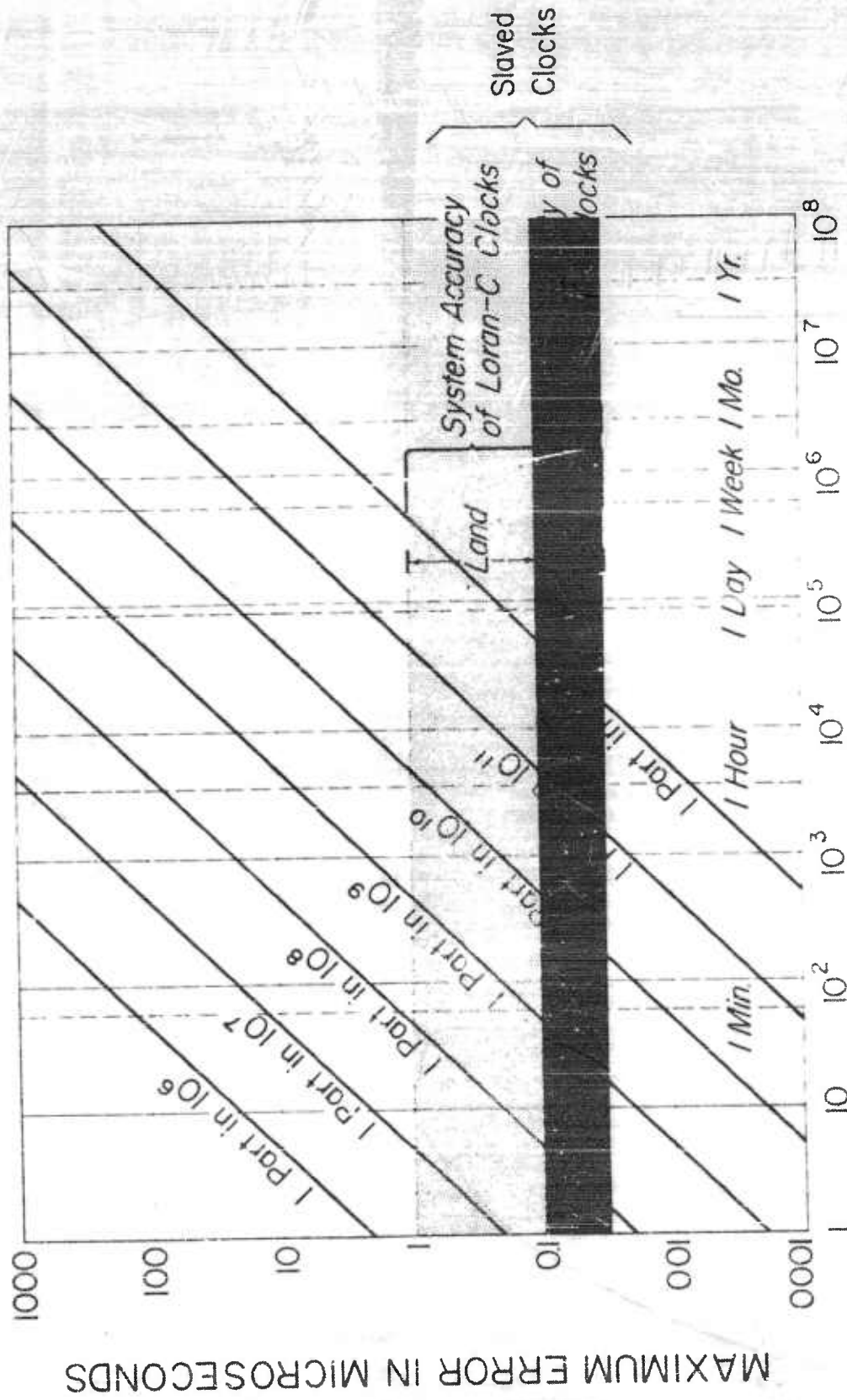

FIGURE 10
SLAVED VS INDEPENDENT CLOCKS

by means of UHF pulses from the aircraft received at several widely spaced points.

4. The location of thunderstorms by precisely fixing the position of lightning discharges.
5. The location of nuclear detonations.
6. The evaluation of the fluctuations of the periodicity of the earth's rotation and other astronomical phenomena.

4.5 HOMING

Normal Automatic Direction Finding (ADF) techniques utilize the principle of reception of a radio frequency signal from a single source. When two or more signals are received from different sources, the direction finding equipment must be capable of separating the received signals in time or radio frequency to obtain a measure of direction. Since all LORAN-C transmissions are at one frequency, the technique of separation in time must be utilized for direction information.

Existing ADF equipment (1961) do not have the built-in features of time separating or time sharing a single frequency. A device has been built by the Coast Guard which time shares the ADF so that individual LORAN-C signals may be observed. During preliminary testing, this modified ADF was able to obtain bearings on each selected LORAN-C signal at ranges as great as 1200 miles from a 60 kilowatt LORAN-C transmitting station.

4.6 PROPAGATION STUDIES

A recent experiment concerning LORAN-C skywaves was conducted as a joint operation between the U. S. Coast Guard and the Central Radio

Propagation Laboratory of the National Bureau of Standards. Selected LORAN-C ground stations monitored remote skywaves for a two-month period during the fall of 1961. Preliminary evaluation of the collected data has indicated a close correlation of skywave phase changes with solar flares and proton events. Results have shown that studies of this type will give a new insight to geomagnetic propagation paths and ionospheric changes. Additional propagation velocity behavior and ionospheric behavior can be realized by the use of LORAN-C signals as a timing signal for other frequency measuring and monitoring techniques.

PART II

LORAN-C SYSTEMS ENGINEERING

PART II

LORAN-C SYSTEMS ENGINEERING

INTRODUCTION

Information presented in this section describes the considerations affecting the choice of LORAN-C characteristics, the equipment required, and planning necessary to implement the LORAN-C radio navigation system. This part is divided into six chapters as follows:

CHAPTER 5 CONSIDERATIONS AFFECTING THE CHOICE OF LORAN-C SYSTEM CHARACTERISTICS

Considerations given to the technical and operational considerations underlying U. S. support of LORAN-C as a long distance aid.

CHAPTER 6 LORAN-C PRINCIPLES OF OPERATION

A general description of the LORAN-C system, its principles of operation and its special features relative to LORAN-A characteristics.

CHAPTER 7 SYSTEM OPERATION AND CALIBRATION

CHAPTER 8 TECHNICAL DESCRIPTION OF COMPONENTS OF LORAN-C SYSTEM

CHAPTER 9 LORAN-C PERFORMANCE

Factors affecting the range and accuracy of the LORAN-C system and a discussion of system performance to date.

CHAPTER 10 LORAN-C SYSTEM PLANNING AND IMPLEMENTATION

The methods of planning, organization, orientation, site selection and implementation from the time of original conception until a LORAN-C chain is operational.

CHAPTER 5

CONSIDERATIONS AFFECTING THE CHOICE OF LORAN-C CHARACTERISTICS

5.1 BASIC SYSTEM TYPES

For the purposes of discussion, the various types of radio navigation systems can be categorized as (a) radial, (b) circular, (c) hyperbolic, or (d) combinations thereof, according to the lines-of-position generated:

1. Radial systems: Non-directional beacons (NDB), consol, etc., have been found to be seriously degraded at extended ranges by propagation variations.
2. Circular systems: Sometimes referred to as range-only systems. Require either radiation from the vehicle desiring position-fixing data or a high-stable oscillator aboard the vehicle for phase-comparison measurements. The system geometry is also unfavorable for large area coverage.
3. Radial-circular systems: Sometimes referred to as range-bearing systems or rho-theta systems. Have shown great promise at times. Such systems are excellent from a geometrical point of view and could theoretically provide coverage over vast areas from a few transmitting sites. From the aviation point of view, the system also has the very significant advantage of full compatibility with present short range navigation systems. However, results to date with such systems at extended ranges have been unsatisfactory due to a combination of equipment and propagation problems.
4. Hyperbolic systems: These systems provide the greatest potential capability to date for coverage of large areas with the smallest number of transmitting sites and the best compromise between

accuracy and coverage. The principal objections to the use of such systems have been from aviation interests with respect to the presentation (read-out) and the compatibility problem in the transition from long range to short range systems.

5.2 CHOICE OF OPTIMUM FREQUENCY

If stable and reliable radio wave propagation over great distances is required, a navigational system must be operated in the VLF or LF portions of the radio frequency spectrum, i.e., from about 10 to about 300 kc/s. In operating within this frequency range, a number of important practical factors must be taken into account in arriving at ultimate selection of an "optimum frequency." Among these factors are included: required transmitter power, ambient noise levels, and the required physical size of the antenna system. The "optimum frequency" will depend to a large degree on the relative weight given in the final analysis to each of these factors. Since one of the most important considerations is atmospheric noise which is characterized by extreme variations in intensity as a function of time, season, and location; our so-called "optimum frequency" becomes merely a "statistical optimum frequency" that varies at different times over wide limits. Nevertheless, there is general agreement that a frequency of approximately 100 kc/s is near optimum; particularly, if (for reasons of accuracy to be subsequently discussed) use of a pulse system is required. Also, the band 90-110 kc/s is the only frequency band in this general area of the spectrum that is available for long range radio navigation.

5.3 COMPARISON OF PULSE AND CONTINUOUS-WAVE RADIO NAVIGATION SYSTEMS

In recent years, a number of systems utilizing the propagation properties

of radio waves for position determination have been developed to operate in the low frequency portion of the spectrum. The majority of these systems involve a measurement of the time required for radio frequency energy to travel over the surface of the earth. Two basically different approaches have been used: (1) measurements on continuous-wave (CW) transmissions; such as in DECCA, RAYDIST, and LORAC and (2) measurements on relatively short radio frequency pulses as in the LORAN system. The outstanding difference between the two basic approaches, pulses vs CW emissions, is the accuracy obtainable at extended ranges. The total radio frequency bandwidths required for the two systems is also of great interest from the point of view of spectrum utilization. These differences are fundamental and must be thoroughly understood in order to appraise one system as opposed to the other.

In both pulse and continuous wave systems, position or time is determined from the phase of the received signal or signals. The instrumentation accuracy for the measurement of phase in both systems is essentially the same. Long or short time constants for integration purposes can be used in one system as well as in the other. The important difference is that in a continuous wave system the phase of the resultant signal (i.e., a signal composed of energy arriving at the receiver via various propagation modes) is measured; in a pulse system, the various modes can be effectively resolved.

A pulse timing or a pulse navigation system derives maximum accuracy when groundwave transmission is utilized. The characteristics of signals that are being propagated via the groundwave mode are reasonably well understood. At 100 kc/s, the phase delay of a signal traversing a path of

mixed conductivities can generally be predicted to within a microsecond. On the other hand, the groundwave phase over these paths is stable within a few hundredths of a microsecond. Therefore, on the basis of time-difference predictions, the expected accuracy of such systems is in the order of one microsecond. In areas that have been calibrated, areas in which measurements have been made and for which correction factors are known, a repeatability accuracy much better than one microsecond can be realized. When homogeneous paths of known conductivity are being considered, particularly sea water, the phase delay can be predicted to better than 0.1 microsecond. Therefore, over exclusively sea water paths the predictability and the repeatability accuracies approach the same value. At 100 kc/s, the phase of the groundwave at a given point is essentially constant. The only factors affecting it are variations in the index of atmospheric refraction and variations in the conductivity and dielectric constant of the earth. The variations of phase delay produced by these factors are normally so small that they are not detectable, and, therefore, have little bearing on the comparison of the two types of systems.

Another important consideration in a properly designed pulse system is its use with skywaves for increasing the useful coverage to distances far beyond the coverage provided by normal groundwave range. In LORAN-C, such use has not been extensively developed to date; but, measurements show that useful navigational coverage exists to distances in excess of twice the groundwave range. For timing and other uses of the LORAN-C emissions, even greater ranges exist. This coverage is obviously less reliable and does not provide the high accuracy obtained through use of the groundwave.

It should be noted that a pulse system operating on skywave propagated signals has a most significant advantage over a continuous wave system operating with skywave signals. A pulse system can use the first available propagation mode and it is effectively resolved from the successive modes. The pulse system, therefore, is affected only by the phase variations of a particular mode. At 100 kc/s, the phase of any particular skywave mode or hop has been found to be usually stable within a microsecond or less (excluding sunset and sunrise period of instability which are approximately half an hour for each ionospheric reflection point involved). Usable 100 kc/s pulse skywaves have been observed to 3000 nautical miles, and indications are that ranges well in excess of this figure are probably obtainable, particularly at night. On the other hand, continuous wave systems must, of necessity, operate on a signal resulting from a summation of signals propagated by all modes. The phase of this composite signal will vary and is dependent upon the phase and amplitude of each component. Such variations can have considerable magnitude since the phase and the amplitude of the skywave modes are subject to diurnal and seasonal ionospheric variations.

Continuous wave transmissions for wide area coverage from a single complex of stations result in two serious problems; namely, ambiguities in position determination and difficulties in discriminating against skywave contamination. Experience has shown that the range and accuracy provided by a continuous wave system is adequate for general purpose navigation in areas where the distances normally traveled are small and where suitable transmitting sites are available. In this regard, it should be noted that maximum permissible baseline lengths of typical high accuracy continuous wave systems are in the order of 80-100 miles. On the other hand, where

high accuracy coverage of long coast lines and vast ocean areas is required and where relatively few suitable sites for transmitting stations are available continuous wave systems are entirely unsatisfactory.

From the point of view of radio frequency utilization, continuous wave radio navigation systems pose serious regulatory problems. The basic principle of these systems requires the simultaneous use of several (as many as five) frequencies having a prescribed mathematical relationship for the determination of a single navigational fix. Inability to clear any one of these frequencies means a new harmonically-related series must be sought. Further, the geographical area within which accurate navigational service is available from a typical four station chain using four or five frequencies is very small (1/50th in some cases) compared with the "interference area" of the chain geographical area within which the four or five frequencies involved cannot be re-used for other purposes. In areas where such systems are extensively used, it has been necessary to resort to exclusive frequency band allocations. In the European area, four frequency bands totaling 12.6 kc/s of the 70 to 130 kc/s band have been exclusively allocated for continuous wave systems.

For the reasons stated above, it was decided that a pulse system is required to meet the basic U. S. requirement for a long range, area-coverage maritime radio navigation system that is technically and operationally suitable for use throughout the world.

5.4 TOTAL BANDWIDTH REQUIRED BY A PULSE SYSTEM

The frequency bandwidth required for a pulse radio navigation system is basically the radio frequency bandwidth required to transmit a radio frequency pulse of the required shape, i.e., the required amplitude vs. time

characteristics of the pulses utilized in the final synchronization or time-measurement process.

It has been previously noted that in order to achieve maximum accuracy from the system, our position-determining information must be derived from measurements on radio frequency cycles that are free of skywave contamination. This requires that measurements be made not later than 25-55 microseconds after the start of the pulse. If the pulse rise time is so slow that the pulse does not reach significant amplitude (50 per cent) at the point where time delay measurements are made, only a small fraction of the transmitted power is utilized. On the other hand, any signal having an amplitude and/or frequency which changes with time has an associated radio frequency spectrum. The two are inexorably linked by the laws of physics, if we describe the amplitude vs. time characteristics of a pulse as the amplitude vs. frequency characteristics of the associated frequency spectrum.

The LORAN-C signal, as well as any pulse signal, must occupy a band of frequencies in the radio spectrum whose width is determined by the spectrum of frequencies required to support the pulse shape and, particularly, the pulse rise time needed to provide discrimination against skywaves.

On the one hand, we desire a pulse that rises from zero to maximum amplitude in the shortest practical length of time. On the other hand, with the high demand for use of radio frequencies in the low frequency bands, it is desirable that the band occupied by LORAN-C emissions be no wider than necessary. In any case, it is essential that the spectrum radiated by the pulse system be in accordance with the relevant provisions of the Radio Regulations of the International Telecommunication Union.

The approximate shape of a single LORAN-C pulse is shown in Figure 11. It will be recognized, of course, that the LORAN-C pulse is not a single frequency but actually comprises a large number of components having significant amplitude over a fairly wide range of frequencies. Therefore, just as a conventional voice modulated emission contains not only the carrier frequency but also sideband frequencies representing the essential frequency components in articulate speech, the LORAN-C emission consists of a nominal carrier, 100 kc/s, and sideband components on either side of 100 kc/s representing the essential frequency components of the pulse modulation waveform shown in Figure 12. The dotted curve of Figure 12 shows the theoretical frequency distribution of the sideband components required for the pulse waveform. The solid curve shows the measured frequency distribution of these sideband components for a typical LORAN-C transmitting station. Computations show that greater than 99 per cent of the total radiated energy is within the 90-110 kc/s band.

As stated above, greater than 99 per cent of the total pulse power is confined within the band 90-110 kc/s, as required by the Radio Regulations. The spectral components outside this band do have significant amplitude in the immediate vicinity of a LORAN-C transmitting station and the reduction of these components is receiving highest priority attention. Results of Coast Guard tests are shown in Figure 13 by curves A and B which show a comparison between the present radiated power spectrum and an improved spectrum from the same equipment. The improved spectrum shown by curve B is a result of minor changes in the present equipment. A review of transmitter equipment techniques indicates that the confined energy can be further increased to the extent shown by curve C. The power spectrum

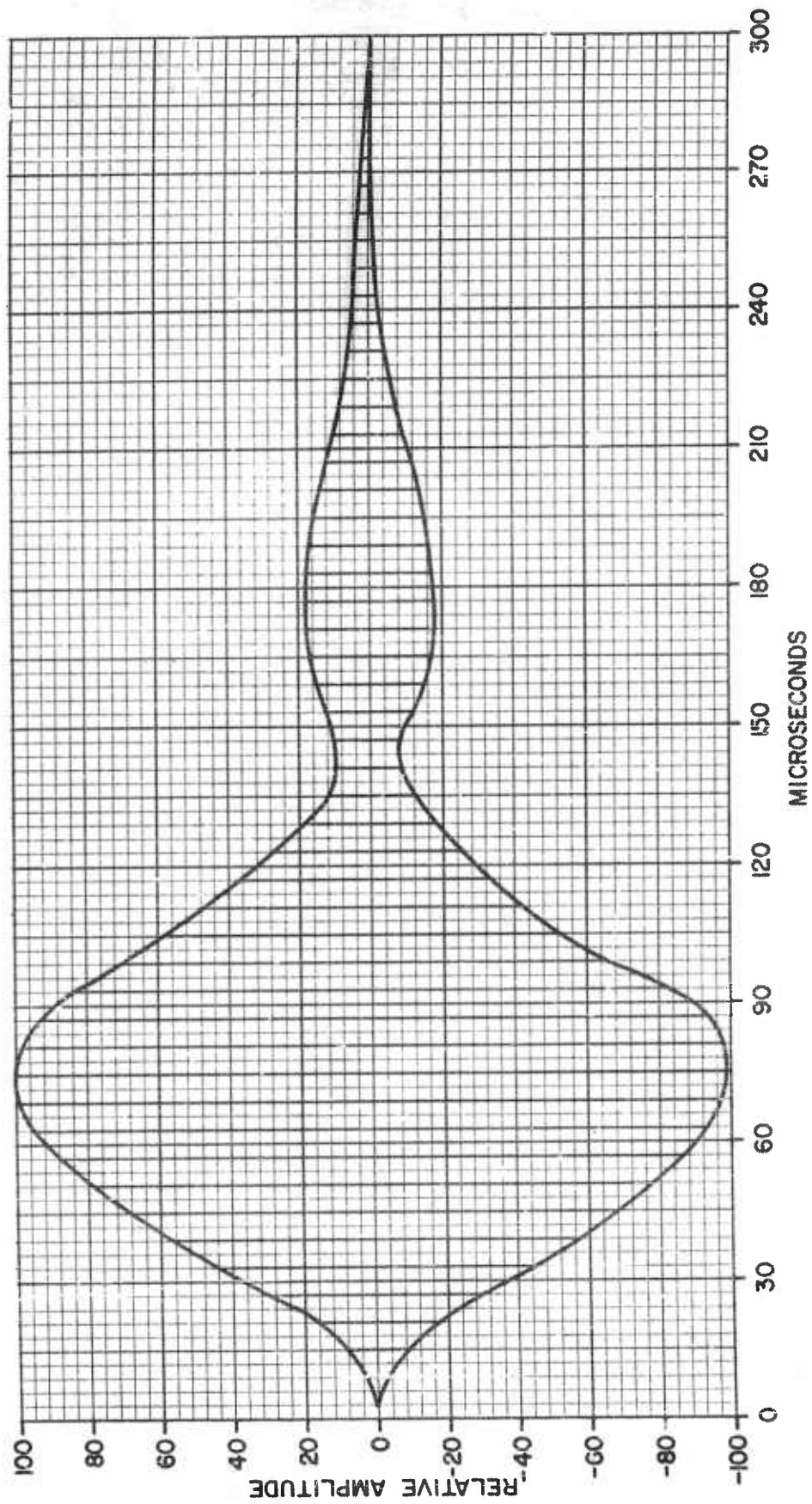

FIGURE 11
LORAN-C PULSE

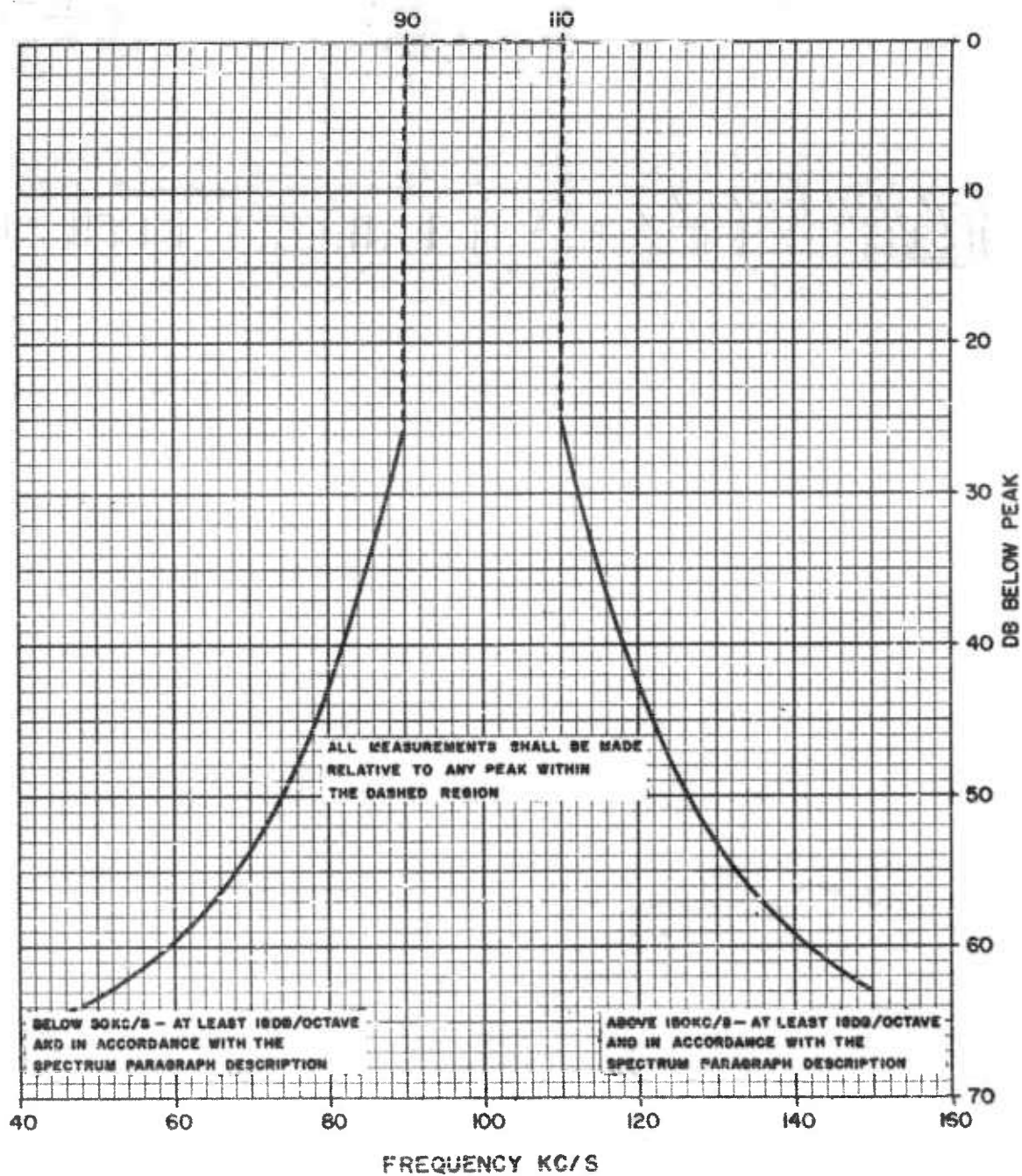

FIGURE 12
LORAN-C IDEAL SPECTRUM

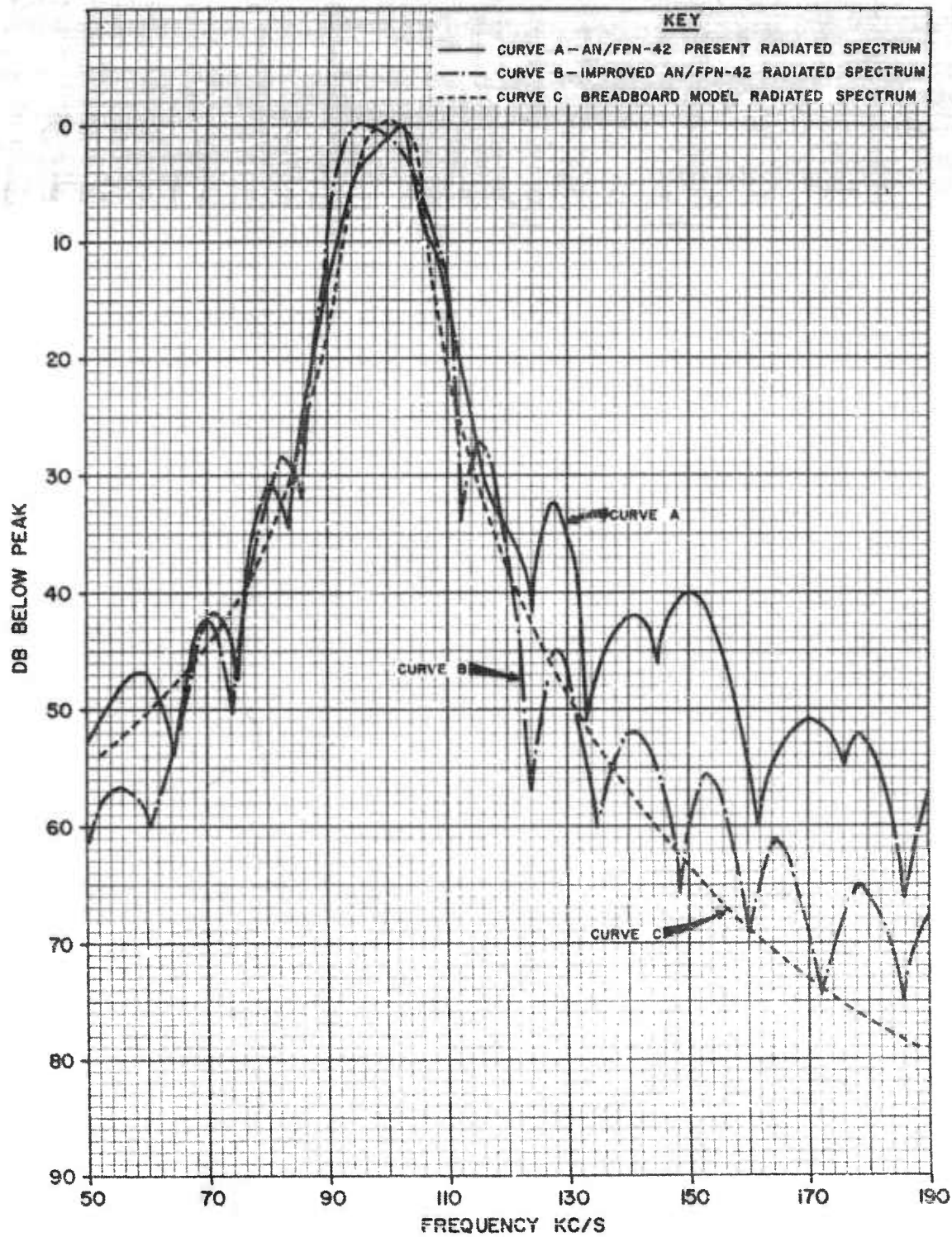

FIGURE 13
LORAN-C SPECTRUM

depicted by curve C was obtained with a preliminary breadboard model of the present equipment with extensive modifications. The per cent of total radiated energy which is confined within the 90 to 110 kc/s band is given below for each of the three curves.

Curve A	99.03 per cent
Curve B	99.42 per cent
Curve C	99.56 per cent

The techniques utilized to obtain the optimum spectrum will be incorporated in all new LORAN-C transmitting equipment. The present document on procurement of transmitting equipment states that "the total out-of-band energy shall be no greater than 0.5 per cent and that the energy above 110 kc/s and the energy below 90 kc/s shall each be no greater than 0.25 per cent of the total radiated energy. Additionally, at a distance of ten nautical miles, recognizable LORAN-C radiations from stations utilizing equipment provided under this purchase description shall not on any discrete frequency below 90 kc/s and above 110 kc/s be greater than three db above the value indicated (see Figure 13). The absolute value of any harmonic or spurious signal above 200 kc/s shall be minimized, and at 300 kc/s and above, shall not exceed 10 μ v per meter." The energy in the 90 to 110 kc/s band required by the statement above and Figure 13 is 99.75 per cent of the total radiated energy.

5.5 OVER-ALL SPECTRUM UTILIZATION EFFICIENCY

In view of the extreme congestion existing in this portion of the spectrum, it is patently incumbent upon those charged with the regulation covering the uses of the radio frequency spectrum to examine carefully each new operation proposed for this band with respect to the impact that it will

have on existing radio communication services. It is important that all operations in this band be examined with respect to both the operational requirement to utilize frequencies in this over-crowded portion of the spectrum and the efficiency with which the total frequency band required by each communication-electronic operation is utilized. Such an examination is especially necessary in the case of long range radio navigation systems which, by their very nature, have world-wide implications. Any such examination must go far beyond mere consideration of the nominal bandwidth of a single transmitting station in the system. Some of the factors that should be considered and have been considered with respect to LORAN-C in this test are:

1. The total radio frequency bandwidth required to establish a navigational fix that is free of operationally significant ambiguities.
2. The accuracy and reliability of the fix information provided.
3. The size of the service area produced by the basic unit of the system. (For purposes of this discussion the "basic unit of radio navigation system" is defined as the total number of stations required to establish a navigational line-of-position free of operationally significant ambiguities.)
4. The size of the interference area produced by the basic unit of the system - i.e., the area in which the total radio frequency band required by the basic unit of the system cannot be re-used because of the probability of harmful interference either to or from the system.
5. The total radio frequency bandwidth required for accurate and reliable world-wide navigation fix coverage.

5. The extent, if any, to which this band could be shared with other users.
7. The collateral or ancillary uses of the system or the emissions from its transmitting stations.

CHAPTER 6

LORAN-C PRINCIPLES OF OPERATION

6.1 HYPERBOLIC PRINCIPLE

Because of the nearly constant propagation velocity of radio waves, measurement of the difference in arrival times of radio energy from two widely separated transmitting stations results in an accurate measurement of the difference in distance from a pair of transmitting stations. Measurement of constant time-differences, and thus constant distance differences, generates hyperbolic lines-of-position relative to the transmitting sites. The intersection of two lines-of-position provides a position fix.

To generate a family of hyperbolic lines-of-position, a pair of transmitting stations is required. These transmitting stations or primary control units are land-based at locations selected to provide position-determining information over pre-selected areas. Two families of hyperbolas are needed for fix coverage. In the LORAN-C system, the hyperbolic grid required for determination of position is obtained from three or four stations - one station common to each family of hyperbolas.

6.2 SYNCHRONIZATION OF SIGNALS FOR TIME MEASUREMENTS

Timing control in the LORAN system is based upon accurate synchronization of the signal transmission time from associated ground stations. The basic time reference pulse is generated at one station - the master station. Pulses subsequent to the reference pulse designating zero time are generated at associated stations - slave stations. There is no significance to the terms master and slave except the master provides a signal reference for the other stations. The master station establishes the pulse recurrence rate

and the exact radio frequency to be transmitted by it and the associated slaves. It also monitors the transmission from the slaves to insure maintenance of system calibration. The master station has a highly stable oscillator whose output is frequency-divided or multiplied to yield the specific pulse recurrence rate and the selected carrier frequency.

The slave station receives the master station transmission; synchronizes its transmission in an established time sequence with regard to the master and transmits its signals precisely on the carrier frequency of the master. Accurate synchronization between the transmission of the master and slaves is essential to the proper functions of the system.

Several configurations of master and slave stations may be used to provide wide area coverage. Three LORAN stations consisting of one master and two slaves constitute a LORAN triad. Four or more stations consisting of one master and three or more slaves provide a LORAN star or square configuration. Operation of the triad, star or square configuration is fundamentally the same with the master station providing a reference for time measurement and the slave signals arranged to follow in proper time sequence.

6.3 PULSE OPERATION

The use of RF pulses in lieu of continuous wave signals and the provision for pulse identification from particular stations enables the LORAN-C system to have many ground stations operating on a single carrier frequency. In addition and of particular importance, is the use of pulses to provide discrimination between components of a received signal that arrives by groundwave and particular skywave modes of propagation. This provides maximum use of groundwave without skywave contamination effects

and also permits use of visual techniques in time difference measurements. The capability for using the stable groundwave signal without skywave contamination also permits the use of long baselines and the achievement of high accuracy synchronizations between associated masters and slaves.

The high accuracy of the LORAN-C system depends upon the use of groundwave propagation at extreme groundwave ranges. At ranges beyond several hundred miles, a portion of the groundwave signal is contaminated with skywave signals. Therefore, ways must be provided to enable the LORAN-C receivers in the service area and receivers at the ground transmitting stations to discriminate between the pulses of the groundwave mode and the first-hop skywave mode. This is accomplished in LORAN-C by taking advantage of the fact that with pulse type emission a small portion of the groundwave arrives at the receivers uncontaminated or not overlapped by skywaves. It has been found theoretically^{1/} and operationally^{2/} that the first-hop skywave delay will be between 25 and 55 microseconds, depending upon the distance between the receiver and the transmitting station, and the geographic latitude. Thus, only the first portion of the groundwave pulse is uncontaminated by skywave and must be utilized to yield desired high accuracy. The first portion of the groundwave pulse is sampled for a small period of time, two to ten microseconds. Means are provided in LORAN-C equipment to establish a fixed time of sampling so that only the groundwave signals are observed even though the amplitude of the signals may fluctuate due to changing distances.

1/ R.F. Linfield, R.H. Doherty, G. Hefley; NBS Report 4CB101, Evaluation of Propagation Aspects of the CYTAC System, 1957.

2/ R.H. Doherty; NBS Report 6CB103, Pulse Sky Wave Phenomena at 100 KC, 1957.

In conventional operation of the LORAN-A system, each master and slave transmitter radiates a single RF pulse in each repetition interval. This single pulse transmission has been found sufficient to provide visual observation techniques to the limits of the service area. In order to provide an increase in the average transmitted power, the LORAN-C system employs multi-pulse transmissions at all stations under normal operating conditions. Each station radiates eight pulses spaced 1000 microseconds apart. Additionally, the master station transmits a ninth pulse for visual identification and for providing the system with a method of transmitting information relative to system accuracy and usability to stations within the chain and to the receivers using the signals.

Within each of these multi-pulse groups from the master and slave stations, the phase of the RF carrier is changed with respect to the pulse envelope in a systematic manner from pulse-to-pulse. The phase of each pulse in an eight or nine-pulse group is changed in accordance with a prescribed code so that it is either in phase (+) or 180° out of phase (-) with a stable 100 kc/s reference signal. The phase code used at a master station is different from the phase code used at a slave, but all slave stations use the same code and currently (1962) all LORAN-C chains use the same code. The sequence utilized in a typical LORAN-C star chain is given below:

	<u>MASTER</u>	<u>X-SLAVE</u>	<u>Y-SLAVE</u>	<u>Z-SLAVE</u>
First repetition period	+ - - + + + + +	+ - - + + + - -	+ - - + + - - -	+ - - + + - - -
Second repetition period	+ + - - + + - -	+ + + + + - - +	+ + + + - - - +	+ + + + - - - +
Third repetition period		Same as first repetition period		
Fourth repetition period		Same as second repetition period		
		ETC.		

The use of phase-coded pulses by the system provides a measure of protection against interference from outside sources and also reduces contamination of the groundwave of pulses transmitted subsequent to skywaves from preceding pulses; i.e., the skywave of the first pulse arriving at the same time as the groundwave of the second pulse. Contamination by preceding skywaves without phase coding would nullify the effect of sampling only the groundwave, thereby degrading the inherent accuracy of the system. The use of phase coding also provides the receiver with necessary logical information for automatic search for the master and slave signals. Automatic search can be utilized for convenience or when the signal-to-noise ratio of the received signals precludes visual identification.

In addition to sampling the received signals for short durations and using cycle or phase detectors, the LORAN-C system also employs information smoothing after detection. This post-detection smoothing coupled with synchronous detection is mathematically equivalent to a correlation operation. The net result of the correlation technique is that the LORAN-C information is received in the form of numerous discrete narrowband spectral components. These spectral components form an effective comb filter with the spacing of the comb teeth determined by the phase code of the signals, the pulse spacing and the duration of the sampling interval. The correlation of received signals is the optimum method of detection resulting in the maximum protection from noise and interference.

6.4 TIME SPACING OF MASTER AND SLAVE SIGNALS

To prevent simultaneous reception of a pair of master and slave signals, the groups of similarly shaped RF pulses from the paired stations are time-

spaced and synchronized. Time spacing is achieved by having a slave station wait a predetermined interval after reception of the master signals before the slave commences transmitting. This time spacing or time delay of transmission is called the coding delay and is predetermined by system propagation times and equipment operating characteristics. The complete sequence of operation is described in the following chapter.

6.5 IDENTIFICATION OF A PARTICULAR GROUP OF MASTER AND SLAVES

The use of pulses for LORAN-C makes possible the sharing of the same RF channel by all stations in the system. Identification of particular groups of stations must be provided by some means other than channel selection. Accordingly, provision has been made in existing LORAN-C equipment for 48 different pulse repetition intervals or rates. The 48 rates are divided into 6 basic rates, each subdivided into 8 specific rates. The present LORAN-C repetition rate structure is given again in Table 6.^{1/} Chains are identified by their basic and specific rate; for example, chain SH4 would transmit at a pulse recurrence interval of 59,600 microseconds. Selection of a particular chain is accomplished by setting

TABLE 6

SPECIFIC RATE SELECTION	PULSE REPETITION RATES (MICROSECONDS)					
	BASIC RATE SELECTION					
	SS	SL	SH	S	L	H
0	100,000	80,000	60,000	50,000	40,000	30,000
1	99,900	79,900	59,900	49,900	39,900	29,900
2	99,800	79,800	59,800	49,800	39,800	29,800
3	99,700	79,700	59,700	49,700	39,700	29,700
4	99,600	79,600	59,600	49,600	39,600	29,600
5	99,500	79,500	59,500	49,500	39,500	29,500
6	99,400	79,400	59,400	49,400	39,400	29,400
7	99,300	79,300	59,300	49,300	39,300	29,300

^{1/} Same as Table 4 shown on Page 39.

a receiver to synchronize on the desired pulse repetition frequency (PRF).

6.6 SPECIAL FEATURES OF LORAN-C RELATIVE TO CORRESPONDING FEATURES OF LORAN-A

Each individual type of LORAN adds additional functions to meet specific needs of range and accuracy. Thus, the LORAN-C system and the LORAN-A system follow a similar pattern and yet differ in many functions as noted below:

1. Frequency

The LORAN-A system operates in the medium frequency band at specific frequencies of 1850, 1900 and 1950 kc/s. Medium frequency operation yields groundwave ranges of 700-1100 nautical miles over an all seawater path when radiating one megawatt peak pulse power.

The LORAN-C system operates in the low frequency band (90-110 kc/s). The use of the 100 kc/s carrier frequency has advantages over the medium (2 Mc/s) frequencies because the attenuation of the lower frequency signal (100 kc/s) is significantly less. Transmission on or near the 100 kc/s frequency has additional features which make it desirable for radio navigation systems. One of these features is based on the fact that a graph of field intensity versus frequency for the same power radiated indicates that above 120 kc/s the field intensity curves for propagation over a good conductor (seawater) and a poor conductor (land) diverge rapidly beyond 500 miles. Thus, intervening land masses do not affect 100 kc/s propagation nearly as much as higher frequencies.

It is not desirable to attempt pulse transmission at frequencies below 100 kc/s. Radiated pulses of sufficiently short rise time are

difficult to achieve due to decreasing antenna bandwidths as frequency is lowered. As frequency is lowered, physical size limitations make practical antennas very inefficient. Propagation considerations of the ionosphere indicate that the first-hop skywave delay decreases at lower frequencies thereby reducing the amount of uncontaminated groundwave available for obtaining information.

2. Baseline Length

The use of the 90-110 kc/s frequency band and the transmission of pulse groups for LORAN-C operations has resulted in longer range reception of the pulses. The increase in range makes possible longer baselines between ground transmitting stations and increases in the service area from each set of stations. In general, longer baselines provide an increase in the total area where crossing angles between lines-of-position are favorable (greater than 15°). Thus, the area of high accuracy from a set of stations can be increased provided the baseline length is not too long to preclude signal reception from the most distant station.

3. Cycle Matching

The general method of obtaining time-difference readings from two received signals in the LORAN-A system involves the matching of the envelope of the two signals. In addition to envelope matching, the LORAN-C system adds the technique of RF cycle matching to provide a vernier measurement within the pulse envelope. This vernier measurement of RF cycles enables the LORAN-C system to obtain the increased accuracy required for precise navigation.

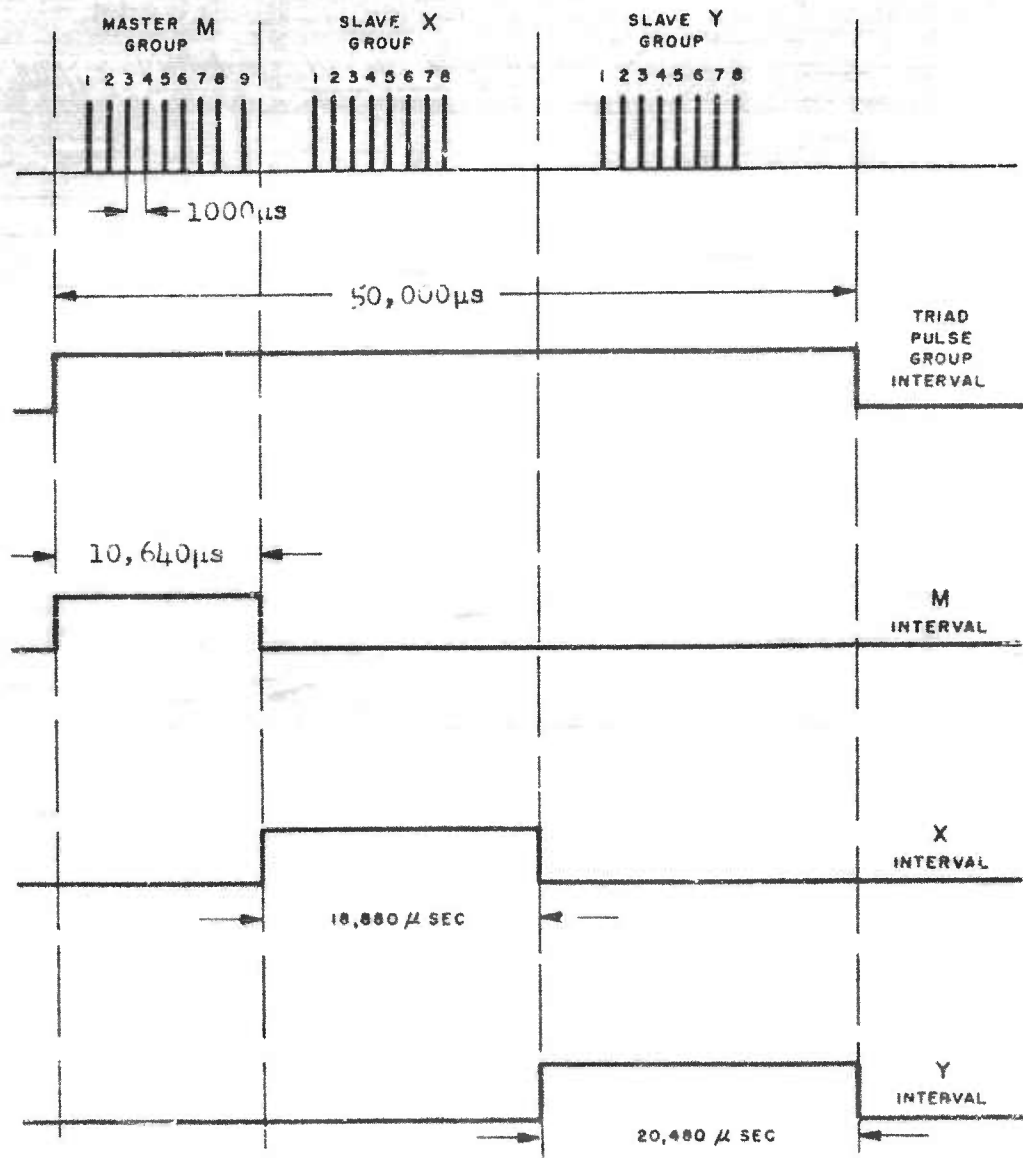

SLAVE PULSE GROUPS MAY BE SHIFTED WITHIN THEIR RESPECTIVE INTERVALS

FIGURE 14
TIME-SHARING OPERATION OF LORAN-C TRIAD

4. Chain Configuration

Previous paragraphs described the technique of operating with a master and a slave station on the same frequency. Other paragraphs describe the rate structure used for LORAN system operation. The LORAN-C system combines these two techniques in a manner slightly different than LORAN-A. In LORAN-A, a single slave operates with a master station such that the pair of stations have a common RF carrier frequency and repetition rate. When it is desired to add adjacent stations to form two pairs, the new pair would operate on a different repetition rate. In order to obtain a fix from the two lines-of-position, separate measurements must be made on each rate of transmission.

The LORAN-C mode of operation involves operation of a single master and two or more slaves on the same repetition rate. Figure 14 illustrates the time-spacing of transmissions from a master and two slave stations in a triad configuration. Each station operates in the multi-pulse mode with appropriate coding delays inserted at the slave stations X and Y to provide unambiguous signals in the service area. When a fourth slave is added to the triad to form a star configuration, the fourth station is termed the Z slave and is timed so that its transmissions occur after the Y signals. LORAN-C repetition rates are selected to be compatible with LORAN-A system operation, thereby permitting easier A/C receiver construction.

CHAPTER 7

SYSTEM OPERATION AND CALIBRATION

The preceding chapter has described the fundamental principles of LORAN-C and its relations to LORAN-A. This chapter will describe: (1) the operation of a typical LORAN-C triad and the facilities provided for calibrating the navigational grid which it provides and (2) the operation of a LORAN-C receiver to obtain fix information.

7.1 OPERATION OF A LORAN-C TRIAD

At time zero, the master station commences radiating a pulse of RF energy with a carrier frequency of 100 kc/s. The pulse has an envelope waveform which rises from a zero to peak amplitude in approximately 80 microseconds and has a duration at the 10 per cent amplitude points of approximately 250 microseconds. Successive pulse radiations are spaced 1000 microseconds apart and have the RF carrier phase coded in the prescribed manner for a master station. After nine pulses have been radiated, the master station stops transmitting until the time interval prescribed by the triad pulse recurrence interval has elapsed. After this prescribed time, the master station again radiates nine pulses with the prescribed phase code.

At time zero plus the travel time from the master to slave X, the master groundwave signals begin to arrive at slave X. Slave X commences monitoring the received signals; sampling them prior to the arrival of the skywaves. Through a cross-correlation detection and cycle matching process, the slave station locks its oscillator to the phase and frequency of the received 100 kc/s signal. The oscillator at the slave station is then used to generate the carrier frequency and pulse recurrence interval required for slave transmissions. The slave station inserts a prescribed coding delay

after the arrival of the first pulse of the master pulse group and then commences radiating similarly shaped pulses with the phase code prescribed for a slave station.

Slave Y operates in the same manner as slave X except that a different coding delay is inserted between the time of reception of the master signals and the beginning of slave Y transmissions. This coding delay is greater than the X coding delay so that there is no overlap of X and Y signals at any point in the service area.

The master station monitors the time of receipt of the slave X and slave Y signals to determine the accuracy and stability of their transmissions. Each slave station monitors the other slave station in a like fashion to collect additional data concerning system stability and accuracy. Monitor stations in the service areas and/or in the vicinity of each transmitting stations record time-difference readings and compare these readings with time differences based upon the geographic coordinates of the monitor site. Each transmitting station maintains a continuous monitoring of its own radiated signal to ascertain that there are no changes in the immediate area of transmission which will affect accuracy in the service area.

Corrections are applied to the system to maintain the desired accuracy in the selected service area. These corrections are determined by analyzing data collected at the various transmitting and monitor sites. Corrections are inserted at the slave stations in the form of changes to the coding delays so that the hyperbolic grid of time-difference readings remains fixed with respect to geographic position.

Information concerning system malfunction is broadcast to users in the form of a blink code. The blink code from the master station involves

an on-and-off keying of the ninth pulse in a coded fashion determined by the portion of the system having the malfunction. If the malfunction occurs at the master station such that the master is off the air the slave stations inform users by a time shift of the complete pulse group similar to blinking in the LORAN-A system. When system malfunctions are corrected, all stations resume the regular sequence of operation.

7.2 MONITORING AND CALIBRATING OPERATIONS

The purposes of monitor stations in LORAN-C systems are to make an initial system calibration and to maintain operational timing accuracy at the calibrated values. The purpose of system calibration is to provide the ground transmitting control units with the information required to maintain accurate time-difference readings in the service area. System calibration is accomplished by locating monitor stations in the vicinity of the transmitting stations and in the service area and also by sampling the system accuracy at many points in the service area. System corrections are determined from the calibration data and applied in the form of coding delay adjustments at the slave stations.

Calibrating near the transmitting stations assists in determining the transmission time over each master-slave baseline and assists the transmitting stations in maintaining a fixed coding delay during initial system operation. Service area calibration can be accomplished if the position of some island or other land mass in the LORAN service area can be determined with sufficient accuracy by gravity or astro-static survey techniques to serve as an area monitor station. Present accuracies of such techniques are determined by the observation techniques and the survey datum. Time-difference readings are observed at various surveyed positions and compared

with predicted readings. The system corrections are then calculated and applied so that the observed readings will have the desired position accuracy.

After the LORAN system has been calibrated, there are several methods for holding the LORAN lines-of-position at the calibration values through system monitoring. This may be accomplished completely within the transmitting system as the master station, completely outside the system at the service area monitor, or by a combination of the two.

When monitoring entirely within the system, the object is to hold the slave coding delay plus the one-way transmission time at the calibration value. Since the one-way transmission time may vary as much as 0.06 microseconds and equipment operation may also vary, the slave station coding delay must be adjusted to correct system timing. The equipment variations can be as great as 0.05 microseconds. These equipment variations are caused by adverse signal-to-noise and signal-to-interference ratios in conjunction with operator performance. The variations in the sum of slave coding delay and one-way transmission time can be observed on the master station timer-synchronizer. Thus, the master station can calculate the correction necessary to adjust the slave coding delay until the calibrated value is observed at the master.

The most difficult problem encountered in monitoring one of the ground transmitting stations involves the effect of the local radiated signal. The receiving antenna for the ground synchronizing equipment is located well within the limits of the near field of the local signal. Variations in the near field may be very pronounced due to changes in antenna characteristics, transmitter characteristics, and ground conductivity. These variations

are reflected as a change in the measured time-difference of the remote signal. It is also extremely difficult to prevent the local signal from reaching the receiver by devious uncontrolled paths. Consequently, LORAN-C systems are normally operated with monitoring assistance from a service area monitor.

The function of a service area monitor is to supply coding delay adjustments to the slave stations. Adjustments are based on observations of the LORAN-C time-difference readings at the monitor. Holding the time-differences constant at a service area monitor provides for near-perfect grid accuracy over a very large area centered about the area monitor.

In LORAN systems having a triangular configuration, the area monitor should be approximately in the center of the groundwave service area. In systems having a star configuration, it would be desirable to have two area monitors. A compromise arrangement would be to locate a single monitor in the vicinity of the master, but it should be at least 10 to 20 miles from the master station.

7.3 OPERATION OF A LORAN-C RECEIVER FOR OBTAINING A POSITION FIX

To obtain high position accuracy over long transmission paths, receivers must be designed specifically for LORAN-C system use. With the proper equipment, the user is capable of obtaining the maximum amount of information available from the transmitted LORAN-C signals. The technique of obtaining this information is described briefly as follows:

1. The receiver is designed to accept a carrier frequency of 100 kc/s with a bandwidth commensurate with requirements for pulse type reception (approximately 25 kc/s).

2. The receiver operator selects the pulse recurrence rate of the LORAN-C chain to be observed. This selection aligns timing within the receiver to the timing of the signals to be observed. When the received signals are of sufficient amplitude to be observed on an oscilloscope swept at the rate of transmission, the received signals appear stationary. Signals on rates other than that selected at the receiver drift through the stationary signals.
3. After selecting the proper recurrence rate, the operator then synchronizes the receiver with the master signals. Synchronization can be accomplished in either of two ways on most LORAN-C receivers. In the first method, the operator utilizes the ninth pulse of the master station for visual identification of the time sequence of transmission. In the second method, the automatic search feature of the receiver is used. Automatic search is made possible through the use of the phase coded pulses and logic circuits in the receiver. In either of the two methods, the sampling gates are aligned in time with the receiver master pulses allowing the receiver to commence automatic tracking of these signals.
4. Synchronization of the receiver on slave signals is then accomplished by visual or automatic means.
5. When the receiver has synchronized on a master and a slave signal, the arrival time-difference is directly and continuously displayed as the receiver moves in the service area. These time-difference readings are then translated into geographic coordinates by the use of computers, charts, or tables.

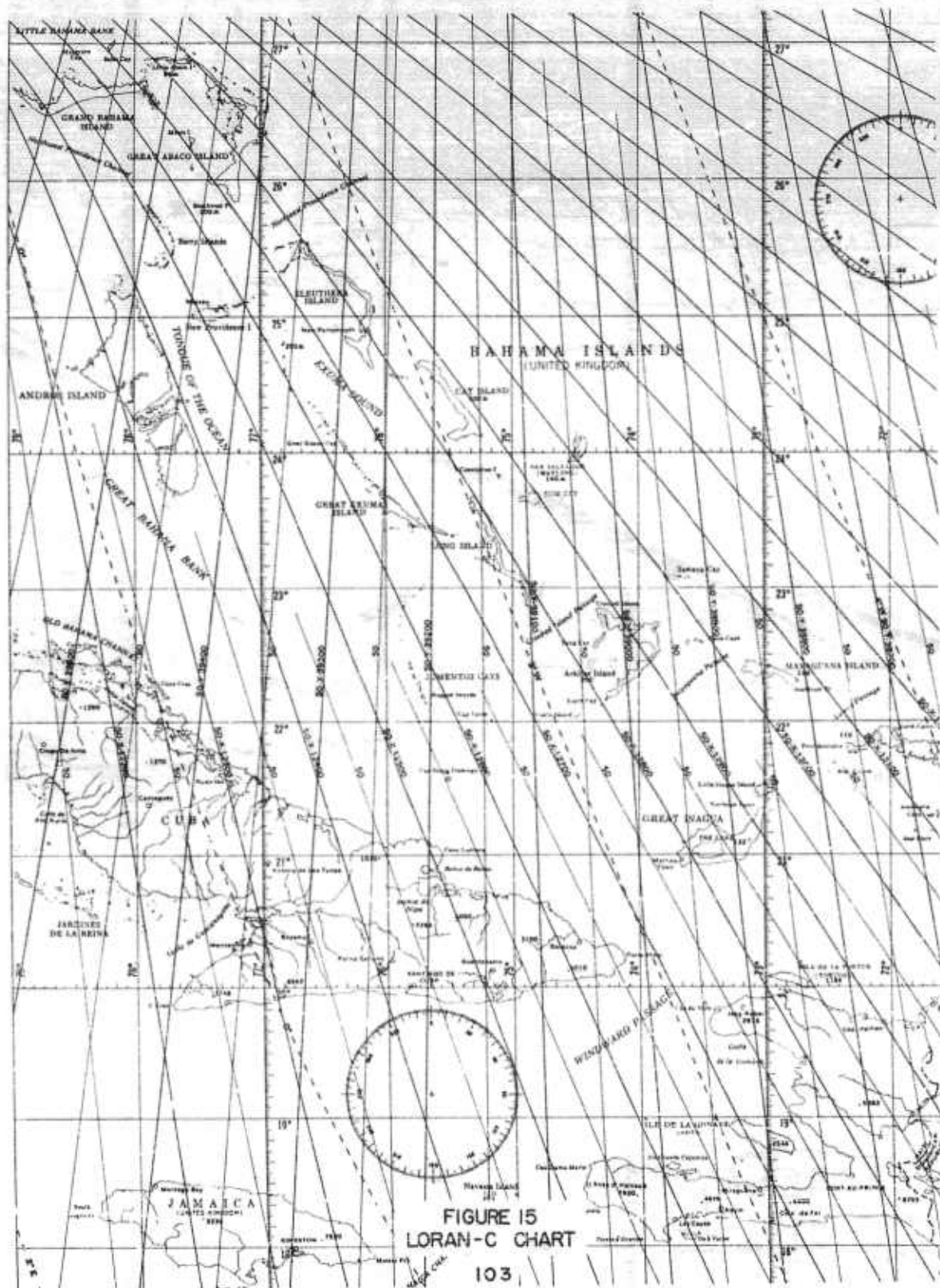

6. Automatic alarms have been incorporated in most receivers to inform the operator when the receiver is tracking on a combined groundwave-skywave signal. Alarms also inform the operator when the receiver has lost a particular signal either through improper sampling or when a transmitting station is off-air.

LORAN-C charts are prepared and sold by the U. S. Navy Hydrographic Office, Washington 25, D. C. The charts are standard projections and show the chain rate identification, isogonic lines, the first-hop skywave corrections for day and night. Ionosphere heights for day and night corrections are assumed to be 73 and 91 kilometers, respectively. The hyperbolic lines-of-position, the main feature of the charts, are spaced approximately 10 to 50 microseconds apart depending on the local geometric accuracy potential of the area. Scale of the VLC-30 series is 1.2:188,800. Figure 15 is a section of a VLC Chart.

CHAPTER 8

TECHNICAL DESCRIPTION OF COMPONENTS OF LORAN-C SYSTEM

8.1 LORAN-C GROUND STATION EQUIPMENT

An entire LORAN-C transmitting complex occupies a land area of approximately one-tenth of a square mile or about one-quarter of a square kilometer. Figure 16 is a picture of a typical transmitting station. A 625-foot transmitting antenna is shown in Figure 17. Figure 18 shows a typical station layout.

Two buildings are required for the LORAN-C equipment. The transmitter building at the base of the transmitting antenna houses only the equipment required to radiate the LORAN-C pulse. The signal and power building contains an RF protective screened room with ground station synchronizers and associated recording and test equipment. Various offices, shops, storage rooms, and the primary power source for the station are usually included in this operations building. Thirty-five foot whip antennas located a maximum of 1500 feet from the signal building are used to receive associated station signals. A more complete description of station siting is contained in Chapter 10.

Each LORAN-C transmitting station basically consists of a high-powered pulse transmitter, a transmitter synchronizer, and associated equipment. The transmitters and the synchronizers at all stations are capable of performing the same functions, but synchronizers at the master stations are used in a different manner than those at the slave stations.

Each LORAN-C station has two synchronizers, two transmitters, switching and control equipment, a receiving antenna, and a transmitting antenna. In normal station operation, one synchronizer and one transmitter are used to

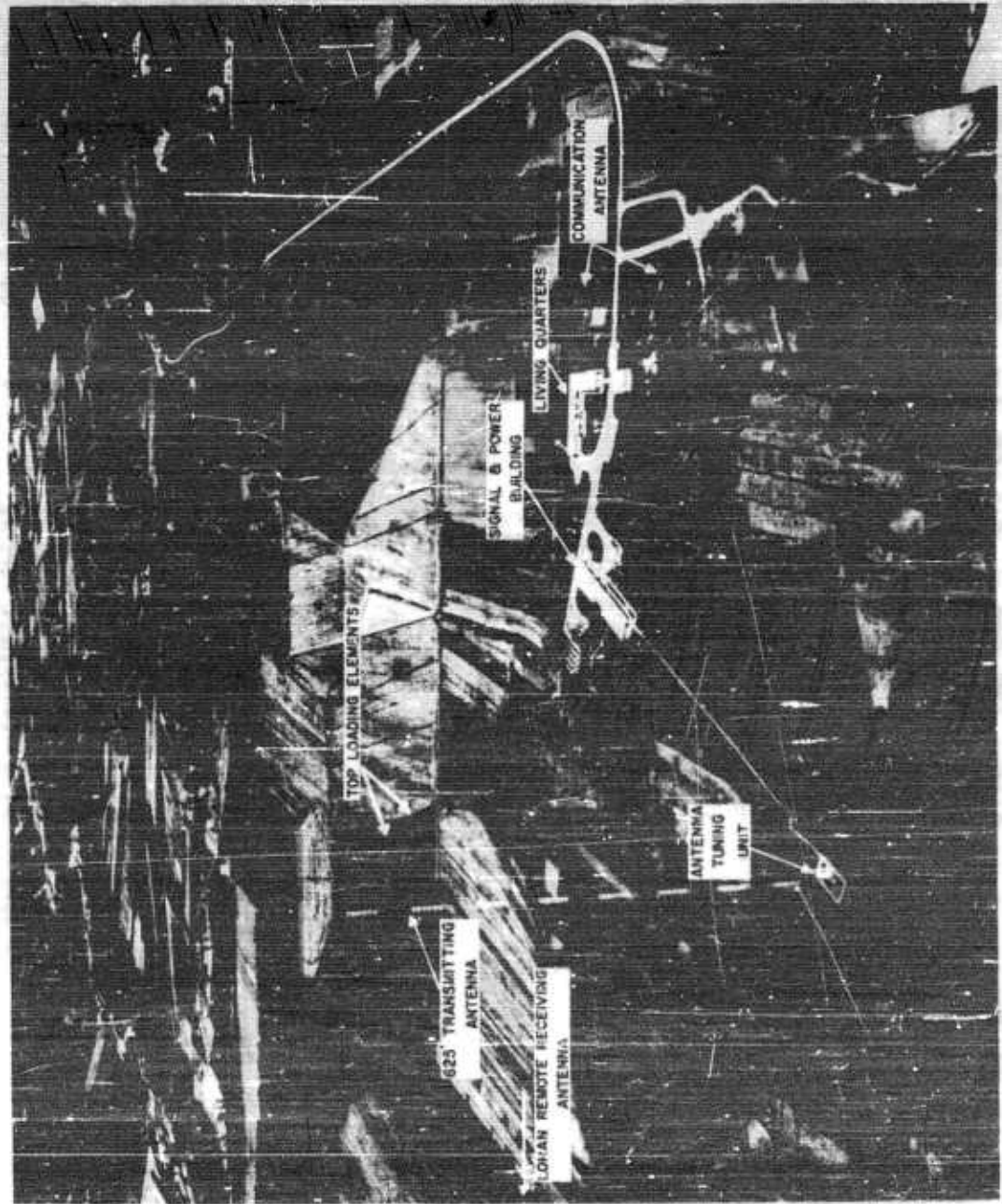

FIGURE 16
A TYPICAL LORAN-C TRANSMITTING STATION

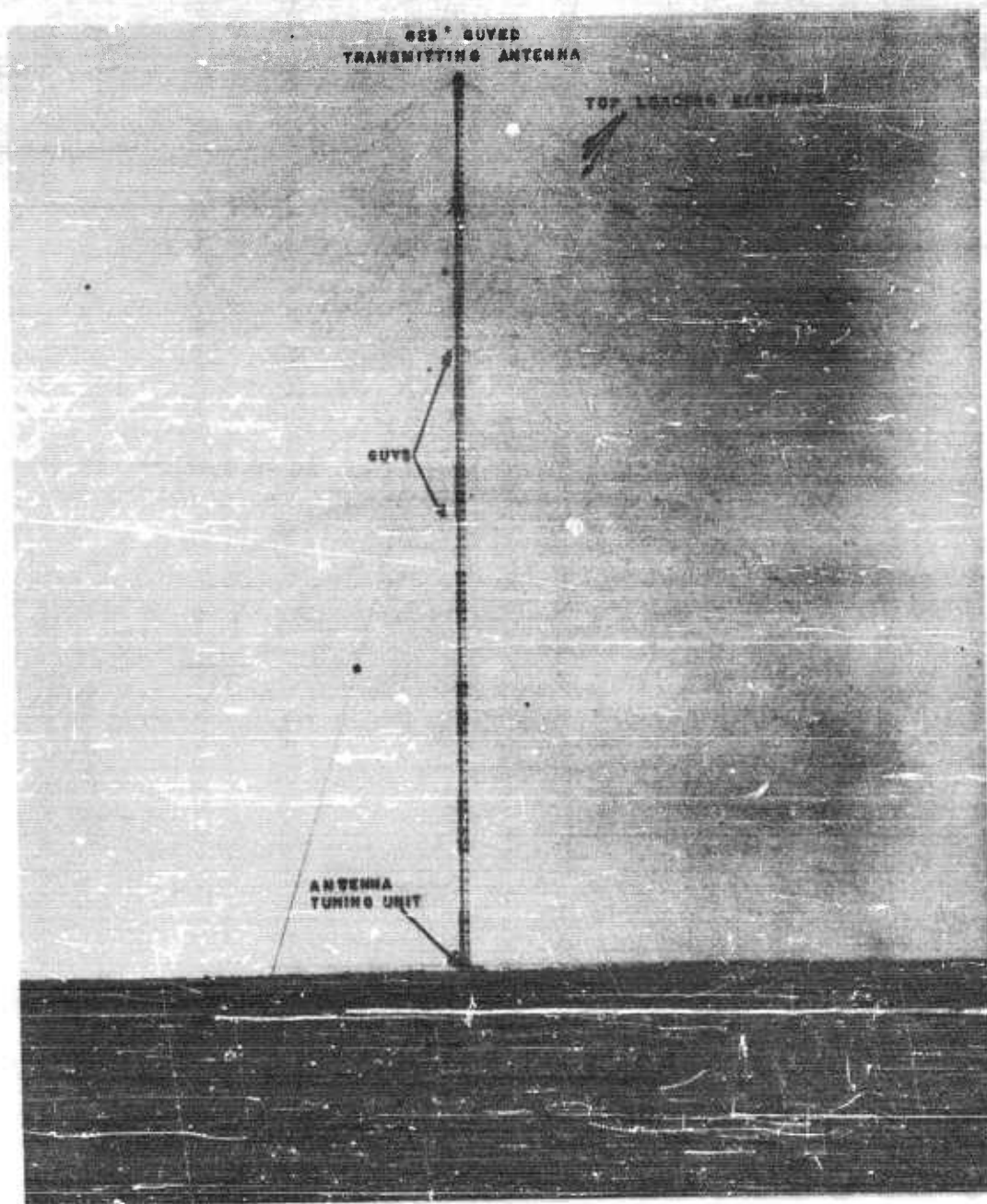

FIGURE 17
A 625-FOOT GUYED LORAN-C TRANSMITTING ANTENNA

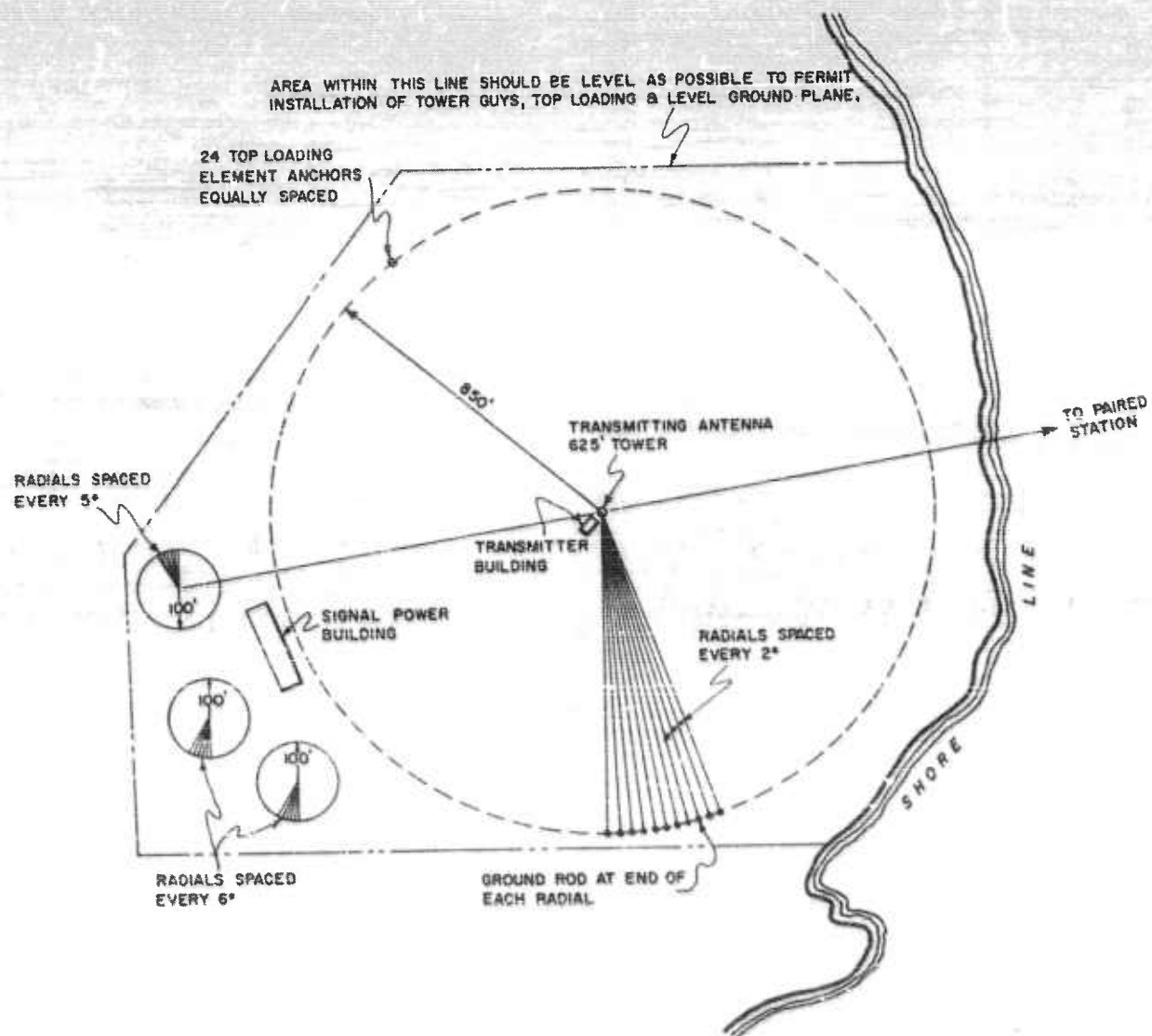

FIGURE 18
TYPICAL LORAN-C STATION

maintain on-air operation. The other sets are kept in standby readiness to insure high reliability operation. The standby synchronizer is also used to perform monitoring functions.

Improvements have been made in LORAN-C station equipment in every new installation so that the stations differ somewhat in equipment and layout. Originally, the transmitters were located approximately a thousand feet from the base of the transmitting antenna and in the same building as the synchronizers. In the newer installations, the transmitters are always located at the base of the transmitting antenna to minimize transmission line losses and to reduce stray coupling between transmitters and synchronizers.

Three generations of equipment are now in use. The first generation is the modified CYTAC equipment in the East Coast chain. The AN/FPN-15 (XW-1) transmitters and specially designed synchronizers used in this system were of excellent quality when new, but also cumbersome and quite expensive. The equipment was modified for LORAN-C use in 1953 and will be replaced early in 1962. The second generation equipment consists of AN/FPN-38 synchronizers and AN/FPN-39 transmitters employed in the Mediterranean and Norwegian Sea chains. The transmitters are similar to the first generation transmitters but have a higher reliability and power output, improved suppression of harmonic and spurious output; the synchronizers are more compact and easier to operate and maintain. The third generation equipment consists of AN/FPN-41 synchronizers and AN/FPN-42 transmitters which have a higher power output and reliability than either the AN/FPN-15 (XW-1) or AN/FPN-39. The synchronizers also have improved reliability and can be synchronized very accurately under high noise and

interference conditions. Third generation equipment is now (1961) installed in the Aleutian and Hawaiian chains and in early 1962 will replace first generation equipment in the East Coast chain. Figures 19 and 20 are pictures of the third generation equipment. Figure 21 is a block diagram of the equipment at a typical LORAN-C station.

A simplified functional block diagram of a master station is shown in Figure 22. The 100 kc/s oscillator is the basic timing unit of the chain. The oscillator output is applied to a gated amplifier and then to the power amplifier and transmitting antenna. The output is also applied to a phase shifter in the monitor receiver and to the Pulse Recurrence Rate (PRR) Divider. The transmitter excitation and phase reference are coded for station identification by the phase coder. The output from the PRR Divider is passed through a variable delay system and applied to the envelope sampling circuitry. The delayed sample gates are brought into coincidence with the arriving slave signal by the envelope servo loop. The indicator on the variable delay system indicates the coarse envelope time-difference measurement between transmissions of the master pulse and reception of a slave pulse.

The cycle servo loop measures the phase difference between the cycles of the arriving slave signal and the 100 kc/s continuous-wave reference signal. The phase difference measurements are indicated on the fine time-difference dial. The phase difference detector system is gated by pulses from the variable delay circuit so that it operates only during the time of reception of the slave signal. The function of the servo loops is to provide an indication of the performance of the slave stations. The loops, therefore, do not affect the transmission of the master station

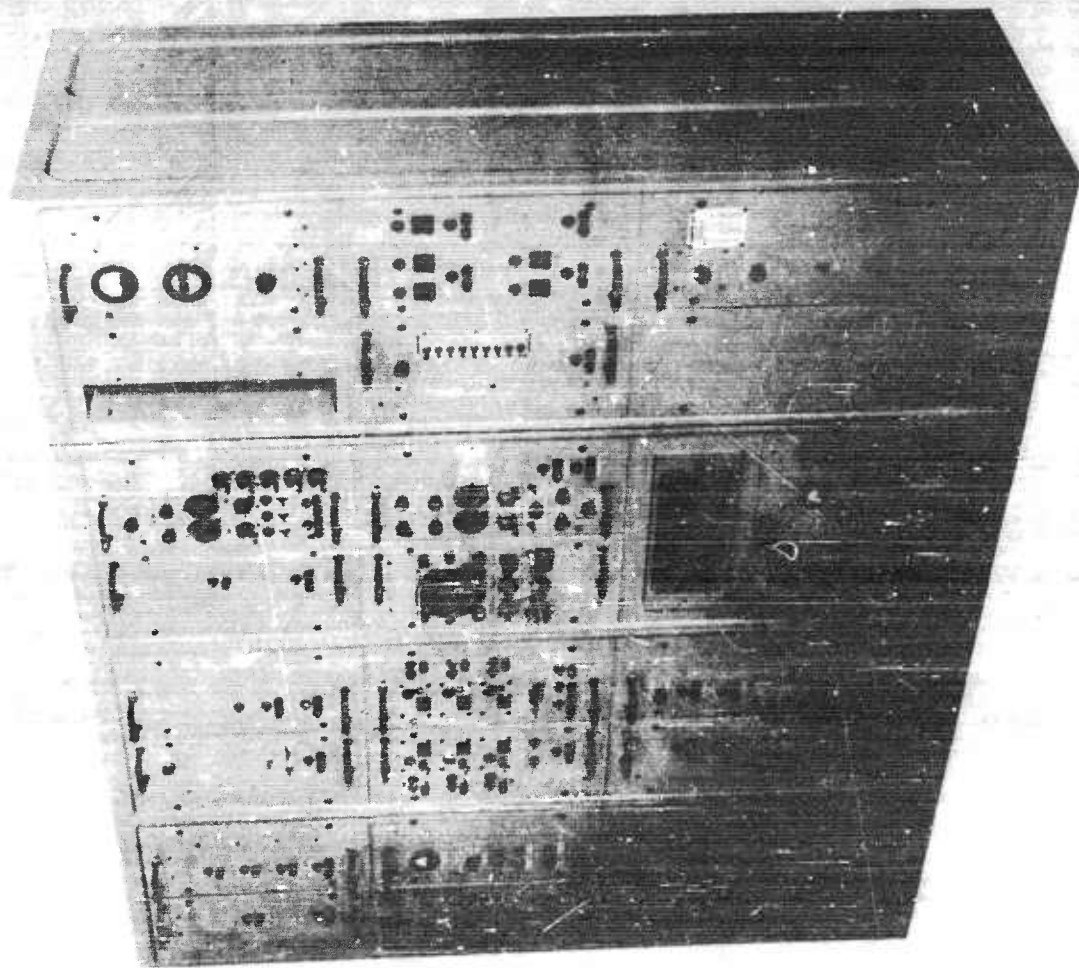
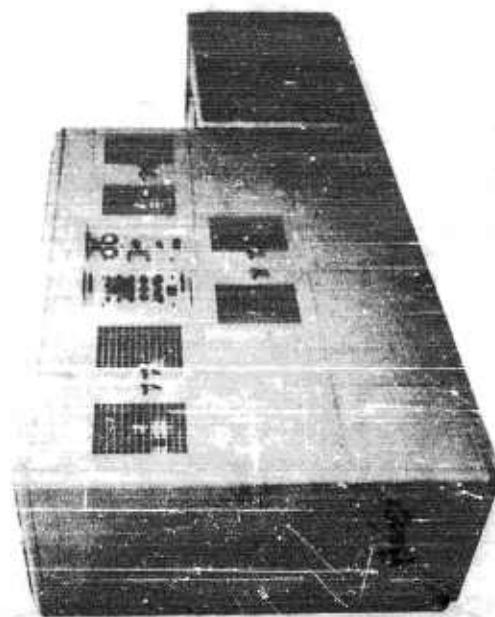
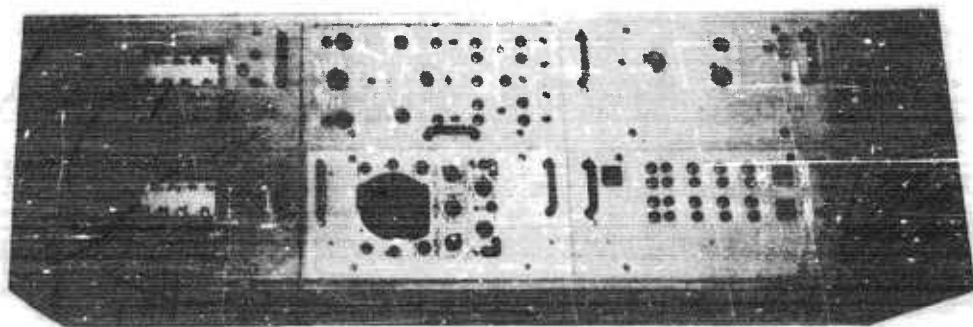

FIGURE 19
AN/FPN-41 Loran-C Timer-Synchronizer



POWER AMPLIFIER AND BLOWER



PULSE CONTROL

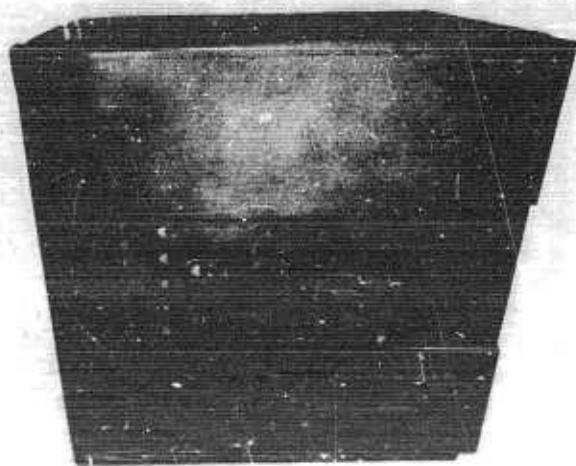

HIGH-VOLTAGE POWER SUPPLY

FIGURE 20
AN/FPN-42 Loran-C Transmitter

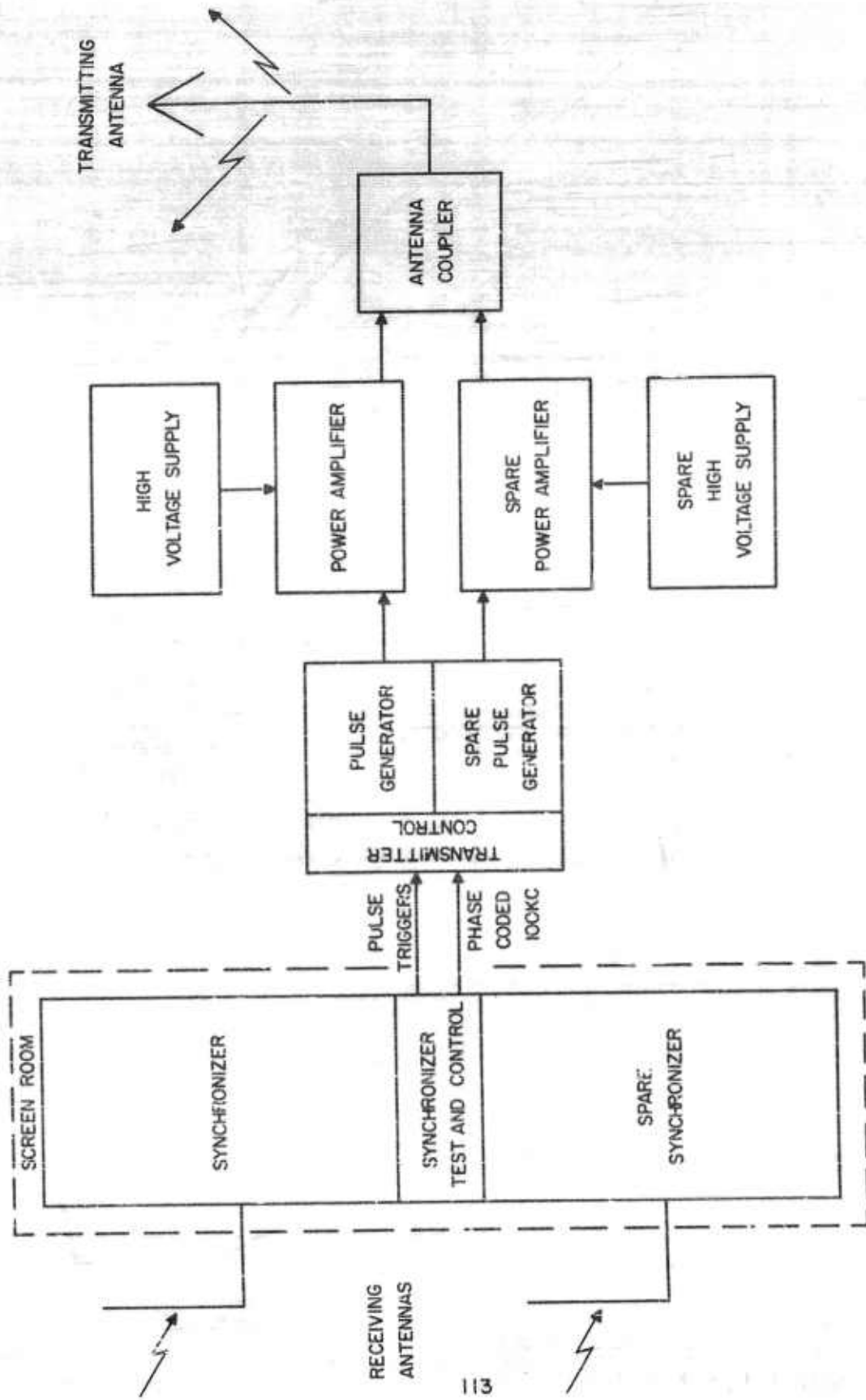

FIGURE 21
LORAN-C STATION EQUIPMENT

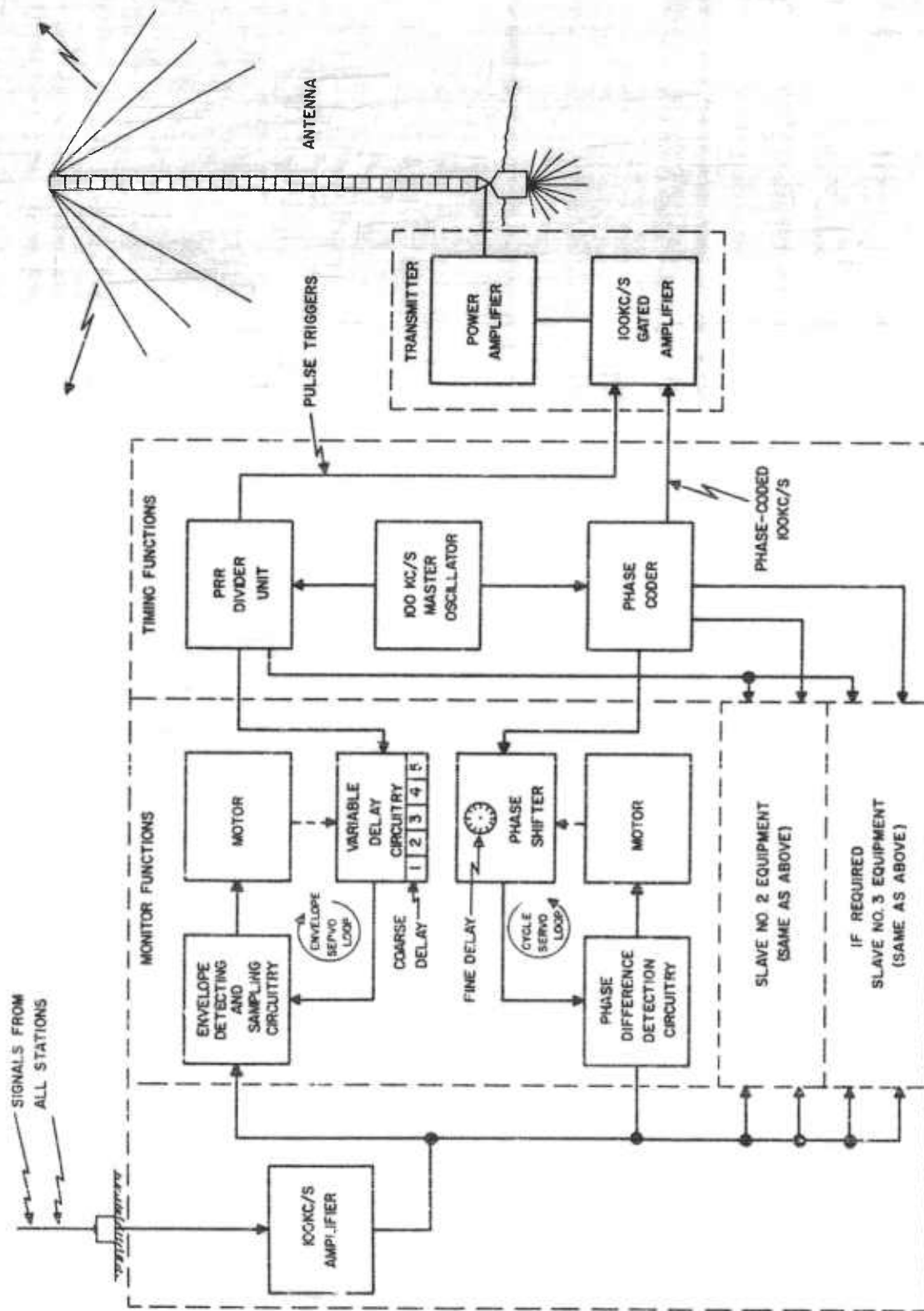

FIGURE 22
LORAN-C MASTER STATION FUNCTIONAL BLOCK DIAGRAM

signals. Identical servos are provided for each additional slave station.

Two signals formed in the synchronizer control the operation of the transmitter. These are the triggers from the Pulse Recurrence Rate Divider and the phase coded 100 kc/s signal. Nine triggers are required at a master station; eight with a spacing of 1000 microseconds and the ninth trigger spaced either 600 or 1300 microseconds after the eighth trigger. The triggers and the phase coded 100 kc/s signals are combined in the 100 kc/s gated amplifier to form the modulated 100 kc/s driving waveform required by the final amplifier. The final amplifier feeds a modified form of the input signal to the antenna through a broadband coupling network. The resultant radiated signal has the desired shape for LORAN-C operations.

The ground station equipment has been constructed so that it can be used at a master or any slave location. The manner of changing from master station operation to slave station operation involves removing or adding circuits which are installed in the equipment and changing various positions on selector switches.

A simplified functional block diagram of a LORAN-C slave station is shown in Figure 23. The 100 kc/s output signal of the oscillator is brought into a fixed phase and frequency relationship with the received signal from the master station by means of the cycle servomechanism loop through the use of phase detector error output.

The envelope servomechanism system synchronizes the output of the PRR generator with the envelope sampling point of the received master signal. The output of the PRR generator is passed to the delay unit wherein the

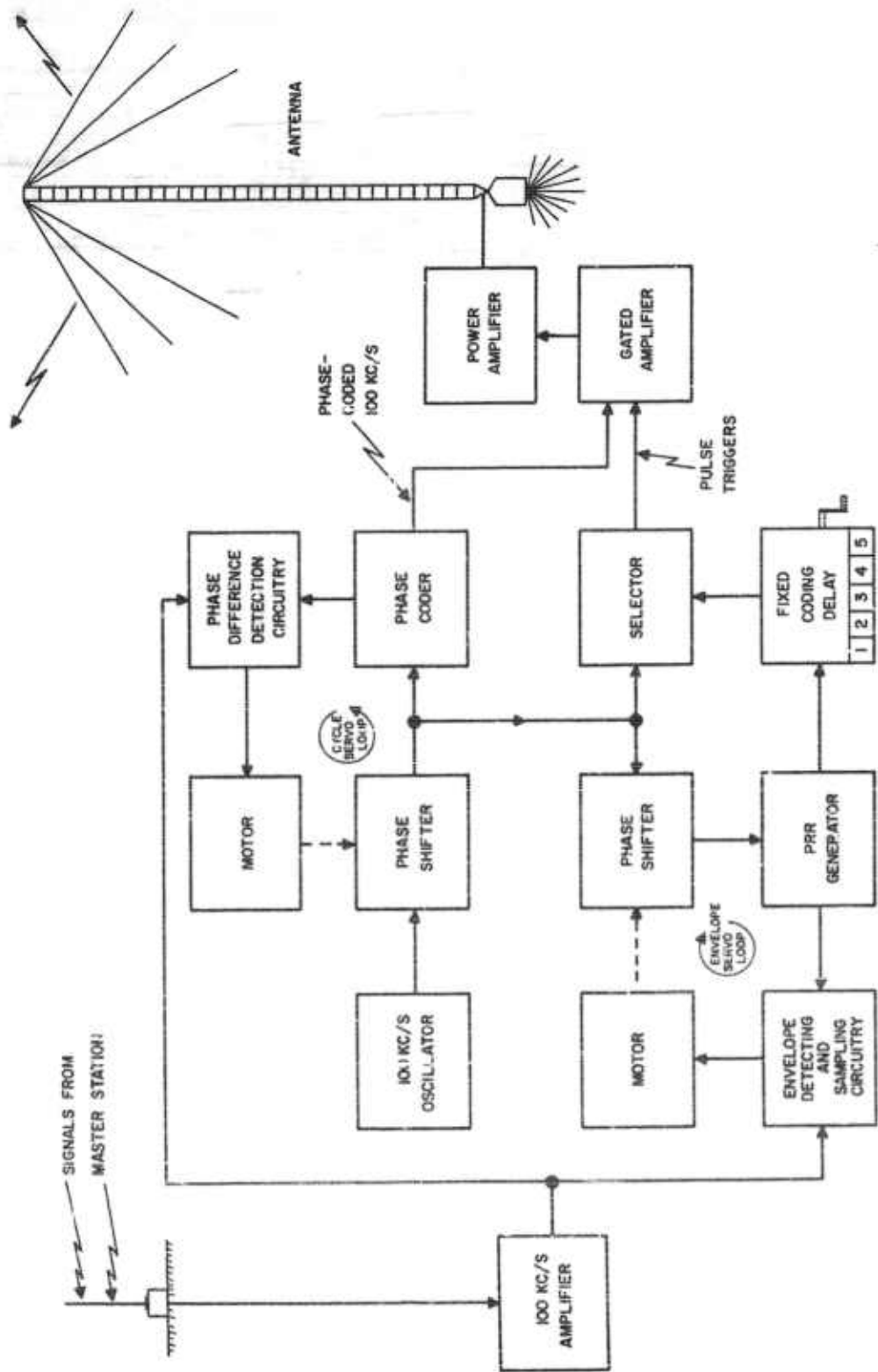

FIGURE 23
LORAN-C SLAVE STATION FUNCTIONAL BLOCK DIAGRAM

coding delay assigned to the particular slave station is inserted.

The PRR triggers are used to select a precise trigger formed by the uncoded 100 kc/s waveform. These precise triggers are then combined with the phase coded 100 kc/s to form the transmitter excitation. By this method, the slave envelope as well as the RF cycles are accurately synchronized to the master signals. Vernier adjustments of the coding delay can then be made by adjusting the phase of the uncoded 100 kc/s.

8.2 TECHNICAL DESCRIPTION OF LORAN-C RECEIVING EQUIPMENT

The following paragraphs describe a typical LORAN-C receiver capable of utilizing the maximum accuracy of the LORAN-C system; that is, both envelope and cycle techniques are employed. Other receivers have been built or adapted to utilize certain portions of the LORAN-C system. However, these receivers will not be described in detail. In addition to the automatic envelope and cycle matching receiver, the following types of LORAN-C receivers have been built or are under development:

1. Visual or manual envelope and cycle matching
2. Visual or manual envelope matching

LORAN-C receivers are fixed-tuned to a center frequency of 100 kc/s. Acceptance bandwidths between 3 db and 6 db points are approximately 25 kc/s and 33 kc/s, respectively. This relatively large bandwidth is utilized to insure that the relative amplitude and phase of the essential spectral components of the received pulses are not significantly altered by the tuned circuits of the receiver. A simplified functional block diagram of a typical LORAN-C receiver is shown in Figure 24. This diagram is also representative of the receivers used at monitor stations and is similar to the receiver portion of a LORAN-C station synchronizer. A brief description follows.

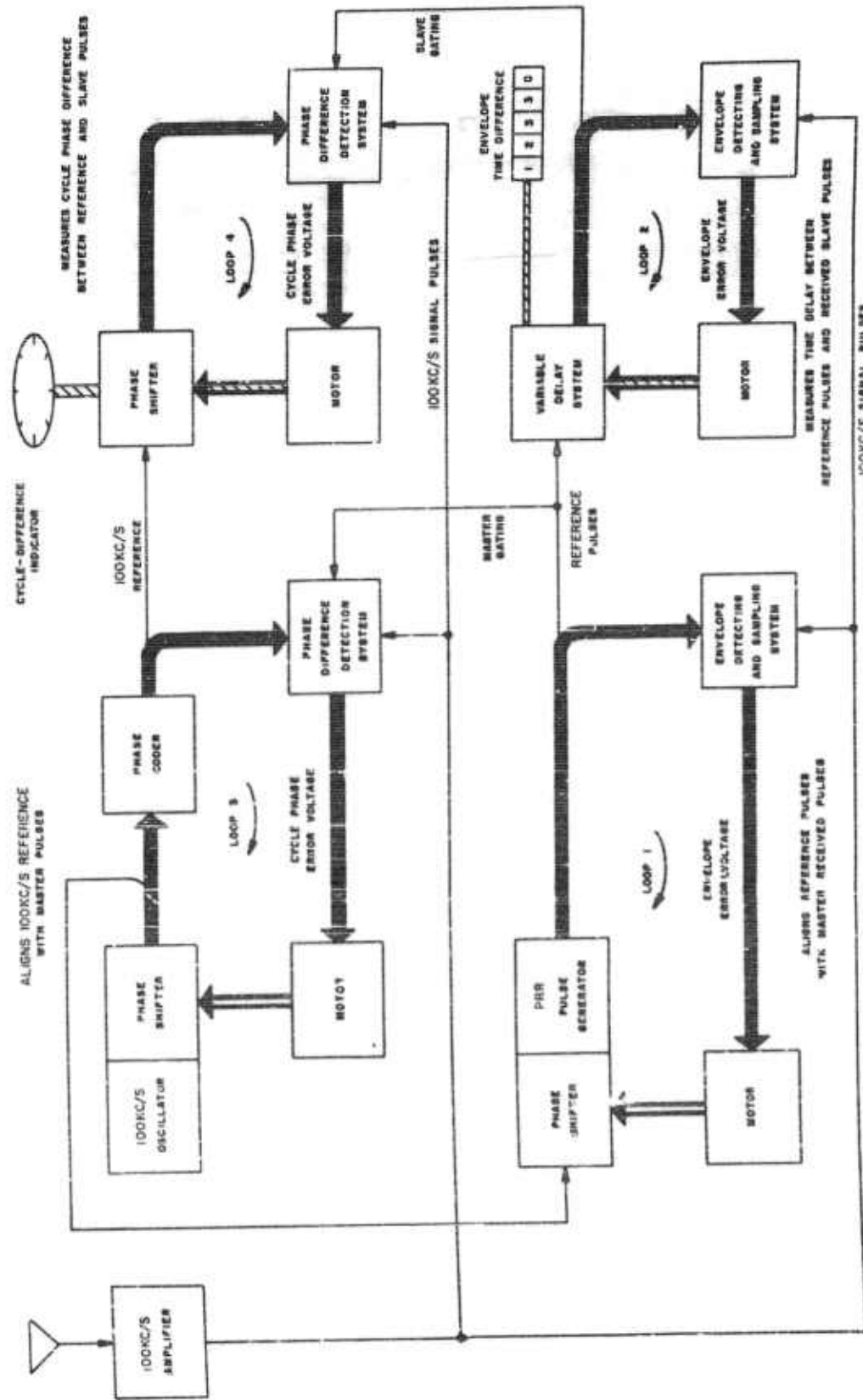

FIGURE 24
RECEIVER BLOCK DIAGRAM

Pulsed LORAN-C signals from the short receiving antenna are amplified and applied simultaneously to two over-all servo-loop systems. Servo loops 1 and 2 comprise one system used to measure envelope time-difference and servo loops 3 and 4 comprise the system used to measure phase-difference between the RF cycles. In each case, the measurement is performed in two steps:

1. Servo Loop #1 brings the signal from the pulse recurrence rate (PRR) generator into time coincidence with the envelope of the received master signal.
2. Servo Loop #2 operates the variable delay system to bring the delayed sampling pulses into coincidence with the received slave signals. The amount of delay introduced (total delay between the master and slave pulse) is indicated on the Coarse Delay Indicator.
3. Servo Loop #3 brings the cycles of the 100 kc/s reference oscillator into a fixed phase relationship with the 100 kc/s RF cycles in the master pulse.
4. Servo Loop #4 measures the phase difference between the 100 kc/s cycles of the reference oscillator and selected 100 kc/s cycles in the received slave pulses and displays these measurements on the Fine Delay Indicator. Since the reference oscillator cycles were brought into a fixed phase relationship with the master pulse cycles, Servo Loop #4 is, in effect, measuring the phase difference between selected RF cycles in the master and slave pulses.
5. Omitted from Figure 24 in the interest of simplification, are the additional servo loops for each receiver. These are similar to loops #2 and #4 and provide for the second slave delay readings

which are displayed simultaneously with the delays indicated by loops #2 and #4.

Additional features, not shown in the simplified block diagram, are incorporated in most of the automatic tracking receivers, and these will now be described. All automatic receivers to date measure two simultaneous time-differences continuously so that accurate fix information is continuously available when the receiver is tracking automatically. The two time-difference measurements may be communicated electrically to an auxiliary computer or recorder for automatic processing into any desired form, such as course-to-steer, latitude and longitude, or a position plot. The normal procedure in using a LORAN-C receiver is to read the time-difference dials and plot current positions on a LORAN-C Chart.

Some receivers have the capability of searching in time for the master and slave signals; identifying them by their phase codes then tracking without operator assistance. Other receivers may require operator assistance in slewing the sampling pulses into time coincidence with the LORAN-C pulses. Most receivers are equipped with a cathode ray indicator to permit the operator to assist the receiver in searching.

Once the receiver is synchronized with the LORAN-C signals and is tracking automatically, all of the advantages of the LORAN-C system technique become available. The envelope and phase detectors perform synchronous detection and integration operations upon 16 pulses (8 from the master and 8 from a slave) in each repetition period. The servo systems are designed for zero velocity error so that the time-difference measurements will be correct even though the receiver is moving in a vehicle. Accelerating vehicles such as maneuvering aircraft may cause errors to occur, but the

integration time can be reduced automatically so that the error will be reduced rapidly when the acceleration ceases.

All of the automatic receivers are equipped with alarm lights. One type of alarm indicates the loss of signals from any of the LORAN-C stations. Another type of alarm indicates when the receiver is tracking on the skywave portion of a composite ground and skywave signal. A third type of alarm is the discrepancy alarm, operated by a mechanical differential between the envelope and cycle counters. If the discrepancy between the envelope and cycle measurements exceeds 5 microseconds, the alarm light goes on. The nature of a discrepancy can be read directly from a dial. The discrepancy indications are useful at a monitor station to assist in maintaining zero envelope to cycle discrepancy and will not be normally provided on user type receivers.

Figures 25 thru 29 contain the summary of characteristics of five automatic LORAN-C receivers. Four of these receivers were developed under military contracts for use on military ships and aircraft. There are no security restrictions on any of the receivers which would preclude civil use of a commercial equivalent. Other receivers have been built which do not use the full capabilities of the LORAN-C system. Further information about LORAN-C receivers and their suitability for particular applications can be obtained by contacting the manufacturers of various types of receivers. Currently, Sperry Gyroscope Company, IIT Laboratories, Collins Radio Company, Radio Corporation of America, EDO Corporation, Decca Navigator Co., Ltd., and Motorola, Inc. are building these equipments.

The costs of LORAN-C automatic receivers have varied considerably since the first receivers were developed. In 1959, a LORAN-C receiver cost

approximately \$57,000. In 1960, the cost was approximately \$45,000 and in 1961 the cost has been reduced to approximately \$23,000. These figures are based upon development costs and production runs of 30 or less and include full instrumentation for envelope and cycle tracking, automatic search, and automatic indicating and alarm systems.

AUTOMATIC LORAN-C RECEIVER SPECIFICATION

Military Designations:	AN/SPN-29 AN/WPN-2
Manufacturer:	ITT Federal Laboratories
Use:	Marine
Weight; Size:	250 pounds; 5.5 cubic feet
Power:	900 watts, 115 volts, 400 cycles
Precision:	0.02 microsecond
Maximum Signal Unbalance:	80 db
Search:	Semi-automatic
Note:	No longer in production

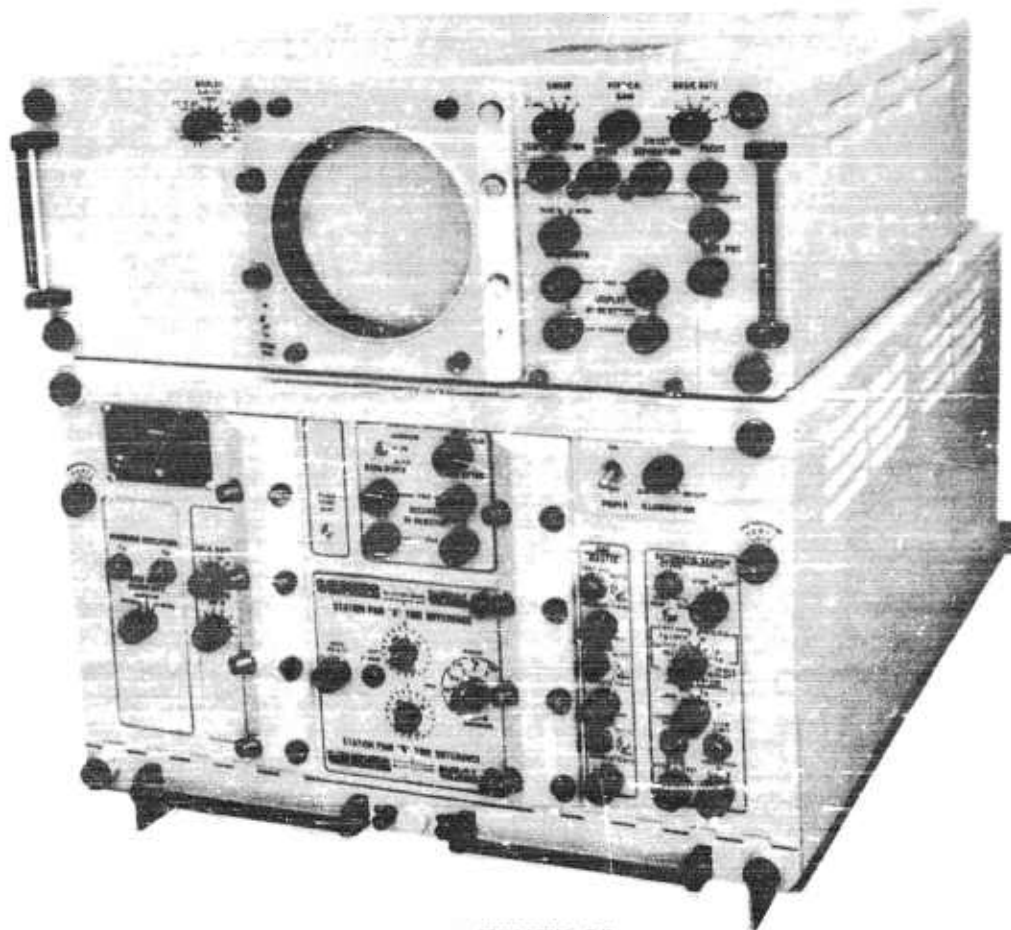

FIGURE 25

AUTOMATIC LORAN-C RECEIVER SPECIFICATION

Military Designations:	AN/SPN-30
Commercial Designation:	LR-101
Manufacturer:	Collins Radio Company
Use:	Marine, Monitor, Aircraft
Weight; Size:	204 pounds; 5.8 cubic feet
Power:	270 watts, 115 volts, 400 cycles
Precision:	0.02 microsecond
Search:	Automatic

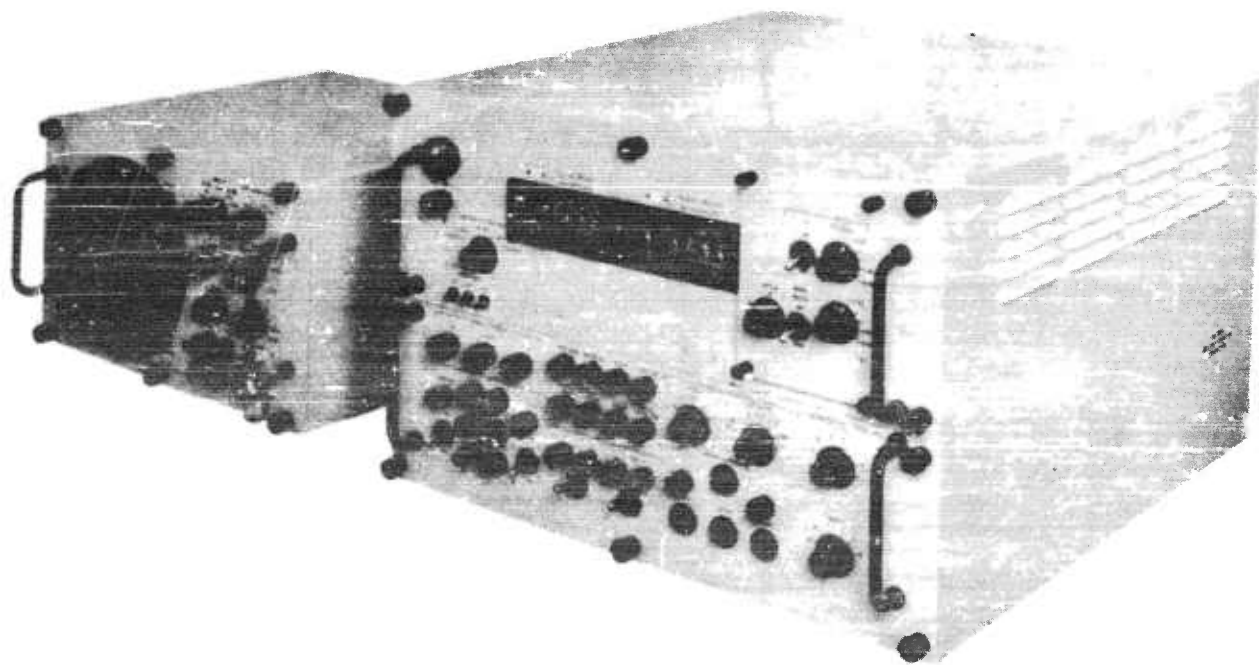

FIGURE 26

AUTOMATIC LORAN-C RECEIVER SPECIFICATION

Military Designations:	AN/SPN-32 AN/WPN-3,4
Manufacturer:	Sperry Gyroscope Company
Use:	Marine
Power:	500 watts, 115 volts, 400 cycles
Precision:	0.02 microseconds
Maximum Signal Unbalance:	80 db
Search:	Automatic
Note:	These receivers are similar to the AN/APN-145. The AN/WPN-3 is a LORAN-A, C receiver.

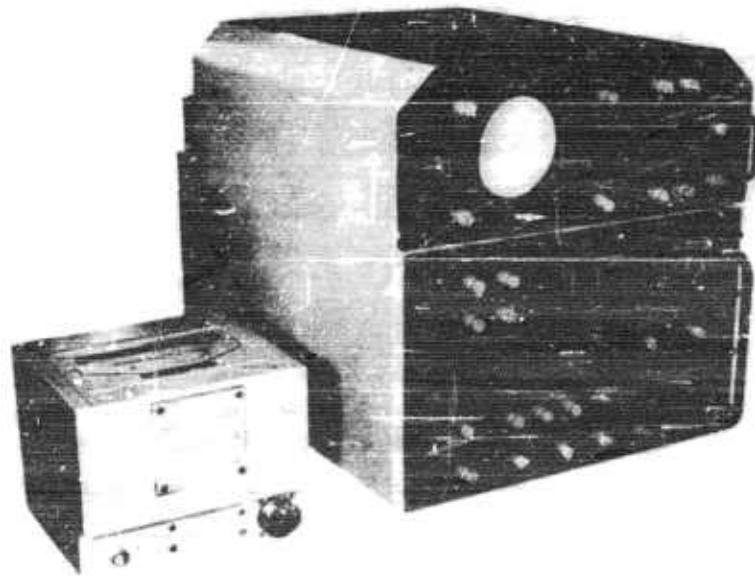

FIGURE 27

AUTOMATIC LORAN-C RECEIVER SPECIFICATION

Designation:	Automatic Airborne LORAN-C Receiver
Manufacturer:	ITT Federal Laboratories
Use:	Aircraft, Marine
Weight; Size:	75 pounds; 1.75 cubic feet
Power:	110 watts, 115 volts, 400 cycles; 10 watts, 24 volts DC
Precision:	0.02 microseconds
Maximum Signal Unbalance:	80 db
Search:	Semi-automatic

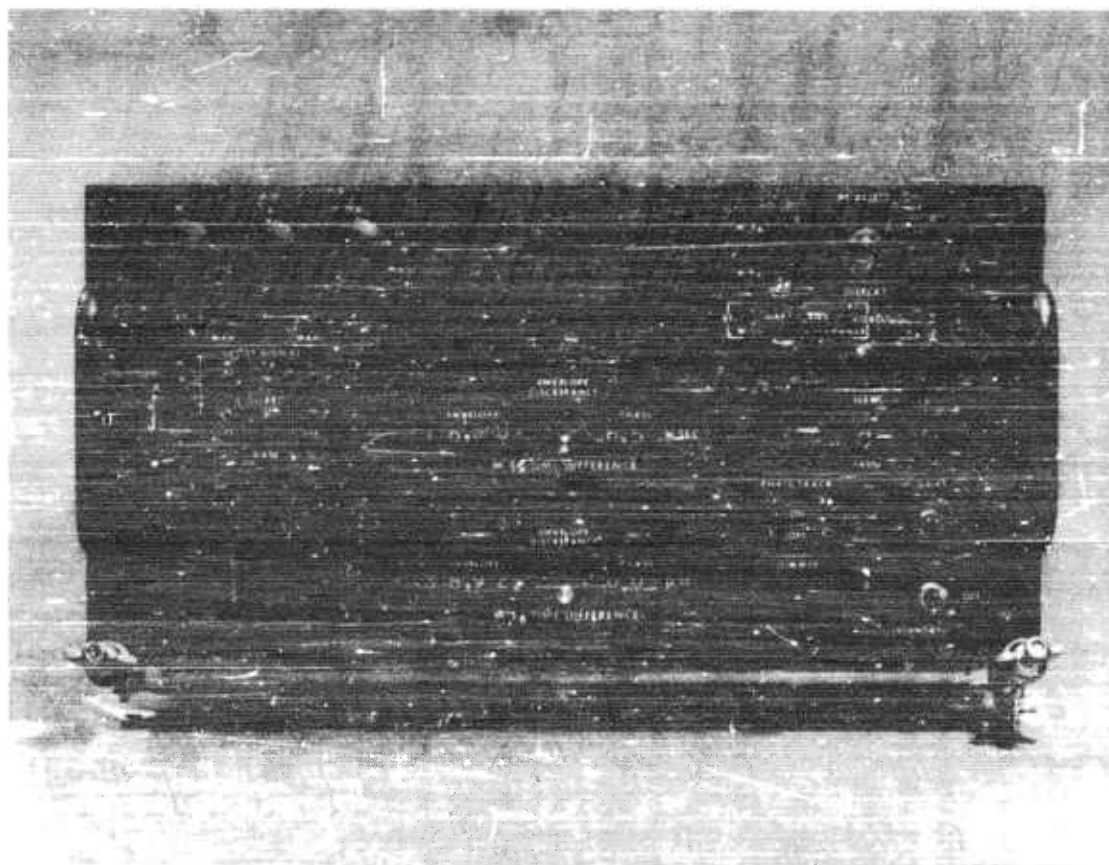

FIGURE 28

AUTOMATIC LORAN-A, C RECEIVER SPECIFICATION

Military Designation:	AN/APN-145
Manufacturer:	Sperry Gyroscope Company
Use:	Aircraft
Weight; Size:	100 pounds; 2.5 cubic feet
Power:	500 watts, 115 volts, 400 cycles
Precision:	0.02 microseconds
Maximum Signal Unbalance:	80 db
Search:	Automatic



FIGURE 29

CHAPTER 9

LORAN-C PERFORMANCE

9.1 INTRODUCTION

This chapter contains a discussion of LORAN-C operational performance. In describing the performance of a navigation system, the following factors must be discussed: (1) system accuracy, (2) reliability, and (3) coverage. LORAN-C provides navigational service using both groundwave and skywave propagation modes. However, the groundwave mode will be emphasized in this chapter since the system was primarily designed to operate in this mode to provide highly accurate position fixes. This chapter also includes a partition and explanation of various system errors, a summary of observed performance, and a summary of LORAN-C coverage and use.

9.2 PARTITION OF SYSTEM ERRORS

Position inaccuracies in the LORAN-C system are dependent upon: (1) geometrical configuration of the stations contributing to a fix, (2) prediction error, and (3) instrumental errors in ground station and user equipments.

9.3 EFFECTS OF GEOMETRY ON LORAN SYSTEM ERROR

LORAN-C stations are normally configured in triads, stars, squares, and other arrangements. Each of these configurations has advantages and disadvantages in system coverage and accuracy. Therefore, various configurations must be considered in planning navigational coverage of a designated area. In order to determine which arrangement might give optimum accuracy, it is necessary to develop the mathematical relation between radial error and the geographic or geometric configuration of the ground stations. Because of the variable divergence of hyperbolic

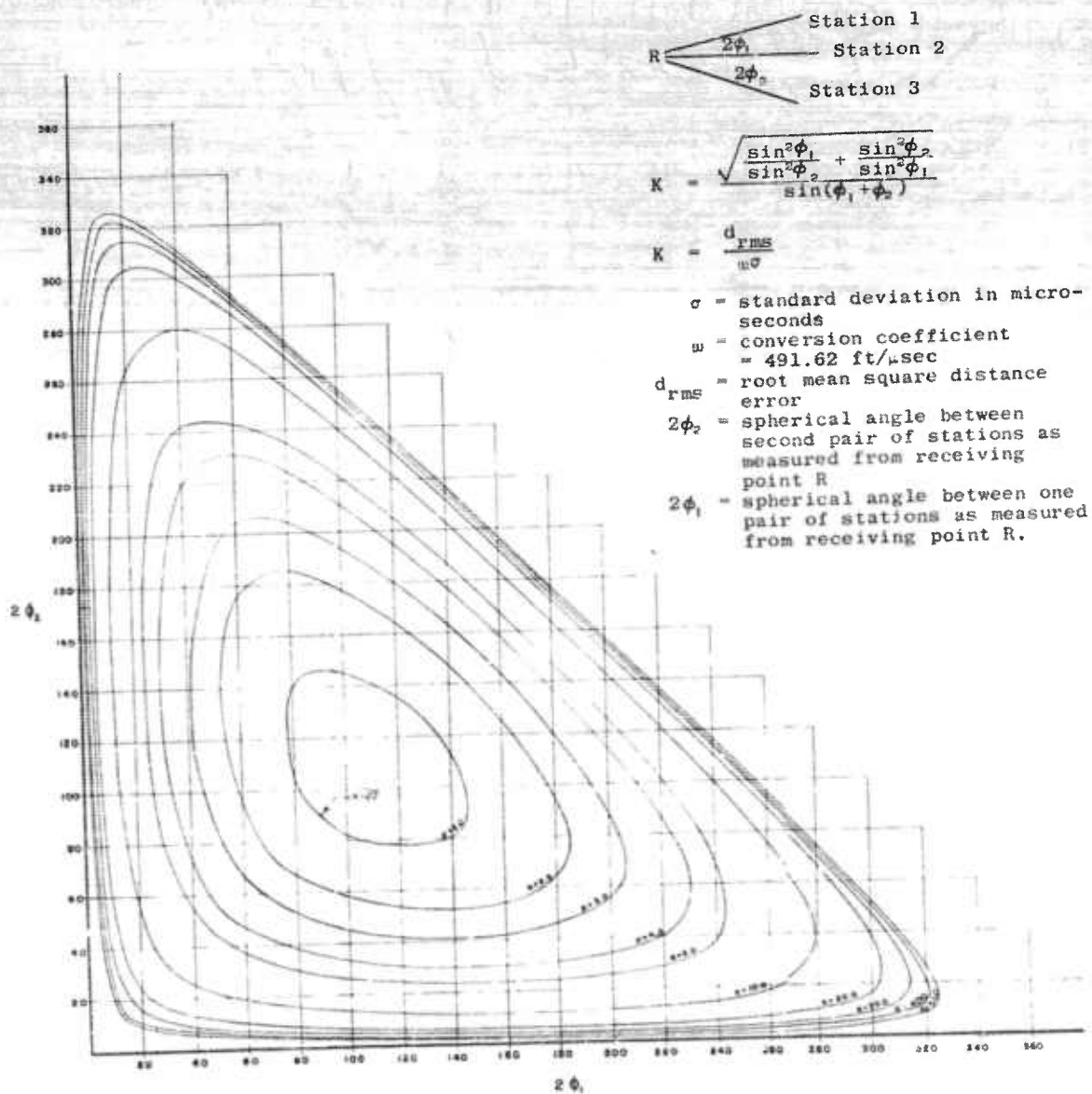

FIGURE 30
 NOMOGRAM FOR COMPUTING CONTOURS
 OF CONSTANT GEOMETRIC ACCURACY

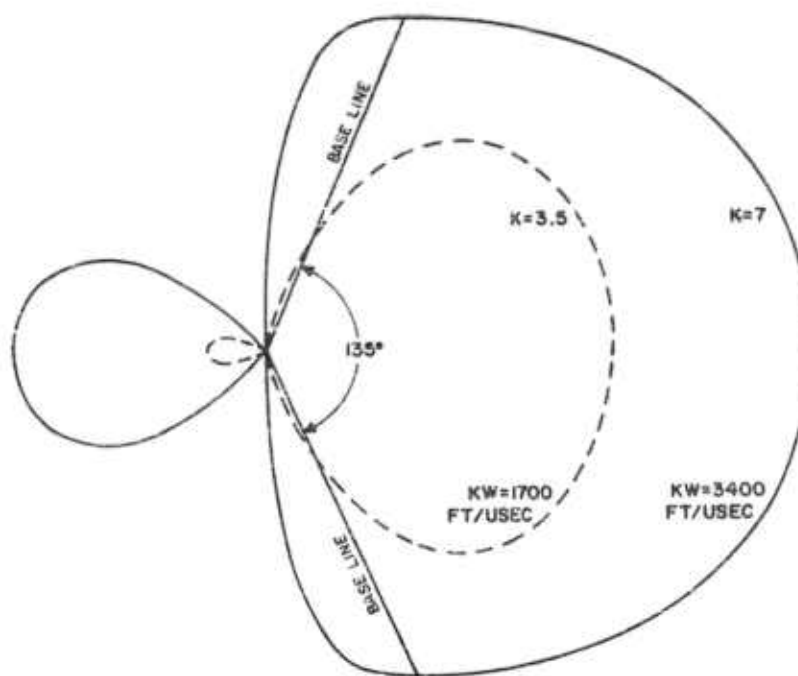
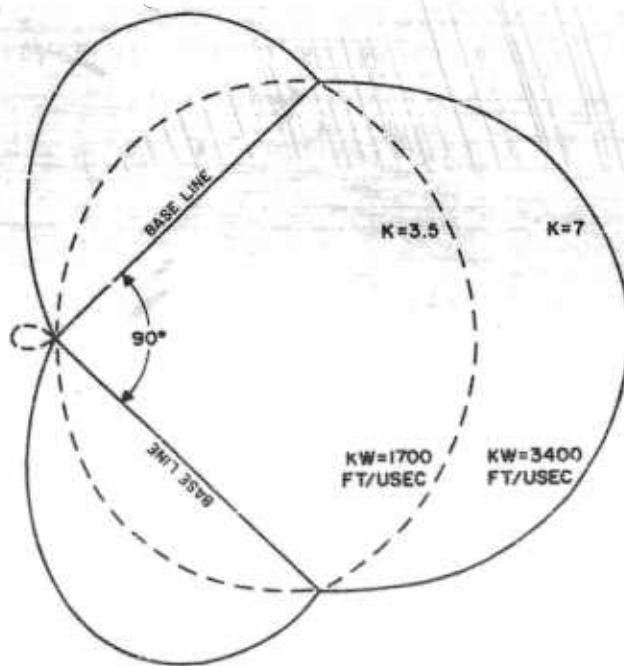

FIGURE 31
CONSTANT GEOMETRIC ACCURACY CONTOURS

lines generated by each station contributing to a fix and the variable angle between each set of hyperbolic lines, the accuracy of position determination and radial error is also variable throughout a coverage area. This problem has been studied and solved in the general case for hyperbolic systems. The Coast Guard has developed a nomograph (see Figure 30) for plotting radial error contours using a three-armed protractor. Values for ϕ_1 and ϕ_2 can be determined from the nomograph. Contours of radial error are plotted in terms of feet per microsecond of over-all system deviation (σ) and can be statistically related to probable error, root mean square error, or 95 per cent error figures. Thus, radial error in feet may be determined for various contours for any specified statistical value of time-difference error. Two contours are shown in Figure 31.

Error contour charts should be drawn on small area Lambert conformal or Gnomonic projections since great circles are shown as straight lines making it possible to determine angles with reasonable accuracy. An appreciable distortion of accuracy contours is obtained when a Mercator projection map is used.

9.4 GROUNDWAVE PERFORMANCE

Since LORAN-C provides service on the basis of both groundwaves and skywaves and the system performance varies widely depending upon which propagation mode prevails, system performance will be discussed separately for each mode. The LORAN-C system was designed primarily to utilize groundwaves for precise navigation. Synchronization of ground stations is based upon the use of groundwaves.

Groundwave Prediction Error

In the discussion of factors which contribute to position error, mention was made of prediction error. The computation of a LORAN-C time-difference grid is based upon station locations on the earth and assumptions of ground conductivity and dielectric constants. If stations were located on a perfect sphere having a surface of uniform conductivity and dielectric constant, propagation time-differences for arrival of signals at each geographic point could be computed with a high degree of accuracy. Ideal conditions can be realized when the propagation is entirely over water. In the practical situation, however, land masses having non-homogeneous characteristics are located on the paths from transmitting stations to the user's receiver. Computations based on assumption of uniform conductivity and dielectric constant could result in differences of three to five microseconds between predicted and established hyperbolic grids.

In order to reduce this prediction error to 0.5 microseconds or less, computations for each point of a LORAN-C grid are based upon the best estimates of conductivity and dielectric constants over the propagation paths between that point and the hyperbolic line-of-position associated with the transmitting LORAN-C station. Further reduction in this error is achieved by a comparison between predicted and measured time-difference values at certain selected geographic points for which precise position information is available. In areas like the United States where geographic positions are accurately known, the selection of such points is relatively simple and prediction errors can be reduced by calibration to the order of 0.05 microseconds. In other cases, such as Bermuda, uncertainty of geographic position with reference to a particular datum is considerably larger than the

uncertainty due to error in prediction computations.

Groundwave Propagation Anomalies

In regions where groundwaves are used for determination of time-difference, propagation anomalies have been found to be generally less than the instrumental errors in ground station and user equipment. Most recent studies of system operation in the Mediterranean and Pacific areas show no determinable instability during the critical sunrise and sunset periods. Seasonal variations in these areas have also been found to be of no significance.

In the North Atlantic area, winter propagation paths are over frozen sea water and summer paths over unfrozen sea water. Additionally, there is a large variation in the index of atmospheric refraction from winter to summer. The combined effect of these factors results in variation between winter and summer propagation producing time-difference variations (+0.02 microseconds) in the service area. These variations are of little significance.

Early studies of LORAN-C system performance indicated diurnal variations in the order of 0.02 microseconds and seasonal variations in the order of 0.1 microseconds. Since these early studies were based upon operation of old CYTAC component equipment in the U.S. East Coast chain and results are consistently at variance with tests in other chains having newer and vastly improved equipment, it is evident that early observed diurnal and seasonal variations were systematically introduced by the equipment and were not due to propagation anomalies as originally supposed.

System Area Monitors

At LORAN-C ground stations, it is necessary for the timer synchronizer

to sample the local and remote signals in order to maintain precise synchronization. At 100 kc/s, one wavelength is 9848 feet. Practical physical limitations preclude location of the timer receiving antenna outside of the near field of the local transmitting antenna. The timer synchronizer, therefore, samples a far field signal from the remote station and a combined near field and far field signal from its own transmitter. Synchronization variations of the order of hundredths of microseconds (0.03 - 0.06 us) could occur from day to day due to variations in the relative magnitude and phase of near field and far field local signals received. To eliminate this source of system errors, an area monitor observes the degree of synchronization being maintained by the station pair and provides correction information to these stations to eliminate system errors in the service area.

Geographic Accuracy

From the discussion of prediction and propagation error, it is evident that the hyperbolic LORAN-C grids for geographic position determination are highly accurate and extremely stable. Over continental areas where geographic positions are referred very accurately to a specific geodetic datum, the LORAN-C grid and the geodetic grid can be made to correspond within 0.06 microseconds by calibration. Over vast sea areas, the LORAN-C grid currently offers the best available means for determining geographic positions.

LORAN-C Position Measurement Repeatability and Instrumental Errors

Instrumental errors in ground station and user equipment constitute a portion of the resultant time-difference error. Further instrumental errors result from systematic errors incident to measurement techniques

under clean signal conditions and are influenced by offset or fluctuation errors caused by interference and noise superimposed on the desired LORAN-C signals. Systematic instrumental error in both ground station and receiving equipment has been reduced in each case to less than 0.02 microsecond. Noise and interference on desired LORAN-C signals have different effects on the envelope and cycle portions of the system.

As range from the receiver to each station is increased, the signal-to-noise ratio is degraded and offsets and/or fluctuations in indicated time-difference measurements increase. As the signal-to-noise ratio decreases and as interference increases, envelope deviations increase more rapidly than cycle deviations. This effect results in loss of cycle resolution at a specific signal-to-noise ratio and constitutes the limit of effective range from each particular station. Currently (1961), the limits are based upon a signal-to-noise ratio of -20 db. Figure 32 shows the effects of noise and interference on the cycle and envelope channels.

The effect of interference upon the performance of the LORAN-C system are minimized by several factors. The system utilizes ultra stable transmission with its frequency controlled to one part in 10^{10} per day. Cross correlation and phase coding techniques completely reject a large number of frequencies in and out of the 90-110 kc/s band when the dynamic range of the receiver is not exceeded. On frequencies which may be synchronous, normal velocities of ships and aircraft introduce Doppler shifts which make interfering frequencies synchronous only when certain conditions are met. In aircraft, normal variation in relative velocity and direction of the vehicle virtually eliminate synchronous effects. Current (1961) LORAN-C equipment is designed for proper operation at signal-to-interference

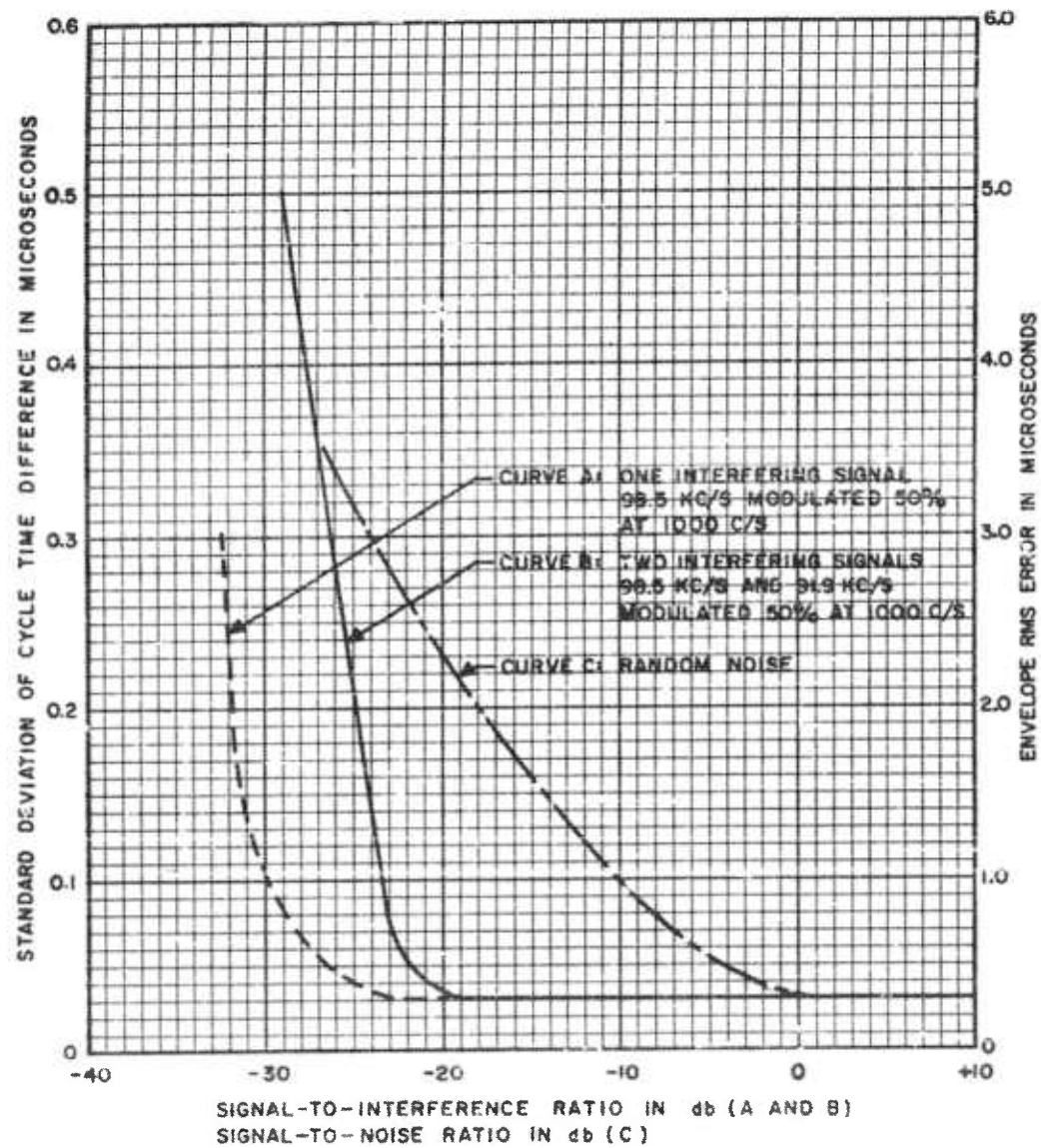

FIGURE 32
EFFECT OF INTERFERENCE ON PERFORMANCE
OF A TYPICAL LORAN-C RECEIVER
(AN/SPN-28)

ratios of -35 db (interference in the 85-115 kc/s band). Furthermore, adjustable notch filters are provided to reduce the effects of very strong interfering signals and a large receiver dynamic range (80 db) is employed.

9.5 SKYWAVE PERFORMANCE OF LORAN-C

In the preceding discussion of groundwave performance, it was evident that the groundwave grid prediction is dependent upon certain factors which can be determined analytically or experimentally to a high degree of accuracy with the result that errors due to propagation anomalies are reduced to a small factor - about the same order of magnitude as instrumentation errors. This is not the case when skywaves are used. With skywaves, the propagation anomalies produce errors which can predominate. The short term stability of skywave propagation is extremely good, but there are wide variations between day and night and from season to season. These variations are predictable and corrections are printed on charts to permit compensation for the variations in measurement resulting from the use of skywaves.

Skywave Discrimination

The use of skywave modes can materially increase the effective range of LORAN-C for general ship or aircraft navigation. However, special precautions are necessary to obtain satisfactory results. In particular, it is necessary to take particular care in discriminating between energy that is received via a particular skywave mode and the energy arriving via groundwave or other order of skywave modes. This discrimination must be accomplished by differentiating between arrival times of energy via the different modes. Complications arise because the time-differences are less

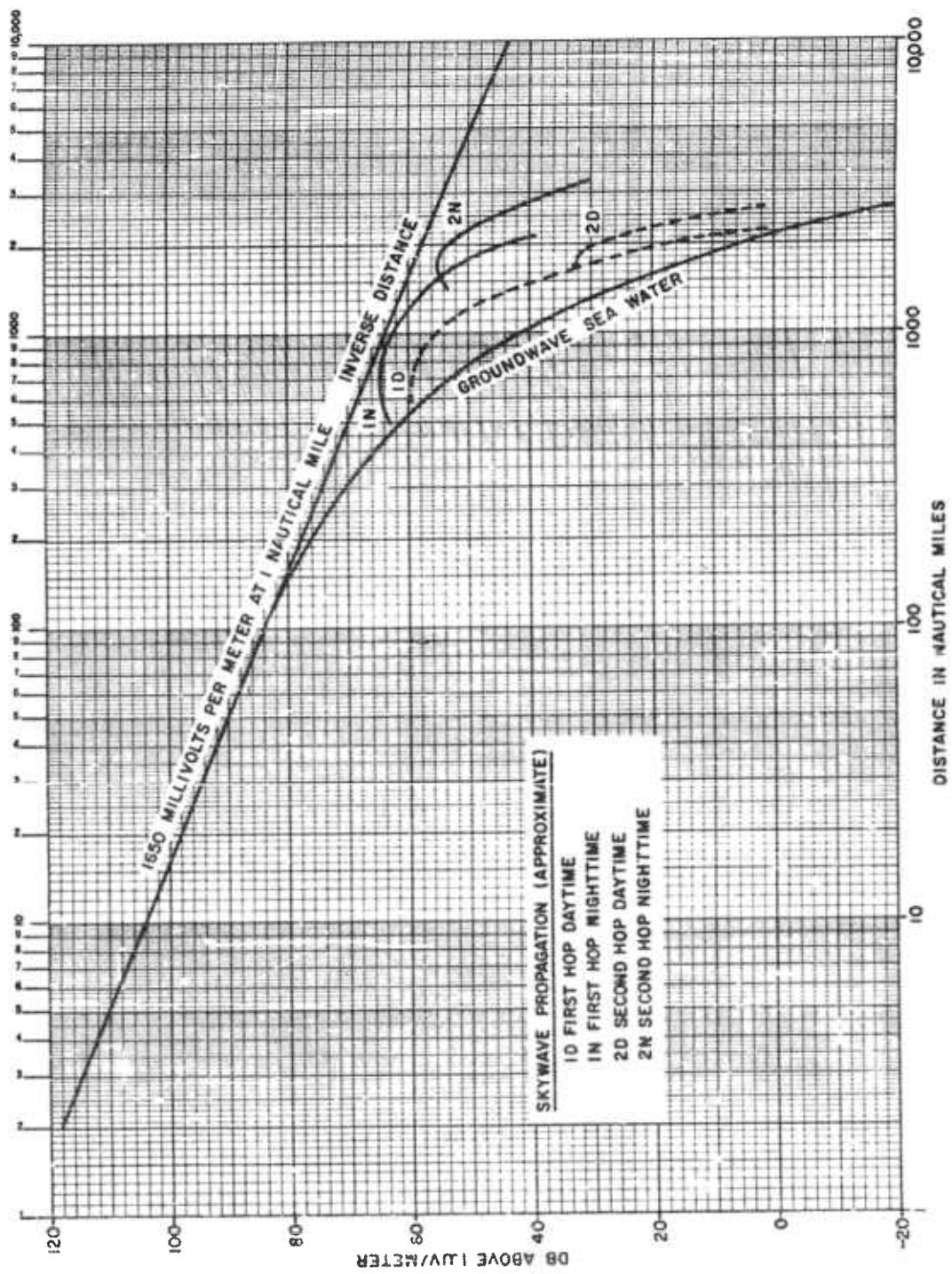

FIGURE 33
 SKYWAVE FIELD INTENSITY
 90-100 KC/S 100 KW RADIATED POWER

than the pulse width used for LORAN-C. Discrimination between contributions that fall with a single pulse is required.

In order to use a particular skywave mode, it must be predominant over the preceding mode so that errors introduced by reception of earlier mode signals are reduced to an acceptable value. For example, the first-hop skywave begins to appear at 400 miles from a particular station. It does not become predominant over the groundwave until a range of about 1100 miles from the station is reached. Similarly, the second-hop skywave begins to come in at about 1000 miles, but does not become predominant over the first-hop wave until the range is 1800 to 2000 miles from the station. Figure 33 shows these conditions.

Skywave Corrections

To compensate for skywave variations, skywave corrections must be applied to signals from each station involved in a measurement. The resultant corrections are relatively complex. Particular care and judgment are required of the operator when determining initial position fix in the skywave area. Thereafter, with the receiver tracking continuously and positions plotted systematically, transition of a station signal from one mode to another is readily apparent.

9.6 USE OF LORAN-A RECEIVERS FOR MAKING MEASUREMENT OF LORAN-C SIGNALS

LORAN-A receivers utilize video envelope pulse matching techniques to obtain time-difference information. These receivers may be used to obtain visual measurement of LORAN-C pulses if certain modifications are made. In particular, it is necessary that the LORAN-A receiver be provided with an RF channel for receiving on 100 kc/s, the frequency of LORAN-C transmissions. Certain LORAN-A receivers (AN/APN-70) have a 100 kc/s channel.

Other LORAN-A receivers could be utilized if a converter were provided to convert LORAN-C signals at 100 kc/s to the carrier frequency of a LORAN-A channel.

The video envelope matching techniques have definite accuracy limitations imposed by the fact that the received pulse is a composite of groundwave and various skywave modes at ranges beyond 700 miles from a station. It is very difficult to discriminate between the signals received by different modes using visual pulse matching techniques. Thus, while envelope time-differences may be obtained at ranges out to 1500 miles, errors may be from zero up to twenty microseconds. Errors of this magnitude are not acceptable for precise navigation, but can be extremely useful for general shipboard and aircraft navigation. The visual envelope matching technique is also highly susceptible to interference and rapidly loses its usefulness in areas where communications or other services operate in or adjacent to the LORAN-C band.

A further factor which complicates the use of LORAN-A receivers for LORAN-C time-difference determination is the fact that some LORAN-C installations utilize basic repetition periods which are twice as long as conventional LORAN-A basic periods.

The last factor affecting use of LORAN-A receivers for LORAN-C reception is the limitation in available delay range in LORAN-A receivers. The conventional LORAN-A receiver measures its time delay in microseconds from the half repetition interval point. For example, on the E-1 rate, the repetition interval is 49,900 microseconds. From a LORAN-A station pair, an observed time-difference might be 3140 microseconds. The actual master-slave delay would be 24,950 microseconds (half the repetition interval) plus 3140

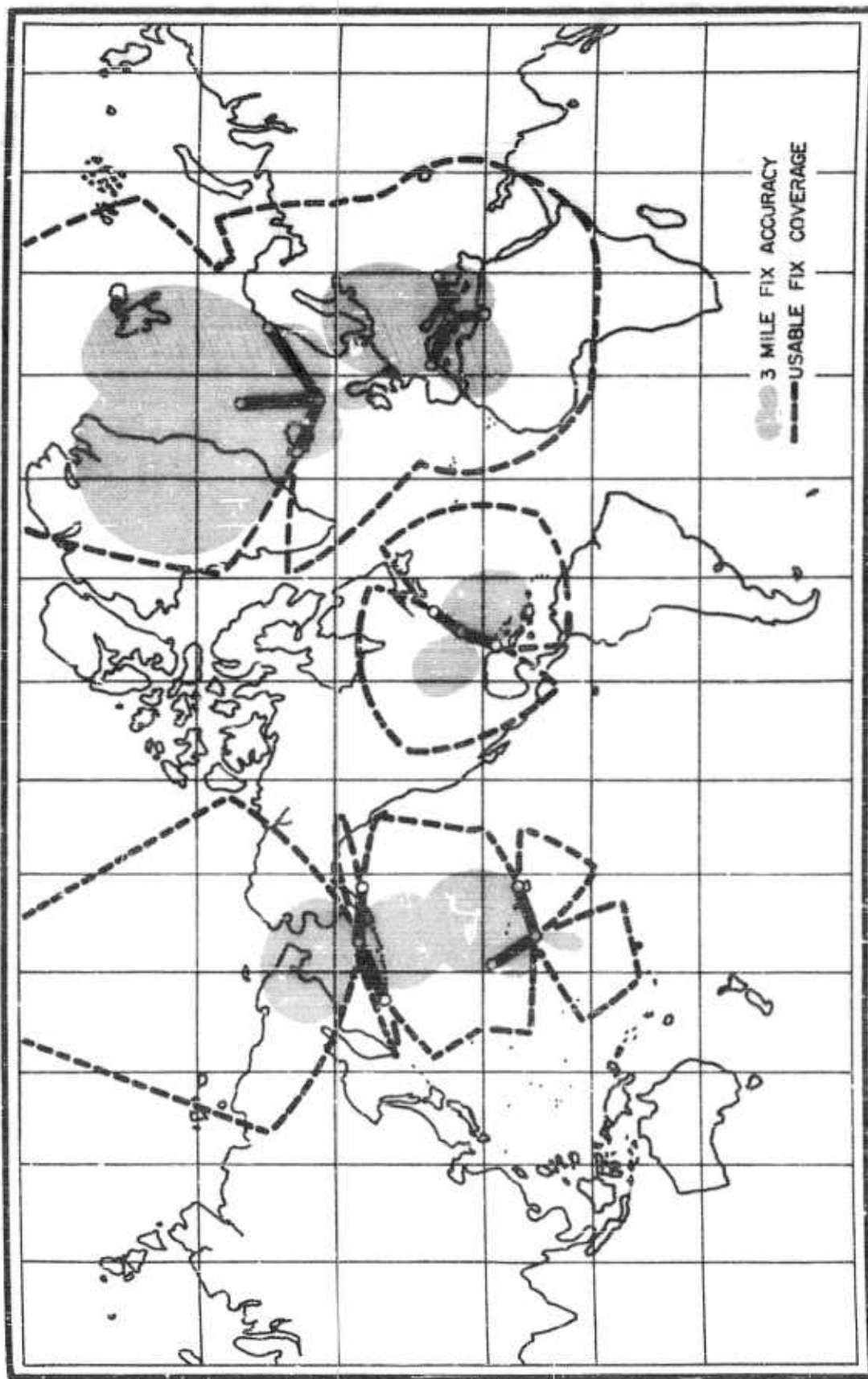

FIGURE 34
PRESENT (1961) LORAN - C COVERAGE WITH 17 STATIONS

microseconds or 28,090 microseconds. Since LORAN-C signals utilize the delays in the entire repetition interval, special computations and matching techniques are necessary to obtain LORAN-C time-differences.

Several special LORAN-A/C receivers have been built to utilize envelope and/or cycle matching techniques for LORAN-C reception and envelope techniques for LORAN-A reception. Full evaluation of these receivers is to be accomplished by June 1962.

9.7 SUMMARY OF OBSERVED PERFORMANCE OF LORAN-C

Operational use of the LORAN-C system from 1957 to 1961 has shown that ground stations provide hyperbolic time-difference grids synchronized within 0.06 microseconds more than 99.5 per cent of the time. LORAN-C monitor receivers located at various points have demonstrated that over-all system error in the groundwave region is less than 0.1 microseconds 95 per cent of the time. In the skywave regions, excepting sunrise and sunset transition periods, over-all system error has been less than five (5) microseconds 95 per cent of the time.

9.8 LORAN-C COVERAGE

Groundwave coverages available from stations established and operating during 1961 are shown in Figure 34. Future expansion of the system is planned.

CHAPTER 10

LORAN-C SYSTEM PLANNING AND IMPLEMENTATION

10.1 INTRODUCTION

When a need for LORAN-C navigation service has been determined for a given area, careful preliminary planning will lead to the development of an efficient system equipped to meet the desired requirements. The electronic, construction, logistic, and personnel problems as well as peculiarities of the area are carefully evaluated before actual design construction is started. For providing accurate navigational fix information, LORAN-C networks require optimum lengths and careful orientation of the baselines. The baseline length and extent of the coverage area are also influenced by the signal-to-noise ratio which the LORAN-C synchronizing and receiving equipments require to operate effectively. Thus, the selection of transmitting sites is guided by considerations of providing navigational position accuracy through system geometry and is further guided by insuring that the transmitting stations deliver an adequate signal to the other transmitting equipments and receivers in the user's area.

10.2 NOISE CONSIDERATIONS

One of the first items to be considered for the area under investigation is the determination of the atmospheric noise present in the area. Noise information for different regions in the world is published in reports by the International Radio Consultative Committee (presently CCIR Report #65). These reports permit an accurate estimate to be made of the noise levels which can be expected in areas of the world for different times of the day and for different seasons. The practice in previous LORAN planning

has been to develop a figure representing the noise which is exceeded only 5 per cent of the time during an entire year. Thus the predicted signal-to-noise ratio figure represents the propagation performance of the LORAN-C signal for 95 per cent of the time during the entire year.

10.3 SIGNAL CONSIDERATIONS

Early in the planning of a LORAN-C chain, a decision must be made on the power of the transmitting equipment which will be used. For this radiated power, Figure 35 is consulted to determine the strength of the received signals at various ranges over the different propagation paths in the area to be covered. Figure 35 is based on radiated output of 300 kilowatts. To convert to the power radiated by the planned system to field strength the following conversion factor is used:

$$\left(\begin{array}{l} \text{Field Strength to} \\ \text{be used on curve} \end{array} \right) = \left(\begin{array}{l} \text{Field strength} \\ \text{for 300 KW} \end{array} \right) \times \sqrt{\frac{\text{Radiated power} \\ \text{in KW}}{300}}$$

It should be noted that this conversion formula is valid only if the field strength is in voltage units (microvolts per meter). The factor cannot be used for decibel conversion. A satisfactory means for determining the signal strength received over different types of paths is the Millington (Variable Attenuation) Method. The method is described in the following articles:

G. Millinton, "Ground Wave Propagation Over an Inhomogeneous Smooth Earth," Proc. I. R. E., Part III, Vol. 96, Page 53, January 1949.

G. Millington, "Ground Wave Propagation Over an Inhomogeneous Smooth Earth, Part 2. Experimental Evidence and Practical Implications," Proc. I. R. E., Part III, Vol. 97, Page 204, July 1955.

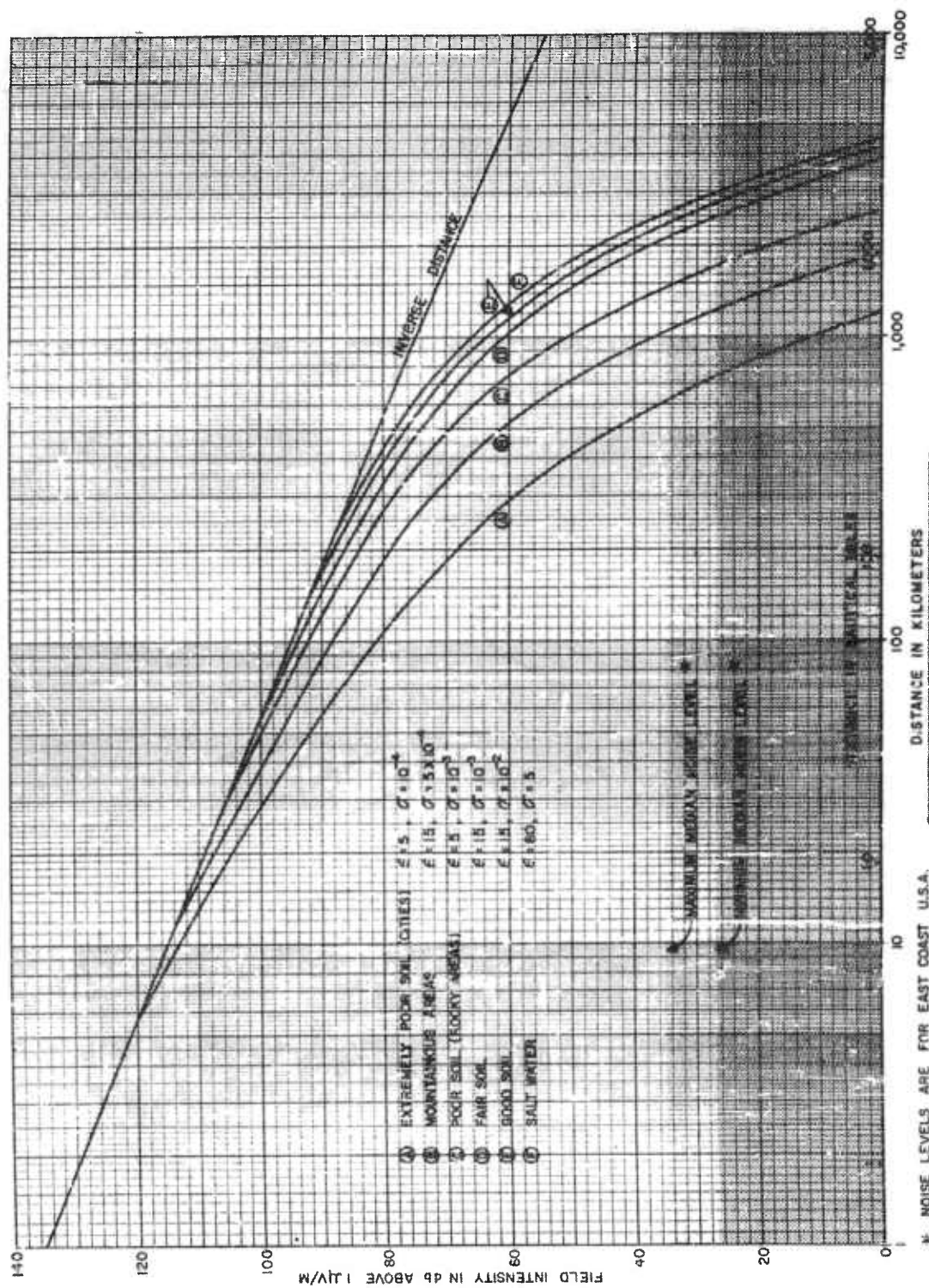

FIGURE 35
GROUND WAVE FIELD INTENSITY
90 - 110 KC/S
300 KW RADIATED POWER

Following is an example illustrating the Millington Method.

Assume a 435 nautical mile propagation path between two stations which consists of 3 miles poor soil, 52 miles sea water and 380 miles poor soil. Transmission is on 100 kilocycles for a 300 kilowatt transmitter. From Figure 35, it is seen that the inverse distance signal strength for 435 miles is 77.0 db above one microvolt per meter. This signal field strength is reduced by the terrain over which the signal travels. Referring to Figure 35 the additional attenuation of the 0 to 3 miles of poor soil is insignificant (0 db). The additional attenuation of the sea water path from 3 to 55 miles is also insignificant (0 db). The attenuation of the poor soil path from 55 to 435 miles is 16 db (19 minus 3). The first estimate of field strength over the 435 mile path is 77.0 (inverse distance) minus 16 db which results in 61.0 db above one microvolt per meter. The same procedure is repeated in the opposite direction along the path of propagation resulting in a second field strength estimate of 59.8 db above one microvolt per meter. The geometric mean of the first and second estimates is considered the most probable predicted field strength. To find the geometric mean, it is only necessary to determine the arithmetic mean of the field strength expressed in db. In this example, the predicted field strength is 60.4 db above one microvolt per meter which is easily converted to its equivalent of 1045 microvolts per meter. With a little experimentation, it is possible to develop techniques for carrying out these computations directly from the graph shown in Figure 35.

10.4 GEOMETRIC CONSIDERATIONS

Having determined the signal to be expected and knowing the noise

level of the region, station locations can be tentatively selected. A signal-to-noise ratio of 1:3 is considered more than adequate in LORAN-C for good station synchronization. Tentative locations are now designated and the accuracy contours for the coverage area can be developed. A nomograph (see Figure 30) is used to develop accuracy contours for a LORAN chain. Plotting of accuracy contours with the aid of the nomograph insures that the geometry of the system provides the required accuracy. These contours can be altered by moving the selected sites of transmitting stations. Thus a tentative station configuration can be designated and an investigation to meet the signal-to-noise ratio problem requirements is made. Relatively small movements of selected transmitting sites do not materially affect accuracy.

10.5 RECONCILIATION OF GEOMETRIC AND SIGNAL CONSIDERATIONS

After the accuracy contours are drawn on the planning charts, these contours are investigated to insure that an adequate signal covers the area. If the geometry of the chain provides the desired accuracy over a region but the signal paths are such that the signal is so greatly attenuated that the receiver is unable to deliver the navigation information, the accuracy contours must be limited by range radii (based on the specifications of the receiver) which indicate the limit of signal coverage. Reconciliation between these two requirements results in the final coverage diagram showing the effective area covered by the navigational system.

10.6 MONITOR STATIONS

The coverage diagram is inspected to locate a suitable site at which a monitor station can be located. The monitor station's function is to aid the system in maintaining proper synchronization and insure that correct

navigational information is being delivered to the area. Essentially the monitor station consists of receiving and recording equipment with communication facilities to inform the LORAN transmitting net of its performance. The main consideration in the selection of this site is to choose a location which receives strong signals from all of the transmitting stations. Outside interference generators such as commercial communication and power facilities must be kept at a minimum. If the LORAN-C chain consists of more than three stations, it may be necessary to have more than one station of this type to monitor the entire system.

10.7 INITIAL STUDIES OF POTENTIAL TRANSMITTING SITES

Having completed the preliminary study of the area, a new study is launched regarding the selected sites. Intelligence reports, tourist folders, road maps, photographs, preliminary visits, and aircraft flights over the area may be necessary to determine if any major disadvantages at pre-selected sites exist prior to planning the actual construction of the station. When these preliminary surveys have been completed, a site survey team thoroughly investigates the feasibility of constructing a LORAN station at the chosen locations. The site survey team is responsible for determining the suitability of the sites and must collect information about the chosen locations to permit detailed planning of the construction of the chain.

10.8 PHYSICAL CONSIDERATIONS OF THE SITE

A suitable LORAN-C site must include a minimum of 75 acres of ground for a station using a 625-foot tower. At least 175 acres are needed for a 1350-foot tower. The entire site should be as level as possible with particular consideration being given to a circular area of 850-foot radius

for the ground plane of the 625-foot transmitting antenna and a 1500-foot radius for the 1350-foot antenna. Within this area, a grade greater than 10 per cent is not acceptable. In addition to the site itself being level, the surrounding terrain should be free of bluffs and hills; particularly, in the direction of the paired station(s) and the service area. Although the distance from the transmitting antenna to the shoreline is not critical, past experience has indicated that a site adjacent to the shore with an over-water take-off to the paired station and service area is the optimum orientation.

10.9 SITE ANTENNA CONSIDERATIONS

The transmitting antenna for a LORAN-C station is either a 625-foot guyed tower with twenty-four top-loading elements, or a 1350-foot tower with 6 top-loading elements. The site selected must be capable of providing adequate footing for such a tower with its associated guy and top-loading anchors. The ground system for a 625-foot antenna consists of 850-foot copper radials spaced every 2° with a copper ground rod at the end of each radial. For the 1350-foot tower the ground system radials are also spaced every 2° but are 1500 feet in length. In addition to the LORAN-C transmitting antenna, three other antennas are required. These antennas are 35-foot whips on concrete pedestals, each with a ground plane consisting of 100-foot radials. Two of the whip antennas are used for communications while the third is a LORAN-C remote receiving antenna. The location of the communication antennas should be such that the length of the transmission line from the signal-power building is not greater than 1000 feet. The LORAN-C receiving antenna should be located on the baseline extension outside the transmitting antenna ground system. The optimum

distance between the receiving antenna and the signal power building should be approximately 100 to 1000 feet. The location of this antenna on the baseline extension is highly desirable but not a necessity since corrections can be made to compensate for its displacement from the baseline extension. Location of all antennas shall be such that the individual ground systems are completely isolated from each other.

10.10 ENVIRONMENTAL CONSIDERATIONS

Since interference from and to LORAN-C are important considerations, the detailed site survey should list all major electronics installations within 40 miles of the site. The distance from the site and the frequency and type of emission must be determined. Open wire telephone carrier lines in the vicinity of the site are of particular importance. The site survey party should note and report any such lines in order that possible interference problems may be solved as early as possible. On-site monitoring of the 50-200 kc/s frequency band is an important aspect of the electronic portion of the site survey. Two field intensity meters should be used for this purpose - a narrow and broad bandwidth meter. The types of meters used must be fully described in the site survey report. The narrow band meter is used to determine the frequency, type of transmission, and intensity of various signals appearing in the band. The broad band meter is used primarily to monitor the noise and pulsed signals in the band. In the event that an existing chain is being extended, the signal strength from the existing stations should be measured and recorded for a period of at least 24 hours. Noise measurements should be made for the same period. In the event interfering signals make the wide band noise measurement impossible, the noise measurements should be made with the narrow band

instrument in that portion of the spectrum near 100 kc/s which is free of interfering signals.

10.11 TOPOGRAPHIC AND GEOGRAPHIC CONSIDERATIONS

The type of soil and vegetation and the ground conductivity at the site should be determined. The antenna and building locations should be selected using the previously described transmitting and remote receiving antenna orientation requirements. The geographic survey is as important to the success of the over-all survey as any other one factor. A geographic survey is not only time consuming and expensive but may have a decisive influence in the choice of sites. Improper selecting results not only in eventual added cost and labor but may seriously impair the effectiveness of station operation.

The geographic investigation properly begins with a thorough search and careful study of the best available charts, sailing directions, coast pilots, fleet guides, etc., which cover the locations to be considered. Detailed information about the sea approaches, beaches, tides, currents, and anchorages or vessel moorings are determined by the site survey group. This information is especially important if the personnel, construction machinery and materials, fuels, and supplies are to be landed by amphibious operations at the site.

An accurate topographic survey and the subsequent topographic map are essential to the economical layout of the station and the planning of buildings. Contours and elevations of points within the building and antenna areas should be sufficiently reliable so that the scope of the project and locations and sizes of buildings and facilities may be changed on the plot plan without introducing appreciable errors in the estimated

cost and quantities of construction items. The reduction of earthwork to a minimum is an important factor in speeding construction. The area accurately surveyed should extend a reasonable distance beyond the limits of the locations chosen in the field for station facilities since station requirements frequently change between the time the site survey is made and the start of construction. This often necessitates addition, expansion, and the rearrangement of facilities into areas not covered by the site survey.

Sufficient probings, borings, or test holes must be made to establish foundation conditions under all proposed buildings and structures. One or more borings or holes should be made within the area occupied by each building. The holes should extend to bed rock, perma-frost or to a depth of several feet below the bottoms of the deepest proposed footings if in soil or loose material.

10.12 SITE OWNERSHIP CONSIDERATIONS

Before action toward acquiring the site can be initiated, the legal description, ownership, and area of the required tract must be known. The boundary or property survey, therefore, should furnish the legal description of the land, the area or areas of the tracts required, and sufficient data for making a property map showing thereon the names of the owners of the site.

10.13 PHOTOGRAPHY IN SITE PLANNING

Photography is used for quickly and accurately recording and illustrating site information which is difficult to describe in reports or on maps and drawings. Photographs often permit extending site surveys to areas not thoroughly covered in the detailed survey. The site survey

group, therefore, should utilize this means of recording information as thoroughly as possible keeping in mind that the photographs are useless unless good identification data accompanies them.

10.14 OPERATIONAL CONSIDERATIONS

From an operational viewpoint, certain requirements must be fulfilled either by existing conditions at the site or by implementation. Among these considerations are security, personnel, health conditions, climatology, logistics, and general support of the station and its personnel.

The site survey group must determine the location and identity of authoritative forces who can afford protection to the unit. "Will fencing be required to insure protection to the station?" is a question that must be answered. The issuance of small arms to personnel may be required for protection against man-made or natural dangers.

Each station will require a rotation of personnel, either on a vacation basis or as a permanent change of operating personnel because of the undesirability of the location from a "livability" standpoint. The modes of transportation to and from the site in order of preference must be determined. The frequency and reliability of the mail service to the site must be investigated and recommendations made if a mail service is to be set up by the operating agency.

The survey group should investigate the availability of medical and dental facilities and hospitalization in the area, including distance from the site and means of regular as well as emergency transportation. Any diseases which are prevalent in the area and type of immunization and inoculation required of personnel not native to the area must be determined.

The type of housing available in the region including schools, churches, and recreational facilities must be determined and reported in the site survey report.

Local settlements, villages or towns, including population and the principal language spoken should be investigated.

The site survey group should compile a list of the names, titles, and addresses of local officials who will be interested in the existence and operation of the station.

When the station is operating normally and problems of construction and initial operation have been overcome, the main problem of station operation then will be logistic support. In order to solve this problem during the planning stage, the site survey party must investigate local conditions affecting this problem. The class of food stuffs available locally and the restrictions on their procurement must be listed. Sources of fuels to operate the station should be determined. The availability of local labor to aid in station maintenance and upkeep should be investigated.

If considerable logistic support is to be carried out by outside agencies, the accessibility of the site becomes of primary concern. If the supplies are to be air-lifted into the area, adequate landing facilities must be provided. If logistic support is landwise or seawise, then these support facilities must be determined and fully reported.

The site survey group must carefully observe the local weather conditions and inspect such meteorological records as may be available to give an accurate description of the type and severity.

10.15 SITE SURVEY REPORT

When the site survey group has completed its site survey operations, a written report is prepared containing as much information as possible in regard to the items listed below. The list below can be used as a check-off list to insure that essential information is gathered.

Check-Off List

1. Local name for the site
2. Geographic position of the LORAN antenna
3. Description of the antenna location monument
4. Chart or charts showing the site location
5. Boundary description of the site
6. Photographs of the site including aerial photographs
7. The nearest anchorage or harbor to the site
8. Beach landing conditions
9. Vehicular support required for the station
10. Existing transportation facilities
11. Availability of local labor and logistics support
12. Road construction necessary
13. Topography of the site
14. Ground conditions (physical and electronic)
15. Earthwork required to grade the station properly
16. Potable water supply and sewage disposal facilities
17. External electric power sources
18. Heating and air conditioning requirements
19. Climatology
20. Conditions affecting the construction force

21. Recommended type of construction
22. Recommended storage requirements
23. Fuel delivery and storage
24. Prospective contractors
25. Obstruction lighting
26. Drawings and sketches
27. Signal predictions from paired stations
28. Predicted noise figures
29. Observed noise data
30. Interference considerations
31. Communication facilities (existing and recommended)
32. Antenna layout sketch
33. Description of any local peculiarities
34. Photographs

The completed site survey report is the basis for making detailed plans of the proposed station and also guides those responsible for scheduling the delivery of equipments to the site. This planning is necessary to insure that the inside equipments arrive at the best time for their installation, testing, and initial operation.

10.16 PLANNING GROUP DUTIES

Based on the site survey report, the agency responsible for chain construction and operation now makes a final decision and indicates the sites at which stations are to be built and a target date for commencement of operation. The planning group is now in a position to commence procurement action for equipment and services and indicates the desired delivery dates. Personnel requirements for the operation of the station

are decided upon and a program is started to train personnel so that they will be ready to man the station when it is ready. The personnel requirements for housekeeping and administrative duties are also met during this planning phase. Personnel agencies prepare a program to issue the necessary orders, make arrangement for the employment of civilian personnel, and alert the training agencies which will be involved in this phase of the program. Another planning group commences to negotiate with local (site) organizations (via the appropriate channels) to gain the desired local support of the station such as power, fuel, and other logistic services which can be obtained locally.

10.17 CALIBRATION OF THE SYSTEM

After the station is on the air and its paired stations are also transmitting navigational signals, the system must be calibrated to insure that the service being delivered is accurate within the specified limits. To accomplish this purpose, a calibration team visits various sites in the navigational service area, locates itself exactly with assistance from geodetic agencies, and determines the most probable observed reading at each of the monitoring locations. When the geodetic agency has determined the exact position of a monitor location, the time-difference reading to be expected is computed. This computed value is compared with the actual observed reading which must be corrected for effects caused by the changes in the conductivity of the propagation path. These comparisons, together with a detailed study of the propagation paths, determine any errors present in the system. The result of the calibration team's observations, calculations, and analysis is a correction factor which will be applied to the system either by the network or by the user to provide the desired service.

10.18 CALIBRATION TEAM COMPOSITION AND TASKS

The calibration team usually consists of a calibration leader, a technician to insure maximum performance of the team's receiving equipment, and support personnel to operate the vehicle transporting the calibration team to the various monitoring locations. The vehicle may be airborne, landborne or waterborne; depending upon the monitoring sites to be visited. The team should be self-sustaining as much as possible to reduce interference to other units' operations.

One of the first tasks of the calibration team is to choose sites at which monitoring will take place. The desires of the calibration team and the capabilities of the vehicular support members must be reconciled when the monitoring locations are chosen. The calibration team will select places which are as free from interference as possible. The existence of power lines, broadcast stations, and other "interference" generators will influence the team to reject the site. On the other hand, a noise-free location may be so remote that the vehicular support team is unable to deliver the calibration group to the site. Thus, the selection of monitor sites is tempered by a reconciliation of the two groups. Generally, the locations at which the monitoring team will desire to measure time-differences are well inside the service area of the network. There may be some locations which are completely inaccessible to the calibration team but observed and predicted time-differences for such locations would be highly desirable. In this case, the calibration team may settle for "fly-overs" of such positions and take readings as the monitor spot is crossed.

The calibration team will use a similar technique by making repeated

passes over the baseline extensions at various distances from the nearest station to determine the coding delay being held by the station. The reason for making these readings at different distances is to aid in estimating the conductivity of the ground on the baseline extension.

During calibration operations, it is extremely important to have good control of the stations to insure stable operation. Calibration procedures are absolutely useless if each station in the chain is making adjustments to its transmitted signals. During the calibration operation, the calibration team leader should have complete control of transmitting stations. Only such adjustments as he may direct can be made. Such firm control is absolutely essential for a successful calibration operation.

In addition to maintaining rigid control over the transmitted signals, the personnel at the transmitting stations must keep accurate records of the observed readings at their stations. These readings must be made available to the calibration team as soon as possible so that apparent fluctuations in readings by the calibration team can be correlated to observed time-difference fluctuations observed at the transmitters.

After all locations have been properly monitored, all transmitting station records have been collected, and predicted readings have been computed for the monitor locations, the calibration team reduces this data to determine the system error and what corrections can be made to off-set this error. The most difficult part of the reduction of the data is the determination of ground conductivities to use for correcting observed readings. The system error must be substantiated by the readings observed at the various monitor locations. Corrections to observed readings (secondary phase factor corrections) for various conductivities are displayed in Figure 36.

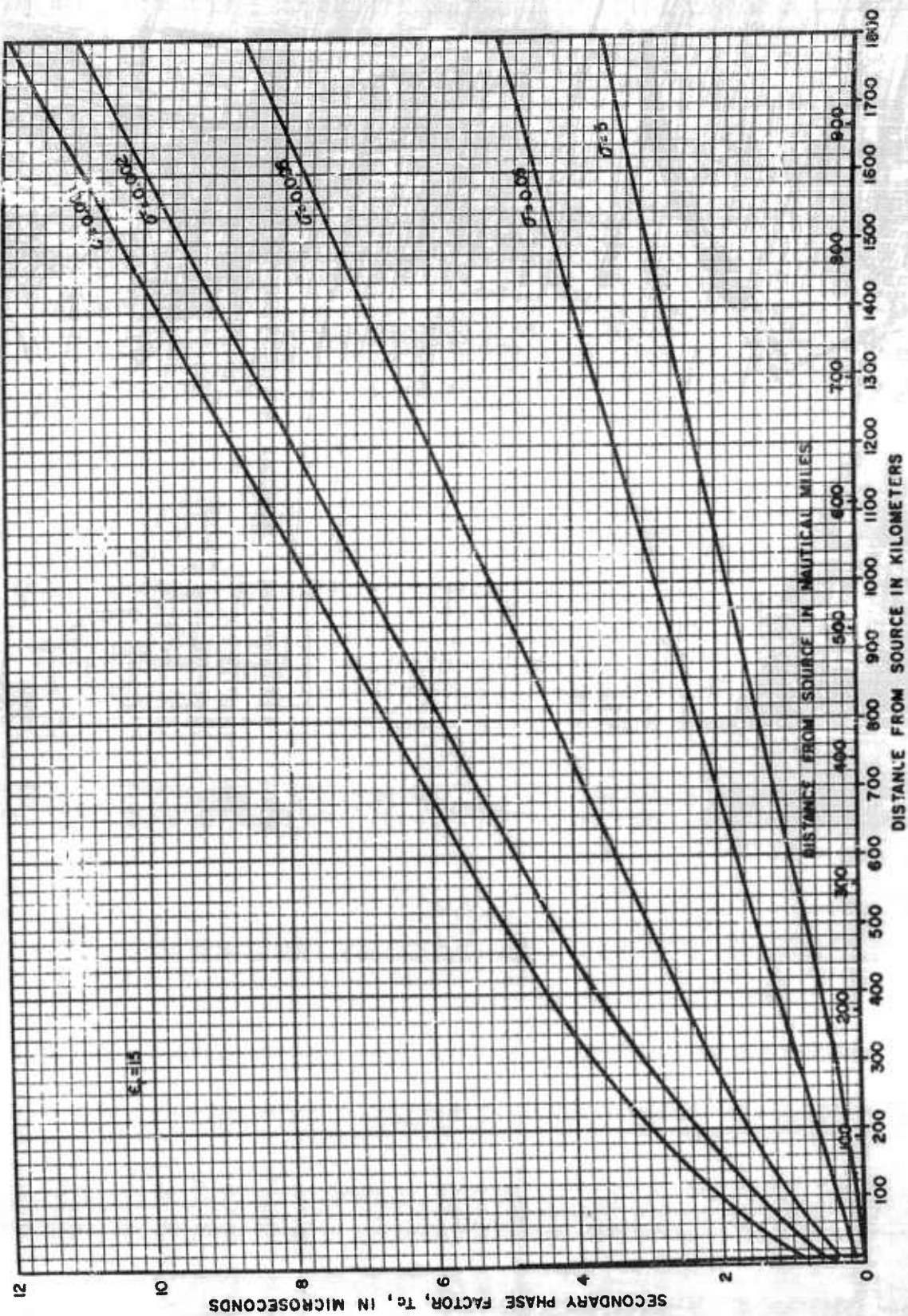

FIGURE 36
SECONDARY PHASE FACTOR
OF GROUNDWAVE AT 100 KC/S

When the system error is finally determined, a decision is made on whether adjustment(s) in the coding delays held at the stations will minimize this error or if a correction factor should be supplied to the users so that they may correct their observed readings. An ideal solution is one that permits an adjustment in system constants so that the user does not have to be concerned about a correction factor to his observations. The calibration team leader must make the final determination of what action must be taken to correct for the system error.

10.19 NORMAL OPERATION OF THE LORAN-C CHAIN

After the system is properly calibrated and corrected, it is declared operationally usable and normal day-to-day operation is effected. To insure that the system does not drift and transmit erroneous information, a permanent service area monitor station is utilized. This station continually monitors the service and furnishes the results to the transmitting stations for the chain commander if one is designated. In this way a check is kept on the system at all times. If later correction is necessary to the system because of insufficient or erroneous data collected during the calibration phase, the first indication of such a situation will develop from the long-time monitor data gathered by the service area monitor station. The responsibility of initiating such action is in the office directing chain operations.

The agencies or offices which initially programmed the selection and training of personnel to man the station must maintain a continuing program to select and train replacements. This is especially important if the stations are in an isolated location. A rotation program must be kept in effect to insure properly trained personnel being at the station

controls. The station itself will initiate the necessary action to solve the problem of continuing logistics. The spare parts, fuel, housekeeping, and commissary supplies which are needed will be requisitioned from the operating agency which issues the necessary procurement instructions.

10.20 FURTHER IMPROVEMENT IN SERVICE

The cognizant agency has the additional responsibility of keeping itself informed on newer equipment and techniques in LORAN-C operations so that improvements can be made in the chain to provide even more accurate navigational service. Such action insures that the most effective service is being furnished in tune with the present "state of the art."