

UNCLASSIFIED

AD 268 498

*Reproduced
by the*

**ARMED SERVICES TECHNICAL INFORMATION AGENCY
ARLINGTON HALL STATION
ARLINGTON 12, VIRGINIA**



UNCLASSIFIED

NOTICE: When government or other drawings, specifications or other data are used for any purpose other than in connection with a definitely related government procurement operation, the U. S. Government thereby incurs no responsibility, nor any obligation whatsoever; and the fact that the Government may have formulated, furnished, or in any way supplied the said drawings, specifications, or other data is not to be regarded by implication or otherwise as in any manner licensing the holder or any other person or corporation, or conveying any rights or permission to manufacture, use or sell any patented invention that may in any way be related thereto.

268498

U. S. A R M Y
TRANSPORTATION RESEARCH COMMAND
FORT EUSTIS, VIRGINIA

CATALOGED BY: F10111
AS AD NO.

268 498

TCREC TECHNICAL REPORT 61-136

RTM 34

OPERATIONAL GUIDE FOR LAUNCHING THE LCM-8

December 1961

ASTIA
NOV 22 1961
IPDR B



62-1-5
NOX

ASTIA AVAILABILITY NOTICE

Qualified requesters may obtain copies of this report from

**Armed Services Technical Information Agency
Arlington Hall Station
Arlington 12, Virginia**

This report has been released to the Office of Technical Services, U. S. Department of Commerce, Washington 25, D. C., for sale to the general public.

RESEARCH TECHNICAL MEMORANDUM 34

OPERATIONAL GUIDE FOR LAUNCHING THE LCM-8

December 1961

Project 9R98-05-009, House Task 9.45

Prepared by

Rocco Fama, Project Engineer
John Newman, Assistant Project Engineer

U. S. ARMY TRANSPORTATION RESEARCH COMMAND

FORT EUSTIS, VIRGINIA

CONTENTS

	Page
LIST OF ILLUSTRATIONS	v
SUMMARY	1
CONCLUSION	2
INTRODUCTION	3
DESCRIPTION OF BASIC MATERIALS USED IN TEST	4
LIST OF MATERIAL FOR DROP TEST OF ONE LCM-8	11
SEQUENCE OF PRELAUNCHING OPERATIONS	14
PRELAUNCHING PROCEDURE	20
POSTLAUNCHING INSPECTION PROCEDURE	27
EVALUATION	28
APPENDIXES.	
I. Report of Postlaunch Inspection	29
II. Task Assignment Letter	30
DISTRIBUTION	32

LIST OF ILLUSTRATIONS

Figures	Page
1. Landing Craft (LCM-8)	1
2. Launcher, General Assembly	5
3. Assembly and Details of the Sliding Ways	7
4. Assembly and Details of the Sliding Ways	9
5. Deflection Location Markings	15
6. The Power Boat Assigned to Retrieve the LCM-8 After Launch	18
7. View Showing the Trigger Releasing Lanyard	18
8. LCM-8 Sliding From Steel Standing Ways	19
9. LCM-8 at Moment of Impact With the Water	19
10. LCM-8 Placed on Steel Standing Ways at an Angle of 12-1/2 Degrees. Note the vertical layer of aircombing on the bow ramp (1) and the steel standing ways (2).	21
11. Sliding Ways Placed 12 Feet 11-1/2 Inches Apart (1). Note chain attachments used primarily for maintaining alignment of the sliding ways during launching (2) and the steel crossbeams (3).	22
12. View Showing Turnbuckle (1) and Trigger Bracket (2)	24
13. View Showing the Trigger-Arm Angle	25
14. The LCM-8 and the Sliding Ways Mounted on the Ground Ways. Note sliding ways (1), ground ways (2), and position of tricing lines (3)	26

SUMMARY

This Research Technical Memorandum describes the methods and equipment used to launch a landing craft (LCM-8) from a height of approximately 20 feet above the surface of the water at an angle of 12-1/2 degrees. The procedure outlined herein can be used as a guide for the execution of future tests of a similar nature; it can also be adapted to the discharging of landing craft from the decks of cargo vessels in an oversea area.

The procedure presented in this report is based on the experience gained from several test launchings. It has been found to be economical of time, funds, and personnel, and is consistent with safe operational practices. Drop tests in which this procedure was used have proved that an LCM-8 (Figure 1) in good operating condition can be dropped with no resulting damage from a height of approximately 20 feet. Appendix I is a report of an



Figure 1. Landing Craft (LCM-8).

inspection that was conducted after a test launch of the LCM on 21 April 1961. This test was conducted under ideal conditions in the Third Port Area, Fort Eustis, Virginia.

The section containing the Evaluation enumerates the launching equipment and the operational methods that have been improved since the LCM-8 was drop-tested in April 1961.

CONCLUSION

It is concluded that the method of launching described herein is adequate and economical and may be easily adapted to the deck of a merchant vessel where ships' heavy lift gear or shoreside cranes are not available.

INTRODUCTION

A requirement exists for the establishment of a procedure for launching landing crafts (LCM-8's) from the main deck of loaded cargo vessels from heights of 20 feet above water during good sea conditions. The requirement further stipulates that the craft must be operational from the moment it is water-borne. Tests were conducted under ideal conditions in the Third Port Area of Fort Eustis, Virginia, to establish if the strength of the LCM-8 was such that it could withstand the impact loads of launching from a cargo vessel in an off-loading operation. (Appendix II gives the authority for the test.)

The basic equipment and material used for the test launching of the LCM-8 consisted of the following: steel standing ways, wood sliding ways, and aircombing (honeycombed impact-absorbing material) for protection of the bow ramp during launch. To describe the launching operation in brief: aircombing is attached to the bow ramp, the landing craft is laid in the sliding ways, and the trigger mechanism between the sliding ways and the standing ways is set up.

DESCRIPTION OF BASIC MATERIALS USED IN TEST

STANDING WAYS

The standing ways are structural I-beams that measure approximately 33 inches in depth by 51 feet 0 inches in length. The top flanges of the beam are 12 inches wide and have guide bars welded on the inboard and outboard edges. The standing ways are braced transversely with three steel cross-members, which are bolted below the flanges to form a rigid structure. Prior to setting the LCM-8 together with the sliding ways, the standing ways (Figure 2) must be coated with beeswax and grease.

SLIDING WAYS

The sliding ways are fabricated in four sections of 6-inch by 10-inch and 6-inch by 12-inch oak timbers that are held together by dowels and shaped to fit the bottom of the LCM-8. Steel hinge pins connect the forward and after section of the ways. The ways are equipped with steel plates (located on the inboard and outboard sides) to which tricing lines can be secured for lashing the boat and to which chains can be attached for the transverse positioning of the sliding ways, or cradle. Steel padeyes are installed on the ways to which rope can be attached for lashing the cradle to the LCM-8 (Figure 3).

TRICING LINES

The tricing lines are wire rope of 5/8-inch diameter. Five of the lines are for transverse lashings and two are for the forward and aft lashings. The lines can be attached to the steel plates of the sliding ways by means of shackles and clamps and can be looped over the deck and tensioned by 5/8-inch turnbuckles (Figure 4).

AIRCOMBING

The aircombing consists of two layers of honeycombed impact-absorbing material, which can be lashed to tiedown washers on the outboard side of the ramp to protect the LCM-8 during the drop.

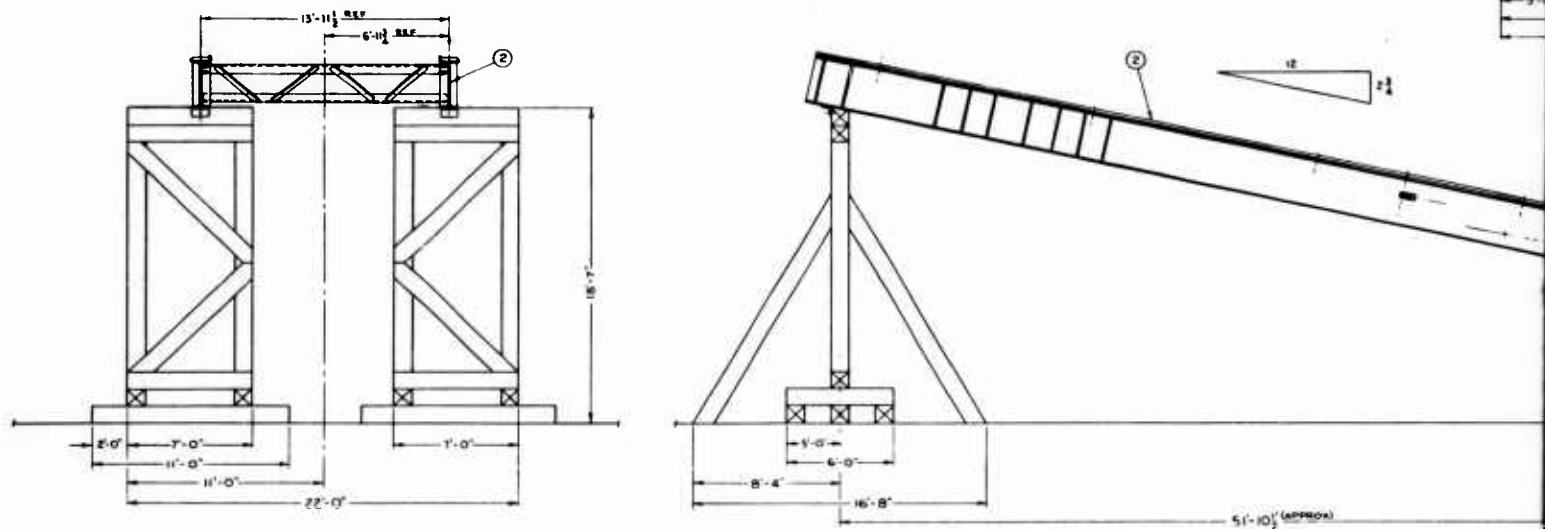

① LAUNCHER, GENERAL ASSEMBLY
SCALE: 1/8" = 1'-0"

Figure 2. Launcher, General Assembly.

REVISION			
NO.	DESCRIPTION	DATE	APPROVAL

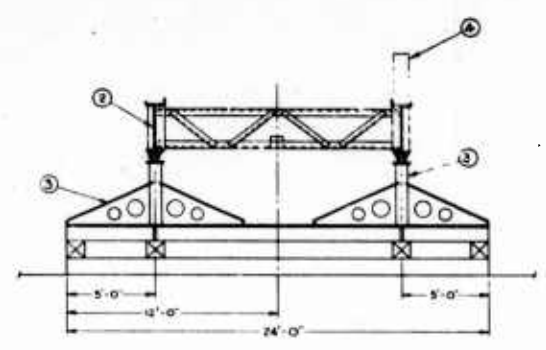

SECTION A-A

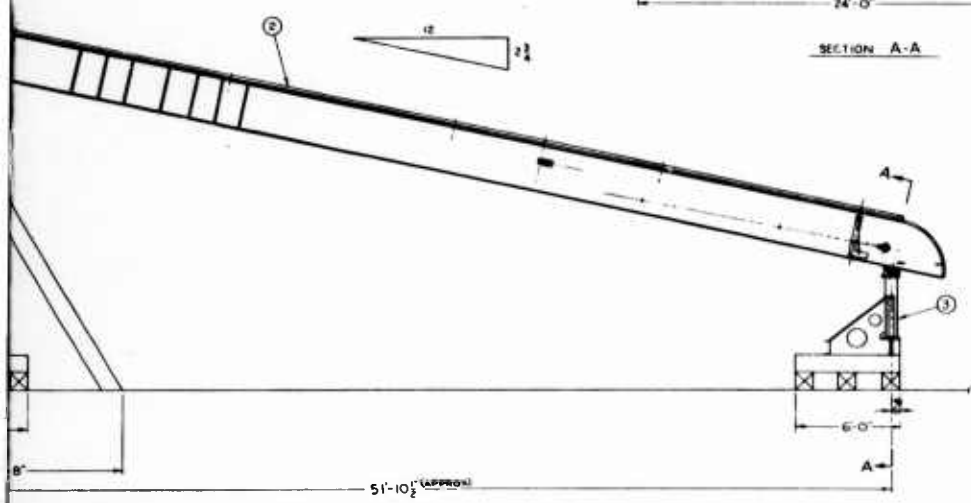

320H61-296

QTY	PART NO.	CODE	DESCRIPTION	MATERIAL	MATL SPEC
1	320H61-296-1		PWD SLIDING WAYS ASSY		
1	320H61-296-2		PIVOT FIDUCIAL FOUNDATION ASSY		
1	320H61-296-3		STANDING WAYS UNDER ASSEMBLY		
1	320H61-296-4		LAUNCHER, GENERAL ASSEMBLY		

LIST OF MATERIAL	
FORM	REQ.
DATE	BY
APPROVED	BY
SCALE	1/2" = 1'-0"

APPROVED	DATE	BY	SCALE

LAUNCHER
GENERAL ASSEMBLY
(NER ONLY)

DEPARTMENT OF THE ARMY
TRANSPORTATION CENTER
TRANSPORTATION RESEARCH
AND DEVELOPMENT COMMAND
FORT MONROE, VIRGINIA
DRAWING NO. 320H61-296
CODE SHEET 1 OF 1

Figure 2. Launcher, General Assembly.



REVISIONS			
NO.	DESCRIPTION	DATE	APPROVAL
A	THIS DRAWING SUPERSEDES DWG. 320D61-246, DATED, 30 MARCH, 1961		

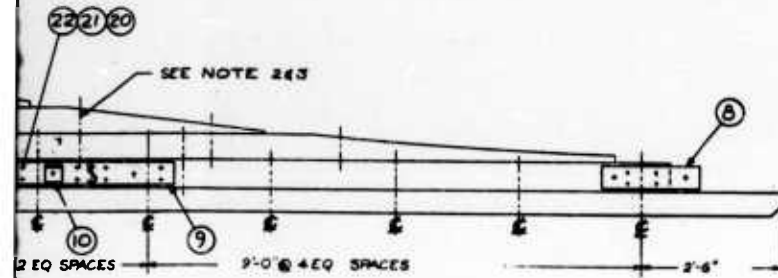

- NOTES:
1. SMALL ENDS OF TIMBER TO BE SPIKED AS REQD. & HEADS OF SPIKES TO BE SET
 2. UPPER PORTIONS OF TIMBERS TO BE DOWELED WITH 1/2" DIA. STEEL DOWELS
 3. HOLES TO BE 1/8" UNDERSIZE TO ASSURE TIGHT FIT. LOCATION OF DOWELS TO BE DETERMINED BY SHOP PERSONNEL
 4. CHAINS TO BE PLACED ON SLIDING WAYS AS REQD. SEE VIEW A-A FOR MOUNTING

SLIDING WAY ASSEMBLY (R SIDE SHOWN)

SLIDING WAY ASSEMBLY (L SIDE OPP HAND)

SCALE: 3/4" = 1'-0"

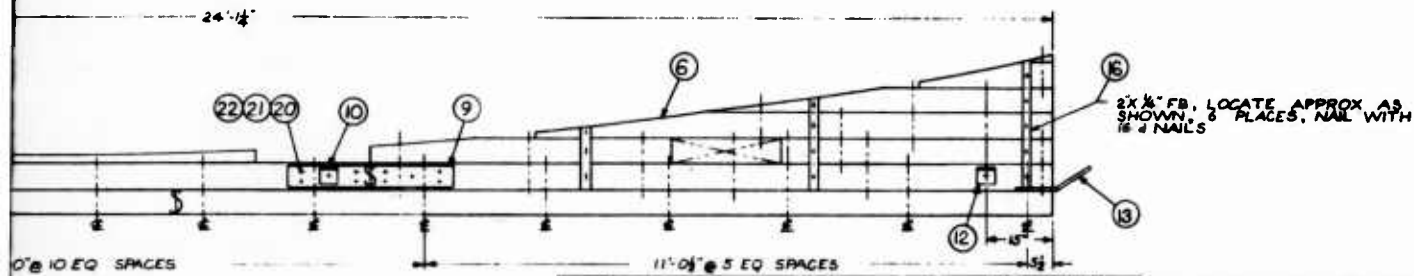

FWD SLIDING WAY ASSEMBLY (R SIDE SHOWN)

FWD SLIDING WAY ASSEMBLY (L SIDE OPP HAND)

SCALE: 3/4" = 1'-0"

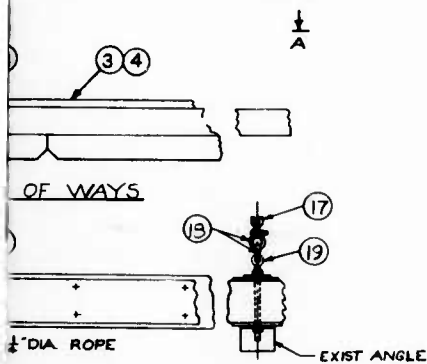

NO.	REQD	REQD	REQD	REQD	QTY	PART NO.	CODE	DESCRIPTION	MATERIAL	MATL SPEC
	AS	REQD				25		16 D NAILS		
	AS	REQD				24		DOWELS 1/2" DIA X 12" LG.		
	AS	REQD				23	MS3751-201	CARRIAGE BOLT		
	AS	REQD				22	MSK200-100	BOLT		
	AS	REQD				21	AN960-1216	WASHER		
	AS	REQD				20	AN335-12	NUT		
	AS	REQD				19		EYE BOLT 1 X 18 LG		
	AS	REQD				18		3/8 SHACKLE		
	AS	REQD				17		1/2" DIA CHAIN		
	AS	REQD				16		1/2 X 2 FB		
						15		BULK MATERIAL		
1	1					14	320D61-292-1	TRIGGER BOLSTER		
1	1	1	1			13	320D61-291-10	BRACKET		
1	1	1	1			12		ANGLE		
2	2					11		PLATE		
2	2	1	1			10		ANGLE		
4	4	2	2			9		FISH PLATE		
						8		PLATE		
						7	320D61-291-1	CONNECTING PLATE		
1	1					6	320D61-245-2	FWD SLIDING WAY		
						5	320D61-245-1	AFT SLIDING WAY		
						4	320D61-293	FWD SLIDING WAY		
						3		FWD SLIDING WAY		
						2		AFT SLIDING WAY		
						1	320D61-293	AFT SLIDING WAY		

320D61-293

NO. REQD	NO. REQD PER-4 ASSY	NO. REQD PER-3 ASSY	NO. REQD PER-2 ASSY	NO. REQD PER-1 ASSY	QTY	PART NO.	CODE	DESCRIPTION	MATERIAL	MATL SPEC

LIST OF MATERIAL		DEPARTMENT OF THE ARMY TRANSPORTATION CORPS	
LCM-8 LAUNCHING	SLIDING WAYS ASSEMBLY & DETAILS	TRANSPORTATION RESEARCH COMMAND FORT EUSTIS, VIRGINIA	
SCALE NOTED	SPEC	DWG NO. 320D61-293 CODE 01000 SHEET OF	

3. Assembly and Details of the Sliding Ways.

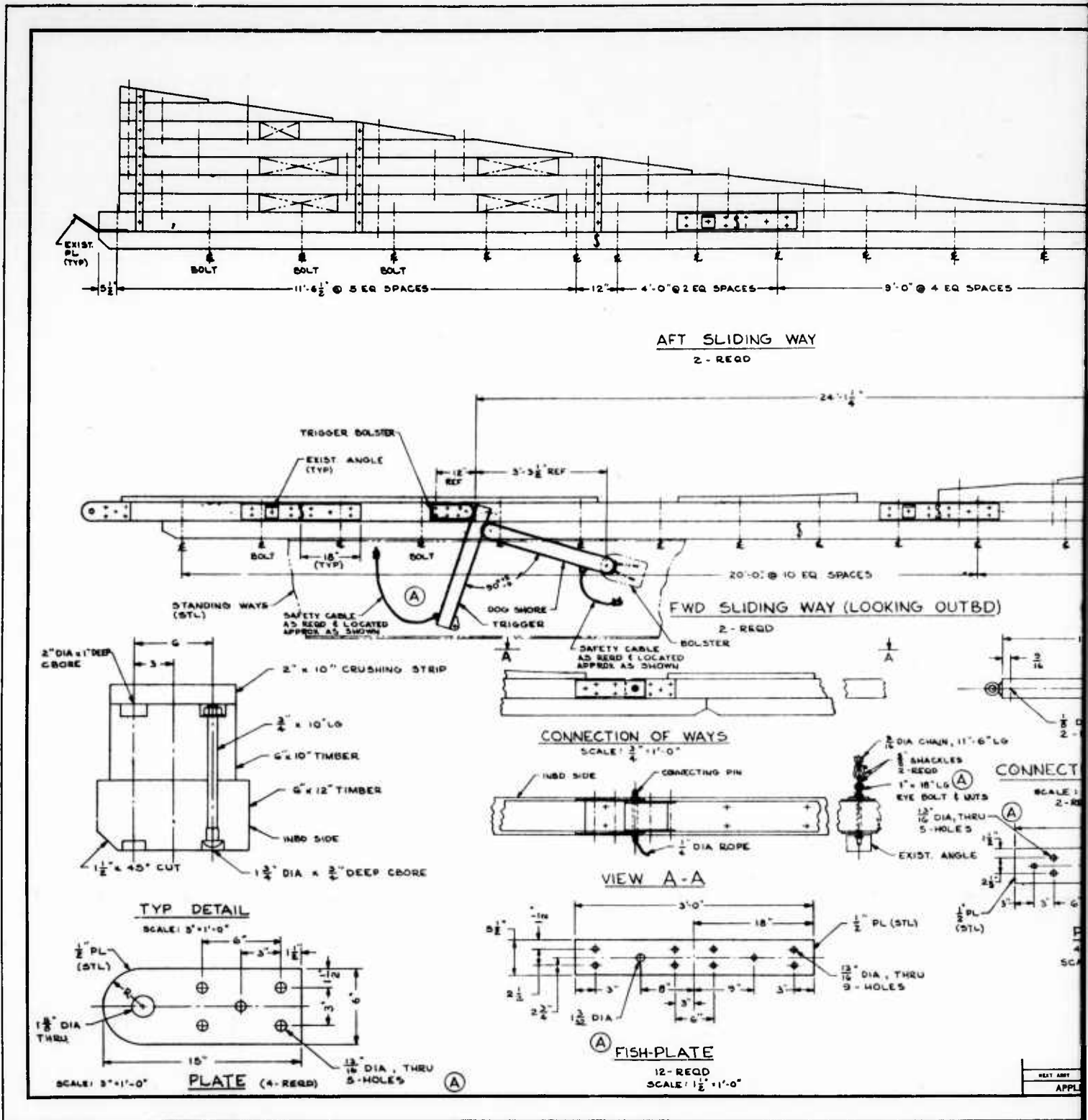

Figure 4. Assembly and Details of the Sliding Way

2

REVISIONS			
SYM	DESCRIPTION	DATE	APPROVAL

NOTES:

1. SMALL ENDS OF TIMBER TO BE SPIKED AS REQD AND HEADS OF SPIKES TO BE SET.
2. UPPER PORTIONS OF TIMBERS TO BE DOWELED WITH $\frac{3}{4}$ " DIA X 12" LG STEEL DOWELS.
3. HOLES TO BE $\frac{1}{8}$ " UNDERSIZE TO ASSURE TIGHT FIT. LOCATION OF DOWELS TO BE DETERMINED BY SHOP PERSONNEL.

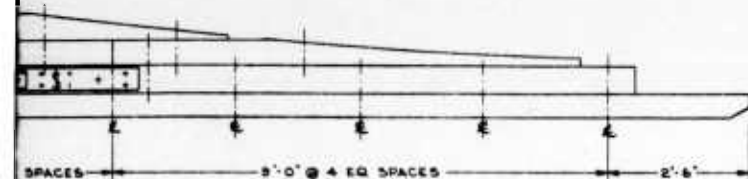

SLIDING WAY
REQD

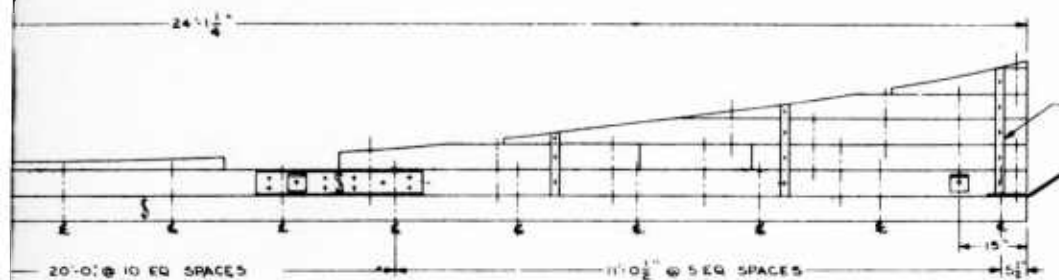

1" x 2" FB, LOCATE APPROX AS SHOWN, 6 PLACES, NAIL WITH 16d NAILS

SLIDING WAY (LOOKING OUTBD)

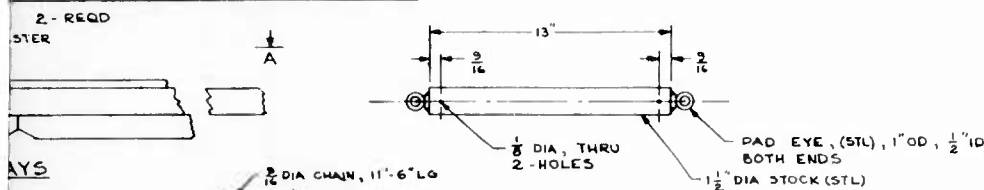

CONNECTING PIN

SCALE: 3" = 1'-0"
2-REQD

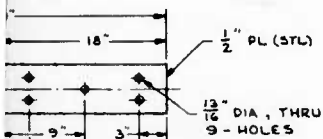
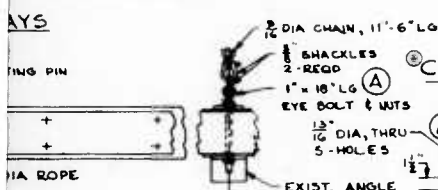

PLATE

4-REQD
SCALE: 1 1/2" = 1'-0"

320D61-248

QTY	FIND NO.	PART NO.	CODE	DESCRIPTION	MATERIAL	MATL SPEC
LIST OF MATERIAL						
UNLESS OTHERWISE SPECIFIED DIMENSIONS ARE IN INCHES				LCM-8 LAUNCHING		DEPARTMENT OF THE ARMY
TOLERANCES ON FRACTIONS 2				SLIDING WAYS		TRANSPORTATION CORPS
DECIMALS 2				ASSEMBLY & DETAILS		TRANSPORTATION RESEARCH
DO NOT SCALE THE DRAWING				SCALE 3/4" = 1'-0" SPEC		COMMAND
DRAWN M. SUTTON				APPROVED DATE		FORT EUSTIS, VIRGINIA
CHECKED J. J. B. B.				4.7.58		DWG NO. 320D61-248
SUBMITTED				DATE		CODE 81996 SHEET OF
APPROVED				DATE		
HEAT ARMY				USED ON		
APPLICATION				QTY REQD		

Assembly and Details of the Sliding Ways.

LIST OF MATERIAL FOR DROP TEST OF ONE LCM-8

<u>Description of Material</u>	<u>Quantity</u>	<u>Remarks</u>
Aircombing, 18 in. wide by 6 in. deep	500 lb.	Used for protecting the bow ramp. Sections are stretched in the manner described under Prelaunching Procedures.
Wrapping paper, heavy duty	256 ft.	To be glued on the outside face of each strip of aircombing.
Glue, NS cement, Nr. 1128	4 gal.	Required for gluing the paper to the aircombing.
Manila line, * 1/4-in.	280 ft.	To be used for securing air-combing.
Washers, 1/2-in., steel	140	To be welded on the ramp of the LCM-8 for securing aircombing.
Grease, Keystone	425 lb. (40 gal.)	To be used as a slip coating for the sliding ways.
Beeswax, NS, Keystone	170 lb.	To be used as a base coating for the sliding ways.
Wire rope, galvanized, steel, 6 x 19		Required for lashing.
⊙ 3/4 in.	162 ft.	
5/8 in.	300 ft.	
1/2 in.	80 ft.	
Cable clips		" " "
3/4 in.	48	
5/8 in.	50	
1/2 in.	16	

*Two hundred feet of 1/2-inch cotton line may be substituted for this item.

<u>Description of Material</u>	<u>Quantity</u>	<u>Remarks</u>
Turnbuckles		Required for lashing.
1 in. , heavy duty	4	
5/8 in. , standard	12	
Wire rope thimbles 1/2-in. , galvanized	8	"
Oak, dressed, dry, and free of knots		Required for sliding ways.
6 in. by 10 in. by 16 ft.	1,760 bd. -ft.	
6 in. by 12 in. by 16 ft.	768 bd. -ft.	
2 in. by 12 in. by 16 ft.	96 bd. -ft.	
Carriage bolts, 3/4 in. by 10 in. , steel, with nuts and washers	132	"
Cold rolled steel, 3/4 round stock, 20-ft. lengths	200	"
Steel plate (1/2 in.) 4 ft. by 8 ft.	1	"
Steel angle, 5 in. by 3-1/2 in. by 3/8 in. by 20 ft. long	1	"
Steel bar, 1/4 in. by 2 in.	200 ft.	"
Nails, 40 p. , common	50 lb.	"
Eyebolts (1 in.) , 18 in. long, full length thread, two nuts, each bolt	10	"

<u>Description of Material</u>	<u>Quantity</u>	<u>Remarks</u>
Bolts, square head, 3/4 in. by 12 in.	74	Required for sliding ways.
Chain, 9/16 in.	100 ft.	"
Shackles, 5/8 in.	20	"

SEQUENCE OF PRELAUNCHING OPERATIONS

In general, the procedure for launching the LCM-8 is as follows:

1. Weld washers to the ramp of the LCM-8 for securing the air-combing.
2. Weld the padeyes in position along the catwalk for stowing hoisting slings during launching operations.
3. Set the sliding ways on hardstand on the proper blocks (a 20-ton crane is needed for this operation). Set the LCM on the sliding ways for the fitting of tricing lines, etc. (a 100-ton crane is needed for this operation).
4. Cut cable in 5/8-inch lengths for all locations for securing the cradle to the LCM. (Replace the cable as necessary on subsequent launchings.)
5. Have the marine surveyor conduct a technical inspection of the LCM-8 and submit a report prior to launching.
6. Apply the necessary reference markings along the hull of the LCM-8.
7. Apply datum lines and reference points on the propeller shafts and skegs to indicate possible deflection (Figure 5).
8. From tide tables, compute the time for the drop so that a correct drop of approximately 20 feet can be made.
9. Hook the standing ways to a 100-ton crane; when a slight tension is felt on the line, remove the cable sway braces at the rear of the ways and at the securing brackets. Next, remove the pin from the forward part of the ways (Figure 3).
10. Lift the steel standing ways and set them on the proper blocking on the pier (approximately three sets of blocks will be required).
11. Scrape the excess grease from the ways.
12. Melt and pour the base coat and the slip coat of grease.
13. Set the LCM on the hardstand or on the pier for examination (a 100-ton crane is needed for this operation).

2

MARKS

REVISIONS			
SYM	DESCRIPTION	DATE	APPROVAL

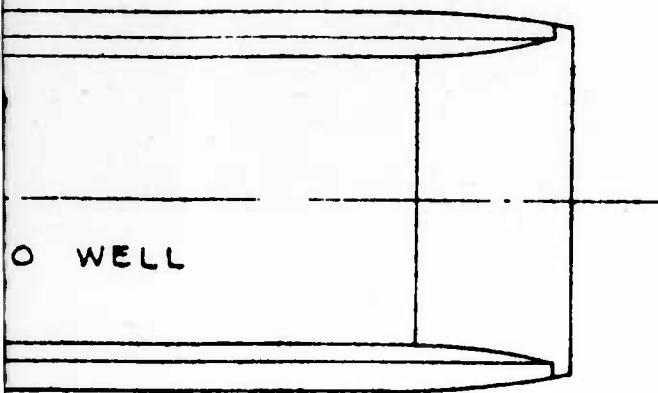

O WELL

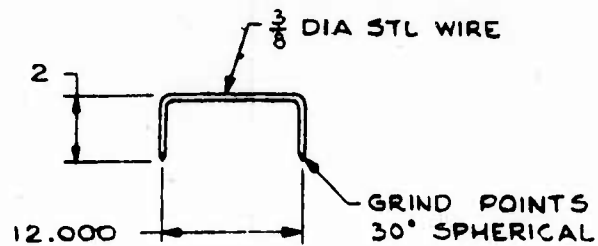

TRAM DETAIL

E CROSS MARK
T OR TAPE

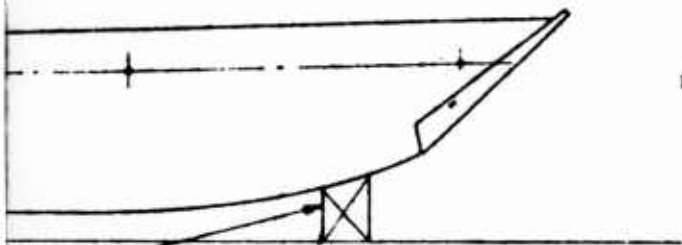

BLOCKING TO BE LOCATED IN THE SAME PLACE WHEN CHECKING AFTER LAUNCHING AS IT WAS WHEN MARKED BEFORE LAUNCHING.

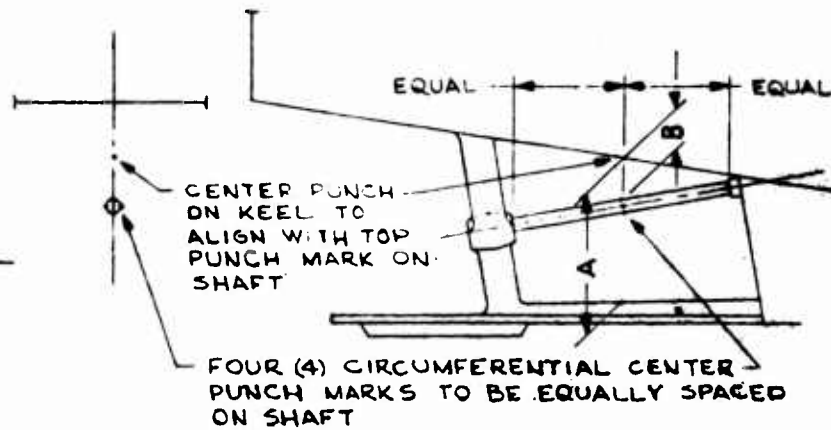

FIND NO.	PART NO.	CODE	DESCRIPTION	MATERIAL	MATL SPEC
LIST OF MATERIAL					
UNLESS OTHERWISE SPECIFIED DIMENSIONS ARE IN INCHES			LCM-8 LAUNCHING	DEPARTMENT OF THE ARMY TRANSPORTATION CORPS TRANSPORTATION RESEARCH COMMAND FORT EUSTIS, VIRGINIA	
DIMENSIONS ON FRACTIONS ± —					
DIMENSIONS ON DECIMALS ± — ANGLES ± —					
DO NOT SCALE THIS DRAWING					
APPROVED					
DRAWN			DEFLECTION & PHOTOGRAPHIC LOCATION MARKINGS	DWG NO. 320B61-256	
CHECKED					
SUBMITTED					
APPROVED					
DATE					
USA M&T DIV.			SCALE NONE	SPEC	CODE 81995 SHEET OF

5. Deflection Location Markings.

14. Transport the LCM to the launching site.
15. Pass the 36-foot wire ropes, which are to be attached later to the forward end of the sliding ways, over the bow ramp before the air-combing is attached.
16. Secure two layers of aircombing to the bow ramp.
17. Place the LCM and the sliding ways in position on the standing ways. Then properly secure the sliding ways to the standing ways and install and adjust the trigger system.
18. Hoist the standing ways and the LCM to the inclined launching position.
19. Place the securing pins in the forward support stands through the steel standing ways to the rear supports, reattach the sway brace cables to the rear of the standing ways, and tighten the turnbuckles.
20. Reinstall the trigger system for launching (Figure 4).
21. Cast off the securing turnbuckles between the sliding ways and the standing ways.
22. Hook up the lanyard to the trigger arm.
23. Clear the water area at the launching site and assign a power boat to retrieve the LCM after launch (Figure 6).
24. Pull the releasing lanyard to launch (Figures 7, 8, and 9).



Figure 6. The Power Boat Assigned to Retrieve the LCM-8 After Launch.

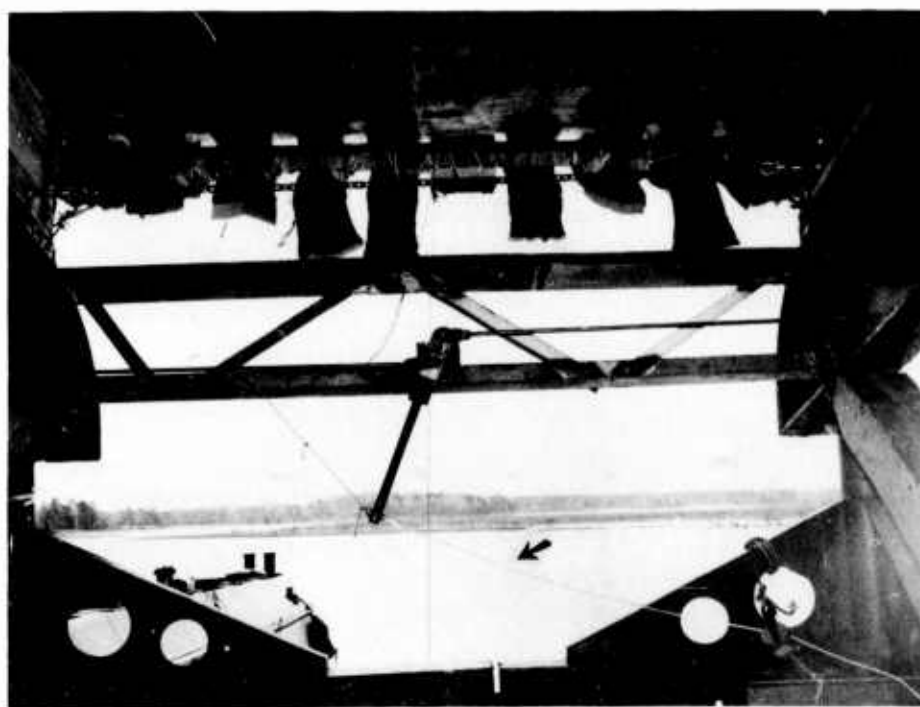

Figure 7. View Showing the Trigger Releasing Lanyard.

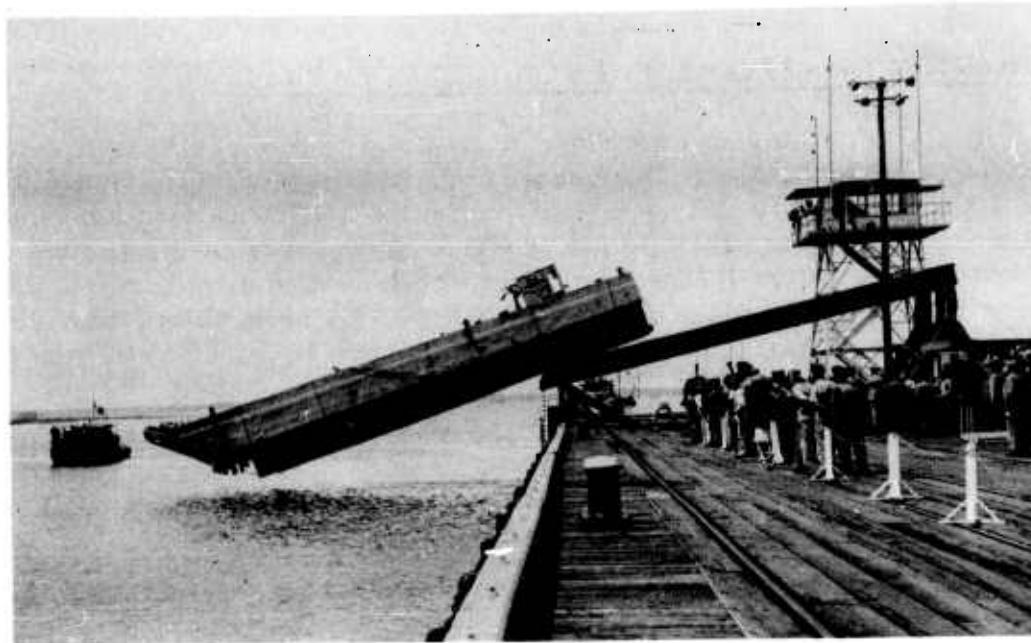

Figure 8. LCM-8 Sliding From Steel Standing Ways.

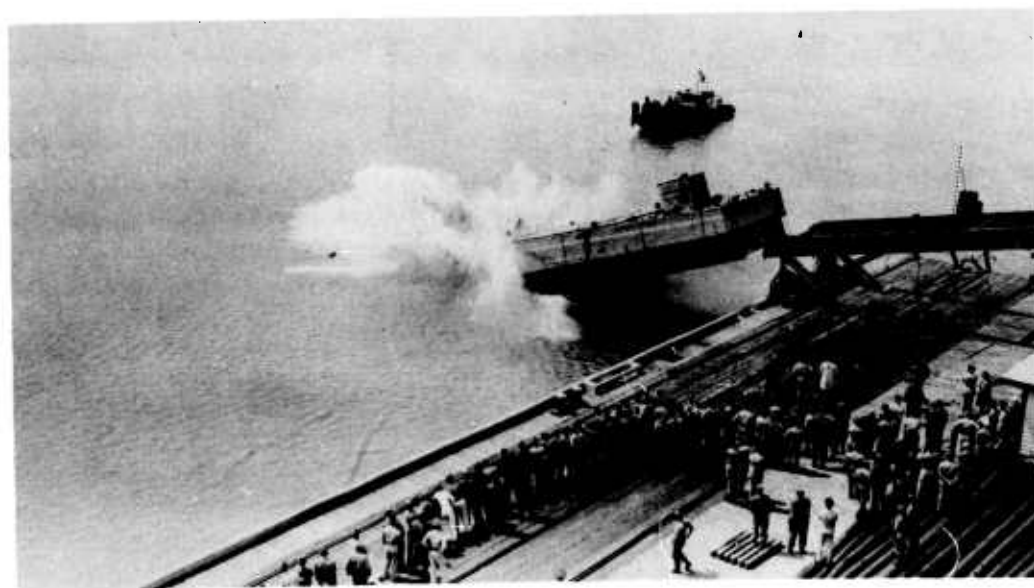

Figure 9. LCM-8 at Moment of Impact With the Water.

PRELAUNCHING PROCEDURES

PREPARATION OF AIRCOMBING FOR INSTALLATION

Immerse the aircombing in water overnight, and then stretch each section to a minimum of 20 to 22 feet. Run metal rods through the aircombing (two on each end) approximately 1/2 inch from the sides. (For satisfactory results, the aircombing must be stretched on a warm, dry day.) After the material is stretched, glue paper facing on the outside face of the material and store the aircombing in a dry place until it is needed. A level floor, four 1/2-inch-diameter steel rods, one hammer, one water hose, and six men are required for this operation.

ATTACHMENT OF AIRCOMBING TO RAMP

Before the aircombing (one horizontal and one vertical layer) is attached to the bow ramp, * eighty 1/2-inch lashing eyelets, set on 20-inch centers, should be welded to the outer face of the ramp. One edge of the eyelets should be bent to a 90-degree angle prior to welding.

To form a horizontal layer of impact-absorbing material, attach six lengths of aircombing between the horizontal eyelets and secure with 1/2-inch rope. (The aircombing should be long enough to extend at least 5 or 6 inches past both sides of the ramp.)

To form the vertical layer of impact-absorbing material, attach ten lengths of aircombing between the vertical eyelets by the same method described in the preceding paragraph (Figure 10). (The aircombing should be long enough to extend below the ramp hinges to which it is secured.) Extend the material over the top of the bow ramp and secure the ends with rope. The closed side of the aircombing must face forward to be effective.

*Pass the 36-foot wire ropes, which are to be attached later to the forward end of the sliding ways, over the bow ramp before the aircombing is attached.

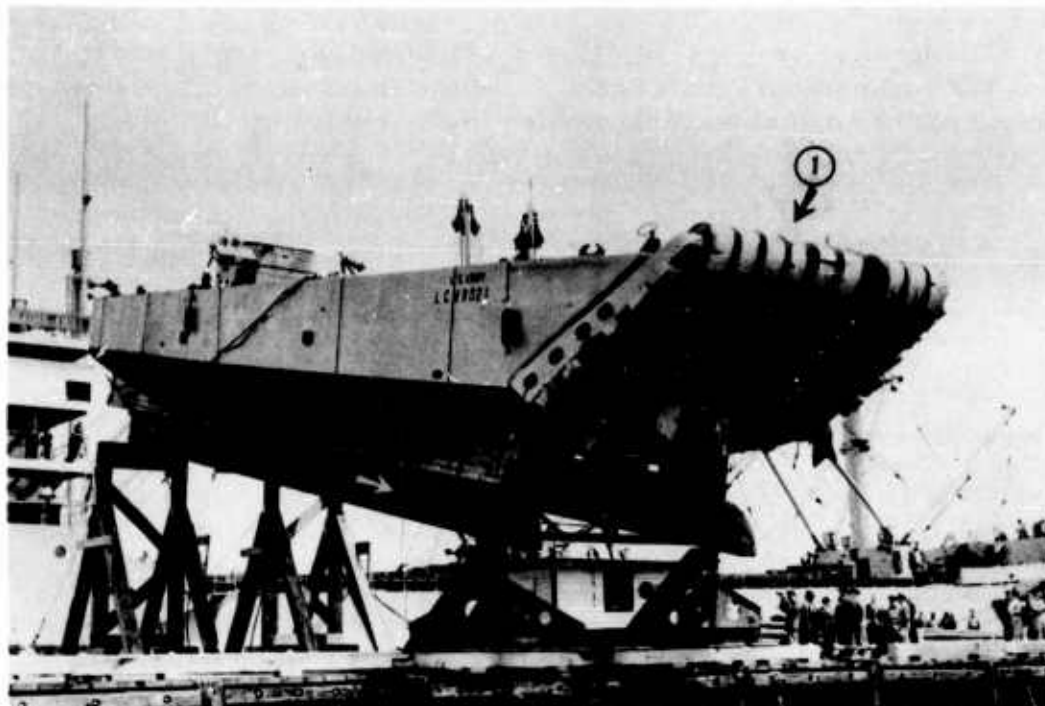

Figure 10. LCM-8 Placed on Steel Standing Ways at an Angle of 12-1/2 Degrees. Note the vertical layer of air on the bow ramp (1) and the steel standing ways (2).

PLACEMENT OF REFERENCE MARKS

To determine damage or distortion resulting from launching, make the following reference punch marks:

1. One mark at the center of the port side of the skeg shoe (Figure 5).
2. Four marks on the port shaft, 90 degrees apart (Figure 5).
3. One mark on the shell directly above the shaft (Figure 5).

Measurement of the two distances A and B (indicated in Figure 5) should be taken before and after each drop in order to determine if damage has occurred.

PREPARATION OF SLIDING WAYS FOR LAUNCHING

Place the sliding ways (Figures 2, 3, and 11) throughout their entire length 12 feet 11-1/2 inches apart (measured from the inboard side of the ways) and symmetrical to the fore and aft centerline of the craft.

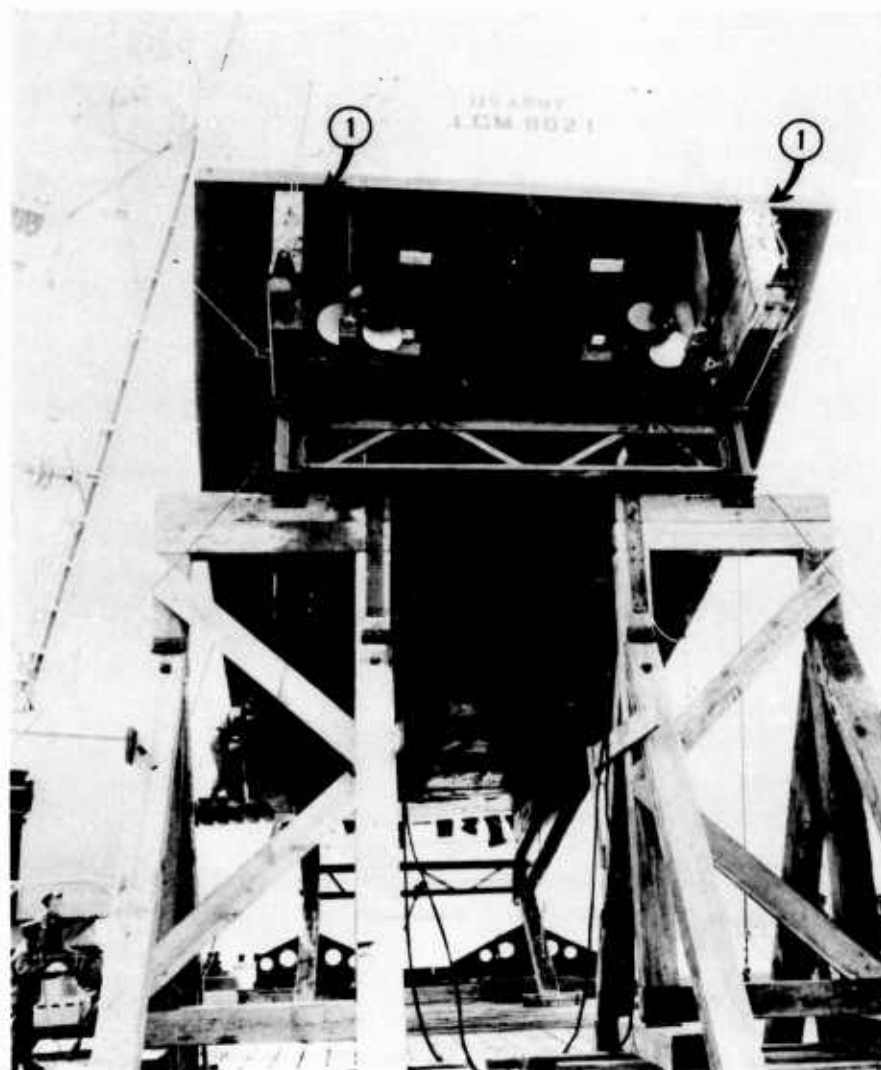

Figure 11. Sliding Ways Placed 12 Feet 11-1/2 Inches Apart (1). Note chain attachments used primarily for maintaining alignment of the sliding ways during launching (2) and the steel crossbeams (3).

Five chains are required for transverse location of the ways. Connect the chains to the 1-inch eyebolts by two 9-/16-inch shackles at each end. The first three forward chains are 10 feet 8-1/2 inches long; the fourth chain is 12 feet 9 inches long; and the fifth chain is 12 feet 11 inches long. Assemble the chains and eyebolts with the sliding ways as follows: Place one nut on the eyebolt and leave approximately 2 inches of threads showing between the eye and the nut; then place one large washer next to the nut. Insert eyebolts through the eyebolt holes from the inboard side of the sliding ways. Place angle clips on the outboard side of the sliding ways with the wide flange facing the ways and the other flange facing upward. Next, put on the nuts and snug down. At this stage, there should be some slack in the chain between the two eyebolts. Adjust the inboard and outboard nuts on each eyebolt to make the chain taut without destroying the distance (12 feet 11-1/2 inches) that must be maintained between the inboard sides of the sliding ways. Tighten all of the eyebolt nuts. Two sections of wire rope are required for each tricing line. For the first two tricing lines from the bow, aft, the ropes which are connected to angle clips, should measure 21 feet in length. The next three lines running aft should measure 24 feet in length. Assemble the wire ropes to the tricing lines as follows: Run the wire rope through the hole in the angle clip and secure the running end of the rope to the standing part with cable clamps; a 6-inch tail must be left from the clamp nearest the free end. Install wire ropes in the same manner on the opposite way.

Run wire ropes up and over the boat and attach them to a turnbuckle and a pelican hook with cable clamps; at least a 6-inch tail must be left on the ends. Tighten the turnbuckle to obtain a taut tricing-line assembly.

Attach 36-foot wire ropes to the forward end of the sliding ways as follows: Fasten a 3/4-inch turnbuckle to the sliding ways by means of two shackles. Attach two 5/8-inch wire ropes to the two 3/4-inch turnbuckles by means of cable clamps (a 6-inch tail must be left). Attach the wire ropes with clamps to the padeyes in the forward well deck. The wire ropes that are attached to the after end of the sliding ways are 13 feet long and are assembled in the same manner as that used at the forward end.

Recheck all shackles, clamps, and turnbuckles to ensure that all rigging is tight and in readiness for lifting the LCM-8 and the sliding ways as a unit to the standing ways.

PREPARATION OF GROUND WAYS FOR LAUNCHING

Grease the ground ways by pouring a 1/2-inch-thick layer of melted beeswax the full length of the ground ways and coat the beeswax with a slip coat of grease 1/8 to 1/2 inch thick while the ways are level.

Secure the sliding ways to the ground ways with turnbuckles attached to the clips on the ground ways and to the trigger bracket on the sliding ways (Figure 12).

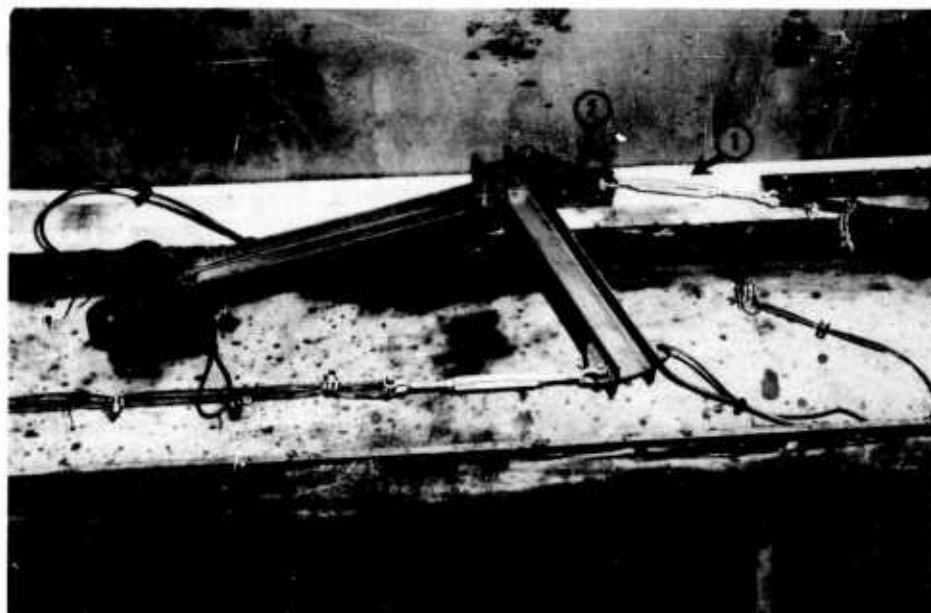

Figure 12. View Showing Turnbuckle (1) and Trigger Bracket (2).

Sling the entire assembly and hoist to the inclined position.

Insert pins through the forward pedestal supports, stretch the ground-way sway braces at the after end, and take up the slack in the braces.

Remove the hoisting slings.

Insert the trigger arms, dogshores, and trigger lines, and recheck the trigger arm angles; readjust as necessary. It is important that the angle be not less than 90 degrees and not more than 95 degrees so that the dogshores will fall clear when the triggers are released (Figure 13).

Attach the trigger-release lanyard (Figure 9).

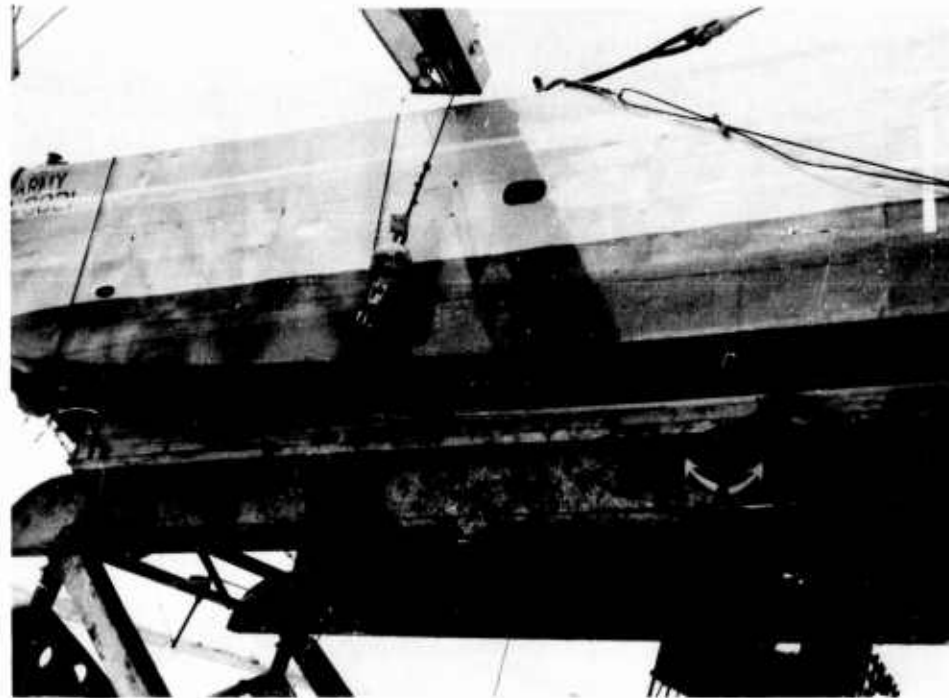

Figure 13. View Showing the Trigger-Arm Angle.

MOUNTING THE LCM-8

Mount the LCM-8 and the sliding ways on the ground ways as a unit. The after end of the sliding ways should extend about 4 feet beyond the ground ways (Figure 14). A final location is made later to suit the trigger setting (Figure 7).



Figure 14. The LCM-8 and the Sliding Ways Mounted on the Ground Ways. Note sliding ways (1), ground ways (2), and the position of the tricing lines (3).

POSTLAUNCHING INSPECTION PROCEDURE

The following procedure should be followed in making the postlaunch inspection.

1. The marine inspector boards the LCM-8 to obtain data for report.
2. Start engines for the marine inspector to check compressor and piping systems, and the hull structure.
3. Using a 100-ton crane, lift the LCM-8 with cradle intact and place on wooden blocks at the pier. Blocking will be marked so that the LCM-8 is placed in the proper location.
4. Inspect wooden cradle, tricing lines, turnbuckles, and connecting pins for possible damage and make necessary adjustments prior to the next launching.
5. Adjust the sliding ways if required for another launching.
6. Inspect the propeller strut, skeg, and rudder for possible damages and make necessary adjustments prior to another launching.
7. Check the punch marks for indications of possible deflection of the shell plating. Make the necessary adjustments or repairs prior to another launching.

EVALUATION

The method of launching described herein is adequate and economical and may be easily adapted to the deck of a merchant vessel where ships' heavy lift gear or shoreside cranes are not available; however, more recent tests have aided in the improvement of the launching equipment and operational methods as follows:

1. The sliding ways can be fabricated of steel.
2. The entire launching kit can be fabricated to suit a particular type or types of merchant vessels.
3. Welded flat bars can be used on the underside of the shell of the present LCM-8's so that the landing craft can be launched on steel rollers or pneumatic wheels.
4. Aircombing is not essential for protection of the bow ramp during launch.

APPENDIX I

REPORT OF POST-LAUNCH INSPECTION

C
O
P
Y

TRANSPORTATION DIVISION
MARINE INSPECTION BRANCH
Fort Eustis, Virginia

INSPECTION OF LCM-8021

1. Purpose of this inspection was to note any change to the structure of the vessel and its operating machinery after Drop Test at 1030 hours, 21 April 1961.
2. Vessel was operated after test for approximately 30 minutes. Temperatures and pressures of operating engines were taken and were normal. There was no operational malfunction of machinery.
3. Condition of vessel as shown on Marine Condition Survey Report, dated 29 March 1961 was not changed by Drop Test performed.

/s/Charles D. Hogan
CHARLES D. HOGAN
Marine Inspector

/s/Joseph A. Mayer
JOSEPH A. MAYER
Marine Inspector

APPENDIX II

DISPOSITION FORM		SECURITY CLASSIFICATION (If any)
		C O P Y
FILE NO. TCREC-DPE	SUBJECT House Task 9.45, Project 9R98-05-009, Launching Test of LCM-8 (Revised)	
TO Dir/Surface Mobility	FROM DCO/P&P	DATE 10 March 1961 COMMENT NO. 1 Mr. Persson/ah/21994
<p>1. The following revised house task is assigned to your Directorate for prosecution:</p> <p>a. Title: Launching Test of LCM-8 (Revised)</p> <p>b. House Task Number: 9.45</p> <p>c. Project Number: 9R98-05-009</p> <p>d. Date of Revision: 10 Mar 60 (original date 31 Aug 59, revised 19 Aug 60).</p> <p>e. Target Date for Completion: 1 Jun 61.</p> <p>f. Scope:</p> <p>(1) Obtain LCM in good operating condition from USA T/C.</p> <p>(2) Fabricate wood sliding ways for LCM-8 and erect same on existing steel launching stand at 3d Port Pier, Fort Eustis, Va.</p> <p>(3) Prepare work order through Technical Operations for necessary support.</p> <p>(4) Conduct test and obtain test data.</p> <p>(5) Compile and evaluate test results.</p> <p>(6) Finalize report to include drawings, photos, and other technical data.</p> <p>(7) Obtain still and motion pictures.</p> <p>(8) Publication of Research Technical Manual.</p> <p>h. References:</p> <p>(1) DF, file TCCAD-D, 25 May 60, subject: "Launching Test of LCM-8".</p> <p>(2) DF, file TCCAD-D, 13 Jul 60, subject: "Launching Test of LCM-8".</p> <p>(3) DF, file TCREC-SDM, 11 Aug 60, subject: "Request for House Task (Sep 60, Launching of LCM-8)".</p>		

APPENDIX II (Cont'd)

TCREC-DPE
SUBJECT: House Task 9.45, Project 9R98-05-009,
Launching Test of LCM-8 (Revised)

10 March 1961

C
O
P
Y

(4) USATRECOM Monthly Technical Meeting, 2 Dec 60.

(5) Meeting held at TRECOM on 28 Feb 61 between T-Board and TRECOM personnel.

(6) Ltr, TCREC-SDM, Jan 61, subject "Request for Funds to cover additional LCM-8 Drop Tests".

(7) DF, file TCREC-SDM, 3 Mar 61, subject: "Request for Revision to House Task 9.45".

g. Remarks: It is planned that the launching of the LCM-8 would be on or about 15 Apr 61.

2. Estimated cost of test and evaluation is \$7,000. Funds are available for this house task.

FOR THE COMMANDER:

N. A. GAGE, Jr.
Colonel IC
Commander for
Plans and Programs

DISTRIBUTION

Transport & Ships Division, OFMO, ODDR&E	(1)
First US Army	(1)
Second US Army	(1)
Third US Army	(1)
Fourth US Army	(1)
Fifth US Army	(1)
Sixth US Army	(2)
Deputy Chief of Staff for Logistics, DA	(2)
Deputy Chief of Staff for Military Operations, DA	(1)
Chief of Transportation, DA	(5)
USA Transportation Board	(12)
USA Transportation Materiel Command	(16) [®]
USA Transportation Research Command	(31)
TC Liaison Officer, USAERDL	(1)
USATRECOM Liaison Officer, Detroit Arsenal	(1)
USA Transportation Terminal Command, Atlantic	(1)
USA Transportation Terminal Command, Pacific	(3)
USA Transportation Terminal Agency, Seattle	(1)
Captain Robert A. Kizer, OUSARMA	(2)
US Army Port of Embarkation, Bremerhaven	(3)
US Army, Pacific	(2)
US Army, Alaska	(3)
US Army, Port of Whittier	(1)
Eighth US Army	(2)
US Army, Ryukyu Islands/IX Corps	(1)
US Army, Hawaii	(3)
US Army, Caribbean	(2)
US Army Transportation Terminal Agency, Japan	(2)
Chief of Naval Operations, D/N	(2)
Chief, Bureau of Yards and Docks	(2)
Hq, US Marine Corps	(1)
MC Liaison Officer, USA Transportation School	(1)
US Government Printing Office	(1)
Armed Services Technical Information Agency	(10)

Army Transportation Research
Command, Fort Eustis, Virginia
OPERATIONAL GUIDE FOR
LAUNCHING THE LCM-8, by Rocco
Fama and John Newman. Research
technical memorandum 34. Dec 1961.
32p. incl. illus., (TCREC technical
rept. 61-136) Unclassified report

1. Landing Craft,
Launching
LCM-8

1. Landing Craft,
Launching
LCM-8

2. Bow Launching,
LCM-8

Army Transportation Research
Command, Fort Eustis, Virginia
OPERATIONAL GUIDE FOR
LAUNCHING THE LCM-8, by Rocco
Fama and John Newman. Research
technical memorandum 34. Dec 1961.
32p. incl. illus., (TCREC technical
rept. 61-136) Unclassified report

This Research Technical Memorandum describes the methods and equipment used to launch a landing craft (LCM-8) from a height of approximately

(over)

This Research Technical Memorandum describes the methods and equipment used to launch a landing craft (LCM-8) from a height of approximately

(over)

Army Transportation Research
Command, Fort Eustis, Virginia
OPERATIONAL GUIDE FOR
LAUNCHING THE LCM-8, by Rocco
Fama and John Newman. Research
technical memorandum 34. Dec 1961.
32p. incl. illus., (TCREC technical
rept. 61-136) Unclassified report

1. Landing Craft,
Launching
LCM-8

1. Landing Craft,
Launching
LCM-8

2. Bow Launching,
LCM-8

Army Transportation Research
Command, Fort Eustis, Virginia
OPERATIONAL GUIDE FOR
LAUNCHING THE LCM-8, by Rocco
Fama and John Newman. Research
technical memorandum 34. Dec 1961.
32p. incl. illus., (TCREC technical
rept. 61-136) Unclassified report

This Research Technical Memorandum describes the methods and equipment used to launch a landing craft (LCM-8) from a height of approximately

(over)

This Research Technical Memorandum describes the methods and equipment used to launch a landing craft (LCM-8) from a height of approximately

(over)

mately 20 feet above the surface of the water at an angle of 12-1/2 degrees. The procedure outlined herein can be used as a guide for the execution of future tests of a similar nature; it can also be adapted to the discharging of landing craft from the decks of cargo vessels in an oversea area.

The procedure presented in this report is based on the experience gained from several test launchings. It has been found to be economical of time, funds, and personnel, and is consistent with safe operational practices. Drop tests in which this procedure was used have proved that an LCM-8 in good operating condition can be dropped with no resulting damage from a height of approximately 20 feet.

mately 20 feet above the surface of the water at an angle of 12-1/2 degrees. The procedure outlined herein can be used as a guide for the execution of future tests of a similar nature; it can also be adapted to the discharging of landing craft from the decks of cargo vessels in an oversea area.

The procedure presented in this report is based on the experience gained from several test launchings. It has been found to be economical of time, funds, and personnel, and is consistent with safe operational practices. Drop tests in which this procedure was used have proved that an LCM-8 in good operating condition can be dropped with no resulting damage from a height of approximately 20 feet.

mately 20 feet above the surface of the water at an angle of 12-1/2 degrees. The procedure outlined herein can be used as a guide for the execution of future tests of a similar nature; it can also be adapted to the discharging of landing craft from the decks of cargo vessels in an oversea area.

The procedure presented in this report is based on the experience gained from several test launchings. It has been found to be economical of time, funds, and personnel, and is consistent with safe operational practices. Drop tests in which this procedure was used have proved that an LCM-8 in good operating condition can be dropped with no resulting damage from a height of approximately 20 feet.

mately 20 feet above the surface of the water at an angle of 12-1/2 degrees. The procedure outlined herein can be used as a guide for the execution of future tests of a similar nature; it can also be adapted to the discharging of landing craft from the decks of cargo vessels in an oversea area.

The procedure presented in this report is based on the experience gained from several test launchings. It has been found to be economical of time, funds, and personnel, and is consistent with safe operational practices. Drop tests in which this procedure was used have proved that an LCM-8 in good operating condition can be dropped with no resulting damage from a height of approximately 20 feet.

Army Transportation Research
Command, Fort Eustis, Virginia
OPERATIONAL GUIDE FOR
LAUNCHING THE LCM-8, by Rocco 2.
Fama and John Newman. Research
technical memorandum 34. Dec 1961.
32p. incl. illus., (TCREC technical
rept. 61-136) Unclassified report

1. Landing Craft,
Launching
2. Bow Launching,
LCM-8

Army Transportation Research
Command, Fort Eustis, Virginia
OPERATIONAL GUIDE FOR
LAUNCHING THE LCM-8, by Rocco 2.
Fama and John Newman. Research
technical memorandum 34. Dec 1961.
32p. incl. illus., (TCREC technical
rept. 61-136) Unclassified report

1. Landing Craft,
Launching
2. Bow Launching,
LCM-8

This Research Technical Memorandum describes the methods and equipment used to launch a landing craft (LCM-8) from a height of approximately

(over)

This Research Technical Memorandum describes the methods and equipment used to launch a landing craft (LCM-8) from a height of approxi-

(over)

Army Transportation Research
Command, Fort Eustis, Virginia
OPERATIONAL GUIDE FOR
LAUNCHING THE LCM-8, by Rocco 2.
Fama and John Newman. Research
technical memorandum 34. Dec 1961.
32p. incl. illus., (TCREC technical
rept. 61-136) Unclassified report

1. Landing Craft,
Launching
2. Bow Launching,
LCM-8

Army Transportation Research
Command, Fort Eustis, Virginia
OPERATIONAL GUIDE FOR
LAUNCHING THE LCM-8, by Rocco 2.
Fama and John Newman. Research
technical memorandum 34. Dec 1961.
32p. incl. illus., (TCREC technical
rept. 61-136) Unclassified report

1. Landing Craft,
Launching
2. Bow Launching,
LCM-8

This Research Technical Memorandum describes the methods and equipment used to launch a landing craft (LCM-8) from a height of approxi-

(over)

This Research Technical Memorandum describes the methods and equipment used to launch a landing craft (LCM-8) from a height of approxi-

(over)

mately 20 feet above the surface of the water at an angle of 12-1/2 degrees. The procedure outlined herein can be used as a guide for the execution of future tests of a similar nature; it can also be adapted to the discharging of landing craft from the decks of cargo vessels in an oversea area.

The procedure presented in this report is based on the experience gained from several test launchings. It has been found to be economical of time, funds, and personnel, and is consistent with safe operational practices. Drop tests in which this procedure was used have proved that an LCM-8 in good operating condition can be dropped with no resulting damage from a height of approximately 20 feet.

mately 20 feet above the surface of the water at an angle of 12-1/2 degrees. The procedure outlined herein can be used as a guide for the execution of future tests of a similar nature; it can also be adapted to the discharging of landing craft from the decks of cargo vessels in an oversea area.

The procedure presented in this report is based on the experience gained from several test launchings. It has been found to be economical of time, funds, and personnel, and is consistent with safe operational practices. Drop tests in which this procedure was used have proved that an LCM-8 in good operating condition can be dropped with no resulting damage from a height of approximately 20 feet.

mately 20 feet above the surface of the water at an angle of 12-1/2 degrees. The procedure outlined herein can be used as a guide for the execution of future tests of a similar nature; it can also be adapted to the discharging of landing craft from the decks of cargo vessels in an oversea area.

The procedure presented in this report is based on the experience gained from several test launchings. It has been found to be economical of time, funds, and personnel, and is consistent with safe operational practices. Drop tests in which this procedure was used have proved that an LCM-8 in good operating condition can be dropped with no resulting damage from a height of approximately 20 feet.

mately 20 feet above the surface of the water at an angle of 12-1/2 degrees. The procedure outlined herein can be used as a guide for the execution of future tests of a similar nature; it can also be adapted to the discharging of landing craft from the decks of cargo vessels in an oversea area.

The procedure presented in this report is based on the experience gained from several test launchings. It has been found to be economical of time, funds, and personnel, and is consistent with safe operational practices. Drop tests in which this procedure was used have proved that an LCM-8 in good operating condition can be dropped with no resulting damage from a height of approximately 20 feet.

UNCLASSIFIED

UNCLASSIFIED