

UNCLASSIFIED

AD 260 226

*Reproduced
by the*

ARMED SERVICES TECHNICAL INFORMATION AGENCY
ARLINGTON HALL STATION
ARLINGTON 12, VIRGINIA



UNCLASSIFIED

NOTICE: When government or other drawings, specifications or other data are used for any purpose other than in connection with a definitely related government procurement operation, the U. S. Government thereby incurs no responsibility, nor any obligation whatsoever; and the fact that the Government may have formulated, furnished, or in any way supplied the said drawings, specifications, or other data is not to be regarded by implication or otherwise as in any manner licensing the holder or any other person or corporation, or conveying any rights or permission to manufacture, use or sell any patented invention that may in any way be related thereto.

OTS PB 171424

DMIC Report 136B
May 29, 1961

CATALOGED BY ASTIA
260226
ASAD No. _____

61-4-1
NOX

**THE EFFECTS OF ALLOYING ELEMENTS
IN TITANIUM**

**VOLUME B. PHYSICAL AND CHEMICAL PROPERTIES,
DEFORMATION AND TRANSFORMATION
CHARACTERISTICS**

ASTIA
RECEIVED
JUL 27 1961
RECEIVED
TIPDR

DEFENSE METALS INFORMATION CENTER
Battelle Memorial Institute
Columbus 1, Ohio

OTS PB 171424

DMIC Report 136B
May 29, 1961

THE EFFECTS OF ALLOYING ELEMENTS
IN TITANIUM

VOLUME B. PHYSICAL AND CHEMICAL PROPERTIES,
DEFORMATION AND TRANSFORMATION
CHARACTERISTICS

by

D. J. Maykuth, F. C. Holden, D. N. Williams,
H. R. Ogden, and R. I. Jaffee

to

OFFICE OF THE DIRECTOR OF DEFENSE
RESEARCH AND ENGINEERING

DEFENSE METALS INFORMATION CENTER
Battelle Memorial Institute
Columbus 1, Ohio

PREFACE

This report, DMIC Report 136B, is the second of a series on the effects of alloying elements in titanium. The first, DMIC Report 136A, dealt with the constitution of binary and ternary alloys. A subsequent volume, to be designated DMIC Report 136C, will be concerned with mechanical properties of titanium alloys.

ADDENDUM TO DMIC REPORT 136A

During the preparation of DMIC Report 136A, the magnifications of several photomicrographs were inadvertently omitted. Specifically, the photographs shown in Figures 32 and 93 (pages 61 and 146, respectively) were taken at a magnification of 250X while the photograph shown in Figure 94 (page 147) was taken at a magnification of 7500X.

TABLE OF CONTENTS

	<u>Page</u>
SUMMARY	1
INTRODUCTION	3
PHYSICAL PROPERTIES	3
Density	3
Thermal Properties	3
Heats of Formation	3
Free Energy and Activity Coefficients	7
Thermal Conductivity	10
Thermal Expansion	10
Specific Heat	15
Heat Capacity	15
Electrical Properties	16
Resistivity	16
Magnetoresistance, Hall Coefficient, and Magnetic Susceptibility	19
CHEMICAL PROPERTIES	20
Corrosion Resistance	20
Gas-Metal Reactions	29
Oxygen, Nitrogen, and Air	29
Hydrogen	42
DIFFUSION	50
Interstitial Elements	50
Hydrogen	50
Oxygen	54
Carbon	54
Nitrogen	56
Air Contamination	56
Substitutional Elements	59
Aluminum	59
Chromium	60
Iron	64
Manganese	64
Molybdenum	67
Scandium	67
Tin	67
Uranium	69
Vanadium	69
Zirconium	71
DEFORMATION MECHANISMS AND TEXTURES	71
Deformation Mechanisms	71
Deformation Textures	74
RECOVERY, RECRYSTALLIZATION, AND GRAIN GROWTH	77
Recovery	80
Recrystallization	83
Grain Growth	89

TABLE OF CONTENTS
(Continued)

	<u>Page</u>
REACTION KINETICS	99
The Martensite Transformation	102
M_s Temperature	104
M_f Temperature	109
Habit Planes	109
Orientation Relationships	113
Decomposition	114
Transformation From Beta to Alpha	116
TTT Curves	116
Effects of Alloy Composition	118
Transformation From Beta to Omega	125
Structure of the Omega Phase	125
TTT Curves	126
Effects of Alloy Composition	126
The Eutectoid Transformation	133
REFERENCES	137

THE EFFECTS OF ALLOYING ELEMENTS
IN TITANIUM

VOLUME B. PHYSICAL AND CHEMICAL PROPERTIES,
DEFORMATION AND TRANSFORMATION
CHARACTERISTICS

SUMMARY

Considerable data on the physical, electrical, and chemical properties of titanium alloys have been generated. However, few systematic studies of the effects of alloying additions on these properties of titanium have been made. This report reviews the pertinent data and attempts to correlate changes in these properties, where they have been observed, with alloy content.

Information on the diffusion of interstitial elements in titanium is reasonably complete and reliable diffusion data on the more important substitutional alloying additions are also available.

An analysis of the effects of alloying additions on the deformation mechanisms and textures, recovery, recrystallization, and grain-growth characteristics of this metal is presented.

A considerable amount of information concerning the reaction kinetics of titanium alloys has been developed. These data are reviewed in terms of the effects of alloying additions on the martensitic, beta-to-alpha, beta-to-omega, and/or eutectoid transformation temperatures.

INTRODUCTION

This is the second in a series of reports which is intended to summarize the state of the art in the development of titanium alloys as of the year 1960. The first report (DMIC Report 136A), dealing with the constitution of titanium alloys, was issued on September 15, 1960. A third report, devoted exclusively to mechanical properties, is now in preparation.

The purpose of these reports is twofold. First, they will provide an up-to-date review for those already familiar with the properties of titanium. Also, for those unfamiliar with the metal, these reports should provide a good basis for understanding the capabilities as well as the limitations of this metal and its alloys.

The over-all objective is to promote the most effective use of titanium and its alloys in solving both current and future materials problems in defense applications.

PHYSICAL PROPERTIES

Density

Obviously, the densities of titanium alloys are proportional to both the amount and density of the individual alloying metals. This is apparent in Figure 1 which shows the experimentally determined densities in a number of binary titanium-alloy systems as a function of alloy composition.

It is of interest to note that aluminum is the only element which is capable of forming structurally useful titanium-base alloys of significantly lower density. Because aluminum also imparts other useful properties to titanium, it is a common alloy addition in most of the present commercial alloys. The importance of aluminum as a lightweight strengthener for titanium is shown in Table 1 which lists the compositions of most of the known commercial alloys in order of increasing density.

Thermal Properties

Heats of Formation

The titanium-aluminum system is the only binary alloy system for which the exothermic heats of reaction have been published over the entire alloying range. The results of this work are shown graphically in Figure 2

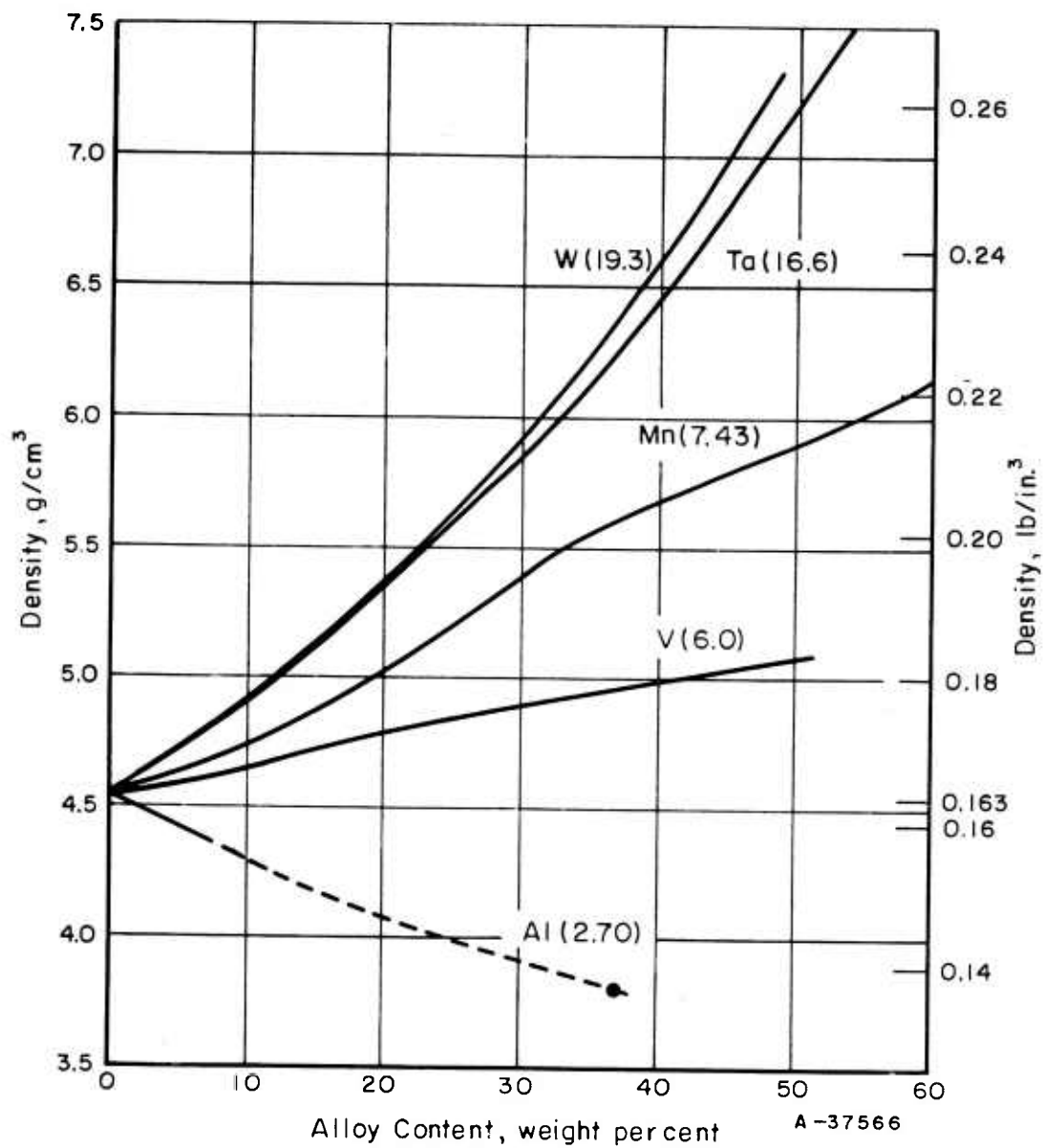


FIGURE 1. DENSITY OF BINARY TITANIUM-ALUMINUM⁽¹⁾,
-MANGANESE⁽²⁾, -TANTALUM⁽²⁾, -VANADIUM⁽³⁾,
AND -TUNGSTEN⁽²⁾ ALLOYS AS A FUNCTION
OF COMPOSITION

Values given in parentheses in figure represent
densities, in g/cm^3 , of the alloy addition elements.

TABLE 1. DENSITIES OF COMMERCIAL TITANIUM ALLOYS

Density, lb/in. ³	Nominal Alloy Content, weight per cent	Manufacturers Designation
0.159	8Al, 2Cb, 1Ta	MST-8Al-2Cb-1Ta
0.160	6Al, 4V	C-120AV, MST-6Al-4V, RS-120A, Ti-6Al-4V
0.161	5Al, 2.5Sn	A-110AT, RS-110C, Ti-5Al-2.5Sn
0.162	7Al, 4Mo	C-135AMo, RS-135, Ti-7Al-4Mo
0.163	100Ti 1.5Al, 3Mn 4Al, 4Mn 5Al, 2.75Cr, 1.25Fe 4Al, 3Mo, 1V	Various RS-110BX C-130AM, MST-4Mn-4Al, RS-130 RS-140 C-115AMoV, RS-115, Ti-4Al-3Mo-1V
0.165	2Al, 2Fe	MST-2Al-2Fe
0.166	3Al, 5Cr	MST-3Al-5Cr
0.167	2.8Cr, 1.5Fe 2.5Fe, 2.5V 12Zr, 4.5Al(a)	Ti-150A MST-2.5Fe-2.5V A-120ZA
0.168	2.5Al, 16V 3Cr, 1.5Fe	C-105VA, MST-16V-2.5Al RS-110
0.169	2.1Cr, 2.2Fe, 2Mo	Ti-140A
0.171	8Mn	C-110M, MST-8Mn, RS-110A
0.175	13V, 11Cr, 3Al	B-120VCA, RS-120B, Ti-13V-11Cr-3Al
0.199	30Mo	(b)

(a) Composition not finalized.

(b) Alloy patented, but not yet commercially manufactured, by Crucible Steel.

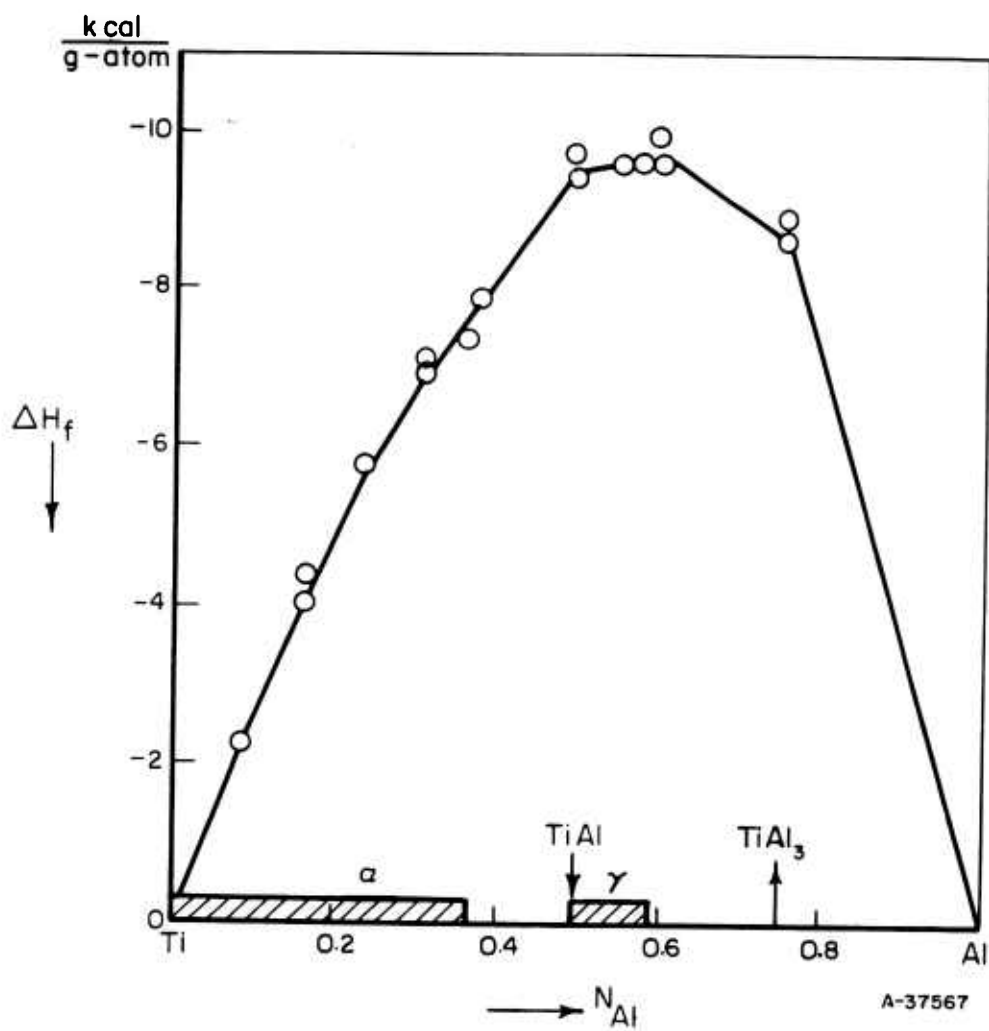


FIGURE 2. HEATS OF FORMATION IN THE SYSTEM TITANIUM-ALUMINUM⁽⁴⁾

and are tabulated in Table 2. As indicated by these data, the minimum heat of formation occurs for the γ (TiAl) phase saturated with aluminum.

In this same study, Kubaschewski and Dench^{(4)*} observed a heat of formation for TiFe of -4850 cal/g-atom, as indicated in Table 2. Attempts to determine the heat of formation of alloys with higher iron contents were unsuccessful due to the inability to complete the alloying action of powder samples within the calorimeter. Similarly, very little alloying was observed in attempts to react compacts of titanium containing 10, 20, and 30 per cent tin at temperatures up to 1000 C (1832 F). On the basis of this latter observation, Kubaschewski and Dench conclude that the heats of formation of titanium-tin alloys are probably much less than that of "any other alloys" investigated.

Kubaschewski and Cotterall⁽⁵⁾ also reported the heats of formation of three titanium-silicon compounds as shown below:

<u>Compound</u>	<u>H₂₉₈, cal/g-atom</u>
Ti ₅ Si ₃	-17,300 ± 1000
TiSi	-15,500 ± 1000
TiSi ₂	-10,700 ± 700

Free Energy and Activity Coefficients

The free energies and activity coefficients of beta-titanium solid solutions in the titanium-chromium and titanium-iron systems have been calculated by Herosymenko and Winters⁽⁶⁾ and are given in Figure 3.

The activity coefficient of titanium in the beta phase of titanium-chromium alloys is practically equal to unity up to about 4.5 atomic per cent chromium. Thus, the beta phase may be regarded as nearly an ideal solution in this composition range. Above 4.5 atomic per cent chromium, the activity coefficient reaches a maximum value, then decreases to values less than unity at about 8.5 atomic per cent. In the titanium-iron system, the activity coefficient of titanium in the beta phase increases above unity at the smallest addition of iron.

These workers point out that the activity coefficient of titanium in beta phase can be taken as an approximate measure of the tendency to form alpha titanium. Alloys having a low activity coefficient are more likely to retain beta on quenching from high temperatures than alloys with $\alpha_{Ti} > 1$. Some experimental evidence supporting this hypothesis was obtained.

*References are given on page 137.

TABLE 2. HEAT OF FORMATION OF VARIOUS TITANIUM-ALUMINUM AND TITANIUM-IRON ALLOYS⁽⁴⁾

Alloy Content		Heat of Formation, cal/g-atom
Weight Per Cent	Atomic Per Cent	
5Al	8.55Al	-2260 ± 240
10Al	16.45Al	-4390 ± 230
10Al	16.45Al	-4030 ± 230
15Al	23.85Al	-5720 ± 240
20Al	30.75Al	-6940 ± 220
20Al	30.75Al	-7130 ± 210
24Al	35.9Al	-7380 ± 230
25Al	37.2Al	-7870 ± 200
35Al	48.9Al	-9410 ± 240
35Al	48.9Al	-9730 ± 240
40Al	54.2Al	-9600 ± 230
40Al	54.2Al	-9540 ± 240
43.8Al	58.05Al	-9620 ± 200
45Al	59.25Al	-9980 ± 220
45Al	59.25Al	-9600 ± 240
62.8Al	75Al	-8950 ± 260
62.8Al	75Al	-8680 ± 260
53.82Fe	50Fe	-4840 ± 280
53.82Fe	50Fe	-4870 ± 290
53.82Fe	50Fe	-4600 ± 290
53.82Fe	50Fe	-4900 ± 280

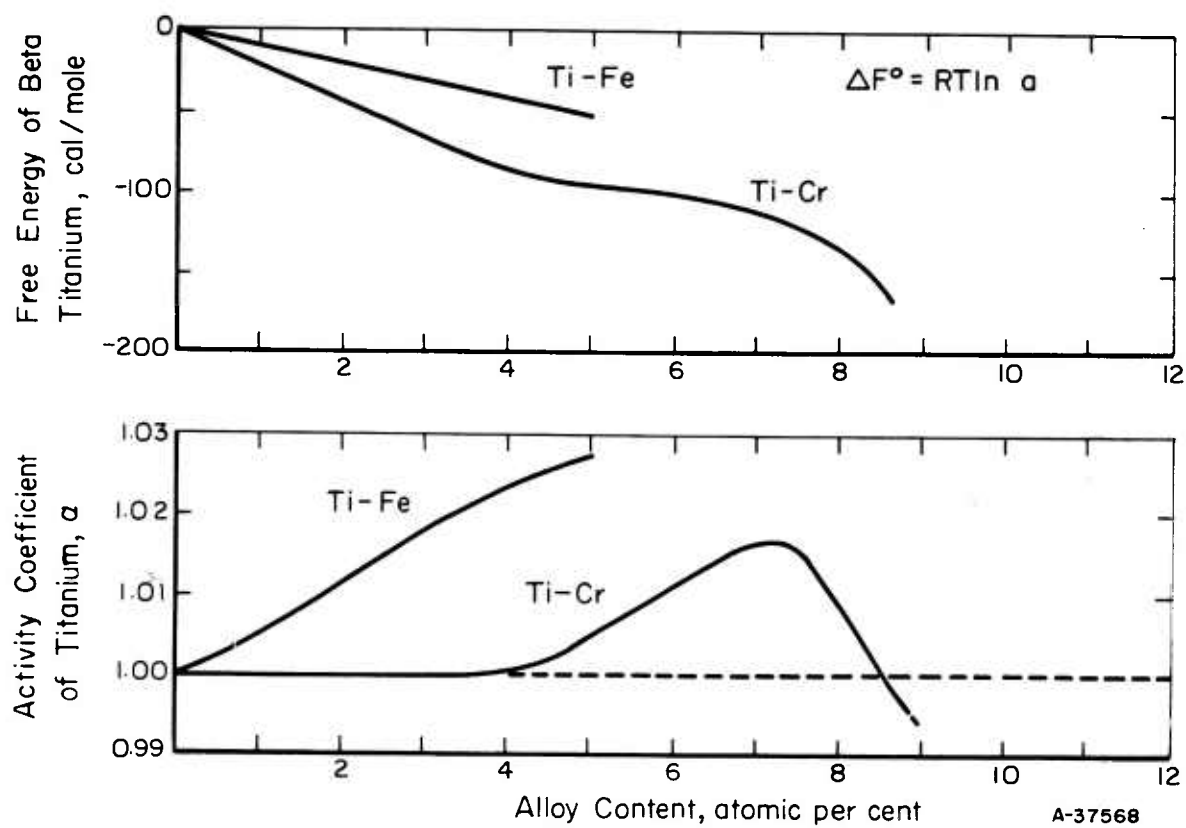


FIGURE 3. FREE ENERGY AND ACTIVITY COEFFICIENT OF TITANIUM AS A FUNCTION OF THE SOLUTE CONTENT IN TITANIUM-CHROMIUM AND TITANIUM-IRON ALLOYS⁽⁶⁾

Thermal Conductivity

Except for various grades of commercial titanium and a number of commercial alloys, the thermal conductivity of titanium has not been systematically studied as a function of alloy content and temperature. Nevertheless, Mendelssohn and Rosenberg⁽⁷⁾ have shown that, at low temperatures, the thermal conductivity of pure titanium is quite sensitive to impurities. Thus, values of 11.2 and 6.6 Btu/(hr)(ft²)(ft)(F) were obtained on two grades of titanium assaying 99.99 and 99.9 per cent pure, respectively.

The available thermal-conductivity data for various titanium alloys have been summarized in Figure 4. The large crosshatched area across the top of this figure illustrates the facts that (1) the thermal conductivity versus temperature curve for pure titanium has not been established, and (2) impurities contained in the commercial grades have a significant effect on thermal conductivity at least up to about 1400 F.

Alloying additions tend to lower the conductivity of titanium at low temperatures. While little can be said regarding the specific effects of the various alloying elements, it appears that, on an equivalent weight basis, aluminum causes a greater decrease in conductivity than does manganese. It is further noted from Figure 4 that, at temperatures of 800 to 1400 F, the thermal-conductivity curves for all of the commercial titanium-base alloys tend to converge and to be slightly below the curve for the unalloyed metal.

The work of Deem, Wood, and Lucks⁽¹³⁾ indicates that the thermal conductivities of titanium alloys can be calculated, with a fair degree of accuracy, from their electrical conductivities using the relationship

$$K = 0.626 \sigma T \times 10^{-8} + 0.00497,$$

where K is the thermal conductivity (in cal/(sec)(cm²)(cm/C), σ is the electrical conductivity (in ohm-cm), and T is temperature (K).

Thermal Expansion

Various investigators have studied the thermal-expansion characteristics of titanium alloys as a function of temperature over the range of 70 F to about 1600 F. These data can be summarized as illustrated in Figure 5 which shows that, generally, alloy additions decrease the coefficient of expansion of titanium in this temperature interval. This appears clearly to be the case for both interstitial and substitutional alpha stabilizers, as shown by the separate alloy curves in Figure 5.

As indicated by the crosshatched area in this figure, the expansion coefficients of commercial alpha-beta alloys lie in a broad band below the

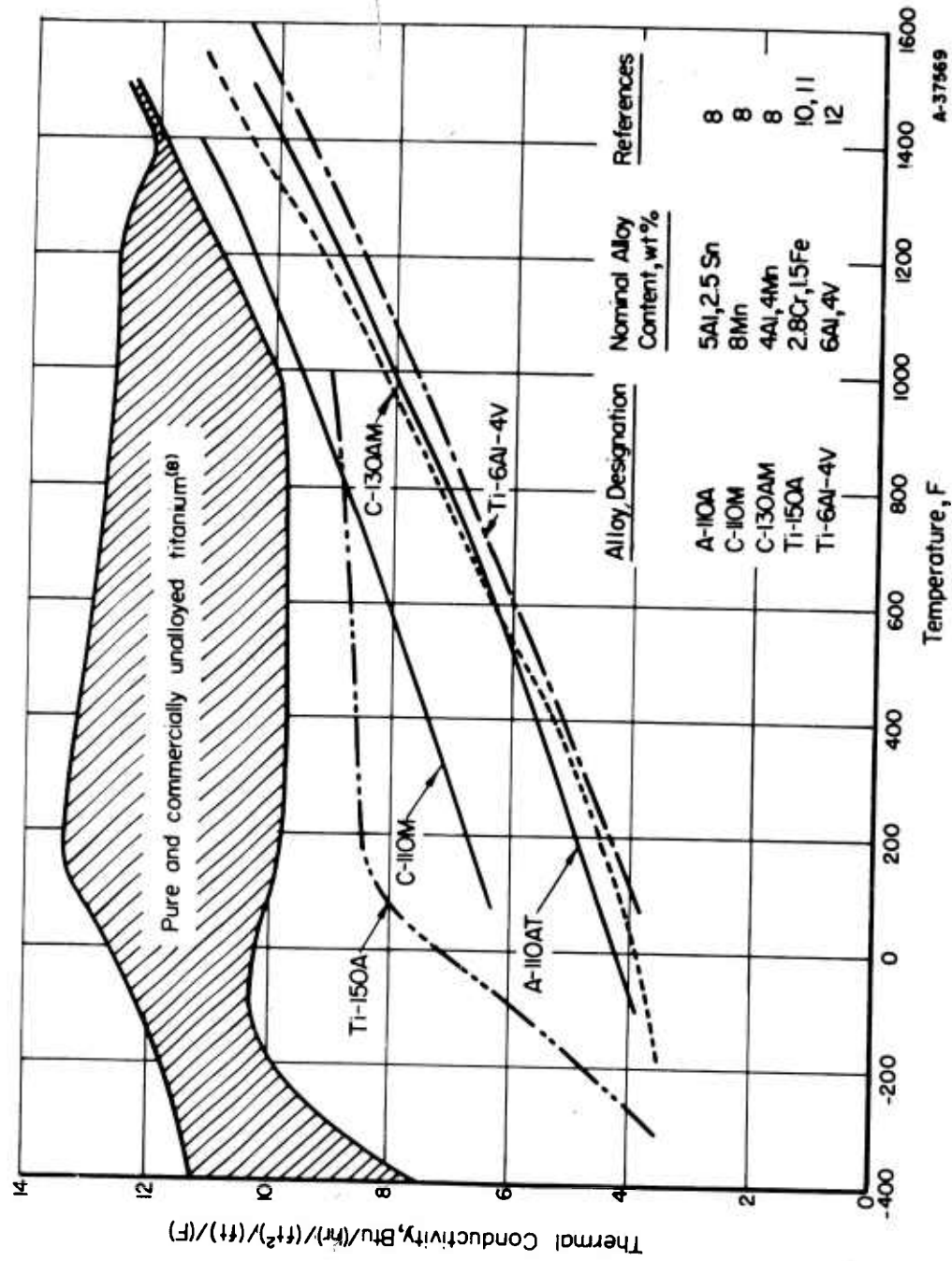


FIGURE 4. EFFECT OF TEMPERATURE ON THE THERMAL CONDUCTIVITY OF TITANIUM AND VARIOUS ALLOYS

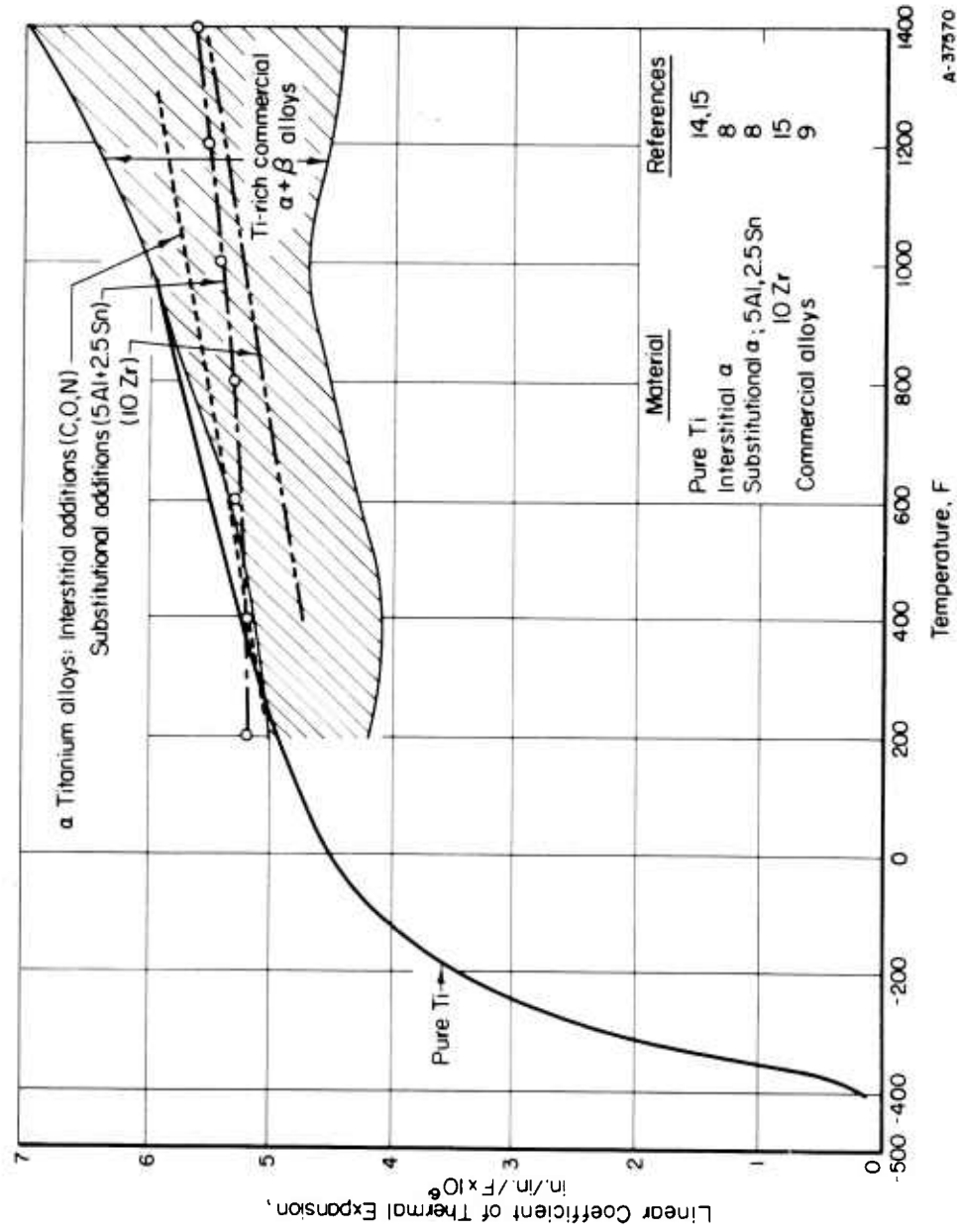


FIGURE 5. EFFECT OF ALLOY ADDITIONS ON THE MEAN LINEAR COEFFICIENTS OF THERMAL EXPANSION OF TITANIUM

curve for unalloyed titanium. However, the expansion coefficients of these and other beta-stabilized alloys can change appreciably when the alloys are heated to temperatures where phase transformations occur. This is illustrated by the data below which were obtained on the MST 3Mn complex alloy (nominally containing 3Mn, 1Cr, 1Fe, 1Mo, and 1V) after three conditions of heat treatment:

Heat Treatment	Mean Linear Coefficient of Expansion Between 68 F and Indicated Temperature, in./in./F x 10 ⁶ (9)					
	400 F	600 F	800 F	1000 F	1200 F	1400 F
Annealed bar stock	4.7	4.8	5.0	5.1	6.6	9.0
Heated to 1600 F, held 10 minutes, and water quenched	3.6	3.9	12.9	11.8	12.5	12.0
Heated to 1600 F, held 10 minutes, water quenched, aged 26 hours at 1000 F	4.7	4.8	5.1	5.2	4.8	5.2

Also, as illustrated by Figure 6, the thermal-expansion curve of beta-stabilized alloys is not always reproducible on heating and cooling.

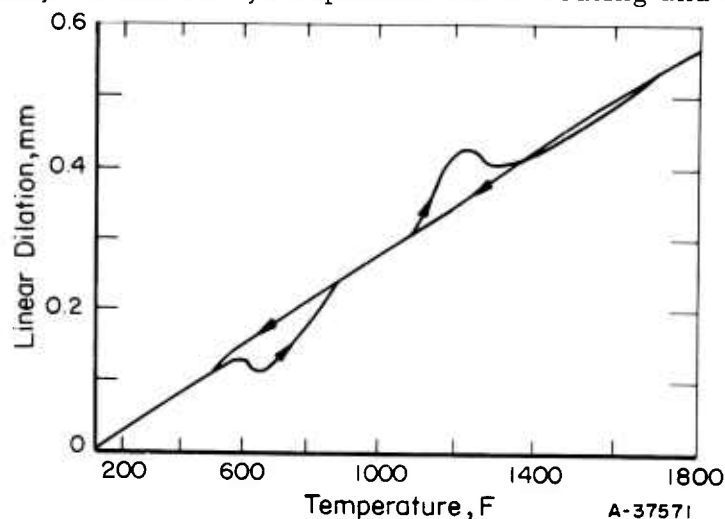


FIGURE 6. DILATOMETER CURVE ON HEATING AND COOLING OF A Ti-15Cr ALLOY⁽¹⁵⁾

Sample quenched from beta field prior to test, heated and cooled at same rate of 1 F per min.

TABLE 3. MEAN LINEAR COEFFICIENTS OF THERMAL EXPANSION OF BINARY TITANIUM ALLOYS AFTER A STABILIZATION HEAT TREATMENT⁽¹⁵⁾

Alloy Content, weight per cent	Mean Linear Coefficient of Thermal Expansion, in./in./F x 10 ⁶ , Between 68 F and Temperature Indicated(a)					
	400 F	600 F	800 F	1000 F	1200 F	1400 F
Iodide Ti	4.80	4.95	5.16	5.29	5.41	5.53
10Cb	4.78	5.01	5.26	5.29	5.28	(5.25)
5Cr	4.83	5.08	5.34	5.52	(5.48)	(5.62)
10Cr	5.07	5.27	5.56	5.74	(6.40)	(5.73)
15Cr	5.15	(5.09)	(5.90)	(6.22)	(6.87)	(6.38)
40Cr	4.64	4.79	5.38	5.47	(6.24)	(5.85)
5Cu	5.06	5.13	5.26	5.45	5.58	5.78
5Mo	4.77	4.93	5.09	5.25	5.34	5.40
2.5Ni	4.60	4.82	5.04	5.23	5.45	(5.48)
7.5Ni	4.82	5.01	5.21	5.45	5.79	(5.85)
10Ni	4.92	5.08	5.23	5.38	(5.49)	(5.43)
1Si	4.99	5.04	5.27	5.40	5.51	5.64
3Si	4.81	4.97	5.16	5.34	5.50	5.69

(a) Parentheses indicate that a phase transformation is taking place at the indicated temperature and that the measured coefficient is of doubtful value.

Generally, however, the expansion coefficients of commercial alpha-beta alloys after a stabilization heat treatment are fairly consistent and fall within the area indicated in Figure 5. Further, as shown by the data of Table 3, the expansion coefficients of a wide variety of experimental, beta-stabilizer-addition alloys also fall in the same area after similar heat treatment.

Specific Heat

The effect of alloying elements on the specific heat of titanium has not been investigated. However, the specific heats of commercial titanium and several commercial titanium alloys have been determined over the range of 32 to 1600 F. These data, given in Table 4, indicate that various alloy additions in amounts up to 10 per cent, have no significant effect on the specific heat of titanium over this temperature interval.

TABLE 4. SPECIFIC HEAT OF TITANIUM AND TITANIUM ALLOYS

Nominal Composition	Alloy Designation	Specific Heat, Btu/F/lb, at the Indicated Temperatures											References
		32 F	68 F	200 F	400 F	600 F	800 F	1000 F	1200 F	1400 F	1550 F	1600 F	
Commercial Ti	A-55, A-70	-	0.125 ^(a)	0.130	0.136	0.143	0.151	0.160	0.171	0.183	0.193	-	8
Commercial Ti	Ti-75A	-	0.125 ^(b)	0.126	0.130	0.138	0.150	0.166	0.186	0.186	0.209	-	11
4Al-4Mn	C-130AM	0.128	0.130 ^(c)	0.133	0.139	0.148	0.157	0.168	0.181	0.195	0.207	-	8
5Al-2.5Sn	A-110AT	0.126	0.128 ^(c)	0.131	0.137	0.145	0.153	0.161	0.170	0.180	0.188	-	8
6Al-4V	Ti-6Al-4V	-	0.135	0.135	0.137	0.144	0.154	0.167	0.184	0.205	-	0.229	12
2.8Cr-1.5Fe	Ti-150A	-	0.120 ^(b)	0.121	0.125	0.133	0.145	0.161	0.181	0.204	-	-	11
8Mn	C-110M	0.112	0.120 ^(c)	0.130	0.141	0.147	0.153	0.166	0.192	0.236	0.286	-	15

(a) At 77 F.

(b) At 70 F.

(c) At 100 F.

Heat Capacity

Mah, et al. (16), have determined the heat capacity of high-purity titanium and titanium-oxygen alloys at low temperatures. These data are summarized in Table 5. At the lowest temperature studied (50 K), oxygen lowers the heat capacity of titanium appreciably. However, as the temperature is increased, this effect of oxygen is reversed. Thus, between 150 and 175 K, oxygen in amounts up to 9.95 per cent has no significant effect on the heat capacity. At higher temperatures, up to 298 K (room temperature), oxygen in the same amount increases the heat capacity of titanium by a small amount.

TABLE 5. HEAT CAPACITY OF HIGH-PURITY TITANIUM AND TITANIUM-OXYGEN ALLOYS AT LOW TEMPERATURES⁽¹⁶⁾

Temperature, K	Heat Capacity (C_p), cal/mole/K		
	Titanium	Ti-1.90 Wt% O	Ti-9.95 Wt% O
50	1.136	1.031	0.683
75	2.402	2.271	1.750
100	3.434	3.310	2.831
125	4.155	4.074	3.780
150	4.684	4.650	4.564
175	5.043	5.067	5.141
200	5.321	5.380	5.697
225	5.539	5.627	6.101
250	5.713	5.822	6.429
275	5.864	5.991	6.703
298.15	5.976	6.130	6.930

Electrical Properties

Resistivity

The electrical resistivity of titanium is sensitive to impurity content and ranges, at room temperature, from a value of about 42 $\mu\text{ohm-cm}$ for the pure metal to values of 48 to 61 $\mu\text{ohm-cm}$ for the commercially pure grades. These values of resistivity are high for a metal, although the resistivity of titanium is comparable with that of zirconium and hafnium which are the other Group IV-A transition metals.

The temperature dependence of the resistivity of titanium is unusual in that it increases linearly up to about 750 F (400 C), after which it begins to decrease and then shows a sharp drop at the alpha/beta transformation temperature. These features are illustrated in Figure 7. As part of a study of the effect of alloying elements on the resistivity of titanium, Ames and McQuillan⁽¹⁷⁾ determined resistivity versus temperature curves for binary alpha-titanium alloys containing up to 1 atomic per cent columbium and copper, 1.45 atomic per cent oxygen, 8 atomic per cent aluminum and tin, and 50 atomic per cent zirconium. The curves determined for the aluminum and zirconium alloys are representative of those obtained and are reproduced in Figures 8 and 9. Generally, these authors observed that the effect of these alloying additions was to increase the magnitude of the high-temperature deviation of the resistivity-temperature curve from linearity.

The room-temperature resistivities of the various alloys were plotted as shown in Figure 10. As pointed out by Ames and McQuillan,

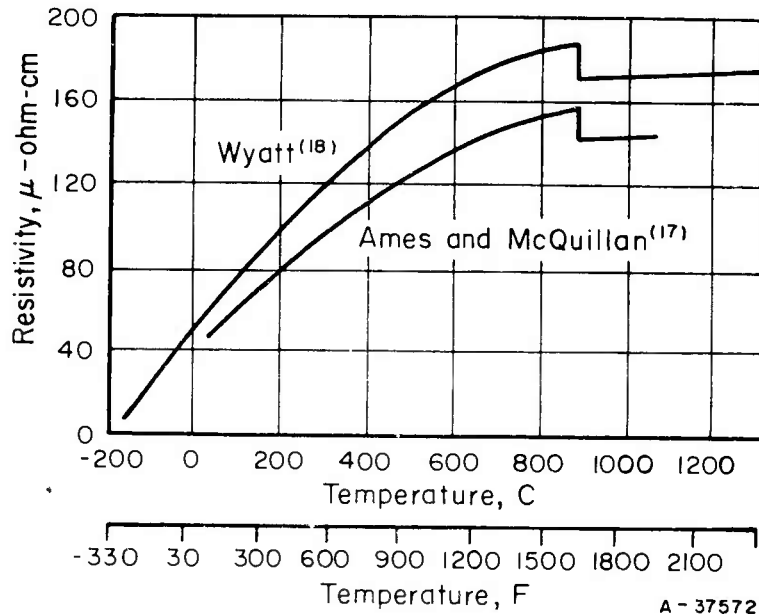


FIGURE 7. THE ELECTRICAL RESISTIVITY OF HIGH-PURITY TITANIUM AT VARIOUS TEMPERATURES

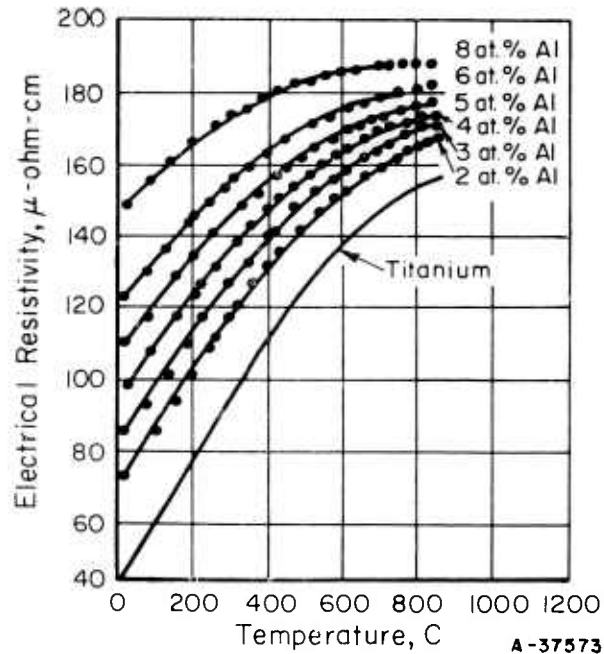


FIGURE 8. THE EFFECT OF TEMPERATURE ON THE RESISTIVITY OF A SERIES OF α -PHASE TITANIUM-ALUMINUM ALLOYS⁽¹⁷⁾

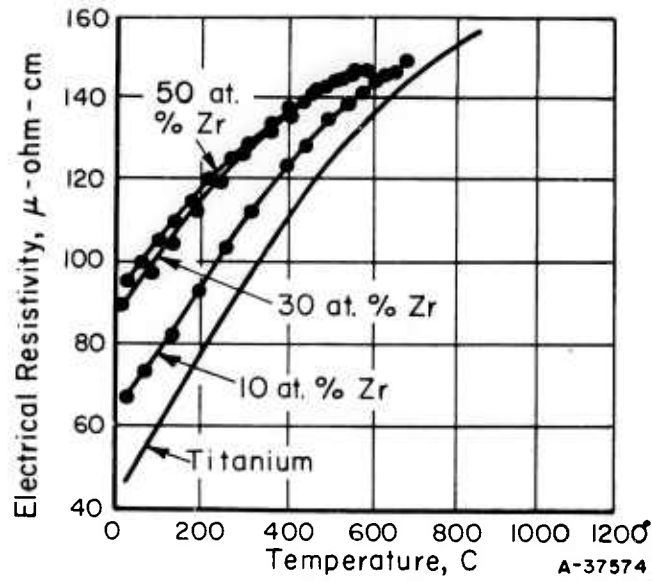


FIGURE 9. THE EFFECT OF TEMPERATURE ON THE RESISTIVITY OF A SERIES OF TITANIUM-ZIRCONIUM ALLOYS⁽¹⁷⁾

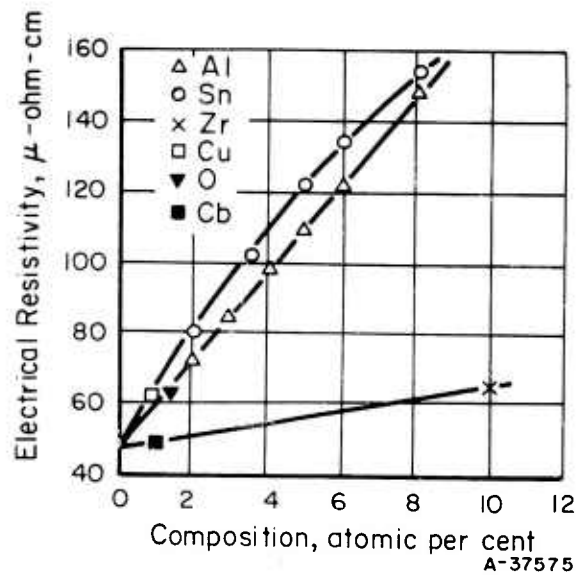


FIGURE 10. THE EFFECT OF VARIOUS ADDITION ELEMENTS ON THE RESISTIVITY OF α -TITANIUM AT ROOM TEMPERATURE⁽¹⁷⁾

the increase in resistivity of alpha titanium on alloying bears little or no relationship to the usually accepted valence of the added metal. They made the further observation that solute elements which lie close to titanium in the periodic table (i. e. , zirconium and columbium) result in a relatively small increase in the resistivity of titanium. On the other hand, the non-transitional elements appear to have a much greater effect.

In a similar study on binary alpha titanium-aluminum, titanium-gallium, and titanium-silver alloys, Denny⁽¹⁹⁾ observed discontinuities in the room-temperature resistivity curve for dilute solutions of aluminum and gallium in titanium. Neither Ames and McQuillan nor Sagel, et al.⁽²⁰⁾ (who also studied the resistivity of titanium-aluminum alloys containing up to 22 per cent aluminum), observed the change in slope of the titanium-aluminum resistivity curve found by Denny. The latter, however, also observed similar discontinuities in the magnetoresistance and lattice parameters of the titanium-aluminum and titanium-gallium alloys near the same composition range (2.3 to 3 atomic per cent). On the basis of this study, Denny concluded that titanium has approximately two electrons in anti-ferromagnetic coupling between neighboring atoms and about two electrons per atom in the conduction band. However, as discussed by Ames and McQuillan, the present state of knowledge of the electronic structure of titanium is still not sufficient to explain satisfactorily the anomalous effects of alloying on the resistivity of titanium.

The low temperature coefficient of beta titanium is also unusual. In normal pure metals, the resistivity approaches zero at absolute zero temperature. However, extrapolation of the beta-titanium resistivity curve to low temperatures indicates that this behavior would not be shown by titanium. A study of beta-stabilized titanium-columbium alloys by Ames and McQuillan⁽²¹⁾ tends to support this conclusion. Still later work⁽²²⁾ by the same authors on beta-stabilized titanium-hydrogen alloys showed that the resistivity of beta titanium decreased from the transition temperature (1620 F) to a minimum of about 140 $\mu\text{ohm-cm}$ at 1290 F, and then increased as the temperature was lowered to 750 F. The unusual electrical behavior of beta titanium is further demonstrated by the fact that, within certain composition ranges, the temperature coefficient of resistivity is negative in the titanium-molybdenum⁽²³⁾, titanium-vanadium⁽²⁴⁾, and titanium-columbium⁽²¹⁾ alloy systems.

An excellent compilation of the available resistivity data for commercial as well as experimental titanium alloys appeared in an earlier Defense Metals Information Center report.⁽⁹⁾

Magnetoresistance, Hall Coefficient, and Magnetic Susceptibility

Denny⁽¹⁹⁾ has studied the effects of small alpha-solute additions of aluminum, gallium, and silver on the magnetoresistance of titanium and of

aluminum and silver on the Hall coefficient and magnetic susceptibility of titanium. The results of this work are given in Tables 6 and 7 which also include data from other sources.

Denny found a sharp drop in the magnetoresistance of the aluminum and gallium (which are both trivalent elements) alloys at compositions of between 2 and 3 atomic per cent of each. Additions of silver, which is monovalent, depressed the magnetoresistance of titanium in a smooth, continuous curve. Neither aluminum nor silver, in amounts up to about 2.5 and 10.8 per cent, respectively, had any significant effect on either the Hall coefficient or magnetic susceptibility of alpha titanium.

Denny believes that the discontinuities in the slopes of the magnetoresistance curves of the titanium-aluminum and titanium-gallium alloys are related to the effect of solute valency. No explanation was offered as to why solute valency has no effect on the Hall coefficient or magnetic susceptibility of titanium.

However, at higher aluminum contents, Munster, et al.,⁽²⁸⁾ observed several peaks and valleys in the magnetic susceptibility versus titanium-aluminum composition curve. The values obtained from this work are also listed in Table 7. While no interpretation of these anomalous effects could be given, these changes in slope of the curve were later presented⁽²⁰⁾ as partial evidence for the existence of an ordered structure in the titanium-rich alpha solid solutions.

Trzebiatowski and Stalinski⁽²⁶⁾ investigated the effects of hydrogen and deuterium on the susceptibility of titanium. These workers found the susceptibility approximately proportional to hydrogen concentration in the range of (1) alpha solid solution and (2) alpha plus TiH. The properties of the titanium deuterides appeared quite similar to those of the corresponding hydrides. This work and that of Wohlfarth⁽³¹⁾ suggest that TiH₂, like titanium, is also antiferromagnetic.

CHEMICAL PROPERTIES

Corrosion Resistance

For most applications where corrosion is a prime factor, titanium is normally used in the unalloyed condition. In this form, it is outstanding in applications for marine and brine service. It has found application in handling the following media because of its superior resistance: (1) wet chlorine gas and solutions containing chlorine, (2) bleach solutions containing hypochlorous acid and hypochlorites, (3) nitric acid in the more concentrated

TABLE 6. MAGNETORESISTANCE AND HALL COEFFICIENTS OF
TITANIUM ALLOYS

Alloy Content, weight per cent	Magnetoresistance Coefficient, $B_t \times 10^{13}/\text{oersted}^2$	Hall Coefficient, volt-cm/amp/oersted $\times 10^{-13}$
Iodide Ti	6.6	1.82
0.26Al	7.0	--
0.83Al	8.6	1.90
1.07Al	8.8	--
1.25Al	9.2	--
1.52Al	8.8	--
1.80Al	3.9	--
1.99Al	2.5	1.73
2.51Al	1.4	1.51
3.97Al	1.5	--
0.40Ga	6.8	--
0.91Ga	7.2	--
0.95Ga	7.0	--
1.52Ga	7.2	--
1.54Ga	7.5	--
2.16Ga	6.9	--
2.35Ga	5.6	--
2.64Ga	2.6	--
2.94Ga	1.4	--
1.19Ag	4.0	--
2.42Ag	1.9	1.68
3.38Ag	1.6	--
4.27Ag	1.1	--
5.55Ag	1.7	--
6.45Ag	1.4	--
7.57Ag	1.5	1.44
8.46Ag	1.4	--

TABLE 7. MAGNETIC SUSCEPTIBILITY OF TITANIUM AND TITANIUM ALLOYS

Composition, weight per cent	Magnetic Susceptibility, cgs units $\times 10^6$, at Indicated Temperature, F										Reference	
	-300	-100	32	68	77	81	400	800	1200	1600		2000
Iodide Ti	-	-	-	-	3.17	-	3.36	-	-	-	-	25
Iodide Ti	-	-	-	-	3.31	-	-	-	-	-	-	19
Sponge Ti (99.5%)	3.03	3.09	-	3.18	-	-	3.39	-	-	-	-	26
Ti	1.70	1.25	1.25	1.25	-	-	-	-	-	-	-	27
Ti-0.83Al	-	-	-	-	3.27	-	-	-	-	-	-	19
Ti-1.0Al	-	-	-	2.75	-	-	-	-	-	-	-	28
Ti-1.52Al	-	-	-	-	3.24	-	-	-	-	-	-	19
Ti-1.99Al	-	-	-	-	3.22	-	-	-	-	-	-	19
Ti-2.51Al	-	-	-	-	3.21	-	-	-	-	-	-	19
Ti-3Al	-	-	-	2.50	-	-	-	-	-	-	-	28
Ti-7Al	-	-	-	2.25	-	-	-	-	-	-	-	28
Ti-8Al	-	-	-	4.00	-	-	-	-	-	-	-	28
Ti-9Al	-	-	-	2.35	-	-	-	-	-	-	-	28
Ti-12Al	-	-	-	2.25	-	-	-	-	-	-	-	28
Ti-18Al	-	-	-	4.60	-	-	-	-	-	-	-	28
Ti-20Al	-	-	-	4.40	-	-	-	-	-	-	-	28
Ti-22Al	-	-	-	5.00	-	-	-	-	-	-	-	28
Ti-30Al	-	-	-	3.50	-	-	-	-	-	-	-	28
Ti-36Al	-	-	-	3.95	-	-	-	-	-	-	-	28
Ti-40Al	-	-	-	3.15	-	-	-	-	-	-	-	28
Ti-2.42Ag	-	-	-	-	3.11	-	-	-	-	-	-	19
Ti-7.57Ag	-	-	-	-	3.14	-	-	-	-	-	-	19
Ti-10.5Ag	-	-	-	-	3.02	-	-	-	-	-	-	19
Ti-2.5H-2Si	-	-	-	-	-	3.78	-	-	-	-	-	29
Ti-2Si	3.1	3.2	-	3.3	-	-	3.4	3.7	4.0	4.5	5.2	30
Ti-2Si	-	-	-	-	-	3.2	-	-	-	-	-	29

range at elevated temperatures and including boiling dilute aqua regia, and (4) food processing solutions containing tomatoes and pickles.

Titanium has fair resistance to some of the mineral acids. Among the comparatively few substances capable of causing severe attack on metallic titanium are the mineral and organic acids, including hydrofluoric, sulfuric, hydrochloric, oxalic, and formic, and the extremely corrosive compound aluminum chloride. As pointed out by A. D. and M. K. McQuillan⁽³²⁾, in each case the corrosive action of the above named media can be traced to their ability to attack the otherwise extremely tenacious protective film covering the titanium surface. Frequently, the corrosive effects of these media are minimized or even prevented by the presence of oxidizing agents which maintain the passive oxide film on the metal. For example, the presence of ferric ions will noticeably reduce the attack of titanium in hydrochloric and sulfuric acid solutions. Under similar conditions, stainless steel would be severely corroded. It is of practical interest here, however, to review how alloying additions to titanium affect its corrosion behavior in these media in the absence of inhibiting additions.

A good general picture of these alloying effects is possible due to the very extensive studies of Yoshida, Okamoto, and Araki.^(33,34,35) These workers prepared binary alloys of aluminum, tin, copper, silver, chromium, molybdenum, tungsten, manganese, iron, cobalt, nickel, and silicon with titanium. Each of the alloys was prepared in the same manner (hot rolled and finished as cold-rolled sheet) and tested in the same media under identical conditions. The general results of this work are summarized in Table 8 which also contains some data on titanium-zirconium, titanium-vanadium, titanium-columbium, titanium-tantalum, and titanium-beryllium alloys from the work of Rüdiger, et al.⁽³⁶⁾ Representative curves showing the effect of alloy composition in various concentrations of selected acids are given in Figure 11. Similarly, typical corrosion rates for a variety of alloys in boiling 10 per cent HCl and/or 15 per cent H₂SO₄ are listed, for purposes of comparison, in Table 9 and Figure 12.

Of the various alloy additions, only molybdenum, platinum, and palladium are known to improve the corrosion resistance of titanium to both hot and cold solutions of H₂SO₄ and HCl. Molybdenum also appears to be the only addition element which affords protection of titanium to saturated oxalic acid solutions. As indicated by the curves in Figure 11, a minimum of about 30 per cent molybdenum is required for optimum corrosion resistance to H₂SO₄ and HCl. On the other hand, additions of as little as 0.1 per cent of platinum or palladium appear almost as effective in improving the corrosion resistance of titanium to boiling HCl (compare data of Table 9 with Figure 12).

Aqua regia is about the only solution in which the Ti-30Mo alloy appears less corrosion resistant than titanium. Here, as shown in Figure 11, chromium additions appear most effective. From Table 8, it appears that nickel is the only addition element effective in improving the

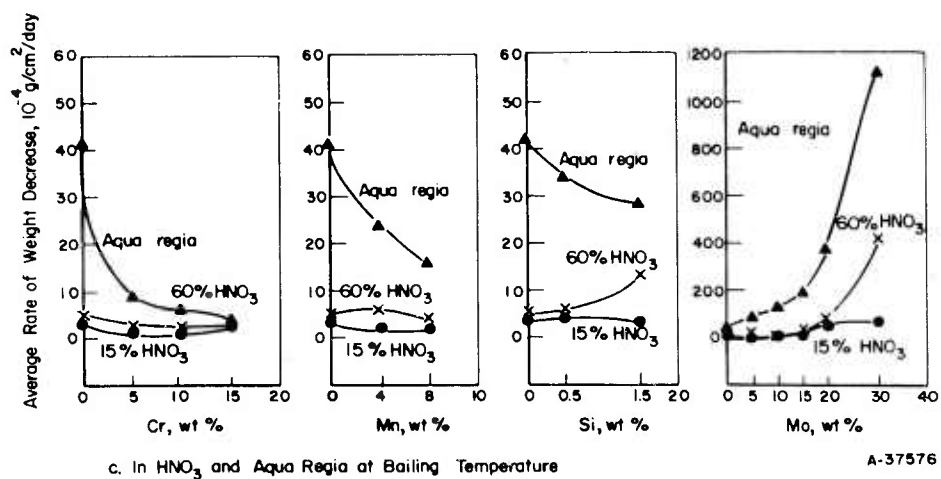
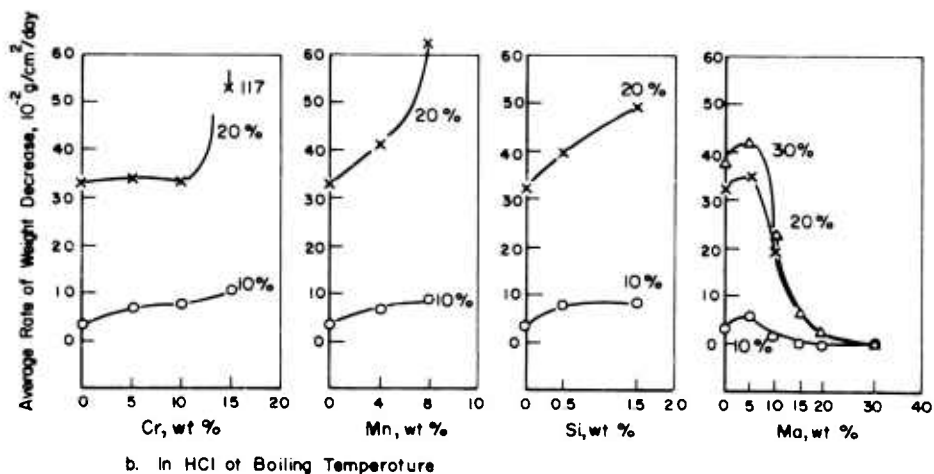
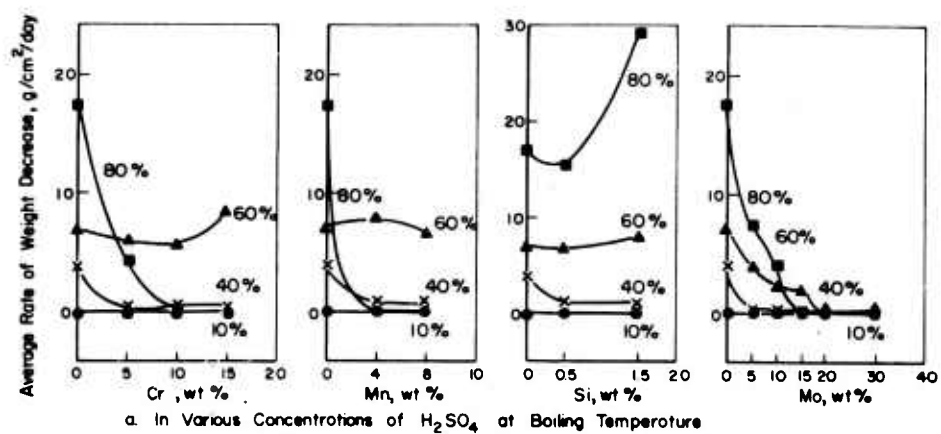
TABLE 8. EFFECTS OF VARIOUS BINARY ALLOY ADDITIONS ON THE CORROSION RESISTANCE OF TITANIUM^(a)

Alloy Content, weight per cent	H ₂ SO ₄ , 10-80%		HCl, 10%, 20%		Aqua Regia, Boiling	Saturated Oxalic Acid		Saturated AlCl ₃ , Boiling	Formic Acid, 25% Boiling	References
	RT	Boiling	RT	Boiling		RT	Boiling			
<u>Alpha Stabilizers</u>										
1-5Al	0	0	-	-	0	0	-	+	0	33
5-15Sn	-	-	-	-	-	-	-	+	-	35
1-50Zr		+(b)		+(c)						36
<u>Beta Stabilizers</u>										
4-8Cu	-	+	-	-	-	-	-	0	0	35
4-8Ag	-	+	-	-	-	0	-	+	0	35
1-50V		+(b)		+(c)						36
2-10Cb		-(b)		-(c)						36
2-10Ta		0 ^(h)		+(c)						36
5-15Cr	-	+	-	-	++	0	-	++	0	34
5-30Mo	++	++	++	++	-	+	++	++	0	34
5-10W	-	-	0	-	-	-	-	+	0	35
4-8Mn	-	+	-	-	+	-	-	++	0	34
5-15Fe	-	+	-	-	0	-	-	0	-	35
4-8Co	-	-	-	-	-	-	-	0	-	35
1-10Ni	-	-	-	-	-	0	-	+	+	33
<u>Compound Formers</u>										
2-10Be		-(b)		-(c)						36
0.5-1.5Si	-	0	-	-	+	-	-	++	0	34

(a) Terminology: ++ Corrosion resistance much improved
 + Corrosion resistance improved
 0 Corrosion resistance not significantly changed
 - Corrosion resistance decreased.

(b) 10 per cent solution only.

(c) 15 per cent solution only.



A-37576

FIGURE 11. COMPARATIVE CORROSION RESISTANCE OF TITANIUM-CHROMIUM, TITANIUM-MANGANESE, TITANIUM-SILICON, AND TITANIUM-MOLYBDENUM ALLOYS TO MINERAL ACIDS⁽³⁴⁾

TABLE 9. CORROSION RESISTANCE OF SELECTED ALLOYS TO
10 PER CENT HCl AND 15 PER CENT H₂SO₄⁽³⁶⁾

Alloy Composition, weight per cent	Rate of attack, mm/yr	
	10 Per Cent Hydrochloric Acid (Boiling)	15 Per Cent Sulfuric Acid (Boiling)
Pure titanium	60	95
2-10Cu	230 to > 250	95-20
1-10Ag	70-190	130-180
6Ag, 3Al	140	180
4Ag, 6Al	115	160
2-10Be	> 200	> 200
1-10Al	70 to > 150	120 to > 150
4Al, 4V	--	90
6Al, 4V	--	70
1-50Zr	50-5	90-8
1-50V	65-20	100-15
2-10Cb	80-200	105-230
2-10Ta	60-50	95-50
1-10Cr	90-165	130-215
5Cr, 3Al	140	200
20Mo	0.2	0.2
30Mo	<0.1	<0.1
2-10Fe	> 200	> 200
2-10Co	235 to > 300	200 to > 270
2-10Ni	170 to > 200	> 200
Hastelloy C	40	1.5

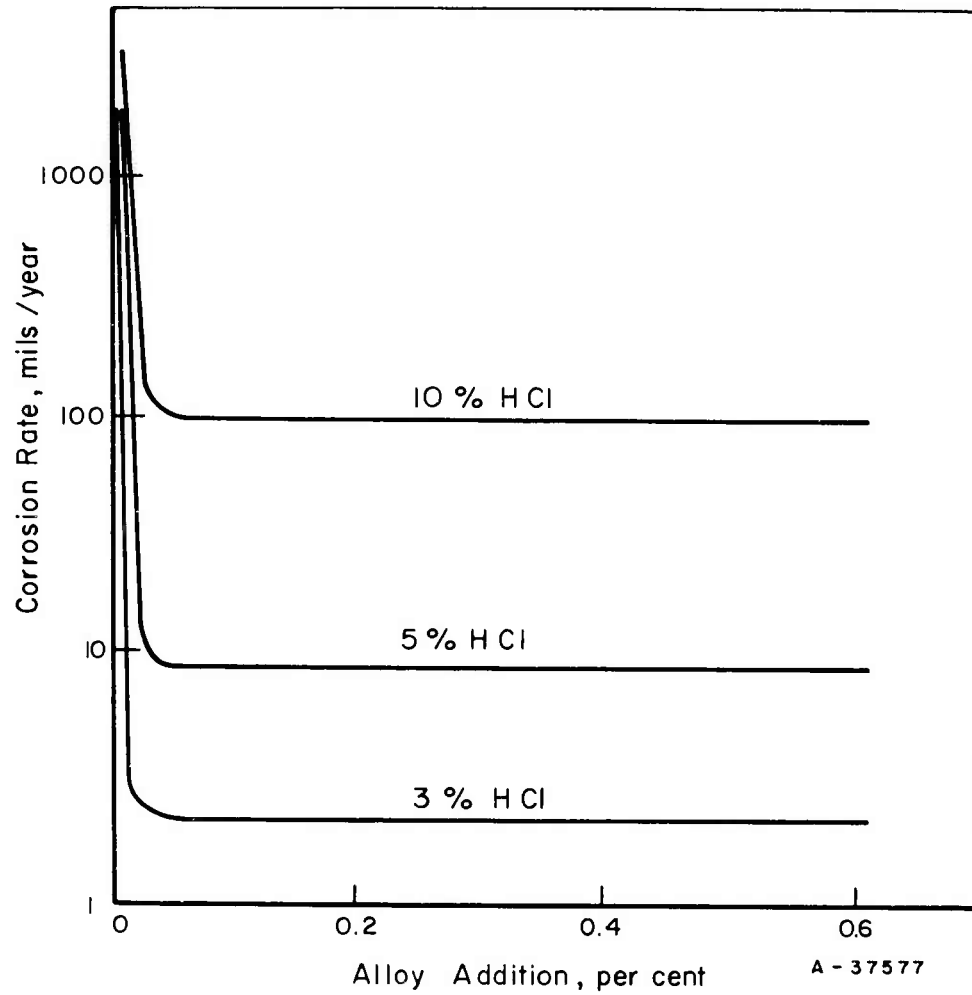


FIGURE 12. EFFECT OF PLATINUM AND PALLADIUM ADDITIONS ON CORROSION RATE OF TITANIUM IN BOILING HYDROCHLORIC ACID SOLUTIONS⁽³⁷⁾

resistance of titanium to boiling 25 per cent formic acid. On the other hand, most of the binary addition elements investigated improved the resistance of titanium to AlCl_3 , the most effective of these being chromium, molybdenum, manganese, and silicon.

Generally, those metals which are most noble against acid attack are also those which improve the corrosion resistance of titanium to these same media (e. g. , zirconium, tantalum, molybdenum, platinum, and palladium). Also, excepting platinum and palladium, appreciable amounts of these alloying additions appear to be required to effect a significant degree of improvement in the corrosion resistance of titanium. It is of interest to note that, of the beta-isomorphous elements studied, only vanadium and molybdenum were used in amounts large enough to obtain single-phase beta alloys. Columbium and tantalum, which are also isomorphous with beta titanium, also show good resistance to acid solutions, particularly HCl. Presumably, therefore, single beta-phase titanium-columbium and titanium-tantalum alloys might be expected to show a degree of corrosion resistance similar to that obtained in the Ti-30Mo alloy.

The influence of alloy microstructure on the corrosion resistance of titanium alloys has not been studied in any detail, and the results which have been obtained are largely negative. Thus, Battelle(38) found that additions of manganese to commercial titanium increased its corrosion rate in HCl regardless of the relative amounts of the alpha and beta phases present. Nevertheless, selective attack on either the beta phase or the alpha-beta interface has been observed in several instances of stress-corroded titanium alloys. (39)

Unalloyed titanium and most, if not all, of the commercial titanium alloys are susceptible to stress corrosion by certain media. Solid sodium chloride and red fuming nitric acid (containing less than 1.5 per cent water) appear especially detrimental and can cause failure of titanium and such alloys as Ti-5Al-2.5Sn, Ti-6Al-4V, and Ti-2Fe-2Cr-2Mo under certain conditions of stress and temperature. Also, instances of stress corrosion in the Ti-5Al-2.5Sn alloy by hydrochloric acid solutions and in the Ti-8Mn and Ti-4Al-4Mn alloys by molten cadmium have been encountered. Similarly, unalloyed titanium and several commercial alloys (including Ti-6Al-4V, Ti-5Al-2.5Sn, Ti-2Fe-2Cr-2Mo, and Ti-8Mn) are also susceptible to a spontaneous, pyrophoric, explosive reaction in red fuming nitric acid. Catastrophic failure of an unalloyed titanium part in a uranyl sulfate solution under an oxygen atmosphere has also been reported. A detailed account of these case histories was given in two earlier Defense Metals Information Center reports. (38, 40)

In regard to selective chemical attack, the possibility exists that alloying additions may produce a significant potential difference between the alpha and beta phases which may, in turn, be quite helpful in explaining the corrosion and stress-corrosion behavior of alpha-beta alloys. An electrochemical theory along these lines has been proposed by Sterns(37)

to explain the role of platinum and palladium additions in providing passivity to titanium exposed in reducing corrosive environments. According to this theory, the noble metal is essentially insoluble in the corrosive environment and has a high exchange current for the hydrogen-ion reduction process. When added to titanium, the noble-metal addition appears at the alloy surface to create a galvanic couple which acts as a site with a low hydrogen overvoltage. This results in passivity with a marked decrease in corrosion rate.

The commercial application of some of these alloying effects is in the process of development and evaluation.

Gas-Metal Reactions

Oxygen, Nitrogen, and Air

The reactions of unalloyed titanium with oxygen, nitrogen, and air have been studied in some detail and a great deal is known concerning the kinetics and mechanisms involved in these reactions. For background purposes, this information is summarized briefly in the following paragraphs on the basis of a review by Albrecht. (41)

Unalloyed titanium reacts readily with oxygen at all temperatures. At temperatures from 25 to 350 C (75 to 660 F), this reaction follows a logarithmic rate law which changes to a cubic rate law at a temperature around 350 C (660 F). At higher temperatures, 650 to 825 C (1200 to 1515 F) the oxidation follows a parabolic rate law. With increasing time at 650 C or increasing temperatures above 825 C, the reaction is best described by a linear law.

The thin, self-healing oxide film which forms at temperatures up to about 550 C (1020 F) is quite protective and results in decreasing weight gains with continued exposure. Because the diffusion rate of oxygen is low at these temperatures, the reaction is limited to a thin surface layer under most practical conditions of heat treatment or exposure. At temperatures in the range of 550 to 650 C, the surface oxide becomes more porous and nonadherent. Further, since the diffusion rate of oxygen increases rapidly with temperature, the inward diffusion of oxygen through the scale becomes a serious problem.

The reactions of unalloyed titanium with nitrogen and air are similar to those which occur with pure oxygen. Although titanium reacts with nitrogen, the reaction is considerably slower than that with oxygen. (42) For these and other reasons, the reaction of titanium with oxygen is regarded as the rate-controlling process in hot-air reactions, and it has generally been assumed that the same laws apply to the oxidation of titanium in air as in pure oxygen.

Surprising as it may seem, no systematic study has been published on the effects of alloying on the kinetics or mechanisms involved in the reactions of oxygen, nitrogen, or air with titanium. However, several laboratories have conducted preliminary-type oxidation tests on a large number of titanium alloys. In all of this work, air has been the oxidation medium. The results of this work are summarized as follows.

Binary Alloys With Alpha Stabilizers (Aluminum, Antimony, Tin, or Zirconium). Increasing additions of aluminum to titanium improve its resistance to oxidation in hot air, both in terms of reducing its scaling rates as well as increasing its resistance to oxygen penetration. Unfortunately, however, the degree of improvement obtained by aluminum in the workable range of alloys (a maximum of about 8 per cent aluminum) is only slight. Thus, as indicated by the data in Figure 13, the oxidation behavior of alloys containing up through 2 per cent aluminum is not significantly different from that of the unalloyed metal. However, the oxidation resistance of the single gamma-phase titanium-aluminum alloy (containing from 33 to 46 per cent aluminum) is the most outstanding of all known binary titanium-base alloys. As shown by the data in Figures 14 and 15, such alloys not only have low scaling rates but also resist inward diffusion of oxygen after exposures up to 24 hours at a temperature up to 1920 F (1050 C). Work by McAndrew and Kessler⁽⁴³⁾ has indicated that small amounts of various ternary additions result in further slight improvements in the oxidation resistance of the single-phase-gamma alloy. Unfortunately, however, neither the single-gamma-phase binary alloys nor any of the ternary alloys based on this phase are hot workable.

As shown by the data in Table 10, additions of 5 to 15 per cent of antimony or tin to titanium increase the weight gained upon exposure to

TABLE 10. OXIDATION DATA FOR ALLOYS HEATED 4 HOURS AT 1050 C (1920 F) IN AIR AND FURNACE COOLED^(46,47)

Composition (Balance Titanium), per cent	Weight Gain, g/dm ²	Metal Thickness Loss, mils	Depth of Contamination, mils	Increase in VHN 5 Mils Below Surface
100Ti	3.5	10	60	240
5Sb	4.7	5	60	200
10Sb	4.4	4	40	110
15Sb	7.0	7	Nil	Nil
5Sn	15.5	18	40	60
10Sn	13.5	19	Nil	Nil
15Sn	11.9	18	Nil	Nil

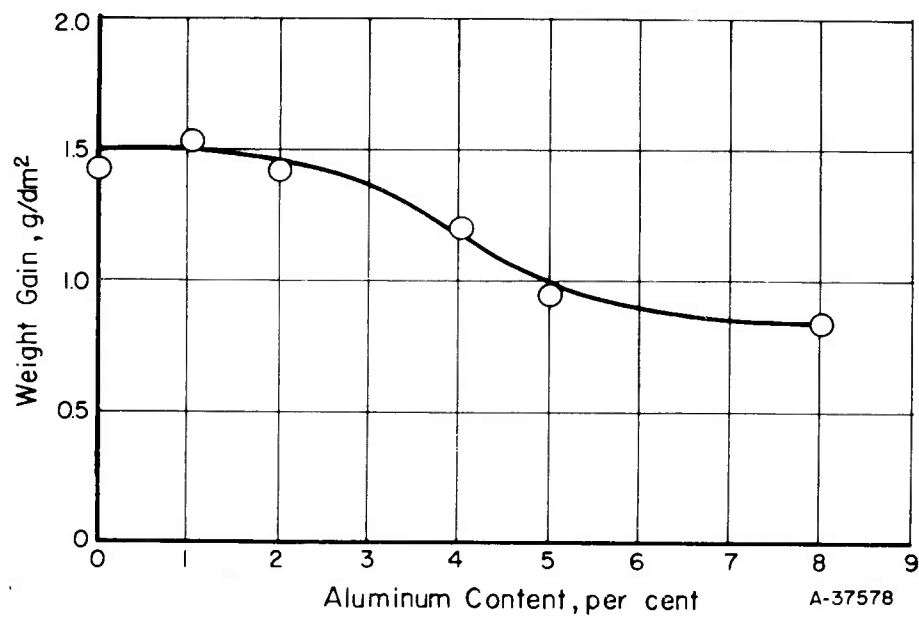
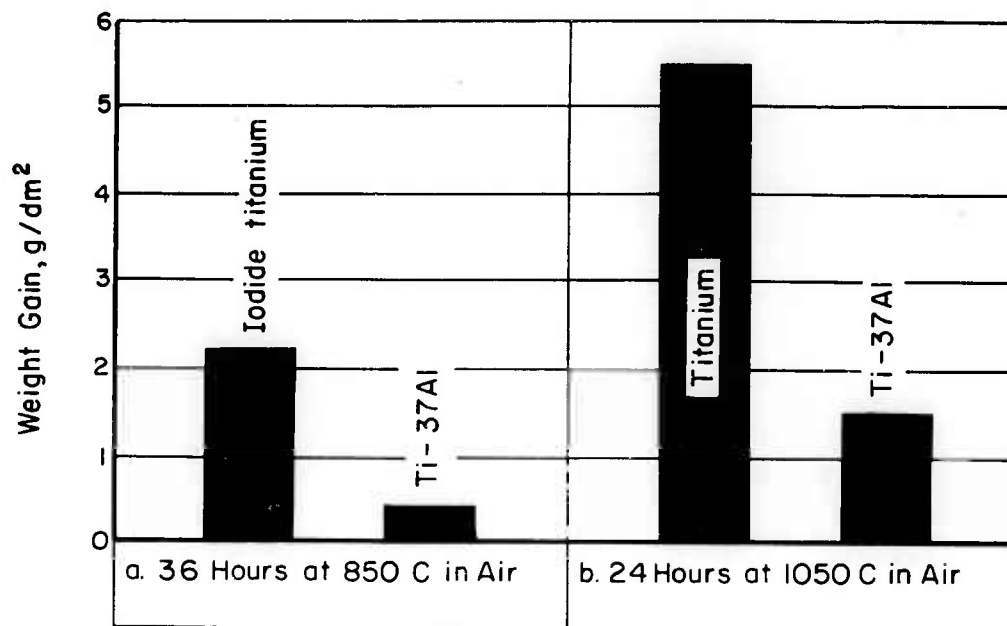
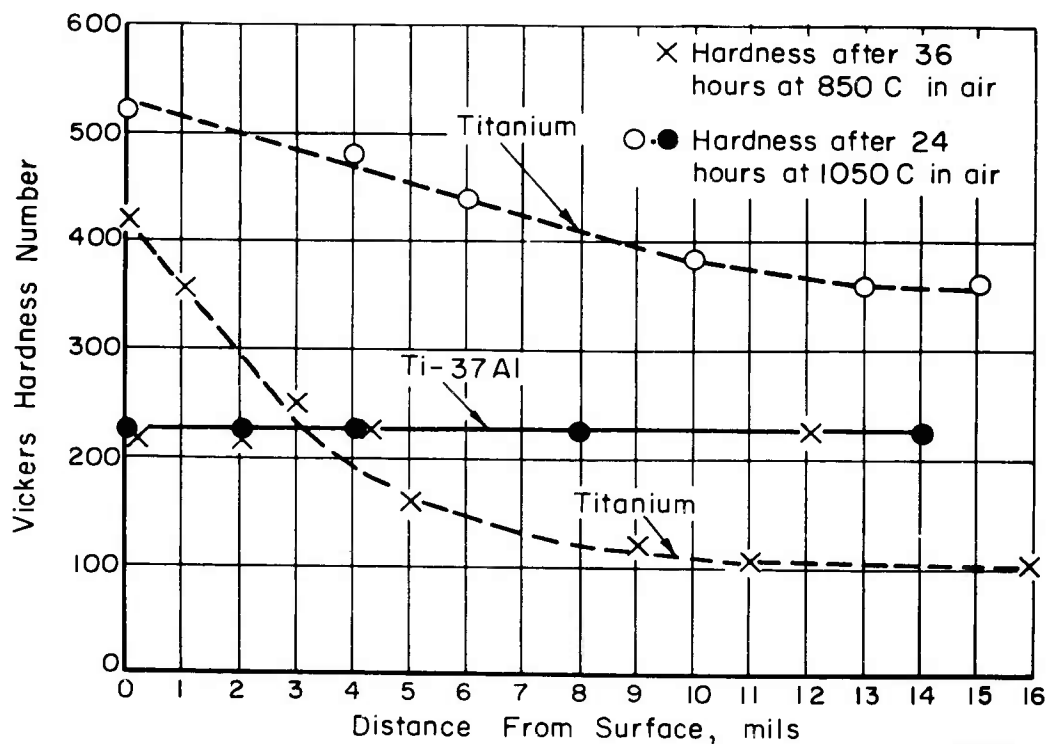


FIGURE 13. WEIGHT GAIN FOR TITANIUM-ALUMINUM ALLOYS HEATED IN AIR FOR 24 HOURS AT 850 C⁽⁴⁵⁾



A-37579

FIGURE 14. WEIGHT-GAIN DATA FOR A GAMMA-PHASE IODIDE TITANIUM-37 PER CENT ALUMINUM ALLOY⁽⁴⁵⁾



A-37580

FIGURE 15. HARDNESS DATA FOR A GAMMA-PHASE IODIDE TITANIUM-37 PER CENT ALUMINUM ALLOY⁽⁴⁵⁾

1050 C (1920 F) in air. While these titanium-antimony alloys show slightly lower metal losses than unalloyed titanium, the titanium-tin alloys show appreciably higher metal losses. The most important observation regarding both antimony and tin additions, however, is that, with alloy contents above about 15 per cent antimony or 10 per cent tin, no significant contamination hardening occurs.

Binary alloys of titanium and zirconium apparently show much poorer resistance to oxidation than is shown by either of these metals alone. Thus, Hayes, et al.,⁽⁴⁴⁾ have observed that the resistance of titanium-zirconium alloys becomes "progressively worse as the 34.5 (50 atom) per cent composition is approached". Alloys containing 25 to 45 per cent titanium were reduced to powder after 24 hours in air at 1200 F.

Binary Alloys With Beta Stabilizers (Columbium, Cobalt, Chromium, Iron, Manganese, Molybdenum, Nickel, Tantalum, Vanadium, and Tungsten. The effects of a number of beta-stabilizing alloying additions on the scaling rate of titanium in air at various temperatures are summarized in Figure 16.

Of the various alloys depicted, only those containing 1 to 4.5 per cent of columbium, tantalum, and tungsten or 1.19 per cent molybdenum show significantly lower weight losses than titanium at temperatures above 1400 F.* As indicated by the weight-gain curves in Figure 17 for the titanium-tantalum alloys, the beneficial action of these elements probably results from an alteration in the characteristics of the surface oxide which forms. Both the titanium-tantalum and titanium-tungsten alloys form surface oxides which are partially protective to titanium at temperatures above 1400 F, while the unalloyed metal oxidizes at a nearly linear rate. It is important to note, however, that even though these elements (columbium, tantalum, tungsten, and molybdenum) reduce the scaling rate of titanium in air, apparently none of them is effective in reducing the diffusion rate of oxygen into titanium. This is evident from hardness-contamination data obtained on oxidized samples of both titanium-tantalum (see Figure 18) and titanium-tungsten alloys.⁽²⁾

Additions of 1 to 4 per cent of cobalt, nickel, manganese, vanadium, iron, or chromium (in the approximate order listed) generally result in increasing the scaling losses of titanium. At higher alloying levels, the same approximate order of effect of these elements on scaling rate exists, as shown in Figure 19. The effect of small binary chromium additions appears exceedingly detrimental to the weight loss of titanium heated in air, as originally shown by McPherson and Fontana.⁽⁴⁸⁾

*The effect of silicon is described in the following section of this report.

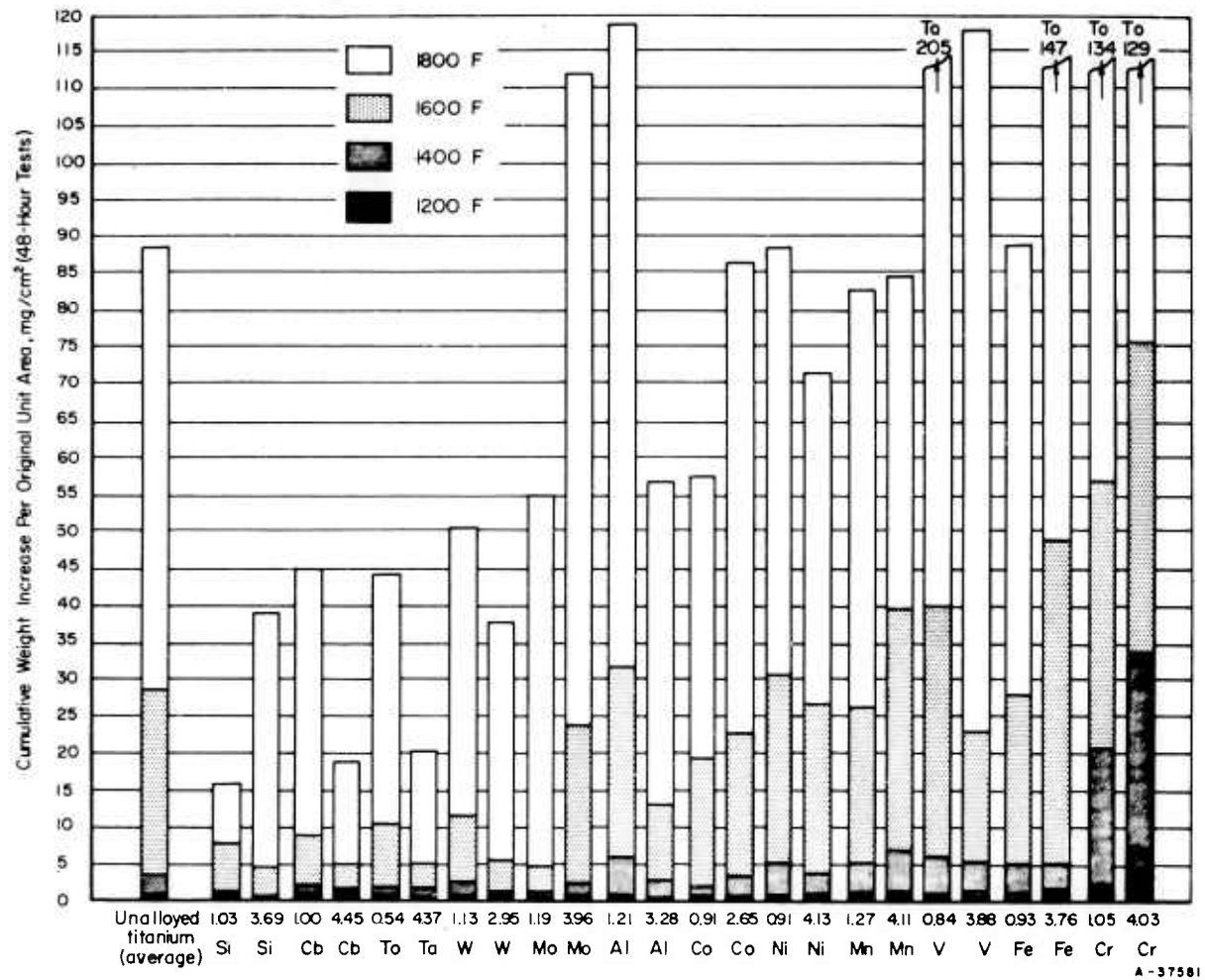


FIGURE 16. A COMPARISON OF THE SCALING RATES IN AIR OF VARIOUS EXPERIMENTAL BINARY TITANIUM ALLOYS⁽⁴⁹⁾

Compositions in per cent.

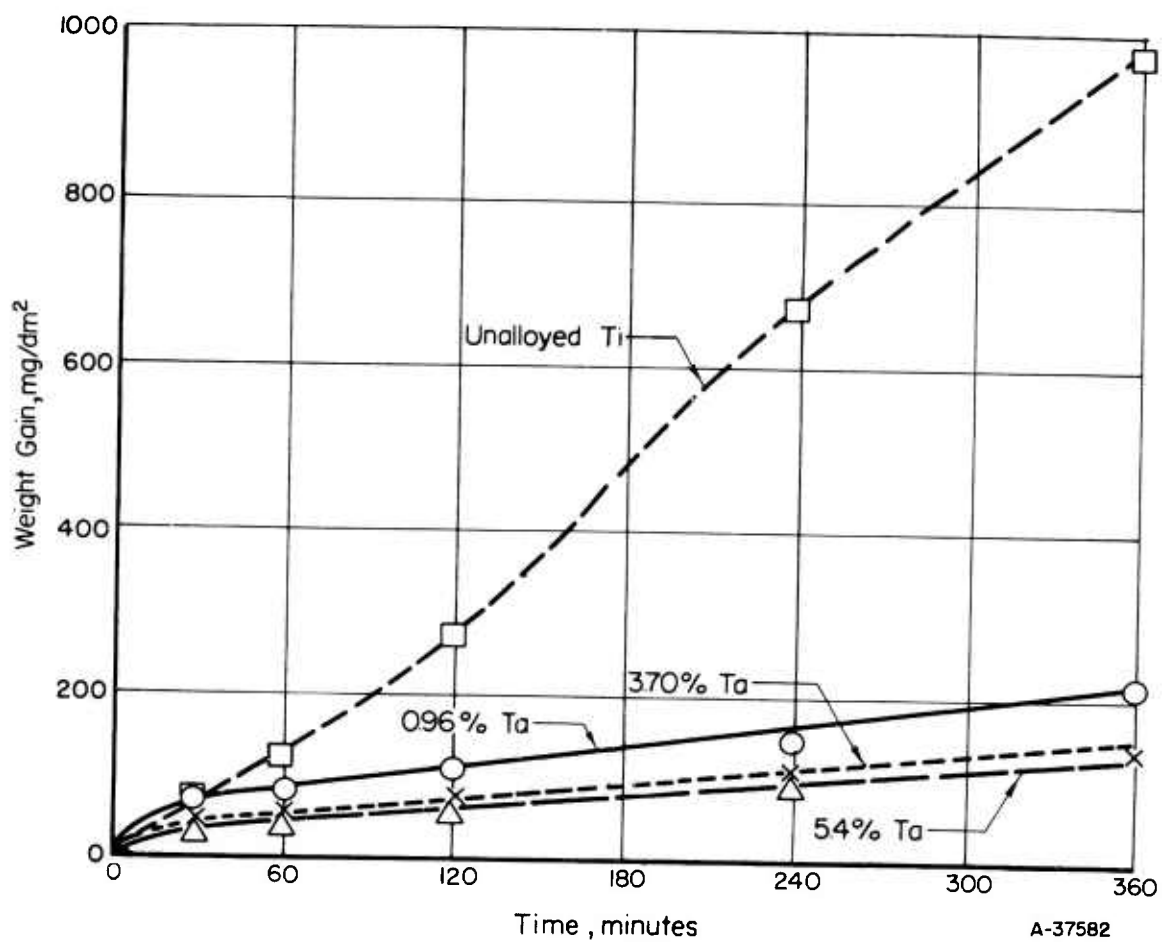


FIGURE 17. WEIGHT-CHANGE DATA FOR IODIDE TITANIUM-TANTALUM ALLOYS IN STILL AIR AT 900 C (1652 F)⁽²⁾

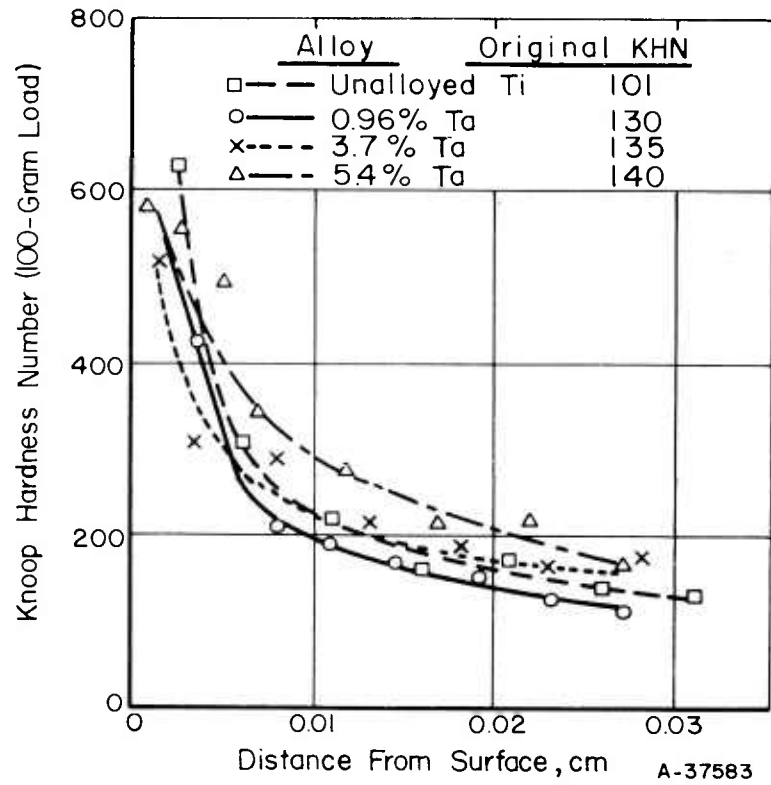


FIGURE 18. HARDNESS-CONTAMINATION CURVES IN TITANIUM-TANTALUM ALLOYS EXPOSED 6 HOURS AT 900 C (1652 F) IN STILL AIR⁽²⁾

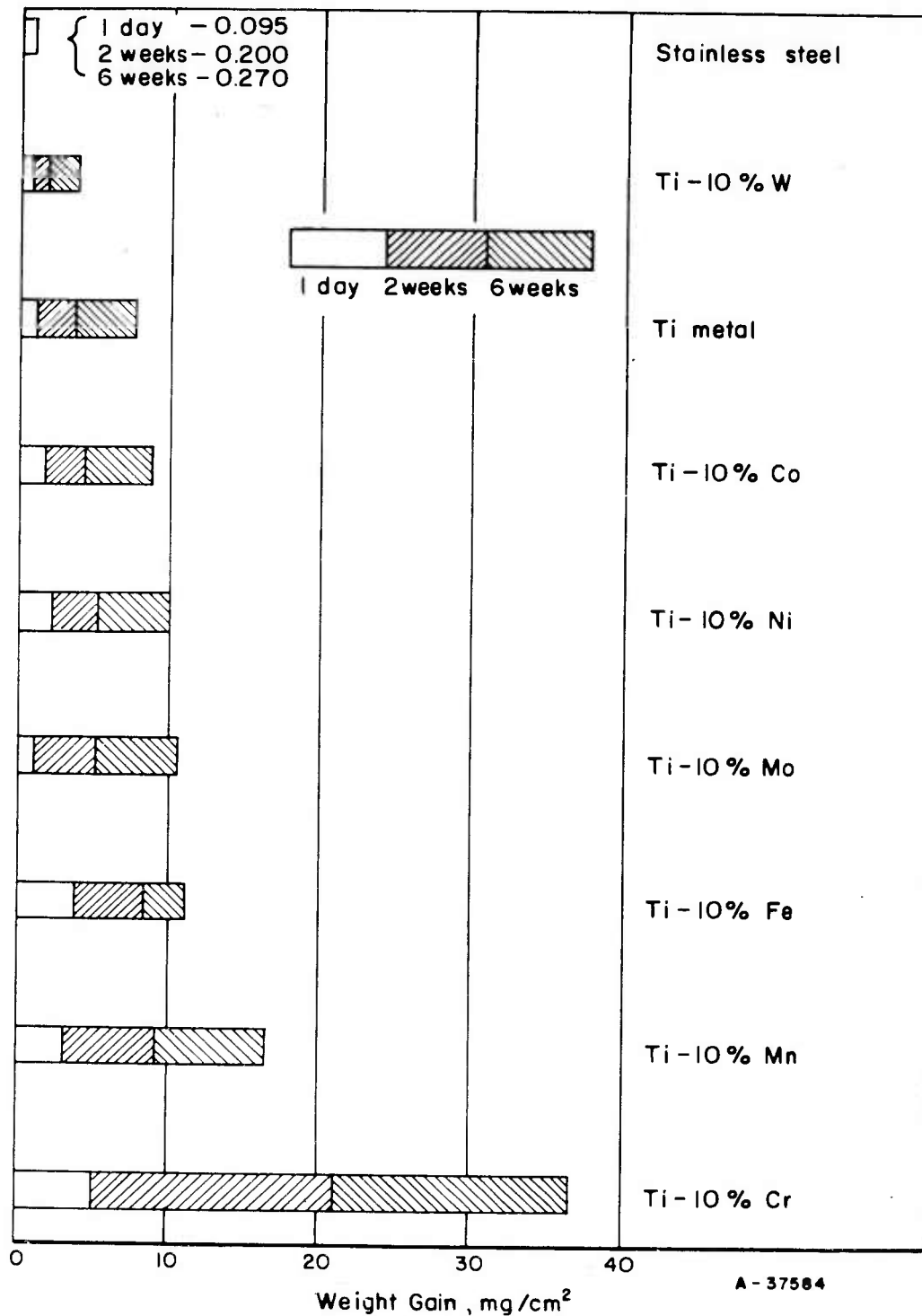


FIGURE 19. RELATIVE WEIGHT GAIN IN AIR OF BINARY ALLOYS OF TITANIUM AT 730 C (1350 F)⁽⁵⁰⁾

Binary Alloys With Miscellaneous Elements (Silicon and Rare Earths).

On the basis of weight-gain data, silicon appears to be the most effective single binary addition element in reducing the oxidation rate of titanium. This is indicated by the comparative data given in Figure 16. Further, Sutcliffe⁽⁵¹⁾ has shown (Figure 20) that the addition of as little as 0.28 per cent silicon substantially reduces the weight gained by titanium in flowing air at 800 C (1470 F) over periods up to 250 hours. Increasing the silicon content to 4.6 per cent resulted in further lowering of the weight gains and appeared to improve the adherence of the surface oxide which formed at 1000 C (in 3-hour exposures) as well as that which formed at 800 C. As in the case of binary tantalum and tungsten alloys, silicon additions appear to promote the formation of a protective scale.

The effects of cerium, lanthanum, neodymium, and thorium, at alloying levels around 1 per cent, on the air oxidation rates of titanium in the range of 650 to 980 C (1200 to 1800 F) have been investigated.⁽⁴⁹⁾ Generally, binary additions of these elements result in a slight lowering of the scaling rate of titanium at temperatures up through 1600 F. However, none of these additions appear so effective as silicon, columbium, tantalum, or tungsten.

Ternary and More Complex Alloys. The scaling rates of a large number of ternary and more complex alloys, including several commercial alloys, have been investigated in air from 650 to 980 C (1200 to 1800 F).⁽⁴⁹⁾ Generally, this work indicates that those elements which reduce the scaling rate of titanium as binary additions are even more effective in ternary or more complex combinations. Thus, as indicated by comparisons of Figure 21 with Figure 16, alloys containing combinations of tantalum, columbium, silicon, tungsten, aluminum, and molybdenum show weight losses which are among the lowest observed for any workable titanium-base alloys. Conversely, ternary alloys containing combinations of iron, manganese, chromium, or vanadium (which are not effective, as binary additions, in lowering weight losses) showed no better, or worse, behavior than unalloyed titanium.

It is again pertinent to mention that in the above-described work, weight change alone was used as the criterion of alloy behavior.

A more intensive investigation of the hot-air oxidation behavior of commercial titanium and two commercial alloys (Ti-5Al-2.5Sn and Ti-4Al-4Mn) has shown that, of the three materials, the Ti-5Al-2.5Sn alloy has the greatest resistance to contamination at temperatures above 870 C (1600 F).⁽⁵²⁾ Below this temperature, commercial titanium and the Ti-5Al-2.5Sn are about equal in this respect. Figure 22 illustrates the comparative behavior of these materials. The contamination resistance of the alpha-beta Ti-4Al-4Mn alloy is inferior to that of the two alpha alloys up to about 925 C (1700 F) where its oxidation resistance improves over that

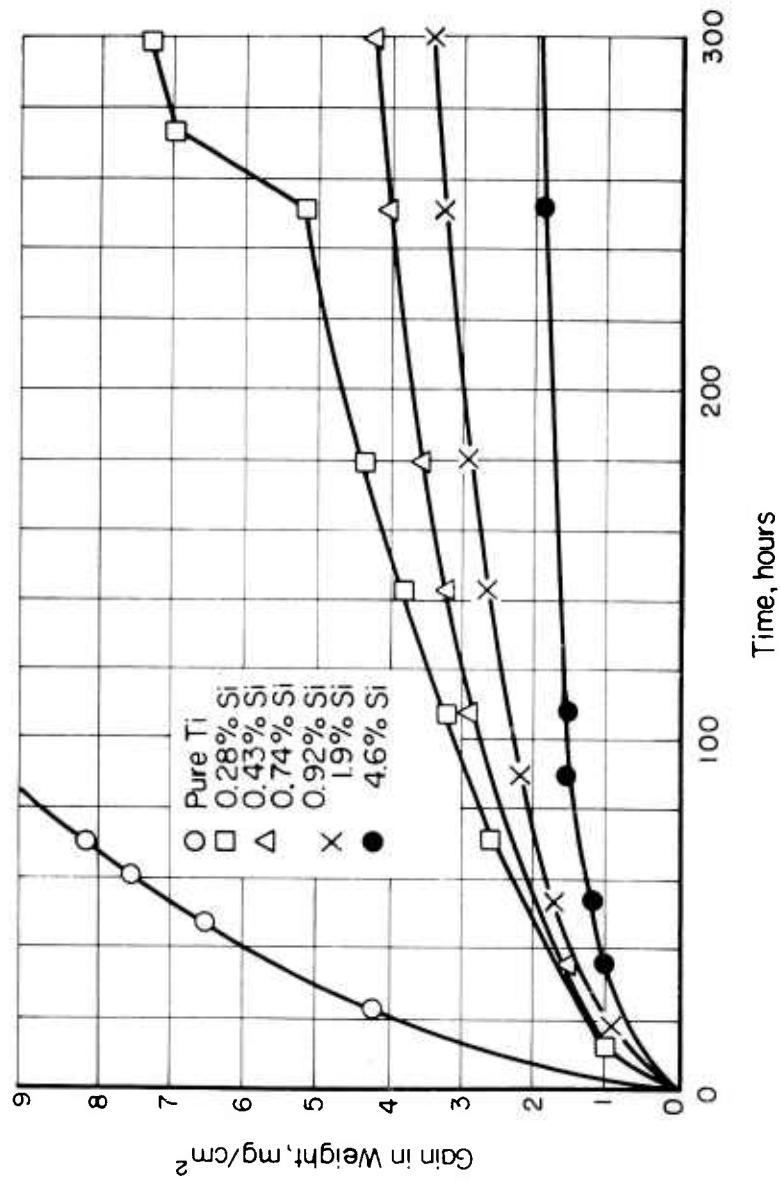
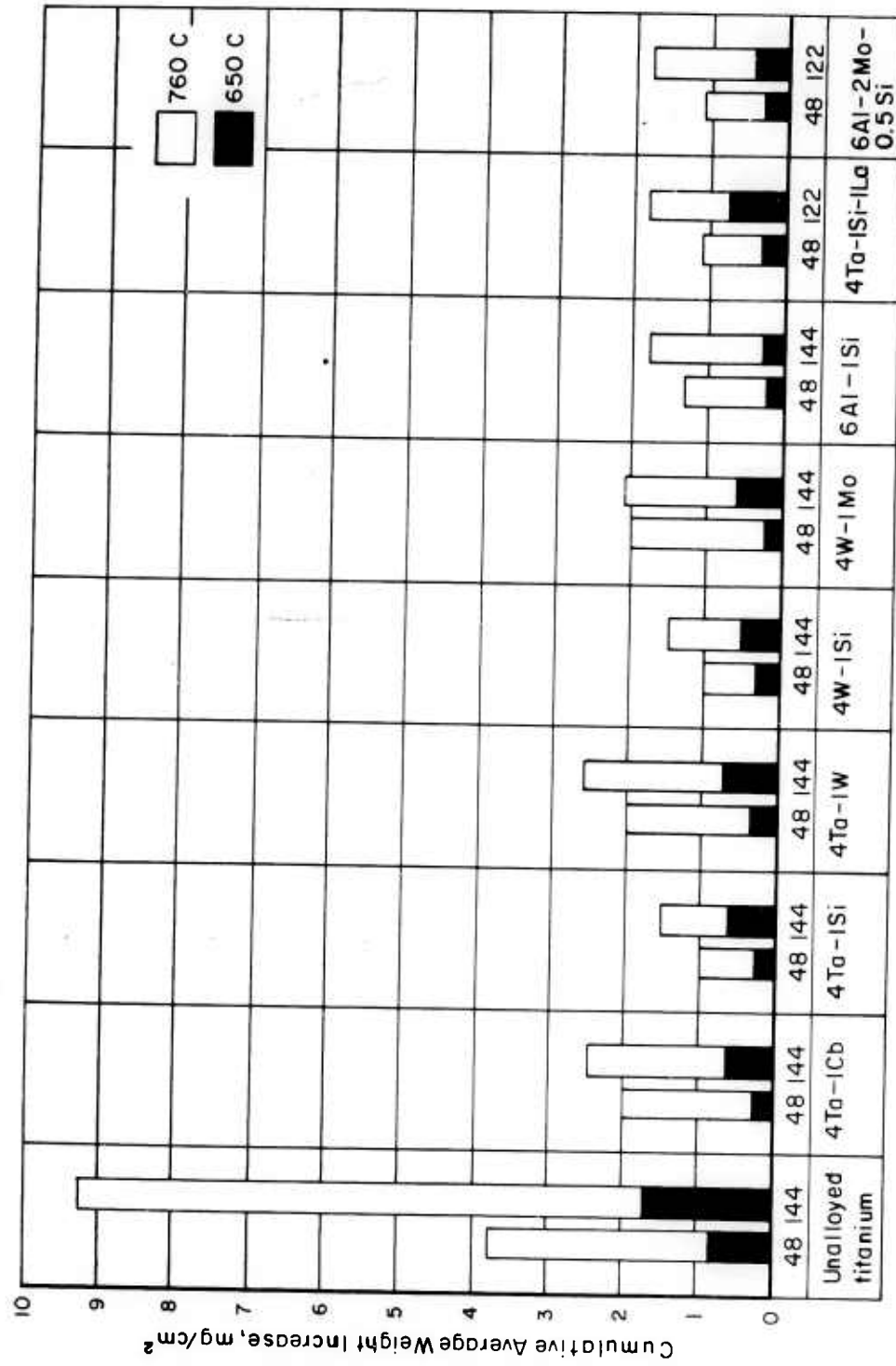


FIGURE 20. OXIDATION RATES OF TITANIUM-SILICON ALLOYS AT 800 C⁽⁵¹⁾



A-37586

FIGURE 21. CUMULATIVE WEIGHT INCREASE IN AIR AFTER 48 AND 144 (OR 122) HOURS FOR VARIOUS EXPERIMENTAL TERNARY AND QUATERNARY TITANIUM ALLOYS AT 650 C AND 760 C(49)

of unalloyed titanium but not over that of the Ti-5Al-2.5Sn alloy. Although the latter alloy shows the greatest resistance to contamination hardening, it also shows appreciably higher scaling losses above about 980 C (1800 F). This free-scaling behavior apparently results from the tin addition which is also believed to be instrumental in limiting the contamination of the alloy.

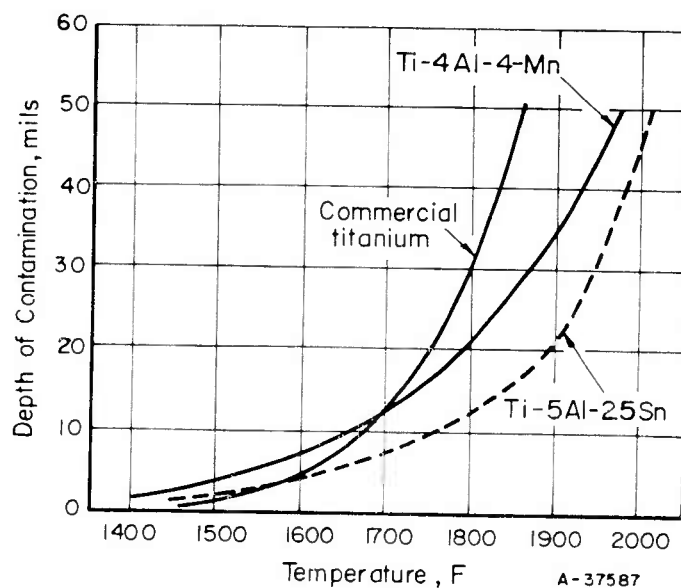


FIGURE 22. A COMPARISON OF THE CONTAMINATION OF COMMERCIAL TITANIUM, Ti-5Al-2.5Sn, AND Ti-4Al-4Mn AFTER A HYPOTHETICAL EXPOSURE OF 10 HOURS IN AIR⁽⁵²⁾

The criterion for each alloy is a hardness increase of 75 Knoop points.

Several ternary Ti-(5-15)Sn-base alloys containing 2.5 to 15 per cent of tantalum, tungsten, columbium, vanadium, aluminum, molybdenum, iron, chromium, or manganese were found to display the same high degree of contamination resistance to 1050 C (1920 F) air as did binary titanium-tin alloys.⁽⁴⁷⁾ All of these alloys were relatively free-scaling with the exceptions of a Ti-5Sn-2Al and the Ti-(5-15)Sn-10Cr alloys. The oxidation resistance of the latter alloys was outstanding; not only did they have an adherent scale (after 4 hours' exposure in 1050 C), but they also suffered little loss by oxidation and no noticeable contamination as measured by hardness.

Alloy Oxidation Behavior Summarized. Within the range of workable titanium alloys, about six alloy additions have been found which significantly

improve the scaling resistance of titanium to air at 650 to 980 C (1200 to 1800 F). These include silicon, columbium, tantalum, tungsten, molybdenum, and aluminum (Group A) listed in approximate order of decreasing effectiveness. Most of the other binary addition elements investigated were not effective in reducing the weight loss of titanium or actually increased it. These elements (Group B) include cobalt, nickel, manganese, vanadium, iron, and chromium (increasing weight gains in the order listed) as well as tin, antimony, and zirconium which, as binary additions, result in free-scaling alloys with very high weight losses.

Ternary or more complex alloys appear to show oxidation resistance (in terms of weight gains) which is roughly additive on the basis of the effect of individual alloy constituents as binary additions. Thus, the lowest weight gains are observed in ternary or more complex alloy combinations of the Group A (see above) elements, each of which by themselves is beneficial. Also, the combination of Group A with Group B elements tends to improve the scaling resistance over that shown by the Group B elements alone or in combination with each other. The most notable exception to this rule is the behavior shown by ternary alloy combinations of Ti-(5-15)Sn-10Cr, which not only show low weight losses but, perhaps more significantly, also appear to be highly resistant to contamination hardening.

Hydrogen

A considerable amount of information has been obtained concerning the reaction of hydrogen and its effects on the properties of titanium and its alloys. This information is discussed in detail in TML Report No. 100. For the purposes of this report, the effects of alloying on the reaction of titanium with hydrogen are briefly summarized below.

Absorption From Pure Hydrogen. Unalloyed titanium reacts readily with hydrogen at all temperatures. The rate of absorption is basically dependent on the surface absorption and subsequent inward diffusion of the hydrogen into the bulk material, and varies markedly with a number of factors including:

- (1) The partial pressure of hydrogen
- (2) Temperature
- (3) Surface cleanliness
- (4) Microstructure.

The amount of hydrogen entering titanium or any alloy at a given temperature is governed by the partial pressure of hydrogen surrounding the material. The solubility of hydrogen in titanium varies considerably

with alloy content, as previously discussed in DMIC Report 136A. Generally, however, at elevated temperatures, both titanium and its alloys show a nearly linear dependence of absorption upon the square root of the hydrogen pressure, indicating that the dissociation of molecular to atomic hydrogen occurs at the surface. (53) The rate of absorption is, of course, also dependent on surface area, the total amount absorbed increasing as the ratio of surface area to volume increases.

In unalloyed titanium, the absorption of hydrogen at room temperature and at quite low pressures has been reported. (54) Generally, however, at temperatures up to about 250 C (480 F), hydrogen absorption occurs very slowly. Certain alloying additions appear to affect the minimum temperature at which hydrogen can be absorbed. It has been reported that the Ti-4Al-4Mn alloy absorbed hydrogen at 100 C (212 F) in 8 months, whereas the Ti-5Al-2.5Sn alloy did not absorb hydrogen at either 100 or 230 C (450 F). (55) The presence of an oxide surface film could explain these data. It has been shown (53, 54), for example, that an oxidized surface considerably retards the absorption of hydrogen on unalloyed titanium, and there is no reason to suspect that titanium alloys will behave differently in this respect. If this is so, the alloying effects could be secondary, merely controlling the rate of absorption through the oxide film.

At temperatures above about 300 C (570 F), the rate of absorption in titanium and its alloys becomes quite rapid. As an example, Figure 23 illustrates the hydrogen-absorption-rate curves for two grades of titanium and two commercial alloys. For each material, the curves level off rapidly, indicating an approach toward the equilibrium concentration of hydrogen. As indicated, the absorption is most rapid for the Ti-8Mn alloy and slowest for the Ti-4Al-4Mn. The diffusion coefficient of hydrogen in these materials varies in the decreasing order iodide titanium, Ti-4Al-4Mn, commercial-purity titanium, and Ti-8Mn. Hence, some factor other than composition, possibly microstructure, is affecting the results shown in Figure 23.

Similar studies (56) at 600 C (1110 F) indicate that the rate of absorption decreased in the following order: iodide titanium, Ti-4Al-4V, Ti-3Al-5Cr, and Ti-5Al. These results are substantially in agreement with those given in Figure 23. Aluminum apparently retards the absorption of hydrogen quite strongly.

The significance of microstructures in the absorption of hydrogen by titanium is indicated by studies in which cathodically charged samples were examined. (57) In predominantly alpha alloys, hydrogen absorption was limited to a thin surface layer of hydride. When a beta network was present, hydrogen penetrated much more deeply into the alloy. Acicular structures having a more continuous beta network showed greater absorption than did equiaxed structures, as indicated in Figure 24. Large amounts of hydrogen were absorbed in alloys containing moderate amounts of beta with no evidence of hydride at the surface or in the alloy. One

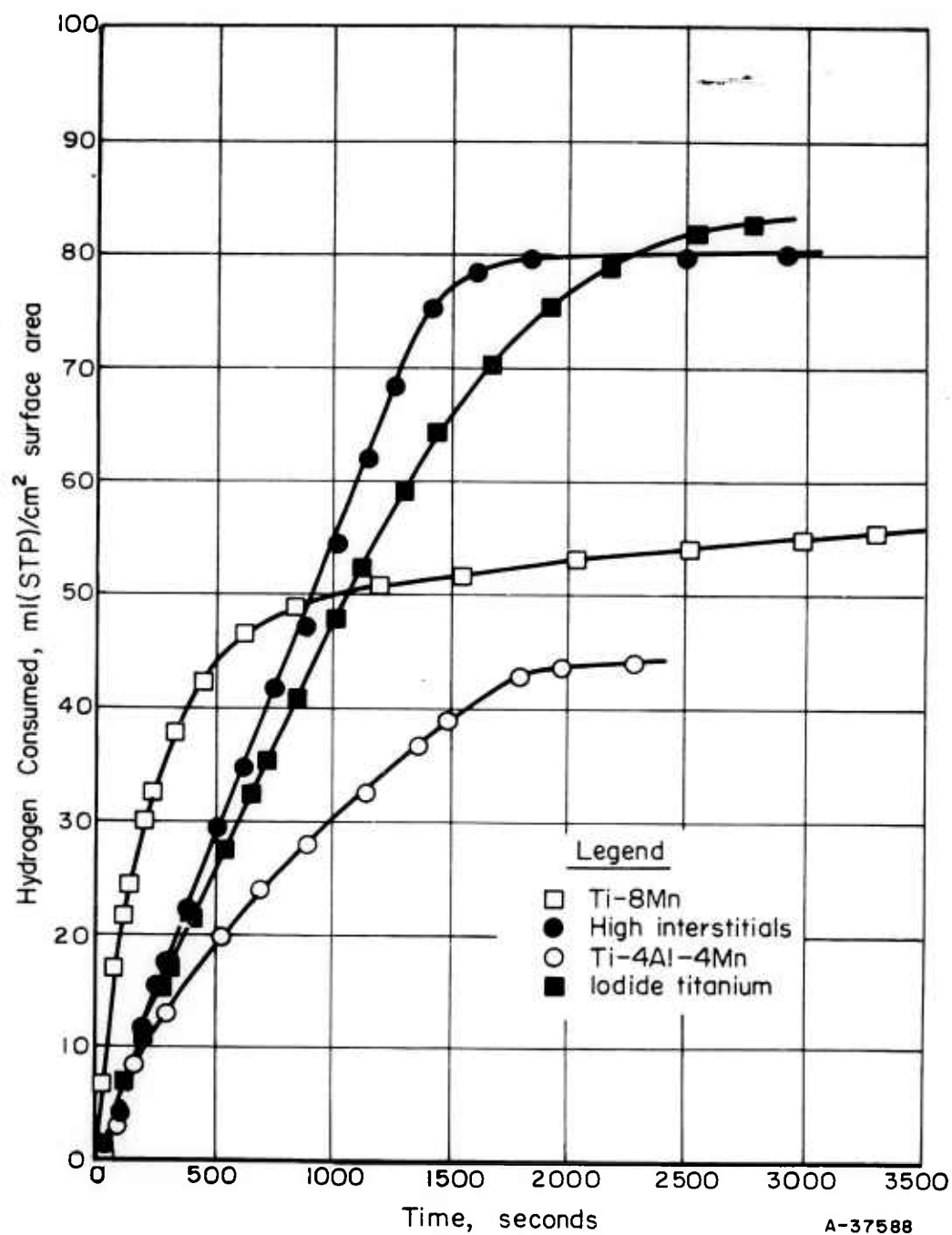


FIGURE 23. REACTION RATES OF TITANIUM ALLOYS WITH H_2 AT 1290 F AND 0.13 ATMOSPHERIC PRESSURE⁽⁵³⁾

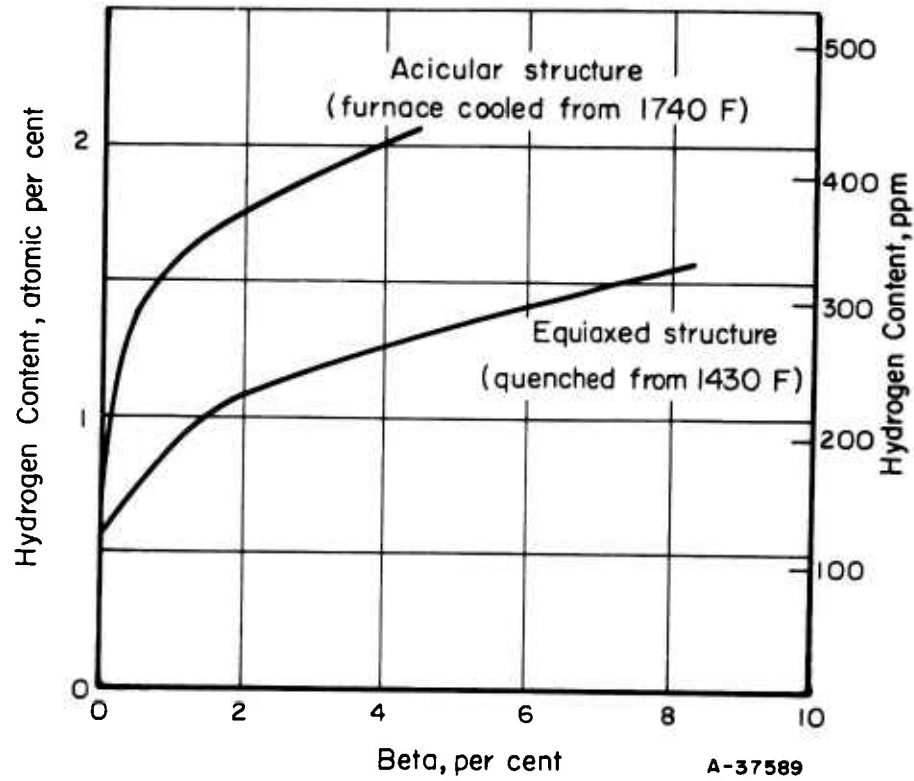


FIGURE 24. EFFECT OF STRUCTURE ON THE ABSORPTION OF HYDROGEN BY TITANIUM-IRON ALLOYS DURING ACID PICKLING⁽⁵⁷⁾

alloy (Ti-8Mn) absorbed 12,100 ppm (37 atomic per cent) during cathodic charging without producing visible signs of the hydride phase.

Absorption From Gases or Vapors Containing Hydrogen. Titanium and its alloys can absorb hydrogen from atmospheres containing water vapor⁽⁵⁶⁾, ammonia⁽³²⁾, and propane⁽⁵⁸⁾, and it is probable that hydrogen can also be absorbed from most other hydrocarbons, as well. Very few quantitative data have been obtained relating the rate of hydrogen absorption from these media to alloy content, the data below being typical of those available.

Hydrogen Analyses of 1/2-Inch Bars of Various Titanium Alloys Exposed 6 Hours at 1010 C (1850 F) in an Argon-1/2 Per Cent Propane Mixture⁽⁵⁸⁾

Alloy	Hydrogen Content, ppm	
	Before Treatment	After Treatment
Commercial Ti (Ti-75A)	75	690
RC-130A (Ti-8Mn)	59	540
RC-130B (Ti-4Al-4Mn)	40	430

The rate of absorption has been somewhat academic since sufficient hydrogen to impair the properties of all commercial titanium alloys can be absorbed from improperly controlled atmospheres containing these gases.

Fortunately, as pointed out previously, the presence of an oxide surface film hinders hydrogen absorption considerably. Since an oxide film is formed quite readily, trouble with hydrogen absorption is seldom encountered in neutral or oxidizing atmospheres. Thus, it has been established⁽⁵³⁾ that no significant hydrogen pickup occurs during the heating of unalloyed titanium in ordinary air or in neutral gas-fired-furnace atmospheres for times up to 4 hours at 700 C (1290 F).

Limited data indicate that the hydrogen pickup in reducing atmospheres at this (700 C) temperature is not so great as might be anticipated. Thus, a cylindrical 5/8-in. diameter titanium bar (surface-to-volume ratio of 10:1) heated 4 hours in an atmosphere containing 2 per cent hydrogen and 0.5 volume per cent methane increased its bulk hydrogen content from 10 to only 26 ppm. A sheet sample (surface-to-volume ratio of 65:1) of the same material under identical conditions increased its hydrogen content from 8 to 60 ppm, indicating the importance of surface-to-volume ratio in the reaction.

The rate of hydrogen absorption from reducing atmospheres rises sharply with increasing temperatures. For this reason, electrically heated air atmospheres are preferred for commercial heating furnaces or, when

gas-fired furnaces are used, the flame is adjusted to produce oxidizing conditions.

Absorption From Liquid Media. Titanium and its alloys can apparently absorb hydrogen from any liquid media in which nascent hydrogen is formed as one of the reaction products. This is evident from early experiences with descaling and pickling procedures that led to a considerable increase in the hydrogen content of the commercial metal and its alloys. In this work, either fused salts, based on NaOH, or aqueous pickling solutions containing HF were used, since titanium is relatively inert to most other reagents. Fortunately, effective means of controlling hydrogen pickup from these media are available.

So far as fused salts are concerned, unalloyed titanium (and, presumably, most titanium-base alloys) absorbs a very large amount of hydrogen in pure NaOH at elevated temperatures. Du Pont, for example, has shown that titanium exposed 15 minutes in NaOH at 900 F picks up from 3400 to 4000 ppm of hydrogen. (59) However, by the addition of small amounts of such oxidizing salts as NaNO₃, NaNO₂, and NaCl, the rate of hydrogen absorption can be reduced to insignificant levels. This is apparent from the data of Table 11 which lists the hydrogen pickup observed for commercially pure titanium and several commercial alloys in various oxidizing caustic baths. Several proprietary descaling baths of this type are available.

TABLE 11. HYDROGEN PICKUP IN COMMERCIAL PURE TITANIUM AND SEVERAL TITANIUM ALLOYS IN VARIOUS OXIDIZING CAUSTIC BATHS (59)

Composition, weight per cent	Bath Composition, weight per cent	Hydrogen Pickup, in ppm, Under Exposure Conditions Cited		
		30	15	30
		Minutes at 800 F	Minutes at 900 F	Minutes at 900 F
100Ti	100NaOH	--	4000	--
	90NaOH, 5NaNO ₃ , 5NaNO ₂	--	0	--
	80NaOH, 10NaNO ₃ , 10NaNO ₂	--	5	--
	60NaOH, 10NaNO ₃ , 10NaNO ₂ , 20NaCl	--	4	--
	80NaOH, 5NaNO ₃ , 5NaNO ₂ , 10NaCl	-6 to +15	--	20 to 120
Ti-8Mn	Ditto	-11 to +20	--	5 to 15
Ti-5Al-2.5Sn	Ditto	-25	--	0

Fused NaOH solutions containing a small amount (1 to 2 per cent) of NaH have also been used to descale titanium and its alloys with good success. The reducing bath of this type which has been most commonly used is the sodium hydride descaling process⁽⁶⁰⁾. In this process, the NaH attacks and reduces the titanium scale. Attack of the metal continues after the scale is removed, and the large hydrogen concentration leads to rapid contamination. Results of studies⁽⁶¹⁾ of hydrogen contamination occurring in alloys descaled with the sodium hydride process have shown that hydrogen contamination can be quite severe. Contamination appears more severe in alpha-beta alloys (Ti-8Mn) than in unalloyed titanium. Also, contamination increases with time but at a lower rate as time increases. Although a number of factors control the pickup of hydrogen, the time of immersion is generally the most important. If the material to be descaled is removed as soon as the oxide is dissolved, contamination is virtually eliminated.

Additions of TiO₂ to the hydride bath markedly decrease the amount of hydrogen absorbed by unalloyed titanium.^(62,63) Optimum performance is obtained when the bath is saturated with the alkali-metal titanates formed when the TiO₂ reacts with the melt. This point is reached when the melt contains the equivalent of about 0.30 to 0.35 per cent TiO₂.

In acid reactions, the concentration of hydrogen atoms at the metal surface may reach an effective pressure of many atmospheres, so that absorption can occur with ease at the low temperatures normally involved. However, relatively few acids attack titanium rapidly enough to be of concern as sources of hydrogen contamination. Hydrofluoric acid is, of course, one of the most potent solvents for titanium, and hydrogen absorption data from this media have been observed, as will be discussed below. Several other acid solutions, including fluoroboric, hydrochloric, and sulfuric also attack titanium and may be potential sources of hydrogen pickup for the metal. While each of the above acids have been used to descale and/or pickle titanium and its alloys, no hydrogen absorption data are available from these investigations.

Work by Crucible Steel⁽⁶⁴⁾ has indicated that atomic hydrogen is generated by the reaction of titanium with HF. The data in Figure 25, for various alloys pickled in a 2 per cent HF solution, show that the amount of hydrogen absorbed increases for these materials in the following order: Ti-5Al-2.5Sn, commercially pure titanium, Ti-6Al-4V, Ti-8Mn, and Ti-4Al-4Mn. Thus, hydrogen absorption is more rapid for the alpha-beta type alloys than for the alpha types. It has been shown that hydrogen pickup in predominantly alpha alloys is characterized by the formation of thin surface layers of hydride. The presence of small amounts of beta (as in Ti-6Al-4V) results in more hydrogen pickup and deeper hydrogen penetration. Hydrogen pickup in alloys containing a continuous beta-phase network (as in Ti-8Mn and Ti-4Al-4Mn) is characterized by a lack of a hydride layer, rapid penetration, and a tendency toward a higher hydrogen content than with alpha alloys.

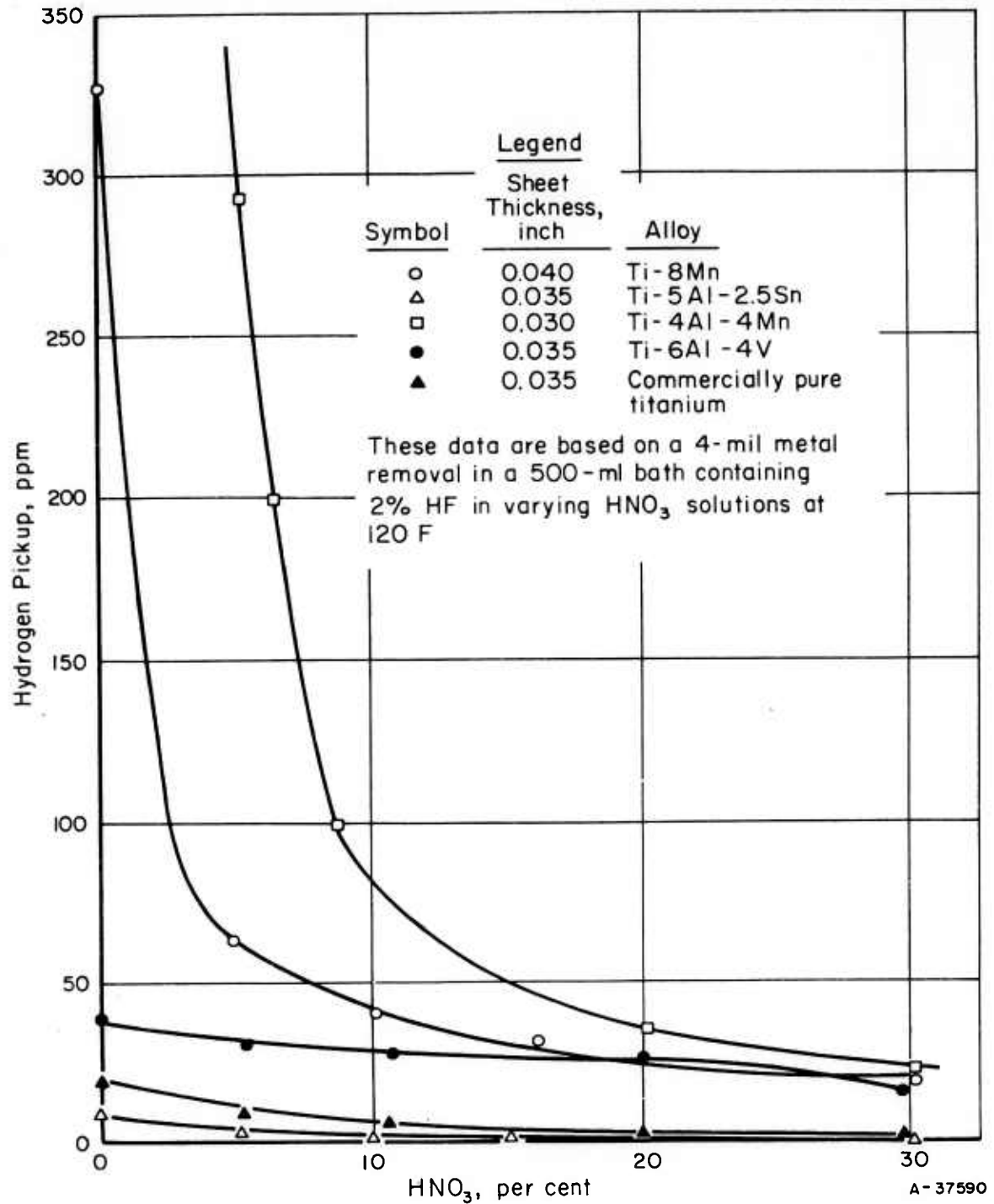


FIGURE 25. HYDROGEN PICKUP VERSUS NITRIC ACID CONTENT FOR COMMERCIALLY PURE TITANIUM AND FOUR ALLOYS⁽⁶⁵⁾

As indicated by the data of Figure 25, the rate of hydrogen absorption from HF solutions can be greatly retarded by the addition of nitric acid in sufficient amounts.

DIFFUSION

Despite the intensive research effort that has been applied to titanium-alloy development, comparatively few diffusion data have been reported. Until recently, the lack of data has been particularly noticeable for the diffusion of substitutional elements into titanium and its alloys. The self-diffusion coefficient for titanium has not been determined experimentally (although various estimates have been made), mainly because no satisfactory radioactive isotope of titanium is available. In addition to diffusion data, information is available on hydrogen degassing coefficients, and on the air contamination coefficients for titanium and a few of its alloys.

All of the work reported has been done using non-steady-state methods. In most instances, the diffusion rates of the substitutional elements were determined using diffusion couples, with analysis of the concentration data by the Grube⁽⁶⁶⁾ or Matano⁽⁶⁷⁾ method. A few measurements using radioactive tracer methods have been reported. The diffusion rates of oxygen and nitrogen into beta titanium were determined from gas-metal exposures; the diffusion rates of these elements into alpha titanium were determined by more indirect methods. The diffusivity of carbon into alpha and beta titanium was determined from diffusion couples of pure titanium and a titanium-carbon alloy, the analysis being that developed by Jost and Wagner.⁽⁶⁸⁾

Interstitial Elements

The important elements which dissolve interstitially in titanium are carbon, oxygen, and nitrogen as alpha stabilizers and hydrogen which stabilizes the beta phase. Some work has been done in the USSR on the diffusion of boron into titanium⁽⁶⁹⁾, but the diffusion coefficients were not reported in a form suitable for inclusion here.

Hydrogen

Hydrogen diffuses rapidly in both alpha and beta titanium. Diffusion (degassing) coefficients have been reported by Wasilewski and Kehl⁽⁷⁰⁾, Albrecht and Mallet⁽⁷¹⁾, and Kusamichi, et al.⁽⁷²⁾ Diffusivities were calculated from data obtained by the infusion or effusion of hydrogen in a specimen of simple geometry; thus, it must be assumed that diffusion

(not surface effects) is the limiting factor in the rate at which hydrogen is absorbed or extracted from the specimen. Figure 26 summarizes the Arrhenius plots for the diffusion of hydrogen in alpha titanium and in one alpha-titanium alloy (Ti-5Al-2.5Sn). With the exception of the two lower-temperature data points, obtained for high-purity titanium by Albrecht and Mallett, the activation energies are in good agreement, ranging from 12,380 to 14,200 cal/mole. This also is shown by the numerical data presented in Table 12.

TABLE 12. SUMMARY OF EXPERIMENTAL DATA FOR THE DIFFUSION OF HYDROGEN IN ALPHA TITANIUM AND AN ALPHA-TITANIUM ALLOY

Solvent	Temperature Range, C	D_0 , 10^{-2} cm ² /sec	Q, cal/mole	References
Iodide titanium	650-850	1.8	12,380	70
Iodide titanium	650-850 (a)	1.45	12,750	71
Commercial titanium	600-800	0.86	12,400	71
Commercial titanium	700-900	0.27	14,200	72
Ti-5Al-2.5Sn	600-700	1.22	12,700	71

(a) Two additional points at 600 and 620 C lie below the line extrapolated from these data. See Figure 26.

The diffusion rates of hydrogen in beta titanium and in several beta-stabilized alloys have been reported; data are shown in Figure 27 and in Table 13. Activation energies are low, ranging from 6640 to 8920 cal/mole. Alloying appears to slow the diffusion of hydrogen, possibly by the blocking of interstitial sites in the bcc beta-titanium lattice.

TABLE 13. SUMMARY OF EXPERIMENTAL DATA FOR THE DIFFUSION OF HYDROGEN IN BETA TITANIUM AND TWO BETA-STABILIZED ALLOYS

Solvent	Temperature Range, C	D_0 , 10^{-3} cm ² /sec	Q, cal/mole	References
Iodide titanium	900-1020	1.95	6460	70
Iodide titanium	900-1020	3.75	8440	71
Ti-4Al-4Mn	600-800	1.68	8920	71
8Mn	600-800	0.405	7170	71

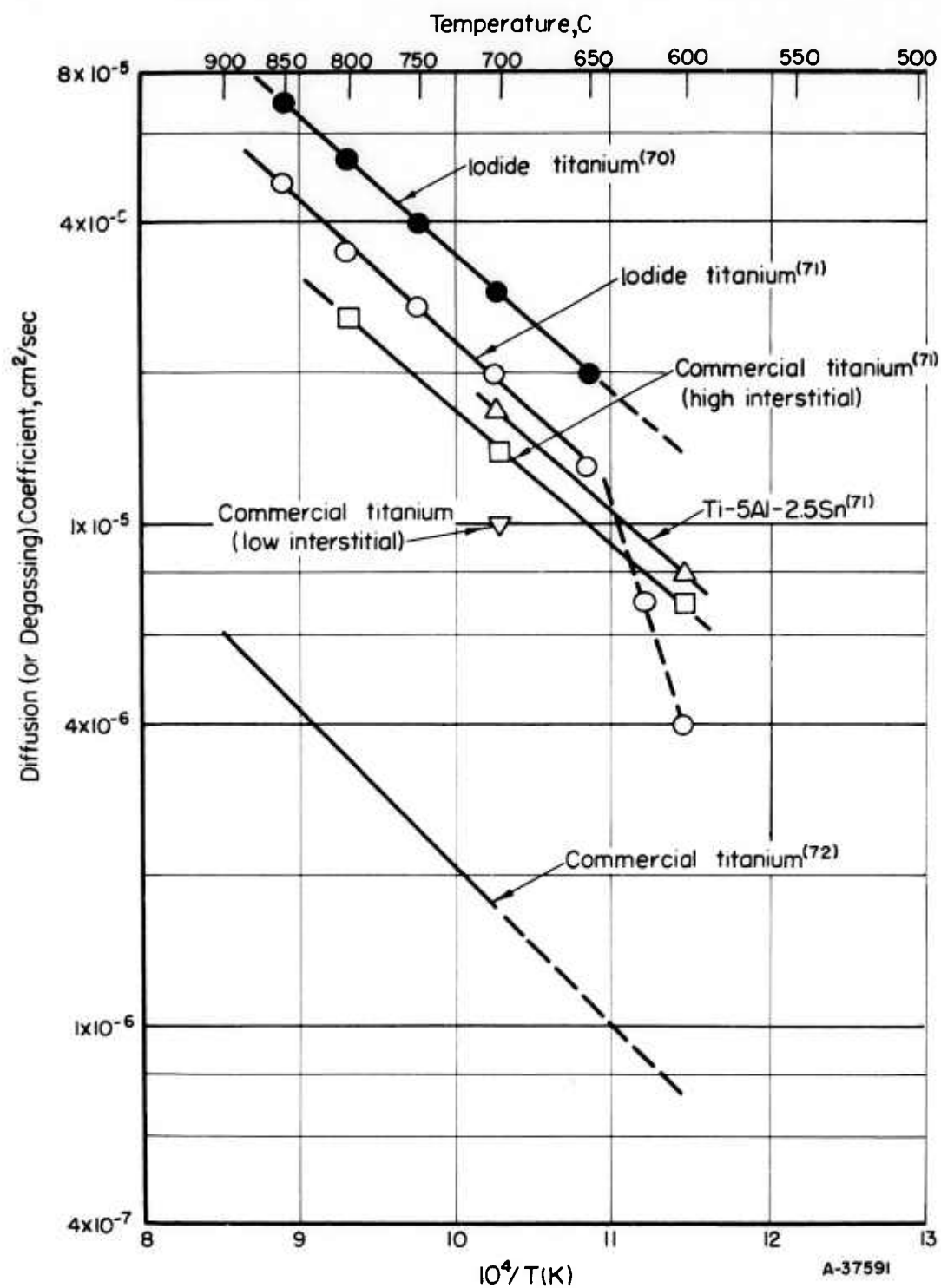


FIGURE 26. DIFFUSION (OR DEGASSING) COEFFICIENTS FOR HYDROGEN IN ALPHA TITANIUM AND AN ALPHA-TITANIUM ALLOY

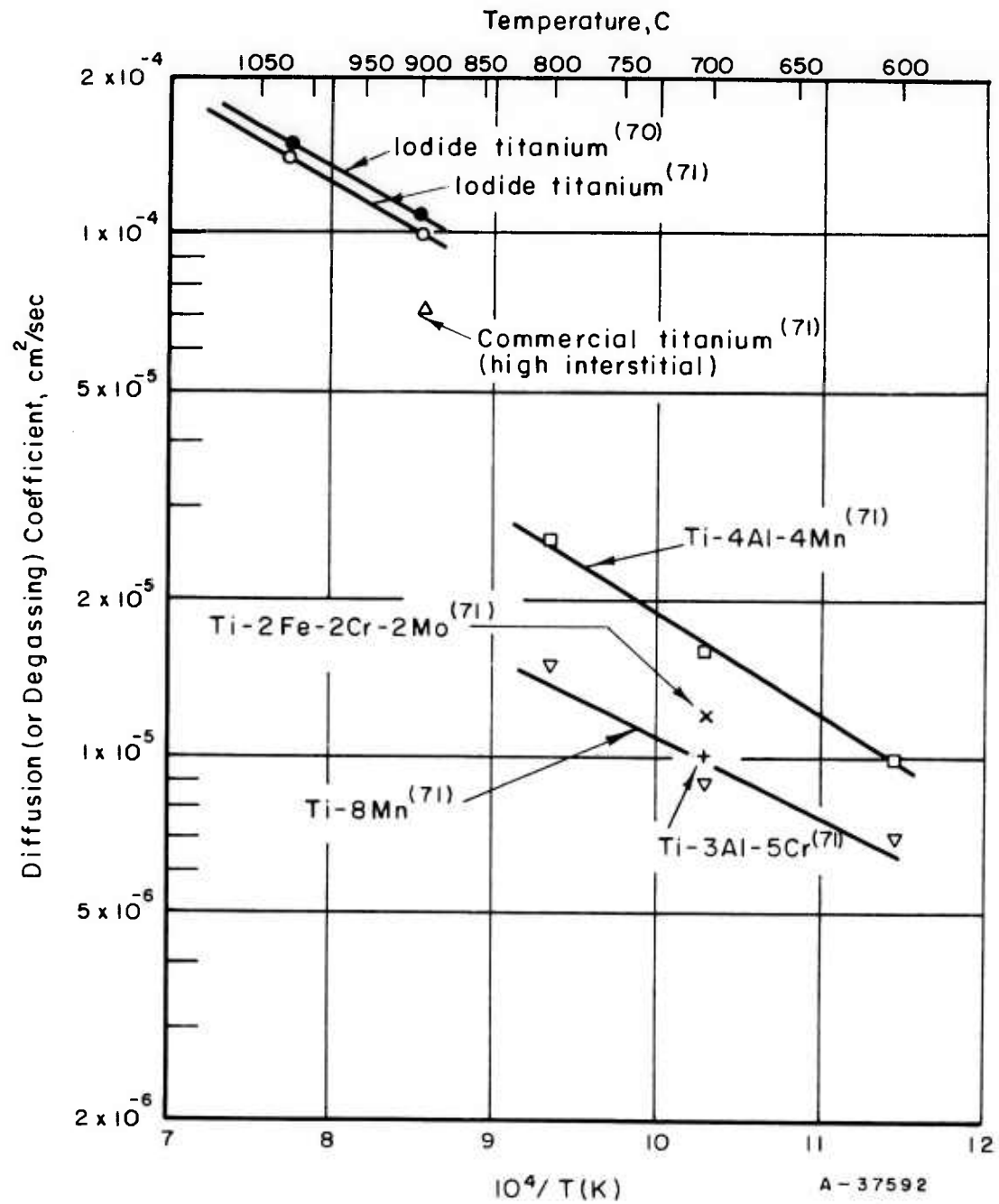


FIGURE 27. DEGASSING AND DIFFUSION COEFFICIENTS FOR HYDROGEN IN BETA TITANIUM AND IN BETA-STABILIZED TITANIUM ALLOYS

An internal-friction peak was observed by Köster, et al. (73), in quenched alpha titanium; the magnitude of the peak was directly proportional to the hydrogen content. If this is interpreted to be the result of stress-induced interstitial diffusion of hydrogen, the activation energy of 15,000 cal/mole is in reasonable agreement with the activation energies reported for the diffusion of hydrogen in alpha titanium.

Oxygen

Oxygen is a common contaminant in titanium, and its diffusivity has been studied by several investigators. The earliest work reported was that of Pratt, et al. (74), who studied the internal-friction behavior of an alloy of titanium containing 0.10 atomic per cent iron. An activation energy of 48,000 cal/mole was reported, from which the diffusivity of oxygen in alpha titanium could be calculated using the Langmuir-Dushman equation. This work was followed by that of Wasilewski and Kehl (75), who determined a similar (48,200 cal/mole) activation energy for the diffusion of oxygen in beta titanium.

Later studies (76,77) have indicated widely varying diffusivities and activation energies. These are listed in Table 14 and plotted in Figure 28. In addition to those shown in Table 14, Gupta and Weinig (78), using internal-friction techniques similar to those used by Pratt, et al., have reported activation energies ranging from 34,000 to 67,000 cal/mole. The data reported for air-contamination rates are discussed in a later section, but these generally are within the range of oxygen diffusivities shown here.

TABLE 14. SUMMARY OF EXPERIMENTAL DATA FOR THE DIFFUSION OF OXYGEN IN ALPHA AND BETA TITANIUM

Solvent	Temperature Range, C	D_o , cm^2/sec	Q , cal/mole	References
Alpha titanium	--	0.427(a)	48,000	74
Alpha titanium	700-850	5.08×10^{-3}	33,500	76
Beta titanium	1127-1377	8.3×10^{-2}	31,200	77
Beta titanium	950-1414	1.6	48,200	75
Beta titanium	930-1150	3.14×10^4	68,700	76

(a) Calculated from Langmuir-Dushman equation.

Carbon

The diffusion rate of carbon in titanium was reported by F. C. Wagner, et al. (79), who used diffusion couples consisting of high-purity titanium in contact with titanium-carbon alloys. The concentration

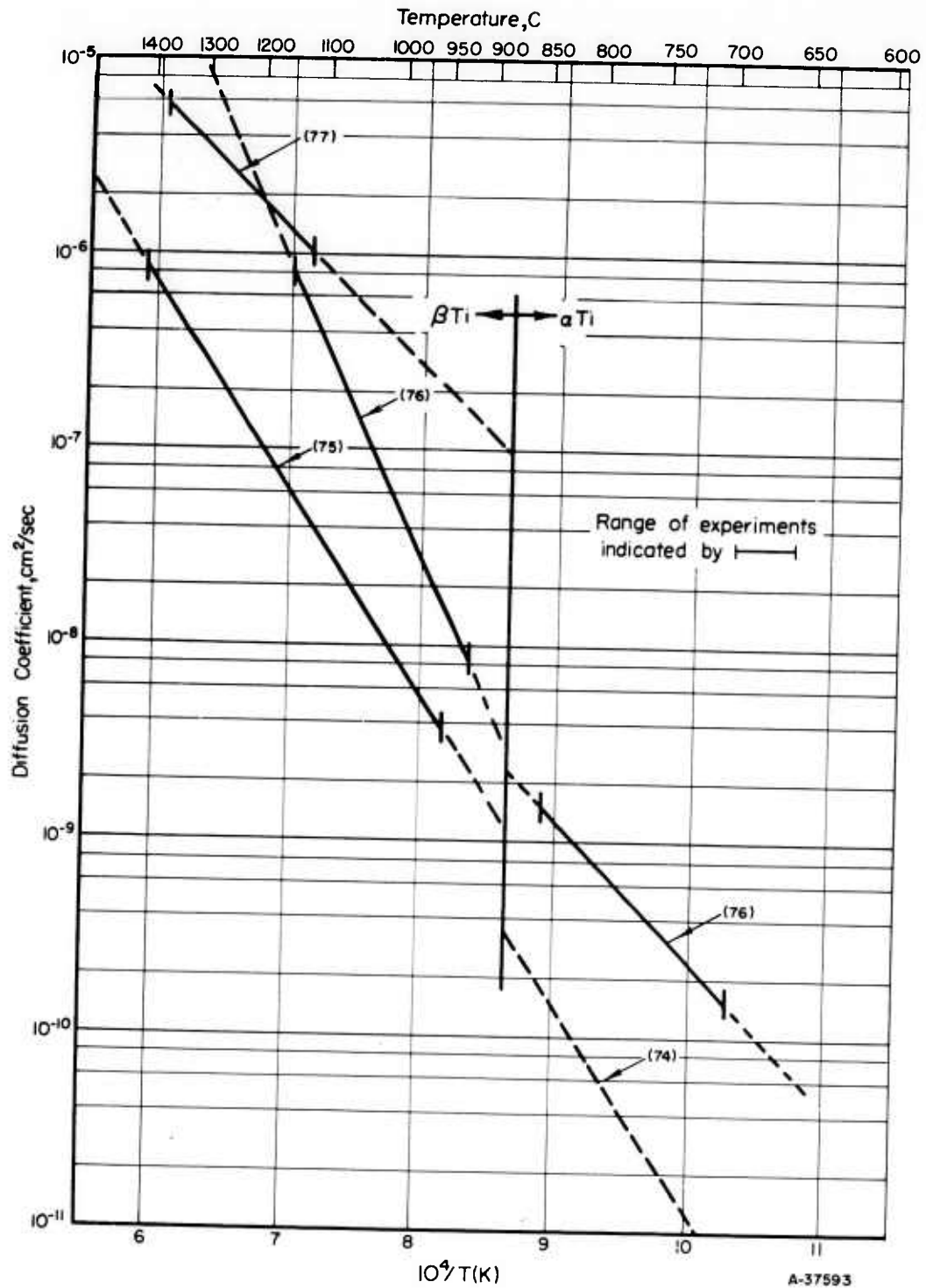


FIGURE 28. EFFECT OF TEMPERATURE ON THE DIFFUSION OF OXYGEN IN ALPHA AND BETA TITANIUM

gradients were established by diffusion anneals at temperatures ranging from 700 to 1200 C. The specimens were sectioned, and slices were machined off for carbon analysis by combustion. The data are presented in Figure 29; the diffusion coefficients can be represented by the Arrhenius-type equations:

$$D_{\alpha} = 5.06 \exp(-43,500/RT) \quad (700-880 \text{ C})$$

$$D_{\beta} = 108 \exp(-48,400/RT) \quad (920-1200 \text{ C}).$$

Nitrogen

The diffusivity of nitrogen in beta titanium has been reported by Wasilewski and Kehl⁽⁷⁵⁾. The equation $D_{\beta} = 3.5 \times 10^{-2} \exp(-33,800/RT)$ was found to describe the data between 900 and 1570 C. Using a somewhat indirect method of calculation, the approximate values for diffusion of nitrogen in alpha titanium also were determined from the same data and for the same range of temperatures. The diffusivity was given as: $D_{\alpha} = 1.2 \times 10^{-2} \exp(-45,250/RT)$. These data are shown in Figure 29. It should be noted, of course, that the alpha phase in pure titanium is stable only up to 882 C, whereas all the data were obtained from tests made at higher temperatures.

Air Contamination

Two studies have been reported on the air contamination of titanium alloys, in both of which diffusion coefficients associated with the contamination process were computed. (52, 80) In all the tests, specimens were exposed in air for various times and temperatures. Using the assumption that hardness is a linear function of the concentration of the contaminant, an analysis of the Van Ostrand-Dewey type can be made, and the resulting data can be used to determine contamination coefficients. The temperature dependency of the contamination coefficients can be expressed by the usual Arrhenius equation. Results of tests on a number of titanium alloys are listed in Table 15, and are plotted in Figure 30.

TABLE 15. SUMMARY OF EXPERIMENTAL DATA FOR THE AIR CONTAMINATION (DIFFUSION) OF TITANIUM AND TITANIUM ALLOYS

Composition	Temperature Range, C	D_0 , cm^2/sec	Q, cal/mole	References
Commercial titanium	815-1149	2.03×10^5	75,300	52
Ti-5Al-2.5Sn	815-1149	92.4	58,800	52
Ti-4Al-4Mn	815-1093	74.9	55,500	52
Ti-6Al-4V	815-1093	388	59,500	80
Ti-4Al-3Mo-1V	760-1038	388	59,500	80
Ti-13V-11Cr-3Al	815-1038	0.348	38,700	80
Ti-2.5Al-16V	760-125	2.0×10^4	60,700	80

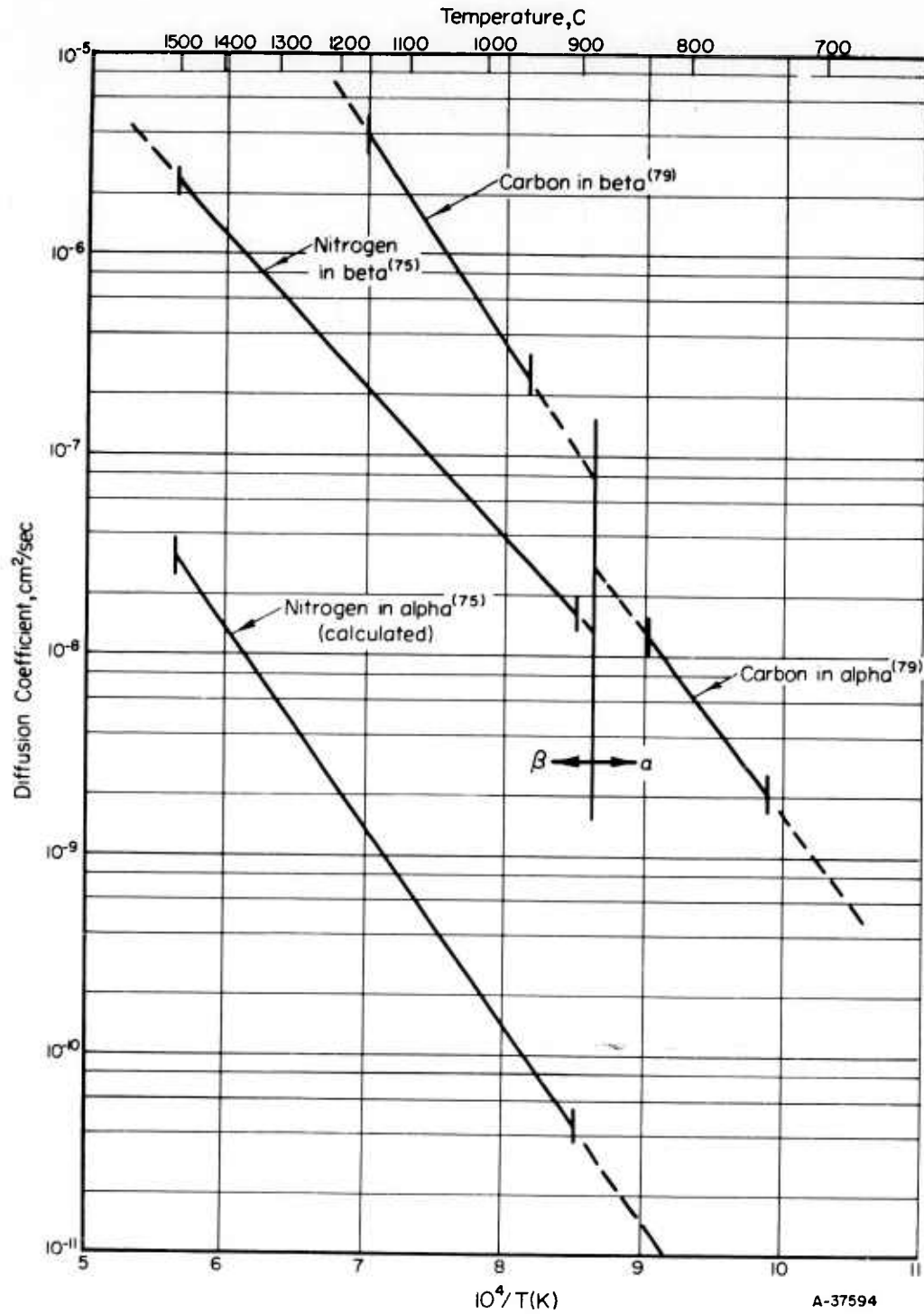


FIGURE 29. EFFECT OF TEMPERATURE ON THE DIFFUSION OF CARBON AND NITROGEN IN TITANIUM

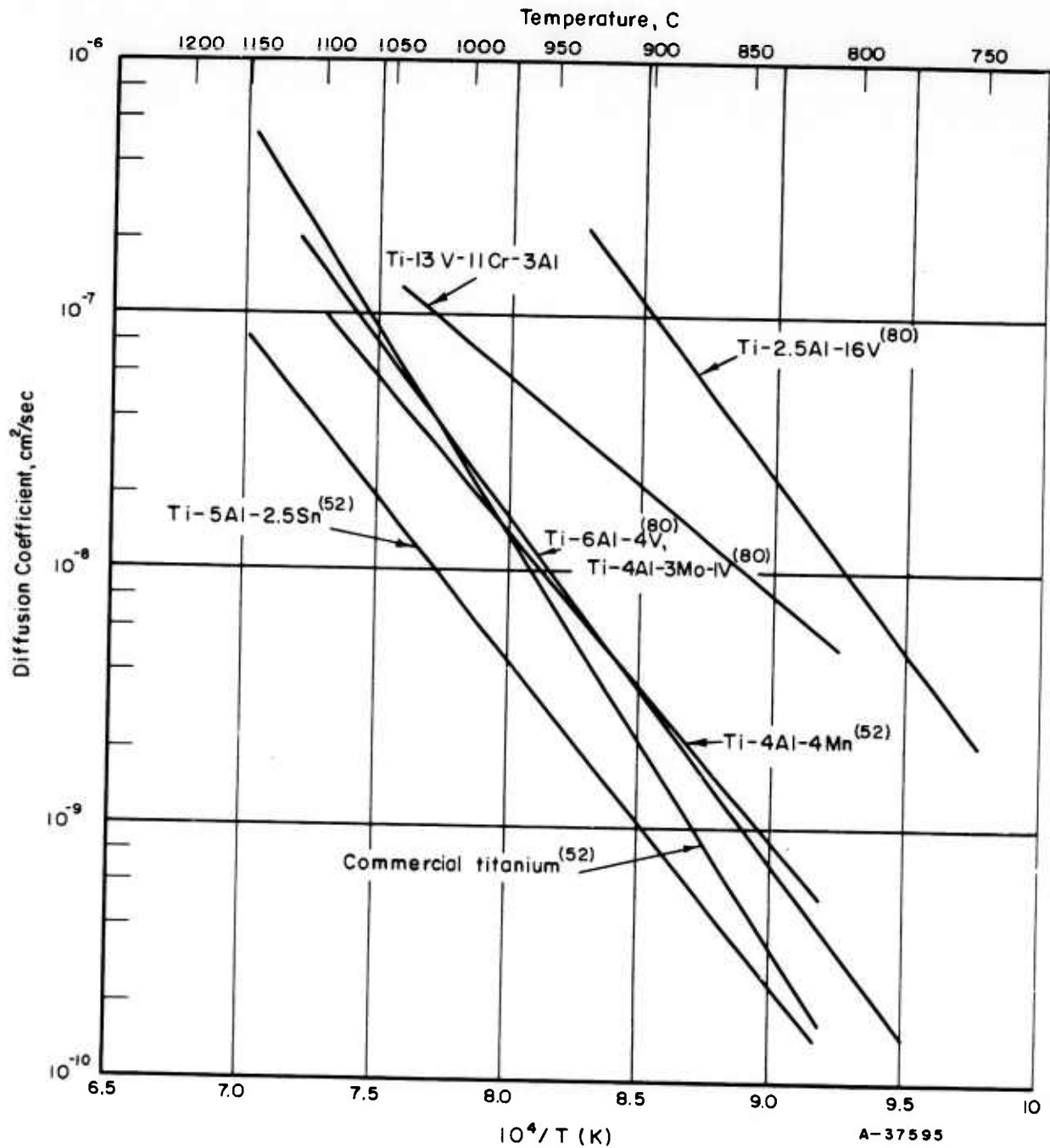


FIGURE 30. EFFECT OF TEMPERATURE ON THE AIR-CONTAMINATION (DIFFUSION) COEFFICIENTS FOR TITANIUM AND SEVERAL OF ITS ALLOYS

Activation energies for the air-contamination process range from 38,700 cal/mole for the Ti-13V-11Cr-3Al alloy to 75,300 cal/mole for unalloyed titanium. There may be a trend toward lower activation energies for the alloys containing increasing amounts of beta, although this is by no means definite. Except for the Ti-2.5Al-16V and Ti-13V-11Cr-3Al data, all the points lie within a reasonable scatter band, as shown in Figure 30.

A comparison of these results with previously reported oxygen-diffusion data reveals that D-values are of the same order of magnitude. The agreement between activation energies for oxygen and air contamination is not so good, and the value for air contamination of unalloyed titanium (75,300 cal/mole) appears particularly high. It was speculated that a process other than the diffusion of oxygen through titanium (i. e. , a surface reaction or diffusion through an oxide layer) might be the rate-controlling process.

Substitutional Elements

Of the metallic elements that dissolve substitutionally in titanium, comparatively few are of importance in present commercial alloys. The most important elements include aluminum, tin, zirconium, chromium, iron, manganese, molybdenum, and vanadium. Until recently, only a few scattered tests had been conducted on the diffusivities of these elements in titanium, and most of the reported diffusion constants were based upon a minimum number of experiments. Despite the fact that the early data reported by Schwöpe⁽⁸¹⁾ were of questionable accuracy, they were widely reproduced in the literature for the lack of more comprehensive values.

Recent publications have provided a more complete coverage of the diffusivities of substitutional elements in titanium and its dilute alloys. Included are most of the more important alloying additions, plus a few of the less common elements such as scandium and uranium.

A number of studies relating to diffusion of titanium have been reported in the Russian literature during the past decade. With a few exceptions, most of these contributions are concerned with the diffusion of various elements in nickel-base or iron-base alloys that contain relatively small amounts of titanium. (82-85) These results are not included here.

Aluminum

Aluminum is one of the more important alloying additions to titanium, imparting strength, stability, and resistance to oxidation. Aluminum stabilizes the alpha phase, and introduces an alpha-plus-beta region between the two phases. The diffusion rates of aluminum in dilute titanium-aluminum alloys were reported in a recent publication by Goold⁽⁸⁶⁾.

Diffusion couples were exposed at temperatures up to 1250 C, in both the alpha- and beta-phase regions. The couples were sectioned, analyzed chemically, and the diffusivities calculated using the Matano analysis for the higher temperature data and the Grube method for the lower temperature data.

The results showed a pronounced increase in the diffusivity as the aluminum concentration of the alloy was increased up to about 12 atomic per cent. At a constant composition, the diffusion coefficients varied with temperature in accordance with the usual Arrhenius-type law, as illustrated in Figure 31. The results are summarized in Table 16.

The activation energies reported are relatively low (21,900 to 25,500 cal/mole). The over-all diffusivity of aluminum in titanium appears to be of a magnitude similar to that of many other metallic elements.

Chromium

Unlike aluminum, chromium dissolves preferentially in the beta phase of titanium, and the beta-transus temperature is decreased with increasing chromium concentration. A total of five diffusivities have been reported, three for unalloyed (or dilute alloys of) titanium, and two for alloys containing up to 18 per cent chromium. The early work reported by Schwöpe, et al. (81), was based on measurements made on three diffusion couples at 800, 900, and 1000 C. Concentrations were determined by sectioning and chemical analysis, and the data were reduced to diffusivities using the Grube method. Mortlock and Tomlin(89) used sandwich-type diffusion couples prepared with a layer of radioactive chromium (Cr^{51}) between layers of unalloyed or alloyed titanium. The penetration curves were determined by autoradiography using a microdensitometer to measure the distribution.

The results of the various determinations are shown as Arrhenius plots for log diffusivity versus reciprocal temperature in Figure 32. The reported frequency factors and activation energies are included in Table 16.

The results show activation energies ranging from 23,300 to 44,000 cal/mole, with the higher values reported for the two alloys. From the low activation energy for diffusion of chromium in titanium compared with that expected for self-diffusion of titanium, Mortlock and Tomlin proposed a modified vacancy mechanism for the diffusion process. This was suggested in view of the lack of agreement between the solute and self-diffusion activation energies usually observed. Schwöpe (whose activation-energy value was much lower than those determined by Mortlock and Tomlin) suggested the possibility of more rapid grain-boundary diffusion, although relatively large grain sizes must have resulted from the diffusion anneals. Mortlock and Tomlin reported beta-grain diameters of 0.2 to 2 millimeters.

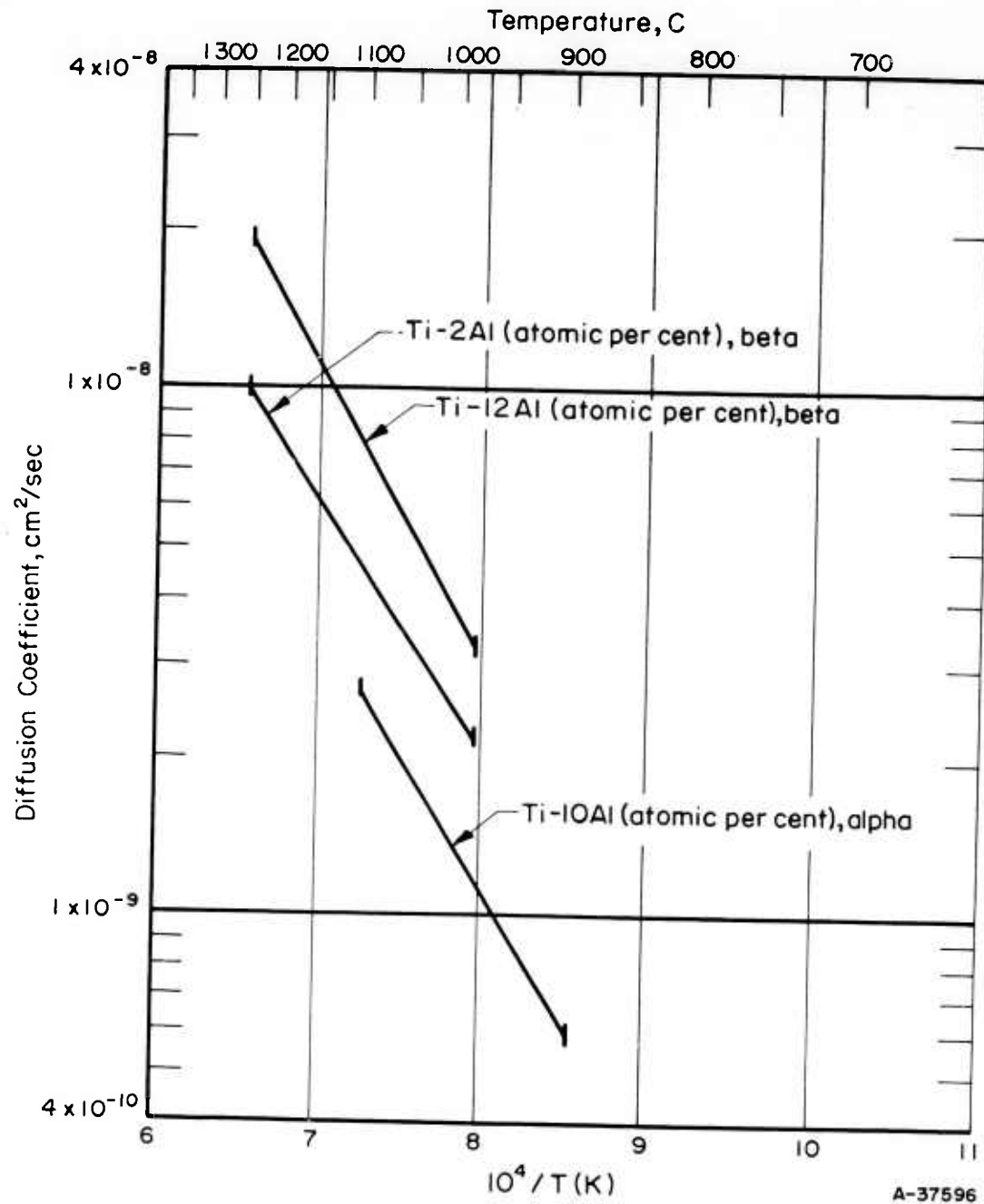


FIGURE 31. EFFECT OF TEMPERATURE ON THE DIFFUSION OF ALUMINUM IN DILUTE TITANIUM-ALUMINUM ALLOYS(86)

TABLE 16. SUMMARY OF EXPERIMENTAL DATA FOR THE DIFFUSION OF SUBSTITUTIONAL ELEMENTS IN TITANIUM AND TITANIUM ALLOYS

Element	Alloy Composition	Temperature	D_0 , cm ² /sec	Q, cal/mole	Remarks	References
		Range, C				
Titanium	Titanium	--	0.66 (a)	77,000	Estimated from melting-point data	87
Titanium	Titanium	--	0.515 (a)	60,000		Estimated from stress-rupture-data correlation
Aluminum	Ti-2 at. % Al (β)	983-1250	1.4×10^{-5}	21,900		86
Aluminum	Ti-12 at. % Al (β)	983-1250	9.0×10^{-5}	25,500		86
Aluminum	Ti-10 at. % Al (β)	834-900	1.6×10^{-5}	23,700		86
Chromium	Ti-(0-5)Cr	800-1000	7.8×10^{-5}	23,300	From three measurements; radioactive tracer-method used	81
Chromium	Ti (Commercial)	980-1178	0.005	35,300		89
Chromium	Ti (iodide)	926-1193	0.010	37,700		89
Chromium	Ti-10Cr	926-1177	0.02	40,200		89
Chromium	Ti-18Cr	925-1178	0.09	44,500		
Iron	Ti-(0-5)Fe	800-1000	0.01	31,000	From three measurements	81
Manganese	Ti-8 at. % Mn (β)	830-1190	1.0×10^{-3}	35,200		86
Molybdenum	Ti-(0-5)Mo (β)	900-1100	6.43×10^{-7}	13,700	From three measurements	81
Molybdenum	Ti-1 at. % Mo (β)	938-1248	1.0×10^{-5}	24,000		86
Scandium	Ti (β)	1000-1200	0.003	25,290	From radioactive-tracer methods	90
Tin	Ti-1 at. % Sn (β)	1004-1250	8.4×10^{-7}	15,300		86
Tin	Ti-8 at. % Sn (β)	1090-1250	2.7×10^{-4}	29,800		86
Tin	Ti-4 at. % Sn (β)	834	0.5×10^{-10}	--		Diffusivity ($\approx D_0$)
Uranium	Ti-5 at. % U (β)	950-1075	4.6×10^{-4}	30,200	Microanalyzer technique	91
Vanadium	Ti-2 at. % V (β)	900-1248	6.0×10^{-3}	39,600		86
Zirconium	Ti-15 at. % Zr (β)		0.00706	27,640		92
Zirconium	Ti-30 at. % Zr (β)		0.00171	24,280		92

(a) Calculated from the Langmuir-Dushman equation.

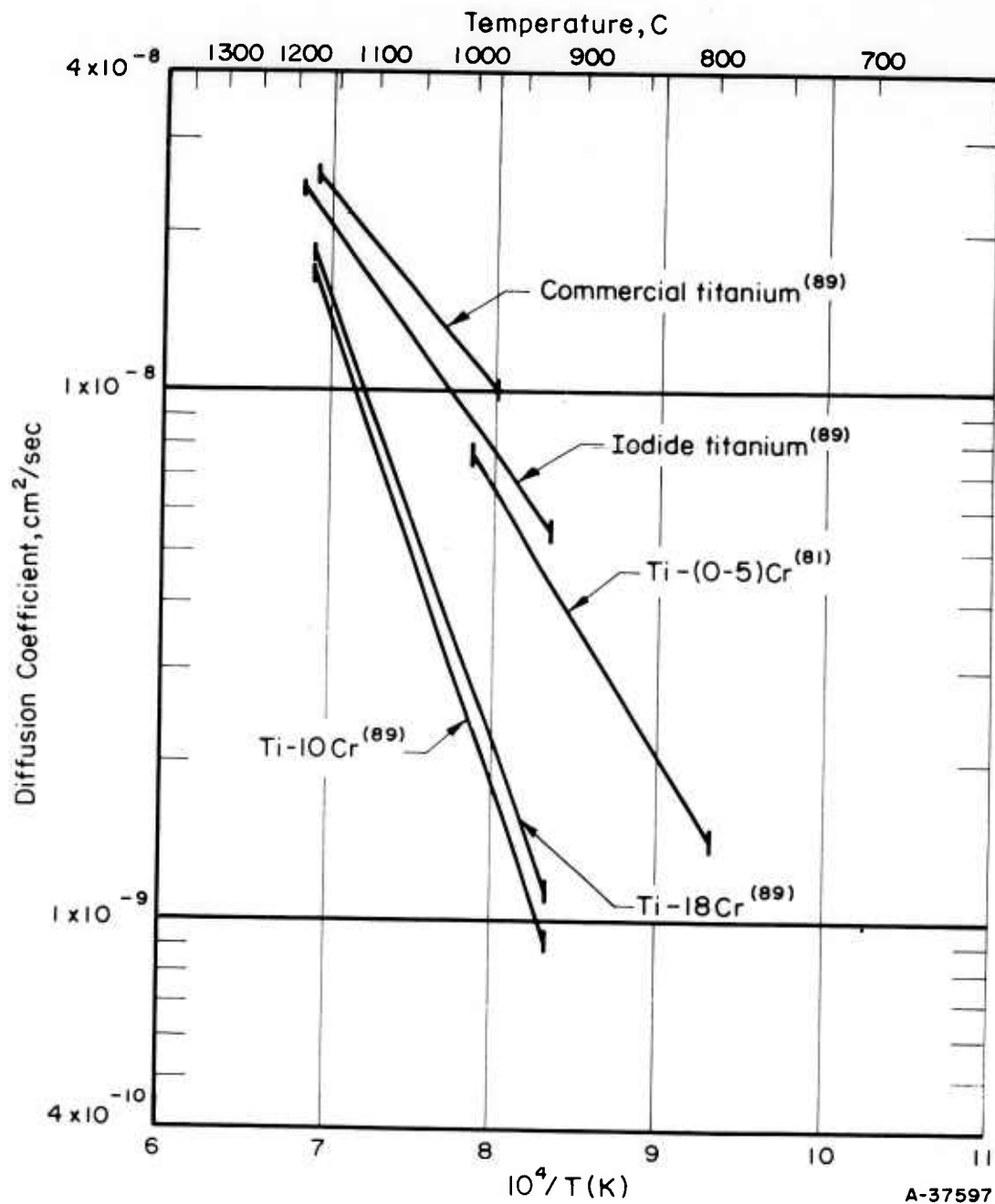


FIGURE 32. EFFECT OF TEMPERATURE ON THE DIFFUSION OF CHROMIUM IN TITANIUM AND TITANIUM-CHROMIUM ALLOYS

Iron

Iron, like chromium, stabilizes the beta phase of titanium and has a relatively low solubility in the alpha phase. Iron is not widely used as an alloying addition to titanium, although it frequently is present as an impurity in rather small concentrations.

The only diffusivity data available for iron in titanium are those reported by Schwöpe, et al. (81) Couples were prepared and exposed at 800, 900, and 1000 C. The concentration gradients were determined by sectioning and chemical analysis, and the diffusion coefficients were calculated using the Grube method. The results are plotted in Figure 33 and listed in Table 16.

The activation energy reported (31,000 cal/mole) is low for a vacancy mechanism; however, the value was taken from a plot based on only three data points. The general order of magnitude of the diffusivity appears reasonable in comparison with values reported for similar elements.

Manganese

Like chromium and iron, manganese is a beta-stabilizing element forming a eutectoid alloy system. Solubility in the alpha phase is limited to less than 0.5 per cent manganese. Manganese was one of the additions used in several early commercial titanium alloys; however, none of the more recently developed alloys contain manganese as an intentional addition.

One determination of the diffusivity of manganese in titanium has been reported by Goold (86), using diffusion couples exposed at temperatures in the beta field (830 to 1190 C). The diffusivities were calculated from data obtained by analysis of turnings from sections of the exposed couples, using the Matano analysis. Because manganese volatilizes readily at high temperatures, radial as well as longitudinal concentration gradients were measured and analyzed.

The results showed a comparatively slight dependence of diffusivity on alloy content for compositions up to 14 atomic per cent manganese. The diffusion constants calculated for a concentration of 8 atomic per cent manganese are presented in Table 16 and plotted in Figure 34. The activation energy reported (35,200 cal/mole) is similar to the values presented for chromium and iron by other workers. Although the results show only a slight composition dependence, it appears that the diffusivity does increase slightly with increasing manganese content.

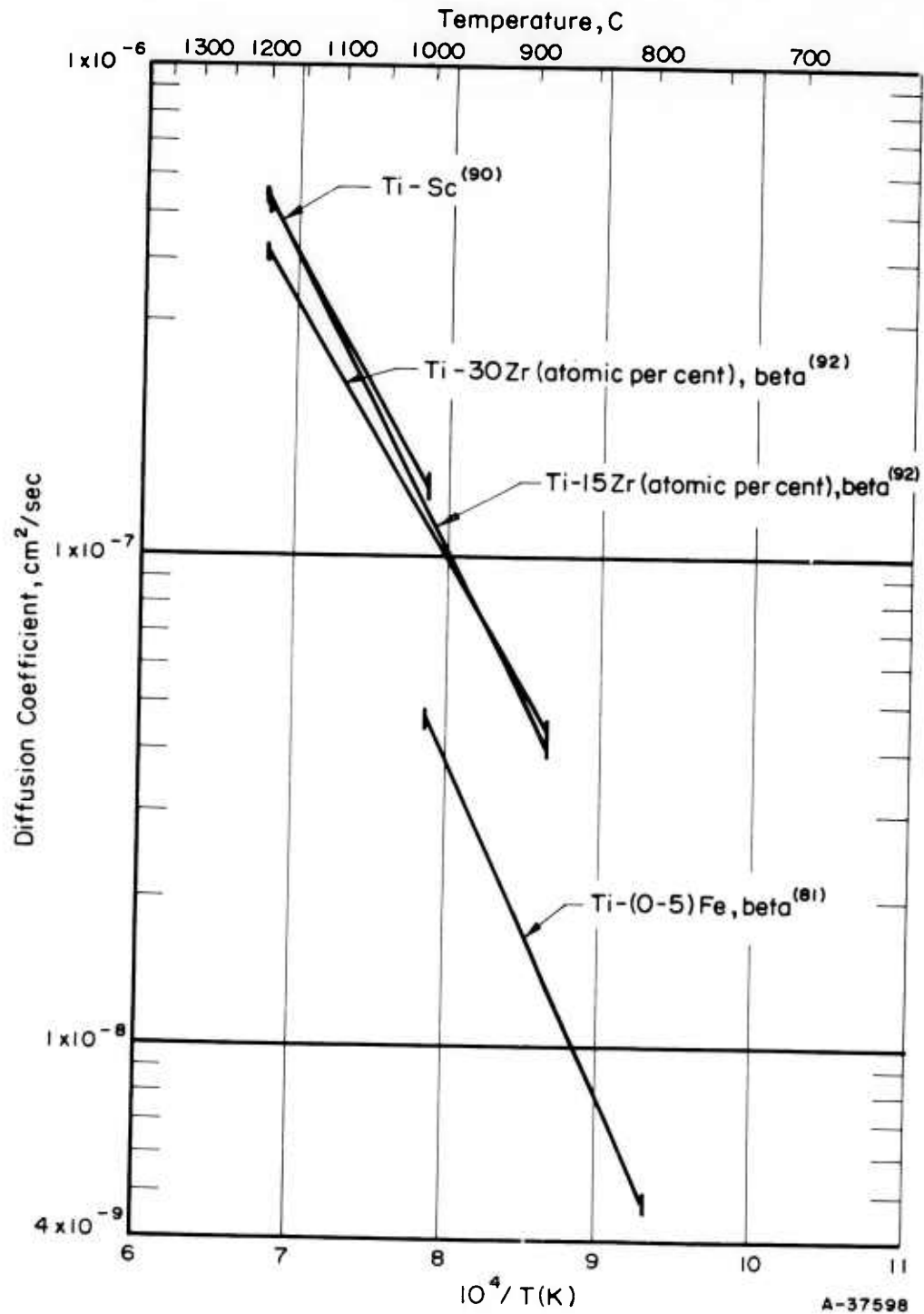


FIGURE 33. EFFECT OF TEMPERATURE ON THE DIFFUSION OF IRON, SCANDIUM, AND ZIRCONIUM IN TITANIUM

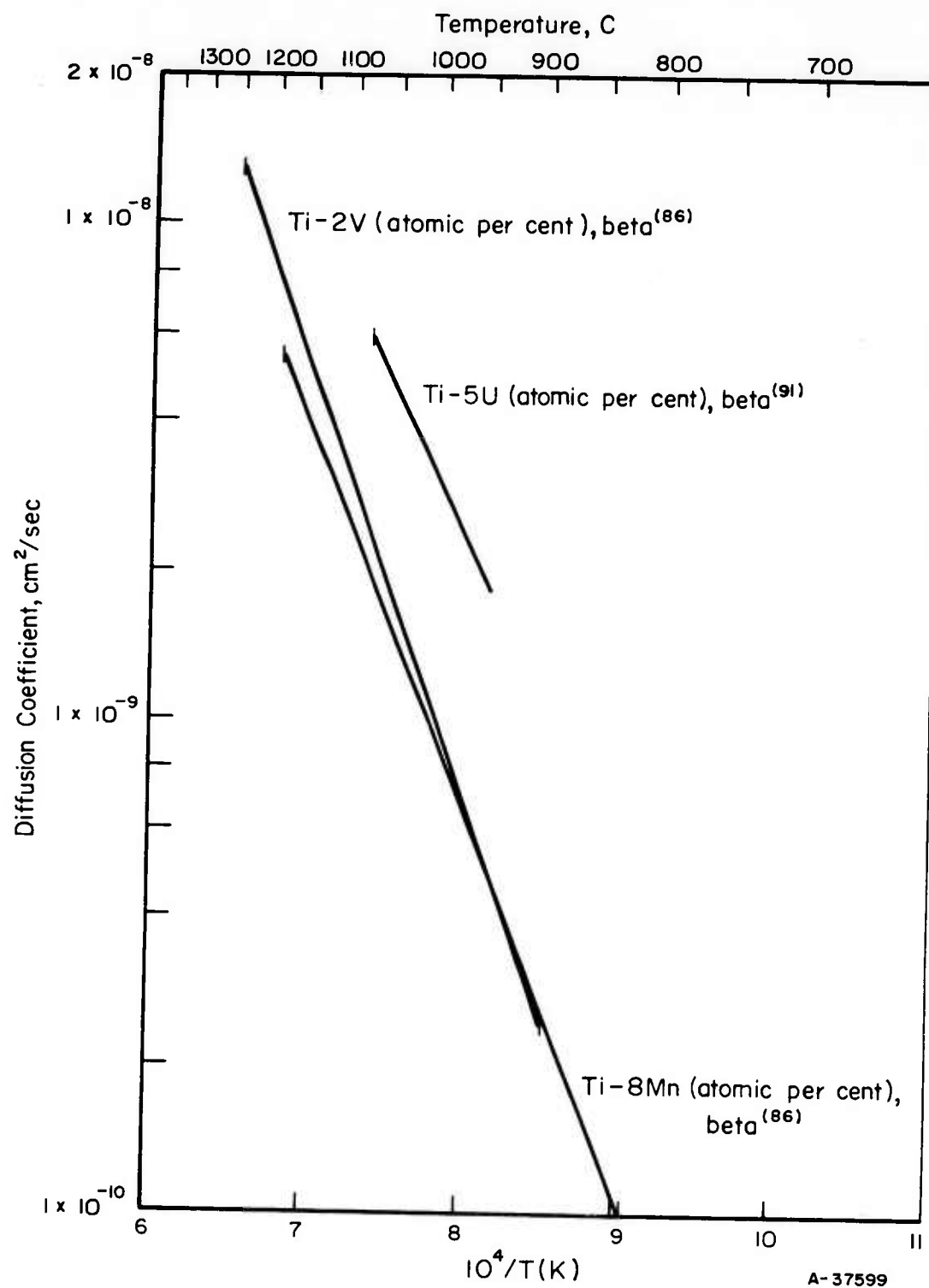


FIGURE 34. EFFECT OF TEMPERATURE ON THE DIFFUSION OF MANGANESE, URANIUM, AND VANADIUM IN TITANIUM

Molybdenum

Molybdenum is a beta-isomorphous alloy addition to titanium, having a relatively low solubility in the alpha phase and complete solubility in the beta phase. Molybdenum is a moderate strengthener, and has been used in a few commercial alloys.

The diffusion rates of molybdenum in titanium have been reported by Schwoppe⁽⁸¹⁾ and Goold⁽⁸⁶⁾. Both workers used couples of titanium and a titanium-molybdenum alloy, with exposures at temperatures above the beta transus. The penetration curves were determined by chemical analyses of turnings taken from longitudinal sections of the couples after exposure. Schwoppe determined the diffusion coefficients by the Grube method, whereas Goold used the Matano analysis.

The earlier results reported by Schwoppe⁽⁸¹⁾ indicated an activation energy of 13,700 cal/mole, a very low value for a substitutional solute. This value was, however, based on points at only three temperatures and thus may be subject to considerable error. Goold⁽⁸⁶⁾ reported an activation energy of 24,000 cal/mole, a value also lower than might be expected. The results obtained by Goold also showed a slightly decreasing rate of diffusion as the molybdenum concentration in the alloy was increased up to about 6 atomic per cent. Both results are included in Table 16, and are shown in Figure 35.

Scandium

The diffusion of radioactive scandium (Sc^{46}) into a series of titanium-columbium alloys was studied at two temperatures by Grum-Gyzhimailo⁽⁹⁰⁾. Values for the diffusion coefficient at 1000 and 1200 C, and the activation energy, were reported for titanium-columbium alloys at 10 atomic per cent intervals. Peaks in the activation energy-composition curve were attributed to the formation of the compounds Ti_2Cb_3 and Ti_3Cb , although these compounds are not shown in the presently accepted equilibrium diagram. Also, inconsistencies between the tabulated diffusion data and the plotted values indicate that the tabular values are incorrect. The data for the diffusion of scandium in unalloyed titanium are included in Table 16 and Figure 33.

Tin

Tin dissolves extensively in both the alpha and beta phases of titanium. It is a moderate strengthener and is used in conjunction with aluminum to form the commercial all-alpha alloy, Ti-5Al-2.5Sn.

Data for the diffusion of tin in titanium have been reported by Goold⁽⁸⁶⁾. Diffusion couples were prepared and exposed at temperatures within both

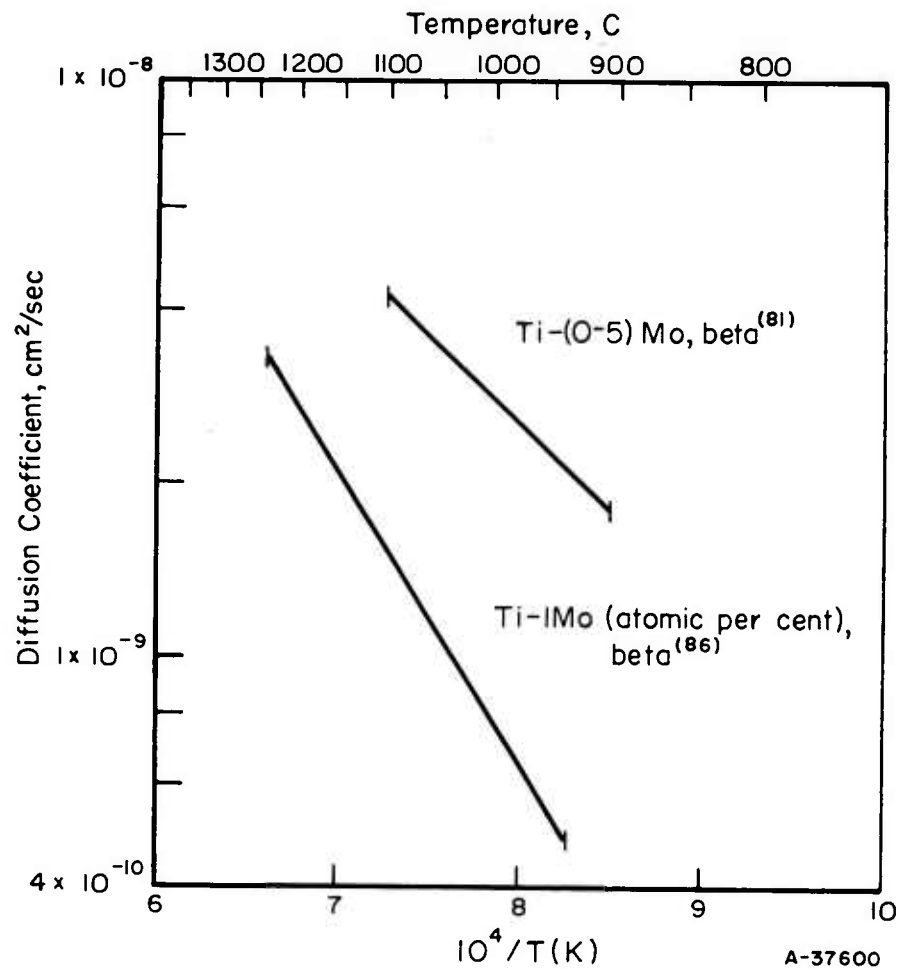


FIGURE 35. EFFECT OF TEMPERATURE ON THE DIFFUSION OF MOLYBDENUM IN DILUTE TITANIUM-MOLYBDENUM ALLOYS

the alpha and the beta fields. Chemical analyses of sections were used to obtain penetration curves, and the resulting data were reduced to diffusion coefficients by the Matano or Grube analysis.

A pronounced composition dependency was observed, with the diffusion rate of tin in beta titanium increasing markedly as the concentration of tin in the alloy was increased. Diffusivities in the lower temperature alpha were slow, so that the temperature dependency was not determined. The activation energy increased from 15,300 to 29,800 cal/mole with a composition change from 1 to 8 atomic per cent tin. The data are listed in Table 16 and plotted in Figure 36.

Uranium

The diffusion of uranium into alloys of titanium with uranium was studied by Adda and Philibert(91). Diffusion couples were prepared between uranium and titanium, and exposed in vacuum at temperatures from 950 to 1075 C. The penetration-time curves were established by use of an X-ray microanalyzer, and the resulting data were reduced to diffusion coefficients by means of the Matano analysis. The diffusivity of uranium in a titanium-5 atomic per cent uranium alloy is shown in Figure 34 and listed in Table 16.

The activation energy (30,200 cal/mole) and the diffusivity are both similar to those found for many of the other metallic substitutional elements. The diffusivity was found to be temperature dependent, with a minimum at about 40 atomic per cent uranium. Thus, uranium additions up to this amount decrease the diffusivity of uranium in titanium alloys.

Vanadium

Vanadium is a beta-isomorphous alloying element with respect to titanium. It is characterized by a somewhat larger solubility in alpha phase than most beta stabilizers, and by complete solubility in beta. Vanadium, like molybdenum, is a moderate strengthener in titanium. It is a constituent of several of the more recent and widely used commercial alloys, and may be considered as one of the more important alloying elements.

The diffusivity of vanadium in titanium has been reported by Goold(86). Diffusion couples were exposed at 900 to 1248 C (in the beta field), and the penetration-time curves determined from chemical analyses of turnings for longitudinal sections. The diffusivities were calculated using the Matano analysis.

The resulting diffusion coefficients are presented in Figure 34 and Table 16. A comparatively slight composition dependency was observed, with the diffusivity decreasing slightly with increasing concentration up to

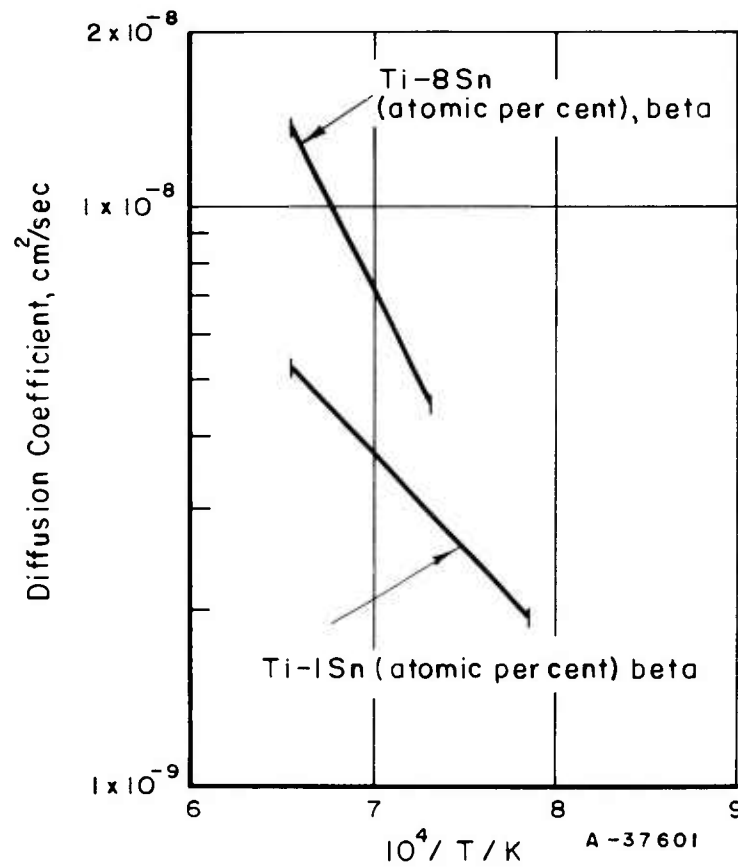


FIGURE 36. EFFECT OF TEMPERATURE ON THE DIFFUSION OF TIN IN DILUTE TITANIUM-TIN ALLOYS⁽⁸⁶⁾

about 12 atomic per cent vanadium. The activation energy, 39,600 cal/mole, and the over-all diffusivity show that vanadium and manganese behave similarly.

Zirconium

Zirconium, a Group V-A metal, is completely soluble in both the alpha and beta phases of titanium. Zirconium is a moderate strengthener, and has been used as an auxiliary strengthener in alpha-titanium alloys.

The only data reported for the diffusion of zirconium in titanium are the preliminary values given by Martens⁽⁹²⁾. This work was conducted using a sandwich of radioactive zirconium (Zr^{95}) between two layers of titanium. The diffusion anneals were made at temperatures in the beta field. Concentration curves were made from measurements of residual radioactivity, and the resulting penetration-time curves were analyzed by means of the Matano method. The resulting data are plotted in Figure 33 and are listed in Table 16.

The results show relatively high diffusion rates, with only a slight dependency on concentration. The activation energy was shown to decrease slightly as the zirconium-titanium ratio was increased from 0.15 to 0.30.

DEFORMATION MECHANISMS AND TEXTURES

When a material is deformed beyond its elastic limit, major internal structural rearrangements occur. These rearrangements, which are not eliminated when the stress is removed, take place primarily by the processes of slip and twinning. Since the ease with which the material can deform is related to the mechanisms by which the rearrangement occurs, while the properties of the material after deformation are related to the final internal arrangement or texture of the material, studies of deformation mechanisms and textures are of considerable interest. As a result, several studies of the effects of alloying upon the deformation mechanisms and texture formation of titanium have been made. These studies are described below.

Deformation Mechanisms

Unalloyed titanium exists in a hexagonal close-packed crystal structure at temperatures below 1620 F. Above this temperature, a body-centered cubic structure is observed. The c/a ratio at room temperature for the hexagonal modification of titanium is 1.587, 2.81 per cent less than

the ideal value of 1.633. As a result of the low c/a ratio, a number of slip and twinning systems are observed.

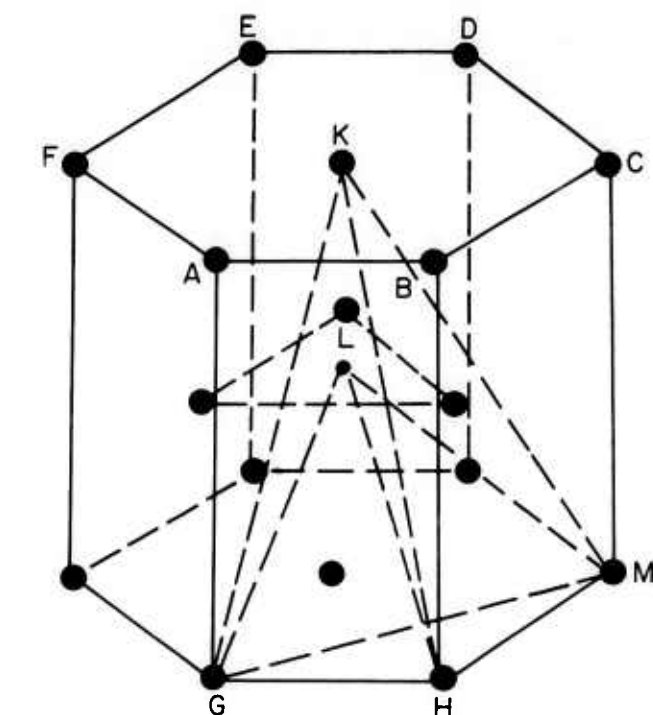
Both slip and twinning systems are operative at room temperature. Slip is observed on the $\{10\bar{1}0\}$, $\{10\bar{1}1\}$, and $\{0001\}$ planes in the $\langle 11\bar{2}0 \rangle$ directions, while twinning is observed on the $\{11\bar{2}1\}$, $\{11\bar{2}2\}$, and $\{10\bar{1}2\}$ planes. In special cases, twinning is also observed on the $\{11\bar{2}3\}$ and $\{11\bar{2}4\}$ planes. The six major slip and twinning systems are shown diagrammatically in Figure 37.

The relative importance of these deformation elements varies with temperature, grain size, and crystal orientation. Increasing temperature tends to favor slip at the expense of twinning, while at very low temperature slip is of negligible importance. Twinning is favored by a coarser grain size, as is slip on the $\{0001\}$ planes. Orientation of the crystal with respect to the stress axis is also of considerable significance. A more complete discussion of these effects may be found in TML Report No. 30.(93)

The effect of alloying upon the deformation mechanisms has not received a large amount of attention. Interstitial contamination is known to cause major changes in the relative importance of the active slip systems, as shown in Table 17. It is seen that, in high-purity material, $\{10\bar{1}0\}$ slip was predominant. Slip on the $\{0001\}$ planes occurred only at certain highly favored orientations, while $\{10\bar{1}1\}$ slip was not observed. In material having a higher interstitial content, the three slip systems were more equally favored. It would appear that interstitials are much more effective in inhibiting $\{10\bar{1}0\}$ slip than $\{0001\}$ or $\{10\bar{1}1\}$ slip. It has been reported that twinning occurs with about the same frequency in iodide- as in sponge-base titanium(95). However, this same investigation failed to observe any difference in the importance of the various slip systems in iodide- and sponge-base titanium, apparently as a result of the limited number of crystal orientations studied.

TABLE 17. CRITICAL RESOLVED SHEAR STRESS FOR SLIP IN TITANIUM AS A FUNCTION OF PURITY (94)

Oxygen Plus Nitrogen, weight per cent	Hardness, VPN	Slip Plane	Critical Resolved Shear Stress, psi
0.01	90	$10\bar{1}0$	2000
		0001	9000
0.1	160-170	$10\bar{1}0$	13,075
		$10\bar{1}1$	14,075
		0001	15,500



Slip Planes
 (0001) ABCDEF
 $(10\bar{1}0)$ ABHG
 $(10\bar{1}1)$ GHK

Slip Direction
 $(11\bar{2}0)$ EKB (of the type AB, BC, CD, etc.)

Twin Planes
 $(10\bar{1}2)$ GHL
 $(11\bar{2}1)$ GMK
 $(11\bar{2}2)$ GML

A-37602

FIGURE 37. LOCATION OF MAJOR SLIP AND TWINNING SYSTEMS IN THE CLOSE-PACKED HEXAGONAL TITANIUM LATTICE

Solid-solution alloying would be expected to affect deformation mechanisms to some significant degree, but information in this area is limited. Deformation markings similar to those in unalloyed titanium are known to occur in alloyed titanium. Some interesting examples of such markings are shown in Figures 38 and 39. The structure shown in Figure 38 shows twinning apparently being transmitted quite freely through the beta phase to successive alpha particles in an alpha-beta Ti-4Al-4Mn alloy. The final twin configuration shown is typical of the observed $\{10\bar{1}2\}$ twinning in unalloyed titanium, but no analysis of the twinning systems was made. Deformation markings observed in two titanium-manganese alloys are shown in Figure 39. Deformation was observed to be restricted to a large extent to the beta phase in this study except when a very large alpha grain size was produced as illustrated in the right-hand photomicrograph of Figure 39a. Pitting of the alpha phase may have obscured fine slip lines, however. The markings observed in the beta phase were identified as representing both slip and twin traces. It is probable that the latter identification is erroneous, however, and that the structures identified as twins were actually strain-induced martensite. The origin of the slip traces in these alloys was not identified.

Studies of the slip mechanisms in an all-beta Ti-26V alloy have suggested that noncrystalline slip of the (112)-(123) type is occurring. (98) It is not known whether slip of this type also occurs in unalloyed beta titanium. Measurements of the critical resolved shear stress for eight single crystals at the Ti-26V composition gave values ranging from 27,550 to 56,150 psi.

Deformation Textures

The deformation textures of unalloyed titanium have been described in considerable detail in a previous Titanium Metallurgical Laboratory report⁽⁹³⁾. The textures developed may be summarized as follows:

Compression texture - 0001 planes inclined $17\frac{1}{2}$ to 30 degrees from the axis of compression

Wire (tension) texture - $10\bar{1}0$ direction parallel to wire (tension) axis

Cold-rolled texture - $10\bar{1}0$ direction parallel to the rolling direction with the 0001 plane inclined 30 degrees from the rolling plane toward the transverse direction

Hot-rolled texture - Similar to cold-rolled texture except that angle of inclination of 0001 planes may approach 40 degrees and the 1120 direction shows some tendency to parallel the rolling direction.

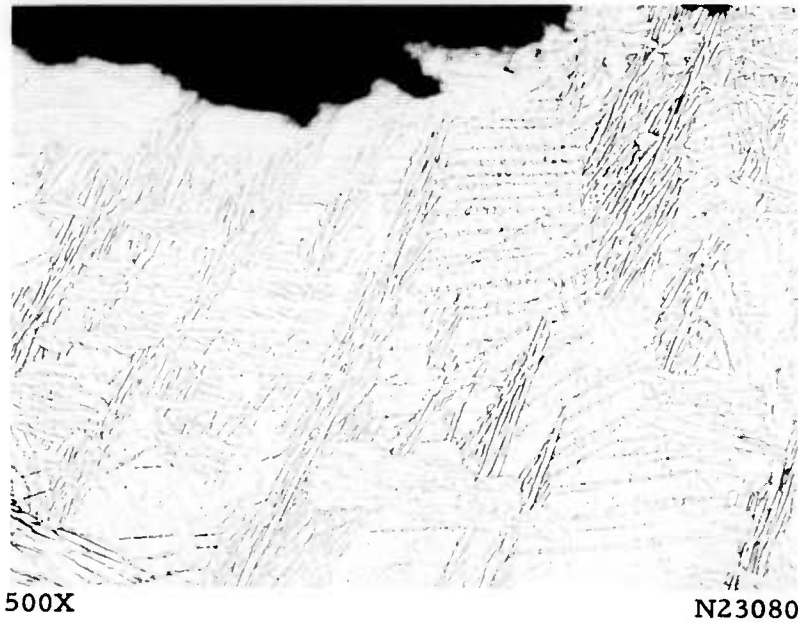
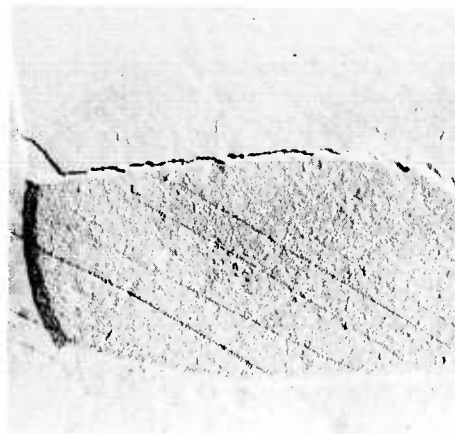


FIGURE 38. MECHANICAL TWINS IN Ti-4Al-4Mn⁽⁹⁶⁾



10,000X

E5233B



10,000X

E5216E

a. Ti-6Mn



15,000X

E5239A

b. Ti-3.4Mn

FIGURE 39. DEFORMATION MARKINGS IN COMPRESSED
Ti-Mn ALLOYS(97)

Alpha is the heavily pitted phase.

Interstitial content has not been found to affect the texture developed by cold rolling to any appreciable extent, although the development of a tendency for 0001 rotation toward the rolling direction as well as the transverse direction has been observed in an isolated case.⁽⁹⁹⁾ Solid-solution additions to alpha titanium do alter the texture developed by cold rolling, however, as shown in Figure 40. The major change in texture was observed in the titanium-aluminum alloy, where the tendency for rotation of the 0001 plane in the transverse direction (double maxima in other 0001 pole figures) was not present. Instead, the 0001 plane tended to be parallel to the rolling plane. The other three alloy systems - titanium-zirconium, titanium-tantalum, and titanium-columbium - were not greatly different from unalloyed titanium. However, differences in the degree of preferred orientation and the angle of rotation of the 0001 planes were evident. The angle of rotation is indicated in parentheses for each alloy in Figure 40. The texture developed in a Ti-0.38Mo alloy on cold rolling has also been found to be similar to that of iodide titanium.

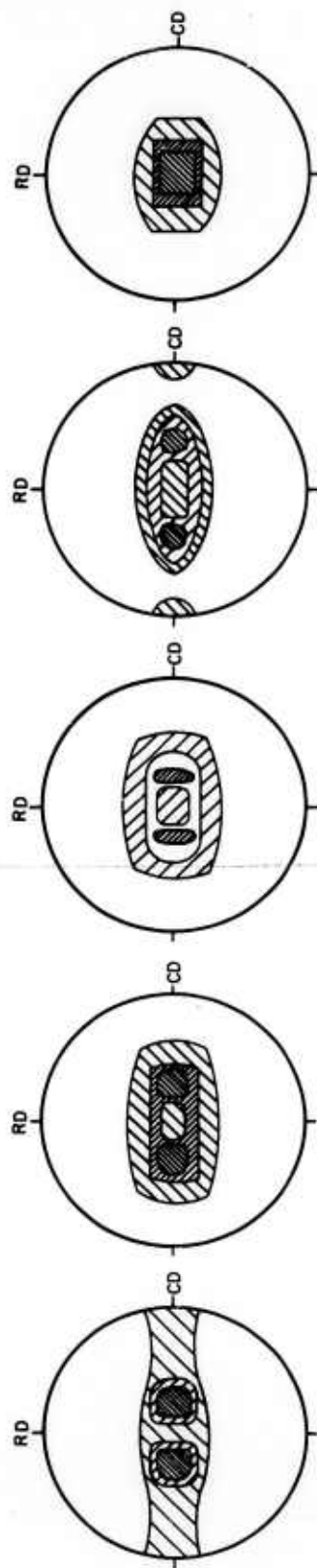
An all-beta Ti-31.8Mo alloy has been found to develop a $\{100\} \langle 110 \rangle$ texture on cold rolling.⁽¹⁰⁰⁾ This is the texture commonly observed in rolled body-centered cubic metals. A Ti-7Mn alloy hot rolled at 1380 F showed traces of both the $\{112\} \langle 110 \rangle$ and $\{111\} \langle 112 \rangle$ textures, but none of the $\{100\} \langle 110 \rangle$ texture.

Alpha-beta alloys would be expected to show textures resulting from deformation of both the alpha and beta phases. In two alloys examined, Ti-5Cr-3Al⁽¹⁰¹⁾ and Ti-14.3Mo⁽¹⁰⁰⁾, this has been found to be the case.

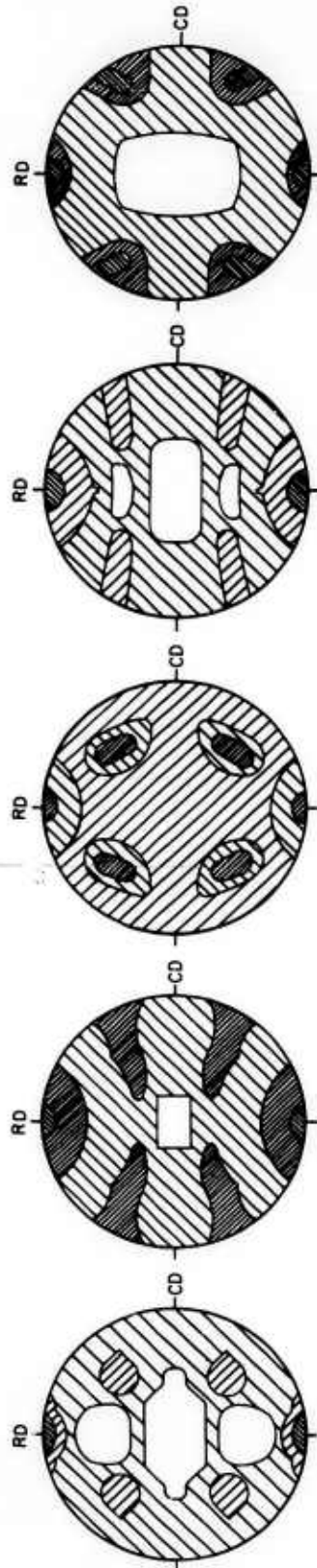
RECOVERY, RECRYSTALLIZATION, AND GRAIN GROWTH

The changes in properties or structure which occur in an alloy during annealing heat treatments are separable into three categories: recovery, recrystallization, and grain growth. The characteristics of these three processes can be best described by reference to the schematic drawing shown in Figure 41.

The recovery process does not generally produce a visible microstructural change. Although differences in the rate of etchant attack during metallographic sample preparation often permit the onset of recovery to be observed, this is not a true structural difference. As shown in Figure 41, anneals in the recovery range result in decreased internal (residual) stress levels in the alloy. This is apparently accomplished by small atomic rearrangements. Strength properties are only slightly affected by the recovery process.



0001 Pole Figures



1010 Pole Figures

N26273

Iodide Titanium
(27°)
c/a=1.500

N26276

Ti-7.1Zr
(30°)
c/a=1.590

N26274

Ti-3.6 Ta
(27°)
c/a=1.584

N26272

Ti-3.6 Cb
(40°)
c/a=1.592

N26275

Ti-3.8Al
(0°)
c/a=1.600 A-37603

FIGURE 40. POLE FIGURES OF IODIDE TITANIUM AND FOUR ALPHA-TITANIUM ALLOYS AFTER COLD ROLLING(102)

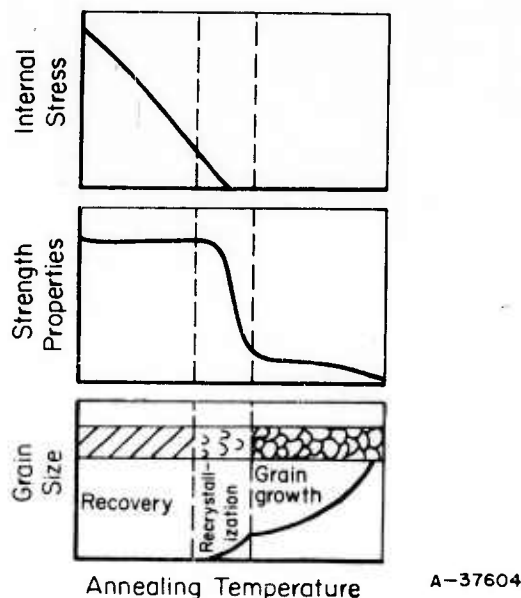


FIGURE 41. SCHEMATIC REPRESENTATION OF RECOVERY, RECRYSTALLIZATION, AND GRAIN GROWTH⁽¹⁰³⁾

At annealing temperatures slightly above those which result in recovery, a major structural rearrangement may occur. New grains are formed within the metal by a process of nucleation and growth, completely removing the structure previously present. This is accompanied by major changes in the strength properties, removal of remaining internal stresses, and changes in a number of other mechanical and physical properties. Recrystallization can occur only when the metal or alloy is initially in a deformed or otherwise unstable condition.

On completion of recrystallization, further annealing may result in grain growth. Grain growth may be either continuous, such that a uniform and gradual increase in grain size occurs, or discontinuous, in which a few grains grow quite rapidly at the expense of the remainder. In both cases, a slight reduction in strength will occur. Grain growth is detrimental primarily through the tendency for large-grained material to be of marginal formability and to respond unevenly to further heat treatments of a strengthening nature. Discontinuous grain growth may also occur in wrought alloys insufficiently strained to induce recrystallization.

Two-phase titanium-base alloys are often given an annealing treatment referred to as a stabilization anneal. The purpose of this treatment is to distribute the alloying additions between the alpha and beta phases in such a manner as to prevent further transformation in service. This type of annealing treatment, not intended primarily to soften the alloy, is described in the Reaction Kinetics section of this report.

In the following sections, the effects of annealing treatments on recovery, recrystallization, and grain growth in titanium are described and the changes in the response to annealing treatments brought about by alloying are outlined. In general, information on the effects of alloying is quite limited at the present time.

Recovery

Annealing treatments designed to produce recovery in titanium alloys are of considerable industrial importance. Those treatments, generally referred to as stress-relief anneals, are universally used to remove forming or assembly stresses in fabricated parts and high residual stresses in mill products. As a result, a considerable amount of data has been collected regarding the effects of various annealing conditions on recovery in the more common titanium alloys.

Since the recovery process is dependent on annealing time and the amount of internal stress initially in the alloy, as well as on the annealing temperature, it is necessary to know all three factors before a comparison of the effects of various alloying additions can be made. The removal of residual stress in annealed commercial-purity titanium (A-55) as a function of annealing time and temperature is shown in Figure 42. These curves show the reduction in the residual stress level of a material initially containing stresses equal to the elastic limit at room temperature (50,000 psi). Removal of all but 10 per cent of the initial stress (reducing the stress level to 5,000 psi) can be accomplished in about 5 minutes at 1100 F (590 C), 2 hours at 1000 F (540 C), or in 50 hours at 900 F (480 C). The major part of the internal stress is removed in the first portion of the stress-relief anneal. Temperature is therefore a much more effective variable than time in stress-relief annealing. The importance of initial stress concentration is shown in Figure 43. Although the final stress level after a given treatment is somewhat dependent on the initial stress level, this dependency is quite temperature sensitive and becomes less significant as temperature is increased. At 1100 F, for example, the final stress level is practically independent of the initial stress.

From these data, it is seen that unalloyed titanium in the annealed condition will be completely stress relieved in about 30 minutes at 1050 F (565 C). This treatment will cause recrystallization in titanium containing moderate amounts of cold work, as will be pointed out later. As a result, recrystallization and recovery occur concurrently in worked unalloyed titanium. In severely rolled iodide titanium, it has been reported that significant amounts of recovery are measurable even after recrystallization is complete. (104)

Alloying would be expected to affect the recovery process to an appreciable extent. The recovery temperatures of several annealed or

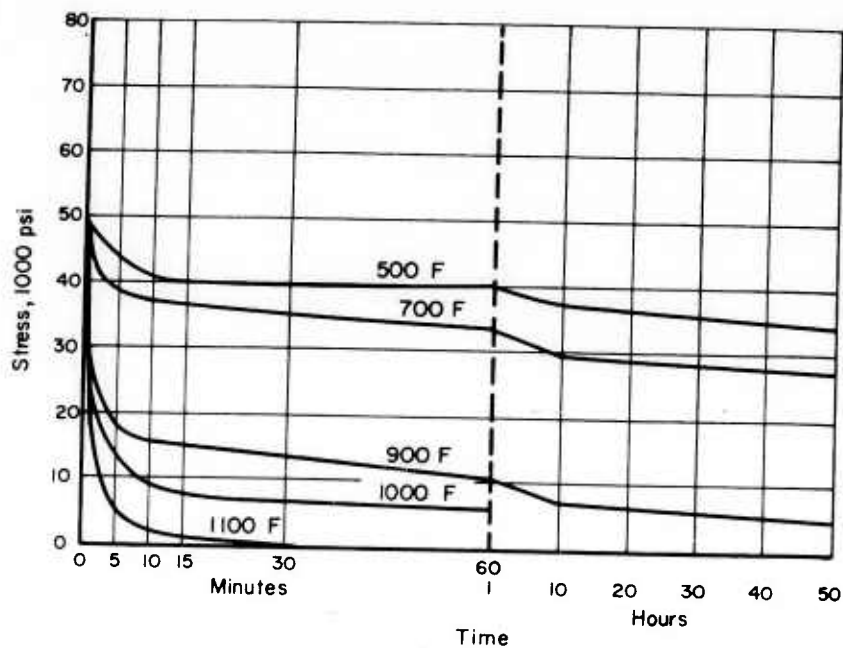


FIGURE 42. RECOVERY DURING ANNEALING OF A-55 TITANIUM ALLOY⁽¹⁰⁵⁾

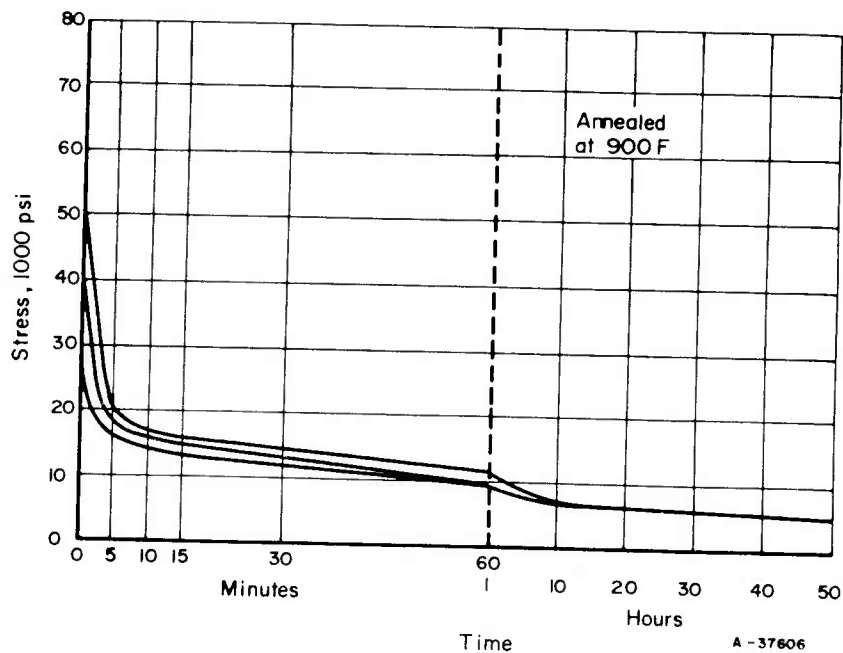


FIGURE 43. EFFECT OF INITIAL STRESS LEVEL IN THE RECOVERY OF A-55 TITANIUM ALLOY DURING ANNEALING⁽¹⁰⁵⁾

stabilized titanium alloys are given in Table 18. Two alloy effects are apparent in these data. Alpha alloys (unalloyed titanium and Ti-5Al-2.5Sn) respond more sluggishly to stress relief than do alpha-beta alloys (Ti-8Mn and Ti-6Al-4V), and aluminum increases the sluggishness of both alpha and alpha-beta alloys.

TABLE 18. STRESS-RELIEF TREATMENTS FOR SEVERAL TITANIUM ALLOYS⁽¹⁰⁵⁾

Alloy	Stress-Relief Temperature, F	Treatment(a) Time, hours
Unalloyed titanium (A-55)	1050	1/2
Ti-8Mn	1000	1/2
Ti-6Al-4V	1100	1/2
Ti-5Al-2.5Sn	1400	1/2

(a) To remove 90 per cent of residual stress in alloys in the annealed or stabilized condition containing stresses equal to the elastic limit at room temperature.

Data comparing the effectiveness of two stress-relief treatments in promoting recovery in titanium alloys are shown in Table 19. These studies also show the greater sluggishness of alpha alloys as compared with alpha-beta alloys and of high-aluminum alloys as compared with aluminum-free alloys. In both investigations it was found that recovery behavior was closely related to creep behavior. Grain size, for example, affected recovery in much the same manner as it affects creep, stress relief in a coarse-grained material occurring more sluggishly than in a fine-grained material, particularly at higher annealing temperatures.⁽¹⁰⁵⁾

TABLE 19. EFFECTIVENESS OF TWO STRESS-RELIEF TREATMENTS IN PROMOTING RECOVERY IN TITANIUM ALLOYS

Alloy	Per Cent of Initial Stress Remaining After 1000 Hours (a)		
	600 F	800 F	References
Unalloyed titanium (A-70)	74	17	105
Ti-5Al-2.5Sn	88	70	105
Ditto	85	80	106
Ti-3Mn-1Fe-1Mo-1Cr-1V	75	13	106
Ti-4Al-4Mn	89	18	105
Ditto	90	33	106

(a) Alloys initially stressed to approximately 80 per cent of the yield strength at the stress-relief temperature. Annealed or stabilized condition.

The observation that recovery rate was closely related to creep rate suggested that recovery might be affected by heat treatment or cold work. Samples of Ti-4Al-4Mn and Ti-3Mn-1Fe-1Mn-1Cr-1V were examined after solution heat treating and aging, and were found to vary only slightly from stabilized samples in rate of recovery.⁽¹⁰⁶⁾ Cold working increased the rate of recovery in Ti-5Al-2.5Sn with the difference in rate of recovery becoming greater at higher temperatures.⁽¹⁰⁶⁾

Stress-relief anneals on alpha-beta alloys should be conducted at or below the final temperature of the stabilization anneal, usually 1050 to 1100 F, to prevent changes in the structural configuration of the alloys. It would appear from Tables 18 and 19 that this requirement can be met in present alpha-beta alloys without difficulty.

Recrystallization

Recrystallization in unalloyed titanium occurs considerably below the alpha-beta transformation temperature (882 C or 1620 F) and is a function of both annealing time and temperature. The amount of prior deformation is also significant. The effect of the amount of deformation by cold rolling on the recrystallization process in unalloyed titanium (146 Bhn) is shown in Table 20. It is seen that recrystallization temperature can vary appreciably with per cent reduction. Grain size of the recrystallized material also varies with amount of reduction, as shown in Figure 44. Grain size is relatively independent of amount of reduction beyond about 20 per cent, but increases rather markedly with recrystallization temperature. Some grain growth may have occurred in these studies. At reduction of less than 20 per cent, grain size increases as amount of reduction decreases. The effects of amount of deformation on recrystallization temperature and recrystallized grain sizes have been confirmed by separate investigation of commercial-purity titanium.^(108,109) It was also reported in one of these studies that recrystallization between 5 and 20 per cent deformation did not occur by a nucleation and growth process, but by grain-boundary migration.⁽¹⁰⁸⁾ If so, this represents discontinuous grain growth rather than recrystallization. It has been reported that grain size after recrystallization is independent of initial grain size.⁽¹⁰⁷⁾

Increased purity decreases the recrystallization temperature. Recrystallization is evident in heavily worked iodide titanium after short annealing treatments at 750 F.^(110,111) As shown in Table 20, recrystallization is not observed in commercial-purity titanium until annealing at around 880 F. Complete recrystallization in iodide titanium also occurs at lower temperatures.⁽¹¹²⁾ At equivalent amounts of deformation, iodide titanium will apparently show complete recrystallization with an annealing treatment about 100 F lower than that needed for commercial-purity titanium. Recrystallized grain size is not greatly affected by purity. The

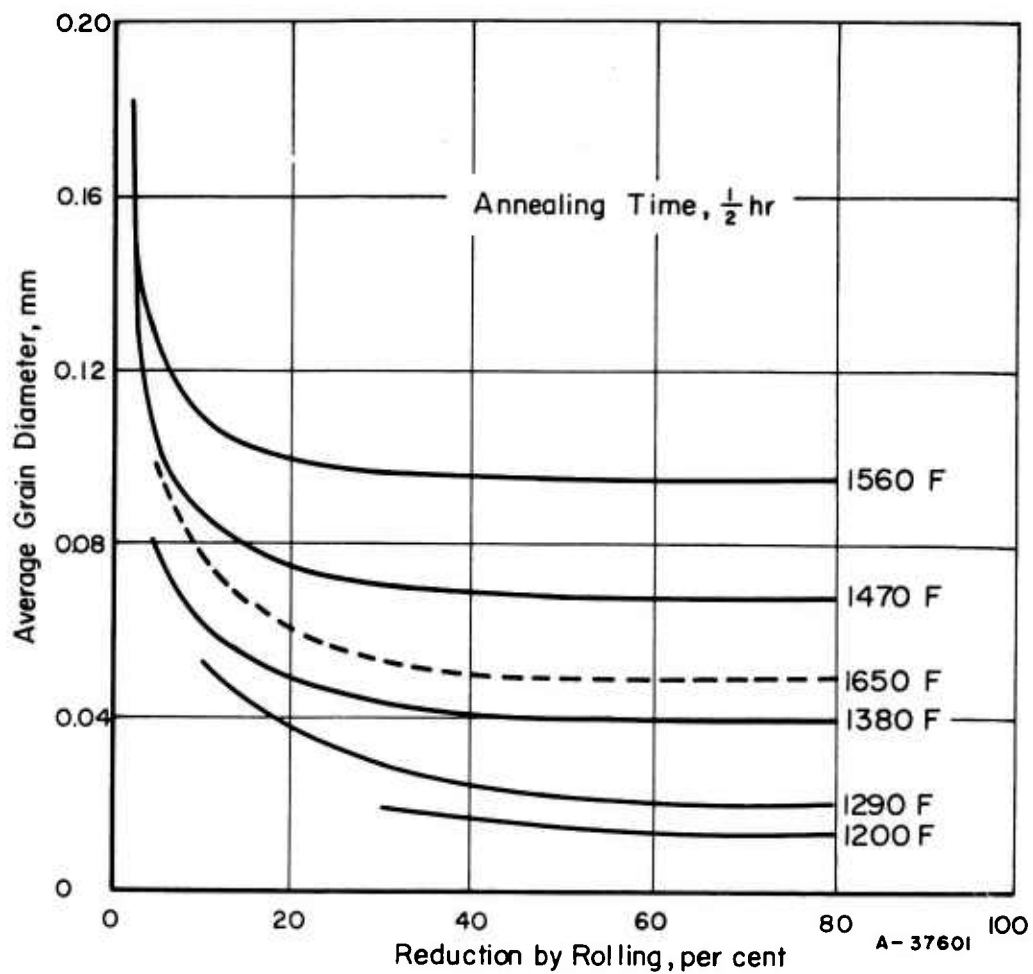


FIGURE 44. EFFECT OF AMOUNT OF DEFORMATION ON RECRYSTALLIZED GRAIN SIZE OF UNALLOYED TITANIUM⁽¹⁰⁷⁾

grain size of iodide titanium is comparable to that for commercial titanium shown in Figure 44. (113)

TABLE 20. EFFECT OF DEFORMATION ON RECRYSTALLIZATION OF UNALLOYED TITANIUM⁽¹⁰⁷⁾

Reduction by Cold Rolling, per cent	Recrystallization Temperature Range, F ^(a)	
	Initiation	Completion
10	1065-1110	1200-1290
20	1020-1065	1155-1200
30	930-1020	1155-1200
40	930-1020	1155-1200
50	840-930	1155-1200
65	840-930	~1155
80	840-930	1110-1155

(a) Annealed 30 minutes at indicated temperature.

Comparisons of the effects of alloying on the recrystallization of titanium may be made by determining the time for recrystallization at a single annealing temperature or by determining the temperature for recrystallization at a single annealing time. Both methods have been used in studies of titanium alloys.

The effects of six alloying additions on the time required to complete recrystallization of alpha or near-alpha sponge-base alloys at 895 F are shown in Table 21. Cobalt, aluminum, and iron additions retard recrystallization only slightly according to this investigation. The most effective addition studied from the standpoint of retarding recrystallization was chromium. Tantalum and tin were intermediate in their effect on recrystallization. Another comparison of the effects of alloying on recrystallization of titanium is shown in Table 22. In this study, the temperature at which recrystallization was first evident after annealing 1/2 hour was measured for fourteen binary titanium-alloy systems prepared from iodide titanium. If the effects of the additions in alpha or near-alpha alloys are considered, it is seen that the more effective additions in raising recrystallization temperature of alpha are, in decreasing order, as follows: aluminum (4.5%), tin (8.9%), rhenium (3.7%), vanadium (2.5%), oxygen (0.827%), nitrogen (0.236%), and carbon (0.54%). These additions raised the recrystallization temperature from 45 to 225 F. Alpha-soluble amounts of cobalt (0.37%), chromium (0.66%), and manganese (0.46%) had no effect on recrystallization temperature, while columbium (3.0%) lowered the recrystallization temperature. The effectiveness of aluminum in raising the recrystallization temperature of alpha titanium has been confirmed by two

other investigations^(45,115) in which the recrystallization temperature of alpha titanium was raised by 220 to 370 F by 4 to 5 per cent aluminum. The relatively small increase in recrystallization temperature resulting from alloying with oxygen has also been confirmed. ⁽¹¹⁶⁾

TABLE 21. EFFECT OF ALLOY COMPOSITION ON RECRYSTALLIZATION OF TITANIUM⁽¹¹⁰⁾

Alloying Addition	Time for Complete Recrystallization at 895 F, hours ^(a)
None (sponge-base titanium)	10
0.2-0.5Co	20
0.2-1.0Fe	30
0.2-1.0Al	40
0.2-0.4Ta	130
0.2-1.0Sn	130
0.2-0.5Cr	<1000

(a) Cold rolled 50 per cent before annealing.

Because of the differences in base-metal purity and methods of measuring recrystallization, a direct comparison of the data in Tables 21 and 22 is not possible. However, it is apparent that the results in Table 21 are in disagreement with those in Table 22 in two instances, the relative effectiveness of aluminum and of chromium. The slight effect of aluminum reported in Table 21 may be due to the smaller amounts of alloy addition studied. The reason for the differences between the studies relating to the effectiveness of chromium additions are difficult to rationalize, however, and further study of the effect of chromium upon recrystallization temperature would appear desirable.

The data in Table 22 also show that two-phase structures retard recrystallization. This is true both for alpha-beta structures [rhenium (5.8%), vanadium (10.3%), manganese (3.58%), and iron (5.0%)], where the recrystallization temperature was raised by 180 to 450 F, and for alpha-compound structures [boron (0.25%), oxygen (0.8%), and beryllium (1.0%)], where recrystallization temperature was raised by 80 F. One alpha-beta alloy, 7.7 per cent columbium, and one alpha-compound alloy, 4.05 per cent cobalt, showed a reduced recrystallization temperature.

The recrystallization temperature of beta alloys appears to be less than that of the two-phase alloys, as shown by the results reported in Table 22 for Ti-30V. A decreased recrystallization temperature at higher alloy contents is also seen in the titanium-chromium system. Other work has shown a Ti-15Mo beta alloy to be completely recrystallized in 3.5 minutes at 1380 F (750 C) after 50 per cent reduction. ⁽¹¹⁷⁾

TABLE 22. EFFECT OF ALLOY COMPOSITION UPON THE INITIATION OF RECRYSTALLIZATION IN TITANIUM⁽¹¹⁴⁾

Alloy Addition	Temperature at Which Recrystallization is Initiated in 1/2 Hour, F(a)
None (iodide titanium)	1020
0.82V	1020
2.55V	1150
10.3V	1380
30V	1200
0.13Cb	1020
3.0Cb	975
5.0Cb	975
7.7Cb	975
0.49Re	1065
0.96Re	1155
3.7Re	1200
5.8Re	1470
0.66Cr	1020
2.98Cr	1150
4.64Cr	1380
9.47Cr	1110
0.2Fe	1020
1.3Fe	1020
5.0Fe	1200
0.46Mn	1020
1.0Mn	1065
3.58Mn	1200
0.37Co	1020
1.52Co	1020
4.05Co	975
0.2Be	1065
0.5Be	1155
1.0Be	1200
0.04B	1065
0.11B	1065
0.25B	1110

TABLE 22. (Continued)

Alloy Addition	Temperature at Which Recrystallization is Initiated in 1/2 Hour, F ^(a)
0.03C	1065
0.54C	1065
0.80C	1110
1.3Al	1200
2.7Al	1110
4.5Al	1245
0.8Sn	1020
1.8Sn	1110
5.9Sn	1155
8.9Sn	1245
0.04 O	1065
0.1 O	1065
0.25 O	1110
0.82 O	1110
0.05N	1065
0.134N	1065
0.236N	1065

(a) Cold rolled 40 per cent before annealing.

The annealing treatments recommended for use with commercial titanium alloys are shown in Table 23. These treatments are of two types: either a simple recrystallization anneal or, in the case of more complex alloys, a recrystallization anneal followed by a stabilization anneal to return the alloy to a stable configuration.

Although a moderate amount of information on the effects of alloying additions upon the recrystallization temperature (or time) of titanium alloys is available, the effect of alloying on recrystallized grain size has received little attention. It has been reported that certain compound-forming additions reduce the grain size of alpha. (118, 119) Whether these additions are effective by inhibiting grain growth or whether they also reduce recrystallized grain size has not been determined. It seems likely that both recrystallized grain size and grain growth would be affected, however.

Grain Growth

The importance of grain size has resulted in a fairly large number of studies of grain growth in titanium alloys. The type of behavior observed is shown in Figure 45. The constant grain size observed on annealing at 1560 F (850 C) has been related to the presence of impurities located in the original grain boundaries of the material before cold rolling. Grain-growth data for commercial-purity titanium are shown in Figure 46. The absence of grain growth at 1830 F in this study was related to the precipitation of a nonmetallic phase at high temperatures. These curves also differ from those shown in Figure 45 by showing a decreased slope at lower temperature, which has been tentatively related to the presence of impurity-stabilized beta in the alloy.

Grain growth in an alloy is related to the grain size by an equation of the following type(119):

$$\frac{dD}{dt} = \frac{K}{D^m},$$

where dD/dt is the linear rate of grain growth, D is the grain size, and K and m are constants. Thus, grain-growth rates should be compared at a constant grain size. The rates of grain growth of unalloyed titanium at several temperatures for two different grain sizes are given in Table 24.

The rate of grain growth at an initial grain size of 0.1 mm is shown in Figure 47, using the data from Table 24. The two studies made with iodide titanium are in general agreement, and show a progressive increase in the rate of grain growth with temperature. The results of studies with commercial-purity titanium show a similar dependence of grain growth on annealing temperature. At low temperature, the difference in rate of grain

TABLE 23. ANNEALING TREATMENTS FOR COMMERCIAL
TITANIUM ALLOYS⁽¹²⁰⁾

Alloy Composition	Annealing Treatment ^(a)
Unalloyed titanium (A70)	1 hr 1250 F, A. C.
Ti-5Al-2.5Sn	1/2 hr 1500 F, A. C.
3Mn-1.5Al	1/3 hr 1350 F, A. C.
3.25Mn-2.25Al	Ditto
6Al-4V	1/2 to 2 hr 1500 to 1300 F, F. C. to 1100 F, A. C.
4Al-4Mn	1 hr 1300 F, A. C.
5Al-2.75Cr-1.25Fe	1 hr 1450 F, F. C. to 1100 F, A. C.
3Al-5Cr	1 hr 1300 F, A. C.
8Mn	1 hr 1300 F, F. C. to 1050 F, A. C.
8Al-1Mo-1V	24 hr 1400 F, A. C.; or 1 hr 1650 F, A. C., 24 hr 1100 F; or 1 hr 1850 F, A. C., 24 hr 1100 F
8Al-2Cb-1Ta	1/3 to 1 hr 1650 F, A. C.
8V-5Fe-1.33Al	1/2 hr 1250 F, F. C. to 900 F, A. C.
13V-11Cr-4Al	1/4 to 1/2 hr 1400 F, A. C.

(a) A. C. = air cool, F. C. = furnace cool.

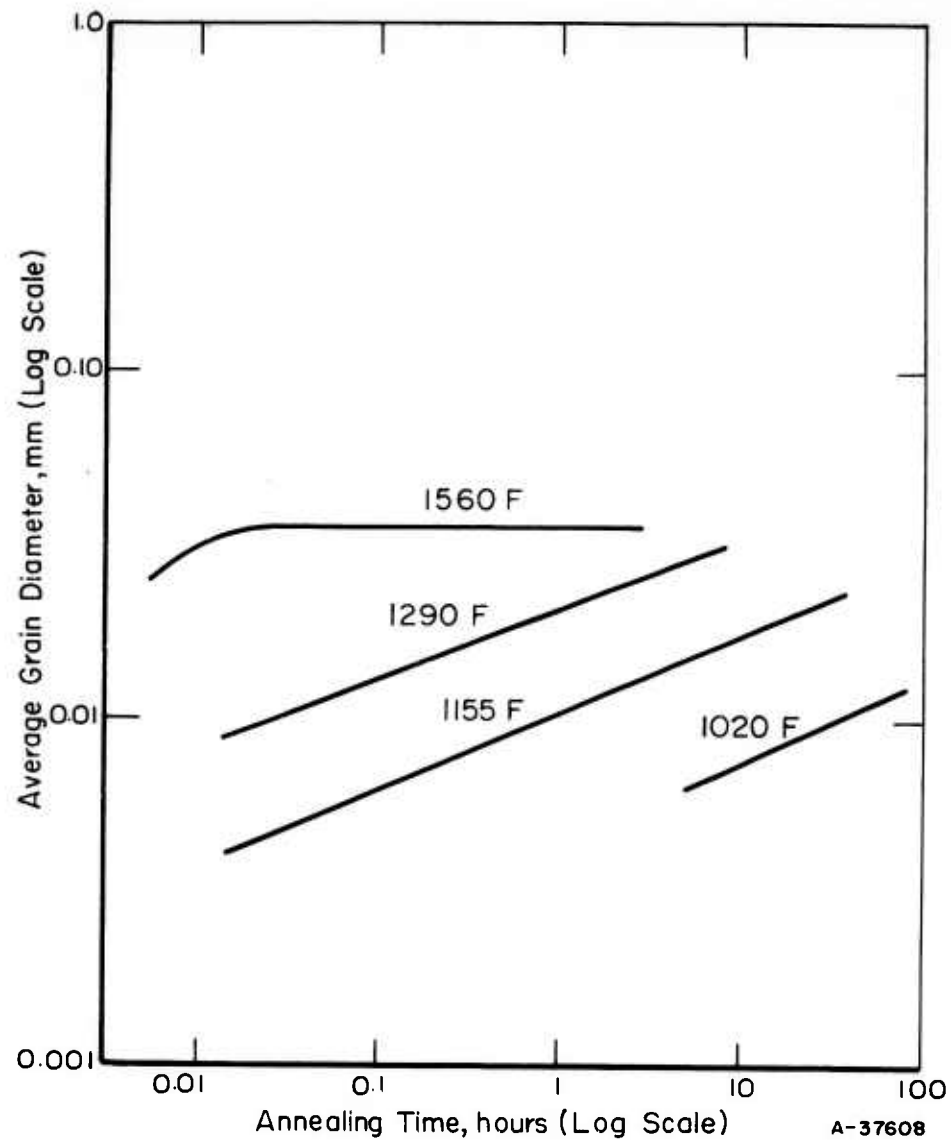


FIGURE 45. GRAIN GROWTH IN IODIDE TITANIUM COLD ROLLED 94 PER CENT AND ANNEALED AS INDICATED⁽¹⁰⁴⁾

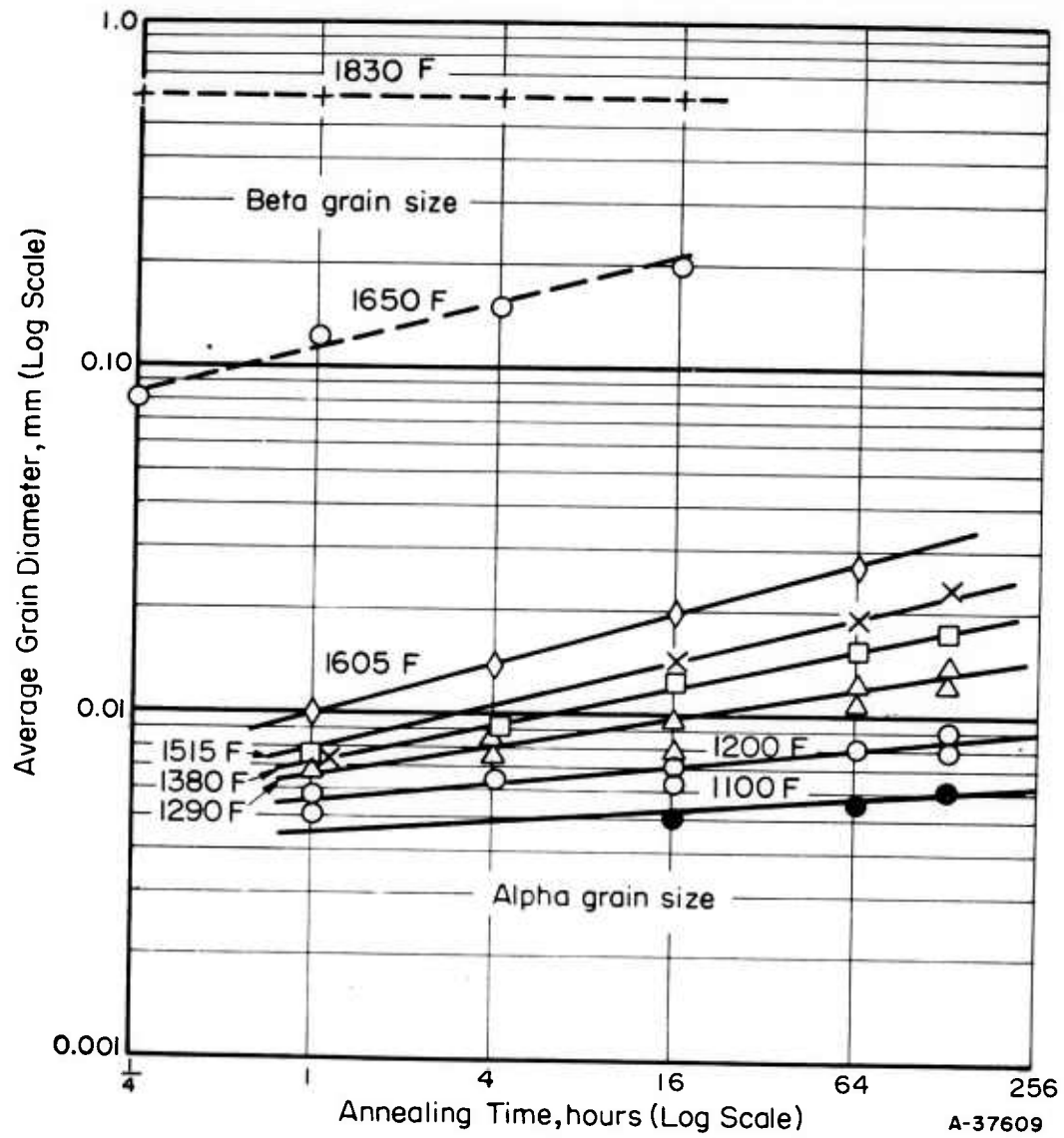


FIGURE 46. GRAIN GROWTH IN HOT WORKED (1300 F) COMMERCIAL-PURITY TITANIUM⁽¹¹⁷⁾

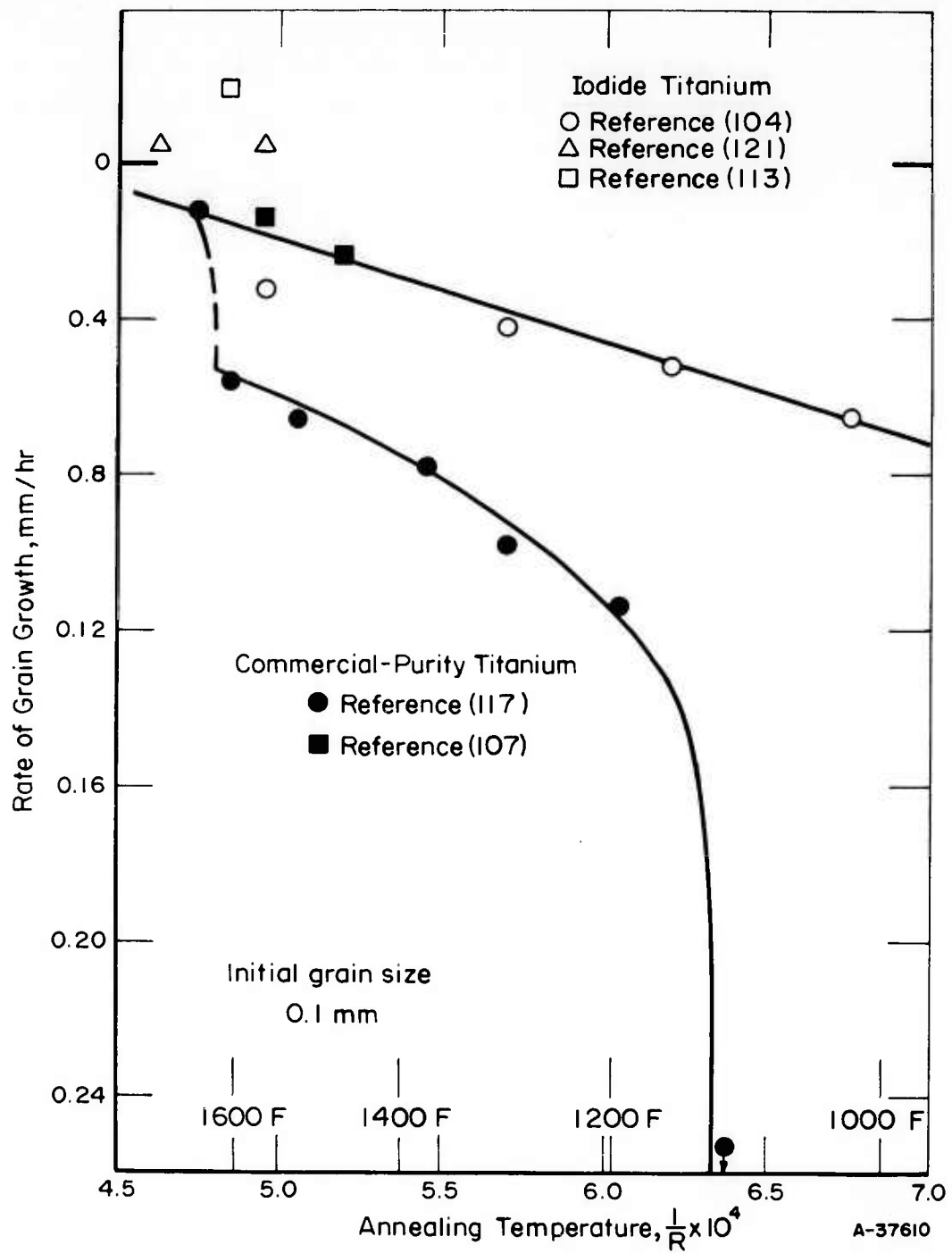


FIGURE 47. RATE OF GRAIN GROWTH IN UNALLOYED TITANIUM

growth between iodide and commercial-purity titanium observed in one of the studies⁽¹¹⁷⁾ was quite large. As indicated above, this was believed due to the presence of significant amounts of stabilized beta in the alloy. As the annealing temperature was increased, the difference became less. When the transformation temperature was exceeded (>1620 F, $\frac{1}{T(R)} \times 10^4 = 4.81$), commercial-purity titanium exhibited a rate of grain growth similar to that for iodide titanium. The rate of grain growth observed in commercial-purity titanium in the second study⁽¹⁰⁷⁾ was similar to that of iodide titanium. The material used in this study was relatively free of second-phase material. The data on the grain growth in beta titanium is quite meager. It would appear, however, that, for iodide titanium, the rate of grain growth is not greatly different in beta titanium at 1700 F (925 C) than that which alpha titanium would show at that temperature if it were stable. In commercial-purity titanium, the alloy shows an appreciably greater grain growth rate at 1650 F (900 C) than would have been estimated from the growth rates of alpha. As pointed out previously, this is the result of inhibited grain growth in commercial-purity alpha titanium.

TABLE 24. RATE OF GRAIN GROWTH IN UNALLOYED TITANIUM

Material	Annealing Temp, F	Rate of Grain Growth, mm/hr		References
		Initial Grain Size, 0.1 MM	Initial Grain Size, 1.0 MM	
Iodide titanium	1020	3.5×10^{-7}	7.9×10^{-10}	104
	1155	5.3×10^{-6}	8.3×10^{-9}	104
	1290	7.2×10^{-5}	5.9×10^{-8}	104
	1560	6.8×10^{-4}	2.7×10^{-6}	104
Iodide titanium	1550	3.4	2.0×10^{-6}	121
	1700	2.9	5.0×10^{-4}	121
Iodide titanium	1605	1.1×10^{-2}	1.1×10^{-6}	113
Commercial-purity titanium	1110	6.9×10^{-27}	8.9×10^{-44}	117
	1200	4.9×10^{-12}	1.5×10^{-18}	117
	1290	1.4×10^{-10}	2.2×10^{-16}	117
	1380	1.8×10^{-8}	9.1×10^{-13}	117
	1515	3.0×10^{-7}	1.1×10^{-10}	117
	1605	2.2×10^{-6}	2.1×10^{-9}	117
	1650	7.4×10^{-2}	7.8×10^{-6}	117
Commercial-purity titanium	1470	7.2×10^{-3}	1.4×10^{-8}	107
	1560	6.2×10^{-2}	3.6×10^{-3}	107

Discontinuous grain growth has been observed in both iodide and commercial-purity titanium strained less than the amount necessary to induce recrystallization.⁽¹¹¹⁾ In this case, the grain-growth rate did not

decrease as grain size increased, but was constant at each annealing temperature, such that very large grains were developed. The rate of growth of iodide titanium at 1380 F (750 C), for example, was 9.4×10^{-2} millimeters, resulting in a grain size of about 0.50 millimeters after only 6 hours at temperature.

The results of grain-growth measurements on four binary titanium-molybdenum alloys are shown in Figure 48. All of these alloys were annealed in the beta region. It is seen that the Ti-3Mo and Ti-7Mo show slightly more rapid grain growth, Ti-11Mo about the same rate of growth, and Ti-15Mo a lower rate of growth than iodide titanium (based on the extrapolated curve in Figure 47). A similar plot of the results of a study of grain growth in ternary titanium-molybdenum-chromium alloys is shown in Figure 49. In the Ti-2.5Cr-2.5Mo alloy, the rate of grain growth is quite retarded up to the beta transus (~1600 F or 870 C). Above this temperature, the rate of growth is slightly less than that for iodide titanium. The Ti-7.5Cr-7.5Mo alloy shows a rate of grain growth only slightly less than that of iodide titanium, and about the same as that described in Figure 48 for Ti-15Mo. The rate of grain growth of both of these alloys appeared to be less affected by high temperatures than iodide titanium or binary titanium alloys.

These results suggest that the rate of grain growth of titanium alloys is not greatly affected by compositional changes so long as a new phase is not introduced into the structure. A study of a number of alloying additions in small amounts in iodide titanium gave a similar result.⁽¹¹⁸⁾ This study also included an examination of the grain-refining action of additions which formed a second phase. Several of these were effective in reducing grain size, notably combinations of boron and carbon, beryllium and carbon, or boron and silicon. Sulfur⁽¹²¹⁾ and carbon⁽¹²²⁾ are also known to act as grain refiners in titanium. An indication of the amount of grain refinement observed in beta titanium alloys when a finely dispersed second phase is present is shown in Figure 50. Although the dispersion may act to reduce the recrystallized grain size as well as grain growth, the data given in Table 25 indicate that the rate of grain growth in these alloys has been reduced by a considerable amount. As already pointed out, the presence of small amounts of alpha in beta has a similar retarding effect on grain growth.

It would appear that the rate of grain growth in titanium alloys is affected much more strongly by the presence of a dispersed second phase than by solid-solution alloy modification. Pending discovery of a solution addition which retards the rate of grain growth, therefore, grain-refining additions should be those which form a reasonably stable, low-solubility second phase. Alternately, a dispersion of either alpha or beta titanium can be used to prevent grain growth in suitably alloyed materials. This procedure is used quite extensively both during fabrication and during heat treatment

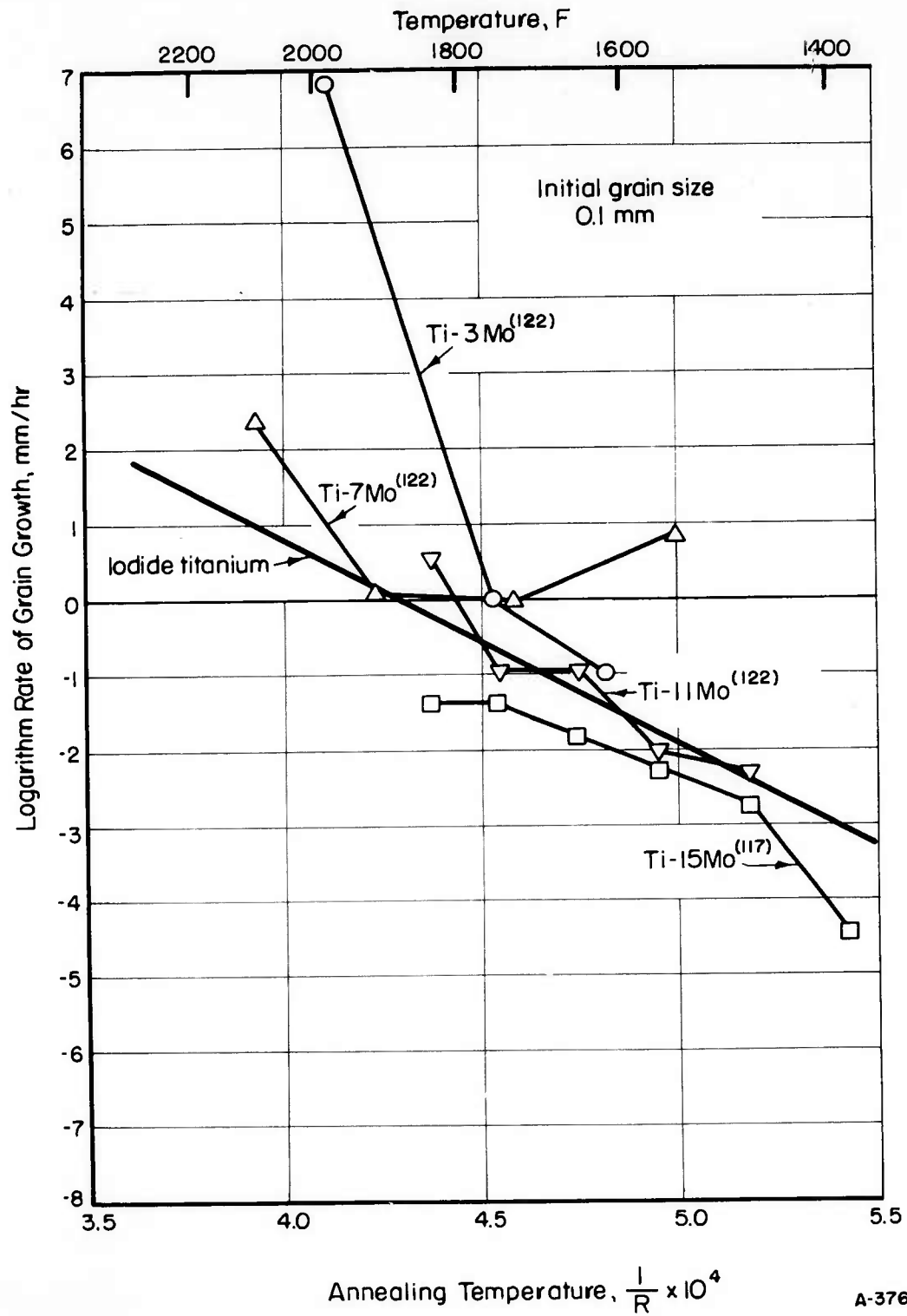


FIGURE 48. RATE OF GRAIN GROWTH IN BINARY TITANIUM-MOLYBDENUM ALLOYS

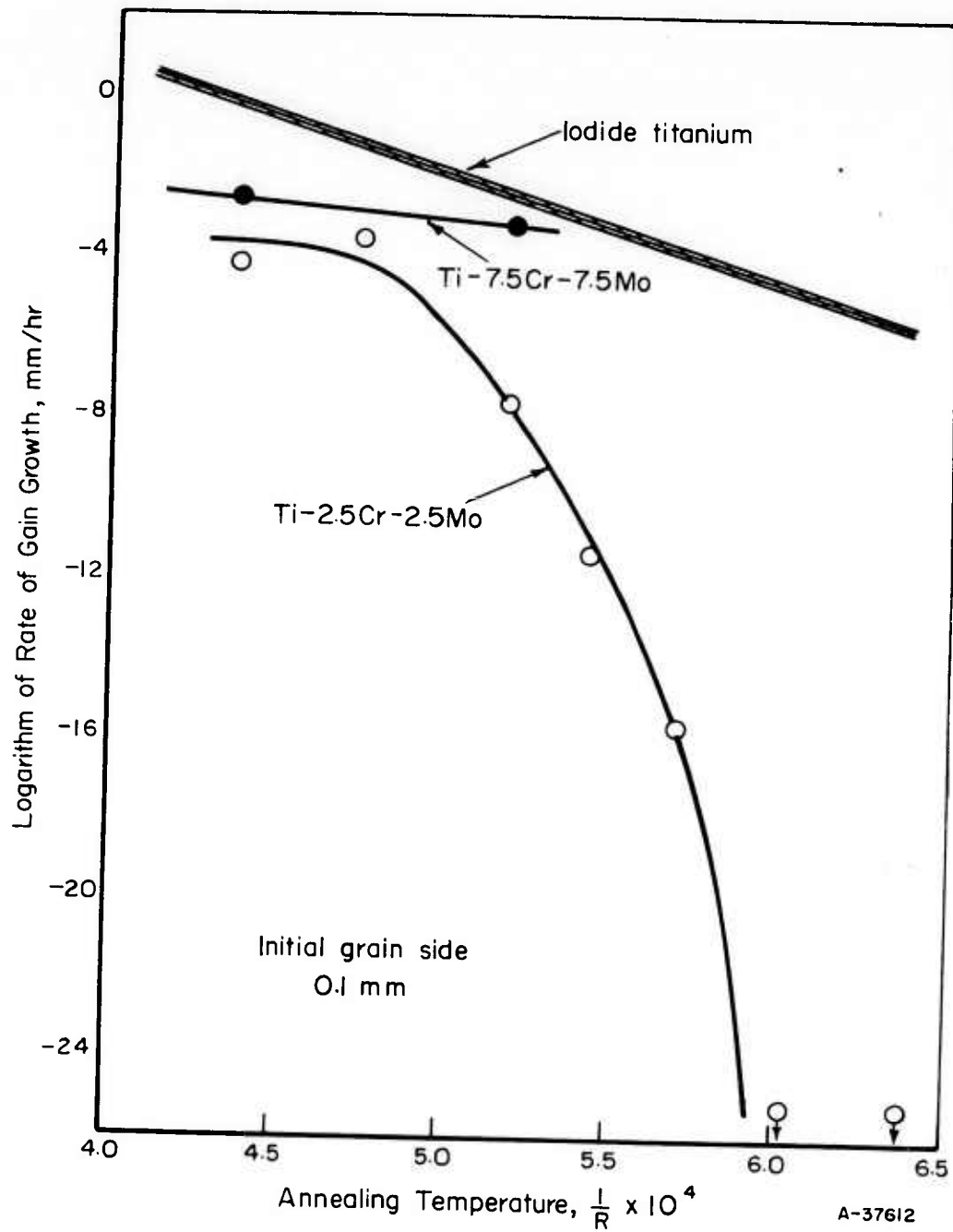


FIGURE 49. RATE OF GRAIN GROWTH IN TERNARY Ti-Mo-Cr ALLOYS⁽¹¹⁷⁾

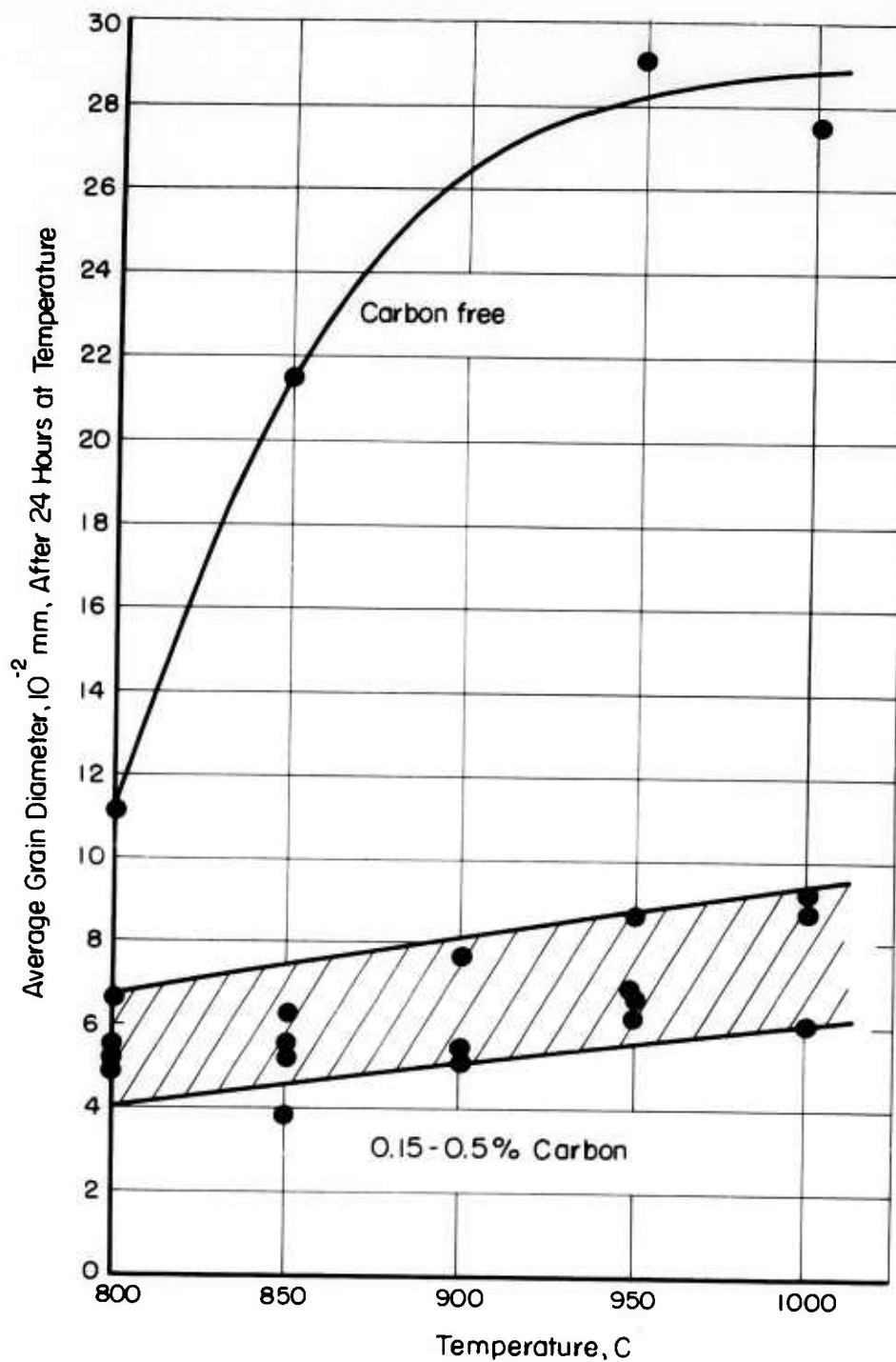


FIGURE 50. DIFFERENCE IN GRAIN SIZE OBSERVED IN Ti-11Mo ALLOYS, WITH AND WITHOUT CARBON, AFTER ANNEALING 24 HOURS⁽¹²²⁾

of alpha-beta alloys by controlling the maximum temperature of the treatment slightly below the beta transus of the alloy.

TABLE 25. EFFECT OF CARBON ON THE RATE OF GRAIN GROWTH (122)

Temperature, F	Rate of Grain Growth, mm/hr, at a Grain Size of 0.1 Mm	
	Ti-11Mo	Ti-11Mo + Carbon
1470	5.1×10^{-3}	5.9×10^{-8}
1650	1.2×10^{-1}	2.1×10^{-4}
1830	3.7	5.7×10^{-5}

REACTION KINETICS

Among the alloy systems of practical interest, the alloys of titanium produce a wide variety of microstructural types. With continued progress in the interpretation of these microstructures, it becomes more possible to predict how mechanical properties are affected by changes in structure. It is known that the final structures and the corresponding properties are determined not only by the transformations or reactions that may be involved but also by the rates at which these reactions take place, and by their degree of completion. It further is well established that the reaction kinetics are influenced by variations in alloy content, the presence of impurities, stresses, and conventional time-temperature effects.

In a sense, these effects are evaluated whenever the results of a heat-treatment procedure are considered. However, a better understanding of the individual variables is needed so that they may be controlled properly and used to produce the desired mechanical properties. Mechanical properties are established by alloy composition and by structure; the latter is determined largely by the thermal history, and thus by the reactions that occur during fabrication and heat treatment. This section is concerned with the transformations that occur in titanium alloys, how their rates are affected by the variables of interest, and how the final structures are affected by these reactions. The related subject of grain growth has been discussed in the preceding section.

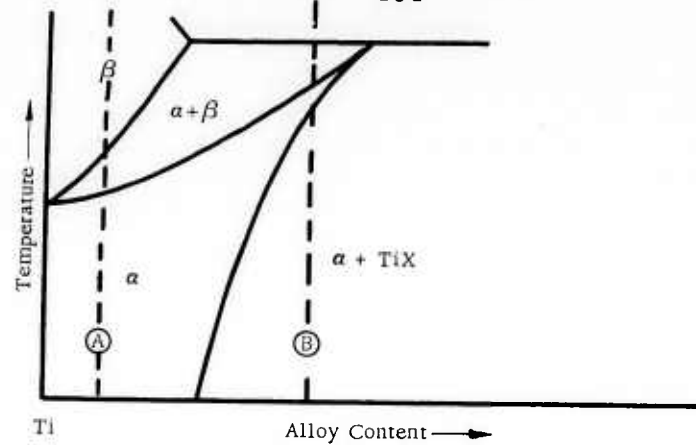
Transformations occur in titanium alloys either under isothermal conditions or during heating and cooling. Of particular interest are those reactions which occur in the final steps in fabrication or heat treatment, and therefore are more important in determining the final microstructure and mechanical properties of the alloy. Transformations that occur on heating are of interest (to the fabricator or heat treater, for example), but are less easily controlled and thus far have not received much attention from research workers.

The representative types of constitution diagrams included in Figure 51 show that transformations during cooling may occur with initial structures of beta, alpha, or a mixture of the two. Transformations from an initial alpha-plus-compound or beta-plus-compound structure are possible, but these are of less interest from a practical point of view because most useful alloys do not fall in this range of compositions.

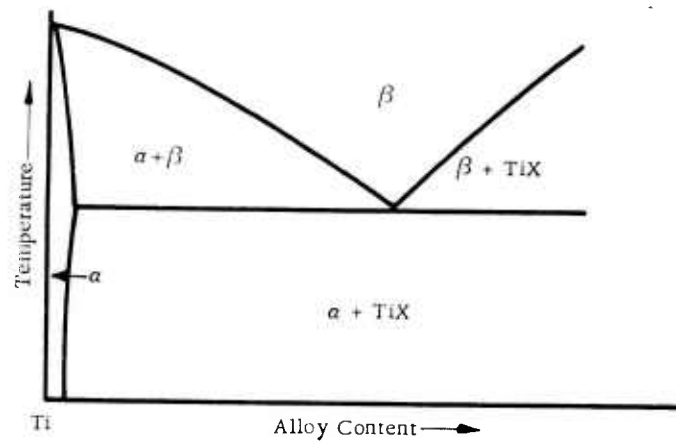
The reactions that take place during transformation may produce stable structures that appear on the constitution diagram, or metastable structures that do not appear on the constitution diagram. The latter are not self-evident and cannot be interpreted in terms of the equilibrium diagrams alone. In titanium alloys, these include the alpha-prime, or martensite structure, and the omega phase. The former usually is easily recognizable metallographically from its acicular appearance. The omega phase particles cannot be observed metallographically, although evidence of omega phase can be seen in electron micrographs. Positive identification of the omega phase usually requires an X-ray diffraction pattern, although abnormally high hardness values frequently are sufficient evidence of the presence of omega.

The transformations that occur during fabrication or heat treatment of commercial alloys frequently do not start with a single-phase structure. Usually, both alpha and beta phases are present. For simplicity, however, most of the experimental studies on reaction kinetics have been made starting with an all-beta or all-alpha structure. The results of these tests may be used in conjunction with the constitution diagrams to infer the reaction that would occur with an initial alpha-beta structure.

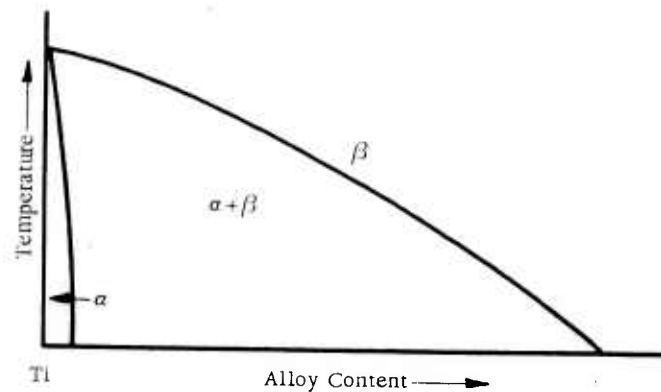
Included under the general heading of alpha alloys are unalloyed titanium, and alloys of titanium where the alpha phase is in equilibrium at room temperature. These are represented by Figure 51a. The transformations of interest that may occur during cooling include (1) $\beta \rightarrow \alpha$, for pure unalloyed titanium, (2) $\beta \rightarrow \alpha + \beta \rightarrow \alpha$, for the composition indicated at **(A)**, and (3) $\alpha \rightarrow \alpha + \text{TiX}$, for the composition indicated at **(B)**. It may be noted that the latter is a precipitation or aging type of reaction, and that it also may occur in some alloys of the beta-eutectoid type, provided that the alloy composition is low enough. The transformation of beta to alpha for pure titanium is very rapid, and occurs by a martensitic, or nucleation and shear process.



a. Alpha Peritectoid



b. Beta Eutectoid



c. Beta Isomorphous

FIGURE 51. PRINCIPAL TYPES OF TITANIUM ALLOY CONSTITUTION DIAGRAMS

In beta-stabilized alloys, four types of transformations have been observed. These are (1) martensite transformation, (2) transformation from beta to alpha, (3) transformation from beta to omega, and (4) transformation from beta to eutectoid. Two of these, Items (2) and (4), are transformations to the stable reaction products represented on the equilibrium diagram. The other two, Items (1) and (3), are transformations to metastable reaction products, which do not appear on the equilibrium diagram.

The transformations from the beta phase to its reaction products may be described graphically by the time-temperature-transformation or TTT diagram. In the following sections, examples of these diagrams are used to illustrate the various types of transformations and some of the important effects of alloying. Table 26 lists the systems for which TTT diagrams are available.

In ferrous metallurgy, additions of alloying elements are used to control the austenite transformation. In a similar way, the beta transformation in titanium alloys can be modified by changes in alloy composition. The alloy additions affect the final mechanical properties in two ways: first, by solid-solution strengthening of the alpha and beta phases, and second, by controlling the rates at which transformations occur. These, in turn, determine the mechanical properties of the heat-treated alloys.

The Martensite Transformation

The general characteristics for a martensite reaction have been summarized by Troiano and Greninger⁽¹³²⁾ as follows:

- (1) The transformation is diffusionless and involves no change in chemical composition.
- (2) The transformation is independent of time and depends for its progress only on the decrease in temperature.
- (3) The temperature range of formation of martensite is characteristic of a given alloy and cannot be lowered by increasing the cooling velocity.
- (4) The martensite transformation is reversible below the equilibrium temperature (considerable hysteresis may be involved; also, in some instances, tempering of the martensite on reheating may prevent reversal).
- (5) All metastable phases that have an M_f appreciably below room temperature will also produce martensite during deformation at room temperature.

- (6) In general, the structure can be considered as a transition between the unstable phase and the final equilibrium condition. More than one transitional (martensitic) structure may exist at the same time.
- (7) The martensitic structure always has a greater hardness than the parent solid solution from which it is formed. However, extreme hardnesses are associated with martensitic only in steel that contains appreciable amounts of carbon.
- (8) The martensite plates always form parallel to a given crystallographic plane of the parent lattice, and there is always a unique relationship between the lattices of martensite and the parent phase.

Although some of these characteristics are open to question (the time independence, for example), the studies made thus far on titanium alloys show generally good conformity to these rules. It is necessary, however, to point out that the martensite (alpha prime) in titanium metallurgy is not strictly analogous to the martensite of ferrous metallurgy.

The transformation from beta to martensite may or may not involve a supersaturated end product. No change in composition, of course, occurs with unalloyed titanium. In alpha alloys, and in low-alloy-content beta alloys, the transformation product lies within the alpha solubility limit, so that no supersaturation is involved. In the majority of the beta-stabilized alloys, however, the martensite contains more alloy addition than can be dissolved in the alpha phase, so that the martensite (alpha prime) is supersaturated. Diffuse diffraction patterns are observed, indicating that the observed hexagonal lattice of the alpha-prime structure has been strained during transformation.

Because martensite is not an equilibrium phase, it will decompose to the normal equilibrium products on reheating. These products normally would be alpha plus beta or alpha plus compound (in a eutectoid system), depending on the temperature of decomposition.

The temperatures at which the transformations to martensite begin (M_s) and are completed (M_f) are dependent upon alloy composition. Although the M_s temperatures are reasonably well established as functions of alloy content for most of the binary alloys, few reliable determinations of M_f have been made. It has been shown that the M_s temperature for unalloyed titanium is depressed by increasing the rate of cooling. For alloys of titanium, however, no effect of cooling rate on M_s has been observed.

The appearance of martensite plates in a metallographic structure suggests that a definite orientation exists between the martensite plates

and the parent beta phase. The family of crystallographic planes of the matrix on which the platelets are formed are called the habit planes. A relationship also exists between the crystal structures of the parent beta and the martensite phases, and some experimental and theoretical research has been done to determine this relationship.

Isothermal transformation of beta to martensite by deformation has been observed for a number of titanium alloys. These frequently are called "mechanically unstable" alloys. In at least one system, the transformation has resulted in an exceptionally high uniform elongation.

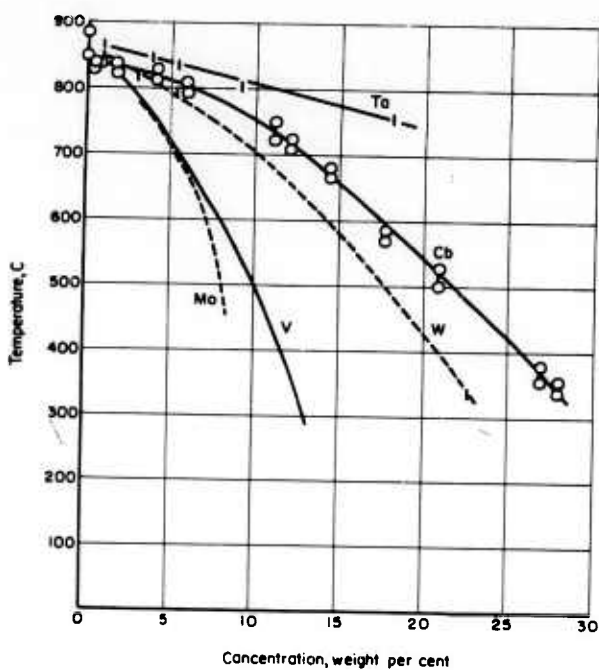
M_S Temperature

Although the general conditions for a martensite transformation included the stipulation that the transformation be independent of time, experiments have shown that the beta to alpha transformation in titanium is affected by cooling rate. Duwez⁽¹³³⁾, using very small samples, employed the thermal-arrest technique to detect the transformation temperature at very high cooling rates. For unalloyed titanium, it was found that the transition temperature could be lowered from about 882 to 855 C (1620 to 1570 F) by an increase in cooling rate from 10 to 10,000 C per minute.

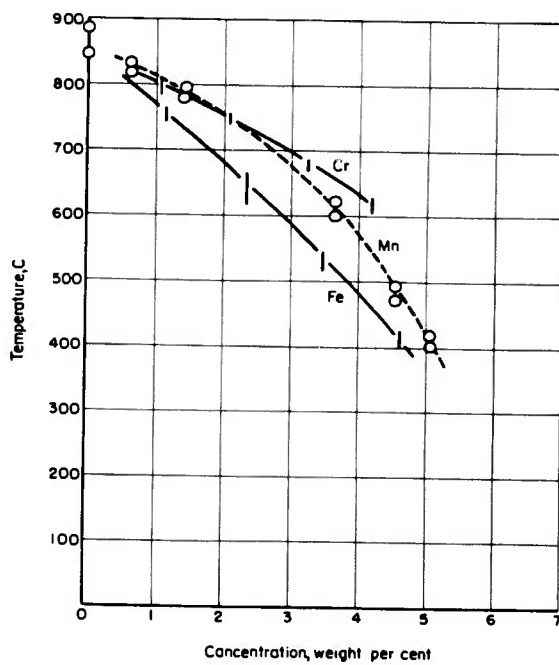
In the beta-stabilized alloys, the M_S temperature is decreased by an increase in the alloy concentration. In general, the rate at which the M_S temperature is lowered corresponds roughly to the rate at which the beta transus temperature is decreased by that element. The alloy composition at which the M_S is at room temperature marks the lower limit for retaining the beta phase during rapid cooling. At lower compositions, some martensite will be formed during a quench.

The principal methods used experimentally to determine the M_S temperature include metallographic, electrical-resistance, and thermal-arrest techniques. The latter has been used extensively by Duwez^(133,134), who reported M_S temperatures as functions of composition for a number of beta-stabilized alloys. The results of these experiments are presented in Figure 52. No effect of cooling rate on the M_S temperature was observed for the alloys. This is in contrast with unalloyed titanium where the transformation temperature was depressed 30 C by increasing the cooling rate. The thermal-arrest techniques are effective at temperatures as low as about 300 C.

The composition limits for retained beta phase (room-temperature M_S) may be located by metallographic observation. Table 26 lists these compositions for a number of beta-stabilized alloy systems. Included also are the eutectoid compositions and temperatures for those alloy systems in which a eutectoid is observed. Comparison with the curves in Figure 52 shows that the M_S-composition curves may be extended to the room-temperature values without difficulty.



a.



b.

FIGURE 52. EFFECTS OF ALLOY CONTENT ON THE M_s TEMPERATURES OF EIGHT BINARY ALLOYS^(133, 134)

TABLE 26. MINIMUM COMPOSITIONS FOR RETAINING BETA PHASE IN QUENCHED BINARY TITANIUM ALLOYS

Alloy Element	Eutectoid Temperature, C	Eutectoid Composition, weight per cent	Minimum Alloy Content to Retain Beta After Quenching, weight per cent
Manganese	550	20	6.4
Iron	590	16	3.5
Chromium	670	15	6.3
Cobalt	685	~9	7
Tungsten	715	28	22.5
Nickel	768	5.5	~9
Copper	787	8.1	13
Gold	832.5	15.9	(a)
Silver	852	19.8	(a)
Molybdenum	Beta-isomorphous alloys)
Vanadium			{ 14.9
Columbium			{ 36
Tantalum			{ ~45

(a) Systems in which β phase cannot be retained on quenching.

Another useful method for locating the M_s temperature is through the examination of microstructures. The procedure originally proposed by Greninger and Troiano for steels has been modified slightly and used in titanium-alloy studies. This modified procedure was described by DeLazaro, et al. (135), for studies of binary titanium-molybdenum alloys. Specimens are quenched to progressively lower temperatures, encompassing the M_s temperature, and then transformed isothermally to alpha plus beta at a higher temperature. This is usually taken near the nose of the TTT curve, where the transformation to alpha is most rapid. The M_s temperature then is located at the highest temperature to which the alloy can be quenched to produce visible martensite. This method requires that the isothermal transformation of the untransformed beta proceed rapidly enough so that the martensite needles are not decomposed during the reheat and isothermal anneal. It also requires that the martensite does not revert to beta on reheating. The results of the M_s determinations on titanium-molybdenum and titanium-copper alloys using this procedure are shown in Figure 53.

A few data are available which show the effects of alpha-stabilizing additions on the M_s temperature of the titanium-molybdenum alloys. Early work reported by Kessler, et al. (136), showed that the M_s temperature of titanium-molybdenum alloys was lowered by aluminum additions. Work by Kehl and Riccardo (137), on the other hand, showed an increase in M_s temperature with increasing oxygen content for two titanium-molybdenum alloys, as shown in Figure 54. These effects are not well understood at present. Both aluminum and oxygen raise the beta-transus temperature,

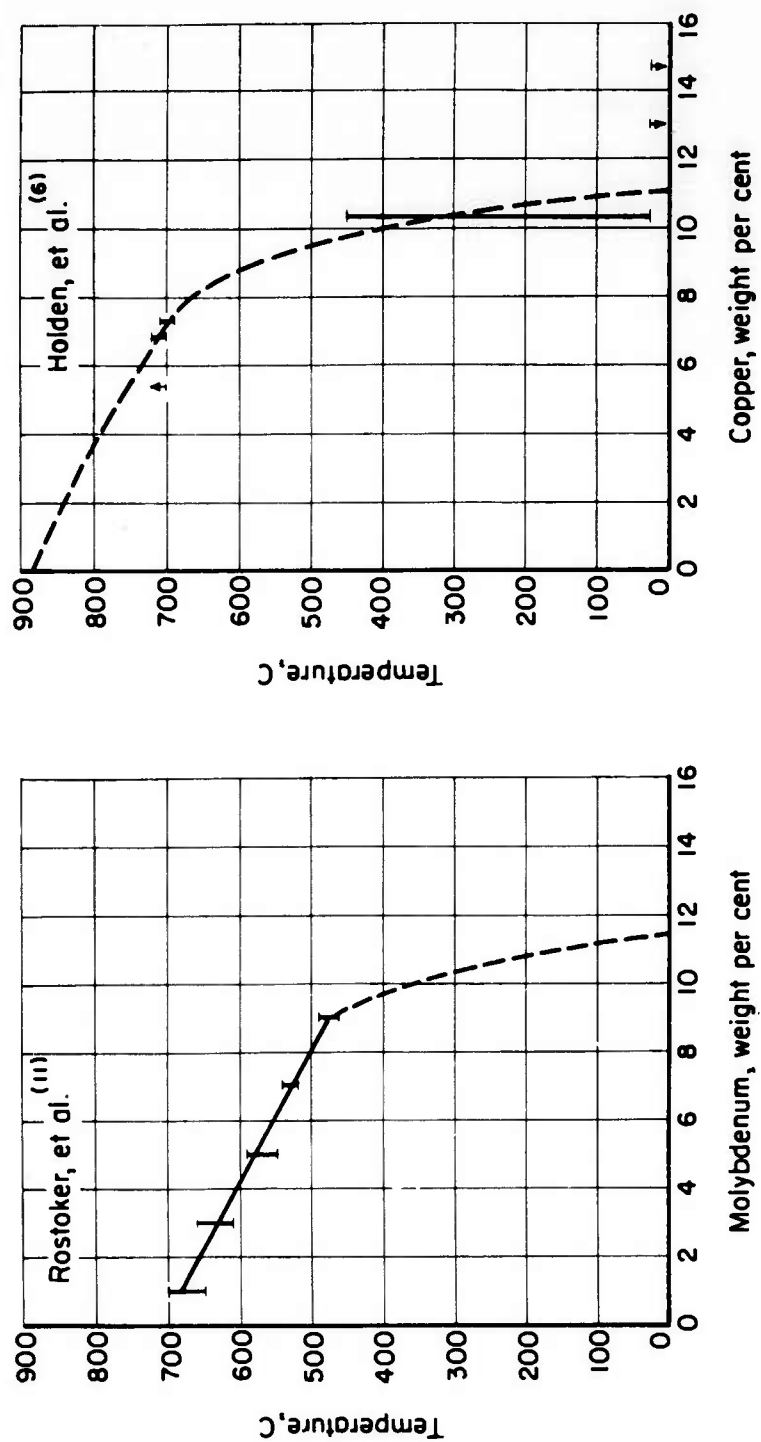


FIGURE 53. M_s CURVES FOR TITANIUM-MOLYBDENUM⁽¹³⁸⁾ AND TITANIUM-CHROMIUM⁽¹³⁹⁾ ALLOYS
A-16532

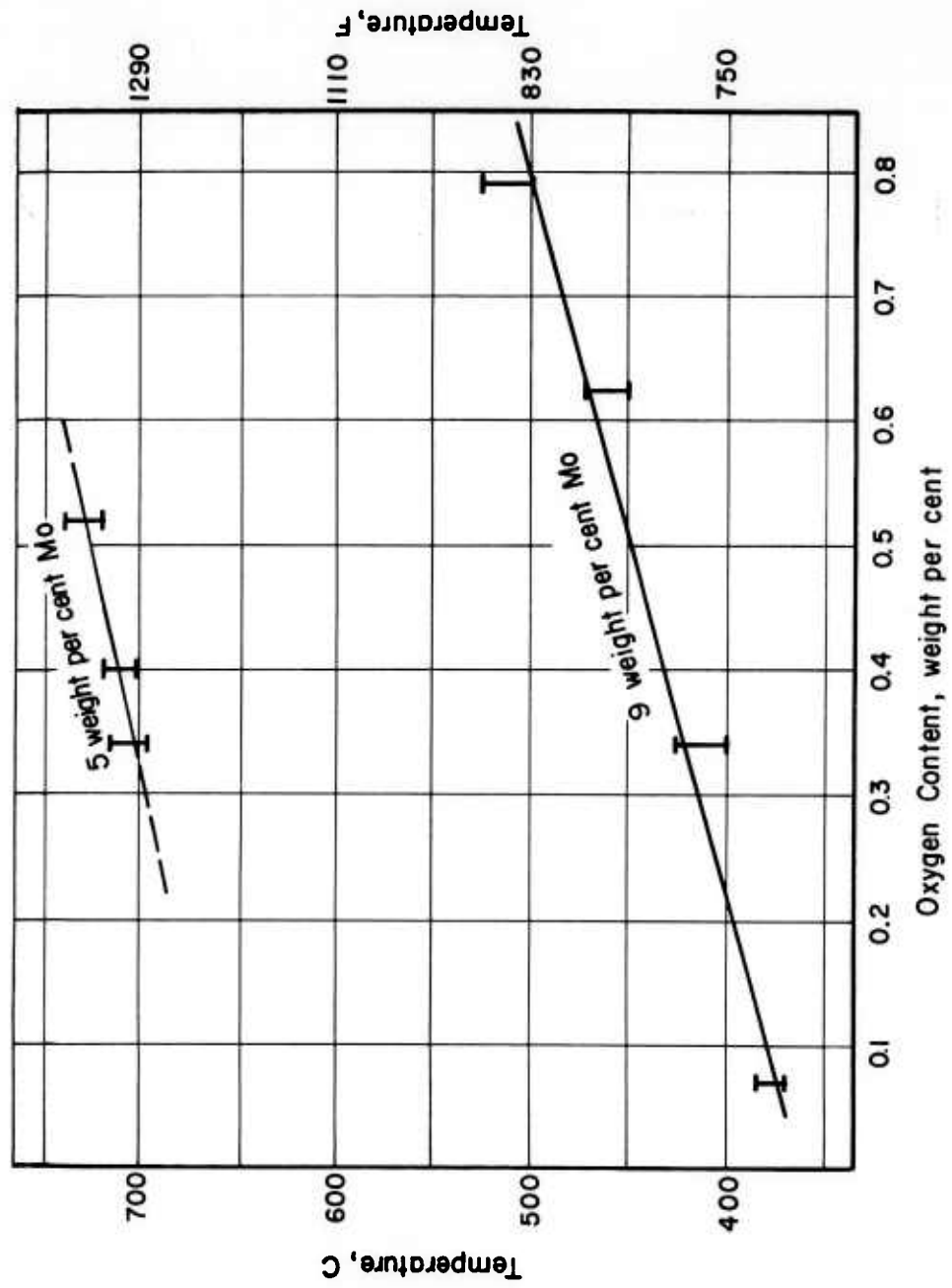


FIGURE 54. M_s TEMPERATURE VERSUS OXYGEN CONTENT FOR TITANIUM ALLOYS WITH INDICATED MOLYBDENUM CONTENT(137)

and thus might be expected to raise the M_s temperature. On the other hand, these two elements are known to behave oppositely in their effects on the transformation from beta to omega, as will be discussed later.

M_f Temperature

The temperature at which the transformation from beta to martensite is complete is called the M_f temperature. For pure titanium, the M_s and M_f temperatures coincide at the single allotropic transformation temperature of 882 C (1620 F). With the addition of beta-stabilizing alloying elements, the M_s and M_f temperatures diverge.

Although curves of M_s and M_f as functions of composition frequently are presented in schematic diagrams, the experimental determination of M_f is difficult and few good data have been reported. The difficulty is that of determining the degree of completion of the martensite reaction. This problem is common to many transformations; frequently, a 50 per cent or a 95 per cent completion curve is used to describe the degree of completeness. The relative amounts of martensite and retained-beta-phase present in a quenched structure are difficult to measure metallographically. By using measurements of diffraction-line intensities in quenched alloys, Parr and co-workers^(140, 141, 142, 143) have estimated the amount of alpha prime. Figure 55 is a plot of their results. It should be noted that this work was conducted using powder specimens, and that the results obtained are not generally in agreement with data obtained using more massive specimens. An example is the observation that martensite was found, on quenching, in alloys containing up to 14 weight per cent iron, whereas the limit usually reported is at about 4 weight per cent.

Habit Planes

The habit planes for the formation of martensite in β -titanium and titanium alloys have been investigated by several workers. Experimental determinations for unalloyed titanium, based on surface trace methods, were reported by Newkirk and Geisler⁽¹⁴⁴⁾ as $\{8, 8, 11\}$, by McHargue⁽¹⁴⁵⁾ as $\{331\}$, and by Williams, et al.⁽¹⁴⁶⁾, as $\{8, 9, 12\}$. The positions of these planes in the stereographic triangle are shown in Figure 56. This diagram also shows the position of $\{334\}_\beta$ and $\{112\}_\beta$, which is the habit plane predicted by the Burgers' mechanism⁽¹⁴⁷⁾ for titanium. As noted by Liu⁽¹⁴⁸⁾ and by Gaunt and Christian⁽¹⁴⁹⁾, it is convenient to refer to the two martensite habit planes observed in titanium alloys as the $\{334\}_\beta$ and $\{344\}_\beta$, although there is considerable scatter of the experimental points about these poles. The habit plane for unalloyed titanium appears to be close to the $\{334\}_\beta$.

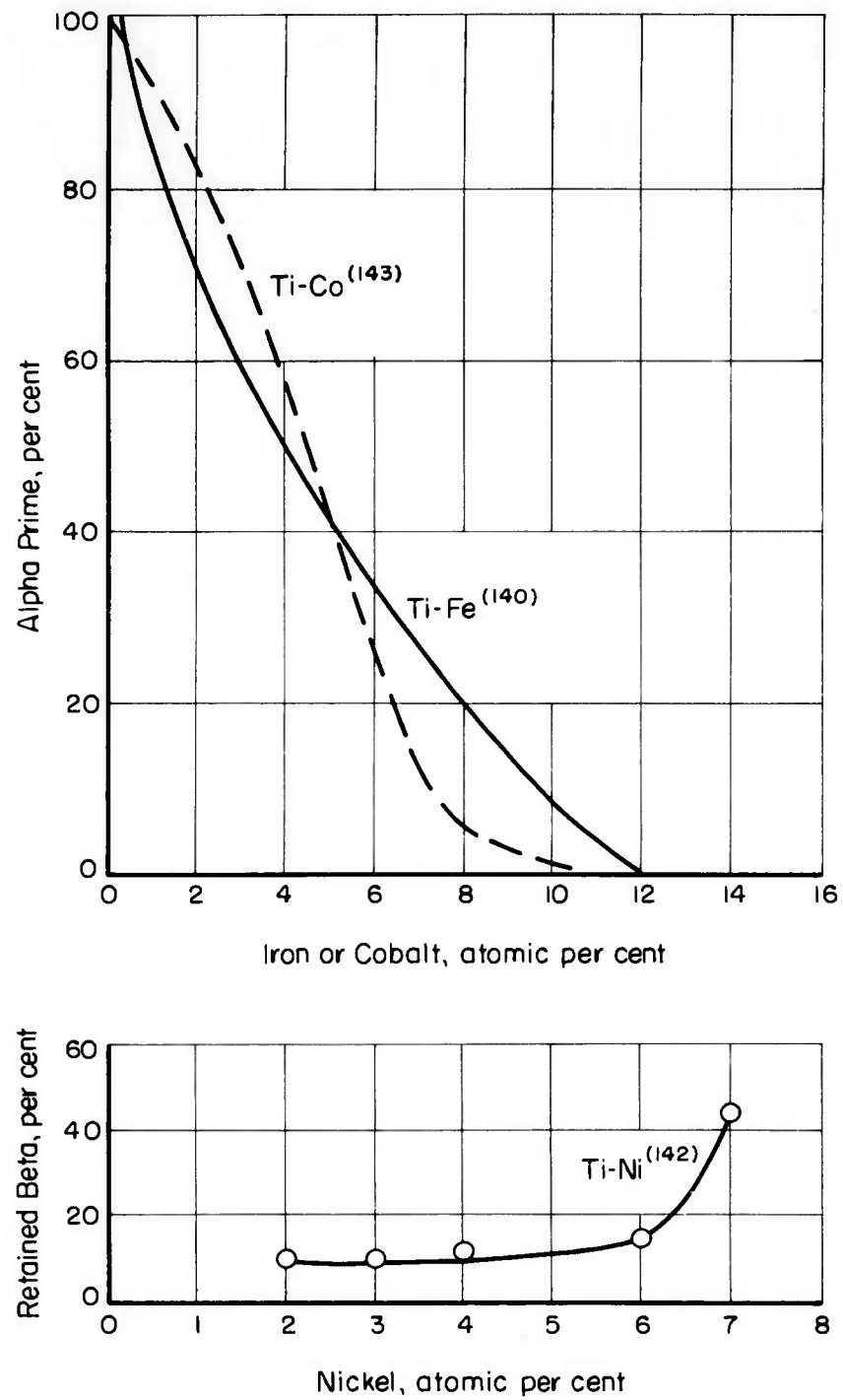


FIGURE 55. EFFECT OF ALLOY COMPOSITION ON THE COMPLETION OF THE BETA-TO-ALPHA PRIME TRANSFORMATION

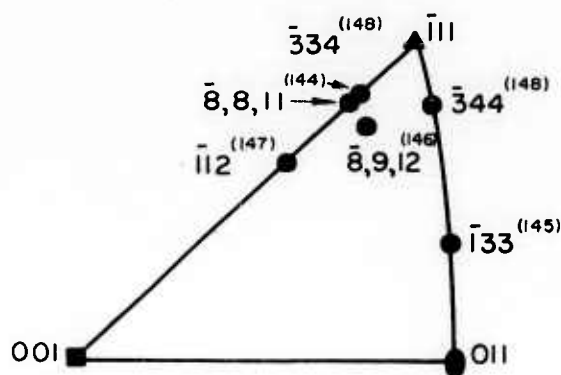


FIGURE 56. REPORTED HABIT PLANES FOR MARTENSITE IN BETA TITANIUM

The habit planes for a number of beta-stabilized titanium alloys have been reported by Liu⁽¹⁴⁸⁾ and by Liu and Margolin⁽¹⁵⁰⁾. The stereographic triangles illustrating the location of poles of martensite habit planes for several binary alloy systems are presented in Figure 57. Following a series of studies on four binary titanium-alloy systems, Liu concluded that in two of these, the titanium-chromium and titanium-iron alloys, only the $\{334\}_\beta$ habit was observed. It should be pointed out that the sole formation of $\{334\}$ martensite in water-quenched titanium-iron alloys was inconclusive, since a sufficient number of tests were not made to ensure the absence of the $\{344\}_\beta$ habit plane in this system. In water-quenched titanium-molybdenum and titanium-manganese alloys, both the $\{334\}_\beta$ and $\{344\}_\beta$ habit planes were observed, with the former being more prevalent. It further was noted that the martensite produced in the titanium-molybdenum alloys, either by subzero treatment or by deformation at room temperature, occurred in the $\{344\}_\beta$ habit. As a result of his work on titanium-molybdenum alloys, Liu further concluded that the martensite habit plane is determined not by the stresses but by the temperature at which the martensite forms in those systems where two martensite habit planes are possible. This idea was illustrated schematically in a plot of M_s temperature versus weight per cent molybdenum. At low alloy contents, the curve showing the start of the martensite transformation of the $\{334\}_\beta$ habit is above that for the $\{344\}_\beta$ habit. The intersection occurs at room temperature in the vicinity of 12 weight per cent molybdenum. These results were not confirmed by more recent work done by Gaunt and Christian⁽¹⁴⁹⁾. In their studies, only the $\{344\}_\beta$ martensite was produced in the titanium-12.5 per cent molybdenum alloy, in agreement with the data reported by Liu. However, in an alloy containing 11 per cent molybdenum, both types were formed by stress, with the $\{334\}_\beta$ type being predominant. This difference in behavior was attributed as possibly being a result of the formation of $\{334\}_\beta$ martensite during

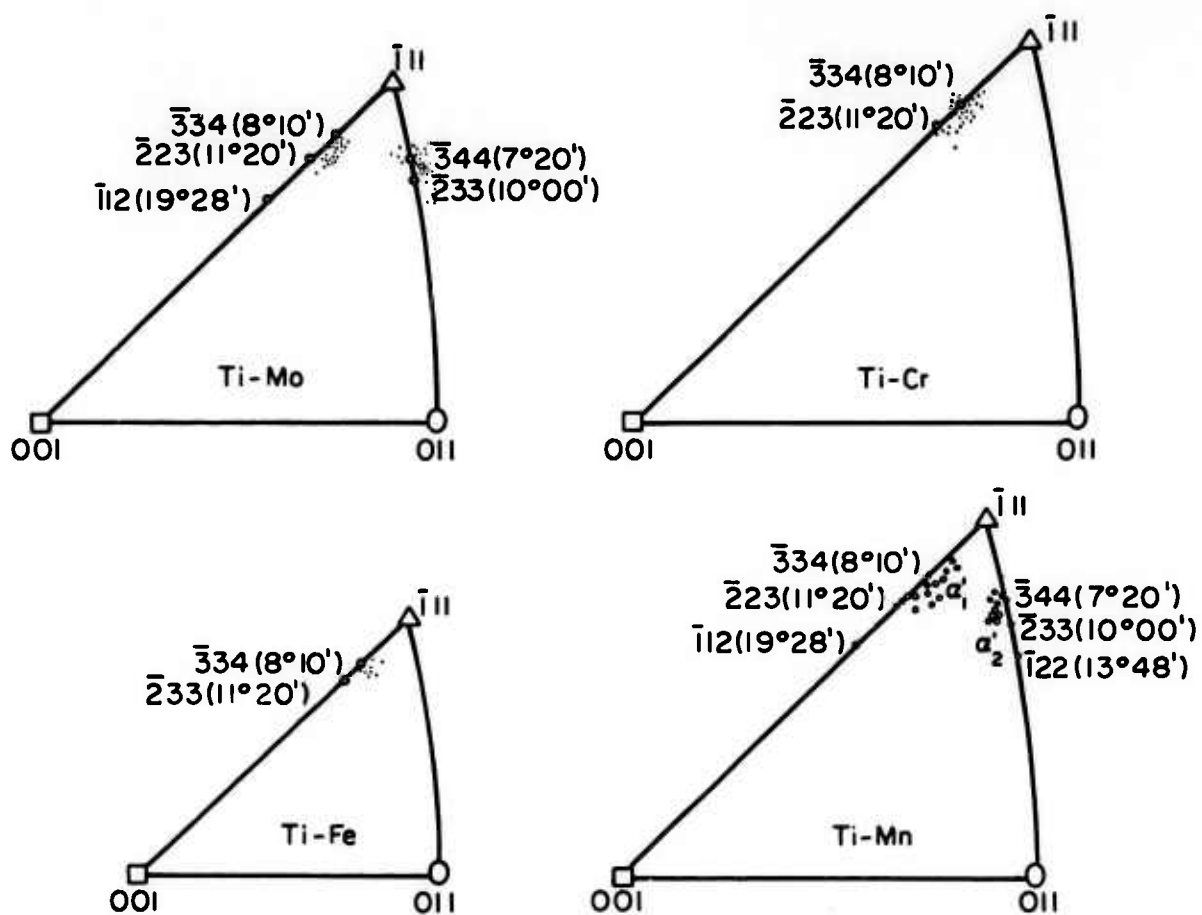


FIGURE 57. LOCATION OF POLES OF MARTENSITE HABIT PLANES IN TITANIUM-MANGANESE⁽¹⁵⁰⁾, TITANIUM-MOLYBDENUM⁽¹⁴⁸⁾, TITANIUM-IRON⁽¹⁴⁸⁾, AND TITANIUM-CHROMIUM⁽¹⁴⁸⁾ ALLOYS IN STEREOGRAPHIC TRIANGLES

quenching to room temperature in Liu's work. However, it should be noted that the results do not support the hypothesis that the martensite habit plane is dependent only on temperature of formation. Gaunt and Christian concluded that the potential nuclei on different habit-plane variants may be made to grow by the application of stress, and that the choice of habit plane depends on the stress axis. However, it should be pointed out that the resolved shear stress in the shear direction of the $\{344\}_\beta$ system of the Ti-11Mo alloy was greater than that in any of the $\{334\}_\beta$ systems, although only one out of five sets of habit planes was in fact $\{344\}_\beta$. The conclusion was that, in this alloy, the $\{334\}_\beta$ nuclei either are more numerous or are more readily capable of growing under stress.

Orientation Relationships

A characteristic of the martensite transformation is that a unique relationship exists between the lattices of the newly formed martensite and that of the parent (beta) phase. Like the determinations of habit planes, these orientations have been studied both for high-purity unalloyed titanium and for four binary titanium alloys. The orientation relationship in unalloyed titanium has been established by Williams, et al. (146), as:

$$(0001)_\alpha \parallel \{110\}_\beta$$

$$[11\bar{2}0]_\alpha : [111]_\beta$$

This corresponds to the Burgers' relationship for zirconium with a slight modification required in the mechanism. The orientation relationship between martensite and the matrix beta phase has been studied by Liu (148, 150) in high-purity titanium-manganese, titanium-molybdenum, titanium-chromium, and titanium-iron alloys. For martensite of the $\{334\}_\beta$ habit, the relationship:

$$(0001)_\alpha \quad (110)_\beta$$

$$[11\bar{2}0]_\alpha : [111]_\beta \sim 0 - \frac{1}{2} \text{ degrees}$$

was established. This corresponds closely with the Burgers' orientation relationship and was found to be valid for all four alloys studied. For martensite of the $\{344\}_\beta$ habit, the orientation relationship between the matrix and martensite was found to be of two types. In the first,

$$(1\bar{1}0)_\beta \parallel (001)_{\alpha'} \sim 14 \text{ degrees}$$

$$[110]_\beta : [1010]_{\alpha'} \sim 1 \text{ degree;}$$

for the second specimen,

$$(110)_\beta \parallel (0001)_{\alpha'}$$

$$[111]_\beta : [1120]_{\alpha'} \sim 1 \text{ degree.}$$

The results of Weinig and Machlin⁽¹⁵¹⁾ also agree with the second set of relationships reported above. These are based on measurements of strain-induced martensite made on an alloy containing 11 per cent molybdenum.

In work reported by Polonis and Parr⁽¹⁵²⁾, orientation relationships in a titanium-8 atomic per cent nickel alloy were reported as follows:

Observed Parallelisms	
Reflections From β Phase	Reflections From α' Phase
(011)	(0002)
(200)	(10 $\bar{1}$ 2)
(222)	(21 $\bar{3}$ 0)
(211)	(10 $\bar{1}$ 3)

Again, the conclusion was made that the shear transformation in titanium-nickel alloys probably is similar to that suggested for zirconium by Burgers.

Decomposition

Martensite in titanium alloys, similar to the martensite in steels, is a metastable transformation product. Thus, further decomposition of this structure may be effected by tempering heat treatments. The transformation may result in an equilibrium structure of $\alpha + \beta$ or a structure of $\alpha +$ compound, depending upon the type of alloy system being investigated. For example, in a titanium-molybdenum alloy system, a beta-isomorphous type, the stable reaction products would be $\alpha + \beta$. On the other hand, in the beta-eutectoid system, titanium-chromium, the stable equilibrium product at high temperatures would be $\alpha + \beta$; at lower temperatures, that is below the eutectoid temperature, $\alpha + \text{TiCr}_2$ compound would be formed. Thus, the reaction products that may be expected will depend upon the type of system. Among the earlier studies on this phenomena was the work of Domagala and Rostoker⁽¹⁵³⁾, who investigated titanium-molybdenum and titanium-chromium alloys as representative of the two alpha-beta alloy types. As a result of their studies, three types of mechanisms were postulated for the decomposition of martensite in a Ti-13Mo alloy: (1) rejection of a dispersion of alloy-rich beta of the composition characteristic of the tempering temperature, causing depletion of the solute content of α' ; (2) rejection of alloy-poor α , enriching the remaining α' until it reverts to

an enriched beta; (3) mass transfer of solute and solvent atoms across the α'/β interface, causing no essential change in the configuration.

In the titanium-chromium alloys, a fourth possibility is the rejection of TiCr_2 from the α' . From metallographic observations, they concluded that, when the Ti-6Cr alloy was tempered at 700 C (1290 F), the most frequent mechanism was the transfer of atoms across the α'/β interface, as in Item (3) above. In some instances, an oriented growth of beta within the α' needles also was observed as in Item (1).

For the Ti-13Mo alloy, tempering at 700 C resulted principally in the rejection of alpha particles as in Item (2) above, with diffusion across the α'/β interface as a possible second mechanism. The observations reported by Domagala and Rostoker were followed by studies made by Polonis and Parr(87), Brotzen, et al. (154), and more recently by Gomez and Polonis(155). These workers studied the decomposition of α' and, from the resulting data, determined the rate constants at which the reaction occurred. In the work of Polonis and Parr, X-ray techniques were used to study the decomposition rate of α' in a Ti-6Ni (atomic per cent) alloy. The reaction from α' to $\alpha + \text{Ti}_2\text{Ni}$ was found to occur at a rate governed by an activation energy of 84,000 cal/mole. The compound phase Ti_2Ni was observed to form in platelets during tempering at the lower temperatures (450 to 525 C or 840 to 975 F) and in spheroidal shapes at higher tempering temperatures. It was suggested that the rate-controlling mechanism was the self-diffusion of titanium. In the work reported by Brotzen, et al. (154), the decomposition of α' in titanium-vanadium alloys was studied by measuring changes in electrical resistance during tempering. The rate at which the resistivity changed was assumed proportional to the amount of transformation. Their results showed a reaction in which the activation energy for the α' to $\alpha + \beta$ reaction was approximately 15,000 cal/mole. However, as later noted by Gomez and Polonis(155), for purposes of comparison with other data, the activation energy for the tempering in the titanium-vanadium system would be approximately 44,500 cal/mole. This is of the order of magnitude that might be anticipated for the activation energy for diffusion of vanadium in titanium; this might then be the rate-controlling process in the reaction. The results obtained by Brotzen, et al., show that the tempering of martensite in a Ti-7.5V alloy follows the same rate law as the first stage of tempering of martensite in steels. The mechanism was described as the precipitation of equilibrium beta from supersaturated alpha titanium or martensite.

The work reported by Gomez and Polonis(155) involved the decomposition of martensite formed by quenching a Ti-7Cu alloy. Resistivity data were used to describe the degree of transformation. Up to approximately 60 per cent of the transformation, the tempering of martensite was found to have the characteristics of a log autocatalytic reaction. Beyond this point, a Cohen-type equation represented the transformation more closely, particularly at higher temperatures. The following mechanism was suggested for the tempering reaction. At the start of tempering, two

processes occur: (1) precipitation inside the prior beta grains with an initial increase in hardness, and (2) precipitation at a faster rate at the prior beta boundaries. Both microstructure and resistivity data indicated that, during the initial part of the reaction, the precipitation at prior beta grain boundaries will have a greater effect on the over-all reaction than the precipitation within the grains. As a result, it was suggested that the nucleation of Ti_2Cu within prior beta grains contributed only slightly to the activation energy of the process. The activation energy reported for the controlling reaction at 50 per cent transformation was 45,000 cal/mole. Again, this is of the same order of magnitude as the value that might be expected for the diffusion of copper in titanium.

Transformation From Beta to Alpha

In most of the commercial titanium-base alloys in use today, both the alpha and beta phases are present in the microstructure. These alloys contain beta-stabilizing elements, either the isomorphous types, such as vanadium and molybdenum, or the eutectoid types, such as chromium and manganese. These alloys are almost invariably heat treated to produce a final structure in the alpha-plus-beta field. Fabrication and heat treatment involve transformations between the high-temperature beta phase and the alpha-plus-beta structures that are in equilibrium at lower temperatures. In a few instances, transformations to other stable reaction products such as the eutectoid alpha-plus compound or the omega structure may be encountered.

The reaction involved in the transformation from beta to alpha plus beta is controlled by nucleation and growth processes. It, therefore, is convenient to describe the progress of this transformation in terms of time-temperature-transformation or TTT curves. These have been developed by numerous workers for many of the binary titanium-alloy systems, and for several of the commercial alloys.

The morphology of the alpha-beta structures is determined by the alloy composition and its prior mechanical and thermal history. It has been found that the mechanical properties are affected to a considerable degree by the way in which the alpha and beta phases are distributed in the microstructure. Accordingly, several investigations have been made to study these effects.

TTT Curves

The time-temperature-transformation curves showing the start and finish of the beta-to-alpha reaction have the characteristic C shape in time-temperature coordinates. This results from the fact that nucleation

rates are low at the higher temperatures and growth rates are low at the lower temperatures; thus, a maximum reaction rate occurs at some intermediate temperature. The minimum time required for the start of the beta-to-beta plus alpha reaction usually is short. In most of the published curves, for example, the transformation begins from 0.1 to 1 minute after quenching to the reaction temperature. Most of the curves that have been presented in the literature were obtained for isothermally transformed specimens. That is, the specimens were quenched from the solution-annealing temperature in the beta field to a transformation temperature in the alpha-beta field, and held for various periods of time. The start and finish of the transformation at the isothermal holding temperature then may be established, for example, from observations of the microstructure of specimens held for various times. In a few instances, similar curves have been prepared for specimens quenched to room temperature and subsequently heated to the reaction temperature. These curves show the same general form, but are not coincident with those obtained by quenching directly to the transformation temperature. It is reasonably well established that the application of stress during an isothermal exposure in the alpha-beta field will accelerate the precipitation of alpha from beta; thus, it is possible to construct a TTT diagram using the degree of deformation as a frame of reference.

The transformation from beta to alpha usually is easily observed microstructurally. Thus, metallographic procedures to determine the various degrees of transformation can be developed. In addition, techniques such as measurements of resistivity and changes in dimensions have been used to determine the degree of transformation. Some of these techniques involve transformation of a specimen at a specified temperature followed by rapid cooling or quenching to room temperature; after this the specimen is examined, either by metallography or by measurement of resistance. The dilatometer procedure, on the other hand, measures the change in length of the specimen at temperature during the transformation. Measurements of resistivity likewise may be made at the transformation temperature, rather than after cooling to room temperature.

It should be noted that the TTT curves usually found in the literature have been determined for specimens heated initially into the all-beta field. On the other hand, most of the commercial heat treatments involve transformations from a temperature high in the alpha-beta field, so that both alpha and beta are present in the initial microstructure. The resulting morphologies, or the way in which the alpha and beta phases are distributed in a specimen following these two treatments can differ considerably. The specimen cooled from the all-beta field shows a transformation structure having the characteristic Widmanstätten or basketweave appearance. On the other hand, specimens in which the initial structure contained both alpha and beta phases show a more nearly equiaxed structure. The latter structure usually is considered more desirable from the viewpoint of mechanical properties.

Figure 58 shows the effect of isothermal holding temperature on the microstructure of a titanium-molybdenum alloy quenched from the beta field and held for 60 minutes at various temperatures. It is apparent from the microstructures that those specimens held at the higher temperatures (above approximately 1100 F or 590 C) are not completely transformed, whereas those held at temperatures near the nose of the curve are transformed completely. At these temperatures, nucleation is rapid, so that a fine dispersion of alpha particles results. Nucleation at beta grain boundaries in preference to sites within the grains is apparent in the specimens transformed at the higher temperatures. At lower temperatures, the dispersion appears fairly uniform over the entire structure. The decreased rate of nucleation at the higher temperatures results in an increase in the coarseness of the structure, as may be noted in the microstructures of the specimens transformed at the higher temperatures.

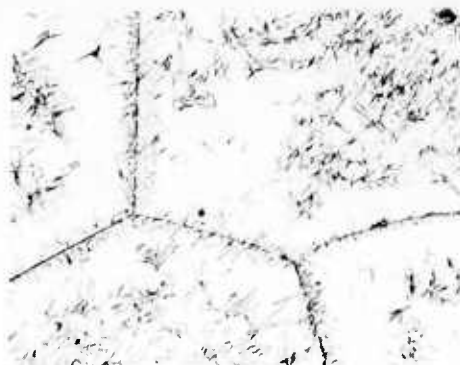
In Figure 59 the sequence of isothermal transformation in the Ti-3Mo alloy is shown. At the indicated isothermal holding temperature, the transformation starts at less than 1 minute, and is completed in less than 100 minutes. The first photomicrograph shows the structure resulting after a transformation time of 5 minutes. The preferential formation of alpha at the prior beta grain boundaries is apparent. The final photomicrograph shows the completely transformed structure. It may be noted that a martensitic structure appears in the background for those specimens in which the transformation to alpha is not completed. The martensite is formed during the quenching from the transformation temperature, as indicated by the two horizontal lines in the TTT diagram.

The transformation of beta phase into proeutectoid alpha and eutectoid or proeutectoid $TiCr_2$ and eutectoid were studied in titanium-chromium alloys by Aaronson, et al. (124, 125, 126) These workers studied two compositions of TiCr alloys, established TTT diagrams, and conducted a comprehensive study of the resulting morphologies. The latter were classified in a manner similar to that developed by Mehl and Dube (156) for the proeutectoid ferrite reaction in steels.

The alpha precipitate usually occurs as a Widmanstätten array of platelets. Although few data have been published, Hahn (157) has determined the habit plane of isothermal alpha and beta for a titanium-iron alloy as the $\{334\}_\beta$. It appears probable from this result that isothermal alpha and the martensitic α' are oriented similarly with respect to the apparent beta phase in titanium alloys.

Effects of Alloy Composition

Increasing amounts of the beta-stabilizing elements tend to lower the temperature at which beta phase is transformed to alpha. An increase in beta-stabilizer content, either by increasing the amount of a single alloy addition or by adding a second beta-stabilizing element will correspondingly



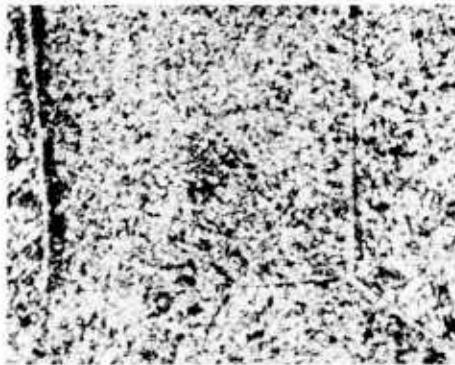
750X 6370
a. Ti-11Mo held 60 minutes at 1290 F and water quenched (10HF-60HNO₃-30 glycerine)



750X 6372
b. Ti-11Mo held 60 minutes at 1200 F and water quenched (10HF-60HNO₃-30 glycerine)



750X 6371
c. Ti-11Mo held 60 minutes at 1110 F and water quenched (10HF-60HNO₃-30 glycerine)



750X 6373
d. Ti-11Mo held 60 minutes at 1020 F and water quenched (10HF-60HNO₃-30 glycerine)



500X 6488
e. Ti-11Mo held 60 minutes at 930 F and water quenched (10HF-60HNO₃-30 glycerine)

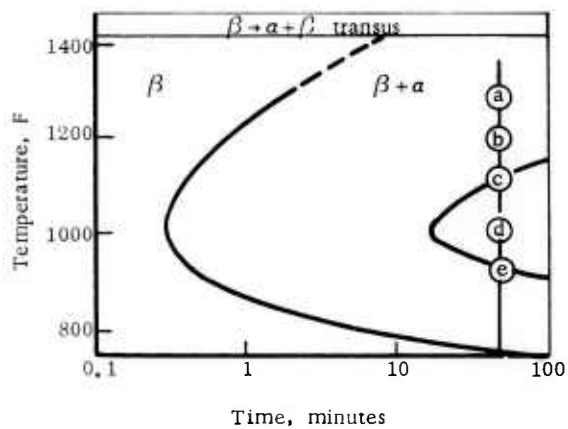
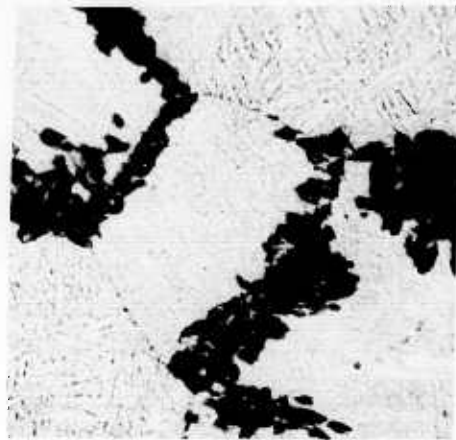


FIGURE 58. EFFECT OF ISOTHERMAL HOLDING TEMPERATURE ON THE MICROSTRUCTURES OF TITANIUM-MOLYBDENUM ALLOYS QUENCHED FROM THE BETA FIELD AND HELD 60 MINUTES AT TEMPERATURE

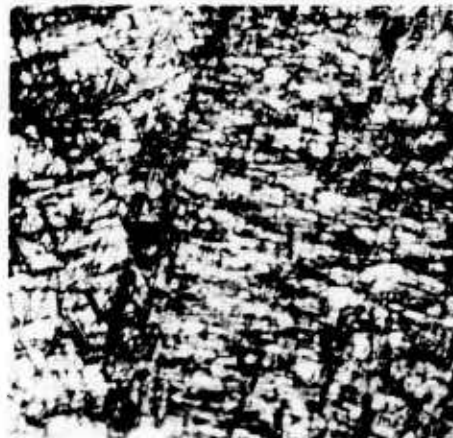
(Armour Research Foundation)



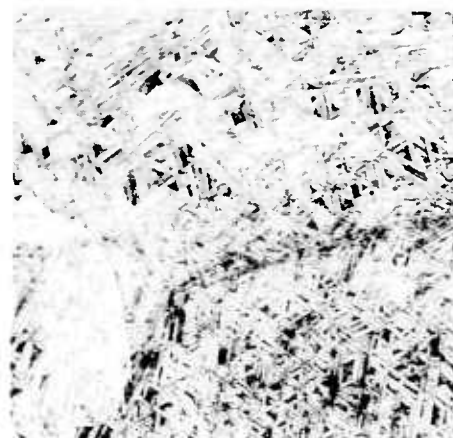
750X 6859

a. 5 minutes (10HF-60HNO₃-30 glycerine)

750X 6377

b. 15 minutes (10HF-60HNO₃-30 glycerine)

750X 6376

c. 30 minutes (10HF-60HNO₃-30 glycerine)

750X 6375

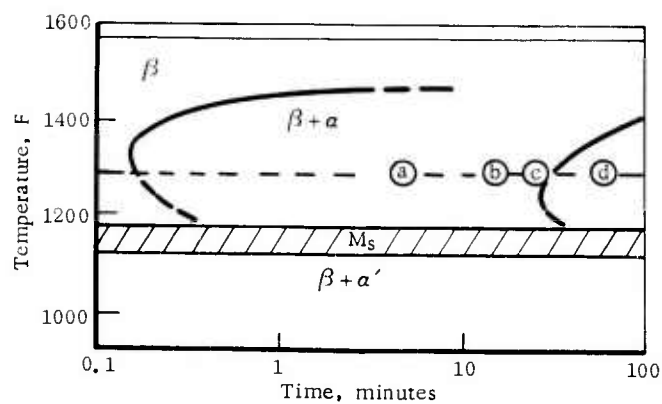
d. 60 minutes (10HF-60HNO₃-30 glycerine)

FIGURE 59. EFFECT OF ISOTHERMAL HOLDING TIME ON THE MICROSTRUCTURES OF A Ti-3Mo ALLOY QUENCHED FROM THE BETA FIELD TO 1290 F (Armour Research Foundation)

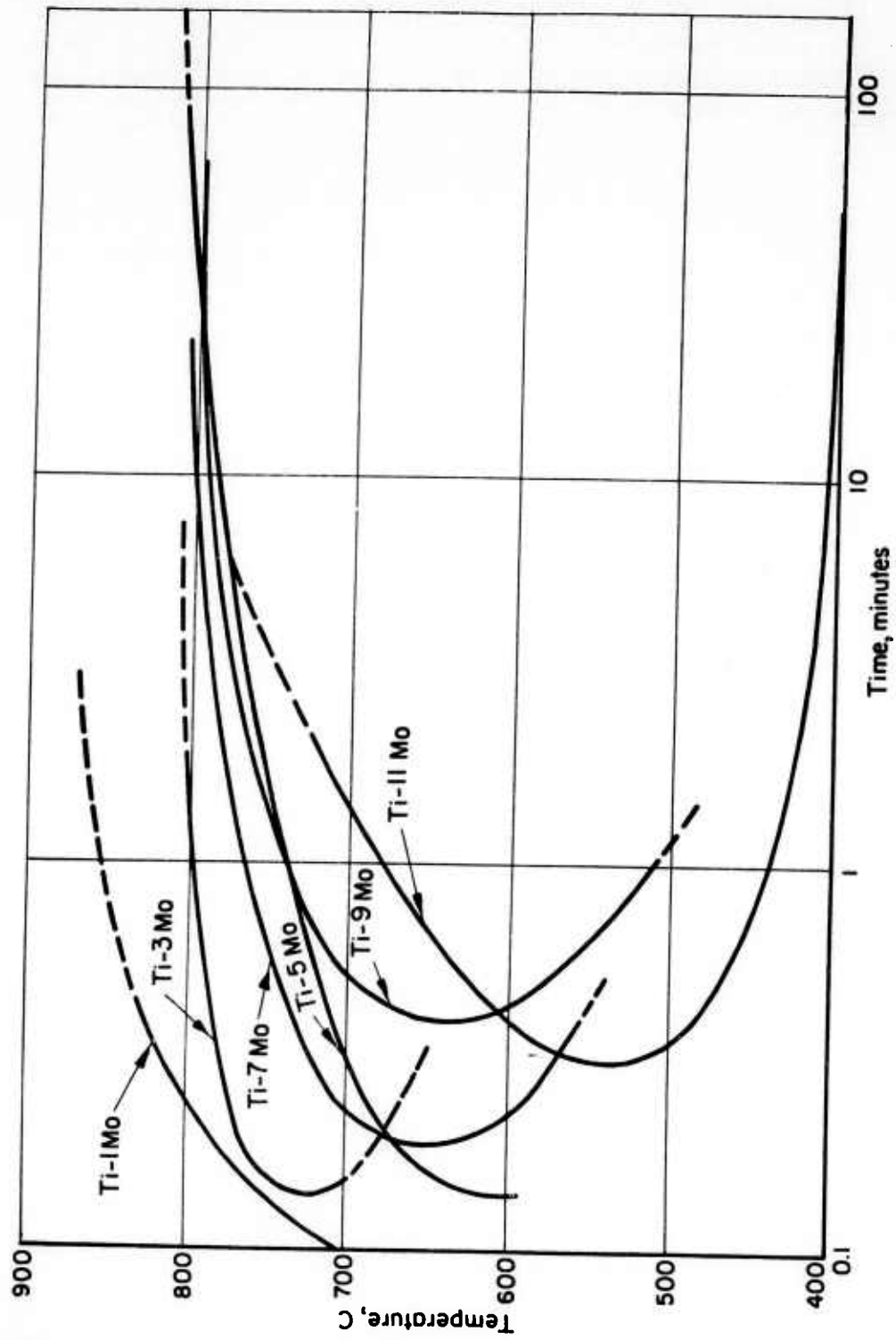


FIGURE 60. CURVES SHOWING THE EFFECT OF COMPOSITION ON THE START OF THE BETA-TO-ALPHA TRANSFORMATION IN TITANIUM-MOLYBDENUM ALLOYS(138)

lower the temperature at which the maximum rate of transformation occurs. Because the nucleation and growth process is strongly dependent on the rate of diffusion, this decrease in the transus temperature results in a decreased reaction rate of the beta to beta-plus-alpha reaction. Figure 60 shows the results of increasing molybdenum content on the start of the beta-to-alpha transformation in a series of titanium-molybdenum alloys. As might be expected, the curves show that the minimum time required to form alpha is increased with increasing molybdenum content. Further, the nose of the TTT curve is progressively lowered as the molybdenum content is raised from 1 to 11 per cent.

The rate of the beta-to-alpha transformation is increased with additions of the interstitial alpha stabilizers, oxygen, nitrogen, and carbon. This was demonstrated first by DeLazaro and Rostoker(158) for a Ti-11Mo alloy. As shown in Figure 61, the time required to start the transformation is decreased with increasing oxygen content. Further, the nose of the C curve appears at higher temperatures. The same effect also has been observed by Kehl, et al.(137), for Ti-5Mo, -9Mo, and -11Mo alloys.

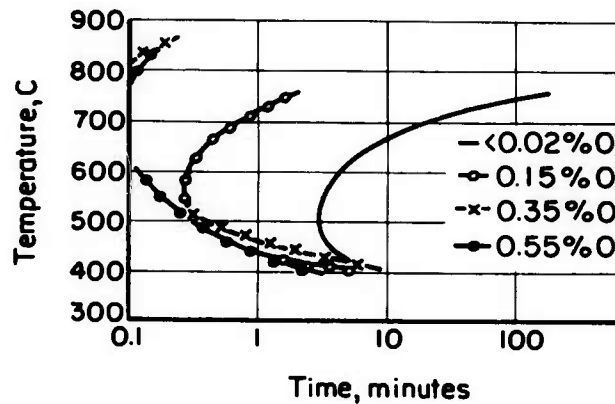


FIGURE 61. COMPARISON OF CURVES OF INITIATION OF VISIBLE TRANSFORMATION IN Ti-11Mo ALLOYS WITH VARIOUS OXYGEN CONTENTS(158)

Although the effects of metallic alpha-stabilizing conditions on the beta-to-alpha transformation are not so clearly established, aluminum has been shown to increase the beta-transus temperature and to decrease the time required to start the formation of alpha.(159)

Additional TTT diagrams for binary and ternary titanium-base alloy systems may be found in the references cited in Table 27.

TABLE 27. LIST OF AVAILABLE TTT DIAGRAMS^(a) IN TITANIUM-BASE ALLOYS

Alloy System	References	Remarks
<u>Binary Alloys</u>		
Titanium-chromium	123, 124, 125, 126, 127, 128	Effect of stress on TTT curves, Reference 128
Titanium-copper	123	
Titanium-iron	123	
Titanium-manganese	123	
Titanium-molybdenum	123, 127	
Titanium-nickel	123	
Titanium-vanadium	123, 129	Both isothermal and quench- temper diagrams shown for Ti-15V alloy
<u>Ternary Alloys</u>		
Titanium-aluminum-chromium	123	
Titanium-aluminum-copper	123	
Titanium-aluminum-iron	123	
Titanium-aluminum-manganese	123	
Titanium-aluminum-molybdenum	123	
Titanium-aluminum-vanadium	123	
Titanium-chromium-iron	123	
Titanium-chromium-molybdenum	123	
Titanium-manganese-carbon	123	
Titanium-molybdenum-carbon	123	
Titanium-molybdenum-oxygen	123	
<u>Quaternary Alloys</u>		
Titanium-aluminum-copper-tin	130, 123	

TABLE 27. (Continued)

Alloy System	References	Remarks
<u>Commercial Alloys</u>		
Ti-8Mn (RC 130A)	123	
Ti-4Al-4Mn (RC 130B)	123	
Ti-2.7Cr-1.3Fe (Ti150A)	123	
Ti-2.5Al-16V	131	} Transformation diagrams are shown both for isothermal and quench-temper treatments
Ti-4Al-3Mo-1V	131	
Ti-6Al-4V	131	
Ti-13V-11Cr-3Al (B120VCA)	131	

(a) Isothermal transformations are used except where otherwise indicated.

Transformation From Beta to Omega

In many of the earlier studies on titanium-base alloys, specimens apparently composed of beta-phase were found with anomalously high hardness and strength. These structures, in contrast with the softer retained beta phase, were designated beta prime to distinguish them from the normal structures of identical appearance. Beta prime usually was observed in alloys having a composition at or near that at which beta phase could be fully retained during a quench to room temperature. This effect, which generally was accepted as a preprecipitation phenomenon, was shown by Frost^(160,161) to be caused by the presence of a metastable transition phase, designated omega. Frost's original work was done on titanium-chromium and titanium-molybdenum alloys. Since that time, the presence of the omega phase has been established in binary alloys of titanium containing copper, nickel, iron, manganese, vanadium, and probably columbium.

The presence of the omega phase results in a structure with high hardness, high strength, and very low ductility. Further, the omega phase is difficult to identify microstructurally because the fineness of the particles does not permit identification by the usual microstructural procedures. Much work has been done to identify the phase, to determine its crystal structure, and to study the effects of its formation on the resulting mechanical properties.

Structure of the Omega Phase

The identification of the omega phase in titanium alloys from X-ray diffraction patterns has been a subject of considerable controversy. Various workers have identified the patterns as cubic⁽¹⁶²⁾, orthorhombic⁽¹⁶³⁾, and hexagonal^(164,165). Austin and Doig⁽¹⁶²⁾, basing their results on single-crystal Weissenberg X-ray diffraction procedures, showed the structure of omega to be in space group $\bar{1}43m$, with 54 atoms per unit cell. The structure is a complex body-centered cubic unit cell encompassing 27 of the original beta unit cells. Atoms of the alloying element were located at the center and corners, making a total of two atoms per unit cell. A [100] direction of omega is parallel to the [100] direction of the parent beta phase. More recent work by Silcock, et al.^(164,165), has shown that the cubic structure reported by Austin and Doig could be reduced to a simpler hexagonal unit cell. The hexagonal cell showed atoms at positions 000, $1/3\ 2/3\ 1/2$ and $2/3\ 1/3\ 1/2$. This corresponds with space group A'_6 , $P6/mmm$ with the orientation relationship $(0001)_\alpha \parallel (111)_\beta$, and $(\bar{1}\bar{2}10)_\alpha \parallel (1\bar{1}0)_\beta$. The study of the omega phase made by Spachner⁽¹⁶³⁾ showed that the lines could be indexed to an orthorhombic lattice pattern. The fit was described as tentative however, and, because

the work was conducted using powder samples, it may be considered somewhat less authoritative than that of Silcock, et al.

Although the omega phase is too fine to be resolved under the light microscope, evidence of the presence of a second phase has been obtained by use of an electron microscope. A series of titanium-manganese alloy specimens was quenched from the beta field and reheated to various temperatures for 1 hour. Microstructures of the as-quenched and aged specimens are shown in Figure 62. The presence of the omega phase, as revealed by the high hardness and characteristic X-ray diffraction lines given in Table 28, correlated with the presence of a fine dispersion of pits in the structure. Aging at higher temperatures resulted in the formation of alpha as noted in the last two photomicrographs.

TTT Curves

Omega, like alpha, is formed by a process of nucleation and growth. Thus, the kinetics of the transformation can be described in time-temperature coordinates by the conventional TTT diagram. Because omega cannot be detected by conventional metallographic procedures, the transformation was not detected in much of the early work. Thus, many of the earlier TTT diagrams do not show the presence of the omega transformation. More recent studies have used dilatometry, resistivity measurements, elastic modulus changes, and X-ray diffraction procedures to show the presence of the omega phase in other alloy systems; these include titanium-vanadium, titanium-chromium, and titanium-molybdenum. Examples of the TTT curves for selected alloys in these systems are shown in Figures 63, 64, and 65.

In general, the omega transformation curve is C shaped like that of the beta-to-alpha transformation, with the nose of the curve appearing at a temperature lower than that for the beta-to-alpha transformation. A characteristic of the omega transformation in many alloys is that the time required for the start of the reaction is short. In many instances, partial transformation occurs during quenching to room temperature. This accounts for the high hardness observed in the quenched structures that formerly were denoted as beta prime.

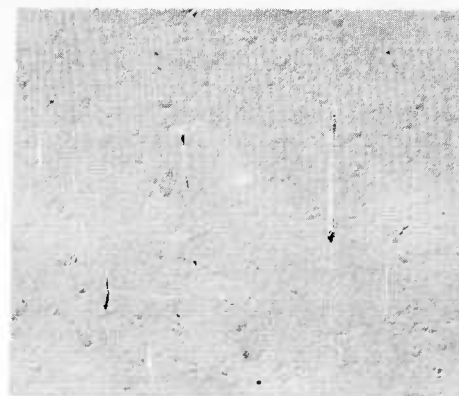
Effects of Alloy Composition

The shape and position of the TTT curve showing the start of the beta-to-omega transformation are determined by alloy composition. An increase in the beta-stabilizing alloy content decreases the rate at which omega is formed. This was demonstrated by Brotzen, et al. (154), for a series of titanium-vanadium alloys. At 15 per cent vanadium, the omega transformation occurred on quenching, whereas at 20 per cent vanadium,



10,000X E5253E

a. Ti-6.4Mn as quenched (very small specimen)



10,000X E5142C

b. Ti-6.4Mn as quenched



10,000X E5131B

c. Ti-6.4Mn beta quenched and aged 1 hour at 570 F



10,000X E5133C

d. Ti-6.4Mn beta quenched and aged 1 hour at 750 F



10,000X E5134B

e. Ti-6.4Mn beta quenched and aged 1 hour at 930 F



10,000X E5135E

f. Ti-6.4Mn beta quenched and aged 1 hour at 1110 F

FIGURE 62. ELECTRON MICROGRAPHS OF A Ti-6.4Mn ALLOY BETA QUENCHED AND AGED(166)

TABLE 28. HARDNESS AND X-RAY DIFFRACTION DATA FOR QUENCHED AND AGED SPECIMENS OF A Ti-6.4Mn ALLOY(166)

(All specimens were solution annealed 1 hour at 810 C and quenched)

Aging Treatment	Vickers Hardness	Intensities (a) of Phase Patterns Observed					
		Untransformed		Partially Enriched		Fully Enriched	
		Beta	Beta	Beta	Beta	Omega	Alpha
None	396 (b)	S	0	0	0	0	0
1 hr at 300 C	489	S	0	0	0	Fvd	0
1 hr at 400 C	521	M	Mvvd	0	0	Md	0
1 hr at 500 C	402	0	0	MSd	0	0	S
1 hr at 600 C	305	--	--	--	--	--	--

(a) Abbreviations: S = strong; M = medium; F = faint; v = very; d = diffuse; 0 = zero intensity.

(b) The hardness of a very small specimen as quenched was 344VHN.

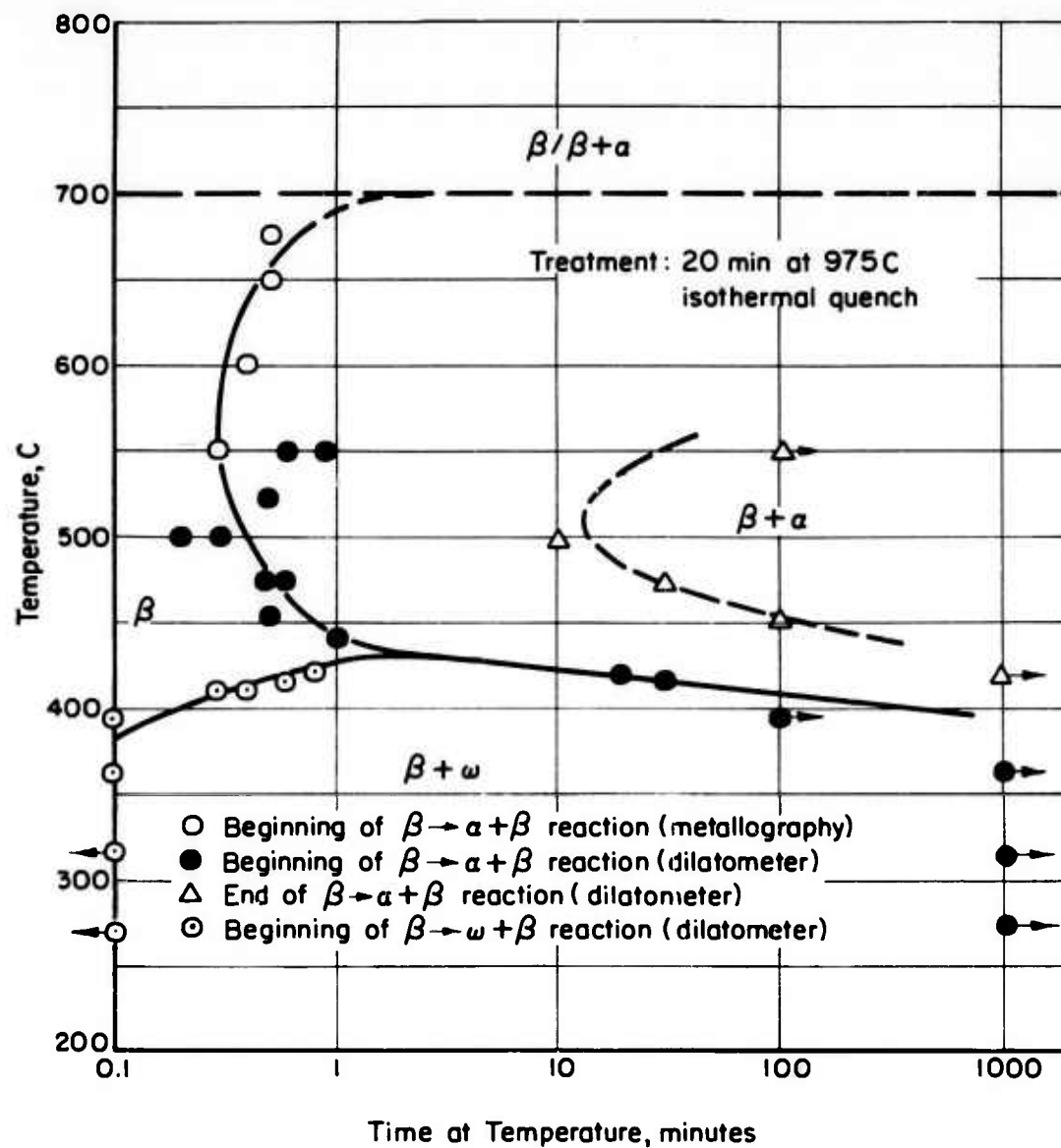


FIGURE 63. TTT DIAGRAM FOR A TITANIUM ALLOY CONTAINING 15 PER CENT VANADIUM⁽¹⁵⁴⁾

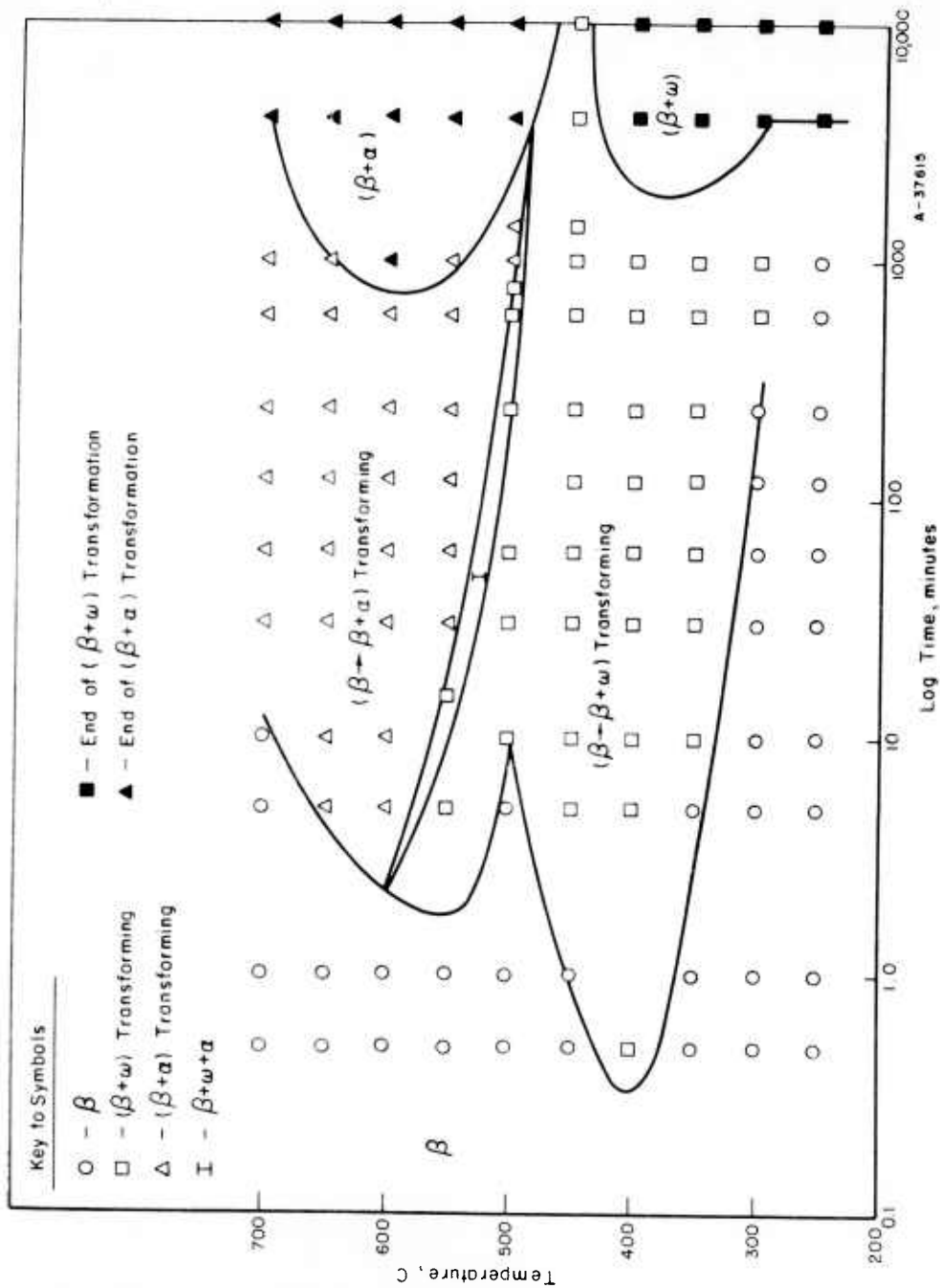


FIGURE 64. TTT CURVE FOR A Ti-13Mo ALLOY(127)

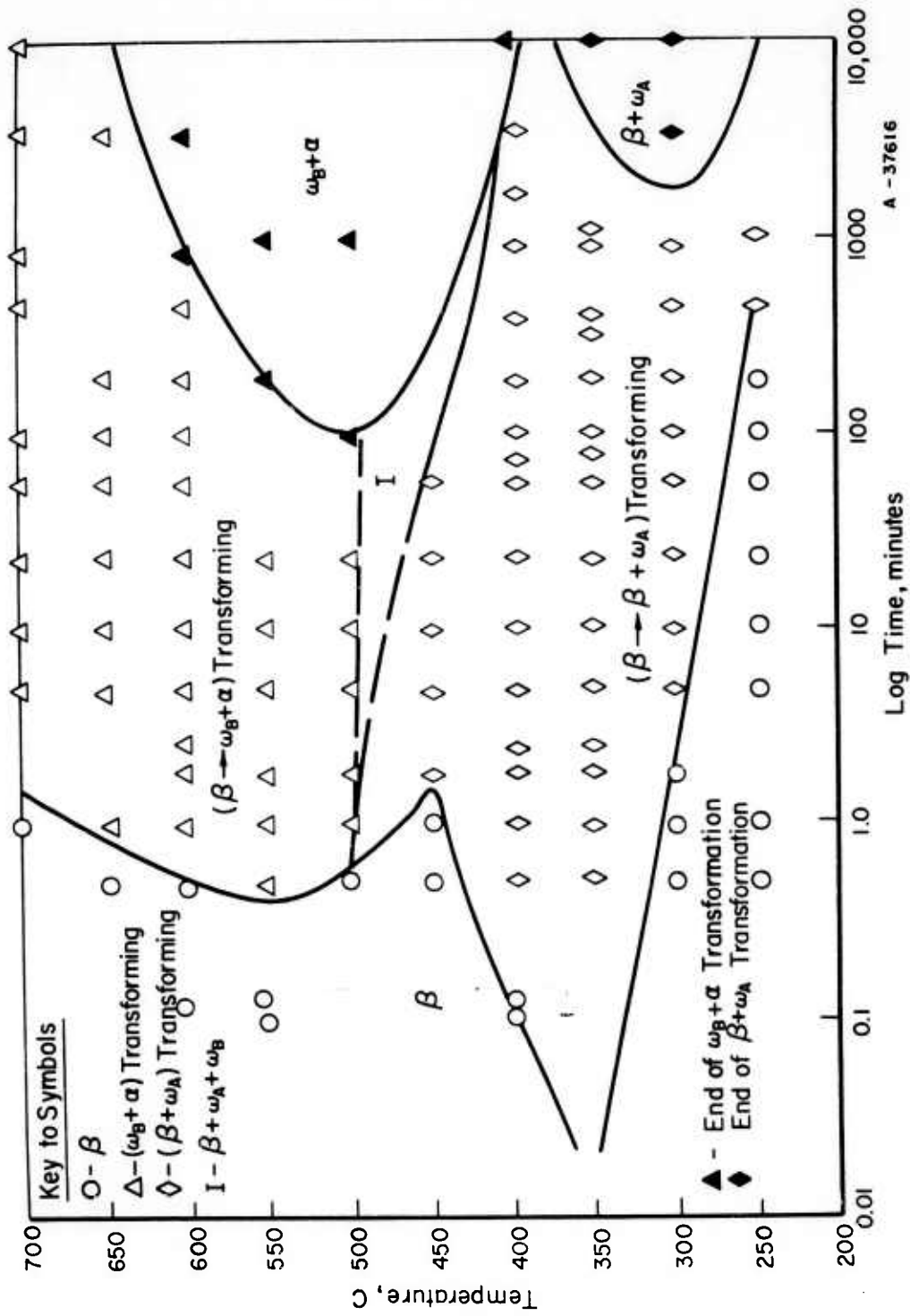


FIGURE 65. TTT CURVE FOR A Ti-8Cr ALLOY(127)

the reaction was slowed sufficiently so that the beta phase could be retained during quenching. The same effect has been demonstrated more indirectly by observations on the effect of cooling rate on hardness; thus, as the alloy content of titanium-manganese⁽¹⁶⁷⁾ and titanium-iron⁽¹⁶⁸⁾ alloys is increased, lower cooling rates are required to reach peak hardness. This implies that the rate of omega formation, this being the hardening mechanism, is decreased with increasing manganese or iron content.

Measurements of the hardness of quenched and aged specimens, although indirect, provide a convenient means for observing the effects of alloy additions on the omega-transformation rate. Comparatively few TTT diagrams have been prepared to include the omega-transformation curves. Most of these have been for binary-titanium alloys, and none provide information that shows clearly the effects of interstitial or other alpha-solute additions on the reaction kinetics. From the quench and aging data, however, information can be interpreted to show effects of these additions on the rate of omega formation. The hardness data discussed here are a reasonably good measure of omega formation, because the aging data were obtained close to the temperature (750 F or 400 C) at which the transformation rate is maximum.

The data obtained from the series of experiments⁽¹⁶⁹⁾ in which interstitial (nitrogen, carbon) and substitutional (aluminum) alpha additions were made to a series of titanium-manganese alloys showed that (1) the interstitial alpha stabilizers increase the rate of omega formation, whereas (2) aluminum decreases the rate of omega formation. The latter conclusion is particularly important because aluminum additions improve the heat treatability (i. e. , the "hardenability") of commercial alloys. For example, the Ti-2.5Al-6Mn alloy can be quenched to a soft retained-beta structure, whereas the binary Ti-6Mn alloy is hard, indicating the presence of omega. The increase in the rate of omega formation imparted by the addition of the interstitial alpha stabilizers (nitrogen, oxygen, and aluminum) is shown by the increased rate at which high hardness is attained in specimens aged at 750 F (400 C).

As shown by Brotzen, et al. ⁽¹⁵⁴⁾, the normal low-temperature sequence of transformations would be $\beta \rightarrow \beta + \omega \rightarrow \beta + \omega + \alpha \rightarrow \beta + \alpha$. Other workers have proposed slightly different mechanisms for different temperature and composition ranges; for example, Spachner and Rostoker^(127,163) proposed the presence of two slightly differing forms of the omega phase for a Ti-8Cr alloy. One of these was found after transformation in the region below 400 C (750 F), and the other at temperatures in the vicinity of 600 C (1110 F).

The Eutectoid Transformation

In many of the common and useful titanium alloys, a transformation of the beta phase by a eutectoid reaction is indicated. The eutectoid compositions and reaction temperatures known for nine binary titanium alloy systems were listed previously in Table 26.

The eutectoid commonly is composed of a mixture of alpha plus an intermetallic compound; for example, $\alpha + \text{TiFe}$ in titanium-iron alloys, or $\alpha + \text{TiCr}_2$ in titanium-chromium alloys. In at least one instance (Ti-W), the eutectoid is composed of alpha plus a solid solution of the second element (tungsten). The eutectoid temperatures and compositions vary widely, ranging from the titanium-manganese system (550 C) to the titanium-silver alloys (852 C). Similarly, the activity of the eutectoid reaction increases roughly with temperature. For example, the transformation to the eutectoid in the titanium-copper alloys is very rapid, whereas the eutectoid transformation in titanium-manganese is so sluggish that it has never been observed in hypoeutectoid alloys. The three least active of the eutectoid-forming beta stabilizers (manganese, chromium, and iron) have been used frequently as alloy additions in commercial alloys. Although the eutectoid reaction offers a possible basis for heat treatment, thus far no alloys which contain significant amounts of active eutectoid forming elements have been used commercially. For this reason, the eutectoid reaction generally is not employed in current heat-treatment procedures, although it may become important when considerations of thermal stability are made.

The transformation from beta to eutectoid proceeds by a nucleation and growth process. Like the transformation from beta to alpha, its progress can be mapped by means of a conventional TTT diagram, and many of the available diagrams in the literature show this reaction (see Table 26). The ranges of composition and temperature in which the direct transformation from beta to eutectoid decomposition products may be expected is shown schematically in Figure 66. At compositions and temperatures to the left of this shaded range, proeutectoid alpha would be expected. To the right of the shaded range, proeutectoid compounds would be precipitated. The amount of proeutectoid alpha rejected should decrease as the alloy content is increased toward the range indicated by the crosshatched area. For hypoeutectoid alloys, the time required to start the eutectoid decomposition should decrease with increasing alloy content. This is illustrated in Figure 67 by a series of titanium-chromium alloys. Although the curves showing the transformation for the Ti-5Cr and Ti-7Cr alloys are not completely consistent, the time generally is seen to decrease as the chromium content is increased.

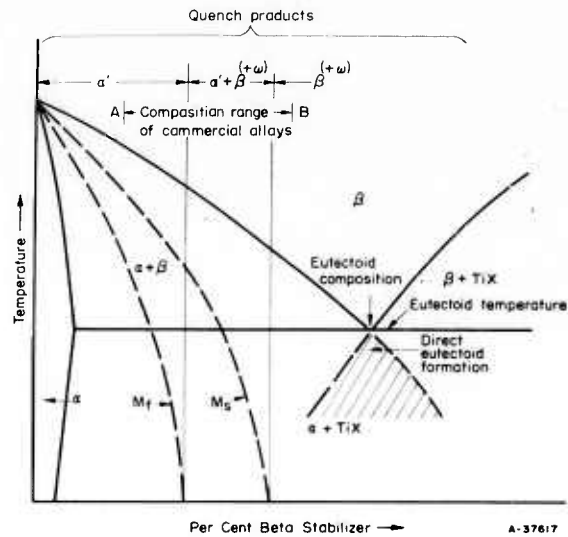


FIGURE 66. SCHEMATIC EQUILIBRIUM DIAGRAM FOR A TYPICAL BETA-STABILIZED TITANIUM ALLOY

The eutectoid transformation may cause embrittlement of a structural member under stress at moderately elevated temperatures. The reaction can be accelerated further by the application of stress. Thus, studies of the thermal stability of commercial alloys frequently are made using stressed specimens. Goldenstein, et al. (128) have shown the increased transformation rate under stress for a series of titanium-chromium alloys. The TTT curve shown in Figure 68 illustrates this effect for a Ti-7.5Cr alloy.

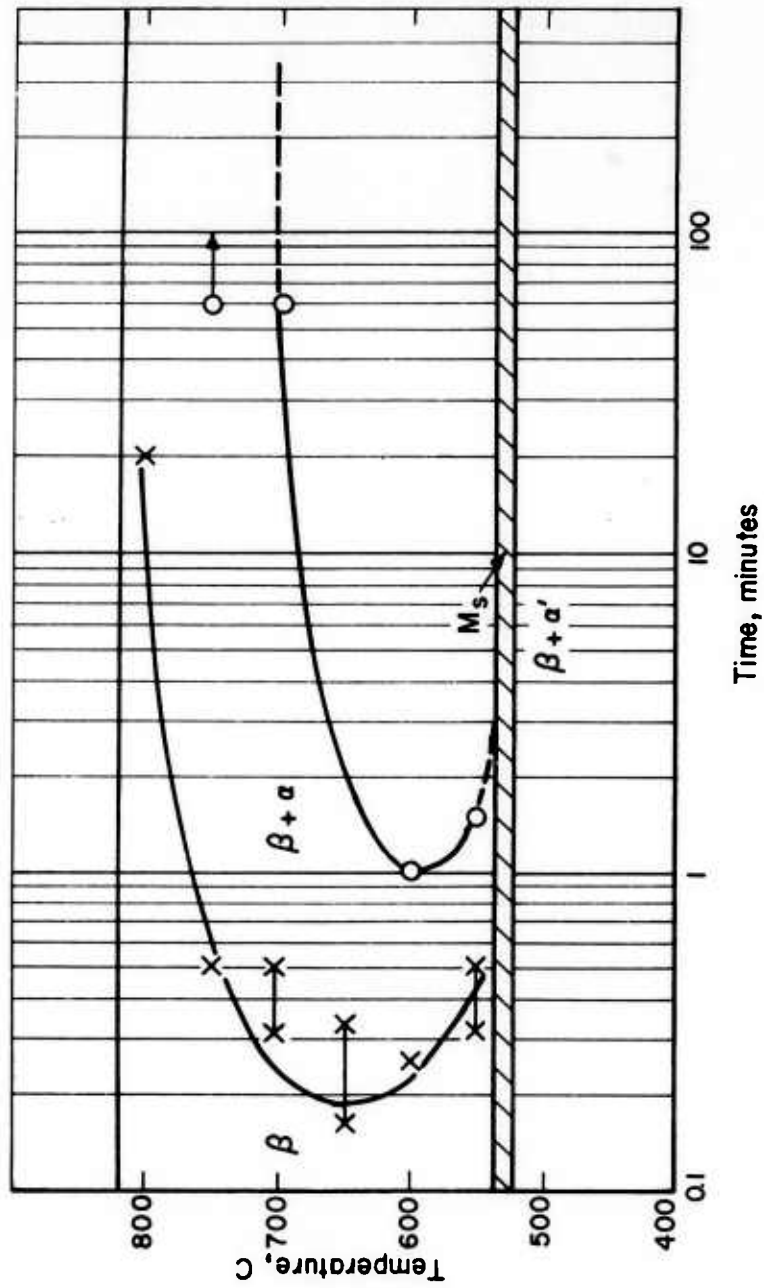
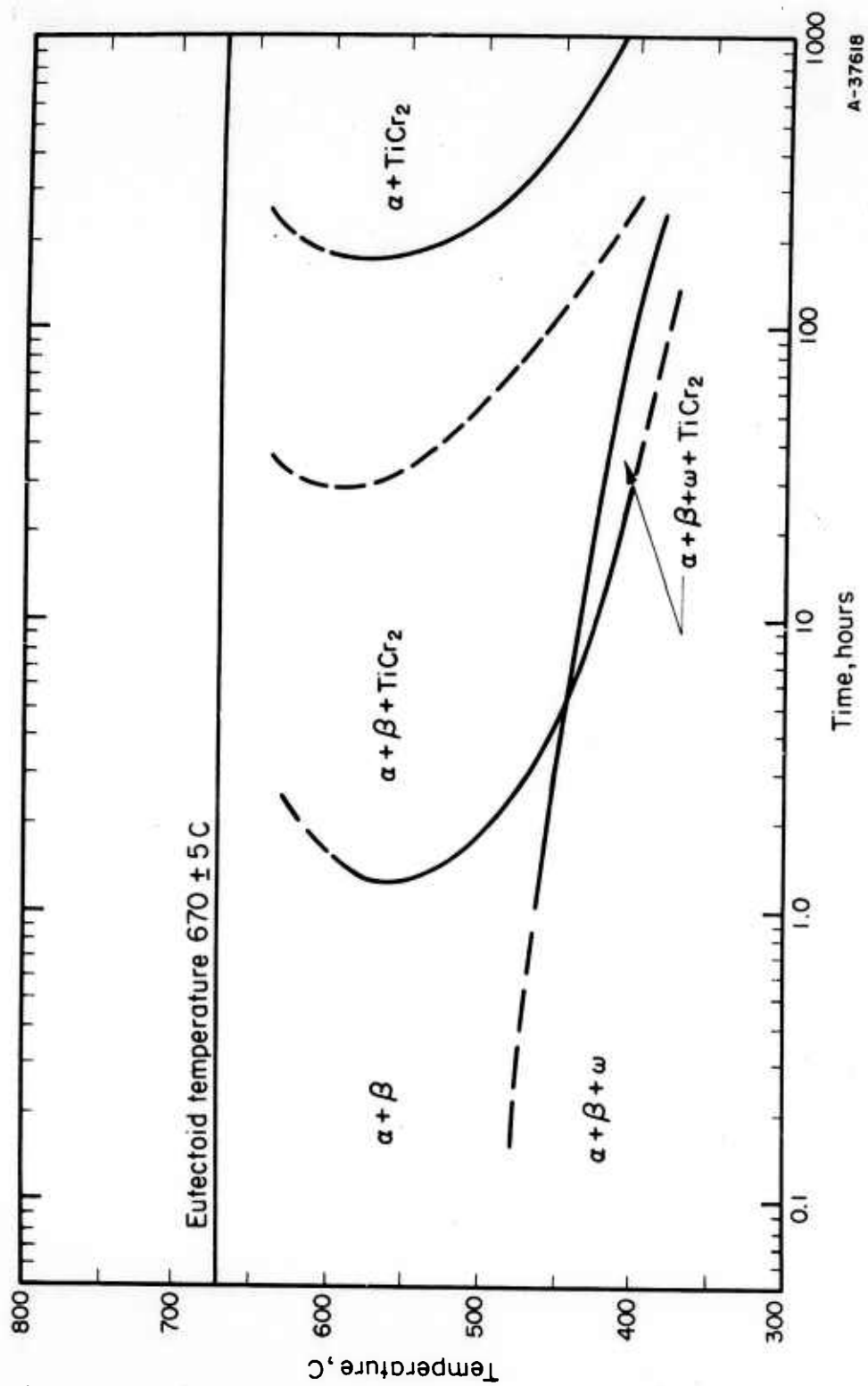


FIGURE 67. CURVES SHOWING THE EFFECT OF COMPOSITION ON THE START OF THE EUTECTOID DECOMPOSITION IN TITANIUM-CHROMIUM ALLOYS(138)



A-37618

FIGURE 68. TTT DIAGRAM OF Ti-7.5Cr ALLOY EQUILIBRATED AT 685 C (128)

The dashed line represents the displacement of the end of transformation due to stress. (128)

REFERENCES

- (1) Ogden, H. R. , Maykuth, D. J. , Finlay, W. L. , and Jaffee, R. I. , "Constitution of Titanium-Aluminum Alloys", Trans. AIME, 191, 1150 (1951).
- (2) Maykuth, D. J. , et al. , "The Titanium-Manganese, Titanium-Tungsten, and Titanium-Tantalum Phase Diagrams", AFTR 6516, Part II (January, 1953).
- (3) Powers, R. M. , and Wilhelm, H. A. , Ames Laboratory Report 15C-228, AEC (September, 1952).
- (4) Kubaschewski, O. , and Dench, W. A. , "The Heats of Formation in the Systems Ti-Al and Ti-Fe", Acta Met. , 3, 339 (July, 1955).
- (5) Kubaschewski, O. , and Cotterall, J. , Thermochemical Data of Alloys, Pergamon Press (1956).
- (6) Herosymenko, P. , and Winter, J. , "A Method for Retaining Beta Phase in the Core of Plates and Rods of Titanium Alloys", WADC TR 54-280 (November, 1954).
- (7) Mendelssohn, K. , and Rosenberg, H. M. , "The Thermal Conductivity of Metals at Low Temperatures: I, The Elements of Group 1, 2, and 3; II, The Transition Elements", Proc. Phys. Soc. (London), 65A, 385 (1952).
- (8) "Crucible Titanium Manual", Crucible Steel Company of America, Midland, Pennsylvania.
- (9) Lepkowski, W. J. , and Holladay, J. W. , "The Physical Properties of Titanium and Titanium Alloys", Battelle Memorial Institute, Titanium Metallurgical Laboratory Report No. 73, p 20 (July 25, 1957).
- (10) Rigney, E. J. , and Bockstabler, L. I. , "The Thermal Conductivity of Titanium Between 20 and 273 Degrees Kelvin", Phys. Rev. , 83, 220 (1951).
- (11) Loewen, E. G. , "Thermal Properties of Titanium Alloys and Selected Tool Steels", Trans. ASME, 78, 667 (1956).
- (12) Production Design Bulletin, "Engineering Characteristics of Titanium-6 Aluminum-4 Vanadium Alloy", Bulletin 11, Douglas Aircraft Corporation (November 19, 1956).

- (13) Deem, H. W. , Wood, W. D. , and Lucks, C. F. , "Relationship Between Electrical and Thermal Conductivities of Titanium Alloys", Trans. AIME, 212, 520 (1958).
- (14) Altman, W. W. , Rubin, T. , and Johnson, H. L. , "Coefficient of Thermal Expansion of Solids at Low Temperatures: III, The Thermal Expansion of Pure Metals with the Data for Aluminum, Nickel, Titanium, and Zirconium", Technical Report TR-264-27, Cryogenic Laboratory, The Ohio State University (February 10, 1954).
- (15) Adenstedt, H. K. , "Handbook on Titanium", WADC TR 54-305, Part I (August, 1954).
- (16) Mah, A. D. , Kelley, K. K. , Gellert, N. L. , King, E. G. , and O'Brien, C. J. , "Thermodynamic Properties of Titanium-Oxygen Solutions and Compounds", U. S. Bur. Mines Rept. Invest. , 5316 (March, 1957).
- (17) Ames, S. L. , and McQuillan, A. D. , "The Effect of Addition Elements on the Electrical Resistivity of Alpha Titanium", Acta Met. , 4, 619 (November, 1956).
- (18) Wyatt, J. L. , "Electrical Resistance of Titanium Metal", J. Metals, 5 (7), 903 (1953).
- (19) Denny, J. M. , "A Study of Electron Effects in Solid Solution Alloys of Titanium", California Institute of Technology Physical Met. Lab. , 6th Tech. Rept. to Office of Naval Research on Contract No. N6onr-24430 (January, 1955).
- (20) Sagel, K. , Schulz, E. , and Zwicker, U. , "Studies of the Titanium-Aluminum System", Z. Metallk. , 47 (6), 529 (August, 1956).
- (21) Ames, S. L. , and McQuillan, A. D. , "The Resistivity-Temperature Concentration Relationships in the System Niobium-Titanium", Acta Met. , 2, 831 (November, 1954).
- (22) Ames, S. L. , and McQuillan, A. D. , "The Resistivity-Temperature Concentration Relationships in Beta-Phase Titanium-Hydrogen Alloys", Acta Met. , 4, 602 (November, 1956).
- (23) Speich, G. R. , "Low-Temperature Resistivity Measurements of Ti-Mo Alloys", Report No. 8 to Watertown Arsenal Laboratory, Project OOTB4-911, Contract No. DA-593-26-006 (July, 1955).
- (24) Brotzen, F. R. , Harmon, E. L. , and Troiani, A. R. , "Investigation of Mechanical Properties of Ti-Base Alloys", Tech. Rpt. No. 3, WAL 401/93-34 (August 31, 1954).

- (25) Reckie, J. , and Yao, Y. L. , "Magnetic Anisotropy and Cold Worked Texture of Titanium", Proc. Phys. Soc. , 69B, 417 (1956).
- (26) Trzebiatowski, W. , and Stalinski, B. , "Magnetic Properties of Titanium Hydrides", Bull. acad. Polon. sci. , 1 (3-4) (1953).
- (27) Metals Handbook, ASM, Cleveland, Ohio (1948), p 1143.
- (28) Munster, A. , Sagel, K. , and Zwicker, V. , "Electrical Conductivity and Susceptibility of the System Titanium-Aluminum", Acta Met. , 4 (5), 558 (1956).
- (29) Fitzwilliam, J. , Kaufmann, A. , and Squire, C. , "Magnetic and X-Ray Studies on Titanium and Zirconium with Dissolved Hydrogen", J. Chem. Phys. , 9, 678 (1941).
- (30) Squire, C. F. , and Kaufmann, A. R. , "The Magnetic Susceptibility of Titanium and Zirconium", J. Chem. Phys. , 9, 673 (1941).
- (31) Wohlfarth, E. P. , "Antiferromagnetism in the System Ti-H", Acta Met. , 4 (2), 225 (1956).
- (32) McQuillan, A. D. , and McQuillan, M. K. , Titanium, Academic Press, Inc. , New York (1956).
- (33) Yoshida, S. , Okamoto, S. , and Araki, T. , "Studies of Corrosion Resistance of Ti-Ni and Ti-Al Alloys", Kikai Shikenjo Shoho , 9 (2) (March, 1955).
- (34) Yoshida, S. , Okamoto, S. , and Araki, T. , "Studies of Corrosion Resistance of Ti-Cr, Ti-Mn, Ti-Si, and Ti-Mo Alloys", Kikai Shikenjo Shoho , 10 (2) (1956).
- (35) Yoshida, S. , Okamoto, S. , and Araki, T. , "Studies of Corrosion Resistance of Ti-Ag, Ti-Cu, Ti-Fe, Ti-Co, Ti-W, and Ti-Sn Alloys", Kikai Shikenjo Shoho , 11 (3) (1957).
- (36) Rüdiger, O. , Fischer, W. R. , and Kuon, W. , "On the Corrosion of Titanium Alloys", Z. Metallk. , 47 (8), 599 (August, 1956).
- (37) Sterns, M. , "Titanium + Palladium = Better Corrosion Resistance", Metal Progr. , 75 (5), 117 (1959).
- (38) Stough, D. W. , Fink, F. W. , and Peoples, R. S. , "The Stress Corrosion and Pyrophoric Behavior of Titanium and Titanium Alloys", Battelle Memorial Institute, Titanium Metallurgical Laboratory Report No. 84, p 25 (September 15, 1957).

- (39) Fontana, M. G. , "Stress Corrosion in Titanium and Its Alloys", *Ind. Eng. Chem.* , 48 (9), 59A-60A (1956).
- (40) "Progress Report on the Salt Corrosion of Titanium Alloys at Elevated Temperature and Stress", Battelle Memorial Institute, Titanium Metallurgical Laboratory Report No. 88 (November 20, 1957).
- (41) Albrecht, W. M. , "Mechanisms in the Oxidation of Titanium", Battelle Memorial Institute, Titanium Metallurgical Laboratory Memorandum (August 5, 1957).
- (42) Gulbransen, E. A. , and Andrews, K. E. , "Kinetics of the Reaction of Titanium with Oxygen, Nitrogen, and Hydrogen", *J. Metals* , p 741 (1949).
- (43) McAndrew, J. B. , and Kessler, H. D. , "Ti-36Al as a Base for High-Temperature Alloys", *J. Metals* , 8 (10), 1348 (1956).
- (44) Hayes, E. T. , Roberson, A. H. , and Paaschi, O. G. , "Zirconium-Titanium System: Constitution Diagram and Properties", U. S. Bur. Mines Rept. Invest. , No. 4485 (November, 1951).
- (45) Ogden, H. R. , Maykuth, D. J. , Finlay, W. L. , and Jaffee, R. I. , "Mechanical Properties of High-Purity Titanium-Aluminum Alloys", *J. Metals* , 5 (2), 267 (1953).
- (46) Jaffee, R. I. , Ogden, H. R. , and Happe, R. A. , "Titanium Base Alloys", U. S. Patent 2,796,347.
- (47) Jaffee, R. I. , Ogden, H. R. , and Maykuth, D. J. , "Titanium Base Alloys", U. S. Patent 2,796,996 (February 9, 1957).
- (48) McPherson, D. J. , and Fontana, M. G. , "Preparation and Properties of Titanium-Chromium Binary Alloys", *Trans. ASM* , 43 , 1098 (1951).
- (49) Maynor, H. W. , Jr. , Barrett, B. R. , and Swift, R. E. , "Scaling of Titanium and Titanium Alloys", WADC TR 54-190, Parts 1 and 2 (March and June, 1955).
- (50) Kuhn, Kinsey, and Ellis, "A Study of Some Alloys of Titanium", *Can. Mining and Met. Bull.* , No. 454, 74 (1950).
- (51) Sutcliffe, D. A. , "Titanium-Silicon Alloys", *Metal Treatment and Drop Forging* , 21 , 191 (1954).

- (52) Reynolds, J. E. , Ogden, H. R. , and Jaffee, R. I. , "A Study of the Air Contamination of Three Titanium Alloys", Trans. ASM, 49, 280 (1957).
- (53) Williams, D. N. , Schwartzberg, F. R. , Wilson, P. R. , Albrecht, W. M. , Mallet, M. W. , and Jaffee, R. I. , "Hydrogen Contamination in Titanium and Titanium Alloys: Part IV. The Effect of Hydrogen on the Mechanical Properties and Control of Hydrogen in Titanium Alloys", Battelle Memorial Institute Report on Contract AF 33(616)-2813 (March, 1957).
- (54) Stout, V. L. , and Gibbons, M. D. , "Gettering of Gas by Titanium", J. Appl. Phys. , 26 (12), 1488 (1955).
- (55) Savidge, R. E. , "Hydrogen Absorption by Two Commercial Titanium Alloys", M.S. Thesis, Rensselaer Polytechnic Institute (April 1, 1957).
- (56) Schliecher, H. , and Zwicker, U. , "The Effects of Hydrogen in Titanium Alloys", Z. Metallk. , 47 (8), 570 (1956).
- (57) McKinsey, C. R. , Stern, M. , and Perkins, R. A. , "Factors Affecting the Absorption and Distribution of Hydrogen in Titanium During Acid Pickling", Trans. ASM, 50, 438 (1958).
- (58) Griest, A. J. , Moorehead, P. E. , Frost, P. D. , and Jackson, J. H. , "Surface Hardening of Titanium by Carburizing and Induction Heat Treatment", Trans. ASM, 46, 257 (1954).
- (59) "Descaling and Cleaning of Titanium and Titanium Alloys", Battelle Memorial Institute, Titanium Metallurgical Laboratory Report No. 96 (March 28, 1958).
- (60) Barth, W. J. , and Field, A. L. , Jr. , "Sodium Hydride Descaling of Titanium", Metal Progress, 68 (2), 114 (August, 1955).
- (61) Lenning, G. A. , Craighead, C. M. , and Jaffee, R. I. , "Hydrogen Contamination in Descaling and Acid Pickling of Titanium", Trans. ASM, 45, 726 (1956).
- (62) Wheatley, Q. D. , "Hydride Modified to Reduce Hydrogen Absorption", Metal Progr. , 68, 119 (August 1, 1955).
- (63) Alexander, H. L. , Farrel, H. , and Wheatley, Q. D. , "Hydrogen Contamination of Titanium Minimized by Modified Descaling Rate", Metal Progr. , 69 (2), 78 (1956).
- (64) "Acid Pickling of Titanium and Titanium Alloys", Crucible Steel Company of America, Midland, Pennsylvania (1958).

- (65) Rem-Cru Titanium Review (now Crucible Titanium Review), 5 (2), p 6 (April, 1957).
- (66) Grube, G. , and Jedele, A. , "Die Diffusion der Metalle. in Feston Zustand", Z. Electrochem. , 38, 799 (1932).
- (67) Matano, C. , "On the Relation Between the Diffusion Coefficients and Concentration of Solid Metals", Journal of Physics (Japan), 8, 109 (1933).
- (68) Jost, W. , Diffusion in Solids, Liquids, and Gases, Academic Press, Inc. , New York (1952), pp 68-72.
- (69) Samsonov, G. V. , and Latysheva, V. P. , "Investigation of the Diffusion of Boron and Carbon Into Some Metals of the Transition Group", Fizika Metallov i Metallovedenie, 2, 309-319 (1956).
- (70) Wasilewski, R. J. , and Kehl, G. L. , Metallurgia, p 225 (November, 1954).
- (71) Albrecht, W. M. , and Mallet, M. W. , Trans. AIME, 212, 204 (Journal of Metals, April, 1958).
- (72) Kusamichi, H. , Yaki, Y. , Yukawa, T. , and Noda, T. , Nippon Kinsoku Gakkaishi, 20, 39 (1956).
- (73) Köster, W. , Bangert, L. , and Evers, M. , Z. Metallk. , 47, 564 (1956).
- (74) Pratt, J. N. , Bratina, W. J. , and Chalmers, B. , Acta Met. , 2 (2), 203 (March, 1954).
- (75) Wasilewski, R. J. , and Kehl, G. L. , J. Inst. Metals, 83, 94 (November, 1954).
- (76) Roe, W. P. , Palmer, H. R. , and Opie, W. R. , Trans. ASM, 52, 191-200 (1960).
- (77) Claisse, F. , and Koenig, H. P. , Acta Met. , 4, 650 (November, 1956).
- (78) Gupta, D. , and Weinig, S. , WADC TR 57-420, ASTIA AD 142145 (November, 1957).
- (79) Wagner, F. C. , Bucur, E. J. , and Steinberg, M. A. , Trans. ASM, 48, 742 (1956).
- (80) Hatch, A. J. , Interim Report No. 2, Contract No. AF 33(600)-36830 (April 16-August 31, 1959), ASTIA AD 226593.

- (81) Schwope, A. D., Marsh, L. L., and Mangio, C. A., "Investigations of Diffusion Rates in Titanium-Base Alloys", report from Battelle Memorial Institute to Wright Air Development Center, Contract AF 33(616)-103 (March, 1953).
- (82) Kornilov, I. I., and Shinyayaev, A. Ia., "Relationship Between Diffusion and Heat Resistance in Ni Alloys", *Izvest. Akad. Nauk, SSSR Otdel. Tekn. Nauk*, No. 9, 50-55 (1957).
- (83) Arkharov, V. I., Efremova, K. A., Ivanovskaya, S. I., Shtol'ts, A. K., and Yunikov, B. A., "Frontal Diffusion in Iron of Commercial Purity", *Doklady Akad. Nauk SSSR*, 89, 269-270 (1953), English translation issued as USAEC NSF-tr-48 (1953).
- (84) Arkharov, V. I., Efremova, K. A., Ivanovskaya, S. I., Shtol'ts, A. K., and Yunikov, B. A., "The Shape of the Diffusion Front During Diffusion of Nickel and Certain Other Elements in Iron and the Effects on it of Small Amounts of Dissolved Impurities", *Trudy Inst. Fiz. Metal. Akad. Nauk SSSR, Ural Filial*, No. 16, 56-61 (1955).
- (85) Bokshien, S. Z., Kazakova, V. A., Kishkin, S. T., and Mirsky, L. M., "A Study of the Influence of High-Melting Point Metals on the Self-Diffusion of Iron Using Radioisotope", *Izvest. Akad. Nauk SSSR (Tekhn.)* No. 12, 18-27 (1955).
- (86) Goold, D., "Diffusion of Aluminum, Tin, Vanadium, Molybdenum, and Manganese in Titanium", *J. Inst. Metals*, 27, 444-448 (June, 1960).
- (87) Polonis, D. H., and Parr, J. G., "Isothermal Decomposition of Transformed Beta Phase in a Titanium-Nickel Alloy", *Acta Metallurgica*, 3, 307 (1955).
- (88) Dorn, J. E., "Some Fundamental Experiments on High-Temperature Creep", *Proc. National Physical Lab. Symposium on Creep and Fracture of Metals at High Temperature, N.M.S.O.*, June, 1954.
- (89) Mortlock, A. S., and Tomlin, D. H., "The Diffusion of Chromium in Titanium Studied by an Autoradiographic Method", *Proc. Phys. Soc. (London)*, B69, Part 2, 248 (February, 1956).
- (90) Grum-Gyzhimailo, N. V., "Diffusion in Titanium-Niobium Alloys", *Izvest. Akad. Nauk SSSR, Otdel. Tekh. Nauk*, No. 7, 24-28 (1957).
- (91) Adda, Y., and Philibert, J., "Determination des Coefficients de Diffusion et Etude de L'effect Kirkendall sur le Couple Uranium-Titane", Note, presented by M. Georges Chaudron.

- (92) Martens, H. E. , reported in "Minutes of Titanium Symposium on Diffusion and Mechanical Behavior", Columbia University, June, 1954, under auspices of Metallurgical Advisory Committee on Titanium.
- (93) Holden, F. C. , Williams, D. N. , Riley, W. E. , and Jaffee, R. I. , "Flow Properties, Deformation Textures, and Slip Systems of Titanium and Titanium Alloys", Titanium Metallurgical Laboratory Report, No. 30 (Jan. 31, 1956).
- (94) Churchman, A. T. , "The Slip Modes of Titanium and the Effect of Purity on Their Occurrence During Tensile Deformation of Single Crystals", Proc. Roy. Soc. , A226, 216 (1954).
- (95) Rosi, F. D. , Perkins, F. C. , and Siegle, L. L. , "Mechanisms of Plastic Flow of Titanium at Low and High Temperatures", Trans. AIME, 206, 115 (1956).
- (96) Williams, D. N. , "Metallographic Evidence of Mechanical Twinning in an Alpha-Beta Titanium Alloy, Nature, 177, 436 (March, 1956).
- (97) Holden, F. C. , Young, A. P. , Ogden, H. R. , Schwartz, C. M. , and Jaffee, R. I. , "An Investigation of the Usefulness of the Electron Microscope in the Study of Titanium Alloy Structures", WADC TR 56-269, March 1956 (Battelle Memorial Institute).
- (98) Liu, Y. C. , Nielson, J. P. , and Albert, P. , "Beta Plasticity in Titanium Base Alloys", Final Report to Watertown Arsenal Laboratories on Contract No. DA-30-069-ORD-869, Oct. 15, 1954 (New York University).
- (99) Williams, D. N. , and Eppelsheimer, D. S. , "The Cold Rolled Texture of Titanium", Trans. AIME, 197, 1378 (1953).
- (100) Sparks, C. J. , McHargue, C. J. , and Holland, J. R. , "Preferred Orientation and Deformation in Titanium and Titanium Alloys", Third Summary Report to WADC on Contract No. AF 33(038)19574, February, 1954.
- (101) Sagel, K. , and Zwicker, U. , "Deformation and Recrystallization Textures of Titanium and Titanium Alloys", Z. Metallk. , 46, 835 (1955).
- (102) McHargue, C. J. , Adair, S. E. , Jr. , and Hammond, J. P. , "Effects of Solid Solution Alloying on the Cold-Rolled Texture of Titanium", Trans. AIME, 197, 1199 (1953).

- (103) Sachs, G. , and Van Horn, K. R. , Practical Metallurgy, American Society for Metals, 1940, p 123.
- (104) Sparks, C. J. , and Hammond, J. P. , "Preferred Orientations and Kinetics of Recrystallization in Titanium", WADC TR 56-421, July, 1956 (University of Kentucky).
- (105) Gillig, F. J. , Cornell Aeronautical Laboratory, reports on stress relief and relaxation behavior of titanium, WADC TR 55-410, August, 1956, and TR 55-458, December, 1956.
- (106) Sticha, E. A. , "Relaxation Behavior of Titanium Alloys", WADC TR 55-458, Part I, October, 1955.
- (107) Obinata, I. , and Nishimura, K. , "On the Recrystallization of Cold Rolled Commercially Pure Titanium", J. Inst. Metals, 84, 97 (1955-56).
- (108) Bartholomew, E. L. , Jr. , "Grain Growth and Recrystallization Studies of Commercial Titanium, RC-55, and Alloy Ti-100A", Trans. ASM, 50, 370 (1958).
- (109) Damiano, V. V. , "Titanium Ti-100A Sheet, Anisotropic and Recrystallization Characteristics", Aeronautical Materials Lab. Report No. AML NAM AE 4123, Naval Exp. Station, Philadelphia, Pennsylvania, March 17, 1953.
- (110) Reinbach, R. , and Nowikow, A. , "Influence of Alloying Additions on the Recrystallization of Titanium", Z. Metallk. , 47, 583 (August, 1956).
- (111) Castleman, L. S. , Rosi, F. D. , and Siegle, L. L. , "Recrystallization of Titanium", WADC TR 55-321, September, 1955.
- (112) Liu, Y. C. , and Margolin, H. , "Grain Size Control in Titanium and Effect Thereon of Various Addition Agents", Final Report to WAL on Contract No. DA-30-069-ORD-200 (Part I) November 14, 1952.
- (113) Holden, F. C. , Ogden, H. R. , and Jaffee, R. I. , "Microstructure and Mechanical Properties of Iodide Titanium", Trans. AIME, 197, 238 (1953).
- (114) Savitski, E. M. , Tylkina, M. A. , and Tsyganova, I. A. , "Influence of the Alloying Additions on the Temperature of Recrystallization and the Mechanical Properties of Titanium", Isvest. Akad. Nauk SSSR, Otdel. Tekh. Nauk, No. 3, 96 (1958).

- (115) Yogi, Y. , "Characteristics of Work Hardening and Anneal Softening of Titanium-Base Ti-Al Alloy Wires", J. Japan Inst. Metals, 21 (5), 360 (1957).
- (116) Jenkins, A. E. , and Worner, H. W. , "The Structure and Some Properties of Ti-O Alloys Containing 0-5 a/o O₂, J. Inst. Met. , 80, 157 (1951-1952).
- (117) Ogden, H. R. , Holden, F. C. , and Jaffee, R. I. , "Mechanical Properties of Ti-Cr-Mo Alloys as Affected by Grain Size and Grain Shape", Trans. ASM, 48, 627 (1956).
- (118) Liu, Y. C. , "Grain Size Control in Titanium and The Effect Thereon of Various Addition Agents", Final Report to WAL, Contract No. DA-30-069-ORD-840, Nov. 30, 1953, WAL 401/105-25 (New York University).
- (119) Burke, J. E. , Grain Control in Industrial Metallurgy, American Society for Metals, 1949, pp 1-73.
- (120) Mote, M. W. , Hooper, R. B. , and Frost, P. D. , "The Engineering Properties of Commercial Ti Alloys", Titanium Metallurgical Laboratory Report, No. 92, June 4, 1958.
- (121) Berger, L. W. , Williams, D. N. , and Jaffee, R. I. , "The Effect of Sulphur on the Properties of Ti and Ti Alloys", Trans. ASM, 49, 300 (1957).
- (122) Levinson, D. W. , and Rostoker, W. , "Structural Changes of Commercial Titanium and Titanium-Base Alloys on Heat Treatment", WADC TR 54-244, May, 1954.
- (123) Holden, F. C. , and Jaffee, R. I. , "Beta Transformation in Titanium Alloys", Titanium Metallurgical Laboratory Report No. 25, December 5, 1955 (OTS PB 124570).
- (124) Aaronson, H. I. , Triplett, W. B. , and Andes, G. M. , "Phase Transformations in Hypoeutectoid TiCr Alloys", Trans. AIME, 209, 1227-1235 (1957).
- (125) Aaronson, H. I. , Triplett, W. B. , and Andes, G. M. , "Effects of Composition on Transformations in Titanium-Chromium Alloys", Trans. AIME, 212, 624-626 (1958).
- (126) Aaronson, H. I. , Triplett, W. B. , and Andes, G. M. , "Transformation Mechanisms in a Hypereutectoid Titanium-Chromium Alloy", Trans. AIME, 218, 331-339.

- (127) Spachner, S. A. , and Rostoker, W. , "Transformation Kinetics of Two Titanium Alloys in the Transition Phase Region", Trans. AIME, 212, 765-769 (1958).
- (128) Goldstein, A. W. , Metcalfe, A. G. , and Rostoker, W. , "The Effect of Stress on the Eutectoid Decomposition of Titanium-Chromium Alloys", Trans. ASM, 51, 1036-1054 (1959).
- (129) Harmon, E. L. , Kozol, J. , and Troiano, A. R. , "Mechanical Properties Correlated With Transformation Characteristics of Titanium-Vanadium Alloys", Trans. ASM, 50, 418-437 (1958).
- (130) Bunshah, R. F. , and Margolin, H. , "Microstructure and Mechanical Properties of Ti-Cu-Al and Ti-Cu-Al-Sn Alloys", Trans. ASM, 51, 961-980 (1959).
- (131) Tanner, L. E. , "Department of Defense Titanium Sheet-Rolling Program; Time-Temperature-Transformation Diagrams of the Titanium Sheet-Rolling-Program Alloys", DMIC Report No. 46G, October 19, 1959 (OTS PB 151075).
- (132) Troiano, A. R. , and Greninger, A. B. , "The Martensite Transformation", Metals Handbook, ASM (1948), pp 263-266.
- (133) Duwez, Pol, "The Martensite Transformation Temperature in Titanium Binary Alloys", Trans. ASM, 45, 934-940 (1953).
- (134) Duwez, Pol, "Effect of Rate of Cooling on the α - β Transformation in Titanium and Titanium-Molybdenum Alloys", Trans. AIME, pp 765-771 (Journal of Metals, October 1951).
- (135) DeLazaro, D. J. , Hanson, M. , Riley, R. E. , and Rostoker, W. , "Time-Temperature-Transformation Characteristics of Titanium-Molybdenum Alloys", Trans. AIME, 194, 265-269 (1952).
- (136) Kessler, H. D. , and Hanson, M. , "Transformation Kinetics and Mechanical Properties of Titanium-Molybdenum-Aluminum Alloys", Trans. ASM, 46, 587-608 (1954).
- (137) Kehl, G. L. , and Riccardo, A. E. , "The Influence of Oxygen on the Transformation Characteristics of Some Titanium-Molybdenum Alloys", Final Technical Report, Contract No. DA-30-069-ORD-1420 (October 31, 1955).
- (138) Rostoker, W. , and Hansen, M. , "Structural Changes of Commercial Titanium and Titanium-Base Alloys", AFTR No. 6686, November, 1951, Contract No. AF 33(038)-16347.

- (139) Holden, F. C., Ogden, H. R., and Jaffee, R. I., "The Effect of Microstructure on the Mechanical Properties of Titanium Alloys", Summary Report to Watertown Arsenal, February, 1955, Contract No. DA-33-019-ORD-1397.
- (140) Polonis, D. H., and Parr, J. G., "Phase Transformations in Titanium-Rich Alloys of Iron and Titanium", Trans. AIME, 200, 1148-1154 (1954).
- (141) Polonis, D. H., and Parr, J. G., "Martensite Formation in Powder and Lump Specimens in Ti-Fe Alloys", Trans. AIME, 203, 64 (1955).
- (142) Polonis, D. H., and Parr, J. G., "Phase Transformations in Titanium-Rich Alloys of Nickel and Titanium", Trans. AIME, 206, 531-536 (1956).
- (143) Swann, P. R., and Parr, J. G., "Phase Transformations in Titanium-Rich Alloys of Titanium and Cobalt", Trans. AIME, 212, 276-279 (1958).
- (144) Newkirk, J. B., and Geisler, A. H., Acta Metallurgica, 1, 370 (1953).
- (145) McHargue, C. J., Acta Crystallographica, 6, 529 (1953).
- (146) Williams, A. J., Cahn, R. W., and Barrett, C. S., "The Crystallography of the β - α Transformation in Titanium", Acta Metallurgica, 2, 117-128 (1954).
- (147) Burgers, W. G., Physica, 1, 561 (1934).
- (148) Liu, Y. C., "Martensitic Transformation in Binary Titanium Alloys", Trans. AIME, 206, 1036-1040 (1956), J. Metals (August, 1956).
- (149) Gaunt, P., and Christian, J. W., "The Crystallography of the β to α Transformation in Zirconium and in Two Titanium-Molybdenum Alloys", Acta Metallurgica, 7, 534-543 (1959).
- (150) Liu, Y. C., and Margolin, H., "Martensite Habit Plane in Quenched Ti-Mn Alloys", Trans. AIME, 197, 667-670 (1953).
- (151) Weinig, S., and Machlin, E. S., "Data for One of the Martensitic Transformations in an 11 Per Cent Molybdenum Alloy", Trans. AIME, 200, 1280-1281 (1954); J. Metals (1954).
- (152) Polonis, D. H., and Parr, J. G., "Orientation Relationships Between α' and β Phases in a Titanium-Nickel Alloy", Trans. AIME, 206, 892-893 (1956); J. Metals (August, 1956).

- (153) Domagala, R. F., and Rostoker, W., "Metallography of Tempering of α' in Titanium Alloys", *Trans. ASM*, 48, 762-772 (1956).
- (154) Brotzen, F. R., Harmon, E. L., and Troiano, A. R., "Nature and Decomposition Kinetics of α' in Titanium-Vanadium Alloys", *Trans. ASM*, 48, 774-782 (1956).
- (155) Gomez, M. P., and Polonis, D. H., "Kinetics of Decomposition of α' in a Titanium-Copper Alloy", *Trans. ASM*, 52, 201-217 (1960).
- (156) Mehl, R. F., and Dube, C. A., "The Eutectoid Reaction", *Phase Transformations in Solids*, John Wiley & Sons, Inc., New York (1951), p 545.
- (157) Hahn, G., "The Habit Plane of Isothermal Alpha in Beta of Ti-Fe Alloys", Senior Thesis, New York University (June, 1952).
- (158) DeLazaro, D. J., and Rostoker, W., "The Influence of Oxygen Contents on Transformation in Titanium Alloy Containing 11 Per Cent Molybdenum", *Acta Metallurgica*, 1 (6), 674-678 (1953).
- (159) Kessler, H. D., and Hansen, M., "Transformation Kinetics and Mechanical Properties of Titanium-Aluminum-Molybdenum Alloys", *Trans. ASM*, 46, 587-608 (1954).
- (160) Frost, P. D., Parris, W. M., Hirsch, L. L., Doig, J. R., and Schwartz, C. M., "Isothermal Transformation of Titanium-Chromium Alloys", *Trans. ASM*, 46, 231-251 (1954).
- (161) Frost, P. D., Parris, W. M., Hirsch, L. K., Doig, J. R., and Schwartz, C. M., "Isothermal Transformation of Titanium-Manganese Alloys", *Trans. ASM*, 46, 1056-1071 (1954).
- (162) Austin, A. E., and Doig, J. R., "Structure of the Transition Phase Omega in Ti-Cr Alloys", *Trans. AIME*, 209, 27-30 (1957).
- (163) Spachner, S. A., "Comparison of the Structure of the Omega Transition Phase in Three Titanium Alloys", *Trans. AIME*, 212, 57-59 (1958).
- (164) Silcock, J. M., Davies, H. M., and Hardy, H. K., "Structure of the Omega Precipitation in Titanium-16 Per Cent Vanadium Alloy", *Nature*, 175 (4460), 731 (1955).
- (165) Silcock, J. M., "An X-Ray Examination of the Omega Phase in Ti-V, Ti-Mo, and Ti-Cr Alloys", *Acta Metallurgica*, 6, 481-493 (1958).

- (166) Holden, F. C. , and Young, A. P. , "Electron Micrographic Study of Aging in a Beta-Titanium Alloy", Trans. AIME, 212, 287-288 (1958).
- (167) Holden, F. C. , Ogden, H. R. , and Jaffee, R. I. , "Heat Treatment, Structure, and Mechanical Properties of Ti-Mn Alloys", Trans. AIME, 200, 169-184 (1954).
- (168) Holden, F. C. , Ogden, H. R. , and Jaffee, R. I. , "Heat Treatment and Mechanical Properties of Ti-Fe Alloys", Trans. AIME, 206, 521-528 (1956).
- (169) Ogden, H. R. , Holden, F. C. , and Jaffee, R. I. , "Effect of Alpha Solute on the Heat Treatment Response of Ti-Mn Alloys", Trans. AIME, 203, 105-112 (1955).

DJM/FCH/DNW/HRO/RIJ:ims

LIST OF DMIC TECHNICAL REPORTS ISSUED
DEFENSE METALS INFORMATION CENTER

Battelle Memorial Institute

Columbus 1, Ohio

Copies of the technical reports listed below may be obtained from DMIC at no cost by Government agencies, and by Government contractors, subcontractors, and their suppliers. Others may obtain copies from the Office of Technical Services, Department of Commerce, Washington 25, D. C. See PB numbers and prices in parentheses.

DMIC Report Number	Title
46D	Department of Defense Titanium Sheet-Rolling Program - Uniform Testing Procedure for Sheet Materials, September 12, 1958 (PB 121649 \$1.25)
46E	Department of Defense Titanium Sheet-Rolling Program - Thermal Stability of the Titanium Sheet-Rolling-Program Alloys, November 25, 1958 (PB 151061 \$1.25)
46F	Department of Defense Titanium Sheet-Rolling Program Status Report No. 4, March 20, 1959 (PB 151065 \$2.25)
46G	Department of Defense Titanium Sheet-Rolling Program - Time-Temperature-Transformation Diagrams of the Titanium Sheet-Rolling Program Alloys, October 19, 1959 (PB 151075 \$2.25)
46H	Department of Defense Titanium Sheet-Rolling Program, Status Report No. 5, June 1, 1960 (PB 151087 \$2.00)
46I	Statistical Analysis of Tensile Properties of Heat-Treated Ti-4Al-3Mo-1V Sheet, September 16, 1960 (PB 151095 \$1.25)
106	Beryllium for Structural Applications, August 15, 1958 (PB 121648 \$3.00)
107	Tensile Properties of Titanium Alloys at Low Temperature, January 15, 1959 (PB 151062 \$1.25)
108	Welding and Brazing of Molybdenum, March 1, 1959 (PB 151063 \$1.25)
109	Coatings for Protecting Molybdenum From Oxidation at Elevated Temperature, March 6, 1959 (PB 151064 \$1.25)
110	The α - β Titanium Alloy (Ti-13V-11Cr-3Al), April 17, 1959 (PB 151066 \$3.00)
111	The Physical Metallurgy of Precipitation-Hardenable Stainless Steels, April 20, 1959 (PB 151067 \$2.00)
112	Physical and Mechanical Properties of Nine Commercial Precipitation-Hardenable Stainless Steels, May 1, 1959 (PB 151068 \$3.25)
113	Properties of Certain Cold-Rolled Austenitic Stainless Sheet Steels, May 15, 1959 (PB 151069 \$1.75)
114	Ductile-Brittle Transition in the Refractory Metals, June 25, 1959 (PB 151070 \$2.00)
115	The Fabrication of Tungsten, August 14, 1959 (PB 151071 \$1.75)
116R	Design Information on 5Cr-Mo-V Alloy Steels (H-11 and 5Cr-Mo-V Aircraft Steel) for Aircraft and Missiles (Revised), September 30, 1960 (PB 151072-R \$1.50)
117	Titanium Alloys for High-Temperature Use Strengthened by Fibers or Dispersed Particles, August 31, 1959 (PB 151073 \$2.00)
118	Welding of High-Strength Steels for Aircraft and Missile Applications, October 12, 1959 (PB 151074 \$2.25)
119	Heat Treatment of High-Strength Steels for Aircraft Applications, November 27, 1959 (PB 151076 \$2.50)
120	A Review of Certain Ferrous Castings Applications in Aircraft and Missiles, December 18, 1959 (PB 151077 \$1.50)
121	Methods for Conducting Short-Time Tensile, Creep, and Creep-Rupture Tests Under Conditions of Rapid Heating, December 20, 1959 (PB 151078 \$1.25)
122	The Welding of Titanium and Titanium Alloys, December 31, 1959 (PB 151079 \$1.75)
123	Oxidation Behavior and Protective Coatings for Columbium and Columbium-Base Alloys, January 15, 1960 (PB 151080 \$2.25)
124	Current Tests for Evaluating Fracture Toughness of Sheet Metals at High Strength Levels, January 28, 1960 (PB 151081 \$2.00)
125	Physical and Mechanical Properties of Columbium and Columbium-Base Alloys, February 22, 1960 (PB 151082 \$1.75)
126	Structural Damage in Thermally Cycled Rene 41 and Astroloy Sheet Materials, February 29, 1960 (PB 151083 \$0.75)
127	Physical and Mechanical Properties of Tungsten and Tungsten-Base Alloys, March 15, 1960 (PB 151084)
128	A Summary of Comparative Properties of Air-Melted and Vacuum-Melted Steels and Superalloys, March 28, 1960 (PB 151085 \$2.75)
129	Physical Properties of Some Nickel-Base Alloys, May 20, 1960 (PB 151086 \$2.75)
130	Selected Short-Time Tensile and Creep Data Obtained Under Conditions of Rapid Heating, June 17, 1960 (PB 151088 \$2.25)
131	New Developments in the Welding of Metals, June 24, 1960 (PB 151089 \$1.25)
132	Design Information on Nickel-Base Alloys for Aircraft and Missiles, July 20, 1960 (PB 151090 \$3.00)
133	Tantalum and Tantalum Alloys, July 25, 1960 (PB 151091 \$5.00)
134	Strain Aging of Refractory Metals, August 12, 1960 (PB 151092 \$1.75)
135	Design Information on PH 15-7 Mo Stainless Steel for Aircraft and Missiles, August 22, 1960 (PB 151093 \$1.25)

DMIC Report Number	Title
136A	The Effects of Alloying Elements in Titanium, Volume A. Constitution, September 15, 1960 (PB 151094 \$3.50)
137	Design Information on 17-7 PH Stainless Steels for Aircraft and Missiles, September 23, 1960 (PB 151096 \$1.00)
138	Availability and Mechanical Properties of High-Strength Steel Extrusions, October 26, 1960 (PB 151097 \$1.75)
139	Melting and Casting of the Refractory Metals Molybdenum, Columbium, Tantalum, and Tungsten, November 18, 1960 (PB 151098 \$1.00)
140	Physical and Mechanical Properties of Commercial Molybdenum-Base Alloys, November 30, 1960
141	Titanium-Alloy Forgings, December 19, 1960 (PB 151100 \$2.25)
142	Environmental Factors Influencing Metals Applications in Space Vehicles, December 27, 1960 (PB 151101 \$1.25)
143	High-Strength-Steel Forgings, January 5, 1961
144	Stress-Corrosion Cracking - A Nontechnical Introduction to the Problem, January 6, 1961 (PB 151103 \$0.75)
145	Design Information on Titanium Alloys for Aircraft and Missiles, January 10, 1961
146	Manual for Beryllium Prospectors, January 18, 1961
147	The Factors Influencing the Fracture Characteristics of High-Strength Steel, February 6, 1961
148	Review of Current Data on the Tensile Properties of Metals at Very Low Temperatures, February 14, 1961
149	Brazing for High Temperature Service, February 21, 1961
150	A Review of Bending Methods for Stainless Steel Tubing, March 2, 1961
151	Environmental and Metallurgical Factors of Stress-Corrosion Cracking in High-Strength Steels, April 14, 1961
152	Binary and Ternary Phase Diagrams of Columbium, Molybdenum, Tantalum, and Tungsten, April 28, 1961
153	Physical Metallurgy of Nickel-Base Superalloys, May 5, 1961.
154	Evolution of Ultrahigh-Strength, Hardenable Steels for Solid-Propellant Rocket-Motor Cases, May 25, 1961.

<p>Battelle Memorial Institute, Defense Metals Information Center, Columbus Ohio. THE EFFECTS OF ALLOYING ELEMENTS IN TITANIUM. VOLUME B. PHYSICAL AND CHEMICAL PROPERTIES, DEFORMATION AND TRANSFORMATION CHARACTERISTICS. by D. J. Maykuth, F. C. Holden, D. N. Williams, H. R. Ogden, and R. I. Jaffee. 29 May 1961. 150 pp incl. illus., tables, 169 refs. (OTS PB 171424; DMIC Report 1368) [AF 33(616)-7747] Unclassified report</p> <p>Data on the physical, electrical, and chemical properties of titanium alloys are reviewed. Information is presented on the diffusion of interstitial and substitutional elements. The effects (over)</p> <p>of alloying additions on deformation, recovery, recrystallization, and grain-growth characteristics are analyzed, and transformations are discussed in terms of the reaction kinetics.</p>	<p style="text-align: center;">UNCLASSIFIED</p> <ol style="list-style-type: none"> 1. Titanium alloys - Physical properties 2. Titanium alloys - Chemical properties 3. Titanium alloys - Deformation 4. Titanium alloys - Transformation I. Maykuth, D. J. II. Holden, F. C. III. Williams, D. N. IV. Defense Metals Information Center V. Contract AF 33(616)-7747 <p style="text-align: center;">UNCLASSIFIED</p>	<p>Battelle Memorial Institute, Defense Metals Information Center, Columbus Ohio. THE EFFECTS OF ALLOYING ELEMENTS IN TITANIUM. VOLUME B. PHYSICAL AND CHEMICAL PROPERTIES, DEFORMATION AND TRANSFORMATION CHARACTERISTICS. by D. J. Maykuth, F. C. Holden, D. N. Williams, H. R. Ogden, and R. I. Jaffee. 29 May 1961. 150 pp incl. illus., tables, 169 refs. (OTS PB 171424; DMIC Report 1368) [AF 33(616)-7747] Unclassified report</p> <p>Data on the physical, electrical, and chemical properties of titanium alloys are reviewed. Information is presented on the diffusion of interstitial and substitutional elements. The effects (over)</p> <p>of alloying additions on deformation, recovery, recrystallization, and grain-growth characteristics are analyzed, and transformations are discussed in terms of the reaction kinetics.</p>	<p style="text-align: center;">UNCLASSIFIED</p> <ol style="list-style-type: none"> 1. Titanium alloys - Physical properties 2. Titanium alloys - Chemical properties 3. Titanium alloys - Deformation 4. Titanium alloys - Transformation I. Maykuth, D. J. II. Holden, F. C. III. Williams, D. N. IV. Defense Metals Information Center V. Contract AF 33(616)-7747 <p style="text-align: center;">UNCLASSIFIED</p>
<p style="text-align: center;">UNCLASSIFIED</p>	<p style="text-align: center;">UNCLASSIFIED</p>	<p style="text-align: center;">UNCLASSIFIED</p>	<p style="text-align: center;">UNCLASSIFIED</p>

<p>Battelle Memorial Institute, Defense Metals Information Center, Columbus Ohio.</p> <p>THE EFFECTS OF ALLOYING ELEMENTS IN TITANIUM. VOLUME B. PHYSICAL AND CHEMICAL PROPERTIES, DEFORMATION AND TRANSFORMATION CHARACTERISTICS, by D. J. Maykuth, F. C. Holden, D. N. Williams, H. R. Ogden, and R. I. Jaffee. 29 May 1961. 150 pp incl. illus., tables, 169 refs. (OTS PB 171424; DMIC Report 136B) [AF 33(616)-7747] Unclassified report</p> <p>Data on the physical, electrical, and chemical properties of titanium alloys are reviewed. Information is presented on the diffusion of interstitial and substitutional elements. The effects (over)</p> <p>of alloying additions on deformation, recovery, recrystallization, and grain-growth characteristics are analyzed, and transformations are discussed in terms of the reaction kinetics.</p>	<p>UNCLASSIFIED</p> <ol style="list-style-type: none"> 1. Titanium alloys - Physical properties 2. Titanium alloys - Chemical properties 3. Titanium alloys - Deformation 4. Titanium alloys - Transformation <ol style="list-style-type: none"> I. Maykuth, D. J. II. Holden, F. C. III. Williams, D. N. IV. Defense Metals Information Center V. Contract AF 33(616)-7747 <p>UNCLASSIFIED</p> <p>UNCLASSIFIED</p> <p>UNCLASSIFIED</p>	<p>Battelle Memorial Institute, Defense Metals Information Center, Columbus Ohio.</p> <p>THE EFFECTS OF ALLOYING ELEMENTS IN TITANIUM. VOLUME B. PHYSICAL AND CHEMICAL PROPERTIES, DEFORMATION AND TRANSFORMATION CHARACTERISTICS, by D. J. Maykuth, F. C. Holden, D. N. Williams, H. R. Ogden, and R. I. Jaffee. 29 May 1961. 150 pp incl. illus., tables, 169 refs. (OTS PB 171424; DMIC Report 136B) [AF 33(616)-7747] Unclassified report</p> <p>Data on the physical, electrical, and chemical properties of titanium alloys are reviewed. Information is presented on the diffusion of interstitial and substitutional elements. The effects (over)</p> <p>of alloying additions on deformation, recovery, recrystallization, and grain-growth characteristics are analyzed, and transformations are discussed in terms of the reaction kinetics.</p>	<p>UNCLASSIFIED</p> <ol style="list-style-type: none"> 1. Titanium alloys - Physical properties 2. Titanium alloys - Chemical properties 3. Titanium alloys - Deformation 4. Titanium alloys - Transformation <ol style="list-style-type: none"> I. Maykuth, D. J. II. Holden, F. C. III. Williams, D. N. IV. Defense Metals Information Center V. Contract AF 33(616)-7747 <p>UNCLASSIFIED</p> <p>UNCLASSIFIED</p> <p>UNCLASSIFIED</p>
---	--	---	--

<p>Battelle Memorial Institute, Defense Metals Information Center, Columbus Ohio.</p> <p>THE EFFECTS OF ALLOYING ELEMENTS IN TITANIUM. VOLUME B. PHYSICAL AND CHEMICAL PROPERTIES, DEFORMATION AND TRANSFORMATION CHARACTERISTICS, by D. J. Maykuth, F. C. Holden, D. N. Williams, H. R. Ogden, and R. I. Jaffee. 29 May 1961. 150 pp incl. illus., tables, 169 refs. (OTS PB 171424; DMIC Report 1368) [AF 33(616)-7747] Unclassified report</p> <p>Data on the physical, electrical, and chemical properties of titanium alloys are reviewed. Information is presented on the diffusion of interstitial and substitutional elements. The effects (over)</p> <p>of alloying additions on deformation, recovery, recrystallization, and grain-growth characteristics are analyzed, and transformations are discussed in terms of the reaction kinetics.</p>	<p style="text-align: center;">UNCLASSIFIED</p> <ol style="list-style-type: none"> 1. Titanium alloys - Physical properties 2. Titanium alloys - Chemical properties 3. Titanium alloys - Deformation 4. Titanium alloys - Transformation <ol style="list-style-type: none"> I. Maykuth, D. J. II. Holden, F. C. III. Williams, D. N. IV. Defense Metals Information Center V. Contract AF 33(616)-7747 <p style="text-align: center;">UNCLASSIFIED</p>	<p>Battelle Memorial Institute, Defense Metals Information Center, Columbus Ohio.</p> <p>THE EFFECTS OF ALLOYING ELEMENTS IN TITANIUM. VOLUME B. PHYSICAL AND CHEMICAL PROPERTIES, DEFORMATION AND TRANSFORMATION CHARACTERISTICS, by D. J. Maykuth, F. C. Holden, D. N. Williams, H. R. Ogden, and R. I. Jaffee. 29 May 1961. 150 pp incl. illus., tables, 169 refs. (OTS PB 171424; DMIC Report 1368) [AF 33(616)-7747] Unclassified report</p> <p>Data on the physical, electrical, and chemical properties of titanium alloys are reviewed. Information is presented on the diffusion of interstitial and substitutional elements. The effects (over)</p> <p>of alloying additions on deformation, recovery, recrystallization, and grain-growth characteristics are analyzed, and transformations are discussed in terms of the reaction kinetics.</p>	<p style="text-align: center;">UNCLASSIFIED</p> <ol style="list-style-type: none"> 1. Titanium alloys - Physical properties 2. Titanium alloys - Chemical properties 3. Titanium alloys - Deformation 4. Titanium alloys - Transformation <ol style="list-style-type: none"> I. Maykuth, D. J. II. Holden, F. C. III. Williams, D. N. IV. Defense Metals Information Center V. Contract AF 33(616)-7747 <p style="text-align: center;">UNCLASSIFIED</p>
	<p style="text-align: center;">UNCLASSIFIED</p>		<p style="text-align: center;">UNCLASSIFIED</p>

<p>Battelle Memorial Institute, Defense Metals Information Center, Columbus Ohio.</p> <p>THE EFFECTS OF ALLOYING ELEMENTS IN TITANIUM. VOLUME B. PHYSICAL AND CHEMICAL PROPERTIES, DEFORMATION AND TRANSFORMATION CHARACTERISTICS, by D. J. Maykuth, F. C. Holden, D. N. Williams, H. R. Ogden, and R. I. Jaffee, 29 May 1961, 150 pp incl. illus., tables, 169 refs. (OTS PB 171424; DMIC Report 1368) [AF 33(616)-7747]</p> <p>Data on the physical, electrical, and chemical properties of titanium alloys are reviewed. Information is presented on the diffusion of interstitial and substitutional elements. The effects (over)</p> <p>of alloying additions on deformation, recovery, recrystallization, and grain-growth characteristics are analyzed, and transformations are discussed in terms of the reaction kinetics.</p>	<p style="text-align: center;">UNCLASSIFIED</p> <ol style="list-style-type: none"> 1. Titanium alloys - Physical properties 2. Titanium alloys - Chemical properties 3. Titanium alloys - Deformation 4. Titanium alloys - Transformation <ol style="list-style-type: none"> I. Maykuth, D. J. II. Holden, F. C. III. Williams, D. N. IV. Defense Metals Information Center V. Contract AF 33(616)-7747 <p style="text-align: center;">UNCLASSIFIED</p>	<p>Battelle Memorial Institute, Defense Metals Information Center, Columbus Ohio.</p> <p>THE EFFECTS OF ALLOYING ELEMENTS IN TITANIUM. VOLUME B. PHYSICAL AND CHEMICAL PROPERTIES, DEFORMATION AND TRANSFORMATION CHARACTERISTICS, by D. J. Maykuth, F. C. Holden, D. N. Williams, H. R. Ogden, and R. I. Jaffee, 29 May 1961, 150 pp incl. illus., tables, 169 refs. (OTS PB 171424; DMIC Report 1368) [AF 33(616)-7747]</p> <p>Data on the physical, electrical, and chemical properties of titanium alloys are reviewed. Information is presented on the diffusion of interstitial and substitutional elements. The effects (over)</p> <p>of alloying additions on deformation, recovery, recrystallization, and grain-growth characteristics are analyzed, and transformations are discussed in terms of the reaction kinetics.</p>	<p style="text-align: center;">UNCLASSIFIED</p> <ol style="list-style-type: none"> 1. Titanium alloys - Physical properties 2. Titanium alloys - Chemical properties 3. Titanium alloys - Deformation 4. Titanium alloys - Transformation <ol style="list-style-type: none"> I. Maykuth, D. J. II. Holden, F. C. III. Williams, D. N. IV. Defense Metals Information Center V. Contract AF 33(616)-7747 <p style="text-align: center;">UNCLASSIFIED</p>
<p style="text-align: center;">UNCLASSIFIED</p>	<p style="text-align: center;">UNCLASSIFIED</p>	<p style="text-align: center;">UNCLASSIFIED</p>	<p style="text-align: center;">UNCLASSIFIED</p>