

UNCLASSIFIED

---

---

AD 259 093

*Reproduced  
by the*

ARMED SERVICES TECHNICAL INFORMATION AGENCY  
ARLINGTON HALL STATION  
ARLINGTON 12, VIRGINIA



---

---

UNCLASSIFIED

NOTICE: When government or other drawings, specifications or other data are used for any purpose other than in connection with a definitely related government procurement operation, the U. S. Government thereby incurs no responsibility, nor any obligation whatsoever; and the fact that the Government may have formulated, furnished, or in any way supplied the said drawings, specifications, or other data is not to be regarded by implication or otherwise as in any manner licensing the holder or any other person or corporation, or conveying any rights or permission to manufacture, use or sell any patented invention that may in any way be related thereto.

AFOSR-401

TECHNICAL DOCUMENTARY REPORT  
AIR FORCE RESEARCH DIVISION (ARDC)  
AIR FORCE OFFICE OF SCIENTIFIC RESEARCH

259 093

CATALOGED BY ASTIA  
AS AD NO. \_\_\_\_\_

# THE OXIDATION OF TETRABORANE

by

Kenneth H. Ludlum

Stephen E. Wiberley

Walter H. Bauer

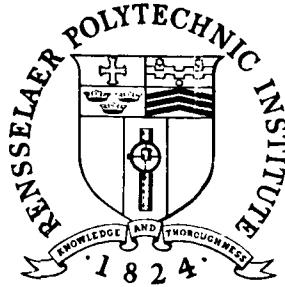

June, 1961

CONTRACT NO. AF 49(638)-897

XEROX

8147-14

RENSELAER POLYTECHNIC INSTITUTE

TROY, NEW YORK

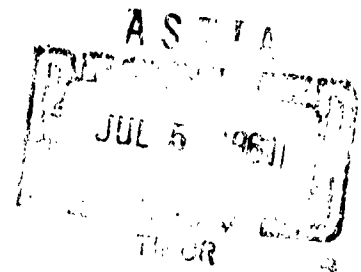

AFOSR-401

TECHNICAL DOCUMENTARY REPORT

AIR FORCE RESEARCH DIVISION (ARDC)  
AIR FORCE OFFICE OF SCIENTIFIC RESEARCH

THE OXIDATION OF TETRABORANE

by

Kenneth H. Ludlum\*

Stephen E. Wiberley

Walter H. Bauer

Rensselaer Polytechnic Institute

Department of Chemistry

Troy, New York

June, 1961

CONTRACT NO. AF 49(638)-897

\*This report was submitted as a Ph. D. thesis by Mr.  
Kenneth H. Ludlum in December, 1960.

## ABSTRACT

An investigation of the explosive oxidation of tetraborane and the partial oxidation of tetraborane was undertaken. The explosive oxidation of tetraborane was studied in Pyrex glass bulbs of different diameters and with the added inert gases helium and nitrogen as well as in Pyrex glass bulbs packed with glass wool. A study of the explosive reaction which occurred when lead tetraethyl was added as an inhibitor was also undertaken in Pyrex glass bulbs. The partial oxidation of tetraborane, mixtures of tetraborane and diborane, and tetraborane and argon was studied in an infrared gas reaction cell. The partial oxidation reaction was brought about by the controlled slow addition of oxygen to the reactant gases contained in the infrared reaction cell.

Mixtures of tetraborane with oxygen, and with oxygen and inert gas were prepared at known pressures and temperatures in the reaction bulbs; these mixtures exploded on heating. The data obtained indicated a branching chain reaction with chain initiation in the gas phase and chain breaking on the wall of the vessel. The entire range of pressures and temperatures investigated shows the behavior generally attributed to the first explosion limit of a branching chain reaction. Lead tetraethyl was found to inhibit the reaction erratically and in some cases prevented explosion.

The partial oxidation of tetraborane was brought about by the slow addition of oxygen to tetraborane in the infrared gas reaction cell. Upon admission of oxygen, a reaction occurred which produced diborane, partial oxidation product, hydrogen and boric acid anhydride. The main reaction can be represented by the stoichiometric equation

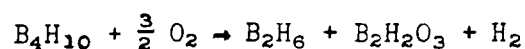

while evidence is presented that the  $\text{B}_2\text{H}_2\text{O}_3$  slowly reacts as follows, at the temperatures and conditions studied

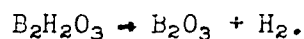

Mixtures of tetraborane and diborane to which oxygen was slowly added reacted similarly except that the net change in the moles of diborane in the reaction was much less than expected.

The inert gas argon had no effect on the system under the conditions studied.

When a few millimeters of water vapor or diethyl ether were present in tetraborane, no reaction occurred on the slow addition of oxygen.

A proposed mechanism for the oxidation of tetraborane follows:

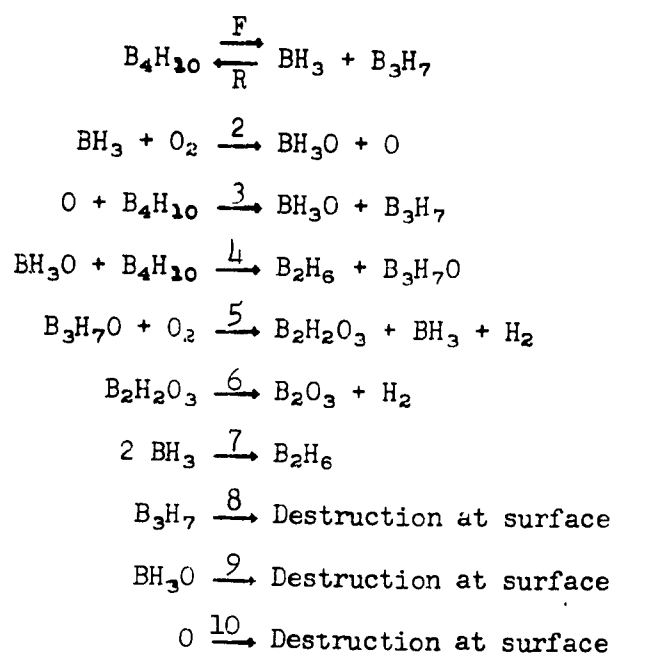

TABLE OF CONTENTS

	Page
ABSTRACT	iii
LIST OF TABLES	viii
LIST OF FIGURES	ix
I. INTRODUCTION . . . . .	1
A. Historical Review of Tetraborane . . . . .	1
B. Properties of Tetraborane . . . . .	4
II. THEORY . . . . .	7
A. Chain Reactions . . . . .	7
1. Explosive Reactions . . . . .	7
2. Slow Reactions . . . . .	9
III. EXPERIMENTAL PROCEDURES . . . . .	11
A. Procedure in the Investigation of the Explosive Oxidation of Tetraborane . . . . .	11
1. Material . . . . .	11
2. Apparatus . . . . .	12
3. Procedure . . . . .	17
B. Procedure in the Investigation of the Partial Oxidation of Tetraborane . . . . .	20
1. Material . . . . .	21
2. Apparatus . . . . .	21
3. Procedure . . . . .	21
IV. EXPERIMENTAL RESULTS . . . . .	31
A. Results in the Investigation of the Explosive Oxidation of Tetraborane . . . . .	31
B. Results in the Investigation of the Partial Oxidation of Tetraborane . . . . .	43
V. DISCUSSION . . . . .	59
A. Discussion of Results of Explosive Reaction . . . . .	59
B. Discussion of Results of the Partial Oxidation of Tetraborane . . . . .	62



	Page
VI. CONCLUSION . . . . .	73
A. Nature of Explosive Reaction . . . . .	73
B. Mechanism of the Oxidation Reaction . . . . .	74
VII. LITERATURE CITED . . . . .	78
VIII. APPENDIX . . . . .	81

LIST OF TABLES

		Page
TABLE I	Properties of Tetraborane . . . . .	5
TABLE II	Absorbance Coefficients for Gases (Tetraborane, Diborane and Partial Oxidation Product) . . . . .	27
TABLE III	Explosion Data for Tetraborane-Oxygen Mixtures in the Ratio 1 to 5 <sup>1</sup> / <sub>2</sub> in 6.8 cm Diameter Bulbs . . . . .	32
TABLE IV	Explosion Data for Tetraborane-Oxygen Mixtures in the Ratio 1 to 5 <sup>1</sup> / <sub>2</sub> in 4.0 cm Diameter Bulbs . . . . .	33
TABLE V	Explosion Data for Tetraborane-Oxygen Mixtures in the Ratio 1 to 5 <sup>1</sup> / <sub>2</sub> in 6.8 cm Diameter Bulbs Packed with Glass Wool . . . . .	34
TABLE VI	Explosion Data for Tetraborane-Oxygen-Helium Mixtures in the Ratio 1 to 5 <sup>1</sup> / <sub>2</sub> to 5 <sup>1</sup> / <sub>2</sub> in 6.8 cm Diameter Bulbs . . . . .	35
TABLE VII	Explosion Data for Tetraborane-Oxygen-Nitrogen Mixtures in the Ratio 1 to 5 <sup>1</sup> / <sub>2</sub> to 5 <sup>1</sup> / <sub>3</sub> in 6.8 cm Diameter Bulbs . . . . .	36
TABLE VIII	Explosion Data for Tetraborane-Oxygen Mixtures in the Ratio 1 to 5 <sup>1</sup> / <sub>2</sub> with Lead Tetraethyl Added in 6.8 cm Diameter Bulbs . . . . .	44
TABLE IX	Mass Intensity Data for Tetraborane-Oxygen Reaction System . . . . .	52
TABLE X	Comparison of Total Pressure Based upon Infrared Absorbance with Total Pressure Obtained Manometrically, at t <sub>1/4</sub> . . . . .	54
TABLE XI	Partial Oxidation of Tetraborane . . . . .	63
TABLE XII	Partial Oxidation of Mixture of Tetraborane and Diborane . . . . .	64
TABLE XIII	Partial Oxidation of Mixture of Tetraborane and Argon . . . . .	65
TABLE XIV	Inhibition of Partial Oxidation Reaction . . . . .	69

LIST OF FIGURES

	Page
Figure 1 Molecular Structure of Tetraborane . . . . .	6
Figure 2 Diborane Synthesis Apparatus and Degassing System for Explosion Limit Bulbs . . . . .	13
Figure 3 Tetraborane Synthesis Apparatus . . . . .	15
Figure 4 Vacuum System for Loading Explosion Bulbs and Infrared Cell . . . . .	18
Figure 5 Infrared Absorbance vs Pressure Curve for Tetraborane at $4.65 \mu$ ( $2150 \text{ cm}^{-1}$ ) in 9 cm Path Length . . . . .	23
Figure 6 Infrared Absorbance vs Pressure Curves for Tetraborane and Diborane at $5.30 \mu$ ( $1890 \text{ cm}^{-1}$ ) in 9 cm Path Length . . . . .	24
Figure 7 Infrared Absorbance vs Pressure Curve for Partial Oxidation Product at $11.35 \mu$ ( $882 \text{ cm}^{-1}$ ) in 9 cm Path Length . . . . .	26
Figure 8 Explosion Region for Tetraborane-Oxygen Mixtures in the Ratio 1 to $5^{1/2}$ in 6.8 cm Diameter Bulbs . . . . .	37
Figure 9 Explosion Region for Tetraborane-Oxygen Mixtures in the Ratio 1 to $5^{1/2}$ in 4.0 cm Diameter Bulbs . . . . .	38
Figure 10 Explosion Region for Tetraborane-Oxygen Mixtures in the Ratio 1 to $5^{1/2}$ in 6.8 cm Diameter Bulbs Packed with Glass Wool . . . . .	39
Figure 11 Explosion Region for Tetraborane-Oxygen-Helium Mixtures in the Ratio 1 to $5^{1/2}$ to $5^{1/2}$ in 6.8 cm Diameter Bulbs . . . . .	40
Figure 12 Explosion Region for Tetraborane-Oxygen-Nitrogen Mixtures in the Ratio 1 to $5^{1/2}$ to $5^{1/3}$ in 6.8 cm Diameter Bulbs . . . . .	41
Figure 13 Composite of Explosion Region Data Using Mean Lines of Explosion . . . . .	42
Figure 14 Partial Oxidation Reaction of Tetraborane with Oxygen .	45
Figure 15 Partial Oxidation Reaction of Tetraborane with Oxygen .	46
Figure 16 Partial Oxidation Reaction of Tetraborane with Oxygen .	47

	Page
Figure 17 Partial Oxidation Reaction of Tetraborane with Oxygen .	48
Figure 18 Partial Oxidation Reaction of Tetraborane with Oxygen .	49
Figure 19 Partial Oxidation Reaction of Tetraborane with Oxygen .	50
Figure 20 Representative Infrared Spectrum of Pure Tetraborane and Tetraborane-Oxygen Reaction Mixture . . . . .	51
Figure 21 Partial Oxidation Reaction of Premixed Diborane and Tetraborane with Oxygen . . . . .	55
Figure 22 Partial Oxidation Reaction of Premixed Diborane and Tetraborane with Oxygen . . . . .	56
Figure 23 Partial Oxidation Reaction of Premixed Argon and Tetraborane with Oxygen . . . . .	58
Figure 24 Partial Oxidation Reaction of Tetraborane with Oxygen, Reaction Mixture Allowed to Stand Three Days . . . . .	67

## PART I.

## INTRODUCTION

A. Historical Review of Tetraborane

Tetraborane was the first of the compounds of boron and hydrogen produced by Stock<sup>1</sup> in his classic work which extended over the period from 1912 to 1931. It was generated by the decomposition of magnesium boride with hydrochloric acid in the absence of air, and isolated and characterized as to its physical and chemical properties by him and his coworkers. Since this borane is thermally quite unstable, it received little attention from other workers, who were inclined to work with more stable boranes which were easily stored and handled.

In 1952, Burg<sup>2</sup> and Stone investigated the reaction of tetraborane with trimethyl amine and ethanol. They reported the formation of  $(\text{CH}_3)_3\text{NBH}_3$  and  $[(\text{CH}_3)_3\text{N}]_x\text{BH}$  according to the reaction

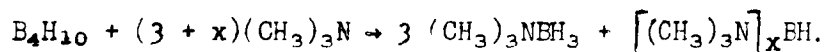

This type of reaction was also verified by Edwards<sup>3</sup> and coworkers and Kodama<sup>4</sup> and Parry who isolated the compounds  $(\text{CH}_3)_3\text{NBH}_3$  and  $(\text{CH}_3)_3\text{NB}_3\text{H}_7$  as products of the reaction of tetraborane with trimethyl amine. Their reported results were

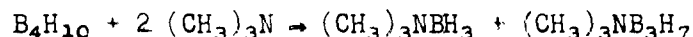

and

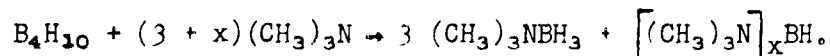

Parry<sup>5</sup> and Edwards have explained much of the chemistry of tetraborane on the basis of symmetrical and nonsymmetrical cleavage of the double-triple bond and the behavior of borane reactive species as Lewis acids

and bases.

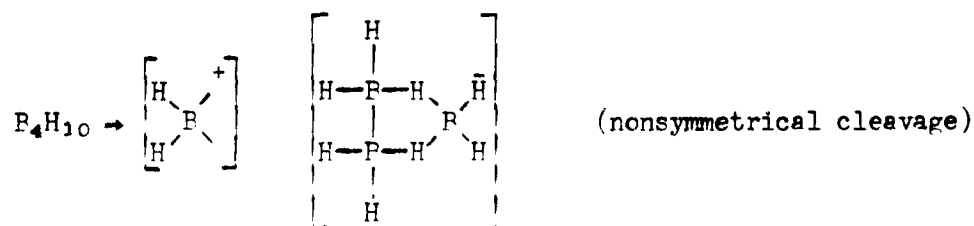

Todd<sup>6</sup> and Koski investigated the kinetics of the exchange of deuterium between diborane and tetraborane and found it to be complex. The results indicate that the exchange proceeds by two different paths; one involves two hydrogen positions in tetraborane, and the other involves the remaining eight or all ten positions. The major reaction is interpreted in terms of a rate determining reaction of  $\text{BD}_3$  from diborane with  $\text{B}_4\text{H}_{10}$  while the minor reaction is envisaged as a rate-determining activation of two sites in tetraborane followed by rapid deuterium exchange with  $\text{B}_2\text{D}_6$ . Boron atoms also exchange in this system.

Shapiro<sup>7</sup> and Weiss have investigated the alcoholysis of boron-boron bonds in a number of the higher hydrides of boron, including tetraborane. The overall reaction of tetraborane can be shown by the equation

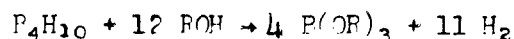

where the number of moles of molecular hydrogen in excess of the number of hydrogens in the boron hydride represent the number of boron-boron bonds that must be broken and two ROH molecules are required for each of these boron-boron bonds. Reaction of the isotopically labeled reagent  $\text{C}_2\text{H}_5\text{OD}$  with a compound such as tetraborane shows that a deuteride is created from the alcoholic deuterium during the breaking of a boron-boron

bond. The ethoxy group apparently attaches itself to one boron atom, and the deuterium goes to the other boron atom, viz.,



The thermal decomposition of tetraborane was investigated by Pearson<sup>8</sup> and Edwards at 60°, 80°, and 100°C. They interpreted the result in terms of a kinetic order of unity with estimated rate constants  $1.8 \times 10^{-5}$ ,  $1.1 \times 10^{-4}$ , and  $7.9 \times 10^{-4} \text{ sec}^{-1}$  at the above temperatures, respectively. The reaction occurred predominantly in the gas phase with the production of diborane, pentaborane-11, hydrogen, and yellow solid polymers. Smaller quantities of pentaborane-9, decaborane, and hexaborane were also formed. These authors suggested two simultaneous paths, both first order, to explain the data they obtained:

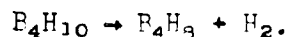
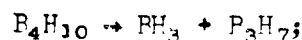

The actual experimental order varied from about 0.7 to 1.4, and the calculated energy of activation varied from 21.2 to 25.9 kcal/mole over the range of 60° to 100°C.

At the present time, the utilization of the high heats of combustion of the boranes has spurred large amounts of work with systems of diborane and air or oxygen,<sup>9-19</sup> pentaborane-9 and oxygen,<sup>20-21</sup> and decaborane and oxygen;<sup>22</sup> all these boranes are relatively stable. However very little has been done with the reactions of the thermally unstable boranes with oxygen, and this work was undertaken as an effort to begin to fill this gap.

## B. Properties of Tetraborane

### 1. Physical Properties of Tetraborane

At room temperature tetraborane is a colorless liquid or gas having a peculiar highly disagreeable odor. Its physical properties are difficult to determine precisely due to its thermal instability. Table I shows a list of some of these properties.

### 2. Molecular Structure of Tetraborane<sup>24</sup>

The molecular structure and data pertaining to it are shown in Figure 1.



TABLE I.

Properties of Tetraborane

Molecular weight <sup>23</sup> . . . . .	53.36
State at room temperature <sup>23</sup> 20°C . . . . .	gas
Melting point <sup>23</sup> . . . . .	-120°C
Boiling point . . . . .	+16.1°C
Half life for first order decomposition of B <sub>4</sub> H <sub>10</sub> at 25°C (calculated from Parry and Edwards' data) . . . . .	10.8 hours

Vapor pressures at selected temperatures:

Vapor pressure (mm Hg)	Temperature (°C)
1	-90.9
10	-64.3
40	-44.3
100	-28.1
400	+0.8
760	+16.1

Figure 1  
Molecular Structure of Tetraborane

Reference List

$$B^2 - B^3 = 1.845 \text{ \AA}$$

$$B^3 - B^4 = 1.750 \text{ \AA}$$

$$B^1 - B^2 = 2.786 \text{ \AA}$$

$$\angle B^1 B^4 B^2 = 98^\circ$$

$$R^1 H = B^3 H$$

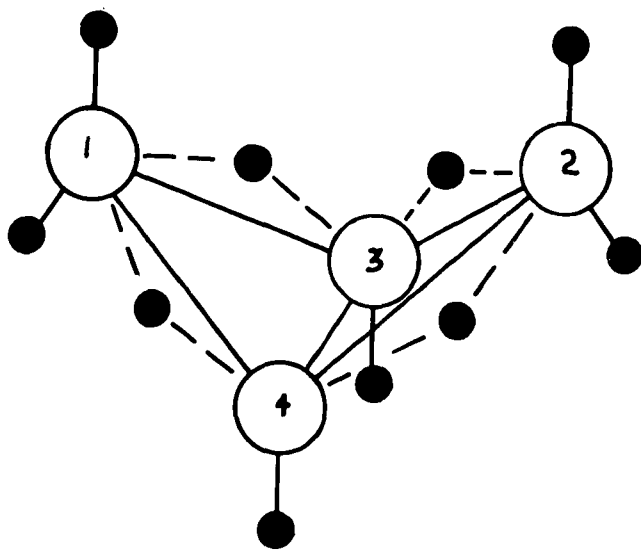

○ BORON

● HYDROGEN

## PART II.

## THEORY

A. Chain Reactions1. Explosive Reactions

a. The concept of the thermal explosion, introduced by Semenov<sup>25</sup> and coworkers in 1927, was the first successful attempt to systematize explosion phenomena. The sharp transition between slow reaction and explosion is explained as follows: Under certain conditions of temperature and pressure the reaction rate reaches a critical value for which the equality between the heat release due to reaction and heat removal into the surrounding medium becomes impossible. This disruption of the heat balance leads to self-heating and auto-acceleration of the rate and is observed as an explosion. This phenomenon is represented by the equation<sup>26</sup>

$$P_{cr} = KT_0^{1 + \frac{2}{N}} \exp\left(\frac{E}{NRT_0}\right)$$

where  $P_{cr}$  is the critical pressure.

$K$  is a constant related to the mole fractions of the reactants, the overall order of the reaction, and the gas constant.

$T_0$  is the temperature of explosion.

$E$  is the energy of activation.

$N$  is the overall order of the reaction.

$R$  is the universal gas constant.

b. The concept of the branching chain explosion was also introduced by Semenov<sup>25</sup> and coworkers, 1927--1929, and the isothermal character

of this type of explosion was subsequently proved by special experiments and calculations. A branching chain reaction can be shown by the equation



where  $\alpha$  is greater than unity. That is, one chain carrier (R) produces two or more chain carriers ( $\alpha R$ ). When reactions of this type occur to a sufficient extent that the rate of destruction of the chain carriers is much smaller than their rate of formation, an explosion may occur. This phenomenon can be represented by the equation<sup>26</sup>

$$v = \frac{F}{f_s + f_g + A(1 - \alpha)}$$

where F represents the rate of chain initiation;

$f_s$  represents the rate of destruction of the radicals at the surface;

$f_g$  represents the rate of destruction of the radicals in the gas phase;

A represents a function related to the branching chain process;

$\alpha$  is the number of chains formed for each chain used;

v is the velocity of the reaction.

When  $\alpha$  is large enough so that  $A(1 - \alpha)$  is equal to or greater than  $f_s + f_g$  then the velocity becomes infinite. At this point, we have an explosion limit. Branching chain reactions show three limits, and these three limits are explained as follows: The first limit is obtained where the rate of chain branching is equal to the rate of destruction of chain carrier at the surface of the vessel, and occurs at low pressures where the mean free path of the reactive species is relatively large. This

limit is sensitive to the surface area of the vessel, and the ability of the surface to destroy chains, which varies with the surface material and its treatment. The second limit is obtained when the rate of chain branching is equal to the rate of destruction of the chain carrier in the gas phase, and occurs at moderate pressures where diffusion of the chain carriers to the wall is no longer important due to the short mean free path. This limit is insensitive to surface area, the surface material, and its treatment. Because of the insensitiveness of the second limit to surface effects, this limit is most directly amenable to theoretical treatment. In a number of systems, a continued increase of pressure results in a turning of the explosion boundary and formation of a third limit having a negative slope characteristic of a thermal limit. This designation "third limit" refers to a limit that is a kinetic consequence of reactions in the gas phase which occur predominantly on the vessel surface at the lower pressures of the second limit. Experimentally, it is difficult to distinguish between such a third limit and a thermal limit which may intersect the second limit at high pressures.<sup>27</sup>

## 2. Slow Reactions

The concept of the chain reaction was first introduced successfully by Christiansen,<sup>28-31</sup> Herzfeld and Polyani in 1919 to explain the kinetics of the hydrogen bromide reaction which had been investigated by Bodenstein thirteen years previously. The proof of the transient existence of free radicals by Paneth<sup>32 33</sup> and coworkers in 1929 and the subsequent investigation of the thermal decomposition of

hydrocarbons by Rice<sup>34</sup> and coworkers in 1932-34 showed that the thermal decomposition of many hydrocarbons could be explained by free radical chain reactions. This concept has been so successful in explaining slow (nonexplosive) reactions and explosive reactions that its utility has been virtually accepted by all workers in the field of reaction kinetics. The great utility, yet simplicity, of this concept can be summed up by listing the main types of radical reactions which may occur in chain reactions and noting their number. The main types of radical reactions<sup>35</sup> are:

- (1) Substitution reaction



where  $R_1, R_2, R_3$  are atoms, free radicals, or other reactive species.

- (2) Reactions of addition to a multiple bond or to an atom with unpaired electrons or its reverse, decomposition of a radical or a reactive species.

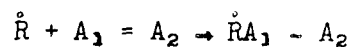

or

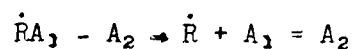

or

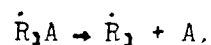

- (3) Isomerization of free radicals.



These, and special cases of these general types, explain practically all the reactions which occur in chain type processes.

## PART III.

## EXPERIMENTAL PROCEDURES

A. Procedure in the Investigation  
of the Explosive Oxidation of B<sub>4</sub>H<sub>10</sub>1. Material

a. Diborane. Diborane<sup>36</sup> was made by the reaction of boron trifluoride ether complex with lithium aluminum hydride in diethyl ether. The boron trifluoride ether complex was Baker and Adamson technical grade. It was distilled at 90 mm Hg and 78°C. A clear liquid was obtained as the distillation product which turned yellow brown upon aging. The lithium aluminum hydride was obtained from Metal Hydrides, Inc., 95% pure grade. After synthesis, the diborane was purified by distillation from a -112°C trap to a -195°C trap, and no impurity was detected by infrared analysis.

b. Tetraborane. Tetraborane<sup>37</sup> was synthesized by the pyrolysis of diborane in a hot-cold tube reactor which quantitatively converts diborane to tetraborane. The tetraborane was separated from the diborane by distillation from a -130°C trap to a liquid nitrogen trap at -195°C. The tetraborane was separated from higher hydrides by distillation from a -78°C trap to a liquid nitrogen trap at -195°C. Final traces of diborane were removed by holding the tetraborane in a trap at -130°C and opening it to the vacuum pumps.

c. Oxygen. Oxygen, 99.5% pure, manufacturer's analysis, was obtained from Linde Air Products. The oxygen was liquefied in a trap by



liquid nitrogen. The first third was pumped off, the second third was expanded into an oxygen storage vessel for later use, the third part was pumped off.

d. Lead tetraethyl. Lead tetraethyl was obtained from the Ethyl Corporation of Detroit, Michigan. It was distilled under its own vapor pressure of about 0.50 mm Hg from a trap at room temperature to a  $-195^{\circ}\text{C}$  trap. A clear heavy liquid was obtained which turned yellow-orange upon aging.

e. Nitrogen. Nitrogen, 99.5% pure, manufacturer's analysis, was obtained from Linde Air Products. It was used directly from the tank without further purification.

f. Helium. Helium, 99.8% pure, manufacturer's analysis, was obtained from the Matheson Company. It was used directly from the tank without further purification.

## 2. Apparatus

a. Diborane synthesis system. The apparatus used in the synthesis of diborane is illustrated in Figure 2. The reaction system was demountable and was assembled each time diborane was made. Attachment to the vacuum line was made by a ground-glass, ball-joint connection. The reaction vessel, a three-liter, three-necked flask, was stirred magnetically. Thirty-six milliliters of boron trifluoride ether complex were diluted to 100 ml with diethyl ether and placed in a dropping funnel which fitted into one neck of the reaction flask. One hundred milliliters of ether were added to the reaction flask, and six grams of lithium aluminum hydride were added to the flask and stirred to dissolve

Figure 2  
Diborane Synthesis Apparatus and Degassing  
System for Explosion Limit Bulbs

Reference List

- A - Silicone Oil Baths
- B - Traps for Condensation of  $B_2H_6$
- C - Reactor
- D - Dewar Dry Ice Trap to Remove Ether
- E - Dropping Funnel
- F - Nitrogen Inlet
- G - Ground Joints for Reaction Bulbs
- H - Nitrogen Outlet
- J - Closed-end Manometer
- K - Three-liter Storage Bulb

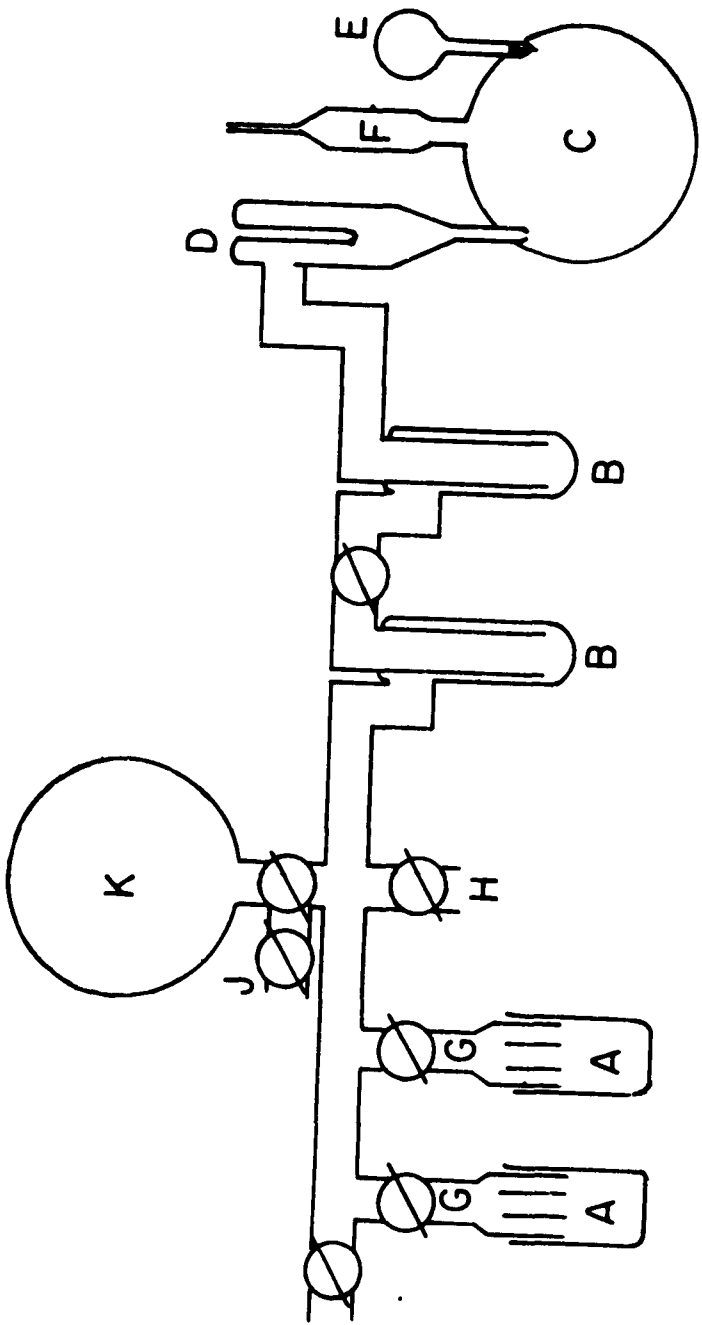

it in the ether. The reaction vessel was swept with dry nitrogen during the entire course of the reaction. Boron trifluoride ether complex was admitted from the dropping funnel at such a rate that complete addition was effected in two hours. The product gas and nitrogen were swept past a cold trap at  $-78^{\circ}\text{C}$  which returned the ether to the system but allowed the diborane and nitrogen to pass through. The diborane was condensed in traps maintained at  $-195^{\circ}\text{C}$  and the nitrogen was vented through a one-way mercury valve. The diborane was purified by distillation from a  $-112^{\circ}\text{C}$  trap to a  $-195^{\circ}\text{C}$  trap.

b. Tetraborane synthesis system. The apparatus used in the synthesis of tetraborane is illustrated in Figure 3. After the diborane was prepared, it was purified by fractional condensation from a  $-112^{\circ}\text{C}$  to a  $-195^{\circ}\text{C}$  trap. Sufficient diborane was distilled into the tetraborane synthesis reactor to maintain the vapor pressure of diborane at  $-78^{\circ}\text{C}$ . The inner tube of the reactor was filled with ethylene glycol, and the temperature was adjusted to  $120^{\circ}\text{C}$  by means of a quartz immersion heater. The bath was stirred continually. The liquid nitrogen bath around the outer wall of the reactor was removed and a Dry Ice bath at  $-78^{\circ}\text{C}$  was placed around it. The pressure in the reactor was monitored by means of a blowout manometer. The pressure rose to 1,400 mm Hg fairly rapidly and then more slowly to 1,700 mm Hg where it slowed abruptly. The Dry Ice bath was removed, a liquid nitrogen bath was replaced around the outside, and the noncondensable gases were pumped off. This procedure was repeated three times in order to obtain sufficient tetraborane. The reaction may be represented by the equation

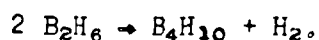
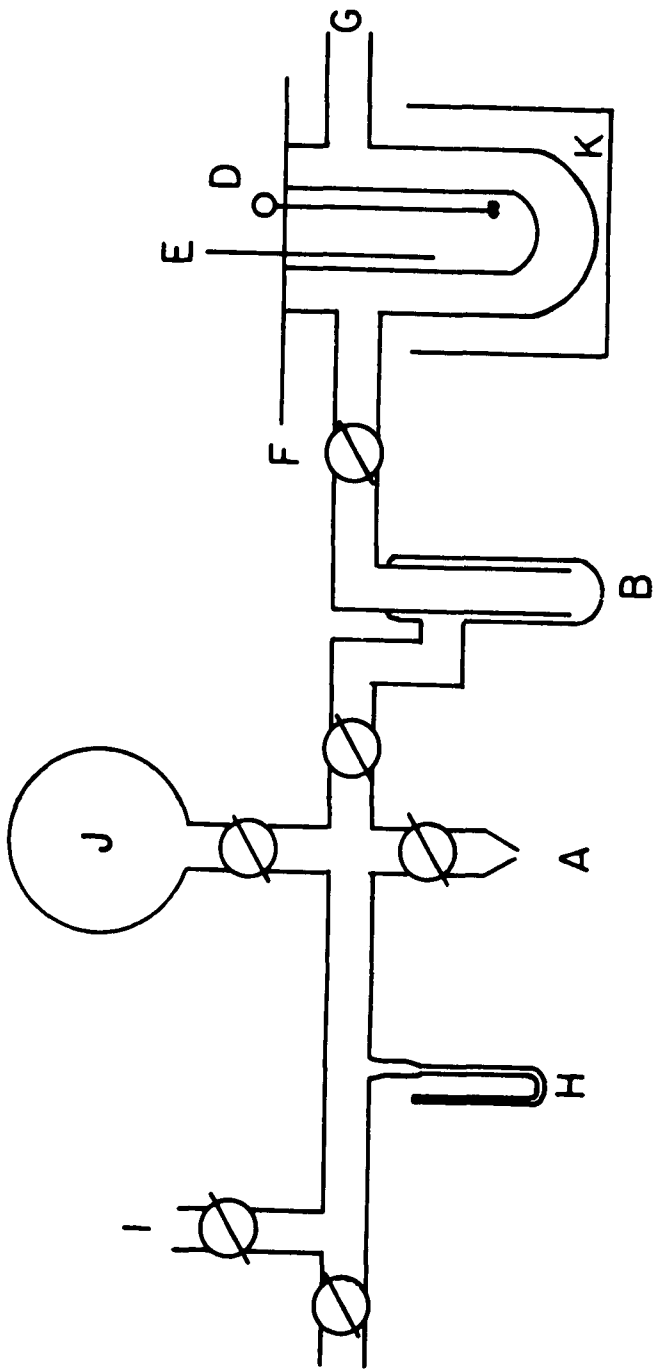

Figure 3  
Tetraborane Synthesis Apparatus

Reference List

- A - 12/30 Ground Glass Male Joint
- B - Condensation Trap
- C - Tetraborane Synthesis Reactor with Inner Area  
Filled with Ethylene Glycol and Outer Area  
Surrounded with Dry Ice Slush
- D - Stirrer
- E - Thermocouple Wires Connected to Recording  
Potentiometer
- F - Spring Backed Stopcock
- G - Open-end Blowout Manometer
- H - Closed-end Manometer
- I - Vent to Atmosphere
- J - Three-liter Storage Vessel
- K - Dry Ice Slush



After the reaction was complete, the hydrogen (a noncondensable gas) was removed as before; and the tetraborane was separated from the diborane by distillation from the reaction vessel at  $-130^{\circ}\text{C}$  to a  $-195^{\circ}\text{C}$  trap. The vapor pressure of diborane at  $-130^{\circ}\text{C}$  is 40 mm Hg; tetraborane is a solid. After the diborane was removed, the Dry Ice bath was placed around the outside of the reaction vessel, and the tetraborane was separated from any higher hydrides formed. Spot checks showed little higher hydride formed, the reaction being quite clean under these conditions. A yield of about 0.08 grams was obtained each time tetraborane was made. The tetraborane was checked for purity by infrared analysis. The main impurity was small traces of diborane which were removed by pumping at  $-130^{\circ}\text{C}$ . The tetraborane was distilled from the synthesis apparatus into a Stock trap and was stored under liquid nitrogen until it was to be used.

c. Infrared spectroscopic system. Gas analysis was done almost entirely by infrared spectroscopy. The spectra were obtained with a Perkin-Elmer Model 21 recording spectrophotometer. The gases were contained in a brass reaction cell with sodium chloride windows, provided with a manometer, and with an oxygen inlet attachment, described by Hammond<sup>21</sup> and Goldstein,<sup>10</sup> for slow oxidation studies. The sodium chloride windows were made airtight by O-ring inserts between the windows and window holders, and small metal Hoke bellows valves were mounted on the arm through which the cell was evacuated prior to gas loading.

d. Degassing apparatus. The degassing system, also shown in Figure 2, was part of the system used for diborane synthesis. The reaction bulbs were placed in the silicone oil bath. the temperature was

raised to 110°C and the bulb pressures were kept at  $1 \times 10^{-4}$  mm Hg for twenty-four hours.

e. Bulb loading apparatus. The bulbs were loaded with tetraborane and oxygen on the vacuum system shown in Figure 4. The bulbs were transferred from the degassing system, two at a time, and pressures were lowered to  $1 \times 10^{-5}$  mm Hg prior to loading with the reaction mixture.

f. Explosion limit apparatus. In explosion limit studies, bulbs containing the mixture of tetraborane and oxygen were placed in an ice-water bath at 0°C. The bath was heated by means of a Variac connected with a heating coil, and a rate of heating of two degrees/minute was obtained with the Variac at 120 volts. The bath was stirred automatically while being heated, and a thermometer was mounted so that its bulb extended to a level equal to that of the reaction bulb. The temperatures of the explosions were noted visually, and the pressures of explosions were calculated by the gas law.

g. Construction of reaction bulb. Reaction bulbs of 6.8 cm diameter and 4.0 cm diameter were used. Reaction bulbs were made from Pyrex glass distilling flasks after removal of the side arm and neck. A piece of 8-mm-O.D. tubing was attached with a 4 mm bore stopcock and 14/35 ground-glass joint. In the 4.0 cm diameter reaction bulbs, capillary tubing was substituted for the 8-mm-O.D. tubing. After construction, the bulbs were annealed for twenty-four hours prior to use.

### 3. Procedure.

a. Preparation of reaction bulbs. Before each use, reaction bulbs were washed three times with from fifteen to twenty-five ml of methanol,



Figure 4  
Vacuum System for Loading Explosion Bulbs and Infrared Cell

Reference List

- A - Mercury Diffusion Pump
- B - Condensation Trap
- C - Three-liter Storage Vessel
- D - Ground Glass Joints for Connection to Vacuum System
- E - Bypass Trap to Condense out Borane Gases
- F - Vacuum Manometer
- G - Joints for Attachment of Explosion Bulbs
- H - Attachment to McLeod Gauge
- I - Attachment to Open-end Manometer
- J - To Vacuum Pump

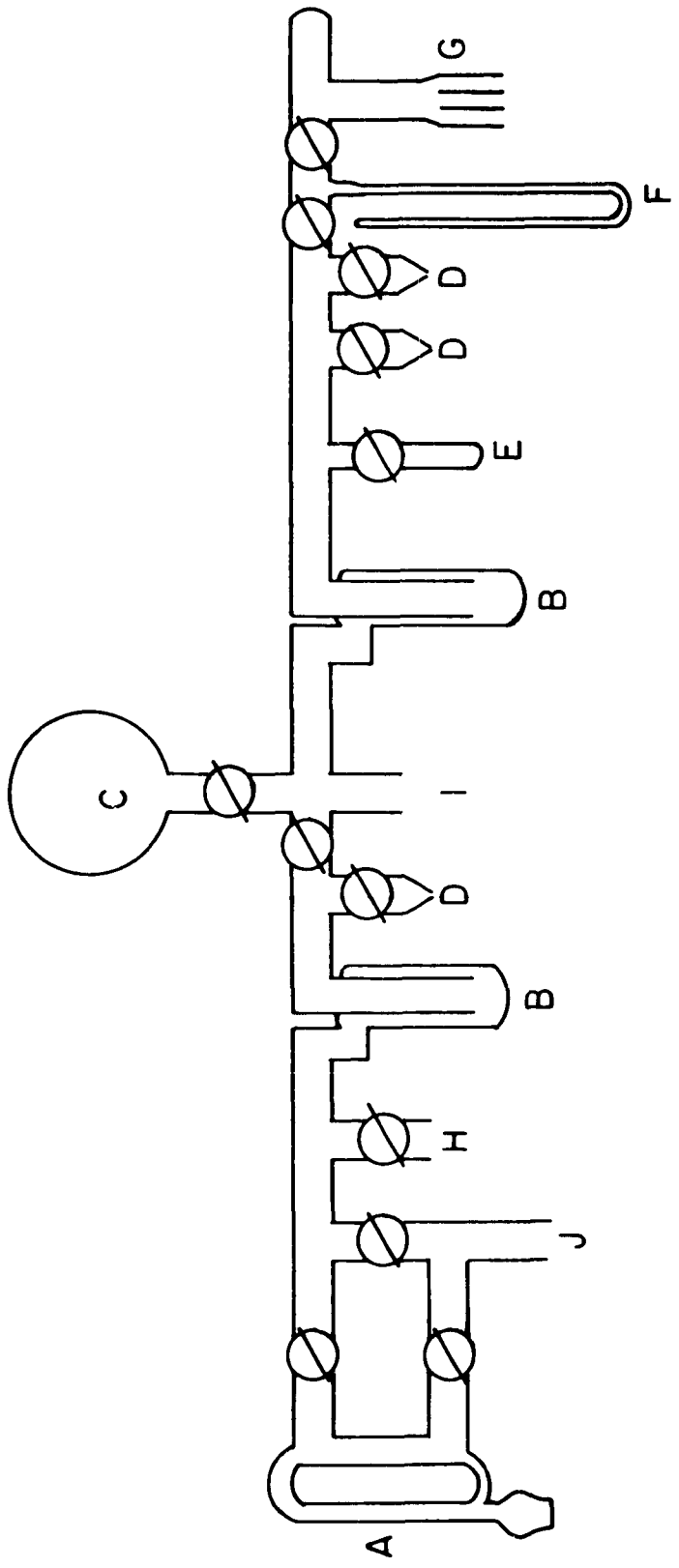

K O P A K S A F T Y A F I L M

and the washings were discarded. This removed nearly all traces of solid product from prior explosions. Occasionally the methanol was heated to remove stubborn traces of explosion products. After washing, the bulbs were then degassed as previously described. Bulbs of 6.8-cm diameter, in which Pyrex glass wool was placed, were broken at the stem-bulb junction, rinsed three times as explained above, packed with 35-45 grams of glass wool, rejoined, rinsed with a fourth washing of methanol, and degassed as explained before.

b. Preparation of reaction mixtures. Mixtures of tetraborane and oxygen could not be prepared by regular mixing techniques due to the low explosion limits and the rapid decomposition of tetraborane at room temperature. Even preparation of large amounts of these mixtures at low temperature was not feasible due to the small amounts (0.08 gr) of tetraborane which were synthesized and stored. In view of the inherent difficulties presented, a method was adopted which, although it brought a larger error into the system, made possible a safe and convenient method of mixing tetraborane and oxygen. After the reaction bulb was degassed, transferred to the bulb-loading apparatus, and pumped out to a pressure of  $10^{-5}$  mm Hg, tetraborane which had been previously frozen out in a trap connected to the system by a stopcock was vaporized at room temperature into the system and bulb until its desired partial pressure was obtained. This pressure was read on a Gaertner Scientific cathetometer, with a sensitivity of  $\pm 0.1$  mm Hg. The tetraborane was then frozen out in the reaction bulb by completely immersing it in a Dewar of liquid nitrogen. With the reaction bulb at  $-195^{\circ}\text{C}$ , oxygen of desired partial pressure was added to the bulb in such quantity that upon warming to

room temperature, the ratio of  $O_2$  to  $B_4H_{10}$  was 5.5. Any error in measuring the oxygen pressure was multiplied by a factor,  $\frac{\text{room temp.}}{78^\circ K}$ , or about four. Also, it was very difficult to adjust the oxygen pressure to the desired value of exactly five and one-half times the tetraborane pressure.

c. Explosive reaction. After the bulb was loaded with tetraborane and oxygen, it was removed from the vacuum system while still in the liquid nitrogen Dewar. It was then transferred to the ice-water bath at  $0^\circ C$  and allowed to warm to this temperature for five minutes. During this time, the tetraborane would vaporize into the oxygen. If no explosion was observed after five minutes, the bulb was heated at a rate of two degrees per minute until explosion occurred. If no explosion occurred when room temperature was reached, the bulb was immediately transferred to a silicone oil bath and heated at four degrees per minute until explosion occurred. Explosion was easily noted by a sharp crack and flash of light. When the inhibitor, lead tetraethyl, was added to the reaction bulb, a known pressure of inhibitor was expanded into a known volume, and then condensed into the bulb with the liquid nitrogen Dewar around the bulb. The inhibitor was added after the tetraborane but before the oxygen.

B. Procedure in the Investigation of  
the Partial Oxidation\* of Tetraborane

\*(Throughout this entire paper the term partial oxidation is used to mean the oxidation carried out in the infrared cell by the controlled admission of oxygen to tetraborane under the conditions specified.)

### 1. Material

Diborane, tetraborane and oxygen were obtained by the same method as was used in the explosive oxidation studies. Argon, 99.7% pure, manufacturer's analysis, was obtained from Linde Air Products. It was used directly from the tank without further purification.

### 2. Apparatus

The diborane synthesis system and tetraborane synthesis system were the same as were used in the explosive oxidation studies. The infrared spectroscopic system used in the partial oxidation investigation was similar to that used during the explosive oxidation. However, the attachment of an oxygen reservoir and a microcapillary leak port allowed oxygen to be slowly admitted to the tetraborane in the gas cell at a known rate. This rate could be varied by changing the pressure of oxygen in the oxygen reservoir.

Mass spectra were obtained using a Model 21-6-20 Consolidated Electrodynamics Corporation mass spectrometer with a modified d.c. amplifier circuit for greater sensitivity.

### 3. Procedure

#### a. Determination of absorbance coefficients.

(1) Tetraborane of greater than 95% purity was condensed into the infrared gas reaction cell. Its pressure was measured by the mercury manometer attached to the cell, and an infrared spectrum was obtained. Then, progressively larger amounts of tetraborane were condensed into the trap attached to the cell and another spectrum was taken for each decrement of pressure. Infrared spectra of known mixtures of tetraborane

and diborane, and tetraborane and argon, were also obtained at known total and partial pressures for each constituent. The peak at 4.65 microns ( $2,150\text{ cm}^{-1}$ ) was used to identify tetraborane. No pressure broadening was observed. No interference by other reactants or products was observed at this peak, and a plot of absorbance versus pressure in mm Hg gave a straight line, Figure 5. Thus, the partial pressure of tetraborane in the cell could be obtained at any time from absorbance measurement.

(2) Diborane was condensed into the infrared gas reaction cell, and the same procedure used for tetraborane was followed. Infrared absorption spectra were also determined for mixtures of diborane and tetraborane, and diborane and oxygen. Pressure broadening at all peaks was observed except at 5.30 microns ( $1,890\text{ cm}^{-1}$ ) where tetraborane also absorbs very weakly. Thus two curves for absorbance at 5.30 microns were prepared, one for tetraborane and one for diborane. If the tetraborane partial pressure was independently known, its absorbance contribution could be subtracted from the total absorbance at 5.30 microns to obtain that of the diborane and the partial pressure of diborane could be obtained at any time, as shown in Figure 6. As the tetraborane was consumed during the reaction, this correction for tetraborane became progressively smaller so that by the time the reaction was three-fourths complete, the tetraborane absorbance contribution at 5.30 microns was negligible relative to that of diborane which was formed as a product.

(3) Partial oxidation product. Absorbance coefficients for this compound were obtained from the independent work of both Hammond<sup>21</sup> and Shapiro.<sup>3a</sup> These values at 11.25 microns ( $882\text{ cm}^{-1}$ ) were in virtual

Figure 5  
Infrared Absorbance vs Pressure Curve for Tetraborane  
at  $4.65 \mu$  ( $2150 \text{ cm}^{-1}$ ) in 9 cm Path Length

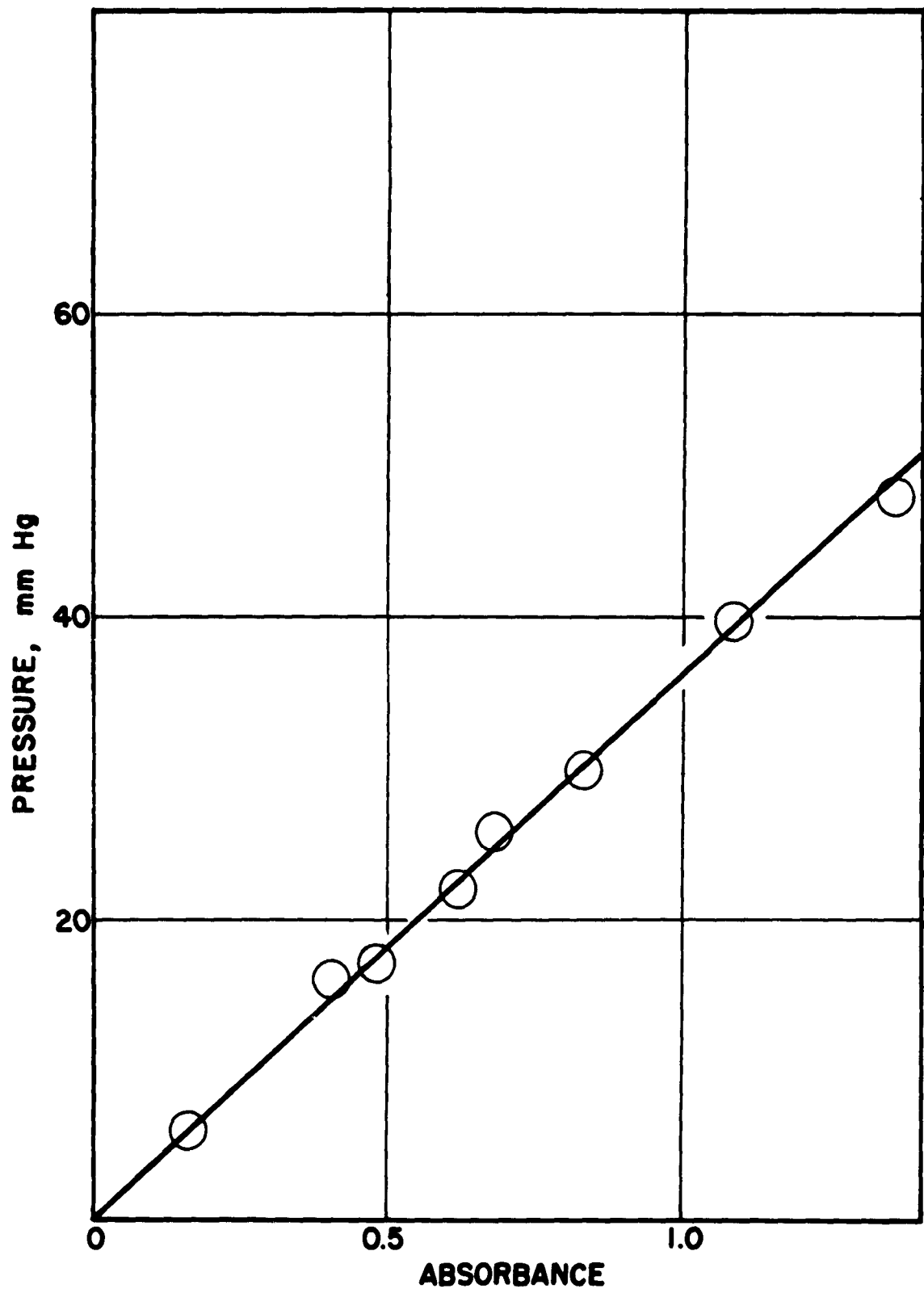
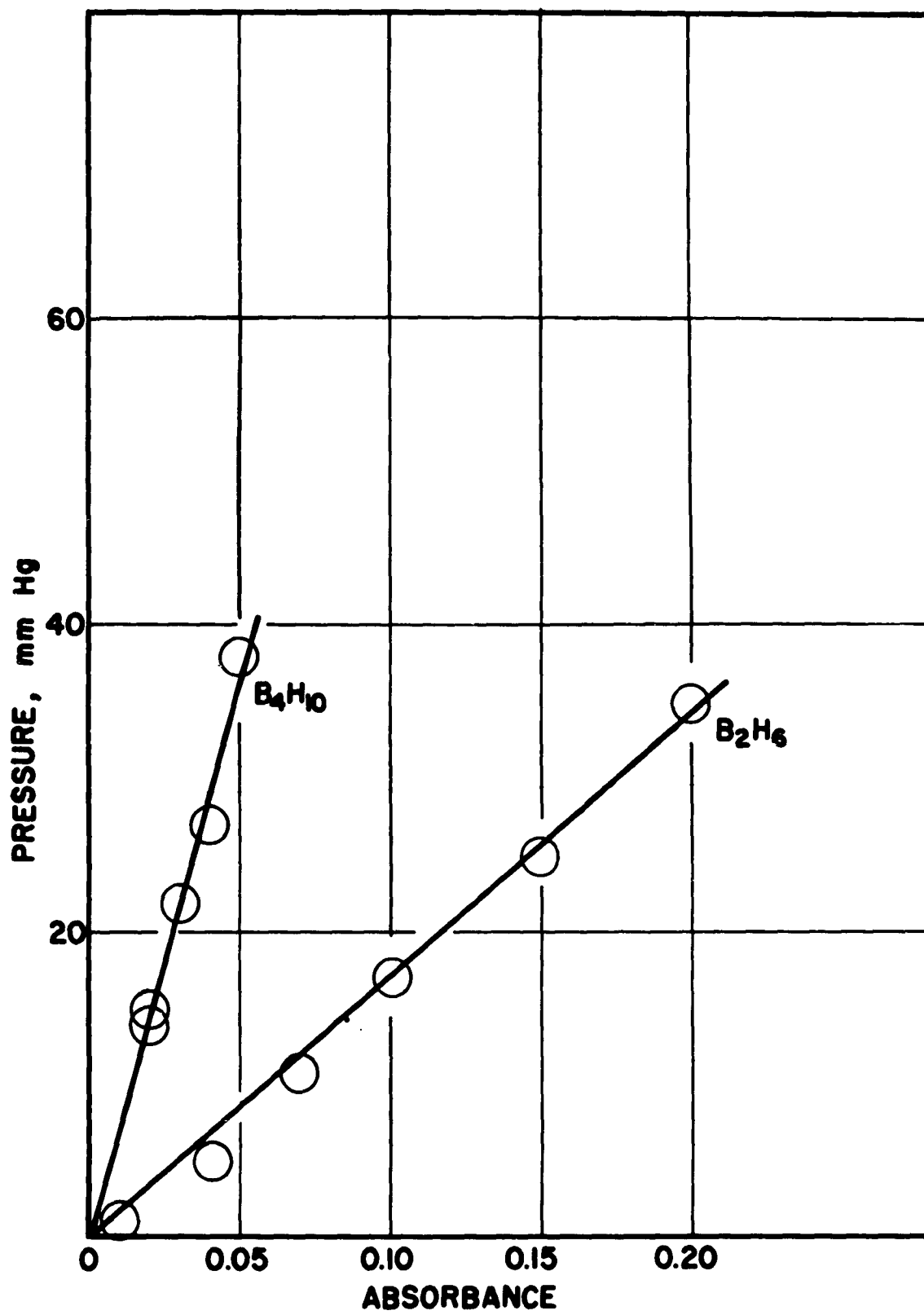



Figure 6  
Infrared Absorbance vs Pressure Curves for Tetraborane  
and Diborane at  $5.30 \mu$  ( $1890 \text{ cm}^{-1}$ ) in 9 cm Path Length



agreement and therefore a curve of absorbance versus pressure of partial oxidation product at 11.35 microns was constructed from them, as shown in Figure 7.

(4) Boric acid anhydride. The presence of the solid product, boric acid anhydride, was qualitatively identified by comparison of its known spectrum<sup>21</sup> with the solid deposited on the walls and windows of the gas reaction cell. No quantitative estimate of the amount of this solid was made by absorbance methods.

(5) Absorbance coefficients for each infrared active gas were computed using the form

$$A = abp$$

where

A = absorbance measured

a = absorbance coefficient

b = path length of reaction cell in cm

p = pressure of gas measured in mm Hg.

These coefficients are shown in Table II.

b. Calibration of infrared reaction cell. The infrared spectroscopic gas reaction cell could be manipulated so that a known rate of flow of oxygen was delivered initially. Known pressures of pure oxygen were expanded into the oxygen reservoir of the gas reaction cell, generally from 250 to 300 mm Hg; known pressures of air were allowed to enter the cell itself, usually from 15 to 35 mm Hg; the stopcock separating the two parts of the cell was opened and the oxygen was allowed to leak or flow slowly into the reaction cell itself, since there was a pressure difference of 220-285 mm Hg. The change in pressure versus time over a finite time interval could be obtained. Pressures were measured on the

Figure 7  
Infrared Absorbance vs Pressure Curve for Partial Oxidation  
Product at  $11.35 \mu$  ( $882 \text{ cm}^{-1}$ ) in 9 cm Path Length

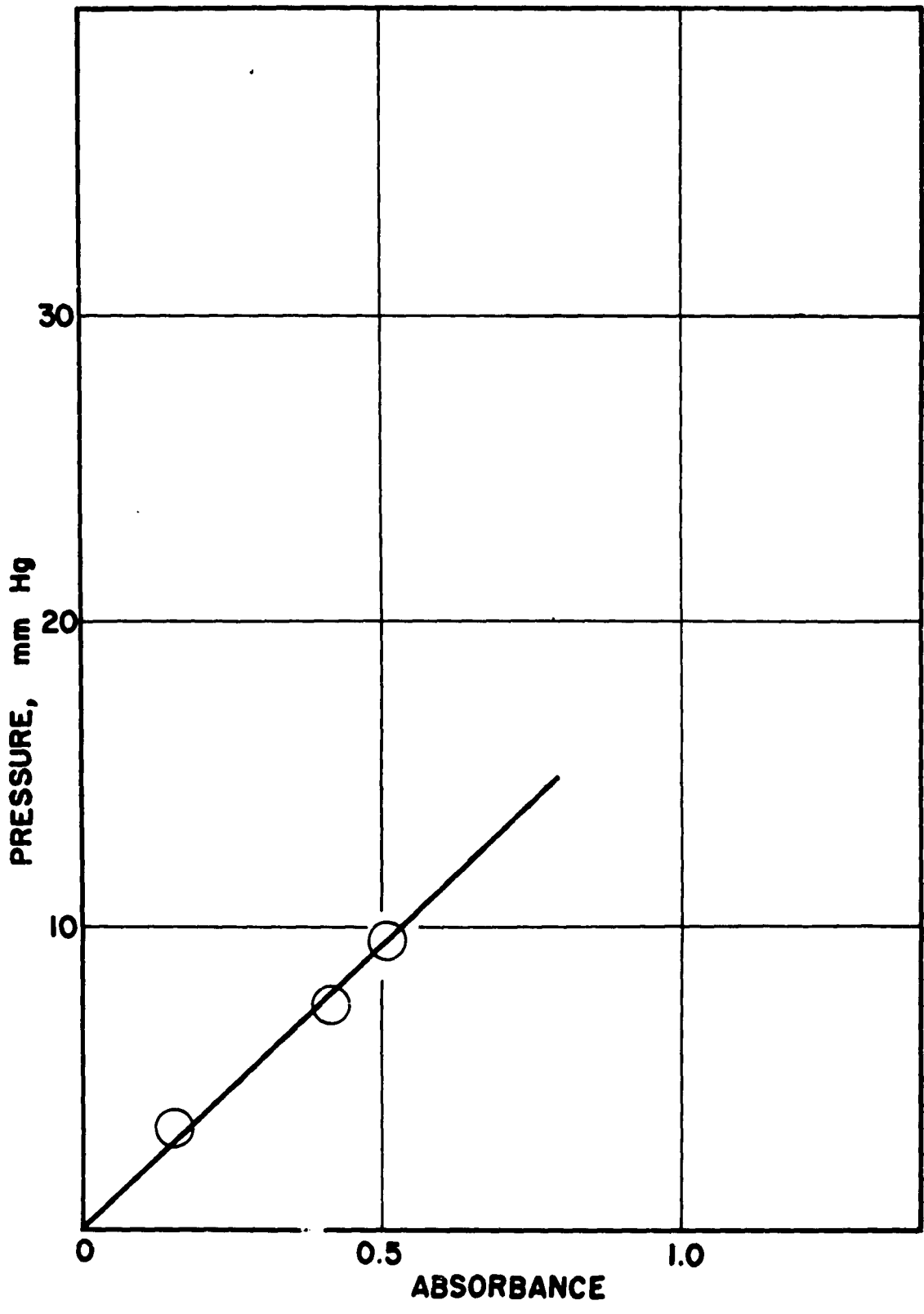

TABLE II.

Absorbance Coefficients for Gases (Tetraborane,  
Diborane and Partial Oxidation Product)

Gas	Wave Length, microns	Absorbance Coefficient, $a^*$
$B_4H_{10}$	4.65	$3.12 \times 10$
$B_4H_{10}$	5.3	$1.48 \times 10$
$B_2H_6$	5.3	$6.7 \times 10$
$B_2H_2O_3$	11.35	$6.2 \times 10$

\*The absorbance coefficient,  $a$ , has units: (total absorbance) (cm path length)<sup>-1</sup> (mm Hg pressure)<sup>-1</sup>.

mercury manometer attached to the gas reaction cell. Thus, by using a known pressure of oxygen in the oxygen reservoir, and starting initially with 15-35 mm of tetraborane, a known rate of admission of oxygen to tetraborane could be obtained. Due to the relatively large pressure difference between oxygen and tetraborane, the rate of admission of oxygen to tetraborane was always linear for the first ten minutes. Rates of oxygen admission used varied from  $0.60 \frac{\text{mm}}{\text{min}}$ ,  $\left( 3.2 \times 10^{-6} \frac{\text{mole}}{\text{cm}^3 \text{ min}} \right)$  to  $2.3 \frac{\text{mm}}{\text{min}}$ ,  $\left( 1.2 \times 10^{-5} \frac{\text{mole}}{\text{cm}^3 \text{ min}} \right)$ .

c. Preparation of reactants.

(1) Tetraborane and oxygen. The oxygen reservoir on the infrared gas reaction cell was attached to the vacuum rack by means of a flexible piece of Tygon tubing with appropriate ground-glass joints in each end and was evacuated to  $1 \times 10^{-4}$  mm Hg. Oxygen of desired pressure was then expanded into the oxygen reservoir of the gas reaction cell. The tubing was removed from the oxygen reservoir and connected to the brass cell itself through the appropriate metal joint. The cell and vacuum rack were evacuated to  $1 \times 10^{-4}$  mm Hg and tetraborane of known pressure was expanded into the metal cell and frozen out in the small attached trap. Prior to the admission of oxygen, and after infrared absorption was measured in the absence of any gases, the tetraborane was vaporized into the gas reaction cell. Ten minutes were allowed for this vaporization.

(2) Tetraborane, diborane and oxygen. The oxygen was expanded into the oxygen reservoir as explained in (1). The metal cell was connected to the vacuum rack as was done for tetraborane, the cell

was evacuated to  $1 \times 10^{-4}$  mm Hg, and diborane of known pressure was admitted to the cell. The diborane was condensed into the trap attached to the metal cell and this trap was cut off from the cell by means of a Hoke bellows valve. Tetraborane was then admitted to the cell, its approximate pressure was read on the manometer, and it was condensed into the same trap as the diborane. When the gas reaction cell was placed on the spectrophotometer, an infrared absorption curve was recorded in the absence of gases, and the two reactants were allowed to diffuse into the cell itself. Ten minutes were allowed for diffusion equilibrium as estimated from Einstein's law. When this equilibrium was established, the total pressure of the gases was measured on the attached mercury manometer. Since the pressure of diborane had been carefully measured previously, the partial pressure of tetraborane was obtained by difference. Pressures measured were always compared with pressures calculated by absorbance coefficients and agreed to  $\pm 1$  mm Hg.

(3) Tetraborane, argon and oxygen. The oxygen was expanded into the oxygen reservoir as explained in (1). The metal cell was again connected to the vacuum rack, and the cell was evacuated to  $1 \times 10^{-4}$  mm Hg. Tetraborane of known pressure was admitted to the gas reaction cell and then condensed into the trap. The trap was cut off from the cell by means of the Hoke bellows valve, and argon of approximately the desired pressure was admitted to the cell. When the gas reaction cell was placed on the infrared spectrophotometer, an infrared absorption curve was taken with argon in the cell. Argon is infrared inactive. Tetraborane was allowed to diffuse into the argon for ten minutes and the total pressure was measured on the mercury manometer. The pressure of



argon was computed by subtracting the pressure of tetraborane from the total pressure.

d. Partial oxidation reaction. After scanning in the absence of gases or in the presence of argon, diffusion of the gas or gases from the trap into the cell was allowed to take place. The infrared spectrum was then taken of the gas or gaseous mixture prior to the admission of oxygen through the leak cell apparatus. This gave the partial pressures of the gases at time zero. Then the stopcock connecting the oxygen reservoir to the gas reaction cell was opened and oxygen was admitted to the tetraborane or mixture of gases at a known rate; an immediate reaction ensued. The pen and chart drive were started and continuous scans from 2 to 15 microns were made until the reaction ceased. Total pressure was measured at two-minute intervals for the first twenty minutes and thereafter at five-minute intervals. Absorbance and time values at 4.65 microns, 5.30 microns and 11.35 microns were recorded each time the spectrophotometer scanned across a desired peak. Generally the reaction ceased after about thirty minutes, although oxygen and tetraborane were still present. Temperature of the reactants was measured to  $\pm 0.1^\circ\text{C}$  and held constant through the course of the reaction.

## PART IV.

## EXPERIMENTAL RESULTS

A. Results in the Investigation of the  
Explosive Oxidation of Tetraborane

The explosion limits of mixtures of tetraborane and oxygen in the ratio of 1 to  $5\frac{1}{2}$  were investigated in 6.8 cm diameter bulbs, 4.0-cm diameter bulbs, and 6.8 cm diameter bulbs packed with glass wool. Mixtures of tetraborane, oxygen and nitrogen, and tetraborane, oxygen and helium in the ratios 1 to  $5\frac{1}{2}$  to  $5\frac{1}{2}$  were investigated in 6.8 cm diameter bulbs. Pressures of tetraborane were measured at room temperature. Pressures of oxygen or oxygen and inert gas were measured and adjusted at 78°K so that upon warming to room temperature the pressure ratio of tetraborane to oxygen would be 1 to  $5\frac{1}{2}$ . When an inert gas such as helium or nitrogen was to be added, mixtures of these in a one to one ratio with oxygen were prepared at room temperature and measured as previously described. Explosion pressures were calculated from the temperature of explosion assuming no reaction prior to explosion and ideal gas behavior. The pressures of tetraborane which were measured at room temperatures were adjusted to give pressures at 25°C for convenience in interpretation of the data shown in the tables. Pressures of oxygen are not given in the tables but can be computed from the pressure ratios shown for each set of data.

Results of the experiments are recorded in Tables III through VII and Figures 8 through 13 which follow. The figures, in graphical form, show the explosion points observed and a shaded area as the region

TABLE III.

Explosion Data for Tetraborane-Oxygen Mixtures in the Ratio  
1 to 5<sup>1</sup>/<sub>2</sub> in 6.8 cm Diameter Bulbs

Serial No.	Temp. Explosion °C	Pressure Explosion mm Hg	Pressure B <sub>4</sub> H <sub>10</sub> mm Hg, 25°C	Ratio $\frac{C_2}{B_4H_{10}}$
1	33.0	24.8	3.5	5.9
2	35.0	11.6	1.6	5.9
3	38.0	19.3	3.0	5.2
4	38.0	16.9	2.5	5.5
5	39.0	45.3	6.8	5.4
6	37.0	41.7	6.1	5.6
7	31.0	32.6	5.0	5.4
8	32.0	34.7	5.3	5.5
9	16.2	50.0	8.1	5.5
10	27.0	49.7	7.5	5.6
11	28.0	59.1	9.2	5.4
12	26.0	52.6	8.2	5.4
13	35.0	28.3	4.4	5.3

TABLE IV.

Explosion Data for Tetraborane-Oxygen Mixtures in the Ratio  
1 to 5<sup>3</sup>/<sub>2</sub> in 4.0 cm Diameter Bulbs

Serial No.	Temp. Explosion °C	Pressure Explosion mm Hg	Pressure B <sub>4</sub> H <sub>10</sub> mm Hg, 25°C	Ratio $\frac{O_2}{B_4H_{10}}$
14	44.0	56.3	7.9	5.7
15	43.0	52.4	7.9	5.3
16	46.0	21.9	3.2	5.4
17	40.0	35.6	5.2	5.7
18	39.0	46.0	6.5	5.7
19	41.5	34.9	4.8	5.8
20	39.0	44.0	6.7	5.3
21	49.5	21.1	3.2	5.1

TABLE V.

Explosion Data for Tetraborane-Oxygen Mixtures in the Ratio  
1 to 5<sup>1</sup>/<sub>2</sub> in 6.3 cm Diameter Bulbs Packed with Glass Wool

Serial No.	Temp. Explosion °C	Pressure Explosion mm Hg	Pressure B <sub>4</sub> H <sub>10</sub> mm Hg, 25°C	Ratio $\frac{O_2}{B_4H_{10}}$
22	62.0	34.2	4.9	5.3
23	55.5	40.5	5.6	5.6
24	71.0	20.4	2.6	5.8
25	55.5	56.6	7.8	5.6
26	69.0	27.7	3.9	5.2
27	52.0	55.1	7.5	5.7
28	54.5	68.0	9.2	5.7
29	57.0	54.0	7.2	5.8
30	65.0	48.6	6.2	5.7

TABLE VI.

Explosion Data for Tetraborane-Oxygen-Helium Mixtures in the Ratio  
1 to 5<sup>1</sup>/<sub>2</sub> to 5<sup>1</sup>/<sub>2</sub> in 6.8 cm Diameter Bulbs

Serial No.	Temp. Explosion °C	Pressure Explosion mm Hg	Pressure B <sub>4</sub> H <sub>10</sub> mm Hg, 25°C	Ratio $\frac{O_2}{B_4H_{10}}$
31	1.0	58.0	9.5	5.7
32	11.0	43.0	7.0	5.5
33	9.0	22.8	3.7	5.6
34	17.0	38.3	5.9	5.7
35	20.0	16.1	2.6	5.3
36	19.0	17.7	2.7	5.7

TABLE VII.

Explosion Data for Tetraborane-Oxygen-Nitrogen Mixtures in the Ratio  
1 to 5<sup>3</sup>/<sub>2</sub> to 5<sup>3</sup>/<sub>2</sub> in 6.8 cm Diameter Bulbs

Serial No.	Temp. Explosion °C	Pressure Explosion mm Hg	Pressure B <sub>4</sub> H <sub>10</sub> mm Hg, 25°C	Ratio $\frac{O_2}{B_4H_{10}}$
37	23.0	32.0	4.9	5.6
38	19.0	26.0	3.9	5.7
39	21.5	40.0	6.0	5.7
40	19.0	45.0	7.1	5.5
41	36.0	14.8	2.4	5.0
42	34.0	20.2	3.0	5.6

Figure 8  
Explosion Region for Tetraborane-Oxygen Mixtures  
in the Ratio 1 to  $5\frac{1}{2}$  in 6.8 cm Diameter Bulbs



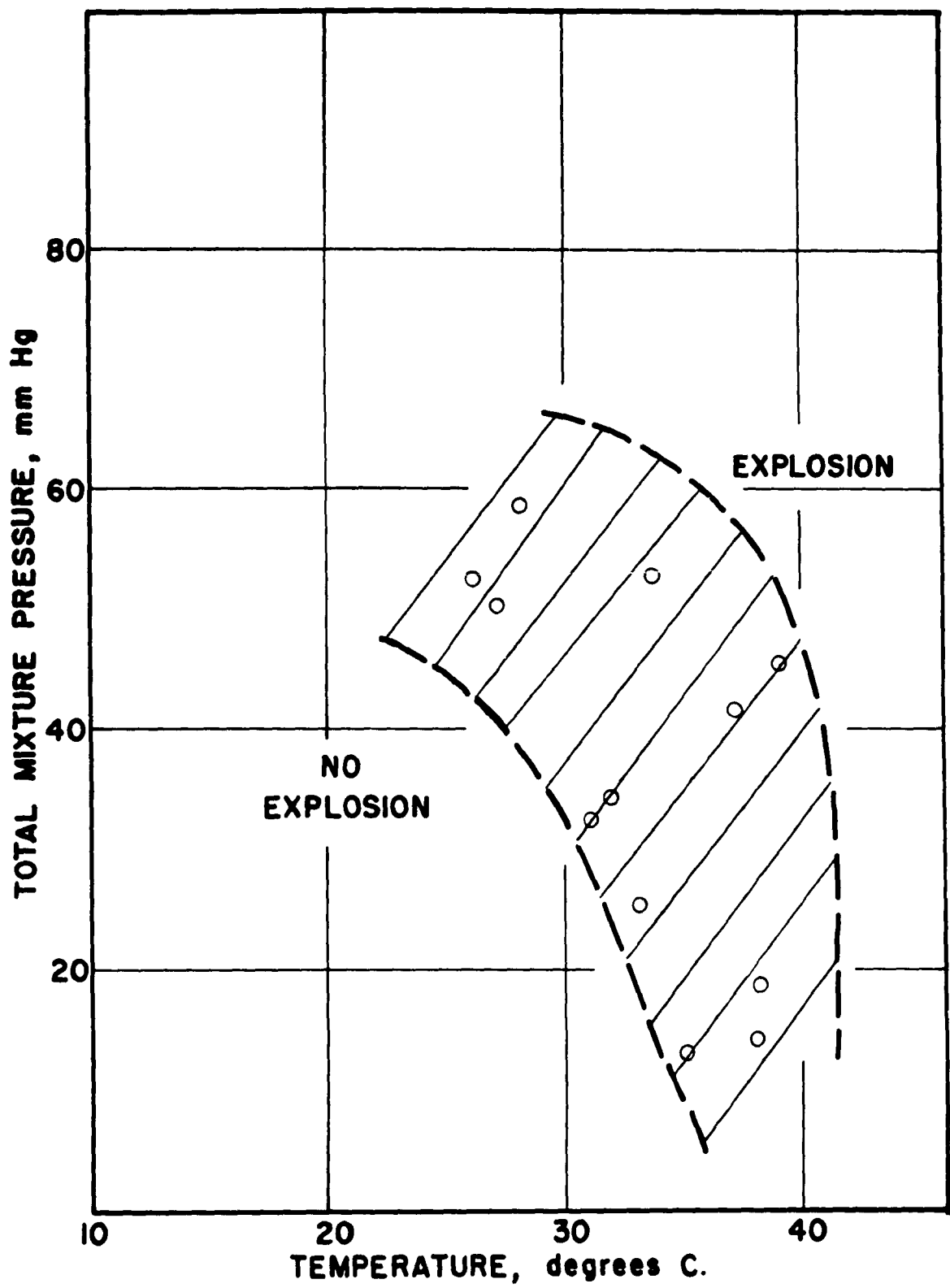

Figure 9  
Explosion Region for Tetraborane-Oxygen Mixtures  
in the Ratio 1 to  $5\frac{1}{2}$  in 4.0 cm Diameter Bulbs

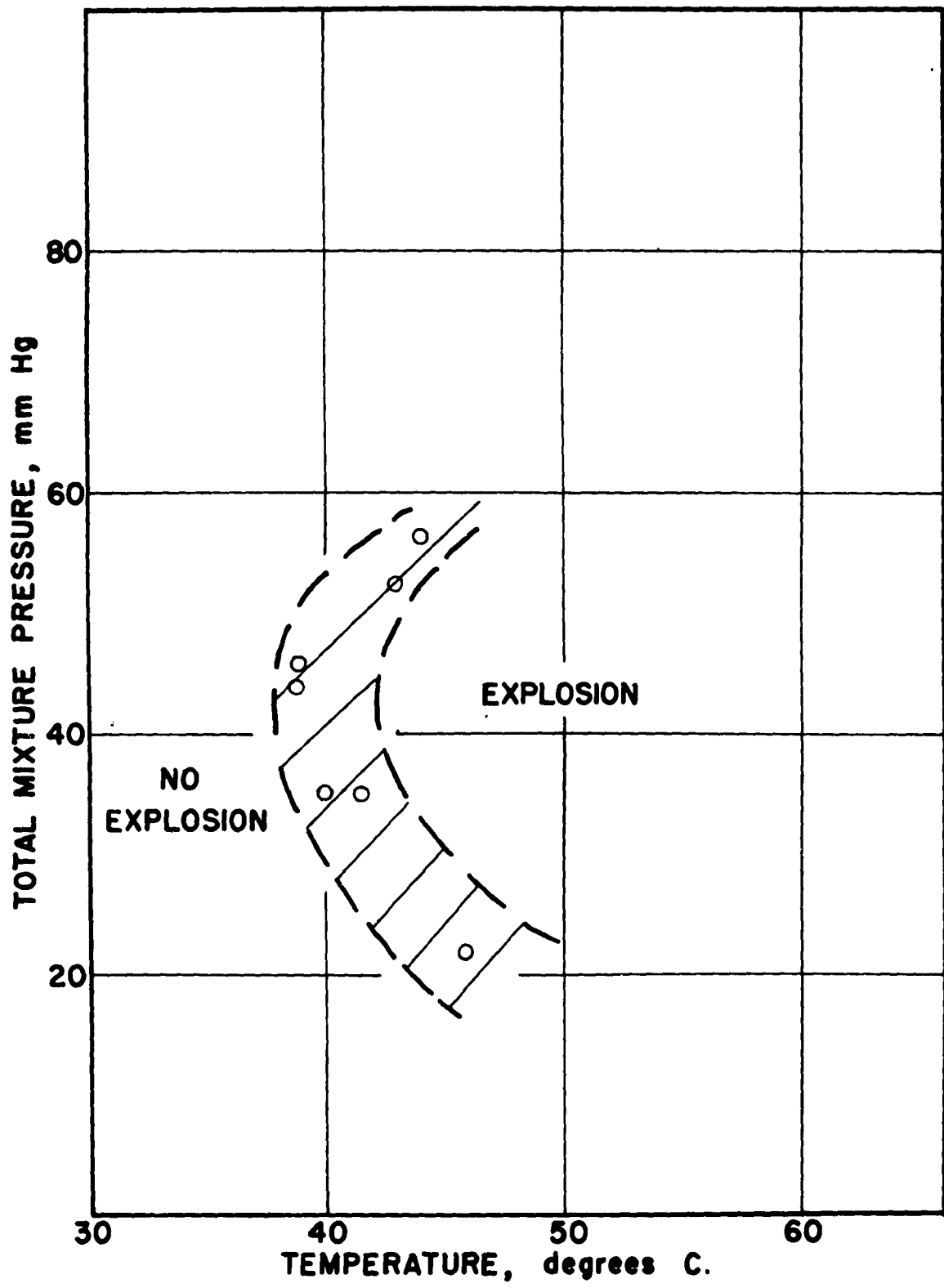
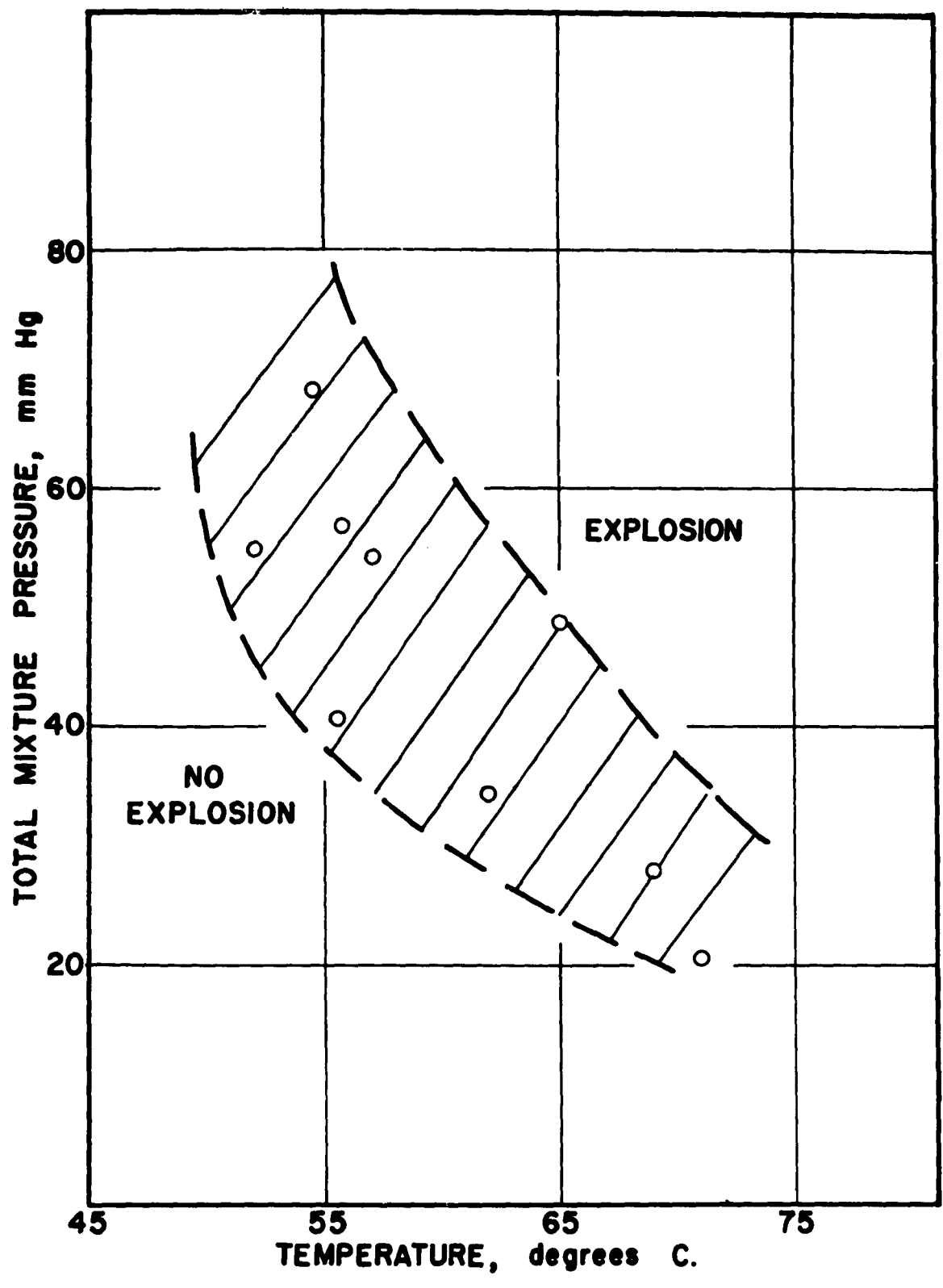

Figure 10  
Explosion Region for Tetraborane-Oxygen Mixtures  
in the Ratio 1 to  $5\frac{1}{2}$  in 6.8 cm Diameter Bulbs  
Packed with Glass Wool



## Figure 11

Explosion Region for Tetraborane-Oxygen-Helium Mixtures  
in the Ratio 1 to  $5^{1/2}$  to  $5^{1/2}$  in 6.8 cm Diameter Bulbs

(Figure follows page 41.)

Figure 12  
Explosion Region for Tetraborane-Oxygen-Nitrogen Mixtures  
in the Ratio 1 to  $5/2$  to  $5/2$  in 6.8 cm Diameter Bulbs

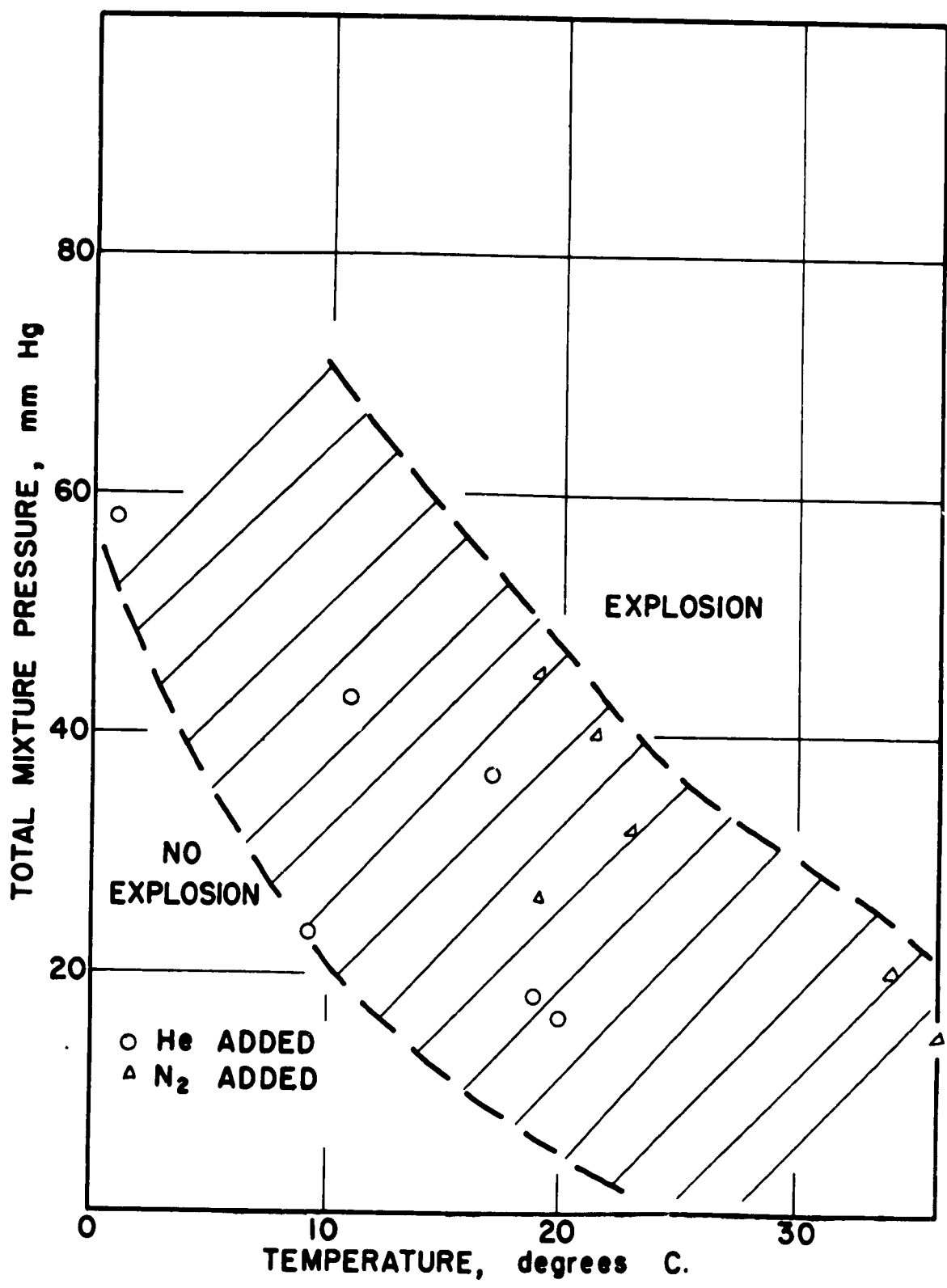



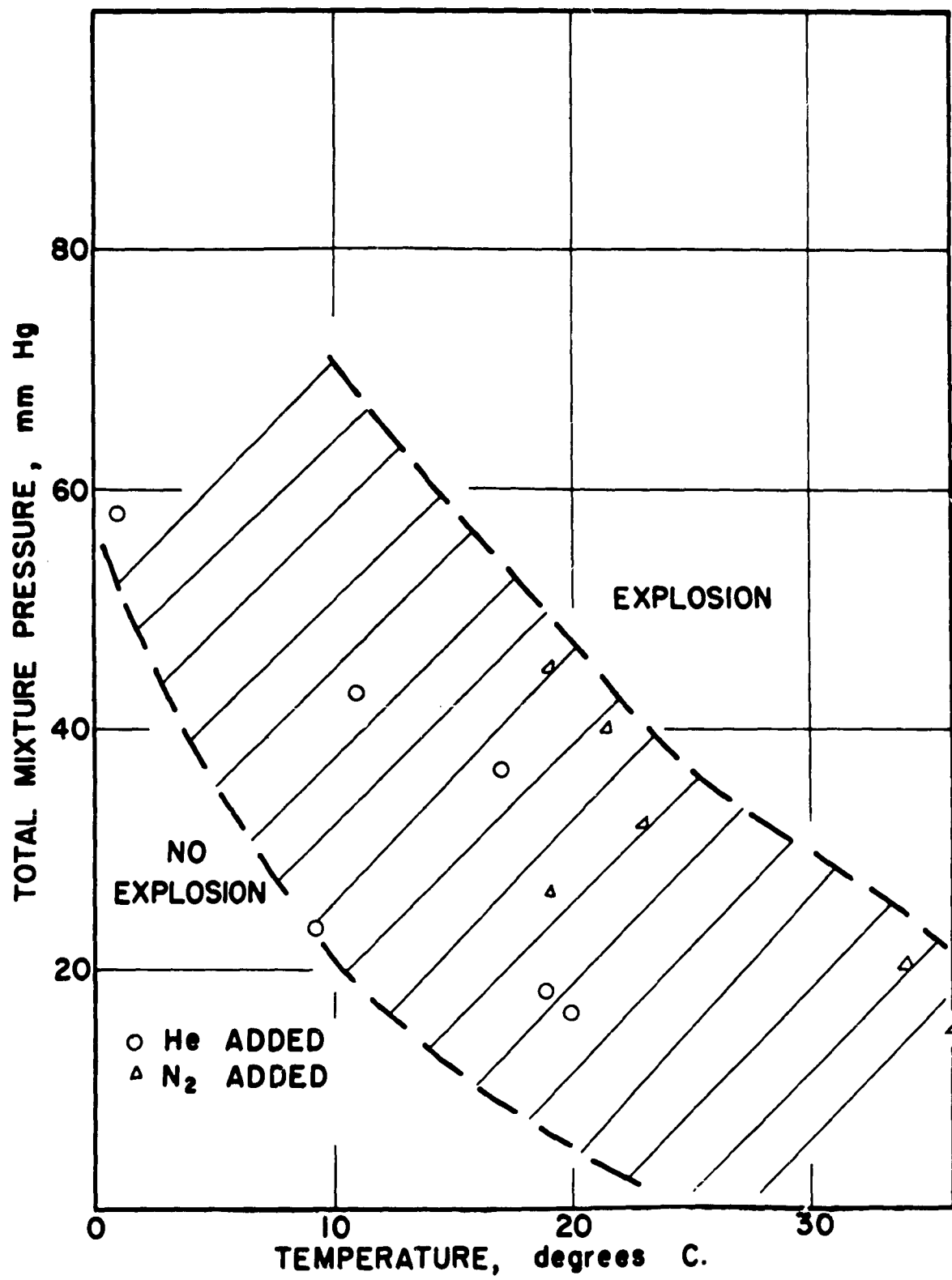
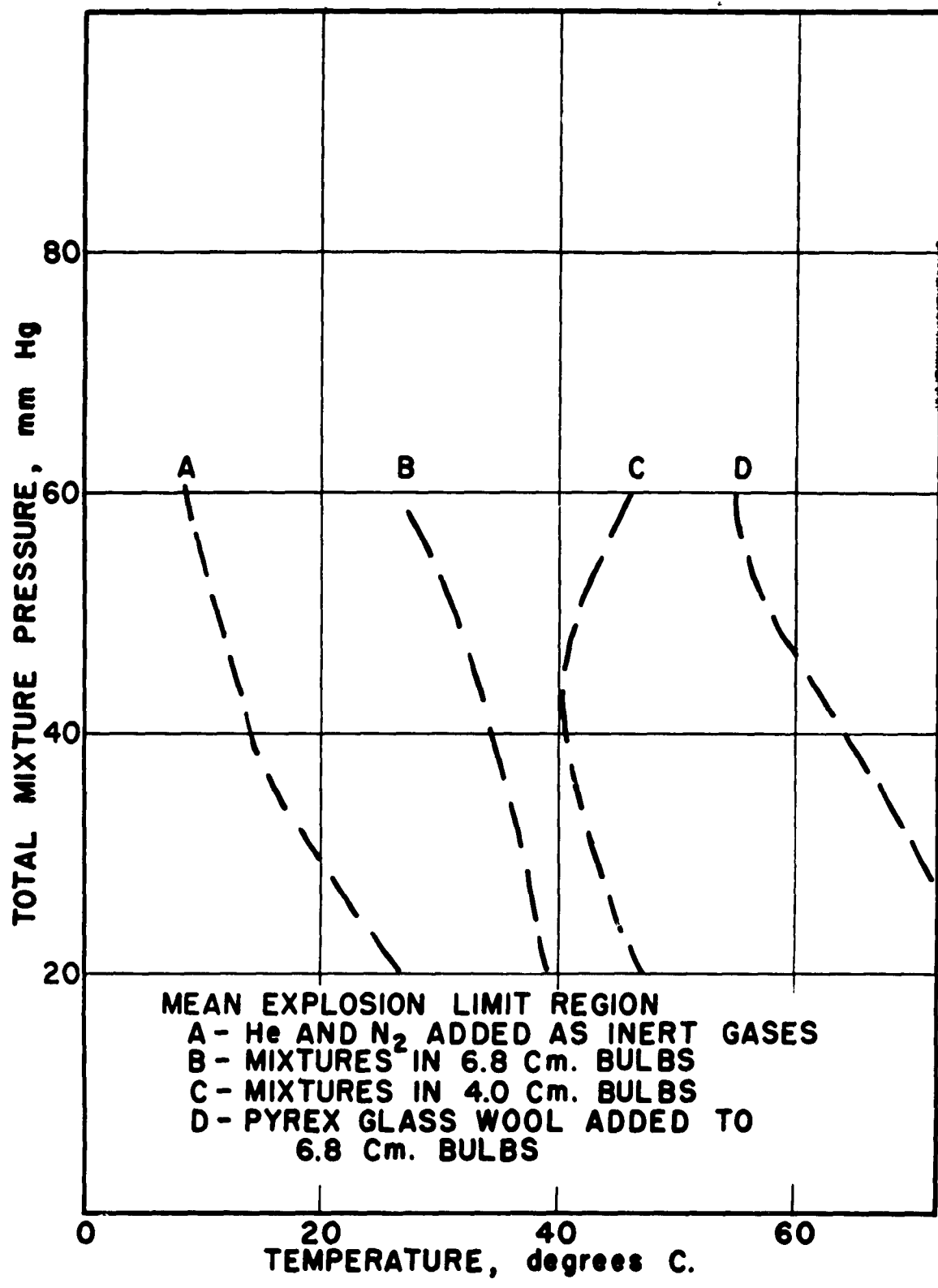

Figure 13  
Composite of Explosion Region Data  
Using Mean Lines of Explosion



of explosion since the explosion limits were not reproducible within the limits of error of pressure, temperature, and mixture composition.

Through the middle of each shaded area can be drawn a mean line of explosion, and this mean line is shown on the composite figure of the explosion data.

The reaction which occurred when the inhibitor lead tetraethyl was added to the mixture was surprising since in a number of cases no explosion was observed, only slow reaction. Table VIII shows this with appropriate observations pertaining to the slow reaction. This slow reaction in the Pyrex bulb was never observed in the absence of the inhibitor lead tetraethyl.

## B. Results in the Investigation of the Partial Oxidation of Tetraborane

### 1. Slow Addition of Oxygen to Tetraborane

Slow addition of oxygen to tetraborane resulted in the immediate reaction of both tetraborane and oxygen with the production of partial oxidation product, diborane, hydrogen and boric acid anhydride as shown in Figures 14 through 19. The presence of tetraborane, diborane, and partial oxidation product were confirmed by the infrared spectra, Figure 20. The presence of hydrogen and unreacted oxygen at the conclusion of the reaction, as well as the presence of some unreacted tetraborane, the products, diborane and partial oxidation product, were confirmed by the introduction of a portion of the reaction mixture into the mass spectrometer, Table IX. The presence of boric acid anhydride was confirmed by the comparison of the infrared spectrum of the solid deposited

TABLE VIII.

Explosion Data for Tetraborane-Oxygen Mixtures in the Ratio 1 to 5<sup>1</sup>/<sub>2</sub> with

## Lead Tetraethyl Added in 6.8 cm Diameter Bulbs

Serial No.	Temp. Explosion °C	Pres. Explosion mm Hg	Pres. B <sub>4</sub> H <sub>10</sub> mm Hg, 25°C	Ratio O <sub>2</sub> B <sub>4</sub> H <sub>10</sub>	Observation
43	23.0	25.2	3.5	6.2	Heated to 80°C, no explosion, white coat formed on inside surface. Heated to 80°C, no explosion, white coat formed on inside surface. Heated to 80°C, no explosion, white coat formed on inside surface. Heated to 80°C, no explosion, white coat formed on inside surface. Heated to 90°C, no explosion, white coat formed on inside surface. Heated to 28°C, no reaction; heated to 40°C, no explosion, white coat formed on inside surface. Heated to 75°C, no explosion, white coat formed on inside surface. Heated to 40°C, no explosion, white coat formed on inside surface.
44	38.0	17.9	2.6	5.6	
45	0.0	25.4	4.3	5.5	
46	5.0	17.3	3.0	5.2	
47	22.0	20.4	2.8	6.4	
*48	none	none	1.9	5.3	
*49	none	none	3.5	6.2	
*50	none	none	2.6	5.7	
*51	none	none	1.2	5.4	
*52	none	none	2.3	5.9	
*53	none	none	3.2	5.3	

(0.2 mm Pb(C<sub>2</sub>H<sub>5</sub>)<sub>4</sub> added to each bulb)

\*Qualitative mass spectral analysis showed the presence of tetraborane, diborane, oxygen and hydrogen present in the bulbs where a slow reaction occurred. Analysis of the solid product showed it to be boric acid.

Figure 14  
Partial Oxidation Reaction of  
Tetraborane with Oxygen

RATE OF O<sub>2</sub> ADMISSION

$1.2 \times 10^{-5}$  MOLES CM<sup>-3</sup> MIN<sup>-1</sup>

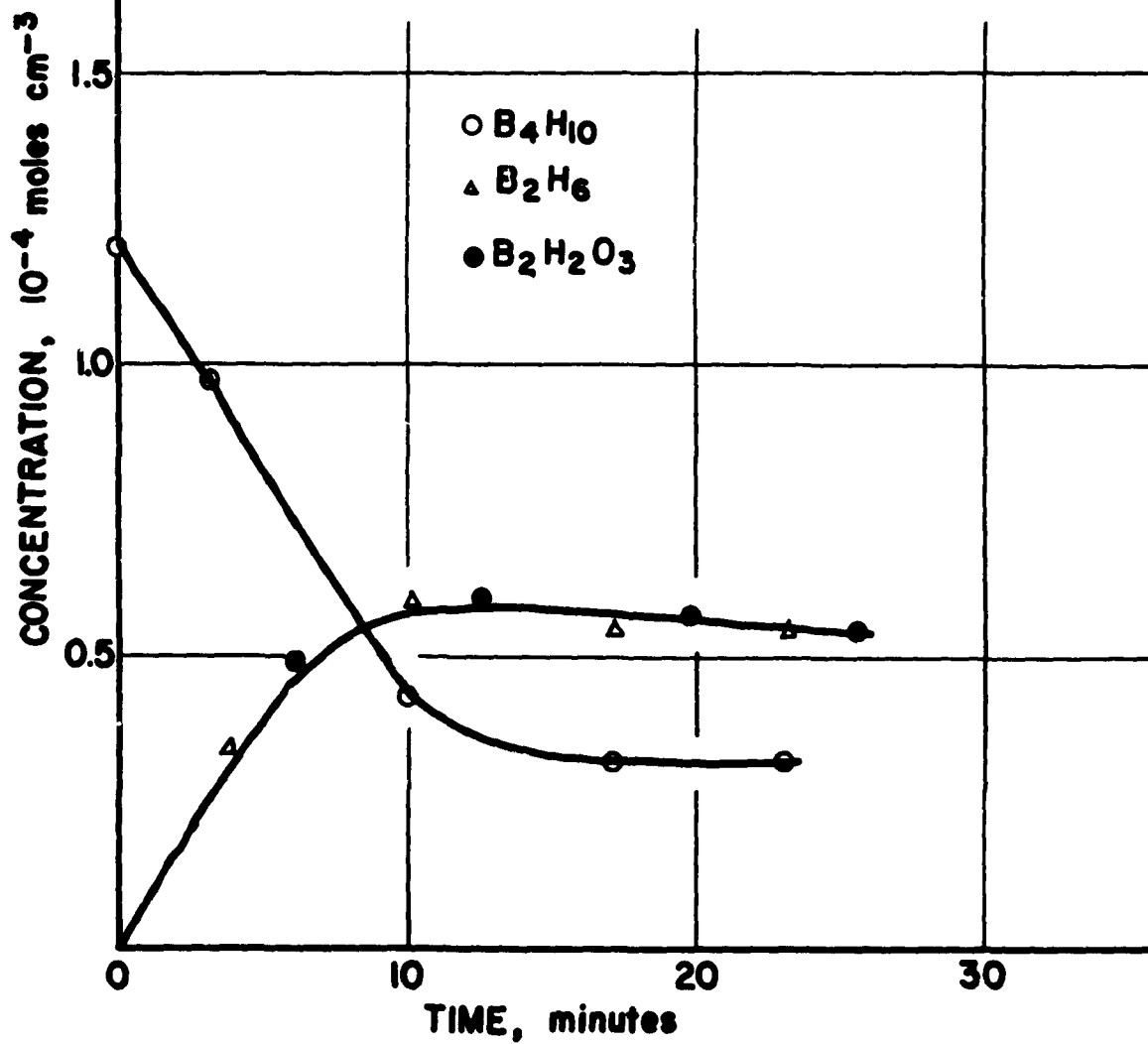

Figure 15  
Partial Oxidation Reaction of  
Tetraborane with Oxygen



RATE OF O<sub>2</sub> ADMISSION  
1.2 x 10<sup>-5</sup> MOLES CM<sup>-3</sup> MIN<sup>-1</sup>

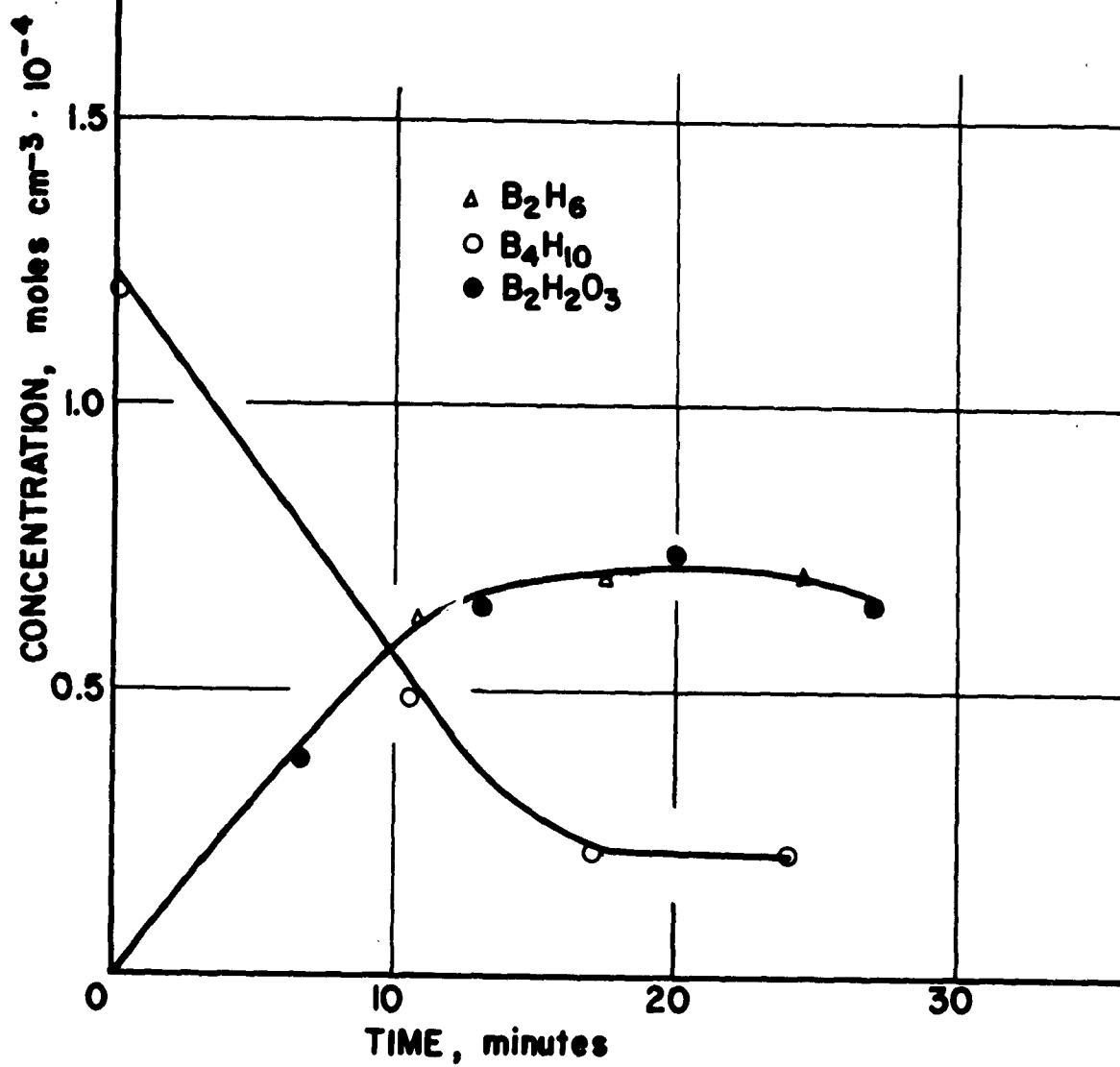

Figure 16  
Partial Oxidation Reaction of  
Tetraborane with Oxygen

RATE OF O<sub>2</sub> ADMISSION  
1.2 x 10<sup>-5</sup> MOLES CM<sup>-3</sup> MIN<sup>-1</sup>

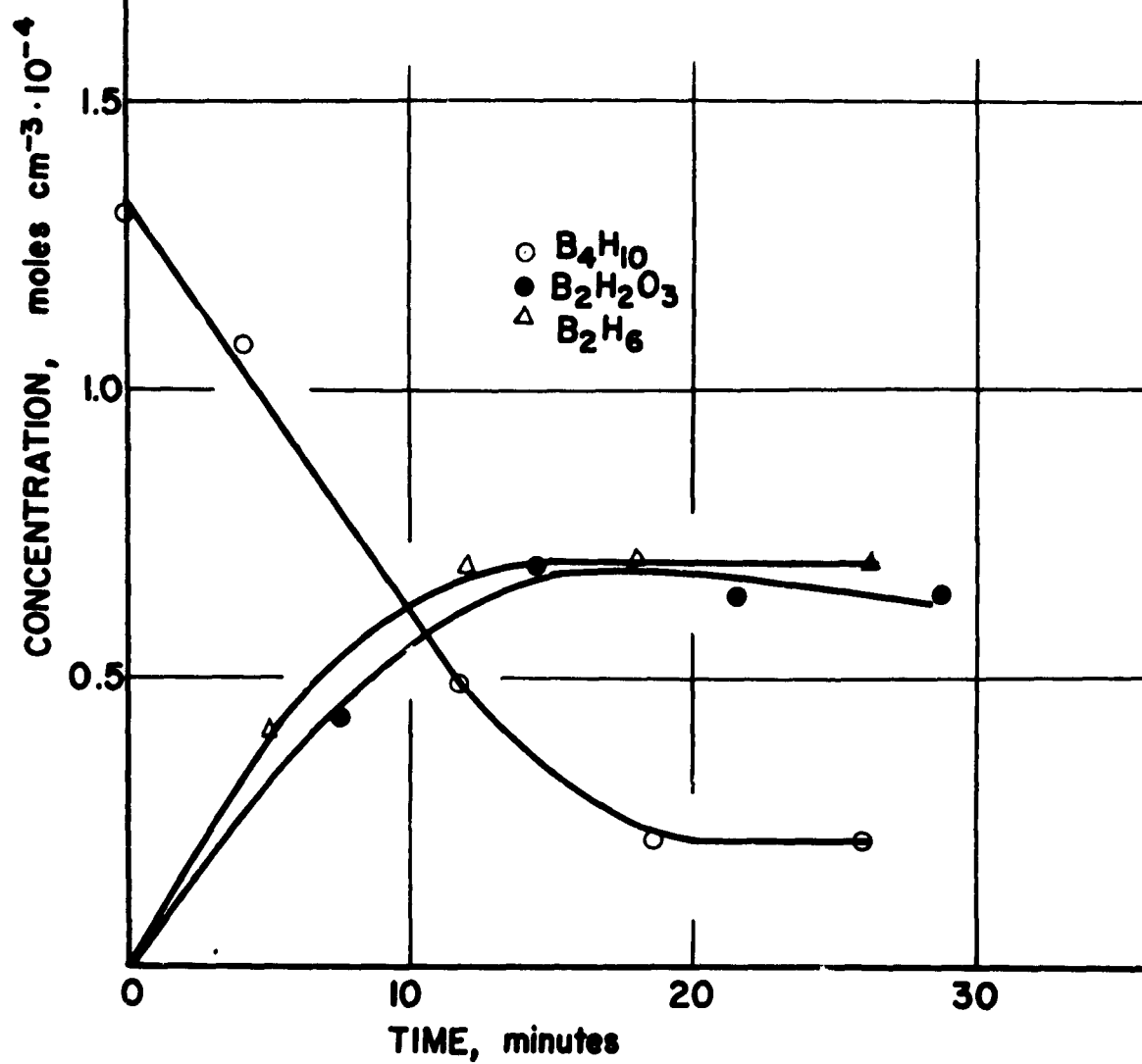

Figure 17  
Partial Oxidation Reaction of  
Tetraborane with Oxygen

RATE OF O<sub>2</sub> ADMISSION  
1.2 x 10<sup>-5</sup> MOLES CM<sup>-3</sup> MIN<sup>-1</sup>

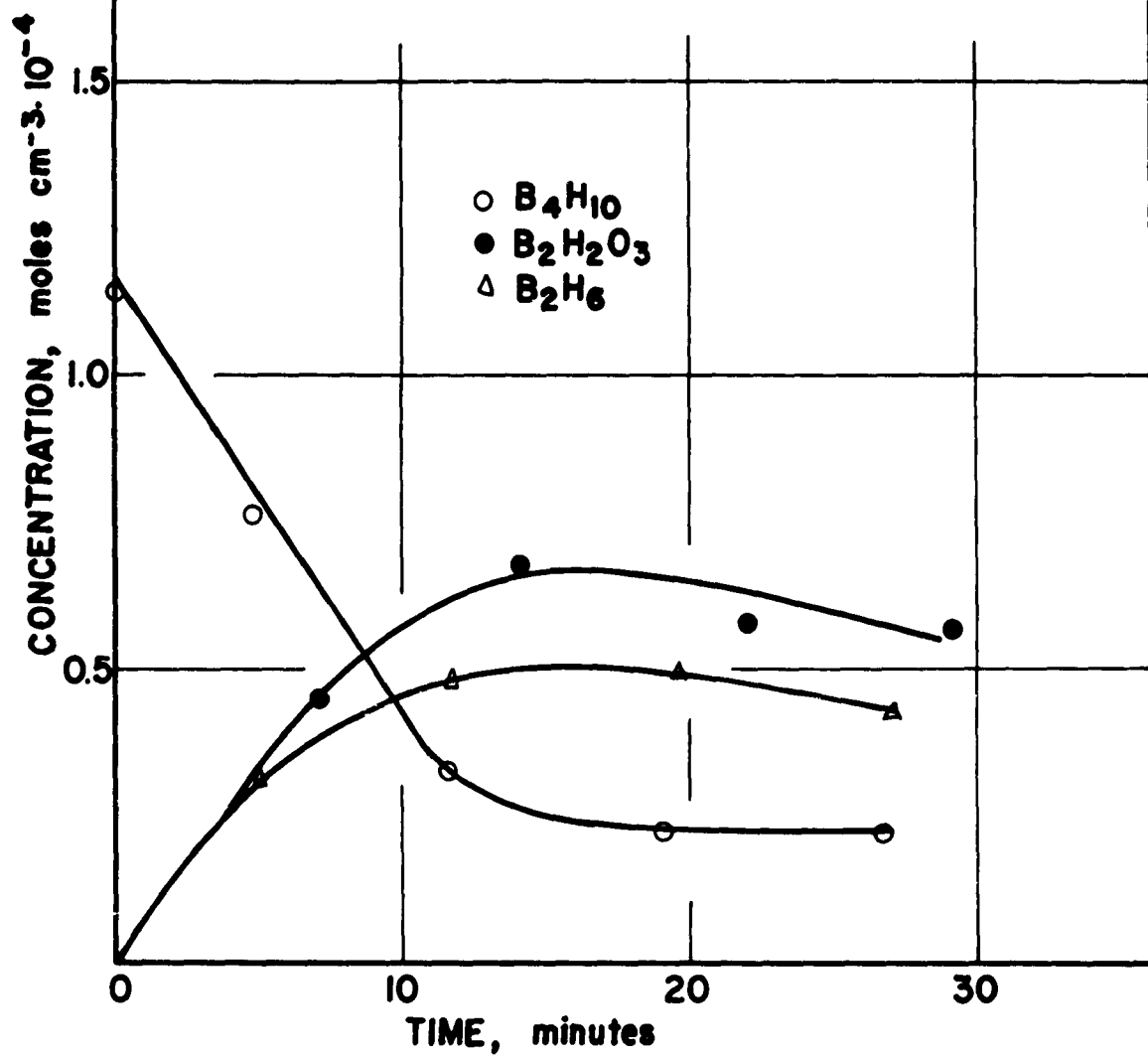

Figure 18  
Partial Oxidation Reaction of  
Tetraborane with Oxygen

RATE OF O<sub>2</sub> ADMISSION  
1.2 x 10<sup>-5</sup> MOLES CM<sup>-3</sup> MIN<sup>-1</sup>

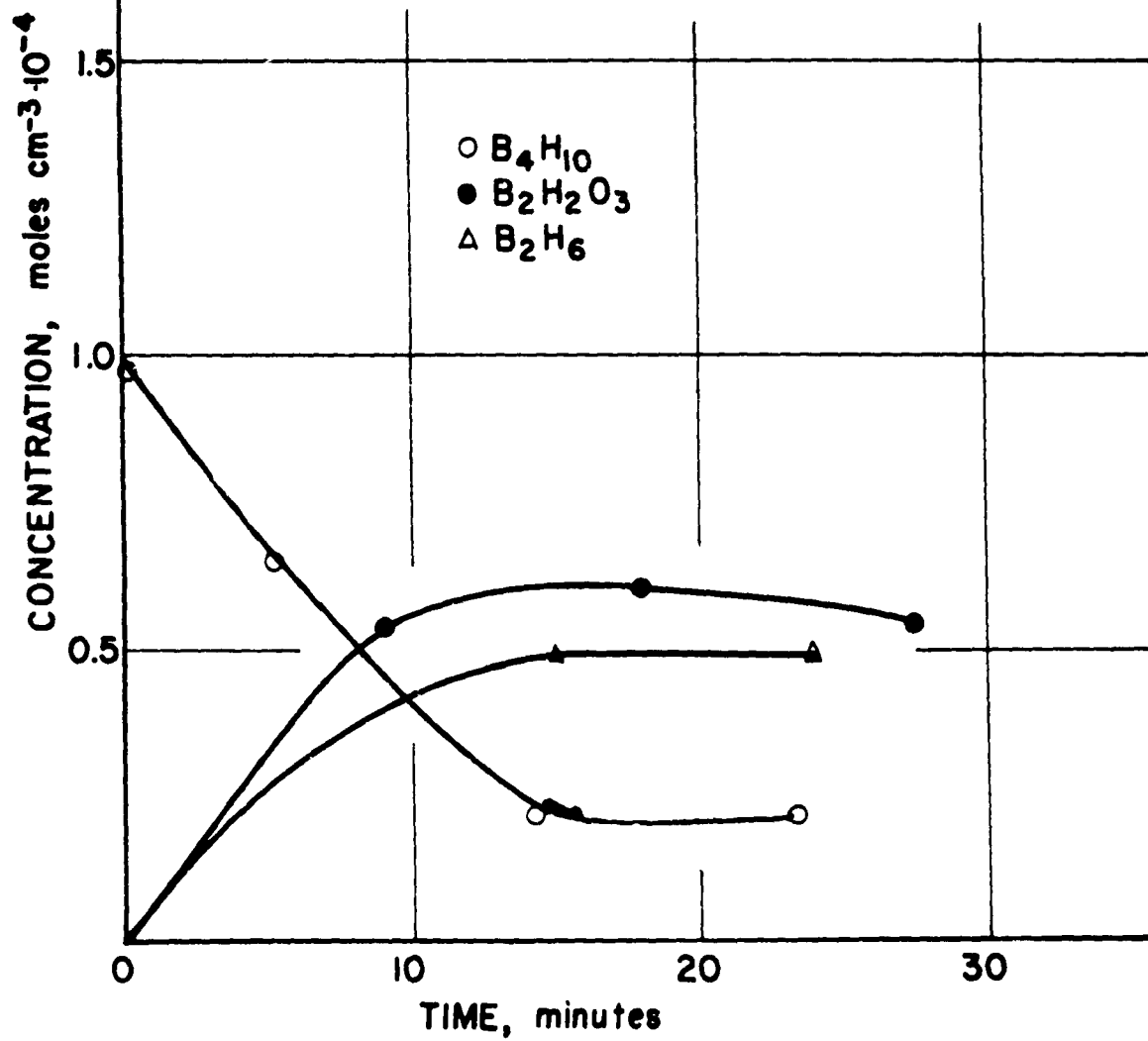

Figure 19  
Partial Oxidation Reaction of  
Tetraborane with Oxygen



RATE OF O<sub>2</sub> ADMISSION  
1.2 x 10<sup>-5</sup> MOLES CM<sup>-3</sup> MIN<sup>-1</sup>

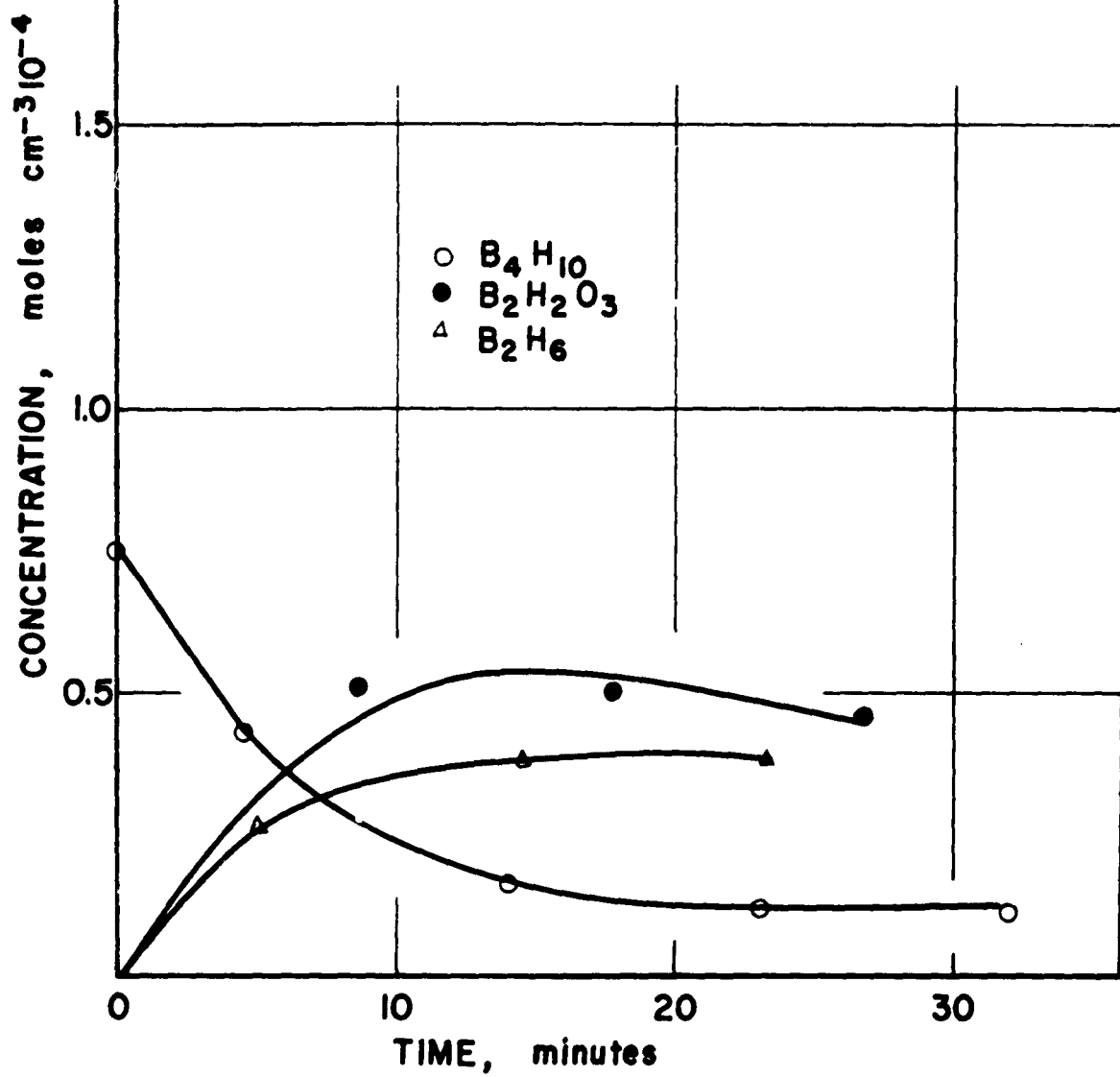

Figure 20  
Representative Infrared Spectra of Pure Tetraborane  
and Tetraborane-Oxygen Reaction Mixture

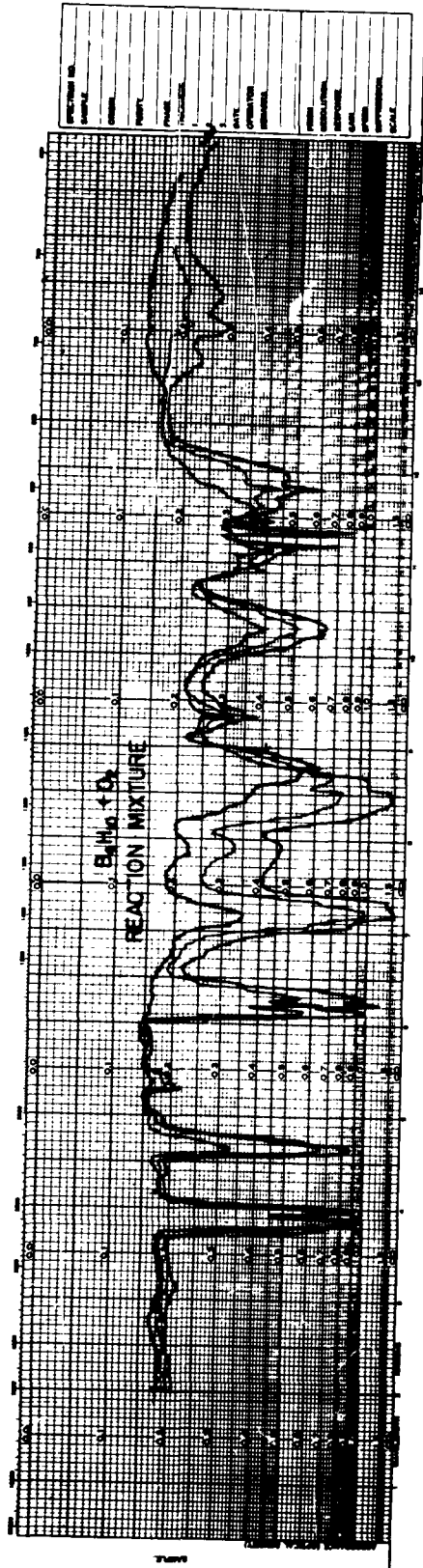
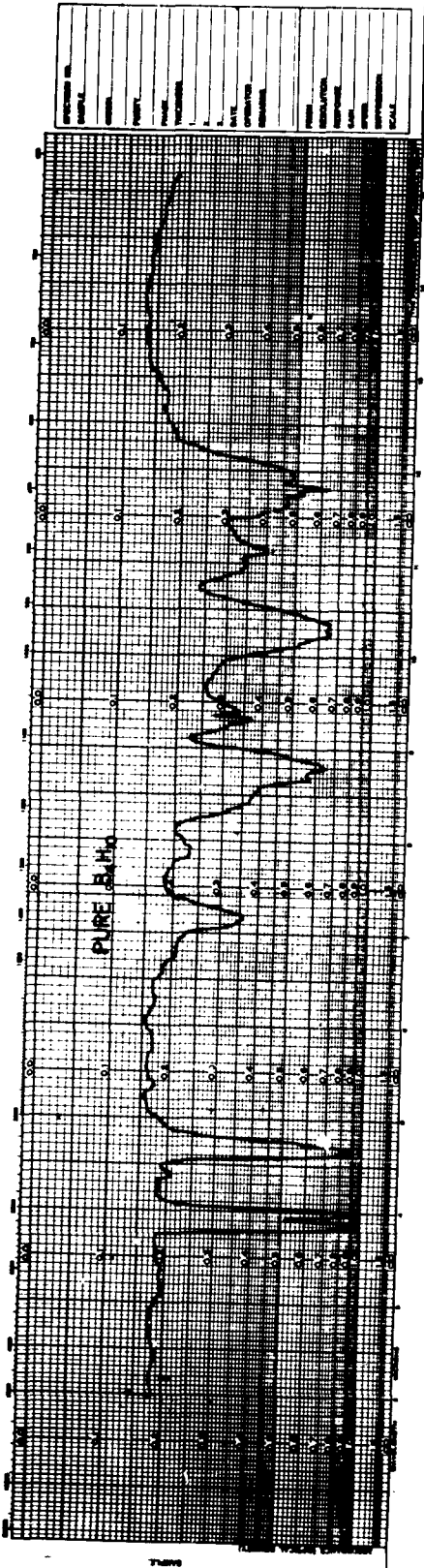

TABLE IX.

Mass-Intensity Data for Tetraborane-  
Oxygen Reaction System

m/e	Intensity x 10 <sup>2</sup>	m/e	Intensity x 10 <sup>2</sup>
*2	174	43	14
18	6	44	14
22	6	45	10
23	26	46	12
24	52	47	20
25	32	48	25
26	54	*49	27
*27	56	50	26
28	27	51	5
*32	120	52	2
33	1	69	2
34	3	70	8
35	6	*71	16
36	7	72	5
37	2		
38	2		
42	1		

\*Peaks and/or associated patterns indicate presence of hydrogen, diborane, oxygen, tetraborane and partial oxidation product.

on the cell windows with the spectrum of a known sample of boric acid anhydride.

The immediate reaction of oxygen on its admission to the tetraborane was demonstrated by stopping the flow of oxygen after a few minutes and observation of any change in pressure and absorbance of reactants and products for ten minutes. No change was noted. The oxygen was again allowed to flow into the tetraborane for a minute and again the flow was stopped. Observation of the pressure and scanning of the infrared spectrum showed no change for ten minutes when the oxygen flow was cut off. Also, the experimental total pressure was checked against total pressure calculated from absorbance data at  $t_{1/4}$ , the time when one-fourth of the tetraborane was consumed, assuming that all oxygen was used, and that one mole of hydrogen was produced for each mole of tetraborane used. This is shown in Table X. A comparison of the last two columns shows that within experimental error the calculated pressure agrees with observed pressure indicating the assumptions were plausible.

## 2. Slow Addition of Oxygen to a Mixture of Tetraborane and Diborane

Slow addition of oxygen to a gaseous mixture of tetraborane and diborane resulted in the consumption of both tetraborane and oxygen and the production of diborane, partial oxidation product, hydrogen, and boric acid anhydride. However, the net change in the moles of diborane per mole of tetraborane used at any time, was much less than was found when oxygen was added to pure tetraborane; while the amount of partial oxidation product formed per mole of tetraborane used was virtually unchanged; see Figures 21 and 22.

TABLE X.

Comparison of Total Pressure Based upon Infrared Absorbance  
with Total Pressure Obtained Manometrically, at  $t_{1/4}$

Serial No.	Pressure of Gases, mm Hg					Total Pressure, mm Hg	
	B <sub>4</sub> H <sub>10</sub> Initial	B <sub>4</sub> H <sub>10</sub> at $t_{1/4}$	B <sub>2</sub> H <sub>6</sub> at $t_{1/4}$	B <sub>2</sub> H <sub>2</sub> O <sub>3</sub> at $t_{1/4}$	H <sub>2</sub> * at $t_{1/4}$	Calculated Spectrometric Pressure, mm Hg	Manometric Pressure Measured $\pm 1$ mm Hg
54	27	20	9	8	7	44	43
55	23	17	4	6	6	33	31
56	23	17	8	5	6	36	37
57	23	17	6	6	6	35	37
58	28	21	12	6	7	46	44
59	22	16	7	7	6	36	34
60	24	18	7	7	6	38	36
61	21	16	5	5	5	31	29
62	18	13	5	5	5	28	26
63	14	10	2	5	4	21	20

\*Estimated on the assumption of one mole of H<sub>2</sub> formed per mole of B<sub>4</sub>H<sub>10</sub> consumed.

$t_{1/4}$  is the time required for one-fourth of the tetraborane to react while oxygen was added at a constant rate.

All pressures have been corrected to a temperature of 23.0°C.

Pressures of B<sub>4</sub>H<sub>10</sub>, B<sub>2</sub>H<sub>6</sub> and B<sub>2</sub>H<sub>2</sub>O<sub>3</sub> are from infrared absorbance measurements.

Figure 21  
Partial Oxidation Reaction of Premixed Diborane  
and Tetraborane with Oxygen

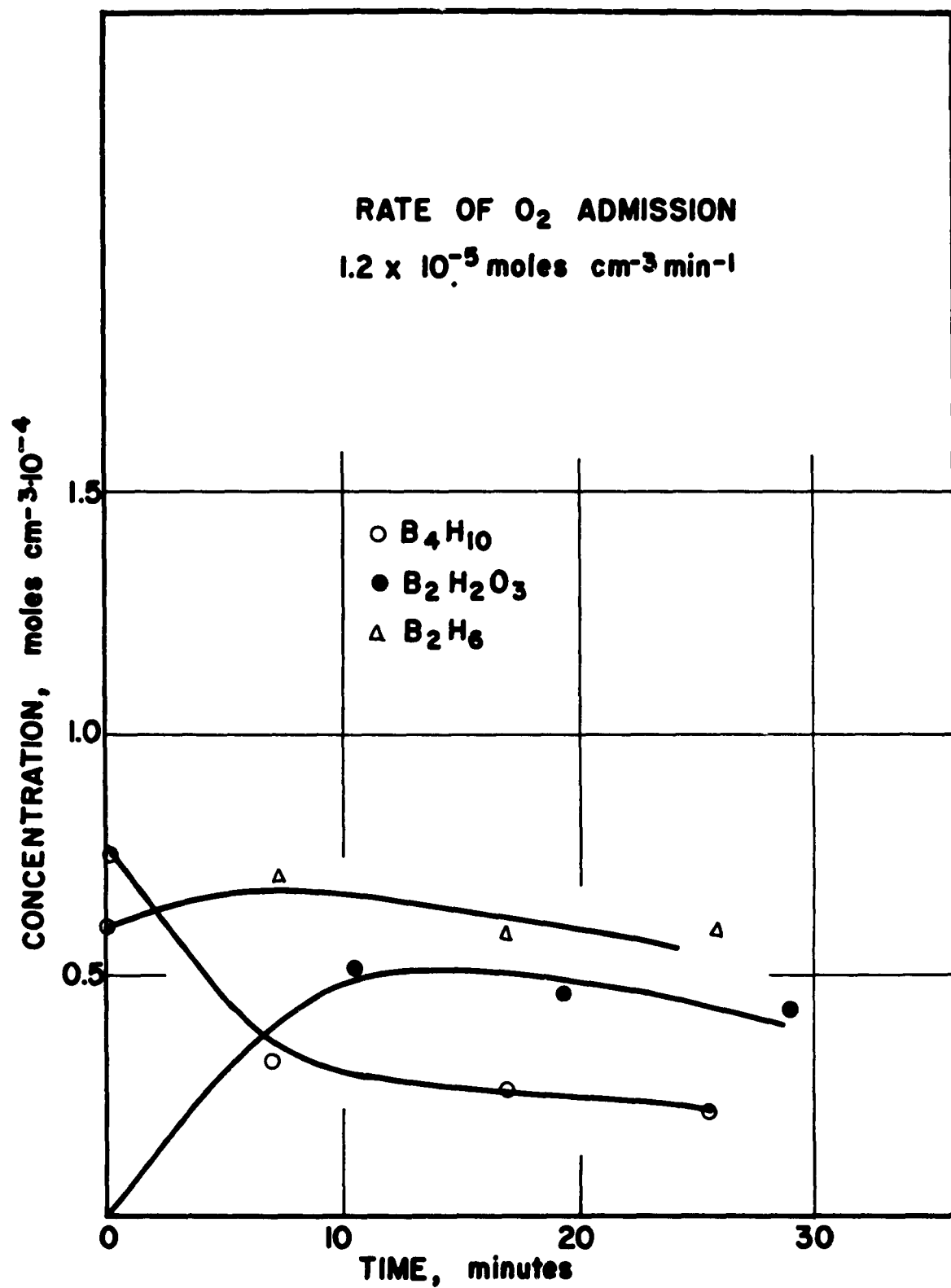
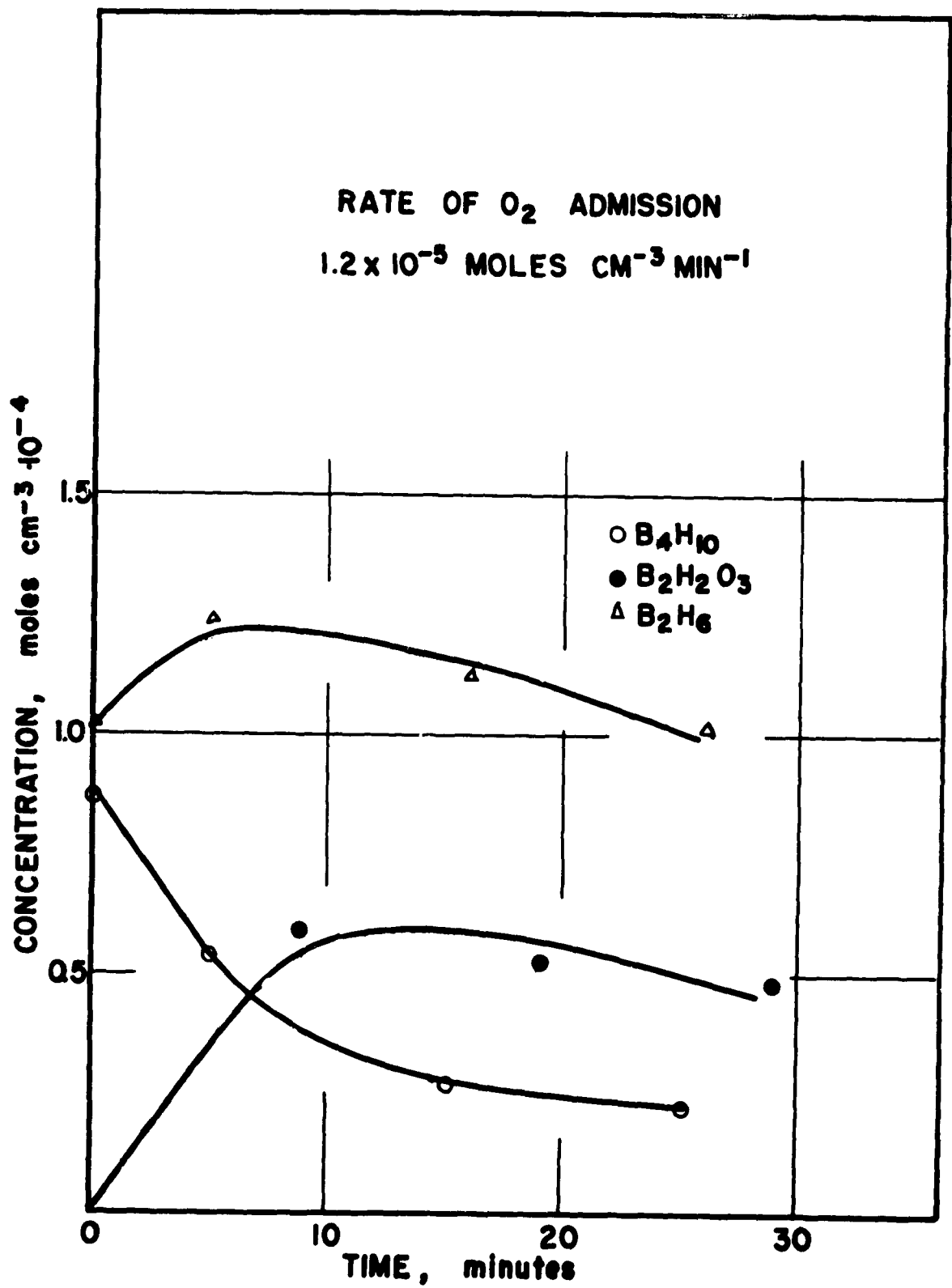



Figure 22  
Partial Oxidation Reaction of Premixed Diborane  
and Tetraborane with Oxygen



### 3. Slow Addition of Oxygen to a Mixture of Tetraborane and Argon

Slow addition of oxygen to a gaseous mixture of tetraborane and argon resulted in immediate reaction of both tetraborane and oxygen and the production of diborane, partial oxidation product, hydrogen and boric acid anhydride. The number of moles of diborane formed and the number of moles of partial oxidation product formed at half time showed no significant difference from the data obtained for the reaction of tetraborane and oxygen without any added gas, see Figure 23.

### 4. Inhibition of the Reaction by Additives

The reaction of tetraborane on slow addition of oxygen was either inhibited or prevented when 1-2 mm of water vapor and diethyl ether were added to the original tetraborane.

Figure 23  
Partial Oxidation Reaction of Premixed Argon  
and Tetraborane with Oxygen

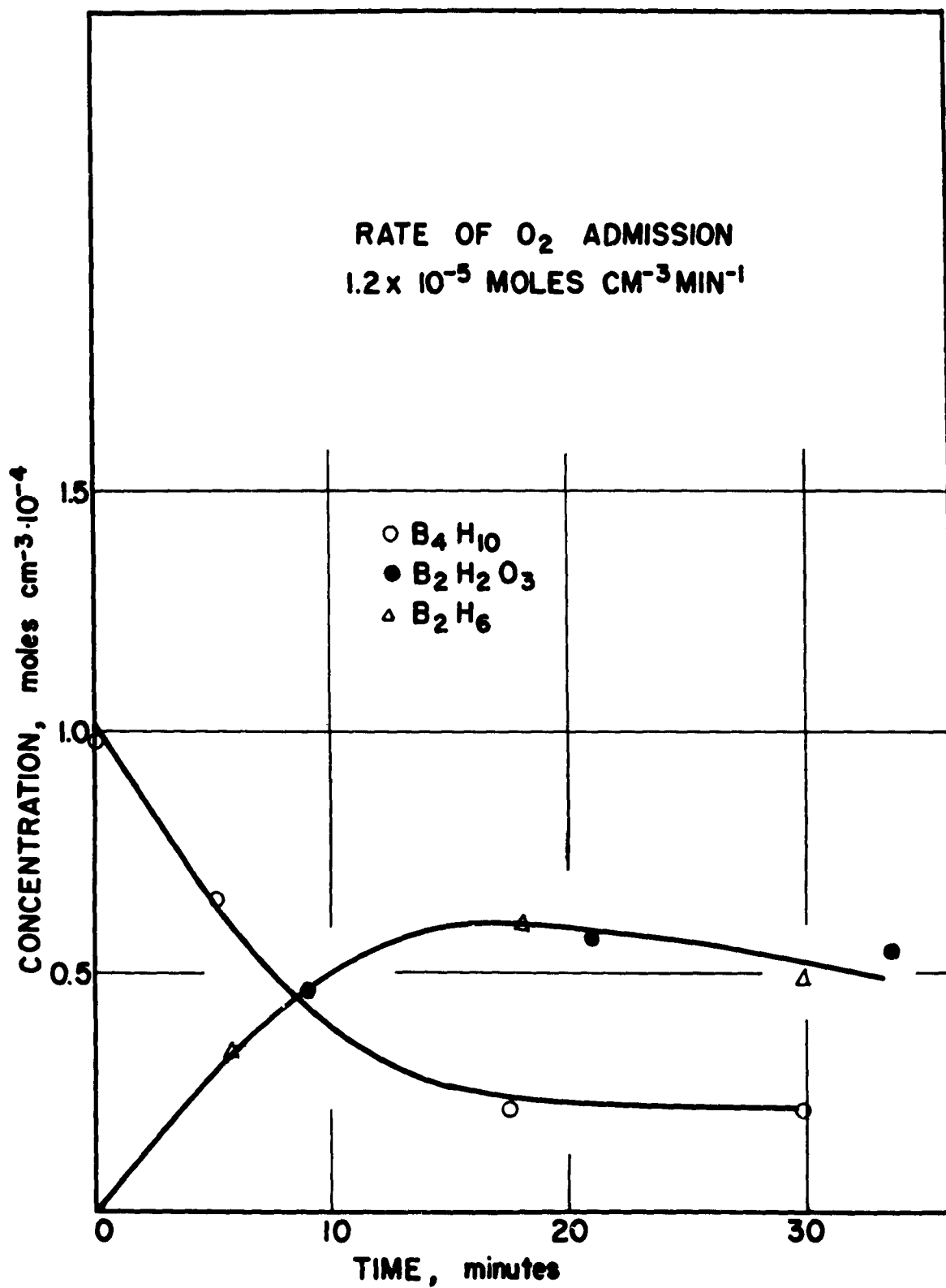

PART V.  
DISCUSSION

A. Discussion of Results of Explosive Reaction

(Developments in the theory by Semenov have influenced the interpretation of the data.<sup>39</sup>)

1. Chain Initiation and Termination

The data from Figures 8 through 12, respectively, show a net result of chain initiation in the gas phase and chain breaking at the wall. In the 4.0 cm diameter bulbs, the mean line of explosion temperatures are raised by five to nineteen degrees Centigrade over those in a 6.8 cm diameter bulb; see Figure 13. This may be explained by a change in the surface to volume ratio from  $\frac{3}{3.4}$  to  $\frac{3}{2}$  in going from 6.8 cm diameter bulbs to 4.0 cm diameter bulbs. As the effect of surface chain breaking becomes more important, higher temperatures are required to bring about explosion. In the 6.8 cm diameter bulbs packed with glass wool, the mean line of explosion temperatures are raised by twenty-eight to thirty-four degrees Centigrade over those in unpacked bulbs; see Figure 13. In these bulbs, the surface area of the Pyrex glass wool is very high and therefore affords enhanced chain breaking.

In the 6.8 cm diameter bulbs filled with the reaction mixture plus the inert gas He or N<sub>2</sub>, the mean line of explosion temperatures are lowered by twelve to twenty-one degrees for helium and nitrogen; see Figure 13. This shows that the inert gas prevents diffusion of reactive species to the wall and prevents chain breaking, thus facilitating explosion.

This experimental result suggests that the explosive reaction

is a branching chain reaction. The addition of helium to a mixture of tetraborane and oxygen will increase the thermal conductivity of the mixture quite markedly over the addition of nitrogen to a mixture of tetraborane and oxygen. The ratio of the difference in thermal conductivity can be approximated by the following:

$$\frac{\text{Thermal conductivity helium mixture}}{\text{Thermal conductivity nitrogen mixture}} = \frac{X_1k_1 + X_2k_2 + X_3k_3}{X_1k_1 + X_2k_2 + X_4k_4} = 3.3$$

where  $X_1$ ,  $X_2$ ,  $X_3$ ,  $X_4$  are the mole fractions of tetraborane, oxygen, helium and nitrogen respectively, and  $k_1$ ,  $k_2$ ,  $k_3$ ,  $k_4$  are their respective coefficients of thermal conductivity. For a thermal reaction, an explosive limit is reached when the rate of heat produced in the reaction bulb equals or exceeds the rate of conduction of heat from the bulb. This inability to maintain heat balance leads to acceleration of the reaction rate and explosion. If an inert gas such as helium is added to the reaction mixture the thermal conductivity of the mixture will be increased. This will enable heat to escape from the reaction vessel more rapidly, and in order to facilitate explosion the critical temperature must be raised. Thus, the explosion limit will be shifted toward higher temperature in the presence of helium. That this is not the case is clearly seen in Figure 13. Actually, the presence of helium and nitrogen tends to lower the region of explosion. Thus, the reaction is not affected by a marked increase in thermal conductivity. This, coupled with the demonstrated presence of surface effects shows that a heterogeneous step is operative in the reaction mixture. For a thermal explosion<sup>26</sup> the pressure of critical explosion is independent of the nature of the vessel surface.

## 2. Wall Effect

When the surface area is raised by a large factor, on packing the bulbs with glass wool, the temperature of explosion rises only thirty to forty degrees, showing moderate inhibition. This indicates that the wall may be acting to form reactive species as well as to destroy them, although not to such a great extent.

## 3. Inhibitor Effect

In the fifty explosions conducted without addition of lead tetraethyl to the tetraborane-oxygen mixture, no slow reaction was ever observed. When lead tetraethyl was added to the test mixture, no explosion was observed in six trials. Since the role of inhibitors is not definitely known, no attempt to explain these results was made.

## 4. Errors

Determinate errors exist in the measurement of pressure of the reactant gases, temperature of explosion and concentration of the reactants. The pressure of the gas in the reaction bulb could normally be read to  $\pm 0.1$  mm. However, tetraborane reacts with or dissolves in Hg and destroys the round meniscus, preventing precise readings. Therefore, after taking a reading five times it was estimated that the limit of error was  $\pm 0.40$  mm. The limit of error in the pressure measurement is at least

$$E_{PT} = E_{P_{B_4H_{10}}} + \frac{\text{room temp}}{78^\circ K} E_{P_{O_2}} = \pm 0.4 + 4 \times \pm 0.4 = \pm 2.0 \text{ mm Hg.}$$



The error in temperature readings at the exact instant of explosion was estimated to be  $\pm 0.5^\circ\text{C}$ . Examination of the data in Tables III through VII shows that the reproducibility of the explosion is not as good as expected from estimated experimental error and must be influenced by some unknown factor. This other factor is thought to be the inability to control the nature of the wall in the reaction vessel. Regions of explosion were drawn on the graphs, Figures 8-12, and mean lines of explosion were then shown on the composite explosion limit graph, Figure 13.

B. Discussion of Results of the Partial Oxidation of Tetraborane (See Tables XI, XII, XIII.)

1. Results of the Reaction

When the oxygen was admitted at a known rate to the tetraborane an immediate reaction occurred. The overall reaction at half time with respect to tetraborane consumption is represented by the following equation:

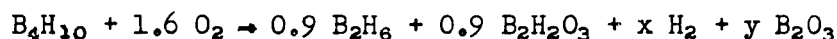

where  $x$  and  $y$  are unknown, and the number of moles of oxygen reacting per mole of tetraborane was obtained by measuring the ratio of the initial rate of oxygen addition to the initial rate of tetraborane consumption, assuming oxygen is not accumulating. This ratio is shown in column 7 in Tables XI, XII, and XIII. The three averages for the reaction under different conditions were 1.6, 1.7, and 1.7. The mole ratio of diborane formed to tetraborane used was 0.9 with tetraborane alone, see Table XI, and 0.9 with a mixture of tetraborane and argon;

TABLE XI  
Partial Oxidation of Tetraborane

1	2	3	4	5	6	7	8	9
Ser. No.	Temp. °C	Half Time Min	Pres. B <sub>4</sub> H <sub>10</sub> Time Zero	Initial Rate of O <sub>2</sub> Added mm/min	Initial Rate of B <sub>4</sub> H <sub>10</sub> Used mm/min	Mole Ratio O <sub>2</sub> Added / B <sub>4</sub> H <sub>10</sub> Used	Moles B <sub>2</sub> H <sub>6</sub> Formed / Divided by Moles B <sub>4</sub> H <sub>10</sub> Used	Moles B <sub>2</sub> H <sub>2</sub> O <sub>3</sub> Formed / Divided by Moles B <sub>4</sub> H <sub>10</sub> Used
54	26.0	13.0	27	2.1	1.2	1.8	0.8	0.8
54a	28.5	8.0	25	2.0	1.6	1.3	0.8	0.9
55	23.0	10.0	23	1.4	1.2	1.2	0.6	0.7
56	22.0	18.0	23	1.1	0.7	1.6	1.2	1.0
57	23.0	8.5	23	2.2	1.5	1.5	0.9	0.9
58	23.0	9.0	28	2.2	1.7	1.3	1.1	0.8
59	23.0	9.5	22	2.2	1.2	1.8	0.9	0.9
60	23.5	10.0	24	2.2	1.3	1.7	0.9	0.8
61	23.5	7.5	21	2.2	1.4	1.6	0.7	0.9
62	24.0	8.0	18	2.2	1.2	1.8	0.8	1.0
63	27.0	5.5	14	2.2	1.3	1.7	0.7	1.0
						AVERAGE 1.6	0.9	0.9

Columns 8 and 9 measured at half-time with respect to disappearance of tetraborane.

(Volume of infrared cell 204 cm<sup>3</sup>.)

\*Plots of concentration vs time shown for these spectra as representative of data.

†Obtained by dividing column 5 by column 6.

TABLE XII.  
Partial Oxidation of Mixture of  $B_4H_{10}$  and  $B_2H_6$

1	2	3	4	5	6	7	8	9
Ser. No.	Temp. °C	Half Time Mjn	Added Gas mm Hg $B_2H_6$ Zero	Initial Rate of $O_2$ Added mm/min	Initial Rate of $B_4H_{10}$ Used mm/min	Mole Ratio $O_2$ Added $B_4H_{10}$ Used	Moles $B_2H_6$ Formed Divided by Moles $B_4H_{10}$ Used	Moles $B_2H_2O_3$ Formed Divided by Moles $B_4H_{10}$ Used
64	25.0	7.0	14	2.3	1.2	1.9	0.3	1.0
65	24.0	8.5	14	1.0	0.8	1.3	0.2	1.0
66	25.0	15.0	18	1.0	0.6	1.7	0.3	0.9
67	25.5	15.5	16	1.0	0.6	1.7	0.4	0.9
68	25.5	24.0	14	0.6	0.4	1.5	0.3	0.7
69	25.0	8.0	16	2.3	1.3	1.8	0.5	1.1
						AVERAGE 1.7	0.3	0.9

Columns 8 and 9 measured at half-time with respect to disappearance of tetraborane.  
(Volume of infrared cell 204 cm<sup>3</sup>.)

\*Plots of concentration vs time shown for these spectra as representative of data.

†Obtained by dividing column 5 by column 6.

TABLE XIII

Partial Oxidation of Mixture of  $B_4H_{10}$  and Argon

1	2	3	4	5	6	7	8	9	
Ser. No.	Fig. No. <sup>*</sup> Temp. °C	Half Time Min	Added Gas mm Hg Argon	Pres. $B_4H_{10}$ Time Zero	Initial Rate of $O_2$ Added mm/min	Initial Rate of $B_4H_{10}$ Used mm/min	Mole Ratio $O_2$ Added / $B_4H_{10}$ Used	Moles $B_2H_6$ Formed Divided by Moles $B_4H_{10}$ Used	Moles $B_2H_2O_3$ Formed Divided by Moles $B_4H_{10}$ Used
70	24.0	7.0	15	16	2.2	1.2	1.8	1.0	1.1
71	22.5	8.0	17	18	2.0	1.4	1.6	0.8	0.8
72	24.0	9.0	19	18	2.0	1.1	1.8	0.9	0.9
73	24.5	7.0	11	12	1.8	1.1	1.6	0.8	1.0
							AVERAGE 1.7	0.9	0.9

Columns 8 and 9 measured at half-time with respect to disappearance of tetraborane.

(Volume of infrared cell 204 cm<sup>3</sup>.)

\*Plot of concentration vs time shown for this spectrum as representative of data.

†Obtained by dividing column 5 by column 6.

see Table XIII. The net change in the moles of diborane per mole of tetraborane used when tetraborane and diborane were premixed was 0.3; see Table XII. (Column 8, Table XII, is actually the net change in moles of  $B_2H_6$  per mole of  $B_4H_{10}$  used, but it can be compared to column 8 in Tables XI and XIII.) Furthermore, the ratio of moles of partial oxidation product formed to moles of tetraborane used is about 0.9, with or without the presence of excess diborane. This indicates that the kinetic steps which involve diborane production do not need to lead directly to the formation of partial oxidation product. Thus the reaction may be understood more readily if represented approximately as follows:

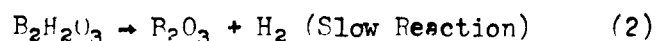
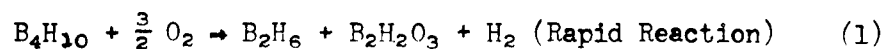

## 2. Partial Oxidation Product Identification

Identification of the partial oxidation product  $B_2H_2O_3$  was made by comparison of its mass spectrum and infrared spectrum with those obtained by both Hammond and Bauer,<sup>21</sup> and Shapiro<sup>38</sup> independently in the oxidation of pentaborane-9. During the course of the reaction between tetraborane and oxygen, the pressure of partial oxidation product was seen to rise to a maximum and then recede. Figure 24 shows the change that occurs in the infrared gas reaction cell after the oxygen flow has been stopped. The mixture was allowed to stand for about three days and an infrared spectrum was obtained. The results show that in about seventy-two hours  $2.0 \times 10^{-5}$  moles  $cm^{-3}$  of tetraborane are lost,  $2.3 \times 10^{-5}$  moles  $cm^{-3}$  of diborane are formed,  $5.3 \times 10^{-5}$

Figure 24  
Partial Oxidation Reaction of Tetraborane with Oxygen,  
Reaction Mixture Allowed to Stand Three Days

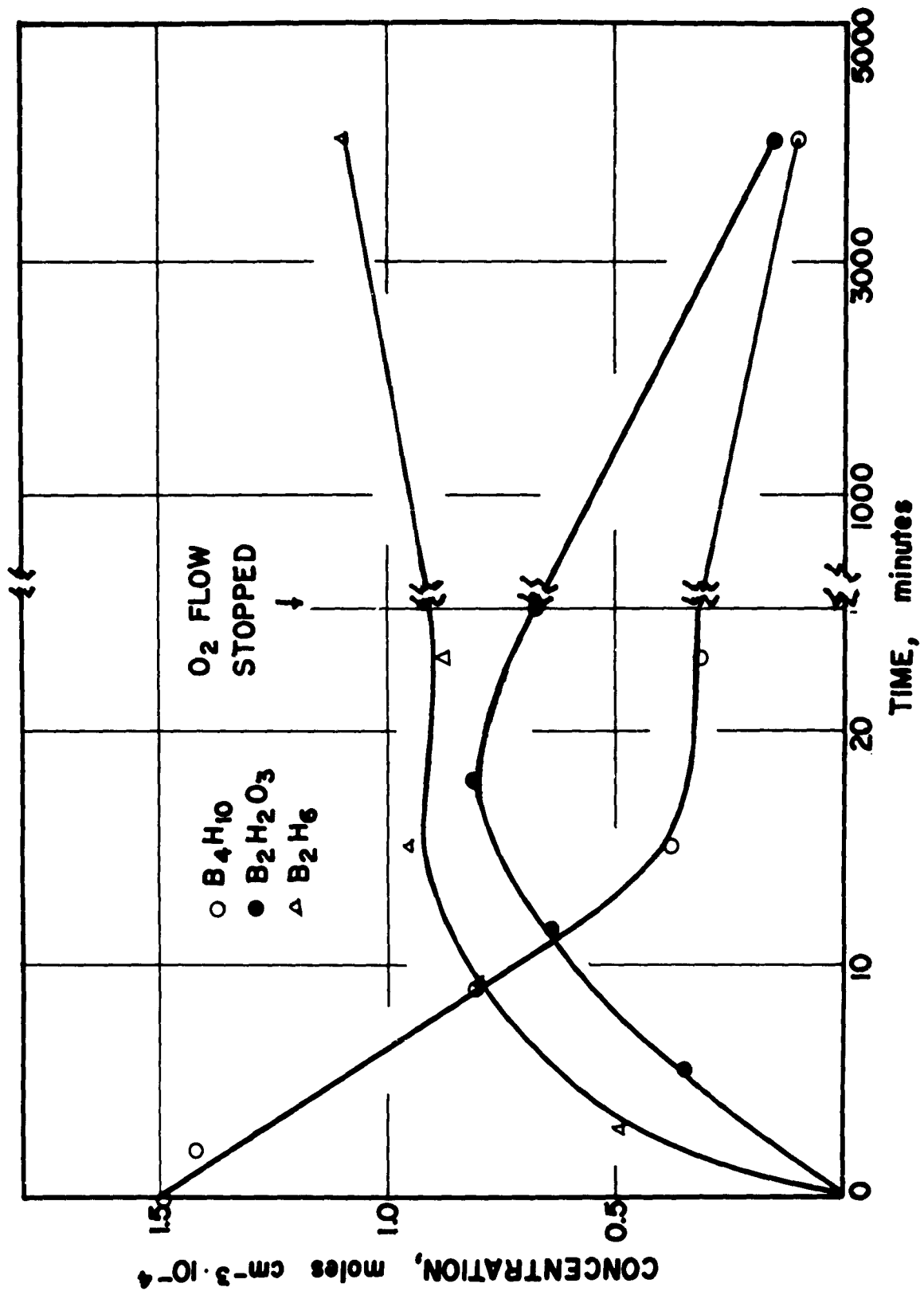

moles  $\text{cm}^{-3}$  of partial oxidation product are lost and a total molar gaseous concentration change corresponding to  $+2.7 \times 10^{-5}$  moles  $\text{cm}^{-3}$  is observed. Since tetraborane will thermally decompose to give both hydrogen and diborane, this would account for an apparent increase in concentration of  $2.0 \times 10^{-5}$  to  $2.3 \times 10^{-5}$  moles  $\text{cm}^{-3}$  while actually an increase of  $2.7 \times 10^{-5}$  moles  $\text{cm}^{-3}$  was observed. The concentration of partial oxidation product drops from  $6.8 \times 10^{-5}$  to  $1.5 \times 10^{-5}$  moles  $\text{cm}^{-3}$  during this interval. Any change in the number of gaseous molecules due to its decomposition should be either plus or minus  $5.3 \times 10^{-5}$  moles  $\text{cm}^{-3}$ . Since such a large change is not observed, this could be explained by the reaction

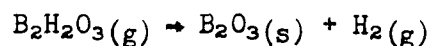

where no change in total molar gaseous concentration would be observed. Direct verification of this could only be obtained by studying the behavior of partial oxidation product under controlled conditions.

### 3. Interesting Features of the Partial Oxidation Reaction

In the course of studying the partial oxidation of tetraborane, it was observed that one mm Hg of water vapor completely stops the reaction. One to two mm Hg of diethyl ether inhibits or completely stops the reaction; see Table XIV. The reaction does not proceed in the same manner if tetraborane is leaked slowly into oxygen or if tetraborane and oxygen are premixed and heated; rather, an explosion may result. The order of admission of one reactant to another is important, and we observe the partial oxidation does not proceed if the partial pressure of oxygen is high relative to the partial pressure of tetraborane, rather



TABLE XIV

Inhibition of Partial Oxidation Reaction

1	2	3	4	5	$t_6$	7	8	9	10
Ser. No.	Temp. °C	Pres. B <sub>4</sub> H <sub>10</sub> Time Zero	Initial Rate of O <sub>2</sub> Added mm/min	Initial Rate of B <sub>4</sub> H <sub>10</sub> Used mm/min	Mole Ratio $\frac{O_2 \text{ Added}}{B_4H_{10} \text{ Used}}$	Moles B <sub>2</sub> H <sub>6</sub> Formed Divided by Moles B <sub>4</sub> H <sub>10</sub> Used	Moles B <sub>2</sub> H <sub>2</sub> O <sub>3</sub> Formed Divided by Moles B <sub>4</sub> H <sub>10</sub> Used	Inhibitor	Length of Time O <sub>2</sub> Added Min
74	27.0	14	2.4	0.2	12.0	0	0.10	Ether, 1 mm	26
75	24.0	16	2.4	0.3	8.0	0	0	Ether, 2 mm	18
76	24.8	16	2.4	0	∞	0	0	Ether, 2 mm	20
77	29.0	20	2.4	0	∞	0	0	Water, 2 mm	55

Columns 7 and 8 measured at half-time with respect to disappearance of tetraborane.

(Volume of infrared cell 204 cm<sup>3</sup>.)

† Obtained by dividing column 4 by column 5.

explosion may result. It is believed that water vapor reacts much more rapidly with  $BH_3$  groups than any other borane reactive species, and would be considered an excellent scavenger<sup>40</sup> for  $BH_3$  groups.

#### 4. Requirement of Any Reaction Mechanism

Any reaction mechanism to explain equations (1) and (2), page 66, would be quite complicated since a product, partial oxidation product, is decomposing during the reaction period. Furthermore, in the presence of the reaction product diborane, the reaction proceeded with a changed net production of diborane from tetraborane. There is an indication that the diborane which is present in the infrared reaction cell is reacting as shown in Figures 17, 21 and 22. The diborane concentration is seen to rise to a maximum and recede as the partial oxidation of tetraborane proceeds.

Any reaction mechanism to explain the explosive-nonexplosive system of reactions should take into account the following:

- a. Show  $BH_3$  as a reacting group because of the inhibition of the reaction by water vapor.
- b. Explain the formation of relatively large amounts of diborane.
- c. Explain why explosion always results in the presence of high oxygen concentration. This was shown in the fifty explosions using Pyrex glass bulbs where the oxygen was added to tetraborane in the condensed state and the mixture was allowed to warm to room temperature and then heated to explosion. On the other hand, the partial

oxidation of tetraborane could be obtained by a slow addition of oxygen to tetraborane through a microport but not by the controlled addition of tetraborane to oxygen.

- d. Explain why the partial oxidation does not appear to go to completion; that is, all the tetraborane is not consumed although oxygen and tetraborane are present when the reaction ceases.

##### 5. Discussion of Error Sources in the Partial Oxidation Reaction

Experimental errors in the investigation of the partial oxidation were estimated to be the following, at least:

- a. Error in reading the mercury manometer attached to the infrared gas reaction cell  $\pm 1.0$  mm Hg.
- b. Error due to the temperature change during the course of the reaction  $\pm 0.1^\circ\text{C}$ .
- c. Error in obtaining pressure from absorbance values  $\pm 10\%$ .

The error in obtaining pressure from absorbance values is much larger at high absorbances due to compression of the log scale; however, the relative error remains about the same since the pressure is increasing as the error in absorbance increases. That the total pressure of gases measured experimentally agrees with the pressure calculated from absorbance values assuming the

equation

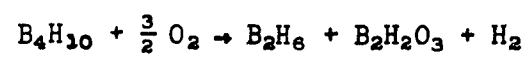

at  $t_{3/4}$  can be seen in Table X, the last two columns.

## PART VI.

## CONCLUSION

A. Nature of the Explosive Reaction

Calculations on the dissociation of oxygen show there are practically no oxygen atoms present on initial mixing of oxygen and tetraborane at 300°K; therefore chain branching would be the only reasonable way for transition from no explosion to explosion.  $K_p$  for the reaction  $O_2 \rightleftharpoons 2 O$  is about  $10^{-33}$  at 300°K,

$$P_O = 10^{-19} \sqrt{P_{O_2}},$$

where  $P_O$  is the pressure of oxygen atoms at 300°K. Therefore the concentration of oxygen atoms is about 0.48 atoms oxygen per  $cm^3$ . If we take 1 atom of oxygen per  $cm^3$  of reacting material, and each oxygen atom regenerates an oxygen atom upon reaction, the rate of reaction would be no greater than the collision frequency

$$ZNONB_4H_{10} = 10^{-10} \times 1 \times 10^{17} = 10^7.$$

So  $10^7$  molecules per  $cm^3$  per second would react, and if we have about 30 mm pressure it would take  $\frac{10^{17}}{10^7} = 10^{10}$  seconds for reaction.

On the other hand, if the reaction involved one oxygen atom regenerating two oxygen atoms or two free radicals (that is, we have one forms two, and two forms four, etc.), then  $1 + 2 + 4 + 8 \dots 10^{17}$  or approximately  $2^n = 10^{17}$ , then  $n = 85$  collisions at 100% efficiency. Even at efficiencies of one percent, only 8,500 collisions are needed. If we have  $10^7$  collisions per second, we need only about  $8.5 \times 10^{-4}$  seconds to complete the reaction. Thus, chain branching provides a more logical picture of what is happening at 300°K to the

reaction mixture of tetraborane plus oxygen.

One result of the explosion limit data indicates that the region where a homogeneous reaction may be found is above 70 mm Hg total pressure, or in other words, the entire region investigated appears to be the region of the first explosion limit.<sup>26</sup> Any further explosion limit work should include the region from 70 mm Hg to 760 mm Hg with the proper safeguards which would be necessary to undertake this work. Somewhere in this region we would expect the explosion limits for the reaction in bulbs of varying diameters to merge, indicating that the wall of the vessel no longer plays such an important role in the reaction.

#### B. Mechanism of the Oxidation Reaction

A mechanism for the oxidation of tetraborane which takes into account other oxidations, pyrolysis reactions, and the main characteristics of the oxidation reaction, is proposed as follows:

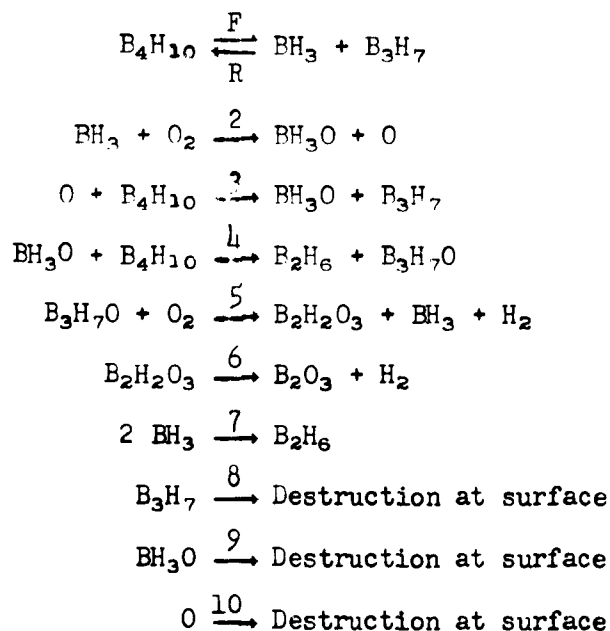

The first steps given in the mechanism are the reactions of decomposition of tetraborane to form  $\text{BH}_3$  and  $\text{B}_3\text{H}_7$ , and the recombination of these two groups to form tetraborane. These reactions are proposed since the presence of  $\text{BH}_3$  was inferred from the inhibition of the reaction by water vapor. Also, much of the chemistry of tetraborane has been explained by Parry<sup>5</sup> and Edwards, and Pearson<sup>6</sup> and Edwards, using these reactions. Reaction 2, the attack of  $\text{BH}_3$  on  $\text{O}_2$ , was first proposed by Roth<sup>9</sup> and Bauer in the investigation of the explosive oxidation of diborane. In this reaction, two materials are being formed which can carry the chain,  $\text{BH}_3\text{O}$  and  $\text{O}$ , and this coupled with reaction 3 produces two  $\text{BH}_3\text{O}$  groups for one  $\text{BH}_3$  group used.

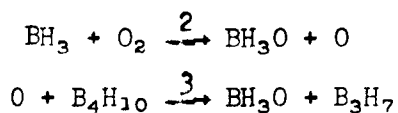

Furthermore, both the  $\text{BH}_3\text{O}$  group and the oxygen atom formed in reaction 2 would be expected to react with the substance in largest concentration, tetraborane.



Thus, the  $\text{BH}_3\text{O}$  group in reaction 4 can react with tetraborane to produce diborane which is a reaction product in the infrared cell, and  $\text{B}_3\text{H}_7\text{O}$  which is capable of further reaction. The reaction of  $\text{B}_3\text{H}_7\text{O}$  with  $\text{O}_2$  is proposed to explain the formation of partial oxidation product and hydrogen as was observed in the infrared reaction cell, as well as to provide another source of  $\text{BH}_3$  groups.



The reactive species  $\text{BH}_3$  is furnished by the decomposition of tetraborane as well as by reaction 5 and is removed by reactions R, 2 and 7 as shown

below.

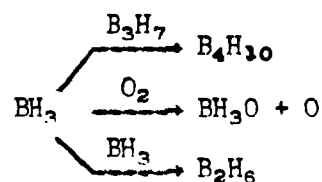

of these three possible reactions, reaction with  $\text{O}_2$  would be most probable since it is in largest concentration in the glass bulbs. Reaction 6, the decomposition of partial oxidation product, is included since evidence for it was previously given. The further removal of the reactive species  $\text{BH}_3\text{O}$ ,  $\text{O}$ , and  $\text{B}_3\text{H}_7$  by collision with the wall of the vessel is proposed to explain the results of the explosive oxidation of tetraborane. The net result of chain initiation in the gas phase and breaking on the wall as was observed, and the facilitation of explosion by the presence of inert gas in the reaction mixture are the basis for inclusion of these steps. The reaction which proceeds in the infrared reaction cell is believed to be one of extreme rapidity, which is limited by the supply of the reactant oxygen. Reaction 2 would be an extremely rapid reaction and would certainly be limited if the concentration of oxygen were small. The proposed mechanism includes a chain initiating reaction, the tetraborane decomposition, a chain branching reaction, 2, and several chain propagating reactions, 3, 4, and 5, as well as the chain breaking steps R, 7, 8, 9, and 10.

The proposed mechanism is undoubtedly an oversimplification of the true reaction mechanism and is deficient to the extent that it does not explain why the partial oxidation reaction does not go to completion. The presence of reactions other than those proposed is certainly possible in such a complicated system, but it is felt that these reactions postulated explain most of the experimental facts.



Since the explosive oxidation and the partial oxidation of tetraborane show many similarities to the oxidation of pentaborane-9, it would be interesting to study the explosive reaction of tetraborane in the presence of the inhibitor iron pentacarbonyl as was done by Baden.<sup>20</sup> The discovery of a nonexplosive reaction between tetraborane and oxygen in the presence of lead tetraethyl should be pursued further due to its unusual behavior contrasted with tetraborane and oxygen alone. The role of the inhibitor would undoubtedly involve experimental work on an important chemical problem.

Now that the oxidation of tetraborane and the oxidation of pentaborane-9 have been studied and their similarities noted, the oxidation of pentaborane-11 would be of great interest since one could not help but expect similarities in the reaction of this compound with oxygen.

Work should now be undertaken to investigate the behavior of partial oxidation product. Since this compound has been found in the reaction systems of diborane, pentaborane-9, and tetraborane with oxygen, its mechanism of decomposition and apparent stability as a gas and instability in the condensed state deserve further attention. Furthermore, the equilibrium between diborane and partial oxidation product as proposed by Shapiro<sup>38</sup> and Goldstein<sup>10</sup> should be investigated.

A more concentrated effort should now be undertaken to put the oxidation of the boron hydrides on a basis which explains the experimental facts these reactions have in common: specifically, the production of partial oxidation product from the oxidation of diborane, tetraborane and pentaborane-9, and the formation of diborane from the partial oxidation of tetraborane and pentaborane-9.

## PART VII.

## LITERATURE CITED

1. Stock, A., "Hydrides of Boron and Silicon," Cornell University Press, Ithaca, N.Y., 1933.
2. Burg, A., and Stone, F., J. Am. Chem. Soc., 75, 228 (1953).
3. Edwards, L., and Hough, W., Callery Chemical Company, unpublished data.
4. Kodama, G., and Parry, R., Doctoral Dissertation, University of Michigan, 1957.
5. Parry, R., and Edwards, L., J. Am. Chem. Soc., 81, 3554 (1959).
6. Todd, J. E., and Koski, W. E., J. Am. Chem. Soc., 81, 2319 (1959).
7. Shapiro, I., and Weiss, H. G., J. Phys. Chem., 63, 1319 (1959).
8. Pearson, R., and Edwards, L., Callery Chemical Company, "The Thermal Decomposition of Tetraborane," unpublished data.
9. Roth, W., and Bauer, W. H., J. Phys. Chem., 60, 639 (1956).
10. Goldstein, M. S., Ph. D. Thesis, Rensselaer Polytechnic Institute, 1960.
11. Whatley, A. T., and Pease, R. N., J. Am. Chem. Soc., 76, 1997-9 (1954).
12. Price, F. P., J. Am. Chem. Soc., 72, 5361 (1950).
13. Berl, W. G., and Dembrow, D. W., Nature, 170, 367 (1952).
14. Kurz, P. F., Ind. Eng. Chem., 48, 1863-8 (1956).
15. Parker, W. G., and Wolfhard, H. G., Fuel, 35, 323-32 (1956).
16. Breisacher, P., Dembrow, D., and Berl, W. G., "Seventh Symposium on Combustion," pp. 894-902, Academic Press Inc., New York, 1959.
17. Roth, W., J. Chem. Phys., 28, 668-70 (1958).
18. Poling, E. L., and Simon, H. P., Ind. Eng. Chem., 50, 1695-8 (1958).
19. Sample, P. E., and Simon, H. P., Ind. Eng. Chem., 50, 1699-1702 (1958).

20. Baden, H., Ph. D. Thesis, Rensselaer Polytechnic Institute, 1954;  
Baden, H., Wiberley, S. E., and Bauer, W. H., J. Phys. Chem.,  
59, 287 (1955).
21. Hammond, J. A., Ph. D. Thesis, Rensselaer Polytechnic Institute,  
1958.
22. Snyder, A. D., Ph. D. Thesis, Rensselaer Polytechnic Institute,  
1957.
23. "Handbook of Chemistry and Physics," 38th ed., Chemical Rubber  
Publishing Company, Cleveland, Ohio.
24. Nordman, C. E., and Lipscomb, W. N., J. Am. Chem. Soc., 75, 4116  
(1953).
25. Semenov, N. N., "Some Problems in Chemical Kinetics and Teactivity,"  
Vol. II, pp. 81-86, Princeton University Press, Princeton, N.J.,  
1959.
26. Hinshelwood, C. N., "Chemical Kinetics and Chain Reactions," Oxford  
University Press, New York, 1935.
27. Roth, W., and Scheer, M. D., Advances in Chem. Ser., "Literature on  
the Combustion of Petroleum," J. Am. Chem. Soc., pp. 85-103.
28. Christiansen, J. A., Kgl. Danske Videnskab. Selskab Mat.-fys. Medd.,  
1, 14 (1919).
29. Herzfeld, K. F., Z. Elektrochem., 25, 301 (1919).
30. Herzfeld, K. F., Ann. Physik, 59, 635 (1919).
31. Polanyi, M., Z. Elektrochem., 26, 50 (1920).
32. Paneth, F., and Hofeditz, W., Ber., B, 62, 1335 (1929).
33. Paneth, F., and Lautsch, W., Ber., B, 64, 2702 (1931).
34. Rice, F. O., and Herzfeld, K. F., J. Am. Chem. Soc., 56, 284 (1934).
35. Semenov, N. N., "Some Problems in Chemical Kinetics and Reactivity,"  
Vol. I, p. 1, Princeton University Press, Princeton, N.J.,  
1959.
36. Shapiro, I., Weiss, H. G., Schmich, M., Skolnik, S., and Smith,  
G. B. L., J. Am. Chem. Soc., 74, 901 (1952).
37. Klein, M. J., Harrison, B. C., and Solomon, I. J., J. Am. Chem.  
Soc., 80, 4149 (1958).

38. Ditter, J. F., and Shapiro, I. J., Am. Chem. Soc., 81, 1022 (1959).
39. Semenov, N. N., "Some Problems in Chemical Kinetics and Reactivity," Vol. I, Chap. VI, Princeton University Press, Princeton, N.J., 1959.
40. Weiss, H. G., and Shapiro, I., J. Am. Chem. Soc., 75, 1221 (1953).
41. Schaeffer, R. W., Ludlum, K. H., and Wiberley, S. E., J. Am. Chem. Soc., 81, 3157 (1959).
42. Schaeffer, Riley, "Report of Evidence for Heptaborane," American Chemical Society Meeting, April, 1959.

## PART VIII.

## APPENDIX

Mass Spectrometric Evidence for Heptaborane<sup>41</sup>

In mass spectrometric examination of tetraborane prepared by the method of Klein,<sup>37</sup> Harrison and Solomon, the mass versus intensity pattern of a new group of peaks from 77 through 89, with a maximum at 83, was noted. This was attributed to a B<sub>7</sub> compound B<sub>7</sub>H<sub>15</sub> for which other independent data had been presented by Riley Schaeffer.<sup>42</sup>